



# **Falcon Highlands South**

## **Preliminary Drainage Report**

### **Owner/Developer**

Challenger Homes  
8605 Explorer Drive Ste. 250  
Colorado Springs, CO 80920  
(719) 598-5192  
Contact: Jim Byers

### **Engineer**

Atwell, LLC  
143 Union Blvd., Suite 700  
Lakewood, CO 80228  
303-462-1100  
Contact: Daniel Madruga, PE

### **Atwell Project Number**

21005234

***Submitted by: Atwell, LLC***

**March 06, 2024**

**PUDSP-22-005**



## Table of Contents

INTRODUCTION .....	1
GENERAL LOCATION AND DESCRIPTION.....	1
SOILS AND EXISTING SITE CONDITIONS .....	3
FLOODPLAIN .....	4
DRAINAGE DESIGN CRITERIA.....	4
EXISTING ONSITE AND OFFSITE DRAINAGE BASINS .....	5
PROPOSED DRAINAGE BASINS .....	8
STORM WATER CONVEYANCE AND STORAGE FACILITIES.....	26
FOUR STEP PROCESS .....	29
WATER QUALITY ENHANCEMENT BEST MANAGEMENT PRACTICES.....	30
MAINTENANCE .....	30
FLOODPLAIN MODIFICATIONS.....	31
CONCLUSION.....	31
REFERENCES .....	32
APPENDIX A	VICINITY MAP
APPENDIX B	SOILS SURVEY
APPENDIX C	FEMA FIRMETTE
APPENDIX D	HYDROLOGICAL CALCULATIONS
APPENDIX E	HYDRAULIC CALCULATIONS
APPENDIX F	REFERENCE DOCUMENTS
APPENDIX G	DRAINAGE MAPS

## **INTRODUCTION**

This Preliminary Drainage Report (PDR) has been completed for Challenger Homes in order to present an effective storm water management plan for the Falcon Highlands South development, hereinafter referred to as the Site. This report is intended to guide the development of the site and recommend general drainage concepts that can be implemented as development progresses. Included within this report is a proposed drainage plan for the Site along with reference information for drainage basins and storm water conveyance facilities.

The Site was most recently studied at the Final Drainage Report (FDR) level in the *Falcon Highlands Filing No. 2 & 3 Final Drainage Report* by Terra Nova Engineering, Inc., latest revision August 2010 for the development of Filing No. 2. It was reassessed for the new site plan layout in the most recent Master Development Drainage Report (MDDP) by Atwell, LLC. dated March of 2022, which is pending County approval as part of the Sketch Plan Amendment for Falcon Highlands South (named as Falcon Highlands Filing No. 3 during Sketch Plan, SKP-21-4). The PDR follows the concepts discussed in the 2022 MDDP and provides more design details for public and private storm infrastructure including the subdivision's public storm sewer systems and water quality and full-spectrum detention facilities.

The entire site for Falcon Highlands South is approximately 125.6 acres and will include a total of approximately 378 single-family residential units. This is an additional 222 units from the previously approved reports of 156 units which had more quarter-acre and half-acre lots. In addition to greater lot density, roadway alignments have changed to accommodate the new lot layouts with approximately 2.75 miles of right-of-way improvements for paved roadways, curb and gutter, and attached sidewalks with 12.2 acres of open space interior to the subdivision not including tracts for drainage easements, with a dedicated park area central to the subdivision. This compares to the previously approved plans which had approximately 2.5 miles of right-of-way improvements and 7.0 acres of open space interior to the subdivision not including tracts for drainage easements, with no designated park areas. The drainage exhibits and calculations within the appendix present Filing No. 2 and other off-site basins consistent with that of previous reports. The total acreage of Filing No. 2 and 3 is approximately 257.7 acres and a portion of Filing No. 1 area totaling 10.6 acre was included for consistency in presenting tributary areas to existing detention ponds with that of previous studies.

Proposed herein is a network of storm infrastructure, ponds and channels that will meet the relevant criteria for storm water quality and detention, but also allow for aesthetically pleasing landscape and enjoyable green spaces within the PUD community.

## **GENERAL LOCATION AND DESCRIPTION**

The Site is located within Section 12, Township 13 South, Range 65 West of the Sixth Principal Meridian, County of El Paso, State of Colorado. The Site is bounded by Tamlin Road to the south and east, Birch Hollow Way to the north and Bridal Vail Way to the west for the northern portion of the Site and Antelope Meadow Circle to the north for the western end of the Site. The Site, or

Falcon Highlands South specifically, is directly adjacent and south of Falcon Highlands Filing No. 2 and adjacent to the east and north of Banning Lewis Ranch subdivisions. The overall area consists of approximately 125.6 acres that is proposed to be developed into approximately 380 single-family residential units including 24 nearly half-acre lots, 243 one-eighth acre lots, 113 smaller (one-twelfth acre) lots. In addition to the single-family residential units and lots, there is proposed development for approximately 37 acres of open space, a well site, and associated roadways and landscaping. Of these 37 acres, approximately 12.2 acres is interior to the development which includes a park area of 3.53 acres. An off-site lift station property subject to potential upgrades to serve the development exists to the south-central area of the Site.

The filing is initially planned to be built in two phases and two subsequent future phases pending a second well for water supply. This phasing will allow the Metro District time to plan and accommodate for the approximately 55 water service taps in the initial Phase 1 of the development based on the current available water. Phase 2 is for the additional 191 taps following the new well connection. Two future phases that include the remaining lots are included within this study to encompass the development of the entire Falcon Highlands South as well as off-site, upstream Filing No. 2.

A map displaying the location and delineation of the Falcon Highlands Filings 1, 2, and 3 is shown below.



## **SOILS AND EXISTING SITE CONDITIONS**

The majority of the Site is currently undeveloped. Of the development within the Site, there are existing dirt roadways and sanitary sewer infrastructure installed per the Construction Drawings for Falcon Highlands Filing No. 2 prepared by Terra Nova Engineering, most recent revised date of September 7, 2010. The ALTA survey conducted by Atwell, LLC., shows the existing conditions of Falcon Highlands South and adjacent development of Filing No. 2. The Site is nearly 100% existing natural grass vegetation typical of the eastern plains with sparse vegetative cover at its outer limits to the south and southeast. There is an existing regional drainage pond referred to as Pond WU, east of the Site within Falcon Highlands Filing No. 2 dedicated to water quality and detention for storm water runoff from Falcon Highlands Filing No. 1, 2, and a small portion (Basin D) of Falcon Highlands South. There are two existing water quality and detention ponds to the south of the Site that were constructed for the development of Filing No. 2 that were designed for future development of Falcon Highlands South. The on-site slopes range from 0 percent to 10 percent and generally sheet flows from west to east. An Existing Conditions Drainage Map is included in Appendix G showing the delineated drainage basins.

The west boundary of the Site has existing electric power lines and natural gas main within an existing utility easement. There are existing sanitary sewer and storm lines within existing dedicated easements within the western part of the Site that connect to Filing No. 2 to service sanitary sewer to the lift station and storm water daylighting within the Falcon Highlands South property. The south side of the Site has a 12" water main and a fiber optic line within what is considered future Tamlin Road right of way.

The Site is made up of mostly loamy sand soils with 100 percent of the soils being Hydrologic Soil Group A. The on-site soils are specified as Blakeland loamy sand (8), Blakeland Complex (9), and Columbine (19) as mapped by the Soil Conservation Service (SCS). The Natural Resources Conservation Service of the United State Department of Agriculture Web Soil Survey has been included in Appendix B for reference.

The western two thirds of the Site are contained within the Sand Creek Basin, the rest within the Falcon Basin. The delineations is shown on the Drainage Maps within Appendix G.

Per previous drainage studies for the Site and the environmental study for Filing No. 1, there is a high ground water table that should be addressed with the final soils reports for this development. It is recommended that subsurface drains be installed for proposed structures. No basements or crawlspaces are proposed in the southwest area of the Site due to the high ground water table and any proposed garden level or walkout lots on the preliminary grading plans are to be assessed in further in the final subsurface investigation report.

Drainage improvements for the Site will include storm sewer infrastructure to capture runoff before street capacities are exceeded and at sump locations as well as channels and swales for potential overflow areas. The existing detention and water quality ponds south of the Site are assessed in this report at a preliminary stage to determine if any required retrofitting of the storm infrastructure within the existing ponds is to be constructed according to engineered construction

drawings and a Final Drainage Report for Falcon Highlands South. This infrastructure includes general earthwork efforts, concrete trickle channels, micropools and outlet structures with orifice plates sized for new runoff calculations, Water Quality Capture Volumes (WQCV), Excess Urban Runoff Volumes (EURV), and 100-year detention with the allowable release rates.

## **FLOODPLAIN**

According to the Federal Emergency Management Agency's (FEMA) Flood Insurance Rate Map No. 08041C0561G and 08041C0545G dated December 7, 2018, the vast majority of the Site lies within Zone X, which is designated as "Areas determined to be outside the 0.2% annual chance flood hazard area", a portion of the site to the east that is proposed open space is located within a Zone A, which is designated as "Areas determined to be within the 0.2% annual chance flood hazard area". The Zone A designation to the east of Tamlin Road is comprised of an Unnamed Tributary that drains to the Black Squirrel Creek No. 2. The FEMA FIRM, Community Panels Nos. 08041 C 0561 G and 08041 C 0545 G (effective December 7,2018) are included in Appendix C for reference.

El Paso County is involved with the Colorado Hazard Mapping Program (CHAMP) because the CWCB delegates its authority to the County to enforce the regulatory floodplain. El Paso County is part of the NFIP (National Flood Insurance Program) which provides assistance to property owners affected by flooding. Inclusion into this program requires that the County enforce floodplain regulations and any changes made to the regulatory maps. Failure to implement these changes could result in the County losing its NFIP status as such a Preliminary FEMA FIRM panel is also included in Appendix C that was remapped as part of CHAMP.

The site falls within the Sand Creek Drainage Basin as well as partially within the Falcon Drainage Basin. The Sand Creek DBPS was adopted by the City, but not the county, and the Falcon DBPS was adopted by the County, but not the City. The Drainage Basin Planning Studies for the respective basins do not show or mention any existing or future plans within the Site. Drainage from the site will outflow per existing drainage patterns and there will be no drainage basin transfer. The wetland area located near the Site will not be affected by development of the Site and is to be designated as protected wetland mitigation area on the final plat. There is to be no disturbance of this area and it is to remain within its jurisdiction for maintenance as needed.

## **DRAINAGE DESIGN CRITERIA**

The El Paso County Drainage Criteria Manual (EPC DCM) and El Paso County Engineering Criteria Manual (EPC ECM) were used in conjunction with the Mile High Flood District (MHFD) Criteria Manual. The rational method was used for drainage basin less than 100-acres. The 5-year design frequency was used for the minor storm and a 100-year design frequency was used for the major storm in calculating onsite storm facility hydraulics. The one-hour point rainfall depth used for the 5-year storm was 1.50 inches and 2.52 inches for the 100-year event. The City of Colorado Springs IDF Curve (Figure 6-5 of the Drainage Criteria Manual Volume 1) was used for calculating rainfall intensity. Wetland permit conditions are being met, USACE Wetland Mitigation Permit 2000-00359 was received on January 25, 2005.

## **EXISTING ONSITE AND OFFSITE DRAINAGE BASINS**

The Site has been assessed previously via the *Falcon Highlands Phase 2, Filing No. 2 & 3 Master Development Drainage Plan and Preliminary Drainage Report* (County Project SF-05-003) developed by Terra Nova Engineering, Inc. latest revision September 2005. Additionally, the site has been assessed in the *Falcon Highlands South Master Development Drainage Plan* developed by Atwell, LLC dated March of 2022, pending County approval.

The developments of Falcon Highlands Filing Nos. 1 & 2 remained consistent with their respective Master Development Drainage Plans and Final Drainage Reports and therefore offsite drainage basin descriptions and delineations provided in this report are based on those previous County approved reports. Relevant excerpts from these reports are included in Appendix F including hydrology tabulations and drainage maps in which pipe runs were utilized to determine offsite drainage contributions to Falcon Highlands South storm water facilities.

All off-site drainage basin runoff data and calculations have been updated for current codes and standards consistent with the EPC DCM. Part of the Site lies within the Sand Creek Basin and the other part within the Falcon Basin. Therefore, the *Sand Creek Drainage Basin Study* and the *Falcon Basin Drainage Basin Planning Study* were both referenced as well as the El Paso County Master Plan approved in May of 2021. Previous studies show the delineation between the two basins and this delineation is shown on the Drainage Basin Maps in Appendix G.

The site has been broken down into eight major off-site basins upstream of Falcon Highlands South, within the existing development of Filing No. 2 and relatively small portions of Filing No. 1. The off-site basins match the naming convention of the previous 2010 Final Drainage Report for Filing No. 2 and 3 to be consistent and for ease of comparison between this report and previous reports. An Existing Conditions Drainage Map is in Appendix G.

### **Off-Site Basins (Filing No. 2):**

**OS-1 (6.38 ac,  $Q_5 = 10.7$  cfs,  $Q_{100} = 21.7$  cfs)** is an off-site basin located on the northwestern part of Falcon Highlands Filing No. 2 and consists of the rear yard areas of PUD residential zoned lots. The historic drainage pattern sheet flows southwesterly where it is captured by basin OS-5 at **Design Point 7** and ultimately outfalls into existing Pond 1 through the public 60" RCP storm pipe that runs through Falcon Highlands South, the pipe run at **Design Point 11**.

**OS-2 (3.12 ac,  $Q_5 = 7.8$  cfs,  $Q_{100} = 13.6$  cfs)** is an off-site sub-basin within the developed area of Filing No. 1 for quarter-acre lots and is an off-site basin that was included in the MDDP for Filing No. 2. The basin's runoff sheet flows due south in Filing No. 2 and is captured by the roadways and storm system in Filing No. 2 that runs through Falcon Highlands South, and ultimately outfalls into the existing Pond 1. The basin flows to OS-5 at **Design Point 8**.

**OS-3 (1.14 ac,  $Q_5 = 3.4$  cfs,  $Q_{100} = 6.0$  cfs)** is an off-site basin within Filing No. 1 that includes the developed right-of-way of Rolling Thunder Way. This sub-basin was included in the previous



MDDP as an off-site basin and represents a portion of the landscaped right-of-way on the south side of Rolling Thunder Way that sheet flows due south into the developed areas of Filing No. 2 at **Design Point 9** and ultimately into the public storm system shared with Falcon Highlands South, outfalling to existing Detention Pond 2.

**OS-4 (13.09 ac,  $Q_5 = 12.3$  cfs,  $Q_{100} = 26.3$  cfs)** is an off-site basin located on the southwestern part of Falcon Highlands Filing No. 2 and consists of mostly Tract A and portions of PUD residential zoned lots rear yard areas. The historic drainage pattern sheet flows south where it is captured by basin A at **Design Point 10**, and per existing drainage patterns is not tributary to on-site detention ponds and drains directly offsite via overland sheet flow.

**OS-5 (59.62 ac,  $Q_5 = 80.1$  cfs,  $Q_{100} = 160.7$  cfs)** is an off-site basin that stretches from the eastern border of basin OS-4 to the eastern edge of Bridal Vail Way within Filing No. 2. The basin is zoned as PUD residential lots of about quarter-acre size. Runoff is carried in the public rights-of-way where the flow travels south through a series of public curb and gutters, sump inlets and storm infrastructure within Filing No. 2. The flow outfalls into the existing Pond 1 through the public 60" RCP storm pipe that runs through Falcon Highlands South, the pipe run at **Design Point 11**. No surface flow from this basin enters the Site.

**OS-6 (35.75 ac,  $Q_5 = 31.9$  cfs,  $Q_{100} = 58.4$  cfs)** is off-site basin located between Bridal Vail Way and Antelope Meadows Circle within Filing 2. This basin includes PUD residential zoned lots of half-acre size and contains drainage tracts. The basin is captured by a series of public curb and gutter systems in the rights-of-way where public storm infrastructure conveys storm water to the end of the cul-de-sac of Wagon Track Drive where the public storm system of Filing No. 2 (**Design Point 12**) connects and daylights to Falcon Highlands South within future Antelope Meadows Circle right-of-way. Flows continue through Falcon Highlands South via an existing diversion ditch to Pond 2.

**OS-7 (6.47 ac,  $Q_5 = 5.2$  cfs,  $Q_{100} = 18.3$  cfs)** is the off-site basin located within Filing 2, just north of Basin D of Filing 3. The basin includes PUD residential zoned lots of half-acre size with right of way. The basin runoff is captured in the public right-of-way curb and gutter where it travels south and is released at the road end at **Deign Point 13** where it continues south through Antelope Meadows Circle and then due east through Falcon Highlands South's Basin D in the existing access path where it outfalls to Pond WU.

**OS-8 (13.79 ac,  $Q_5 = 4.6$  cfs,  $Q_{100} = 31.1$  cfs)** is an off-site basin located east of Basin D. The basin consists of native grasses and an existing Regional Pond WU. Runoff within the basin flows into the Pond WU (**Design Point 4**) and drains to the northwest side of Highway 24 via the existing private 42" and three 60" RCP outlet pipes to the low point in the offsite grasslined swale at **Design Point 6**.

## **On-site Basins (Falcon Highlands South, Undeveloped):**

The site has been broken down into seven major on-site basins upstream within the limits of Falcon Highlands South. A drainage map is in the appendix.

**Basin A (3.74 ac,  $Q_5 = 1.15$  cfs,  $Q_{100} = 7.7$  cfs)** is the basin located southwest of Antelope Meadow Circle, just below basin OS-4, west of Basin B. The majority of the basin is comprised of Tract F and consists of some rear yard runoff from the PUD lots at the western edge of Basin B. The storm water runoff from this basin sheet flows south and off-site at **Design Point 1** with the combined flow of OS-4, and per existing drainage patterns is not tributary to on-site detention ponds.

**Basin B (38.93 ac,  $Q_5 = 11.65$  cfs,  $Q_{100} = 78.20$  cfs)** is located south of Antelope Meadow Circle, adjacent to basin A. The site is covered in native grasses with limited grading work from a previous development. Runoff from the site sheet flows southwesterly overland to existing Pond 1 (**Design Point 2**). The private 42" RCP outlet pipe from the outlet structure of the pond daylights at the grassland swale south of the abandoned future Tamlin Road right-of-way at **Design Point 5**.

**Basin C (57.81 ac,  $Q_5 = 18.4$  cfs,  $Q_{100} = 123.57$  cfs)** is located adjacent to Basin B and covered in native grasses and weeds. The site has limited grading due to work from a previous development that did not finish. Runoff from the site sheet flows southwesterly overland to an existing diversion ditch that spans from an existing public 24" RCP storm sewer main that daylights within Falcon Highlands South south of Wagon Track Way. The diversion ditch flows directly to existing Pond 2 (**Design Point 3**). The private 42" RCP outlet pipe from the outlet structure of the pond daylights at the grassland swale south of the project site at **Design Point 6**.

**Basin D (10.54 ac,  $Q_5 = 3.47$  cfs,  $Q_{100} = 23.31$  cfs)** is located to the northeast of the Filing and consists of undeveloped area with native grasses. The basin's runoff drains directly to existing Pond WU (**Design Point 4**).

**Basin E (3.14 ac,  $Q_5 = 1.12$  cfs,  $Q_{100} = 7.5$  cfs)** is the undeveloped, natural landscaped area between Tamlin Road and the existing Pond 1. Runoff from Basin E is directed by a ditch section to a low point between the future Dublin Road and Highway 24 (**Design Point 5**). This drainage concept and its associated storm infrastructure is presented in the previous master plan and is to remain as the intended plan. The 2005 PDR suggested that an inline grate inlet be installed but there is no evidence that this was installed. The existing drainage pattern consists of pooling within the local low point of the ditch that surcharges and is directed south through the grassland swale.

**Basin F (3.67 ac,  $Q_5 = 1.19$  cfs,  $Q_{100} = 7.99$  cfs)** is the undeveloped area between Tamlin Road and the existing Detention Pond 2. The runoff from Basin F is directed to the low point in the downstream grasslined swale between the Site and Tamlin Road (**Design Point 6**). This drainage concept and its associated storm infrastructure is presented in the previous master plan and is to remain as the intended plan. The 2005 PDR suggested that a 4'x4' area inlet be constructed but

there is no evidence that this was installed. The existing drainage pattern consists of pooling within the local low point of the ditch that surcharges and is directed south through the grassland swale.

**Basin G (8.84 ac,  $Q_5 = 6.8$  cfs,  $Q_{100} = 16.0$  cfs)** is the area east of Basin C that is not to be disturbed and remain as open, natural landscape. The runoff from Basin G is collected in a local topographic low point and when overtopping the low point, the runoff continues southeast to the low point in the grasslined swale along Highway 24, **Design Point 6**.

## **PROPOSED DRAINAGE BASINS**

This report has been prepared in accordance with the EPC DCM and the MHFD Criteria Manual. The 5-year storm was used as the minor storm event, while the 100-year storm was used as the major event. The one-hour point rainfall depth used for the 5-year storm was 1.50 inches and 2.52 inches for the 100-year event.

Preliminary grading design of the site has been completed to include right of way design and assignment of lot type A, B, Transition (T), and Walkout (WO). The assigned lots drain per a typical lot template into roadways where sump inlets are located to convey stormwater through the public storm system and outfall to their respective ponds.

The overarching premise of the drainage design is to route overland flow from residential lots and units to adjacent rights-of-way where public storm infrastructure will be installed and ultimately convey the storm water to respective ponds to provide water quality treatment as well as flow attenuation and detention. Previous studies designed Ponds 1 and 2 in order to provide full spectrum detention and water quality for Filing Nos. 2 and 3. The analysis within this report provides more defined pond sizing requirements due to the change in layout for Falcon Highlands South as well as preliminary locations and sizes for inlets, pipes, culverts, and swales. This idea is intended to be followed for the entirety of the developed site. Basins which are not along the main drainageways within the proposed developed areas or which are expected to flow offsite have been analyzed. There are no engineered channels that exit the Site.

There is a proposed grass-lined, natural swale to convey stormwater from the rear of B-lot sites and cul-de-sacs that are the downstream area of roadways within Basin C to existing Pond 2. The design of this swale is to be included in the Final Drainage Report, but preliminary calculations and design have been done for the PDR to accurately assess the width and depth of the drainageway for the minor and major storm events including freeboard requirements. All Pond outlets daylight to south of the future Tamlin Road right-of-way via existing public RCP culvert pipes, but are not directed to any formal channels or drainageways.

The existing Ponds will be analyzed as part of this PDR to ensure that the design meets the standards set forward in the El Paso County Engineering Criteria Manual as well as the Mile-High Flood Control Criteria Manual. The existing pond's detention volume capacity will be confirmed as adequate and infrastructure will be retrofitted as required.

As with the existing conditions, the fourteen existing major drainage basins have been delineated into seven major basins based on preliminary grading of the Site – basins A through G within the limits of Falcon Highlands South and basins OS-1 through OS-8 for off-site basins consistent with the existing conditions for the developed areas of Filing No. 2 and relatively small developed area of Filing No. 1. Of the major basins within the Site, basins A, E, F, and G are consistent with previous reports for Filing Nos. 2 and 3 as these basins are not to be altered during the development of Falcon Highlands South. Basins B, C, and D are the basins in which development of Falcon Highlands South is to occur. Sub-basin analysis within these major basins is provided as a part of the hydrology calculations in order to plan for storm infrastructure and channels on the Site.

There are basins within Falcon Highlands South that are not tributary to on-site water quality and detention ponds. These basins include Basin A, E, F, and G. Basin A consists of the west boundary of Falcon Highlands South and includes electric transmission easement and a small portion of rear lots in which minimal disturbance for landscaped yards is anticipated. There is to be no impervious development within these rear yards and therefore water quality is achieved via grass buffers yielding 100 percent runoff reduction as the vast majority of Basin A is pervious area. Basins E and F are exclusions as they are areas in which there is land disturbance to undeveloped land that will remain undeveloped. Their disturbances are for daylight grading for edges of pond maintenance pathways. Basin G is an exclusion as it will be undisturbed area including the protected wetland area as designated by the plat.

The rational method was used to estimate runoff rates for the proposed development and are in accordance to EPC DCM and any references within the County criteria to the City of Colorado Springs Drainage Criteria Manuals, Volumes 1, 2, and 3. These calculations can be found in Appendix D.

**Basins OS-1, OS-2, OS-3, OS-4, OS-6, OS-7, OS-8, & G** do not differ from existing conditions.

**OS-5 (59.62 ac,  $Q_5 = 80.1$  cfs,  $Q_{100} = 160.7$  cfs)** is an off-site basin that stretches from the eastern border of basin OS-4 to the eastern edge of Bridal Vail Way within Filing No. 2. The basin is zoned as PUD residential lots of about quarter-acre size. Runoff is carried in the public rights-of-way where the flow travels south through a series of public curb and gutters, sump inlets and storm infrastructure within Filing No. 2. The flow outfalls into the existing Pond 1 through the public 60" RCP storm pipe that runs through Falcon Highlands South, the pipe run at **Design Point 11**.

**OS-5.1 (0.79 ac,  $Q_5 = 1.5$  cfs,  $Q_{100} = 3.3$  cfs)** is an off-site basin that encompasses the southern portion of Antelope Meadows Circle west of Honeycomb Drive and the back portion of several proposed residential lots within Falcon Highlands South. Runoff is carried in the public rights-of-way where the flow travels south through a series of public curb and gutters, sump inlets and storm infrastructure within Filing No. 2. The flow outfalls into the existing Pond 1 through the public 60" RCP storm pipe that runs through Falcon Highlands South, the pipe run at **Design Point 11**.

**OS-5.2 (1.18 ac,  $Q_5 = 3.1$  cfs,  $Q_{100} = 6.2$  cfs)** is an off-site basin that encompasses the southern portion of Antelope Meadows Circle east of Honeycomb Drive and west of Bridal Vail Way. Runoff is carried in the public rights-of-way where the flow travels south through a series of public

curb and gutters, sump inlets and storm infrastructure within Filing No. 2. The flow outfalls into the existing Pond 1 through the public 60" RCP storm pipe that runs through Falcon Highlands South, the pipe run at **Design Point 11**.

**OS-5.3 (0.61 ac,  $Q_5 = 1.7$  cfs,  $Q_{100} = 3.4$  cfs)** is an off-site basin that encompasses the southern portion of Antelope Meadows Circle due south of Bridal Vail Way. Runoff is carried in the public rights-of-way where the flow travels south through a series of public curb and gutters, sump inlets and storm infrastructure within Filing No. 2. The flow outfalls into the existing Pond 1 through the public 60" RCP storm pipe that runs through Falcon Highlands South, the pipe run at **Design Point 11**.

**Basin A (4.03 ac,  $Q_5 = 1.1$  cfs,  $Q_{100} = 7.7$  cfs)** is the basin located southwest of Antelope Meadow Circle, just below basin OS-4, west of Basin B. The majority of the basin is comprised of Tract F and consists of some rear yard runoff from the PUD lots at the western edge of Basin B. Tract F qualifies for water quality exclusion I.7.1.B.7, Sites with land disturbance to undeveloped land that will remain undeveloped. The backyards of the western lots along Lanner Lane drain to the west and will utilize the 1-acre area limit allowed under Exclusion I.7.1.C.1 as an area that is not practicable to capture runoff into the detention pond for the site.

The storm water runoff from this basin sheet flows south and off-site at **Design Point 1** with the combined flow of OS-4, and per existing drainage patterns and the exclusions mentioned above is not tributary to on-site detention ponds.

**Basin B (33.21 ac,  $Q_5 = 45.4$  cfs,  $Q_{100} = 112.3$  cfs)** is the southwestern portion of Falcon Highlands South consisting of the area south of Antelope Meadows Circle and west of Basin C. Basin B is laid out with several 50' public right of way roadways with curb and gutter, detached pedestrian sidewalk, and landscape areas. The PUD residential developments within Basin B are shown as 123 lots, varying from 50'x110' to 60'x110'. The roadways consist of low points at the southeastern and southwestern edges and a high point central to the basin with drainage Tract F that flows north to south. The general drainage pattern is due south to the existing Pond 1. Within the roadways is a public storm system and a series of public sump inlets at the low points to capture surface runoff and convey storm water to forebays within the existing Pond 1 (Design Point 2).

Basin B was delineated into several smaller basins to assess roadway capacities and proposed public storm sewer inlet locations. These smaller basins are described below.

**Basin B1 (5.30 ac,  $Q_5 = 8.1$  cfs,  $Q_{100} = 17.9$  cfs)** is the west side of Basin B that consists of the north half of the 50' right of way of **ELEANORA TRAIL** and the west side of 50' public right of way of **LANNER LANE** and PUD residential lots where runoff flows south to a low point at the road curve. The runoff is collected in a Public 10' CDOT Type R Curb Sump Inlet, **Design Point 2.1**. Storm infrastructure will direct flow to outfall in Pond 1. The emergency overflow would result in pooling at the sump location until overtopping the nearest high point in the roadway located to the south. The storm water would overtop prior to exceeding the roadway capacity and

continue to flow due south to downstream Tract F, between lots 22 and 23, which is connected to Pond 1.

**Basin B2 (4.06 ac,  $Q_5 = 6.4$  cfs,  $Q_{100} = 14.2$  cfs)** is located between **ELEANORA TRAIL** and **RYLAND WAY** and collects runoff from half of the public right of way along sections of **ELEANORA TRAIL**, **LANNER LAND** and **RYLAND WAY** and the PUD residential lots and flows to a low point at the intersection of **LANNER LANE** and **RYLAND WAY**. The runoff is collected in a Public 10' CDOT Type R Curb Sump Inlet, **Design Point 2.2**. Storm infrastructure will direct flow to outfall in Pond 1. The emergency overflow would result in pooling at the sump location until overtopping the nearest high point in the roadway located to the south. The storm water would overtop prior to exceeding the roadway capacity and continue to flow due south to downstream Tract F, between lots 22 and 23, which is connected to Pond 1.

**Basin B3 (4.41 ac,  $Q_5 = 7.0$  cfs,  $Q_{100} = 15.4$  cfs)** is located between **RYLAND WAY** and **ALMUR TRAIL** and collects runoff from half of sections of **RYLAND WAY**, **ALMUR TRAIL** and **LANNER LANE** and the PUD residential lots. Runoff flows to a low point within **ALMUR TRAIL**. The runoff is collected in a Public 10' CDOT Type R Curb Sump Inlet, **Design Point 2.3**. Storm infrastructure will direct flow to outfall in Pond 1. The emergency overflow would result in pooling at the sump location until overtopping the nearest high point in the roadway located to the south. The storm water would overtop prior to exceeding the roadway capacity and continue to flow due south to downstream Tract F, between lots 22 and 23, which is connected to Pond 1.

**Basin B4 (8.02 ac,  $Q_5 = 2.7$  cfs,  $Q_{100} = 18.3$  cfs)** is the area located along the southern edge of the project and adjacent to the Pond 1. It consists of the back half of PUD residential lots along **ALMUR TRAIL** and 3.14 acres of Pond 1, which is mostly pervious. Runoff will sheet flow south into Pond 1, **Design Point 2**.

**Basin B5 (1.01 ac,  $Q_5 = 2.3$  cfs,  $Q_{100} = 5.2$  cfs)** consists of the south half of a section of **ALMUR TRAIL** and the north half of the adjacent PUD residential lots. Runoff from the area will be directed by curb and gutter to the inlet at the intersection of **ALMUR TRAIL** and **SCOOTY LANE**. The runoff is collected in a Public 5' CDOT Type R Curb Sump Inlet, **Design Point 2.5**. Storm infrastructure will direct flow to outfall in Pond 1. The emergency overflow would result in pooling at the sump location until overtopping the nearest high point in the roadway located to the south. The storm water would overtop prior to exceeding the roadway capacity and continue to flow due south to downstream Tract F, between lots 37 and 38, which is connected to Pond 1.

**Basin B6 (0.50 ac,  $Q_5 = 0.9$  cfs,  $Q_{100} = 2.0$ )** is located at the northwest of the intersection of **ALMUR TRAIL** and **SCOOTY LANE** and includes half of the 50' right of way of **ALMUR TRAIL** and the adjacent PUD residential lots. The runoff is collected at the intersection of **ALMUR TRAIL** and **SCOOTY LANE** in a Public 5' CDOT Type R Curb Sump Inlet, **Design Point 2.6**. Storm infrastructure will direct flow to outfall in Pond 1. The emergency overflow would result in pooling at the sump location until overtopping the nearest high point in the roadway located to the south. The storm water would overtop prior to exceeding the roadway capacity and

continue to flow due south to downstream Tract F, between lots 37 and 38, which is connected to Pond 1.

**Basin B7 (0.90 ac,  $Q_5 = 2.1$  cfs,  $Q_{100} = 4.6$  cfs)** is located at the southwest of the intersection of **RYLAND WAY** and **SCOOTY LANE**. Runoff flow will be collected for half of the 50' right of way and the PUD residential lots at a low point along **SCOOTY LANE**. The runoff is collected in a Public 5' CDOT Type R Curb Sump Inlet, **Design Point 2.7**. Storm infrastructure will direct flow to outfall in Pond 1. The emergency overflow would result in pooling at the sump location until overtopping the nearest high point in the roadway located to the south. The storm water would overtop prior to exceeding the roadway capacity and continue to flow due south to downstream Tract F, between lots 37 and 38, which is connected to Pond 1.

**Basin B8 (1.75 ac,  $Q_5 = 3.0$  cfs,  $Q_{100} = 6.5$  cfs)** is located at the eastern end between **ELEANORA TRAIL** and **RYLAND WAY** and collects runoff from half of both streets and the PUD residential lot at a low point near the intersection of **RYLAND WAY** and **SCOOTY LANE**. The runoff is collected in a Public 5' CDOT Type R Curb Sump Inlet, **Design Point 2.8**. Storm infrastructure will direct flow to outfall in Pond 1. The emergency overflow would result in pooling at the sump location until overtopping the nearest high point in the roadway located to the south. The storm water would overtop prior to exceeding the roadway capacity and continue to flow due south to downstream Tract F, between lots 37 and 38, which is connected to Pond 1.

**Basin B9 (2.28 ac,  $Q_5 = 3.9$  cfs,  $Q_{100} = 8.6$  cfs)** consists of the north/east half of **ELEANORA TRAIL** and **SCOOTY LANE** right of way and residential lots. The runoff is collected at a low point along **SCOOTY LANE** in a Public 5' CDOT Type R Curb Sump Inlet, **Design Point 2.9**. Storm infrastructure will direct flow to outfall in Pond 1. The emergency overflow would result in pooling at the sump location until overtopping the nearest high point in the roadway located to the south. The storm water would overtop prior to exceeding the roadway capacity and continue to flow due south to downstream Tract F, between lots 37 and 38, which is connected to Pond 1.

**Basin B10 (2.07 ac,  $Q_5 = 3.7$  cfs,  $Q_{100} = 8.2$  cfs)** includes the southeast end of **SCOOTY LANE** at the intersection of **ALMUR TRAIL** and **SCOOTY LANE**. Runoff from the east half of the right of way and the PUD residential lots will be collected at a low point along **ALMUR TRAIL**. The runoff is collected in a Public 5' CDOT Type R Curb Sump Inlet, **Design Point 2.10**. Storm infrastructure will direct flow to outfall in Pond 1. The emergency overflow would result in pooling at the sump location until overtopping the nearest high point in the roadway located to the south. The storm water would overtop prior to exceeding the roadway capacity and continue to flow due south to downstream Tract F, between lots 37 and 38, which is connected to Pond 1.

**Basin B11 (0.31 ac,  $Q_5 = 0.6$  cfs,  $Q_{100} = 1.4$  cfs)** is located along **APLOMADO TRAIL** and collects runoff from half of the public right of way and the front half residential lots. Flow is directed south to a low point at the intersection of **ALMUR TRAIL** and **APLOMADO TRAIL**. The runoff is collected in a Public 5' CDOT Type R Curb Sump Inlet, **Design Point 2.11**. Storm infrastructure will direct flow to outfall in Pond 1. The emergency overflow would result in pooling at the sump location until overtopping the nearest high point in the roadway located to the south.

The storm water would overtop prior to exceeding the roadway capacity and continue to flow due south to downstream Tract F, between lots 37 and 38, which is connected to Pond 1.

**Basin B12 (0.56 ac,  $Q_5 = 0.9$  cfs,  $Q_{100} = 1.9$  cfs)** is located along **APLOMADO TRAIL** and collects runoff from half of the public right of way and the front half residential lots. Flow in directed south to a low point within **APLOMADO TRAIL**. The runoff is collected in a Public 5' CDOT Type R Curb Sump Inlet, **Design Point 2.12**. Storm infrastructure will direct flow to outfall in Pond 1. The emergency overflow would result in pooling at the sump location until overtopping the nearest high point in the roadway located to the south. The storm water would overtop prior to exceeding the roadway capacity and continue to flow due south to downstream Tract F, between lots 37 and 38, which is connected to Pond 1.

**Basin B13 (1.18 ac,  $Q_5 = 2.1$  cfs,  $Q_{100} = 4.5$  cfs)** is located along **APLOMADO TRAIL** and collects runoff from half of the public right of way and the front half residential lots. Flow in directed south to a low point within **APLOMADO TRAIL**. The runoff is collected in a Public 5' CDOT Type R Curb Sump Inlet, **Design Point 2.13**. Storm infrastructure will direct flow to outfall in Pond 1. The emergency overflow would result in pooling at the sump location until overtopping the nearest high point in the roadway located to the south. The storm water would overtop prior to exceeding the roadway capacity and continue to flow due south to downstream Tract F, between lots 37 and 38, which is connected to Pond 1.

**Basin B14 (0.28 ac,  $Q_5 = 0.5$  cfs,  $Q_{100} = 1.0$  cfs)** is located along **APLOMADO TRAIL** and collects runoff from half of the public right of way and the front half residential lots. Flow in directed south to a low point within **APLOMADO TRAIL**. The runoff is collected in a Public 5' CDOT Type R Curb Sump Inlet, **Design Point 2.14**. Storm infrastructure will direct flow to outfall in Pond 1. The emergency overflow would result in pooling at the sump location until overtopping the nearest high point in the roadway located to the south. The storm water would overtop prior to exceeding the roadway capacity and continue to flow due south to downstream Tract F, between lots 37 and 38, which is connected to Pond 1.

**Basin B15 (0.30 ac,  $Q_5 = 0.5$  cfs,  $Q_{100} = 1.2$  cfs)** is located along **APLOMADO TRAIL** and collects runoff from half of the public right of way and the front half residential lots. Flow in directed south to a low point within **APLOMADO TRAIL**. The runoff is collected in a Public 5' CDOT Type R Curb Sump Inlet, **Design Point 2.15**. Storm infrastructure will direct flow to outfall in Pond 1. The emergency overflow would result in pooling at the sump location until overtopping the nearest high point in the roadway located to the south. The storm water would overtop prior to exceeding the roadway capacity and continue to flow due south to downstream Tract F, between lots 37 and 38, which is connected to Pond 1.

**Basin B16 (0.28 ac,  $Q_5 = 0.6$  cfs,  $Q_{100} = 1.4$  cfs)** is located along **APLOMADO TRAIL** and **ALMUR TRAIL** and collects runoff from half of the public right of way and the PUD residential lots for that area. Flow in directed south to a low point at the intersection of **ALMUR TRAIL** and **APLOMADO TRAIL**. The runoff is collected in a Public 5' CDOT Type R Curb Sump Inlet, **Design Point 2.16**. Storm infrastructure will direct flow to outfall in Pond 1. The emergency



overflow would result in pooling at the sump location until overtopping the nearest high point in the roadway located to the south. The storm water would overtop prior to exceeding the roadway capacity and continue to flow through a swale, due south to downstream Tract F, between lots 37 and 38, which is the emergency overflow path that conveys runoff directly to Pond 1.

**Basin C (62.88 ac,  $Q_5 = 87.0$  cfs,  $Q_{100} = 222.9$  cfs)** is the more central to east basin within Falcon Highlands South that is tributary to Pond 2. The basin includes the majority of the half-acre PUD residential lots in the northern area south of Filing No. 2 and east of Bridal Vail Way, and stretches south to the very south and east edges of the Filing with the exception of Pond WU areas and Basin D. Basin C areas south of Antelope Meadows Circle consists of approximately 248 lots with some lots of 35'x110' and others of 50'x110' and 60'x110' in size. A public storm system is to be designed within the roadways to convey storm water from the off-site Basin OS-5 and Basin OS-6 within Filing No. 2 and the runoff from the entire Basin C areas. The storm system is to outfall into the existing Pond 2 (Design Point 3).

**Basin C1 (9.83 ac,  $Q_5 = 5.6$  cfs,  $Q_{100} = 23.9$  cfs)** is the northern most portion of Basin C with PUD residential lots, the east half of the 50' public right of way for **SAHALEE TRAIL** and the north half of the 50' right of way of **FOX KESTREL COURT**. The runoff is collected within **SAHALEE TRAIL** in a Public 10' CDOT Type R Curb Sump Inlet, **Design Point 3.1**. Storm infrastructure will direct flow to outfall in Pond 2. The emergency overflow would result in pooling at the sump location until overtopping the nearest high point in the roadway located to the south. The storm water would overtop prior to exceeding the roadway capacity and continue to flow due south to downstream Tract F, northwest of lot 176, which is connected to Pond 2.

**Basin C2 (3.67 ac,  $Q_5 = 3.1$  cfs,  $Q_{100} = 11.0$  cfs)** is the north-western portion of Basin C with PUD residential lots and the west half of the 50' public right of way for **FOX KESTREL COURT** and **SAHALEE TRAIL**. The runoff is collected within **SAHALEE TRAIL** in a Public 5' CDOT Type R Curb Sump Inlet, **Design Point 3.2**. Storm infrastructure will direct flow to outfall in Pond 2. The emergency overflow would result in pooling at the sump location until overtopping the nearest high point in the roadway located to the south. The storm water would overtop prior to exceeding the roadway capacity and continue to flow due south to Tract F, northwest of lot 176, which is connected to Pond 2.

**Basin C3 (3.81 ac,  $Q_5 = 3.2$  cfs,  $Q_{100} = 11.1$  cfs)** is located between **FOX KESTREL COURT** and Antelope Meadow Circle, on the east side of **SAHALEE TRAIL** consisting of PUD residential lots and the 50' public right of way **FOX KESTREL COURT** and **SAHALEE TRAIL**. The runoff is collected at the intersection of **SAHALEE TRAIL** and Antelope Meadows Cir. in a Public 5' CDOT Type R Curb Sump Inlet, **Design Point 3.3**. Storm infrastructure will direct flow to outfall in Pond 2. The emergency overflow would result in pooling at the sump location until overtopping the nearest high point in the roadway located to the south. The storm water would overtop prior to exceeding the roadway capacity and continue to flow due south to the downstream Tract F, northwest of lot 176, which is connected to Pond 2.

**Basin C4 (1.95 ac,  $Q_5 = 1.7$  cfs,  $Q_{100} = 6.0$  cfs)** is located between **FOX KESTREL COURT** and Antelope Meadow Circle, on the west side of **SAHALEE TRAIL** consisting of PUD residential lots and the 50' public right of way **FOX KESTREL COURT** and **SAHALEE TRAIL**. The runoff is collected at the intersection of **SAHALEE TRAIL** and Antelope Meadows Cir. in a Public 5' CDOT Type R Curb Sump Inlet, **Design Point 3.4**. Storm infrastructure will direct flow to outfall in Pond 2. The emergency overflow would result in pooling at the sump location until overtopping the nearest high point in the roadway located to the south. The storm water would overtop prior to exceeding the roadway capacity and continue to flow due south to the downstream Tract F, northwest of lot 176, which is connected to Pond 2.

**Basin C5 (0.41 ac,  $Q_5 = 1.9$  cfs,  $Q_{100} = 3.4$  cfs)** is located on Antelope Meadows Circle, on the east side of the intersection with **SAHALEE TRAIL** and consists of the 50' public right of way Antelope Meadows Circle. The runoff is collected at the intersection in a Public 5' CDOT Type R Curb Sump Inlet, **Design Point 3.5**. Storm infrastructure will direct flow to outfall in Pond 2. The emergency overflow would result in pooling at the sump location until overtopping the nearest high point in the roadway located to the south. The storm water would overtop prior to exceeding the roadway capacity and continue to flow due south to the downstream Tract F, northwest of lot 176, which is connected to Pond 2.

**Basin C6 (0.37 ac,  $Q_5 = 1.7$  cfs,  $Q_{100} = 3.1$  cfs)** is located on Antelope Meadows Circle, on the west side of the intersection with **SAHALEE TRAIL** and consists of the 50' public right of way Antelope Meadows Circle. The runoff is collected at the intersection in a Public 5' CDOT Type R Curb Sump Inlet, **Design Point 3.6**. Storm infrastructure will direct flow to outfall in Pond 2. The emergency overflow would result in pooling at the sump location until overtopping the nearest high point in the roadway located to the south. The storm water would overtop prior to exceeding the roadway capacity and continue to flow due south to the downstream Tract F, northwest of lot 176, which is connected to Pond 2.

**Basin C7 (2.05 ac,  $Q_5 = 3.5$  cfs,  $Q_{100} = 7.7$  cfs)** is a centrally located portion of Basin C with PUD residential lots and the 50' public right of way of **APLOMADO TRAIL** and **SAHALEE TRAIL**. The runoff is collected at the intersection of **SAHALEE TRAIL** and **APLOMADO TRAIL** in a Public 5' CDOT Type R Curb Sump Inlet, **Design Point 3.7**. Storm infrastructure will direct flow to outfall in Pond 2. The emergency overflow would result in pooling at the sump location until overtopping the nearest high point in the roadway located to the south. The storm water would overtop prior to exceeding the roadway capacity and continue to flow due south to the downstream Tract F, northwest of lot 176, which is connected to Pond 2.

**Basin C8 (1.43 ac,  $Q_5 = 2.5$  cfs,  $Q_{100} = 5.4$  cfs)** is a centrally located portion of Basin C with PUD residential lots and the 50' public right of way of **APLOMADO TRAIL** and **SAHALEE TRAIL**. The runoff is collected at the intersection of **SAHALEE TRAIL** and **APLOMADO TRAIL** in a Public 5' CDOT Type R Curb Sump Inlet, **Design Point 3.8**. Storm infrastructure will direct flow to outfall in Pond 2. The emergency overflow would result in pooling at the sump location until overtopping the nearest high point in the roadway located to the south. The storm water would

overtop prior to exceeding the roadway capacity and continue to flow due south to the downstream Tract F, northwest of lot 176, which is connected to Pond 2.

**Basin C9 (2.96 ac,  $Q_5 = 5.5$  cfs,  $Q_{100} = 12.1$  cfs)** is a centrally located portion of Basin C with PUD residential lots and the 50' public right of way of **SAHALEE TRAIL** and **APLOMADO TRAIL**. The runoff is collected at a low point on **SAHALEE TRAIL** in a Public 5' CDOT Type R Curb Sump Inlet, **Design Point 3.9**. Storm infrastructure will direct flow to outfall in Pond 2. The emergency overflow would result in pooling at the sump location until overtopping the nearest high point in the roadway located to the south. The storm water would overtop prior to exceeding the roadway capacity and continue to flow due south to the downstream Tract F, northwest of lot 176, which is connected to Pond 2.

**Basin C10 (1.72 ac,  $Q_5 = 1.5$  cfs,  $Q_{100} = 4.9$  cfs)** is a centrally located portion of Basin C with PUD residential lots, the open space and the 50' public right of way of **SAHALEE TRAIL**, **APLOMADO TRAIL** and **ALMUR TRAIL**. The runoff is collected at a low point on **APLOMADO TRAIL** in a Public 5' CDOT Type R Curb Sump Inlet, **Design Point 3.10**. Storm infrastructure will direct flow to outfall in Pond 2. The emergency overflow would result in pooling at the sump location until overtopping the nearest high point in the roadway located to the south. The storm water would overtop prior to exceeding the roadway capacity and continue to flow due south to the downstream Tract F, northwest of lot 176, which is connected to Pond 2.

**Basin C11 (4.21 ac,  $Q_5 = 4.9$  cfs,  $Q_{100} = 16.3$  cfs)** is located in the southern portion of Basin C with PUD residential lots, the open space and the 50' public right of way of **ALMUR TRAIL**. The runoff is collected at a low point on **ALMUR TRAIL** in a Public 10' CDOT Type R Curb Sump Inlet, **Design Point 3.11**. Storm infrastructure will direct flow to outfall in Pond 2. The emergency overflow would result in pooling at the sump location until overtopping the nearest high point in the roadway located to the south. The storm water would overtop prior to exceeding the roadway capacity and continue to flow due south to the downstream Tract F, northwest of lot 176, which is connected to Pond 2.

**Basin C12 (0.41 ac,  $Q_5 = 1.9$  cfs,  $Q_{100} = 3.4$  cfs)** is located in the southwest portion of Basin C and is made up of the 50' public right of way of **ALMUR TRAIL** and 8.18 acres of pond 2, which is mostly pervious. The runoff is collected at a low point on **ALMUR TRAIL** in a Public 5' CDOT Type R Curb Sump Inlet, **Design Point 3.12**. Storm infrastructure will direct flow to outfall in Pond 2. The emergency overflow would result in pooling at the sump location until overtopping the nearest high point in the roadway located to the south. The storm water would overtop prior to exceeding the roadway capacity and continue to flow due south to the downstream Tract F, northwest of lot 176, which is connected to Pond 2.

**Basin C13 (5.93 ac,  $Q_5 = 7.1$  cfs,  $Q_{100} = 18.8$  cfs)** is located at the southern boundary of the Site. It consists of the PUD residential lots along **ALMUR TRAIL** and **SAHALEE TRAIL**. Runoff will sheet flow south into Pond 1, **Design Point 3.13**.

**Basin C14 (2.96 ac,  $Q_5 = 4.9$  cfs,  $Q_{100} = 10.8$  cfs)** is located between **APLOMADO TRAIL** and **SPOTTED KESTREL WAY** and drains to a low point at the intersection of **GREY FALCON LANE** and **SPOTTED KESTREL WAY**. It collects runoff from PUD residential lots and the 50' public right of way of **APLOMADO TRAIL**, **DUNFORD LANE**, **GREY FALCON LANE**, and **SPOTTED KESTREL WAY**. The runoff is collected in a Public 5' CDOT Type R Curb Sump Inlet, **Design Point 3.14**. Storm infrastructure will direct flow to outfall in Pond 2. The emergency overflow would result in pooling at the sump location until overtopping the nearest high point in the roadway located to the south. The storm water would overtop prior to exceeding the roadway capacity and continue to flow due south to the downstream Tract F, northwest of lot 176, which is connected to Pond 2.

**Basin C15 (1.42 ac,  $Q_5 = 2.2$  cfs,  $Q_{100} = 4.8$  cfs)** is the southern portion of Basin C with PUD residential lots and the 50' public right of way of **DUNFORD LANE**. The runoff is collected in a Public 5' CDOT Type R Curb Sump Inlet, **Design Point 3.15**. Storm infrastructure will direct flow to outfall into a swale along the southern Site boundary. The swale will release into Pond 2. The emergency overflow would result in pooling at the sump location until overtopping the nearest high point in the roadway located to the south. The storm water would overtop prior to exceeding the roadway capacity and continue to flow due south to the downstream Tract F, northwest of lot 176, which is connected to Pond 2.

**Basin C16 (5.71 ac,  $Q_5 = 6.2$  cfs,  $Q_{100} = 18.3$  cfs)** is the southern most portion of basin C with PUD residential. The runoff sheet flows into a storm drainage swale along the site boundary and flows from there into Pond 2, **Design Point 3.16**. Storm infrastructure will direct flow to outfall into a swale along the southern Site boundary. The swale will release into Pond 2. The emergency overflow would result in pooling at the sump location until overtopping the nearest high point in the roadway located to the south. The storm water would overtop prior to exceeding the roadway capacity and continue to flow due south to downstream Tract F that is connected to Pond 2.

**Basin C17 (2.05 ac,  $Q_5 = 6.5$  cfs,  $Q_{100} = 12.4$  cfs)** is located along the north-eastern portion of basin C with the right of way of Antelope Meadow Circle. The runoff flows to a low point towards the center of the right of way of Antelope Meadow Circle. The runoff is collected in a Public 5' CDOT Type R Curb Sump Inlet, **Design Point 3.17**. Storm infrastructure will direct flow to outfall into a swale along the southern Site boundary. The swale will release into Pond 2. The emergency overflow would result in pooling at the sump location until overtopping the nearest high point in the roadway located to the south. The storm water would overtop prior to exceeding the roadway capacity and continue to flow due south to downstream Tract F, between lots 188 and 189, which is connected to Pond 2.

**Basin C18 (0.76 ac,  $Q_5 = 3.2$  cfs,  $Q_{100} = 5.7$  cfs)** is located along the north-eastern portion of basin C with the right of way of Antelope Meadow Circle. The runoff flows to a low point towards the center of the right of way of Antelope Meadow Circle. The runoff is collected in a Public 5' CDOT Type R Curb Sump Inlet, **Design Point 3.18**. Storm infrastructure will direct flow to outfall into a swale along the southern Site boundary. The swale will release into Pond 2. The emergency overflow would result in pooling at the sump location until overtopping the nearest high point in

the roadway located to the south. The storm water would overtop prior to exceeding the roadway capacity and continue to flow due south to downstream Tract F, between lots 188 and 189, which is connected to Pond 2.

**Basin C19 (0.74 ac,  $Q_5 = 1.4$  cfs,  $Q_{100} = 3.0$  cfs)** is located at the intersection of **APLOMADO TRAIL** and **NANKEEN COURT**. The runoff flows to a low in **APLOMADO TRAIL**. The runoff is collected in a Public 5' CDOT Type R Curb Sump Inlet, **Design Point 3.19**. Storm infrastructure will direct flow to outfall into a swale along the southern Site boundary. The swale will release into Pond 2. The emergency overflow would result in pooling at the sump location until overtopping the nearest high point in the roadway located to the south. The storm water would overtop prior to exceeding the roadway capacity and continue to flow due south to downstream Tract F, between lots 188 and 189, which is connected to Pond 2.

**Basin C20 (1.51 ac,  $Q_5 = 2.7$  cfs,  $Q_{100} = 6.0$  cfs)** is located at the intersection of **APLOMADO TRAIL** and **NANKEEN COURT**. The runoff flows to a low in **APLOMADO TRAIL**. The runoff is collected in a Public 5' CDOT Type R Curb Sump Inlet, **Design Point 3.20**. Storm infrastructure will direct flow to outfall into a swale along the southern Site boundary. The swale will release into Pond 2. The emergency overflow would result in pooling at the sump location until overtopping the nearest high point in the roadway located to the south. The storm water would overtop prior to exceeding the roadway capacity and continue to flow due south to downstream Tract F, between lots 188 and 189, which is connected to Pond 2.

**Basin C21 (3.52 ac,  $Q_5 = 6.1$  cfs,  $Q_{100} = 13.4$  cfs)** is the north-east portion of Basin C with PUD residential lots and the 50' public right of way. Flow is collected in the curb and gutter of **NANKEEN COURT** and released into an inlet at the cul-de-sac. The runoff is collected in a Public 5' CDOT Type R Curb Sump Inlet, **Design Point 3.21**. Storm infrastructure will direct flow to outfall into a swale along the southern Site boundary. The swale will release into Pond 2. The emergency overflow would result in pooling at the sump location until overtopping the nearest high point in the roadway located to the south. The storm water would overtop prior to exceeding the roadway capacity and continue to flow due south to the downstream Tract F, at the end of the cul-de-sac along the frontage of Lot 257, which is connected to Pond 2. The runoff is then released into a stormwater swale along the south side of the project. The swale releases into Pond 2. Culvert pipe sizing is provided in the appendix for the trail crossings across the swale and typical sections are provided on the drainage maps.

**Basin C22 (2.29 ac,  $Q_5 = 4.0$  cfs,  $Q_{100} = 8.9$  cfs)** is the north-east portion of Basin C with PUD residential lots and the 50' public right of way. Flow is collected in the curb and gutter of **BANDED FALCON WAY** and released into an inlet at the cul-de-sac. The runoff is collected in a Public 5' CDOT Type R Curb Sump Inlet, **Design Point 3.22**. Storm infrastructure will direct flow to outfall into a swale along the southern Site boundary. The swale will release into Pond 2. The emergency overflow would result in pooling at the sump location until overtopping the nearest high point in the roadway located to the south. The storm water would overtop prior to exceeding the roadway capacity and continue to flow due south to the downstream Tract F, at the end of the cul-de-sac along the frontage of Lot 276, which is connected to Pond 2. The swale releases into

Pond 2. Culvert pipe sizing is provided in the appendix for the trail crossings across the swale and typical sections are provided on the drainage maps.

**Basin C23 (1.57 ac,  $Q_5 = 2.8$  cfs,  $Q_{100} = 6.2$  cfs)** is between Antelope Meadow Circle and **APLOMADO TRAIL** of basin C with PUD residential lots and the public right of way of **APLOMADO TRAIL** and **BIRCH HOLLOW WAY**. The runoff flows to a low point within **APLOMADO TRAIL** with a sump inlet. The runoff is collected in a Public 5' CDOT Type R Curb Sump Inlet, **Design Point 3.23**. Storm infrastructure will direct flow to outfall into a swale along the southern Site boundary. The swale will release into Pond 2. The emergency overflow would result in pooling at the sump location until overtopping the nearest high point in the roadway located to the south. The storm water would overtop prior to exceeding the roadway capacity and continue to flow due south to the downstream Tract F, at the end of the cul-de-sac along the frontage of Lot 291, which is connected to Pond 2. The swale releases into Pond 2.

**Basin C24 (0.13 ac,  $Q_5 = 0.3$  cfs,  $Q_{100} = 0.7$  cfs)** is a centrally located portion of basin C with the 50' public right of way of **APLOMADO TRAIL**. The runoff is captured in curb and gutter and flows into an inlet on **APLOMADO TRAIL**. The runoff is collected in a Public 5' CDOT Type R Curb Sump Inlet, **Design Point 3.24**. Storm infrastructure will direct flow to outfall into a swale along the southern Site boundary. The swale will release into Pond 2. The emergency overflow would result in pooling at the sump location until overtopping the nearest high point in the roadway located to the south. The storm water would overtop prior to exceeding the roadway capacity and continue to flow due south to downstream Tract F, at the end of the cul-de-sac along the frontage of Lot 291, which is connected to Pond 2. The swale releases into Pond 2.

**Basin C25 (1.47 ac,  $Q_5 = 2.6$  cfs,  $Q_{100} = 5.8$  cfs)** is the southern portion of basin C with PUD residential lots and the 50' public right of way of **BRAHMINY COURT**. The runoff is captured in curb and gutter and flows into an inlet on **BRAHMINY COURT**. The runoff is collected in a Public 5' CDOT Type R Curb Sump Inlet, **Design Point 3.25**. Storm infrastructure will direct flow to outfall into a swale along the southern Site boundary. The swale will release into Pond 2. The emergency overflow would result in pooling at the sump location until overtopping the nearest high point in the roadway located to the south. The storm water would overtop prior to exceeding the roadway capacity and continue to flow due south to the downstream F, at the end of the cul-de-sac along the frontage of Lot 291, which is connected to Pond 2. The swale releases into Pond 2. Culvert pipe sizing is provided in the appendix for the trail crossings across the swale and typical sections are provided on the drainage maps.

**Basin D (7.36 ac,  $Q_5 = 11.5$  cfs,  $Q_{100} = 26.7$  cfs)** is the northeast area of the Filing for one-eighth acre PUD residential lots at the extension of Birch Hollow Way. The basin is tributary to existing Pond WU which is an existing and recently improved pond under the jurisdiction of El Paso County. The basin drains directly to the existing pond (Design Point 4) via overland flow.

**Basin D1 (1.87 ac,  $Q_5 = 3.4$  cfs,  $Q_{100} = 7.4$  cfs)** is a centrally located portion of basin D with PUD residential lots and the 50' public right of way of **APLOMADO TRAIL** and **BIRCH HOLLOW WAY**. The runoff is captured in curb and gutter and flows into an inlet on **BIRCH HOLLOW**

**WAY.** The runoff is collected in a Public 5' CDOT Type R Curb Sump Inlet, **Design Point 4.1.** Storm infrastructure will direct flow to outfall in Pond WU. The emergency overflow would result in pooling at the sump location until overtopping the nearest high point in the roadway located to the south. The storm water would overtop prior to exceeding the roadway capacity and continue to flow due south to downstream Tract F, between Lots 305 and 306, which is connected to Pond WU. The inlet then outflows into Pond WU.

**Basin D2 (3.90 ac,  $Q_5 = 6.3$  cfs,  $Q_{100} = 13.9$  cfs)** is a centrally located portion of basin D with PUD residential lots and the 50' public right of way of **APLOMADO TRAIL and BIRCH HOLLOW WAY.** The runoff is captured in curb and gutter and flows into an inlet on **BIRCH HOLLOW WAY.** The runoff is collected in a Public 10' CDOT Type R Curb Sump Inlet, **Design Point 4.2.** Storm infrastructure will direct flow to outfall in Pond WU. The emergency overflow would result in runoff overtopping the curb and entering an emergency overflow swale to be conveyed to the area inlet at **Design Point 4.3**

**Basin D3 (1.59 ac,  $Q_5 = 1.8$  cfs,  $Q_{100} = 5.3$  cfs)** is located along the northeast corner of the site and consists of the back half of PUD residual lots along **BIRCH HOLLOW WAY.** Runoff from the lots sheet flows to be collected in grass lined swales and area inlets. Upon being captured in the area inlets, **Design Point 4.3,** the runoff is conveyed southeast and discharged into Pond WU. The final calculations and grading of this swale and storm run will be completed after the final plat is approved and at the final drainage report level. A preliminary section of this swale is provided within the report appendix demonstrating adequate capacity to convey the runoff of Basin D3.

---

**Basin E (1.77 ac,  $Q_5 = 0.6$  cfs,  $Q_{100} = 4.3$  cfs)** is the undeveloped, natural landscaped area between Tamlin Road and existing Detention Pond 1. Runoff from Basin E flows to a ditch section at the south boundary of the site, just north of the future Tamlin Road right-of-way and ultimately sheet flows to **Design Point 5** and is directed offsite at the southwest corner of the Filing via existing topography in this area. The maintenance path along the south side of the pond follows existing elevations and contours, remaining undisturbed and allowing for the existing drainage patterns of this area to remain the as they have been in the historic condition. This design is in conformance with ECM 3.2.4 because runoff from an undisturbed area in the post development condition is being conveyed via natural topography to its historic outfall location off-site.

**Basin F (6.06 ac,  $Q_5 = 2.3$  cfs,  $Q_{100} = 15.6$  cfs)** is the area south of Basin C that is not to be disturbed and remain as open, natural landscape. The runoff from Basin F sheet flows downstream and is undetained and no water quality is provided as it is an exclusion for undisturbed and undeveloped land that historically drains offsite. There is no increase runoff and the drainage pattern remains that of its existing flow path which is to a ditch at the south of the Site, north of existing Tamlin Road right-of-way. The basin sheet flows to **Design Point 6** and is directed offsite through Tract K. This design is in conformance with ECM 3.2.4 due to the fact that in the post development condition, the natural drainage patterns are maintained and the undetained runoff leaving the site is conveyed to its historic discharge location.

A summary of the proposed design points and routing for each one is presented in the table below.

<b>PROPOSED DESIGN POINT SUMMARY TABLE</b>						
<b>Design Point</b>	<b>Contributing Sub Basins</b>	<b>Area (acres)</b>	<b>C<sub>5</sub></b>	<b>C<sub>100</sub></b>	<b>Q<sub>5</sub> (cfs)</b>	<b>Q<sub>100</sub> (cfs)</b>
2.1	B1	5.30	0.45	0.59	8.12	17.87
2.10	B10	2.07	0.45	0.59	3.71	8.17
2.11	B11	0.31	0.45	0.59	0.65	1.43
2.12	B12	0.56	0.45	0.59	0.88	1.93
2.13	B13	1.18	0.45	0.59	2.05	4.52
2.14	B14	0.28	0.45	0.59	0.48	1.05
2.15	B15	0.30	0.45	0.59	0.54	1.19
2.16	B16	0.28	0.45	0.59	0.64	1.42
2.17	B4 - B16	19.44	0.45	0.59	23.88	64.88
2.18	OS-5	59.62	0.30	0.50	80.10	160.70
2.19	B1,B2,B3	13.77	0.45	0.59	21.56	47.45
2.2	B2	4.06	0.45	0.59	6.44	14.18
2.3	B3	4.41	0.45	0.59	7.00	15.40
2	B4	8.02	0.10	0.39	2.73	18.32
2.5	B5	1.01	0.45	0.59	2.35	5.17
2.6	B6	0.50	0.45	0.59	0.90	1.98
2.7	B7	0.90	0.45	0.59	2.09	4.61
2.8	B8	1.75	0.45	0.59	2.96	6.51
2.9	B9	2.28	0.45	0.59	3.90	8.59
3.1	C1	9.83	0.16	0.42	5.61	23.91
3.10	C10	1.72	0.23	0.45	1.51	4.91
3.11	C11	4.21	0.22	0.45	4.86	16.27
3.12	C12	0.41	0.90	0.96	1.91	3.42
3	C13	5.93	0.32	0.51	7.13	18.82
3.14	C14	2.96	0.45	0.59	4.91	10.81
3.15	C15	1.42	0.45	0.59	2.16	4.76
3.16	C16	5.71	0.27	0.47	6.16	18.35
3.17	C17	2.05	0.72	0.81	6.54	12.39
3.18	C18	0.76	0.90	0.96	3.16	5.67
3.19	C19	0.74	0.45	0.59	1.36	2.98
3.2	C2	3.67	0.22	0.46	3.12	10.95



3.20	C20	1.51	0.45	0.59	2.73	6.02
3.21	C21	3.52	0.45	0.59	6.09	13.40
3.22	C22	2.29	0.45	0.59	4.02	8.86
3.23	C23	1.57	0.45	0.59	2.82	6.20
3.24	C24	0.13	0.45	0.59	0.30	0.67
3.25	C25	1.47	0.45	0.59	2.63	5.80
3.26	C1-C12, C14, C15	37.20	0.45	0.59	44.01	123.81
3.27	C23, C24,C25	3.17	0.45	0.59	5.75	12.67
3.28	C22 - C25	5.46	0.45	0.59	9.78	21.52
3.29	C21-25	8.98	0.45	0.59	15.86	34.92
3.3	C3	3.81	0.22	0.46	3.16	11.09
3.4	C4	1.95	0.22	0.46	1.72	6.02
3.5	C5	0.41	0.90	0.96	1.88	3.38
3.6	C6	0.37	0.90	0.96	1.72	3.08
3.7	C7	2.05	0.45	0.59	3.51	7.73
3.8	C8	1.43	0.45	0.59	2.47	5.44
3.9	C9	2.96	0.45	0.59	5.48	12.06
4.1	D1	1.87	0.45	0.59	3.38	7.44
4.2	D2	3.90	0.45	0.59	6.34	13.95
4.3	D3	1.59	0.26	0.47	1.77	5.30
4.4	D1, D2,D3	7.36	0.45	0.59	11.49	26.69
OS.2	OS-2	0.79	0.45	0.59	1.50	3.31
OS.3	OS-3	1.18	0.60	0.71	3.10	6.20
OS.4	OS-4	0.61	0.60	0.71	1.72	3.44

**Existing Pond 1:** The existing Detention Pond 1 (Design Point 2) was designed as a 17 acre-foot for water quality and detention basin for the 100-year storm event according to the 2010 FDR and has a contributing area of 122.03 acres with 40.1% imperviousness. The basins that are tributary to Pond 1 are Offsite Basins OS-1, OS-2, OS-4, and OS-5, OS-5.1, OS5.2, OS-5.3, and On-site Basin B. The undetained storm water runoff from Basin A is accounted for within the pond as disturbance will occur within that basin. Previously approved release rates for the pond were 34.4 cfs for the minor storm and 77.6 cfs for the major storm, while proposed release rates are 1.4 cfs for the minor storm and 44.6 cfs for the major storm with the new outlet structure and orifice plate.

Existing Pond 1 was sized using Haestad’s Pondpack program in the previous study by Terra Nova, dated September of 2010. The pond will need to have more detail taken into account at the time of the Final Drainage Report when runoff calculations are finalized and the required pond volumes for WQCV (Water Quality Capture Volume), EURV (Excess Urban Runoff Volume), and 100-year detention and release rates are determined. The Existing Pond has been assessed for as-built conditions to determine if earthwork for volume adjustments is required and if retrofitting of

existing pond infrastructure is required including the outlet structure, orifice plate, micropool, and spillway. The pond has sufficient volume to meet full-spectrum detention requirements. The required WQCV, EURV, and 100-year detention volumes are listed in a table in the next section of this report. It is determined that the existing outlet structure and orifice plate and restrictor plate are no longer valid for the new layout in Filing 3 and required release rate for the combined tributary area flow. A new outlet structure with orifice plate will be required to be designed and constructed as a part of the Final Drainage Report. In addition to the new outlet structure with micropool, a concrete trickle channel at the bottom of the pond with a minimum slope of 0.5 percent reaching forebays for inlet pipes is to be constructed. Maintenance paths were found to be too steep in existing pathways and a new maintenance path is to be constructed that meets County criteria.

An existing 42" RCP outlet pipe from the existing outlet structure discharges flow from existing Pond 1 due south under the existing dedicated right-of-way of Tamlin Road (that has been abandoned) onto the adjacent undeveloped Banning Lewis Ranch property. Rip rap protection was to be constructed at the end of the outlet pipe at the time of final construction and is to be inspected for the Final Drainage Report as-built conditions. According to the previous study from 2010, "the released runoff drains south across a defined broad open grassland swale to Highway 24. A 72' wide emergency spillway set at 6817.00 will pass the complete 100-year developed flow safely over the proposed riprap lined weir." Downstream drainage patterns mentioned in the previous report are to be assessed in the Final Drainage Report. The previous FDR and Construction Drawings detailed an outlet structure and orifice plates to meet the required release rates of 40 hours for WQCV, approximately 68 hours for EURV, and 72 hours for the 100-year storm event. It is anticipated that new outlet structures with orifice plate, a micropool, and trickle channel will be required to be designed in order to satisfy release rate requirements for the proposed developed conditions. All runoff from the 100-year storm event will be conveyed through Tracts to Pond 1. Swale sections through the tracts at the ultimate downstream emergency overflows are shown in Appendix E. Some earthwork may be required to provide permanent stabilization of more defined contouring within the pond to ensure that runoff reaches the outlet structure. The existing 42" culvert from existing Pond 1 runs under Tamlin Road and drains to an existing wetland channel flowing south offsite and will be maintained in its historic condition. Since the release rate from Pond 1 is proposed to be less than the current release rate, the downstream wetland channel will remain hydraulically adequate. Further analysis of the downstream wetland channel will be conducted with the Final Drainage Report. This design is in conformance with ECM 3.2.4. Runoff from an undisturbed area in the post development condition is being conveyed via natural topography to its historic outfall location off-site.

Pond spreadsheets included within the appendix present proposed outlet configurations that are to replace the existing outlet structures that are to be removed during pond reconstruction.

Preliminary calculations for the proposed site layout can be found in Appendix E of this report including WQCV, EURV, and 100-year detention calculations using the UD-Detention spreadsheet by the Mile High Flood District.

**Existing Pond 2:** The existing Detention Pond 2 (Design Point 3) was designed as a 7 acre-foot pond for water quality and detention basin for the 100-year storm event according to the 2010 FDR and has a contributing area of 103.07 acres with 36.4% imperviousness. The basins that are tributary to the existing pond are Offsite Basins OS-3 and OS-6 and On-site Basin C. Previously approved release rates for the pond were 57.3 cfs for the minor storm and 130.1 cfs for the major storm, while proposed release rates are 1.1 cfs for the minor storm and 74.5 cfs for the major storm with the new outlet structure and orifice plate.

Existing Pond 2 was sized using Haestad's Pondpack program in the previous study by Terra Nova, dated September of 2010. The pond will need to have more detail taken into account at the time of the Final Drainage Report when runoff calculations are finalized and the required pond volumes for WQCV, EURV, and 100-year detention and release rates are determined. The Existing Pond has been assessed for as-built conditions to determine if earthwork for volume adjustments is required and if retrofitting of existing pond infrastructure is required including the outlet structure, orifice plate, micropool, and spillway. The pond has sufficient volume to meet full-spectrum detention requirements. The required WQCV, EURV, and 100-year detention volumes are listed in a table in the next section of this report. It is determined that the existing outlet structure and orifice plate and restrictor plate are no longer valid for the new layout in Filing 3 and required release rate for the combined tributary area flow. A new outlet structure with orifice plate will be required to be designed and constructed as a part of the Final Drainage Report. In addition to the new outlet structure with micropool, a concrete trickle channel at the bottom of the pond with a minimum slope of 0.5 percent reaching forebays for inlet pipes is to be constructed. There was a lack of a distinct maintenance path that reached the outlet structure and any future forebays. A new maintenance path is to be constructed that meets County criteria. The flows from existing pond 2 flow southwest to Tamlin Road and across to the existing wetland channel flowing south offsite. The existing wetland channel will be maintained in its historic condition. Further analysis of the downstream wetland channel will be conducted with the Final Drainage Report. Since the release rate from the pond is proposed to be less than the current release rate, the outfall swale will remain hydraulically adequate. This design is in conformance with ECM 3.2.4. Runoff from an undisturbed area in the post development condition is being conveyed via natural topography to its historic outfall location off-site.

The 2010 FDR proposed a 42" RCP outlet pipe from the existing outlet structure to discharge flow from existing Pond 2 due south under the future dedicated right-of-way of Tamlin Road onto the adjacent undeveloped Banning Lewis Ranch property. It was proposed that rip rap protection will need to be provided at the end of the outlet pipe at the time of final construction and this is to be verified for the Final Drainage Report. From here the runoff drains south to an existing wetland channel and then is directed to an existing Highway 24 culvert. These proposed offsite improvements are to be assessed further in the Final Drainage Report. Current survey field data suggests that these improvements were not constructed as a part of Filing No. 2 and are to be verified in further studies. According to the 2010 study, "a 52' wide emergency spillway set at 6316.56 will pass the complete 100-year developed flow." Impervious factors and extended detention basin calculations for this pond can be found in Appendix E of this report. The previous FDR and Construction Drawings detailed an outlet structure and orifice plates to meet the required

release rates of 40 hours for WQCV, approximately 68 hours for EURV, and 72 hours for the 100-year storm event. It is anticipated that new outlet structures with orifice plate, a micropool, and trickle channel will be required to be designed in order to satisfy release rate requirements for the proposed developed conditions. All runoff from the 100-year storm even will be conveyed through Tracts to Pond 2. Swale sections through the tracts at the ultimate downstream emergency overflows are shown in Appendix E. Some earthwork may be required to provide permanent stabilization of more defined contouring within the pond to ensure that runoff reaches the outlet structure.

Pond spreadsheets included within the appendix present proposed outlet configurations that are to replace the existing outlet structures that are to be removed during pond reconstruction.

**Existing Pond WU:** The existing Detention Pond WU is a recently improved storm water quality and detention facility that is anticipated to be owned and maintained by El Paso County. The previous MDDP called for developed flow conditions to drain to this existing facility and it was accounted for in the recent improvements by Galloway and Company.

Falcon Highlands South generally consists of a more dense layout, however, in the area of Basin D there is a flood zone delineation resulting in the removal of previously sited lots. Additionally, the proposed layout more appropriately aligns with the Sand Creek and Falcon drainage basin delineation. The result is a less impervious and smaller basin area that is tributary to Pond WU from Falcon Highlands South as compared to the PDR that Galloway and Company utilized for sizing and release rates. As a result, there is less runoff to Pond WU in the proposed plan, therefore there is no increase to water quality capture volume or 100-year detention volume from the previous study or from recent improvements. The pond design volume was 18.9 ac-ft and built at a capacity of 50.8 ac-ft with a pond bottom elevation of 6816.3 and top of pond elevation of 6830.2 according to the 2020 Galloway and Company Final Drainage Report for Bent Grass Subdivision. The report approved release rates for the pond are provided in a Stage-Storage-Discharge Table in the Appendix which shows a peak total outflow of 1,402.59 cfs when the pond is at full capacity and 183.81 cfs is discharged via the emergency spillway. Pond WU has a 2312.70 acre tributary area with 7.3% imperviousness and was designed as a 50.8 ac-ft pond (Galloway and Company, 2020) for a required 39.54 ac-ft according to the Falcon DBPS by the County.

The report anticipated a 100-year flow rate of 65.4 cfs to Pond WU from the Falcon Highlands South development including the tributary area from Falcon Highlands Filing No. 2 that flows through the Site. The proposed conditions yield 59.2 cfs directed to Pond WU for the 100-year storm resulting in no added water quality or detention volume. This 6.2 cfs difference has no significant impact on the outlet structure of Pond WU which has capacity for an inflow upwards of nearly 6,800 cfs from upstream tributary areas.

Pond infrastructure will need to be constructed within Pond WU to meet current criteria, particularly a concrete trickle channel and forebay for the public storm main that will flow from Basin D of Falcon Highlands South to Pond WU. There is no evidence of an existing concrete trickle channel within the pond, nor was one designed as a part of the Construction Drawings and

Grading Plans by Galloway and Company in 2020. As a part of this project, the development of the Filing that contains Basin D will require a new concrete forebay and trickle channel that will terminate prior to the end of the existing swale from the channel, just before the outlet structure.

The Developed Condition’s runoff flows are kept at or below historic flows by way of detention within existing Pond WU, existing Detention Pond 1, and existing Detention Pond 2; all of which are designed for water quality capture and to release storm water at rates conforming to the El Paso County Drainage Criteria Manual. It is anticipated that there will be no negative affects to downstream areas due to developed drainage conditions

<b>HISTORIC AND PROPOSED BASIN SUMMARY</b>					
<b>Basin</b>	<b>Design Point</b>	<b>HISTORIC Q<sub>5</sub> (cfs)</b>	<b>HISTORIC Q<sub>100</sub> (cfs)</b>	<b>PROPOSED Q<sub>5</sub> (cfs)</b>	<b>PROPOSED Q<sub>100</sub> (cfs)</b>
A	1	1.1	7.7	1.1	7.7
B	2	34.4	77.6	2.2	5.6
C	3	57.3	130.1	4.4	5.2
D, OS-8	4	1.3	1,402.6	1.3	1,402.6
E	5	1.1	7.5	0.6	4.3
F, G	6	8.0	24.0	9.1	31.6

## **STORM WATER CONVEYANCE AND STORAGE FACILITIES**

The proposed on-site conveyance facilities will consist of a combination of storm pipe, swales/channels, curb/gutter, and inlets. Proposed drainage patterns will generally follow the historic drainage patterns outlined in the previous sections of this report, including previous master plans and reports for upstream filings. Within the proposed roadway network, stormwater runoff will be conveyed overland via surface flow of streets in the curb and gutter until street capacities have been exceeded or where storm sewer inlets have been designed. Interior lot flows are through side yard grasslined swales contributing to water quality prior to overland flow onto adjacent roadways and into the public storm systems. Designs for swales are located within Appendix E. At sump locations, inlets will be sized to collect 100-year flows. Any emergency overflow or bypass flows are discussed and explicitly stated in each sub-basin section, along with the type of inlet. Runoff entering the inlets will be conveyed within the public storm sewer system to the existing detention and water quality ponds. The general onsite drainage paths and patterns were previously discussed in the Proposed Drainage Basins section of this report.

A proposed grasslined swale is designed to convey stormwater to Pond 2 for tributary areas within the southeast area of the Site. This swale is to be designed to El Paso County standards with one foot of freeboard. Design calculations and cross sections are included within the appendix.

The existing pond outfalls are routed to the Sand Creek Basin. These outfalls have been preliminarily sized based on standard pond release rates required by the MHFD criteria. Release rates will be further evaluated during the preliminary and final drainage studies. The sizing of the facilities have been assessed for their as-built conditions.

Detention and Water Quality Ponds for the Site have been preliminarily designed based on previous MDDP and FDR studies for off-site basins and for Falcon Highlands South with the methods outlined in the MHFD Urban Storm Drainage Criteria Manual Volumes 1, 2 and 3 along with the MHFD MHFD-Detention\_v4.00. The ponds are designed to detain the EURV and the 100-year Detention Volume.

The existing ponds have outlet structures but do not have micropools, a concrete trickle channel or forebays meeting County criteria. The 5-year release rate is controlled by an orifice plate designed to meet the MHFD release rate criteria when designed in 2010. The 100-year storage volume is routed through a grate and restricted by a plate that was sized to limit the release rate to the allowable release rate. A new outlet structure with orifice plate, micropool, and concrete trickle channel that meets current criteria for WQCV, EURV, and 100-year are to be designed as a part of the Final Drainage Report.

The existing ponds have been previously designed using the runoff data from the Final Drainage Reports from Filing No. 1 and Filing No. 2 as well as assumed runoff data for Falcon Highlands South via the most recent FDR in August of 2010 for the development of Filing No. 2. While the ponds are adequately sized for the new, denser lot layout of Falcon Highlands South, the pond infrastructure is inadequate and not up to current standards.

This report provides more concise drainage calculations for Falcon Highlands South, consistent with the new layout and grading concept and thus for the tributary areas to Ponds 1 and 2. The MHFD UD-Detention calculator was used to determine existing Pond 1 and Pond 2's required WQCV, EURV, the 100-year detention volumes. The ponds are to be designed and updated to function as full-spectrum detention facilities.

A summary of the required pond volumes is presented in the table below.

<b>Extended Detention Pond Volumes</b>				
	<b>Zone 1 (WQCV)</b>	<b>Zone 2 (EURV - Zone 1)</b>	<b>Zone 3 (100- Year - Zones 1 &amp; 2)</b>	<b>Total Volume Required</b>
Pond 1	1.805 ac-ft	3.538 ac-ft	3.615 ac-ft	8.958 ac-ft
Pond 2	1.461 ac-ft	2.497 ac-ft	2.950 ac-ft	6.908 ac-ft

This MDDP consists of the most up to date calculations for percent imperviousness for the tributary areas to existing Ponds 1 and 2 and therefore has new, adjusted volume requirements compared to that of previous reports.

The existing Pond 1 was calculated to require 8.958 ac-ft and was sized for a 17 ac-ft pond using Haestad's Pondpack Program and HEC modeling according to the 2010 report. The as-built conditions for the constructed pond have the spillway weir at an elevation of 6416.5 and top of pond berm at 6817, yielding a total pond size of approximately 15.89 ac-ft. A Final Drainage Report for Falcon Highlands South will require analysis of Pond 1's infrastructure to adjust to final hydrology and hydraulic conditions tributary to the pond for the new, more dense site layout. Based on the calculations and as-built conditions for this Preliminary Drainage Report, the pond has sufficient volume for full spectrum detention.

Our calculations require 6.908 ac-ft within existing Pond 2 and the original report sized the pond for 9.43 ac-ft according to the Haestad's Pondpack Program and HEC modeling. The as-built conditions for the constructed pond have the spillway weir at an elevation of 6816.5 and top of pond berm at 6817.5 yielding a total pond size of approximately 10.51 ac-ft. A Final Drainage Report for Falcon Highlands South will require analysis of Pond 2's size and infrastructure to adjust to final hydrology and hydraulic conditions tributary to the pond. Based on the calculations and as-built conditions for this Preliminary Drainage Report, the pond has sufficient volume for full spectrum detention.

A Final Drainage Report for Falcon Highlands South will require analysis of both existing ponds for size and infrastructure to adjust to final hydrology and hydraulic conditions tributary to the respective facilities. Pond sizing looks to be sufficient but it is anticipated that the WQCV, EURV, and 100-year volumes now differ from the original 2010 design and new pond infrastructure will be required in order to meet release rate criteria at approximately 40 hours for WQCV, 68 hours for EURV, and 72 hours for the 100-year detention outflow times.

Existing Regional Detention Pond WU was designed and built as a part of Filing No. 2 and more recently retrofit with outlet structures and pipes. The pond accounted for the future development within Basin D of Falcon Highlands South according to the previous MDDP and FDR. The peak runoff from Basin D is less than the previous approved reports and therefore WQCV and 100-year detention volumes for the Falcon Highlands South area tributary to Pond WU is less than the designed and as-built condition of the pond. Additionally, the reduction in runoff is an insignificant amount relative to the enormity of the pond's inflow by order of magnitude, yielding no change in the release rates. No further assessment of volume for Pond WU is necessary. Retrofits for a forebay and concrete trickle channel for the storm outfall from Falcon Highlands South will be required.

## **FOUR STEP PROCESS**

The Four Step Process focuses on reducing runoff volumes, treating the WQCV, stabilizing drainageways, and implementing long-term source controls. The Four Step Process pertains to management of smaller, frequently occurring events, as opposed to larger storms for which drainage and flood control infrastructure are sized. The Four Step Process is summarized below and elements of the designed development are presented as a means to address and follow this process.

### 1. Step 1: Employ Runoff Reduction Practices

The Site is developed to capture runoff from impervious areas at sump locations and local low points within the public storm system. Impervious area is avoided where functional hardscape is not needed and open space is provided within the subdivision and remains undisturbed where developed lots are not laid out. Pervious landscaped areas are proposed where feasible in order to reduce runoff and typical lot layouts will be followed which include pervious landscape areas surrounding the residences including front and rear yards and side yard swales for drainage. IRF Spreadsheet calculations are included in the appendix to show the effective imperviousness of the Site as a whole and to calculate the stormwater runoff and WQCV reduction as a result of implementing pervious landscaped areas. WQCV reduction is not accounted for in the EDB calculations and therefore ponds are conservatively sized.

### 2. Step 2: Implement Control Measures That Provide A Water Quality Capture Volume with Slow Release

Outlet Structures with orifice plates are proposed for Ponds 1 and 2. Pond WU is designed with WQCV, EURV, and 100-year allowable release rates. The WQCV is released to meet the standard 40-hour drain time by way of an orifice plate. The public storm drain system throughout the subdivision collects and conveys stormwater runoff from impervious areas directly to the WQ control measure. Areas within the subdivision drain to a grasslined swale that conveys stormwater to Pond 2 over the length of approximately a half of a mile. This swale provides WQCV as it will be a pervious, naturally stabilized BMP that allows infiltration during small rain events.

### 3. Step 3: Stabilize Drainageways

The Site utilizes concrete curb and gutter to channel stormwater from impervious runoff, mostly from paved roadways and residential lots. Landscaped areas that drain offsite are to be permanently stabilized with native seeding and mulching as well as trees and shrubbery according to the landscaping plan. There are no formal drainageways within the Site. Sloped landscaped areas do not exceed 3H:1V grades and are to be seeded and mulched where plantings are not proposed. All new and re-development projects are required to construct or participate in the funding of channel stabilization measures. Drainage basin fees paid, at the time of platting, go towards channel stabilization within the drainage basin. The proposed grasslined swale follows El Paso County



drainage criteria to qualify as a stabilized drainageway with no potential for erosion as it is designed with 4:1 side slopes.

#### 4. Step 4: Implement Site Specific and Other Source Control Measures

Site construction is to follow a Stormwater Management Report and Grading and Erosion Control Plan that includes non-structural control measures during the initial, interim, and final phases of construction. As the development is multifamily residential land use, there are no anticipated site-specific permanent source control measures required for the Site.

### **WATER QUALITY ENHANCEMENT BEST MANAGEMENT PRACTICES**

The existing detention ponds discussed in the previous section are to have new infrastructure constructed in order to meet MHFD Urban Storm Drainage Criteria Manual Volumes 1, 2 and 3 as well as the El Paso County and City of Colorado Springs Drainage Criteria Manuals. The ponds are currently designed to provide WQCV and detain the EURV and the 100-year Detention Volumes but are to have retrofit of storm infrastructure including the outlet structure and orifice plate in order to meet release rate criteria. Runoff from the upstream tributary areas will be conveyed to the ponds via storm sewer and designed channels as emergency overflow routes directed to the ponds for water quality capture and treatment.

Non-structural Best Management Practices that will be incorporated into the project are anticipated to include grass swales. Water quality is provided via side yard grass swales between lots in developed areas throughout the subdivision. It is provided for basins that drain directly offsite and are not tributary to the ponds by way of grass-lined swales, and by having minimal grading with no developed imperviousness in these areas as either open space or permanently seeded and landscaped rear yard areas.

Structural Best Management Practices that are incorporated in the Site design include storm infrastructure within the extended detention basins such as outlet structures and spillways.

### **MAINTENANCE**

Maintenance of Detention Ponds 1 and 2 shall be by the Falcon Highlands Metro District via maintenance paths that will allow access to outlet structures and forebays within the pond along with the outlet works for the pond. The maintenance paths are to follow El Paso County standards for width, slope, and follow that of County standard details. Public Pond WU will be maintained by El Paso County. The eastern channel is to be maintained by the Metro District and will follow ECM standards. The proposed storm sewer system in the internal streets will be owned and maintained by El Paso County.

## **FLOODPLAIN MODIFICATIONS**

A portion of the Site within Flood Zone AE is delineated as Basin G and previously discussed in this report. Basin G is an open natural landscaped area not to be disturbed therefore there will be no modifications to the 100-year floodplain, nor will the development be impacted by said floodplain.

## **CONCLUSION**

This Preliminary Drainage Plan report covers the proposed storm water management plan for the Falcon Highlands South development. Detailed design will be required to develop individual portions of the site, but this document will provide guidance so that the drainage infrastructure constructed throughout the Falcon Highlands South development will function efficiently and effectively. A Final Drainage Report will address a more detailed stormwater management design with final inlet and pipe sizing with locations and elevations as well as design details for existing pond infrastructure. This report follows all standard criteria set forth by the El Paso County Drainage Criteria Manual, El Paso County Engineering Criteria Manual, the City of Colorado Springs Drainage Criteria Manuals Volumes 1, 2, and 3, and the Mile High Flood District Urban Storm Drainage Criteria Manual, with no requested variances. Downstream drainage facilities will not be negatively affected, as existing drainage patterns and allowable release rates are planned to be maintained. The Drainage Basin Planning Studies for both Sand Creek and Falcon have no existing or future plans within The Site. Furthermore, Pond WU will remain undisturbed with the exception of the installation of a concrete trickle channel and forebays and it has been concluded that the proposed Falcon Highlands South development will have no negative impact to the existing Pond and downstream infrastructure and development.

## **REFERENCES**

- 1) Urban Storm Drainage Criteria Manuals; Mile High Flood District; latest edition
- 2) El Paso County Engineering Criteria Manual (ECM), latest revision October 14, 2020
- 3) El Paso County Drainage Criteria Manual (DCM), October 1991; latest revision October 31, 2018
- 4) City of Colorado Springs Drainage Criteria Manuals, Volumes 1, 2, and 3, latest revision May 2014 (Not Adopted by El Paso County)
- 5) Flood Insurance Rate Map of El Paso County Colorado, Federal Emergency Management Agency, Flood Insurance Rate Map No. 08041C0561G and 08041C0545G dated December 7, 2018.
- 6) Hydrologic Soil Group – El Paso County, Colorado, Web Soil Survey, National Cooperative Soils Survey, May 21, 2021
- 7) *Falcon Highlands Filing No. 2 & 3 Final Drainage Report* by Terra Nova Engineering, Inc., latest revision August 2010.
- 8) *Falcon Highlands Phase 2, Filing No. 2 & 3 Master Development Drainage Plan and Preliminary Drainage Report* by Terra Nova Engineering, Inc. latest revision September 2005
- 9) *Bent Grass Residential Subdivision Filing No. 2 (SF-19-014) Final Drainage Report*, latest revision March 2020.
- 10) URS Section for Regional Detention Pond WU, developed by Galloway & Company
- 11) Sand Creek DBPS, developed by Stantec, HDR, and Dewberry dated January 2021 (Not Adopted by El Paso County)
- 12) Falcon DBS, developed by Matrix Design Group dated September 2015

**APPENDIX A**

**VICINITY MAP**

# Falcon Highlands - Filing No. 3

A PART OF SECTION 12, TOWNSHIP 13 SOUTH, RANGE 65 WEST  
OF THE SIXTH PRINCIPAL MERIDIAN,  
COUNTY OF EL PASO,  
STATE OF COLORADO

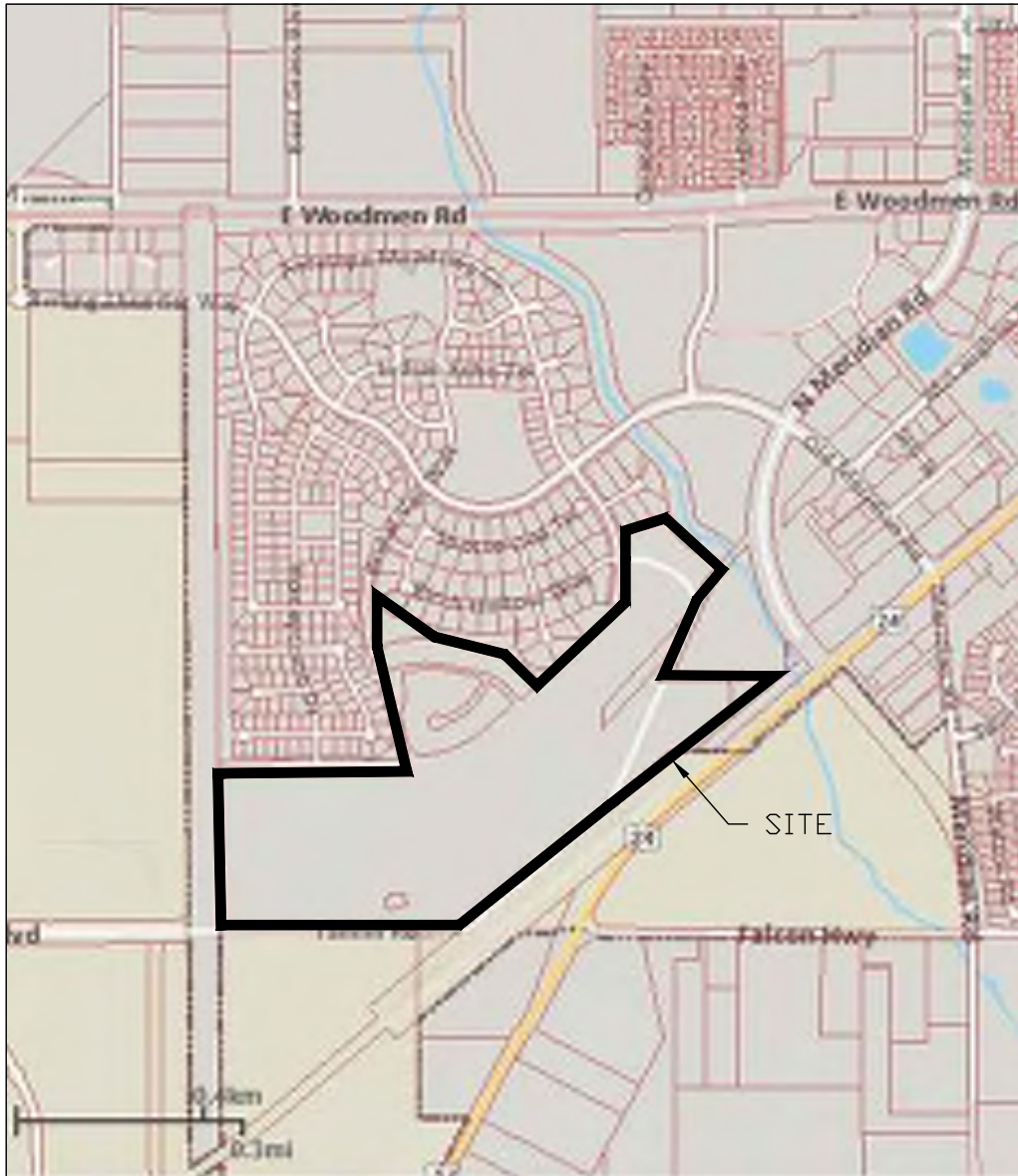

PROJECT NO.: 21000656  
DATE: 01/28/2022



SCALE: 1" = 0.3mi



**ATWELL**

866.850.4200 [www.atwell-group.com](http://www.atwell-group.com)

6200 S. SYRACUSE WAY, SUITE 470  
GREENWOOD VILLAGE, CO 80111  
303.825.7100

CONTACT: DAN CHARDY/DON  
DCHARDY@ATWELLCORPORATION.COM

**APPENDIX B**

**SOILS SURVEY**



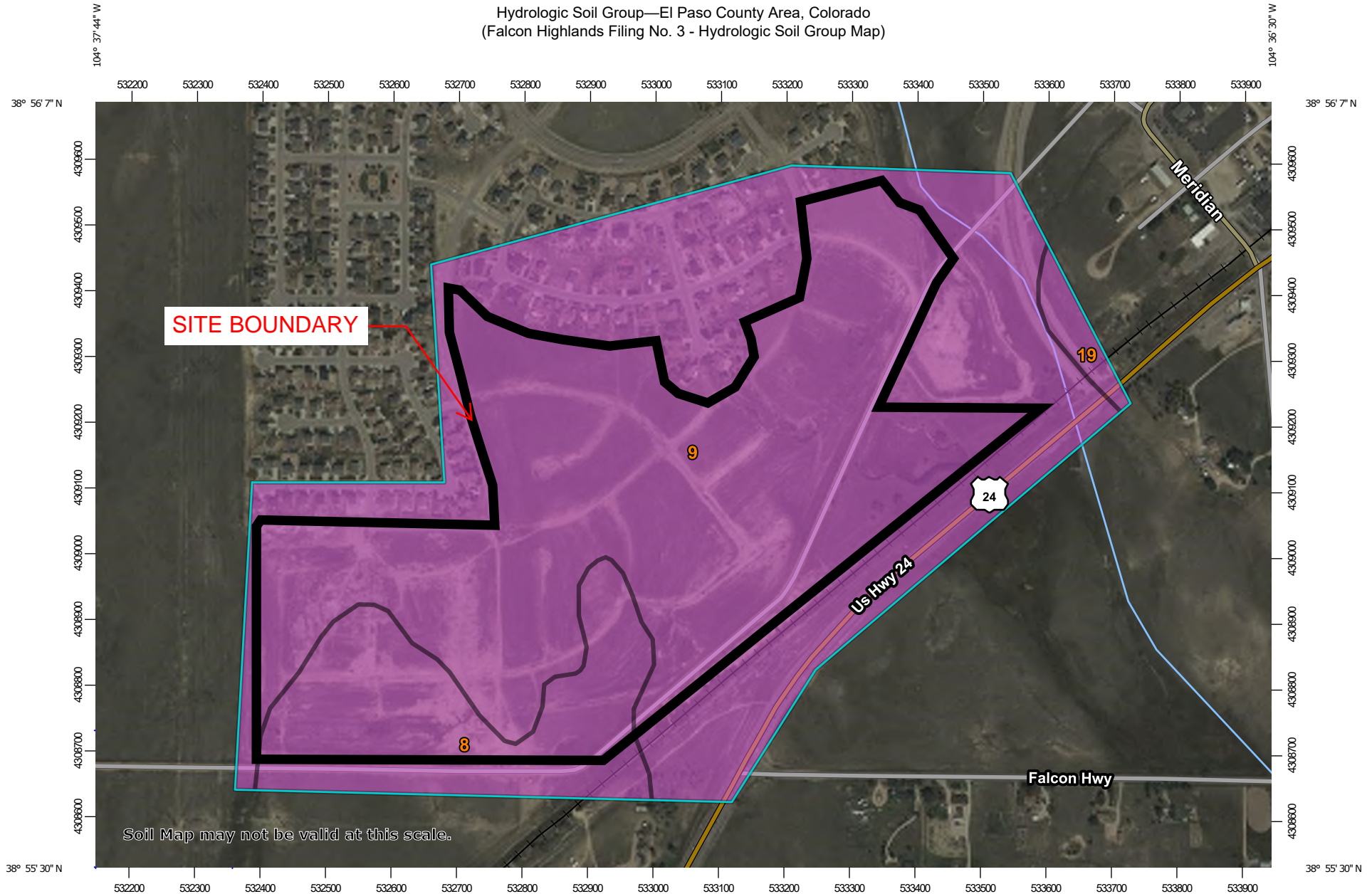



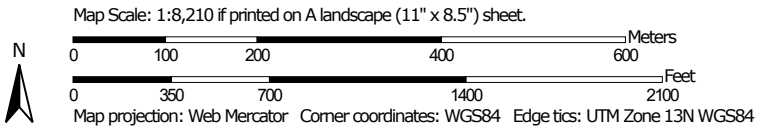























Hydrologic Soil Group—El Paso County Area, Colorado  
(Falcon Highlands Filing No. 3 - Hydrologic Soil Group Map)



Soil Map may not be valid at this scale.



## MAP LEGEND

<b>Area of Interest (AOI)</b>	 C
Area of Interest (AOI)	 C/D
<b>Soils</b>	 D
<b>Soil Rating Polygons</b>	 Not rated or not available
 A	
 A/D	
 B	
 B/D	
 C	
 C/D	
 D	
 Not rated or not available	
<b>Soil Rating Lines</b>	<b>Water Features</b>
 A	 Streams and Canals
 A/D	<b>Transportation</b>
 B	 Rails
 B/D	 Interstate Highways
 C	 US Routes
 C/D	 Major Roads
 D	 Local Roads
 Not rated or not available	<b>Background</b>
<b>Soil Rating Points</b>	 Aerial Photography
 A	
 A/D	
 B	
 B/D	

## MAP INFORMATION

The soil surveys that comprise your AOI were mapped at 1:24,000.

Warning: Soil Map may not be valid at this scale.

Enlargement of maps beyond the scale of mapping can cause misunderstanding of the detail of mapping and accuracy of soil line placement. The maps do not show the small areas of contrasting soils that could have been shown at a more detailed scale.

Please rely on the bar scale on each map sheet for map measurements.

Source of Map: Natural Resources Conservation Service  
 Web Soil Survey URL:  
 Coordinate System: Web Mercator (EPSG:3857)

Maps from the Web Soil Survey are based on the Web Mercator projection, which preserves direction and shape but distorts distance and area. A projection that preserves area, such as the Albers equal-area conic projection, should be used if more accurate calculations of distance or area are required.

This product is generated from the USDA-NRCS certified data as of the version date(s) listed below.

Soil Survey Area: El Paso County Area, Colorado  
 Survey Area Data: Version 18, Jun 5, 2020

Soil map units are labeled (as space allows) for map scales 1:50,000 or larger.

Date(s) aerial images were photographed: Sep 11, 2018—Oct 20, 2018

The orthophoto or other base map on which the soil lines were compiled and digitized probably differs from the background imagery displayed on these maps. As a result, some minor shifting of map unit boundaries may be evident.



## Hydrologic Soil Group

Map unit symbol	Map unit name	Rating	Acres in AOI	Percent of AOI
8	Blakeland loamy sand, 1 to 9 percent slopes	A	31.0	14.2%
9	Blakeland-Fluvaquentic Haplaquolls	A	184.2	84.5%
19	Columbine gravelly sandy loam, 0 to 3 percent slopes	A	2.8	1.3%
<b>Totals for Area of Interest</b>			<b>218.0</b>	<b>100.0%</b>

## Description

Hydrologic soil groups are based on estimates of runoff potential. Soils are assigned to one of four groups according to the rate of water infiltration when the soils are not protected by vegetation, are thoroughly wet, and receive precipitation from long-duration storms.

The soils in the United States are assigned to four groups (A, B, C, and D) and three dual classes (A/D, B/D, and C/D). The groups are defined as follows:

Group A. Soils having a high infiltration rate (low runoff potential) when thoroughly wet. These consist mainly of deep, well drained to excessively drained sands or gravelly sands. These soils have a high rate of water transmission.

Group B. Soils having a moderate infiltration rate when thoroughly wet. These consist chiefly of moderately deep or deep, moderately well drained or well drained soils that have moderately fine texture to moderately coarse texture. These soils have a moderate rate of water transmission.

Group C. Soils having a slow infiltration rate when thoroughly wet. These consist chiefly of soils having a layer that impedes the downward movement of water or soils of moderately fine texture or fine texture. These soils have a slow rate of water transmission.

Group D. Soils having a very slow infiltration rate (high runoff potential) when thoroughly wet. These consist chiefly of clays that have a high shrink-swell potential, soils that have a high water table, soils that have a claypan or clay layer at or near the surface, and soils that are shallow over nearly impervious material. These soils have a very slow rate of water transmission.

If a soil is assigned to a dual hydrologic group (A/D, B/D, or C/D), the first letter is for drained areas and the second is for undrained areas. Only the soils that in their natural condition are in group D are assigned to dual classes.

## Rating Options

*Aggregation Method:* Dominant Condition

*Component Percent Cutoff:* None Specified

*Tie-break Rule:* Higher

**APPENDIX C**  
**FEMA FIRMETTE**

**NOTES TO USERS**

This map is for use in administering the National Flood Insurance Program. It does not necessarily identify all areas subject to flooding, particularly from local drainage sources of small size. The community map repository should be consulted for possible updated or additional flood hazard information.

To obtain more detailed information in areas where **Base Flood Elevations (BFEs)** and/or **floodways** have been determined, users are encouraged to consult the Flood Profiles and Floodway Data and/or Summary of Stillwater Elevations tables contained within the Flood Insurance Study (FIS) report that accompanies this FIRM. Users should be aware that BFEs shown on the FIRM represent rounded whole-foot elevations. These BFEs are intended for flood insurance rating purposes only and should not be used as the sole source of flood elevation information. Accordingly, flood elevation data presented in the FIS report should be utilized in conjunction with the FIRM for purposes of construction and/or floodplain management.

**Coastal Base Flood Elevations** shown on this map apply only landward of 0.0' North American Vertical Datum of 1988 (NAVD88). Users of this FIRM should be aware that coastal flood elevations are also provided in the Summary of Stillwater Elevations table in the Flood Insurance Study report for this jurisdiction. Elevations shown in the Summary of Stillwater Elevations table should be used for construction and/or floodplain management purposes when they are higher than the elevations shown on this FIRM.

Boundaries of the **floodways** were computed at cross sections and interpolated between cross sections. The floodways were based on hydraulic considerations with regard to requirements of the National Flood Insurance Program. Floodway widths and other pertinent floodway data are provided in the Flood Insurance Study report for this jurisdiction.

Certain areas not in Special Flood Hazard Areas may be protected by **flood control structures**. Refer to section 2.4 "Flood Protection Measures" of the Flood Insurance Study report for information on flood control structures for this jurisdiction.

The **projection** used in the preparation of this map was Universal Transverse Mercator (UTM) zone 13. The **horizontal datum** was NAD83, GRS80 spheroid. Differences in datum, spheroid, projection or UTM zones zones used in the production of FIRMs for adjacent jurisdictions may result in slight positional differences in map features across jurisdiction boundaries. These differences do not affect the accuracy of this FIRM.

Flood elevations on this map are referenced to the **North American Vertical Datum of 1988 (NAVD88)**. These flood elevations must be compared to structure and ground elevations referenced to the same **vertical datum**. For information regarding conversion between the National Geodetic Vertical Datum of 1929 and the North American Vertical Datum of 1988, visit the National Geodetic Survey website at <http://www.ngs.noaa.gov/> or contact the National Geodetic Survey at the following address:

NGS Information Services  
NOAA, NIMS12  
National Geodetic Survey  
SSMC-3, #9202  
1315 East-West Highway  
Silver Spring, MD 20910-3282

To obtain current elevation, description, and/or location information for **bench marks** shown on this map, please contact the Information Services Branch of the National Geodetic Survey at (301) 713-3242 or visit its website at <http://www.ngs.noaa.gov/>.

**Base Map** information shown on this FIRM was provided in digital format by El Paso County, Colorado Springs Utilities, City of Fountain, Bureau of Land Management, National Oceanic and Atmospheric Administration, United States Geological Survey, and Anderson Consulting Engineers, Inc. These data are current as of 2006.

This map reflects more detailed and up-to-date **stream channel configurations and floodplain delineations** than those shown on the previous FIRM for this jurisdiction. The floodplains and floodways that were transferred from the previous FIRM may have been adjusted to conform to these new stream channel configurations. As a result, the Flood Profiles and Floodway Data tables in the Flood Insurance Study Report (which contains authoritative hydraulic data) may reflect stream channel distances that differ from what is shown on this map. The profile baselines depicted on this map represent the hydraulic modeling baselines that match the flood profiles and Floodway Data Tables if applicable, in the FIS report. As a result, the profile baselines may deviate significantly from the new base map channel representation and may appear outside of the floodplain.

**Corporate limits** shown on this map are based on the best data available at the time of publication. Because changes due to annexations or de-annexations may have occurred after this map was published, map users should contact appropriate community officials to verify current corporate limit locations.

Please refer to the separately printed **Map Index** for an overview map of the county showing the layout of map panels; community map repository addresses; and a Listing of Communities table containing National Flood Insurance Program dates for each community as well as a listing of the panels on which each community is located.

Contact **FEMA Map Service Center (MSC)** via the FEMA Map Information eXchange (FMIX) 1-877-336-2627 for information on available products associated with this FIRM. Available products may include previously issued Letters of Map Change, a Flood Insurance Study Report, and/or digital versions of this map. The MSC may also be reached by Fax at 1-800-358-9620 and its website at <http://www.msc.fema.gov/>.

If you have **questions about this map** or questions concerning the National Flood Insurance Program in general, please call 1-877-FEMA MAP (1-877-336-2627) or visit the FEMA website at <http://www.fema.gov/business/nfip>.

**El Paso County Vertical Datum Offset Table**

Flooding Source	Vertical Datum Offset (ft)
REFER TO SECTION 3.3 OF THE EL PASO COUNTY FLOOD INSURANCE STUDY FOR STREAM BY STREAM VERTICAL DATUM CONVERSION INFORMATION	

**Panel Location Map**

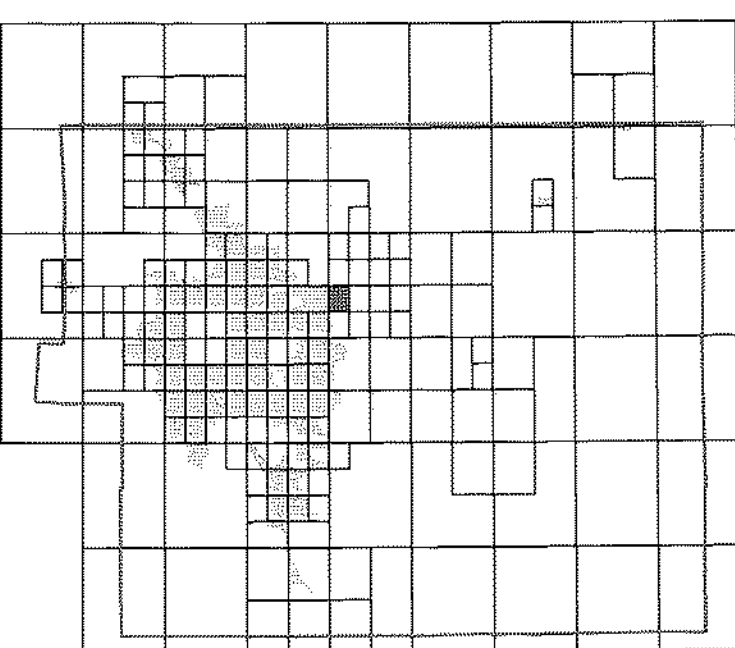

This Digital Flood Insurance Rate Map (DFIRM) was produced through a Cooperating Technical Partner (CTP) agreement between the State of Colorado Water Conservation Board (CWCB) and the Federal Emergency Management Agency (FEMA).



Additional Flood Hazard information and resources are available from local communities and the Colorado Water Conservation Board.

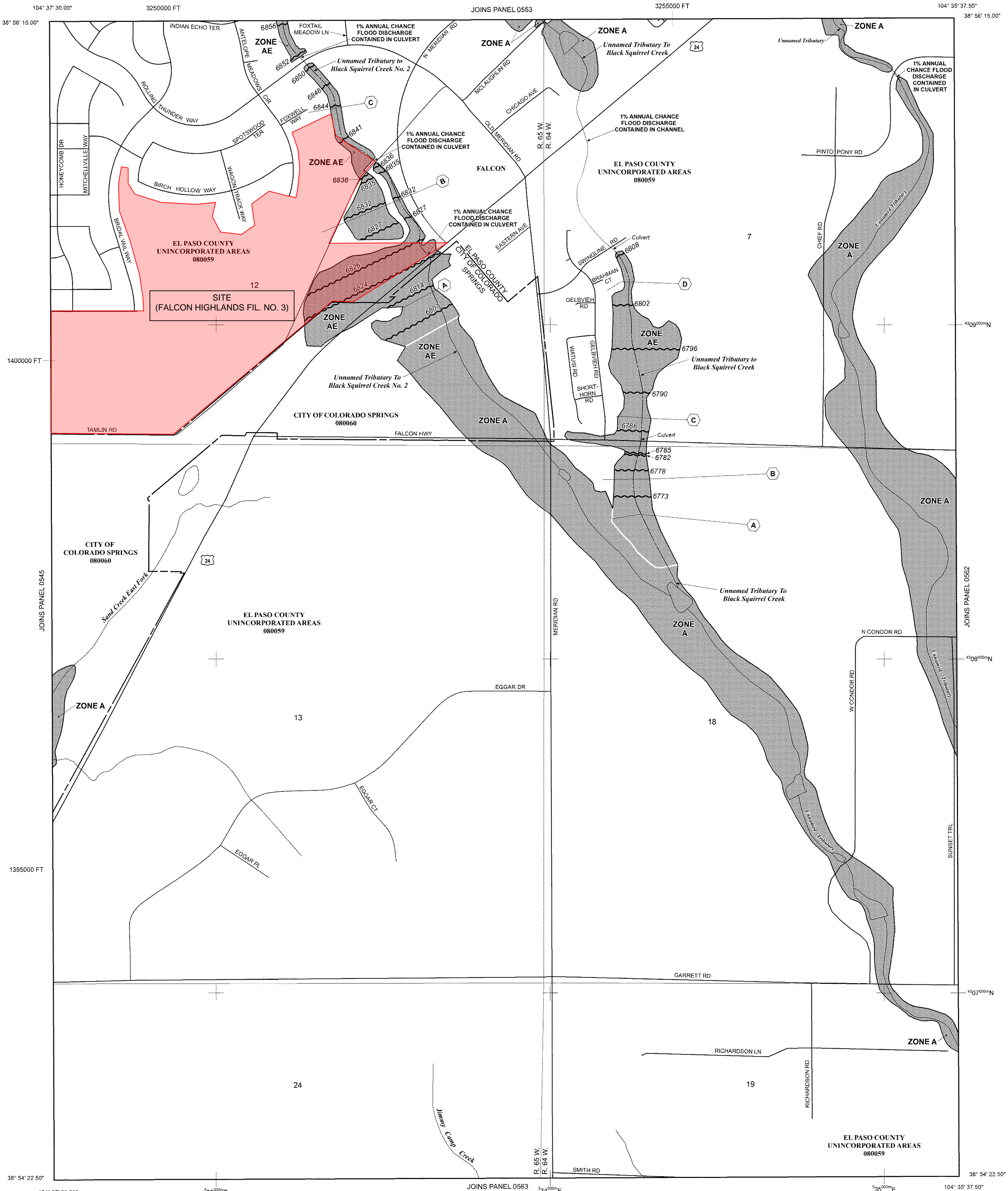

NOTE: MAP AREA SHOWN ON THIS PANEL IS LOCATED WITHIN TOWNSHIP 13 SOUTH, RANGE 64 WEST, AND TOWNSHIP 13 SOUTH, RANGE 65 WEST.

**LEGEND**

**SPECIAL FLOOD HAZARD AREAS (SFHAs) SUBJECT TO INUNDATION BY THE 1% ANNUAL CHANCE FLOOD**

The 1% annual chance flood (100-year flood), also known as the base flood, is the flood that has a 1% chance of being equalled or exceeded in any given year. The Special Flood Hazard Area is the area subject to flooding by the 1% annual chance flood. Areas of Special Flood Hazard are ZONE A, AE, AH, AO, AR, A99, V, and VE. The Base Flood Elevation is the water-surface elevation of the 1% annual chance flood.

- ZONE A** No Base Flood Elevations determined. Base Flood Elevations determined.
- ZONE AE** Flood depths of 1 to 3 feet (usually areas of ponding); Base Flood Elevations determined.
- ZONE AH** Flood depths of 1 to 3 feet (usually sheet flow on sloping terrain); average depths determined. For areas of alluvial fan flooding, velocities also determined.
- ZONE AO** Special Flood Hazard Area Formerly protected from the 1% annual chance flood by a flood control system that was subsequently dewatered. Zone AH indicates that the former flood control system is being restored to provide protection from the 1% annual chance or greater flood.
- ZONE AR** Area to be protected from 1% annual chance flood by a Federal flood protection system under construction; no Base Flood Elevations determined.
- ZONE A99** Coastal flood zone with velocity hazard (wave action); no Base Flood Elevations determined.
- ZONE V** Coastal flood zone with velocity hazard (wave action); Base Flood Elevations determined.
- ZONE VE** Floodway Areas in ZONE AE

The floodway is the channel of a stream plus any adjacent floodplain areas that must be kept free of encroachment so that the 1% annual chance flood can be carried without substantial increases in flood heights.

**OTHER FLOOD AREAS**

**ZONE X** Areas of 0.2% annual chance flood; areas of 1% annual chance flood with average depths of less than 1 foot or with drainage areas less than 1 square mile; and areas protected by levees from 1% annual chance flood.

**OTHER AREAS**

**ZONE X** Areas determined to be outside the 0.2% annual chance floodplain.

**ZONE D** Areas in which flood hazards are undetermined, but possible.

**COASTAL BARRIER RESOURCES SYSTEM (CBRS) AREAS**

**OTHERWISE PROTECTED AREAS (OPAs)**

CBRS areas and OPAs are normally located within or adjacent to Special Flood Hazard Areas.

- Floodplain boundary
- Floodway boundary
- Zone D Boundary
- CBRS and OPA boundary
- Boundary dividing Special Flood Hazard Areas of different Base Flood Elevations, flood depths or flood velocities.
- Base Flood Elevation line and value; elevation in feet\* (EL 987)
- Base Flood Elevation value where uniform within zone; elevation in feet\*

\* Referenced to the North American Vertical Datum of 1988 (NAVD 88)

**A** Cross section line

**23** Transsect line

57° 07' 30.00" Geographic coordinates referenced to the North American Datum of 1983 (NAD 83)

4756000N 1000-meter Universal Transverse Mercator grid ticks, zone 13

6000000 FT 5000-foot grid ticks: Colorado State Plane coordinate system, central zone (FIPSZONE 0502), Lambert Conformal Conic Projection

DX5510 Bench mark (see explanation in Notes to Users section of this FIRM panel)

M1.5 River Mile

MAP REPOSITORIES Refer to Map Repositories list on Map Index

EFFECTIVE DATE OF COUNTYWIDE FLOOD INSURANCE RATE MAP MARCH 17, 1997

EFFECTIVE DATE(S) OF REVISION(S) TO THIS PANEL DECEMBER 7, 2018 - to update corporate limits, to change Base Flood Elevations and Special Flood Hazard Areas, to update map format, to add roads and road names, and to incorporate previously issued Letters of Map Revision

For community map revision history prior to countywide mapping, refer to the Community Map History Table located in the Flood Insurance Study report for this jurisdiction. To determine if flood insurance is available in this community, contact your insurance agent or call the National Flood Insurance Program at 1-800-638-6620.

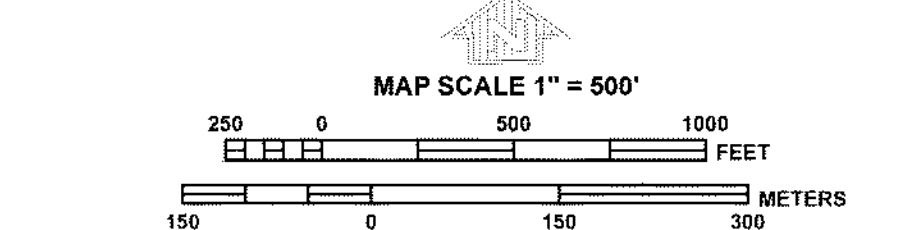

**PANEL 0561G**

**FIRM**  
**FLOOD INSURANCE RATE MAP**  
**EL PASO COUNTY,**  
**COLORADO**  
**AND INCORPORATED AREAS**

**PANEL 561 OF 1300**  
(SEE MAP INDEX FOR FIRM PANEL LAYOUT)

CONTAINS	COMMUNITY	NUMBER	PANEL	SUFFIX
	COLORADO SPRINGS, CITY OF	08060	0561	G
	EL PASO COUNTY	08009	0561	G

MAP NUMBER  
**08041C0561G**

MAP REVISED  
**DECEMBER 7, 2018**  
Federal Emergency Management Agency

**APPENDIX D**  
**HYDROLOGICAL CALCULATIONS**

**RUNOFF COEFFICIENTS AND IMPERVIOUSNESS**  
**Falcon Highlands Filing No. 3 - EXISTING CONDITIONS**  
**El Paso County, Colorado**

Basin No	Hydrologic Grouping	Total Area (AC)	1/8 Acre or Less			Paved			Drive and Walks			Lawns			1/2 Acre			1/4 Acre			Historic Flow Analysis -- Greenbelts, Agriculture			Runoff Coefficient		Imperviousness (%)
			65%			100%			100%			0%			25%			40%			2%			5-Year	100-Year	
			C5	C100	(AC)	C5	C100	(AC)	C5	C100	(AC)	C5	C100	(AC)	C5	C100	(AC)	C5	C100	(AC)	C5	C100	(AC)			
A	A	3.74	0.45	0.59	0.00	0.90	0.96	0.00	0.90	0.96	0.00	0.08	0.35	0.00	0.22	0.46	0.00	0.30	0.50	0.00	0.09	0.36	3.74	0.09	0.36	2.0%
B	A	38.93	0.45	0.59	0.00	0.90	0.96	0.00	0.90	0.96	0.00	0.08	0.35	0.00	0.22	0.46	0.00	0.30	0.50	0.00	0.09	0.36	38.93	0.09	0.36	2.0%
C	A	57.81	0.45	0.59	0.00	0.90	0.96	0.00	0.90	0.96	0.00	0.08	0.35	0.00	0.22	0.46	0.00	0.30	0.50	0.00	0.09	0.36	57.81	0.09	0.36	2.0%
D	A	10.54	0.45	0.59	0.00	0.90	0.96	0.00	0.90	0.96	0.00	0.08	0.35	0.00	0.22	0.46	0.00	0.30	0.50	0.00	0.09	0.36	10.54	0.09	0.36	2.0%
E	A	3.14	0.45	0.59	0.00	0.90	0.96	0.00	0.90	0.96	0.00	0.08	0.35	0.00	0.22	0.46	0.00	0.30	0.50	0.00	0.09	0.36	3.14	0.09	0.36	2.0%
F	A	3.67	0.45	0.59	0.00	0.90	0.96	0.00	0.90	0.96	0.00	0.08	0.35	0.00	0.22	0.46	0.00	0.30	0.50	0.00	0.09	0.36	3.67	0.09	0.36	2.0%
G	A	8.84	0.45	0.59	0.00	0.90	0.96	0.00	0.90	0.96	0.00	0.08	0.35	0.00	0.22	0.46	0.00	0.30	0.50	0.00	0.09	0.36	8.84	0.09	0.36	2.0%
OS-1	A	6.38	0.45	0.59	1.00	0.90	0.96	0.00	0.90	0.96	0.00	0.08	0.35	0.00	0.22	0.46	0.00	0.30	0.50	3.77	0.09	0.36	1.61	0.27	0.48	34.3%
OS-2	A	3.12	0.45	0.59	0.00	0.90	0.96	0.00	0.90	0.96	0.00	0.08	0.35	0.00	0.22	0.46	0.00	0.30	0.50	3.12	0.09	0.36	0.00	0.30	0.50	40.0%
OS-3	A	1.14	0.45	0.59	0.00	0.90	0.96	0.00	0.90	0.96	1.14	0.08	0.35	0.00	0.22	0.46	0.00	0.30	0.50	0.00	0.09	0.36	0.00	0.90	0.96	100.0%
OS-4	A	13.09	0.45	0.59	0.00	0.90	0.96	0.00	0.90	0.96	0.00	0.08	0.35	0.00	0.22	0.46	0.00	0.30	0.50	7.50	0.09	0.36	5.59	0.34	0.44	23.8%
OS-5	A	59.62	0.45	0.59	0.00	0.90	0.96	0.00	0.90	0.96	0.00	0.08	0.35	0.00	0.22	0.46	0.00	0.30	0.50	59.62	0.09	0.36	0.00	0.30	0.50	40.0%
OS-6	A	35.75	0.45	0.59	0.00	0.90	0.96	0.00	0.90	0.96	0.00	0.08	0.35	0.00	0.22	0.46	35.75	0.30	0.50	0.00	0.09	0.36	0.00	0.22	0.46	25.0%
OS-7	A	6.47	0.45	0.59	0.00	0.90	0.96	0.00	0.90	0.96	0.00	0.08	0.35	0.00	0.22	0.46	6.47	0.30	0.50	0.00	0.09	0.36	0.00	0.22	0.46	25.0%
OS-8	A	13.79	0.45	0.59	0.00	0.90	0.96	0.00	0.90	0.96	0.00	0.08	0.35	0.00	0.22	0.46	0.00	0.30	0.50	0.00	0.09	0.36	13.79	0.09	0.36	2.0%
<b>TOTAL</b>		<b>266.0</b>			<b>1.0</b>			<b>0.0</b>			<b>1.1</b>			<b>0.0</b>			<b>42.2</b>			<b>74.0</b>			<b>133.9</b>			<b>16.8%</b>

**TIME OF CONCENTRATION**  
**Falcon Highlands Filing No. 3 - EXISTING CONDITIONS**  
**El Paso County, Colorado**

DATE: 8/25/2022  
 CALCULATED BY: AMC/ARP

PROJECT: 21000656  
 DESIGN STORM: 5 Year

TRIBUTARY BASINS	AREA Ac (2)	C5 (3)	INITIAL/OVERLAND TIME (ti)			TRAVEL TIME (tt)					tc CHECK (URBANIZED BASINS)			FINAL tc
			LENGTH Ft (4)	SLOPE % (5)	ti Min. (6)	LENGTH Ft. (7)	SLOPE % (8)	Conveyance Coefficient	VEL fps (9)	tt Min. (10)	COMP. tc (11)	TOTAL LENGTH (12)	(L/180)+10 Min. (13)	Min. (14)
A	3.74	0.09	202	1.00	25.92	910	1.00	15	1.50	10.11	36.03	1112	16.18	16.18
B	38.93	0.09	300	1.00	31.58	979	1.00	15	1.50	10.88	42.46	1279	17.11	17.11
C	57.81	0.09	300	2.00	25.13	571	1.00	15	1.50	6.34	31.47	871	14.84	14.84
D	10.54	0.09	300	1.00	31.58	360	1.00	15	1.50	4.00	35.58	660	13.67	13.67
E	3.14	0.09	75	2.00	12.56	150	3.50	15	2.81	0.89	13.45	225	11.25	11.25
F	3.67	0.09	125	3.00	14.19	630	1.60	15	1.90	5.53	19.72	755	14.19	14.19
G	8.84	0.09	200	3.00	17.95	360	1.10	15	1.57	3.81	21.76	560	13.11	13.11
OS-1	6.38	0.27	25	2.00	5.96	650	2.00	20	2.83	3.83	9.79	675	13.75	9.79
OS-2	3.12	0.30	50	2.00	8.13	2180	1.00	20	2.00	18.17	26.29	2230	22.39	22.39
OS-3	1.14	0.90	20	2.00	1.28	1190	2.00	20	2.83	7.01	8.30	1210	16.72	8.30
OS-4	13.09	0.34	80	2.00	9.76	2300	2.00	20	2.83	13.55	23.32	2380	23.22	23.22
OS-5	59.62	0.30	100	2.00	11.49	608	2.00	20	2.83	3.58	15.07	708	13.93	13.93
OS-6	35.75	0.22	100	2.00	12.64	0	0.60	20	1.55	0.00	12.64	100	10.56	10.56
OS-7	6.47	0.22	300	2.00	21.89	300	0.60	15	1.16	4.30	26.20	600	13.33	13.33
OS-8	13.79	0.09	300	2.00	25.13	0	0.60	15	1.16	0.00	25.13	300	11.67	11.67

Table 6-2. NRCS Conveyance factors, K

Type of Land Surface	Conveyance Factor, K
Heavy meadow	2.5
Tillage/field	5
Short pasture and lawns	7
Nearly bare ground	10
Grassed waterway	15
Paved areas and shallow paved swales	20

**NOTES:**

$T_i = [0.395 \times (1.1 - C_2) \times L^{0.5}] / (S^{0.33})$  \*S IN %\*

$T_t = L / (60 \times V)$

$V = K \times S^{0.5}$

$T_c \text{ Check} = 10 + L/180$  (Urbanized Basins Only)

$T_c \text{ Min} = 5$  Minutes

**5-YEAR RUNOFF CALCULATIONS**  
**Falcon Highlands Filing No. 3 - EXISTING CONDITIONS**  
**El Paso County, Colorado**

DATE: 8/25/2022  
 CALCULATED BY: RDL

PROJECT: 21000656  
 DESIGN STORM: 5-Year

Sub-Basin	Design Point	FLOW TO INLETS								Minimum Street Slope (%)	Maximum Street/Paseo Capacity (cfs)	Under Capacity?	INLETS						Carry-Over to Sub-basin/ Design Point (DP)
		Area (acres)	C	C x A	Tc (min)	Intensity (in/hr)	Qd = CIA (cfs)	Qco (cfs)	Qt (cfs)				Inlet	Type	Condition	Slope at Inlet (%)	Inlet Capacity (cfs)	R	
A	1	3.74	0.09	0.34	16.18	3.41	1.15	0.00	1.15	-	-	-	-	-	-	-	-	-	
B	2	38.93	0.09	3.50	17.11	3.32	11.65	0.00	11.65	-	-	-	-	-	-	-	-	-	
C	3	57.81	0.09	5.20	14.84	3.54	18.40	0.00	18.40	-	-	-	-	-	-	-	-	-	
D	4	10.54	0.09	0.95	13.67	3.66	3.47	0.00	3.47	-	-	-	-	-	-	-	-	-	
E	5	3.14	0.09	0.28	11.25	3.95	1.12	0.00	1.12	-	-	-	-	-	-	-	-	-	
F	6	3.67	0.09	0.33	14.19	3.60	1.19	0.00	1.19	-	-	-	-	-	-	-	-	-	
G	6	8.84	0.09	0.80			6.80	0.00	6.80	-	-	-	-	-	-	-	-	-	
OS-1	7	6.38	0.27	1.73			10.70	0.00	10.70	-	-	-	-	-	-	-	-	-	
OS-2	8	3.12	0.30	0.94			7.80	0.00	7.80	-	-	-	-	-	-	-	-	-	
OS-3	9	1.14	0.90	1.03			3.40	0.00	3.40	-	-	-	-	-	-	-	-	-	
OS-4	10	13.09	0.34	4.45			12.30	0.00	12.30	-	-	-	-	-	-	-	-	-	
OS-5	11	59.62	0.30	17.89			80.10	0.00	80.10	-	-	-	-	-	-	-	-	-	
OS-6	12	35.75	0.22	7.87			31.90	0.00	31.90	-	-	-	-	-	-	-	-	-	
OS-7	13	6.47	0.22	1.42	13.33	3.70	5.26	0.00	5.26	-	-	-	-	-	-	-	-	-	
OS-8	4	13.79	0.09	1.24	11.67	3.90	4.84	0.00	4.84	-	-	-	-	-	-	-	-	-	

Notes:  
 \*DATA IN RED REPRESENTS VALUES PER PREVIOUS DRAINAGE REPORTS FOR SUBDIVISION



**100-YEAR RUNOFF CALCULATIONS**  
**Falcon Highlands Filing No. 3 - EXISTING CONDITIONS**  
**El Paso County, Colorado**

DATE: 8/25/2022  
 CALCULATED BY: RDL

PROJECT: 21000656  
 DESIGN STORM: 100-Year

Sub-Basin	Design Point	FLOW TO INLETS								Minimum Street Slope (%)	Maximum Street/Paseo Capacity (cfs)	Under Capacity?	INLETS						Carry-Over to Sub-basin/ Design Point (DP)
		Area (acres)	C	C x A	Tc (min)	Intensity (in/hr)	Qd = CIA (cfs)	Qco (cfs)	Qt (cfs)				Inlet	Type	Condition	Slope at Inlet (%)	Inlet Capacity (cfs)	R	
A	1	3.74	0.36	1.35	16.18	5.72	7.70	0.00	7.70	-	-	-	-	-	-	-	-	-	-
B	2	38.93	0.36	14.01	17.11	5.58	78.20	0.00	78.20	-	-	-	-	-	-	-	-	-	-
C	3	57.81	0.36	20.81	14.84	5.94	123.57	0.00	123.57	-	-	-	-	-	-	-	-	-	-
D	4	10.54	0.36	3.79	13.67	6.15	23.31	0.00	23.31	-	-	-	-	-	-	-	-	-	-
E	5	3.14	0.36	1.13	11.25	6.64	7.50	0.00	7.50	-	-	-	-	-	-	-	-	-	-
F	6	3.67	0.36	1.32	14.19	6.05	7.99	0.00	7.99	-	-	-	-	-	-	-	-	-	-
G	6	8.84	0.36	3.18			16.00	0.00	16.00	-	-	-	-	-	-	-	-	-	-
OS-1	7	6.38	0.48	3.05			21.70	0.00	21.70	-	-	-	-	-	-	-	-	-	-
OS-2	8	3.12	0.50	1.56			13.60	0.00	13.60	-	-	-	-	-	-	-	-	-	-
OS-3	9	1.14	0.96	1.09			6.00	0.00	6.00	-	-	-	-	-	-	-	-	-	-
OS-4	10	13.09	0.44	5.76			26.30	0.00	26.30	-	-	-	-	-	-	-	-	-	-
OS-5	11	59.62	0.50	29.81			160.70	0.00	160.70	-	-	-	-	-	-	-	-	-	-
OS-6	12	35.75	0.46	16.45			58.40	0.00	58.40	-	-	-	-	-	-	-	-	-	-
OS-7	13	6.47	0.46	2.98	13.33	6.21	18.47	0.00	18.47	-	-	-	-	-	-	-	-	-	-
OS-8	4	13.79	0.36	4.96	11.67	6.54	32.49	0.00	32.49	-	-	-	-	-	-	-	-	-	-

Notes:  
 \*DATA IN RED REPRESENTS VALUES PER PREVIOUS DRAINAGE REPORTS FOR SUBDIVISION

## EXISTING CONDITIONS DRAINAGE BASIN SUMMARY

Basin	Design Point	Area (acres)	C <sub>5</sub>	C <sub>100</sub>	Q <sub>5</sub> (cfs)	Q <sub>100</sub> (cfs)
A	1	3.74	0.09	0.36	1.15	7.70
B	2	38.93	0.09	0.36	11.65	78.20
C	3	57.81	0.09	0.36	18.40	123.57
D	4	10.54	0.09	0.36	3.47	23.31
E	5	3.14	0.09	0.36	1.12	7.50
F	6	3.67	0.09	0.36	1.19	7.99
G	6	8.84	0.09	0.36	6.80	16.00
OS-1	7	6.38	0.27	0.48	10.70	21.70
OS-2	8	3.12	0.30	0.50	7.80	13.60
OS-3	9	1.14	0.90	0.96	3.40	6.00
OS-4	10	13.09	0.34	0.44	12.30	26.30
OS-5	11	59.62	0.30	0.50	80.10	160.70
OS-6	12	35.75	0.22	0.46	31.90	58.40
OS-7	13	6.47	0.22	0.46	5.26	18.47
OS-8	4	13.79	0.09	0.36	4.84	32.49
<b>TOTAL</b>		<b>266.0</b>			<b>200.1</b>	<b>601.9</b>

**EXISTING CONDITIONS DESIGN POINT SUMMARY  
(CUMULATIVE FLOW)**

<b>Design Point</b>	<b>Contributing Basins</b>	<b>Q<sub>5</sub> (cfs)</b>	<b>Q<sub>100</sub> (cfs)</b>
1	A, DP-10	13.4	34.0
2	B, DP-11	99.5	252.5
3	C, DP-12	53.7	188.0
4	D, DP-13	13.6	74.3
5	E, DP-2	100.7	260.0
6	F, G, DP-2, DP-4	75.3	286.2
7	OS-1	10.7	21.7
8	OS-2	7.8	13.6
9	OS-3	3.4	6.0
10	OS-4	12.3	26.3
11	DP-8, OS-5	87.9	174.3
12	DP-9, OS-6	35.3	64.4
13	OS-7	5.3	18.5

**RUNOFF COEFFICIENTS AND IMPERVIOUSNESS**  
**Falcon Highlands Filing No. 3 - PROPOSED CONDITIONS**  
 El Paso County, Colorado  
 9/17/2023

Basin No	Hydrologic Grouping	Total Area (AC)	1/8 Acre or Less 65%			Drive and Walks 100%			Lawns 0%			1/2 Acre 25%			1/4 Acre 40%			Historic Flow Analysis -- 2%			Runoff Coefficient		ImperVIOUSNESS (%)
			C5	C100	(AC)	C5	C100	(AC)	C5	C100	(AC)	C5	C100	(AC)	C5	C100	(AC)	C5	C100	(AC)	5-Year	100-Year	
B1	A	5.30	0.45	0.59	5.30	0.90	0.96	0.00	0.08	0.35	0.00	0.22	0.46	0.00	0.30	0.5	0.00	0.09	0.36	0.00	0.45	0.59	65.0%
B2	A	4.06	0.45	0.59	4.06	0.90	0.96	0.00	0.08	0.35	0.00	0.22	0.46	0.00	0.30	0.5	0.00	0.09	0.36	0.00	0.45	0.59	65.0%
B3	A	4.41	0.45	0.59	4.41	0.90	0.96	0.00	0.08	0.35	0.00	0.22	0.46	0.00	0.30	0.5	0.00	0.09	0.36	0.00	0.45	0.59	65.0%
B4	A	8.02	0.45	0.59	0.00	0.90	0.96	0.00	0.08	0.35	0.00	0.22	0.46	0.00	0.30	0.5	0.00	0.09	0.36	8.65	0.10	0.39	2.2%
B5	A	1.01	0.45	0.59	1.01	0.90	0.96	0.00	0.08	0.35	0.00	0.22	0.46	0.00	0.30	0.5	0.00	0.09	0.36	0.00	0.45	0.59	65.0%
B6	A	0.50	0.45	0.59	0.50	0.90	0.96	0.00	0.08	0.35	0.00	0.22	0.46	0.00	0.30	0.5	0.00	0.09	0.36	0.00	0.45	0.59	65.0%
B7	A	0.90	0.45	0.59	0.90	0.90	0.96	0.00	0.08	0.35	0.00	0.22	0.46	0.00	0.30	0.5	0.00	0.09	0.36	0.00	0.45	0.59	65.0%
B8	A	1.75	0.45	0.59	1.75	0.90	0.96	0.00	0.08	0.35	0.00	0.22	0.46	0.00	0.30	0.5	0.00	0.09	0.36	0.00	0.45	0.59	65.0%
B9	A	2.28	0.45	0.59	2.28	0.90	0.96	0.00	0.08	0.35	0.00	0.22	0.46	0.00	0.30	0.5	0.00	0.09	0.36	0.00	0.45	0.59	65.0%
B10	A	2.07	0.45	0.59	2.07	0.90	0.96	0.00	0.08	0.35	0.00	0.22	0.46	0.00	0.30	0.5	0.00	0.09	0.36	0.00	0.45	0.59	65.0%
B11	A	0.31	0.45	0.59	0.31	0.90	0.96	0.00	0.08	0.35	0.00	0.22	0.46	0.00	0.30	0.5	0.00	0.09	0.36	0.00	0.45	0.59	65.0%
B12	A	0.56	0.45	0.59	0.56	0.90	0.96	0.00	0.08	0.35	0.00	0.22	0.46	0.00	0.30	0.5	0.00	0.09	0.36	0.00	0.45	0.59	65.0%
B13	A	1.18	0.45	0.59	1.18	0.90	0.96	0.00	0.08	0.35	0.00	0.22	0.46	0.00	0.30	0.5	0.00	0.09	0.36	0.00	0.45	0.59	65.0%
B14	A	0.28	0.45	0.59	0.28	0.90	0.96	0.00	0.08	0.35	0.00	0.22	0.46	0.00	0.30	0.5	0.00	0.09	0.36	0.00	0.45	0.59	65.0%
B15	A	0.30	0.45	0.59	0.30	0.90	0.96	0.00	0.08	0.35	0.00	0.22	0.46	0.00	0.30	0.5	0.00	0.09	0.36	0.00	0.45	0.59	65.0%
B16	A	0.28	0.45	0.59	0.28	0.90	0.96	0.00	0.08	0.35	0.00	0.22	0.46	0.00	0.30	0.5	0.00	0.09	0.36	0.00	0.45	0.59	65.0%
C1	A	9.83	0.45	0.59	0.00	0.90	0.96	0.00	0.08	0.35	0.00	0.22	0.46	5.61	0.30	0.5	0.00	0.09	0.36	4.22	0.16	0.42	15.1%
C2	A	3.67	0.45	0.59	0.00	0.90	0.96	0.00	0.08	0.35	0.00	0.22	0.46	3.67	0.30	0.5	0.00	0.09	0.36	0.00	0.22	0.46	25.0%
C3	A	3.81	0.45	0.59	0.00	0.90	0.96	0.00	0.08	0.35	0.00	0.22	0.46	3.81	0.30	0.5	0.00	0.09	0.36	0.00	0.22	0.46	25.0%
C4	A	1.95	0.45	0.59	0.00	0.90	0.96	0.00	0.08	0.35	0.00	0.22	0.46	1.95	0.30	0.5	0.00	0.09	0.36	0.00	0.22	0.46	25.0%
C5	A	0.41	0.45	0.59	0.00	0.90	0.96	0.41	0.08	0.35	0.00	0.22	0.46	0.00	0.30	0.5	0.00	0.09	0.36	0.00	0.90	0.96	100.0%
C6	A	0.37	0.45	0.59	0.00	0.90	0.96	0.37	0.08	0.35	0.00	0.22	0.46	0.00	0.30	0.5	0.00	0.09	0.36	0.00	0.90	0.96	100.0%
C7	A	2.05	0.45	0.59	2.05	0.90	0.96	0.00	0.08	0.35	0.00	0.22	0.46	0.00	0.30	0.5	0.00	0.09	0.36	0.00	0.45	0.59	65.0%
C8	A	1.43	0.45	0.59	1.43	0.90	0.96	0.00	0.08	0.35	0.00	0.22	0.46	0.00	0.30	0.5	0.00	0.09	0.36	0.00	0.45	0.59	65.0%
C9	A	2.96	0.45	0.59	2.96	0.90	0.96	0.00	0.08	0.35	0.00	0.22	0.46	0.00	0.30	0.5	0.00	0.09	0.36	0.00	0.45	0.59	65.0%
C10	A	1.72	0.45	0.59	0.68	0.90	0.96	0.00	0.08	0.35	0.00	0.22	0.46	0.00	0.30	0.5	0.00	0.09	0.36	1.04	0.23	0.45	26.9%
C11	A	4.21	0.45	0.59	1.56	0.90	0.96	0.00	0.08	0.35	0.00	0.22	0.46	0.00	0.30	0.5	0.00	0.09	0.36	2.65	0.22	0.45	25.3%
C12	A	0.41	0.45	0.59	0.00	0.90	0.96	0.41	0.08	0.35	0.00	0.22	0.46	0.00	0.30	0.5	0.00	0.09	0.36	0.00	0.90	0.96	100.0%
C13	A	5.93	0.45	0.59	3.85	0.90	0.96	0.00	0.08	0.35	0.00	0.22	0.46	0.00	0.30	0.5	0.00	0.09	0.36	2.08	0.32	0.51	42.9%
C14	A	2.96	0.45	0.59	2.96	0.90	0.96	0.00	0.08	0.35	0.00	0.22	0.46	0.00	0.30	0.5	0.00	0.09	0.36	0.00	0.45	0.59	65.0%
C15	A	1.42	0.45	0.59	1.42	0.90	0.96	0.00	0.08	0.35	0.00	0.22	0.46	0.00	0.30	0.5	0.00	0.09	0.36	0.00	0.45	0.59	65.0%
C16	A	5.71	0.45	0.59	2.80	0.90	0.96	0.00	0.08	0.35	0.00	0.22	0.46	0.00	0.30	0.5	0.00	0.09	0.36	2.91	0.27	0.47	32.9%
C17	A	2.05	0.45	0.59	0.82	0.90	0.96	1.23	0.08	0.35	0.00	0.22	0.46	0.00	0.30	0.5	0.00	0.09	0.36	0.00	0.72	0.81	86.0%
C18	A	0.76	0.45	0.59	0.00	0.90	0.96	0.76	0.08	0.35	0.00	0.22	0.46	0.00	0.30	0.5	0.00	0.09	0.36	0.00	0.90	0.96	100.0%
C19	A	0.74	0.45	0.59	0.74	0.90	0.96	0.00	0.08	0.35	0.00	0.22	0.46	0.00	0.30	0.5	0.00	0.09	0.36	0.00	0.45	0.59	65.0%
C20	A	1.51	0.45	0.59	1.51	0.90	0.96	0.00	0.08	0.35	0.00	0.22	0.46	0.00	0.30	0.5	0.00	0.09	0.36	0.00	0.45	0.59	65.0%
C21	A	3.52	0.45	0.59	3.52	0.90	0.96	0.00	0.08	0.35	0.00	0.22	0.46	0.00	0.30	0.5	0.00	0.09	0.36	0.00	0.45	0.59	65.0%
C22	A	2.29	0.45	0.59	2.29	0.90	0.96	0.00	0.08	0.35	0.00	0.22	0.46	0.00	0.30	0.5	0.00	0.09	0.36	0.00	0.45	0.59	65.0%
C23	A	1.57	0.45	0.59	1.57	0.90	0.96	0.00	0.08	0.35	0.00	0.22	0.46	0.00	0.30	0.5	0.00	0.09	0.36	0.00	0.45	0.59	65.0%
C24	A	0.13	0.45	0.59	0.13	0.90	0.96	0.00	0.08	0.35	0.00	0.22	0.46	0.00	0.30	0.5	0.00	0.09	0.36	0.00	0.45	0.59	65.0%
C25	A	1.47	0.45	0.59	1.47	0.90	0.96	0.00	0.08	0.35	0.00	0.22	0.46	0.00	0.30	0.5	0.00	0.09	0.36	0.00	0.45	0.59	65.0%
D1	A	1.87	0.45	0.59	1.87	0.90	0.96	0.00	0.08	0.35	0.00	0.22	0.46	0.00	0.30	0.5	0.00	0.09	0.36	0.00	0.45	0.59	65.0%
D2	A	3.90	0.45	0.59	3.90	0.90	0.96	0.00	0.08	0.35	0.00	0.22	0.46	0.00	0.30	0.5	0.00	0.09	0.36	0.00	0.45	0.59	65.0%
D3	A	1.59	0.45	0.59	0.77	0.90	0.96	0.00	0.08	0.35	0.00	0.22	0.46	0.00	0.30	0.5	0.00	0.09	0.36	0.82	0.26	0.47	32.5%
OS-5.1	A	0.79	0.45	0.59	0.79	0.90	0.96	0.00	0.08	0.35	0.00	0.22	0.46	0.00	0.30	0.5	0.00	0.09	0.36	0.00	0.45	0.59	65.0%
OS-5.2	A	1.18	0.45	0.59	0.79	0.90	0.96	0.39	0.08	0.35	0.00	0.22	0.46	0.00	0.30	0.5	0.00	0.09	0.36	0.00	0.60	0.71	76.6%
OS-5.3	A	0.61	0.45	0.59	0.41	0.90	0.96	0.20	0.08	0.35	0.00	0.22	0.46	0.00	0.30	0.5	0.00	0.09	0.36	0.00	0.60	0.71	76.5%
A	A	4.03	0.45	0.59	0.00	0.90	0.96	0.00	0.08	0.35	0.00	0.22	0.46	0.00	0.30	0.5	0.00	0.09	0.36	3.74	0.08	0.33	1.9%
E	A	1.77	0.45	0.59	0.00	0.90	0.96	0.00	0.08	0.35	0.00	0.22	0.46	0.00	0.30	0.5	0.00	0.09	0.36	1.77	0.09	0.36	2.0%
F	A	6.06	0.45	0.59	0.00	0.90	0.96	0.00	0.08	0.35	0.00	0.22	0.46	0.00	0.30	0.5	0.00	0.09	0.36	6.91	0.10	0.41	2.3%
G	A	8.84	0.45	0.59	0.00	0.90	0.96	0.00	0.08	0.35	0.00	0.22	0.46	0.00	0.30	0.5	0.00	0.09	0.36	8.84	0.09	0.36	2.0%
OS-1	A	6.38	0.45	0.59	1.00	0.90	0.96	0.00	0.08	0.35	0.00	0.22	0.46	0.00	0.30	0.5	3.77	0.09	0.36	1.61	0.27	0.48	34.3%
OS-2	A	3.12	0.45	0.59	0.00	0.90	0.96	0.00	0.08	0.35	0.00	0.22	0.46	0.00	0.30	0.5	3.12	0.09	0.36	0.00	0.30	0.50	40.0%
OS-3	A	1.14	0.45	0.59	0.00	0.90	0.96	1.14	0.08	0.35	0.00	0.22	0.46	0.00	0.30	0.5	0.00	0.09	0.36	0.00	0.90	0.96	100.0%
OS-4	A	13.09	0.45	0.59	0.00	0.90	0.96	0.00	0.08	0.35	0.00	0.22	0.46	0.00	0.30	0.5	7.50	0.09	0.36	5.59	0.34	0.44	23.8%
OS-5	A	59.62	0.45	0.59	0.00	0.90	0.96	0.00	0.08	0.35	0.00	0.22	0.46	0.00	0.30								

**TIME OF CONCENTRATION**  
**Falcon Highlands Filing No. 3 - PROPOSED CONDITIONS**  
**El Paso County, Colorado**

DATE: 9/17/2023  
 CALCULATED BY: SLP

PROJECT: 21005234  
 DESIGN STORM: 5 Year

TRIBUTARY BASINS	AREA Ac (2)	C5 (3)	INITIAL/OVERLAND TIME (t)			TRAVEL TIME (t)					tc CHECK (URBANIZED BASINS)			FINAL tc
			LENGTH Ft (4)	SLOPE % (5)	ti Min. (6)	LENGTH Ft. (7)	SLOPE % (8)	Conveyance Coefficient	VEL fps (9)	tt Min. (10)	COMP. tc (11)	TOTAL LENGTH (12)	(L/180)+10 Min. (13)	Min. (14)
B1	5.30	0.45	100	1.70	9.85	1020	1.00	20	2.00	8.50	18.35	1120	16.22	16.22
B2	4.06	0.45	100	1.75	9.76	790	1.00	20	2.00	6.58	16.34	890	14.94	14.94
B3	4.41	0.45	100	1.30	10.76	790	1.00	20	2.00	6.58	17.35	890	14.94	14.94
B4	8.02	0.10	100	1.10	17.55	830	1.00	20	2.00	6.92	24.47	930	15.17	15.17
B5	1.01	0.45	100	0.00	0.00	586	1.00	20	2.00	4.88	4.88	686	13.81	5.00
B6	0.50	0.45	100	1.00	11.74	56	1.00	20	2.00	0.47	12.20	156	10.87	10.87
B7	0.90	0.45	100	0.00	0.00	269	1.00	20	2.00	2.24	2.24	369	12.05	5.00
B8	1.75	0.45	100	1.00	11.74	412	1.00	20	2.00	3.43	15.17	512	12.84	12.84
B9	2.28	0.45	100	1.10	11.37	334	1.00	20	2.00	2.78	14.16	434	12.41	12.41
B10	2.07	0.45	100	2.20	9.05	235	1.00	20	2.00	1.96	11.01	335	11.86	11.01
B11	0.31	0.45	66	2.50	7.05	163	0.00	20	0.00	0.00	7.05	229	11.27	7.05
B12	0.56	0.45	100	2.50	8.67	138	1.00	20	2.00	1.15	9.82	238	11.32	9.82
B13	1.18	0.45	100	2.50	8.67	122	1.00	20	2.00	1.02	9.69	222	11.23	9.69
B14	0.28	0.45	100	2.50	8.67	0	0.00	20	0.00	0.00	8.67	100	10.56	8.67
B15	0.30	0.45	100	1.20	11.05	0	0.00	20	0.00	0.00	11.05	100	10.56	10.56
B16	0.28	0.45	100	1.20	11.05	0	0.00	20	0.00	0.00	11.05	100	10.56	10.56
C1	9.83	0.16	100	1.90	13.67	887	1.00	20	2.00	7.39	21.06	987	15.48	15.48
C2	3.67	0.22	100	1.30	14.57	247	1.00	20	2.00	2.06	16.63	347	11.93	11.93
C3	3.81	0.22	100	0.90	16.45	387	1.20	20	2.19	2.94	19.39	487	12.71	12.71
C4	1.95	0.22	100	1.70	13.34	64	1.00	20	2.00	0.53	13.87	164	10.91	10.91
C5	0.41	0.90	0	0.00	0.00	625	1.00	20	2.00	5.21	5.21	625	13.47	5.21
C6	0.37	0.90	0	0.00	0.00	355	1.00	20	2.00	2.96	2.96	355	11.97	5.00
C7	2.05	0.45	100	2.70	8.46	475	1.00	20	2.00	3.96	12.41	575	13.19	12.41
C8	1.43	0.45	100	2.50	8.67	417	1.00	20	2.00	3.48	12.15	517	12.87	12.15
C9	2.96	0.45	100	2.50	8.67	173	1.00	20	2.00	1.44	10.12	273	11.52	10.12
C10	1.72	0.23	100	2.50	11.58	386	1.00	20	2.00	3.22	14.79	486	12.70	12.70
C11	4.21	0.22	0	0.00	0.00	472	1.00	20	2.00	3.93	3.93	472	12.62	5.00
C12	0.41	0.90	100	3.00	2.51	0	0.00	20	0.00	0.00	2.51	100	10.56	5.00
C13	5.93	0.32	100	2.50	10.36	477	1.00	20	2.00	3.98	14.33	577	13.21	13.21
C14	2.96	0.45	100	2.40	8.79	558	1.00	20	2.00	4.65	13.44	658	13.66	13.44
C15	1.42	0.45	76	2.40	7.66	1083	1.00	20	2.00	9.03	16.69	1159	16.44	16.44
C16	5.71	0.27	100	2.50	11.12	0	0.00	20	0.00	0.00	11.12	100	10.56	10.56
C17	2.05	0.72	0	0.00	0.00	981	1.00	20	2.00	8.18	8.18	981	15.45	8.18
C18	0.76	0.90	0	0.00	0.00	818	0.90	20	1.90	7.19	7.19	818	14.54	7.19
C19	0.74	0.45	100	2.50	8.67	208	1.00	20	2.00	1.73	10.41	308	11.71	10.41
C20	1.51	0.45	0	0.00	0.00	1013	1.10	15	1.57	10.73	10.73	1013	15.63	10.73
C21	3.52	0.45	100	1.50	10.27	279	1.00	20	2.00	2.33	12.59	379	12.11	12.11
C22	2.29	0.45	100	1.40	10.50	190	1.00	20	2.00	1.58	12.09	290	11.61	11.61
C23	1.57	0.45	100	2.40	8.79	322	1.50	20	2.45	2.19	10.98	422	12.34	10.98
C24	0.13	0.45	0	0.00	0.00	197	1.00	20	2.00	1.64	1.64	197	11.09	5.00
C25	1.47	0.45	100	0.90	12.15	86	1.30	20	2.28	0.63	12.78	186	11.03	11.03
D1	1.87	0.45	100	2.50	8.67	263	1.10	20	2.10	2.09	10.76	363	12.02	10.76
D2	3.90	0.45	100	2.50	8.67	650	1.75	15	1.98	5.46	14.13	750	14.17	14.13
D3	1.59	0.26	100	4.10	9.47	54	0.00	20	0.00	0.00	9.47	154	10.86	9.47
OS-5.1	0.79	0.45	78	2.00	8.25	118	1.00	20	2.00	0.98	9.23	196	11.09	9.23
OS-5.2	1.18	0.60	76	2.00	6.28	189	1.00	15	1.50	2.10	8.38	265	11.47	8.38
OS-5.3	0.61	0.60	74	2.00	6.21	64	1.00	20	2.00	0.53	6.74	138	10.77	6.74
A	4.03	0.08	202	1.00	26.08	910	1.00	15	1.50	10.11	36.19	1112	16.18	16.18
E	1.77	0.09	149	0.20	37.86	0	0.00	20	0.00	0.00	37.86	149	10.83	10.83
F	6.06	0.10	300	1.10	30.22	235	1.10	20	2.10	1.87	32.09	535	12.97	12.97
G	8.84	0.09	300	1.40	28.27	239	1.40	20	2.37	1.68	29.95	539	12.99	12.99
OS-1	6.38	0.27	25	2.00	5.96	650	2.00	20	2.83	3.83	9.79	675	13.75	9.79
OS-2	3.12	0.30	50	2.00	8.13	2180	1.00	20	2.00	18.17	26.29	2230	22.39	22.39
OS-3	1.14	0.90	20	2.00	1.28	1190	2.00	20	2.83	7.01	8.30	1210	16.72	8.30
OS-4	13.09	0.34	80	2.00	9.76	2300	2.00	20	2.83	13.55	23.32	2380	23.22	23.22
OS-5	59.62	0.30	100	2.00	11.49	608	2.00	20	2.83	3.58	15.07	708	13.93	13.93
OS-6	35.75	0.22	100	2.00	12.64	0	0.60	20	1.55	0.00	12.64	100	10.56	10.56
OS-7	6.47	0.22	100	2.00	12.64	300	0.60	20	1.55	3.23	15.87	400	12.22	12.22
OS-8	13.79	0.09	300	2.00	25.13	0	0.60	20	1.55	0.00	25.13	300	11.67	11.67

**5-YEAR RUNOFF CALCULATIONS**  
**Falcon Highlands Filing No. 3 - PROPOSED CONDITIONS**  
**El Paso County, Colorado**

DATE: 9/17/2023  
 CALCULATED BY: EAF

PROJECT: 21005234  
 DESIGN STORM: 5 Year

Sub-Basin	Design Point	FLOW TO INLETS									Minimum Street Slope (%)	Maximum Street/Paseo Capacity (cfs)	Under Capacity?	INLETS							Carry-Over to Sub-basin/ Design Point (DP)
		Area (acres)	C	C x A	Tc (min)	Intensity (in/hr)	Qd = CIA (cfs)	Qco (cfs)	Qt (cfs)	Inlet				Type	Condition	Slope at Inlet (%)	Inlet Capacity (cfs)	R	Intercepted (cfs)	Carry-Over (cfs)	
B1	2.1	5.30	0.45	2.39	16.22	3.40	8.12	0.00	8.12	1.02	8.20	N	15'	CDOT TYPE R	SUMP	-	22.73	-	8.12	0.00	2.4
B2	2.2	4.06	0.45	1.83	14.94	3.53	6.44	0.00	6.44	1.02	8.20	N	10'	CDOT TYPE R	SUMP	-	16.90	-	6.44	0.00	2.3
B3	2.3	4.41	0.45	1.98	14.94	3.53	7.00	0.00	7.00	1.02	8.20	N	10'	CDOT TYPE R	SUMP	-	16.90	-	7.00	0.00	2.1
B4	2.4	8.02	0.10	0.78	15.17	3.50	2.73	0.00	2.73	1.00	8.20	-	-	-	-	-	-	-	-	-	-
B5	2.5	1.01	0.45	0.45	5.00	5.17	2.35	0.00	2.35	1.10	8.20	N	5'	CDOT TYPE R	SUMP	-	11.07	-	2.35	0.00	2.4
B6	2.6	0.50	0.45	0.23	10.87	4.00	0.90	0.00	0.90	1.00	8.20	N	5'	CDOT TYPE R	SUMP	-	11.07	-	0.90	0.00	2.10
B7	2.7	0.90	0.45	0.41	5.00	5.17	2.09	0.00	2.09	1.00	8.20	N	5'	CDOT TYPE R	SUMP	-	11.07	-	2.09	0.00	2.6
B8	2.8	1.75	0.45	0.79	12.84	3.75	2.96	0.00	2.96	1.00	8.20	N	5'	CDOT TYPE R	SUMP	-	11.07	-	2.96	0.00	2.7
B9	2.9	2.28	0.45	1.03	12.41	3.81	3.90	0.00	3.90	1.00	8.20	N	5'	CDOT TYPE R	SUMP	-	11.07	-	3.90	0.00	2.10
B10	2.10	2.07	0.45	0.93	11.01	3.99	3.71	0.00	3.71	1.00	8.20	N	5'	CDOT TYPE R	SUMP	-	11.07	-	3.71	0.00	2.4
B11	2.11	0.31	0.45	0.14	7.05	4.65	0.65	0.00	0.65	1.00	8.20	N	5'	CDOT TYPE R	SUMP	-	11.07	-	0.65	0.00	2.10
B12	2.12	0.56	0.45	0.25	15.48	3.47	0.88	0.00	0.88	1.00	8.20	N	5'	CDOT TYPE R	SUMP	-	11.07	-	0.88	0.00	2.11
B13	2.13	1.18	0.45	0.53	11.93	3.86	2.05	0.00	2.05	1.00	8.20	N	5'	CDOT TYPE R	SUMP	-	11.07	-	2.05	0.00	2.12
B14	2.14	0.28	0.45	0.13	12.71	3.77	0.48	0.00	0.48	1.00	8.20	N	5'	CDOT TYPE R	SUMP	-	11.07	-	0.48	0.00	2.15
B15	2.15	0.30	0.45	0.14	10.91	4.00	0.54	0.00	0.54	1.00	8.20	N	5'	CDOT TYPE R	SUMP	-	11.07	-	0.54	0.00	2.16
B16	2.16	0.28	0.45	0.13	5.21	5.11	0.64	0.00	0.64	1.00	8.20	N	5'	CDOT TYPE R	SUMP	-	11.07	-	0.64	0.00	2.10
C1	3.1	9.83	0.16	1.61	15.48	3.47	5.61	0.00	5.61	1.00	8.20	N	15'	CDOT TYPE R	SUMP	-	22.73	-	5.61	0.00	3.3
C2	3.2	3.67	0.22	0.81	11.93	3.86	3.12	0.00	3.12	1.00	8.20	N	5'	CDOT TYPE R	SUMP	-	11.07	-	3.12	0.00	3.4
C3	3.3	3.81	0.22	0.84	12.71	3.77	3.16	0.00	3.16	1.00	8.20	N	10'	CDOT TYPE R	SUMP	-	16.90	-	3.16	0.00	3.7
C4	3.4	1.95	0.22	0.43	10.91	4.00	1.72	0.00	1.72	1.00	8.20	N	5'	CDOT TYPE R	SUMP	-	11.07	-	1.72	0.00	3.7
C5	3.5	0.41	0.90	0.37	5.21	5.11	1.88	0.00	1.88	1.00	8.20	N	5'	CDOT TYPE R	SUMP	-	11.07	-	1.88	0.00	3.7
C6	3.6	0.37	0.90	0.33	5.00	5.17	1.72	0.00	1.72	1.00	8.20	N	5'	CDOT TYPE R	SUMP	-	11.07	-	1.72	0.00	3.8
C7	3.7	2.05	0.45	0.92	12.41	3.80	3.51	0.00	3.51	1.29	8.20	N	5'	CDOT TYPE R	SUMP	-	11.07	-	3.51	0.00	3.9
C8	3.8	1.43	0.45	0.64	12.15	3.84	2.47	0.00	2.47	1.08	8.20	N	5'	CDOT TYPE R	SUMP	-	11.07	-	2.47	0.00	3.12
C9	3.9	2.96	0.45	1.33	10.12	4.11	5.48	0.00	5.48	1.00	8.20	N	10'	CDOT TYPE R	SUMP	-	16.90	-	5.48	0.00	3.13
C10	3.10	1.72	0.23	0.40	12.70	3.77	1.51	0.00	1.51	1.17	8.20	N	5'	CDOT TYPE R	SUMP	-	11.07	-	1.51	0.00	3.12
C11	3.11	4.21	0.22	0.94	5.00	5.17	4.86	0.00	4.86	1.00	8.20	N	10'	CDOT TYPE R	SUMP	-	16.90	-	4.86	0.00	3.13
C12	3.12	0.41	0.90	0.37	5.00	5.17	1.91	0.00	1.91	1.00	8.20	N	5'	CDOT TYPE R	SUMP	-	11.07	-	1.91	0.00	3.13
C13	3.13	5.93	0.32	1.92	13.21	3.71	7.13	0.00	7.13	1.17	8.20	-	-	-	-	-	-	-	-	-	-
C14	3.14	2.96	0.45	1.33	13.44	3.69	4.91	0.00	4.91	1.29	8.20	N	5'	CDOT TYPE R	SUMP	-	11.07	-	4.91	0.00	3.15
C15	3.15	1.42	0.45	0.64	16.44	3.38	2.16	0.00	2.16	1.00	8.20	N	5'	CDOT TYPE R	SUMP	-	11.07	-	2.16	0.00	3.13
C16	3.16	5.71	0.27	1.52	10.56	4.05	6.16	0.00	6.16	1.00	8.20	N	-	-	-	-	-	-	-	-	3.13
C17	3.17	2.05	0.72	1.48	8.18	4.43	6.54	0.00	6.54	1.00	8.20	N	10'	CDOT TYPE R	SUMP	-	16.90	-	6.54	0.00	3.19
C18	3.18	0.76	0.90	0.68	7.19	4.62	3.16	0.00	3.16	1.00	8.20	N	5'	CDOT TYPE R	SUMP	-	11.07	-	3.16	0.00	3.20
C19	3.19	0.74	0.45	0.33	10.41	4.07	1.36	0.00	1.36	1.34	8.20	N	5'	CDOT TYPE R	SUMP	-	11.07	-	1.36	0.00	3.21
C20	3.20	1.51	0.45	0.68	10.73	4.02	2.73	0.00	2.73	1.34	8.20	N	5'	CDOT TYPE R	SUMP	-	11.07	-	2.73	0.00	3.21
C21	3.21	3.52	0.45	1.58	12.11	3.84	6.09	0.00	6.09	1.00	8.20	N	10'	CDOT TYPE R	SUMP	-	16.90	-	6.09	0.00	3
C22	3.22	2.29	0.45	1.03	11.61	3.91	4.02	0.00	4.02	1.00	8.20	N	5'	CDOT TYPE R	SUMP	-	11.07	-	4.02	0.00	3.13
C23	3.23	1.57	0.45	0.71	10.98	3.99	2.82	0.00	2.82	1.30	8.20	N	5'	CDOT TYPE R	SUMP	-	11.07	-	2.82	0.00	3.24
C24	3.24	0.13	0.45	0.06	5.00	5.17	0.30	0.00	0.30	1.14	8.20	N	5'	CDOT TYPE R	SUMP	-	11.07	-	0.30	0.00	3.25
C25	3.25	1.47	0.45	0.66	11.03	3.98	2.63	0.00	2.63	0.87	8.20	N	5'	CDOT TYPE R	SUMP	-	11.07	-	2.63	0.00	3
D1	4.1	1.87	0.45	0.84	10.76	4.02	3.38	0.00	3.38	1.69	8.20	N	5'	CDOT TYPE R	SUMP	-	11.07	-	3.38	0.00	4.2
D2	4.2	3.90	0.45	1.76	14.13	3.61	6.34	0.00	6.34	1.39	8.20	N	10'	CDOT TYPE R	SUMP	-	16.90	-	6.34	0.00	4
D3	4.3	1.59	0.26	0.42	9.47	4.21	1.77	0.00	1.77	1.00	8.20	N	5'	CDOT TYPE R	SUMP	-	11.07	-	1.77	0.00	4
OS-5.1	11	0.79	0.45	0.35	9.23	4.25	1.50	0.00	1.50	-	-	-	-	-	-	-	-	-	-	-	-
OS-5.2	11	1.18	0.60	0.71	8.38	4.39	3.10	0.00	3.10	-	-	-	-	-	-	-	-	-	-	-	-
OS-5.3	11	0.61	0.60	0.36	6.74	4.72	1.72	0.00	1.72	-	-	-	-	-	-	-	-	-	-	-	-
A	1	4.03	0.08	0.34	16.18	3.41	1.15	0.00	1.15	-	-	-	-	-	-	-	-	-	-	-	-
E	5	1.77	0.09	0.16	10.83	4.01	0.64	0.00	0.64	-	-	-	-	-	-	-	-	-	-	-	-
F	6	6.06	0.10	0.62	12.97	3.74	2.33	0.00	2.33	-	-	-	-	-	-	-	-	-	-	-	-
G	6	8.84	0.09	0.80			6.80	0.00	6.80	-	-	-	-	-	-	-	-	-	-	-	-
OS-1	7	6.38	0.27	1.73			10.70	0.00	10.70	-	-	-	-	-	-	-	-	-	-	-	-
OS-2	8	3.12	0.30	0.94			7.80	0.00	7.80	-	-	-	-	-	-	-	-	-	-	-	-
OS-3	9	1.14	0.90	1.03			3.40	0.00	3.40	-	-	-	-	-	-	-	-	-	-	-	-
OS-4	10	13.09	0.34	4.45			12.30	0.00	12.30	-	-	-	-	-	-	-	-	-	-	-	-
OS-5	11	59.62	0.30	17.89			80.10	0.00	80.10	-	-	-	-	-	-	-	-	-	-	-	-
OS-6	12	35.75	0.22	7.87			31.90	0.00	31.90	-	-	-	-	-	-	-	-	-	-	-	-
OS-7	13	6.47	0.22	1.42	12.22	3.83	5.45	0.00	5.45	-	-	-	-	-	-	-	-	-	-	-	-
OS-8	4	13.79	0.09	1.24	11.67	3.90	4.84	0.00	4.84	-	-	-	-	-	-	-	-	-	-	-	-

Notes:

\*DATA IN RED REPRESENTS VALUES PER PREVIOUS DRAINAGE REPORTS FOR FILING NOS. 1 AND 2



**100-YEAR RUNOFF CALCULATIONS**  
**Falcon Highlands Filing No. 3 - PROPOSED CONDITIONS**  
**El Paso County, Colorado**

DATE: 9/17/2023  
 CALCULATED BY: EAF

PROJECT: 21005234  
 DESIGN STORM: 100-Year

Sub-Basin	Design Point	FLOW TO INLETS								Minimum Street Slope (%)	Maximum Street/Paseo Capacity (cfs)	Under Capacity?	INLETS						Carry-Over to Sub-basin/ Design Point (DP)
		Area (acres)	C	C x A	Tc (min)	Intensity (in/hr)	Qd = CIA (cfs)	Qco (cfs)	Qt (cfs)				Inlet	Type	Condition	Slope at Inlet (%)	Inlet Capacity (cfs)	R	
OS-3	9	1.14	0.96	1.09			6.00	0.00	6.00	-	-	-	-	-	-	-	-	-	-
OS-4	10	13.09	0.44	5.76			26.30	0.00	26.30	-	-	-	-	-	-	-	-	-	-
OS-5	11	59.62	0.50	29.81			160.70	0.00	160.70	-	-	-	-	-	-	-	-	-	-
OS-6	12	35.75	0.46	16.45			58.40	0.00	58.40	-	-	-	-	-	-	-	-	-	-
OS-7	13	6.47	0.46	2.98	12.22	6.43	19.13	0.00	19.13	-	-	-	-	-	-	-	-	-	-
OS-8	4	13.79	0.36	4.96	11.67	6.54	32.49	0.00	32.49	-	-	-	-	-	-	-	-	-	-

Notes:

\*DATA IN RED REPRESENTS VALUES PER PREVIOUS DRAINAGE REPORTS FOR FILING NOS. 1 AND 2



**PROPOSED CONDITIONS SUB-BASIN SUMMARY**

<b>Basin</b>	<b>Design Point</b>	<b>Area (acres)</b>	<b>C<sub>5</sub></b>	<b>C<sub>100</sub></b>	<b>Q<sub>5</sub> (cfs)</b>	<b>Q<sub>100</sub> (cfs)</b>
B1	2.1	5.30	0.45	0.59	8.1	17.9
B2	2.2	4.06	0.45	0.59	6.4	14.2
B3	2.3	4.41	0.45	0.59	7.0	15.4
B4	2.4	8.02	0.10	0.39	2.7	18.3
B5	2.5	1.01	0.45	0.59	2.3	5.2
B6	2.6	0.50	0.45	0.59	0.9	2.0
B7	2.7	0.90	0.45	0.59	2.1	4.6
B8	2.8	1.75	0.45	0.59	3.0	6.5
B9	2.9	2.28	0.45	0.59	3.9	8.6
B10	2.10	2.07	0.45	0.59	3.7	8.2
B11	2.11	0.31	0.45	0.59	0.6	1.4
B12	2.12	0.56	0.45	0.59	0.9	1.9
B13	2.13	1.18	0.45	0.59	2.1	4.5
B14	2.14	0.28	0.45	0.59	0.5	1.0
B15	2.15	0.30	0.45	0.59	0.5	1.2
B16	2.16	0.28	0.45	0.59	0.6	1.4
C1	3.1	9.83	0.16	0.42	5.6	23.9
C2	3.2	3.67	0.22	0.46	3.1	11.0
C3	3.3	3.81	0.22	0.46	3.2	11.1
C4	3.4	1.95	0.22	0.46	1.7	6.0
C5	3.5	0.41	0.90	0.96	1.9	3.4
C6	3.6	0.37	0.90	0.96	1.7	3.1
C7	3.7	2.05	0.45	0.59	3.5	7.7
C8	3.8	1.43	0.45	0.59	2.5	5.4
C9	3.9	2.96	0.45	0.59	5.5	12.1
C10	3.10	1.72	0.23	0.45	1.5	4.9
C11	3.11	4.21	0.22	0.45	4.9	16.3
C12	3.12	0.41	0.90	0.96	1.9	3.4
C13	3.13	5.93	0.32	0.51	7.1	18.8
C14	3.14	2.96	0.45	0.59	4.9	10.8
C15	3.15	1.42	0.45	0.59	2.2	4.8
C16	3.16	5.71	0.27	0.47	6.2	18.3
C17	3.17	2.05	0.72	0.81	6.5	12.4
C18	3.18	0.76	0.90	0.96	3.2	5.7
C19	3.19	0.74	0.45	0.59	1.4	3.0
C20	3.20	1.51	0.45	0.59	2.7	6.0
C21	3.21	3.52	0.45	0.59	6.1	13.4
C22	3.22	2.29	0.45	0.59	4.0	8.9
C23	3.23	1.57	0.45	0.59	2.8	6.2
C24	3.24	0.13	0.45	0.59	0.3	0.7
C25	3.25	1.47	0.45	0.59	2.6	5.8
D1	4.1	1.87	0.45	0.59	3.4	7.4
D2	4.2	3.90	0.45	0.59	6.3	13.9
D3	4.3	1.59	0.26	0.47	1.8	5.3
OS-5.1	11	0.79	0.45	0.59	1.5	3.3
OS-5.2	11	1.18	0.60	0.71	3.1	6.2
OS-5.3	11	0.61	0.60	0.71	1.7	3.4
A	1	4.03	0.08	0.33	1.1	7.7
E	5	1.77	0.09	0.36	0.6	4.3
F	6	6.06	0.10	0.41	2.3	15.6
G	6	8.84	0.09	0.36	6.8	16.0
OS-1	7	6.38	0.27	0.48	10.7	21.7
OS-2	8	3.12	0.30	0.50	7.8	13.6
OS-3	9	1.14	0.90	0.96	3.4	6.0
OS-4	10	13.09	0.34	0.44	12.3	26.3
OS-5	11	59.62	0.30	0.50	80.1	160.7
OS-6	12	35.75	0.22	0.46	31.9	58.4
OS-7	13	6.47	0.22	0.46	5.4	19.1
OS-8	4	13.79	0.09	0.36	4.8	32.5
<b>Total</b>		<b>266.09</b>			<b>317.6</b>	<b>756.8</b>

PROPOSED CONDITIONS DESIGN POINT SUMMARY									
Basin	INLETS		Design Point	Area (acres)	C <sub>5</sub>	C <sub>100</sub>	Q <sub>5</sub> (cfs)	Q <sub>100</sub> (cfs)	
B1	15'	SUMP	CDOT TYPE R	2.1	5.30	0.45	0.59	8.12	17.87
B2	10'	SUMP	CDOT TYPE R	2.2	4.06	0.45	0.59	6.44	14.18
B3	10'	SUMP	CDOT TYPE R	2.3	4.41	0.45	0.59	7.00	15.40
B4	-	-	-	2.4	8.02	0.10	0.39	2.73	18.32
B5	5'	SUMP	CDOT TYPE R	2.5	1.01	0.45	0.59	2.35	5.17
B6	5'	SUMP	CDOT TYPE R	2.6	0.50	0.45	0.59	0.90	1.98
B7	5'	SUMP	CDOT TYPE R	2.7	0.90	0.45	0.59	2.09	4.61
B8	5'	SUMP	CDOT TYPE R	2.8	1.75	0.45	0.59	2.96	6.51
B9	5'	SUMP	CDOT TYPE R	2.9	2.28	0.45	0.59	3.90	8.59
B10	5'	SUMP	CDOT TYPE R	2.10	2.07	0.45	0.59	3.71	8.17
B11	5'	SUMP	CDOT TYPE R	2.11	0.31	0.45	0.59	0.65	1.43
B12	5'	SUMP	CDOT TYPE R	2.12	0.56	0.45	0.59	0.88	1.93
B13	5'	SUMP	CDOT TYPE R	2.13	1.18	0.45	0.59	2.05	4.52
B14	5'	SUMP	CDOT TYPE R	2.14	0.28	0.45	0.59	0.48	1.05
B15	5'	SUMP	CDOT TYPE R	2.15	0.30	0.45	0.59	0.54	1.19
B16	5'	SUMP	CDOT TYPE R	2.16	0.28	0.45	0.59	0.64	1.42
C1	15'	SUMP	CDOT TYPE R	3.1	9.83	0.16	0.42	5.61	23.91
C2	5'	SUMP	CDOT TYPE R	3.2	3.67	0.22	0.46	3.12	10.95
C3	10'	SUMP	CDOT TYPE R	3.3	3.81	0.22	0.46	3.16	11.09
C4	5'	SUMP	CDOT TYPE R	3.4	1.95	0.22	0.46	1.72	6.02
C5	5'	SUMP	CDOT TYPE R	3.5	0.41	0.90	0.96	1.88	3.38
C6	5'	SUMP	CDOT TYPE R	3.6	0.37	0.90	0.96	1.72	3.08
C7	5'	SUMP	CDOT TYPE R	3.7	2.05	0.45	0.59	3.51	7.73
C8	5'	SUMP	CDOT TYPE R	3.8	1.43	0.45	0.59	2.47	5.44
C9	10'	SUMP	CDOT TYPE R	3.9	2.96	0.45	0.59	5.48	12.06
C10	5'	SUMP	CDOT TYPE R	3.10	1.72	0.23	0.45	1.51	4.91
C11	10'	SUMP	CDOT TYPE R	3.11	4.21	0.22	0.45	4.86	16.27
C12	5'	SUMP	CDOT TYPE R	3.12	0.41	0.90	0.96	1.91	3.42
C13	-	-	-	3.13	5.93	0.32	0.51	7.13	18.82
C14	5'	SUMP	CDOT TYPE R	3.14	2.96	0.45	0.59	4.91	10.81
C15	5'	SUMP	CDOT TYPE R	3.15	1.42	0.45	0.59	2.16	4.76
C16	-	-	-	3.16	5.71	0.27	0.47	6.16	18.35
C17	10'	SUMP	CDOT TYPE R	3.17	2.05	0.72	0.81	6.54	12.39
C18	5'	SUMP	CDOT TYPE R	3.18	0.76	0.90	0.96	3.16	5.67
C19	5'	SUMP	CDOT TYPE R	3.19	0.74	0.45	0.59	1.36	2.98
C20	5'	SUMP	CDOT TYPE R	3.20	1.51	0.45	0.59	2.73	6.02
C21	10'	SUMP	CDOT TYPE R	3.21	3.52	0.45	0.59	6.09	13.40
C22	5'	SUMP	CDOT TYPE R	3.22	2.29	0.45	0.59	4.02	8.86
C23	5'	SUMP	CDOT TYPE R	3.23	1.57	0.45	0.59	2.82	6.20
C24	5'	SUMP	CDOT TYPE R	3.24	0.13	0.45	0.59	0.30	0.67
C25	5'	SUMP	CDOT TYPE R	3.25	1.47	0.45	0.59	2.63	5.80
D1	5'	SUMP	CDOT TYPE R	4.1	1.87	0.45	0.59	3.38	7.44
D2	10'	SUMP	CDOT TYPE R	4.2	3.90	0.45	0.59	6.34	13.95
D3	5'	SUMP	CDOT TYPE R	4.3	1.59	0.26	0.47	1.77	5.30
OS-5.1	-	-	-	11	0.79	0.45	0.59	1.50	3.31
OS-5.2	-	-	-	11	1.18	0.60	0.71	3.10	6.20
OS-5.3	-	-	-	11	0.61	0.60	0.71	1.72	3.44
A	-	-	-	1	4.03	0.08	0.33	1.15	7.70
E	-	-	-	5	1.77	0.09	0.36	0.64	4.29
F	-	-	-	6	6.06	0.10	0.41	2.33	15.61
G	-	-	-	6	8.84	0.09	0.36	6.80	16.00
OS-1	-	-	-	7	6.38	0.27	0.48	10.70	21.70
OS-2	-	-	-	8	3.12	0.30	0.50	7.80	13.60
OS-3	-	-	-	9	1.14	0.90	0.96	3.40	6.00
OS-4	-	-	-	10	13.09	0.34	0.44	12.30	26.30
OS-5	-	-	-	11	59.62	0.30	0.50	80.10	160.70
OS-6	-	-	-	12	35.75	0.22	0.46	31.90	58.40
OS-7	-	-	-	13	6.47	0.22	0.46	5.45	19.13
OS-8	-	-	-	4	13.79	0.09	0.36	4.84	32.49

PROPOSED DESIGN POINT SUMMARY TABLE						
Design Point	Contributing Sub Basins	Area (acres)	C <sub>6</sub>	C <sub>100</sub>	Q <sub>6</sub> (cfs)	Q <sub>100</sub> (cfs)
1	A	4.03	0.08	0.33	1.15	7.70
2.1	B1	5.30	0.45	0.59	8.12	17.87
2.10	B10	2.07	0.45	0.59	3.71	8.17
2.11	B11	0.31	0.45	0.59	0.65	1.43
2.12	B12	0.56	0.45	0.59	0.88	1.93
2.13	B13	1.18	0.45	0.59	2.05	4.52
2.14	B14	0.28	0.45	0.59	0.48	1.05
2.15	B15	0.30	0.45	0.59	0.54	1.19
2.16	B16	0.28	0.45	0.59	0.64	1.42
2.17	B4 - B16	19.44	0.45	0.59	23.88	64.88
2.18	OS-5	59.62	0.30	0.50	80.10	160.70
2.19	B1,B2,B3	13.77	0.45	0.59	21.56	47.45
2.2	B2	4.06	0.45	0.59	6.44	14.18
2.3	B3	4.41	0.45	0.59	7.00	15.40
2	B4	8.02	0.10	0.39	2.73	18.32
2.5	B5	1.01	0.45	0.59	2.35	5.17
2.6	B6	0.50	0.45	0.59	0.90	1.98
2.7	B7	0.90	0.45	0.59	2.09	4.61
2.8	B8	1.75	0.45	0.59	2.96	6.51
2.9	B9	2.28	0.45	0.59	3.90	8.59
3.1	C1	9.83	0.16	0.42	5.61	23.91
3.10	C10	1.72	0.23	0.45	1.51	4.91
3.11	C11	4.21	0.22	0.45	4.86	16.27
3.12	C12	0.41	0.90	0.96	1.91	3.42
3	C13	5.93	0.32	0.51	7.13	18.82
3.14	C14	2.96	0.45	0.59	4.91	10.81
3.15	C15	1.42	0.45	0.59	2.16	4.76
3.16	C16	5.71	0.27	0.47	6.16	18.35
3.17	C17	2.05	0.72	0.81	6.54	12.39
3.18	C18	0.76	0.90	0.96	3.16	5.67
3.19	C19	0.74	0.45	0.59	1.36	2.98
3.2	C2	3.67	0.22	0.46	3.12	10.95
3.20	C20	1.51	0.45	0.59	2.73	6.02
3.21	C21	3.52	0.45	0.59	6.09	13.40
3.22	C22	2.29	0.45	0.59	4.02	8.86
3.23	C23	1.57	0.45	0.59	2.82	6.20
3.24	C24	0.13	0.45	0.59	0.30	0.67
3.25	C25	1.47	0.45	0.59	2.63	5.80
3.26	C1-C12, C14, C15	37.20	0.45	0.59	44.01	123.81
3.27	C23,C24,C25	3.17	0.45	0.59	5.75	12.67
3.28	C22 - C25	5.46	0.45	0.59	9.78	21.52
3.29	C21-25	8.98	0.45	0.59	15.86	34.92
3.3	C3	3.81	0.22	0.46	3.16	11.09
3.4	C4	1.95	0.22	0.46	1.72	6.02
3.5	C5	0.41	0.90	0.96	1.88	3.38
3.6	C6	0.37	0.90	0.96	1.72	3.08
3.7	C7	2.05	0.45	0.59	3.51	7.73
3.8	C8	1.43	0.45	0.59	2.47	5.44
3.9	C9	2.96	0.45	0.59	5.48	12.06
4.1	D1	1.87	0.45	0.59	3.38	7.44
4.2	D2	3.90	0.45	0.59	6.34	13.95
4.3	D3	1.59	0.26	0.47	1.77	5.30
4.4	D1,D2,D3	7.36	0.45	0.59	11.49	26.69
4	OS-8	13.79	0.09	0.36	4.84	32.49
5	E	1.77	0.09	0.36	0.64	4.29
6	F, G	14.90	0.09	0.38	9.13	31.61
7	OS-1	6.38	0.27	0.48	10.70	21.70
8	OS-2	3.12	0.30	0.50	7.80	13.60
9	OS-3	1.14	0.90	0.96	3.40	6.00
10	OS-4	13.09	0.34	0.44	12.30	26.30
11	OS-5, OS-5.1, OS-5.2, OS-5.3	62.20	0.34	0.55	86.43	173.65
12	OS-6	35.75	0.22	0.46	31.90	58.40
13	OS-7	6.47	0.22	0.46	5.45	19.13

**Figure 7-7. Street Capacity Charts Residential (Detached Sidewalk)**

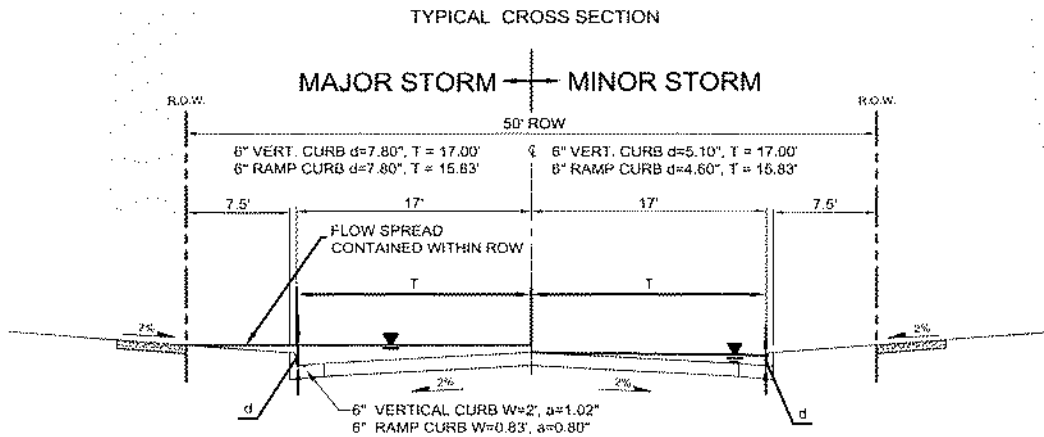

**Minor Storm Street Capacity Chart**

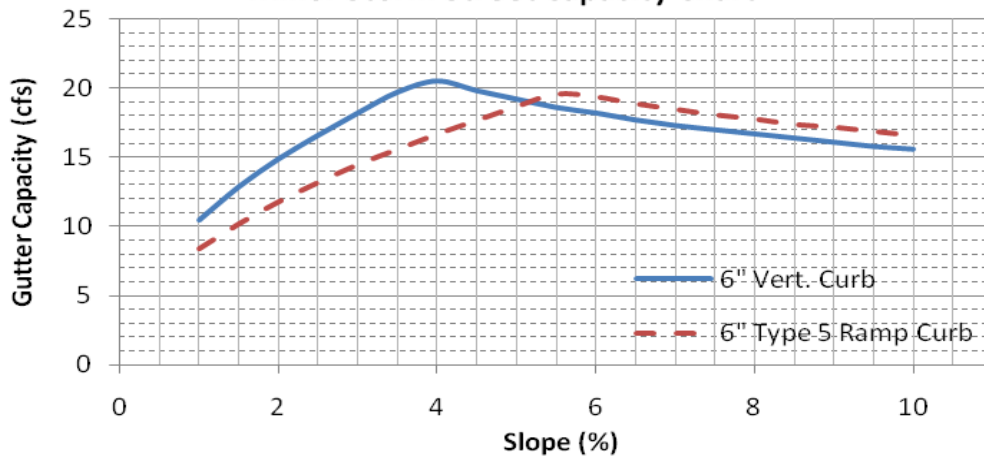

**Major Storm Street Capacity Chart**

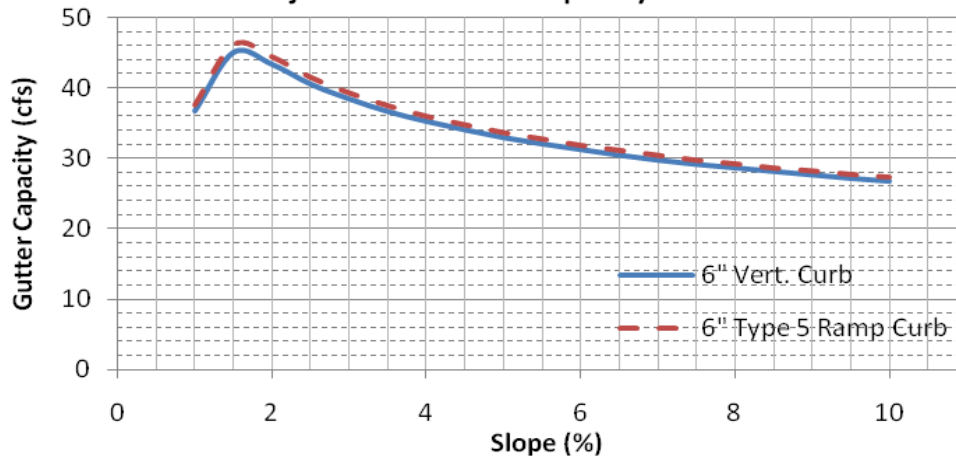

These charts shall only be used for the standard street sections as shown. The capacity shown is based on 1/2 the street section as calculated by the UD-Inlet spreadsheets. Minor storm capacities are based on no crown overtopping, curb height or maximum allowable spread widths. Major storm capacities are based on flow being contained within the public right-of-way, including conveyance capacity behind the curb. The UDFCD Safety Reduction Factor was applied. An 'n<sub>STREET</sub>' of 0.016 and 'n<sub>BACK</sub>' of 0.020 was used. Calculations were done using UD-Inlet 3.00.xls, March, 2011.

**50' R.O.W. ROADWAY DRAINAGE CAPACITY  
CALCULATIONS - MINOR STORM**

**Worksheet for Street Section - 5.5" Flooding**

---

Results	
Velocity Head	3.36 in
Specific Energy	0.74 ft
Froude Number	1.567
Flow Type	Supercritical

---

GVF Input Data	
Downstream Depth	0.0 in
Length	0.0 ft
Number Of Steps	0

---

GVF Output Data	
Upstream Depth	0.0 in
Profile Description	N/A
Profile Headloss	0.00 ft
Downstream Velocity	Infinity ft/s
Upstream Velocity	Infinity ft/s
Normal Depth	5.5 in
Critical Depth	6.5 in
Channel Slope	1.000 %
Critical Slope	0.371 %

---

**50' R.O.W. ROADWAY DRAINAGE CAPACITY  
CALCULATIONS - MINOR STORM**

**Cross Section for Street Section - 5.5" Flooding**

Project Description	
Friction Method	Manning Formula
Solve For	Discharge
Input Data	
Channel Slope	1.000 %
Normal Depth	5.5 in
Discharge	33.90 cfs

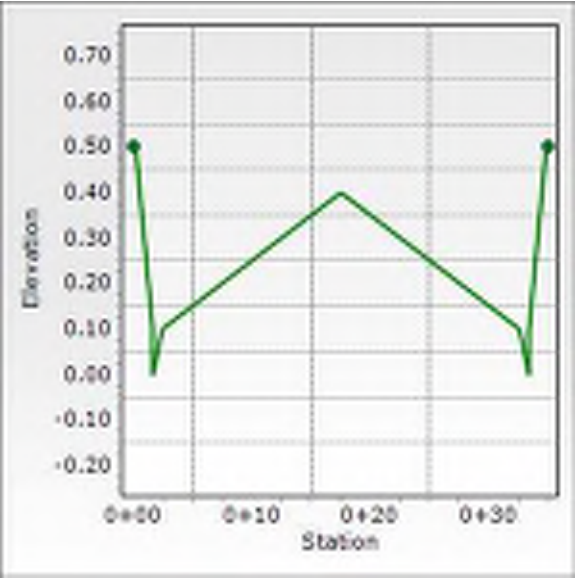

**50' R.O.W. ROADWAY DRAINAGE CAPACITY  
CALCULATIONS - MAJOR STORM**

**Worksheet for Street Section - 7.5" Flooding**

Project Description	
Friction Method	Manning Formula
Solve For	Discharge
Input Data	
Channel Slope	1.000 %
Normal Depth	7.5 in

**Section Definitions**

Station (ft)	Elevation (in)
0+00	5.50
0+00	5.50
0+02	1.00
0+02	0.00
0+03	1.00
0+18	4.60
0+33	1.00
0+33	0.00
0+33	1.00
0+35	5.50
0+35	5.50

**Roughness Segment Definitions**

Start Station	Ending Station	Roughness Coefficient
(0+00, 5.50)	(0+35, 5.50)	0.013

**Options**

Current Roughness Weighted Method	Pavlovskii's Method
Open Channel Weighting Method	Pavlovskii's Method
Closed Channel Weighting Method	Pavlovskii's Method

**Results**

Discharge	84.03 cfs
Roughness Coefficient	0.013
Elevation Range	0.0 to 0.5 ft
Flow Area	13.8 ft <sup>2</sup>
Wetted Perimeter	35.6 ft
Hydraulic Radius	4.7 in
Top Width	35.00 ft
Normal Depth	7.5 in
Critical Depth	9.5 in
Critical Slope	0.309 %
Velocity	6.08 ft/s

**50' R.O.W. ROADWAY DRAINAGE CAPACITY  
CALCULATIONS - MAJOR STORM**

**Worksheet for Street Section - 7.5" Flooding**

---

Results	
Velocity Head	6.90 in
Specific Energy	1.20 ft
Froude Number	1.706
Flow Type	Supercritical

---

GVF Input Data	
Downstream Depth	0.0 in
Length	0.0 ft
Number Of Steps	0

---

GVF Output Data	
Upstream Depth	0.0 in
Profile Description	N/A
Profile Headloss	0.00 ft
Downstream Velocity	Infinity ft/s
Upstream Velocity	Infinity ft/s
Normal Depth	7.5 in
Critical Depth	9.5 in
Channel Slope	1.000 %
Critical Slope	0.309 %

---



**50' R.O.W. ROADWAY DRAINAGE CAPACITY  
CALCULATIONS - MAJOR STORM**

**Cross Section for Street Section - 7.5" Flooding**

Project Description	
Friction Method	Manning Formula
Solve For	Discharge
Input Data	
Channel Slope	1.000 %
Normal Depth	7.5 in
Discharge	84.03 cfs

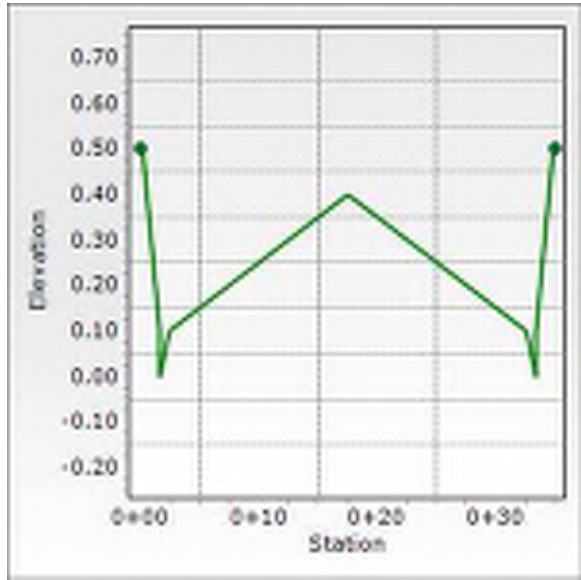

**POND 1 TRIBUTARY AREA AND IMPERVIOUSNESS**  
**Falcon Highlands Filing No. 3 - PROPOSED CONDITIONS**  
**El Paso County, Colorado**  
**9/15/2023**

<b>Basin No</b>	<b>Total Area (AC)</b>	<b>Effective Imperviousness (%)</b>
B1	5.30	65.0%
B2	4.06	65.0%
B3	4.41	65.0%
B4	8.02	2.2%
B5	1.01	65.0%
B6	0.50	65.0%
B7	0.90	65.0%
B8	1.75	65.0%
B9	2.28	65.0%
B10	2.07	65.0%
B11	0.31	65.0%
B12	0.56	65.0%
B13	1.18	65.0%
B14	0.28	65.0%
B15	0.30	65.0%
B16	0.28	65.0%
<b>Onsite Subtotal</b>	<b>33.21</b>	<b>49.8%</b>
OS-1	6.38	34.3%
OS-2	3.12	40.0%
OS-4	13.09	23.8%
OS-5	59.62	40.0%
OS-5.1	0.79	65.0%
OS-5.2	1.18	76.6%
OS-5.3	0.61	76.5%
<b>Offsite Subtotal</b>	<b>84.79</b>	<b>38.1%</b>
<b>TOTAL</b>	<b>118.00</b>	<b>41.4%</b>

# DETENTION BASIN STAGE-STORAGE TABLE BUILDER

*MHFD-Detention, Version 4.04 (February 2021)*

**Project:** FALCON HIGHLANDS FILING NO. 3  
**Basin ID:** DETENTION POND 1 (BASINS B, OS-1, OS-2, OS-4, OS-5)

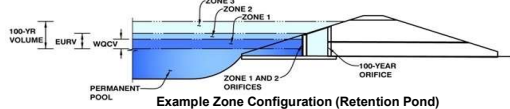

**Watershed Information**

Selected BMP Type =	<b>EDB</b>
Watershed Area =	118.00 acres
Watershed Length =	4,140 ft
Watershed Length to Centroid =	2,070 ft
Watershed Slope =	0.020 ft/ft
Watershed Imperviousness =	41.40% percent
Percentage Hydrologic Soil Group A =	100.0% percent
Percentage Hydrologic Soil Group B =	0.0% percent
Percentage Hydrologic Soil Groups C/D =	0.0% percent
Target WQCV Drain Time =	40.0 hours
Location for 1-hr Rainfall Depths =	User Input

After providing required inputs above including 1-hour rainfall depths, click 'Run CUHP' to generate runoff hydrographs using the embedded Colorado Urban Hydrograph Procedure.

Water Quality Capture Volume (WQCV) =	1.805	acre-feet
Excess Urban Runoff Volume (EURV) =	5.343	acre-feet
2-yr Runoff Volume (P1 = 1.19 in.) =	4.072	acre-feet
5-yr Runoff Volume (P1 = 1.5 in.) =	5.470	acre-feet
10-yr Runoff Volume (P1 = 1.75 in.) =	6.585	acre-feet
25-yr Runoff Volume (P1 = 2 in.) =	8.616	acre-feet
50-yr Runoff Volume (P1 = 2.25 in.) =	10.599	acre-feet
100-yr Runoff Volume (P1 = 2.52 in.) =	13.184	acre-feet
500-yr Runoff Volume (P1 = 3.14 in.) =	18.759	acre-feet
Approximate 2-yr Detention Volume =	3.407	acre-feet
Approximate 5-yr Detention Volume =	4.507	acre-feet
Approximate 10-yr Detention Volume =	5.550	acre-feet
Approximate 25-yr Detention Volume =	6.870	acre-feet
Approximate 50-yr Detention Volume =	7.754	acre-feet
Approximate 100-yr Detention Volume =	8.958	acre-feet

**Optional User Overrides**

		acre-feet
		acre-feet
	1.19	inches
	1.50	inches
	1.75	inches
	2.00	inches
	2.25	inches
	2.52	inches

**Define Zones and Basin Geometry**

Zone 1 Volume (WQCV) =	1.805	acre-feet
Zone 2 Volume (EURV - Zone 1) =	3.538	acre-feet
Zone 3 Volume (100-year - Zones 1 & 2) =	3.615	acre-feet
Total Detention Basin Volume =	8.958	acre-feet
Initial Surcharge Volume (ISV) =	user	ft <sup>3</sup>
Initial Surcharge Depth (ISD) =	user	ft
Total Available Detention Depth (H <sub>total</sub> ) =	user	ft
Depth of Trickle Channel (H <sub>TC</sub> ) =	user	ft
Slope of Trickle Channel (S <sub>TC</sub> ) =	user	ft/ft
Slopes of Main Basin Sides (S <sub>main</sub> ) =	user	H:V
Basin Length-to-Width Ratio (R <sub>L/W</sub> ) =	user	
Initial Surcharge Area (A <sub>ISV</sub> ) =	user	ft <sup>2</sup>
Surcharge Volume Length (L <sub>ISV</sub> ) =	user	ft
Surcharge Volume Width (W <sub>ISV</sub> ) =	user	ft
Depth of Basin Floor (H <sub>FLOOR</sub> ) =	user	ft
Length of Basin Floor (L <sub>FLOOR</sub> ) =	user	ft
Width of Basin Floor (W <sub>FLOOR</sub> ) =	user	ft
Area of Basin Floor (A <sub>FLOOR</sub> ) =	user	ft <sup>2</sup>
Volume of Basin Floor (V <sub>FLOOR</sub> ) =	user	ft <sup>3</sup>
Depth of Main Basin (H <sub>MAIN</sub> ) =	user	ft
Length of Main Basin (L <sub>MAIN</sub> ) =	user	ft
Width of Main Basin (W <sub>MAIN</sub> ) =	user	ft
Area of Main Basin (A <sub>MAIN</sub> ) =	user	ft <sup>2</sup>
Volume of Main Basin (V <sub>MAIN</sub> ) =	user	ft <sup>3</sup>
Calculated Total Basin Volume (V <sub>total</sub> ) =	user	acre-feet

Depth Increment = 0.50 ft

Stage - Storage Description	Stage (ft)	Optional Override Stage (ft)	Length (ft)	Width (ft)	Area (ft <sup>2</sup> )	Optional Override Area (ft <sup>2</sup> )	Area (acre)	Volume (ft <sup>3</sup> )	Volume (ac-ft)
<b>Top of Micropool</b>	--	0.00	--	--	--	10	0.000	--	--
<b>6808</b>	--	0.50	--	--	--	1,084	0.025	273	0.006
<b>6809</b>	--	1.50	--	--	--	14,526	0.333	8,078	0.185
<b>6810</b>	--	2.50	--	--	--	19,471	0.447	25,077	0.576
<b>6811</b>	--	3.50	--	--	--	31,417	0.721	50,521	1.160
<b>WQCV: 6811.75</b>	--	4.25	--	--	--	59,321	1.362	84,547	1.941
<b>6812</b>	--	4.50	--	--	--	62,850	1.443	99,819	2.292
<b>6813</b>	--	5.50	--	--	--	79,388	1.822	170,938	3.924
<b>EURV: 6813.94</b>	--	6.44	--	--	--	112,050	2.572	260,913	5.990
<b>6814</b>	--	6.50	--	--	--	114,851	2.637	267,720	6.146
<b>6814.5</b>	--	7.00	--	--	--	122,500	2.812	327,058	7.508
<b>6815</b>	--	7.50	--	--	--	134,572	3.089	391,326	8.984
<b>100-YR: 6815.28</b>	--	7.78	--	--	--	139,480	3.202	429,693	9.864
<b>6816</b>	--	8.50	--	--	--	152,970	3.512	534,975	12.281
<b>WEIR: 6817</b>	--	9.50	--	--	--	177,276	4.070	700,098	16.072

# DETENTION BASIN STAGE-STORAGE TABLE BUILDER

*MHFD-Detention, Version 4.04 (February 2021)*

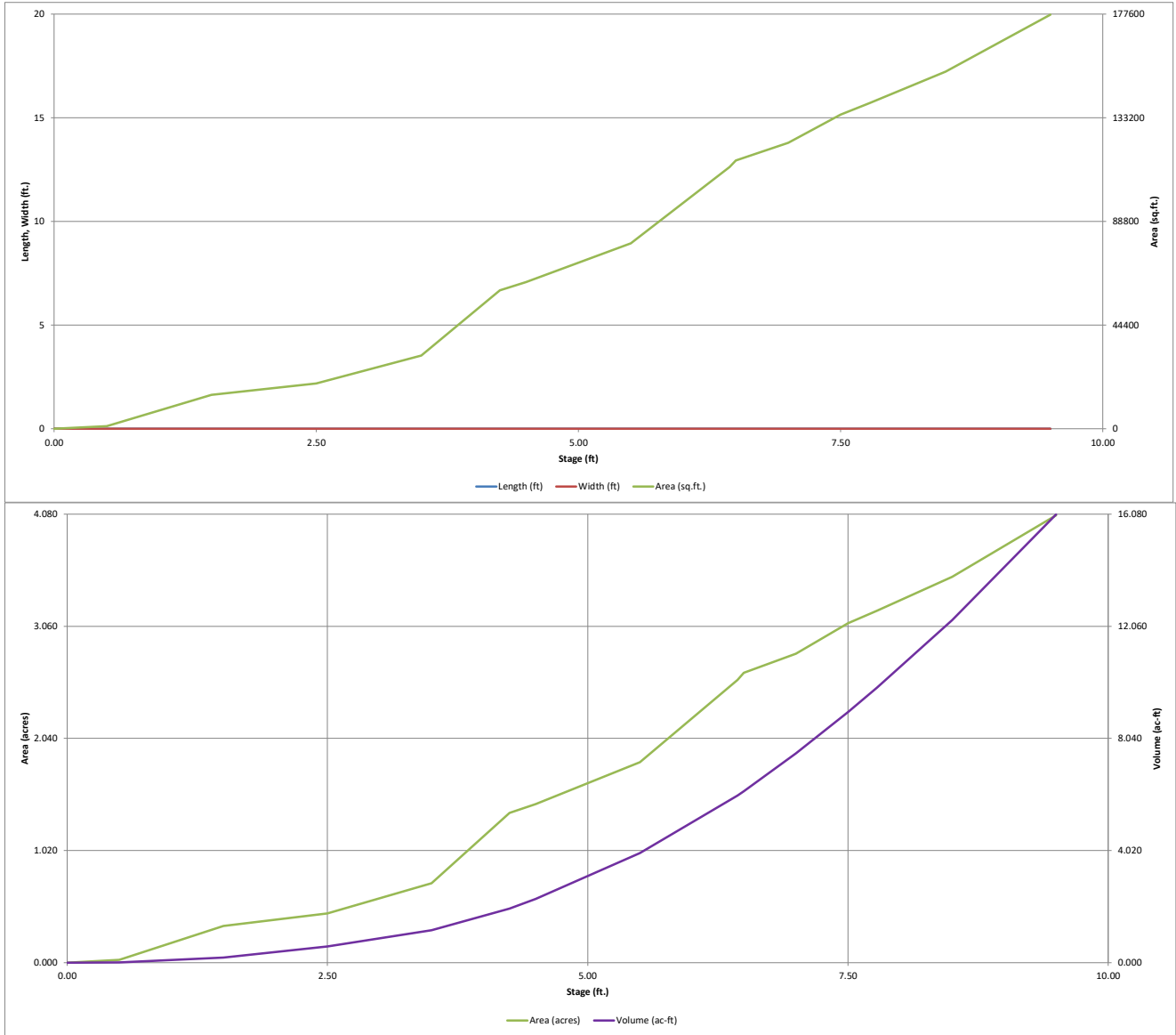

# DETENTION BASIN OUTLET STRUCTURE DESIGN

MHFD-Detention, Version 4.04 (February 2021)

**Project: FALCON HIGHLANDS FILING NO. 3**  
**Basin ID: DETENTION POND 1 (BASINS B, OS-1, OS-2, OS-4, OS-5)**

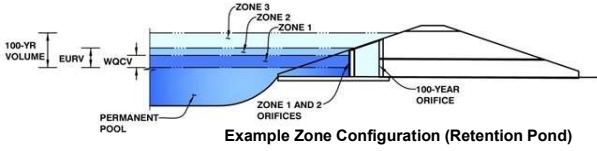

	Estimated Stage (ft)	Estimated Volume (ac-ft)	Outlet Type
Zone 1 (WQCV)	4.15	1.805	Orifice Plate
Zone 2 (EURV)	6.18	3.538	Orifice Plate
Zone 3 (100-year)	7.50	3.615	Weir&Pipe (Restrict)
<b>Total (all zones)</b>		<b>8.958</b>	

**Example Zone Configuration (Retention Pond)**

**User Input: Orifice at Underdrain Outlet (typically used to drain WQCV in a Filtration BMP)**

Underdrain Orifice Invert Depth =  ft (distance below the filtration media surface)  
 Underdrain Orifice Diameter =  inches

**Calculated Parameters for Underdrain**  
 Underdrain Orifice Area =  ft<sup>2</sup>  
 Underdrain Orifice Centroid =  feet

**User Input: Orifice Plate with one or more orifices or Elliptical Slot Weir (typically used to drain WQCV and/or EURV in a sedimentation BMP)**

Invert of Lowest Orifice =  ft (relative to basin bottom at Stage = 0 ft)  
 Depth at top of Zone using Orifice Plate =  ft (relative to basin bottom at Stage = 0 ft)  
 Orifice Plate: Orifice Vertical Spacing =  inches  
 Orifice Plate: Orifice Area per Row =  sq. inches (use rectangular openings)

**Calculated Parameters for Plate**  
 WQ Orifice Area per Row =  ft<sup>2</sup>  
 Elliptical Half-Width =  feet  
 Elliptical Slot Centroid =  feet  
 Elliptical Slot Area =  ft<sup>2</sup>

**User Input: Stage and Total Area of Each Orifice Row (numbered from lowest to highest)**

	Row 1 (required)	Row 2 (optional)	Row 3 (optional)	Row 4 (optional)	Row 5 (optional)	Row 6 (optional)	Row 7 (optional)	Row 8 (optional)
Stage of Orifice Centroid (ft)	0.00	2.00	4.00	6.00				
Orifice Area (sq. inches)	7.28	7.28	7.28	7.28				

	Row 9 (optional)	Row 10 (optional)	Row 11 (optional)	Row 12 (optional)	Row 13 (optional)	Row 14 (optional)	Row 15 (optional)	Row 16 (optional)
Stage of Orifice Centroid (ft)								
Orifice Area (sq. inches)								

**User Input: Vertical Orifice (Circular or Rectangular)**

	Not Selected	Not Selected
Invert of Vertical Orifice =	N/A	N/A
Depth at top of Zone using Vertical Orifice =	N/A	N/A
Vertical Orifice Diameter =	N/A	N/A

ft (relative to basin bottom at Stage = 0 ft)  
 ft (relative to basin bottom at Stage = 0 ft)  
 inches

**Calculated Parameters for Vertical Orifice**

	Not Selected	Not Selected
Vertical Orifice Area =	N/A	N/A
Vertical Orifice Centroid =	N/A	N/A

ft<sup>2</sup>  
 feet

**User Input: Overflow Weir (Dropbox with Flat or Sloped Grate and Outlet Pipe OR Rectangular/Trapezoidal Weir (and No Outlet Pipe))**

	Zone 3 Weir	Not Selected
Overflow Weir Front Edge Height, Ho =	6.18	N/A
Overflow Weir Front Edge Length =	5.00	N/A
Overflow Weir Grate Slope =	0.00	N/A
Horiz. Length of Weir Sides =	5.00	N/A
Overflow Grate Type =	Type C Grate	N/A
Debris Clogging % =	50%	N/A

ft (relative to basin bottom at Stage = 0 ft)  
 feet  
 H:V  
 feet  
 %

**Calculated Parameters for Overflow Weir**

	Zone 3 Weir	Not Selected
Height of Grate Upper Edge, H <sub>u</sub> =	6.18	N/A
Overflow Weir Slope Length =	5.00	N/A
Grate Open Area / 100-yr Orifice Area =	159.56	N/A
Overflow Grate Open Area w/o Debris =	17.40	N/A
Overflow Grate Open Area w/ Debris =	8.70	N/A

feet  
 feet  
 feet  
 ft<sup>2</sup>  
 ft<sup>2</sup>

**User Input: Outlet Pipe w/ Flow Restriction Plate (Circular Orifice, Restrictor Plate, or Rectangular Orifice)**

	Zone 3 Restrictor	Not Selected
Depth to Invert of Outlet Pipe =	1.00	N/A
Outlet Pipe Diameter =	42.00	N/A
Restrictor Plate Height Above Pipe Invert =	1.50	N/A

ft (distance below basin bottom at Stage = 0 ft)  
 inches  
 inches

**Calculated Parameters for Outlet Pipe w/ Flow Restriction Plate**

	Zone 3 Restrictor	Not Selected
Outlet Orifice Area =	0.11	N/A
Outlet Orifice Centroid =	0.07	N/A
Half-Central Angle of Restrictor Plate on Pipe =	0.38	N/A

ft<sup>2</sup>  
 feet  
 radians

**User Input: Emergency Spillway (Rectangular or Trapezoidal)**

Spillway Invert Stage =  ft (relative to basin bottom at Stage = 0 ft)  
 Spillway Crest Length =  feet  
 Spillway End Slopes =  H:V  
 Freeboard above Max Water Surface =  feet

**Calculated Parameters for Spillway**

Spillway Design Flow Depth =	0.98	feet
Stage at Top of Freeboard =	9.50	feet
Basin Area at Top of Freeboard =	4.07	acres
Basin Volume at Top of Freeboard =	16.07	acre-ft

## Routed Hydrograph Results

The user can override the default CUHP hydrographs and runoff volumes by entering new values in the Inflow Hydrographs table (Columns W through AF).

	WQCV	EURV	2 Year	5 Year	10 Year	25 Year	50 Year	100 Year	500 Year
Design Storm Return Period =	N/A	N/A	1.19	1.50	1.75	2.00	2.25	2.52	3.14
One-Hour Rainfall Depth (in) =	N/A	N/A	1.19	1.50	1.75	2.00	2.25	2.52	3.14
CUHP Runoff Volume (acre-ft) =	1.805	5.343	4.072	5.470	6.585	8.616	10.599	13.184	18.759
Inflow Hydrograph Volume (acre-ft) =	N/A	N/A	4.072	5.470	6.585	8.616	10.599	13.184	18.759
CUHP Predevelopment Peak Q (cfs) =	N/A	N/A	0.7	1.3	1.8	16.4	32.9	55.1	101.8
OPTIONAL Override Predevelopment Peak Q (cfs) =	N/A	N/A							
Predevelopment Unit Peak Flow, q (cfs/acre) =	N/A	N/A	0.01	0.01	0.02	0.14	0.28	0.47	0.86
Peak Inflow Q (cfs) =	N/A	N/A	43.5	59.0	71.0	104.2	132.5	167.4	239.4
Peak Outflow Q (cfs) =	0.9	1.4	1.3	1.4	1.4	1.5	15.5	44.6	114.4
Ratio Peak Outflow to Predevelopment Q =	N/A	N/A	N/A	1.1	0.8	0.1	0.5	0.8	1.1
Structure Controlling Flow =	Plate	Outlet Plate 1	Plate	Outlet Plate 1	Outlet Plate 1	Outlet Plate 1	Spillway	Spillway	Spillway
Max Velocity through Grate 1 (fps) =	N/A	N/A	N/A	N/A	0.0	0.0	0.0	0.0	0.0
Max Velocity through Grate 2 (fps) =	N/A	N/A	N/A	N/A	N/A	N/A	N/A	N/A	N/A
Time to Drain 97% of Inflow Volume (hours) =	38	68	59	70	78	92	97	94	90
Time to Drain 99% of Inflow Volume (hours) =	40	73	63	75	83	99	105	104	102
Maximum Ponding Depth (ft) =	4.15	6.18	5.44	6.11	6.55	7.27	7.71	7.93	8.28
Area at Maximum Ponding Depth (acres) =	1.28	2.36	1.80	2.30	2.65	2.96	3.17	3.26	3.42
Maximum Volume Stored (acre-ft) =	1.809	5.348	3.798	5.161	6.252	8.288	9.641	10.317	11.519

**POND 2 TRIBUTARY AREA AND IMPERVIOUSNESS**  
**Falcon Highlands Filing No. 3 - PROPOSED CONDITIONS**  
**El Paso County, Colorado**  
**9/14/2023**

<b>Basin No</b>	<b>Total Area (AC)</b>	<b>Effective Imperviousness (%)</b>
C1	9.83	15.1%
C2	3.67	25.0%
C3	3.81	25.0%
C4	1.95	25.0%
C5	0.41	100.0%
C6	0.37	100.0%
C7	2.05	65.0%
C8	1.43	65.0%
C9	2.96	65.0%
C10	1.72	26.9%
C11	4.21	25.3%
C12	0.41	100.0%
C13	5.93	42.9%
C14	2.96	65.0%
C15	1.42	65.0%
C16	5.71	32.9%
C17	2.05	86.0%
C18	0.76	100.0%
C19	0.74	65.0%
C20	1.51	65.0%
C21	3.52	65.0%
C22	2.29	65.0%
Onsite Subtotal	59.71	43.2%
OS-3	1.14	100.0%
OS-6	35.75	25.0%
OS-7	6.47	25.0%
Offsite Subtotal	43.36	27.0%
<b>TOTAL</b>	<b>103.07</b>	<b>36.4%</b>



# DETENTION BASIN STAGE-STORAGE TABLE BUILDER

*MHFD-Detention, Version 4.06 (July 2022)*

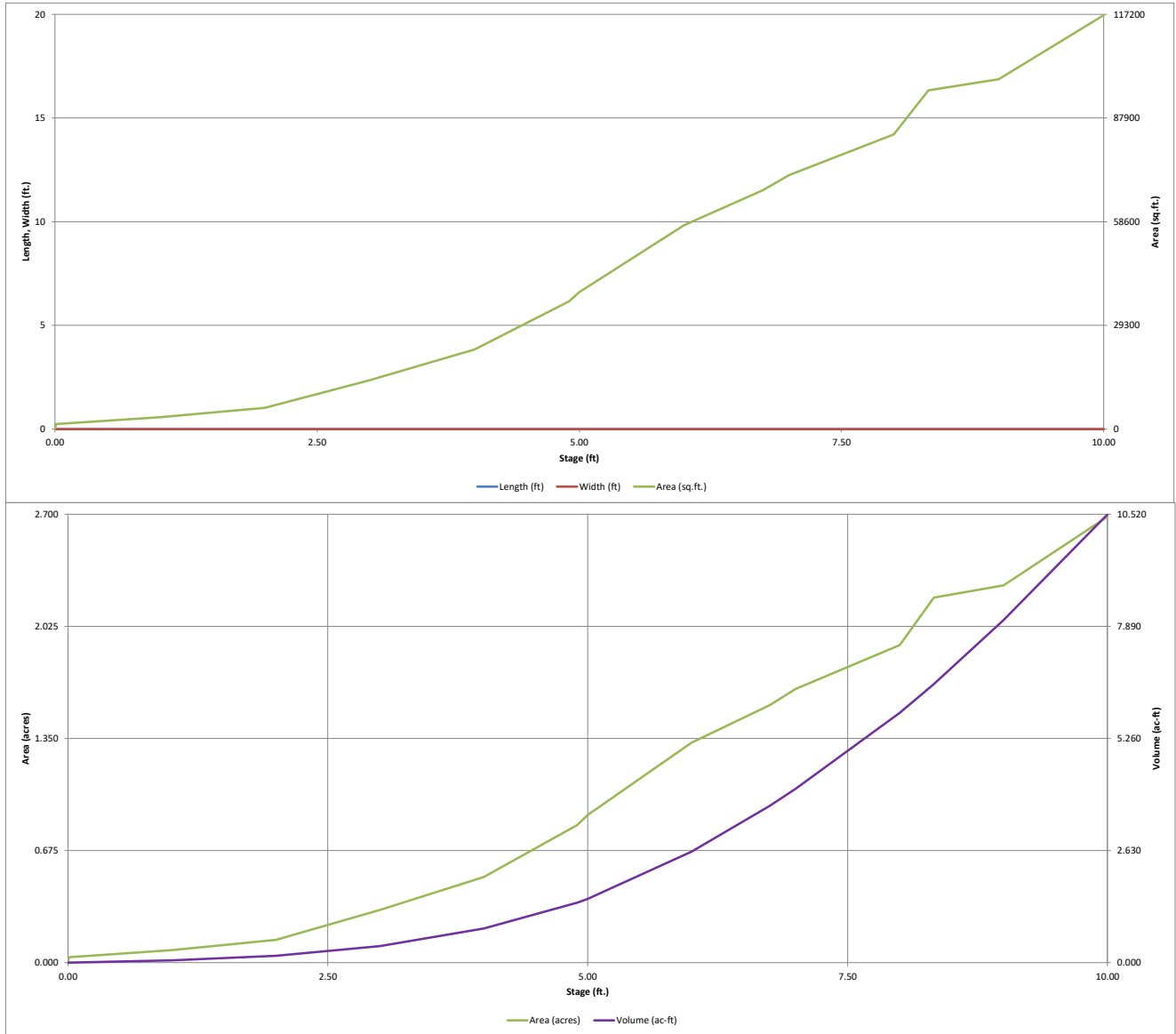



# DETENTION BASIN OUTLET STRUCTURE DESIGN

MHFD-*Detention*, Version 4.06 (July 2022)

**Project: FALCON HIGHLANDS SOUTH**  
**Basin ID: DETENTION POND 2 - (BASINS C, OS-3, OS-6, OS-7)**

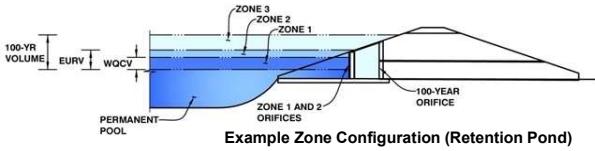

	Estimated Stage (ft)	Estimated Volume (ac-ft)	Outlet Type
Zone 1 (WQCV)	4.97	1.461	Orifice Plate
Zone 2 (EURV)	6.93	2.497	Orifice Plate
Zone 3 (100-year)	8.50	2.950	Weir&Pipe (Restrict)
<b>Total (all zones)</b>		<b>6.908</b>	

**Example Zone Configuration (Retention Pond)**

**User Input: Orifice at Underdrain Outlet (typically used to drain WQCV in a Filtration BMP)**

Underdrain Orifice Invert Depth =	N/A	ft (distance below the filtration media surface)
Underdrain Orifice Diameter =	N/A	inches

Calculated Parameters for Underdrain	
Underdrain Orifice Area =	N/A ft <sup>2</sup>
Underdrain Orifice Centroid =	N/A feet

**User Input: Orifice Plate with one or more orifices or Elliptical Slot Weir (typically used to drain WQCV and/or EURV in a sedimentation BMP)**

Centroid of Lowest Orifice =	0.00	ft (relative to basin bottom at Stage = 0 ft)
Depth at top of Zone using Orifice Plate =	6.93	ft (relative to basin bottom at Stage = 0 ft)
Orifice Plate: Orifice Vertical Spacing =	24.00	inches
Orifice Plate: Orifice Area per Row =	4.60	sq. inches (use rectangular openings)

Calculated Parameters for Plate	
WQ Orifice Area per Row =	3.194E-02 ft <sup>2</sup>
Elliptical Half-Width =	N/A feet
Elliptical Slot Centroid =	N/A feet
Elliptical Slot Area =	N/A ft <sup>2</sup>

**User Input: Stage and Total Area of Each Orifice Row (numbered from lowest to highest)**

	Row 1 (required)	Row 2 (optional)	Row 3 (optional)	Row 4 (optional)	Row 5 (optional)	Row 6 (optional)	Row 7 (optional)	Row 8 (optional)
Stage of Orifice Centroid (ft)	0.00	2.00	4.00	6.00				
Orifice Area (sq. inches)	4.60	4.60	4.60	4.60				

	Row 9 (optional)	Row 10 (optional)	Row 11 (optional)	Row 12 (optional)	Row 13 (optional)	Row 14 (optional)	Row 15 (optional)	Row 16 (optional)
Stage of Orifice Centroid (ft)								
Orifice Area (sq. inches)								

**User Input: Vertical Orifice (Circular or Rectangular)**

	Not Selected	Not Selected	
Invert of Vertical Orifice =	N/A	N/A	ft (relative to basin bottom at Stage = 0 ft)
Depth at top of Zone using Vertical Orifice =	N/A	N/A	ft (relative to basin bottom at Stage = 0 ft)
Vertical Orifice Diameter =	N/A	N/A	inches

Calculated Parameters for Vertical Orifice	
Vertical Orifice Area =	N/A ft <sup>2</sup>
Vertical Orifice Centroid =	N/A feet

**User Input: Overflow Weir (Dropbox with Flat or Sloped Grate and Outlet Pipe OR Rectangular/Trapezoidal Weir and No Outlet Pipe)**

	Zone 3 Weir	Not Selected	
Overflow Weir Front Edge Height, Ho =	6.93	N/A	ft (relative to basin bottom at Stage = 0 ft)
Overflow Weir Front Edge Length =	5.00	N/A	feet
Overflow Weir Grate Slope =	0.00	N/A	H:V
Horiz. Length of Weir Sides =	5.00	N/A	feet
Overflow Grate Type =	Type C Grate	N/A	
Debris Clogging % =	50%	N/A	%

Calculated Parameters for Overflow Weir	
Height of Grate Upper Edge, H <sub>u</sub> =	6.93 feet
Overflow Weir Slope Length =	5.00 feet
Grate Open Area / 100-yr Orifice Area =	84.53
Overflow Grate Open Area w/o Debris =	17.40 ft <sup>2</sup>
Overflow Grate Open Area w/ Debris =	8.70 ft <sup>2</sup>

**User Input: Outlet Pipe w/ Flow Restriction Plate (Circular Orifice, Restrictor Plate, or Rectangular Orifice)**

	Zone 3 Restrictor	Not Selected	
Depth to Invert of Outlet Pipe =	1.00	N/A	ft (distance below basin bottom at Stage = 0 ft)
Outlet Pipe Diameter =	42.00	N/A	inches
Restrictor Plate Height Above Pipe Invert =	2.30		inches

Calculated Parameters for Outlet Pipe w/ Flow Restriction Plate	
Outlet Orifice Area =	0.21 ft <sup>2</sup>
Outlet Orifice Centroid =	0.11 feet
Half-Central Angle of Restrictor Plate on Pipe =	0.47 radians

**User Input: Emergency Spillway (Rectangular or Trapezoidal)**

Spillway Invert Stage =	8.50	ft (relative to basin bottom at Stage = 0 ft)
Spillway Crest Length =	185.00	feet
Spillway End Slopes =	4.00	H:V
Freeboard above Max Water Surface =	1.00	feet

Calculated Parameters for Spillway	
Spillway Design Flow Depth =	0.50 feet
Stage at Top of Freeboard =	10.00 feet
Basin Area at Top of Freeboard =	2.68 acres
Basin Volume at Top of Freeboard =	10.51 acre-ft

## Routed Hydrograph Results

*The user can override the default CUHP hydrographs and runoff volumes by entering new values in the Inflow Hydrographs table (Columns W through AF).*

	WQCV	EURV	2 Year	5 Year	10 Year	25 Year	50 Year	100 Year	500 Year
Design Storm Return Period =	N/A	N/A	1.19	1.50	1.75	2.00	2.25	2.52	3.14
One-Hour Rainfall Depth (in) =	N/A	N/A	2.917	3.952	4.788	6.549	8.231	10.450	15.215
CUHP Runoff Volume (acre-ft) =	1.461	3.958	2.917	3.952	4.788	6.549	8.231	10.450	15.215
Inflow Hydrograph Volume (acre-ft) =	N/A	N/A	2.917	3.952	4.788	6.549	8.231	10.450	15.215
CUHP Predevelopment Peak Q (cfs) =	N/A	N/A	1.1	2.1	2.9	26.8	52.9	86.5	153.8
OPTIONAL Override Predevelopment Peak Q (cfs) =	N/A	N/A							
Predevelopment Unit Peak Flow, q (cfs/acre) =	N/A	N/A	0.01	0.02	0.03	0.26	0.51	0.84	1.49
Peak Inflow Q (cfs) =	N/A	N/A	47.4	65.9	80.5	119.8	155.5	201.3	293.5
Peak Outflow Q (cfs) =	0.8	1.2	1.0	1.1	2.8	3.0	18.8	74.5	185.6
Ratio Peak Outflow to Predevelopment Q =	N/A	N/A	N/A	0.5	1.0	0.1	0.4	0.9	1.2
Structure Controlling Flow =	Plate	Overflow Weir 1	Plate	Plate	Outlet Plate 1	Outlet Plate 1	Spillway	Spillway	Spillway
Max Velocity through Grate 1 (fps) =	N/A	N/A	N/A	N/A	0.1	0.1	0.1	0.1	0.1
Max Velocity through Grate 2 (fps) =	N/A	N/A	N/A	N/A	N/A	N/A	N/A	N/A	N/A
Time to Drain 97% of Inflow Volume (hours) =	38	65	56	65	69	73	75	72	68
Time to Drain 99% of Inflow Volume (hours) =	41	70	60	71	75	81	83	81	78
Maximum Ponding Depth (ft) =	4.97	6.93	6.12	6.80	7.23	8.14	8.59	8.75	8.97
Area at Maximum Ponding Depth (acres) =	0.87	1.62	1.36	1.57	1.71	2.02	2.23	2.24	2.27
Maximum Volume Stored (acre-ft) =	1.469	3.965	2.750	3.758	4.465	6.115	7.113	7.470	7.967

**APPENDIX E**  
**HYDRAULIC CALCULATIONS**

## **DESIGN POINT 2.1**

$$Q_5 = 8.1 \text{ cfs}$$

$$Q_{100} = 17.9 \text{ cfs}$$

$$d_{\max,5} = 0.50 \text{ ft}$$

$$d_{\max,100} = 0.67 \text{ ft}$$

$$Q_i = 1.7(L_i + 1.8(W))(d_{\max,i} + a/12)^{1.85}$$

### GUTTER INFO:

$$W = 2 \text{ ft}$$

$$a = 3 \text{ inches}$$

$$\text{CLOGGING FACTOR} = 1.25$$

### RESULTS:

$$\text{MINOR STORM EVENT (5-YR)} = 6.0 \text{ LF INLET REQUIRED}$$

$$\text{MAJOR STORM EVENT (100-YR)} = 11.0 \text{ LF INLET REQUIRED}$$

$$\text{PROPOSED INLET SIZE} = 15 \text{ LF CDOT TYPE R CURB INLET}$$

-OR-

$$\text{PROPOSED INLET SIZE} = 12 \text{ LF CO SPGS D-10-R}$$

## **DESIGN POINT 2.2**

$$Q_5 = 6.4 \text{ cfs}$$

$$Q_{100} = 14.2 \text{ cfs}$$

$$d_{\max,5} = 0.50 \text{ ft}$$

$$d_{\max,100} = 0.67 \text{ ft}$$

$$Q_i = 1.7(L_i + 1.8(W))(d_{\max,i} + a/12)^{1.85}$$

### GUTTER INFO:

$$W = 2 \text{ ft}$$

$$a = 3 \text{ inches}$$

$$\text{CLOGGING FACTOR} = 1.25$$

### RESULTS:

$$\text{MINOR STORM EVENT (5-YR)} = 4.0 \text{ LF INLET REQUIRED}$$

$$\text{MAJOR STORM EVENT (100-YR)} = 8.0 \text{ LF INLET REQUIRED}$$

$$\text{PROPOSED INLET SIZE} = 10 \text{ LF CDOT TYPE R CURB INLET}$$

-OR-

$$\text{PROPOSED INLET SIZE} = 8 \text{ LF CO SPGS D-10-R}$$

### **DESIGN POINT 2.3**

$$Q_5 = 7.0 \text{ cfs}$$

$$Q_{100} = 15.4 \text{ cfs}$$

$$d_{\max,5} = 0.50 \text{ ft}$$

$$d_{\max,100} = 0.67 \text{ ft}$$

$$Q_i = 1.7(L_i + 1.8(W))(d_{\max,i} + a/12)^{1.85}$$

#### GUTTER INFO:

$$W = 2 \text{ ft}$$

$$a = 3 \text{ inches}$$

$$\text{CLOGGING FACTOR} = 1.25$$

#### RESULTS:

$$\text{MINOR STORM EVENT (5-YR)} = 5.0 \text{ LF INLET REQUIRED}$$

$$\text{MAJOR STORM EVENT (100-YR)} = 9.0 \text{ LF INLET REQUIRED}$$

$$\text{PROPOSED INLET SIZE} = 10 \text{ LF CDOT TYPE R CURB INLET}$$

-OR-

$$\text{PROPOSED INLET SIZE} = 8 \text{ LF CO SPGS D-10-R}$$

### **DESIGN POINT 2.5**

$$Q_5 = 2.3 \text{ cfs}$$

$$Q_{100} = 5.2 \text{ cfs}$$

$$d_{\max,5} = 0.50 \text{ ft}$$

$$d_{\max,100} = 0.67 \text{ ft}$$

$$Q_i = 1.7(L_i + 1.8(W))(d_{\max,i} + a/12)^{1.85}$$

#### GUTTER INFO:

$$W = 2 \text{ ft}$$

$$a = 3 \text{ inches}$$

$$\text{CLOGGING FACTOR} = 1.25$$

#### RESULTS:

$$\text{MINOR STORM EVENT (5-YR)} = 4.0 \text{ LF INLET REQUIRED}$$

$$\text{MAJOR STORM EVENT (100-YR)} = 4.0 \text{ LF INLET REQUIRED}$$

$$\text{PROPOSED INLET SIZE} = 5 \text{ LF CDOT TYPE R CURB INLET}$$

-OR-

$$\text{PROPOSED INLET SIZE} = 4 \text{ LF CO SPGS D-10-R}$$

### **DESIGN POINT 2.6**

$$Q_5 = 0.9 \text{ cfs}$$

$$Q_{100} = 2.0 \text{ cfs}$$

$$d_{\max,5} = 0.50 \text{ ft}$$

$$d_{\max,100} = 0.67 \text{ ft}$$

$$Q_i = 1.7(L_i + 1.8(W))(d_{\max,i} + a/12)^{1.85}$$

#### GUTTER INFO:

$$W = 2 \text{ ft}$$

$$a = 3 \text{ inches}$$

$$\text{CLOGGING FACTOR} = 1.25$$

#### RESULTS:

$$\text{MINOR STORM EVENT (5-YR)} = 4.0 \text{ LF INLET REQUIRED}$$

$$\text{MAJOR STORM EVENT (100-YR)} = 4.0 \text{ LF INLET REQUIRED}$$

$$\text{PROPOSED INLET SIZE} = 5 \text{ LF CDOT TYPE R CURB INLET}$$

-OR-

$$\text{PROPOSED INLET SIZE} = 4 \text{ LF CO SPGS D-10-R}$$

### **DESIGN POINT 2.7**

$$Q_5 = 2.1 \text{ cfs}$$

$$Q_{100} = 4.6 \text{ cfs}$$

$$d_{\max,5} = 0.50 \text{ ft}$$

$$d_{\max,100} = 0.67 \text{ ft}$$

$$Q_i = 1.7(L_i + 1.8(W))(d_{\max,i} + a/12)^{1.85}$$

#### GUTTER INFO:

$$W = 2 \text{ ft}$$

$$a = 3 \text{ inches}$$

$$\text{CLOGGING FACTOR} = 1.25$$

#### RESULTS:

$$\text{MINOR STORM EVENT (5-YR)} = 4.0 \text{ LF INLET REQUIRED}$$

$$\text{MAJOR STORM EVENT (100-YR)} = 4.0 \text{ LF INLET REQUIRED}$$

$$\text{PROPOSED INLET SIZE} = 5 \text{ LF CDOT TYPE R CURB INLET}$$

-OR-

$$\text{PROPOSED INLET SIZE} = 4 \text{ LF CO SPGS D-10-R}$$

### **DESIGN POINT 2.8**

$$Q_5 = 2.9 \text{ cfs}$$

$$Q_{100} = 6.5 \text{ cfs}$$

$$d_{\max,5} = 0.50 \text{ ft}$$

$$d_{\max,100} = 0.67 \text{ ft}$$

$$Q_i = 1.7(L_i + 1.8(W))(d_{\max,i} + a/12)^{1.85}$$

#### GUTTER INFO:

$$W = 2 \text{ ft}$$

$$a = 3 \text{ inches}$$

$$\text{CLOGGING FACTOR} = 1.25$$

#### RESULTS:

$$\text{MINOR STORM EVENT (5-YR)} = 4.0 \text{ LF INLET REQUIRED}$$

$$\text{MAJOR STORM EVENT (100-YR)} = 4.0 \text{ LF INLET REQUIRED}$$

$$\text{PROPOSED INLET SIZE} = 5 \text{ LF CDOT TYPE R CURB INLET}$$

-OR-

$$\text{PROPOSED INLET SIZE} = 4 \text{ LF CO SPGS D-10-R}$$

### **DESIGN POINT 2.9**

$$Q_5 = 3.8 \text{ cfs}$$

$$Q_{100} = 8.3 \text{ cfs}$$

$$d_{\max,5} = 0.50 \text{ ft}$$

$$d_{\max,100} = 0.67 \text{ ft}$$

$$Q_i = 1.7(L_i + 1.8(W))(d_{\max,i} + a/12)^{1.85}$$

#### GUTTER INFO:

$$W = 2 \text{ ft}$$

$$a = 3 \text{ inches}$$

$$\text{CLOGGING FACTOR} = 1.25$$

#### RESULTS:

$$\text{MINOR STORM EVENT (5-YR)} = 4.0 \text{ LF INLET REQUIRED}$$

$$\text{MAJOR STORM EVENT (100-YR)} = 4.0 \text{ LF INLET REQUIRED}$$

$$\text{PROPOSED INLET SIZE} = 5 \text{ LF CDOT TYPE R CURB INLET}$$

-OR-

$$\text{PROPOSED INLET SIZE} = 4 \text{ LF CO SPGS D-10-R}$$

### **DESIGN POINT 2.10**

$$Q_5 = 3.5 \text{ cfs}$$

$$Q_{100} = 7.7 \text{ cfs}$$

$$d_{\max,5} = 0.50 \text{ ft}$$

$$d_{\max,100} = 0.67 \text{ ft}$$

$$Q_i = 1.7(L_i + 1.8(W))(d_{\max,i} + a/12)^{1.85}$$

#### GUTTER INFO:

$$W = 2 \text{ ft}$$

$$a = 3 \text{ inches}$$

$$\text{CLOGGING FACTOR} = 1.25$$

#### RESULTS:

$$\text{MINOR STORM EVENT (5-YR)} = 4.0 \text{ LF INLET REQUIRED}$$

$$\text{MAJOR STORM EVENT (100-YR)} = 20.0 \text{ LF INLET REQUIRED}$$

$$\text{PROPOSED INLET SIZE} = 5 \text{ LF CDOT TYPE R CURB INLET}$$

-OR-

$$\text{PROPOSED INLET SIZE} = 4 \text{ LF CO SPGS D-10-R}$$

### **DESIGN POINT 2.11**

$$Q_5 = 0.7 \text{ cfs}$$

$$Q_{100} = 1.4 \text{ cfs}$$

$$d_{\max,5} = 0.50 \text{ ft}$$

$$d_{\max,100} = 0.67 \text{ ft}$$

$$Q_i = 1.7(L_i + 1.8(W))(d_{\max,i} + a/12)^{1.85}$$

#### GUTTER INFO:

$$W = 2 \text{ ft}$$

$$a = 3 \text{ inches}$$

$$\text{CLOGGING FACTOR} = 1.25$$

#### RESULTS:

$$\text{MINOR STORM EVENT (5-YR)} = 4.0 \text{ LF INLET REQUIRED}$$

$$\text{MAJOR STORM EVENT (100-YR)} = 4.0 \text{ LF INLET REQUIRED}$$

$$\text{PROPOSED INLET SIZE} = 5 \text{ LF CDOT TYPE R CURB INLET}$$

-OR-

$$\text{PROPOSED INLET SIZE} = 4 \text{ LF CO SPGS D-10-R}$$

### **DESIGN POINT 2.12**

$$Q_5 = 0.9 \text{ cfs}$$

$$Q_{100} = 1.9 \text{ cfs}$$

$$d_{\max,5} = 0.50 \text{ ft}$$

$$d_{\max,100} = 0.67 \text{ ft}$$

$$Q_i = 1.7(L_i + 1.8(W))(d_{\max,i} + a/12)^{1.85}$$

#### GUTTER INFO:

$$W = 2 \text{ ft}$$

$$a = 3 \text{ inches}$$

$$\text{CLOGGING FACTOR} = 1.25$$

#### RESULTS:

$$\text{MINOR STORM EVENT (5-YR)} = 4.0 \text{ LF INLET REQUIRED}$$

$$\text{MAJOR STORM EVENT (100-YR)} = 4.0 \text{ LF INLET REQUIRED}$$

$$\text{PROPOSED INLET SIZE} = 5 \text{ LF CDOT TYPE R CURB INLET}$$

-OR-

$$\text{PROPOSED INLET SIZE} = 4 \text{ LF CO SPGS D-10-R}$$

### **DESIGN POINT 2.13**

$$Q_5 = 2.0 \text{ cfs}$$

$$Q_{100} = 4.4 \text{ cfs}$$

$$d_{\max,5} = 0.50 \text{ ft}$$

$$d_{\max,100} = 0.67 \text{ ft}$$

$$Q_i = 1.7(L_i + 1.8(W))(d_{\max,i} + a/12)^{1.85}$$

#### GUTTER INFO:

$$W = 2 \text{ ft}$$

$$a = 3 \text{ inches}$$

$$\text{CLOGGING FACTOR} = 1.25$$

#### RESULTS:

$$\text{MINOR STORM EVENT (5-YR)} = 4.0 \text{ LF INLET REQUIRED}$$

$$\text{MAJOR STORM EVENT (100-YR)} = 4.0 \text{ LF INLET REQUIRED}$$

$$\text{PROPOSED INLET SIZE} = 5 \text{ LF CDOT TYPE R CURB INLET}$$

-OR-

$$\text{PROPOSED INLET SIZE} = 4 \text{ LF CO SPGS D-10-R}$$



### **DESIGN POINT 2.14**

$$Q_5 = 0.5 \text{ cfs}$$

$$Q_{100} = 1.0 \text{ cfs}$$

$$d_{\max,5} = 0.50 \text{ ft}$$

$$d_{\max,100} = 0.67 \text{ ft}$$

$$Q_i = 1.7(L_i + 1.8(W))(d_{\max,i} + a/12)^{1.85}$$

GUTTER INFO:

$$W = 2 \text{ ft}$$

$$a = 3 \text{ inches}$$

$$\text{CLOGGING FACTOR} = 1.25$$

RESULTS:

$$\text{MINOR STORM EVENT (5-YR)} = 4.0 \text{ LF INLET REQUIRED}$$

$$\text{MAJOR STORM EVENT (100-YR)} = 4.0 \text{ LF INLET REQUIRED}$$

$$\text{PROPOSED INLET SIZE} = 5 \text{ LF CDOT TYPE R CURB INLET}$$

-OR-

$$\text{PROPOSED INLET SIZE} = 4 \text{ LF CO SPGS D-10-R}$$

### **DESIGN POINT 2.15**

$$Q_5 = 0.5 \text{ cfs}$$

$$Q_{100} = 1.2 \text{ cfs}$$

$$d_{\max,5} = 0.50 \text{ ft}$$

$$d_{\max,100} = 0.67 \text{ ft}$$

$$Q_i = 1.7(L_i + 1.8(W))(d_{\max,i} + a/12)^{1.85}$$

GUTTER INFO:

$$W = 2 \text{ ft}$$

$$a = 3 \text{ inches}$$

$$\text{CLOGGING FACTOR} = 1.25$$

RESULTS:

$$\text{MINOR STORM EVENT (5-YR)} = 4.0 \text{ LF INLET REQUIRED}$$

$$\text{MAJOR STORM EVENT (100-YR)} = 4.0 \text{ LF INLET REQUIRED}$$

$$\text{PROPOSED INLET SIZE} = 5 \text{ LF CDOT TYPE R CURB INLET}$$

-OR-

$$\text{PROPOSED INLET SIZE} = 4 \text{ LF CO SPGS D-10-R}$$

### **DESIGN POINT 2.16**

$$Q_5 = 0.6 \text{ cfs}$$

$$Q_{100} = 1.4 \text{ cfs}$$

$$d_{\max,5} = 0.50 \text{ ft}$$

$$d_{\max,100} = 0.67 \text{ ft}$$

$$Q_i = 1.7(L_i + 1.8(W))(d_{\max,i} + a/12)^{1.85}$$

#### GUTTER INFO:

$$W = 2 \text{ ft}$$

$$a = 3 \text{ inches}$$

$$\text{CLOGGING FACTOR} = 1.25$$

#### RESULTS:

MINOR STORM EVENT (5-YR) = 4.0 LF INLET REQUIRED

MAJOR STORM EVENT (100-YR) = 4.0 LF INLET REQUIRED

PROPOSED INLET SIZE = 5 LF CDOT TYPE R CURB INLET

-OR-

PROPOSED INLET SIZE = 4 LF CO SPGS D-10-R

### **DESIGN POINT 3.1**

$$Q_5 = 5.5 \text{ cfs}$$

$$Q_{100} = 22.3 \text{ cfs}$$

$$d_{\max,5} = 0.50 \text{ ft}$$

$$d_{\max,100} = 0.67 \text{ ft}$$

$$Q_i = 1.7(L_i + 1.8(W))(d_{\max,i} + a/12)^{1.85}$$

#### GUTTER INFO:

$$W = 2 \text{ ft}$$

$$a = 3 \text{ inches}$$

$$\text{CLOGGING FACTOR} = 1.25$$

#### RESULTS:

$$\text{MINOR STORM EVENT (5-YR)} = 4.0 \text{ LF INLET REQUIRED}$$

$$\text{MAJOR STORM EVENT (100-YR)} = 15.0 \text{ LF INLET REQUIRED}$$

$$\text{PROPOSED INLET SIZE} = 15 \text{ LF CDOT TYPE R CURB INLET}$$

-OR-

$$\text{PROPOSED INLET SIZE} = 12 \text{ LF CO SPGS D-10-R}$$

### **DESIGN POINT 3.2**

$$Q_5 = 3.1 \text{ cfs}$$

$$Q_{100} = 11.0 \text{ cfs}$$

$$d_{\max,5} = 0.50 \text{ ft}$$

$$d_{\max,100} = 0.67 \text{ ft}$$

$$Q_i = 1.7(L_i + 1.8(W))(d_{\max,i} + a/12)^{1.85}$$

#### GUTTER INFO:

$$W = 2 \text{ ft}$$

$$a = 3 \text{ inches}$$

$$\text{CLOGGING FACTOR} = 1.25$$

#### RESULTS:

$$\text{MINOR STORM EVENT (5-YR)} = 4.0 \text{ LF INLET REQUIRED}$$

$$\text{MAJOR STORM EVENT (100-YR)} = 5.0 \text{ LF INLET REQUIRED}$$

$$\text{PROPOSED INLET SIZE} = 5 \text{ LF CDOT TYPE R CURB INLET}$$

-OR-

$$\text{PROPOSED INLET SIZE} = 4 \text{ LF CO SPGS D-10-R}$$

### DESIGN POINT 3.3

$$Q_5 = 3.2 \text{ cfs}$$

$$Q_{100} = 11.1 \text{ cfs}$$

$$d_{\max,5} = 0.50 \text{ ft}$$

$$d_{\max,100} = 0.67 \text{ ft}$$

$$Q_i = 1.7(L_i + 1.8(W))(d_{\max,i} + a/12)^{1.85}$$

#### GUTTER INFO:

$$W = 2 \text{ ft}$$

$$a = 3 \text{ inches}$$

$$\text{CLOGGING FACTOR} = 1.25$$

#### RESULTS:

$$\text{MINOR STORM EVENT (5-YR)} = 4.0 \text{ LF INLET REQUIRED}$$

$$\text{MAJOR STORM EVENT (100-YR)} = 6.0 \text{ LF INLET REQUIRED}$$

$$\text{PROPOSED INLET SIZE} = 10 \text{ LF CDOT TYPE R CURB INLET}$$

-OR-

$$\text{PROPOSED INLET SIZE} = 4 \text{ LF CO SPGS D-10-R}$$

### DESIGN POINT 3.4

$$Q_5 = 1.7 \text{ cfs}$$

$$Q_{100} = 6.0 \text{ cfs}$$

$$d_{\max,5} = 0.50 \text{ ft}$$

$$d_{\max,100} = 0.67 \text{ ft}$$

$$Q_i = 1.7(L_i + 1.8(W))(d_{\max,i} + a/12)^{1.85}$$

#### GUTTER INFO:

$$W = 2 \text{ ft}$$

$$a = 3 \text{ inches}$$

$$\text{CLOGGING FACTOR} = 1.25$$

#### RESULTS:

$$\text{MINOR STORM EVENT (5-YR)} = 4.0 \text{ LF INLET REQUIRED}$$

$$\text{MAJOR STORM EVENT (100-YR)} = 4.0 \text{ LF INLET REQUIRED}$$

$$\text{PROPOSED INLET SIZE} = 5 \text{ LF CDOT TYPE R CURB INLET}$$

-OR-

$$\text{PROPOSED INLET SIZE} = 4 \text{ LF CO SPGS D-10-R}$$

### DESIGN POINT 3.5

$$Q_5 = 1.9 \text{ cfs}$$

$$Q_{100} = 3.4 \text{ cfs}$$

$$d_{\max,5} = 0.50 \text{ ft}$$

$$d_{\max,100} = 0.67 \text{ ft}$$

$$Q_i = 1.7(L_i + 1.8(W))(d_{\max,i} + a/12)^{1.85}$$

#### GUTTER INFO:

$$W = 2 \text{ ft}$$

$$a = 3 \text{ inches}$$

$$\text{CLOGGING FACTOR} = 1.25$$

#### RESULTS:

$$\text{MINOR STORM EVENT (5-YR)} = 4.0 \text{ LF INLET REQUIRED}$$

$$\text{MAJOR STORM EVENT (100-YR)} = 4.0 \text{ LF INLET REQUIRED}$$

$$\text{PROPOSED INLET SIZE} = 20 \text{ LF CDOT TYPE R CURB INLET}$$

-OR-

$$\text{PROPOSED INLET SIZE} = 4 \text{ LF CO SPGS D-10-R}$$

### DESIGN POINT 3.6

$$Q_5 = 1.7 \text{ cfs}$$

$$Q_{100} = 3.1 \text{ cfs}$$

$$d_{\max,5} = 0.50 \text{ ft}$$

$$d_{\max,100} = 0.67 \text{ ft}$$

$$Q_i = 1.7(L_i + 1.8(W))(d_{\max,i} + a/12)^{1.85}$$

#### GUTTER INFO:

$$W = 2 \text{ ft}$$

$$a = 3 \text{ inches}$$

$$\text{CLOGGING FACTOR} = 1.25$$

#### RESULTS:

$$\text{MINOR STORM EVENT (5-YR)} = 4.0 \text{ LF INLET REQUIRED}$$

$$\text{MAJOR STORM EVENT (100-YR)} = 4.0 \text{ LF INLET REQUIRED}$$

$$\text{PROPOSED INLET SIZE} = 5 \text{ LF CDOT TYPE R CURB INLET}$$

-OR-

$$\text{PROPOSED INLET SIZE} = 4 \text{ LF CO SPGS D-10-R}$$

### DESIGN POINT 3.7

$$Q_5 = 3.5 \text{ cfs}$$

$$Q_{100} = 7.7 \text{ cfs}$$

$$d_{\max,5} = 0.50 \text{ ft}$$

$$d_{\max,100} = 0.67 \text{ ft}$$

$$Q_i = 1.7(L_i + 1.8(W))(d_{\max,i} + a/12)^{1.85}$$

#### GUTTER INFO:

$$W = 2 \text{ ft}$$

$$a = 3 \text{ inches}$$

$$\text{CLOGGING FACTOR} = 1.25$$

#### RESULTS:

$$\text{MINOR STORM EVENT (5-YR)} = 4.0 \text{ LF INLET REQUIRED}$$

$$\text{MAJOR STORM EVENT (100-YR)} = 4.0 \text{ LF INLET REQUIRED}$$

$$\text{PROPOSED INLET SIZE} = 5 \text{ LF CDOT TYPE R CURB INLET}$$

-OR-

$$\text{PROPOSED INLET SIZE} = 4 \text{ LF CO SPGS D-10-R}$$

### DESIGN POINT 3.8

$$Q_5 = 2.5 \text{ cfs}$$

$$Q_{100} = 5.4 \text{ cfs}$$

$$d_{\max,5} = 0.50 \text{ ft}$$

$$d_{\max,100} = 0.67 \text{ ft}$$

$$Q_i = 1.7(L_i + 1.8(W))(d_{\max,i} + a/12)^{1.85}$$

#### GUTTER INFO:

$$W = 2 \text{ ft}$$

$$a = 3 \text{ inches}$$

$$\text{CLOGGING FACTOR} = 1.25$$

#### RESULTS:

$$\text{MINOR STORM EVENT (5-YR)} = 4.0 \text{ LF INLET REQUIRED}$$

$$\text{MAJOR STORM EVENT (100-YR)} = 4.0 \text{ LF INLET REQUIRED}$$

$$\text{PROPOSED INLET SIZE} = 5 \text{ LF CDOT TYPE R CURB INLET}$$

-OR-

$$\text{PROPOSED INLET SIZE} = 4 \text{ LF CO SPGS D-10-R}$$

### **DESIGN POINT 3.9**

$$Q_5 = 5.5 \text{ cfs}$$

$$Q_{100} = 12.1 \text{ cfs}$$

$$d_{\max,5} = 0.50 \text{ ft}$$

$$d_{\max,100} = 0.67 \text{ ft}$$

$$Q_i = 1.7(L_i + 1.8(W))(d_{\max,i} + a/12)^{1.85}$$

#### GUTTER INFO:

$$W = 2 \text{ ft}$$

$$a = 3 \text{ inches}$$

$$\text{CLOGGING FACTOR} = 1.25$$

#### RESULTS:

$$\text{MINOR STORM EVENT (5-YR)} = 4.0 \text{ LF INLET REQUIRED}$$

$$\text{MAJOR STORM EVENT (100-YR)} = 6.0 \text{ LF INLET REQUIRED}$$

$$\text{PROPOSED INLET SIZE} = 10 \text{ LF CDOT TYPE R CURB INLET}$$

-OR-

$$\text{PROPOSED INLET SIZE} = 8 \text{ LF CO SPGS D-10-R}$$

### **DESIGN POINT 3.10**

$$Q_5 = 1.5 \text{ cfs}$$

$$Q_{100} = 4.9 \text{ cfs}$$

$$d_{\max,5} = 0.50 \text{ ft}$$

$$d_{\max,100} = 0.67 \text{ ft}$$

$$Q_i = 1.7(L_i + 1.8(W))(d_{\max,i} + a/12)^{1.85}$$

#### GUTTER INFO:

$$W = 2 \text{ ft}$$

$$a = 3 \text{ inches}$$

$$\text{CLOGGING FACTOR} = 1.25$$

#### RESULTS:

$$\text{MINOR STORM EVENT (5-YR)} = 4.0 \text{ LF INLET REQUIRED}$$

$$\text{MAJOR STORM EVENT (100-YR)} = 4.0 \text{ LF INLET REQUIRED}$$

$$\text{PROPOSED INLET SIZE} = 5 \text{ LF CDOT TYPE R CURB INLET}$$

-OR-

$$\text{PROPOSED INLET SIZE} = 4 \text{ LF CO SPGS D-10-R}$$

### DESIGN POINT 3.11

$$Q_5 = 4.9 \text{ cfs}$$

$$Q_{100} = 16.3 \text{ cfs}$$

$$d_{\max,5} = 0.50 \text{ ft}$$

$$d_{\max,100} = 0.67 \text{ ft}$$

$$Q_i = 1.7(L_i + 1.8(W))(d_{\max,i} + a/12)^{1.85}$$

#### GUTTER INFO:

$$W = 2 \text{ ft}$$

$$a = 3 \text{ inches}$$

$$\text{CLOGGING FACTOR} = 1.25$$

#### RESULTS:

$$\text{MINOR STORM EVENT (5-YR)} = 4.0 \text{ LF INLET REQUIRED}$$

$$\text{MAJOR STORM EVENT (100-YR)} = 10.0 \text{ LF INLET REQUIRED}$$

$$\text{PROPOSED INLET SIZE} = 10 \text{ LF CDOT TYPE R CURB INLET}$$

-OR-

$$\text{PROPOSED INLET SIZE} = 8 \text{ LF CO SPGS D-10-R}$$

### DESIGN POINT 3.12

$$Q_5 = 1.9 \text{ cfs}$$

$$Q_{100} = 3.4 \text{ cfs}$$

$$d_{\max,5} = 0.50 \text{ ft}$$

$$d_{\max,100} = 0.67 \text{ ft}$$

$$Q_i = 1.7(L_i + 1.8(W))(d_{\max,i} + a/12)^{1.85}$$

#### GUTTER INFO:

$$W = 2 \text{ ft}$$

$$a = 3 \text{ inches}$$

$$\text{CLOGGING FACTOR} = 1.25$$

#### RESULTS:

$$\text{MINOR STORM EVENT (5-YR)} = 4.0 \text{ LF INLET REQUIRED}$$

$$\text{MAJOR STORM EVENT (100-YR)} = 4.0 \text{ LF INLET REQUIRED}$$

$$\text{PROPOSED INLET SIZE} = 5 \text{ LF CDOT TYPE R CURB INLET}$$

-OR-

$$\text{PROPOSED INLET SIZE} = 4 \text{ LF CO SPGS D-10-R}$$



### **DESIGN POINT 3.14**

$$Q_5 = 4.9 \text{ cfs}$$

$$Q_{100} = 10.8 \text{ cfs}$$

$$d_{\max,5} = 0.50 \text{ ft}$$

$$d_{\max,100} = 0.67 \text{ ft}$$

$$Q_i = 1.7(L_i + 1.8(W))(d_{\max,i} + a/12)^{1.85}$$

#### GUTTER INFO:

$$W = 2 \text{ ft}$$

$$a = 3 \text{ inches}$$

$$\text{CLOGGING FACTOR} = 1.25$$

#### RESULTS:

$$\text{MINOR STORM EVENT (5-YR)} = 4.0 \text{ LF INLET REQUIRED}$$

$$\text{MAJOR STORM EVENT (100-YR)} = 5.0 \text{ LF INLET REQUIRED}$$

$$\text{PROPOSED INLET SIZE} = 5 \text{ LF CDOT TYPE R CURB INLET}$$

-OR-

$$\text{PROPOSED INLET SIZE} = 4 \text{ LF CO SPGS D-10-R}$$

### **DESIGN POINT 3.15**

$$Q_5 = 2.2 \text{ cfs}$$

$$Q_{100} = 4.8 \text{ cfs}$$

$$d_{\max,5} = 0.50 \text{ ft}$$

$$d_{\max,100} = 0.67 \text{ ft}$$

$$Q_i = 1.7(L_i + 1.8(W))(d_{\max,i} + a/12)^{1.85}$$

#### GUTTER INFO:

$$W = 2 \text{ ft}$$

$$a = 3 \text{ inches}$$

$$\text{CLOGGING FACTOR} = 1.25$$

#### RESULTS:

$$\text{MINOR STORM EVENT (5-YR)} = 4.0 \text{ LF INLET REQUIRED}$$

$$\text{MAJOR STORM EVENT (100-YR)} = 4.0 \text{ LF INLET REQUIRED}$$

$$\text{PROPOSED INLET SIZE} = 5 \text{ LF CDOT TYPE R CURB INLET}$$

-OR-

$$\text{PROPOSED INLET SIZE} = 4 \text{ LF CO SPGS D-10-R}$$

### **DESIGN POINT 3.17**

$$Q_5 = 6.5 \text{ cfs}$$

$$Q_{100} = 12.4 \text{ cfs}$$

$$d_{\max,5} = 0.50 \text{ ft}$$

$$d_{\max,100} = 0.67 \text{ ft}$$

$$Q_i = 1.7(L_i + 1.8(W))(d_{\max,i} + a/12)^{1.85}$$

#### GUTTER INFO:

$$W = 2 \text{ ft}$$

$$a = 3 \text{ inches}$$

$$\text{CLOGGING FACTOR} = 1.25$$

#### RESULTS:

$$\text{MINOR STORM EVENT (5-YR)} = 4.0 \text{ LF INLET REQUIRED}$$

$$\text{MAJOR STORM EVENT (100-YR)} = 7.0 \text{ LF INLET REQUIRED}$$

$$\text{PROPOSED INLET SIZE} = 10 \text{ LF CDOT TYPE R CURB INLET}$$

-OR-

$$\text{PROPOSED INLET SIZE} = 8 \text{ LF CO SPGS D-10-R}$$

### **DESIGN POINT 3.18**

$$Q_5 = 3.2 \text{ cfs}$$

$$Q_{100} = 5.7 \text{ cfs}$$

$$d_{\max,5} = 0.50 \text{ ft}$$

$$d_{\max,100} = 0.67 \text{ ft}$$

$$Q_i = 1.7(L_i + 1.8(W))(d_{\max,i} + a/12)^{1.85}$$

#### GUTTER INFO:

$$W = 2 \text{ ft}$$

$$a = 3 \text{ inches}$$

$$\text{CLOGGING FACTOR} = 1.25$$

#### RESULTS:

$$\text{MINOR STORM EVENT (5-YR)} = 4.0 \text{ LF INLET REQUIRED}$$

$$\text{MAJOR STORM EVENT (100-YR)} = 4.0 \text{ LF INLET REQUIRED}$$

$$\text{PROPOSED INLET SIZE} = 5 \text{ LF CDOT TYPE R CURB INLET}$$

-OR-

$$\text{PROPOSED INLET SIZE} = 4 \text{ LF CO SPGS D-10-R}$$

### **DESIGN POINT 3.19**

$$Q_5 = 1.4 \text{ cfs}$$

$$Q_{100} = 3.0 \text{ cfs}$$

$$d_{\max,5} = 0.50 \text{ ft}$$

$$d_{\max,100} = 0.67 \text{ ft}$$

$$Q_i = 1.7(L_i + 1.8(W))(d_{\max,i} + a/12)^{1.85}$$

#### GUTTER INFO:

$$W = 2 \text{ ft}$$

$$a = 3 \text{ inches}$$

$$\text{CLOGGING FACTOR} = 1.25$$

#### RESULTS:

MINOR STORM EVENT (5-YR) = 4.0 LF INLET REQUIRED

MAJOR STORM EVENT (100-YR) = 4.0 LF INLET REQUIRED

PROPOSED INLET SIZE = 5 LF CDOT TYPE R CURB INLET

-OR-

PROPOSED INLET SIZE = 4 LF CO SPGS D-10-R

### **DESIGN POINT 3.20**

$$Q_5 = 2.7 \text{ cfs}$$

$$Q_{100} = 6.0 \text{ cfs}$$

$$d_{\max,5} = 0.50 \text{ ft}$$

$$d_{\max,100} = 0.67 \text{ ft}$$

$$Q_i = 1.7(L_i + 1.8(W))(d_{\max,i} + a/12)^{1.85}$$

#### GUTTER INFO:

$$W = 2 \text{ ft}$$

$$a = 3 \text{ inches}$$

$$\text{CLOGGING FACTOR} = 1.25$$

#### RESULTS:

MINOR STORM EVENT (5-YR) = 4.0 LF INLET REQUIRED

MAJOR STORM EVENT (100-YR) = 4.0 LF INLET REQUIRED

PROPOSED INLET SIZE = 5 LF CDOT TYPE R CURB INLET

-OR-

PROPOSED INLET SIZE = 4 LF CO SPGS D-10-R

### **DESIGN POINT 3.21**

$$Q_5 = 6.1 \text{ cfs}$$

$$Q_{100} = 13.4 \text{ cfs}$$

$$d_{\max,5} = 0.50 \text{ ft}$$

$$d_{\max,100} = 0.67 \text{ ft}$$

$$Q_i = 1.7(L_i + 1.8(W))(d_{\max,i} + a/12)^{1.85}$$

#### GUTTER INFO:

$$W = 2 \text{ ft}$$

$$a = 3 \text{ inches}$$

$$\text{CLOGGING FACTOR} = 1.25$$

#### RESULTS:

$$\text{MINOR STORM EVENT (5-YR)} = 4.0 \text{ LF INLET REQUIRED}$$

$$\text{MAJOR STORM EVENT (100-YR)} = 8.0 \text{ LF INLET REQUIRED}$$

$$\text{PROPOSED INLET SIZE} = 10 \text{ LF CDOT TYPE R CURB INLET}$$

-OR-

$$\text{PROPOSED INLET SIZE} = 8 \text{ LF CO SPGS D-10-R}$$

### **DESIGN POINT 3.22**

$$Q_5 = 4.0 \text{ cfs}$$

$$Q_{100} = 8.9 \text{ cfs}$$

$$d_{\max,5} = 0.50 \text{ ft}$$

$$d_{\max,100} = 0.67 \text{ ft}$$

$$Q_i = 1.7(L_i + 1.8(W))(d_{\max,i} + a/12)^{1.85}$$

#### GUTTER INFO:

$$W = 2 \text{ ft}$$

$$a = 3 \text{ inches}$$

$$\text{CLOGGING FACTOR} = 1.25$$

#### RESULTS:

$$\text{MINOR STORM EVENT (5-YR)} = 4.0 \text{ LF INLET REQUIRED}$$

$$\text{MAJOR STORM EVENT (100-YR)} = 4.0 \text{ LF INLET REQUIRED}$$

$$\text{PROPOSED INLET SIZE} = 5 \text{ LF CDOT TYPE R CURB INLET}$$

-OR-

$$\text{PROPOSED INLET SIZE} = 4 \text{ LF CO SPGS D-10-R}$$

### **DESIGN POINT 3.23**

$$Q_5 = 2.8 \text{ cfs}$$

$$Q_{100} = 6.2 \text{ cfs}$$

$$d_{\max,5} = 0.50 \text{ ft}$$

$$d_{\max,100} = 0.67 \text{ ft}$$

$$Q_i = 1.7(L_i + 1.8(W))(d_{\max,i} + a/12)^{1.85}$$

#### GUTTER INFO:

$$W = 2 \text{ ft}$$

$$a = 3 \text{ inches}$$

$$\text{CLOGGING FACTOR} = 1.25$$

#### RESULTS:

MINOR STORM EVENT (5-YR) = 4.0 LF INLET REQUIRED

MAJOR STORM EVENT (100-YR) = 4.0 LF INLET REQUIRED

PROPOSED INLET SIZE = 5 LF CDOT TYPE R CURB INLET

-OR-

PROPOSED INLET SIZE = 4 LF CO SPGS D-10-R

### **DESIGN POINT 3.24**

$$Q_5 = 0.3 \text{ cfs}$$

$$Q_{100} = 0.7 \text{ cfs}$$

$$d_{\max,5} = 0.50 \text{ ft}$$

$$d_{\max,100} = 0.67 \text{ ft}$$

$$Q_i = 1.7(L_i + 1.8(W))(d_{\max,i} + a/12)^{1.85}$$

#### GUTTER INFO:

$$W = 2 \text{ ft}$$

$$a = 3 \text{ inches}$$

$$\text{CLOGGING FACTOR} = 1.25$$

#### RESULTS:

MINOR STORM EVENT (5-YR) = 4.0 LF INLET REQUIRED

MAJOR STORM EVENT (100-YR) = 4.0 LF INLET REQUIRED

PROPOSED INLET SIZE = 5 LF CDOT TYPE R CURB INLET

-OR-

PROPOSED INLET SIZE = 4 LF CO SPGS D-10-R

### DESIGN POINT 3.25

$$Q_5 = 2.6 \text{ cfs}$$

$$Q_{100} = 5.8 \text{ cfs}$$

$$d_{\max,5} = 0.50 \text{ ft}$$

$$d_{\max,100} = 0.67 \text{ ft}$$

$$Q_i = 1.7(L_i + 1.8(W))(d_{\max,i} + a/12)^{1.85}$$

#### GUTTER INFO:

$$W = 2 \text{ ft}$$

$$a = 3 \text{ inches}$$

$$\text{CLOGGING FACTOR} = 1.25$$

#### RESULTS:

MINOR STORM EVENT (5-YR) = 4.0 LF INLET REQUIRED

MAJOR STORM EVENT (100-YR) = 4.0 LF INLET REQUIRED

PROPOSED INLET SIZE = 5 LF CDOT TYPE R CURB INLET

-OR-

PROPOSED INLET SIZE = 4 LF CO SPGS D-10-R

### DESIGN POINT 4.1

$$Q_5 = 3.4 \text{ cfs}$$

$$Q_{100} = 7.4 \text{ cfs}$$

$$d_{\max,5} = 0.50 \text{ ft}$$

$$d_{\max,100} = 0.67 \text{ ft}$$

$$Q_i = 1.7(L_i + 1.8(W))(d_{\max,i} + a/12)^{1.85}$$

#### GUTTER INFO:

$$W = 2 \text{ ft}$$

$$a = 3 \text{ inches}$$

$$\text{CLOGGING FACTOR} = 1.25$$

#### RESULTS:

MINOR STORM EVENT (5-YR) = 4.0 LF INLET REQUIRED

MAJOR STORM EVENT (100-YR) = 4.0 LF INLET REQUIRED

PROPOSED INLET SIZE = 5 LF CDOT TYPE R CURB INLET

-OR-

PROPOSED INLET SIZE = 4 LF CO SPGS D-10-R

### DESIGN POINT 4.2

$$Q_5 = 6.3 \text{ cfs}$$

$$Q_{100} = 13.9 \text{ cfs}$$

$$d_{\max,5} = 0.50 \text{ ft}$$

$$d_{\max,100} = 0.67 \text{ ft}$$

$$Q_i = 1.7(L_i + 1.8(W))(d_{\max,i} + a/12)^{1.85}$$

#### GUTTER INFO:

$$W = 2 \text{ ft}$$

$$a = 3 \text{ inches}$$

$$\text{CLOGGING FACTOR} = 1.25$$

#### RESULTS:

$$\text{MINOR STORM EVENT (5-YR)} = 4.0 \text{ LF INLET REQUIRED}$$

$$\text{MAJOR STORM EVENT (100-YR)} = 8.0 \text{ LF INLET REQUIRED}$$

$$\text{PROPOSED INLET SIZE} = 10 \text{ LF CDOT TYPE R CURB INLET}$$

-OR-

$$\text{PROPOSED INLET SIZE} = 8 \text{ LF CO SPGS D-10-R}$$

### DESIGN POINT 4.3

$$Q_5 = 1.8 \text{ cfs}$$

$$Q_{100} = 5.3 \text{ cfs}$$

$$d_{\max,5} = 0.50 \text{ ft}$$

$$d_{\max,100} = 0.67 \text{ ft}$$

$$Q_i = 1.7(L_i + 1.8(W))(d_{\max,i} + a/12)^{1.85}$$

#### GUTTER INFO:

$$W = 2 \text{ ft}$$

$$a = 3 \text{ inches}$$

$$\text{CLOGGING FACTOR} = 1.25$$

#### RESULTS:

$$\text{MINOR STORM EVENT (5-YR)} = 4.0 \text{ LF INLET REQUIRED}$$

$$\text{MAJOR STORM EVENT (100-YR)} = 4.0 \text{ LF INLET REQUIRED}$$

$$\text{PROPOSED INLET SIZE} = 5 \text{ LF CDOT TYPE R CURB INLET}$$

-OR-

$$\text{PROPOSED INLET SIZE} = 4 \text{ LF CO SPGS D-10-R}$$

# CIRCULAR CONDUIT FLOW (Normal & Critical Depth Computation)

*MHFD-Culvert, Version 4.00 (May 2020)*

**Project: Falcon Highlands**  
**Pipe ID: C.21**

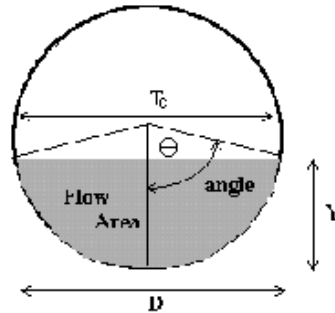

<u>Design Information (Input)</u>			
Pipe Invert Slope	So = <table border="1" style="display: inline-table; vertical-align: middle;"><tr><td style="text-align: center;">0.0200</td><td style="text-align: left;">ft/ft</td></tr></table>	0.0200	ft/ft
0.0200	ft/ft		
Pipe Manning's n-value	n = <table border="1" style="display: inline-table; vertical-align: middle;"><tr><td style="text-align: center;">0.0130</td><td></td></tr></table>	0.0130	
0.0130			
Pipe Diameter	D = <table border="1" style="display: inline-table; vertical-align: middle;"><tr><td style="text-align: center;">18.00</td><td style="text-align: left;">inches</td></tr></table>	18.00	inches
18.00	inches		
Design discharge	Q = <table border="1" style="display: inline-table; vertical-align: middle;"><tr><td style="text-align: center;">13.40</td><td style="text-align: left;">cfs</td></tr></table>	13.40	cfs
13.40	cfs		
<u>Full-Flow Capacity (Calculated)</u>			
Full-flow area	Af = <table border="1" style="display: inline-table; vertical-align: middle;"><tr><td style="text-align: center;">1.77</td><td style="text-align: left;">sq ft</td></tr></table>	1.77	sq ft
1.77	sq ft		
Full-flow wetted perimeter	Pf = <table border="1" style="display: inline-table; vertical-align: middle;"><tr><td style="text-align: center;">4.71</td><td style="text-align: left;">ft</td></tr></table>	4.71	ft
4.71	ft		
Half Central Angle	Theta = <table border="1" style="display: inline-table; vertical-align: middle;"><tr><td style="text-align: center;">3.14</td><td style="text-align: left;">radians</td></tr></table>	3.14	radians
3.14	radians		
Full-flow capacity	Qf = <table border="1" style="display: inline-table; vertical-align: middle;"><tr><td style="text-align: center;">14.90</td><td style="text-align: left;">cfs</td></tr></table>	14.90	cfs
14.90	cfs		
<u>Calculation of Normal Flow Condition</u>			
Half Central Angle ( $0 < \theta < 3.14$ )	Theta = <table border="1" style="display: inline-table; vertical-align: middle;"><tr><td style="text-align: center;">2.07</td><td style="text-align: left;">radians</td></tr></table>	2.07	radians
2.07	radians		
Flow area	An = <table border="1" style="display: inline-table; vertical-align: middle;"><tr><td style="text-align: center;">1.40</td><td style="text-align: left;">sq ft</td></tr></table>	1.40	sq ft
1.40	sq ft		
Top width	Tn = <table border="1" style="display: inline-table; vertical-align: middle;"><tr><td style="text-align: center;">1.31</td><td style="text-align: left;">ft</td></tr></table>	1.31	ft
1.31	ft		
Wetted perimeter	Pn = <table border="1" style="display: inline-table; vertical-align: middle;"><tr><td style="text-align: center;">3.11</td><td style="text-align: left;">ft</td></tr></table>	3.11	ft
3.11	ft		
Flow depth	Yn = <table border="1" style="display: inline-table; vertical-align: middle;"><tr><td style="text-align: center;">1.11</td><td style="text-align: left;">ft</td></tr></table>	1.11	ft
1.11	ft		
Flow velocity	Vn = <table border="1" style="display: inline-table; vertical-align: middle;"><tr><td style="text-align: center;">9.54</td><td style="text-align: left;">fps</td></tr></table>	9.54	fps
9.54	fps		
Discharge	Qn = <table border="1" style="display: inline-table; vertical-align: middle;"><tr><td style="text-align: center;">13.40</td><td style="text-align: left;">cfs</td></tr></table>	13.40	cfs
13.40	cfs		
Percent of Full Flow	Flow = <table border="1" style="display: inline-table; vertical-align: middle;"><tr><td style="text-align: center;">90.0%</td><td style="text-align: left;">of full flow</td></tr></table>	90.0%	of full flow
90.0%	of full flow		
Normal Depth Froude Number	Fr <sub>n</sub> = <table border="1" style="display: inline-table; vertical-align: middle;"><tr><td style="text-align: center;">1.63</td><td style="text-align: left;">supercritical</td></tr></table>	1.63	supercritical
1.63	supercritical		
<u>Calculation of Critical Flow Condition</u>			
Half Central Angle ( $0 < \theta_c < 3.14$ )	Theta-c = <table border="1" style="display: inline-table; vertical-align: middle;"><tr><td style="text-align: center;">2.53</td><td style="text-align: left;">radians</td></tr></table>	2.53	radians
2.53	radians		
Critical flow area	Ac = <table border="1" style="display: inline-table; vertical-align: middle;"><tr><td style="text-align: center;">1.69</td><td style="text-align: left;">sq ft</td></tr></table>	1.69	sq ft
1.69	sq ft		
Critical top width	Tc = <table border="1" style="display: inline-table; vertical-align: middle;"><tr><td style="text-align: center;">0.86</td><td style="text-align: left;">ft</td></tr></table>	0.86	ft
0.86	ft		
Critical flow depth	Yc = <table border="1" style="display: inline-table; vertical-align: middle;"><tr><td style="text-align: center;">1.36</td><td style="text-align: left;">ft</td></tr></table>	1.36	ft
1.36	ft		
Critical flow velocity	Vc = <table border="1" style="display: inline-table; vertical-align: middle;"><tr><td style="text-align: center;">7.94</td><td style="text-align: left;">fps</td></tr></table>	7.94	fps
7.94	fps		
Critical Depth Froude Number	Fr <sub>c</sub> = <table border="1" style="display: inline-table; vertical-align: middle;"><tr><td style="text-align: center;">1.00</td><td></td></tr></table>	1.00	
1.00			



# CIRCULAR CONDUIT FLOW (Normal & Critical Depth Computation)

*MHFD-Culvert, Version 4.00 (May 2020)*

**Project: Falcon Highlands**  
**Pipe ID: C.22**

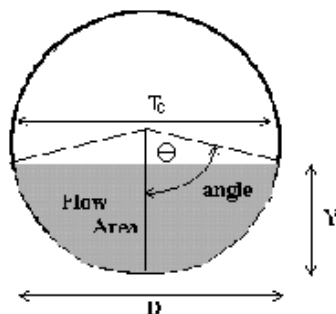

<u>Design Information (Input)</u>			
Pipe Invert Slope	So = <table border="1" style="display: inline-table; vertical-align: middle;"><tr><td style="text-align: center;">0.0200</td><td style="text-align: left;">ft/ft</td></tr></table>	0.0200	ft/ft
0.0200	ft/ft		
Pipe Manning's n-value	n = <table border="1" style="display: inline-table; vertical-align: middle;"><tr><td style="text-align: center;">0.0130</td><td></td></tr></table>	0.0130	
0.0130			
Pipe Diameter	D = <table border="1" style="display: inline-table; vertical-align: middle;"><tr><td style="text-align: center;">18.00</td><td style="text-align: left;">inches</td></tr></table>	18.00	inches
18.00	inches		
Design discharge	Q = <table border="1" style="display: inline-table; vertical-align: middle;"><tr><td style="text-align: center;">8.86</td><td style="text-align: left;">cfs</td></tr></table>	8.86	cfs
8.86	cfs		
<u>Full-Flow Capacity (Calculated)</u>			
Full-flow area	Af = <table border="1" style="display: inline-table; vertical-align: middle;"><tr><td style="text-align: center;">1.77</td><td style="text-align: left;">sq ft</td></tr></table>	1.77	sq ft
1.77	sq ft		
Full-flow wetted perimeter	Pf = <table border="1" style="display: inline-table; vertical-align: middle;"><tr><td style="text-align: center;">4.71</td><td style="text-align: left;">ft</td></tr></table>	4.71	ft
4.71	ft		
Half Central Angle	Theta = <table border="1" style="display: inline-table; vertical-align: middle;"><tr><td style="text-align: center;">3.14</td><td style="text-align: left;">radians</td></tr></table>	3.14	radians
3.14	radians		
Full-flow capacity	Qf = <table border="1" style="display: inline-table; vertical-align: middle;"><tr><td style="text-align: center;">14.90</td><td style="text-align: left;">cfs</td></tr></table>	14.90	cfs
14.90	cfs		
<u>Calculation of Normal Flow Condition</u>			
Half Central Angle ( $0 < \theta < 3.14$ )	Theta = <table border="1" style="display: inline-table; vertical-align: middle;"><tr><td style="text-align: center;">1.68</td><td style="text-align: left;">radians</td></tr></table>	1.68	radians
1.68	radians		
Flow area	An = <table border="1" style="display: inline-table; vertical-align: middle;"><tr><td style="text-align: center;">1.01</td><td style="text-align: left;">sq ft</td></tr></table>	1.01	sq ft
1.01	sq ft		
Top width	Tn = <table border="1" style="display: inline-table; vertical-align: middle;"><tr><td style="text-align: center;">1.49</td><td style="text-align: left;">ft</td></tr></table>	1.49	ft
1.49	ft		
Wetted perimeter	Pn = <table border="1" style="display: inline-table; vertical-align: middle;"><tr><td style="text-align: center;">2.52</td><td style="text-align: left;">ft</td></tr></table>	2.52	ft
2.52	ft		
Flow depth	Yn = <table border="1" style="display: inline-table; vertical-align: middle;"><tr><td style="text-align: center;">0.83</td><td style="text-align: left;">ft</td></tr></table>	0.83	ft
0.83	ft		
Flow velocity	Vn = <table border="1" style="display: inline-table; vertical-align: middle;"><tr><td style="text-align: center;">8.79</td><td style="text-align: left;">fps</td></tr></table>	8.79	fps
8.79	fps		
Discharge	Qn = <table border="1" style="display: inline-table; vertical-align: middle;"><tr><td style="text-align: center;">8.86</td><td style="text-align: left;">cfs</td></tr></table>	8.86	cfs
8.86	cfs		
Percent of Full Flow	Flow = <table border="1" style="display: inline-table; vertical-align: middle;"><tr><td style="text-align: center;">59.5%</td><td style="text-align: left;">of full flow</td></tr></table>	59.5%	of full flow
59.5%	of full flow		
Normal Depth Froude Number	Fr <sub>n</sub> = <table border="1" style="display: inline-table; vertical-align: middle;"><tr><td style="text-align: center;">1.88</td><td style="text-align: left;">supercritical</td></tr></table>	1.88	supercritical
1.88	supercritical		
<u>Calculation of Critical Flow Condition</u>			
Half Central Angle ( $0 < \theta_c < 3.14$ )	Theta-c = <table border="1" style="display: inline-table; vertical-align: middle;"><tr><td style="text-align: center;">2.14</td><td style="text-align: left;">radians</td></tr></table>	2.14	radians
2.14	radians		
Critical flow area	Ac = <table border="1" style="display: inline-table; vertical-align: middle;"><tr><td style="text-align: center;">1.46</td><td style="text-align: left;">sq ft</td></tr></table>	1.46	sq ft
1.46	sq ft		
Critical top width	Tc = <table border="1" style="display: inline-table; vertical-align: middle;"><tr><td style="text-align: center;">1.27</td><td style="text-align: left;">ft</td></tr></table>	1.27	ft
1.27	ft		
Critical flow depth	Yc = <table border="1" style="display: inline-table; vertical-align: middle;"><tr><td style="text-align: center;">1.15</td><td style="text-align: left;">ft</td></tr></table>	1.15	ft
1.15	ft		
Critical flow velocity	Vc = <table border="1" style="display: inline-table; vertical-align: middle;"><tr><td style="text-align: center;">6.08</td><td style="text-align: left;">fps</td></tr></table>	6.08	fps
6.08	fps		
Critical Depth Froude Number	Fr <sub>c</sub> = <table border="1" style="display: inline-table; vertical-align: middle;"><tr><td style="text-align: center;">1.00</td><td></td></tr></table>	1.00	
1.00			

**CULVERT DESIGN FOR LOCATIONS  
WHERE PUBLIC TRAIL CROSSES SWALE**

# CIRCULAR CONDUIT FLOW (Normal & Critical Depth Computation)

*MHFD-Culvert, Version 4.00 (May 2020)*

**Project: Falcon Highlands**  
**Pipe ID: C.25**

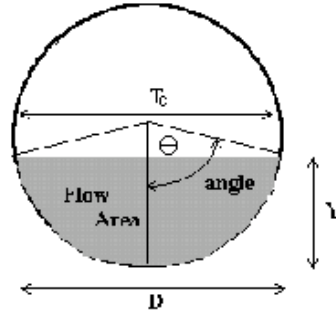

<u>Design Information (Input)</u>			
Pipe Invert Slope	So = <table border="1" style="display: inline-table; vertical-align: middle;"><tr><td style="text-align: center;">0.0200</td><td style="text-align: left;">ft/ft</td></tr></table>	0.0200	ft/ft
0.0200	ft/ft		
Pipe Manning's n-value	n = <table border="1" style="display: inline-table; vertical-align: middle;"><tr><td style="text-align: center;">0.0130</td><td></td></tr></table>	0.0130	
0.0130			
Pipe Diameter	D = <table border="1" style="display: inline-table; vertical-align: middle;"><tr><td style="text-align: center;">18.00</td><td style="text-align: left;">inches</td></tr></table>	18.00	inches
18.00	inches		
Design discharge	Q = <table border="1" style="display: inline-table; vertical-align: middle;"><tr><td style="text-align: center;">5.80</td><td style="text-align: left;">cfs</td></tr></table>	5.80	cfs
5.80	cfs		
<u>Full-Flow Capacity (Calculated)</u>			
Full-flow area	Af = <table border="1" style="display: inline-table; vertical-align: middle;"><tr><td style="text-align: center;">1.77</td><td style="text-align: left;">sq ft</td></tr></table>	1.77	sq ft
1.77	sq ft		
Full-flow wetted perimeter	Pf = <table border="1" style="display: inline-table; vertical-align: middle;"><tr><td style="text-align: center;">4.71</td><td style="text-align: left;">ft</td></tr></table>	4.71	ft
4.71	ft		
Half Central Angle	Theta = <table border="1" style="display: inline-table; vertical-align: middle;"><tr><td style="text-align: center;">3.14</td><td style="text-align: left;">radians</td></tr></table>	3.14	radians
3.14	radians		
Full-flow capacity	Qf = <table border="1" style="display: inline-table; vertical-align: middle;"><tr><td style="text-align: center;">14.90</td><td style="text-align: left;">cfs</td></tr></table>	14.90	cfs
14.90	cfs		
<u>Calculation of Normal Flow Condition</u>			
Half Central Angle ( $0 < \theta < 3.14$ )	Theta = <table border="1" style="display: inline-table; vertical-align: middle;"><tr><td style="text-align: center;">1.44</td><td style="text-align: left;">radians</td></tr></table>	1.44	radians
1.44	radians		
Flow area	An = <table border="1" style="display: inline-table; vertical-align: middle;"><tr><td style="text-align: center;">0.73</td><td style="text-align: left;">sq ft</td></tr></table>	0.73	sq ft
0.73	sq ft		
Top width	Tn = <table border="1" style="display: inline-table; vertical-align: middle;"><tr><td style="text-align: center;">1.49</td><td style="text-align: left;">ft</td></tr></table>	1.49	ft
1.49	ft		
Wetted perimeter	Pn = <table border="1" style="display: inline-table; vertical-align: middle;"><tr><td style="text-align: center;">2.16</td><td style="text-align: left;">ft</td></tr></table>	2.16	ft
2.16	ft		
Flow depth	Yn = <table border="1" style="display: inline-table; vertical-align: middle;"><tr><td style="text-align: center;">0.65</td><td style="text-align: left;">ft</td></tr></table>	0.65	ft
0.65	ft		
Flow velocity	Vn = <table border="1" style="display: inline-table; vertical-align: middle;"><tr><td style="text-align: center;">7.90</td><td style="text-align: left;">fps</td></tr></table>	7.90	fps
7.90	fps		
Discharge	Qn = <table border="1" style="display: inline-table; vertical-align: middle;"><tr><td style="text-align: center;">5.80</td><td style="text-align: left;">cfs</td></tr></table>	5.80	cfs
5.80	cfs		
Percent of Full Flow	Flow = <table border="1" style="display: inline-table; vertical-align: middle;"><tr><td style="text-align: center;">38.9%</td><td style="text-align: left;">of full flow</td></tr></table>	38.9%	of full flow
38.9%	of full flow		
Normal Depth Froude Number	Fr <sub>n</sub> = <table border="1" style="display: inline-table; vertical-align: middle;"><tr><td style="text-align: center;">1.98</td><td style="text-align: left;">supercritical</td></tr></table>	1.98	supercritical
1.98	supercritical		
<u>Calculation of Critical Flow Condition</u>			
Half Central Angle ( $0 < \theta_c < 3.14$ )	Theta-c = <table border="1" style="display: inline-table; vertical-align: middle;"><tr><td style="text-align: center;">1.81</td><td style="text-align: left;">radians</td></tr></table>	1.81	radians
1.81	radians		
Critical flow area	Ac = <table border="1" style="display: inline-table; vertical-align: middle;"><tr><td style="text-align: center;">1.15</td><td style="text-align: left;">sq ft</td></tr></table>	1.15	sq ft
1.15	sq ft		
Critical top width	Tc = <table border="1" style="display: inline-table; vertical-align: middle;"><tr><td style="text-align: center;">1.46</td><td style="text-align: left;">ft</td></tr></table>	1.46	ft
1.46	ft		
Critical flow depth	Yc = <table border="1" style="display: inline-table; vertical-align: middle;"><tr><td style="text-align: center;">0.93</td><td style="text-align: left;">ft</td></tr></table>	0.93	ft
0.93	ft		
Critical flow velocity	Vc = <table border="1" style="display: inline-table; vertical-align: middle;"><tr><td style="text-align: center;">5.04</td><td style="text-align: left;">fps</td></tr></table>	5.04	fps
5.04	fps		
Critical Depth Froude Number	Fr <sub>c</sub> = <table border="1" style="display: inline-table; vertical-align: middle;"><tr><td style="text-align: center;">1.00</td><td></td></tr></table>	1.00	
1.00			

## Worksheet for Falcon Highland Grass Swale Section A-A

Project Description	
Friction Method	Manning Formula
Solve For	Normal Depth
Input Data	
Channel Slope	0.010 ft/ft
Discharge	5.80 cfs

### Section Definitions

Station (ft)	Elevation (ft)
0+00	2.25
0+07	0.00
0+08	0.00
0+15	2.25

### Roughness Segment Definitions

Start Station	Ending Station	Roughness Coefficient
(0+00, 2.25)	(0+15, 2.25)	0.030

Options	
Current Roughness Weighted Method	Pavlovskii's Method
Open Channel Weighting Method	Pavlovskii's Method
Closed Channel Weighting Method	Pavlovskii's Method

Results	
Normal Depth	8.3 in
Roughness Coefficient	0.030
Elevation	0.69 ft
Elevation Range	0.0 to 2.3 ft
Flow Area	2.2 ft <sup>2</sup>
Wetted Perimeter	5.5 ft
Hydraulic Radius	4.7 in
Top Width	5.30 ft
Normal Depth	8.3 in
Critical Depth	7.2 in
Critical Slope	0.019 ft/ft
Velocity	2.66 ft/s
Velocity Head	0.11 ft
Specific Energy	0.80 ft
Froude Number	0.733
Flow Type	Subcritical

### GVF Input Data

## Worksheet for Falcon Highland Grass Swale Section A-A

---

### GVF Input Data

---

Downstream Depth	0.0 in
Length	0.0 ft
Number Of Steps	0

---

### GVF Output Data

---

Upstream Depth	0.0 in
Profile Description	N/A
Profile Headloss	0.00 ft
Downstream Velocity	Infinity ft/s
Upstream Velocity	Infinity ft/s
Normal Depth	8.3 in
Critical Depth	7.2 in
Channel Slope	0.010 ft/ft
Critical Slope	0.019 ft/ft

---

## Cross Section for Falcon Highland Grass Swale Section A-A

Project Description	
Friction Method	Manning Formula
Solve For	Normal Depth

Input Data	
Channel Slope	0.010 ft/ft
Normal Depth	8.3 in
Discharge	5.80 cfs

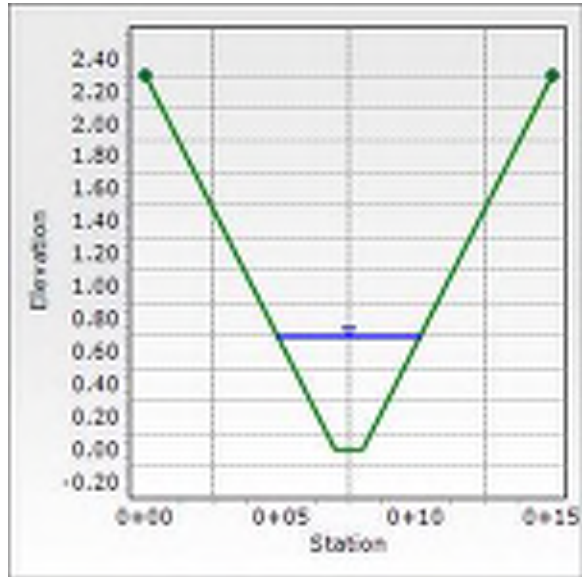

## Worksheet for Falcon Highland Grass Swale Section B-B

Project Description	
Friction Method	Manning Formula
Solve For	Normal Depth
Input Data	
Channel Slope	0.010 ft/ft
Discharge	14.70 cfs

### Section Definitions

Station (ft)	Elevation (ft)
0+00	2.25
0+09	0.00
0+10	0.00
0+19	2.25

### Roughness Segment Definitions

Start Station	Ending Station	Roughness Coefficient
(0+00, 2.25)	(0+19, 2.25)	0.030

Options	
Current Roughness Weighted Method	Pavlovskii's Method
Open Channel Weighting Method	Pavlovskii's Method
Closed Channel Weighting Method	Pavlovskii's Method

Results	
Normal Depth	11.5 in
Roughness Coefficient	0.030
Elevation	0.95 ft
Elevation Range	0.0 to 2.3 ft
Flow Area	4.6 ft <sup>2</sup>
Wetted Perimeter	8.9 ft
Hydraulic Radius	6.2 in
Top Width	8.64 ft
Normal Depth	11.5 in
Critical Depth	10.2 in
Critical Slope	0.017 ft/ft
Velocity	3.20 ft/s
Velocity Head	0.16 ft
Specific Energy	1.11 ft
Froude Number	0.772
Flow Type	Subcritical

### GVF Input Data

## Worksheet for Falcon Highland Grass Swale Section B-B

---

### GVF Input Data

---

Downstream Depth	0.0 in
Length	0.0 ft
Number Of Steps	0

---

### GVF Output Data

---

Upstream Depth	0.0 in
Profile Description	N/A
Profile Headloss	0.00 ft
Downstream Velocity	Infinity ft/s
Upstream Velocity	Infinity ft/s
Normal Depth	11.5 in
Critical Depth	10.2 in
Channel Slope	0.010 ft/ft
Critical Slope	0.017 ft/ft

---

## Cross Section for Falcon Highland Grass Swale Section B-B

Project Description	
Friction Method	Manning Formula
Solve For	Normal Depth

Input Data	
Channel Slope	0.010 ft/ft
Normal Depth	11.5 in
Discharge	14.70 cfs



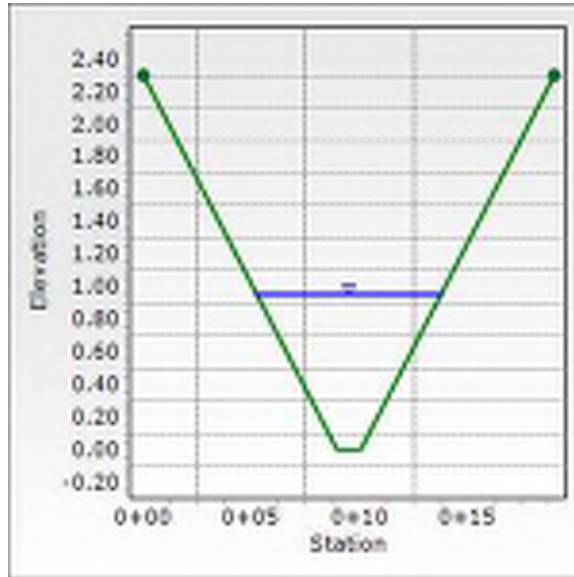

## Worksheet for Falcon Highland Grass Swale Section C-C

Project Description	
Friction Method	Manning Formula
Solve For	Normal Depth
Input Data	
Channel Slope	0.010 ft/ft
Discharge	28.10 cfs

### Section Definitions

Station (ft)	Elevation (ft)
0+00	2.25
0+09	0.00
0+10	0.00
0+19	2.25

### Roughness Segment Definitions

Start Station	Ending Station	Roughness Coefficient
(0+00, 2.25)	(0+19, 2.25)	0.030

Options	
Current Roughness Weighted Method	Pavlovskii's Method
Open Channel Weighting Method	Pavlovskii's Method
Closed Channel Weighting Method	Pavlovskii's Method

Results	
Normal Depth	15.0 in
Roughness Coefficient	0.030
Elevation	1.25 ft
Elevation Range	0.0 to 2.3 ft
Flow Area	7.5 ft <sup>2</sup>
Wetted Perimeter	11.3 ft
Hydraulic Radius	7.9 in
Top Width	10.98 ft
Normal Depth	15.0 in
Critical Depth	13.6 in
Critical Slope	0.016 ft/ft
Velocity	3.76 ft/s
Velocity Head	0.22 ft
Specific Energy	1.47 ft
Froude Number	0.804
Flow Type	Subcritical

### GVF Input Data

## Worksheet for Falcon Highland Grass Swale Section C-C

---

### GVF Input Data

---

Downstream Depth	0.0 in
Length	0.0 ft
Number Of Steps	0

---

### GVF Output Data

---

Upstream Depth	0.0 in
Profile Description	N/A
Profile Headloss	0.00 ft
Downstream Velocity	Infinity ft/s
Upstream Velocity	Infinity ft/s
Normal Depth	15.0 in
Critical Depth	13.6 in
Channel Slope	0.010 ft/ft
Critical Slope	0.016 ft/ft

---

## Cross Section for Falcon Highland Grass Swale Section C-C

Project Description	
Friction Method	Manning Formula
Solve For	Normal Depth

Input Data	
Channel Slope	0.010 ft/ft
Normal Depth	15.0 in
Discharge	28.10 cfs

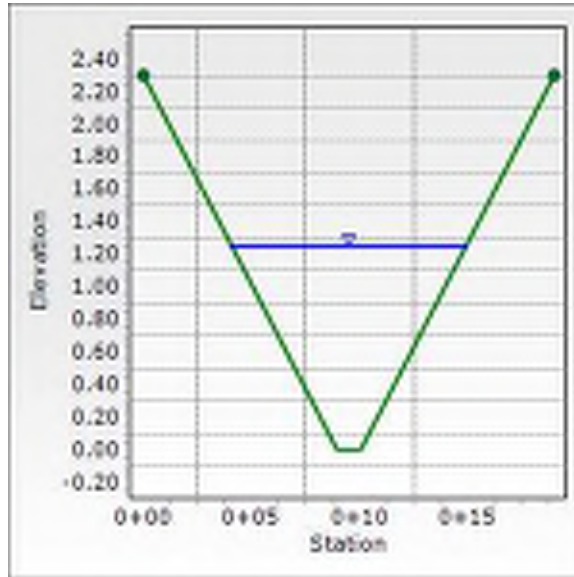

## Worksheet for Falcon Highland Grass Swale Section D-D

Project Description	
Friction Method	Manning Formula
Solve For	Normal Depth
Input Data	
Channel Slope	0.010 ft/ft
Discharge	46.40 cfs

### Section Definitions

Station (ft)	Elevation (ft)
0+00	2.25
0+09	0.00
0+21	0.00
0+30	2.25

### Roughness Segment Definitions

Start Station	Ending Station	Roughness Coefficient
(0+00, 2.25)	(0+30, 2.25)	0.033

Options	
Current Roughness Weighted Method	Pavlovskii's Method
Open Channel Weighting Method	Pavlovskii's Method
Closed Channel Weighting Method	Pavlovskii's Method

Results	
Normal Depth	10.3 in
Roughness Coefficient	0.033
Elevation	0.85 ft
Elevation Range	0.0 to 2.3 ft
Flow Area	13.2 ft <sup>2</sup>
Wetted Perimeter	19.0 ft
Hydraulic Radius	8.3 in
Top Width	18.83 ft
Normal Depth	10.3 in
Critical Depth	8.5 in
Critical Slope	0.019 ft/ft
Velocity	3.52 ft/s
Velocity Head	0.19 ft
Specific Energy	1.05 ft
Froude Number	0.743
Flow Type	Subcritical

### GVF Input Data

## Worksheet for Falcon Highland Grass Swale Section D-D

---

### GVF Input Data

---

Downstream Depth	0.0 in
Length	0.0 ft
Number Of Steps	0

---

### GVF Output Data

---

Upstream Depth	0.0 in
Profile Description	N/A
Profile Headloss	0.00 ft
Downstream Velocity	0.00 ft/s
Upstream Velocity	0.00 ft/s
Normal Depth	10.3 in
Critical Depth	8.5 in
Channel Slope	0.010 ft/ft
Critical Slope	0.019 ft/ft

---

## Cross Section for Falcon Highland Grass Swale Section D-D

Project Description	
Friction Method	Manning Formula
Solve For	Normal Depth

Input Data	
Channel Slope	0.010 ft/ft
Normal Depth	10.3 in
Discharge	46.40 cfs

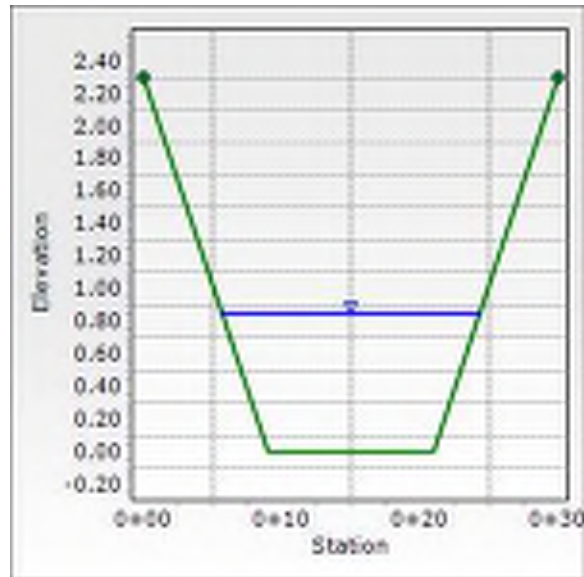

## Worksheet for Street Section - 5.5" Flooding

Project Description	
Friction Method	Manning Formula
Solve For	Discharge
Input Data	
Channel Slope	1.000 %
Normal Depth	5.5 in

### Section Definitions

Station (ft)		Elevation (in)
	0+00	5.50
	0+00	5.50
	0+02	1.00
	0+02	0.00
	0+03	1.00
	0+18	4.60
	0+33	1.00
	0+33	0.00
	0+33	1.00
	0+35	5.50
	0+35	5.50

### Roughness Segment Definitions

Start Station	Ending Station	Roughness Coefficient
(0+00, 5.50)	(0+35, 5.50)	0.013

Options	
Current Roughness Weighted Method	Pavlovskii's Method
Open Channel Weighting Method	Pavlovskii's Method
Closed Channel Weighting Method	Pavlovskii's Method

Results	
Discharge	33.90 cfs
Roughness Coefficient	0.013
Elevation Range	0.0 to 0.5 ft
Flow Area	8.0 ft <sup>2</sup>
Wetted Perimeter	35.3 ft
Hydraulic Radius	2.7 in
Top Width	35.00 ft
Normal Depth	5.5 in
Critical Depth	6.5 in
Critical Slope	0.371 %
Velocity	4.25 ft/s

## Worksheet for Tract Section Between Lots 22 - 23

Project Description	
Friction Method	Manning Formula
Solve For	Normal Depth
Input Data	
Channel Slope	1.000 ft/ft
Discharge	47.45 cfs

### Section Definitions

Station (ft)	Elevation (ft)
0+00	2.70
0+08	0.00
0+10	0.00
0+20	2.70

### Roughness Segment Definitions

Start Station	Ending Station	Roughness Coefficient
(0+00, 2.70)	(0+20, 2.70)	0.033

Options	
Current Roughness Weighted Method	Pavlovskii's Method
Open Channel Weighting Method	Pavlovskii's Method
Closed Channel Weighting Method	Pavlovskii's Method

Results	
Normal Depth	6.6 in
Roughness Coefficient	0.033
Elevation	0.55 ft
Elevation Range	0.0 to 2.7 ft
Flow Area	2.1 ft <sup>2</sup>
Wetted Perimeter	5.8 ft
Hydraulic Radius	4.3 in
Top Width	5.64 ft
Normal Depth	6.6 in
Critical Depth	16.7 in
Critical Slope	0.018 ft/ft
Velocity	22.75 ft/s
Velocity Head	8.04 ft
Specific Energy	8.59 ft
Froude Number	6.596
Flow Type	Supercritical

### GVF Input Data



## Worksheet for Tract Section Between Lots 22 - 23

GVF Input Data	
Downstream Depth	0.0 in
Length	0.0 ft
Number Of Steps	0
GVF Output Data	
Upstream Depth	0.0 in
Profile Description	N/A
Profile Headloss	0.00 ft
Downstream Velocity	Infinity ft/s
Upstream Velocity	Infinity ft/s
Normal Depth	6.6 in
Critical Depth	16.7 in
Channel Slope	1.000 ft/ft
Critical Slope	0.018 ft/ft

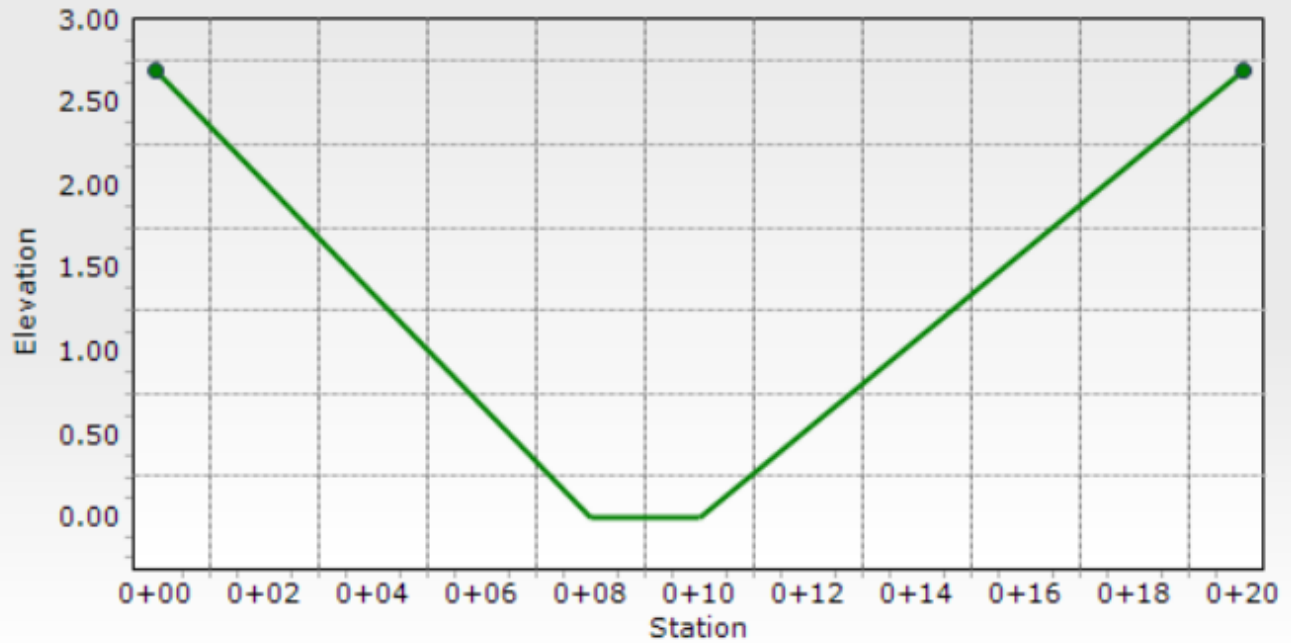

## Worksheet for Tract Section Between Lots 37-38

Project Description	
Friction Method	Manning Formula
Solve For	Normal Depth
Input Data	
Channel Slope	1.000 ft/ft
Discharge	64.88 cfs

### Section Definitions

Station (ft)		Elevation (ft)
	0+00	2.70
	0+08	0.00
	0+10	0.00
	0+20	2.70

### Roughness Segment Definitions

Start Station	Ending Station	Roughness Coefficient
(0+00, 2.70)	(0+20, 2.70)	0.033

Options	
Current Roughness Weighted Method	Pavlovskii's Method
Open Channel Weighting Method	Pavlovskii's Method
Closed Channel Weighting Method	Pavlovskii's Method

Results	
Normal Depth	7.6 in
Roughness Coefficient	0.033
Elevation	0.64 ft
Elevation Range	0.0 to 2.7 ft
Flow Area	2.6 ft <sup>2</sup>
Wetted Perimeter	6.4 ft
Hydraulic Radius	4.9 in
Top Width	6.24 ft
Normal Depth	7.6 in
Critical Depth	19.3 in
Critical Slope	0.017 ft/ft
Velocity	24.76 ft/s
Velocity Head	9.52 ft
Specific Energy	10.16 ft
Froude Number	6.734
Flow Type	Supercritical

GVF Input Data
----------------

## Worksheet for Tract Section Between Lots 37-38

### GVF Input Data

Downstream Depth	0.0 in
Length	0.0 ft
Number Of Steps	0

### GVF Output Data

Upstream Depth	0.0 in
Profile Description	N/A
Profile Headloss	0.00 ft
Downstream Velocity	Infinity ft/s
Upstream Velocity	Infinity ft/s
Normal Depth	7.6 in
Critical Depth	19.3 in
Channel Slope	1.000 ft/ft
Critical Slope	0.017 ft/ft

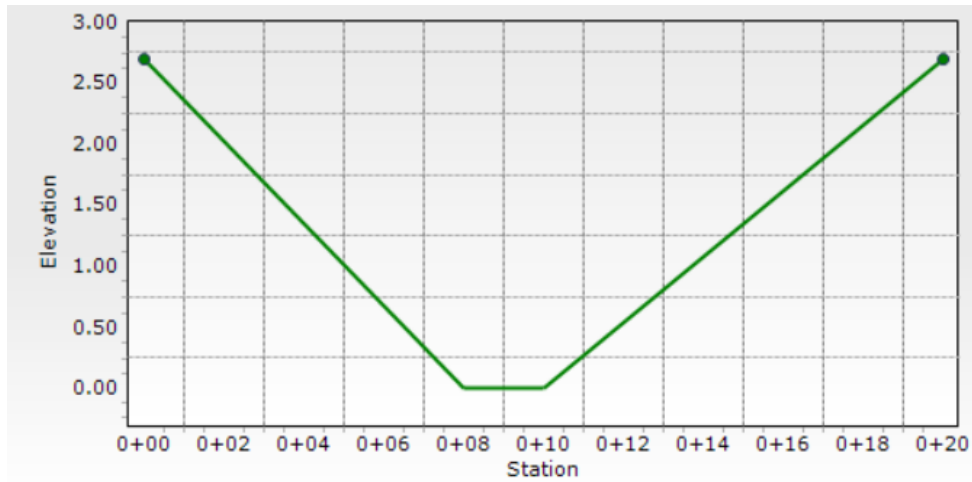

## Worksheet for Tract Section Between Lots 305-306

Project Description	
Friction Method	Manning Formula
Solve For	Normal Depth
Input Data	
Channel Slope	1.000 ft/ft
Discharge	26.69 cfs

### Section Definitions

Station (ft)	Elevation (ft)
0+00	2.70
0+08	0.00
0+10	0.00
0+20	2.70

### Roughness Segment Definitions

Start Station	Ending Station	Roughness Coefficient
(0+00, 2.70)	(0+20, 2.70)	0.033

Options	
Current Roughness Weighted Method	Pavlovskii's Method
Open Channel Weighting Method	Pavlovskii's Method
Closed Channel Weighting Method	Pavlovskii's Method

Results	
Normal Depth	4.9 in
Roughness Coefficient	0.033
Elevation	0.41 ft
Elevation Range	0.0 to 2.7 ft
Flow Area	1.4 ft <sup>2</sup>
Wetted Perimeter	4.8 ft
Hydraulic Radius	3.4 in
Top Width	4.73 ft
Normal Depth	4.9 in
Critical Depth	12.7 in
Critical Slope	0.019 ft/ft
Velocity	19.42 ft/s
Velocity Head	5.86 ft
Specific Energy	6.27 ft
Froude Number	6.347
Flow Type	Supercritical

### GVF Input Data

## Worksheet for Tract Section Between Lots 305-306

---

### GVF Input Data

---

Downstream Depth	0.0 in
Length	0.0 ft
Number Of Steps	0

---

### GVF Output Data

---

Upstream Depth	0.0 in
Profile Description	N/A
Profile Headloss	0.00 ft
Downstream Velocity	Infinity ft/s
Upstream Velocity	Infinity ft/s
Normal Depth	4.9 in
Critical Depth	12.7 in
Channel Slope	1.000 ft/ft
Critical Slope	0.019 ft/ft

---

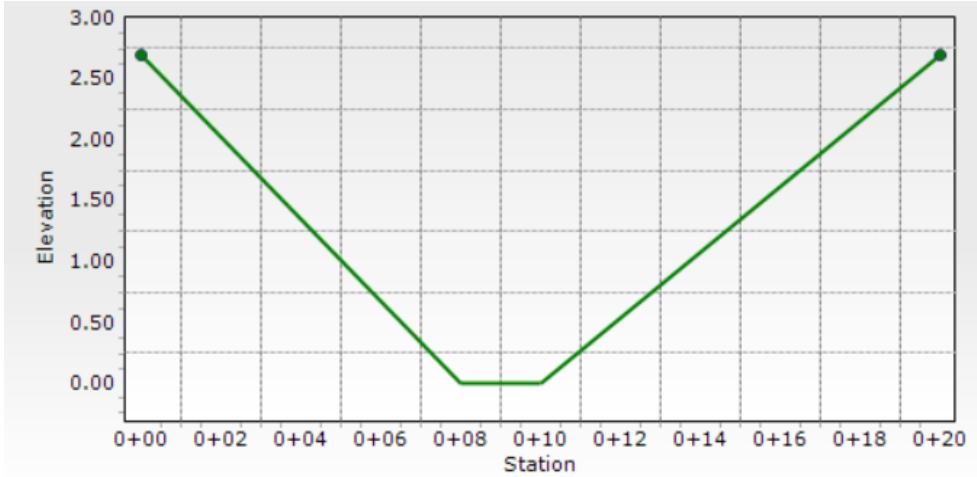

## Worksheet for Tract Section NW of Lot 176

Project Description	
Friction Method	Manning Formula
Solve For	Normal Depth

---

Input Data	
Channel Slope	1.000 ft/ft
Discharge	123.81 cfs

### Section Definitions

Station (ft)	Elevation (ft)
0+00	2.70
0+08	0.00
0+10	0.00
0+20	2.70

### Roughness Segment Definitions

Start Station	Ending Station	Roughness Coefficient
(0+00, 2.70)	(0+20, 2.70)	0.033

Options	
Current Roughness Weighted Method	Pavlovskii's Method
Open Channel Weighting Method	Pavlovskii's Method
Closed Channel Weighting Method	Pavlovskii's Method

Results	
Normal Depth	10.4 in
Roughness Coefficient	0.033
Elevation	0.86 ft
Elevation Range	0.0 to 2.7 ft
Flow Area	4.2 ft <sup>2</sup>
Wetted Perimeter	8.0 ft
Hydraulic Radius	6.3 in
Top Width	7.76 ft
Normal Depth	10.4 in
Critical Depth	25.9 in
Critical Slope	0.016 ft/ft
Velocity	29.35 ft/s
Velocity Head	13.38 ft
Specific Energy	14.25 ft
Froude Number	7.018
Flow Type	Supercritical

### GVF Input Data

## Worksheet for Tract Section NW of Lot 176

### GVF Input Data

Downstream Depth	0.0 in
Length	0.0 ft
Number Of Steps	0

### GVF Output Data

Upstream Depth	0.0 in
Profile Description	N/A
Profile Headloss	0.00 ft
Downstream Velocity	Infinity ft/s
Upstream Velocity	Infinity ft/s
Normal Depth	10.4 in
Critical Depth	25.9 in
Channel Slope	1.000 ft/ft
Critical Slope	0.016 ft/ft

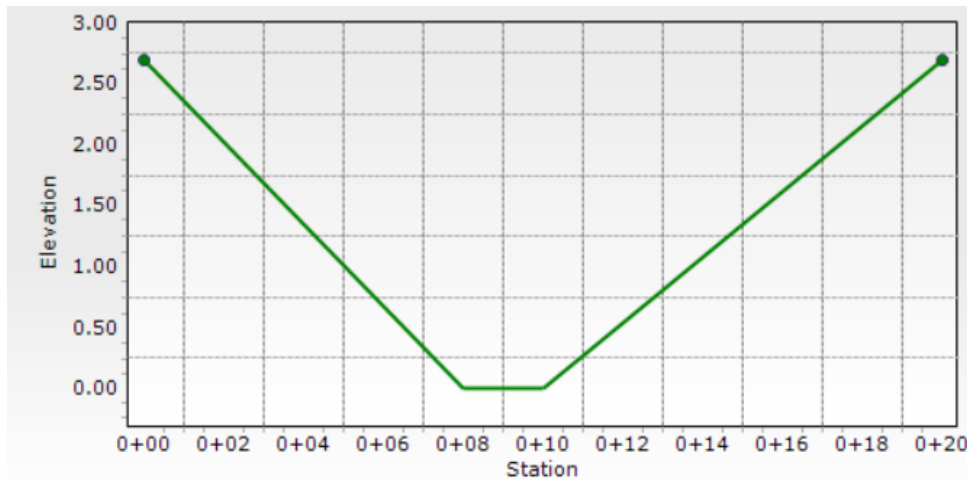

## Worksheet for Falcon Highland Grass Swale Section Basin D3

Project Description	
Friction Method	Manning Formula
Solve For	Normal Depth
Input Data	
Channel Slope	2.000 %
Discharge	5.30 cfs

### Section Definitions

Station (ft)	Elevation (in)
0+00	27.00
0+07	0.00
0+08	0.00
0+15	27.00

### Roughness Segment Definitions

Start Station	Ending Station	Roughness Coefficient
(0+00, 27.00)	(0+15, 27.00)	0.030

Options	
Current Roughness Weighted Method	Pavlovskii's Method
Open Channel Weighting Method	Pavlovskii's Method
Closed Channel Weighting Method	Pavlovskii's Method

Results	
Normal Depth	6.8 in
Roughness Coefficient	0.030
Elevation	6.82 in
Elevation Range	0.0 to 2.3 ft
Flow Area	1.6 ft <sup>2</sup>
Wetted Perimeter	4.7 ft
Hydraulic Radius	4.0 in
Top Width	4.54 ft
Normal Depth	6.8 in
Critical Depth	6.9 in
Critical Slope	1.963 %
Velocity	3.37 ft/s
Velocity Head	2.12 in
Specific Energy	0.74 ft
Froude Number	1.008
Flow Type	Supercritical

### GVF Input Data



## Worksheet for Falcon Highland Grass Swale Section Basin D3

---

### GVF Input Data

---

Downstream Depth	0.0 in
Length	0.0 ft
Number Of Steps	0

---

### GVF Output Data

---

Upstream Depth	0.0 in
Profile Description	N/A
Profile Headloss	0.00 ft
Downstream Velocity	Infinity ft/s
Upstream Velocity	Infinity ft/s
Normal Depth	6.8 in
Critical Depth	6.9 in
Channel Slope	2.000 %
Critical Slope	1.963 %

---

## Cross Section for Falcon Highland Grass Swale Section Basin D3

Project Description	
Friction Method	Manning Formula
Solve For	Normal Depth

Input Data	
Channel Slope	2.000 %
Normal Depth	6.8 in
Discharge	5.30 cfs

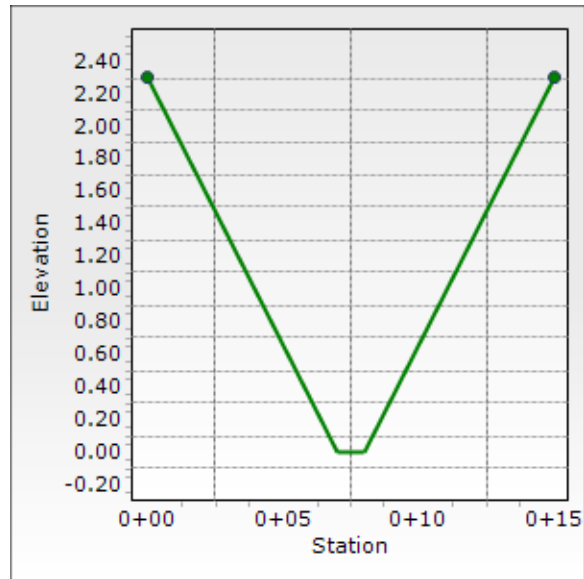

**Design Procedure Form: Runoff Reduction**

UD-BMP (Version 3.07, March 2018)

Sheet 1 of 1

**Designer:** SNB  
**Company:** Atwell, LLC  
**Date:** March 6, 2024  
**Project:** Falcon Highlands  
**Location:** El Paso County

**SITE INFORMATION (User Input in Blue Cells)**

WQCV Rainfall Depth = 0.60 inches  
 Depth of Average Runoff Producing Storm,  $d_6$  = 0.43 inches (for Watersheds Outside of the Denver Region, Figure 3-1 in USDCM Vol. 3)

Area Type	UIA:RPA	UIA:RPA											
Area ID	A	B & C											
Downstream Design Point ID	E	F											
Downstream BMP Type	None	None											
DCIA (ft <sup>2</sup> )	--	--											
UIA (ft <sup>2</sup> )	34,529	36,225											
RPA (ft <sup>2</sup> )	17,866	10,423											
SPA (ft <sup>2</sup> )	--	--											
HSG A (%)	100%	100%											
HSG B (%)	0%	0%											
HSG C/D (%)	0%	0%											
Average Slope of RPA (ft/ft)	0.020	0.076											
UIA:RPA Interface Width (ft)	800.00	525.00											

**CALCULATED RUNOFF RESULTS**

Area ID	A	B & C											
UIA:RPA Area (ft <sup>2</sup> )	52,395	46,648											
L / W Ratio	0.08	0.17											
UIA / Area	0.6590	0.7766											
Runoff (in)	0.00	0.00											
Runoff (ft <sup>3</sup> )	0	0											
Runoff Reduction (ft <sup>3</sup> )	1439	1509											

**CALCULATED WQCV RESULTS**

Area ID	A	B & C											
WQCV (ft <sup>3</sup> )	1439	1509											
WQCV Reduction (ft <sup>3</sup> )	1439	1509											
WQCV Reduction (%)	100%	100%											
Untreated WQCV (ft <sup>3</sup> )	0	0											

**CALCULATED DESIGN POINT RESULTS (sums results from all columns with the same Downstream Design Point ID)**

Downstream Design Point ID	E	F											
DCIA (ft <sup>2</sup> )	0	0											
UIA (ft <sup>2</sup> )	34,529	36,225											
RPA (ft <sup>2</sup> )	17,866	10,423											
SPA (ft <sup>2</sup> )	0	0											
Total Area (ft <sup>2</sup> )	52,395	46,648											
Total Impervious Area (ft <sup>2</sup> )	34,529	36,225											
WQCV (ft <sup>3</sup> )	1,439	1,509											
WQCV Reduction (ft <sup>3</sup> )	1,439	1,509											
WQCV Reduction (%)	100%	100%											
Untreated WQCV (ft <sup>3</sup> )	0	0											

**CALCULATED SITE RESULTS (sums results from all columns in worksheet)**

Total Area (ft <sup>2</sup> )	99,043
Total Impervious Area (ft <sup>2</sup> )	70,754
WQCV (ft <sup>3</sup> )	2,948
WQCV Reduction (ft <sup>3</sup> )	2,948
WQCV Reduction (%)	100%
Untreated WQCV (ft <sup>3</sup> )	0

**APPENDIX F**  
**REFERENCE DOCUMENTS**

From Final Drainage Report for Bent Grass Residential Subdivision Filing  
No. 2 (SF-19-014) revised date of March 2020

*STAGE - STORAGE - DISCHARGE TABLE (POND WU - OUTLET REVISIONS)*

per UDFCD UD-Detention Spreadsheet

Elevation	Stage	Orifice Plate	Horiz Weir	Total Collection Capacity (WOCV & Weir)	Controlling Flowrate Culvert #1 (48")	Controlling Flowrate Culvert #2 (60")	Controlling Flowrate Culvert #3 (60")	Controlling Flowrate Culvert #4 (60")	Total Controlling Flowrate - Outlet Culverts	Spill Way	Total Outflow*
[ft]	[ft]	[cfs]	[cfs]	[cfs]	[cfs]	[cfs]	[cfs]	[cfs]	[cfs]	[cfs]	[cfs]
6816.30	0.00	0.00	0.00	0.00	0.00	0.00	0.00	0.00	0.00	0.00	0.00
6818.20	1.90	1.34	0.00	1.34	1.34	1.34	1.34	1.34	5.36	0.00	1.34
6819.00	2.70	2.18	0.00	2.18	2.18	2.18	2.18	2.18	8.72	0.00	2.18
6820.00	3.70	3.28	0.00	3.28	3.28	3.28	3.28	3.28	13.12	0.00	3.28
6821.00	4.70	4.53	0.00	4.53	4.53	4.53	4.53	4.53	18.12	0.00	4.53
6822.00	5.70	5.90	78.71	84.61	84.61	84.61	84.61	84.61	338.44	0.00	84.61
6823.00	6.70	6.91	544.70	551.61	116.75	134.68	453.58	150.75	855.76	0.00	551.61
6824.00	7.70	7.75	1233.69	1241.44	135.78	174.76	189.73	187.47	687.74	0.00	687.74
6825.00	8.70	8.50	2087.92	2096.42	152.52	207.28	220.03	218.07	797.90	0.00	797.90
6826.00	9.70	9.19	3080.00	3089.19	167.63	235.34	246.62	244.87	894.46	0.00	894.46
6827.00	10.70	9.82	4292.88	4302.70	181.43	260.37	270.62	269.03	981.45	0.00	981.45
6828.00	11.70	10.42	5414.65	5425.07	194.30	283.23	292.66	291.20	1061.39	0.00	1061.39
6829.00	12.70	10.98	6249.18	6260.16	206.36	304.32	313.16	311.78	1135.62	16.43	1152.05
6830.00	13.70	11.51	6659.12	6670.63	217.74	324.10	332.39	331.10	1205.33	148.29	1353.62
6830.20	13.90	11.61	6738.12	6749.73	219.95	327.91	336.10	334.82	1218.78	183.81	1402.59

\* - Based on Spillway flow plus lesser flow of Total Collection Capacity or Total Controlling Flowrate - Outlet Culverts









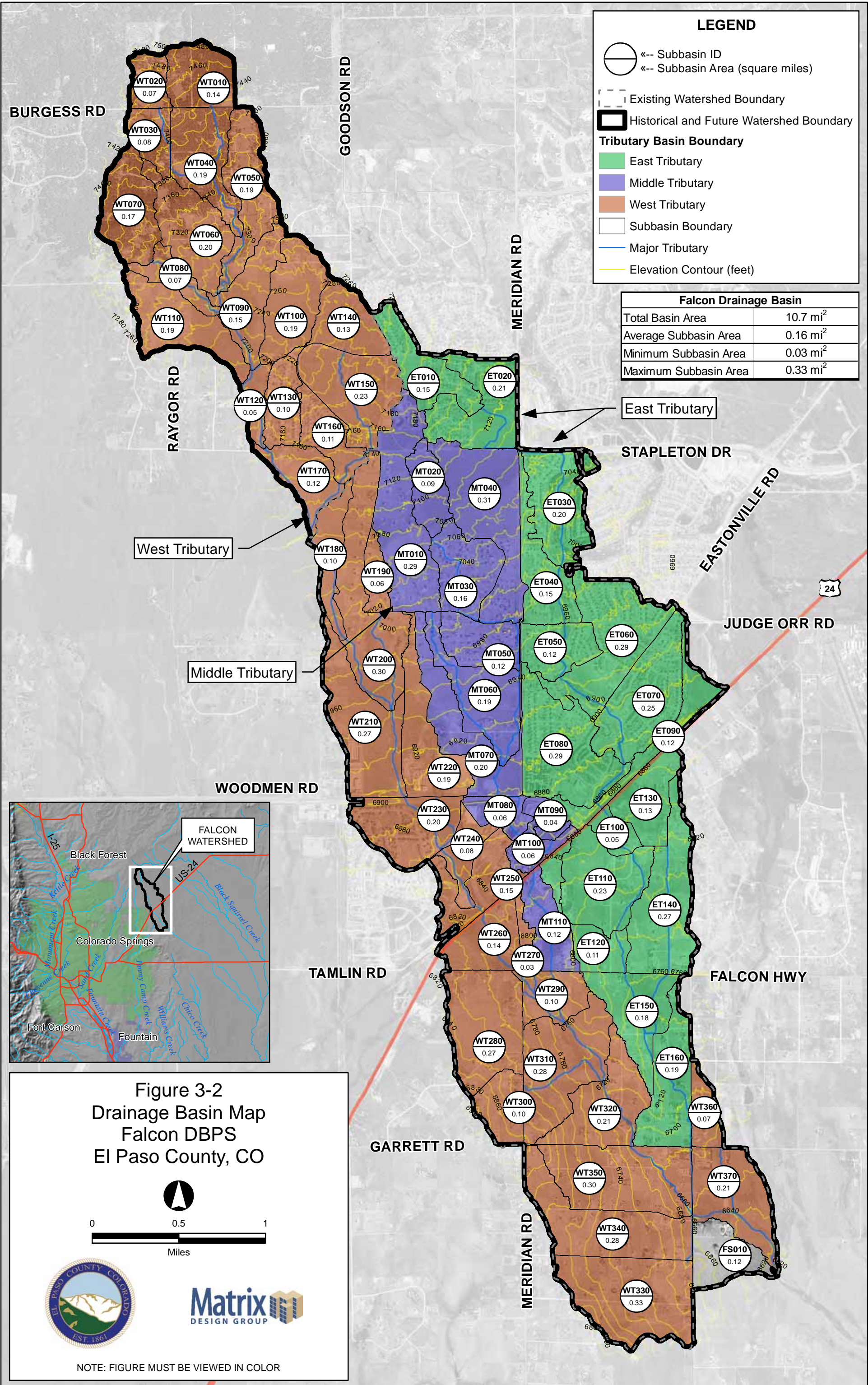

### LEGEND

- Subbasin ID
- Subbasin Area (square miles)
- Existing Watershed Boundary
- Historical and Future Watershed Boundary
- Tributary Basin Boundary**
- East Tributary
- Middle Tributary
- West Tributary
- Subbasin Boundary
- Major Tributary
- Elevation Contour (feet)

Falcon Drainage Basin	
Total Basin Area	10.7 mi <sup>2</sup>
Average Subbasin Area	0.16 mi <sup>2</sup>
Minimum Subbasin Area	0.03 mi <sup>2</sup>
Maximum Subbasin Area	0.33 mi <sup>2</sup>

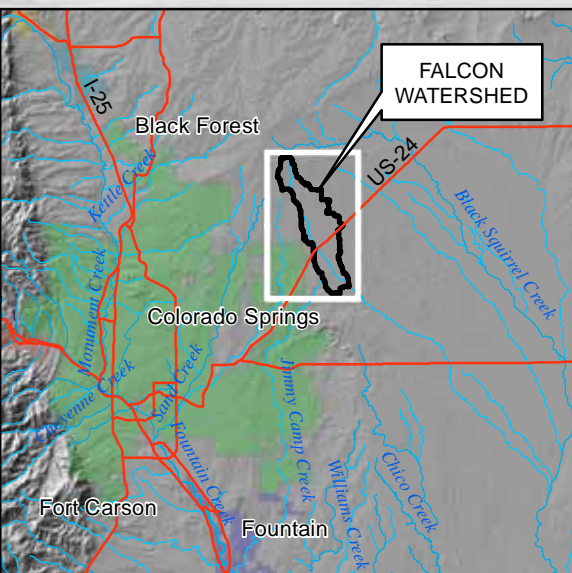

### Figure 3-2 Drainage Basin Map Falcon DBPS El Paso County, CO

0 0.5 1  
Miles

NOTE: FIGURE MUST BE VIEWED IN COLOR

FILE: G:\gis\_projects\Falcon\_Creek\_DBPS\active\apps\20110613\basin\_map.mxd, 8/29/2011, wilson\_wheeler

**APPENDIX G**  
**DRAINAGE MAPS**

**811**  
Know what's below.  
Call before you dig.

THE LOCATIONS OF EXISTING UNDERGROUND UTILITIES ARE SHOWN IN AN APPROXIMATE WAY ONLY AND HAVE NOT BEEN INDEPENDENTLY VERIFIED BY THE OWNER OR ITS REPRESENTATIVE. THE CONTRACTOR SHALL DETERMINE THE EXACT LOCATION OF ALL EXISTING UTILITIES BEFORE COMMENCING WORK, AND AGREES TO BE FULLY RESPONSIBLE FOR ANY AND ALL DAMAGES WHICH MIGHT BE OCCASIONED BY THE CONTRACTOR'S FAILURE TO EXACTLY LOCATE AND PRESERVE ANY AND ALL UNDERGROUND UTILITIES.

NOTICE: CONSTRUCTION SITE SAFETY IS THE SOLE RESPONSIBILITY OF THE CONTRACTOR. NEITHER THE OWNER NOR THE ENGINEER SHALL BE EXPECTED TO ASSUME ANY RESPONSIBILITY FOR SAFETY OF THE WORK OF PERSONS ENGAGED IN THE WORK, OF ANY NEARBY STRUCTURES, OR OF ANY OTHER PERSONS.

COPYRIGHT © 2023 ATWELL LLC. NO REPRODUCTION SHALL BE MADE WITHOUT THE PRIOR WRITTEN CONSENT OF ATWELL LLC.

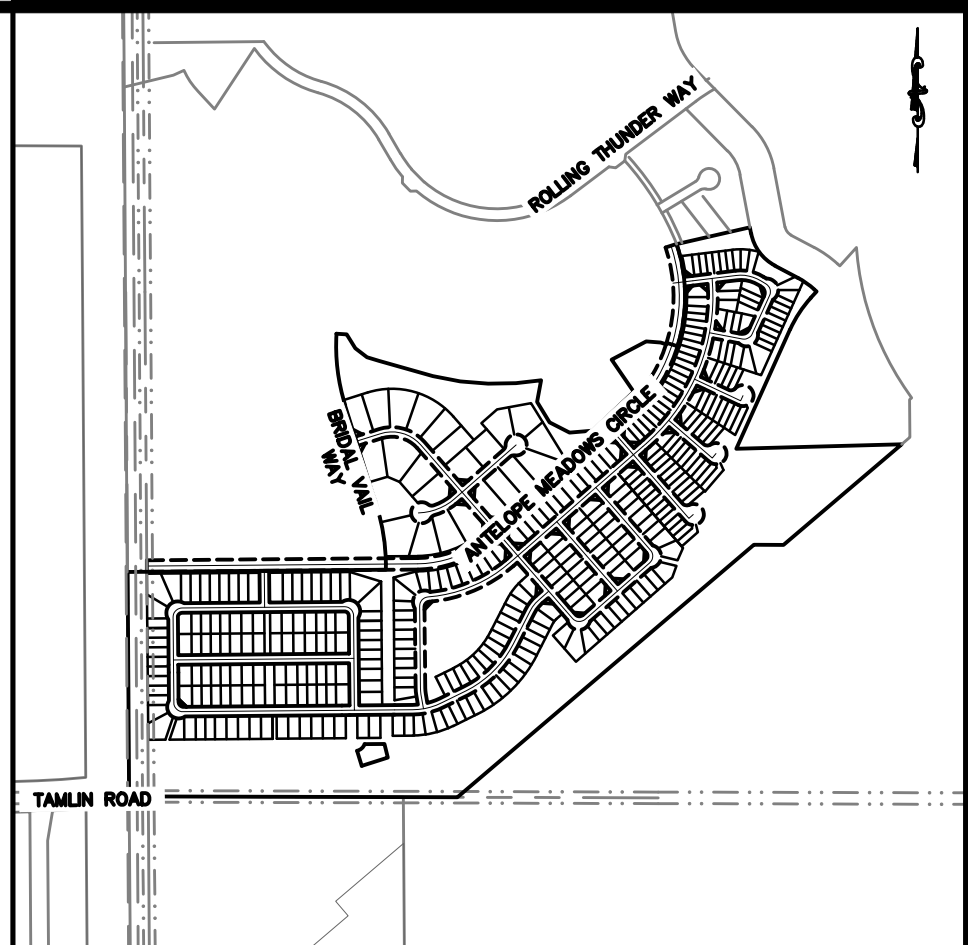

**EXISTING CONDITIONS DRAINAGE BASIN SUMMARY**

Basin	Design Point	Area (acres)	C <sub>s</sub>	C <sub>100</sub>	Q <sub>s</sub> (cfs)	Q <sub>100</sub> (cfs)
A	1	3.74	0.09	0.36	1.15	7.70
B	2	38.93	0.09	0.36	11.65	78.20
C	3	57.81	0.09	0.36	18.40	123.57
D	4	10.54	0.09	0.36	3.47	23.31
E	5	3.14	0.09	0.36	1.12	7.50
F	6	3.67	0.09	0.36	1.19	7.99
G	6	8.84	0.09	0.36	6.80	16.00
OS-1	7	6.38	0.27	0.48	10.70	21.70
OS-2	8	3.12	0.30	0.50	7.80	13.60
OS-3	9	1.14	0.90	0.96	3.40	6.00
OS-4	10	13.09	0.34	0.44	12.30	26.30
OS-5	11	59.62	0.30	0.50	80.10	160.70
OS-6	12	35.75	0.22	0.46	31.90	58.40
OS-7	13	6.47	0.22	0.46	5.26	18.47
OS-8	4	13.79	0.09	0.36	4.84	32.49
<b>TOTAL</b>		<b>266.0</b>			<b>200.1</b>	<b>601.9</b>

**EXISTING CONDITIONS DESIGN POINT SUMMARY (CUMULATIVE FLOW)**

Design Point	Contributing Basins	Q <sub>s</sub> (cfs)	Q <sub>100</sub> (cfs)
1	A, DP-10	13.4	34.0
2	B, DP-11	99.5	252.5
3	C, DP-12	53.7	188.0
4	D, DP-13	13.6	74.3
5	E, DP-2	100.7	260.0
6	F, G, DP-2, DP-4	75.3	286.2
7	OS-1	10.7	21.7
8	OS-2	7.8	13.6
9	OS-3	3.4	6.0
10	OS-4	12.3	26.3
11	DP-8, OS-5	87.9	174.3
12	DP-9, OS-6	35.3	64.4
13	OS-7	5.3	18.5

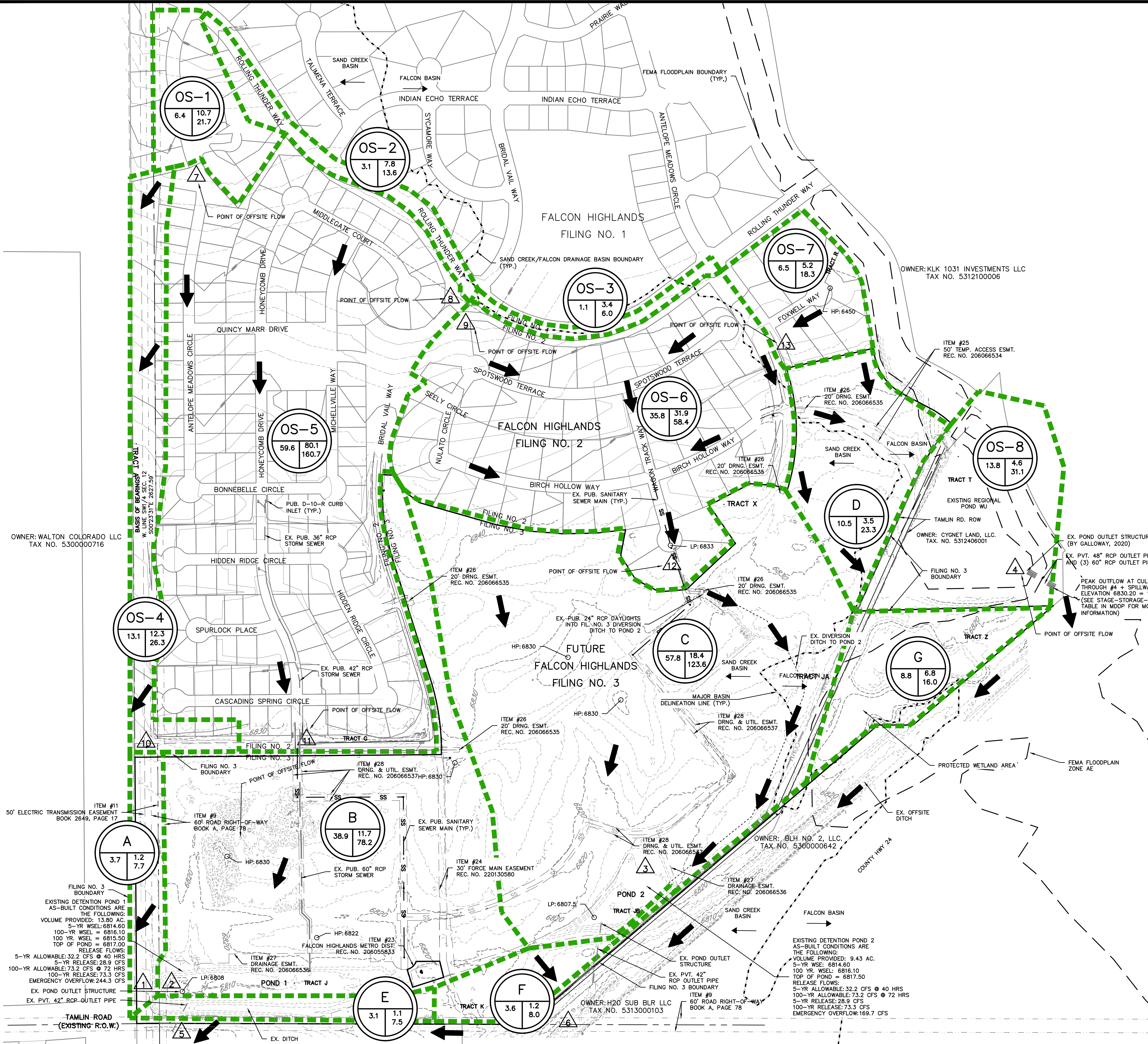
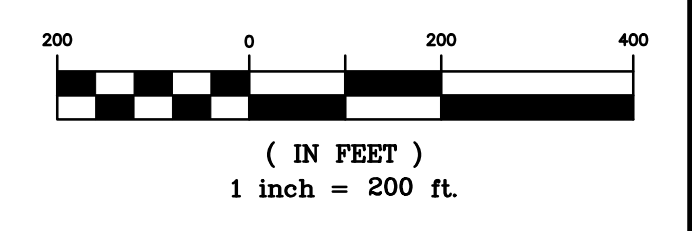
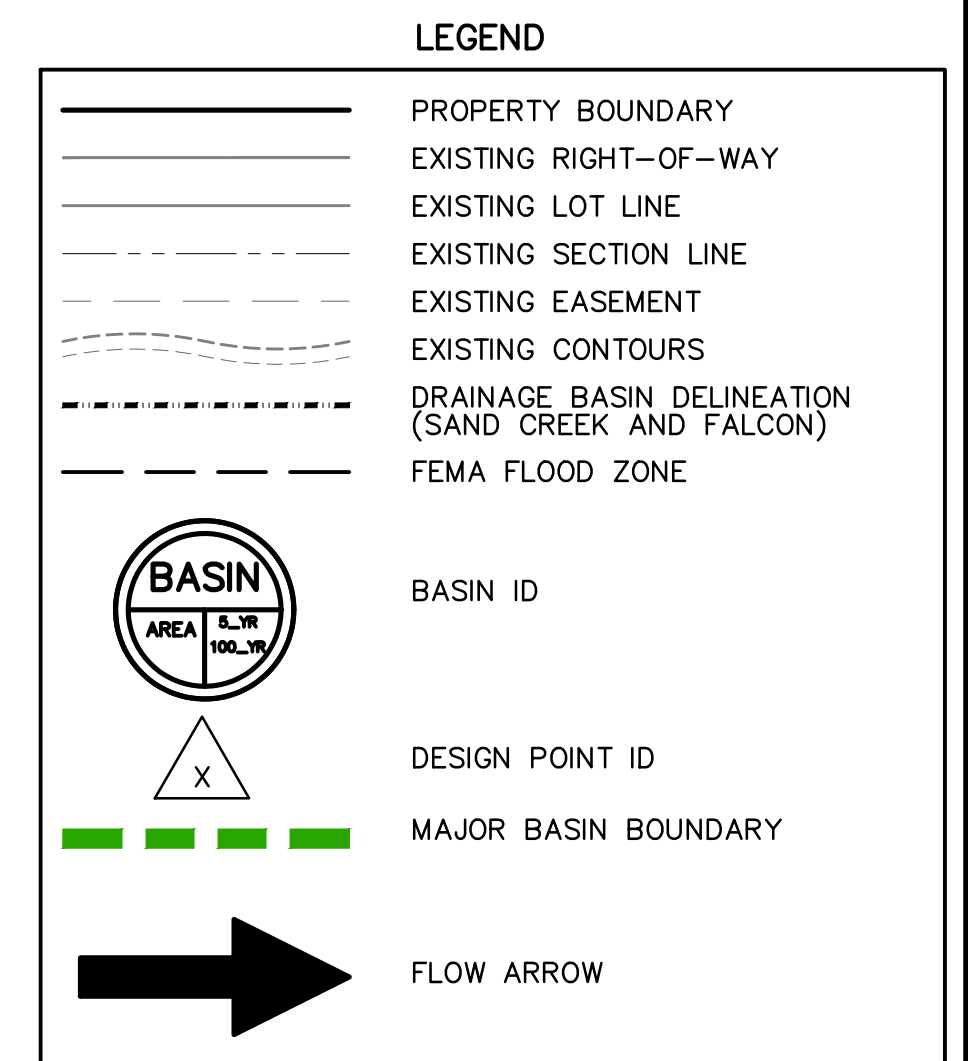

OWNER: WALTON COLORADO LLC  
TAX NO. 5300000716

OWNER: KLK 1031 INVESTMENTS LLC  
TAX NO. 5312100006

OWNER: CYONET LAND, LLC.  
TAX NO. 5312406001

OWNER: BLH NO. 2, LLC.  
TAX NO. 5300000642

OWNER: H2O SUB BLR LLC  
TAX NO. 5313000103

EXISTING DETENTION POND 1 AS-BUILT CONDITIONS ARE THE FOLLOWING:  
VOLUME PROVIDED: 13.80 AC.  
5-YR WSEL: 6814.60  
100-YR WSEL = 6816.10  
100 YR WSEL = 6815.50  
TOP OF POND = 6817.00  
RELEASE FLOWS:  
5-YR ALLOWABLE: 32.2 CFS @ 40 HRS  
5-YR RELEASE: 28.9 CFS  
100-YR ALLOWABLE: 73.2 CFS @ 72 HRS  
100-YR RELEASE: 73.3 CFS  
EMERGENCY OVERFLOW: 244.3 CFS  
EX. POND OUTLET STRUCTURE  
EX. PVT. 42" RCP OUTLET PIPE

EXISTING DETENTION POND 2 AS-BUILT CONDITIONS ARE THE FOLLOWING:  
VOLUME PROVIDED: 9.43 AC.  
5-YR WSEL: 6814.60  
100 YR WSEL = 6816.10  
TOP OF POND = 6817.50  
RELEASE FLOWS:  
5-YR ALLOWABLE: 32.2 CFS @ 40 HRS  
100-YR ALLOWABLE: 73.2 CFS @ 72 HRS  
5-YR RELEASE: 28.9 CFS  
100-YR RELEASE: 73.3 CFS  
EMERGENCY OVERFLOW: 169.7 CFS

**ATWELL**  
866.850.4200 www.atwell-group.com  
143 UNION BOULEVARD, SUITE 700  
LAKEWOOD, CO 80228  
303.462.1100

CHALLENGER HOMES  
8605 EXPLORER DRIVE, STE. 250  
COLORADO SPRINGS, CO 80920  
(719) 598-5192  
JIM BYERS

CHALLENGER HOMES  
FALCON HIGHLANDS FILING NO. 3  
EL PASO COUNTY, COLORADO  
DRAINAGE MAP  
EXISTING CONDITIONS

CLIENT: CHALLENGER HOMES  
DATE: 08/26/2022

A	1st SUBMITTAL TO EPIC	07/17/2022	- RDL
B	2nd SUBMITTAL TO EPIC	08/28/2022	- RDL
C	3rd SUBMITTAL TO EPIC	04/28/2023	- RDL
D	4th SUBMITTAL TO EPIC	07/21/2023	- RDL

REVISIONS

DR: SLP CH: DJM  
P.M: DJM

JOB: 21002568  
SHEET NO. 1  
EX-01

CAD FILE: 21002568-DRAINAGE MAPS-EXISTING CONDITIONS-FROM MDDP.DWG

NOTE: SEE SHEETS DR-3 THRU DR-5 FOR SUB-BASINS B, C, & D

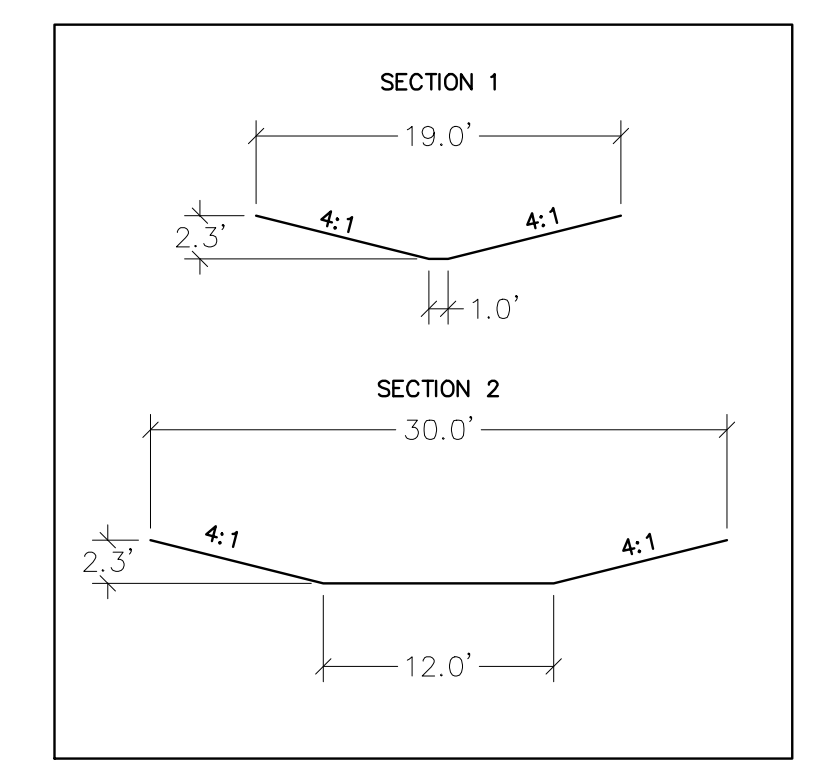

GRASS LINED SWALE SECTIONS  
N.T.S.

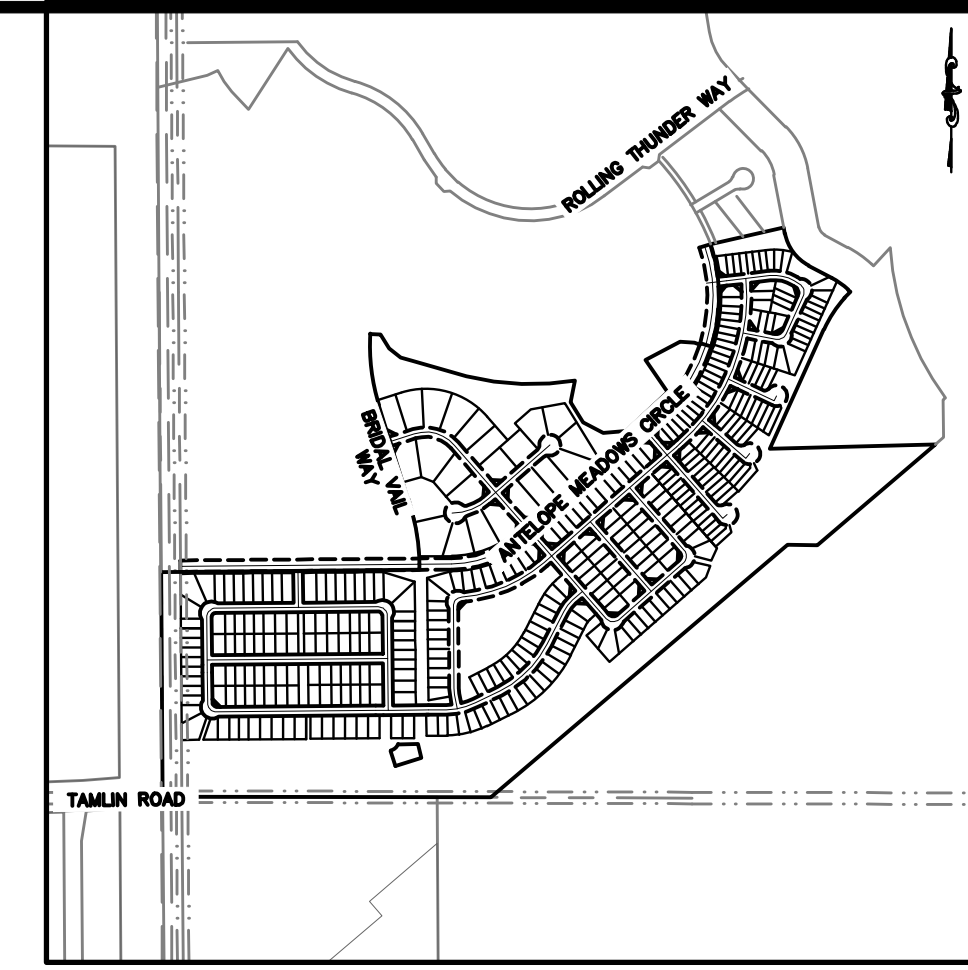

KEY MAP  
1" = 1000'

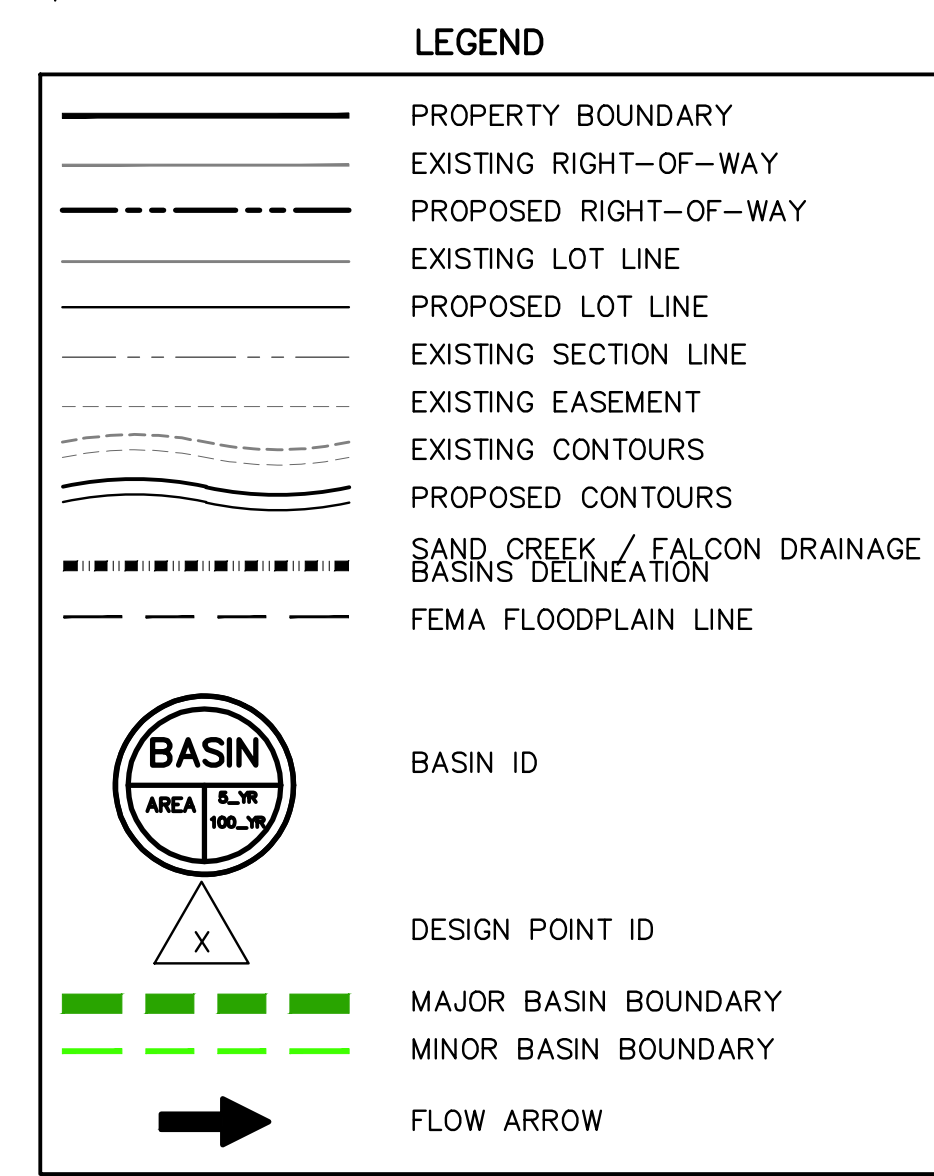
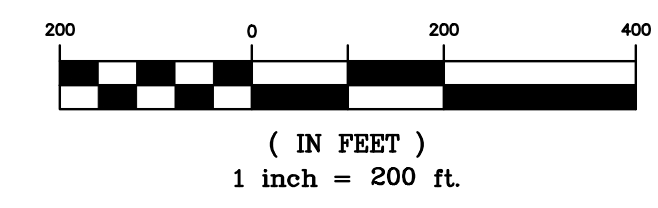

**811**  
Know what's below.  
Call before you dig.

THE LOCATIONS OF EXISTING UNDERGROUND UTILITIES ARE SHOWN IN AN APPROXIMATE WAY ONLY AND HAVE NOT BEEN INDEPENDENTLY VERIFIED BY THE CONTRACTOR. THE CONTRACTOR SHALL DETERMINE THE EXACT LOCATION OF ALL EXISTING UTILITIES BEFORE COMMENCING WORK, AND AGREES TO BE FULLY RESPONSIBLE FOR ANY AND ALL DAMAGES WHICH MIGHT BE OCCURRED BY THE CONTRACTOR'S FAILURE TO EXACTLY LOCATE AND PRESERVE ANY AND ALL UNDERGROUND UTILITIES.

NOTICE: CONSTRUCTION SITE SAFETY IS THE SOLE RESPONSIBILITY OF THE CONTRACTOR. NEITHER THE OWNER NOR THE ENGINEER SHALL BE EXPECTED TO ASSUME ANY RESPONSIBILITY FOR SAFETY OF THE WORK OF PERSONS ENGAGED IN THE WORK, OF ANY NEARBY STRUCTURES, OR OF ANY OTHER PERSONS.

COPYRIGHT © 2023 ATWELL LLC. NO REPRODUCTION SHALL BE MADE WITHOUT THE PRIOR WRITTEN CONSENT OF ATWELL LLC.

**ATWELL**  
866.850.4200 www.atwell-group.com  
143 UNION BOULEVARD, SUITE 700  
LAKEWOOD, CO 80228  
303.462.1100

CHALLENGER HOMES  
8605 EXPLORER DRIVE, STE. 250  
COLORADO SPRINGS, CO 80920  
(719) 598-5192  
JIM BYERS

CHALLENGER HOMES  
FALCON HIGHLANDS FILING NO. 3  
EL PASO COUNTY, COLORADO  
DRAINAGE MAP  
MAJOR BASINS PROPOSED CONDITIONS

DATE: 08/26/2022

A	1st SUBMITTAL TO EPIC	07/31/2022	- RDL
B	2nd SUBMITTAL TO EPIC	08/28/2022	- RDL
C	3rd SUBMITTAL TO EPIC	09/26/2023	- RDL
D	4TH SUBMITTAL TO EPIC	07/21/2023	- RDL

REVISIONS

DR.	SLP	CH.	DJM
P.M.	DJM		

JOB: 21002568  
SHEET NO. 1  
DR-02

PROPOSED CONDITIONS CUMULATIVE DRAINAGE BASIN SUMMARY

Basin	Design Point	Area (acres)	WEIGHTED		Q <sub>s</sub> (cfs)	Q <sub>100</sub> (cfs)
			C <sub>5</sub>	C <sub>100</sub>		
A	1	4.03	0.08	0.33	1.1	7.7
B	2	33.21	0.36	0.54	45.4	112.3
C	3	62.88	0.34	0.53	87.0	222.9
D	4	7.36	0.42	0.57	11.5	26.7
E	5	1.77	0.09	0.36	0.6	4.3
F	6	6.06	0.10	0.41	2.3	15.6
G	6	8.84	0.09	0.36	6.8	16.0
OS-1	7	6.38	0.27	0.48	10.7	21.7
OS-2	8	3.12	0.30	0.50	7.8	13.6
OS-3	9	1.14	0.90	0.96	3.4	6.0
OS-4	10	13.09	0.34	0.44	12.3	26.3
OS-5	11	62.20	0.34	0.55	86.4	173.7
OS-6	12	35.75	0.22	0.46	31.9	58.4
OS-7	13	6.47	0.22	0.46	5.4	19.1
OS-8	4	13.79	0.09	0.36	4.8	32.5
TOTAL		266.09			317.6	756.8

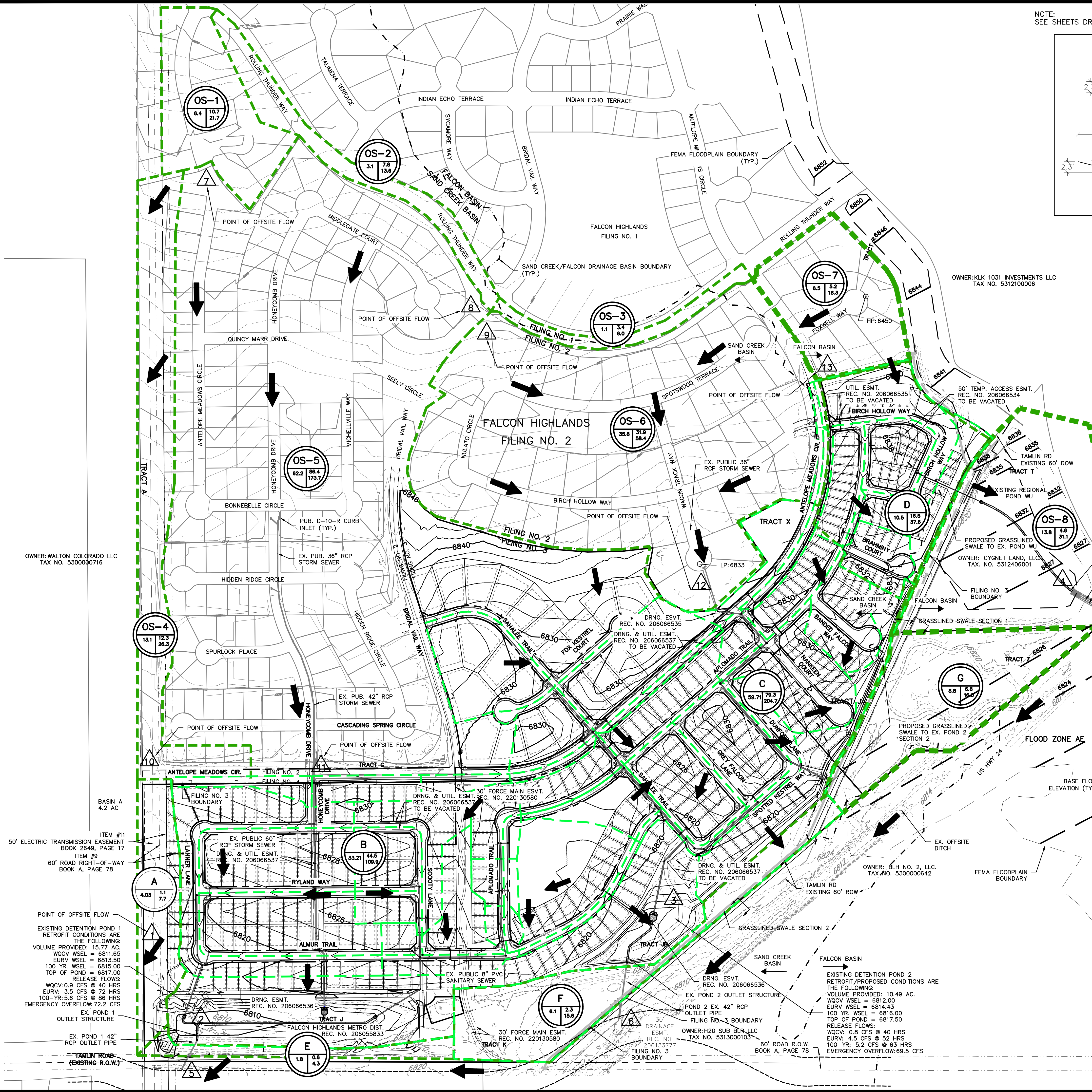

OWNER: WALTON COLORADO LLC  
TAX NO. 530000716

ITEM #11  
50' ELECTRIC TRANSMISSION EASEMENT  
BOOK 2549, PAGE 17

ITEM #9  
60' ROAD RIGHT-OF-WAY  
BOOK A, PAGE 78

POINT OF OFFSITE FLOW

EXISTING DETENTION POND 1  
RETROFIT CONDITIONS ARE  
THE FOLLOWING:  
VOLUME PROVIDED: 15.77 AC.  
WQCV WSEL = 6811.65  
EURV WSEL = 6813.50  
100 YR. WSEL = 6815.00  
TOP OF POND = 6817.00  
RELEASE FLOWS:  
WQCV: 0.9 CFS @ 40 HRS  
EURV: 3.5 CFS @ 72 HRS  
100-YR: 5.6 CFS @ 85 HRS  
EMERGENCY OVERFLOW: 72.2 CFS

EX. POND 1  
OUTLET STRUCTURE

EX. POND 1 42"  
RCP OUTLET PIPE

TAMLIN ROAD  
(EXISTING R.O.W.)

EXISTING DETENTION POND 2  
RETROFIT/PROPOSED CONDITIONS ARE  
THE FOLLOWING:  
VOLUME PROVIDED: 10.49 AC.  
WQCV WSEL = 6812.00  
EURV WSEL = 6814.43  
100 YR. WSEL = 6816.00  
TOP OF POND = 6817.50  
RELEASE FLOWS:  
WQCV: 0.8 CFS @ 40 HRS  
EURV: 4.5 CFS @ 52 HRS  
100-YR: 5.2 CFS @ 63 HRS  
EMERGENCY OVERFLOW: 69.5 CFS

OWNER: H2O SUB BLR LLC  
TAX NO. 5313000103

OWNER: BLH NO. 2, LLC  
TAX NO. 530000642

OWNER: H2O SUB BLR LLC  
TAX NO. 5313000103

OWNER: H2O SUB BLR LLC  
TAX NO. 5313000103

OWNER: H2O SUB BLR LLC  
TAX NO. 5313000103

NOTE: SEE SHEET DR-05, SUB-BASINS SHEET 3, FOR DESIGN POINT AND SUB-BASIN SUMMARY WITH INLET SIZES

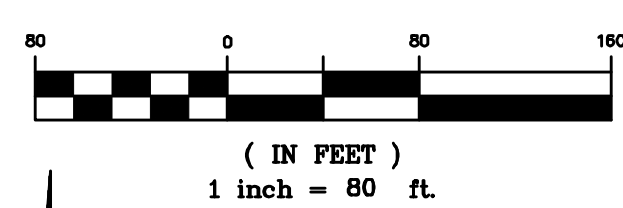

( IN FEET )  
1 inch = 80 ft.

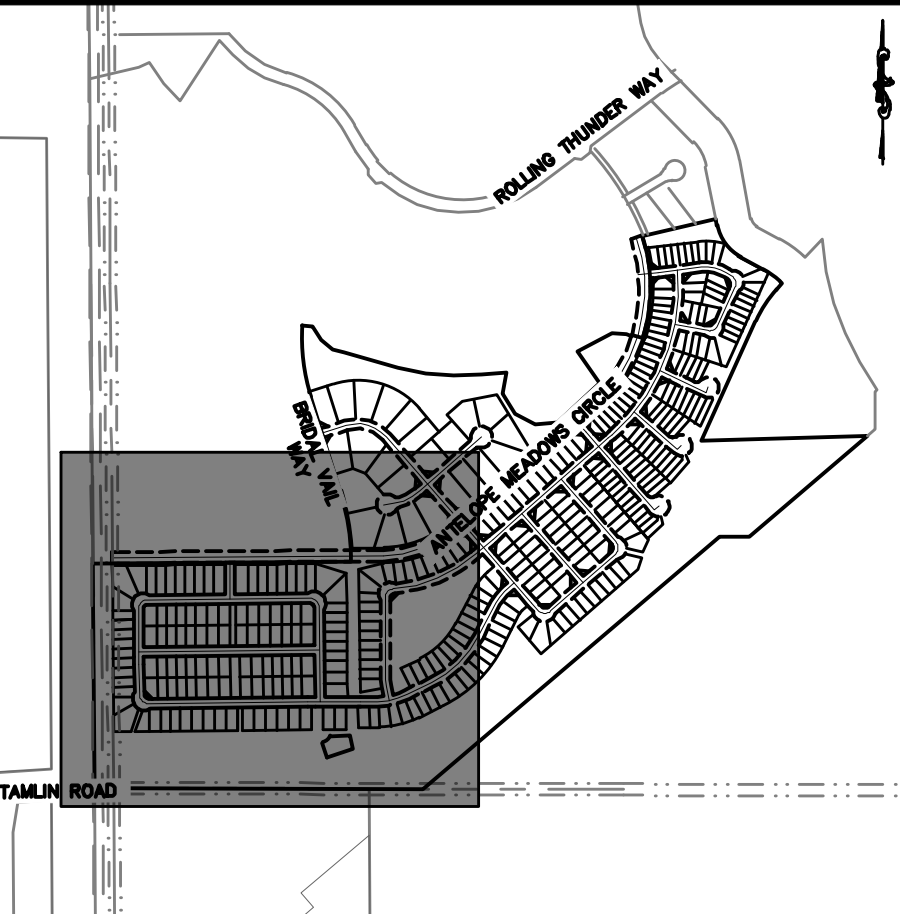
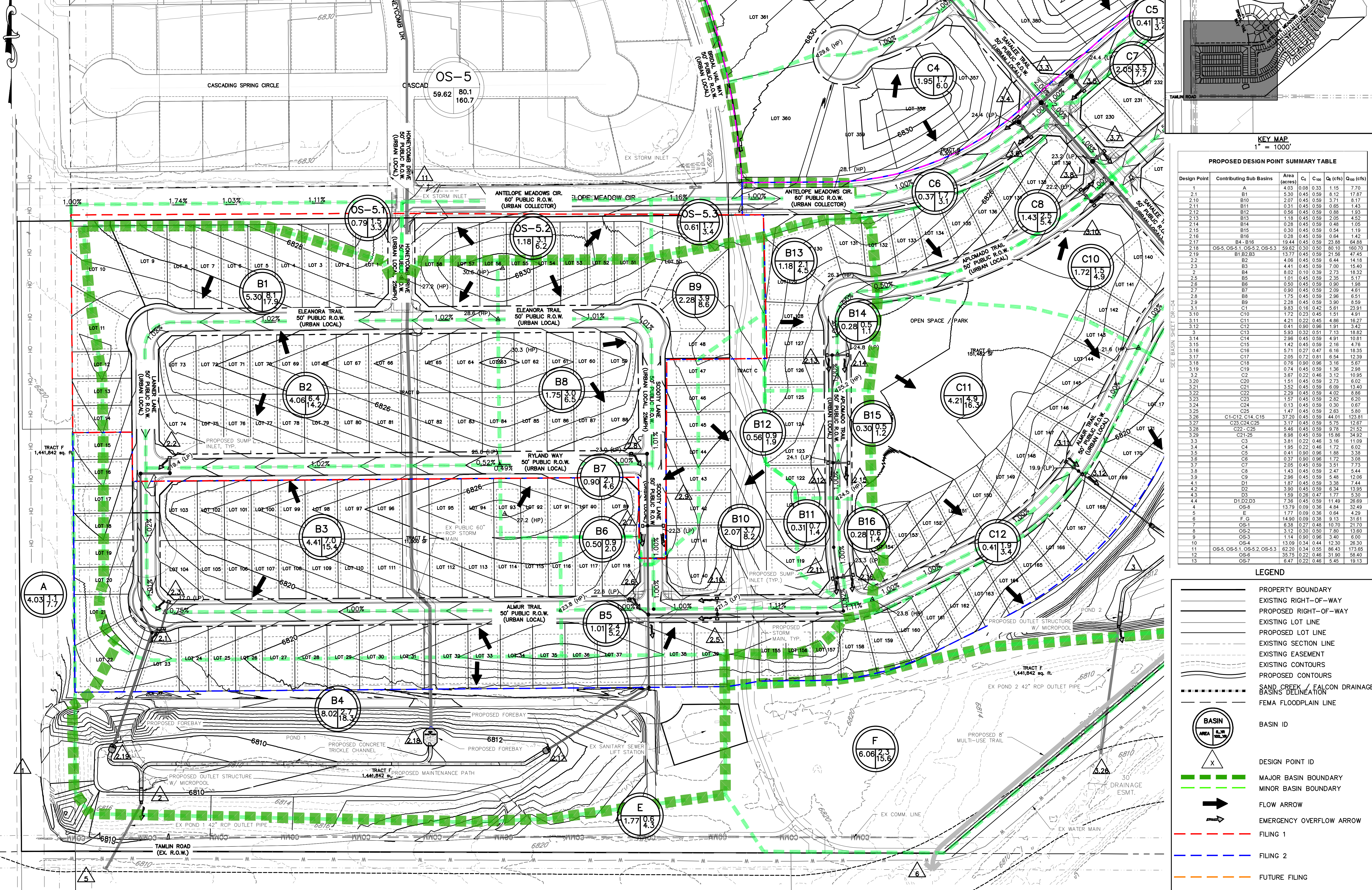

KEY MAP  
1" = 1000'

PROPOSED DESIGN POINT SUMMARY TABLE

Design Point	Contributing Sub Basins	Area (acres)	C <sub>100</sub>	C <sub>50</sub>	Q <sub>c</sub> (cfs)	Q <sub>100</sub> (cfs)
1	A	4.03	0.08	0.33	1.15	7.70
2.1	B1	5.30	0.45	0.59	8.12	17.67
2.10	B10	2.07	0.45	0.59	3.71	8.17
2.11	B11	0.31	0.45	0.59	0.65	1.43
2.12	B12	0.56	0.45	0.59	0.98	1.93
2.13	B13	1.18	0.45	0.59	2.05	4.52
2.14	B14	0.28	0.45	0.59	0.48	1.05
2.15	B15	0.30	0.45	0.59	0.54	1.19
2.16	B16	0.28	0.45	0.59	0.54	1.42
2.17	B4-B16	19.44	0.45	0.59	23.88	64.88
2.18	OS-5, OS-5.1, OS-5.2, OS-5.3	59.62	0.30	0.50	80.10	160.70
2.19	B1-B2, B3	13.77	0.45	0.59	21.56	47.45
2.2	B2	4.06	0.45	0.59	6.44	14.18
2.2	B3	4.41	0.45	0.59	7.00	15.40
2.2	B4	8.02	0.10	0.39	2.73	18.32
2.25	B5	1.01	0.45	0.59	2.55	5.17
2.26	B6	0.50	0.45	0.59	0.90	1.98
2.7	B7	0.90	0.45	0.59	2.09	4.61
2.8	B8	1.75	0.45	0.59	2.96	6.51
2.9	B9	2.28	0.45	0.59	3.90	8.59
3.1	C1	0.83	0.18	0.42	0.81	23.91
3.10	C10	1.72	0.23	0.45	1.51	4.91
3.11	C11	4.21	0.22	0.45	4.86	16.27
3.12	C12	0.41	0.90	0.96	1.91	3.42
3.2	C13	0.32	0.51	1.13	1.82	18.82
3.14	C14	2.96	0.45	0.59	4.91	10.81
3.15	C15	1.42	0.45	0.59	2.16	4.76
3.16	C16	5.71	0.27	0.47	6.16	16.35
3.17	C17	2.05	0.72	0.81	6.54	12.39
3.18	C18	0.76	0.90	0.96	3.16	5.87
3.19	C19	0.74	0.45	0.59	1.36	2.98
3.2	C2	3.87	0.22	0.46	3.12	10.95
3.20	C20	1.51	0.45	0.59	2.73	6.02
3.21	C21	3.52	0.45	0.59	6.09	13.40
3.22	C22	2.29	0.45	0.59	4.02	8.86
3.23	C23	1.57	0.45	0.59	2.82	6.20
3.24	C24	0.13	0.45	0.59	0.30	0.67
3.25	C25	1.47	0.45	0.59	2.63	5.80
3.26	C1-C12, C14, C15	37.20	0.45	0.59	44.01	123.81
3.27	C23, C24, C25	3.17	0.45	0.59	5.75	12.67
3.28	C22-C25	5.46	0.45	0.59	9.78	21.52
3.29	C21-25	8.98	0.45	0.59	15.86	34.82
3.3	C3	3.81	0.22	0.46	3.16	11.09
3.4	C4	1.55	0.22	0.46	1.72	6.02
3.5	C5	0.41	0.90	0.96	1.88	3.38
3.6	C6	0.37	0.90	0.96	1.72	3.08
3.7	C7	2.05	0.45	0.59	3.51	7.73
3.8	C8	1.43	0.45	0.59	2.47	5.44
3.9	C9	2.96	0.45	0.59	5.46	12.06
4.1	D1	1.87	0.45	0.59	3.38	7.44
4.2	D2	3.90	0.45	0.59	6.34	13.95
4.3	D3	1.59	0.26	0.47	1.77	5.30
4.4	D1, D2, D3	7.36	0.45	0.59	11.49	26.69
4	OS-8	13.79	0.09	0.36	4.84	32.49
5	E	1.77	0.09	0.36	0.84	4.29
6	F	14.90	0.09	0.36	9.13	31.61
7	OS-1	6.38	0.27	0.48	10.70	21.70
8	OS-2	3.12	0.30	0.50	7.80	13.60
9	OS-3	1.14	0.90	0.96	3.40	6.00
10	OS-4	13.09	0.34	0.44	12.30	26.30
11	OS-5, OS-5.1, OS-5.2, OS-5.3	62.20	0.34	0.55	86.43	173.65
12	OS-6	35.75	0.22	0.46	31.90	58.40
13	OS-7	6.47	0.22	0.46	5.45	19.13

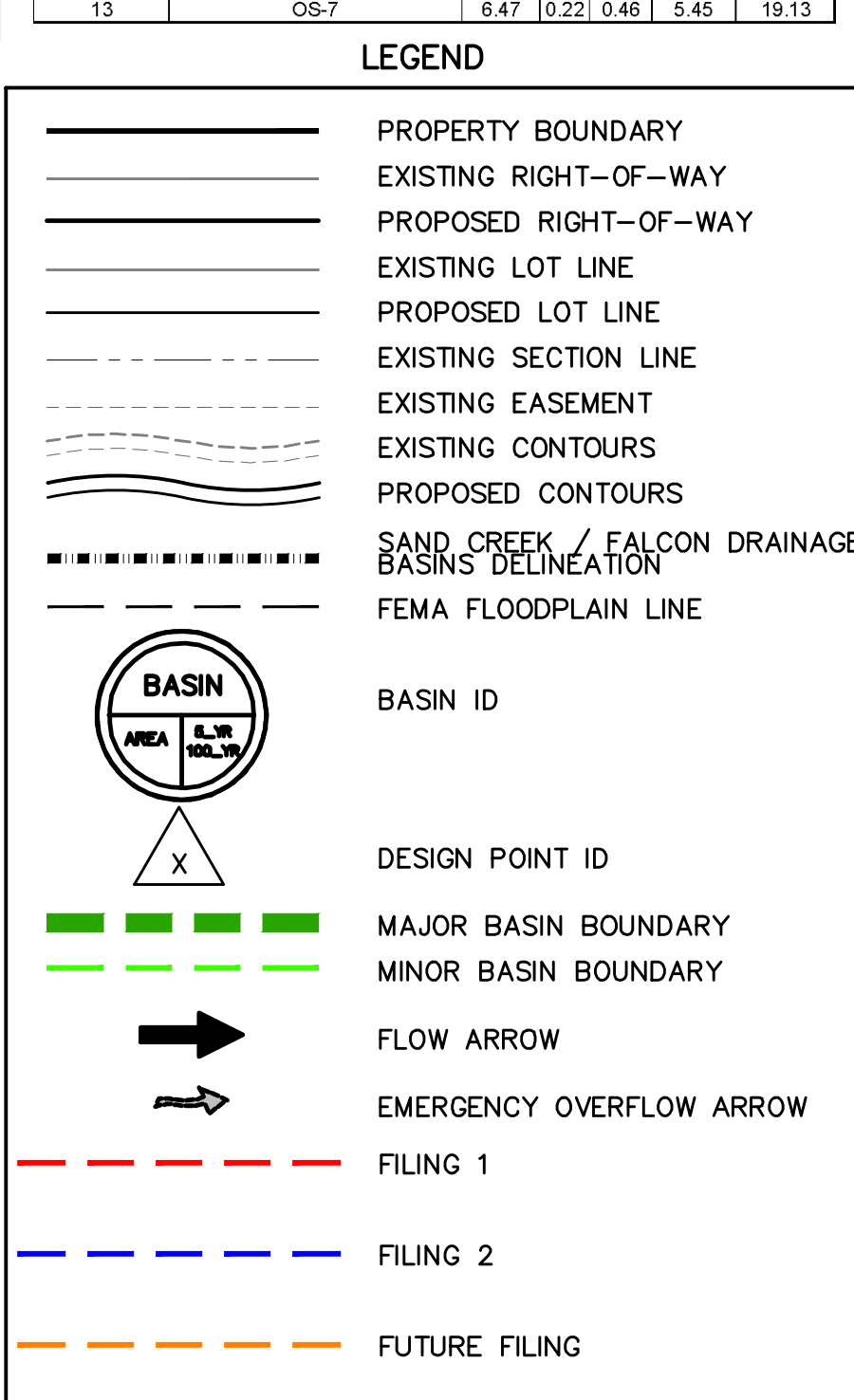

**811**  
Know what's below.  
Call before you dig.

THE LOCATIONS OF EXISTING UNDERGROUND UTILITIES ARE SHOWN IN AN APPROXIMATE WAY ONLY AND HAVE NOT BEEN INDEPENDENTLY VERIFIED BY THE OWNER OR ITS REPRESENTATIVE. THE CONTRACTOR SHALL DETERMINE THE EXACT LOCATION OF ALL EXISTING UTILITIES BEFORE COMMENCING WORK, AND AGREES TO BE FULLY RESPONSIBLE FOR ANY AND ALL DAMAGES WHICH MIGHT BE OCCURRED BY THE CONTRACTOR'S FAILURE TO EXACTLY LOCATE AND UNDERGROUND UTILITIES.

NOTICE: CONSTRUCTION, SITE SAFETY IS THE SOLE RESPONSIBILITY OF THE CONTRACTOR. NEITHER THE OWNER NOR THE ENGINEER SHALL BE EXPECTED TO ASSUME ANY RESPONSIBILITY FOR SAFETY OF THE WORK OF PERSONS ENGAGED IN THE WORK OF ANY NEARBY STRUCTURES, OR OF ANY OTHER PERSONS.

COPYRIGHT © 2023 ATWELL LLC. NO REPRODUCTION SHALL BE MADE WITHOUT THE PRIOR WRITTEN CONSENT OF ATWELL LLC.

**ATWELL**  
866.850.4200 www.atwell-group.com  
143 UNION BOULEVARD, SUITE 700  
LAKEWOOD, CO 80228  
303.462.1100

CHALLENGER HOMES  
8605 EXPLORER DRIVE, STE. 250  
COLORADO SPRINGS, CO 80920  
(719) 598-5192  
JIM BYERS

CHALLENGER HOMES  
FALCON HIGHLANDS FILING NO. 3  
EL PASO COUNTY, COLORADO  
DRAINAGE MAP  
SUB-BASINS  
SHEET 1

DATE: 08/26/2022

A 1st SUBMITTAL TO EPIC 07/31/2022 - BDL  
B 2nd SUBMITTAL TO EPIC 08/26/2022 - BDL  
C 3rd SUBMITTAL TO EPIC 09/28/2022 - BDL  
D 4TH SUBMITTAL TO EPIC 09/28/2023 - BDL  
E 5TH SUBMITTAL TO EPIC 07/21/2023 - BDL

REVISIONS

DR: SLP CH: DJM  
P.M: DJM

JOB: 21002568  
SHEET NO.: DR-03

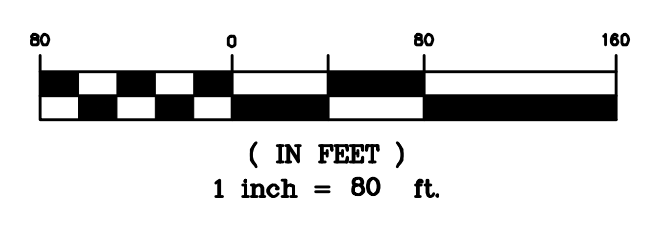

NOTE: SEE SHEETS EX-01, DR-03, & DR-05 FOR HISTORIC AND DEVELOPED DESIGN POINT AND SUB-BASIN SUMMARY

LEGEND	
	PROPERTY BOUNDARY
	EXISTING RIGHT-OF-WAY
	PROPOSED RIGHT-OF-WAY
	EXISTING LOT LINE
	PROPOSED LOT LINE
	EXISTING SECTION LINE
	EXISTING EASEMENT
	EXISTING CONTOURS
	PROPOSED CONTOURS
	SAND CREEK / FALCON DRAINAGE BASINS DELINEATION
	FEMA FLOODPLAIN LINE
	BASIN ID
	DESIGN POINT ID
	MAJOR BASIN BOUNDARY
	MINOR BASIN BOUNDARY
	FLOW ARROW
	EMERGENCY OVERFLOW ARROW
	FILING 1
	FILING 2
	FUTURE FILING
	FUTURE FILING

Know what's below. Call before you dig.

THE LOCATIONS OF EXISTING UNDERGROUND UTILITIES ARE SHOWN IN AN APPROXIMATE WAY ONLY AND HAVE NOT BEEN INDEPENDENTLY VERIFIED BY THE CONTRACTOR. THE CONTRACTOR SHALL DETERMINE THE EXACT LOCATION OF ALL EXISTING UTILITIES BEFORE COMMENCING WORK, AND AGREES TO BE FULLY RESPONSIBLE FOR ANY AND ALL DAMAGES WHICH MIGHT BE OCCASIONED BY THE CONTRACTOR'S FAILURE TO EXACTLY LOCATE AND PRESERVE ANY AND ALL UNDERGROUND UTILITIES.

NOTICE: CONSTRUCTION, SITE SAFETY IS THE SOLE RESPONSIBILITY OF THE CONTRACTOR. NEITHER THE OWNER NOR THE ENGINEER SHALL BE EXPECTED TO ASSUME ANY RESPONSIBILITY FOR SAFETY OF THE WORK OF PERSONS ENGAGED IN THE WORK OF ANY NEARBY STRUCTURES, OR OF ANY OTHER PERSONS.

COPYRIGHT © 2023 ATWELL, LLC. NO REPRODUCTION SHALL BE MADE WITHOUT THE PRIOR WRITTEN CONSENT OF ATWELL, LLC.

866.850.4200 [www.atwell-group.com](http://www.atwell-group.com)  
143 UNION BOULEVARD, SUITE 700  
LAKEWOOD, CO 80228  
303.462.1100

---

CLIENT: CHALLENGER HOMES

DATE: 08/26/2022

REVISIONS:

A	1st SUBMITTAL TO EPIC	07/31/2022	- RDL
B	2nd SUBMITTAL TO EPIC	08/28/2022	- RDL
C	3rd SUBMITTAL TO EPIC	09/28/2023	- RDL
D	4TH SUBMITTAL TO EPIC	07/21/2023	- RDL

---

DR: SLP CH: DJM  
P.M: DJM

JOB: 21002568  
SHEET NO: DR-04

CHALLENGER HOMES  
8605 EXPLORER DRIVE, STE. 250  
COLORADO SPRINGS, CO 80920  
(719) 598-5192  
JIM BYERS

CHALLENGER HOMES  
FALCON HIGHLANDS FILING NO. 3  
EL PASO COUNTY, COLORADO  
DRAINAGE MAP  
SUB-BASINS  
SHEET 2

CAD FILE: 21002568-DRAINAGE\_MAPS-SUB\_BASINS-BASIN\_EDITING

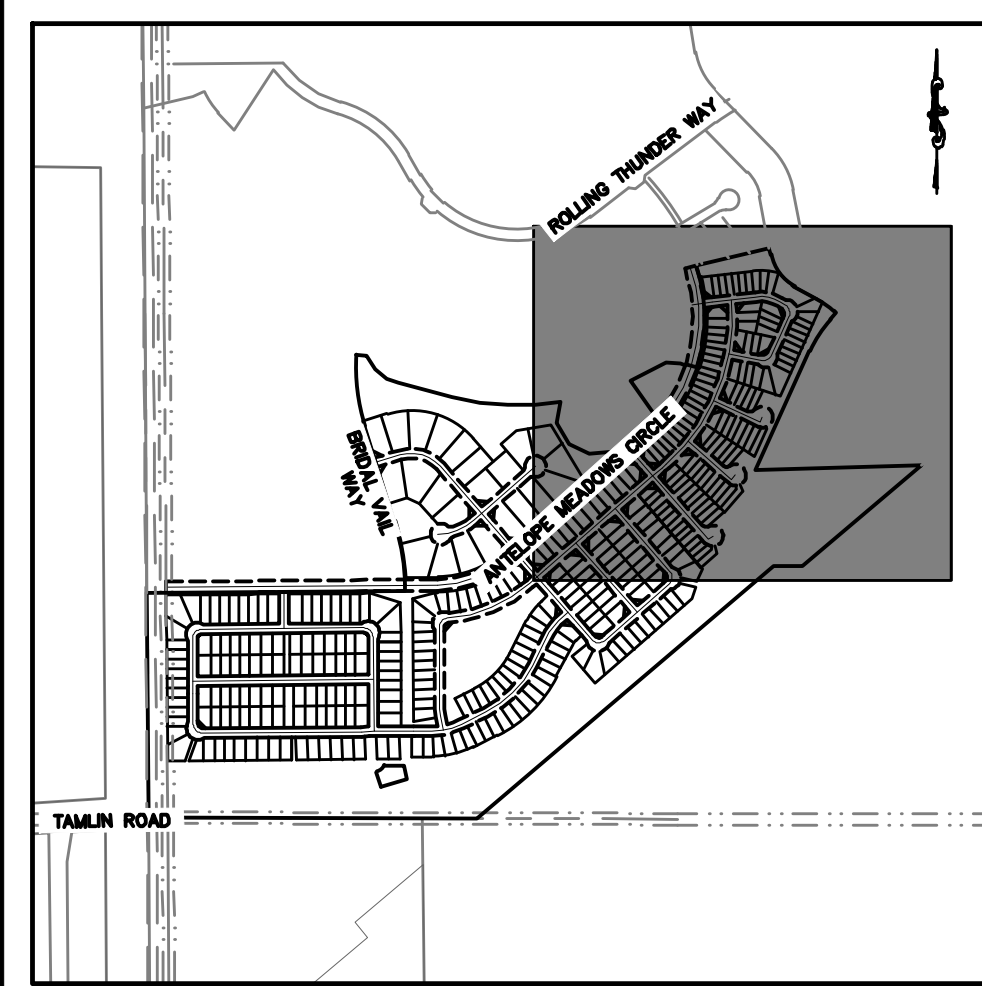

KEY MAP  
1" = 1000'

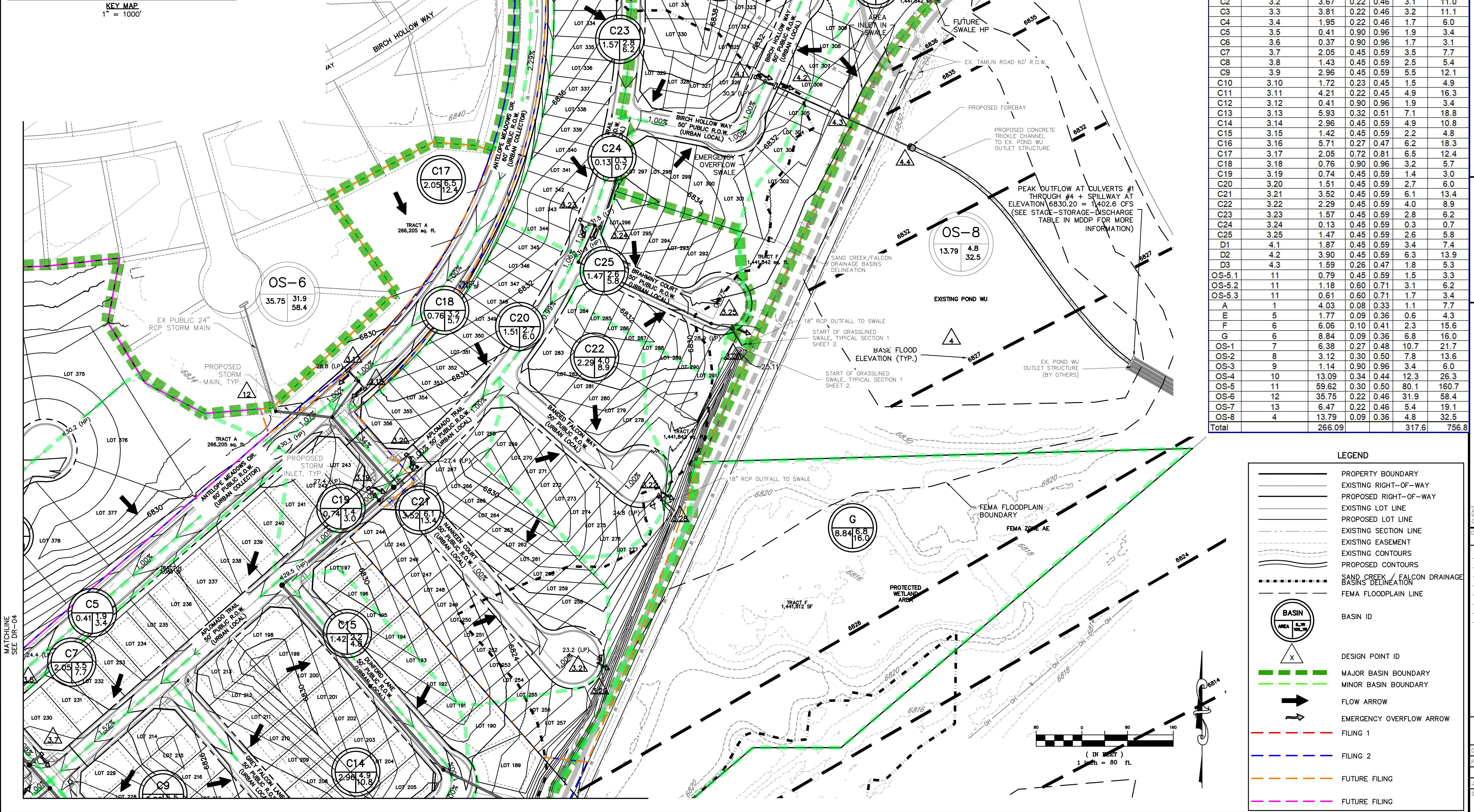

PROPOSED CONDITIONS SUB-BASIN SUMMARY

Basin	Design Point	Area (acres)	C <sub>5</sub>	C <sub>100</sub>	Q <sub>5</sub> (cfs)	Q <sub>100</sub> (cfs)
B1	2.1	5.30	0.45	0.59	8.1	17.9
B2	2.2	4.06	0.45	0.59	6.4	14.2
B3	2.3	4.41	0.45	0.59	7.0	15.4
B4	2.4	8.02	0.10	0.39	2.7	18.3
B5	2.5	1.01	0.45	0.59	2.3	5.2
B6	2.6	0.50	0.45	0.59	0.9	2.0
B7	2.7	0.90	0.45	0.59	2.1	4.6
B8	2.8	1.75	0.45	0.59	3.0	6.5
B9	2.9	2.28	0.45	0.59	3.9	8.6
B10	2.10	2.07	0.45	0.59	3.7	8.2
B11	2.11	0.31	0.45	0.59	0.6	1.4
B12	2.12	0.56	0.45	0.59	0.9	1.9
B13	2.13	1.18	0.45	0.59	2.1	4.5
B14	2.14	0.28	0.45	0.59	0.5	1.0
B15	2.15	0.30	0.45	0.59	0.5	1.2
B16	2.16	0.28	0.45	0.59	0.6	1.4
C1	3.1	9.83	0.16	0.42	5.6	23.9
C2	3.2	3.67	0.22	0.46	3.1	11.0
C3	3.3	3.81	0.22	0.46	3.2	11.1
C4	3.4	1.95	0.22	0.46	1.7	6.0
C5	3.5	0.41	0.90	0.96	1.9	3.4
C6	3.6	0.37	0.90	0.96	1.7	3.1
C7	3.7	2.05	0.45	0.59	3.5	7.7
C8	3.8	1.43	0.45	0.59	2.5	5.4
C9	3.9	2.96	0.45	0.59	5.5	12.1
C10	3.10	1.72	0.23	0.45	1.5	4.9
C11	3.11	4.21	0.22	0.45	4.9	16.3
C12	3.12	0.41	0.90	0.96	1.9	3.4
C13	3.13	5.93	0.32	0.51	7.1	18.8
C14	3.14	2.96	0.45	0.59	4.9	10.8
C15	3.15	1.42	0.45	0.59	2.2	4.8
C16	3.16	5.71	0.27	0.47	6.2	18.3
C17	3.17	2.05	0.72	0.81	6.5	12.4
C18	3.18	0.76	0.90	0.96	3.2	5.7
C19	3.19	0.74	0.45	0.59	1.4	3.0
C20	3.20	1.51	0.45	0.59	2.7	6.0
C21	3.21	3.52	0.45	0.59	6.1	13.4
C22	3.22	2.29	0.45	0.59	4.0	8.9
C23	3.23	1.57	0.45	0.59	2.8	6.2
C24	3.24	0.13	0.45	0.59	0.3	0.7
C25	3.25	1.47	0.45	0.59	2.6	5.8
D1	4.1	1.87	0.45	0.59	3.4	7.4
D2	4.2	3.90	0.45	0.59	6.3	13.9
D3	4.3	1.59	0.26	0.47	1.8	5.3
OS-5-1	11	0.79	0.45	0.59	1.5	3.3
OS-5-2	11	1.18	0.60	0.71	3.1	6.2
OS-5-3	11	0.61	0.60	0.71	1.7	3.4
A	1	4.03	0.08	0.33	1.1	7.7
E	5	1.77	0.09	0.36	0.6	4.3
F	6	6.06	0.10	0.41	2.3	15.6
G	6	8.84	0.09	0.36	6.8	16.0
OS-1	7	6.38	0.27	0.48	10.7	21.7
OS-2	8	3.12	0.30	0.50	7.8	13.6
OS-3	9	1.14	0.90	0.96	3.4	6.0
OS-4	10	13.09	0.34	0.44	12.3	26.3
OS-5	11	59.62	0.30	0.50	80.1	160.7
OS-6	12	35.75	0.22	0.46	31.9	58.4
OS-7	13	6.47	0.22	0.46	5.4	19.1
OS-8	4	13.79	0.09	0.36	4.8	32.5
Total		266.09			317.6	756.8

**811**  
Know what's below. Call before you dig.

THE LOCATIONS OF EXISTING UNDERGROUND UTILITIES ARE SHOWN IN AN APPROXIMATE WAY ONLY AND HAVE NOT BEEN INDEPENDENTLY VERIFIED BY THE OWNER OR ITS REPRESENTATIVE. THE CONTRACTOR SHALL DETERMINE THE EXACT LOCATION OF ALL EXISTING UTILITIES BEFORE COMMENCING WORK, AND AGREES TO BE FULLY RESPONSIBLE FOR ANY AND ALL DAMAGES WHICH MIGHT BE OCCASIONED BY THE CONTRACTOR'S FAILURE TO EXACTLY LOCATE AND PRESERVE ANY AND ALL UNDERGROUND UTILITIES.

NOTICE: CONSTRUCTION SITE SAFETY IS THE SOLE RESPONSIBILITY OF THE CONTRACTOR. NEITHER THE OWNER NOR THE ENGINEER SHALL BE EXPECTED TO ASSUME ANY RESPONSIBILITY FOR SAFETY OF THE WORK OF PERSONS ENGAGED IN THE WORK OF ANY NEARBY STRUCTURES, OR OF ANY OTHER PERSONS.

COPYRIGHT © 2023 ATWELL LLC. NO REPRODUCTION SHALL BE MADE WITHOUT THE PRIOR WRITTEN CONSENT OF ATWELL LLC.

**ATWELL**  
866.850.4200 www.atwell-group.com  
143 UNION BOULEVARD, SUITE 700  
LAKEWOOD, CO 80228  
303.462.1100

CHALLENGER HOMES  
8605 EXPLORER DRIVE, STE. 250  
COLORADO SPRINGS, CO 80920  
(719) 598-5192  
JIM BYERS

CHALLENGER HOMES  
FALCON HIGHLANDS FILING NO. 3  
EL PASO COUNTY, COLORADO  
DRAINAGE MAP  
SUB-BASINS  
SHEET 3

CLIENT: CHALLENGER HOMES  
DATE: 08/26/2022

REV.	DATE	DESCRIPTION
A	07/21/2022	SUBMITTAL TO EPIC
B	07/21/2022	REVISED SUBMITTAL TO EPIC
C	08/28/2022	REVISED SUBMITTAL TO EPIC
D	09/28/2023	REVISED SUBMITTAL TO EPIC
E	07/21/2023	REVISED SUBMITTAL TO EPIC

DR: SLP CH: DJM  
P.M. DJM  
JOB: 21002568  
SHEET NO. 1  
DR-05

CAD FILE: 21002568-DRAINAGE\_MAPS-SUB-BASINS-EPIC.DWG

**LEGEND**

- PROPERTY BOUNDARY
- EXISTING RIGHT-OF-WAY
- PROPOSED RIGHT-OF-WAY
- EXISTING LOT LINE
- PROPOSED LOT LINE
- EXISTING SECTION LINE
- EXISTING EASEMENT
- EXISTING CONTOURS
- PROPOSED CONTOURS
- SAND CREEK / FALCON DRAINAGE BASINS DELINEATION
- FEMA FLOODPLAIN BOUNDARY
- FEMA FLOODPLAIN LINE
- FEMA ZONE AE
- PROTECTED WETLAND AREA

**BASIN**

- BASIN ID
- DESIGN POINT ID
- MAJOR BASIN BOUNDARY
- MINOR BASIN BOUNDARY
- FLOW ARROW
- EMERGENCY OVERFLOW ARROW
- FILING 1
- FILING 2
- FUTURE FILING
- FUTURE FILING

( IN FEET )  
1" = 80 ft.



THE LOCATIONS OF EXISTING UNDERGROUND UTILITIES ARE SHOWN IN AN APPROXIMATE WAY ONLY AND HAVE NOT BEEN INDEPENDENTLY VERIFIED BY THE CONTRACTOR. THE CONTRACTOR SHALL DETERMINE THE EXACT LOCATION OF ALL EXISTING UTILITIES BEFORE COMMENCING WORK, AND AGREES TO BE FULLY RESPONSIBLE FOR ANY AND ALL DAMAGES WHICH MIGHT BE OCCASIONED BY THE CONTRACTOR'S FAILURE TO EXACTLY LOCATE AND PRESERVE ANY AND ALL UNDERGROUND UTILITIES.

NOTICE: CONSTRUCTION, SITE SAFETY IS THE SOLE RESPONSIBILITY OF THE CONTRACTOR. NEITHER THE OWNER NOR THE ENGINEER SHALL BE EXPECTED TO ASSUME ANY RESPONSIBILITY FOR SAFETY OF THE WORK OF PERSONS ENGAGED IN THE WORK, OF ANY NEARBY STRUCTURES, OR OF ANY OTHER PERSONS.

COPYRIGHT © 2024 ATWELL LLC. NO REPRODUCTION SHALL BE MADE WITHOUT THE PRIOR WRITTEN CONSENT OF ATWELL LLC.

**ATWELL**  
 866.850.4200 www.atwell-group.com  
 143 UNION BOULEVARD, SUITE 700  
 LAKEWOOD, CO 80228  
 303.462.1100

**CHALLENGER HOMES**  
 8605 EXPLORER DRIVE, STE. 250  
 COLORADO SPRINGS, CO 80920  
 (719) 598-5192  
 JIM BYERS

**CHALLENGER HOMES**  
 FALCON HIGHLANDS FILING NO. 3  
 EL PASO COUNTY, COLORADO  
 DRAINAGE MAP  
 WATER QUALITY MAP

CLIENT: CHALLENGER HOMES  
 DATE: 04/19/2022

A	1st SUBMITTAL TO EPIC	08/24/2021	- RDL
B	2nd SUBMITTAL TO EPIC	01/26/2022	- RDL
C	3rd SUBMITTAL TO EPIC	03/20/2022	- RDL
D	4th SUBMITTAL TO EPIC	04/19/2022	- RDL

REVISIONS

DR. RDL CH. RDL  
 P.M. RDL

JOB: 21000656  
 SHEET NO. 1

DR-06

CAD FILE: 21000656-DRAINAGE\_MAPS-WQ.DWG

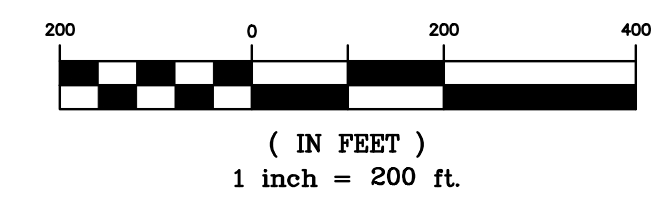

**LEGEND**

- PROPERTY BOUNDARY
- EXISTING RIGHT-OF-WAY
- PROPOSED RIGHT-OF-WAY
- EXISTING LOT LINE
- PROPOSED LOT LINE
- EXISTING SECTION LINE
- EXISTING EASEMENT
- EXISTING CONTOURS
- PROPOSED CONTOURS
- SAND CREEK / FALCON DRAINAGE BASINS DELINEATION
- FEMA FLOODPLAIN LINE

**BASIN**

- BASIN ID
- DESIGN POINT ID
- MAJOR BASIN BOUNDARY
- MINOR BASIN BOUNDARY
- FLOW ARROW
- UNCONNECTED IMPERVIOUS AREA
- RECEIVING PERVIOUS AREAS

OWNER: WALTON COLORADO LLC  
 TAX NO. 530000716

OWNER: KLK 1031 INVESTMENTS LLC  
 TAX NO. 531210006

OWNER: H20 SUB BLR LLC  
 TAX NO. 5313000103

RECEIVING PERVIOUS AREA: 17,866 SF  
 OF UNDEVELOPED PRAIRIE/GREENBELT

RECEIVING PERVIOUS AREA: 10,423 SF  
 OF UNDEVELOPED PRAIRIE

BASIN F: 6.1 AC.  
 DIRECT OFFSITE FLOW,  
 FULLY UNDEVELOPED PERVIOUS AREA

BASIN G: 8.8 AC.  
 DIRECT OFFSITE FLOW,  
 FULLY UNDEVELOPED PERVIOUS AREA  
 AND PROTECTED WETLAND