

FOUNTAIN VALLEY SCHOOL ACADEMIC BUILDING

FINAL DRAINAGE REPORT

6155 Fountain Valley School Road, Colorado Springs, CO

Martin/Martin, Inc. Project No.: 23.0895

PCD File No. PPR2610

May 15, 2026

Prepared For: Fountain Valley School of Colorado
6155 Fountain Valley School Road
Colorado Springs, CO, 80911
719-391-5231
Attn: Dave Mesko, John Litchenberg

Prepared By: MARTIN/MARTIN, INC.
12499 WEST COLFAX AVENUE
LAKEWOOD, COLORADO 80215
303.431.6100

Principal-in-Charge: Peter S. Buckley, PE
Project Manager: Nicole Kontour, PE
Project Engineer: Alecsander Guevara-Petrone, PE



Statements and Acknowledgements

ENGINEERS STATEMENT:

The attached drainage plan and report were prepared under my direct supervision and are correct to the best of my knowledge and belief. Said drainage report has been prepared according to the criteria established by the County for drainage reports and said report is in conformity with the master plan of the drainage basin. I accept responsibility for any liability caused by any negligent acts, errors or omissions on my part in preparing this report.

Peter S. Buckley, PE
PE. No: 40671
Martin/Martin Consulting Engineers

DEVELOPERS STATEMENT:

I, Fountain Valley School of Colorado, the developer have read and will comply with all of the requirements specified in this drainage report and plan.

Fountain Valley School of Colorado
By: _____
Title: _____
Address: _____

EL PASO COUNTY:

Filed in accordance with the requirements of the Drainage Criteria Manual, Volumes 1 and 2, El Paso County Engineering Criteria Manual and Land Development Code as amended.

County Engineer / ECM Administrator

Date

Conditions:

TABLE OF CONTENTS

I.	GENERAL LOCATION AND DESCRIPTION.....	1
A.	Location.....	1
B.	Description of Property.....	1
II.	DRAINAGE BASINS AND SUB-BASINS	3
A.	Major Basin Descriptions	3
B.	Sub-Basin Descriptions.....	4
III.	DRAINAGE DESIGN CRITERIA	11
A.	Regulations.....	11
B.	Development Criteria Reference and Constraints	11
C.	Hydrologic Criteria	11
D.	Hydraulic Criteria	12
IV.	DRAINAGE FACILITY DESIGN	15
A.	General Concept	15
V.	CONCLUSIONS.....	16
A.	Compliance with Standards	16
B.	Drainage Concept.....	16
	REFERENCES.....	17

APPENDICES

- Appendix A – Maps and Design Aids
- Appendix B – Hydrologic Calculations
- Appendix C – Hydraulic Calculations
- Appendix D – Supporting Documents and Reference Reports
- Appendix E – Drainage Plans

I. GENERAL LOCATION AND DESCRIPTION

A. Location

The Fountain Valley School of Colorado Academic Center project (hereafter referred to as the “PROJECT”) is located within the Northeast Quarter of the Southwest Corner of Section 18 and in the Northwest Quarter of the Southeast Corner of Section 18, Township 15 South, Range 65 West of the 6th Principal Meridian, City of Colorado Springs, County of El Paso, State of Colorado. The Fountain Valley School of Colorado is a privately owned preparatory school, with a campus encompassing approximately 937 acres, and is located east of Security, Colorado and within the south-central portion of El Paso County, Colorado. The PROJECT is an approximate 11.02 acre redevelopment of the heart of campus with 10.17 acres of the site being disturbed. The existing campus is bound by Fontaine Boulevard to the South, Grinnell Boulevard to the West, and Goldfield Drive to the North and East. The proposed site is nested between the Big Johnson Reservoir and the McCrae Reservoir. The Fountain Valley School of Colorado property is surrounded by residential developments to the south, west, and north. The remaining area adjacent to the property is undeveloped land.



Figure 1: Vicinity Map

B. Description of Property

The existing site consists of a hacienda, library, dormitories, classroom building, chapel, student center, administrative building, health center, science building, and gymnasium/performing arts center. The existing site has various asphalt drive lanes and roads, parking lots, asphalt,



concrete, and brick paver pathways, and a roundabout. Existing ground coverage throughout the site is limited to native grass, trees, shrubs, and bushes. A portion of the existing irrigation ditch that services the approximate 989.4 acre campus passes through the proposed site and is to undergo realignment and restoration with the PROJECT.

A geotechnical investigation and study was carried out for this project completed by Terracon. The report titled "Fountain Valley School Academic Center Improvements" and dated May 31, 2024 provided recommendations for foundations, grading and drainage, pavements, and findings from the subsurface explorations such as soil types, groundwater depths, and soil infiltration rates. The report was further supplemented by an NRCS Web Soils Survey. Per the NRCS Soils Survey, the majority of the proposed site is underlain by Truckton Sandy Loam, 0 to 3 percent slopes (96) and Truckton Sandy Loam, 3 to 9 percent slopes(97). The soils are considered to have high infiltration potential with well drained class and low to very low runoff potential and characterized as Hydrologic Soil Group A. Hydrologic and Runoff Calculations have been completed utilizing Type A soils. The NRCS Soils Survey shall be included in Appendix A for reference. It should be noted that the previous drainage study, to be referenced in this report, titled "Master Development Drainage Plan Fountain Valley School," prepared by Kiowa Engineering Corporation, and dated received April 28, 2011 utilized Hydrologic Soil Group B for Hydrologic and Rational calculations. Based on the NRCS soils report, geotechnical investigation, Hydrologic Soils Group characteristics, and the engineer's judgement, it is believed that the onsite soils more closely align with Hydrologic Soil Group A.

During the onsite geotechnical investigation, it was documented that groundwater levels are relatively shallow, ranging in depth from 2 to 15 feet below the existing surface. Recommendations for site grading and design, construction activities, and dewatering operations have been provided by the geotechnical engineer and are documented within the referenced report. It should be noted that the groundwater levels observed during the site investigation may be subject to change resulting in groundwater elevations higher or lower than originally documented. A perimeter drain has not been recommended for the proposed structures associated with the PROJECT, however sump pumps are required at the elevator pits.

The existing site generally slopes west to east with existing slopes ranging from 4%-20% and an approximate elevation difference of 40 feet. In general, stormwater conveyance consists of overland flow from the chapel and sage residence hall to the existing private irrigation ditch west of the existing surface parking lot. In addition, storm sewer infrastructure such as area inlets, roadway inlets, and storm sewer pipe support drainage operations. Further discussion of existing drainage patterns and reference to the master drainage report, titled "Master Development Drainage Plan Fountain Valley School," prepared by Kiowa Engineering Corporation, and dated received April 28, 2011 (hereafter referred to as the "MASTER REPORT") will occur in the following sections of this report.

Various existing dry and wet utilities exist beneath the existing site and have been mapped to the best of the engineer's ability. Where conflicts occur, coordination to relocate or adjust utilities has occurred and is accounted for in the construction documents.



The proposed development for the Fountain Valley School of Colorado Academic Center Project consists of a major demolition phase consisting of the removal of the existing administration building and classroom/motel building, the existing asphalt parking lot southeast of the irrigation ditch, the existing asphalt drive lane and asphalt parking lot west of the Chapel and Hacienda, the roundabout, all pathways within the heart of campus, various landscaping elements. In addition a portion of the private irrigation ditch set to be relocated with the PROJECT. Construction for the proposed development consists of one 2-story, 33,339 SF, Humanities Building, one 2-story, 22,408 SF, STEM Building, a bioswale, wet meadow, realignment of pedestrian pathways and circulation, realignment of the west drive lane and associated parking, realignment of the north drive lane, new surface parking southeast of the wet meadow, fire rescue accessibility improvements, and various landscaping improvements throughout the site. This development is anticipated to have a total area of 10.43 acres. Due to the existing campus foliage, grading operations and tiebacks have been strategic to protect various existing trees on site while adhering to existing drainage patterns.

II. DRAINAGE BASINS AND SUB-BASINS

A. Major Basin Descriptions

Per the MASTER REPORT, the proposed development is within the Big Johnson Reservoir/Crews Gulch Basin. A Drainage Basin Planning Study (DBPS) was referenced in the MASTER REPORT and states that detention will not be required with any development in this area since detention is accomplished with Carp Lake, otherwise known as McRae Reservoir, downstream of the school and north of Fontaine Boulevard. According to the MASTER REPORT and provided topographic survey, the existing campus generally drains north to south through a combination of sheet flow, gutter flow, storm sewer and associated infrastructure, and swales. As observed on site and described in the MASTER REPORT, a system of irrigation ditches runs through the campus and has portions that function as the main conveyance path of all stormwater runoff associated with the western half of the Fountain Valley School of Colorado campus. While that general drainage pattern remains consistent with the PROJECT, due to existing buildings within the location of the proposed site within the larger Fountain Valley Campus, runoff generally overland flows west to east before flowing south. Ultimately, runoff generated from the campus discharges into Crews Gulch and Carp Lake south of the school property. It was stated in the MASTER REPORT that water quality is indirectly provided by segments of the irrigation ditch due to their flat nature, slowing water down and allowing for sediment to deposit along the channel. In addition to indirect water quality, the length and roughness of the irrigation ditch increases time of concentration and lowers peak flows reaching Carp Lake. Excerpts from the MASTER REPORT will be provided within Appendix D for reference.

It should be noted that analysis discussed within MASTER REPORT elected to assume the irrigation ditch is flowing full. However, the irrigation ditch and laterals are used infrequently during the irrigation season. In addition, the MASTER REPORT utilized the 5-YR and 100-YR storm events for runoff calculations. Per the El Paso County Drainage Criteria, minor and major storm event reoccurrence intervals to be analyzed are the 10-YR and 100-YR events, respectively. When validating runoff quantities, only the Q_{100} values provided in the MASTER



REPORT have been considered. Variability in runoff results is expected as the proposed study will be utilizing Hydrologic Soil Group A whereas the MASTER REPORT utilized Hydrologic Soil Group B for runoff calculations.

Floodplain Statement: According to the Federal Emergency Management Agency (FEMA), Flood Insurance Rate Map (FIRM), Panel No. 08041C0952G, dated December 7, 2018, the existing site is within unshaded Zone X, Area of Minimal Flood Hazard. A portion of the existing campus, approximately 0.21 miles to the southeast of the proposed site, is within Zone AE, Regulatory Floodway. No development or construction associated with the PROJECT is planned within Zone AE. If future development is planned within a Regulatory Floodway at the Fountain Valley School of Colorado, a Floodplain Development Permit may be required. A copy of the FEMA FIRMette has been included in Appendix A for reference.

B. Sub-Basin Descriptions

Existing Drainage

In the existing condition, stormwater runoff within the proposed site is typically conveyed via overland flow west to east, with additional collection and conveyance support via storm sewer infrastructure, before ultimately flowing south once runoff enters in the irrigation ditch. The drainage plan associated with the MASTER REPORT has divided the campus into three basin groupings: 'A' sub-basins, 'B' sub-basins, and 'C' sub-basin. Each set of sub-basins have specific design points associated with multiple individual basins to identify a final outfall location and quantify runoff. Sub-basins have individual collection elements, where applicable, such as roadway or area inlets, however for the purposes of understanding total runoff associated with a larger area having similar drainage patterns, sub-basins B-1 through B-3 and Design Point 3a for example, a singular design point has been assigned. For the purposes of this study, existing sub-basins A-1, A-2, B-1, B-2, B-3, C-1, C-2, C-3, D-1, and D-2 and design points 1, 3a, 5, and 6 will be further discussed and analyzed. While the MASTER REPORT is intended to be referenced when discussing developed runoff and existing drainage patterns, it should be noted that the study described within then MASTER REPORT considered future development and master planning provided by the Fountain Valley School of Colorado. The existing conditions associated with the proposed drainage study outlined in this report do not reflect all of the assumptions made in the MASTER REPORT. Where applicable, additional analysis will be provided on existing sub-basins to create a more cohesive picture of the existing campus to date, proposed improvements, imperviousness, and runoff. An exhibit of the existing drainage plan and proposed drainage basins associated with the PROJECT has been developed and included in Appendix E for reference.

Existing Sub-Basin A-2: Approximately 3.94 ac, comprised of asphalt road, a portion of the existing chapel, a portion of the existing dining hall/hacienda, a future performing arts center, and associated landscaping and hardscaping. This existing sub-basin is located on the western frontage of the existing campus and proposed site and is tributary to design point 1. Improvements within this sub-basin are limited and consist mostly of removal and replacement of surface features, such as the existing asphalt road and surface parking. The runoff associated



with existing sub-basin A-2 is not tributary to the proposed outfalls designed and installed with this project. It is assumed that the minimal increase in imperviousness to this basin, if any, is negligible and will have no adverse impacts on downstream existing infrastructure. Future key elements assumed during the study of this existing sub-basin that do not exist onsite at the time of this drainage analysis are the future performing arts building and future garden amphitheater. Existing sub-basin A-2 is considered an off-site basin for the purposes of this drainage study.

Existing Sub-Basins D-1 and D-2: The total area of these sub-basins is approximately 24.96 ac, comprised of existing buildings, faculty residences, asphalt drive lanes, and associated landscaping and hardscaping. These sub-basins are undisturbed and will have no improvements occur as part of the PROJECT but should be considered as they are tributary to design point 6 being the furthest upstream end of the irrigation ditch the PROJECT will be outfalling to. It is important to understand assumed flows to design point 6 to verify capacity of the newly aligned portion of the existing irrigation ditch, now being described as the wet meadow with the PROJECT. In general, future key elements associated with these sub-basins have been installed in some capacity based on the existing drainage plan and onsite observations.

Existing Sub-Basins C-1 and C-2: The total area of these sub-basins is approximately 51.16 ac, comprised of existing buildings, faculty residences, gravel drive lanes, and associated landscaping and hardscaping. Sub-basin C-1 is undisturbed and will have no improvements occur as part of the PROJECT but should be considered as sub-basin C-1 is tributary to design point 5 being an upstream portion of the irrigation ditch the PROJECT will be outfalling to. Sub-Basin C-2 will be subject to minor improvements as part of the PROJECT such as realignment of the existing asphalt road and demolition of the existing classroom building. Due to the proposed drainage strategy and layout of the existing and proposed site, a small area, no more than 0.5ac will no longer be tributary to design point 5 as the remainder of existing sub-basin C-2 still is. Further discussion will be provided in the proposed drainage section. It is important to understand assumed flows to design point 5 to verify capacity of the newly aligned portion of the existing irrigation ditch, now being described as the wet meadow with the PROJECT. Future key elements assumed during the MASTER REPORT analysis that are no longer considered for construction or to be demolished with this project are the existing and future classroom buildings.

Existing Sub-Basins, B-1, B-2, B-3, and C-3: The total area of these sub-basins is approximately 24.8 ac, comprised of existing buildings, faculty residences, asphalt and gravel drive lanes, and associated hardscaping and landscaping. Sub-basin B-1 is generally undisturbed and will have no major improvements occur as part of the PROJECT but should be considered as sub-basin B-1 introduces approximately 35.5cfs during the 100-YR event to the proposed storm sewer system and is tributary to design point 3a also being downstream most outfall of the irrigation ditch and the final design point of the proposed PROJECT stormwater infrastructure. Improvements to sub-basin B-1 generally include realignment of the existing asphalt drive lane, relocation of existing storm sewer curb inlets, and minor hardscaping and landscaping improvements. Sub-basins B-2, B-3, and C-3 in the MASTER REPORT encompass the PROJECT and proposed



development and shall be further sub-divided and analyzed as part of this drainage study. Further discussion will occur within the proposed drainage section of this report.

In general, runoff generated within western portion the existing Fountain Valley School of Colorado campus is intended to be collected and conveyed via overland flow and storm sewer infrastructure to the existing irrigation ditch starting north of the existing tennis courts, also being design point 5, and ending at design point 3a also being the final campus outfall. From this point, runoff is conveyed via irrigation ditch east of Fountain Valley School Road before being discharged to flood irrigate the existing heavily vegetated hay fields south of the track and field and east of Fountain Valley School Road. These hay fields also function as the water quality facility servicing the existing campus per the approved drainage criteria deviation. DEV17015, submitted and approved with a 2007 development, requests deviation from ECM Section I.7.1.B. The proposed deviation was for a 'non-standard' BMP, in lieu of a 'standard' BMP, being the private irrigation system and hay fields to provide water quality to an extent equal to or greater than a constructed BMP. In the deviation review and decision form, the following was stated: "Theoretical analysis of the water quality control is difficult to impossible to determine for BMPs. However, empirically the required water quality control is provided as the required water quality capture volume is met not only for the proposed development, but for the entire developed core area of the school." A copy of the deviation request form has been included in Appendix D for reference.

Proposed Drainage

Runoff generated within the proposed development is intended to be collected and conveyed via overland flow, storm sewer infrastructure, and surface features such as a BioSwale and Wet Meadow to the existing design point 3a at the southeast corner of the proposed site. Due to the nature of improvements associated with the PROJECT various existing elements for drainage conveyance have been removed and replaced. Most notably the existing culvert at design point 3a and the grass lined portion of the irrigation ditch southeast of the existing administrative building. These improvements do not fundamentally change the conveyance of runoff but provide a more functional use of the space to better fit the campus programmatic updates associated with the PROJECT. As stated previously, the proposed development is approximately 10.43 acres of disturbed area. The rational calculations prepared for this report pertain to the area, approximately 9.39 acres, tributary to design point 3a, also being the existing culvert at the southeast corner of the site north of existing site access road east of the campus main entry roundabout. The remaining 1.04 acres is limited to offsite bases that are not tributary to design point 3a. These areas being the redeveloped MASTER REPORT sub-basin A-2 and the proposed southeast surface parking lot. These areas are tributary to MASTER REPORT design points 1 and 8, respectively.

The PROJECT proposes a heart of campus redevelopment that is approximately 9.39 acres and 36.8% impervious with approximate 10-YR and 100-YR runoff quantities of 21.37cfs and 43.67cfs, respectively. In comparison to the existing sub-basins, analyzed within the MASTER REPORT, to be redeveloped, the acreage and 100-YR runoff quantities are as follows, 10.01 acres and 37.8cfs, respectively. It is important to note that the 5.87cfs delta in runoff quantities



between the proposed and existing site may be largely attributed to the assumptions taken with respect to the MASTER REPORT and the future development that was quantified. The PROJECT is redeveloping existing sub-basins B-2, B-3, and C-3 which assumed minimal building additions whereas larger building additions were slated for construction in adjacent existing sub-basins. In the existing condition at the time of this report, various future buildings and/or additions assumed by the MASTER REPORT did not materialize and the PROJECT has proposed two larger structures amounting to approximately 30,754SF. Demolition of two structures is set to occur with the PROJECT amounting to approximately 9,729SF, resulting in a net addition of 21,025SF of roof area not originally assumed or accounted for in runoff calculations for the existing sub-basins in question which amounts to approximately 3.92cfs additional runoff that assumed in the MASTER REPORT for the respective existing basins. During a past development within the Fountain Valley School of Colorado Campus, a drainage study was complete to determine the additional required storage associated with the development. The study titled “Drainage Memo Fountain Valley School” PCD File No. PPR1917, prepared by Kiowa Engineering Corporation, dated May 23, 2019 prepared a drainage analysis in which the following were documented:

- Full spectrum analysis of the currently (as of 2019) developed portion of the campus requires 2.35 acre-feet of detention storage
- The proposed 2019 development contributed an additional 0.05 acre-feet of required storage
- Over 6,000 lineal feet of private irrigation ditches provide 1.11 acre-feet of detention storage.
- Remaining 1.29 acre-feet of required detention storage will occur within the existing hay fields, resulting in a ponding depth across the hay fields of 0.29”

For the purposes of this study, an analysis of the existing MASTER REPORT basins impacted with the PROJECT has been carried out and compared with the proposed development. See Table 1 below for results:

Detention Summary				
	Basins	Area (AC)	Imperviousness	Required Detention Volume (AC-FT)
Existing	B-2, B-3, C-3	10.01	35.00%	0.700
Proposed	A1-A13, B1-B26, C1-C21, OS1-OS4	11.02	36.8%	0.840
Delta	-	-	-	0.140

Table 1: Existing and Proposed Detention Summary Table



The proposed development will require an additional 0.140 acre-feet of detention storage. Following the analysis provided in the abovementioned drainage memo, the excess 0.140 acre-feet associated with the PROJECT in addition to the previously assumed excess 1.29 acre-feet, results in a required detention storage volume of 1.43 acre-feet to be provided by the existing hay fields. The additional runoff results in an additional 0.03" of ponding depth dispersed over the hay fields totaling 0.32-inches of depth over the tributary hay fields. Based on the calculations provided in the drainage memo, it is assumed that the hay fields amount to 53.38ac of receiving area.

Based on the analysis provided in the MASTER REPORT, Drainage Memo (PPR1917), and this report, it is assumed that any delta in runoff quantities is negligible to the entire campus drainage system, water quality provided by the hay fields, and capacity of the downstream detention provided by Carp Lake. This report and the accompanying appendices will demonstrate that the proposed storm sewer infrastructure, BioSwale, and Wet Meadow, have been adequately sized to convey the minor and major events, in addition to ensuring that the final outfall for the proposed site, existing design point 3a, has been adequately sized for all tributary runoff.

Proposed Site Drainage Specific Details

The proposed site and associated drainage strategy has been sub-divided into four primary catchment areas. Three of the four areas are tributary to three, proposed, primary collection or conveyance elements. The fourth area is limited to off-site basins which will not enter any of the proposed collection or conveyance elements but still remain within the larger campus wide site drainage strategy and patterns. Further discussion of off-site basins will be given below in this report. The remaining onsite areas tributary to existing design point 3a, the ultimate site outfall, also being proposed design point C20, can be further described as follows:

- 'A' Sub-Basins
 - 'A' sub-basins are limited to A1-A17, have surfaces characteristics limited to landscaping, concrete, roof, gravel, and grasspave system. The general drainage strategy is limited to overland flow, with the exception of specific areas where storm infrastructure is required to convey runoff bound by various site/building elements. Runoff within 'A' sub-basins will generally flow west to east, curb chases have been strategically placed to provide areas for runoff to traverse beneath walks and avoid overtopping of walks. Ultimately, all 'A' sub-basins are tributary to the BioSwale located west of the proposed buildings. Developed runoff associated with the 'A' sub-basins has been calculated at 8.5cfs for the minor storm and 17.69cfs for the major storm event. The bioswale has been designed to convey both the minor and major events while indirectly providing additional water quality, that has not been accounted for, via sediment deposits along the bottom channel of the BioSwale. Sections along the BioSwale have been analyzed to determine water surface elevation and ensure adequate



clearance beneath pedestrian bridge and walkway crossings. Once runoff associated with the 'A' sub-basins is discharged from the BioSwale flared end section, it will enter a gravel swale and sediment basin to dissipate energy and trap sediment prior to entering the Wet Meadow. Once runoff enters the Wet Meadow, all flows from 'A' and 'C' sub-basins will be conveyed to design point C20 which is the ultimate outfall point for all runoff associated with the PROJECT. Design point C20 is a proposed 45"x29" HERCP culvert that has replaced the existing 30"x19" existing HERCP culvert. From here, runoff will enter the existing irrigation ditch south of Fountain Valley School Road before adhering to existing drainage patterns and flood irrigating the existing hay fields.

- 'B' Sub-Basins
 - 'B' sub-basins are limited to B1-B24, have surface characteristics limited to landscaping, asphalt, concrete, grasspave and gravelpave systems, roof, and gravel. The general drainage strategy is limited to minor overland flows directed towards concentrated conveyance paths via grass swales, gravel swales, and curb and gutter, to be collected by area inlets and roadway inlets. All developed runoff within the proposed 'B' sub-basins shall be collected and conveyed via storm sewer infrastructure. The main site trunk line responsible for the conveyance of proposed 'B' sub-basin runoff, and the MASTER REPORT existing sub-basin B-1, is Stormline A, which has a secondary outfall that has been divorced from the BioSwale and Wet Meadow. To reduce the size of energy dissipation structures, sediment forebays, and proposed culverts, runoff within the proposed 'B' sub-basins and the existing 35.5cfs per the MASTER REPORT has been elected to be divorced from the overland site runoff. The secondary outfall is intended to maintain existing drainage patterns by discharging on the south side of Fountain Valley School Road and reintroducing runoff to the existing irrigation ditch before entering existing conveyance paths and flood irrigating the existing hay fields to provide water quality as mentioned above. All runoff associated with the 'B' sub-basins tributary to Stormline A, located west of the proposed buildings, has been calculated at 4.79cfs for the minor storm and 9.51cfs for the major storm event in the proposed condition. Hydraulic modeling has been completed and includes the additional 35.5cfs in the major storm event associated with the MASTER REPORT B-1 sub-basin to ensure all storm infrastructure has been adequately sized.
- 'C' Sub-Basins
 - 'C' sub-basins are limited to C1-C21, have surface characteristics limited to landscaping, grasspave and gravel pave systems, gravel, concrete, asphalt, and roof. The general drainage strategy is limited to minor overland flows directed towards concentrated conveyance paths via grass swales, gravel swales, and curb and gutter, to be collected by area inlets and roadway inlets. All developed runoff within the proposed 'C' sub-basins shall be collected and conveyed via storm sewer infrastructure before ultimately outfalling to the Wet Meadow in the southeast portion of the site. Stormlines B and C are the main trunk line associated with the conveyance of this portion of the site. 'C' sub-basins cover



the remaining site area being the eastern portion of the buildings and PROJECT site in addition to the proposed asphalt drive lane along the northern portion of the PROJECT site and a portion of site northeast of the existing student center. Runoff will generally flow overland or be discharged via flared end section into the proposed Wet Meadow before ultimately being conveyed via culvert to the existing irrigation ditch southeast of fountain valley school road. From here, runoff will enter the existing irrigation ditch south of Fountain Valley School Road before adhering to existing drainage patterns and flood irrigating the existing hay fields.

Proposed Site Drainage – Off-site Drainage

Off-site drainage is limited to two areas within the PROJECT site. The first area where off-site drainage is to occur is within MASTER REPORT sub-basin A-1 and A-2, the existing asphalt road, west of the existing chapel, and the associated landscaping and hardscaping. In the existing condition, drainage within MASTER REPORT sub-basin A-1 overland flows to existing design point 1, west of the main entry roundabout, before entering a 24" CMP culvert. Runoff within MASTER REPORT sub-basin A-2 is conveyed via roadside ditch to a 24" CMP culvert northwest of the main entry roundabout before being conveyed to design point 1. Improvements to these basins are limited to a realignment of the existing asphalt road, additional surface parking, concrete sidewalk, and grasspave system. It should be noted that in the existing MASTER REPORT drainage plan various future improvements such as future surface parking, future preforming arts building, future amphitheater, and a future classroom expansion were accounted for when designing this basin. In the existing condition at the time of this report, none of the abovementioned improvements have been constructed. In addition, the assumed for future parking encompasses a much greater area than the additional surface parking provided with the PROJECT.

Proposed off-site basins OS1 and OS2 and the impacted MASTER REPORT basins can be more specifically described as follows:

Sub-Basin OS1/Ex. Basin A-1: 0.15acres, $Q_{100}=0.94\text{cfs}/25.46\text{ac}$, $Q_{100}=45.0\text{cfs}$

Sub-Basin OS2/Ex. Basin A-2: 0.75acres, $Q_{100}=3.0\text{cfs}/3.94\text{ac}$, $Q_{100}=45.0\text{cfs}$

Ex. Basin A-1 accounted for a proposed additional surface parking lot and future building when evaluating runoff calculations. These total areas amount to 7840SF roof (90% impervious) and 6705SF pavement (100% impervious) resulting in approximately 2.94cfs. By comparison, the additional impervious area added within Sub-Basin OS-1 is limited to 2935SF of pavement resulting in 0.59cfs. Based on these calculations, there is no increase in developed runoff based on the improvements associated with this PROJECT to Ex. Basin A-1.

Ex. Basin A-2 accounted for a proposed future building and amphitheater when evaluating runoff calculations. These total areas amount to 9300SF roof (90% impervious) and 10285SF pavement (100% impervious) resulting in approximately 3.96cfs. By comparison, the additional impervious area added within Sub-Basin OS-1 is limited to 8055SF of pavement and 2950SF of



grasspave system (35% impervious) resulting in 0.65cfs. Based on these calculations, there is no increase in developed runoff based on the improvements associated with this PROJECT to Ex. Basin A-2.

The development associated with the PROJECT within Ex. Basin A-1 and Ex. Basin A-2 is a reduction in assumed impervious area and therefore will have no increase in developed runoff, or adverse effects on the downstream infrastructure. The additional area where off-site drainage occurs is located in the southeast portion of the site, also being the proposed surface parking lot. The improvements associated with the PROJECT are limited to the asphalt surface parking lot which is a revitalization of the existing surface parking lot. During the drainage and grading analysis of the proposed project, it was intended to maintain existing drainage patterns. Existing topography suggests that runoff within this portion of the existing campus generally slopes west to east. In order to maintain historic drainage patterns, the proposed surface parking lot was designed to best match the existing condition resulting in off-site flows adhering to historic drainage patterns. In total, offsite drainage accounts for 1.62 acres of disturbed area resulting in a total disturbed PROJECT area of 10.17 acres. Refer to the Existing Drainage Plan Exhibit included in Appendix D.

III. DRAINAGE DESIGN CRITERIA

A. Regulations

The proposed drainage design is in compliance with the following criteria:

- El Paso County Drainage Criterial Manual Volume 1 and 2, October 2018 (CRITERIA)
- El Paso County Engineering Criterial Manual, January 2025 (E-CRITERIA)
- Mile High Flood District (MHFD) Drainage Criteria Manual Volumes 1, 2, and 3, latest revision (MANUAL)
- The City of Colorado Springs Drainage Criteria Manual Volume 1, January 2021 (CS CRITERIA)

B. Development Criteria Reference and Constraints

Development constraints the PROJECT and existing campus must adhere to are the requirements laid out in the MASTER REPORT for future development and the approved drainage criteria deviation, DEV17015.

C. Hydrologic Criteria

The proposed design is in accordance with the CRITERIA and the MANUAL. The major and minor design storms utilized for the hydrologic and hydraulic calculations are the 100-year and 10-year events, respectively, per the criteria. The rational method was utilized to determine unrouted, 100-year and 5-year, stormwater runoff associated with the proposed development. Soils were classified as NRCS Hydrologic Soil Group A for rational calculations. Per the CRITERIA, NOAA Atlas 14 one-hour point rainfall data was utilized to ensure the most accurate values were taken into consideration. The 100-year, one-hour precipitation depth utilized for calculations was 2.73



inches, while the 10-year, one-hour precipitation depth utilized was 1.55 inches. Runoff coefficients and surface characteristic impervious values were based on the CRITERIA. In general, one-hour point rainfall depths for the sub-basins tributary to the existing drainage conveyance system are summarized in the table below:

One (1) Hour Point Rainfall (inches)					
2-Year	5-Year	10-Year	25-Year	50-Year	100-Year
1.00	1.28	1.55	1.97	2.33	2.73

Table 2: One-Hour Point Rainfall Data for Fountain Valley School of Colorado, Colorado Springs, CO

All hydrologic calculations are available for reference within Appendix B.

D. Hydraulic Criteria

Hydraulic analysis for the proposed drainage infrastructure has been designed in accordance with the CRITERIA and CS CRITERIA using Bentley StormCAD hydraulic modeling software. Per the CRITERIA the minor and major storm intervals were considered to have 10-Year and 100-Year return periods, respectively. Supporting calculations and profiles have been provided in Appendix C. The table below provided in Chapter 9 of the CS CRITERIA defines the bend and lateral loss coefficients utilized with the standard headloss method in StormCAD:

Table 9-4. STORMCAD Standard Method Coefficients

Bend Loss		
Bend Angle	K Coefficient	
0°	0.05	
22.5°	0.10	
45°	0.40	
60°	0.64	
90°	1.32	
LATERAL LOSS		
One Lateral K Coefficient		
Bend Angle	Non-surcharged	Surcharged
45°	0.27	0.47
60°	0.52	0.90
90°	1.02	1.77
Two Laterals K Coefficient		
45°	0.96	
60°	1.16	
90°	1.52	

Table 3: StormCAD Standard Headloss Coefficients, CS CRITERIA



E. Four-Step Process

The Four-Step Process, as outlined in the CRITERIA, is a stormwater management procedure utilized in the design of newly developed or significant redeveloped properties such as the PROJECT. Below is an in-depth discussion of how the proposed site layout and drainage design implement various best management practices from each section of the Four-Step Process in order to increase overland travel time, minimize impervious surfaces, promote infiltration, and indirectly provide water quality, upstream of the existing hayfields which provide water quality to the campus.

Step 1 – Employment of Runoff Reduction Practices

The proposed drainage design utilizes various methods of stormwater conveyance. In general, the drainage design can be split into three separate functions. Existing offsite flows utilizing the same downstream outfall as this project will be conveyed via storm sewer infrastructure. The redevelopment associated with this project has not adversely impacted the existing conveyance method but instead realigned existing storm sewer infrastructure to meet the function of the proposed development. Runoff within the area of the proposed campus development will predominately flow overland through a majority landscaped site before entering the BioSwale or Wet Meadow, two grass lined swales intended to collect and convey a majority of the runoff associated with the proposed development. In addition, the roof drainage system has been designed to split flows and provide ample opportunity for roof drains to discharge at grade to cobble lined swales and cobble splash pads. In areas where existing and proposed site grades do not provide an overland flow path to either of the two above mentioned campus drainage features, grass and cobble swales have been designed to convey runoff within these basins, particularly areas of landscaping adjacent to the east side of proposed structures, to proposed drain basins which will then be piped via proposed storm sewer. Along the west side of the proposed structures, runoff captured by area drains will be conveyed via storm sewer to the Wet Meadow. The proposed site is approximately 58% Landscaping, 13% Pavement, and 29% building coverage. Within the heart of campus, pavement is limited to pedestrian paths, providing an accessible route to all buildings adjacent to the proposed development. In addition to the high pervious to impervious ratio, grasspave2 and gravelpave2 systems have been utilized for fire access lanes and areas of student congregation in lieu of paved surfaces to promote infiltration, decrease imperviousness, and decrease runoff and required storm sewer sizes.

Step 2 – Stabilize Drainageways

The drainage design utilizes various grass and rock lined swales in areas of concentrated flows. Roof drains along the east side of the Humanities building will discharge at grade to one of three gravel line conveyance channels. Check dams have been placed in various locations along the gravel swales to assist with energy dissipation, controlling the direction of flow, and deposition of larger sediment. Along the northeast and southeast sides of the STEM building, gravel swales have been designed to convey runoff adjacent to the buildings. Flood resistant plantings have been selected by the landscape architect to create a more natural riparian vegetated area while providing an enhanced aesthetic to the functional drainageways. Where applicable, grass line swales have been designed to facilitate the conveyance of water away from structures to design low points with area inlets before ultimately outfalling to the wet meadow or the downstream



receiving landscaping and hay fields, where water quality is provided for the entire campus. The wet meadow and bioswale provide a combination of grass and gravel lined drainageways with the inclusion of riparian vegetation. The drainage features have been designed to incorporate low flow and high flow conveyance zones. The bioswale utilizes a gravel lined flat bottom, with a width ranging from 5' to 10'. Outside of this low flow zone designed to convey the minor storm event, the bioswale spans approximately 25' with the remaining surface area being densely vegetated. The method of design implemented in the bioswale stabilizes the drainageway, promotes riparian aesthetic, and indirectly provides water quality through the use of a gravel lined bottom, flood resistant dense vegetation, and seeded side slopes. Lastly, the wet meadow has been designed to mimic the bioswale – provide low flow and high flow zones to convey the minor and major storm events. The wet meadow has been designed with a 6'-wide triangular bottom sloped up at 2% from the flowline of the drainageway. Longitudinal slopes have been designed at 0.5% for the majority of the wet meadow to reduce the runoff velocity, promote the settling of sediment particles, and promote infiltration. Similarly to the bioswale, dense vegetation has been included along the embankment of the wet meadow to provide a riparian aesthetic. The wet meadow has been fully seeded with flood resistant grasses to stabilize the drainageway.

Step 3 – Provide Water Quality Capture Volume (WQCV)

The proposed redevelopment will leverage the large lot exclusion as outlined in the El Paso County Engineering Criteria Manual (E-CRITERIA) Appendix I.7.1.B.5, which waives the requirement for water quality treatment for lot exceeding 2.5 acres and have less than 10% (or up to 20% with a study) imperviousness. The Fountain Valley School of Colorado campus is approximately 989.4 acres. The drainage study associated with the MASTER REPORT analyzed a total area amounting to 263.41 acres, inclusive of the area associated with the PROJECT. As described in this report above, the MASTER REPORT accounts for various future developments and has a conservative total runoff discharge and imperviousness. The improvements associated with the project are within conformance of the MASTER REPORT and are believed to have no net impervious increase on the entire campus as various assumed future developments studied within the MASTER REPORT have not come to fruition. A site composite runoff coefficient utilized in the MASTER REPORT for the 263.41 acres analysis of the 100YR storm event was 0.41, indicative of a predominately pervious site with a site composite imperviousness of approximately 35%. It should be noted that a majority of the 263.41 acres studied in the MASTER REPORT is landscaping. In evaluating the remaining 725.99 acres, this report has calculated, through the use of aerial imagery, approximately 7 miles or 36,960 feet of dirt roadway/maintenance paths outside of the MASTER REPORT analysis. The maintenance paths range in width from 5' to 10'. Assuming an average width of 8', the total square footage of impervious surfaces within the remaining 725.99 acres amounts to 295,680 SF. Based on the MASTER REPORT 263.41 acres with 35% impervious and the remaining 725.99 acres with an estimated 0.6% impervious, the total 989.4 acre weighted composite campus impervious has been calculated to be 9.73% imperviousness, satisfying the E-CRITERIA requirements for a large lot exclusion from Water Quality. It should be noted that when calculating the weighted campus imperviousness, Mile High Flood District Drainage Criteria Manual Volume 1 (MANUAL) was utilized to determine the imperviousness of a dirt maintenance path. The CRITERIA does not



carry an impervious value associated with gravel and dirt roads/maintenance paths. It is the engineer's opinion that utilizing the imperviousness value associated with gravel listed in the CRITERIA (80% imperviousness) is not an accurate representation of the maintenance paths within the campus property. Based on these calculations, it is believed that the Fountain Valley School of Colorado campus qualifies for a large lot exclusion from the requirement to provide water quality.

Step 4 – Consider Need for Industrial and Commercial BMPs

The proposed redevelopment does not fall within a standard commercial or industrial site characterization. While the Fountain Valley School of Colorado is a high school, it is an atypical boarding school with a majority of faculty and staff living on campus. The campus, in its nature, is predominately landscaping with an emphasis on outdoor activities and outdoor greenspace where student can congregate.

IV. DRAINAGE FACILITY DESIGN

A. General Concept

The PROJECT anticipates a total of 10.17 acres to be disturbed with 9.39 acres tributary to MASTER REPORT design point 3a. Per the MASTER REPORT, no maximum developed imperviousness was provided however the proposed development has remained within the constraints provided by the MASTER REPORT.

The proposed site has been sub-divided into 59 individual basins and then further categorized into three separate tributary quadrants, namely the BioSwale Flows, Wet Meadow Flows, and Piped Flows. The areas tributary to the BioSwale account for approximately 4.19 acres and produces runoff quantities of 8.5cfs and 17.69cfs for the minor and major events, respectively. Cross sections of the bioswale have been analyzed with the use of Bentley FlowMaster. The geometry of the bioswale consists of a 5'-wide flat bottom, with side slopes ranging from 2%-25% and variable distances. The bioswale has been designed such that during the 100-Year event the normal depth will not exceed 15", while maintaining a minimum 12 inches of freeboard between the 100-YR water surface elevation and the bottom of the pedestrian bridge. The area tributary to the Wet Meadow is approximately 3.64 acres and produces runoff quantities of 8.08cfs and 16.47cfs for the minor and major events, respectively. The wet meadow has been designed as a trapezoidal channel with bottom side slopes of 2% for the first 1.5' offset on either side of the centerline with the remaining channel having side slopes ranging from 2%-25%. Bentley FlowMaster was utilized for cross section analysis. The Piped Flows are limited to the remainder of the PROJECT site and account for approximately 1.56 acres and produces runoff quantities of 4.79cfs and 9.51cfs for the minor and major events, respectively. StormCAD was utilized to evaluate the hydraulics of the system for the proposed and existing developments.



V. CONCLUSIONS

A. Compliance with Standards

This drainage study conforms to The City of Colorado Springs/El Paso County Drainage Criterial Manual Volume 1 and 2, October 2018, the latest revision of the Mile High Flood District Manual Volumes 1-3, and the City of Colorado Springs Drainage Criteria Manual Volume 1, January 2021.

B. Drainage Concept

The proposed storm drainage system outline in this report is designed to fully accommodate the 100-Year storm event in the developed condition. As the entirety of the PROJECT site is not capturable, off-site flows will adhere to existing drainage patterns before ultimately being conveyed to the existing heavily vegetated hay fields where water quality is provided. The development of this site will not adversely impact any downstream existing waterways, infrastructure, or Carp Lake.

REFERENCES

The City of Colorado Springs/El Paso County Drainage Criteria Manual Volume 1 and 2, October 2018 (CRITERIA)

Mile High Flood District (MHFD) Drainage Criteria Manual Volumes 1, 2, and 3, latest revision (MANUAL)

The City of Colorado Springs Drainage Criteria Manual Volume 1, January 2021 (CS CRITERIA)

“Master Development Drainage Plan Fountain Valley School” prepared by Kiowa Engineering Corporation, and dated received April 28, 2011

“Drainage Memo Fountain Valley School” prepared by Kiowa Engineering Corporation, and dated May 23, 2019

APPENDIX A – Maps and Design Aids

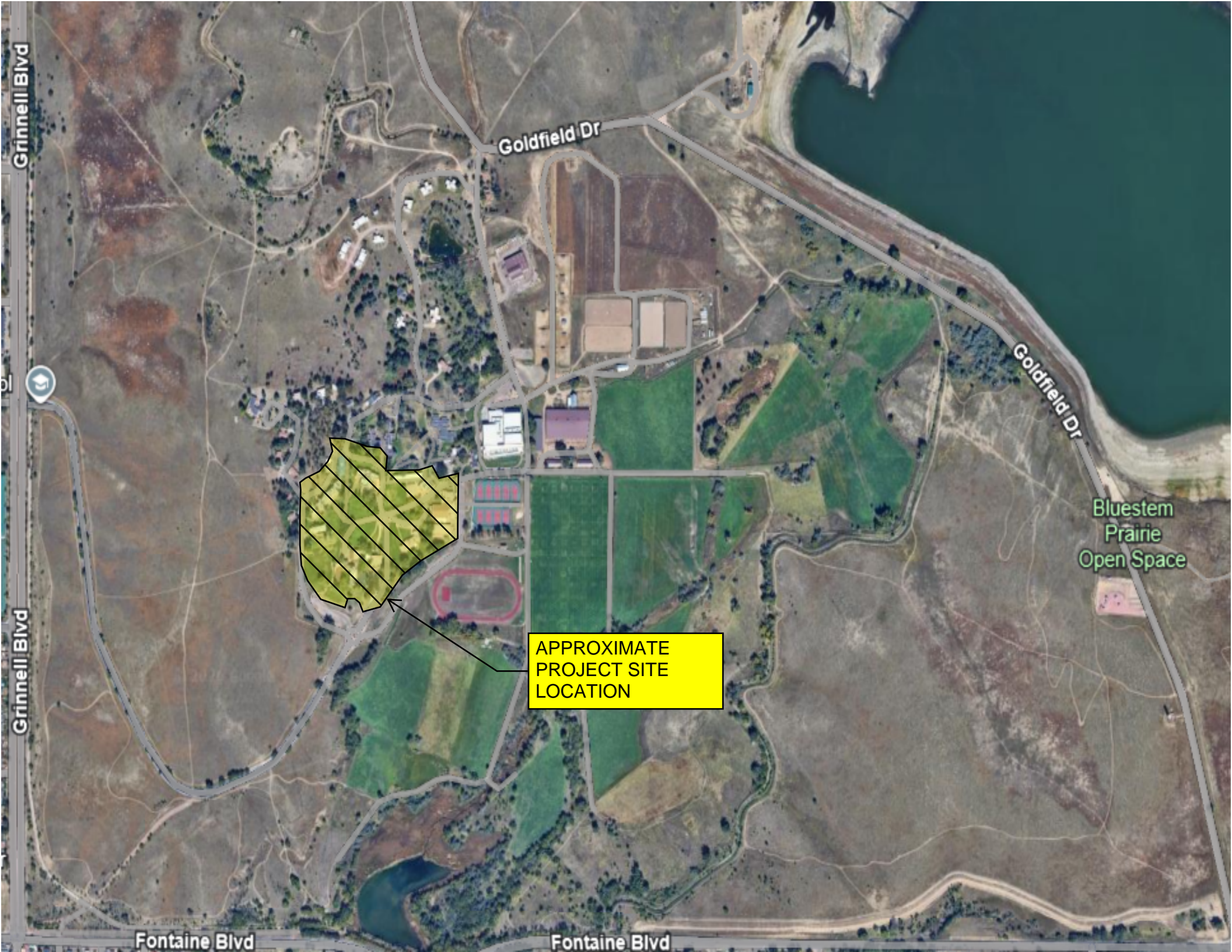

Goldfield Dr

Goldfield Dr

Grinnell Blvd

Grinnell Blvd

Fontaine Blvd

Fontaine Blvd

Bluestem
Prairie
Open Space

APPROXIMATE
PROJECT SITE
LOCATION



National Flood Hazard Layer FIRMette



104°42'56"W 38°44'51"N

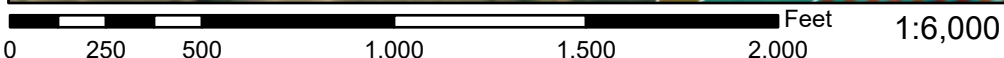

Basemap Imagery Source: USGS National Map 2023

Legend

SEE FIS REPORT FOR DETAILED LEGEND AND INDEX MAP FOR FIRM PANEL LAYOUT

SPECIAL FLOOD HAZARD AREAS		Without Base Flood Elevation (BFE) <i>Zone A, V, A99</i>
		With BFE or Depth <i>Zone AE, AO, AH, VE, AR</i>
		Regulatory Floodway
OTHER AREAS OF FLOOD HAZARD		0.2% Annual Chance Flood Hazard, Areas of 1% annual chance flood with average depth less than one foot or with drainage areas of less than one square mile <i>Zone X</i>
		Future Conditions 1% Annual Chance Flood Hazard <i>Zone X</i>
		Area with Reduced Flood Risk due to Levee. See Notes. <i>Zone X</i>
		Area with Flood Risk due to Levee <i>Zone D</i>
OTHER AREAS		NO SCREEN Area of Minimal Flood Hazard <i>Zone X</i>
		Effective LOMRs
GENERAL STRUCTURES		Area of Undetermined Flood Hazard <i>Zone D</i>
		Channel, Culvert, or Storm Sewer
OTHER FEATURES		Levee, Dike, or Floodwall
		20.2 Cross Sections with 1% Annual Chance Water Surface Elevation
MAP PANELS		17.5 Cross Sections with 1% Annual Chance Water Surface Elevation
		Coastal Transect
OTHER FEATURES		Base Flood Elevation Line (BFE)
		Limit of Study
OTHER FEATURES		Jurisdiction Boundary
		Coastal Transect Baseline
OTHER FEATURES		Profile Baseline
		Hydrographic Feature
MAP PANELS		Digital Data Available
		No Digital Data Available
		Unmapped
		The pin displayed on the map is an approximate point selected by the user and does not represent an authoritative property location.

This map complies with FEMA's standards for the use of digital flood maps if it is not void as described below. The basemap shown complies with FEMA's basemap accuracy standards

The flood hazard information is derived directly from the authoritative NFHL web services provided by FEMA. This map was exported on **11/14/2023 at 5:54 PM** and does not reflect changes or amendments subsequent to this date and time. The NFHL and effective information may change or become superseded by new data over time.

This map image is void if the one or more of the following map elements do not appear: basemap imagery, flood zone labels, legend, scale bar, map creation date, community identifiers, FIRM panel number, and FIRM effective date. Map images for unmapped and unmodernized areas cannot be used for regulatory purposes.

Custom Soil Resource Report for El Paso County Area, Colorado



Preface

Soil surveys contain information that affects land use planning in survey areas. They highlight soil limitations that affect various land uses and provide information about the properties of the soils in the survey areas. Soil surveys are designed for many different users, including farmers, ranchers, foresters, agronomists, urban planners, community officials, engineers, developers, builders, and home buyers. Also, conservationists, teachers, students, and specialists in recreation, waste disposal, and pollution control can use the surveys to help them understand, protect, or enhance the environment.

Various land use regulations of Federal, State, and local governments may impose special restrictions on land use or land treatment. Soil surveys identify soil properties that are used in making various land use or land treatment decisions. The information is intended to help the land users identify and reduce the effects of soil limitations on various land uses. The landowner or user is responsible for identifying and complying with existing laws and regulations.

Although soil survey information can be used for general farm, local, and wider area planning, onsite investigation is needed to supplement this information in some cases. Examples include soil quality assessments (<http://www.nrcs.usda.gov/wps/portal/nrcs/main/soils/health/>) and certain conservation and engineering applications. For more detailed information, contact your local USDA Service Center (<https://offices.sc.egov.usda.gov/locator/app?agency=nrcs>) or your NRCS State Soil Scientist (http://www.nrcs.usda.gov/wps/portal/nrcs/detail/soils/contactus/?cid=nrcs142p2_053951).

Great differences in soil properties can occur within short distances. Some soils are seasonally wet or subject to flooding. Some are too unstable to be used as a foundation for buildings or roads. Clayey or wet soils are poorly suited to use as septic tank absorption fields. A high water table makes a soil poorly suited to basements or underground installations.

The National Cooperative Soil Survey is a joint effort of the United States Department of Agriculture and other Federal agencies, State agencies including the Agricultural Experiment Stations, and local agencies. The Natural Resources Conservation Service (NRCS) has leadership for the Federal part of the National Cooperative Soil Survey.

Information about soils is updated periodically. Updated information is available through the NRCS Web Soil Survey, the site for official soil survey information.

The U.S. Department of Agriculture (USDA) prohibits discrimination in all its programs and activities on the basis of race, color, national origin, age, disability, and where applicable, sex, marital status, familial status, parental status, religion, sexual orientation, genetic information, political beliefs, reprisal, or because all or a part of an individual's income is derived from any public assistance program. (Not all prohibited bases apply to all programs.) Persons with disabilities who require

alternative means for communication of program information (Braille, large print, audiotape, etc.) should contact USDA's TARGET Center at (202) 720-2600 (voice and TDD). To file a complaint of discrimination, write to USDA, Director, Office of Civil Rights, 1400 Independence Avenue, S.W., Washington, D.C. 20250-9410 or call (800) 795-3272 (voice) or (202) 720-6382 (TDD). USDA is an equal opportunity provider and employer.

Contents

Preface	2
How Soil Surveys Are Made	5
Soil Map	8
Soil Map.....	9
Legend.....	10
Map Unit Legend.....	11
Map Unit Descriptions.....	11
El Paso County Area, Colorado.....	13
96—Truckton sandy loam, 0 to 3 percent slopes.....	13
97—Truckton sandy loam, 3 to 9 percent slopes.....	14
References	17

How Soil Surveys Are Made

Soil surveys are made to provide information about the soils and miscellaneous areas in a specific area. They include a description of the soils and miscellaneous areas and their location on the landscape and tables that show soil properties and limitations affecting various uses. Soil scientists observed the steepness, length, and shape of the slopes; the general pattern of drainage; the kinds of crops and native plants; and the kinds of bedrock. They observed and described many soil profiles. A soil profile is the sequence of natural layers, or horizons, in a soil. The profile extends from the surface down into the unconsolidated material in which the soil formed or from the surface down to bedrock. The unconsolidated material is devoid of roots and other living organisms and has not been changed by other biological activity.

Currently, soils are mapped according to the boundaries of major land resource areas (MLRAs). MLRAs are geographically associated land resource units that share common characteristics related to physiography, geology, climate, water resources, soils, biological resources, and land uses (USDA, 2006). Soil survey areas typically consist of parts of one or more MLRA.

The soils and miscellaneous areas in a survey area occur in an orderly pattern that is related to the geology, landforms, relief, climate, and natural vegetation of the area. Each kind of soil and miscellaneous area is associated with a particular kind of landform or with a segment of the landform. By observing the soils and miscellaneous areas in the survey area and relating their position to specific segments of the landform, a soil scientist develops a concept, or model, of how they were formed. Thus, during mapping, this model enables the soil scientist to predict with a considerable degree of accuracy the kind of soil or miscellaneous area at a specific location on the landscape.

Commonly, individual soils on the landscape merge into one another as their characteristics gradually change. To construct an accurate soil map, however, soil scientists must determine the boundaries between the soils. They can observe only a limited number of soil profiles. Nevertheless, these observations, supplemented by an understanding of the soil-vegetation-landscape relationship, are sufficient to verify predictions of the kinds of soil in an area and to determine the boundaries.

Soil scientists recorded the characteristics of the soil profiles that they studied. They noted soil color, texture, size and shape of soil aggregates, kind and amount of rock fragments, distribution of plant roots, reaction, and other features that enable them to identify soils. After describing the soils in the survey area and determining their properties, the soil scientists assigned the soils to taxonomic classes (units). Taxonomic classes are concepts. Each taxonomic class has a set of soil characteristics with precisely defined limits. The classes are used as a basis for comparison to classify soils systematically. Soil taxonomy, the system of taxonomic classification used in the United States, is based mainly on the kind and character of soil properties and the arrangement of horizons within the profile. After the soil

Custom Soil Resource Report

scientists classified and named the soils in the survey area, they compared the individual soils with similar soils in the same taxonomic class in other areas so that they could confirm data and assemble additional data based on experience and research.

The objective of soil mapping is not to delineate pure map unit components; the objective is to separate the landscape into landforms or landform segments that have similar use and management requirements. Each map unit is defined by a unique combination of soil components and/or miscellaneous areas in predictable proportions. Some components may be highly contrasting to the other components of the map unit. The presence of minor components in a map unit in no way diminishes the usefulness or accuracy of the data. The delineation of such landforms and landform segments on the map provides sufficient information for the development of resource plans. If intensive use of small areas is planned, onsite investigation is needed to define and locate the soils and miscellaneous areas.

Soil scientists make many field observations in the process of producing a soil map. The frequency of observation is dependent upon several factors, including scale of mapping, intensity of mapping, design of map units, complexity of the landscape, and experience of the soil scientist. Observations are made to test and refine the soil-landscape model and predictions and to verify the classification of the soils at specific locations. Once the soil-landscape model is refined, a significantly smaller number of measurements of individual soil properties are made and recorded. These measurements may include field measurements, such as those for color, depth to bedrock, and texture, and laboratory measurements, such as those for content of sand, silt, clay, salt, and other components. Properties of each soil typically vary from one point to another across the landscape.

Observations for map unit components are aggregated to develop ranges of characteristics for the components. The aggregated values are presented. Direct measurements do not exist for every property presented for every map unit component. Values for some properties are estimated from combinations of other properties.

While a soil survey is in progress, samples of some of the soils in the area generally are collected for laboratory analyses and for engineering tests. Soil scientists interpret the data from these analyses and tests as well as the field-observed characteristics and the soil properties to determine the expected behavior of the soils under different uses. Interpretations for all of the soils are field tested through observation of the soils in different uses and under different levels of management. Some interpretations are modified to fit local conditions, and some new interpretations are developed to meet local needs. Data are assembled from other sources, such as research information, production records, and field experience of specialists. For example, data on crop yields under defined levels of management are assembled from farm records and from field or plot experiments on the same kinds of soil.

Predictions about soil behavior are based not only on soil properties but also on such variables as climate and biological activity. Soil conditions are predictable over long periods of time, but they are not predictable from year to year. For example, soil scientists can predict with a fairly high degree of accuracy that a given soil will have a high water table within certain depths in most years, but they cannot predict that a high water table will always be at a specific level in the soil on a specific date.

After soil scientists located and identified the significant natural bodies of soil in the survey area, they drew the boundaries of these bodies on aerial photographs and

Custom Soil Resource Report

identified each as a specific map unit. Aerial photographs show trees, buildings, fields, roads, and rivers, all of which help in locating boundaries accurately.

Soil Map

The soil map section includes the soil map for the defined area of interest, a list of soil map units on the map and extent of each map unit, and cartographic symbols displayed on the map. Also presented are various metadata about data used to produce the map, and a description of each soil map unit.

Custom Soil Resource Report Soil Map



Map Scale: 1:2,780 if printed on A landscape (11" x 8.5") sheet.



Map projection: Web Mercator Corner coordinates: WGS84 Edge tics: UTM Zone 13N WGS84

MAP LEGEND

Area of Interest (AOI)

 Area of Interest (AOI)



















Soils







 Soil Map Unit Polygons

 Soil Map Unit Lines

 Soil Map Unit Points

Special Point Features





-  Blowout
-  Borrow Pit
-  Clay Spot
-  Closed Depression
-  Gravel Pit
-  Gravelly Spot
-  Landfill
-  Lava Flow
-  Marsh or swamp
-  Mine or Quarry
-  Miscellaneous Water
-  Perennial Water
-  Rock Outcrop
-  Saline Spot
-  Sandy Spot
-  Severely Eroded Spot
-  Sinkhole
-  Slide or Slip
-  Sodic Spot

-  Spoil Area
-  Stony Spot
-  Very Stony Spot
-  Wet Spot
-  Other
-  Special Line Features

Water Features

 Streams and Canals

Transportation

-  Rails
-  Interstate Highways
-  US Routes
-  Major Roads
-  Local Roads

Background

 Aerial Photography

MAP INFORMATION

The soil surveys that comprise your AOI were mapped at 1:24,000.

Warning: Soil Map may not be valid at this scale.

Enlargement of maps beyond the scale of mapping can cause misunderstanding of the detail of mapping and accuracy of soil line placement. The maps do not show the small areas of contrasting soils that could have been shown at a more detailed scale.

Please rely on the bar scale on each map sheet for map measurements.

Source of Map: Natural Resources Conservation Service
 Web Soil Survey URL:
 Coordinate System: Web Mercator (EPSG:3857)

Maps from the Web Soil Survey are based on the Web Mercator projection, which preserves direction and shape but distorts distance and area. A projection that preserves area, such as the Albers equal-area conic projection, should be used if more accurate calculations of distance or area are required.

This product is generated from the USDA-NRCS certified data as of the version date(s) listed below.

Soil Survey Area: El Paso County Area, Colorado
 Survey Area Data: Version 22, Sep 3, 2024

Soil map units are labeled (as space allows) for map scales 1:50,000 or larger.

Date(s) aerial images were photographed: Jul 23, 2024—Aug 4, 2024

The orthophoto or other base map on which the soil lines were compiled and digitized probably differs from the background imagery displayed on these maps. As a result, some minor shifting of map unit boundaries may be evident.

Map Unit Legend

Map Unit Symbol	Map Unit Name	Acres in AOI	Percent of AOI
96	Truckton sandy loam, 0 to 3 percent slopes	4.0	22.7%
97	Truckton sandy loam, 3 to 9 percent slopes	13.7	77.3%
Totals for Area of Interest		17.7	100.0%

Map Unit Descriptions

The map units delineated on the detailed soil maps in a soil survey represent the soils or miscellaneous areas in the survey area. The map unit descriptions, along with the maps, can be used to determine the composition and properties of a unit.

A map unit delineation on a soil map represents an area dominated by one or more major kinds of soil or miscellaneous areas. A map unit is identified and named according to the taxonomic classification of the dominant soils. Within a taxonomic class there are precisely defined limits for the properties of the soils. On the landscape, however, the soils are natural phenomena, and they have the characteristic variability of all natural phenomena. Thus, the range of some observed properties may extend beyond the limits defined for a taxonomic class. Areas of soils of a single taxonomic class rarely, if ever, can be mapped without including areas of other taxonomic classes. Consequently, every map unit is made up of the soils or miscellaneous areas for which it is named and some minor components that belong to taxonomic classes other than those of the major soils.

Most minor soils have properties similar to those of the dominant soil or soils in the map unit, and thus they do not affect use and management. These are called noncontrasting, or similar, components. They may or may not be mentioned in a particular map unit description. Other minor components, however, have properties and behavioral characteristics divergent enough to affect use or to require different management. These are called contrasting, or dissimilar, components. They generally are in small areas and could not be mapped separately because of the scale used. Some small areas of strongly contrasting soils or miscellaneous areas are identified by a special symbol on the maps. If included in the database for a given area, the contrasting minor components are identified in the map unit descriptions along with some characteristics of each. A few areas of minor components may not have been observed, and consequently they are not mentioned in the descriptions, especially where the pattern was so complex that it was impractical to make enough observations to identify all the soils and miscellaneous areas on the landscape.

The presence of minor components in a map unit in no way diminishes the usefulness or accuracy of the data. The objective of mapping is not to delineate pure taxonomic classes but rather to separate the landscape into landforms or landform segments that have similar use and management requirements. The delineation of such segments on the map provides sufficient information for the development of resource plans. If intensive use of small areas is planned, however,

Custom Soil Resource Report

onsite investigation is needed to define and locate the soils and miscellaneous areas.

An identifying symbol precedes the map unit name in the map unit descriptions. Each description includes general facts about the unit and gives important soil properties and qualities.

Soils that have profiles that are almost alike make up a *soil series*. Except for differences in texture of the surface layer, all the soils of a series have major horizons that are similar in composition, thickness, and arrangement.

Soils of one series can differ in texture of the surface layer, slope, stoniness, salinity, degree of erosion, and other characteristics that affect their use. On the basis of such differences, a soil series is divided into *soil phases*. Most of the areas shown on the detailed soil maps are phases of soil series. The name of a soil phase commonly indicates a feature that affects use or management. For example, Alpha silt loam, 0 to 2 percent slopes, is a phase of the Alpha series.

Some map units are made up of two or more major soils or miscellaneous areas. These map units are complexes, associations, or undifferentiated groups.

A *complex* consists of two or more soils or miscellaneous areas in such an intricate pattern or in such small areas that they cannot be shown separately on the maps. The pattern and proportion of the soils or miscellaneous areas are somewhat similar in all areas. Alpha-Beta complex, 0 to 6 percent slopes, is an example.

An *association* is made up of two or more geographically associated soils or miscellaneous areas that are shown as one unit on the maps. Because of present or anticipated uses of the map units in the survey area, it was not considered practical or necessary to map the soils or miscellaneous areas separately. The pattern and relative proportion of the soils or miscellaneous areas are somewhat similar. Alpha-Beta association, 0 to 2 percent slopes, is an example.

An *undifferentiated group* is made up of two or more soils or miscellaneous areas that could be mapped individually but are mapped as one unit because similar interpretations can be made for use and management. The pattern and proportion of the soils or miscellaneous areas in a mapped area are not uniform. An area can be made up of only one of the major soils or miscellaneous areas, or it can be made up of all of them. Alpha and Beta soils, 0 to 2 percent slopes, is an example.

Some surveys include *miscellaneous areas*. Such areas have little or no soil material and support little or no vegetation. Rock outcrop is an example.

El Paso County Area, Colorado

96—Truckton sandy loam, 0 to 3 percent slopes

Map Unit Setting

National map unit symbol: 2yvrd

Elevation: 5,400 to 7,000 feet

Mean annual precipitation: 14 to 23 inches

Mean annual air temperature: 45 to 52 degrees F

Frost-free period: 90 to 155 days

Farmland classification: Prime farmland if irrigated and the product of I (soil erodibility) x C (climate factor) does not exceed 60

Map Unit Composition

Truckton and similar soils: 85 percent

Minor components: 15 percent

Estimates are based on observations, descriptions, and transects of the mapunit.

Description of Truckton

Setting

Landform: Fan remnants, interfluves

Down-slope shape: Linear

Across-slope shape: Linear

Parent material: Wind re-worked alluvium derived from arkose

Typical profile

A - 0 to 4 inches: sandy loam

Bt1 - 4 to 12 inches: sandy loam

Bt2 - 12 to 19 inches: sandy loam

C - 19 to 80 inches: sandy loam

Properties and qualities

Slope: 0 to 3 percent

Depth to restrictive feature: More than 80 inches

Drainage class: Well drained

Runoff class: Very low

Capacity of the most limiting layer to transmit water (Ksat): High (2.00 to 6.00 in/hr)

Depth to water table: More than 80 inches

Frequency of flooding: None

Frequency of ponding: None

Calcium carbonate, maximum content: 1 percent

Maximum salinity: Nonsaline to very slightly saline (0.1 to 2.0 mmhos/cm)

Available water supply, 0 to 60 inches: Moderate (about 6.6 inches)

Interpretive groups

Land capability classification (irrigated): 3e

Land capability classification (nonirrigated): 4e

Hydrologic Soil Group: A

Ecological site: R049XB210CO - Sandy Foothill

Hydric soil rating: No

Minor Components

Blakeland

Percent of map unit: 5 percent
Landform: Hills, interfluves
Landform position (two-dimensional): Shoulder, backslope, summit
Landform position (three-dimensional): Side slope, crest
Down-slope shape: Convex, linear
Across-slope shape: Convex, linear
Ecological site: R049XB210CO - Sandy Foothill
Hydric soil rating: No

Bresser

Percent of map unit: 5 percent
Landform: Terraces, interfluves
Landform position (three-dimensional): Tread
Down-slope shape: Linear
Across-slope shape: Linear
Ecological site: R049XB210CO - Sandy Foothill
Hydric soil rating: No

Pleasant, frequently ponded

Percent of map unit: 2 percent
Landform: Closed depressions
Down-slope shape: Concave, linear
Across-slope shape: Concave
Ecological site: R067BY010CO - Closed Depression
Hydric soil rating: Yes

Urban land

Percent of map unit: 2 percent
Hydric soil rating: No

Ellicott, occasionally flooded

Percent of map unit: 1 percent
Landform: Drainageways, flood plains
Down-slope shape: Linear
Across-slope shape: Concave, linear
Ecological site: R067BY031CO - Sandy Bottomland
Hydric soil rating: No

97—Truckton sandy loam, 3 to 9 percent slopes

Map Unit Setting

National map unit symbol: 2x0j2
Elevation: 5,300 to 6,850 feet
Mean annual precipitation: 14 to 19 inches
Mean annual air temperature: 48 to 52 degrees F
Frost-free period: 85 to 155 days
Farmland classification: Not prime farmland

Map Unit Composition

Truckton and similar soils: 85 percent

Minor components: 15 percent

Estimates are based on observations, descriptions, and transects of the mapunit.

Description of Truckton

Setting

Landform: Hillslopes, interfluves

Landform position (two-dimensional): Backslope

Landform position (three-dimensional): Side slope

Down-slope shape: Linear

Across-slope shape: Linear

Parent material: Re-worked alluvium derived from arkose

Typical profile

A - 0 to 4 inches: sandy loam

Bt1 - 4 to 12 inches: sandy loam

Bt2 - 12 to 19 inches: sandy loam

C - 19 to 80 inches: sandy loam

Properties and qualities

Slope: 3 to 9 percent

Depth to restrictive feature: More than 80 inches

Drainage class: Well drained

Runoff class: Low

Capacity of the most limiting layer to transmit water (Ksat): High (2.00 to 6.00 in/hr)

Depth to water table: More than 80 inches

Frequency of flooding: None

Frequency of ponding: None

Calcium carbonate, maximum content: 1 percent

Maximum salinity: Nonsaline (0.1 to 1.9 mmhos/cm)

Available water supply, 0 to 60 inches: Moderate (about 6.6 inches)

Interpretive groups

Land capability classification (irrigated): 6e

Land capability classification (nonirrigated): 6e

Hydrologic Soil Group: A

Ecological site: R049XB210CO - Sandy Foothill

Hydric soil rating: No

Minor Components

Blakeland

Percent of map unit: 8 percent

Landform: Hillslopes, interfluves

Landform position (two-dimensional): Shoulder, backslope, summit

Landform position (three-dimensional): Side slope, crest

Down-slope shape: Convex, linear

Across-slope shape: Convex, linear

Ecological site: R049XB210CO - Sandy Foothill

Hydric soil rating: No

Bresser

Percent of map unit: 7 percent

Custom Soil Resource Report

Landform: Low hills, interfluves

Landform position (two-dimensional): Foothlope, toeslope

Landform position (three-dimensional): Base slope

Down-slope shape: Concave, linear

Across-slope shape: Concave, linear

Ecological site: R049XB210CO - Sandy Foothill

Hydric soil rating: No

References

- American Association of State Highway and Transportation Officials (AASHTO). 2004. Standard specifications for transportation materials and methods of sampling and testing. 24th edition.
- American Society for Testing and Materials (ASTM). 2005. Standard classification of soils for engineering purposes. ASTM Standard D2487-00.
- Cowardin, L.M., V. Carter, F.C. Golet, and E.T. LaRoe. 1979. Classification of wetlands and deep-water habitats of the United States. U.S. Fish and Wildlife Service FWS/OBS-79/31.
- Federal Register. July 13, 1994. Changes in hydric soils of the United States.
- Federal Register. September 18, 2002. Hydric soils of the United States.
- Hurt, G.W., and L.M. Vasilas, editors. Version 6.0, 2006. Field indicators of hydric soils in the United States.
- National Research Council. 1995. Wetlands: Characteristics and boundaries.
- Soil Survey Division Staff. 1993. Soil survey manual. Soil Conservation Service. U.S. Department of Agriculture Handbook 18. http://www.nrcs.usda.gov/wps/portal/nrcs/detail/national/soils/?cid=nrcs142p2_054262
- Soil Survey Staff. 1999. Soil taxonomy: A basic system of soil classification for making and interpreting soil surveys. 2nd edition. Natural Resources Conservation Service, U.S. Department of Agriculture Handbook 436. http://www.nrcs.usda.gov/wps/portal/nrcs/detail/national/soils/?cid=nrcs142p2_053577
- Soil Survey Staff. 2010. Keys to soil taxonomy. 11th edition. U.S. Department of Agriculture, Natural Resources Conservation Service. http://www.nrcs.usda.gov/wps/portal/nrcs/detail/national/soils/?cid=nrcs142p2_053580
- Tiner, R.W., Jr. 1985. Wetlands of Delaware. U.S. Fish and Wildlife Service and Delaware Department of Natural Resources and Environmental Control, Wetlands Section.
- United States Army Corps of Engineers, Environmental Laboratory. 1987. Corps of Engineers wetlands delineation manual. Waterways Experiment Station Technical Report Y-87-1.
- United States Department of Agriculture, Natural Resources Conservation Service. National forestry manual. http://www.nrcs.usda.gov/wps/portal/nrcs/detail/soils/home/?cid=nrcs142p2_053374
- United States Department of Agriculture, Natural Resources Conservation Service. National range and pasture handbook. <http://www.nrcs.usda.gov/wps/portal/nrcs/detail/national/landuse/rangepasture/?cid=stelprdb1043084>

Custom Soil Resource Report

United States Department of Agriculture, Natural Resources Conservation Service. National soil survey handbook, title 430-VI. http://www.nrcs.usda.gov/wps/portal/nrcs/detail/soils/scientists/?cid=nrcs142p2_054242

United States Department of Agriculture, Natural Resources Conservation Service. 2006. Land resource regions and major land resource areas of the United States, the Caribbean, and the Pacific Basin. U.S. Department of Agriculture Handbook 296. http://www.nrcs.usda.gov/wps/portal/nrcs/detail/national/soils/?cid=nrcs142p2_053624

United States Department of Agriculture, Soil Conservation Service. 1961. Land capability classification. U.S. Department of Agriculture Handbook 210. http://www.nrcs.usda.gov/Internet/FSE_DOCUMENTS/nrcs142p2_052290.pdf

APPENDIX B – Hydrologic Calculations

PROJECT INFORMATION

PROJECT NAME: FVS - Academic Center
 PROJECT NO: 23.0895
 DESIGN BY: AG
 REVIEWED BY: NK
 JURISDICTION: El Paso County
 REPORT TYPE: Drainage - Final
 DATE: 05/15/26



JURISDICTIONAL STANDARD	C2	C5	C10	C100	% IMPERV
LANDSCAPE	0.02	0.08	0.25	0.35	0%
GRAVEL	0.57	0.59	0.80	0.85	80%
ROOF	0.71	0.73	0.90	0.95	90%
PAVED	0.88	0.89	0.90	0.95	100%

TOTAL SITE COMPOSITE	11.02	0.24	0.25	0.27	0.41	38.3%
-----------------------------	--------------	-------------	-------------	-------------	-------------	--------------

SUB-BASIN	SURFACE CHARACTERISTICS	AREA (ACRES)	COMPOSITE RUNOFF COEFFICIENTS				PERCENT IMPERVIOUSNESS
			C2	C5	C10	C100	
A1	LANDSCAPE	0.98	0.02	0.08	0.25	0.35	0%
	GRAVEL	0.01	0.57	0.59	0.80	0.85	80%
	PAVED	0.11	0.88	0.89	0.90	0.95	100%
SUB-BASIN COMPOSITE		1.10	0.11	0.16	0.32	0.41	10.3%

SUB-BASIN	SURFACE CHARACTERISTICS	AREA (ACRES)	COMPOSITE RUNOFF COEFFICIENTS				PERCENT IMPERVIOUSNESS
			C2	C5	C10	C100	
A2	LANDSCAPE	0.15	0.02	0.08	0.25	0.35	0%
	PAVED	0.01	0.88	0.89	0.90	0.95	100%
SUB-BASIN COMPOSITE		0.16	0.05	0.11	0.27	0.37	3.4%

SUB-BASIN	SURFACE CHARACTERISTICS	AREA (ACRES)	COMPOSITE RUNOFF COEFFICIENTS				PERCENT IMPERVIOUSNESS
			C2	C5	C10	C100	
A3	LANDSCAPE	0.24	0.02	0.08	0.25	0.35	0%
	PAVED	0.07	0.88	0.89	0.90	0.95	100%
SUB-BASIN COMPOSITE		0.31	0.21	0.25	0.39	0.48	21.5%

SUB-BASIN	SURFACE CHARACTERISTICS	AREA (ACRES)	COMPOSITE RUNOFF COEFFICIENTS				PERCENT IMPERVIOUSNESS
			C2	C5	C10	C100	
A4	LANDSCAPE	0.72	0.02	0.08	0.25	0.35	0%
	PAVED	0.05	0.88	0.89	0.90	0.95	100%
SUB-BASIN COMPOSITE		0.77	0.07	0.13	0.29	0.39	6.1%

SUB-BASIN	SURFACE CHARACTERISTICS	AREA (ACRES)	COMPOSITE RUNOFF COEFFICIENTS				PERCENT IMPERVIOUSNESS
			C2	C5	C10	C100	
A5	LANDSCAPE	0.02	0.02	0.08	0.25	0.35	0%
	PAVED	0.02	0.88	0.89	0.90	0.95	100%
	INVISIBLE STRUCTURES	0.01	0.21	0.23	0.24	0.38	35%
SUB-BASIN COMPOSITE		0.05	0.36	0.39	0.46	0.56	43.4%

SUB-BASIN	SURFACE CHARACTERISTICS	AREA (ACRES)	COMPOSITE RUNOFF COEFFICIENTS				PERCENT IMPERVIOUSNESS
			C2	C5	C10	C100	
A6	LANDSCAPE	0.01	0.02	0.08	0.25	0.35	0%
	PAVED	0.05	0.88	0.89	0.90	0.95	100%
	INVISIBLE STRUCTURES	0.02	0.21	0.23	0.24	0.38	35%
SUB-BASIN COMPOSITE		0.08	0.62	0.64	0.67	0.75	73.2%

SUB-BASIN	SURFACE CHARACTERISTICS	AREA (ACRES)	COMPOSITE RUNOFF COEFFICIENTS				PERCENT IMPERVIOUSNESS
			C2	C5	C10	C100	
A7	LANDSCAPE	0.11	0.02	0.08	0.25	0.35	0%
	PAVED	0.01	0.88	0.89	0.90	0.95	100%
	INVISIBLE STRUCTURES	0.08	0.21	0.23	0.24	0.38	35%
SUB-BASIN COMPOSITE		0.20	0.14	0.18	0.28	0.39	19.2%

SUB-BASIN	SURFACE CHARACTERISTICS	AREA (ACRES)	COMPOSITE RUNOFF COEFFICIENTS				PERCENT IMPERVIOUSNESS
			C2	C5	C10	C100	
A8	LANDSCAPE	0.02	0.02	0.08	0.25	0.35	0%
	ROOF	0.04	0.71	0.73	0.90	0.95	90%
	GRAVEL	0.003	0.57	0.59	0.80	0.85	80%
SUB-BASIN COMPOSITE		0.06	0.52	0.55	0.73	0.79	66.1%

SUB-BASIN	SURFACE CHARACTERISTICS	AREA (ACRES)	COMPOSITE RUNOFF COEFFICIENTS				PERCENT IMPERVIOUSNESS
			C2	C5	C10	C100	
A9	LANDSCAPE	0.01	0.02	0.08	0.25	0.35	0%
	ROOF	0.05	0.71	0.73	0.90	0.95	90%
SUB-BASIN COMPOSITE		0.06	0.62	0.64	0.81	0.87	78.2%

SUB-BASIN	SURFACE CHARACTERISTICS	AREA (ACRES)	COMPOSITE RUNOFF COEFFICIENTS				PERCENT IMPERVIOUSNESS
			C2	C5	C10	C100	
A10	LANDSCAPE	0.004	0.02	0.08	0.25	0.35	0%
	ROOF	0.06	0.71	0.73	0.90	0.95	90%
SUB-BASIN COMPOSITE		0.07	0.67	0.69	0.86	0.91	84.3%

SUB-BASIN	SURFACE CHARACTERISTICS	AREA (ACRES)	COMPOSITE RUNOFF COEFFICIENTS				PERCENT IMPERVIOUSNESS
			C2	C5	C10	C100	
A11	ROOF	0.09	0.71	0.73	0.90	0.95	90%
	GRAVEL	0.03	0.57	0.59	0.80	0.85	80%
	PAVED	0.003	0.88	0.89	0.90	0.95	100%
SUB-BASIN COMPOSITE		0.12	0.68	0.70	0.88	0.93	87.9%

SUB-BASIN	SURFACE CHARACTERISTICS	AREA (ACRES)	COMPOSITE RUNOFF COEFFICIENTS				PERCENT IMPERVIOUSNESS
			C2	C5	C10	C100	
A12	LANDSCAPE	0.08	0.02	0.08	0.25	0.35	0%
	GRAVEL	0.03	0.57	0.59	0.80	0.85	80%
	PAVED	0.06	0.88	0.89	0.90	0.95	100%
SUB-BASIN COMPOSITE		0.17	0.44	0.47	0.59	0.66	51.8%

SUB-BASIN	SURFACE CHARACTERISTICS	AREA (ACRES)	COMPOSITE RUNOFF COEFFICIENTS				PERCENT IMPERVIOUSNESS
			C2	C5	C10	C100	
A13	LANDSCAPE	0.48	0.02	0.08	0.25	0.35	0%
	GRAVEL	0.10	0.57	0.59	0.80	0.85	80%
	PAVED	0.28	0.88	0.89	0.90	0.95	100%
	ROOF	0.20	0.71	0.73	0.90	0.95	90%
SUB-BASIN COMPOSITE		1.06	0.43	0.46	0.60	0.67	50.8%

SUB-BASIN	SURFACE CHARACTERISTICS	AREA (ACRES)	COMPOSITE RUNOFF COEFFICIENTS				PERCENT IMPERVIOUSNESS
			C2	C5	C10	C100	
B1	LANDSCAPE	0.11	0.02	0.08	0.25	0.35	0%
	GRAVEL	0.01	0.57	0.59	0.80	0.85	80%
	PAVED	0.02	0.88	0.89	0.90	0.95	100%
	INVISIBLE STRUCTURES	0.04	0.21	0.23	0.24	0.38	35%
SUB-BASIN COMPOSITE		0.18	0.18	0.22	0.34	0.44	22.2%

SUB-BASIN	SURFACE CHARACTERISTICS	AREA	COMPOSITE RUNOFF COEFFICIENTS				PERCENT IMPERVIOUSNESS
		(ACRES)	C2	C5	C10	C100	
B2	ROOF	0.14	0.71	0.73	0.90	0.95	90%
SUB-BASIN COMPOSITE		0.14	0.71	0.73	0.90	0.95	90.0%

SUB-BASIN	SURFACE CHARACTERISTICS	AREA	COMPOSITE RUNOFF COEFFICIENTS				PERCENT IMPERVIOUSNESS
		(ACRES)	C2	C5	C10	C100	
B3	LANDSCAPE	0.13	0.02	0.08	0.25	0.35	0%
	PAVED	0.18	0.88	0.89	0.90	0.95	100%
	INVISIBLE STRUCTURES	0.002	0.21	0.23	0.24	0.38	35%
SUB-BASIN COMPOSITE		0.31	0.51	0.54	0.62	0.69	57.5%

SUB-BASIN	SURFACE CHARACTERISTICS	AREA	COMPOSITE RUNOFF COEFFICIENTS				PERCENT IMPERVIOUSNESS
		(ACRES)	C2	C5	C10	C100	
B4	LANDSCAPE	0.03	0.02	0.08	0.25	0.35	0%
	GRAVEL	0.003	0.57	0.59	0.80	0.85	80%
SUB-BASIN COMPOSITE		0.03	0.08	0.13	0.31	0.40	8.3%

SUB-BASIN	SURFACE CHARACTERISTICS	AREA	COMPOSITE RUNOFF COEFFICIENTS				PERCENT IMPERVIOUSNESS
		(ACRES)	C2	C5	C10	C100	
B5	ROOF	0.03	0.71	0.73	0.90	0.95	90%
SUB-BASIN COMPOSITE		0.03	0.71	0.73	0.90	0.95	90.0%

SUB-BASIN	SURFACE CHARACTERISTICS	AREA	COMPOSITE RUNOFF COEFFICIENTS				PERCENT IMPERVIOUSNESS
		(ACRES)	C2	C5	C10	C100	
B6	ROOF	0.04	0.71	0.73	0.90	0.95	90%
SUB-BASIN COMPOSITE		0.04	0.71	0.73	0.90	0.95	90.0%

SUB-BASIN	SURFACE CHARACTERISTICS	AREA	COMPOSITE RUNOFF COEFFICIENTS				PERCENT IMPERVIOUSNESS
		(ACRES)	C2	C5	C10	C100	
B7	LANDSCAPE	0.02	0.02	0.08	0.25	0.35	0%
	GRAVEL	0.01	0.57	0.59	0.80	0.85	80%
SUB-BASIN COMPOSITE		0.02	0.15	0.21	0.38	0.47	19.6%

SUB-BASIN	SURFACE CHARACTERISTICS	AREA	COMPOSITE RUNOFF COEFFICIENTS				PERCENT IMPERVIOUSNESS
		(ACRES)	C2	C5	C10	C100	
B8	LANDSCAPE	0.01	0.02	0.08	0.25	0.35	0%
	GRAVEL	0.004	0.57	0.59	0.80	0.85	80%
	PAVED	0.01	0.88	0.89	0.90	0.95	100%
SUB-BASIN COMPOSITE		0.03	0.39	0.43	0.55	0.63	45.8%

SUB-BASIN	SURFACE CHARACTERISTICS	AREA	COMPOSITE RUNOFF COEFFICIENTS				PERCENT IMPERVIOUSNESS
		(ACRES)	C2	C5	C10	C100	
B9	LANDSCAPE	0.09	0.02	0.08	0.25	0.35	0%
	PAVED	0.01	0.88	0.89	0.90	0.95	100%
	INVISIBLE STRUCTURES	0.02	0.21	0.23	0.24	0.38	35%
SUB-BASIN COMPOSITE		0.12	0.16	0.20	0.33	0.43	17.7%

SUB-BASIN	SURFACE CHARACTERISTICS	AREA	COMPOSITE RUNOFF COEFFICIENTS				PERCENT IMPERVIOUSNESS
		(ACRES)	C2	C5	C10	C100	
B10	ROOF	0.02	0.71	0.73	0.90	0.95	90%
SUB-BASIN COMPOSITE		0.02	0.71	0.73	0.90	0.95	90.0%

SUB-BASIN	SURFACE CHARACTERISTICS	AREA	COMPOSITE RUNOFF COEFFICIENTS				PERCENT IMPERVIOUSNESS
		(ACRES)	C2	C5	C10	C100	
B11	ROOF	0.05	0.71	0.73	0.90	0.95	90%
SUB-BASIN COMPOSITE		0.05	0.71	0.73	0.90	0.95	90.0%

SUB-BASIN	SURFACE CHARACTERISTICS	AREA	COMPOSITE RUNOFF COEFFICIENTS				PERCENT IMPERVIOUSNESS
		(ACRES)	C2	C5	C10	C100	
B12	LANDSCAPE	0.01	0.02	0.08	0.25	0.35	0%
	GRAVEL	0.002	0.57	0.59	0.80	0.85	80%
	PAVED	0.003	0.88	0.89	0.90	0.95	100%
SUB-BASIN COMPOSITE		0.02	0.23	0.28	0.43	0.51	26.9%

SUB-BASIN	SURFACE CHARACTERISTICS	AREA	COMPOSITE RUNOFF COEFFICIENTS				PERCENT IMPERVIOUSNESS
		(ACRES)	C2	C5	C10	C100	
B13	LANDSCAPE	0.02	0.02	0.08	0.25	0.35	0%
	PAVED	0.01	0.88	0.89	0.90	0.95	100%
SUB-BASIN COMPOSITE		0.03	0.41	0.45	0.54	0.62	45.2%

SUB-BASIN	SURFACE CHARACTERISTICS	AREA	COMPOSITE RUNOFF COEFFICIENTS				PERCENT IMPERVIOUSNESS
		(ACRES)	C2	C5	C10	C100	
B14	LANDSCAPE	0.01	0.02	0.08	0.25	0.35	0%
	GRAVEL	0.001	0.57	0.59	0.80	0.85	80%
SUB-BASIN COMPOSITE		0.01	0.05	0.11	0.28	0.38	5.1%

SUB-BASIN	SURFACE CHARACTERISTICS	AREA	COMPOSITE RUNOFF COEFFICIENTS				PERCENT IMPERVIOUSNESS
		(ACRES)	C2	C5	C10	C100	
B15	LANDSCAPE	0.01	0.02	0.08	0.25	0.35	0%
	PAVED	0.05	0.88	0.89	0.90	0.95	100%
SUB-BASIN COMPOSITE		0.06	0.78	0.79	0.82	0.88	88.2%

SUB-BASIN	SURFACE CHARACTERISTICS	AREA	COMPOSITE RUNOFF COEFFICIENTS				PERCENT IMPERVIOUSNESS
		(ACRES)	C2	C5	C10	C100	
B16	LANDSCAPE	0.02	0.02	0.08	0.25	0.35	0%
SUB-BASIN COMPOSITE		0.02	0.02	0.08	0.25	0.35	0.0%

SUB-BASIN	SURFACE CHARACTERISTICS	AREA	COMPOSITE RUNOFF COEFFICIENTS				PERCENT IMPERVIOUSNESS
		(ACRES)	C2	C5	C10	C100	
B17	ROOF	0.05	0.71	0.73	0.90	0.95	90%
SUB-BASIN COMPOSITE		0.05	0.71	0.73	0.90	0.95	90.0%

SUB-BASIN	SURFACE CHARACTERISTICS	AREA	COMPOSITE RUNOFF COEFFICIENTS				PERCENT IMPERVIOUSNESS
		(ACRES)	C2	C5	C10	C100	
B18	LANDSCAPE	0.03	0.02	0.08	0.25	0.35	0%
	PAVED	0.02	0.88	0.89	0.90	0.95	100%
SUB-BASIN COMPOSITE		0.05	0.41	0.45	0.55	0.62	45.8%

SUB-BASIN	SURFACE CHARACTERISTICS	AREA	COMPOSITE RUNOFF COEFFICIENTS				PERCENT IMPERVIOUSNESS
		(ACRES)	C2	C5	C10	C100	
B19	LANDSCAPE	0.02	0.02	0.08	0.25	0.35	0%
SUB-BASIN COMPOSITE		0.02	0.02	0.08	0.25	0.35	0.0%

SUB-BASIN	SURFACE CHARACTERISTICS	AREA	COMPOSITE RUNOFF COEFFICIENTS				PERCENT IMPERVIOUSNESS
		(ACRES)	C2	C5	C10	C100	
B20	LANDSCAPE	0.02	0.02	0.08	0.25	0.35	0%
	GRAVEL	0.003	0.57	0.59	0.80	0.85	80%
	INVISIBLE STRUCTURES	0.01	0.21	0.23	0.24	0.38	35%
	PAVED	0.001	0.88	0.89	0.90	0.95	100%
SUB-BASIN COMPOSITE		0.03	0.17	0.21	0.34	0.45	22.3%

SUB-BASIN	SURFACE CHARACTERISTICS	AREA	COMPOSITE RUNOFF COEFFICIENTS				PERCENT IMPERVIOUSNESS
		(ACRES)	C2	C5	C10	C100	
B21	LANDSCAPE	0.07	0.02	0.08	0.25	0.35	0%
	PAVED	0.03	0.88	0.89	0.90	0.95	100%
	INVISIBLE STRUCTURES	0.02	0.21	0.23	0.24	0.38	35%
SUB-BASIN COMPOSITE		0.12	0.24	0.28	0.38	0.48	27.5%

SUB-BASIN	SURFACE CHARACTERISTICS	AREA	COMPOSITE RUNOFF COEFFICIENTS				PERCENT IMPERVIOUSNESS
		(ACRES)	C2	C5	C10	C100	
B22	ROOF	0.02	0.71	0.73	0.90	0.95	90%
SUB-BASIN COMPOSITE		0.02	0.71	0.73	0.90	0.95	90.0%

SUB-BASIN	SURFACE CHARACTERISTICS	AREA	COMPOSITE RUNOFF COEFFICIENTS				PERCENT IMPERVIOUSNESS
		(ACRES)	C2	C5	C10	C100	
B23	ROOF	0.04	0.71	0.73	0.90	0.95	90%
SUB-BASIN COMPOSITE		0.04	0.71	0.73	0.90	0.95	90.0%

SUB-BASIN	SURFACE CHARACTERISTICS	AREA	COMPOSITE RUNOFF COEFFICIENTS				PERCENT IMPERVIOUSNESS
		(ACRES)	C2	C5	C10	C100	
B24	ROOF	0.04	0.71	0.73	0.90	0.95	90%
SUB-BASIN COMPOSITE		0.04	0.71	0.73	0.90	0.95	90.0%

SUB-BASIN	SURFACE CHARACTERISTICS	AREA	COMPOSITE RUNOFF COEFFICIENTS				PERCENT IMPERVIOUSNESS
		(ACRES)	C2	C5	C10	C100	
B25	LANDSCAPE	0.01	0.02	0.08	0.25	0.35	0%
	GRAVEL	0.004	0.57	0.59	0.80	0.85	80%
	PAVED	0.003	0.88	0.89	0.90	0.95	100%
SUB-BASIN COMPOSITE		0.02	0.28	0.32	0.47	0.55	33.1%

SUB-BASIN	SURFACE CHARACTERISTICS	AREA	COMPOSITE RUNOFF COEFFICIENTS				PERCENT IMPERVIOUSNESS
		(ACRES)	C2	C5	C10	C100	
B26	LANDSCAPE	0.03	0.02	0.08	0.25	0.35	0%
	GRAVEL	0.01	0.57	0.59	0.80	0.85	80%
	PAVED	0.02	0.88	0.89	0.90	0.95	100%
	INVISIBLE STRUCTURES	0.01	0.21	0.23	0.24	0.38	35%
SUB-BASIN COMPOSITE		0.06	0.32	0.36	0.47	0.56	38.6%

SUB-BASIN	SURFACE CHARACTERISTICS	AREA	COMPOSITE RUNOFF COEFFICIENTS				PERCENT IMPERVIOUSNESS
		(ACRES)	C2	C5	C10	C100	
C1	LANDSCAPE	0.32	0.02	0.08	0.25	0.35	0%
	GRAVEL	0.02	0.57	0.59	0.80	0.85	80%
	PAVED	0.09	0.88	0.89	0.90	0.95	100%
	INVISIBLE STRUCTURES	0.06	0.21	0.23	0.24	0.38	35%
SUB-BASIN COMPOSITE		0.49	0.22	0.27	0.39	0.49	25.8%

SUB-BASIN	SURFACE CHARACTERISTICS	AREA	COMPOSITE RUNOFF COEFFICIENTS				PERCENT IMPERVIOUSNESS
		(ACRES)	C2	C5	C10	C100	
C2	LANDSCAPE	0.27	0.02	0.08	0.25	0.35	0%
	PAVED	0.02	0.88	0.89	0.90	0.95	100%
SUB-BASIN COMPOSITE		0.28	0.07	0.12	0.28	0.38	5.3%

SUB-BASIN	SURFACE CHARACTERISTICS	AREA	COMPOSITE RUNOFF COEFFICIENTS				PERCENT IMPERVIOUSNESS
		(ACRES)	C2	C5	C10	C100	
C3	LANDSCAPE	0.03	0.02	0.08	0.25	0.35	0%
	PAVED	0.24	0.88	0.89	0.90	0.95	100%
SUB-BASIN COMPOSITE		0.27	0.77	0.79	0.82	0.88	87.7%

SUB-BASIN	SURFACE CHARACTERISTICS	AREA	COMPOSITE RUNOFF COEFFICIENTS				PERCENT IMPERVIOUSNESS
		(ACRES)	C2	C5	C10	C100	
C4	ROOF	0.06	0.71	0.73	0.90	0.95	90%
SUB-BASIN COMPOSITE		0.06	0.71	0.73	0.90	0.95	90.0%

SUB-BASIN	SURFACE CHARACTERISTICS	AREA	COMPOSITE RUNOFF COEFFICIENTS				PERCENT IMPERVIOUSNESS
		(ACRES)	C2	C5	C10	C100	
C5	ROOF	0.08	0.71	0.73	0.90	0.95	90%
SUB-BASIN COMPOSITE		0.08	0.71	0.73	0.90	0.95	90.0%

SUB-BASIN	SURFACE CHARACTERISTICS	AREA	COMPOSITE RUNOFF COEFFICIENTS				PERCENT IMPERVIOUSNESS
		(ACRES)	C2	C5	C10	C100	
C6	LANDSCAPE	0.01	0.02	0.08	0.25	0.35	0%
	GRAVEL	0.001	0.57	0.59	0.80	0.85	80%
SUB-BASIN COMPOSITE		0.01	0.05	0.11	0.28	0.38	4.8%

SUB-BASIN	SURFACE CHARACTERISTICS	AREA	COMPOSITE RUNOFF COEFFICIENTS				PERCENT IMPERVIOUSNESS
		(ACRES)	C2	C5	C10	C100	
C7	LANDSCAPE	0.03	0.02	0.08	0.25	0.35	0%
	GRAVEL	0.01	0.57	0.59	0.80	0.85	80%
	PAVED	0.01	0.88	0.89	0.90	0.95	100%
SUB-BASIN COMPOSITE		0.05	0.32	0.36	0.50	0.58	38.3%

SUB-BASIN	SURFACE CHARACTERISTICS	AREA	COMPOSITE RUNOFF COEFFICIENTS				PERCENT IMPERVIOUSNESS
		(ACRES)	C2	C5	C10	C100	
C8	LANDSCAPE	0.02	0.02	0.08	0.25	0.35	0%
SUB-BASIN COMPOSITE		0.02	0.02	0.08	0.25	0.35	0.0%

SUB-BASIN	SURFACE CHARACTERISTICS	AREA	COMPOSITE RUNOFF COEFFICIENTS				PERCENT IMPERVIOUSNESS
		(ACRES)	C2	C5	C10	C100	
C9	LANDSCAPE	0.01	0.02	0.08	0.25	0.35	0%
	PAVED	0.003	0.88	0.89	0.90	0.95	100%
	INVISIBLE STRUCTURES	0.01	0.21	0.23	0.24	0.38	35%
SUB-BASIN COMPOSITE		0.01	0.30	0.33	0.40	0.50	36.8%

SUB-BASIN	SURFACE CHARACTERISTICS	AREA	COMPOSITE RUNOFF COEFFICIENTS				PERCENT IMPERVIOUSNESS
		(ACRES)	C2	C5	C10	C100	
C10	LANDSCAPE	0.14	0.02	0.08	0.25	0.35	0%
	PAVED	0.04	0.88	0.89	0.90	0.95	100%
	INVISIBLE STRUCTURES	0.06	0.21	0.23	0.24	0.38	35%
SUB-BASIN COMPOSITE		0.25	0.22	0.25	0.36	0.46	25.9%

SUB-BASIN	SURFACE CHARACTERISTICS	AREA	COMPOSITE RUNOFF COEFFICIENTS				PERCENT IMPERVIOUSNESS
		(ACRES)	C2	C5	C10	C100	
C11	LANDSCAPE	0.03	0.02	0.08	0.25	0.35	0%
	PAVED	0.01	0.88	0.89	0.90	0.95	100%
	INVISIBLE STRUCTURES	0.01	0.21	0.23	0.24	0.38	35%
SUB-BASIN COMPOSITE		0.05	0.17	0.21	0.33	0.43	20.3%

SUB-BASIN	SURFACE CHARACTERISTICS	AREA	COMPOSITE RUNOFF COEFFICIENTS				PERCENT IMPERVIOUSNESS
		(ACRES)	C2	C5	C10	C100	
C12	ROOF	0.01	0.71	0.73	0.90	0.95	90%
SUB-BASIN COMPOSITE		0.01	0.71	0.73	0.90	0.95	90.0%

SUB-BASIN	SURFACE CHARACTERISTICS	AREA	COMPOSITE RUNOFF COEFFICIENTS				PERCENT IMPERVIOUSNESS
		(ACRES)	C2	C5	C10	C100	
C13	ROOF	0.07	0.71	0.73	0.90	0.95	90%
SUB-BASIN COMPOSITE		0.07	0.71	0.73	0.90	0.95	90.0%

SUB-BASIN	SURFACE CHARACTERISTICS	AREA	COMPOSITE RUNOFF COEFFICIENTS				PERCENT IMPERVIOUSNESS
		(ACRES)	C2	C5	C10	C100	
C14	ROOF	0.03	0.71	0.73	0.90	0.95	90%
SUB-BASIN COMPOSITE		0.03	0.71	0.73	0.90	0.95	90.0%

SUB-BASIN	SURFACE CHARACTERISTICS	AREA	COMPOSITE RUNOFF COEFFICIENTS				PERCENT IMPERVIOUSNESS
		(ACRES)	C2	C5	C10	C100	
C15	LANDSCAPE	0.02	0.02	0.08	0.25	0.35	0%
	GRAVEL	0.001	0.57	0.59	0.80	0.85	80%
SUB-BASIN COMPOSITE		0.02	0.04	0.10	0.27	0.37	2.5%

SUB-BASIN	SURFACE CHARACTERISTICS	AREA	COMPOSITE RUNOFF COEFFICIENTS				PERCENT IMPERVIOUSNESS
		(ACRES)	C2	C5	C10	C100	
C16	LANDSCAPE	0.02	0.02	0.08	0.25	0.35	0%
	GRAVEL	0.01	0.57	0.59	0.80	0.85	80%
SUB-BASIN COMPOSITE		0.02	0.16	0.21	0.39	0.47	19.7%

SUB-BASIN	SURFACE CHARACTERISTICS	AREA	COMPOSITE RUNOFF COEFFICIENTS				PERCENT IMPERVIOUSNESS
		(ACRES)	C2	C5	C10	C100	
C17	ROOF	0.04	0.71	0.73	0.90	0.95	90%
SUB-BASIN COMPOSITE		0.04	0.71	0.73	0.90	0.95	90.0%

SUB-BASIN	SURFACE CHARACTERISTICS	AREA	COMPOSITE RUNOFF COEFFICIENTS				PERCENT IMPERVIOUSNESS
		(ACRES)	C2	C5	C10	C100	
C18	ROOF	0.05	0.71	0.73	0.90	0.95	90%
SUB-BASIN COMPOSITE		0.05	0.71	0.73	0.90	0.95	90.0%

SUB-BASIN	SURFACE CHARACTERISTICS	AREA	COMPOSITE RUNOFF COEFFICIENTS				PERCENT IMPERVIOUSNESS
		(ACRES)	C2	C5	C10	C100	
C19	ROOF	0.06	0.02	0.08	0.25	0.35	90%
SUB-BASIN COMPOSITE		0.06	0.02	0.08	0.25	0.35	90.0%

SUB-BASIN	SURFACE CHARACTERISTICS	AREA	COMPOSITE RUNOFF COEFFICIENTS				PERCENT IMPERVIOUSNESS
		(ACRES)	C2	C5	C10	C100	
C20	LANDSCAPE	1.09	0.02	0.08	0.25	0.35	0%
	GRAVEL	0.05	0.57	0.59	0.80	0.85	80%
	PAVED	0.13	0.88	0.89	0.90	0.95	100%
	INVISIBLE STRUCTURES	0.08	0.21	0.23	0.24	0.38	35%
	ROOF	0.24	0.71	0.73	0.90	0.95	90%
SUB-BASIN COMPOSITE		1.59	0.22	0.27	0.42	0.51	25.9%

SUB-BASIN	SURFACE CHARACTERISTICS	AREA	COMPOSITE RUNOFF COEFFICIENTS				PERCENT IMPERVIOUSNESS
		(ACRES)	C2	C5	C10	C100	
C21	ROOF	0.12	0.71	0.73	0.90	0.95	90%
	PAVED	0.04	0.88	0.89	0.90	0.95	100%
SUB-BASIN COMPOSITE		0.16	0.75	0.77	0.90	0.95	92.3%

SUB-BASIN	SURFACE CHARACTERISTICS	AREA	COMPOSITE RUNOFF COEFFICIENTS				PERCENT IMPERVIOUSNESS
		(ACRES)	C2	C5	C10	C100	
OS1	LANDSCAPE	0.05	0.02	0.08	0.25	0.35	0%
	PAVED	0.10	0.88	0.89	0.90	0.95	100%
SUB-BASIN COMPOSITE		0.15	0.60	0.61	0.62	0.66	67.8%

SUB-BASIN	SURFACE CHARACTERISTICS	AREA	COMPOSITE RUNOFF COEFFICIENTS				PERCENT IMPERVIOUSNESS
		(ACRES)	C2	C5	C10	C100	
OS2	LANDSCAPE	0.43	0.02	0.08	0.25	0.35	0%
	ROOF	0.07	0.71	0.73	0.90	0.95	90%
	PAVED	0.18	0.88	0.89	0.90	0.95	100%
	INVISIBLE STRUCTURES	0.07	0.21	0.23	0.24	0.38	35%
SUB-BASIN COMPOSITE		0.75	0.24	0.27	0.36	0.43	36.5%

SUB-BASIN	SURFACE CHARACTERISTICS	AREA	COMPOSITE RUNOFF COEFFICIENTS				PERCENT IMPERVIOUSNESS
		(ACRES)	C2	C5	C10	C100	
OS3	LANDSCAPE	0.26	0.02	0.08	0.25	0.35	0%
	ROOF	0.00	0.71	0.73	0.90	0.95	90%
	PAVED	0.06	0.88	0.89	0.90	0.95	100%
SUB-BASIN COMPOSITE		0.32	0.18	0.23	0.37	0.46	18.5%

SUB-BASIN	SURFACE CHARACTERISTICS	AREA	COMPOSITE RUNOFF COEFFICIENTS				PERCENT IMPERVIOUSNESS
		(ACRES)	C2	C5	C10	C100	
OS4	LANDSCAPE	0.08	0.02	0.08	0.25	0.35	0%
	PAVED	0.32	0.88	0.89	0.90	0.95	100%
SUB-BASIN COMPOSITE		0.40	0.72	0.74	0.78	0.84	81.1%

TOTAL SITE COMPOSITE		11.02	0.24	0.25	0.27	0.41	38.3%
----------------------	--	-------	------	------	------	------	-------

CALCULATED BY: AG
 CHECKED BY: NK
 DATE: 05/15/26

STANDARD FORM SF-2
 TIME OF CONCENTRATION SUMMARY
 (RATIONAL METHOD PROCEDURE)

23.0895
 FVS - Academic Center

SUB-BASIN DATA				INITIAL/OVERLAND TIME (t _i)			TRAVEL TIME (t _t)					t _c CHECK (URBANIZED BASINS)					REMARKS	
BASIN	DESIGN POINT (1)	C _s (2)	AREA ac (3)	LENGTH ft (4)	SLOPE ft/ft (5)	t _i min (6)	LENGTH ft (7)	SLOPE ft/ft (8)	C _v (9)	VEL. fps (10)	t _t min (11)	COMP. t _c (12)	Is Project Urban?		tc First DP (16)	tc min (17)		
													TOT. LENGTH ft (13)	SLOPE ft/ft (14)				IMP % (15)
A1	A1	0.16	1.10	270	0.1000	13.0	92	0.0080	20	1.79	0.9	13.9	361.6	0.08	10.3%	25.9	13.9	
A2	A2	0.11	0.16	106	0.1940	6.9	60	0.0200	2.5	0.35	2.8	9.8	166.4	0.13	3.4%	26.2	9.8	
A3	A3	0.25	0.31	116	0.1090	7.5	10	0.1090	2.5	0.83	0.2	7.7	125.5	0.11	21.5%	22.4	7.7	
A4	A4	0.13	0.77	204	0.0970	11.8	165	0.0610	2.5	0.62	4.4	16.3	368.6	0.08	6.1%	26.1	16.3	
A5	A5	0.39	0.05	9	0.1050	1.8	22	0.0200	2.5	0.35	1.0	2.8	30.8	0.04	43.4%	18.8	5.0	
A6	A6	0.64	0.08	54	0.0180	5.0	27	0.0200	10	1.41	0.3	5.4	80.6	0.02	73.2%	13.7	5.4	
A7	A7	0.18	0.20	28	0.0200	7.0	48	0.0200	7	0.99	0.8	7.8	76.0	0.02	19.2%	23.2	7.8	
A8	A8	0.55	0.06	13	0.1040	1.6	45	0.0250	15	2.37	0.3	2.0	58.3	0.04	66.1%	15.0	5.0	
A9	A9	0.64	0.06	10	0.1430	1.1	22	0.0200	7	0.99	0.4	1.4	31.5	0.06	78.2%	12.8	5.0	
A10	A10	0.69	0.07	12	0.1040	1.2	8	0.1000	7	2.21	0.1	1.3	19.9	0.10	84.3%	11.7	5.0	
A11	A11	0.70	0.12	50	0.1860	1.9	50	0.0500	10	2.24	0.4	2.3	100.0	0.12	87.9%	11.2	5.0	
A12	A12	0.47	0.17	69	0.0900	4.5	43	0.0200	2.5	0.35	2.0	6.6	111.5	0.06	51.8%	17.5	6.6	
A13	A13	0.46	1.06	35	0.2500	2.4	460	0.0310	15	2.64	2.9	5.3	495.0	0.05	50.8%	20.1	5.3	
B1	B1	0.22	0.18	99	0.1000	7.4	63	0.0567	20	4.76	0.2	7.6	161.3	0.08	22.2%	22.6	7.6	
B2	B2	0.73	0.14			0.0			20	0.00	0.0	0.0	0.0	#DIV/0!	90.0%		5.0	Roof Basin
B3	B3	0.54	0.31	20	0.0200	3.6	235	0.0504	20	4.49	0.9	4.4	255.0	0.05	57.5%	17.2	5.0	
B4	B4	0.13	0.03	20	0.0850	3.8	35	0.0200	15	2.12	0.3	4.1	54.2	0.04	8.3%	25.0	5.0	
B5	B5	0.73	0.03			0.0			20	0.00	0.0	0.0	0.0	#DIV/0!	90.0%		5.0	Roof Basin
B6	B6	0.73	0.04			0.0			20	0.00	0.0	0.0	0.0	#DIV/0!	90.0%		5.0	Roof Basin
B7	B7	0.21	0.02	22	0.0900	3.7	53	0.0200	15	2.12	0.4	4.1	75.1	0.04	19.6%	23.2	5.0	
B8	B8	0.43	0.03	25	0.1200	2.7	23	0.0200	15	2.12	0.2	2.8	47.7	0.07	45.8%	18.4	5.0	
B9	B9	0.20	0.12	20	0.2270	2.6	56	0.0507	2.5	0.56	1.6	4.2	75.5	0.10	17.7%	23.4	5.0	
B10	B10	0.73	0.02			0.0			20	0.00	0.0	0.0	0.0	#DIV/0!	90.0%		5.0	Roof Basin
B11	B11	0.73	0.05			0.0			20	0.00	0.0	0.0	0.0	#DIV/0!	90.0%		5.0	Roof Basin
B12	B12	0.28	0.02	21	0.0550	3.9	24	0.0200	15	2.12	0.2	4.1	45.6	0.04	26.9%	21.7	5.0	
B13	B13	0.45	0.03	34	0.0470	4.1	23	0.0870	7	2.06	0.2	4.3	57.1	0.06	45.2%	18.4	5.0	
B14	B14	0.11	0.01	7	0.0820	2.3	19	0.0526	7	1.61	0.2	2.5	25.6	0.06	5.1%	25.3	5.0	
B15	B15	0.79	0.06	78	0.0490	2.9	5	0.0180	20	2.68	0.0	2.9	83.0	0.05	88.2%	11.0	5.0	
B16	B16	0.08	0.02	12	0.1000	3.0	22	0.0396	7	1.39	0.3	3.3	34.4	0.06	0.0%	26.2	5.0	
B17	B17	0.73	0.05			0.0			20	0.00	0.0	0.0	0.0	#DIV/0!	90.0%		5.0	Roof Basin
B18	B18	0.45	0.05	33	0.0900	3.3	34	0.0150	20	2.45	0.2	3.5	67.0	0.05	45.8%	18.5	5.0	
B19	B19	0.08	0.02	17	0.0500	4.4	17	0.0200	7	0.99	0.3	4.7	33.8	0.03	0.0%	26.2	5.0	
B20	B20	0.21	0.03	20	0.0600	4.0	20	0.0200	2.5	0.35	1.0	4.9	40.2	0.04	22.3%	22.4	5.0	
B21	B21	0.28	0.12	36	0.0815	4.5	49	0.0321	2.5	0.45	1.8	6.3	85.2	0.05	27.5%	21.7	6.3	
B22	B22	0.73	0.02			0.0			20	0.00	0.0	0.0	0.0	#DIV/0!	90.0%		5.0	Roof Basin
B23	B23	0.73	0.04			0.0			20	0.00	0.0	0.0	0.0	#DIV/0!	90.0%		5.0	Roof Basin
B24	B24	0.73	0.04			0.0			20	0.00	0.0	0.0	0.0	#DIV/0!	90.0%		5.0	Roof Basin

CALCULATED BY: AG
 CHECKED BY: NK
 DATE: 05/15/26

STANDARD FORM SF-2
 TIME OF CONCENTRATION SUMMARY
 (RATIONAL METHOD PROCEDURE)

23.0895
 FVS - Academic Center

SUB-BASIN DATA				INITIAL/OVERLAND TIME (t _i)			TRAVEL TIME (t _t)					t _c CHECK (URBANIZED BASINS)					REMARKS	
BASIN	DESIGN POINT (1)	C _s (2)	AREA ac (3)	LENGTH ft (4)	SLOPE ft/ft (5)	t _i min (6)	LENGTH ft (7)	SLOPE ft/ft (8)	C _v (9)	VEL. fps (10)	t _t min (11)	Is Project Urban?		IMP % (15)	t _c First DP (16)	t _c min (17)		
												COMP. t _c (12)	TOT. LENGTH ft (13)					SLOPE ft/ft (14)
B25	B25	0.32	0.02	23	0.0200	5.4	20	0.0200	20	2.83	0.1	5.5	43.1	0.02	33.1%	20.5	5.5	
B26	B26	0.36	0.06	50	0.0250	7.0	27	0.0250	20	3.16	0.1	7.1	77.0	0.03	38.6%	19.6	7.1	
C1	C1	0.27	0.49	54	0.1700	4.3	200	0.0106	20	2.06	1.6	6.0	254.4	0.04	25.8%	24.2	6.0	
C2	C2	0.12	0.28	64	0.0700	7.4	72	0.0200	2.5	0.35	3.4	10.8	135.7	0.04	5.3%	26.0	10.8	
C3	C3	0.79	0.27	20	0.0200	2.0	351	0.0291	20	3.41	1.7	3.7	370.6	0.03	87.7%	12.7	5.0	
C4	C4	0.73	0.06			0.0			20	0.00	0.0	0.0	0.0	#DIV/0!	90.0%		5.0	Roof Basin
C5	C5	0.73	0.08			0.0			20	0.00	0.0	0.0	0.0	#DIV/0!	90.0%		5.0	Roof Basin
C6	C6	0.11	0.01	21	0.0750	4.2	10	0.1000	2.5	0.79	0.2	4.4	30.5	0.08	4.8%	25.2	5.0	
C7	C7	0.36	0.05	13	0.2050	1.8	76	0.0377	15	2.91	0.4	2.2	89.1	0.06	38.3%	20.0	5.0	
C8	C8	0.08	0.02	6	0.2500	1.6	33	0.0200	2.5	0.35	1.6	3.1	39.0	0.06	0.0%	26.4	5.0	
C9	C9	0.33	0.01	25	0.0130	6.4	14	0.0200	7	0.99	0.2	6.7	39.3	0.02	36.8%	19.9	6.7	
C10	C10	0.25	0.25	31	0.0720	4.4	113	0.0381	2.5	0.49	3.9	8.3	144.0	0.05	25.9%	22.4	8.3	
C11	C11	0.21	0.05	20	0.0200	5.7	30	0.0200	15	2.12	0.2	5.9	50.0	0.02	20.3%	22.8	5.9	
C12	C12	0.73	0.01			0.0			20	0.00	0.0	0.0	0.0	#DIV/0!	90.0%		5.0	Roof Basin
C13	C13	0.73	0.07			0.0			20	0.00	0.0	0.0	0.0	#DIV/0!	90.0%		5.0	Roof Basin
C14	C14	0.73	0.03			0.0			20	0.00	0.0	0.0	0.0	#DIV/0!	90.0%		5.0	Roof Basin
C15	C15	0.10	0.02	18	0.0700	4.0	21	0.0200	7	0.99	0.4	4.4	38.9	0.04	2.5%	25.8	5.0	
C16	C16	0.21	0.02	13	0.1180	2.6	22	0.0600	15	3.67	0.1	2.7	34.3	0.08	19.7%	22.8	5.0	
C17	C17	0.73	0.04			0.0			20	0.00	0.0	0.0	0.0	#DIV/0!	90.0%		5.0	Roof Basin
C18	C18	0.73	0.05			0.0			20	0.00	0.0	0.0	0.0	#DIV/0!	90.0%		5.0	Roof Basin
C19	C19	0.08	0.06			0.0			20	0.00	0.0	0.0	0.0	#DIV/0!	90.0%		5.0	Roof Basin
C20	C20	0.27	1.59	120	0.0710	8.6	431	0.0060	15	1.16	6.2	14.8	551.0	0.02	25.9%	28.9	14.8	
C21	C21	0.77	0.16			0.0			20	0.00	0.0	0.0	0.0	#DIV/0!	92.3%		5.0	Roof Basin

*Velocity (V) = C_vS_w^{0.5}

TABLE 6-2

Type of Land Surface	Conveyance Coefficient, C _v
Heavy Meadow	2.5
Tillage / Field	5
Short Pasture and Lawns	7
Nearly Bare Ground	10
Grassed Waterway	15
Paved Areas and Shallow Paved Swales	20

*Table 6-2, UDFCD (V.1), Chapter 6, Page 6-5

in which: C_v = Conveyance Coefficient (See Table Above)
 S_w = Watercourse Slope (ft/ft)



CALCULATED BY: AG
 CHECKED BY: NK
 DATE: 05/15/26

STANDARD FORM SF-3
 STORM DRAINAGE SYSTEM DESIGN
 (RATIONAL METHOD PROCEDURE)

JOB NO: 23.0895
 PROJECT: FVS - Academic Center
 DESIGN STORM: 10-YEAR
 ONE-HR PRECIP: 1.55

BASIN	DESIGN POINT	DIRECT RUNOFF						TOTAL RUNOFF				REMARKS
		AREA (AC)	RUNOFF COEFF	t _c (MIN)	CxA (AC)	I (IN/HR)	Q (CFS)	t _c (MIN)	S(CxA) (AC)	I (IN/HR)	Q (CFS)	
(1)	(2)	(3)	(4)	(5)	(6)	(7)	(8)	(9)	(10)	(11)	(12)	(13)
A1	A1	1.10	0.32	13.9	0.35	3.65	1.27					
A2	A2	0.16	0.27	9.8	0.04	4.23	0.18					
A3	A3	0.31	0.39	7.7	0.12	4.62	0.56					
A4	A4	0.77	0.29	16.3	0.22	3.38	0.75					
A5	A5	0.05	0.46	5.0	0.02	5.26	0.11					
A6	A6	0.08	0.67	5.4	0.05	5.16	0.27					
A7	A7	0.20	0.28	7.8	0.05	4.60	0.25					
A8	A8	0.06	0.73	5.0	0.04	5.26	0.23					
A9	A9	0.06	0.81	5.0	0.05	5.26	0.24					
A10	A10	0.07	0.86	5.0	0.06	5.26	0.30					
A11	A11	0.12	0.88	5.0	0.11	5.26	0.57					
A12	A12	0.17	0.59	6.6	0.10	4.86	0.49					
A13	A13	1.06	0.60	5.3	0.63	5.19	3.28					
B1	B1	0.18	0.34	7.6	0.06	4.63	0.28					
B2	B2	0.14	0.90	5.0	0.13	5.26	0.68					
B3	B3	0.31	0.62	5.0	0.19	5.26	1.00					
B4	B4	0.03	0.31	5.0	0.01	5.26	0.05					
B5	B5	0.03	0.90	5.0	0.03	5.26	0.13					
B6	B6	0.04	0.90	5.0	0.04	5.26	0.21					
B7	B7	0.02	0.38	5.0	0.01	5.26	0.05					
B8	B8	0.03	0.55	5.0	0.02	5.26	0.08					
B9	B9	0.12	0.33	5.0	0.04	5.26	0.21					
B10	B10	0.02	0.90	5.0	0.02	5.26	0.10					
B11	B11	0.05	0.90	5.0	0.04	5.26	0.23					
B12	B12	0.02	0.43	5.0	0.01	5.26	0.04					
B13	B13	0.03	0.54	5.0	0.02	5.26	0.09					
B14	B14	0.01	0.28	5.0	0.00	5.26	0.01					
B15	B15	0.06	0.82	5.0	0.05	5.26	0.27					
B16	B16	0.02	0.25	5.0	0.00	5.26	0.02					
B17	B17	0.05	0.90	5.0	0.05	5.26	0.26					
B18	B18	0.05	0.55	5.0	0.03	5.26	0.15					
B19	B19	0.02	0.25	5.0	0.00	5.26	0.02					
B20	B20	0.03	0.34	5.0	0.01	5.26	0.05					
B21	B21	0.12	0.38	6.3	0.05	4.92	0.23					
B22	B22	0.02	0.90	5.0	0.02	5.26	0.11					

CALCULATED BY: AG
 CHECKED BY: NK
 DATE: 05/15/26

STANDARD FORM SF-3
 STORM DRAINAGE SYSTEM DESIGN
 (RATIONAL METHOD PROCEDURE)

JOB NO: 23.0895
 PROJECT: FVS - Academic Center
 DESIGN STORM: 10-YEAR
 ONE-HR PRECIP: 1.55

BASIN	DESIGN POINT	DIRECT RUNOFF						TOTAL RUNOFF				REMARKS
		AREA (AC)	RUNOFF COEFF	t _c (MIN)	CxA (AC)	I (IN/HR)	Q (CFS)	t _c (MIN)	S(CxA) (AC)	I (IN/HR)	Q (CFS)	
(1)	(2)	(3)	(4)	(5)	(6)	(7)	(8)	(9)	(10)	(11)	(12)	(13)
B23	B23	0.04	0.90	5.0	0.03	5.26	0.17					
B24	B24	0.04	0.90	5.0	0.03	5.26	0.17					
B25	B25	0.02	0.47	5.5	0.01	5.11	0.05					
B26	B26	0.06	0.47	7.1	0.03	4.74	0.13					
C1	C1	0.49	0.39	6.0	0.19	5.01	0.96					
C2	C2	0.28	0.28	10.8	0.08	4.07	0.33					
C3	C3	0.27	0.82	5.0	0.22	5.26	1.17					
C4	C4	0.06	0.90	5.0	0.06	5.26	0.29					
C5	C5	0.08	0.90	5.0	0.07	5.26	0.36					
C6	C6	0.01	0.28	5.0	0.00	5.26	0.01					
C7	C7	0.05	0.50	5.0	0.03	5.26	0.14					
C8	C8	0.02	0.25	5.0	0.01	5.26	0.03					
C9	C9	0.01	0.40	6.7	0.01	4.84	0.03					
C10	C10	0.25	0.36	8.3	0.09	4.50	0.40					
C11	C11	0.05	0.33	5.9	0.02	5.01	0.08					
C12	C12	0.01	0.90	5.0	0.01	5.26	0.06					
C13	C13	0.07	0.90	5.0	0.06	5.26	0.33					
C14	C14	0.03	0.90	5.0	0.03	5.26	0.17					
C15	C15	0.02	0.27	5.0	0.00	5.26	0.03					
C16	C16	0.02	0.39	5.0	0.01	5.26	0.05					
C17	C17	0.04	0.90	5.0	0.04	5.26	0.21					
C18	C18	0.05	0.90	5.0	0.05	5.26	0.25					
C19	C19	0.06	0.25	5.0	0.02	5.26	0.08					
C20	C20	1.59	0.42	14.8	0.66	3.54	2.35					
C21	C21	0.16	0.90	5.0	0.14	5.26	0.75					

I. One-Hr Precipitation Values from NOAA Atlas 14 PFDS

Return Period:	2-YEAR	5-YEAR	10-YEAR	100-YEAR
Depth In Inches:	1.00	1.28	1.55	2.73

*Equation 5-1, UDFCD (V.1), Chapter 5, Page 5-9

*Rainfall Intensity:
$$I = \frac{(28.5 \times P1)}{(10 + t_c)^{0.786}}$$

In Which: I = Rainfall Intensity (Inches Per Hour)
 P1 = 1-Hour Point Rainfall Depth (Inches)
 t_c = Time Of Concentration (Minutes)



CALCULATED BY: AG
 CHECKED BY: NK
 DATE: 05/15/26

STANDARD FORM SF-3
 STORM DRAINAGE SYSTEM DESIGN
 (RATIONAL METHOD PROCEDURE)

JOB NO: 23.0895
 PROJECT: FVS - Academic Center
 DESIGN STORM: 100-YEAR
 ONE-HR PRECIP: 2.73

BASIN	DESIGN POINT	DIRECT RUNOFF						TOTAL RUNOFF				REMARKS
		AREA (AC)	RUNOFF COEFF	t _c (MIN)	CxA (AC)	I (IN/HR)	Q (CFS)	t _c (MIN)	S(CxA) (AC)	I (IN/HR)	Q (CFS)	
(1)	(2)	(3)	(4)	(5)	(6)	(7)	(8)	(9)	(10)	(11)	(12)	(13)
A1	A1	1.10	0.41	13.9	0.45	6.43	2.90					
A2	A2	0.16	0.37	9.8	0.06	7.45	0.43					
A3	A3	0.31	0.48	7.7	0.15	8.14	1.22					
A4	A4	0.77	0.39	16.3	0.30	5.96	1.76					
A5	A5	0.05	0.56	5.0	0.03	9.26	0.24					
A6	A6	0.08	0.75	5.4	0.06	9.09	0.53					
A7	A7	0.20	0.39	7.8	0.08	8.10	0.63					
A8	A8	0.06	0.79	5.0	0.05	9.26	0.44					
A9	A9	0.06	0.87	5.0	0.05	9.26	0.45					
A10	A10	0.07	0.91	5.0	0.06	9.26	0.57					
A11	A11	0.12	0.93	5.0	0.12	9.26	1.07					
A12	A12	0.17	0.66	6.6	0.11	8.56	0.97					
A13	A13	1.06	0.67	5.3	0.71	9.14	6.48					
B1	B1	0.18	0.44	7.6	0.08	8.16	0.65					
B2	B2	0.14	0.95	5.0	0.14	9.26	1.27					
B3	B3	0.31	0.69	5.0	0.21	9.26	1.96					
B4	B4	0.03	0.40	5.0	0.01	9.26	0.11					
B5	B5	0.03	0.95	5.0	0.03	9.26	0.25					
B6	B6	0.04	0.95	5.0	0.04	9.26	0.39					
B7	B7	0.02	0.47	5.0	0.01	9.26	0.11					
B8	B8	0.03	0.63	5.0	0.02	9.26	0.16					
B9	B9	0.12	0.43	5.0	0.05	9.26	0.48					
B10	B10	0.02	0.95	5.0	0.02	9.26	0.19					
B11	B11	0.05	0.95	5.0	0.05	9.26	0.44					
B12	B12	0.02	0.51	5.0	0.01	9.26	0.07					
B13	B13	0.03	0.62	5.0	0.02	9.26	0.18					
B14	B14	0.01	0.38	5.0	0.00	9.26	0.03					
B15	B15	0.06	0.88	5.0	0.05	9.26	0.50					
B16	B16	0.02	0.35	5.0	0.01	9.26	0.06					
B17	B17	0.05	0.95	5.0	0.05	9.26	0.48					

CALCULATED BY: AG
 CHECKED BY: NK
 DATE: 05/15/26

STANDARD FORM SF-3
 STORM DRAINAGE SYSTEM DESIGN
 (RATIONAL METHOD PROCEDURE)

JOB NO: 23.0895
 PROJECT: FVS - Academic Center
 DESIGN STORM: 100-YEAR
 ONE-HR PRECIP: 2.73

BASIN	DESIGN POINT	DIRECT RUNOFF						TOTAL RUNOFF				REMARKS
		AREA (AC)	RUNOFF COEFF	t _c (MIN)	CxA (AC)	I (IN/HR)	Q (CFS)	t _c (MIN)	S(CxA) (AC)	I (IN/HR)	Q (CFS)	
(1)	(2)	(3)	(4)	(5)	(6)	(7)	(8)	(9)	(10)	(11)	(12)	(13)
B18	B18	0.05	0.62	5.0	0.03	9.26	0.31					
B19	B19	0.02	0.35	5.0	0.01	9.26	0.05					
B20	B20	0.03	0.45	5.0	0.01	9.26	0.11					
B21	B21	0.12	0.48	6.3	0.06	8.67	0.52					
B22	B22	0.02	0.95	5.0	0.02	9.26	0.20					
B23	B23	0.04	0.95	5.0	0.03	9.26	0.31					
B24	B24	0.04	0.95	5.0	0.03	9.26	0.31					
B25	B25	0.02	0.55	5.5	0.01	9.01	0.10					
B26	B26	0.06	0.56	7.1	0.03	8.35	0.27					
C1	C1	0.49	0.49	6.0	0.24	8.82	2.10					
C2	C2	0.28	0.38	10.8	0.11	7.16	0.77					
C3	C3	0.27	0.88	5.0	0.24	9.26	2.21					
C4	C4	0.06	0.95	5.0	0.06	9.26	0.54					
C5	C5	0.08	0.95	5.0	0.07	9.26	0.67					
C6	C6	0.01	0.38	5.0	0.00	9.26	0.03					
C7	C7	0.05	0.58	5.0	0.03	9.26	0.29					
C8	C8	0.02	0.35	5.0	0.01	9.26	0.07					
C9	C9	0.01	0.50	6.7	0.01	8.52	0.06					
C10	C10	0.25	0.46	8.3	0.11	7.92	0.90					
C11	C11	0.05	0.43	5.9	0.02	8.83	0.18					
C12	C12	0.01	0.95	5.0	0.01	9.26	0.11					
C13	C13	0.07	0.95	5.0	0.07	9.26	0.61					
C14	C14	0.03	0.95	5.0	0.03	9.26	0.31					
C15	C15	0.02	0.37	5.0	0.01	9.26	0.06					
C16	C16	0.02	0.47	5.0	0.01	9.26	0.10					
C17	C17	0.04	0.95	5.0	0.04	9.26	0.38					
C18	C18	0.05	0.95	5.0	0.05	9.26	0.47					
C19	C19	0.06	0.35	5.0	0.02	9.26	0.20					
C20	C20	1.59	0.51	14.8	0.80	6.23	5.01					
C21	C21	0.16	0.95	5.0	0.15	9.26	1.40					

I. One-Hr Precipitation Values from NOAA Atlas 14 PFDS

Return Period:	2-YEAR	5-YEAR	10-YEAR	100-YEAR
Depth In Inches:	1.00	1.28	1.55	2.73

*Equation 5-1, UDFCD (V.1), Chapter 5, Page 5-9

*Rainfall Intensity:

$$I = \frac{28.5 \times P1}{(10 + t_c)^{0.786}}$$

In Which:

I = Rainfall Intensity (Inches Per Hour)
 P1 = 1-Hour Point Rainfall Depth (Inches)
 t_c = Time Of Concentration (Minutes)



PROJECT: FVS - Academic Center
JOB NO: 23.090
DATE: 05/15/26



RUNOFF SUMMARY							
BASIN	DESIGN POINT	AREA (ACRES)	% IMP.	C ₁₀	C ₁₀₀	Q ₁₀ (CFS)	Q ₁₀₀ (CFS)
A1	A1	1.10	10.3%	0.32	0.41	1.27	2.90
A2	A2	0.16	3.4%	0.27	0.37	0.18	0.43
A3	A3	0.31	21.5%	0.39	0.48	0.56	1.22
A4	A4	0.77	6.1%	0.29	0.39	0.75	1.76
A5	A5	0.05	43.4%	0.46	0.56	0.11	0.24
A6	A6	0.08	73.2%	0.67	0.75	0.27	0.53
A7	A7	0.20	19.2%	0.28	0.39	0.25	0.63
A8	A8	0.06	66.1%	0.73	0.79	0.23	0.44
A9	A9	0.06	78.2%	0.81	0.87	0.24	0.45
A10	A10	0.07	84.3%	0.86	0.91	0.30	0.57
A11	A11	0.12	87.9%	0.88	0.93	0.57	1.07
A12	A12	0.17	51.8%	0.59	0.66	0.49	0.97
A13	A13	1.06	50.8%	0.60	0.67	3.28	6.48
B1	B1	0.18	22.2%	0.34	0.44	0.28	0.65
B2	B2	0.14	90.0%	0.90	0.95	0.68	1.27
B3	B3	0.31	57.5%	0.62	0.69	1.00	1.96
B4	B4	0.03	8.3%	0.31	0.40	0.05	0.11
B5	B5	0.03	90.0%	0.90	0.95	0.13	0.25
B6	B6	0.04	90.0%	0.90	0.95	0.21	0.39
B7	B7	0.02	19.6%	0.38	0.47	0.05	0.11
B8	B8	0.03	45.8%	0.55	0.63	0.08	0.16
B9	B9	0.12	17.7%	0.33	0.43	0.21	0.48
B10	B10	0.02	90.0%	0.90	0.95	0.10	0.19
B11	B11	0.05	90.0%	0.90	0.95	0.23	0.44
B12	B12	0.02	26.9%	0.43	0.51	0.04	0.07
B13	B13	0.03	45.2%	0.54	0.62	0.09	0.18
B14	B14	0.01	5.1%	0.28	0.38	0.01	0.03
B15	B15	0.06	88.2%	0.82	0.88	0.27	0.50
B16	B16	0.02	0.0%	0.25	0.35	0.02	0.06
B17	B17	0.05	90.0%	0.90	0.95	0.26	0.48
B18	B18	0.05	45.8%	0.55	0.62	0.15	0.31
B19	B19	0.02	0.0%	0.25	0.35	0.02	0.05
B20	B20	0.03	22.3%	0.34	0.45	0.05	0.11
B21	B21	0.12	27.5%	0.38	0.48	0.23	0.52
B22	B22	0.02	90.0%	0.90	0.95	0.11	0.20
B23	B23	0.04	90.0%	0.90	0.95	0.17	0.31
B24	B24	0.04	90.0%	0.90	0.95	0.17	0.31

RUNOFF_SUMMARY
 5/15/2026 3:30 PM

G:\BUCKLEY\23.0895-Fountain Valley School Academic
 Building\ENG\DRAINAGE\CALCS\RATIONAL\2026.05.15_FVS_Site_Rational_OFFSITE (MHFD).xslm

PROJECT: FVS - Academic Center
 JOB NO: 23.090
 DATE: 05/15/26



RUNOFF SUMMARY							
BASIN	DESIGN POINT	AREA (ACRES)	% IMP.	C ₁₀	C ₁₀₀	Q ₁₀ (CFS)	Q ₁₀₀ (CFS)
B25	B25	0.02	33.1%	0.47	0.55	0.05	0.10
B26	B26	0.06	38.6%	0.47	0.56	0.13	0.27
C1	C1	0.49	25.8%	0.39	0.49	0.96	2.10
C2	C2	0.28	5.3%	0.28	0.38	0.33	0.77
C3	C3	0.27	87.7%	0.82	0.88	1.17	2.21
C4	C4	0.06	90.0%	0.90	0.95	0.29	0.54
C5	C5	0.08	90.0%	0.90	0.95	0.36	0.67
C6	C6	0.01	4.8%	0.28	0.38	0.01	0.03
C7	C7	0.05	38.3%	0.50	0.58	0.14	0.29
C8	C8	0.02	0.0%	0.25	0.35	0.03	0.07
C9	C9	0.01	36.8%	0.40	0.50	0.03	0.06
C10	C10	0.25	25.9%	0.36	0.46	0.40	0.90
C11	C11	0.05	20.3%	0.33	0.43	0.08	0.18
C12	C12	0.01	90.0%	0.90	0.95	0.06	0.11
C13	C13	0.07	90.0%	0.90	0.95	0.33	0.61
C14	C14	0.03	90.0%	0.90	0.95	0.17	0.31
C15	C15	0.02	2.5%	0.27	0.37	0.03	0.06
C16	C16	0.02	19.7%	0.39	0.47	0.05	0.10
C17	C17	0.04	90.0%	0.90	0.95	0.21	0.38
C18	C18	0.05	90.0%	0.90	0.95	0.25	0.47
C19	C19	0.06	90.0%	0.25	0.35	0.08	0.20
C20	C20	1.59	25.9%	0.42	0.51	2.35	5.01
C21	C21	0.16	92.3%	0.90	0.95	0.75	1.40
OS1	OS1	0.15	67.8%	0.61	0.66	0.41	0.94
OS2	OS2	0.75	36.5%	0.27	0.43	0.89	3.00
OS3	OS3	0.32	18.5%	0.23	0.46	0.32	1.39
OS4	OS4	0.40	81.1%	0.74	0.84	1.28	3.09
SITE COMPOSITE		11.02	38.3%	0.25	0.41	24.26	52.09

MM Comment:
 Please note: Site composite includes off-site basins that are not tributary to the BioSwale, Wet Meadow, or storm sewer infrastructure associated with this project. Off-site basins are tributary to existing hayfields providing water quality.

 See next page for on-site specific runoff summary.

PROJECT: FVS - Academic Center
 JOB NO: 23.090
 DATE: 03/16/26



RUNOFF SUMMARY							
BASIN	DESIGN POINT	AREA (ACRES)	% IMP.	C ₁₀	C ₁₀₀	Q ₁₀ (CFS)	Q ₁₀₀ (CFS)
A1	A1	1.10	10.3%	0.32	0.41	1.27	2.90
A2	A2	0.16	3.4%	0.27	0.37	0.18	0.43
A3	A3	0.31	21.5%	0.39	0.48	0.56	1.22
A4	A4	0.77	6.1%	0.29	0.39	0.75	1.76
A5	A5	0.05	43.4%	0.46	0.56	0.11	0.24
A6	A6	0.08	73.2%	0.67	0.75	0.27	0.53
A7	A7	0.20	19.2%	0.28	0.39	0.25	0.63
A8	A8	0.06	66.1%	0.73	0.79	0.23	0.44
A9	A9	0.06	78.2%	0.81	0.87	0.24	0.45
A10	A10	0.07	84.3%	0.86	0.91	0.30	0.57
A11	A11	0.12	87.9%	0.88	0.93	0.57	1.07
A12	A12	0.17	51.8%	0.59	0.66	0.49	0.97
A13	A13	1.06	50.8%	0.60	0.67	3.28	6.48
B1	B1	0.18	22.2%	0.34	0.44	0.28	0.65
B2	B2	0.14	90.0%	0.90	0.95	0.68	1.27
B3	B3	0.31	57.5%	0.62	0.69	1.00	1.96
B4	B4	0.03	8.3%	0.31	0.40	0.05	0.11
B5	B5	0.03	90.0%	0.90	0.95	0.13	0.25
B6	B6	0.04	90.0%	0.90	0.95	0.21	0.39
B7	B7	0.02	19.6%	0.38	0.47	0.05	0.11
B8	B8	0.03	45.8%	0.55	0.63	0.08	0.16
B9	B9	0.12	17.7%	0.33	0.43	0.21	0.48
B10	B10	0.02	90.0%	0.90	0.95	0.10	0.19
B11	B11	0.05	90.0%	0.90	0.95	0.23	0.44
B12	B12	0.02	26.9%	0.43	0.51	0.04	0.07
B13	B13	0.03	45.2%	0.54	0.62	0.09	0.18
B14	B14	0.01	5.1%	0.28	0.38	0.01	0.03
B15	B15	0.06	88.2%	0.82	0.88	0.27	0.50
B16	B16	0.02	0.0%	0.25	0.35	0.02	0.06
B17	B17	0.05	90.0%	0.90	0.95	0.26	0.48
B18	B18	0.05	45.8%	0.55	0.62	0.15	0.31
B19	B19	0.02	0.0%	0.25	0.35	0.02	0.05
B20	B20	0.03	22.3%	0.34	0.45	0.05	0.11
B21	B21	0.12	27.5%	0.38	0.48	0.23	0.52
B22	B22	0.02	90.0%	0.90	0.95	0.11	0.20
B23	B23	0.04	90.0%	0.90	0.95	0.17	0.31
B24	B24	0.04	90.0%	0.90	0.95	0.17	0.31

RUNOFF_SUMMARY
 3/16/2026 2:37 PM

G:\BUCKLEY\23.0895-Fountain Valley School Academic
 Building\ENG\DRAINAGE_CALCS_RATIONAL\2026.02.17_FVS_Site_Rational (MHFD).xslm

PROJECT: FVS - Academic Center
JOB NO: 23.090
DATE: 03/16/26



RUNOFF SUMMARY							
BASIN	DESIGN POINT	AREA (ACRES)	% IMP.	C ₁₀	C ₁₀₀	Q ₁₀ (CFS)	Q ₁₀₀ (CFS)
B25	B25	0.02	33.1%	0.47	0.55	0.05	0.10
B26	B26	0.06	38.6%	0.47	0.56	0.13	0.27
C1	C1	0.49	25.8%	0.39	0.49	0.96	2.10
C2	C2	0.28	5.3%	0.28	0.38	0.33	0.77
C3	C3	0.27	87.7%	0.82	0.88	1.17	2.21
C4	C4	0.06	90.0%	0.90	0.95	0.29	0.54
C5	C5	0.08	90.0%	0.90	0.95	0.36	0.67
C6	C6	0.01	4.8%	0.28	0.38	0.01	0.03
C7	C7	0.05	38.3%	0.50	0.58	0.14	0.29
C8	C8	0.02	0.0%	0.25	0.35	0.03	0.07
C9	C9	0.01	36.8%	0.40	0.50	0.03	0.06
C10	C10	0.25	25.9%	0.36	0.46	0.40	0.90
C11	C11	0.05	20.3%	0.33	0.43	0.08	0.18
C12	C12	0.01	90.0%	0.90	0.95	0.06	0.11
C13	C13	0.07	90.0%	0.90	0.95	0.33	0.61
C14	C14	0.03	90.0%	0.90	0.95	0.17	0.31
C15	C15	0.02	2.5%	0.27	0.37	0.03	0.06
C16	C16	0.02	19.7%	0.39	0.47	0.05	0.10
C17	C17	0.04	90.0%	0.90	0.95	0.21	0.38
C18	C18	0.05	90.0%	0.90	0.95	0.25	0.47
C19	C19	0.06	90.0%	0.25	0.35	0.08	0.20
C20	C20	1.59	25.9%	0.42	0.51	2.35	5.01
C21	C21	0.16	92.3%	0.90	0.95	0.75	1.40
SITE COMPOSITE		9.39	36.8%	0.24	0.40	21.37	43.67

FVSD Site Flow Summary

Bioswale	Flowrates		Piped East	Flowrates		Piped West	Flowrates	
	Basins	Q10		Q100	Basins		Q10	Q100
A1	1.27	2.9	C1	0.96	2.1	B1	0.28	0.65
A2	0.18	0.43	C2	0.33	0.77	B2	0.68	1.27
A3	0.56	1.22	C3	1.17	2.21	B3	1	1.96
A4	0.75	1.76	C4	0.29	0.54	B4	0.05	0.11
A5	0.11	0.24	C5	0.36	0.67	B5	0.13	0.25
A6	0.27	0.53	C6	0.01	0.03	B6	0.21	0.39
A7	0.25	0.63	C7	0.14	0.29	B7	0.05	0.11
A8	0.23	0.44	C8	0.03	0.07	B8	0.08	0.16
A9	0.24	0.45	C9	0.03	0.06	B9	0.21	0.48
A10	0.3	0.57	C10	0.4	0.9	B10	0.1	0.19
A11	0.57	1.07	C11	0.08	0.18	B11	0.23	0.44
A12	0.49	0.97	C12	0.06	0.11	B12	0.04	0.07
A13	3.28	6.48	C13	0.33	0.61	B13	0.09	0.18
TOTAL	8.5	17.69	C14	0.17	0.31	B14	0.01	0.03
			C15	0.03	0.06	B15	0.27	0.5
			C16	0.05	0.1	B16	0.02	0.06
			C17	0.21	0.38	B17	0.26	0.48
			C18	0.25	0.47	B18	0.15	0.31
			C19	0.08	0.2	B19	0.02	0.05
			C20	2.35	5.01	B20	0.05	0.11
			C21	0.75	1.4	B21	0.23	0.52
			TOTAL	8.08	16.47	B22	0.11	0.2
						B23	0.17	0.31
						B24	0.17	0.31
						B25	0.05	0.1
						B26	0.13	0.27
						TOTAL	4.79	9.51

APPENDIX C – Hydraulic Calculations

10-YEAR EVENT
Conduit Table - Time: 0.00 hours

Label	Start Node	Invert (Start) (ft)	Stop Node	Invert (Stop) (ft)	Length (Unified) (ft)	Slope (Calculated) (ft/ft)	Velocity (ft/s)	Diameter (in)	Material	Manning's n	Flow (cfs)	Capacity (Full Flow) (cfs)	Hydraulic Grade Line (In) (ft)	Hydraulic Grade Line (Out) (ft)
CO-1	ST INLET #I-3	5,768.17	ST MH #I-2	5,767.11	30.3	0.035	3.55	24.0	Concrete	0.013	0.22	42.34	5,768.33	5,767.21
CO-2	ST MH #I-2	5,766.61	ST MH #I-1	5,762.78	109.5	0.035	4.97	24.0	Concrete	0.013	0.67	42.30	5,766.89	5,764.79
CO-3	ST MH #I-1	5,762.58	ST MH #A-7	5,761.47	31.7	0.035	12.63	24.0	Concrete	0.013	16.49	42.33	5,764.04	5,762.46
CO-5	ST MH #A-6	5,755.13	KOR-N-TEE #A-7	5,754.06	53.8	0.020	10.20	30.0	Concrete	0.013	16.72	57.84	5,756.51	5,756.06
CO-6	KOR-N-TEE #A-7	5,754.06	ST MH #A-5	5,752.78	63.7	0.020	10.28	30.0	Concrete	0.013	16.98	58.14	5,755.45	5,753.75
CO-7	ST MH #A-5	5,751.78	KOR-N-TEE #A-6	5,750.92	28.5	0.030	11.77	36.0	Concrete	0.013	17.31	115.82	5,753.11	5,752.95
CO-8	KOR-N-TEE #A-6	5,750.92	ST MH #A-4	5,748.94	66.2	0.030	11.95	30.0	Concrete	0.013	17.40	70.93	5,752.33	5,749.83
CO-10	KOR-N-TEE #A-2	5,747.10	KOR-N-TEE #A-1	5,746.69	32.6	0.013	8.70	36.0	Concrete	0.013	17.96	74.81	5,748.46	5,748.60
CO-11	KOR-N-TEE #A-1	5,746.69	ST MH #A-3	5,746.08	49.0	0.012	8.67	36.0	Concrete	0.013	17.98	74.41	5,748.05	5,747.13
CO-13	ST INLET #A-1.1	5,753.71	ST FES #A-1.1	5,752.85	41.5	0.021	8.37	24.0	Concrete	0.013	7.33	32.56	5,754.67	5,753.52
CO-14	ST AREA INLET #A1.1	5,748.73	KOR-N-TEE #A-1	5,747.77	24.0	0.040	3.17	10.0	PVC	0.010	0.05	5.70	5,748.82	5,748.60
CO-15	ST AREA INLET #A1.2	5,748.72	KOR-N-TEE #A-2	5,748.18	6.8	0.079	5.53	10.0	PVC	0.010	0.13	8.03	5,749.00	5,749.01
CO-16	ST AREA INLET #J-2	5,753.40	ST AREA INLET #J-1	5,751.64	44.1	0.040	4.48	10.0	PVC	0.010	0.15	5.69	5,753.57	5,751.73
CO-17	ST AREA INLET #J-1	5,751.44	ST MH #A-4	5,751.17	27.3	0.010	3.65	10.0	PVC	0.010	0.39	2.83	5,751.71	5,751.38
CO-18	TRENCH DRAIN CONNECTION	5,752.71	KOR-N-TEE #A-6	5,751.84	43.8	0.020	3.59	8.0	PVC	0.010	0.15	2.21	5,752.92	5,752.95
CO-19	TRENCH DRAIN CONNECTION	5,756.29	ST CO #E-1	5,756.07	10.8	0.020	4.28	8.0	PVC	0.010	0.26	2.24	5,756.53	5,756.42
CO-20	ST CO #E-1	5,756.07	ST MH #E-1	5,755.44	31.9	0.020	4.25	8.0	PVC	0.010	0.26	2.21	5,756.31	5,755.59
CO-21	ST MH #E-1	5,755.10	ST MH #A-5	5,754.36	74.0	0.010	3.93	12.0	PVC	0.010	0.54	4.63	5,755.40	5,754.59
CO-22	SCUPPER DRAIN #E-1	5,756.62	ST AREA INLET #E-2	5,756.47	7.7	0.020	4.25	6.0	PVC	0.010	0.24	1.02	5,756.87	5,756.65
CO-23	ST AREA INLET #E-2	5,756.27	ST MH #E-1	5,755.98	14.6	0.020	4.34	6.0	PVC	0.010	0.25	1.03	5,756.52	5,756.15
CO-25	ST AREA INLT #E-1	5,756.27	ST MH #E-1	5,755.98	14.7	0.020	2.23	6.0	PVC	0.010	0.03	1.03	5,756.35	5,756.04
CO-26	ST AREA INLET #C-5	5,754.44	ST AREA INLET #C-4	5,753.06	46.0	0.030	2.19	10.0	PVC	0.010	0.02	4.93	5,754.50	5,753.10
CO-27	ST AREA INLET #C-4	5,752.86	ST AREA INLET #C-3	5,751.91	31.7	0.030	3.05	10.0	PVC	0.010	0.06	4.93	5,752.96	5,752.02
CO-29	ST AREA INLET #C-1	5,753.26	ST AREA INLET #C-2	5,752.86	20.1	0.020	2.55	6.0	PVC	0.010	0.04	1.03	5,753.36	5,752.93
CO-31	ST AREA INLET #K-1	5,753.55	ST INLET #K-1	5,753.27	27.3	0.010	3.50	8.0	PVC	0.010	0.30	1.59	5,753.80	5,753.47
CO-37	ST MH #B-3	5,748.16	ST MH #B-2	5,747.35	65.5	0.012	5.37	18.0	Concrete	0.013	2.68	11.68	5,748.78	5,747.84
CO-47	ST AREA INLET #H-2	5,758.20	STRM TEE	5,758.05	19.0	0.008	1.10	6.0	PVC	0.010	0.22	0.65	5,759.50	5,759.48
CO-50	ST AREA INLET #H-1	5,758.66	STRM TEE	5,758.05	30.5	0.020	0.75	6.0	PVC	0.010	0.15	1.03	5,759.49	5,759.48
CO-51	ST MH #A-8	5,761.40	ST MH #A-7	5,760.15	35.8	0.035	0.00	24.0	Concrete	0.013	0.00	42.28	5,761.51	5,761.51
CO-52	ST INLET #I-2	5,767.61	ST MH #I-2	5,767.11	10.0	0.050	5.18	24.0	Concrete	0.013	0.51	50.58	5,767.85	5,767.26
CO-53	ST INLET #I-1	5,762.98	ST MH #I-1	5,762.78	10.6	0.019	9.98	24.0	Concrete	0.013	16.02	31.13	5,764.80	5,764.79
CO-57	ST AREA INLET #F-1	5,755.13	KOR-N-TEE #A-7	5,754.89	23.2	0.010	1.19	8.0	PVC	0.010	0.42	1.60	5,756.08	5,756.06
CO-60	EX. MANHOLE	5,778.02	ST MH #I-2	5,769.77	110.4	0.075	0.00	24.0	Concrete	0.013	0.00	61.85	5,778.02	5,769.77

10-YEAR EVENT
Conduit Table - Time: 0.00 hours

Label	Start Node	Invert (Start) (ft)	Stop Node	Invert (Stop) (ft)	Length (Unified) (ft)	Slope (Calculated) (ft/ft)	Velocity (ft/s)	Diameter (in)	Material	Manning's n	Flow (cfs)	Capacity (Full Flow) (cfs)	Hydraulic Grade Line (In) (ft)	Hydraulic Grade Line (Out) (ft)
CO-64	ST MH #B-2	5,746.85	ST FES #B-1	5,746.06	62.9	0.013	5.49	24.0	Concrete	0.013	3.15	25.35	5,747.47	5,746.54
CO-65	ST CO #D-1	5,753.58	ST AREA INLET #D-1	5,752.70	43.9	0.020	0.00	6.0	PVC	0.010	0.00	1.03	5,753.58	5,752.70
CO-66	ST AREA INLET #D-1	5,751.70	ST MH #B-3	5,749.24	82.8	0.030	5.95	8.0	PVC	0.010	0.51	2.71	5,752.04	5,749.44
CO-67	ST INLET #B-1	5,750.60	ST MH #B-5	5,750.31	23.5	0.012	4.23	18.0	Concrete	0.013	1.17	11.67	5,751.00	5,750.63
CO-68	ST MH #B-5	5,750.11	ST MH #B-4	5,749.66	35.7	0.013	4.26	18.0	Concrete	0.013	1.17	11.80	5,750.51	5,750.17
CO-69	ST INLET #K-1	5,752.17	ST MH #B-4	5,749.66	100.5	0.025	5.77	18.0	Concrete	0.013	1.45	16.60	5,752.62	5,750.17
CO-70	O-6	5,784.89	CB-40	5,784.62	34.9	0.008	2.30	10.0	PVC	0.010	1.26	2.51	5,785.59	5,785.39
CO-71	CB-40	5,785.24	CB-42	5,784.89	35.0	0.010	0.48	10.0	PVC	0.010	0.26	2.85	5,785.62	5,785.59
CO-72	CB-40	5,785.13	CB-41	5,784.89	21.8	0.011	1.82	10.0	PVC	0.010	0.99	2.99	5,785.73	5,785.59
CO-73	CB-41	5,785.53	CB-43	5,785.13	35.3	0.011	1.61	10.0	PVC	0.010	0.88	3.03	5,786.11	5,785.95
CO-74	CB-43	5,785.77	CB-45	5,785.53	23.8	0.010	0.85	10.0	PVC	0.010	0.46	2.86	5,786.20	5,786.13
CO-75	CB-45	5,786.04	CB-46	5,785.77	27.6	0.010	0.43	10.0	PVC	0.010	0.23	2.82	5,786.33	5,786.25
CO-76	CB-43	5,785.99	CB-44	5,785.53	40.9	0.011	0.58	10.0	PVC	0.010	0.32	3.02	5,786.34	5,786.24
CO-77	ST AREA INLET #H-3	5,758.69	STRM BEND	5,758.58	15.7	0.007	0.96	6.0	PVC	0.010	0.19	0.61	5,759.55	5,759.54
CO-78	STRM BEND	5,758.58	ST AREA INLET #H-2	5,758.20	50.7	0.007	0.95	6.0	PVC	0.010	0.19	0.63	5,759.53	5,759.50
CO-79	ST MH #B-4	5,749.46	ST MH #B-3	5,748.36	88.6	0.012	5.16	18.0	Concrete	0.013	2.32	11.71	5,750.04	5,748.81
CO-4(1)	ST MH #A-7	5,759.65	KOR-N-TEE #A-8	5,757.15	125.3	0.020	10.25	24.0	Concrete	0.013	16.49	31.95	5,761.11	5,759.38
CO-4(2)	KOR-N-TEE #A-8	5,757.15	ST MH #A-6	5,755.63	75.8	0.020	10.31	24.0	Concrete	0.013	16.72	32.04	5,758.62	5,757.14
CO-81	STRM TEE	5,758.05	KOR-N-TEE #A-8	5,757.90	20.6	0.007	1.80	6.0	PVC	0.010	0.35	0.62	5,759.43	5,759.38
CO-82	SCUPPER DRAIN #H-1	5,759.00	ST AREA INLET #H-1	5,758.66	17.1	0.020	0.33	6.0	PVC	0.010	0.07	1.03	5,759.50	5,759.50
CO-83	SCUPPER DRAIN #H-2	5,758.82	ST AREA INLET #H-3	5,758.69	16.3	0.008	0.73	6.0	PVC	0.010	0.14	0.65	5,759.57	5,759.57
CO-84	SCUPPER DRAIN #K-1	5,753.75	ST AREA INLET #K-1	5,753.55	9.9	0.020	4.53	6.0	PVC	0.010	0.29	1.04	5,754.02	5,753.74
CO-85	SCUPPER DRAIN #D-1	5,753.28	ST AREA INLET #D-1	5,752.70	29.2	0.020	4.84	6.0	PVC	0.010	0.38	1.03	5,753.59	5,752.91
CO-86	ST RD #C-1	5,756.00	ST AREA INLET #C-5	5,755.82	9.1	0.020	0.00	6.0	PVC	0.010	0.00	1.03	5,756.00	5,755.82
CO-87	SCUPPER DRAIN #C-2	5,752.61	ST AREA INLET #C-3	5,752.64	18.4	-0.002	1.70	6.0	PVC	0.010	0.33	0.29	5,753.05	5,752.93
CO-88	SCUPPER DRAIN #C-1	5,753.33	ST AREA INLET #C-2	5,752.86	23.6	0.020	3.69	6.0	PVC	0.010	0.14	1.03	5,753.52	5,752.99
CO-89	ST AREA INLET #C-2	5,752.66	STORM TEE	5,750.91	53.6	0.033	4.76	8.0	PVC	0.010	0.21	2.84	5,752.87	5,751.29
CO-90	STORM TEE	5,750.82	ST MH #B-2	5,750.00	27.4	0.030	6.09	10.0	PVC	0.010	0.59	4.93	5,751.16	5,750.20
CO-91	ST AREA INLET #C-3	5,751.71	STORM TEE	5,750.82	29.8	0.030	5.41	10.0	PVC	0.010	0.40	4.92	5,751.98	5,751.29
CO-94	SCUPPER DRAIN #J-1	5,754.15	ST AREA INLET #J-2	5,753.73	10.6	0.040	4.19	6.0	PVC	0.010	0.10	1.45	5,754.30	5,753.82
CO-95	ST RD #A-2	5,753.50	DROP STRUCTURE #A-2	5,752.24	28.0	0.045	5.37	6.0	PVC	0.010	0.19	1.55	5,753.72	5,752.36
CO-9(1)	ST MH #A-4	5,748.42	KOR-N-TEE #A-5	5,747.89	41.8	0.013	8.68	36.0	Concrete	0.013	17.65	75.06	5,749.76	5,749.79
CO-96	DROP STRUCTURE #A-2	5,750.24	KOR-N-TEE #A-5	5,749.14	36.6	0.030	4.63	6.0	PVC	0.010	0.19	1.26	5,750.46	5,749.79
CO-97	ST RD #A-1	5,752.50	DROP STRUCTURE #A-1	5,751.74	13.8	0.055	0.00	6.0	PVC	0.010	0.00	1.71	5,752.50	5,751.74
CO-9(2)(1)	KOR-N-TEE #A-5	5,747.89	KOR-N-TEE #A-4	5,747.44	36.0	0.013	8.66	36.0	Concrete	0.013	17.76	74.62	5,749.24	5,749.48

10-YEAR EVENT
Conduit Table - Time: 0.00 hours

Label	Start Node	Invert (Start) (ft)	Stop Node	Invert (Stop) (ft)	Length (Unified) (ft)	Slope (Calculated) (ft/ft)	Velocity (ft/s)	Diameter (in)	Material	Manning's n	Flow (cfs)	Capacity (Full Flow) (cfs)	Hydraulic Grade Line (In) (ft)	Hydraulic Grade Line (Out) (ft)
CO-98	DROP STRUCTURE #A-1	5,749.74	KOR-N-TEE #A-4	5,748.67	35.5	0.030	0.00	6.0	PVC	0.010	0.00	1.27	5,749.74	5,749.48
CO-9(2)(2)(1)	KOR-N-TEE #A-4	5,747.44	KOR-N-TEE #A-3	5,747.17	21.7	0.012	8.63	36.0	Concrete	0.013	17.75	74.33	5,749.20	5,749.26
CO-9(2)(2)(2)	KOR-N-TEE #A-3	5,747.17	KOR-N-TEE #A-2	5,747.10	5.8	0.012	8.54	36.0	Concrete	0.013	17.87	73.08	5,749.00	5,749.01
CO-99	SCUPPER DRAIN #A-1	5,749.43	ST CO #A-1	5,749.31	6.0	0.020	4.02	6.0	PVC	0.010	0.19	1.03	5,749.65	5,749.47
CO-100	ST CO #A-1	5,749.11	KOR-N-TEE #A-3	5,748.42	15.3	0.045	5.36	6.0	PVC	0.010	0.19	1.55	5,749.33	5,749.26
CO-101	H-1	5,743.89	O-4	5,743.52	63.0	0.006	5.89	45.0	Concrete	0.013	13.98	50.62	5,744.90	5,744.41
CO-102	ST MH #A-3	5,745.08	ST MH #A-2	5,742.65	161.9	0.015	9.27	36.0	Concrete	0.013	17.98	81.72	5,746.44	5,744.38
CO-103	ST MH #A-2	5,742.34	ST MH #A-1	5,739.60	68.5	0.040	13.15	36.0	Concrete	0.013	17.96	133.35	5,743.70	5,740.38
CO-104	ST MH #A-1	5,738.60	ST FES #A-1	5,737.91	137.8	0.005	6.22	36.0	Concrete	0.013	17.95	47.19	5,739.96	5,739.19
CO-59(1)	ST AREA INLET #G-1	5,757.72	ST TEE	5,757.35	8.2	0.045	4.24	6.0	PVC	0.010	0.09	1.55	5,757.86	5,757.55
CO-59(2)	ST TEE	5,757.35	ST AREA INLET #F-1	5,756.18	25.9	0.045	4.24	6.0	PVC	0.010	0.09	1.55	5,757.49	5,756.26
CO-105	ST RD #F-1	5,758.00	ST TEE	5,757.35	32.5	0.020	0.00	6.0	PVC	0.010	0.00	1.03	5,758.00	5,757.55
CO-61(1)	SCUPPER DRAIN #F-1	5,755.67	ST AREA INLET #F-2	5,755.51	15.7	0.010	2.58	6.0	PVC	0.010	0.10	0.74	5,756.10	5,756.10
CO-61(2)	ST AREA INLET #F-2	5,755.34	ST AREA INLET #F-1	5,755.13	21.6	0.010	0.40	8.0	PVC	0.010	0.14	1.55	5,756.10	5,756.10
CO-107	ST CO #AC-1	5,755.45	ST MH #A-6	5,755.33	12.1	0.010	0.00	6.0	PVC	0.010	0.00	0.73	5,757.14	5,757.14
CO-108	TYPE C INLET	5,754.78	ST INLET #K-1	5,753.00	87.0	0.020	4.81	12.0	PVC	0.010	0.45	6.62	5,755.06	5,753.18
CO-93(1)	ST AREA INLET #J1.1	5,752.14	ST WYE CONNECTION	5,752.11	3.2	0.009	1.73	6.0	PVC	0.010	0.03	0.71	5,752.22	5,752.19
CO-93(2)	ST WYE CONNECTION	5,752.11	ST AREA INLET #J-1	5,751.64	47.0	0.010	1.76	6.0	PVC	0.010	0.03	0.73	5,752.19	5,751.74
CO-109	ST RD #A-3	5,752.25	ST WYE CONNECTION	5,752.11	9.2	0.015	0.00	6.0	PVC	0.010	0.00	0.90	5,752.25	5,752.19

10-YEAR EVENT

Catch Basin Table - Time: 0.00 hours

Label	Elevation (Ground) (ft)	Elevation (Invert) (ft)	Headloss Coefficient (Standard)	Hydraulic Grade Line (In) (ft)	Hydraulic Grade Line (Out) (ft)	Flow (Total Out) (cfs)	Flow (Additional Subsurface) (cfs)	Capacity (Inlet) (cfs)
ST INLET #I-2	5,776.82	5,767.61	0.050	5,767.86	5,767.85	0.51	0.00	(N/A)
ST INLET #I-1	5,772.38	5,762.98	0.050	5,764.82	5,764.80	16.02	0.00	(N/A)
ST INLET #I-3	5,774.64	5,768.17	0.050	5,768.33	5,768.33	0.22	0.00	(N/A)
ST AREA INLET #H-3	5,761.12	5,758.69	1.320	5,759.57	5,759.55	0.19	0.00	(N/A)
ST AREA INLET #H-2	5,761.13	5,758.20	0.050	5,759.50	5,759.50	0.22	0.00	(N/A)
ST AREA INLET #H-1	5,761.28	5,758.66	1.120	5,759.50	5,759.49	0.15	0.00	(N/A)
ST AREA INLET #G-1	5,761.27	5,757.72	0.050	5,757.87	5,757.86	0.09	0.00	(N/A)
SCUPPER DRAIN #E-1	5,760.72	5,756.62	0.050	5,756.87	5,756.87	0.24	0.00	(N/A)
ST AREA INLET #K-1	5,761.90	5,753.55	0.050	5,753.81	5,753.80	0.30	0.00	(N/A)
ST INLET #K-1	5,760.96	5,752.17	1.560	5,752.88	5,752.62	1.45	0.00	(N/A)
ST INLET #B-1	5,760.12	5,750.60	0.050	5,751.01	5,751.00	1.17	0.00	(N/A)
ST AREA INLET #D-1	5,759.17	5,751.70	0.570	5,752.11	5,752.04	0.51	0.00	(N/A)
ST AREA INLET #C-5	5,758.88	5,754.44	0.400	5,754.51	5,754.50	0.02	0.00	(N/A)
ST AREA INLET #C-4	5,758.42	5,752.86	0.640	5,752.99	5,752.96	0.06	0.00	(N/A)
ST AREA INLET #C-3	5,758.81	5,751.71	0.320	5,752.02	5,751.98	0.40	0.00	(N/A)
ST AREA INLET #C-2	5,758.56	5,752.66	0.620	5,752.92	5,752.87	0.21	0.00	(N/A)
ST AREA INLET #C-1	5,757.50	5,753.26	0.050	5,753.36	5,753.36	0.04	0.00	(N/A)
ST AREA INLET #J-2	5,758.60	5,753.40	0.100	5,753.57	5,753.57	0.15	0.00	(N/A)
ST AREA INLET #J-1	5,758.33	5,751.44	0.320	5,751.74	5,751.71	0.39	0.00	(N/A)
ST AREA INLET #A1.2	5,758.59	5,748.72	0.050	5,749.00	5,749.00	0.13	0.00	(N/A)
ST AREA INLET #A1.1	5,758.87	5,748.73	0.050	5,748.83	5,748.82	0.05	0.00	(N/A)
ST INLET #A-1.1	5,757.46	5,753.71	0.050	5,754.69	5,754.67	7.33	0.00	(N/A)
ST AREA INLT #E-1	5,758.75	5,756.27	0.050	5,756.35	5,756.35	0.03	0.00	(N/A)
TRENCH DRAIN CONNECTION	5,759.72	5,752.71	0.050	5,752.93	5,752.92	0.15	0.00	(N/A)
TRENCH DRAIN CONNECTION	5,759.95	5,756.29	0.050	5,756.53	5,756.53	0.26	0.00	(N/A)
SCUPPER DRAIN #H-1	5,762.00	5,759.00	0.050	5,759.50	5,759.50	0.07	0.00	(N/A)
SCUPPER DRAIN #F-1	5,762.01	5,755.67	0.050	5,756.10	5,756.10	0.10	0.00	(N/A)
CB-40	5,785.77	5,784.89	0.050	5,785.59	5,785.59	1.26	0.00	(N/A)
CB-41	5,786.94	5,785.13	0.050	5,785.73	5,785.73	0.99	0.00	(N/A)
CB-42	5,786.70	5,785.24	0.050	5,785.62	5,785.62	0.26	0.00	(N/A)
CB-43	5,787.54	5,785.53	0.600	5,786.13	5,786.11	0.88	0.00	(N/A)
CB-44	5,786.88	5,785.99	0.050	5,786.34	5,786.34	0.32	0.00	(N/A)
CB-45	5,786.89	5,785.77	0.050	5,786.20	5,786.20	0.46	0.00	(N/A)
CB-46	5,787.74	5,786.04	0.050	5,786.33	5,786.33	0.23	0.00	(N/A)
ST AREA INLET #F-1	5,761.47	5,755.13	1.120	5,756.10	5,756.08	0.42	0.00	(N/A)
SCUPPER DRAIN #H-2	5,762.02	5,758.82	0.050	5,759.57	5,759.57	0.14	0.00	(N/A)
SCUPPER DRAIN #K-1	5,762.02	5,753.75	0.050	5,754.03	5,754.02	0.29	0.00	(N/A)
SCUPPER DRAIN #D-1	5,761.82	5,753.28	0.050	5,753.60	5,753.59	0.38	0.00	(N/A)
SCUPPER DRAIN #C-2	5,759.79	5,752.61	0.050	5,753.05	5,753.05	0.33	0.00	(N/A)
SCUPPER DRAIN #C-1	5,758.93	5,753.33	0.050	5,753.52	5,753.52	0.14	0.00	(N/A)
ST AREA INLET #E-2	5,760.18	5,756.27	0.100	5,756.53	5,756.52	0.25	0.00	(N/A)
ST AREA INLET #J1.1	5,758.49	5,752.14	0.720	5,752.24	5,752.22	0.03	0.00	(N/A)
SCUPPER DRAIN #J-1	5,759.43	5,754.15	0.050	5,754.31	5,754.30	0.10	0.00	(N/A)
SCUPPER DRAIN #A-1	5,759.46	5,749.43	0.050	5,749.65	5,749.65	0.19	0.00	(N/A)

10-YEAR EVENT

Catch Basin Table - Time: 0.00 hours

Label	Elevation (Ground) (ft)	Elevation (Invert) (ft)	Headloss Coefficient (Standard)	Hydraulic Grade Line (In) (ft)	Hydraulic Grade Line (Out) (ft)	Flow (Total Out) (cfs)	Flow (Additional Subsurface) (cfs)	Capacity (Inlet) (cfs)
ST AREA INLET #F-2	5,761.78	5,755.34	0.050	5,756.10	5,756.10	0.14	0.00	(N/A)
TYPE C INLET	5,761.95	5,754.78	0.050	5,755.06	5,755.06	0.45	0.00	(N/A)

10-YEAR EVENT

Manhole Table - Time: 0.00 hours

Label	Elevation (Rim) (ft)	Elevation (Invert) (ft)	Headloss Coefficient (Standard)	Hydraulic Grade Line (In) (ft)	Hydraulic Grade Line (Out) (ft)	Flow (Total Out) (cfs)	System Flow Time (min)
ST MH #I-2	5,776.98	5,766.61	1.570	5,767.04	5,766.89	0.67	7.752
ST MH #I-1	5,772.69	5,762.58	1.070	5,764.79	5,764.04	16.49	17.518
ST MH #A-7	5,772.87	5,759.65	0.570	5,761.51	5,761.11	16.49	17.559
ST MH #A-8	5,773.06	5,761.40	0.100	5,761.51	5,761.51	0.00	0.000
ST MH #A-6	5,763.82	5,755.13	1.120	5,757.14	5,756.51	16.72	17.886
ST MH #A-5	5,763.00	5,751.78	1.070	5,753.65	5,753.11	17.31	18.077
ST MH #E-1	5,760.85	5,755.10	1.570	5,755.58	5,755.40	0.54	5.167
ST MH #A-4	5,760.33	5,748.42	1.070	5,750.31	5,749.76	17.65	18.210
ST MH #A-3	5,759.01	5,745.08	0.100	5,746.49	5,746.44	17.98	18.569
ST MH #B-2	5,754.32	5,746.85	0.370	5,747.55	5,747.47	3.15	11.881
ST MH #B-3	5,754.60	5,748.16	0.370	5,748.87	5,748.78	2.68	11.678
EX. MANHOLE	5,784.16	5,778.02	0.370	5,778.02	5,778.02	0.00	0.000
ST MH #B-5	5,760.11	5,750.11	0.520	5,750.59	5,750.51	1.17	5.092
ST MH #B-4	5,756.73	5,749.46	0.620	5,750.17	5,750.04	2.32	11.392
ST RD #C-1	5,759.92	5,756.00	0.050	5,756.00	5,756.00	0.00	0.000
ST RD #A-3	5,759.40	5,752.25	0.050	5,752.25	5,752.25	0.00	0.000
ST RD #A-2	5,759.99	5,753.50	0.050	5,753.72	5,753.72	0.19	5.000
DROP STRUCTURE #A-2	5,759.62	5,750.24	0.370	5,750.49	5,750.46	0.19	5.087
ST RD #A-1	5,759.98	5,752.50	0.050	5,752.50	5,752.50	0.00	0.000
DROP STRUCTURE #A-1	5,759.81	5,749.74	0.100	5,749.74	5,749.74	0.00	0.000
ST CO #A-1	5,759.35	5,749.11	0.620	5,749.38	5,749.33	0.19	5.025
ST MH #A-1	5,750.76	5,738.60	0.050	5,739.98	5,739.96	17.95	18.947
ST MH #A-2	5,764.24	5,742.34	1.320	5,744.38	5,743.70	17.96	18.860
ST RD #F-1	5,762.92	5,758.00	0.050	5,758.00	5,758.00	0.00	0.000
ST CO #AC-1	5,762.81	5,755.45	2.370	5,757.14	5,757.14	0.00	0.000
ST CO #D-1	5,760.75	5,753.58	0.400	5,753.58	5,753.58	0.00	0.000

10-YEAR EVENT

Transition Table - Time: 0.00 hours

ID	Label	Elevation (Ground) (ft)	Elevation (Top) (ft)	Elevation (Invert) (ft)	Flow (Total Out) (cfs)	Hydraulic Grade Line (Out) (ft)
84	STRM TEE	5,765.23	5,758.55	5,758.05	0.35	5,759.43
87	ST CO #E-1	5,760.10	5,760.10	5,756.07	0.26	5,756.31
90	KOR-N-TEE #A -2	5,758.89	5,750.10	5,747.10	17.96	5,748.46
160	STRM BEND	5,763.05	5,759.08	5,758.58	0.19	5,759.53
201	KOR-N-TEE #A -8	5,765.76	5,759.15	5,757.15	16.72	5,758.62
218	STORM TEE	5,758.98	5,751.65	5,750.82	0.59	5,751.16
223	KOR-N-TEE #A -6	5,762.43	5,762.43	5,750.92	17.40	5,752.33
233	KOR-N-TEE #A -5	5,759.50	5,750.89	5,747.89	17.76	5,749.24
240	KOR-N-TEE #A -4	5,759.47	5,750.44	5,747.44	17.75	5,749.20
245	KOR-N-TEE #A -3	5,759.07	5,750.17	5,747.17	17.87	5,749.00
251	KOR-N-TEE #A -1	5,759.29	5,749.69	5,746.69	17.98	5,748.05
261	ST TEE	5,762.24	5,757.85	5,757.35	0.09	5,757.49
272	KOR-N-TEE #A -7	5,765.29	5,756.56	5,754.06	16.98	5,755.45
275	ST WYE CONNECTION	5,758.80	5,752.61	5,752.11	0.03	5,752.19

10-YEAR EVENT

Outfall Table - Time: 0.00 hours

Label	Elevation (Ground) (ft)	Elevation (Invert) (ft)	Boundary Condition Type	Elevation (User Defined Tailwater) (ft)	Hydraulic Grade (ft)	Flow (Total Out) (cfs)	System Flow Time (min)
ST FES #A-1.1	5,755.10	5,752.85	Free Outfall	0.00	5,753.52	7.31	5.333
O-4	5,745.94	5,743.52	Free Outfall	0.00	5,744.41	13.95	7.633
ST FES #B-1	5,748.08	5,746.05	Free Outfall	0.00	5,746.54	3.13	12.072
O-6	5,785.50	5,784.62	Free Outfall	0.00	5,785.39	1.24	9.246
ST FES #A-1	5,740.91	5,737.91	Free Outfall	0.00	5,739.19	17.93	19.316

10-YEAR EVENT

Catchment Table - Time: 0.00 hours

Label	Outflow Element	Area (User Defined) (acres)	Runoff Coefficient (Rational)	Time of Concentration (min)	Flow (Total Out) (cfs)
B3/2	ST INLET #I-2	0.155	0.620	5.000	0.51
B1	ST INLET #I-3	0.140	0.340	7.610	0.22
B3/2	ST INLET #I-1	0.155	0.620	5.000	0.51
A-8	CB-46	0.060	0.730	5.000	0.23
A-7	CB-42	0.200	0.280	7.770	0.26
A-9	CB-45	0.060	0.810	5.000	0.26
A-10	CB-44	0.070	0.860	5.000	0.32
A6/2	CB-43	0.040	0.670	5.350	0.14
A6/2	CB-41	0.040	0.670	5.350	0.14
A-5	CB-40	0.050	0.460	5.000	0.12
A-13	ST INLET #A-1.1	1.060	0.600	5.250	3.33
B-25	ST AREA INLET #A1.1	0.020	0.470	5.540	0.05
C-17.18.19.20	H-1	1.750	0.430	7.455	3.54
B-24	SCUPPER DRAIN #A-1	0.040	0.900	5.000	0.19
B-26	ST AREA INLET #A1.2	0.060	0.470	7.120	0.13
B21	ST AREA INLET #J-1	0.120	0.380	6.300	0.23
B22	SCUPPER DRAIN #J-1	0.020	0.900	5.000	0.10
C15	ST AREA INLET #C-2	0.020	0.270	5.000	0.03
B20	ST AREA INLET #J-2	0.030	0.340	5.000	0.05
C16	ST AREA INLET #C-1	0.020	0.390	5.000	0.04
C14	SCUPPER DRAIN #C-1	0.030	0.900	5.000	0.14
C13	SCUPPER DRAIN #C-2	0.070	0.900	5.000	0.33
B19	ST AREA INLET #J1.1	0.020	0.250	5.000	0.03
C9	ST AREA INLET #C-5	0.010	0.400	6.670	0.02
C11/2	ST AREA INLET #C-4	0.025	0.330	5.940	0.04
C11/2	ST AREA INLET #C-3	0.025	0.330	5.940	0.04
B18	TRENCH DRAIN CONNECTION	0.050	0.550	5.000	0.15
B16	ST AREA INLT #E-1	0.020	0.250	5.000	0.03
B15	TRENCH DRAIN CONNECTION	0.060	0.820	5.000	0.26

10-YEAR EVENT

Catchment Table - Time: 0.00 hours

Label	Outflow Element	Area (User Defined) (acres)	Runoff Coefficient (Rational)	Time of Concentration (min)	Flow (Total Out) (cfs)
B13	ST AREA INLET #G-1	0.030	0.540	5.000	0.09
B9	ST AREA INLET #F-1	0.120	0.330	5.000	0.21
B12	ST AREA INLET #F-2	0.020	0.430	5.000	0.05
B11	SCUPPER DRAIN #E-1	0.050	0.900	5.000	0.24
B14	ST AREA INLET #E-2	0.010	0.280	5.000	0.01
C5	SCUPPER DRAIN #D-1	0.080	0.900	5.000	0.38
C7	ST AREA INLET #D-1	0.050	0.500	5.000	0.13
B10	SCUPPER DRAIN #F-1	0.020	0.900	5.000	0.10
C4	SCUPPER DRAIN #K-1	0.060	0.900	5.000	0.29
C6	ST AREA INLET #K-1	0.010	0.280	5.000	0.01
C1	ST INLET #K-1	0.490	0.390	5.970	0.96
C-3	ST INLET #B-1	0.270	0.820	5.000	1.17
B5	SCUPPER DRAIN #H-2	0.030	0.900	5.000	0.14
B4	ST AREA INLET #H-3	0.030	0.310	5.000	0.05
C-2	TYPE C INLET	0.280	0.390	10.800	0.45
B7	ST AREA INLET #H-2	0.020	0.380	5.000	0.04
B6	SCUPPER DRAIN #H-1	0.040	0.310	5.000	0.07
B8	ST AREA INLET #H-1	0.030	0.550	5.000	0.09
B23	ST RD #A-2	0.040	0.900	5.000	0.19

STORMLINE A - 10-YR

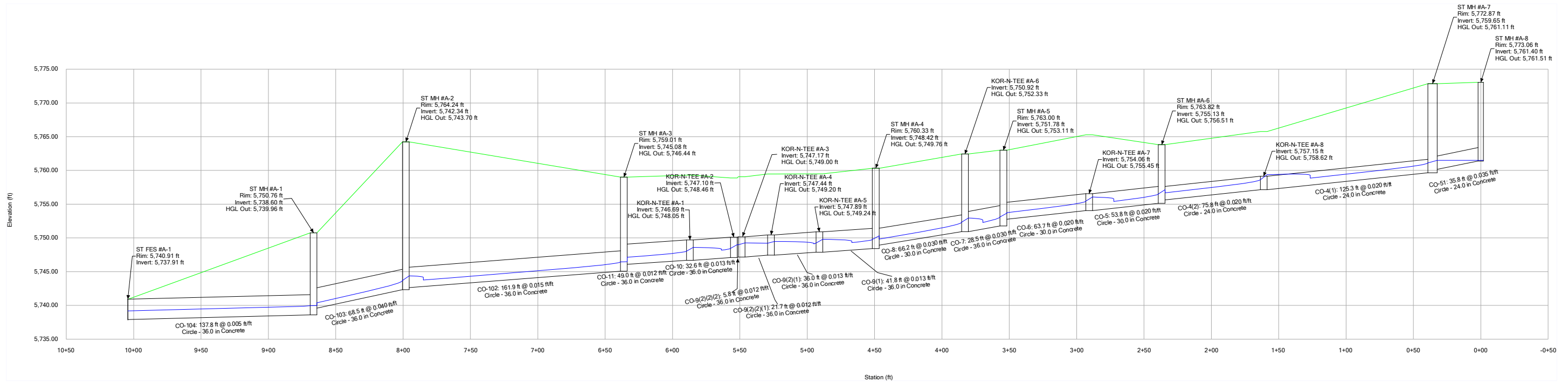

STORMLINE B - 10-YR

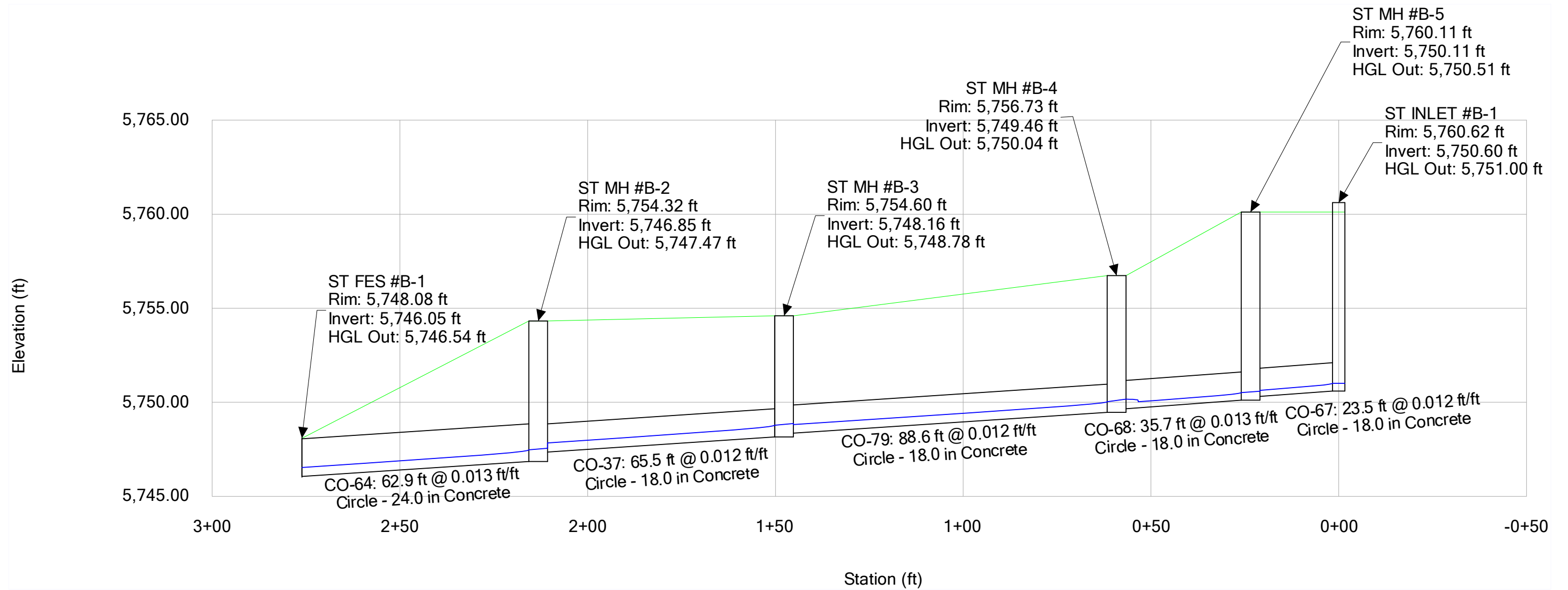

STORMLINE C - 10-YR

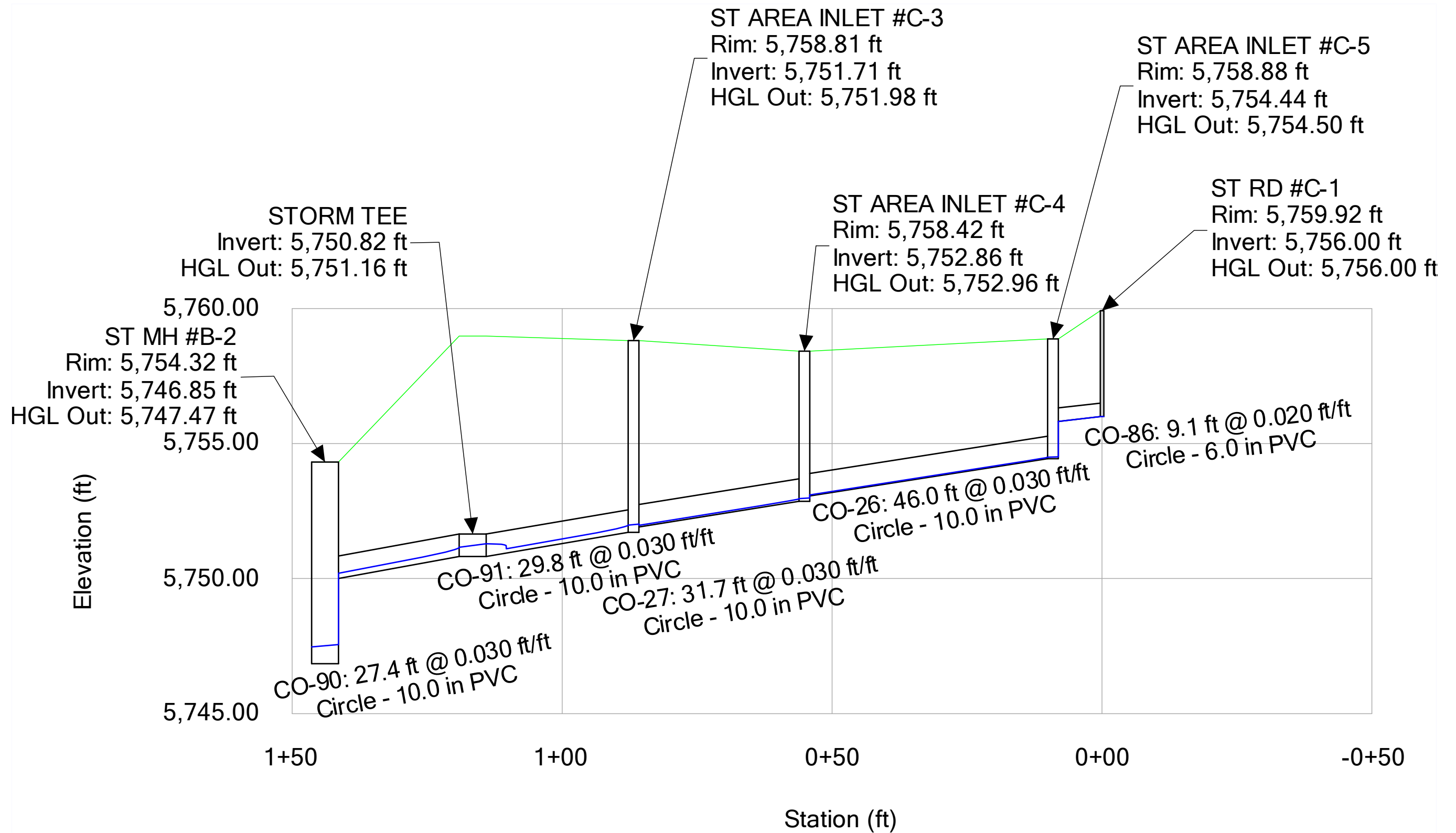

STORMLINE D - 10-YR

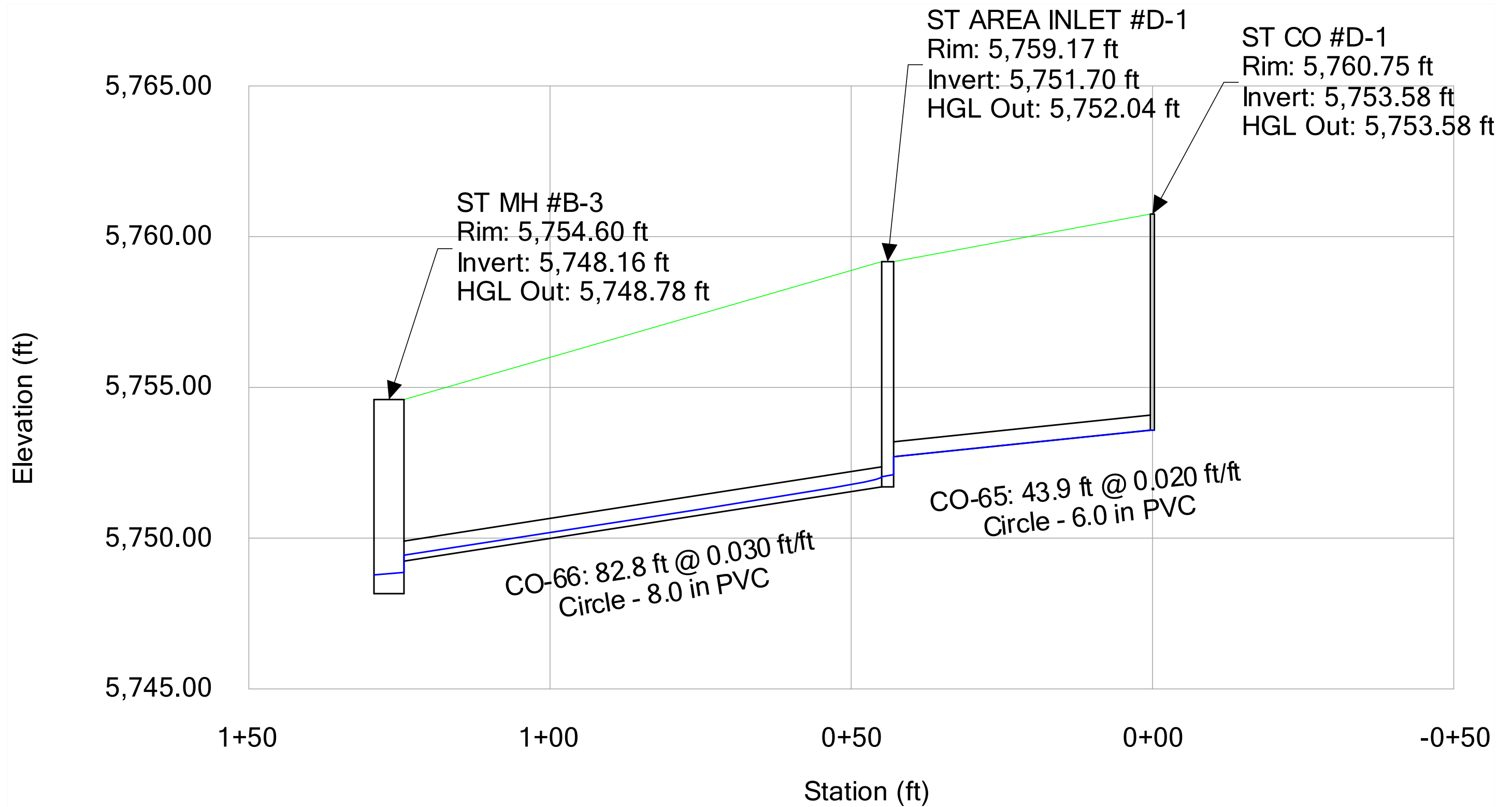

STORMLINE E - 10-YR

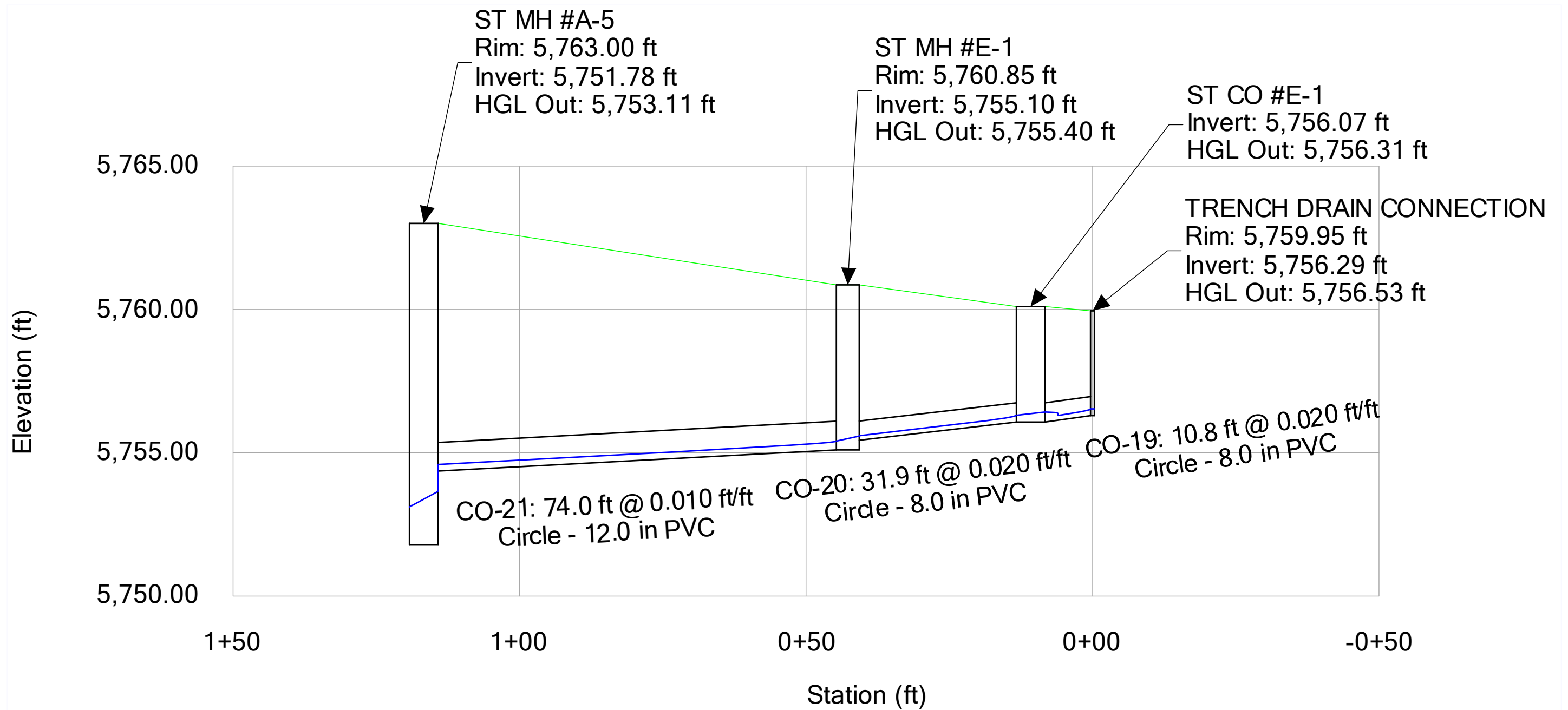

STORMLINE F - 10-YR

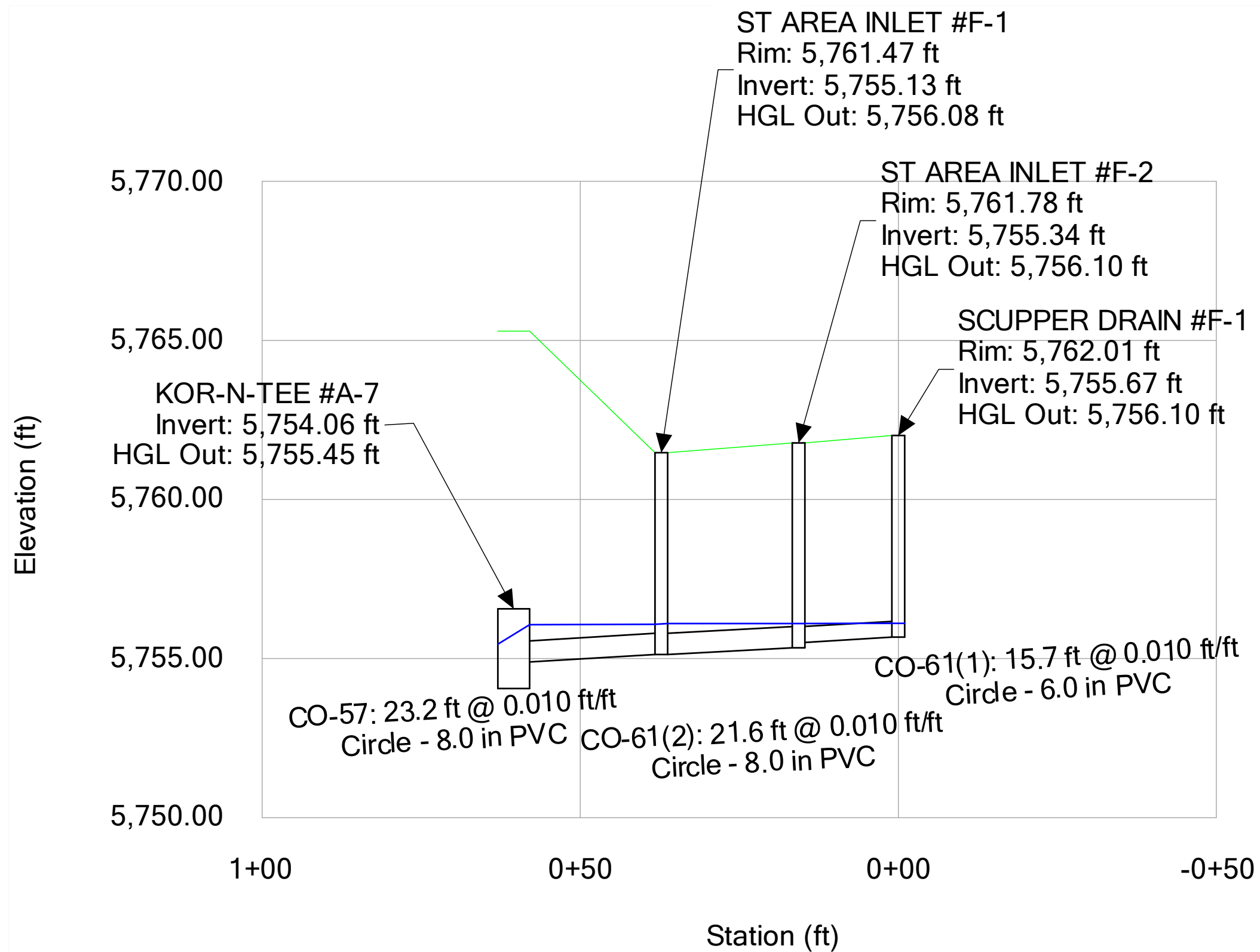

STORMLINE H - 10-YR

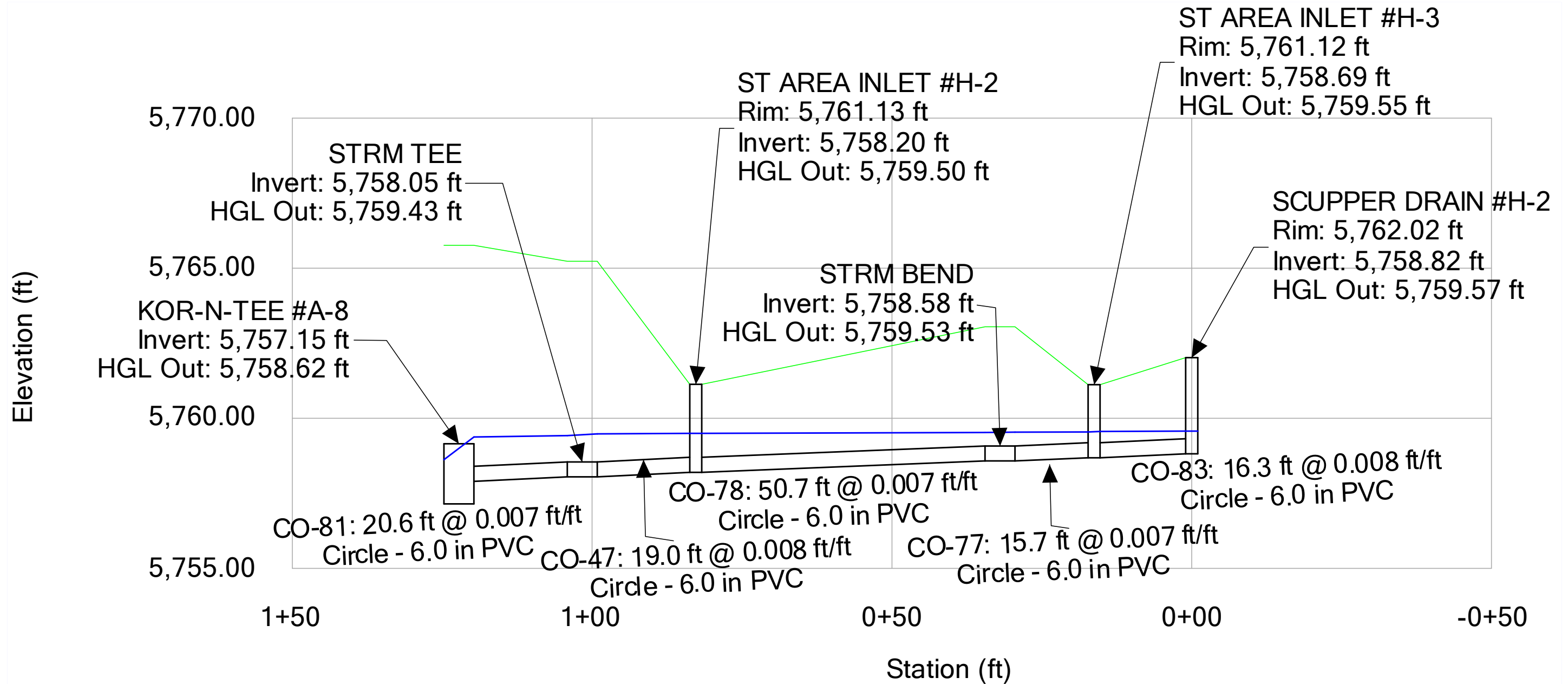

STORMLINE I - 10-YR

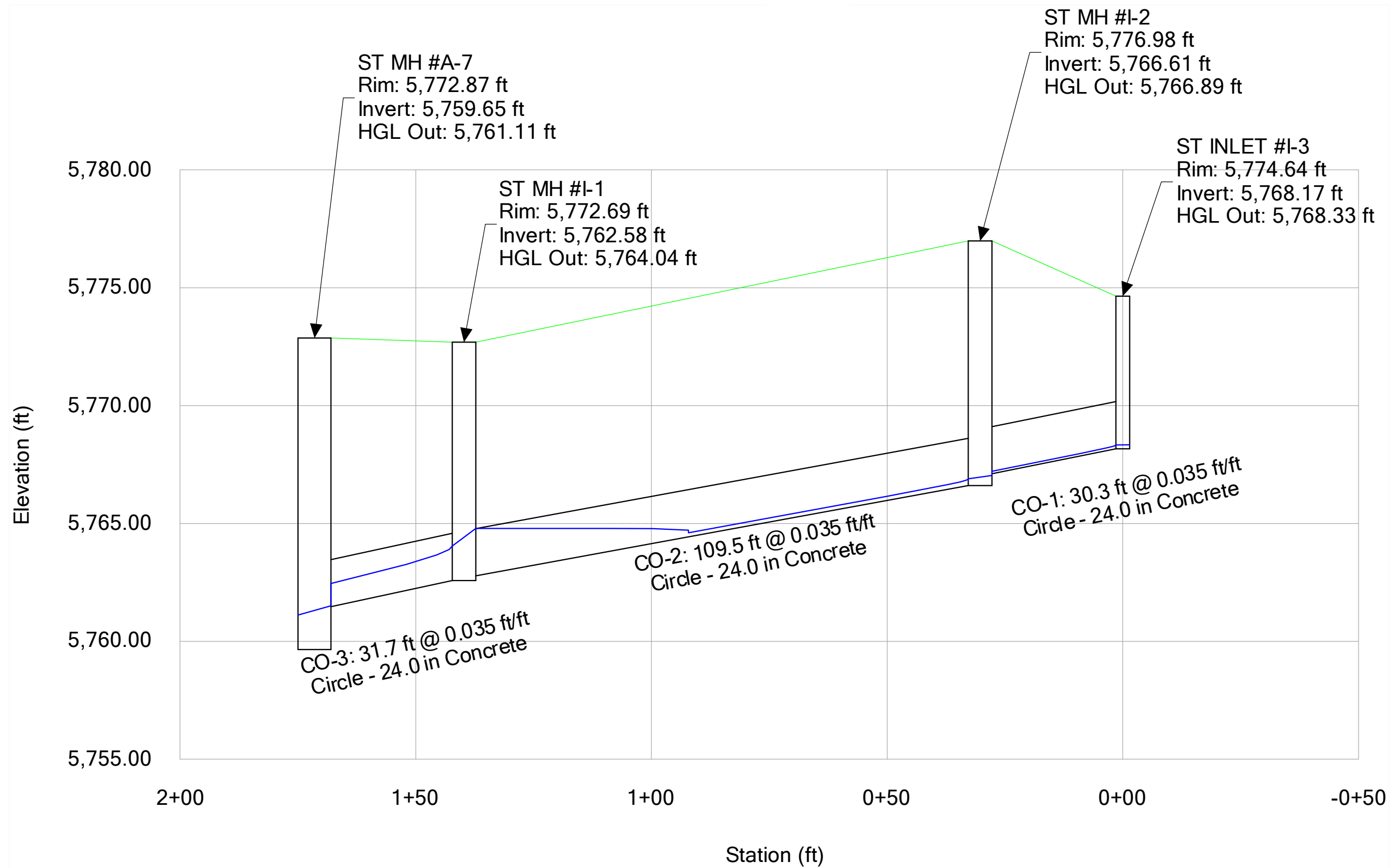

STORMLINE J - 10-YR

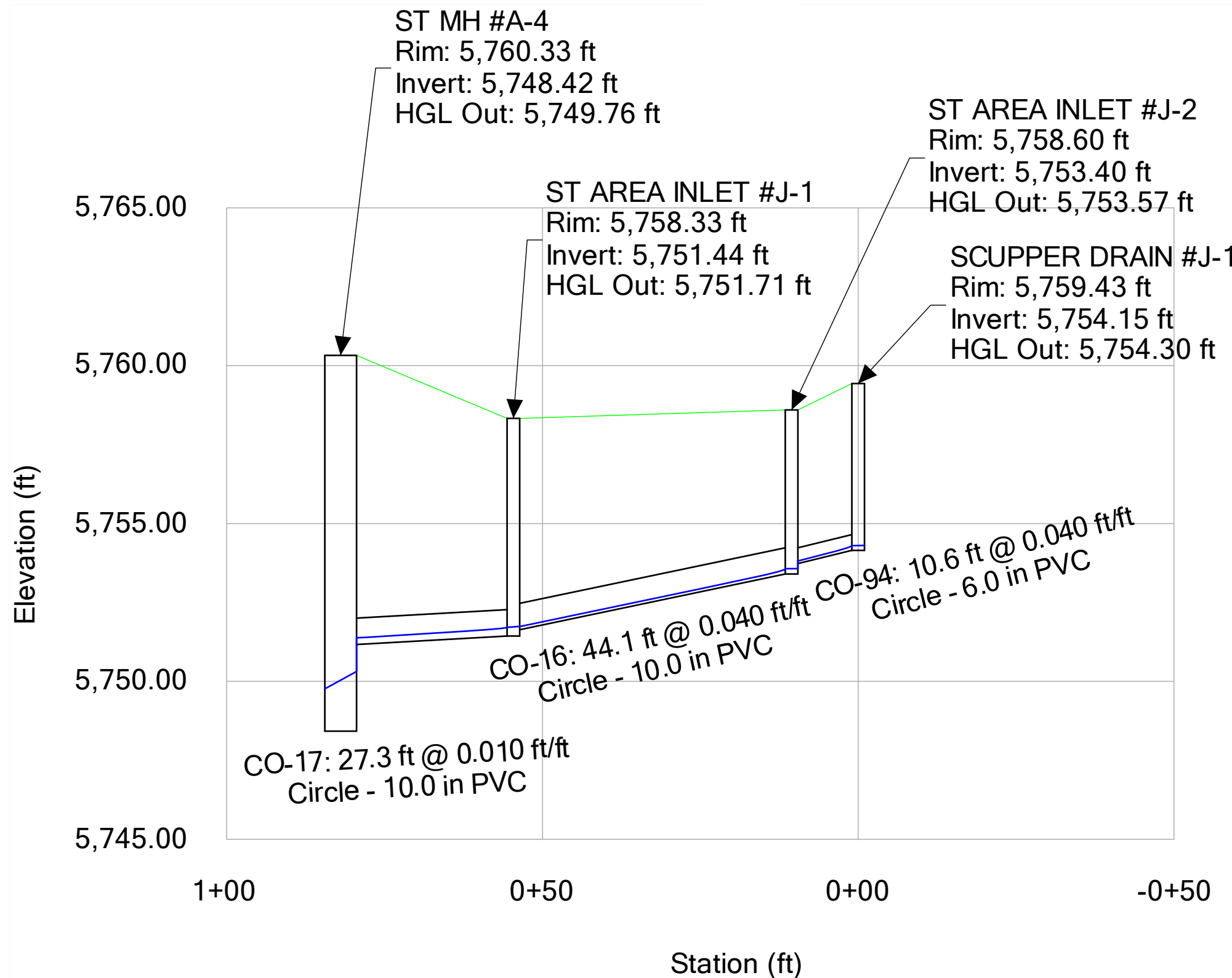

STORMLINE K - 10-YR

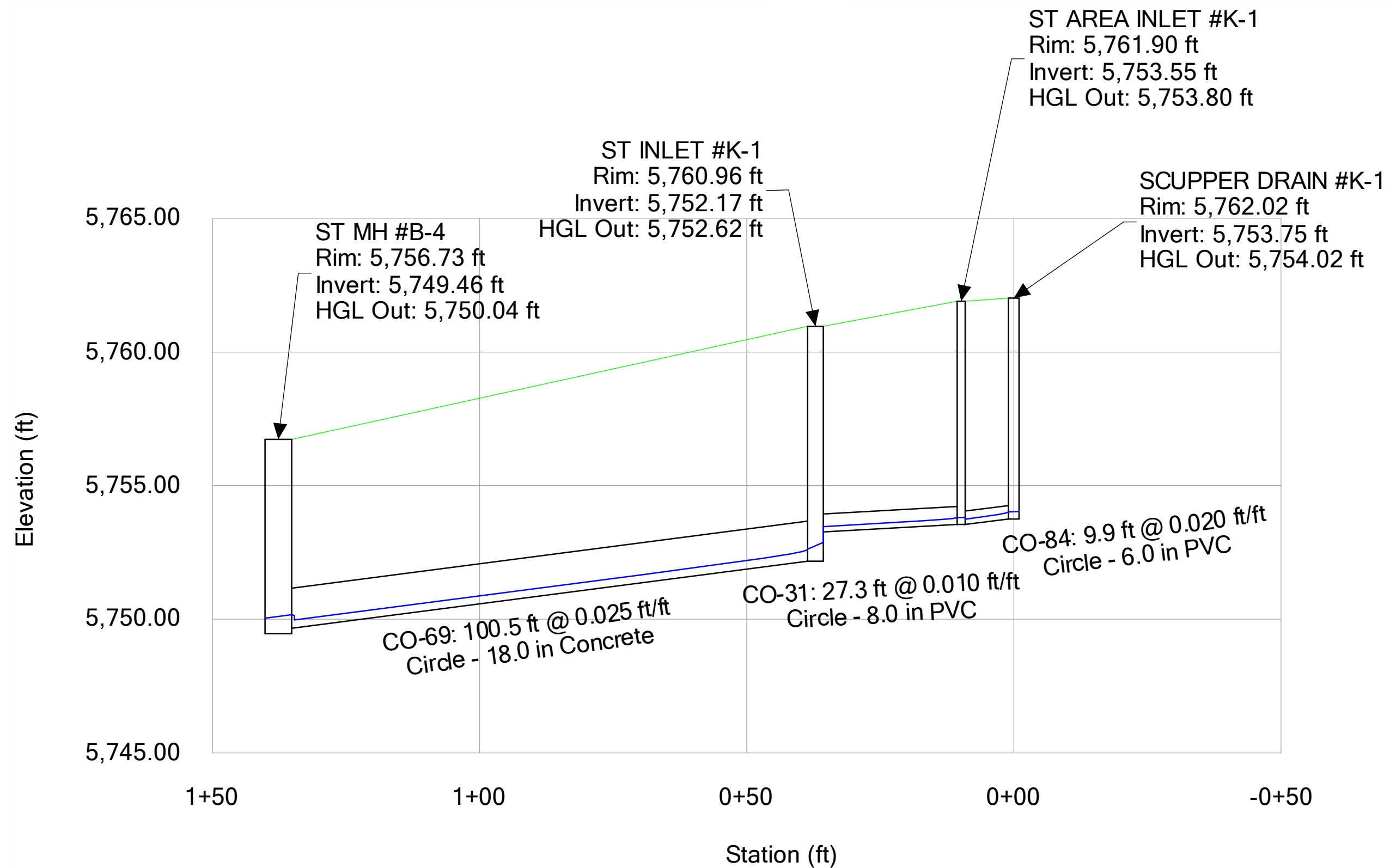

STORMLINE A-A - 10-YR

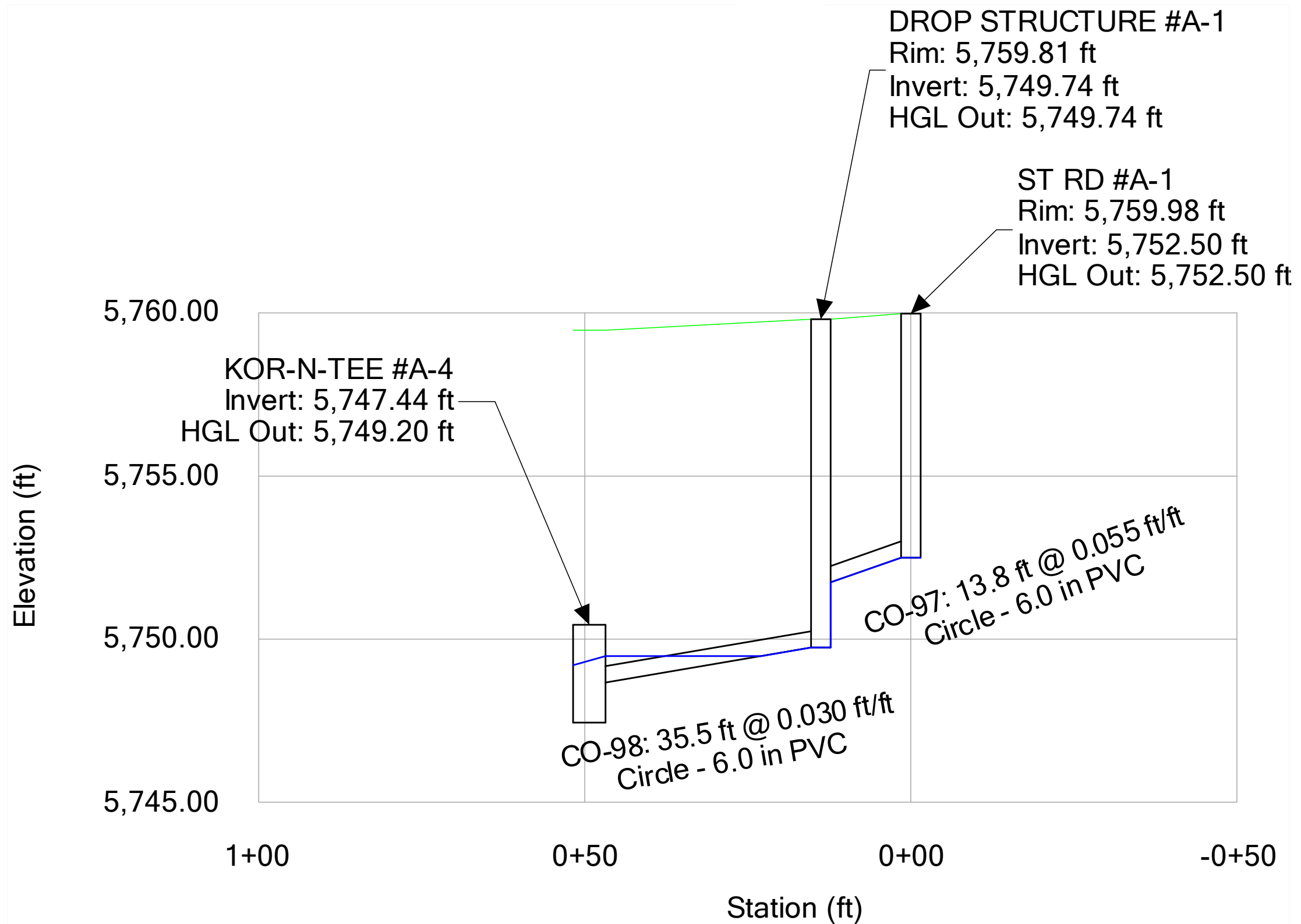

STORMLINE A-B - 10-YR

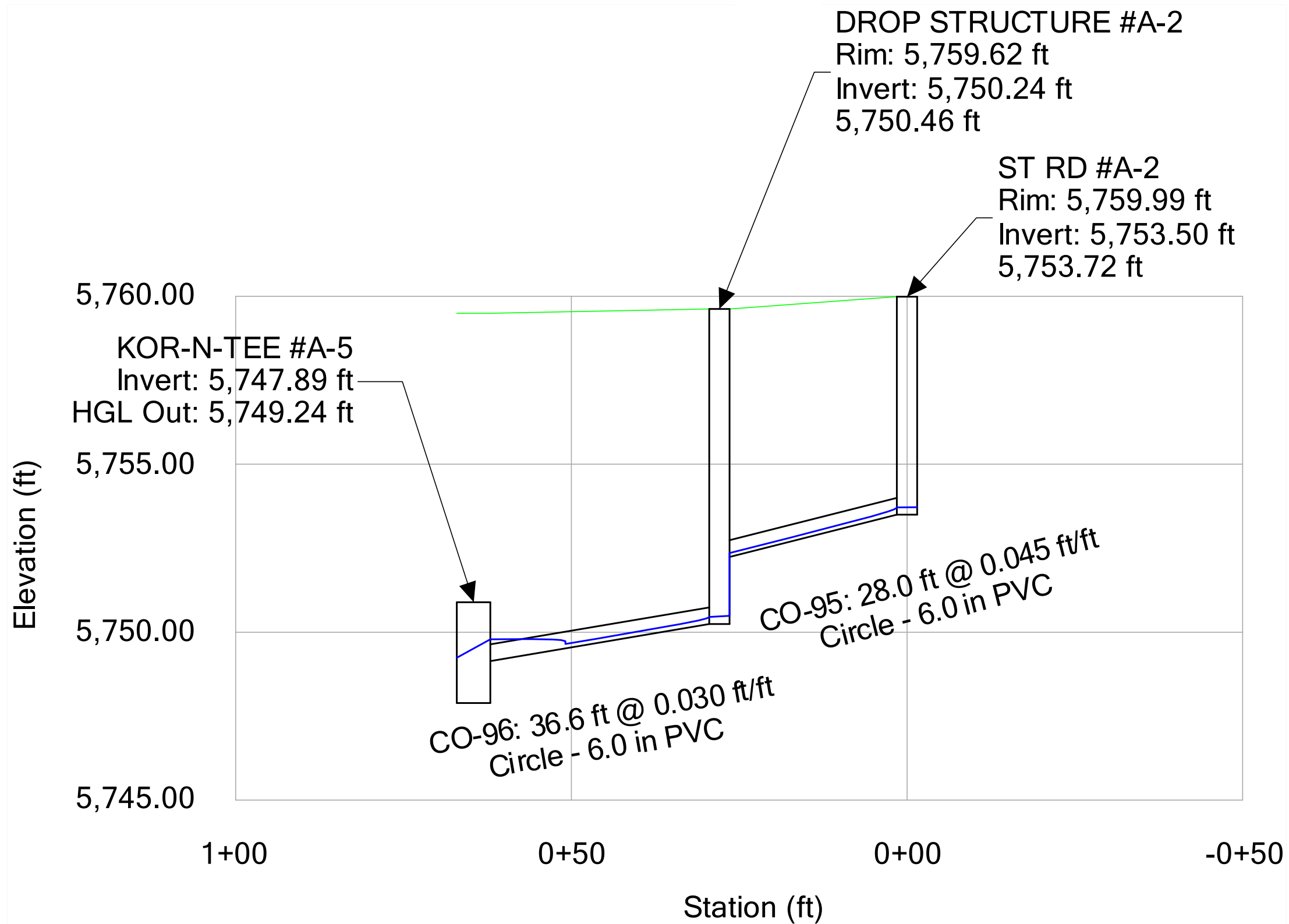

MEADOW OUTFALL - 10-YR

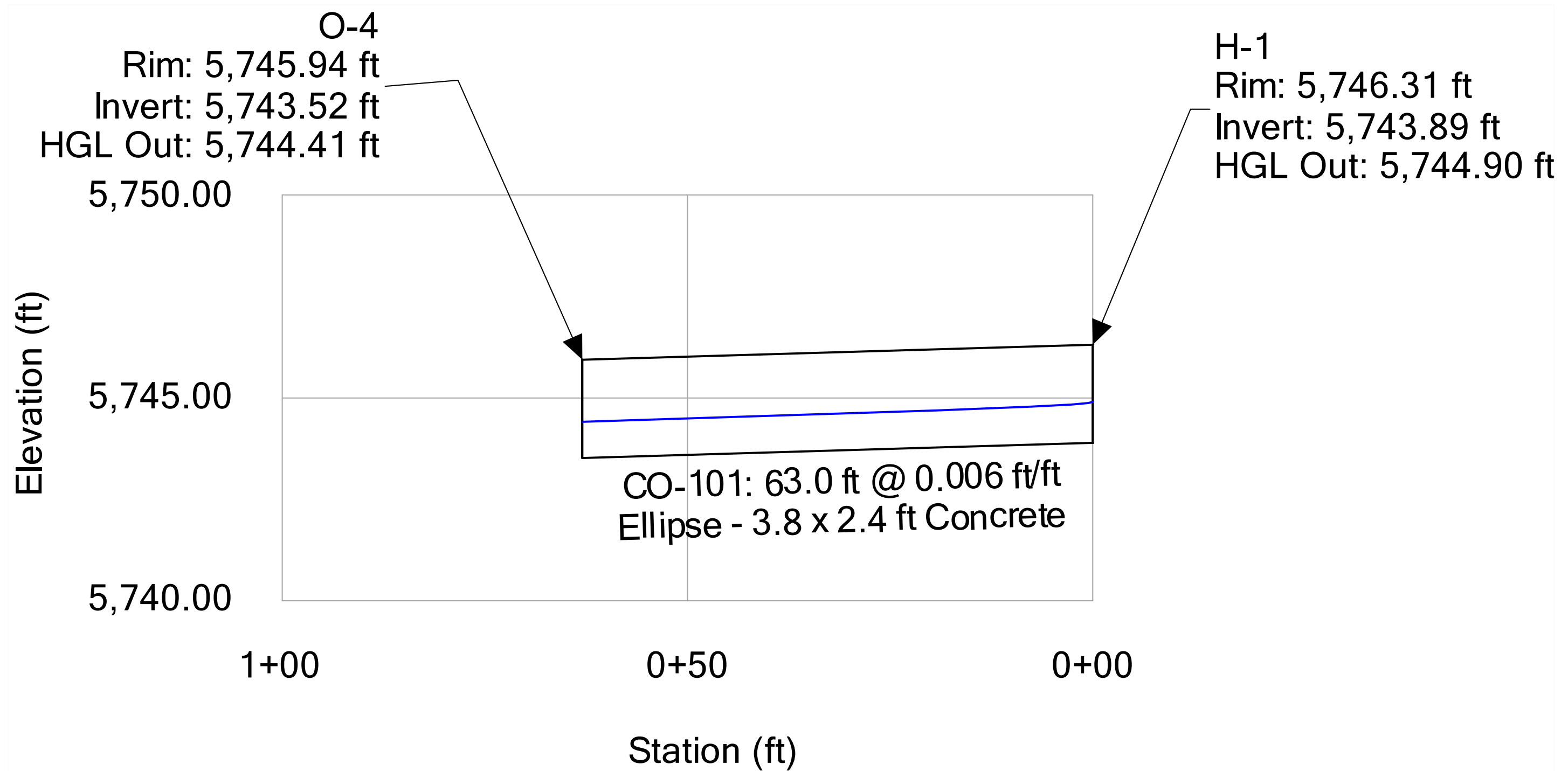

100-YEAR EVENT
Conduit Table - Time: 0.00 hours

Label	Start Node	Invert (Start) (ft)	Stop Node	Invert (Stop) (ft)	Length (Unified) (ft)	Slope (Calculated) (ft/ft)	Velocity (ft/s)	Diameter (in)	Material	Manning's n	Flow (cfs)	Capacity (Full Flow) (cfs)	Hydraulic Grade Line (In) (ft)	Hydraulic Grade Line (Out) (ft)
CO-1	ST INLET #I-3	5,768.17	ST MH #I-2	5,767.11	30.3	0.035	0.21	24.0	Concrete	0.013	0.65	42.34	5,771.26	5,771.26
CO-2	ST MH #I-2	5,766.61	ST MH #I-1	5,762.78	109.5	0.035	0.44	24.0	Concrete	0.013	1.38	42.30	5,771.26	5,771.25
CO-3	ST MH #I-1	5,762.58	ST MH #A-7	5,761.47	31.7	0.035	11.84	24.0	Concrete	0.013	37.20	42.33	5,768.92	5,768.07
CO-5	ST MH #A-6	5,755.13	KOR-N-TEE #A-7	5,754.06	53.8	0.020	7.70	30.0	Concrete	0.013	37.80	57.84	5,757.88	5,757.42
CO-6	KOR-N-TEE #A-7	5,754.06	ST MH #A-5	5,752.78	63.7	0.020	12.65	30.0	Concrete	0.013	38.36	58.14	5,756.15	5,755.17
CO-7	ST MH #A-5	5,751.78	KOR-N-TEE #A-6	5,750.92	28.5	0.030	14.78	36.0	Concrete	0.013	38.98	115.82	5,754.65	5,754.57
CO-8	KOR-N-TEE #A-6	5,750.92	ST MH #A-4	5,748.94	66.2	0.030	7.98	30.0	Concrete	0.013	39.16	70.93	5,753.51	5,752.91
CO-10	KOR-N-TEE #A-2	5,747.10	KOR-N-TEE #A-1	5,746.69	32.6	0.013	10.78	36.0	Concrete	0.013	40.28	74.81	5,749.82	5,749.76
CO-11	KOR-N-TEE #A-1	5,746.69	ST MH #A-3	5,746.08	49.0	0.012	10.74	36.0	Concrete	0.013	40.33	74.41	5,748.76	5,747.76
CO-13	ST INLET #A-1.1	5,753.71	ST FES #A-1.1	5,752.85	41.5	0.021	10.23	24.0	Concrete	0.013	15.47	32.56	5,755.13	5,753.89
CO-14	ST AREA INLET #A1.1	5,748.73	KOR-N-TEE #A-1	5,747.77	24.0	0.040	0.18	10.0	PVC	0.010	0.10	5.70	5,749.76	5,749.76
CO-15	ST AREA INLET #A1.2	5,748.72	KOR-N-TEE #A-2	5,748.18	6.8	0.079	0.52	10.0	PVC	0.010	0.28	8.03	5,750.41	5,750.41
CO-16	ST AREA INLET #J-2	5,753.40	ST AREA INLET #J-1	5,751.64	44.1	0.040	5.54	10.0	PVC	0.010	0.30	5.69	5,753.64	5,752.94
CO-17	ST AREA INLET #J-1	5,751.44	ST MH #A-4	5,751.17	27.3	0.010	1.47	10.0	PVC	0.010	0.80	2.83	5,752.93	5,752.91
CO-18	TRENCH DRAIN CONNECTION	5,752.71	KOR-N-TEE #A-6	5,751.84	43.8	0.020	0.83	8.0	PVC	0.010	0.29	2.21	5,754.58	5,754.57
CO-19	TRENCH DRAIN CONNECTION	5,756.29	ST CO #E-1	5,756.07	10.8	0.020	5.14	8.0	PVC	0.010	0.49	2.24	5,756.62	5,756.57
CO-20	ST CO #E-1	5,756.07	ST MH #E-1	5,755.44	31.9	0.020	5.10	8.0	PVC	0.010	0.49	2.21	5,756.40	5,755.78
CO-21	ST MH #E-1	5,755.10	ST MH #A-5	5,754.36	74.0	0.010	4.74	12.0	PVC	0.010	1.03	4.63	5,755.53	5,755.17
CO-22	SCUPPER DRAIN #E-1	5,756.62	ST AREA INLET #E-2	5,756.47	7.7	0.020	5.02	6.0	PVC	0.010	0.44	1.02	5,756.96	5,756.72
CO-23	ST AREA INLET #E-2	5,756.27	ST MH #E-1	5,755.98	14.6	0.020	5.14	6.0	PVC	0.010	0.48	1.03	5,756.62	5,756.23
CO-25	ST AREA INLT #E-1	5,756.27	ST MH #E-1	5,755.98	14.7	0.020	2.93	6.0	PVC	0.010	0.07	1.03	5,756.40	5,756.07
CO-26	ST AREA INLET #C-5	5,754.44	ST AREA INLET #C-4	5,753.06	46.0	0.030	2.77	10.0	PVC	0.010	0.04	4.93	5,754.53	5,753.12
CO-27	ST AREA INLET #C-4	5,752.86	ST AREA INLET #C-3	5,751.91	31.7	0.030	3.92	10.0	PVC	0.010	0.13	4.93	5,753.02	5,752.15
CO-29	ST AREA INLET #C-1	5,753.26	ST AREA INLET #C-2	5,752.86	20.1	0.020	3.19	6.0	PVC	0.010	0.09	1.03	5,753.41	5,753.03
CO-31	ST AREA INLET #K-1	5,753.55	ST INLET #K-1	5,753.27	27.3	0.010	4.18	8.0	PVC	0.010	0.57	1.59	5,753.90	5,753.55
CO-37	ST MH #B-3	5,748.16	ST MH #B-2	5,747.35	65.5	0.012	6.44	18.0	Concrete	0.013	5.27	11.68	5,749.04	5,748.06
CO-47	ST AREA INLET #H-2	5,758.20	STRM TEE	5,758.05	19.0	0.008	2.28	6.0	PVC	0.010	0.45	0.65	5,764.25	5,764.18
CO-50	ST AREA INLET #H-1	5,758.66	STRM TEE	5,758.05	30.5	0.020	2.68	6.0	PVC	0.010	0.53	1.03	5,764.33	5,764.18
CO-51	ST MH #A-8	5,761.40	ST MH #A-7	5,760.15	35.8	0.035	0.00	24.0	Concrete	0.013	0.00	42.28	5,768.07	5,768.07
CO-52	ST INLET #I-2	5,767.61	ST MH #I-2	5,767.11	10.0	0.050	0.32	24.0	Concrete	0.013	1.00	50.58	5,771.26	5,771.26
CO-53	ST INLET #I-1	5,762.98	ST MH #I-1	5,762.78	10.6	0.019	11.50	24.0	Concrete	0.013	36.12	31.13	5,771.52	5,771.25
CO-57	ST AREA INLET #F-1	5,755.13	KOR-N-TEE #A-7	5,754.89	23.2	0.010	2.56	8.0	PVC	0.010	0.89	1.60	5,757.50	5,757.42
CO-60	EX. MANHOLE	5,778.02	ST MH #I-2	5,769.77	110.4	0.075	0.00	24.0	Concrete	0.013	0.00	61.85	5,778.02	5,771.26

100-YEAR EVENT
Conduit Table - Time: 0.00 hours

Label	Start Node	Invert (Start) (ft)	Stop Node	Invert (Stop) (ft)	Length (Unified) (ft)	Slope (Calculated) (ft/ft)	Velocity (ft/s)	Diameter (in)	Material	Manning's n	Flow (cfs)	Capacity (Full Flow) (cfs)	Hydraulic Grade Line (In) (ft)	Hydraulic Grade Line (Out) (ft)
CO-64	ST MH #B-2	5,746.85	ST FES #B-1	5,746.06	62.9	0.013	6.67	24.0	Concrete	0.013	6.20	25.35	5,747.73	5,746.74
CO-65	ST CO #D-1	5,753.58	ST AREA INLET #D-1	5,752.70	43.9	0.020	0.00	6.0	PVC	0.010	0.00	1.03	5,753.58	5,752.70
CO-66	ST AREA INLET #D-1	5,751.70	ST MH #B-3	5,749.24	82.8	0.030	7.13	8.0	PVC	0.010	0.98	2.71	5,752.17	5,749.52
CO-67	ST INLET #B-1	5,750.60	ST MH #B-5	5,750.31	23.5	0.012	5.08	18.0	Concrete	0.013	2.22	11.67	5,751.16	5,750.76
CO-68	ST MH #B-5	5,750.11	ST MH #B-4	5,749.66	35.7	0.013	5.12	18.0	Concrete	0.013	2.21	11.80	5,750.67	5,750.49
CO-69	ST INLET #K-1	5,752.17	ST MH #B-4	5,749.66	100.5	0.025	7.07	18.0	Concrete	0.013	2.91	16.60	5,752.82	5,750.49
CO-70	O-6	5,784.89	CB-40	5,784.62	34.9	0.008	4.83	10.0	PVC	0.010	2.63	2.51	5,785.97	5,785.61
CO-71	CB-40	5,785.24	CB-42	5,784.89	35.0	0.010	1.17	10.0	PVC	0.010	0.64	2.85	5,785.81	5,785.77
CO-72	CB-40	5,785.13	CB-41	5,784.89	21.8	0.011	3.63	10.0	PVC	0.010	1.98	2.99	5,785.97	5,785.77
CO-73	CB-41	5,785.53	CB-43	5,785.13	35.3	0.011	3.17	10.0	PVC	0.010	1.73	3.03	5,786.37	5,786.12
CO-74	CB-43	5,785.77	CB-45	5,785.53	23.8	0.010	1.66	10.0	PVC	0.010	0.90	2.86	5,786.50	5,786.46
CO-75	CB-45	5,786.04	CB-46	5,785.77	27.6	0.010	0.81	10.0	PVC	0.010	0.44	2.82	5,786.53	5,786.50
CO-76	CB-43	5,785.99	CB-44	5,785.53	40.9	0.011	1.09	10.0	PVC	0.010	0.59	3.02	5,786.52	5,786.46
CO-77	ST AREA INLET #H-3	5,758.69	STRM BEND	5,758.58	15.7	0.007	1.91	6.0	PVC	0.010	0.37	0.61	5,761.33	5,761.28
CO-78	STRM BEND	5,758.58	ST AREA INLET #H-2	5,758.20	50.7	0.007	1.89	6.0	PVC	0.010	0.37	0.63	5,761.26	5,761.13
CO-79	ST MH #B-4	5,749.46	ST MH #B-3	5,748.36	88.6	0.012	6.21	18.0	Concrete	0.013	4.57	11.71	5,750.28	5,749.01
CO-4(1)	ST MH #A-7	5,759.65	KOR-N-TEE #A-8	5,757.15	125.3	0.020	11.84	24.0	Concrete	0.013	37.20	31.95	5,766.82	5,763.44
CO-4(2)	KOR-N-TEE #A-8	5,757.15	ST MH #A-6	5,755.63	75.8	0.020	12.03	24.0	Concrete	0.013	37.80	32.04	5,761.03	5,758.91
CO-81	STRM TEE	5,758.05	KOR-N-TEE #A-8	5,757.90	20.6	0.007	4.84	6.0	PVC	0.010	0.95	0.62	5,763.79	5,763.44
CO-82	SCUPPER DRAIN #H-1	5,759.00	ST AREA INLET #H-1	5,758.66	17.1	0.020	1.81	6.0	PVC	0.010	0.35	1.03	5,761.32	5,761.28
CO-83	SCUPPER DRAIN #H-2	5,758.82	ST AREA INLET #H-3	5,758.69	16.3	0.008	1.35	6.0	PVC	0.010	0.27	0.65	5,761.14	5,761.12
CO-84	SCUPPER DRAIN #K-1	5,753.75	ST AREA INLET #K-1	5,753.55	9.9	0.020	5.32	6.0	PVC	0.010	0.53	1.04	5,754.12	5,753.83
CO-85	SCUPPER DRAIN #D-1	5,753.28	ST AREA INLET #D-1	5,752.70	29.2	0.020	5.65	6.0	PVC	0.010	0.71	1.03	5,753.70	5,753.01
CO-86	ST RD #C-1	5,756.00	ST AREA INLET #C-5	5,755.82	9.1	0.020	0.00	6.0	PVC	0.010	0.00	1.03	5,756.00	5,755.82
CO-87	SCUPPER DRAIN #C-2	5,752.61	ST AREA INLET #C-3	5,752.64	18.4	-0.002	3.16	6.0	PVC	0.010	0.62	0.29	5,753.22	5,753.04
CO-88	SCUPPER DRAIN #C-1	5,753.33	ST AREA INLET #C-2	5,752.86	23.6	0.020	4.39	6.0	PVC	0.010	0.27	1.03	5,753.59	5,753.03
CO-89	ST AREA INLET #C-2	5,752.66	STORM TEE	5,750.91	53.6	0.033	5.83	8.0	PVC	0.010	0.42	2.84	5,752.96	5,751.51
CO-90	STORM TEE	5,750.82	ST MH #B-2	5,750.00	27.4	0.030	7.39	10.0	PVC	0.010	1.16	4.93	5,751.30	5,750.29
CO-91	ST AREA INLET #C-3	5,751.71	STORM TEE	5,750.82	29.8	0.030	6.60	10.0	PVC	0.010	0.78	4.92	5,752.10	5,751.51
CO-94	SCUPPER DRAIN #J-1	5,754.15	ST AREA INLET #J-2	5,753.73	10.6	0.040	5.02	6.0	PVC	0.010	0.18	1.45	5,754.36	5,753.85
CO-95	ST RD #A-2	5,753.50	DROP STRUCTURE #A-2	5,752.24	28.0	0.045	6.40	6.0	PVC	0.010	0.35	1.55	5,753.80	5,752.40
CO-9(1)	ST MH #A-4	5,748.42	KOR-N-TEE #A-5	5,747.89	41.8	0.013	5.62	36.0	Concrete	0.013	39.70	75.06	5,752.38	5,752.24
CO-96	DROP STRUCTURE #A-2	5,750.24	KOR-N-TEE #A-5	5,749.14	36.6	0.030	1.80	6.0	PVC	0.010	0.35	1.26	5,752.32	5,752.24
CO-97	ST RD #A-1	5,752.50	DROP STRUCTURE #A-1	5,751.74	13.8	0.055	0.00	6.0	PVC	0.010	0.00	1.71	5,752.50	5,751.74
CO-9(2)(1)	KOR-N-TEE #A-5	5,747.89	KOR-N-TEE #A-4	5,747.44	36.0	0.013	5.64	36.0	Concrete	0.013	39.90	74.62	5,751.71	5,751.58

100-YEAR EVENT
Conduit Table - Time: 0.00 hours

Label	Start Node	Invert (Start) (ft)	Stop Node	Invert (Stop) (ft)	Length (Unified) (ft)	Slope (Calculated) (ft/ft)	Velocity (ft/s)	Diameter (in)	Material	Manning's n	Flow (cfs)	Capacity (Full Flow) (cfs)	Hydraulic Grade Line (In) (ft)	Hydraulic Grade Line (Out) (ft)
CO-98	DROP STRUCTURE #A-1	5,749.74	KOR-N-TEE #A-4	5,748.67	35.5	0.030	0.00	6.0	PVC	0.010	0.00	1.27	5,751.58	5,751.58
CO-9(2)(2)(1)	KOR-N-TEE #A-4	5,747.44	KOR-N-TEE #A-3	5,747.17	21.7	0.012	5.64	36.0	Concrete	0.013	39.88	74.33	5,751.05	5,750.97
CO-9(2)(2)(2)	KOR-N-TEE #A-3	5,747.17	KOR-N-TEE #A-2	5,747.10	5.8	0.012	5.67	36.0	Concrete	0.013	40.09	73.08	5,750.44	5,750.41
CO-99	SCUPPER DRAIN #A-1	5,749.43	ST CO #A-1	5,749.31	6.0	0.020	1.81	6.0	PVC	0.010	0.35	1.03	5,751.05	5,751.04
CO-100	ST CO #A-1	5,749.11	KOR-N-TEE #A-3	5,748.42	15.3	0.045	1.80	6.0	PVC	0.010	0.35	1.55	5,751.01	5,750.97
CO-101	H-1	5,743.89	O-4	5,743.52	63.0	0.006	7.40	45.0	Concrete	0.013	29.16	50.62	5,745.38	5,744.84
CO-102	ST MH #A-3	5,745.08	ST MH #A-2	5,742.65	161.9	0.015	11.52	36.0	Concrete	0.013	40.32	81.72	5,747.15	5,745.64
CO-103	ST MH #A-2	5,742.34	ST MH #A-1	5,739.60	68.5	0.040	16.53	36.0	Concrete	0.013	40.29	133.35	5,744.41	5,740.86
CO-104	ST MH #A-1	5,738.60	ST FES #A-1	5,737.91	137.8	0.005	7.50	36.0	Concrete	0.013	40.28	47.19	5,740.73	5,739.98
CO-59(1)	ST AREA INLET #G-1	5,757.72	ST TEE	5,757.35	8.2	0.045	5.20	6.0	PVC	0.010	0.17	1.55	5,757.93	5,757.64
CO-59(2)	ST TEE	5,757.35	ST AREA INLET #F-1	5,756.18	25.9	0.045	5.21	6.0	PVC	0.010	0.17	1.55	5,757.58	5,757.61
CO-105	ST RD #F-1	5,758.00	ST TEE	5,757.35	32.5	0.020	0.00	6.0	PVC	0.010	0.00	1.03	5,758.00	5,757.64
CO-61(1)	SCUPPER DRAIN #F-1	5,755.67	ST AREA INLET #F-2	5,755.51	15.7	0.010	0.90	6.0	PVC	0.010	0.18	0.74	5,757.63	5,757.62
CO-61(2)	ST AREA INLET #F-2	5,755.34	ST AREA INLET #F-1	5,755.13	21.6	0.010	0.77	8.0	PVC	0.010	0.27	1.55	5,757.62	5,757.61
CO-107	ST CO #AC-1	5,755.45	ST MH #A-6	5,755.33	12.1	0.010	0.00	6.0	PVC	0.010	0.00	0.73	5,758.91	5,758.91
CO-108	TYPE C INLET	5,754.78	ST INLET #K-1	5,753.00	87.0	0.020	5.63	12.0	PVC	0.010	0.77	6.62	5,755.15	5,753.23
CO-93(1)	ST AREA INLET #J1.1	5,752.14	ST WYE CONNECTION	5,752.11	3.2	0.009	0.33	6.0	PVC	0.010	0.07	0.71	5,752.94	5,752.94
CO-93(2)	ST WYE CONNECTION	5,752.11	ST AREA INLET #J-1	5,751.64	47.0	0.010	0.33	6.0	PVC	0.010	0.06	0.73	5,752.94	5,752.94
CO-109	ST RD #A-3	5,752.25	ST WYE CONNECTION	5,752.11	9.2	0.015	0.00	6.0	PVC	0.010	0.00	0.90	5,752.94	5,752.94

100-YEAR EVENT

Catch Basin Table - Time: 0.00 hours

Label	Elevation (Ground) (ft)	Elevation (Invert) (ft)	Headloss Coefficient (Standard)	Hydraulic Grade Line (In) (ft)	Hydraulic Grade Line (Out) (ft)	Flow (Total Out) (cfs)	Flow (Additional Subsurface) (cfs)	Capacity (Inlet) (cfs)
ST INLET #I-2	5,776.82	5,767.61	0.050	5,771.26	5,771.26	1.00	0.00	(N/A)
ST INLET #I-1	5,772.38	5,762.98	0.050	5,771.63	5,771.52	36.12	0.00	(N/A)
ST INLET #I-3	5,774.64	5,768.17	0.050	5,771.26	5,771.26	0.65	0.00	(N/A)
ST AREA INLET #H-3	5,761.12	5,758.69	1.320	5,761.19	5,761.12	0.37	0.00	(N/A)
ST AREA INLET #H-2	5,761.13	5,758.20	0.050	5,761.13	5,761.13	0.45	0.00	(N/A)
ST AREA INLET #H-1	5,761.28	5,758.66	1.120	5,761.41	5,761.28	0.53	0.00	(N/A)
ST AREA INLET #G-1	5,761.27	5,757.72	0.050	5,757.93	5,757.93	0.17	0.00	(N/A)
SCUPPER DRAIN #E-1	5,760.72	5,756.62	0.050	5,756.97	5,756.96	0.44	0.00	(N/A)
ST AREA INLET #K-1	5,761.90	5,753.55	0.050	5,753.91	5,753.90	0.57	0.00	(N/A)
ST INLET #K-1	5,760.96	5,752.17	1.560	5,753.20	5,752.82	2.91	0.00	(N/A)
ST INLET #B-1	5,760.12	5,750.60	0.050	5,751.17	5,751.16	2.22	0.00	(N/A)
ST AREA INLET #D-1	5,759.17	5,751.70	0.570	5,752.29	5,752.17	0.98	0.00	(N/A)
ST AREA INLET #C-5	5,758.88	5,754.44	0.400	5,754.54	5,754.53	0.04	0.00	(N/A)
ST AREA INLET #C-4	5,758.42	5,752.86	0.640	5,753.05	5,753.02	0.13	0.00	(N/A)
ST AREA INLET #C-3	5,758.81	5,751.71	0.320	5,752.15	5,752.10	0.78	0.00	(N/A)
ST AREA INLET #C-2	5,758.56	5,752.66	0.620	5,753.03	5,752.96	0.42	0.00	(N/A)
ST AREA INLET #C-1	5,757.50	5,753.26	0.050	5,753.41	5,753.41	0.09	0.00	(N/A)
ST AREA INLET #J-2	5,758.60	5,753.40	0.100	5,753.65	5,753.64	0.30	0.00	(N/A)
ST AREA INLET #J-1	5,758.33	5,751.44	0.320	5,752.94	5,752.93	0.80	0.00	(N/A)
ST AREA INLET #A1.2	5,758.59	5,748.72	0.050	5,750.42	5,750.41	0.28	0.00	(N/A)
ST AREA INLET #A1.1	5,758.87	5,748.73	0.050	5,749.76	5,749.76	0.10	0.00	(N/A)
ST INLET #A-1.1	5,757.46	5,753.71	0.050	5,755.16	5,755.13	15.47	0.00	(N/A)
ST AREA INLT #E-1	5,758.75	5,756.27	0.050	5,756.40	5,756.40	0.07	0.00	(N/A)
TRENCH DRAIN CONNECTION	5,759.72	5,752.71	0.050	5,754.58	5,754.58	0.29	0.00	(N/A)
TRENCH DRAIN CONNECTION	5,759.95	5,756.29	0.050	5,756.63	5,756.62	0.49	0.00	(N/A)
SCUPPER DRAIN #H-1	5,762.00	5,759.00	0.050	5,761.32	5,761.32	0.35	0.00	(N/A)
SCUPPER DRAIN #F-1	5,762.01	5,755.67	0.050	5,757.63	5,757.63	0.18	0.00	(N/A)
CB-40	5,785.77	5,784.89	0.050	5,785.79	5,785.77	2.63	0.00	(N/A)
CB-41	5,786.94	5,785.13	0.050	5,785.98	5,785.97	1.98	0.00	(N/A)
CB-42	5,786.70	5,785.24	0.050	5,785.82	5,785.81	0.64	0.00	(N/A)
CB-43	5,787.54	5,785.53	0.600	5,786.46	5,786.37	1.73	0.00	(N/A)
CB-44	5,786.88	5,785.99	0.050	5,786.52	5,786.52	0.59	0.00	(N/A)
CB-45	5,786.89	5,785.77	0.050	5,786.50	5,786.50	0.90	0.00	(N/A)
CB-46	5,787.74	5,786.04	0.050	5,786.53	5,786.53	0.44	0.00	(N/A)
ST AREA INLET #F-1	5,761.47	5,755.13	1.120	5,757.61	5,757.50	0.89	0.00	(N/A)
SCUPPER DRAIN #H-2	5,762.02	5,758.82	0.050	5,761.14	5,761.14	0.27	0.00	(N/A)
SCUPPER DRAIN #K-1	5,762.02	5,753.75	0.050	5,754.13	5,754.12	0.53	0.00	(N/A)
SCUPPER DRAIN #D-1	5,761.82	5,753.28	0.050	5,753.72	5,753.70	0.71	0.00	(N/A)
SCUPPER DRAIN #C-2	5,759.79	5,752.61	0.050	5,753.23	5,753.22	0.62	0.00	(N/A)
SCUPPER DRAIN #C-1	5,758.93	5,753.33	0.050	5,753.60	5,753.59	0.27	0.00	(N/A)
ST AREA INLET #E-2	5,760.18	5,756.27	0.100	5,756.64	5,756.62	0.48	0.00	(N/A)
ST AREA INLET #J1.1	5,758.49	5,752.14	0.720	5,752.95	5,752.94	0.07	0.00	(N/A)
SCUPPER DRAIN #J-1	5,759.43	5,754.15	0.050	5,754.36	5,754.36	0.18	0.00	(N/A)
SCUPPER DRAIN #A-1	5,759.46	5,749.43	0.050	5,751.05	5,751.05	0.35	0.00	(N/A)

100-YEAR EVENT

Catch Basin Table - Time: 0.00 hours

Label	Elevation (Ground) (ft)	Elevation (Invert) (ft)	Headloss Coefficient (Standard)	Hydraulic Grade Line (In) (ft)	Hydraulic Grade Line (Out) (ft)	Flow (Total Out) (cfs)	Flow (Additional Subsurface) (cfs)	Capacity (Inlet) (cfs)
ST AREA INLET #F-2	5,761.78	5,755.34	0.050	5,757.62	5,757.62	0.27	0.00	(N/A)
TYPE C INLET	5,761.95	5,754.78	0.050	5,755.15	5,755.15	0.77	0.00	(N/A)

100-YEAR EVENT

Manhole Table - Time: 0.00 hours

Label	Elevation (Rim) (ft)	Elevation (Invert) (ft)	Headloss Coefficient (Standard)	Hydraulic Grade Line (In) (ft)	Hydraulic Grade Line (Out) (ft)	Flow (Total Out) (cfs)	System Flow Time (min)
ST MH #I-2	5,776.98	5,766.61	1.570	5,771.26	5,771.26	1.38	10.041
ST MH #I-1	5,772.69	5,762.58	1.070	5,771.25	5,768.92	37.20	17.515
ST MH #A-7	5,772.87	5,759.65	0.570	5,768.07	5,766.82	37.20	17.560
ST MH #A-8	5,773.06	5,761.40	0.100	5,768.07	5,768.07	0.00	0.000
ST MH #A-6	5,763.82	5,755.13	1.120	5,758.91	5,757.88	37.80	17.841
ST MH #A-5	5,763.00	5,751.78	1.070	5,755.17	5,754.65	38.98	18.042
ST MH #E-1	5,760.85	5,755.10	1.570	5,755.78	5,755.53	1.03	5.139
ST MH #A-4	5,760.33	5,748.42	1.070	5,752.91	5,752.38	39.70	18.212
ST MH #A-3	5,759.01	5,745.08	0.100	5,747.24	5,747.15	40.32	18.650
ST MH #B-2	5,754.32	5,746.85	0.370	5,747.86	5,747.73	6.20	11.702
ST MH #B-3	5,754.60	5,748.16	0.370	5,749.18	5,749.04	5.27	11.532
EX. MANHOLE	5,784.16	5,778.02	0.370	5,778.02	5,778.02	0.00	0.000
ST MH #B-5	5,760.11	5,750.11	0.520	5,750.78	5,750.67	2.21	5.077
ST MH #B-4	5,756.73	5,749.46	0.620	5,750.49	5,750.28	4.57	11.295
ST RD #C-1	5,759.92	5,756.00	0.050	5,756.00	5,756.00	0.00	0.000
ST RD #A-3	5,759.40	5,752.25	0.050	5,752.94	5,752.94	0.00	0.000
ST RD #A-2	5,759.99	5,753.50	0.050	5,753.81	5,753.80	0.35	5.000
DROP STRUCTURE #A-2	5,759.62	5,750.24	0.370	5,752.34	5,752.32	0.35	5.073
ST RD #A-1	5,759.98	5,752.50	0.050	5,752.50	5,752.50	0.00	0.000
DROP STRUCTURE #A-1	5,759.81	5,749.74	0.100	5,751.58	5,751.58	0.00	0.000
ST CO #A-1	5,759.35	5,749.11	0.620	5,751.04	5,751.01	0.35	5.055
ST MH #A-1	5,750.76	5,738.60	0.050	5,740.78	5,740.73	40.28	18.954
ST MH #A-2	5,764.24	5,742.34	1.320	5,745.64	5,744.41	40.29	18.884
ST RD #F-1	5,762.92	5,758.00	0.050	5,758.00	5,758.00	0.00	0.000
ST CO #AC-1	5,762.81	5,755.45	2.370	5,758.91	5,758.91	0.00	0.000
ST CO #D-1	5,760.75	5,753.58	0.400	5,753.58	5,753.58	0.00	0.000

100-YEAR EVENT

Transition Table - Time: 0.00 hours

ID	Label	Elevation (Ground) (ft)	Elevation (Top) (ft)	Elevation (Invert) (ft)	Flow (Total Out) (cfs)	Hydraulic Grade Line (Out) (ft)
84	STRM TEE	5,765.23	5,758.55	5,758.05	0.95	5,763.79
87	ST CO #E-1	5,760.10	5,760.10	5,756.07	0.49	5,756.40
90	KOR-N-TEE #A -2	5,758.89	5,750.10	5,747.10	40.28	5,749.82
160	STRM BEND	5,763.05	5,759.08	5,758.58	0.37	5,761.26
201	KOR-N-TEE #A -8	5,765.76	5,759.15	5,757.15	37.80	5,761.03
218	STORM TEE	5,758.98	5,751.65	5,750.82	1.16	5,751.30
223	KOR-N-TEE #A -6	5,762.43	5,762.43	5,750.92	39.16	5,753.51
233	KOR-N-TEE #A -5	5,759.50	5,750.89	5,747.89	39.90	5,751.71
240	KOR-N-TEE #A -4	5,759.47	5,750.44	5,747.44	39.88	5,751.05
245	KOR-N-TEE #A -3	5,759.07	5,750.17	5,747.17	40.09	5,750.44
251	KOR-N-TEE #A -1	5,759.29	5,749.69	5,746.69	40.33	5,748.76
261	ST TEE	5,762.24	5,757.85	5,757.35	0.17	5,757.58
272	KOR-N-TEE #A -7	5,765.29	5,756.56	5,754.06	38.36	5,756.15
275	ST WYE CONNECTION	5,758.80	5,752.61	5,752.11	0.06	5,752.94

100-YEAR EVENT

Outfall Table - Time: 0.00 hours

Label	Elevation (Ground) (ft)	Elevation (Invert) (ft)	Boundary Condition Type	Elevation (User Defined Tailwater) (ft)	Hydraulic Grade (ft)	Flow (Total Out) (cfs)	System Flow Time (min)
ST FES #A-1.1	5,755.10	5,752.85	Free Outfall	0.00	5,753.89	15.45	5.318
O-4	5,745.94	5,743.52	Free Outfall	0.00	5,744.84	29.11	7.597
ST FES #B-1	5,748.08	5,746.05	Free Outfall	0.00	5,746.74	6.17	11.859
O-6	5,785.50	5,784.62	Free Outfall	0.00	5,785.61	2.62	8.389
ST FES #A-1	5,740.91	5,737.91	Free Outfall	0.00	5,739.98	40.24	19.260

100-YEAR EVENT

Catchment Table - Time: 0.00 hours

Label	Outflow Element	Area (User Defined) (acres)	Runoff Coefficient (Rational)	Time of Concentration (min)	Flow (Total Out) (cfs)
B3/2	ST INLET #I-2	0.155	0.690	5.000	1.00
B1	ST INLET #I-3	0.180	0.440	7.610	0.65
B3/2	ST INLET #I-1	0.155	0.690	5.000	1.00
A-8	CB-46	0.060	0.790	5.000	0.44
A-7	CB-42	0.200	0.390	7.770	0.64
A-9	CB-45	0.060	0.870	5.000	0.49
A-10	CB-44	0.070	0.910	5.000	0.59
A6/2	CB-43	0.040	0.750	5.350	0.27
A6/2	CB-41	0.040	0.750	5.350	0.27
A-5	CB-40	0.050	0.560	5.000	0.26
A-13	ST INLET #A-1.1	1.060	0.670	5.250	6.54
B-25	ST AREA INLET #A1.1	0.020	0.550	5.540	0.10
C-17.18.19.20	H-1	1.750	0.520	7.455	7.54
B-24	SCUPPER DRAIN #A-1	0.040	0.950	5.000	0.35
B-26	ST AREA INLET #A1.2	0.060	0.560	7.120	0.28
B21	ST AREA INLET #J-1	0.120	0.480	6.300	0.50
B22	SCUPPER DRAIN #J-1	0.020	0.950	5.000	0.18
C15	ST AREA INLET #C-2	0.020	0.370	5.000	0.07
B20	ST AREA INLET #J-2	0.030	0.450	5.000	0.13
C16	ST AREA INLET #C-1	0.020	0.470	5.000	0.09
C14	SCUPPER DRAIN #C-1	0.030	0.950	5.000	0.27
C13	SCUPPER DRAIN #C-2	0.070	0.950	5.000	0.62
B19	ST AREA INLET #J1.1	0.020	0.350	5.000	0.07
C9	ST AREA INLET #C-5	0.010	0.500	6.670	0.04
C11/2	ST AREA INLET #C-4	0.025	0.430	5.940	0.10
C11/2	ST AREA INLET #C-3	0.025	0.430	5.940	0.10
B18	TRENCH DRAIN CONNECTION	0.050	0.620	5.000	0.29
B16	ST AREA INLT #E-1	0.020	0.350	5.000	0.07
B15	TRENCH DRAIN CONNECTION	0.060	0.880	5.000	0.49

100-YEAR EVENT

Catchment Table - Time: 0.00 hours

Label	Outflow Element	Area (User Defined) (acres)	Runoff Coefficient (Rational)	Time of Concentration (min)	Flow (Total Out) (cfs)
B13	ST AREA INLET #G-1	0.030	0.620	5.000	0.17
B9	ST AREA INLET #F-1	0.120	0.430	5.000	0.48
B12	ST AREA INLET #F-2	0.020	0.510	5.000	0.10
B11	SCUPPER DRAIN #E-1	0.050	0.950	5.000	0.44
B14	ST AREA INLET #E-2	0.010	0.380	5.000	0.04
C5	SCUPPER DRAIN #D-1	0.080	0.950	5.000	0.71
C7	ST AREA INLET #D-1	0.050	0.580	5.000	0.27
B10	SCUPPER DRAIN #F-1	0.020	0.950	5.000	0.18
C4	SCUPPER DRAIN #K-1	0.060	0.950	5.000	0.53
C6	ST AREA INLET #K-1	0.010	0.380	5.000	0.04
C1	ST INLET #K-1	0.490	0.490	5.970	2.13
C-3	ST INLET #B-1	0.270	0.880	5.000	2.22
B5	SCUPPER DRAIN #H-2	0.030	0.950	5.000	0.27
B4	ST AREA INLET #H-3	0.030	0.400	5.000	0.11
C-2	TYPE C INLET	0.280	0.380	10.800	0.77
B7	ST AREA INLET #H-2	0.020	0.470	5.000	0.09
B6	SCUPPER DRAIN #H-1	0.040	0.950	5.000	0.35
B8	ST AREA INLET #H-1	0.030	0.630	5.000	0.18
B23	ST RD #A-2	0.040	0.950	5.000	0.35

STORMLINE A - 100-YR

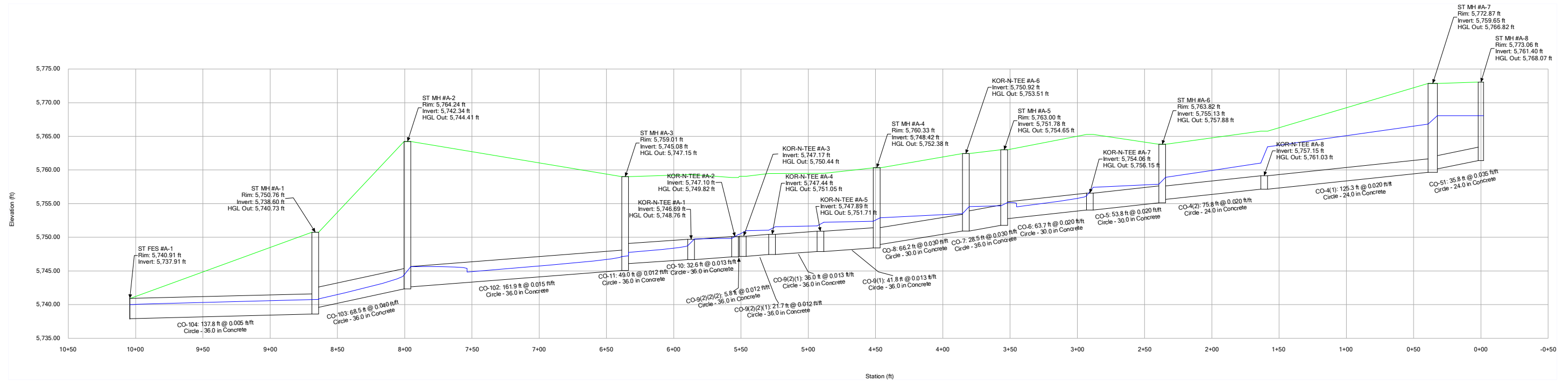

STORMLINE B - 100-YR

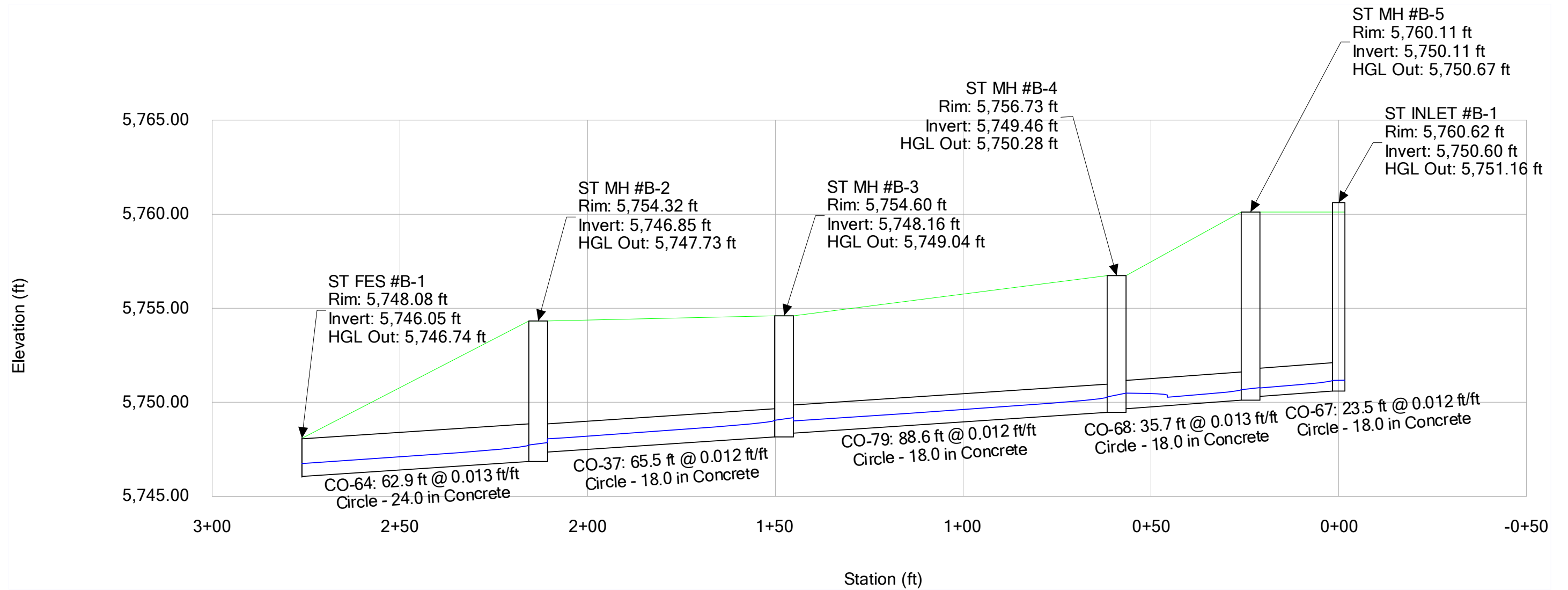

STORMLINE C - 100-YR

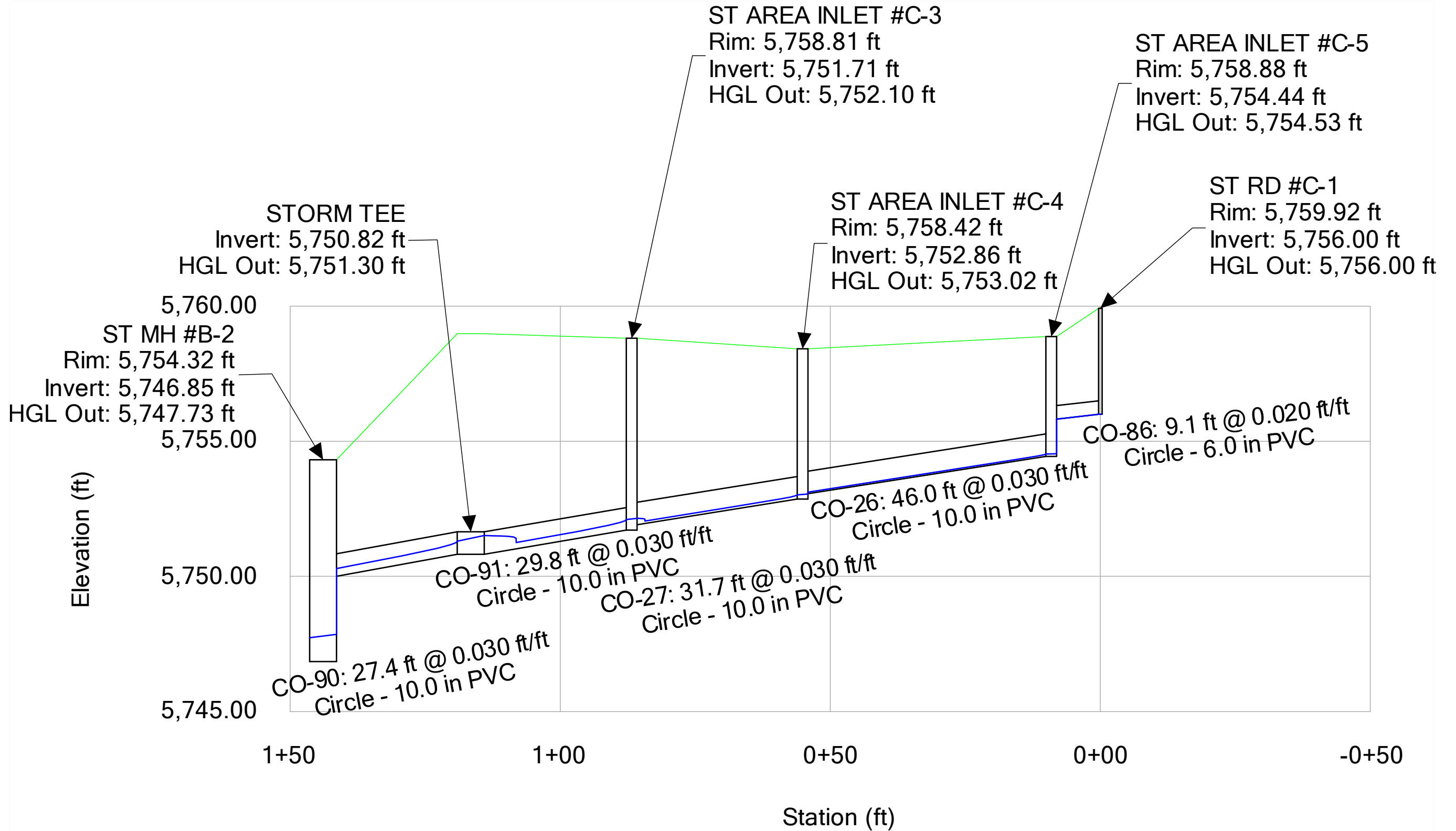

STORMLINE D - 100-YR

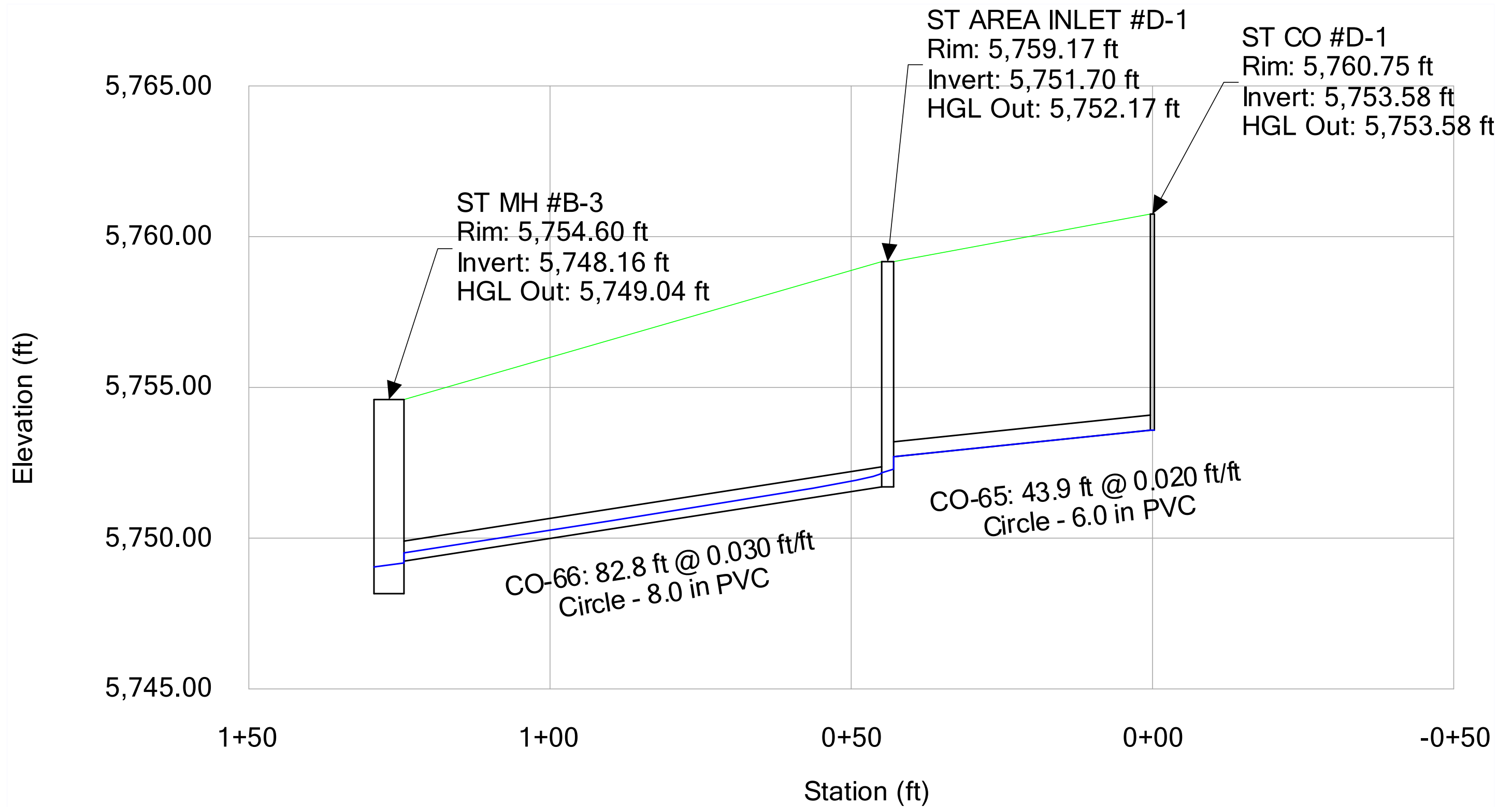

STORMLINE E - 100-YR

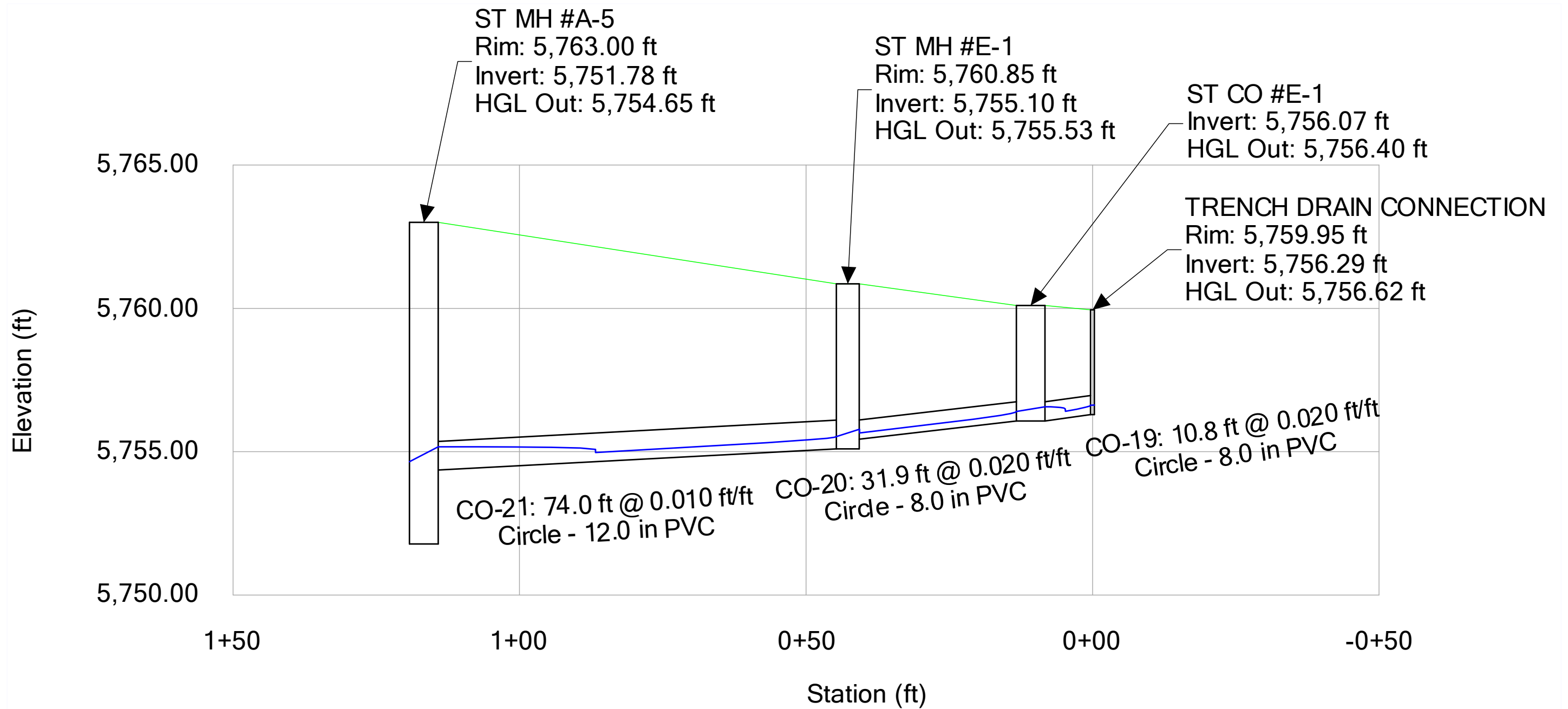

STORMLINE F - 100-YR

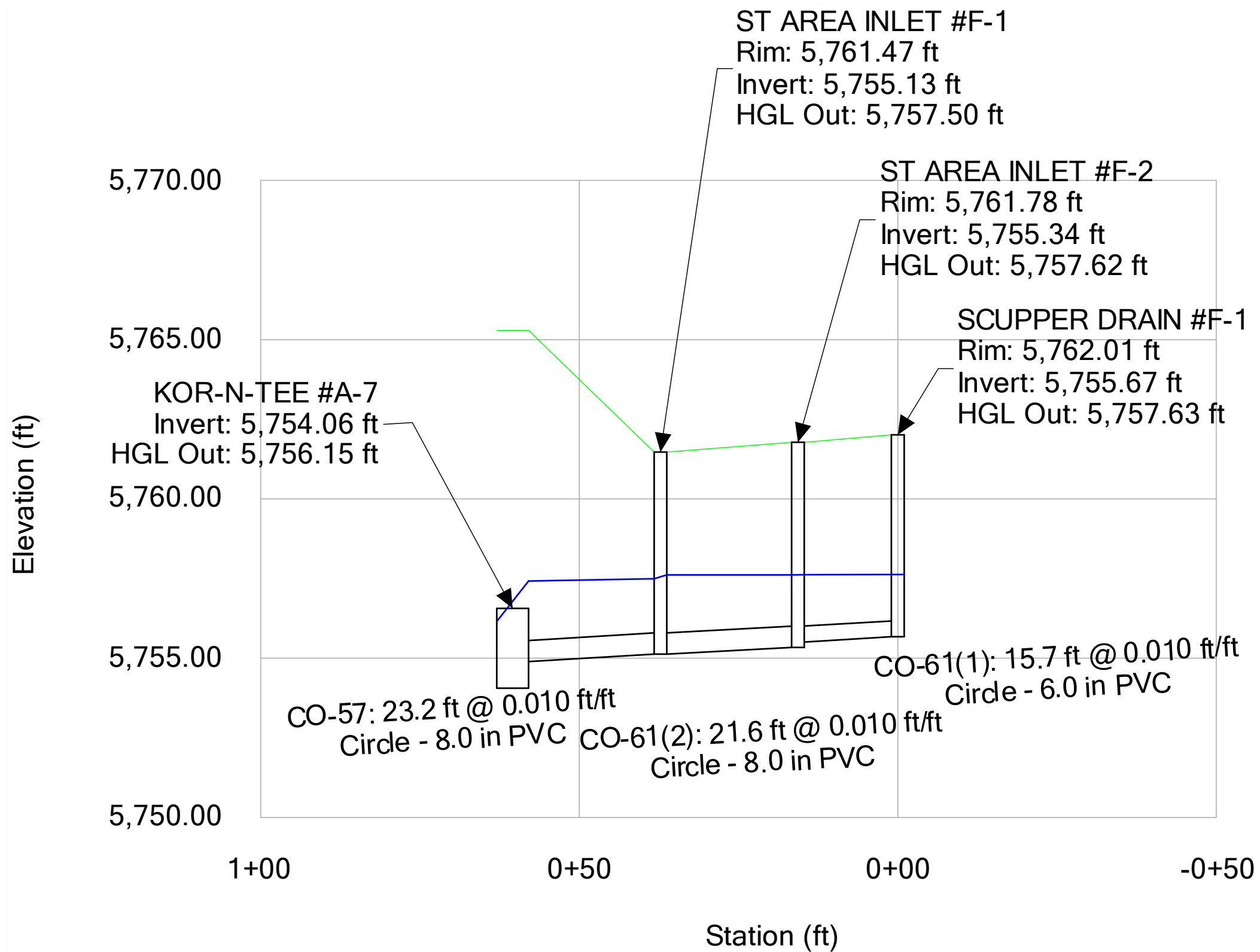

STORMLINE H - 100-YR



STORMLINE I - 100-YR

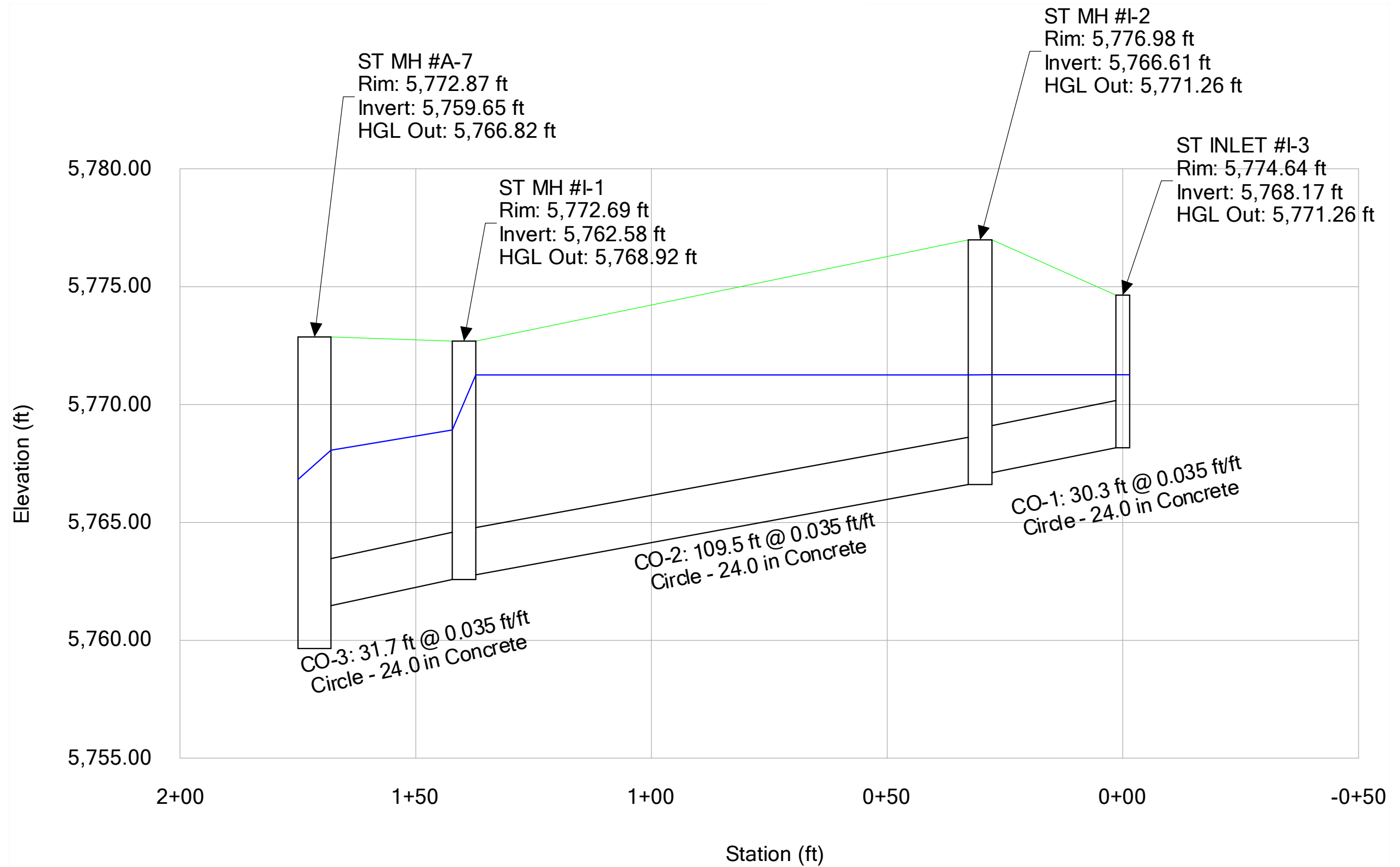

STORMLINE J - 100-YR

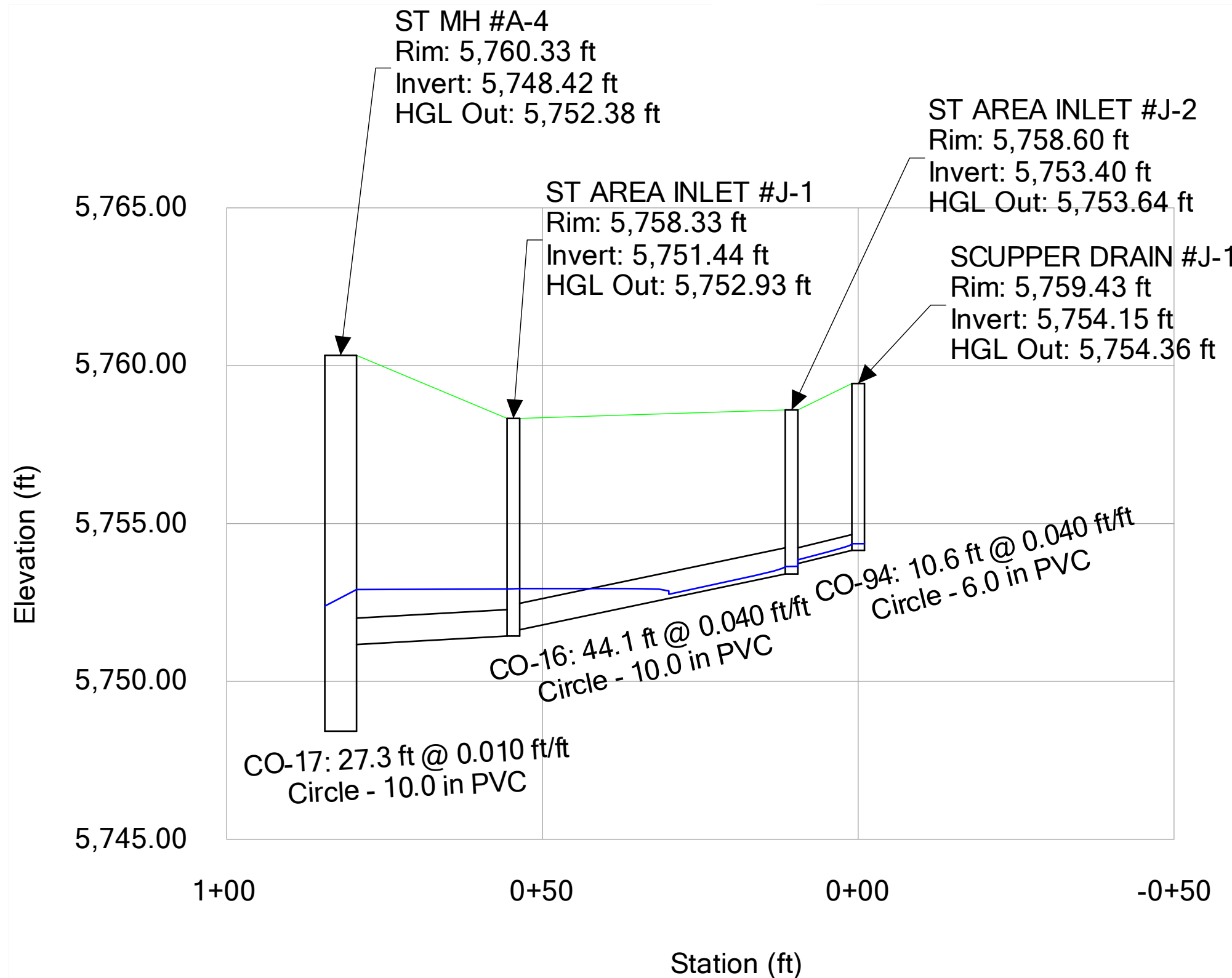

STORMLINE K - 100-YR

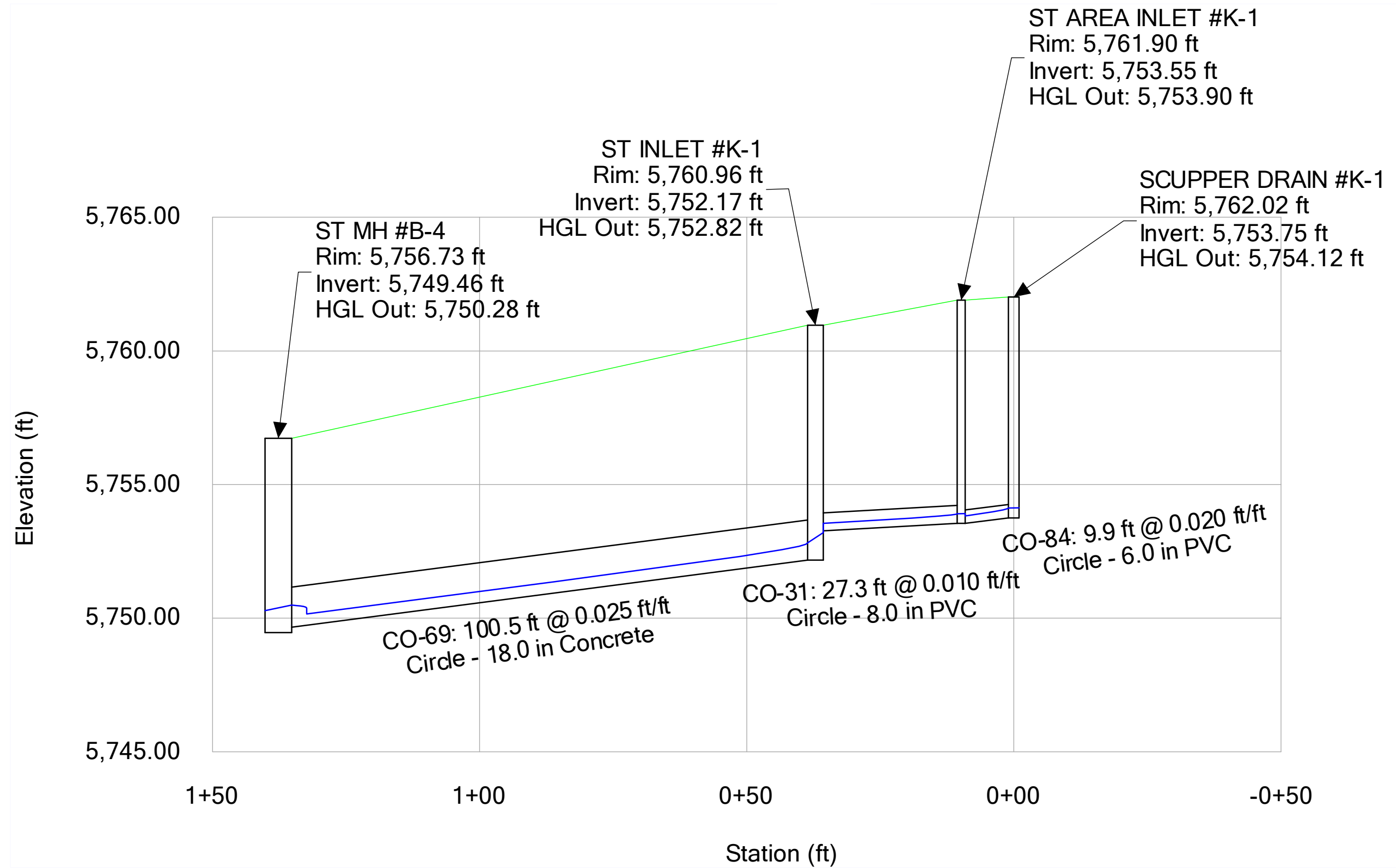

STORMLINE A-A - 100-YR

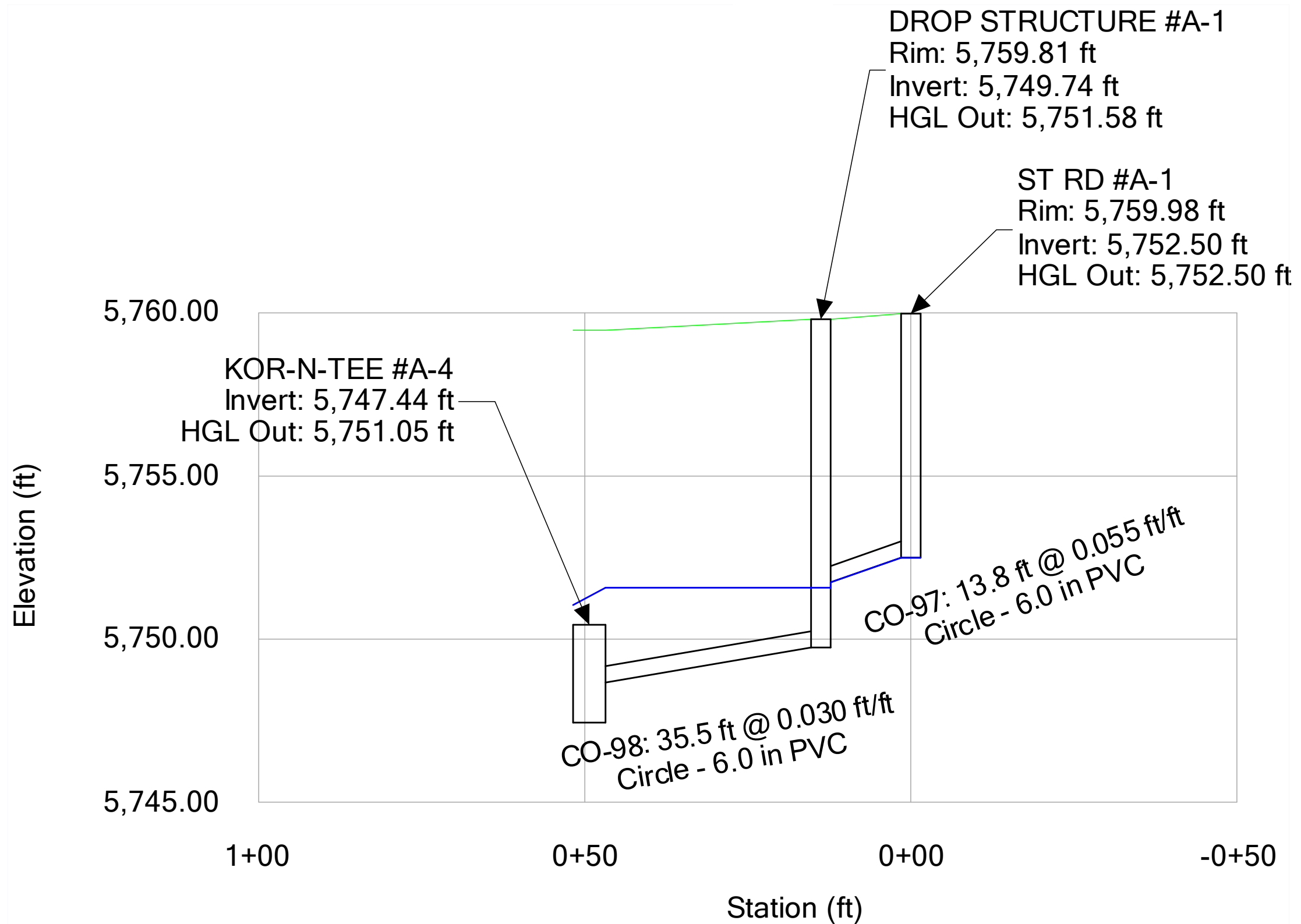

STORMLINE A-B - 100-YR

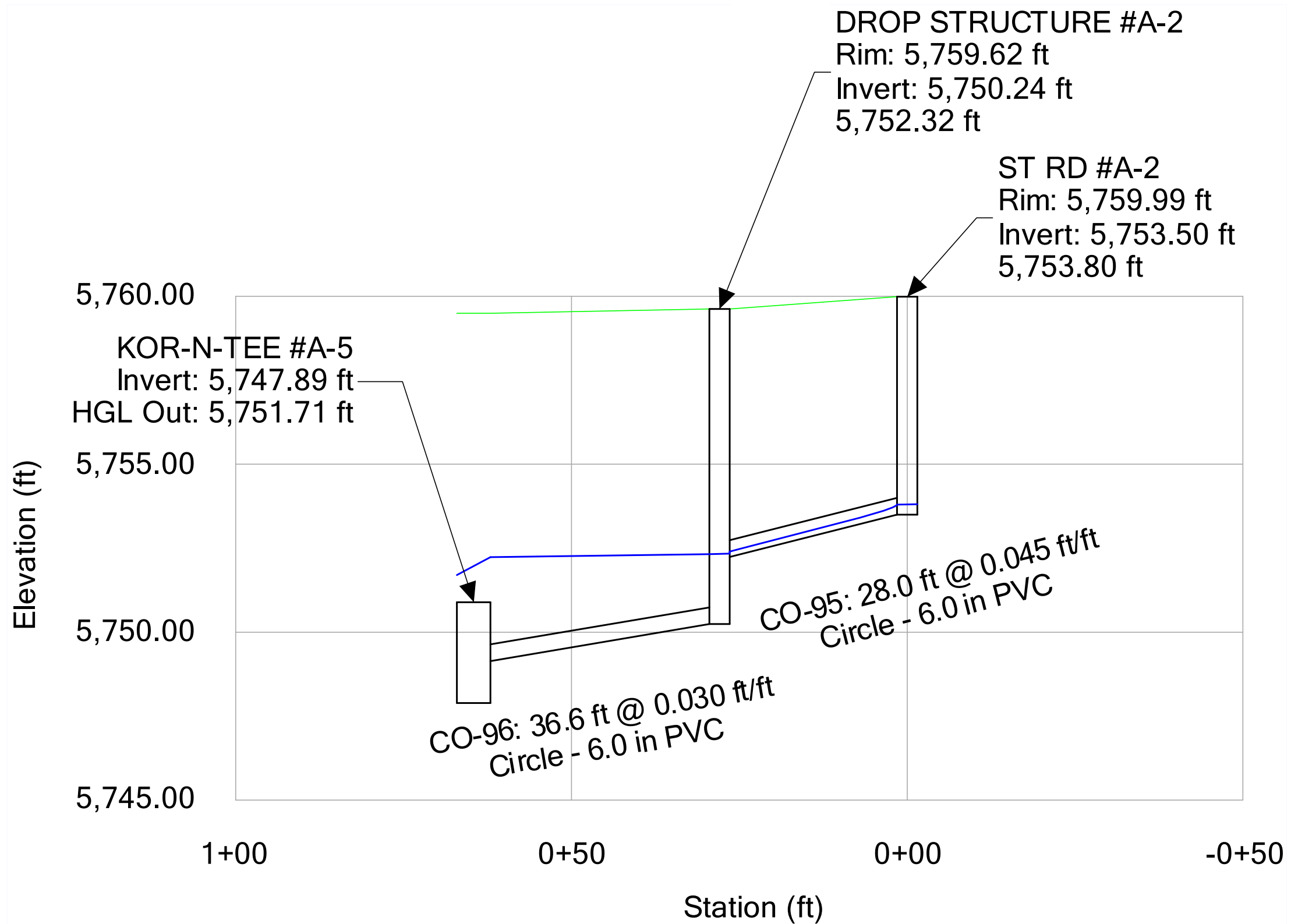

MEADOW OUTFALL - 100-YR

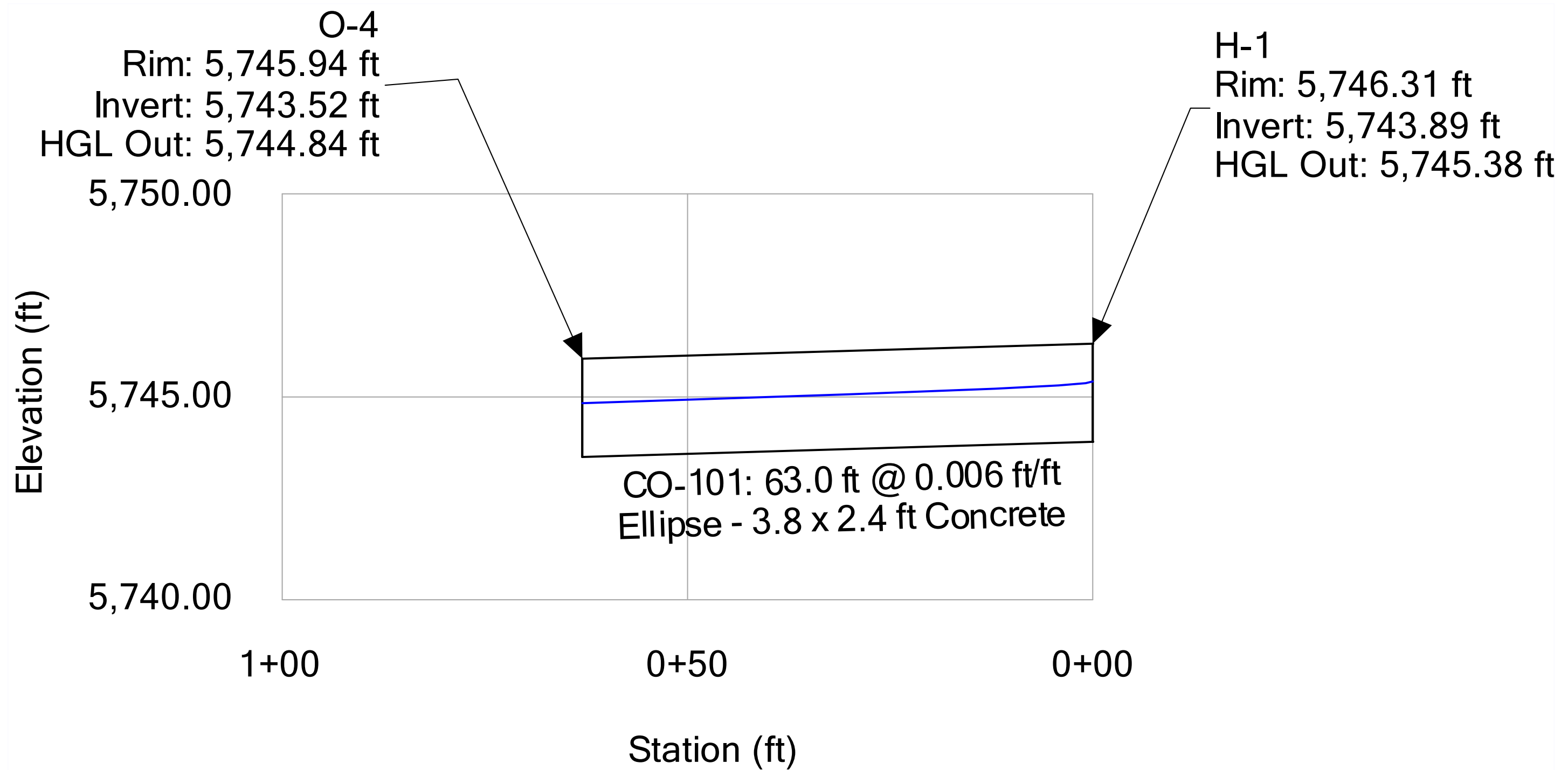

Normal Depth at Bioswale

Project Description	
Friction Method	Manning Formula
Solve For	Normal Depth

Input Data	
Roughness Coefficient	0.050
Channel Slope	0.020 ft/ft
Normal Depth	11.1 in
Left Side Slope	25.000 %
Right Side Slope	25.000 %
Bottom Width	5.00 ft
Discharge	25.00 cfs

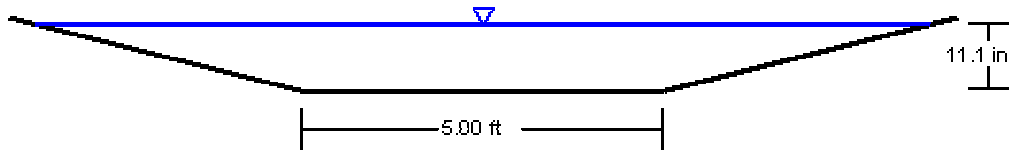

V: 1
H: 1

Normal Depth at Bioswale

Project Description	
Friction Method	Manning Formula
Solve For	Normal Depth
Input Data	
Roughness Coefficient	0.050
Channel Slope	0.020 ft/ft
Left Side Slope	25.000 %
Right Side Slope	25.000 %
Bottom Width	5.00 ft
Discharge	25.00 cfs
Results	
Normal Depth	11.1 in
Flow Area	8.0 ft ²
Wetted Perimeter	12.6 ft
Hydraulic Radius	7.6 in
Top Width	12.39 ft
Critical Depth	9.0 in
Critical Slope	0.046 ft/ft
Velocity	3.11 ft/s
Velocity Head	0.15 ft
Specific Energy	1.07 ft
Froude Number	0.681
Flow Type	Subcritical
GVF Input Data	
Downstream Depth	0.0 in
Length	0.0 ft
Number Of Steps	0
GVF Output Data	
Upstream Depth	0.0 in
Profile Description	N/A
Profile Headloss	0.00 ft
Downstream Velocity	Infinity ft/s
Upstream Velocity	Infinity ft/s
Normal Depth	11.1 in
Critical Depth	9.0 in
Channel Slope	0.020 ft/ft
Critical Slope	0.046 ft/ft

Normal Depth at Wet Meadow, Minor Event

Project Description	
Friction Method	Manning Formula
Solve For	Normal Depth

Input Data	
Roughness Coefficient	0.050
Channel Slope	0.005 ft/ft
Normal Depth	11.2 in
Left Side Slope	2.000 %
Right Side Slope	2.000 %
Bottom Width	5.00 ft
Discharge	63.46 cfs

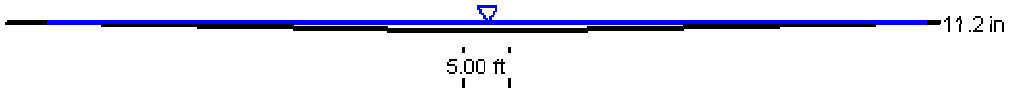

V: 1
H: 1

Normal Depth at Wet Meadow, Minor Event

Project Description	
Friction Method	Manning Formula
Solve For	Normal Depth
Input Data	
Roughness Coefficient	0.050
Channel Slope	0.005 ft/ft
Left Side Slope	2.000 %
Right Side Slope	2.000 %
Bottom Width	5.00 ft
Discharge	63.46 cfs
Results	
Normal Depth	11.2 in
Flow Area	48.5 ft ²
Wetted Perimeter	98.6 ft
Hydraulic Radius	5.9 in
Top Width	98.60 ft
Critical Depth	7.0 in
Critical Slope	0.054 ft/ft
Velocity	1.31 ft/s
Velocity Head	0.03 ft
Specific Energy	0.96 ft
Froude Number	0.329
Flow Type	Subcritical
GVF Input Data	
Downstream Depth	0.0 in
Length	0.0 ft
Number Of Steps	0
GVF Output Data	
Upstream Depth	0.0 in
Profile Description	N/A
Profile Headloss	0.00 ft
Downstream Velocity	0.00 ft/s
Upstream Velocity	0.00 ft/s
Normal Depth	11.2 in
Critical Depth	7.0 in
Channel Slope	0.005 ft/ft
Critical Slope	0.054 ft/ft

Normal Depth at Wet Meadow, Major Event

Project Description	
Friction Method	Manning Formula
Solve For	Normal Depth

Input Data	
Roughness Coefficient	0.050
Channel Slope	0.005 ft/ft
Normal Depth	15.1 in
Left Side Slope	2.000 %
Right Side Slope	2.000 %
Bottom Width	9.00 ft
Discharge	145.00 cfs

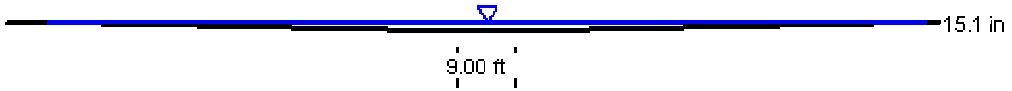

V: 1
H: 1

Normal Depth at Wet Meadow, Major Event

Project Description	
Friction Method	Manning
	Formula
Solve For	Normal Depth
Input Data	
Roughness Coefficient	0.050
Channel Slope	0.005 ft/ft
Left Side Slope	2.000 %
Right Side Slope	2.000 %
Bottom Width	9.00 ft
Discharge	145.00 cfs
Results	
Normal Depth	15.1 in
Flow Area	90.1 ft ²
Wetted Perimeter	134.6 ft
Hydraulic Radius	8.0 in
Top Width	134.57 ft
Critical Depth	9.5 in
Critical Slope	0.048 ft/ft
Velocity	1.61 ft/s
Velocity Head	0.04 ft
Specific Energy	1.30 ft
Froude Number	0.346
Flow Type	Subcritical
GVF Input Data	
Downstream Depth	0.0 in
Length	0.0 ft
Number Of Steps	0
GVF Output Data	
Upstream Depth	0.0 in
Profile Description	N/A
Profile Headloss	0.00 ft
Downstream Velocity	0.00 ft/s
Upstream Velocity	0.00 ft/s
Normal Depth	15.1 in
Critical Depth	9.5 in
Channel Slope	0.005 ft/ft
Critical Slope	0.048 ft/ft

Project Fountain Valley School - Acadmiec Center
Project # 23.0895
Date 3/16/2026
Title 12" Square Flat Grate Inlet



INLET CAPACITY BASED ON CAPTURE CHART FROM INLET MANUFACTURER

References ADS

GENERAL

Inlet type/name 12" Nyloplast Inlet - Standard Grate
 X 50% Effective inlet capture (50%-70%)

	10-Year	100-year		
Q	0.01	0.03	cfs	Required flow for inlet
d	0.25	0.50	ft	Maximum Ponding depth

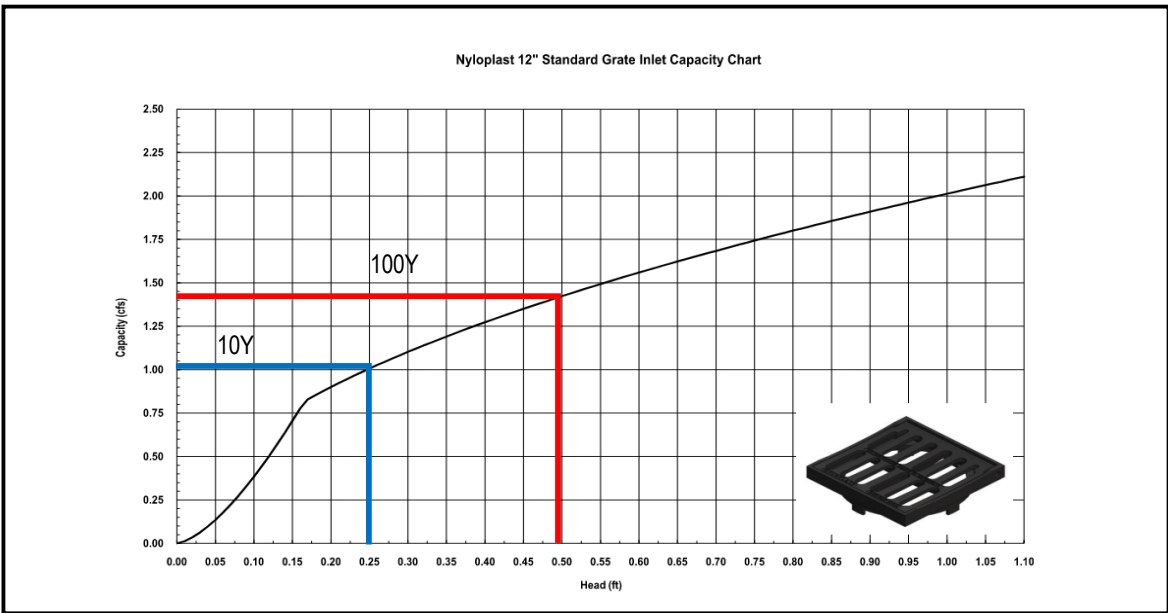

	10-Year	100-year		
Q_{inlet}	1.00	1.40	cfs	Inlet capture
$Q_{inlet-reduced}$	0.50	0.70	cfs	Inlet effective capture capacity
	Good	Good		

Notes

Project Fountain Valley School - Acadmiec Center
Project # 23.0895
Date 3/16/2026
Title 15" Round Flat Grate Inlet



INLET CAPACITY BASED ON CAPTURE CHART FROM INLET MANUFACTURER

References ADS

GENERAL

Inlet type/name 15" Nyloplast Inlet - Standard Grate
 X 50% Effective inlet capture (50%-70%)

	10-Year	100-year		
Q	0.8	0.16	cfs	Required flow for inlet
d	0.25	0.50	ft	Maximum Ponding depth

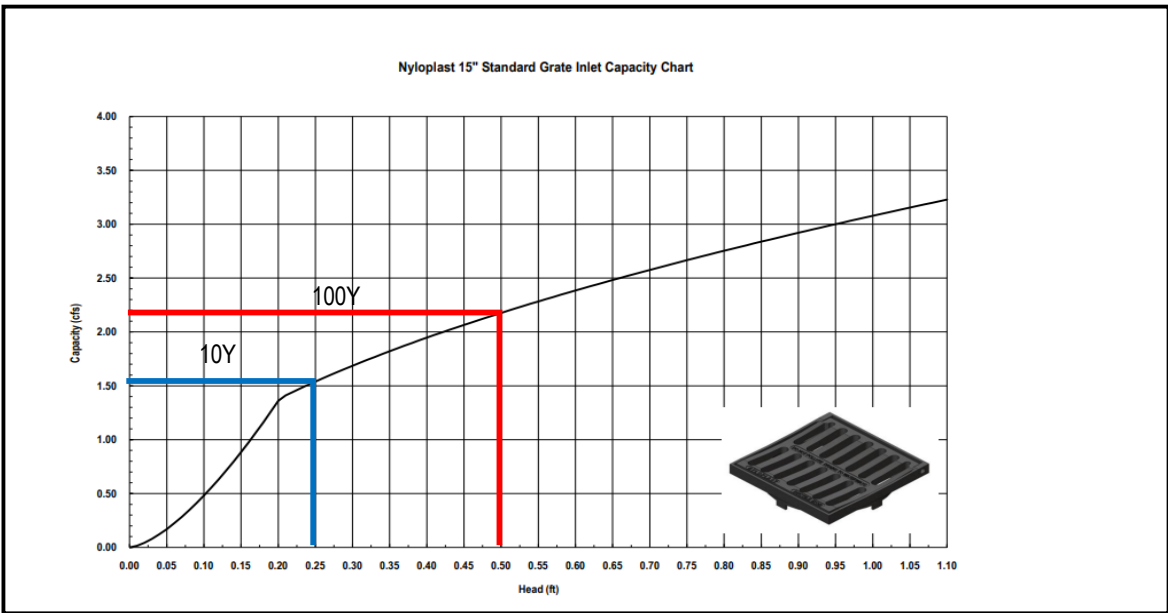

	10-Year	100-year		
Q _{inlet}	1.50	2.20	cfs	Inlet capture
Q _{inlet-reduced}	0.75	1.10	cfs	Inlet effective capture capacity
	No Good	Good		

Notes

Project Fountain Valley School - Acadmiec Center
Project # 23.0895
Date 3/16/2026
Title 18" Round Flat Grate Inlet



INLET CAPACITY BASED ON CAPTURE CHART FROM INLET MANUFACTURER

References ADS

GENERAL

Inlet type/name 18" Nyloplast Inlet - Standard Grate
 X 50% Effective inlet capture (50%-70%)

	10-Year	100-year		
Q	0.23	0.52	cfs	Required flow for inlet
d	0.25	0.50	ft	Maximum Ponding depth

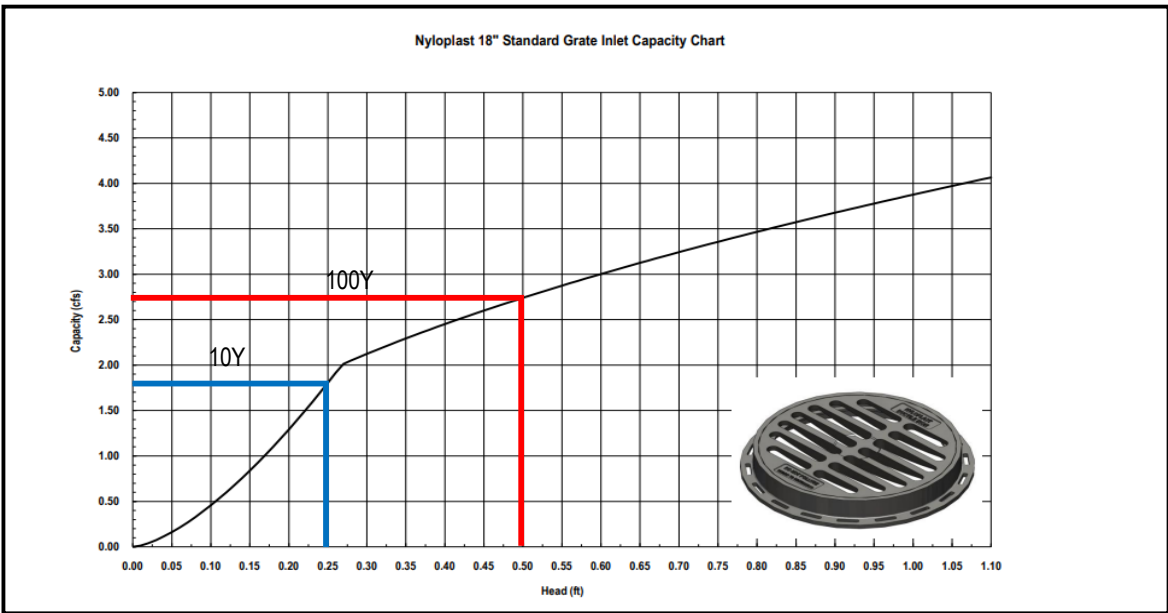

	10-Year	100-year		
Q_{inlet}	1.80	2.70	cfs	Inlet capture
$Q_{inlet-reduced}$	0.90	1.35	cfs	Inlet effective capture capacity
	Good	Good		

Notes

Project Fountain Valley School - Acadmiec Center
Project # 23.0895
Date 3/16/2026
Title 24" Round Flat Grate Inlet



INLET CAPACITY BASED ON CAPTURE CHART FROM INLET MANUFACTURER

References ADS

GENERAL

Inlet type/name **24" Nyloplast Inlet - Standard Grate**
 X **50%** Effective inlet capture (50%-70%)

	10-Year	100-year		
Q	0.23	0.52	cfs	Required flow for inlet
d	0.25	0.6	ft	Maximum Ponding depth

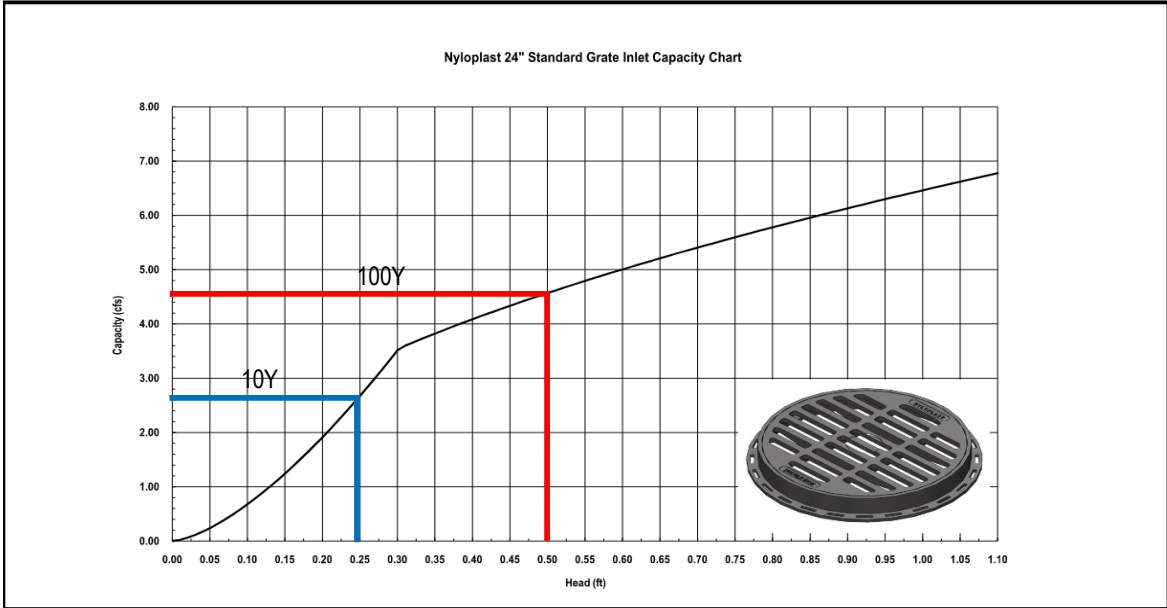

	10-Year	100-year		
Q_{inlet}	2.60	4.60	cfs	Inlet capture
$Q_{inlet-reduced}$	1.30	2.30	cfs	Inlet effective capture capacity
	Good	Good		

Notes

Project Fountain Valley School - Acadmiec Center
Project # 23.0895
Date 3/16/2026
Title 18" Beehive Inlet



INLET CAPACITY BASED ON CAPTURE CHART FROM INLET MANUFACTURER

References ADS

GENERAL

Inlet type/name 18" Nyloplast Inlet - Dome Grate
 X 50% Effective inlet capture (50%-70%)

	10-Year	100-year		
Q	0.23	0.52	cfs	Required flow for inlet
d	0.25	0.5	ft	Maximum Ponding depth

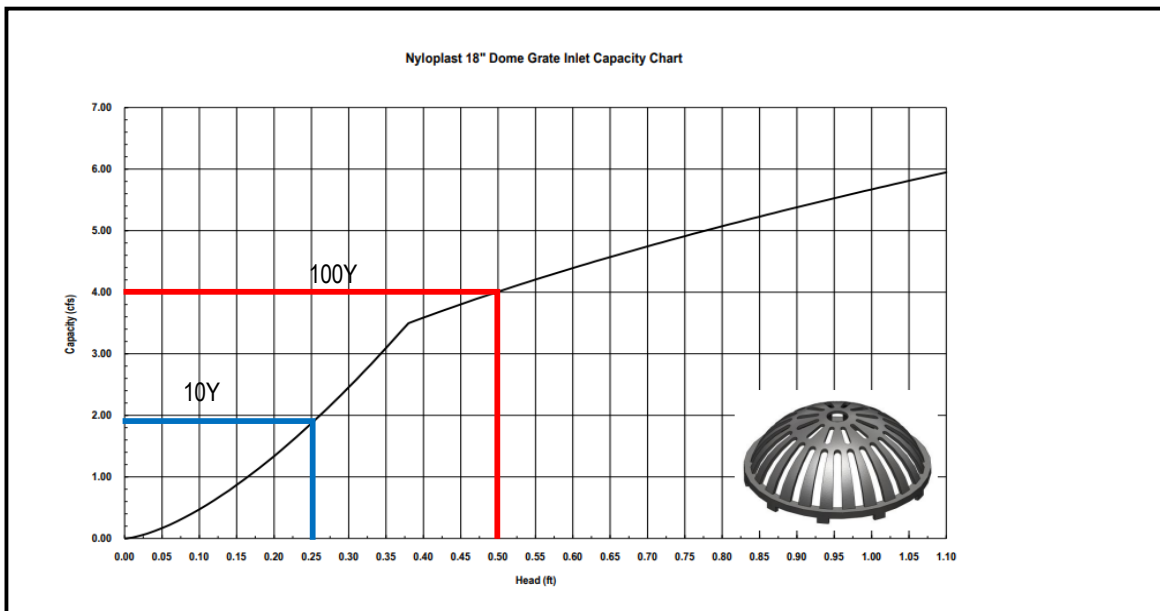

	10-Year	100-year		
Q _{inlet}	1.90	4.00	cfs	Inlet capture
Q _{inlet-reduced}	0.95	2.00	cfs	Inlet effective capture capacity
	Good	Good		

Notes

Project Fountain Valley School - Acadmiec Center
Project # 23.0895
Date 3/16/2026
Title 24" Beehive Grate



INLET CAPACITY BASED ON CAPTURE CHART FROM INLET MANUFACTURER

References ADS

GENERAL

Inlet type/name 24" Nyloplast Inlet - Dome Grate
 X 50% Effective inlet capture (50%-70%)

	10-Year	100-year		
Q	0.23	0.52	cfs	Required flow for inlet
d	0.25	0.50	ft	Maximum Ponding depth

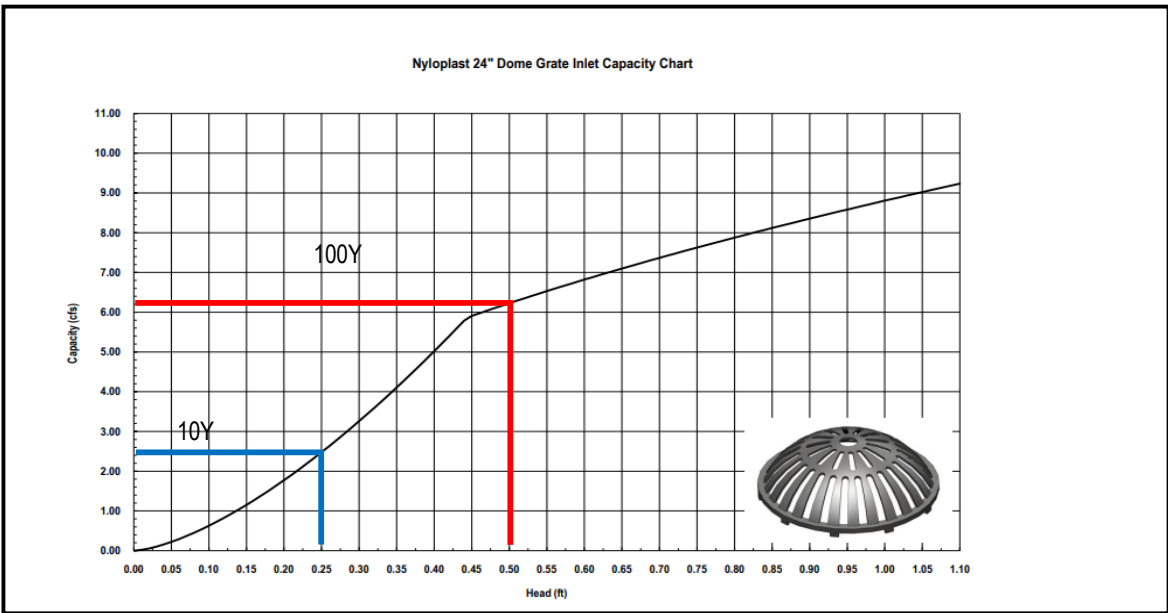

	10-Year	100-year		
Q _{inlet}	2.40	6.20	cfs	Inlet capture
Q _{inlet-reduced}	1.20	3.10	cfs	Inlet effective capture capacity
	Good	Good		

Notes

APPENDIX D – Supporting Documents and Reference Reports



RECEIVED
APR 28 2011
EPC DEVELOPMENT SERVICES

**Master Development Drainage Plan
Fountain Valley School
El Paso County, Colorado**

Prepared for:
Fountain Valley School
c/o Next Level Development
118 N. Tejon Street, Suite 205
Colorado Springs, Colorado 80903

Prepared by:
KIOWA
Engineering Corporation

1604 South 21st Street
Colorado Springs, Colorado 80904
(719) 630-7342

Kiowa Project No. 10034

January 17, 2011
Revised April 18, 2011

		<u>Page</u>
Table of Contents		ii
Engineer’s Statement		iii
I.	General Location and Description.....	1
II.	Previous Reports	1
III.	Drainage Design Criteria	5
IV.	Hydraulic Calculations.....	5
V.	Existing Drainage Patterns	6
VI.	Site Drainage Plan	7
VII.	Water Quality Facilities.....	9
VIII.	Irrigation Ditches / Drainage Channels.....	9
IX.	Wetland Areas	10
X.	Floodplain Statement.....	10
XI.	Drainage and Bridge Fees	11

LIST OF TABLES

Table 5-1	Recommended Average Runoff Coefficients.....	Appendix A
-----------	--	------------

LIST OF FIGURES

Figure 1	Vicinity Map	2
Figure 2	Soil Survey of El Paso County	3
Figure 3	Flood Insurance Rate Map.....	12
Figure 4	Drainage Basin Boundary Map	13
Figure 5	Overall Drainage Basin Map.....	Map Pocket
Figure 6	Master Development Drainage Plan – Existing Condition	Map Pocket
Figure 7	Master Development Drainage Plan - Proposed Condition.....	Map Pocket

Appendix A – Hydrologic Calculations

Appendix B – Hydraulic Calculations

ENGINEER'S STATEMENT:

The attached drainage plan and report were prepared under my direction and supervision and are correct to the best of my knowledge and belief. Said drainage report has been prepared according to the criteria established by the City/County for drainage reports and said report is in conformity with the applicable master plan of the drainage basin. I accept responsibility for any liability caused by any negligent acts, errors or omissions on my part in preparing this report.

Kiowa Engineering Corporation, 1604 South 21st Street, Colorado Springs, Colorado 80904



Jennifer G. Davison, P.E.
Registered Engineer #39738

4/19/2011
Date

For and on Behalf of Kiowa Engineering Corporation

DEVELOPER'S STATEMENT:

I, the Developer, have read and will comply with all of the requirements specified in this drainage report and plan.

BY: Wayne M. Timura

Date

4/28/11
Date

PRINT NAME: WAYNE M. TIMURA

ADDRESS: Next Level Development
118 N. Tejon Street, Suite 205
Colorado Springs, Colorado 80903

EL PASO COUNTY:

Filed in accordance with the requirements of the Drainage Criteria Manual, Volumes 1 & 2, El Paso County Engineering Criteria Manual and Land Development code, as amended.



Andre P. Brackin, P.E.
El Paso County Engineer/ECM Administrator

5-11-11
Date

Conditions: _____

I. General Location and Description

Fountain Valley School is an existing preparatory school located east of Security in the south central portion of El Paso County, Colorado. The developed portion of the school property is located in the central portion of the property. The campus is currently developed with administrative buildings, a dining hall, a library, a student center, classrooms, dormitories, faculty residences, a health center, a gymnasium, an athletic field and track, tennis courts, maintenance buildings, barns, stables, equestrian arenas, and storage sheds. Numerous driveways and parking areas provide access to the main campus area. Hay fields comprise the area to the east and south of the campus. The remainder of the property to the west and north is undeveloped.

The Fountain Valley School property encompasses approximately 937 acres and is roughly bounded by Grinnell Street to the west, Bradley Road to the north, Goldfield Drive to the east, and Fontaine Boulevard to the south. The campus area of the site is located in Section 18, Township 15 South, Range 66 West of the 6th P.M. A vicinity map showing the location of the site is presented on Figure 1 on the following page.

The Fountain Valley School property is being masterplanned and the 2000 AL-00-024 Special Use Permit is being updated. This Master Development Drainage Plan (MDDP) is being submitted as a part of the Special Use and Site Development Plan. Future plans for the school are anticipated to be constructed in phases. Improvements will expand the campus slightly to the north, east, and south and include construction of new buildings, additions to buildings, roadway improvements, new roadways and parking areas, and new athletic and maintenance areas. Proposed buildings include faculty residences, classroom facilities, a performing arts facility, dormitories, Athletic Complex, a multi-purpose arena, and maintenance/storage buildings. Plans also include expanding the existing gymnasium and administration building. Additional athletic fields and riding arenas are proposed along the east side of the campus. Roadway and parking improvements are located on the southern side of the campus. A roundabout is proposed just inside the main gate to the campus. New parking is planned west of the roundabout, south of the existing track, east of the proposed Athletic Complex, and adjacent to the proposed multi-purpose arena.

The main campus area generally slopes from the north to the south at slopes of approximately 2%-10%. According to the *Soil Survey for El Paso County, Colorado*, the site's soil, as shown on Figure 2, consists of several different soil types, most of which fall into the Hydrologic Soil Group B category. Some Hydrologic Soil Group C and D soils lie east of the main campus area and include the existing athletic field.

II. Previous Reports

- 1) *Drainage Letter and Erosion Control Plan for Fountain Valley School Strategic Development Plan*, prepared by URS, dated July 31, 2000.

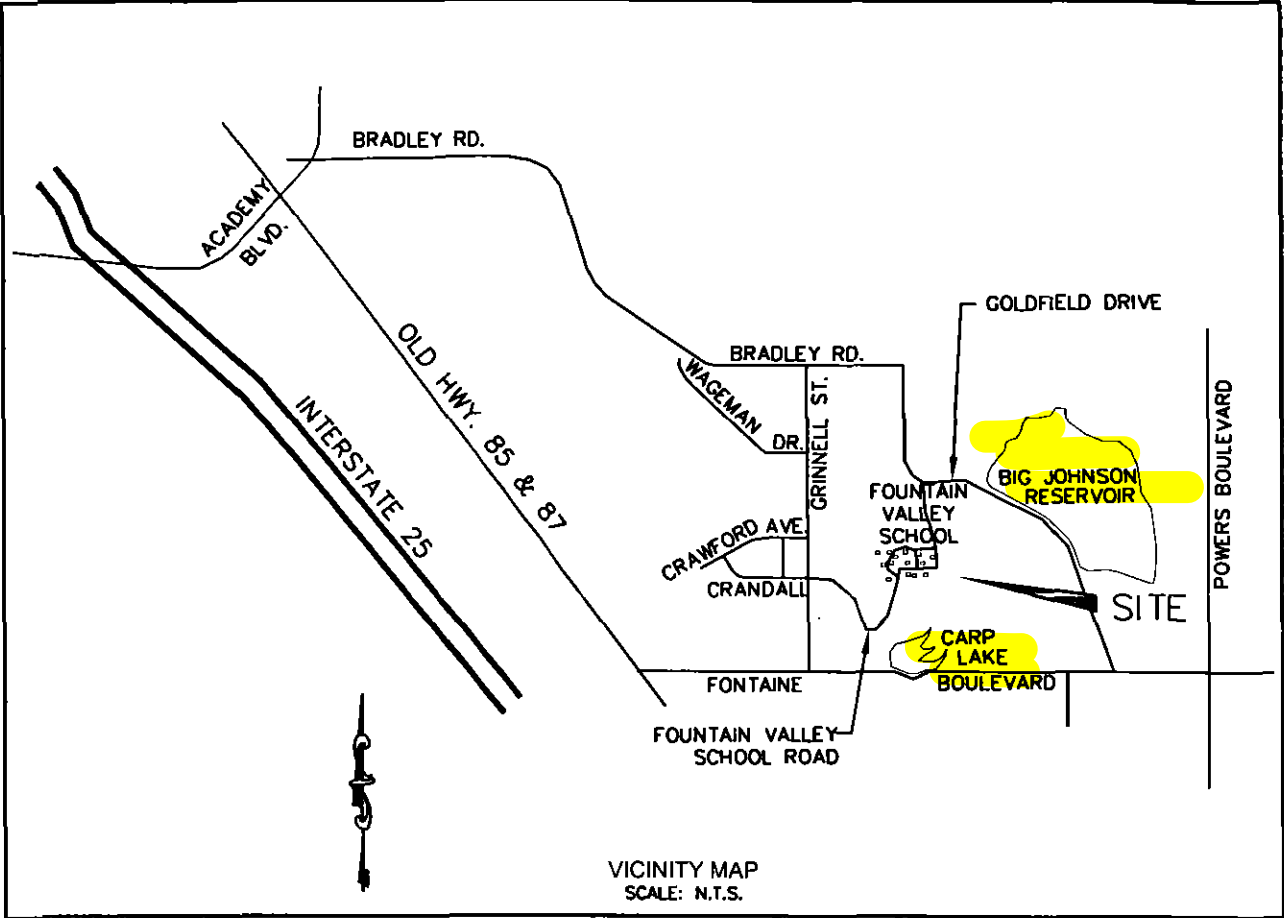
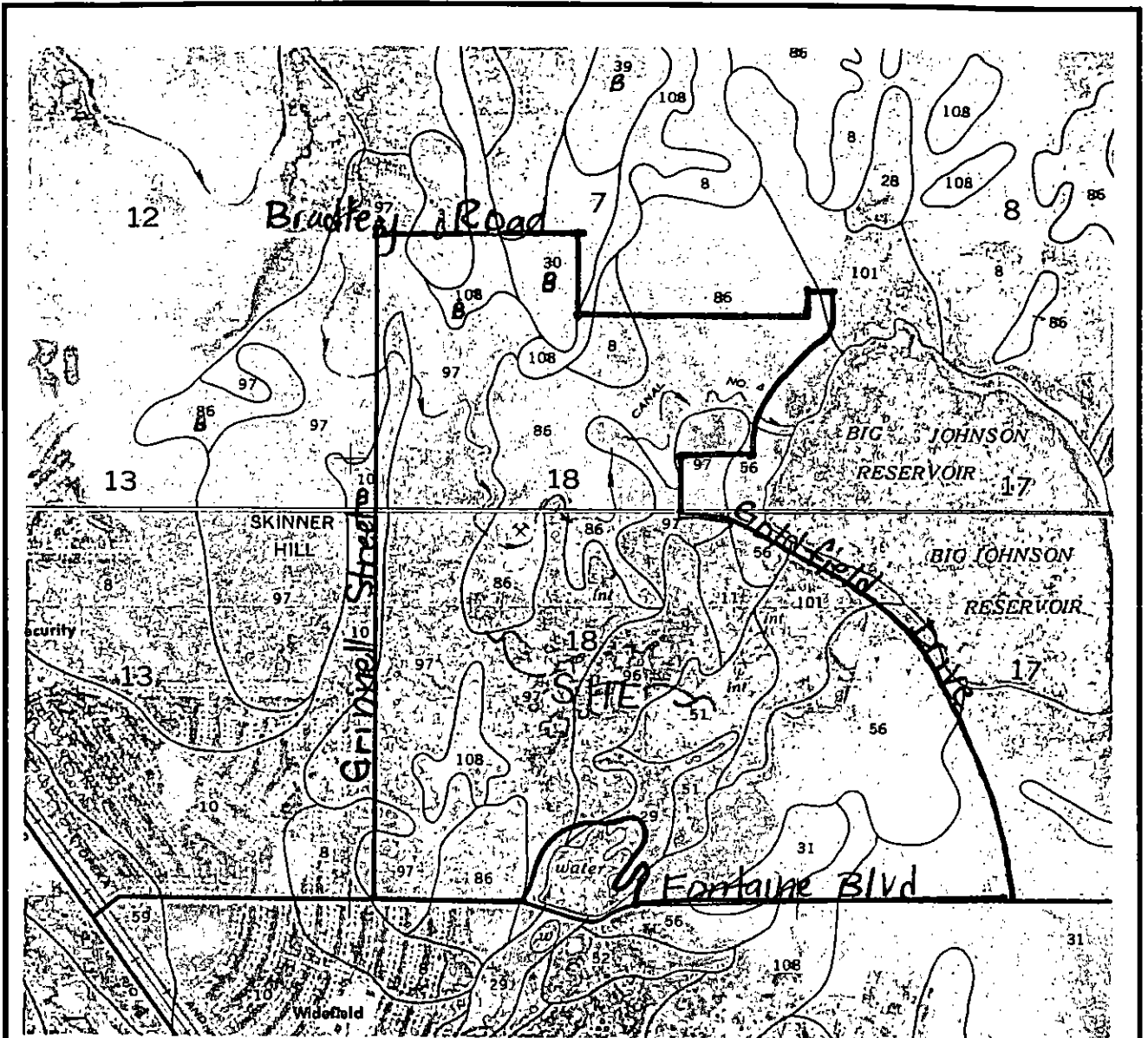



FIGURE 1
VICINITY MAP
FOUNTAIN VALLEY SCHOOL



SHEET NO. 24
 EL PASO COUNTY AREA, COLORADO
 (FOUNTAIN QUADRANGLE)

SOIL SERIES	
11	BRESSER SANDY LOAM (B)
29	FLUVAQUENTIC HAPLAQUOLLS (B/D)
30	FORT COLLINS LOAM (B)
31	FORT COLLINS LOAM (B)
39	KEITH SILT LOAM (B)
51	MANZANOLA CLAY LOAM (C)
56	NELSON-TASSEL FINE SANDY LOAMS (B/D)
86	STONEHAM SANDY LOAM (B)
96	TRUCKTON SANDY LOAM (B)
97	TRUCKTON SANDY LOAM (B)
108	WILEY SILT LOAM (B)



SCALE: N.T.S.

FIGURE 2
 SOIL SURVEY OF EL PASO COUNTY
 FOUNTAIN VALLEY SCHOOL

- 2) *Drainage Letter and Erosion Control Plan for Fountain Valley School Dormitory Expansion*, prepared by Kiowa Engineering Corp., filed October 29, 1998.
- 3) *Big Johnson Reservoir/Crews Gulch Drainage Basin Planning Study*, prepared by Kiowa Engineering Corporation, dated June, 1991.
- 4) *City of Colorado Springs and El Paso County Drainage Criteria Manual*, dated October 1997.
- 5) *City of Colorado Springs Drainage Criteria Manual Volume 2*, dated November 2002.
- 6) *El Paso County, Engineering Criteria Manual*, dated January 9, 2006 and revised January 1, 2008.
- 7) *Soil Survey of El Paso County Area, Colorado*, prepared by United States Department of Agriculture Soil Conservation Service, dated June 1981.

The Drainage Basin Planning Study (DBPS) (Reference 3) was prepared to identify feasible stormwater management plans to satisfy the existing and future needs within the Big Johnson Reservoir / Crews Gulch Basin. Drainage and bridge fees were also established in the DBPS. Fountain Valley School is located within Reach 4 per the DBPS. Generally speaking, detention will not be required with any development in this area since detention will be accomplished with Carp Lake, aka McRae Reservoir, downstream of the school. The DBPS assumed no new development would occur at Fountain Valley School. According to the DBPS, if new development occurs at the school, peak discharge rates were to be limited to historic rates. Therefore, detention may be required with the proposed new development at Fountain Valley School.

Improvements were recommended near Fountain Valley School in the DBPS. A new outlet structure with an energy dissipater was planned for in the DBPS at the outlet of Carp Lake at Fontaine Boulevard, which is located south of the school. This outlet structure drains into Widefield Park along the south side of Fontaine Boulevard and has been installed.

Assuming the area draining to Big Johnson Reservoir from the north, east and south, was to be developed as part of the Waterview Property development, construction of a new outlet structure was proposed to increase the reservoir's discharge capacity to pass developed runoff through the reservoir. Improvements were planned in the DBPS to convey the increased flows from Big Johnson Reservoir to Carp Lake. A 36-inch RCP was planned to carry runoff from the outlet structure under Goldfield Drive to the west through the Fountain Valley School property. Improvements to the existing drainage channel were planned to route runoff from this storm pipe to the southwest to an existing drainage channel that outfalls directly into Carp Lake. Bank lining was proposed for both the existing and proposed channels. The existing drainage channel currently travels across the Fountain Valley School property south and east of the existing athletic field.

Neither the channel improvements nor the improvements to the outlet structure have been constructed. Subsequent to the DBPS, the property surrounding Big Johnson Reservoir to the north, east, and south was purchased by the City of Colorado Springs

Trails and Open Space Program and established as Open Space. Since the vast majority of the area draining to Big Johnson Reservoir is now dedicated Open Space and will no longer be developed, an increase in runoff draining to or discharging from Big Johnson Reservoir is no longer anticipated. As such, the planned outlet and drainage channel improvements are no longer necessary.

III. Drainage Design Criteria

Per our pre-application meeting with the County, the focus of this MDDP is on the developed area of the Fountain Valley School campus and not the entire property owned by Fountain Valley School.

The hydrology for this site was estimated using the methods outlined in the *City of Colorado Springs and El Paso County, Drainage Criteria Manual*. The topography for the site was compiled using FIMS mapping with a two-foot contour interval and is presented at a horizontal scale of 1-inch to 200-feet on Figure 5 and 1-inch to 100-feet on Figures 6 and 7. Figure 4 presents the full extent of the drainage basin boundaries using USGS mapping with a 20-foot contour interval at a scale of 1-inch to 2000-feet. Figures 5 and 6 present the existing drainage patterns and Figure 7 presents the proposed drainage patterns for the site, including the sub-basins and the corresponding flow rates. The flow rates for the sub-basins were estimated using the Rational Method. The 5-year and 100-year recurrence intervals were determined. The hydrologic calculations can be found in Appendix A of this report.

The runoff coefficients for the site were determined using Table 5-1 of the *City of Colorado Springs and El Paso County, Drainage Criteria Manual*. Pasture/Meadow and Lawns were assumed for the pervious areas of the site and Paved Streets, Drive and Walks, and Roofs were assumed for impervious areas for both the existing and proposed conditions. A copy of Table 5-1 is located in Appendix A of this report. **The hydrologic calculations were performed assuming Hydrologic Soil Group B for the majority of the site with Hydrologic Soil Group C being used for Basins E-4 and E-5 only.** The hydrologic calculations can be found in Appendix A of this report.

IV. Hydraulic Calculations

The sizing of the proposed onsite drainage structures were made using the methods outlined in the *City of Colorado Springs and El Paso County, Drainage Criteria Manual*. The hydraulic capacities of curb and grated inlets were determined using the UDINLET computer model developed by the University of Colorado at Denver. Colorado Department of Transportation (CDOT) **Type R curb inlets and Type C and Type D grated inlets are planned to be used within the site.** The culverts were sized assuming inlet control, a 100-year storm and a maximum **headwater to depth ratio of 1.2.** The hydraulic capacities of the culverts were determined using the UD-Culvert analysis and design program developed by the University of Colorado at Denver. All road culverts are to be

reinforced concrete or HDPE with flared end sections. The outlets of all culverts will be protected with riprap and sized to meet the outlet velocity condition at each culvert.

V. Existing Drainage Patterns

Presented on Figures 5 and 6 are the existing sub-basin boundaries, data relevant to these basins, and the existing drainage facilities adjacent to and within the Fountain Valley School campus. Figure 4 shows the full extent of the sub-basins.

The site generally drains from the north to the south through a combination of sheet flow, gutter flow, storm sewer, culverts and drainage swales/channels. A system of irrigation ditches runs through the site but is assumed to be running full for purposes of this report. Runoff generated from the Fountain Valley School campus ultimately discharges into Crews Gulch and Carp Lake south of the school property. From Carp Lake, runoff drains to the south under Fontaine Boulevard to Widefield Park, to the southwest in Crews Gulch, and ultimately to Fountain Creek.

Even though the onsite irrigation laterals are assumed to be flowing full, they are only used infrequently during the irrigation season. Some of the site's storm runoff drains to and is conveyed by the ditches. This routing, through relatively flat ditches, slows the runoff and allows sediment to drop out of the storm runoff. Thus, water quality is indirectly provided by the irrigation ditches. This longer and slower route also increases the time of concentration which results in lower peak flows reaching Carp Lake.

The 'A' sub-basins are located at the southwest portion of the campus area. These sub-basins are primarily undeveloped. Runoff generated from these basins drain to an existing 24-inch CMP culvert located near the gated entrance to the school. Runoff draining to this culvert discharges under the Fountain Valley School Road to the southeast. Runoff then sheet flows and is directed to channels that convey runoff to the south and east to Carp Lake.

The 'B' sub-basins are located in the western portion of the campus. These sub-basins are currently developed with faculty residences, dormitories, a student center, a dining hall, a library, an administration building, roadways, and parking areas. Several existing curb inlets intercept runoff in the upper (northern) portion of these sub-basins. An existing 24-inch HDPE storm sewer conveys the collected runoff to the south between the administration building and the library. Several other grated inlets collect runoff near the administration building. A storm pipe directs this runoff, and connects, to the 24-inch system. A grated inlet and culvert along the west side of Fountain Valley Ranch Road discharges runoff to the east near the end of the 24-inch system. This culvert frequently conveys collected ground water. Runoff from these storm pipes drain to an existing earthen irrigation ditch to the south. Assuming the ditch is flowing full, runoff from these sub-basins continues to sheet flow and channel flow to the south to Carp Lake.

The 'C' sub-basins are located in the northern and western portion of the campus. These sub-basins are currently developed with faculty residences, a health center, classrooms, dormitories, a gymnasium, a student center, roadways, and parking areas. The upper

(northern) portion of these sub-basins drains to an existing 30-inch RCP storm sewer system. This system discharges to the existing concrete irrigation ditch located along the west side of the tennis courts. Another storm sewer system collects runoff near the gymnasium and conveys it to the south under the earthen irrigation ditch. A system of roof drains from the administration building and from the building to the north combines and is conveyed to the earthen irrigation ditch to the south via a 12-inch PVC. Assuming the irrigation ditches are full, runoff generated from these sub-basins drain to the south/southeast across the tennis courts and around the track via an existing grass swale. Runoff discharges into an existing drainage channel which directs runoff to the south to Carp Lake.

The 'D' sub-basins are located in the east central portion of the campus. These sub-basins include faculty residences, dormitories, tennis courts, and the track. An existing concrete irrigation ditch runs along a portion of the eastern side of these sub-basins. The ditch also runs in a westerly/easterly direction, cutting the 'D' sub-basins in half. Assuming the ditch is full, runoff generated from these sub-basins sheet flow to the south. Grass swales direct runoff to the south to an existing drainage channel that conveys runoff to Carp Lake south of the site.

The 'E' sub-basins are located along the eastern side of the campus area. These sub-basins include an athletic field, equestrian arenas, barns, and stables. Two different earthen irrigation ditches run in a westerly/easterly direction, dividing the 'E' sub-basins into different sections. Assuming the ditches are full, runoff generated from these sub-basins sheet flow to the south to an existing drainage channel south of the athletic field. The channel conveys runoff to the southwest to Carp Lake.

VI. Site Drainage Plan

The proposed drainage patterns and drainage facilities for the site are conceptual in nature and are shown on Figure 7 located in the pocket at the rear of this report. Runoff can be routed numerous ways through the site. A general description of the drainage patterns and the hydraulic structures within the school site follows.

Detention: Per the DBPS, drainage facilities are required onsite with new development to restrict peak discharges from the school site to historic levels. The hydrologic calculations indicate that proposed runoff slightly increases from existing conditions by only 5.4% for the areas draining to Carp Lake (DP 12) on Figure 5 for the 100-year storm event. Approximately 142.1 cfs and 343.0 cfs currently drain to Carp Lake (DP-12) for the 5-year and 100-year events, respectively. With the proposed development at Fountain Valley School, approximately 152.7 cfs and 361.4 cfs will drain to Carp Lake (DP-12) for the 5-year and 100-year storm events, respectively.

Compared to the 2000 Drainage Letter prepared by URS and listed as Reference 1 under Section II of this report, calculated runoff figures draining to Carp Lake are similar. The previous report calculated flows draining to Carp Lake using the Rational Method and only one basin. This basin contained 204 acres compared to multiple smaller basins

totaling approximately 263 acres in this report. Typically, basins are no larger than 100 acres when using the Rational Method. Existing runoff per the previous report was estimated at $Q_5=110$ cfs and $Q_{100}=256$ cfs with proposed runoff draining to Carp Lake estimated at $Q_5=113$ cfs and $Q_{100}=260$ cfs. On a per acre basis, these existing flows equate to $Q_5=0.54$ cfs/acre and $Q_{100}=1.25$ cfs/acres and these proposed flows equate to $Q_5=0.55$ cfs/acre and $Q_{100}=1.27$ cfs/acre. Compared to flows on a per acre basis calculated in this report, flows are similar and fall within 7% of each other. Since hydrologic calculations are subjective, these slight differences are reasonable. Flows draining to Carp Lake at DP-12 in this report equate to $Q_5=0.54$ cfs/acre and $Q_{100}=1.30$ cfs/acres for the existing condition and $Q_5=0.58$ cfs/acre and $Q_{100}=1.37$ cfs/acres for the proposed condition.

Although the hydrologic calculations in this report show a slight increase in runoff, the physical features of the Fountain Valley School site actually provide incidental detention prior to reaching Carp Lake. However, modeling this is difficult and not feasible. Since incidental detention is provided on the site, formal detention facilities are not necessary with the proposed development at Fountain Valley School to maintain runoff at historic peak rates. The majority of the runoff draining to design point 12 will drain to the existing earthen irrigation ditch east of the proposed roundabout. The ditch will slow down the runoff and increase the conveyance time to reach Carp Lake. If the irrigation ditch overflows, runoff from the ditch will be widely spread and sheet flow slowly from the ditch to the southeast to Carp Lake. This increase in time will decrease the peak rate. In addition to an increase in the travel time, the hay fields and wetland areas south of the school site act as a natural detention area. **The small increase in impervious area and increase in runoff can be handled within this relatively flat and highly vegetated area. This area also acts as a natural water quality facility whereby sediment drops out as runoff meanders slowly prior to reaching Carp Lake.**

Channels: **Several proposed roadside ditches are proposed to route runoff alongside the uphill side of several of the new roadways.** These ditches will help prevent runoff from travelling across those roadways. Another proposed channel includes a riprap-lined channel that runs along the southern side of the tennis courts and western side of the existing athletic field. This channel will provide an overflow for the existing concrete channel that will reroute runoff to the east around the new gymnasium.

Road Crossings: **With the improvements to Fountain Valley School, several culverts are proposed to convey stormwater under roadways.** A 24-inch culvert is proposed to convey runoff from Sub-basin A-2 under the proposed roundabout to the existing 24-inch culvert near the gated entrance. A 42-inch culvert is proposed to convey runoff in the existing earthen irrigation ditch under the new roadway east of the roundabout. A 15-inch culvert is proposed west of the new parking lot south of the track. A 36-inch culvert is proposed under the new parking lot access driveway east of the future gymnasium. A 24-inch culvert is proposed under the driveway providing access to the new parking lot south of the track. This culvert will convey runoff collected in the existing drainage channel to the southeast.

Storm Sewer Facilities: With the proposed improvements at Fountain Valley School, the existing 24-inch storm sewer system will need to be extended to route runoff past the new buildings and parking areas. The existing 24-inch storm sewer system will be extended to the southwest as a 30-inch and 36-inch storm sewer through the new parking lot adjacent to the new multi-purpose arena. The existing 12-inch PVC system along the east side of the administration building will connect to this storm sewer system. This system will also be extended to the northeast as a 24-inch storm pipe to collect runoff in the new cul-de-sac between the administration building and gymnasium. This 24-inch pipe will also convey runoff from the existing earthen irrigation ditch. Once the new gym is constructed, the 24-inch storm will be extended to the northeast connect to the existing concrete irrigation ditch. Irrigation water will continue to drain through this storm sewer system. Any overflow will be split and directed to the east from the end of the concrete ditch along the south side of the tennis courts.

The existing 30-inch RCP storm system will continue to drain to the existing concrete irrigation ditch. With the development of the new gymnasium, runoff in the concrete ditch will be rerouted to the east in a riprap-lined channel with an option to alternatively direct runoff in a 42-inch storm sewer. The storm system would run in an easterly direction alongside the tennis courts and then in a southerly direction alongside the athletic field prior to discharging into an existing drainage channel. The outlet would be protected with riprap. Inlets could be installed in the proposed parking lots east of the tennis courts and Athletic Complex and connect to the 42-inch storm system.

VII. Water Quality Facilities

As required by El Paso County in Volume 2 of the *City/County Drainage Criteria Manual*, water quality measures need to be introduced in new developments in order to reduce the detrimental effects of urbanized impervious areas upon stormwater runoff. Water quality best management practices (BMPs) will need to be implemented within the areas of new development in order to mitigate erosion. Water quality facilities will not be required for existing development.

Future projects at the school should be evaluated on a case-by-case basis to determine if water quality is necessary for that project. If it is established that an assessment is needed for a certain project, runoff discharging at the southern property boundary will be examined to determine the need for water quality facilities.

Due to the fact that runoff from the Fountain Valley School site drains to the heavily vegetated hay fields and wetland areas to the south, specific water quality features should not be required with future development. These areas to the south provide natural water quality features for the site prior to runoff reaching Carp Lake.

The low impact development techniques listed below could be considered for minimizing or eliminating the need for specific water quality features in conjunction with future development at Fountain Valley School.

1. Roof leaders from proposed buildings and expansions of buildings will be directed to the landscaped areas adjacent to the buildings and away from driveways, streets and sidewalks. This will allow for percolation of most storm events that normally would be discharged into the private street section and eventually into downstream storm water systems. This effectively reduces the percent impervious value for the site and lowers the total volume of runoff.
2. In the landscaped areas between the buildings and parking areas, grass-lined swales can be constructed to carry runoff to a storm sewer system, culvert, or drainage channel. The swales will be designed with a pervious invert.
3. Depending upon the layout and frequency of use of the proposed parking areas, pervious pavement systems may be feasible.
4. The practice of minimizing directly connected impervious areas (MDCIA) can be implemented to reduce the amount of impervious areas, slow down runoff, and promote filtration. MDCIA reduces peaks flows and reduces the need for specific water quality features. Reduction in paved areas and the use of porous pavement, grass buffers, and grass swales can be employed with this approach.

VIII. Irrigation Ditches / Drainage Channels

With the proposed future development at Fountain Valley School, some of the existing irrigation ditches and drainage channels will be affected to the south and east.

The irrigation ditch that runs along the south side of the gymnasium and administration building is presently used for irrigation purposes and will need to be rerouted with the current layout of the proposed facilities. The expansion of the gymnasium, the new parking lot for the multi-purpose arena, and the new roadway providing access to these buildings will be constructed where the irrigation ditch is now situated. With the construction of the multi-purpose arena and the adjacent parking area, runoff from the existing earthen irrigation ditch can be collected in an inlet and piped through this area. Downstream of this area, the pipe can discharge back into the earthen ditch. With the construction of the new gymnasium, the pipe can be extended to the north and connected to the existing concrete irrigation ditch.

A portion of the existing drainage channel that runs in a southwesterly direction east of the existing athletic field may need to be relocated or piped, depending on the location of the future athletic field. With the present plan, a portion of the channel runs through the southeastern portion of the field. This existing channel is the main channel draining from Big Johnson Reservoir.

IX. Wetland Areas

The majority of wetland areas on the Fountain Valley School property reside in the vicinity of Carp Lake and the drainage channel (Crews Gulch) conveying runoff from Big Johnson Reservoir to Carp Lake. Per the *Drainage Letter and Erosion Control Plan for*

Fountain Valley School Dormitory Expansion, the U.S. Corps of Engineers determined that no waters of the U.S. were affected by the proposed development and a 404 permit was not required. No wetland areas are anticipated to be affected by the proposed future development of the school. However, the property owner should be aware of possible impacts with future development. Because wetland areas can change over time, it is possible that portions of future development may lie within jurisdictional wetland or jurisdictional waters of the U.S. Any required environmental studies and permits related to the impact upon any potential wetland areas around these future facilities will be prepared and submitted to the U.S. Army Corps of Engineers as part of obtaining a 404 permit.

X. Flood Plain Statement

According to the Federal Emergency Management Agency (FEMA), the Fountain Valley School property does lie within a designated floodplain. The Floodplain Insurance Rate Map (FIRM) for El Paso County panel 08041C0952 F, dated March 17, 1997 was reviewed to determine any potential floodplain delineation. The southeastern corner of the existing athletic field and a majority of the proposed athletic field to the east both lay within a Zone AE 100-year floodplain as delineated in the Flood Insurance Study. Zone AE indicates that base flood elevations have been determined as shown on the floodplain map. Along the western edge of the Zone AE area, a small sliver of these fields lay within a Zone X 500-year floodplain. If development is planned within a designated floodplain at Fountain Valley School, a Floodplain Development Permit may be required through the Pikes Peak Regional Floodplain Management Office prior to any construction or modification within that floodplain. A copy of the relevant portion of the FIRM panel is shown on Figure 3.

XI. Drainage and Bridge Fees

Fountain Valley School lies within the Big Johnson / Crews Gulch Drainage Basin. The DBPS assumed that no new development would occur within the school property. See the discussion on Page 73 of the DBPS. As such, the school area was removed from the area subject to fee assessment. The drainage and bridge fees for the Big Johnson / Crews Gulch Drainage Basin were established based upon the exclusion of the Fountain Valley School property. Therefore, no drainage or bridge fees are due with the proposed development at Fountain Valley School. See page 82 in the DBPS for the basin fee determination.

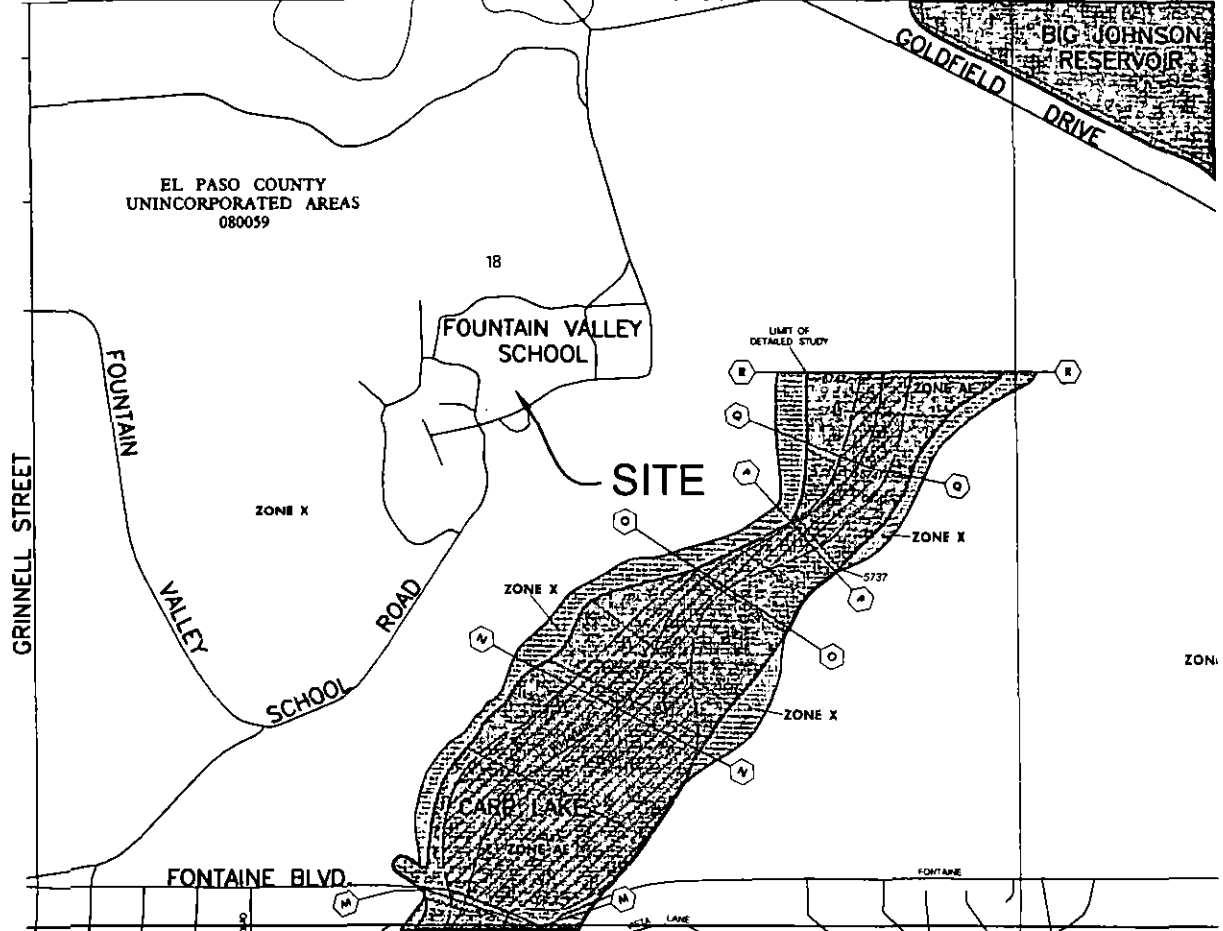

NATIONAL FLOOD INSURANCE PROGRAM

FIRM
FLOOD INSURANCE RATE MAP

EL PASO COUNTY,
COLORADO AND
INCORPORATED AREAS

PANEL 952 OF 1300
SEE MAP INDEX FOR PANELS NOT PRINTED

COUNTY	PANEL	DATE
EL PASO COUNTY	952	3/17/97
INCORPORATED AREAS	952	3/17/97

MAP NUMBER
08041C0952 F

EFFECTIVE DATE:
MARCH 17, 1997

Federal Emergency Management Agency



SCALE: N.T.S.

FIGURE 3
FLOOD INSURANCE RATE MAP
FOUNTAIN VALLEY SCHOOL

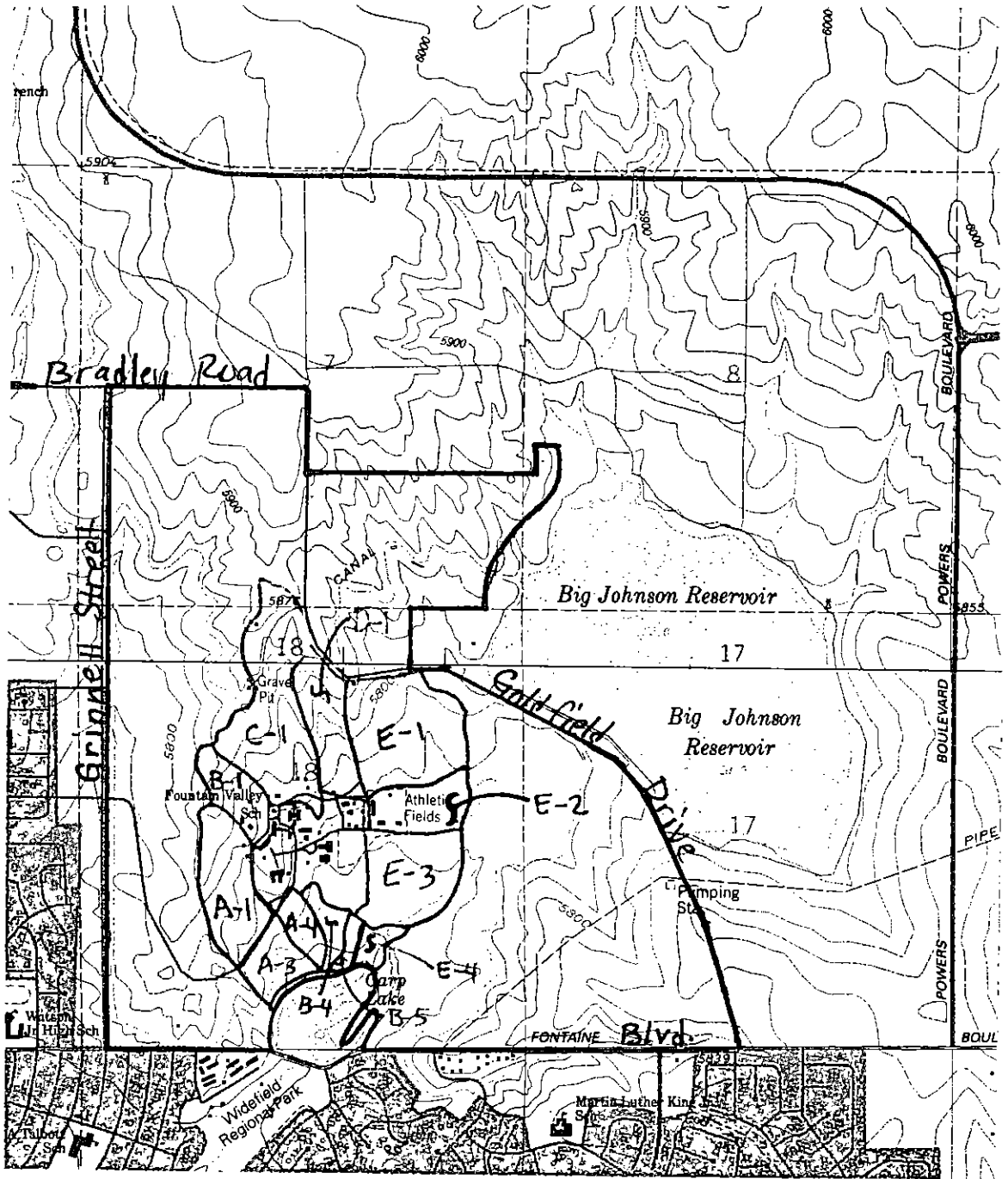

SCALE: 1"=2000'

FIGURE 4
DRAINAGE BASIN BOUNDARY MAP
 USGS 7.5' MAP (ELSEMERE & FOUNTAIN)
 FOUNTAIN VALLEY SCHOOL

Appendix A
Hydrologic Calculations
Runoff Coefficient Calculations
Time of Concentration
Runoff Calculations

TABLE 5-1

RECOMMENDED AVERAGE RUNOFF COEFFICIENTS AND PERCENT IMPERVIOUS

LAND USE OR SURFACE CHARACTERISTICS	PERCENT IMPERVIOUS	"C" FREQUENCY			
		10		100	
		A&B*	C&D*	A&B*	C&D*
Business					
Commercial Areas	95	0.90	0.90	0.90	0.90
Neighborhood Areas	70	0.75	0.75	0.80	0.80
Residential					
1/8 Acre or less	65	0.60	0.70	0.70	0.80
1/4 Acre	40	0.50	0.60	0.60	0.70
1/3 Acre	30	0.40	0.50	0.55	0.60
1/2 Acre	25	0.35	0.45	0.45	0.55
1 Acre	20	0.30	0.40	0.40	0.50
Industrial					
Light Areas	80	0.70	0.70	0.80	0.80
Heavy Areas	90	0.80	0.80	0.90	0.90
Parks and Cemeteries	7	0.30	0.35	0.55	0.60
Playgrounds	13	0.30	0.35	0.60	0.65
Railroad Yard Areas	40	0.50	0.55	0.60	0.65
Undeveloped Areas					
Historic Flow Analysis- Greenbelts, Agricultural	2	0.15	0.25	0.20	0.30
Pasture/Meadow	0	0.25	0.30	0.35	0.45
Forest	0	0.10	0.15	0.15	0.20
Exposed Rock	100	0.90	0.90	0.95	0.95
Offsite Flow Analysis (when land use not defined)	45	0.55	0.60	0.65	0.70
Streets					
Paved	100	0.90	0.90	0.95	0.95
Gravel	80	0.80	0.80	0.85	0.85
Drive and Walks	100	0.90	0.90	0.95	0.95
Roofs	90	0.90	0.90	0.95	0.95
Lawns	0	0.25	0.30	0.35	0.45

* Hydrologic Soil Group

9/30/90

**Fountain Valley School
Existing Condition
Runoff Coefficient Calculation**

Basin	Area 1			Area 2			Basin C ₅	Basin C ₁₀₀	Basin
	% Area	C ₅	C ₁₀₀	% Area	C ₅	C ₁₀₀			
A-1	3 %	0.90	0.95	97 %	0.25	0.35	0.27	0.37	A-1
A-2	8 %	0.90	0.95	92 %	0.25	0.35	0.30	0.40	A-2
A-3	1 %	0.90	0.95	99 %	0.25	0.35	0.26	0.36	A-3
A-4	1 %	0.90	0.95	99 %	0.25	0.35	0.26	0.36	A-4
B-1	12 %	0.90	0.95	88 %	0.25	0.35	0.33	0.42	B-1
B-2	36 %	0.90	0.95	64 %	0.25	0.35	0.49	0.57	B-2
B-3	5 %	0.90	0.95	95 %	0.25	0.35	0.29	0.38	B-3
B-4	0 %	0.90	0.95	100 %	0.25	0.35	0.25	0.35	B-4
B-5	0 %	0.90	0.95	100 %	0.25	0.35	0.25	0.35	B-5
C-1	2 %	0.90	0.95	98 %	0.25	0.35	0.26	0.36	C-1
C-2	39 %	0.90	0.95	61 %	0.25	0.35	0.51	0.59	C-2
C-3	21 %	0.90	0.95	79 %	0.25	0.35	0.39	0.47	C-3
D-1	6 %	0.90	0.95	94 %	0.25	0.35	0.29	0.39	D-1
D-2	34 %	0.90	0.95	66 %	0.25	0.35	0.47	0.55	D-2
D-3	30 %	0.90	0.95	70 %	0.25	0.35	0.45	0.53	D-3
D-4	14 %	0.90	0.95	86 %	0.25	0.35	0.34	0.43	D-4
E-1	1 %	0.90	0.95	99 %	0.25	0.35	0.26	0.36	E-1
E-2	4 %	0.90	0.95	96 %	0.25	0.35	0.28	0.37	E-2
E-3	0 %	0.90	0.95	100 %	0.30	0.45	0.30	0.45	E-3
E-4	0 %	0.90	0.95	100 %	0.30	0.45	0.30	0.45	E-4

Design Point	Basin	Area	% Area	C ₅	C ₁₀₀	C ₅	C ₁₀₀
DP 1	A-1	25.48 ac	86.68 %	0.27	0.37	0.23	0.32
	A-2	3.91 ac	13.32 %	0.30	0.40	0.04	0.05
		29.40 ac	100.0 %			0.27	0.37

Design Point	Basin	Area	% Area	C ₅	C ₁₀₀	C ₅	C ₁₀₀
DP 2	DP 1	29.40 ac	56.32 %	0.27	0.37	0.15	0.21
	A-3	15.15 ac	29.03 %	0.26	0.36	0.08	0.10
	A-4	7.65 ac	14.66 %	0.26	0.36	0.04	0.05
		52.20 ac	100.0 %			0.27	0.36

Design Point	Basin	Area	% Area	C ₅	C ₁₀₀	C ₅	C ₁₀₀
DP 3	B-1	14.79 ac	75.57 %	0.33	0.42	0.25	0.32
	B-2	2.67 ac	13.66 %	0.49	0.57	0.07	0.08
	B-3	2.11 ac	10.77 %	0.29	0.38	0.03	0.04
		19.57 ac	100.0 %			0.35	0.44

Design Point	Basin	Area	% Area	C ₅	C ₁₀₀	C ₅	C ₁₀₀
DP 4	DP 3	19.57 ac	66.32 %	0.35	0.44	0.23	0.29
	B-4	6.07 ac	20.57 %	0.25	0.35	0.05	0.07
	B-5	3.87 ac	13.10 %	0.25	0.35	0.03	0.05
		29.50 ac	100.0 %			0.31	0.41

Design Point	Basin	Area	% Area	C ₅	C ₁₀₀	C ₅	C ₁₀₀
DP 5	C-1	45.99 ac	90.02 %	0.26	0.36	0.24	0.33
	C-2	5.10 ac	9.98 %	0.51	0.59	0.05	0.06
		51.09 ac	100.0 %			0.29	0.38

**Fountain Valley School
Existing Condition
Runoff Coefficient Calculation**

Design Point	Basin	Area	% Area	C ₅	C ₁₀₀	C ₅	C ₁₀₀
DP 6	D-1	20.59 ac	82.50 %	0.29	0.39	0.24	0.32
	D-2	4.37 ac	17.50 %	0.47	0.55	0.08	0.10
		<u>24.96 ac</u>	<u>100.0 %</u>			0.32	0.42

Design Point	Basin	Area	% Area	C ₅	C ₁₀₀	C ₅	C ₁₀₀
DP 7	DP-5	51.09 ac	58.24 %	0.29	0.38	0.17	0.22
	DP-6	24.96 ac	28.45 %	0.32	0.42	0.09	0.12
	C-3	4.75 ac	5.42 %	0.39	0.47	0.02	0.03
	D-3	6.92 ac	7.89 %	0.45	0.53	0.04	0.04
		<u>87.71 ac</u>	<u>100.0 %</u>			0.31	0.41

Design Point	Basin	Area	% Area	C ₅	C ₁₀₀	C ₅	C ₁₀₀
DP 8	DP 7	87.71 ac	96.33 %	0.31	0.41	0.30	0.39
	D-4	3.34 ac	3.67 %	0.34	0.43	0.01	0.02
		<u>91.05 ac</u>	<u>100.0 %</u>			0.32	0.41

Design Point	Basin	Area	% Area	C ₅	C ₁₀₀	C ₅	C ₁₀₀
DP 9	E-1	40.80 ac	71.81 %	0.26	0.36	0.18	0.26
	E-2	16.02 ac	28.19 %	0.28	0.37	0.08	0.11
		<u>56.81 ac</u>	<u>100.0 %</u>			0.26	0.36

Design Point	Basin	Area	% Area	C ₅	C ₁₀₀	C ₅	C ₁₀₀
DP 10	E-1	40.80 ac	48.20 %	0.26	0.36	0.12	0.17
	E-2	16.02 ac	18.92 %	0.28	0.37	0.05	0.07
	E-3	27.82 ac	32.87 %	0.30	0.45	0.10	0.15
		<u>84.63 ac</u>	<u>100.0 %</u>			0.27	0.39

Design Point	Basin	Area	% Area	C ₅	C ₁₀₀	C ₅	C ₁₀₀
DP 11	DP 8	91.05 ac	51.83 %	0.32	0.41	0.16	0.21
	DP 10	84.63 ac	48.17 %	0.27	0.39	0.13	0.19
		<u>175.68 ac</u>	<u>100.0 %</u>			0.30	0.40

Design Point	Basin	Area	% Area	C ₅	C ₁₀₀	C ₅	C ₁₀₀
DP 12	DP 11	175.68 ac	66.83 %	0.30	0.40	0.20	0.27
	DP 2	52.20 ac	19.86 %	0.27	0.36	0.05	0.07
	DP 4	29.50 ac	11.22 %	0.31	0.41	0.04	0.05
	E-4	5.48 ac	2.08 %	0.30	0.45	0.01	0.01
		<u>262.86 ac</u>	<u>100.0 %</u>			0.29	0.40

Basin A-1

overland 585' from elev 5842 to 5803 \Rightarrow 6.7%

channel 1020' from 5803 to 5750 \Rightarrow 5.2%

assume grass v-ditch w/ 15:1 side slopes

$\Rightarrow v = 4.5$ fps

Basin A-3

overland 350' from 5752' to 5732' \Rightarrow 5.7%

channel 630' from 5732' to 5714' \Rightarrow 2.9%

assume grass v-ditch w/ 40:1 side slopes

$\Rightarrow v = 3.3$ fps

Basin A-2

overland 140' from 5801' to 5794' \Rightarrow 5%

channel 770' from 5794' to 5752' \Rightarrow 5.5%

assume grass v-ditch w/ 15:1 side slopes

$\Rightarrow v = 3.2$ fps

Basin A-4 overland 400' from 5760' to 5730' \Rightarrow 7.5%

channel 800' from 5730' to 5716' \Rightarrow 1.8%

assume grass v-ditch w/ 40:1 side slopes

$\Rightarrow v = 3.1$ fps

Basin B-1 overland 325' from 5848' to 5822 \Rightarrow 8%

channel 510' from 5822 to 5793 \Rightarrow 5.7%

grass v-ditch w/ 30:1 side slopes

$\Rightarrow v = 4.0$ fps

O&G flow 335' from 5793 to 5784 \Rightarrow 2%

$\Rightarrow v = 2.7$ fps

storm 385' @ 5% $\Rightarrow v = 15$ fps

\downarrow 24" HDPE

Basin B-2 Overland 240' from 5795' to 5776' \Rightarrow 7.9%
channel 285' from 5776 to 5757' \Rightarrow 6.7%
grass v-ditch 15:1 side slopes
 $\Rightarrow v = 3.0$ fps

Basin B-3 overland 200' from 5764' to 5751' \Rightarrow 6.5%
pipe flow 280' @ 1.0% $\Rightarrow v = 8$ fps
channel 80' from 5748' to 5742' \Rightarrow 7.5% $\Rightarrow v = 4.3$ fps

Basin B-4 overland 240' from 5741 to 5732' \Rightarrow 3.8%
channel 1000' from 5732 to 5714' \Rightarrow 1.8%
grass $v = 2.0$ fps

Basin B-5 overland 200' from 5728 to 5724' \Rightarrow 1.5%
channel 770' from 5724 to 5714' \Rightarrow 1.3%
grass $\Rightarrow v = 1.7$ fps

Basin C-1 overland 560' from 5890 to 5860' \Rightarrow 5.4%
channel 2680' from 5860 to 5763' \Rightarrow 3.6%
grass v-ditch w/ 20:1 side slopes
 $\Rightarrow v = 4.1$ fps

Basin C-2 overland 110' from 5778 to 5772' \Rightarrow 5.5%
grass channel 700' from 5772 to 5748' \Rightarrow 3.4%
 $\Rightarrow v = 3.3$ fps

Basin C-3 overland 240' from 5798 to 5780' \Rightarrow 7.5%
grass channel 700' from 5780 to 5744' \Rightarrow 5.1%
 $\Rightarrow v = 3.3$ fps

Basin D-1 overland 700' from 5862 to 5820' \Rightarrow 0%
grass channel 1380' from 5820 to 5758' \Rightarrow 4.5%
v-ditch w/ 20:1 side slopes
 $\Rightarrow v = 3.8$ fps

Basin D-2 Overland 225' from 5784 to 5766 \Rightarrow 8%
grass channel 375' from 5766 to 5750 \Rightarrow 4.3%
 $\Rightarrow v = 3.2$ fps

Basin D-3 Overland 300' from 5748 to 5712 \Rightarrow 2%
grass channel 420' from 5742 to 5732 \Rightarrow 2.4%
 $\Rightarrow v = 2.3$ fps

Basin D-4 Overland 175' from 5742 to 5736 \Rightarrow 3.4%
grass channel 625' from 5743 to 5724 \Rightarrow 6.2%
v-ditch w/ 15:1 side slopes $\Rightarrow v = 6$ fps

Basin E-1 Overland 635' from 5840 to 5788 \Rightarrow 8.2%
grass channel 990' from 5788 to 5698 \Rightarrow 9%
 $\Rightarrow v = 4.5$ fps

Basin E-2 Overland 265' from 5758 to 5752 \Rightarrow 2.3%
grass channel 325' from 5752 to 5746 \Rightarrow 1.8%
 $\Rightarrow v = 2$ fps

Basin E-3 Overland 1000' from 5748 to 5728 \Rightarrow 2%
grass channel 250' from 5728 to 5718 \Rightarrow 4%
v-ditch w/ 15:1 side slopes $\Rightarrow v = 5.5$ fps

Basin E-4 Overland 300' from 5736 to 5718 \Rightarrow 4%
grass channel 800' from 5718 to 5714 \Rightarrow 0.5%
20' bottom 3:1 side slopes $\Rightarrow v = 4$ fps

Basin F-1 Overland 1000' from 5966 to 5954 \Rightarrow 1.2%
grass channel 4030' from 5954 to 5794 \Rightarrow 4.0%
v-ditch w/ 10:1 side slopes
 $\Rightarrow v = 6$ fps

Basin F-2 overland 850' from 5840 to 5800 \Rightarrow 7%
grass channel 255' from 5800 to 5750 \Rightarrow 2%
v-ditch w/ 15:1 side slopes \Rightarrow v = 4 fps

Basin F-3 overland 1000' from 5880 to 5800 \Rightarrow 8%
grass channel 2520' from 5800 to 5750 \Rightarrow 2%
v-ditch w/ 15:1 side slopes \Rightarrow v = 4 fps

Basin F-4 overland 620' from 5802 to 5758 \Rightarrow 7%
grass channel 730' from 5758 to 5746 \Rightarrow 1.6%
v-ditch w/ 15:1 side slopes \Rightarrow v = 2 fps

Basin F-5 overland 700' from 5840 to 5800 \Rightarrow 5.7%
grass channel 1260' from 5800 to 5737 \Rightarrow 5%
v-ditch w/ 20:1 side slopes \Rightarrow v = 4.4 fps

DP-1 $T_c = T_c \text{ for Basin A-1} = 23.8 \text{ min}$

DP-2 $T_c = T_c \text{ for DP-1 plus } 1025' \text{ grass channel flow } \Rightarrow v = 3.3 \text{ fps (per Basin A-3)}$
 $T_c = 23.8 + \frac{1025}{3.3(60)} = 29.0 \text{ min}$

DP-3 $T_c = T_c \text{ for Basin B-1 plus } 600' \text{ pipe flow @ } 2.5\% \Rightarrow v = 12 \text{ fps plus channel flow for Basin B-1}$
 $T_c = 17.6 \text{ min} + \frac{600}{12(60)} = 18.4 \text{ min}$

DP-4 $T_c = T_c \text{ for DP-3 plus } 1310' \text{ grass channel } \Rightarrow v = 2 \text{ fps (per Basin B-4)}$
 $T_c = 18.4 + \frac{1310}{60(2)} = 29.3 \text{ min}$

DP-5 $T_c = T_c \text{ for Basin C-1 plus } 300' \text{ pipe flow } 30" \text{ RCP @ } 5.0\% \Rightarrow v = 17 \text{ fps}$
 $T_c = 32.0 \text{ min} + \frac{300}{60(17)} = 32.3 \text{ min}$

DP-6 $T_c = T_c \text{ for Basin D-1 plus } 370' \text{ channel flow @ } 2.2\% \Rightarrow v = 2.3 \text{ fps}$
 $T_c = 28.1 + \frac{370}{60(2.3)} = 30.8 \text{ min}$

DP-7 $T_c = T_c \text{ for DP-5 plus grass channel } 580' \text{ @ } 2\% \Rightarrow v = 2.1 \text{ fps}$
 $T_c = 32.3 + \frac{580}{60(2.1)} = 36.9 \text{ min}$

DP-8 $T_c = T_c$ for DP 7 plus grass swale
300' @ 1.9% $\Rightarrow v = 2.1$ fps
 $T_c = 36.9 + \frac{310}{60(2.1)} = 39.4$ min.

DP-9 $T_c = T_c$ for Basin E-1 plus 530' grass
Channel @ 1.9% $\Rightarrow v = 2.1$ fps
 $T_c = 23.4 + \frac{530}{60(2.1)} = 27.6$ min.

DP-10 $T_c = T_c$ for DP 9 plus:
1) grass swale 950' @ 1.7% $\Rightarrow v = 2$ fps
2) grass channel 480', $v =$ same as Basin E-4
 $T_c = 27.6 + \frac{950}{60(2)} + \frac{480}{60(4)} = 37.5$ min.

DP-11 $T_c =$ DP 8 plus 930' channel
 $\Rightarrow v = 4$ fps (per Basin E-4)
 $T_c = 39.4 + \frac{930}{60(4)} = 43.3$ min.

DP-12 $T_c = T_c$ for DP 11
 $T_c = 43.3$ min.

Fountain Valley School
Existing Time of Concentration Calculation

Basin	Slope				Length				Run Coef. (5-year)	Velocity				T _c				Basin	
	O'land 1	Chan. 1	C&G	Pipe	O'land 1	Chan. 1	C&G	Pipe		O'land 1	Chan. 1	C&G	Pipe	O'land 1	Chan. 1	C&G	Pipe		T _c
A-1	6.7 %	5.2 %			585 lf	1,020 lf			0.27	0.5 ft/sec	4.5 ft/sec			20.0 min.	3.8 min.			23.8 min.	A-1
A-2	5.0 %	5.5 %			140 lf	770 lf			0.30	0.2 ft/sec	3.2 ft/sec			10.3 min.	4.0 min.			14.3 min.	A-2
A-3	5.7 %	2.9 %			350 lf	630 lf			0.26	0.4 ft/sec	3.3 ft/sec			16.5 min.	3.2 min.			19.7 min.	A-3
A-4	7.5 %	1.8 %			400 lf	800 lf			0.26	0.4 ft/sec	3.1 ft/sec			16.1 min.	4.3 min.			20.4 min.	A-4
B-1	8.0 %	5.7 %	2.0 %	5.0 %	325 lf	510 lf	335 lf	385 lf	0.33	0.4 ft/sec	4.0 ft/sec	2.7 ft/sec	15.0 ft/sec	13.0 min.	2.1 min.	2.1 min.	0.4 min.	17.6 min.	B-1
B-2	7.9 %	6.7 %			240 lf	285 lf			0.49	0.4 ft/sec	3.6 ft/sec			8.9 min.	1.3 min.			10.2 min.	B-2
B-3	6.5 %	7.5 %		1.0 %	200 lf	80 lf		280 lf	0.29	0.3 ft/sec	4.3 ft/sec		8.0 ft/sec	11.6 min.	0.3 min.		0.6 min.	12.4 min.	B-3
B-4	3.8 %	1.8 %			240 lf	1,000 lf			0.25	0.3 ft/sec	2.0 ft/sec			15.8 min.	8.3 min.			24.1 min.	B-4
B-5	1.5 %	1.3 %			260 lf	770 lf			0.25	0.2 ft/sec	1.7 ft/sec			22.4 min.	7.5 min.			29.9 min.	B-5
C-1	5.4 %	3.6 %			560 lf	2,680 lf			0.26	0.4 ft/sec	4.1 ft/sec			21.1 min.	10.9 min.			32.0 min.	C-1
C-2	5.5 %	3.4 %			110 lf	700 lf			0.51	0.3 ft/sec	3.3 ft/sec			6.6 min.	3.5 min.			10.1 min.	C-2
C-3	7.5 %	5.1 %			240 lf	700 lf			0.39	0.4 ft/sec	3.3 ft/sec			10.6 min.	3.5 min.			14.1 min.	C-3
D-1	6.0 %	4.5 %			700 lf	1,380 lf			0.29	0.5 ft/sec	3.8 ft/sec			22.0 min.	6.1 min.			28.1 min.	D-1
D-2	8.0 %	4.3 %			225 lf	375 lf			0.47	0.4 ft/sec	3.2 ft/sec			8.9 min.	2.0 min.			10.8 min.	D-2
D-3	2.0 %	2.4 %			300 lf	420 lf			0.45	0.3 ft/sec	2.3 ft/sec			16.8 min.	3.0 min.			19.8 min.	D-3
D-4	3.4 %	6.2 %			175 lf	625 lf			0.34	0.2 ft/sec	6.0 ft/sec			12.5 min.	1.7 min.			14.3 min.	D-4
E-1	8.2 %	9.0 %			635 lf	990 lf			0.26	0.5 ft/sec	4.5 ft/sec			19.7 min.	3.7 min.			23.4 min.	E-1
E-2	2.3 %	1.8 %			265 lf	325 lf			0.28	0.2 ft/sec	2.0 ft/sec			19.0 min.	2.7 min.			21.7 min.	E-2
E-3	2.0 %	4.0 %			1,000 lf	250 lf			0.30	0.4 ft/sec	5.5 ft/sec			37.6 min.	0.8 min.			38.3 min.	E-3
E-4	4.0 %	0.5 %			300 lf	800 lf			0.30	0.3 ft/sec	4.0 ft/sec			16.3 min.	3.3 min.			19.7 min.	E-4
DP-1									0.27									23.8 min.	DP-1
DP-2									0.27									29.0 min.	DP-2
DP-3									0.35									18.4 min.	DP-3
DP-4									0.31									29.3 min.	DP-4
DP-5									0.29									32.3 min.	DP-5
DP-6									0.32									30.8 min.	DP-6
DP-7									0.31									36.9 min.	DP-7
DP-8									0.32									39.4 min.	DP-8
DP-9									0.26									27.6 min.	DP-9
DP-10									0.27									37.5 min.	DP-10
DP-11									0.30									43.3 min.	DP-11
DP-12									0.29									43.3 min.	DP-12

Equations:

Time of Concentration (Overland) = $1.87(1.1 - C_s)L^{0.5} S^{-0.333}$

C_s = Runoff coefficient for five-year flow

L = Length of overland flow in feet

S = Slope of flow path in percent

Velocity (Road) = $10(10^{10 \log S + 0.3})$

S = Slope of flow path in percent

Velocity (Channel) = $(1.49/n)R_n^{2/3} S^{1/2}$

Slope (S) = Slope of the channel

n = Manning's number

R_n = Hydraulic Radius (Reynold's Number)

*Without Detention

**Fountain Valley School
Existing Runoff Calculation**

Basin / Design Point	Contributing Basins	Area	Area	C ₅	C ₁₀₀	Time of Concentration	Rainfall Intensity		Runoff		Basin / Design Point
							i ₅	i ₁₀₀	Q ₅	Q ₁₀₀	
A-1		1,110,000 sf	25.48 ac	0.27	0.37	23.8 min.	2.7 in/hr	4.7 in/hr	18.0 cfs	43.9 cfs	A-1
A-2		170,507 sf	3.91 ac	0.30	0.40	14.3 min.	3.4 in/hr	6.1 in/hr	4.1 cfs	9.5 cfs	A-2
A-3		659,993 sf	15.15 ac	0.26	0.36	19.7 min.	2.9 in/hr	5.2 in/hr	11.5 cfs	28.3 cfs	A-3
A-4		333,283 sf	7.65 ac	0.26	0.36	20.4 min.	2.9 in/hr	5.1 in/hr	5.6 cfs	13.9 cfs	A-4
B-1		644,098 sf	14.79 ac	0.33	0.42	17.6 min.	3.1 in/hr	5.5 in/hr	15.2 cfs	34.7 cfs	B-1
B-2		116,420 sf	2.67 ac	0.49	0.57	10.2 min.	4.0 in/hr	7.1 in/hr	5.2 cfs	10.7 cfs	B-2
B-3		91,831 sf	2.11 ac	0.29	0.38	12.4 min.	3.7 in/hr	6.5 in/hr	2.2 cfs	5.2 cfs	B-3
B-4		264,371 sf	6.07 ac	0.25	0.35	24.1 min.	2.6 in/hr	4.7 in/hr	4.0 cfs	10.0 cfs	B-4
B-5		168,408 sf	3.87 ac	0.25	0.35	29.9 min.	2.3 in/hr	4.1 in/hr	2.2 cfs	5.6 cfs	B-5
C-1		2,003,235 sf	45.99 ac	0.26	0.36	32.0 min.	2.2 in/hr	4.0 in/hr	26.9 cfs	66.0 cfs	C-1
C-2		222,034 sf	5.10 ac	0.51	0.59	10.1 min.	4.0 in/hr	7.1 in/hr	10.4 cfs	21.2 cfs	C-2
C-3		207,012 sf	4.75 ac	0.39	0.47	14.1 min.	3.5 in/hr	6.1 in/hr	6.4 cfs	13.9 cfs	C-3
D-1		896,901 sf	20.59 ac	0.29	0.39	28.1 min.	2.4 in/hr	4.3 in/hr	14.5 cfs	34.3 cfs	D-1
D-2		190,207 sf	4.37 ac	0.47	0.55	10.8 min.	3.9 in/hr	6.9 in/hr	8.0 cfs	16.6 cfs	D-2
D-3		301,276 sf	6.92 ac	0.45	0.53	19.8 min.	2.9 in/hr	5.2 in/hr	9.0 cfs	19.1 cfs	D-3
D-4		145,512 sf	3.34 ac	0.34	0.43	14.3 min.	3.5 in/hr	6.1 in/hr	3.9 cfs	8.8 cfs	D-4
E-1		1,777,100 sf	40.80 ac	0.26	0.36	23.4 min.	2.7 in/hr	4.8 in/hr	28.1 cfs	69.2 cfs	E-1
E-2		697,645 sf	16.02 ac	0.28	0.37	21.7 min.	2.8 in/hr	5.0 in/hr	12.4 cfs	29.7 cfs	E-2
E-3		1,211,867 sf	27.82 ac	0.30	0.45	38.3 min.	2.0 in/hr	3.6 in/hr	16.7 cfs	44.6 cfs	E-3
E-4		238,609 sf	5.48 ac	0.30	0.45	19.7 min.	2.9 in/hr	5.2 in/hr	4.8 cfs	12.9 cfs	E-4
DP-1	A-1, A-2	1,280,507 sf	29.40 ac	0.27	0.37	23.8 min.	2.7 in/hr	4.7 in/hr	21.2 cfs	51.3 cfs	DP-1
DP-2	All 'A' Basins	2,273,783 sf	52.20 ac	0.27	0.36	29.0 min.	2.4 in/hr	4.2 in/hr	32.8 cfs	80.2 cfs	DP-2
DP-3	B-1, B-2, B-3	852,349 sf	19.57 ac	0.35	0.44	18.4 min.	3.0 in/hr	5.4 in/hr	20.7 cfs	46.5 cfs	DP-3
DP-4	All 'B' Basins	1,285,128 sf	29.50 ac	0.31	0.41	29.3 min.	2.3 in/hr	4.2 in/hr	21.8 cfs	50.6 cfs	DP-4
DP-5	C-1, C-2	2,225,269 sf	51.09 ac	0.29	0.38	32.3 min.	2.2 in/hr	3.9 in/hr	32.5 cfs	77.5 cfs	DP-5
DP-6	D-1, D-2	1,087,108 sf	24.96 ac	0.32	0.42	30.8 min.	2.3 in/hr	4.1 in/hr	18.4 cfs	42.3 cfs	DP-6
DP-7	C-1, C-2, C-3, D-1, D-2, D-3	3,820,665 sf	87.71 ac	0.31	0.41	36.9 min.	2.0 in/hr	3.6 in/hr	56.5 cfs	130.9 cfs	DP-7
DP-8	All 'C' and 'D' Basins	3,966,177 sf	91.05 ac	0.32	0.41	39.4 min.	2.0 in/hr	3.5 in/hr	56.5 cfs	130.8 cfs	DP-8
DP-9	E-1, E-2	2,474,745 sf	56.81 ac	0.26	0.36	27.6 min.	2.4 in/hr	4.3 in/hr	36.3 cfs	89.1 cfs	DP-9
DP-10	E-1, E-2, E3	3,686,612 sf	84.63 ac	0.27	0.39	37.5 min.	2.0 in/hr	3.6 in/hr	47.1 cfs	119.3 cfs	DP-10
DP-11	DP 8, DP10	7,652,789 sf	175.68 ac	0.30	0.40	43.3 min.	1.8 in/hr	3.3 in/hr	96.2 cfs	232.3 cfs	DP-11
DP-12	DP 2, DP 4, DP12, Basin E-4	11,450,309 sf	262.86 ac	0.29	0.40	43.3 min.	1.8 in/hr	3.3 in/hr	142.1 cfs	343.0 cfs	DP-12

Equations:

$$i_c = 54.6 / (T_c^{0.83} + 6.72)$$

$$i_{100} = 75 / ((10 + T_c)^{0.786})$$

i₅ = Average 5-year Rainfall Intensity in inches per hour

i₁₀₀ = Average 100-year Rainfall Intensity in inches per hour

T_c = Time of Concentration

Q = CiA

Q = Peak Runoff Rate, in cubic feet per second (cfs)

C = Runoff coefficient representing a ration of peak runoff rate to average rainfall intensity for a duration equal to the runoff time of concentration.

i = average rainfall intensity in inches per hour

A = Drainage area in acres

**Fountain Valley School
Future Condition
Runoff Coefficient Calculation**

Basin	Area 1			Area 2			Basin C ₅	Basin C ₁₀₀	Basin
	% Area	C ₅	C ₁₀₀	% Area	C ₅	C ₁₀₀			
A-1	4 %	0.90	0.95	96 %	0.25	0.35	0.28	0.37	A-1
A-2	19 %	0.90	0.95	81 %	0.25	0.35	0.38	0.47	A-2
A-3	1 %	0.90	0.95	99 %	0.25	0.35	0.26	0.36	A-3
A-4	3 %	0.90	0.95	97 %	0.25	0.35	0.27	0.37	A-4
A-5	23 %	0.90	0.95	77 %	0.25	0.35	0.40	0.49	A-5
A-6	19 %	0.90	0.95	81 %	0.25	0.35	0.37	0.46	A-6
B-1	14 %	0.90	0.95	86 %	0.25	0.35	0.34	0.43	B-1
B-2	40 %	0.90	0.95	60 %	0.25	0.35	0.51	0.59	B-2
B-3	40 %	0.90	0.95	60 %	0.25	0.35	0.51	0.59	B-3
B-4a	39 %	0.90	0.95	61 %	0.25	0.35	0.51	0.59	B-4a
B-4b	0 %	0.90	0.95	100 %	0.25	0.35	0.25	0.35	B-4b
B-5	0 %	0.90	0.95	100 %	0.25	0.35	0.25	0.35	B-5
C-1	5 %	0.90	0.95	95 %	0.25	0.35	0.28	0.38	C-1
C-2	47 %	0.90	0.95	53 %	0.25	0.35	0.55	0.63	C-2
C-3	29 %	0.90	0.95	71 %	0.25	0.35	0.44	0.53	C-3
D-1	7 %	0.90	0.95	93 %	0.25	0.35	0.29	0.39	D-1
D-2	34 %	0.90	0.95	66 %	0.25	0.35	0.47	0.55	D-2
D-3	53 %	0.90	0.95	47 %	0.25	0.35	0.60	0.67	D-3
D-4	16 %	0.90	0.95	84 %	0.25	0.35	0.35	0.45	D-4
E-1	2 %	0.90	0.95	98 %	0.25	0.35	0.26	0.36	E-1
E-2	4 %	0.90	0.95	96 %	0.25	0.35	0.28	0.38	E-2
E-3	1 %	0.90	0.95	99 %	0.30	0.45	0.30	0.45	E-3
E-4	0 %	0.90	0.95	100 %	0.30	0.45	0.30	0.45	E-4

Design Point	Basin	Area	% Area	C ₅	C ₁₀₀	C ₅	C ₁₀₀
DP 1	A-1	25.46 ac	86.61 %	0.28	0.37	0.24	0.32
	A-2	3.94 ac	13.39 %	0.38	0.47	0.05	0.06
		<u>29.40 ac</u>	<u>100.0 %</u>			0.29	0.39

Design Point	Basin	Area	% Area	C ₅	C ₁₀₀	C ₅	C ₁₀₀
DP 2	DP 1	29.40 ac	38.65 %	0.29	0.39	0.11	0.15
	A-3	15.03 ac	19.76 %	0.26	0.36	0.05	0.07
	A-4	5.07 ac	6.67 %	0.27	0.37	0.02	0.02
	DP-3b	26.57 ac	34.92 %	0.39	0.48	0.14	0.17
	<u>76.07 ac</u>	<u>100.0 %</u>			0.32	0.41	

Design Point	Basin	Area	% Area	C ₅	C ₁₀₀	C ₅	C ₁₀₀
DP 3a	B-1	14.79 ac	59.62 %	0.34	0.43	0.20	0.26
	B-2	2.67 ac	10.78 %	0.51	0.59	0.05	0.06
	B-3	2.30 ac	9.28 %	0.51	0.59	0.05	0.05
	C-3	5.04 ac	20.32 %	0.44	0.53	0.09	0.11
	<u>24.80 ac</u>	<u>100.0 %</u>			0.39	0.48	

Design Point	Basin	Area	% Area	C ₅	C ₁₀₀	C ₅	C ₁₀₀
DP 3b	DP 3a	24.80 ac	93.36 %	0.39	0.48	0.37	0.45
	A-5	1.76 ac	6.64 %	0.40	0.49	0.03	0.03
		<u>26.57 ac</u>	<u>100.0 %</u>			0.39	0.48

Design Point	Basin	Area	% Area	C ₅	C ₁₀₀	C ₅	C ₁₀₀
DP 4a	A-6	1.20 ac	39.78 %	0.37	0.46	0.15	0.18
	B-4a	1.81 ac	60.22 %	0.51	0.59	0.30	0.35
		<u>3.01 ac</u>	<u>100.0 %</u>			0.45	0.54

**Fountain Valley School
Future Condition
Runoff Coefficient Calculation**

Design Point	Basin	Area	% Area	C ₅	C ₁₀₀	C ₅	C ₁₀₀
DP 4b	DP 4a	3.01 ac	47.24 %	0.45	0.54	0.21	0.25
	B-4b	3.36 ac	52.76 %	0.25	0.35	0.13	0.18
		6.37 ac	100.0 %			0.35	0.44

Design Point	Basin	Area	% Area	C ₅	C ₁₀₀	C ₅	C ₁₀₀
DP 5	C-1	45.99 ac	89.89 %	0.28	0.38	0.25	0.34
	C-2	5.17 ac	10.11 %	0.55	0.63	0.06	0.06
		51.16 ac	100.0 %			0.31	0.40

Design Point	Basin	Area	% Area	C ₅	C ₁₀₀	C ₅	C ₁₀₀
DP 6	D-1	20.59 ac	82.50 %	0.29	0.39	0.24	0.32
	D-2	4.37 ac	17.50 %	0.47	0.55	0.08	0.10
		24.96 ac	100.0 %			0.32	0.42

Design Point	Basin	Area	% Area	C ₅	C ₁₀₀	C ₅	C ₁₀₀
DP 7	DP-5	51.16 ac	61.53 %	0.31	0.40	0.19	0.25
	DP-6	24.96 ac	30.02 %	0.32	0.42	0.10	0.13
	D-3	7.03 ac	8.46 %	0.60	0.67	0.05	0.06
		83.15 ac	100.0 %			0.34	0.43

Design Point	Basin	Area	% Area	C ₅	C ₁₀₀	C ₅	C ₁₀₀
DP 8	DP 7	83.15 ac	95.87 %	0.34	0.43	0.32	0.41
	D-4	3.58 ac	4.13 %	0.35	0.45	0.01	0.02
		86.73 ac	100.0 %			0.34	0.43

Design Point	Basin	Area	% Area	C ₅	C ₁₀₀	C ₅	C ₁₀₀
DP 9	E-1	40.80 ac	71.81 %	0.26	0.36	0.19	0.26
	E-2	16.02 ac	28.19 %	0.28	0.38	0.08	0.11
		56.81 ac	100.0 %			0.27	0.37

Design Point	Basin	Area	% Area	C ₅	C ₁₀₀	C ₅	C ₁₀₀
DP 10	E-1	40.80 ac	48.09 %	0.26	0.36	0.13	0.17
	E-2	16.02 ac	18.88 %	0.28	0.38	0.05	0.07
	E-3	28.02 ac	33.03 %	0.30	0.45	0.10	0.15
		84.83 ac	100.0 %			0.28	0.39

Design Point	Basin	Area	% Area	C ₅	C ₁₀₀	C ₅	C ₁₀₀
DP 11	DP 8	86.73 ac	50.55 %	0.34	0.43	0.17	0.22
	DP 10	84.83 ac	49.45 %	0.28	0.39	0.14	0.19
		171.56 ac	100.0 %			0.31	0.41

Design Point	Basin	Area	% Area	C ₅	C ₁₀₀	C ₅	C ₁₀₀
DP 12	DP 11	171.56 ac	65.13 %	0.31	0.41	0.20	0.27
	DP 2	76.07 ac	28.88 %	0.32	0.41	0.09	0.12
	DP 4b	6.37 ac	2.42 %	0.35	0.44	0.01	0.01
	B-5	3.93 ac	1.49 %	0.25	0.35	0.00	0.01
	E-4	5.48 ac	2.08 %	0.30	0.45	0.01	0.01
		263.41 ac	100.0 %			0.31	0.41

Basin A-1 Overland - same as Existing
channel 1030' - assume $v =$ same as Existing condition

Basin A-2 Overland 100' from 5801 to 5797 \Rightarrow 4%
grass channel 750' - assume $v =$ same as existing

Basin A-3 Overland } Same as existing
channel }

Basin A-4 Overland 300' from 5746 to 5732 \Rightarrow 4.7%
grass channel 415' from 5732 to 5716 \Rightarrow 2.6%
 $\Rightarrow v = 2.4$ fps

Basin A-5 Overland 215' from 5754 to 5739 \Rightarrow 7%
grass channel 50' @ 2% $\Rightarrow v = 2.2$ fps

Basin A-6 Overland 300' from 5742 to 5728 \Rightarrow 4.7%
grass channel 40' @ 2.5% $\Rightarrow v = 2.4$ fps

Basin B-1 Overland } Same as existing
channel }
C&G }
Pipe }

Basin B-2 Overland } same as existing
channel }

Basin B-3 Overland - same as existing
pipe 280' @ 1% $\Rightarrow v = 8$ fps - same as exist.
pipe 240' @ 1.7% $\Rightarrow v = 10$ fps
combine 2 pipes for avg of $v = 8.9$ fps

Basin B-4a overland 190' from 5738 to 5732 \Rightarrow 3.2%
grass channel 190' from 5732 to 5727 \Rightarrow 2.6%
c&g/sheet flow 100' @ 1% $\Rightarrow v = 2$ fps $\Rightarrow v = 2.4$ fps

Basin B-4b overland 265' from 5727 to 5723 \Rightarrow 1.5%
grass channel 550' from 5723 to 5714 \Rightarrow 1.6%
 $\Rightarrow v = 1.8$ fps

Basin B-5 overland } same as existing
channel }

Basin C-1 overland } same as existing
channel }

Basin C-2 overland - same as existing
grass channel 750' from 5772 to 5748 \Rightarrow 3.2%
 $\Rightarrow v = 2.8$ fps

Basin C-3 overland - same as existing
grass channel 660' $\Rightarrow v =$ same as existing
pipe flow 80' @ 1% $\Rightarrow v = 6.5$ fps

Basin D-1 overland } same as existing
channel }

Basin D-2 overland } same as existing
channel }

Basin D-3 overland } same as existing
channel }

Basin D-4 Overland 70' from 5740 to 5738 \Rightarrow 2.9%
grass channel 700' \Rightarrow v = same as existing

Basin E-1 Overland } Same as existing
channel }

Basin E-2 Overland } Same as existing
channel }

Basin E-3 Overland 880' @ 2%
grass channel 950' from 5726 to 5714 \Rightarrow 0.8%
v-ditch w/ 3:1 side slopes \Rightarrow v = 5 fps

Basin E-4 Overland } Same as existing
channel }

Basin F-1 Overland
channel

Basin F-2 Overland
channel

Basin F-3 Overland
channel } Same as existing

Basin F-4 Overland
channel

Basin F-5 Overland
channel

DP-1 $T_c = T_c \text{ for Basin A-1} = 23.6 \text{ min}$

DP-2 $T_c = T_c \text{ for DP-3b plus channel } \frac{780' @ 3.9\%}{\text{as shown for existing top}}$
 $\Rightarrow v = 3 \text{ fps}$
 $T_c = \frac{780}{3} + \frac{1000}{900} = \frac{26.7}{26.8} \text{ min}$

DP-3a $T_c = T_c \text{ for Basin B-1 plus } 600' \text{ pipe flow}$
 $@ v = 12 \text{ fps AND } 240' \text{ pipe flow}$
 $@ v = 10 \text{ fps}$
 $T_c = 17.5 + \frac{600}{60(12)} + \frac{240}{60(10)} = 18.7 \text{ min}$

DP-3b $T_c = T_c \text{ for A-5 plus DP-3a plus:}$
 $60' \text{ pipe @ } \frac{1.2}{2.2} \Rightarrow v = 1.2 \text{ fps}$
 $225' \text{ gross channel @ } 0.5\% \Rightarrow v = 2.4 \text{ fps}$
 $T_c = \frac{18.7}{18.8} + \frac{60}{60(1.2)} + \frac{225}{60(2.4)} = \frac{21.9}{21.6} \text{ min}$

DP-4a $T_c = T_c \text{ for DP-3 plus Basin A-6}$

- 1) ~~285' channel @ 1.4% $\Rightarrow v = 3.7 \text{ fps}$ (1/4 ditch 6:1 side)~~
- 2) ~~pipe flow~~
- 3) ~~channel~~

 } per DP-4a

$14.4 \text{ min} = T_c = \frac{18}{18} + \frac{285}{60(3.7)} + \frac{110}{60(6)} + \frac{275}{60(2.4)} = \frac{27.3}{27.3} \text{ min}$

DP-4b $T_c = T_c \text{ for DP-4a plus channel flow}$
 $745' @ 1.4\% \Rightarrow v = \text{same as Basin B-4b (proposed)}$
 $T_c = \frac{14.4}{27.3} + \frac{745}{60(1.8)} = \frac{24.3}{29.2} \text{ min}$

DP-5

$T_c = T_c$ for Basin C-1 plus:
 pipe flow - 300' of 30" RCP @ 5% $\Rightarrow v = 17 \text{ fps}$
 $T_c = 31.6 + \frac{300}{60(17)} = 31.9 \text{ min.}$

DP-6

$T_c = T_c$ for Basin D-1 plus 370' channel
 flow @ 2.2% $\Rightarrow v = 2.3 \text{ fps}$
 $T_c = 28.0 + \frac{370}{60(2.3)} = 30.7 \text{ min.}$

DP-7

$T_c = T_c$ for DP 5 plus grass channel
 580' @ 2% $\Rightarrow v = 2.1 \text{ fps}$
 $T_c = 31.9 + \frac{580}{60(2.1)} = 36.5 \text{ min}$

DP-8

$T_c = T_c$ for DP 7 plus grass swale 310' @ 1.9%
 $\Rightarrow v = 2.1 \text{ fps}$
 $T_c = 36.5 + \frac{310}{60(2.1)} = 39.0 \text{ min}$

DP-9

$T_c = T_c$ for Basin E-1 plus 530' grass
 channel @ 1.9% $\Rightarrow v = 2.1 \text{ fps}$
 $T_c = 23.3 + \frac{530}{60(2.1)} = 27.5 \text{ min.}$

DP-10

$T_c = T_c$ for DP 9 plus:
 1) grass swale 950' $\Rightarrow v = 2 \text{ fps}$ (same as Ex. DP 11)
 2) grass channel 480', $v =$ same as Basin E-4
 $T_c = 27.5 + \frac{950}{60(2)} + \frac{480}{60(4)} = 37.4 \text{ min}$

DP 11 $T_c = DP 8$ plus $930'$ grass channel
 $\Rightarrow v = 4$ fps (per Basin E-4)

$$T_c = 39.0 + \frac{930}{60(4)} = 42.9 \text{ min}$$

DP 12 $T_c = T_c$ for DP 11

$$T_c = 42.9 \text{ min}$$

**Fountain Valley School
Future Time of Concentration Calculation**

Basin	Slope				Length				Run Coef. (5-year)	Velocity				T _c				Basin	
	O'land 1	Chan. 1	C&G	Pipe	O'land 1	Chan. 1	C&G	Pipe		O'land 1	Chan. 1	C&G	Pipe	O'land 1	Chan. 1	C&G	Pipe		T _c
A-1	6.7%	5.2%			585 lf	1,030 lf			0.28	0.5 ft/sec	4.5 ft/sec		19.8 min.	3.8 min.			23.6 min.	A-1	
A-2	4.0%	5.5%			100 lf	750 lf			0.38	0.2 ft/sec	3.2 ft/sec		8.5 min.	3.9 min.			12.4 min.	A-2	
A-3	5.7%	2.9%			350 lf	630 lf			0.26	0.4 ft/sec	3.3 ft/sec		16.5 min.	3.2 min.			19.7 min.	A-3	
A-4	4.7%	2.6%			300 lf	615 lf			0.27	0.3 ft/sec	2.4 ft/sec		16.1 min.	4.3 min.			20.3 min.	A-4	
A-5	7.0%	2.0%			215 lf	50 lf			0.40	0.4 ft/sec	2.2 ft/sec		10.1 min.	0.4 min.			10.5 min.	A-5	
A-6	4.7%	2.5%			300 lf	40 lf			0.37	0.4 ft/sec	2.4 ft/sec		14.1 min.	0.3 min.			14.4 min.	A-6	
B-1	8.0%	5.7%	2.0%	5.0%	325 lf	510 lf	335 lf	385 lf	0.34	0.4 ft/sec	4.0 ft/sec	2.7 ft/sec	15.0 ft/sec	12.8 min.	2.1 min.	2.1 min.	0.4 min.	17.5 min.	B-1
B-2	7.9%	6.7%			240 lf	285 lf			0.51	0.5 ft/sec	3.6 ft/sec			8.6 min.	1.3 min.			9.9 min.	B-2
B-3	6.5%			1.3%	200 lf			520 lf	0.51	0.4 ft/sec			8.9 ft/sec	8.4 min.			1.0 min.	9.4 min.	B-3
B-4a	3.2%	2.6%	1.0%		190 lf	190 lf	100 lf		0.51	0.3 ft/sec	2.4 ft/sec	2.0 ft/sec		10.4 min.	1.3 min.	0.8 min.		12.6 min.	B-4a
B-4b	1.5%	1.6%			265 lf	550 lf			0.25	0.2 ft/sec	1.8 ft/sec			22.6 min.	5.1 min.			27.7 min.	B-4b
B-5	1.5%	1.3%			260 lf	770 lf			0.25	0.2 ft/sec	1.7 ft/sec			22.3 min.	7.5 min.			29.9 min.	B-5
C-1	5.4%	3.6%			560 lf	2,680 lf			0.28	0.5 ft/sec	4.1 ft/sec			20.7 min.	10.9 min.			31.6 min.	C-1
C-2	5.5%	3.2%			110 lf	750 lf			0.55	0.3 ft/sec	2.8 ft/sec			6.1 min.	4.5 min.			10.5 min.	C-2
C-3	7.5%	5.1%		1.0%	240 lf	660 lf		80 lf	0.44	0.4 ft/sec	3.3 ft/sec		6.5 ft/sec	9.8 min.	3.3 min.		0.2 min.	13.3 min.	C-3
D-1	6.0%	4.5%			700 lf	1,380 lf			0.29	0.5 ft/sec	3.8 ft/sec			21.9 min.	6.1 min.			28.0 min.	D-1
D-2	8.0%	4.3%			225 lf	375 lf			0.47	0.4 ft/sec	3.2 ft/sec			8.9 min.	2.0 min.			10.8 min.	D-2
D-3	2.0%	2.4%			300 lf	420 lf			0.60	0.4 ft/sec	2.3 ft/sec			13.0 min.	3.0 min.			16.0 min.	D-3
D-4	2.9%	6.2%			70 lf	700 lf			0.35	0.1 ft/sec	6.0 ft/sec			8.2 min.	1.9 min.			10.1 min.	D-4
E-1	8.2%	9.0%			635 lf	990 lf			0.26	0.5 ft/sec	4.5 ft/sec			19.6 min.	3.7 min.			23.3 min.	E-1
E-2	2.3%	1.8%			265 lf	325 lf			0.28	0.2 ft/sec	2.0 ft/sec			18.9 min.	2.7 min.			21.6 min.	E-2
E-3	2.0%	0.8%			880 lf	950 lf			0.30	0.4 ft/sec	5.0 ft/sec			35.1 min.	3.2 min.			38.3 min.	E-3
E-4	4.0%	0.5%			300 lf	800 lf			0.30	0.3 ft/sec	4.0 ft/sec			16.3 min.	3.3 min.			19.7 min.	E-4
DP-1									0.29									23.6 min.	DP-1
DP-2									0.32									26.9 min.	DP-2
DP-3a									0.39									18.7 min.	DP-3a
DP-3b									0.39									21.9 min.	DP-3b
DP-4a									0.45									14.4 min.	DP-4a
DP-4b									0.35									21.3 min.	DP-4b
DP-5									0.31									31.9 min.	DP-5
DP-6									0.32									30.7 min.	DP-6
DP-7									0.34									36.5 min.	DP-7
DP-8									0.34									38.9 min.	DP-8
DP-9									0.27									27.5 min.	DP-9
DP-10									0.28									37.4 min.	DP-10
DP-11									0.31									42.8 min.	DP-11
DP-12									0.31									42.8 min.	DP-12

Equations:

Time of Concentration (Overland) = $1.87(1.1 - C_s)L^{0.5} S^{-0.333}$

C_s = Runoff coefficient for five-year flow

L = Length of overland flow in feet

S = Slope of flow path in percent

Velocity (Road) = $10(10^{0.25 \log S - 0.3})$

S = Slope of flow path in percent

Velocity (Channel) = $(1.49/n)R_h^{2/3} S^{1/2}$

Slope (S) = Slope of the channel

n = Manning's number

R_h = Hydraulic Radius (Reynold's Number)

*Without Detention

**Fountain Valley School
Future Runoff Calculation**

Basin / Design Point	Contributing Basins	Area	Area	C _s	C ₁₀₀	Time of Concentration	Rainfall Intensity		Runoff		Basin / Design Point
							I ₅	I ₁₀₀	Q ₅	Q ₁₀₀	
A-1		1,109,126 sf	25.46 ac	0.28	0.37	23.6 min.	2.7 in/hr	4.7 in/hr	18.7 cfs	45.0 cfs	A-1
A-2		171,463 sf	3.94 ac	0.38	0.47	12.4 min.	3.7 in/hr	6.5 in/hr	5.4 cfs	11.9 cfs	A-2
A-3		654,584 sf	15.03 ac	0.26	0.36	19.7 min.	2.9 in/hr	5.2 in/hr	11.4 cfs	28.1 cfs	A-3
A-4		221,064 sf	5.07 ac	0.27	0.37	20.3 min.	2.9 in/hr	5.1 in/hr	3.9 cfs	9.6 cfs	A-4
A-5		76,883 sf	1.76 ac	0.40	0.49	10.5 min.	4.0 in/hr	7.0 in/hr	2.8 cfs	6.0 cfs	A-5
A-6		52,142 sf	1.20 ac	0.37	0.46	14.4 min.	3.4 in/hr	6.1 in/hr	1.5 cfs	3.4 cfs	A-6
B-1		644,098 sf	14.79 ac	0.34	0.43	17.5 min.	3.1 in/hr	5.5 in/hr	15.7 cfs	35.5 cfs	B-1
B-2		116,420 sf	2.67 ac	0.51	0.59	9.9 min.	4.1 in/hr	7.1 in/hr	5.5 cfs	11.2 cfs	B-2
B-3		100,277 sf	2.30 ac	0.51	0.59	9.4 min.	4.2 in/hr	7.3 in/hr	4.9 cfs	9.9 cfs	B-3
B-4a		78,922 sf	1.81 ac	0.51	0.59	12.6 min.	3.7 in/hr	6.5 in/hr	3.4 cfs	6.9 cfs	B-4a
B-4b		146,375 sf	3.36 ac	0.25	0.35	27.7 min.	2.4 in/hr	4.3 in/hr	2.0 cfs	5.1 cfs	B-4b
B-5		171,338 sf	3.93 ac	0.25	0.35	29.9 min.	2.3 in/hr	4.1 in/hr	2.3 cfs	5.7 cfs	B-5
C-1		2,003,235 sf	45.99 ac	0.28	0.38	31.6 min.	2.2 in/hr	4.0 in/hr	29.0 cfs	69.6 cfs	C-1
C-2		225,232 sf	5.17 ac	0.55	0.63	10.5 min.	4.0 in/hr	7.0 in/hr	11.4 cfs	22.8 cfs	C-2
C-3		219,537 sf	5.04 ac	0.44	0.53	13.3 min.	3.6 in/hr	6.3 in/hr	7.9 cfs	16.7 cfs	C-3
D-1		896,901 sf	20.59 ac	0.29	0.39	28.0 min.	2.4 in/hr	4.3 in/hr	14.6 cfs	34.6 cfs	D-1
D-2		190,207 sf	4.37 ac	0.47	0.55	10.8 min.	3.9 in/hr	6.9 in/hr	8.0 cfs	16.6 cfs	D-2
D-3		306,287 sf	7.03 ac	0.60	0.67	16.0 min.	3.3 in/hr	5.8 in/hr	13.7 cfs	27.2 cfs	D-3
D-4		156,154 sf	3.58 ac	0.35	0.45	10.1 min.	4.0 in/hr	7.1 in/hr	5.1 cfs	11.3 cfs	D-4
E-1		1,777,100 sf	40.80 ac	0.26	0.36	23.3 min.	2.7 in/hr	4.8 in/hr	28.7 cfs	70.3 cfs	E-1
E-2		697,645 sf	16.02 ac	0.28	0.38	21.6 min.	2.8 in/hr	5.0 in/hr	12.5 cfs	29.9 cfs	E-2
E-3		1,220,449 sf	28.02 ac	0.30	0.45	38.3 min.	2.0 in/hr	3.6 in/hr	17.0 cfs	45.2 cfs	E-3
E-4		238,609 sf	5.48 ac	0.30	0.45	19.7 min.	2.9 in/hr	5.2 in/hr	4.8 cfs	12.9 cfs	E-4
DP-1	A-1, A-2	1,280,589 sf	29.40 ac	0.29	0.39	23.6 min.	2.7 in/hr	4.7 in/hr	22.6 cfs	53.7 cfs	DP-1
DP-2	A-1, A-2, A-3, A-4, A-5, B-1, B-2, B-3, C-3	3,313,452 sf	76.07 ac	0.32	0.41	26.9 min.	2.5 in/hr	4.4 in/hr	59.8 cfs	138.2 cfs	DP-2
DP-3a	B-1, B-2, B-3, C-3	1,080,332 sf	24.80 ac	0.39	0.48	18.7 min.	3.0 in/hr	5.4 in/hr	29.5 cfs	64.2 cfs	DP-3a
DP-3b	A-5, B-1, B-2, B-3, C-3	1,157,215 sf	26.57 ac	0.39	0.48	21.9 min.	2.8 in/hr	4.9 in/hr	29.0 cfs	63.2 cfs	DP-3b
DP-4a	A-6, B-4A	131,064 sf	3.01 ac	0.45	0.54	14.4 min.	3.4 in/hr	6.1 in/hr	4.7 cfs	9.8 cfs	DP-4a
DP-4b	A-6, B-4A, B-4b	277,439 sf	6.37 ac	0.35	0.44	21.3 min.	2.8 in/hr	5.0 in/hr	6.2 cfs	14.0 cfs	DP-4b
DP-5	C-1, C-2	2,228,467 sf	51.16 ac	0.31	0.40	31.9 min.	2.2 in/hr	4.0 in/hr	35.2 cfs	82.2 cfs	DP-5
DP-6	D-1, D-2	1,087,108 sf	24.96 ac	0.32	0.42	30.7 min.	2.3 in/hr	4.1 in/hr	18.6 cfs	42.6 cfs	DP-6
DP-7	C-1, C-2, D-1, D-2, D-3	3,621,862 sf	83.15 ac	0.34	0.43	36.5 min.	2.1 in/hr	3.7 in/hr	57.8 cfs	131.4 cfs	DP-7
DP-8	All 'C' and 'D' Basins except C-3	3,778,016 sf	86.73 ac	0.34	0.43	38.9 min.	2.0 in/hr	3.5 in/hr	58.0 cfs	131.8 cfs	DP-8
DP-9	E-1, E-2	2,474,745 sf	56.81 ac	0.27	0.37	27.5 min.	2.4 in/hr	4.3 in/hr	37.0 cfs	90.3 cfs	DP-9
DP-10	E-1, E-2, E-3	3,695,194 sf	84.83 ac	0.28	0.39	37.4 min.	2.0 in/hr	3.6 in/hr	48.0 cfs	120.9 cfs	DP-10
DP-11	DP 8, DP10	7,473,210 sf	171.56 ac	0.31	0.41	42.8 min.	1.9 in/hr	3.3 in/hr	98.6 cfs	235.1 cfs	DP-11
DP-12	DP 2, DP 4b, DP 11, Basin B-5, Basin E-4	11,474,048 sf	263.41 ac	0.31	0.41	42.8 min.	1.9 in/hr	3.3 in/hr	152.7 cfs	361.4 cfs	DP-12

Equations:

$$I_c = 54.6 / (T_c^{0.83} + 6.72)$$

$$I_{100} = 75 / ((10 + T_c)^{0.786})$$

I₅ = Average 5-year Rainfall Intensity in inches per hour

I₁₀₀ = Average 100-year Rainfall Intensity in inches per hour

T_c = Time of Concentration

Q = CIA

Q = Peak Runoff Rate, in cubic feet per second (cfs)

C = Runoff coefficient representing a ratio of peak runoff rate to average rainfall intensity for a duration equal to the runoff time of concentration.

I = average rainfall intensity in inches per hour

A = Drainage area in acres

Appendix B
Hydraulic Calculations

**Fountain Valley School
CDot Type C Grated Inlet Sizing**

Proposed CDOT Type C Grated Inlet - Basin B-3

Proposed CDOT Type C Grated Inlet - Orifice Equation

Orifice Coefficient, c		0.6
Opening Size	Length	2.92 ft
	Depth	2.9 ft
Opening Area		8.52 sf
Opening Area w/50% Blockage*		4.26 sf
Opening Elevation		5743.00

Water Elevation	Head / Flow Depth, h	Orifice Flow, Q
5743.25	0.25 ft	10.3 cfs
5743.50	0.50 ft	14.5 cfs
5743.75	0.75 ft	17.8 cfs
5744.00	1.00 ft	20.5 cfs

*Clogging Factor = 2.0 for Grated Inlet in Sump Condition

Orifice Equation
 $Q=cA(2gh)^{0.5}$
 g=gravity=32.2 fps

Proposed CDOT Type C Grated Inlet - Weir Equation

Opening Size	Length	2.92 ft
	Depth	2.9 ft
Perimeter		11.68 ft
Clogging Factor, F		2.0
Grate Elevation		5743.00

Water Elevation	Head / Flow Depth, d	Weir Flow, Q
5743.25	0.25 ft	2.2 cfs
5743.50	0.50 ft	6.2 cfs
5743.75	0.75 ft	11.4 cfs
5744.00	1.00 ft	17.5 cfs

*Clogging Factor = 2.0 for Grated Inlet in Sump Condition

Weir Equation
 $Q=(3.0 \cdot P \cdot d^{1.5})/F$
 P=perimeter of grate opening, in feet
 d=depth fo water at grate, in feet
 F=Clogging Factor

**Fountain Valley School
CDot Type C Grated Inlet Sizing**

Proposed CDOT Type C Grated Inlet - Basin D-4

Proposed CDOT Type C Grated Inlet - Orifice Equation

Orifice Coefficient, c		0.6
Opening Size	Length	2.92 ft
	Depth	2.9 ft
Opening Area		8.52 sf
Opening Area w/50% Blockage*		4.26 sf
Opening Elevation		5726.00

Water Elevation	Head / Flow Depth, h	Orifice Flow, Q
5726.25	0.25 ft	10.3 cfs
5726.50	0.50 ft	14.5 cfs
5726.75	0.75 ft	17.8 cfs
5727.00	1.00 ft	20.5 cfs

*Clogging Factor = 2.0 for Grated Inlet in Sump Condition

Orifice Equation
 $Q=cA(2gh)^{0.5}$
 $g=gravity=32.2\text{ fps}$

Proposed CDOT Type C Grated Inlet - Weir Equation

Opening Size	Length	2.92 ft
	Depth	2.9 ft
Perimeter		11.68 ft
Clogging Factor, F		2.0
Grate Elevation		5726.00

Water Elevation	Head / Flow Depth, d	Weir Flow, Q
5726.25	0.25 ft	2.2 cfs
5726.50	0.50 ft	6.2 cfs
5726.75	0.75 ft	11.4 cfs
5727.00	1.00 ft	17.5 cfs

*Clogging Factor = 2.0 for Grated Inlet in Sump Condition

Weir Equation
 $Q=(3.0 \cdot P \cdot d^{1.5})/F$
 P =perimeter of grate opening, in feet
 d =depth fo water at grate, in feet
 F =Clogging Factor

**Fountain Valley School
CDot Type D Grated Inlet Sizing**

Proposed CDOT Type D Grated Inlet - Basin D-6 (5-year = DP 5, DP 6, Basin D-3 = 35.2+18.6+13.7 = 67.5 cfs

Proposed CDOT Type D Grated Inlet - Orifice Equation

Orifice Coefficient, c		0.6
Opening Size	Length	2.92 ft
	Depth	5.7 ft
Opening Area		16.53 sf
Opening Area w/50% Blockage*		8.26 sf
Opening Elevation		5737.00

Water Elevation	Head / Flow Depth, h	Orifice Flow, Q
5738.50	1.50 ft	48.7 cfs
5739.00	2.00 ft	56.3 cfs
5739.50	2.50 ft	62.9 cfs
5740.00	3.00 ft	68.9 cfs

*Clogging Factor = 2.0 for Grated Inlet in Sump Condition

Orifice Equation

$$Q=cA(2gh)^{0.5}$$

g=gravity=32.2 fps

Proposed CDOT Type D Grated Inlet - Weir Equation

Opening Size	Length	2.92 ft
	Depth	5.7 ft
Perimeter		17.17 ft
Clogging Factor, F		2.0
Grate Elevation		5737.00

Water Elevation	Head / Flow Depth, d	Weir Flow, Q
5738.50	1.50 ft	47.3 cfs
5739.00	2.00 ft	72.9 cfs
5739.50	2.50 ft	101.8 cfs
5740.00	3.00 ft	133.9 cfs

*Clogging Factor = 2.0 for Grated Inlet in Sump Condition

Weir Equation

$$Q=(3.0*P*d^{1.5})/F$$

P=perimeter of grate opening, in feet

d=depth fo water at grate, in feet

F=Clogging Factor

Fountain Valley School Storm Sewer Capacity Calculations

Pipe #	Q ₁₀₀	Contributing Flows	Mannings 'n'	Pipe Slope	Calculated Pipe Diameter	Proposed Pipe Diameter	Min. Slope of Pipe	Flow Velocity	Pipe Capacity
1	16.7 cfs	Basin C-3	0.013	1.00 %	21-inch	24-inch	0.545 %	7.2 ft/sec	23 cfs
2	64.2 cfs	DP 3a	0.013	1.00 %	35-inch	36-inch	0.927 %	9.5 ft/sec	67 cfs
3	46.7 cfs	Basins B-1, B-2	0.013	1.50 %	29-inch	30-inch	1.297 %	10.3 ft/sec	50 cfs
4*	67.5 cfs	DP 5 & DP 6, Basin D-3	0.013	2.00 %	32-inch	36-inch	1.025 %	13.4 ft/sec	95 cfs
5	124.8 cfs	DP 5 & DP 6	0.013	1.50 %	42-inch	42-inch	1.540 %	12.8 ft/sec	124 cfs

Equations:

$$\text{Pipe Diameter} = ((2.16Qn)/(S^{0.5}))^{0.375}$$

Q = Discharge in cubic feet per second

n = Manning's roughness coefficient

S = Slope of the pipe

$$\text{Flow Velocity} = (1.49/n)R_h^{2/3} S^{1/2}$$

n = Manning's roughness coefficient

R_h = Hydraulic Radius

S = Slope of the pipe

$$\text{Pipe Capacity} = (1.49/n)AR_h^{2/3} S^{1/2}$$

A = Cross-sectional area of pipe

$$A = p(D^2/4)$$

D = Inside Diameter of Pipe

$$R_h = A_w/W_p$$

$$A_w = p(d^2/4)$$

A_w = Water Cross Sectional Area

d = Water (Flow) Depth Within Pipe

W_p = pd (For Capacity Calculation)

W_p = Wetted Perimeter of Pipe

* 5-year storm event

Headwater Depth For Circular Culvert

Project: 10034 Fountain Valley School
 Pipe ID: Culvert in Basin A-5 (DP 3b - 100-year)

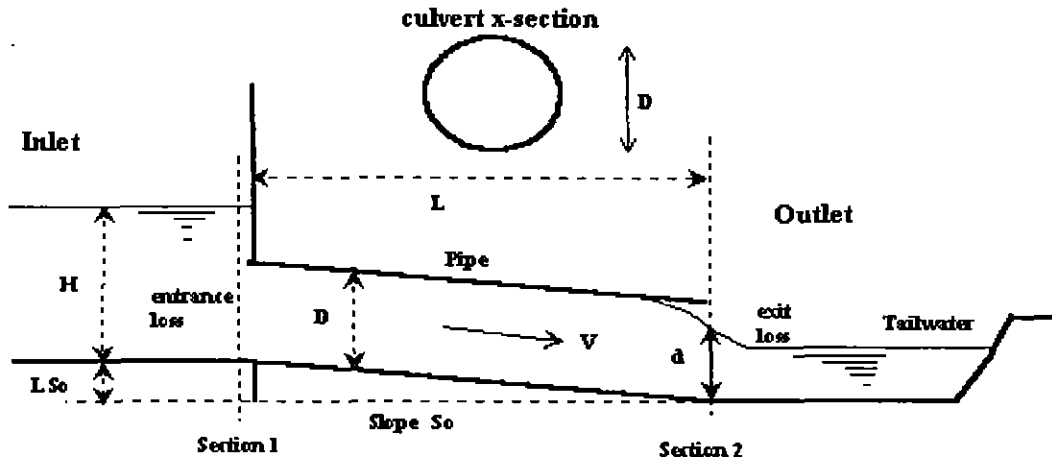

Design Information (input)	
Design Discharge	$Q = \underline{63.2 \text{ cfs}}$
Pipe Diameter	$D = \underline{42.00 \text{ inches}}$
Inlet Edge Type (choose from pull-down list)	Inlet Type = <u>Square End Projection</u>
Inlet Invert Elevation	$I_o = \underline{5740.00 \text{ ft}}$
Outlet Invert Elevation	$O_e = \underline{5739.50 \text{ ft}}$
Pipe Length	$L = \underline{50.0 \text{ ft}}$
Manning's Roughness n-value	$n = \underline{0.013}$
Bend Loss Coefficient	$K_b = \underline{0.00}$
Exit Loss Coefficient	$K_x = \underline{1.00}$
Tailwater Water Surface Elevation	$El. Y_t = \underline{0.00 \text{ ft}}$
Calculations (output)	
Pipe Cross Sectional Area	$A_o = \underline{9.62 \text{ sq ft}}$
Culvert Slope	$S_o = \underline{0.0100 \text{ ft/ft}}$
Normal Flow Depth	$Y_n = \underline{2.01 \text{ ft}}$
Critical Flow Depth	$Y_c = \underline{2.49 \text{ ft}}$
Headwater Depth by Inlet Control	
Headwater Depth by Inlet Control	HW-inlet= <u>4.11 ft</u>
Headwater Depth by Outlet Control	
Tailwater Depth for Design	$d = \underline{3.00 \text{ ft}}$
Friction Loss Coefficient over Culvert Length	$K_f = \underline{0.29}$
Sum of All Loss Coefficients	$K_s = \underline{1.49}$
Headwater Depth by Outlet Control	HW-outlet= <u>4.17 ft</u>
Design Headwater Depth	
HW=	<u>4.17 ft</u>
HW/D Ratio =	HW/D= <u>1.19</u>

Headwater Depth For Circular Culvert

Project: **10034 Fountain Valley School**

Pipe ID: **Culvert under roundabout in Basin A-6 (100-year)**

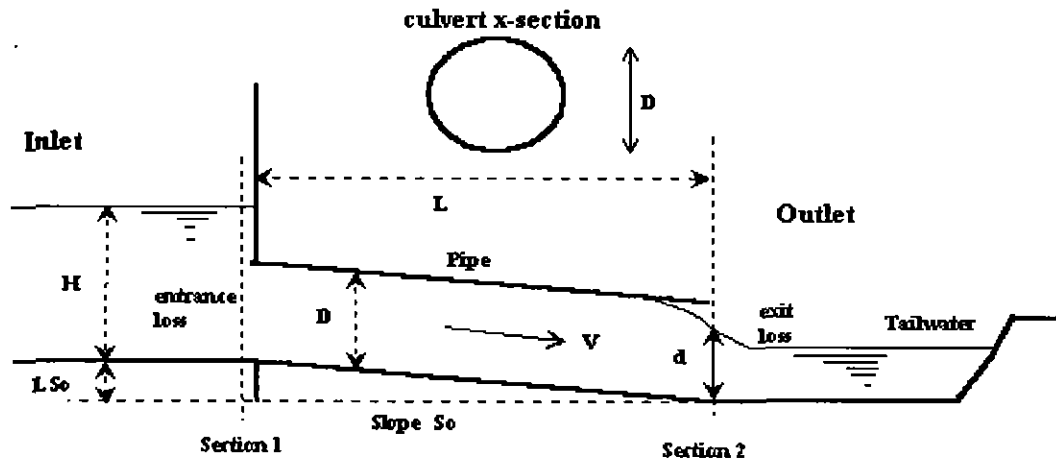

Design Information (input)	
Design Discharge	$Q = 3.4$ cfs
Pipe Diameter	$D = 15.00$ inches
Inlet Edge Type (choose from pull-down list)	Inlet Type = Square End Projection
Inlet Invert Elevation	$I_o = 5726.00$ ft
Outlet Invert Elevation	$O_e = 5725.40$ ft
Pipe Length	$L = 60.0$ ft
Manning's Roughness n-value	$n = 0.013$
Bend Loss Coefficient	$K_b = 0.00$
Exit Loss Coefficient	$K_x = 1.00$
Tailwater Water Surface Elevation	El. $Y_t = 0.00$ ft
Calculations (output)	
Pipe Cross Sectional Area	$A_o = 1.23$ sq ft
Culvert Slope	$S_o = 0.0100$ ft/ft
Normal Flow Depth	$Y_n = 0.64$ ft
Critical Flow Depth	$Y_c = 0.74$ ft
Headwater Depth by Inlet Control	
Headwater Depth by Inlet Control	HW-inlet = 1.13 ft
Headwater Depth by Outlet Control	
Tailwater Depth for Design	$d = 1.00$ ft
Friction Loss Coefficient over Culvert Length	$K_f = 1.39$
Sum of All Loss Coefficients	$K_s = 2.59$
Headwater Depth by Outlet Control	HW-outlet = 0.82 ft
Design Headwater Depth	
HW = 1.13 ft	
HW/D Ratio =	HW/D = 0.90

Note 01

Note 01: A Hw / D ratio of less than 1.0 may indicate an oversized culvert.

Headwater Depth For Circular Culvert

Project: 10034 Fountain Valley School
 Pipe ID: Culvert in Basin D-4 (100-year)

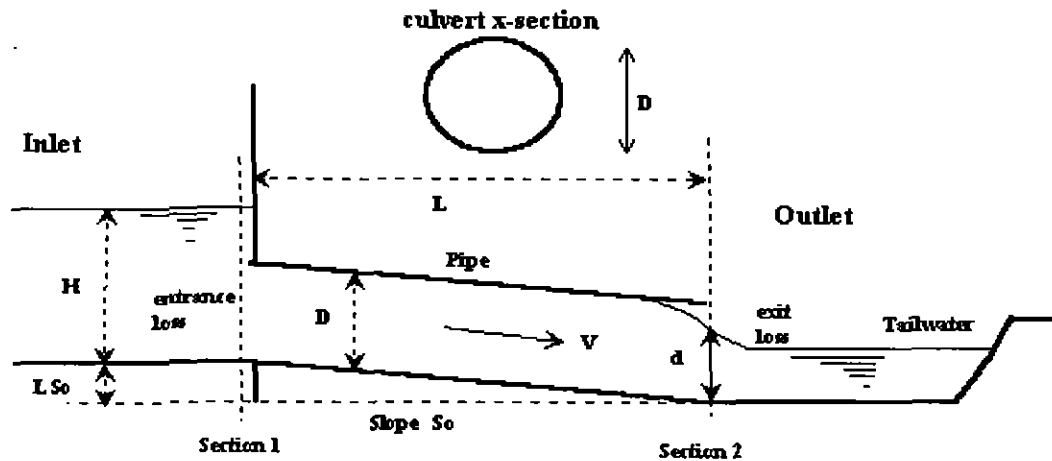

Design Information (input)	
Design Discharge	$Q =$ <u>11.3</u> cfs
Pipe Diameter	$D =$ <u>24.00</u> inches
Inlet Edge Type (choose from pull-down list)	Inlet Type = <u>Square End Projection</u>
Inlet Invert Elevation	$I_o =$ <u>5722.00</u> ft
Outlet Invert Elevation	$O_o =$ <u>5721.00</u> ft
Pipe Length	$L =$ <u>60.0</u> ft
Manning's Roughness n-value	$n =$ <u>0.013</u>
Bend Loss Coefficient	$K_b =$ <u>0.00</u>
Exit Loss Coefficient	$K_x =$ <u>1.00</u>
Tailwater Water Surface Elevation	El. $Y_t =$ <u>0.00</u> ft
Calculations (output)	
Pipe Cross Sectional Area	$A_o =$ <u>3.14</u> sq ft
Culvert Slope	$S_o =$ <u>0.0167</u> ft/ft
Normal Flow Depth	$Y_n =$ <u>0.86</u> ft
Critical Flow Depth	$Y_c =$ <u>1.21</u> ft
Headwater Depth by Inlet Control	
Headwater Depth by Inlet Control	HW-Inlet= <u>1.83</u> ft
Headwater Depth by Outlet Control	
Tailwater Depth for Design	$d =$ <u>1.60</u> ft
Friction Loss Coefficient over Culvert Length	$K_f =$ <u>0.74</u>
Sum of All Loss Coefficients	$K_s =$ <u>1.94</u>
Headwater Depth by Outlet Control	HW-outlet= <u>1.19</u> ft
Design Headwater Depth	
Design Headwater Depth	HW= <u>1.83</u> ft
HW/D Ratio =	HW/D= <u>0.92</u>

Note 01

Note 01: A Hw / D ratio of less than 1.0 may indicate an oversized culvert.

Headwater Depth For Circular Culvert

Project: **10034 Fountain Valley School**
 Pipe ID: **Culvert under roundabout in Basin A-2 (100-year)**

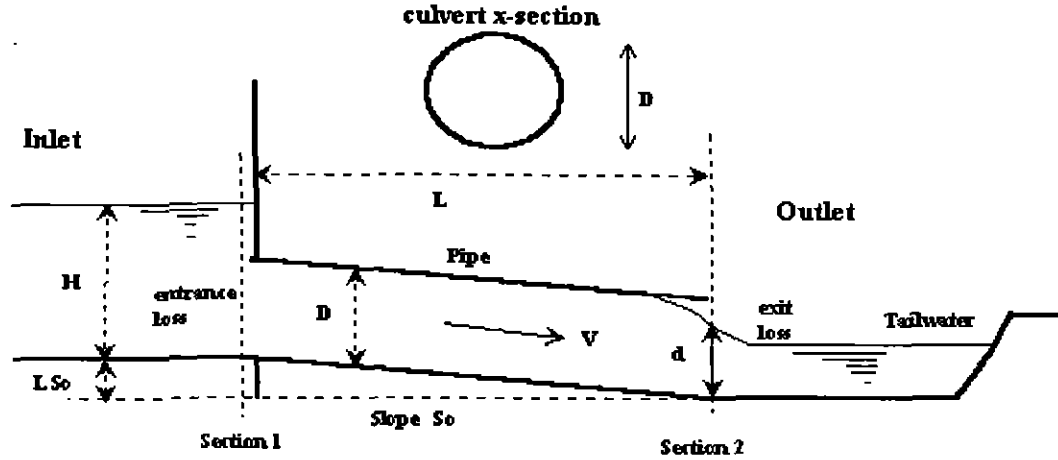

Design Information (input)	
Design Discharge	Q = <u>11.9</u> cfs
Pipe Diameter	D = <u>24.00</u> inches
Inlet Edge Type (choose from pull-down list)	Inlet Type = <u>Square End Projection</u>
Inlet Invert Elevation	I _e = <u>5751.50</u> ft
Outlet Invert Elevation	O _e = <u>5750.00</u> ft
Pipe Length	L = <u>150.0</u> ft
Manning's Roughness n-value	n = <u>0.013</u>
Bend Loss Coefficient	K _b = <u>0.00</u>
Exit Loss Coefficient	K _x = <u>1.00</u>
Tailwater Water Surface Elevation	El. Y _t = <u>0.00</u> ft
Calculations (output)	
Pipe Cross Sectional Area	A _o = <u>3.14</u> sq ft
Culvert Slope	S _o = <u>0.0100</u> ft/ft
Normal Flow Depth	Y _n = <u>1.03</u> ft
Critical Flow Depth	Y _c = <u>1.24</u> ft
Headwater Depth by Inlet Control	
Headwater Depth by Inlet Control	HW-inlet = <u>1.91</u> ft
Headwater Depth by Outlet Control	
Tailwater Depth for Design	d = <u>1.62</u> ft
Friction Loss Coefficient over Culvert Length	K _f = <u>1.85</u>
Sum of All Loss Coefficients	K _s = <u>3.05</u>
Headwater Depth by Outlet Control	HW-outlet = <u>1.02</u> ft
Design Headwater Depth	
HW = <u>1.91</u> ft	
HW/D Ratio =	HW/D = <u>0.95</u>

Note 01

Note 01: A Hw / D ratio of less than 1.0 may indicate an oversized culvert.

Fountain Valley School Road Side Ditch Capacity Calculation

Channel Section Structure 1

Trapezoidal Channel Capacity Calculation (Values to be Input)			
Design Flow*	11.9 cfs	Left Channel Side Slope	6:1
Bottom Width	2.0 ft	Right Channel Side Slope	6:1
Depth of Flow	0.49 ft	Channel Longitudinal Slope	5.0 %
Freeboard	0.51 ft	Manning's Roughness Coef.	0.030

Channel Flow Velocity	5.0 ft/sec
Channel Flow Capacity	12.2 cfs
Swale Depth	1.0 ft
Top Width	14.0 ft
Capacity Check	Okay

Channel Area (not include Freeb)	2.4 sf
Channel Wetted Perimeter	8.0 ft
Hydraulic Radius	0.30 ft

*Q100 = Basin A-2 = 11.9 cfs

Equations:

$$\text{Area (A)} = b(d) + zd^2$$

b = width

d = depth

$$\text{Perimeter (P)} = b + 2d(1+z^2)^{0.5}$$

z = side slope

$$\text{Hydraulic Radius} = A/P$$

$$\text{Velocity} = (1.49/n)R_n^{2/3} S^{1/2}$$

Slope (S) = Slope of the channel

n = Manning's number

R_n = Hydraulic Radius (Reynold's Number)

$$\text{Flow} = (1.49/n)AR_n^{2/3} S^{1/2}$$

**Fountain Valley School
Road Side Ditch Capacity Calculation**

Channel Section Structure 2

Trapezoidal Channel Capacity Calculation (Values to be Input)			
Design Flow*	3.4 cfs	Left Channel Side Slope	6:1
Bottom Width	2.0 ft	Right Channel Side Slope	6:1
Depth of Flow	0.32 ft	Channel Longitudinal Slope	2.5 %
Freeboard	0.68 ft	Manning's Roughness Coef.	0.030

Channel Flow Velocity	2.8 ft/sec
Channel Flow Capacity	3.5 cfs
Swale Depth	1.0 ft
Top Width	14.0 ft
Capacity Check	Okay

Channel Area (not include Freeb)	1.3 sf
Channel Wetted Perimeter	5.9 ft
Hydraulic Radius	0.21 ft

*Q100 = Basin A-6= 3.4 cfs

Equations:

$$\text{Area (A)} = b(d) + zd^2$$

b = width

d = depth

$$\text{Perimeter (P)} = b + 2d(1+z^2)^{0.5}$$

z = side slope

$$\text{Hydraulic Radius} = A/P$$

$$\text{Velocity} = (1.49/n)R_n^{2/3} S^{1/2}$$

Slope (S) = Slope of the channel

n = Manning's number

R_n = Hydraulic Radius (Reynold's Number)

$$\text{Flow} = (1.49/n)AR_n^{2/3} S^{1/2}$$

**Fountain Valley School
Road Side Ditch Capacity Calculation**

Channel Section Structure 3

Trapezoidal Channel Capacity Calculation (Values to be Input)			
Design Flow*	152.0 cfs	Left Channel Side Slope	3:1
Bottom Width	4.0 ft	Right Channel Side Slope	3:1
Depth of Flow	1.97 ft	Channel Longitudinal Slope	2.0 %
Freeboard	1.03 ft	Manning's Roughness Coef.	0.030

Channel Flow Velocity	7.9 ft/sec
Channel Flow Capacity	153.7 cfs
Swale Depth	3.0 ft
Top Width	22.0 ft
Capacity Check	Okay

Channel Area (not include Freeb)	19.5 sf
Channel Wetted Perimeter	16.5 ft
Hydraulic Radius	1.19 ft

*Q100 = DP 5, DP 6 and Basin D-3 = 82.2+42.6+27.2=152.0 cfs

Equations:

$$\text{Area (A)} = b(d) + zd^2$$

b = width

d = depth

$$\text{Perimeter (P)} = b + 2d(1 + z^2)^{0.5}$$

z = side slope

$$\text{Hydraulic Radius} = A/P$$

$$\text{Velocity} = (1.49/n)R_n^{2/3} S^{1/2}$$

Slope (S) = Slope of the channel

n = Manning's number

R_n = Hydraulic Radius (Reynold's Number)

$$\text{Flow} = (1.49/n)AR_n^{2/3} S^{1/2}$$

Fountain Valley School
Channel Lining Calculations

100-year Design Frequency
Design assumes 3:1 side slopes

Permissible Shear Stress for Grassline Netting	2.10 psf
--	----------

Description	Mannings 'n'	Q	Slope	Bottom Width (B)	d/B Factor	Normal Depth (d/B Ratio)	Depth of Flow	Shear Stress	Channel Type
Ditch #2 in Basin A-6	0.030	3.4 cfs	2.5%	2.00 ft	0.068	0.160	0.32 ft	0.50 psf	Grasslined
Ditch #1 in Basin A-2	0.030	11.9 cfs	5.0%	2.00 ft	0.169	0.245	0.49 ft	1.53 psf	Grasslined
Ditch #3 in Basin D-3	0.030	152.0 cfs	2.0%	4.00 ft	0.537	0.493	1.97 ft	2.46 psf	Riprap

Calculation method taken from 'Design of Roadside Channels with Flexible Linings, Hydraulic Engineering Circular No. 15'

$D/B \text{ Factor} = Qn / (1.486S^{1/2} B^{2.67})$

Q = Runoff Rate, in cubic feet per second (cfs)

n = Manning's roughness coefficient

S = Slope of the Channel

B = Channel Bottom Width (ft)

d/B Ratio = Normal Depth interpolated value from Chart 4.1
(Curves for Computing Normal Depth in Trap. Channels)

Flow Depth (d) = Normal Depth * B

Shear Stress = $62.4 S^2 D$

**Fountain Valley School
Riprap Design Calculation**

Proposed Hydraulic Structure Location	Description	Design Flow	Channel Flow Velocity	Channel Slope	Riprap Value	Calculated Riprap Type	Proposed Riprap Type
Ditch #3	Basin D-3	152.0 cfs	7.9 ft/sec	2.0 %	2.9	VL	L

Equations:

$$\text{Riprap Value} = VS^{0.17} / (S_s - 1)^{0.66}$$

V = mean channel flow velocity

S = Longitudinal channel slope (ft/ft)

S_s = Specific Gravity of stone (minimum S_s = 2.50)

S_s = 2.64 (most cases)

Riprap Value	Riprap Type	D50
1.4 to 3.2	VL	6 inches
3.3 to 3.9	L	9 inches
4.0 to 4.5	M	12 inches
4.6 to 5.5	H	18 inches
5.6 to 6.4	VH	24 inches

Equations taken from Section 10.10.2, City of Colorado Springs & El Paso County Drainage Criteria Manual

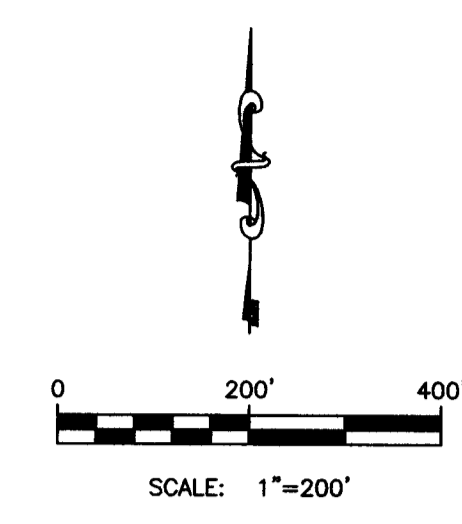
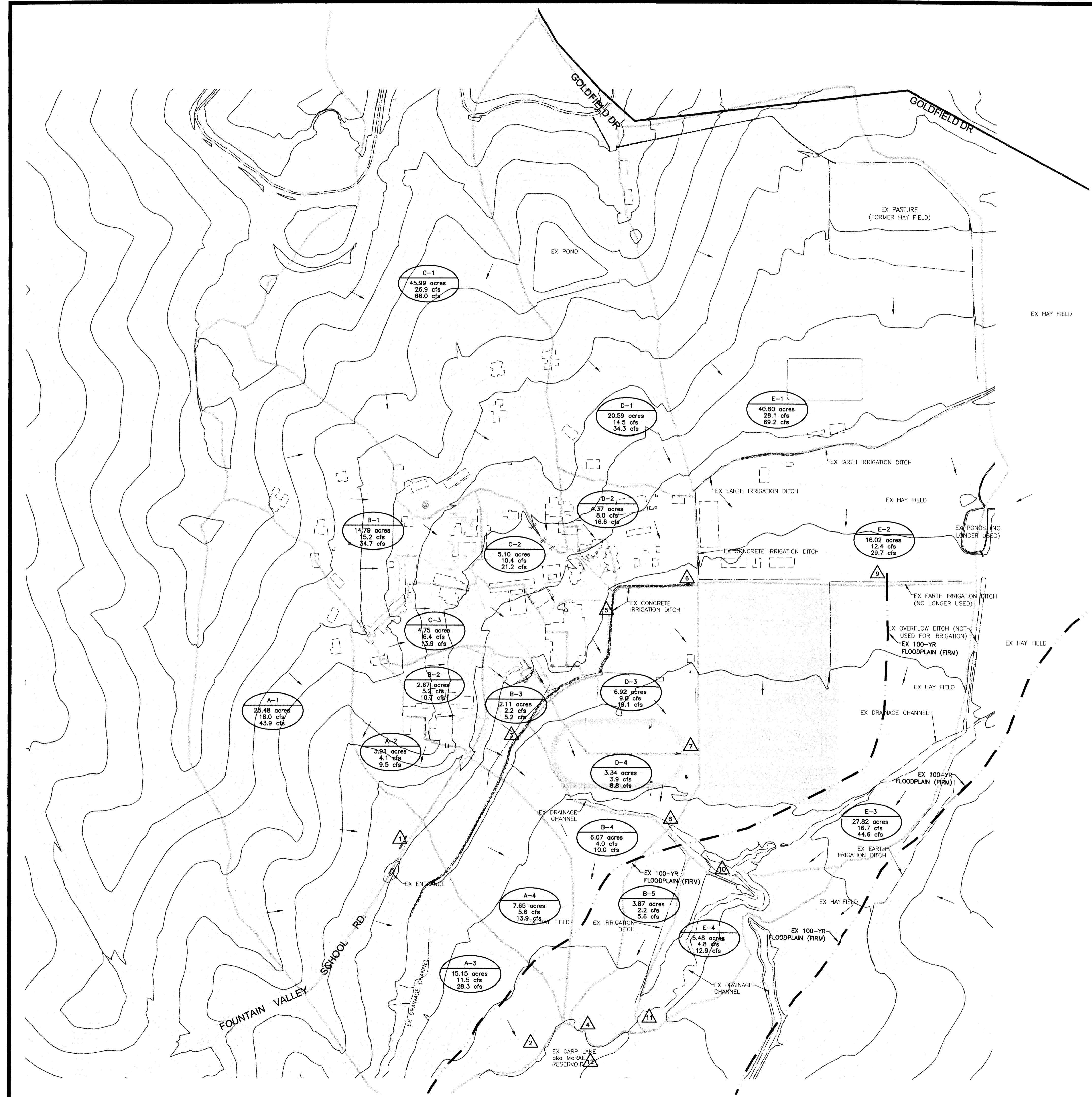

DESIGN POINT FLOWS		
	5-YEAR	100-YEAR
△1	21.2 cfs	51.3 cfs
△2	32.8 cfs	80.2 cfs
△3	20.7 cfs	46.5 cfs
△4	21.8 cfs	50.6 cfs
△5	32.5 cfs	77.5 cfs
△6	18.4 cfs	42.3 cfs
△7	56.5 cfs	130.9 cfs
△8	56.5 cfs	130.8 cfs
△9	36.3 cfs	89.1 cfs
△10	47.1 cfs	119.3 cfs
△11	96.2 cfs	232.3 cfs
△12	142.1 cfs	343.0 cfs

LEGEND	
R	DRAINAGE BASIN DESIGNATION
10.24 ac	DRAINAGE BASIN AREA
7.9 cfs	5-YEAR BASIN RUNOFF
28.9 cfs	100-YEAR BASIN RUNOFF
2.2 cfs	5-YEAR EXISTING RUNOFF
4.3 cfs	100-YEAR EXISTING RUNOFF
△	EXISTING DESIGN POINT
---	EXISTING DRAINAGE BASIN BOUNDARY
→	FLOW DIRECTION
---	TIME OF CONCENTRATION PATH

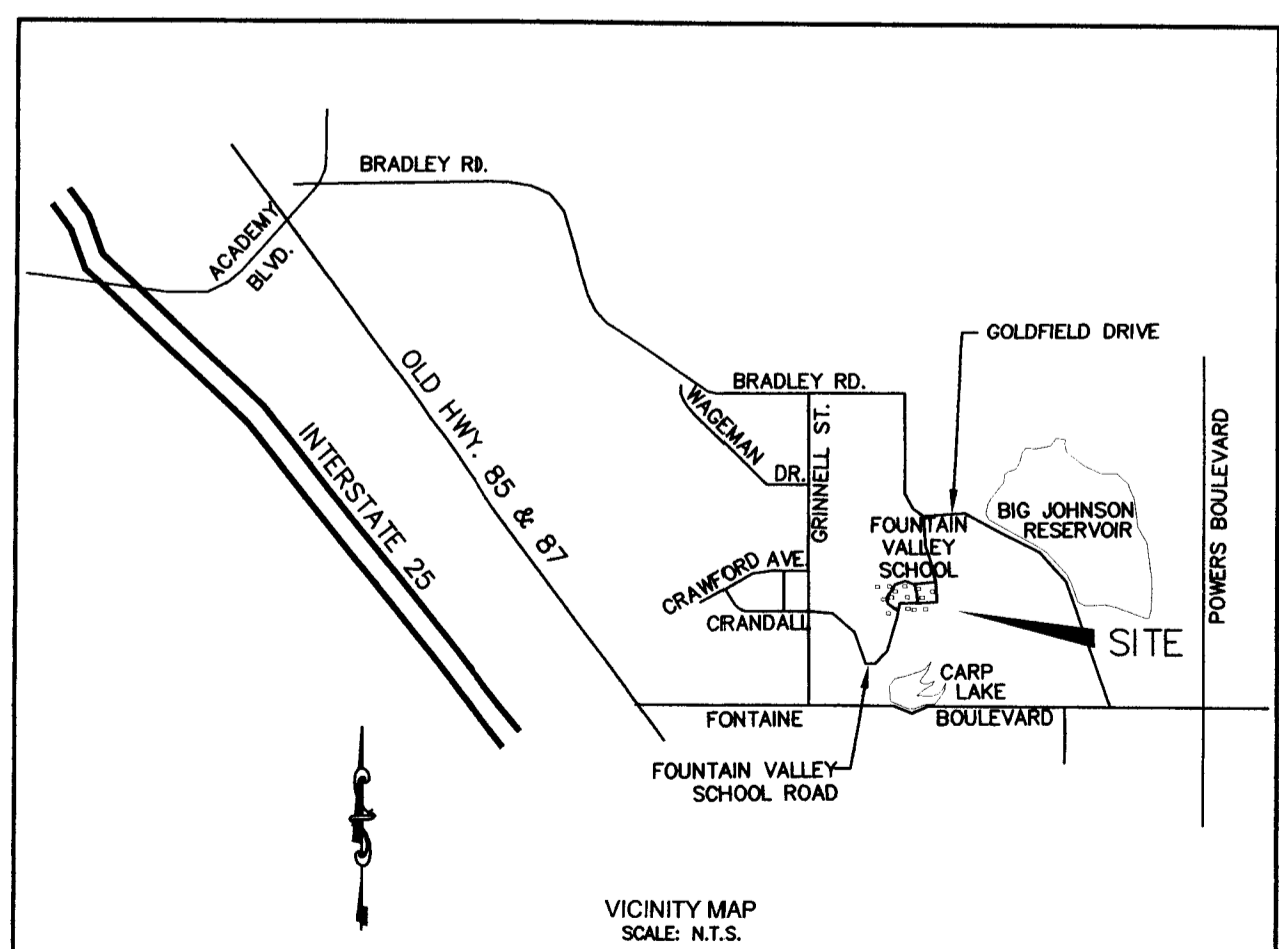

Kiowa
Engineering Corporation
1604 South 21st Street
Colorado Springs, Colorado 80904
(719) 530-7342

**FOUNTAIN VALLEY SCHOOL
MASTER DEVELOPMENT DRAINAGE PLAN
OVERALL DRAINAGE BASIN MAP
EL PASO COUNTY, COLORADO**

Project No.:	10034
Date:	April 18, 2011
Design:	JGD
Drawn:	JGD
Check:	AWMc
Revisions:	

SHEET
5
OF 7 SHEETS

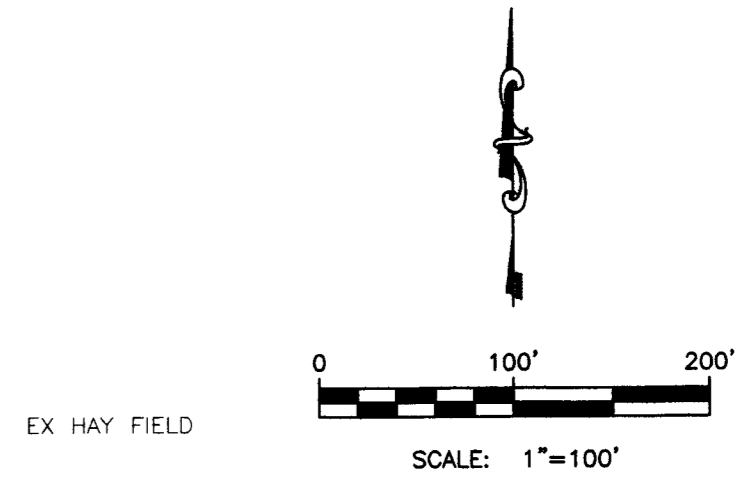
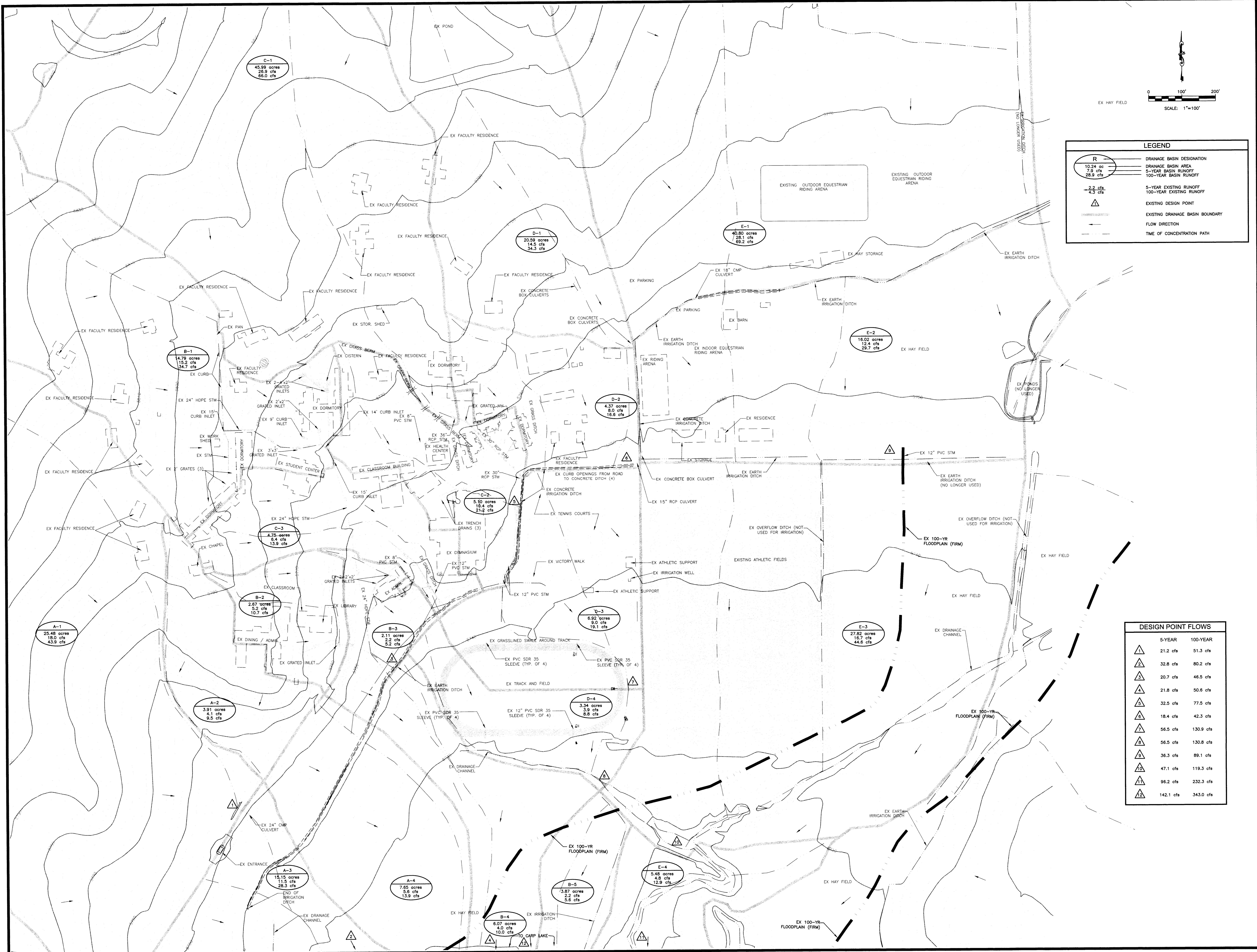

LEGEND

R	DRAINAGE BASIN DESIGNATION
10.24 ac	DRAINAGE BASIN AREA
7.9 cfs	5-YEAR BASIN RUNOFF
28.5 cfs	100-YEAR BASIN RUNOFF
2.2 cfs	5-YEAR EXISTING RUNOFF
4.3 cfs	100-YEAR EXISTING RUNOFF
Δ	EXISTING DESIGN POINT
---	EXISTING DRAINAGE BASIN BOUNDARY
→	FLOW DIRECTION
---	TIME OF CONCENTRATION PATH

DESIGN POINT FLOWS

	5-YEAR	100-YEAR
Δ	21.2 cfs	51.3 cfs
Δ	32.8 cfs	80.2 cfs
Δ	20.7 cfs	46.5 cfs
Δ	21.8 cfs	50.6 cfs
Δ	32.5 cfs	77.5 cfs
Δ	18.4 cfs	42.3 cfs
Δ	56.5 cfs	130.9 cfs
Δ	56.5 cfs	130.8 cfs
Δ	36.3 cfs	89.1 cfs
Δ	47.1 cfs	119.3 cfs
Δ	96.2 cfs	232.3 cfs
Δ	142.1 cfs	343.0 cfs

**FOUNTAIN VALLEY SCHOOL
MASTER DEVELOPMENT DRAINAGE PLAN
EXISTING CONDITION
EL PASO COUNTY, COLORADO**

Project No.: 10034
Date: April 18, 2011
Design: JGD
Drawn: JGD
Check: AWMc
Revisions:

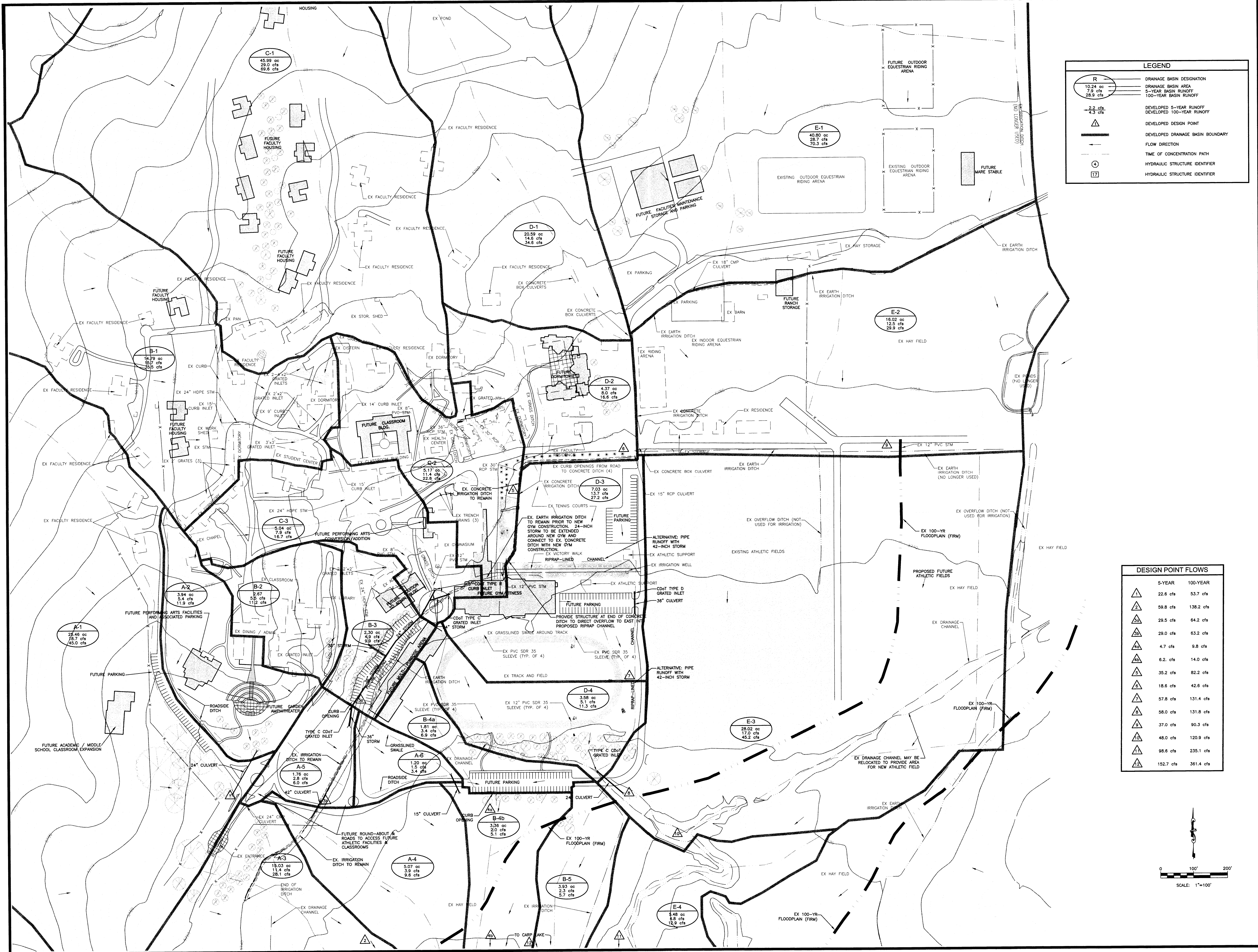

LEGEND

R	DRAINAGE BASIN DESIGNATION
10.24 ac	DRAINAGE BASIN AREA
7.8 cfs	5-YEAR BASIN RUNOFF
28.9 cfs	100-YEAR BASIN RUNOFF
2.2 cfs	DEVELOPED 5-YEAR RUNOFF
4.3 cfs	DEVELOPED 100-YEAR RUNOFF
△	DEVELOPED DESIGN POINT
—	DEVELOPED DRAINAGE BASIN BOUNDARY
→	FLOW DIRECTION
○	TIME OF CONCENTRATION PATH
○	HYDRAULIC STRUCTURE IDENTIFIER
□	HYDRAULIC STRUCTURE IDENTIFIER

DESIGN POINT FLOWS

	5-YEAR	100-YEAR
△1	22.6 cfs	53.7 cfs
△2	59.8 cfs	138.2 cfs
△3	29.5 cfs	64.2 cfs
△4	29.0 cfs	63.2 cfs
△5	4.7 cfs	9.8 cfs
△6	6.2 cfs	14.0 cfs
△7	35.2 cfs	82.2 cfs
△8	18.6 cfs	42.6 cfs
△9	57.8 cfs	131.4 cfs
△10	58.0 cfs	131.8 cfs
△11	37.0 cfs	90.3 cfs
△12	48.0 cfs	120.9 cfs
△13	98.6 cfs	235.1 cfs
△14	152.7 cfs	381.4 cfs

**FOUNTAIN VALLEY SCHOOL
MASTER DEVELOPMENT DRAINAGE PLAN
PROPOSED CONDITION
EL PASO COUNTY, COLORADO**

Project No.: 10034
Date: April 18, 2011
Design: JGD
Drawn: JGD
Check: AWMc
Revisions:

10034CP.dwg/Apr 18, 2011

**Update to
Master Development Drainage Plan
Fountain Valley School
El Paso County, Colorado**

Prepared for:
Fountain Valley School
c/o Next Level Development
118 N. Tejon Street, Suite 205
Colorado Springs, Colorado 80903



1604 South 21st Street
Colorado Springs, Colorado 80904
(719) 630-7342

Kiowa Project No. 12018

June 6, 2012

AL-11-3
PR-07-030

Page

Table of Contents..... ii

Engineer's Statementiii

I. **General Location and Description**..... 1

II. **Previous Reports** 1

III. **Site Drainage** 2

IV. **Conclusion**..... 2

ENGINEER'S STATEMENT:

The attached drainage plan and report were prepared under my direction and supervision and are correct to the best of my knowledge and belief. Said drainage report has been prepared according to the criteria established by the City/County for drainage reports and said report is in conformity with the applicable master plan of the drainage basin. I accept responsibility for any liability caused by any negligent acts, errors or omissions on my part in preparing this report.

Kiowa Engineering Corporation, 1604 South 21st Street, Colorado Springs, Colorado 80904

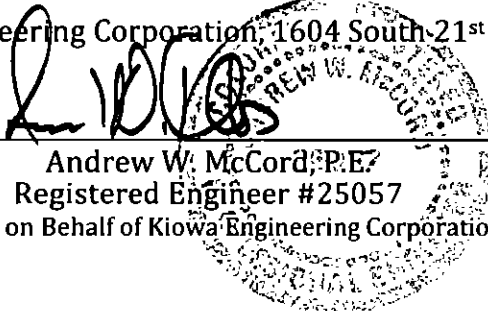

6/6/2012
Date

Andrew W. McCord, P.E.
Registered Engineer #25057
For and on Behalf of Kiowa Engineering Corporation

DEVELOPER'S STATEMENT:

I, the Developer, have read and will comply with all of the requirements specified in this drainage report and plan.

BY: Wayne M. Timura

6/6/12
Date

PRINT NAME: WAYNE M. TIMURA

ADDRESS: Next Level Development
118 N. Tejon Street, Suite 205
Colorado Springs, Colorado 80903

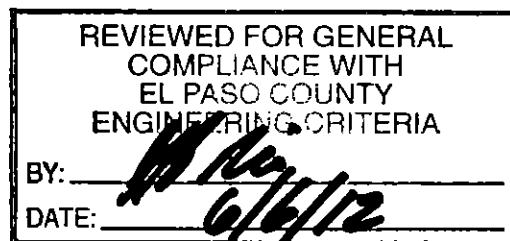

I. General Location and Description

Fountain Valley School is an existing preparatory school located east of Security in the south central portion of El Paso County, Colorado. The developed portion of the school property is located in the central portion of the property. The campus is currently developed with administrative buildings, a dining hall, a library, a student center, classrooms, dormitories, faculty residences, a health center, a gymnasium, an athletic field and track, tennis courts, maintenance buildings, barns, stables, equestrian arenas, and storage sheds. Numerous driveways and parking areas provide access to the main campus area. Hay fields comprise the area to the east and south of the campus. The remainder of the property to the west and north is undeveloped.

The Fountain Valley School property encompasses approximately 937 acres and is roughly bounded by Grinnell Street to the west, Bradley Road to the north, Goldfield Drive to the east, and Fontaine Boulevard to the south. The campus area of the site is located in Section 18, Township 15 South, Range 66 West of the 6th P.M. A vicinity map showing the location of the site is presented on Figure 1 on the following page.

The Fountain Valley School property has been masterplanned and the Special Use Permit has been updated. This update to the Master Development Drainage Plan (MDDP) is being submitted as a part of the Amended Site Development Plan for the proposed Athletic Facilities Building. The proposed Athletic Facilities Building is a change to previously approved Special Use and Site Development Plan. The proposed Athletic Facilities Building has been relocated within the Fountain Valley School campus. The originally proposed location of the Athletic Facilities Building, which consists on a gymnasium, bouldering area, wellness center, and pool, was located immediately south of the existing Gymnasium. The proposed location of the Athletic Facilities Building is now north of the existing tennis courts and east of the existing dormitories. A portion of the proposed Athletic Facilities Building will encroach upon the existing maintenance buildings. The maintenance facilities has been previously masterplanned to move to the northeast from their existing location.

II. Previous Reports

- 1) *Master Development Drainage Plan Fountain Valley School*, prepared by Kiowa Engineering Corporation, dated April 18, 2011.
- 2) *Drainage Letter and Erosion Control Plan for Fountain Valley School Strategic Development Plan*, prepared by URS, dated July 31, 2000.
- 3) *Drainage Letter and Erosion Control Plan for Fountain Valley School Dormitory Expansion*, prepared by Kiowa Engineering Corp., filed October 29, 1998.
- 4) *Big Johnson Reservoir/Crews Gulch Drainage Basin Planning Study*, prepared by Kiowa Engineering Corporation, dated June, 1991.
- 5) *City of Colorado Springs and El Paso County Drainage Criteria Manual*, dated October 1997.

- 6) *City of Colorado Springs Drainage Criteria Manual Volume 2*, dated November 2002.
- 7) *El Paso County, Engineering Criteria Manual*, dated January 9, 2006 and revised January 1, 2008.
- 8) *Soil Survey of El Paso County Area, Colorado*, prepared by United States Department of Agriculture Soil Conservation Service, dated June 1981.

III. Site Drainage

The proposed general drainage patterns and drainage facilities for the site will remain the same as described in the approved MDDP. The MDDP Drainage patterns and facilities are conceptual in nature, and runoff is generally routed to the south utilizing existing drainage facilities, new site-specific facilities, irrigation laterals, and existing fields. The ultimate outfall will be to Carp Lake.

The impervious area is effectively the same between the previously proposed Gymnasium location and the newly proposed Athletic Facilities Building. The new Athletic Facilities Building footprint has an approximately 2,500 square feet smaller footprint than the previously proposed gymnasium expansion. With the proposed ancillary site features, including parking, the change in imperviousness area is negligible.

With the negligible increase in site imperviousness, the volume and rate of runoff will remain essentially as defined in the previously approved MDDP with the new proposed location of the Athletic Facilities.

IV. Conclusion

The site drainage patterns immediately adjacent to the proposed Athletic Facilities Building will change to accommodate the site development, however, the overall drainage patterns, amount, and rate will remain the same as studied in the previously approved Master Development Drainage Plan. The new location of the Athletic Facilities Building, will not affect downstream drainage impact from the Fountain valley School.

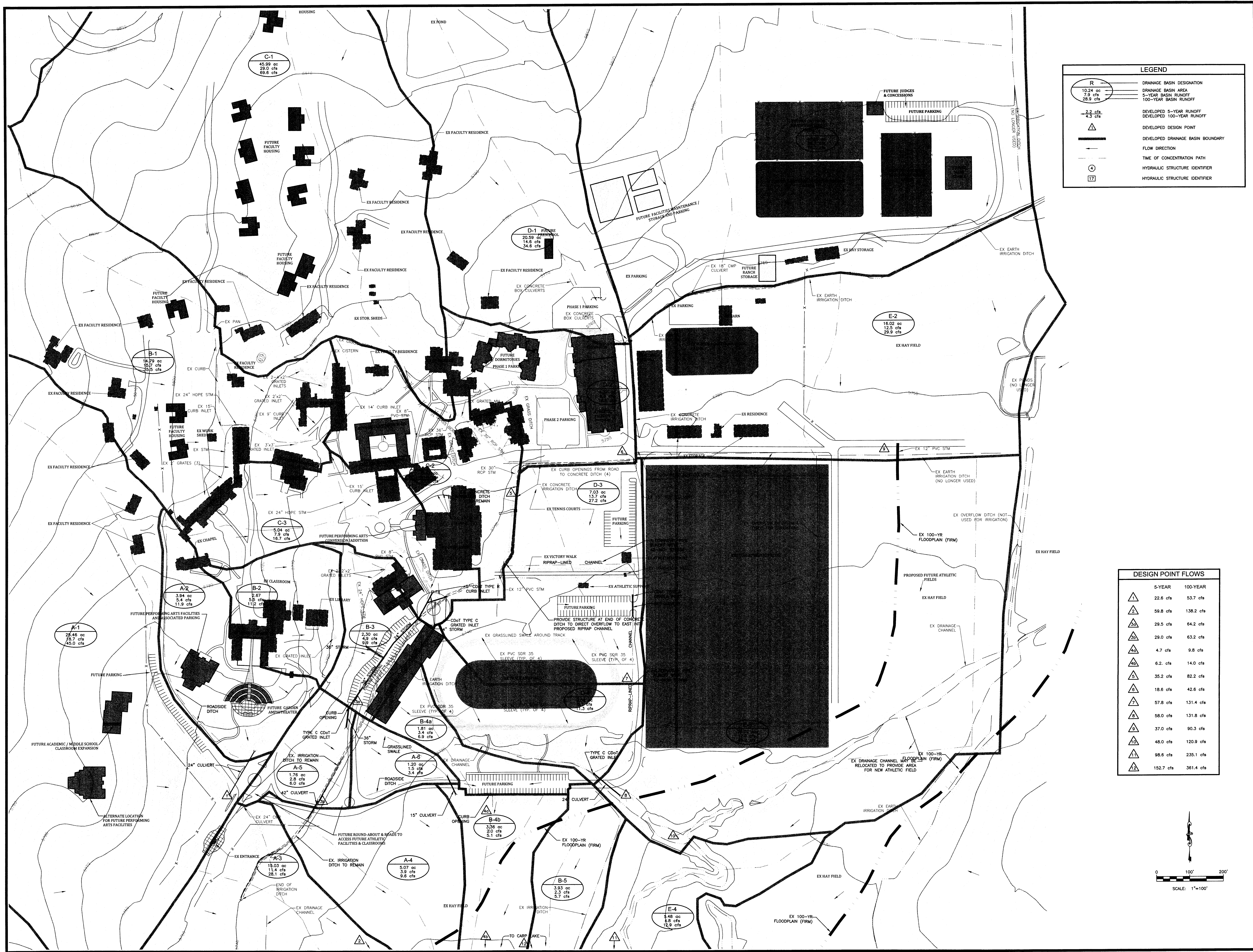

LEGEND

R	DRAINAGE BASIN DESIGNATION
10.24 ac 7.9 cfs 28.9 cfs	DRAINAGE BASIN AREA 5-YEAR BASIN RUNOFF 100-YEAR BASIN RUNOFF
2.2 cfs 4.3 cfs	DEVELOPED 5-YEAR RUNOFF DEVELOPED 100-YEAR RUNOFF
△	DEVELOPED DESIGN POINT
—	DEVELOPED DRAINAGE BASIN BOUNDARY
→	FLOW DIRECTION
—	TIME OF CONCENTRATION PATH
④	HYDRAULIC STRUCTURE IDENTIFIER
①⑦	HYDRAULIC STRUCTURE IDENTIFIER

DESIGN POINT FLOWS

	5-YEAR	100-YEAR
△1	22.6 cfs	53.7 cfs
△2	59.8 cfs	138.2 cfs
△3	29.5 cfs	64.2 cfs
△4	29.0 cfs	63.2 cfs
△5	4.7 cfs	9.8 cfs
△6	6.2 cfs	14.0 cfs
△7	35.2 cfs	82.2 cfs
△8	18.6 cfs	42.6 cfs
△9	57.8 cfs	131.4 cfs
△10	58.0 cfs	131.8 cfs
△11	37.0 cfs	90.3 cfs
△12	48.0 cfs	120.9 cfs
△13	98.6 cfs	235.1 cfs
△14	152.7 cfs	361.4 cfs

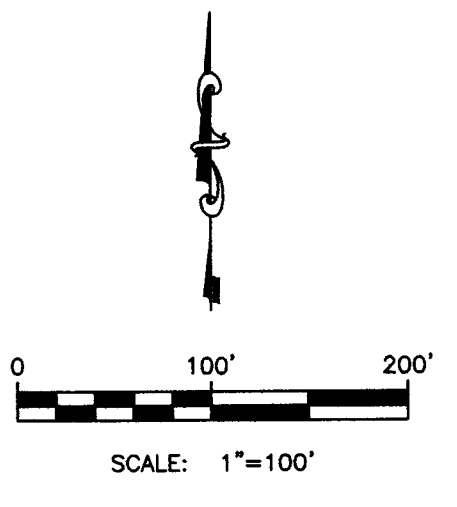

**FOUNTAIN VALLEY SCHOOL
UPDATED MASTER DEVELOPMENT DRAINAGE PLAN
PROPOSED CONDITION
EL PASO COUNTY, COLORADO**

Project No.:	12018
Date:	June 6, 2012
Design:	AWMc
Drawn:	CAD
Check:	AWMc
Revisions:	

12018DP.dwg/Jun 05, 2012

**Drainage Memo
Fountain Valley School**

El Paso County, Colorado

Prepared for:
Fountain Valley School
6155 Fountain Valley School Road
Colorado Springs, Colorado 80911



1604 South 21st Street
Colorado Springs, Colorado 80904
(719) 630-7342

PCD File No. PPR1917

Kiowa Project No. 19006

May 23, 2019

	<u>Page</u>
Table of Contents	ii
Engineer’s Statement.....	iii
I. General Location and Description.....	4
II. Previous Reports.....	4
III. Existing Drainage Patterns.....	5
IV. Site Drainage Plan.....	5
V. Floodplain Statement.....	6
VI. Grading and Erosion Control.....	6
VII. Drainage and Bridge Fees.....	7
VIII. Four Step Process	7

LIST OF FIGURES

- Figure 1 Vicinity Map
- Figure 2 Proposed Improvements

ENGINEER'S STATEMENT:

The attached drainage plan and report were prepared under my direction and supervision and are correct to the best of my knowledge and belief. Said drainage report has been prepared according to the criteria established by the County for drainage reports and said report is in conformity with the master plan of the drainage basin. I accept responsibility for any liability caused by any negligent acts, errors or omissions on my part in preparing this report.

Kiowa Engineering Corporation, 1604 South 21st Street, Colorado Springs, Colorado 80904

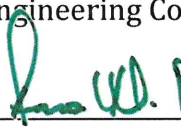
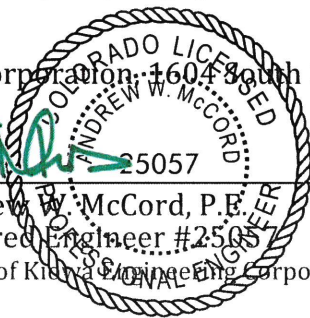
Andrew W. McCord, P.E.
Registered Engineer #25057
For and on Behalf of Kiowa Engineering Corporation

May 23, 2019
Date

DEVELOPER'S STATEMENT:

I, the Developer, have read and will comply with all of the requirements specified in this drainage report and plan.

BUSINESS NAME: iiCON Construction Group

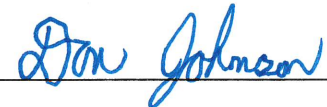
BY:  _____
Date 5/23/2019

PRINT NAME: Don Johnson

ADDRESS: 76 South Sierra Madre Street Suite L
Colorado Springs, Colorado 80903

EL PASO COUNTY:

Filed in accordance with the requirements of the Drainage Criteria Manual, Volumes 1 & 2, El Paso County Engineering Criteria Manual and Land Development code, as amended.

Jennifer Irvine, P.E.
County Engineer/ECM Administrator

Approved
by Elizabeth Nijkamp
El Paso County Planning and Community Development
on behalf of Jennifer Irvine, County Engineer, ECM Administrator

06/06/2019 6:46:14 AM

Conditions: _____

I. General Location and Description

Fountain Valley School is an existing preparatory school located east of Security in the south central portion of El Paso County, Colorado. The developed portion of the school property is located in the central portion of the property. The campus is currently developed with administrative buildings, dining hall, library, student center, classrooms, dormitories, faculty residences, health center, gymnasium, athletic field and track, tennis courts, maintenance buildings, barns, stables, equestrian arenas, and storage sheds. Numerous driveways and parking areas provide access to the main campus area. Hay fields comprise the area to the east and south of the campus. The remainder of the property to the west is undeveloped.

The Fountain Valley School property encompasses approximately 989.4 acres and is roughly bounded by Grinnell Street to the west, Bradley Road to the north, Goldfield Drive to the east, and Fontaine Boulevard to the south. The campus area of the site is located in Section 18, Township 15 South, Range 65 West of the 6th P.M. A vicinity map showing the location of the site is presented on Figure 1, which can be found at the end of this memo.

This memo is presented as part of a Minor Site Development Plan and addresses improvements to the Fountain Valley School property which consists of the construction of two new faculty residences, with footprints of approximately 2600 square feet, just north of the main campus area. Construction of these new faculty residences will have no significant impact on the overall drainage of the site. Construction of the new faculty residences will disturb approximately 0.94 acres of an area that generally slopes from the north to the south at a slope of approximately 7.5%%.

II. Previous Reports

- 1) *Master Development Drainage Plan*, prepared by Kiowa Engineering Corp., dated August 19, 2010.
- 2) *Drainage Letter, Fountain Valley School Maintenance Facility*, prepared by Kiowa Engineering Corp., dated May 18, 2017
- 3) *Drainage Letter and Erosion Control Plan for Fountain Valley School Strategic Development Plan*, prepared by URS, dated July 31, 2000.
- 4) *Drainage Letter and Erosion Control Plan for Fountain Valley School Dormitory Expansion*, prepared by Kiowa Engineering Corp., filed October 29, 1998.
- 5) *Big Johnson Reservoir/Crews Gulch Drainage Basin Planning Study*, prepared by Kiowa Engineering Corporation, dated June 1991.
- 6) *Procedures for Determining Peak Flows in Colorado*, prepared by Soil Conservation Service, USDA, dated March 1980.
- 7) *El Paso County Drainage Criteria Manual, Volumes 1 and 2*.
- 8) *El Paso County, Engineering Criteria Manual*, dated December 12, 2014 and revised July 29, 2015.
- 9) *Soil Survey of El Paso County Area, Colorado*, prepared by United States Department of Agriculture Soil Conservation Service, dated June 1981.

The *Master Development Drainage Plan* (MDDP, reference 1) was prepared as part of a Special Use and Site Development Plan, and to identify stormwater management to satisfy existing and future needs within the Fountain Valley School property. Drainage and bridge fees were established in the *Big Johnson Reservoir/Crews Gulch Drainage Basin Planning Study* (DBPS, reference 5). Fountain Valley School is located within Reach 4 per the DBPS. The DBPS assumed that Fountain Valley School peak discharge rates are to be limited to historic rates and that detention may be required with any new development at Fountain Valley School. The MDDP indicates that the increase in peak discharges based upon the proposed Master Plan would increase by 5.4% in the 100-year storm. This increase can be considered insignificant especially in light of the site conditions at Fountain Valley School which limit the amount of runoff that leaves the site.

III. Existing Drainage Patterns

According to the DBPS, the new faculty residences are located in sub-basin 36, which sheet flows generally from the northwest to the southeast, across fields and undeveloped ground, into a system of irrigation ditches running through the site. Minimal runoff generated from the development site ultimately discharges into Crews Gulch and Carp Lake south of the school property. From Carp Lake, runoff drains to the south under Fontaine Boulevard to Widefield Park, to the southwest into Crews Gulch, and ultimately into Fountain Creek.

The Fountain Valley School of Colorado campus is just under 1,000 acres in size. The core campus area is located roughly in the center of the site and is at least a quarter mile from any boundary. The remainder of the site is either native ground (generally north and west) or irrigated hay fields (generally south and east). The site is irrigated with water from the FMIC ditch with a private irrigation ditch system that is managed by the school with a full-time groundskeeper. The private irrigation system is contained entirely within the school's property and is over 19,000 feet in length. The irrigation ditches are designed to flood irrigate the campus. There are almost 175 acres of hay fields on the site.

Storm runoff from the core campus area flows to the irrigation ditch system either by existing stormsewer systems or sheet flow. The irrigation ditches capture the runoff. Should the runoff overwhelm the irrigation ditches either due to the volume of runoff or the fact that the ditches are currently irrigating, the runoff is then sheet flowed across the many hay fields on the site as the system is designed to flood irrigate these fields. The irrigation ditches and hay fields provide detention and water quality for the site. This routing, through relatively flat ditches, slows the runoff and increases the time of concentration which results in much lower peak flows reaching Carp Lake.

IV. Site Drainage Plan

As stated previously, the Fountain Valley School site in its existing condition provides detention and water quality for the site. Based upon our knowledge of the site and its operation along with inspection, the site produces very little runoff compared to historical

conditions. The entire Fountain Valley School property is well vegetated in general and portions of the site are irrigated with a private irrigation ditch system. This ditch system allows for the flood irrigation of the many hay fields on site. There are no visible locations where runoff from the site is concentrated.

Based upon a full spectrum analysis of the currently developed portion of the site, 2.35 acre-feet of total detention storage is required. With the development of the new faculty residences, an additional 0.05 acre-feet (see Figure 3) is required. There are over 6,000 lineal feet of private irrigation ditches on the property that have a storage capacity of 1.11 acre-feet. The hay fields will provide for the detention and water quality for the site. The excess 1.29 acre-feet will be handled by the fields. 1.29 acre-feet equates to approximately 0.29-inches of depth over the tributary hay fields. Using a typical curve number of 58 for a meadow with continuous grass, protected from grazing and generally mowed for hay with B hydrologic soil, and according to the *Procedures for Determining Peak Flows in Colorado*, there would be no runoff generated from the fields for 0.29 inches.

There are no proposed private or public storm sewer facilities associated with the Minor Site Development Plan for Fountain Valley School. The proposed improvements for the site are shown on Figure 2 at the end of this report and will not adversely affect any existing downstream storm sewer facilities or adjacent properties. Proposed improvements are also in conformance with all previously approved drainage studies and reports.

V. Flood Plain Statement

According to the Federal Emergency Management Agency (FEMA), the faculty residence site does not lie within a designated floodplain. The Floodplain Insurance Rate Map (FIRM) 08041C0952 G, dated December 7, 2018 was reviewed to determine any potential floodplain delineation.

VI. Grading and Erosion Control

Earth disturbing activities will result from the construction of the proposed faculty residences and associated drives. It is the developer's responsibility to monitor the condition of the temporary erosion control features. Should any of the erosion control facilities come into disrepair prior to the establishment of the native or natural erosion control measures, the developer is responsible for the maintenance and any associated costs. The developer is also responsible for the clean-up of offsite areas affected by any excessive erosion that may leave the site. All erosion control measures shall be installed and maintained in accordance with the *El Paso County Drainage Criteria Manuals*. Final grading and erosion control plans will be provided within the design plans to be prepared for this project.

The primary erosion control measures to be utilized in this project will include seeding and mulching of all the disturbed areas with the native seed mix. All areas disturbed by

construction shall be seeded and mulched within 21 days after the rough grading has occurred. Cut and fill slopes will be reseeded and the slopes equal to or greater than three-to-one will be protected with erosion control fabric. Silt fences will be placed along the site at the bottom of the re-vegetated and rough graded slopes.

VII. Drainage and Bridge Fees

According to the DBPS, the Fountain Valley School was not included in establishing the drainage and bridge fees for the Big Johnson / Crews Gulch Basin. As the site is not being platted, no drainage or bridge fees are due with the Fountain Valley School Minor Site Development Plan.

VIII. Four Step Process

The site will be developed to minimize wherever possible the rate of developed runoff that will leave the site and to provide water quality management for the runoff produced by the site as proposed on the Minor Site Development Plan. The following steps should be considered when the storm water collection and storage facilities are designed:

Step 1: Employ Runoff Reduction Practices

Gravel has been used as an alternative to concrete or asphalt for the drive areas of the site. Runoff is reduced when gravel is used compared to a concrete or asphalt surfaces. Additionally, the gravel will be able to absorb leakage that might occur from stored vehicles and reduce the amount of greases and oils that could be carried off by runoff.

Step 2: Stabilize Drainageways

No major drainageways cross through the faculty residence site. Runoff from the site will ultimately be collected by existing stabilized irrigation ditches on the Fountain Valley School Property.

Step 3: Implement BMP's That Provide a Water Quality Capture Volume with Slow Release

The minimal increase in impervious area for the overall site and increase in runoff from the proposed improvements will be handled with the existing private irrigation ditch system and hay fields. The irrigation ditches will capture and slow down runoff allowing sediment to settle out and storage to occur. The hay fields effectively act as a grass buffer and provide water quality and flood storage through percolation.

Step 4: Implement Site Specific and Other Source Control BMP's

The school will provide proper spill prevention, containment and control for any potentially hazardous wastes associated with the faculty residence site. During construction source control will be provided with the proper installation of erosion control BMPs to limit erosion and transport of sediment. Areas disturbed by construction will be seeded and mulched. Cut and fill slopes will be reseeded, and the slopes equal to or greater than three-to-one will be protected with erosion control fabric. Silt fences will be placed at the bottom of re-vegetated and rough graded slopes.

Figures

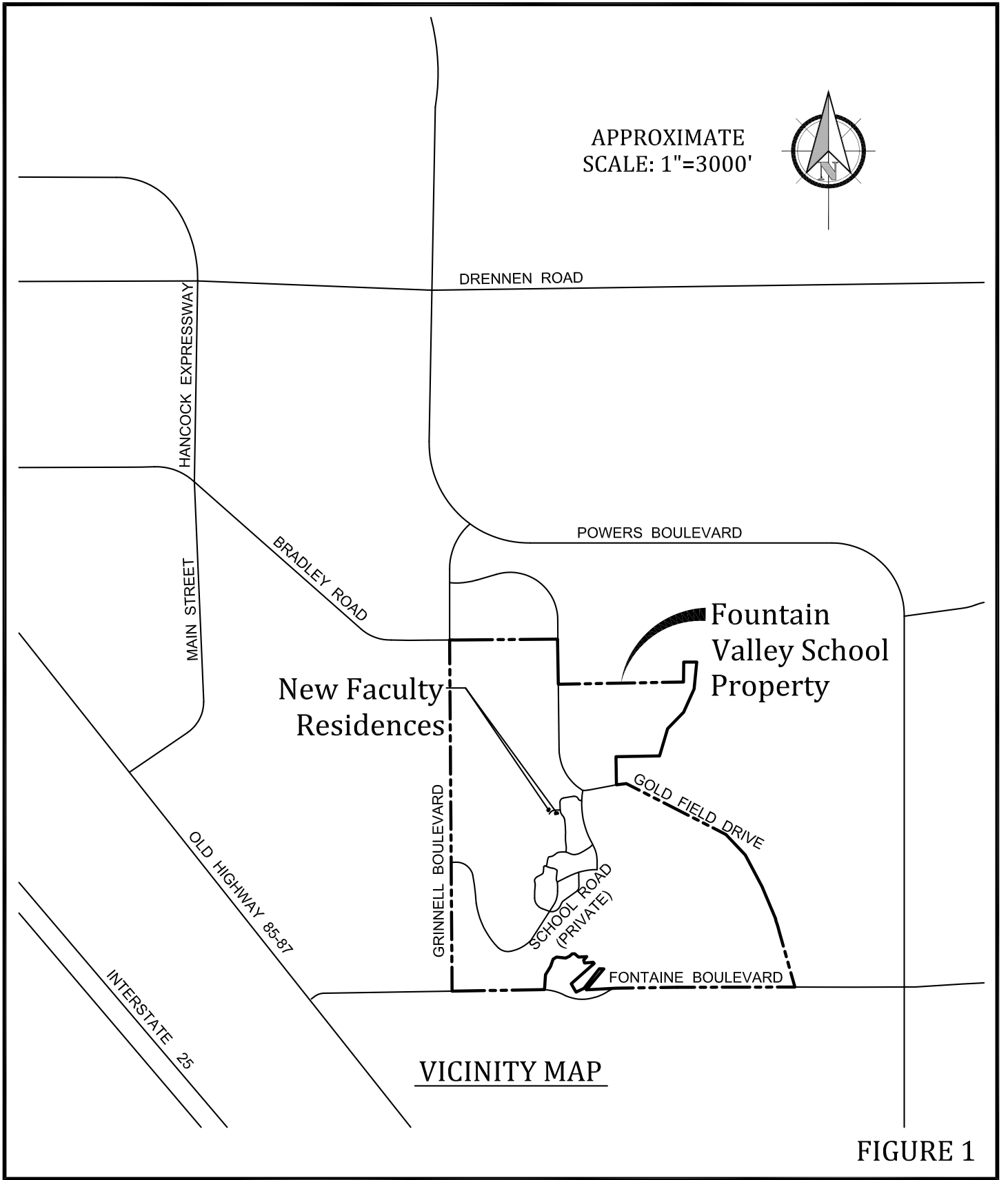

FIGURE 1

Figures 1-3.dwg/Mar. 28, 2019

Fountain Valley School of Colorado
Minor Site Development Plan

6155 Fountain Valley School Road, Colorado Springs, Colorado 80911

Celebrating 30 years
Kiowa
Engineering Corporation

1604 South 21st Street
Colorado Springs, Colorado 80904
(719) 630-7342

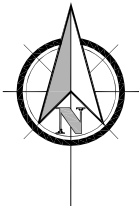

SCALE: 1"=60'

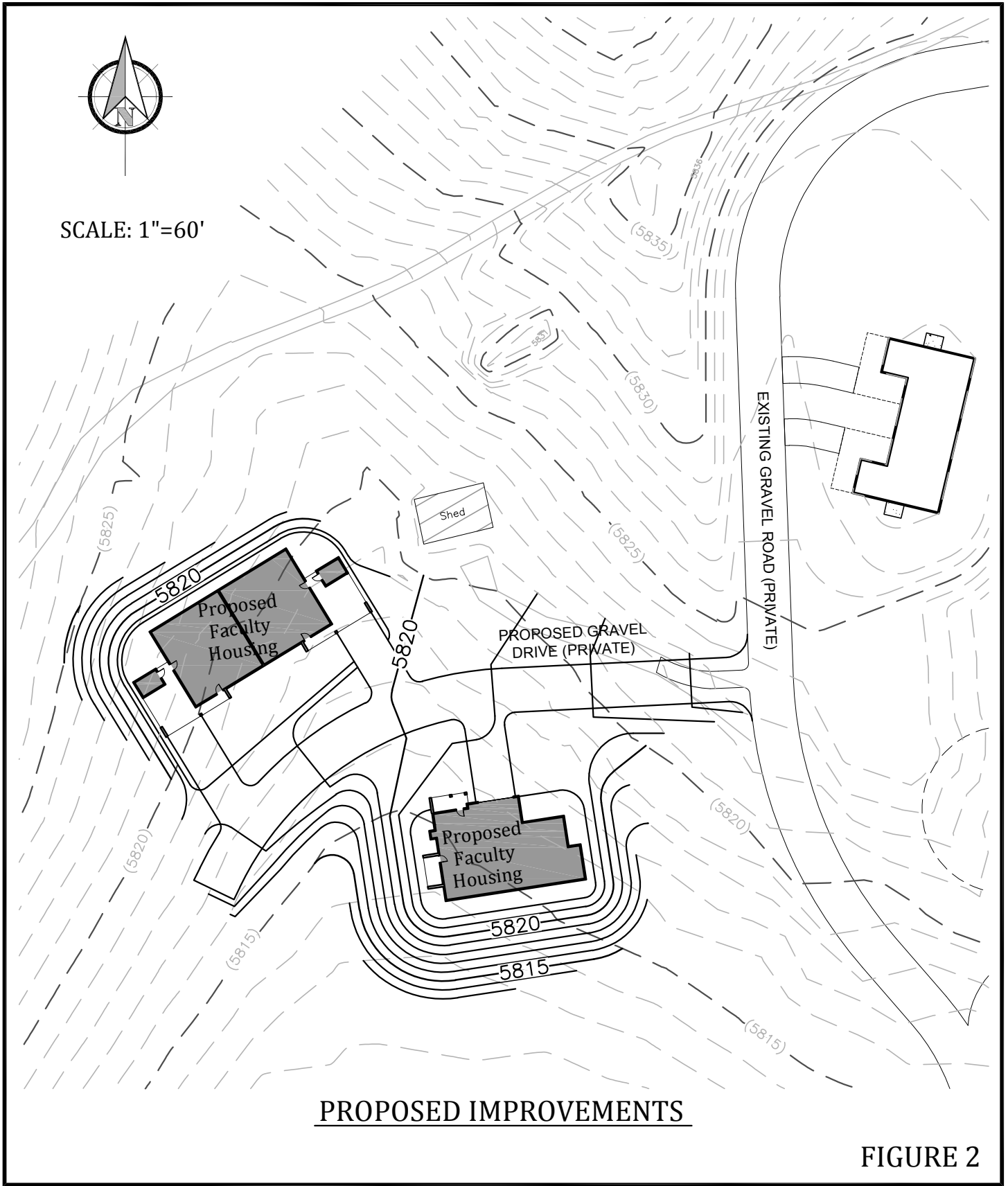

FIGURE 2

Figures 1-3.dwg/May 02, 2019

Fountain Valley School of Colorado Minor Site Development Plan

6155 Fountain Valley School Road, Colorado Springs, Colorado 80911

Celebrating 39 years
Kiowa
Engineering Corporation

1604 South 21st Street
Colorado Springs, Colorado 80904
(719) 630-7342

APPENDIX E – Drainage Plans

PLOT DATE: Friday, May 15, 2026 3:49 PM LAST SAVED BY: AGUEVARA
 DRAWING LOCATION: C:\BUCKLEY\23-0895-Fountain Valley School Academic Building\Plans\Exhibits\Drainage Plans\D1 - DRAINAGE PLAN.dwg

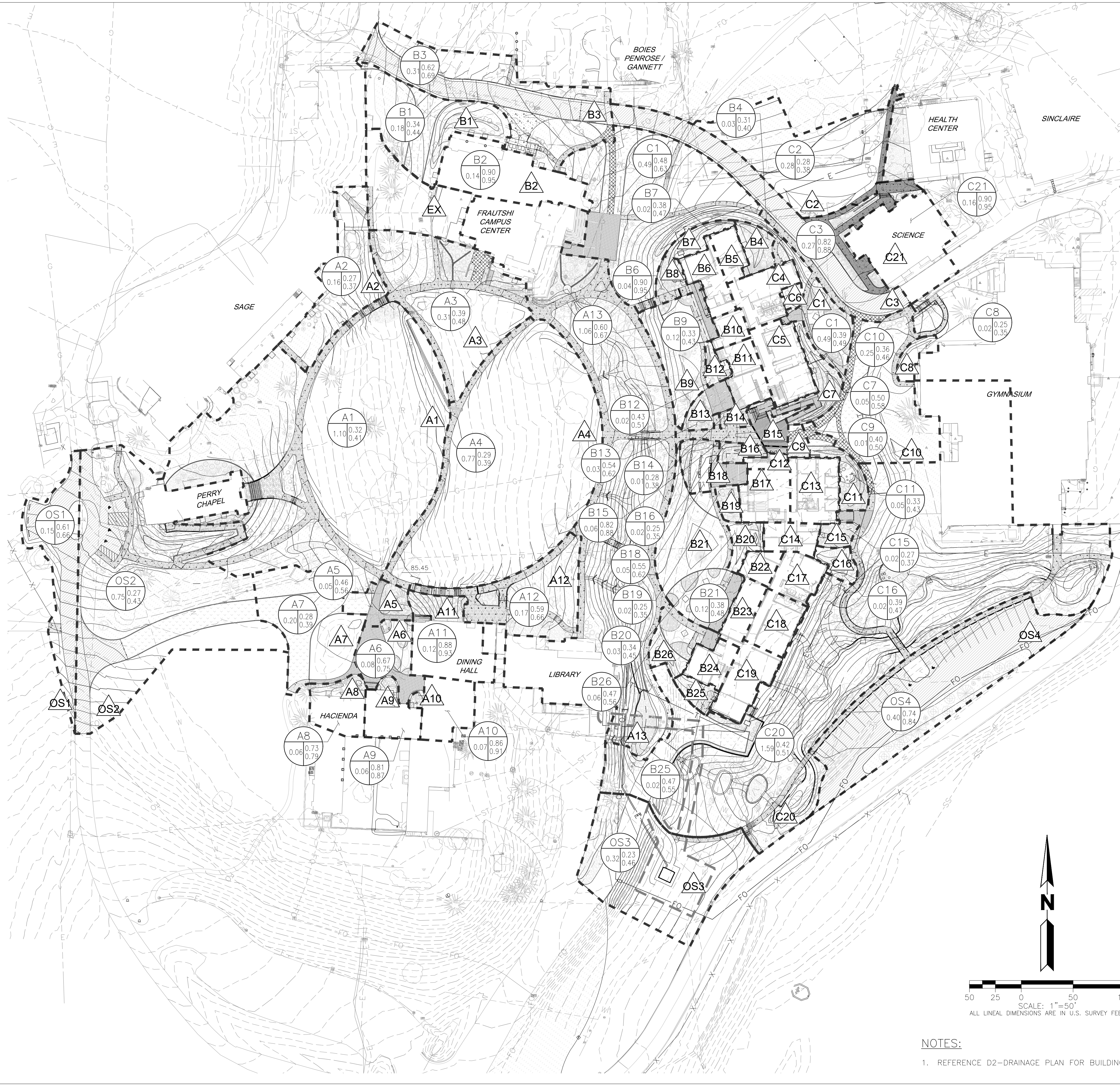

LEGEND

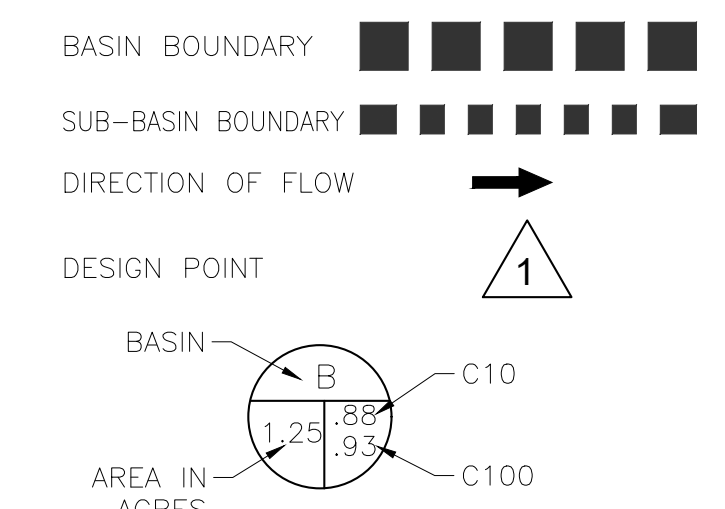

RUNOFF SUMMARY							
BASIN	DESIGN POINT	AREA (ACRES)	% IMP.	C _{II}	C _{III}	Q _{II} (CFS)	Q _{III} (CFS)
A1	A1	1.10	10.3%	0.32	0.41	1.27	2.30
A2	A2	0.16	3.4%	0.27	0.37	0.18	0.43
A3	A3	0.31	21.5%	0.39	0.48	0.56	1.22
A4	A4	0.77	6.1%	0.29	0.39	0.75	1.76
A5	A5	0.05	43.4%	0.46	0.56	0.11	0.24
A6	A6	0.08	73.2%	0.67	0.75	0.27	0.53
A7	A7	0.20	19.2%	0.28	0.38	0.25	0.63
A8	A8	0.06	66.1%	0.73	0.78	0.23	0.44
A9	A9	0.06	78.2%	0.81	0.87	0.24	0.45
A10	A10	0.07	84.3%	0.86	0.91	0.30	0.57
A11	A11	0.12	81.3%	0.88	0.93	0.57	1.07
A12	A12	0.17	51.8%	0.59	0.66	0.43	0.37
A13	A13	1.06	50.8%	0.60	0.67	3.28	6.48
B1	B1	0.18	22.2%	0.34	0.44	0.28	0.65
B2	B2	0.14	30.0%	0.30	0.35	0.68	1.27
B3	B3	0.31	57.5%	0.62	0.68	1.00	1.96
B4	B4	0.03	8.3%	0.31	0.40	0.13	0.11
B5	B5	0.03	30.0%	0.30	0.35	0.13	0.25
B6	B6	0.04	30.0%	0.30	0.35	0.21	0.39
B7	B7	0.02	19.6%	0.38	0.47	0.05	0.11
B8	B8	0.03	45.8%	0.55	0.63	0.08	0.16
B9	B9	0.12	17.7%	0.33	0.43	0.21	0.48
B10	B10	0.02	30.0%	0.30	0.35	0.10	0.19
B11	B11	0.05	30.0%	0.30	0.35	0.23	0.44
B12	B12	0.02	26.3%	0.43	0.51	0.04	0.07
B13	B13	0.03	45.2%	0.54	0.62	0.03	0.18
B14	B14	0.01	5.1%	0.28	0.38	0.01	0.03
B15	B15	0.06	88.2%	0.82	0.88	0.27	0.50
B16	B16	0.02	0.0%	0.25	0.35	0.02	0.06
B17	B17	0.05	30.0%	0.30	0.35	0.26	0.48
B18	B18	0.05	45.8%	0.55	0.62	0.15	0.31
B19	B19	0.02	0.0%	0.25	0.35	0.02	0.05
B20	B20	0.03	22.3%	0.34	0.45	0.05	0.11
B21	B21	0.12	27.5%	0.38	0.48	0.23	0.52
B22	B22	0.02	30.0%	0.30	0.35	0.11	0.20
B23	B23	0.04	30.0%	0.30	0.35	0.17	0.31
B24	B24	0.04	30.0%	0.30	0.35	0.17	0.31
B25	B25	0.02	33.1%	0.47	0.55	0.05	0.10
B26	B26	0.06	38.6%	0.47	0.56	0.13	0.27
C1	C1	0.43	25.8%	0.39	0.43	0.96	2.10
C2	C2	0.28	5.3%	0.28	0.38	0.33	0.77
C3	C3	0.27	81.7%	0.82	0.88	1.17	2.21
C4	C4	0.06	30.0%	0.30	0.35	0.23	0.54
C5	C5	0.08	30.0%	0.30	0.35	0.36	0.67
C6	C6	0.01	4.8%	0.28	0.38	0.01	0.03
C7	C7	0.05	38.3%	0.50	0.58	0.14	0.23
C8	C8	0.02	0.0%	0.25	0.35	0.03	0.07
C9	C9	0.01	36.8%	0.40	0.50	0.03	0.06
C10	C10	0.25	25.3%	0.36	0.46	0.40	0.30
C11	C11	0.05	20.3%	0.33	0.43	0.08	0.18
C12	C12	0.01	30.0%	0.30	0.35	0.06	0.11
C13	C13	0.07	30.0%	0.30	0.35	0.53	0.61
C14	C14	0.03	30.0%	0.30	0.35	0.17	0.31
C15	C15	0.02	2.5%	0.27	0.37	0.03	0.06
C16	C16	0.02	13.7%	0.39	0.47	0.05	0.10
C17	C17	0.04	30.0%	0.30	0.35	0.21	0.38
C18	C18	0.05	30.0%	0.30	0.35	0.25	0.47
C19	C19	0.06	30.0%	0.25	0.35	0.08	0.20
C20	C20	1.53	25.3%	0.42	0.51	2.35	5.01
C21	C21	0.16	32.3%	0.30	0.35	0.75	1.40
SITE COMPOSITE		9.39	36.82	0.24	0.40	21.37	43.67

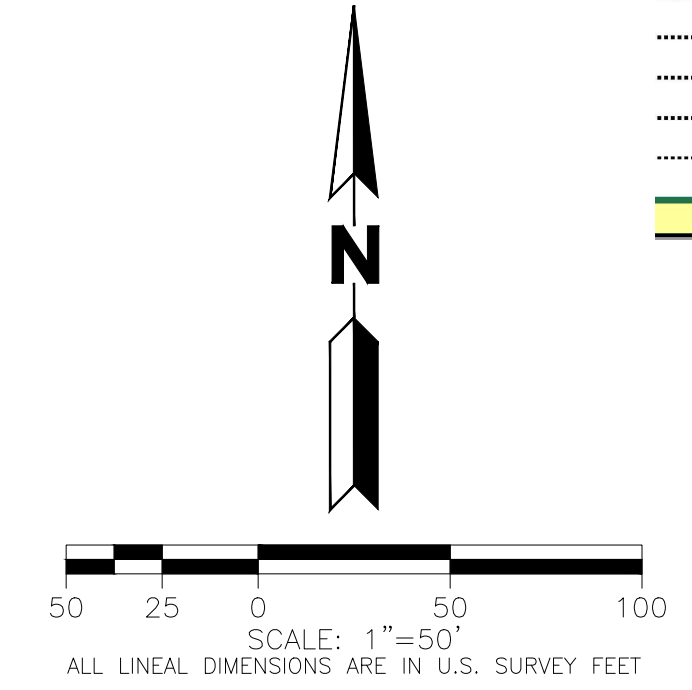

NOTES:
 1. REFERENCE D2--DRAINAGE PLAN FOR BUILDING BASIN BREAKDOWN

BASIS OF BEARING:
 BEARINGS ARE BASED ON THE COLORADO STATE PLANE CENTRAL ZONE NAD83 BEARING OF N89°11'31"E ALONG THE NORTHERLY LINE OF THE NORTHWEST QUARTER OF SECTION 5, T15S, R65W OF THE 6TH P.M. BEING MONUMENTED BY A FOUND 3-3/4" ALUMINUM CAP AT THE NORTHWEST CORNER AND A FOUND 3-3/4" ALUMINUM CAP PLS 17502 AT THE NORTH QUARTER CORNER.

BENCHMARK:
 ELEVATIONS ARE BASED NGS POINT HOWELLS, A NGS BRASS DISK SET IN CONCRETE ON THE SOUTH SIDE OF POWERS ROAD APPROXIMATELY 950 WEST OF THE INTERSECTION WITH PEAK INNOVATION PARKWAY
 ELEVATION = 5934.60 (NAVD1988) DATUM.

12499 West Colfax Avenue
 303.431.6100
 martinmartin.com

FOUNTAIN VALLEY SCHOOL ACADEMIC CENTER DRAINAGE PLAN

No.	Issue / Revision	Date	Name
1	1ST ENGINEERING SUBMITTAL	03/13/26	NLK
2	2ND ENGINEERING SUBMITTAL	05/15/26	NLK

Job Number: 23-0895
 Project Manager: N.KONTOUR
 Design By: A.GUEVARA
 Drawn By: J.D/AZ
 Principal in Charge: P.BUCKLEY

THE DESIGN SHOWN HEREBY INCLUDES ALL TECHNICAL DRAWINGS, GRAPHIC REPRESENTATION & MODELS THEREOF, ARE PROPRIETARY & CAN NOT BE COPIED, DUPLICATED, OR COMMERCIALY EXPLOITED IN WHOLE OR IN PART WITHOUT THE EXPRESS WRITTEN PERMISSION FROM MARTIN/MARTIN, INC.

Sheet Number:
D1
 1 of 2

NOT FOR CONSTRUCTION

PLOT DATE: Monday, March 16, 2026 4:46 PM LAST SAVED BY: MMOLINA
 DRAWING LOCATION: G:\BUCKLEY\23.0895-Fountain Valley School Academic Building\PLANS\EXHIBITS\Drainage Plans\D2 - DRAINAGE PLAN-ROOF PLAN.dwg

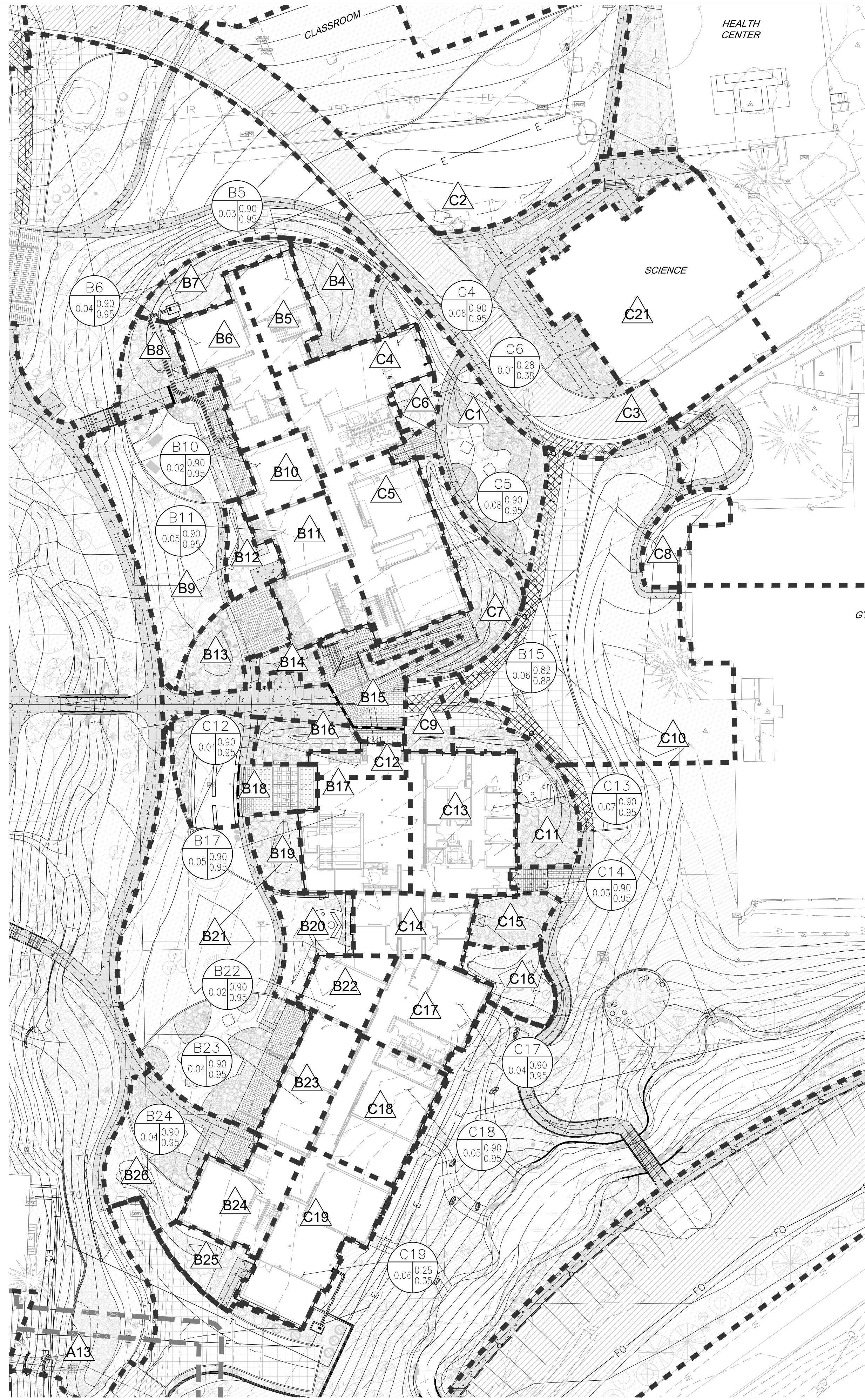

RUNOFF SUMMARY							
BASIN	DESIGN POINT	AREA (ACRES)	% IMP.	C ₁₁	C ₁₁₁	Q ₁₁ (CFS)	Q ₁₁₁ (CFS)
A1	A1	1.10	10.3%	0.32	0.41	1.27	2.90
A2	A2	0.16	3.4%	0.27	0.37	0.18	0.43
A3	A3	0.31	21.5%	0.39	0.48	0.56	1.22
A4	A4	0.77	6.1%	0.29	0.39	0.75	1.76
A5	A5	0.05	43.4%	0.46	0.56	0.11	0.24
A6	A6	0.08	73.2%	0.67	0.75	0.27	0.53
A7	A7	0.20	19.2%	0.28	0.39	0.25	0.63
A8	A8	0.06	66.1%	0.73	0.79	0.23	0.44
A9	A9	0.06	78.2%	0.81	0.87	0.24	0.45
A10	A10	0.07	84.3%	0.86	0.91	0.30	0.57
A11	A11	0.12	67.9%	0.88	0.93	0.57	1.07
A12	A12	0.17	51.8%	0.59	0.66	0.49	0.97
A13	A13	1.06	50.8%	0.60	0.67	3.28	6.48
B1	B1	0.18	22.2%	0.34	0.44	0.38	0.65
B2	B2	0.14	90.0%	0.30	0.35	0.68	1.27
B3	B3	0.31	57.5%	0.62	0.69	1.00	1.96
B4	B4	0.03	8.3%	0.31	0.40	0.05	0.11
B5	B5	0.03	90.0%	0.30	0.35	0.13	0.25
B6	B6	0.04	90.0%	0.30	0.35	0.21	0.39
B7	B7	0.02	19.6%	0.38	0.47	0.05	0.11
B8	B8	0.03	45.8%	0.55	0.63	0.08	0.16
B9	B9	0.12	17.7%	0.33	0.43	0.21	0.48
B10	B10	0.02	90.0%	0.30	0.35	0.10	0.19
B11	B11	0.05	90.0%	0.30	0.35	0.23	0.44
B12	B12	0.02	26.9%	0.43	0.51	0.04	0.07
B13	B13	0.03	45.2%	0.54	0.62	0.09	0.18
B14	B14	0.01	5.1%	0.28	0.38	0.01	0.03
B15	B15	0.06	88.2%	0.82	0.88	0.27	0.50
B16	B16	0.02	0.0%	0.25	0.35	0.02	0.06
B17	B17	0.05	90.0%	0.30	0.35	0.26	0.48
B18	B18	0.05	45.8%	0.55	0.62	0.15	0.31
B19	B19	0.02	0.0%	0.25	0.35	0.02	0.05
B20	B20	0.03	22.3%	0.34	0.45	0.05	0.11
B21	B21	0.12	27.5%	0.38	0.48	0.23	0.52
B22	B22	0.02	90.0%	0.30	0.35	0.11	0.20
B23	B23	0.04	90.0%	0.30	0.35	0.17	0.31
B24	B24	0.04	90.0%	0.30	0.35	0.17	0.31
B25	B25	0.02	33.1%	0.47	0.55	0.05	0.10
B26	B26	0.06	38.6%	0.47	0.56	0.13	0.27
C1	C1	0.49	25.8%	0.39	0.49	0.96	2.10
C2	C2	0.28	5.3%	0.28	0.38	0.33	0.77
C3	C3	0.27	67.7%	0.82	0.88	1.17	2.21
C4	C4	0.06	90.0%	0.30	0.35	0.29	0.54
C5	C5	0.08	90.0%	0.30	0.35	0.36	0.67
C6	C6	0.01	4.8%	0.28	0.38	0.01	0.03
C7	C7	0.05	38.3%	0.50	0.58	0.14	0.29
C8	C8	0.02	0.0%	0.25	0.35	0.03	0.07
C9	C9	0.01	36.6%	0.40	0.50	0.03	0.06
C10	C10	0.25	25.3%	0.36	0.46	0.40	0.90
C11	C11	0.05	20.3%	0.33	0.43	0.08	0.18
C12	C12	0.01	90.0%	0.30	0.35	0.06	0.11
C13	C13	0.07	90.0%	0.30	0.35	0.33	0.61
C14	C14	0.03	90.0%	0.30	0.35	0.17	0.31
C15	C15	0.02	2.5%	0.27	0.37	0.03	0.06
C16	C16	0.02	19.7%	0.39	0.47	0.05	0.10
C17	C17	0.04	90.0%	0.30	0.35	0.21	0.38
C18	C18	0.05	90.0%	0.30	0.35	0.25	0.47
C19	C19	0.06	90.0%	0.25	0.35	0.08	0.20
C20	C20	1.59	25.9%	0.42	0.51	2.35	5.01
C21	C21	0.16	92.3%	0.30	0.35	0.75	1.40
SITE COMPOSITE		9.39	36.8%	0.24	0.40	21.37	43.67

NOTES:

1. REFERENCE D1-DRAINAGE PLAN FOR SITE BASIN BREAKDOWN.

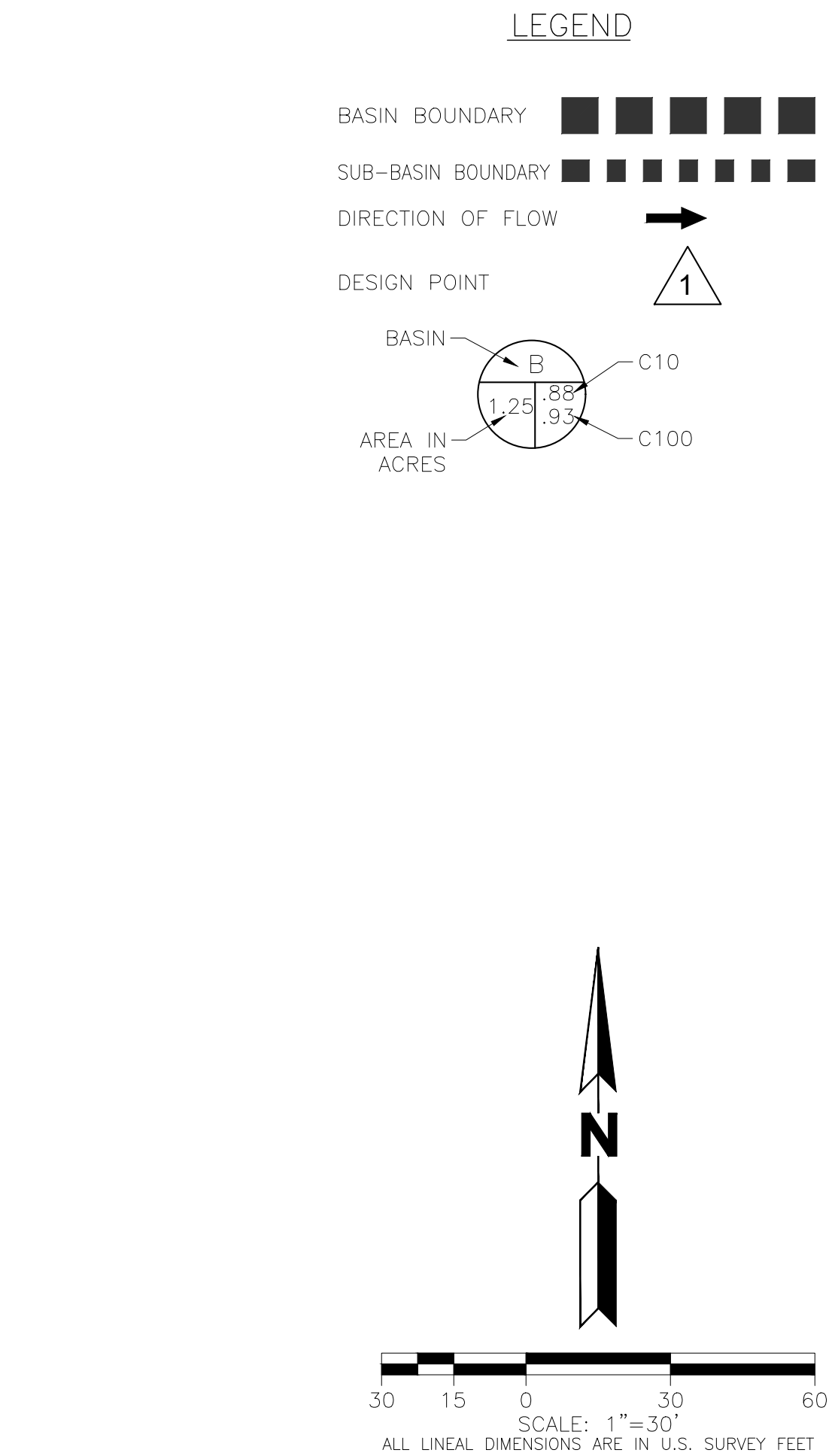

BASIS OF BEARING:
 BEARINGS ARE BASED ON THE COLORADO STATE PLANE CENTRAL ZONE NAD83 BEARING OF N89°11'31"E ALONG THE NORTHERLY LINE OF THE NORTHWEST QUARTER OF SECTION 5, T15S, R65W OF THE 6TH P.M. BEING MONUMENTED BY A FOUND 3-1/4" ALUMINUM CAP AT THE NORTHWEST CORNER AND A FOUND 3-1/4" ALUMINUM CAP PLS 17502 AT THE NORTH QUARTER CORNER.

BENCHMARK:
 ELEVATIONS ARE BASED NGS POINT HOWELLS, A NGS BRASS DISK SET IN CONCRETE ON THE SOUTH SIDE OF POWERS ROAD APPROXIMATELY 950 WEST OF THE INTERSECTION WITH PEAK INNOVATION PARKWAY.
 ELEVATION = 5934.60 (NAVD1988) DATUM.

12495 West Colfax Avenue
Lakewood, Colorado 80215
303.431.6100
martinmartin.com

FOUNTAIN VALLEY SCHOOL ACADEMIC CENTER

DRAINAGE PLAN

NOT FOR CONSTRUCTION

No.	Issue / Revision	Date	Name
1	1ST ENGINEERING SUBMITTAL	03/13/26	NLK
2	2ND ENGINEERING SUBMITTAL	05/15/26	NLK

Job Number	23.0895
Project Manager	N.KONTOUR
Design By	A.GUEVARA
Drawn By	J.DIAZ
Principal in Charge	P.BUCKLEY

THE DESIGN SHOWN HEREIN INCLUDING TECHNICAL DRAWINGS, CALCULATIONS, AND EXHIBITS IS THE PROPERTY OF MARTIN/MARTIN CONSULTING ENGINEERS. IT IS TO BE USED ONLY FOR THE PROJECT AND SITE SPECIFICALLY IDENTIFIED HEREIN. IT IS NOT TO BE REPRODUCED, COPIED, OR COMMERCIALLY EXPLOITED IN WHOLE OR IN PART WITHOUT THE WRITTEN PERMISSION FROM MARTIN/MARTIN, INC.

Sheet Number:

D2

2 of 2

PLOT DATE: Monday, March 16, 2026 5:07 PM LAST SAVED BY: MMOLINA
 DRAWING LOCATION: G:\BUCKLEY\23,0895-Fountain Valley School Academic Building\PLANS\EXHIBITS\Drainage Plans\Existing Drainage Plan Exhibit.dwg

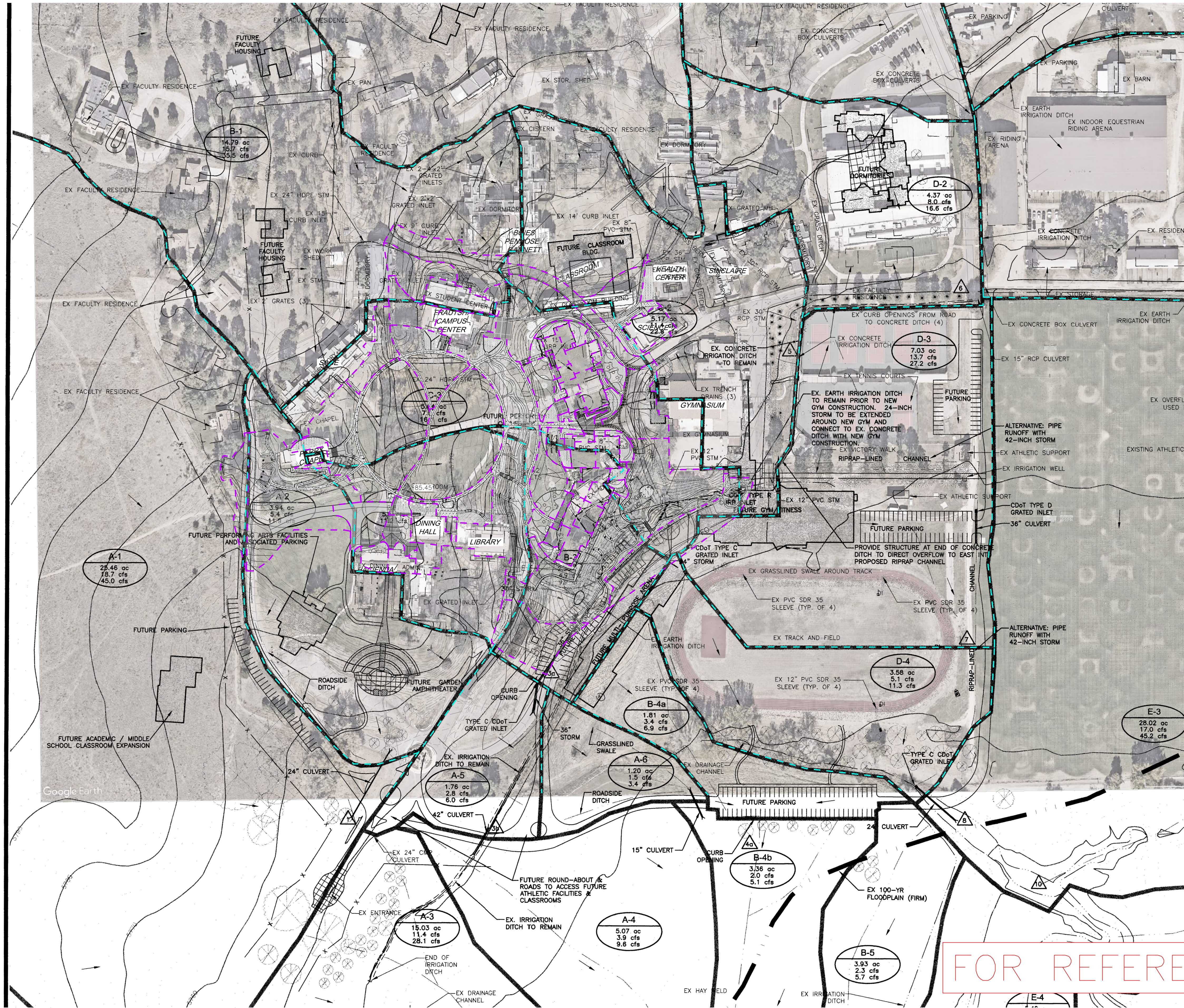

- - - PROPOSED DRAINAGE BASIN
- - - EXISTING DRAINAGE BASIN



FOUNTAIN VALLEY SCHOOL ACADEMIC CENTER
DRAINAGE PLAN

No.	Issue / Revision	Date	Name
1	1ST ENGINEERING SUBMITTAL	03/13/25	NJK

Job Number: 23,0895
 Project Manager: N.KONTOUR
 Design By: A. GUEVARA
 Drawn By: M.MOLINA
 Principal In Charge: P.BUCKLEY
 SHEETS SHOWN HEREIN INCLUDING ALL TECHNICAL DRAWINGS, FIGURES, TABLES, AND NOTES ARE THE PROPERTY OF MARTIN/MARTIN, INC. AND CAN NOT BE COPIED, REPRODUCED, OR COMMERCIALY EXPLOITED IN WHOLE OR IN PART WITHOUT THE WRITTEN PERMISSION FROM MARTIN/MARTIN, INC.

Sheet Number:
EX-1
 1 OF 1

NOT FOR CONSTRUCTION