



HYDROLOGIC SOIL GROUP	
MAP UNIT NUMBER	DESCRIPTION
40	KETTLE GRAVELLY LOAMY SAND, HYDROLOGIC SOIL GROUP B, SLIGHT TO MODERATE HAZARD OF EROSION
71	PRING COARSE SANDY LOAM, HYDROLOGIC SOIL GROUP B, MODERATE HAZARD OF EROSION

EROSION CONTROL DATA	
<b>TIMING</b>	
ANTICIPATED START & COMPLETION TIME PERIOD OF SITE GRADING	--
EXPECTED DATE ON WHICH FINAL STABILIZATION WILL BE COMPLETED	--
<b>AREAS</b>	
TOTAL AREA OF SITE	35.296 ACRES
AREA OF THE SITE TO BE CLEARED, EXCAVATED OR GRADED	3.14 ACRES
<b>RECEIVING WATERS</b>	
NAME OF RECEIVING WATERS	COTTONWOOD CREEK
<b>SOIL DATA</b>	
PRIMARY SOIL DESCRIPTION	SEE TABLE
PERMEABILITY	RAPID
SURFACE RUNOFF	MEDIUM
HAZARD OF EROSION	MODERATE
HYDROLOGIC SOIL GROUP	B
EXISTING PERCENT IMPERVIOUS	8%
DEVELOPED PERCENT IMPERVIOUS	13.9%

**BMP LEGEND**

MAP SYMBOL	KEY	DESCRIPTION
[Symbol]	SP	STOCKPILE MANAGEMENT (Initial BMP)
[Symbol]	SSA	STABILIZED STAGING AREA (Initial BMP)
[Symbol]	SCL	SEDIMENT CONTROL LOG (Initial BMP)
[Symbol]	VTC	VEHICLE TRACKING CONTROL (Initial BMP)
[Symbol]	SF	SILT FENCE (Initial BMP)
[Symbol]	IP	CULVERT INLET PROTECTION (Initial BMP)
[Symbol]	ECB	EROSION CONTROL BLANKET (Interim BMP)
[Symbol]	SBB	STRAW BALE BARRIER AS CHECK DAM (Interim BMP)
[Symbol]	OP	OUTLET PROTECTION (RIP-RAP) (Interim BMP)

**BMP LEGEND**

MAP SYMBOL	KEY	DESCRIPTION
[Symbol]	SR	SURFACE ROUGHENING (Final BMP)
[Symbol]	MU	MULCHING (Final BMP)
[Symbol]	PS	PERMANENT SEEDING (Final BMP)
[Symbol]	RCD	ROCK CHECK DAM (Final BMP)
[Symbol]		DRAINAGE FLOW ARROW
[Symbol]		LIMITS OF CONSTRUCTION/DISTURBANCE
[Symbol]		LIMITS OF SOIL TYPE
[Symbol]		CUT/FILL BOUNDARY

**EROSION CONTROL NOTES**

- 1.) ALL DISTURBED AREAS SHALL BE REVEGETATED. SEE GENERAL NOTES FOR SEED MIX AND APPLICATION NOTES.
- 2.) RIP-RAP APRONS WILL BE PLACED AT ALL CULVERT OUTLETS. (SEE DETAILS FOR RIP-RAP APRONS ON THIS SHEET.)
- 3.) HAY BALES WILL BE PLACED UPSTREAM OF CULVERTS IN NEW ROADSIDE DITCHES AS DETERMINED IN THE FIELD BY THE ENGINEER.
- 4.) ALL PERSONS ENGAGED IN EARTH DISTURBANCE SHALL IMPLEMENT AND MAINTAIN ACCEPTABLE SOIL EROSION AND SEDIMENT CONTROL MEASURES INCLUDING BMPs IN CONFORMANCE WITH THIS EROSION CONTROL PLAN AND THE BMP DETAILS SHOWN ON THIS PLAN.
- 5.) THE INSTALLATION OF THE FIRST LEVEL OF TEMPORARY EROSION CONTROL FACILITIES AND BMPs SHALL BE INSTALLED PRIOR TO ANY EARTH DISTURBANCE OPERATIONS TAKING PLACE.
- 6.) CONTRACTOR SHALL PROVIDE APPROPRIATE EROSION CONTROL MEASURES DURING EARTHWORK OPERATIONS TO CONTROL EROSION AND SEDIMENT TRANSFER TO ADJACENT PROPERTIES. EROSION CONTROL MEASURES ARE NOT LIMITED TO THOSE NOTED ON THIS PLAN.
- 7.) SEDIMENT (MUD AND DIRT) TRANSPORTED ONTO A PUBLIC ROAD, REGARDLESS OF THE SIZE OF THE SITE, SHALL BE CLEANED AT THE END OF EACH DAY.
- 8.) SOIL EROSION CONTROL MEASURES FOR ALL SLOPES, CHANNELS, DITCHES, OR ANY DISTURBED LAND AREA SHALL BE COMPLETED WITHIN FOURTEEN (14) CALENDAR DAYS AFTER FINAL GRADING OR FINAL EARTH DISTURBANCE HAS BEEN COMPLETED. DISTURBED AREAS AND STOCKPILES WHICH ARE NOT AT FINAL GRADE BUT WILL REMAIN DORMANT FOR LONGER THAN 30 DAYS SHALL ALSO BE MULCHED WITHIN 14 DAYS AFTER INTERIM GRADING. AN AREA THAT IS GOING TO REMAIN IN AN INTERIM STATE FOR MORE THAN 60 DAYS SHALL ALSO BE SEEDED. ALL TEMPORARY SOIL EROSION CONTROL MEASURES AND BMPs SHALL BE MAINTAINED UNTIL PERMANENT SOIL EROSION CONTROL MEASURES ARE IMPLEMENTED.

**GENERAL NOTES**

THERE ARE NO PROPOSED BATCH PLANTS ON SITE  
 THERE ARE NOT ANY NO-BUILD AREAS INDICATED ON THIS PLAN

VEGETATION:  
 SITE CONSIST OF OPEN PRAIRIE WITH NATIVE GRASSES.

\*NOTE: CONTRACTOR MAY NEED EPC \*WORK IN THE ROW PERMIT FOR THE CONNECTION TO THE EXISTING ROAD.

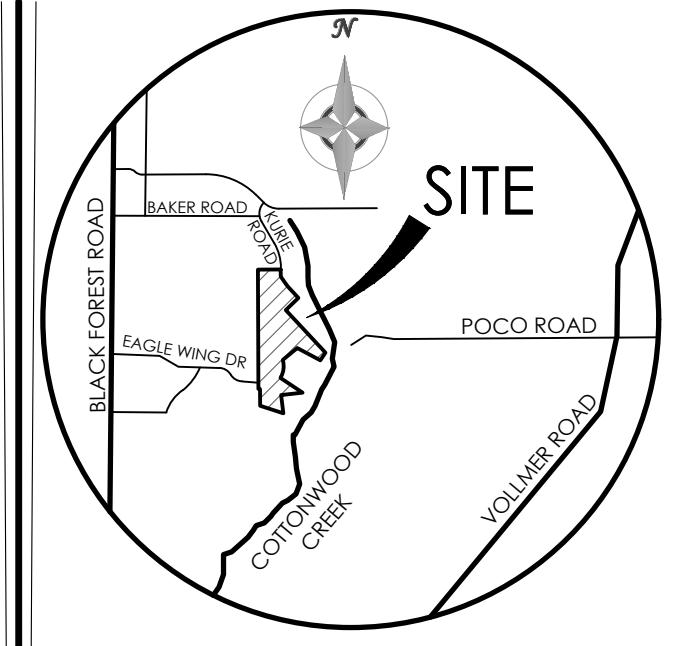

VICINITY MAP  
NOT TO SCALE

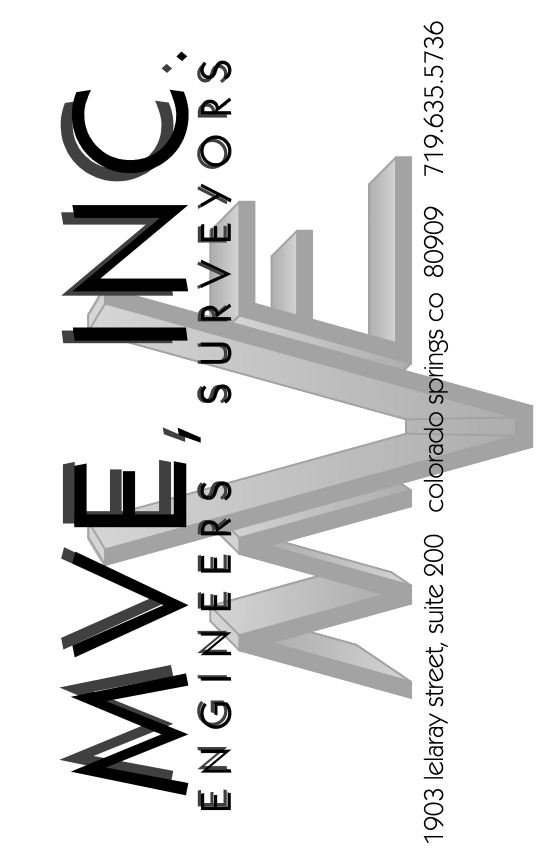
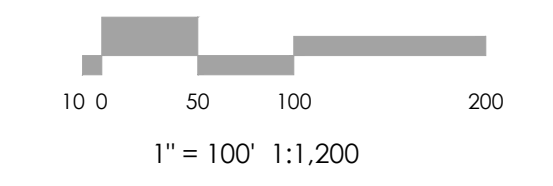
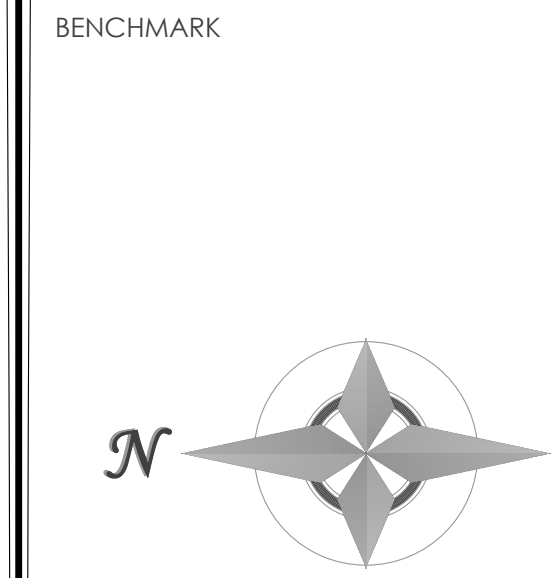

REVISIONS

DESIGNED BY \_\_\_\_\_  
 DRAWN BY \_\_\_\_\_  
 CHECKED BY \_\_\_\_\_  
 AS-BUILTS BY \_\_\_\_\_  
 CHECKED BY \_\_\_\_\_

EAGLE RISING FILING NO. 1

GRADING & EROSION CONTROL PLAN  
 EROSION CONTROL

MVE PROJECT 61145  
 MVE DRAWING GEC-EC

JULY 1, 2022  
 C1.2 SHEET 2 OF 4

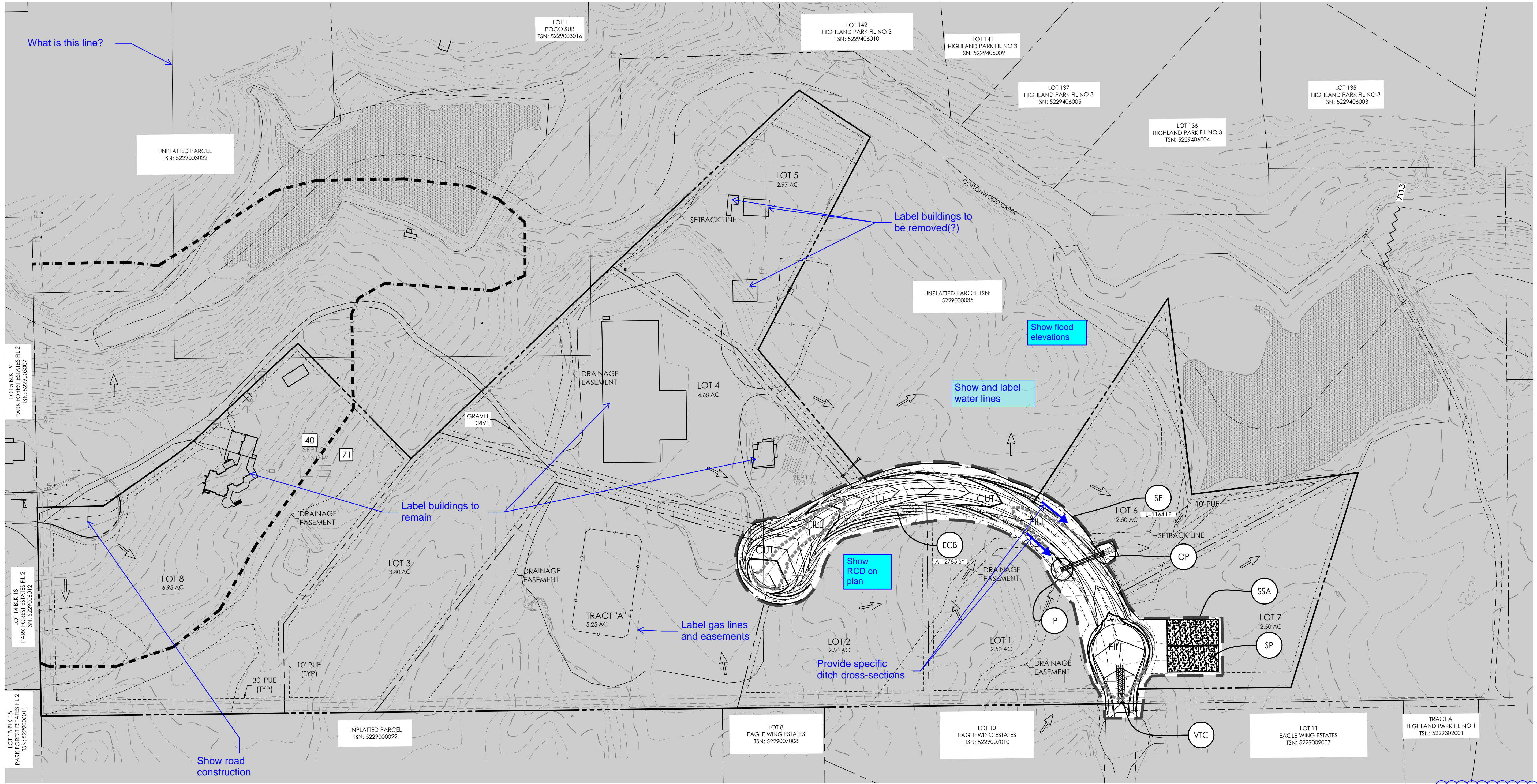

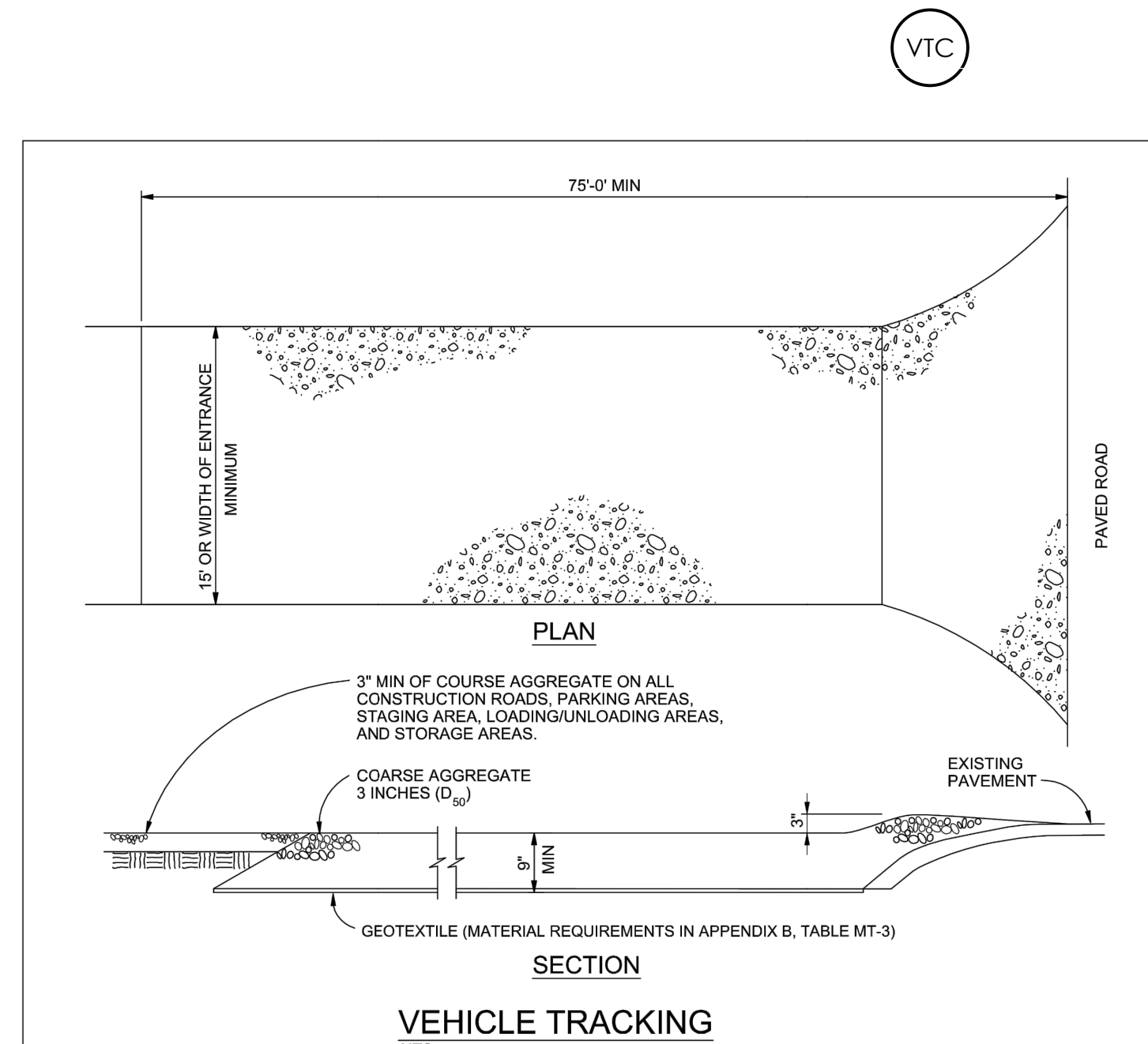

**VEHICLE TRACKING NOTES**

**INSTALLATION REQUIREMENTS**

1. ALL ENTRANCES TO THE CONSTRUCTION SITE ARE TO BE STABILIZED PRIOR TO CONSTRUCTION BEGINNING.
2. CONSTRUCTION ENTRANCES ARE TO BE BUILT WITH AN APRON TO ALLOW FOR TURNING TRAFFIC, BUT SHOULD NOT BE BUILT OVER EXISTING PAVEMENT EXCEPT FOR A SLIGHT OVERLAP.
3. AREAS TO BE STABILIZED ARE TO BE PROPERLY GRADED AND COMPACTED PRIOR TO LAYING DOWN GEOTEXTILE AND STONE.
4. CONSTRUCTION ROADS, PARKING AREAS, LOADING/UNLOADING ZONES, STORAGE AREAS, AND STAGING AREAS ARE TO BE STABILIZED.
5. CONSTRUCTION ROADS ARE TO BE BUILT TO CONFORM TO SITE GRADES, BUT SHOULD NOT HAVE SIDE SLOPES OR ROAD GRADES THAT ARE EXCESSIVELY STEEP.

**MAINTENANCE REQUIREMENTS**

1. REGULAR INSPECTIONS ARE TO BE MADE OF ALL STABILIZED AREAS, ESPECIALLY AFTER STORM EVENTS.
2. STONES ARE TO BE REAPPLIED PERIODICALLY AND WHEN REPAIR IS NECESSARY.
3. SEDIMENT TRACKED ONTO PAVED ROADS IS TO BE REMOVED DAILY BY SHOVELING OR SWEEPING. SEDIMENT IS NOT TO BE WASHED DOWN STORM SEWER DRAINS.
4. STORM SEWER INLET PROTECTION IS TO BE IN PLACE, INSPECTED, AND CLEANED IF NECESSARY.
5. OTHER ASSOCIATED SEDIMENT CONTROL MEASURES ARE TO BE INSPECTED TO ENSURE GOOD WORKING CONDITION.

City of Colorado Springs  
Stormwater Quality

Figure VT-2  
Vehicle Tracking  
Application Examples

3-54

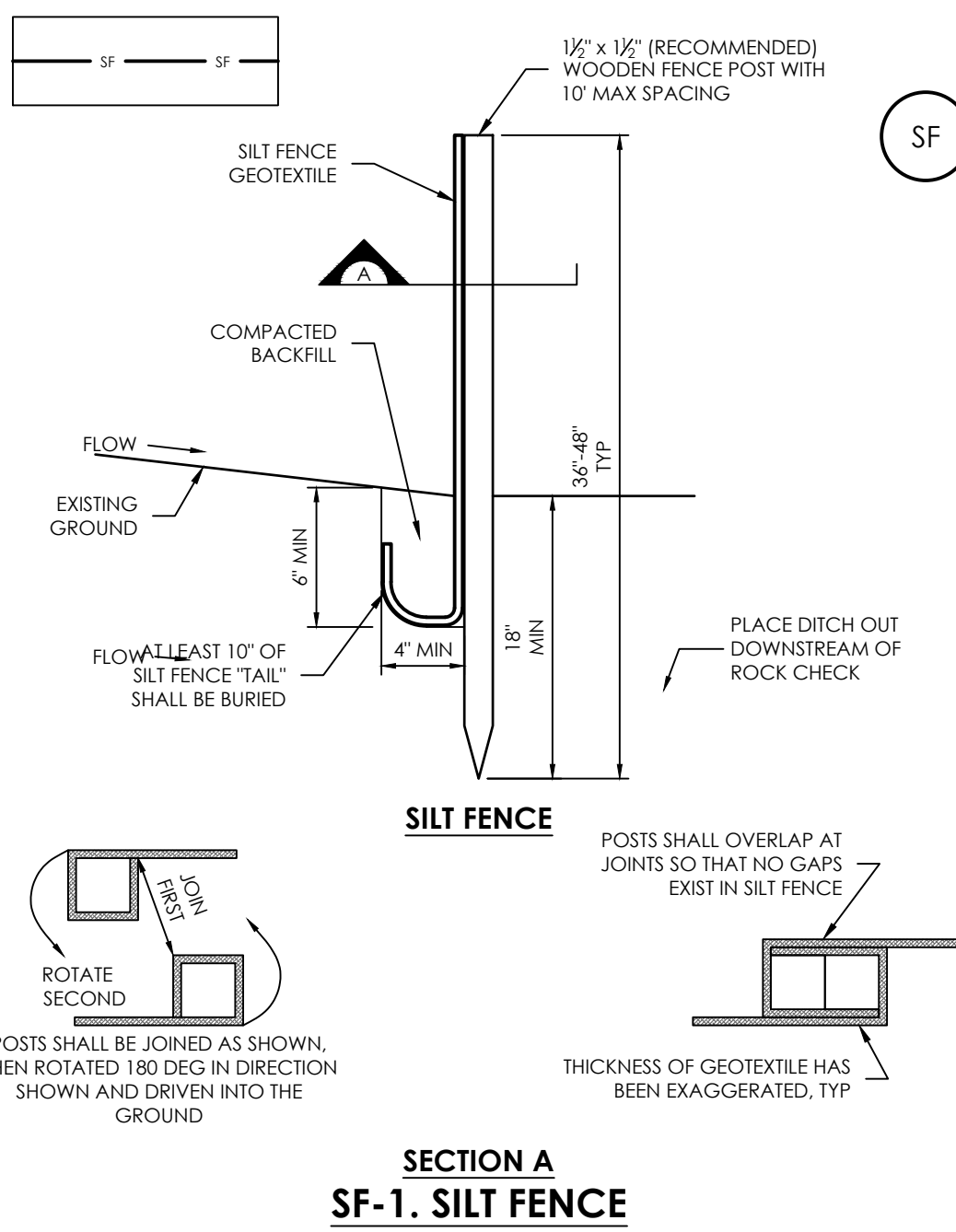

**SECTION A  
SF-1. SILT FENCE**

**SILT FENCE INSTALLATION NOTES**

1. SILT FENCE MUST BE PLACED AWAY FROM THE TOE OF THE SLOPE TO ALLOW FOR WATER PONDING. SILT FENCE AT THE TOE OF A SLOPE SHOULD BE INSTALLED IN A FLAT LOCATION AT LEAST SEVERAL FEET (2-5 FT) FROM THE TOE OF THE SLOPE TO ALLOW ROOM FOR PONDING AND DEPOSITION.
2. A UNIFORM 6\"/>

**SILT FENCE MAINTENANCE NOTES**

1. INSPECT BMPs EACH WORKDAY, AND MAINTAIN THEM IN EFFECTIVE OPERATING CONDITION. MAINTENANCE OF BMPs SHOULD BE PROACTIVE, NOT REACTIVE. INSPECT BMPs AS SOON AS POSSIBLE (AND ALWAYS WITHIN 24 HOURS) FOLLOWING A STORM THAT CAUSES SURFACE EROSION, AND PERFORM NECESSARY MAINTENANCE.
2. FREQUENT OBSERVATIONS AND MAINTENANCE ARE NECESSARY TO MAINTAIN BMPs IN EFFECTIVE OPERATING CONDITION. INSPECTIONS AND CORRECTIVE MEASURES SHOULD BE DOCUMENTED THOROUGHLY.
3. WHERE BMPs HAVE FAILED, REPAIR OR REPLACEMENT SHOULD BE INITIATED UPON DISCOVERY OF THE FAILURE.
4. SEDIMENT ACCUMULATED UPSTREAM OF THE SILT FENCE SHALL BE REMOVED AS NEEDED TO MAINTAIN THE FUNCTIONALITY OF THE BMP, TYPICALLY WHEN DEPTH OF ACCUMULATED SEDIMENTS IS APPROXIMATELY 6\"/>

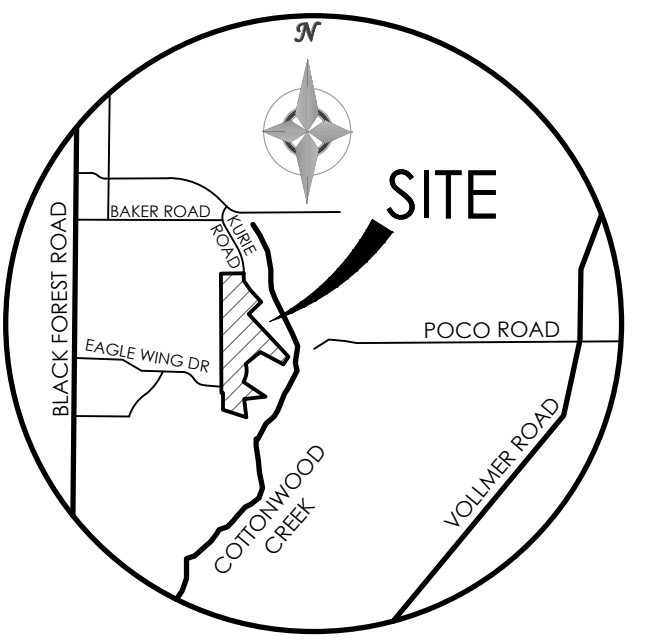

**VICINITY MAP**

NOT TO SCALE

BENCHMARK

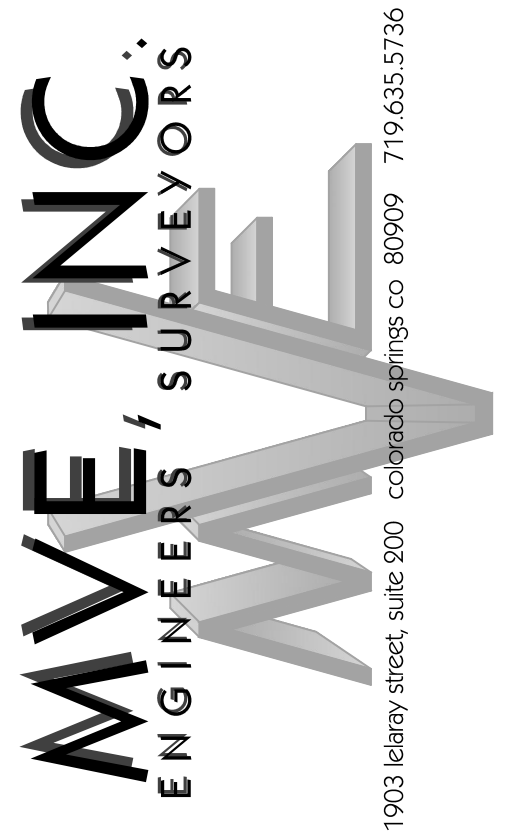
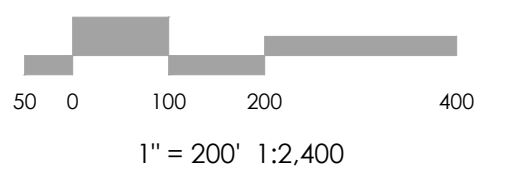
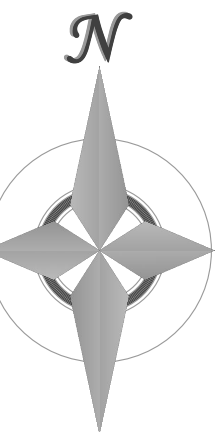

REVISIONS

DESIGNED BY \_\_\_\_\_  
DRAWN BY \_\_\_\_\_  
CHECKED BY \_\_\_\_\_  
AS-BUILTS BY \_\_\_\_\_  
CHECKED BY \_\_\_\_\_

**EAGLE RISING  
FILING NO. 1**

**GRADING & EROSION  
CONTROL PLAN  
DETALS**

MVE PROJECT 61145  
MVE DRAWING GEC-EC2

JULY 1, 2022  
**C1.3 SHEET 3 OF 4**

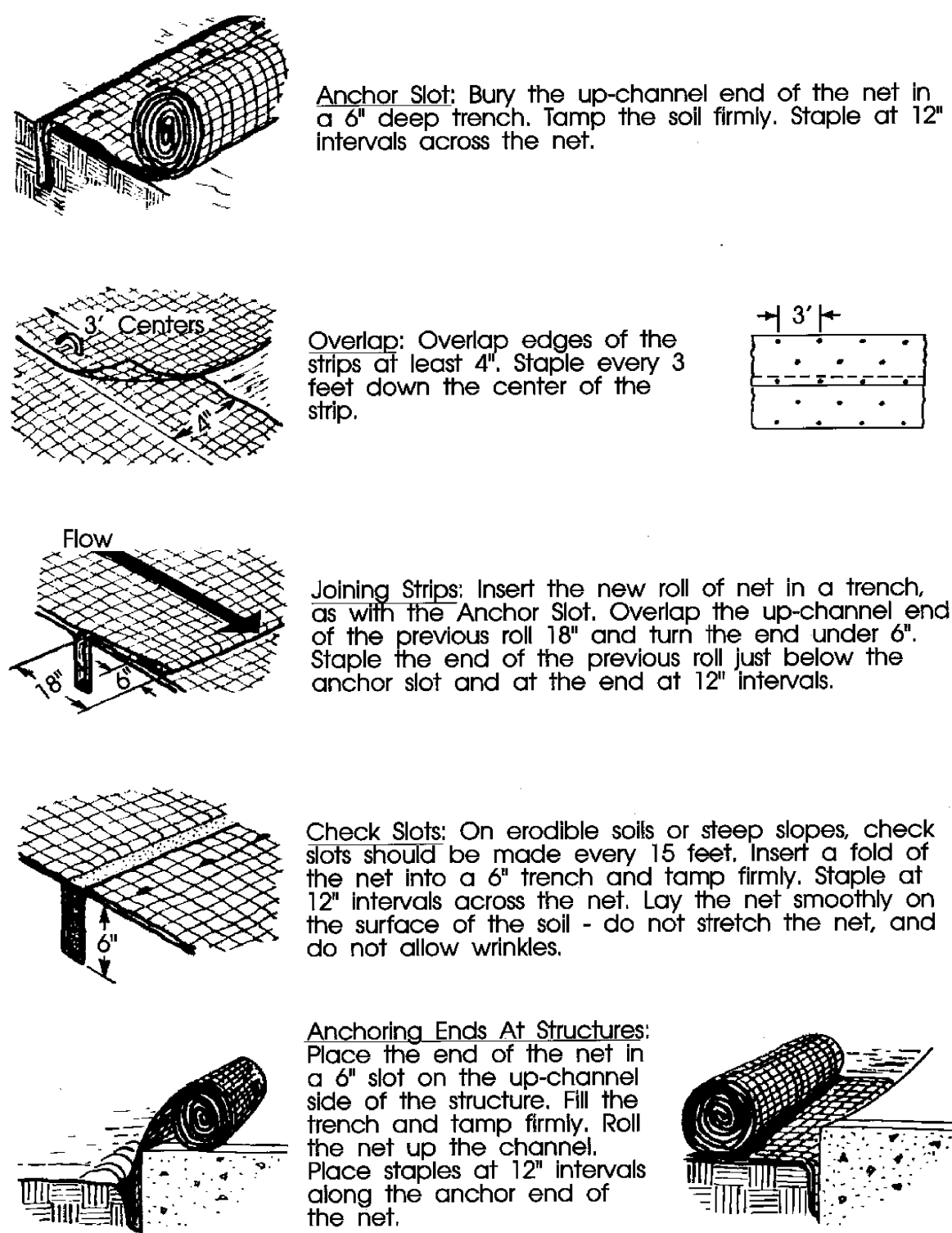

City of Colorado Springs  
Storm Water Quality

Figure ECB-2  
Erosion Control Blanket  
Installation Requirements

3-23

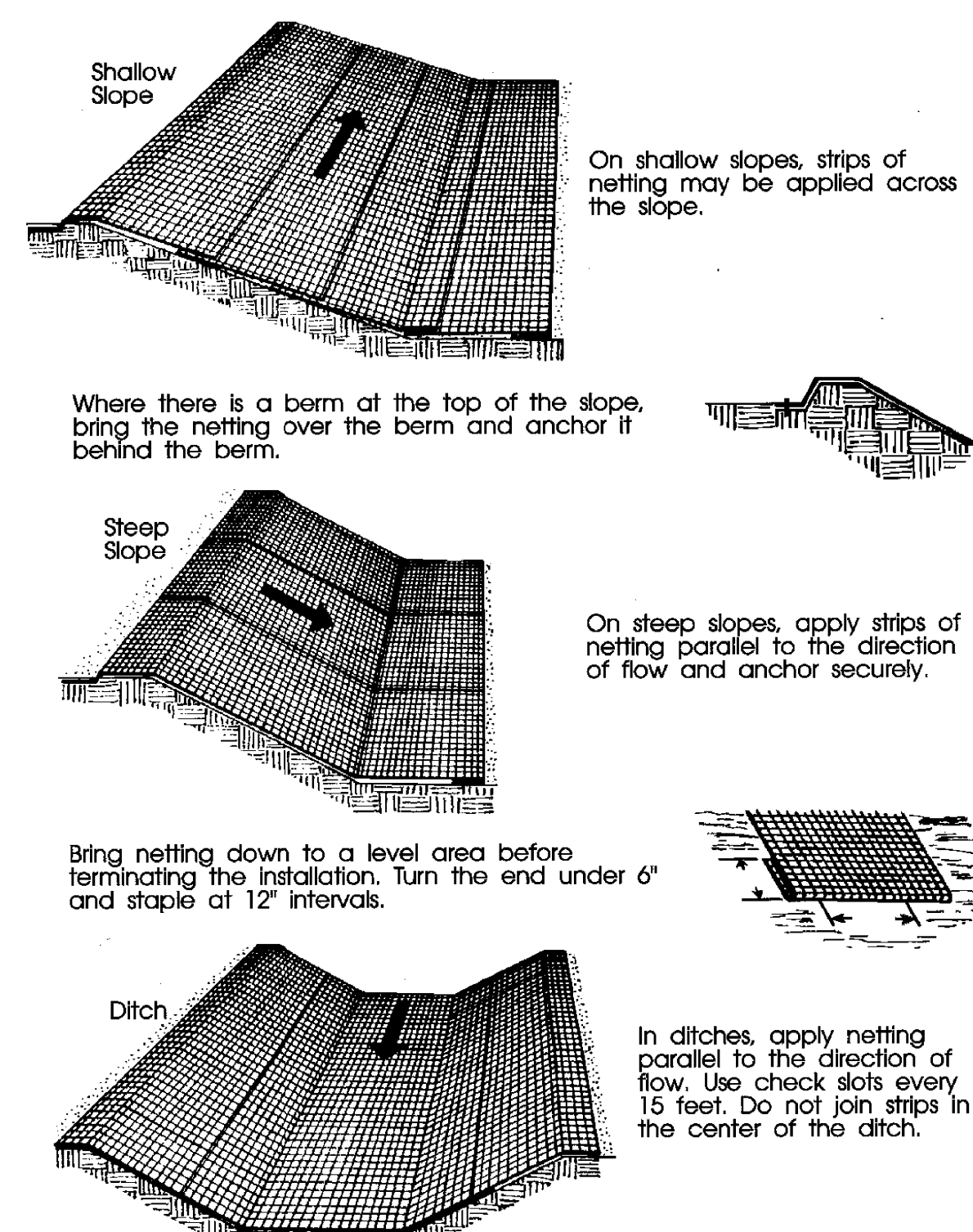

City of Colorado Springs  
Storm Water Quality

Figure ECB-1  
Erosion Control Blanket  
Application Examples

3-22

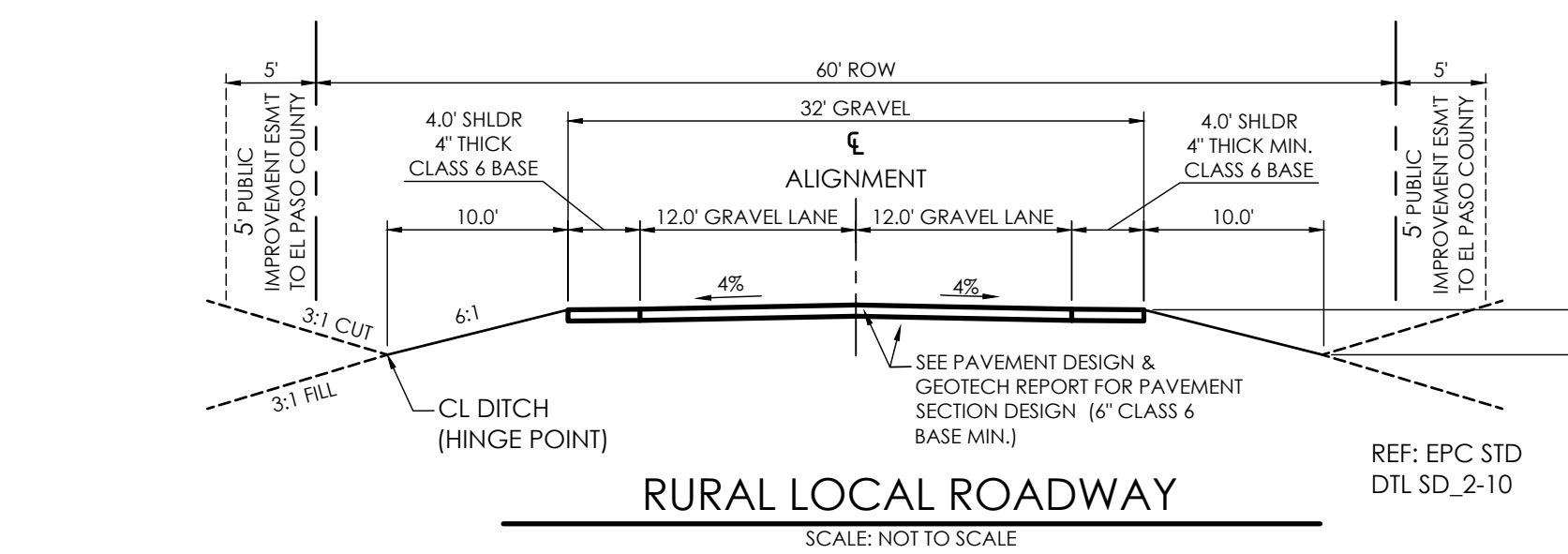

NOTE: A PAVEMENT DESIGN REPORT WILL BE REQUIRED BEFORE PLACEMENT OF GRAVEL.

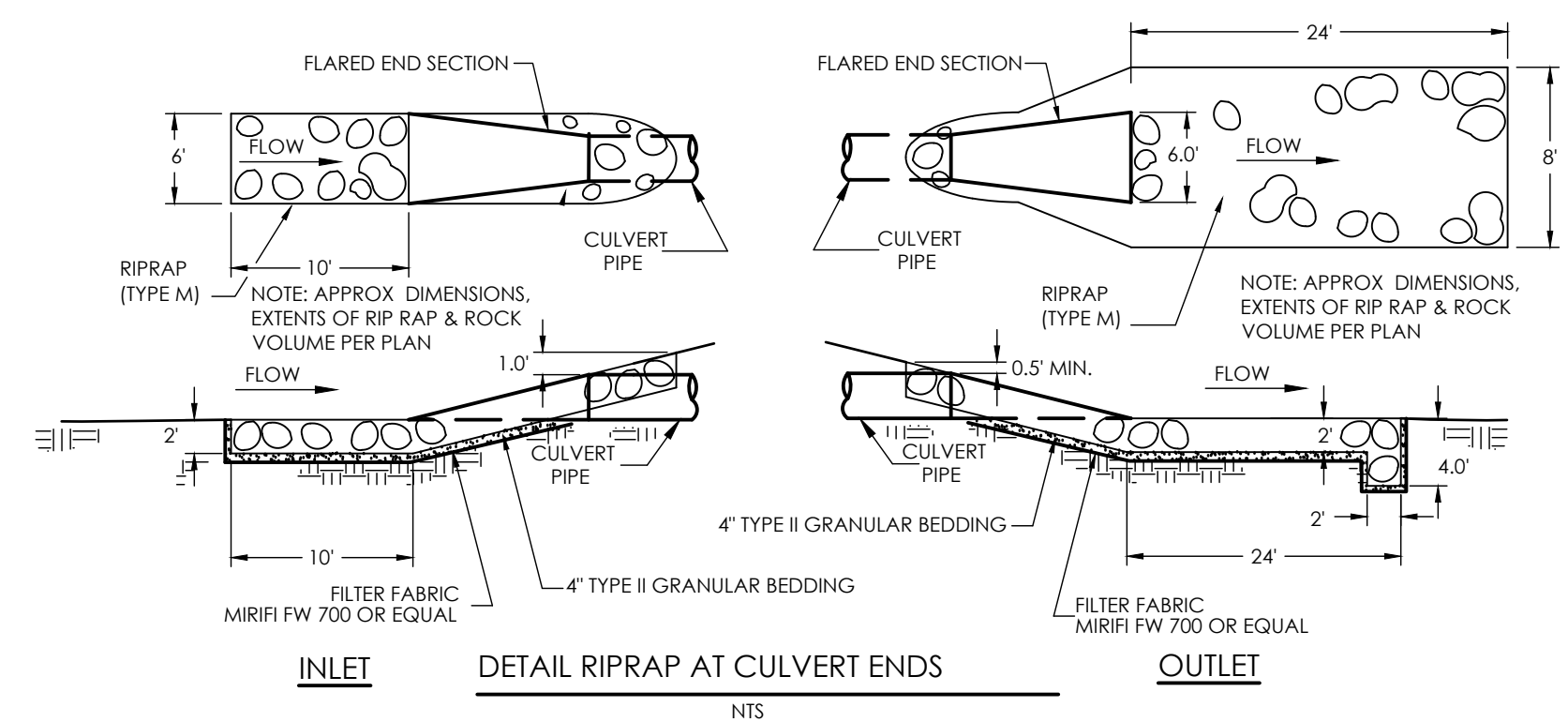

**Stabilized Staging Area (SSA) SM-6**

SSA
SSA

**SSA-1. STABILIZED STAGING AREA**

**STABILIZED STAGING AREA INSTALLATION NOTES**

- SEE PLAN VIEW FOR:
  - LOCATION OF STAGING AREA(S).
  - CONTRACTOR MAY ADJUST LOCATION AND SIZE OF STAGING AREA WITH APPROVAL FROM THE LOCAL JURISDICTION.
- STABILIZED STAGING AREA SHOULD BE APPROPRIATE FOR THE NEEDS OF THE SITE. OVERSIZING RESULTS IN A LARGER AREA TO STABILIZE FOLLOWING CONSTRUCTION.
- STAGING AREA SHALL BE STABILIZED PRIOR TO OTHER OPERATIONS ON THE SITE.
- THE STABILIZED STAGING AREA SHALL CONSIST OF A MINIMUM 3" THICK GRANULAR MATERIAL.
- UNLESS OTHERWISE SPECIFIED BY LOCAL JURISDICTION, ROCK SHALL CONSIST OF DOT SECT. #703, AASHTO #3 COARSE AGGREGATE OR 6" (MINUS) ROCK.
- ADDITIONAL PERIMETER BMPs MAY BE REQUIRED INCLUDING BUT NOT LIMITED TO SILT FENCE AND CONSTRUCTION FENCING AS NEEDED.

**STABILIZED STAGING AREA MAINTENANCE NOTES**

- INSPECT BMPs EACH WORKDAY, AND MAINTAIN THEM IN EFFECTIVE OPERATING CONDITION. MAINTENANCE OF BMPs SHOULD BE PROACTIVE, NOT REACTIVE. INSPECT BMPs AS SOON AS POSSIBLE (AND ALWAYS WITHIN 24 HOURS) FOLLOWING A STORM THAT CAUSES SURFACE EROSION, AND PERFORM NECESSARY MAINTENANCE.
- FREQUENT OBSERVATIONS AND MAINTENANCE ARE NECESSARY TO MAINTAIN BMPs IN EFFECTIVE OPERATING CONDITION. INSPECTIONS AND CORRECTIVE MEASURES SHOULD BE DOCUMENTED THOROUGHLY.
- WHERE BMPs HAVE FAILED, REPAIR OR REPLACEMENT SHOULD BE INITIATED UPON DISCOVERY OF THE FAILURE.
- ROCK SHALL BE REAPPLIED OR REGRADED AS NECESSARY IF RUTTING OCCURS OR UNDERLYING SUBGRADE BECOMES EXPOSED.

November 2010      Urban Drainage and Flood Control District      SSA-3  
Urban Storm Drainage Criteria Manual Volume 3

**SM-6 Stabilized Staging Area (SSA)**

SSA

**STABILIZED STAGING AREA MAINTENANCE NOTES**

- STABILIZED STAGING AREA SHALL BE ENLARGED IF NECESSARY TO CONTAIN PARKING, STORAGE, AND UNLOADING/LOADING OPERATIONS.
- THE STABILIZED STAGING AREA SHALL BE REMOVED AT THE END OF CONSTRUCTION. THE GRANULAR MATERIAL SHALL BE REMOVED OR, IF APPROVED BY THE LOCAL JURISDICTION, USED ON SITE AND THE AREA COVERED WITH TOPSOIL, SEEDS AND MULCH OR OTHERWISE STABILIZED IN A MANNER APPROVED BY LOCAL JURISDICTION.
- NOTE: MANY MUNICIPALITIES PROHIBIT THE USE OF RECYCLED CONCRETE AS GRANULAR MATERIAL FOR STABILIZED STAGING AREAS DUE TO DIFFICULTIES WITH RE-ESTABLISHMENT OF VEGETATION IN AREAS WHERE RECYCLED CONCRETE WAS PLACED.
- NOTE: MANY JURISDICTIONS HAVE BMP DETAILS THAT VARY FROM UDFCD STANDARD DETAILS. CONSULT WITH LOCAL JURISDICTIONS AS TO WHICH DETAIL SHOULD BE USED WHEN DIFFERENCES ARE NOTED.

(DETAILS ADAPTED FROM DOUGLAS COUNTY, COLORADO, NOT AVAILABLE IN AUTOCAD)

SSA-4      Urban Drainage and Flood Control District      November 2010  
Urban Storm Drainage Criteria Manual Volume 3

**Stockpile Management (SP) MM-2**

SP
SP

**SP-1. STOCKPILE PROTECTION**

**STOCKPILE PROTECTION INSTALLATION NOTES**

- SEE PLAN VIEW FOR:
  - LOCATION OF STOCKPILES.
  - TYPE OF STOCKPILE PROTECTION.
- INSTALL PERIMETER CONTROLS IN ACCORDANCE WITH THEIR RESPECTIVE DESIGN DETAILS. SILT FENCE IS SHOWN IN THE STOCKPILE PROTECTION DETAILS; HOWEVER, OTHER TYPES OF PERIMETER CONTROLS INCLUDING SEDIMENT CONTROL LOGS OR ROCK SOCKS MAY BE SUITABLE IN SOME CIRCUMSTANCES. CONSIDERATIONS FOR DETERMINING THE APPROPRIATE TYPE OF PERIMETER CONTROL FOR A STOCKPILE INCLUDE WHETHER THE STOCKPILE IS LOCATED ON A PERVIOUS OR IMPERVIOUS SURFACE, THE RELATIVE HEIGHTS OF THE PERIMETER CONTROL AND STOCKPILE, THE ABILITY OF THE PERIMETER CONTROL TO CONTAIN THE STOCKPILE WITHOUT FAILING IN THE EVENT THAT MATERIAL FROM THE STOCKPILE SHIFTS OR SLUMPS AGAINST THE PERIMETER, AND OTHER FACTORS.
- STABILIZE THE STOCKPILE SURFACE WITH SURFACE ROUGHENING, TEMPORARY SEEDING AND MULCHING, EROSION CONTROL BLANKETS, OR SOIL BINDERS. SOILS STOCKPILED FOR AN EXTENDED PERIOD (TYPICALLY FOR MORE THAN 60 DAYS) SHOULD BE SEEDS AND MULCHED WITH A TEMPORARY GRASS COVER ONCE THE STOCKPILE IS PLACED (TYPICALLY WITHIN 14 DAYS). USE OF MULCH ONLY OR A SOIL BINDER IS ACCEPTABLE IF THE STOCKPILE WILL BE IN PLACE FOR A MORE LIMITED TIME PERIOD (TYPICALLY 30-60 DAYS).
- FOR TEMPORARY STOCKPILES ON THE INTERIOR PORTION OF A CONSTRUCTION SITE, WHERE OTHER DOWNGRADE CONTROLS, INCLUDING PERIMETER CONTROL, ARE IN PLACE, STOCKPILE PERIMETER CONTROLS MAY NOT BE REQUIRED.

November 2010      Urban Drainage and Flood Control District      SP-3  
Urban Storm Drainage Criteria Manual Volume 3

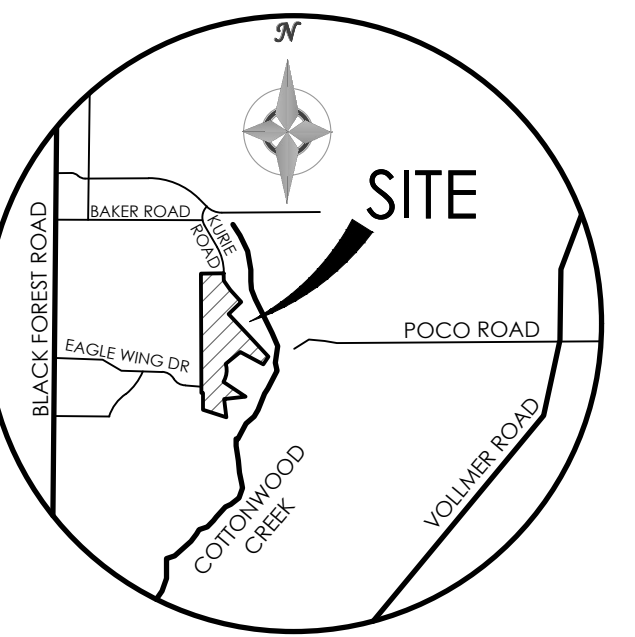

**VICINITY MAP**  
NOT TO SCALE

BENCHMARK

**EC-1 Surface Roughening (SR)**

SP
SR

**SURFACE ROUGHENING INSTALLATION NOTES**

- SEE PLAN VIEW FOR:
  - LOCATION(S) OF SURFACE ROUGHENING.
- SURFACE ROUGHENING SHALL BE PROVIDED PROMPTLY AFTER COMPLETION OF FINISHED GRADING (FOR AREAS NOT RECEIVING TOPSOIL) OR PRIOR TO TOPSOIL PLACEMENT OR ANY FORECASTED RAIN EVENT.
- AREAS WHERE BUILDING FOUNDATIONS, PAVEMENT, OR SOD WILL BE PLACED WITHOUT DELAY IN THE CONSTRUCTION SEQUENCE, SURFACE ROUGHENING IS NOT REQUIRED.
- DISTURBED SURFACES SHALL BE ROUGHENED USING RIPPING OR TILLING EQUIPMENT ON THE CONTOUR OR TRACKING UP AND DOWN A SLOPE USING EQUIPMENT TREADS.
- A FARMING DISK SHALL NOT BE USED FOR SURFACE ROUGHENING.

**SURFACE ROUGHENING MAINTENANCE NOTES**

- INSPECT BMPs EACH WORKDAY, AND MAINTAIN THEM IN EFFECTIVE OPERATING CONDITION. MAINTENANCE OF BMPs SHOULD BE PROACTIVE, NOT REACTIVE. INSPECT BMPs AS SOON AS POSSIBLE (AND ALWAYS WITHIN 24 HOURS) FOLLOWING A STORM THAT CAUSES SURFACE EROSION, AND PERFORM NECESSARY MAINTENANCE.
- FREQUENT OBSERVATIONS AND MAINTENANCE ARE NECESSARY TO MAINTAIN BMPs IN EFFECTIVE OPERATING CONDITION. INSPECTIONS AND CORRECTIVE MEASURES SHOULD BE DOCUMENTED THOROUGHLY.
- WHERE BMPs HAVE FAILED, REPAIR OR REPLACE UPON DISCOVERY OF THE FAILURE.
- VEHICLES AND EQUIPMENT SHALL NOT BE DRIVEN OVER AREAS THAT HAVE BEEN SURFACE ROUGHENED.
- IN NON-TURF GRASS FINISHED AREAS, SEEDING AND MULCHING SHALL TAKE PLACE DIRECTLY OVER SURFACE ROUGHENED AREAS WITHOUT FIRST SMOOTHING OUT THE SURFACE.
- IN AREAS NOT SEEDS AND MULCHED AFTER SURFACE ROUGHENING, SURFACES SHALL BE RE-ROUGHENED AS NECESSARY TO MAINTAIN GROOVE DEPTH AND SMOOTH OVER RILL EROSION.

(DETAILS ADAPTED FROM TOWN OF PARKER, COLORADO, NOT AVAILABLE IN AUTOCAD)

NOTE: MANY JURISDICTIONS HAVE BMP DETAILS THAT VARY FROM UDFCD STANDARD DETAILS. CONSULT WITH LOCAL JURISDICTIONS AS TO WHICH DETAIL SHOULD BE USED WHEN DIFFERENCES ARE NOTED.

SR-4      Urban Drainage and Flood Control District      November 2010  
Urban Storm Drainage Criteria Manual Volume 3

**Surface Roughening (SR) EC-1**

SR
SR

**SR-1. SURFACE ROUGHENING**  
FOR STEEP SLOPES (3:1 OR STEEPER)

**SR-2. SURFACE ROUGHENING**  
FOR LOW SLOPES (LESS THAN 3:1)

November 2010      Urban Drainage and Flood Control District      SR-3  
Urban Storm Drainage Criteria Manual Volume 3

**MM-2 Stockpile Management (SM)**

SR
SR

**STOCKPILE PROTECTION MAINTENANCE NOTES**

- INSPECT BMPs EACH WORKDAY, AND MAINTAIN THEM IN EFFECTIVE OPERATING CONDITION. MAINTENANCE OF BMPs SHOULD BE PROACTIVE, NOT REACTIVE. INSPECT BMPs AS SOON AS POSSIBLE (AND ALWAYS WITHIN 24 HOURS) FOLLOWING A STORM THAT CAUSES SURFACE EROSION, AND PERFORM NECESSARY MAINTENANCE.
- FREQUENT OBSERVATIONS AND MAINTENANCE ARE NECESSARY TO MAINTAIN BMPs IN EFFECTIVE OPERATING CONDITION. INSPECTIONS AND CORRECTIVE MEASURES SHOULD BE DOCUMENTED THOROUGHLY.
- WHERE BMPs HAVE FAILED, REPAIR OR REPLACEMENT SHOULD BE INITIATED UPON DISCOVERY OF THE FAILURE.

**STOCKPILE PROTECTION MAINTENANCE NOTES**

- IF PERIMETER PROTECTION MUST BE MOVED TO ACCESS SOIL STOCKPILE, REPLACE PERIMETER CONTROLS BY THE END OF THE WORKDAY.
- STOCKPILE PERIMETER CONTROLS CAN BE REMOVED ONCE ALL THE MATERIAL FROM THE STOCKPILE HAS BEEN USED.

(DETAILS ADAPTED FROM PARKER, COLORADO, NOT AVAILABLE IN AUTOCAD)

NOTE: MANY JURISDICTIONS HAVE BMP DETAILS THAT VARY FROM UDFCD STANDARD DETAILS. CONSULT WITH LOCAL JURISDICTIONS AS TO WHICH DETAIL SHOULD BE USED WHEN DIFFERENCES ARE NOTED.

SP-4      Urban Drainage and Flood Control District      November 2010  
Urban Storm Drainage Criteria Manual Volume 3

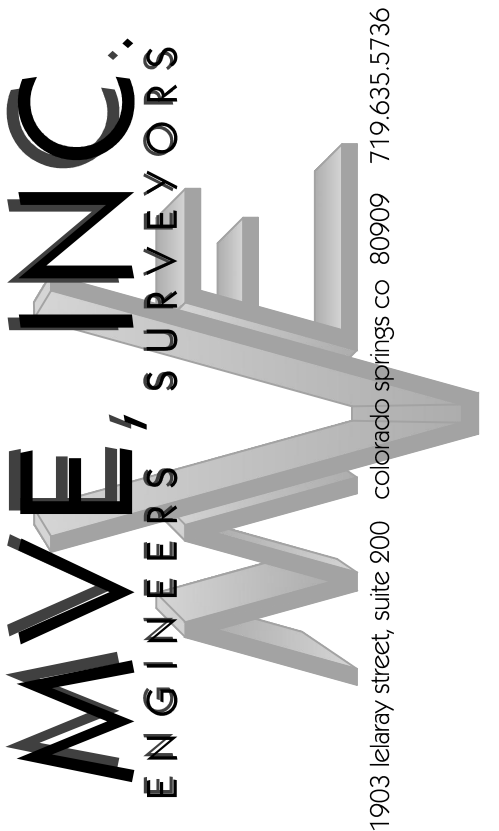

1903 library street, suite 200      colorado springs co 80909      719.635.5726

REVISIONS

DESIGNED BY \_\_\_\_\_  
DRAWN BY \_\_\_\_\_  
CHECKED BY \_\_\_\_\_  
AS-BUILTS BY \_\_\_\_\_  
CHECKED BY \_\_\_\_\_

**EAGLE RISING**  
FILING NO. 1

**GRADING & EROSION**  
CONTROL PLAN  
DETAILS

MVE PROJECT      61145  
MVE DRAWING      GEC-EC3

JULY 1, 2022  
**C1.4 SHEET 4 OF 4**