

**Traffic Impact Study  
Southern Colorado Rail Park  
El Paso County, Colorado**

Submitted by:  
Wilson & Company  
5755 Mark Dabling Boulevard, Suite 100  
Colorado Springs, CO 80919  
(719) 520-5800

April 2024

Wilson & Company, Inc., Engineers & Architects

By



Eric Lundberg, PE, PTOE, RSP1  
Senior Traffic Planning Project Manager

**Accepted for File**

By: **Gilbert LaForce, P.E.**  
Engineering Manager

Date: **04/30/2024 8:26:47 AM**

El Paso County Department of Public Works



# TABLE OF CONTENTS

1 – Introduction .....	4
1.1 Project Description .....	4
1.2 Study Objectives .....	4
1.3 Intersection Analysis Methodology.....	6
2 – Existing Conditions .....	8
2.1 Roadway System .....	8
2.2 Traffic Volumes.....	8
2.3 Traffic Operations.....	9
3 – Project Trip Generation .....	11
4 – Trip Distribution and Assignment.....	15
5 – Forecast Traffic Volumes .....	20
5.1 Background Traffic .....	20
5.2 Total Traffic.....	20
6 – Intersection LOS Analysis.....	27
6.1 Background Conditions Traffic Operations Analysis .....	27
6.1.1 Traffic Operations Analysis for 2035 Background Traffic .....	27
6.1.2 Traffic Operations Analysis for 2040 Background Traffic .....	27
6.1.3 Traffic Operations Analysis for 2045 Background Traffic .....	28
6.2 Background Plus Site Conditions Traffic Operations Analysis.....	27
6.2.1 Traffic Operations Analysis for 2035 Total Traffic .....	28
6.2.2 Traffic Operations Analysis for 2040 Total Traffic .....	29
6.2.3 Traffic Operations Analysis for 2045 Total Traffic .....	29
7 – Recommendations .....	30
7.1 Future Connection to I-25.....	30
7.2 Internal Roadway Classifications.....	30
7.3 Future Traffic Impact Studies .....	30
List of Acronyms and Definitions .....	31
List of References .....	33

## List of Figures

Figure 1-1 Southern Colorado Rail Park Site Location .....	5
Figure 2-1. 2023 Existing Traffic Volumes .....	10
Figure 4-1. Trip Directional Distribution .....	16
Figure 4-2. Phases 1&2 Site-Generated Traffic Assignment .....	17
Figure 4-3. Phases 1-3 Site-Generated Traffic Assignment .....	18
Figure 4-4. Buildout Site-Generated Traffic Assignment .....	19
Figure 5-1. 2035 Background Traffic .....	21
Figure 5-2. 2040 Background Traffic .....	22
Figure 5-3. 2045 Background Traffic .....	23
Figure 5-4. 2035 Total Traffic .....	24
Figure 5-5. 2040 Total Traffic .....	25
Figure 5-6. 2045 Total Traffic .....	26

## List of Tables

Table 1-1. LOS Criteria for Signalized Intersections .....	6
Table 1-2. LOS Criteria for Unsignalized Intersections .....	7
Table 2-1. Existing Conditions Traffic Operations Summary.....	9
Table 3-1. Southern Colorado Rail Park– Trip Generation Estimate (Phases 1-2).....	12
Table 3-2. Southern Colorado Rail Park– Trip Generation Estimate (Phases 1-3).....	13
Table 3-3. Southern Colorado Rail Park– Trip Generation Estimate (Phases 1-4).....	14
Table 6-1. Traffic Operations Summary for 2035 Background Traffic .....	27
Table 6-2. Traffic Operations Summary for 2040 Background Traffic .....	27
Table 6-3. Traffic Operations Summary for 2045 Background Traffic .....	28
Table 6-4. Traffic Operations Summary for 2035 Total Traffic .....	28
Table 6-5. Traffic Operations Summary for 2040 Total Traffic .....	29
Table 6-6. Traffic Operations Summary for 2045 Total Traffic .....	29

## Appendices

Appendix A: Sketch Plan .....	34-35
Appendix B: Traffic Counts .....	36-62
Appendix C: Existing Conditions Synchro Analysis Reports.....	63-73
Appendix D: Background Traffic Synchro Analysis Reports.....	74-100
Appendix E: Total Traffic Synchro Analysis Reports.....	101-147



## 1 – INTRODUCTION

### 1.1 Project Description

The Southern Colorado Rail Park (SCRP) is a proposed industrial park located within El Paso County, Colorado, with potential future annexation into the City of Fountain. As shown in **Figure 1-1**, the site is bordered by Fort Carson to the north, south, and west, City of Fountain property to the east, and the Ray Nixon powerplant to the southeast. The site is planned to be developed over four phases, with all but the first phase, which involves only extension of the rail line into Fort Carson, evaluated for this study. The planned land use mix for the site will be primarily light and heavy industrial, with some retail and storage/warehousing uses also expected. The Sketch Plan exhibit is included in **Appendix A**.

Build-out of the site is expected to progress over a period of about 20 years, with construction planned to begin in Spring 2025 and each subsequent phase beginning in five-year intervals.

Initially, access to the site will be to Charter Oak Ranch Road only. A planned future connection to Interstate 25 (I-25) near milepoint (MP) 125.7 (or approximately 2.25 miles south of the US 85 interchange) will improve access to the site and provide the connectivity to adequately serve full buildout of the development. The planned connection to I-25 would align with the proposed extension of Powers Boulevard, which will connect with I-25 from the east.

Pedestrian facilities will be accommodated throughout the site within the public right-of-way, per the City of Fountain typical roadway cross sections. Given the location of the site and the nature of the proposed development as an industrial park, bicycle traffic is expected to be very light. Therefore, no specific bike facilities are currently planned and as such, bicyclists traveling through the site would share the road with other vehicles.

### 1.2 Study Objectives

This report provides an assessment of potential traffic impacts to Charter Oak Ranch Road and US 85 associated with each phase of the development of the Rail Park. Recommendations for the functional classification of the roadways internal to the site are also provided.

Although assumed to be in place by the full buildout of the site for this study, the planned future connection to I-25 is not analyzed as part of this report. The planned I-25 interchange will be evaluated as part of a future interstate access request.



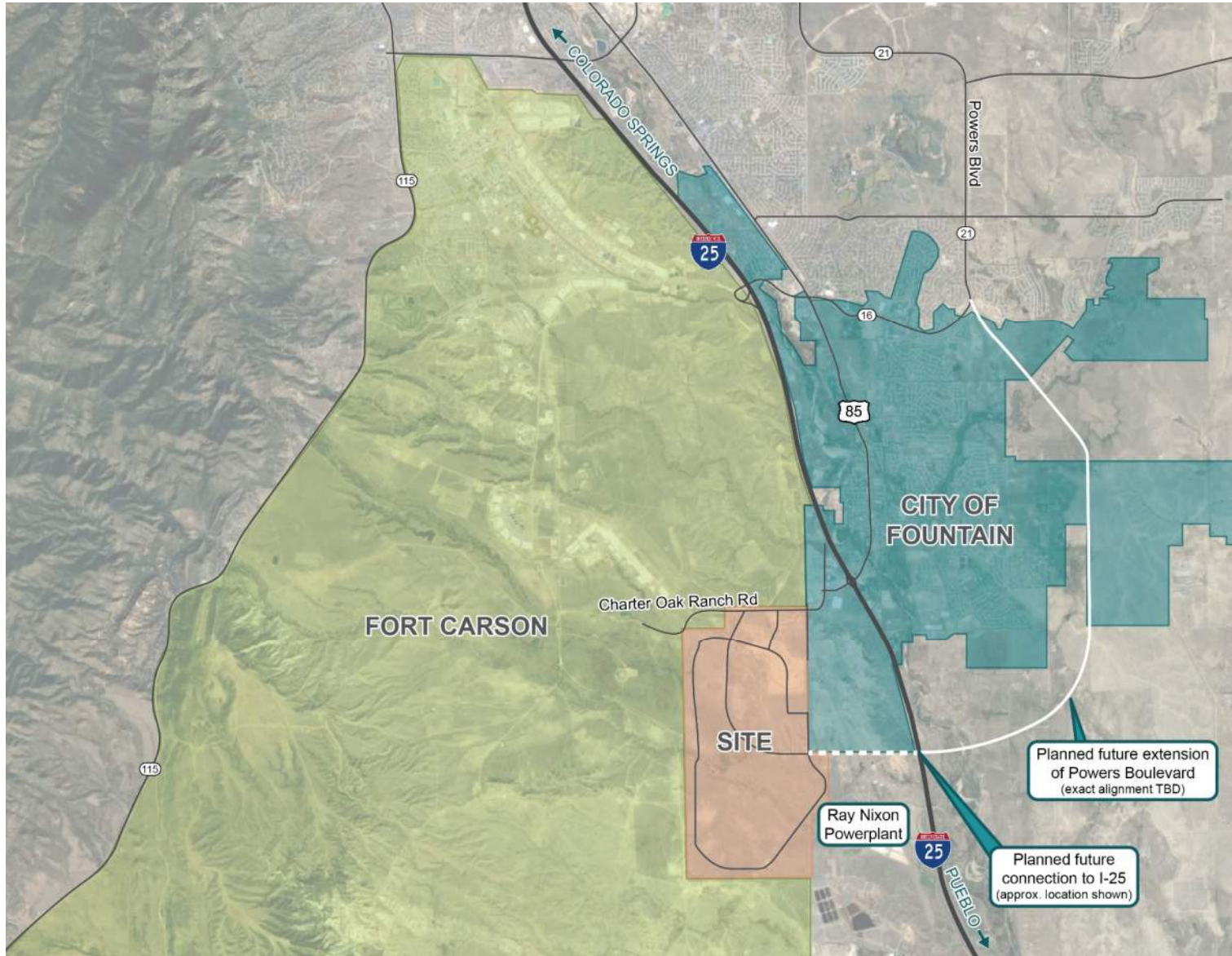

**Figure 1-1.** Southern Colorado Rail Park Site Location

## 1.3 Intersection Analysis Methodology

### Traffic Operations

The traffic operations analysis addresses unsignalized, signalized and modern roundabout intersection operations using the procedures and methodologies contained in the Highway Capacity Manual Sixth Edition (HCM6) (Transportation Research Board, 2016) for weekday AM and PM peak hour traffic operations. Study intersection operations were evaluated using level of service calculations as analyzed in the Synchro software version 11.

To measure and describe the operational status of the local roadway network and corresponding intersections, transportation engineers and planners commonly use a grading system called level of service (LOS). LOS is a description of an intersection's operation, ranging from LOS A (indicating free flow traffic conditions with little or no delay) to LOS F (representing oversaturated conditions where traffic flows exceed design capacity, resulting in long queues and delays).

### Signalized Intersections

At signalized intersections, the operational analysis uses various intersection characteristics (such as traffic volumes, lane geometry, and signal phasing) to estimate the intersection's volume-to-capacity (v/c) ratio. For signalized intersections, the HCM defines the LOS as the average delay per vehicle for the overall intersection. **Table 1-1** summarizes the relationship between delay and LOS for signalized intersections.

Level of Service	Interpretation	Control Delay (sec/vehicle)
<b>A</b>	Progression is extremely favorable and most vehicles arrive during the green phase. Most vehicles do not stop at all. Short cycle lengths may contribute to low delay.	≤10
<b>B</b>	Good progression, short cycle lengths, or both. More vehicles stop than with LOS A.	>10 and ≤20
<b>C</b>	Fair progression longer cycle lengths, or both. The number of vehicles stopping is significant, though many still pass through without stopping.	>20 and ≤35
<b>D</b>	Longer delays result from some combination of unfavorable progression, long cycle lengths, or high v/c ratios. Many vehicles stop.	>35 and ≤55
<b>E</b>	High delay values generally indicate poor progression, long cycle lengths, and high v/c ratios. Individual cycle failures are frequent occurrences.	>55 and ≤80
<b>F</b>	This level often occurs with oversaturation when arrival flow rates exceed the capacity of the intersection. Poor progression and long cycle lengths may be major contributing factors to such delays.	>80

### Roundabouts

At roundabout intersections, the operational analysis uses various intersection characteristics (such as traffic volumes and lane geometry) to estimate the roundabout's v/c ratio. The HCM defines the LOS as the average delay per vehicle for the overall intersection. Approach delay detail is also generated. The relationship between delay and LOS for roundabouts is the same as shown in the following table for unsignalized intersections.

## Unsignalized Intersections

For unsignalized stop sign-controlled intersections, operations are defined by the average control delay per vehicle (measured in seconds) for each stop-controlled movement. The method incorporates delay associated with deceleration, acceleration, stopping, and moving up in the queue. For two-way stop-controlled (TWSC) intersections, LOS is reported for the approach with the highest average delay/vehicle. **Table 1-2** summarizes the relationship between delay and LOS for unsignalized intersections.

<b>Level of Service</b>	<b>Interpretation</b>	<b>Control Delay (sec/vehicle)</b>
<b>a</b>	Little or no delay	$0 \leq 10$
<b>b</b>	Short traffic delays	$>10 \leq 15$
<b>c</b>	Average traffic delays	$>15 \leq 25$
<b>d</b>	Long traffic delays	$>25 \leq 35$
<b>e</b>	Very long traffic delays	$>35 \leq 50$
<b>f</b>	When demand volume exceeds the capacity of the lane, extreme delays will be encountered with queuing that may cause severe congestion affecting other traffic movements in the intersection. This condition usually warrants improving the intersection.	$>50$

## 2 – EXISTING CONDITIONS

### 2.1 Roadway System

Key existing roadways that serve the site include Charter Oak Ranch Road, US 85 (Santa Fe Avenue), and I-25. Initially, access to the site will be to Charter Oak Ranch Road only. A future connection to I-25 near MP 125.7 is also planned.

**Charter Oak Ranch Road** is a two-lane roadway extending through Fort Carson as a frontage road on the west side of I-25, continuing south through the City of Fountain where it crosses US 85 and then curves to the west and runs along the northern boundary of the site. Just outside of Fort Carson Gate 19, Charter Oak Ranch Road turns to the south, ultimately terminating within the project site. Along the northern border of the site, the roadway was recently reconstructed with a 40-foot cross-section, having 12-foot lanes and 8-foot shoulders. Curb and gutter, left-turn deceleration lanes, and a sidewalk along its north side were also added. Its intersection with US 85 was re-constructed as a one-lane roundabout. The roadway is classified as a Collector on the El Paso County 2040 Major Transportation Corridor Plan. The posted speed limit is 35 miles per hour (mph) in the vicinity of the site.

**US 85A (Santa Fe Avenue)** is a state highway nearly 10 miles in length, beginning at Charter Oak Ranch Road 1,800 feet west of I-25, extending through the City of Fountain, and ending at B Street. It is primarily a two-lane roadway. The posted speed limit is 35 mph in the vicinity of the site.

**Interstate 25 (I-25)** is a freeway that extends in a north-south direction throughout Colorado, providing access to/from Colorado Springs to the north and to/from Pueblo to the south. It has two lanes in each direction and a speed limit of 75 mph in the study area.

**Powers Boulevard (SH 21)** is an Expressway that extends north from Mesa Ridge Parkway in the City of Fountain for about 22.5 miles to SH 83 on the north side of Colorado Springs. SH 21 is planned to be extended north from SH 83 to connect with I-25 and is also planned to be extended south from Mesa Ridge Parkway through the City of Fountain, eventually connecting with I-25 near MP 125.7. The planned future connection to I-25 from the site will align with SH 21.

### 2.2 Traffic Volumes

Traffic count data was collected on Tuesday, June 13, 2023, including intersection turning-movement counts (TMC) between the hours of 5:00-8:00 a.m. and 4:00-6:00 p.m., and an average daily count (ADT) on Charter Oak Ranch Road east of Fort Carson Gate 19. The existing traffic volumes are shown in **Figure 2.1**. The traffic count data is included in **Appendix B**.

It should be noted that for the morning peak-period analysis of this report, the peak hour at the I-25/US 85 interchange (6:45-7:45 a.m.) was used, whereas the peak hour of Fort Carson traffic using Gate 19 was shown to be either about an hour earlier or about an hour later based on the TMC and ADT counts, respectively. It is expected that the morning peak period of the proposed Rail Park will coincide with the traditional peak period as exhibited by the I-25/US 85 interchange counts, rather than the atypical peak periods of Fort Carson traffic, as exhibited by the counts west of the interchange.

## 2.3 Traffic Operations

All analyzed intersections are reported to currently operate at LOS B or better during both the AM and PM peak hours. Existing overall intersection LOS and delay results are summarized in **Table 2-1**. Full Synchro analysis reports for existing conditions are included in **Appendix C**.

<b>Table 2-1. Existing Conditions Traffic Operations Summary</b>			
<b>Control</b>	<b>Intersection</b>	<b>LOS/Delay [in seconds/vehicle] (Critical Movement)</b>	
		<b>AM Peak Hour</b>	<b>PM Peak Hour</b>
Signal	US 85 & I-25 NB Ramps	A / 5.6	A / 5.7
Signal	US 85 & I-25 SB Ramps	B / 16.5	B / 18.3
Roundabout	Charter Oak Ranch Road & US 85	A / 4.3	A / 5.8
TWSC	Charter Oak Ranch Road & Fountain Utilities Access	a / 9.5 (NB)	a / 9.5 (NB)
TWSC	Charter Oak Ranch Road & Essayons Road	a / 8.2 (WB LT)	a / 8.0 (WB LT)



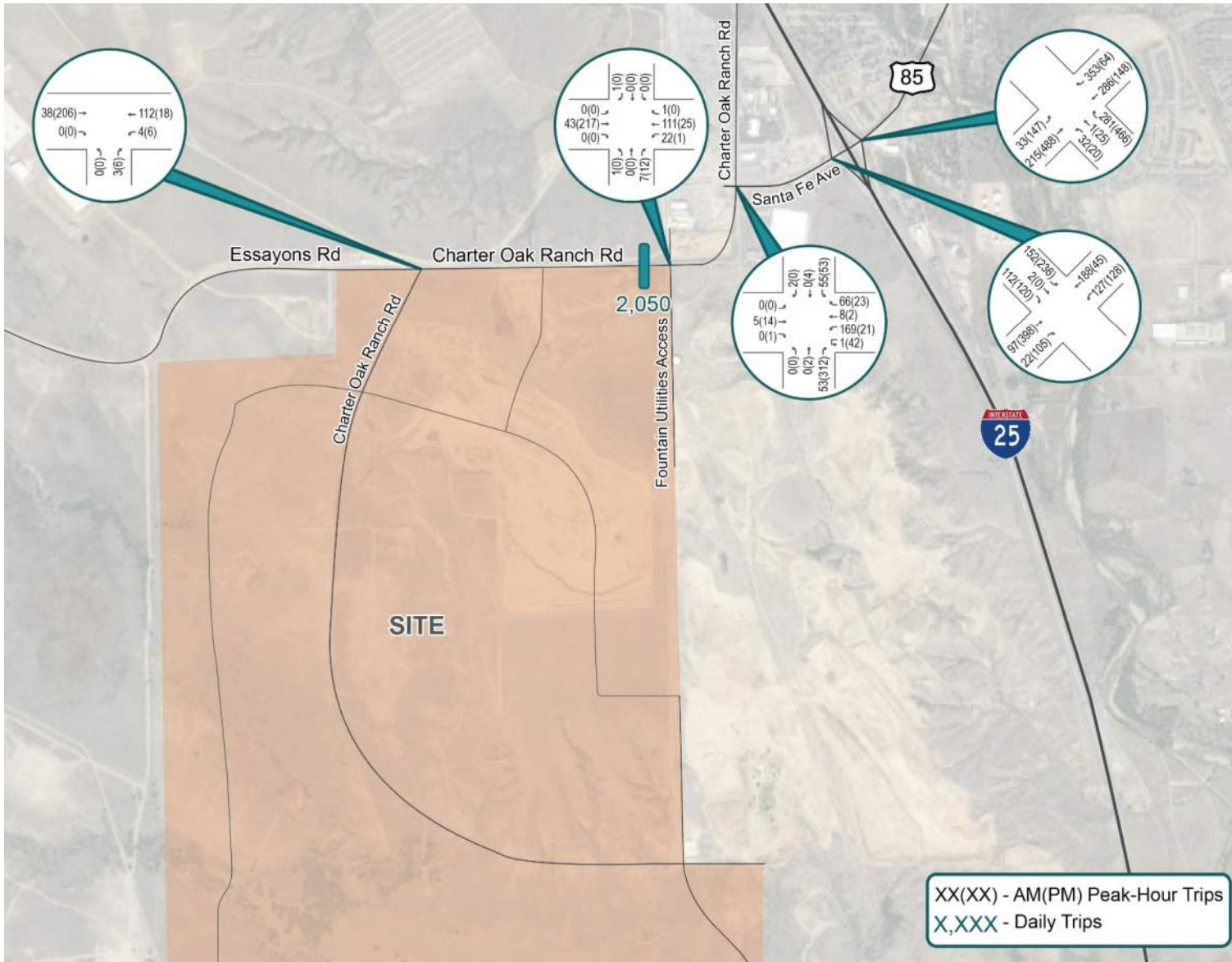

Figure 2-1. 2023 Existing Traffic Volumes

### 3 – PROJECT TRIP GENERATION

The vehicle trips to be generated by the site were estimated using the *ITE Trip Generation Manual*, Eleventh Edition (Institute of Traffic Engineers 2021). Trip generation estimates were developed for Phases 2-4. Because Phase 1 only involves the rail line extension into Fort Carson, it is not expected to generate any vehicle traffic on the roadway network.

The ITE method consists of choosing an appropriate independent variable for each land use, the value of which is multiplied by a weighted average rate or inserted into a regression equation to calculate the trips that can be expected to be generated by the land use. The ITE land uses applied for the trip generation estimate of this site are:

- Industrial Park (130)
- Warehousing (150)
- Mini-Warehouse (151)
- Shopping Plaza (40-150 ksf) (821)

As part of the development of the Sketch Plan, floor area ratios (FAR) were assumed for each land use type in order to calculate an expected building square-footage given the acreage of each parcel. These building square footages were used in the trip generation estimate.

#### Rail Trips

Given that this site is being developed as a rail park, with a railroad extension planned to traverse it, a trip reduction has been applied to account for trips that will be made by rail rather than by motor vehicle. A reduction of 15% has been applied to the portions of the site designated for heavy industrial and a reduction of 5% has been applied to the portions of the site designated for light industrial. These trip reduction percentages are based on engineering judgement, as no guidance for this particular situation could be found.

#### Pass-by Trips

Given the location of the proposed retail land use, it is expected to primarily serve the employees of the industrial park as well as those entering/exiting Fort Carson. As such, a high pass-by trip percentage (70%) has been assumed for the proposed retail parcel. A pass-by trip is made by a motorist who would already be on the adjacent roadway regardless of the development, but who stops in at the site while passing by. The motorist would then continue on their way to a final destination in the original direction.

The site will generate approximately 6,650 new daily trips, 10,240 new daily trips, and 17,585 new daily trips at the completion of Phase 2, Phase 3, and Phase 4, respectively. Approximately 8-9% of the daily traffic will be generated during the morning peak hour and approximately 9-10% will be generated during the afternoon peak hour, depending on the phase of completion.

**Tables 3-1 through 3-3** show the trip generation at each phase of the development.

Table 3-1. Southern Colorado Rail Park - Trip Generation Estimate (Phases 1-2)																											
Sketch Plan Zone	Land Use Code	Land Use Description	Developable Acres	Units	Trip Generation Rates					Total Trips Generated					Pass-by/Rail Trip Reduction	Pass-by/Rail Trips Generated					Primary/Non-Rail Trips Generated						
					Average Weekday Traffic	Morning Peak Hour		Afternoon Peak Hour		Average Weekday Traffic	Morning Peak Hour		Afternoon Peak Hour			Average Weekday Traffic	Morning Peak Hour		Afternoon Peak Hour		Average Weekday Traffic	Morning Peak Hour		Afternoon Peak Hour			
						In	Out	In	Out		In	Out	In	Out			In	Out	In	Out		In	Out				
<b>PHASES 1-2</b>																											
7	130	Industrial Park	125.20	169.28	KSF	3.37	0.28	0.06	0.07	0.27	570	47	11	13	45	15%	86	7	2	2	7	485	40	9	11	38	
8	130	Industrial Park	9.80	13.25	KSF	3.37	0.28	0.06	0.07	0.27	45	4	1	1	4	15%	7	1	0	0	1	38	3	1	1	3	
9	130	Industrial Park	39.30	53.14	KSF	3.37	0.28	0.06	0.07	0.27	179	15	3	4	14	15%	27	2	1	1	2	152	12	3	3	12	
10	130	Industrial Park	61.10	82.61	KSF	3.37	0.28	0.06	0.07	0.27	278	23	5	6	22	15%	42	3	1	1	3	237	19	5	5	19	
11	130	Industrial Park	144.70	195.65	KSF	3.37	0.28	0.06	0.07	0.27	659	54	13	15	52	15%	99	8	2	2	8	560	46	11	12	44	
14	---	Low Impact Use	100.60	---	---	---	---	---	---	---	0	0	0	0	0	0%	0	0	0	0	0	0	0	0	0	0	
15	130	Industrial Park	26.80	36.24	KSF	3.37	0.28	0.06	0.07	0.27	122	10	2	3	10	15%	18	1	0	0	1	104	8	2	2	8	
16	130	Industrial Park	32.90	44.48	KSF	3.37	0.28	0.06	0.07	0.27	150	12	3	3	12	15%	22	2	0	0	2	127	10	2	3	10	
17	130	Industrial Park	57.90	78.29	KSF	3.37	0.28	0.06	0.07	0.27	264	22	5	6	21	15%	40	3	1	1	3	224	18	4	5	18	
18	130	Industrial Park	56.00	195.15	KSF	3.37	0.28	0.06	0.07	0.27	658	54	13	15	52	5%	33	3	1	1	3	625	51	12	14	49	
19	130	Industrial Park	63.70	221.98	KSF	3.37	0.28	0.06	0.07	0.27	748	61	14	17	59	5%	37	3	1	1	3	711	58	14	16	56	
27	130	Industrial Park	59.60	207.69	KSF	3.37	0.28	0.06	0.07	0.27	700	57	13	16	55	5%	35	3	1	1	3	665	54	13	15	52	
31	130	Industrial Park	24.00	83.64	KSF	3.37	0.28	0.06	0.07	0.27	282	23	5	6	22	5%	14	1	0	0	1	268	22	5	6	21	
32	130	Industrial Park	18.30	63.77	KSF	3.37	0.28	0.06	0.07	0.27	215	18	4	5	17	5%	11	1	0	0	1	204	17	4	5	16	
33	130	Industrial Park	28.60	99.67	KSF	3.37	0.28	0.06	0.07	0.27	336	27	6	7	26	5%	17	1	0	0	1	319	26	6	7	25	
34	130	Industrial Park	23.80	82.94	KSF	3.37	0.28	0.06	0.07	0.27	280	23	5	6	22	5%	14	1	0	0	1	266	22	5	6	21	
39	151	Mini-Warehouse	20.40	106.63	KSF	1.45	0.05	0.04	0.07	0.08	155	6	4	8	8	0%	0	0	0	0	0	155	6	4	8	8	
40	821	Shopping Plaza (40-150k) - Supermarket - No	10.70	74.57	KSF	67.52	1.07	0.66	2.54	2.65	5035	80	49	190	197	70%	3525	45	45	135	135	1511	35	4	54	62	
<b>PHASES 1-2 TOTAL</b>	<b>Industrial Park (Light/Heavy Industrial)</b>		<b>772</b>	<b>1627.78</b>	<b>KSF</b>						<b>10,676</b>	<b>534</b>	<b>158</b>	<b>319</b>	<b>638</b>		<b>4,026</b>	<b>86</b>	<b>55</b>	<b>147</b>	<b>175</b>	<b>6,650</b>	<b>448</b>	<b>103</b>	<b>172</b>	<b>463</b>	
	<b>Warehousing (Commercial Services)</b>		<b>20.4</b>	<b>106.63</b>	<b>KSF</b>																						
	<b>Shopping Plaza (Commercial)</b>		<b>10.7</b>	<b>74.57</b>	<b>KSF</b>																						



Table 3-2. Southern Colorado Rail Park - Trip Generation Estimate (Phases 1-3)

Sketch Plan Zone	Land Use Code	Land Use Description	Developable Acres	Units	Trip Generation Rates					Total Trips Generated				Pass-by/ Rail Trip Reduction	Pass-by/Rail Trips Generated					Primary/Non-Rail Trips Generated							
					Average Weekday Traffic	Morning Peak Hour		Afternoon Peak Hour		Average Weekday Traffic	Morning Peak Hour		Afternoon Peak Hour		Average Weekday Traffic	Morning Peak Hour		Afternoon Peak Hour		Average Weekday Traffic	Morning Peak Hour		Afternoon Peak Hour				
						In	Out	In	Out		In	Out	In			Out	In	Out	In		Out	In	Out				
<b>PHASES 1-3</b>																											
1	130	Industrial Park	93.70	126.69	KSF	3.37	0.28	0.06	0.07	0.27	427	35	8	9	34	15%	64	5	1	1	5	363	30	7	8	29	
2	130	Industrial Park	47.00	63.55	KSF	3.37	0.28	0.06	0.07	0.27	214	18	4	5	17	15%	32	3	1	1	3	182	15	3	4	14	
3	130	Industrial Park	124.20	167.93	KSF	3.37	0.28	0.06	0.07	0.27	566	46	11	13	45	15%	85	7	2	2	7	481	39	9	11	38	
4	130	Industrial Park	186.50	252.17	KSF	3.37	0.28	0.06	0.07	0.27	850	69	16	19	67	15%	127	10	2	3	10	722	59	14	16	57	
5	130	Industrial Park	164.60	222.56	KSF	3.37	0.28	0.06	0.07	0.27	750	61	14	17	59	15%	113	9	2	2	9	638	52	12	14	50	
6	130	Industrial Park	181.00	244.73	KSF	3.37	0.28	0.06	0.07	0.27	825	67	16	18	65	15%	124	10	2	3	10	701	57	13	16	55	
7	130	Industrial Park	125.20	169.28	KSF	3.37	0.28	0.06	0.07	0.27	570	47	11	13	45	15%	86	7	2	2	7	485	40	9	11	38	
8	130	Industrial Park	9.80	13.25	KSF	3.37	0.28	0.06	0.07	0.27	45	4	1	1	4	15%	7	1	0	0	1	38	3	1	1	3	
9	130	Industrial Park	39.30	53.14	KSF	3.37	0.28	0.06	0.07	0.27	179	15	3	4	14	15%	27	2	1	1	2	152	12	3	3	12	
10	130	Industrial Park	61.10	82.61	KSF	3.37	0.28	0.06	0.07	0.27	278	23	5	6	22	15%	42	3	1	1	3	237	19	5	5	19	
11	130	Industrial Park	144.70	195.65	KSF	3.37	0.28	0.06	0.07	0.27	659	54	13	15	52	15%	99	8	2	2	8	560	46	11	12	44	
12	130	Industrial Park	74.10	100.19	KSF	3.37	0.28	0.06	0.07	0.27	338	28	6	7	27	15%	51	4	1	1	4	287	23	6	6	23	
13	130	Industrial Park	56.50	76.39	KSF	3.37	0.28	0.06	0.07	0.27	257	21	5	6	20	15%	39	3	1	1	3	219	18	4	5	17	
14	---	Low Impact Use	100.60	---	---	---	---	---	---	---	0	0	0	0	0	0%	0	0	0	0	0	0	0	0	0	0	
15	130	Industrial Park	26.80	36.24	KSF	3.37	0.28	0.06	0.07	0.27	122	10	2	3	10	15%	18	1	0	0	1	104	8	2	2	8	
16	130	Industrial Park	32.90	44.48	KSF	3.37	0.28	0.06	0.07	0.27	150	12	3	3	12	15%	22	2	0	0	2	127	10	2	3	10	
17	130	Industrial Park	57.90	78.29	KSF	3.37	0.28	0.06	0.07	0.27	264	22	5	6	21	15%	40	3	1	1	3	224	18	4	5	18	
18	130	Industrial Park	56.00	195.15	KSF	3.37	0.28	0.06	0.07	0.27	658	54	13	15	52	5%	33	3	1	1	3	625	51	12	14	49	
19	130	Industrial Park	63.70	221.98	KSF	3.37	0.28	0.06	0.07	0.27	748	61	14	17	59	5%	37	3	1	1	3	711	58	14	16	56	
27	130	Industrial Park	59.60	207.69	KSF	3.37	0.28	0.06	0.07	0.27	700	57	13	16	55	5%	35	3	1	1	3	665	54	13	15	52	
31	130	Industrial Park	24.00	83.64	KSF	3.37	0.28	0.06	0.07	0.27	282	23	5	6	22	5%	14	1	0	0	1	268	22	5	6	21	
32	130	Industrial Park	18.30	63.77	KSF	3.37	0.28	0.06	0.07	0.27	215	18	4	5	17	5%	11	1	0	0	1	204	17	4	5	16	
33	130	Industrial Park	28.60	99.67	KSF	3.37	0.28	0.06	0.07	0.27	336	27	6	7	26	5%	17	1	0	0	1	319	26	6	7	25	
34	130	Industrial Park	23.80	82.94	KSF	3.37	0.28	0.06	0.07	0.27	280	23	5	6	22	5%	14	1	0	0	1	266	22	5	6	21	
39	151	Mini-Warehouse	20.40	106.63	KSF	1.45	0.05	0.04	0.07	0.08	155	6	4	8	8	0%	0	0	0	0	0	155	6	4	8	8	
40	821	Shopping Plaza (40-150k) - Supermarket - No	10.70	74.57	KSF	67.52	1.07	0.66	2.54	2.65	5035	80	49	190	197	70%	3525	45	45	135	135	1511	35	4	54	62	
<b>PHASES 1-3 TOTAL</b>	<b>Industrial Park (Light/Heavy Industrial)</b>		<b>1699</b>	<b>2881.99</b>	<b>KSF</b>						<b>14,902</b>	<b>879</b>	<b>239</b>	<b>413</b>	<b>970</b>		<b>4,660</b>	<b>138</b>	<b>67</b>	<b>161</b>	<b>225</b>	<b>10,242</b>	<b>741</b>	<b>172</b>	<b>252</b>	<b>745</b>	
	<b>Warehousing (Commercial Services)</b>		<b>20.4</b>	<b>106.63</b>	<b>KSF</b>																						
	<b>Shopping Plaza (Commercial)</b>		<b>10.7</b>	<b>74.57</b>	<b>KSF</b>																						

Table 3-3. Southern Colorado Rail Park - Trip Generation Estimate (Phases 1-4)

Sketch Plan Zone	Land Use Code	Land Use Description	Developable Acres	Units	Trip Generation Rates					Total Trips Generated				Pass-by/Rail Trip Reduction	Pass-by/Rail Trips Generated					Primary/Non-Rail Trips Generated							
					Average Weekday Traffic	Morning Peak Hour		Afternoon Peak Hour		Average Weekday Traffic	Morning Peak Hour		Afternoon Peak Hour		Average Weekday Traffic	Morning Peak Hour		Afternoon Peak Hour		Average Weekday Traffic	Morning Peak Hour		Afternoon Peak Hour				
						In	Out	In	Out		In	Out	In			Out	In	Out	In		Out	In	Out				
					PROJECT BUILDOUT (PHASES 1-4)																						
1	130	Industrial Park	93.70	126.69	KSF	3.37	0.28	0.06	0.07	0.27	427	35	8	9	34	15%	64	5	1	1	5	363	30	7	8	29	
2	130	Industrial Park	47.00	63.55	KSF	3.37	0.28	0.06	0.07	0.27	214	18	4	5	17	15%	32	3	1	1	3	182	15	3	4	14	
3	130	Industrial Park	124.20	167.93	KSF	3.37	0.28	0.06	0.07	0.27	566	46	11	13	45	15%	85	7	2	2	7	481	39	9	11	38	
4	130	Industrial Park	186.50	252.17	KSF	3.37	0.28	0.06	0.07	0.27	850	69	16	19	67	15%	127	10	2	3	10	722	59	14	16	57	
5	130	Industrial Park	164.60	222.56	KSF	3.37	0.28	0.06	0.07	0.27	750	61	14	17	59	15%	113	9	2	2	9	638	52	12	14	50	
6	130	Industrial Park	181.00	244.73	KSF	3.37	0.28	0.06	0.07	0.27	825	67	16	18	65	15%	124	10	2	3	10	701	57	13	16	55	
7	130	Industrial Park	125.20	169.28	KSF	3.37	0.28	0.06	0.07	0.27	570	47	11	13	45	15%	86	7	2	2	7	485	40	9	11	38	
8	130	Industrial Park	9.80	13.25	KSF	3.37	0.28	0.06	0.07	0.27	45	4	1	1	4	15%	7	1	0	0	1	38	3	1	1	3	
9	130	Industrial Park	39.30	53.14	KSF	3.37	0.28	0.06	0.07	0.27	179	15	3	4	14	15%	27	2	1	1	2	152	12	3	3	12	
10	130	Industrial Park	61.10	82.61	KSF	3.37	0.28	0.06	0.07	0.27	278	23	5	6	22	15%	42	3	1	1	3	237	19	5	5	19	
11	130	Industrial Park	144.70	195.65	KSF	3.37	0.28	0.06	0.07	0.27	659	54	13	15	52	15%	99	8	2	2	8	560	46	11	12	44	
12	130	Industrial Park	74.10	100.19	KSF	3.37	0.28	0.06	0.07	0.27	338	28	6	7	27	15%	51	4	1	1	4	287	23	6	6	23	
13	130	Industrial Park	56.50	76.39	KSF	3.37	0.28	0.06	0.07	0.27	257	21	5	6	20	15%	39	3	1	1	3	219	18	4	5	17	
14	---	Low Impact Use	100.60	---	---	---	---	---	---	---	0	0	0	0	0	0%	0	0	0	0	0	0	0	0	0	0	
15	130	Industrial Park	26.80	36.24	KSF	3.37	0.28	0.06	0.07	0.27	122	10	2	3	10	15%	18	1	0	0	1	104	8	2	2	8	
16	130	Industrial Park	32.90	44.48	KSF	3.37	0.28	0.06	0.07	0.27	150	12	3	3	12	15%	22	2	0	0	2	127	10	2	3	10	
17	130	Industrial Park	57.90	78.29	KSF	3.37	0.28	0.06	0.07	0.27	264	22	5	6	21	15%	40	3	1	1	3	224	18	4	5	18	
18	130	Industrial Park	56.00	195.15	KSF	3.37	0.28	0.06	0.07	0.27	658	54	13	15	52	5%	33	3	1	1	3	625	51	12	14	49	
19	130	Industrial Park	63.70	221.98	KSF	3.37	0.28	0.06	0.07	0.27	748	61	14	17	59	5%	37	3	1	1	3	711	58	14	16	56	
20	130	Industrial Park	67.20	234.18	KSF	3.37	0.28	0.06	0.07	0.27	789	64	15	18	62	5%	39	3	1	1	3	750	61	14	17	59	
21	130	Industrial Park	66.40	231.39	KSF	3.37	0.28	0.06	0.07	0.27	780	64	15	17	61	5%	39	3	1	1	3	741	61	14	16	58	
22	130	Industrial Park	40.80	142.18	KSF	3.37	0.28	0.06	0.07	0.27	479	39	9	11	38	5%	24	2	0	1	2	455	37	9	10	36	
23	130	Industrial Park	57.00	198.63	KSF	3.37	0.28	0.06	0.07	0.27	669	55	13	15	53	5%	33	3	1	1	3	636	52	12	14	50	
24	130	Industrial Park	63.00	219.54	KSF	3.37	0.28	0.06	0.07	0.27	740	60	14	16	58	5%	37	3	1	1	3	703	57	13	16	55	
25	130	Industrial Park	63.60	221.63	KSF	3.37	0.28	0.06	0.07	0.27	747	61	14	17	59	5%	37	3	1	1	3	710	58	14	16	56	
26	130	Industrial Park	61.60	214.66	KSF	3.37	0.28	0.06	0.07	0.27	723	59	14	16	57	5%	36	3	1	1	3	687	56	13	15	54	
27	130	Industrial Park	59.60	207.69	KSF	3.37	0.28	0.06	0.07	0.27	700	57	13	16	55	5%	35	3	1	1	3	665	54	13	15	52	
28	130	Industrial Park	34.80	121.27	KSF	3.37	0.28	0.06	0.07	0.27	409	33	8	9	32	5%	20	2	0	0	2	388	32	7	9	31	
29	130	Industrial Park	63.40	220.94	KSF	3.37	0.28	0.06	0.07	0.27	745	61	14	17	59	5%	37	3	1	1	3	707	58	14	16	56	
30	130	Industrial Park	57.20	199.33	KSF	3.37	0.28	0.06	0.07	0.27	672	55	13	15	53	5%	34	3	1	1	3	638	52	12	14	50	
31	130	Industrial Park	24.00	83.64	KSF	3.37	0.28	0.06	0.07	0.27	282	23	5	6	22	5%	14	1	0	0	1	268	22	5	6	21	
32	130	Industrial Park	18.30	63.77	KSF	3.37	0.28	0.06	0.07	0.27	215	18	4	5	17	5%	11	1	0	0	1	204	17	4	5	16	
33	130	Industrial Park	28.60	99.67	KSF	3.37	0.28	0.06	0.07	0.27	336	27	6	7	26	5%	17	1	0	0	1	319	26	6	7	25	
34	130	Industrial Park	23.80	82.94	KSF	3.37	0.28	0.06	0.07	0.27	280	23	5	6	22	5%	14	1	0	0	1	266	22	5	6	21	
35	151	Mini-Warehouse	32.50	169.88	KSF	1.45	0.05	0.04	0.07	0.08	246	9	6	12	14	0%	0	0	0	0	0	246	9	6	12	14	
36	150	Warehousing	25.00	130.68	KSF	1.71	0.13	0.04	0.05	0.13	223	17	5	7	17	0%	0	0	0	0	0	223	17	5	7	17	
37	150	Warehousing	25.40	132.77	KSF	1.71	0.13	0.04	0.05	0.13	227	17	5	7	17	0%	0	0	0	0	0	227	17	5	7	17	
38	150	Warehousing	25.80	134.86	KSF	1.71	0.13	0.04	0.05	0.13	231	18	5	7	17	0%	0	0	0	0	0	231	18	5	7	17	
39	151	Mini-Warehouse	20.40	106.63	KSF	1.45	0.05	0.04	0.07	0.08	155	6	4	8	8	0%	0	0	0	0	0	155	6	4	8	8	
40	821	Shopping Plaza (40-150k) - Supermarket - No	10.70	74.57	KSF	67.52	1.07	0.66	2.54	2.65	5035	80	49	190	197	70%	3525	45	45	135	135	1511	35	4	54	62	
<b>BUILDOUT TOTAL</b>	<b>Industrial Park (Light/Heavy Industrial)</b>		<b>2274</b>	<b>4885.75</b>	<b>KSF</b>						<b>22,582</b>	<b>1,492</b>	<b>390</b>	<b>595</b>	<b>1,567</b>		<b>4,997</b>	<b>166</b>	<b>73</b>	<b>168</b>	<b>251</b>	<b>17,585</b>	<b>1,327</b>	<b>317</b>	<b>427</b>	<b>1,315</b>	
	<b>Warehousing (Commercial Services)</b>		<b>129</b>	<b>674.83</b>	<b>KSF</b>																						
	<b>Shopping Plaza (Commercial)</b>		<b>10.7</b>	<b>74.57</b>	<b>KSF</b>																						

## 4 – TRIP DISTRIBUTION AND ASSIGNMENT

The trip distribution used for the assignment of site-generated traffic was estimated based on the following factors: the location of the site with respect to nearby employment, commercial, and activity centers including Fort Carson, Fountain, Colorado Springs, and Pueblo; the land uses proposed for the site; the proposed access system for the site; and the roadway system serving the site. Through Phase 3, the trip distribution was based on the existing roadway network, with site access via Charter Oak Ranch Road only. For full project buildout, the trip distribution was based on the planned roadway network within and surrounding the site, including the planned connection from the site to I-25, aligning with the planned extension of Powers Boulevard south from Mesa Ridge Parkway to I-25.

**Figure 4-1** shows the trip distribution estimates for the short-term and long-term.

The trips estimated to be generated by Phases 1-2, as well as those estimated to be generated by Phases 1-3, were assigned based upon access via Charter Oak Ranch Road only. For Phases 1-4 (full site buildout), the trips were assigned based on completion of the planned roadway network. The assignment of site-generated traffic volumes on the surrounding roadway network is determined by applying the distribution percentages in **Figure 4-1** to the trip generation estimates shown in **Tables 3-1** through **3-3**. **Figures 4-2** to **4-4** show the trips as assigned for Phases 1-2, Phases 1-3, and full project buildout, respectively.

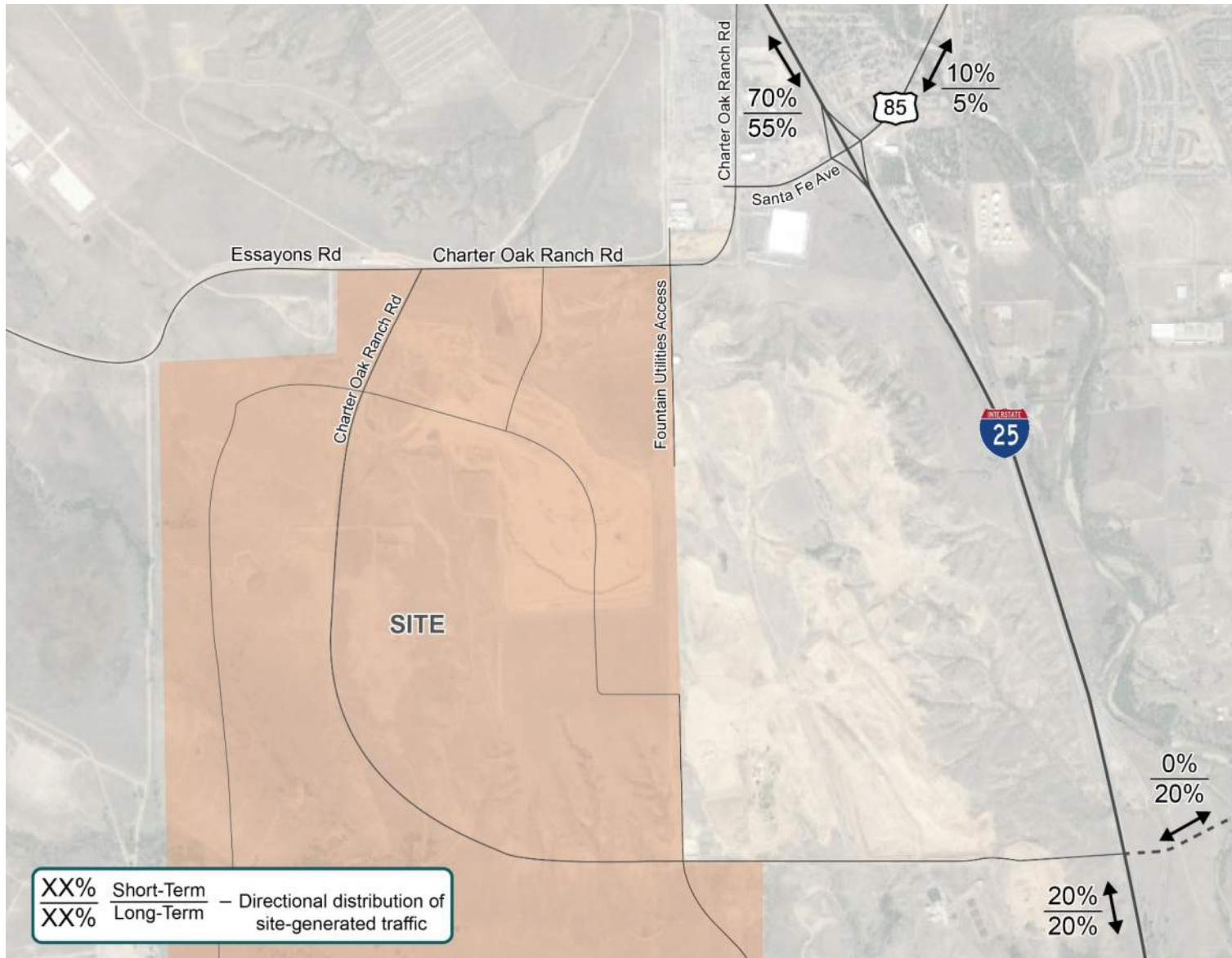

Figure 4-1. Trip Directional Distribution

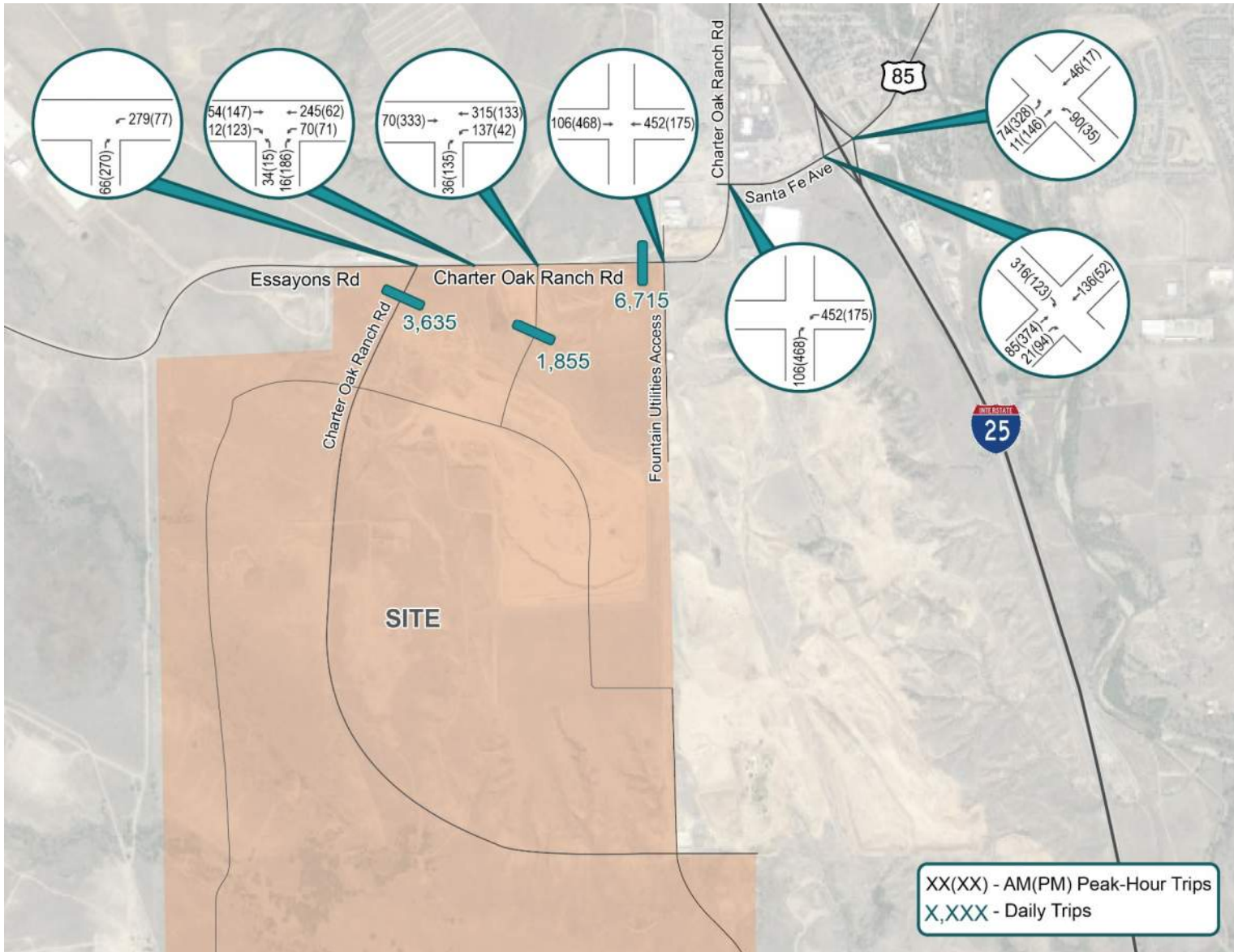

Figure 4-2. Phases 1&2 Site-Generated Traffic Assignment



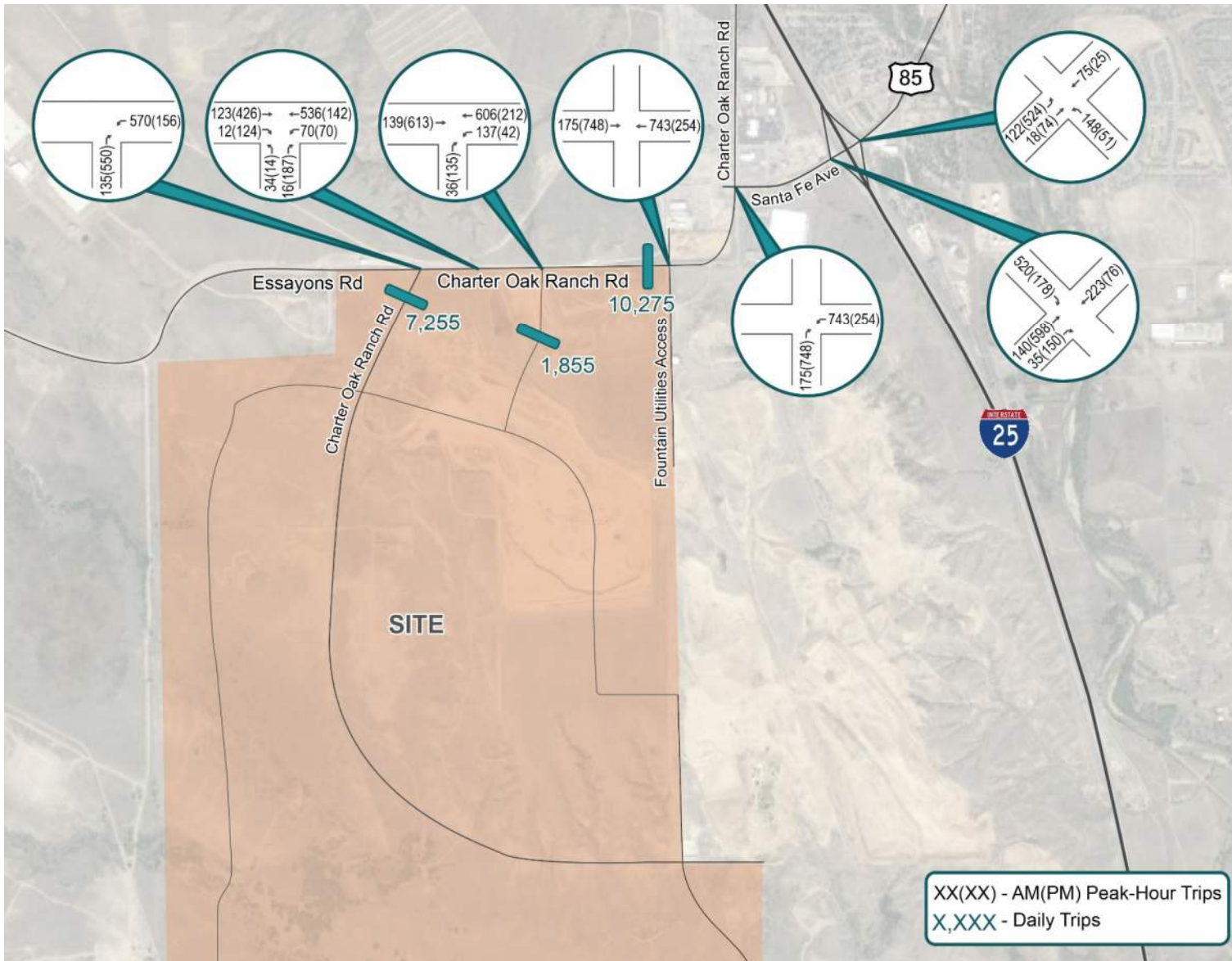

Figure 4-3. Phases 1-3 Site-Generated Traffic Assignment

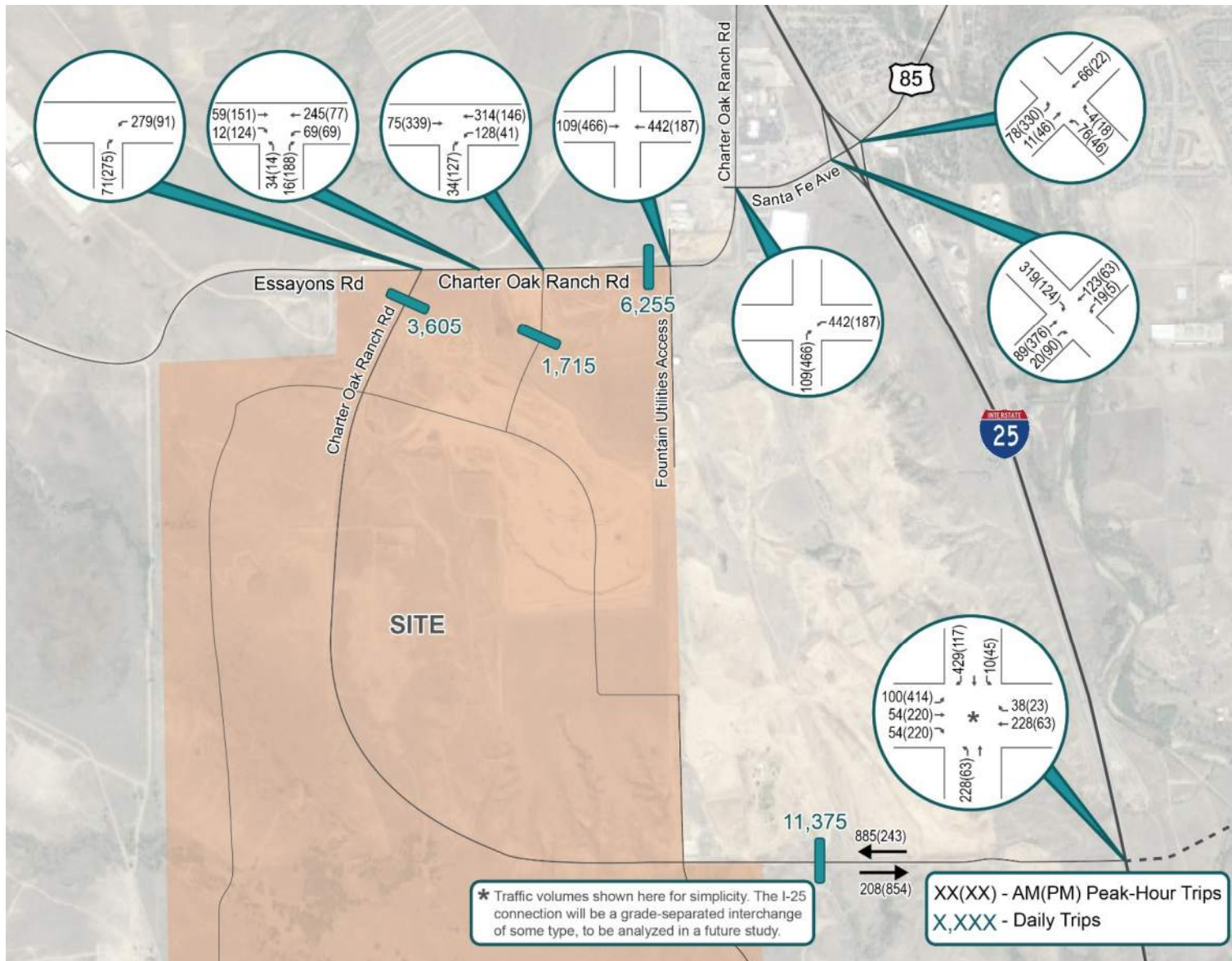

Figure 4-4. Buildout Site-Generated Traffic Assignment

## 5 – FORECAST TRAFFIC VOLUMES

### 5.1 Background Traffic

Background traffic is the traffic that would be on adjacent roads without the trips that will be generated by the proposed development. Background traffic includes through traffic as well as trips generated by developed and currently undeveloped parcels within the project area. Background traffic volumes were estimated for 2035, 2040, and 2045. These are the identified planning horizons for completion of Phases 2-4 of the development.

The background traffic forecasts were developed by applying a combination of growth factors to the existing traffic volumes. The 20-year growth factor for the southern end of US 85 from CDOT's OTIS website of 1.25 was applied to the study area roadway network (1.1%/year). However, the growth in traffic using Gate 19 was determined from a study completed by Fort Carson in January 2023, which showed an anticipated future traffic volume using Gate 19 nearly three times the amount counted in June 2023 (~5%/year assuming linear growth through 2045). The combination of these two annual growth rates was applied to the existing traffic counts to calculate the future background traffic volumes. The 2035, 2040, and 2045 background traffic volumes are shown in **Figures 5-1 to 5-3**.

### 5.2 Total Traffic

Phases 1-2 were evaluated with 2035 background traffic to assess short-term project impacts to the currently existing roadway network. Year 2040 was evaluated utilizing the Year 2040 background traffic and Phases 1-3 site traffic to identify the intermediate-term impacts of the development to the roadway network. Year 2045 was evaluated utilizing the Year 2045 background traffic and full buildout of the site to identify the long-term impacts of the development to the planned future roadway network.

The 2035 total traffic conditions include 2035 background traffic plus development traffic generated by Phases 1-2 of the site. The 2035 Total traffic volumes are shown in **Figure 5-4**.

The 2040 total traffic conditions include 2040 background traffic plus development traffic generated by Phases 1-3 of the site. The 2040 Total traffic volumes are shown in **Figure 5-5**.

The 2045 total traffic conditions include 2045 background traffic plus development traffic generated by full build-out of the site. The 2045 Total traffic volumes are shown in **Figure 5-6**.



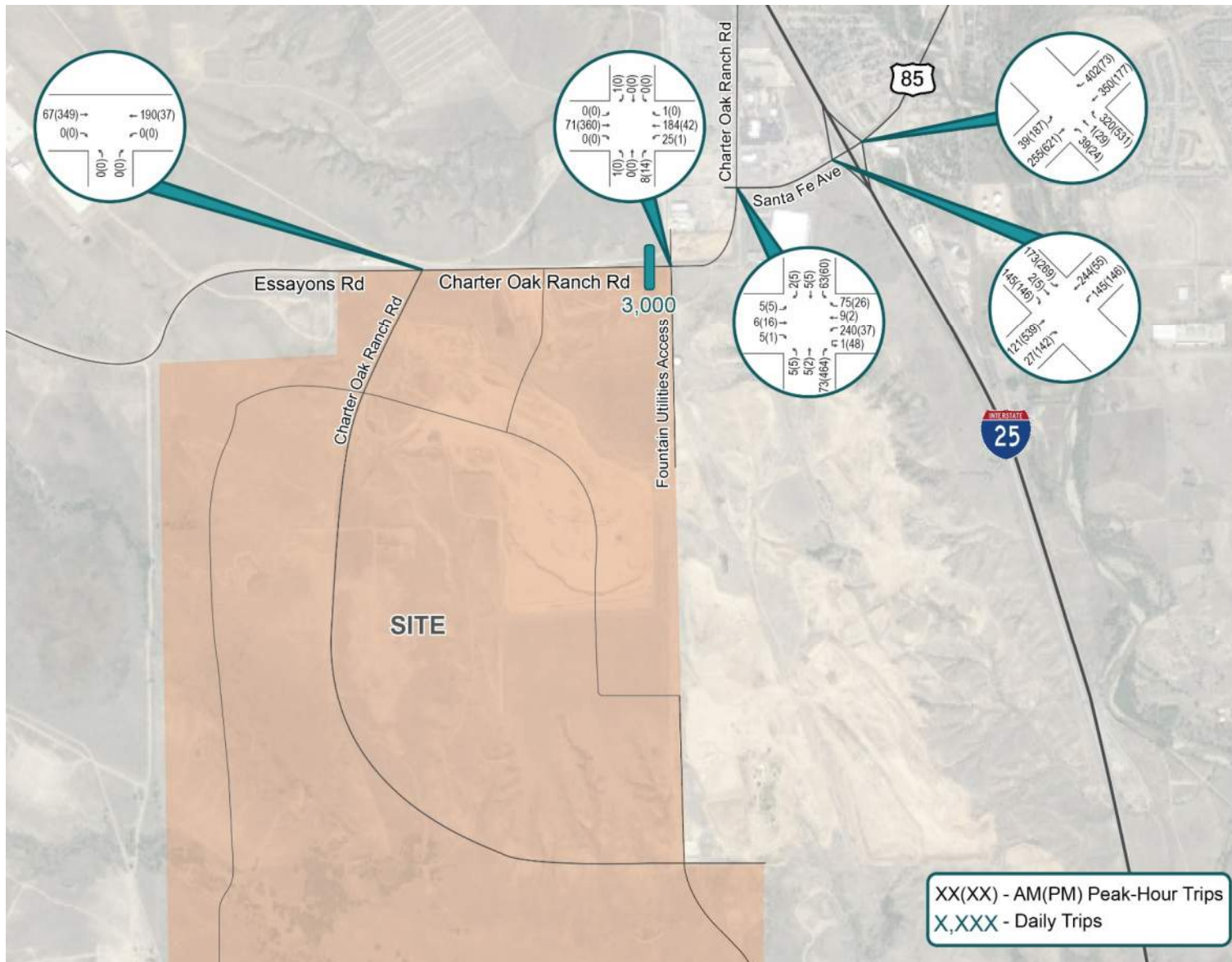

Figure 5-1. 2035 Background Traffic

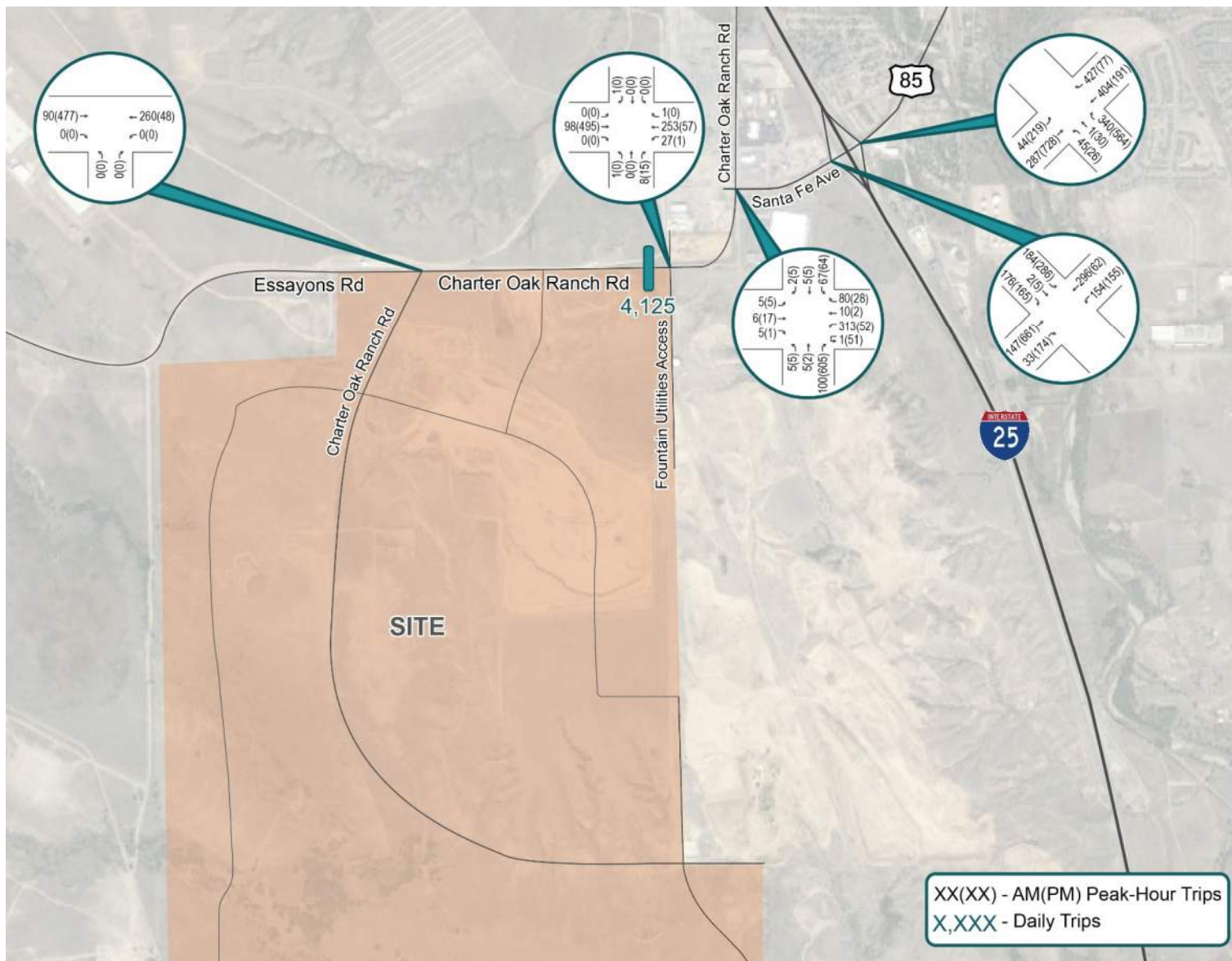

Figure 5-2. 2040 Background Traffic

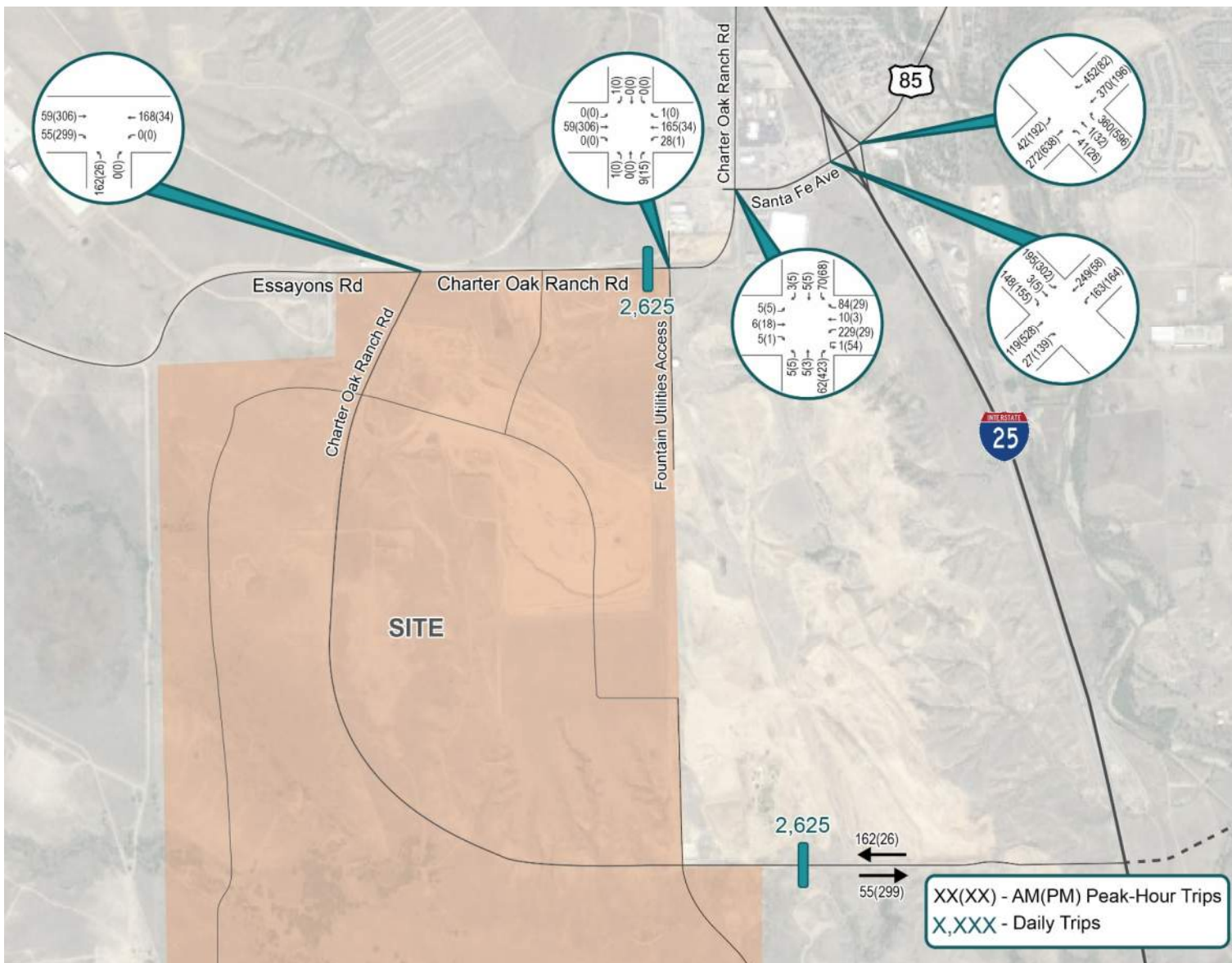

Figure 5-3. 2045 Background Traffic



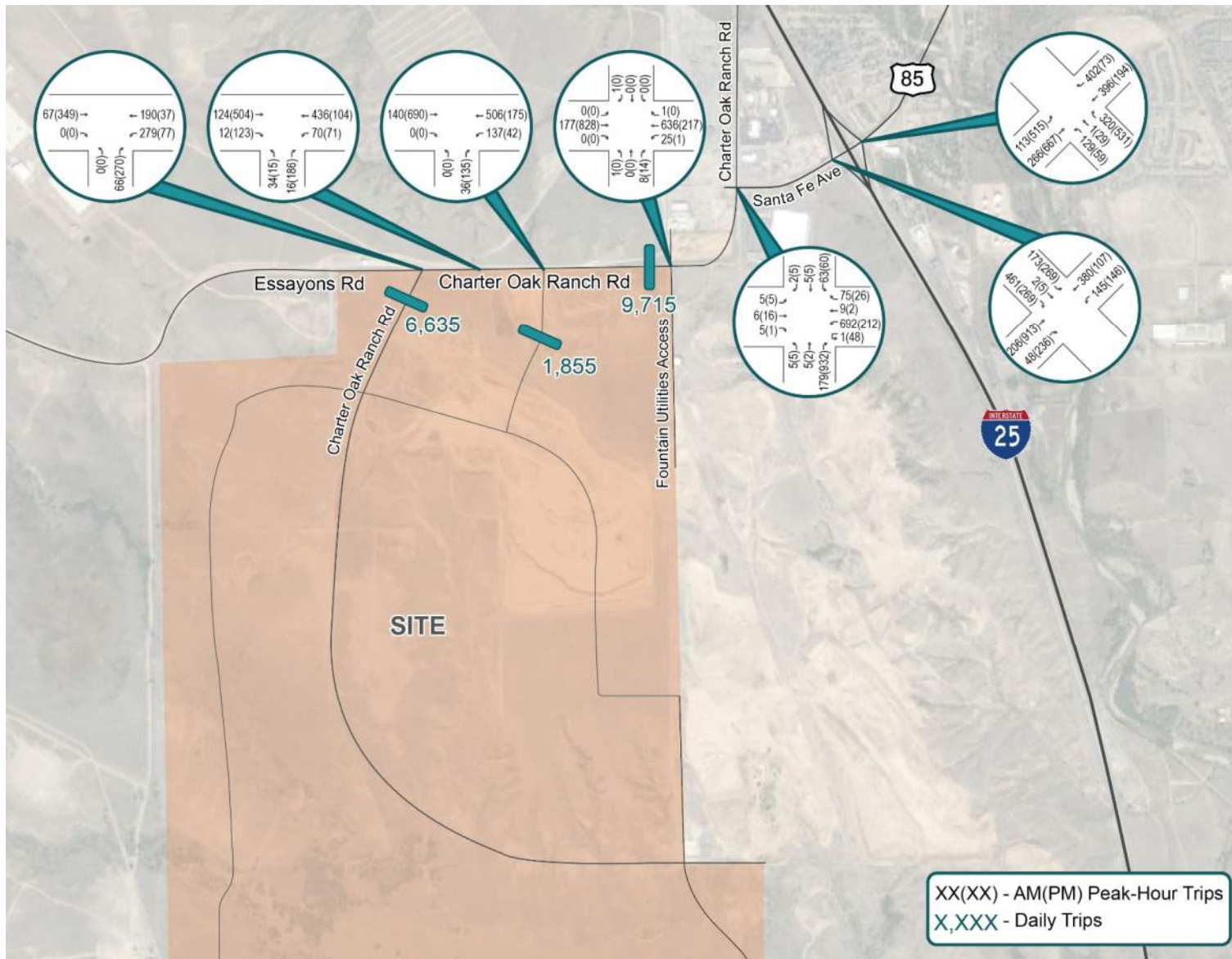

Figure 5-4. 2035 Total Traffic

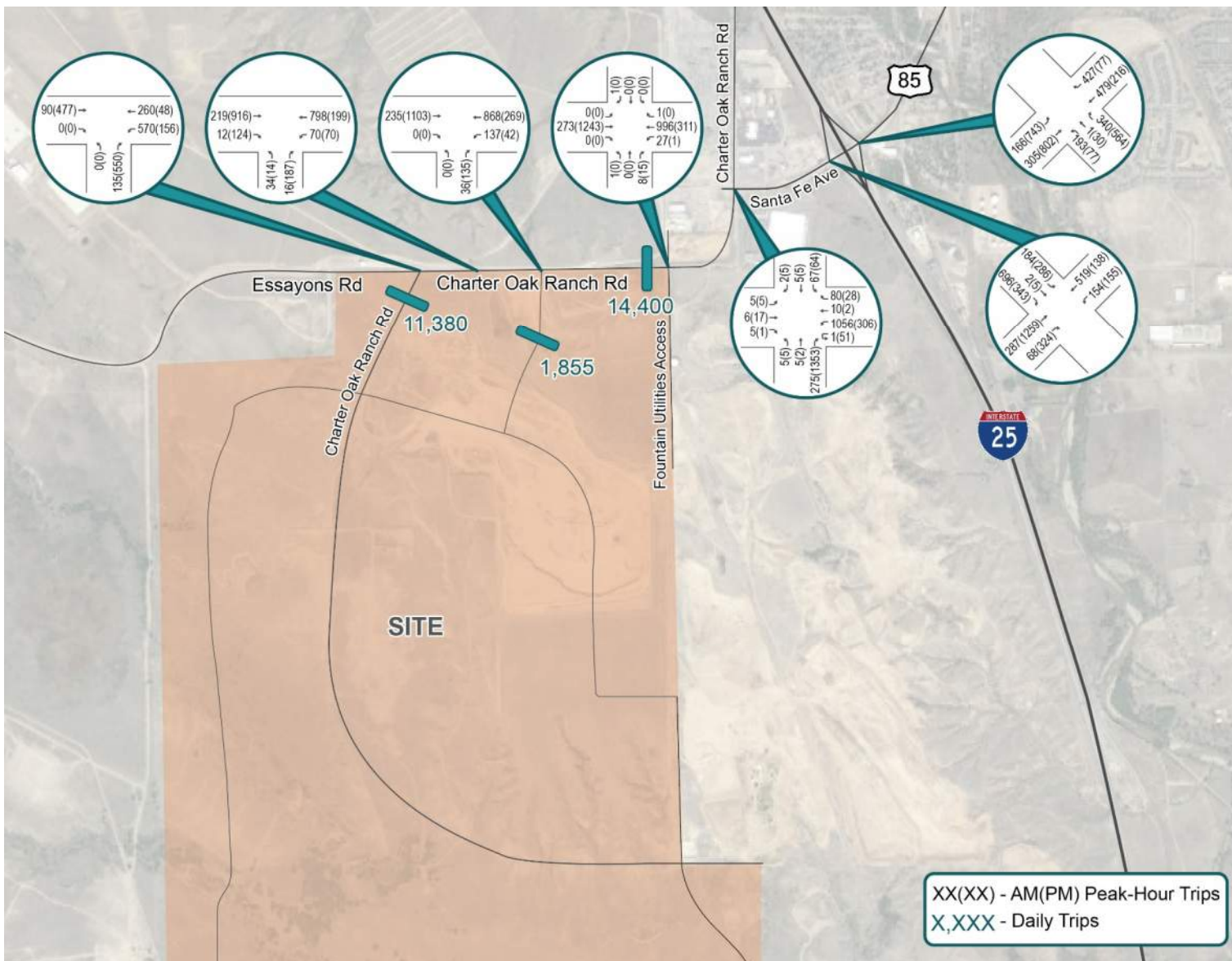

Figure 5-5. 2040 Total Traffic



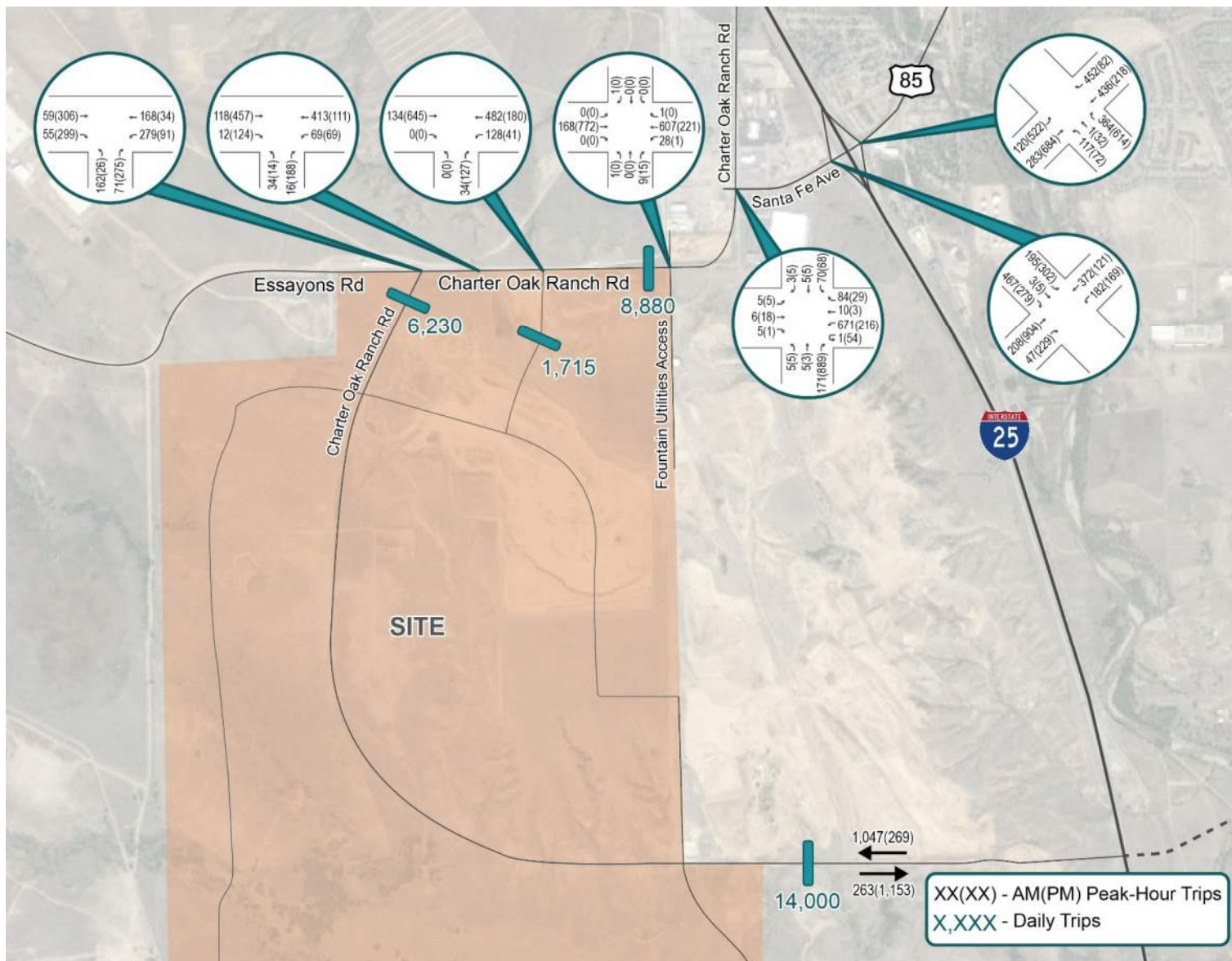

Figure 5-6. 2045 Total Traffic

## 6 – INTERSECTION LOS ANALYSIS

### 6.1 Background Conditions Traffic Operations Analysis

Intersection level of service analysis was completed for future background conditions to determine an operational baseline without the traffic to be generated by the site. Full Synchro analysis reports for the background conditions are included in **Appendix D**.

#### 6.1.1 Traffic Operations Analysis for 2035 Background Traffic

It is anticipated that Phases 1-2 of the site will be completed by 2035. Traffic operations performance was evaluated for 2035 background conditions without site development traffic. Intersection LOS and delay results for 2035 background traffic conditions are summarized in **Table 6-1**.

Based on the analysis of 2035 background traffic, all analyzed intersections are reported to operate at LOS B or better during the AM and PM peak hours.

Control	Intersection	LOS/Delay [in seconds/vehicle] (Critical Movement)	
		AM Peak Hour	PM Peak Hour
Signal	US 85 & I-25 NB Ramps	A / 7.4	A / 4.7
Signal	US 85 & I-25 SB Ramps	B / 16.5	B / 19.3
Roundabout	Charter Oak Ranch Road & US 85	A / 5.1	A / 6.8
TWSC	Charter Oak Ranch Rd & Fountain Utilities Access	a / 9.8 (NB)	b / 10.8 (NB)

#### 6.1.2 Traffic Operations Analysis for 2040 Background Traffic

It is anticipated that Phases 1-3 of the site will be completed by 2040. Traffic operations performance was evaluated for 2040 background conditions without site development traffic. Intersection LOS and delay results for 2040 background traffic conditions are summarized in **Table 6-2**.

Based on the analysis of 2040 background traffic, all analyzed intersections are reported to operate at LOS B or better during the AM and PM peak hours.

Control	Intersection	LOS/Delay [in seconds/vehicle] (Critical Movement)	
		AM Peak Hour	PM Peak Hour
Signal	US 85 & I-25 NB Ramps	A / 7.6	A / 4.6
Signal	US 85 & I-25 SB Ramps	B / 16.0	B / 19.1
Roundabout	Charter Oak Ranch Road & US 85	A / 5.4	A / 8.2
TWSC	Charter Oak Ranch Rd & Fountain Utilities Access	b / 10.0 (NB)	b / 11.8 (NB)

### 6.1.3 Traffic Operations Analysis for 2045 Background Traffic

It is anticipated that full buildout of the site will be completed by 2045. Traffic operations performance was evaluated for 2045 background conditions without site development traffic. Intersection LOS and delay results for 2045 background traffic conditions are summarized in **Table 6-3**. The analysis of 2045 background traffic includes the planned connection between Fort Carson and I-25 through the site.

Based on the analysis of 2045 background traffic, all analyzed intersections are reported to operate at LOS B or better during the AM and PM peak hours.

Control	Intersection	LOS/Delay [in seconds/vehicle] (Critical Movement)	
		AM Peak Hour	PM Peak Hour
Signal	US 85 & I-25 NB Ramps	A / 7.2	A / 4.8
Signal	US 85 & I-25 SB Ramps	B / 16.9	B / 19.6
Roundabout	Charter Oak Ranch Road & US 85	A / 4.8	A / 5.9
TWSC	Charter Oak Ranch Rd & Fountain Utilities Access	a / 9.6 (NB)	b / 10.1 (NB)
TWSC	Charter Oak Ranch Road & Essayons Road	b / 11.5 (NB LT)	b / 12.3 (NB LT)

### 6.2 Background Plus Site Conditions Traffic Operations Analysis

Intersection level of service analysis was completed for future total traffic conditions to determine the impacts of the traffic to be generated by the site. Full Synchro analysis reports for the total traffic conditions are included in **Appendix E**.

#### 6.2.1 Traffic Operations Analysis for 2035 Total Traffic

The 2035 Total intersection LOS and delay results are summarized in **Table 6-4**. The analysis shows that all analyzed intersections are reported to operate at LOS D or better during the AM and PM peak hours.

Control	Intersection	LOS/Delay [in seconds/vehicle] (Critical Movement)	
		AM Peak Hour	PM Peak Hour
Signal	US 85 & I-25 NB Ramps	B / 14.0	A / 6.7
Signal	US 85 & I-25 SB Ramps	B / 15.3	B / 19.8
Roundabout	Charter Oak Ranch Road & US 85	B / 10.9	D / 25.3
TWSC	Charter Oak Ranch Rd & Fountain Utilities Access	b / 13.7 (SB)	c / 17.3 (NB)
TWSC	Charter Oak Ranch Road & retail access	c / 17.7 (NB LT)	c / 18.5 (NB LT)
TWSC	Charter Oak Ranch Road & site access	a / 9.3 (NB)	c / 21.2 (NB)
TWSC	Charter Oak Ranch Road & Essayons Road	a / 9.8 (WB LT)	a / 9.0 (WB LT)



### 6.2.2 Traffic Operations Analysis for 2040 Total Traffic

The 2040 Total intersection LOS and delay results are summarized in **Table 6-5**. The analysis shows that during the PM peak hour, the roundabout at Charter Oak Ranch Road/US 85 is projected to operate at LOS F due to the NB approach being over capacity. Additionally, the stop-controlled approaches to Charter Oak Ranch Road at the site accesses are project to operate at LOS E during the PM peak hour.

Table 6-5. Traffic Operations Summary for 2040 Total Traffic			
Control	Intersection	LOS/Delay [in seconds/vehicle] (Critical Movement)	
		AM Peak Hour	PM Peak Hour
Signal	US 85 & I-25 NB Ramps	B / 16.4	A / 9.9
Signal	US 85 & I-25 SB Ramps	B / 15.0	C / 21.8
Roundabout	Charter Oak Ranch Road & US 85	D / 27.2	F / 103.2
TWSC	Charter Oak Ranch Rd & Fountain Utilities Access	c / 18.6 (SB)	d / 26.2 (NB)
TWSC	Charter Oak Ranch Road & retail access	d / 30.4 (NB LT)	e / 39.8 (NB RT)
TWSC	Charter Oak Ranch Road & site access	a / 9.8 (NB)	e / 46.3 (NB)
TWSC	Charter Oak Ranch Road & Essayons Road	b / 13.2 (WB LT)	a / 9.9 (WB LT)

### 6.2.3 Traffic Operations Analysis for 2045 Total Traffic

Intersection LOS and delay results for 2045 total traffic conditions are summarized in **Table 6-6**. The analysis shows that for 2045 total traffic conditions, all analyzed intersections are reported to operate at LOS C or better during the AM and PM peak hours, except at the intersection of Charter Oak Ranch Road & Essayons Road, which is anticipated to operate at an unacceptable LOS F for the northbound left turn movement as a stop sign-controlled intersection. Alternative scenarios were analyzed for this intersection, changing the control type to a traffic signal or a roundabout. The alternative scenarios' LOS results are shown in **Table 6-6**, indicating a LOS C or better during the AM and PM peak hours could be achieved.

Table 6-6. Traffic Operations Summary for 2045 Total Traffic			
Control	Intersection	LOS/Delay [in seconds/vehicle] (Critical Movement)	
		AM Peak Hour	PM Peak Hour
Signal	US 85 & I-25 NB Ramps	B / 12.7	A / 6.9
Signal	US 85 & I-25 SB Ramps	B / 15.6	B / 19.3
Roundabout	Charter Oak Ranch Road & US 85	A / 9.0	B / 14.4
TWSC	Charter Oak Ranch Rd & Fountain Utilities Access	b / 12.5 (SB)	b / 14.8 (NB)
TWSC	Charter Oak Ranch Road & retail access	c / 15.4 (NB LT)	c / 15.6 (NB LT)
TWSC	Charter Oak Ranch Road & site access	a / 9.1 (NB)	c / 16.3 (NB)
TWSC	Charter Oak Ranch Road & Essayons Road	f / 52.5 (NB LT)	c / 16.0 (NB LT)
Signal		C / 20.6	A / 6.8
Roundabout		B / 12.5	A / 8.3



## 7 – RECOMMENDATIONS

### 7.1 Future Connection to I-25

Based on the results of this study that show poor intersection levels of service along Charter Oak Ranch Road at buildout of Phase 3, it is likely that the planned future connection to I-25 will be needed prior to completion of Phase 3 to maintain acceptable levels of service at the intersections within the study area. However, given the high-level planning stage of the Sketch Plan, the relatively unique nature of the proposed development as a large rail-served industrial park, and the assumptions made as to the ultimate intensity of development, the actual timing of the need for the new connection to I-25 should be re-evaluated as development progresses within the site.

### 7.2 Internal Roadway Classifications

The analysis results indicate that the proposed functional classifications of the internal roadways as shown on the Sketch Plan are appropriate based on their projected buildout daily traffic volumes, connectivity, and expected use.

### 7.3 Future Traffic Impact Studies

Traffic impact studies should be completed with each future concept plan and/or development plan submittal. These studies should include more detailed analysis of the traffic impacts of the proposed development, such as vehicle queuing, auxiliary lane requirements, and safety assessments.



## List of Acronyms and Definitions

### **Average Daily Traffic (ADT)**

The amount of vehicular traffic that crosses an imaginary line across a roadway in a 24-hour period. ADT information typically includes both directions of vehicle travel (if on a two-way street). When the term ADT is used specifically to mean typical weekday traffic, it is often called Average Weekday Daily Traffic (AWDT).

### **Colorado Department of Transportation (CDOT)**

The Colorado Department of Transportation Online Traffic Information System (OTIS) was used as a data source for historical trends-based annual and 20-year traffic growth factors. CDOT has jurisdiction over Colorado's State Highway System, including facilities within the project study area.

### **Gap in Traffic**

A gap in traffic is the space between vehicles approaching the pedestrian crossing. Gaps are typically measured in seconds, not distance, as it is the length of the gap in time in which a pedestrian must be able to cross the street. A directional gap is the gap between vehicles approaching in a single direction. A directional gap can be measured between vehicles in a single lane, or between vehicles approaching in the same direction but in different lanes on a multilane approach. If there is no median refuge at the crossing, a pedestrian will need to find an acceptable gap in traffic approaching from two directions at once. This is much more challenging than finding a gap in each approach direction separately.

### **Highway Capacity Manual (HCM)**

The Highway Capacity Manual is a publication of the U.S. Transportation Research Board of the National Academies of Science. It contains concepts, guidelines, and computational procedures for computing the capacity and quality of service of various highway facilities, including freeways, highways, arterial roads, roundabouts, signalized and unsignalized intersections, and rural highways, and the effects of mass transit, pedestrians, and bicycles on the performance of these systems. The Highway Capacity Manual Sixth Edition (HCM6) was used as part of this study.

### **Lane**

A portion of the roadway surface designated for motor vehicle travel, typically in a single direction, that is delineated by pavement marking stripes. Types of lanes include: "through lanes" for travel along the length of the roadway, often through intersections; "turn lanes" which are typically on intersection approaches and provide space for left or right turning motorists; "bike lanes" which are designated for bicycle travel in the same direction as the automobile travel, are typically narrower than vehicle lanes, and are usually located along the outside edges of the roadway.



### **Left Turn (LT)**

Refers to traffic that turns left at an intersection, often using a designated left-turn lane, and is sometimes afforded a dedicated left-turn phase in traffic signal timing.

### **Level of Service (LOS)**

A qualitative measure used to relate the quality of traffic service. LOS is used to analyze highways by categorizing traffic flow and assigning quality levels of traffic based on performance measure such as speed, density, and so forth.

### **Online Transportation Information System (OTIS)**

This is a publicly available website maintained by the Colorado Department of Transportation, providing information on current and projected traffic volumes, state highway attributes, summary roadway statistics, demographics and geographic data.

### **Right Turn (RT)**

Refers to traffic that turns right at an intersection, sometimes using a designated right-turn lane.

### **Through/Right Turn**

Refers to traffic (and the lane that carries it) at an intersection that is continuing forward straight through without turning, together with traffic that turns right at the intersection.

### **Two-Way Stop Controlled (TWSC)**

Cross street minor approaches that are controlled by STOP signs.

### **Turning Movement Counts**

Traffic counts for a given time interval that specify how many vehicles turn left or right, as well as counting vehicles that proceed straight forward through the intersection.



## List of References

Institute of Traffic Engineers (ITE). 2021. *Trip Generation Manual, 11<sup>th</sup> Edition*. 5 vols. Washington, DC: National Academies Press.

Online Traffic Information System (OTIS). n.d. Colorado Department of Transportation (website). Accessed July 17, 2023. <http://dtdapps.coloradodot.info/otis>.

Transportation Research Board. 2016. *Highway Capacity Manual Sixth Edition: A Guide for Multimodal Mobility Analysis* (HCM6). Washington, DC: National Academies Press.





# SOUTHERN COLORADO RAIL PARK

PARCELS OF LAND IN SECTIONS 12, 13, 14, 23, 24, 25 AND 26 T16S R66W OF THE 6TH P.M., COUNTY OF EL PASO, STATE OF COLORADO

## SKETCH PLAN

**CONSTRUCTION TIMELINE**

PHASE 1	BEGINS SPRING 2025
PHASE 2	BEGINS SPRING 2030
PHASE 3	BEGINS SPRING 2035
PHASE 4	BEGINS SPRING 2040

PHASE 1	36.8 AC	TOTAL
	96.8 AC RAIL SPUR & ESMT	
PHASE 2	906.4 AC	TOTAL
	10.9 AC COMMERCIAL	
	20.4 AC COMMERCIAL SERVICES	
	274.6 AC LIGHT INDUSTRIAL	
	490.9 AC HEAVY INDUSTRIAL	
	109.6 AC DETENTION & FLOOD CONTROL	
PHASE 3	949.3 AC	TOTAL
	891.3 AC HEAVY INDUSTRIAL	
	58 AC DETENTION & FLOOD CONTROL	
PHASE 4	719.9 AC	TOTAL
	110.5 AC COMMERCIAL SERVICES	
	581.4 AC LIGHT INDUSTRIAL	
	28 AC DETENTION	

**LAND USE LEGEND**

- COMMERCIAL CENTER
- COMMERCIAL SERVICES
- LIGHT INDUSTRIAL
- HEAVY INDUSTRIAL
- PRESERVATION / LOW IMPACT USES
- DRAINAGE, FLOOD CONTROL, & OPEN SPACE
- 100 YR FLOODPLAIN
- RAIL EASEMENT
- ROADWAYS
- FUTURE / PROPOSED ROADWAYS, BY OTHERS
- PRESERVED ROW FOR FUTURE PROPOSED ROADWAYS

**SYMBOL & LINETYPE LEGEND**

- SITE ACCESS POINT
- WATERWAYS
- RAILWAYS
- PROPERTY BOUNDARY
- PHASE 1
- PHASE 2
- PHASE 3
- PHASE 4
- NO-BUILD AREA
- 100-YR FLOOD AREA
- CURRENT MINING OPERATION TO BE DEVELOPED UPON COMPLETION OF MINING OPERATION

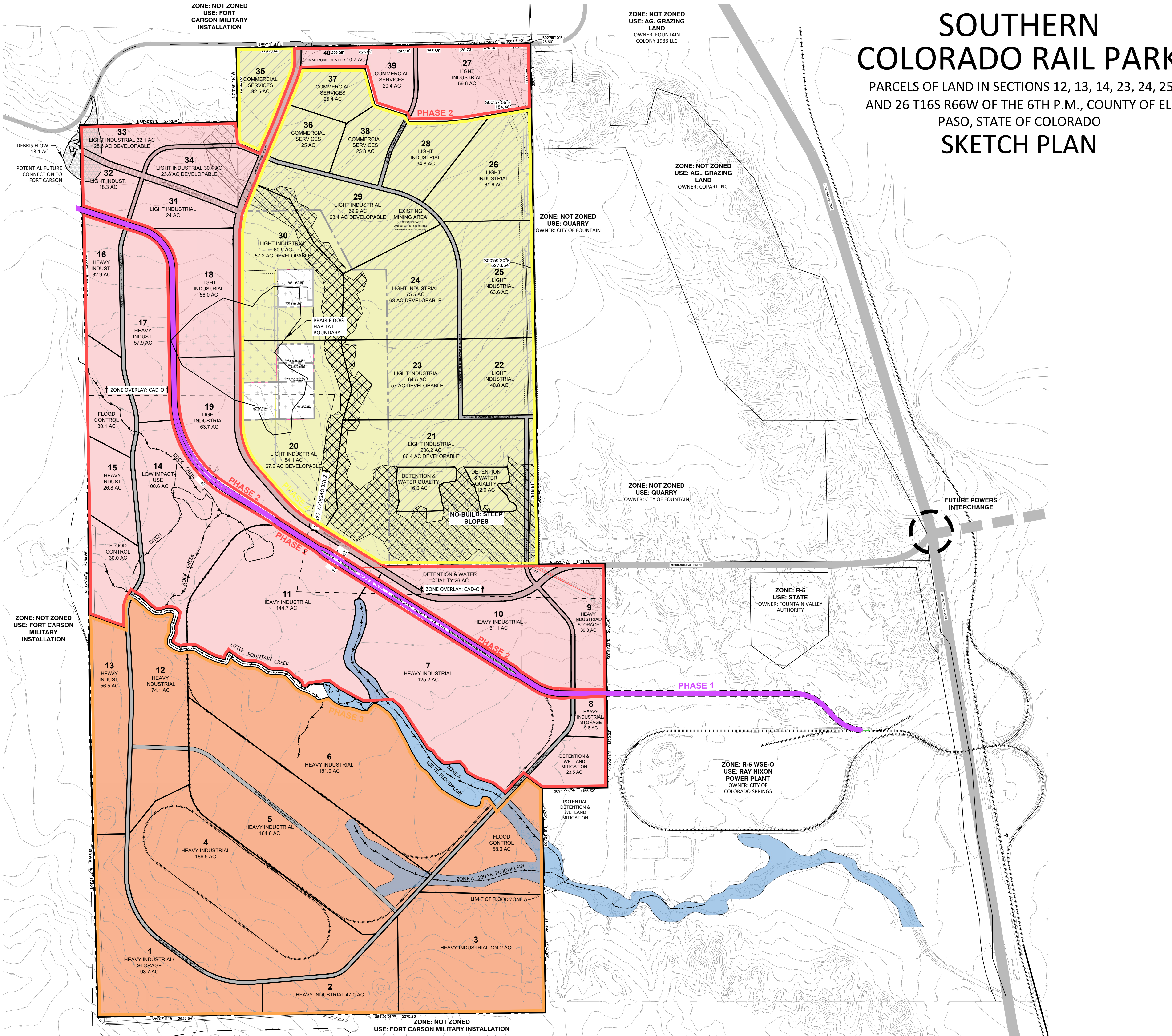

N.E.S. Inc.  
619 N. Cascade Avenue, Suite 200  
Colorado Springs, CO 80903  
Tel. 719.471.0073  
Fax 719.471.0267  
www.nescolorado.com  
© 2012. All Rights Reserved.

### SOUTHERN COLORADO RAIL PARK

#### SKETCH PLAN

EAST OF FORT CARSON, WEST OF I-25,  
SOUTH OF CHARTER OAK RANCH ROAD

DATE: 06/05/2023  
PROJECT MGR: A. BARLOW  
PREPARED BY: J. SMITH

DATE:	BY:	DESCRIPTION:
03/19/2024	JS	PER EPC REVIEW COMMENTS

**PHASING PLAN**

**6**

6 OF 6

SKP234

P:\Edw. C. Levy, Cdr. dfa, Schmidt Construction Company\Fountain Railroad Project\Drawings\Phasing\Sketch Plan\_0411\_0411.dwg (Sketch Plan Phasing) 3/28/2024 2:21:00 PM Jsmith



## Appendix B: Traffic Counts



# Charter Oak Ranch Rd Eassayons Rd



Peak Hour

Date: 06/13/2023

Count Period: 5:00 AM to 8:00 AM

Peak Hour: 5:30 AM to 6:30 AM

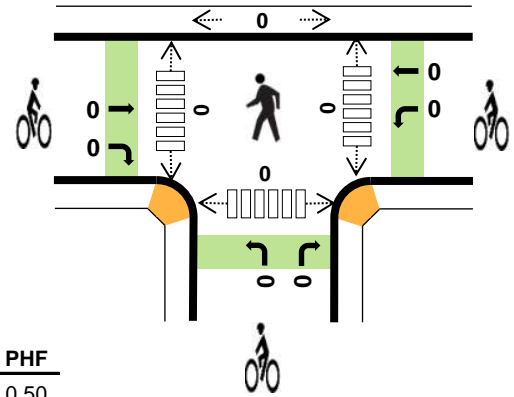
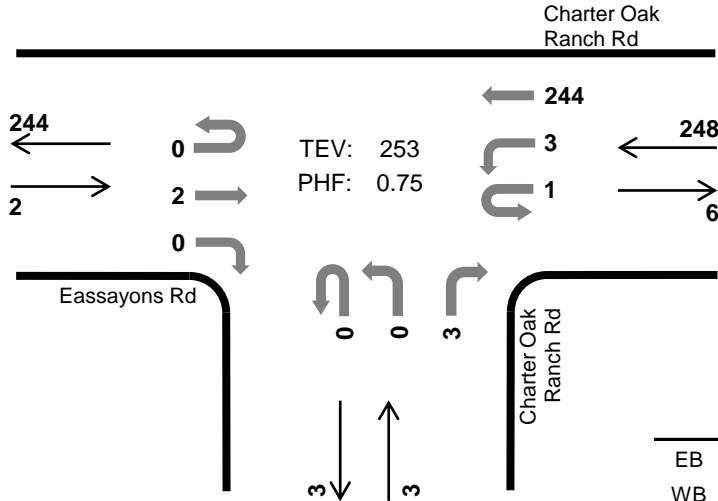

	HV %:	PHF
EB	0.0%	0.50
WB	1.2%	0.75
NB	0.0%	0.75
SB	-	-
TOTAL	1.2%	0.75

### Three-Hour Count Summaries

Interval Start	Eassayons Rd				Charter Oak Ranch Rd				Charter Oak Ranch Rd				n/a				15-min Total	Rolling One Hour	
	Eastbound				Westbound				Northbound				Southbound						
	UT	LT	TH	RT	UT	LT	TH	RT	UT	LT	TH	RT	UT	LT	TH	RT			
5:30 AM	0	0	0	0	0	0	52	0	0	0	0	1	0	0	0	0	53	0	
5:45 AM	0	0	0	0	1	2	80	0	0	0	0	1	0	0	0	0	84	0	
6:00 AM	0	0	1	0	0	1	74	0	0	0	0	1	0	0	0	0	77	0	
6:15 AM	0	0	1	0	0	0	38	0	0	0	0	0	0	0	0	0	39	253	
Peak Hour	All	0	0	2	0	1	3	244	0	0	0	0	3	0	0	0	0	253	0
	HV	0	0	0	0	0	0	3	0	0	0	0	0	0	0	0	0	3	0
	HV%	-	-	0%	-	0%	0%	1%	-	-	-	-	0%	-	-	-	-	1%	0

Note: For all three-hour count summary, see next page.

Interval Start	Heavy Vehicle Totals					Bicycles					Pedestrians (Crossing Leg)				
	EB	WB	NB	SB	Total	EB	WB	NB	SB	Total	East	West	North	South	Total
5:30 AM	0	0	0	0	0	0	0	0	0	0	0	0	0	0	0
5:45 AM	0	0	0	0	0	0	0	0	0	0	0	0	0	0	0
6:00 AM	0	1	0	0	1	0	0	0	0	0	0	0	0	0	0
6:15 AM	0	2	0	0	2	0	0	0	0	0	0	0	0	0	0
Peak Hour	0	3	0	0	3	0	0	0	0	0	0	0	0	0	0

**Three-Hour Count Summaries**

Interval Start	Eassayons Rd				Charter Oak Ranch Rd				Charter Oak Ranch Rd				n/a				15-min Total	Rolling One Hour
	Eastbound				Westbound				Northbound				Southbound					
	UT	LT	TH	RT	UT	LT	TH	RT	UT	LT	TH	RT	UT	LT	TH	RT		
5:00 AM	0	0	0	0	0	0	10	0	0	0	0	0	0	0	0	10	0	
5:15 AM	0	0	1	0	0	0	23	0	0	0	0	0	0	0	0	24	0	
5:30 AM	0	0	0	0	0	0	52	0	0	0	0	1	0	0	0	53	0	
5:45 AM	0	0	0	0	1	2	80	0	0	0	0	1	0	0	0	84	171	
6:00 AM	0	0	1	0	0	1	74	0	0	0	0	1	0	0	0	77	238	
6:15 AM	0	0	1	0	0	0	38	0	0	0	0	0	0	0	0	39	253	
6:30 AM	0	0	10	0	0	1	37	0	0	0	0	0	0	0	0	48	248	
6:45 AM	0	0	6	0	0	0	36	0	0	0	0	1	0	0	0	43	207	
7:00 AM	0	0	7	0	0	1	23	0	0	0	0	1	0	0	0	32	162	
7:15 AM	0	0	10	0	0	1	27	0	0	0	0	0	0	0	0	38	161	
7:30 AM	0	0	15	0	0	2	26	0	0	0	0	1	0	0	0	44	157	
7:45 AM	0	0	17	0	1	0	36	0	0	0	0	2	0	0	0	56	170	
Count Total	0	0	68	0	2	8	462	0	0	0	0	8	0	0	0	548	0	
Peak Hour	All	0	0	2	0	1	3	244	0	0	0	0	3	0	0	0	253	0
	HV	0	0	0	0	0	0	3	0	0	0	0	0	0	0	0	3	0
	HV%	-	-	0%	-	0%	0%	1%	-	-	-	-	0%	-	-	-	1%	0

Note: Three-hour count summary volumes include heavy vehicles but exclude bicycles in overall count.

Interval Start	Heavy Vehicle Totals					Bicycles					Pedestrians (Crossing Leg)				
	EB	WB	NB	SB	Total	EB	WB	NB	SB	Total	East	West	North	South	Total
5:00 AM	0	0	0	0	0	0	0	0	0	0	0	0	0	0	0
5:15 AM	0	0	0	0	0	0	0	0	0	0	0	0	0	0	0
5:30 AM	0	0	0	0	0	0	0	0	0	0	0	0	0	0	0
5:45 AM	0	0	0	0	0	0	0	0	0	0	0	0	0	0	0
6:00 AM	0	1	0	0	1	0	0	0	0	0	0	0	0	0	0
6:15 AM	0	2	0	0	2	0	0	0	0	0	0	0	0	0	0
6:30 AM	0	0	0	0	0	0	0	0	0	0	0	0	0	0	0
6:45 AM	0	0	0	0	0	0	0	0	0	0	0	0	0	0	0
7:00 AM	0	1	1	0	2	0	0	0	0	0	0	0	0	0	0
7:15 AM	0	1	0	0	1	0	0	0	0	0	0	0	0	0	0
7:30 AM	0	2	1	0	3	0	0	0	0	0	0	0	0	0	0
7:45 AM	0	0	2	0	2	0	0	0	0	0	0	0	0	0	0
Count Total	0	7	4	0	11	0	0	0	0	0	0	0	0	0	0
Peak Hr	0	3	0	0	3	0	0	0	0	0	0	0	0	0	0

**Three-Hour Count Summaries - Heavy Vehicles**

Interval Start	Eassayons Rd				Charter Oak Ranch Rd				Charter Oak Ranch Rd				n/a				15-min Total	Rolling One Hour
	Eastbound				Westbound				Northbound				Southbound					
	UT	LT	TH	RT	UT	LT	TH	RT	UT	LT	TH	RT	UT	LT	TH	RT		
5:00 AM	0	0	0	0	0	0	0	0	0	0	0	0	0	0	0	0	0	0
5:15 AM	0	0	0	0	0	0	0	0	0	0	0	0	0	0	0	0	0	0
<b>5:30 AM</b>	<b>0</b>	<b>0</b>	<b>0</b>	<b>0</b>	<b>0</b>	<b>0</b>	<b>0</b>	<b>0</b>	<b>0</b>	<b>0</b>	<b>0</b>	<b>0</b>	<b>0</b>	<b>0</b>	<b>0</b>	<b>0</b>	<b>0</b>	<b>0</b>
<b>5:45 AM</b>	<b>0</b>	<b>0</b>	<b>0</b>	<b>0</b>	<b>0</b>	<b>0</b>	<b>0</b>	<b>0</b>	<b>0</b>	<b>0</b>	<b>0</b>	<b>0</b>	<b>0</b>	<b>0</b>	<b>0</b>	<b>0</b>	<b>0</b>	<b>0</b>
6:00 AM	0	0	0	0	0	0	1	0	0	0	0	0	0	0	0	1	1	1
6:15 AM	0	0	0	0	0	0	2	0	0	0	0	0	0	0	0	2	3	3
6:30 AM	0	0	0	0	0	0	0	0	0	0	0	0	0	0	0	0	3	3
6:45 AM	0	0	0	0	0	0	0	0	0	0	0	0	0	0	0	0	3	3
7:00 AM	0	0	0	0	0	1	0	0	0	0	0	1	0	0	0	2	4	4
7:15 AM	0	0	0	0	0	1	0	0	0	0	0	0	0	0	0	1	3	3
7:30 AM	0	0	0	0	0	2	0	0	0	0	0	1	0	0	0	3	6	6
7:45 AM	0	0	0	0	0	0	0	0	0	0	0	2	0	0	0	2	8	8
Count Total	0	0	0	0	0	4	3	0	0	0	0	4	0	0	0	11	0	0
Peak Hour	0	0	0	0	0	0	3	0	0	0	0	0	0	0	0	3	0	0

**Three-Hour Count Summaries - Bikes**

Interval Start	Eassayons Rd			Charter Oak Ranch Rd			Charter Oak Ranch Rd			n/a			15-min Total	Rolling One Hour
	Eastbound			Westbound			Northbound			Southbound				
	LT	TH	RT	LT	TH	RT	LT	TH	RT	LT	TH	RT		
5:00 AM	0	0	0	0	0	0	0	0	0	0	0	0	0	0
5:15 AM	0	0	0	0	0	0	0	0	0	0	0	0	0	0
<b>5:30 AM</b>	<b>0</b>	<b>0</b>	<b>0</b>	<b>0</b>	<b>0</b>	<b>0</b>	<b>0</b>	<b>0</b>	<b>0</b>	<b>0</b>	<b>0</b>	<b>0</b>	<b>0</b>	<b>0</b>
<b>5:45 AM</b>	<b>0</b>	<b>0</b>	<b>0</b>	<b>0</b>	<b>0</b>	<b>0</b>	<b>0</b>	<b>0</b>	<b>0</b>	<b>0</b>	<b>0</b>	<b>0</b>	<b>0</b>	<b>0</b>
6:00 AM	0	0	0	0	0	0	0	0	0	0	0	0	0	0
6:15 AM	0	0	0	0	0	0	0	0	0	0	0	0	0	0
6:30 AM	0	0	0	0	0	0	0	0	0	0	0	0	0	0
6:45 AM	0	0	0	0	0	0	0	0	0	0	0	0	0	0
7:00 AM	0	0	0	0	0	0	0	0	0	0	0	0	0	0
7:15 AM	0	0	0	0	0	0	0	0	0	0	0	0	0	0
7:30 AM	0	0	0	0	0	0	0	0	0	0	0	0	0	0
7:45 AM	0	0	0	0	0	0	0	0	0	0	0	0	0	0
Count Total	0	0	0	0	0	0	0	0	0	0	0	0	0	0
Peak Hour	0	0	0	0	0	0	0	0	0	0	0	0	0	0

Note: U-Turn volumes for bikes are included in Left-Turn, if any.

# Charter Oak Ranch Rd Eassayons Rd



Peak Hour

Date: 06/13/2023

Count Period: 4:00 PM to 6:00 PM

Peak Hour: 4:30 PM to 5:30 PM

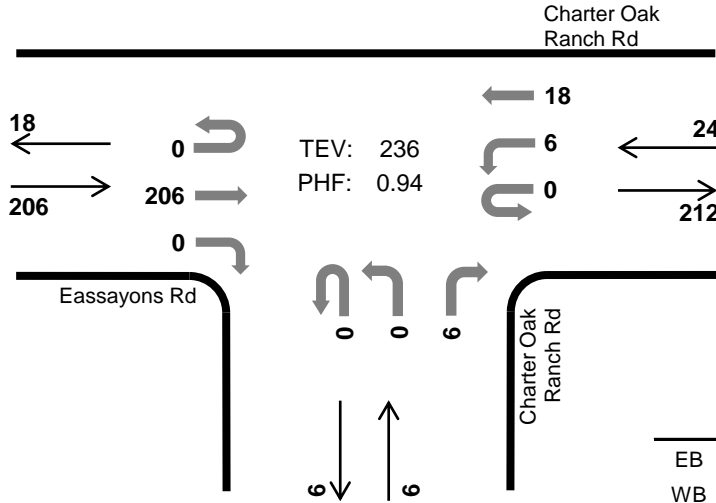

TEV: 236  
PHF: 0.94

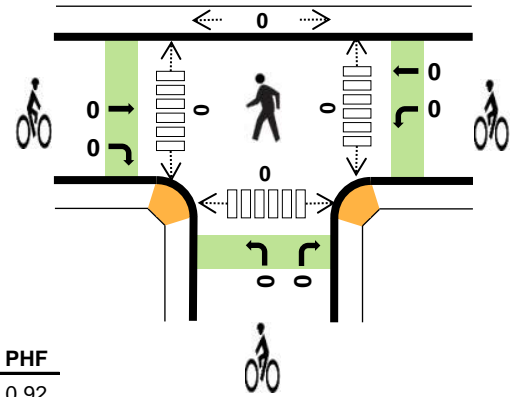

	HV %:	PHF
EB	0.0%	0.92
WB	12.5%	0.86
NB	16.7%	0.38
SB	-	-
TOTAL	1.7%	0.94

## Two-Hour Count Summaries

Interval Start	Eassayons Rd				Charter Oak Ranch Rd				Charter Oak Ranch Rd				n/a				15-min Total	Rolling One Hour	
	Eastbound				Westbound				Northbound				Southbound						
	UT	LT	TH	RT	UT	LT	TH	RT	UT	LT	TH	RT	UT	LT	TH	RT			
4:00 PM	0	0	48	0	0	0	5	0	0	0	0	1	0	0	0	0	54	0	
4:15 PM	0	0	42	0	0	0	2	0	0	0	0	0	0	0	0	0	44	0	
4:30 PM	0	0	48	0	0	2	3	0	0	0	0	0	0	0	0	0	53	0	
4:45 PM	0	0	53	0	0	3	4	0	0	0	0	1	0	0	0	0	61	212	
5:00 PM	0	0	49	0	0	1	5	0	0	0	0	4	0	0	0	0	59	217	
5:15 PM	0	0	56	0	0	0	6	0	0	0	0	1	0	0	0	0	63	236	
5:30 PM	0	0	27	0	0	0	6	0	0	0	0	2	0	0	0	0	35	218	
5:45 PM	0	0	12	1	0	0	0	0	0	0	0	2	0	0	0	0	15	172	
Count Total	0	0	335	1	0	6	31	0	0	0	0	11	0	0	0	0	384	0	
Peak Hour	All	0	0	206	0	0	6	18	0	0	0	0	6	0	0	0	0	236	0
	HV	0	0	0	0	0	2	1	0	0	0	0	1	0	0	0	0	4	0
	HV%	-	-	0%	-	-	33%	6%	-	-	-	-	17%	-	-	-	-	2%	0

Note: Two-hour count summary volumes include heavy vehicles but exclude bicycles in overall count.

Interval Start	Heavy Vehicle Totals					Bicycles					Pedestrians (Crossing Leg)				
	EB	WB	NB	SB	Total	EB	WB	NB	SB	Total	East	West	North	South	Total
4:00 PM	0	0	0	0	0	0	0	0	0	0	0	0	0	0	0
4:15 PM	0	0	0	0	0	0	0	0	0	0	0	0	0	0	0
4:30 PM	0	0	0	0	0	0	0	0	0	0	0	0	0	0	0
4:45 PM	0	3	1	0	4	0	0	0	0	0	0	0	0	0	0
5:00 PM	0	0	0	0	0	0	0	0	0	0	0	0	0	0	0
5:15 PM	0	0	0	0	0	0	0	0	0	0	0	0	0	0	0
5:30 PM	0	0	1	0	1	0	0	0	0	0	0	0	0	0	0
5:45 PM	0	0	0	0	0	0	0	0	0	0	0	0	0	0	0
Count Total	0	3	2	0	5	0	0	0	0	0	0	0	0	0	0
Peak Hr	0	3	1	0	4	0	0	0	0	0	0	0	0	0	0



**Two-Hour Count Summaries - Heavy Vehicles**

Interval Start	Eassayons Rd				Charter Oak Ranch Rd				Charter Oak Ranch Rd				n/a				15-min Total	Rolling One Hour	
	Eastbound				Westbound				Northbound				Southbound						
	UT	LT	TH	RT	UT	LT	TH	RT	UT	LT	TH	RT	UT	LT	TH	RT			
4:00 PM	0	0	0	0	0	0	0	0	0	0	0	0	0	0	0	0	0	0	0
4:15 PM	0	0	0	0	0	0	0	0	0	0	0	0	0	0	0	0	0	0	0
<b>4:30 PM</b>	<b>0</b>	<b>0</b>	<b>0</b>	<b>0</b>	<b>0</b>	<b>0</b>	<b>0</b>	<b>0</b>	<b>0</b>	<b>0</b>	<b>0</b>	<b>0</b>	<b>0</b>	<b>0</b>	<b>0</b>	<b>0</b>	<b>0</b>	<b>0</b>	<b>0</b>
4:45 PM	0	0	0	0	0	2	1	0	0	0	0	0	1	0	0	0	0	4	4
5:00 PM	0	0	0	0	0	0	0	0	0	0	0	0	0	0	0	0	0	0	4
<b>5:15 PM</b>	<b>0</b>	<b>0</b>	<b>0</b>	<b>0</b>	<b>0</b>	<b>0</b>	<b>0</b>	<b>0</b>	<b>0</b>	<b>0</b>	<b>0</b>	<b>0</b>	<b>0</b>	<b>0</b>	<b>0</b>	<b>0</b>	<b>0</b>	<b>0</b>	<b>4</b>
5:30 PM	0	0	0	0	0	0	0	0	0	0	0	0	1	0	0	0	0	1	5
5:45 PM	0	0	0	0	0	0	0	0	0	0	0	0	0	0	0	0	0	0	1
Count Total	0	0	0	0	0	2	1	0	0	0	0	2	0	0	0	0	5	0	0
Peak Hour	0	0	0	0	0	2	1	0	0	0	0	1	0	0	0	0	4	0	0

**Two-Hour Count Summaries - Bikes**

Interval Start	Eassayons Rd			Charter Oak Ranch Rd			Charter Oak Ranch Rd			n/a			15-min Total	Rolling One Hour	
	Eastbound			Westbound			Northbound			Southbound					
	LT	TH	RT	LT	TH	RT	LT	TH	RT	LT	TH	RT			
4:00 PM	0	0	0	0	0	0	0	0	0	0	0	0	0	0	0
4:15 PM	0	0	0	0	0	0	0	0	0	0	0	0	0	0	0
<b>4:30 PM</b>	<b>0</b>	<b>0</b>	<b>0</b>	<b>0</b>	<b>0</b>	<b>0</b>	<b>0</b>	<b>0</b>	<b>0</b>	<b>0</b>	<b>0</b>	<b>0</b>	<b>0</b>	<b>0</b>	<b>0</b>
4:45 PM	0	0	0	0	0	0	0	0	0	0	0	0	0	0	0
5:00 PM	0	0	0	0	0	0	0	0	0	0	0	0	0	0	0
<b>5:15 PM</b>	<b>0</b>	<b>0</b>	<b>0</b>	<b>0</b>	<b>0</b>	<b>0</b>	<b>0</b>	<b>0</b>	<b>0</b>	<b>0</b>	<b>0</b>	<b>0</b>	<b>0</b>	<b>0</b>	<b>0</b>
5:30 PM	0	0	0	0	0	0	0	0	0	0	0	0	0	0	0
5:45 PM	0	0	0	0	0	0	0	0	0	0	0	0	0	0	0
Count Total	0	0	0	0	0	0	0	0	0	0	0	0	0	0	0
Peak Hour	0	0	0	0	0	0	0	0	0	0	0	0	0	0	0

Note: U-Turn volumes for bikes are included in Left-Turn, if any.

# Fountain Utilities Access Charter Oak Ranch Rd



Date: 06/13/2023

Count Period: 5:00 AM to 8:00 AM

Peak Hour: 5:30 AM to 6:30 AM

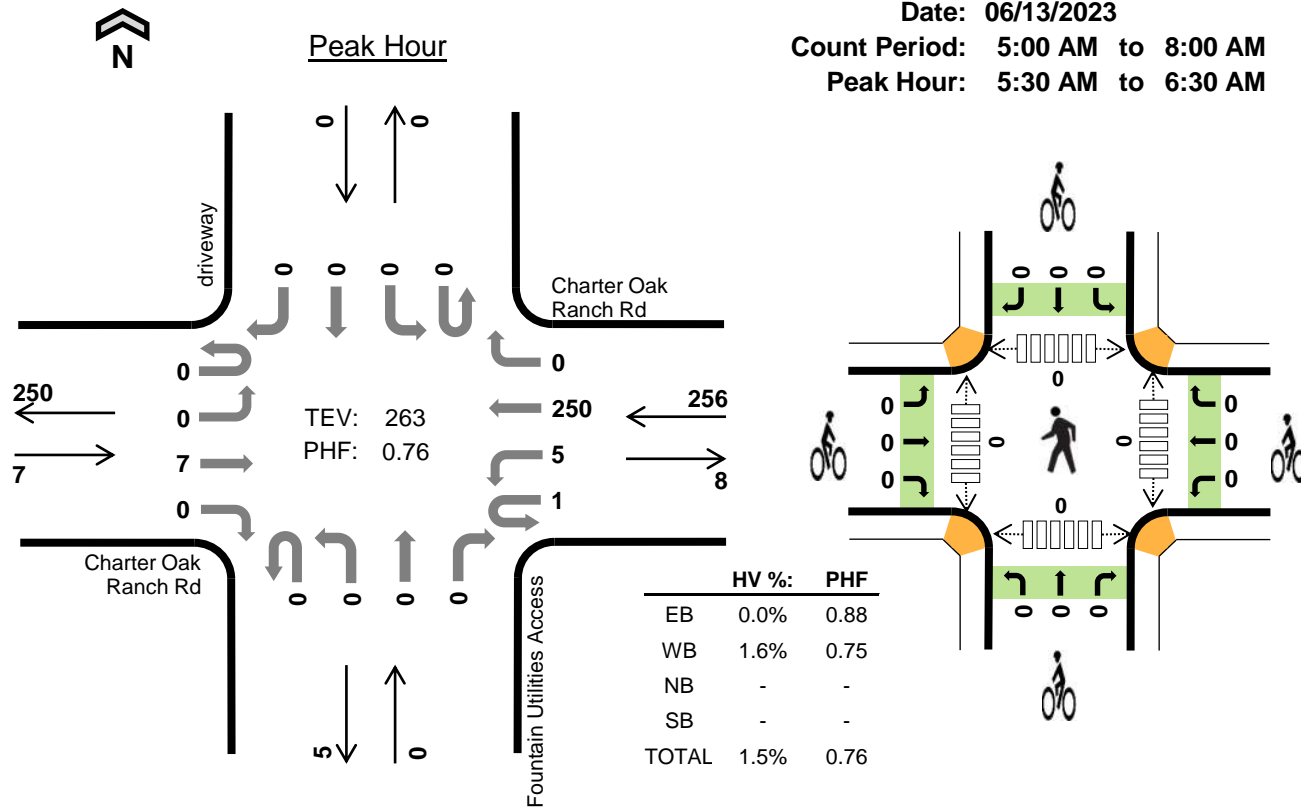

### Three-Hour Count Summaries

Interval Start	Charter Oak Ranch Rd				Charter Oak Ranch Rd				Fountain Utilities Access				driveway				15-min Total	Rolling One Hour
	Eastbound		Westbound		Northbound				Southbound									
	UT	LT	TH	RT	UT	LT	TH	RT	UT	LT	TH	RT	UT	LT	TH	RT		
5:30 AM	0	0	1	0	0	0	59	0	0	0	0	0	0	0	0	0	60	0
5:45 AM	0	0	2	0	0	1	84	0	0	0	0	0	0	0	0	0	87	0
6:00 AM	0	0	2	0	1	2	72	0	0	0	0	0	0	0	0	0	77	0
6:15 AM	0	0	2	0	0	2	35	0	0	0	0	0	0	0	0	0	39	263
Peak Hour	All	0	0	7	0	1	5	250	0	0	0	0	0	0	0	0	263	0
	HV	0	0	0	0	0	1	3	0	0	0	0	0	0	0	0	4	0
	HV%	-	-	0%	-	0%	20%	1%	-	-	-	-	-	-	-	-	2%	0

Note: For all three-hour count summary, see next page.

Interval Start	Heavy Vehicle Totals					Bicycles					Pedestrians (Crossing Leg)				
	EB	WB	NB	SB	Total	EB	WB	NB	SB	Total	East	West	North	South	Total
5:30 AM	0	0	0	0	0	0	0	0	0	0	0	0	0	0	0
5:45 AM	0	0	0	0	0	0	0	0	0	0	0	0	0	0	0
6:00 AM	0	1	0	0	1	0	0	0	0	0	0	0	0	0	0
6:15 AM	0	3	0	0	3	0	0	0	0	0	0	0	0	0	0
Peak Hour	0	4	0	0	4	0	0	0	0	0	0	0	0	0	0

Three-Hour Count Summaries																		
Interval Start	Charter Oak Ranch Rd				Charter Oak Ranch Rd				Fountain Utilities Access				driveway				15-min Total	Rolling One Hour
	Eastbound				Westbound				Northbound				Southbound					
	UT	LT	TH	RT	UT	LT	TH	RT	UT	LT	TH	RT	UT	LT	TH	RT		
5:00 AM	0	0	0	0	0	0	11	0	0	0	0	0	0	0	0	0	11	0
5:15 AM	0	0	1	0	0	0	22	0	0	0	0	0	0	0	0	0	23	0
<b>5:30 AM</b>	<b>0</b>	<b>0</b>	<b>1</b>	<b>0</b>	<b>0</b>	<b>0</b>	<b>59</b>	<b>0</b>	<b>0</b>	<b>0</b>	<b>0</b>	<b>0</b>	<b>0</b>	<b>0</b>	<b>0</b>	<b>0</b>	<b>60</b>	<b>0</b>
<b>5:45 AM</b>	<b>0</b>	<b>0</b>	<b>2</b>	<b>0</b>	<b>0</b>	<b>1</b>	<b>84</b>	<b>0</b>	<b>0</b>	<b>0</b>	<b>0</b>	<b>0</b>	<b>0</b>	<b>0</b>	<b>0</b>	<b>0</b>	<b>87</b>	181
6:00 AM	0	0	2	0	1	2	72	0	0	0	0	0	0	0	0	0	77	247
6:15 AM	0	0	2	0	0	2	35	0	0	0	0	0	0	0	0	0	39	263
6:30 AM	0	0	6	0	0	7	41	0	0	0	0	0	0	0	0	0	54	257
6:45 AM	0	0	9	0	0	11	36	0	0	0	0	0	0	0	0	0	56	226
7:00 AM	0	0	7	0	1	3	22	1	0	0	0	1	0	0	0	1	36	185
7:15 AM	0	0	10	0	0	2	24	0	0	1	0	0	0	0	0	0	37	183
7:30 AM	0	0	17	0	0	6	29	0	0	0	0	6	0	0	0	0	58	187
7:45 AM	0	0	20	0	1	6	36	0	0	0	0	4	0	0	0	0	67	198
Count Total	0	0	77	0	3	40	471	1	0	1	0	11	0	0	0	1	605	0
Peak Hour	All	0	0	7	0	1	5	250	0	0	0	0	0	0	0	0	263	0
	HV	0	0	0	0	0	1	3	0	0	0	0	0	0	0	0	4	0
	HV%	-	-	0%	-	0%	20%	1%	-	-	-	-	-	-	-	-	2%	0

Note: Three-hour count summary volumes include heavy vehicles but exclude bicycles in overall count.

Interval Start	Heavy Vehicle Totals					Bicycles					Pedestrians (Crossing Leg)				
	EB	WB	NB	SB	Total	EB	WB	NB	SB	Total	East	West	North	South	Total
5:00 AM	0	0	0	0	0	0	0	0	0	0	0	0	0	0	0
5:15 AM	0	0	0	0	0	0	0	0	0	0	0	0	0	0	0
<b>5:30 AM</b>	<b>0</b>	<b>0</b>	<b>0</b>	<b>0</b>	<b>0</b>	<b>0</b>	<b>0</b>	<b>0</b>	<b>0</b>	<b>0</b>	<b>0</b>	<b>0</b>	<b>0</b>	<b>0</b>	<b>0</b>
<b>5:45 AM</b>	<b>0</b>	<b>0</b>	<b>0</b>	<b>0</b>	<b>0</b>	<b>0</b>	<b>0</b>	<b>0</b>	<b>0</b>	<b>0</b>	<b>0</b>	<b>0</b>	<b>0</b>	<b>0</b>	<b>0</b>
6:00 AM	0	1	0	0	1	0	0	0	0	0	0	0	0	0	0
6:15 AM	0	3	0	0	3	0	0	0	0	0	0	0	0	0	0
6:30 AM	0	0	0	0	0	0	0	0	0	0	0	0	0	0	0
6:45 AM	0	1	0	0	1	0	0	0	0	0	0	0	0	0	0
7:00 AM	1	2	0	0	3	0	0	0	0	0	0	0	0	0	0
7:15 AM	0	2	1	0	3	0	0	0	0	0	0	0	0	0	0
7:30 AM	1	1	4	0	6	0	0	0	0	0	0	0	0	0	0
7:45 AM	2	1	1	0	4	0	0	0	0	0	0	0	0	0	0
Count Total	4	11	6	0	21	0	0	0	0	0	0	0	0	0	0
Peak Hour	0	4	0	0	4	0	0	0	0	0	0	0	0	0	0

Three-Hour Count Summaries - Heavy Vehicles																		
Interval Start	Charter Oak Ranch Rd				Charter Oak Ranch Rd				Fountain Utilities Access				driveway				15-min Total	Rolling One Hour
	Eastbound				Westbound				Northbound				Southbound					
	UT	LT	TH	RT	UT	LT	TH	RT	UT	LT	TH	RT	UT	LT	TH	RT		
5:00 AM	0	0	0	0	0	0	0	0	0	0	0	0	0	0	0	0	0	
5:15 AM	0	0	0	0	0	0	0	0	0	0	0	0	0	0	0	0	0	
5:30 AM	0	0	0	0	0	0	0	0	0	0	0	0	0	0	0	0	0	
5:45 AM	0	0	0	0	0	0	0	0	0	0	0	0	0	0	0	0	0	
6:00 AM	0	0	0	0	0	0	1	0	0	0	0	0	0	0	0	1	1	
6:15 AM	0	0	0	0	0	1	2	0	0	0	0	0	0	0	0	3	4	
6:30 AM	0	0	0	0	0	0	0	0	0	0	0	0	0	0	0	0	4	
6:45 AM	0	0	0	0	0	1	0	0	0	0	0	0	0	0	0	1	5	
7:00 AM	0	0	1	0	1	0	1	0	0	0	0	0	0	0	0	3	7	
7:15 AM	0	0	0	0	0	1	1	0	0	1	0	0	0	0	0	3	7	
7:30 AM	0	0	1	0	0	0	1	0	0	0	0	4	0	0	0	6	13	
7:45 AM	0	0	2	0	1	0	0	0	0	0	0	1	0	0	0	4	16	
Count Total	0	0	4	0	2	3	6	0	0	1	0	5	0	0	0	21	0	
Peak Hour	0	0	0	0	0	1	3	0	0	0	0	0	0	0	0	4	0	

Three-Hour Count Summaries - Bikes																
Interval Start	Charter Oak Ranch Rd			Charter Oak Ranch Rd			Fountain Utilities Access			driveway			15-min Total	Rolling One Hour		
	Eastbound			Westbound			Northbound			Southbound						
	LT	TH	RT	LT	TH	RT	LT	TH	RT	LT	TH	RT				
5:00 AM	0	0	0	0	0	0	0	0	0	0	0	0	0	0	0	0
5:15 AM	0	0	0	0	0	0	0	0	0	0	0	0	0	0	0	0
5:30 AM	0	0	0	0	0	0	0	0	0	0	0	0	0	0	0	0
5:45 AM	0	0	0	0	0	0	0	0	0	0	0	0	0	0	0	0
6:00 AM	0	0	0	0	0	0	0	0	0	0	0	0	0	0	0	0
6:15 AM	0	0	0	0	0	0	0	0	0	0	0	0	0	0	0	0
6:30 AM	0	0	0	0	0	0	0	0	0	0	0	0	0	0	0	0
6:45 AM	0	0	0	0	0	0	0	0	0	0	0	0	0	0	0	0
7:00 AM	0	0	0	0	0	0	0	0	0	0	0	0	0	0	0	0
7:15 AM	0	0	0	0	0	0	0	0	0	0	0	0	0	0	0	0
7:30 AM	0	0	0	0	0	0	0	0	0	0	0	0	0	0	0	0
7:45 AM	0	0	0	0	0	0	0	0	0	0	0	0	0	0	0	0
Count Total	0	0	0	0	0	0	0	0	0	0	0	0	0	0	0	0
Peak Hour	0	0	0	0	0	0	0	0	0	0	0	0	0	0	0	0

Note: U-Turn volumes for bikes are included in Left-Turn, if any.



# Fountain Utilities Access Charter Oak Ranch Rd



Date: 06/13/2023

Count Period: 4:00 PM to 6:00 PM

Peak Hour: 4:30 PM to 5:30 PM

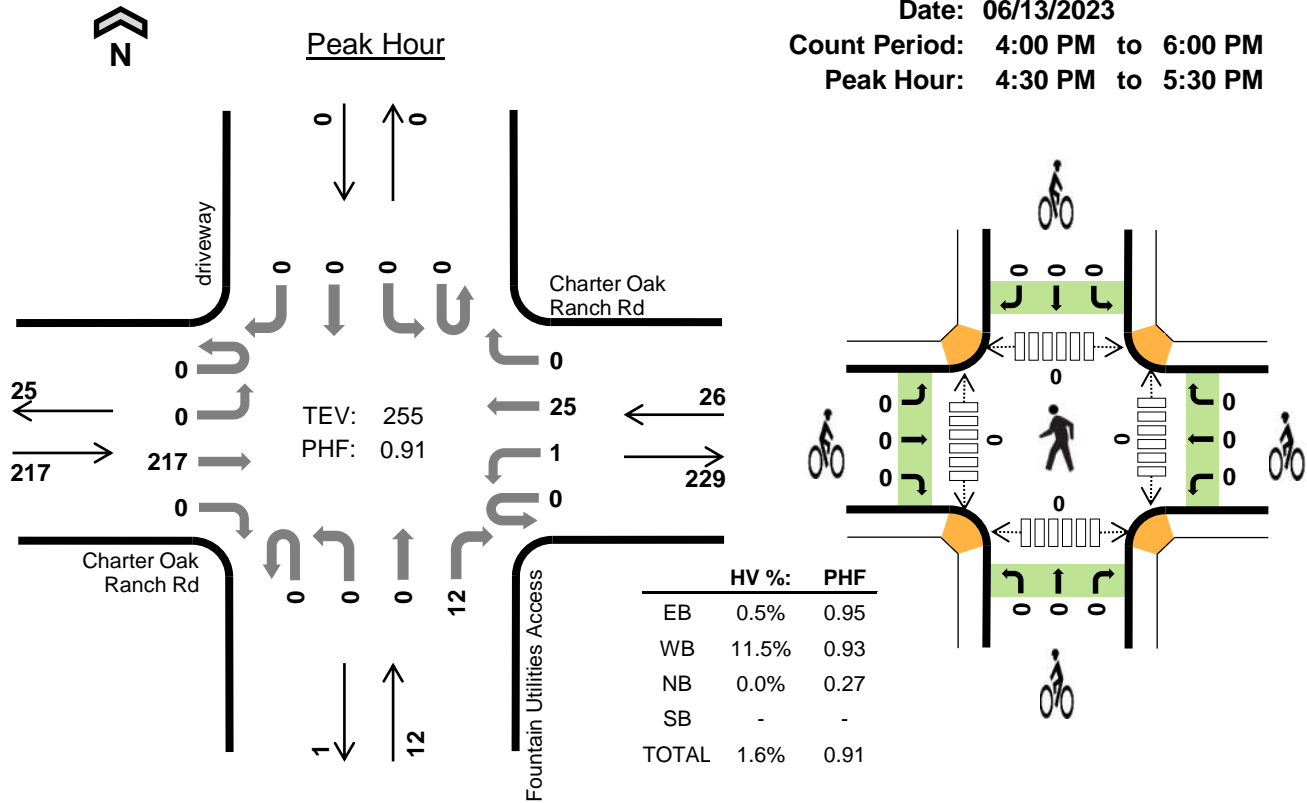

### Two-Hour Count Summaries

Interval Start	Charter Oak Ranch Rd				Charter Oak Ranch Rd				Fountain Utilities Access				driveway				15-min Total	Rolling One Hour	
	Eastbound		Westbound		Westbound		Northbound		Southbound		Southbound		Southbound						
	UT	LT	TH	RT	UT	LT	TH	RT	UT	LT	TH	RT	UT	LT	TH	RT			
4:00 PM	0	0	44	0	0	1	4	0	0	0	0	3	0	0	0	0	52	0	
4:15 PM	0	0	40	0	0	0	4	0	0	0	0	2	0	0	0	0	46	0	
<b>4:30 PM</b>	<b>0</b>	<b>0</b>	<b>52</b>	<b>0</b>	<b>0</b>	<b>0</b>	<b>7</b>	<b>0</b>	<b>0</b>	<b>0</b>	<b>0</b>	<b>11</b>	<b>0</b>	<b>0</b>	<b>0</b>	<b>0</b>	<b>70</b>	0	
4:45 PM	0	0	52	0	0	0	5	0	0	0	0	0	0	0	0	0	57	225	
5:00 PM	0	0	57	0	0	1	6	0	0	0	0	0	0	0	0	0	64	237	
5:15 PM	0	0	56	0	0	0	7	0	0	0	0	1	0	0	0	0	64	255	
5:30 PM	0	0	30	0	0	0	5	0	0	0	0	0	0	0	0	0	35	220	
5:45 PM	0	0	16	0	0	0	0	0	0	0	0	0	0	0	0	0	16	179	
Count Total	0	0	347	0	0	2	38	0	0	0	0	17	0	0	0	0	404	0	
Peak Hour	All	0	0	217	0	0	1	25	0	0	0	0	12	0	0	0	0	255	0
	HV	0	0	1	0	0	0	3	0	0	0	0	0	0	0	0	0	4	0
	HV%	-	-	0%	-	-	0%	12%	-	-	-	0%	-	-	-	-	-	2%	0

Note: Two-hour count summary volumes include heavy vehicles but exclude bicycles in overall count.

Interval Start	Heavy Vehicle Totals					Bicycles					Pedestrians (Crossing Leg)				
	EB	WB	NB	SB	Total	EB	WB	NB	SB	Total	East	West	North	South	Total
4:00 PM	0	0	0	0	0	0	0	0	0	0	0	0	0	0	0
4:15 PM	0	0	0	0	0	0	0	0	0	0	0	0	0	0	0
<b>4:30 PM</b>	<b>0</b>	<b>2</b>	<b>0</b>	<b>0</b>	<b>2</b>	<b>0</b>	<b>0</b>	<b>0</b>	<b>0</b>	<b>0</b>	<b>0</b>	<b>0</b>	<b>0</b>	<b>0</b>	<b>0</b>
4:45 PM	1	1	0	0	2	0	0	0	0	0	0	0	0	0	0
5:00 PM	0	0	0	0	0	0	0	0	0	0	0	0	0	0	0
5:15 PM	0	0	0	0	0	0	0	0	0	0	0	0	0	0	0
5:30 PM	1	0	0	0	1	0	0	0	0	0	0	0	0	0	0
5:45 PM	0	0	0	0	0	0	0	0	0	0	0	0	0	0	0
Count Total	2	3	0	0	5	0	0	0	0	0	0	0	0	0	0
Peak Hour	1	3	0	0	4	0	0	0	0	0	0	0	0	0	0

<b>Two-Hour Count Summaries - Heavy Vehicles</b>																		
Interval Start	Charter Oak Ranch Rd				Charter Oak Ranch Rd				Fountain Utilities Access				driveway				15-min Total	Rolling One Hour
	Eastbound				Westbound				Northbound				Southbound					
	UT	LT	TH	RT	UT	LT	TH	RT	UT	LT	TH	RT	UT	LT	TH	RT		
4:00 PM	0	0	0	0	0	0	0	0	0	0	0	0	0	0	0	0	0	0
4:15 PM	0	0	0	0	0	0	0	0	0	0	0	0	0	0	0	0	0	0
<b>4:30 PM</b>	<b>0</b>	<b>0</b>	<b>0</b>	<b>0</b>	<b>0</b>	<b>0</b>	<b>2</b>	<b>0</b>	<b>0</b>	<b>0</b>	<b>0</b>	<b>0</b>	<b>0</b>	<b>0</b>	<b>0</b>	<b>0</b>	<b>2</b>	<b>0</b>
4:45 PM	0	0	1	0	0	0	1	0	0	0	0	0	0	0	0	0	2	4
5:00 PM	0	0	0	0	0	0	0	0	0	0	0	0	0	0	0	0	0	4
5:15 PM	0	0	0	0	0	0	0	0	0	0	0	0	0	0	0	0	0	4
5:30 PM	0	0	1	0	0	0	0	0	0	0	0	0	0	0	0	0	1	3
5:45 PM	0	0	0	0	0	0	0	0	0	0	0	0	0	0	0	0	0	1
Count Total	0	0	2	0	0	0	3	0	0	0	0	0	0	0	0	0	5	0
Peak Hour	0	0	1	0	0	0	3	0	0	0	0	0	0	0	0	0	4	0

<b>Two-Hour Count Summaries - Bikes</b>																	
Interval Start	Charter Oak Ranch Rd			Charter Oak Ranch Rd			Fountain Utilities Access			driveway			15-min Total	Rolling One Hour			
	Eastbound			Westbound			Northbound			Southbound							
	LT	TH	RT	LT	TH	RT	LT	TH	RT	LT	TH	RT					
4:00 PM	0	0	0	0	0	0	0	0	0	0	0	0	0	0	0	0	0
4:15 PM	0	0	0	0	0	0	0	0	0	0	0	0	0	0	0	0	0
<b>4:30 PM</b>	<b>0</b>	<b>0</b>	<b>0</b>	<b>0</b>	<b>0</b>	<b>0</b>	<b>0</b>	<b>0</b>	<b>0</b>	<b>0</b>	<b>0</b>	<b>0</b>	<b>0</b>	<b>0</b>	<b>0</b>	<b>0</b>	<b>0</b>
4:45 PM	0	0	0	0	0	0	0	0	0	0	0	0	0	0	0	0	0
5:00 PM	0	0	0	0	0	0	0	0	0	0	0	0	0	0	0	0	0
5:15 PM	0	0	0	0	0	0	0	0	0	0	0	0	0	0	0	0	0
5:30 PM	0	0	0	0	0	0	0	0	0	0	0	0	0	0	0	0	0
5:45 PM	0	0	0	0	0	0	0	0	0	0	0	0	0	0	0	0	0
Count Total	0	0	0	0	0	0	0	0	0	0	0	0	0	0	0	0	0
Peak Hour	0	0	0	0	0	0	0	0	0	0	0	0	0	0	0	0	0

Note: U-Turn volumes for bikes are included in Left-Turn, if any.

## Charter Oak Ranch Rd Santa Fe Ave



Date: 06/13/2023

Count Period: 5:00 AM to 8:00 AM

Peak Hour: 5:15 AM to 6:15 AM

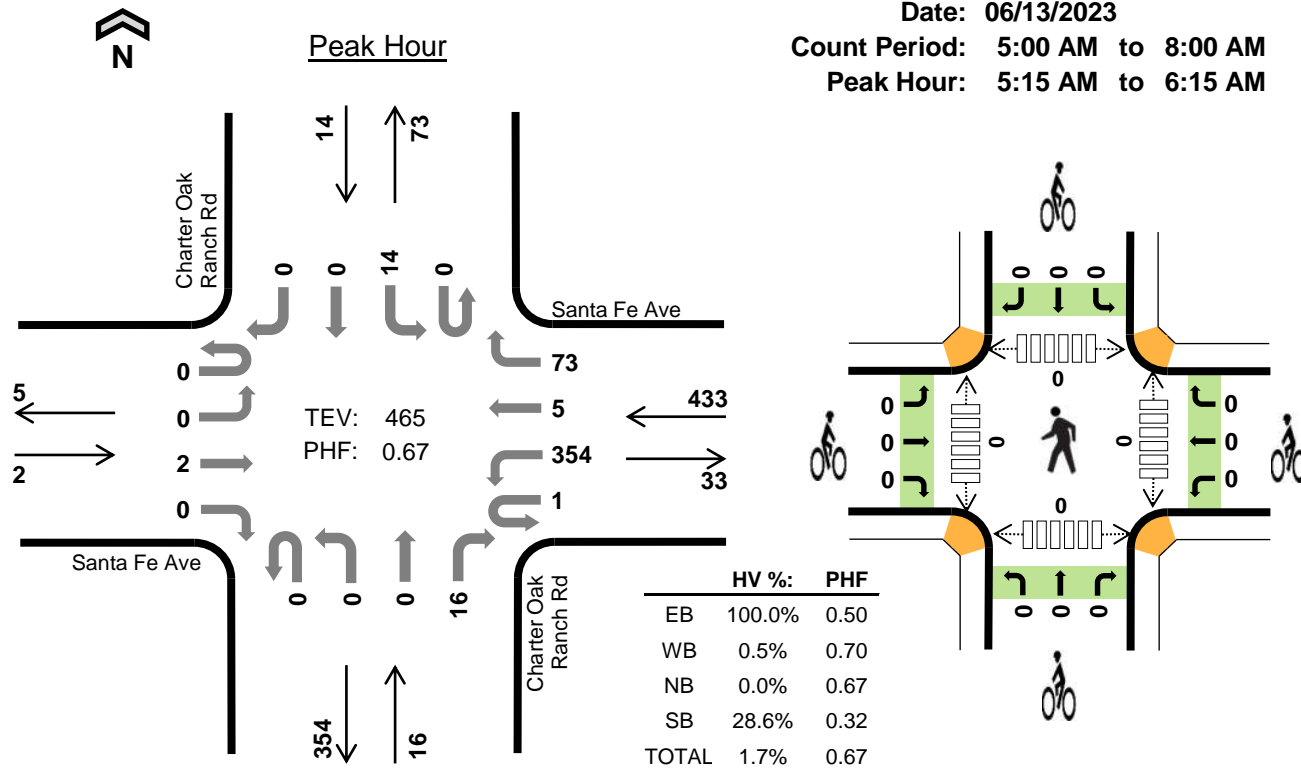

### Three-Hour Count Summaries

Interval Start	Santa Fe Ave Eastbound				Santa Fe Ave Westbound				Charter Oak Ranch Rd Northbound				Charter Oak Ranch Rd Southbound				15-min Total	Rolling One Hour	
	UT	LT	TH	RT	UT	LT	TH	RT	UT	LT	TH	RT	UT	LT	TH	RT			
5:15 AM	0	0	0	0	0	16	2	45	0	0	0	2	0	0	0	0	65	0	
5:30 AM	0	0	1	0	0	115	1	11	0	0	0	5	0	0	0	0	133	0	
5:45 AM	0	0	1	0	0	144	1	10	0	0	0	6	0	11	0	0	173	0	
6:00 AM	0	0	0	0	1	79	1	7	0	0	0	3	0	3	0	0	94	465	
Peak Hour	All	0	0	2	0	1	354	5	73	0	0	0	16	0	14	0	0	465	0
	HV	0	0	2	0	0	2	0	0	0	0	0	0	0	4	0	0	8	0
	HV%	-	-	100%	-	0%	1%	0%	0%	-	-	-	0%	-	29%	-	-	2%	0

Note: For all three-hour count summary, see next page.

Interval Start	Heavy Vehicle Totals					Bicycles					Pedestrians (Crossing Leg)				
	EB	WB	NB	SB	Total	EB	WB	NB	SB	Total	East	West	North	South	Total
5:15 AM	0	1	0	0	1	0	0	0	0	0	0	0	0	0	0
5:30 AM	1	0	0	0	1	0	0	0	0	0	0	0	0	0	0
5:45 AM	1	1	0	1	3	0	0	0	0	0	0	0	0	0	0
6:00 AM	0	0	0	3	3	0	0	0	0	0	0	0	0	0	0
Peak Hour	2	2	0	4	8	0	0	0	0	0	0	0	0	0	0

Three-Hour Count Summaries																			
Interval Start	Santa Fe Ave				Santa Fe Ave				Charter Oak Ranch Rd				Charter Oak Ranch Rd				15-min Total	Rolling One Hour	
	Eastbound				Westbound				Northbound				Southbound						
	UT	LT	TH	RT	UT	LT	TH	RT	UT	LT	TH	RT	UT	LT	TH	RT			
5:00 AM	0	0	0	0	0	4	1	9	0	0	0	0	0	0	0	0	14	0	
5:15 AM	0	0	0	0	0	16	2	45	0	0	0	2	0	0	0	0	65	0	
5:30 AM	0	0	1	0	0	115	1	11	0	0	0	5	0	0	0	0	133	0	
5:45 AM	0	0	1	0	0	144	1	10	0	0	0	6	0	11	0	0	173	385	
6:00 AM	0	0	0	0	1	79	1	7	0	0	0	3	0	3	0	0	94	465	
6:15 AM	0	0	0	0	0	43	1	7	0	0	0	2	0	1	0	0	54	454	
6:30 AM	0	0	0	0	0	48	4	9	0	0	0	6	0	5	0	0	72	393	
6:45 AM	0	0	0	0	0	63	0	24	0	0	0	13	0	3	0	1	104	324	
7:00 AM	0	0	0	0	1	34	0	16	0	0	0	6	0	44	0	1	102	332	
7:15 AM	0	0	1	0	0	33	6	14	0	0	0	10	0	6	0	0	70	348	
7:30 AM	0	0	4	0	1	39	2	12	0	0	0	24	0	2	0	0	84	360	
7:45 AM	0	0	0	0	0	46	2	14	0	0	0	25	0	8	0	0	95	351	
Count Total	0	0	7	0	3	664	21	178	0	0	0	102	0	83	0	2	1,060	0	
Peak Hour	All	0	0	2	0	1	354	5	73	0	0	0	16	0	14	0	0	465	0
	HV	0	0	2	0	0	2	0	0	0	0	0	0	0	4	0	0	8	0
	HV%	-	-	100%	-	0%	1%	0%	0%	-	-	-	0%	-	29%	-	-	2%	0

Note: Three-hour count summary volumes include heavy vehicles but exclude bicycles in overall count.

Interval Start	Heavy Vehicle Totals					Bicycles					Pedestrians (Crossing Leg)				
	EB	WB	NB	SB	Total	EB	WB	NB	SB	Total	East	West	North	South	Total
5:00 AM	0	0	0	0	0	0	0	0	0	0	0	0	0	0	0
5:15 AM	0	1	0	0	1	0	0	0	0	0	0	0	0	0	0
5:30 AM	1	0	0	0	1	0	0	0	0	0	0	0	0	0	0
5:45 AM	1	1	0	1	3	0	0	0	0	0	0	0	0	0	0
6:00 AM	0	0	0	3	3	0	0	0	0	0	0	0	0	0	0
6:15 AM	0	2	0	0	2	0	0	0	0	0	0	0	0	0	0
6:30 AM	0	0	0	1	1	0	0	0	0	0	0	0	0	0	0
6:45 AM	0	0	0	2	2	0	0	0	0	0	0	0	0	0	0
7:00 AM	0	3	1	3	7	0	0	0	0	0	0	0	0	0	0
7:15 AM	1	5	1	1	8	0	0	0	0	0	0	0	0	0	0
7:30 AM	4	3	2	0	9	0	0	0	0	0	0	0	0	0	0
7:45 AM	0	2	3	0	5	0	0	0	0	0	0	0	0	0	0
Count Total	7	17	7	11	42	0	0	0	0	0	0	0	0	0	0
Peak Hour	2	2	0	4	8	0	0	0	0	0	0	0	0	0	0



<b>Three-Hour Count Summaries - Heavy Vehicles</b>																		
Interval Start	Santa Fe Ave				Santa Fe Ave				Charter Oak Ranch Rd				Charter Oak Ranch Rd				15-min Total	Rolling One Hour
	Eastbound				Westbound				Northbound				Southbound					
	UT	LT	TH	RT	UT	LT	TH	RT	UT	LT	TH	RT	UT	LT	TH	RT		
5:00 AM	0	0	0	0	0	0	0	0	0	0	0	0	0	0	0	0	0	
5:15 AM	0	0	0	0	0	1	0	0	0	0	0	0	0	0	0	0	1	
5:30 AM	0	0	1	0	0	0	0	0	0	0	0	0	0	0	0	0	1	
5:45 AM	0	0	1	0	0	1	0	0	0	0	0	0	0	0	1	0	3	
6:00 AM	0	0	0	0	0	0	0	0	0	0	0	0	0	3	0	0	3	
6:15 AM	0	0	0	0	0	2	0	0	0	0	0	0	0	0	0	0	2	
6:30 AM	0	0	0	0	0	0	0	0	0	0	0	0	0	1	0	0	1	
6:45 AM	0	0	0	0	0	0	0	0	0	0	0	0	0	1	0	1	2	
7:00 AM	0	0	0	0	0	2	0	1	0	0	0	1	0	2	0	1	7	
7:15 AM	0	0	1	0	0	2	3	0	0	0	0	1	0	1	0	0	8	
7:30 AM	0	0	4	0	0	2	0	1	0	0	0	2	0	0	0	0	9	
7:45 AM	0	0	0	0	0	0	1	1	0	0	0	3	0	0	0	0	5	
Count Total	0	0	7	0	0	10	4	3	0	0	0	7	0	9	0	2	42	
Peak Hour	0	0	2	0	0	2	0	0	0	0	0	0	0	4	0	0	8	

<b>Three-Hour Count Summaries - Bikes</b>																
Interval Start	Santa Fe Ave			Santa Fe Ave			Charter Oak Ranch Rd			Charter Oak Ranch Rd			15-min Total	Rolling One Hour		
	Eastbound			Westbound			Northbound			Southbound						
	LT	TH	RT	LT	TH	RT	LT	TH	RT	LT	TH	RT				
5:00 AM	0	0	0	0	0	0	0	0	0	0	0	0	0	0	0	0
5:15 AM	0	0	0	0	0	0	0	0	0	0	0	0	0	0	0	0
5:30 AM	0	0	0	0	0	0	0	0	0	0	0	0	0	0	0	0
5:45 AM	0	0	0	0	0	0	0	0	0	0	0	0	0	0	0	0
6:00 AM	0	0	0	0	0	0	0	0	0	0	0	0	0	0	0	0
6:15 AM	0	0	0	0	0	0	0	0	0	0	0	0	0	0	0	0
6:30 AM	0	0	0	0	0	0	0	0	0	0	0	0	0	0	0	0
6:45 AM	0	0	0	0	0	0	0	0	0	0	0	0	0	0	0	0
7:00 AM	0	0	0	0	0	0	0	0	0	0	0	0	0	0	0	0
7:15 AM	0	0	0	0	0	0	0	0	0	0	0	0	0	0	0	0
7:30 AM	0	0	0	0	0	0	0	0	0	0	0	0	0	0	0	0
7:45 AM	0	0	0	0	0	0	0	0	0	0	0	0	0	0	0	0
Count Total	0	0	0	0	0	0	0	0	0	0	0	0	0	0	0	0
Peak Hour	0	0	0	0	0	0	0	0	0	0	0	0	0	0	0	0

Note: U-Turn volumes for bikes are included in Left-Turn, if any.

# Charter Oak Ranch Rd Santa Fe Ave



Date: 06/13/2023

Count Period: 4:00 PM to 6:00 PM

Peak Hour: 4:30 PM to 5:30 PM

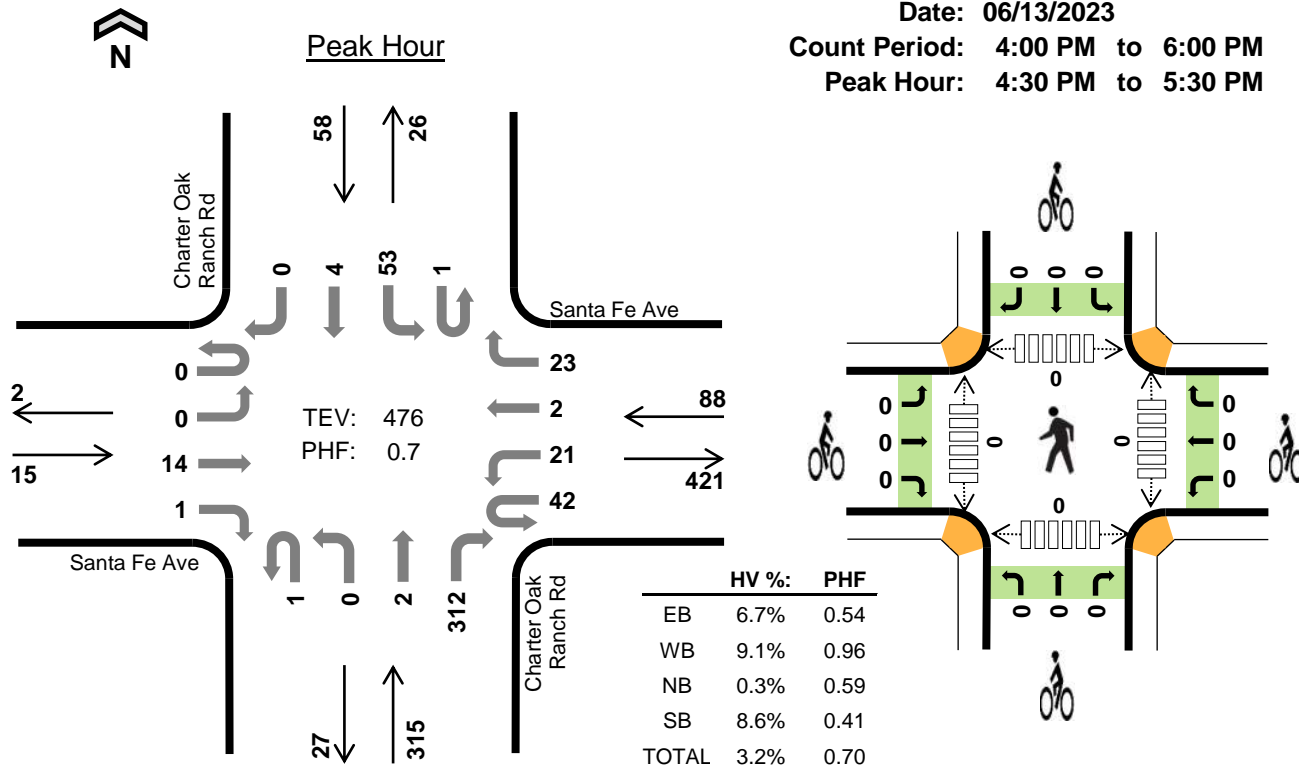

## Two-Hour Count Summaries

Interval Start	Santa Fe Ave				Santa Fe Ave				Charter Oak Ranch Rd				Charter Oak Ranch Rd				15-min Total	Rolling One Hour	
	Eastbound				Westbound				Northbound				Southbound						
	UT	LT	TH	RT	UT	LT	TH	RT	UT	LT	TH	RT	UT	LT	TH	RT			
4:00 PM	0	0	8	0	0	4	1	7	0	0	0	52	0	21	0	0	93	0	
4:15 PM	0	0	1	0	1	5	0	5	0	0	0	54	0	19	0	0	85	0	
<b>4:30 PM</b>	<b>0</b>	<b>0</b>	<b>6</b>	<b>1</b>	<b>7</b>	<b>6</b>	<b>1</b>	<b>8</b>	<b>1</b>	<b>0</b>	<b>1</b>	<b>132</b>	<b>0</b>	<b>5</b>	<b>1</b>	<b>0</b>	<b>169</b>	<b>0</b>	
4:45 PM	0	0	4	0	8	7	0	6	0	0	1	78	0	8	0	0	112	459	
5:00 PM	0	0	2	0	11	4	0	7	0	0	0	40	1	31	3	0	99	465	
5:15 PM	0	0	2	0	16	4	1	2	0	0	0	62	0	9	0	0	96	476	
5:30 PM	0	0	1	0	2	1	1	0	0	0	0	59	0	7	0	0	71	378	
5:45 PM	0	0	1	0	3	1	0	1	0	0	0	18	0	4	0	0	28	294	
Count Total	0	0	25	1	48	32	4	36	1	0	2	495	1	104	4	0	753	0	
Peak Hour	All	0	0	14	1	42	21	2	23	1	0	2	312	1	53	4	0	476	0
	HV	0	0	0	1	3	2	1	2	0	0	0	1	0	5	0	0	15	0
	HV%	-	-	0%	100%	7%	10%	50%	9%	0%	-	0%	0%	0%	9%	0%	-	3%	0

Note: Two-hour count summary volumes include heavy vehicles but exclude bicycles in overall count.

Interval Start	Heavy Vehicle Totals					Bicycles					Pedestrians (Crossing Leg)				
	EB	WB	NB	SB	Total	EB	WB	NB	SB	Total	East	West	North	South	Total
4:00 PM	1	1	0	4	6	0	0	0	0	0	0	0	0	0	0
4:15 PM	0	1	0	4	5	0	0	0	0	0	0	0	0	0	0
<b>4:30 PM</b>	<b>1</b>	<b>4</b>	<b>0</b>	<b>1</b>	<b>6</b>	<b>0</b>	<b>0</b>	<b>0</b>	<b>0</b>	<b>0</b>	<b>0</b>	<b>0</b>	<b>0</b>	<b>0</b>	<b>0</b>
4:45 PM	0	2	1	2	5	0	0	0	0	0	0	0	0	0	0
5:00 PM	0	2	0	2	4	0	0	0	0	0	0	0	0	0	0
5:15 PM	0	0	0	0	0	0	0	0	0	0	0	0	0	0	0
5:30 PM	1	0	1	0	2	0	0	0	0	0	0	0	0	0	0
5:45 PM	0	0	0	0	0	0	0	0	0	0	0	0	0	0	0
Count Total	3	10	2	13	28	0	0	0	0	0	0	0	0	0	0
Peak Hour	1	8	1	5	15	0	0	0	0	0	0	0	0	0	0

<b>Two-Hour Count Summaries - Heavy Vehicles</b>																		
Interval Start	Santa Fe Ave				Santa Fe Ave				Charter Oak Ranch Rd				Charter Oak Ranch Rd				15-min Total	Rolling One Hour
	Eastbound				Westbound				Northbound				Southbound					
	UT	LT	TH	RT	UT	LT	TH	RT	UT	LT	TH	RT	UT	LT	TH	RT		
4:00 PM	0	0	1	0	0	1	0	0	0	0	0	0	0	4	0	0	6	0
4:15 PM	0	0	0	0	0	1	0	0	0	0	0	0	0	4	0	0	5	0
<b>4:30 PM</b>	<b>0</b>	<b>0</b>	<b>0</b>	<b>1</b>	<b>1</b>	<b>0</b>	<b>1</b>	<b>2</b>	<b>0</b>	<b>0</b>	<b>0</b>	<b>0</b>	<b>0</b>	<b>1</b>	<b>0</b>	<b>0</b>	<b>6</b>	<b>0</b>
4:45 PM	0	0	0	0	1	1	0	0	0	0	0	1	0	2	0	0	5	22
5:00 PM	0	0	0	0	1	1	0	0	0	0	0	0	0	2	0	0	4	20
5:15 PM	0	0	0	0	0	0	0	0	0	0	0	0	0	0	0	0	0	15
5:30 PM	0	0	1	0	0	0	0	0	0	0	0	1	0	0	0	0	2	11
5:45 PM	0	0	0	0	0	0	0	0	0	0	0	0	0	0	0	0	0	6
Count Total	0	0	2	1	3	4	1	2	0	0	0	2	0	13	0	0	28	0
Peak Hour	0	0	0	1	3	2	1	2	0	0	0	1	0	5	0	0	15	0

<b>Two-Hour Count Summaries - Bikes</b>																
Interval Start	Santa Fe Ave			Santa Fe Ave			Charter Oak Ranch Rd			Charter Oak Ranch Rd			15-min Total	Rolling One Hour		
	Eastbound			Westbound			Northbound			Southbound						
	LT	TH	RT	LT	TH	RT	LT	TH	RT	LT	TH	RT				
4:00 PM	0	0	0	0	0	0	0	0	0	0	0	0	0	0		
4:15 PM	0	0	0	0	0	0	0	0	0	0	0	0	0	0		
<b>4:30 PM</b>	<b>0</b>	<b>0</b>	<b>0</b>	<b>0</b>	<b>0</b>	<b>0</b>	<b>0</b>	<b>0</b>	<b>0</b>	<b>0</b>	<b>0</b>	<b>0</b>	<b>0</b>	<b>0</b>		
4:45 PM	0	0	0	0	0	0	0	0	0	0	0	0	0	0		
5:00 PM	0	0	0	0	0	0	0	0	0	0	0	0	0	0		
5:15 PM	0	0	0	0	0	0	0	0	0	0	0	0	0	0		
5:30 PM	0	0	0	0	0	0	0	0	0	0	0	0	0	0		
5:45 PM	0	0	0	0	0	0	0	0	0	0	0	0	0	0		
Count Total	0	0	0	0	0	0	0	0	0	0	0	0	0	0		
Peak Hour	0	0	0	0	0	0	0	0	0	0	0	0	0	0		

Note: U-Turn volumes for bikes are included in Left-Turn, if any.

### I25 SB Ramps Santa Fe Ave



Date: 06/13/2023

Count Period: 5:00 AM to 8:00 AM

Peak Hour: 6:45 AM to 7:45 AM

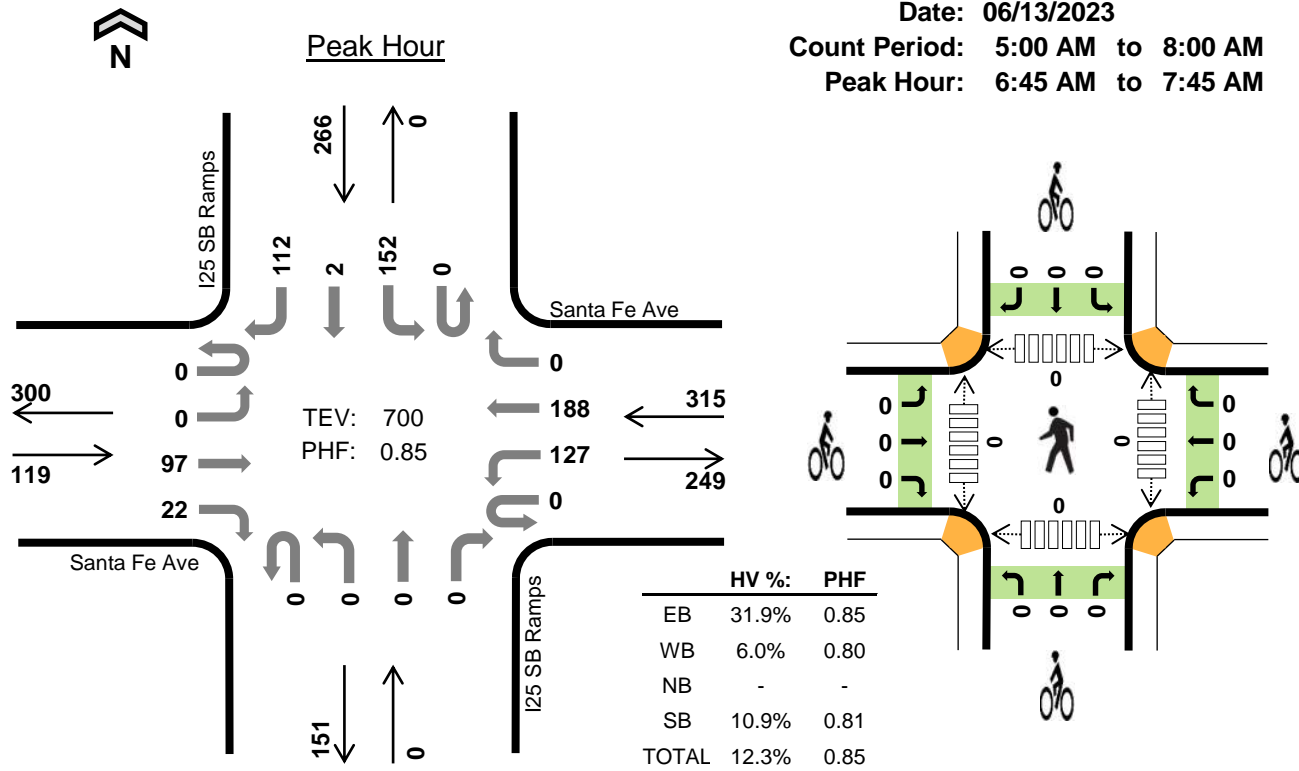

#### Three-Hour Count Summaries

Interval Start	Santa Fe Ave Eastbound				Santa Fe Ave Westbound				I25 SB Ramps Northbound				I25 SB Ramps Southbound				15-min Total	Rolling One Hour
	UT	LT	TH	RT	UT	LT	TH	RT	UT	LT	TH	RT	UT	LT	TH	RT		
6:45 AM	0	0	21	5	0	27	71	0	0	0	0	0	0	47	0	35	206	0
7:00 AM	0	0	22	4	0	20	34	0	0	0	0	0	0	37	1	28	146	0
7:15 AM	0	0	23	9	0	38	40	0	0	0	0	0	0	44	1	26	181	0
7:30 AM	0	0	31	4	0	42	43	0	0	0	0	0	0	24	0	23	167	700
Peak Hour	All	0	0	97	22	0	127	188	0	0	0	0	0	152	2	112	700	0
	HV	0	0	32	6	0	10	9	0	0	0	0	0	10	1	18	86	0
	HV%	-	-	33%	27%	-	8%	5%	-	-	-	-	-	7%	50%	16%	12%	0

Note: For all three-hour count summary, see next page.

Interval Start	Heavy Vehicle Totals					Bicycles					Pedestrians (Crossing Leg)				
	EB	WB	NB	SB	Total	EB	WB	NB	SB	Total	East	West	North	South	Total
6:45 AM	4	3	0	7	14	0	0	0	0	0	0	0	0	0	0
7:00 AM	6	3	0	5	14	0	0	0	0	0	0	0	0	0	0
7:15 AM	16	5	0	10	31	0	0	0	0	0	0	0	0	0	0
7:30 AM	12	8	0	7	27	0	0	0	0	0	0	0	0	0	0
Peak Hour	38	19	0	29	86	0	0	0	0	0	0	0	0	0	0

Three-Hour Count Summaries																			
Interval Start	Santa Fe Ave				Santa Fe Ave				I25 SB Ramps				I25 SB Ramps				15-min Total	Rolling One Hour	
	Eastbound				Westbound				Northbound				Southbound						
	UT	LT	TH	RT	UT	LT	TH	RT	UT	LT	TH	RT	UT	LT	TH	RT			
5:00 AM	0	0	3	2	0	10	23	0	0	0	0	0	0	2	0	14	54	0	
5:15 AM	0	0	4	1	0	14	52	0	0	0	0	0	0	5	0	21	97	0	
5:30 AM	0	0	5	2	0	19	87	0	0	0	0	0	0	13	0	42	168	0	
5:45 AM	0	0	13	9	0	40	116	0	0	0	0	0	0	21	0	42	241	560	
6:00 AM	0	0	8	2	0	29	75	0	0	0	0	0	0	8	0	20	142	648	
6:15 AM	0	0	7	2	0	34	37	0	0	0	0	0	0	15	0	15	110	661	
6:30 AM	0	0	12	4	0	40	48	0	0	0	0	0	0	34	0	23	161	654	
<b>6:45 AM</b>	<b>0</b>	<b>0</b>	<b>21</b>	<b>5</b>	<b>0</b>	<b>27</b>	<b>71</b>	<b>0</b>	<b>0</b>	<b>0</b>	<b>0</b>	<b>0</b>	<b>0</b>	<b>47</b>	<b>0</b>	<b>35</b>	<b>206</b>	619	
7:00 AM	0	0	22	4	0	20	34	0	0	0	0	0	0	37	1	28	146	623	
7:15 AM	0	0	23	9	0	38	40	0	0	0	0	0	0	44	1	26	181	694	
7:30 AM	0	0	31	4	0	42	43	0	0	0	0	0	0	24	0	23	167	700	
7:45 AM	0	0	41	5	0	33	58	0	0	0	0	0	0	31	0	19	187	681	
Count Total	0	0	190	49	0	346	684	0	0	0	0	0	0	281	2	308	1,860	0	
Peak Hour	All	0	0	97	22	0	127	188	0	0	0	0	0	0	152	2	112	700	0
	HV	0	0	32	6	0	10	9	0	0	0	0	0	0	10	1	18	86	0
	HV%	-	-	33%	27%	-	8%	5%	-	-	-	-	-	-	7%	50%	16%	12%	0

Note: Three-hour count summary volumes include heavy vehicles but exclude bicycles in overall count.

Interval Start	Heavy Vehicle Totals					Bicycles					Pedestrians (Crossing Leg)				
	EB	WB	NB	SB	Total	EB	WB	NB	SB	Total	East	West	North	South	Total
5:00 AM	4	1	0	1	6	0	0	0	0	0	0	0	0	0	0
5:15 AM	1	1	0	2	4	0	0	0	0	0	0	0	0	0	0
5:30 AM	1	2	0	4	7	0	0	0	0	0	0	1	0	1	2
5:45 AM	5	3	0	2	10	0	0	0	0	0	0	0	0	0	0
6:00 AM	4	1	0	2	7	0	0	0	0	0	0	0	1	0	1
6:15 AM	4	6	0	2	12	0	0	0	0	0	0	0	0	0	0
6:30 AM	4	0	0	5	9	0	0	0	0	0	0	0	0	0	0
<b>6:45 AM</b>	<b>4</b>	<b>3</b>	<b>0</b>	<b>7</b>	<b>14</b>	<b>0</b>	<b>0</b>	<b>0</b>	<b>0</b>	<b>0</b>	<b>0</b>	<b>0</b>	<b>0</b>	<b>0</b>	<b>0</b>
7:00 AM	6	3	0	5	14	0	0	0	0	0	0	0	0	0	0
7:15 AM	16	5	0	10	31	0	0	0	0	0	0	0	0	0	0
7:30 AM	12	8	0	7	27	0	0	0	0	0	0	0	0	0	0
7:45 AM	11	13	0	6	30	0	0	0	0	0	0	0	0	0	0
Count Total	72	46	0	53	171	0	0	0	0	0	0	1	1	1	3
Peak Hour	38	19	0	29	86	0	0	0	0	0	0	0	0	0	0



Three-Hour Count Summaries - Heavy Vehicles																		
Interval Start	Santa Fe Ave				Santa Fe Ave				I25 SB Ramps				I25 SB Ramps				15-min Total	Rolling One Hour
	Eastbound				Westbound				Northbound				Southbound					
	UT	LT	TH	RT	UT	LT	TH	RT	UT	LT	TH	RT	UT	LT	TH	RT		
5:00 AM	0	0	3	1	0	0	1	0	0	0	0	0	0	1	0	0	6	0
5:15 AM	0	0	1	0	0	0	1	0	0	0	0	0	0	0	0	0	4	0
5:30 AM	0	0	0	1	0	2	0	0	0	0	0	0	0	1	0	3	7	0
5:45 AM	0	0	2	3	0	1	2	0	0	0	0	0	0	1	0	1	10	27
6:00 AM	0	0	4	0	0	0	1	0	0	0	0	0	0	1	0	1	7	28
6:15 AM	0	0	2	2	0	2	4	0	0	0	0	0	0	2	0	0	12	36
6:30 AM	0	0	2	2	0	0	0	0	0	0	0	0	0	5	0	0	9	38
<b>6:45 AM</b>	<b>0</b>	<b>0</b>	<b>3</b>	<b>1</b>	<b>0</b>	<b>2</b>	<b>1</b>	<b>0</b>	<b>0</b>	<b>0</b>	<b>0</b>	<b>0</b>	<b>0</b>	<b>4</b>	<b>0</b>	<b>3</b>	<b>14</b>	42
<b>7:00 AM</b>	<b>0</b>	<b>0</b>	<b>5</b>	<b>1</b>	<b>0</b>	<b>1</b>	<b>2</b>	<b>0</b>	<b>0</b>	<b>0</b>	<b>0</b>	<b>0</b>	<b>0</b>	<b>1</b>	<b>1</b>	<b>3</b>	<b>14</b>	49
<b>7:15 AM</b>	<b>0</b>	<b>0</b>	<b>14</b>	<b>2</b>	<b>0</b>	<b>0</b>	<b>5</b>	<b>0</b>	<b>0</b>	<b>0</b>	<b>0</b>	<b>0</b>	<b>0</b>	<b>4</b>	<b>0</b>	<b>6</b>	<b>31</b>	68
<b>7:30 AM</b>	<b>0</b>	<b>0</b>	<b>10</b>	<b>2</b>	<b>0</b>	<b>7</b>	<b>1</b>	<b>0</b>	<b>0</b>	<b>0</b>	<b>0</b>	<b>0</b>	<b>0</b>	<b>1</b>	<b>0</b>	<b>6</b>	<b>27</b>	86
7:45 AM	0	0	10	1	0	7	6	0	0	0	0	0	0	2	0	4	30	102
Count Total	0	0	56	16	0	22	24	0	0	0	0	0	0	23	1	29	171	0
Peak Hour	0	0	32	6	0	10	9	0	0	0	0	0	0	10	1	18	86	0

Three-Hour Count Summaries - Bikes																		
Interval Start	Santa Fe Ave			Santa Fe Ave			I25 SB Ramps			I25 SB Ramps			15-min Total	Rolling One Hour				
	Eastbound			Westbound			Northbound			Southbound								
	LT	TH	RT	LT	TH	RT	LT	TH	RT	LT	TH	RT						
5:00 AM	0	0	0	0	0	0	0	0	0	0	0	0	0	0	0	0	0	0
5:15 AM	0	0	0	0	0	0	0	0	0	0	0	0	0	0	0	0	0	0
5:30 AM	0	0	0	0	0	0	0	0	0	0	0	0	0	0	0	0	0	0
5:45 AM	0	0	0	0	0	0	0	0	0	0	0	0	0	0	0	0	0	0
6:00 AM	0	0	0	0	0	0	0	0	0	0	0	0	0	0	0	0	0	0
6:15 AM	0	0	0	0	0	0	0	0	0	0	0	0	0	0	0	0	0	0
6:30 AM	0	0	0	0	0	0	0	0	0	0	0	0	0	0	0	0	0	0
<b>6:45 AM</b>	<b>0</b>	<b>0</b>	<b>0</b>	<b>0</b>	<b>0</b>	<b>0</b>	<b>0</b>	<b>0</b>	<b>0</b>	<b>0</b>	<b>0</b>	<b>0</b>	<b>0</b>	<b>0</b>	<b>0</b>	<b>0</b>	<b>0</b>	0
<b>7:00 AM</b>	<b>0</b>	<b>0</b>	<b>0</b>	<b>0</b>	<b>0</b>	<b>0</b>	<b>0</b>	<b>0</b>	<b>0</b>	<b>0</b>	<b>0</b>	<b>0</b>	<b>0</b>	<b>0</b>	<b>0</b>	<b>0</b>	<b>0</b>	0
<b>7:15 AM</b>	<b>0</b>	<b>0</b>	<b>0</b>	<b>0</b>	<b>0</b>	<b>0</b>	<b>0</b>	<b>0</b>	<b>0</b>	<b>0</b>	<b>0</b>	<b>0</b>	<b>0</b>	<b>0</b>	<b>0</b>	<b>0</b>	<b>0</b>	0
<b>7:30 AM</b>	<b>0</b>	<b>0</b>	<b>0</b>	<b>0</b>	<b>0</b>	<b>0</b>	<b>0</b>	<b>0</b>	<b>0</b>	<b>0</b>	<b>0</b>	<b>0</b>	<b>0</b>	<b>0</b>	<b>0</b>	<b>0</b>	<b>0</b>	0
7:45 AM	0	0	0	0	0	0	0	0	0	0	0	0	0	0	0	0	0	0
Count Total	0	0	0	0	0	0	0	0	0	0	0	0	0	0	0	0	0	0
Peak Hour	0	0	0	0	0	0	0	0	0	0	0	0	0	0	0	0	0	0

Note: U-Turn volumes for bikes are included in Left-Turn, if any.

### I25 SB Ramps Santa Fe Ave



Date: 06/13/2023

Count Period: 4:00 PM to 6:00 PM

Peak Hour: 4:30 PM to 5:30 PM

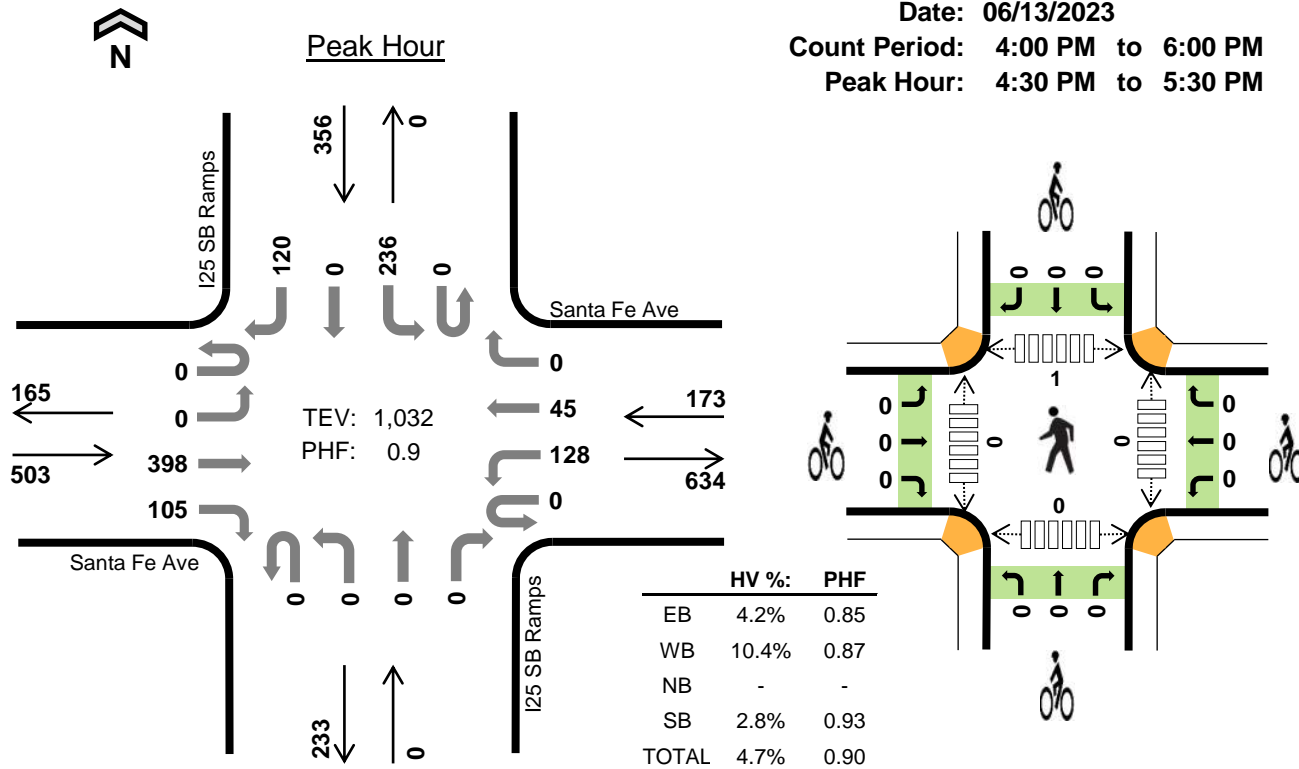

#### Two-Hour Count Summaries

Interval Start	Santa Fe Ave				Santa Fe Ave				I25 SB Ramps				I25 SB Ramps				15-min Total	Rolling One Hour	
	Eastbound		Westbound		Northbound		Southbound		Northbound		Southbound		Southbound						
	UT	LT	TH	RT	UT	LT	TH	RT	UT	LT	TH	RT	UT	LT	TH	RT			
4:00 PM	0	0	75	23	0	31	11	0	0	0	0	0	0	97	0	11	248	0	
4:15 PM	0	0	74	15	0	36	8	0	0	0	0	0	0	70	0	11	214	0	
<b>4:30 PM</b>	<b>0</b>	<b>0</b>	<b>114</b>	<b>34</b>	<b>0</b>	<b>32</b>	<b>11</b>	<b>0</b>	<b>0</b>	<b>0</b>	<b>0</b>	<b>0</b>	<b>0</b>	<b>75</b>	<b>0</b>	<b>21</b>	<b>287</b>	<b>0</b>	
4:45 PM	0	0	89	27	0	29	21	0	0	0	0	0	0	50	0	42	258	1,007	
5:00 PM	0	0	105	22	0	32	8	0	0	0	0	0	0	57	0	27	251	1,010	
5:15 PM	0	0	90	22	0	35	5	0	0	0	0	0	0	54	0	30	236	1,032	
5:30 PM	0	0	104	26	0	27	5	0	0	0	0	0	0	58	0	18	238	983	
5:45 PM	0	0	66	4	0	27	4	0	0	0	0	0	0	68	0	36	205	930	
Count Total	0	0	717	173	0	249	73	0	0	0	0	0	0	529	0	196	1,937	0	
Peak Hour	All	0	0	398	105	0	128	45	0	0	0	0	0	0	236	0	120	1,032	0
	HV	0	0	12	9	0	6	12	0	0	0	0	0	0	2	0	8	49	0
	HV%	-	-	3%	9%	-	5%	27%	-	-	-	-	-	-	1%	-	7%	5%	0

Note: Two-hour count summary volumes include heavy vehicles but exclude bicycles in overall count.

Interval Start	Heavy Vehicle Totals					Bicycles					Pedestrians (Crossing Leg)				
	EB	WB	NB	SB	Total	EB	WB	NB	SB	Total	East	West	North	South	Total
4:00 PM	9	2	0	5	16	0	0	0	0	0	0	0	0	0	0
4:15 PM	10	6	0	3	19	0	0	0	0	0	0	0	0	0	0
<b>4:30 PM</b>	<b>5</b>	<b>3</b>	<b>0</b>	<b>2</b>	<b>10</b>	<b>0</b>	<b>0</b>	<b>0</b>	<b>0</b>	<b>0</b>	<b>0</b>	<b>0</b>	<b>0</b>	<b>0</b>	<b>0</b>
4:45 PM	4	10	0	5	19	0	0	0	0	0	0	0	0	0	0
5:00 PM	7	2	0	2	11	0	0	0	0	0	0	0	1	0	1
5:15 PM	5	3	0	1	9	0	0	0	0	0	0	0	0	0	0
5:30 PM	7	2	0	6	15	0	0	0	0	0	0	0	0	0	0
5:45 PM	5	1	0	4	10	0	0	0	0	0	0	0	0	0	0
Count Total	52	29	0	28	109	0	0	0	0	0	0	0	1	0	1
Peak Hour	21	18	0	10	49	0	0	0	0	0	0	0	1	0	1

<b>Two-Hour Count Summaries - Heavy Vehicles</b>																		
Interval Start	Santa Fe Ave				Santa Fe Ave				I25 SB Ramps				I25 SB Ramps				15-min Total	Rolling One Hour
	Eastbound				Westbound				Northbound				Southbound					
	UT	LT	TH	RT	UT	LT	TH	RT	UT	LT	TH	RT	UT	LT	TH	RT		
4:00 PM	0	0	5	4	0	1	1	0	0	0	0	0	0	1	0	4	16	0
4:15 PM	0	0	9	1	0	1	5	0	0	0	0	0	0	1	0	2	19	0
<b>4:30 PM</b>	<b>0</b>	<b>0</b>	<b>2</b>	<b>3</b>	<b>0</b>	<b>2</b>	<b>1</b>	<b>0</b>	<b>0</b>	<b>0</b>	<b>0</b>	<b>0</b>	<b>0</b>	<b>0</b>	<b>0</b>	<b>2</b>	<b>10</b>	<b>0</b>
4:45 PM	0	0	4	0	0	1	9	0	0	0	0	0	0	2	0	3	19	64
5:00 PM	0	0	3	4	0	0	2	0	0	0	0	0	0	0	0	2	11	59
5:15 PM	0	0	3	2	0	3	0	0	0	0	0	0	0	0	0	1	9	49
5:30 PM	0	0	4	3	0	0	2	0	0	0	0	0	0	0	0	6	15	54
5:45 PM	0	0	4	1	0	0	1	0	0	0	0	0	0	0	0	4	10	45
Count Total	0	0	34	18	0	8	21	0	0	0	0	0	0	4	0	24	109	0
Peak Hour	0	0	12	9	0	6	12	0	0	0	0	0	0	2	0	8	49	0

<b>Two-Hour Count Summaries - Bikes</b>																
Interval Start	Santa Fe Ave			Santa Fe Ave			I25 SB Ramps			I25 SB Ramps			15-min Total	Rolling One Hour		
	Eastbound			Westbound			Northbound			Southbound						
	LT	TH	RT	LT	TH	RT	LT	TH	RT	LT	TH	RT				
4:00 PM	0	0	0	0	0	0	0	0	0	0	0	0	0	0		
4:15 PM	0	0	0	0	0	0	0	0	0	0	0	0	0	0		
<b>4:30 PM</b>	<b>0</b>	<b>0</b>	<b>0</b>	<b>0</b>	<b>0</b>	<b>0</b>	<b>0</b>	<b>0</b>	<b>0</b>	<b>0</b>	<b>0</b>	<b>0</b>	<b>0</b>	<b>0</b>		
4:45 PM	0	0	0	0	0	0	0	0	0	0	0	0	0	0		
5:00 PM	0	0	0	0	0	0	0	0	0	0	0	0	0	0		
5:15 PM	0	0	0	0	0	0	0	0	0	0	0	0	0	0		
5:30 PM	0	0	0	0	0	0	0	0	0	0	0	0	0	0		
5:45 PM	0	0	0	0	0	0	0	0	0	0	0	0	0	0		
Count Total	0	0	0	0	0	0	0	0	0	0	0	0	0	0		
Peak Hour	0	0	0	0	0	0	0	0	0	0	0	0	0	0		

Note: U-Turn volumes for bikes are included in Left-Turn, if any.

### I25 NB Ramps Santa Fe Ave



Date: 06/13/2023

Count Period: 5:00 AM to 8:00 AM

Peak Hour: 6:45 AM to 7:45 AM

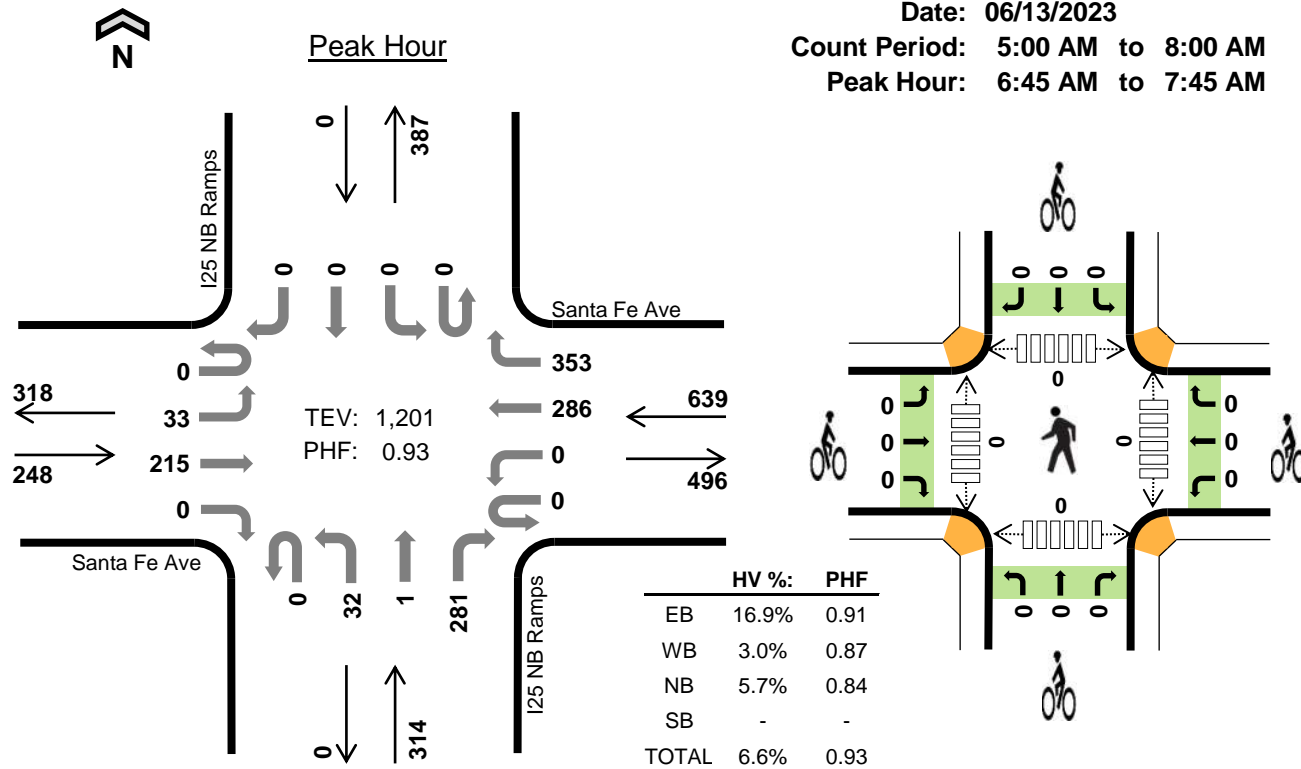

#### Three-Hour Count Summaries

Interval Start	Santa Fe Ave Eastbound				Santa Fe Ave Westbound				I25 NB Ramps Northbound				I25 NB Ramps Southbound				15-min Total	Rolling One Hour	
	UT	LT	TH	RT	UT	LT	TH	RT	UT	LT	TH	RT	UT	LT	TH	RT			
6:45 AM	0	8	60	0	0	0	91	93	0	9	0	63	0	0	0	0	324	0	
7:00 AM	0	8	52	0	0	0	49	98	0	9	0	69	0	0	0	0	285	0	
7:15 AM	0	11	53	0	0	0	67	83	0	7	1	86	0	0	0	0	308	0	
7:30 AM	0	6	50	0	0	0	79	79	0	7	0	63	0	0	0	0	284	1,201	
Peak Hour	All	0	33	215	0	0	0	286	353	0	32	1	281	0	0	0	0	1,201	0
	HV	0	20	22	0	0	0	15	4	0	3	0	15	0	0	0	0	79	0
	HV%	-	61%	10%	-	-	-	5%	1%	-	9%	0%	5%	-	-	-	-	7%	0

Note: For all three-hour count summary, see next page.

Interval Start	Heavy Vehicle Totals					Bicycles					Pedestrians (Crossing Leg)				
	EB	WB	NB	SB	Total	EB	WB	NB	SB	Total	East	West	North	South	Total
6:45 AM	7	4	0	0	11	0	0	0	0	0	0	0	0	0	0
7:00 AM	5	2	4	0	11	0	0	0	0	0	0	0	0	0	0
7:15 AM	18	6	8	0	32	0	0	0	0	0	0	0	0	0	0
7:30 AM	12	7	6	0	25	0	0	0	0	0	0	0	0	0	0
Peak Hour	42	19	18	0	79	0	0	0	0	0	0	0	0	0	0

Three-Hour Count Summaries																			
Interval Start	Santa Fe Ave				Santa Fe Ave				I25 NB Ramps				I25 NB Ramps				15-min Total	Rolling One Hour	
	Eastbound				Westbound				Northbound				Southbound						
	UT	LT	TH	RT	UT	LT	TH	RT	UT	LT	TH	RT	UT	LT	TH	RT			
5:00 AM	0	2	4	0	0	0	25	28	0	5	1	4	0	0	0	0	69	0	
5:15 AM	0	2	7	0	0	0	47	43	0	14	0	11	0	0	0	0	124	0	
5:30 AM	0	2	16	0	0	0	75	66	0	31	0	15	0	0	0	0	205	0	
5:45 AM	0	11	22	0	0	0	122	74	0	33	0	10	0	0	0	0	272	670	
6:00 AM	0	5	12	0	0	0	84	92	0	13	0	15	0	0	0	0	221	822	
6:15 AM	0	4	19	0	0	0	63	75	0	9	0	22	0	0	0	0	192	890	
6:30 AM	0	11	35	0	0	0	74	98	0	20	0	40	0	0	0	0	278	963	
<b>6:45 AM</b>	<b>0</b>	<b>8</b>	<b>60</b>	<b>0</b>	<b>0</b>	<b>0</b>	<b>91</b>	<b>93</b>	<b>0</b>	<b>9</b>	<b>0</b>	<b>63</b>	<b>0</b>	<b>0</b>	<b>0</b>	<b>0</b>	<b>324</b>	1,015	
7:00 AM	0	8	52	0	0	0	49	98	0	9	0	69	0	0	0	0	285	1,079	
7:15 AM	0	11	53	0	0	0	67	83	0	7	1	86	0	0	0	0	308	1,195	
7:30 AM	0	6	50	0	0	0	79	79	0	7	0	63	0	0	0	0	284	1,201	
7:45 AM	0	10	60	0	0	0	84	52	0	12	0	83	0	0	0	0	301	1,178	
Count Total	0	80	390	0	0	0	860	881	0	169	2	481	0	0	0	0	2,863	0	
Peak Hour	All	0	33	215	0	0	0	286	353	0	32	1	281	0	0	0	0	1,201	0
	HV	0	20	22	0	0	0	15	4	0	3	0	15	0	0	0	0	79	0
	HV%	-	61%	10%	-	-	-	5%	1%	-	9%	0%	5%	-	-	-	-	7%	0

Note: Three-hour count summary volumes include heavy vehicles but exclude bicycles in overall count.

Interval Start	Heavy Vehicle Totals					Bicycles					Pedestrians (Crossing Leg)				
	EB	WB	NB	SB	Total	EB	WB	NB	SB	Total	East	West	North	South	Total
5:00 AM	4	0	1	0	5	0	0	0	0	0	0	0	0	0	0
5:15 AM	1	0	2	0	3	0	0	0	0	0	0	0	0	0	0
5:30 AM	1	2	1	0	4	0	0	0	0	0	0	0	0	0	0
5:45 AM	3	5	1	0	9	0	0	0	0	0	0	0	0	0	0
6:00 AM	5	4	5	0	14	0	0	0	0	0	0	0	1	0	1
6:15 AM	5	6	3	0	14	0	0	0	0	0	0	0	0	0	0
6:30 AM	7	3	3	0	13	0	0	0	0	0	0	0	0	0	0
<b>6:45 AM</b>	<b>7</b>	<b>4</b>	<b>0</b>	<b>0</b>	<b>11</b>	<b>0</b>	<b>0</b>	<b>0</b>	<b>0</b>	<b>0</b>	<b>0</b>	<b>0</b>	<b>0</b>	<b>0</b>	<b>0</b>
7:00 AM	5	2	4	0	11	0	0	0	0	0	0	0	0	0	0
7:15 AM	18	6	8	0	32	0	0	0	0	0	0	0	0	0	0
7:30 AM	12	7	6	0	25	0	0	0	0	0	0	0	0	0	0
7:45 AM	11	12	16	0	39	0	0	0	0	0	0	0	0	0	0
Count Total	79	51	50	0	180	0	0	0	0	0	0	0	1	0	1
Peak Hour	42	19	18	0	79	0	0	0	0	0	0	0	0	0	0



Three-Hour Count Summaries - Heavy Vehicles																			
Interval Start	Santa Fe Ave				Santa Fe Ave				I25 NB Ramps				I25 NB Ramps				15-min Total	Rolling One Hour	
	Eastbound				Westbound				Northbound				Southbound						
	UT	LT	TH	RT	UT	LT	TH	RT	UT	LT	TH	RT	UT	LT	TH	RT			
5:00 AM	0	1	3	0	0	0	0	0	0	1	0	0	0	0	0	0	0	5	0
5:15 AM	0	1	0	0	0	0	0	0	0	1	0	1	0	0	0	0	0	3	0
5:30 AM	0	0	1	0	0	0	1	1	0	0	0	1	0	0	0	0	0	4	0
5:45 AM	0	2	1	0	0	0	3	2	0	1	0	0	0	0	0	0	0	9	21
6:00 AM	0	3	2	0	0	0	0	4	0	1	0	4	0	0	0	0	0	14	30
6:15 AM	0	3	2	0	0	0	6	0	0	1	0	2	0	0	0	0	0	14	41
6:30 AM	0	5	2	0	0	0	1	2	0	0	0	3	0	0	0	0	0	13	50
<b>6:45 AM</b>	<b>0</b>	<b>4</b>	<b>3</b>	<b>0</b>	<b>0</b>	<b>0</b>	<b>2</b>	<b>2</b>	<b>0</b>	<b>0</b>	<b>0</b>	<b>0</b>	<b>0</b>	<b>0</b>	<b>0</b>	<b>0</b>	<b>11</b>	<b>52</b>	
7:00 AM	0	4	1	0	0	0	2	0	0	0	0	4	0	0	0	0	0	11	49
7:15 AM	0	9	9	0	0	0	4	2	0	2	0	6	0	0	0	0	0	32	67
7:30 AM	0	3	9	0	0	0	7	0	0	1	0	5	0	0	0	0	0	25	79
7:45 AM	0	2	9	0	0	0	11	1	0	2	0	14	0	0	0	0	0	39	107
Count Total	0	37	42	0	0	0	37	14	0	10	0	40	0	0	0	0	0	180	0
Peak Hour	0	20	22	0	0	0	15	4	0	3	0	15	0	0	0	0	0	79	0

Three-Hour Count Summaries - Bikes																			
Interval Start	Santa Fe Ave			Santa Fe Ave			I25 NB Ramps			I25 NB Ramps			15-min Total	Rolling One Hour					
	Eastbound			Westbound			Northbound			Southbound									
	LT	TH	RT	LT	TH	RT	LT	TH	RT	LT	TH	RT							
5:00 AM	0	0	0	0	0	0	0	0	0	0	0	0	0	0	0	0	0	0	0
5:15 AM	0	0	0	0	0	0	0	0	0	0	0	0	0	0	0	0	0	0	0
5:30 AM	0	0	0	0	0	0	0	0	0	0	0	0	0	0	0	0	0	0	0
5:45 AM	0	0	0	0	0	0	0	0	0	0	0	0	0	0	0	0	0	0	0
6:00 AM	0	0	0	0	0	0	0	0	0	0	0	0	0	0	0	0	0	0	0
6:15 AM	0	0	0	0	0	0	0	0	0	0	0	0	0	0	0	0	0	0	0
6:30 AM	0	0	0	0	0	0	0	0	0	0	0	0	0	0	0	0	0	0	0
<b>6:45 AM</b>	<b>0</b>	<b>0</b>	<b>0</b>	<b>0</b>	<b>0</b>	<b>0</b>	<b>0</b>	<b>0</b>	<b>0</b>	<b>0</b>	<b>0</b>	<b>0</b>	<b>0</b>	<b>0</b>	<b>0</b>	<b>0</b>	<b>0</b>	<b>0</b>	<b>0</b>
7:00 AM	0	0	0	0	0	0	0	0	0	0	0	0	0	0	0	0	0	0	0
7:15 AM	0	0	0	0	0	0	0	0	0	0	0	0	0	0	0	0	0	0	0
7:30 AM	0	0	0	0	0	0	0	0	0	0	0	0	0	0	0	0	0	0	0
7:45 AM	0	0	0	0	0	0	0	0	0	0	0	0	0	0	0	0	0	0	0
Count Total	0	0	0	0	0	0	0	0	0	0	0	0	0	0	0	0	0	0	0
Peak Hour	0	0	0	0	0	0	0	0	0	0	0	0	0	0	0	0	0	0	0

Note: U-Turn volumes for bikes are included in Left-Turn, if any.

### I25 NB Ramps Santa Fe Ave



Date: 06/13/2023

Count Period: 4:00 PM to 6:00 PM

Peak Hour: 4:00 PM to 5:00 PM

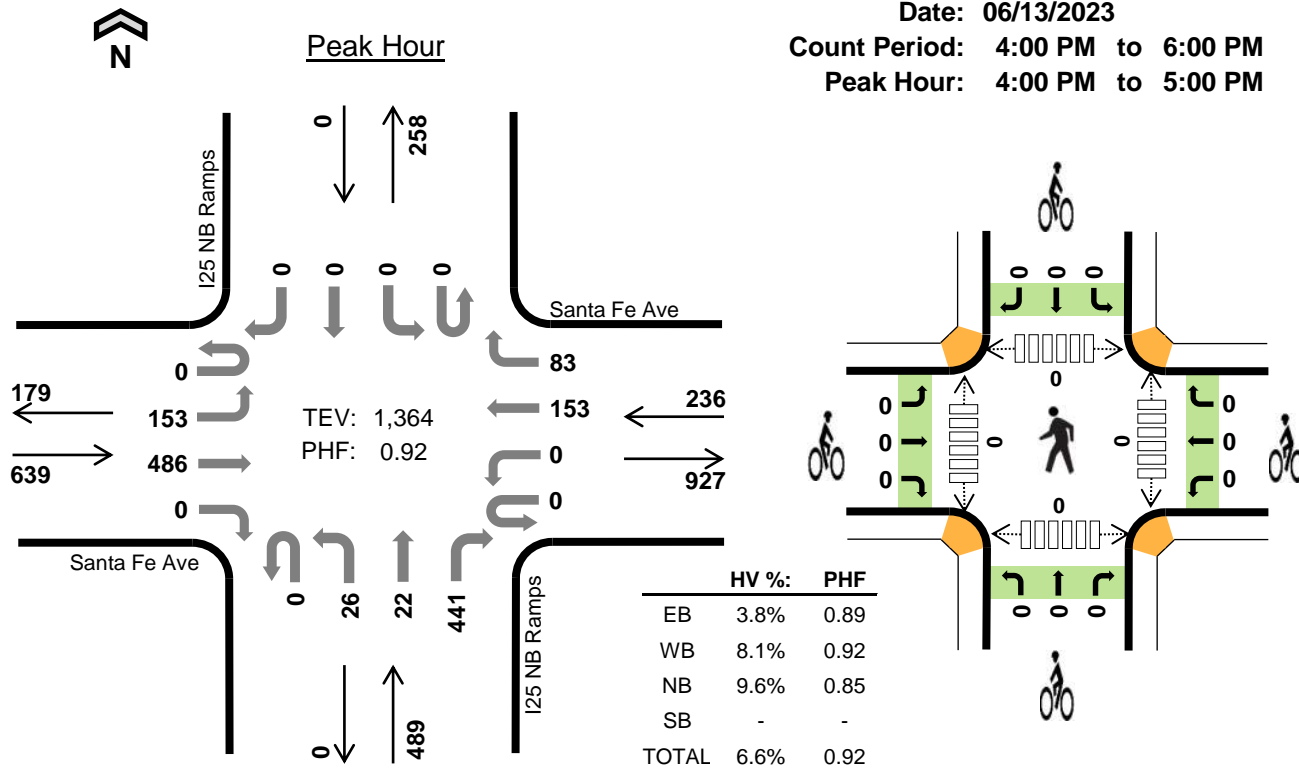

#### Two-Hour Count Summaries

Interval Start	Santa Fe Ave				Santa Fe Ave				I25 NB Ramps				I25 NB Ramps				15-min Total	Rolling One Hour	
	Eastbound		Westbound		Northbound		Southbound		Eastbound		Westbound		Southbound						
	UT	LT	TH	RT	UT	LT	TH	RT	UT	LT	TH	RT	UT	LT	TH	RT			
4:00 PM	0	28	142	0	0	0	40	24	0	6	2	101	0	0	0	0	343	0	
4:15 PM	0	42	101	0	0	0	37	24	0	5	7	101	0	0	0	0	317	0	
4:30 PM	0	44	136	0	0	0	32	15	0	6	8	129	0	0	0	0	370	0	
4:45 PM	0	39	107	0	0	0	44	20	0	9	5	110	0	0	0	0	334	1,364	
5:00 PM	0	38	127	0	0	0	32	16	0	4	5	114	0	0	0	0	336	1,357	
5:15 PM	0	26	118	0	0	0	40	13	0	1	7	113	0	0	0	0	318	1,358	
5:30 PM	0	28	132	0	0	0	32	16	0	3	1	120	0	0	0	0	332	1,320	
5:45 PM	0	18	122	0	0	0	29	9	0	4	1	107	0	0	0	0	290	1,276	
Count Total	0	263	985	0	0	0	286	137	0	38	36	895	0	0	0	0	2,640	0	
Peak Hour	All	0	153	486	0	0	0	153	83	0	26	22	441	0	0	0	0	1,364	0
	HV	0	11	13	0	0	0	13	6	0	6	0	41	0	0	0	0	90	0
	HV%	-	7%	3%	-	-	-	8%	7%	-	23%	0%	9%	-	-	-	-	7%	0

Note: Two-hour count summary volumes include heavy vehicles but exclude bicycles in overall count.

Interval Start	Heavy Vehicle Totals					Bicycles					Pedestrians (Crossing Leg)				
	EB	WB	NB	SB	Total	EB	WB	NB	SB	Total	East	West	North	South	Total
4:00 PM	7	5	12	0	24	0	0	0	0	0	0	0	0	0	0
4:15 PM	11	2	14	0	27	0	0	0	0	0	0	0	0	0	0
4:30 PM	2	5	8	0	15	0	0	0	0	0	0	0	0	0	0
4:45 PM	4	7	13	0	24	0	0	0	0	0	0	0	0	0	0
5:00 PM	3	2	7	0	12	0	0	0	0	0	0	0	1	0	1
5:15 PM	5	5	6	0	16	0	0	0	0	0	0	0	0	0	0
5:30 PM	4	2	11	0	17	0	0	0	0	0	0	0	0	0	0
5:45 PM	3	0	5	0	8	0	0	0	0	0	0	0	0	0	0
Count Total	39	28	76	0	143	0	0	0	0	0	0	0	1	0	1
Peak Hour	24	19	47	0	90	0	0	0	0	0	0	0	0	0	0

<b>Two-Hour Count Summaries - Heavy Vehicles</b>																		
Interval Start	Santa Fe Ave				Santa Fe Ave				I25 NB Ramps				I25 NB Ramps				15-min Total	Rolling One Hour
	Eastbound				Westbound				Northbound				Southbound					
	UT	LT	TH	RT	UT	LT	TH	RT	UT	LT	TH	RT	UT	LT	TH	RT		
4:00 PM	0	4	3	0	0	0	3	2	0	0	0	12	0	0	0	0	24	0
4:15 PM	0	5	6	0	0	0	2	0	0	3	0	11	0	0	0	0	27	0
4:30 PM	0	1	1	0	0	0	3	2	0	0	0	8	0	0	0	0	15	0
4:45 PM	0	1	3	0	0	0	5	2	0	3	0	10	0	0	0	0	24	90
5:00 PM	0	1	2	0	0	0	1	1	0	0	0	7	0	0	0	0	12	78
5:15 PM	0	2	3	0	0	0	4	1	0	0	0	6	0	0	0	0	16	67
5:30 PM	0	1	3	0	0	0	1	1	0	2	1	8	0	0	0	0	17	69
5:45 PM	0	1	2	0	0	0	0	0	0	2	0	3	0	0	0	0	8	53
Count Total	0	16	23	0	0	0	19	9	0	10	1	65	0	0	0	0	143	0
Peak Hour	0	11	13	0	0	0	13	6	0	6	0	41	0	0	0	0	90	0

<b>Two-Hour Count Summaries - Bikes</b>																
Interval Start	Santa Fe Ave			Santa Fe Ave			I25 NB Ramps			I25 NB Ramps			15-min Total	Rolling One Hour		
	Eastbound			Westbound			Northbound			Southbound						
	LT	TH	RT	LT	TH	RT	LT	TH	RT	LT	TH	RT				
4:00 PM	0	0	0	0	0	0	0	0	0	0	0	0	0	0		
4:15 PM	0	0	0	0	0	0	0	0	0	0	0	0	0	0		
4:30 PM	0	0	0	0	0	0	0	0	0	0	0	0	0	0		
4:45 PM	0	0	0	0	0	0	0	0	0	0	0	0	0	0		
5:00 PM	0	0	0	0	0	0	0	0	0	0	0	0	0	0		
5:15 PM	0	0	0	0	0	0	0	0	0	0	0	0	0	0		
5:30 PM	0	0	0	0	0	0	0	0	0	0	0	0	0	0		
5:45 PM	0	0	0	0	0	0	0	0	0	0	0	0	0	0		
Count Total	0	0	0	0	0	0	0	0	0	0	0	0	0	0		
Peak Hour	0	0	0	0	0	0	0	0	0	0	0	0	0	0		

Note: U-Turn volumes for bikes are included in Left-Turn, if any.

Location: Charter Oak Ranch Rd W/O Santa Fe Ave  
 Date Range: 6/13/2023 - 6/19/2023  
 Site Code: 01

Time	Tuesday 6/13/2023			Wednesday 6/14/2023			Thursday 6/15/2023			Friday 6/16/2023			Saturday 6/17/2023			Sunday 6/18/2023			Monday 6/19/2023			Mid-Week Average		
	EB	WB	Total	EB	WB	Total	EB	WB	Total	EB	WB	Total	EB	WB	Total	EB	WB	Total	EB	WB	Total	EB	WB	Total
12:00 AM	0	0	0	-	-	-	-	-	-	-	-	-	-	-	-	-	-	-	-	-	-	0	0	0
1:00 AM	0	1	1	-	-	-	-	-	-	-	-	-	-	-	-	-	-	-	-	-	-	0	1	1
2:00 AM	1	1	2	-	-	-	-	-	-	-	-	-	-	-	-	-	-	-	-	-	-	1	1	2
3:00 AM	1	0	1	-	-	-	-	-	-	-	-	-	-	-	-	-	-	-	-	-	-	1	0	1
4:00 AM	2	4	6	-	-	-	-	-	-	-	-	-	-	-	-	-	-	-	-	-	-	2	4	6
5:00 AM	3	177	180	-	-	-	-	-	-	-	-	-	-	-	-	-	-	-	-	-	-	3	177	180
6:00 AM	21	184	205	-	-	-	-	-	-	-	-	-	-	-	-	-	-	-	-	-	-	21	184	205
7:00 AM	53	115	168	-	-	-	-	-	-	-	-	-	-	-	-	-	-	-	-	-	-	53	115	168
8:00 AM	24	318	342	-	-	-	-	-	-	-	-	-	-	-	-	-	-	-	-	-	-	24	318	342
9:00 AM	28	120	148	-	-	-	-	-	-	-	-	-	-	-	-	-	-	-	-	-	-	28	120	148
10:00 AM	39	24	63	-	-	-	-	-	-	-	-	-	-	-	-	-	-	-	-	-	-	39	24	63
11:00 AM	97	24	121	-	-	-	-	-	-	-	-	-	-	-	-	-	-	-	-	-	-	97	24	121
12:00 PM	55	78	133	-	-	-	-	-	-	-	-	-	-	-	-	-	-	-	-	-	-	55	78	133
1:00 PM	54	38	92	-	-	-	-	-	-	-	-	-	-	-	-	-	-	-	-	-	-	54	38	92
2:00 PM	53	24	77	-	-	-	-	-	-	-	-	-	-	-	-	-	-	-	-	-	-	53	24	77
3:00 PM	96	21	117	-	-	-	-	-	-	-	-	-	-	-	-	-	-	-	-	-	-	96	21	117
4:00 PM	194	20	214	-	-	-	-	-	-	-	-	-	-	-	-	-	-	-	-	-	-	194	20	214
5:00 PM	152	17	169	-	-	-	-	-	-	-	-	-	-	-	-	-	-	-	-	-	-	152	17	169
6:00 PM	1	0	1	-	-	-	-	-	-	-	-	-	-	-	-	-	-	-	-	-	-	1	0	1
7:00 PM	0	2	2	-	-	-	-	-	-	-	-	-	-	-	-	-	-	-	-	-	-	0	2	2
8:00 PM	0	0	0	-	-	-	-	-	-	-	-	-	-	-	-	-	-	-	-	-	-	0	0	0
9:00 PM	0	0	0	-	-	-	-	-	-	-	-	-	-	-	-	-	-	-	-	-	-	0	0	0
10:00 PM	0	0	0	-	-	-	-	-	-	-	-	-	-	-	-	-	-	-	-	-	-	0	0	0
11:00 PM	1	0	1	-	-	-	-	-	-	-	-	-	-	-	-	-	-	-	-	-	-	1	0	1
<b>Total</b>	<b>875</b>	<b>1,168</b>	<b>2,043</b>	-	-	-	-	-	-	-	-	-	-	-	-	-	-	-	-	-	-	<b>875</b>	<b>1,168</b>	<b>2,043</b>
<b>Percent</b>	<b>43%</b>	<b>57%</b>		-	-	-	-	-	-	-	-	-	-	-	-	-	-	-	-	-	-	<b>43%</b>	<b>57%</b>	
AM Peak	11:00	08:00	08:00	-	-	-	-	-	-	-	-	-	-	-	-	-	-	-	-	-	-	11:00	08:00	08:00
Vol.	97	318	342	-	-	-	-	-	-	-	-	-	-	-	-	-	-	-	-	-	-	97	318	342
PM Peak	16:00	12:00	16:00	-	-	-	-	-	-	-	-	-	-	-	-	-	-	-	-	-	-	16:00	12:00	16:00
Vol.	194	78	214	-	-	-	-	-	-	-	-	-	-	-	-	-	-	-	-	-	-	194	78	214

1. Mid-week average includes data between Tuesday and Thursday.

Appendix C: Existing Conditions Synchro Analysis Reports



HCM 6th Signalized Intersection Summary  
 3: I-25 NB Ramps & US 85

07/17/2023

Movement	EBL	EBT	EBR	WBL	WBT	WBR	NBL	NBT	NBR	SBL	SBT	SBR
Lane Configurations												
Traffic Volume (veh/h)	33	215	0	0	286	353	32	1	281	0	0	0
Future Volume (veh/h)	33	215	0	0	286	353	32	1	281	0	0	0
Initial Q (Qb), veh	0	0	0	0	0	0	0	0	0			
Ped-Bike Adj(A_pbT)	1.00		1.00	1.00		1.00	1.00		1.00			
Parking Bus, Adj	1.00	1.00	1.00	1.00	1.00	1.00	1.00	1.00	1.00			
Work Zone On Approach		No			No			No				
Adj Sat Flow, veh/h/ln	996	1752	0	0	1826	1885	1767	1900	1826			
Adj Flow Rate, veh/h	35	231	0	0	308	0	34	1	0			
Peak Hour Factor	0.93	0.93	0.93	0.93	0.93	0.93	0.93	0.93	0.93			
Percent Heavy Veh, %	61	10	0	0	5	1	9	0	5			
Cap, veh/h	505	1408	0	0	2433		59	2				
Arrive On Green	0.03	0.80	0.00	0.00	0.70	0.00	0.03	0.03	0.00			
Sat Flow, veh/h	949	1752	0	0	3561	1598	1760	52	1547			
Grp Volume(v), veh/h	35	231	0	0	308	0	35	0	0			
Grp Sat Flow(s),veh/h/ln	949	1752	0	0	1735	1598	1812	0	1547			
Q Serve(g_s), s	0.7	2.4	0.0	0.0	2.3	0.0	1.5	0.0	0.0			
Cycle Q Clear(g_c), s	0.7	2.4	0.0	0.0	2.3	0.0	1.5	0.0	0.0			
Prop In Lane	1.00		0.00	0.00		1.00	0.97		1.00			
Lane Grp Cap(c), veh/h	505	1408	0	0	2433		61	0				
V/C Ratio(X)	0.07	0.16	0.00	0.00	0.13		0.57	0.00				
Avail Cap(c_a), veh/h	586	1408	0	0	2433		419	0				
HCM Platoon Ratio	1.00	1.00	1.00	1.00	1.00	1.00	1.00	1.00	1.00			
Upstream Filter(I)	1.00	1.00	0.00	0.00	1.00	0.00	1.00	0.00	0.00			
Uniform Delay (d), s/veh	2.5	1.8	0.0	0.0	3.9	0.0	38.1	0.0	0.0			
Incr Delay (d2), s/veh	0.1	0.3	0.0	0.0	0.1	0.0	8.1	0.0	0.0			
Initial Q Delay(d3),s/veh	0.0	0.0	0.0	0.0	0.0	0.0	0.0	0.0	0.0			
%ile BackOfQ(50%),veh/ln	0.1	0.4	0.0	0.0	0.6	0.0	0.8	0.0	0.0			
Unsig. Movement Delay, s/veh												
LnGrp Delay(d),s/veh	2.6	2.0	0.0	0.0	4.0	0.0	46.2	0.0	0.0			
LnGrp LOS	A	A	A	A	A		D	A				
Approach Vol, veh/h		266			308			35				
Approach Delay, s/veh		2.1			4.0			46.2				
Approach LOS		A			A			D				
Timer - Assigned Phs		2			5	6		8				
Phs Duration (G+Y+Rc), s		70.8			8.2	62.6		9.2				
Change Period (Y+Rc), s		6.5			5.5	6.5		6.5				
Max Green Setting (Gmax), s		48.5			9.5	33.5		18.5				
Max Q Clear Time (g_c+I1), s		4.4			2.7	4.3		3.5				
Green Ext Time (p_c), s		1.4			0.0	2.0		0.1				
<b>Intersection Summary</b>												
HCM 6th Ctrl Delay					5.6							
HCM 6th LOS					A							
<b>Notes</b>												
Unsignalized Delay for [NBR, WBR] is excluded from calculations of the approach delay and intersection delay.												

HCM 6th Signalized Intersection Summary  
6: I-25 SB Ramps & US 85

07/17/2023



Movement	EBL	EBT	EBR	WBL	WBT	WBR	NBL	NBT	NBR	SBL	SBT	SBR
Lane Configurations		↑↑	↗	↘	↑						↖	↗
Traffic Volume (veh/h)	0	97	22	127	188	0	0	0	0	152	2	112
Future Volume (veh/h)	0	97	22	127	188	0	0	0	0	152	2	112
Initial Q (Qb), veh	0	0	0	0	0	0				0	0	0
Ped-Bike Adj(A_pbT)	1.00		1.00	1.00		1.00				1.00		1.00
Parking Bus, Adj	1.00	1.00	1.00	1.00	1.00	1.00				1.00	1.00	1.00
Work Zone On Approach		No			No						No	
Adj Sat Flow, veh/h/ln	0	1411	1500	1781	1826	0				1796	1159	1663
Adj Flow Rate, veh/h	0	114	0	149	221	0				179	2	0
Peak Hour Factor	0.85	0.85	0.85	0.85	0.85	0.85				0.85	0.85	0.85
Percent Heavy Veh, %	0	33	27	8	5	0				7	50	16
Cap, veh/h	0	1384		797	1181	0				208	2	
Arrive On Green	0.00	0.52	0.00	0.06	0.65	0.00				0.19	0.19	0.00
Sat Flow, veh/h	0	2751	1271	1697	1826	0				1092	12	1409
Grp Volume(v), veh/h	0	114	0	149	221	0				181	0	0
Grp Sat Flow(s),veh/h/ln	0	1340	1271	1697	1826	0				1104	0	1409
Q Serve(g_s), s	0.0	1.7	0.0	3.1	3.9	0.0				12.7	0.0	0.0
Cycle Q Clear(g_c), s	0.0	1.7	0.0	3.1	3.9	0.0				12.7	0.0	0.0
Prop In Lane	0.00		1.00	1.00		0.00				0.99		1.00
Lane Grp Cap(c), veh/h	0	1384		797	1181	0				211	0	
V/C Ratio(X)	0.00	0.08		0.19	0.19	0.00				0.86	0.00	
Avail Cap(c_a), veh/h	0	1384		831	1181	0				462	0	
HCM Platoon Ratio	1.00	1.00	1.00	1.00	1.00	1.00				1.00	1.00	1.00
Upstream Filter(l)	0.00	1.00	0.00	1.00	1.00	0.00				1.00	0.00	0.00
Uniform Delay (d), s/veh	0.0	9.8	0.0	7.0	5.7	0.0				31.3	0.0	0.0
Incr Delay (d2), s/veh	0.0	0.1	0.0	0.1	0.4	0.0				9.7	0.0	0.0
Initial Q Delay(d3),s/veh	0.0	0.0	0.0	0.0	0.0	0.0				0.0	0.0	0.0
%ile BackOfQ(50%),veh/lr0.0	0.0	0.5	0.0	0.9	1.3	0.0				3.7	0.0	0.0
Unsig. Movement Delay, s/veh												
LnGrp Delay(d),s/veh	0.0	9.9	0.0	7.1	6.0	0.0				41.1	0.0	0.0
LnGrp LOS	A	A		A	A	A				D	A	
Approach Vol, veh/h		114			370						181	
Approach Delay, s/veh		9.9			6.5						41.1	
Approach LOS		A			A						D	
Timer - Assigned Phs	1	2		4		6						
Phs Duration (G+Y+Rc), s	47.8			21.8		58.2						
Change Period (Y+Rc), s	5.5	6.5		6.5		6.5						
Max Green Setting (Gmax), s	21.5			33.5		33.5						
Max Q Clear Time (g_c+1/5), s	3.7			14.7		5.9						
Green Ext Time (p_c), s	0.1	0.5		0.9		1.2						

Intersection Summary

HCM 6th Ctrl Delay	16.5
HCM 6th LOS	B

Notes

Unsignalized Delay for [EBR, SBR] is excluded from calculations of the approach delay and intersection delay.

HCM 6th Roundabout  
 11: Charter Oak Ranch Rd & US 85

07/17/2023

Intersection				
Intersection Delay, s/veh	4.3			
Intersection LOS	A			
Approach	EB	WB	NB	SB
Entry Lanes	1	1	1	1
Conflicting Circle Lanes	1	1	1	1
Adj Approach Flow, veh/h	6	280	61	65
Demand Flow Rate, veh/h	12	293	66	71
Vehicles Circulating, veh/h	270	0	80	215
Vehicles Exiting, veh/h	16	146	202	78
Ped Vol Crossing Leg, #/h	0	0	0	0
Ped Cap Adj	1.000	1.000	1.000	1.000
Approach Delay, s/veh	7.0	4.5	3.5	4.1
Approach LOS	A	A	A	A
Lane	Left	Left	Left	Left
Designated Moves	LTR	LTR	LTR	LTR
Assumed Moves	LTR	LTR	LTR	LTR
RT Channelized				
Lane Util	1.000	1.000	1.000	1.000
Follow-Up Headway, s	2.609	2.609	2.609	2.609
Critical Headway, s	4.976	4.976	4.976	4.976
Entry Flow, veh/h	12	293	66	71
Cap Entry Lane, veh/h	1048	1380	1272	1108
Entry HV Adj Factor	0.500	0.955	0.924	0.915
Flow Entry, veh/h	6	280	61	65
Cap Entry, veh/h	524	1317	1175	1015
V/C Ratio	0.011	0.212	0.052	0.064
Control Delay, s/veh	7.0	4.5	3.5	4.1
LOS	A	A	A	A
95th %tile Queue, veh	0	1	0	0

Intersection												
Int Delay, s/veh	1.3											
Movement	EBL	EBT	EBR	WBL	WBT	WBR	NBL	NBT	NBR	SBL	SBT	SBR
Lane Configurations		↕		↕	↕			↕			↕	
Traffic Vol, veh/h	0	43	0	22	111	1	1	0	7	0	0	1
Future Vol, veh/h	0	43	0	22	111	1	1	0	7	0	0	1
Conflicting Peds, #/hr	0	0	0	0	0	0	0	0	0	0	0	0
Sign Control	Free	Free	Free	Free	Free	Free	Stop	Stop	Stop	Stop	Stop	Stop
RT Channelized	-	-	None	-	-	None	-	-	None	-	-	None
Storage Length	-	-	-	300	-	-	-	-	-	-	-	-
Veh in Median Storage, #	-	0	-	-	0	-	-	0	-	-	0	-
Grade, %	-	0	-	-	0	-	-	0	-	-	0	-
Peak Hour Factor	81	81	81	81	81	81	81	81	81	81	81	81
Heavy Vehicles, %	2	5	2	9	3	0	100	2	57	2	2	0
Mvmt Flow	0	53	0	27	137	1	1	0	9	0	0	1

Major/Minor	Major1		Major2		Minor1		Minor2					
Conflicting Flow All	138	0	0	53	0	0	245	245	53	250	245	138
Stage 1	-	-	-	-	-	-	53	53	-	192	192	-
Stage 2	-	-	-	-	-	-	192	192	-	58	53	-
Critical Hdwy	4.12	-	-	4.19	-	-	8.1	6.52	6.77	7.12	6.52	6.2
Critical Hdwy Stg 1	-	-	-	-	-	-	7.1	5.52	-	6.12	5.52	-
Critical Hdwy Stg 2	-	-	-	-	-	-	7.1	5.52	-	6.12	5.52	-
Follow-up Hdwy	2.218	-	-	2.281	-	-	4.4	4.018	3.813	3.518	4.018	3.3
Pot Cap-1 Maneuver	1446	-	-	1509	-	-	546	657	879	703	657	916
Stage 1	-	-	-	-	-	-	761	851	-	810	742	-
Stage 2	-	-	-	-	-	-	629	742	-	954	851	-
Platoon blocked, %	-	-	-	-	-	-	-	-	-	-	-	-
Mov Cap-1 Maneuver	1446	-	-	1509	-	-	538	645	879	687	645	916
Mov Cap-2 Maneuver	-	-	-	-	-	-	538	645	-	687	645	-
Stage 1	-	-	-	-	-	-	761	851	-	810	729	-
Stage 2	-	-	-	-	-	-	617	729	-	945	851	-

Approach	EB		WB		NB		SB	
HCM Control Delay, s	0		1.2		9.5		8.9	
HCM LOS					A		A	

Minor Lane/Major Mvmt	NBLn1	EBL	EBT	EBR	WBL	WBT	WBR	SBLn1
Capacity (veh/h)	814	1446	-	-	1509	-	-	916
HCM Lane V/C Ratio	0.012	-	-	-	0.018	-	-	0.001
HCM Control Delay (s)	9.5	0	-	-	7.4	-	-	8.9
HCM Lane LOS	A	A	-	-	A	-	-	A
HCM 95th %tile Q(veh)	0	0	-	-	0.1	-	-	0

HCM 6th TWSC  
 18: Charter Oak Ranch Rd & Essayons Rd

07/17/2023

Intersection						
Int Delay, s/veh	0.2					
Movement	EBT	EBR	WBL	WBT	NBL	NBR
Lane Configurations						
Traffic Vol, veh/h	38	0	4	112	0	3
Future Vol, veh/h	38	0	4	112	0	3
Conflicting Peds, #/hr	0	0	0	0	0	0
Sign Control	Free	Free	Free	Free	Stop	Stop
RT Channelized	-	None	-	None	-	Free
Storage Length	-	-	350	-	0	0
Veh in Median Storage, #	0	-	-	0	0	-
Grade, %	0	-	-	0	0	-
Peak Hour Factor	89	89	89	89	89	89
Heavy Vehicles, %	0	2	100	0	2	67
Mvmt Flow	43	0	4	126	0	3

Major/Minor	Major1	Major2	Minor1		
Conflicting Flow All	0	0	43	0	177
Stage 1	-	-	-	-	43
Stage 2	-	-	-	-	134
Critical Hdwy	-	-	5.1	-	6.42
Critical Hdwy Stg 1	-	-	-	-	5.42
Critical Hdwy Stg 2	-	-	-	-	5.42
Follow-up Hdwy	-	-	3.1	-	3.518
Pot Cap-1 Maneuver	-	-	1113	-	813
Stage 1	-	-	-	-	979
Stage 2	-	-	-	-	892
Platoon blocked, %	-	-	-	-	-
Mov Cap-1 Maneuver	-	-	1113	-	810
Mov Cap-2 Maneuver	-	-	-	-	810
Stage 1	-	-	-	-	979
Stage 2	-	-	-	-	888

Approach	EB	WB	NB
HCM Control Delay, s	0	0.3	0
HCM LOS			A

Minor Lane/Major Mvmt	NBLn1	NBLn2	EBT	EBR	WBL	WBT
Capacity (veh/h)	-	-	-	-	1113	-
HCM Lane V/C Ratio	-	-	-	-	0.004	-
HCM Control Delay (s)	0	0	-	-	8.2	-
HCM Lane LOS	A	A	-	-	A	-
HCM 95th %tile Q(veh)	-	-	-	-	0	-

HCM 6th Signalized Intersection Summary  
 3: I-25 NB Ramps & US 85

07/17/2023



Movement	EBL	EBT	EBR	WBL	WBT	WBR	NBL	NBT	NBR	SBL	SBT	SBR
Lane Configurations												
Traffic Volume (veh/h)	147	488	0	0	148	64	20	25	466	0	0	0
Future Volume (veh/h)	147	488	0	0	148	64	20	25	466	0	0	0
Initial Q (Qb), veh	0	0	0	0	0	0	0	0	0			
Ped-Bike Adj(A_pbT)	1.00		1.00	1.00		1.00	1.00		1.00			
Parking Bus, Adj	1.00	1.00	1.00	1.00	1.00	1.00	1.00	1.00	1.00			
Work Zone On Approach		No			No			No				
Adj Sat Flow, veh/h/ln	1826	1870	0	0	1796	1781	1455	1900	1781			
Adj Flow Rate, veh/h	160	530	0	0	161	0	22	27	0			
Peak Hour Factor	0.92	0.92	0.92	0.92	0.92	0.92	0.92	0.92	0.92			
Percent Heavy Veh, %	5	2	0	0	7	8	30	0	8			
Cap, veh/h	995	1527	0	0	2391		33	40				
Arrive On Green	0.05	0.82	0.00	0.00	0.70	0.00	0.04	0.04	0.00			
Sat Flow, veh/h	1739	1870	0	0	3503	1510	834	1024	1510			
Grp Volume(v), veh/h	160	530	0	0	161	0	49	0	0			
Grp Sat Flow(s),veh/h/ln	1739	1870	0	0	1706	1510	1858	0	1510			
Q Serve(g_s), s	2.0	6.5	0.0	0.0	1.3	0.0	2.3	0.0	0.0			
Cycle Q Clear(g_c), s	2.0	6.5	0.0	0.0	1.3	0.0	2.3	0.0	0.0			
Prop In Lane	1.00		0.00	0.00		1.00	0.45		1.00			
Lane Grp Cap(c), veh/h	995	1527	0	0	2391		73	0				
V/C Ratio(X)	0.16	0.35	0.00	0.00	0.07		0.67	0.00				
Avail Cap(c_a), veh/h	1084	1527	0	0	2391		279	0				
HCM Platoon Ratio	1.00	1.00	1.00	1.00	1.00	1.00	1.00	1.00	1.00			
Upstream Filter(l)	0.98	0.98	0.00	0.00	1.00	0.00	1.00	0.00	0.00			
Uniform Delay (d), s/veh	2.5	2.1	0.0	0.0	4.2	0.0	42.7	0.0	0.0			
Incr Delay (d2), s/veh	0.1	0.6	0.0	0.0	0.1	0.0	10.2	0.0	0.0			
Initial Q Delay(d3),s/veh	0.0	0.0	0.0	0.0	0.0	0.0	0.0	0.0	0.0			
%ile BackOfQ(50%),veh/ln	0.4	1.4	0.0	0.0	0.4	0.0	1.2	0.0	0.0			
Unsig. Movement Delay, s/veh												
LnGrp Delay(d),s/veh	2.6	2.7	0.0	0.0	4.3	0.0	52.9	0.0	0.0			
LnGrp LOS	A	A	A	A	A		D	A				
Approach Vol, veh/h		690			161			49				
Approach Delay, s/veh		2.7			4.3			52.9				
Approach LOS		A			A			D				
Timer - Assigned Phs		2			5	6		8				
Phs Duration (G+Y+Rc), s		80.0			10.4	69.6		10.0				
Change Period (Y+Rc), s		6.5			5.5	6.5		6.5				
Max Green Setting (Gmax), s		63.5			9.5	48.5		13.5				
Max Q Clear Time (g_c+I1), s		8.5			4.0	3.3		4.3				
Green Ext Time (p_c), s		3.8			0.2	1.1		0.1				

Intersection Summary

HCM 6th Ctrl Delay	5.7
HCM 6th LOS	A

Notes

User approved pedestrian interval to be less than phase max green.  
 Unsignalized Delay for [NBR, WBR] is excluded from calculations of the approach delay and intersection delay.



# HCM 6th Signalized Intersection Summary

## 6: I-25 SB Ramps & US 85

07/17/2023



Movement	EBL	EBT	EBR	WBL	WBT	WBR	NBL	NBT	NBR	SBL	SBT	SBR
Lane Configurations		↑↑	↗	↖	↑						↖	↗
Traffic Volume (veh/h)	0	398	105	128	45	0	0	0	0	236	0	120
Future Volume (veh/h)	0	398	105	128	45	0	0	0	0	236	0	120
Initial Q (Qb), veh	0	0	0	0	0	0				0	0	0
Ped-Bike Adj(A_pbT)	1.00		1.00	1.00		1.00				1.00		1.00
Parking Bus, Adj	1.00	1.00	1.00	1.00	1.00	1.00				1.00	1.00	1.00
Work Zone On Approach		No			No						No	
Adj Sat Flow, veh/h/ln	0	1856	1767	1826	1500	0				1885	1870	1796
Adj Flow Rate, veh/h	0	442	0	142	50	0				262	0	0
Peak Hour Factor	0.90	0.90	0.90	0.90	0.90	0.90				0.90	0.90	0.90
Percent Heavy Veh, %	0	3	9	5	27	0				1	2	7
Cap, veh/h	0	1980		635	1015	0				318	0	
Arrive On Green	0.00	0.56	0.00	0.05	0.68	0.00				0.18	0.00	0.00
Sat Flow, veh/h	0	3618	1497	1739	1500	0				1781	0	1522
Grp Volume(v), veh/h	0	442	0	142	50	0				262	0	0
Grp Sat Flow(s),veh/h/ln	0	1763	1497	1739	1500	0				1781	0	1522
Q Serve(g_s), s	0.0	5.7	0.0	2.9	1.0	0.0				12.7	0.0	0.0
Cycle Q Clear(g_c), s	0.0	5.7	0.0	2.9	1.0	0.0				12.7	0.0	0.0
Prop In Lane	0.00		1.00	1.00		0.00				1.00		1.00
Lane Grp Cap(c), veh/h	0	1980		635	1015	0				318	0	
V/C Ratio(X)	0.00	0.22		0.22	0.05	0.00				0.82	0.00	
Avail Cap(c_a), veh/h	0	1980		667	1015	0				762	0	
HCM Platoon Ratio	1.00	1.00	1.00	1.00	1.00	1.00				1.00	1.00	1.00
Upstream Filter(I)	0.00	1.00	0.00	1.00	1.00	0.00				1.00	0.00	0.00
Uniform Delay (d), s/veh	0.0	9.9	0.0	6.8	4.9	0.0				35.6	0.0	0.0
Incr Delay (d2), s/veh	0.0	0.3	0.0	0.2	0.1	0.0				5.3	0.0	0.0
Initial Q Delay(d3),s/veh	0.0	0.0	0.0	0.0	0.0	0.0				0.0	0.0	0.0
%ile BackOfQ(50%),veh/ln	0.0	2.1	0.0	0.9	0.3	0.0				5.7	0.0	0.0
Unsig. Movement Delay, s/veh												
LnGrp Delay(d),s/veh	0.0	10.1	0.0	7.0	5.0	0.0				40.9	0.0	0.0
LnGrp LOS	A	B		A	A	A				D	A	
Approach Vol, veh/h		442			192						262	
Approach Delay, s/veh		10.1			6.5						40.9	
Approach LOS		B			A						D	
Timer - Assigned Phs	1	2		4		6						
Phs Duration (G+Y+Rc), s	57.1			22.6		67.4						
Change Period (Y+Rc), s	5.5	6.5		6.5		6.5						
Max Green Setting (Gmax), s	6.5	26.5		38.5		38.5						
Max Q Clear Time (g_c+14), s	7.7			14.7		3.0						
Green Ext Time (p_c), s	0.1	2.7		1.4		0.2						

### Intersection Summary

HCM 6th Ctrl Delay	18.3
HCM 6th LOS	B

### Notes

Unsignalized Delay for [EBR, SBR] is excluded from calculations of the approach delay and intersection delay.

Intersection				
Intersection Delay, s/veh	5.8			
Intersection LOS	A			
Approach	EB	WB	NB	SB
Entry Lanes	1	1	1	1
Conflicting Circle Lanes	1	1	1	1
Adj Approach Flow, veh/h	21	126	449	82
Demand Flow Rate, veh/h	22	137	449	89
Vehicles Circulating, veh/h	186	3	167	101
Vehicles Exiting, veh/h	4	613	41	39
Ped Vol Crossing Leg, #/h	0	0	0	0
Ped Cap Adj	1.000	1.000	1.000	1.000
Approach Delay, s/veh	3.5	3.7	7.0	3.7
Approach LOS	A	A	A	A
Lane	Left	Left	Left	Left
Designated Moves	LTR	LTR	LTR	LTR
Assumed Moves	LTR	LTR	LTR	LTR
RT Channelized				
Lane Util	1.000	1.000	1.000	1.000
Follow-Up Headway, s	2.609	2.609	2.609	2.609
Critical Headway, s	4.976	4.976	4.976	4.976
Entry Flow, veh/h	22	137	449	89
Cap Entry Lane, veh/h	1141	1376	1164	1245
Entry HV Adj Factor	0.955	0.916	1.000	0.921
Flow Entry, veh/h	21	125	449	82
Cap Entry, veh/h	1090	1260	1164	1147
V/C Ratio	0.019	0.100	0.386	0.071
Control Delay, s/veh	3.5	3.7	7.0	3.7
LOS	A	A	A	A
95th %tile Queue, veh	0	0	2	0

Intersection												
Int Delay, s/veh	0.5											
Movement	EBL	EBT	EBR	WBL	WBT	WBR	NBL	NBT	NBR	SBL	SBT	SBR
Lane Configurations		↕		↕	↕			↕			↕	
Traffic Vol, veh/h	0	217	0	1	25	0	0	0	12	0	0	0
Future Vol, veh/h	0	217	0	1	25	0	0	0	12	0	0	0
Conflicting Peds, #/hr	0	0	0	0	0	0	0	0	0	0	0	0
Sign Control	Free	Free	Free	Free	Free	Free	Stop	Stop	Stop	Stop	Stop	Stop
RT Channelized	-	-	None	-	-	None	-	-	None	-	-	None
Storage Length	-	-	-	300	-	-	-	-	-	-	-	-
Veh in Median Storage, #	-	0	-	-	0	-	-	0	-	-	0	-
Grade, %	-	0	-	-	0	-	-	0	-	-	0	-
Peak Hour Factor	91	91	91	91	91	91	91	91	91	91	91	91
Heavy Vehicles, %	2	0	2	0	12	2	2	2	0	2	2	2
Mvmt Flow	0	238	0	1	27	0	0	0	13	0	0	0

Major/Minor	Major1		Major2		Minor1			Minor2				
Conflicting Flow All	27	0	0	238	0	0	267	267	238	274	267	27
Stage 1	-	-	-	-	-	-	238	238	-	29	29	-
Stage 2	-	-	-	-	-	-	29	29	-	245	238	-
Critical Hdwy	4.12	-	-	4.1	-	-	7.12	6.52	6.2	7.12	6.52	6.22
Critical Hdwy Stg 1	-	-	-	-	-	-	6.12	5.52	-	6.12	5.52	-
Critical Hdwy Stg 2	-	-	-	-	-	-	6.12	5.52	-	6.12	5.52	-
Follow-up Hdwy	2.218	-	-	2.2	-	-	3.518	4.018	3.3	3.518	4.018	3.318
Pot Cap-1 Maneuver	1587	-	-	1341	-	-	686	639	806	678	639	1048
Stage 1	-	-	-	-	-	-	765	708	-	988	871	-
Stage 2	-	-	-	-	-	-	988	871	-	759	708	-
Platoon blocked, %	-	-	-	-	-	-	-	-	-	-	-	-
Mov Cap-1 Maneuver	1587	-	-	1341	-	-	685	638	806	666	638	1048
Mov Cap-2 Maneuver	-	-	-	-	-	-	685	638	-	666	638	-
Stage 1	-	-	-	-	-	-	765	708	-	988	870	-
Stage 2	-	-	-	-	-	-	987	870	-	747	708	-

Approach	EB		WB		NB		SB	
HCM Control Delay, s	0		0.3		9.5		0	
HCM LOS					A		A	

Minor Lane/Major Mvmt	NBLn1	EBL	EBT	EBR	WBL	WBT	WBR	SBLn1
Capacity (veh/h)	806	1587	-	-	1341	-	-	-
HCM Lane V/C Ratio	0.016	-	-	-	0.001	-	-	-
HCM Control Delay (s)	9.5	0	-	-	7.7	-	-	0
HCM Lane LOS	A	A	-	-	A	-	-	A
HCM 95th %tile Q(veh)	0.1	0	-	-	0	-	-	-

HCM 6th TWSC  
 18: Charter Oak Ranch Rd & Essayons Rd

07/17/2023

Intersection						
Int Delay, s/veh	0.2					
Movement	EBT	EBR	WBL	WBT	NBL	NBR
Lane Configurations						
Traffic Vol, veh/h	206	0	6	18	0	6
Future Vol, veh/h	206	0	6	18	0	6
Conflicting Peds, #/hr	0	0	0	0	0	0
Sign Control	Free	Free	Free	Free	Stop	Stop
RT Channelized	-	None	-	None	-	Free
Storage Length	-	-	350	-	0	0
Veh in Median Storage, #	0	-	-	0	0	-
Grade, %	0	-	-	0	0	-
Peak Hour Factor	94	94	94	94	94	94
Heavy Vehicles, %	0	2	33	6	2	17
Mvmt Flow	219	0	6	19	0	6

Major/Minor	Major1	Major2	Minor1		
Conflicting Flow All	0	0	219	0	250
Stage 1	-	-	-	-	219
Stage 2	-	-	-	-	31
Critical Hdwy	-	-	4.43	-	6.42
Critical Hdwy Stg 1	-	-	-	-	5.42
Critical Hdwy Stg 2	-	-	-	-	5.42
Follow-up Hdwy	-	-	2.497	-	3.518
Pot Cap-1 Maneuver	-	-	1187	-	739
Stage 1	-	-	-	-	817
Stage 2	-	-	-	-	992
Platoon blocked, %	-	-	-	-	-
Mov Cap-1 Maneuver	-	-	1187	-	735
Mov Cap-2 Maneuver	-	-	-	-	735
Stage 1	-	-	-	-	817
Stage 2	-	-	-	-	987

Approach	EB	WB	NB
HCM Control Delay, s	0	2	0
HCM LOS			A

Minor Lane/Major Mvmt	NBLn1	NBLn2	EBT	EBR	WBL	WBT
Capacity (veh/h)	-	-	-	-	1187	-
HCM Lane V/C Ratio	-	-	-	-	0.005	-
HCM Control Delay (s)	0	0	-	-	8	-
HCM Lane LOS	A	A	-	-	A	-
HCM 95th %tile Q(veh)	-	-	-	-	0	-

## Appendix D: Background Traffic Synchro Analysis Reports

HCM 6th Signalized Intersection Summary  
3: I-25 NB Ramps & US 85

2035 Background  
AM Peak Hour



Movement	EBL	EBT	EBR	WBL	WBT	WBR	NBL	NBT	NBR	SBL	SBT	SBR
Lane Configurations	↖	↑			↑↑	↗		↖	↗			
Traffic Volume (veh/h)	39	255	0	0	350	402	39	1	320	0	0	0
Future Volume (veh/h)	39	255	0	0	350	402	39	1	320	0	0	0
Initial Q (Qb), veh	0	0	0	0	0	0	0	0	0			
Ped-Bike Adj(A_pbT)	1.00		1.00	1.00		1.00	1.00		1.00			
Parking Bus, Adj	1.00	1.00	1.00	1.00	1.00	1.00	1.00	1.00	1.00			
Work Zone On Approach		No			No			No				
Adj Sat Flow, veh/h/ln	996	1752	0	0	1826	1885	1767	1900	1826			
Adj Flow Rate, veh/h	46	300	0	0	412	0	46	1	0			
Peak Hour Factor	0.85	0.85	0.85	0.85	0.85	0.85	0.85	0.85	0.85			
Percent Heavy Veh, %	61	10	0	0	5	1	9	0	5			
Cap, veh/h	463	1396	0	0	2388		72	2				
Arrive On Green	0.03	0.53	0.00	0.00	0.69	0.00	0.04	0.04	0.00			
Sat Flow, veh/h	949	1752	0	0	3561	1598	1773	39	1547			
Grp Volume(v), veh/h	46	300	0	0	412	0	47	0	0			
Grp Sat Flow(s),veh/h/ln	949	1752	0	0	1735	1598	1811	0	1547			
Q Serve(g_s), s	1.0	7.2	0.0	0.0	3.4	0.0	2.0	0.0	0.0			
Cycle Q Clear(g_c), s	1.0	7.2	0.0	0.0	3.4	0.0	2.0	0.0	0.0			
Prop In Lane	1.00		0.00	0.00		1.00	0.98		1.00			
Lane Grp Cap(c), veh/h	463	1396	0	0	2388		73	0				
V/C Ratio(X)	0.10	0.21	0.00	0.00	0.17		0.64	0.00				
Avail Cap(c_a), veh/h	538	1396	0	0	2388		419	0				
HCM Platoon Ratio	0.67	0.67	1.00	1.00	1.00	1.00	1.00	1.00	1.00			
Upstream Filter(I)	1.00	1.00	0.00	0.00	1.00	0.00	1.00	0.00	0.00			
Uniform Delay (d), s/veh	2.8	5.5	0.0	0.0	4.4	0.0	37.8	0.0	0.0			
Incr Delay (d2), s/veh	0.1	0.4	0.0	0.0	0.2	0.0	9.0	0.0	0.0			
Initial Q Delay(d3),s/veh	0.0	0.0	0.0	0.0	0.0	0.0	0.0	0.0	0.0			
%ile BackOfQ(50%),veh/ln	0.1	1.7	0.0	0.0	0.9	0.0	1.0	0.0	0.0			
Unsig. Movement Delay, s/veh												
LnGrp Delay(d),s/veh	2.9	5.8	0.0	0.0	4.6	0.0	46.8	0.0	0.0			
LnGrp LOS	A	A	A	A	A		D	A				
Approach Vol, veh/h		346			412			47				
Approach Delay, s/veh		5.4			4.6			46.8				
Approach LOS		A			A			D				
Timer - Assigned Phs		2			5	6		8				
Phs Duration (G+Y+Rc), s		70.3			8.7	61.6		9.7				
Change Period (Y+Rc), s		6.5			5.5	6.5		6.5				
Max Green Setting (Gmax), s		48.5			9.5	33.5		18.5				
Max Q Clear Time (g_c+I1), s		9.2			3.0	5.4		4.0				
Green Ext Time (p_c), s		1.9			0.0	2.8		0.1				

Intersection Summary

HCM 6th Ctrl Delay	7.4
HCM 6th LOS	A

Notes

Unsignalized Delay for [NBR, WBR] is excluded from calculations of the approach delay and intersection delay.



HCM 6th Signalized Intersection Summary  
6: I-25 SB Ramps & US 85

2035 Background  
AM Peak Hour



Movement	EBL	EBT	EBR	WBL	WBT	WBR	NBL	NBT	NBR	SBL	SBT	SBR
Lane Configurations		↑↑	↗	↘	↑						↖	↗
Traffic Volume (veh/h)	0	121	27	145	244	0	0	0	0	173	2	145
Future Volume (veh/h)	0	121	27	145	244	0	0	0	0	173	2	145
Initial Q (Qb), veh	0	0	0	0	0	0				0	0	0
Ped-Bike Adj(A_pbT)	1.00		1.00	1.00		1.00				1.00		1.00
Parking Bus, Adj	1.00	1.00	1.00	1.00	1.00	1.00				1.00	1.00	1.00
Work Zone On Approach		No			No						No	
Adj Sat Flow, veh/h/ln	0	1411	1500	1781	1826	0				1796	1159	1663
Adj Flow Rate, veh/h	0	142	0	171	287	0				204	2	0
Peak Hour Factor	0.85	0.85	0.85	0.85	0.85	0.85				0.85	0.85	0.85
Percent Heavy Veh, %	0	33	27	8	5	0				7	50	16
Cap, veh/h	0	1295		749	1137	0				235	2	
Arrive On Green	0.00	0.48	0.00	0.07	0.62	0.00				0.21	0.21	0.00
Sat Flow, veh/h	0	2751	1271	1697	1826	0				1094	11	1409
Grp Volume(v), veh/h	0	142	0	171	287	0				206	0	0
Grp Sat Flow(s),veh/h/ln	0	1340	1271	1697	1826	0				1104	0	1409
Q Serve(g_s), s	0.0	2.3	0.0	3.8	5.6	0.0				14.4	0.0	0.0
Cycle Q Clear(g_c), s	0.0	2.3	0.0	3.8	5.6	0.0				14.4	0.0	0.0
Prop In Lane	0.00		1.00	1.00		0.00				0.99		1.00
Lane Grp Cap(c), veh/h	0	1295		749	1137	0				237	0	
V/C Ratio(X)	0.00	0.11		0.23	0.25	0.00				0.87	0.00	
Avail Cap(c_a), veh/h	0	1295		767	1137	0				462	0	
HCM Platoon Ratio	1.00	1.00	1.00	1.00	1.00	1.00				1.00	1.00	1.00
Upstream Filter(I)	0.00	1.00	0.00	0.99	0.99	0.00				1.00	0.00	0.00
Uniform Delay (d), s/veh	0.0	11.3	0.0	8.0	6.8	0.0				30.3	0.0	0.0
Incr Delay (d2), s/veh	0.0	0.2	0.0	0.2	0.5	0.0				9.3	0.0	0.0
Initial Q Delay(d3),s/veh	0.0	0.0	0.0	0.0	0.0	0.0				0.0	0.0	0.0
%ile BackOfQ(50%),veh/ln	0.0	0.7	0.0	1.2	2.0	0.0				4.1	0.0	0.0
Unsig. Movement Delay, s/veh												
LnGrp Delay(d),s/veh	0.0	11.5	0.0	8.2	7.3	0.0				39.7	0.0	0.0
LnGrp LOS	A	B		A	A	A				D	A	
Approach Vol, veh/h		142			458						206	
Approach Delay, s/veh		11.5			7.6						39.7	
Approach LOS		B			A						D	
Timer - Assigned Phs	1	2		4		6						
Phs Duration (G+Y+Rc), s	1.2	45.1		23.7		56.3						
Change Period (Y+Rc), s	5.5	6.5		6.5		6.5						
Max Green Setting (Gmax), s	6.5	21.5		33.5		33.5						
Max Q Clear Time (g_c+1/5), s	1.5	4.3		16.4		7.6						
Green Ext Time (p_c), s	0.0	0.7		1.0		1.6						

Intersection Summary

HCM 6th Ctrl Delay	16.5
HCM 6th LOS	B

Notes

Unsignalized Delay for [EBR, SBR] is excluded from calculations of the approach delay and intersection delay.

Intersection				
Intersection Delay, s/veh	5.1			
Intersection LOS	A			
Approach	EB	WB	NB	SB
Entry Lanes	1	1	1	1
Conflicting Circle Lanes	1	1	1	1
Adj Approach Flow, veh/h	19	382	98	82
Demand Flow Rate, veh/h	26	400	105	89
Vehicles Circulating, veh/h	379	18	100	315
Vehicles Exiting, veh/h	25	187	305	103
Ped Vol Crossing Leg, #/h	0	0	0	0
Ped Cap Adj	1.000	1.000	1.000	1.000
Approach Delay, s/veh	5.5	5.4	3.8	4.7
Approach LOS	A	A	A	A
Lane	Left	Left	Left	Left
Designated Moves	LTR	LTR	LTR	LTR
Assumed Moves	LTR	LTR	LTR	LTR
RT Channelized				
Lane Util	1.000	1.000	1.000	1.000
Follow-Up Headway, s	2.609	2.609	2.609	2.609
Critical Headway, s	4.976	4.976	4.976	4.976
Entry Flow, veh/h	26	400	105	89
Cap Entry Lane, veh/h	937	1355	1246	1001
Entry HV Adj Factor	0.731	0.955	0.932	0.920
Flow Entry, veh/h	19	382	98	82
Cap Entry, veh/h	685	1293	1162	921
V/C Ratio	0.028	0.295	0.084	0.089
Control Delay, s/veh	5.5	5.4	3.8	4.7
LOS	A	A	A	A
95th %tile Queue, veh	0	1	0	0

Intersection												
Int Delay, s/veh	1											
Movement	EBL	EBT	EBR	WBL	WBT	WBR	NBL	NBT	NBR	SBL	SBT	SBR
Lane Configurations		↕		↕	↕			↕			↕	
Traffic Vol, veh/h	0	71	0	25	184	1	1	0	8	0	0	1
Future Vol, veh/h	0	71	0	25	184	1	1	0	8	0	0	1
Conflicting Peds, #/hr	0	0	0	0	0	0	0	0	0	0	0	0
Sign Control	Free	Free	Free	Free	Free	Free	Stop	Stop	Stop	Stop	Stop	Stop
RT Channelized	-	-	None	-	-	None	-	-	None	-	-	None
Storage Length	-	-	-	300	-	-	-	-	-	-	-	-
Veh in Median Storage, #	-	0	-	-	0	-	-	0	-	-	0	-
Grade, %	-	0	-	-	0	-	-	0	-	-	0	-
Peak Hour Factor	85	85	85	85	85	85	85	85	85	85	85	85
Heavy Vehicles, %	2	5	2	9	3	0	100	2	57	2	2	0
Mvmt Flow	0	84	0	29	216	1	1	0	9	0	0	1

Major/Minor	Major1			Major2			Minor1			Minor2		
Conflicting Flow All	217	0	0	84	0	0	359	359	84	364	359	217
Stage 1	-	-	-	-	-	-	84	84	-	275	275	-
Stage 2	-	-	-	-	-	-	275	275	-	89	84	-
Critical Hdwy	4.12	-	-	4.19	-	-	8.1	6.52	6.77	7.12	6.52	6.2
Critical Hdwy Stg 1	-	-	-	-	-	-	7.1	5.52	-	6.12	5.52	-
Critical Hdwy Stg 2	-	-	-	-	-	-	7.1	5.52	-	6.12	5.52	-
Follow-up Hdwy	2.218	-	-	2.281	-	-	4.4	4.018	3.813	3.518	4.018	3.3
Pot Cap-1 Maneuver	1353	-	-	1470	-	-	451	568	843	592	568	828
Stage 1	-	-	-	-	-	-	729	825	-	731	683	-
Stage 2	-	-	-	-	-	-	560	683	-	918	825	-
Platoon blocked, %	-	-	-	-	-	-	-	-	-	-	-	-
Mov Cap-1 Maneuver	1353	-	-	1470	-	-	444	557	843	577	557	828
Mov Cap-2 Maneuver	-	-	-	-	-	-	444	557	-	577	557	-
Stage 1	-	-	-	-	-	-	729	825	-	731	669	-
Stage 2	-	-	-	-	-	-	548	669	-	908	825	-

Approach	EB			WB			NB			SB		
HCM Control Delay, s	0			0.9			9.8			9.4		
HCM LOS							A			A		

Minor Lane/Major Mvmt	NBLn1	EBL	EBT	EBR	WBL	WBT	WBR	SBLn1
Capacity (veh/h)	766	1353	-	-	1470	-	-	828
HCM Lane V/C Ratio	0.014	-	-	-	0.02	-	-	0.001
HCM Control Delay (s)	9.8	0	-	-	7.5	-	-	9.4
HCM Lane LOS	A	A	-	-	A	-	-	A
HCM 95th %tile Q(veh)	0	0	-	-	0.1	-	-	0

HCM 6th Signalized Intersection Summary  
3: I-25 NB Ramps & US 85

2040 Background  
AM Peak Hour

Movement	EBL	EBT	EBR	WBL	WBT	WBR	NBL	NBT	NBR	SBL	SBT	SBR
Lane Configurations												
Traffic Volume (veh/h)	44	287	0	0	404	427	45	1	340	0	0	0
Future Volume (veh/h)	44	287	0	0	404	427	45	1	340	0	0	0
Initial Q (Qb), veh	0	0	0	0	0	0	0	0	0			
Ped-Bike Adj(A_pbT)	1.00		1.00	1.00		1.00	1.00		1.00			
Parking Bus, Adj	1.00	1.00	1.00	1.00	1.00	1.00	1.00	1.00	1.00			
Work Zone On Approach		No			No			No				
Adj Sat Flow, veh/h/ln	996	1752	0	0	1826	1885	1767	1900	1826			
Adj Flow Rate, veh/h	48	312	0	0	439	0	49	1	0			
Peak Hour Factor	0.92	0.92	0.92	0.92	0.92	0.92	0.92	0.92	0.92			
Percent Heavy Veh, %	61	10	0	0	5	1	9	0	5			
Cap, veh/h	453	1394	0	0	2379		74	2				
Arrive On Green	0.03	0.53	0.00	0.00	0.69	0.00	0.04	0.04	0.00			
Sat Flow, veh/h	949	1752	0	0	3561	1598	1775	36	1547			
Grp Volume(v), veh/h	48	312	0	0	439	0	50	0	0			
Grp Sat Flow(s),veh/h/ln	949	1752	0	0	1735	1598	1811	0	1547			
Q Serve(g_s), s	1.1	7.6	0.0	0.0	3.6	0.0	2.2	0.0	0.0			
Cycle Q Clear(g_c), s	1.1	7.6	0.0	0.0	3.6	0.0	2.2	0.0	0.0			
Prop In Lane	1.00		0.00	0.00		1.00	0.98		1.00			
Lane Grp Cap(c), veh/h	453	1394	0	0	2379		76	0				
V/C Ratio(X)	0.11	0.22	0.00	0.00	0.18		0.66	0.00				
Avail Cap(c_a), veh/h	527	1394	0	0	2379		419	0				
HCM Platoon Ratio	0.67	0.67	1.00	1.00	1.00	1.00	1.00	1.00	1.00			
Upstream Filter(I)	1.00	1.00	0.00	0.00	1.00	0.00	1.00	0.00	0.00			
Uniform Delay (d), s/veh	2.9	5.6	0.0	0.0	4.5	0.0	37.8	0.0	0.0			
Incr Delay (d2), s/veh	0.1	0.4	0.0	0.0	0.2	0.0	9.3	0.0	0.0			
Initial Q Delay(d3),s/veh	0.0	0.0	0.0	0.0	0.0	0.0	0.0	0.0	0.0			
%ile BackOfQ(50%),veh/ln	0.1	1.9	0.0	0.0	1.0	0.0	1.1	0.0	0.0			
Unsig. Movement Delay, s/veh												
LnGrp Delay(d),s/veh	3.0	6.0	0.0	0.0	4.7	0.0	47.1	0.0	0.0			
LnGrp LOS	A	A	A	A	A		D	A				
Approach Vol, veh/h		360			439			50				
Approach Delay, s/veh		5.6			4.7			47.1				
Approach LOS		A			A			D				
Timer - Assigned Phs		2			5	6		8				
Phs Duration (G+Y+Rc), s		70.1			8.8	61.4		9.9				
Change Period (Y+Rc), s		6.5			5.5	6.5		6.5				
Max Green Setting (Gmax), s		48.5			9.5	33.5		18.5				
Max Q Clear Time (g_c+I1), s		9.6			3.1	5.6		4.2				
Green Ext Time (p_c), s		2.0			0.0	3.0		0.1				

Intersection Summary

HCM 6th Ctrl Delay	7.6
HCM 6th LOS	A

Notes

Unsignalized Delay for [NBR, WBR] is excluded from calculations of the approach delay and intersection delay.

HCM 6th Signalized Intersection Summary  
6: I-25 SB Ramps & US 85

2040 Background  
AM Peak Hour



Movement	EBL	EBT	EBR	WBL	WBT	WBR	NBL	NBT	NBR	SBL	SBT	SBR
Lane Configurations		↑↑	↗	↖	↑						↖	↗
Traffic Volume (veh/h)	0	147	33	154	296	0	0	0	0	184	2	176
Future Volume (veh/h)	0	147	33	154	296	0	0	0	0	184	2	176
Initial Q (Qb), veh	0	0	0	0	0	0				0	0	0
Ped-Bike Adj(A_pbT)	1.00		1.00	1.00		1.00				1.00		1.00
Parking Bus, Adj	1.00	1.00	1.00	1.00	1.00	1.00				1.00	1.00	1.00
Work Zone On Approach		No			No						No	
Adj Sat Flow, veh/h/ln	0	1411	1500	1781	1826	0				1796	1159	1663
Adj Flow Rate, veh/h	0	160	0	167	322	0				200	2	0
Peak Hour Factor	0.92	0.92	0.92	0.92	0.92	0.92				0.92	0.92	0.92
Percent Heavy Veh, %	0	33	27	8	5	0				7	50	16
Cap, veh/h	0	1309		740	1144	0				231	2	
Arrive On Green	0.00	0.49	0.00	0.07	0.63	0.00				0.21	0.21	0.00
Sat Flow, veh/h	0	2751	1271	1697	1826	0				1093	11	1409
Grp Volume(v), veh/h	0	160	0	167	322	0				202	0	0
Grp Sat Flow(s),veh/h/ln	0	1340	1271	1697	1826	0				1104	0	1409
Q Serve(g_s), s	0.0	2.6	0.0	3.6	6.4	0.0				14.1	0.0	0.0
Cycle Q Clear(g_c), s	0.0	2.6	0.0	3.6	6.4	0.0				14.1	0.0	0.0
Prop In Lane	0.00		1.00	1.00		0.00				0.99		1.00
Lane Grp Cap(c), veh/h	0	1309		740	1144	0				233	0	
V/C Ratio(X)	0.00	0.12		0.23	0.28	0.00				0.87	0.00	
Avail Cap(c_a), veh/h	0	1309		760	1144	0				462	0	
HCM Platoon Ratio	1.00	1.00	1.00	1.00	1.00	1.00				1.00	1.00	1.00
Upstream Filter(I)	0.00	1.00	0.00	0.99	0.99	0.00				1.00	0.00	0.00
Uniform Delay (d), s/veh	0.0	11.1	0.0	7.9	6.8	0.0				30.5	0.0	0.0
Incr Delay (d2), s/veh	0.0	0.2	0.0	0.2	0.6	0.0				9.4	0.0	0.0
Initial Q Delay(d3),s/veh	0.0	0.0	0.0	0.0	0.0	0.0				0.0	0.0	0.0
%ile BackOfQ(50%),veh/ln	0.0	0.7	0.0	1.2	2.2	0.0				4.1	0.0	0.0
Unsig. Movement Delay, s/veh												
LnGrp Delay(d),s/veh	0.0	11.3	0.0	8.0	7.4	0.0				39.9	0.0	0.0
LnGrp LOS		A	B	A	A	A				D	A	
Approach Vol, veh/h		160			489						202	
Approach Delay, s/veh		11.3			7.6						39.9	
Approach LOS		B			A						D	
Timer - Assigned Phs	1	2		4		6						
Phs Duration (G+Y+Rc), s	1.0	45.6		23.4		56.6						
Change Period (Y+Rc), s	5.5	6.5		6.5		6.5						
Max Green Setting (Gmax), s	6.5	21.5		33.5		33.5						
Max Q Clear Time (g_c+1/5), s	6.5	4.6		16.1		8.4						
Green Ext Time (p_c), s	0.0	0.8		0.9		1.9						

Intersection Summary

HCM 6th Ctrl Delay	16.0
HCM 6th LOS	B

Notes

Unsignalized Delay for [EBR, SBR] is excluded from calculations of the approach delay and intersection delay.

Intersection				
Intersection Delay, s/veh	5.4			
Intersection LOS	A			
Approach	EB	WB	NB	SB
Entry Lanes	1	1	1	1
Conflicting Circle Lanes	1	1	1	1
Adj Approach Flow, veh/h	17	439	119	80
Demand Flow Rate, veh/h	24	460	128	87
Vehicles Circulating, veh/h	438	15	98	375
Vehicles Exiting, veh/h	24	211	364	100
Ped Vol Crossing Leg, #/h	0	0	0	0
Ped Cap Adj	1.000	1.000	1.000	1.000
Approach Delay, s/veh	6.1	5.9	4.0	5.0
Approach LOS	A	A	A	A
Lane	Left	Left	Left	Left
Designated Moves	LTR	LTR	LTR	LTR
Assumed Moves	LTR	LTR	LTR	LTR
RT Channelized				
Lane Util	1.000	1.000	1.000	1.000
Follow-Up Headway, s	2.609	2.609	2.609	2.609
Critical Headway, s	4.976	4.976	4.976	4.976
Entry Flow, veh/h	24	460	128	87
Cap Entry Lane, veh/h	883	1359	1249	941
Entry HV Adj Factor	0.708	0.954	0.929	0.918
Flow Entry, veh/h	17	439	119	80
Cap Entry, veh/h	625	1296	1160	865
V/C Ratio	0.027	0.339	0.103	0.092
Control Delay, s/veh	6.1	5.9	4.0	5.0
LOS	A	A	A	A
95th %tile Queue, veh	0	2	0	0



Intersection												
Int Delay, s/veh	0.8											
Movement	EBL	EBT	EBR	WBL	WBT	WBR	NBL	NBT	NBR	SBL	SBT	SBR
Lane Configurations		↕		↕	↕			↕			↕	
Traffic Vol, veh/h	0	98	0	27	253	1	1	0	8	0	0	1
Future Vol, veh/h	0	98	0	27	253	1	1	0	8	0	0	1
Conflicting Peds, #/hr	0	0	0	0	0	0	0	0	0	0	0	0
Sign Control	Free	Free	Free	Free	Free	Free	Stop	Stop	Stop	Stop	Stop	Stop
RT Channelized	-	-	None	-	-	None	-	-	None	-	-	None
Storage Length	-	-	-	300	-	-	-	-	-	-	-	-
Veh in Median Storage, #	-	0	-	-	0	-	-	0	-	-	0	-
Grade, %	-	0	-	-	0	-	-	0	-	-	0	-
Peak Hour Factor	92	92	92	92	92	92	92	92	92	92	92	92
Heavy Vehicles, %	2	5	2	9	3	0	100	2	57	2	2	0
Mvmt Flow	0	107	0	29	275	1	1	0	9	0	0	1

Major/Minor	Major1			Major2			Minor1			Minor2		
Conflicting Flow All	276	0	0	107	0	0	441	441	107	446	441	276
Stage 1	-	-	-	-	-	-	107	107	-	334	334	-
Stage 2	-	-	-	-	-	-	334	334	-	112	107	-
Critical Hdwy	4.12	-	-	4.19	-	-	8.1	6.52	6.77	7.12	6.52	6.2
Critical Hdwy Stg 1	-	-	-	-	-	-	7.1	5.52	-	6.12	5.52	-
Critical Hdwy Stg 2	-	-	-	-	-	-	7.1	5.52	-	6.12	5.52	-
Follow-up Hdwy	2.218	-	-	2.281	-	-	4.4	4.018	3.813	3.518	4.018	3.3
Pot Cap-1 Maneuver	1287	-	-	1441	-	-	392	510	817	523	510	768
Stage 1	-	-	-	-	-	-	707	807	-	680	643	-
Stage 2	-	-	-	-	-	-	516	643	-	893	807	-
Platoon blocked, %	-	-	-	-	-	-	-	-	-	-	-	-
Mov Cap-1 Maneuver	1287	-	-	1441	-	-	385	500	817	509	500	768
Mov Cap-2 Maneuver	-	-	-	-	-	-	385	500	-	509	500	-
Stage 1	-	-	-	-	-	-	707	807	-	680	630	-
Stage 2	-	-	-	-	-	-	505	630	-	883	807	-

Approach	EB			WB			NB			SB		
HCM Control Delay, s	0			0.7			10			9.7		
HCM LOS							B			A		

Minor Lane/Major Mvmt	NBLn1	EBL	EBT	EBR	WBL	WBT	WBR	SBLn1
Capacity (veh/h)	726	1287	-	-	1441	-	-	768
HCM Lane V/C Ratio	0.013	-	-	-	0.02	-	-	0.001
HCM Control Delay (s)	10	0	-	-	7.5	-	-	9.7
HCM Lane LOS	B	A	-	-	A	-	-	A
HCM 95th %tile Q(veh)	0	0	-	-	0.1	-	-	0

HCM 6th Signalized Intersection Summary  
3: I-25 NB Ramps & US 85

2045 Background  
AM Peak Hour



Movement	EBL	EBT	EBR	WBL	WBT	WBR	NBL	NBT	NBR	SBL	SBT	SBR
Lane Configurations	↖	↗			↖	↗		↖	↗			
Traffic Volume (veh/h)	42	272	0	0	370	452	41	1	360	0	0	0
Future Volume (veh/h)	42	272	0	0	370	452	41	1	360	0	0	0
Initial Q (Qb), veh	0	0	0	0	0	0	0	0	0			
Ped-Bike Adj(A_pbT)	1.00		1.00	1.00		1.00	1.00		1.00			
Parking Bus, Adj	1.00	1.00	1.00	1.00	1.00	1.00	1.00	1.00	1.00			
Work Zone On Approach		No			No			No				
Adj Sat Flow, veh/h/ln	996	1752	0	0	1826	1885	1767	1900	1826			
Adj Flow Rate, veh/h	44	286	0	0	389	0	43	1	0			
Peak Hour Factor	0.95	0.95	0.95	0.95	0.95	0.95	0.95	0.95	0.95			
Percent Heavy Veh, %	61	10	0	0	5	1	9	0	5			
Cap, veh/h	472	1399	0	0	2396		69	2				
Arrive On Green	0.03	0.54	0.00	0.00	0.69	0.00	0.04	0.04	0.00			
Sat Flow, veh/h	949	1752	0	0	3561	1598	1770	41	1547			
Grp Volume(v), veh/h	44	286	0	0	389	0	44	0	0			
Grp Sat Flow(s),veh/h/ln	949	1752	0	0	1735	1598	1811	0	1547			
Q Serve(g_s), s	1.0	6.8	0.0	0.0	3.1	0.0	1.9	0.0	0.0			
Cycle Q Clear(g_c), s	1.0	6.8	0.0	0.0	3.1	0.0	1.9	0.0	0.0			
Prop In Lane	1.00		0.00	0.00		1.00	0.98		1.00			
Lane Grp Cap(c), veh/h	472	1399	0	0	2396		71	0				
V/C Ratio(X)	0.09	0.20	0.00	0.00	0.16		0.62	0.00				
Avail Cap(c_a), veh/h	548	1399	0	0	2396		419	0				
HCM Platoon Ratio	0.67	0.67	1.00	1.00	1.00	1.00	1.00	1.00	1.00			
Upstream Filter(I)	1.00	1.00	0.00	0.00	1.00	0.00	1.00	0.00	0.00			
Uniform Delay (d), s/veh	2.7	5.3	0.0	0.0	4.3	0.0	37.9	0.0	0.0			
Incr Delay (d2), s/veh	0.1	0.3	0.0	0.0	0.1	0.0	8.7	0.0	0.0			
Initial Q Delay(d3),s/veh	0.0	0.0	0.0	0.0	0.0	0.0	0.0	0.0	0.0			
%ile BackOfQ(50%),veh/ln	0.1	1.6	0.0	0.0	0.9	0.0	1.0	0.0	0.0			
Unsig. Movement Delay, s/veh												
LnGrp Delay(d),s/veh	2.8	5.7	0.0	0.0	4.5	0.0	46.5	0.0	0.0			
LnGrp LOS	A	A	A	A	A		D	A				
Approach Vol, veh/h		330			389			44				
Approach Delay, s/veh		5.3			4.5			46.5				
Approach LOS		A			A			D				
Timer - Assigned Phs		2			5	6		8				
Phs Duration (G+Y+Rc), s		70.4			8.6	61.8		9.6				
Change Period (Y+Rc), s		6.5			5.5	6.5		6.5				
Max Green Setting (Gmax), s		48.5			9.5	33.5		18.5				
Max Q Clear Time (g_c+I1), s		8.8			3.0	5.1		3.9				
Green Ext Time (p_c), s		1.8			0.0	2.6		0.1				

Intersection Summary

HCM 6th Ctrl Delay	7.2
HCM 6th LOS	A

Notes

Unsignalized Delay for [NBR, WBR] is excluded from calculations of the approach delay and intersection delay.

HCM 6th Signalized Intersection Summary  
6: I-25 SB Ramps & US 85

2045 Background  
AM Peak Hour



Movement	EBL	EBT	EBR	WBL	WBT	WBR	NBL	NBT	NBR	SBL	SBT	SBR
Lane Configurations		↑↑	↗	↖	↑						↙	↘
Traffic Volume (veh/h)	0	119	27	163	249	0	0	0	0	195	3	148
Future Volume (veh/h)	0	119	27	163	249	0	0	0	0	195	3	148
Initial Q (Qb), veh	0	0	0	0	0	0				0	0	0
Ped-Bike Adj(A_pbT)	1.00		1.00	1.00		1.00				1.00		1.00
Parking Bus, Adj	1.00	1.00	1.00	1.00	1.00	1.00				1.00	1.00	1.00
Work Zone On Approach		No			No						No	
Adj Sat Flow, veh/h/ln	0	1411	1500	1781	1826	0				1796	1159	1663
Adj Flow Rate, veh/h	0	125	0	172	262	0				205	3	0
Peak Hour Factor	0.95	0.95	0.95	0.95	0.95	0.95				0.95	0.95	0.95
Percent Heavy Veh, %	0	33	27	8	5	0				7	50	16
Cap, veh/h	0	1288		760	1134	0				236	3	
Arrive On Green	0.00	0.48	0.00	0.07	0.62	0.00				0.22	0.22	0.00
Sat Flow, veh/h	0	2751	1271	1697	1826	0				1089	16	1409
Grp Volume(v), veh/h	0	125	0	172	262	0				208	0	0
Grp Sat Flow(s),veh/h/ln	0	1340	1271	1697	1826	0				1105	0	1409
Q Serve(g_s), s	0.0	2.0	0.0	3.8	5.1	0.0				14.5	0.0	0.0
Cycle Q Clear(g_c), s	0.0	2.0	0.0	3.8	5.1	0.0				14.5	0.0	0.0
Prop In Lane	0.00		1.00	1.00		0.00				0.99		1.00
Lane Grp Cap(c), veh/h	0	1288		760	1134	0				239	0	
V/C Ratio(X)	0.00	0.10		0.23	0.23	0.00				0.87	0.00	
Avail Cap(c_a), veh/h	0	1288		777	1134	0				463	0	
HCM Platoon Ratio	1.00	1.00	1.00	1.00	1.00	1.00				1.00	1.00	1.00
Upstream Filter(l)	0.00	1.00	0.00	0.99	0.99	0.00				1.00	0.00	0.00
Uniform Delay (d), s/veh	0.0	11.3	0.0	8.1	6.7	0.0				30.2	0.0	0.0
Incr Delay (d2), s/veh	0.0	0.2	0.0	0.1	0.5	0.0				9.3	0.0	0.0
Initial Q Delay(d3),s/veh	0.0	0.0	0.0	0.0	0.0	0.0				0.0	0.0	0.0
%ile BackOfQ(50%),veh/ln	0.0	0.6	0.0	1.2	1.8	0.0				4.2	0.0	0.0
Unsig. Movement Delay, s/veh												
LnGrp Delay(d),s/veh	0.0	11.5	0.0	8.2	7.2	0.0				39.6	0.0	0.0
LnGrp LOS	A	B		A	A	A				D	A	
Approach Vol, veh/h		125			434						208	
Approach Delay, s/veh		11.5			7.6						39.6	
Approach LOS		B			A						D	
Timer - Assigned Phs	1	2		4		6						
Phs Duration (G+Y+Rc), s	1.2	44.9		23.8		56.2						
Change Period (Y+Rc), s	5.5	6.5		6.5		6.5						
Max Green Setting (Gmax), s	6.5	21.5		33.5		33.5						
Max Q Clear Time (g_c+1/5), s	1.5	4.0		16.5		7.1						
Green Ext Time (p_c), s	0.0	0.6		1.0		1.5						

Intersection Summary

HCM 6th Ctrl Delay	16.9
HCM 6th LOS	B

Notes

Unsignalized Delay for [EBR, SBR] is excluded from calculations of the approach delay and intersection delay.

Intersection				
Intersection Delay, s/veh	4.8			
Intersection LOS	A			
Approach	EB	WB	NB	SB
Entry Lanes	1	1	1	1
Conflicting Circle Lanes	1	1	1	1
Adj Approach Flow, veh/h	16	348	81	82
Demand Flow Rate, veh/h	22	365	87	90
Vehicles Circulating, veh/h	343	15	97	279
Vehicles Exiting, veh/h	26	169	268	101
Ped Vol Crossing Leg, #/h	0	0	0	0
Ped Cap Adj	1.000	1.000	1.000	1.000
Approach Delay, s/veh	5.3	5.1	3.7	4.6
Approach LOS	A	A	A	A
Lane	Left	Left	Left	Left
Designated Moves	LTR	LTR	LTR	LTR
Assumed Moves	LTR	LTR	LTR	LTR
RT Channelized				
Lane Util	1.000	1.000	1.000	1.000
Follow-Up Headway, s	2.609	2.609	2.609	2.609
Critical Headway, s	4.976	4.976	4.976	4.976
Entry Flow, veh/h	22	365	87	90
Cap Entry Lane, veh/h	973	1359	1250	1038
Entry HV Adj Factor	0.727	0.953	0.930	0.910
Flow Entry, veh/h	16	348	81	82
Cap Entry, veh/h	707	1295	1162	945
V/C Ratio	0.023	0.269	0.070	0.087
Control Delay, s/veh	5.3	5.1	3.7	4.6
LOS	A	A	A	A
95th %tile Queue, veh	0	1	0	0

Intersection												
Int Delay, s/veh	1.1											
Movement	EBL	EBT	EBR	WBL	WBT	WBR	NBL	NBT	NBR	SBL	SBT	SBR
Lane Configurations		↕		↕	↕			↕			↕	
Traffic Vol, veh/h	0	64	0	28	171	1	1	0	9	0	0	1
Future Vol, veh/h	0	64	0	28	171	1	1	0	9	0	0	1
Conflicting Peds, #/hr	0	0	0	0	0	0	0	0	0	0	0	0
Sign Control	Free	Free	Free	Free	Free	Free	Stop	Stop	Stop	Stop	Stop	Stop
RT Channelized	-	-	None	-	-	None	-	-	None	-	-	None
Storage Length	-	-	-	300	-	-	-	-	-	-	-	-
Veh in Median Storage, #	-	0	-	-	0	-	-	0	-	-	0	-
Grade, %	-	0	-	-	0	-	-	0	-	-	0	-
Peak Hour Factor	95	95	95	95	95	95	95	95	95	95	95	95
Heavy Vehicles, %	2	5	2	9	3	0	100	2	57	2	2	0
Mvmt Flow	0	67	0	29	180	1	1	0	9	0	0	1

Major/Minor	Major1		Major2		Minor1		Minor2					
Conflicting Flow All	181	0	0	67	0	0	306	306	67	311	306	181
Stage 1	-	-	-	-	-	-	67	67	-	239	239	-
Stage 2	-	-	-	-	-	-	239	239	-	72	67	-
Critical Hdwy	4.12	-	-	4.19	-	-	8.1	6.52	6.77	7.12	6.52	6.2
Critical Hdwy Stg 1	-	-	-	-	-	-	7.1	5.52	-	6.12	5.52	-
Critical Hdwy Stg 2	-	-	-	-	-	-	7.1	5.52	-	6.12	5.52	-
Follow-up Hdwy	2.218	-	-	2.281	-	-	4.4	4.018	3.813	3.518	4.018	3.3
Pot Cap-1 Maneuver	1394	-	-	1491	-	-	493	608	862	642	608	867
Stage 1	-	-	-	-	-	-	747	839	-	764	708	-
Stage 2	-	-	-	-	-	-	589	708	-	938	839	-
Platoon blocked, %	-	-	-	-	-	-	-	-	-	-	-	-
Mov Cap-1 Maneuver	1394	-	-	1491	-	-	485	596	862	625	596	867
Mov Cap-2 Maneuver	-	-	-	-	-	-	485	596	-	625	596	-
Stage 1	-	-	-	-	-	-	747	839	-	764	695	-
Stage 2	-	-	-	-	-	-	577	695	-	928	839	-

Approach	EB	WB	NB	SB
HCM Control Delay, s	0	1	9.6	9.2
HCM LOS			A	A

Minor Lane/Major Mvmt	NBLn1	EBL	EBT	EBR	WBL	WBT	WBR	SBLn1
Capacity (veh/h)	800	1394	-	-	1491	-	-	867
HCM Lane V/C Ratio	0.013	-	-	-	0.02	-	-	0.001
HCM Control Delay (s)	9.6	0	-	-	7.5	-	-	9.2
HCM Lane LOS	A	A	-	-	A	-	-	A
HCM 95th %tile Q(veh)	0	0	-	-	0.1	-	-	0

Intersection						
Int Delay, s/veh	4.2					
Movement	EBT	EBR	WBL	WBT	NBL	NBR
Lane Configurations	↔		↔	↑	↔	↔
Traffic Vol, veh/h	59	55	0	168	162	0
Future Vol, veh/h	59	55	0	168	162	0
Conflicting Peds, #/hr	0	0	0	0	0	0
Sign Control	Free	Free	Free	Free	Stop	Stop
RT Channelized	-	None	-	None	-	Free
Storage Length	-	-	350	-	0	0
Veh in Median Storage, #	0	-	-	0	0	-
Grade, %	0	-	-	0	0	-
Peak Hour Factor	95	95	95	95	95	95
Heavy Vehicles, %	0	2	100	0	2	67
Mvmt Flow	62	58	0	177	171	0

Major/Minor	Major1	Major2	Minor1		
Conflicting Flow All	0	0	120	0	268
Stage 1	-	-	-	-	91
Stage 2	-	-	-	-	177
Critical Hdwy	-	-	5.1	-	6.42
Critical Hdwy Stg 1	-	-	-	-	5.42
Critical Hdwy Stg 2	-	-	-	-	5.42
Follow-up Hdwy	-	-	3.1	-	3.518
Pot Cap-1 Maneuver	-	-	1031	-	721
Stage 1	-	-	-	-	933
Stage 2	-	-	-	-	854
Platoon blocked, %	-	-	-	-	-
Mov Cap-1 Maneuver	-	-	1031	-	721
Mov Cap-2 Maneuver	-	-	-	-	721
Stage 1	-	-	-	-	933
Stage 2	-	-	-	-	854

Approach	EB	WB	NB
HCM Control Delay, s	0	0	11.5
HCM LOS			B

Minor Lane/Major Mvmt	NBLn1	NBLn2	EBT	EBR	WBL	WBT
Capacity (veh/h)	721	-	-	-	1031	-
HCM Lane V/C Ratio	0.237	-	-	-	-	-
HCM Control Delay (s)	11.5	0	-	-	0	-
HCM Lane LOS	B	A	-	-	A	-
HCM 95th %tile Q(veh)	0.9	-	-	-	0	-

# HCM 6th Signalized Intersection Summary

## 3: I-25 NB Ramps & US 85

2035 Background  
PM Peak Hour



Movement	EBL	EBT	EBR	WBL	WBT	WBR	NBL	NBT	NBR	SBL	SBT	SBR
Lane Configurations												
Traffic Volume (veh/h)	187	621	0	0	177	73	24	29	531	0	0	0
Future Volume (veh/h)	187	621	0	0	177	73	24	29	531	0	0	0
Initial Q (Qb), veh	0	0	0	0	0	0	0	0	0			
Ped-Bike Adj(A_pbT)	1.00		1.00	1.00		1.00	1.00		1.00			
Parking Bus, Adj	1.00	1.00	1.00	1.00	1.00	1.00	1.00	1.00	1.00			
Work Zone On Approach		No			No			No				
Adj Sat Flow, veh/h/ln	1826	1870	0	0	1796	1781	1455	1900	1781			
Adj Flow Rate, veh/h	220	731	0	0	208	0	28	34	0			
Peak Hour Factor	0.85	0.85	0.85	0.85	0.85	0.85	0.85	0.85	0.85			
Percent Heavy Veh, %	5	2	0	0	7	8	30	0	8			
Cap, veh/h	951	1517	0	0	2360		37	45				
Arrive On Green	0.08	1.00	0.00	0.00	0.69	0.00	0.04	0.04	0.00			
Sat Flow, veh/h	1739	1870	0	0	3503	1510	839	1019	1510			
Grp Volume(v), veh/h	220	731	0	0	208	0	62	0	0			
Grp Sat Flow(s),veh/h/ln	1739	1870	0	0	1706	1510	1858	0	1510			
Q Serve(g_s), s	3.1	0.0	0.0	0.0	1.8	0.0	3.0	0.0	0.0			
Cycle Q Clear(g_c), s	3.1	0.0	0.0	0.0	1.8	0.0	3.0	0.0	0.0			
Prop In Lane	1.00		0.00	0.00		1.00	0.45		1.00			
Lane Grp Cap(c), veh/h	951	1517	0	0	2360		83	0				
V/C Ratio(X)	0.23	0.48	0.00	0.00	0.09		0.75	0.00				
Avail Cap(c_a), veh/h	1033	1517	0	0	2360		279	0				
HCM Platoon Ratio	1.33	1.33	1.00	1.00	1.00	1.00	1.00	1.00	1.00			
Upstream Filter(I)	0.92	0.92	0.00	0.00	1.00	0.00	1.00	0.00	0.00			
Uniform Delay (d), s/veh	2.7	0.0	0.0	0.0	4.6	0.0	42.5	0.0	0.0			
Incr Delay (d2), s/veh	0.1	1.0	0.0	0.0	0.1	0.0	12.8	0.0	0.0			
Initial Q Delay(d3),s/veh	0.0	0.0	0.0	0.0	0.0	0.0	0.0	0.0	0.0			
%ile BackOfQ(50%),veh/ln	0.7	0.4	0.0	0.0	0.5	0.0	1.6	0.0	0.0			
Unsig. Movement Delay, s/veh												
LnGrp Delay(d),s/veh	2.8	1.0	0.0	0.0	4.6	0.0	55.3	0.0	0.0			
LnGrp LOS	A	A	A	A	A		E	A				
Approach Vol, veh/h		951			208			62				
Approach Delay, s/veh		1.4			4.6			55.3				
Approach LOS		A			A			E				
Timer - Assigned Phs		2			5	6		8				
Phs Duration (G+Y+Rc), s		79.5			10.8	68.7		10.5				
Change Period (Y+Rc), s		6.5			5.5	6.5		6.5				
Max Green Setting (Gmax), s		63.5			9.5	48.5		13.5				
Max Q Clear Time (g_c+I1), s		2.0			5.1	3.8		5.0				
Green Ext Time (p_c), s		6.1			0.2	1.4		0.1				

### Intersection Summary

HCM 6th Ctrl Delay	4.7
HCM 6th LOS	A

### Notes

User approved pedestrian interval to be less than phase max green.

Unsignalized Delay for [NBR, WBR] is excluded from calculations of the approach delay and intersection delay.



HCM 6th Signalized Intersection Summary  
6: I-25 SB Ramps & US 85

2035 Background  
PM Peak Hour



Movement	EBL	EBT	EBR	WBL	WBT	WBR	NBL	NBT	NBR	SBL	SBT	SBR
Lane Configurations		↑↑	↑	↑	↑						↑	↑
Traffic Volume (veh/h)	0	539	142	146	55	0	0	0	0	269	5	146
Future Volume (veh/h)	0	539	142	146	55	0	0	0	0	269	5	146
Initial Q (Qb), veh	0	0	0	0	0	0				0	0	0
Ped-Bike Adj(A_pbT)	1.00		1.00	1.00		1.00				1.00		1.00
Parking Bus, Adj	1.00	1.00	1.00	1.00	1.00	1.00				1.00	1.00	1.00
Work Zone On Approach		No			No						No	
Adj Sat Flow, veh/h/ln	0	1856	1767	1826	1500	0				1885	1870	1796
Adj Flow Rate, veh/h	0	634	0	172	65	0				316	6	0
Peak Hour Factor	0.85	0.85	0.85	0.85	0.85	0.85				0.85	0.85	0.85
Percent Heavy Veh, %	0	3	9	5	27	0				1	2	7
Cap, veh/h	0	1816		510	962	0				375	7	
Arrive On Green	0.00	0.52	0.00	0.07	0.64	0.00				0.21	0.21	0.00
Sat Flow, veh/h	0	3618	1497	1739	1500	0				1750	33	1522
Grp Volume(v), veh/h	0	634	0	172	65	0				322	0	0
Grp Sat Flow(s),veh/h/ln	0	1763	1497	1739	1500	0				1783	0	1522
Q Serve(g_s), s	0.0	9.6	0.0	3.9	1.5	0.0				15.6	0.0	0.0
Cycle Q Clear(g_c), s	0.0	9.6	0.0	3.9	1.5	0.0				15.6	0.0	0.0
Prop In Lane	0.00		1.00	1.00		0.00				0.98		1.00
Lane Grp Cap(c), veh/h	0	1816		510	962	0				382	0	
V/C Ratio(X)	0.00	0.35		0.34	0.07	0.00				0.84	0.00	
Avail Cap(c_a), veh/h	0	1816		522	962	0				763	0	
HCM Platoon Ratio	1.00	1.00	1.00	1.00	1.00	1.00				1.00	1.00	1.00
Upstream Filter(I)	0.00	1.00	0.00	1.00	1.00	0.00				1.00	0.00	0.00
Uniform Delay (d), s/veh	0.0	12.9	0.0	8.8	6.0	0.0				33.9	0.0	0.0
Incr Delay (d2), s/veh	0.0	0.5	0.0	0.4	0.1	0.0				5.1	0.0	0.0
Initial Q Delay(d3),s/veh	0.0	0.0	0.0	0.0	0.0	0.0				0.0	0.0	0.0
%ile BackOfQ(50%),veh/ln	0.0	3.6	0.0	1.3	0.4	0.0				6.9	0.0	0.0
Unsig. Movement Delay, s/veh												
LnGrp Delay(d),s/veh	0.0	13.4	0.0	9.2	6.2	0.0				39.0	0.0	0.0
LnGrp LOS		A	B	A	A	A				D	A	
Approach Vol, veh/h		634			237						322	
Approach Delay, s/veh		13.4			8.4						39.0	
Approach LOS		B			A						D	
Timer - Assigned Phs	1	2		4		6						
Phs Duration (G+Y+Rc), s	1.4	52.9		25.8		64.2						
Change Period (Y+Rc), s	5.5	6.5		6.5		6.5						
Max Green Setting (Gmax), s	6.5	26.5		38.5		38.5						
Max Q Clear Time (g_c+1/5), s	11.6	11.6		17.6		3.5						
Green Ext Time (p_c), s	0.0	3.7		1.7		0.3						

Intersection Summary

HCM 6th Ctrl Delay	19.3
HCM 6th LOS	B

Notes

Unsignalized Delay for [EBR, SBR] is excluded from calculations of the approach delay and intersection delay.

Intersection				
Intersection Delay, s/veh	6.8			
Intersection LOS	A			
Approach	EB	WB	NB	SB
Entry Lanes	1	1	1	1
Conflicting Circle Lanes	1	1	1	1
Adj Approach Flow, veh/h	26	133	554	83
Demand Flow Rate, veh/h	27	145	554	89
Vehicles Circulating, veh/h	191	14	162	117
Vehicles Exiting, veh/h	15	702	56	42
Ped Vol Crossing Leg, #/h	0	0	0	0
Ped Cap Adj	1.000	1.000	1.000	1.000
Approach Delay, s/veh	3.5	3.8	8.2	3.8
Approach LOS	A	A	A	A
Lane	Left	Left	Left	Left
Designated Moves	LTR	LTR	LTR	LTR
Assumed Moves	LTR	LTR	LTR	LTR
RT Channelized				
Lane Util	1.000	1.000	1.000	1.000
Follow-Up Headway, s	2.609	2.609	2.609	2.609
Critical Headway, s	4.976	4.976	4.976	4.976
Entry Flow, veh/h	27	145	554	89
Cap Entry Lane, veh/h	1136	1360	1170	1225
Entry HV Adj Factor	0.963	0.918	1.000	0.933
Flow Entry, veh/h	26	133	554	83
Cap Entry, veh/h	1094	1248	1170	1142
V/C Ratio	0.024	0.107	0.474	0.073
Control Delay, s/veh	3.5	3.8	8.2	3.8
LOS	A	A	A	A
95th %tile Queue, veh	0	0	3	0

Intersection												
Int Delay, s/veh	0.4											
Movement	EBL	EBT	EBR	WBL	WBT	WBR	NBL	NBT	NBR	SBL	SBT	SBR
Lane Configurations		↕		↕	↕			↕			↕	
Traffic Vol, veh/h	0	360	0	1	42	0	0	0	14	0	0	0
Future Vol, veh/h	0	360	0	1	42	0	0	0	14	0	0	0
Conflicting Peds, #/hr	0	0	0	0	0	0	0	0	0	0	0	0
Sign Control	Free	Free	Free	Free	Free	Free	Stop	Stop	Stop	Stop	Stop	Stop
RT Channelized	-	-	None	-	-	None	-	-	None	-	-	None
Storage Length	-	-	-	300	-	-	-	-	-	-	-	-
Veh in Median Storage, #	-	0	-	-	0	-	-	0	-	-	0	-
Grade, %	-	0	-	-	0	-	-	0	-	-	0	-
Peak Hour Factor	85	85	85	85	85	85	85	85	85	85	85	85
Heavy Vehicles, %	2	0	2	0	12	2	2	2	0	2	2	2
Mvmt Flow	0	424	0	1	49	0	0	0	16	0	0	0

Major/Minor	Major1			Major2			Minor1			Minor2		
Conflicting Flow All	49	0	0	424	0	0	475	475	424	483	475	49
Stage 1	-	-	-	-	-	-	424	424	-	51	51	-
Stage 2	-	-	-	-	-	-	51	51	-	432	424	-
Critical Hdwy	4.12	-	-	4.1	-	-	7.12	6.52	6.2	7.12	6.52	6.22
Critical Hdwy Stg 1	-	-	-	-	-	-	6.12	5.52	-	6.12	5.52	-
Critical Hdwy Stg 2	-	-	-	-	-	-	6.12	5.52	-	6.12	5.52	-
Follow-up Hdwy	2.218	-	-	2.2	-	-	3.518	4.018	3.3	3.518	4.018	3.318
Pot Cap-1 Maneuver	1558	-	-	1146	-	-	500	488	634	494	488	1020
Stage 1	-	-	-	-	-	-	608	587	-	962	852	-
Stage 2	-	-	-	-	-	-	962	852	-	602	587	-
Platoon blocked, %	-	-	-	-	-	-	-	-	-	-	-	-
Mov Cap-1 Maneuver	1558	-	-	1146	-	-	500	488	634	481	488	1020
Mov Cap-2 Maneuver	-	-	-	-	-	-	500	488	-	481	488	-
Stage 1	-	-	-	-	-	-	608	587	-	962	851	-
Stage 2	-	-	-	-	-	-	961	851	-	586	587	-

Approach	EB			WB			NB			SB		
HCM Control Delay, s	0			0.2			10.8			0		
HCM LOS							B			A		

Minor Lane/Major Mvmt	NBLn1	EBL	EBT	EBR	WBL	WBT	WBR	SBLn1
Capacity (veh/h)	634	1558	-	-	1146	-	-	-
HCM Lane V/C Ratio	0.026	-	-	-	0.001	-	-	-
HCM Control Delay (s)	10.8	0	-	-	8.1	-	-	0
HCM Lane LOS	B	A	-	-	A	-	-	A
HCM 95th %tile Q(veh)	0.1	0	-	-	0	-	-	-

# HCM 6th Signalized Intersection Summary

## 3: I-25 NB Ramps & US 85

2040 Background  
PM Peak Hour



Movement	EBL	EBT	EBR	WBL	WBT	WBR	NBL	NBT	NBR	SBL	SBT	SBR
Lane Configurations												
Traffic Volume (veh/h)	219	728	0	0	191	77	26	30	564	0	0	0
Future Volume (veh/h)	219	728	0	0	191	77	26	30	564	0	0	0
Initial Q (Qb), veh	0	0	0	0	0	0	0	0	0			
Ped-Bike Adj(A_pbT)	1.00		1.00	1.00		1.00	1.00		1.00			
Parking Bus, Adj	1.00	1.00	1.00	1.00	1.00	1.00	1.00	1.00	1.00			
Work Zone On Approach		No			No			No				
Adj Sat Flow, veh/h/ln	1826	1870	0	0	1796	1781	1455	1900	1781			
Adj Flow Rate, veh/h	238	791	0	0	208	0	28	33	0			
Peak Hour Factor	0.92	0.92	0.92	0.92	0.92	0.92	0.92	0.92	0.92			
Percent Heavy Veh, %	5	2	0	0	7	8	30	0	8			
Cap, veh/h	954	1518	0	0	2350		37	44				
Arrive On Green	0.08	1.00	0.00	0.00	0.69	0.00	0.04	0.04	0.00			
Sat Flow, veh/h	1739	1870	0	0	3503	1510	853	1005	1510			
Grp Volume(v), veh/h	238	791	0	0	208	0	61	0	0			
Grp Sat Flow(s),veh/h/ln	1739	1870	0	0	1706	1510	1857	0	1510			
Q Serve(g_s), s	3.3	0.0	0.0	0.0	1.8	0.0	2.9	0.0	0.0			
Cycle Q Clear(g_c), s	3.3	0.0	0.0	0.0	1.8	0.0	2.9	0.0	0.0			
Prop In Lane	1.00		0.00	0.00		1.00	0.46		1.00			
Lane Grp Cap(c), veh/h	954	1518	0	0	2350		81	0				
V/C Ratio(X)	0.25	0.52	0.00	0.00	0.09		0.75	0.00				
Avail Cap(c_a), veh/h	1030	1518	0	0	2350		279	0				
HCM Platoon Ratio	1.33	1.33	1.00	1.00	1.00	1.00	1.00	1.00	1.00			
Upstream Filter(I)	0.89	0.89	0.00	0.00	1.00	0.00	1.00	0.00	0.00			
Uniform Delay (d), s/veh	2.7	0.0	0.0	0.0	4.6	0.0	42.6	0.0	0.0			
Incr Delay (d2), s/veh	0.1	1.1	0.0	0.0	0.1	0.0	13.0	0.0	0.0			
Initial Q Delay(d3),s/veh	0.0	0.0	0.0	0.0	0.0	0.0	0.0	0.0	0.0			
%ile BackOfQ(50%),veh/ln	0.7	0.5	0.0	0.0	0.5	0.0	1.6	0.0	0.0			
Unsig. Movement Delay, s/veh												
LnGrp Delay(d),s/veh	2.9	1.1	0.0	0.0	4.7	0.0	55.5	0.0	0.0			
LnGrp LOS	A	A	A	A	A		E	A				
Approach Vol, veh/h		1029			208			61				
Approach Delay, s/veh		1.5			4.7			55.5				
Approach LOS		A			A			E				
Timer - Assigned Phs		2			5	6		8				
Phs Duration (G+Y+Rc), s		79.6			11.1	68.5		10.4				
Change Period (Y+Rc), s		6.5			5.5	6.5		6.5				
Max Green Setting (Gmax), s		63.5			9.5	48.5		13.5				
Max Q Clear Time (g_c+I1), s		2.0			5.3	3.8		4.9				
Green Ext Time (p_c), s		6.9			0.3	1.4		0.1				

### Intersection Summary

HCM 6th Ctrl Delay	4.6
HCM 6th LOS	A

### Notes

User approved pedestrian interval to be less than phase max green.

Unsignalized Delay for [NBR, WBR] is excluded from calculations of the approach delay and intersection delay.

HCM 6th Signalized Intersection Summary  
6: I-25 SB Ramps & US 85

2040 Background  
PM Peak Hour



Movement	EBL	EBT	EBR	WBL	WBT	WBR	NBL	NBT	NBR	SBL	SBT	SBR
Lane Configurations		↑↑	↗	↖	↑						↖	↗
Traffic Volume (veh/h)	0	661	174	155	62	0	0	0	0	286	5	165
Future Volume (veh/h)	0	661	174	155	62	0	0	0	0	286	5	165
Initial Q (Qb), veh	0	0	0	0	0	0				0	0	0
Ped-Bike Adj(A_pbT)	1.00		1.00	1.00		1.00				1.00		1.00
Parking Bus, Adj	1.00	1.00	1.00	1.00	1.00	1.00				1.00	1.00	1.00
Work Zone On Approach		No			No						No	
Adj Sat Flow, veh/h/ln	0	1856	1767	1826	1500	0				1885	1870	1796
Adj Flow Rate, veh/h	0	718	0	168	67	0				311	5	0
Peak Hour Factor	0.92	0.92	0.92	0.92	0.92	0.92				0.92	0.92	0.92
Percent Heavy Veh, %	0	3	9	5	27	0				1	2	7
Cap, veh/h	0	1834		475	967	0				369	6	
Arrive On Green	0.00	0.52	0.00	0.06	0.64	0.00				0.21	0.21	0.00
Sat Flow, veh/h	0	3618	1497	1739	1500	0				1754	28	1522
Grp Volume(v), veh/h	0	718	0	168	67	0				316	0	0
Grp Sat Flow(s),veh/h/ln	0	1763	1497	1739	1500	0				1783	0	1522
Q Serve(g_s), s	0.0	11.0	0.0	3.8	1.5	0.0				15.3	0.0	0.0
Cycle Q Clear(g_c), s	0.0	11.0	0.0	3.8	1.5	0.0				15.3	0.0	0.0
Prop In Lane	0.00		1.00	1.00		0.00				0.98		1.00
Lane Grp Cap(c), veh/h	0	1834		475	967	0				375	0	
V/C Ratio(X)	0.00	0.39		0.35	0.07	0.00				0.84	0.00	
Avail Cap(c_a), veh/h	0	1834		490	967	0				763	0	
HCM Platoon Ratio	1.00	1.00	1.00	1.00	1.00	1.00				1.00	1.00	1.00
Upstream Filter(I)	0.00	1.00	0.00	1.00	1.00	0.00				1.00	0.00	0.00
Uniform Delay (d), s/veh	0.0	13.0	0.0	9.0	5.9	0.0				34.1	0.0	0.0
Incr Delay (d2), s/veh	0.0	0.6	0.0	0.4	0.1	0.0				5.1	0.0	0.0
Initial Q Delay(d3),s/veh	0.0	0.0	0.0	0.0	0.0	0.0				0.0	0.0	0.0
%ile BackOfQ(50%),veh/ln	0.0	4.2	0.0	1.3	0.4	0.0				6.7	0.0	0.0
Unsig. Movement Delay, s/veh												
LnGrp Delay(d),s/veh	0.0	13.6	0.0	9.4	6.1	0.0				39.2	0.0	0.0
LnGrp LOS		A	B	A	A	A				D	A	
Approach Vol, veh/h		718			235						316	
Approach Delay, s/veh		13.6			8.5						39.2	
Approach LOS		B			A						D	
Timer - Assigned Phs	1	2		4		6						
Phs Duration (G+Y+Rc), s	1.2	53.3		25.5		64.5						
Change Period (Y+Rc), s	5.5	6.5		6.5		6.5						
Max Green Setting (Gmax), s	6.5	26.5		38.5		38.5						
Max Q Clear Time (g_c+1/5), s	13.0	13.0		17.3		3.5						
Green Ext Time (p_c), s	0.0	4.0		1.7		0.3						

Intersection Summary

HCM 6th Ctrl Delay		19.1										
HCM 6th LOS			B									

Notes

Unsignalized Delay for [EBR, SBR] is excluded from calculations of the approach delay and intersection delay.

Intersection				
Intersection Delay, s/veh	8.2			
Intersection LOS	A			
Approach	EB	WB	NB	SB
Entry Lanes	1	1	1	1
Conflicting Circle Lanes	1	1	1	1
Adj Approach Flow, veh/h	24	144	665	80
Demand Flow Rate, veh/h	25	158	665	86
Vehicles Circulating, veh/h	203	12	158	130
Vehicles Exiting, veh/h	13	811	70	40
Ped Vol Crossing Leg, #/h	0	0	0	0
Ped Cap Adj	1.000	1.000	1.000	1.000
Approach Delay, s/veh	3.5	3.9	9.8	3.8
Approach LOS	A	A	A	A
Lane	Left	Left	Left	Left
Designated Moves	LTR	LTR	LTR	LTR
Assumed Moves	LTR	LTR	LTR	LTR
RT Channelized				
Lane Util	1.000	1.000	1.000	1.000
Follow-Up Headway, s	2.609	2.609	2.609	2.609
Critical Headway, s	4.976	4.976	4.976	4.976
Entry Flow, veh/h	25	158	665	86
Cap Entry Lane, veh/h	1122	1363	1174	1209
Entry HV Adj Factor	0.960	0.912	1.000	0.930
Flow Entry, veh/h	24	144	665	80
Cap Entry, veh/h	1077	1243	1174	1124
V/C Ratio	0.022	0.116	0.566	0.071
Control Delay, s/veh	3.5	3.9	9.8	3.8
LOS	A	A	A	A
95th %tile Queue, veh	0	0	4	0

HCM 6th TWSC  
 15: Fountain Utilities access & Charter Oak Ranch Rd

2040 Background  
 PM Peak Hour

Intersection												
Int Delay, s/veh	0.3											
Movement	EBL	EBT	EBR	WBL	WBT	WBR	NBL	NBT	NBR	SBL	SBT	SBR
Lane Configurations		↕		↕	↕			↕			↕	
Traffic Vol, veh/h	0	495	0	1	57	0	0	0	15	0	0	0
Future Vol, veh/h	0	495	0	1	57	0	0	0	15	0	0	0
Conflicting Peds, #/hr	0	0	0	0	0	0	0	0	0	0	0	0
Sign Control	Free	Free	Free	Free	Free	Free	Stop	Stop	Stop	Stop	Stop	Stop
RT Channelized	-	-	None	-	-	None	-	-	None	-	-	None
Storage Length	-	-	-	300	-	-	-	-	-	-	-	-
Veh in Median Storage, #	-	0	-	-	0	-	-	0	-	-	0	-
Grade, %	-	0	-	-	0	-	-	0	-	-	0	-
Peak Hour Factor	92	92	92	92	92	92	92	92	92	92	92	92
Heavy Vehicles, %	2	0	2	0	12	2	2	2	0	2	2	2
Mvmt Flow	0	538	0	1	62	0	0	0	16	0	0	0

Major/Minor	Major1			Major2			Minor1			Minor2		
Conflicting Flow All	62	0	0	538	0	0	602	602	538	610	602	62
Stage 1	-	-	-	-	-	-	538	538	-	64	64	-
Stage 2	-	-	-	-	-	-	64	64	-	546	538	-
Critical Hdwy	4.12	-	-	4.1	-	-	7.12	6.52	6.2	7.12	6.52	6.22
Critical Hdwy Stg 1	-	-	-	-	-	-	6.12	5.52	-	6.12	5.52	-
Critical Hdwy Stg 2	-	-	-	-	-	-	6.12	5.52	-	6.12	5.52	-
Follow-up Hdwy	2.218	-	-	2.2	-	-	3.518	4.018	3.3	3.518	4.018	3.318
Pot Cap-1 Maneuver	1541	-	-	1040	-	-	412	414	547	407	414	1003
Stage 1	-	-	-	-	-	-	527	522	-	947	842	-
Stage 2	-	-	-	-	-	-	947	842	-	522	522	-
Platoon blocked, %	-	-	-	-	-	-	-	-	-	-	-	-
Mov Cap-1 Maneuver	1541	-	-	1040	-	-	412	414	547	394	414	1003
Mov Cap-2 Maneuver	-	-	-	-	-	-	412	414	-	394	414	-
Stage 1	-	-	-	-	-	-	527	522	-	947	841	-
Stage 2	-	-	-	-	-	-	946	841	-	506	522	-

Approach	EB			WB			NB			SB		
HCM Control Delay, s	0			0.1			11.8			0		
HCM LOS							B			A		

Minor Lane/Major Mvmt	NBLn1	EBL	EBT	EBR	WBL	WBT	WBR	SBLn1
Capacity (veh/h)	547	1541	-	-	1040	-	-	-
HCM Lane V/C Ratio	0.03	-	-	-	0.001	-	-	-
HCM Control Delay (s)	11.8	0	-	-	8.5	-	-	0
HCM Lane LOS	B	A	-	-	A	-	-	A
HCM 95th %tile Q(veh)	0.1	0	-	-	0	-	-	-



HCM 6th Signalized Intersection Summary  
3: I-25 NB Ramps & US 85

2045 Background  
PM Peak Hour



Movement	EBL	EBT	EBR	WBL	WBT	WBR	NBL	NBT	NBR	SBL	SBT	SBR
Lane Configurations	↘	↑			↑↑	↗		↗	↗			
Traffic Volume (veh/h)	192	638	0	0	196	82	26	32	596	0	0	0
Future Volume (veh/h)	192	638	0	0	196	82	26	32	596	0	0	0
Initial Q (Qb), veh	0	0	0	0	0	0	0	0	0			
Ped-Bike Adj(A_pbT)	1.00		1.00	1.00		1.00	1.00		1.00			
Parking Bus, Adj	1.00	1.00	1.00	1.00	1.00	1.00	1.00	1.00	1.00			
Work Zone On Approach		No			No			No				
Adj Sat Flow, veh/h/ln	1826	1870	0	0	1796	1781	1455	1900	1781			
Adj Flow Rate, veh/h	202	672	0	0	206	0	27	34	0			
Peak Hour Factor	0.95	0.95	0.95	0.95	0.95	0.95	0.95	0.95	0.95			
Percent Heavy Veh, %	5	2	0	0	7	8	30	0	8			
Cap, veh/h	952	1519	0	0	2374		36	45				
Arrive On Green	0.07	1.00	0.00	0.00	0.70	0.00	0.04	0.04	0.00			
Sat Flow, veh/h	1739	1870	0	0	3503	1510	823	1036	1510			
Grp Volume(v), veh/h	202	672	0	0	206	0	61	0	0			
Grp Sat Flow(s),veh/h/ln	1739	1870	0	0	1706	1510	1859	0	1510			
Q Serve(g_s), s	2.8	0.0	0.0	0.0	1.8	0.0	2.9	0.0	0.0			
Cycle Q Clear(g_c), s	2.8	0.0	0.0	0.0	1.8	0.0	2.9	0.0	0.0			
Prop In Lane	1.00		0.00	0.00		1.00	0.44		1.00			
Lane Grp Cap(c), veh/h	952	1519	0	0	2374		81	0				
V/C Ratio(X)	0.21	0.44	0.00	0.00	0.09		0.75	0.00				
Avail Cap(c_a), veh/h	1040	1519	0	0	2374		279	0				
HCM Platoon Ratio	1.33	1.33	1.00	1.00	1.00	1.00	1.00	1.00	1.00			
Upstream Filter(I)	0.94	0.94	0.00	0.00	1.00	0.00	1.00	0.00	0.00			
Uniform Delay (d), s/veh	2.7	0.0	0.0	0.0	4.4	0.0	42.6	0.0	0.0			
Incr Delay (d2), s/veh	0.1	0.9	0.0	0.0	0.1	0.0	13.0	0.0	0.0			
Initial Q Delay(d3),s/veh	0.0	0.0	0.0	0.0	0.0	0.0	0.0	0.0	0.0			
%ile BackOfQ(50%),veh/ln	0.6	0.4	0.0	0.0	0.5	0.0	1.6	0.0	0.0			
Unsig. Movement Delay, s/veh												
LnGrp Delay(d),s/veh	2.8	0.9	0.0	0.0	4.5	0.0	55.5	0.0	0.0			
LnGrp LOS	A	A	A	A	A		E	A				
Approach Vol, veh/h		874			206			61				
Approach Delay, s/veh		1.3			4.5			55.5				
Approach LOS		A			A			E				
Timer - Assigned Phs		2			5	6		8				
Phs Duration (G+Y+Rc), s		79.6			10.5	69.1		10.4				
Change Period (Y+Rc), s		6.5			5.5	6.5		6.5				
Max Green Setting (Gmax), s		63.5			9.5	48.5		13.5				
Max Q Clear Time (g_c+I1), s		2.0			4.8	3.8		4.9				
Green Ext Time (p_c), s		5.3			0.2	1.4		0.1				

Intersection Summary

HCM 6th Ctrl Delay	4.8
HCM 6th LOS	A

Notes

User approved pedestrian interval to be less than phase max green.  
Unsignalized Delay for [NBR, WBR] is excluded from calculations of the approach delay and intersection delay.

HCM 6th Signalized Intersection Summary  
6: I-25 SB Ramps & US 85

2045 Background  
PM Peak Hour



Movement	EBL	EBT	EBR	WBL	WBT	WBR	NBL	NBT	NBR	SBL	SBT	SBR
Lane Configurations		↑↑	↗	↖	↑						↖	↗
Traffic Volume (veh/h)	0	528	139	164	58	0	0	0	0	302	5	155
Future Volume (veh/h)	0	528	139	164	58	0	0	0	0	302	5	155
Initial Q (Qb), veh	0	0	0	0	0	0				0	0	0
Ped-Bike Adj(A_pbT)	1.00		1.00	1.00		1.00				1.00		1.00
Parking Bus, Adj	1.00	1.00	1.00	1.00	1.00	1.00				1.00	1.00	1.00
Work Zone On Approach		No			No						No	
Adj Sat Flow, veh/h/ln	0	1856	1767	1826	1500	0				1885	1870	1796
Adj Flow Rate, veh/h	0	556	0	173	61	0				318	5	0
Peak Hour Factor	0.95	0.95	0.95	0.95	0.95	0.95				0.95	0.95	0.95
Percent Heavy Veh, %	0	3	9	5	27	0				1	2	7
Cap, veh/h	0	1813		546	961	0				377	6	
Arrive On Green	0.00	0.51	0.00	0.07	0.64	0.00				0.21	0.21	0.00
Sat Flow, veh/h	0	3618	1497	1739	1500	0				1755	28	1522
Grp Volume(v), veh/h	0	556	0	173	61	0				323	0	0
Grp Sat Flow(s),veh/h/ln	0	1763	1497	1739	1500	0				1783	0	1522
Q Serve(g_s), s	0.0	8.2	0.0	4.0	1.4	0.0				15.6	0.0	0.0
Cycle Q Clear(g_c), s	0.0	8.2	0.0	4.0	1.4	0.0				15.6	0.0	0.0
Prop In Lane	0.00		1.00	1.00		0.00				0.98		1.00
Lane Grp Cap(c), veh/h	0	1813		546	961	0				383	0	
V/C Ratio(X)	0.00	0.31		0.32	0.06	0.00				0.84	0.00	
Avail Cap(c_a), veh/h	0	1813		558	961	0				763	0	
HCM Platoon Ratio	1.00	1.00	1.00	1.00	1.00	1.00				1.00	1.00	1.00
Upstream Filter(I)	0.00	1.00	0.00	1.00	1.00	0.00				1.00	0.00	0.00
Uniform Delay (d), s/veh	0.0	12.6	0.0	8.6	6.1	0.0				33.9	0.0	0.0
Incr Delay (d2), s/veh	0.0	0.4	0.0	0.3	0.1	0.0				5.1	0.0	0.0
Initial Q Delay(d3),s/veh	0.0	0.0	0.0	0.0	0.0	0.0				0.0	0.0	0.0
%ile BackOfQ(50%),veh/ln	0.0	3.1	0.0	1.4	0.4	0.0				6.9	0.0	0.0
Unsig. Movement Delay, s/veh												
LnGrp Delay(d),s/veh	0.0	13.1	0.0	9.0	6.2	0.0				39.0	0.0	0.0
LnGrp LOS		A	B	A	A	A				D	A	
Approach Vol, veh/h		556			234						323	
Approach Delay, s/veh		13.1			8.2						39.0	
Approach LOS		B			A						D	
Timer - Assigned Phs	1	2		4		6						
Phs Duration (G+Y+Rc), s	1.4	52.8		25.8		64.2						
Change Period (Y+Rc), s	5.5	6.5		6.5		6.5						
Max Green Setting (Gmax), s	6.5	26.5		38.5		38.5						
Max Q Clear Time (g_c+1/6), s	6.5	10.2		17.6		3.4						
Green Ext Time (p_c), s	0.0	3.3		1.7		0.3						

Intersection Summary

HCM 6th Ctrl Delay	19.6
HCM 6th LOS	B

Notes

Unsignalized Delay for [EBR, SBR] is excluded from calculations of the approach delay and intersection delay.

Intersection				
Intersection Delay, s/veh	5.9			
Intersection LOS	A			
Approach	EB	WB	NB	SB
Entry Lanes	1	1	1	1
Conflicting Circle Lanes	1	1	1	1
Adj Approach Flow, veh/h	25	122	453	82
Demand Flow Rate, veh/h	26	133	453	88
Vehicles Circulating, veh/h	178	13	163	104
Vehicles Exiting, veh/h	14	603	41	42
Ped Vol Crossing Leg, #/h	0	0	0	0
Ped Cap Adj	1.000	1.000	1.000	1.000
Approach Delay, s/veh	3.4	3.7	7.0	3.7
Approach LOS	A	A	A	A
Lane	Left	Left	Left	Left
Designated Moves	LTR	LTR	LTR	LTR
Assumed Moves	LTR	LTR	LTR	LTR
RT Channelized				
Lane Util	1.000	1.000	1.000	1.000
Follow-Up Headway, s	2.609	2.609	2.609	2.609
Critical Headway, s	4.976	4.976	4.976	4.976
Entry Flow, veh/h	26	133	453	88
Cap Entry Lane, veh/h	1151	1362	1169	1241
Entry HV Adj Factor	0.962	0.915	1.000	0.932
Flow Entry, veh/h	25	122	453	82
Cap Entry, veh/h	1107	1246	1169	1156
V/C Ratio	0.023	0.098	0.388	0.071
Control Delay, s/veh	3.4	3.7	7.0	3.7
LOS	A	A	A	A
95th %tile Queue, veh	0	0	2	0

Intersection												
Int Delay, s/veh	0.4											
Movement	EBL	EBT	EBR	WBL	WBT	WBR	NBL	NBT	NBR	SBL	SBT	SBR
Lane Configurations		↕		↕	↕			↕			↕	
Traffic Vol, veh/h	0	306	0	1	34	0	0	0	15	0	0	0
Future Vol, veh/h	0	306	0	1	34	0	0	0	15	0	0	0
Conflicting Peds, #/hr	0	0	0	0	0	0	0	0	0	0	0	0
Sign Control	Free	Free	Free	Free	Free	Free	Stop	Stop	Stop	Stop	Stop	Stop
RT Channelized	-	-	None	-	-	None	-	-	None	-	-	None
Storage Length	-	-	-	300	-	-	-	-	-	-	-	-
Veh in Median Storage, #	-	0	-	-	0	-	-	0	-	-	0	-
Grade, %	-	0	-	-	0	-	-	0	-	-	0	-
Peak Hour Factor	95	95	95	95	95	95	95	95	95	95	95	95
Heavy Vehicles, %	2	0	2	0	12	2	2	2	0	2	2	2
Mvmt Flow	0	322	0	1	36	0	0	0	16	0	0	0

Major/Minor	Major1			Major2			Minor1			Minor2		
Conflicting Flow All	36	0	0	322	0	0	360	360	322	368	360	36
Stage 1	-	-	-	-	-	-	322	322	-	38	38	-
Stage 2	-	-	-	-	-	-	38	38	-	330	322	-
Critical Hdwy	4.12	-	-	4.1	-	-	7.12	6.52	6.2	7.12	6.52	6.22
Critical Hdwy Stg 1	-	-	-	-	-	-	6.12	5.52	-	6.12	5.52	-
Critical Hdwy Stg 2	-	-	-	-	-	-	6.12	5.52	-	6.12	5.52	-
Follow-up Hdwy	2.218	-	-	2.2	-	-	3.518	4.018	3.3	3.518	4.018	3.318
Pot Cap-1 Maneuver	1575	-	-	1249	-	-	596	567	724	588	567	1037
Stage 1	-	-	-	-	-	-	690	651	-	977	863	-
Stage 2	-	-	-	-	-	-	977	863	-	683	651	-
Platoon blocked, %	-	-	-	-	-	-	-	-	-	-	-	-
Mov Cap-1 Maneuver	1575	-	-	1249	-	-	595	566	724	575	566	1037
Mov Cap-2 Maneuver	-	-	-	-	-	-	595	566	-	575	566	-
Stage 1	-	-	-	-	-	-	690	651	-	977	862	-
Stage 2	-	-	-	-	-	-	976	862	-	668	651	-

Approach	EB			WB			NB			SB		
HCM Control Delay, s	0			0.2			10.1			0		
HCM LOS							B			A		

Minor Lane/Major Mvmt	NBLn1	EBL	EBT	EBR	WBL	WBT	WBR	SBLn1
Capacity (veh/h)	724	1575	-	-	1249	-	-	-
HCM Lane V/C Ratio	0.022	-	-	-	0.001	-	-	-
HCM Control Delay (s)	10.1	0	-	-	7.9	-	-	0
HCM Lane LOS	B	A	-	-	A	-	-	A
HCM 95th %tile Q(veh)	0.1	0	-	-	0	-	-	-

Intersection						
Int Delay, s/veh	0.5					
Movement	EBT	EBR	WBL	WBT	NBL	NBR
Lane Configurations	↔		↔	↑	↔	↔
Traffic Vol, veh/h	306	299	0	34	26	0
Future Vol, veh/h	306	299	0	34	26	0
Conflicting Peds, #/hr	0	0	0	0	0	0
Sign Control	Free	Free	Free	Free	Stop	Stop
RT Channelized	-	None	-	None	-	Free
Storage Length	-	-	350	-	0	0
Veh in Median Storage, #	0	-	-	0	0	-
Grade, %	0	-	-	0	0	-
Peak Hour Factor	95	95	95	95	95	95
Heavy Vehicles, %	0	2	33	6	2	17
Mvmt Flow	322	315	0	36	27	0

Major/Minor	Major1	Major2	Minor1		
Conflicting Flow All	0	0	637	0	516
Stage 1	-	-	-	-	480
Stage 2	-	-	-	-	36
Critical Hdwy	-	-	4.43	-	6.42
Critical Hdwy Stg 1	-	-	-	-	5.42
Critical Hdwy Stg 2	-	-	-	-	5.42
Follow-up Hdwy	-	-	2.497	-	3.518
Pot Cap-1 Maneuver	-	-	814	-	519
Stage 1	-	-	-	-	622
Stage 2	-	-	-	-	986
Platoon blocked, %	-	-	-	-	-
Mov Cap-1 Maneuver	-	-	814	-	519
Mov Cap-2 Maneuver	-	-	-	-	519
Stage 1	-	-	-	-	622
Stage 2	-	-	-	-	986



















Approach	EB	WB	NB
HCM Control Delay, s	0	0	12.3
HCM LOS			B

Minor Lane/Major Mvmt	NBLn1	NBLn2	EBT	EBR	WBL	WBT
Capacity (veh/h)	519	-	-	-	814	-
HCM Lane V/C Ratio	0.053	-	-	-	-	-
HCM Control Delay (s)	12.3	0	-	-	0	-
HCM Lane LOS	B	A	-	-	A	-
HCM 95th %tile Q(veh)	0.2	-	-	-	0	-

Appendix E: Total Traffic Synchro Analysis Report

HCM 6th Signalized Intersection Summary  
3: I-25 NB Ramps & US 85

Phase 1-2 Traffic  
AM Peak Hour

												
Movement	EBL	EBT	EBR	WBL	WBT	WBR	NBL	NBT	NBR	SBL	SBT	SBR
Lane Configurations												
Traffic Volume (veh/h)	39	255	0	0	350	402	39	1	320	0	0	0
Future Volume (veh/h)	113	266	0	0	396	402	129	1	320	0	0	0
Initial Q (Qb), veh	0	0	0	0	0	0	0	0	0			
Ped-Bike Adj(A_pbT)	1.00		1.00	1.00		1.00	1.00		1.00			
Parking Bus, Adj	1.00	1.00	1.00	1.00	1.00	1.00	1.00	1.00	1.00			
Work Zone On Approach		No			No			No				
Adj Sat Flow, veh/h/ln	996	1752	0	0	1826	1885	1767	1900	1826			
Adj Flow Rate, veh/h	133	313	0	0	466	0	152	1	0			
Peak Hour Factor	0.85	0.85	0.85	0.85	0.85	0.85	0.85	0.85	0.85			
Percent Heavy Veh, %	61	10	0	0	5	1	9	0	5			
Cap, veh/h	416	1276	0	0	2042		196	1				
Arrive On Green	0.02	0.24	0.00	0.00	0.59	0.00	0.11	0.11	0.00			
Sat Flow, veh/h	949	1752	0	0	3561	1598	1798	12	1547			
Grp Volume(v), veh/h	133	313	0	0	466	0	153	0	0			
Grp Sat Flow(s),veh/h/ln	949	1752	0	0	1735	1598	1810	0	1547			
Q Serve(g_s), s	3.9	11.5	0.0	0.0	5.1	0.0	6.6	0.0	0.0			
Cycle Q Clear(g_c), s	3.9	11.5	0.0	0.0	5.1	0.0	6.6	0.0	0.0			
Prop In Lane	1.00		0.00	0.00		1.00	0.99		1.00			
Lane Grp Cap(c), veh/h	416	1276	0	0	2042		197	0				
V/C Ratio(X)	0.32	0.25	0.00	0.00	0.23		0.77	0.00				
Avail Cap(c_a), veh/h	462	1276	0	0	2042		419	0				
HCM Platoon Ratio	0.33	0.33	1.00	1.00	1.00	1.00	1.00	1.00	1.00			
Upstream Filter(l)	0.99	0.99	0.00	0.00	1.00	0.00	1.00	0.00	0.00			
Uniform Delay (d), s/veh	5.3	12.6	0.0	0.0	7.8	0.0	34.7	0.0	0.0			
Incr Delay (d2), s/veh	0.4	0.5	0.0	0.0	0.3	0.0	6.4	0.0	0.0			
Initial Q Delay(d3),s/veh	0.0	0.0	0.0	0.0	0.0	0.0	0.0	0.0	0.0			
%ile BackOfQ(50%),veh/ln	0.7	5.3	0.0	0.0	1.7	0.0	3.1	0.0	0.0			
Unsig. Movement Delay, s/veh												
LnGrp Delay(d),s/veh	5.7	13.1	0.0	0.0	8.1	0.0	41.1	0.0	0.0			
LnGrp LOS	A	B	A	A	A		D	A				
Approach Vol, veh/h		446			466			153				
Approach Delay, s/veh		10.9			8.1			41.1				
Approach LOS		B			A			D				
Timer - Assigned Phs		2			5	6		8				
Phs Duration (G+Y+Rc), s		64.8			11.2	53.6		15.2				
Change Period (Y+Rc), s		6.5			5.5	6.5		6.5				
Max Green Setting (Gmax), s		48.5			9.5	33.5		18.5				
Max Q Clear Time (g_c+I1), s		13.5			5.9	7.1		8.6				
Green Ext Time (p_c), s		1.9			0.1	3.1		0.4				
<b>Intersection Summary</b>												
HCM 6th Ctrl Delay				14.0								
HCM 6th LOS				B								
<b>Notes</b>												
Unsignalized Delay for [NBR, WBR] is excluded from calculations of the approach delay and intersection delay.												



HCM 6th Signalized Intersection Summary  
6: I-25 SB Ramps & US 85

Phase 1-2 Traffic  
AM Peak Hour



Movement	EBL	EBT	EBR	WBL	WBT	WBR	NBL	NBT	NBR	SBL	SBT	SBR
Lane Configurations		↑↑	↗	↘	↑						↖	↗
Traffic Volume (veh/h)	0	121	27	145	244	0	0	0	0	173	2	145
Future Volume (veh/h)	0	206	48	145	380	0	0	0	0	173	2	461
Initial Q (Qb), veh	0	0	0	0	0	0				0	0	0
Ped-Bike Adj(A_pbT)	1.00		1.00	1.00		1.00				1.00		1.00
Parking Bus, Adj	1.00	1.00	1.00	1.00	1.00	1.00				1.00	1.00	1.00
Work Zone On Approach		No			No						No	
Adj Sat Flow, veh/h/ln	0	1411	1500	1781	1826	0				1796	1159	1663
Adj Flow Rate, veh/h	0	242	0	171	447	0				204	2	0
Peak Hour Factor	0.85	0.85	0.85	0.85	0.85	0.85				0.85	0.85	0.85
Percent Heavy Veh, %	0	33	27	8	5	0				7	50	16
Cap, veh/h	0	1295		678	1137	0				235	2	
Arrive On Green	0.00	0.48	0.00	0.07	0.62	0.00				0.21	0.21	0.00
Sat Flow, veh/h	0	2751	1271	1697	1826	0				1094	11	1409
Grp Volume(v), veh/h	0	242	0	171	447	0				206	0	0
Grp Sat Flow(s),veh/h/ln	0	1340	1271	1697	1826	0				1104	0	1409
Q Serve(g_s), s	0.0	4.1	0.0	3.8	9.8	0.0				14.4	0.0	0.0
Cycle Q Clear(g_c), s	0.0	4.1	0.0	3.8	9.8	0.0				14.4	0.0	0.0
Prop In Lane	0.00		1.00	1.00		0.00				0.99		1.00
Lane Grp Cap(c), veh/h	0	1295		678	1137	0				237	0	
V/C Ratio(X)	0.00	0.19		0.25	0.39	0.00				0.87	0.00	
Avail Cap(c_a), veh/h	0	1295		696	1137	0				462	0	
HCM Platoon Ratio	1.00	1.00	1.00	1.00	1.00	1.00				1.00	1.00	1.00
Upstream Filter(I)	0.00	1.00	0.00	0.97	0.97	0.00				1.00	0.00	0.00
Uniform Delay (d), s/veh	0.0	11.8	0.0	8.2	7.5	0.0				30.3	0.0	0.0
Incr Delay (d2), s/veh	0.0	0.3	0.0	0.2	1.0	0.0				9.3	0.0	0.0
Initial Q Delay(d3),s/veh	0.0	0.0	0.0	0.0	0.0	0.0				0.0	0.0	0.0
%ile BackOfQ(50%),veh/ln	0.0	1.2	0.0	1.2	3.4	0.0				4.1	0.0	0.0
Unsig. Movement Delay, s/veh												
LnGrp Delay(d),s/veh	0.0	12.1	0.0	8.4	8.5	0.0				39.7	0.0	0.0
LnGrp LOS		A	B	A	A	A				D	A	
Approach Vol, veh/h		242			618						206	
Approach Delay, s/veh		12.1			8.5						39.7	
Approach LOS		B			A						D	
Timer - Assigned Phs	1	2		4		6						
Phs Duration (G+Y+Rc), s	1.2	45.1		23.7		56.3						
Change Period (Y+Rc), s	5.5	6.5		6.5		6.5						
Max Green Setting (Gmax), s	6.5	21.5		33.5		33.5						
Max Q Clear Time (g_c+1/5), s	6.1	6.1		16.4		11.8						
Green Ext Time (p_c), s	0.0	1.3		1.0		2.7						

Intersection Summary

HCM 6th Ctrl Delay	15.3
HCM 6th LOS	B

Notes

Unsignalized Delay for [EBR, SBR] is excluded from calculations of the approach delay and intersection delay.

Intersection				
Intersection Delay, s/veh	10.9			
Intersection LOS	B			
Approach	EB	WB	NB	SB
Entry Lanes	1	1	1	1
Conflicting Circle Lanes	1	1	1	1
Adj Approach Flow, veh/h	19	914	223	82
Demand Flow Rate, veh/h	26	954	240	89
Vehicles Circulating, veh/h	933	18	100	869
Vehicles Exiting, veh/h	25	322	859	103
Ped Vol Crossing Leg, #/h	0	0	0	0
Ped Cap Adj	1.000	1.000	1.000	1.000
Approach Delay, s/veh	10.0	12.6	4.8	8.9
Approach LOS	A	B	A	A
Lane	Left	Left	Left	Left
Designated Moves	LTR	LTR	LTR	LTR
Assumed Moves	LTR	LTR	LTR	LTR
RT Channelized				
Lane Util	1.000	1.000	1.000	1.000
Follow-Up Headway, s	2.609	2.609	2.609	2.609
Critical Headway, s	4.976	4.976	4.976	4.976
Entry Flow, veh/h	26	954	240	89
Cap Entry Lane, veh/h	533	1355	1246	569
Entry HV Adj Factor	0.731	0.958	0.929	0.920
Flow Entry, veh/h	19	914	223	82
Cap Entry, veh/h	389	1298	1157	523
V/C Ratio	0.049	0.704	0.193	0.156
Control Delay, s/veh	10.0	12.6	4.8	8.9
LOS	A	B	A	A
95th %tile Queue, veh	0	6	1	1

HCM 6th TWSC  
 15: Fountain Utilities access & Charter Oak Ranch Rd

Phase 1-2 Traffic  
 AM Peak Hour

Intersection												
Int Delay, s/veh	0.4											
Movement	EBL	EBT	EBR	WBL	WBT	WBR	NBL	NBT	NBR	SBL	SBT	SBR
Lane Configurations		↕		↕	↕			↕			↕	
Traffic Vol, veh/h	0	71	0	25	184	1	1	0	8	0	0	1
Future Vol, veh/h	0	177	0	25	636	1	1	0	8	0	0	1
Conflicting Peds, #/hr	0	0	0	0	0	0	0	0	0	0	0	0
Sign Control	Free	Free	Free	Free	Free	Free	Stop	Stop	Stop	Stop	Stop	Stop
RT Channelized	-	-	None	-	-	None	-	-	None	-	-	None
Storage Length	-	-	-	300	-	-	-	-	-	-	-	-
Veh in Median Storage, #	-	0	-	-	0	-	-	0	-	-	0	-
Grade, %	-	0	-	-	0	-	-	0	-	-	0	-
Peak Hour Factor	85	85	85	85	85	85	85	85	85	85	85	85
Heavy Vehicles, %	2	5	2	9	3	0	100	2	57	2	2	0
Mvmt Flow	0	208	0	29	748	1	1	0	9	0	0	1

Major/Minor	Major1			Major2			Minor1			Minor2		
Conflicting Flow All	749	0	0	208	0	0	1015	1015	208	1020	1015	749
Stage 1	-	-	-	-	-	-	208	208	-	807	807	-
Stage 2	-	-	-	-	-	-	807	807	-	213	208	-
Critical Hdwy	4.12	-	-	4.19	-	-	8.1	6.52	6.77	7.12	6.52	6.2
Critical Hdwy Stg 1	-	-	-	-	-	-	7.1	5.52	-	6.12	5.52	-
Critical Hdwy Stg 2	-	-	-	-	-	-	7.1	5.52	-	6.12	5.52	-
Follow-up Hdwy	2.218	-	-	2.281	-	-	4.4	4.018	3.813	3.518	4.018	3.3
Pot Cap-1 Maneuver	860	-	-	1322	-	-	146	238	711	215	238	415
Stage 1	-	-	-	-	-	-	615	730	-	375	394	-
Stage 2	-	-	-	-	-	-	262	394	-	789	730	-
Platoon blocked, %	-	-	-	-	-	-	-	-	-	-	-	-
Mov Cap-1 Maneuver	860	-	-	1322	-	-	143	233	711	209	233	415
Mov Cap-2 Maneuver	-	-	-	-	-	-	143	233	-	209	233	-
Stage 1	-	-	-	-	-	-	615	730	-	375	385	-
Stage 2	-	-	-	-	-	-	256	385	-	779	730	-

Approach	EB			WB			NB			SB		
HCM Control Delay, s	0			0.3			12.5			13.7		
HCM LOS							B			B		

Minor Lane/Major Mvmt	NBLn1	EBL	EBT	EBR	WBL	WBT	WBR	SBLn1
Capacity (veh/h)	493	860	-	-	1322	-	-	415
HCM Lane V/C Ratio	0.021	-	-	-	0.022	-	-	0.003
HCM Control Delay (s)	12.5	0	-	-	7.8	-	-	13.7
HCM Lane LOS	B	A	-	-	A	-	-	B
HCM 95th %tile Q(veh)	0.1	0	-	-	0.1	-	-	0

Intersection						
Int Delay, s/veh	5.1					
Movement	EBT	EBR	WBL	WBT	NBL	NBR
Lane Configurations	↔		↔	↑	↔	↔
Traffic Vol, veh/h	67	0	0	190	0	0
Future Vol, veh/h	67	0	279	190	0	66
Conflicting Peds, #/hr	0	0	0	0	0	0
Sign Control	Free	Free	Free	Free	Stop	Stop
RT Channelized	-	None	-	None	-	Free
Storage Length	-	-	350	-	0	0
Veh in Median Storage, #	0	-	-	0	0	-
Grade, %	0	-	-	0	0	-
Peak Hour Factor	85	85	85	85	85	85
Heavy Vehicles, %	0	2	100	0	2	67
Mvmt Flow	79	0	328	224	0	78

Major/Minor	Major1	Major2	Minor1		
Conflicting Flow All	0	0	79	0	959
Stage 1	-	-	-	-	79
Stage 2	-	-	-	-	880
Critical Hdwy	-	-	5.1	-	6.42
Critical Hdwy Stg 1	-	-	-	-	5.42
Critical Hdwy Stg 2	-	-	-	-	5.42
Follow-up Hdwy	-	-	3.1	-	3.518
Pot Cap-1 Maneuver	-	-	1074	-	285
Stage 1	-	-	-	-	944
Stage 2	-	-	-	-	406
Platoon blocked, %	-	-	-	-	-
Mov Cap-1 Maneuver	-	-	1074	-	198
Mov Cap-2 Maneuver	-	-	-	-	198
Stage 1	-	-	-	-	944
Stage 2	-	-	-	-	282

Approach	EB	WB	NB
HCM Control Delay, s	0	5.8	0
HCM LOS			A

Minor Lane/Major Mvmt	NBLn1	NBLn2	EBT	EBR	WBL	WBT
Capacity (veh/h)	-	-	-	-	1074	-
HCM Lane V/C Ratio	-	-	-	-	0.306	-
HCM Control Delay (s)	0	0	-	-	9.8	-
HCM Lane LOS	A	A	-	-	A	-
HCM 95th %tile Q(veh)	-	-	-	-	1.3	-

Intersection						
Int Delay, s/veh	1.9					
Movement	EBT	EBR	WBL	WBT	NBL	NBR
Lane Configurations	↑	↗	↘	↑	↘	↗
Traffic Vol, veh/h	70	0	0	191	0	0
Future Vol, veh/h	124	12	70	436	34	16
Conflicting Peds, #/hr	0	0	0	0	0	0
Sign Control	Free	Free	Free	Free	Stop	Stop
RT Channelized	-	None	-	None	-	None
Storage Length	-	0	250	-	150	0
Veh in Median Storage, #	0	-	-	0	0	-
Grade, %	0	-	-	0	0	-
Peak Hour Factor	85	85	85	85	85	85
Heavy Vehicles, %	2	2	2	2	2	2
Mvmt Flow	146	14	82	513	40	19

Major/Minor	Major1	Major2	Minor1		
Conflicting Flow All	0	0	160	0	823 146
Stage 1	-	-	-	-	146 -
Stage 2	-	-	-	-	677 -
Critical Hdwy	-	-	4.12	-	6.42 6.22
Critical Hdwy Stg 1	-	-	-	-	5.42 -
Critical Hdwy Stg 2	-	-	-	-	5.42 -
Follow-up Hdwy	-	-	2.218	-	3.518 3.318
Pot Cap-1 Maneuver	-	-	1419	-	343 901
Stage 1	-	-	-	-	881 -
Stage 2	-	-	-	-	505 -
Platoon blocked, %	-	-	-	-	-
Mov Cap-1 Maneuver	-	-	1419	-	323 901
Mov Cap-2 Maneuver	-	-	-	-	323 -
Stage 1	-	-	-	-	881 -
Stage 2	-	-	-	-	476 -

Approach	EB	WB	NB
HCM Control Delay, s	0	1.1	14.9
HCM LOS			B

Minor Lane/Major Mvmt	NBLn1	NBLn2	EBT	EBR	WBL	WBT
Capacity (veh/h)	323	901	-	-	1419	-
HCM Lane V/C Ratio	0.124	0.021	-	-	0.058	-
HCM Control Delay (s)	17.7	9.1	-	-	7.7	-
HCM Lane LOS	C	A	-	-	A	-
HCM 95th %tile Q(veh)	0.4	0.1	-	-	0.2	-

Intersection						
Int Delay, s/veh	1.7					
Movement	EBT	EBR	WBL	WBT	NBL	NBR
Lane Configurations						
Traffic Vol, veh/h	70	0	0	191	0	0
Future Vol, veh/h	140	0	137	506	0	36
Conflicting Peds, #/hr	0	0	0	0	0	0
Sign Control	Free	Free	Free	Free	Stop	Stop
RT Channelized	-	None	-	None	-	None
Storage Length	-	-	300	-	0	-
Veh in Median Storage, #	0	-	-	0	0	-
Grade, %	0	-	-	0	0	-
Peak Hour Factor	85	85	85	85	85	85
Heavy Vehicles, %	2	2	2	2	2	2
Mvmt Flow	165	0	161	595	0	42



















Major/Minor	Major1	Major2	Minor1		
Conflicting Flow All	0	0	165	0	1082
Stage 1	-	-	-	-	165
Stage 2	-	-	-	-	917
Critical Hdwy	-	-	4.12	-	6.42
Critical Hdwy Stg 1	-	-	-	-	5.42
Critical Hdwy Stg 2	-	-	-	-	5.42
Follow-up Hdwy	-	-	2.218	-	3.518
Pot Cap-1 Maneuver	-	-	1413	-	241
Stage 1	-	-	-	-	864
Stage 2	-	-	-	-	390
Platoon blocked, %	-	-	-	-	-
Mov Cap-1 Maneuver	-	-	1413	-	214
Mov Cap-2 Maneuver	-	-	-	-	214
Stage 1	-	-	-	-	864
Stage 2	-	-	-	-	346

Approach	EB	WB	NB
HCM Control Delay, s	0	1.7	9.3
HCM LOS			A

Minor Lane/Major Mvmt	NBLn1	EBT	EBR	WBL	WBT
Capacity (veh/h)	879	-	-	1413	-
HCM Lane V/C Ratio	0.048	-	-	0.114	-
HCM Control Delay (s)	9.3	-	-	7.9	-
HCM Lane LOS	A	-	-	A	-
HCM 95th %tile Q(veh)	0.2	-	-	0.4	-

HCM 6th Signalized Intersection Summary  
3: I-25 NB Ramps & US 85

Phase 1-3 Traffic  
AM Peak Hour

												
Movement	EBL	EBT	EBR	WBL	WBT	WBR	NBL	NBT	NBR	SBL	SBT	SBR
Lane Configurations												
Traffic Volume (veh/h)	44	287	0	0	404	427	45	1	340	0	0	0
Future Volume (veh/h)	166	305	0	0	479	427	193	1	340	0	0	0
Initial Q (Qb), veh	0	0	0	0	0	0	0	0	0			
Ped-Bike Adj(A_pbT)	1.00		1.00	1.00		1.00	1.00		1.00			
Parking Bus, Adj	1.00	1.00	1.00	1.00	1.00	1.00	1.00	1.00	1.00			
Work Zone On Approach		No			No			No				
Adj Sat Flow, veh/h/ln	996	1752	0	0	1826	1885	1767	1900	1826			
Adj Flow Rate, veh/h	180	332	0	0	521	0	210	1	0			
Peak Hour Factor	0.92	0.92	0.92	0.92	0.92	0.92	0.92	0.92	0.92			
Percent Heavy Veh, %	61	10	0	0	5	1	9	0	5			
Cap, veh/h	392	1215	0	0	1821		259	1				
Arrive On Green	0.03	0.23	0.00	0.00	0.52	0.00	0.14	0.14	0.00			
Sat Flow, veh/h	949	1752	0	0	3561	1598	1801	9	1547			
Grp Volume(v), veh/h	180	332	0	0	521	0	211	0	0			
Grp Sat Flow(s),veh/h/ln	949	1752	0	0	1735	1598	1810	0	1547			
Q Serve(g_s), s	6.1	12.5	0.0	0.0	6.7	0.0	9.0	0.0	0.0			
Cycle Q Clear(g_c), s	6.1	12.5	0.0	0.0	6.7	0.0	9.0	0.0	0.0			
Prop In Lane	1.00		0.00	0.00		1.00	1.00		1.00			
Lane Grp Cap(c), veh/h	392	1215	0	0	1821		260	0				
V/C Ratio(X)	0.46	0.27	0.00	0.00	0.29		0.81	0.00				
Avail Cap(c_a), veh/h	409	1215	0	0	1821		419	0				
HCM Platoon Ratio	0.33	0.33	1.00	1.00	1.00	1.00	1.00	1.00	1.00			
Upstream Filter(I)	0.98	0.98	0.00	0.00	1.00	0.00	1.00	0.00	0.00			
Uniform Delay (d), s/veh	7.3	14.3	0.0	0.0	10.6	0.0	33.2	0.0	0.0			
Incr Delay (d2), s/veh	0.8	0.5	0.0	0.0	0.4	0.0	6.2	0.0	0.0			
Initial Q Delay(d3),s/veh	0.0	0.0	0.0	0.0	0.0	0.0	0.0	0.0	0.0			
%ile BackOfQ(50%),veh/ln	1.2	5.9	0.0	0.0	2.4	0.0	4.1	0.0	0.0			
Unsig. Movement Delay, s/veh												
LnGrp Delay(d),s/veh	8.1	14.8	0.0	0.0	11.0	0.0	39.3	0.0	0.0			
LnGrp LOS	A	B	A	A	B		D	A				
Approach Vol, veh/h		512			521			211				
Approach Delay, s/veh		12.4			11.0			39.3				
Approach LOS		B			B			D				
Timer - Assigned Phs		2			5	6		8				
Phs Duration (G+Y+Rc), s		62.0			13.5	48.5		18.0				
Change Period (Y+Rc), s		6.5			5.5	6.5		6.5				
Max Green Setting (Gmax), s		48.5			9.5	33.5		18.5				
Max Q Clear Time (g_c+I1), s		14.5			8.1	8.7		11.0				
Green Ext Time (p_c), s		2.1			0.1	3.5		0.6				
<b>Intersection Summary</b>												
HCM 6th Ctrl Delay				16.4								
HCM 6th LOS				B								
<b>Notes</b>												
Unsignalized Delay for [NBR, WBR] is excluded from calculations of the approach delay and intersection delay.												



HCM 6th Signalized Intersection Summary  
6: I-25 SB Ramps & US 85

Phase 1-3 Traffic  
AM Peak Hour



Movement	EBL	EBT	EBR	WBL	WBT	WBR	NBL	NBT	NBR	SBL	SBT	SBR
Lane Configurations		↑↑	↗	↖	↑						↖	↗
Traffic Volume (veh/h)	0	147	33	154	296	0	0	0	0	184	2	176
Future Volume (veh/h)	0	287	68	154	519	0	0	0	0	184	2	696
Initial Q (Qb), veh	0	0	0	0	0	0				0	0	0
Ped-Bike Adj(A_pbT)	1.00		1.00	1.00		1.00				1.00		1.00
Parking Bus, Adj	1.00	1.00	1.00	1.00	1.00	1.00				1.00	1.00	1.00
Work Zone On Approach		No			No						No	
Adj Sat Flow, veh/h/ln	0	1411	1500	1781	1826	0				1796	1159	1663
Adj Flow Rate, veh/h	0	312	0	167	564	0				200	2	0
Peak Hour Factor	0.92	0.92	0.92	0.92	0.92	0.92				0.92	0.92	0.92
Percent Heavy Veh, %	0	33	27	8	5	0				7	50	16
Cap, veh/h	0	1309		636	1144	0				231	2	
Arrive On Green	0.00	0.49	0.00	0.07	0.63	0.00				0.21	0.21	0.00
Sat Flow, veh/h	0	2751	1271	1697	1826	0				1093	11	1409
Grp Volume(v), veh/h	0	312	0	167	564	0				202	0	0
Grp Sat Flow(s),veh/h/ln	0	1340	1271	1697	1826	0				1104	0	1409
Q Serve(g_s), s	0.0	5.4	0.0	3.6	13.4	0.0				14.1	0.0	0.0
Cycle Q Clear(g_c), s	0.0	5.4	0.0	3.6	13.4	0.0				14.1	0.0	0.0
Prop In Lane	0.00		1.00	1.00		0.00				0.99		1.00
Lane Grp Cap(c), veh/h	0	1309		636	1144	0				233	0	
V/C Ratio(X)	0.00	0.24		0.26	0.49	0.00				0.87	0.00	
Avail Cap(c_a), veh/h	0	1309		656	1144	0				462	0	
HCM Platoon Ratio	1.00	1.00	1.00	1.00	1.00	1.00				1.00	1.00	1.00
Upstream Filter(l)	0.00	1.00	0.00	0.96	0.96	0.00				1.00	0.00	0.00
Uniform Delay (d), s/veh	0.0	11.8	0.0	8.1	8.1	0.0				30.5	0.0	0.0
Incr Delay (d2), s/veh	0.0	0.4	0.0	0.2	1.5	0.0				9.4	0.0	0.0
Initial Q Delay(d3),s/veh	0.0	0.0	0.0	0.0	0.0	0.0				0.0	0.0	0.0
%ile BackOfQ(50%),veh/ln	0.0	1.5	0.0	1.2	4.7	0.0				4.1	0.0	0.0
Unsig. Movement Delay, s/veh												
LnGrp Delay(d),s/veh	0.0	12.3	0.0	8.3	9.5	0.0				39.9	0.0	0.0
LnGrp LOS	A	B		A	A	A				D	A	
Approach Vol, veh/h		312			731						202	
Approach Delay, s/veh		12.3			9.3						39.9	
Approach LOS		B			A						D	
Timer - Assigned Phs	1	2		4		6						
Phs Duration (G+Y+Rc), s	1.0	45.6		23.4		56.6						
Change Period (Y+Rc), s	5.5	6.5		6.5		6.5						
Max Green Setting (Gmax), s	6.5	21.5		33.5		33.5						
Max Q Clear Time (g_c+1/5), s	6.5	7.4		16.1		15.4						
Green Ext Time (p_c), s	0.0	1.6		0.9		3.4						

Intersection Summary

HCM 6th Ctrl Delay		15.0										
HCM 6th LOS			B									

Notes

Unsignalized Delay for [EBR, SBR] is excluded from calculations of the approach delay and intersection delay.

Intersection				
Intersection Delay, s/veh	27.2			
Intersection LOS	D			
Approach	EB	WB	NB	SB
Entry Lanes	1	1	1	1
Conflicting Circle Lanes	1	1	1	1
Adj Approach Flow, veh/h	17	1247	309	80
Demand Flow Rate, veh/h	24	1300	333	87
Vehicles Circulating, veh/h	1278	15	98	1215
Vehicles Exiting, veh/h	24	416	1204	100
Ped Vol Crossing Leg, #/h	0	0	0	0
Ped Cap Adj	1.000	1.000	1.000	1.000
Approach Delay, s/veh	14.8	33.6	5.6	13.6
Approach LOS	B	D	A	B
Lane	Left	Left	Left	Left
Designated Moves	LTR	LTR	LTR	LTR
Assumed Moves	LTR	LTR	LTR	LTR
RT Channelized				
Lane Util	1.000	1.000	1.000	1.000
Follow-Up Headway, s	2.609	2.609	2.609	2.609
Critical Headway, s	4.976	4.976	4.976	4.976
Entry Flow, veh/h	24	1300	333	87
Cap Entry Lane, veh/h	375	1359	1249	400
Entry HV Adj Factor	0.708	0.959	0.928	0.918
Flow Entry, veh/h	17	1247	309	80
Cap Entry, veh/h	265	1303	1158	367
V/C Ratio	0.064	0.957	0.267	0.218
Control Delay, s/veh	14.8	33.6	5.6	13.6
LOS	B	D	A	B
95th %tile Queue, veh	0	18	1	1

HCM 6th TWSC  
 15: Fountain Utilities access & Charter Oak Ranch Rd

Phase 1-3 Traffic  
 AM Peak Hour

Intersection												
Int Delay, s/veh	0.3											
Movement	EBL	EBT	EBR	WBL	WBT	WBR	NBL	NBT	NBR	SBL	SBT	SBR
Lane Configurations		↕		↕	↕			↕			↕	
Traffic Vol, veh/h	0	98	0	27	253	1	1	0	8	0	0	1
Future Vol, veh/h	0	273	0	27	996	1	1	0	8	0	0	1
Conflicting Peds, #/hr	0	0	0	0	0	0	0	0	0	0	0	0
Sign Control	Free	Free	Free	Free	Free	Free	Stop	Stop	Stop	Stop	Stop	Stop
RT Channelized	-	-	None	-	-	None	-	-	None	-	-	None
Storage Length	-	-	-	300	-	-	-	-	-	-	-	-
Veh in Median Storage, #	-	0	-	-	0	-	-	0	-	-	0	-
Grade, %	-	0	-	-	0	-	-	0	-	-	0	-
Peak Hour Factor	92	92	92	92	92	92	92	92	92	92	92	92
Heavy Vehicles, %	2	5	2	9	3	0	100	2	57	2	2	0
Mvmt Flow	0	297	0	29	1083	1	1	0	9	0	0	1

Major/Minor	Major1			Major2			Minor1			Minor2		
Conflicting Flow All	1084	0	0	297	0	0	1439	1439	297	1444	1439	1084
Stage 1	-	-	-	-	-	-	297	297	-	1142	1142	-
Stage 2	-	-	-	-	-	-	1142	1142	-	302	297	-
Critical Hdwy	4.12	-	-	4.19	-	-	8.1	6.52	6.77	7.12	6.52	6.2
Critical Hdwy Stg 1	-	-	-	-	-	-	7.1	5.52	-	6.12	5.52	-
Critical Hdwy Stg 2	-	-	-	-	-	-	7.1	5.52	-	6.12	5.52	-
Follow-up Hdwy	2.218	-	-	2.281	-	-	4.4	4.018	3.813	3.518	4.018	3.3
Pot Cap-1 Maneuver	643	-	-	1225	-	-	68	133	629	110	133	266
Stage 1	-	-	-	-	-	-	543	668	-	244	275	-
Stage 2	-	-	-	-	-	-	160	275	-	707	668	-
Platoon blocked, %	-	-	-	-	-	-	-	-	-	-	-	-
Mov Cap-1 Maneuver	643	-	-	1225	-	-	67	130	629	106	130	266
Mov Cap-2 Maneuver	-	-	-	-	-	-	67	130	-	106	130	-
Stage 1	-	-	-	-	-	-	543	668	-	244	268	-
Stage 2	-	-	-	-	-	-	156	268	-	697	668	-

Approach	EB			WB			NB			SB		
HCM Control Delay, s	0			0.2			16.4			18.6		
HCM LOS							C			C		

Minor Lane/Major Mvmt	NBLn1	EBL	EBT	EBR	WBL	WBT	WBR	SBLn1
Capacity (veh/h)	326	643	-	-	1225	-	-	266
HCM Lane V/C Ratio	0.03	-	-	-	0.024	-	-	0.004
HCM Control Delay (s)	16.4	0	-	-	8	-	-	18.6
HCM Lane LOS	C	A	-	-	A	-	-	C
HCM 95th %tile Q(veh)	0.1	0	-	-	0.1	-	-	0

Intersection						
Int Delay, s/veh	8.1					
Movement	EBT	EBR	WBL	WBT	NBL	NBR
Lane Configurations	↔		↔	↑	↔	↔
Traffic Vol, veh/h	90	0	0	260	0	0
Future Vol, veh/h	90	0	570	260	0	135
Conflicting Peds, #/hr	0	0	0	0	0	0
Sign Control	Free	Free	Free	Free	Stop	Stop
RT Channelized	-	None	-	None	-	Free
Storage Length	-	-	350	-	0	0
Veh in Median Storage, #	0	-	-	0	0	-
Grade, %	0	-	-	0	0	-
Peak Hour Factor	92	92	92	92	92	92
Heavy Vehicles, %	0	2	100	0	2	67
Mvmt Flow	98	0	620	283	0	147

Major/Minor	Major1	Major2	Minor1			
Conflicting Flow All	0	0	98	0	1621	-
Stage 1	-	-	-	-	98	-
Stage 2	-	-	-	-	1523	-
Critical Hdwy	-	-	5.1	-	6.42	-
Critical Hdwy Stg 1	-	-	-	-	5.42	-
Critical Hdwy Stg 2	-	-	-	-	5.42	-
Follow-up Hdwy	-	-	3.1	-	3.518	-
Pot Cap-1 Maneuver	-	-	1054	-	113	0
Stage 1	-	-	-	-	926	0
Stage 2	-	-	-	-	199	0
Platoon blocked, %	-	-	-	-	-	-
Mov Cap-1 Maneuver	-	-	1054	-	47	-
Mov Cap-2 Maneuver	-	-	-	-	47	-
Stage 1	-	-	-	-	926	-
Stage 2	-	-	-	-	82	-

Approach	EB	WB	NB
HCM Control Delay, s	0	9	0
HCM LOS			A

Minor Lane/Major Mvmt	NBLn1	NBLn2	EBT	EBR	WBL	WBT
Capacity (veh/h)	-	-	-	-	1054	-
HCM Lane V/C Ratio	-	-	-	-	0.588	-
HCM Control Delay (s)	0	0	-	-	13.2	-
HCM Lane LOS	A	A	-	-	B	-
HCM 95th %tile Q(veh)	-	-	-	-	4	-

Intersection						
Int Delay, s/veh	1.5					
Movement	EBT	EBR	WBL	WBT	NBL	NBR
Lane Configurations	↑	↗	↘	↑	↘	↗
Traffic Vol, veh/h	96	0	0	262	0	0
Future Vol, veh/h	219	12	70	798	34	16
Conflicting Peds, #/hr	0	0	0	0	0	0
Sign Control	Free	Free	Free	Free	Stop	Stop
RT Channelized	-	None	-	None	-	None
Storage Length	-	0	250	-	150	0
Veh in Median Storage, #	0	-	-	0	0	-
Grade, %	0	-	-	0	0	-
Peak Hour Factor	92	92	92	92	92	92
Heavy Vehicles, %	2	2	2	2	2	2
Mvmt Flow	238	13	76	867	37	17

Major/Minor	Major1	Major2	Minor1		
Conflicting Flow All	0	0	251	0	1257
Stage 1	-	-	-	-	238
Stage 2	-	-	-	-	1019
Critical Hdwy	-	-	4.12	-	6.42
Critical Hdwy Stg 1	-	-	-	-	5.42
Critical Hdwy Stg 2	-	-	-	-	5.42
Follow-up Hdwy	-	-	2.218	-	3.518
Pot Cap-1 Maneuver	-	-	1314	-	189
Stage 1	-	-	-	-	802
Stage 2	-	-	-	-	348
Platoon blocked, %	-	-	-	-	-
Mov Cap-1 Maneuver	-	-	1314	-	178
Mov Cap-2 Maneuver	-	-	-	-	178
Stage 1	-	-	-	-	802
Stage 2	-	-	-	-	328

Approach	EB	WB	NB
HCM Control Delay, s	0	0.6	23.7
HCM LOS			C

Minor Lane/Major Mvmt	NBLn1	NBLn2	EBT	EBR	WBL	WBT
Capacity (veh/h)	178	801	-	-	1314	-
HCM Lane V/C Ratio	0.208	0.022	-	-	0.058	-
HCM Control Delay (s)	30.4	9.6	-	-	7.9	-
HCM Lane LOS	D	A	-	-	A	-
HCM 95th %tile Q(veh)	0.8	0.1	-	-	0.2	-

Intersection						
Int Delay, s/veh	1.1					
Movement	EBT	EBR	WBL	WBT	NBL	NBR
Lane Configurations						
Traffic Vol, veh/h	96	0	0	262	0	0
Future Vol, veh/h	235	0	137	868	0	36
Conflicting Peds, #/hr	0	0	0	0	0	0
Sign Control	Free	Free	Free	Free	Stop	Stop
RT Channelized	-	None	-	None	-	None
Storage Length	-	-	300	-	0	-
Veh in Median Storage, #	0	-	-	0	0	-
Grade, %	0	-	-	0	0	-
Peak Hour Factor	92	92	92	92	92	92
Heavy Vehicles, %	2	2	2	2	2	2
Mvmt Flow	255	0	149	943	0	39

Major/Minor	Major1	Major2	Minor1		
Conflicting Flow All	0	0	255	0	1496
Stage 1	-	-	-	-	255
Stage 2	-	-	-	-	1241
Critical Hdwy	-	-	4.12	-	6.42
Critical Hdwy Stg 1	-	-	-	-	5.42
Critical Hdwy Stg 2	-	-	-	-	5.42
Follow-up Hdwy	-	-	2.218	-	3.518
Pot Cap-1 Maneuver	-	-	1310	-	135
Stage 1	-	-	-	-	788
Stage 2	-	-	-	-	273
Platoon blocked, %	-	-	-	-	-
Mov Cap-1 Maneuver	-	-	1310	-	120
Mov Cap-2 Maneuver	-	-	-	-	120
Stage 1	-	-	-	-	788
Stage 2	-	-	-	-	242



















Approach	EB	WB	NB
HCM Control Delay, s	0	1.1	9.8
HCM LOS			A

Minor Lane/Major Mvmt	NBLn1	EBT	EBR	WBL	WBT
Capacity (veh/h)	784	-	-	1310	-
HCM Lane V/C Ratio	0.05	-	-	0.114	-
HCM Control Delay (s)	9.8	-	-	8.1	-
HCM Lane LOS	A	-	-	A	-
HCM 95th %tile Q(veh)	0.2	-	-	0.4	-

# HCM 6th Signalized Intersection Summary

## 3: I-25 NB Ramps & US 85

Buildout Traffic  
AM Peak Hour

												
Movement	EBL	EBT	EBR	WBL	WBT	WBR	NBL	NBT	NBR	SBL	SBT	SBR
Lane Configurations												
Traffic Volume (veh/h)	42	272	0	0	370	452	41	1	360	0	0	0
Future Volume (veh/h)	120	283	0	0	436	452	117	1	364	0	0	0
Initial Q (Qb), veh	0	0	0	0	0	0	0	0	0			
Ped-Bike Adj(A_pbT)	1.00		1.00	1.00		1.00	1.00		1.00			
Parking Bus, Adj	1.00	1.00	1.00	1.00	1.00	1.00	1.00	1.00	1.00			
Work Zone On Approach		No			No			No				
Adj Sat Flow, veh/h/ln	996	1752	0	0	1826	1885	1767	1900	1826			
Adj Flow Rate, veh/h	126	298	0	0	459	0	123	1	0			
Peak Hour Factor	0.95	0.95	0.95	0.95	0.95	0.95	0.95	0.95	0.95			
Percent Heavy Veh, %	61	10	0	0	5	1	9	0	5			
Cap, veh/h	427	1309	0	0	2127		162	1				
Arrive On Green	0.02	0.25	0.00	0.00	0.61	0.00	0.09	0.09	0.00			
Sat Flow, veh/h	949	1752	0	0	3561	1598	1796	15	1547			
Grp Volume(v), veh/h	126	298	0	0	459	0	124	0	0			
Grp Sat Flow(s),veh/h/ln	949	1752	0	0	1735	1598	1810	0	1547			
Q Serve(g_s), s	3.5	10.9	0.0	0.0	4.7	0.0	5.4	0.0	0.0			
Cycle Q Clear(g_c), s	3.5	10.9	0.0	0.0	4.7	0.0	5.4	0.0	0.0			
Prop In Lane	1.00		0.00	0.00		1.00	0.99		1.00			
Lane Grp Cap(c), veh/h	427	1309	0	0	2127		163	0				
V/C Ratio(X)	0.29	0.23	0.00	0.00	0.22		0.76	0.00				
Avail Cap(c_a), veh/h	478	1309	0	0	2127		419	0				
HCM Platoon Ratio	0.33	0.33	1.00	1.00	1.00	1.00	1.00	1.00	1.00			
Upstream Filter(I)	0.99	0.99	0.00	0.00	1.00	0.00	1.00	0.00	0.00			
Uniform Delay (d), s/veh	4.6	11.7	0.0	0.0	6.9	0.0	35.5	0.0	0.0			
Incr Delay (d2), s/veh	0.4	0.4	0.0	0.0	0.2	0.0	7.0	0.0	0.0			
Initial Q Delay(d3),s/veh	0.0	0.0	0.0	0.0	0.0	0.0	0.0	0.0	0.0			
%ile BackOfQ(50%),veh/ln	0.6	4.7	0.0	0.0	1.5	0.0	2.5	0.0	0.0			
Unsig. Movement Delay, s/veh												
LnGrp Delay(d),s/veh	5.0	12.1	0.0	0.0	7.1	0.0	42.6	0.0	0.0			
LnGrp LOS	A	B	A	A	A		D	A				
Approach Vol, veh/h		424			459			124				
Approach Delay, s/veh		10.0			7.1			42.6				
Approach LOS		A			A			D				
Timer - Assigned Phs		2			5	6		8				
Phs Duration (G+Y+Rc), s		66.3			10.7	55.6		13.7				
Change Period (Y+Rc), s		6.5			5.5	6.5		6.5				
Max Green Setting (Gmax), s		48.5			9.5	33.5		18.5				
Max Q Clear Time (g_c+I1), s		12.9			5.5	6.7		7.4				
Green Ext Time (p_c), s		1.8			0.1	3.1		0.4				

### Intersection Summary

HCM 6th Ctrl Delay	12.7
HCM 6th LOS	B

### Notes

Unsignalized Delay for [NBR, WBR] is excluded from calculations of the approach delay and intersection delay.



HCM 6th Signalized Intersection Summary  
6: I-25 SB Ramps & US 85

Buildout Traffic  
AM Peak Hour



Movement	EBL	EBT	EBR	WBL	WBT	WBR	NBL	NBT	NBR	SBL	SBT	SBR
Lane Configurations		↑↑	↗	↘	↑						↖	↗
Traffic Volume (veh/h)	0	119	27	163	249	0	0	0	0	195	3	148
Future Volume (veh/h)	0	208	47	182	372	0	0	0	0	195	3	467
Initial Q (Qb), veh	0	0	0	0	0	0				0	0	0
Ped-Bike Adj(A_pbT)	1.00		1.00	1.00		1.00				1.00		1.00
Parking Bus, Adj	1.00	1.00	1.00	1.00	1.00	1.00				1.00	1.00	1.00
Work Zone On Approach		No			No						No	
Adj Sat Flow, veh/h/ln	0	1411	1500	1781	1826	0				1796	1159	1663
Adj Flow Rate, veh/h	0	219	0	192	392	0				205	3	0
Peak Hour Factor	0.95	0.95	0.95	0.95	0.95	0.95				0.95	0.95	0.95
Percent Heavy Veh, %	0	33	27	8	5	0				7	50	16
Cap, veh/h	0	1271		695	1134	0				236	3	
Arrive On Green	0.00	0.47	0.00	0.08	0.62	0.00				0.22	0.22	0.00
Sat Flow, veh/h	0	2751	1271	1697	1826	0				1089	16	1409
Grp Volume(v), veh/h	0	219	0	192	392	0				208	0	0
Grp Sat Flow(s),veh/h/ln	0	1340	1271	1697	1826	0				1105	0	1409
Q Serve(g_s), s	0.0	3.7	0.0	4.3	8.3	0.0				14.5	0.0	0.0
Cycle Q Clear(g_c), s	0.0	3.7	0.0	4.3	8.3	0.0				14.5	0.0	0.0
Prop In Lane	0.00		1.00	1.00		0.00				0.99		1.00
Lane Grp Cap(c), veh/h	0	1271		695	1134	0				239	0	
V/C Ratio(X)	0.00	0.17		0.28	0.35	0.00				0.87	0.00	
Avail Cap(c_a), veh/h	0	1271		701	1134	0				463	0	
HCM Platoon Ratio	1.00	1.00	1.00	1.00	1.00	1.00				1.00	1.00	1.00
Upstream Filter(I)	0.00	1.00	0.00	0.98	0.98	0.00				1.00	0.00	0.00
Uniform Delay (d), s/veh	0.0	12.0	0.0	8.3	7.3	0.0				30.2	0.0	0.0
Incr Delay (d2), s/veh	0.0	0.3	0.0	0.2	0.8	0.0				9.3	0.0	0.0
Initial Q Delay(d3),s/veh	0.0	0.0	0.0	0.0	0.0	0.0				0.0	0.0	0.0
%ile BackOfQ(50%),veh/ln	0.0	1.1	0.0	1.4	2.9	0.0				4.2	0.0	0.0
Unsig. Movement Delay, s/veh												
LnGrp Delay(d),s/veh	0.0	12.3	0.0	8.5	8.1	0.0				39.6	0.0	0.0
LnGrp LOS	A	B		A	A	A				D	A	
Approach Vol, veh/h		219			584						208	
Approach Delay, s/veh		12.3			8.3						39.6	
Approach LOS		B			A						D	
Timer - Assigned Phs	1	2		4		6						
Phs Duration (G+Y+Rc), s	17	44.4		23.8		56.2						
Change Period (Y+Rc), s	5.5	6.5		6.5		6.5						
Max Green Setting (Gmax), s	10.5	21.5		33.5		33.5						
Max Q Clear Time (g_c+1/3), s	10.3	5.7		16.5		10.3						
Green Ext Time (p_c), s	0.0	1.1		1.0		2.3						

Intersection Summary

HCM 6th Ctrl Delay	15.6
HCM 6th LOS	B

Notes

Unsignalized Delay for [EBR, SBR] is excluded from calculations of the approach delay and intersection delay.

Intersection				
Intersection Delay, s/veh	9.0			
Intersection LOS	A			
Approach	EB	WB	NB	SB
Entry Lanes	1	1	1	1
Conflicting Circle Lanes	1	1	1	1
Adj Approach Flow, veh/h	16	806	190	82
Demand Flow Rate, veh/h	22	841	204	90
Vehicles Circulating, veh/h	819	15	97	755
Vehicles Exiting, veh/h	26	286	744	101
Ped Vol Crossing Leg, #/h	0	0	0	0
Ped Cap Adj	1.000	1.000	1.000	1.000
Approach Delay, s/veh	8.8	10.2	4.5	7.9
Approach LOS	A	B	A	A
Lane	Left	Left	Left	Left
Designated Moves	LTR	LTR	LTR	LTR
Assumed Moves	LTR	LTR	LTR	LTR
RT Channelized				
Lane Util	1.000	1.000	1.000	1.000
Follow-Up Headway, s	2.609	2.609	2.609	2.609
Critical Headway, s	4.976	4.976	4.976	4.976
Entry Flow, veh/h	22	841	204	90
Cap Entry Lane, veh/h	599	1359	1250	639
Entry HV Adj Factor	0.727	0.958	0.931	0.910
Flow Entry, veh/h	16	806	190	82
Cap Entry, veh/h	435	1302	1163	581
V/C Ratio	0.037	0.619	0.163	0.141
Control Delay, s/veh	8.8	10.2	4.5	7.9
LOS	A	B	A	A
95th %tile Queue, veh	0	5	1	0

HCM 6th TWSC  
 15: Fountain Utilities access & Charter Oak Ranch Rd

Buildout Traffic  
 AM Peak Hour

Intersection												
Int Delay, s/veh	0.4											
Movement	EBL	EBT	EBR	WBL	WBT	WBR	NBL	NBT	NBR	SBL	SBT	SBR
Lane Configurations		↕		↕	↕			↕			↕	
Traffic Vol, veh/h	0	59	0	28	165	1	1	0	9	0	0	1
Future Vol, veh/h	0	168	0	28	607	1	1	0	9	0	0	1
Conflicting Peds, #/hr	0	0	0	0	0	0	0	0	0	0	0	0
Sign Control	Free	Free	Free	Free	Free	Free	Stop	Stop	Stop	Stop	Stop	Stop
RT Channelized	-	-	None	-	-	None	-	-	None	-	-	None
Storage Length	-	-	-	300	-	-	-	-	-	-	-	-
Veh in Median Storage, #	-	0	-	-	0	-	-	0	-	-	0	-
Grade, %	-	0	-	-	0	-	-	0	-	-	0	-
Peak Hour Factor	95	95	95	95	95	95	95	95	95	95	95	95
Heavy Vehicles, %	2	5	2	9	3	0	100	2	57	2	2	0
Mvmt Flow	0	177	0	29	639	1	1	0	9	0	0	1

Major/Minor	Major1			Major2			Minor1			Minor2		
Conflicting Flow All	640	0	0	177	0	0	875	875	177	880	875	640
Stage 1	-	-	-	-	-	-	177	177	-	698	698	-
Stage 2	-	-	-	-	-	-	698	698	-	182	177	-
Critical Hdwy	4.12	-	-	4.19	-	-	8.1	6.52	6.77	7.12	6.52	6.2
Critical Hdwy Stg 1	-	-	-	-	-	-	7.1	5.52	-	6.12	5.52	-
Critical Hdwy Stg 2	-	-	-	-	-	-	7.1	5.52	-	6.12	5.52	-
Follow-up Hdwy	2.218	-	-	2.281	-	-	4.4	4.018	3.813	3.518	4.018	3.3
Pot Cap-1 Maneuver	944	-	-	1358	-	-	186	288	742	268	288	479
Stage 1	-	-	-	-	-	-	642	753	-	431	442	-
Stage 2	-	-	-	-	-	-	307	442	-	820	753	-
Platoon blocked, %	-	-	-	-	-	-	-	-	-	-	-	-
Mov Cap-1 Maneuver	944	-	-	1358	-	-	183	282	742	260	282	479
Mov Cap-2 Maneuver	-	-	-	-	-	-	183	282	-	260	282	-
Stage 1	-	-	-	-	-	-	642	753	-	431	433	-
Stage 2	-	-	-	-	-	-	300	433	-	810	753	-

Approach	EB			WB			NB			SB		
HCM Control Delay, s	0			0.3			11.5			12.5		
HCM LOS							B			B		

Minor Lane/Major Mvmt	NBLn1	EBL	EBT	EBR	WBL	WBT	WBR	SBLn1
Capacity (veh/h)	568	944	-	-	1358	-	-	479
HCM Lane V/C Ratio	0.019	-	-	-	0.022	-	-	0.002
HCM Control Delay (s)	11.5	0	-	-	7.7	-	-	12.5
HCM Lane LOS	B	A	-	-	A	-	-	B
HCM 95th %tile Q(veh)	0.1	0	-	-	0.1	-	-	0

Intersection						
Int Delay, s/veh	15.6					
Movement	EBT	EBR	WBL	WBT	NBL	NBR
Lane Configurations	↔		↔	↑	↔	↔
Traffic Vol, veh/h	59	55	0	168	162	0
Future Vol, veh/h	59	55	279	168	162	71
Conflicting Peds, #/hr	0	0	0	0	0	0
Sign Control	Free	Free	Free	Free	Stop	Stop
RT Channelized	-	None	-	None	-	Free
Storage Length	-	-	350	-	0	0
Veh in Median Storage, #	0	-	-	0	0	-
Grade, %	0	-	-	0	0	-
Peak Hour Factor	95	95	95	95	95	95
Heavy Vehicles, %	0	2	100	0	2	67
Mvmt Flow	62	58	294	177	171	75

Major/Minor	Major1	Major2	Minor1		
Conflicting Flow All	0	0	120	0	856
Stage 1	-	-	-	-	91
Stage 2	-	-	-	-	765
Critical Hdwy	-	-	5.1	-	6.42
Critical Hdwy Stg 1	-	-	-	-	5.42
Critical Hdwy Stg 2	-	-	-	-	5.42
Follow-up Hdwy	-	-	3.1	-	3.518
Pot Cap-1 Maneuver	-	-	1031	-	328
Stage 1	-	-	-	-	933
Stage 2	-	-	-	-	459
Platoon blocked, %	-	-	-	-	-
Mov Cap-1 Maneuver	-	-	1031	-	235
Mov Cap-2 Maneuver	-	-	-	-	235
Stage 1	-	-	-	-	933
Stage 2	-	-	-	-	328

Approach	EB	WB	NB
HCM Control Delay, s	0	6.2	52.5
HCM LOS			F

Minor Lane/Major Mvmt	NBLn1	NBLn2	EBT	EBR	WBL	WBT
Capacity (veh/h)	235	-	-	-	1031	-
HCM Lane V/C Ratio	0.726	-	-	-	0.285	-
HCM Control Delay (s)	52.5	0	-	-	9.9	-
HCM Lane LOS	F	A	-	-	A	-
HCM 95th %tile Q(veh)	4.9	-	-	-	1.2	-

Intersection						
Int Delay, s/veh	1.8					
Movement	EBT	EBR	WBL	WBT	NBL	NBR
Lane Configurations	↑	↗	↘	↑	↘	↗
Traffic Vol, veh/h	59	0	0	168	0	0
Future Vol, veh/h	118	12	69	413	34	16
Conflicting Peds, #/hr	0	0	0	0	0	0
Sign Control	Free	Free	Free	Free	Stop	Stop
RT Channelized	-	None	-	None	-	None
Storage Length	-	0	250	-	150	0
Veh in Median Storage, #	0	-	-	0	0	-
Grade, %	0	-	-	0	0	-
Peak Hour Factor	95	95	95	95	95	95
Heavy Vehicles, %	2	2	2	2	2	2
Mvmt Flow	124	13	73	435	36	17

Major/Minor	Major1	Major2	Minor1		
Conflicting Flow All	0	0	137	0	705
Stage 1	-	-	-	-	124
Stage 2	-	-	-	-	581
Critical Hdwy	-	-	4.12	-	6.42
Critical Hdwy Stg 1	-	-	-	-	5.42
Critical Hdwy Stg 2	-	-	-	-	5.42
Follow-up Hdwy	-	-	2.218	-	3.518
Pot Cap-1 Maneuver	-	-	1447	-	403
Stage 1	-	-	-	-	902
Stage 2	-	-	-	-	559
Platoon blocked, %	-	-	-	-	-
Mov Cap-1 Maneuver	-	-	1447	-	383
Mov Cap-2 Maneuver	-	-	-	-	383
Stage 1	-	-	-	-	902
Stage 2	-	-	-	-	531

Approach	EB	WB	NB
HCM Control Delay, s	0	1.1	13.4
HCM LOS			B



















Minor Lane/Major Mvmt	NBLn1	NBLn2	EBT	EBR	WBL	WBT
Capacity (veh/h)	383	927	-	-	1447	-
HCM Lane V/C Ratio	0.093	0.018	-	-	0.05	-
HCM Control Delay (s)	15.4	9	-	-	7.6	-
HCM Lane LOS	C	A	-	-	A	-
HCM 95th %tile Q(veh)	0.3	0.1	-	-	0.2	-

Intersection						
Int Delay, s/veh	1.7					
Movement	EBT	EBR	WBL	WBT	NBL	NBR
Lane Configurations						
Traffic Vol, veh/h	59	0	0	168	0	0
Future Vol, veh/h	134	0	128	482	0	34
Conflicting Peds, #/hr	0	0	0	0	0	0
Sign Control	Free	Free	Free	Free	Stop	Stop
RT Channelized	-	None	-	None	-	None
Storage Length	-	-	300	-	0	-
Veh in Median Storage, #	0	-	-	0	0	-
Grade, %	0	-	-	0	0	-
Peak Hour Factor	95	95	95	95	95	95
Heavy Vehicles, %	2	2	2	2	2	2
Mvmt Flow	141	0	135	507	0	36
Major/Minor	Major1	Major2	Minor1			
Conflicting Flow All	0	0	141	0	918	141
Stage 1	-	-	-	-	141	-
Stage 2	-	-	-	-	777	-
Critical Hdwy	-	-	4.12	-	6.42	6.22
Critical Hdwy Stg 1	-	-	-	-	5.42	-
Critical Hdwy Stg 2	-	-	-	-	5.42	-
Follow-up Hdwy	-	-	2.218	-	3.518	3.318
Pot Cap-1 Maneuver	-	-	1442	-	302	907
Stage 1	-	-	-	-	886	-
Stage 2	-	-	-	-	453	-
Platoon blocked, %	-	-	-	-	-	-
Mov Cap-1 Maneuver	-	-	1442	-	274	907
Mov Cap-2 Maneuver	-	-	-	-	274	-
Stage 1	-	-	-	-	886	-
Stage 2	-	-	-	-	410	-
Approach	EB	WB	NB			
HCM Control Delay, s	0	1.6	9.1			
HCM LOS			A			
Minor Lane/Major Mvmt	NBLn1	EBT	EBR	WBL	WBT	
Capacity (veh/h)	907	-	-	1442	-	
HCM Lane V/C Ratio	0.039	-	-	0.093	-	
HCM Control Delay (s)	9.1	-	-	7.8	-	
HCM Lane LOS	A	-	-	A	-	
HCM 95th %tile Q(veh)	0.1	-	-	0.3	-	

# HCM 6th Signalized Intersection Summary

## 3: I-25 NB Ramps & US 85

Phase 1-2 Traffic  
PM Peak Hour

												
Movement	EBL	EBT	EBR	WBL	WBT	WBR	NBL	NBT	NBR	SBL	SBT	SBR
Lane Configurations												
Traffic Volume (veh/h)	187	621	0	0	177	73	24	29	531	0	0	0
Future Volume (veh/h)	515	667	0	0	194	73	59	29	531	0	0	0
Initial Q (Qb), veh	0	0	0	0	0	0	0	0	0			
Ped-Bike Adj(A_pbT)	1.00		1.00	1.00		1.00	1.00		1.00			
Parking Bus, Adj	1.00	1.00	1.00	1.00	1.00	1.00	1.00	1.00	1.00			
Work Zone On Approach		No			No			No				
Adj Sat Flow, veh/h/ln	1826	1870	0	0	1796	1781	1455	1900	1781			
Adj Flow Rate, veh/h	606	785	0	0	228	0	69	34	0			
Peak Hour Factor	0.85	0.85	0.85	0.85	0.85	0.85	0.85	0.85	0.85			
Percent Heavy Veh, %	5	2	0	0	7	8	30	0	8			
Cap, veh/h	925	1463	0	0	2101		90	44				
Arrive On Green	0.14	1.00	0.00	0.00	0.62	0.00	0.07	0.07	0.00			
Sat Flow, veh/h	1739	1870	0	0	3503	1510	1232	607	1510			
Grp Volume(v), veh/h	606	785	0	0	228	0	103	0	0			
Grp Sat Flow(s),veh/h/ln	1739	1870	0	0	1706	1510	1838	0	1510			
Q Serve(g_s), s	9.5	0.0	0.0	0.0	2.5	0.0	5.0	0.0	0.0			
Cycle Q Clear(g_c), s	9.5	0.0	0.0	0.0	2.5	0.0	5.0	0.0	0.0			
Prop In Lane	1.00		0.00	0.00		1.00	0.67		1.00			
Lane Grp Cap(c), veh/h	925	1463	0	0	2101		135	0				
V/C Ratio(X)	0.65	0.54	0.00	0.00	0.11		0.76	0.00				
Avail Cap(c_a), veh/h	925	1463	0	0	2101		276	0				
HCM Platoon Ratio	1.33	1.33	1.00	1.00	1.00	1.00	1.00	1.00	1.00			
Upstream Filter(I)	0.63	0.63	0.00	0.00	1.00	0.00	1.00	0.00	0.00			
Uniform Delay (d), s/veh	5.8	0.0	0.0	0.0	7.1	0.0	40.9	0.0	0.0			
Incr Delay (d2), s/veh	1.1	0.9	0.0	0.0	0.1	0.0	8.7	0.0	0.0			
Initial Q Delay(d3),s/veh	0.0	0.0	0.0	0.0	0.0	0.0	0.0	0.0	0.0			
%ile BackOfQ(50%),veh/ln	3.1	0.4	0.0	0.0	0.8	0.0	2.5	0.0	0.0			
Unsig. Movement Delay, s/veh												
LnGrp Delay(d),s/veh	6.8	0.9	0.0	0.0	7.2	0.0	49.6	0.0	0.0			
LnGrp LOS	A	A	A	A	A		D	A				
Approach Vol, veh/h		1391			228			103				
Approach Delay, s/veh		3.5			7.2			49.6				
Approach LOS		A			A			D				
Timer - Assigned Phs		2			5	6		8				
Phs Duration (G+Y+Rc), s		76.9			15.0	61.9		13.1				
Change Period (Y+Rc), s		6.5			5.5	6.5		6.5				
Max Green Setting (Gmax), s		63.5			9.5	48.5		13.5				
Max Q Clear Time (g_c+I1), s		2.0			11.5	4.5		7.0				
Green Ext Time (p_c), s		6.8			0.0	1.5		0.2				

### Intersection Summary

HCM 6th Ctrl Delay	6.7
HCM 6th LOS	A

### Notes

User approved pedestrian interval to be less than phase max green.

Unsignalized Delay for [NBR, WBR] is excluded from calculations of the approach delay and intersection delay.



HCM 6th Signalized Intersection Summary  
6: I-25 SB Ramps & US 85

Phase 1-2 Traffic  
PM Peak Hour



Movement	EBL	EBT	EBR	WBL	WBT	WBR	NBL	NBT	NBR	SBL	SBT	SBR
Lane Configurations		↑↑	↗	↖	↑						↖	↗
Traffic Volume (veh/h)	0	539	142	146	55	0	0	0	0	269	5	146
Future Volume (veh/h)	0	913	236	146	107	0	0	0	0	269	5	269
Initial Q (Qb), veh	0	0	0	0	0	0				0	0	0
Ped-Bike Adj(A_pbT)	1.00		1.00	1.00		1.00				1.00		1.00
Parking Bus, Adj	1.00	1.00	1.00	1.00	1.00	1.00				1.00	1.00	1.00
Work Zone On Approach		No			No						No	
Adj Sat Flow, veh/h/ln	0	1856	1767	1826	1500	0				1885	1870	1796
Adj Flow Rate, veh/h	0	1074	0	172	126	0				316	6	0
Peak Hour Factor	0.85	0.85	0.85	0.85	0.85	0.85				0.85	0.85	0.85
Percent Heavy Veh, %	0	3	9	5	27	0				1	2	7
Cap, veh/h	0	1816		349	962	0				375	7	
Arrive On Green	0.00	0.52	0.00	0.07	0.64	0.00				0.21	0.21	0.00
Sat Flow, veh/h	0	3618	1497	1739	1500	0				1750	33	1522
Grp Volume(v), veh/h	0	1074	0	172	126	0				322	0	0
Grp Sat Flow(s),veh/h/ln	0	1763	1497	1739	1500	0				1783	0	1522
Q Serve(g_s), s	0.0	19.1	0.0	3.9	3.0	0.0				15.6	0.0	0.0
Cycle Q Clear(g_c), s	0.0	19.1	0.0	3.9	3.0	0.0				15.6	0.0	0.0
Prop In Lane	0.00		1.00	1.00		0.00				0.98		1.00
Lane Grp Cap(c), veh/h	0	1816		349	962	0				382	0	
V/C Ratio(X)	0.00	0.59		0.49	0.13	0.00				0.84	0.00	
Avail Cap(c_a), veh/h	0	1816		361	962	0				763	0	
HCM Platoon Ratio	1.00	1.00	1.00	1.00	1.00	1.00				1.00	1.00	1.00
Upstream Filter(I)	0.00	1.00	0.00	1.00	1.00	0.00				1.00	0.00	0.00
Uniform Delay (d), s/veh	0.0	15.2	0.0	11.6	6.3	0.0				33.9	0.0	0.0
Incr Delay (d2), s/veh	0.0	1.4	0.0	1.1	0.3	0.0				5.1	0.0	0.0
Initial Q Delay(d3),s/veh	0.0	0.0	0.0	0.0	0.0	0.0				0.0	0.0	0.0
%ile BackOfQ(50%),veh/ln	0.0	7.3	0.0	1.4	0.9	0.0				6.9	0.0	0.0
Unsig. Movement Delay, s/veh												
LnGrp Delay(d),s/veh	0.0	16.6	0.0	12.7	6.6	0.0				39.0	0.0	0.0
LnGrp LOS	A	B		B	A	A				D	A	
Approach Vol, veh/h		1074			298						322	
Approach Delay, s/veh		16.6			10.1						39.0	
Approach LOS		B			B						D	
Timer - Assigned Phs	1	2		4		6						
Phs Duration (G+Y+Rc), s	1.4	52.9		25.8		64.2						
Change Period (Y+Rc), s	5.5	6.5		6.5		6.5						
Max Green Setting (Gmax), s	6.5	26.5		38.5		38.5						
Max Q Clear Time (g_c+1/5), s	15.5	21.1		17.6		5.0						
Green Ext Time (p_c), s	0.0	3.2		1.7		0.7						

Intersection Summary

HCM 6th Ctrl Delay	19.8
HCM 6th LOS	B

Notes

Unsignalized Delay for [EBR, SBR] is excluded from calculations of the approach delay and intersection delay.

Intersection				
Intersection Delay, s/veh	25.3			
Intersection LOS	D			
Approach	EB	WB	NB	SB
Entry Lanes	1	1	1	1
Conflicting Circle Lanes	1	1	1	1
Adj Approach Flow, veh/h	26	338	1104	83
Demand Flow Rate, veh/h	27	371	1104	89
Vehicles Circulating, veh/h	417	14	162	343
Vehicles Exiting, veh/h	15	1252	282	42
Ped Vol Crossing Leg, #/h	0	0	0	0
Ped Cap Adj	1.000	1.000	1.000	1.000
Approach Delay, s/veh	4.4	5.4	33.5	4.8
Approach LOS	A	A	D	A
Lane	Left	Left	Left	Left
Designated Moves	LTR	LTR	LTR	LTR
Assumed Moves	LTR	LTR	LTR	LTR
RT Channelized				
Lane Util	1.000	1.000	1.000	1.000
Follow-Up Headway, s	2.609	2.609	2.609	2.609
Critical Headway, s	4.976	4.976	4.976	4.976
Entry Flow, veh/h	27	371	1104	89
Cap Entry Lane, veh/h	902	1360	1170	973
Entry HV Adj Factor	0.963	0.911	1.000	0.933
Flow Entry, veh/h	26	338	1104	83
Cap Entry, veh/h	868	1240	1170	907
V/C Ratio	0.030	0.273	0.944	0.092
Control Delay, s/veh	4.4	5.4	33.5	4.8
LOS	A	A	D	A
95th %tile Queue, veh	0	1	17	0

Intersection												
Int Delay, s/veh	0.2											
Movement	EBL	EBT	EBR	WBL	WBT	WBR	NBL	NBT	NBR	SBL	SBT	SBR
Lane Configurations		↕		↕	↕			↕			↕	
Traffic Vol, veh/h	0	360	0	1	42	0	0	0	14	0	0	0
Future Vol, veh/h	0	828	0	1	217	0	0	0	14	0	0	0
Conflicting Peds, #/hr	0	0	0	0	0	0	0	0	0	0	0	0
Sign Control	Free	Free	Free	Free	Free	Free	Stop	Stop	Stop	Stop	Stop	Stop
RT Channelized	-	-	None	-	-	None	-	-	None	-	-	None
Storage Length	-	-	-	300	-	-	-	-	-	-	-	-
Veh in Median Storage, #	-	0	-	-	0	-	-	0	-	-	0	-
Grade, %	-	0	-	-	0	-	-	0	-	-	0	-
Peak Hour Factor	85	85	85	85	85	85	85	85	85	85	85	85
Heavy Vehicles, %	2	0	2	0	12	2	2	2	0	2	2	2
Mvmt Flow	0	974	0	1	255	0	0	0	16	0	0	0

Major/Minor	Major1			Major2			Minor1			Minor2		
Conflicting Flow All	255	0	0	974	0	0	1231	1231	974	1239	1231	255
Stage 1	-	-	-	-	-	-	974	974	-	257	257	-
Stage 2	-	-	-	-	-	-	257	257	-	982	974	-
Critical Hdwy	4.12	-	-	4.1	-	-	7.12	6.52	6.2	7.12	6.52	6.22
Critical Hdwy Stg 1	-	-	-	-	-	-	6.12	5.52	-	6.12	5.52	-
Critical Hdwy Stg 2	-	-	-	-	-	-	6.12	5.52	-	6.12	5.52	-
Follow-up Hdwy	2.218	-	-	2.2	-	-	3.518	4.018	3.3	3.518	4.018	3.318
Pot Cap-1 Maneuver	1310	-	-	716	-	-	154	177	308	152	177	784
Stage 1	-	-	-	-	-	-	303	330	-	748	695	-
Stage 2	-	-	-	-	-	-	748	695	-	300	330	-
Platoon blocked, %		-	-		-	-						
Mov Cap-1 Maneuver	1310	-	-	716	-	-	154	177	308	144	177	784
Mov Cap-2 Maneuver	-	-	-	-	-	-	154	177	-	144	177	-
Stage 1	-	-	-	-	-	-	303	330	-	748	694	-
Stage 2	-	-	-	-	-	-	747	694	-	284	330	-

Approach	EB			WB			NB			SB		
HCM Control Delay, s	0			0			17.3			0		
HCM LOS							C			A		

Minor Lane/Major Mvmt	NBLn1	EBL	EBT	EBR	WBL	WBT	WBR	SBLn1
Capacity (veh/h)	308	1310	-	-	716	-	-	-
HCM Lane V/C Ratio	0.053	-	-	-	0.002	-	-	-
HCM Control Delay (s)	17.3	0	-	-	10	-	-	0
HCM Lane LOS	C	A	-	-	B	-	-	A
HCM 95th %tile Q(veh)	0.2	0	-	-	0	-	-	-

Intersection						
Int Delay, s/veh	1.5					
Movement	EBT	EBR	WBL	WBT	NBL	NBR
Lane Configurations	↔		↔	↑	↔	↔
Traffic Vol, veh/h	349	0	0	37	0	0
Future Vol, veh/h	349	0	77	37	0	270
Conflicting Peds, #/hr	0	0	0	0	0	0
Sign Control	Free	Free	Free	Free	Stop	Stop
RT Channelized	-	None	-	None	-	Free
Storage Length	-	-	350	-	0	0
Veh in Median Storage, #	0	-	-	0	0	-
Grade, %	0	-	-	0	0	-
Peak Hour Factor	85	85	85	85	85	85
Heavy Vehicles, %	0	2	33	6	2	17
Mvmt Flow	411	0	91	44	0	318

Major/Minor	Major1	Major2	Minor1	Minor2	Minor3
Conflicting Flow All	0	0	411	0	637
Stage 1	-	-	-	-	411
Stage 2	-	-	-	-	226
Critical Hdwy	-	-	4.43	-	6.42
Critical Hdwy Stg 1	-	-	-	-	5.42
Critical Hdwy Stg 2	-	-	-	-	5.42
Follow-up Hdwy	-	-	2.497	-	3.518
Pot Cap-1 Maneuver	-	-	999	-	441
Stage 1	-	-	-	-	669
Stage 2	-	-	-	-	812
Platoon blocked, %	-	-	-	-	-
Mov Cap-1 Maneuver	-	-	999	-	401
Mov Cap-2 Maneuver	-	-	-	-	401
Stage 1	-	-	-	-	669
Stage 2	-	-	-	-	738

Approach	EB	WB	NB
HCM Control Delay, s	0	6.1	0
HCM LOS			A

Minor Lane/Major Mvmt	NBLn1	NBLn2	EBT	EBR	WBL	WBT
Capacity (veh/h)	-	-	-	-	999	-
HCM Lane V/C Ratio	-	-	-	-	0.091	-
HCM Control Delay (s)	0	0	-	-	9	-
HCM Lane LOS	A	A	-	-	A	-
HCM 95th %tile Q(veh)	-	-	-	-	0.3	-

Intersection						
Int Delay, s/veh	4.2					
Movement	EBT	EBR	WBL	WBT	NBL	NBR
Lane Configurations	↑	↗	↖	↑	↖	↗
Traffic Vol, veh/h	357	0	0	42	0	0
Future Vol, veh/h	504	123	71	104	15	186
Conflicting Peds, #/hr	0	0	0	0	0	0
Sign Control	Free	Free	Free	Free	Stop	Stop
RT Channelized	-	None	-	None	-	None
Storage Length	-	0	250	-	150	0
Veh in Median Storage, #	0	-	-	0	0	-
Grade, %	0	-	-	0	0	-
Peak Hour Factor	85	85	85	85	85	85
Heavy Vehicles, %	2	2	2	2	2	2
Mvmt Flow	593	145	84	122	18	219

Major/Minor	Major1	Major2	Minor1		
Conflicting Flow All	0	0	738	0	883
Stage 1	-	-	-	-	593
Stage 2	-	-	-	-	290
Critical Hdwy	-	-	4.12	-	6.42
Critical Hdwy Stg 1	-	-	-	-	5.42
Critical Hdwy Stg 2	-	-	-	-	5.42
Follow-up Hdwy	-	-	2.218	-	3.518
Pot Cap-1 Maneuver	-	-	868	-	316
Stage 1	-	-	-	-	552
Stage 2	-	-	-	-	759
Platoon blocked, %	-	-	-	-	-
Mov Cap-1 Maneuver	-	-	868	-	285
Mov Cap-2 Maneuver	-	-	-	-	285
Stage 1	-	-	-	-	552
Stage 2	-	-	-	-	685

Approach	EB	WB	NB
HCM Control Delay, s	0	3.9	17.5
HCM LOS			C

Minor Lane/Major Mvmt	NBLn1	NBLn2	EBT	EBR	WBL	WBT
Capacity (veh/h)	285	506	-	-	868	-
HCM Lane V/C Ratio	0.062	0.432	-	-	0.096	-
HCM Control Delay (s)	18.5	17.4	-	-	9.6	-
HCM Lane LOS	C	C	-	-	A	-
HCM 95th %tile Q(veh)	0.2	2.2	-	-	0.3	-

Intersection						
Int Delay, s/veh	3.1					
Movement	EBT	EBR	WBL	WBT	NBL	NBR
Lane Configurations	↶		↷	↶	↷	
Traffic Vol, veh/h	357	0	0	42	0	0
Future Vol, veh/h	690	0	42	175	0	135
Conflicting Peds, #/hr	0	0	0	0	0	0
Sign Control	Free	Free	Free	Free	Stop	Stop
RT Channelized	-	None	-	None	-	None
Storage Length	-	-	300	-	0	-
Veh in Median Storage, #	0	-	-	0	0	-
Grade, %	0	-	-	0	0	-
Peak Hour Factor	85	85	85	85	85	85
Heavy Vehicles, %	2	2	2	2	2	2
Mvmt Flow	812	0	49	206	0	159

Major/Minor	Major1	Major2	Minor1	Minor2	Minor3
Conflicting Flow All	0	0	812	0	1116
Stage 1	-	-	-	-	812
Stage 2	-	-	-	-	304
Critical Hdwy	-	-	4.12	-	6.42
Critical Hdwy Stg 1	-	-	-	-	5.42
Critical Hdwy Stg 2	-	-	-	-	5.42
Follow-up Hdwy	-	-	2.218	-	3.518
Pot Cap-1 Maneuver	-	-	814	-	230
Stage 1	-	-	-	-	437
Stage 2	-	-	-	-	748
Platoon blocked, %	-	-	-	-	-
Mov Cap-1 Maneuver	-	-	814	-	216
Mov Cap-2 Maneuver	-	-	-	-	216
Stage 1	-	-	-	-	437
Stage 2	-	-	-	-	703



















Approach	EB	WB	NB
HCM Control Delay, s	0	1.9	21.2
HCM LOS			C

Minor Lane/Major Mvmt	NBLn1	EBT	EBR	WBL	WBT
Capacity (veh/h)	379	-	-	814	-
HCM Lane V/C Ratio	0.419	-	-	0.061	-
HCM Control Delay (s)	21.2	-	-	9.7	-
HCM Lane LOS	C	-	-	A	-
HCM 95th %tile Q(veh)	2	-	-	0.2	-

# HCM 6th Signalized Intersection Summary

## 3: I-25 NB Ramps & US 85

Phase 1-3 Traffic  
PM Peak Hour

												
Movement	EBL	EBT	EBR	WBL	WBT	WBR	NBL	NBT	NBR	SBL	SBT	SBR
Lane Configurations												
Traffic Volume (veh/h)	219	728	0	0	191	77	26	30	564	0	0	0
Future Volume (veh/h)	743	802	0	0	216	77	77	30	564	0	0	0
Initial Q (Qb), veh	0	0	0	0	0	0	0	0	0			
Ped-Bike Adj(A_pbT)	1.00		1.00	1.00		1.00	1.00		1.00			
Parking Bus, Adj	1.00	1.00	1.00	1.00	1.00	1.00	1.00	1.00	1.00			
Work Zone On Approach		No			No			No				
Adj Sat Flow, veh/h/ln	1826	1870	0	0	1796	1781	1455	1900	1781			
Adj Flow Rate, veh/h	808	872	0	0	235	0	84	33	0			
Peak Hour Factor	0.92	0.92	0.92	0.92	0.92	0.92	0.92	0.92	0.92			
Percent Heavy Veh, %	5	2	0	0	7	8	30	0	8			
Cap, veh/h	909	1446	0	0	2070		108	43				
Arrive On Green	0.14	1.00	0.00	0.00	0.61	0.00	0.08	0.08	0.00			
Sat Flow, veh/h	1739	1870	0	0	3503	1510	1317	517	1510			
Grp Volume(v), veh/h	808	872	0	0	235	0	117	0	0			
Grp Sat Flow(s),veh/h/ln	1739	1870	0	0	1706	1510	1834	0	1510			
Q Serve(g_s), s	9.5	0.0	0.0	0.0	2.6	0.0	5.6	0.0	0.0			
Cycle Q Clear(g_c), s	9.5	0.0	0.0	0.0	2.6	0.0	5.6	0.0	0.0			
Prop In Lane	1.00		0.00	0.00		1.00	0.72		1.00			
Lane Grp Cap(c), veh/h	909	1446	0	0	2070		151	0				
V/C Ratio(X)	0.89	0.60	0.00	0.00	0.11		0.77	0.00				
Avail Cap(c_a), veh/h	909	1446	0	0	2070		275	0				
HCM Platoon Ratio	1.33	1.33	1.00	1.00	1.00	1.00	1.00	1.00	1.00			
Upstream Filter(I)	0.32	0.32	0.00	0.00	1.00	0.00	1.00	0.00	0.00			
Uniform Delay (d), s/veh	11.0	0.0	0.0	0.0	7.5	0.0	40.5	0.0	0.0			
Incr Delay (d2), s/veh	3.9	0.6	0.0	0.0	0.1	0.0	8.2	0.0	0.0			
Initial Q Delay(d3),s/veh	0.0	0.0	0.0	0.0	0.0	0.0	0.0	0.0	0.0			
%ile BackOfQ(50%),veh/ln	7.5	0.2	0.0	0.0	0.9	0.0	2.8	0.0	0.0			
Unsig. Movement Delay, s/veh												
LnGrp Delay(d),s/veh	14.9	0.6	0.0	0.0	7.6	0.0	48.7	0.0	0.0			
LnGrp LOS	B	A	A	A	A		D	A				
Approach Vol, veh/h		1680			235			117				
Approach Delay, s/veh		7.5			7.6			48.7				
Approach LOS		A			A			D				
Timer - Assigned Phs		2			5	6		8				
Phs Duration (G+Y+Rc), s		76.1			15.0	61.1		13.9				
Change Period (Y+Rc), s		6.5			5.5	6.5		6.5				
Max Green Setting (Gmax), s		63.5			9.5	48.5		13.5				
Max Q Clear Time (g_c+I1), s		2.0			11.5	4.6		7.6				
Green Ext Time (p_c), s		8.3			0.0	1.6		0.2				

### Intersection Summary

HCM 6th Ctrl Delay	9.9
HCM 6th LOS	A

### Notes

User approved pedestrian interval to be less than phase max green.  
 Unsignalized Delay for [NBR, WBR] is excluded from calculations of the approach delay and intersection delay.



HCM 6th Signalized Intersection Summary  
6: I-25 SB Ramps & US 85

Phase 1-3 Traffic  
PM Peak Hour



Movement	EBL	EBT	EBR	WBL	WBT	WBR	NBL	NBT	NBR	SBL	SBT	SBR
Lane Configurations		↑↑	↗	↘	↑						↖	↗
Traffic Volume (veh/h)	0	661	174	155	62	0	0	0	0	286	5	165
Future Volume (veh/h)	0	1259	324	155	138	0	0	0	0	286	5	343
Initial Q (Qb), veh	0	0	0	0	0	0				0	0	0
Ped-Bike Adj(A_pbT)	1.00		1.00	1.00		1.00				1.00		1.00
Parking Bus, Adj	1.00	1.00	1.00	1.00	1.00	1.00				1.00	1.00	1.00
Work Zone On Approach		No			No						No	
Adj Sat Flow, veh/h/ln	0	1856	1767	1826	1500	0				1885	1870	1796
Adj Flow Rate, veh/h	0	1368	0	168	150	0				311	5	0
Peak Hour Factor	0.92	0.92	0.92	0.92	0.92	0.92				0.92	0.92	0.92
Percent Heavy Veh, %	0	3	9	5	27	0				1	2	7
Cap, veh/h	0	1834		275	967	0				369	6	
Arrive On Green	0.00	0.52	0.00	0.06	0.64	0.00				0.21	0.21	0.00
Sat Flow, veh/h	0	3618	1497	1739	1500	0				1754	28	1522
Grp Volume(v), veh/h	0	1368	0	168	150	0				316	0	0
Grp Sat Flow(s),veh/h/ln	0	1763	1497	1739	1500	0				1783	0	1522
Q Serve(g_s), s	0.0	27.4	0.0	3.8	3.6	0.0				15.3	0.0	0.0
Cycle Q Clear(g_c), s	0.0	27.4	0.0	3.8	3.6	0.0				15.3	0.0	0.0
Prop In Lane	0.00		1.00	1.00		0.00				0.98		1.00
Lane Grp Cap(c), veh/h	0	1834		275	967	0				375	0	
V/C Ratio(X)	0.00	0.75		0.61	0.16	0.00				0.84	0.00	
Avail Cap(c_a), veh/h	0	1834		289	967	0				763	0	
HCM Platoon Ratio	1.00	1.00	1.00	1.00	1.00	1.00				1.00	1.00	1.00
Upstream Filter(I)	0.00	1.00	0.00	1.00	1.00	0.00				1.00	0.00	0.00
Uniform Delay (d), s/veh	0.0	16.9	0.0	16.1	6.3	0.0				34.1	0.0	0.0
Incr Delay (d2), s/veh	0.0	2.8	0.0	3.5	0.3	0.0				5.1	0.0	0.0
Initial Q Delay(d3),s/veh	0.0	0.0	0.0	0.0	0.0	0.0				0.0	0.0	0.0
%ile BackOfQ(50%),veh/ln	0.0	10.6	0.0	1.8	1.1	0.0				6.7	0.0	0.0
Unsig. Movement Delay, s/veh												
LnGrp Delay(d),s/veh	0.0	19.7	0.0	19.6	6.6	0.0				39.2	0.0	0.0
LnGrp LOS	A	B		B	A	A				D	A	
Approach Vol, veh/h		1368			318						316	
Approach Delay, s/veh		19.7			13.5						39.2	
Approach LOS		B			B						D	
Timer - Assigned Phs	1	2		4		6						
Phs Duration (G+Y+Rc), s	1.2	53.3		25.5		64.5						
Change Period (Y+Rc), s	5.5	6.5		6.5		6.5						
Max Green Setting (Gmax), s	6.5	26.5		38.5		38.5						
Max Q Clear Time (g_c+1/5), s	15.8	29.4		17.3		5.6						
Green Ext Time (p_c), s	0.0	0.0		1.7		0.8						

Intersection Summary

HCM 6th Ctrl Delay	21.8
HCM 6th LOS	C

Notes

Unsignalized Delay for [EBR, SBR] is excluded from calculations of the approach delay and intersection delay.

Intersection				
Intersection Delay, s/veh 103.2				
Intersection LOS F				
Approach	EB	WB	NB	SB
Entry Lanes	1	1	1	1
Conflicting Circle Lanes	1	1	1	1
Adj Approach Flow, veh/h	24	420	1478	80
Demand Flow Rate, veh/h	25	461	1478	86
Vehicles Circulating, veh/h	506	12	158	433
Vehicles Exiting, veh/h	13	1624	373	40
Ped Vol Crossing Leg, #/h	0	0	0	0
Ped Cap Adj	1.000	1.000	1.000	1.000
Approach Delay, s/veh	4.8	6.1	137.7	5.3
Approach LOS	A	A	F	A
Lane	Left	Left	Left	Left
Designated Moves	LTR	LTR	LTR	LTR
Assumed Moves	LTR	LTR	LTR	LTR
RT Channelized				
Lane Util	1.000	1.000	1.000	1.000
Follow-Up Headway, s	2.609	2.609	2.609	2.609
Critical Headway, s	4.976	4.976	4.976	4.976
Entry Flow, veh/h	25	461	1478	86
Cap Entry Lane, veh/h	824	1363	1174	887
Entry HV Adj Factor	0.960	0.911	1.000	0.930
Flow Entry, veh/h	24	420	1478	80
Cap Entry, veh/h	791	1242	1174	825
V/C Ratio	0.030	0.338	1.258	0.097
Control Delay, s/veh	4.8	6.1	137.7	5.3
LOS	A	A	F	A
95th %tile Queue, veh	0	2	49	0

HCM 6th TWSC  
 15: Fountain Utilities access & Charter Oak Ranch Rd

Phase 1-3 Traffic  
 PM Peak Hour

Intersection												
Int Delay, s/veh	0.3											
Movement	EBL	EBT	EBR	WBL	WBT	WBR	NBL	NBT	NBR	SBL	SBT	SBR
Lane Configurations		↕		↕	↕			↕			↕	
Traffic Vol, veh/h	0	495	0	1	57	0	0	0	15	0	0	0
Future Vol, veh/h	0	1243	0	1	311	0	0	0	15	0	0	0
Conflicting Peds, #/hr	0	0	0	0	0	0	0	0	0	0	0	0
Sign Control	Free	Free	Free	Free	Free	Free	Stop	Stop	Stop	Stop	Stop	Stop
RT Channelized	-	-	None	-	-	None	-	-	None	-	-	None
Storage Length	-	-	-	300	-	-	-	-	-	-	-	-
Veh in Median Storage, #	-	0	-	-	0	-	-	0	-	-	0	-
Grade, %	-	0	-	-	0	-	-	0	-	-	0	-
Peak Hour Factor	92	92	92	92	92	92	92	92	92	92	92	92
Heavy Vehicles, %	2	0	2	0	12	2	2	2	0	2	2	2
Mvmt Flow	0	1351	0	1	338	0	0	0	16	0	0	0

Major/Minor	Major1			Major2			Minor1			Minor2		
Conflicting Flow All	338	0	0	1351	0	0	1691	1691	1351	1699	1691	338
Stage 1	-	-	-	-	-	-	1351	1351	-	340	340	-
Stage 2	-	-	-	-	-	-	340	340	-	1359	1351	-
Critical Hdwy	4.12	-	-	4.1	-	-	7.12	6.52	6.2	7.12	6.52	6.22
Critical Hdwy Stg 1	-	-	-	-	-	-	6.12	5.52	-	6.12	5.52	-
Critical Hdwy Stg 2	-	-	-	-	-	-	6.12	5.52	-	6.12	5.52	-
Follow-up Hdwy	2.218	-	-	2.2	-	-	3.518	4.018	3.3	3.518	4.018	3.318
Pot Cap-1 Maneuver	1221	-	-	516	-	-	74	93	186	73	93	704
Stage 1	-	-	-	-	-	-	185	219	-	675	639	-
Stage 2	-	-	-	-	-	-	675	639	-	183	219	-
Platoon blocked, %	-	-	-	-	-	-	-	-	-	-	-	-
Mov Cap-1 Maneuver	1221	-	-	516	-	-	74	93	186	67	93	704
Mov Cap-2 Maneuver	-	-	-	-	-	-	74	93	-	67	93	-
Stage 1	-	-	-	-	-	-	185	219	-	675	638	-
Stage 2	-	-	-	-	-	-	674	638	-	167	219	-

Approach	EB			WB			NB			SB		
HCM Control Delay, s	0			0			26.2			0		
HCM LOS							D			A		

Minor Lane/Major Mvmt	NBLn1	EBL	EBT	EBR	WBL	WBT	WBR	SBLn1
Capacity (veh/h)	186	1221	-	-	516	-	-	-
HCM Lane V/C Ratio	0.088	-	-	-	0.002	-	-	-
HCM Control Delay (s)	26.2	0	-	-	12	-	-	0
HCM Lane LOS	D	A	-	-	B	-	-	A
HCM 95th %tile Q(veh)	0.3	0	-	-	0	-	-	-

Intersection						
Int Delay, s/veh	2.3					
Movement	EBT	EBR	WBL	WBT	NBL	NBR
Lane Configurations	↔		↔	↑	↔	↔
Traffic Vol, veh/h	477	0	0	48	0	0
Future Vol, veh/h	477	0	156	48	0	550
Conflicting Peds, #/hr	0	0	0	0	0	0
Sign Control	Free	Free	Free	Free	Stop	Stop
RT Channelized	-	None	-	None	-	Free
Storage Length	-	-	350	-	0	0
Veh in Median Storage, #	0	-	-	0	0	-
Grade, %	0	-	-	0	0	-
Peak Hour Factor	92	92	92	92	92	92
Heavy Vehicles, %	0	2	33	6	2	17
Mvmt Flow	518	0	170	52	0	598

Major/Minor	Major1	Major2	Minor1		
Conflicting Flow All	0	0	518	0	910
Stage 1	-	-	-	-	518
Stage 2	-	-	-	-	392
Critical Hdwy	-	-	4.43	-	6.42
Critical Hdwy Stg 1	-	-	-	-	5.42
Critical Hdwy Stg 2	-	-	-	-	5.42
Follow-up Hdwy	-	-	2.497	-	3.518
Pot Cap-1 Maneuver	-	-	907	-	305
Stage 1	-	-	-	-	598
Stage 2	-	-	-	-	683
Platoon blocked, %	-	-	-	-	-
Mov Cap-1 Maneuver	-	-	907	-	248
Mov Cap-2 Maneuver	-	-	-	-	248
Stage 1	-	-	-	-	598
Stage 2	-	-	-	-	555

Approach	EB	WB	NB
HCM Control Delay, s	0	7.6	0
HCM LOS			A

Minor Lane/Major Mvmt	NBLn1	NBLn2	EBT	EBR	WBL	WBT
Capacity (veh/h)	-	-	-	-	907	-
HCM Lane V/C Ratio	-	-	-	-	0.187	-
HCM Control Delay (s)	0	0	-	-	9.9	-
HCM Lane LOS	A	A	-	-	A	-
HCM 95th %tile Q(veh)	-	-	-	-	0.7	-

Intersection						
Int Delay, s/veh	5.8					
Movement	EBT	EBR	WBL	WBT	NBL	NBR
Lane Configurations	↑	↗	↘	↑	↘	↗
Traffic Vol, veh/h	490	0	0	57	0	0
Future Vol, veh/h	916	124	70	199	14	187
Conflicting Peds, #/hr	0	0	0	0	0	0
Sign Control	Free	Free	Free	Free	Stop	Stop
RT Channelized	-	None	-	None	-	None
Storage Length	-	0	250	-	150	0
Veh in Median Storage, #	0	-	-	0	0	-
Grade, %	0	-	-	0	0	-
Peak Hour Factor	92	92	92	92	92	92
Heavy Vehicles, %	2	2	2	2	2	2
Mvmt Flow	996	135	76	216	15	203

Major/Minor	Major1	Major2	Minor1	Minor2	Minor3
Conflicting Flow All	0	0	1131	0	1364
Stage 1	-	-	-	-	996
Stage 2	-	-	-	-	368
Critical Hdwy	-	-	4.12	-	6.42
Critical Hdwy Stg 1	-	-	-	-	5.42
Critical Hdwy Stg 2	-	-	-	-	5.42
Follow-up Hdwy	-	-	2.218	-	3.518
Pot Cap-1 Maneuver	-	-	618	-	163
Stage 1	-	-	-	-	357
Stage 2	-	-	-	-	700
Platoon blocked, %	-	-	-	-	-
Mov Cap-1 Maneuver	-	-	618	-	143
Mov Cap-2 Maneuver	-	-	-	-	143
Stage 1	-	-	-	-	357
Stage 2	-	-	-	-	614

Approach	EB	WB	NB
HCM Control Delay, s	0	3	39.3
HCM LOS			E

Minor Lane/Major Mvmt	NBLn1	NBLn2	EBT	EBR	WBL	WBT
Capacity (veh/h)	143	297	-	-	618	-
HCM Lane V/C Ratio	0.106	0.684	-	-	0.123	-
HCM Control Delay (s)	33.2	39.8	-	-	11.6	-
HCM Lane LOS	D	E	-	-	B	-
HCM 95th %tile Q(veh)	0.3	4.7	-	-	0.4	-

Intersection						
Int Delay, s/veh	4.4					
Movement	EBT	EBR	WBL	WBT	NBL	NBR
Lane Configurations						
Traffic Vol, veh/h	490	0	0	57	0	0
Future Vol, veh/h	1103	0	42	269	0	135
Conflicting Peds, #/hr	0	0	0	0	0	0
Sign Control	Free	Free	Free	Free	Stop	Stop
RT Channelized	-	None	-	None	-	None
Storage Length	-	-	300	-	0	-
Veh in Median Storage, #	0	-	-	0	0	-
Grade, %	0	-	-	0	0	-
Peak Hour Factor	92	92	92	92	92	92
Heavy Vehicles, %	2	2	2	2	2	2
Mvmt Flow	1199	0	46	292	0	147

Major/Minor	Major1	Major2	Minor1	Minor2	Minor3
Conflicting Flow All	0	0	1199	0	1583
Stage 1	-	-	-	-	1199
Stage 2	-	-	-	-	384
Critical Hdwy	-	-	4.12	-	6.42
Critical Hdwy Stg 1	-	-	-	-	5.42
Critical Hdwy Stg 2	-	-	-	-	5.42
Follow-up Hdwy	-	-	2.218	-	3.518
Pot Cap-1 Maneuver	-	-	582	-	120
Stage 1	-	-	-	-	286
Stage 2	-	-	-	-	688
Platoon blocked, %	-	-	-	-	-
Mov Cap-1 Maneuver	-	-	582	-	111
Mov Cap-2 Maneuver	-	-	-	-	111
Stage 1	-	-	-	-	286
Stage 2	-	-	-	-	634



















Approach	EB	WB	NB
HCM Control Delay, s	0	1.6	46.3
HCM LOS			E

Minor Lane/Major Mvmt	NBLn1	EBT	EBR	WBL	WBT
Capacity (veh/h)	226	-	-	582	-
HCM Lane V/C Ratio	0.649	-	-	0.078	-
HCM Control Delay (s)	46.3	-	-	11.7	-
HCM Lane LOS	E	-	-	B	-
HCM 95th %tile Q(veh)	4	-	-	0.3	-

# HCM 6th Signalized Intersection Summary

## 3: I-25 NB Ramps & US 85

Buildout Traffic  
PM Peak Hour

												
Movement	EBL	EBT	EBR	WBL	WBT	WBR	NBL	NBT	NBR	SBL	SBT	SBR
Lane Configurations												
Traffic Volume (veh/h)	192	638	0	0	196	82	26	32	596	0	0	0
Future Volume (veh/h)	522	684	0	0	218	82	72	32	614	0	0	0
Initial Q (Qb), veh	0	0	0	0	0	0	0	0	0			
Ped-Bike Adj(A_pbT)	1.00		1.00	1.00		1.00	1.00		1.00			
Parking Bus, Adj	1.00	1.00	1.00	1.00	1.00	1.00	1.00	1.00	1.00			
Work Zone On Approach		No			No			No				
Adj Sat Flow, veh/h/ln	1826	1870	0	0	1796	1781	1455	1900	1781			
Adj Flow Rate, veh/h	549	720	0	0	229	0	76	34	0			
Peak Hour Factor	0.95	0.95	0.95	0.95	0.95	0.95	0.95	0.95	0.95			
Percent Heavy Veh, %	5	2	0	0	7	8	30	0	8			
Cap, veh/h	919	1455	0	0	2085		99	44				
Arrive On Green	0.14	1.00	0.00	0.00	0.61	0.00	0.08	0.08	0.00			
Sat Flow, veh/h	1739	1870	0	0	3503	1510	1269	568	1510			
Grp Volume(v), veh/h	549	720	0	0	229	0	110	0	0			
Grp Sat Flow(s),veh/h/ln	1739	1870	0	0	1706	1510	1837	0	1510			
Q Serve(g_s), s	9.5	0.0	0.0	0.0	2.5	0.0	5.3	0.0	0.0			
Cycle Q Clear(g_c), s	9.5	0.0	0.0	0.0	2.5	0.0	5.3	0.0	0.0			
Prop In Lane	1.00		0.00	0.00		1.00	0.69		1.00			
Lane Grp Cap(c), veh/h	919	1455	0	0	2085		143	0				
V/C Ratio(X)	0.60	0.49	0.00	0.00	0.11		0.77	0.00				
Avail Cap(c_a), veh/h	919	1455	0	0	2085		275	0				
HCM Platoon Ratio	1.33	1.33	1.00	1.00	1.00	1.00	1.00	1.00	1.00			
Upstream Filter(I)	0.72	0.72	0.00	0.00	1.00	0.00	1.00	0.00	0.00			
Uniform Delay (d), s/veh	5.2	0.0	0.0	0.0	7.3	0.0	40.7	0.0	0.0			
Incr Delay (d2), s/veh	0.8	0.9	0.0	0.0	0.1	0.0	8.4	0.0	0.0			
Initial Q Delay(d3),s/veh	0.0	0.0	0.0	0.0	0.0	0.0	0.0	0.0	0.0			
%ile BackOfQ(50%),veh/ln	2.8	0.4	0.0	0.0	0.8	0.0	2.6	0.0	0.0			
Unsig. Movement Delay, s/veh												
LnGrp Delay(d),s/veh	6.0	0.9	0.0	0.0	7.4	0.0	49.1	0.0	0.0			
LnGrp LOS	A	A	A	A	A		D	A				
Approach Vol, veh/h		1269			229			110				
Approach Delay, s/veh		3.1			7.4			49.1				
Approach LOS		A			A			D				
Timer - Assigned Phs		2			5	6		8				
Phs Duration (G+Y+Rc), s		76.5			15.0	61.5		13.5				
Change Period (Y+Rc), s		6.5			5.5	6.5		6.5				
Max Green Setting (Gmax), s		63.5			9.5	48.5		13.5				
Max Q Clear Time (g_c+I1), s		2.0			11.5	4.5		7.3				
Green Ext Time (p_c), s		5.9			0.0	1.5		0.2				

### Intersection Summary

HCM 6th Ctrl Delay	6.9
HCM 6th LOS	A

### Notes

User approved pedestrian interval to be less than phase max green.

Unsignalized Delay for [NBR, WBR] is excluded from calculations of the approach delay and intersection delay.



HCM 6th Signalized Intersection Summary  
6: I-25 SB Ramps & US 85

Buildout Traffic  
PM Peak Hour



Movement	EBL	EBT	EBR	WBL	WBT	WBR	NBL	NBT	NBR	SBL	SBT	SBR
Lane Configurations		↑↑	↗	↖	↑						↖	↗
Traffic Volume (veh/h)	0	528	139	164	58	0	0	0	0	302	5	155
Future Volume (veh/h)	0	904	229	169	121	0	0	0	0	302	5	279
Initial Q (Qb), veh	0	0	0	0	0	0				0	0	0
Ped-Bike Adj(A_pbT)	1.00		1.00	1.00		1.00				1.00		1.00
Parking Bus, Adj	1.00	1.00	1.00	1.00	1.00	1.00				1.00	1.00	1.00
Work Zone On Approach		No			No						No	
Adj Sat Flow, veh/h/ln	0	1856	1767	1826	1500	0				1885	1870	1796
Adj Flow Rate, veh/h	0	952	0	178	127	0				318	5	0
Peak Hour Factor	0.95	0.95	0.95	0.95	0.95	0.95				0.95	0.95	0.95
Percent Heavy Veh, %	0	3	9	5	27	0				1	2	7
Cap, veh/h	0	1808		388	961	0				377	6	
Arrive On Green	0.00	0.51	0.00	0.07	0.64	0.00				0.21	0.21	0.00
Sat Flow, veh/h	0	3618	1497	1739	1500	0				1755	28	1522
Grp Volume(v), veh/h	0	952	0	178	127	0				323	0	0
Grp Sat Flow(s),veh/h/ln	0	1763	1497	1739	1500	0				1783	0	1522
Q Serve(g_s), s	0.0	16.2	0.0	4.1	3.0	0.0				15.6	0.0	0.0
Cycle Q Clear(g_c), s	0.0	16.2	0.0	4.1	3.0	0.0				15.6	0.0	0.0
Prop In Lane	0.00		1.00	1.00		0.00				0.98		1.00
Lane Grp Cap(c), veh/h	0	1808		388	961	0				383	0	
V/C Ratio(X)	0.00	0.53		0.46	0.13	0.00				0.84	0.00	
Avail Cap(c_a), veh/h	0	1808		397	961	0				763	0	
HCM Platoon Ratio	1.00	1.00	1.00	1.00	1.00	1.00				1.00	1.00	1.00
Upstream Filter(I)	0.00	1.00	0.00	1.00	1.00	0.00				1.00	0.00	0.00
Uniform Delay (d), s/veh	0.0	14.6	0.0	10.6	6.3	0.0				33.9	0.0	0.0
Incr Delay (d2), s/veh	0.0	1.1	0.0	0.8	0.3	0.0				5.1	0.0	0.0
Initial Q Delay(d3),s/veh	0.0	0.0	0.0	0.0	0.0	0.0				0.0	0.0	0.0
%ile BackOfQ(50%),veh/ln	0.0	6.2	0.0	1.4	0.9	0.0				6.9	0.0	0.0
Unsig. Movement Delay, s/veh												
LnGrp Delay(d),s/veh	0.0	15.7	0.0	11.5	6.6	0.0				39.0	0.0	0.0
LnGrp LOS	A	B		B	A	A				D	A	
Approach Vol, veh/h		952			305						323	
Approach Delay, s/veh		15.7			9.4						39.0	
Approach LOS		B			A						D	
Timer - Assigned Phs	1	2		4		6						
Phs Duration (G+Y+Rc), s	1.5	52.6		25.8		64.2						
Change Period (Y+Rc), s	5.5	6.5		6.5		6.5						
Max Green Setting (Gmax), s	6.5	26.5		38.5		38.5						
Max Q Clear Time (g_c+1/6), s	6.5	18.2		17.6		5.0						
Green Ext Time (p_c), s	0.0	4.0		1.7		0.7						

Intersection Summary

HCM 6th Ctrl Delay	19.3
HCM 6th LOS	B

Notes

Unsignalized Delay for [EBR, SBR] is excluded from calculations of the approach delay and intersection delay.

Intersection				
Intersection Delay, s/veh	14.4			
Intersection LOS	B			
Approach	EB	WB	NB	SB
Entry Lanes	1	1	1	1
Conflicting Circle Lanes	1	1	1	1
Adj Approach Flow, veh/h	25	318	944	82
Demand Flow Rate, veh/h	26	349	944	88
Vehicles Circulating, veh/h	394	13	163	320
Vehicles Exiting, veh/h	14	1094	257	42
Ped Vol Crossing Leg, #/h	0	0	0	0
Ped Cap Adj	1.000	1.000	1.000	1.000
Approach Delay, s/veh	4.3	5.2	18.6	4.7
Approach LOS	A	A	C	A
Lane	Left	Left	Left	Left
Designated Moves	LTR	LTR	LTR	LTR
Assumed Moves	LTR	LTR	LTR	LTR
RT Channelized				
Lane Util	1.000	1.000	1.000	1.000
Follow-Up Headway, s	2.609	2.609	2.609	2.609
Critical Headway, s	4.976	4.976	4.976	4.976
Entry Flow, veh/h	26	349	944	88
Cap Entry Lane, veh/h	923	1362	1169	996
Entry HV Adj Factor	0.962	0.910	1.000	0.932
Flow Entry, veh/h	25	318	944	82
Cap Entry, veh/h	888	1239	1169	928
V/C Ratio	0.028	0.256	0.808	0.088
Control Delay, s/veh	4.3	5.2	18.6	4.7
LOS	A	A	C	A
95th %tile Queue, veh	0	1	9	0

HCM 6th TWSC  
 15: Fountain Utilities access & Charter Oak Ranch Rd

Buildout Traffic  
 PM Peak Hour

Intersection												
Int Delay, s/veh	0.2											
Movement	EBL	EBT	EBR	WBL	WBT	WBR	NBL	NBT	NBR	SBL	SBT	SBR
Lane Configurations		↕		↕	↕			↕			↕	
Traffic Vol, veh/h	0	306	0	1	34	0	0	0	15	0	0	0
Future Vol, veh/h	0	772	0	1	221	0	0	0	15	0	0	0
Conflicting Peds, #/hr	0	0	0	0	0	0	0	0	0	0	0	0
Sign Control	Free	Free	Free	Free	Free	Free	Stop	Stop	Stop	Stop	Stop	Stop
RT Channelized	-	-	None	-	-	None	-	-	None	-	-	None
Storage Length	-	-	-	300	-	-	-	-	-	-	-	-
Veh in Median Storage, #	-	0	-	-	0	-	-	0	-	-	0	-
Grade, %	-	0	-	-	0	-	-	0	-	-	0	-
Peak Hour Factor	95	95	95	95	95	95	95	95	95	95	95	95
Heavy Vehicles, %	2	0	2	0	12	2	2	2	0	2	2	2
Mvmt Flow	0	813	0	1	233	0	0	0	16	0	0	0

Major/Minor	Major1			Major2			Minor1			Minor2		
Conflicting Flow All	233	0	0	813	0	0	1048	1048	813	1056	1048	233
Stage 1	-	-	-	-	-	-	813	813	-	235	235	-
Stage 2	-	-	-	-	-	-	235	235	-	821	813	-
Critical Hdwy	4.12	-	-	4.1	-	-	7.12	6.52	6.2	7.12	6.52	6.22
Critical Hdwy Stg 1	-	-	-	-	-	-	6.12	5.52	-	6.12	5.52	-
Critical Hdwy Stg 2	-	-	-	-	-	-	6.12	5.52	-	6.12	5.52	-
Follow-up Hdwy	2.218	-	-	2.2	-	-	3.518	4.018	3.3	3.518	4.018	3.318
Pot Cap-1 Maneuver	1335	-	-	823	-	-	206	228	382	203	228	806
Stage 1	-	-	-	-	-	-	372	392	-	768	710	-
Stage 2	-	-	-	-	-	-	768	710	-	369	392	-
Platoon blocked, %	-	-	-	-	-	-	-	-	-	-	-	-
Mov Cap-1 Maneuver	1335	-	-	823	-	-	206	228	382	194	228	806
Mov Cap-2 Maneuver	-	-	-	-	-	-	206	228	-	194	228	-
Stage 1	-	-	-	-	-	-	372	392	-	768	709	-
Stage 2	-	-	-	-	-	-	767	709	-	354	392	-

Approach	EB			WB			NB			SB		
HCM Control Delay, s	0			0			14.8			0		
HCM LOS							B			A		

Minor Lane/Major Mvmt	NBLn1	EBL	EBT	EBR	WBL	WBT	WBR	SBLn1
Capacity (veh/h)	382	1335	-	-	823	-	-	-
HCM Lane V/C Ratio	0.041	-	-	-	0.001	-	-	-
HCM Control Delay (s)	14.8	0	-	-	9.4	-	-	0
HCM Lane LOS	B	A	-	-	A	-	-	A
HCM 95th %tile Q(veh)	0.1	0	-	-	0	-	-	-

Intersection						
Int Delay, s/veh	1.8					
Movement	EBT	EBR	WBL	WBT	NBL	NBR
Lane Configurations	↔		↔	↑	↔	↔
Traffic Vol, veh/h	306	299	0	34	26	0
Future Vol, veh/h	306	299	91	34	26	275
Conflicting Peds, #/hr	0	0	0	0	0	0
Sign Control	Free	Free	Free	Free	Stop	Stop
RT Channelized	-	None	-	None	-	Free
Storage Length	-	-	350	-	0	0
Veh in Median Storage, #	0	-	-	0	0	-
Grade, %	0	-	-	0	0	-
Peak Hour Factor	95	95	95	95	95	95
Heavy Vehicles, %	0	2	33	6	2	17
Mvmt Flow	322	315	96	36	27	289

Major/Minor	Major1	Major2	Minor1		
Conflicting Flow All	0	0	637	0	708
Stage 1	-	-	-	-	480
Stage 2	-	-	-	-	228
Critical Hdwy	-	-	4.43	-	6.42
Critical Hdwy Stg 1	-	-	-	-	5.42
Critical Hdwy Stg 2	-	-	-	-	5.42
Follow-up Hdwy	-	-	2.497	-	3.518
Pot Cap-1 Maneuver	-	-	814	-	401
Stage 1	-	-	-	-	622
Stage 2	-	-	-	-	810
Platoon blocked, %	-	-	-	-	-
Mov Cap-1 Maneuver	-	-	814	-	354
Mov Cap-2 Maneuver	-	-	-	-	354
Stage 1	-	-	-	-	622
Stage 2	-	-	-	-	714

Approach	EB	WB	NB
HCM Control Delay, s	0	7.3	16
HCM LOS			C

Minor Lane/Major Mvmt	NBLn1	NBLn2	EBT	EBR	WBL	WBT
Capacity (veh/h)	354	-	-	-	814	-
HCM Lane V/C Ratio	0.077	-	-	-	0.118	-
HCM Control Delay (s)	16	0	-	-	10	-
HCM Lane LOS	C	A	-	-	B	-
HCM 95th %tile Q(veh)	0.2	-	-	-	0.4	-

Intersection						
Int Delay, s/veh	3.7					
Movement	EBT	EBR	WBL	WBT	NBL	NBR
Lane Configurations	↑	↗	↘	↑	↘	↗
Traffic Vol, veh/h	306	0	0	34	0	0
Future Vol, veh/h	457	124	69	111	14	188
Conflicting Peds, #/hr	0	0	0	0	0	0
Sign Control	Free	Free	Free	Free	Stop	Stop
RT Channelized	-	None	-	None	-	None
Storage Length	-	0	250	-	150	0
Veh in Median Storage, #	0	-	-	0	0	-
Grade, %	0	-	-	0	0	-
Peak Hour Factor	95	95	95	95	95	95
Heavy Vehicles, %	2	2	2	2	2	2
Mvmt Flow	481	131	73	117	15	198

Major/Minor	Major1	Major2	Minor1		
Conflicting Flow All	0	0	612	0	744 481
Stage 1	-	-	-	-	481 -
Stage 2	-	-	-	-	263 -
Critical Hdwy	-	-	4.12	-	6.42 6.22
Critical Hdwy Stg 1	-	-	-	-	5.42 -
Critical Hdwy Stg 2	-	-	-	-	5.42 -
Follow-up Hdwy	-	-	2.218	-	3.518 3.318
Pot Cap-1 Maneuver	-	-	967	-	382 585
Stage 1	-	-	-	-	622 -
Stage 2	-	-	-	-	781 -
Platoon blocked, %	-	-	-	-	-
Mov Cap-1 Maneuver	-	-	967	-	353 585
Mov Cap-2 Maneuver	-	-	-	-	353 -
Stage 1	-	-	-	-	622 -
Stage 2	-	-	-	-	722 -

Approach	EB	WB	NB
HCM Control Delay, s	0	3.5	14.4
HCM LOS			B

Minor Lane/Major Mvmt	NBLn1	NBLn2	EBT	EBR	WBL	WBT
Capacity (veh/h)	353	585	-	-	967	-
HCM Lane V/C Ratio	0.042	0.338	-	-	0.075	-
HCM Control Delay (s)	15.6	14.3	-	-	9	-
HCM Lane LOS	C	B	-	-	A	-
HCM 95th %tile Q(veh)	0.1	1.5	-	-	0.2	-

Intersection						
Int Delay, s/veh	2.5					
Movement	EBT	EBR	WBL	WBT	NBL	NBR
Lane Configurations						
Traffic Vol, veh/h	306	0	0	34	0	0
Future Vol, veh/h	645	0	41	180	0	127
Conflicting Peds, #/hr	0	0	0	0	0	0
Sign Control	Free	Free	Free	Free	Stop	Stop
RT Channelized	-	None	-	None	-	None
Storage Length	-	-	300	-	0	-
Veh in Median Storage, #	0	-	-	0	0	-
Grade, %	0	-	-	0	0	-
Peak Hour Factor	95	95	95	95	95	95
Heavy Vehicles, %	2	2	2	2	2	2
Mvmt Flow	679	0	43	189	0	134

Major/Minor	Major1	Major2	Minor1	Minor2	Minor3
Conflicting Flow All	0	0	679	0	954
Stage 1	-	-	-	-	679
Stage 2	-	-	-	-	275
Critical Hdwy	-	-	4.12	-	6.42
Critical Hdwy Stg 1	-	-	-	-	5.42
Critical Hdwy Stg 2	-	-	-	-	5.42
Follow-up Hdwy	-	-	2.218	-	3.518
Pot Cap-1 Maneuver	-	-	913	-	287
Stage 1	-	-	-	-	504
Stage 2	-	-	-	-	771
Platoon blocked, %	-	-	-	-	-
Mov Cap-1 Maneuver	-	-	913	-	274
Mov Cap-2 Maneuver	-	-	-	-	274
Stage 1	-	-	-	-	504
Stage 2	-	-	-	-	735

Approach	EB	WB	NB
HCM Control Delay, s	0	1.7	16.3
HCM LOS			C

Minor Lane/Major Mvmt	NBLn1	EBT	EBR	WBL	WBT
Capacity (veh/h)	452	-	-	913	-
HCM Lane V/C Ratio	0.296	-	-	0.047	-
HCM Control Delay (s)	16.3	-	-	9.1	-
HCM Lane LOS	C	-	-	A	-
HCM 95th %tile Q(veh)	1.2	-	-	0.1	-

HCM 6th Signalized Intersection Summary  
 18: Charter Oak Ranch Rd & Essayons Rd

Buildout Traffic  
 AM Peak Hour



Movement	EBT	EBR	WBL	WBT	NBL	NBR
Lane Configurations	→		←	→	←	→
Traffic Volume (veh/h)	59	55	0	168	162	0
Future Volume (veh/h)	59	55	279	168	162	71
Initial Q (Qb), veh	0	0	0	0	0	0
Ped-Bike Adj(A_pbT)		1.00	1.00		1.00	1.00
Parking Bus, Adj	1.00	1.00	1.00	1.00	1.00	1.00
Work Zone On Approach	No			No	No	
Adj Sat Flow, veh/h/ln	1900	1870	418	1900	1870	907
Adj Flow Rate, veh/h	62	58	294	177	171	0
Peak Hour Factor	0.95	0.95	0.95	0.95	0.95	0.95
Percent Heavy Veh, %	0	2	100	0	2	67
Cap, veh/h	608	569	334	1280	249	
Arrive On Green	0.67	0.67	0.67	0.67	0.14	0.00
Sat Flow, veh/h	903	845	284	1900	1781	769
Grp Volume(v), veh/h	0	120	294	177	171	0
Grp Sat Flow(s),veh/h/ln	0	1748	284	1900	1781	769
Q Serve(g_s), s	0.0	1.2	31.3	1.6	4.4	0.0
Cycle Q Clear(g_c), s	0.0	1.2	32.5	1.6	4.4	0.0
Prop In Lane		0.48	1.00		1.00	1.00
Lane Grp Cap(c), veh/h	0	1177	334	1280	249	
V/C Ratio(X)	0.00	0.10	0.88	0.14	0.69	
Avail Cap(c_a), veh/h	0	1177	334	1280	683	
HCM Platoon Ratio	1.00	1.00	1.00	1.00	1.00	1.00
Upstream Filter(I)	0.00	1.00	1.00	1.00	1.00	0.00
Uniform Delay (d), s/veh	0.0	2.8	14.3	2.8	19.7	0.0
Incr Delay (d2), s/veh	0.0	0.0	22.7	0.0	3.3	0.0
Initial Q Delay(d3),s/veh	0.0	0.0	0.0	0.0	0.0	0.0
%ile BackOfQ(50%),veh/ln	0.0	0.2	5.1	0.3	1.9	0.0
Unsig. Movement Delay, s/veh						
LnGrp Delay(d),s/veh	0.0	2.8	37.0	2.9	23.1	0.0
LnGrp LOS	A	A	D	A	C	
Approach Vol, veh/h	120			471	171	
Approach Delay, s/veh	2.8			24.2	23.1	
Approach LOS	A			C	C	
Timer - Assigned Phs		2		4		8
Phs Duration (G+Y+Rc), s		11.3		37.0		37.0
Change Period (Y+Rc), s		4.5		4.5		4.5
Max Green Setting (Gmax), s		18.5		32.5		32.5
Max Q Clear Time (g_c+I1), s		6.4		3.2		34.5
Green Ext Time (p_c), s		0.3		0.6		0.0
<b>Intersection Summary</b>						
HCM 6th Ctrl Delay			20.6			
HCM 6th LOS			C			
<b>Notes</b>						
Unsignalized Delay for [NBR] is excluded from calculations of the approach delay and intersection delay.						



Intersection			
Intersection Delay, s/veh	12.5		
Intersection LOS	B		
Approach	EB	WB	NB
Entry Lanes	1	1	1
Conflicting Circle Lanes	1	1	1
Adj Approach Flow, veh/h	120	471	246
Demand Flow Rate, veh/h	121	765	299
Vehicles Circulating, veh/h	588	174	62
Vehicles Exiting, veh/h	351	187	647
Ped Vol Crossing Leg, #/h	0	0	0
Ped Cap Adj	1.000	1.000	1.000
Approach Delay, s/veh	6.5	17.7	5.5
Approach LOS	A	C	A
Lane	Left	Left	Left
Designated Moves	TR	LT	LR
Assumed Moves	TR	LT	LR
RT Channelized			
Lane Util	1.000	1.000	1.000
Follow-Up Headway, s	2.609	2.609	2.609
Critical Headway, s	4.976	4.976	4.976
Entry Flow, veh/h	121	765	299
Cap Entry Lane, veh/h	758	1155	1295
Entry HV Adj Factor	0.992	0.616	0.823
Flow Entry, veh/h	120	471	246
Cap Entry, veh/h	751	711	1066
V/C Ratio	0.160	0.662	0.231
Control Delay, s/veh	6.5	17.7	5.5
LOS	A	C	A
95th %tile Queue, veh	1	5	1

HCM 6th Signalized Intersection Summary  
 18: Charter Oak Ranch Rd & Essayons Rd

Buildout Traffic  
 PM Peak Hour



Movement	EBT	EBR	WBL	WBT	NBL	NBR
Lane Configurations	→		←	→	←	→
Traffic Volume (veh/h)	306	299	0	34	26	0
Future Volume (veh/h)	306	299	91	34	26	275
Initial Q (Qb), veh	0	0	0	0	0	0
Ped-Bike Adj(A_pbT)		1.00	1.00		1.00	1.00
Parking Bus, Adj	1.00	1.00	1.00	1.00	1.00	1.00
Work Zone On Approach	No			No	No	
Adj Sat Flow, veh/h/ln	1900	1870	1411	1811	1870	1648
Adj Flow Rate, veh/h	322	315	96	36	27	0
Peak Hour Factor	0.95	0.95	0.95	0.95	0.95	0.95
Percent Heavy Veh, %	0	2	33	6	2	17
Cap, veh/h	458	448	392	941	306	
Arrive On Green	0.52	0.52	0.52	0.52	0.17	0.00
Sat Flow, veh/h	882	863	597	1811	1781	1397
Grp Volume(v), veh/h	0	637	96	36	27	0
Grp Sat Flow(s),veh/h/ln	0	1745	597	1811	1781	1397
Q Serve(g_s), s	0.0	8.1	4.2	0.3	0.4	0.0
Cycle Q Clear(g_c), s	0.0	8.1	12.3	0.3	0.4	0.0
Prop In Lane		0.49	1.00		1.00	1.00
Lane Grp Cap(c), veh/h	0	907	392	941	306	
V/C Ratio(X)	0.00	0.70	0.24	0.04	0.09	
Avail Cap(c_a), veh/h	0	1886	727	1957	1192	
HCM Platoon Ratio	1.00	1.00	1.00	1.00	1.00	1.00
Upstream Filter(I)	0.00	1.00	1.00	1.00	1.00	0.00
Uniform Delay (d), s/veh	0.0	5.3	9.9	3.4	10.2	0.0
Incr Delay (d2), s/veh	0.0	1.0	0.3	0.0	0.1	0.0
Initial Q Delay(d3),s/veh	0.0	0.0	0.0	0.0	0.0	0.0
%ile BackOfQ(50%),veh/ln	0.0	1.0	0.4	0.0	0.1	0.0
Unsig. Movement Delay, s/veh						
LnGrp Delay(d),s/veh	0.0	6.3	10.3	3.4	10.3	0.0
LnGrp LOS	A	A	B	A	B	
Approach Vol, veh/h	637			132	27	
Approach Delay, s/veh	6.3			8.4	10.3	
Approach LOS	A			A	B	
Timer - Assigned Phs		2		4		8
Phs Duration (G+Y+Rc), s		9.5		19.6		19.6
Change Period (Y+Rc), s		4.5		4.5		4.5
Max Green Setting (Gmax), s		19.5		31.5		31.5
Max Q Clear Time (g_c+I1), s		2.4		10.1		14.3
Green Ext Time (p_c), s		0.0		4.5		0.9

Intersection Summary

HCM 6th Ctrl Delay	6.8
HCM 6th LOS	A

Notes

Unsignalized Delay for [NBR] is excluded from calculations of the approach delay and intersection delay.

Intersection			
Intersection Delay, s/veh	8.3		
Intersection LOS	A		
Approach	EB	WB	NB
Entry Lanes	1	1	1
Conflicting Circle Lanes	1	1	1
Adj Approach Flow, veh/h	637	132	316
Demand Flow Rate, veh/h	643	166	366
Vehicles Circulating, veh/h	128	28	322
Vehicles Exiting, veh/h	66	660	449
Ped Vol Crossing Leg, #/h	0	0	0
Ped Cap Adj	1.000	1.000	1.000
Approach Delay, s/veh	9.0	4.5	8.5
Approach LOS	A	A	A
Lane	Left	Left	Left
Designated Moves	TR	LT	LR
Assumed Moves	TR	LT	LR
RT Channelized			
Lane Util	1.000	1.000	1.000
Follow-Up Headway, s	2.609	2.609	2.609
Critical Headway, s	4.976	4.976	4.976
Entry Flow, veh/h	643	166	366
Cap Entry Lane, veh/h	1211	1341	994
Entry HV Adj Factor	0.991	0.794	0.863
Flow Entry, veh/h	637	132	316
Cap Entry, veh/h	1200	1065	858
V/C Ratio	0.531	0.124	0.368
Control Delay, s/veh	9.0	4.5	8.5
LOS	A	A	A
95th %tile Queue, veh	3	0	2

