



FINAL DRAINAGE LETTER

LOT 1, OWL MARKETPLACE FILING NO. 1

MURPHY OIL #7968
7440 MERIDIAN PARK DRIVE
FALCON, CO 80831

PCD File No. PPR244

PREPARED FOR:
Murphy Oil USA
200 Peach Street
El Dorado, AR 71730
Contact: Grant Dennis
Phone: (870) 315-3430

PREPARED BY:
Galloway & Company, Inc.
1155 Kelly Johnson Blvd., Suite 305
Colorado Springs, CO 80920
Contact: Kyle Goodwin, P.E.
Phone: (719) 900-7220

DATE:
May 17, 2024



Signature Page
Lot 1, Owl Marketplace Filing No. 1

Engineer's Statement

The attached drainage plan and report were prepared under my direction and supervision and are correct to the best of my knowledge and belief. Said drainage report has been prepared according to the criteria established by the County for drainage reports and said report is in conformity with the applicable master plan of the drainage basin. I accept responsibility for any liability caused by any negligent acts, errors, or omissions on my part in preparing this report.

ENGR Stamp, signature and date

Kyle Goodwin, PE # 63208
For and on behalf of Galloway & Company, Inc.

Date

Developer's Certification

I, the developer, have read and will comply with all of the requirements specified in this drainage report and plan.

Owner sign and date

By: _____

Date

Address: Grant Dennis
200 Peach Street
El Dorado, AR 71730

El Paso County Certification

Filed in accordance with the requirements of the Drainage Criteria Manual, Volumes 1 and 2, El Paso County Engineering Criteria Manual and Land Development Code as amended.

Joshua Palmer, P.E.
County Engineer/ECM Administrator

Date

Conditions:

TABLE OF CONTENTS

I. Introduction	4
II. Existing Drainage Patterns and Features	5
Major Basin Description	5
Existing Drainage Patterns	5
Sub-Basin Descriptions.....	5
III. Drainage Design Criteria.....	6
Development Criteria Reference.....	6
Hydrologic Criteria.....	6
IV. Proposed Drainage Patterns and Features	7
Proposed Drainage Plan	9
Sub-Basin Descriptions.....	10
V. Basin Fees	11
IV. Conclusion	11
V. References	11

Appendices:

- A. Exhibits and Figures
- B. Existing Drainage Reports
- C. Hydraulic Computations
- D. Hydrologic Computations
- E. Drainage Maps

Review C1: The small subdivision drainage report is required for which a complete drainage report has previously been approved by the County Engineer, and no significant changes from such report are proposed. This drainage letter cannot be approved until the previous FDR gets approved. Please include the approved date once it gets approved.

I. Introduction

Review C2: Unresolved. This comment will stay unresolved until VR2321 gets approved.

This document is the Final Drainage Report for Murphy Oil #7968. The purpose of this report is to show that this development is in conformance with the governing drainage documents. The project consists of a fuel dispensing facility on approximately 1.11 acres, including a 1-story building with approximately 2,842 GSF and a fueling canopy with 6 multi-dispenser pumps. The project's total disturbance is 1.14 acres. Black Squirrel Creek is the receiving water for the proposed development. Flows onsite are directed through an existing storm drain system that outfalls into Sub Regional Pond SR4, approximately 1,200 feet southwest of the project site.

The Small Subdivision Drainage Report Format is being utilized instead of the Final Drainage Report because there is a complete drainage report pending approval for the subdivision, "Final Drainage Report for Owl Marketplace Filing No. 1" prepared by Drexel, Barrell & Co. dated January 2024 (Owl Marketplace FDR), and the proposed site will follow existing drainage patterns.

Please use approval date of the VR2321 once it is known.

Location

Lot 1, Owl Marketplace Filing No. 1 is located in the North Half of the Southeast Quarter of Section 1, Township 13 South, Range 66 West of the 6th Principal Meridian, County of El Paso, State of Colorado.

The project site is located at 7440 Meridian Park Drive, bounded to the North by Lot 2, Owl Marketplace Filing No. 1, to the South by Eastonville Road, to the West by Meridian Park Drive, and to the East by Meridian Road. A Vicinity Map is provided in **Appendix A**.

Description of Property

The site consists of an existing 1-story restaurant building and associated parking with zoning classified as CS (Commercial). The site is not located within the Streamside Zone. The existing ground is covered with gravel/dirt and scattered with native vegetation. In the present condition, the parcel drains from northeast to southwest at approximately 2% with a planned imperviousness of 95%, per Owl Marketplace FDR. The proposed development will have an approximate composite imperviousness of 69.3% for the overall development. The approximate disturbed area associated with this development is +/- 1.18 acres.

The property is located within the Falcon Drainage Basin as described in the "Falcon Drainage Basin Planning Study" prepared by Matrix Design Group dated October 6, 2015 (DBPS). This property conforms to the requirements of the DBPS.

Existing drainage reports are provided in **Appendix B** for reference.

Flood Insurance Rate Map

According to the Federal Emergency Management Agency (FEMA) Flood Insurance Rate Map (FIRM) #08041C0553G, effective date December 7, 2018, the majority of the project site is located in Zone X (0.2% Annual Chance Flood Hazard). The western portion of the site is located within Zone A (Without Base Flood Elevation (BFE)). A copy of the FIRM map is provided in **Appendix A** for reference.

A CLOMR to modify the effective floodplain was approved by FEMA, Case No. 22-08-0669R (December 21, 2022).

Soil Survey

According to the U.S. Department of Agriculture Natural Resources Conservation Service Soil Survey of El Paso County, Colorado the primary soil found are Columbine gravelly sandy loam, classified as Soil Conservation Service (SCS) hydrologic soil group "A".

Table 1 – USDA NRCS Soil Data

Soil Name	HSG	Percent of Site
Columbine gravelly sandy loam	A	100%

The predominant on-site HSG is 'A'. Refer to **Appendix A** for soils information.

II. Existing Drainage Patterns and Features

Major Basin Description

Murphy Oil #7968 (Lot 1, Owl Marketplace Filing No. 1) is located within the MT060 drainage basin as described in the Falcon DBPS. The Falcon Watershed is located in the north central portion of El Paso County and flows southeasterly from the southern slope of the Black Forest. The Falcon watershed contains three perennial streams and has a contributing drainage area of approximately 10.6 square miles at its confluence with Black Squirrel Creek.

Existing drainage reports are provided in **Appendix B** for reference.

Existing Drainage Patterns

On-Site:

The existing drainage patterns sheet flow from northeast to southwest, entering Meridian Park Drive by flowing over top of the curb. Flows become concentrated in the existing curb and gutter on the east side of Meridian Park Drive where they are conveyed south to an existing 10' CDOT Type R Inlet (Public) near the roundabout at the intersection of Meridian Park Drive and Eastonville road. Therefore, no changes to existing drainage patterns, flows, calculations, conveyance system, and detention facilities are anticipated with this development.

Off-Site:

The existing off-site drainage patterns sheet flow from northeast to southwest, entering the site across the northern property line bordering Lot 2, Owl Marketplace Filing No. 1. Although the existing condition of the site conveys water onto the project site, the **Owl Marketplace FDR** plans for the developed condition of the other lots within Owl Marketplace Filing No. 1 to contain the flows within the respective properties.

Sub-Basin Descriptions

Note: Existing drainage map is provided in **Appendix E** and should be referenced when reading the basin descriptions below.

Basin D (1.08 acres, Q5 = 4.5 cfs, Q100 = 8.2 cfs): a basin that encompasses all of Lot 1, Owl Marketplace Filing No. 1 (project site). Runoff is conveyed by sheet flows to the southwestern driveway

and then out into Meridian Park Drive, **DP4**. The flows are then conveyed in curb and gutter to an existing 10' CDOT Type R Inlet (Public) on the northeast corner of the roundabout at the intersection of Meridian Park Drive and Eastonville Road.

III. Drainage Design Criteria

Development Criteria Reference

The analysis and design of the drainage concept and stormwater management system for this project was prepared in accordance with the criteria set forth in the El Paso County Drainage Criteria Manual (DCM) dated October 31, 2018 and supplemented by the Mile High Flood District (MHFD) Urban Storm Drainage Criteria Manual (USDCM) dated January 2016.

Hydrologic Criteria

The rational method was used to calculate peak flows as the tributary areas are less than 100 acres. An analysis of the hydrology using the rational method can be found in **Appendix C** - Hydrologic Calculations. The rational method has proved to be accurate for basins of this size and is based on the following formula:

$$Q = CIA$$

Where:

- Q = Peak Discharge (cfs)
- C = Runoff Coefficient
- I = Runoff intensity (inches/hour)
- A = Drainage area (acres)

The rainfall intensity calculations are based on the DCM Figure 6-5 and IDF equations. The one-hour point rainfall data for the design is listed in Table 1 below.

Table 2 - Precipitation Data

Return Period	One Hour Depth (in.)	Intensity (in/hr)
5-year	1.50	5.17
100-year	2.52	8.68

*The intensities above are calculated using $T_c=5$ minutes

Time of concentrations have been adapted from equation 6-7 of The City of Colorado Springs Drainage Criteria Manual, Volume 1 which are as follows:

$$T_c = T_i + T_t$$

Where:

- T_c = time of concentration (min)
- T_i = overland (initial) flow time (min)
- T_t = travel time in the ditch, channel, gutter, storm sewer, etc. (min)

Overland (Initial) Flow Time: from equations 6-8 from the City of Colorado Springs Drainage Criteria Manual, Volume 1.

$$t_t = \frac{0.395(1.1 - C_5)\sqrt{L}}{S^{0.33}}$$

Where:

T_i = overland (initial) flow (min)

C_5 = runoff coefficient for 5-year frequency

L = length of overland flow (ft) (300 ft maximum for non-urban land uses, 100 ft maximum for urban land uses)

S = average basin slope (ft/ft)

Travel Time

$$V = C_v * S_w^{0.5}$$

Where:

V = Velocity (ft/s)

C_v = conveyance coefficient

S_w = watercourse slope (ft/ft)

The runoff coefficients are calculated based on land use, percent imperviousness, and design storm for each basin, as shown in the DCM, (Table 6-6).

Hydraulic Criteria

Street Capacity

Existing streets around Lot 1, Owl Marketplace Filing No. 1 are Meridian Park Drive, local road to the west of the site, Eastonville Road, local road to the south of the site, and Meridian Road, principal arterial to the east of the site. Because overland flows from this site are reduced compared to the flows in the existing condition, street capacity is not anticipated to be exceeded.

Storm Inlets

A majority of the runoff for the site will be captured by a CDOT Type C Inlet (Private) located at the southwest corner of the site. The 10' CDOT Type R Storm Inlet (Public) at the northeast corner of the roundabout at the intersection of Meridian Park Drive and Eastonville Road receives all runoff that leaves the site into Meridian Park Drive. Due to the fact that runoff generated by this site will be reduced compared to the flows in the existing condition, respective storm inlet capacities are not anticipated to be exceeded.

Detention Pond

Sub-Regional Detention Pond, SR4 (Public), was designed as part of the **DBPS**. Excerpts from the **DBPS** with respect to the detention pond design have been included in **Appendix B** for reference. Excerpts from the **Owl Marketplace FDR** have also been included in **Appendix B** to show the planned flows entering *Sub-Regional Detention Pond, SR4 (Public)* from each lot of Owl Marketplace Filing No. 1. With generated runoff from this site being reduced compared to the flows anticipated in the above referenced reports, the *Sub-Regional Detention Pond, SR4 (Public)* has capacity to accommodate full-spectrum detention for the proposed project site.

Four Step Process

The Four Step Process is used to minimize the adverse impacts of urbanization and is a vital component of developing a balanced, sustainable project. Below identifies the approach to the four-step process:

1. Employ Runoff Reduction Practices

This step uses low impact development (LID) practices to reduce runoff at the source. Generally, rather than creating point discharges that are directly connected to impervious areas, runoff is routed through pervious areas to promote infiltration. The roof drains for the proposed fueling canopy will drain directly to proposed conveyance pipe beneath the drive aisles and connect to the proposed CDOT Type C Storm Inlet (Private) in the southwest corner of the site. The remainder of hardscaped surfaces sheet flow across the site to the south and west to the landscaped area, including a proposed grassed swale, between the proposed parking lot and Meridian Park Drive to the west, where it will enter the existing storm drain system through the proposed CDOT Type C Storm Inlet (Private) in the southwest corner of the site. Planned Infiltration Areas (PIA) have been designed to serve as Receiving Pervious Areas (RPA) mitigating the impacts of the on-site impervious areas. The proposed drainage plan incorporates the landscaping to the south and west of the site to receive the flows from hardscaped areas, including the drive aisles, sidewalks, and convenience store roof.

2. Implement CM's That Provide a Water Quality Capture Volume with Slow Release

The proposed development utilizes formalized water quality capture volume to slow the release of runoff from the site. An existing public Sub-Regional Detention Pond (SR4) provides EURV volume for the new development which incorporates a 72-hour release. Water quality treatment will be provided for 100% of the disturbed area, 1.11 acres in total, by the Sub-Regional Detention Pond, SR4 (Public). This Sub-Regional Detention Pond, SR4 (Public) was designed to receive runoff from this site at a higher imperviousness than what is being proposed and has been analyzed as a part of the **Owl Marketplace FDR**. Although the site is considered a potential high-risk site due to the classification of being a gas station, hydrocarbons entering the storm system will be minimal. The highest potential area for hydrocarbon collection, the fueling canopy, will be protected by the canopy itself and the grading design, as flows are not directed across the canopy pad. For any hydrocarbons that manage to be picked up by storm runoff, pretreatment will be provided by a SNOOT Water Quality Device manufactured by BMP, Inc. This device will remove hydrocarbons from runoff prior to leaving the site and will be equivalent to utilizing Pervious Landscape Detention or Sand Filters as pretreatment. The proposed development will not have any adverse impacts on existing drainageways, conveyance system, or the existing detention pond (Public). The proposed disturbed areas of the site will ultimately be captured and treated by the existing Sub-Regional Detention Pond, SR4 (Public).

3. Stabilize Drainageways

This step implements stabilization of channels to accommodate developed flows while protecting infrastructure and controlling sediment loading from erosion in the drainageways. All new re-development projects are required to construct or participate in the funding of channel stabilization within the drainage basin. Black Squirrel Creek has had improvements made in the past to stabilize it, as well as proposed improvements as part of the proposed developments immediately upstream. The proposed development is approximately 1,200-ft northeast of the outlet to Sub Regional Pond SR4 and Black Squirrel Creek that the adjacent public storm drain system discharges to.

4. Implement Site Specific and Other Source Control Measures

The biggest source control BMP is public education which can be found on the El Paso County website and discuss topics such as: pet waste, car washing, private maintenance landscaping, fall leaves, and snow melt and deicer. A no vehicle maintenance policy will be enforced to avoid the potential contaminations caused from vehicle fluid replacement, and equipment replacement and repair. In addition, the landscaping and snow removal is handled completely by the property management to ensure proper lawn mowing and grass clipping disposal, lawn aeration, and fertilizer application is being followed. Snow removal will also be handled by the property manager to ensure proper consideration of snow pile placement and use of deicing chemicals.

IV. Proposed Drainage Patterns and Features

Proposed Drainage Plan

On-Site:

The proposed condition of the project site consists of a 1-story convenience store building and a fuel canopy with 6 multi-dispenser pumps with one shared access driveway to Meridian Park Drive on the northwest corner of the property. The drainage design maintains existing drainage patterns by sheet flowing runoff through the site to a proposed grassed swale along the western and southern borders of the site. The swale then directs flows to a CDOT Type C Storm Inlet (Private) located at the southwest corner of the site. Portion of the site to the north and south sheet flow runoff into Meridian Park Drive to be captured by the existing 10' CDOT Type R Storm Inlet (Public) located at the northeast corner of the roundabout at the intersection of Meridian Park Drive and Eastonville Road.

Off-Site:

No off-site flows are anticipated on entering the site.

The existing imperviousness of Basin D (see the Existing Drainage Map in **Appendix D**) is 95.0% of the basin (1.03 acres of imperviousness). The proposed basin delineation of this area includes Basins A-1, A-2, B-1, and B-2 (see the Proposed Drainage Map in **Appendix D**) and will have a proposed imperviousness of 69.3% (0.77 acres of imperviousness). This will provide reduced runoff in this area of the site compared to the planned imperviousness, per the **Owl Marketplace FDR**.

The overall planned imperviousness of the site (overall site acreage = 1.11 acres) is 95.0% ($1.11 \times 0.93 = 1.05$ acres of imperviousness), per the **Owl Marketplace FDR**. The proposed imperviousness of the site is 69.3% ($1.11 \times 0.693 = 0.77$ acres of imperviousness). The reduced runoff for the overall project site

Please revise to be
Appendix E.

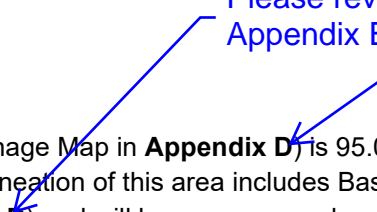

presents no adverse impacts to the overall development and is in conformance with the governing drainage documents.

Sub-Basin Descriptions

Note: a proposed drainage map is provided in **Appendix E** and should be referenced when reading the basin descriptions below.

Basin A-1 (0.84 acres, Q5 = 1.78 cfs, Q100 = 3.71 cfs): a basin that encompasses the majority of Lot 1, Owl Marketplace Filing No. 1 (project site). Runoff is conveyed by sheet flows and in curb and gutter directed to a proposed grassed swale along the western and southern borders of the site. The proposed roof is pitched in one direction, forcing runoff to the south where runoff is directed to roof drains utilizing internal piping that daylight into the proposed grassed swale. Runoff is ultimately directed into a proposed CDOT Type C Storm Sump Inlet (Private), **DP1**. Should the inlet clog, runoff will be directed to the existing Storm Inlet (Public) to the south and the existing 10' CDOT Type R Inlet (Public) located just outside the southwest corner of the site. A portion of the basin encompasses the roof of the convenience store building. The flows are then conveyed in pipes through the existing storm drain system.

Basin A-2 (0.09 acres, Q5 = 0.40 cfs, Q100 = 0.70 cfs): a basin that encompasses the roof of the fuel canopy. The proposed roof is pitched so that runoff is directed to roof drains connected to internal piping in the canopy columns. The internal piping connects to proposed PVC storm pipe (Private) running underneath the canopy to the southwest. The proposed storm system conveys flows to a CDOT Type C Storm Inlet (Private), **DP1**. Should the inlet clog, runoff will be directed to the existing Storm Inlet (Public) to the south and the existing 10' CDOT Type R Inlet (Public) located just outside the southwest corner of the site. The flows are then conveyed in pipes through the existing storm drain system.

Basin B-1 (0.14 acres, Q5 = 1.31 cfs, Q100 = 2.29 cfs): a basin that covers an area along the northern border of the site. Runoff sheet flows to the west where it leaves the site through the driveway entrance. Flows are then conveyed in curb and gutter, ultimately captured in an existing 10' CDOT Type R Storm Inlet (Public). The flows are then conveyed in pipes through the existing storm drain system.

Basin B-2 (0.04 acres, Q5 = 0.00 cfs, Q100 = 0.02 cfs): a basin that encompasses a portion of the landscape area along the southern property line of Lot 1, Owl Marketplace Filing No. 1. Runoff sheet flows to the southwest to existing curb and gutter and into the existing 10' CDOT Type R Storm Inlet (Public). The flows are then conveyed in pipes through the existing storm drain system.

A table has been provided below to show the difference in area and runoff between the original values of the basins described above from the planned condition:

BASIN	PLANNED SITE				PROPOSED SITE				
	AREA (Ac)	Q5	Q100	IMPERVIOUSNESS	BASIN	AREA (Ac)	Q5	Q100	IMPERVIOUSNESS
D	1.11	4.5	8.2	95.0%	A-1, A-2, B-1, B-2	1.28	2.2	4.4	69.3%

Since there are some proposed storm infrastructure elements within this project, please provide an engineer's cost estimate.

V. Basin Fees

The project is located within the Falcon Drainage Basin. The property is already platted, therefore no drainage basin fees are required.

IV. Conclusion

This Final Drainage Letter for Lot 1, Owl Marketplace Filing No. 1 has demonstrated that the proposed development will comply with the governing DCM, DBPS, and El Paso County MS4 permit. The downstream facilities are adequate to protect the runoff proposed from the site. The site runoff will not adversely affect the downstream and surrounding developments. Therefore, we recommend approval of the proposed development.

Variances

No variances are being requested at this time. Any variances that arise at the construction plan stage will be addressed within an FDL Amendment.

V. References

1. *Drainage Criteria Manual*, El Paso County, dated October 31, 2018.
2. *Urban Storm Drainage Criteria Manual*, Urban Drainage and Flood Control District, latest revision.
3. Flood Insurance Rate Map – El Paso County, Colorado and Incorporated Areas Community Panel No. 08041C0553G, Effective December 7th, 2018.
4. Soil Map – El Paso County Area, Colorado as available through the Natural Resources Conservation Service National Cooperative Soil Survey web site via Web Soil Survey 2.0.
5. “Final Drainage Report for Owl Marketplace Filing No. 1” prepared by Drexel, Barrell & Co., **dated January 2023.**
6. “Falcon Drainage Basin Planning Study” prepared by Matrix Design Group, dated October 6th, 2015. (**DBPS**)

Please revise it to be approved date once it is known.

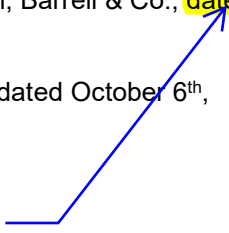

APPENDIX A
EXHIBITS AND FIGURES



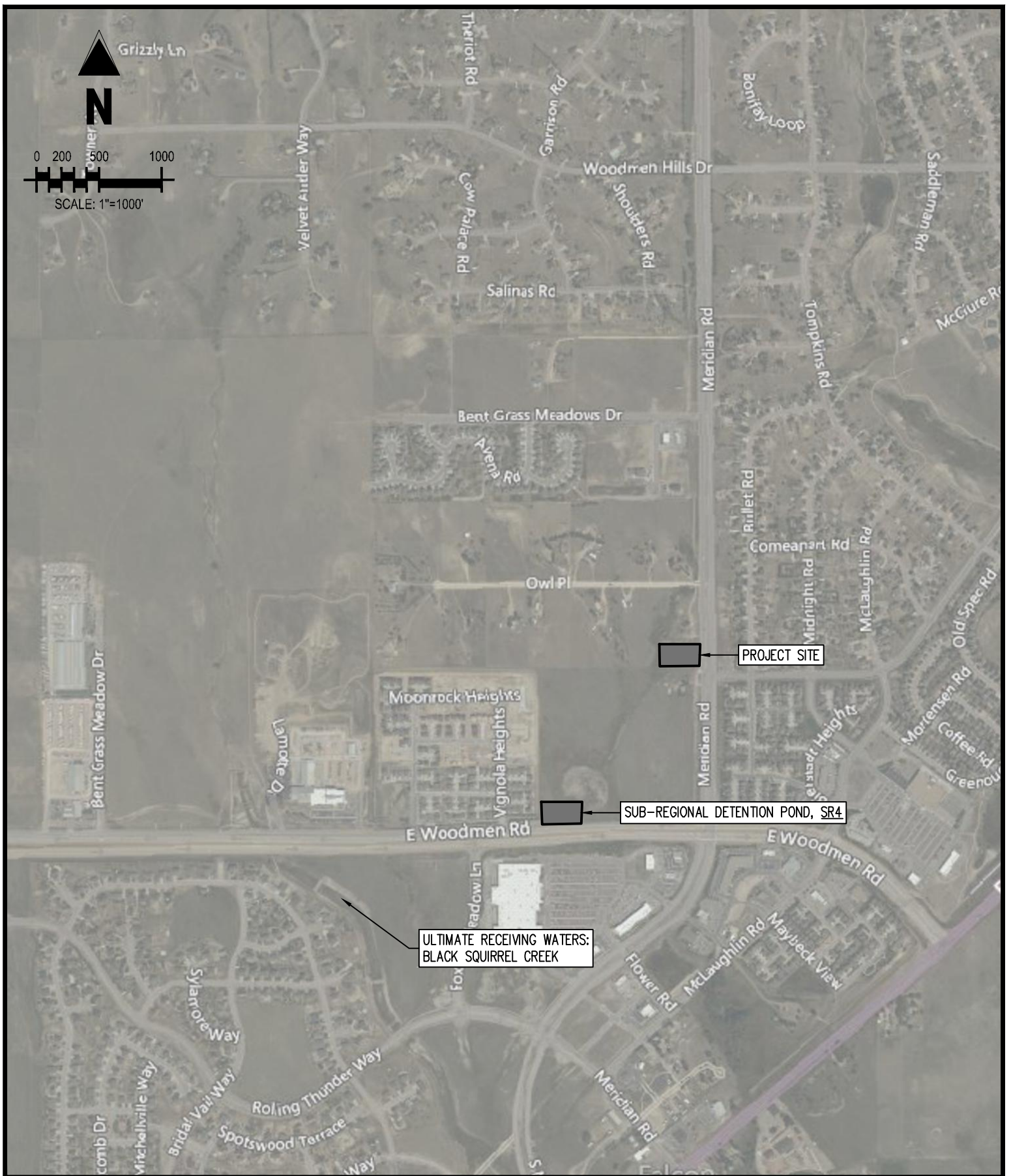

LOT 1, OWL MARKETPLACE FILING NO. 1
 MURPHY OIL #7968
 7440 MERIDIAN PARK DRIVE
 FALCON, CO 80831
 VICINITY MAP

Project No:	MOC99
Drawn By:	ASA
Checked By:	KG
Date:	02/16/2024

Galloway

1155 Kelly Johnson Blvd., Suite 305
 Colorado Springs, CO 80920
 719.900.7220 • GallowayUS.com

National Flood Hazard Layer FIRMMette



104°36'49"W 38°56'55"N

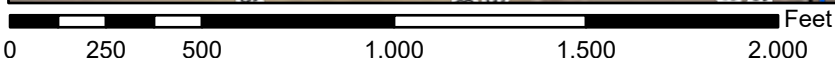
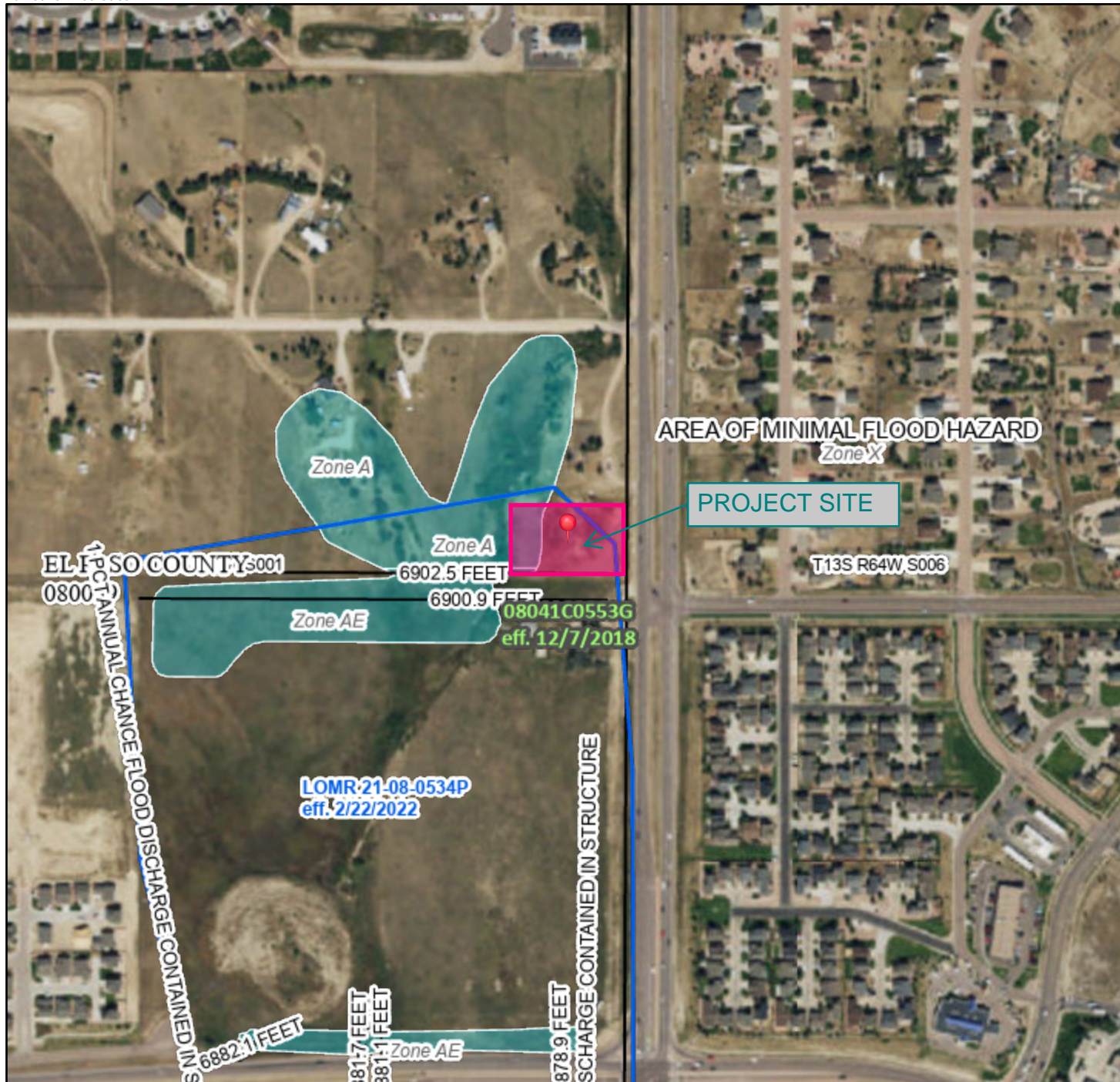

1:6,000 104°36'12"W 38°56'27"N

Basemap Imagery Source: USGS National Map 2023

Legend

SEE FIS REPORT FOR DETAILED LEGEND AND INDEX MAP FOR FIRM PANEL LAYOUT

SPECIAL FLOOD HAZARD AREAS		Without Base Flood Elevation (BFE) Zone A, V, A99
		With BFE or Depth Zone AE, AO, AH, VE, AR
		Regulatory Floodway
OTHER AREAS OF FLOOD HAZARD		0.2% Annual Chance Flood Hazard, Areas of 1% annual chance flood with average depth less than one foot or with drainage areas of less than one square mile Zone X
		Future Conditions 1% Annual Chance Flood Hazard Zone X
		Area with Reduced Flood Risk due to Levee. See Notes. Zone X
		Area with Flood Risk due to Levee Zone D
OTHER AREAS		NO SCREEN Area of Minimal Flood Hazard Zone X
		Effective LOMRs
GENERAL STRUCTURES		Area of Undetermined Flood Hazard Zone D
		Channel, Culvert, or Storm Sewer
OTHER FEATURES		Levee, Dike, or Floodwall
		20.2 Cross Sections with 1% Annual Chance Water Surface Elevation
OTHER FEATURES		17.5 Water Surface Elevation
		Coastal Transect
OTHER FEATURES		Base Flood Elevation Line (BFE)
		Limit of Study
OTHER FEATURES		Jurisdiction Boundary
		Coastal Transect Baseline
OTHER FEATURES		Profile Baseline
		Hydrographic Feature
MAP PANELS		Digital Data Available
		No Digital Data Available
		Unmapped
		The pin displayed on the map is an approximate point selected by the user and does not represent an authoritative property location.



This map complies with FEMA's standards for the use of digital flood maps if it is not void as described below. The basemap shown complies with FEMA's basemap accuracy standards

The flood hazard information is derived directly from the authoritative NFHL web services provided by FEMA. This map was exported on 2/6/2024 at 8:31 PM and does not reflect changes or amendments subsequent to this date and time. The NFHL and effective information may change or become superseded by new data over time.

This map image is void if the one or more of the following map elements do not appear: basemap imagery, flood zone labels, legend, scale bar, map creation date, community identifiers, FIRM panel number, and FIRM effective date. Map images for unmapped and unmodernized areas cannot be used for regulatory purposes.

Soil Map—El Paso County Area, Colorado



Soil Map may not be valid at this scale.

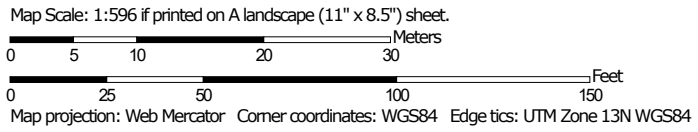

MAP LEGEND

Area of Interest (AOI)

 Area of Interest (AOI)

Soils

 Soil Map Unit Polygons

 Soil Map Unit Lines

 Soil Map Unit Points

Special Point Features



Blowout



Borrow Pit



Clay Spot



Closed Depression



Gravel Pit



Gravelly Spot



Landfill



Lava Flow



Marsh or swamp



Mine or Quarry



Miscellaneous Water



Perennial Water



Rock Outcrop



Saline Spot



Sandy Spot



Severely Eroded Spot



Sinkhole



Slide or Slip



Sodic Spot



Spoil Area



Stony Spot



Very Stony Spot



Wet Spot



Other



Special Line Features

Water Features



Streams and Canals

Transportation



Rails



Interstate Highways



US Routes



Major Roads



Local Roads

Background



Aerial Photography

MAP INFORMATION

The soil surveys that comprise your AOI were mapped at 1:24,000.

Warning: Soil Map may not be valid at this scale.

Enlargement of maps beyond the scale of mapping can cause misunderstanding of the detail of mapping and accuracy of soil line placement. The maps do not show the small areas of contrasting soils that could have been shown at a more detailed scale.

Please rely on the bar scale on each map sheet for map measurements.

Source of Map: Natural Resources Conservation Service

Web Soil Survey URL:

Coordinate System: Web Mercator (EPSG:3857)

Maps from the Web Soil Survey are based on the Web Mercator projection, which preserves direction and shape but distorts distance and area. A projection that preserves area, such as the Albers equal-area conic projection, should be used if more accurate calculations of distance or area are required.

This product is generated from the USDA-NRCS certified data as of the version date(s) listed below.

Soil Survey Area: El Paso County Area, Colorado

Survey Area Data: Version 21, Aug 24, 2023

Soil map units are labeled (as space allows) for map scales 1:50,000 or larger.

Date(s) aerial images were photographed: Sep 11, 2018—Oct 20, 2018

The orthophoto or other base map on which the soil lines were compiled and digitized probably differs from the background imagery displayed on these maps. As a result, some minor shifting of map unit boundaries may be evident.

Map Unit Legend

Map Unit Symbol	Map Unit Name	Acres in AOI	Percent of AOI
19	Columbine gravelly sandy loam, 0 to 3 percent slopes	1.8	100.0%
Totals for Area of Interest		1.8	100.0%

El Paso County Area, Colorado

19—Columbine gravelly sandy loam, 0 to 3 percent slopes

Map Unit Setting

National map unit symbol: 367p
Elevation: 6,500 to 7,300 feet
Mean annual precipitation: 14 to 16 inches
Mean annual air temperature: 46 to 50 degrees F
Frost-free period: 125 to 145 days
Farmland classification: Not prime farmland

Map Unit Composition

Columbine and similar soils: 97 percent
Minor components: 3 percent
Estimates are based on observations, descriptions, and transects of the mapunit.

Description of Columbine

Setting

Landform: Flood plains, fan terraces, fans
Down-slope shape: Linear
Across-slope shape: Linear
Parent material: Alluvium

Typical profile

A - 0 to 14 inches: gravelly sandy loam
C - 14 to 60 inches: very gravelly loamy sand

Properties and qualities

Slope: 0 to 3 percent
Depth to restrictive feature: More than 80 inches
Drainage class: Well drained
Runoff class: Very low
Capacity of the most limiting layer to transmit water (Ksat): High to very high (5.95 to 19.98 in/hr)
Depth to water table: More than 80 inches
Frequency of flooding: None
Frequency of ponding: None
Available water supply, 0 to 60 inches: Very low (about 2.5 inches)

Interpretive groups

Land capability classification (irrigated): 4e
Land capability classification (nonirrigated): 6e
Hydrologic Soil Group: A
Ecological site: R049XY214CO - Gravelly Foothill
Hydric soil rating: No

Minor Components

Fluvaquentic haplaquolls

Percent of map unit: 1 percent

Landform: Swales
Hydric soil rating: Yes

Other soils

Percent of map unit: 1 percent
Hydric soil rating: No

Pleasant

Percent of map unit: 1 percent
Landform: Depressions
Hydric soil rating: Yes

Data Source Information

Soil Survey Area: El Paso County Area, Colorado
Survey Area Data: Version 21, Aug 24, 2023

APPENDIX B
EXISTING DRAINAGE REPORTS



Review C1: This FDR has not been approved. Please update the excerpt once it gets approved. This comment stays unresolved until FDR gets approved and updated.

Review C2: Unresolved. This comment will stay unresolved until the FDR gets approved, and updated.

FINAL DRAINAGE REPORT

for

OWL MARKETPLACE FILING NO. 1

Falcon, Colorado

January 2024

Prepared for:

Meridian & Owl X, LLC
450 N McClintock Drive
Chandler, AZ 85226
Contact: Brian Zurek
(480)-313-2724

Prepared by:

Drexel, Barrell & Co.
3 South 7th Street
Colorado Springs, CO 80905
Contact: Tim McConnell, P.E.
(719) 260-0887

El Paso County File No. VR2321

(Basin A). Flows continue south from this manhole via proposed public 24" RCP storm sewer.

Design Point 3 is located at the manhole where Basin C combines with Design Point DP2. Flows continue south from this manhole via proposed public 24" RCP storm sewer.

Rational Method Runoff Summary

DEVELOPED				
BASIN	DP	Area (Ac.)	Q ₅ (CFS)	Q ₁₀₀ (CFS)
A	1	1.27	5.2	9.5
B		0.68	2.8	5.1
	2	1.95	8.0	14.5
C		1.07	4.4	8.0
	3	3.02	12.2	22.2
D	4	1.08	4.5	8.2
	5	0.00	0.6	1.5
	6	0.00	1.0	2.1
E		0.83	3.5	6.3
	7	1.91	8.2	15.3
F		0.53	2.4	4.4
	8	0.53	3.4	6.5
	9	5.46	22.8	42.2
G	10	0.23	0.1	0.6
H	11	0.11	0.0	0.3

Design Point 4 is located at the proposed temporary sediment basin and subsequent private 18" RCP storm sewer stub for the southernmost basin D.

Due to the concurrent development to the north (Falcon Ranchettes Filing No. 1a – Meridian Storage), the flowrates entering this property from the north are based on those defined in the aforementioned report for Falcon Ranchettes Filing No. 1a, by Galloway & Co. See appendix for excerpts and further information. **Design Point 5** receives rates of Q₅=0.6 cfs and Q₁₀₀=1.5 cfs (identified as DP12 in Galloway report) and **Design Point 6** (identified as DP13 in the Galloway report) receives flows of Q₅=1.0 cfs and Q₁₀₀=2.1 cfs. These design points are located at the north end of Meridian Park Drive at Owl Place. These flows are inclusive of any bypass flow from the proposed upstream at-grade inlets, and are straight added to the downstream design points further described in this report.

Basin E covers 0.84-acres and includes Owl Place along the property boundary to the north, as well as the eastern half of the proposed Meridian Park Drive. Within the basin, flows will travel west along proposed curb and gutter on Owl Place, before combining with those flows from Design Point 5, turning south and traveling along the proposed easterly curb and gutter of Meridian Park Drive. Flows will be captured in their entirety by a proposed public 10' Type R sump inlet located at **Design Point 7**. Emergency overflow for this inlet is to the east behind the curb, and south to the existing inlet on Eastonville Road.

Basin F represents the western half of Meridian Park Drive and a small portion of the southwestern part of Owl Place. Runoff from this basin, which totals 0.53 acres in size, will combine with that from Design Point 6 and travel to the south along the westerly curb line

PROJECT INFORMATION

PROJECT: Owl Marketplace
PROJECT NO: 21611-01CSCV
DESIGN BY: KGV
REV. BY: TDM
AGENCY: El Paso County
REPORT TYPE: Final
DATE: 1/5/2024



	C2*	C5*	C10*	C100*	% IMPERV
Business - Commercial Area		0.81		0.88	95
Pasture/Meadow/Lawn		0.08		0.35	0
Streets - Gravel		0.90		0.96	100
Streets - Paved		0.90		0.96	100

*C-Values and Basin Imperviousness based on Table 6-6, City of Colorado Springs Drainage Criteria Manual

C	Business - Commercial Area	1.07		0.81		0.88	95
	Pasture/Meadow/Lawn	0.00		0.08		0.35	0
	Streets - Paved	0.00		0.90		0.96	100
C TOTAL	<i>WEIGHTED AVERAGE</i>	1.07		0.81		0.88	95
D	Business - Commercial Area	1.08		0.81		0.88	95
	Pasture/Meadow/Lawn	0.00		0.08		0.35	0
	Streets - Paved	0.00		0.90		0.96	100
D TOTAL	<i>WEIGHTED AVERAGE</i>	1.08		0.81		0.88	95
E	Business - Commercial Area	0.00		0.81		0.88	95
	Pasture/Meadow/Lawn	0.00		0.08		0.35	0
	Streets - Paved	0.83		0.90		0.96	100
E TOTAL	<i>WEIGHTED AVERAGE</i>	0.83		0.90		0.96	100
F	Business - Commercial Area	0.00		0.81		0.88	95
	Pasture/Meadow/Lawn	0.00		0.08		0.35	0
	Streets - Paved	0.53		0.90		0.96	100
F TOTAL	<i>WEIGHTED AVERAGE</i>	0.53		0.90		0.96	100
G	Business - Commercial Area	0.00		0.81		0.88	95
	Pasture/Meadow/Lawn	0.23		0.08		0.35	0
	Streets - Paved	0.00		0.90		0.96	100
G TOTAL	<i>WEIGHTED AVERAGE</i>	0.23		0.08		0.35	0
H	Business - Commercial Area	0.00		0.81		0.88	95
	Pasture/Meadow/Lawn	0.11		0.08		0.35	0
	Streets - Paved	0.00		0.90		0.96	100
H TOTAL	<i>WEIGHTED AVERAGE</i>	0.11		0.08		0.35	0

PROJECT INFORMATION

PROJECT: Owl Marketplace
 PROJECT NO: 21611-01CSCV
 DESIGN BY: KGV
 REV. BY: TDM
 AGENCY: El Paso County
 REPORT TYPE: Final
 DATE: 1/5/2024



RATIONAL METHOD CALCULATIONS FOR STORM WATER RUNOFF
 DEVELOPED TIME OF CONCENTRATION STANDARD FORM SF-2

SUB-BASIN DATA					INITIAL/OVERLAND TIME (t _i)			TRAVEL TIME (t _t)				TIME OF CONC. t _c		FINAL t _c
BASIN	DESIGN PT.	C _s	C ₁₀₀	AREA	LENGTH	SLOPE	t _i	LENGTH	SLOPE	VEL.	t _t	COMP.	MINIMUM	
				Ac	Ft	%	Min	Ft	%	FPS	Min	t _c	t _c	Min
EXISTING														
RMT064	X1	Flow directly added												
OSE1	E1	0.20	0.41	1.26	100	3.0	11.7	150	1.0	1.5	1.7	13.3	5.0	13.3
E2		0.08	0.35	1.95	100	2.0	15.1	340	3.0	4.3	1.3	16.5	5.0	16.5
OS1+E2	E2	0.13	0.37	3.21	From OSE1		13.3	350	3.0	4.3	1.4	14.7	5.0	14.7
E3	E3	0.08	0.35	2.34	100	2.0	15.1	410	3.0	4.3	1.6	16.7	5.0	16.7
E4	E4	0.08	0.35	0.33	50	2.0	10.7	550	2.0	3.8	2.4	13.1	5.0	13.1
MT060	X2	Flow directly added												
DEVELOPED														
A	1	0.81	0.88	1.27	50	3.0	2.7	366	2.3	4.3	1.4	4.1	5.0	5.0
B		0.81	0.88	0.68	50	3.0	2.7	291	2.5	4.3	1.1	3.8	5.0	5.0
DP1+B	2	0.81	0.88	1.95	From DP1		5.0	110	1.4	11.3	0.2	5.2	5.0	5.2
C		0.81	0.88	1.07	50	3.0	2.7	318	2.5	4.3	1.2	3.9	5.0	5.0
DP2+C	3	0.81	0.88	3.02	From DP2		5.2	167	1.3	11.3	0.2	5.4	5.0	5.4
D	4	0.81	0.88	1.08	50	3.0	2.7	270	2.3	4.3	1.0	3.7	5.0	5.0
Offsite	5	Flow directly added from offsite basin - Falcon Ranchettes #1A DP12												
Offsite 2	6	Flow directly added from offsite basin - Falcon Ranchettes #1A DP13												
E		0.90	0.96	0.83	50	2.0	2.1	1036	2.0	3.8	4.5	6.6	5.0	6.6
DP4+DP5+E	7	0.85	0.91	1.91	From Basin E		6.6					6.6	5.0	6.6
F		0.90	0.96	0.53	50	2.0	2.1	617	1.5	3.8	2.7	4.8	5.0	5.0
DP6+F	8	0.90	0.96	0.53	From Basin F		5.0				0.0	5.0	5.0	5.0
DP3+DP7+DP8	9	0.83	0.90	5.46	From DP7		6.6	45	1.2	11.3	0.1	6.7	5.0	6.7
G	10	0.08	0.35	0.23	50	20.0	5.0	669	1.7	3.8	2.9	7.9	5.0	7.9
H	11	0.08	0.35	0.11	50	20.0	5.0					5.0	5.0	5.0

PROJECT INFORMATION

PROJECT: Owl Marketplace
 PROJECT NO: 21611-01CSCV
 DESIGN BY: KGV
 REV. BY: TDM
 AGENCY: El Paso County
 REPORT TYPE: Final
 DATE: 1/5/2024



RATIONAL METHOD CALCULATIONS FOR STORM WATER RUNOFF

DEVELOPED RUNOFF 5 YR STORM P1= **1.50**

BASIN (S)	DIRECT RUNOFF						
	DESIGN POINT	AREA (AC)	RUNOFF COEFF	t _c (MIN)	C * A	I (IN/HR)	Q (CFS)
EXISTING							
RMT064	X1						288.5
OSE1	E1	1.26	0.20	13.3	0.25	3.60	0.9
E2		1.95	0.08	16.5	0.16	3.26	0.5
	E2	3.21	0.13	14.7	0.41	3.44	1.4
E3	E3	2.34	0.08	16.7	0.19	3.23	0.6
E4	E4	0.33	0.08	13.1	0.03	3.62	0.1
MT060	X2						60.1
DEVELOPED							
A	1	1.27	0.81	5.0	1.03	5.09	5.2
B		0.68	0.81	5.0	0.55	5.09	2.8
	2	1.95	0.81	5.2	1.58	5.04	8.0
C		1.07	0.81	5.0	0.86	5.09	4.4
	3	3.02	0.81	5.4	2.44	4.98	12.2
D	4	1.08	0.81	5.0	0.88	5.09	4.5
	5						0.6
	6						1.0
E		0.83	0.90	6.6	0.74	4.69	3.5
	7	1.91	0.85	6.6	1.62	4.69	8.2
F		0.53	0.90	5.0	0.48	5.09	2.4
	8	0.53	0.90	5.0	0.48	5.09	3.4
	9	5.46	0.83	6.7	4.54	4.67	22.8
G	10	0.23	0.08	7.9	0.02	4.43	0.1
H	11	0.11	0.08	5.0	0.01	5.09	0.0

PROJECT INFORMATION

PROJECT: Owl Marketplace
 PROJECT NO: 21611-01CSCV
 DESIGN BY: KGV
 REV. BY: TDM
 AGENCY: El Paso County
 REPORT TYPE: Final
 DATE: 1/5/2024



RATIONAL METHOD CALCULATIONS FOR STORM WATER RUNOFF

DEVELOPED RUNOFF 100 YR STORM P1= 2.52

BASIN (S)	DIRECT RUNOFF						
	DESIGN POINT	AREA (AC)	RUNOFF COEFF	t _c (MIN)	C * A	I (IN/HR)	Q (CFS)
EXISTING							
RMT064	X1						920.0
OSE1	E1	1.26	0.41	13.3	0.52	6.04	3.1
E2		1.95	0.35	16.5	0.68	5.47	3.7
	E2	3.21	0.37	14.7	1.20	5.78	6.9
E3	E3	2.34	0.35	16.7	0.82	5.43	4.4
E4	E4	0.33	0.35	13.1	0.12	6.08	0.7
MT060	X2						196.8
DEVELOPED							
A	1	1.27	0.88	5.0	1.11	8.55	9.5
B		0.68	0.88	5.0	0.60	8.55	5.1
	2	1.95	0.88	5.2	1.72	8.48	14.5
C		1.07	0.88	5.0	0.94	8.55	8.0
	3	3.02	0.88	5.4	2.65	8.37	22.2
D	4	1.08	0.88	5.0	0.95	8.55	8.2
	5						1.5
	6						2.1
E		0.83	0.96	6.6	0.79	7.88	6.3
	7	1.91	0.91	6.6	1.75	7.88	15.3
F		0.53	0.96	5.0	0.51	8.55	4.4
	8	0.53	0.96	5.0	0.51	8.55	6.5
	9	5.46	0.90	6.7	4.91	7.85	42.2
G	10	0.23	0.35	7.9	0.08	7.44	0.6
H	11	0.11	0.35	5.0	0.04	8.55	0.3

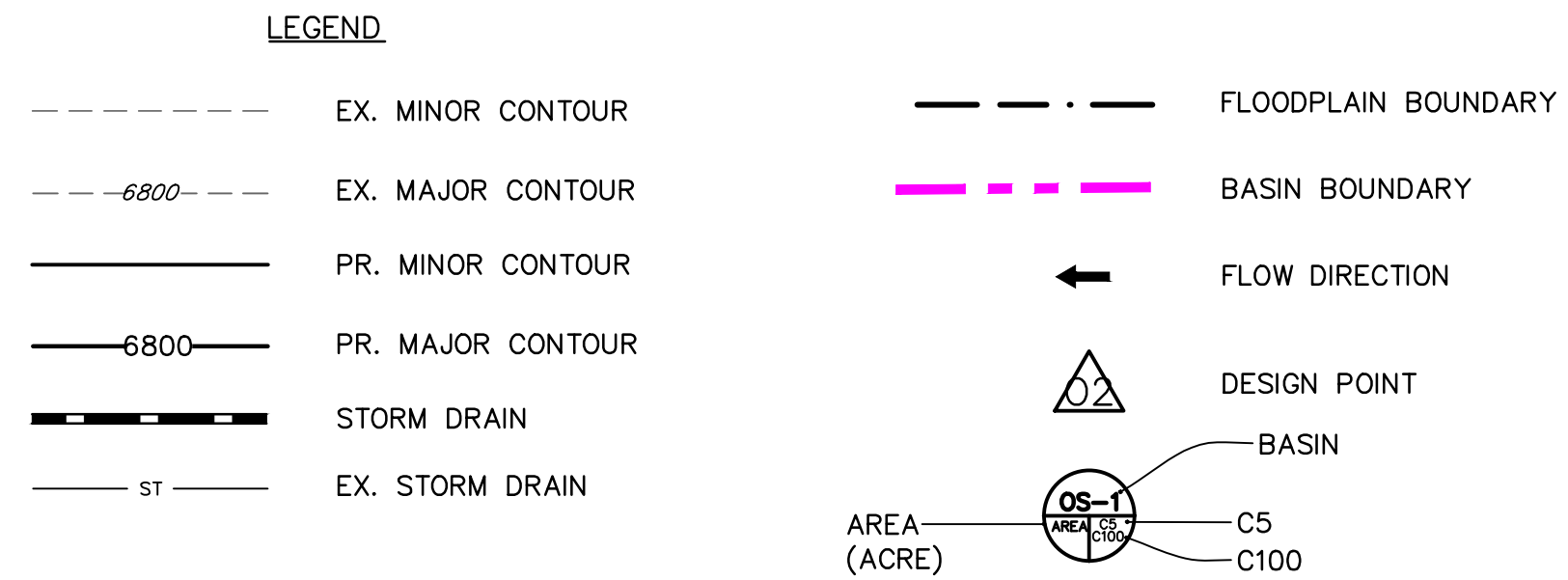

DEVELOPED				
BASIN	DP	Area (Ac.)	Q ₅ (CFS)	Q ₁₀₀ (CFS)
A	1	1.27	5.2	9.5
B	2	0.68	2.8	5.1
C	3	1.07	4.4	8.0
D	4	3.02	12.2	22.2
E	5	1.08	4.5	8.2
F	6	0.00	0.6	1.5
G	7	0.83	3.5	6.3
H	8	1.91	8.2	15.3
	9	0.53	2.4	4.4
	10	5.46	22.8	42.2
	11	0.23	0.1	0.6
		0.11	0.0	0.3

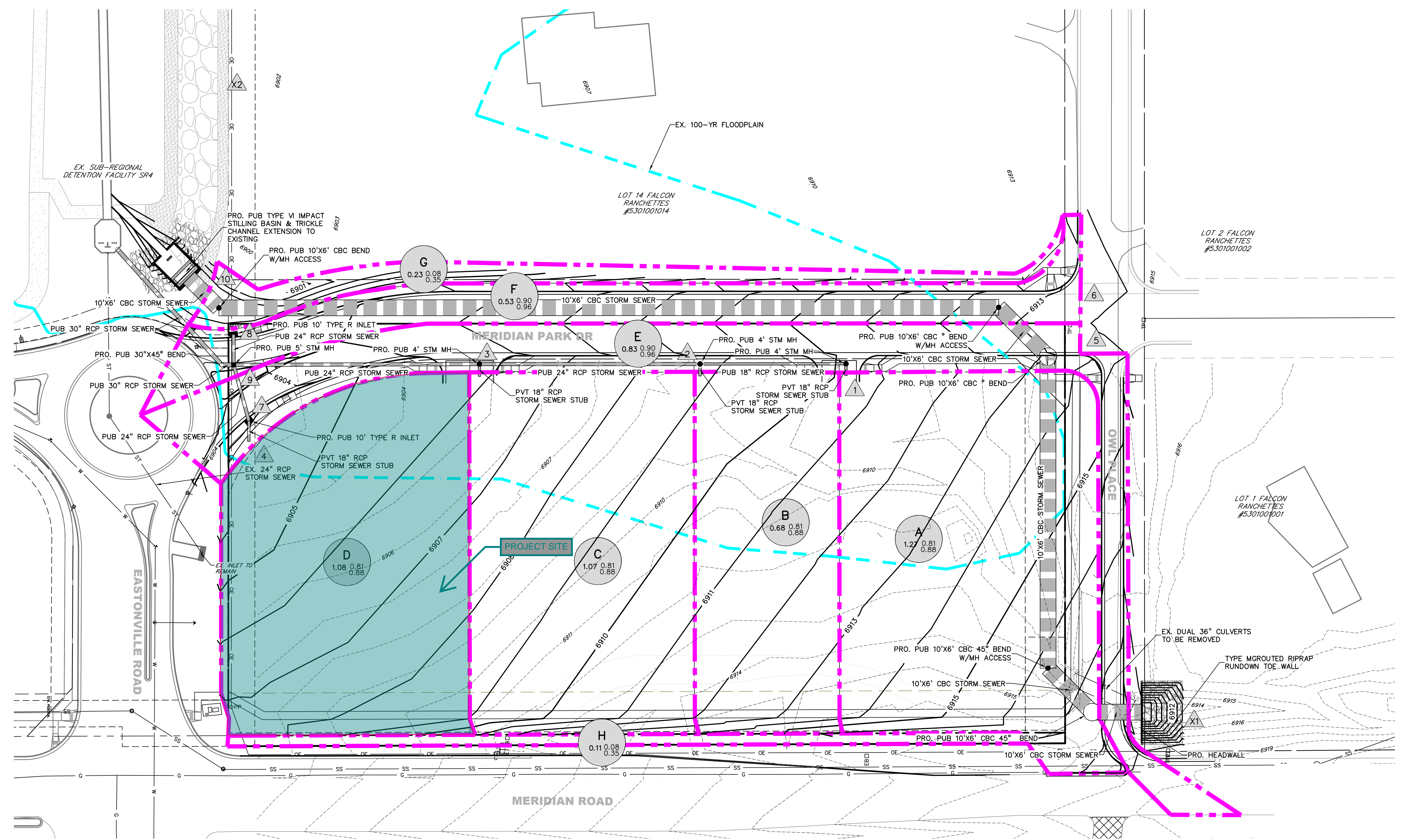
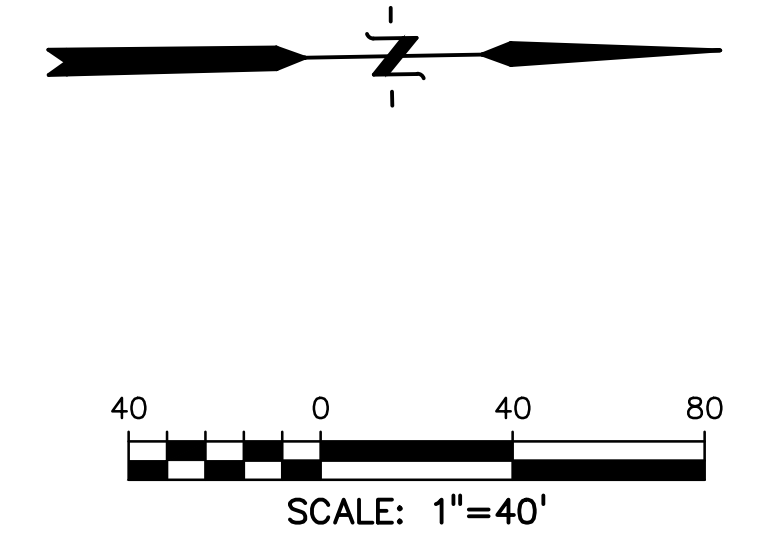

PREPARED BY:

DREXEL, BARRELL & CO.
 Engineers • Surveyors
 101 S SAWATCH ST., #100
 COLORADO SPGS, COLORADO 80903
 CONTACT: TIM D. McCONNELL, P.E.
 (719) 260-0887
 COLORADO SPRINGS • LAFAYETTE

CLIENT:
BH RE INVESTMENTS, LLC
 450 N MCCLINTOCK DRIVE
 CHANDLER, AZ 85226
 (480) 313-2724

DRAINAGE PLANS FOR:
OWL MARKETPLACE
 FALCON, COLORADO

ISSUE	DATE
INITIAL ISSUE	9-29-2023
RESUBMITTAL	1-4-2024
DESIGNED BY:	KGV
DRAWN BY:	CGH
CHECKED BY:	TDM
FILE NAME:	21611-DRN-PP

PREPARED UNDER MY DIRECT SUPERVISION FOR AND ON BEHALF OF DREXEL, BARRELL & CO.
 DRAWING SCALE:
 HORIZONTAL: 1" = 40"
 VERTICAL: N/A

PROPOSED DRAINAGE MAP
 PROJECT NO. 21611-01CSCV
 DRAWING NO.

DRN
 SHEET: 2 OF 2

FALCON DRAINAGE BASIN PLANNING STUDY
SELECTED PLAN REPORT
FINAL - SEPTEMBER 2015

Prepared for:



El Paso County Public Services Department
3275 Akers Drive
Colorado Springs, CO 80922

Prepared By:



Matrix Design Group
2435 Research Parkway, Suite 300
Colorado Springs, CO 80920

Matrix Project No. 10.122.003

Sheet 6-23 Falcon DBPS Conceptual Plan Middle Tributary El Paso County, CO

- Drainageway Crossing
- Stream Centerline
- Existing Approximate 100-yr Floodplain*
- Floodplain Study Limit
- Storm Sewer**
 - Inlet
 - Manhole
 - Pipe
- Reach Improvements**
 - Natural Channel Design
 - Protect In Place
 - Roadside Ditch Improvement
 - Small Drop Structures w/ Toe Protection
 - Existing Detention
 - Proposed Detention
 - Proposed Detention Grading
 - Small Drop Structure
 - Cross Vane
 - Immediate Action Required to Preserve Existing Condition

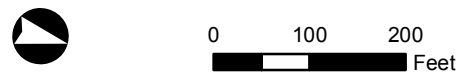

* These approximate 100-yr floodplain boundaries are for planning purposes only. This information is not intended to replace the information provided on the FEMA Flood Insurance Rate Maps for this area.
 ** These are conceptual design drawings and are subject to change. These drawings are not intended for construction purposes.



MT 6 - Woodmen Rd.
 EX Size: 4' Circular RCP (x3)
 PR Size: 5' Circular RCP (x3)
 * Sub-Regional Pond SR4 will be designed to mitigate capacity issues.

Floodplain Enters Underground Storm System

Sub Regional Pond SR4
 WQCV = 7.3 AF
 100-yr Volume = 19 AF
 $Q_{2 \text{ in}} = 130 \text{ cfs}$
 $Q_{2 \text{ out}} = 27 \text{ cfs}$
 $Q_{100 \text{ in}} = 1000 \text{ cfs}$
 $Q_{100 \text{ out}} = 730 \text{ cfs}$
 See Detail on Sheet 6-55

MT 7 - Owl Place
 EX Size: 1.75' (W) x 1.25' (H) CMP Elliptical (x4)
 PR Size: 4' (W) x 2' (H) Concrete Box (x9)
 * Road profile would need to be raised to implement a feasible solution.

MT 6-2 - Woodmen Rd.
 EX Size: 4' Circular RCP (x3)
 PR Size: 5' Circular RCP (x3)
 * Sub-Regional Pond SR4 will be designed to mitigate capacity issues.

Small Drop Structure
 See Detail on Sheet 6-54

Note:
 Infrastructure and channel improvements shown may vary slightly from the final list published in the accompanying report as a result of fee revisions that have occurred following the preparation of this figure. For current information as of September 2015, please see tables in Section 6 of the accompanying report.

Future conveyance from Meridian Rd roadside ditch TBD

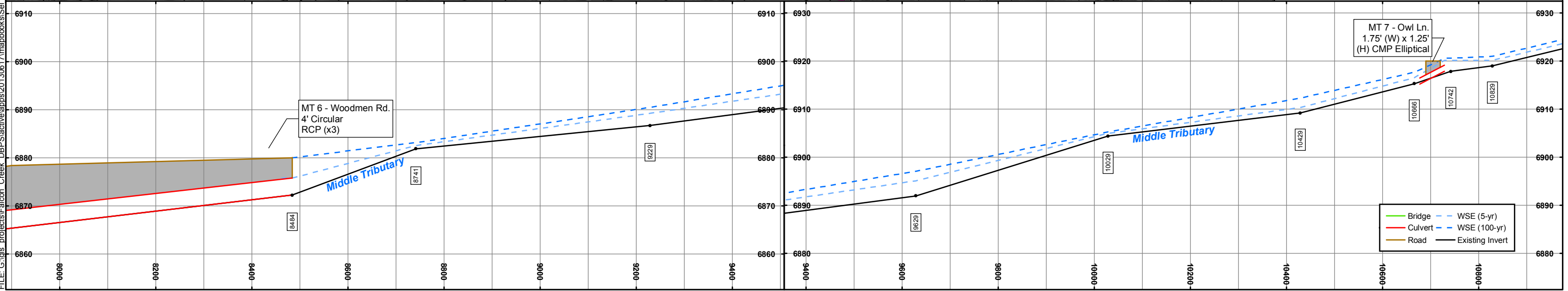
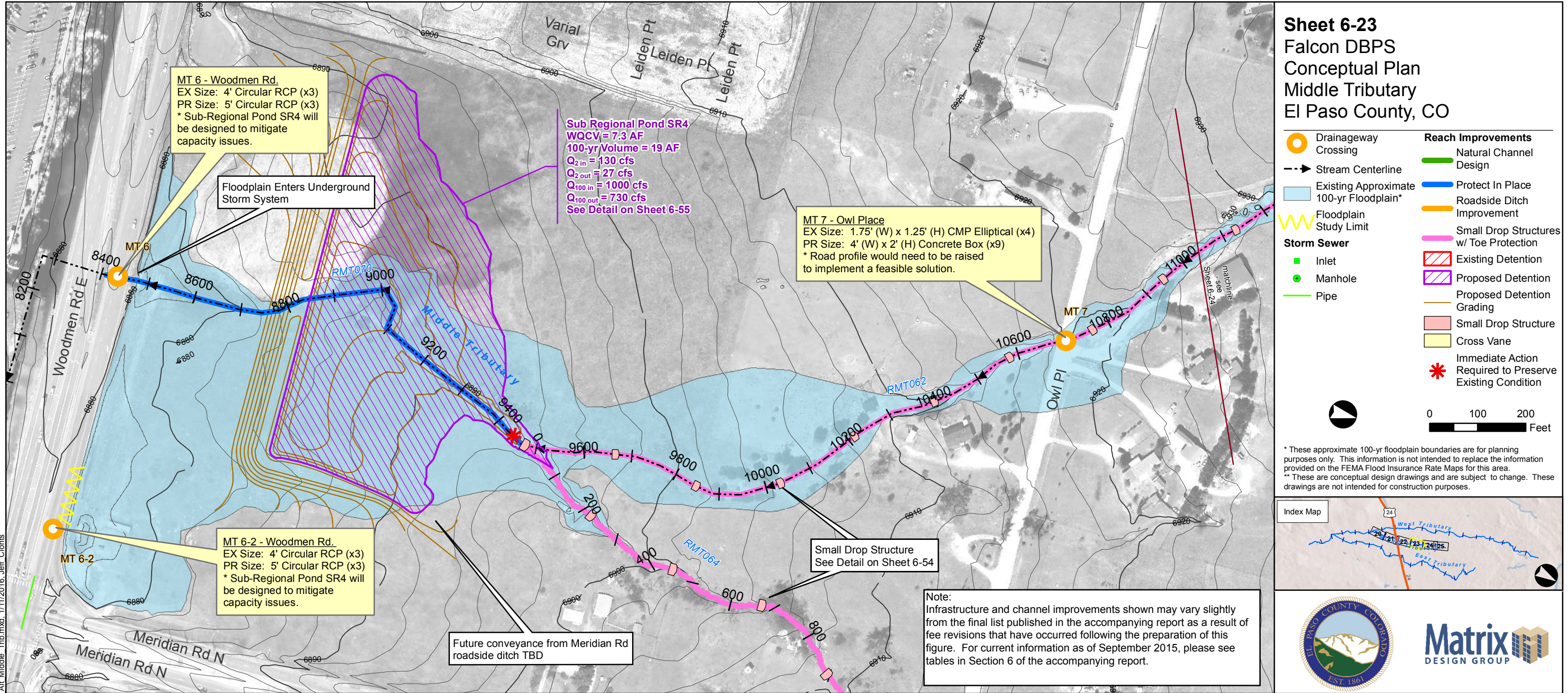

FILE: G:\gis_projects\Falcon_Creek_DBPS\active\ppps20130617\mapbooks\sel Alt Middle Trib.mxd, 1/11/2016, Jeff Clonis

APPENDIX C

HYDRAULIC COMPUTATIONS



Worksheet for Rock Cobble Swale

Project Description

Friction Method	Manning Formula
Solve For	Normal Depth

Input Data

Roughness Coefficient	0.041	
Channel Slope	0.02500	ft/ft
Left Side Slope	4.00	ft/ft (H:V)
Right Side Slope	4.00	ft/ft (H:V)
Bottom Width	1.00	ft
Discharge	3.57	ft ³ /s

Results

Normal Depth	0.49	ft
Flow Area	1.43	ft ²
Wetted Perimeter	5.01	ft
Hydraulic Radius	0.29	ft
Top Width	4.89	ft
Critical Depth	0.44	ft
Critical Slope	0.03918	ft/ft
Velocity	2.49	ft/s
Velocity Head	0.10	ft
Specific Energy	0.58	ft
Froude Number	0.81	
Flow Type	Subcritical	

GVF Input Data

Downstream Depth	0.00	ft
Length	0.00	ft
Number Of Steps	0	

GVF Output Data

Upstream Depth	0.00	ft
Profile Description		
Profile Headloss	0.00	ft
Downstream Velocity	Infinity	ft/s
Upstream Velocity	Infinity	ft/s
Normal Depth	0.49	ft
Critical Depth	0.44	ft
Channel Slope	0.02500	ft/ft

Worksheet for Rock Cobble Swale

GVF Output Data

Critical Slope 0.03918 ft/ft

APPENDIX D
HYDROLOGIC COMPUTATIONS



COMPOSITE % IMPERVIOUS CALCULATIONS

Subdivision: Owl Marketplace Filing No. 1
Location: CO, Colorado Springs

Project Name: Murphy Oil - Falcon
Project No.: MOC99
Calculated By: ASA
Checked By: KG
Date: 5/17/24

Basin ID	Total Area (ac)	Paved Roads			Lawns			Roofs			Basins Total Weighted % Imp.
		% Imp.	Area (ac)	Weighted % Imp.	% Imp.	Area (ac)	Weighted % Imp.	% Imp.	Area (ac)	Weighted % Imp.	
A-1	0.84	100	0.48	57.1	0	0.29	0.0	100	0.07	8.30	65.4
A-2	0.09	100	0.00	0.0	0	0.00	0.0	100	0.09	100.00	100.0
B-1	0.32	100	0.31	96.9	0	0.01	0.0	100	0.00	0.00	96.9
B-2	0.03	100	0.00	0.0	0	0.03	0.0	100	0.00	0.00	0.0

**STANDARD FORM SF-2
TIME OF CONCENTRATION**

Subdivision: Owl Marketplace Filing No. 1
Location: CO, Colorado Springs

Project Name: Murphy Oil - Falcon
Project No.: MOC99
Calculated By: ASA
Checked By: KG
Date: 5/17/24

SUB-BASIN						INITIAL/OVERLAND			TRAVEL TIME					T _c CHECK			FINAL
DATA						(T _i)			(T _t)					(URBANIZED BASINS)			
BASIN ID	D.A. (AC)	Hydrologic Soils Group	Impervious (%)	C ₁₀₀	C ₅	L (FT)	S (%)	T _i (MIN)	L (FT)	S (%)	C _v	VEL. (FPS)	T _t (MIN)	COMP. T _c (MIN)	TOTAL LENGTH (FT)	Urbanized T _c (MIN)	T _c (MIN)
A-1	0.84	A	65.4	0.62	0.50	100	2.2	8.4	117	2.5	15.0	2.4	0.8	9.3	217.0	11.2	9.3
A-2	0.09	A	100.0	0.89	0.86	15	2.0	1.4	138	2.0	20.0	2.8	0.8	2.2	153.0	10.9	5.0
B-1	0.32	A	96.9	0.86	0.83	100	1.4	4.4	185	1.3	20.0	2.3	1.4	5.8	285.0	11.6	5.8
B-2	0.03	A	0.0	0.11	0.00	12	1.5	6.1	155	1.5	7.0	0.9	3.0	9.1	167.0	10.9	9.1

NOTES:

$T_i = (0.395 * (1.1 - C_5) * (L)^{0.5}) / ((S)^{0.33})$, S in ft/ft

$T_t = L / 60V$ (Velocity From Fig. 501)

Velocity $V = C_v * S^{0.5}$, S in ft/ft

T_c Check = $10 + L / 180$

For Urbanized basins a minimum T_c of 5.0 minutes is required.

For non-urbanized basins a minimum T_c of 10.0 minutes is required

STANDARD FORM SF-3
STORM DRAINAGE SYSTEM DESIGN
(RATIONAL METHOD PROCEDURE)

Subdivision: Owl Marketplace Filing No. 1
 Location: CO, Colorado Springs
 Design Storm: 5-Year

Project Name: Murphy Oil - Falcon
 Project No.: MOC99
 Calculated By: ASA
 Checked By: KG
 Date: 5/17/24

STREET	Design Point	DIRECT RUNOFF							TOTAL RUNOFF				STREET		PIPE			TRAVEL TIME			REMARKS
		Basin ID	Area (Ac)	Runoff Coeff.	Tc (min)	C* A (Ac)	I (in/hr)	Q (cfs)	Tc (min)	C* A (Ac)	I (in/hr)	Q (cfs)	Slope (%)	Street Flow (cfs)	Design Flow (cfs)	Slope (%)	Pipe Size (inches)	Length (ft)	Velocity (fps)	Tt (min)	
		A-1	0.84	0.50	9.3	0.42	4.24	1.8													
		A-2	0.09	0.86	5.0	0.08	5.17	0.4													
	DP1								9.3	0.50	4.24	2.2									Total Proposed Flow at DP1 = 2.2 cfs
		B-1	0.32	0.83	5.8	0.27	4.95	1.3													
		B-2	0.03	0.00	9.1	0.00	4.27	0.0													
									9.1	0.27	4.27	1.3									Proposed Flow Leaving the Site = 1.3 cfs



STANDARD FORM SF-3
STORM DRAINAGE SYSTEM DESIGN
(RATIONAL METHOD PROCEDURE)

Subdivision: Owl Marketplace Filing No. 1 _____
 Location: CO, Colorado Springs _____
 Design Storm: 100-Year _____

Project Name: Murphy Oil - Falcon
 Project No.: MOC99
 Calculated By: ASA
 Checked By: KG
 Date: 5/17/24

STREET	Design Point	DIRECT RUNOFF							TOTAL RUNOFF				STREET		PIPE			TRAVEL TIME			REMARKS	
		Basin ID	Area (Ac)	Runoff Coeff.	Tc (min)	C* A (Ac)	I (in/hr)	Q (cfs)	Tc (min)	C* A (Ac)	I (in/hr)	Q (cfs)	Slope (%)	Street Flow (cfs)	Design Flow (cfs)	Slope (%)	Pipe Size (inches)	Length (ft)	Velocity (fps)	Tt (min)		
	P1	A-1	0.84	0.62	9.3	0.52	7.12	3.7														
		A-2	0.09	0.89	5.0	0.08	8.68	0.7														
									9.3	0.60	7.12	4.4									Total Proposed Flow at DP1 = 4.4 cfs	
		B-1	0.32	0.86	5.8	0.28	8.32	2.3														
		B-2	0.03	0.11	9.1	0.00	7.17	0.0														
									9.1	0.28	7.17	2.3									Proposed Flow Leaving the Site = 2.3 cfs	



APPENDIX E
DRAINAGE MAPS



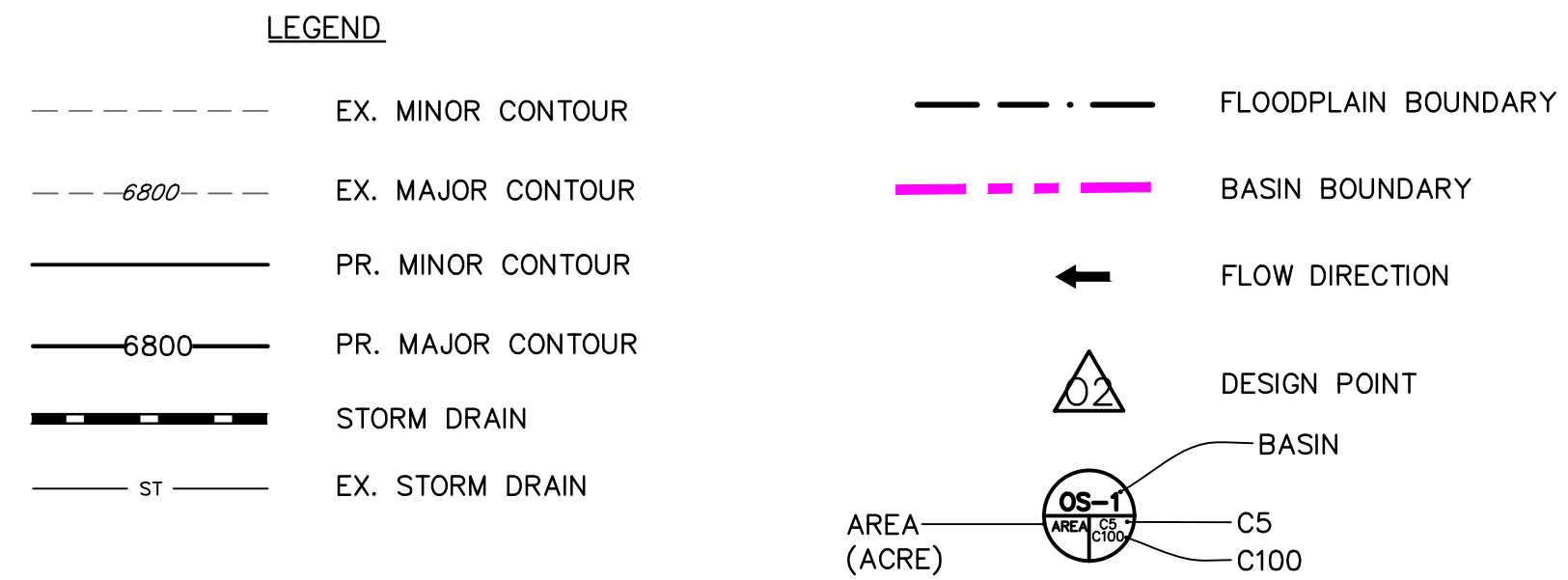

DEVELOPED				
BASIN	DP	Area (Ac.)	Q ₅ (CFS)	Q ₁₀₀ (CFS)
A	1	1.27	5.2	9.5
B	2	0.68	2.8	5.1
C	3	1.95	8.0	14.5
D	4	1.08	4.5	8.2
	5	0.00	0.6	1.5
	6	0.00	1.0	2.1
E	7	0.83	3.5	6.3
	8	0.53	2.4	4.4
F	9	5.46	22.8	42.2
G	10	0.23	0.1	0.6
H	11	0.11	0.0	0.3

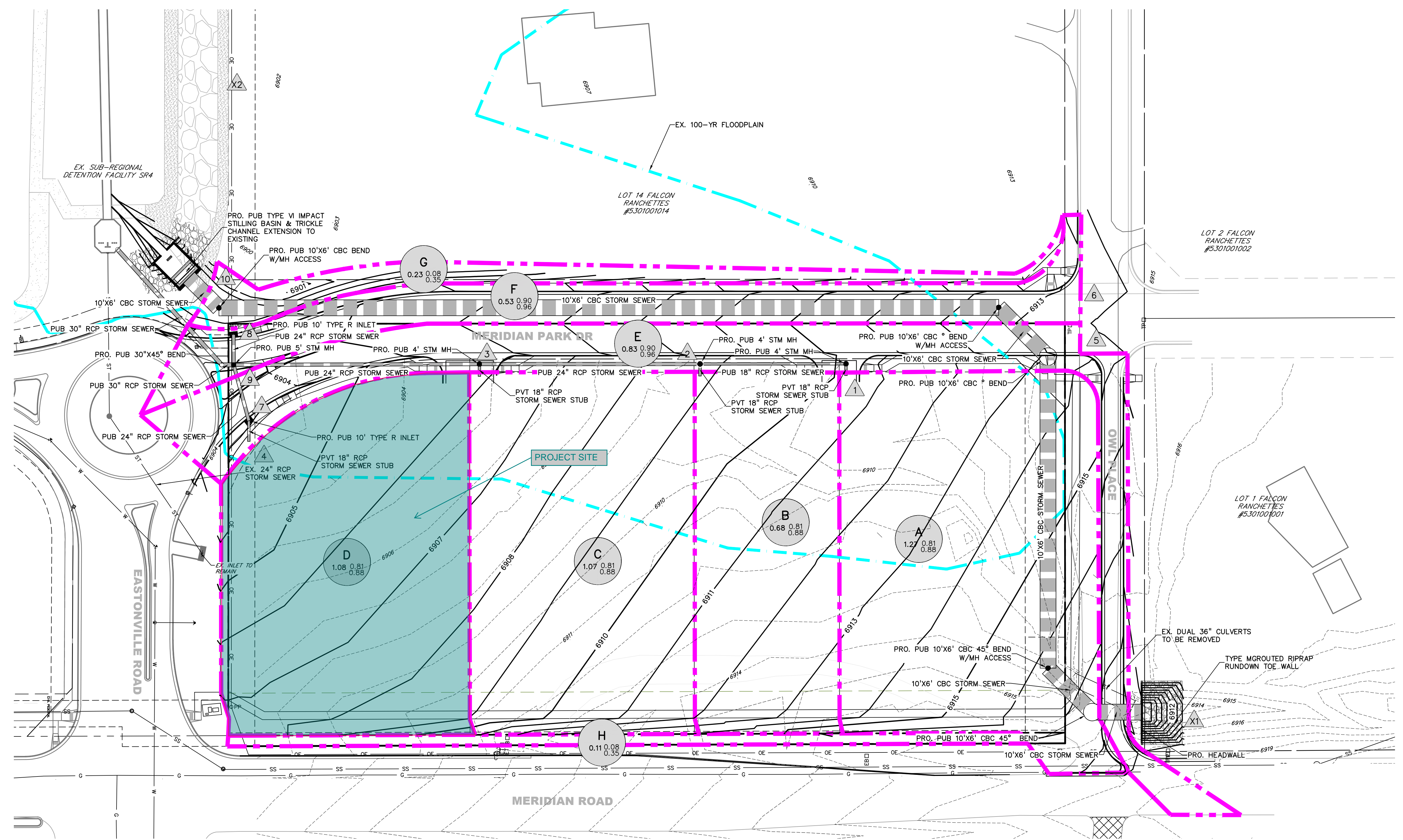
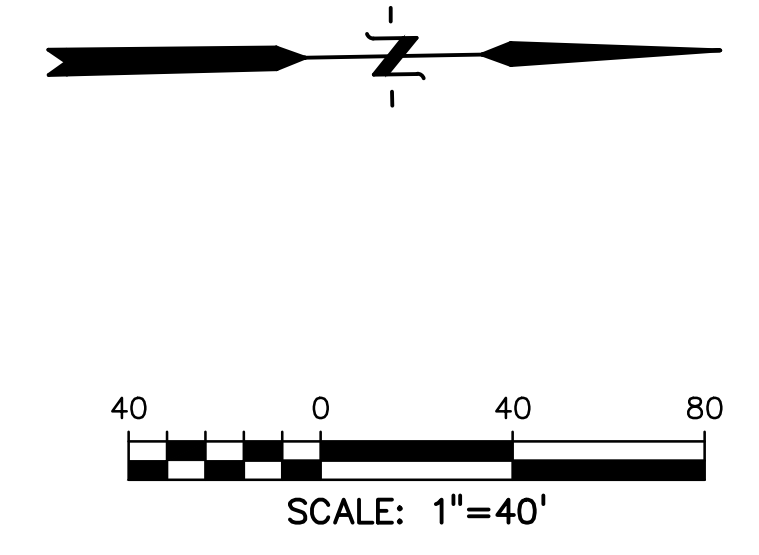

Please update both existing and proposed drainage maps to match the drainage map of VR2321 once the VR2321 gets approved.

PREPARED BY:



CLIENT:

BH RE INVESTMENTS, LLC
450 N MCCLINTOCK DRIVE
CHANDLER, AZ 85226
(480) 313-2724

DRAINAGE PLANS FOR:
OWL MARKETPLACE
FALCON, COLORADO

ISSUE	DATE
INITIAL ISSUE	9-29-2023
RESUBMITTAL	1-4-2024

DESIGNED BY:	KGV
DRAWN BY:	CGH
CHECKED BY:	TDM
FILE NAME:	21611-DRN-PP

PREPARED UNDER MY DIRECT SUPERVISION FOR AND ON BEHALF OF DREXEL, BARRELL & CO.
DRAWING SCALE:
HORIZONTAL: 1" = 40"
VERTICAL: N/A

PROPOSED DRAINAGE MAP

PROJECT NO. 21611-01CSCV
DRAWING NO.

DRN

PRELIMINARY
 NOT FOR BIDDING
 NOT FOR CONSTRUCTION

COPYRIGHT
 THESE PLANS ARE AN INSTRUMENT OF SERVICE AND ARE THE PROPERTY OF GALLOWAY, AND MAY NOT BE DUPLICATED, DISCLOSED, OR REPRODUCED WITHOUT THE WRITTEN CONSENT OF GALLOWAY. COPYRIGHTS AND INFRINGEMENTS WILL BE ENFORCED AND PROSECUTED.

MURPHY OIL USA, INC.
MURPHY OIL USA
 200 PEACH STREET
 EL DORADO, AR 71730

DRAINAGE PLAN
MURPHY OIL USA #7968
 7825 MERIDIAN PARK DRIVE
 EL PASO COUNTY, COLORADO

#	Date	Issue / Description	Init.

Project No: MOC99
 Drawn By: ASA
 Checked By: KG
 Date: 05/17/2024

PROPOSED DRAINAGE MAP

DR1.1
 Sheet 1 of 1

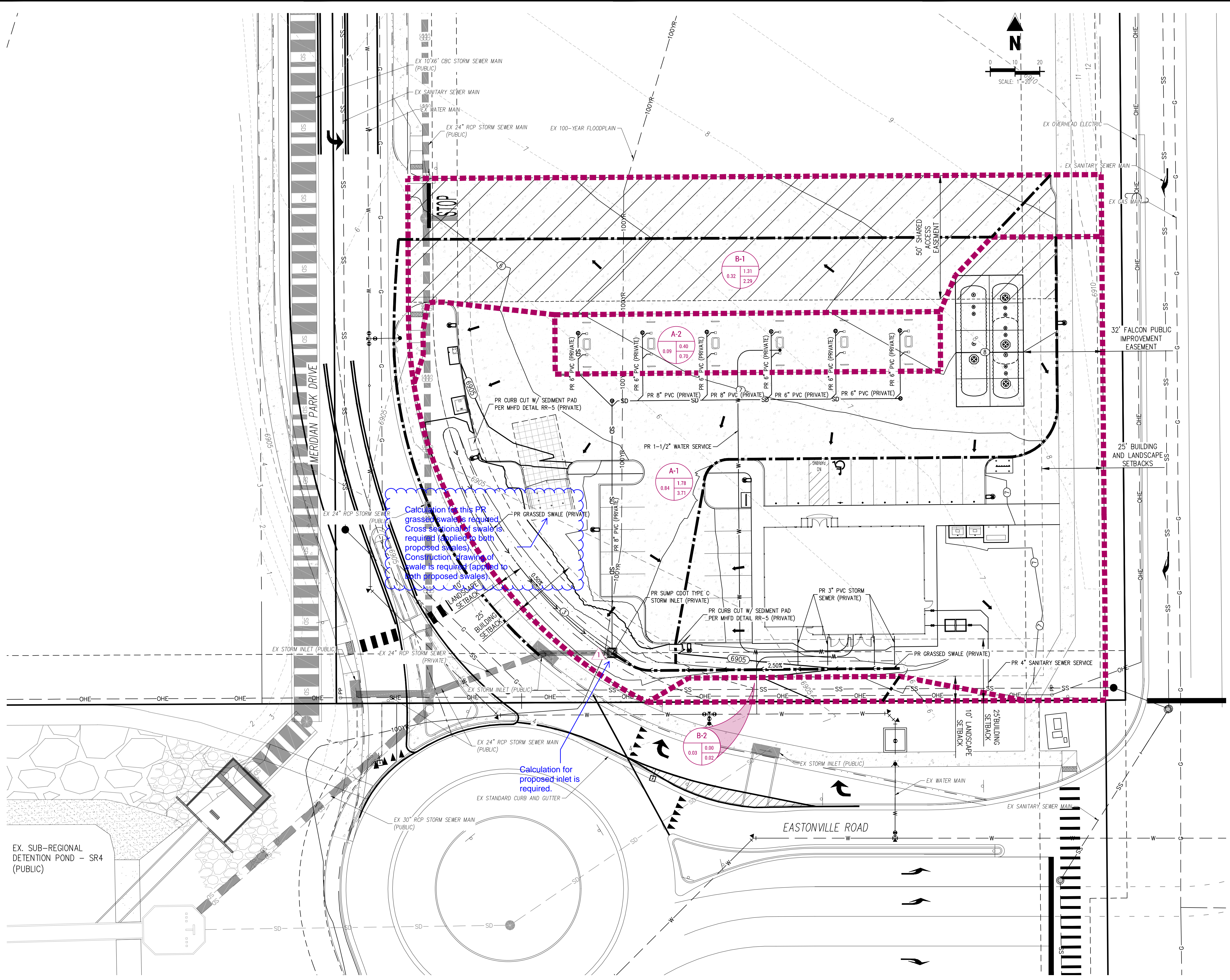

SITE LEGEND

- PROPERTY BOUNDARY LINE
- ADJACENT PROPERTY BOUNDARY LINE
- RIGHT OF WAY BOUNDARY LINE
- EXISTING ADJACENT LOT LINE
- PROPOSED LOT LINE
- EXISTING EASEMENT LINE
- PROPOSED EASEMENT LINE
- ROAD CENTERLINE
- PROPOSED CURB AND GUTTER
- EXISTING CURB AND GUTTER
- EXISTING SIGN
- PROPOSED SIGN

PAVING LEGEND

- PROPOSED CONCRETE
- REINFORCED CONCRETE PAVING

UTILITY LEGEND

- EXISTING WATER LINE
- PROPOSED WATER LINE
- EXISTING SANITARY SEWER
- PROPOSED SANITARY SEWER
- EXISTING STORM SEWER
- PROPOSED STORM SEWER (LESS THAN 12"Ø)
- EXISTING GAS LINE
- PROPOSED GAS LINE
- EXISTING STREET LIGHT
- PROPOSED STREET LIGHT
- PROPOSED WATER METER
- EXISTING WATER VALVE
- PROPOSED WATER VALVE
- EXISTING FIRE HYDRANT
- PROPOSED FIRE HYDRANT
- EXISTING STORM SEWER MANHOLE
- PROPOSED STORM SEWER MANHOLE
- EXISTING SANITARY SEWER MANHOLE
- PROPOSED SANITARY SEWER MANHOLE

DRAINAGE LEGEND

- EXISTING MAJOR CONTOUR
- EXISTING MINOR CONTOUR
- PROPOSED MAJOR CONTOUR
- PROPOSED MINOR CONTOUR
- EXISTING 100-YR FLOODPLAIN
- BASIN BOUNDARY
- FLOW FOR CALCULATING TIME OF CONCENTRATION
- PROPOSED FLOW DIRECTION
- BASIN DESIGNATION
- 5-YEAR RUNOFF IN CUBIC FEET PER SECOND
- 100-YEAR RUNOFF IN CUBIC FEET PER SECOND
- BASIN AREA IN ACRES
- DESIGN POINT

NOTES
 1. SEE APPENDIX A FOR LIMITS OF DISTURBANCE EXHIBIT

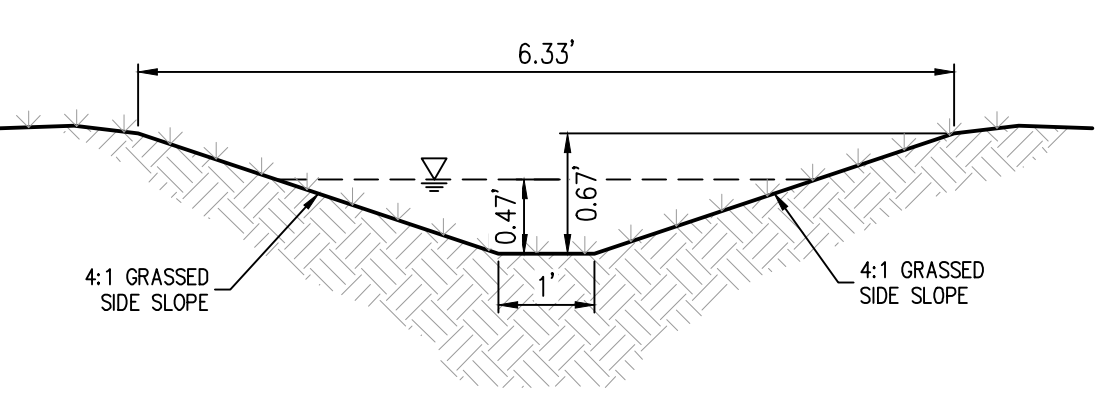

GRASSED SWALE
 N.T.S.
 (BTM WIDTH: 1.0'; DEPTH: 0.47'; SIDE SLOPES: 4:1; SLOPE: 2.5%; Q₁₀₀: 3.57 CFS; V₁₀₀: 2.60 FPS)

PRE-CONSTRUCTION IMPERVIOUS SITE RATIO (ISR)

AREA	SQUARE FEET	%
IMPERVIOUS (ROOF AND PAVING)	2,412.20	5.00
LANDSCAPE AREA	45,860.80	95.00
GROSS SITE	48,273.00	100

POST-CONSTRUCTION IMPERVIOUS SITE RATIO (ISR)

AREA	SQUARE FEET	%
IMPERVIOUS (ROOF AND PAVING)	33,433.09	69.30
LANDSCAPE AREA	14,839.91	30.70
GROSS SITE	48,273.00	100

BASIN SUMMARY TABLE

Tributary Sub-basin	Area (acres)	C _s	C ₁₀₀	t _c (min)	Q _s (cfs)	Q ₁₀₀ (cfs)
A-1	0.84	0.50	0.62	9.27	1.78	3.71
A-2	0.09	0.86	0.89	5.00	0.40	0.70
B-1	0.32	0.83	0.86	5.77	1.31	2.29
B-2	0.03	0.00	0.11	9.11	0.00	0.02

DESIGN POINT TABLE

Design Point	Q ₅ (cfs)	Q ₁₀₀ (cfs)
1	2.19	4.40

CAUTION - NOTICE TO CONTRACTOR

1. ALL UTILITY LOCATIONS SHOWN ARE BASED ON MAPS PROVIDED BY THE APPROPRIATE UTILITY COMPANY AND FIELD SURFACE EVIDENCE AT THE TIME OF SURVEY AND IS TO BE CONSIDERED AN APPROXIMATE LOCATION ONLY. IT IS THE CONTRACTOR'S RESPONSIBILITY TO FIELD VERIFY THE LOCATION OF ALL UTILITIES, PUBLIC OR PRIVATE, WHETHER SHOWN ON THE PLANS OR NOT, PRIOR TO CONSTRUCTION. REPORT ANY DISCREPANCIES TO THE ENGINEER PRIOR TO CONSTRUCTION.

2. WHERE A PROPOSED UTILITY CROSSES AN EXISTING UTILITY, IT IS THE CONTRACTOR'S RESPONSIBILITY TO FIELD VERIFY THE HORIZONTAL AND VERTICAL LOCATION OF SUCH EXISTING UTILITY, EITHER THROUGH POTHOLING OR ALTERNATIVE METHOD. REPORT INFORMATION TO THE ENGINEER PRIOR TO CONSTRUCTION.



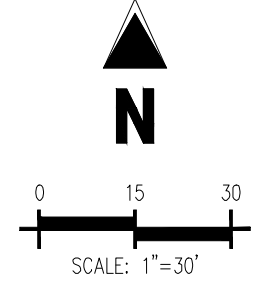
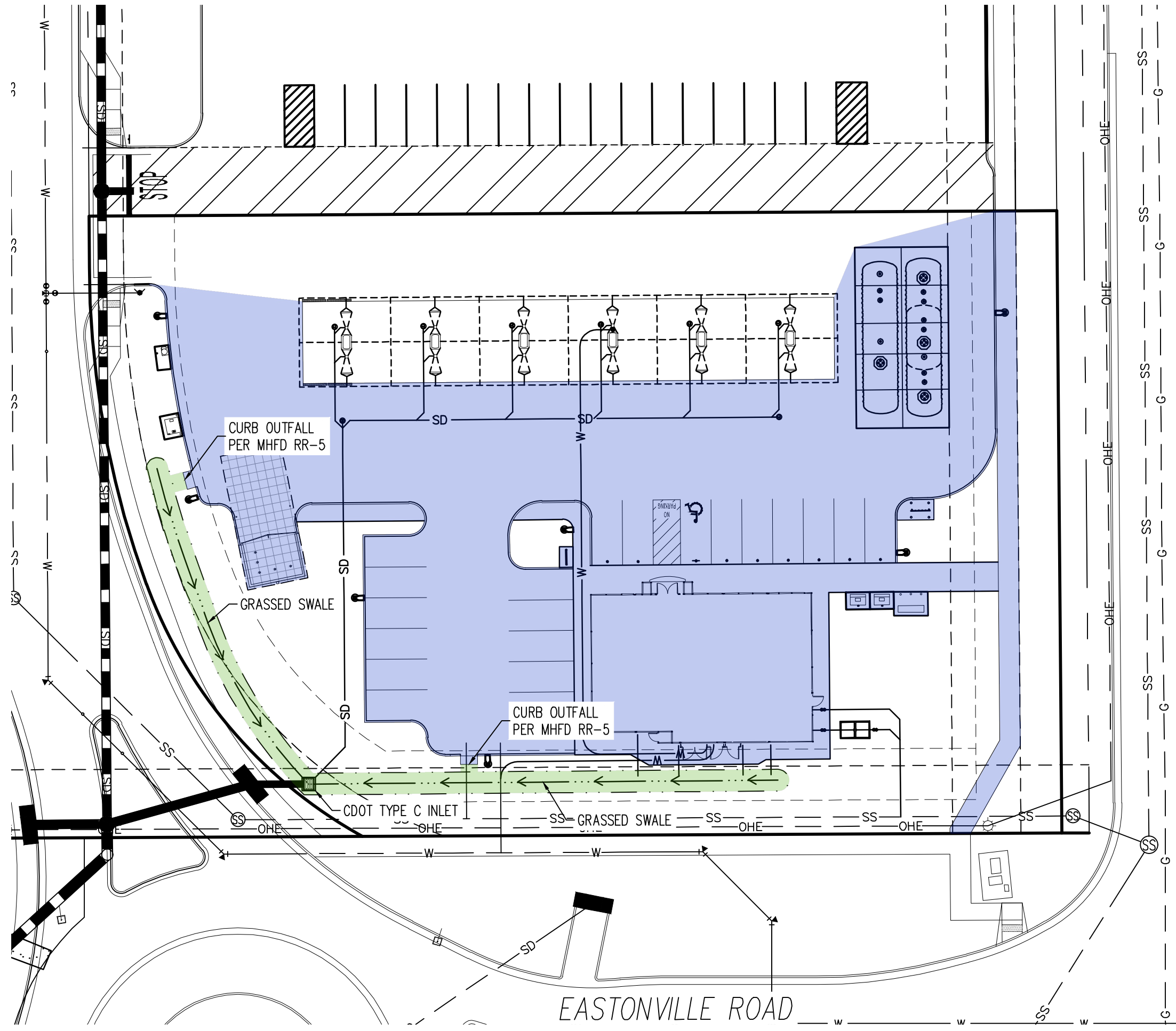

MURPHY OIL – MERIDIAN RD. & EASTONVILLE RD.	
TOTAL SITE DISTURBED AREA, SF	49,691
LOT AREA, SF	48,250
UPSTREAM IMPERVIOUS AREA (IN BLUE), SF	23,823
RECEIVING PERVIOUS AREA (IN GREEN), SF	1,589
PLANNED IMPERVIOUS AREA, SF	44,873
PROPOSED IMPERVIOUS AREA, SF	33,814

LOT 1, OWL MARKETPLACE FILING NO. 1
 MURPHY OIL - MERIDIAN RD. & EASTONVILLE RD.
 7440 MERIDIAN PARK DRIVE
 FALCON, CO 80831
 GREEN INFRASTRUCTURE EXHIBIT

Project No: MOC99
 Drawn By: ASA
 Checked By: KG
 Date: 02/16/2024