



STORMWATER MANAGEMENT PLAN (SWMP)

FOR

Project:

WOODMEN HILLS METROPOLITAN DISTRICT
REGIONAL WATER RECLAMATION FACILITY

Permittee:

Wally Eaves
8046 Eastonville Rd
Peyton, Colorado 80831

Preparing Engineer:

Kimley-Horn and Associates, Inc.
2 North Nevada Avenue, Suite 900
Colorado Springs, CO 80903
Kevin Kofford, P.E.
(719) 453-0180

QUALIFIED STORMWATER MANAGER

Name: _____

Company: _____

Address: _____

CONTRACTOR

Name: _____

Company: _____

Address: _____

Project No.:

June 19, 2026

DEVELOPER/OWNER’S STATEMENT 3

INTRODUCTION 4

 PERMIT COVERAGE AND APPLICATIONS 4

 GENERAL PROJECT DESCRIPTION 4

 PROJECT LOCATION 4

 VICINITY MAP 4

SITE CONDITIONS 5

 VEGETATION 5

 DRAINAGE CHARACTERISTICS 6

 ULTIMATE DISCHARGE 6

 SOILS 6

 DEWATERING 6

AREAS & VOLUMES 7

EROSION & SEDIMENT CONTROL MEASURES..... 7

TIMING & SCHEDULE..... 8

STORMWATER MANAGEMENT CONTROLS 11

 QUALIFIED STORMWATER MANAGER 11

 SITE SPECIFIC POLLUTION SOURCES 11

 IDENTIFICATION OF POLLUTANT SOURCES 11

 BEST MANAGEMENT PRACTICES FOR STORMWATER POLLUTION PREVENTION 12

STABILIZATION AND STORMWATER MANAGEMENT 17

 TEMPORARY STABILIZATION AND SHORT-TERM STORMWATER MANAGEMENT..... 17

 FINAL STABILIZATION AND LONG-TERM STORMWATER MANAGEMENT..... 17

INSPECTION AND MAINTENANCE..... 17

 INSPECTION SCHEDULE REQUIREMENTS 17

 INSPECTION PROCEDURES 17

 CONTROL MEASURE MAINTENANCE / REPLACEMENT AND FAILED CONTROL MEASURES 20

 DISPOSITION OF TEMPORARY MEASURES 20

 PLAN MODIFICATIONS 20

REFERENCES..... 21

APPENDIX A – STORMWATER MANAGEMENT PLANS / SITE MAPS

APPENDIX B – CDPHE STORMWATER PERMIT

APPENDIX C – FEMA FIRM MAP

APPENDIX D – SOILS INFORMATION

APPENDIX E – IDENTIFICATION OF POLLUTANT SOURCES

APPENDIX F – LAND DISTURBANCE / CONTROL MEASURE / STABILIZATION LOG

APPENDIX G – CDPHE ENVIRONMENTAL SPILL REPORTING / CONTROL MEASURE

APPENDIX H – STORM EVENT LOG

APPENDIX I – INSPECTION AND SAMPLING REPORTS

APPENDIX J – SWMP AMENDMENT LOG

DEVELOPER/OWNER'S STATEMENT

"The owner will comply with the requirements of the Erosion and Stormwater Quality Control Plan including temporary BMP inspection requirements and final stabilization requirements. I acknowledge the responsibility to determine whether the construction activities on these plans require Colorado Discharge Permit System (CDPS) permitting for Stormwater discharges associated with Construction Activity."

Developer/Owner Signature: _____

Name of Developer/Owner: _____ Date: _____

DBA: _____ Phone: _____

Title: _____ Email: _____

Address: 8046 Eastonville Rd, Peyton, CO80831 Fax: _____

ENGINEER'S STATEMENT

"This Erosion and Stormwater Quality Control/Grading Plan was prepared under my direction and supervision and is correct to the best of my knowledge and belief. If such work is performed in accordance with the grading and erosion control plan, the work will not become a hazard to life and limb, endanger property, or adversely affect the safety, use, or stability of a public way, drainage channel, or other property."

Signature: _____ Date: _____

Printed Name: Kevin Kofford, P.E.

INTRODUCTION

The purpose of this report is to outline the SWMP plan for the Woodmen Hills Metropolitan District Regional Water Reclamation Facility (RWRF) ("Project"), located within the jurisdictional limits of El Paso County ("the County").

PERMIT COVERAGE AND APPLICATIONS

Based upon a Site Disturbance Area of one (1) acre or more, this Site requires the approval of this Stormwater Management Plan and a Grading and Erosion Control Plan with the County and the issuance of a Colorado Discharge Permit System (CDPS) - Stormwater Discharge Associated with Construction Activities Application (the General Permit) through the Colorado Department of Public Health and Environment (CDPHE).

The primary goal of pollution prevention efforts during Project construction is to control sediment and pollutants that originate on the site and prevent them from flowing to surface waters. A successful pollution prevention program also relies upon careful inspection and adjustments during the construction process to enhance its effectiveness. It is the intent of this plan to implement stormwater control measures, also referred to as best management practices (BMP) for enhancing the quality of stormwater discharges associated with the construction activity. Control measures designs are based on the criteria set forth by the General Permit, the Urban Storm Drainage Criteria Manual, Volume 3, El Paso County Drainage Criteria Manual Vol. 2 ("DCM") and the El Paso County Engineering Criteria Manual ("ECM"). This plan must be implemented before construction begins on the site. It primarily addresses the impact of storm rainfall and runoff on areas of the ground surface disturbed during the construction process. In addition, there are recommendations for controlling other sources of pollution that could accompany the major construction activities. Applicability of this plan shall be terminated when disturbed areas are stabilized, temporary erosion controls are removed, construction activities covered herein have ceased and the permit has been inactivated.

SITE DESCRIPTION

GENERAL PROJECT DESCRIPTION

The existing facility is located on a 13.95 acre piece of property but the project proposes to install drainage infrastructure to help the existing conditions that will only disturb approximately 1.988 acres. The ultimate goal of the project is to provide stormwater improvements to mitigate flooding issues present on site. The proposed stormwater improvements include site civil improvements (grading, curb and gutter, and asphalt surface improvements), and private storm infrastructure that connects to an existing storm main in Stapleton Drive that eventually flows into Bennett Ranch Regional Detention Pond. No additional Site improvements are proposed at this time.

PROJECT LOCATION

The Project Site located on the northeast corner of Meridian Ranch Boulevard and Stapleton Drive within El Paso County, Colorado including parcel 4230312001. More specifically, the site is a Portion of Section 06, Township 13 South, Range 64 West of the 6th PM, County of El Paso, State of Colorado. North and east of the project site are single-family residential development and Antler Creek Golf Course, to the south is Stapleton Drive, and to the west is Meridian Ranch Boulevard.

VICINITY MAP

A vicinity map is provided below for reference:

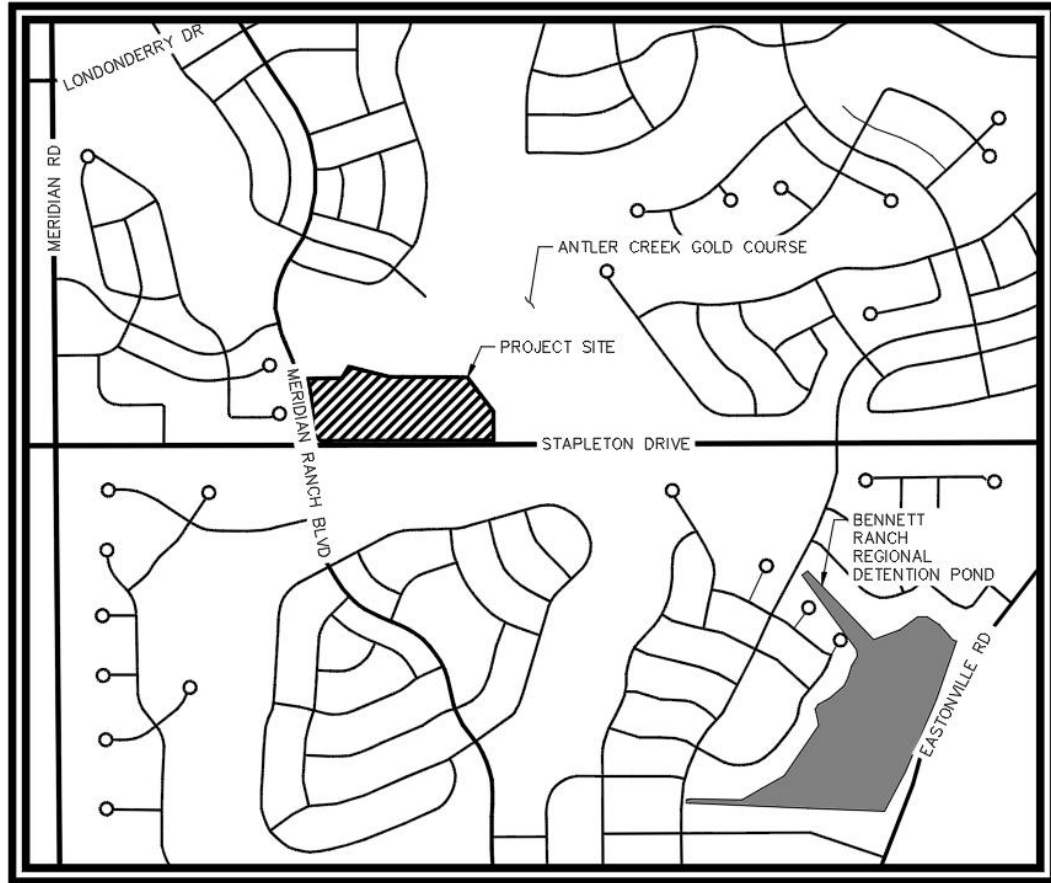

VICINITY MAP

SCALE: 1"=5000'



SITE CONDITIONS

VEGETATION

The existing Site is currently developed with onsite conditions consisting of 50% native grasses, shrubs, and trees and 50% gravel and dirt based on visual inspection from Site visits on the property.

DRAINAGE CHARACTERISTICS

The existing topography consists of slopes ranging from 1% to 40%. The Site currently drains to Bennett Ranch Regional Detention Pond, located in Woodmen Hills Filling No. 11 which provides the water quality and detention facility. This historic runoff pattern will generally be maintained and unaffected with the proposed Project. The 5-year and 100-year design storm events were used in determining rainfall and runoff for the proposed drainage system per chapter 6 of the El Paso County Drainage Criteria. Table 6-2 of the El Paso County Drainage Criteria is the source for rainfall data for the 5-year and 100-year design storm events. Design runoff was calculated using the Rational Method for developed conditions as established in the El Paso County Drainage Criteria Manual and the Mile-High Flood District Manual. Runoff coefficients for the proposed development were determined using Table 6-6 of the El Paso County Drainage Manual by calculating weighted impervious values for each specific site basin. The detention storage requirement was calculated using Full Spectrum Detention methods as specified in the El Paso County Drainage Criteria Manual and the Mile-High Flood District Manual. The detention basin's outlet structure was designed to release the Water Quality Capture Volume (WQCV) in 40 hours. Based upon this approach, we feel that the drainage design provided for the Site is conservative and in keeping with the zoning and historic drainage concept for the area.

Water quality treatment will be provided by the existing Bennett Ranch Regional Detention Pond. The controlled 5-year and 100-year release from the existing detention basin outlet structure will eventually outfall to existing drainageways downstream.

The Site is located outside the 500-year floodplain and within Zone X (an area of minimal flood hazard) as noted on the FEMA FIRM Map No. 08041C0551G revised on December 7, 2018 (See **Appendix C**).

ULTIMATE DISCHARGE

The site will ultimately discharge into the Bennett Ranch Regional Detention Pond which ultimately flows into the Black Squirrel Creek.

SOILS

According to NRCS soil mapping data, USCS Type A soils are the primary soil type within the site. Type A soils having a high infiltration rate (low runoff potential) when thoroughly wet. These consist mainly of deep, well drained to excessively drained sands or gravelly sands. These soils have a high rate of water transmission.

DEWATERING

A minimum separation of 4 feet between the OWTS field and groundwater levels is recommended. Fluctuation in groundwater conditions may occur due to variations in rainfall and other factors not readily apparent at this time. It should be noted that in the sandy materials on-site, some groundwater conditions might be encountered due to the variability in the soil profile. Isolated sand and gravel layers within the soils, sometimes only a few feet in thickness and width, can carry water in the subsurface. Groundwater may also flow on top of the underlying bedrock. Builders and planners should be cognizant of the potential for the occurrence of such subsurface water features during construction on-site and deal with each individual problem as necessary at the time of construction.

AREAS & VOLUMES

The total Site area is 13.95 acres with a total anticipated Project disturbance area is approximately 1.988 acres, with 1.969 acres of disturbance onsite and 0.019 acres of disturbance off-site. The estimated earthwork quantities are as follows:

Cut: ±4223 cubic yards
Fill: ±106.50 cubic yards
Net: ±4117 cubic yards (FILL)
*Fill Factor=1.15

EROSION & SEDIMENT CONTROL MEASURES

Construction operations including grading, hauling of soil, drainage, pavement work, and final stabilization shall implement erosion and sediment control measures as described below and in the Timing section of this report. Additional measures shall be implemented as appropriate.

Erosion and sediment control measures shall be implemented during construction of the Project. One construction entrance with vehicle tracking control (VTC) shall be implemented to reduce off-site sediment tracking. The entrance will be located on the existing Meridian Ranch Boulevard. Temporary Soil Stockpiles (SP) shall be protected from stormwater using Sediment Control Logs (SCL) or other perimeter control such as Silt Fence (SF) to inhibit soil transport as well as at material storage areas. Silt Fence will also be used for controlling sediment from entering existing sanitary structures or facilities such as the Sludge or BNR facility. A Concrete Washout Area (CWA) shall be placed near the entrances to the site. In addition to those measures noted above, Portable Toilets will also be utilized on Site. Portable toilets shall be located on flat surfaces away from drainage paths, tied-down or staked-down, emptied regularly, and where possible secondary containment pans shall be provided under the portable toilets. Please see the Grading and Erosion Control Plans for locations and sizing of recommended erosion control measures.

All persons engaged in earth disturbances shall design, implement, and maintain acceptable soil erosion and sedimentation control measures in conformance with the erosion and sediment control technical standards adopted by the County. All temporary erosion and sediment control facilities, and all permanent facilities intended to control erosion of any earth disturbance operation shall be installed before any earth disturbance operations take place. Any earth disturbances shall be conducted in such a manner to effectively control runoff volumes, reduce accelerated soil erosion, sediment movement, and deposition off-site. All earth disturbances shall be completed in such a manner so that the total amount of soil exposed at any given time shall be minimized, and the exposed area of any disturbed land shall be limited to the shortest possible period of time. Temporary soil erosion control facilities shall be removed, and earth disturbance areas graded and stabilized with permanent soil erosion control measures pursuant to approved plans and specifications.

Permanent soil erosion control measures for all slopes, channels, ditches, or any disturbed land area shall be completed within fourteen (14) calendar days after final grading or the final earth disturbances have been completed. When it is not possible to permanently stabilize a disturbed area after an earth disturbance has been completed or where significant earth disturbance activity ceases, temporary soil erosion control measures shall be implemented within fourteen (14) calendar days. All temporary soil erosion control measures shall be maintained until final stabilization has been achieved.

Paved and impervious surfaces which are adjacent to construction sites must be swept on a daily basis and as needed during the day when sediment and other materials are tracked or discharged onto them.

Either sweeping by hand or use of street sweepers is acceptable. Street sweepers using water while sweeping is preferred in order to minimize dust. Flushing off paved surfaces with water is prohibited.

All construction site operators shall control waste such as discarded building materials, hazardous chemicals (to include but not be limited to, heavy equipment maintenance fluids, motor oil, antifreeze and secondary containment of vehicle fuel), litter, and sanitary waste at the construction Site that may cause adverse impacts to water quality. Chemicals, paints, solvents, fertilizers, and other toxic materials must be stored in weatherproof containers. Except during application, the contents must be kept in trucks or within storage facilities. Runoff containing such material must be collected, removed from the Site, treated, and disposed at an approved solid waste or chemical disposal facility. On-site fueling is not expected with this Project.

Throughout build-out, the developer shall be responsible for implementing and maintaining Best Management Practices (BMPs) to control erosion and sediment problems on all idle lots.

All stockpiles shall require erosion and sediment control. All stockpiles shall:

- Not be located adjacent to a waterway.
- Be stabilized within 14 days after establishment. Stabilization shall include, but not be limited to, surface roughening, seeding, and mulching.
- Not exceed 10 feet in height.
- Utilize silt fence in all down slope sides of the stockpile.

TIMING & SCHEDULE

The proposed project will begin in Fall 2026 to Spring 2027 with an anticipated final stabilization of Summer 2027. The general sequence of the phasing of the related construction activities will occur according to the following anticipated sequence:

Project sequence:

Phased BMP Implementation – Initial Phase

The initial phase shall consist of the temporary construction BMPs to minimize potential for erosion and sediment transfer while mobilizing and preparing the Site for construction activities. The operator shall complete the anticipated initial phase sequencing as follows:

1. Prepare and submit the state of Colorado, Colorado department of public health and environment (CDPHE) application. A copy of the permit shall be provided to the owner upon receipt from the CDPHE.
2. Install SWMP information sign (S) in accordance with applicable city, state, and owner requirements.
3. Ensure that general construction BMPs which are required throughout the Project at locations shown on the GEC plans or as dictated by construction activities are operational.
4. Install perimeter controls and ensure that the limits of construction (LOC) are defined as necessary or known by all parties which will be responsible for construction on the Site.
5. Install stabilized vehicle tracking control pads (VTC) as indicated on the GEC plans.

6. Construct required stabilized staging area (SSA).
7. Install silt fence (SF) as shown on the GEC plans.
8. Upon completion of the initial BMP installation the operator shall schedule a pre-construction meeting with the owner and the County erosion control inspector to confirm BMPs installed are adequate prior to proceeding with additional land disturbing activities.
9. Complete clearing and grubbing of the Site as necessary to proceed with initial grading operations. Stockpile materials in accordance with the stockpile management (SP) BMP.

Phased BMP Implementation - Interim Phase

The Interim phase shall consist of the temporary construction BMPs to minimize potential for erosion and sediment transfer during the construction of the proposed roadways and associated limited site improvements. The operator shall complete the anticipated Interim phase sequencing as follows:

1. Confirm existing BMPs from the initial phase, which are to be maintained throughout construction, are in working order and compliant with applicable regulations.
2. Repair and/or replace any existing BMPs which are deemed inadequate.
3. Complete required temporary grading operations necessary for construction. Conduct excavation as needed for the underground utilities. Stockpile materials in accordance with the stockpile management (SP) BMP.
4. Temporary stabilize (TS) all areas of the Site which will remain inactive for a period greater than 30 days. Temporary stabilization shall be implemented within 14 days of disturbance.
5. Install concrete washout area (CWA) prior to construction of concrete improvements.
6. Complete required grading operations necessary for construction of the proposed commercial building and associated site and utility improvements. Stockpile materials in accordance with the stockpile management (SP) BMP.
7. Construct underground dry utilities.
8. Install Inlet Protection (IP) around the upstream and downstream side of each installed culvert.
9. Complete fine grading and proceed with temporary stabilization (TS) and permanent stabilization (PS) practices in accordance with approved landscape plans.

Phased BMP Implementation - Final Phase

The Final phase shall consist of the temporary construction BMPs to minimize potential for erosion and sediment transfer during the construction of the proposed paving and associated limited site improvements to achieve final stabilization:

1. Confirm existing BMPs from the initial phase, which are to be maintained throughout construction, are in working order and compliant with applicable regulations.
2. Repair and/or replace any existing BMPs which are deemed inadequate.
3. Complete required temporary grading operations necessary for construction. Conduct excavation as needed for the underground utilities. Stockpile materials in accordance with the stockpile management (SP) BMP.
4. Temporary stabilize (TS) all areas of the Site which will remain inactive for a period greater than 30 days. Temporary stabilization shall be implemented within 14 days of disturbance
5. Add base course and commence roadway paving.
6. Achieve permanent stabilization in accordance with El Paso County, CDPHE and owner requirements.
7. Remove remaining BMPs once permanent stabilization (PS) has been achieved. Repair and stabilize areas disturbed through BMP removal.
8. Notify the owner of intent to file the notice of inactivation with the EL PASO COUNTY and CDPHE and receive owner acceptance to proceed with stormwater management close-out.
9. Notify the EL PASO COUNTY of the intent to file the notice of inactivation and receive EL PASO COUNTY field acceptance prior to proceeding with filing the notice of inactivation with the EL PASO COUNTY.
10. Proceed with filing the notice of inactivation with the EL PASO COUNTY and CDPHE.
11. Provide the owner with a copy of all stormwater documentation (permits, inspection reports, logs, etc.). Upon completion of Project, file the notice of inactivation.

STORMWATER MANAGEMENT CONTROLS

QUALIFIED STORMWATER MANAGER

The Qualified Stormwater Manager is the Operator selected for the project. The Qualified Stormwater Manager is an individual knowledgeable in the principles and practices of erosion and sediment control and pollution prevention, and with the skills to assess the effectiveness of stormwater controls implemented to meet the requirements of the General Permit. The Qualified Stormwater Manager will be sufficiently qualified for the required duties per the ECM Appendix 1.5. The Qualified Stormwater Manager is responsible for developing, implementing, maintaining and revising the Grading, Erosion and Sediment Control Plan. The activities and responsibilities of the Qualified Stormwater Manager shall address all aspects of the facility's Grading, Erosion and Sediment Control Plan.

Company:
Contact:
Address:
Phone:
Email:

SITE SPECIFIC POLLUTION SOURCES

Further identification of site-specific pollutants that fall within the categories outlined in the next section may be field noted using the corresponding log included in the appendices of this report. The logs are intended to record site-specific pollutants, the date of arrival on the Site, the date removed from the Site, and the methods of treatment.

IDENTIFICATION OF POLLUTANT SOURCES

Evaluation of general sediment and non-sediment pollution sources associated with Site construction activities, as outlined within the General Permit, consist of the following:

- **Disturbed and Stored Soils** – Earth disturbing activities (grading, excavation, etc.) will be necessary for this Project; therefore, the potential exists for disturbed site soils to contribute sediment to stormwater discharges.
- **Vehicle Tracking and Sediment** – Construction traffic will be entering and exiting the Site; therefore, the potential exists for vehicle tracking to contribute sediment to stormwater discharges.
- **Management of Contaminated Soils** – Contaminated soils are not anticipated on this Site. If encountered, the SWMP Administrator shall take appropriate containment and treatment measures.
- **Loading and Unloading Operations** – Loading and unloading operations will be taking place at the Site; therefore, the potential exists for these operations to introduce sediment and non-sediment pollutants to stormwater discharges.
- **Outdoor Storage of Materials** – Limited outdoor storage of materials is anticipated with construction of this Site; however, outdoor storage of chemicals, fertilizers, etc. is not anticipated.
- **Vehicle and Equipment Maintenance and Fueling** – Routine maintenance and fueling of vehicles and equipment is anticipated with this Site; therefore, the potential exists for pollutants associated with these activities to contribute pollutants to stormwater discharges.
- **Significant Dust or Particulate Generating Processes** – Earth disturbing activities (grading, excavation, etc.) will be necessary for this Project; therefore, the potential exists for windblown site soils to contribute sediment to stormwater discharges.

- **Routine Maintenance** – Routine maintenance involving fertilizers, pesticides, detergents, fuels, solvents, oils, etc., other than those identified within Vehicle and Equipment Maintenance and Fueling are not anticipated with this Project. If encountered, the SWMP Administrator shall take appropriate containment and treatment measures.
- **Onsite Waste Management** – Waste management consisting of solid waste piles, liquid wastes, dumpsters, etc. are anticipated onsite; therefore, the potential exists for these operations to introduce sediment and non-sediment pollutants to stormwater discharges.
- **Concrete Truck / Equipment Washing** – Concrete truck and equipment washing are anticipated with this Project. The SWMP Administrator shall take appropriate containment and treatment measures.
- **Dedicated Asphalt and Concrete Batch Plants** – Dedicated asphalt and/or concrete batch plants are not anticipated with this Project. If encountered, the SWMP Administrator shall take appropriate containment and treatment measures and document as necessary.
- **Non-Industrial Waste Sources** – Non-Industrial waste sources limited to portable sanitary facilities are anticipated with this Project.
- **Additional Pollutant Sources** – Additional areas or procedures where potential spills could occur are not anticipated with this Project.

Logs for the identification of pollutant sources are included in the Appendices for reference and use.

Based on the following, the potential to contribute pollutants to stormwater discharges is not significant for most of the pollutants identified above:

- Relatively Low Frequency of the Activities
- The Ability to Schedule Activities During Dry Weather
- Existing Site Topography
- The Ability to Implement Primary and Secondary Containment for Product Storage
- The Ability to Locate Activities Away from Drainage Ways

Potential pollutant sources noted below shall be mitigated by use of Best Management Practices (BMPs) as noted in the following sections:

- Disturbed and Stored Soils
- Vehicle Tracking and Sediment
- Loading and Unloading Operations
- Outdoor Storage
- Vehicle Equipment and Maintenance Fueling
- Significant Dust or Particulate Generating Processes
- Non-Industrial Waste Sources

BEST MANAGEMENT PRACTICES FOR STORMWATER POLLUTION PREVENTION

Structural Practices for Erosion and Sediment Control

Structural BMPs shall be implemented onsite to minimize erosion and sediment transport. Recommended BMPs based upon a limited site review may be seen within the SWMP Site Map included in the Appendices of this report. Additional BMPs shall be implemented by the SWMP Administrator if necessary to prevent sediment-laden runoff from leaving the Project Site. The SWMP shall be updated to reflect any changes or revisions enacted in the field. Temporary Structural BMPs for this Site consist of:

- Silt Fence (SF): A silt fence is a woven geotextile fabric attached to wooden posts and trenched

into the ground. It is designed as a sediment barrier to intercept sheet flow runoff from disturbed areas.

- Check Dams/Erosion Bales (CD): Check dams are temporary grade control structures placed in drainage channels to limit the erosivity of stormwater by reducing flow velocity. Sediment control logs may also be used as check dams
- Vehicle Tracking Control (VTC): Vehicle tracking controls provide stabilized construction site access where vehicles exit the site onto paved public roads. An effective vehicle tracking control helps remove sediment (mud or dirt) from vehicles, reducing tracking onto the paved surface.
- Sediment Control Logs (SCL): A sediment control log is a linear roll made of natural materials such as straw, coconut fiber, or compost. The most common type of sediment control log has straw filling and is often referred to as a "straw wattle." All sediment control logs are used as a sediment barrier to intercept sheet flow runoff from disturbed areas.
- Erosion Control Blanket (ECB): A temporary degradable rolled erosion control product composed of processed natural or polymer fibers which are mechanically, structurally or chemically bound together to form a continuous matrix to provide erosion control and facilitate vegetation establishment. ECBs can be further differentiated into rapidly degrading single-net and double-net types or slowly degrading types.
- Temporary Sediment Basins (SB): A sediment basin is a temporary pond built on a construction site to capture eroded or disturbed soil transported in storm runoff prior to discharge from the site. Sediment basins are designed to capture site runoff and slowly release it to allow time for settling of sediment prior to discharge
- Inlet Protection (IP): Inlet protection consists of permeable barriers installed around an inlet to filter runoff and remove sediment prior to entering a storm drain inlet. Inlet protection can be constructed from rock socks, sediment control logs, silt fence, block and rock socks, or other materials

Permanent Structural BMPs for this Site consist of:

- Full Spectrum Extended Detention Basins (EDB) (3)

Non-Structural Practices for Erosion and Sediment Control

Non-Structural BMPs shall be implemented onsite to minimize erosion and sediment transport. Recommended BMPs based upon a limited site review may be seen within the SWMP Site Map included in the Appendices of this report. Additional BMPs shall be implemented by the SWMP Administrator if necessary to prevent sediment-laden runoff from leaving the Project Site. The SWMP shall be updated to reflect any changes or revisions enacted in the field. Non- Structural BMPs for this Site consist of:

- Temporary Seeding and Mulching (SM): Temporary seeding can be used to stabilize disturbed areas that will be inactive for an extended period. provide temporary vegetative cover on disturbed areas which will not be paved, built upon, or fully landscaped or worked for an extended period (typically 30 days or more), plant an annual grass appropriate for the time of planting and mulch the planted areas
- Permanent Seeding and Mulching (SM): To provide vegetative cover on disturbed areas that have reached final grade, a perennial grass mix should be established. Permanent seeding should be performed promptly (typically within 14 days) after reaching final grade.
- Good Housekeeping (Multiple Practices): Implement construction site good housekeeping practices to prevent pollution associated with solid, liquid and hazardous construction-related materials and wastes. Stormwater Management Plans (SWMPs) should clearly specify BMPs including these good housekeeping practices: 1. Provide for waste management. 2. Establish

- proper building material staging areas. 3. Designate paint and concrete washout areas. 4. Establish proper equipment/vehicle fueling and maintenance practices. 5. Control equipment/vehicle washing and allowable nonstormwater discharges. 6. Develop a spill prevention and response plan.
- Stabilized Staging and Storage Area (SSA): A stabilized staging area is a clearly designated area where construction equipment and vehicles, stockpiles, waste bins, and other construction-related materials are stored. The contractor office trailer may also be located in this area.
 - Concrete Washout Area (CWA): Concrete waste management involves designating and properly managing a specific area of the construction site as a concrete washout area. A concrete washout area can be created using one of several approaches designed to receive wash water from washing of tools and concrete mixer chutes, liquid concrete waste from dump trucks, mobile batch mixers, or pump trucks.
 - Stockpile Management (SP): Stockpile management includes measures to minimize erosion and sediment transport from soil stockpiles.

Phased BMP Implementation

Construction of the identified improvements will take place under three main phases of construction anticipated as identified within the construction sequencing included within this report.

A Land Disturbance, BMP Installation, and Stabilization Log is provided in the Appendices and shall be filled out accordingly during BMP implementation.

Materials Handling and Spill Prevention

Any hazardous or potentially hazardous material that is brought onto the construction Site shall be handled properly in order to reduce the potential for stormwater pollution. In an effort to minimize the potential for a spill of petroleum product or hazardous materials to come in contact with stormwater, the following steps shall be implemented:

- Material Safety Data Sheets (MSDS) information shall be kept on Site for any and all applicable materials.
- All materials with hazardous properties (such as pesticides, petroleum products, fertilizers, detergents, construction chemicals, acids, paints, paint solvents, additives for soil stabilization, concrete, curing compounds and additives, etc.) shall be stored in a secure location, under cover and in appropriate, tightly sealed containers when not in use.
- The minimum practical quantity of all such materials shall be kept on the job Site and scheduled for delivery as close to time of use as practical.
- A spill control and containment kit (containing, for example, absorbent material, acid neutralizing agent, brooms, dust pans, mops, rags, gloves, goggles, plastic and metal trash containers, etc.) shall be provided on the construction Site and location(s) shown on Site Maps.
- All of the product in a container shall be used before the container is disposed of. All such containers shall be triple rinsed, with water prior to disposal. The rinse water used in these containers shall be disposed of in a manner in compliance with State and Federal regulations and shall not be allowed to mix with stormwater discharges.
- All products shall be stored in and used from the original container with the original product label and used in strict compliance with the instructions on the product label.
- The disposal of excess or used products shall be in strict compliance with instructions on the product label.

Temporary onsite fuel tanks for construction vehicles shall meet all state and federal regulations. Tanks shall have approved spill containment with the capacity required by the applicable regulations. From NFPA 30: All tanks shall be provided with secondary containment (i.e. containment external to and separate from primary containment). Secondary containment shall be constructed of materials of sufficient thickness, density and composition so as not to be structurally weakened as a result of contact with the fuel stored and capable of containing discharged fuel for a period of time equal to or longer than the maximum anticipated time sufficient to allow recovery of discharged fuel.

The tanks shall be in sound condition free of rust or other damage which might compromise containment. Fuel storage areas shall meet all Environmental Protection Agency (EPA), OSHA and other regulatory requirements for signage, fire extinguisher, etc. Hoses, valves, fittings, caps, filler nozzles and associated hardware shall be maintained in proper working condition at all times. The location of fuel tanks shall be shown on the Site Maps and shall be located to minimize exposure to weather and surface water drainage features.

The Operator shall develop and implement a Materials Handling and Spill Prevention Plan (MHSPP) in accordance with the EPA and State of Colorado requirements. In the event of an accidental spill, immediate action shall be undertaken by the Operator to contain and remove the spilled material. All hazardous materials, including contaminated soil, shall be disposed of by the Operator in the manner specified by federal, state and local regulations and by the manufacturer of such products. As soon as possible, the spill shall be reported to the appropriate agencies. As required under the provisions of the Clean Water Act, any spill or discharge entering waters of the United States shall be properly reported. The Operator shall prepare a written record of any spill and associated clean-up activities of petroleum products or hazardous materials in excess of 1 gallon or reportable quantities, whichever is less.

Any spills of petroleum products or hazardous materials in excess of Reportable Quantities as defined by EPA or the state or local agency regulations, shall be immediately reported to the Colorado Department of Public Health and Environment spill reporting lines.

- CDPHE Environmental Release and Incident Reporting Line (877) 518-5608.

For reference, a bulletin on Environmental Spill Reporting published by the CDPHE, has been included in the Appendices of this report.

Vehicle Tracking and Dust Control

Vehicle Tracking Control BMPs (structural and non-structural) shall be implemented in order to control potential sediment discharges from vehicle tracking. Practices shall be implemented for all areas of potential vehicle tracking which include but are not limited to reduced Site access and utilization of designated haul routes.

Areas of soil that are denuded of vegetation and have little protection from particles being picked up and carried by wind should be protected with a temporary cover or kept under control with water or other soil adhering products to limit wind transported particles exiting the Site perimeter.

Waste Management and Disposal

An effective first step towards preventing pollution in stormwater from work sites involves using a commonsense approach to improve the facility's basic housekeeping methods. Poor housekeeping practices result in increased waste and potential for stormwater contamination.

No solid materials are allowed to be discharged from the Site with stormwater. All solid waste, including disposable materials incidental to the construction activities, must be collected and placed in containers. Secure covers for the containers shall be provided at all times to meet state and local requirements. The location of solid waste receptacles shall be identified on the SWMP by the Operator.

Concrete waste is anticipated with this Project; and therefore, a dedicated concrete washout is required. The SWMP Administrator shall take appropriate containment and treatment measures and document as necessary.

Portable Toilets

Portable toilets shall be provided on-site as necessary for construction personnel. Portable toilets shall be located on flat surfaces away from drainage paths, tied-down or staked-down, emptied regularly, and where possible secondary containment pans shall be provided under the portable toilets. Portable toilets will be located a minimum of 10 feet from stormwater inlets and 50 feet from state waters. They will be secured at all four corners to prevent overturning and cleaned on a weekly basis. They will be inspected daily for spills. In the event of a spill, the Permittee shall follow spill prevention measures as noted in the Appendix.

NON-STORMWATER DISCHARGE COMPONENTS

Only specifically authorized non-stormwater discharges are allowed to enter the storm sewer and all authorized non-stormwater discharges shall be eliminated or reduced to the extent practical. There are no non-stormwater discharges anticipated at the Site.

Appropriate control measures shall be used to minimize the discharge of pollutants. Such control measures will be strictly followed to ensure any impacts from non-stormwater discharges are reduced or eliminated. Appropriate control measures are:

- Emergency Fire Fighting Activities
- Uncontaminated ground water or spring water
If possible, direct uncontaminated ground water or spring water to stabilized points of discharge. If discharged to a disturbed area, assure measures to control erosive velocities and sediment control measures are implemented. Velocity control measures include riprap aprons and other conveyance measures. Sediment control measures might include stone check dams, sediment traps and basins.

If uncontaminated ground water is discharged off-site, a Construction Dewatering Permit will be required. This Permit will not apply if dewatering is not performed or if water is not discharged off-site.

- Landscape Irrigation Return Flows
Volume of water used for irrigation prior to establishment of vegetation shall be controlled to prevent excess runoff and erosion. Temporary sediment control measures shall remain in place until all upstream disturbed areas are stabilized. Sediment loss will be controlled using sediment control measures such as wattles, sediment fence, and vegetative buffers.

STABILIZATION AND STORMWATER MANAGEMENT

TEMPORARY STABILIZATION AND SHORT-TERM STORMWATER MANAGEMENT

The County considers the completion of over-lot grading operations, by definition, to be substantially complete; therefore, all areas that will be dormant for more than 30 days after the completion of the over-lot grading will require temporary seeding within 14 days of establishment. This does not preclude the 7-day requirement for areas fully completed in the future. At a minimum, in ensuring that this requirement is followed, adequate phasing/scheduling will be required.

FINAL STABILIZATION AND LONG-TERM STORMWATER MANAGEMENT

In the natural condition, the site soil is stabilized by means of native vegetation. The final stabilization technique to be used at this project for stabilizing soils shall be to provide a protective cover of landscaping vegetation, pavement and granular stabilization material. Seeding should be conducted after final grade is achieved and soils are prepared to take advantage of soil moisture and seed germination. The Qualified Stormwater Manager should evaluate the short and long-term forecasts prior to applying permanent seed.

Final site stabilization is achieved when vegetative cover provides permanent stabilization with a density greater than 70 percent of the pre-disturbance levels, or equivalent permanent, physical erosion reduction methods have been employed over the entire area to be stabilized by vegetative cover.

INSPECTION AND MAINTENANCE

Inspections shall be the responsibility of the Qualified Stormwater Manager throughout the construction process.

INSPECTION SCHEDULE REQUIREMENTS

Inspection and maintenance of erosion control measures shall comply with the criteria set forth by the General Permit (COR400000), or the following, whichever is more stringent.

The Permittee or Contractor shall produce written and signed records every seven (7) days and after within 24 hours after every significant precipitation events or snow melt that causes surface erosion. All necessary maintenance and repair shall be completed immediately. If more frequent inspections are required to ensure that control measures are properly maintained and operated, the inspection schedule shall be modified to meet this need.

When snow cover exists over the entire site for an extended period, inspections are not always feasible. This condition should be documented, including date of snowfall and date of melting conditions to bring awareness of and preparation for areas where melting conditions may pose a risk of surface erosion. A copy of the SWMP shall be maintained at the site at all times. Any degradation of the control measures described in the SWMP or excessive accumulation of sediments shall be remedied immediately upon discovery. The Contractor shall record all storm events on the Storm Event Log included in **Appendix**.

INSPECTION PROCEDURES

The inspection shall include observations of:

- The Construction Site Perimeter and Discharge Points;
- All Disturbed Areas;
- Vehicles and Equipment;
- Areas Used for Material / Waste Storage That are Exposed to Precipitation;
- Other Areas Determined to Have a Significant Potential for Stormwater Pollution;
- Erosion and Sediment Control Measures Identified in the SWMP; and
- Any Other Structural Control Measures That May Require Maintenance.

The inspection must determine if there is evidence of, or the potential for, pollutants entering the drainage system. Control measures should be reviewed to determine if they still meet the design intent and operational criteria in the SWMP and if they continue to adequately control pollutants at the site. Any control measures not operating in accordance with the SWMP must be addressed as soon as possible, immediately in most cases, to minimize the discharge of pollutants and the SWMP must be updated and inspections must be documented.

Examples of specific items to evaluate during site inspections are listed below. This list is not intended to be comprehensive. Ultimately, it is the responsibility of the Contractor to assure the adequacy of site pollutant discharge controls. Actual physical site conditions or contractor practices could make it necessary to install more controls than are shown on the plans. Assessing the need for additional controls and implementing them or adjusting existing controls will be an ongoing requirement until the site achieves final stabilization.

1. Vehicle Tracking Control - Locations where vehicles enter and exit the site shall be inspected for evidence of offsite sediment tracking. Exits shall be maintained as necessary to prevent the release of sediment from vehicles leaving the site. Any sediment deposited on the adjacent roadway shall be removed as necessary throughout the day or at the end of every day and disposed of in an appropriate manner. Sediment shall not be washed into storm sewer systems.
2. Erosion Control Devices - Rolled erosion control products (nets, blankets, turf reinforcement mats) and marginally vegetated areas (areas not meeting required vegetative densities for final stabilization) must be inspected frequently. Riling, rutting and other signs of erosion indicate the erosion control device is not functioning properly and additional erosion control devices are warranted.
3. Sediment Control Devices - Sediment barriers (silt fence, sediment control logs, etc.), traps and basins must be inspected, and they must be cleaned out at such time as their original capacity has been reduced by 50 percent. All material excavated from behind sediment barriers or in traps and basins shall be incorporated into onsite soils or spread out on an upland portion of the site and stabilized. To minimize the potential for sediment releases from the Project, site perimeter control devices shall be inspected with consideration given to changing up-gradient conditions.
4. Material Storage Areas - Material storage areas should be located to minimize exposure to weather. Inspections shall evaluate disturbed areas and areas used for storing materials that are exposed to rainfall for evidence of, or the potential for, pollutants entering the drainage system or discharging from the site. If necessary, the materials must be covered, or original covers must be repaired or supplemented. Also, protective berms must be constructed, if needed, in order to contain runoff from material storage areas. All state and local regulations pertaining to material storage areas shall be adhered to.

5. Vegetation - Seed/Sod shall be free of weedy species and appropriate for site soils and regional climate. Seeding, sodding, tacking, and mulching shall be completed, in accordance with the requirements outlined within the Project Manual and locations identified within the plans, immediately after topsoil is applied and final grade is reached. Grassed areas shall be inspected to confirm that a healthy stand of grass is maintained. Rip-rap, mulch, gravel, decomposed granite or other equivalent permanent stabilization measures may be employed in lieu of vegetation based on site-specific conditions and Owner approval.
6. Discharge Points - All discharge points must be inspected to determine whether erosion and sediment control measures are effective in preventing discharge of sediment from the site or impacts to receiving waters.

Based on the inspection results, all necessary maintenance and repair shall be completed immediately and in no cases longer than seventy-two (72) hours after identification. The inspection reports must be completed after each inspection. An important aspect of the inspection report is the description of additional measures that need to be taken to enhance plan effectiveness. The inspection report must identify whether the site was in compliance with the SWMP at the time of inspection and specifically identify all incidents of non-compliance.

The Qualified Stormwater Manager shall ensure that, at a minimum, the following is recorded for each inspection and kept onsite for reference:

- a. The inspector's name and signature (must be a Qualified Stormwater Manager),
- b. The date and type of the inspection (regular inspection vs. post-storm inspection),
- c. Weather conditions at the time of the inspection,
- d. Phase of construction at the time of the inspection,
- e. Estimated acreage of disturbance at the time of inspection,
- f. The minimum frequency of inspections chosen,
- g. Location(s) of discharges of sediment or other pollutants from the site,
- h. Location(s) of control measures needing maintenance,
- i. Location(s) and identification of inadequate control measures
- j. Location(s) and identification of additional control measures are needed that were not in place at the time of inspection, and
- k. Any corrective actions taken.

If repairs are needed to any control measures, they shall be completed immediately. After adequate corrective action(s) and maintenance have been taken, or where a report does not identify any incidents requiring corrective action or maintenance, the report shall contain a statement stating the following:

"I verify that, to the best of my knowledge and belief, all corrective action and maintenance items identified during the inspection are complete, and the site is currently in compliance with the permit."

This statement must be signed by a Qualified Stormwater Manager. If it is infeasible to install or repair of control measure immediately after discovering the deficiency, the following information must be documented and kept on record:

1. Describe why it is infeasible to initiate the installation or repair immediately; and
2. Provide a schedule for installing or repairing the control measure and returning it to an effective operating condition as soon as possible.

The use and maintenance of log books, photographs, field notebooks, drawings or maps should also be included in the SWMP records when appropriate. Copies of the Inspection and Sampling Report Forms have been included in **Appendix** for reference and use.

CONTROL MEASURE MAINTENANCE / REPLACEMENT AND FAILED CONTROL MEASURES

Site inspection procedures noted above must address maintenance of control measures that are found to no longer function as needed and designed, as well as preventive measures to proactively ensure continued operation.

The Qualified Stormwater Manager shall implement a preventative maintenance program to ensure that control measure breakdowns and failures are handled proactively. Site inspections should uncover any conditions which could result in the discharge of pollutants to storm sewers and surface waters and shall be rectified. For example, sediment shall be removed from silt fences on a regular basis to prevent failure of the control measure. Sediment shall be removed to an appropriate location so that it will not become an additional pollutant source.

The inspection process must also include replacement of control measures when needed or the addition of new control measures in order to adequately manage the pollutant sources at the site.

Any control measure deficiencies, replacement or additional control measures that may be required shall be documented on the Stormwater Management Site Map and on the appropriate Inspection Form. If amendments to the SWMP are required, these amendments shall be documented on the SWMP Amendment Log included in **Appendix** for reference and use.

DISPOSITION OF TEMPORARY MEASURES

Most temporary erosion and sediment control measures must be removed within 30 days after final site stabilization is achieved. Trapped sediment and disturbed soil areas resulting from the disposal of temporary measures must be returned to final plan grades and permanently stabilized to prevent further soil erosion.

PLAN MODIFICATIONS

This document should be viewed as a “living document” that is continuously being reviewed and modified as a part of the overall process of evaluating and managing stormwater quality issues at the site. The Qualified Stormwater Manager shall amend the SWMP when there is a change in design, construction, operation or maintenance of the site which would require the implementation of new or revised BMPs or if the SWMP proves to be ineffective in achieving the general objectives of controlling pollutants in stormwater discharges associated with construction activity or when BMPs are no longer necessary and are removed. These actions are defined under the Control Measure Maintenance/Replacement and Failed Control Measure Section of this report.

Plan revisions made prior to or following a change(s) onsite, including revisions to sections addressing site conditions and control measures, a notation must be included in the plan that identifies:

- Date of site change,
- The control measure removed or modified,
- The location(s) of those control measures, and
- Any changes to the control measure.

This document does not incorporate or rely on control measures owned or operated by another entity.

REFERENCES

Colorado Discharge Permit System (CDPS) – Stormwater Discharge Associated with Construction Activities Application - Prepared by Water Quality Control Division, Colorado Department of Public Health and Environment; Revised April 2019.

Colorado Discharge Permit System (CDPS) General Permit – Stormwater Discharges Associated with Construction Activity - Prepared by Water Quality Control Division, Colorado Department of Public Health and Environment; signed and issued on May 31, 2007 and administratively continued effective July 1, 2012.

Custom Soil Resource Report for El Paso County Area, Colorado – Prepared by USGS National Cooperative Soil Survey; June 2, 2026.

Flood Insurance Rate Map, El Paso County, Colorado and Incorporated Areas, Map Number 08041C0551G – Prepared by the Federal Emergency Management Agency (FEMA); Revised on December 7, 2018.

NRCS Web Soil Survey - Website: <http://websoilsurvey.nrcs.usda.gov>

Stormwater Discharges Associated with Construction Activity – Stormwater Management Plan Preparation Guidance - Prepared by Water Quality Control Division, Colorado Department of Public Health and Environment; Revised April 2011.

Urban Storm Drainage Criteria Manual, Volume 3 – Mile High Flood District, Denver, CO.; November 2015.

APPENDICES

**APPENDIX A
STORMWATER MANAGEMENT PLANS / SITE MAPS**

WOODMEN HILLS METROPOLITAN DISTRICT REGIONAL WATER RECLAMATION FACILITY GRADING AND EROSION CONTROL PLAN

THE SOUTHWEST QUARTER OF THE NORTHEAST QUARTER, SECTION 06, TOWNSHIP 13 SOUTH, RANGE 64
WEST OF THE 6TH P.M., COUNTY OF EL PASO, STATE OF COLORADO

CONTACTS:

OWNER:
WOODMEN HILLS METRO DISTRICT
8046 EASTONVILLE RD,
PEYTON, CO 80831
CONTACT: WALLY EAVES
TEL: (719) 210-0659

ENGINEER:
KIMLEY-HORN AND ASSOCIATES, INC.
2 NEVADA NORTH AVE., SUITE 300
COLORADO SPRINGS, CO 80903
CONTACT: KEVIN KOFFORD, PE
TEL: 719-453-0180

SURVEYOR:
TOPOGRAPHIC, CO.
520 STACY COURT, UNIT B
LAFAYETTE, CO 80026
CONTACT: KYLE WALKER, PLS
TEL: (303) 253-0549

EL PASO COUNTY:
EL PASO COUNTY
PLANNING AND COMMUNITY DEVELOPMENT DEPARTMENT
2880 INTERNATIONAL CIRCLE, SUITE 110
COLORADO SPRINGS, CO 80910
PHONE: (719) 520-6300

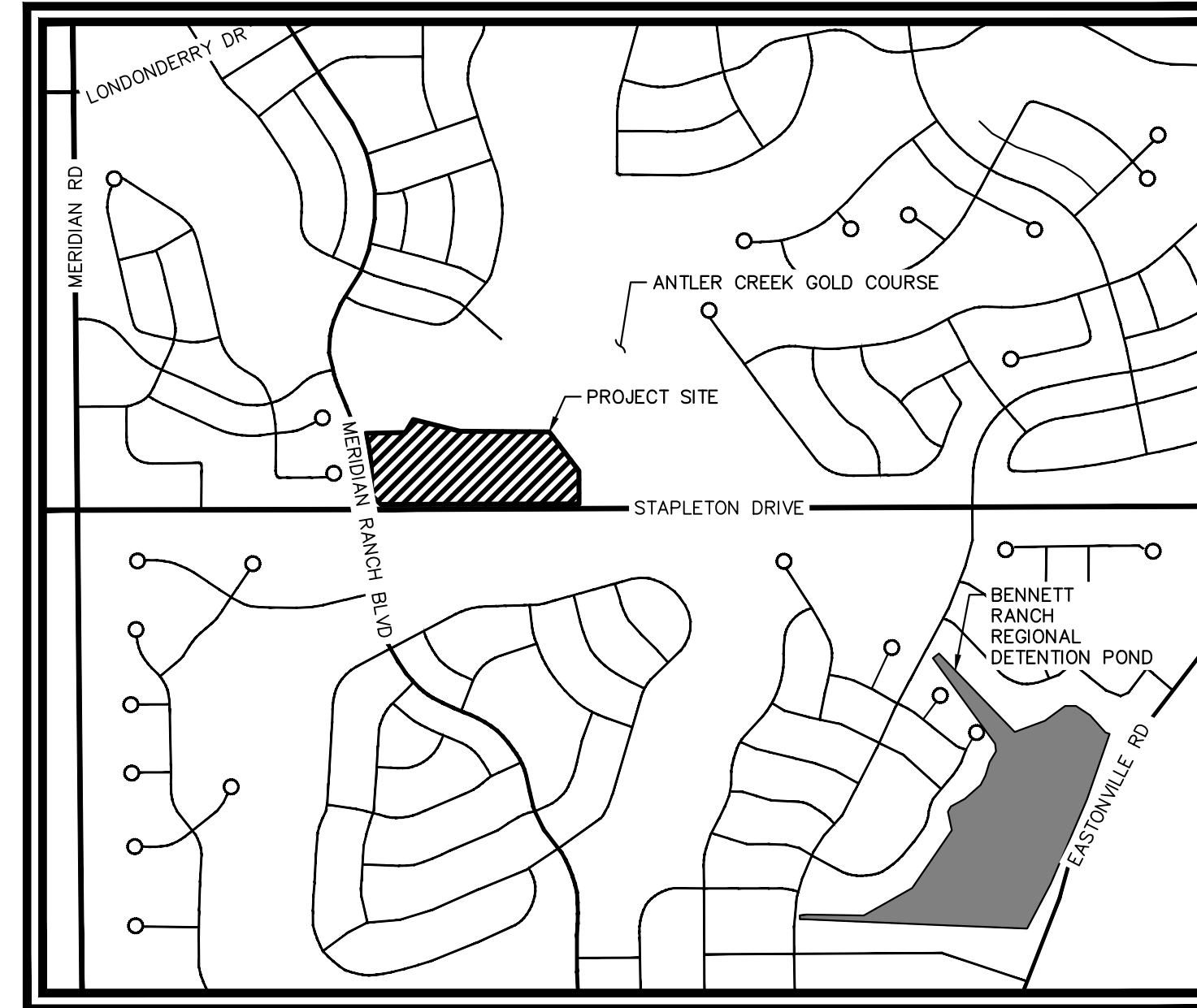

VICINITY MAP

SCALE: 1"=5000'

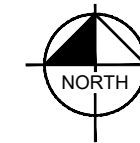

BENCHMARK

SITE BENCHMARK IS A NUMBER 5 REBAR WITH 2" ALUMINUM CAP STAMPED "TOPOGRAPHIC CP" AT THE WEST SIDE OF THE ENTRY GATE TO THE WHMD FACILITY, WITH A NAVD 88 ELEVATION OF 7058.81'.

BASIS OF BEARING

BEARINGS CONTAINED HEREIN ARE BASED UPON THE GRID BEARING OF N51°24'46"W BETWEEN CONTROL POINT DM1 AND DM2, BOTH BEING SET NUMBER 5 REBARS WITH 2 -INCH ALUMINUM CAPS STAMPED "TOPOGRAPHIC CP".

LEGAL DESCRIPTION

TRACT K MERIDIAN RANCH FIL NO 1

| SHEET LIST TABLE | |
|------------------|-----------------------|
| SHEET NUMBER | SHEET TITLE |
| 1 | COVER SHEET |
| 2 | GENERAL NOTES |
| 3 | GEC INITIAL PLAN |
| 4 | GEC INTERIM PLAN |
| 5 | GEC FINAL PLAN |
| 6 | DETAIL SHEET (1 OF 3) |
| 7 | DETAIL SHEET (2 OF 3) |
| 8 | DETAIL SHEET (3 OF 3) |

FLOODPLAIN NOTE

FEDERAL EMERGENCY MANAGEMENT AGENCY, FLOOD INSURANCE RATE MAP, MAP NUMBER 09041C0551G, EFFECTIVE DECEMBER 7, 2018 INDICATES THE PROJECT AREA TO BE IN ZONE X (AREA DETERMINED TO BE OUT OF THE 500 YEAR FLOODPLAIN).

SOIL TYPE

THE SOIL ON SITE IS USGS HYDROLOGIC SOIL GROUP A.

SITE INFORMATION

TIMING:
ANTICIPATED STARTING AND COMPLETION TIME PERIOD OF SITE GRADING:
START: FALL 2026
END: WINTER 2027
EXPECTED DATE ON WHICH THE FINAL STABILIZATION WILL BE COMPLETE:
WINTER 2027

AREAS:
TOTAL FILING NO. 1 DISTURBED AREA: 31.52 ACRES

RECEIVING WATERS:
NAME OF RECEIVING WATERS: UPPER BLACK SQUIRREL, LA VEGA RANCH

DESCRIPTION OF EXISTING VEGETATION:
THE EXISTING SITE IS CURRENTLY DEVELOPED AND GROUND COVER CONSISTS OF 50% NATIVE GRASSES, SHRUBS, AND TREES. 50% GRAVEL AND DIRT.

DESCRIPTION OF PERMANENT BMPS:
BENNETT RANCH REGIONAL DETENTION POND

LIMITS OF CONSTRUCTION

ONSITE DISTURBANCE = 1.969 ACRES
OFFSITE DISTURBANCE = 0.019 ACRES
TOTAL = 1.988 ACRES

GEC PLAN SIGNATURES:

DEVELOPER'S/OWNER'S SIGNATURE BLOCK

I, THE OWNER/DEVELOPER HAVE READ AND WILL COMPLY WITH THE REQUIREMENTS OF THE GRADING AND EROSION CONTROL PLAN.

PT OVERLOOK, LLC

DATE

ENGINEER'S SIGNATURE BLOCK

THIS GRADING AND EROSION CONTROL PLAN WAS PREPARED UNDER MY DIRECTION AND SUPERVISION AND IS CORRECT TO THE BEST OF MY KNOWLEDGE AND BELIEF. SAID PLAN HAS BEEN PREPARED ACCORDING TO THE CRITERIA ESTABLISHED BY THE COUNTY FOR GRADING AND EROSION CONTROL PLANS. I ACCEPT RESPONSIBILITY FOR ANY LIABILITY CAUSED BY ANY NEGLIGENT ACTS, ERRORS OR OMISSIONS ON MY PART IN PREPARING THIS PLAN.

KEVIN KOFFORD, P.E. 57234 - KIMLEY-HORN AND ASSOCIATES, INC. DATE

EL PASO COUNTY

COUNTY PLAN REVIEW IS PROVIDED ONLY FOR GENERAL CONFORMANCE WITH COUNTY DESIGN CRITERIA. THE COUNTY IS NOT RESPONSIBLE FOR THE ACCURACY AND ADEQUACY OF THE DESIGN, DIMENSIONS, AND/OR ELEVATIONS WHICH SHALL BE CONFIRMED AT THE JOB SITE. THE COUNTY THROUGH THE APPROVAL OF THIS DOCUMENT ASSUMES NO RESPONSIBILITY FOR COMPLETENESS AND/OR ACCURACY OF THIS DOCUMENT.

FILED IN ACCORDANCE WITH THE REQUIREMENTS OF THE EL PASO COUNTY LAND DEVELOPMENT CODE, DRAINAGE CRITERIA MANUAL VOLUMES 1 AND 2, AND ENGINEERING CRITERIA MANUAL, AS AMENDED.

IN ACCORDANCE WITH ECM SECTION 1.12, THESE CONSTRUCTION DOCUMENTS WILL BE VALID FOR CONSTRUCTION FOR A PERIOD OF 2 YEARS FROM THE DATE SIGNED BY THE EL PASO COUNTY ENGINEER. IF CONSTRUCTION HAS NOT STARTED WITHIN THOSE 2 YEARS, THE PLANS WILL NEED TO BE RESUBMITTED FOR APPROVAL, INCLUDING PAYMENT OF REVIEW FEES AT THE PLANNING AND COMMUNITY DEVELOPMENT DIRECTOR'S DISCRETION.

JOSHUA PALMER, P.E. - COUNTY ENGINEER/ECM ADMINISTRATOR DATE

Kimley»Horn

2026 KIMLEY-HORN AND ASSOCIATES, INC.
2 North Nevada Avenue, Suite 900
Colorado Springs, Colorado 80903 (719) 453-0180

DESIGNED BY: MEO
DRAWN BY: MEO
CHECKED BY: KRK
DATE: 6/22/26

WHMD RWRWF STORM IMPROVEMENTS
EL PASO COUNTY, COLORADO

GEC PLANS
COVER SHEET

PRELIMINARY
FOR REVIEW ONLY
NOT FOR
CONSTRUCTION
Kimley»Horn
Kimley-Horn and Associates, Inc.

PROJECT NO.
196013004

SHEET

1

| NO. | REVISION | BY | DATE | APPR |
|-----|----------|----|------|------|
| | | | | |

C:\ACC\ACCDocs\Kimley-Horn\196013001 WHMD Expansion Study\Project Files\DWG\PlanSheets\Stormwater Improvements\Plansheets\GEC\GEC_CV.dwg 6/22/2026 10:59 AM

C:\ACC\AccDocs\Kimley-Horn\196013001 WHMD Expansion Study\Project Files\DWG\PlanSheets\Stormwater Improvements\GEC_INTERIM.dwg Olesen, Maria (Langer) 6/22/2026 11:00 AM

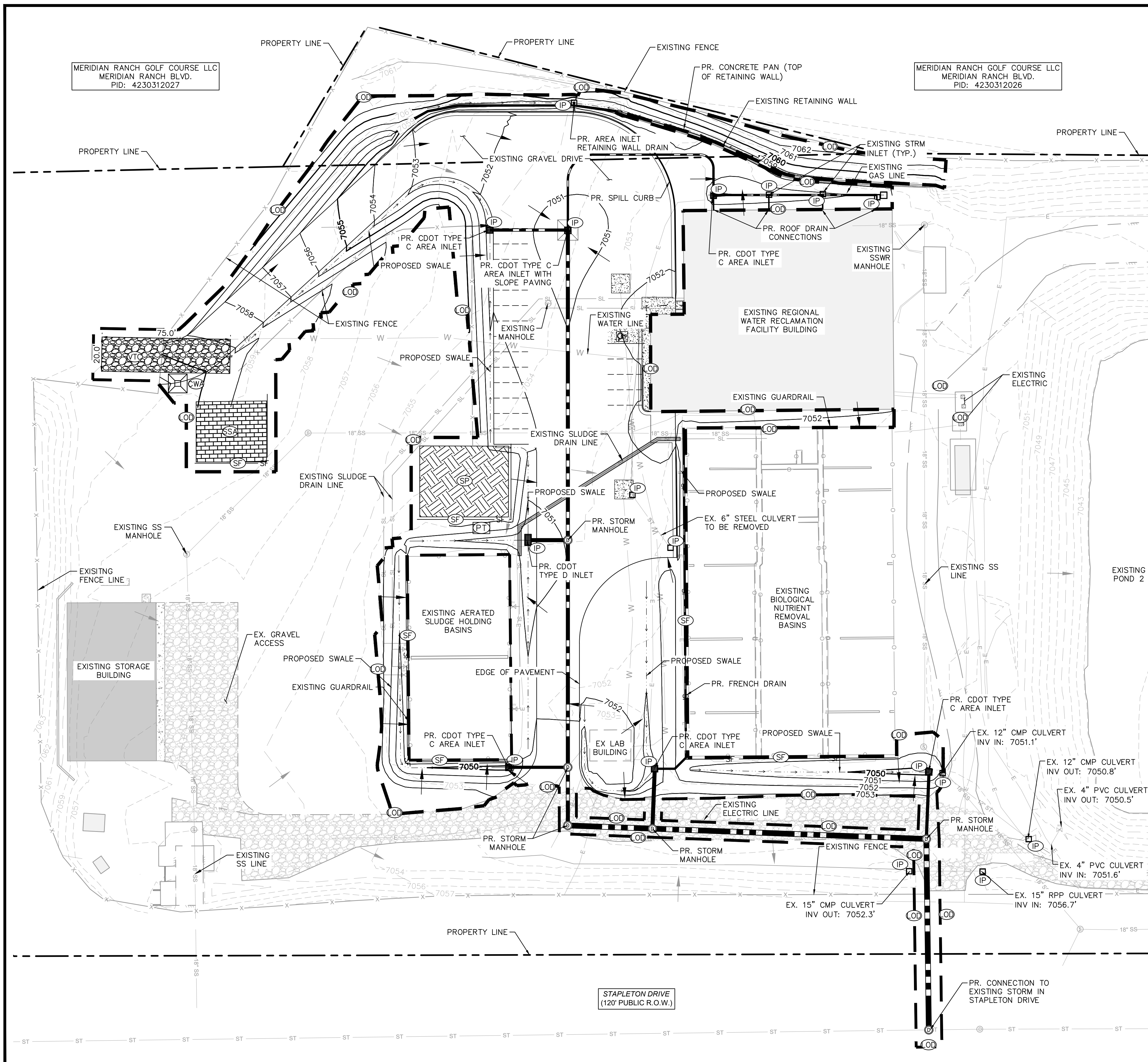

LEGEND

- PROPERTY LINE
- - - ADJACENT PROPERTY LINE
- LIMITS OF CONSTRUCTION/DISTURBANCE
- SF --- SILT FENCE
- EXISTING GRAVEL
- SSA --- STABILIZED STAGING AREA
- CWA --- CONCRETE WASHOUT
- VTC --- VEHICLE TRACKING CONTROL
- SP --- SOIL STOCKPILE
- IP --- INLET PROTECTION
- PT --- PORTABLE TOILET
- EXISTING FLOW DIRECTION ARROW
- PROPOSED FLOW DIRECTION ARROW

LIMITS OF CONSTRUCTION

ONSITE DISTURBANCE = 1.969 ACRES
 OFFSITE DISTURBANCE = 0.019 ACRES
 TOTAL = 1.988 ACRES

NOTES

1. THE INTENT OF THIS PLAN IS TO IDENTIFY THE EROSION CONTROL PRACTICES RECOMMENDED. THE CONTRACTOR SHALL REFERENCE ADDITIONAL CONSTRUCTION PLANS FOR DEMOLITION OF EXISTING AND CONSTRUCTION OF PROPOSED IMPROVEMENTS.
2. ADJACENT STREETS SHALL BE KEPT CLEAN AND FREE OF SEDIMENT AND/OR DEBRIS AT ALL TIMES. CONTRACTOR SHALL PERFORM STREET SWEEPING AT ALL TIMES DURING ACTIVE TRACKING AND AT A MINIMUM ON A DAILY BASIS AT THE END OF EACH CONSTRUCTION DAY.
3. TEMPORARY STABILIZATION (TS) SHALL BE IMPLEMENTED WITHIN THE DISTURBED PORTIONS OF THE PROJECT SITE NO LATER THAN 14 DAYS FOLLOWING THE CEASE OF CONSTRUCTION ACTIVITIES WITHIN THE DISTURBED AREAS.
4. PERMANENT STABILIZATION (PS) MAY BE USED WITHIN AREAS OF TEMPORARY STABILIZATION (TS) AT THE CONTRACTOR'S DISCRETION. STABILIZATION SHALL BE APPLIED IN ACCORDANCE WITH APPLICABLE TEMPORARY STABILIZATION SEQUENCING REQUIREMENTS.
5. CONTRACTOR SHALL UTILIZE ROLLED EROSION CONTROL PRODUCTS ON ALL SLOPES 3H:1V OR GREATER TO ACHIEVE REQUIRED STABILIZATION.
6. CONTRACTOR SHALL MAINTAIN ACCEPTABLE EROSION CONTROL PRACTICES WITHIN THE ANTICIPATED LIMITS OF CONSTRUCTION IDENTIFIED HEREIN. BEST MANAGEMENT PRACTICES AND STABILIZATION SHALL BE COMPLETED AS IDENTIFIED HEREIN IN ACCORDANCE WITH OWNER REQUIREMENTS.
7. ALL WORK IN THE STAPLETON DRIVE ROW REQUIRES A ROW PERMIT FROM ADAMS COUNTY. CONTRACTOR IS RESPONSIBLE FOR APPLYING FOR AND OBTAINING ALL NECESSARY ROW PERMITS.
8. CONTRACTOR SHALL REFER TO THE APPROVED GEOTECHNICAL REPORT FOR OVEREXCAVATION REQUIREMENTS AND ADDITIONAL INFORMATION.
9. CONTRACTOR SHALL MAINTAIN STABILIZED STAGING AREA (SSA), VEHICLE TRACKING CONTROL (VTC), AND CONCRETE WASHOUT AREA (CWA) AT THE CONSTRUCTION ENTRANCE AT ALL TIMES. CONTRACTOR SHALL UPDATE THE EROSION CONTROL PLAN IN THE FIELD TO INDICATE THE LOCATION OF THE SSA, VTC, AND CWA BMPS AS EXCAVATION SEQUENCING DICTATES.
10. CONTRACTOR MAY SUBSTITUTE SEDIMENT CONTROL LOGS (SCL) FOR SILT FENCE (SF) AS PERIMETER CONTROL DEPENDING UPON SITE CONDITIONS. SCL, AND SF MAY BE INTERCHANGED DEPENDING ON SITE CONDITIONS.

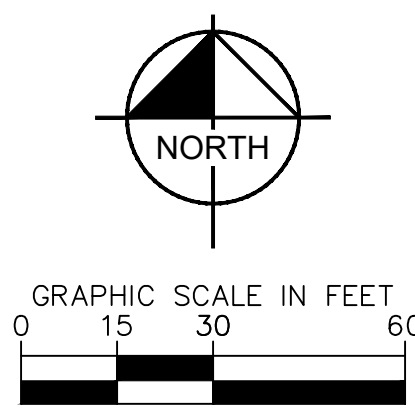

| | |
|---|--|
| <p>Kimley-Horn</p> <p>2026 KIMLEY-HORN AND ASSOCIATES, INC. 2 North Nevada Avenue, Suite 900 Colorado Springs, Colorado 80903 (719) 453-0180</p> | <p>DESIGNED BY: MEO DRAWN BY: MEO CHECKED BY: KRK DATE: 6/22/26</p> |
| <p>WHMD RWRF STORM IMPROVEMENTS EL PASO COUNTY, COLORADO GEC PLANS GEC INTERIM PLAN</p> | <p>PRELIMINARY FOR REVIEW ONLY NOT FOR CONSTRUCTION</p> <p>Kimley-Horn Kimley-Horn and Associates, Inc.</p> |
| <p>PROJECT NO. 196013004</p> | <p>SHEET 4</p> |

C:\ACC\AccDocs\Kimley-Horn\196013001 WHMD Expansion Study\Project Files\DWG\PlanSheets\Stormwater Improvements\Plansheets\GEC_FINAL.dwg Olesen, Maria (Langer) 6/22/2026 11:00 AM

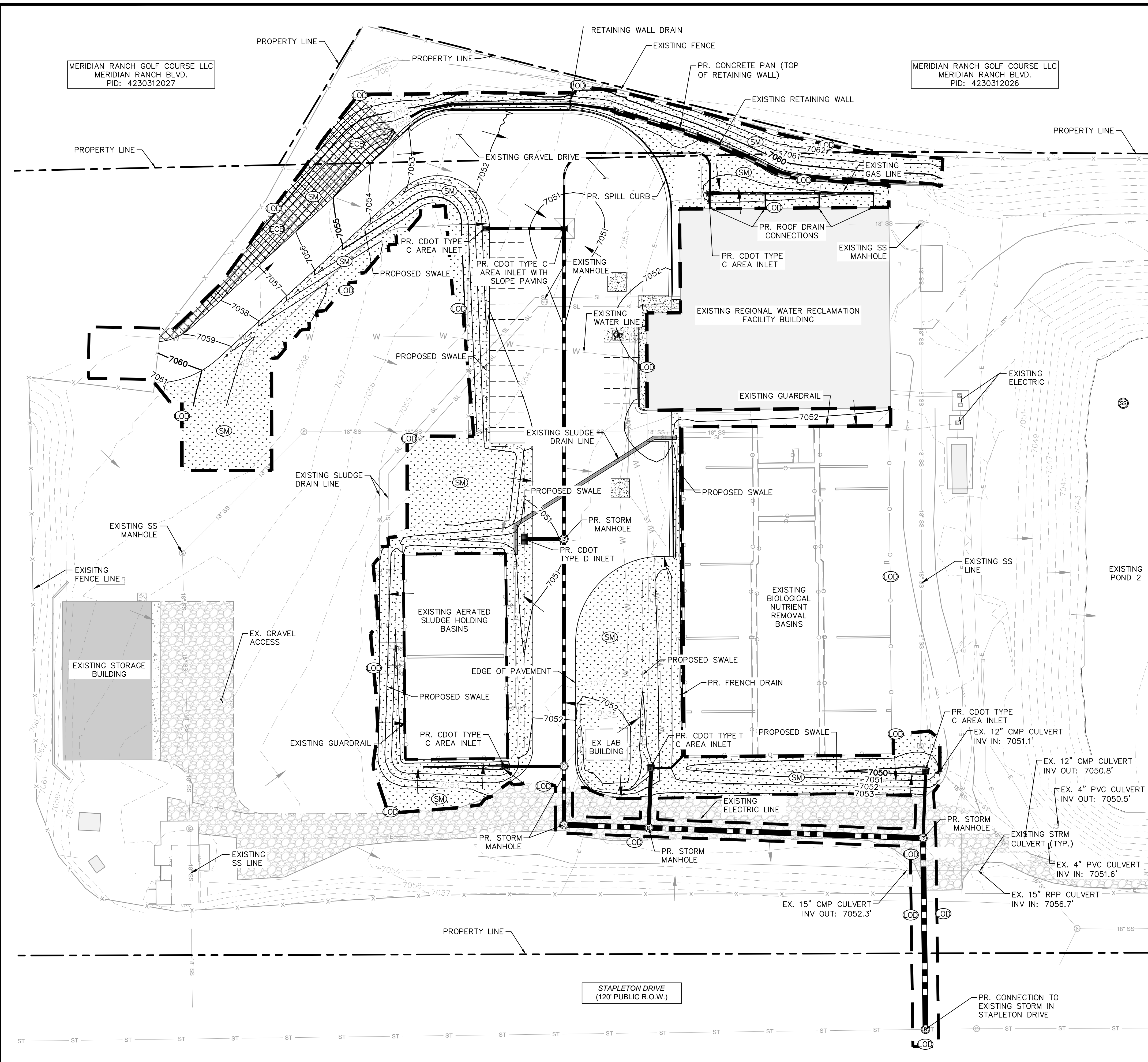

LEGEND

- PROPERTY LINE
- - - ADJACENT PROPERTY LINE
- LIMITS OF CONSTRUCTION/DISTURBANCE
- EXISTING GRAVEL
- SEEDING AND MULCHING
- EROSION CONTROL BLANKET
- EXISTING FLOW DIRECTION ARROW
- PROPOSED FLOW DIRECTION ARROW

LIMITS OF CONSTRUCTION

| | |
|---------------------|----------------------|
| ONSITE DISTURBANCE | = 1.969 ACRES |
| OFFSITE DISTURBANCE | = 0.019 ACRES |
| TOTAL | = 1.988 ACRES |

NOTES

1. THE INTENT OF THIS PLAN IS TO IDENTIFY THE EROSION CONTROL PRACTICES RECOMMENDED. THE CONTRACTOR SHALL REFERENCE ADDITIONAL CONSTRUCTION PLANS FOR DEMOLITION OF EXISTING AND CONSTRUCTION OF PROPOSED IMPROVEMENTS.
2. ADJACENT STREETS SHALL BE KEPT CLEAN AND FREE OF SEDIMENT AND/OR DEBRIS AT ALL TIMES. CONTRACTOR SHALL PERFORM STREET SWEEPING AT ALL TIMES DURING ACTIVE TRACKING AND AT A MINIMUM ON A DAILY BASIS AT THE END OF EACH CONSTRUCTION DAY.
3. TEMPORARY STABILIZATION (TS) SHALL BE IMPLEMENTED WITHIN THE DISTURBED PORTIONS OF THE PROJECT SITE NO LATER THAN 14 DAYS FOLLOWING THE CEASE OF CONSTRUCTION ACTIVITIES WITHIN THE DISTURBED AREAS.
4. PERMANENT STABILIZATION (PS) MAY BE USED WITHIN AREAS OF TEMPORARY STABILIZATION (TS) AT THE CONTRACTOR'S DISCRETION. STABILIZATION SHALL BE APPLIED IN ACCORDANCE WITH APPLICABLE TEMPORARY STABILIZATION SEQUENCING REQUIREMENTS.
5. CONTRACTOR SHALL UTILIZE ROLLED EROSION CONTROL PRODUCTS ON ALL SLOPES 3H:1V OR GREATER TO ACHIEVE REQUIRED STABILIZATION.
6. CONTRACTOR SHALL MAINTAIN ACCEPTABLE EROSION CONTROL PRACTICES WITHIN THE ANTICIPATED LIMITS OF CONSTRUCTION IDENTIFIED HEREIN. BEST MANAGEMENT PRACTICES AND STABILIZATION SHALL BE COMPLETED AS IDENTIFIED HEREIN IN ACCORDANCE WITH OWNER REQUIREMENTS.
7. ALL WORK IN THE STAPLETON DRIVE ROW REQUIRES A ROW PERMIT FROM ADAMS COUNTY. CONTRACTOR IS RESPONSIBLE FOR APPLYING FOR AND OBTAINING ALL NECESSARY ROW PERMITS.
8. CONTRACTOR SHALL REFER TO THE APPROVED GEOTECHNICAL REPORT FOR OVEREXCAVATION REQUIREMENTS AND ADDITIONAL INFORMATION.
9. CONTRACTOR SHALL MAINTAIN STABILIZED STAGING AREA (SSA), VEHICLE TRACKING CONTROL (VTC), AND CONCRETE WASHOUT AREA (CWA) AT THE CONSTRUCTION ENTRANCE AT ALL TIMES. CONTRACTOR SHALL UPDATE THE EROSION CONTROL PLAN IN THE FIELD TO INDICATE THE LOCATION OF THE SSA, VTC, AND CWA BMPS AS EXCAVATION SEQUENCING DICTATES.
10. CONTRACTOR MAY SUBSTITUTE SEDIMENT CONTROL LOGS (SCL) FOR SILT FENCE (SF) AS PERIMETER CONTROL, DEPENDING UPON SITE CONDITIONS. SCL, AND SF MAY BE INTERCHANGED DEPENDING ON SITE CONDITIONS.

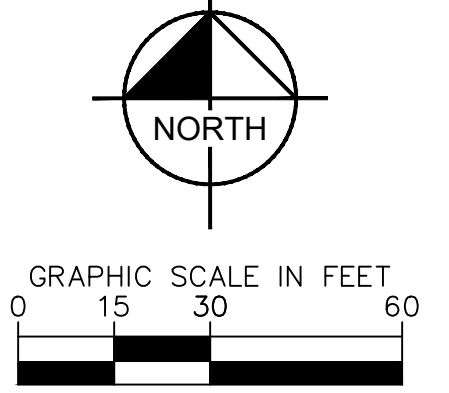

| | |
|---|---|
| <p>Kimley-Horn</p> <p>2026 KIMLEY-HORN AND ASSOCIATES, INC. 2 North Nevada Avenue, Suite 900 Colorado Springs, Colorado 80903 (719) 453-0180</p> | <p>NO. _____</p> <p>BY _____ DATE _____</p> <p>REVISION _____</p> |
| <p>WHMD RWRF STORM IMPROVEMENTS</p> <p>EL PASO COUNTY, COLORADO</p> <p>GEC PLANS</p> <p>GEC FINAL PLAN</p> | |
| <p>DESIGNED BY: MEO DRAWN BY: MEO CHECKED BY: KKK DATE: 6/22/26</p> | |
| <p>PRELIMINARY FOR REVIEW ONLY NOT FOR CONSTRUCTION</p> <p>Kimley-Horn Kimley-Horn and Associates, Inc.</p> | |
| <p>PROJECT NO. 196013004</p> <p>SHEET</p> <p style="font-size: 24pt;">5</p> | |

SC-6 Inlet Protection (IP)

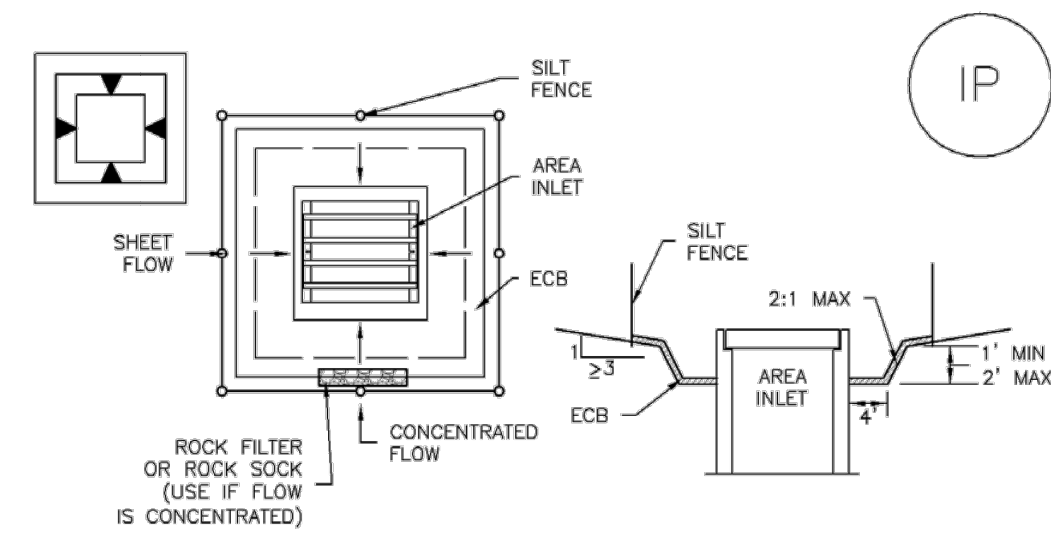

IP-5. OVEREXCAVATION INLET PROTECTION

OVEREXCAVATION INLET PROTECTION INSTALLATION NOTES

1. THIS FORM OF INLET PROTECTION IS PRIMARILY APPLICABLE FOR SITES THAT HAVE NOT YET REACHED FINAL GRADE AND SHOULD BE USED ONLY FOR INLETS WITH A RELATIVELY SMALL CONTRIBUTING DRAINAGE AREA.
2. WHEN USING FOR CONCENTRATED FLOWS, SHAPE BASIN IN 2:1 RATIO WITH LENGTH ORIENTED TOWARDS DIRECTION OF FLOW.
3. SEDIMENT MUST BE PERIODICALLY REMOVED FROM THE OVEREXCAVATED AREA.

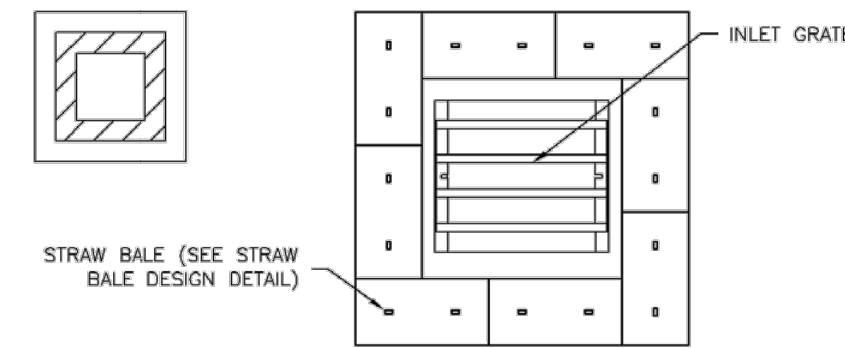

IP-6. STRAW BALE FOR SUMP INLET PROTECTION

STRAW BALE BARRIER INLET PROTECTION INSTALLATION NOTES

1. SEE STRAW BALE DESIGN DETAIL FOR INSTALLATION REQUIREMENTS.
2. BALES SHALL BE PLACED IN A SINGLE ROW AROUND THE INLET WITH ENDS OF BALES TIGHTLY ABUTTING ONE ANOTHER.

IP-6 Urban Drainage and Flood Control District August 2013
Urban Storm Drainage Criteria Manual Volume 3

Inlet Protection (IP) SC-6

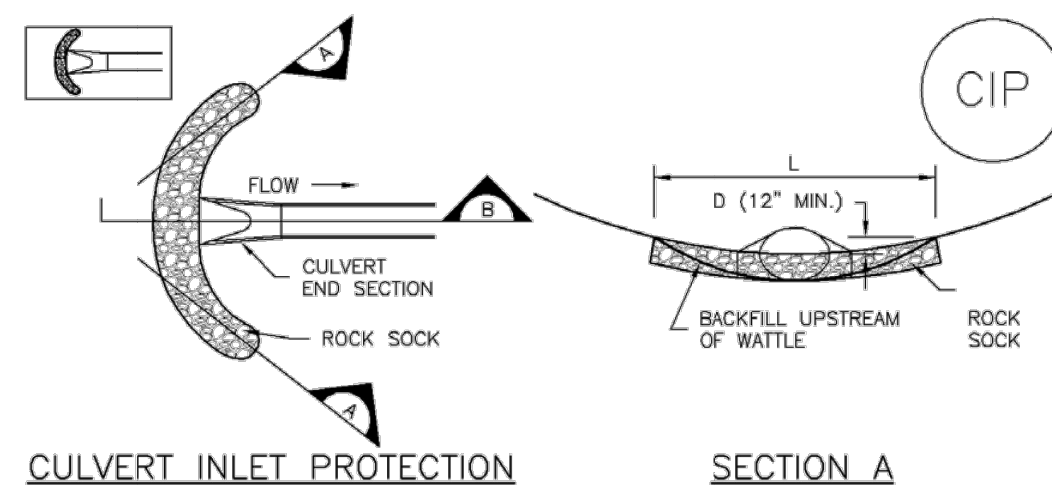

CULVERT INLET PROTECTION SECTION A

CIP-1. CULVERT INLET PROTECTION

CULVERT INLET PROTECTION INSTALLATION NOTES

1. SEE PLAN VIEW FOR LOCATION OF CULVERT INLET PROTECTION.
2. SEE ROCK SOCK DESIGN DETAIL FOR ROCK GRADATION REQUIREMENTS AND JOINTING DETAIL.

CULVERT INLET PROTECTION MAINTENANCE NOTES

1. INSPECT BMPs EACH WORKDAY, AND MAINTAIN THEM IN EFFECTIVE OPERATING CONDITION. MAINTENANCE OF BMPs SHOULD BE PROACTIVE, NOT REACTIVE. INSPECT BMPs AS SOON AS POSSIBLE (AND ALWAYS WITHIN 24 HOURS) FOLLOWING A STORM THAT CAUSES SURFACE EROSION, AND PERFORM NECESSARY MAINTENANCE.
2. FREQUENT OBSERVATIONS AND MAINTENANCE ARE NECESSARY TO MAINTAIN BMPs IN EFFECTIVE OPERATING CONDITION. INSPECTIONS AND CORRECTIVE MEASURES SHOULD BE DOCUMENTED THOROUGHLY.
3. WHERE BMPs HAVE FAILED, REPAIR OR REPLACEMENT SHOULD BE INITIATED UPON DISCOVERY OF THE FAILURE.
4. SEDIMENT ACCUMULATED UPSTREAM OF THE CULVERT SHALL BE REMOVED WHEN THE SEDIMENT DEPTH IS 1/2 THE HEIGHT OF THE ROCK SOCK.
5. CULVERT INLET PROTECTION SHALL REMAIN IN PLACE UNTIL THE UPSTREAM DISTURBED AREA IS PERMANENTLY STABILIZED AND APPROVED BY THE LOCAL JURISDICTION.

(DETAILS ADAPTED FROM AURORA, COLORADO, NOT AVAILABLE IN AUTOCAD)
NOTE: MANY JURISDICTIONS HAVE BMP DETAILS THAT VARY FROM UDFCD STANDARD DETAILS. CONSULT WITH LOCAL JURISDICTIONS AS TO WHICH DETAIL SHOULD BE USED WHEN DIFFERENCES ARE NOTED.

August 2013 Urban Drainage and Flood Control District August 2013
Urban Storm Drainage Criteria Manual Volume 3 IP-7

SC-6 Inlet Protection (IP)

GENERAL INLET PROTECTION INSTALLATION NOTES

1. SEE PLAN VIEW FOR:
 - LOCATION OF INLET PROTECTION.
 - TYPE OF INLET PROTECTION (IP.1, IP.2, IP.3, IP.4, IP.5, IP.6)
2. INLET PROTECTION SHALL BE INSTALLED PROMPTLY AFTER INLET CONSTRUCTION OR PAVING IS COMPLETE (TYPICALLY WITHIN 48 HOURS). IF A RAINFALL/RUNOFF EVENT IS FORECAST, INSTALL INLET PROTECTION PRIOR TO ONSET OF EVENT.
3. MANY JURISDICTIONS HAVE BMP DETAILS THAT VARY FROM UDFCD STANDARD DETAILS. CONSULT WITH LOCAL JURISDICTIONS AS TO WHICH DETAIL SHOULD BE USED WHEN DIFFERENCES ARE NOTED.

INLET PROTECTION MAINTENANCE NOTES

1. INSPECT BMPs EACH WORKDAY, AND MAINTAIN THEM IN EFFECTIVE OPERATING CONDITION. MAINTENANCE OF BMPs SHOULD BE PROACTIVE, NOT REACTIVE. INSPECT BMPs AS SOON AS POSSIBLE (AND ALWAYS WITHIN 24 HOURS) FOLLOWING A STORM THAT CAUSES SURFACE EROSION, AND PERFORM NECESSARY MAINTENANCE.
2. FREQUENT OBSERVATIONS AND MAINTENANCE ARE NECESSARY TO MAINTAIN BMPs IN EFFECTIVE OPERATING CONDITION. INSPECTIONS AND CORRECTIVE MEASURES SHOULD BE DOCUMENTED THOROUGHLY.
3. WHERE BMPs HAVE FAILED, REPAIR OR REPLACEMENT SHOULD BE INITIATED UPON DISCOVERY OF THE FAILURE.
4. SEDIMENT ACCUMULATED UPSTREAM OF INLET PROTECTION SHALL BE REMOVED AS NECESSARY TO MAINTAIN BMP EFFECTIVENESS. TYPICALLY WHEN STORAGE VOLUME REACHES 50% OF CAPACITY, A DEPTH OF 6" WHEN SILT FENCE IS USED, OR 1/4 OF THE HEIGHT FOR STRAW BALES.
5. INLET PROTECTION IS TO REMAIN IN PLACE UNTIL THE UPSTREAM DISTURBED AREA IS PERMANENTLY STABILIZED, UNLESS THE LOCAL JURISDICTION APPROVES EARLIER REMOVAL OF INLET PROTECTION IN STREETS.
6. WHEN INLET PROTECTION AT AREA INLETS IS REMOVED, THE DISTURBED AREA SHALL BE COVERED WITH TOP SOIL, SEEDED AND MULCHED, OR OTHERWISE STABILIZED IN A MANNER APPROVED BY THE LOCAL JURISDICTION.

(DETAILS ADAPTED FROM TOWN OF PARKER, COLORADO AND CITY OF AURORA, COLORADO, NOT AVAILABLE IN AUTOCAD)
NOTE: MANY JURISDICTIONS HAVE BMP DETAILS THAT VARY FROM UDFCD STANDARD DETAILS. CONSULT WITH LOCAL JURISDICTIONS AS TO WHICH DETAIL SHOULD BE USED WHEN DIFFERENCES ARE NOTED.

NOTE: THE DETAILS INCLUDED WITH THIS FACT SHEET SHOW COMMONLY USED, CONVENTIONAL METHODS OF INLET PROTECTION IN THE DENVER METROPOLITAN AREA. THERE ARE MANY PROPRIETARY INLET PROTECTION METHODS ON THE MARKET. UDFCD NEITHER ENDORSES NOR DISCOURAGES USE OF PROPRIETARY INLET PROTECTION; HOWEVER, IN THE EVENT PROPRIETARY METHODS ARE USED, THE APPROPRIATE DETAIL FROM THE MANUFACTURER MUST BE INCLUDED IN THE SWMP AND THE BMP MUST BE INSTALLED AND MAINTAINED AS SHOWN IN THE MANUFACTURER'S DETAILS.
NOTE: SOME MUNICIPALITIES DISCOURAGE OR PROHIBIT THE USE OF STRAW BALES FOR INLET PROTECTION. CHECK WITH LOCAL JURISDICTION TO DETERMINE IF STRAW BALE INLET PROTECTION IS ACCEPTABLE.

IP-8 Urban Drainage and Flood Control District August 2013
Urban Storm Drainage Criteria Manual Volume 3

Inlet Protection (IP) SC-6

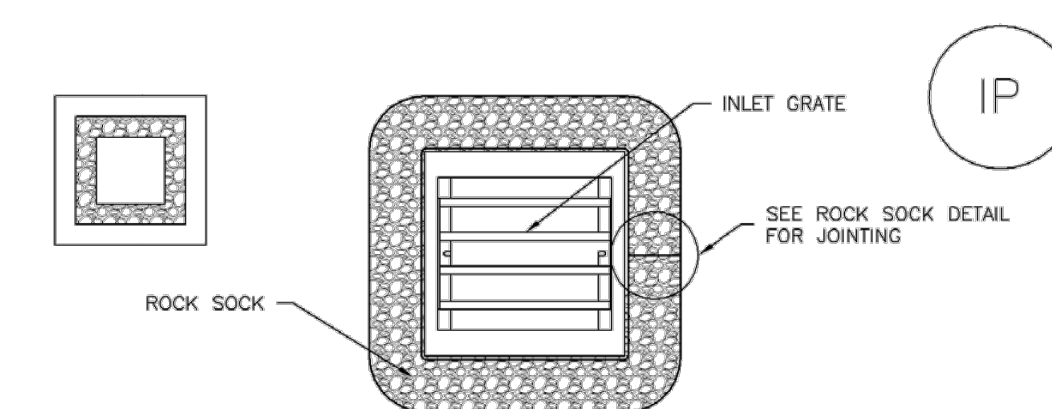

IP-3. ROCK SOCK SUMP/AREA INLET PROTECTION

ROCK SOCK SUMP/AREA INLET PROTECTION INSTALLATION NOTES

1. SEE ROCK SOCK DESIGN DETAIL FOR INSTALLATION REQUIREMENTS.
2. STRAW WATTLES/SEDIMENT CONTROL LOGS MAY BE USED IN PLACE OF ROCK SOCKS FOR INLETS IN PEROUS AREAS. INSTALL PER SEDIMENT CONTROL LOG DETAIL.

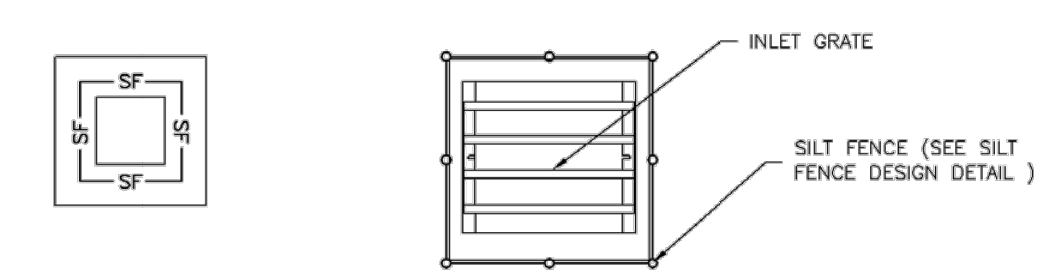

IP-4. SILT FENCE FOR SUMP INLET PROTECTION

SILT FENCE INLET PROTECTION INSTALLATION NOTES

1. SEE SILT FENCE DESIGN DETAIL FOR INSTALLATION REQUIREMENTS.
2. POSTS SHALL BE PLACED AT EACH CORNER OF THE INLET AND AROUND THE EDGES AT A MAXIMUM SPACING OF 3 FEET.
3. STRAW WATTLES/SEDIMENT CONTROL LOGS MAY BE USED IN PLACE OF SILT FENCE FOR INLETS IN PEROUS AREAS. INSTALL PER SEDIMENT CONTROL LOG DETAIL.

August 2013 Urban Drainage and Flood Control District August 2013
Urban Storm Drainage Criteria Manual Volume 3 IP-5

Silt Fence (SF) SC-1

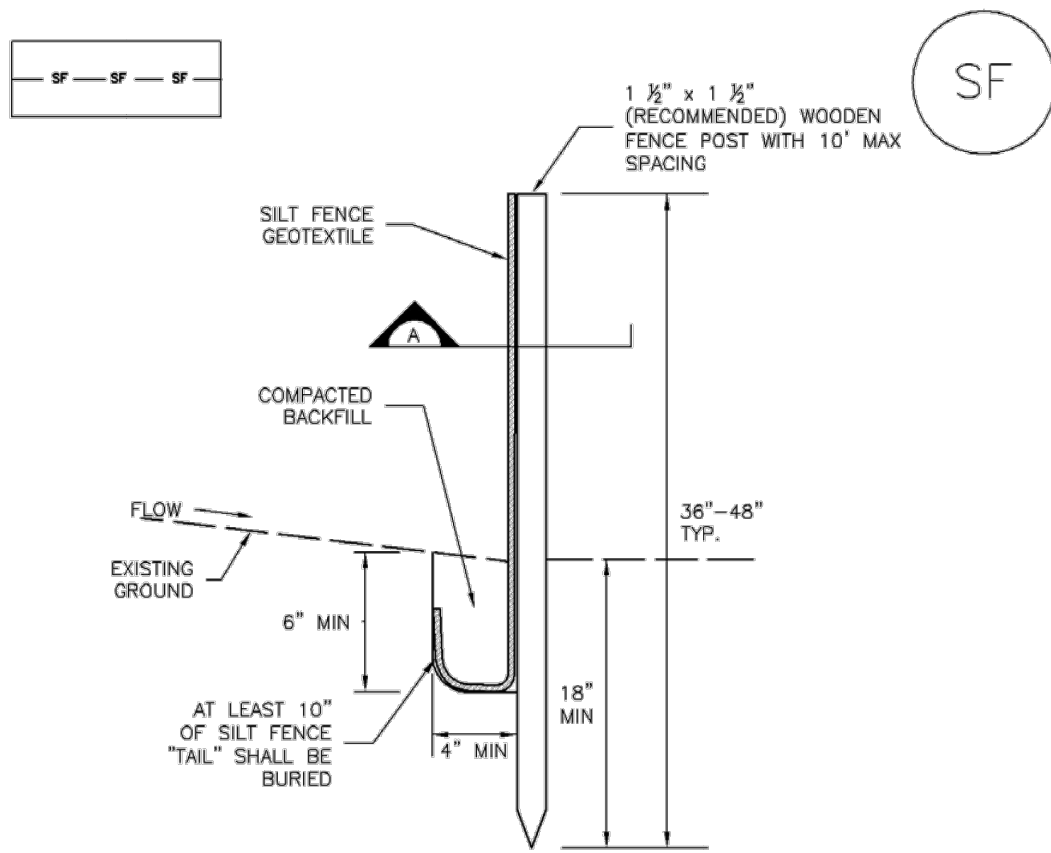

SILT FENCE

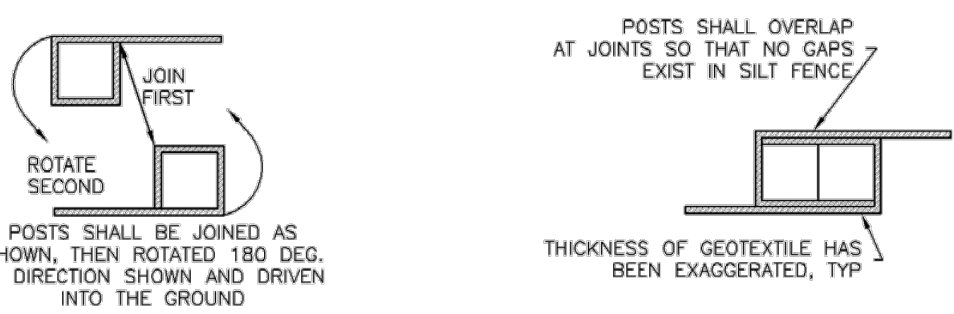

SECTION A

SF-1. SILT FENCE

November 2010 Urban Drainage and Flood Control District November 2010
Urban Storm Drainage Criteria Manual Volume 3 SF-3

SC-1 Silt Fence (SF)

SILT FENCE INSTALLATION NOTES

1. SILT FENCE MUST BE PLACED AWAY FROM THE TOE OF THE SLOPE TO ALLOW FOR WATER PONDING. SILT FENCE THE TOE OF A SLOPE SHOULD BE INSTALLED IN A FLAT LOCATION AT LEAST SEVERAL FEET (2-5 FT) FROM THE TOE OF THE SLOPE TO ALLOW ROOM FOR PONDING AND DEPOSITION.
2. A UNIFORM 6" X 4" ANCHOR TRENCH SHALL BE EXCAVATED USING TRENCHER OR SILT FENCE INSTALLATION DEVICE. NO ROAD GRADERS, BACKHOES, OR SIMILAR EQUIPMENT SHALL BE USED.
3. COMPACT ANCHOR TRENCH BY HAND WITH A "JUMPING JACK" OR BY WHEEL ROLLING. COMPACTION SHALL BE SUCH THAT SILT FENCE RESISTS BEING PULLED OUT OF ANCHOR TRENCH BY HAND.
4. SILT FENCE SHALL BE PULLED TIGHT AS IT IS ANCHORED TO THE STAKES. THERE SHOULD BE NO NOTICEABLE SAG BETWEEN STAKES AFTER IT HAS BEEN ANCHORED TO THE STAKES.
5. SILT FENCE FABRIC SHALL BE ANCHORED TO THE STAKES USING 1" HEAVY DUTY STAPLES OR NAILS WITH 1" HEADS. STAPLES AND NAILS SHOULD BE PLACED 3" ALONG THE FABRIC DOWN THE STAKE.
6. AT THE END OF A RUN OF SILT FENCE ALONG A CONTOUR, THE SILT FENCE SHOULD BE TURNED PERPENDICULAR TO THE CONTOUR TO CREATE A "J-HOOK." THE "J-HOOK" EXTENDING PERPENDICULAR TO THE CONTOUR SHOULD BE OF SUFFICIENT LENGTH TO KEEP RUNOFF FROM FLOWING AROUND THE END OF THE SILT FENCE (TYPICALLY 10' - 20').
7. SILT FENCE SHALL BE INSTALLED PRIOR TO ANY LAND DISTURBING ACTIVITIES.

SILT FENCE MAINTENANCE NOTES

1. INSPECT BMPs EACH WORKDAY, AND MAINTAIN THEM IN EFFECTIVE OPERATING CONDITION. MAINTENANCE OF BMPs SHOULD BE PROACTIVE, NOT REACTIVE. INSPECT BMPs AS SOON AS POSSIBLE (AND ALWAYS WITHIN 24 HOURS) FOLLOWING A STORM THAT CAUSES SURFACE EROSION, AND PERFORM NECESSARY MAINTENANCE.
2. FREQUENT OBSERVATIONS AND MAINTENANCE ARE NECESSARY TO MAINTAIN BMPs IN EFFECTIVE OPERATING CONDITION. INSPECTIONS AND CORRECTIVE MEASURES SHOULD BE DOCUMENTED THOROUGHLY.
3. WHERE BMPs HAVE FAILED, REPAIR OR REPLACEMENT SHOULD BE INITIATED UPON DISCOVERY OF THE FAILURE.
4. SEDIMENT ACCUMULATED UPSTREAM OF THE SILT FENCE SHALL BE REMOVED AS NEEDED TO MAINTAIN THE FUNCTIONALITY OF THE BMP. TYPICALLY WHEN DEPTH OF ACCUMULATED SEDIMENTS IS APPROXIMATELY 6".
5. REPAIR OR REPLACE SILT FENCE WHEN THERE ARE SIGNS OF WEAR, SUCH AS SAGGING, TEARING, OR COLLAPSE.
6. SILT FENCE IS TO REMAIN IN PLACE UNTIL THE UPSTREAM DISTURBED AREA IS STABILIZED AND APPROVED BY THE LOCAL JURISDICTION, OR IS REPLACED BY AN EQUIVALENT PERIMETER SEDIMENT CONTROL BMP.
7. WHEN SILT FENCE IS REMOVED, ALL DISTURBED AREAS SHALL BE COVERED WITH TOPSOIL, SEEDED AND MULCHED OR OTHERWISE STABILIZED AS APPROVED BY LOCAL JURISDICTION.

(DETAILS ADAPTED FROM TOWN OF PARKER, COLORADO AND CITY OF AURORA, NOT AVAILABLE IN AUTOCAD)
NOTE: MANY JURISDICTIONS HAVE BMP DETAILS THAT VARY FROM UDFCD STANDARD DETAILS. CONSULT WITH LOCAL JURISDICTIONS AS TO WHICH DETAIL SHOULD BE USED WHEN DIFFERENCES ARE NOTED.

SF-4 Urban Drainage and Flood Control District November 2010
Urban Storm Drainage Criteria Manual Volume 3

MM-2 Stockpile Management (SM)

STOCKPILE PROTECTION MAINTENANCE NOTES

1. INSPECT BMPs EACH WORKDAY, AND MAINTAIN THEM IN EFFECTIVE OPERATING CONDITION. MAINTENANCE OF BMPs SHOULD BE PROACTIVE, NOT REACTIVE. INSPECT BMPs AS SOON AS POSSIBLE (AND ALWAYS WITHIN 24 HOURS) FOLLOWING A STORM THAT CAUSES SURFACE EROSION, AND PERFORM NECESSARY MAINTENANCE.
2. FREQUENT OBSERVATIONS AND MAINTENANCE ARE NECESSARY TO MAINTAIN BMPs IN EFFECTIVE OPERATING CONDITION. INSPECTIONS AND CORRECTIVE MEASURES SHOULD BE DOCUMENTED THOROUGHLY.
3. WHERE BMPs HAVE FAILED, REPAIR OR REPLACEMENT SHOULD BE INITIATED UPON DISCOVERY OF THE FAILURE.
4. IF PERIMETER PROTECTION MUST BE MOVED TO ACCESS SOIL STOCKPILE, REPLACE PERIMETER CONTROLS BY THE END OF THE WORKDAY.
5. STOCKPILE PERIMETER CONTROLS CAN BE REMOVED ONCE ALL THE MATERIAL FROM THE STOCKPILE HAS BEEN USED.

(DETAILS ADAPTED FROM TOWN OF PARKER, COLORADO, NOT AVAILABLE IN AUTOCAD)
NOTE: MANY JURISDICTIONS HAVE BMP DETAILS THAT VARY FROM UDFCD STANDARD DETAILS. CONSULT WITH LOCAL JURISDICTIONS AS TO WHICH DETAIL SHOULD BE USED WHEN DIFFERENCES ARE NOTED.

SP-4 Urban Drainage and Flood Control District November 2010
Urban Storm Drainage Criteria Manual Volume 3

Stockpile Management (SP) MM-2

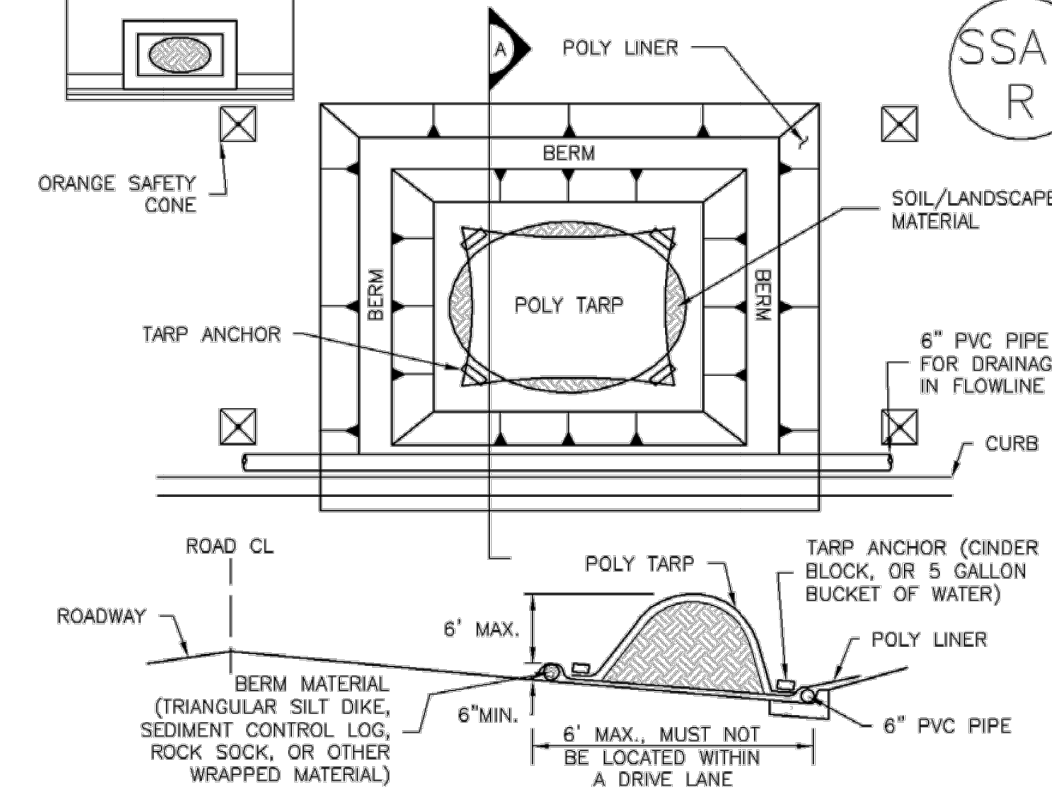

SP-2. MATERIALS STAGING IN ROADWAY

MATERIALS STAGING IN ROADWAYS INSTALLATION NOTES

1. SEE PLAN VIEW FOR:
 - LOCATION OF MATERIAL STAGING AREA(S).
 - CONTRACTOR MAY ADJUST LOCATION AND SIZE OF STAGING AREA WITH APPROVAL FROM THE LOCAL JURISDICTION.
2. FEATURE MUST BE INSTALLED PRIOR TO EXCAVATION, EARTHWORK OR DELIVERY OF MATERIALS.
3. MATERIALS MUST BE STATIONED ON THE POLY LINER. ANY INCIDENTAL MATERIALS DEPOSITED ON PAVED SECTION OR ALONG CURB LINE MUST BE CLEANED UP PROMPTLY.
4. POLY LINER AND TARP COVER SHOULD BE OF SIGNIFICANT THICKNESS TO PREVENT DAMAGE OR LOSS OF INTEGRITY.
5. SAND BAGS MAY BE SUBSTITUTED TO ANCHOR THE COVER TARP OR PROVIDE BERMING UNDER THE BASE LINER.
6. FEATURE IS NOT INTENDED FOR USE WITH WET MATERIAL THAT WILL BE DRAINING AND/OR SPREADING OUT ON THE POLY LINER OR FOR DEMOLITION MATERIALS.
7. THIS FEATURE CAN BE USED FOR:
 - UTILITY REPAIRS.
 - WHEN OTHER STAGING LOCATIONS AND OPTIONS ARE LIMITED.
 - OTHER LIMITED APPLICATION AND SHORT DURATION STAGING.

November 2010 Urban Drainage and Flood Control District November 2010
Urban Storm Drainage Criteria Manual Volume 3 SP-5

C:\ACC\ACCDocs\Kimley-Horn\196013001 WHMD Expansion Study\Project Files\DWG\PlanSheets\Stormwater Improvements\Plansheets\GEC\GEC_DT.dwg Olesen, Maria (Langer) 6/22/2026 11:00 AM

| NO. | REVISION | BY | DATE | APPR |
|-----|----------|----|------|------|
| | | | | |

Kimley-Horn
2026 KIMLEY-HORN AND ASSOCIATES, INC.
2 North Nevada Avenue, Suite 900
Colorado Springs, Colorado 80903 (719) 453-0180

DESIGNED BY: MEO
DRAWN BY: MEO
CHECKED BY: KRK
DATE: 6/22/26

WHMD RWRFS STORM IMPROVEMENTS
EL PASO COUNTY, COLORADO
GEC PLANS
DETAIL SHEET (1 OF 3)

PRELIMINARY
FOR REVIEW ONLY
NOT FOR
CONSTRUCTION
Kimley-Horn
Kimley-Horn and Associates, Inc.

PROJECT NO.
196013004

SHEET

6

Stockpile Management (SP)

MM-2

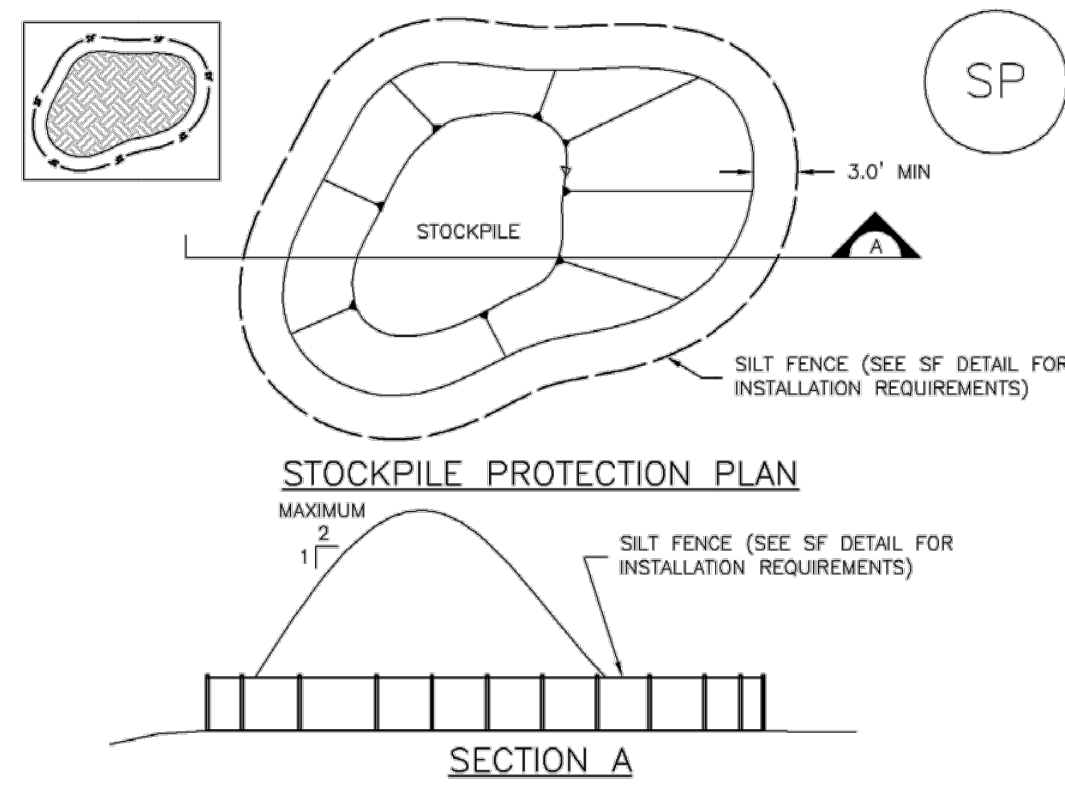

SP-1. STOCKPILE PROTECTION

STOCKPILE PROTECTION INSTALLATION NOTES

- SEE PLAN VIEW FOR:
 - LOCATION OF STOCKPILES.
 - TYPE OF STOCKPILE PROTECTION.
- INSTALL PERIMETER CONTROLS IN ACCORDANCE WITH THEIR RESPECTIVE DESIGN DETAILS. SILT FENCE IS SHOWN IN THE STOCKPILE PROTECTION DETAILS; HOWEVER, OTHER TYPES OF PERIMETER CONTROLS INCLUDING SEGMENT CONTROL LOGS OR ROCK SOCKS MAY BE SUITABLE IN SOME CIRCUMSTANCES. CONSIDERATIONS FOR DETERMINING THE APPROPRIATE TYPE OF PERIMETER CONTROL FOR A STOCKPILE INCLUDE WHETHER THE STOCKPILE IS LOCATED ON A PERVIOUS OR IMPERVIOUS SURFACE, THE RELATIVE HEIGHTS OF THE PERIMETER CONTROL AND STOCKPILE, THE ABILITY OF THE PERIMETER CONTROL TO CONTAIN THE STOCKPILE WITHOUT FAILING IN THE EVENT THAT MATERIAL FROM THE STOCKPILE SHIFTS OR SLUMPS AGAINST THE PERIMETER, AND OTHER FACTORS.
- STABILIZE THE STOCKPILE SURFACE WITH SURFACE ROUGHENING, TEMPORARY SEEDING AND MULCHING, EROSION CONTROL BLANKETS, OR SOIL BINDERS. SOILS STOCKPILED FOR AN EXTENDED PERIOD (TYPICALLY FOR MORE THAN 60 DAYS) SHOULD BE SEEDED AND MULCHED WITH A TEMPORARY GRASS COVER ONCE THE STOCKPILE IS PLACED (TYPICALLY WITHIN 14 DAYS). USE OF MULCH ONLY OR A SOIL BINDER IS ACCEPTABLE IF THE STOCKPILE WILL BE IN PLACE FOR A MORE LIMITED TIME PERIOD (TYPICALLY 30-50 DAYS).
- FOR TEMPORARY STOCKPILES ON THE INTERIOR PORTION OF A CONSTRUCTION SITE, WHERE OTHER DOWNGRADIENT CONTROLS, INCLUDING PERIMETER CONTROL, ARE IN PLACE, STOCKPILE PERIMETER CONTROLS MAY NOT BE REQUIRED.

November 2010 Urban Drainage and Flood Control District SP-3
Urban Storm Drainage Criteria Manual Volume 3

Temporary and Permanent Seeding (TS/PS) EC-2

Seeding dates for the highest success probability of perennial species along the Front Range are generally in the spring from April through early May and in the fall after the first of September until the ground freezes. If the area is irrigated, seeding may occur in summer months, as well. See Table TS/PS-3 for appropriate seeding dates.

Table TS/PS-1. Minimum Drill Seeding Rates for Various Temporary Annual Grasses

| Species* (Common name) | Growth Season ¹ | Pounds of Pure Live Seed (PLS)/acre ² | Planting Depth (inches) |
|---------------------------|----------------------------|--|-------------------------|
| 1. Oats | Cool | 35 - 50 | 1 - 2 |
| 2. Spring wheat | Cool | 25 - 35 | 1 - 2 |
| 3. Spring barley | Cool | 25 - 35 | 1 - 2 |
| 4. Annual ryegrass | Cool | 10 - 15 | ½ |
| 5. Millet | Warm | 3 - 15 | ½ - ¾ |
| 6. Sudangrass | Warm | 5-10 | ½ - ¾ |
| 7. Sorghum | Warm | 5-10 | ½ - ¾ |
| 8. Winter wheat | Cool | 20-35 | 1 - 2 |
| 9. Winter barley | Cool | 20-35 | 1 - 2 |
| 10. Winter rye | Cool | 20-35 | 1 - 2 |
| 11. Triticale | Cool | 25-40 | 1 - 2 |

* Successful seeding of annual grass resulting in adequate plant growth will usually produce enough dead-plant residue to provide protection from wind and water erosion for an additional year. This assumes that the cover is not disturbed or moved closer than 8 inches.

Hydraulic seeding may be substituted for drilling only where slopes are steeper than 3:1 or where access limitations exist. When hydraulic seeding is used, hydraulic mulching should be applied as a separate operation, when practical, to prevent the seeds from being encapsulated in the mulch.

^b See Table TS/PS-3 for seeding dates. Irrigation, if consistently applied, may extend the use of cool season species during the summer months.

^c Seeding rates should be doubled if seed is broadcast, or increased by 50 percent if done using a Brillion Drill or by hydraulic seeding.

June 2012 Urban Drainage and Flood Control District TS/PS-3
Urban Storm Drainage Criteria Manual Volume 3

Stockpile Management (SM) MM-2

MATERIALS STAGING IN ROADWAY MAINTENANCE NOTES

- INSPECT BMPs EACH WORKDAY, AND MAINTAIN THEM IN EFFECTIVE OPERATING CONDITION. MAINTENANCE OF BMPs SHOULD BE PROACTIVE, NOT REACTIVE. INSPECT BMPs AS SOON AS POSSIBLE (AND ALWAYS WITHIN 24 HOURS) FOLLOWING A STORM THAT CAUSES SURFACE EROSION, AND PERFORM NECESSARY MAINTENANCE.
- FREQUENT OBSERVATIONS AND MAINTENANCE ARE NECESSARY TO MAINTAIN BMPs IN EFFECTIVE OPERATING CONDITION. INSPECTIONS AND CORRECTIVE MEASURES SHOULD BE DOCUMENTED THOROUGHLY.
- WHERE BMPs HAVE FAILED, REPAIR OR REPLACEMENT SHOULD BE INITIATED UPON DISCOVERY OF THE FAILURE.
- INSPECT PVC PIPE ALONG CURB LINE FOR CLOGGING AND DEBRIS. REMOVE OBSTRUCTIONS PROMPTLY.
- CLEAN MATERIAL FROM PAVED SURFACES BY SWEEPING OR VACUUMING.

NOTE: MANY JURISDICTIONS HAVE BMP DETAILS THAT VARY FROM UDFCD STANDARD DETAILS. CONSULT WITH LOCAL JURISDICTIONS AS TO WHICH DETAIL SHOULD BE USED WHEN DIFFERENCES ARE NOTED.

(DETAILS ADAPTED FROM AURORA, COLORADO)

November 2010 Urban Drainage and Flood Control District SP-6
Urban Storm Drainage Criteria Manual Volume 3

Temporary and Permanent Seeding (TS/PS) EC-2

Table TS/PS-2. Minimum Drill Seeding Rates for Perennial Grasses

| Common Name | Botanical Name | Growth Season ³ | Growth Form | Seeds/Pound | Pounds of PLS/acre |
|---|--|----------------------------|-------------|-------------|--------------------|
| Alkali Soil Seed Mix | | | | | |
| Alkali sacaton | <i>Sporobolus airoides</i> | Cool | Bunch | 1,750,000 | 0.25 |
| Basin wildrye | <i>Elymus cinereus</i> | Cool | Bunch | 165,000 | 2.5 |
| Sodar streambank wheatgrass | <i>Agropyron riparium 'Sodar'</i> | Cool | Sod | 170,000 | 2.5 |
| Jose tall wheatgrass | <i>Agropyron elongatum 'Jose'</i> | Cool | Bunch | 79,000 | 7.0 |
| Arriba western wheatgrass | <i>Agropyron smithii 'Arriba'</i> | Cool | Sod | 110,000 | 5.5 |
| Total | | | | | 17.75 |
| Fertile Loamy Soil Seed Mix | | | | | |
| Ephraim crested wheatgrass | <i>Agropyron cristatum 'Ephraim'</i> | Cool | Sod | 175,000 | 2.0 |
| Dural hard fescue | <i>Festuca ovina 'durisculca'</i> | Cool | Bunch | 565,000 | 1.0 |
| Lincoln smooth brome | <i>Bromus inermis leysii 'Lincoln'</i> | Cool | Sod | 130,000 | 3.0 |
| Sodar streambank wheatgrass | <i>Agropyron riparium 'Sodar'</i> | Cool | Sod | 170,000 | 2.5 |
| Arriba western wheatgrass | <i>Agropyron smithii 'Arriba'</i> | Cool | Sod | 110,000 | 7.0 |
| Total | | | | | 15.5 |
| High Water Table Soil Seed Mix | | | | | |
| Meadow foxtail | <i>Alopecurus pratensis</i> | Cool | Sod | 900,000 | 0.5 |
| Redtop | <i>Aegrotis alba</i> | Warm | Open sod | 5,000,000 | 0.25 |
| Reed canarygrass | <i>Phalaris arundinacea</i> | Cool | Sod | 68,000 | 0.5 |
| Lincoln smooth brome | <i>Bromus inermis leysii 'Lincoln'</i> | Cool | Sod | 130,000 | 3.0 |
| Pathfinder switchgrass | <i>Panicum virgatum 'Pathfinder'</i> | Warm | Sod | 389,000 | 1.0 |
| Alkar tall wheatgrass | <i>Agropyron elongatum 'Alkar'</i> | Cool | Bunch | 79,000 | 5.5 |
| Total | | | | | 10.75 |
| Transition Turf Seed Mix⁴ | | | | | |
| Ruebens Canadian bluegrass | <i>Poa compressa 'Ruebens'</i> | Cool | Sod | 2,500,000 | 0.5 |
| Dural hard fescue | <i>Festuca ovina 'durisculca'</i> | Cool | Bunch | 565,000 | 1.0 |
| Citation perennial ryegrass | <i>Lolium perenne 'Citation'</i> | Cool | Sod | 247,000 | 3.0 |
| Lincoln smooth brome | <i>Bromus inermis leysii 'Lincoln'</i> | Cool | Sod | 130,000 | 3.0 |
| Total | | | | | 7.5 |

June 2012 Urban Drainage and Flood Control District TS/PS-4
Urban Storm Drainage Criteria Manual Volume 3

Concrete Washout Area (CWA) MM-1

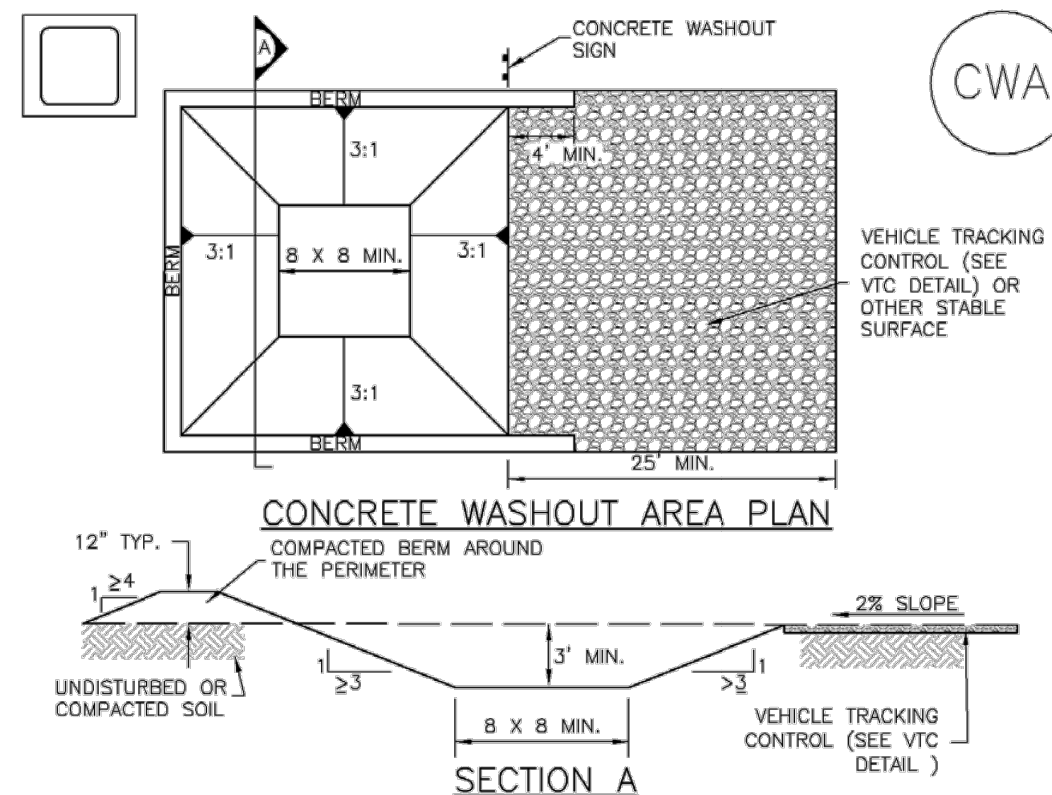

CWA-1. CONCRETE WASHOUT AREA

CWA INSTALLATION NOTES

- SEE PLAN VIEW FOR:
 - CWA INSTALLATION LOCATION.
- DO NOT LOCATE AN UNLINED CWA WITHIN 400' OF ANY NATURAL DRAINAGE PATHWAY OR WATERBODY. DO NOT LOCATE WITHIN 1,000' OF ANY WELLS OR DRINKING WATER SOURCES. IF SITE CONSTRAINTS MAKE THIS INFEASIBLE, OR IF HIGHLY PERMEABLE SOILS EXIST ON SITE, THE CWA MUST BE INSTALLED WITH AN IMPERMEABLE LINER (16 MIL MIN. THICKNESS) OR SURFACE STORAGE ALTERNATIVES USING PREFABRICATED CONCRETE WASHOUT DEVICES OR A LINED ABOVE GROUND STORAGE ARE SHOULD BE USED.
- THE CWA SHALL BE INSTALLED PRIOR TO CONCRETE PLACEMENT ON SITE.
- CWA SHALL INCLUDE A FLAT SUBSURFACE PIT THAT IS AT LEAST 8' BY 8' SLOPES LEADING OUT OF THE SUBSURFACE PIT SHALL BE 3:1 OR FLATTER. THE PIT SHALL BE AT LEAST 3' DEEP.
- BERM SURROUNDING SIDES AND BACK OF THE CWA SHALL HAVE MINIMUM HEIGHT OF 1'.
- VEHICLE TRACKING PAD SHALL BE SLOPED 2% TOWARDS THE CWA.
- SIGNS SHALL BE PLACED AT THE CONSTRUCTION ENTRANCE, AT THE CWA, AND ELSEWHERE AS NECESSARY TO CLEARLY INDICATE THE LOCATION OF THE CWA TO OPERATORS OF CONCRETE TRUCKS AND PUMP RIGS.
- USE EXCAVATED MATERIAL FOR PERIMETER BERM CONSTRUCTION.

November 2010 Urban Drainage and Flood Control District CWA-3
Urban Storm Drainage Criteria Manual Volume 3

Temporary and Permanent Seeding (TS/PS) EC-2

Table TS/PS-2. Minimum Drill Seeding Rates for Perennial Grasses (cont.)

| Common Name | Botanical Name | Growth Season ³ | Growth Form | Seeds/Pound | Pounds of PLS/acre |
|--|---|----------------------------|------------------------|-------------|--------------------|
| Sandy Soil Seed Mix | | | | | |
| Blue grama | <i>Bouteloua gracilis</i> | Warm | Sod-forming bunchgrass | 825,000 | 0.5 |
| Camper little bluestem | <i>Schizachyrium scoparium 'Camper'</i> | Warm | Bunch | 240,000 | 1.0 |
| Prairie sandreed | <i>Calamovilfa longifolia</i> | Warm | Open sod | 274,000 | 1.0 |
| Sand dropseed | <i>Sporobolus cryptandrus</i> | Cool | Bunch | 5,298,000 | 0.25 |
| Vaughn sideoats grama | <i>Bouteloua curtipendula 'Vaughn'</i> | Warm | Sod | 191,000 | 2.0 |
| Arriba western wheatgrass | <i>Agropyron smithii 'Arriba'</i> | Cool | Sod | 110,000 | 5.5 |
| Total | | | | | 10.25 |
| Heavy Clay, Rocky Foothill Seed Mix | | | | | |
| Ephraim crested wheatgrass ⁵ | <i>Agropyron cristatum 'Ephraim'</i> | Cool | Sod | 175,000 | 1.5 |
| Oahe Intermediate wheatgrass | <i>Agropyron intermedium 'Oahe'</i> | Cool | Sod | 115,000 | 5.5 |
| Vaughn sideoats grama ⁶ | <i>Bouteloua curtipendula 'Vaughn'</i> | Warm | Sod | 191,000 | 2.0 |
| Lincoln smooth brome | <i>Bromus inermis leysii 'Lincoln'</i> | Cool | Sod | 130,000 | 3.0 |
| Arriba western wheatgrass | <i>Agropyron smithii 'Arriba'</i> | Cool | Sod | 110,000 | 5.5 |
| Total | | | | | 17.5 |

^a All of the above seeding mixes and rates are based on drill seeding followed by crimped straw mulch. These rates should be doubled if seed is broadcast and should be increased by 50 percent if the seeding is done using a Brillion Drill or is applied through hydraulic seeding. Hydraulic seeding may be substituted for drilling only where slopes are steeper than 3:1. If hydraulic seeding is used, hydraulic mulching should be done as a separate operation.

^b See Table TS/PS-3 for seeding dates.

^c If site is to be irrigated, the transition turf seed rates should be doubled.

^d Crested wheatgrass should not be used on slopes steeper than 6H to 1V.

^e Can substitute 0.5 lbs PLS of blue grama for the 2.0 lbs PLS of Vaughn sideoats grama.

June 2012 Urban Drainage and Flood Control District TS/PS-5
Urban Storm Drainage Criteria Manual Volume 3

Concrete Washout Area (CWA) MM-1

CWA MAINTENANCE NOTES

- INSPECT BMPs EACH WORKDAY, AND MAINTAIN THEM IN EFFECTIVE OPERATING CONDITION. MAINTENANCE OF BMPs SHOULD BE PROACTIVE, NOT REACTIVE. INSPECT BMPs AS SOON AS POSSIBLE (AND ALWAYS WITHIN 24 HOURS) FOLLOWING A STORM THAT CAUSES SURFACE EROSION, AND PERFORM NECESSARY MAINTENANCE.
- FREQUENT OBSERVATIONS AND MAINTENANCE ARE NECESSARY TO MAINTAIN BMPs IN EFFECTIVE OPERATING CONDITION. INSPECTIONS AND CORRECTIVE MEASURES SHOULD BE DOCUMENTED THOROUGHLY.
- WHERE BMPs HAVE FAILED, REPAIR OR REPLACEMENT SHOULD BE INITIATED UPON DISCOVERY OF THE FAILURE.
- THE CWA SHALL BE REPAIRED, CLEANED, OR ENLARGED AS NECESSARY TO MAINTAIN CAPACITY FOR CONCRETE WASTE. CONCRETE MATERIALS, ACCUMULATED IN PIT, SHALL BE REMOVED ONCE THE MATERIALS HAVE REACHED A DEPTH OF 2'.
- CONCRETE WASHOUT WATER, WASTED PIECES OF CONCRETE AND ALL OTHER DEBRIS IN THE SUBSURFACE PIT SHALL BE TRANSPORTED FROM THE JOB SITE IN A WATER-TIGHT CONTAINER AND DISPOSED OF PROPERLY.
- THE CWA SHALL REMAIN IN PLACE UNTIL ALL CONCRETE FOR THE PROJECT IS PLACED.
- WHEN THE CWA IS REMOVED, COVER THE DISTURBED AREA WITH TOP SOIL, SEED AND MULCH OR OTHERWISE STABILIZED IN A MANNER APPROVED BY THE LOCAL JURISDICTION.

(DETAIL ADAPTED FROM DOUGLAS COUNTY, COLORADO AND THE CITY OF PARKER, COLORADO, NOT AVAILABLE IN AUTOCAD)
NOTE: MANY JURISDICTIONS HAVE BMP DETAILS THAT VARY FROM UDFCD STANDARD DETAILS. CONSULT WITH LOCAL JURISDICTIONS AS TO WHICH DETAIL SHOULD BE USED WHEN DIFFERENCES ARE NOTED.

November 2010 Urban Drainage and Flood Control District CWA-4
Urban Storm Drainage Criteria Manual Volume 3

Temporary and Permanent Seeding (TS/PS) EC-2

Table TS/PS-3. Seeding Dates for Annual and Perennial Grasses

| Seeding Dates | Annual Grasses (Numbers in table reference species in Table TS/PS-1) | | Perennial Grasses | |
|--------------------------|---|-----------|-------------------|------|
| | Warm | Cool | Warm | Cool |
| January 1-March 15 | | | ✓ | ✓ |
| March 16-April 30 | 4 | 1,2,3 | ✓ | ✓ |
| May 1-May 15 | 4 | | ✓ | |
| May 16-June 30 | 4,5,6,7 | | | |
| July 1-July 15 | 5,6,7 | | | |
| July 16-August 31 | | | | |
| September 1-September 30 | | 8,9,10,11 | | |
| October 1-December 31 | | | ✓ | ✓ |

Mulch

Cover seeded areas with mulch or an appropriate rolled erosion control product to promote establishment of vegetation. Anchor mulch by crimping, netting or use of a non-toxic tackifier. See the Mulching BMP Fact Sheet for additional guidance.

Maintenance and Removal

Monitor and observe seeded areas to identify areas of poor growth or areas that fail to germinate. Reseed and mulch these areas, as needed.

An area that has been permanently seeded should have a good stand of vegetation within one growing season if irrigated and within three growing seasons without irrigation in Colorado. Reseed portions of the site that fail to germinate or remain bare after the first growing season.

Seeded areas may require irrigation, particularly during extended dry periods. Targeted weed control may also be necessary.

Protect seeded areas from construction equipment and vehicle access.

June 2012 Urban Drainage and Flood Control District TS/PS-6
Urban Storm Drainage Criteria Manual Volume 3

| NO. | REVISION | BY | DATE | APPR |
|-----|----------|----|------|------|
| | | | | |

Kimley»Horn
2026 KIMLEY-HORN AND ASSOCIATES, INC.
2 North Nevada Avenue, Suite 900
Colorado Springs, Colorado 80903 (719) 453-0180

DESIGNED BY: MEO
DRAWN BY: MEO
CHECKED BY: KKK
DATE: 6/22/26

WHMD RWRFF STORM IMPROVEMENTS
EL PASO COUNTY, COLORADO
GEC PLANS
DETAIL SHEET (2 OF 3)

PRELIMINARY
FOR REVIEW ONLY
NOT FOR
CONSTRUCTION
Kimley»Horn
Kimley-Horn and Associates, Inc.

PROJECT NO.
196013004

SHEET

7

SM-6 Stabilized Staging Area (SSA)

Minimizing Long-Term Stabilization Requirements

- Utilize off-site parking and restrict vehicle access to the site.
- Use construction mats in lieu of rock when staging is provided in an area that will not be disturbed otherwise.
- Consider use of a bermed contained area for materials and equipment that do not require a stabilized surface.
- Consider phasing of staging areas to avoid disturbance in an area that will not be otherwise disturbed.

See Detail SSA-1 for a typical stabilized staging area and SSA-2 for a stabilized staging area when materials staging in roadways is required.

Maintenance and Removal

Maintenance of stabilized staging areas includes maintaining a stable surface cover of gravel, repairing perimeter controls, and following good housekeeping practices.

When construction is complete, debris, unused stockpiles and materials should be recycled or properly disposed. In some cases, this will require disposal of contaminated soil from equipment leaks in an appropriate landfill. Staging areas should then be permanently stabilized with vegetation or other surface cover planned for the development.

SSA-2 Urban Drainage and Flood Control District
Urban Storm Drainage Criteria Manual Volume 3 November 2010

SM-6 Stabilized Staging Area (SSA)

STABILIZED STAGING AREA MAINTENANCE NOTES

- STABILIZED STAGING AREA SHALL BE ENLARGED IF NECESSARY TO CONTAIN PARKING, STORAGE, AND UNLOADING/LOADING OPERATIONS.
- THE STABILIZED STAGING AREA SHALL BE REMOVED AT THE END OF CONSTRUCTION. THE GRANULAR MATERIAL SHALL BE REMOVED OR, IF APPROVED BY THE LOCAL JURISDICTION, USED ON SITE, AND THE AREA COVERED WITH TOPSOIL, SEEDED AND MULCHED OR OTHERWISE STABILIZED IN A MANNER APPROVED BY LOCAL JURISDICTION.

NOTE: MANY MUNICIPALITIES PROHIBIT THE USE OF RECYCLED CONCRETE AS GRANULAR MATERIAL FOR STABILIZED STAGING AREAS DUE TO DIFFICULTIES WITH RE-ESTABLISHMENT OF VEGETATION IN AREAS WHERE RECYCLED CONCRETE WAS PLACED.

NOTE: MANY JURISDICTIONS HAVE BMP DETAILS THAT VARY FROM UDFCD STANDARD DETAILS. CONSULT WITH LOCAL JURISDICTIONS AS TO WHICH DETAIL SHOULD BE USED WHEN DIFFERENCES ARE NOTED.

(DETAILS ADAPTED FROM DOUGLAS COUNTY, COLORADO, NOT AVAILABLE IN AUTOCAD)

SSA-4 Urban Drainage and Flood Control District
Urban Storm Drainage Criteria Manual Volume 3 November 2010

Stabilized Staging Area (SSA) SM-6

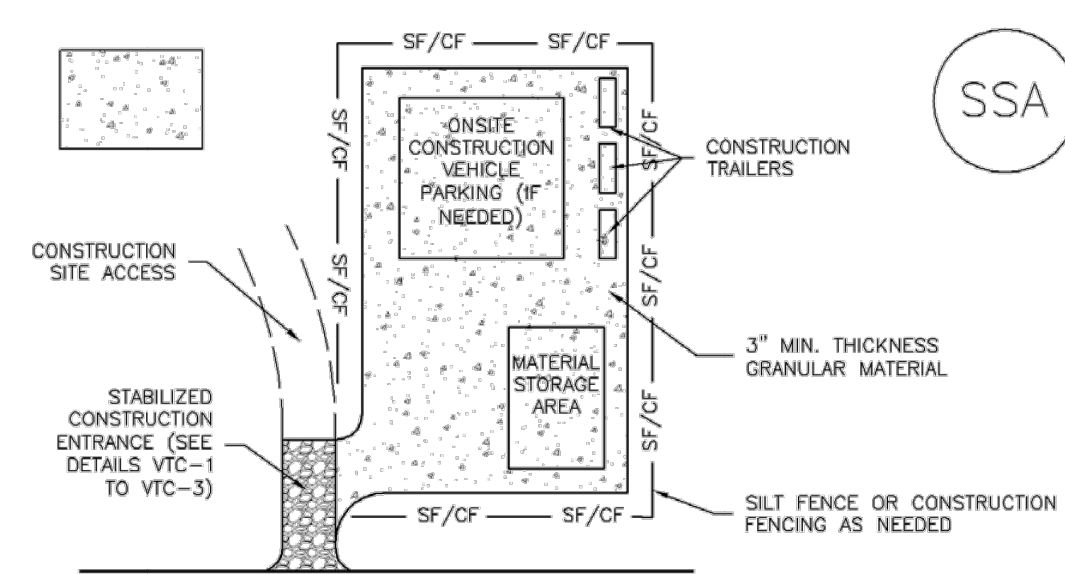

SSA-1. STABILIZED STAGING AREA

STABILIZED STAGING AREA INSTALLATION NOTES

- SEE PLAN VIEW FOR:
 - LOCATION OF STAGING AREA(S).
 - CONTRACTOR MAY ADJUST LOCATION AND SIZE OF STAGING AREA WITH APPROVAL FROM THE LOCAL JURISDICTION.
- STABILIZED STAGING AREA SHOULD BE APPROPRIATE FOR THE NEEDS OF THE SITE. OVERSIZING RESULTS IN A LARGER AREA TO STABILIZE FOLLOWING CONSTRUCTION.
- STAGING AREA SHALL BE STABILIZED PRIOR TO OTHER OPERATIONS ON THE SITE.
- THE STABILIZED STAGING AREA SHALL CONSIST OF A MINIMUM 3" THICK GRANULAR MATERIAL.
- UNLESS OTHERWISE SPECIFIED BY LOCAL JURISDICTION, ROCK SHALL CONSIST OF DOT SECT. #703, AASHTO #3 COARSE AGGREGATE OR 6" (MINUS) ROCK.
- ADDITIONAL PERIMETER BMPs MAY BE REQUIRED INCLUDING BUT NOT LIMITED TO SILT FENCE AND CONSTRUCTION FENCING.

STABILIZED STAGING AREA MAINTENANCE NOTES

- INSPECT BMPs EACH WORKDAY, AND MAINTAIN THEM IN EFFECTIVE OPERATING CONDITION. MAINTENANCE OF BMPs SHOULD BE PROACTIVE, NOT REACTIVE. INSPECT BMPs AS SOON AS POSSIBLE (AND ALWAYS WITHIN 24 HOURS) FOLLOWING A STORM THAT CAUSES SURFACE EROSION, AND PERFORM NECESSARY MAINTENANCE.
- FREQUENT OBSERVATIONS AND MAINTENANCE ARE NECESSARY TO MAINTAIN BMPs IN EFFECTIVE OPERATING CONDITION. INSPECTIONS AND CORRECTIVE MEASURES SHOULD BE DOCUMENTED THOROUGHLY.
- WHERE BMPs HAVE FAILED, REPAIR OR REPLACEMENT SHOULD BE INITIATED UPON DISCOVERY OF THE FAILURE.
- ROCK SHALL BE REAPPLIED OR REGRADED AS NECESSARY IF RUTTING OCCURS OR UNDERLYING SUBGRADE BECOMES EXPOSED.

November 2010 Urban Drainage and Flood Control District
Urban Storm Drainage Criteria Manual Volume 3 SSA-3

SM-4 Vehicle Tracking Control (VTC)

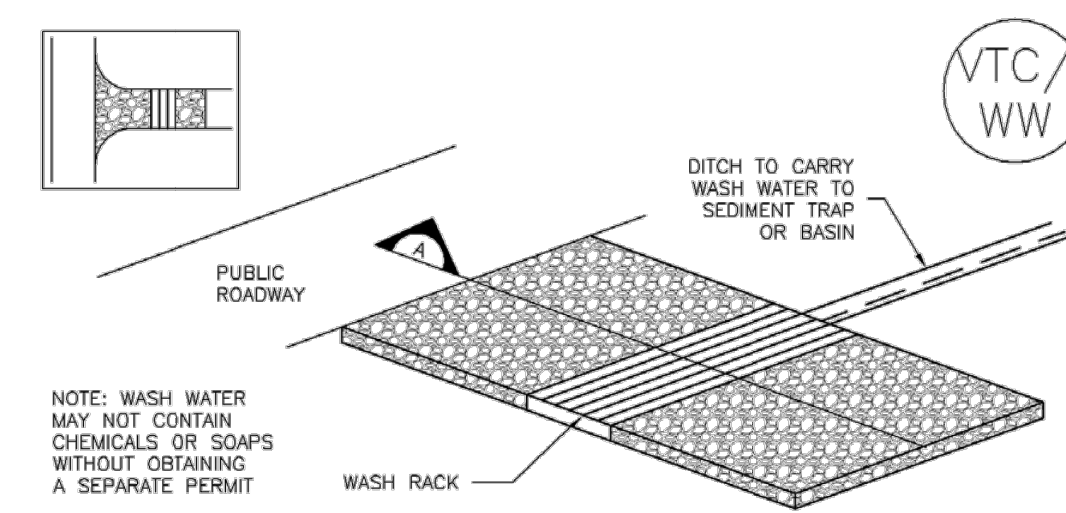

NOTE: WASH WATER MAY NOT CONTAIN CHEMICALS OR SOAPS WITHOUT OBTAINING A SEPARATE PERMIT

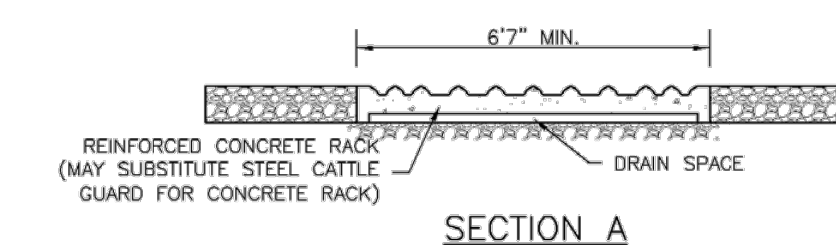

VTC-2. AGGREGATE VEHICLE TRACKING CONTROL WITH WASH RACK

VTC-4 Urban Drainage and Flood Control District
Urban Storm Drainage Criteria Manual Volume 3 November 2010

Vehicle Tracking Control (VTC) SM-4

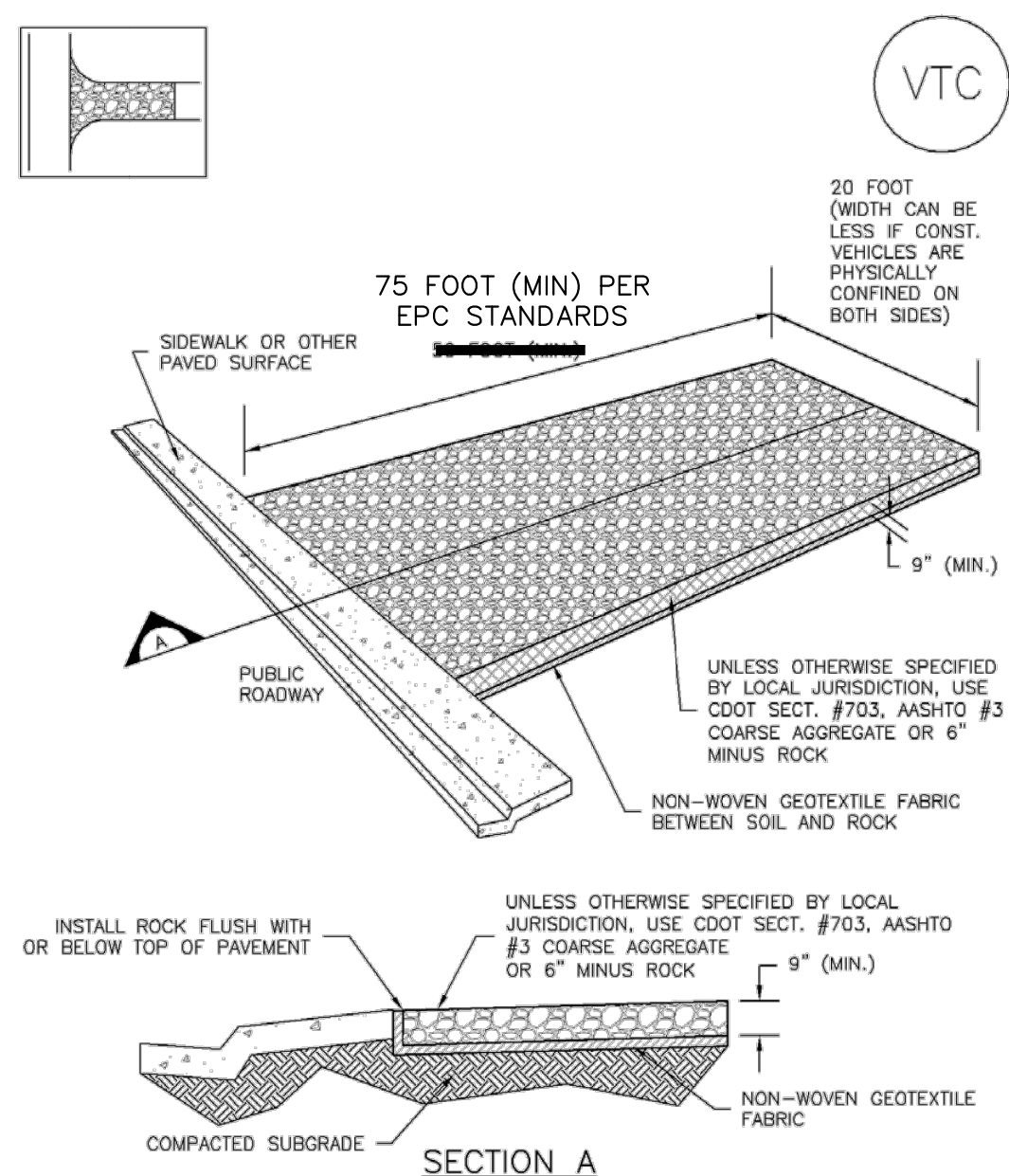

VTC-1. AGGREGATE VEHICLE TRACKING CONTROL

November 2010 Urban Drainage and Flood Control District
Urban Storm Drainage Criteria Manual Volume 3 VTC-3

Vehicle Tracking Control (VTC) SM-4

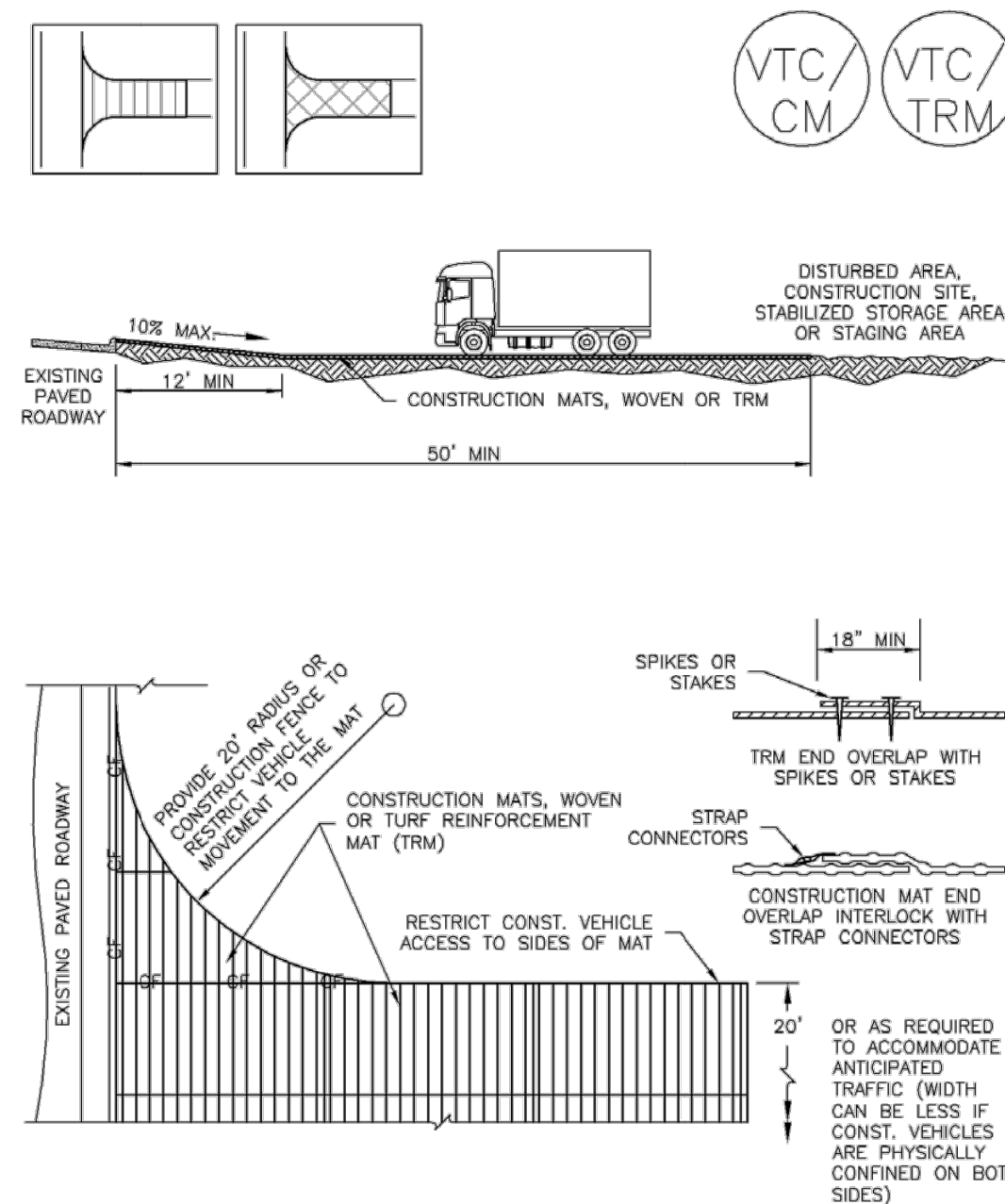

VTC-3. VEHICLE TRACKING CONTROL W/ CONSTRUCTION MAT OR TURF REINFORCEMENT MAT (TRM)

November 2010 Urban Drainage and Flood Control District
Urban Storm Drainage Criteria Manual Volume 3 VTC-5

SM-4 Vehicle Tracking Control (VTC)

STABILIZED CONSTRUCTION ENTRANCE/EXIT INSTALLATION NOTES

- SEE PLAN VIEW FOR:
 - LOCATION OF CONSTRUCTION ENTRANCE(S)/EXIT(S).
 - TYPE OF CONSTRUCTION ENTRANCE(S)/EXIT(S) (WITH/WITHOUT WHEEL WASH, CONSTRUCTION MAT OR TRM).
- CONSTRUCTION MAT OR TRM STABILIZED CONSTRUCTION ENTRANCES ARE ONLY TO BE USED ON SHORT DURATION PROJECTS (TYPICALLY RANGING FROM A WEEK TO A MONTH) WHERE THERE WILL BE LIMITED VEHICULAR ACCESS.
- A STABILIZED CONSTRUCTION ENTRANCE/EXIT SHALL BE LOCATED AT ALL ACCESS POINTS WHERE VEHICLES ACCESS THE CONSTRUCTION SITE FROM PAVED RIGHT-OF-WAYS.
- STABILIZED CONSTRUCTION ENTRANCE/EXIT SHALL BE INSTALLED PRIOR TO ANY LAND DISTURBING ACTIVITIES.
- A NON-WOVEN GEOTEXTILE FABRIC SHALL BE PLACED UNDER THE STABILIZED CONSTRUCTION ENTRANCE/EXIT PRIOR TO THE PLACEMENT OF ROCK.
- UNLESS OTHERWISE SPECIFIED BY LOCAL JURISDICTION, ROCK SHALL CONSIST OF DOT SECT. #703, AASHTO #3 COARSE AGGREGATE OR 6" (MINUS) ROCK.

STABILIZED CONSTRUCTION ENTRANCE/EXIT MAINTENANCE NOTES

- INSPECT BMPs EACH WORKDAY, AND MAINTAIN THEM IN EFFECTIVE OPERATING CONDITION. MAINTENANCE OF BMPs SHOULD BE PROACTIVE, NOT REACTIVE. INSPECT BMPs AS SOON AS POSSIBLE (AND ALWAYS WITHIN 24 HOURS) FOLLOWING A STORM THAT CAUSES SURFACE EROSION, AND PERFORM NECESSARY MAINTENANCE.
- FREQUENT OBSERVATIONS AND MAINTENANCE ARE NECESSARY TO MAINTAIN BMPs IN EFFECTIVE OPERATING CONDITION. INSPECTIONS AND CORRECTIVE MEASURES SHOULD BE DOCUMENTED THOROUGHLY.
- WHERE BMPs HAVE FAILED, REPAIR OR REPLACEMENT SHOULD BE INITIATED UPON DISCOVERY OF THE FAILURE.
- ROCK SHALL BE REAPPLIED OR REGRADED AS NECESSARY TO THE STABILIZED ENTRANCE/EXIT TO MAINTAIN A CONSISTENT DEPTH.
- SEDIMENT TRACKED ONTO PAVED ROADS IS TO BE REMOVED THROUGHOUT THE DAY AND AT THE END OF THE DAY BY SHOVELING OR SWEEPING. SEDIMENT MAY NOT BE WASHED DOWN STORM SEWER DRAINS.

NOTE: MANY JURISDICTIONS HAVE BMP DETAILS THAT VARY FROM UDFCD STANDARD DETAILS. CONSULT WITH LOCAL JURISDICTIONS AS TO WHICH DETAIL SHOULD BE USED WHEN DIFFERENCES ARE NOTED.

(DETAILS ADAPTED FROM CITY OF BROOMFIELD, COLORADO, NOT AVAILABLE IN AUTOCAD)

VTC-6 Urban Drainage and Flood Control District
Urban Storm Drainage Criteria Manual Volume 3 November 2010

C:\ACC\ACCDocs\Kimley-Horn\196013001 WHMD Expansion Study\Project Files_DWG\PlanSheets\Stormwater Improvements_Plansheets\GEC\GEC_DT.dwg Olesen, Maria (Longer) 6/22/2026 11:00 AM

| | | | | |
|-----|----------|----|------|------|
| NO. | REVISION | BY | DATE | APPR |
| | | | | |

Kimley-Horn
2026 KIMLEY-HORN AND ASSOCIATES, INC.
2 North Nevada Avenue, Suite 900
Colorado Springs, Colorado 80903 (719) 453-0180

DESIGNED BY: MEO
DRAWN BY: MEO
CHECKED BY: KRK
DATE: 6/22/26

WHMD RWRF STORM IMPROVEMENTS
EL PASO COUNTY, COLORADO
GEC PLANS
DETAIL SHEET (3 OF 3)

PRELIMINARY
FOR REVIEW ONLY
NOT FOR CONSTRUCTION

PROJECT NO.
196013004

SHEET

8

**APPENDIX B
CDPHE STOMWATER PERMIT**



STATE OF COLORADO

COLORADO DEPARTMENT OF PUBLIC HEALTH AND ENVIRONMENT

Water Quality Control Division

CDPS GENERAL PERMIT
STORMWATER DISCHARGES ASSOCIATED WITH
CONSTRUCTION ACTIVITY
AUTHORIZATION TO DISCHARGE UNDER THE
COLORADO DISCHARGE PERMIT SYSTEM (CDPS)

In compliance with the provisions of the Colorado Water Quality Control Act, (25-8-101 et seq., CRS, 1973 as amended) and the Federal Water Pollution Control Act, as amended (33 U.S.C. 1251 et seq.; the "Act"), this permit authorizes the discharge of stormwater associated with construction activities (and specific allowable non-stormwater discharges in accordance with Part I.A.1. of the permit) certified under this permit, from those locations specified throughout the State of Colorado to specified waters of the State.

Such discharges shall be in accordance with the conditions of this permit. This permit specifically authorizes the facility listed on the certification to discharge in accordance with permit requirements and conditions set forth in Parts I and II hereof. All discharges authorized herein shall be consistent with the terms and conditions of this permit.

This permit becomes effective on April 1, 2019, and shall expire at midnight March 31, 2024.

Issued and signed this 1st day of November 2018.

COLORADO DEPARTMENT OF PUBLIC HEALTH AND ENVIRONMENT

Ellen Howard Kutzer, Permits Section Manager
Water Quality Control Division

Permit History

Originally signed and issued October 31, 2018; effective April 1, 2019.

Table of Contents

| | |
|--|----|
| Part I | 1 |
| A. COVERAGE UNDER THIS PERMIT..... | 1 |
| 1. Authorized Discharges | 1 |
| 2. Limitations on Coverage..... | 1 |
| 3. Permit Certification and Submittal Procedures | 2 |
| B. EFFLUENT LIMITATIONS | 6 |
| 1. Requirements for Control Measures Used to Meet Effluent Limitations | 6 |
| 2. Discharges to an Impaired Waterbody..... | 9 |
| 3. General Requirements | 10 |
| C. STORMWATER MANAGEMENT PLAN (SWMP) REQUIREMENTS | 11 |
| 1. SWMP General Requirements | 11 |
| 2. SWMP Content | 11 |
| 3. SWMP Review and Revisions | 13 |
| 4. SWMP Availability..... | 14 |
| D. SITE INSPECTIONS..... | 14 |
| 1. Person Responsible for Conducting Inspections | 14 |
| 2. Inspection Frequency | 14 |
| 3. Inspection Frequency for Discharges to Outstanding Waters..... | 15 |
| 4. Reduced Inspection Frequency | 15 |
| 5. Inspection Scope..... | 16 |
| E. DEFINITIONS | 17 |
| F. MONITORING..... | 20 |
| G. Oil and Gas Construction | 21 |
| Part II: Standard Permit Conditions..... | 22 |
| A. DUTY TO COMPLY..... | 22 |
| B. DUTY TO REAPPLY | 22 |
| C. NEED TO HALT OR REDUCE ACTIVITY NOT A DEFENSE | 22 |
| D. DUTY TO MITIGATE | 22 |
| E. PROPER OPERATION AND MAINTENANCE | 22 |
| F. PERMIT ACTIONS | 22 |
| G. PROPERTY RIGHTS | 22 |
| H. DUTY TO PROVIDE INFORMATION | 23 |
| I. INSPECTION AND ENTRY | 23 |
| J. MONITORING AND RECORDS | 23 |
| K. SIGNATORY REQUIREMENTS | 24 |

- 1. Authorization to Sign:..... 24
- 2. Electronic Signatures 25
- 3. Change in Authorization to Sign 25
- L. REPORTING REQUIREMENTS 25
 - 1. Planned Changes..... 25
 - 2. Anticipated Non-Compliance 25
 - 3. Transfer of Ownership or Control 25
 - 4. Monitoring reports..... 26
 - 5. Compliance Schedules 26
 - 6. Twenty-four hour reporting..... 26
 - 7. Other non-compliance 27
 - 8. Other information 27
- M. BYPASS 27
 - 1. Bypass not exceeding limitations 27
 - 2. Notice of bypass 27
 - 3. Prohibition of Bypass..... 27
- N. UPSET..... 28
 - 1. Effect of an upset 28
 - 2. Conditions necessary for demonstration of an Upset 28
 - 3. Burden of Proof 28
- O. RETENTION OF RECORDS..... 28
 - 1. Post-Expiration or Termination Retention 28
 - 2. On-site Retention..... 29
- P. REOPENER CLAUSE..... 29
 - 1. Procedures for modification or revocation 29
 - 2. Water quality protection 29
- Q. SEVERABILITY..... 29
- R. NOTIFICATION REQUIREMENTS 29
 - 1. Notification to Parties 29
- S. RESPONSIBILITIES 30
 - 1. Reduction, Loss, or Failure of Treatment Facility 30
- T. Oil and Hazardous Substance Liability..... 30
- U. Emergency Powers..... 30
- V. Confidentiality 30
- W. Fees..... 30

X. Duration of Permit..... 30

Y. Section 307 Toxics..... 30

Part I

Note: At the first mention of terminology that has a specific connotation for the purposes of this permit, the terminology is electronically linked to the definitions section of the permit in Part I.E.

A. COVERAGE UNDER THIS PERMIT**1. Authorized Discharges**

This general permit authorizes [permittee\(s\)](#) to discharge the following to state waters: stormwater associated with [construction activity](#) and specified non-stormwater associated with construction activity. The following types of stormwater and non-stormwater discharges are authorized under this permit:

a. Allowable Stormwater Discharges

- i. Stormwater discharges associated with construction activity.
- ii. Stormwater discharges associated with producing earthen materials, such as soils, sand, and gravel dedicated to providing material to a single contiguous site, or within ¼ mile of a construction site (i.e. borrow or fill areas)
- iii. Stormwater discharges associated with [dedicated asphalt, concrete batch plants and masonry mixing stations](#) (Coverage under this permit is not required if alternative coverage has been obtained.)

b. Allowable Non-Stormwater Discharges

The following non-stormwater discharges are allowable under this permit if the discharges are identified in the stormwater management plan in accordance with Part I.C. and if they have appropriate [control measures](#) in accordance with Part I.B.1.

- i. Discharges from uncontaminated springs that do not originate from an area of land disturbance.
- ii. Discharges to the ground of concrete washout water associated with the washing of concrete tools and concrete mixer chutes. Discharges of concrete washout water must not leave the site as surface runoff or reach [receiving waters](#) as defined by this permit.
- iii. Discharges of landscape irrigation return flow.

c. Emergency Fire Fighting

Discharges resulting from emergency firefighting activities are authorized by this permit.

2. Limitations on Coverage

Discharges not authorized by this permit include, but are not limited to, the discharges and activities listed below. Permittees may seek individual or alternate general permit coverage for the discharges, as appropriate and available.

a. Discharges of Non-Stormwater

Discharges of non-stormwater, except the authorized non-stormwater discharges listed in Part I.A.1.b., are not eligible for coverage under this permit.

- b. Discharges Currently Covered by another Individual or General Permit
 - c. Discharges Currently Covered by a Water Quality Control Division (division) Low Risk Guidance Document
3. Permit Certification and Submittal Procedures
- a. Duty to apply
The following activities shall apply for coverage under this permit:
 - i. Construction sites that will disturb one acre or more; or
 - ii. Construction sites that are part of a [common plan of development or sale](#); or
 - iii. Stormwater discharges that are designated by the division as needing a stormwater permit because the discharge:
 - (a) Contributes to a violation of a water quality standard; or
 - (b) is a significant contributor of pollutants to state waters.
 - b. Application Requirements
To obtain authorization to discharge under this permit, applicants applying for coverage following the effective date of the renewal permit shall meet the following requirements:
 - i. Owners and operators submitting an application for permit coverage will be co-permittees subject to the same benefits, duties, and obligations under this permit.
 - ii. Signature requirements: Both the [owner](#) and [operator](#) (permittee) of the construction site, as defined in Part I.E., must agree to the terms and conditions of the permit and submit a completed application that includes the signature of both the owner and the operator. In cases where the duties of the owner and operator are managed by the owner, both application signatures may be completed by the owner. Both the owner and operator are responsible for ensuring compliance with all terms and conditions of the permit, including implementation of the stormwater management plan.
 - iii. Applicants must use the paper form provided by the division or the electronic form provided on the division's web-based application platform when applying for coverage under this permit.
 - iv. The applicant(s) must develop a stormwater management plan (SWMP) in accordance with the requirements of Part I.C. The applicant(s) must also certify that the SWMP is complete, or will be complete, prior to commencement of any construction activity.

- v. The applicant(s) must submit a complete, accurate, and signed permit application electronically, by mail or hand delivery to the division at least 10 days prior to the commencement of construction activity except that construction activities that are in response to a **public emergency related site** shall apply for coverage no later than 14 days after the commencement of construction activities. The provisions of this part in no way remove a violation of the Colorado Water Quality Control Act if a point source discharge occurs prior to the issuance of a CDPS permit.
 - vi. The application must be signed in accordance with the requirements of Part IA. Applications submitted by mail or hand delivered should be directed to:

Colorado Department of Public Health and Environment
Water Quality Control Division
Permits Section, WQCD-PS-B2
4300 Cherry Creek Drive South
Denver, CO 80246
 - vii. The applicant(s) must receive written notification that the division granted permit coverage prior to conducting construction activities except for construction activities that are in response to a public emergency related site
- c. Division Review of Permit Application
Within 10 days of receipt of the application, and following review of the application, the division may:
- i. Issue a certification of coverage;
 - ii. request additional information necessary to evaluate the discharge;
 - iii. delay the authorization to discharge pending further review;
 - iv. notify the applicant that additional terms and conditions are necessary; or
 - v. deny the authorization to discharge under this general permit.
- d. Alternative Permit Coverage
- i. Division Required Alternate Permit Coverage:
The Division may require an applicant or permittee to apply for an individual permit or an alternative general permit if it determines the discharge does not fall under the scope of this general permit. In this case, the Division will notify the applicant or permittee that an individual permit application is required.
 - ii. Permittee Request for alternate permit coverage:
A permittee authorized to discharge stormwater under this permit may request to be excluded from coverage under this general permit by applying for an individual permit. In this case, the permittee must submit an individual application, with reasons supporting the request, to the Division at least 180 days prior to any discharge. When an individual permit is issued, the permittee's authorization to discharge under this permit is terminated on the effective date of the individual permit.
- e. Submittal Signature Requirements

Documents required for submittal to the division in accordance with this permit, including applications for permit coverage and other documents as requested by the division, must include signatures by both the owner and the operator, except for instances where the duties of the owner and operator are managed by the owner.

Signatures on all documents submitted to the division as required by this permit must meet the Standard Signatory Requirements in Part II.K. of this permit in accordance with 40 C.F.R. 122.41(k).

i. Signature Certification

Any person(s) signing documents required for submittal to the Division must make the following certification:

"I certify under penalty of law that this document and all attachments were prepared under my direction or supervision in accordance with a system designed to assure that qualified personnel properly gather and evaluate the information submitted. Based on my inquiry of the person or persons who manage the system, or those persons directly responsible for gathering the information, the information submitted is, to the best of my knowledge and belief, true, accurate, and complete. I am aware that there are significant penalties for submitting false information, including the possibility of fine and imprisonment for knowing violations."

f. Compliance Document Signature Requirements

Documents which are required for compliance with the permit, but for which submittal to the division is not required unless specifically requested by the division, must be signed by the individual(s) designated as the Qualified Stormwater Manager, as defined in Part I.E.

i. Any person(s) signing inspection documents required for compliance with the permit must make the following statement:

"I verify that, to the best of my knowledge and belief, all corrective action and maintenance items identified during the inspection are complete, and the site is currently in compliance with the permit."

g. Field Wide Permit Coverage for Oil and Gas Construction

At the discretion of the division, a single permit certification may be issued to a single oil and gas permittee to cover construction activity related discharges from an oil and gas field at multiple locations that are not necessarily contiguous.

h. Permit Coverage without Application

Qualifying Local Program: When a small construction site is within the jurisdiction of a qualifying local program, the owner and operator of the construction activity are authorized to discharge stormwater associated with small construction activity under this general permit without the submittal of an application to the division. Sites covered by a qualifying local program are exempt from the following sections of this general permit:

Part I.A.3.a.; Part I.A.3.b.; Part I.A.3.c.; Part I.A.3.d.; Part I.A.3.g.; Part I.A.3.i.; Part I.A.3.j.; Part I.A.3.k.

Sites covered by a qualifying local program are subject to the following requirements:

- i. **Local Agency Authority:** This permit does not pre-empt or supersede the authority of local agencies to prohibit, restrict, or control discharges of stormwater to storm drain systems or other water courses within their jurisdiction.
 - ii. **Permit Coverage Termination:** When a site under a Qualifying Local Program is finally stabilized, coverage under this permit is automatically terminated.
 - iii. **Compliance with Qualifying Local Program:** Qualifying Local Program requirements that are equivalent to the requirements of this permit are incorporated by reference. Permittees authorized to discharge under this permit, must comply with the equivalent requirements of the Qualifying Local Program that has jurisdiction over the site as a condition of this permit.
 - iv. **Compliance with Remaining Permit Conditions.** Requirements of this permit that are in addition to or more stringent than the requirements of the Qualifying Local Program apply in addition to the requirements of the Qualifying Local Program.
 - v. **Written Authorization of Coverage:** The division or local municipality may require any permittee within the jurisdiction of a Qualifying Local Program covered under this permit to apply for, and obtain written authorization of coverage under this permit. The permittee must be notified in writing that an application for written authorization of coverage is required.
- i. **Permittee Initiated Permit Actions**
Permittee initiated permit actions, including but not limited to modifications, contact changes, transfers, reassignments, and terminations, shall be conducted following division guidance and using appropriate division-provided forms.
 - j. **Sale of Residence to Homeowner**
Residential construction sites only: The permittee may remove residential lots from permit coverage once the lot meets the following criteria:
 - i. the residential lot has been sold to the homeowner(s) for private residential use;
 - ii. a certificate of occupancy, or equivalent, is maintained on-site and is available during division inspections;
 - iii. the lot is less than one acre of disturbance;
 - iv. all construction activity conducted on the lot by the permittee is complete;
 - v. the permittee is not responsible for final stabilization of the lot; and
 - vi. the SWMP was modified to indicate the lot is no longer part of the construction activity.

If the residential lot meets the criteria listed above then activities occurring on the lot are no longer considered to be construction activities with a duty to apply and maintain permit coverage. Therefore, the permittee is not required to meet the final stabilization requirements and may terminate permit coverage for the lot.

k. Permit Expiration and Continuation of Permit Coverage

Authorization to discharge under this general permit shall expire at midnight on March 31, 2024. While Regulation 61.4 requires a permittee to submit an application for continuing permit coverage 180 days before the permit expires, the division is requiring that permittees desiring continued coverage under this general permit must reapply at least 90 days in advance of this permit expiration. The Division will determine if the permittee may continue to discharge stormwater under the terms of the general permit. An individual permit may be required for any facility not reauthorized to discharge under the reissued general permit.

If this permit is not reissued or replaced prior to the expiration date, it will be administratively continued and remain in force and effect. For permittees that have applied for continued permit coverage, discharges authorized under this permit prior to the expiration date will automatically remain covered by this permit until the earliest of:

- i. An authorization to discharge under a reissued permit, or a replacement of this permit, following the timely and appropriate submittal of a complete application requesting authorization to discharge under the new permit and compliance with the requirements of the new permit; or
- ii. The issuance and effect of a termination issued by the Division; or
- iii. The issuance or denial of an individual permit for the facility's discharges; or
- iv. A formal permit decision by the Division not to reissue this general permit, at which time the Division will identify a reasonable time period for covered dischargers to seek coverage under an alternative general permit or an individual permit. Coverage under this permit will cease when coverage under another permit is granted/authorized; or
- v. The Division has informed the permittee that discharges previously authorized under this permit are no longer covered under this permit.

B. EFFLUENT LIMITATIONS

1. Requirements for Control Measures Used to Meet Effluent Limitations

The permittee must implement control measures to **minimize** the discharge of pollutants from all potential pollutant sources at the site. Control measures must be installed prior to commencement of activities that may contribute pollutants to stormwater discharges. Control measures must be selected, designed, installed and maintained in accordance with good engineering, hydrologic and pollution control practices. Control measures implemented at the site must be designed to prevent pollution or degradation of state waters.

a. Stormwater Pollution Prevention

The permittee must implement structural and/or nonstructural control measures that effectively minimize erosion, sediment transport, and the release of other pollutants related to construction activity.

i. Control Measures for Erosion and Sediment Control

Control measures for erosion and sediment control may include, but are not limited to, wattles/sediment control logs, silt fences, earthen dikes, drainage swales, sediment traps, subsurface drains, pipe slope drains, inlet protection, outlet protection, gabions, sediment basins, temporary vegetation, permanent vegetation, mulching, geotextiles, sod stabilization, slope roughening, maintaining existing vegetation, protection of trees, and preservation of mature vegetation. Specific non-structural control measures must meet the requirements listed below.

Specific control measures must meet the requirements listed below.

- (a) Vehicle tracking controls shall either be implemented to minimize vehicle tracking of sediment from disturbed areas, or the areas where vehicle tracking occurs shall meet subsection Part I.B.1.a.i(b);
- (b) Stormwater runoff from all disturbed areas and soil storage areas for which permanent or temporary stabilization is not implemented, must flow to at least one control measure to minimize sediment in the discharge. This may be accomplished through filtering, settling, or straining. The control measure must be selected, designed, installed and adequately sized in accordance with good engineering, hydrologic and pollution control practices. The control measure(s) must contain or filter flows in order to prevent the bypass of flows without treatment and must be appropriate for stormwater runoff from disturbed areas and for the expected flow rate, duration, and flow conditions (i.e., sheet or concentrated flow);
- (c) Outlets that withdraw water from or near the surface shall be installed when discharging from basins and impoundments, unless **infeasible**.
- (d) Maintain pre-existing vegetation or equivalent control measures for areas within 50 horizontal feet of receiving waters as defined by this permit, unless **infeasible**.
- (e) Soil compaction must be minimized for areas where infiltration control measures will occur or where **final stabilization** will be achieved through vegetative cover.
- (f) Unless **infeasible**, topsoil shall be preserved for those areas of a site that will utilize vegetative final stabilization.
- (g) Minimize the amount of soil exposed during construction activity, including the disturbance of steep slopes.

ii. Practices for Other Common Pollutants

- (a) Bulk storage, 55 gallons or greater, for petroleum products and other liquid chemicals must have secondary containment, or equivalent protection, in order to contain **spills** and to prevent spilled material from entering state waters.
- (b) Control measures designed for concrete washout waste must be implemented. This includes washout waste discharged to the ground as authorized under this permit and washout waste from concrete trucks and masonry operations contained on site. The permittee must ensure the washing activities do not contribute pollutants to stormwater runoff, or receiving waters in accordance Part I.A.1.b.ii. Discharges that may reach groundwater must flow through soil

that has buffering capacity prior to reaching groundwater, as necessary to meet the effluent limits in this permit, including Part I.B.3.a. The concrete washout location shall not be located in an area where shallow groundwater may be present and would result in buffering capacity not being adequate, such as near natural drainages, springs, or wetlands. This permit authorizes discharges to the ground of concrete washout waste.

iii. Stabilization Requirements

The following requirements must be implemented for each site.

- (a) Temporary stabilization must be implemented for earth disturbing activities on any portion of the site where ground disturbing construction activity has permanently ceased, or temporarily ceased for more than 14 calendar days. Temporary stabilization methods may include, but are not limited to, tarps, soil tackifier, and hydroseed. The permittee may exceed the 14-day schedule when either the function of the specific area of the site requires it to remain disturbed, or, physical characteristics of the terrain and climate prevent stabilization. The SWMP must document the constraints necessitating the alternative schedule, provide the alternate stabilization schedule, and identify all locations where the alternative schedule is applicable on the site map.
- (b) Final stabilization must be implemented for all construction sites. Final stabilization is reached when all ground surface disturbing activities at the construction site are complete; and, for all areas of ground surface disturbing activities, either a uniform vegetative cover with an individual plant density of at least 70 percent of pre-disturbance levels is established, or equivalent permanent alternative stabilization methods are implemented. The division may approve alternative final stabilization criteria for specific operations.
- (c) Final stabilization must be designed and installed as a permanent feature. Final stabilization measures for obtaining a vegetative cover or alternative stabilization methods include, but are not limited to, the following as appropriate:
 - (1) Seed mix selection and application methods;
 - (2) Soil preparation and amendments;
 - (3) Soil stabilization methods (e.g., crimped straw, hydro mulch or rolled erosion control products);
 - (4) Appropriate sediment control measures as needed until final stabilization is achieved;
 - (5) Permanent pavement, hardscape, xeriscape, stabilized driving surfaces;
 - (6) Other alternative stabilization practices as applicable;

(d) The permittee(s) must ensure all temporary control measures are removed from the construction site once final stabilization is achieved, except when the control measure specifications allow the control measure to be left in place (i.e., bio-degradable control measures).

b. Maintenance

The permittee must ensure that all control measures remain in effective operating condition and are protected from activities that would reduce their effectiveness. Control measures must be maintained in accordance with good engineering, hydrologic and pollution control practices. Observations leading to the required maintenance of control measures can be made during a site inspection, or during general observations of site conditions. The necessary repairs or modifications to a [control measure requiring routine maintenance](#), as defined in Part I.E., must be conducted to maintain an effective operating condition. This section is not subject to the requirements in Part I.B.1.c. below.

c. Corrective Actions

The permittee must assess the adequacy of control measures at the site, and the need for changes to those control measures, to ensure continued effective performance. When an [inadequate control measure](#), as defined in Part I.E., is identified (i.e., new or replacement control measures become necessary), the following corrective action requirements apply. The permittee is in noncompliance with the permit until the inadequate control measure is replaced or corrected and returned to effective operating condition in compliance with Part I.B.1. and the general requirements in Part I.B.3. If the inadequate control measure results in noncompliance that meets the conditions of Part II.L., the permittee must also meet the requirements of that section.

i. The permittee must take all necessary steps to minimize or prevent the discharge of pollutants, until a control measure is implemented and made operational and/or an inadequate control measure is replaced or corrected and returned to effective operating condition. If it is infeasible to install or repair of control measure immediately after discovering the deficiency, the following must be documented and kept on record in accordance with the recordkeeping requirements in Part II.

(a) Describe why it is infeasible to initiate the installation or repair immediately; and

(b) Provide a schedule for installing or repairing the control measure and returning it to an effective operating condition as soon as possible.

ii. If applicable, the permittee must remove and properly dispose of any unauthorized release or discharge (e.g., discharge of non-stormwater, spill, or leak not authorized by this permit.) The permittee must also clean up any contaminated surfaces to minimize discharges of the material in subsequent storm events.

2. Discharges to an Impaired Waterbody

a. Total Maximum Daily Load (TMDL)

If the permittee's discharge flows to or could reasonably be expected to flow to any water body for which a TMDL has been approved, and stormwater discharges

associated with construction activity were assigned a pollutant-specific Wasteload Allocation (WLA) under the TMDL, the division may:

- i. ensure the WLA is implemented properly through alternative local requirements, such as by a municipal stormwater permit; or
- ii. notify the permittee of the WLA and amend the permittee's certification to add specific effluent limits and other requirements, as appropriate. The permittee may be required to do the following:
 - (a) under the permittee's SWMP, implement specific control measures based on requirements of the WLA, and evaluate whether the requirements are met through implementation of existing stormwater control measures or if additional control measures are necessary. Document the calculations or other evidence demonstrating that the requirements are expected to be met; and
 - (b) if the evaluation shows that additional or modified control measures are necessary, describe the type and schedule for the control measure additions or modifications.
- iii. Discharge monitoring may also be required. The permittee may maintain coverage under the general permit provided they comply with the applicable requirements outlined above. The division reserves the right to require individual or alternate general permit coverage.

3. General Requirements

- a. Discharges authorized by this permit shall not cause, have the reasonable potential to cause, or measurably contribute to an exceedance of any applicable water quality standard, including narrative standards for water quality.
- b. The division may require sampling and testing, on a case-by-case basis, in the event that there is reason to suspect that the SWMP is not adequately minimizing pollutants in stormwater or in order to measure the effectiveness of the control measures in removing pollutants in the effluent. Such monitoring may include Whole Effluent Toxicity testing.
- c. The permittee must comply with the lawful requirements of federal agencies, municipalities, counties, drainage districts and other local agencies including applicable requirements in Municipal Stormwater Management Programs developed to comply with CDPS permits. The permittee must comply with local stormwater management requirements, policies and guidelines including those for erosion and sediment control.
- d. All construction site wastes must be properly managed to prevent potential pollution of state waters. This permit does not authorize on-site waste disposal.
- e. This permit does not relieve the permittee of the reporting requirements in 40 CFR 110, 40 CFR 117 or 40 CFR 302. Any discharge of hazardous material must be handled in accordance with the division's Noncompliance Notification Requirements (see Part II.L. of the permit).

C. STORMWATER MANAGEMENT PLAN (SWMP) REQUIREMENTS**1. SWMP General Requirements**

- a. A SWMP shall be developed for each construction site covered by this permit. The SWMP must be prepared in accordance with good engineering, hydrologic and pollution control practices.
 - i. For public emergency related sites a SWMP shall be created no later than 14 days after the commencement of construction activities.
- b. The permittee must implement the provisions of the SWMP as written and updated, from commencement of construction activity until final stabilization is complete. The division may review the SWMP.
- c. A copy of the SWMP must be retained onsite or be onsite when construction activities are occurring at the site unless the permittee specifies another location and obtains approval from the division.

2. SWMP Content

- a. The SWMP, at a minimum, must include the following elements.
 - i. Qualified Stormwater Manager. The SWMP must list individual(s) by title and name who are designated as the site's qualified stormwater manager(s) responsible for implementing the SWMP in its entirety. This role may be filled by more than one individual.
 - ii. Spill Prevention and Response Plan. The SWMP must have a spill prevention and response plan. The plan may incorporate by reference any part of a Spill Prevention Control and Countermeasure (SPCC) plan under section 311 of the Clean Water Act (CWA) or a Spill Prevention Plan required by a separate CDPS permit. The relevant sections of any referenced plans must be available as part of the SWMP consistent with Part I.C.4.
 - iii. Materials Handling. The SWMP must describe and locate all control measures implemented at the site to minimize impacts from handling **significant materials** that could contribute pollutants to runoff. These handling procedures can include control measures for pollutants and activities such as, exposed storage of building materials, paints and solvents, landscape materials, fertilizers or chemicals, sanitary waste material, trash and equipment maintenance or fueling procedures.
 - iv. Potential Sources of Pollution. The SWMP must list all potential sources of pollution which may reasonably be expected to affect the quality of stormwater discharges associated with construction activity from the site. This shall include, but is not limited to, the following pollutant sources:
 - (a) disturbed and stored soils;
 - (b) vehicle tracking of sediments;
 - (c) management of contaminated soils;
 - (d) loading and unloading operations;

- (e) outdoor storage activities (erodible building materials, fertilizers, chemicals, etc.);
 - (f) vehicle and equipment maintenance and fueling;
 - (g) significant dust or particulate generating processes (e.g., saw cutting material, including dust);
 - (h) routine maintenance activities involving fertilizers, pesticides, herbicides, detergents, fuels, solvents, oils, etc.;
 - (i) on-site waste management practices (waste piles, liquid wastes, dumpsters);
 - (j) concrete truck/equipment washing, including washing of the concrete truck chute and associated fixtures and equipment;
 - (k) dedicated asphalt, concrete batch plants and masonry mixing stations;
 - (l) non-industrial waste sources such as worker trash and portable toilets.
- v. Implementation of Control Measures. The SWMP must include design specifications that contain information on the implementation of the control measure in accordance with good engineering hydrologic and pollution control practices; including as applicable drawings, dimensions, installation information, materials, implementation processes, control measure-specific inspection expectations, and maintenance requirements.

The SWMP must include a documented use agreement between the permittee and the owner or operator of any control measures located outside of the permitted area, that are utilized by the permittee's construction site for compliance with this permit, but not under the direct control of the permittee. The permittee is responsible for ensuring that all control measures located outside of their permitted area, that are being utilized by the permittee's construction site, are properly maintained and in compliance with all terms and conditions of the permit. The SWMP must include all information required of and relevant to any such control measures located outside the permitted area, including location, installation specifications, design specifications and maintenance requirements.

- vi. Site Description. The SWMP must include a site description which includes, at a minimum, the following:
- (a) the nature of the construction activity at the site;
 - (b) the proposed schedule for the sequence for major construction activities and the planned implementation of control measures for each phase. (e.g.: clearing, grading, utilities, vertical, etc.);
 - (c) estimates of the total acreage of the site, and the acreage expected to be disturbed by clearing, excavation, grading, or any other construction activities;
 - (d) a summary of any existing data used in the development of the construction site plans or SWMP that describe the soil or existing potential for soil erosion;

- (e) a description of the percent of existing vegetative ground cover relative to the entire site and the method for determining the percentage;
 - (f) a description of any allowable non-stormwater discharges at the site, including those being discharged under a division low risk discharge guidance policy;
 - (g) a description of areas receiving discharge from the site. Including a description of the immediate source receiving the discharge. If the stormwater discharge is to a municipal separate storm sewer system, the name of the entity owning that system, the location of the storm sewer discharge, and the ultimate receiving water(s); and
 - (h) a description of all stream crossings located within the construction site boundary.
- vii. Site Map. The SWMP must include a site map which includes, at a minimum, the following:
- (a) construction site boundaries;
 - (b) flow arrows that depict stormwater flow directions on-site and runoff direction;
 - (c) all areas of ground disturbance including areas of borrow and fill;
 - (d) areas used for storage of soil;
 - (e) locations of all waste accumulation areas, including areas for liquid, concrete, masonry, and asphalt;
 - (f) locations of dedicated asphalt, concrete batch plants and masonry mixing stations;
 - (g) locations of all structural control measures;
 - (h) locations of all non-structural control measures;
 - (i) locations of springs, streams, wetlands and other state waters, including areas that require pre-existing vegetation be maintained within 50 feet of a receiving water, where determined feasible in accordance with Part I.B.1.a.i.(d).; and
 - (j) locations of all stream crossings located within the construction site boundary.
- viii. Final Stabilization and Long Term Stormwater Management. The SWMP must describe the practices used to achieve final stabilization of all disturbed areas at the site and any planned practices to control pollutants in stormwater discharges that will occur after construction operations are completed. Including but not limited to, detention/retention ponds, rain gardens, stormwater vaults, etc.
- ix. Inspection Reports. The SWMP must include documented inspection reports in accordance with Part ID.

3. SWMP Review and Revisions

Permittees must keep a record of SWMP changes made that includes the date and identification of the changes. The SWMP must be amended when the following occurs:

- a. a change in design, construction, operation, or maintenance of the site requiring implementation of new or revised control measures;
- b. the SWMP proves ineffective in controlling pollutants in stormwater runoff in compliance with the permit conditions;
- c. control measures identified in the SWMP are no longer necessary and are removed; and
- d. corrective actions are taken onsite that result in a change to the SWMP.

For SWMP revisions made prior to or following a change(s) onsite, including revisions to sections addressing site conditions and control measures, a notation must be included in the SWMP that identifies the date of the site change, the control measure removed, or modified, the location(s) of those control measures, and any changes to the control measure(s). The permittee must ensure the site changes are reflected in the SWMP. The permittee is noncompliant with the permit until the SWMP revisions have been made.

4. SWMP Availability

A copy of the SWMP must be provided upon request to the division, EPA, and any local agency with authority for approving sediment and erosion plans, grading plans or stormwater management plans within the time frame specified in the request. If the SWMP is required to be submitted to any of these entities, the submission must include a signed certification in accordance with Part I.A.3.e., certifying that the SWMP is complete and compliant with all terms and conditions of the permit.

All SWMPs required under this permit are considered reports that must be available to the public under Section 308(b) of the CWA and Section 61.5(4) of the CDPS regulations. The permittee must make plans available to members of the public upon request. However, the permittee may claim any portion of a SWMP as confidential in accordance with 40 CFR Part 2.

D. SITE INSPECTIONS

Site inspections must be conducted in accordance with the following requirements. The required inspection schedules are a minimum frequency and do not affect the permittee's responsibility to implement control measures in effective operating condition as prescribed in the SWMP. Proper maintenance of control measures may require more frequent inspections. Site inspections shall start within 7 calendar days of the commencement of construction activities on site.

1. Person Responsible for Conducting Inspections

The person(s) inspecting the site may be on the permittee's staff or a third party hired to conduct stormwater inspections under the direction of the permittee(s). The permittee is responsible for ensuring that the inspector is a qualified stormwater manager.

2. Inspection Frequency

Permittees must conduct site inspections in accordance with one of the following minimum frequencies, unless the site meets the requirements of Part ID.3

- a. At least one inspection every 7 calendar days. Or
 - b. At least one inspection every 14 calendar days, if post-storm event inspections are conducted within 24 hours after the end of any precipitation or snowmelt event that causes surface erosion. Post-storm inspections may be used to fulfill the 14-day routine inspection requirement.
 - c. When site conditions make the schedule required in this section impractical, the permittee may petition the Division to grant an alternate inspection schedule. The alternative inspection schedule may not be implemented prior to written approval by the division and incorporation into the SWMP.
3. Inspection Frequency for Discharges to Outstanding Waters

Permittees must conduct site inspections at least once every 7 calendar days for sites that discharge to a water body designated as an Outstanding Water by the Water Quality Control Commission.

4. Reduced Inspection Frequency

The permittee may perform site inspections at the following reduced frequencies when one of the following conditions exists:

- a. Post-Storm Inspections at Temporarily Idle Sites
For permittees choosing to combine 14-day inspections and post-storm-event-inspections, if no construction activities will occur following a storm event, post-storm event inspections must be conducted prior to re-commencing construction activities, but no later than 72 hours following the storm event. The delay of any post-storm event inspection must be documented in the inspection record. Routine inspections must still be conducted at least every 14 calendar days.
- b. Inspections at Completed Sites/Areas
When the site, or portions of a site are awaiting establishment of a vegetative ground cover and final stabilization, the permittee must conduct a thorough inspection of the stormwater management system at least once every 30 days. Post-storm event inspections are not required under this schedule. This reduced inspection schedule is allowed if all of the following criteria are met:
 - i. all construction activities resulting in ground disturbance are complete;
 - ii. all activities required for final stabilization, in accordance with the SWMP, have been completed, with the exception of the application of seed that has not occurred due to seasonal conditions or the necessity for additional seed application to augment previous efforts; and
 - iii. the SWMP has been amended to locate those areas to be inspected in accordance with the reduced schedule allowed for in this paragraph.
- c. Winter Conditions Inspections Exclusion

Inspections are not required for sites that meet all of the following conditions: construction activities are temporarily halted, snow cover exists over the entire site for an extended period, and melting conditions posing a risk of surface erosion do not exist. This inspection exception is applicable only during the period where melting conditions do not exist, and applies to the routine 7-day, 14-day and monthly inspections, as well as the post-storm-event inspections. When this inspection exclusion is implemented, the following information must be documented in accordance with the requirements in Part II:

- i. dates when snow cover existed;
- ii. date when construction activities ceased; and
- iii. date melting conditions began.

5. Inspection Scope

a. Areas to be Inspected

When conducting a site inspection the following areas, if applicable, must be inspected for evidence of, or the potential for, pollutants leaving the construction site boundaries, entering the stormwater drainage system, or discharging to state waters:

- i. construction site perimeter;
- ii. all disturbed areas;
- iii. designated haul routes;
- iv. material and waste storage areas exposed to precipitation;
- v. locations where stormwater has the potential to discharge offsite; and
- vi. locations where vehicles exit the site.

b. Inspection Requirements

- i. Visually verify whether all implemented control measures are in effective operational condition and are working as designed in their specifications to minimize pollutant discharges.
- ii. Determine if there are new potential sources of pollutants.
- iii. Assess the adequacy of control measures at the site to identify areas requiring new or modified control measures to minimize pollutant discharges.
- iv. Identify all areas of non-compliance with the permit requirements and, if necessary, implement corrective action in accordance with Part IB.1.c.

c. Inspection Reports

The permittee must keep a record of all inspections conducted for each permitted site. Inspection reports must identify any incidents of noncompliance with the terms and conditions of this permit. Inspection records must be retained in accordance with Part II.O. and signed in accordance with Part I.A.3.f. At a minimum, the inspection report must include:

- i. the inspection date;

- ii. name(s) and title(s) of personnel conducting the inspection;
- iii. weather conditions at the time of inspection;
- iv. phase of construction at the time of inspection;
- v. estimated acreage of disturbance at the time of inspection
- vi. location(s) of discharges of sediment or other pollutants from the site;
- vii. location(s) of control measures needing maintenance;
- viii. location(s) and identification of inadequate control measures;
- ix. location(s) and identification of additional control measures are needed that were not in place at the time of inspection;
- x. description of the minimum inspection frequency (either in accordance with Part I.D.2., I.D.3. or I.D.4.) utilized when conducting each inspection.
- xi. deviations from the minimum inspection schedule as required in Part I.D.2.;
- xii. after adequate corrective action(s) and maintenance have been taken, or where a report does not identify any incidents requiring corrective action or maintenance, the report shall contain a statement as required in Part I.A.3.f.

E. DEFINITIONS

For the purposes of this permit:

- (1) Bypass - the intentional diversion of waste streams from any portion of a treatment facility in accordance with 40 CFR 122.41(m)(1)(i) and Regulation 61.2(12).
- (2) Common Plan of Development or Sale - A contiguous area where multiple separate and distinct construction activities may be taking place at different times on different schedules, but remain related. The Division has determined that "contiguous" means construction activities located in close proximity to each other (within ¼ mile). Construction activities are considered to be "related" if they share the same development plan, builder or contractor, equipment, storage areas, etc. "Common plan of development or sale" includes construction activities that are associated with the construction of field wide oil and gas permits for facilities that are related.
- (3) Construction Activity - Ground surface disturbing and associated activities (land disturbance), which include, but are not limited to, clearing, grading, excavation, demolition, installation of new or improved haul roads and access roads, staging areas, stockpiling of fill materials, and borrow areas. Construction does not include routine maintenance to maintain the original line and grade, hydraulic capacity, or original purpose of the facility. Activities to conduct repairs that are not part of routine maintenance or for replacement are construction activities and are not routine maintenance. Repaving activities where underlying and/or surrounding soil is exposed as part of the repaving operation are considered construction activities. Construction activity is from initial ground breaking to final stabilization regardless of ownership of the construction activities.
- (4) Control Measure - Any best management practice or other method used to prevent or reduce the discharge of pollutants to state waters. Control measures include, but are not limited to, best management practices. Control measures can include other methods such as the installation, operation, and maintenance of structural controls and treatment devices.

- (5) Control Measure Requiring Routine Maintenance - Any control measure that is still operating in accordance with its design and the requirements of this permit, but requires maintenance to prevent a breach of the control measure. See also inadequate control measure.
- (6) Dedicated Asphalt, Concrete Batch Plants and Masonry Mixing Stations - are batch plants or mixing stations located on, or within $\frac{1}{4}$ mile of, a construction site and that provide materials only to that specific construction site.
- (7) Final Stabilization - The condition reached when all ground surface disturbing activities at the site have been completed, and for all areas of ground surface disturbing activities where a uniform vegetative cover has been established with an individual plant density of at least 70 percent of pre-disturbance levels, or equivalent permanent, physical erosion reduction methods have been employed.
- (8) Good Engineering, Hydrologic and Pollution Control Practices: are methods, procedures, and practices that:
 - a. Are based on basic scientific fact(s).
 - b. Reflect best industry practices and standards.
 - c. Are appropriate for the conditions and pollutant sources.
 - d. Provide appropriate solutions to meet the associated permit requirements, including practice based effluent limits.
- (9) Inadequate Control Measure - Any control measure that is not designed or implemented in accordance with the requirements of the permit and/or any control measure that is not implemented to operate in accordance with its design. See also Control Measure Requiring Routine Maintenance.
- (10) Infeasible - Not technologically possible, or not economically practicable and achievable in light of best industry practices.
- (11) Minimize - reduce or eliminate to the extent achievable using control measures that are technologically available and economically practicable and achievable in light of best industry practice.
- (12) Municipality - A city, town, county, district, association, or other public body created by, or under, State law and having jurisdiction over disposal of sewage, industrial wastes, or other wastes, or a designated and approved management agency under section 208 of CWA (1987).
- (13) Municipal Separate Storm Sewer System (MS4) - A conveyance or system of conveyances (including roads with drainage systems, municipal streets, catch basins, curbs, gutters, ditches, man-made channels, or storm drains):
 - a) owned or operated by a State, city, town, county, district, association, or other public body (created by or pursuant to State law) having jurisdiction over disposal of sewage, industrial wastes, stormwater, or other wastes, including special districts under State law such as a sewer district, flood control district or drainage district, or similar entity, or a designated and approved management agency under section 208 of the CWA that discharges to state waters;
 - i. designed or used for collecting or conveying stormwater;
 - ii. are not a combined sewer; and
 - iii. are not part of a Publicly Owned Treatment Works (POTW). See 5 CCR 1002-61.2(62).
- (14) Municipal Stormwater Management Program - A stormwater program operated by a municipality, typically to meet the requirements of the municipalities MS4 discharge certification.

- (15) Operator - The party that has operational control over day-to-day activities at a project site which are necessary to ensure compliance with the permit. This party is authorized to direct individuals at a site to carry out activities required by the permit. (e.g. the general contractor)
- (16) Owner - The party that has overall control of the activities and that has funded the implementation of the construction plans and specifications. This is the party with ownership of, a long term lease of, or easements on the property on which the construction activity is occurring (e.g., the developer).
- (17) Permittee(s) - The owner and operator named in the discharge certification issued under this permit for the construction site specified in the certification.
- (18) Point Source - Any discernible, confined, and discrete conveyance, including, but not limited to, any pipe, ditch, channel, tunnel, conduit, well, discrete fissure, container, rolling stock, concentrated animal feeding operation, or vessel or other floating craft, from which pollutants are or may be discharged. Point source does not include irrigation return flow. See 5 CCR 102-61.2(75).
- (19) Pollutant - Dredged spoil, dirt, slurry, solid waste, incinerator residue, sewage, sewage sludge, garbage, trash, chemical waste, biological nutrient, biological material, radioactive material, heat, wrecked or discarded equipment, rock, sand, or any industrial, municipal or agricultural waste. See 5 CCR 1002-61.2(76).
- (20) Presentation of credentials - a government issued form of identification, if in person; or (ii) providing name, position and purpose of inspection if request to enter is made via telephone, email or other form of electronic communication. A Permittee's non-response to a request to enter upon presentation of credentials constitutes a denial to such request, and may result in violation of the Permit.
- (21) Process Water - Any water which, during manufacturing or processing, comes into contact with or results from the production of any raw material, intermediate product, finished product, by product or waste product.
- (22) Public Emergency Related Site - a project initiated in response to an unanticipated emergency (e.g., mud slides, earthquake, extreme flooding conditions, disruption in essential public services), for which the related work requires immediate authorization to avoid imminent endangerment to human health or the environment, or to reestablish essential public services.
- (23) Qualified Stormwater Manager - An individual knowledgeable in the principles and practices of erosion and sediment control and pollution prevention, and with the skills to assess conditions at construction sites that could impact stormwater quality and to assess the effectiveness of stormwater controls implemented to meet the requirements of this permit.
- (24) Qualifying Local Program - A municipal program for stormwater discharges associated with small construction activity that was formally approved by the division as a qualifying local program.
- (25) Receiving Water - Any classified or unclassified surface water segment (including tributaries) in the State of Colorado into which stormwater associated with construction activities discharges. This definition includes all water courses, even if they are usually dry, such as borrow ditches, arroyos, and other unnamed waterways.
- (26) Severe Property Damage - substantial physical damage to property, damage to the treatment facilities which causes them to become inoperable, or substantial and permanent loss of natural resources which can reasonably be expected to occur in the absence of a bypass. Severe property damage does not mean economic loss caused by delays in production. See 40 CFR 122.41(m)(1)(ii).

- (27) Significant Materials - Include, but not limited to, raw materials; fuels; materials such as solvents, detergents, and plastic pellets; finished materials such as metallic products; raw materials used in food processing or production; hazardous substances designated under section 101(14) of CERCLA; any chemical the permittee is required to report under section 313 of Title III of the Superfund Amendments and Reauthorization Act (SARA); fertilizers; pesticides; and waste products such as ashes, slag and sludge that have the potential to be released with stormwater discharges.
- (28) Small Construction Activity - The discharge of stormwater from construction activities that result in land disturbance of equal to, or greater than, one acre and less than five acres. Small construction activity also includes the disturbance of less than one acre of total land area that is part of a larger common plan of development or sale, if the larger common plan ultimately disturbs equal to, or greater than, one acre and less than five acres.
- (29) Spill - An unintentional release of solid or liquid material which may pollute state waters.
- (30) State Waters - means any and all surface and subsurface waters which are contained in or flow in or through this state, but does not include waters in sewage systems, waters in treatment works of disposal systems, waters in potable water distribution systems, and all water withdrawn for use until use and treatment have been completed.
- (31) Steep Slopes: where a local government, or industry technical manual (e.g., stormwater BMP manual) has defined what is to be considered a "steep slope", this permit's definition automatically adopts that definition. Where no such definition exists, steep slopes are automatically defined as those that are 3:1 or greater.
- (32) Stormwater - Precipitation runoff, snow melt runoff, and surface runoff and drainage. See 5 CCR 1002-61.2(103).
- (33) Total Maximum Daily Loads (TMDLs) -The sum of the individual wasteload allocations (WLA) for point sources and load allocations (LA) for nonpoint sources and natural background. For the purposes of this permit, a TMDL is a calculation of the maximum amount of a pollutant that a waterbody can receive and still meet water quality standards, and an allocation of that amount to the pollutant's sources. A TMDL includes WLAs, LAs, and must include a margin of safety (MOS), and account for seasonal variations. See section 303(d) of the CWA and 40 C.F.R. 130.2 and 130.7.
- (34) Upset - an exceptional incident in which there is unintentional and temporary noncompliance with permit effluent limitations because of factors beyond the reasonable control of the permittee. An upset does not include noncompliance to the extent caused by operational error, improperly designed treatment facilities, inadequate treatment facilities, lack of preventative maintenance, or careless or improper operation in accordance with 40 CFR 122.41(n) and Regulation 61.2(114).

F. MONITORING

The division may require sampling and testing, on a case-by-case basis. If the division requires sampling and testing, the division will send a notification to the permittee. Reporting procedures for any monitoring data collected will be included in the notification.

If monitoring is required, the following applies:

1. the thirty (30) day average must be determined by the arithmetic mean of all samples collected during a thirty (30) consecutive-day period; and
2. a grab sample, for monitoring requirements, is a single "dip and take" sample.

G. Oil and Gas Construction

Stormwater discharges associated with construction activities directly related to oil and gas exploration, production, processing, and treatment operations or transmission facilities are regulated under the Colorado Discharge Permit System Regulations (5 CCR 1002-61), and require coverage under this permit in accordance with that regulation. However, references in this permit to specific authority under the CWA do not apply to stormwater discharges associated with these oil and gas related construction activities, to the extent that the references are limited by the federal Energy Policy Act of 2005.

Part II: Standard Permit Conditions

A. DUTY TO COMPLY

The permittee must comply with all conditions of this permit. Any permit noncompliance constitutes a violation of the Water Quality Control Act and is grounds for:

- a. enforcement action;
- b. permit termination, revocation and reissuance, or modification; or
- c. denial of a permit renewal application.

B. DUTY TO REAPPLY

If the permittee wishes to continue an activity regulated by this permit after the expiration date of this permit, the permittee must apply for and obtain authorization as required by Part I.A.3.k. of the permit.

C. NEED TO HALT OR REDUCE ACTIVITY NOT A DEFENSE

It shall not be a defense for a permittee in an enforcement action that it would have been necessary to halt or reduce the permitted activity in order to maintain compliance with the conditions of this permit.

D. DUTY TO MITIGATE

A permittee must take all reasonable steps to minimize or prevent any discharge in violation of this permit which has a reasonable likelihood of adversely affecting human health or the environment.

E. PROPER OPERATION AND MAINTENANCE

A permittee must at all times properly operate and maintain all facilities and systems of treatment and control (and related appurtenances) that are installed or used by the permittee to achieve compliance with the conditions of this permit. Proper operation and maintenance also includes adequate laboratory controls and appropriate quality assurance procedures. This provision requires the operation of backup or auxiliary facilities or similar systems which are installed by the permittee only when the operation is necessary to achieve compliance with the conditions of this permit. This requirement can be met by meeting the requirements for Part I.B., I.C., and I.D. above. See also 40 C.F.R. § 122.41(e).

F. PERMIT ACTIONS

This permit may be modified, revoked and reissued, or terminated for cause. The permittee request for a permit modification, revocation and reissuance, or termination, or a notification of planned changes or anticipated noncompliance does not stay any permit condition. Any request for modification, revocation, reissuance, or termination under this permit must comply with all terms and conditions of Regulation 61.8(8).

G. PROPERTY RIGHTS

In accordance with 40 CFR 122.41(g) and 5 CCR 1002-61, 61.8(9):

1. The issuance of a permit does not convey any property or water rights in either real or personal property, or stream flows or any exclusive privilege.

2. The issuance of a permit does not authorize any injury to person or property or any invasion of personal rights, nor does it authorize the infringement of federal, state, or local laws or regulations.
3. Except for any toxic effluent standard or prohibition imposed under Section 307 of the Federal act or any standard for sewage sludge use or disposal under Section 405(d) of the Federal act, compliance with a permit during its term constitutes compliance, for purposes of enforcement, with Sections 301, 302, 306, 318, 403, and 405(a) and (b) of the Federal act. However, a permit may be modified, revoked and reissued, or terminated during its term for cause as set forth in Section 61.8(8) of the Colorado Discharge Permit System Regulations.

H. DUTY TO PROVIDE INFORMATION

The permittee shall furnish to the division, within a reasonable time, any information which the division may request to determine whether cause exists for modifying, revoking and reissuing, or terminating this permit, or to determine compliance with this permit. The permittee shall also furnish to the division, upon request, copies of records required to be kept by this permit in accordance with 40 CFR 122.41(h) and/or Regulation 61.8(3)(q).

I. INSPECTION AND ENTRY

The permittee shall allow the division and the authorized representative, upon the presentation of credentials as required by law, to allow for inspections to be conducted in accordance with 40 CFR 122.41(i), Regulation 61.8(3), and Regulation 61.8(4):

1. to enter upon the permittee's premises where a regulated facility or activity is located or in which any records are required to be kept under the terms and conditions of this permit;
2. at reasonable times to have access to and copy any records required to be kept under the terms and conditions of this permit;
3. at reasonable times, inspect any monitoring equipment or monitoring method required in the permit; and
4. to enter upon the permittee's premises in a reasonable manner and at a reasonable time to inspect or investigate, any actual, suspected, or potential source of water pollution, or any violation of the Colorado Water Quality Control Act. The investigation may include: sampling of any discharges, stormwater or process water, taking of photographs, interviewing site staff on alleged violations and other matters related to the permit, and assessing any and all facilities or areas within the site that may affect discharges, the permit, or an alleged violation.

The permittee shall provide access to the division or other authorized representatives upon presentation of proper credentials. A permittee's non-response to a request to enter upon presentation of credentials constitutes a denial of such request, and may result in a violation of the permit.

J. MONITORING AND RECORDS

1. Samples and measurements taken for the purpose of monitoring must be representative of the volume and nature of the monitored activity.

2. The permittee must retain records of all monitoring information, including all calibration and maintenance records and all original strip chart recordings for continuous monitoring instrumentation, copies of all reports required by this permit, and records of all data used to complete the application for this permit, for a period of at least three years from the date the permit expires or the date the permittee's authorization is terminated. This period may be extended by request of the division at any time.
3. Records of monitoring information must include:
 - a. The date, exact place, and time of sampling or measurements;
 - b. The individual(s) who performed the sampling or measurements;
 - c. The date(s) analyses were performed
 - d. The individual(s) who performed the analyses;
 - e. The analytical techniques or methods used; and
 - f. The results of such analyses.
4. Monitoring must be conducted according to test procedures approved under 40 CFR Part 136, unless other test procedures have been specified in the permit.

K. SIGNATORY REQUIREMENTS

1. Authorization to Sign:

All documents required to be submitted to the division by the permit must be signed in accordance with the following criteria:

- a. For a corporation: By a responsible corporate officer. For the purpose of this subsection, a responsible corporate officer means:
 - i. a president, secretary, treasurer, or vice president of the corporation in charge of a principal business function, or any other person who performs similar policy- or decision-making functions for the corporation, or
 - ii. the manager of one or more manufacturing, production, or operating facilities, provided, the manager is authorized to make management decisions which govern the operation of the regulated facility including having the explicit or implicit duty of making major capital investment recommendations, and initiating and directing other comprehensive measures to assure long term environmental compliance with environmental laws and regulations; the manager can ensure that the necessary systems are established or actions taken to gather complete and accurate information for permit application requirements; and where authority to sign documents has been assigned or delegated to the manager in accordance with corporate procedures.
- b. For a partnership or sole proprietorship: By a general partner or the proprietor, respectively; or
- c. For a municipality, state, federal, or other public agency: By either a principal executive officer or ranking elected official. For purposes of this subsection, a principal executive officer of a federal agency includes
 - i. (i) the chief executive officer of the agency, or

- ii. (ii) a senior executive officer having responsibility for the overall operations of a principal geographic unit of the agency. (e.g., Regional Administrator of EPA)

2. Electronic Signatures

For persons signing applications for coverage under this permit electronically, in addition to meeting other applicable requirements stated above, such signatures must meet the same signature, authentication, and identity-proofing standards set forth at 40 CFR § 3.2000(b) for electronic reports (including robust second-factor authentication). Compliance with this requirement can be achieved by submitting the application using the Colorado Environmental Online Service (CEOS) system.

3. Change in Authorization to Sign

If an authorization is no longer accurate because a different individual or position has responsibility for the overall operation of the facility, a new authorization must be submitted to the division, prior to the re-authorization, or together with any reports, information, or applications to be signed by an authorized representative.

L. REPORTING REQUIREMENTS

1. Planned Changes

The permittee shall give advance notice to the division, in writing, of any planned physical alterations or additions to the permitted facility in accordance with 40 CFR 122.41(l) and Regulation 61.8(5)(a). Notice is required only when:

- a. The alteration or addition to a permitted facility may meet one of the criteria for determining whether a facility is a new source in 40 CFR 122.29(b); or
- b. The alteration or addition could significantly change the nature or increase the quantity of pollutants discharged. This notification applies to pollutants which are subject neither to effluent limitations in the permit, nor to notification requirements under 40 CFR 122.41(a)(1).

2. Anticipated Non-Compliance

The permittee shall give advance notice to the division, in writing, of any planned changes in the permitted facility or activity that may result in noncompliance with permit requirements. The timing of notification requirements differs based on the type of non-compliance as described in subparagraphs 5, 6, 7, and 8 below.

3. Transfer of Ownership or Control

The permittee shall notify the division, in writing, ten (10) calendar days in advance of a proposed transfer of the permit. This permit is not transferable to any person except after notice is given to the division.

- a. Where a facility wants to change the name of the permittee, the original permittee (the first owner or operators) must submit a Notice of Termination.
- b. The new owner or operator must submit an application. See also signature requirements in Part II.K, above.
- c. A permit may be automatically transferred to a new permittee if:
 - i. The current permittee notifies the Division in writing 30 calendar days in advance of the proposed transfer date; and
 - ii. The notice includes a written agreement between the existing and new permittee(s) containing a specific date for transfer of permit responsibility, coverage and liability between them; and
 - iii. The division does not notify the existing permittee and the proposed new permittee of its intent to modify, or revoke and reissue the permit.
 - iv. Fee requirements of the Colorado Discharge Permit System Regulations, Section 61.15, have been met.

4. Monitoring reports

Monitoring results must be reported at the intervals specified in this permit per the requirements of 40 CFR 122.41(l)(4).

5. Compliance Schedules

Reports of compliance or noncompliance with, or any progress reports on, interim and final requirements contained in any compliance schedule in the permit, shall be submitted on the date listed in the compliance schedule section. The fourteen (14) calendar day provision in Regulation 61.8(4)(n)(i) has been incorporated into the due date.

6. Twenty-four hour reporting

In addition to the reports required elsewhere in this permit, the permittee shall report the following circumstances orally within twenty-four (24) hours from the time the permittee becomes aware of the circumstances, and shall mail to the division a written report containing the information requested within five (5) working days after becoming aware of the following circumstances:

- a. Circumstances leading to any noncompliance which may endanger health or the environment regardless of the cause of the incident;
- b. Circumstances leading to any unanticipated bypass which exceeds any effluent limitations in the permit;
- c. Circumstances leading to any upset which causes an exceedance of any effluent limitation in the permit;

- d. Daily maximum violations for any of the pollutants limited by Part I of this permit. This includes any toxic pollutant or hazardous substance or any pollutant specifically identified as the method to control any toxic pollutant or hazardous substance.
- e. The division may waive the written report required under subparagraph 6 of this section if the oral report has been received within 24 hours.

7. Other non-compliance

A permittee must report all instances of noncompliance at the time monitoring reports are due. If no monitoring reports are required, these reports are due at least annually in accordance with Regulation 61.8(4)(p). The annual report must contain all instances of non-compliance required under either subparagraph 5 or subparagraph 6 of this subsection.

8. Other information

Where a permittee becomes aware that it failed to submit any relevant facts in a permit application, or submitted incorrect information in a permit application, or in any report to the Permitting Authority, it has a duty to promptly submit such facts or information.

M. BYPASS

1. Bypass not exceeding limitations

The permittees may allow any bypass to occur which does not cause effluent limitations to be exceeded, but only if it also is for essential maintenance to assure efficient operation. These bypasses are not subject to the provisions of Part II.M.2 of this permit. See 40 CFR 122.41(m)(2).

2. Notice of bypass

- a. Anticipated bypass. If the permittee knows in advance of the need for a bypass, the permittee must submit prior notice, if possible at least ten days before the date of the bypass. See 40 CFR §122.41(m)(3)(i) and/or Regulation 61.9(5)(c).
- b. Unanticipated bypass. The permittee must submit notice of an unanticipated bypass in accordance with Part II.L.6. See 40 CFR §122.41(m)(3)(ii) .

3. Prohibition of Bypass

Bypasses are prohibited and the division may take enforcement action against the permittee for bypass, unless:

- i. the bypass is unavoidable to prevent loss of life, personal injury, or severe property damage;

- ii. There were no feasible alternatives to the bypass, such as the use of auxiliary treatment facilities, retention of untreated wastes, or maintenance during normal periods of equipment downtime. This condition is not satisfied if adequate backup equipment should have been installed in the exercise of reasonable engineering judgment to prevent a bypass which occurred during normal periods of equipment downtime or preventive maintenance; and
- iii. proper notices were submitted to the division.

N. UPSET

1. Effect of an upset

An upset constitutes an affirmative defense to an action brought for noncompliance with permit effluent limitations if the requirements of Part II.N.2. of this permit are met. No determination made during administrative review of claims that noncompliance was caused by upset, and before an action for noncompliance, is final administrative action subject to judicial review in accordance with Regulation 61.8(3)(j).

2. Conditions necessary for demonstration of an Upset

A permittee who wishes to establish the affirmative defense of upset shall demonstrate through properly signed contemporaneous operating logs, or other relevant evidence that

- a. an upset occurred and the permittee can identify the specific cause(s) of the upset;
- b. the permitted facility was at the time being properly operated and maintained; and
- c. the permittee submitted proper notice of the upset as required in Part II.L.6. (24-hour notice); and
- d. the permittee complied with any remedial measure necessary to minimize or prevent any discharge or sludge use or disposal in violation of this permit which has a reasonable likelihood of adversely affecting human health or the environment. In addition to the demonstration required above, a permittee who wishes to establish the affirmative defense of upset for a violation of effluent limitations based upon water quality standards shall also demonstrate through monitoring, modeling or other methods that the relevant standards were achieved in the receiving water.

3. Burden of Proof

In any enforcement proceeding, the permittee seeking to establish the occurrence of an upset has the burden of proof.

O. RETENTION OF RECORDS

1. Post-Expiration or Termination Retention

Copies of documentation required by this permit, including records of all data used to complete the application for permit coverage to be covered by this permit, must be

retained for at least three years from the date that permit coverage expires or is terminated. This period may be extended by request of EPA at any time.

2. On-site Retention

The permittee must retain an electronic version or hardcopy of the SWMP at the construction site from the date of the initiation of construction activities to the date of expiration or inactivation of permit coverage; unless another location, specified by the permittee, is approved by the division.

P. REOPENER CLAUSE

1. Procedures for modification or revocation

Permit modification or revocation of this permit or coverage under this permit will be conducted according to Regulation 61.8(8).

2. Water quality protection

If there is evidence indicating that the stormwater discharges authorized by this permit cause, have the reasonable potential to cause or contribute to an excursion above any applicable water quality standard, the permittee may be required to obtain an individual permit, or the permit may be modified to include different limitations and/or requirements.

Q. SEVERABILITY

The provisions of this permit are severable. If any provisions or the application of any provision of this permit to any circumstances, is held invalid, the application of such provision to other circumstances and the application of the remainder of this permit shall not be affected.

R. NOTIFICATION REQUIREMENTS

1. Notification to Parties

All notification requirements, excluding information submitted using the CEOS portal, shall be directed as follows:

a. Oral Notifications, during normal business hours shall be to:

Clean Water Compliance Section
Water Quality Control Division
Telephone: (303) 692-3500

b. Written notification shall be to:

Clean Water Compliance Section
Water Quality Control Division
Colorado Department of Public Health and Environment
WQCD-WQP-B2
4300 Cherry Creek Drive South
Denver, CO 80246-1530

S. RESPONSIBILITIES**1. Reduction, Loss, or Failure of Treatment Facility**

The permittee has the duty to halt or reduce any activity if necessary to maintain compliance with the effluent limitations of the permit. It shall not be a defense for a permittee in an enforcement action that it would be necessary to halt or reduce the permitted activity in order to maintain compliance with the conditions of this permit.

T. Oil and Hazardous Substance Liability

Nothing in this permit shall be construed to preclude the institution of any legal action or relieve the permittee from any responsibilities, liabilities, or penalties to which the permittee is or may be subject to under Section 311 (Oil and Hazardous Substance Liability) of the CWA.

U. Emergency Powers

Nothing in this permit shall be construed to prevent or limit application of any emergency power of the division.

V. Confidentiality

Any information relating to any secret process, method of manufacture or production, or sales or marketing data which has been declared confidential by the permittee, and which may be acquired, ascertained, or discovered, whether in any sampling investigation, emergency investigation, or otherwise, shall not be publicly disclosed by any member, officer, or employee of the Water Quality Control Commission or the division, but shall be kept confidential. Any person seeking to invoke the protection of of this section shall bear the burden of proving its applicability. This section shall never be interpreted as preventing full disclosure of effluent data.

W. Fees

The permittee is required to submit payment of an annual fee as set forth in the 2016 amendments to the Water Quality Control Act. Section 25-8-502 (1.1) (b), and the Colorado Discharge Permit System Regulations 5 CCR 1002-61, Section 61.15 as amended. Failure to submit the required fee when due and payable is a violation of the permit and will result in enforcement action pursuant to Section 25-8-601 et. seq., C.R.S.1973 as amended.

X. Duration of Permit

The duration of a permit shall be for a fixed term and shall not exceed five (5) years. If the permittee desires to continue to discharge, a permit renewal application shall be submitted at least ninety (90) calendar days before this permit expires. Filing of a timely and complete application shall cause the expired permit to continue in force to the effective date of the new permit. The permit's duration may be extended only through administrative extensions and not through interim modifications. If the permittee anticipates there will be no discharge after the expiration date of this permit, the division should be promptly notified so that it can terminate the permit in accordance with Part I.A.3.i.

Y. Section 307 Toxics

If a toxic effluent standard or prohibition, including any applicable schedule of compliance specified, is established by regulation pursuant to Section 307 of the Federal Act for a toxic pollutant which is present in the permittee's discharge and such standard or prohibition is more stringent than any limitation upon such pollutant in the discharge permit, the division

shall institute proceedings to modify or revoke and reissue the permit to conform to the toxic effluent standard or prohibition

**APPENDIX C
FEMA FIRM MAP**

National Flood Hazard Layer FIRMette



104°36'16"W 38°58'29"N

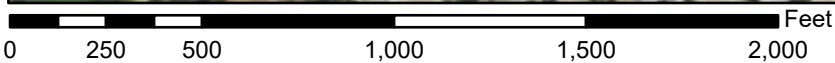
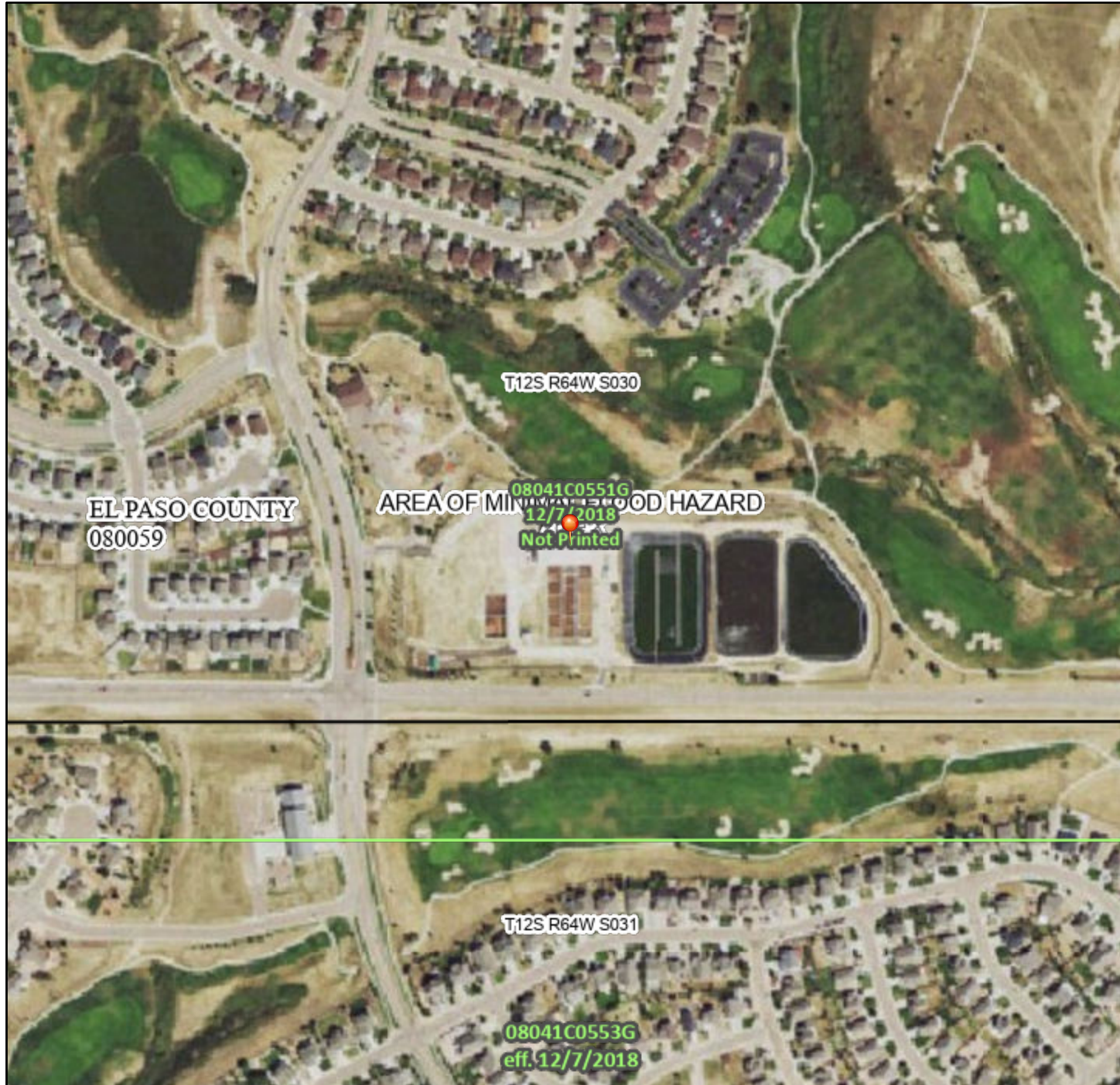

1:6,000

104°35'38"W 38°58'1"N

Basemap Imagery Source: USGS National Map 2023

Legend

SEE FIS REPORT FOR DETAILED LEGEND AND INDEX MAP FOR FIRM PANEL LAYOUT

- | | | |
|------------------------------------|--|--|
| SPECIAL FLOOD HAZARD AREAS | | Without Base Flood Elevation (BFE) <i>Zone A, V, A99</i> |
| | | With BFE or Depth <i>Zone AE, AO, AH, VE, AR</i> |
| | | Regulatory Floodway |
| OTHER AREAS OF FLOOD HAZARD | | 0.2% Annual Chance Flood Hazard, Areas of 1% annual chance flood with average depth less than one foot or with drainage areas of less than one square mile <i>Zone X</i> |
| | | Future Conditions 1% Annual Chance Flood Hazard <i>Zone X</i> |
| | | Area with Reduced Flood Risk due to Levee. See Notes. <i>Zone X</i> |
| | | Area with Flood Risk due to Levee <i>Zone D</i> |
| OTHER AREAS | | NO SCREEN Area of Minimal Flood Hazard <i>Zone X</i> |
| | | Effective LOMRs |
| GENERAL STRUCTURES | | Area of Undetermined Flood Hazard <i>Zone D</i> |
| | | Channel, Culvert, or Storm Sewer |
| | | Levee, Dike, or Floodwall |
| OTHER FEATURES | | 20.2 Cross Sections with 1% Annual Chance |
| | | 17.5 Water Surface Elevation |
| | | Coastal Transect |
| | | Base Flood Elevation Line (BFE) |
| | | Limit of Study |
| MAP PANELS | | Jurisdiction Boundary |
| | | Coastal Transect Baseline |
| | | Profile Baseline |
| | | Hydrographic Feature |
| | | Digital Data Available |
| | | No Digital Data Available |
| | | Unmapped |
| | | The pin displayed on the map is an approximate point selected by the user and does not represent an authoritative property location. |



This map complies with FEMA's standards for the use of digital flood maps if it is not void as described below. The basemap shown complies with FEMA's basemap accuracy standards

The flood hazard information is derived directly from the authoritative NFHL web services provided by FEMA. This map was exported on 6/8/2026 at 8:12 PM and does not reflect changes or amendments subsequent to this date and time. The NFHL and effective information may change or become superseded by new data over time.

This map image is void if the one or more of the following map elements do not appear: basemap imagery, flood zone labels, legend, scale bar, map creation date, community identifiers, FIRM panel number, and FIRM effective date. Map images for unmapped and unmodernized areas cannot be used for regulatory purposes.

**APPENDIX D
SOILS INFORMATION**



United States
Department of
Agriculture

NRCS

Natural
Resources
Conservation
Service

A product of the National
Cooperative Soil Survey,
a joint effort of the United
States Department of
Agriculture and other
Federal agencies, State
agencies including the
Agricultural Experiment
Stations, and local
participants

Custom Soil Resource Report for El Paso County Area, Colorado



Preface

Soil surveys contain information that affects land use planning in survey areas. They highlight soil limitations that affect various land uses and provide information about the properties of the soils in the survey areas. Soil surveys are designed for many different users, including farmers, ranchers, foresters, agronomists, urban planners, community officials, engineers, developers, builders, and home buyers. Also, conservationists, teachers, students, and specialists in recreation, waste disposal, and pollution control can use the surveys to help them understand, protect, or enhance the environment.

Various land use regulations of Federal, State, and local governments may impose special restrictions on land use or land treatment. Soil surveys identify soil properties that are used in making various land use or land treatment decisions. The information is intended to help the land users identify and reduce the effects of soil limitations on various land uses. The landowner or user is responsible for identifying and complying with existing laws and regulations.

Although soil survey information can be used for general farm, local, and wider area planning, onsite investigation is needed to supplement this information in some cases. Examples include soil quality assessments (<http://www.nrcs.usda.gov/wps/portal/nrcs/main/soils/health/>) and certain conservation and engineering applications. For more detailed information, contact your local USDA Service Center (<https://offices.sc.egov.usda.gov/locator/app?agency=nrcs>) or your NRCS State Soil Scientist (http://www.nrcs.usda.gov/wps/portal/nrcs/detail/soils/contactus/?cid=nrcs142p2_053951).

Great differences in soil properties can occur within short distances. Some soils are seasonally wet or subject to flooding. Some are too unstable to be used as a foundation for buildings or roads. Clayey or wet soils are poorly suited to use as septic tank absorption fields. A high water table makes a soil poorly suited to basements or underground installations.

The National Cooperative Soil Survey is a joint effort of the United States Department of Agriculture and other Federal agencies, State agencies including the Agricultural Experiment Stations, and local agencies. The Natural Resources Conservation Service (NRCS) has leadership for the Federal part of the National Cooperative Soil Survey.

Information about soils is updated periodically. Updated information is available through the NRCS Web Soil Survey, the site for official soil survey information.

The U.S. Department of Agriculture (USDA) prohibits discrimination in all its programs and activities on the basis of race, color, national origin, age, disability, and where applicable, sex, marital status, familial status, parental status, religion, sexual orientation, genetic information, political beliefs, reprisal, or because all or a part of an individual's income is derived from any public assistance program. (Not all prohibited bases apply to all programs.) Persons with disabilities who require

alternative means for communication of program information (Braille, large print, audiotape, etc.) should contact USDA's TARGET Center at (202) 720-2600 (voice and TDD). To file a complaint of discrimination, write to USDA, Director, Office of Civil Rights, 1400 Independence Avenue, S.W., Washington, D.C. 20250-9410 or call (800) 795-3272 (voice) or (202) 720-6382 (TDD). USDA is an equal opportunity provider and employer.

Contents

| | |
|--|----|
| Preface | 2 |
| How Soil Surveys Are Made | 5 |
| Soil Map | 8 |
| Soil Map..... | 9 |
| Legend..... | 10 |
| Map Unit Legend..... | 11 |
| Map Unit Descriptions..... | 11 |
| El Paso County Area, Colorado..... | 13 |
| 19—Columbine gravelly sandy loam, 0 to 3 percent slopes..... | 13 |
| Soil Information for All Uses | 15 |
| Soil Properties and Qualities..... | 15 |
| Soil Qualities and Features..... | 15 |
| Hydrologic Soil Group..... | 15 |
| References | 20 |

How Soil Surveys Are Made

Soil surveys are made to provide information about the soils and miscellaneous areas in a specific area. They include a description of the soils and miscellaneous areas and their location on the landscape and tables that show soil properties and limitations affecting various uses. Soil scientists observed the steepness, length, and shape of the slopes; the general pattern of drainage; the kinds of crops and native plants; and the kinds of bedrock. They observed and described many soil profiles. A soil profile is the sequence of natural layers, or horizons, in a soil. The profile extends from the surface down into the unconsolidated material in which the soil formed or from the surface down to bedrock. The unconsolidated material is devoid of roots and other living organisms and has not been changed by other biological activity.

Currently, soils are mapped according to the boundaries of major land resource areas (MLRAs). MLRAs are geographically associated land resource units that share common characteristics related to physiography, geology, climate, water resources, soils, biological resources, and land uses (USDA, 2006). Soil survey areas typically consist of parts of one or more MLRA.

The soils and miscellaneous areas in a survey area occur in an orderly pattern that is related to the geology, landforms, relief, climate, and natural vegetation of the area. Each kind of soil and miscellaneous area is associated with a particular kind of landform or with a segment of the landform. By observing the soils and miscellaneous areas in the survey area and relating their position to specific segments of the landform, a soil scientist develops a concept, or model, of how they were formed. Thus, during mapping, this model enables the soil scientist to predict with a considerable degree of accuracy the kind of soil or miscellaneous area at a specific location on the landscape.

Commonly, individual soils on the landscape merge into one another as their characteristics gradually change. To construct an accurate soil map, however, soil scientists must determine the boundaries between the soils. They can observe only a limited number of soil profiles. Nevertheless, these observations, supplemented by an understanding of the soil-vegetation-landscape relationship, are sufficient to verify predictions of the kinds of soil in an area and to determine the boundaries.

Soil scientists recorded the characteristics of the soil profiles that they studied. They noted soil color, texture, size and shape of soil aggregates, kind and amount of rock fragments, distribution of plant roots, reaction, and other features that enable them to identify soils. After describing the soils in the survey area and determining their properties, the soil scientists assigned the soils to taxonomic classes (units). Taxonomic classes are concepts. Each taxonomic class has a set of soil characteristics with precisely defined limits. The classes are used as a basis for comparison to classify soils systematically. Soil taxonomy, the system of taxonomic classification used in the United States, is based mainly on the kind and character of soil properties and the arrangement of horizons within the profile. After the soil

Custom Soil Resource Report

scientists classified and named the soils in the survey area, they compared the individual soils with similar soils in the same taxonomic class in other areas so that they could confirm data and assemble additional data based on experience and research.

The objective of soil mapping is not to delineate pure map unit components; the objective is to separate the landscape into landforms or landform segments that have similar use and management requirements. Each map unit is defined by a unique combination of soil components and/or miscellaneous areas in predictable proportions. Some components may be highly contrasting to the other components of the map unit. The presence of minor components in a map unit in no way diminishes the usefulness or accuracy of the data. The delineation of such landforms and landform segments on the map provides sufficient information for the development of resource plans. If intensive use of small areas is planned, onsite investigation is needed to define and locate the soils and miscellaneous areas.

Soil scientists make many field observations in the process of producing a soil map. The frequency of observation is dependent upon several factors, including scale of mapping, intensity of mapping, design of map units, complexity of the landscape, and experience of the soil scientist. Observations are made to test and refine the soil-landscape model and predictions and to verify the classification of the soils at specific locations. Once the soil-landscape model is refined, a significantly smaller number of measurements of individual soil properties are made and recorded. These measurements may include field measurements, such as those for color, depth to bedrock, and texture, and laboratory measurements, such as those for content of sand, silt, clay, salt, and other components. Properties of each soil typically vary from one point to another across the landscape.

Observations for map unit components are aggregated to develop ranges of characteristics for the components. The aggregated values are presented. Direct measurements do not exist for every property presented for every map unit component. Values for some properties are estimated from combinations of other properties.

While a soil survey is in progress, samples of some of the soils in the area generally are collected for laboratory analyses and for engineering tests. Soil scientists interpret the data from these analyses and tests as well as the field-observed characteristics and the soil properties to determine the expected behavior of the soils under different uses. Interpretations for all of the soils are field tested through observation of the soils in different uses and under different levels of management. Some interpretations are modified to fit local conditions, and some new interpretations are developed to meet local needs. Data are assembled from other sources, such as research information, production records, and field experience of specialists. For example, data on crop yields under defined levels of management are assembled from farm records and from field or plot experiments on the same kinds of soil.

Predictions about soil behavior are based not only on soil properties but also on such variables as climate and biological activity. Soil conditions are predictable over long periods of time, but they are not predictable from year to year. For example, soil scientists can predict with a fairly high degree of accuracy that a given soil will have a high water table within certain depths in most years, but they cannot predict that a high water table will always be at a specific level in the soil on a specific date.

After soil scientists located and identified the significant natural bodies of soil in the survey area, they drew the boundaries of these bodies on aerial photographs and

Custom Soil Resource Report

identified each as a specific map unit. Aerial photographs show trees, buildings, fields, roads, and rivers, all of which help in locating boundaries accurately.

Soil Map

The soil map section includes the soil map for the defined area of interest, a list of soil map units on the map and extent of each map unit, and cartographic symbols displayed on the map. Also presented are various metadata about data used to produce the map, and a description of each soil map unit.

Custom Soil Resource Report Soil Map



Soil Map may not be valid at this scale.

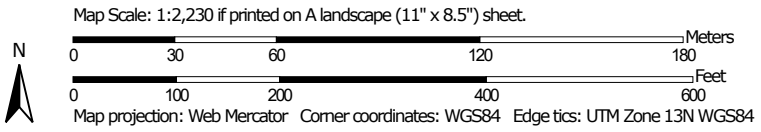

MAP LEGEND

Area of Interest (AOI)

 Area of Interest (AOI)

Soils

 Soil Map Unit Polygons

 Soil Map Unit Lines

 Soil Map Unit Points

Special Point Features

 Blowout

 Borrow Pit

 Clay Spot

 Closed Depression

 Gravel Pit

 Gravelly Spot

 Landfill

 Lava Flow

 Marsh or swamp

 Mine or Quarry

 Miscellaneous Water

 Perennial Water

 Rock Outcrop

 Saline Spot

 Sandy Spot

 Severely Eroded Spot

 Sinkhole

 Slide or Slip

 Sodic Spot

 Spoil Area

 Stony Spot

 Very Stony Spot

 Wet Spot

 Other

 Special Line Features

Water Features

 Streams and Canals

Transportation

 Rails

 Interstate Highways

 US Routes

 Major Roads

 Local Roads

Background

 Aerial Photography

MAP INFORMATION

The soil surveys that comprise your AOI were mapped at 1:24,000.

Warning: Soil Map may not be valid at this scale.

Enlargement of maps beyond the scale of mapping can cause misunderstanding of the detail of mapping and accuracy of soil line placement. The maps do not show the small areas of contrasting soils that could have been shown at a more detailed scale.

Please rely on the bar scale on each map sheet for map measurements.

Source of Map: Natural Resources Conservation Service
 Web Soil Survey URL:
 Coordinate System: Web Mercator (EPSG:3857)

Maps from the Web Soil Survey are based on the Web Mercator projection, which preserves direction and shape but distorts distance and area. A projection that preserves area, such as the Albers equal-area conic projection, should be used if more accurate calculations of distance or area are required.

This product is generated from the USDA-NRCS certified data as of the version date(s) listed below.

Soil Survey Area: El Paso County Area, Colorado
 Survey Area Data: Version 23, Aug 29, 2025

Soil map units are labeled (as space allows) for map scales 1:50,000 or larger.

Date(s) aerial images were photographed: Jul 23, 2024—Aug 4, 2024

The orthophoto or other base map on which the soil lines were compiled and digitized probably differs from the background imagery displayed on these maps. As a result, some minor shifting of map unit boundaries may be evident.

Map Unit Legend

| Map Unit Symbol | Map Unit Name | Acres in AOI | Percent of AOI |
|------------------------------------|---|--------------|----------------|
| 19 | Columbine gravelly sandy loam, 0 to 3 percent slopes | 14.0 | 100.0% |
| Totals for Area of Interest | | 14.0 | 100.0% |

Map Unit Descriptions

The map units delineated on the detailed soil maps in a soil survey represent the soils or miscellaneous areas in the survey area. The map unit descriptions, along with the maps, can be used to determine the composition and properties of a unit.

A map unit delineation on a soil map represents an area dominated by one or more major kinds of soil or miscellaneous areas. A map unit is identified and named according to the taxonomic classification of the dominant soils. Within a taxonomic class there are precisely defined limits for the properties of the soils. On the landscape, however, the soils are natural phenomena, and they have the characteristic variability of all natural phenomena. Thus, the range of some observed properties may extend beyond the limits defined for a taxonomic class. Areas of soils of a single taxonomic class rarely, if ever, can be mapped without including areas of other taxonomic classes. Consequently, every map unit is made up of the soils or miscellaneous areas for which it is named and some minor components that belong to taxonomic classes other than those of the major soils.

Most minor soils have properties similar to those of the dominant soil or soils in the map unit, and thus they do not affect use and management. These are called noncontrasting, or similar, components. They may or may not be mentioned in a particular map unit description. Other minor components, however, have properties and behavioral characteristics divergent enough to affect use or to require different management. These are called contrasting, or dissimilar, components. They generally are in small areas and could not be mapped separately because of the scale used. Some small areas of strongly contrasting soils or miscellaneous areas are identified by a special symbol on the maps. If included in the database for a given area, the contrasting minor components are identified in the map unit descriptions along with some characteristics of each. A few areas of minor components may not have been observed, and consequently they are not mentioned in the descriptions, especially where the pattern was so complex that it was impractical to make enough observations to identify all the soils and miscellaneous areas on the landscape.

The presence of minor components in a map unit in no way diminishes the usefulness or accuracy of the data. The objective of mapping is not to delineate pure taxonomic classes but rather to separate the landscape into landforms or landform segments that have similar use and management requirements. The delineation of such segments on the map provides sufficient information for the development of resource plans. If intensive use of small areas is planned, however, onsite investigation is needed to define and locate the soils and miscellaneous areas.

Custom Soil Resource Report

An identifying symbol precedes the map unit name in the map unit descriptions. Each description includes general facts about the unit and gives important soil properties and qualities.

Soils that have profiles that are almost alike make up a *soil series*. Except for differences in texture of the surface layer, all the soils of a series have major horizons that are similar in composition, thickness, and arrangement.

Soils of one series can differ in texture of the surface layer, slope, stoniness, salinity, degree of erosion, and other characteristics that affect their use. On the basis of such differences, a soil series is divided into *soil phases*. Most of the areas shown on the detailed soil maps are phases of soil series. The name of a soil phase commonly indicates a feature that affects use or management. For example, Alpha silt loam, 0 to 2 percent slopes, is a phase of the Alpha series.

Some map units are made up of two or more major soils or miscellaneous areas. These map units are complexes, associations, or undifferentiated groups.

A *complex* consists of two or more soils or miscellaneous areas in such an intricate pattern or in such small areas that they cannot be shown separately on the maps. The pattern and proportion of the soils or miscellaneous areas are somewhat similar in all areas. Alpha-Beta complex, 0 to 6 percent slopes, is an example.

An *association* is made up of two or more geographically associated soils or miscellaneous areas that are shown as one unit on the maps. Because of present or anticipated uses of the map units in the survey area, it was not considered practical or necessary to map the soils or miscellaneous areas separately. The pattern and relative proportion of the soils or miscellaneous areas are somewhat similar. Alpha-Beta association, 0 to 2 percent slopes, is an example.

An *undifferentiated group* is made up of two or more soils or miscellaneous areas that could be mapped individually but are mapped as one unit because similar interpretations can be made for use and management. The pattern and proportion of the soils or miscellaneous areas in a mapped area are not uniform. An area can be made up of only one of the major soils or miscellaneous areas, or it can be made up of all of them. Alpha and Beta soils, 0 to 2 percent slopes, is an example.

Some surveys include *miscellaneous areas*. Such areas have little or no soil material and support little or no vegetation. Rock outcrop is an example.

El Paso County Area, Colorado

19—Columbine gravelly sandy loam, 0 to 3 percent slopes

Map Unit Setting

National map unit symbol: 367p
Elevation: 6,500 to 7,300 feet
Mean annual precipitation: 14 to 16 inches
Mean annual air temperature: 46 to 50 degrees F
Frost-free period: 125 to 145 days
Farmland classification: Not prime farmland

Map Unit Composition

Columbine and similar soils: 97 percent
Minor components: 3 percent
Estimates are based on observations, descriptions, and transects of the mapunit.

Description of Columbine

Setting

Landform: Fans, Fan terraces, Flood plains
Down-slope shape: Linear
Across-slope shape: Linear
Parent material: Alluvium

Typical profile

A - 0 to 14 inches: gravelly sandy loam
C - 14 to 60 inches: very gravelly loamy sand

Properties and qualities

Slope: 0 to 3 percent
Depth to restrictive feature: More than 80 inches
Drainage class: Well drained
Runoff class: Very low
Capacity of the most limiting layer to transmit water (Ksat): High to very high (5.95 to 19.98 in/hr)
Depth to water table: More than 80 inches
Frequency of flooding: None
Frequency of ponding: None
Available water supply, 0 to 60 inches: Very low (about 2.5 inches)

Interpretive groups

Land capability classification (irrigated): 4e
Land capability classification (nonirrigated): 6e
Hydrologic Soil Group: A
Ecological site: R049XY214CO - Gravelly Foothill
Hydric soil rating: No

Minor Components

Fluvaquentic haplaquolls

Percent of map unit: 1 percent
Landform: Swales
Hydric soil rating: Yes

Custom Soil Resource Report

Other soils

Percent of map unit: 1 percent

Hydric soil rating: No

Pleasant

Percent of map unit: 1 percent

Landform: Depressions

Hydric soil rating: Yes

Soil Information for All Uses

Soil Properties and Qualities

The Soil Properties and Qualities section includes various soil properties and qualities displayed as thematic maps with a summary table for the soil map units in the selected area of interest. A single value or rating for each map unit is generated by aggregating the interpretive ratings of individual map unit components. This aggregation process is defined for each property or quality.

Soil Qualities and Features

Soil qualities are behavior and performance attributes that are not directly measured, but are inferred from observations of dynamic conditions and from soil properties. Example soil qualities include natural drainage, and frost action. Soil features are attributes that are not directly part of the soil. Example soil features include slope and depth to restrictive layer. These features can greatly impact the use and management of the soil.

Hydrologic Soil Group

Hydrologic soil groups are based on estimates of runoff potential. Soils are assigned to one of four groups according to the rate of water infiltration when the soils are not protected by vegetation, are thoroughly wet, and receive precipitation from long-duration storms.

The soils in the United States are assigned to four groups (A, B, C, and D) and three dual classes (A/D, B/D, and C/D). The groups are defined as follows:

Group A. Soils having a high infiltration rate (low runoff potential) when thoroughly wet. These consist mainly of deep, well drained to excessively drained sands or gravelly sands. These soils have a high rate of water transmission.

Group B. Soils having a moderate infiltration rate when thoroughly wet. These consist chiefly of moderately deep or deep, moderately well drained or well drained soils that have moderately fine texture to moderately coarse texture. These soils have a moderate rate of water transmission.

Custom Soil Resource Report

Group C. Soils having a slow infiltration rate when thoroughly wet. These consist chiefly of soils having a layer that impedes the downward movement of water or soils of moderately fine texture or fine texture. These soils have a slow rate of water transmission.

Group D. Soils having a very slow infiltration rate (high runoff potential) when thoroughly wet. These consist chiefly of clays that have a high shrink-swell potential, soils that have a high water table, soils that have a claypan or clay layer at or near the surface, and soils that are shallow over nearly impervious material. These soils have a very slow rate of water transmission.

If a soil is assigned to a dual hydrologic group (A/D, B/D, or C/D), the first letter is for drained areas and the second is for undrained areas. Only the soils that in their natural condition are in group D are assigned to dual classes.

Custom Soil Resource Report
Map—Hydrologic Soil Group

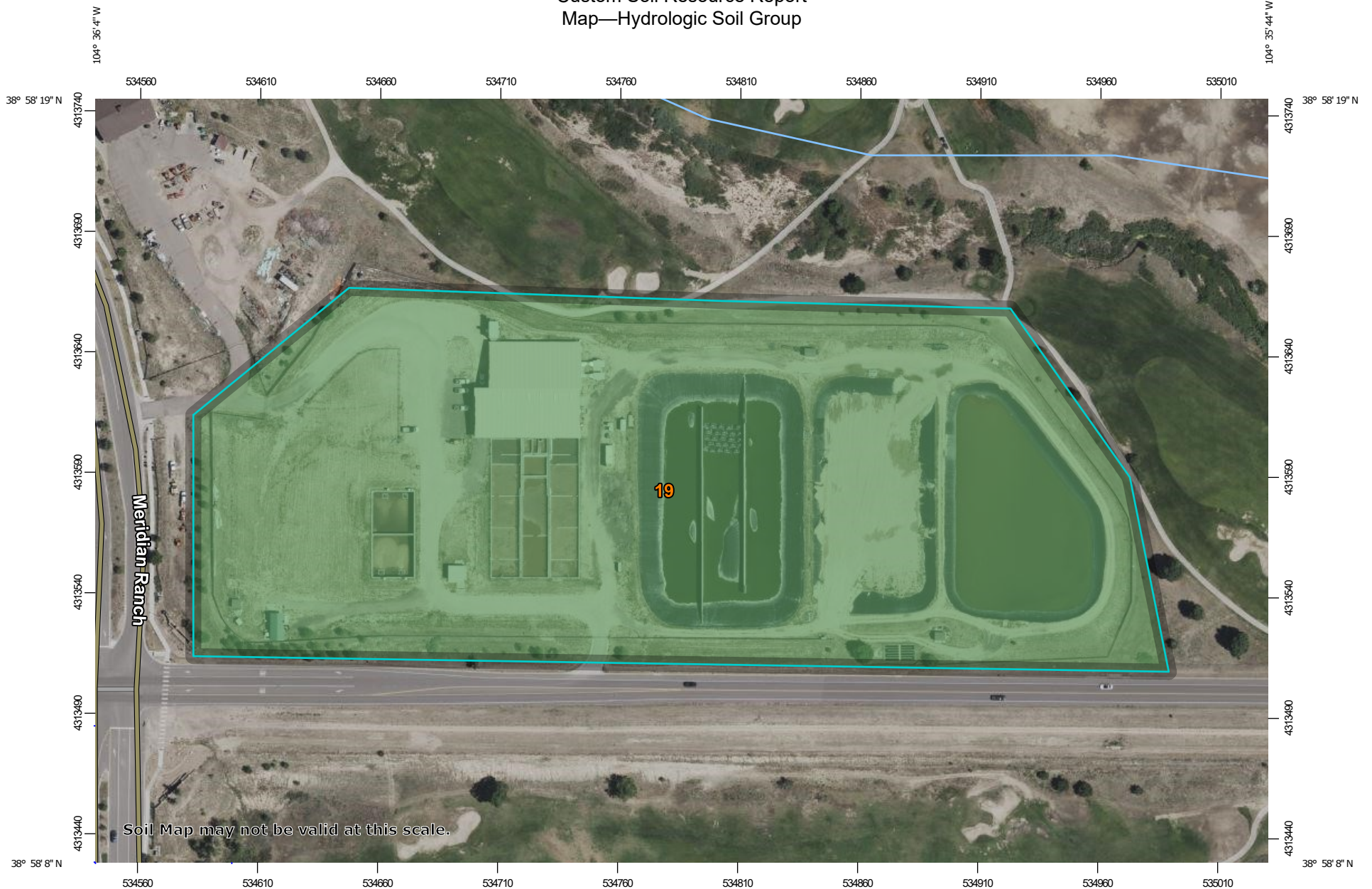

Soil Map may not be valid at this scale.

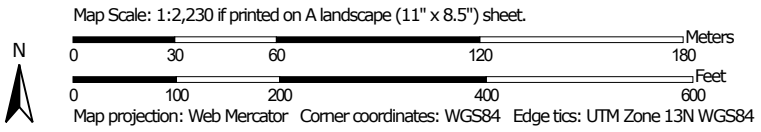

MAP LEGEND

Area of Interest (AOI)









 Area of Interest (AOI)

Soils

Soil Rating Polygons





-  A
-  A/D
-  B
-  B/D
-  C
-  C/D
-  D
-  Not rated or not available

Soil Rating Lines

-  A
-  A/D
-  B
-  B/D
-  C
-  C/D
-  D
-  Not rated or not available

Soil Rating Points





-  A
-  A/D
-  B
-  B/D

-  C
-  C/D
-  D
-  Not rated or not available

Water Features

 Streams and Canals

Transportation

-  Rails
-  Interstate Highways
-  US Routes
-  Major Roads
-  Local Roads

Background

 Aerial Photography

MAP INFORMATION

The soil surveys that comprise your AOI were mapped at 1:24,000.

Warning: Soil Map may not be valid at this scale.

Enlargement of maps beyond the scale of mapping can cause misunderstanding of the detail of mapping and accuracy of soil line placement. The maps do not show the small areas of contrasting soils that could have been shown at a more detailed scale.

Please rely on the bar scale on each map sheet for map measurements.

Source of Map: Natural Resources Conservation Service
 Web Soil Survey URL:
 Coordinate System: Web Mercator (EPSG:3857)

Maps from the Web Soil Survey are based on the Web Mercator projection, which preserves direction and shape but distorts distance and area. A projection that preserves area, such as the Albers equal-area conic projection, should be used if more accurate calculations of distance or area are required.

This product is generated from the USDA-NRCS certified data as of the version date(s) listed below.

Soil Survey Area: El Paso County Area, Colorado
 Survey Area Data: Version 23, Aug 29, 2025

Soil map units are labeled (as space allows) for map scales 1:50,000 or larger.

Date(s) aerial images were photographed: Jul 23, 2024—Aug 4, 2024

The orthophoto or other base map on which the soil lines were compiled and digitized probably differs from the background imagery displayed on these maps. As a result, some minor shifting of map unit boundaries may be evident.

Table—Hydrologic Soil Group

| Map unit symbol | Map unit name | Rating | Acres in AOI | Percent of AOI |
|------------------------------------|--|--------|--------------|----------------|
| 19 | Columbine gravelly sandy loam, 0 to 3 percent slopes | A | 14.0 | 100.0% |
| Totals for Area of Interest | | | 14.0 | 100.0% |

Rating Options—Hydrologic Soil Group

Aggregation Method: Dominant Condition

Component Percent Cutoff: None Specified

Tie-break Rule: Higher

References

- American Association of State Highway and Transportation Officials (AASHTO). 2004. Standard specifications for transportation materials and methods of sampling and testing. 24th edition.
- American Society for Testing and Materials (ASTM). 2005. Standard classification of soils for engineering purposes. ASTM Standard D2487-00.
- Cowardin, L.M., V. Carter, F.C. Golet, and E.T. LaRoe. 1979. Classification of wetlands and deep-water habitats of the United States. U.S. Fish and Wildlife Service FWS/OBS-79/31.
- Federal Register. July 13, 1994. Changes in hydric soils of the United States.
- Federal Register. September 18, 2002. Hydric soils of the United States.
- Hurt, G.W., and L.M. Vasilas, editors. Version 6.0, 2006. Field indicators of hydric soils in the United States.
- National Research Council. 1995. Wetlands: Characteristics and boundaries.
- Soil Survey Division Staff. 1993. Soil survey manual. Soil Conservation Service. U.S. Department of Agriculture Handbook 18. http://www.nrcs.usda.gov/wps/portal/nrcs/detail/national/soils/?cid=nrcs142p2_054262
- Soil Survey Staff. 1999. Soil taxonomy: A basic system of soil classification for making and interpreting soil surveys. 2nd edition. Natural Resources Conservation Service, U.S. Department of Agriculture Handbook 436. http://www.nrcs.usda.gov/wps/portal/nrcs/detail/national/soils/?cid=nrcs142p2_053577
- Soil Survey Staff. 2010. Keys to soil taxonomy. 11th edition. U.S. Department of Agriculture, Natural Resources Conservation Service. http://www.nrcs.usda.gov/wps/portal/nrcs/detail/national/soils/?cid=nrcs142p2_053580
- Tiner, R.W., Jr. 1985. Wetlands of Delaware. U.S. Fish and Wildlife Service and Delaware Department of Natural Resources and Environmental Control, Wetlands Section.
- United States Army Corps of Engineers, Environmental Laboratory. 1987. Corps of Engineers wetlands delineation manual. Waterways Experiment Station Technical Report Y-87-1.
- United States Department of Agriculture, Natural Resources Conservation Service. National forestry manual. http://www.nrcs.usda.gov/wps/portal/nrcs/detail/soils/home/?cid=nrcs142p2_053374
- United States Department of Agriculture, Natural Resources Conservation Service. National range and pasture handbook. <http://www.nrcs.usda.gov/wps/portal/nrcs/detail/national/landuse/rangepasture/?cid=stelprdb1043084>

Custom Soil Resource Report

United States Department of Agriculture, Natural Resources Conservation Service. National soil survey handbook, title 430-VI. http://www.nrcs.usda.gov/wps/portal/nrcs/detail/soils/scientists/?cid=nrcs142p2_054242

United States Department of Agriculture, Natural Resources Conservation Service. 2006. Land resource regions and major land resource areas of the United States, the Caribbean, and the Pacific Basin. U.S. Department of Agriculture Handbook 296. http://www.nrcs.usda.gov/wps/portal/nrcs/detail/national/soils/?cid=nrcs142p2_053624

United States Department of Agriculture, Soil Conservation Service. 1961. Land capability classification. U.S. Department of Agriculture Handbook 210. http://www.nrcs.usda.gov/Internet/FSE_DOCUMENTS/nrcs142p2_052290.pdf

**APPENDIX E
IDENTIFICATION OF POLLUTANT SOURCES**

**APPENDIX F
LAND DISTURBANCE / CONTROL MEASURE / STABILIZATION
LOG**

**APPENDIX G
CDPHE ENVIRONMENTAL SPILL REPORTING / CONTROL
MEASURE**

involving a radioactive or infectious material, or there is a release of a marine pollutant.

Spills and incidents that have or may result in a spill along a highway must be reported to the nearest law enforcement agency immediately. The Colorado State Patrol and CDPHE must also be notified as soon as possible. In the event of a spill of hazardous waste at a transfer facility, the transporter must notify CDPHE within 24 hours if the spill exceeds 55 gallons or if there is a fire or explosion.

The National Response Center should be notified as soon as possible after discovery of a release of a hazardous liquid or carbon dioxide from a pipeline system if a person is killed or injured, there is a fire or explosion, there is property damage of \$50,000 or more, or any nearby water body is contaminated.

The National Response Center and the Colorado Public Utilities Commission Gas Pipeline Safety Section must be notified as soon as possible, but not more than two hours after discovery of a release of gas from a natural gas pipeline or liquefied natural gas facility if a person is killed or injured, there is an emergency shutdown of the facility, or there is property damage of \$50,000 or more. The Colorado Public Utilities Commission should also be notified if there is a gas leak from a pipeline, liquefied natural gas system, master meter system or a propane system that results in the evacuation of 50 or more people from an occupied building or the closure of a roadway.

Oil and Gas Exploration

All Class I major events on federal lands, including releases of hazardous substances in excess of the CERCLA reportable quantity and spills of more than 100 barrels of fluid and/or 500 MCF of gas released, must be reported to the Bureau of Land Management (BLM) immediately. Spills of oil, gas, salt water, toxic liquids and waste materials must also be reported to the BLM and the surface management agency.

Spills of exploration and production (E&P) waste on state or private lands in excess of 20 barrels, and spills of any size that impact or threaten to impact waters of the state, an occupied structure, or public byway must be reported to the Colorado Oil and Gas Conservation Commission as soon as practicable, but not more than 24 hours after discovery. Spills of any

size that impact or threaten to impact waters of the state must be reported to CDPHE immediately. Spills that impact or threaten to impact a surface water intake must be reported to the emergency contact for that facility immediately after discovery. Spills of more than five (5) barrels of E&P waste must be reported in writing to the Oil and Gas Conservation Commission within 10 days of discovery.

REPORTING NUMBERS

National Response Center (24-hour)
1-800-424-8802

CDPHE Colorado Environmental Release and Incident Reporting Line (24-hour)
1-877-518-5608

Radiation Incident Reporting Line (24-hour)
303-877-9757

Colorado State Patrol (24-hour)
303-239-4501

Division of Oil and Public Safety
(business hours)
303-318-8547

Oil and Gas Conservation Commission
(business hours)
303-894-2100

Colorado Public Utilities Commission Gas Pipeline Safety Section (business hours)
303-894-2851

Local Emergency Planning Committees
(to obtain list, business hours)
720-852-6603



**Colorado Department
of Public Health
and Environment**

Environmental Spill Reporting

Colorado Department of Public
Health and Environment
4300 Cherry Creek Drive South
Denver, CO 80246-1530

<http://www.cdphe.state.co.us>

January 2009

When a release of a hazardous material or other substance occurs to the environment, there are a number of reporting and notification requirements that must be followed by the company or individual responsible for the release. Most spills are covered by more than one reporting requirement, and **all** requirements must be met. In addition to verbal notification, written reports are generally required. This brochure briefly explains the major requirements. A more detailed description is provided in the "Reporting Environmental Releases in Colorado" Guidance Document, available on the web.

Releases that must be reported to the Colorado Department of Public Health and Environment (CDPHE) may be reported to the Colorado Environmental Release and Incident Reporting Line.

ENVIRONMENTAL SPILL REPORTING

CERCLA, EPCRA and RCRA

The Comprehensive Environmental Response, Compensation and Liability Act (CERCLA) and the Emergency Planning and Community Right-to-Know Act (EPCRA) require that a release of a reportable quantity or more of a hazardous substance to the environment be reported immediately to the appropriate authorities when the release is discovered.

Under CERCLA, reportable quantities were established for hazardous substances listed or designated under other environmental statutes. These include:

- all hazardous air pollutants (HAPs) listed under Section 112(b) of the Clean Air Act.
- all toxic pollutants designated under Section 307(a) or Section 311(b)(2)(A) of the Clean Water Act.
- all Resource Conservation and Recovery Act (RCRA) characteristic and listed hazardous wastes.
- any element, compound, or substance designated under Section 102 of CERCLA.

EPCRA established a list of extremely hazardous substances (EHS) that could cause serious irreversible health effects from accidental releases. Many substances appear on both the CERCLA and EPCRA lists. EPCRA extremely hazardous substances that are also CERCLA hazardous substances have the same reportable quantity (RQ) as under CERCLA. EPCRA extremely hazardous substances that are not listed under CERCLA have a reportable quantity that is equal to their threshold planning quantity (TPQ). A list of CERCLA reportable quantities is included in 40 CFR Section 302.4. A list of EPCRA threshold planning quantities is included in 40 CFR Part 355 Appendices A & B.

CERCLA-reportable releases must be reported immediately to the National Response Center (NRC), while EPCRA-reportable releases must be reported immediately to the National Response Center, the State Emergency Response Commission (SERC) and the affected Local Emergency Planning Committee (LEPC). If the release is an EPCRA extremely

hazardous substance, but not a CERCLA hazardous substance, and there is absolutely no potential to affect off-site persons, then only the State Emergency Planning Commission (represented by CDPHE for reporting purposes) and the Local Emergency Planning Committee need to be notified.

In the case of a release of hazardous waste stored in tanks, RCRA-permitted facilities and large quantity generators must also notify CDPHE within 24 hours of any release to the environment that is greater than one (1) pound.

Radiation Control

Each licensee or registrant must report to the Radiation Incident Reporting Line in the event of lost, stolen or missing licensed or registered radioactive materials or radiation machines, releases of radioactive materials, contamination events, and fires or explosions involving radioactive materials. Releases of radionuclides are reportable under CERCLA.

Clean Water Act

The Clean Water Act requires the person in charge of a facility or vessel to immediately report to the National Response Center all discharges of oil or designated hazardous substances to water. Oil means oil of any kind or form. Designated hazardous substances are included in the CERCLA list.

The Clean Water Act also requires that facilities with a National Pollutant Discharge Elimination System (NPDES) permit report to the National Response Center within 24 hours of becoming aware of any unanticipated bypasses or upsets that cause an exceedance of the effluent limits in their permit and any violations of their maximum daily discharge limits for pollutants listed in their permit.

A release of any chemical, oil, petroleum product, sewage, etc., which may enter waters of the state of Colorado (which include surface water, ground water and dry gullies and storm sewers leading to surface water) must be reported immediately to CDPHE. Any accidental discharge to the sanitary sewer system must be reported immediately to the local sewer authority and the affected wastewater treatment plant. For additional regarding releases to water, please see "Guidance for Reporting Spills under the Colorado

Water Quality Control Act and Colorado Discharge Permits" at <http://www.cdph.state.co.us/op/wqcc/Resources/Guidance/spillguidance.pdf>.

Clean Air Act

Hazardous air pollutants (HAPs) are designated as hazardous substances under CERCLA. If a facility has an air permit but the permit does not allow for or does not specify the release of a substance, or if the facility does not have an air permit, then all releases in excess of the CERCLA / EPCRA reportable quantity for that substance must be reported to the National Response Center and CDPHE. If the facility releases more of a substance than is allowed under its air permit, the facility must also report the release. Discharges of a substance that are within the allowable limits specified in the facility's permit do not need to be reported.

Regulated Storage Tanks

Owners and operators of regulated storage tank systems must report a release or suspected release of regulated substances to the Division of Oil and Public Safety at the Colorado Department of Labor and Employment within 24 hours. Under this program, the reportable quantity for petroleum releases is 25 gallons or more, or any amount that causes a sheen on nearby surface water. Spills of less than 25 gallons of petroleum must be immediately contained and cleaned up. If cleanup cannot be accomplished within 24 hours, the Division of Oil and Public Safety must be notified immediately.

Spills of hazardous substances from tanks in excess of the CERCLA or EPCRA reportable quantity must be reported immediately to the National Response Center, CDPHE and the local fire authority, and to the Division of Oil and Public Safety within 24 hours.

Transportation and Pipelines

The person in physical possession of a hazardous material must notify the National Response Center as soon as practical, but not to exceed 12 hours after the incident, if as a direct result of the hazardous material, a person is killed or injured, there is an evacuation of the general public lasting more than an hour, a major transportation artery is shut down for an hour or more, the flight pattern of an aircraft is altered, there is fire, spillage or suspected contamination

**APPENDIX H
STORM EVENT LOG**

**APPENDIX I
INSPECTION AND SAMPLING REPORTS**

CONSTRUCTION STORMWATER SITE INSPECTION REPORT

| | | | | | | | |
|--|--------------------------|--------------------|--|-----|----|--------------------------|--------------------------|
| Facility Name | | Permittee | | | | | |
| Date of Inspection | | Weather Conditions | | | | | |
| Permit Certification # | | Disturbed Acreage | | | | | |
| Phase of Construction | | Inspector Title | | | | | |
| Inspector Name | | | | | | | |
| Is the above inspector a qualified stormwater manager? (permittee is responsible for ensuring that the inspector is a qualified stormwater manager) | | | <table border="1" style="width: 100%; border-collapse: collapse;"> <tr> <td style="width: 50%; text-align: center;">YES</td> <td style="width: 50%; text-align: center;">NO</td> </tr> <tr> <td style="text-align: center;"><input type="checkbox"/></td> <td style="text-align: center;"><input type="checkbox"/></td> </tr> </table> | YES | NO | <input type="checkbox"/> | <input type="checkbox"/> |
| YES | NO | | | | | | |
| <input type="checkbox"/> | <input type="checkbox"/> | | | | | | |

| INSPECTION FREQUENCY | | | | | |
|---|--|-----|----|--------------------------|--------------------------|
| Check the box that describes the minimum inspection frequency utilized when conducting each inspection | | | | | |
| At least one inspection every 7 calendar days | <input type="checkbox"/> | | | | |
| At least one inspection every 14 calendar days, with post-storm event inspections conducted within 24 hours after the end of any precipitation or snowmelt event that causes surface erosions | <input type="checkbox"/> | | | | |
| <ul style="list-style-type: none"> • This is this a post-storm event inspection. Event Date: _____ | <input type="checkbox"/> | | | | |
| Reduced inspection frequency - Include site conditions that warrant reduced inspection frequency | <input type="checkbox"/> | | | | |
| <ul style="list-style-type: none"> • Post-storm inspections at temporarily idle sites | <input type="checkbox"/> | | | | |
| <ul style="list-style-type: none"> • Inspections at completed sites/area | <input type="checkbox"/> | | | | |
| <ul style="list-style-type: none"> • Winter conditions exclusion | <input type="checkbox"/> | | | | |
| Have there been any deviations from the minimum inspection schedule? If yes, describe below. | <table border="1" style="width: 100%; border-collapse: collapse;"> <tr> <td style="width: 50%; text-align: center;">YES</td> <td style="width: 50%; text-align: center;">NO</td> </tr> <tr> <td style="text-align: center;"><input type="checkbox"/></td> <td style="text-align: center;"><input type="checkbox"/></td> </tr> </table> | YES | NO | <input type="checkbox"/> | <input type="checkbox"/> |
| YES | NO | | | | |
| <input type="checkbox"/> | <input type="checkbox"/> | | | | |
| | | | | | |

| INSPECTION REQUIREMENTS* |
|---|
| i. Visually verify all implemented control measures are in effective operational condition and are working as designed in the specifications |
| ii. Determine if there are new potential sources of pollutants |
| iii. Assess the adequacy of control measures at the site to identify areas requiring new or modified control measures to minimize pollutant discharges |
| iv. Identify all areas of non-compliance with the permit requirements, and if necessary, implement corrective action |
| *Use the attached Control Measures Requiring Routine Maintenance and Inadequate Control Measures Requiring Corrective Action forms to document results of this assessment that trigger either maintenance or corrective actions |

| AREAS TO BE INSPECTED | | | |
|---|--------------------------|--------------------------|--|
| Is there evidence of, or the potential for, pollutants leaving the construction site boundaries, entering the stormwater drainage system or discharging to state waters at the following locations? | | | |
| | NO | YES | If "YES" describe discharge or potential for discharge below. Document related maintenance, inadequate control measures and corrective actions Inadequate Control Measures Requiring Corrective Action form |
| Construction site perimeter | <input type="checkbox"/> | <input type="checkbox"/> | |
| All disturbed areas | <input type="checkbox"/> | <input type="checkbox"/> | |
| Designated haul routes | <input type="checkbox"/> | <input type="checkbox"/> | |
| Material and waste storage areas exposed to precipitation | <input type="checkbox"/> | <input type="checkbox"/> | |
| Locations where stormwater has the potential to discharge offsite | <input type="checkbox"/> | <input type="checkbox"/> | |
| Locations where vehicles exit the site | <input type="checkbox"/> | <input type="checkbox"/> | |
| Other: _____ | <input type="checkbox"/> | <input type="checkbox"/> | |

REPORTING REQUIREMENTS

The permittee shall report the following circumstances orally within twenty-four (24) hours from the time the permittee becomes aware of the circumstances, and shall mail to the division a written report containing the information requested within five (5) working days after becoming aware of the following circumstances. The division may waive the written report required if the oral report has been received within 24 hours.

| | | |
|---|--|--|
| All Noncompliance Requiring 24-Hour Notification per Part II.L.6 of the Permit | | |
| a. Endangerment to Health or the Environment Circumstances leading to any noncompliance which may endanger health or the environment regardless of the cause of the incident (See Part II.L.6.a of the Permit) <i>This category would primarily result from the discharge of pollutants in violation of the permit</i> | | |
| b. Numeric Effluent Limit Violations <ul style="list-style-type: none"> o Circumstances leading to any unanticipated bypass which exceeds any effluent limitations (See Part II.L.6.b of the Permit) o Circumstances leading to any upset which causes an exceedance of any effluent limitation (See Part II.L.6.c of the Permit) o Daily maximum violations (See Part II.L.6.d of the Permit) <i>Numeric effluent limits are very uncommon in certifications under the COR400000 general permit. This category of noncompliance only applies if numeric effluent limits are included in a permit certification.</i> | | |

| | | | |
|---|--------------------------|--------------------------|-------------------------|
| Has there been an incident of noncompliance requiring 24-hour notification? | NO | YES | |
| | <input type="checkbox"/> | <input type="checkbox"/> | If "YES" document below |

| Date and Time of Incident | Location | Description of Noncompliance | Description of Corrective Action | Date and Time of 24 Hour Oral Notification | Date of 5 Day Written Notification * |
|---------------------------|----------|------------------------------|----------------------------------|--|--------------------------------------|
| | | | | | |
| | | | | | |

*Attach copy of 5 day written notification to report. Indicate if written notification was waived, including the name of the division personnel who granted waiver.

After adequate corrective action(s) and maintenance have been taken, or where a report does not identify any incidents requiring corrective action or maintenance, the individual(s) designated as the Qualified Stormwater Manager, shall sign and certify the below statement:

"I verify that, to the best of my knowledge and belief, all corrective action and maintenance items identified during the inspection are complete, and the site is currently in compliance with the permit."

Name of Qualified Stormwater Manager

Title of Qualified Stormwater Manager

Signature of Qualified Stormwater Manager

Date

Notes/Comments

**APPENDIX J
SWMP AMENDMENT LOG**

