

FINAL DRAINAGE REPORT
for
NEW BREED RANCH FILING THREE

Prepared for:

New Breed Ranch Inc.
12750 Oak Cliff Way
Colorado Springs, CO 80908

February 28, 2024

Prepared by:

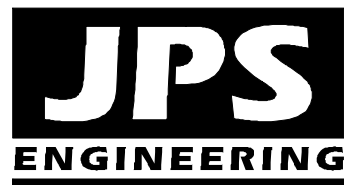

19 E. Willamette Avenue
Colorado Springs, CO 80903
(719)-477-9429
www.jpsegr.com

JPS Project No. 042207
PCD File No.: SF-

SF247



**NEW BREED RANCH FILING THREE
FINAL DRAINAGE REPORT
TABLE OF CONTENTS**

	<u>PAGE</u>
DRAINAGE STATEMENT	i
I. GENERAL LOCATION AND DESCRIPTION.....	1
II. DRAINAGE BASINS AND SUB-BASINS.....	2
III. DRAINAGE DESIGN CRITERIA	3
IV. DRAINAGE PLANNING FOUR STEP PROCESS.....	4
V. GENERAL DRAINAGE RECOMMENDATIONS	5
VI. DRAINAGE FACILITY DESIGN	5
VII. EROSION / SEDIMENT CONTROL	9
VIII. STORMWATER DETENTION AND WATER QUALITY.....	9
IX. DRAINAGE FEES	10
X. SUMMARY	10

APPENDICES

APPENDIX A	Soils Information
APPENDIX B	Hydrologic Calculations
APPENDIX C	Hydraulic Calculations
APPENDIX D	Water Quality Calculations
APPENDIX E	Figures
Figure FIRM	Floodplain Map “New Breed Ranch Filings 1 & 2 Sub-Basins / Design Points” (by Professional Consultants Inc.)
Sheet EX1	Existing Conditions Drainage Plan
Sheet D1	Developed Drainage Plan

DRAINAGE STATEMENT

Engineer's Statement:

The attached drainage plan and report were prepared under my direction and supervision and are correct to the best of my knowledge and belief. Said drainage report has been prepared according to the criteria established by the County for drainage reports and said report is in conformity with the master plan of the drainage basin. I accept responsibility for liability caused by negligent acts, errors or omissions on my part in preparing this report.

John P. Schwab, P.E. No. 29891

Developer's Statement:

I, the developer, have read and will comply with all of the requirements specified in this drainage report and plan.

By:

Printed Name: James Scott, President
New Breed Ranch Inc.
12750 Oak Cliff Way, Colorado Springs, CO 80908

Date

El Paso County's Statement

Filed in accordance with the requirements of the El Paso County Land Development Code, Drainage Criteria Manual, Volumes 1 and 2, and Engineering Criteria Manual as amended.

Joshua Palmer, P.E.
County Engineer / ECM Administrator

Date

Conditions:

I. GENERAL LOCATION AND DESCRIPTION

A. Background

New Breed Subdivision Filing Three is a proposed 7-lot rural residential subdivision filing located in the Black Forest area of northern El Paso County, Colorado. This filing is the third phase of the previously approved New Breed Subdivision Preliminary Plan, and this filing will create seven residential lots on 34.7-acres of the unplatted 279.1-acre balance of the New Breed Ranch, Inc. parcel (El Paso County Assessor's Number 62100-00-002). The property is located on the north side of Meadow Run Circle, generally northeast of the intersection of Shoup Road and New Breed Ranch Road. The proposed lots will be served by extension of Old Arena Way as a new public road extending north from Meadow Run Circle. The site disturbance for the proposed subdivision improvements is anticipated to be approximately 2.6 acres. The property is zoned PUD / RR-5, and the proposed development is entirely consistent with the existing zoning of the parcel.

B. Scope

Please include
Engineering Criteria
Manual,

This report will provide a summary of site drainage issues impacting the proposed rural residential subdivision. The report will analyze upstream drainage patterns, site-specific developed drainage patterns, and impacts on downstream facilities. This report is based on the guidelines and criteria presented in the El Paso County Drainage Criteria Manual, and the report is intended to fulfill the requirements for a "Final Drainage Report" in support of the Final Plat process for this property.

C. Site Location and Description

New Breed Ranch Filing Three is located in the South Half of Section 10, Township 12 South, Range 66 West of the 6th Principal Meridian, El Paso County, Colorado.

The 34.7-acre property encompassing the proposed "Filing Three" is a vacant area located northeast of the existing New Breed Ranch Filing One, and northwest of the existing New Breed Ranch Filing Two. The property is zoned PUD (planned unit development) / RR-5 (rural residential), allowing for a minimum lot size of 3-acres, and an overall average of 5-acre lot sizes within the PUD. The proposed subdivision filing is fully in conformance with the existing zoning of the site, and the previously approved New Breed Ranch Preliminary Plan.

Access to the new lots will be provided by a new public road (Old Arena Way) extending north from Meadow Run Circle.

The project site is bordered by rural residential properties on all sides. The west and south boundaries of the property adjoin previously platted lots of New Breed Ranch Filing One, and the east boundary of the property adjoins previously platted lots within new Breed Ranch Filing Two. The north boundary of this filing adjoins the unplatted area of the remaining New Breed Ranch, Inc. parcel, which is planned for future rural residential lots as part of the previously approved New Breed Ranch Preliminary Plan.

Meadow Run Circle is an improved, asphalt-paved public street along the south boundary of this filing.

The site is located in the Black Squirrel Creek Drainage Basin, and surface drainage from this site generally sheet flows southwesterly to existing drainage ditches and swales, ultimately flowing to the Black Squirrel Creek Channel downstream of this site. The terrain is gently rolling with average grades ranging from 2 to 8 percent. Ground elevations within the site range from approximately 6,980 feet above mean sea level at the southwest corner of the property to approximately 7,100 along the northeast filing boundary.

D. General Soil Conditions

According to the Custom Soil Resource Report for this site (see details in Appendix A) provided by the Natural Resources Conservation Service (NRCS), on-site soils are predominately comprised of the following:

- Type 41: Kettle gravelly loamy sand
- Type 69: Peyton-Pring complex
- Type 93: Tomah-Crowfoot complex

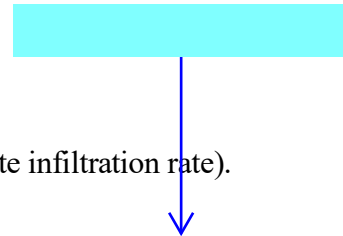

These soils are all classified as hydrologic soils group “B” (moderate infiltration rate).

E. References

City of Colorado Springs & El Paso County “Drainage Criteria Manual,” revised October 31, 2018.

City of Colorado Springs “Drainage Criteria Manual, Volumes 1 and 2,” revised October 31, 2018.

El Paso County “Engineering Criteria Manual,” revised July 18, 2023.

FEMA, Flood Insurance Rate Map (FIRM) Number 08041C0295G, December 7, 2018.

Professional Consultants Incorporated, “Final Drainage Report, New Breed Ranch Subdivision Filings 1 & 2,” February 2002 (approved by El Paso County 3/20/02).

URS Consultants, “Black Squirrel Creek Drainage Basin Planning Study,” January, 1989.

II. DRAINAGE BASINS AND SUB-BASINS

A. Major Basin Description

The proposed subdivision property lies entirely within the Black Squirrel Creek Drainage Basin (FOM 03600) as classified by El Paso County. Drainage from this site flows southwesterly to existing drainage ditches and natural drainage swales flowing to the Black Squirrel Creek drainage channel, which ultimately flows into Monument Creek.

URS Consultants prepared the “Black Squirrel Creek Drainage Basin Planning Study (DBPS)” in January, 1989.

B. Floodplain Impacts

This site is not impacted by any FEMA 100-year floodplain limits. The delineated floodplain limits in vicinity of the site are shown in FEMA Flood Insurance Rate Map (FIRM) Number 08041C0295G, dated December 7, 2018 (see FIRMette exhibit in Appendix E).

C. Sub-Basin Description

The Filing Three property is located within parts of Basins I-3, I-8, and I-9 as delineated in the “Final Drainage Report, New Breed Ranch Subdivision Filings 1 & 2” by Professional Consultants Incorporated (PCI), dated February 2002 (see “New Breed Ranch Filings 1 & 2 Sub-Basins / Design Points...” Exhibit in Appendix E). The previously approved subdivision drainage report identifies developed flows from these basins as flowing southwesterly to the existing downstream drainage swales.

The existing drainage basins lying in and around the proposed development are depicted on Figure EX1 (Appendix E). The New Breed Ranch Filing Three property lies within parts of Basins I-3, I-8, and I-9 as delineated in the PCI drainage report.

Developed runoff in this subdivision will generally continue to follow historic paths. The developed drainage basin areas within New Breed Ranch Filing Three have been labeled as Basins I-3.1, I-8.2, I-9.1, and I-9.2 (Figure D1, Appendix E) for general consistency with the basin designations in the previously approved subdivision drainage report.

III. DRAINAGE DESIGN CRITERIA

A. Development Criteria Reference

Drainage planning for this subdivision was previously studied in the February, 2002 “Final Drainage Report, New Breed Ranch Subdivision Filings 1 & 2” by Professional Consultants Incorporated (approved by El Paso County 3/20/02).

B. Hydrologic Criteria

The tributary drainage basins impacting this site are all less than 100 acres, so Rational Method Hydrology procedures were utilized for calculation of peak flows. Rational Method hydrologic calculations were based on the following assumptions:

- Design storm (minor) 5-year
- Design storm (major) 100-year
- Rainfall Intensities El Paso County I-D-F Curve
- Hydrologic soil type B

	<u>C5</u>	<u>C100</u>
• Runoff Coefficients - undeveloped:		
Existing meadow / forest areas	0.08	0.35
• Runoff Coefficients - developed:		
Proposed residential areas (5-acre lots) (4-ac min. lot size, with open space tracts; equivalent overall density of 5-ac lot sizes)	0.137	0.393

Hydrologic calculations are enclosed in Appendix B, and peak design flows are identified on the drainage plan drawings.

IV. DRAINAGE PLANNING FOUR STEP PROCESS

El Paso County Drainage Criteria require drainage planning to include a Four Step Process for receiving water protection that focuses on reducing runoff volumes, treating the water quality capture volume (WQCV), stabilizing drainageways, and implementing long-term source controls. As stated in DCM Volume 2, the Four Step Process is applicable to all new and re-development projects with construction activities that disturb 1 acre or greater or that disturb less than 1 acre but are part of a larger common plan of development. The Four Step Process has been implemented as follows in the planning of this project:

Step 1: Employ Runoff Reduction Practices

- **Minimize Impacts:** The proposed rural residential subdivision development (overall density of 5-acre lot sizes) provides for inherently minimal drainage impacts based on the limited impervious areas associated with rural residential development.
- **Minimize Directly Connected Impervious Areas (MDCIA):** The rural residential development will have roadside ditches along all roads, providing for impervious areas to drain across pervious areas. Based on the roadside ditches throughout the subdivision, the subdivision is classified as MDCIA Level One.
- **Grass Swales:** The proposed rural residential roads will have grass-lined roadside ditches to encourage stormwater infiltration.

Step 2: Stabilize Drainageways

- There are no major drainageways within the site. Vegetated buffer strips will be maintained between developed areas of the site and downstream drainage channels.
- Proper erosion control measures will be implemented along the roadside ditches and grass-lined drainage channels to provide stabilized drainageways within the site.
- Drainage basin fees will be paid at the time of recording of the subdivision plat, and these fees provide the applicable cost contribution towards regional drainage improvements.

Step 3: Provide Water Quality Capture Volume (WQCV)

- The proposed subdivision consists of rural residential lots (>2.5-acre minimum lot sizes), so the single family lots are excluded from water quality requirements per ECM Section I.7.1.B.5.
- Water quality mitigation for the public roadway improvements (Old Arena Way) will be provided by construction of a proposed Rain Garden as a Permanent Control Measure (PCM).

Step 4: Consider Need for Industrial and Commercial BMPs

- No industrial or commercial land uses are proposed within this rural residential subdivision.

V. GENERAL DRAINAGE RECOMMENDATIONS

The developed drainage plan for the site is to provide and maintain positive drainage away from structures and conform to the established drainage patterns for the overall site. JPS Engineering recommends that positive drainage be established and maintained away from all structures within the site in conformance with applicable building codes and geotechnical engineering recommendations.

Site grading and drainage improvements performed as a part of subdivision infrastructure development will include public road improvements and limited overlot grading as depicted on the subdivision construction drawings. Individual lot grading is the sole responsibility of the individual builders and property owners. Final grading of each home site should establish proper protective slopes and positive drainage in accordance with HUD guidelines and building codes. In general, main floor elevations for each home should be established a minimum of 2 feet above the top of curb of the adjoining street.

In general, we recommend a minimum of 6 inches clearance from the top of concrete foundation walls to adjacent finished site grades. Positive drainage slopes should be maintained away from all structures, with a minimum recommended slope of 5 percent for the first 10 feet away from buildings in landscaped areas, a minimum recommended slope of 2 percent for the first 10 feet away from buildings in paved areas, and a minimum slope of 1 percent for paved areas beyond buildings.

VI. DRAINAGE FACILITY DESIGN

A. General Concept

Development of the proposed subdivision will include site grading and road improvements serving seven new rural residential lots, resulting in additional impervious areas across the site. The general concept for management of developed storm runoff is for individual builders to grade the home sites to provide positive drainage away from the building pads, and divert runoff to the proposed roadside ditches and existing grass-lined swales running through the property, following historic drainage

patterns. A new rain garden will be constructed to mitigate water quality impacts from the public roadway improvements.

B. Specific Details

1. Existing Drainage Conditions

Existing drainage conditions are depicted in Figure EX1 (Appendix E). The Filing Three property is currently undeveloped, and there are no existing drainage facilities within the site. There are no existing irrigation facilities, major utilities, or significant encumbrances impacting the site.

The west side of the New Breed Ranch Filing Three property lies within Basin I-3 (38.7-acres), which encompasses the area between an existing ridge on the west side of the proposed Old Arena Way and the existing Oak Cliff Way further to the west. Basin I-3 drains southwesterly to an existing 36" CMP culvert crossing Meadow Run Circle on the east side of Oak Cliff Way. Historic peak flows at Design Point K are calculated as $Q_5 = 6.5$ cfs and $Q_{100} = 48.0$ cfs.

The east side of the New Breed Ranch Filing Three property lies within Basin I-8 (39.8-acres), which encompasses the area between the proposed Old Arena Way and the northeasterly extension of Meadow Run Circle. Basin I-8 receives off-site drainage from upstream Basin I-1 (72.7-acres), which extends northeasterly from Meadow Run Circle to a ridge within the adjoining Bridle Bit Subdivision to the east of New Breed Ranch. Runoff from Basins I-1 flows southwesterly to an existing triple 24" CMP culvert crossing Meadow Run Circle, draining into Basin I-8. The combined flows from Basins I-1 and I-8 drain southwesterly to an existing 48" CMP culvert crossing Meadow Run Circle on the east side of the proposed Old Arena Way. Historic peak flows at Design Point P are calculated as $Q_5 = 12.5$ cfs and $Q_{100} = 91.5$ cfs.

The drainage area between the west side of Old Arena Way and the existing ridge to the west has been delineated as Basin I-9 (12.4-acres), which flows southwesterly to the existing ditch along the north side of Meadow Run Circle, draining to an existing 30" CMP culvert crossing the road. Historic peak flows at Design Point Q are calculated as $Q_5 = 2.1$ cfs and $Q_{100} = 15.8$ cfs.

2. Developed Drainage Conditions Discuss water quality exclusions or treatment applied to each basin.

The developed drainage basins and projected flows are shown on the Developed Drainage Plan (Figure D1, Appendix E).

The westerly edge of the New Breed Ranch Filing Three property has been delineated as Basin I-3.1 (9.9-acres), which sheet flows southwesterly to the west boundary of Filing Three. Developed peak flows from Basin I-3.1 are calculated as $Q_5 = 3.3$ cfs and $Q_{100} = 6.1$ cfs.

Please state condition (proposed/existing) of this culvert.

Sub-Basin I-3.1 contributes to Basin I-3 which drains southwesterly to the existing 36" CMP culvert crossing Meadow Run Circle on the east side of Oak Cliff Way. Developed peak flows at Design Point K are calculated as $Q_5 = 11.4$ cfs and $Q_{100} = 54.9$ cfs.

The easterly edge of the New Breed Ranch Filing Three property has been delineated as a part of Basin I-8.1 (30.8-acres), which sheet flows southwesterly the existing 48" CMP culvert crossing Meadow Run Circle on the east side of the proposed Old Arena Way. Drainage from upstream Basin I-1 will continue to combine with Basin I-8.1 at Design Point P, with developed peak flows calculated as $Q_5 = 20.1$ cfs and $Q_{100} = 96.6$ cfs.

The developed area along the east side of the proposed Old Arena Way has been delineated as Sub-Basin I-8.2 (9.0-acres), which drains into the roadside ditch along the east side of Old Arena Way, flowing south to the proposed Culvert I-8.2. Developed peak flows at Design Point I-8.2 are calculated as $Q_5 = 4.2$ cfs and $Q_{100} = 20.1$ cfs. Culvert I-8.2 (24" RCP) will convey the flow from Basin I-8.2 westerly across Old Arena Way, draining into the proposed Rain Garden I-9.1 at the northwest corner of Old Arena Way and Meadow Run Circle.

Revise it to be DP

The developed area along the west side of the proposed Old Arena Way has been delineated as Sub-Basin I-9.1 (4.9-acres), which drains into the roadside ditch along the west side of Old Arena Way, flowing south into the proposed Rain Garden I-9.1. Developed peak flows from Basin I-9.1 are calculated as $Q_5 = 2.2$ cfs and $Q_{100} = 10.8$ cfs. Flows from Basins I-8.2 and I-9.1 combine at Design Point I-9.1a, with developed peak flows calculated as $Q_5 = 6.4$ cfs and $Q_{100} = 30.6$ cfs.

Rain Garden I-9.1 will provide stormwater quality mitigation for the new roadway improvements. The underdrain flows and overflows from Rain Garden I-9.1 will discharge into the existing grass-lined roadside ditch along the north side of Meadow Run Circle, which provides a stable and adequate outfall for the developed drainage from this subdivision filing.

The southwest corner of the New Breed Ranch Filing Three property has been delineated as a part of Basin I-9.2 (7.5-acres), which sheet flows southwesterly the existing ditch along the north side of Meadow Run Circle. Drainage from Basins I-8.1, I-9.1, and I-9.2 will drain to the existing 30" CMP culvert crossing at the low point in Meadow Run Circle. Developed peak flows at Design Point Q are calculated as $Q_5 = 6.5$ cfs and $Q_{100} = 31.1$ cfs.

Comparison to Previously Approved Subdivision Drainage Report

The combined developed peak flows from Basins I-1, I-3, I-8, and I-9 are calculated as $Q_5 = 31.7$ cfs and $Q_{100} = 152.6$ cfs. The previously approved subdivision drainage report by PCI identified the total combined flows from these basins as $Q_{100} = 217.1$ cfs. As such, the calculated developed flows are below the previously estimated flows from this part of the subdivision and consistent with the established drainage planning for this subdivision.

Please compare the runoff at the design point (DP) between the existing and proposed conditions as they leave the site. It appears that there is an increase in runoff flow for proposed DP K, P, Q and compared to the existing one. Please explain how erosion to the downstream can be handled with this increase.

Please provide analysis showing the existing grass-lined roadside ditch has capacity to carry the discharge from the rain garden.

The increase is significant. The runoff leaving from proposed DP Q, P, K is approximately twice that of the existing runoff.
Note that downstream consists of single-family residential areas. Increase in flows must be mitigated.

Recognizing the rural residential nature of the proposed subdivision (5-acre average lot sizes), the small increase in developed flows will have no significant impact on downstream facilities.

C. On-Site Drainage Facility Design

add that increase in flows must be mitigated.

Developed sub-basins and proposed drainage facilities are shown on the enclosed Drainage Plan (Sheet D1). In accordance with El Paso County standards, new roadways will be graded with a minimum longitudinal slope of 1.0 percent. On-site drainage facilities will consist of roadside ditches, grass-lined channels, and culverts.

Hydraulic design calculations for sizing of on-site drainage facilities are enclosed in Appendix C and design criteria are summarized as follows:

1. Culverts

Is it 24 or 18 inches?

The road system will be graded to convey surface drainage in roadside ditches to low points along the road profile, where cross-culverts will convey developed flows into grass-lined channels following historic drainage paths. Culvert pipes have been specified as reinforced concrete pipe (RCP) with a minimum diameter of 18-inches. Culvert sizes have been identified based on a maximum headwater-to-depth ratio (HW/D) of 1.0 for the minor (5-year) design storm. Final culvert design has been performed utilizing the FHWA HY-8 software package to perform a detailed analysis of inlet and outlet control conditions, meeting El Paso County criteria for allowable overtopping. Culvert design parameters are tabulated in Appendix C.

Flared end sections have been specified for culvert inlets and outlets, and riprap aprons will be provided at all culvert outlets. The on-site soils are classified as Hydrologic Soils Group B (moderate hazard of erosion). Based on engineering judgement given the site conditions, cutoff walls are not necessary for the culvert inlets and outlets.

2. Open Channels

The existing and proposed drainage ditches and channels have been evaluated utilizing Manning's equation for open channel flow, assuming a friction factor ("n") of 0.030 for dry-land grass channels. Maximum allowable velocities have been evaluated based on El Paso County drainage criteria, generally allowing for a maximum 100-year velocity of 5 feet per second. The proposed channels will be seeded with native grasses for erosion control. Erosion control blanket / turf reinforcement mat linings have been specified where required along the roadside ditches based on erosive velocities. Detailed channel hydraulic calculations are enclosed in Appendix C.

For existing culverts: As the proposed runoff flow increases at DP K, Q, and P, please explain whether the existing culverts have the capacity to carry the new runoff flows. Additionally, please provide a hydraulic analysis of those culverts.

Please provide a discussion how proposed runoff flow interacts with the new channel I-8.1 in the proposed drainage condition.

D. Analysis of Existing and Proposed Downstream Facilities

The proposed subdivision area will drain southwesterly to existing ditches and natural drainage swales flowing to the Black Squirrel Creek Drainage Basin. Development of this property as a rural residential subdivision will have no significant impact on downstream drainage facilities.

There is no evidence of erosive conditions at the outfall points, and the existing downstream grass-lined drainage ditches and channels provide a hydrologically and hydraulically adequate drainage outfall system.

E. Anticipated Drainage Problems and Solutions

The drainage plan for this subdivision consists of maintaining positive drainage away from home sites and conveying drainage through the site in general conformance with historic drainage patterns. The primary drainage problems anticipated within this type of development consist of maintenance of proper drainage patterns and erosion control.

Care will need to be taken to implement proper erosion control measures associated with the proposed driveways, home sites, and drainage swales. Proposed drainage facilities outside the public right-of-way will be owned and maintained by the individual lot owners unless otherwise noted.

VII. EROSION CONTROL / SEDIMENT CONTROL

Contractors and Owners will need to implement and maintain proper control measures (CM's) for erosion and sediment control during and after construction. Erosion control measures should include installation of silt fence at the toe of disturbed areas, straw bales protecting drainage ditches, vehicle tracking control pads at access points, riprap protection at culvert outlets, and revegetation of disturbed areas. Cut slopes will need to be stabilized during excavation as necessary and vegetation will need to be re-established as soon as possible for stabilization of graded areas.

VIII. STORMWATER DETENTION AND WATER QUALITY

Based on the rural residential nature of this subdivision and the large lot sizes proposed, there will be no significant increase in developed flows, and there is no need for on-site flood control detention.

Water quality facilities are not required for the rural residential subdivision lots as this site meets exclusions listed in the revised El Paso County Engineering Criteria Manual (ECM). Section I.7.1.B.5 of the ECM identifies "Large Lot Single Family Sites" as excluded sites under the following definition: "A single-family residential lot, or agricultural zoned lands, greater than or equal to 2.5 acres in size per dwelling and having a total lot impervious area of less than 10 percent." The estimated new impervious area of the proposed 5-acre lots is 7 percent, which is below the "10 percent" threshold.

It is not true. The proposed flow is significantly different from the existing flow.

Please include the criteria being used for rain garden design.

Water quality mitigation for the public road improvements will be provided by constructing a new Rain Garden as a permanent water quality control measure. The proposed drainage and grading plan for this site includes a new Rain Garden (RG) at the northwest corner of Meadow Run Circle and Old Arena Way to provide the required stormwater quality mitigation to address the roadway construction impacts for the new public road of Old Arena Way extending north from Meadow Run Circle (Basins I-8.2 and I-9.1).

According to the calculations in Appendix D, the required Water Quality Capture Volume (WQCV) for Design Point I-9.1 is 1,981 cubic feet, and the proposed Rain Garden I-9.1 provides a volume of 2,134 cubic feet.

The proposed stormwater quality facilities will be privately owned and maintained by the subdivision homeowners association (HOA), and maintenance access is readily available from the adjoining public roads.

reduction only applies to the drainage basin fee not the bridge fee. Please revise.

IX. DRAINAGE FEES

The developer will finance all costs for required subdivision improvements, and there are no reimbursable public drainage facilities proposed as part of this subdivision development.

The property is located entirely within the Black Squirrel Creek Drainage Basin (FOM 03600), which has a 2024 drainage basin fee of \$11,275 per impervious acre and a bridge fee of \$710 per impervious acre. Applicable drainage basin fees are calculated as follows:

Subdivision Area =	34.7 acres
Impervious Area Percentage =	7.0%
Calculated Impervious Area =	2.429 ac.
Adjusted Impervious Area = (2.429 ac) * 75% =	1.822 ac.
(includes 25% reduction on drainage fees for 2.5 to 5-acre lots per ECM Appendix L Section 3.10.2a)	
Drainage Basin Fee = (1.822 ac.) @ \$11,275/ac. =	\$20,543.05
Bridge Fee = (1.822 ac.) @ \$710/ac. =	<u>\$ 1,293.62</u>
Total Fee =	\$21,836.67

X. SUMMARY

New Breed Ranch Subdivision Filing Three is a proposed rural residential subdivision filing consisting of 7 lots comprising the third phase of the previously approved New Breed Ranch Preliminary Plan. Development of the proposed subdivision filing is anticipated to result in a minimal increase in developed runoff from the site, and erosion control measures will be implemented to mitigate developed drainage impacts.

A rain garden will be constructed as a permanent water quality control measure to meet current County stormwater quality requirements for the new roadway improvements. The proposed rural residential subdivision (overall density of 5-acre lots) is fully consistent with the surrounding zoning and character of this site.

The proposed drainage patterns will remain consistent with historic conditions, and new drainage facilities will be constructed to El Paso County standards to safely convey runoff to adequate outfalls. Construction and proper maintenance of the proposed drainage facilities, in conjunction with proper erosion control measures, will ensure that this development has no significant adverse drainage impact on downstream properties.

APPENDIX A
SOILS INFORMATION



United States
Department of
Agriculture

NRCS

Natural
Resources
Conservation
Service

A product of the National
Cooperative Soil Survey,
a joint effort of the United
States Department of
Agriculture and other
Federal agencies, State
agencies including the
Agricultural Experiment
Stations, and local
participants

Custom Soil Resource Report for El Paso County Area, Colorado



Preface

Soil surveys contain information that affects land use planning in survey areas. They highlight soil limitations that affect various land uses and provide information about the properties of the soils in the survey areas. Soil surveys are designed for many different users, including farmers, ranchers, foresters, agronomists, urban planners, community officials, engineers, developers, builders, and home buyers. Also, conservationists, teachers, students, and specialists in recreation, waste disposal, and pollution control can use the surveys to help them understand, protect, or enhance the environment.

Various land use regulations of Federal, State, and local governments may impose special restrictions on land use or land treatment. Soil surveys identify soil properties that are used in making various land use or land treatment decisions. The information is intended to help the land users identify and reduce the effects of soil limitations on various land uses. The landowner or user is responsible for identifying and complying with existing laws and regulations.

Although soil survey information can be used for general farm, local, and wider area planning, onsite investigation is needed to supplement this information in some cases. Examples include soil quality assessments (<http://www.nrcs.usda.gov/wps/portal/nrcs/main/soils/health/>) and certain conservation and engineering applications. For more detailed information, contact your local USDA Service Center (<https://offices.sc.egov.usda.gov/locator/app?agency=nrcs>) or your NRCS State Soil Scientist (http://www.nrcs.usda.gov/wps/portal/nrcs/detail/soils/contactus/?cid=nrcs142p2_053951).

Great differences in soil properties can occur within short distances. Some soils are seasonally wet or subject to flooding. Some are too unstable to be used as a foundation for buildings or roads. Clayey or wet soils are poorly suited to use as septic tank absorption fields. A high water table makes a soil poorly suited to basements or underground installations.

The National Cooperative Soil Survey is a joint effort of the United States Department of Agriculture and other Federal agencies, State agencies including the Agricultural Experiment Stations, and local agencies. The Natural Resources Conservation Service (NRCS) has leadership for the Federal part of the National Cooperative Soil Survey.

Information about soils is updated periodically. Updated information is available through the NRCS Web Soil Survey, the site for official soil survey information.

The U.S. Department of Agriculture (USDA) prohibits discrimination in all its programs and activities on the basis of race, color, national origin, age, disability, and where applicable, sex, marital status, familial status, parental status, religion, sexual orientation, genetic information, political beliefs, reprisal, or because all or a part of an individual's income is derived from any public assistance program. (Not all prohibited bases apply to all programs.) Persons with disabilities who require

alternative means for communication of program information (Braille, large print, audiotape, etc.) should contact USDA's TARGET Center at (202) 720-2600 (voice and TDD). To file a complaint of discrimination, write to USDA, Director, Office of Civil Rights, 1400 Independence Avenue, S.W., Washington, D.C. 20250-9410 or call (800) 795-3272 (voice) or (202) 720-6382 (TDD). USDA is an equal opportunity provider and employer.

Contents

Preface	2
How Soil Surveys Are Made	5
Soil Map	8
Soil Map.....	9
Legend.....	10
Map Unit Legend.....	11
Map Unit Descriptions.....	11
El Paso County Area, Colorado.....	13
41—Kettle gravelly loamy sand, 8 to 40 percent slopes.....	13
69—Peyton-Pring complex, 8 to 15 percent slopes.....	14
93—Tomah-Crowfoot complex, 8 to 15 percent slopes.....	15
References	18

How Soil Surveys Are Made

Soil surveys are made to provide information about the soils and miscellaneous areas in a specific area. They include a description of the soils and miscellaneous areas and their location on the landscape and tables that show soil properties and limitations affecting various uses. Soil scientists observed the steepness, length, and shape of the slopes; the general pattern of drainage; the kinds of crops and native plants; and the kinds of bedrock. They observed and described many soil profiles. A soil profile is the sequence of natural layers, or horizons, in a soil. The profile extends from the surface down into the unconsolidated material in which the soil formed or from the surface down to bedrock. The unconsolidated material is devoid of roots and other living organisms and has not been changed by other biological activity.

Currently, soils are mapped according to the boundaries of major land resource areas (MLRAs). MLRAs are geographically associated land resource units that share common characteristics related to physiography, geology, climate, water resources, soils, biological resources, and land uses (USDA, 2006). Soil survey areas typically consist of parts of one or more MLRA.

The soils and miscellaneous areas in a survey area occur in an orderly pattern that is related to the geology, landforms, relief, climate, and natural vegetation of the area. Each kind of soil and miscellaneous area is associated with a particular kind of landform or with a segment of the landform. By observing the soils and miscellaneous areas in the survey area and relating their position to specific segments of the landform, a soil scientist develops a concept, or model, of how they were formed. Thus, during mapping, this model enables the soil scientist to predict with a considerable degree of accuracy the kind of soil or miscellaneous area at a specific location on the landscape.

Commonly, individual soils on the landscape merge into one another as their characteristics gradually change. To construct an accurate soil map, however, soil scientists must determine the boundaries between the soils. They can observe only a limited number of soil profiles. Nevertheless, these observations, supplemented by an understanding of the soil-vegetation-landscape relationship, are sufficient to verify predictions of the kinds of soil in an area and to determine the boundaries.

Soil scientists recorded the characteristics of the soil profiles that they studied. They noted soil color, texture, size and shape of soil aggregates, kind and amount of rock fragments, distribution of plant roots, reaction, and other features that enable them to identify soils. After describing the soils in the survey area and determining their properties, the soil scientists assigned the soils to taxonomic classes (units). Taxonomic classes are concepts. Each taxonomic class has a set of soil characteristics with precisely defined limits. The classes are used as a basis for comparison to classify soils systematically. Soil taxonomy, the system of taxonomic classification used in the United States, is based mainly on the kind and character of soil properties and the arrangement of horizons within the profile. After the soil

Custom Soil Resource Report

scientists classified and named the soils in the survey area, they compared the individual soils with similar soils in the same taxonomic class in other areas so that they could confirm data and assemble additional data based on experience and research.

The objective of soil mapping is not to delineate pure map unit components; the objective is to separate the landscape into landforms or landform segments that have similar use and management requirements. Each map unit is defined by a unique combination of soil components and/or miscellaneous areas in predictable proportions. Some components may be highly contrasting to the other components of the map unit. The presence of minor components in a map unit in no way diminishes the usefulness or accuracy of the data. The delineation of such landforms and landform segments on the map provides sufficient information for the development of resource plans. If intensive use of small areas is planned, onsite investigation is needed to define and locate the soils and miscellaneous areas.

Soil scientists make many field observations in the process of producing a soil map. The frequency of observation is dependent upon several factors, including scale of mapping, intensity of mapping, design of map units, complexity of the landscape, and experience of the soil scientist. Observations are made to test and refine the soil-landscape model and predictions and to verify the classification of the soils at specific locations. Once the soil-landscape model is refined, a significantly smaller number of measurements of individual soil properties are made and recorded. These measurements may include field measurements, such as those for color, depth to bedrock, and texture, and laboratory measurements, such as those for content of sand, silt, clay, salt, and other components. Properties of each soil typically vary from one point to another across the landscape.

Observations for map unit components are aggregated to develop ranges of characteristics for the components. The aggregated values are presented. Direct measurements do not exist for every property presented for every map unit component. Values for some properties are estimated from combinations of other properties.

While a soil survey is in progress, samples of some of the soils in the area generally are collected for laboratory analyses and for engineering tests. Soil scientists interpret the data from these analyses and tests as well as the field-observed characteristics and the soil properties to determine the expected behavior of the soils under different uses. Interpretations for all of the soils are field tested through observation of the soils in different uses and under different levels of management. Some interpretations are modified to fit local conditions, and some new interpretations are developed to meet local needs. Data are assembled from other sources, such as research information, production records, and field experience of specialists. For example, data on crop yields under defined levels of management are assembled from farm records and from field or plot experiments on the same kinds of soil.

Predictions about soil behavior are based not only on soil properties but also on such variables as climate and biological activity. Soil conditions are predictable over long periods of time, but they are not predictable from year to year. For example, soil scientists can predict with a fairly high degree of accuracy that a given soil will have a high water table within certain depths in most years, but they cannot predict that a high water table will always be at a specific level in the soil on a specific date.

After soil scientists located and identified the significant natural bodies of soil in the survey area, they drew the boundaries of these bodies on aerial photographs and

Custom Soil Resource Report

identified each as a specific map unit. Aerial photographs show trees, buildings, fields, roads, and rivers, all of which help in locating boundaries accurately.

Soil Map

The soil map section includes the soil map for the defined area of interest, a list of soil map units on the map and extent of each map unit, and cartographic symbols displayed on the map. Also presented are various metadata about data used to produce the map, and a description of each soil map unit.

Custom Soil Resource Report Soil Map

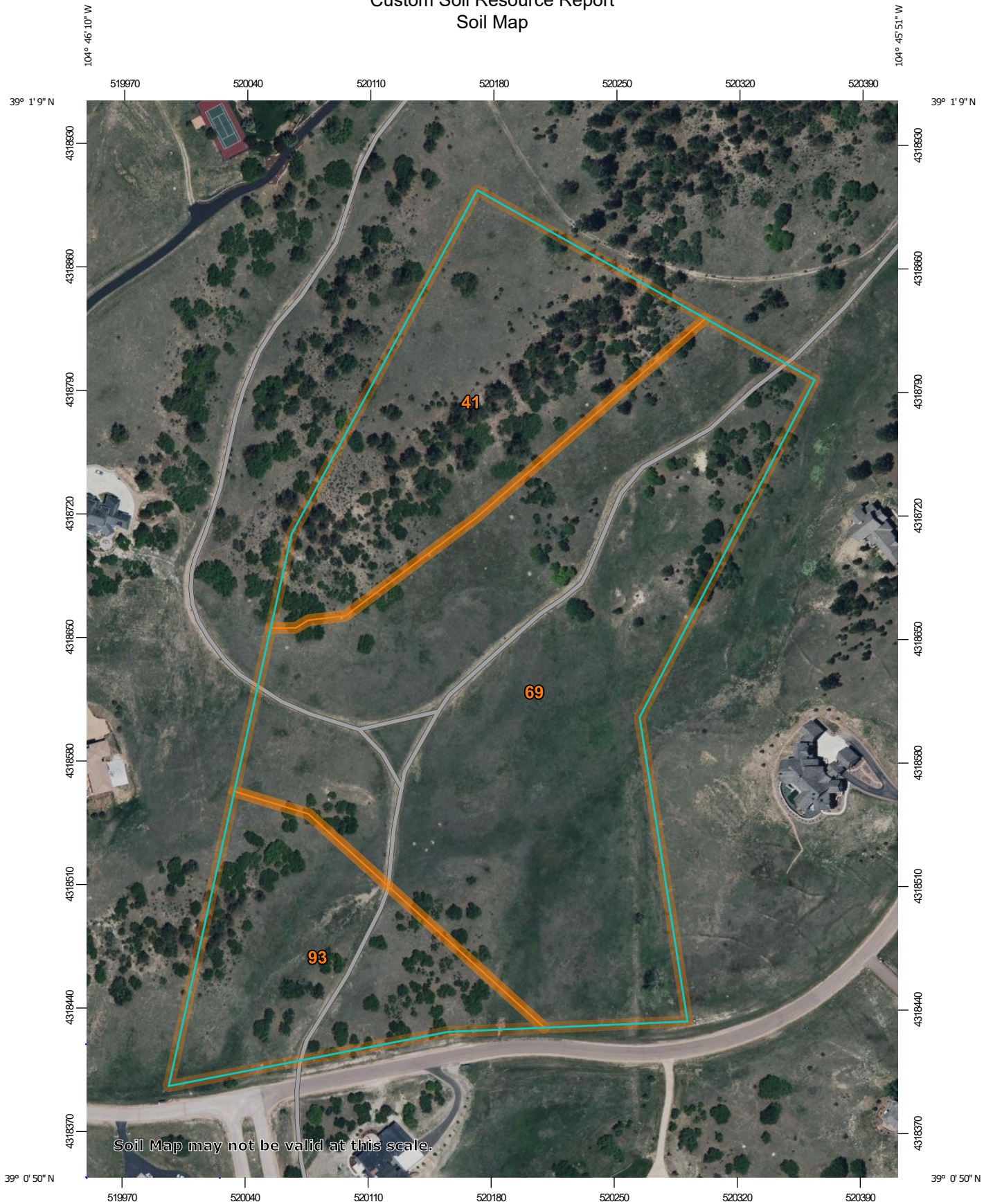

Map Scale: 1:2,970 if printed on A portrait (8.5" x 11") sheet.

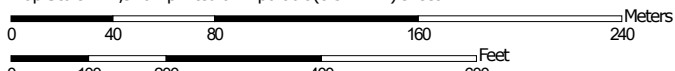

Map projection: Web Mercator Corner coordinates: WGS84 Edge tics: UTM Zone 13N WGS84

MAP LEGEND

Area of Interest (AOI)

 Area of Interest (AOI)

Soils

 Soil Map Unit Polygons

 Soil Map Unit Lines

 Soil Map Unit Points

Special Point Features

-  Blowout
-  Borrow Pit
-  Clay Spot
-  Closed Depression
-  Gravel Pit
-  Gravelly Spot
-  Landfill
-  Lava Flow
-  Marsh or swamp
-  Mine or Quarry
-  Miscellaneous Water
-  Perennial Water
-  Rock Outcrop
-  Saline Spot
-  Sandy Spot
-  Severely Eroded Spot
-  Sinkhole
-  Slide or Slip
-  Sodic Spot

-  Spoil Area
-  Stony Spot
-  Very Stony Spot
-  Wet Spot
-  Other
-  Special Line Features

Water Features

 Streams and Canals

Transportation

-  Rails
-  Interstate Highways
-  US Routes
-  Major Roads
-  Local Roads

Background

 Aerial Photography

MAP INFORMATION

The soil surveys that comprise your AOI were mapped at 1:24,000.

Warning: Soil Map may not be valid at this scale.

Enlargement of maps beyond the scale of mapping can cause misunderstanding of the detail of mapping and accuracy of soil line placement. The maps do not show the small areas of contrasting soils that could have been shown at a more detailed scale.

Please rely on the bar scale on each map sheet for map measurements.

Source of Map: Natural Resources Conservation Service
 Web Soil Survey URL:
 Coordinate System: Web Mercator (EPSG:3857)

Maps from the Web Soil Survey are based on the Web Mercator projection, which preserves direction and shape but distorts distance and area. A projection that preserves area, such as the Albers equal-area conic projection, should be used if more accurate calculations of distance or area are required.

This product is generated from the USDA-NRCS certified data as of the version date(s) listed below.

Soil Survey Area: El Paso County Area, Colorado
 Survey Area Data: Version 20, Sep 2, 2022

Soil map units are labeled (as space allows) for map scales 1:50,000 or larger.

Date(s) aerial images were photographed: Jun 9, 2021—Jun 12, 2021

The orthophoto or other base map on which the soil lines were compiled and digitized probably differs from the background imagery displayed on these maps. As a result, some minor shifting of map unit boundaries may be evident.

Map Unit Legend

Map Unit Symbol	Map Unit Name	Acres in AOI	Percent of AOI
41	Kettle gravelly loamy sand, 8 to 40 percent slopes	6.3	23.7%
69	Peyton-Pring complex, 8 to 15 percent slopes	15.8	59.2%
93	Tomah-Crowfoot complex, 8 to 15 percent slopes	4.5	17.0%
Totals for Area of Interest		26.6	100.0%

Map Unit Descriptions

The map units delineated on the detailed soil maps in a soil survey represent the soils or miscellaneous areas in the survey area. The map unit descriptions, along with the maps, can be used to determine the composition and properties of a unit.

A map unit delineation on a soil map represents an area dominated by one or more major kinds of soil or miscellaneous areas. A map unit is identified and named according to the taxonomic classification of the dominant soils. Within a taxonomic class there are precisely defined limits for the properties of the soils. On the landscape, however, the soils are natural phenomena, and they have the characteristic variability of all natural phenomena. Thus, the range of some observed properties may extend beyond the limits defined for a taxonomic class. Areas of soils of a single taxonomic class rarely, if ever, can be mapped without including areas of other taxonomic classes. Consequently, every map unit is made up of the soils or miscellaneous areas for which it is named and some minor components that belong to taxonomic classes other than those of the major soils.

Most minor soils have properties similar to those of the dominant soil or soils in the map unit, and thus they do not affect use and management. These are called noncontrasting, or similar, components. They may or may not be mentioned in a particular map unit description. Other minor components, however, have properties and behavioral characteristics divergent enough to affect use or to require different management. These are called contrasting, or dissimilar, components. They generally are in small areas and could not be mapped separately because of the scale used. Some small areas of strongly contrasting soils or miscellaneous areas are identified by a special symbol on the maps. If included in the database for a given area, the contrasting minor components are identified in the map unit descriptions along with some characteristics of each. A few areas of minor components may not have been observed, and consequently they are not mentioned in the descriptions, especially where the pattern was so complex that it was impractical to make enough observations to identify all the soils and miscellaneous areas on the landscape.

The presence of minor components in a map unit in no way diminishes the usefulness or accuracy of the data. The objective of mapping is not to delineate pure taxonomic classes but rather to separate the landscape into landforms or

Custom Soil Resource Report

landform segments that have similar use and management requirements. The delineation of such segments on the map provides sufficient information for the development of resource plans. If intensive use of small areas is planned, however, onsite investigation is needed to define and locate the soils and miscellaneous areas.

An identifying symbol precedes the map unit name in the map unit descriptions. Each description includes general facts about the unit and gives important soil properties and qualities.

Soils that have profiles that are almost alike make up a *soil series*. Except for differences in texture of the surface layer, all the soils of a series have major horizons that are similar in composition, thickness, and arrangement.

Soils of one series can differ in texture of the surface layer, slope, stoniness, salinity, degree of erosion, and other characteristics that affect their use. On the basis of such differences, a soil series is divided into *soil phases*. Most of the areas shown on the detailed soil maps are phases of soil series. The name of a soil phase commonly indicates a feature that affects use or management. For example, Alpha silt loam, 0 to 2 percent slopes, is a phase of the Alpha series.

Some map units are made up of two or more major soils or miscellaneous areas. These map units are complexes, associations, or undifferentiated groups.

A *complex* consists of two or more soils or miscellaneous areas in such an intricate pattern or in such small areas that they cannot be shown separately on the maps. The pattern and proportion of the soils or miscellaneous areas are somewhat similar in all areas. Alpha-Beta complex, 0 to 6 percent slopes, is an example.

An *association* is made up of two or more geographically associated soils or miscellaneous areas that are shown as one unit on the maps. Because of present or anticipated uses of the map units in the survey area, it was not considered practical or necessary to map the soils or miscellaneous areas separately. The pattern and relative proportion of the soils or miscellaneous areas are somewhat similar. Alpha-Beta association, 0 to 2 percent slopes, is an example.

An *undifferentiated group* is made up of two or more soils or miscellaneous areas that could be mapped individually but are mapped as one unit because similar interpretations can be made for use and management. The pattern and proportion of the soils or miscellaneous areas in a mapped area are not uniform. An area can be made up of only one of the major soils or miscellaneous areas, or it can be made up of all of them. Alpha and Beta soils, 0 to 2 percent slopes, is an example.

Some surveys include *miscellaneous areas*. Such areas have little or no soil material and support little or no vegetation. Rock outcrop is an example.

El Paso County Area, Colorado

41—Kettle gravelly loamy sand, 8 to 40 percent slopes

Map Unit Setting

National map unit symbol: 368h
Elevation: 7,000 to 7,700 feet
Farmland classification: Not prime farmland

Map Unit Composition

Kettle and similar soils: 85 percent
Estimates are based on observations, descriptions, and transects of the mapunit.

Description of Kettle

Setting

Landform: Hills
Landform position (three-dimensional): Side slope
Down-slope shape: Linear
Across-slope shape: Linear
Parent material: Sandy alluvium derived from arkose

Typical profile

E - 0 to 16 inches: gravelly loamy sand
Bt - 16 to 40 inches: gravelly sandy loam
C - 40 to 60 inches: extremely gravelly loamy sand

Properties and qualities

Slope: 8 to 40 percent
Depth to restrictive feature: More than 80 inches
Drainage class: Somewhat excessively drained
Runoff class: Medium
Capacity of the most limiting layer to transmit water (Ksat): High (2.00 to 6.00 in/hr)
Depth to water table: More than 80 inches
Frequency of flooding: None
Frequency of ponding: None
Available water supply, 0 to 60 inches: Low (about 3.4 inches)

Interpretive groups

Land capability classification (irrigated): None specified
Land capability classification (nonirrigated): 7e
Hydrologic Soil Group: B
Ecological site: F048AY908CO - Mixed Conifer
Hydric soil rating: No

Minor Components

Other soils

Percent of map unit:
Hydric soil rating: No

Pleasant

Percent of map unit:
Landform: Depressions
Hydric soil rating: Yes

69—Peyton-Pring complex, 8 to 15 percent slopes

Map Unit Setting

National map unit symbol: 369g
Elevation: 6,800 to 7,600 feet
Farmland classification: Not prime farmland

Map Unit Composition

Peyton and similar soils: 40 percent
Pring and similar soils: 30 percent
Estimates are based on observations, descriptions, and transects of the mapunit.

Description of Peyton

Setting

Landform: Hills
Landform position (three-dimensional): Side slope
Down-slope shape: Linear
Across-slope shape: Linear
Parent material: Arkosic alluvium derived from sedimentary rock and/or arkosic residuum weathered from sedimentary rock

Typical profile

A - 0 to 12 inches: sandy loam
Bt - 12 to 25 inches: sandy clay loam
BC - 25 to 35 inches: sandy clay loam
C - 35 to 60 inches: sandy loam

Properties and qualities

Slope: 8 to 9 percent
Depth to restrictive feature: More than 80 inches
Drainage class: Well drained
Runoff class: Medium
Capacity of the most limiting layer to transmit water (Ksat): Moderately high (0.20 to 0.60 in/hr)
Depth to water table: More than 80 inches
Frequency of flooding: None
Frequency of ponding: None
Available water supply, 0 to 60 inches: Moderate (about 7.3 inches)

Interpretive groups

Land capability classification (irrigated): None specified
Land capability classification (nonirrigated): 4e
Hydrologic Soil Group: B
Ecological site: R049XY216CO - Sandy Divide
Hydric soil rating: No

Description of Pring

Setting

Landform: Hills
Landform position (three-dimensional): Side slope
Down-slope shape: Linear
Across-slope shape: Linear
Parent material: Arkosic alluvium derived from sedimentary rock

Typical profile

A - 0 to 14 inches: coarse sandy loam
C - 14 to 60 inches: gravelly sandy loam

Properties and qualities

Slope: 8 to 15 percent
Depth to restrictive feature: More than 80 inches
Drainage class: Well drained
Runoff class: Low
Capacity of the most limiting layer to transmit water (Ksat): High (2.00 to 6.00 in/hr)
Depth to water table: More than 80 inches
Frequency of flooding: None
Frequency of ponding: None
Available water supply, 0 to 60 inches: Low (about 6.0 inches)

Interpretive groups

Land capability classification (irrigated): None specified
Land capability classification (nonirrigated): 6e
Hydrologic Soil Group: B
Ecological site: R048AY222CO - Loamy Park
Hydric soil rating: No

Minor Components

Other soils

Percent of map unit:
Hydric soil rating: No

Pleasant

Percent of map unit:
Landform: Depressions
Hydric soil rating: Yes

93—Tomah-Crowfoot complex, 8 to 15 percent slopes

Map Unit Setting

National map unit symbol: 36bb
Elevation: 7,300 to 7,600 feet
Farmland classification: Not prime farmland

Map Unit Composition

Tomah and similar soils: 50 percent

Crowfoot and similar soils: 30 percent

Estimates are based on observations, descriptions, and transects of the mapunit.

Description of Tomah

Setting

Landform: Hills, alluvial fans

Landform position (three-dimensional): Side slope, crest

Down-slope shape: Linear

Across-slope shape: Linear

Parent material: Alluvium derived from arkose and/or residuum weathered from arkose

Typical profile

A - 0 to 10 inches: loamy sand

E - 10 to 22 inches: coarse sand

Bt - 22 to 48 inches: stratified coarse sand to sandy clay loam

C - 48 to 60 inches: coarse sand

Properties and qualities

Slope: 8 to 15 percent

Depth to restrictive feature: More than 80 inches

Drainage class: Well drained

Runoff class: Medium

Capacity of the most limiting layer to transmit water (Ksat): Moderately high to high (0.60 to 2.00 in/hr)

Depth to water table: More than 80 inches

Frequency of flooding: None

Frequency of ponding: None

Available water supply, 0 to 60 inches: Low (about 4.6 inches)

Interpretive groups

Land capability classification (irrigated): None specified

Land capability classification (nonirrigated): 6e

Hydrologic Soil Group: B

Ecological site: R049XY216CO - Sandy Divide

Hydric soil rating: No

Description of Crowfoot

Setting

Landform: Hills, alluvial fans

Landform position (three-dimensional): Side slope, crest

Down-slope shape: Linear

Across-slope shape: Linear

Parent material: Alluvium

Typical profile

A - 0 to 12 inches: loamy sand

E - 12 to 23 inches: sand

Bt - 23 to 36 inches: sandy clay loam

C - 36 to 60 inches: coarse sand

Properties and qualities

Slope: 8 to 15 percent

Custom Soil Resource Report

Depth to restrictive feature: More than 80 inches

Drainage class: Well drained

Runoff class: Medium

Capacity of the most limiting layer to transmit water (Ksat): Moderately high to high
(0.60 to 2.00 in/hr)

Depth to water table: More than 80 inches

Frequency of flooding: None

Frequency of ponding: None

Available water supply, 0 to 60 inches: Low (about 4.7 inches)

Interpretive groups

Land capability classification (irrigated): None specified

Land capability classification (nonirrigated): 6e

Hydrologic Soil Group: B

Ecological site: R049XY216CO - Sandy Divide

Hydric soil rating: No

Minor Components

Other soils

Percent of map unit:

Hydric soil rating: No

Pleasant

Percent of map unit:

Landform: Depressions

Hydric soil rating: Yes

References

- American Association of State Highway and Transportation Officials (AASHTO). 2004. Standard specifications for transportation materials and methods of sampling and testing. 24th edition.
- American Society for Testing and Materials (ASTM). 2005. Standard classification of soils for engineering purposes. ASTM Standard D2487-00.
- Cowardin, L.M., V. Carter, F.C. Golet, and E.T. LaRoe. 1979. Classification of wetlands and deep-water habitats of the United States. U.S. Fish and Wildlife Service FWS/OBS-79/31.
- Federal Register. July 13, 1994. Changes in hydric soils of the United States.
- Federal Register. September 18, 2002. Hydric soils of the United States.
- Hurt, G.W., and L.M. Vasilas, editors. Version 6.0, 2006. Field indicators of hydric soils in the United States.
- National Research Council. 1995. Wetlands: Characteristics and boundaries.
- Soil Survey Division Staff. 1993. Soil survey manual. Soil Conservation Service. U.S. Department of Agriculture Handbook 18. http://www.nrcs.usda.gov/wps/portal/nrcs/detail/national/soils/?cid=nrcs142p2_054262
- Soil Survey Staff. 1999. Soil taxonomy: A basic system of soil classification for making and interpreting soil surveys. 2nd edition. Natural Resources Conservation Service, U.S. Department of Agriculture Handbook 436. http://www.nrcs.usda.gov/wps/portal/nrcs/detail/national/soils/?cid=nrcs142p2_053577
- Soil Survey Staff. 2010. Keys to soil taxonomy. 11th edition. U.S. Department of Agriculture, Natural Resources Conservation Service. http://www.nrcs.usda.gov/wps/portal/nrcs/detail/national/soils/?cid=nrcs142p2_053580
- Tiner, R.W., Jr. 1985. Wetlands of Delaware. U.S. Fish and Wildlife Service and Delaware Department of Natural Resources and Environmental Control, Wetlands Section.
- United States Army Corps of Engineers, Environmental Laboratory. 1987. Corps of Engineers wetlands delineation manual. Waterways Experiment Station Technical Report Y-87-1.
- United States Department of Agriculture, Natural Resources Conservation Service. National forestry manual. http://www.nrcs.usda.gov/wps/portal/nrcs/detail/soils/home/?cid=nrcs142p2_053374
- United States Department of Agriculture, Natural Resources Conservation Service. National range and pasture handbook. <http://www.nrcs.usda.gov/wps/portal/nrcs/detail/national/landuse/rangepasture/?cid=stelprdb1043084>

Custom Soil Resource Report

United States Department of Agriculture, Natural Resources Conservation Service. National soil survey handbook, title 430-VI. http://www.nrcs.usda.gov/wps/portal/nrcs/detail/soils/scientists/?cid=nrcs142p2_054242

United States Department of Agriculture, Natural Resources Conservation Service. 2006. Land resource regions and major land resource areas of the United States, the Caribbean, and the Pacific Basin. U.S. Department of Agriculture Handbook 296. http://www.nrcs.usda.gov/wps/portal/nrcs/detail/national/soils/?cid=nrcs142p2_053624

United States Department of Agriculture, Soil Conservation Service. 1961. Land capability classification. U.S. Department of Agriculture Handbook 210. http://www.nrcs.usda.gov/Internet/FSE_DOCUMENTS/nrcs142p2_052290.pdf

Hydrologic Soil Group—El Paso County Area, Colorado
(New Breed Ranch Filing Three)

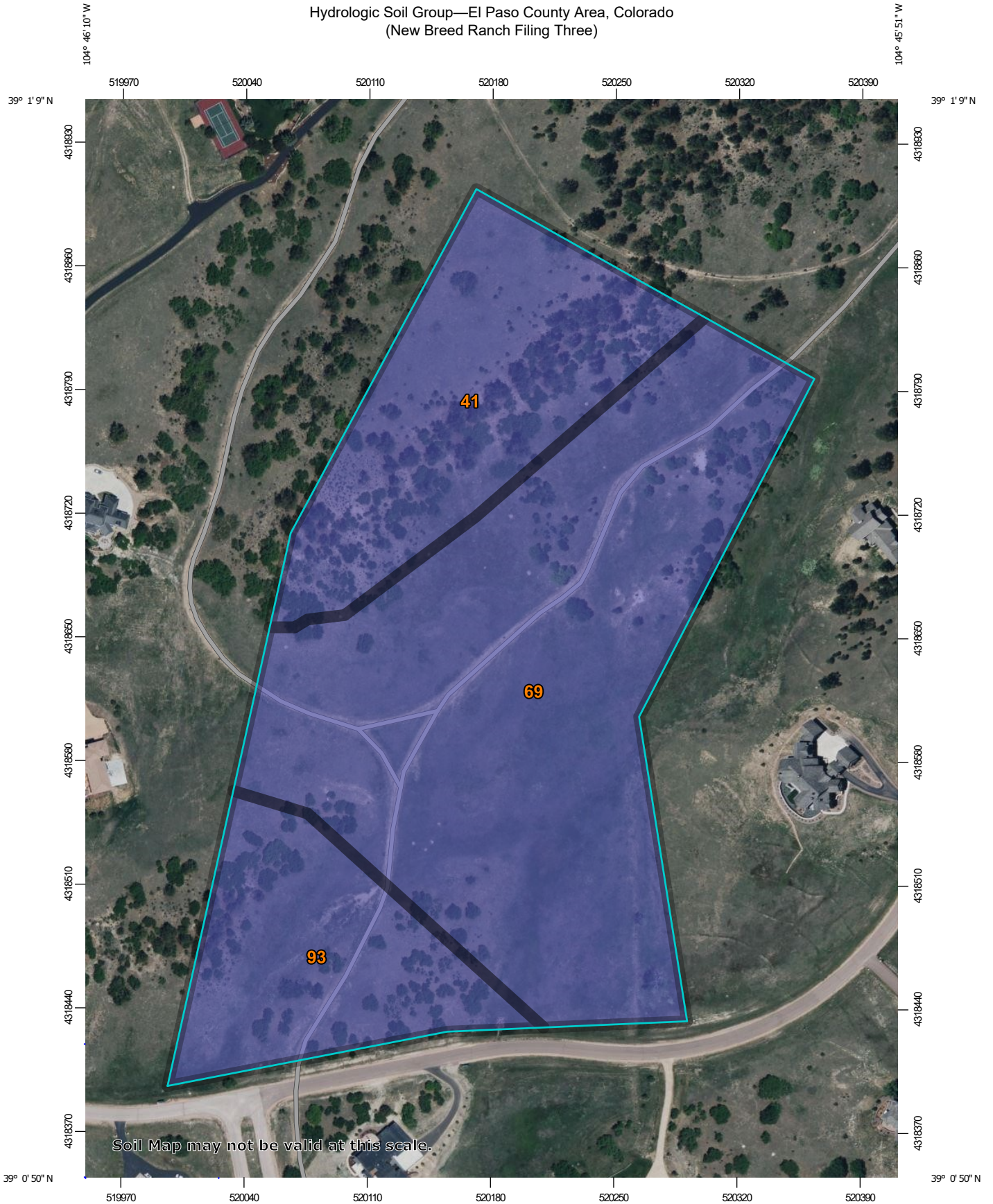

Map Scale: 1:2,970 if printed on A portrait (8.5" x 11") sheet.

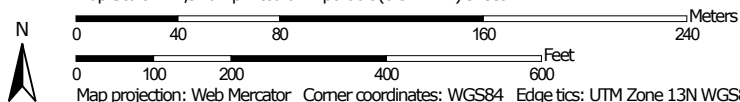

Map projection: Web Mercator Corner coordinates: WGS84 Edge tics: UTM Zone 13N WGS84



Natural Resources
Conservation Service

Web Soil Survey
National Cooperative Soil Survey

5/5/2023
Page 1 of 4

Hydrologic Soil Group—El Paso County Area, Colorado
(New Breed Ranch Filing Three)

MAP LEGEND

Area of Interest (AOI)









 Area of Interest (AOI)

Soils

Soil Rating Polygons





-  A
-  A/D
-  B
-  B/D
-  C
-  C/D
-  D
-  Not rated or not available

Soil Rating Lines

-  A
-  A/D
-  B
-  B/D
-  C
-  C/D
-  D
-  Not rated or not available

Soil Rating Points





-  A
-  A/D
-  B
-  B/D

-  C
-  C/D
-  D
-  Not rated or not available

Water Features

 Streams and Canals

Transportation

-  Rails
-  Interstate Highways
-  US Routes
-  Major Roads
-  Local Roads

Background

 Aerial Photography

MAP INFORMATION

The soil surveys that comprise your AOI were mapped at 1:24,000.

Warning: Soil Map may not be valid at this scale.

Enlargement of maps beyond the scale of mapping can cause misunderstanding of the detail of mapping and accuracy of soil line placement. The maps do not show the small areas of contrasting soils that could have been shown at a more detailed scale.

Please rely on the bar scale on each map sheet for map measurements.

Source of Map: Natural Resources Conservation Service
Web Soil Survey URL:
Coordinate System: Web Mercator (EPSG:3857)

Maps from the Web Soil Survey are based on the Web Mercator projection, which preserves direction and shape but distorts distance and area. A projection that preserves area, such as the Albers equal-area conic projection, should be used if more accurate calculations of distance or area are required.

This product is generated from the USDA-NRCS certified data as of the version date(s) listed below.

Soil Survey Area: El Paso County Area, Colorado
Survey Area Data: Version 20, Sep 2, 2022

Soil map units are labeled (as space allows) for map scales 1:50,000 or larger.

Date(s) aerial images were photographed: Jun 9, 2021—Jun 12, 2021

The orthophoto or other base map on which the soil lines were compiled and digitized probably differs from the background imagery displayed on these maps. As a result, some minor shifting of map unit boundaries may be evident.

Hydrologic Soil Group

Map unit symbol	Map unit name	Rating	Acres in AOI	Percent of AOI
41	Kettle gravelly loamy sand, 8 to 40 percent slopes	B	6.3	23.7%
69	Peyton-Pring complex, 8 to 15 percent slopes	B	15.8	59.2%
93	Tomah-Crowfoot complex, 8 to 15 percent slopes	B	4.5	17.0%
Totals for Area of Interest			26.6	100.0%

Description

Hydrologic soil groups are based on estimates of runoff potential. Soils are assigned to one of four groups according to the rate of water infiltration when the soils are not protected by vegetation, are thoroughly wet, and receive precipitation from long-duration storms.

The soils in the United States are assigned to four groups (A, B, C, and D) and three dual classes (A/D, B/D, and C/D). The groups are defined as follows:

Group A. Soils having a high infiltration rate (low runoff potential) when thoroughly wet. These consist mainly of deep, well drained to excessively drained sands or gravelly sands. These soils have a high rate of water transmission.

Group B. Soils having a moderate infiltration rate when thoroughly wet. These consist chiefly of moderately deep or deep, moderately well drained or well drained soils that have moderately fine texture to moderately coarse texture. These soils have a moderate rate of water transmission.

Group C. Soils having a slow infiltration rate when thoroughly wet. These consist chiefly of soils having a layer that impedes the downward movement of water or soils of moderately fine texture or fine texture. These soils have a slow rate of water transmission.

Group D. Soils having a very slow infiltration rate (high runoff potential) when thoroughly wet. These consist chiefly of clays that have a high shrink-swell potential, soils that have a high water table, soils that have a claypan or clay layer at or near the surface, and soils that are shallow over nearly impervious material. These soils have a very slow rate of water transmission.

If a soil is assigned to a dual hydrologic group (A/D, B/D, or C/D), the first letter is for drained areas and the second is for undrained areas. Only the soils that in their natural condition are in group D are assigned to dual classes.

Rating Options

Aggregation Method: Dominant Condition

Component Percent Cutoff: None Specified

Tie-break Rule: Higher

APPENDIX B
HYDROLOGIC CALCULATIONS

Table 6-6. Runoff Coefficients for Rational Method

(Source: UDFCD 2001)

Land Use or Surface Characteristics	Percent Impervious	Runoff Coefficients											
		2-year		5-year		10-year		25-year		50-year		100-year	
		HSG A&B	HSG C&D	HSG A&B	HSG C&D	HSG A&B	HSG C&D	HSG A&B	HSG C&D	HSG A&B	HSG C&D	HSG A&B	HSG C&D
Business													
Commercial Areas	95	0.79	0.80	0.81	0.82	0.83	0.84	0.85	0.87	0.87	0.88	0.88	0.89
Neighborhood Areas	70	0.45	0.49	0.49	0.53	0.53	0.57	0.58	0.62	0.60	0.65	0.62	0.68
Residential													
1/8 Acre or less	65	0.41	0.45	0.45	0.49	0.49	0.54	0.54	0.59	0.57	0.62	0.59	0.65
1/4 Acre	40	0.23	0.28	0.30	0.35	0.36	0.42	0.42	0.50	0.46	0.54	0.50	0.58
1/3 Acre	30	0.18	0.22	0.25	0.30	0.32	0.38	0.39	0.47	0.43	0.52	0.47	0.57
1/2 Acre	25	0.15	0.20	0.22	0.28	0.30	0.36	0.37	0.46	0.41	0.51	0.46	0.56
1 Acre	20	0.12	0.17	0.20	0.26	0.27	0.34	0.35	0.44	0.40	0.50	0.44	0.55
Industrial													
Light Areas	80	0.57	0.60	0.59	0.63	0.63	0.66	0.66	0.70	0.68	0.72	0.70	0.74
Heavy Areas	90	0.71	0.73	0.73	0.75	0.75	0.77	0.78	0.80	0.80	0.82	0.81	0.83
Parks and Cemeteries	7	0.05	0.09	0.12	0.19	0.20	0.29	0.30	0.40	0.34	0.46	0.39	0.52
Playgrounds	13	0.07	0.13	0.16	0.23	0.24	0.31	0.32	0.42	0.37	0.48	0.41	0.54
Railroad Yard Areas	40	0.23	0.28	0.30	0.35	0.36	0.42	0.42	0.50	0.46	0.54	0.50	0.58
Undeveloped Areas													
Historic Flow Analysis-- Greenbelts, Agriculture	2	0.03	0.05	0.09	0.16	0.17	0.26	0.26	0.38	0.31	0.45	0.36	0.51
Pasture/Meadow	0	0.02	0.04	0.08	0.15	0.15	0.25	0.25	0.37	0.30	0.44	0.35	0.50
Forest	0	0.02	0.04	0.08	0.15	0.15	0.25	0.25	0.37	0.30	0.44	0.35	0.50
Exposed Rock	100	0.89	0.89	0.90	0.90	0.92	0.92	0.94	0.94	0.95	0.95	0.96	0.96
Offsite Flow Analysis (when landuse is undefined)	45	0.26	0.31	0.32	0.37	0.38	0.44	0.44	0.51	0.48	0.55	0.51	0.59
Streets													
Paved	100	0.89	0.89	0.90	0.90	0.92	0.92	0.94	0.94	0.95	0.95	0.96	0.96
Gravel	80	0.57	0.60	0.59	0.63	0.63	0.66	0.66	0.70	0.68	0.72	0.70	0.74
Drive and Walks	100	0.89	0.89	0.90	0.90	0.92	0.92	0.94	0.94	0.95	0.95	0.96	0.96
Roofs	90	0.71	0.73	0.73	0.75	0.75	0.77	0.78	0.80	0.80	0.82	0.81	0.83
Lawns	0	0.02	0.04	0.08	0.15	0.15	0.25	0.25	0.37	0.30	0.44	0.35	0.50

3.2 Time of Concentration

One of the basic assumptions underlying the Rational Method is that runoff is a function of the average rainfall rate during the time required for water to flow from the hydraulically most remote part of the drainage area under consideration to the design point. However, in practice, the time of concentration can be an empirical value that results in reasonable and acceptable peak flow calculations.

For urban areas, the time of concentration (t_c) consists of an initial time or overland flow time (t_i) plus the travel time (t_r) in the storm sewer, paved gutter, roadside drainage ditch, or drainage channel. For non-urban areas, the time of concentration consists of an overland flow time (t_i) plus the time of travel in a concentrated form, such as a swale or drainageway. The travel portion (t_r) of the time of concentration can be estimated from the hydraulic properties of the storm sewer, gutter, swale, ditch, or drainageway. Initial time, on the other hand, will vary with surface slope, depression storage, surface cover, antecedent rainfall, and infiltration capacity of the soil, as well as distance of surface flow. The time of concentration is represented by Equation 6-7 for both urban and non-urban areas.

$$t_c = t_i + t_t \quad (\text{Eq. 6-7})$$

Where:

t_c = time of concentration (min)

t_i = overland (initial) flow time (min)

t_t = travel time in the ditch, channel, gutter, storm sewer, etc. (min)

3.2.1 Overland (Initial) Flow Time

The overland flow time, t_i , may be calculated using Equation 6-8.

$$t_i = \frac{0.395(1.1 - C_5)\sqrt{L}}{S^{0.33}} \quad (\text{Eq. 6-8})$$

Where:

t_i = overland (initial) flow time (min)

C_5 = runoff coefficient for 5-year frequency (see Table 6-6)

L = length of overland flow (300 ft maximum for non-urban land uses, 100 ft maximum for urban land uses)

S = average basin slope (ft/ft)

Note that in some urban watersheds, the overland flow time may be very small because flows quickly concentrate and channelize.

3.2.2 Travel Time

For catchments with overland and channelized flow, the time of concentration needs to be considered in combination with the travel time, t_t , which is calculated using the hydraulic properties of the swale, ditch, or channel. For preliminary work, the overland travel time, t_t , can be estimated with the help of Figure 6-25 or Equation 6-9 (Guo 1999).

$$V = C_v S_w^{0.5} \quad (\text{Eq. 6-9})$$

Where:

V = velocity (ft/s)

C_v = conveyance coefficient (from Table 6-7)

S_w = watercourse slope (ft/ft)

Table 6-7. Conveyance Coefficient, C_v

Type of Land Surface	C_v
Heavy meadow	2.5
Tillage/field	5
Riprap (not buried)*	6.5
Short pasture and lawns	7
Nearly bare ground	10
Grassed waterway	15
Paved areas and shallow paved swales	20

* For buried riprap, select C_v value based on type of vegetative cover.

The travel time is calculated by dividing the flow distance (in feet) by the velocity calculated using Equation 6-9 and converting units to minutes.

The time of concentration (t_c) is then the sum of the overland flow time (t_i) and the travel time (t_t) per Equation 6-7.

3.2.3 First Design Point Time of Concentration in Urban Catchments

Using this procedure, the time of concentration at the first design point (typically the first inlet in the system) in an urbanized catchment should not exceed the time of concentration calculated using Equation 6-10. The first design point is defined as the point where runoff first enters the storm sewer system.

$$t_c = \frac{L}{180} + 10 \quad (\text{Eq. 6-10})$$

Where:

t_c = maximum time of concentration at the first design point in an urban watershed (min)

L = waterway length (ft)

Equation 6-10 was developed using the rainfall-runoff data collected in the Denver region and, in essence, represents regional “calibration” of the Rational Method. Normally, Equation 6-10 will result in a lesser time of concentration at the first design point and will govern in an urbanized watershed. For subsequent design points, the time of concentration is calculated by accumulating the travel times in downstream drainageway reaches.

3.2.4 Minimum Time of Concentration

If the calculations result in a t_c of less than 10 minutes for undeveloped conditions, it is recommended that a minimum value of 10 minutes be used. The minimum t_c for urbanized areas is 5 minutes.

3.2.5 Post-Development Time of Concentration

As Equation 6-8 indicates, the time of concentration is a function of the 5-year runoff coefficient for a drainage basin. Typically, higher levels of imperviousness (higher 5-year runoff coefficients) correspond to shorter times of concentration, and lower levels of imperviousness correspond to longer times of

Figure 6-5. Colorado Springs Rainfall Intensity Duration Frequency

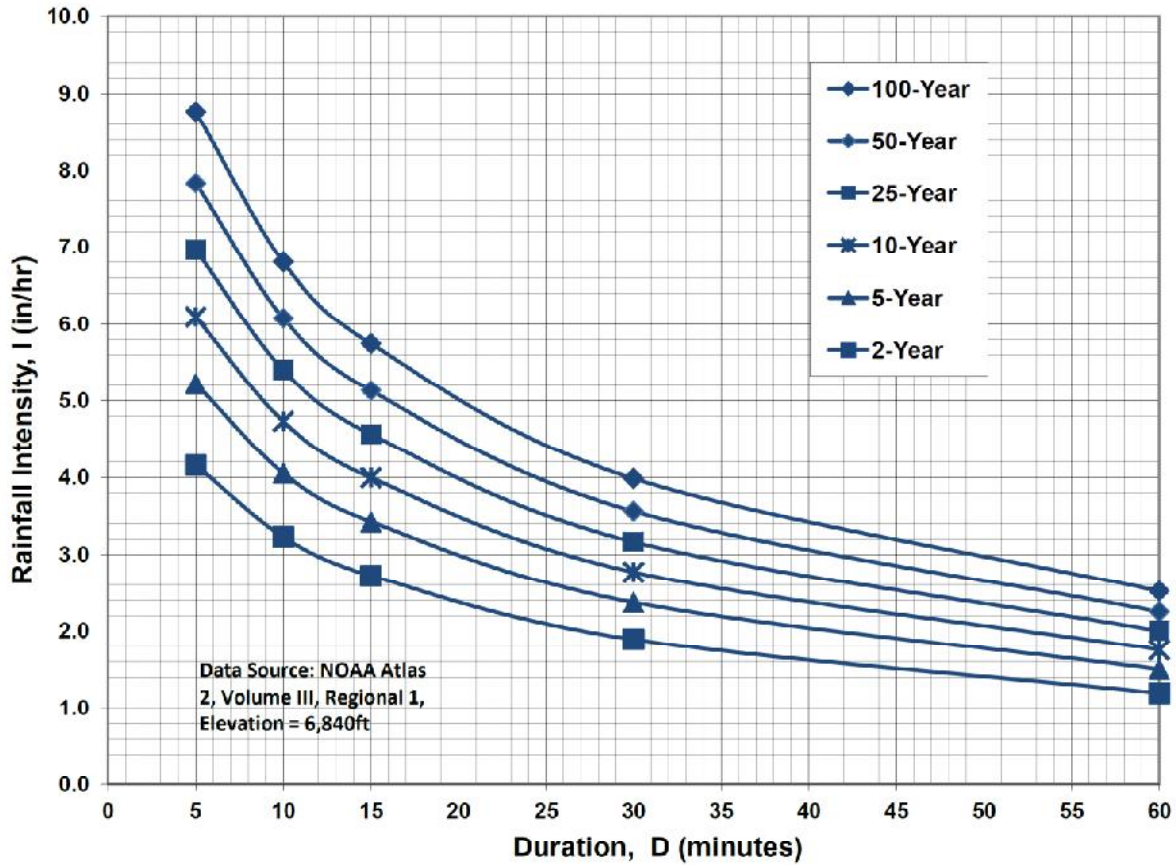

IDF Equations

$$I_{100} = -2.52 \ln(D) + 12.735$$

$$I_{50} = -2.25 \ln(D) + 11.375$$

$$I_{25} = -2.00 \ln(D) + 10.111$$

$$I_{10} = -1.75 \ln(D) + 8.847$$

$$I_5 = -1.50 \ln(D) + 7.583$$

$$I_2 = -1.19 \ln(D) + 6.035$$

Note: Values calculated by equations may not precisely duplicate values read from figure.

**NEW BREED RANCH FILING NO. 3
HISTORIC / PRE-DEVELOPMENT FLOWS**

BASIN	DESIGN POINT	AREA (AC)	Overland Flow					Channel flow						TOTAL Tc ⁽⁴⁾ (MIN)	TOTAL Tc ⁽⁴⁾ (MIN)	INTENSITY ⁽⁵⁾		PEAK FLOW	
			C		LENGTH (FT)	SLOPE (FT/FT)	Tco ⁽¹⁾ (MIN)	CHANNEL LENGTH (FT)	CONVEYANCE COEFFICIENT C	SLOPE (FT/FT)	SCS ⁽²⁾ VELOCITY (FT/S)	Tt ⁽³⁾ (MIN)	5-YR (IN/HR)			100-YR (IN/HR)	Q5 ⁽⁶⁾ (CFS)	Q100 ⁽⁶⁾ (CFS)	
			5-YEAR	100-YEAR															
I-1	I	72.7	0.080	0.350	300	0.033	21.7	4300	15	0.049	3.32	21.6	43.3	43.3	1.93	3.24	11.2	82.4	
I-3	K	38.7	0.080	0.350	300	0.057	18.1	3560	15	0.038	2.92	20.3	38.4	38.4	2.11	3.54	6.5	48.0	
I-8	I-8	39.8	0.080	0.350	300	0.067	17.2	3740	15	0.027	2.46	25.3	42.5	42.5	1.96	3.29	6.2	45.8	
Tt DP-K to DP-P								2585	15	0.023	2.27	18.9							
I-1, I-8	P	112.5	0.080	0.350									62.3	62.3	1.39	2.32	12.5	91.5	
I-9	Q	12.4	0.080	0.350	300	0.053	18.6	3120	15	0.035	2.81	18.5	37.1	37.1	2.16	3.63	2.1	15.8	

1) OVERLAND FLOW Tco = (0.395*(1.1-RUNOFF COEFFICIENT)*(OVERLAND FLOW LENGTH^(0.5))/(SLOPE^(0.333))

2) SCS VELOCITY = C * ((SLOPE(FT/FT)^0.5)

C = 2.5 FOR HEAVY MEADOW

C = 5 FOR TILLAGE/FIELD

C = 7 FOR SHORT PASTURE AND LAWNS

C = 10 FOR NEARLY BARE GROUND

C = 15 FOR GRASSED WATERWAY

C = 20 FOR PAVED AREAS AND SHALLOW PAVED SWALES

3) MANNING'S CHANNEL TRAVEL TIME = L/V (WHEN CHANNEL VELOCITY IS KNOWN)

4) Tc = Tco + Tt

*** IF TOTAL TIME OF CONCENTRATION IS LESS THAN 5 MINUTES, THEN 5 MINUTES IS USED

5) INTENSITY BASED ON I-D-F EQUATIONS IN CITY OF COLORADO SPRINGS DRAINAGE CRITERIA MANUAL

$$I_5 = -1.5 * \ln(Tc) + 7.583$$

$$I_{100} = -2.52 * \ln(Tc) + 12.735$$

6) Q = CiA

NEW BREED RANCH SUBDIVISION - FILING NO. 3												
COMPOSITE RUNOFF COEFFICIENTS - TYPICAL 5-ACRE DEVELOPED RESIDENTIAL AREA												
DEVELOPED CONDITIONS												
100-YEAR C VALUES												
BASIN	TOTAL AREA (AC)	SOIL TYPE	AREA (%)	SUB-AREA 1 DEVELOPMENT/COVER	C	AREA (%)	SUB-AREA 2 DEVELOPMENT/COVER	C	AREA (%)	SUB-AREA 3 DEVELOPMENT/COVER	C	WEIGHTED C VALUE
5-ACRE LOTS	5.00	B	7.00	BLDG/DRIVEWAY	0.9	93.00	LAWN/MEADOW	0.08				0.137
100-YEAR C VALUES												
BASIN	TOTAL AREA (AC)	SOIL TYPE	AREA (%)	SUB-AREA 1 DEVELOPMENT/COVER	C	AREA (%)	SUB-AREA 2 DEVELOPMENT/COVER	C	AREA (%)	SUB-AREA 3 DEVELOPMENT/COVER	C	WEIGHTED C VALUE
5-ACRE LOTS	5.00	B	7.00	BLDG/DRIVEWAY	0.96	93.00	LAWN/MEADOW	0.35				0.393

**NEW BREED RANCH - FILING NO. 3
DEVELOPED FLOWS**

BASIN	DESIGN POINT	AREA (AC)	Overland Flow					Channel flow						TOTAL T _c ⁽⁴⁾ (MIN)	TOTAL T _c ⁽⁴⁾ (MIN)	INTENSITY ⁽⁵⁾		PEAK FLOW	
			C		LENGTH (FT)	SLOPE (FT/FT)	T _{co} ⁽¹⁾ (MIN)	CHANNEL LENGTH (FT)	CONVEYANCE COEFFICIENT C	SLOPE (FT/FT)	SCS ⁽²⁾ VELOCITY (FT/S)	T _t ⁽³⁾ (MIN)	5-YR (IN/HR)			100-YR (IN/HR)	Q5 ⁽⁶⁾ (CFS)	Q100 ⁽⁶⁾ (CFS)	
			5-YEAR	100-YEAR															
I-1	I	72.7	0.137	0.393	300	0.033	20.5	4300	15	0.049	3.32	21.6	42.1	42.1	1.97	3.31	19.6	94.6	
I-3.1	I-3.1	9.9	0.137	0.393	300	0.033	20.5	1900	15	0.047	3.25	9.7	30.3	30.3	2.47	4.14	3.3	16.1	
I-3.2		28.8	0.137	0.393	300	0.057	17.1	3560	15	0.038	2.92	20.3	37.4	37.4	2.15	3.61	8.5	40.8	
I-3.1,I-3.2	K	38.7	0.137	0.393									37.4	37.4	2.15	3.61	11.4	54.9	
I-8.1	I-8.1	30.8	0.137	0.393	300	0.067	16.2	3740	15	0.027	2.46	25.3	41.5	41.5	1.99	3.35	8.4	40.5	
Tt DP-K to DP-P								2585	15	0.023	2.27	18.9							
I-1,I-8.1	P	103.5	0.137	0.393									61.0	61.0	1.42	2.37	20.1	96.6	
I-8.2	I-8.2	9.0	0.137	0.393	100	0.080	8.8	1690	15	0.061	3.70	7.6	16.4	16.4	3.38	5.68	4.2	20.1	
I-9.1	I-9.1	4.9	0.137	0.393	100	0.040	11.1	1370	15	0.069	3.94	5.8	16.9	16.9	3.34	5.61	2.2	10.8	
I-8.2,I-9.1	I-9.1a	13.9	0.137	0.393									16.9	16.9	3.34	5.61	6.4	30.6	
I-9.2		7.5	0.137	0.393	300	0.053	17.5	3120	15	0.035	2.81	18.5	36.1	36.1	2.21	3.70	2.3	10.9	
I-8.2,I-9.1,I-9.2	Q	21.4	0.137	0.393									36.1	36.1	2.21	3.70	6.5	31.1	
I-1,I-3,I-8,I-9	I-1-9	163.6	0.137	0.393									61.0	61.0	1.42	2.37	31.7	152.6	

1) OVERLAND FLOW T_{co} = (0.395*(1.1-RUNOFF COEFFICIENT)*(OVERLAND FLOW LENGTH^(0.5))/(SLOPE^(0.333))

2) SCS VELOCITY = C * ((SLOPE(FT/FT)^0.5)

C = 2.5 FOR HEAVY MEADOW

C = 5 FOR TILLAGE/FIELD

C = 7 FOR SHORT PASTURE AND LAWNS

C = 10 FOR NEARLY BARE GROUND

C = 15 FOR GRASSED WATERWAY

C = 20 FOR PAVED AREAS AND SHALLOW PAVED SWALES

3) MANNING'S CHANNEL TRAVEL TIME = L/V (WHEN CHANNEL VELOCITY IS KNOWN)

4) T_c = T_{co} + T_t

*** IF TOTAL TIME OF CONCENTRATION IS LESS THAN 5 MINUTES, THEN 5 MINUTES IS USED

5) INTENSITY BASED ON I-D-F EQUATIONS IN CITY OF COLORADO SPRINGS DRAINAGE CRITERIA MANUAL

I₅ = -1.5 * ln(T_c) + 7.583

I₁₀₀ = -2.52 * ln(T_c) + 12.735

6) Q = CiA

APPENDIX C
HYDRAULIC CALCULATIONS

**NEW BREED SUBDIVISION - FILING NO. 3
DITCH CALCULATION SUMMARY**

PROPOSED ROADSIDE DITCHES

ROADWAY	FROM STA	TO STA	SIDE	PROPOSED SLOPE (%)	SIDE SLOPE (Z)	CHANNEL DEPTH (FT)	FRICTION FACTOR (n)	ROW WIDTH (ft)	BASIN	Q100 FLOW (CFS)	DITCH FLOW % OF BASIN	DITCH FLOW (CFS)	Q100 DEPTH (FT)	Q100 VELOCITY (FT/S)	DITCH LINING
OLD ARENA WAY	1+16	5+00	E	1.36	4:1/3:1	2.5	0.030	60	I-8.2	20.1	100	20.1	1.2	4.0	GRASS
OLD ARENA WAY	1+16	5+00	W	1.36	4:1/3:1	2.5	0.030	60	I-9.1	10.8	100	10.8	0.9	3.4	GRASS
OLD ARENA WAY	5+00	9+50	E	6.07	4:1/3:1	2.5	0.030	60	I-8.2	20.1	65	13.1	0.8	6.3	GRASS / TRM
OLD ARENA WAY	5+00	9+50	W	6.07	4:1/3:1	2.5	0.030	60	I-9.1	10.8	65	7.0	0.6	5.4	GRASS / TRM
OLD ARENA WAY	9+50	11+38	E	2.00	4:1/3:1	2.5	0.030	60	I-8.2	20.1	30	6.0	0.7	3.4	GRASS
OLD ARENA WAY	9+50	11+38	W	2.00	4:1/3:1	2.5	0.030	60	I-9.1	10.8	30	3.2	0.6	2.9	GRASS

- 1) Channel flow calculations based on Manning's Equation
- 2) Channel depth includes 1' minimum freeboard
- 3) n = 0.03 for grass-lined non-irrigated channels (minimum)
- 4) n = 0.045 for riprap-lined channels
- 5) Vmax = 5.0 fps per El Paso County criteria (p. 10-13) for fescue (dry land grass) for 100-year flows
- 6) Vmax = 8.0 fps with Turf Reinforcement Mat (TRM) Lining (Tensar Eronet SC150 or equal)

The complete line of RollMax™ products offers a variety of options for both short-term and permanent erosion control needs. Reference the RollMax Products Chart below to find the right solution for your next project.



RollMax Product Selection Chart

	TEMPORARY						
	ERONET						BIONET
							
	DS75	DS150	S75	S150	SC150	C125	S75BN
Longevity	45 days	60 days	12 mo.	12 mo.	24 mo.	36 mo.	12 mo.
Applications	Low Flow Channels 4:1-3:1 Slopes	Moderate Flow Channels 3:1-2:1 Slopes	Low Flow Channels 4:1-3:1 Slopes	Moderate Flow Channels 3:1-2:1 Slopes	Medium Flow Channels 2:1-1:1 Slopes	High-Flow Channels 1:1 and Greater Slopes	Low Flow Channels 4:1-3:1 Slopes
Design Permissible Shear Stress lbs/ft ² (Pa)	Unvegetated 1.55 (74)	Unvegetated 1.75 (84)	Unvegetated 1.55 (74)	Unvegetated 1.75 (84)	Unvegetated 2.00 (96)	Unvegetated 2.25 (108)	Unvegetated 1.60 (76)
Design Permissible Velocity ft/s (m/s)	Unvegetated 5.00 (1.52)	Unvegetated 6.00 (1.52)	Unvegetated 5.00 (1.2)	Unvegetated 6.00 (1.83)	Unvegetated 8.00 (2.44)	Unvegetated 10.00 (3.05)	Unvegetated 5.00 (1.52)
Top Net	Lightweight accelerated photodegradable polypropylene 1.50 lbs/1000 ft ² (0.73 kg/100 m ²) approx wt	Lightweight accelerated photodegradable polypropylene 1.50 lbs/1000 ft ² (0.73 kg/100 m ²) approx wt	Lightweight photodegradable polypropylene 1.50 lbs/1000 ft ² (0.73 kg/100 m ²) approx wt	Lightweight photodegradable polypropylene 1.50 lbs/1000 ft ² (0.73 kg/100 m ²) approx wt	Heavyweight UV-stabilized polypropylene 2.9 lbs/1000 ft ² (1.47 kg/100 m ²) approx wt	Heavyweight UV-stabilized polypropylene 2.9 lbs/1000 ft ² (1.47 kg/100 m ²) approx wt	Leno woven, 100% biodegradable jute fiber 9.30 lbs/1000 ft ² (4.53 kg/100 m ²) approx wt
Center Net	N/A	N/A	N/A	N/A	N/A	N/A	N/A
Fiber Matrix	Straw fiber 0.50 lbs/yd ² (0.27 kg/m ²)	Straw fiber 0.50 lbs/yd ² (0.27 kg/m ²)	Straw fiber 0.50 lbs/yd ² (0.27 kg/m ²)	Straw fiber 0.50 lbs/yd ² (0.27 kg/m ²)	Straw/coconut matrix 70% Straw 0.35 lbs/yd ² (0.19 kg/m ²) 30% Coconut 0.15 lbs/yd ² (0.08 kg/m ²)	Coconut fiber 0.50 lbs/yd ² (0.27 kg/m ²)	Straw fiber 0.50 lbs/yd ² (0.27 kg/m ²)
Bottom Net	N/A	Lightweight accelerated photodegradable polypropylene 1.50 lbs/1000 ft ² (0.73 kg/100 m ²) approx wt	N/A	Lightweight photodegradable polypropylene 1.50 lbs/1000 ft ² (0.73 kg/100 m ²) approx wt	Lightweight photodegradable polypropylene 1.50 lbs/1000 ft ² (0.73 kg/100 m ²) approx wt	Heavyweight UV-stabilized polypropylene 2.9 lbs/1000 ft ² (1.47 kg/100 m ²) approx wt	N/A
Thread	Accelerated degradable	Accelerated degradable	Degradable	Degradable	Degradable	UV-stabilized polypropylene	Biodegradable

Hydraulic Analysis Report

Project Data

Project Title: Project - New Breed Sub. Filing 3 - Roadside Ditches

Designer: JPS

Project Date: Sunday, November 28, 2021

Project Units: U.S. Customary Units

Notes:

Please include the channel ID name that matches the drainage map.

Channel Analysis: Ditch-STA-1+16-5+00, E

Notes:

Input Parameters

Channel Type: Triangular

Side Slope 1 (Z1): 4.0000 ft/ft

Side Slope 2 (Z2): 3.0000 ft/ft

Longitudinal Slope: 0.0136 ft/ft

Manning's n: 0.0300

Flow: 20.1000 cfs

Result Parameters

Depth: 1.1985 ft

Area of Flow: 5.0275 ft²

Wetted Perimeter: 8.7317 ft

Hydraulic Radius: 0.5758 ft

Average Velocity: 3.9980 ft/s

Top Width: 8.3896 ft

Froude Number: 0.9101

Critical Depth: 1.1590 ft

Critical Velocity: 4.2754 ft/s

Critical Slope: 0.0163 ft/ft

Critical Top Width: 8.28 ft

Calculated Max Shear Stress: 1.0171 lb/ft²

Calculated Avg Shear Stress: 0.4886 lb/ft²

Channel Analysis: Ditch-STA-1+16-5+00, W

Notes:

Input Parameters

Channel Type: Triangular
Side Slope 1 (Z1): 4.0000 ft/ft
Side Slope 2 (Z2): 3.0000 ft/ft
Longitudinal Slope: 0.0136 ft/ft
Manning's n: 0.0300
Flow: 10.8000 cfs

Result Parameters

Depth: 0.9495 ft
Area of Flow: 3.1552 ft²
Wetted Perimeter: 6.9172 ft
Hydraulic Radius: 0.4561 ft
Average Velocity: 3.4229 ft/s
Top Width: 6.6463 ft
Froude Number: 0.8755
Critical Depth: 0.9040 ft
Critical Velocity: 3.7759 ft/s
Critical Slope: 0.0177 ft/ft
Critical Top Width: 6.46 ft
Calculated Max Shear Stress: 0.8058 lb/ft²
Calculated Avg Shear Stress: 0.3871 lb/ft²

Channel Analysis: Ditch-STA-5+00-9+50, E

Notes:

Input Parameters

Channel Type: Triangular
Side Slope 1 (Z1): 4.0000 ft/ft
Side Slope 2 (Z2): 3.0000 ft/ft
Longitudinal Slope: 0.0607 ft/ft
Manning's n: 0.0300
Flow: 13.1000 cfs

Result Parameters

Depth: 0.7711 ft
Area of Flow: 2.0811 ft²
Wetted Perimeter: 5.6178 ft
Hydraulic Radius: 0.3704 ft
Average Velocity: 6.2947 ft/s **> 5 fps....Use TRM Lining**
Top Width: 5.3977 ft
Froude Number: 1.7865
Critical Depth: 0.9766 ft
Critical Velocity: 3.9245 ft/s
Critical Slope: 0.0172 ft/ft
Critical Top Width: 6.98 ft
Calculated Max Shear Stress: 2.9207 lb/ft²
Calculated Avg Shear Stress: 1.4031 lb/ft²

Channel Analysis: Ditch-STA-5+00-9+50, W

Notes:

Input Parameters

Channel Type: Triangular
Side Slope 1 (Z1): 4.0000 ft/ft
Side Slope 2 (Z2): 3.0000 ft/ft
Longitudinal Slope: 0.0607 ft/ft
Manning's n: 0.0300
Flow: 7.0000 cfs

Result Parameters

Depth: 0.6096 ft
Area of Flow: 1.3007 ft²
Wetted Perimeter: 4.4412 ft
Hydraulic Radius: 0.2929 ft
Average Velocity: 5.3819 ft/s **> 5 fps....Use TRM Lining**
Top Width: 4.2672 ft
Froude Number: 1.7179
Critical Depth: 0.7600 ft
Critical Velocity: 3.4622 ft/s
Critical Slope: 0.0187 ft/ft
Critical Top Width: 5.43 ft
Calculated Max Shear Stress: 2.3090 lb/ft²
Calculated Avg Shear Stress: 1.1093 lb/ft²

Channel Analysis: Ditch-STA-9+50-11+38, E

Notes:

Input Parameters

Channel Type: Triangular
Side Slope 1 (Z1): 4.0000 ft/ft
Side Slope 2 (Z2): 3.0000 ft/ft
Longitudinal Slope: 0.0200 ft/ft
Manning's n: 0.0300
Flow: 6.0000 cfs

Result Parameters

Depth: 0.7085 ft
Area of Flow: 1.7570 ft²
Wetted Perimeter: 5.1618 ft
Hydraulic Radius: 0.3404 ft
Average Velocity: 3.4150 ft/s
Top Width: 4.9596 ft
Froude Number: 1.0111
Critical Depth: 0.7146 ft
Critical Velocity: 3.3571 ft/s
Critical Slope: 0.0191 ft/ft
Critical Top Width: 5.11 ft
Calculated Max Shear Stress: 0.8842 lb/ft²
Calculated Avg Shear Stress: 0.4248 lb/ft²

Channel Analysis: Ditch-STA-9+50-11+38, W

Notes:

Input Parameters

Channel Type: Triangular
Side Slope 1 (Z1): 4.0000 ft/ft
Side Slope 2 (Z2): 3.0000 ft/ft
Longitudinal Slope: 0.0200 ft/ft
Manning's n: 0.0300
Flow: 3.2000 cfs

Result Parameters

Depth: 0.5597 ft
Area of Flow: 1.0965 ft²
Wetted Perimeter: 4.0778 ft
Hydraulic Radius: 0.2689 ft
Average Velocity: 2.9184 ft/s
Top Width: 3.9181 ft
Froude Number: 0.9722
Critical Depth: 0.5557 ft
Critical Velocity: 2.9605 ft/s
Critical Slope: 0.0208 ft/ft
Critical Top Width: 3.97 ft
Calculated Max Shear Stress: 0.6985 lb/ft²
Calculated Avg Shear Stress: 0.3356 lb/ft²

Please include a sectional
cross of the proposed
channels.

**NEW BREED RANCH SUBDIVISION - FILING NO. 3
CULVERT DESIGN SUMMARY**

BASIN	DESIGN POINT	RD CL ELEV	INV IN ELEV	INV OUT ELEV	PIPE LENGTH (FT)	PIPE DIA (FT)	TOTAL Q ₅ (CFS)	Q ₅ MAX ALLOWABLE HEADWATER ¹	CALC Q ₅ HW ELEV	TOTAL Q ₁₀₀ (CFS)	Q ₁₀₀ MAX ALLOWABLE HEADWATER ²	CALC Q ₁₀₀ HW ELEV	CALC Q ₁₀₀ HW/D
OLD ARENA WAY:													
I-8.2	I-8.2	6998.68	6995.74	6995.00	74.0	2.0	4.2	6997.7	6996.7	20.1	6998.86	6998.40	1.33

¹ Q₅ MAX. ALLOWABLE HEADWATER, HW/D = 1.0

² Q₁₀₀ MAX. ALLOWABLE HEADWATER = 6" DEPTH AT SHOULDER (PER DCM TABLE 6-1)

What is the tailwater being used in this calculation? Add to table.

HY-8 Culvert Analysis Report – Culvert I-8.2

Crossing Discharge Data

Discharge Selection Method: Specify Minimum, Design, and Maximum Flow

Minimum Flow: 2 cfs

Design Flow: 4.2 cfs

Maximum Flow: 20.1 cfs

Table 1 - Summary of Culvert Flows at Crossing: Crossing I-8.2

Headwater Elevation (ft)	Total Discharge (cfs)	Culvert Discharge (cfs)	Roadway Discharge (cfs)	Iterations
6996.40	2.00	2.00	0.00	1
6996.67	3.81	3.81	0.00	1
6996.72	4.20	4.20	0.00	1
6997.11	7.43	7.43	0.00	1
6997.29	9.24	9.24	0.00	1
6997.46	11.05	11.05	0.00	1
6997.63	12.86	12.86	0.00	1
6997.80	14.67	14.67	0.00	1
6997.99	16.48	16.48	0.00	1
6998.19	18.29	18.29	0.00	1
6998.40	20.10	20.10	0.00	1
6998.68	22.15	22.15	0.00	Overtopping

Rating Curve Plot for Crossing: Crossing I-8.2

Total Rating Curve

Crossing: Crossing I-8.2

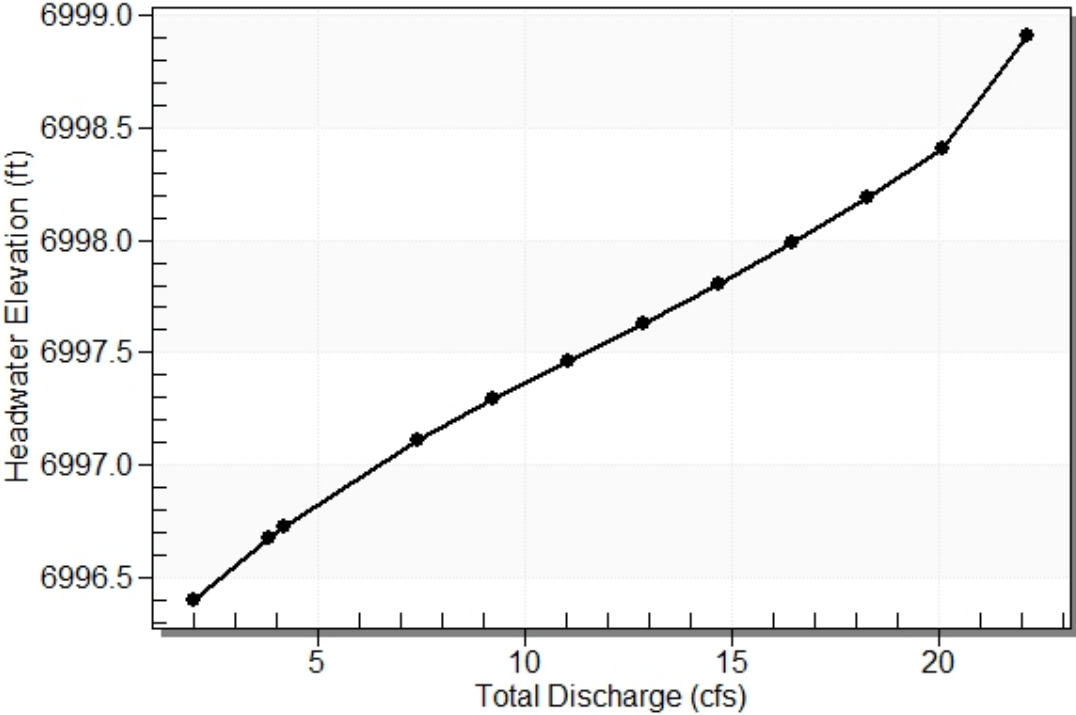

Table 2 - Culvert Summary Table: Culvert

Total Discharge (cfs)	Culvert Discharge (cfs)	Headwater Elevation (ft)	Inlet Control Depth (ft)	Outlet Control Depth (ft)	Flow Type	Normal Depth (ft)	Critical Depth (ft)	Outlet Depth (ft)	Tailwater Depth (ft)	Outlet Velocity (ft/s)	Tailwater Velocity (ft/s)
2.00	2.00	6996.40	0.662	0.0*	1-S2n	0.390	0.485	0.390	0.445	4.483	2.522
3.81	3.81	6996.67	0.930	0.0*	1-S2n	0.540	0.679	0.540	0.567	5.378	2.963
4.20	4.20	6996.72	0.981	0.035	1-S2n	0.568	0.716	0.568	0.588	5.515	3.036
7.43	7.43	6997.11	1.372	0.412	1-S2n	0.768	0.969	0.793	0.728	6.187	3.501
9.24	9.24	6997.29	1.554	0.627	1-S2n	0.866	1.083	0.895	0.790	6.561	3.697
11.05	11.05	6997.46	1.724	0.855	1-S2n	0.960	1.189	0.995	0.845	6.853	3.866
12.86	12.86	6997.63	1.891	1.097	1-S2n	1.051	1.287	1.089	0.895	7.120	4.016
14.67	14.67	6997.80	2.063	1.352	5-S2n	1.141	1.376	1.181	0.940	7.364	4.150
16.48	16.48	6997.99	2.247	1.622	5-S2n	1.232	1.458	1.275	0.982	7.560	4.273
18.29	18.29	6998.19	2.446	2.142	5-S2n	1.327	1.538	1.372	1.021	7.736	4.385
20.10	20.10	6998.40	2.665	2.408	5-S2n	1.428	1.608	1.472	1.058	7.892	4.490

* Full Flow Headwater elevation is below inlet invert.

Straight Culvert

Inlet Elevation (invert): 6995.74 ft, Outlet Elevation (invert): 6995.00 ft

Culvert Length: 74.00 ft, Culvert Slope: 0.0100

Culvert Performance Curve Plot: Culvert

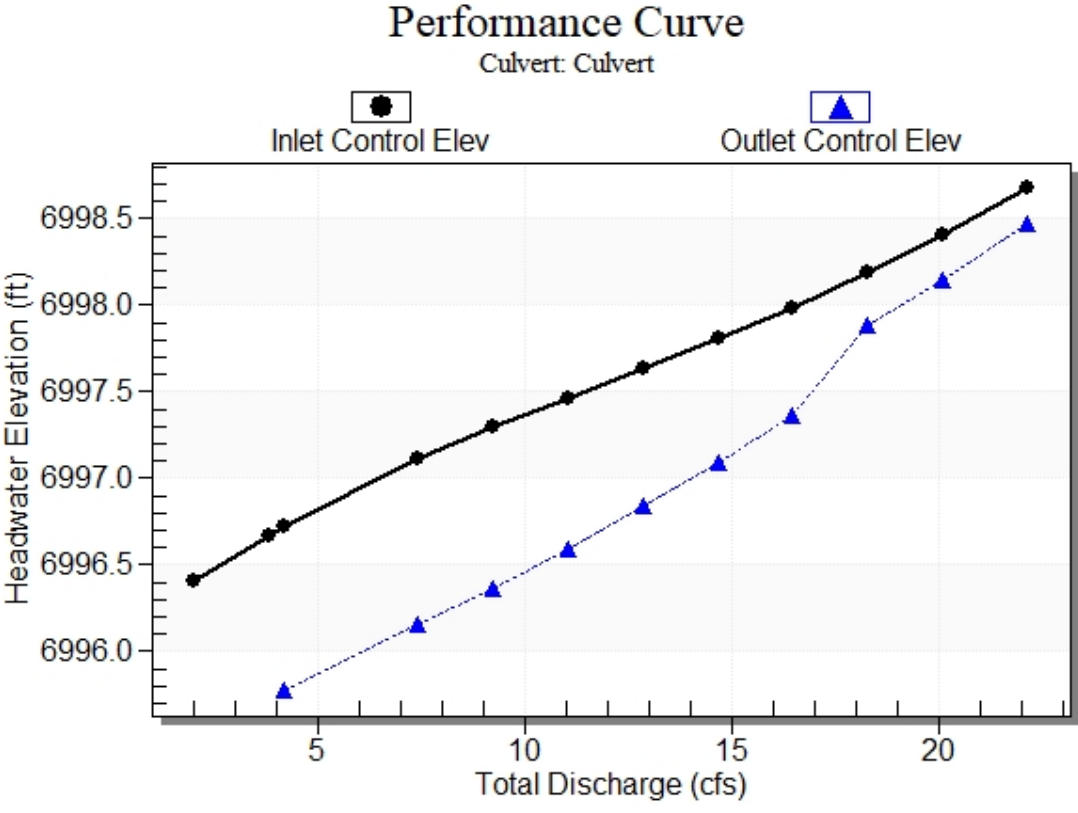

Water Surface Profile Plot for Culvert: Culvert

Crossing - Crossing I-8.2, Design Discharge - 4.2 cfs

Culvert - Culvert, Culvert Discharge - 4.2 cfs

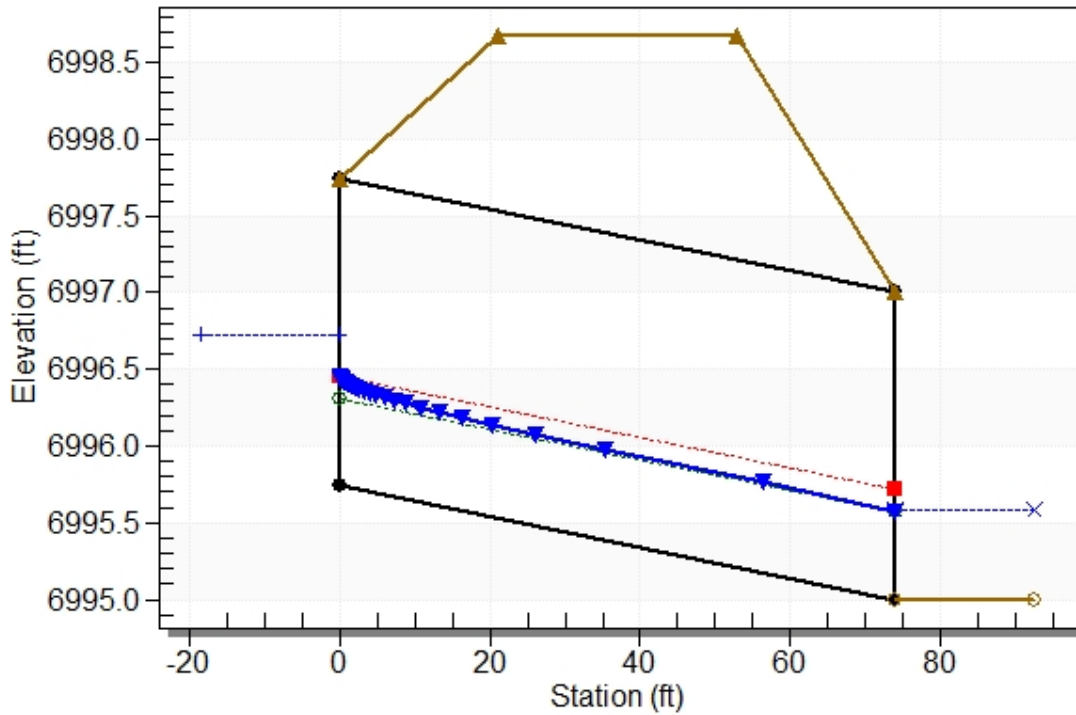

Site Data - Culvert

Site Data Option: Culvert Invert Data

Inlet Station: 0.00 ft

Inlet Elevation: 6995.74 ft

Outlet Station: 74.00 ft

Outlet Elevation: 6995.00 ft

Number of Barrels: 1

Culvert Data Summary - Culvert

Barrel Shape: Circular

Barrel Diameter: 2.00 ft

Barrel Material:

Embedment: 0.00 in

Barrel Manning's n: 0.0130

Culvert Type: Straight

Inlet Configuration: Grooved End Projecting

Inlet Depression: None

Table 3 - Downstream Channel Rating Curve (Crossing: Crossing I-8.2)

Flow (cfs)	Water Surface Elev (ft)	Depth (ft)	Velocity (ft/s)	Shear (psf)	Froude Number
2.00	6995.45	0.45	2.52	0.56	0.94
3.81	6995.57	0.57	2.96	0.71	0.98
4.20	6995.59	0.59	3.04	0.73	0.99
7.43	6995.73	0.73	3.50	0.91	1.02
9.24	6995.79	0.79	3.70	0.99	1.04
11.05	6995.85	0.85	3.87	1.05	1.05
12.86	6995.89	0.89	4.02	1.12	1.06
14.67	6995.94	0.94	4.15	1.17	1.07
16.48	6995.98	0.98	4.27	1.23	1.07
18.29	6996.02	1.02	4.39	1.27	1.08
20.10	6996.06	1.06	4.49	1.32	1.09

Tailwater Channel Data - Crossing I-8.2

Tailwater Channel Option: Triangular Channel

Side Slope (H:V): 4.00 (_:1)

Channel Slope: 0.0200

Channel Manning's n: 0.0300

Channel Invert Elevation: 6995.00 ft

Roadway Data for Crossing: Crossing I-8.2

Roadway Profile Shape: Constant Roadway Elevation

Crest Length: 6998.68 ft

Crest Elevation: 6998.68 ft

Roadway Surface: Paved

Roadway Top Width: 32.00 ft

APPENDIX D

WATER QUALITY CALCULATIONS

Provide spillway calculations and riprap sizing calculations.

NEW BREED RANCH COMPOSITE IMPERVIOUS AREAS												
DEVELOPED CONDITIONS												
IMPERVIOUS AREAS												
BASIN	TOTAL AREA (AC)	SOIL TYPE	AREA (%)	SUB-AREA 1 DEVELOPMENT/COVER	% IMP	AREA (%)	SUB-AREA 2 DEVELOPMENT/COVER	% IMP	AREA (%)	SUB-AREA 3 DEVELOPMENT/COVER	% IMP	WEIGHTED % IMP
I-8.2	9.0	B	100	5-AC LOTS	7							7.000
I-9.1	4.9	B	100	5-AC LOTS	7							7.000
I-8.2,I-9.1	13.9	B										7.000
I-9.2	7.50	B	100.00	5-AC LOTS	7							7.000
I-8.2,I-9.1,I-9.2	21.4	B										7.000

5 Ac lots and half of the roadway. Does the percent imperviousness include the roadway area, driveways, and other assumed imperviousness?

Design Procedure Form: Rain Garden (RG)

UD-BMP (Version 3.07, March 2018)

Sheet 1 of 2

Designer: JPS
Company: JPS
Date: February 14, 2024
Project: NEW BREED FILING NO. 3
Location: RAIN GARDEN I-9.1

<p>1. Basin Storage Volume</p> <p>A) Effective Imperviousness of Tributary Area, I_a (100% if all paved and roofed areas upstream of rain garden)</p> <p>B) Tributary Area's Imperviousness Ratio ($i = I_a/100$)</p> <p>C) Water Quality Capture Volume (WQCV) for a 12-hour Drain Time ($WQCV = 0.8 * (0.91 * i^3 - 1.19 * i^2 + 0.78 * i)$)</p> <p>D) Contributing Watershed Area (including rain garden area)</p> <p>E) Water Quality Capture Volume (WQCV) Design Volume $Vol = (WQCV / 12) * Area$</p> <p>F) For Watersheds Outside of the Denver Region, Depth of Average Runoff Producing Storm</p> <p>G) For Watersheds Outside of the Denver Region, Water Quality Capture Volume (WQCV) Design Volume</p> <p>H) User Input of Water Quality Capture Volume (WQCV) Design Volume (Only if a different WQCV Design Volume is desired)</p>	<p>$I_a =$ <input type="text" value="7.0"/> %</p> <p>$i =$ <input type="text" value="0.070"/></p> <p>WQCV = <input type="text" value="0.04"/> watershed inches</p> <p>Area = <input type="text" value="605,484"/> sq ft</p> <p>$V_{WQCV} =$ <input type="text" value="1,981"/> cu ft</p> <p>$d_6 =$ <input type="text" value=""/> in</p> <p>$V_{WQCV\ OTHER} =$ <input type="text" value=""/> cu ft</p> <p>$V_{WQCV\ USER} =$ <input type="text" value=""/> cu ft</p>
<p>2. Basin Geometry</p> <p>A) WQCV Depth (12-inch maximum)</p> <p>B) Rain Garden Side Slopes ($Z = 4$ min., horiz. dist per unit vertical) (Use "0" if rain garden has vertical walls)</p> <p>C) Minimum Flat Surface Area</p> <p>D) Actual Flat Surface Area</p> <p>E) Area at Design Depth (Top Surface Area)</p> <p>F) Rain Garden Total Volume ($V_T = ((A_{Top} + A_{Actual}) / 2) * Depth$)</p>	<p>$D_{WQCV} =$ <input type="text" value="12"/> in</p> <p>$Z =$ <input type="text" value="4.00"/> ft / ft</p> <p>$A_{Min} =$ <input type="text" value="848"/> sq ft</p> <p>$A_{Actual} =$ <input type="text" value="1764"/> sq ft</p> <p>$A_{Top} =$ <input type="text" value="2504"/> sq ft</p> <p>$V_T =$ <input type="text" value="2,134"/> cu ft</p>
<p>3. Growing Media</p>	<div style="border: 1px solid black; padding: 5px; margin-bottom: 5px;"> <p>Choose One</p> <p><input checked="" type="radio"/> 18" Rain Garden Growing Media</p> <p><input type="radio"/> Other (Explain):</p> </div> <hr/>
<p>4. Underdrain System</p> <p>A) Are underdrains provided?</p> <p>B) Underdrain system orifice diameter for 12 hour drain time</p> <p style="margin-left: 20px;">i) Distance From Lowest Elevation of the Storage Volume to the Center of the Orifice</p> <p style="margin-left: 20px;">ii) Volume to Drain in 12 Hours</p> <p style="margin-left: 20px;">iii) Orifice Diameter, 3/8" Minimum</p>	<div style="border: 1px solid black; padding: 5px; margin-bottom: 5px;"> <p>Choose One</p> <p><input checked="" type="radio"/> YES</p> <p><input type="radio"/> NO</p> </div> <p>$y =$ <input type="text" value="1.5"/> ft</p> <p>$Vol_{12} =$ <input type="text" value="1,981"/> cu ft</p> <p>$D_O =$ <input type="text" value="1 1/16"/> in</p>

Design Procedure Form: Rain Garden (RG)

Designer: JPS
Company: JPS
Date: February 14, 2024
Project: NEW BREED FILING NO. 3
Location: RAIN GARDEN I-9.1

5. Impermeable Geomembrane Liner and Geotextile Separator Fabric A) Is an impermeable liner provided due to proximity of structures or groundwater contamination?	Choose One <input type="radio"/> YES <input checked="" type="radio"/> NO
6. Inlet / Outlet Control A) Inlet Control	Choose One <input type="radio"/> Sheet Flow- No Energy Dissipation Required <input checked="" type="radio"/> Concentrated Flow- Energy Dissipation Provided
7. Vegetation	Choose One <input checked="" type="radio"/> Seed (Plan for frequent weed control) <input type="radio"/> Plantings <input type="radio"/> Sand Grown or Other High Infiltration Sod
8. Irrigation A) Will the rain garden be irrigated?	Choose One <input type="radio"/> YES <input type="radio"/> NO
Notes: _____ _____ _____	

Please include MHFD spreadsheet for the pond calculation.

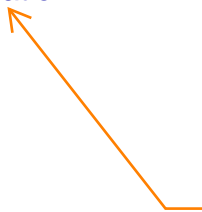

Per previous comments, flows are increased onsite and detention will be needed.

APPENDIX E

FIGURES

National Flood Hazard Layer FIRMette



104°46'18"W 39°1'9"N



Legend

SEE FIS REPORT FOR DETAILED LEGEND AND INDEX MAP FOR FIRM PANEL LAYOUT

SPECIAL FLOOD HAZARD AREAS		Without Base Flood Elevation (BFE) <i>Zone A, V, A99</i>
		With BFE or Depth <i>Zone AE, AO, AH, VE, AR</i>
		Regulatory Floodway
OTHER AREAS OF FLOOD HAZARD		0.2% Annual Chance Flood Hazard, Areas of 1% annual chance flood with average depth less than one foot or with drainage areas of less than one square mile <i>Zone X</i>
		Future Conditions 1% Annual Chance Flood Hazard <i>Zone X</i>
		Area with Reduced Flood Risk due to Levee. See Notes. <i>Zone X</i>
		Area with Flood Risk due to Levee <i>Zone D</i>
OTHER AREAS		NO SCREEN Area of Minimal Flood Hazard <i>Zone X</i>
		Effective LOMRs
GENERAL STRUCTURES		Area of Undetermined Flood Hazard <i>Zone D</i>
		Channel, Culvert, or Storm Sewer
		Levee, Dike, or Floodwall
OTHER FEATURES		20.2 Cross Sections with 1% Annual Chance
		17.5 Water Surface Elevation
		Coastal Transect
		Base Flood Elevation Line (BFE)
		Limit of Study
		Jurisdiction Boundary
		Coastal Transect Baseline
		Profile Baseline
		Hydrographic Feature
MAP PANELS		Digital Data Available
		No Digital Data Available
		Unmapped
		The pin displayed on the map is an approximate point selected by the user and does not represent an authoritative property location.

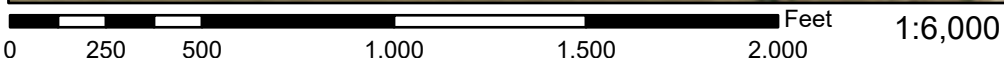

104°45'40"W 39°0'41"N

Basemap: USGS National Map: Orthoimagery: Data refreshed October, 2020

This map complies with FEMA's standards for the use of digital flood maps if it is not void as described below. The basemap shown complies with FEMA's basemap accuracy standards

The flood hazard information is derived directly from the authoritative NFHL web services provided by FEMA. This map was exported on **5/5/2023 at 3:36 PM** and does not reflect changes or amendments subsequent to this date and time. The NFHL and effective information may change or become superseded by new data over time.

This map image is void if the one or more of the following map elements do not appear: basemap imagery, flood zone labels, legend, scale bar, map creation date, community identifiers, FIRM panel number, and FIRM effective date. Map images for unmapped and unmodernized areas cannot be used for regulatory purposes.

Sub-Basin Calculations - 100yr, 24hr Storm - Rational Method

DESIGN POINT	BASIN AREA	Undeveloped Q		Developed Q	
		Q _{in}	Q _{out}	Q _{in}	Q _{out}
1-1	64.62	82.66	85.42	148.66	238.52
1-2	68.7	86.96	89.86	148.66	238.52
1-3	37.99	47.49	49.08	48.08	49.08
1-4	27.64	46.53	46.83	48.08	48.08
1-5	42.08	56.90	58.80	58.80	58.80
1-6	13.23	22.99	23.75	23.75	23.75
1-7	8.69	14.95	15.45	49.08	49.08
1-8	42.07	49.29	50.93	313.20	380.98
1-9	48.24	63.59	67.78	25.42	48.08
1-10	17.12	24.60	25.42	48.08	48.08
1-11	30.54	31.76	32.81	454.48	487.29

Undeveloped Q = 467.28 Developed Q = 487.29

CHANGE IN Q = 20.01 cfs

* NOTE: ASSUMES DEVELOPED FLOW FROM UPSTREAM BASINS

JOB NO.: 980516.0

DESIGNED BY: TJW	DATE: 12/4/2000
DRAWN BY: TJW & SB	DATE: 12/4/2000
CHECKED BY: POW	DATE: 12/4/2000
APPROVED: [Signature]	DATE: 1/9/2001
REVISION: EPCDOT COMMENTS	DATE: 2/28/2001
REVISION: EPCDOT COMMENTS	DATE: 1/31/2002
REVISION: EPCDOT COMMENTS	DATE: 1/31/2002

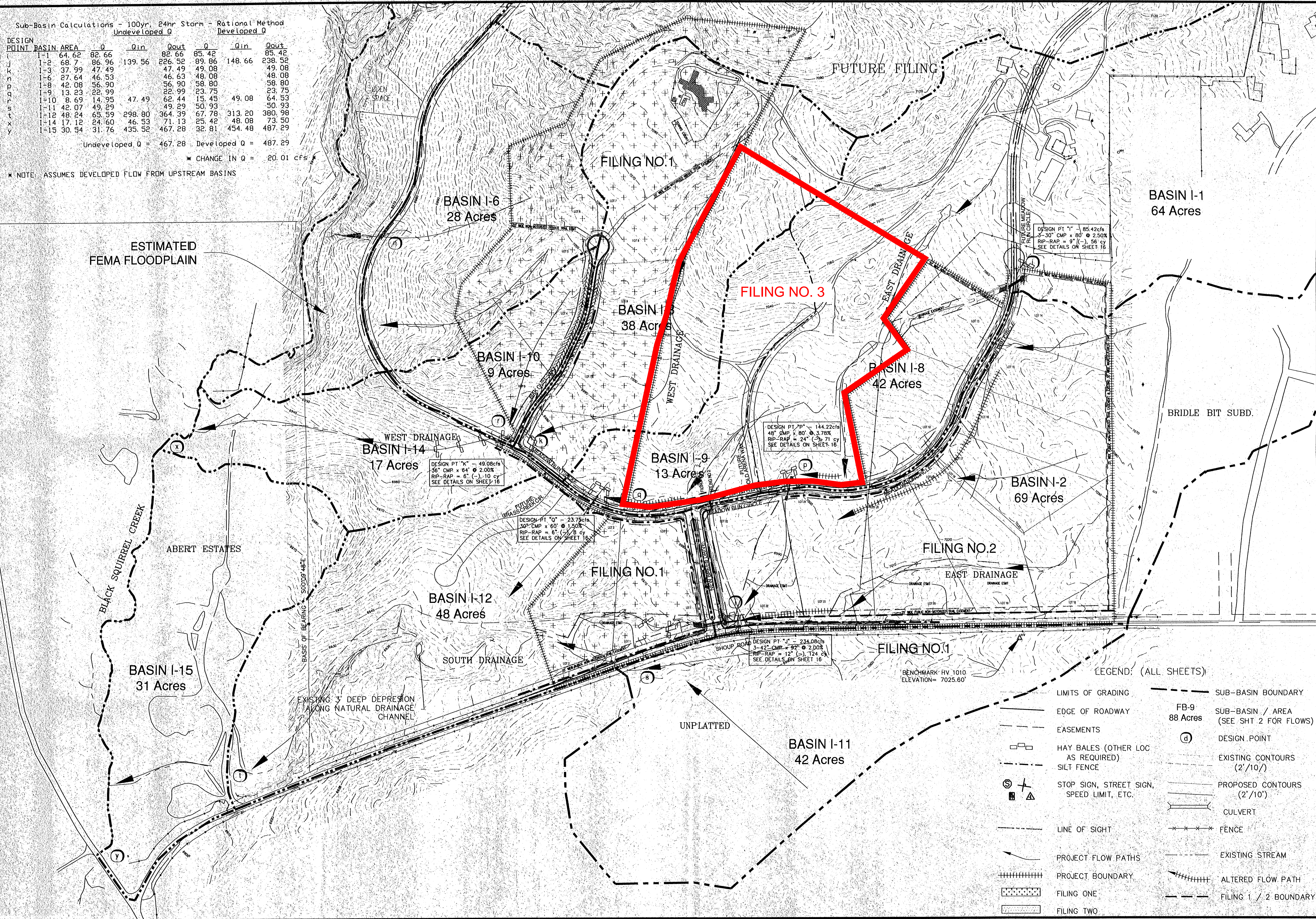

NEW BREED RANCH FILINGS 1 & 2
SUB-BASINS / DESIGN POINTS & EROSION CONTROL
NEW BREED RANCH, EL PASO COUNTY, COLORADO

PROFESSIONAL CONSULTANTS
 INCORPORATED
 1715 S. W. 10th St.
 COLORADO SPRING, CO 80906-1600
 PHONE: 719-593-4977 FAX: 719-593-8868

HORIZ. SCALE: 1" = 200'

SHEET 2 OF 4

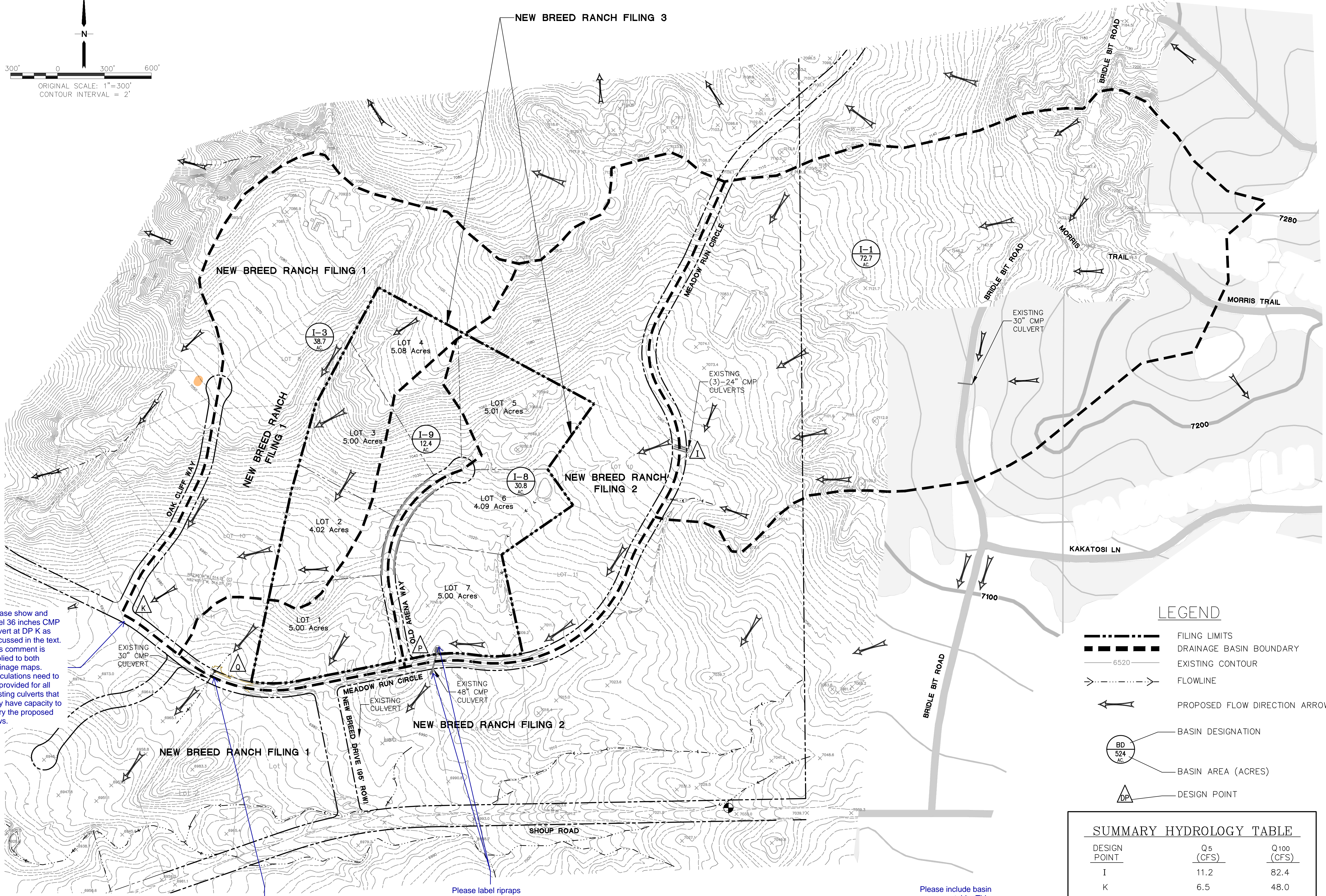
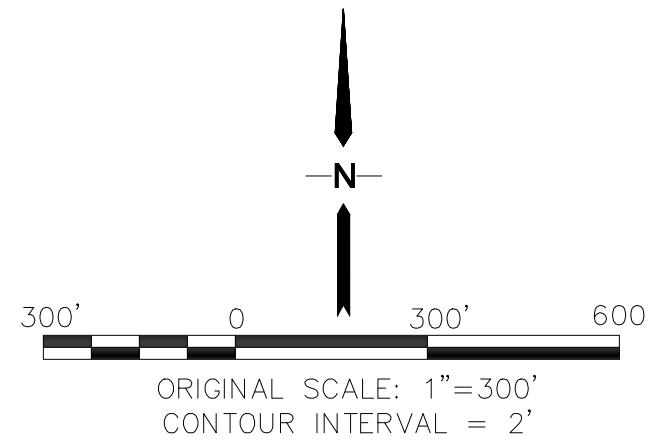

Please show and label 36 inches CMP culvert at DP K as discussed in the text. This comment is applied to both drainage maps. Calculations need to be provided for all existing culverts that they have capacity to carry the proposed flows.

Please label this culvert. This comment is applied to both drainage maps.

Please label ripraps (Size, type, condition, ownership). This comment is applied to both drainage maps.

Please include basin summary table. This comment is applied to both drainage maps.

LEGEND

- FILING LIMITS
- DRAINAGE BASIN BOUNDARY
- EXISTING CONTOUR
- FLOWLINE
- PROPOSED FLOW DIRECTION ARROW
- BASIN DESIGNATION
- BASIN AREA (ACRES)
- DESIGN POINT

SUMMARY HYDROLOGY TABLE

DESIGN POINT	Q ₅ (CFS)	Q ₁₀₀ (CFS)
I	11.2	82.4
K	6.5	48.0
P	12.5	91.5
Q	2.1	15.8

NEW BREED RANCH

EXISTING DRAINAGE CONDITIONS PLAN

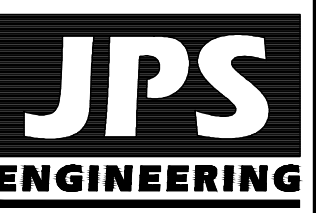

19 E. Willamette Ave.
Colorado Springs, CO 80903
PH: 719-477-9429
FAX: 719-471-0766
www.jpseng.com

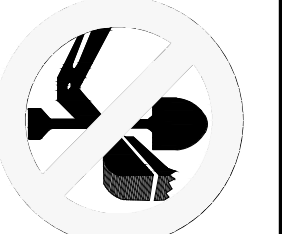

CALL UTILITY NOTIFICATION CENTER OF COLORADO
1-800-922-1987
CALL 2-BUSINESS DAYS IN ADVANCE BEFORE YOU DIG, GRADE, OR EXCAVATE FOR THE MARKING OF UNDERGROUND MEMBER UTILITIES.

NO.	REVISION	BY	DATE

HORIZ. SCALE: 1"=300'
VERT. SCALE: N/A
DRAWN: MSP
DESIGNED: JPS
SURVEYED: HANNIGAN
CHECKED: JPS
CREATED: 11/28/22
LAST MODIFIED: 5/18/23
PROJECT NO: 042207
MODIFIED BY: MSP
SHEET:

EX1

C:\Users\Michael\Dropbox\jpsprojects\042207_new-breed\dwg\Drainage\EX1.dwg May 18, 2023 8:12pm



CALL UTILITY NOTIFICATION
CENTER OF COLORADO
1-800-922-1987
CALL 2-BUSINESS DAYS IN ADVANCE
BEFORE YOU DIG, GRADE, OR EXCAVATE
FOR THE MARKING OF UNDERGROUND
MEMBER UTILITIES.

No.	REVISION	BY	DATE

**DEVELOPED DRAINAGE
CONDITIONS**

HORZ. SCALE: 1"=100'	DRAWN: MSP
VERT. SCALE: N/A	DESIGNED: JPS
SURVEYED: HANNIGAN	CHECKED: JPS
CREATED: 11/28/22	LAST MODIFIED: 2/22/24
PROJECT NO: 042207	MODIFIED BY: MSP

SHEET: **D1**

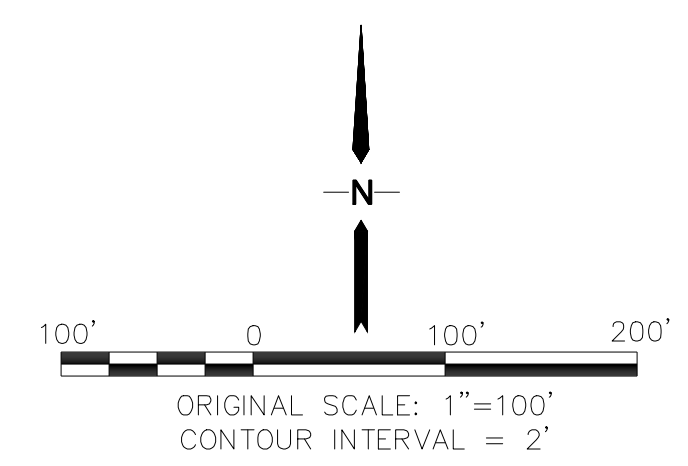

We need to know how much of the proposed area of disturbance is treated vs untreated and if there are any exclusions that apply to the untreated areas. So please create a basic overview map (or modify an existing drainage map) with color shading/hatching that shows areas tributary to the rain garden and those disturbed areas that are not treated by a PBMP, with the applicable exclusion labeled (ex: 20% up to 1ac of development can be excluded per ECM App I.7.1.C.1 and exclusions listed in ECM App I.7.1.B.#). An accompanying summary table on this map would also be very helpful (example provided):

Basin ID	Total Area (ac)	Total Proposed Disturbed Area (ac)	Area Trib to Pond A (ac)	Disturbed Area Treated via Runoff Reduction (ac)	Disturbed Area Excluded from WQ per ECM App I.7.1.C.1 (ac)	Disturbed Area Excluded from WQ per ECM App I.7.1.B.# (ac)	Applicable WQ Exclusions (App I.7.1.B.#)
A	4.50	4.50	4.50				
B	1.25	1.25		1.25			
C	6.00	4.00				4.00	ECM App I.7.1.B.5
D	2.50	2.50	1.00		0.50	1.00	ECM App I.7.1.B.7
E	3.00	3.00					
F	8.25						
Total	25.50	12.25	8.50	1.25	0.50	5.00	
<i>Comments: [For each row, the sum of the values in Columns 4-7 must be greater than or equal to the value in Column 2 above.]</i>							
Total Proposed Disturbed Area (ac)		Total Proposed Treated Area (ac)		Total Proposed Disturbed Area Excluded from WQ (ac)		Minimum Area to be Treated (ac)	
12.25		9.75		5.50		6.75	

GENERAL DRAINAGE NOTES:
 1. INDIVIDUAL BUILDERS SHALL PROVIDE POSITIVE DRAINAGE AWAY FROM STRUCTURES AND ACCOUNT FOR POTENTIAL CROSS-LOT DRAINAGE IMPACTS WITHIN EACH LOT.
 2. BUILDERS AND PROPERTY OWNERS SHALL IMPLEMENT & MAINTAIN EROSION CONTROL BEST MANAGEMENT PRACTICES FOR PROTECTION OF DOWNSTREAM PROPERTIES AND FACILITIES INCLUDING PROTECTION OF EXISTING GRASS BUFFER STRIPS ALONG THE DOWNSTREAM PROPERTY BOUNDARIES.

LEGEND

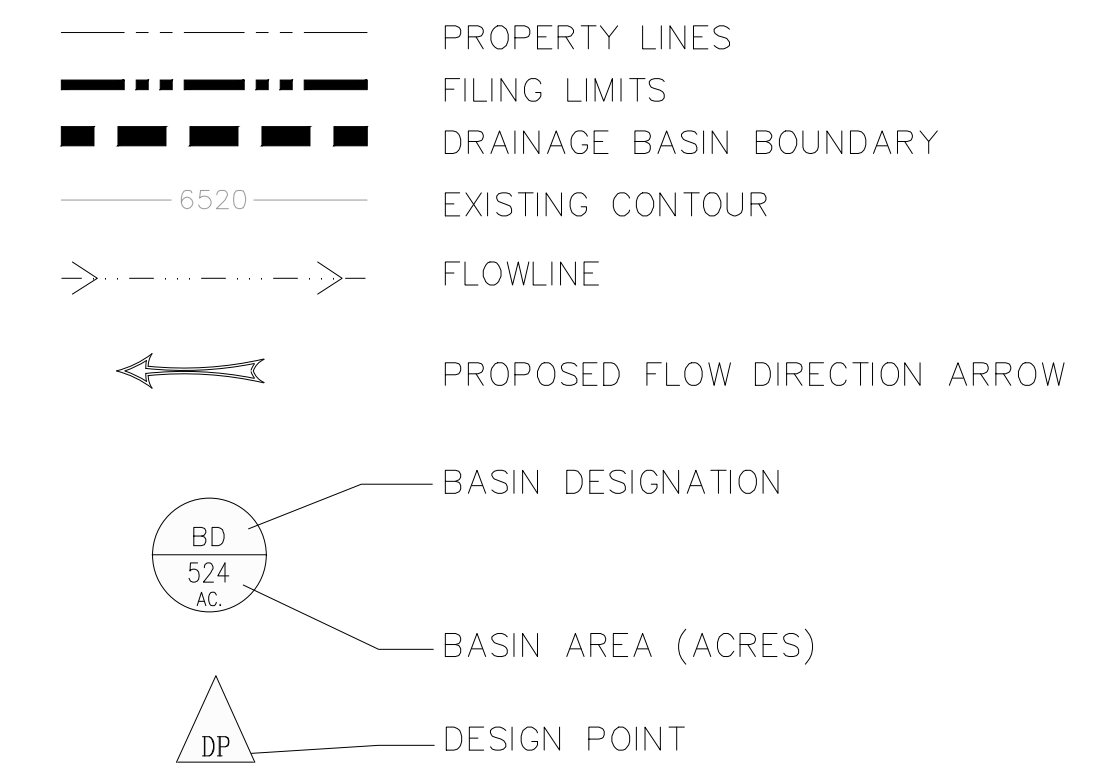

DESIGN POINT	Q 5 (CFS)	Q 100 (CFS)
I-8.2	4.2	20.1
I-9.1	2.2	10.8
P	20.1	96.6
Q	6.5	31.1

Please include DP K and I-1

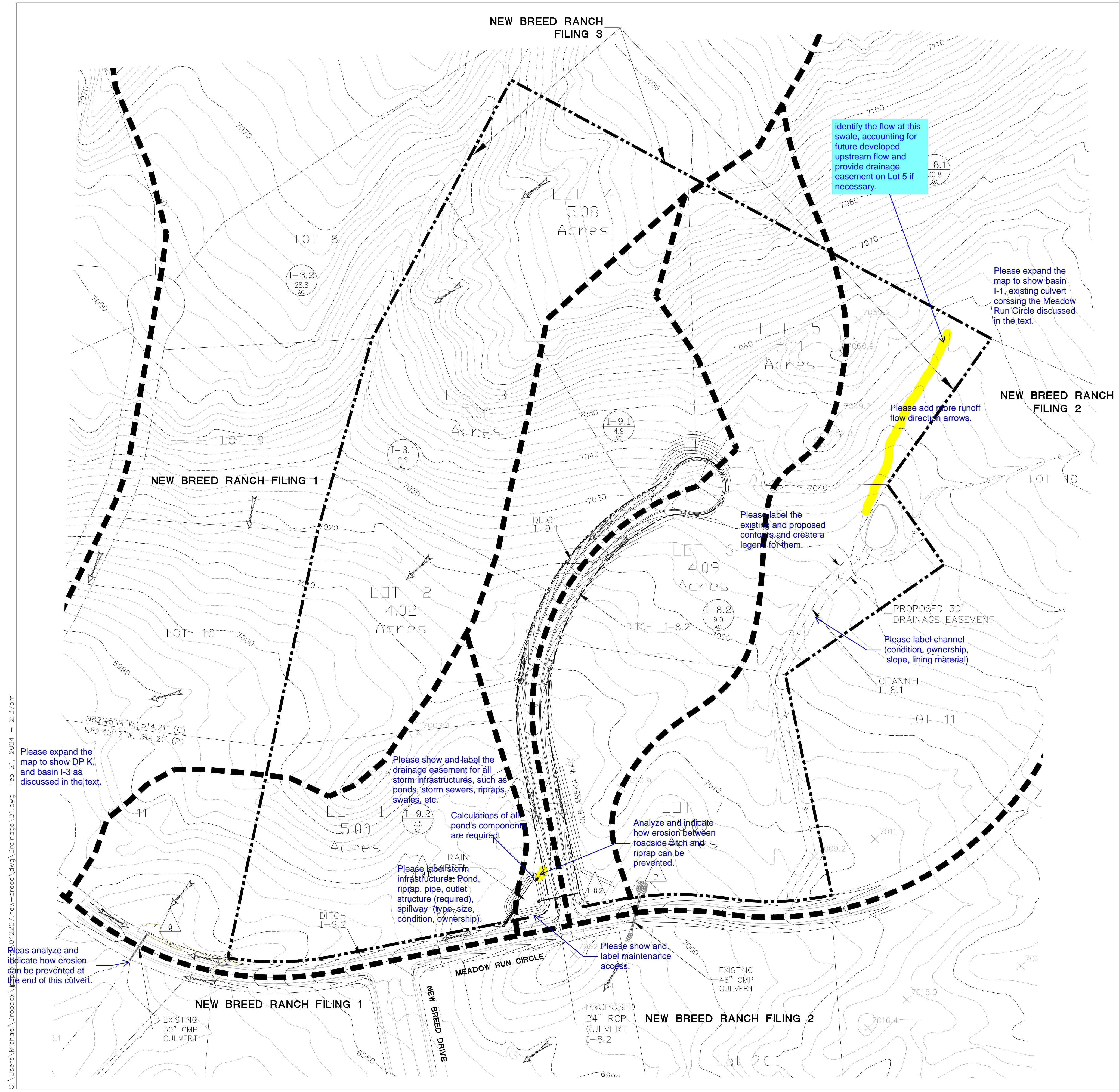

C:\Users\Michael\Dropbox\042207\new-breed\dwg\Drainage\01.dwg Feb 21, 2024 - 2:37pm