

Air vac vent pipe installed. Minor asphalt repair. No settlement.

ABBREVIATIONS:

- EPC EL PASO COUNTY
- PVC POLYVINYL CHLORIDE PIPE
- R.O.W. RIGHT-OF-WAY
- HMA HOT MIX ASPHALT
- ABC AGGREGATE BASE COURSE
- CONC. CONCRETE
- STA STATION
- C&G CURB & GUTTER
- MFL MINIMUM FLOWLINE
- FL FLOWLINE
- TYP. TYPICAL
- L.F.O.B. INSIDE FACE OF BOX

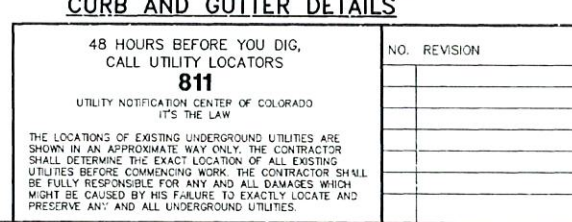
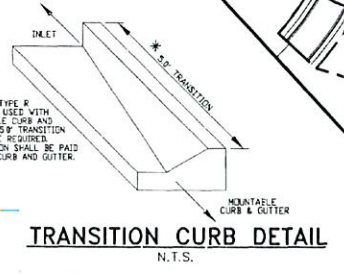
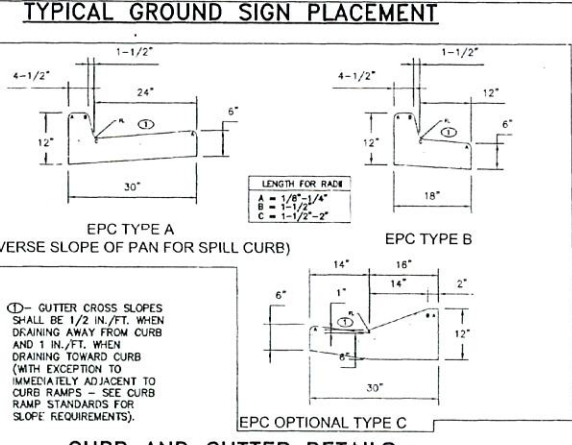
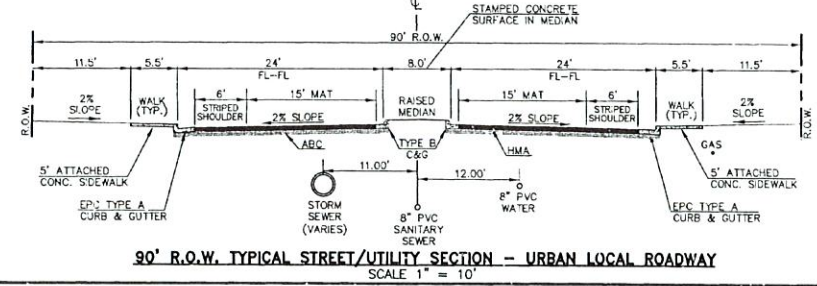
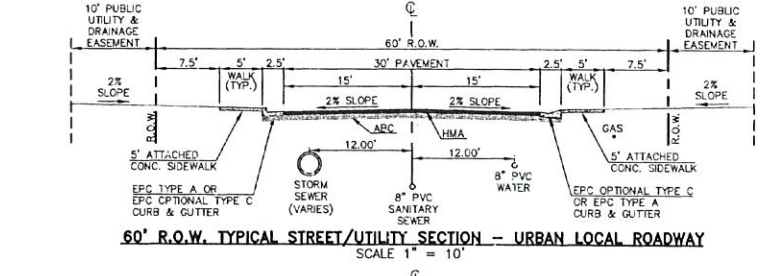
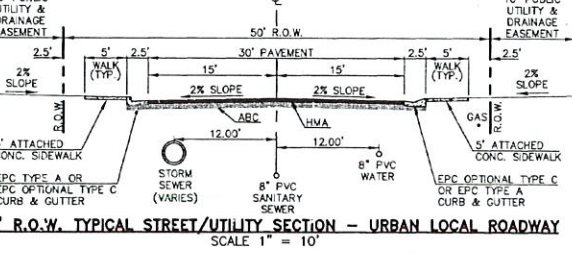
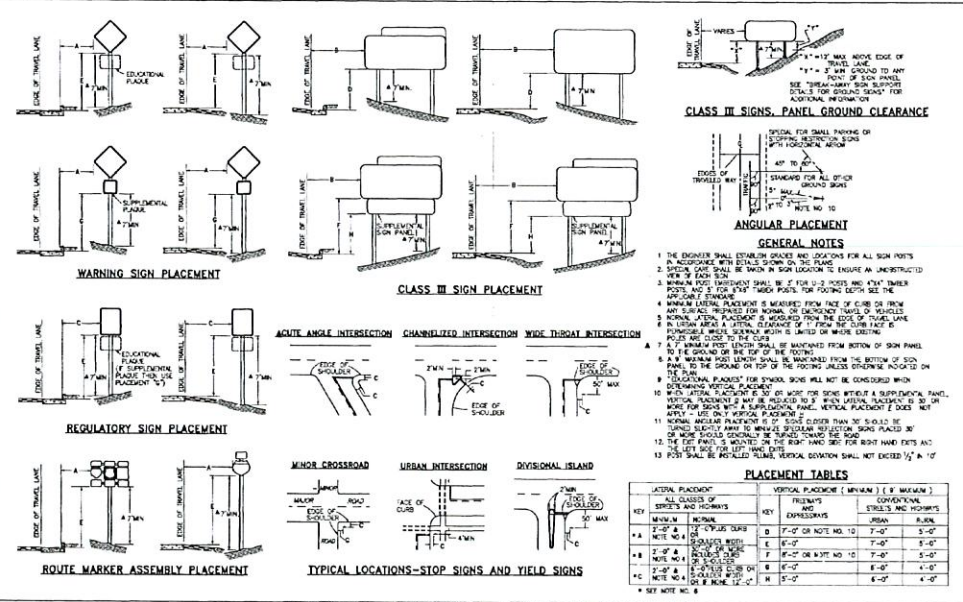
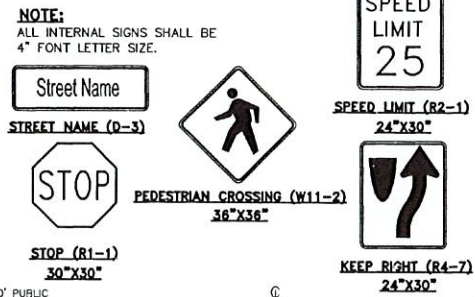

RAIL LENGTH TABLE

TYPE 3 BARRICADE	FIXED	MOVABLE	LENGTH
F - A	M - A		8' - 14'
F - B	M - B		15' - 24'
F - C	M - C		25' - 35'
F - D	M - D		> 35'

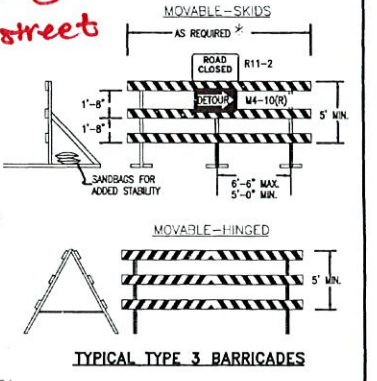

- NOTES:**
1. TYPE 3 BARRICADES HAVE 3 REFLECTORIZED RAIL FACES IF FACING TRAFFIC IN ONE DIRECTION AND 6 IF FACING TRAFFIC IN TWO DIRECTIONS.
 2. THE PORTION OF THE POST ABOVE THE GROUND LINE SHALL BE PAINTED IN ACCORDANCE WITH THE APPROPRIATE GENERAL NOTE.
 3. DETACHABLE EXTENSION WING RAILS FOR BYPASSING OF CONSTRUCTION EQUIPMENT ARE PERMITTED, WHEN NECESSARY, ON FIXED OR MOVABLE TYPE 3 BARRICADES. THE LENGTH SHALL BE ADEQUATE TO CLOSE THE BORROW PIT AND/OR SHOULDER AS REQUIRED.

EPC 5/11/2-21

PCD FILE # SF-20-027

48 HOURS BEFORE YOU DIG, CALL UTILITY LOCATORS 811
UTILITY NOTIFICATION CENTER OF COLORADO
IT'S THE LAW

THE LOCATIONS OF EXISTING UNDERGROUND UTILITIES ARE SHOWN IN AN APPROXIMATE WAY ONLY. THE CONTRACTOR SHALL DETERMINE THE EXACT LOCATION OF ALL EXISTING UTILITIES BEFORE COMMENCING WORK. THE CONTRACTOR SHALL BE FULLY RESPONSIBLE FOR ANY AND ALL DAMAGES WHICH MIGHT BE CAUSED BY HIS FAILURE TO EXACTLY LOCATE AND PRESERVE ANY AND ALL UNDERGROUND UTILITIES.

NO. REVISION	DATE	REVIEW:

PREPARED UNDER MY DIRECT SUPERVISION FOR AND ON BEHALF OF CLASSIC CONSULTING ENGINEERS AND SURVEYORS, LLC

Kyle R. Campbell
KYLE R. CAMPBELL, COLORADO P.E. #29794

DATE: 4.9.21

CLASSIC CONSULTING

619 N. Cascade Avenue, Suite 200
Colorado Springs, Colorado 80903

(719) 785-0790
(719) 785-0799 (Fax)

FOREST LAKES FILING NO. 6
PUBLIC STREET IMPROVEMENT PLAN
KEY MAP WITH TYPICAL STREET SECTIONS

DESIGNED BY	MAL	SCALE	DATE	08/04/2020
DRAWN BY	MES	(H) 1" = 100'	SHEET	9 OF 30
CHECKED BY	(V) 1" = N/A	JOB NO.	1175.60	

N:\117560\UPHAWIND\CONSTRUC\TODAS\SHRIT\T\2019-177560-09-01.dwg, 4/25/2021 1:47:08 PM, 1:1