

# FINAL DRAINAGE REPORT

For the

## WOODMEN HILLS METROPOLITAN DISTRICT



### Engineering Review

07/20/2020 11:30:52 AM

*dsdkuehster*

stevekuehster@elpasoco.com

(719) 520-6813

EPC Planning & Community  
Development Department

### West Water Tank

PPR-20-017

July 2020

Prepared By:

**JDS-HYDRO**

CONSULTANTS, INC.

**FINAL DRAINAGE REPORT  
FOR  
WOODMEN HILLS METROPOLITAN DISTRICT  
WEST WATER TANK**

**DRAINAGE PLAN STATEMENTS**

**Design Engineer's Statement:**

The attached drainage plan and report were prepared under my direction and supervision and are correct to the best of my knowledge and belief. Said drainage report has been prepared according to the criteria established by the County for drainage reports and said report is in conformity with the applicable master plan of the drainage basin. I accept responsibility for any liability caused by any negligent acts, errors or omissions on my part in preparing this report.



\_\_\_\_\_  
*Ryan M. Mangino, P.E.*

\_\_\_\_\_  
07/10/2020

Date

**Owner/Developer's Statement:**

I, the owner/developer have read and will comply with all of the requirements specified in this drainage report and plan.



\_\_\_\_\_  
*Jerry Jacobson, General Manager  
Woodmen Hills Metropolitan District  
8046 Eastonville Road, Peyton, CO 80831*

\_\_\_\_\_  
07/10/2020

Date

**El Paso County:**

Filed in accordance with the requirements of the Drainage Criteria Manual, Volumes 1 and 2, El Paso County Engineering Criteria Manual and Land Development Code as amended.

\_\_\_\_\_  
Jennifer Irvine, P.E.  
County Engineer / ECM Administrator

\_\_\_\_\_  
Date

Conditions:

**FINAL DRAINAGE REPORT  
FOR  
WOODMEN HILLS METROPOLITAN DISTRICT  
WEST WATER TANK**

**TABLE OF CONTENTS**

I) PURPOSE..... 3

II) GENERAL LOCATION AND PROPERTY DESCRIPTION..... 3

III) SOILS ..... 3

IV) FLOOD PLAIN STATEMENT..... 3

V) DRAINAGE CRITERIA ..... 4

VI) FOUR STEP PROCESS ..... 4

VII) HYDROLOGIC CALCULATIONS ..... 5

VIII) HYDRAULIC CALCULATIONS ..... 5

IX) EXISTING DRAINAGE CONDITIONS ..... 5

X) PROPOSED DRAINAGE CONDITIONS ..... 6

XI) EXTENDED DETENTION BASIN (EDB) WITH FULL SPECTRUM DETENTION ..... 7

XII) WATER QUALITY PROVISIONS AND MAINTENANCE ..... 7

XIII) EROSION CONTROL ..... 7

XIV) DRAINAGE AND BRIDGE FEES..... 8

XV) SUMMARY ..... 8

*Appendix A* Soils Map and Reports

*Appendix B* FIRM Map

*Appendix C* Hydrologic Calculations

*Appendix D* WQCV Calculations

*Appendix E* Detention Basin Sizing Calculations

*Appendix F* Drainage Map

## **I) PURPOSE**

This document is the Final Drainage Report for the Woodmen Hills Metropolitan District West Water Tank. The purpose of this document is to identify and analyze the onsite and offsite drainage patterns and to ensure that post development runoff is routed and treated in accordance with the requirements set forth in the El Paso County Drainage Criteria Manual.

## **II) GENERAL LOCATION AND PROPERTY DESCRIPTION**

West Water Tank site is located in Sterling Ranch Metropolitan District (SRMD) and occupies part of the NE ¼ of the NW ¼ of Section 27, Township 12 South, Range 65 West of the 6<sup>th</sup> P.M within unincorporated El Paso County, Colorado. The site is bound on the north by Arroya Ln. and to the south, east, and west by future Sterling Ranch development. A 30-foot Cherokee Metropolitan District Utility Easement borders the site on the west and south. Improvements proposed for the site include a 20-foot wide gravel driveway, two water tanks (3MG tank initially and future 1.5 MG tank), and 15-foot wide gravel pad around each tank.

The West Water Tank site lies within the Sand Creek Drainage Basin. Flows from this basin are tributary to Sand Creek. The West Water Tank parcel consists of 1.47 acres and is presently undeveloped. The site was cleared during construction of the SRMD tank and consists of bare ground with little to no vegetation. Existing site terrain is relatively flat and gently slopes down toward the southwest at grade rates that vary between 2% and 5%. Land use is currently listed as AG – Grazing Land. A vicinity map depicting the tank site is included as an attachment.

## **III) SOILS**

Soils for this project are delineated as Pring Coarse Sandy Loam (71) and are characterized as Hydrologic Soil Group B (moderately low runoff potential when thoroughly wet). Soils were mapped using the NRCS Web Soil Survey. According to a geotechnical evaluation report by Vivid Engineering Group, dated January 6, 2020, site soils are predominately fill materials on the surface consisting of clayey to silty sand with gravel fill encountered at the ground surface extended to depths of 4 – 9 feet below ground surface (bgs) for all five borings. The borings were drilled to depths ranging from approximately 29 to 57 feet below the existing ground surface. At the time of drilling (October/November 2019), groundwater was encountered in one of the borings at a depth of approximately 45 feet below the ground surface at the time of drilling and approximately 52 feet after drilling. Vegetation is very sparse, consisting of native grasses and weeds.

## **IV) FLOOD PLAIN STATEMENT**

The Floodplain Insurance Rate Map (FIRM) for El Paso County (map number 08041C0535G, dated December 7, 2018) was reviewed to determine any potential floodplain delineation. A copy of the relevant portion of this FIRM panel can be found in *Appendix B*. As shown, the proposed site lies within Zone X, defined as areas outside the 100-year floodplain.



## V) DRAINAGE CRITERIA

This drainage analysis has been prepared in accordance with the current El Paso County Drainage Criteria Manual (Volumes 1 and 2). Volume 1 was established in 1991 with subsequent revisions in 1994. In 2002, the City of Colorado Springs Drainage Criteria Manual Volume 2 (DCMV2) was adopted as El Paso County's stormwater quality design criteria with Appendix H of the El Paso County's Engineering Criteria manual (ECM) to provide additions and revisions applicable to the County. In 2015, El Paso County adopted portions of the City of Colorado Springs Drainage Criteria Manual Volume 1 dated May 2014 including Chapter 6 and Section 3.2.1 of Chapter 13. In addition, the Urban Storm Drainage Criteria Manuals, Volumes 1-3 published by the Mile High Flood District (MHFD), formerly known as the Urban Drainage and Flood Control District, and dated November 2010 with subsequent updates were used to prepare this drainage report.

The Site is located within the Sand Creek Watershed. Previous studies include the Sand Creek Drainage Basin Planning Study (DBPS) prepared by Kiowa Corporation, revised March 1996, and the Upper Sand Creek Basin Detention Evaluation Report prepared by Wilson & Company, revised June 2009. The area was studied more recently in the Master Development Drainage Plan for Sterling Ranch prepared by M&S Civil Consultants, Inc. in October 2018. The existing water storage tank site which is adjacent to the proposed WHMD tank site is owned and operated by SRMD. WHMD is unaware of a drainage report prepared for the adjacent SRMD tank site, however, the facility was approved by Pikes Peak Regional Building Department (PPRBD).

## VI) FOUR STEP PROCESS

The Four Step Process for stormwater quality management listed below was utilized during planning for the proposed water tank site when applicable. Further details on how this was implemented for the proposed project is discussed throughout this drainage report.

### **Step 1: Employ Runoff Reduction Practices**

*Gravel driveway rather than a paved driveway is planned. Reduces runoff by disconnecting impervious area, eliminating "unnecessary" impervious area and encouraging infiltration into soils that are suitable.*

### **Step 2: Stabilize Drainageways.**

*By implementing an extended detention basin with full spectrum detention the runoff from the water tank site will be reduced to pre-development conditions and therefore not anticipated to have negative effects on downstream drainageways.*

### **Step 3: Provide Water Quality Capture Volume (WQCV).**

*Extended detention basin combined with full spectrum detention is proposed to encourage infiltration of the WQCV into the soil.*

### **Step 4: Consider Need for Industrial and Commercial BMPs**

*Spill containment and control for equipment fueling and maintenance and bulk storage will be implemented on the site. In addition, silt fence, sediment control logs, vehicle tracking control pad, concrete washout area, and mulching and reseeding will be used to*

mitigate the potential for erosion on the site. Further details are provided in the site's stormwater management plan (SWMP).

## VII) HYDROLOGIC CALCULATIONS

The hydrologic calculations were prepared following guidance from El Paso County Drainage Criteria Manual and resources from the MHFD (formerly known as UDFCD). The Rational Method was used to determine estimated runoff peak discharges for storms between 2-year and 100-year storm recurrence intervals since the drainage basin is less than 130 acres. The 1-hr rainfall depths for each storm recurrence interval were obtained from the NOAA Atlas 14 Volume 8 Version 2 on the NOAA website.

1-hr rainfall depth, P1 (in)						
2-yr	5-yr	10-yr	25-yr	50-yr	100-yr	500-yr
0.94	1.22	1.48	1.87	2.19	2.54	3.47

Runoff coefficients were established based on Equations in Table 6-4 of the UDFCD Drainage Criteria Manual, Volume 1. The percent impervious values for the site was calculated using the existing conditions for pre-development and proposed improvements for post-development. Time of concentration (T<sub>c</sub>) for the basin for both historic and developed flows was calculated using Equations 6-2 through 6-5 of the UDFCD Drainage Criteria Manual, Volume 1. The UDFCD method recommends limiting overland flow to a maximum of 300 feet in suburban areas and 500 ft in rural areas. Calculations were performed using the UDFCD Peak Runoff Prediction by Rational Method – UD Rational 2.00 (dated May 2017) spreadsheet and can be found in *Appendix C*.

## VIII) HYDRAULIC CALCULATIONS

Hydraulic calculations were estimated using methods described in the El Paso County Drainage Criteria Manual and resources from the MHFD. Further discussion of the hydraulic calculations are included in the Extended Detention Basin section.

## IX) EXISTING DRAINAGE CONDITIONS

Runoff from the basin flows via sheet flow to the southwest of the property and eventually discharges into a drainage swale on the SRMD property that continues to the southwest and into a stock pond located on the future Retreat at TimberRidge development. This facility serves as a temporary sediment pond. Discharges from the stock pond flow directly towards Sand Creek. The site is not impacted from off-site flows due to the existing drainage ditch system on Arroya Ln and the previous grading of the SRMD water tank site directly east of the site. Runoff is conveyed via overland sheet flow at a slope of 0.04% resulting in a time of concentration (T<sub>c</sub>) of 23.5 minutes to the southwest corner of the site identified as Design Point 1 (Pre-DP1). Table IX-Pre-development Runoff provides the calculated runoff flows for the pre-development condition.

**Table IX – Pre-Development Runoff**

	2-year	5-year	10-year	25-year	50-year	100-year	500-year
Peak Flow, cfs	0.00	0.00	0.22	1.24	1.91	2.87	4.94

## X) PROPOSED DRAINAGE CONDITIONS

### *General Concept*

Runoff on the site will be conveyed from southern half of the site to the northeast and from the northeast of the site to the southwest to an extended detention basin (EDB) located on the west side of the property before discharging off-site. Approximately 14% of the site (on the east and south side of the property) drains off-site to the east and south onto the SRMD property without treatment. This was due to grading restraints on the site and the limited site area. Overland sheet flow and inverted crown gravel driveways will be used to convey groundwater to the EDB. An EDB providing full spectrum detention will be used to treat the Water Quality Capture Volume (WQCV), Excess Urban Runoff Volume (EURV), and 100-yr flood event before leaving the site. The EURV is similar in magnitude to 10-year detention volume except that the EURV is drained at a much slower rate than the 10-year detention volume would be based on historic criteria. The extended detention basin with full spectrum detention design is based on a drain time of 40 hours for the WQCV and 12 to 32 hours for the EURV. The 100-year release rate is based on draining at 0.9 of predevelopment flows. Note that Colorado law requires 97% of the 5-year storm event to drain within 72 hours.

The detention basin volume required was calculated using the UDFCD USDCM Volume 2, Chapter 12 Simplified Equations (Equations 12-2 and 12-4) for sizing full spectrum detention storage. These equations were used since the drainage basin is less than 10 acres. The WQCV was calculated using Equation 3-1 and 3-2 of Chapter 3 in Volume 3 of the USDCM.

Until future development, flows leaving the site will be discharged into the existing drainage swale at the southwest corner of the property and continue to the SRMD property eventually discharging in the existing stock pond on the future Retreat at TimberRidge development and into Sand Creek as described above.

According to the Retreat at TimberRidge Filing #1, a permanent 24" RCP storm system routing the release from the existing stock pond (a formal outlet pipe is proposed for construction) directly towards Sand Creek is proposed. Eventually, with the development of SRMD, a full spectrum detention (FSD) pond will replace the existing stock pond in accordance with the SRMD MDDP and discharge from the Site will tie into the proposed storm sewer system for the SRMD which will discharge into the proposed FSD pond.

### *Specific Design Details*

The developed drainage basin (identified in the design calculations as Basin A) is 1.47 Acres. Developed runoff is routed via overland sheet flow to an inverted crown gravel driveway at a slope of 0.012% to the proposed EDB with full spectrum detention located on the west side of the property identified as Design Point 1 (Post-DP1). The calculated  $T_c$  is 5.15 minutes. Proposed developed flows are greater than pre-development flows due to the additional impervious area for the new gravel driveway and water storage tanks. Basin A generates developed flows presented in Table X-1 Post-Development Runoff Estimates below.

**Table X-1 Post-Development Runoff Estimates**

	2-yr	5-yr	10-yr	25-yr	50-yr	100-yr	500-yr
Post-Development, cfs	1.59	2.23	3.10	4.86	6.16	7.79	11.62

## XI) EXTENDED DETENTION BASIN (EDB) WITH FULL SPECTRUM DETENTION

The EDB proposed for the site includes volumes, release rates, and components matching the design guidelines in the EPC DCM (Volumes I and II) and the ECM as well as guidance from USDCM. Below is a list of the EDB's major characteristics:

<i>Description</i>	<i>Depth</i>	<i>Volume</i>	<i>Release Rate</i>
Micro-Pool	2.5 ft	75 ft <sup>3</sup> (0.0017 ac-ft)	N/A
WQCV	1.43 ft	0.021 ac-ft	0.011 cfs (45-hr drain time)
EURV	2.71 ft	0.063 ac-ft	0.129 cfs (74-hr drain time)
100-yr	3.89 ft	0.120 ac-ft	1.43 cfs
Freeboard @ 100-Yr (min above max water surface)	1.00 ft	N/A	N/A

The proposed outlet structure is comprised of a sloped inlet concrete box with micro-pool within the outlet structure, WQCV release orifices, and overflow weir for the EURV to 100-yr event including an outlet pipe with circular orifice plate designed to constrict flow to no more than 90% of the pre-development release rate for the 100-yr event. An aluminum bar grate is also designed into the outlet structure to act as a trash rack, preventing debris from clogging the WQCV orifices.

Refer to the detention basin outlet structure design calculations in Appendix E for the WQCV orifice plate, EURV to 100-yr weir and outlet pipe with circular orifice plate design.

An emergency spillway with a crest length of 3 feet, 2:1 sideslopes, and minimum of 1-foot freeboard above the water surface when the emergency spillway is conveying the maximum design flow. Refer to the detention basin outlet structure design calculations in Appendix E for the spillway design.

A concrete trickle channel conveys low flows from the concentrated inflow locations of the detention basin to the outlet structure. The trickle channel is 0.5-ft in depth with a slope ranging from 0.006 to 0.0071 ft/ft. A forebay is not included due to the small size of the site.

## XII) WATER QUALITY PROVISIONS AND MAINTENANCE

The proposed EDB provides water quality for runoff produced on the West Water Tank Site. This water quality basin is designed to treat approximately 1.47 acres and provide 5,500 cubic feet of water quality storage (below the emergency spillway invert). The EDB will be private and maintained by the property owner. Access to be granted to the owner and El Paso County for access and maintenance of the private WQCV facility. A private maintenance agreement accompanies the submittal. The WQCV facility sizing calculations are included as an attachment of this report.

Due to the small size of the detention basin, an access road located on the dam crest will be used to access/clean out the outlet structure using a backhoe.

## XIII) EROSION CONTROL

A Grading, Erosion, and Sediment Control Plan has been prepared for the site and accompanies this report. Proposed erosion and sediment control measures include silt fence at the toe of grading operations, straw bale inlet protection at culvert entrance, culvert outlet protection, concrete washout area, and permanent stabilization of all disturbed areas. Disturbed areas shall be re-seeded with native grasses.

Woodmen Hills Metropolitan District will be responsible for maintenance of all permanent BMP's per the Private Detention Pond/BMP Maintenance Agreement.

**XIV) DRAINAGE AND BRIDGE FEES**

This site is within the Sand Creek Drainage Basin. The 2020 Drainage and Bridge Fees per El Paso County for the West Water Tank site are as follows:

Total Site Area – 1.47 Acres  
 % Impervious – 48%

Drainage Fees: 1.47 Acres x 0.48 x \$19,698/Acre = \$13,898.20

Bridge Fees: 1.47 Acres x 0.48 x \$8,057/Acre = \$5,685.02

---

**TOTAL = \$19,583.22**

**XV) SUMMARY**

Recommendations are made within this report concerning necessary improvements that will be required as a result of development of this property. The West Water Tank site is proposing to construct a detention pond that will detain developed flows and release at historic rates. The extended detention basin with rip rap rundown and plunge pool will sufficiently mitigate the developed flows. The development of the proposed site does not significantly impact any downstream facility or property to an extent greater than that which currently exists due to historic conditions.

# *Appendix A – Soils Map and Reports*

# Custom Soil Resource Report for El Paso County Area, Colorado

**WHMD West Water Tank Site**



# Preface

---

Soil surveys contain information that affects land use planning in survey areas. They highlight soil limitations that affect various land uses and provide information about the properties of the soils in the survey areas. Soil surveys are designed for many different users, including farmers, ranchers, foresters, agronomists, urban planners, community officials, engineers, developers, builders, and home buyers. Also, conservationists, teachers, students, and specialists in recreation, waste disposal, and pollution control can use the surveys to help them understand, protect, or enhance the environment.

Various land use regulations of Federal, State, and local governments may impose special restrictions on land use or land treatment. Soil surveys identify soil properties that are used in making various land use or land treatment decisions. The information is intended to help the land users identify and reduce the effects of soil limitations on various land uses. The landowner or user is responsible for identifying and complying with existing laws and regulations.

Although soil survey information can be used for general farm, local, and wider area planning, onsite investigation is needed to supplement this information in some cases. Examples include soil quality assessments (<http://www.nrcs.usda.gov/wps/portal/nrcs/main/soils/health/>) and certain conservation and engineering applications. For more detailed information, contact your local USDA Service Center (<https://offices.sc.egov.usda.gov/locator/app?agency=nrcs>) or your NRCS State Soil Scientist ([http://www.nrcs.usda.gov/wps/portal/nrcs/detail/soils/contactus/?cid=nrcs142p2\\_053951](http://www.nrcs.usda.gov/wps/portal/nrcs/detail/soils/contactus/?cid=nrcs142p2_053951)).

Great differences in soil properties can occur within short distances. Some soils are seasonally wet or subject to flooding. Some are too unstable to be used as a foundation for buildings or roads. Clayey or wet soils are poorly suited to use as septic tank absorption fields. A high water table makes a soil poorly suited to basements or underground installations.

The National Cooperative Soil Survey is a joint effort of the United States Department of Agriculture and other Federal agencies, State agencies including the Agricultural Experiment Stations, and local agencies. The Natural Resources Conservation Service (NRCS) has leadership for the Federal part of the National Cooperative Soil Survey.

Information about soils is updated periodically. Updated information is available through the NRCS Web Soil Survey, the site for official soil survey information.

The U.S. Department of Agriculture (USDA) prohibits discrimination in all its programs and activities on the basis of race, color, national origin, age, disability, and where applicable, sex, marital status, familial status, parental status, religion, sexual orientation, genetic information, political beliefs, reprisal, or because all or a part of an individual's income is derived from any public assistance program. (Not all prohibited bases apply to all programs.) Persons with disabilities who require



alternative means for communication of program information (Braille, large print, audiotape, etc.) should contact USDA's TARGET Center at (202) 720-2600 (voice and TDD). To file a complaint of discrimination, write to USDA, Director, Office of Civil Rights, 1400 Independence Avenue, S.W., Washington, D.C. 20250-9410 or call (800) 795-3272 (voice) or (202) 720-6382 (TDD). USDA is an equal opportunity provider and employer.

# Contents

---

<b>Preface</b> .....	2
<b>How Soil Surveys Are Made</b> .....	5
<b>Soil Map</b> .....	8
Soil Map.....	9
Legend.....	10
Map Unit Legend.....	11
Map Unit Descriptions.....	11
El Paso County Area, Colorado.....	13
71—Pring coarse sandy loam, 3 to 8 percent slopes.....	13
<b>References</b> .....	15

# How Soil Surveys Are Made

---

Soil surveys are made to provide information about the soils and miscellaneous areas in a specific area. They include a description of the soils and miscellaneous areas and their location on the landscape and tables that show soil properties and limitations affecting various uses. Soil scientists observed the steepness, length, and shape of the slopes; the general pattern of drainage; the kinds of crops and native plants; and the kinds of bedrock. They observed and described many soil profiles. A soil profile is the sequence of natural layers, or horizons, in a soil. The profile extends from the surface down into the unconsolidated material in which the soil formed or from the surface down to bedrock. The unconsolidated material is devoid of roots and other living organisms and has not been changed by other biological activity.

Currently, soils are mapped according to the boundaries of major land resource areas (MLRAs). MLRAs are geographically associated land resource units that share common characteristics related to physiography, geology, climate, water resources, soils, biological resources, and land uses (USDA, 2006). Soil survey areas typically consist of parts of one or more MLRA.

The soils and miscellaneous areas in a survey area occur in an orderly pattern that is related to the geology, landforms, relief, climate, and natural vegetation of the area. Each kind of soil and miscellaneous area is associated with a particular kind of landform or with a segment of the landform. By observing the soils and miscellaneous areas in the survey area and relating their position to specific segments of the landform, a soil scientist develops a concept, or model, of how they were formed. Thus, during mapping, this model enables the soil scientist to predict with a considerable degree of accuracy the kind of soil or miscellaneous area at a specific location on the landscape.

Commonly, individual soils on the landscape merge into one another as their characteristics gradually change. To construct an accurate soil map, however, soil scientists must determine the boundaries between the soils. They can observe only a limited number of soil profiles. Nevertheless, these observations, supplemented by an understanding of the soil-vegetation-landscape relationship, are sufficient to verify predictions of the kinds of soil in an area and to determine the boundaries.

Soil scientists recorded the characteristics of the soil profiles that they studied. They noted soil color, texture, size and shape of soil aggregates, kind and amount of rock fragments, distribution of plant roots, reaction, and other features that enable them to identify soils. After describing the soils in the survey area and determining their properties, the soil scientists assigned the soils to taxonomic classes (units). Taxonomic classes are concepts. Each taxonomic class has a set of soil characteristics with precisely defined limits. The classes are used as a basis for comparison to classify soils systematically. Soil taxonomy, the system of taxonomic classification used in the United States, is based mainly on the kind and character of soil properties and the arrangement of horizons within the profile. After the soil

## Custom Soil Resource Report

scientists classified and named the soils in the survey area, they compared the individual soils with similar soils in the same taxonomic class in other areas so that they could confirm data and assemble additional data based on experience and research.

The objective of soil mapping is not to delineate pure map unit components; the objective is to separate the landscape into landforms or landform segments that have similar use and management requirements. Each map unit is defined by a unique combination of soil components and/or miscellaneous areas in predictable proportions. Some components may be highly contrasting to the other components of the map unit. The presence of minor components in a map unit in no way diminishes the usefulness or accuracy of the data. The delineation of such landforms and landform segments on the map provides sufficient information for the development of resource plans. If intensive use of small areas is planned, onsite investigation is needed to define and locate the soils and miscellaneous areas.

Soil scientists make many field observations in the process of producing a soil map. The frequency of observation is dependent upon several factors, including scale of mapping, intensity of mapping, design of map units, complexity of the landscape, and experience of the soil scientist. Observations are made to test and refine the soil-landscape model and predictions and to verify the classification of the soils at specific locations. Once the soil-landscape model is refined, a significantly smaller number of measurements of individual soil properties are made and recorded. These measurements may include field measurements, such as those for color, depth to bedrock, and texture, and laboratory measurements, such as those for content of sand, silt, clay, salt, and other components. Properties of each soil typically vary from one point to another across the landscape.

Observations for map unit components are aggregated to develop ranges of characteristics for the components. The aggregated values are presented. Direct measurements do not exist for every property presented for every map unit component. Values for some properties are estimated from combinations of other properties.

While a soil survey is in progress, samples of some of the soils in the area generally are collected for laboratory analyses and for engineering tests. Soil scientists interpret the data from these analyses and tests as well as the field-observed characteristics and the soil properties to determine the expected behavior of the soils under different uses. Interpretations for all of the soils are field tested through observation of the soils in different uses and under different levels of management. Some interpretations are modified to fit local conditions, and some new interpretations are developed to meet local needs. Data are assembled from other sources, such as research information, production records, and field experience of specialists. For example, data on crop yields under defined levels of management are assembled from farm records and from field or plot experiments on the same kinds of soil.

Predictions about soil behavior are based not only on soil properties but also on such variables as climate and biological activity. Soil conditions are predictable over long periods of time, but they are not predictable from year to year. For example, soil scientists can predict with a fairly high degree of accuracy that a given soil will have a high water table within certain depths in most years, but they cannot predict that a high water table will always be at a specific level in the soil on a specific date.

After soil scientists located and identified the significant natural bodies of soil in the survey area, they drew the boundaries of these bodies on aerial photographs and

## Custom Soil Resource Report

identified each as a specific map unit. Aerial photographs show trees, buildings, fields, roads, and rivers, all of which help in locating boundaries accurately.

# Soil Map

---

The soil map section includes the soil map for the defined area of interest, a list of soil map units on the map and extent of each map unit, and cartographic symbols displayed on the map. Also presented are various metadata about data used to produce the map, and a description of each soil map unit.

# Custom Soil Resource Report Soil Map

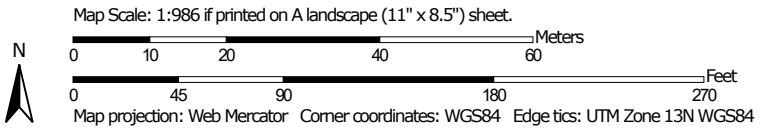
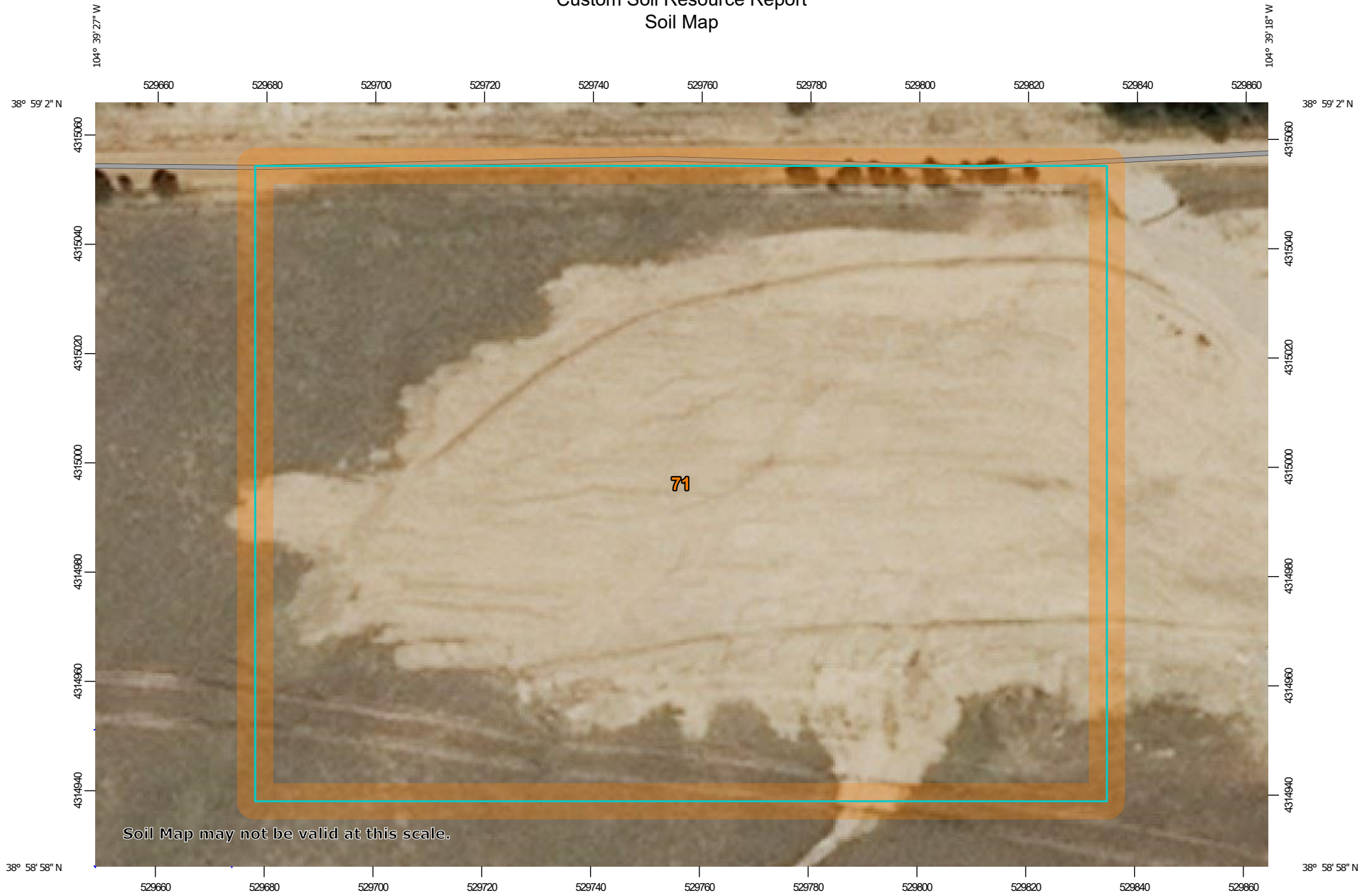

### MAP LEGEND

**Area of Interest (AOI)**

 Area of Interest (AOI)

**Soils**

 Soil Map Unit Polygons

 Soil Map Unit Lines

 Soil Map Unit Points

**Special Point Features**

 Blowout

 Borrow Pit

 Clay Spot

 Closed Depression

 Gravel Pit

 Gravelly Spot

 Landfill

 Lava Flow

 Marsh or swamp

 Mine or Quarry

 Miscellaneous Water

 Perennial Water

 Rock Outcrop

 Saline Spot

 Sandy Spot

 Severely Eroded Spot

 Sinkhole

 Slide or Slip

 Sodic Spot

 Spoil Area

 Stony Spot

 Very Stony Spot

 Wet Spot

 Other

 Special Line Features

**Water Features**

 Streams and Canals

**Transportation**

 Rails

 Interstate Highways

 US Routes

 Major Roads

 Local Roads

**Background**

 Aerial Photography

### MAP INFORMATION

The soil surveys that comprise your AOI were mapped at 1:24,000.

Warning: Soil Map may not be valid at this scale.

Enlargement of maps beyond the scale of mapping can cause misunderstanding of the detail of mapping and accuracy of soil line placement. The maps do not show the small areas of contrasting soils that could have been shown at a more detailed scale.

Please rely on the bar scale on each map sheet for map measurements.

Source of Map: Natural Resources Conservation Service  
 Web Soil Survey URL:  
 Coordinate System: Web Mercator (EPSG:3857)

Maps from the Web Soil Survey are based on the Web Mercator projection, which preserves direction and shape but distorts distance and area. A projection that preserves area, such as the Albers equal-area conic projection, should be used if more accurate calculations of distance or area are required.

This product is generated from the USDA-NRCS certified data as of the version date(s) listed below.

Soil Survey Area: El Paso County Area, Colorado  
 Survey Area Data: Version 17, Sep 13, 2019

Soil map units are labeled (as space allows) for map scales 1:50,000 or larger.

Date(s) aerial images were photographed: Sep 8, 2018—May 26, 2019

The orthophoto or other base map on which the soil lines were compiled and digitized probably differs from the background imagery displayed on these maps. As a result, some minor shifting of map unit boundaries may be evident.



## Map Unit Legend

Map Unit Symbol	Map Unit Name	Acres in AOI	Percent of AOI
71	Pring coarse sandy loam, 3 to 8 percent slopes	4.5	100.0%
<b>Totals for Area of Interest</b>		<b>4.5</b>	<b>100.0%</b>

## Map Unit Descriptions

The map units delineated on the detailed soil maps in a soil survey represent the soils or miscellaneous areas in the survey area. The map unit descriptions, along with the maps, can be used to determine the composition and properties of a unit.

A map unit delineation on a soil map represents an area dominated by one or more major kinds of soil or miscellaneous areas. A map unit is identified and named according to the taxonomic classification of the dominant soils. Within a taxonomic class there are precisely defined limits for the properties of the soils. On the landscape, however, the soils are natural phenomena, and they have the characteristic variability of all natural phenomena. Thus, the range of some observed properties may extend beyond the limits defined for a taxonomic class. Areas of soils of a single taxonomic class rarely, if ever, can be mapped without including areas of other taxonomic classes. Consequently, every map unit is made up of the soils or miscellaneous areas for which it is named and some minor components that belong to taxonomic classes other than those of the major soils.

Most minor soils have properties similar to those of the dominant soil or soils in the map unit, and thus they do not affect use and management. These are called noncontrasting, or similar, components. They may or may not be mentioned in a particular map unit description. Other minor components, however, have properties and behavioral characteristics divergent enough to affect use or to require different management. These are called contrasting, or dissimilar, components. They generally are in small areas and could not be mapped separately because of the scale used. Some small areas of strongly contrasting soils or miscellaneous areas are identified by a special symbol on the maps. If included in the database for a given area, the contrasting minor components are identified in the map unit descriptions along with some characteristics of each. A few areas of minor components may not have been observed, and consequently they are not mentioned in the descriptions, especially where the pattern was so complex that it was impractical to make enough observations to identify all the soils and miscellaneous areas on the landscape.

The presence of minor components in a map unit in no way diminishes the usefulness or accuracy of the data. The objective of mapping is not to delineate pure taxonomic classes but rather to separate the landscape into landforms or landform segments that have similar use and management requirements. The delineation of such segments on the map provides sufficient information for the development of resource plans. If intensive use of small areas is planned, however, onsite investigation is needed to define and locate the soils and miscellaneous areas.

## Custom Soil Resource Report

An identifying symbol precedes the map unit name in the map unit descriptions. Each description includes general facts about the unit and gives important soil properties and qualities.

Soils that have profiles that are almost alike make up a *soil series*. Except for differences in texture of the surface layer, all the soils of a series have major horizons that are similar in composition, thickness, and arrangement.

Soils of one series can differ in texture of the surface layer, slope, stoniness, salinity, degree of erosion, and other characteristics that affect their use. On the basis of such differences, a soil series is divided into *soil phases*. Most of the areas shown on the detailed soil maps are phases of soil series. The name of a soil phase commonly indicates a feature that affects use or management. For example, Alpha silt loam, 0 to 2 percent slopes, is a phase of the Alpha series.

Some map units are made up of two or more major soils or miscellaneous areas. These map units are complexes, associations, or undifferentiated groups.

A *complex* consists of two or more soils or miscellaneous areas in such an intricate pattern or in such small areas that they cannot be shown separately on the maps. The pattern and proportion of the soils or miscellaneous areas are somewhat similar in all areas. Alpha-Beta complex, 0 to 6 percent slopes, is an example.

An *association* is made up of two or more geographically associated soils or miscellaneous areas that are shown as one unit on the maps. Because of present or anticipated uses of the map units in the survey area, it was not considered practical or necessary to map the soils or miscellaneous areas separately. The pattern and relative proportion of the soils or miscellaneous areas are somewhat similar. Alpha-Beta association, 0 to 2 percent slopes, is an example.

An *undifferentiated group* is made up of two or more soils or miscellaneous areas that could be mapped individually but are mapped as one unit because similar interpretations can be made for use and management. The pattern and proportion of the soils or miscellaneous areas in a mapped area are not uniform. An area can be made up of only one of the major soils or miscellaneous areas, or it can be made up of all of them. Alpha and Beta soils, 0 to 2 percent slopes, is an example.

Some surveys include *miscellaneous areas*. Such areas have little or no soil material and support little or no vegetation. Rock outcrop is an example.

## El Paso County Area, Colorado

### 71—Pring coarse sandy loam, 3 to 8 percent slopes

#### Map Unit Setting

*National map unit symbol:* 369k  
*Elevation:* 6,800 to 7,600 feet  
*Farmland classification:* Not prime farmland

#### Map Unit Composition

*Pring and similar soils:* 85 percent  
*Estimates are based on observations, descriptions, and transects of the mapunit.*

#### Description of Pring

##### Setting

*Landform:* Hills  
*Landform position (three-dimensional):* Side slope  
*Down-slope shape:* Linear  
*Across-slope shape:* Linear  
*Parent material:* Arkosic alluvium derived from sedimentary rock

##### Typical profile

*A - 0 to 14 inches:* coarse sandy loam  
*C - 14 to 60 inches:* gravelly sandy loam

##### Properties and qualities

*Slope:* 3 to 8 percent  
*Depth to restrictive feature:* More than 80 inches  
*Natural drainage class:* Well drained  
*Runoff class:* Low  
*Capacity of the most limiting layer to transmit water (Ksat):* High (2.00 to 6.00 in/hr)  
*Depth to water table:* More than 80 inches  
*Frequency of flooding:* None  
*Frequency of ponding:* None  
*Available water storage in profile:* Low (about 6.0 inches)

##### Interpretive groups

*Land capability classification (irrigated):* None specified  
*Land capability classification (nonirrigated):* 3e  
*Hydrologic Soil Group:* B  
*Ecological site:* Loamy Park (R048AY222CO)  
*Hydric soil rating:* No

#### Minor Components

##### Pleasant

*Percent of map unit:*  
*Landform:* Depressions  
*Hydric soil rating:* Yes

##### Other soils

*Percent of map unit:*  
*Hydric soil rating:* No

## Custom Soil Resource Report

# References

---

- American Association of State Highway and Transportation Officials (AASHTO). 2004. Standard specifications for transportation materials and methods of sampling and testing. 24th edition.
- American Society for Testing and Materials (ASTM). 2005. Standard classification of soils for engineering purposes. ASTM Standard D2487-00.
- Cowardin, L.M., V. Carter, F.C. Golet, and E.T. LaRoe. 1979. Classification of wetlands and deep-water habitats of the United States. U.S. Fish and Wildlife Service FWS/OBS-79/31.
- Federal Register. July 13, 1994. Changes in hydric soils of the United States.
- Federal Register. September 18, 2002. Hydric soils of the United States.
- Hurt, G.W., and L.M. Vasilas, editors. Version 6.0, 2006. Field indicators of hydric soils in the United States.
- National Research Council. 1995. Wetlands: Characteristics and boundaries.
- Soil Survey Division Staff. 1993. Soil survey manual. Soil Conservation Service. U.S. Department of Agriculture Handbook 18. [http://www.nrcs.usda.gov/wps/portal/nrcs/detail/national/soils/?cid=nrcs142p2\\_054262](http://www.nrcs.usda.gov/wps/portal/nrcs/detail/national/soils/?cid=nrcs142p2_054262)
- Soil Survey Staff. 1999. Soil taxonomy: A basic system of soil classification for making and interpreting soil surveys. 2nd edition. Natural Resources Conservation Service, U.S. Department of Agriculture Handbook 436. [http://www.nrcs.usda.gov/wps/portal/nrcs/detail/national/soils/?cid=nrcs142p2\\_053577](http://www.nrcs.usda.gov/wps/portal/nrcs/detail/national/soils/?cid=nrcs142p2_053577)
- Soil Survey Staff. 2010. Keys to soil taxonomy. 11th edition. U.S. Department of Agriculture, Natural Resources Conservation Service. [http://www.nrcs.usda.gov/wps/portal/nrcs/detail/national/soils/?cid=nrcs142p2\\_053580](http://www.nrcs.usda.gov/wps/portal/nrcs/detail/national/soils/?cid=nrcs142p2_053580)
- Tiner, R.W., Jr. 1985. Wetlands of Delaware. U.S. Fish and Wildlife Service and Delaware Department of Natural Resources and Environmental Control, Wetlands Section.
- United States Army Corps of Engineers, Environmental Laboratory. 1987. Corps of Engineers wetlands delineation manual. Waterways Experiment Station Technical Report Y-87-1.
- United States Department of Agriculture, Natural Resources Conservation Service. National forestry manual. [http://www.nrcs.usda.gov/wps/portal/nrcs/detail/soils/home/?cid=nrcs142p2\\_053374](http://www.nrcs.usda.gov/wps/portal/nrcs/detail/soils/home/?cid=nrcs142p2_053374)
- United States Department of Agriculture, Natural Resources Conservation Service. National range and pasture handbook. <http://www.nrcs.usda.gov/wps/portal/nrcs/detail/national/landuse/rangepasture/?cid=stelprdb1043084>

## Custom Soil Resource Report

United States Department of Agriculture, Natural Resources Conservation Service. National soil survey handbook, title 430-VI. [http://www.nrcs.usda.gov/wps/portal/nrcs/detail/soils/scientists/?cid=nrcs142p2\\_054242](http://www.nrcs.usda.gov/wps/portal/nrcs/detail/soils/scientists/?cid=nrcs142p2_054242)

United States Department of Agriculture, Natural Resources Conservation Service. 2006. Land resource regions and major land resource areas of the United States, the Caribbean, and the Pacific Basin. U.S. Department of Agriculture Handbook 296. [http://www.nrcs.usda.gov/wps/portal/nrcs/detail/national/soils/?cid=nrcs142p2\\_053624](http://www.nrcs.usda.gov/wps/portal/nrcs/detail/national/soils/?cid=nrcs142p2_053624)

United States Department of Agriculture, Soil Conservation Service. 1961. Land capability classification. U.S. Department of Agriculture Handbook 210. [http://www.nrcs.usda.gov/Internet/FSE\\_DOCUMENTS/nrcs142p2\\_052290.pdf](http://www.nrcs.usda.gov/Internet/FSE_DOCUMENTS/nrcs142p2_052290.pdf)

1/6/2020

# Geotechnical Evaluation Report

**Woodmen Hills Metropolitan District**

**Water Storage Tank**

**Vicinity of Arroya Lane**

**Falcon, Colorado**

**VIVID Project No.: D19-2-260**



Only the client or it's designated representatives may use this document  
and only for the specific project for which this report was prepared.

January 6, 2020

Vivid Project No.: D19-2-260

Report prepared for:

Woodmen Hills Metropolitan District  
8046 Eastonville Road  
Peyton, CO 80831

CC: Mark Volle, PE  
JDS-Hydro Consultants, Inc.  
5540 Tech Center Drive, Suite 100  
Colorado Springs, CO 80919  
[mvolle@jdshydro.com](mailto:mvolle@jdshydro.com)

**GEOTECHNICAL EVALUATION REPORT**  
**Proposed Woodmen Hills Metropolitan District Water Storage Tank**  
**Vicinity of Arroya Lane**  
**Falcon, Colorado**  
**VIVID Project No.: D19-2-260**

Prepared by:



---

Abbas Al Eyoon, EIT  
Staff Engineer



---

William J. Barreire, P.E.  
Senior Geotechnical Engineer

**VIVID Engineering Group, Inc.**  
1053 Elkton Drive  
Colorado Springs, CO 80907  
(719) 896-4356  
(719) 896-4357 fax



## Table of Contents

1.0	INTRODUCTION.....	1
1.1	GENERAL .....	1
1.2	PROJECT DESCRIPTION.....	1
1.3	PURPOSE AND SCOPE .....	1
2.0	FIELD EXPLORATION AND LABORATORY TESTING .....	3
2.1	FIELD EXPLORATION.....	3
2.2	GEOTECHNICAL LABORATORY TESTING.....	3
2.3	ANALYTICAL LABORATORY TESTING .....	3
3.0	SITE CONDITIONS .....	5
3.1	SURFACE.....	5
3.2	Geology .....	5
3.3	SEISMICITY .....	5
3.4	SUBSURFACE .....	5
3.4.1	Groundwater .....	6
4.0	CONCLUSIONS AND RECOMMENDATIONS.....	7
4.1	GEOTECHNICAL FEASIBILITY OF PROPOSED CONSTRUCTION.....	7
4.2	Construction Considerations.....	7
4.2.1	General .....	7
4.2.2	Site Preparation and Grading .....	7
4.2.3	Excavation Characteristics.....	8
4.2.4	Structural Fill.....	8
4.2.5	Utility Trench Backfill.....	9
4.2.6	Compaction Requirements.....	9
4.2.7	Construction in Wet or Cold Weather .....	10
4.2.8	Construction Testing and Observation.....	10
4.2.9	Surface Drainage and Landscaping.....	10
4.2.10	Permanent Cut and Fill Slopes.....	10
4.3	SHALLOW FOUNDATIONS .....	11
4.3.1	Shallow Foundation/Slab Recommendations .....	11
4.4	LATERAL EARTH PRESSURES.....	12
4.5	CORROSIVITY AND CONCRETE .....	12

4.5.1 Corrosion Potential .....	12
4.5.2 Chemical Sulfate Susceptibility and Concrete Type.....	13
5.0 ADDITIONAL SERVICES & LIMITATIONS .....	14
5.1 ADDITIONAL SERVICES .....	14
5.2 LIMITATIONS .....	14

Figure 1: Vicinity Map

Figure 2: Boring Location Plan

Appendix A: Logs of Exploratory Borings

Appendix B: Geotechnical Laboratory Test Results

Appendix C: Analytical Laboratory Test Results

Appendix D: Site Photos

Appendix E: Important Information About This Geotechnical Engineering Report



## 1.0 INTRODUCTION

### 1.1 GENERAL

This report presents the results of a geotechnical investigation performed for a proposed Water Storage tank located near Arroya Lane in Falcon, Colorado. An attached Vicinity Map (Figure 1) shows the general location of the project. Our investigation was performed for JDS-Hydro Consultants Inc. and was authorized by Woodmen Hills Metropolitan District Manager Mr. Jerry Jacobson.

A geotechnical investigation for the associated, proposed pipeline to be constructed from the proposed water tank near Arroya Lane was performed concurrently with the water storage tank investigation and has been submitted under separate cover.

This report includes our recommendations relating to the geotechnical aspects of project design and construction. The conclusions and recommendations stated in this report are based upon the subsurface conditions found at the locations of our exploratory borings at the time our exploration was performed. They also are subject to the provisions stated in the report section titled **Additional Services & Limitations**. Our findings, conclusions, and recommendations should not be extrapolated to other areas or used for other projects without our prior review. Furthermore, they should not be used if the site has been altered, or if a prolonged period has elapsed since the date of the report, without VIVID's prior review to determine if they remain valid.

### 1.2 PROJECT DESCRIPTION

We understand the proposed project consists of the construction of a 3.0 MG above-ground water storage tank of 130' 6" diameter that will comprise a post-tensioned concrete tank. As provided by JDS-Hydro, the tank finished floor elevation, tank overflow elevation, and top of tank elevation are 7296 feet, 7328 feet, and 7342 feet, respectively.

The average existing grade is 7304 which is same as the proposed grade (According to JDS-Hydro). We anticipate there will be a cut on the order of approximately 7 to 9 feet to bring the existing grade to the foundation level. Excavations that will be required for piping and utilities, likely will range from approximately 3 to 9 feet or so in depth.

As provided by DN Tanks the anticipated contact pressure for this tank will be around 2.0 ksf beneath the tank floor and a maximum contact pressure of 2.8 ksf beneath the tank perimeter for an assumed footing dimension of 4'-0" wide and 1'-3" deep and 2 feet of backfill. For the purposes of this report, we anticipate the tank foundation will consist of a shallow foundation system, such as a membrane floor with a perimeter wall footing or a mat-type foundations. Other construction related activities are anticipated to include the connection of the inflow and outflow pipelines, site grading, and installation of utilities.

If the type of construction or actual building loads vary significantly from those assumed above, VIVID should be notified in order to revise our recommendations, if required.

### 1.3 PURPOSE AND SCOPE

The purpose of our investigation was to explore and evaluate subsurface conditions at various locations on the site and, based upon the conditions found, to develop recommendations relating to the



geotechnical aspects of project design and construction. Our conclusions and recommendations in this report are based upon analysis of the data from our field exploration, laboratory tests, and our experience with similar soil and geologic conditions in the area.

VIVID's scope of services included:

- A visual reconnaissance to observe surface and geologic conditions at the project site and locating the exploratory borings;
- Notification of the Utility Notification Center of Colorado (UNCC)/Colorado 811 one-call service to identify underground utility lines at the boring locations prior to our drilling;
- The drilling of 5 exploratory borings at the perimeter and center of the circular water storage tank, which were selected and surveyed by JDS-Hydro based upon DN Tanks requirements, access to the site, and location of existing structures and utilities;
- Performance of plate load test to determine Modulus of Subgrade Reaction at the existing ground surface, based on a 12-inch square plate;
- Laboratory testing of selected samples obtained during the field exploration to evaluate relevant physical and engineering properties of the soil;
- Evaluation and engineering analysis of the field and laboratory data collected to develop our geotechnical conclusions and recommendations; and
- Preparation of this report, which includes a description of the proposed project, a description of the surface and subsurface site conditions found during our investigation, our conclusions and recommendations as to foundation and floor slab design and construction, and other related geotechnical issues, and appendices which summarize our field and laboratory investigations.

## 2.0 FIELD EXPLORATION AND LABORATORY TESTING

### 2.1 FIELD EXPLORATION

A field exploration performed on October 23 and November 4, 2019 included drilling 5 exploratory borings, at the approximate locations specified by JDS-Hydro and indicated on the Boring Location Plan (Figure 2). Borings TK-1, TK-2, TK-4 and TK-5 were drilled near the perimeter of the proposed circular storage tank and advanced to an approximate depth of 30 feet below ground surface. TK-3 was drilled at the approximate location of the circular storage tank center and advanced to a depth of approximately 57 feet below the existing ground surface

All borings were advanced using a truck-mounted CME-55 drill rig equipped with 4-inch diameter, continuous-flight, solid-stem auger. Samples were taken with a standard split-spoon (SPT) sampler and California-type sampler (2.0-inch I.D./2.5-inch O.D.) and by bulk methods. Penetration tests were obtained at the various sample depths as well.

Appendix A to this report includes logs describing the subsurface conditions. The lines defining boundaries between soil types on the logs are based upon drill behavior and interpolation between samples and are therefore approximate. Transition between soil types may be abrupt or may be gradual.

### 2.2 GEOTECHNICAL LABORATORY TESTING

Laboratory tests were performed on selected soil samples to estimate their relative engineering properties. Tests were performed in general accordance with the following methods of ASTM or other recognized standards-setting bodies, and local practice:

- Description and Identification of Soils (Visual-Manual Procedure)
- Classification of Soils for Engineering Purposes
- Moisture Content and Unit Weight of Soils
- Sieve Analysis
- Liquid Limit, Plastic Limit, and Plasticity Index of Soils
- Swell/Settlement Test
- Unconfined Compressive Strength

Results of the geotechnical laboratory tests are presented in the report text, where applicable, and included in Appendix B of this report. Selected test results are also shown on the boring logs in Appendix A.

### 2.3 ANALYTICAL LABORATORY TESTING

Analytical testing for soil corrosivity was performed on select sample and included the following tests:

- pH
- Resistivity
- Redox Potential
- Water-soluble Chlorides
- Sulfides
- Water-soluble Sulfate Content



Results of the analytical laboratory tests are included in Appendix C of this report.

## 3.0 SITE CONDITIONS

### 3.1 SURFACE

At the time of our exploration, the subject site was a vacant property other than an existing tank on this same site located generally east of the new proposed tank. The ground surface was relatively flat and sloped gently down towards the west. The site was within the Black Forest region, bounded from the north by Arroya Lane, and from the east by an existing tank, south and west of the site are vacant areas.

### 3.2 Geology

Prior to drilling, the site geology was evaluated by reviewing available geologic information including the USGS Geologic Map Falcon NW 7.5 minutes Quadrangle, El Paso County (Madole, 2003). Mapping in the area indicates the surficial soils in the general area of the project site comprise alluvial soils underlain by sandstone and claystone bedrock of the Dawson Formation. The mapping is generally consistent with our explorations.

### 3.3 SEISMICITY

Based upon the geologic setting, subsurface soil conditions, and low seismic activity in this region, liquefaction is not expected to be a hazard at the site. Based on correlation of blow count data (N-values) from the borings advanced during this evaluation, the subsurface soil profiles correspond with Site Class C of the 2015 International Building Code (IBC). The intermediate design acceleration values from IBC are presented below.

**Table 1**  
**Design Acceleration for Short Periods**

$S_s$	$F_a$
0.172	1.2

$S_s$  = The mapped spectral accelerations for short periods (SEAOC/OSHPD Seismic Design Maps Tool, 2019)

$F_a$  = Site coefficient (SEAOC/OSHPD Seismic Design Maps Tool, 2019)

**Table 2**  
**Design Acceleration for 1-Second Period**

$S_1$	$F_v$
0.058	1.7

$S_1$  = The mapped spectral accelerations for 1 second period (SEAOC/OSHPD Seismic Design Maps Tool, 2019)

$F_v$  = Site coefficient SEAOC/OSHPD Seismic Design Maps Tool, 2019

### 3.4 SUBSURFACE

VIVID explored the subsurface conditions by drilling, logging and sampling 5 exploratory borings within or near the general area to be occupied by the proposed tank as shown on Figure 2. These borings were drilled to depths ranging from approximately 29 to 57 feet below the existing ground surface. The general profile encountered in our borings consisted of:

### **Existing Fill**

Predominantly clayey to silty sand with gravel fill was encountered at the ground surface in all borings and extended to depths of approximately 4.0 to 9.0 feet below the ground surface. The existing fill was olive grey to olive brown to reddish brown in color, dry to moist, and field penetration testing (blow counts) indicated the soil to be loose to medium dense. Considering the low fines content, this soil may exhibit low compression when loaded and low expansion when subject to wetting.

### **Alluvium**

Alluvial soils were comprised of clayey to silty sand with some gravel and sandy lean clay, underlying the existing fill, and extended to depths ranging from approximately 9 and 12 feet below the ground surface. The soils were generally olive brown to dark brown to light brown, greenish grey to pink, dry to moist, and the sand soils are medium dense to very dense in relative density and the clay soils are hard in consistency.

### **Sandstone and Claystone Bedrock**

Interbedded sandstone and claystone bedrock of the Dawson Formation was encountered underlying the fill materials and alluvium soils described above at each boring location and extended to the maximum depth explored in each boring. Predominantly silty to clayey sandstone was encountered. The sandstone/claystone was greenish grey and pale olive to olive yellow, dry to wet, hard to very hard, uncemented to weakly cemented, and was fine to coarse-grained. One-dimensional swell/settlement testing performed on samples of the bedrock from borings TK-4 and TK-5 resulted in a low expansion potential of 1.1% and 0.5%, respectively, based on measured test results when saturated under a 1 kip per square foot (ksf) surcharge pressure.

The boring logs in appendix A should be reviewed for more detailed descriptions of the subsurface conditions at each of the boring locations explored.

#### **3.4.1 Groundwater**

Groundwater was encountered at the time of drilling in boring TK-3 only at a depth of approximately 45 feet below the ground surface at the time of drilling and approximately 52 feet after drilling. Groundwater at this depth is not anticipated to be a significant factor for building construction. Soil moisture levels and groundwater levels commonly vary over time and space depending on seasonal precipitation, irrigation practices, land use, and runoff conditions. These conditions and the variations that they create often are not apparent at the time of field investigation. Accordingly, the soil moisture and groundwater data in this report pertain only to the locations and times at which exploration was performed. They can be extrapolated to other locations and times only with caution. It should also be noted that VIVID has not performed a hydrologic study to verify the seasonal high-water level.



## 4.0 CONCLUSIONS AND RECOMMENDATIONS

### 4.1 GEOTECHNICAL FEASIBILITY OF PROPOSED CONSTRUCTION

VIVID found no subsurface conditions during this investigation that would preclude development of the site essentially as planned, provided the recommendations in this report are incorporated into the design and construction of the project. Our recommendations for earthwork, foundations, and slabs are discussed further in the following sections of the report.

The primary geotechnical issues associated with development of this project as proposed is the presence of existing fill materials, variable density of clay and sand soils, as well as Interbedded sandstone and claystone bedrock at or near foundation and floor slab elevations that create the potential for differentiated foundation movement in the form of settlement over time. This movement will result in movement and could damage the tank foundation and slab unless mitigated. We have not been provided information on how the existing fill was placed or density testing, therefore, we consider the existing fill to be uncontrolled. We recommend the existing fill be completely removed from the tank footprint and under no circumstance should foundation elements be placed directly on this uncontrolled fill material.

Shallow foundation and slab-on-grade systems can be utilized with improvement of the existing subgrade to minimize the potential for structure damage. To minimize the potential for damage, it is recommended that the existing fill and the clayey sand and sandy clay soil over excavated until exposing bedrock, then the foundations and slabs placed on a minimum 2-foot thick mat of imported, non-expansive, granular structural fill. While the existing sand and clayey sand soils on this site may be reused as structural fill, clay soils should not be used as structural fill. This will require the existing soils be removed to expose bedrock, and to a minimum depth of 2 feet below bottom of footing and slab elevation and replaced with structural fill. The over-excavation should also extend at least 4 feet beyond the edge of the footings. This improvement shall also be performed below piping (where bedrock is within 2 feet below the piping) into and out of the tank that would be sensitive to differential movement especially at its connection with the structure. This treatment should occur to a minimum distance of 10 feet from the tank perimeter then transition to no treatment for another 10 feet.

Foundation/slab system recommendations are described in more detail in Section 4.3.1. Subgrade preparation and placement of structural fill is detailed in Sections 4.2.2, and 4.2.4 respectively.

### 4.2 Construction Considerations

#### 4.2.1 General

All site preparation and earthwork operations should be performed in accordance with applicable codes, safety regulations and other local, State or Federal guidelines.

#### 4.2.2 Site Preparation and Grading

Initial site work should consist of completely removing all organic material and other deleterious materials from all areas to be filled and areas to be cut. All material should be removed for offsite disposal in accordance with local laws and regulations or, if appropriate, stockpiled in proposed non-structural areas for future use. Areas to receive fill should be evaluated by the geotechnical engineer prior to the placement of any fill materials.



After performing the required excavations and prior to the placement of compacted fill, preparation of the exposed subgrade shall be performed. Preparation includes scarifying the soil to a depth of 8-inches moisture conditioning and recompacting. All fill materials should be placed on a horizontal plane and placed in loose lifts not to exceed 8-inches in thickness, unless otherwise accepted by the geotechnical engineer. Compaction requirements are presented in Section 4.2.6 of this report.

#### 4.2.3 Excavation Characteristics

The proposed tank finished floor plan is about 8 feet lower than the existing grade. Excavation should continue until exposing the bedrock and allowing of at least 2 feet of structural fill below the bottom of the foundation\slab components.

Based on our subsurface drilling information, we anticipate excavations on the order of approximately 3 to 12 feet will be required for any connecting pipeline installation and to construct shallow foundations on compacted structural fill.

All excavations must comply with applicable local, State and Federal safety regulations, and particularly with the excavation standards of the Occupational Safety and Health Administration (OSHA). Construction site safety, including excavation safety, is the sole responsibility of the Contractor as part of its overall responsibility for the means, methods and sequencing of construction operations. VIVID's recommendations for excavation support are intended for the Client's use in planning the project, and in no way relieve the Contractor of its responsibility to construct, support and maintain safe slopes. Under no circumstances should the following recommendations be interpreted to mean that VIVID is assuming responsibility for either construction site safety or the Contractor's activities.

We believe that the existing fill, and the sandy soils on this site will classify as Type C materials using OSHA criteria. OSHA requires that unsupported cuts be laid back to ratios no steeper than 1½:1 (horizontal to vertical). In general, we believe that these slope ratios for the soils provided above will be temporarily stable under unsaturated conditions. If groundwater seepage was to occur, flatter slopes may be appropriate. Please note that the actual determination of soil type and allowable sloping must be made in the field by an OSHA-qualified "competent person."

#### 4.2.4 Structural Fill

Structural fill refers to material that is appropriate for placement beneath foundation and slab components, as well as wall backfill. Existing silty to clayey sand fill materials and native soils are considered acceptable for structural fill, provided these materials have a maximum of 30 percent fines, a Plasticity Index less than 20 and be free of deleterious materials. A sample of any fill material should be submitted to our office for approval and testing at least 1 week prior to stockpiling at the site.

Structural fill should be moisture conditioned and compacted according to the recommendations in Section 4.2.6 of this report. We recommend that a qualified representative of VIVID visit the site during excavation and during placement of the structural fill to verify the soils exposed in the excavations are consistent with those encountered during our subsurface exploration and that proper foundation subgrade preparation and placement is performed.

If imported structural fill is required, it should consist of material that meets the requirements of CDOT Class 1 Structure Backfill per CDOT Standard Specifications for Road and Bridge Construction, 2019, with the exception that the fines content (% passing the no. 200 sieve) is between 10 and 30 percent.

#### 4.2.5 Utility Trench Backfill

Backfill material should be essentially free of plant matter, organic soil, debris, trash, other deleterious matter and rock particles larger than 4 inches. However, backfill material in the “pipe zone” (from the trench floor to 1 foot above the top of pipe) should not contain rock particles larger than 1 inch. Strictly observe any requirements specified by the utility agency for bedding and pipe-zone fill. In general, backfill above the pipe zone in utility trenches should be placed in lifts of 6 to 8 inches, and compacted using power equipment designed for trench work. Backfill in the pipe zone should be placed in lifts of 8 inches or less and compacted with hand-held equipment. **Where piping/utilities enter and exist structures, subgrade treatment and structural fill requirements are needed to limit damage due to differential movement. Specific details are presented in section 4.1. Compact trench backfill as recommended in Section 4.2.6 of this report.**

#### 4.2.6 Compaction Requirements

Fill materials should be placed in horizontal lifts compatible with the type of compaction equipment being used, moisture conditioned, and compacted in accordance with the following criteria:

**Table 3  
Compaction Specifications**

FILL LOCATION <sup>1</sup>	MATERIAL TYPE	PERCENT COMPACTION <sup>2</sup> (ASTM D 698)	MOISTURE CONTENT
Subgrade Preparation (after clearing, grubbing, excavation, and prior to placement of new fill and/or structural elements)	On-site Soils	95 minimum	± 2 % of optimum
Structural Fill placed beneath foundations and slabs-on-grade	On-site Granular Soils	95 minimum	± 2 % of optimum
Exterior Wall Backfill	On-site Granular Soils	92 minimum	± 2 % of optimum
Utility Trenches	On-site Soils	92 minimum	± 2 % of optimum

1) Where two or more “Fill Locations” coincide, the more stringent specification should be used.

2) In non-structural or landscaped areas, the compaction specification may be reduced to 90 percent.

Structural fill should be placed in level lifts not exceeding 8-inches in loose thickness and compacted to the specified percent compaction to produce a firm and unyielding surface. If field density tests indicate the required percent compaction has not been obtained, the fill material should be reconditioned as necessary and re-compacted to the required percent compaction before placing any additional material.

#### 4.2.7 Construction in Wet or Cold Weather

During construction, grade the site such that surface water can drain readily away from the tank site. Promptly pump out or otherwise remove any water that may accumulate in excavations or on subgrade surfaces and allow these areas to dry before resuming construction. The use of berms, ditches and similar means may be used to prevent stormwater from entering the work area and to convey any water off site efficiently.

If earthwork is performed during the winter months when freezing is a factor, no grading fill, structural fill or other fill should be placed on frosted or frozen ground, nor should frozen material be placed as fill. Frozen ground should be allowed to thaw or be completely removed prior to placement of fill. A good practice is to cover the compacted fill with a “blanket” of loose fill to help prevent the compacted fill from freezing.

If the structures are erected during cold weather, foundations, concrete slabs-on-grade, or other concrete elements should not be constructed on frozen soil. Frozen soil should be completely removed from beneath the concrete elements, or thawed, scarified and recompact. The amount of time passing between excavation or subgrade preparation and placing concrete should be minimized during freezing conditions to prevent the prepared soils from freezing. The use of blankets, soil cover or heating as required may be utilized to prevent the subgrade from freezing.

#### 4.2.8 Construction Testing and Observation

Testing and construction observation should take place under the direction of VIVID to support that engineer’s professional opinion as to whether the earthwork does or does not substantially conform to the recommendations in this report. Furthermore, the opinions and conclusions of a geotechnical report are based upon the interpretation of a limited amount of information obtained from the field exploration. It is therefore not uncommon to find that actual site conditions differ somewhat from those indicated in the report. The geotechnical engineer should remain involved throughout the project to evaluate such differing conditions as they appear, and to modify or add to the geotechnical recommendations as necessary.

#### 4.2.9 Surface Drainage and Landscaping

Positive drainage away from the tank is essential to the performance of foundations and slabs and should be provided during the life of the structure. Non-paved areas within 10-feet of the structure should slope away at a minimum of 8 percent. Areas where pavements or slabs are constructed adjacent to the structure should slope away at a minimum grade of 2 percent. All downspouts from roof drains should be tight-lined to an on-site stormwater system or, at a minimum, cross all backfilled areas such that they discharge all water away from the backfill zone and the structure. Drainage should be created such that water is diverted off the site and away from backfill areas of adjacent buildings. Landscaping improvements requiring supplemental watering are not recommended adjacent to improved areas including foundations, pavements or slabs.

#### 4.2.10 Permanent Cut and Fill Slopes

If required, permanent cut and fill slopes exposing the materials encountered in our borings are anticipated to be stable at slope ratios as steep as 3:1 (horizontal to vertical) under dry conditions. We



believe that slope ratios of 4:1 or flatter are more reliable if subjected to wetting, and present less of a maintenance problem. New slopes should be revegetated as soon as possible after completion to reduce erosion problems.

### 4.3 SHALLOW FOUNDATIONS

Provided the following recommendations are complied with, the proposed storage tank may be supported on shallow foundations. Our subsurface investigation indicates excavation for construction of shallow foundations for the proposed structure will expose a thin layer of medium dense to dense clayey to silty sand with gravel materials underlaid by interbedded Sandstone/Claystone bedrock. The filled tank loads are anticipated to be heavy.

#### 4.3.1 Shallow Foundation/Slab Recommendations

Based on information provided, we understand the base elevation of the tank will be on the order of 8 feet below the existing grade. This puts the base of the tank approximately 1 to 4 feet above bedrock elevation and bearing on soils with variable characteristics and density. To help reduce differential movement of the proposed tank foundation/slab, we recommend continuing the excavation below the base of the tank elevation and exposing the underlying bedrock. This would be followed by the placement and compaction of structural fill comprising on site granular soils or imported structural fill. There should also be a 2-foot minimum thickness of structural fill below all foundation/slab components. Acceptable structural fill material and compaction requirements are provided in Sections 4.2.4 and 4.2.6, respectively. In addition, structural design should address differential movement between the tank structure and any proposed pipeline(s) and utilities to be connected to the structure. Section 4.1 provides subgrade improvement and fill requirements for utility connections. Measures to limit damage such as slip-joints or other connections that can tolerate some movement should be implemented, as appropriate.

- Foundations and slabs bearing upon compacted structural fill as discussed above should be designed for a maximum allowable soil bearing capacity of 4,000 psf. A one-third increase in bearing capacity is allowable for transient loads. Foundations and slabs should be proportioned as much as practicable to minimize differential settlement.
- According to our settlement analysis, the amount of anticipated total settlement is in the range of 1 inch or less at the center of the tank. Maximum tolerable differential settlement between the tank perimeter and tank center will be on the order of approximately ½ inch.
- For slab-on-grade constructed on at least of 2 feet of structural fill a modulus of subgrade reaction of **200** pounds per cubic inch (pci) can be used.
- Exterior foundations must be protected from frost action. We recommend footings be protected with at least 36 inches of soil cover or that which is required by local building codes. Foundation components must not be placed on frozen soils.
- A representative of VIVID should observe all foundation excavations prior to placement of fill and/or concrete. Additionally, the placement and compaction of structural fill should be observed and tested by a representative of our firm.

## 4.4 LATERAL EARTH PRESSURES

Buried tank walls will be backfilled with soil on one side and will therefore be subjected to lateral earth pressures. The design and construction criteria presented below should be observed for earth retention systems (tank walls in this case) on this site with flat back slopes. Active and at-rest lateral earth pressures apply to the structural fill soils that are “retained” by the foundation walls. Passive lateral earth pressure applies to soils placed adjacent the inside edge of the tank footing/wall beneath the floor slab. The sliding coefficient applies to the friction between the base of the foundation and the underlying soil. The following values were estimated assuming a moist unit weight of 110 pounds per cubic foot and an internal friction angle of 28 degrees for on-site soils.

**Table 4**  
**Lateral Earth Pressure Parameter Summary**

Lateral Earth Pressure Parameter	Values for On-site Granular Soils (ultimate values)
At-Rest <sup>1</sup>	60 pcf
Active <sup>2</sup>	40 pcf
Passive <sup>3</sup>	305 pcf
Unfactored Coefficient of Sliding Friction <sup>3</sup>	0.50

- Notes:
1. Retaining walls that are laterally supported (structurally restrained from rotation) can be expected to undergo only a slight amount of deflection. These walls should be designed for an “at-rest” lateral earth pressure.
  2. Retaining structures which can deflect sufficiently to mobilize the full “active” earth pressure condition should be designed for an “active” lateral earth pressure.
  3. Lateral loads may be resisted using these coefficients of friction for sliding and unfactored passive earth pressures. Due to the relatively large movements required to mobilize the passive pressure, we recommend a minimum factor of safety of 1.5 be utilized.
  4. It should be noted that the above lateral earth pressures assume drained conditions behind the wall and a horizontal backfill surface without surcharges.

## 4.5 CORROSIVITY AND CONCRETE

### 4.5.1 Corrosion Potential

Laboratory testing was completed to provide data regarding corrosivity of onsite soils. Our scope of services does not include corrosion engineering and, therefore, a detailed analysis of the corrosion test results is not included. A qualified corrosion engineer should be retained to review the test results and design protective systems that may be required.

Laboratory chloride concentration, sulfate concentration, sulfide concentration, pH, oxidation reduction potential, and electrical resistivity tests were performed on a sample of onsite materials obtained during our field investigation. The results of the tests are included in Appendix C to this report and are summarized below in Table 5.

**Table 5  
Summary of Laboratory Soil Corrosivity Testing**

Boring No.	Sample Depth (ft)	Water Soluble Chloride (%)	pH	Redox Potential (mV)	Resistivity (ohm-cm)	Water Soluble Sulfate (%)	Sulfide Content
TK-2	0-4.0	0.0004	7.1	317.1	5432	0.002	Trace

Metal and concrete elements in contact with soil, whether part of a foundation system or part of a supported structure, are subject to degradation due to corrosion or chemical attack. Therefore, buried metal and concrete elements should be designed to resist corrosion and degradation based on accepted practices.

Based on the “10-point” method developed by the American Water Works Association (AWWA) in standard AWWA C105/A21.5, the corrosivity test results indicate that the onsite soils have corrosive potential. We recommend that a corrosion engineer be consulted to recommend appropriate protective measures, if required.

#### 4.5.2 Chemical Sulfate Susceptibility and Concrete Type

The degradation of concrete or cement grout can be caused by chemical agents in the soil or groundwater that react with concrete to either dissolve the cement paste or precipitate larger compounds within the concrete, causing cracking and flaking. The concentration of water-soluble sulfates in the soils is a good indicator of the potential for chemical attack of concrete or cement grout. The American Concrete Institute (ACI) in their publication Guide to Durable Concrete (ACI 201.2R-08) provides guidelines for this assessment.

The concentration of water-soluble sulfates measured on subsurface materials submitted for testing represents a Class 0 exposure of sulfate attack on concrete exposed to the soils per CDOT Standard Specifications for Road and Bridge Construction, 2017, Section 601.04. If there is not a significant difference in cost, Type II cement can be considered for added benefit for concrete in contact with soils.

## 5.0 ADDITIONAL SERVICES & LIMITATIONS

### 5.1 ADDITIONAL SERVICES

Attached to this report is a document by the Geoprofessional Business Association (GBA) that summarizes limitations of geotechnical reports as well as additional services that are required to further confirm subgrade materials are consistent with that encountered at the specific boring locations presented in this report. This document should be read in its entirety before implementing design or construction activities. Examples of other services beyond completion of a geotechnical report are necessary or desirable to complete a project satisfactorily include:

- Review of design plans and specifications to verify that our recommendations were properly interpreted and implemented.
- Attendance at pre-bid and pre-construction meetings to highlight important items and clear up misunderstandings, ambiguities, or conflicts with design plans and specifications.
- Performance of construction observation and testing which allows verification that existing materials at locations beyond our borings are consistent with that presented in our report, construction is compliant with the requirements/recommendations, evaluation of changed conditions.

### 5.2 LIMITATIONS

This work was performed in a manner consistent with that level of care and skill ordinarily exercised by other members of VIVID's profession practicing in the same locality, under similar conditions and at the date the services are provided. Our conclusions, opinions, and recommendations are based on a limited number of observations and data. It is possible that conditions could vary between or beyond the data evaluated. VIVID makes no other representation, guarantee, or warranty, express or implied, regarding the services, communication (oral or written), report, opinion, or instrument of service provided.

This report may be used only by the Client and the registered design professional in responsible charge and only for the purposes stated for this specific engagement within a reasonable time from its issuance, but in no event later than two (2) years from the date of the report.

The work performed was based on project information provided by Client. If Client does not retain VIVID to review any plans and specifications, including any revisions or modifications to the plans and specifications, VIVID assumes no responsibility for the suitability of our recommendations. In addition, if there are any changes in the field to the plans and specifications, Client must obtain written approval from VIVID's engineer that such changes do not affect our recommendations. Failure to do so will vitiate VIVID's recommendations. If there is not a significant difference in cost, Type II cement can be considered for added benefit for concrete in contact with soils.



## Figures

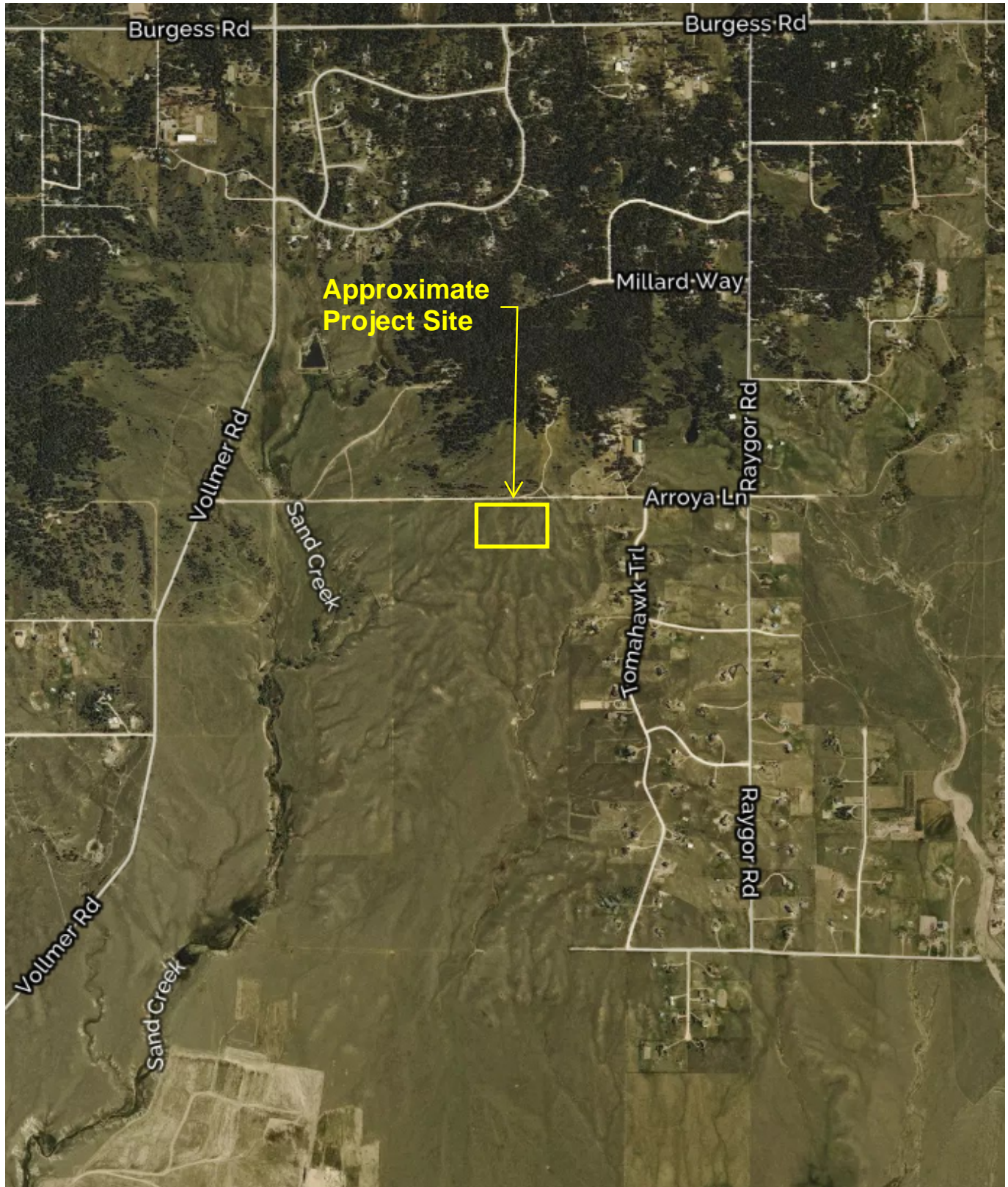

Not to Scale. Base image obtained from www.mapquest.com, 2019



Project No: D19-2-260
Date: November 18, 2019
Drawn by: AAE
Reviewed by: WJB

<b>VICINITY MAP</b>
Woodmen Hills Metropolitan District Water Tank Falcon, Colorado

Figure  <b>1</b>
------------------------



**LEGEND**  
 = APPROXIMATE LOCATION OF TANK BORING

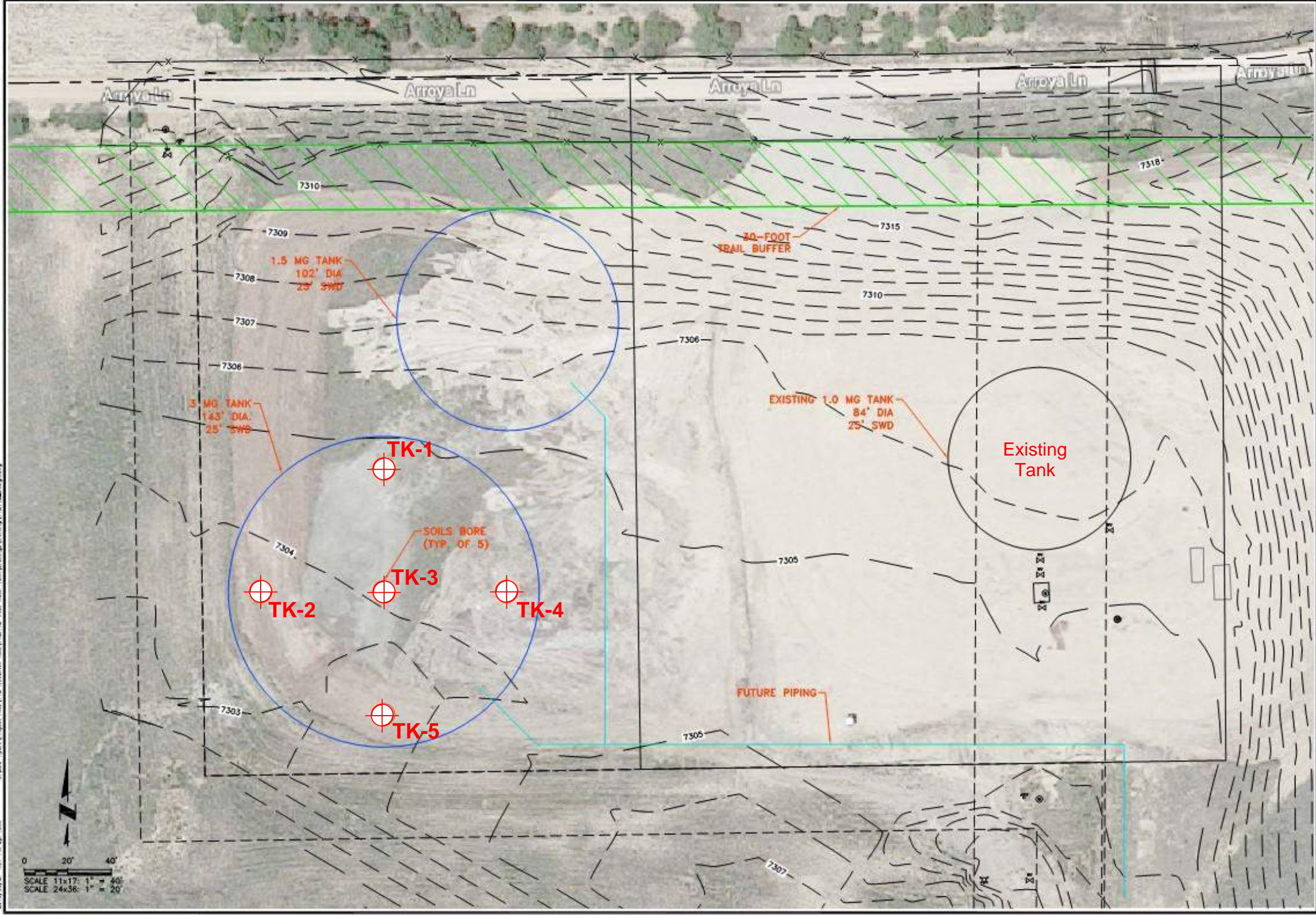

Base image provided by JDS-Hydro on December 19, 2019.

 VIVID Engineering Group, Inc.  
 1053 Elkton Drive  
 Colorado Springs, Colorado 80907  
 719.896.4356

Project No: D19-2-260  
 Date: November 18, 2019  
 Drawn by: AAE  
 Reviewed by: BTM

**BORING LOCATION PLAN**

Woodmen Hills Metropolitan District  
 Water Storage Tank  
 Falcon, Colorado

Figure  
**2**

**Appendix A**  
**Logs of Exploratory Borings**





VIVID Engineering Group, Inc.  
 1053 Elkton Drive  
 Colorado Springs, CO 80907  
 Telephone: 719-896-4356  
 Fax: 719-896-4357

# KEY TO SYMBOLS











CLIENT JDS-Hydro

PROJECT NAME Woodmen Hills Metro District Tank



PROJECT NUMBER D19-2-260

PROJECT LOCATION Falcon, Colorado

## LITHOLOGIC SYMBOLS (Unified Soil Classification System)



-  CL: USCS Low Plasticity Clay
-  CLAYSTONE
-  FILL
-  INTERBEDDED
-  SANDSTONE
-  SC: USCS Clayey Sand
-  SC-SM: USCS Clayey Sand
-  SM: USCS Silty Sand
-  SP-SC: USCS Poorly-graded Sand with Clay
-  WEATHERED CLAYSTONE
-  WEATHERED SANDSTONE

## SAMPLER SYMBOLS

-  Grab Sample
-  2" I.D. Modified California Sampler (MC)
-  Standard Penetration Test (SPT)

## ABBREVIATIONS

- LL - LIQUID LIMIT (%)
- PI - PLASTIC INDEX (%)
- MC - MOISTURE CONTENT (%)
- DD - DRY DENSITY (PCF)
- NP - NON PLASTIC
- FINES- PERCENT PASSING NO. 200 SIEVE
- UCS - UNCONFINED COMPRESSIVE STRENGTH

-  Water Level at Time of Drilling, or as Shown
-  Water Level at End of Drilling, or as Shown
-  Water Level After 24 Hours, or as Shown



VIVID Engineering Group, Inc.  
 1053 Elkton Drive  
 Colorado Springs, CO 80907  
 Telephone: 719-896-4356  
 Fax: 719-896-4357

# BORING NUMBER TK-1

PAGE 1 OF 2

**CLIENT** JDS-Hydro  
**PROJECT NUMBER** D19-2-260  
**DATE STARTED** 10/23/19 **COMPLETED** 10/23/19  
**DRILLING CONTRACTOR** Custom Auger Drilling (CME-55)  
**DRILLING METHOD** 4" Solid Stem Auger  
**LOGGED BY** B. Moore **CHECKED BY** B. Mustain  
**NOTES** Northern tank stake location

**PROJECT NAME** Woodmen Hills Metro District Tank  
**PROJECT LOCATION** Falcon, Colorado  
**GROUND ELEVATION** 7304.38 ft **HOLE SIZE** 4 inches  
**GROUND WATER LEVELS:**  
**AT TIME OF DRILLING** --- None Encountered  
**AT END OF DRILLING** ---  
**AFTER DRILLING** --- 11/4/19 - None Encountered

GENERAL BH / TP / WELL - GINT STD US LAB.GDT - 12/19/19 15:53 - C:\USERS\ABAS\AL EYOONIDESKTOP\MY WORK\19-2-260\_WOODMEN HILLS METRO PIPELINE & TANK GEO\6 - DRAFTING\19-2-260\_UPDATED.GPJ

DEPTH (ft)	SAMPLE TYPE NUMBER	BLOW COUNTS (N VALUE)	TESTS	GRAPHIC LOG	MATERIAL DESCRIPTION
0					
	GB				<b>Existing Fill</b> Clayey SAND with some gravel, pink, olive brown, dark brown, and greenish-gray, dry to slightly moist, medium dense
	SPT	7-4-7 (11)			
	GB				
5	MC	7-7	MC = 12.6%		
					7.0 7297.4
					8.4 7296.0
					Approximate Tank Bearing Elevation 7296'
10	SPT	4-5-7 (12)	MC = 12.4% LL = 38 PL = 17 Fines = 40.0%		11.0 7293.4
					<b>Dawson Formation</b> Interbedded SANDSTONE/CLAYSTONE, olive yellow, pink, greenish-gray, and pale olive, slightly moist, hard to very hard, uncemented to weakly cemented
	MC	50/3"	MC = 9.4%		
15					

(Continued Next Page)



VIVID Engineering Group, Inc.  
 1053 Elkton Drive  
 Colorado Springs, CO 80907  
 Telephone: 719-896-4356  
 Fax: 719-896-4357

# BORING NUMBER TK-1

CLIENT JDS-Hydro PROJECT NAME Woodmen Hills Metro District Tank  
 PROJECT NUMBER D19-2-260 PROJECT LOCATION Falcon, Colorado

DEPTH (ft)	SAMPLE TYPE NUMBER	BLOW COUNTS (N VALUE)	TESTS	GRAPHIC LOG	MATERIAL DESCRIPTION
20	SPT	50/10"		•••• •••	<b>Dawson Formation</b> Interbedded SANDSTONE/CLAYSTONE, olive yellow, pink, greenish-gray, and pale olive, slightly moist, hard to very hard, uncemented to weakly cemented ( <i>continued</i> )
25	MC	50/4"		•••• •••	
	SPT	50/4"		•••• •••	
				29.3	

Bottom of borehole at 29.3 feet. 7275.1

GENERAL BH / TP / WELL - GINT STD US LAB.GDT - 12/19/19 15:53 - C:\USERS\ABBAS AL EYOONIDES\TOP\MY WORK\19-2-260\_WOODMEN HILLS METRO PIPELINE & TANK\_GEO16 - DRAFTING\19-2-260\_UPDATED.GPJ



VIVID Engineering Group, Inc.  
 1053 Elkton Drive  
 Colorado Springs, CO 80907  
 Telephone: 719-896-4356  
 Fax: 719-896-4357

# BORING NUMBER TK-2

PAGE 1 OF 2

**CLIENT** JDS-Hydro  
**PROJECT NUMBER** D19-2-260  
**DATE STARTED** 11/4/19 **COMPLETED** 11/4/19  
**DRILLING CONTRACTOR** Custom Auger Drilling (CME-55)  
**DRILLING METHOD** 4" Solid Stem Auger  
**LOGGED BY** B. Moore **CHECKED BY** B. Mustain  
**NOTES** Western tank stake location

**PROJECT NAME** Woodmen Hills Metro District Tank  
**PROJECT LOCATION** Falcon, Colorado  
**GROUND ELEVATION** 7303.59 ft **HOLE SIZE** 4 inches  
**GROUND WATER LEVELS:**  
**AT TIME OF DRILLING** --- None Encountered  
**AT END OF DRILLING** ---  
**AFTER DRILLING** --- 11/7/19 - None Encountered

GENERAL BH / TP / WELL - GINT STD US LAB.GDT - 12/19/19 15:53 - C:\USERS\ABBAS AL EYOON\DESKTOP\MY WORK\KID19-2-260 - WOODMEN HILLS METRO PIPELINE & TANK GEO16 - DRAFTING\KID19-2-260\_UPDATED.GPJ

DEPTH (ft)	SAMPLE TYPE NUMBER	BLOW COUNTS (N VALUE)	TESTS	GRAPHIC LOG	MATERIAL DESCRIPTION
0					
	GB		Chloride = 0.0004%, pH = 7.1 units, Redox = 317.1 mv, Resistivity = 5432 ohm.cm, Sulfate = 0.002%, Sulfide = Trace		<b>Existing Fill</b> Clayey SAND with some gravel, very moist, reddish-brown and brown, medium dense
	MC	9-9			
	GB				
5	SPT	4-4-5 (9)	MC = 13.1% LL = 38 PL = 22 Fines = 21.0%		
					7.0 7296.6
					7.6 7296.0
					Approximate Tank Bearing Elevation 7296'
10	MC	50/7"	MC = 10.2%		
					11.0 7292.6
					<b>Dawson Formation</b> SANDSTONE, reddish-brown and pale olive, moist, hard, weakly cemented
15	SPT	50/7"			16.0 7287.6
					<b>Dawson Formation</b> Interbedded SANDSTONE/CLAYSTONE, olive and greenish-gray, slightly moist, hard, weakly cemented

(Continued Next Page)





VIVID Engineering Group, Inc.  
 1053 Elkton Drive  
 Colorado Springs, CO 80907  
 Telephone: 719-896-4356  
 Fax: 719-896-4357

# BORING NUMBER TK-2

CLIENT JDS-Hydro PROJECT NAME Woodmen Hills Metro District Tank  
 PROJECT NUMBER D19-2-260 PROJECT LOCATION Falcon, Colorado

GENERAL BH / TP / WELL - GINT STD US LAB.GDT - 12/19/19 15:53 - C:\USERS\ABBAAS AL EYOONIDES\TOP\MY WORK\19-2-260\_WOODMEN HILLS METRO PIPELINE & TANK\_GEO16 - DRAFTING\19-2-260\_UPDATED.GPJ

DEPTH (ft)	SAMPLE TYPE NUMBER	BLOW COUNTS (N VALUE)	TESTS	GRAPHIC LOG	MATERIAL DESCRIPTION
20	X SPT	50/8"		..... — .....	<b>Dawson Formation</b> Interbedded SANDSTONE/CLAYSTONE, olive and greenish-gray, slightly moist, hard, weakly cemented ( <i>continued</i> )
21.0				..... — .....	7282.6
25	X SPT	50/4"		..... — .....	<b>Dawson Formation</b> SANDSTONE, pale olive and olive, slightly moist, very hard, uncemented to weakly cemented
29.3	X SPT	50/4"		..... — .....	7274.3

Bottom of borehole at 29.3 feet.



VIVID Engineering Group, Inc.  
 1053 Elkton Drive  
 Colorado Springs, CO 80907  
 Telephone: 719-896-4356  
 Fax: 719-896-4357

# BORING NUMBER TK-3

PAGE 1 OF 2

**CLIENT** JDS-Hydro  
**PROJECT NUMBER** D19-2-260  
**DATE STARTED** 11/4/19 **COMPLETED** 11/4/19  
**DRILLING CONTRACTOR** Custom Auger Drilling (CME-55)  
**DRILLING METHOD** 4" Solid Stem Auger  
**LOGGED BY** B. Moore **CHECKED BY** B. Mustain  
**NOTES** Center tank stake location

**PROJECT NAME** Woodmen Hills Metro District Tank  
**PROJECT LOCATION** Falcon, Colorado  
**GROUND ELEVATION** 7303.88 ft **HOLE SIZE** 4 inches  
**GROUND WATER LEVELS:**  
 ▽ **AT TIME OF DRILLING** 45.00 ft / Elev 7258.88 ft  
 ▽ **AT END OF DRILLING** ---  
 ▽ **AFTER DRILLING** 52.00 ft / Elev 7251.88 ft - 11/7/19

GENERAL BH / TP / WELL - GINT STD US LAB.GDT - 12/19/19 15:53 - C:\USERS\ABBAS AL EYOON\DESKTOP\MY WORK\19-2-260 - WOODMEN HILLS METRO PIPELINE & TANK GEO\6 - DRAFTING\19-2-260\_UPDATED.GPJ

DEPTH (ft)	SAMPLE TYPE NUMBER	BLOW COUNTS (N VALUE)	TESTS	GRAPHIC LOG	MATERIAL DESCRIPTION
0					
	GB				<b>Existing Fill</b> Silty SAND with gravel, olive brown, dry to slightly moist, loose to medium dense
	MC	8-7	MC = 10.0%		
	GB				
5	SPT	3-3-3 (6)		5.0	
	MC	12-20		7.0	<b>Existing Fill</b> Clay SAND, olive brown, slightly moist, medium dense
				7.9	Clayey SAND with gravel, pink and olive brown, slightly moist, medium dense
				9.0	Approximate Tank Bearing Elevation 7296'
10	SPT	19-42-50/5"	MC = 12.1% LL = 38 PL = 21 Fines = 55.0%	10.0	<b>Dawson Formation</b> Weathered CLAYSTONE, greenish-gray and olive yellow, dry to slightly moist, moderately hard, uncemented
					<b>Dawson Formation</b> Interbedded SANDSTONE/CLAYSTONE, greenish-gray, olive yellow, and pale olive, dry to wet, very hard, uncemented to weakly cemented
15	MC	10-50/3"	MC = 9.3%		
20	SPT	10-50/5"			
					Harder to drill at 22 feet
25	MC	50/5"	MC = 11.1%		
30	SPT	50/3"			
35	SPT	50/4"			

(Continued Next Page)



VIVID Engineering Group, Inc.  
 1053 Elkton Drive  
 Colorado Springs, CO 80907  
 Telephone: 719-896-4356  
 Fax: 719-896-4357

# BORING NUMBER TK-3

PAGE 2 OF 2

CLIENT JDS-Hydro PROJECT NAME Woodmen Hills Metro District Tank  
 PROJECT NUMBER D19-2-260 PROJECT LOCATION Falcon, Colorado

DEPTH (ft)	SAMPLE TYPE NUMBER	BLOW COUNTS (N VALUE)	TESTS	GRAPHIC LOG	MATERIAL DESCRIPTION
35					
				.....	<b>Dawson Formation</b> Interbedded SANDSTONE/CLAYSTONE, greenish-gray, olive yellow, and pale olive, dry to wet, very hard, uncemented to weakly cemented ( <i>continued</i> )
40	SPT	50/4"		.....	
				.....	
45	SPT	50/2"		.....	
				.....	▽  Harder to drill at 46 feet
				.....	
50				.....	
				.....	
				.....	▽
				.....	
				.....	
55				.....	
				.....	
57.2	SPT	50/2"		57.2	Bottom of borehole at 57.2 feet.

7246.7

GENERAL BH / TP / WELL - GINT STD US LAB.GDT - 12/19/19 15:53 - C:\USERS\ABBAS AL EYOONIDES\KTOP\MY WORK\19-2-260\_WOODMEN HILLS METRO PIPELINE & TANK\_GEO6 - DRAFTING\19-2-260\_UPDATED.GPJ



VIVID Engineering Group, Inc.  
 1053 Elkton Drive  
 Colorado Springs, CO 80907  
 Telephone: 719-896-4356  
 Fax: 719-896-4357

# BORING NUMBER TK-4

PAGE 1 OF 2

**CLIENT** JDS-Hydro  
**PROJECT NUMBER** D19-2-260  
**DATE STARTED** 11/4/19 **COMPLETED** 11/4/19  
**DRILLING CONTRACTOR** Custom Auger Drilling (CME-55)  
**DRILLING METHOD** 4" Solid Stem Auger  
**LOGGED BY** B. Moore **CHECKED BY** B. Mustain  
**NOTES** Eastern tank stake location

**PROJECT NAME** Woodmen Hills Metro District Tank  
**PROJECT LOCATION** Falcon, Colorado  
**GROUND ELEVATION** 7304.19 ft **HOLE SIZE** 4 inches  
**GROUND WATER LEVELS:**  
**AT TIME OF DRILLING** --- None Encountered  
**AT END OF DRILLING** ---  
**AFTER DRILLING** --- 11/7/19 - None Encountered

GENERAL BH / TP / WELL - GINT STD US LAB.GDT - 12/19/19 15:53 - C:\USERS\ABBAS AL EYOONIDESKTOP\MY WORK\19-2-260\_WOODMEN HILLS METRO PIPELINE & TANK GEO\6 - DRAFTING\19-2-260\_UPDATED.GPJ

DEPTH (ft)	SAMPLE TYPE NUMBER	BLOW COUNTS (N VALUE)	TESTS	GRAPHIC LOG	MATERIAL DESCRIPTION
0					
0.5					<b>Existing Fill</b> Clayey, Silty SAND with some gravel, pink and olive, slightly moist 7303.7
	SPT	4-6-8 (14)			<b>Existing Fill</b> Clayey SAND, greenish-gray, slightly moist, medium dense
4.0					7300.2
5	MC	18-30	MC = 8.3%		Silty SAND with gravel, pink and olive brown, slightly moist, dense
8.0					7296.2
8.2					Sandy Lean CLAY, greenish-gray, dry to slightly moist, hard Approximate Tank Bearing Elevation 7296'
7296.0					
10	SPT	15-19-30 (49)	MC = 13.5% DD = 116.8 pcf LL = 39 PL = 17 Fines = 59.0%		
12.0					7292.2
					<b>Dawson Formation</b> Interbedded SANDSTONE/CLAYSTONE, greenish-gray, olive yellow, and pale olive, dry to slightly moist, hard to very hard, weakly cemented to uncemented
15	MC	20-50/2"	Compressive Strength = 11475 psf, Shear Strength = 5737 psf, Axial Strain = 3.3%, Swell = 1.1% when wetted under 1.0 ksf		

(Continued Next Page)



VIVID Engineering Group, Inc.  
 1053 Elkton Drive  
 Colorado Springs, CO 80907  
 Telephone: 719-896-4356  
 Fax: 719-896-4357

# BORING NUMBER TK-4

CLIENT JDS-Hydro PROJECT NAME Woodmen Hills Metro District Tank  
 PROJECT NUMBER D19-2-260 PROJECT LOCATION Falcon, Colorado

GENERAL BH / TP / WELL - GINT STD US LAB.GDT - 12/19/19 15:53 - C:\USERS\ABBAS AL EYOONIDES\TOP\MY WORK\19-2-260\_WOODMEN HILLS METRO PIPELINE & TANK\_GEO16 - DRAFTING\19-2-260\_UPDATED.GPJ

DEPTH (ft)	SAMPLE TYPE NUMBER	BLOW COUNTS (N VALUE)	TESTS	GRAPHIC LOG	MATERIAL DESCRIPTION
20	SPT	44-50/2"		..... ..... .....	<b>Dawson Formation</b> Interbedded SANDSTONE/CLAYSTONE, greenish-gray, olive yellow, and pale olive, dry to slightly moist, hard to very hard, weakly cemented to uncemented ( <i>continued</i> )  Harder to drill at 21 feet
25	MC	50/3"		..... ..... ..... ..... ..... ..... ..... ..... .....	
29.3	SPT	50/4"	MC = 8.0% LL = 28 PL = 20 Fines = 26.0%	29.3	Bottom of borehole at 29.3 feet.

7274.9



VIVID Engineering Group, Inc.  
 1053 Elkton Drive  
 Colorado Springs, CO 80907  
 Telephone: 719-896-4356  
 Fax: 719-896-4357

# BORING NUMBER TK-5

PAGE 1 OF 2

**CLIENT** JDS-Hydro  
**PROJECT NUMBER** D19-2-260  
**DATE STARTED** 11/4/19 **COMPLETED** 11/4/19  
**DRILLING CONTRACTOR** Custom Auger Drilling (CME-55)  
**DRILLING METHOD** 4" Solid Stem Auger  
**LOGGED BY** B. Moore **CHECKED BY** B. Mustain  
**NOTES** Southern tank stake location

**PROJECT NAME** Woodmen Hills Metro District Tank  
**PROJECT LOCATION** Falcon, Colorado  
**GROUND ELEVATION** 7304.09 ft **HOLE SIZE** 4 inches  
**GROUND WATER LEVELS:**  
**AT TIME OF DRILLING** --- None Encountered  
**AT END OF DRILLING** ---  
**AFTER DRILLING** --- 11/7/19 - None Encountered

GENERAL BH / TP / WELL - GINT STD US LAB.GDT - 12/19/19 15:53 - C:\USERS\ABAS\AL EYOONIDESK\TOP\MY WORK\ID19-2-260 - WOODMEN HILLS METRO PIPELINE & TANK GEO6 - DRAFTING\ID19-2-260\_UPDATED.GPJ

DEPTH (ft)	SAMPLE TYPE NUMBER	BLOW COUNTS (N VALUE)	TESTS	GRAPHIC LOG	MATERIAL DESCRIPTION
0					
	GB				<b>Existing Fill</b> Clayey SAND with some gravel, olive gray, moist, medium dense
	MC	10-10	MC = 8.6%		
	GB				
5	SPT	5-8-10 (18)	MC = 11.5% LL = 35 PL = 18 Fines = 19.0%		
					8.1 ----- 7296.0 Approximate Tank Bearing Elevation 7296'
					9.0 ----- 7295.1
10	MC	50/8"	MC = 13.5% DD = 116.4 pcf Swell = 0.5% when wetted under 1.0 ksf		<b>Dawson Formation</b> Interbedded SANDSTONE/CLAYSTONE, greenish-gray, moist to slightly moist, hard to very hard, weakly cemented
15	SPT	50/8"			

(Continued Next Page)



VIVID Engineering Group, Inc.  
 1053 Elkton Drive  
 Colorado Springs, CO 80907  
 Telephone: 719-896-4356  
 Fax: 719-896-4357

# BORING NUMBER TK-5

PAGE 2 OF 2

CLIENT JDS-Hydro PROJECT NAME Woodmen Hills Metro District Tank  
 PROJECT NUMBER D19-2-260 PROJECT LOCATION Falcon, Colorado

GENERAL BH / TP / WELL - GINT STD US LAB.GDT - 12/19/19 15:53 - C:\USERS\ABBAS AL EYOONIDES\TOP\MY WORK\19-2-260\_WOODMEN HILLS METRO PIPELINE & TANK\_GEO6 - DRAFTING\19-2-260\_UPDATED.GPJ

DEPTH (ft)	SAMPLE TYPE NUMBER	BLOW COUNTS (N VALUE)	TESTS	GRAPHIC LOG	MATERIAL DESCRIPTION
20	MC	50/6"		..... ..... .....	<b>Dawson Formation</b> Interbedded SANDSTONE/CLAYSTONE, greenish-gray, moist to slightly moist, hard to very hard, weakly cemented ( <i>continued</i> )
25	SPT	50/3"		..... ..... .....	<b>Dawson Formation</b> Interbedded SANDSTONE/CLAYSTONE, greenish-gray and pale olive, dry to slightly moist, very hard, uncemented
	MC	50/4"		..... ..... .....	

20.0

7284.1

29.3

7274.8

Bottom of borehole at 29.3 feet.

**Appendix B**  
**Geotechnical Laboratory Test Results**







VIVID Engineering Group, Inc.  
 1053 Elkton Drive  
 Colorado Springs, CO 80907  
 Telephone: 719-896-4356  
 Fax: 719-896-4357

# GRAIN SIZE DISTRIBUTION

CLIENT JDS-Hydro

PROJECT NAME Woodmen Hills Metro District Tank

PROJECT NUMBER D19-2-260

PROJECT LOCATION Falcon, Colorado

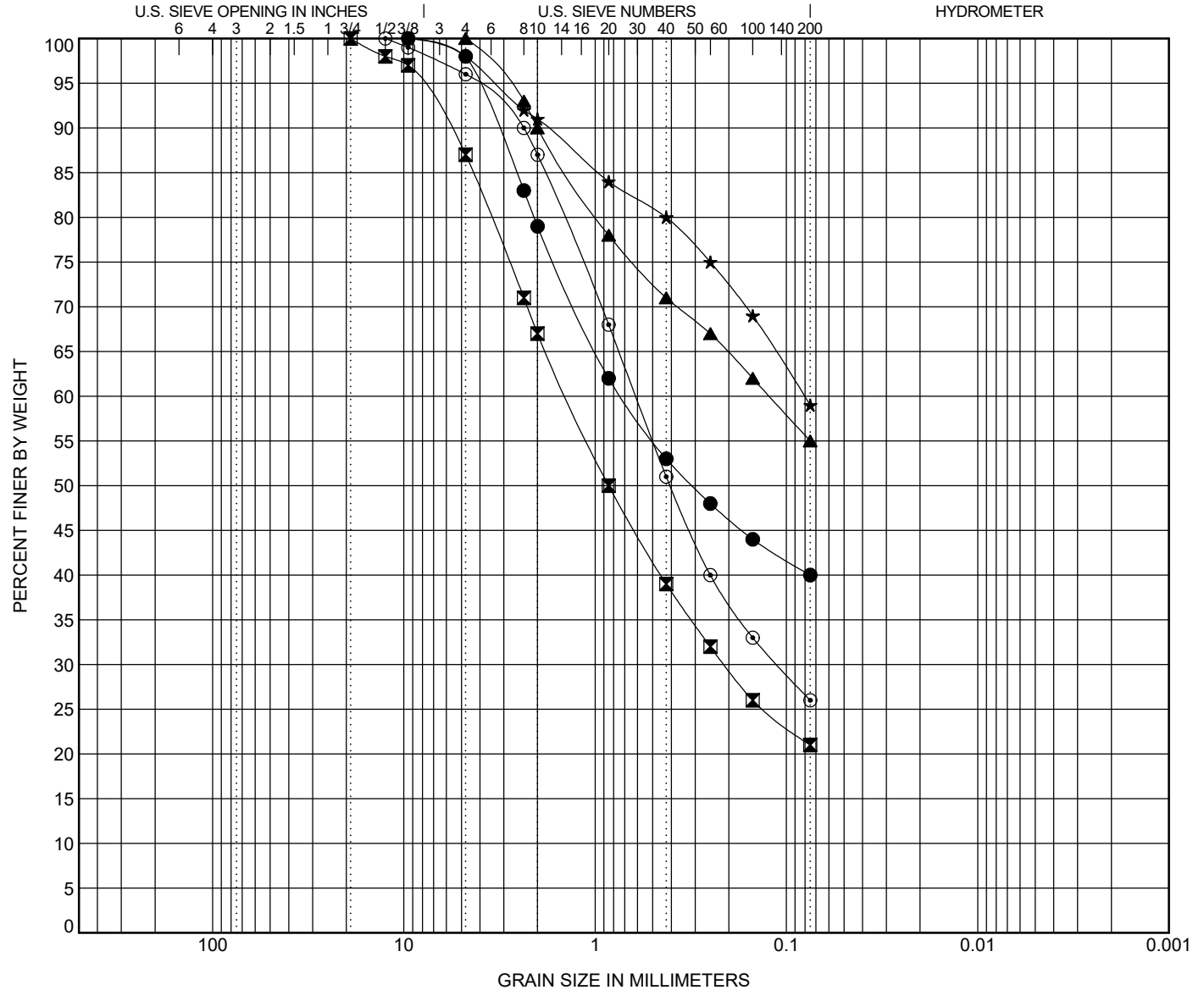

COBBLES	GRAVEL		SAND			SILT OR CLAY
	coarse	fine	coarse	medium	fine	

BOREHOLE	DEPTH	Classification					LL	PL	PI	Cc	Cu
● TK-1	9.0	CLAYEY SAND(SC)					38	17	21		
■ TK-2	4.0	CLAYEY SAND(SC)					38	22	16		
▲ TK-3	9.0	SANDY LEAN CLAY(CL)					38	21	17		
★ TK-4	9.0	SANDY LEAN CLAY(CL)					39	17	22		
○ TK-4	29.0	SANDSTONE / CLAYSTONE / CLAYEY SAND (SC)					28	20	8		
BOREHOLE	DEPTH	D100	D60	D30	D10	%Gravel	%Sand	%Silt	%Clay		
● TK-1	9.0	9.5	0.729			2.0	58.0	40.0			
■ TK-2	4.0	19	1.406	0.211		13.0	66.0	21.0			
▲ TK-3	9.0	4.75	0.123			0.0	45.0	55.0			
★ TK-4	9.0	9.5	0.08			2.0	39.0	59.0			
○ TK-4	29.0	12.5	0.613	0.111		4.0	70.0	26.0			

GRAIN SIZE - GINT STD US LAB.GDT - 12/19/19 15:54 - C:\USERS\ABAS AL EYOONIDESKTOP\MY WORK\19-2-260\_WOODMEN HILLS METRO PIPELINE & TANK\_GEO\6 - DRAFTING\19-2-260\_UPDATED.GPJ



VIVID Engineering Group, Inc.  
 1053 Elkton Drive  
 Colorado Springs, CO 80907  
 Telephone: 719-896-4356  
 Fax: 719-896-4357

# GRAIN SIZE DISTRIBUTION

CLIENT JDS-Hydro

PROJECT NAME Woodmen Hills Metro District Tank

PROJECT NUMBER D19-2-260

PROJECT LOCATION Falcon, Colorado

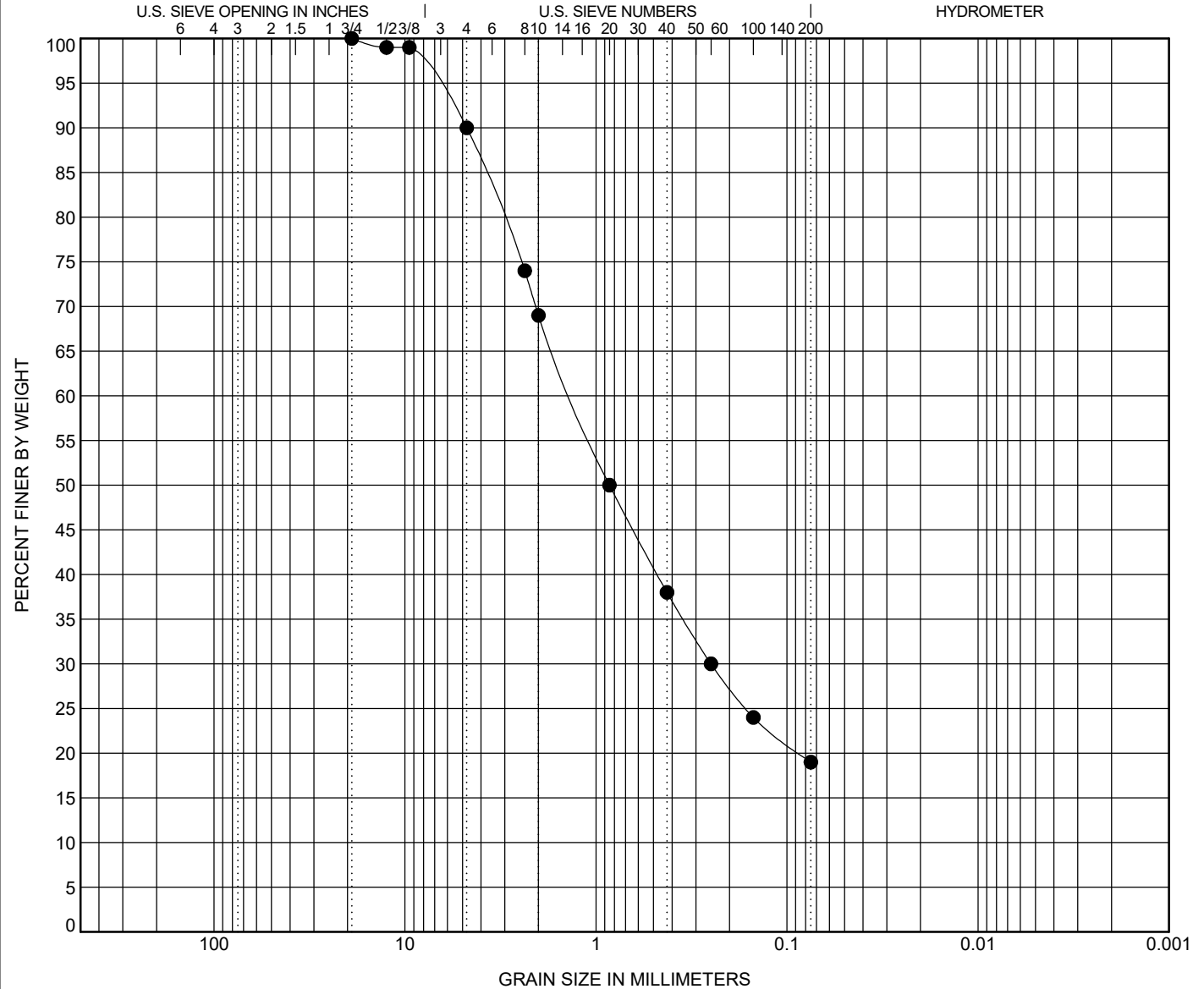

COBBLES	GRAVEL		SAND			SILT OR CLAY
	coarse	fine	coarse	medium	fine	

BOREHOLE	DEPTH	Classification					LL	PL	PI	Cc	Cu
● TK-5	4.0	<b>CLAYEY SAND(SC)</b>					<b>35</b>	<b>18</b>	<b>17</b>		

BOREHOLE	DEPTH	D100	D60	D30	D10	%Gravel	%Sand	%Silt	%Clay
● TK-5	4.0	19	1.334	0.25		10.0	71.0		19.0

GRAIN SIZE - GINT STD US LAB.GDT - 12/19/19 15:54 - C:\USERS\ABAS AL EYOONIDESKTOP\MY WORK\19-2-260\_WOODMEN HILLS METRO PIPELINE & TANK\_GEO\6 - DRAFTING\19-2-260\_UPDATED.GPJ

Project Name:	Woodmen Hills Tank	Date	11/8/2019
Project No.:	D19-2-260		
Boring ID.:	TK4	Sample Depth (ft)	14
Sample Description:	Clay, Sandy, Gravel, Olive		
Swell @ Wetting Weight:			1.1

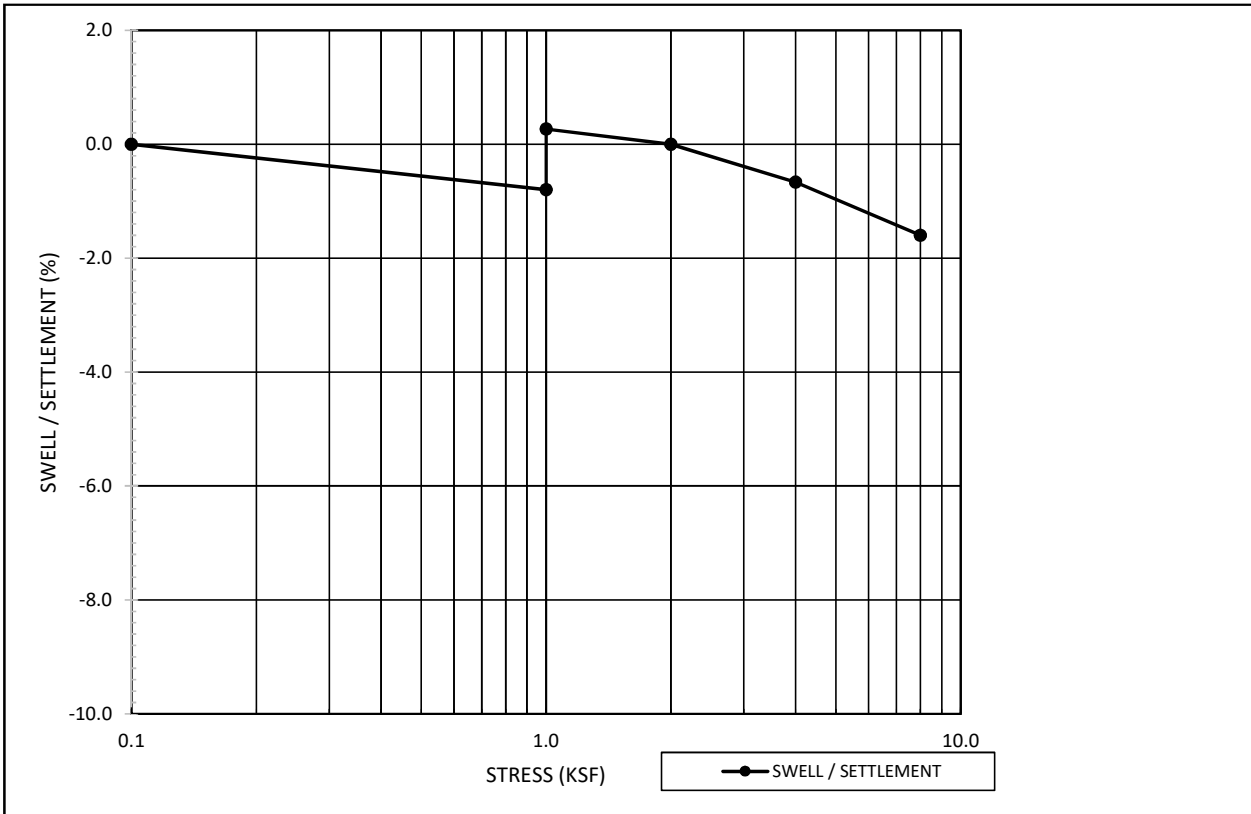

<b>Initial Condition</b>	
Moisture Content %	13.5
Dry Density (pcf)	116.8
<b>Post-Swell Condition</b>	
Moisture Content %	16.3

Project Name:	Woodmen Hills Tank	Date	11/8/2019
Project No.:	D19-2-260		
Boring ID.:	TK5	Sample Depth (ft)	9
Sample Description:	Clay, Sandy, Light Grayish Brown		
		Swell @ Wetting Weight:	0.5 %

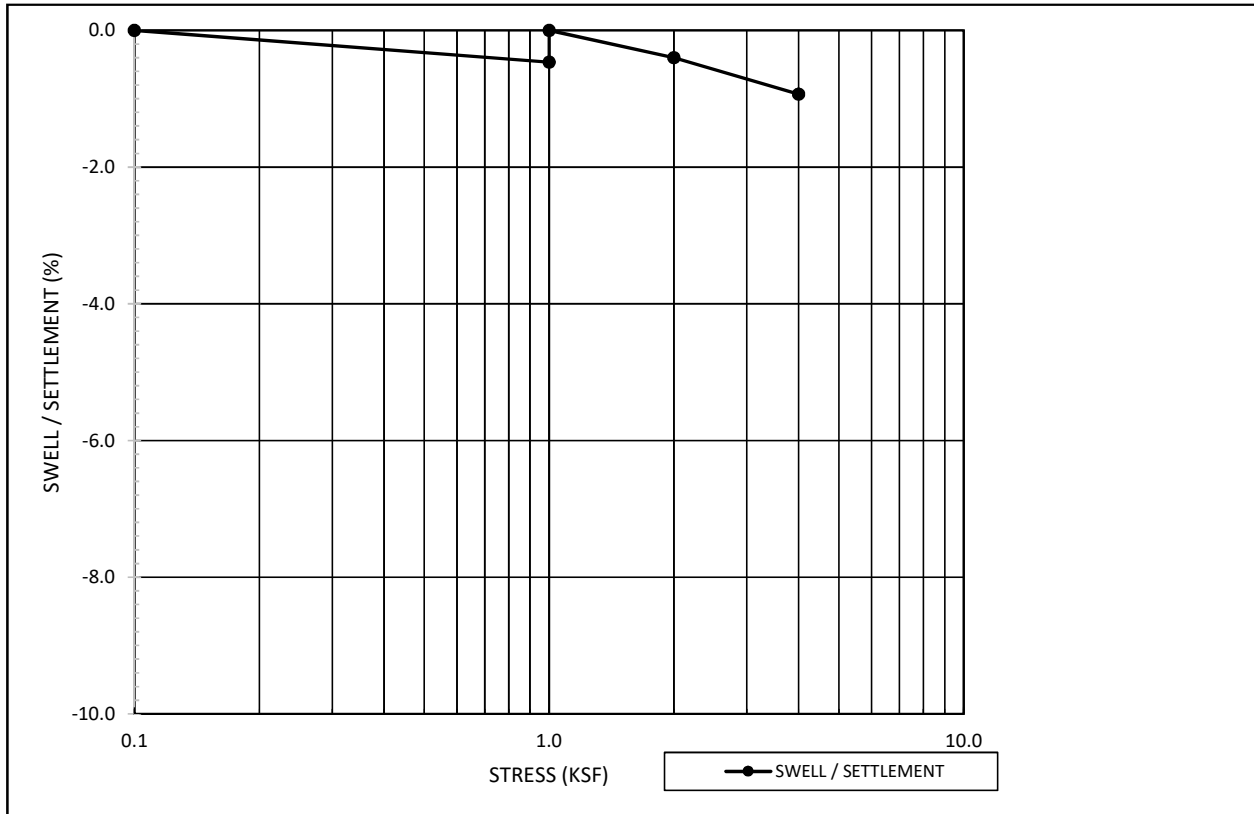

<b>Initial Condition</b>	
Moisture Content %	13.5
Dry Density (pcf)	116.4
<b>Post-Swell Condition</b>	
Moisture Content %	17.2

## UNCONFINED COMPRESSION TEST ASTM D 2166

PROJECT NAME: Woodmen Hills Tank  
 PROJECT NO. : D19-2-260  
 CLIENT NAME: JDS-Hydro

BORING NO. : TK-4  
 SAMPLE NO.: 260-14  
 DEPTH, FT. : 14ft  
 TEST SPECIMEN NO.: #2

PROJECT ENG.: BTM  
 DATE RECEIVED: 11/7/2019  
 DATE TESTED: 11/13/2019  
 TESTED BY: TK  
 DATA ENTRY: TK

DESCRIPTION: Sand, Clayey, Gravelly, Olive Brow

### INITIAL DATA

Avg. Height, In.: 3.980  
 Avg. Diameter, In.: 1.930  
 L/D Ratio: 2.1  
 Moisture Content, %:  
     (Sample, After test) 10.7  
 Dry Density, pcf: 125.4  
 Assumed Specific Gravity: 2.7  
 Saturation, %: 83.7  
 Void Ratio: 0.344

Rate of Strain, %/Minute: 1.0

Compressive Strength @ Failure:  
 Shear Strength @ Failure:  
 Axial Strain @ Failure, %:

	PSF	PSI
Compressive Strength @ Failure:	11475	80
Shear Strength @ Failure:	5737	40
Axial Strain @ Failure, %:	3.3	3.3

Photo:



### Stress - Strain Curve

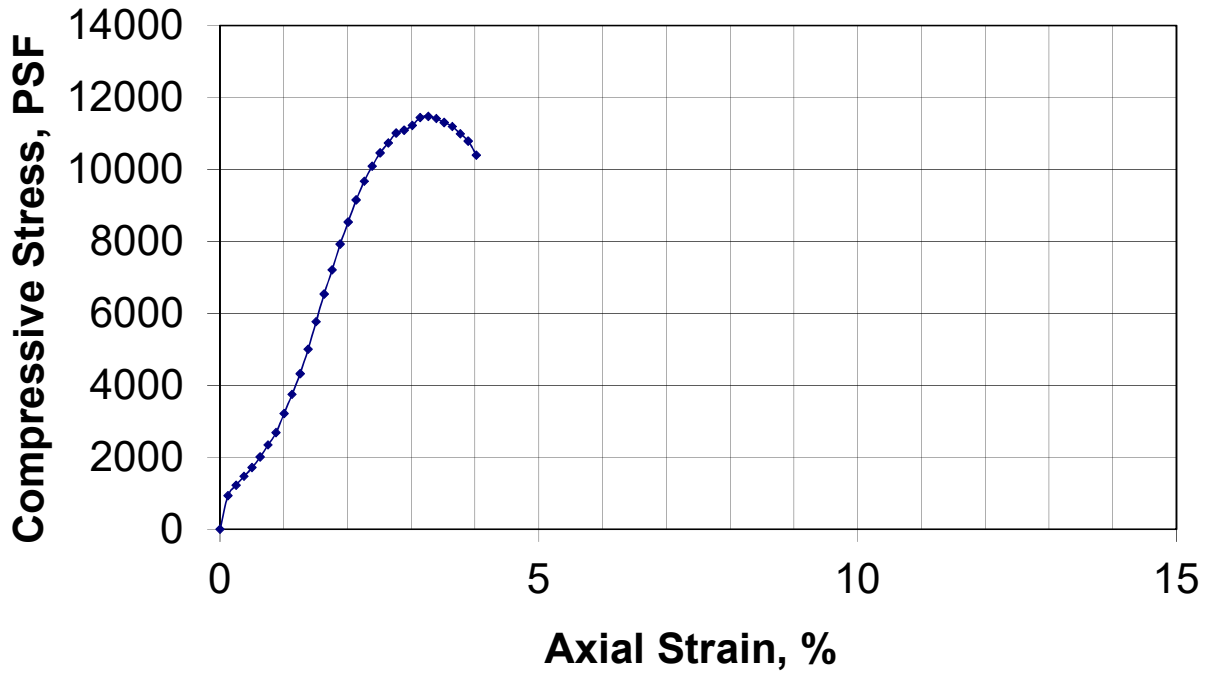



VIVID Engineering Group, Inc.  
 1053 Elkton Drive  
 Colorado Springs, CO 80907  
 Telephone: 719-896-4356  
 Fax: 719-896-4357

# SUMMARY OF LABORATORY RESULTS

**CLIENT** JDS-Hydro **PROJECT NAME** Woodmen Hills Metro District Tank  
**PROJECT NUMBER** D19-2-260 **PROJECT LOCATION** Falcon, Colorado

Borehole	Depth	Liquid Limit	Plastic Limit	Plasticity Index	Maximum Size (mm)	%<#200 Sieve	Classification	Water Content (%)	Dry Density (pcf)		
TK-1	4.0							12.6			
TK-1	9.0	38	17	21	9.5	40	SC	12.4			
TK-1	14.0							9.4			
TK-2	4.0	38	22	16	19	21	SC	13.1			
TK-2	9.0							10.2			
TK-3	1.0							10.0			
TK-3	9.0	38	21	17	4.75	55	CL	12.1			
TK-3	14.0							9.3			
TK-3	24.0							11.1			
TK-4	4.0							8.3			
TK-4	9.0	39	17	22	9.5	59	CL	13.5	116.8		
TK-4	29.0	28	20	8	12.5	26	SC	8.0			
TK-5	2.0							8.6			
TK-5	4.0	35	18	17	19	19	SC	11.5			
TK-5	9.0							13.5	116.4		

LAB SUMMARY - GINT STD US LAB.GDT - 12/19/19 15:55 - C:\USERS\ABBAS AL EYOON\DESKTOP\PI\MY WORK\ID19-2-260\_WOODMEN HILLS METRO PIPELINE & TANK\_GEO16 - DRAFTING\ID19-2-260\_UPDATED.GPJ

**Appendix C**  
**Analytical Laboratory Test Results**



## Analytical Results

**TASK NO: 191112030**

**Company:** Vivid Engineering Group, Inc.  
1053 Elkton Drive  
Colorado Springs CO 80907

**Task No.:** 191112030  
**Client PO:**  
**Client Project:** Woodmen Hills Tank D19-2-260

**Date Received:** 11/12/19  
**Date Reported:** 11/19/19  
**Matrix:** Soil - Geotech

**Customer Sample ID** TK-2 @ 0-4 Ft.  
**Lab Number:** 191112030-01

Test	Result	Method
Chloride - Water Soluble	0.0004 %	AASHTO T291-91/ ASTM D4327
pH	7.1 units	AASHTO T289-91
Redox Potential	317.1 mv	ASTM D1498
Resistivity	5432 ohm.cm	AASHTO T288-91
Sulfate - Water Soluble	0.002 %	CDOT CP-L 2103 / ASTM D4327
Sulfide	Trace	AWWA C105

**Abbreviations/ References:**

AASHTO - American Association of State Highway and Transportation Officials.  
ASTM - American Society for Testing and Materials.  
ASA - American Society of Agronomy.  
DIPRA - Ductile Iron Pipe Research Association Handbook of Ductile Iron Pipe.



DATA APPROVED FOR RELEASE BY

**Appendix D**

**Site Photos**

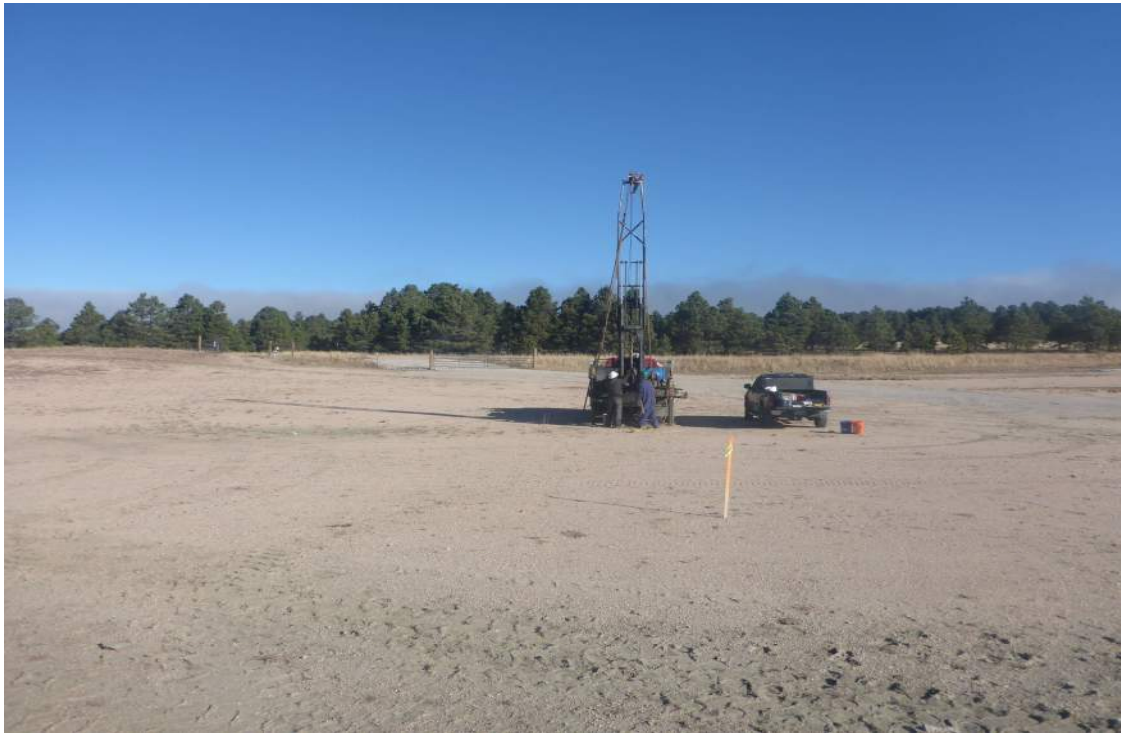

**DRILLING BORING TK-1 - LOOKING NORTH**



**DRILLING BORING TK-3 - LOOKING WEST**



Project No: D19-2-260  
 Date: 11/20/2019  
 Drawn by: AAE  
 Reviewed by: WJB

**SITE PHOTOS**

Woodmen Hills Metropolitan District  
 Water Storage Tank  
 Falcon, Colorado

FIGURE

**D-1**



**DRILLING BORING TK-4 - LOOKING NORTH**



**DRILLING BORING TK-5 - LOOKING WEST**



Project No: D19-2-260  
 Date: 11/20/2019  
 Drawn by: AAE  
 Reviewed by: WJB

**SITE PHOTOS**

Woodmen Hills Metropolitan District  
 Water Storage Tank  
 Falcon, Colorado

FIGURE

**D-2**

## **Appendix E**

### **Important Information About This Geotechnical Engineering Report**



# Important Information about This

# Geotechnical-Engineering Report

Subsurface problems are a principal cause of construction delays, cost overruns, claims, and disputes.

While you cannot eliminate all such risks, you can manage them. The following information is provided to help.

**The Geoprofessional Business Association (GBA) has prepared this advisory to help you – assumedly a client representative – interpret and apply this geotechnical-engineering report as effectively as possible. In that way, clients can benefit from a lowered exposure to the subsurface problems that, for decades, have been a principal cause of construction delays, cost overruns, claims, and disputes. If you have questions or want more information about any of the issues discussed below, contact your GBA-member geotechnical engineer. Active involvement in the Geoprofessional Business Association exposes geotechnical engineers to a wide array of risk-confrontation techniques that can be of genuine benefit for everyone involved with a construction project.**

## Geotechnical-Engineering Services Are Performed for Specific Purposes, Persons, and Projects

Geotechnical engineers structure their services to meet the specific needs of their clients. A geotechnical-engineering study conducted for a given civil engineer will not likely meet the needs of a civil-works constructor or even a different civil engineer. Because each geotechnical-engineering study is unique, each geotechnical-engineering report is unique, prepared *solely* for the client. *Those who rely on a geotechnical-engineering report prepared for a different client can be seriously misled.* No one except authorized client representatives should rely on this geotechnical-engineering report without first conferring with the geotechnical engineer who prepared it. *And no one – not even you – should apply this report for any purpose or project except the one originally contemplated.*

## Read this Report in Full

Costly problems have occurred because those relying on a geotechnical-engineering report did not read it *in its entirety*. Do not rely on an executive summary. Do not read selected elements only. *Read this report in full.*

## You Need to Inform Your Geotechnical Engineer about Change

Your geotechnical engineer considered unique, project-specific factors when designing the study behind this report and developing the confirmation-dependent recommendations the report conveys. A few typical factors include:

- the client's goals, objectives, budget, schedule, and risk-management preferences;
- the general nature of the structure involved, its size, configuration, and performance criteria;
- the structure's location and orientation on the site; and
- other planned or existing site improvements, such as retaining walls, access roads, parking lots, and underground utilities.

Typical changes that could erode the reliability of this report include those that affect:

- the site's size or shape;
- the function of the proposed structure, as when it's changed from a parking garage to an office building, or from a light-industrial plant to a refrigerated warehouse;
- the elevation, configuration, location, orientation, or weight of the proposed structure;
- the composition of the design team; or
- project ownership.

As a general rule, *always* inform your geotechnical engineer of project changes – even minor ones – and request an assessment of their impact. *The geotechnical engineer who prepared this report cannot accept responsibility or liability for problems that arise because the geotechnical engineer was not informed about developments the engineer otherwise would have considered.*

## This Report May Not Be Reliable

*Do not rely on this report* if your geotechnical engineer prepared it:

- for a different client;
- for a different project;
- for a different site (that may or may not include all or a portion of the original site); or
- before important events occurred at the site or adjacent to it; e.g., man-made events like construction or environmental remediation, or natural events like floods, droughts, earthquakes, or groundwater fluctuations.

Note, too, that it could be unwise to rely on a geotechnical-engineering report whose reliability may have been affected by the passage of time, because of factors like changed subsurface conditions; new or modified codes, standards, or regulations; or new techniques or tools. *If your geotechnical engineer has not indicated an "apply-by" date on the report, ask what it should be, and, in general, if you are the least bit uncertain about the continued reliability of this report, contact your geotechnical engineer before applying it.* A minor amount of additional testing or analysis – if any is required at all – could prevent major problems.

## Most of the "Findings" Related in This Report Are Professional Opinions

Before construction begins, geotechnical engineers explore a site's subsurface through various sampling and testing procedures. *Geotechnical engineers can observe actual subsurface conditions only at those specific locations where sampling and testing were performed.* The data derived from that sampling and testing were reviewed by your geotechnical engineer, who then applied professional judgment to form opinions about subsurface conditions throughout the site. Actual sitewide-subsurface conditions may differ – maybe significantly – from those indicated in this report. Confront that risk by retaining your geotechnical engineer to serve on the design team from project start to project finish, so the individual can provide informed guidance quickly, whenever needed.

## This Report's Recommendations Are Confirmation-Dependent

The recommendations included in this report – including any options or alternatives – are confirmation-dependent. In other words, *they are not final*, because the geotechnical engineer who developed them relied heavily on judgment and opinion to do so. Your geotechnical engineer can finalize the recommendations *only after observing actual subsurface conditions* revealed during construction. If through observation your geotechnical engineer confirms that the conditions assumed to exist actually do exist, the recommendations can be relied upon, assuming no other changes have occurred. *The geotechnical engineer who prepared this report cannot assume responsibility or liability for confirmation-dependent recommendations if you fail to retain that engineer to perform construction observation.*

## This Report Could Be Misinterpreted

Other design professionals' misinterpretation of geotechnical-engineering reports has resulted in costly problems. Confront that risk by having your geotechnical engineer serve as a full-time member of the design team, to:

- confer with other design-team members,
- help develop specifications,
- review pertinent elements of other design professionals' plans and specifications, and
- be on hand quickly whenever geotechnical-engineering guidance is needed.

You should also confront the risk of constructors misinterpreting this report. Do so by retaining your geotechnical engineer to participate in prebid and preconstruction conferences and to perform construction observation.

## Give Constructors a Complete Report and Guidance

Some owners and design professionals mistakenly believe they can shift unanticipated-subsurface-conditions liability to constructors by limiting the information they provide for bid preparation. To help prevent the costly, contentious problems this practice has caused, include the complete geotechnical-engineering report, along with any attachments or appendices, with your contract documents, *but be certain to note conspicuously that you've included the material for informational purposes only*. To avoid misunderstanding, you may also want to note that "informational purposes" means constructors have no right to rely on the interpretations, opinions, conclusions, or recommendations in the report, but they may rely on the factual data relative to the specific times, locations, and depths/elevations referenced. Be certain that constructors know they may learn about specific project requirements, including options selected from the report, *only* from the design drawings and specifications. Remind constructors that they may

perform their own studies if they want to, and *be sure to allow enough time* to permit them to do so. Only then might you be in a position to give constructors the information available to you, while requiring them to at least share some of the financial responsibilities stemming from unanticipated conditions. Conducting prebid and preconstruction conferences can also be valuable in this respect.

## Read Responsibility Provisions Closely

Some client representatives, design professionals, and constructors do not realize that geotechnical engineering is far less exact than other engineering disciplines. That lack of understanding has nurtured unrealistic expectations that have resulted in disappointments, delays, cost overruns, claims, and disputes. To confront that risk, geotechnical engineers commonly include explanatory provisions in their reports. Sometimes labeled "limitations," many of these provisions indicate where geotechnical engineers' responsibilities begin and end, to help others recognize their own responsibilities and risks. *Read these provisions closely*. Ask questions. Your geotechnical engineer should respond fully and frankly.

## Geoenvironmental Concerns Are Not Covered

The personnel, equipment, and techniques used to perform an environmental study – e.g., a "phase-one" or "phase-two" environmental site assessment – differ significantly from those used to perform a geotechnical-engineering study. For that reason, a geotechnical-engineering report does not usually relate any environmental findings, conclusions, or recommendations; e.g., about the likelihood of encountering underground storage tanks or regulated contaminants. *Unanticipated subsurface environmental problems have led to project failures*. If you have not yet obtained your own environmental information, ask your geotechnical consultant for risk-management guidance. As a general rule, *do not rely on an environmental report prepared for a different client, site, or project, or that is more than six months old*.

## Obtain Professional Assistance to Deal with Moisture Infiltration and Mold

While your geotechnical engineer may have addressed groundwater, water infiltration, or similar issues in this report, none of the engineer's services were designed, conducted, or intended to prevent uncontrolled migration of moisture – including water vapor – from the soil through building slabs and walls and into the building interior, where it can cause mold growth and material-performance deficiencies. Accordingly, *proper implementation of the geotechnical engineer's recommendations will not of itself be sufficient to prevent moisture infiltration*. Confront the risk of moisture infiltration by including building-envelope or mold specialists on the design team. *Geotechnical engineers are not building-envelope or mold specialists*.



Telephone: 301/565-2733

e-mail: [info@geoprofessional.org](mailto:info@geoprofessional.org) [www.geoprofessional.org](http://www.geoprofessional.org)

# ***Appendix B – FIRM Map***



2020/04/28 3:04 PM By: Ryan Mengino J:\JDS-Hydro\Project Files\112 Woodmen Hills\112.112 West Water Tank\Drawings\Working\112.112\_ToBuild\112112\_3\_FIRM.dwg

**LEGEND**

- SPECIAL FLOOD HAZARD AREAS (SFHAS) SUBJECT TO INUNDATION BY THE 1% ANNUAL CHANCE FLOOD
- The 1% annual chance flood (100-year flood), also known as the base flood, is the flood that has a 1% chance of being equaled or exceeded in any given year. The Special Flood Hazard Area is the area subject to flooding by the 1% annual chance flood. Areas of Special Flood Hazard include Zones A, AE, AH, AO, AR, A99, V, and VE. The Base Flood Elevation is the water-surface elevation of the 1% annual chance flood.
- ZONE A** No Base Flood Elevations determined.
- ZONE AE** Base Flood Elevations determined.
- ZONE AH** Flood depths of 1 to 3 feet (usually areas of ponding); Base Flood Elevations determined.
- ZONE AO** Flood depths of 1 to 3 feet (usually sheet flow on sloping terrain); average depths determined. For areas of alluvial fan flooding, velocities also determined.
- ZONE AR** Special Flood Hazard Area Formerly protected from the 1% annual chance flood by a flood control system that was subsequently decertified. Zone AR indicates that the former flood control system is being restored to provide protection from the 1% annual chance or greater flood.
- ZONE A99** Area to be protected from 1% annual chance flood by a Federal flood protection system under construction; no Base Flood Elevations determined.
- ZONE V** Coastal flood zone with velocity hazard (wave action); no Base Flood Elevations determined.
- ZONE VE** Coastal flood zone with velocity hazard (wave action); Base Flood Elevations determined.
- FLOODWAY AREAS IN ZONE AE
- The floodway is the channel of a stream plus any adjacent floodplain areas that must be kept free of encroachment so that the 1% annual chance flood can be carried without substantial increases in flood heights.
- OTHER FLOOD AREAS
- ZONE X** Areas of 0.2% annual chance flood; areas of 1% annual chance flood with average depths of less than 1 foot or with drainage areas less than 1 square mile; and areas protected by levees from 1% annual chance flood.
- OTHER AREAS
- ZONE X** Areas determined to be outside the 0.2% annual chance floodplain.
- ZONE D** Areas in which flood hazards are undetermined, but possible.
- COASTAL BARRIER RESOURCES SYSTEM (CBRS) AREAS
- OTHERWISE PROTECTED AREAS (OPAs)
- CBRS areas and OPAs are normally located within or adjacent to Special Flood Hazard Areas.
- Floodplain boundary
- Floodway boundary
- Zone D boundary
- CBRS and OPA boundary
- Boundary dividing Special Flood Hazard Areas of different Base Flood Elevations, flood depths or flood velocities.
- Base Flood Elevation line and value; elevation in feet\*
- Base Flood Elevation value where uniform within zone; elevation in feet\*
- \* Referenced to the North American Vertical Datum of 1988 (NAVD 88)
- Cross section line
- Transect line
- Geographic coordinates referenced to the North American Datum of 1983 (NAD 83)
- 1000-meter Universal Transverse Mercator grid ticks, zone 13
- 5000-foot grid ticks: Colorado State Plane coordinate system, central zone (FIPS ZONE 0502), Lambert Conformal Conic Projection
- Bench mark (see explanation in Notes to Users section of this FIRM panel)
- River Mile
- MAP REPOSITORIES**  
Refer to Map Repositories list on Map Index
- EFFECTIVE DATE OF COUNTYWIDE FLOOD INSURANCE RATE MAP**  
MARCH 17, 1997
- EFFECTIVE DATE(S) OF REVISION(S) TO THIS PANEL**  
DECEMBER 7, 2018 - to update corporate limits, to change Base Flood Elevations and Special Flood Hazard Areas, to update map format, to add roads and road names, and to incorporate previously issued Letters of Map Revision.
- For community map revision history prior to countywide mapping, refer to the Community Map History Table located in the Flood Insurance Study report for this jurisdiction.
- To determine if flood insurance is available in this community, contact your insurance agent or call the National Flood Insurance Program at 1-800-638-6620.

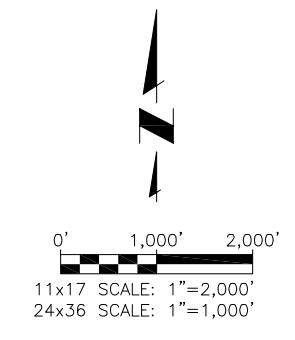
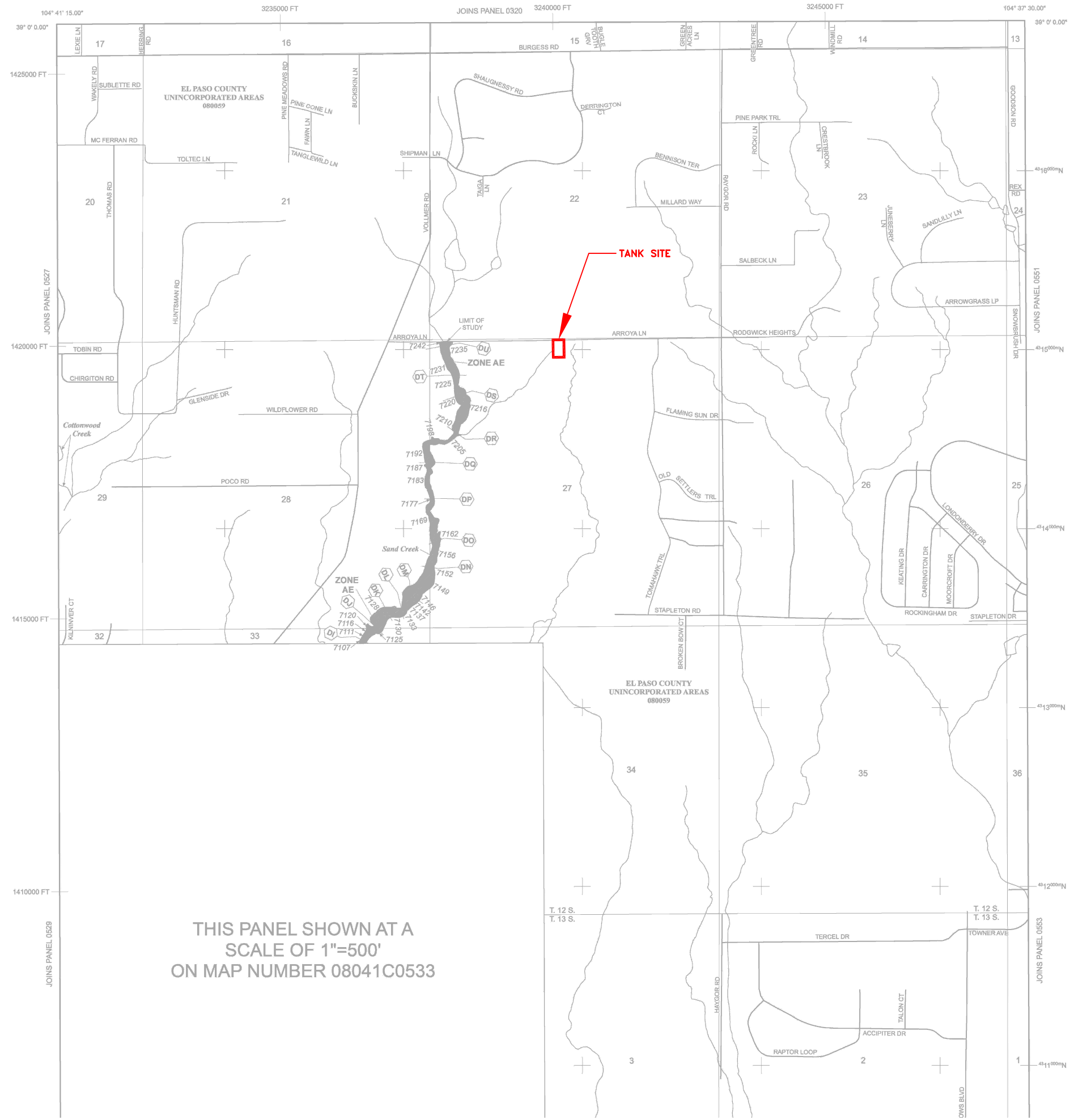

THIS PANEL SHOWN AT A  
SCALE OF 1"=500'  
ON MAP NUMBER 08041C0533

**NFP**

**PANEL 0535G**

---

**FIRM**

**FLOOD INSURANCE RATE MAP**

**EL PASO COUNTY,  
COLORADO  
AND INCORPORATED AREAS**

---

**PANEL 535 OF 1300**

(SEE MAP INDEX FOR FIRM PANEL LAYOUT)

CONTAINS:

COMMUNITY	NUMBER	PANEL	SUFFIX
COLORADO SPRINGS, CITY OF	08000	0535	G
EL PASO COUNTY	08059	0535	G

---

Notice to User: The Map Number shown below should be used when placing map orders; the Community Number shown above should be used on insurance applications for the subject community.

**MAP NUMBER  
08041C0535G**

**MAP REVISED  
DECEMBER 7, 2018**

Federal Emergency Management Agency

**JDS-HYDRO CONSULTANTS, INC.**  
5640 TECH CENTER DR., SUITE 100  
COLORADO SPRINGS, COLORADO 80919  
(719) 227-0072

DISCLAIMER: THE CONTRACTOR SHALL VERIFY ALL DIMENSIONS. ANY ERRORS OR OMISSIONS SHALL BE REPORTED TO JDS-HYDRO CONSULTANTS, INC. JDS-HYDRO ASSUMES NO LIABILITY FOR UNAUTHORIZED CHANGES AND/OR REVISIONS MADE TO PLANS.

**WOODMEN HILLS METROPOLITAN DISTRICT**  
WEST CONCRETE WATER STORAGE TANK  
FEMA FLOODPLAIN MAP

NO.	DESCRIPTION	BY	DATE	REVISIONS		
				NO.	DATE	DESCRIPTION
1						
2						
3						
4						
5						
6						
7						

**100% DESIGN DRAWINGS**

---

Project No.: 112.112  
Date: 04/24/20  
Design: RMM  
Drawn: RMM  
Check: JPM

**C7**

SHEET 8 OF 28

# *Appendix C – Hydrologic Calculations*

### Calculation of Peak Runoff using Rational Method

Designer: Elizabeth Steffens  
 Company: JDS-Hydro Consultants, Inc.  
 Date: 4/24/2020  
 Project: WHMD West Water Tank  
 Location: 9275 Arroya Ln. (Pre-Development)

Version 2.00 released May 2017

Cells of this color are for required user-input  
 Cells of this color are for optional override values  
 Cells of this color are for calculated results based on overrides

$$t_t = \frac{0.395(1.1 - C_2)\sqrt{L_t}}{S^{0.33}}$$

$$t_t = \frac{L_t}{60K\sqrt{S}} = \frac{L_t}{60V_t}$$

Computed  $t_c = t_t + t_f$

Regional  $t_c = (26 - 17i) + \frac{L_t}{60(14i + 9)\sqrt{S}}$

$t_{minimum} = 5$  (urban)  
 $t_{minimum} = 10$  (non-urban)

Selected  $t_c = \max\{t_{minimum}, \min(\text{Computed } t_c, \text{Regional } t_c)\}$

Select UDFCD location for NOAA Atlas 14 Rainfall Depths from the pulldown list OR enter your own depths obtained from the NOAA website (click this link)

2-yr	5-yr	10-yr	25-yr	50-yr	100-yr	500-yr
0.94	1.22	1.48	1.87	2.19	2.54	3.47

1-hour rainfall depth, P1 (in) =  $\frac{a}{(b + t_c)^c}$   
 Rainfall Intensity Equation Coefficients = a: 28.50, b: 10.00, c: 0.786

$Q(cfs) = CIA$

Subcatchment Name	Area (ac)	NRCS Hydrologic Soil Group	Percent Imperviousness	Runoff Coefficient, C							Overland (Initial) Flow Time					Channelized (Travel) Flow Time						Time of Concentration			Rainfall Intensity, I (in/hr)							Peak Flow, Q (cfs)							
				2-yr	5-yr	10-yr	25-yr	50-yr	100-yr	500-yr	Overland Flow Length L <sub>i</sub> (ft)	U/S Elevation (ft) (Optional)	D/S Elevation (ft) (Optional)	Overland Flow Slope S <sub>i</sub> (ft/ft)	Overland Flow Time t <sub>i</sub> (min)	Channelized Flow Length L <sub>i</sub> (ft)	U/S Elevation (ft) (Optional)	D/S Elevation (ft) (Optional)	Channelized Flow Slope S <sub>i</sub> (ft/ft)	NRCS Conveyance Factor K	Channelized Flow Velocity V <sub>i</sub> (ft/sec)	Channelized Flow Time t <sub>i</sub> (min)	Computed t <sub>c</sub> (min)	Regional t <sub>c</sub> (min)	Selected t <sub>c</sub> (min)	2-yr	5-yr	10-yr	25-yr	50-yr	100-yr	500-yr	2-yr	5-yr	10-yr	25-yr	50-yr	100-yr	500-yr
A	1.47	B	0.0	0.00	0.00	0.06	0.25	0.33	0.43	0.54	350.00	7317.00	7303.00	0.040	23.51	0.00			0.010	10	1.00	0.00	23.51	26.00	23.51	1.70	2.20	2.67	3.37	3.95	4.58	6.26	0.00	0.00	0.22	1.24	1.91	2.87	4.94

### Calculation of Peak Runoff using Rational Method

Designer: Elizabeth Steffens  
 Company: JDS-Hydro Consultants, Inc.  
 Date: 4/24/2020  
 Project: WHMD West Water Tank  
 Location: 9275 Arroya Ln. (Post-development)

Version 2.00 released May 2017

Cells of this color are for required user-input  
 Cells of this color are for optional override values  
 Cells of this color are for calculated results based on overrides

$$t_1 = \frac{0.395(1.1 - C_s)\sqrt{L_1}}{S^{0.33}}$$

$$t_1 = \frac{L_1}{60K\sqrt{S}} = \frac{L_1}{60V_1}$$

$$\text{Computed } t_c = t_1 + t_2$$

$$\text{Regional } t_c = (26 - 17i) + \frac{L_1}{60(14i + 9)\sqrt{S_1}}$$

$$t_{\text{minimum}} = 5 \text{ (urban)}$$

$$t_{\text{minimum}} = 10 \text{ (non-urban)}$$

$$\text{Selected } t_c = \max\{t_{\text{minimum}}, \min(\text{Computed } t_c, \text{Regional } t_c)\}$$

Select UDFCD location for NOAA Atlas 14 Rainfall Depths from the pulldown list OR enter your own depths obtained from the NOAA website (click this link)

1-hour rainfall depth, P1 (in) =

2-yr	5-yr	10-yr	25-yr	50-yr	100-yr	500-yr
0.94	1.22	1.47	1.86	2.18	2.53	3.44

Rainfall Intensity Equation Coefficients =

a	b	c
28.50	10.00	0.786

$$I(\text{in/hr}) = \frac{a + P_1}{(b + t_c)^c}$$

$$Q(\text{cfs}) = CIA$$

Subcatchment Name	Area (ac)	NRCS Hydrologic Soil Group	Percent Imperviousness	Runoff Coefficient, C							Overland (Initial) Flow Time					Channelized (Travel) Flow Time					Time of Concentration			Rainfall Intensity, I (in/hr)							Peak Flow, Q (cfs)								
				2-yr	5-yr	10-yr	25-yr	50-yr	100-yr	500-yr	Overland Flow Length L <sub>1</sub> (ft)	U/S Elevation (ft) (Optional)	D/S Elevation (ft) (Optional)	Overland Flow Slope S <sub>1</sub> (ft/ft)	Overland Flow Time t <sub>1</sub> (min)	Channelized Flow Length L <sub>2</sub> (ft)	U/S Elevation (ft) (Optional)	D/S Elevation (ft) (Optional)	Channelized Flow Slope S <sub>2</sub> (ft/ft)	NRCS Conveyance Factor K	Channelized Flow Velocity V <sub>1</sub> (ft/sec)	Channelized Flow Time t <sub>2</sub> (min)	Computed t <sub>c</sub> (min)	Regional t <sub>c</sub> (min)	Selected t <sub>c</sub> (min)	2-yr	5-yr	10-yr	25-yr	50-yr	100-yr	500-yr	2-yr	5-yr	10-yr	25-yr	50-yr	100-yr	500-yr
A	1.39	B	48.0	0.35	0.39	0.44	0.55	0.60	0.65	0.71	50.00	7317.00	7311.00	0.120	4.02	177.00	7311.00	7308.00	0.017	20	2.60	1.13	5.15	19.28	5.15	3.18	4.11	4.95	6.26	7.34	8.51	11.58	1.56	2.20	3.06	4.79	6.08	7.68	11.45

# *Appendix D – WQCV Calculations*

**Calculation of WQCV (per UDFCD-USDCM Volume 3, Chapter 3)**

$WQCV = a(0.91I^3 - 1.19I^2 + 0.78I)$  *Equation 3-1*

Where:

- WQCV = Water Quality Capture Volume (watershed inches)
- a = Coefficient corresponding to WQCV drain time (Table 3-2)
- I = Imperviousness (%/100) (see Figures 3-3 through 3-5 [single family land use] and /or the Runoff chapter of Volume 1 [other typical land uses])

**Table 3-2. Drain Time Coefficients for WQCV Calculations**

Drain Time (hrs)	Coefficient, a
12 hours	0.8
24 hours	0.9
40 hours	1

Using representative values for this project:

- a = 1 Per Table 3-2
- I = 48.0% Calculated using proposed improvements (include gravel drive, tanks)

**Solution:**

$WQCV = a(0.91I^3 - 1.19I^2 + 0.78I)$

WQCV = 0.20086272 Watershed Inches

Find Required BMP Storage Volume (V):

$V = (WQCV/12)A$  *Equation 3-3*

Where:

- V = required storage volume (acre-ft)
- A = tributary catchment area upstream (acres)
- WQCV = Water Quality Capture Volume (watershed inches)

Using representative values for this project:

- A = 60,548 sq. ft. (incl. gravel driveway, concrete water tanks)
- = 1.3900 acres
- WQCV = 0.20 Watershed Inches

**Solution:**

$V = (WQCV/12)A$

V = 0.0233 acre-ft

=	<b>1,013 cubic feet</b>
---	-------------------------

**Provided: 7,308 cubic feet ✓**

# *Appendix E – Detention Basin Sizing Calculations*

**Design Procedure Form: Extended Detention Basin (EDB)**

UD-BMP (Version 3.07, March 2018)

Sheet 1 of 3

**Designer:** Elizabeth Steffens  
**Company:** JDS-Hydro Consultants, Inc.  
**Date:** July 9, 2020  
**Project:** Woodmen Hills Metropolitan District - West Water Tank  
**Location:** Basin A

<p>1. Basin Storage Volume</p> <p>A) Effective Imperviousness of Tributary Area, <math>I_a</math></p> <p>B) Tributary Area's Imperviousness Ratio (<math>i = I_a / 100</math>)</p> <p>C) Contributing Watershed Area</p> <p>D) For Watersheds Outside of the Denver Region, Depth of Average Runoff Producing Storm</p> <p>E) Design Concept (Select EURV when also designing for flood control)</p> <p>F) Design Volume (WQCV) Based on 40-hour Drain Time (<math>V_{DESIGN} = (1.0 * (0.91 * i^3 - 1.19 * i^2 + 0.78 * i) / 12 * Area)</math>)</p> <p>G) For Watersheds Outside of the Denver Region, Water Quality Capture Volume (WQCV) Design Volume (<math>V_{WQCV\ OTHER} = (d_6 * V_{DESIGN} / 0.43)</math>)</p> <p>H) User Input of Water Quality Capture Volume (WQCV) Design Volume (Only if a different WQCV Design Volume is desired)</p> <p>I) NRCS Hydrologic Soil Groups of Tributary Watershed              i) Percentage of Watershed consisting of Type A Soils              ii) Percentage of Watershed consisting of Type B Soils              iii) Percentage of Watershed consisting of Type C/D Soils</p> <p>J) Excess Urban Runoff Volume (EURV) Design Volume              For HSG A: <math>EURV_A = 1.68 * i^{1.28}</math>              For HSG B: <math>EURV_B = 1.36 * i^{1.08}</math>              For HSG C/D: <math>EURV_{C/D} = 1.20 * i^{1.08}</math></p> <p>K) User Input of Excess Urban Runoff Volume (EURV) Design Volume (Only if a different EURV Design Volume is desired)</p>	<p><math>I_a =</math> <input type="text" value="48.0"/> %</p> <p><math>i =</math> <input type="text" value="0.480"/></p> <p>Area = <input type="text" value="1.390"/> ac</p> <p><math>d_6 =</math> <input type="text" value="0.42"/> in</p> <div style="border: 1px solid black; padding: 5px; margin: 5px 0;"> <p>Choose One</p> <p><input checked="" type="radio"/> Water Quality Capture Volume (WQCV)</p> <p><input type="radio"/> Excess Urban Runoff Volume (EURV)</p> </div> <p><math>V_{DESIGN} =</math> <input type="text"/> ac-ft</p> <p><math>V_{DESIGN\ OTHER} =</math> <input type="text" value="0.023"/> ac-ft</p> <p><math>V_{DESIGN\ USER} =</math> <input type="text"/> ac-ft</p> <p>HSG A = <input type="text"/> %</p> <p>HSG B = <input type="text"/> %</p> <p>HSG C/D = <input type="text"/> %</p> <p><math>EURV_{DESIGN} =</math> <input type="text"/> ac-ft</p> <p><math>EURV_{DESIGN\ USER} =</math> <input type="text"/> ac-ft</p>
<p>2. Basin Shape: Length to Width Ratio (A basin length to width ratio of at least 2:1 will improve TSS reduction.)</p>	<p>L : W = <input type="text" value="2.5"/> : 1</p>
<p>3. Basin Side Slopes</p> <p>A) Basin Maximum Side Slopes (Horizontal distance per unit vertical, 4:1 or flatter preferred)</p>	<p>Z = <input type="text" value="3.00"/> ft / ft</p> <p align="center"><b>DIFFICULT TO MAINTAIN, INCREASE WHERE POSSIBLE</b></p>
<p>4. Inlet</p> <p>A) Describe means of providing energy dissipation at concentrated inflow locations:</p>	<p>The concentrated inflow to the detention basin is limited. However, there is a rock lined channel at the concentrated inflow location.</p> <hr/> <hr/> <hr/>
<p>5. Forebay</p> <p>A) Minimum Forebay Volume (<math>V_{FMN} =</math> <input type="text" value="0"/>% of the WQCV)</p> <p>B) Actual Forebay Volume</p> <p>C) Forebay Depth (<math>D_F =</math> <input type="text" value="12"/> inch maximum)</p> <p>D) Forebay Discharge</p> <p>i) Undetained 100-year Peak Discharge</p> <p>ii) Forebay Discharge Design Flow (<math>Q_F = 0.02 * Q_{100}</math>)</p> <p>E) Forebay Discharge Design</p> <div style="border: 1px solid black; padding: 5px; margin: 5px 0;"> <p>Choose One</p> <p><input type="radio"/> Berm With Pipe</p> <p><input type="radio"/> Wall with Rect. Notch</p> <p><input type="radio"/> Wall with V-Notch Weir</p> </div> <p>F) Discharge Pipe Size (minimum 8-inches)</p> <p>G) Rectangular Notch Width</p>	<p><math>V_{FMN} =</math> <input type="text" value="0.000"/> ac-ft <b>A FOREBAY MAY NOT BE NECESSARY FOR THIS SIZE SITE</b></p> <p><math>V_F =</math> <input type="text"/> ac-ft</p> <p><math>D_F =</math> <input type="text"/> in</p> <p><math>Q_{100} =</math> <input type="text"/> cfs</p> <p><math>Q_F =</math> <input type="text"/> cfs</p> <p align="right"><b>Flow too small for berm w/ pipe</b></p> <p>Calculated <math>D_P =</math> <input type="text"/> in</p> <p>Calculated <math>W_N =</math> <input type="text"/> in</p>





**Design Procedure Form: Extended Detention Basin (EDB)**

**Designer:** Elizabeth Steffens  
**Company:** JDS-Hydro Consultants, Inc.  
**Date:** July 9, 2020  
**Project:** Woodmen Hills Metropolitan District - West Water Tank  
**Location:** Basin A

<p>6. Trickle Channel</p> <p>A) Type of Trickle Channel</p> <p>F) Slope of Trickle Channel</p>	<div style="border: 1px solid black; padding: 2px; margin-bottom: 5px;">             Choose One  <input checked="" type="radio"/> Concrete  <input type="radio"/> Soft Bottom         </div> <p>S = <input type="text" value="0.0060"/> ft / ft</p>
<p>7. Micropool and Outlet Structure</p> <p>A) Depth of Micropool (2.5-foot minimum)</p> <p>B) Surface Area of Micropool (10 ft<sup>2</sup> minimum)</p> <p>C) Outlet Type</p> <p>D) Smallest Dimension of Orifice Opening Based on Hydrograph Routing (Use UD-Detention)</p> <p>E) Total Outlet Area</p>	<p>D<sub>M</sub> = <input type="text" value="2.5"/> ft</p> <p>A<sub>M</sub> = <input type="text" value="75"/> sq ft</p> <div style="border: 1px solid black; padding: 2px; margin-bottom: 5px;">             Choose One  <input checked="" type="radio"/> Orifice Plate  <input type="radio"/> Other (Describe):         </div> <hr/> <hr/> <p>D<sub>orifice</sub> = <input type="text" value="0.44"/> inches</p> <p>A<sub>orifice</sub> = <input type="text" value="0.16"/> square inches</p>
<p>8. Initial Surcharge Volume</p> <p>A) Depth of Initial Surcharge Volume (Minimum recommended depth is 4 inches)</p> <p>B) Minimum Initial Surcharge Volume (Minimum volume of 0.3% of the WQCV)</p> <p>C) Initial Surcharge Provided Above Micropool</p>	<p>D<sub>IS</sub> = <input type="text" value="4"/> in</p> <p>V<sub>IS</sub> = <input type="text"/> cu ft</p> <p>V<sub>s</sub> = <input type="text" value="25.0"/> cu ft</p>
<p>9. Trash Rack</p> <p>A) Water Quality Screen Open Area: <math>A_t = A_{ot} * 38.5 * (e^{-0.095D})</math></p> <p>B) Type of Screen (If specifying an alternative to the materials recommended in the USDCM, indicate "other" and enter the ratio of the total open are to the total screen are for the material specified.)</p> <p style="margin-left: 40px;">Other (Y/N): <input type="text" value="N"/></p> <p>C) Ratio of Total Open Area to Total Area (only for type 'Other')</p> <p>D) Total Water Quality Screen Area (based on screen type)</p> <p>E) Depth of Design Volume (EURV or WQCV) (Based on design concept chosen under 1E)</p> <p>F) Height of Water Quality Screen (H<sub>TR</sub>)</p> <p>G) Width of Water Quality Screen Opening (W<sub>opening</sub>) (Minimum of 12 inches is recommended)</p>	<p>A<sub>t</sub> = <input type="text" value="6"/> square inches</p> <div style="border: 1px solid black; padding: 2px; margin-bottom: 5px; width: fit-content;"> <i>S.S. Well Screen with 60% Open Area</i> </div> <hr/> <hr/> <p>User Ratio = <input type="text"/></p> <p>A<sub>total</sub> = <input type="text" value="10"/> sq. in.</p> <p>H = <input type="text" value="2.28"/> feet</p> <p>H<sub>TR</sub> = <input type="text" value="55.36"/> inches</p> <p>W<sub>opening</sub> = <input type="text" value="12.0"/> inches <span style="color: red; font-size: small;">VALUE LESS THAN RECOMMENDED MIN. WIDTH. WIDTH HAS BEEN SET TO 12 INCHES.</span></p>

Design Procedure Form: Extended Detention Basin (EDB)

Sheet 3 of 3

Designer: Elizabeth Steffens  
Company: JDS-Hydro Consultants, Inc.  
Date: July 9, 2020  
Project: Woodmen Hills Metropolitan District - West Water Tank  
Location: Basin A

<p>10. Overflow Embankment</p> <p>A) Describe embankment protection for 100-year and greater overtopping:</p> <p>B) Slope of Overflow Embankment (Horizontal distance per unit vertical, 4:1 or flatter preferred)</p>	<p>Riprap lined emergency spillway provided for 100-yr and greater storm events.</p> <p>Ze = <input type="text" value="35.00"/> ft / ft</p>
<p>11. Vegetation</p>	<p>Choose One</p> <p><input type="radio"/> Irrigated</p> <p><input checked="" type="radio"/> Not Irrigated</p>
<p>12. Access</p> <p>A) Describe Sediment Removal Procedures</p>	<p>Access road located on dam crest will be used to access the outlet structure using a backhoe for maintenance/sediment removal.</p>
<p>Notes: <u>Due to the small size of the site and detention basin, a forebay is not included in the detention basin.</u></p>	

Woodmen Hills Metropolitan District  
 West Water Tank  
 Extended Detention Basin Sizing - Simplified Equations

100-Year Volume	
i	0.48
HSG B	1 100%
P1	2.53 inches
V100	1.09 watershed inches
Watershed Area	1.39 acres
Detention Volume	0.127 ac-ft 5,520 cf

EURV Volume	
i	0.48
EURV <sub>B</sub>	0.616 watershed inches
Watershed Area	1.39 acres
Detention Volume	0.071 ac-ft 3,106 cf

**100-Year Volume.** A simplified equation can be used to determine the required 100-year full spectrum detention volume for tributary areas less than 10 acres. This volume includes the EURV (and the EURV includes the WQCV). UDFCD does not recommend adding additional volume above that provided in Equation 12-4. The derivation of this equation is documented in a Technical Memorandum entitled *Estimation of Runoff and Storage Volumes for Use with Full Spectrum Detention*, dated January 5, 2017 (available at [www.udfcd.org](http://www.udfcd.org)). If a more detailed analysis is desired, see Table 12-5. The 100-year volume in watershed inches is converted to cubic feet or acre-feet by multiplying by watershed area and converting units.

$$V_{100} = P_1 \left[ \begin{aligned} &0.806i^{1.225} + 0.109i^{0.225} \end{aligned} A\% + (0.412i^{1.371} + 0.371i^{0.371})B\% \right] + (0.341i^{1.389} + 0.398i^{0.389})CD\% \quad \text{Equation 12-4}$$

Where:

$V_{100}$  = detention volume in watershed inches

$P_1$  = one-hour rainfall depth (inches)

$i$  = imperviousness ratio (a decimal less than or equal to 1)

$A\%$ ,  $B\%$ , and  $CD\%$  = indicates percentage of each NRCS soils type (expressed as a decimal)

**EURV.** Use equations 12-1, 2 and 3 to find EURV in watershed inches for specific soil types.

$$EURV_A = 1.68i^{1.28} \quad \text{Equation 12-1}$$

$$EURV_B = 1.36i^{1.08} \quad \text{Equation 12-2}$$

$$EURV_{CD} = 1.20i^{1.08} \quad \text{Equation 12-3}$$

Where:

$EURV_K$  = Excess urban runoff volume in watershed inches ( $K$  indicates NRCS soils type),  
 $i$  = Imperviousness ratio (a decimal less than or equal to 1)

The Technical Memorandum entitled *Determination of the EURV for Full Spectrum Detention Design*, dated December 22, 2016 documents the derivation of these equations. This is available at [www.udfcd.org](http://www.udfcd.org). Apply the equations above for each of the soil types found in the watershed and then calculate a weighted average value based on the relative area proportion of each soil type. Convert the EURV in watershed inches to a volume multiplying it by the watershed area.

Whenever NRCS soil surveys are not available for a catchment area, soils investigations are recommended to estimate equivalent soil type.



# DETENTION BASIN STAGE-STORAGE TABLE BUILDER

*MHFD-Detention, Version 4.00 (December 2019)*

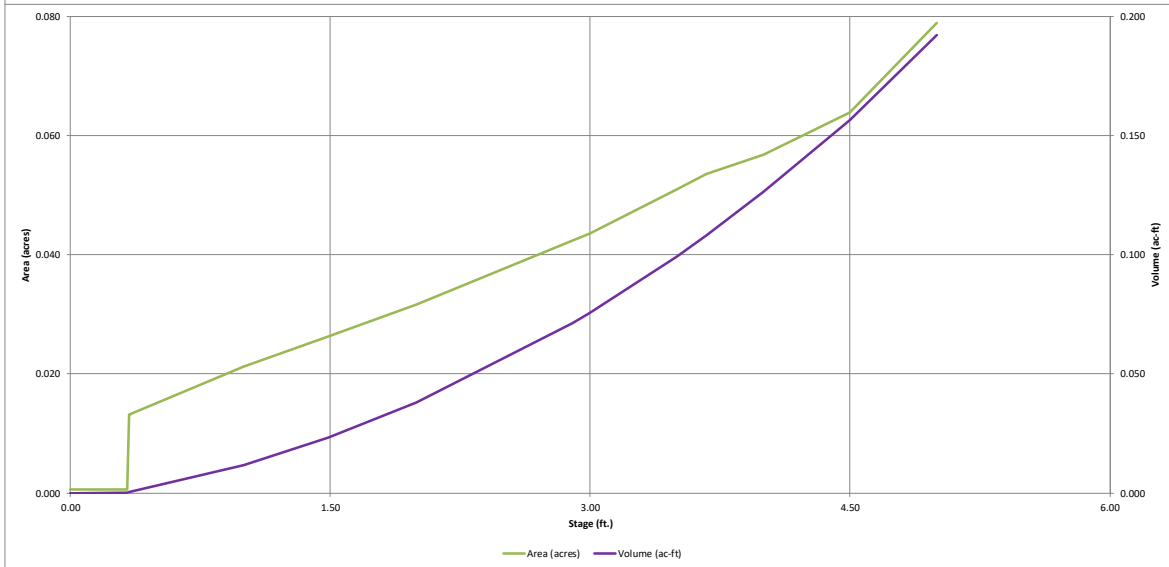
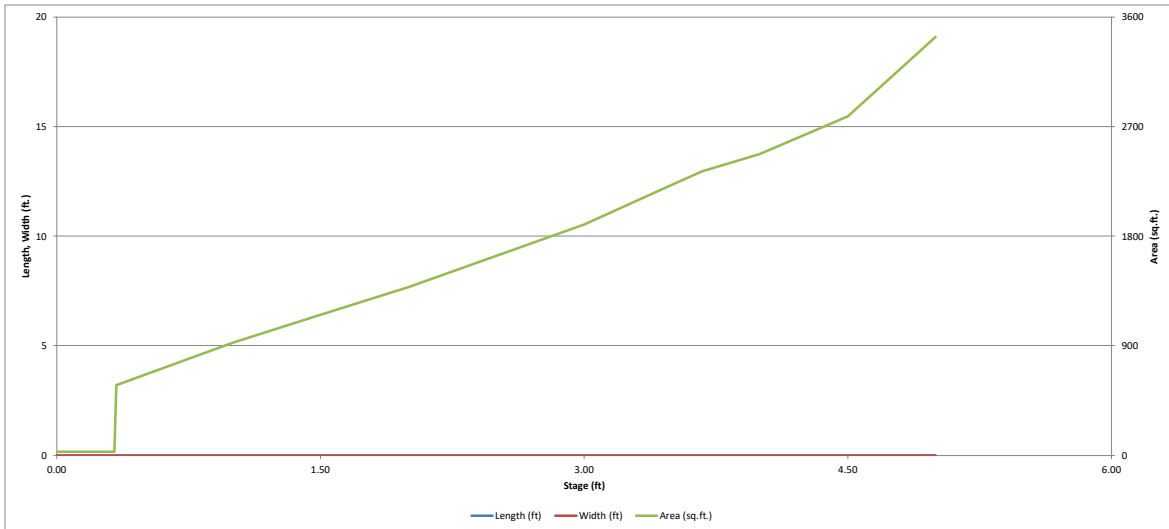

# DETENTION BASIN OUTLET STRUCTURE DESIGN

MHFD-*Detention, Version 4.00 (December 2019)*

**Project: Woodmen Hills Metropolitan District - West Water Tank**

**Basin ID: Basin A**

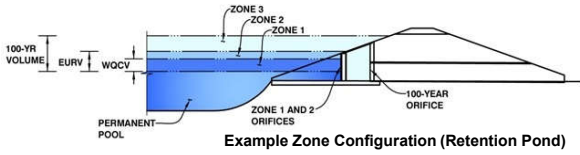

**Example Zone Configuration (Retention Pond)**

	Estimated Stage (ft)	Estimated Volume (ac-ft)	Outlet Type
Zone 1 (WQCV)	1.49	0.023	Orifice Plate
Zone 2 (EURV)	2.90	0.048	Orifice Plate
Zone 3 (100-year)	4.01	0.056	Weir&Pipe (Circular)
<b>Total (all zones)</b>		<b>0.127</b>	

**User Input: Orifice at Underdrain Outlet (typically used to drain WQCV in a Filtration BMP)**

Underdrain Orifice Invert Depth =  ft (distance below the filtration media surface)  
 Underdrain Orifice Diameter =  inches

**Calculated Parameters for Underdrain**  
 Underdrain Orifice Area =  ft<sup>2</sup>  
 Underdrain Orifice Centroid =  feet

**User Input: Orifice Plate with one or more orifices or Elliptical Slot Weir (typically used to drain WQCV and/or EURV in a sedimentation BMP)**

Invert of Lowest Orifice =  ft (relative to basin bottom at Stage = 0 ft)  
 Depth at top of Zone using Orifice Plate =  ft (relative to basin bottom at Stage = 0 ft)  
 Orifice Plate: Orifice Vertical Spacing =  inches  
 Orifice Plate: Orifice Area per Row =  sq. inches (diameter = 7/16 inch)

**Calculated Parameters for Plate**  
 WQ Orifice Area per Row =  ft<sup>2</sup>  
 Elliptical Half-Width =  feet  
 Elliptical Slot Centroid =  feet  
 Elliptical Slot Area =  ft<sup>2</sup>

**User Input: Stage and Total Area of Each Orifice Row (numbered from lowest to highest)**

	Row 1 (required)	Row 2 (optional)	Row 3 (optional)	Row 4 (optional)	Row 5 (optional)	Row 6 (optional)	Row 7 (optional)	Row 8 (optional)
Stage of Orifice Centroid (ft)	0.00	0.81	1.63					
Orifice Area (sq. inches)	0.16	0.16	0.16					

	Row 9 (optional)	Row 10 (optional)	Row 11 (optional)	Row 12 (optional)	Row 13 (optional)	Row 14 (optional)	Row 15 (optional)	Row 16 (optional)
Stage of Orifice Centroid (ft)								
Orifice Area (sq. inches)								

**User Input: Vertical Orifice (Circular or Rectangular)**

	Not Selected	Not Selected	
Invert of Vertical Orifice =	<input type="text" value="N/A"/>	<input type="text" value="N/A"/>	ft (relative to basin bottom at Stage = 0 ft)
Depth at top of Zone using Vertical Orifice =	<input type="text" value="N/A"/>	<input type="text" value="N/A"/>	ft (relative to basin bottom at Stage = 0 ft)
Vertical Orifice Diameter =	<input type="text" value="N/A"/>	<input type="text" value="N/A"/>	inches

**Calculated Parameters for Vertical Orifice**  
 Vertical Orifice Area =  ft<sup>2</sup>  
 Vertical Orifice Centroid =  feet

**User Input: Overflow Weir (Dropbox with Flat or Sloped Gate and Outlet Pipe OR Rectangular/Trapezoidal Weir (and No Outlet Pipe))**

	Zone 3 Weir	Not Selected	
Overflow Weir Front Edge Height, Ho =	2.67	N/A	ft (relative to basin bottom at Stage = 0 ft)
Overflow Weir Front Edge Length =	4.00	N/A	feet
Overflow Weir Gate Slope =	3.00	N/A	H:V
Horiz. Length of Weir Sides =	2.50	N/A	feet
Overflow Gate Open Area % =	70%	N/A	%, gate open area/total area
Debris Clogging % =	0%	N/A	%

**Calculated Parameters for Overflow Weir**  
 Height of Gate Upper Edge, H<sub>1</sub> =  ft  
 Overflow Weir Slope Length =  feet  
 Gate Open Area / 100-yr Orifice Area =  ft<sup>2</sup>  
 Overflow Gate Open Area w/o Debris =  ft<sup>2</sup>  
 Overflow Gate Open Area w/ Debris =  ft<sup>2</sup>

**User Input: Outlet Pipe w/ Flow Restriction Plate (Circular Orifice, Restrictor Plate, or Rectangular Orifice)**

	Zone 3 Circular	Not Selected	
Depth to Invert of Outlet Pipe =	0.25	N/A	ft (distance below basin bottom at Stage = 0 ft)
Circular Orifice Diameter =	5.25	N/A	inches

**Calculated Parameters for Outlet Pipe w/ Flow Restriction Plate**  
 Outlet Orifice Area =  ft<sup>2</sup>  
 Outlet Orifice Centroid =  feet  
 Half-Central Angle of Restrictor Plate on Pipe =  radians

**User Input: Emergency Spillway (Rectangular or Trapezoidal)**

Spillway Invert Stage =  ft (relative to basin bottom at Stage = 0 ft)  
 Spillway Crest Length =  feet  
 Spillway End Slopes =  H:V  
 Freeboard above Max Water Surface =  feet

**Calculated Parameters for Spillway**  
 Spillway Design Flow Depth =  feet  
 Stage at Top of Freeboard =  feet  
 Basin Area at Top of Freeboard =  acres  
 Basin Volume at Top of Freeboard =  acre-ft

**Routed Hydrograph Results**

*The user can override the default CUHP hydrographs and runoff volumes by entering new values in the Inflow Hydrographs table (Columns W through AF).*

	WQCV	EURV	2 Year	5 Year	10 Year	25 Year	50 Year	100 Year	500 Year
Design Storm Return Period =	N/A	N/A	0.94	1.22	1.47	1.86	2.18	2.53	3.44
One-Hour Rainfall Depth (in) =	N/A	N/A	0.044	0.065	0.087	0.134	0.169	0.212	0.314
CUHP Runoff Volume (acre-ft) =	0.023	0.071	0.044	0.065	0.087	0.134	0.169	0.212	0.314
Inflow Hydrograph Volume (acre-ft) =	0.023	0.071	0.044	0.065	0.087	0.134	0.169	0.212	0.314
CUHP Predevelopment Peak Q (cfs) =	0.0	0.0	0.0	0.2	0.5	1.2	1.7	2.3	3.6
OPTIONAL Override Predevelopment Peak Q (cfs) =	0.0	0.0							
Predevelopment Unit Peak Flow, q (cfs/acre) =	0.00	0.00	0.02	0.13	0.33	0.90	1.23	1.64	2.59
Peak Inflow Q (cfs) =	0.4	1.4	0.8	1.3	1.7	2.7	3.4	4.3	6.2
Peak Outflow Q (cfs) =	0.011	0.129	0.0	0.0	0.3	1.3	1.3	1.43	3.6
Ratio Peak Outflow to Predevelopment Q =	N/A	N/A	N/A	0.1	0.8	1.0	0.8	0.6	1.0
Structure Controlling Flow =	Plate	Overflow Weir 1	Plate	Plate	Overflow Weir 1	Outlet Plate 1	Outlet Plate 1	Outlet Plate 1	Spillway
Max Velocity through Gate 1 (fps) =	N/A	0.01	N/A	N/A	0.0	0.2	0.2	0.2	0.2
Max Velocity through Gate 2 (fps) =	N/A	N/A	N/A	N/A	N/A	N/A	N/A	N/A	N/A
Time to Drain 97% of Inflow Volume (hours) =	44	69	59	69	67	63	60	57	50
Time to Drain 99% of Inflow Volume (hours) =	45	74	62	74	73	72	70	69	66
Maximum Ponding Depth (ft) =	1.43	2.71	2.12	2.66	2.75	2.99	3.34	3.89	4.33
Area at Maximum Ponding Depth (acres) =	0.03	0.04	0.03	0.04	0.04	0.04	0.05	0.06	0.06
Maximum Volume Stored (acre-ft) =	0.021	0.063	0.042	0.061	0.065	0.075	0.091	0.120	0.146

# DETENTION BASIN OUTLET STRUCTURE DESIGN

*MHFD-Detention, Version 4.00 (December 2019)*

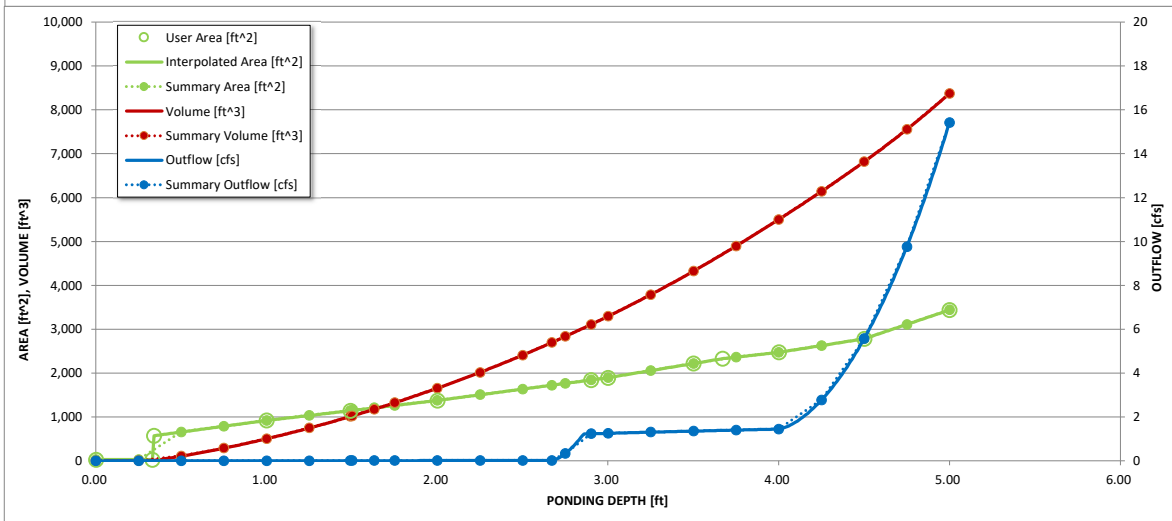
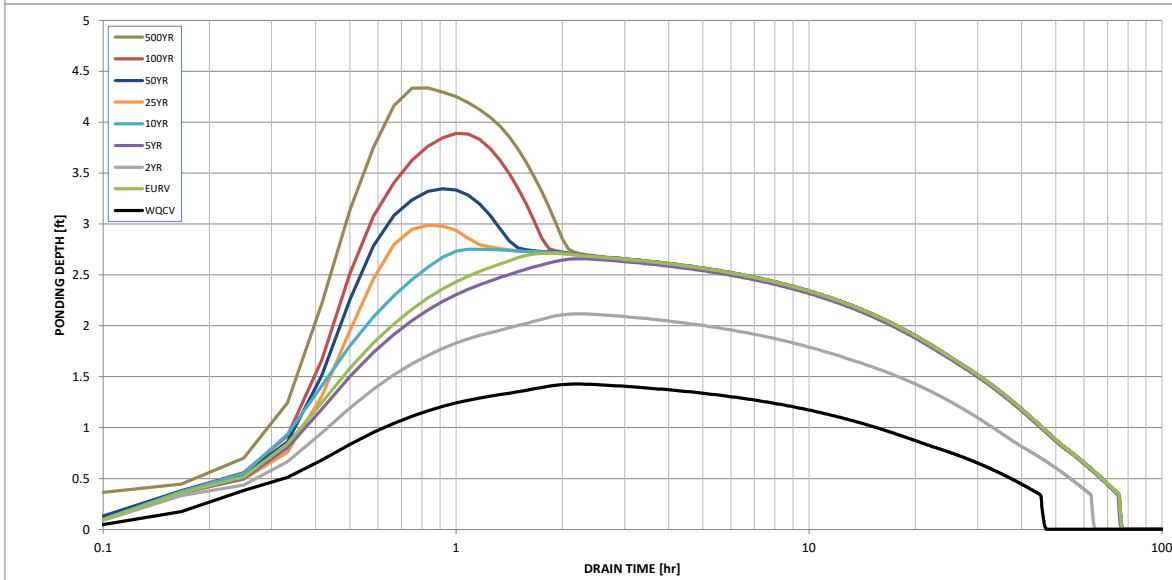
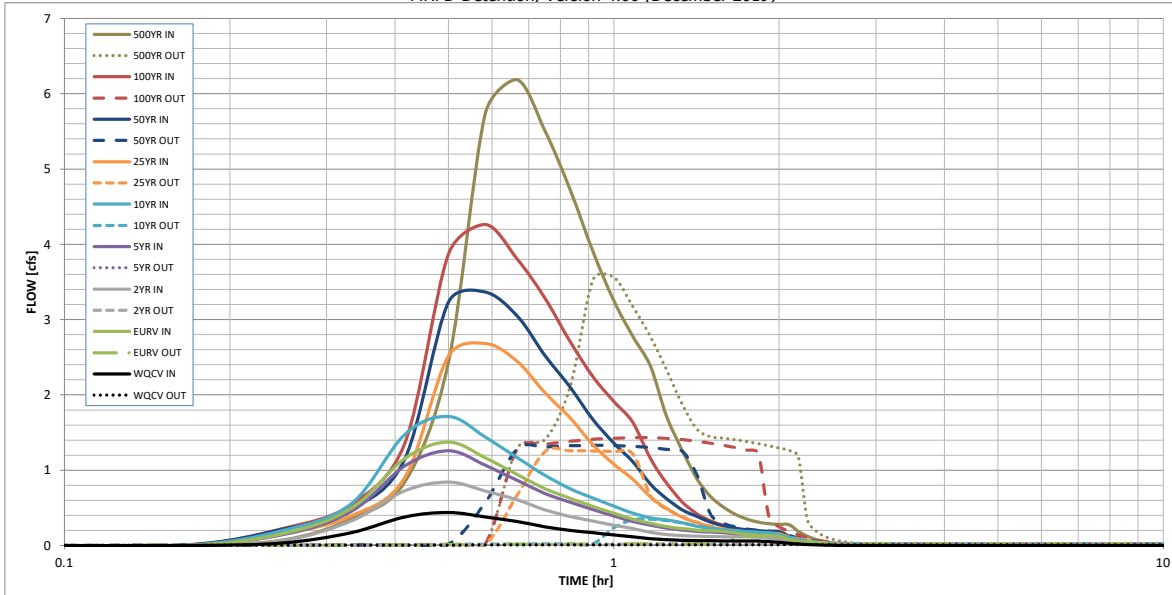

S-A-V-D Chart Axis Override	X-axis	Left Y-Axis	Right Y-Axis
minimum bound			
maximum bound			







# *Appendix F – Drainage Map*

LEGEND

---	EX PROPERTY LINE	---	EX CONTOURS-MAJOR	☀	EX LIGHT POLE	---	PP SANITARY SEWER LINE ALIGNMENT	⊙	PP VEHICLE TRACKING PAD	→	EXISTING FLOW DIRECTION
- - -	EX RIGHT-OF-WAY	---	EX CONTOURS-MINOR	⚡	EX UTILITY POLE	---	PP WATER LINE ALIGNMENT	⊙	PP EROSION CONTROL BALES	→	PROPOSED FLOW DIRECTION
- x -	EX FENCE	⊗	EX FIRE HYDRANT	⚡	EX OVERHANGING LIGHT POLE	---	PP WATER METER & SERVICE	⊙	PP EROSION CONTROL BLANKET	▨	RIPRAP
- W -	EX WATER LINE	⊗	EX WATER VALVE	⚡	EX SIGN	---	PP CONTOURS-MAJOR	⊙	PP FIRE HYDRANT		
- SS -	EX SANITARY SEWER LINE	⊗	EX SANITARY SEWER MANHOLE	☁	EX VEGETATION (SIZE VARIES)	---	PP CONTOURS-MINOR	⊙	PP WATER LINE FITTING		
- OHE -	EX O.H. ELECTRIC	⊗	EX TELEPHONE MANHOLE			5540	PP FENCE	⊙	PP WATER VALVE		
- UGE -	EX U.G. ELECTRIC LINE	⊗	EX STORM SEWER MANHOLE			---	PP U.G. ELECTRIC LINE	⊙	PP WELL		
- GAS -	EX U.G. GAS LINE	⊗	EX GAS METER			---	PP EROSION CONTROL SILT FENCE	⊙	PP SPOT ELEVATION		
- TEL -	EX U.G. TELEPHONE LINE	⊗				---					
- CTV -	EX U.G. CABLE LINE	⊗				---					

**JDS-HYDRO CONSULTANTS, INC.**  
 5540 TECH CENTER DR., SUITE 100  
 COLORADO SPRINGS, COLORADO 80919  
 (719) 227-0072

UNLESS THE CONTRACTOR SHALL VERIFY ALL DIMENSIONS, ANY ERRORS OR OMISSIONS SHALL BE REPORTED TO JDS-HYDRO CONSULTANTS, INC. JDS-HYDRO ASSUMES NO LIABILITY FOR UNAUTHORIZED CHANGES AND/OR REVISIONS MADE TO PLANS.

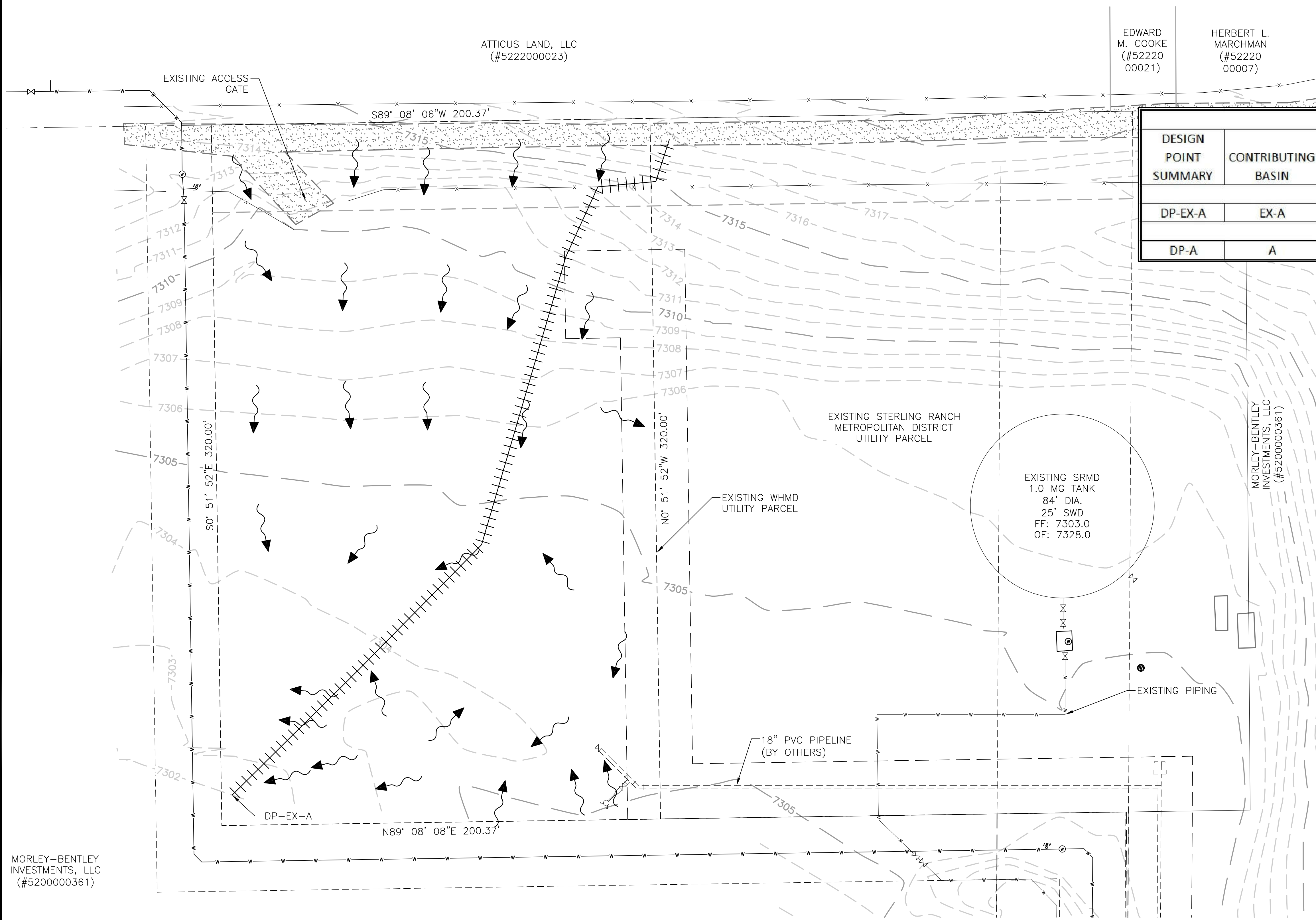

DESIGN POINT SUMMARY						
DESIGN POINT SUMMARY	CONTRIBUTING BASIN	AREA (ACRES)	Tc (MIN)	Q5 (CFS)	Q10 (CFS)	Q100 (CFS)
EXISTING						
DP-EX-A	EX-A	1.47	23.51	0.00	0.22	2.87
PROPOSED						
DP-A	A	1.39	5.15	2.20	3.06	7.68

DESIGN BASIN SUMMARY		
DRAINAGE BASIN	AREA (ACRES)	HYDROLOGIC SOIL GROUP
EX-A	1.47	B
A	1.39	B

\*DETENTION BASIN AREA NOT INCLUDED IN DRAINAGE BASIN AREA.

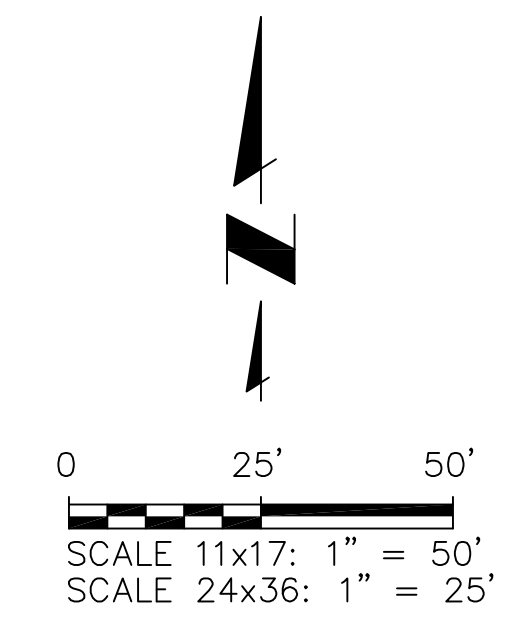

WOODMEN HILLS METROPOLITAN DISTRICT  
 WEST CONCRETE WATER STORAGE TANK  
 SITE DEVELOPMENT PLAN  
 EXISTING SITE DRAINAGE

NO.	DESCRIPTION	BY	APP.	DATE
1				
2				
3				
4				
5				
6				
7				

100% DESIGN FOR REVIEW

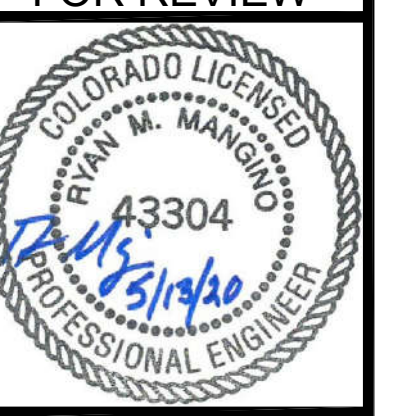

Project No.: 112.115  
 Date: 7/10/20  
 Design: RMM  
 Drawn: RMM  
 Check: JPM

DP1  
 SHEET 1 OF 4

2020/07/14 10:39 AM By: Ryan Mangione J:\JDS-Hydro\Project\_Files\112.115 Woodmen Hills\112.115 West Water Tank\_SDP\Drawings\Working\112.115\_SDP\_Drainage.dwg

MORLEY-BENTLEY INVESTMENTS, LLC  
 (#5200000361)

PCD File No. PPR-20-017



LEGEND

	EX PROPERTY LINE		EX CONTOURS-MAJOR		EX LIGHT POLE		PP SANITARY SEWER LINE ALIGNMENT		PP VEHICLE TRACKING PAD		EXISTING FLOW DIRECTION
	EX RIGHT-OF-WAY		EX CONTOURS-MINOR		EX UTILITY POLE		PP WATER LINE ALIGNMENT		PP EROSION CONTROL BALES		PROPOSED FLOW DIRECTION
	EX FENCE		EX FIRE HYDRANT		EX OVERHANGING LIGHT POLE		PP WATER METER & SERVICE		PP EROSION CONTROL BLANKET		RIPRAP
	EX WATER LINE		EX WATER VALVE		EX SIGN		PP CONTOURS-MAJOR		PP FIRE HYDRANT		
	EX SANITARY SEWER LINE		EX WATER MANHOLE		EX VEGETATION (SIZE VARIES)		PP CONTOURS-MINOR		PP WATER LINE FITTING		
	EX O.H. ELECTRIC		EX SANITARY SEWER MANHOLE				PP FENCE		PP WATER VALVE		
	EX U.G. ELECTRIC LINE		EX TELEPHONE MANHOLE				PP U.G. ELECTRIC LINE		PP WELL		
	EX U.G. GAS LINE		EX STORM SEWER MANHOLE				PP EROSION CONTROL SILT FENCE		PP SPOT ELEVATION		
	EX U.G. TELEPHONE LINE		EX GAS METER								
	EX U.G. CABLE LINE										

**JDS-HYDRO CONSULTANTS, INC.**  
 5540 TECH CENTER DR., SUITE 100  
 COLORADO SPRINGS, COLORADO 80919  
 (719) 227-0072

UNLESS THE CONTRACTOR SHALL VERIFY ALL DIMENSIONS, ANY ERRORS, OMISSIONS, OR DISCREPANCIES SHALL BE REPORTED TO JDS-HYDRO CONSULTANTS, INC. JDS-HYDRO ASSUMES NO LIABILITY FOR UNAUTHORIZED CHANGES AND/OR REVISIONS MADE TO PLANS.

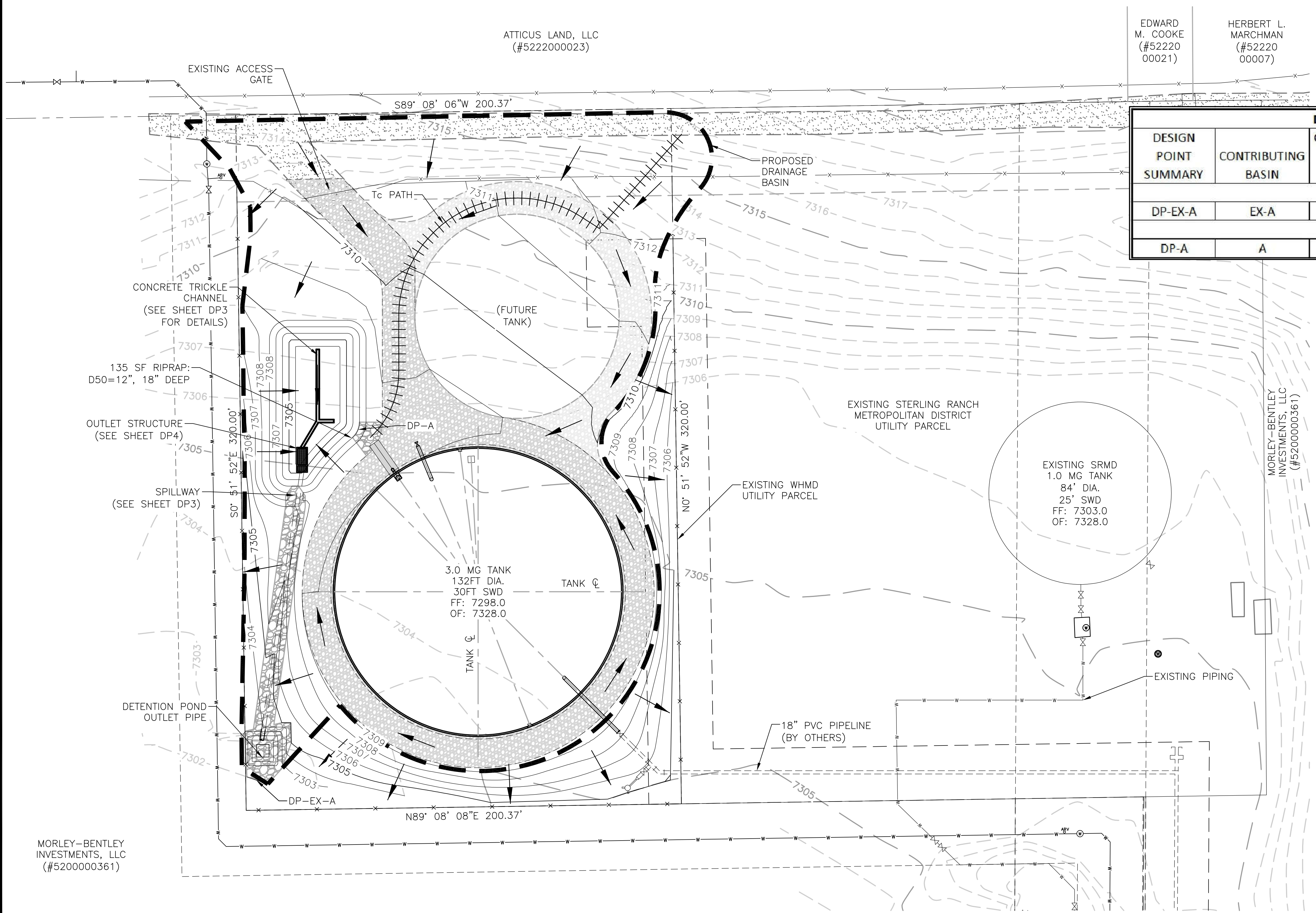

DESIGN POINT SUMMARY						
DESIGN POINT SUMMARY	CONTRIBUTING BASIN	CONTRIBUTING AREA (ACRES)	Tc (MIN)	Q5 (CFS)	Q10 (CFS)	Q100 (CFS)
EXISTING						
DP-EX-A	EX-A	1.47	23.51	0.00	0.22	2.87
PROPOSED						
DP-A	A	1.39	5.15	2.20	3.06	7.68

DESIGN BASIN SUMMARY		
DRAINAGE BASIN	AREA (ACRES)	HYDROLOGIC SOIL GROUP
EX-A	1.47	B
A	1.39	B

\*DETENTION BASIN AREA NOT INCLUDED IN DRAINAGE BASIN AREA.

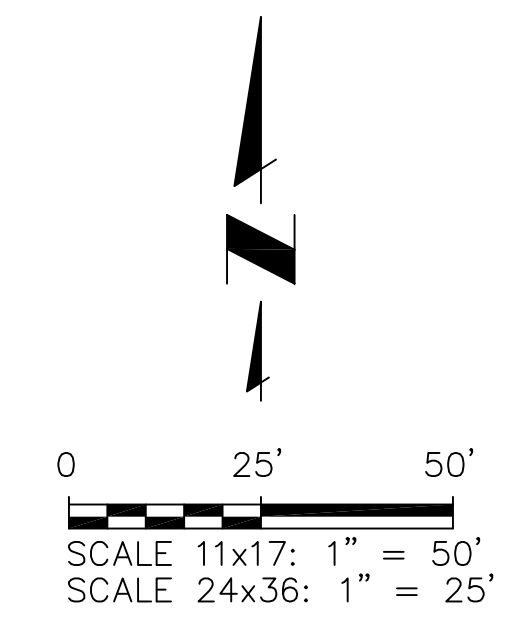

WOODMEN HILLS METROPOLITAN DISTRICT  
 WEST CONCRETE WATER STORAGE TANK  
 SITE DEVELOPMENT PLAN  
 OVERALL DRAINAGE PLAN

NO.	DESCRIPTION	BY	APP.	DATE
1				
2				
3				
4				
5				
6				
7				

100% DESIGN FOR REVIEW

Project No.: 112.115  
 Date: 7/10/20  
 Design: RMM  
 Drawn: RMM  
 Check: JPM

DP2  
 SHEET 2 OF 4

PCD File No. PPR-20-017

2020/07/14 10:39 AM By: Ryan Mangino J:\JDS-Hydro\Project\_Files\112.115 Woodmen Hills\112.115 West Water Tank\_SDP\Drawings\Working\112.115\_SDP\_Drainage.dwg

MORLEY-BENTLEY INVESTMENTS, LLC (#5200000361)



2020/07/14 10:39 AM By: Ryan Mangino J:\JDS-Hydro\Project\_Files\112.115 Woodmen Hills\112.115 West Water Tank\_SDP\Drawings\Working\112.115\_SDP\_Drainage.dwg

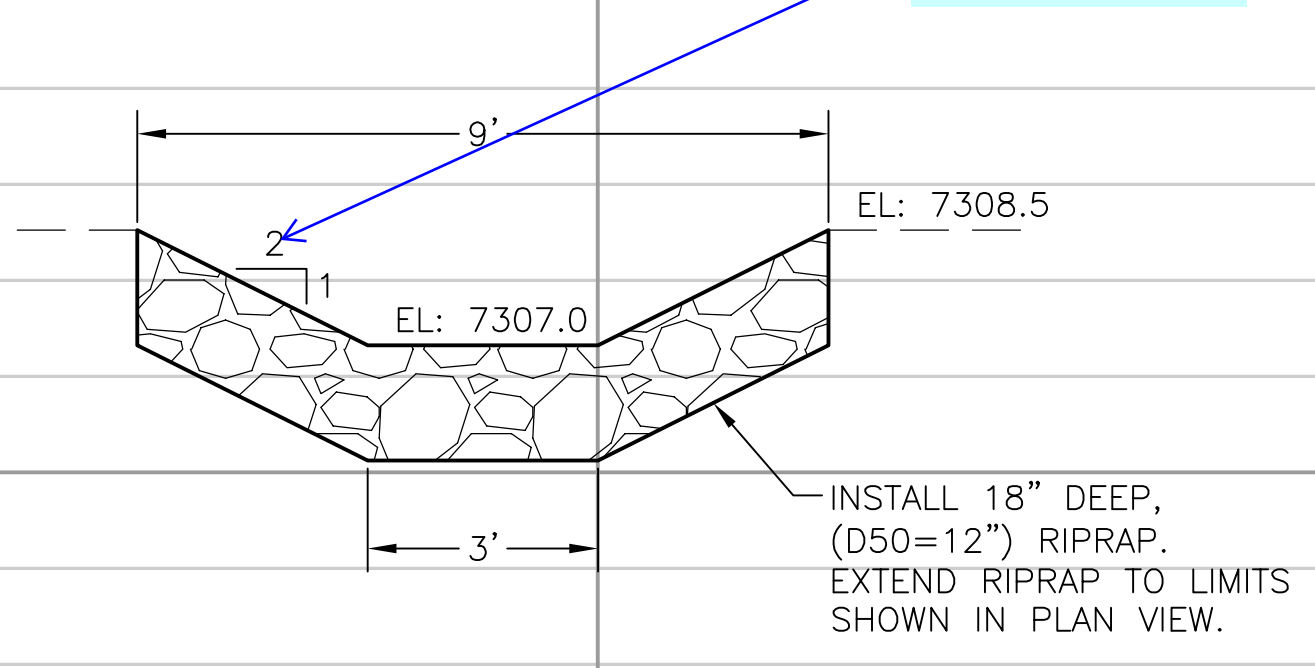
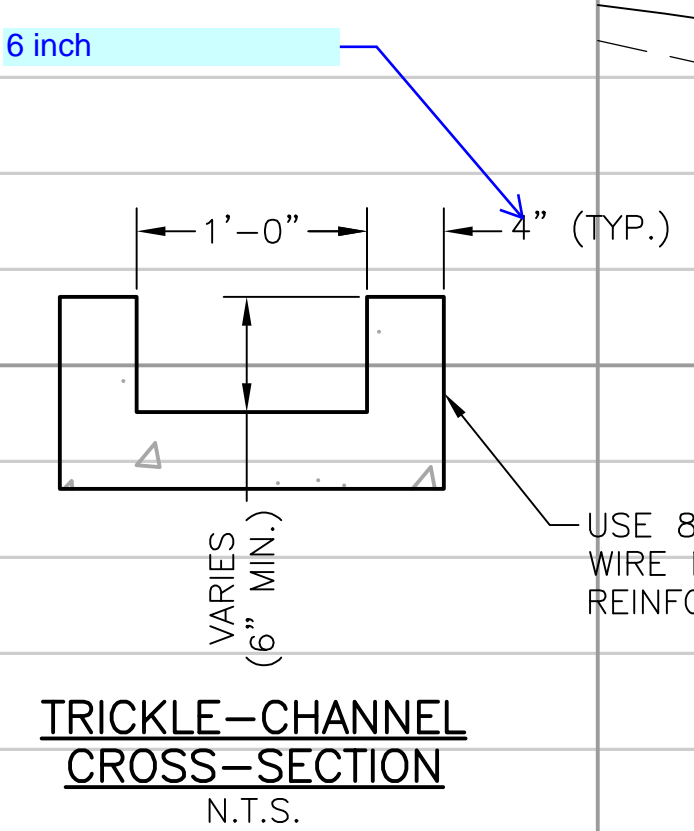
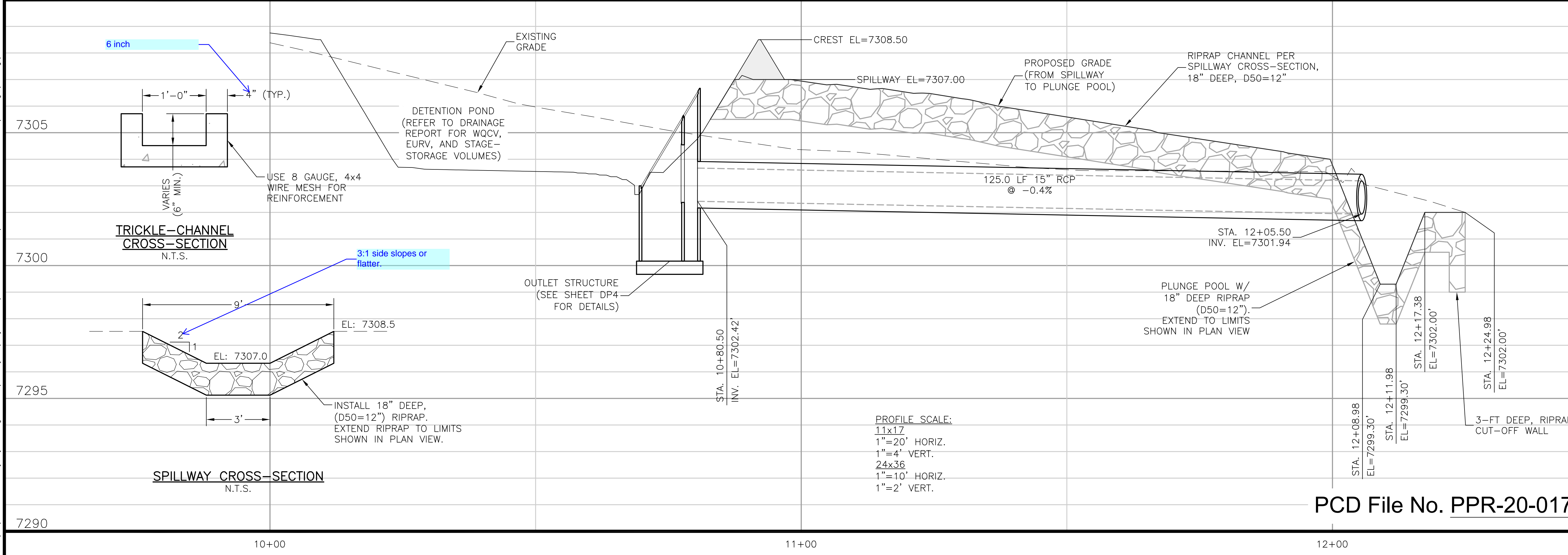
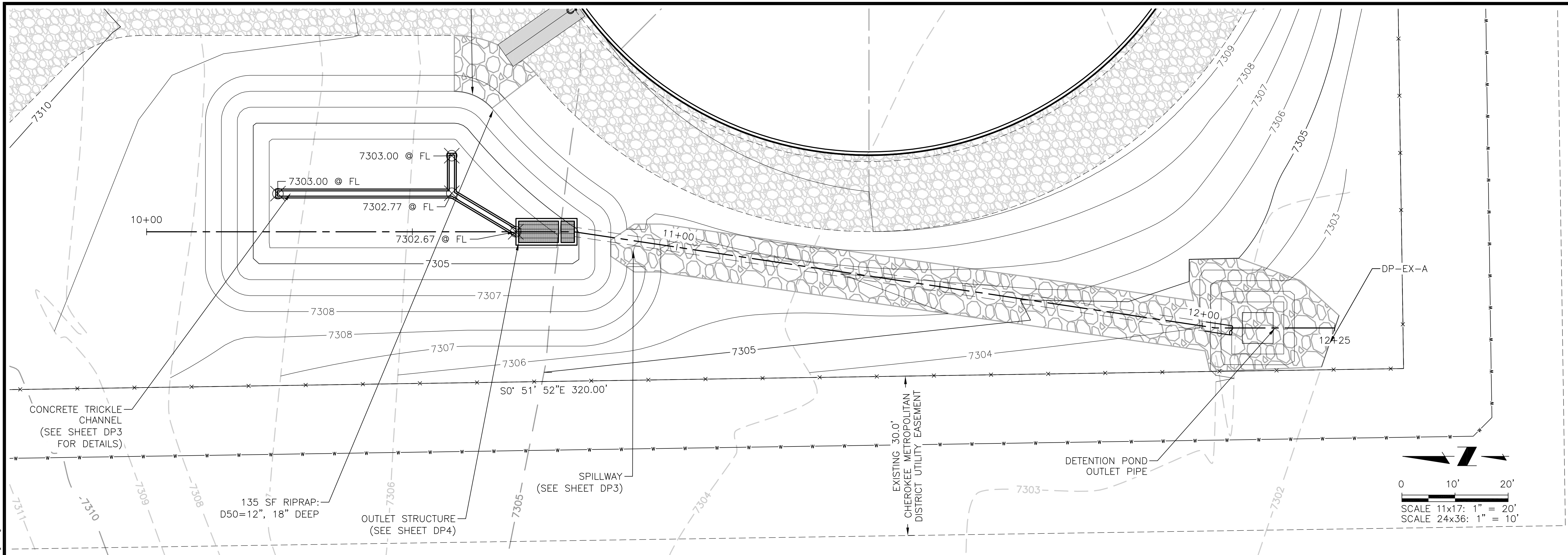

PROFILE SCALE:  
11x17  
1"=20' HORIZ.  
1"=4' VERT.  
24x36  
1"=10' HORIZ.  
1"=2' VERT.

PCD File No. PPR-20-017

**JDS-HYDRO CONSULTANTS, INC.**  
5540 TECH CENTER DR., SUITE 100  
COLORADO SPRINGS, COLORADO 80919  
(719) 227-0072

UNLESS THE CONTRACTOR SHALL VERIFY ALL DIMENSIONS, ANY ERRORS OR OMISSIONS SHALL BE REPORTED TO JDS-HYDRO CONSULTANTS, INC. JDS-HYDRO ASSUMES NO LIABILITY FOR UNAUTHORIZED CHANGES AND/OR REVISIONS MADE TO PLANS.

**WOODMEN HILLS METROPOLITAN DISTRICT**  
WEST CONCRETE WATER STORAGE TANK  
SITE DEVELOPMENT PLAN  
DETENTION POND OUTLET PLAN & PROFILE

NO.	DESCRIPTION	BY	APP.	DATE
1				
2				
3				
4				
5				
6				
7				

100% DESIGN FOR REVIEW

Project No.: 112.115  
Date: 7/10/20  
Design: RMM  
Drawn: RMM  
Check: JPM

**DP3**  
SHEET 3 OF 4



2020/07/14 10:39 AM By: Ryan Mangino J:\JDS-Hydro\Project\_Files\112\_Woodmen\_Hills\112.115\_West\_Water\_Tank\_SDP\Drawings\Working\112115\_SDP\_Drainage.dwg

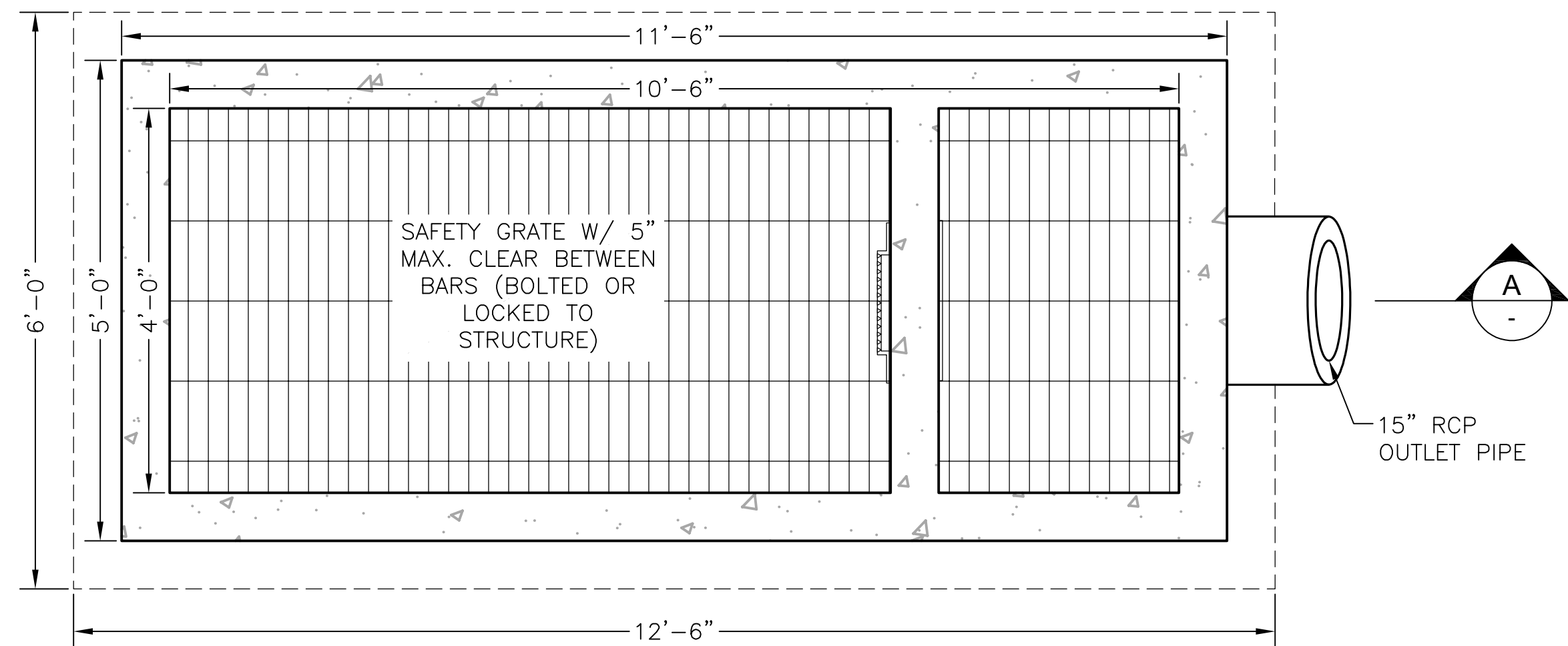

**OUTLET STRUCTURE - TOP VIEW**  
 11x17 SCALE: 3/8"=1'-0"  
 24x36 SCALE: 3/4"=1'-0"

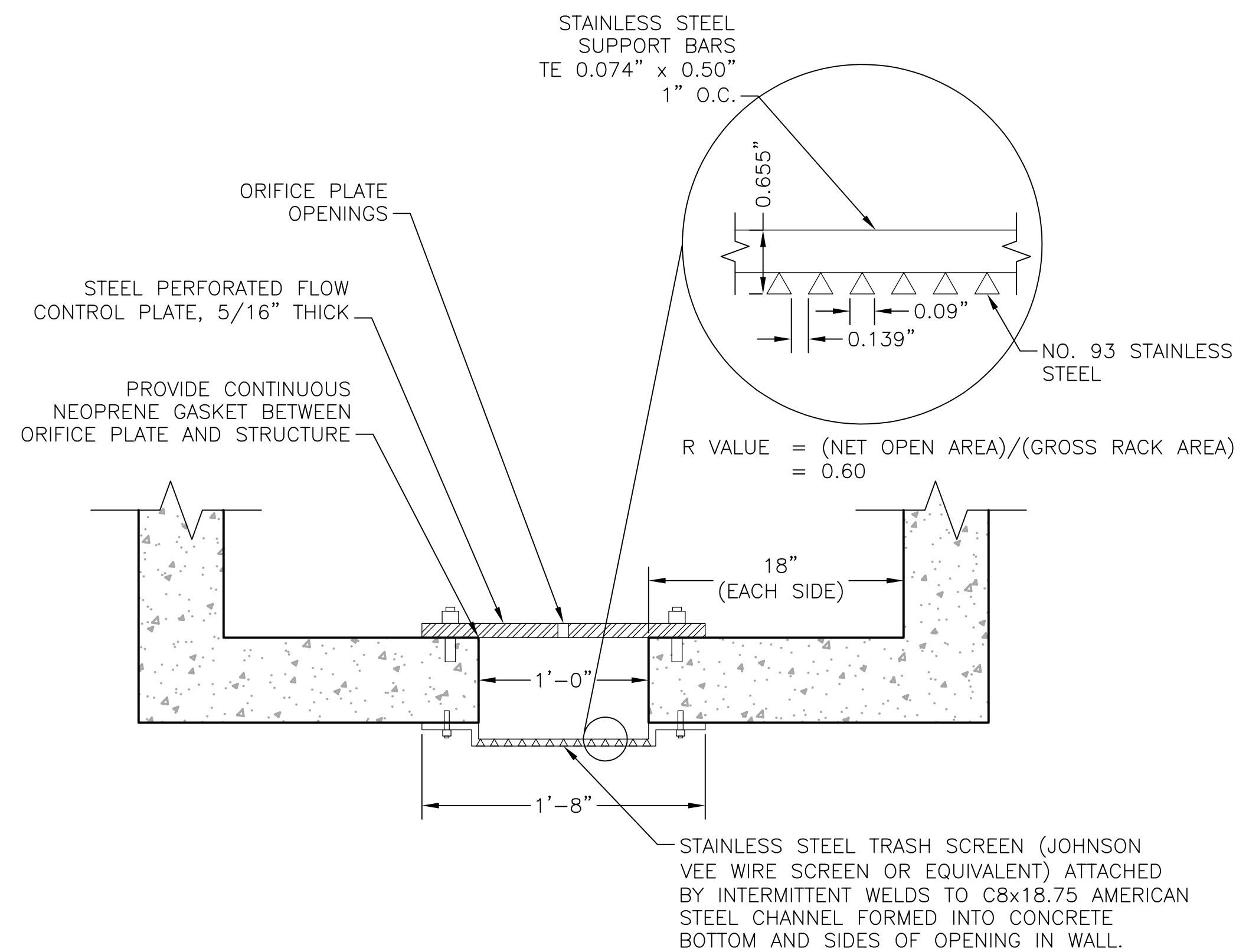

**TRASH SCREEN & ORIFICE PLATE PLAN VIEW**  
 N.T.S.

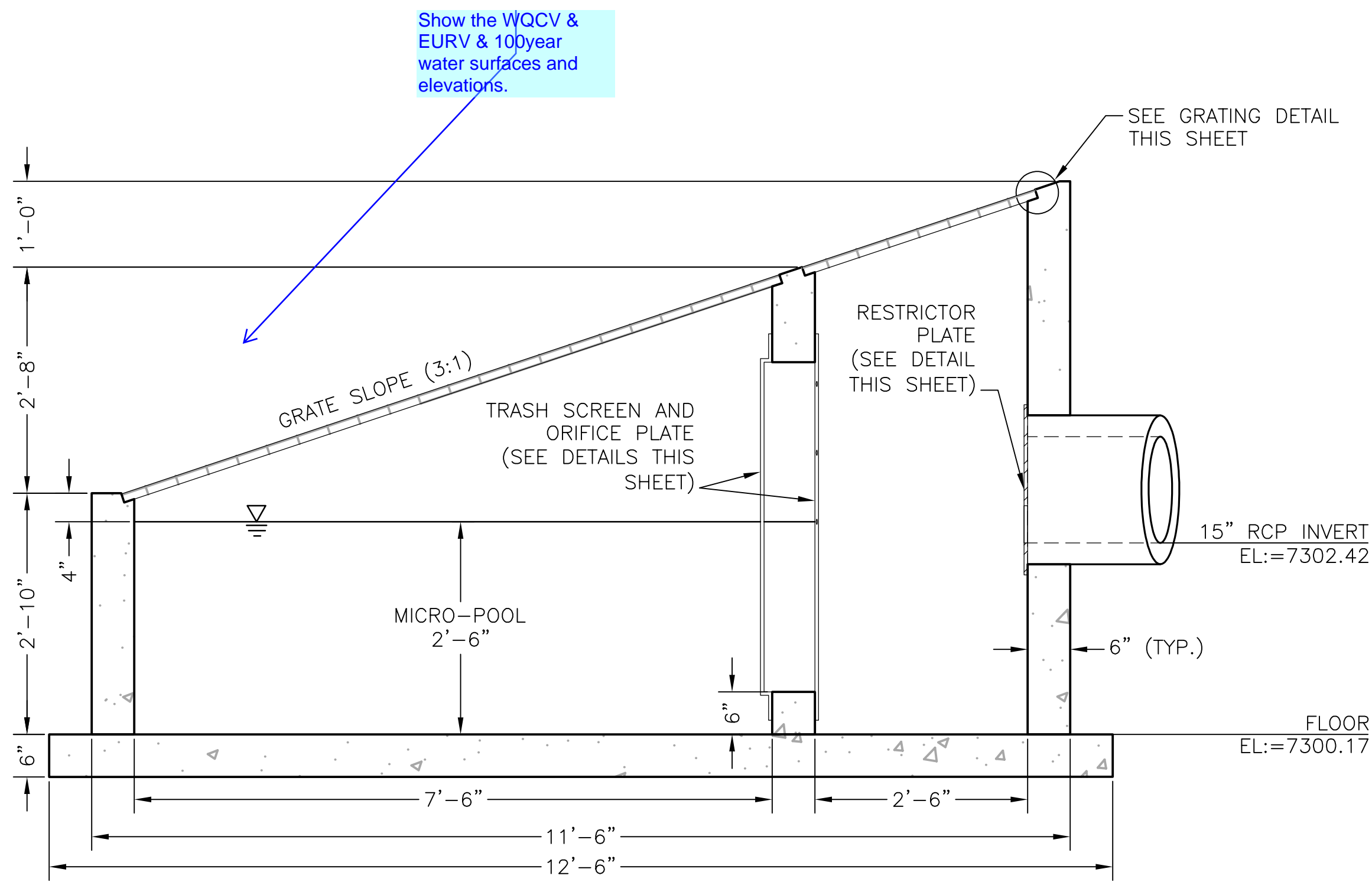

**OUTLET STRUCTURE - SECTION A**  
 11x17 SCALE: 3/8"=1'-0"  
 24x36 SCALE: 3/4"=1'-0"

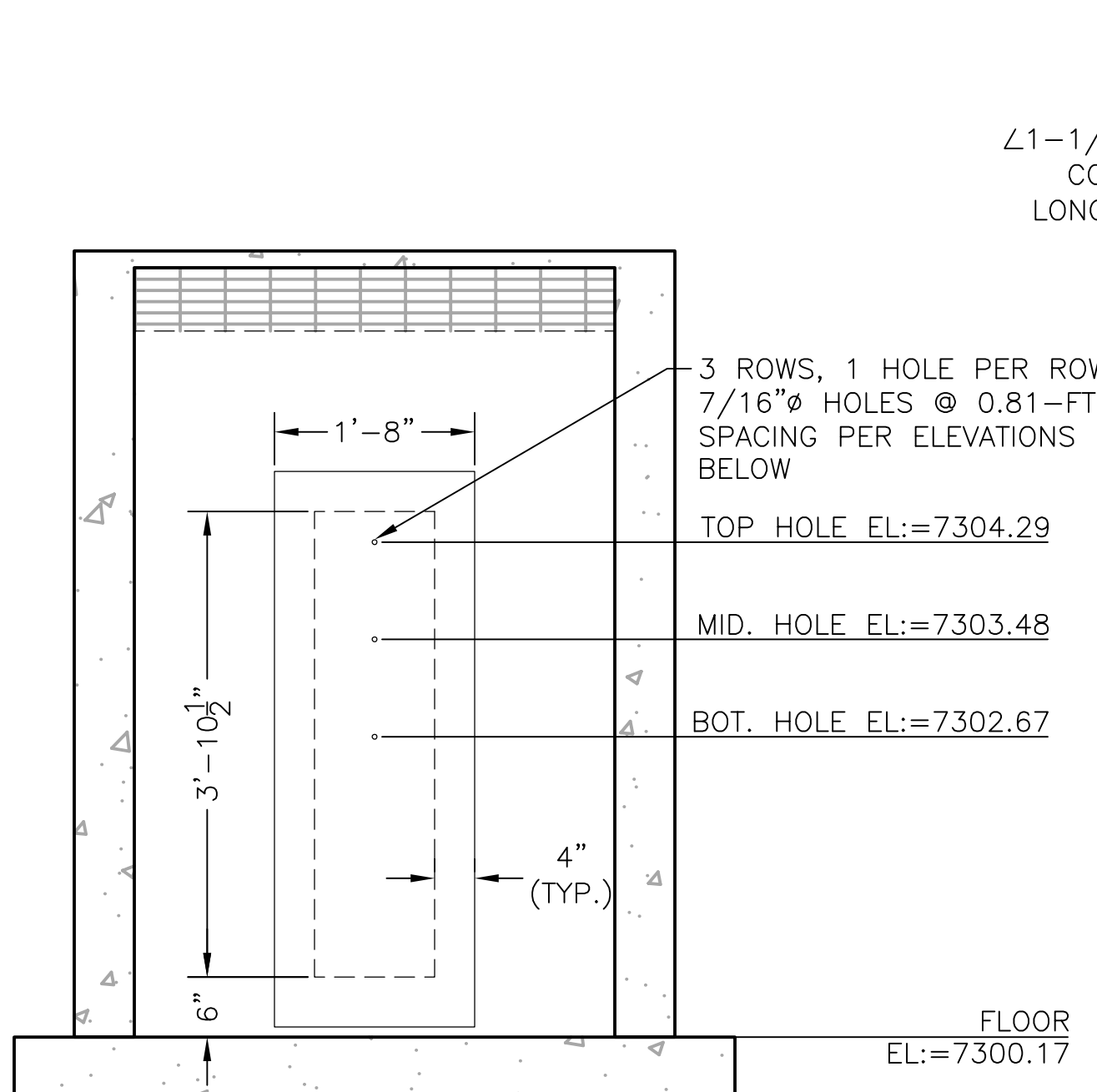

**OUTLET STRUCTURE - SECTION B**  
 11x17 SCALE: 3/8"=1'-0"  
 24x36 SCALE: 3/4"=1'-0"

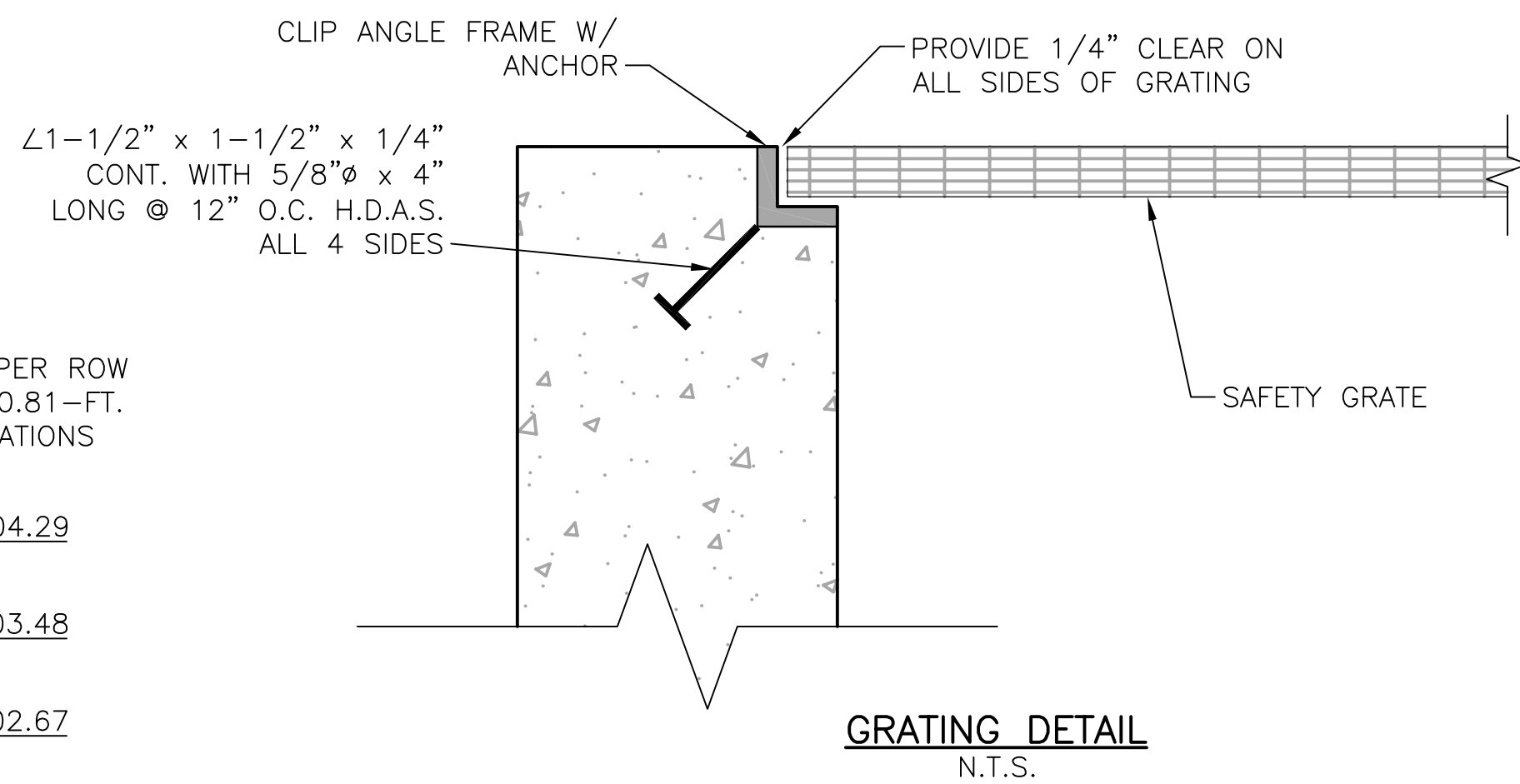

**GRATING DETAIL**  
 N.T.S.

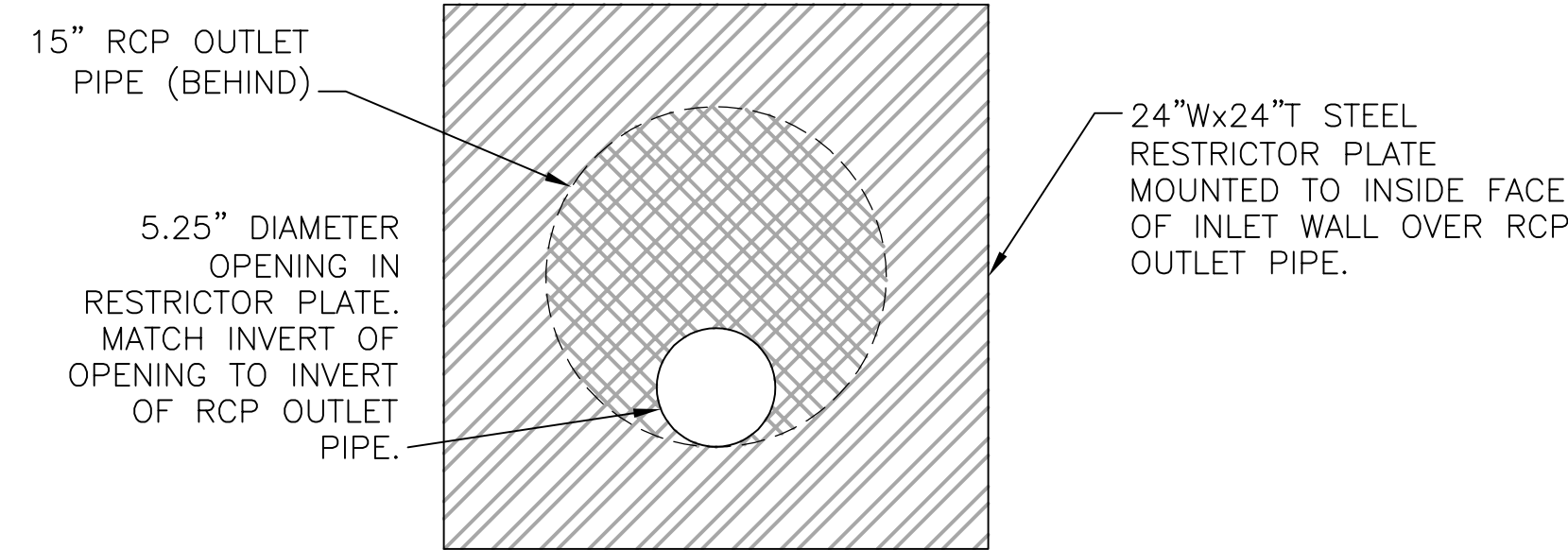

**RESTRICTOR PLATE DETAIL**  
 N.T.S.

**JDS-HYDRO CONSULTANTS, INC.**  
 5540 TECH CENTER DR., SUITE 100  
 COLORADO SPRINGS, COLORADO 80919  
 (719) 227-0072

**WOODMEN HILLS METROPOLITAN DISTRICT**  
 WEST CONCRETE WATER STORAGE TANK  
 SITE DEVELOPMENT PLAN  
 OUTLET STRUCTURE DETAILS

NO.	DESCRIPTION	BY	APP.	DATE
1				
2				
3				
4				
5				
6				
7				

100% DESIGN FOR REVIEW

Project No.: 112.115  
 Date: 7/10/20  
 Design: RMM  
 Drawn: RMM/SKG  
 Check: JPM

**DP4**  
 SHEET 4 OF 4

PCD File No. PPR-20-017