



LSC TRANSPORTATION CONSULTANTS, INC.
2504 East Pikes Peak Avenue, Suite 304
Colorado Springs, CO 80909
(719) 633-2868
FAX (719) 633-5430
E-mail: lsc@lsctrans.com
Website: <http://www.lsctrans.com>

Monument Ridge East
Traffic Impact Study
(LSC #S234450)
March 11, 2024

Add PCD File No. P245

Traffic Engineer's Statement

This traffic report and supporting information were prepared under my responsible charge and they comport with the standard of care. So far as is consistent with the standard of care, said report was prepared in general conformance with the criteria established by the County for traffic reports.

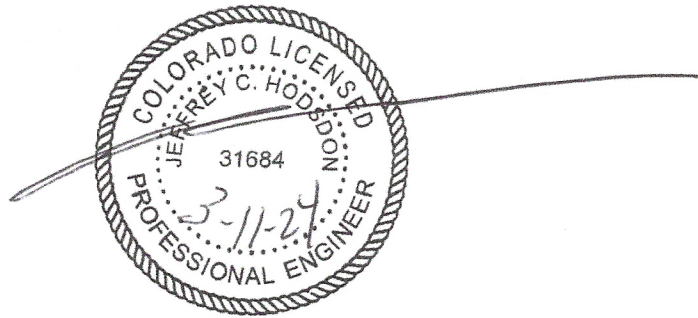

Developer's Statement

I, the Developer, have read and will comply with all commitments made on my behalf within this report.

Maria Larsen

3/12/2024
Date

Monument Ridge East Traffic Impact Study

Prepared for:
Monument Ridge East, LLC
5050 List Drive
Colorado Springs, CO 80919
<via email>

MARCH 11, 2024

LSC Transportation Consultants, Inc.
Prepared by: Jeffrey C. Hodsdon, P.E.

LSC #S234450



CONTENTS

REPORT CONTENTS 1

LIST OF OTHER TRAFFIC REPORTS USED IN THE PREPARATION OF THIS REPORT..... 2

LAND USE AND ACCESS 2

 Proposed Land Uses 2

 Access and Circulation 3

SIGHT DISTANCE..... 3

ROAD AND TRAFFIC CONDITIONS AND MTCP CLASSIFICATION 3

 Existing Traffic Volumes 4

Short Term Baseline Traffic Volumes 5

PEDESTRIAN AND BICYCLE FACILITIES 5

TRIP GENERATION 5

TRIP DISTRIBUTION AND ASSIGNMENT..... 6

 Trip Directional Distribution..... 6

 Site-Generated Traffic..... 6

 Short-Term Total Traffic Volumes 6

 2044 Background Traffic Volumes..... 7

 2044 Total Traffic Volumes 7

LEVEL OF SERVICE ANALYSIS 7

 I-25 Southbound Ramps/County Line Road 8

 Short Term 8

 Long Term 8

 I-25 Northbound Ramps/County Line Road 8

 County Line Road/Misty Acres Boulevard 8

 Short Term 8

 Long Term 8

 Misty Acres Boulevard/Access A 9

 Misty Acres Boulevard/Access B 9

 Misty Acres Boulevard/Access C 9

 Misty Acres Boulevard/Monument Hill Road 9

 Misty Acres Boulevard/Old Antlers Way 9

ROADWAY IMPROVEMENTS	9
Auxiliary Turn-Lane Thresholds and Design Parameters	9
Auxiliary Turn-Lane Needs Analysis.....	10
County Line Road/Misty Acres Boulevard	10
Misty Acres Boulevard/Access C	11
Misty Acres Boulevard/Access A	11
Misty Acres Boulevard/Old Antlers Way/South Site Access	11
Monument Hill Road (Realigned) /Misty Acres Boulevard/Site Access (New proposed Intersection).....	11
Monument Hill Road/Access B	12
Monument Hill Road/Misty Acres Boulevard (South/Existing Intersection).....	12
Intersection Configuration and Traffic Control.....	12
Roundabout Intersection	12
Conventional Intersection	13
Other Recommendations	14
ROADWAY CLASSIFICATIONS	14
COUNTY ROAD IMPROVEMENT FEE PROGRAM	15
Transportation Impact Fees	15
Reimbursable Improvements.....	15
MULTI-MODAL TRANSPORTATION AND TDM OPPORTUNITIES	15
CDOT ACCESS PERMITting.....	15
DEVIATIONS, Design waivers, and ldc waivers	16
Deviations to EPC ECM Criteria	16
CDOT Design Waivers.....	16
EPC Land Development Code (LDC) Waivers.....	16
Potential escrow for future intersection signalization	16
FINDINGS AND CONCLUSIONS	17
Enclosures:.....	17
Table 2	
Figure 1 - Figure 13	
Traffic Count Reports	
Synchro LOS Reports	



LSC TRANSPORTATION CONSULTANTS, INC.
2504 E. Pikes Peak Ave., Suite 304
Colorado Springs, CO 80909
(719) 633-2868
FAX (719) 633-5430
E-mail: lsc@lsctrans.com
Website: <http://www.lsctrans.com>

March 11, 2024

Monument Ridge East, LLC
5050 List Drive
Colorado Springs, CO 80919
<via email>

RE: Monument Ridge East
El Paso County, CO
Traffic Impact Study
LSC #S234450

Dear Mr. Whitehead,

LSC Transportation Consultants, Inc. has prepared this Traffic Impact Study for the proposed Monument Ridge East residential development in El Paso County, Colorado. The site is located south of County Line Road and east of Monument Hill Road (Interstate 25 frontage road) Approximately 342 total dwelling units are planned for the site, including single-family and multi-family housing types.

This report has been prepared for submittal to El Paso County.

REPORT CONTENTS

The preparation of this report included the following:

- An inventory of existing roadway and traffic conditions on major thoroughfares adjacent to the site, including surface conditions, functional classification, widths, pavement markings, traffic-control signs, posted speed limits, intersection and access spacing, roadway and intersection alignments, roadway grades, and auxiliary turn lanes;
- Review of prior traffic reports and applicable data, estimates, and /or other report elements in the vicinity of the site;
- Analysis of intersection and stopping sight distance at the proposed site-access points;
- Weekday peak-hour turning-movement traffic counts at the following study-area intersections:
 - I-25 southbound ramps/County Line Road
 - I-25 northbound ramps/County Line Road
 - County Line Road/Monument Hill Road
 - Monument Hill Road/Misty Acres Boulevard (north)
 - Monument Hill Road/Misty Acres Boulevard (south)
 - Misty Acres Boulevard/Old Antlers Way

- Estimated average daily traffic (ADT) volumes adjacent to the proposed development on the following roadway segments: County Line Road, Monument Hill Road, Misty Acres Boulevard, and Old Antlers Way.
- Projections of 20-year background traffic volumes on the following roadways adjacent to the site: County Line Road, Monument Hill Road, Misty Acres Boulevard, Old Antlers Way;
- The proposed site land use and access plan;
- Estimates of average weekday and weekday peak-hour trip generation for the proposed development and the estimated directional distribution of site-generated vehicle trips on roadways and intersections adjacent to and in the vicinity of the site;
- Projected site-generated and resulting total peak-hour intersection traffic volumes at the following study-area intersections:
 - I-25 southbound ramps/County Line Road
 - I-25 northbound ramps/County Line Road
 - County Line Road/Monument Hill Road (future Misty Acres Boulevard)
 - Monument Hill Road/Misty Acres Boulevard (north)
 - Monument Hill Road/Misty Acres Boulevard (south)
 - Misty Acres Boulevard/Old Antlers Way
- Intersection level of service (LOS) analysis at the study-area intersections;
- Evaluation of short- and long-term projected intersection volumes to determine potential requirements for any auxiliary right-/left-turn lanes at the proposed site access points, based on the criteria in El Paso County's Engineering Criteria Manual (ECM). Also included are potential long-term lane requirements;
- Pedestrian facilities; and
- Findings and recommendations for submittal to El Paso County.

LIST OF OTHER TRAFFIC REPORTS USED IN THE PREPARATION OF THIS REPORT

The following traffic report was completed for this site within the past five years and has been used for reference and background information:

- Monument Ridge Development – by WSB, June 5, 2022

Please include PCD
No. ANX236.

LAND USE AND ACCESS

Proposed Land Uses

Figure 1 shows the site location relative to the adjacent and nearby roadways. The proposed Monument Ridge East residential development site is located south of County Line Road and east of Monument Hill Road (Interstate 25 frontage road).

Approximately 342 total dwelling units are planned for the site, including 36 single-family lots on the east side of the planned extension of Misty Acres Boulevard and duplex, tri-plex, and four-plex dwelling units on the west side of the planned extension of Misty Acres Boulevard. Figure 2 shows the site plan.

Access and Circulation

Figure 2 also shows the proposed roadways, roadway realignments, and access points.

Figure 3 highlights the details of the proposed extension of Misty Acres Boulevard north to County Line Road, the realignment of the north portion of Monument Hill Road to the south to tie into the proposed extension of Misty Acres Boulevard, and the segments of existing roadway to be removed.

Access points are proposed at the following locations.

- Access C – 383 feet south of the future County Line Road/Misty Acres Boulevard intersection.
- Access A – 720 feet south of the future County Line Road/Misty Acres Boulevard intersection.
- Access B – 280 feet west of the future Misty Acres Boulevard/Monument Hill Road intersection.
- New west leg at the existing Misty Acres Boulevard/Old Antlers Way T-intersection

SIGHT DISTANCE



FYI: Sight distance and stopping sight distance that are applicable to the studied intersections will required when the site is subdivided.

Intersection sight distance at all proposed public road/site-access intersection locations on Misty Acres Boulevard and Monument Hill Road must meet intersection sight-distance requirements in *ECM* Table 2-21. Sight distance lines of sight for all public road intersections/access points will need to be kept clear of any sight-distance obstructions, including landscaping, signage, structures, fencing, parking areas, etc.

ROAD AND TRAFFIC CONDITIONS AND MTCP CLASSIFICATION

Figure 1 shows the roads adjacent to and in the vicinity of the site. Adjacent roads serving the site are identified below followed by a brief description of each:

Interstate Highway 25 (I-25) runs north-to-south throughout the entire state of Colorado and is classified as a four-lane F-W – Interstate System, Freeway. The nearest on/off ramps are located approximately 700 to 1,100 feet west of the site at mile marker 163. Adjacent to the site, the posted speed limit on I-25 is 75 miles per hour (mph). Auxiliary left-turn lanes exist on both the eastbound and westbound approaches at the I-25 on-ramps on County Line Road.

County Line Road is classified by El Paso County as a two-lane, Rural Minor Arterial and extends east and west from Interstate 25. The posted speed limit on County Line Road is generally 45 mph, but it decreases to 30 mph near the I-25 interchange between Beacon Lite Road and Doewood Drive. No auxiliary turn lanes currently exist at its intersection with Monument Hill Road.

It appears that Monument Hill Road classified as a rural major collector. Please revise.

Monument Hill Road (I-25 Frontage Road) is a two-lane paved Frontage Road that extends north from Woodmoor Drive to County Line Road. The posted speed limit on Monument Hill Road in the vicinity of the site is 45 mph. No auxiliary turn lanes currently exist at its intersection with County Line Road. The current alignment of the north portion of Monument Hill Road will be shifted to the south as part of this development (please refer to Figure 3).

Misty Acres Boulevard is a two-lane Major Collector that extends north from Monument Hill Road to about 800 feet north of Old Antlers Way. At this point, a temporary road extends west to Monument Hill Road. Misty Acres Boulevard is planned to be extended north to County Line Road and a new intersection would be created basically at the location of the existing Monument Hill Road/County Line Road intersection. The existing Misty Acres Boulevard is one through lane in each direction plus a raised center median. The proposed extension would be constructed as a two-lane, Urban Major Collector with a center left turn median (Non-Residential Collector cross section).

Existing Traffic Volumes

Vehicular turning-movement counts were conducted for the following dates and times at the following intersections, as shown in Figure 4. Raw count data is attached:

- I-25 southbound ramps/County Line Road
 - Thursday, January 18, 2024 from 6:30 – 8:30 a.m.
 - Wednesday, January 17, 2024 from 4:00 – 6:00 p.m.
- I-25 southbound ramps/County Line Road
 - Thursday, January 18, 2024 from 6:30 – 8:30 a.m.
 - Wednesday, January 17, 2024 from 4:00 – 6:00 p.m.
- County Line Road/Monument Hill Road
 - Wednesday, January 10, 2024 from 6:30 – 8:30 a.m.
 - Tuesday, January 9, 2024 from 4:00 – 6:00 p.m.
- Monument Hill Road/Misty Acres Boulevard (north)
 - Tuesday, December 12, 2023 from 6:30 – 8:30 a.m.
 - Tuesday, December 12, 2023 from 3:45 – 5:45 p.m.
- Monument Hill Road/Misty Acres Boulevard (south)
 - Wednesday, January 10, 2024 from 6:30 – 8:30 a.m.
 - Tuesday, January 9, 2024 from 4:00 – 6:00 p.m.
- Misty Acres Boulevard/Old Antlers Way (from the WSB TIS report)
 - Wednesday, April 27, 2022 from 6:30 – 8:30 a.m.
 - Wednesday, April 27, 2022 from 4:00 – 6:00 p.m.

SHORT TERM BASELINE TRAFFIC VOLUMES

Please include the
year of projection for
the short range.

Figure 5 shows the estimated short-term baseline volumes. These volumes account for projected shifts in **existing** traffic volumes following the extension of Misty Acres Boulevard to the north, realignment of Monument Hill Road, and associated closure of some segments of roadway (as depicted in Figure 3). No additional background traffic growth was applied when estimating these volumes. The intent was to show shift/adjustment to existing traffic volumes assuming the roadway changes.

PEDESTRIAN AND BICYCLE FACILITIES

The proposed extension of Misty Acres through the site is proposed as an Urban Non-Residential Collector cross section. This standard cross section to be constructed will include sidewalks and paved outside shoulders, which will accommodate bicycles.

The existing west side of Misty Acres Boulevard on the south end near the high school is striped for an outside paved shoulder, but along most of the roadway, there is no shoulder striping. The roadway has sufficient width to accommodate bicycles. Monument Hill Road and County Line Road do not currently have paved outside shoulders.

TRIP GENERATION

Estimates of the vehicle trips projected to be generated by the proposed Monument Ridge East residential development have been made using the nationally published trip-generation rates from *Trip Generation, 11th Edition, 2021* by the Institute of Transportation Engineers (ITE). Corresponding trip-generation rates from the following ITE Land Use categories have been used to develop trip-generation estimates for the proposed 342 dwelling units:

- “210 – Single-Family (Detached) Housing”
- “215 – Single-Family (Attached) Housing”
- “220 – Multi-Family Housing (Low-Rise)”

did you mean
Conceptual site plan?

Table 1 below presents a summary of the estimated site trip generation. A detailed trip-generation estimate for the site, including ITE rates land uses, is presented Table 2 (attached). The proposed **sketch plan** is attached for reference.

The site plan land uses are projected to generate about 2,525 total vehicle trips on the average weekday during a 24-hour period, with approximately half entering and half exiting the site. During the morning peak hour, approximately 51 entering vehicles and 121 exiting vehicles are estimated to be generated. Approximately 122 entering and 86 exiting vehicles are estimated to be generated by the site during the afternoon peak hour.

Table 1: Summary of Estimated Site Vehicle-Trip Generation

Analysis Period	Trips Generated		
	Entering	Exiting	Total
Morning Peak Hour (veh./hour)	51	121	172
Afternoon Peak Hour (veh./hour)	122	86	208
Daily/24-hour (veh./day)	1,263	1,263	2,525

TRIP DISTRIBUTION AND ASSIGNMENT

Trip Directional Distribution

The directional-distribution estimate of site-generated vehicle trips to the study-area roads and intersections is a necessary component in determining the site’s traffic impacts. Figure 6 shows the percentages of the site-generated vehicle trips projected to be oriented to and from the site’s major approaches. Estimates have been based on the following factors: LCS’s previous traffic impact studies in the vicinity, the proposed new land uses, the area roadway system serving the site, and the site’s geographic location relative to the overall greater El Paso County/Colorado Springs area and the Denver metro area. Figure 6 shows the estimated distribution splits.

Site-Generated Traffic

Site-generated volumes have been calculated by applying the directional-distribution percentages estimated by LSC (from Figure 6) to the trip-generation estimates (from Table 4). Figure 7 shows the projected site-generated traffic volumes for the weekday morning and afternoon peak hours.

Short-Term Total Traffic Volumes

Figure 8 shows the projected short-term total traffic, which is the sum of the short-term baseline (adjusted existing) traffic volumes (from Figure 5) and site-generated traffic volumes (from Figure 7). Laneage and traffic control at the study-area intersections are shown in Figure 8.

Note: as indicated in the “Short-Term Baseline Traffic Volumes” section and as shown in Figure 5, short-term baseline traffic volumes assume that existing traffic patterns would change following the realignment of Monument Hill Boulevard and extension of Misty Acres Boulevard (as depicted in Figure 3).

The TIS by WSB identified the development to the west of I-25 at County Line/Beacon Lite as part of the short term traffic. Please indicate why that development is not considered for the short term background and only in the long term background analysis.

please give your basis for this two percent growth rate

2044 Background Traffic Volumes

Figure 9 shows estimated long-term background volumes. Projected 20-year background traffic volumes do **not** include projected traffic to be generated by the proposed site. Long-term background traffic volumes are estimates by LSC, which assume a two-percent annual growth rate on County Line Road. With site-generated traffic, the total growth rate is about 3.3 percent west of Misty Acres Boulevard and about 2.3 percent east of Misty Acres Boulevard (growth over the short-term baseline/adjusted existing volume).

Traffic generated by planned adjacent and nearby developments, including projected commercial traffic from WSB's traffic study west of I-25, has been included in 2044 background traffic volumes. Additionally, long-term background traffic volumes assume that existing traffic patterns would change following the realignment of Monument Hill Boulevard and extension of Misty Acres Boulevard.

2044 Total Traffic Volumes

Figure 10 shows the sum of 2044 background traffic volumes (from Figure 9) plus site-generated traffic volumes (from Figure 7).

LEVEL OF SERVICE ANALYSIS

Level of service (LOS) is a quantitative measure of the level of congestion or delay at an intersection and is indicated on a scale from "A" to "F." LOS A is indicative of little congestion or delay. LOS F indicates a high level of congestion or delay. Table 3 shows the level of service delay ranges for signalized and unsignalized intersections.

Table 3: Intersection Levels of Service Delay Ranges

Level of Service	Signalized Intersections	Unsignalized Intersections
	Average Control Delay (seconds per vehicle)	Average Control Delay (seconds per vehicle) ¹
A	10.0 sec or less	10.0 sec or less
B	10.1-20.0 sec	10.1-15.0 sec
C	20.1-35.0 sec	15.1-25.0 sec
D	35.1-55.0 sec	25.1-35.0 sec
E	55.1-80.0 sec	35.1-50.0 sec
F	80.1 sec or more	50.1 sec or more

¹ For unsignalized intersections, if V/C ratio is greater than 1.0 the level of service is LOS F, regardless of the projected average control delay per vehicle.

Detailed Synchro reports are attached. A summary of LOS during the weekday morning and evening peak hours for the study-area intersections is shown in the following figures:

- Figure 4: 2024 Existing Traffic, Lane Geometry, Traffic Control, and LOS
- Figure 5: Adjusted Existing Traffic, Lane Geometry, Traffic Control, and LOS
- Figure 8: Short-Term Total Traffic, Lane Geometry, Traffic Control, and LOS
- Figure 9: 2044 Background Traffic, Lane Geometry, Traffic Control, and LOS
- Figure 10: 2044 Background + Site Traffic, Lane Geometry, Traffic Control, and LOS

I-25 Southbound Ramps/County Line Road

Short Term

figure 10 indicates
LOS F

All individual turning movements and approaches are projected to operate at LOS D or better during the short term, with or without the addition of site-generated traffic.

Long Term

The single-lane southbound approach is projected to operate at LOS E or worse during at least one peak hour, with or without the addition of site-generated traffic. This single-lane approach is projected to have a volume-to-capacity (v/c) ratio of 1.03 during the PM peak hour with the addition of site-generated traffic. All other individual turning movements and approaches are projected to operate at LOS D or better during all long-term scenarios. Assuming future all-way, stop-sign traffic control (AWSC) the level of service would improve to acceptable levels for all approaches.

I-25 Northbound Ramps/County Line Road

All individual turning movements and approaches are projected to operate at LOS D or better through the long term, with or without the addition of site-generated traffic.

County Line Road/Misty Acres Boulevard

Short Term

All individual turning movements and approaches are projected to operate at LOS D or better based on the short-term total traffic volumes.

Long Term

The northbound-left turning movement would operate at LOS E or worse during both **long-term** peak hours if the intersection were to remain two-way, stop-sign controlled. This intersection will likely need to be signalized in the future based on the **long-term analysis**. Signalizing this

intersection would result in all individual turning movements operating at LOS D or better during the long-term scenarios.

Misty Acres Boulevard/Access A

All individual turning movements and approaches are projected to operate at LOS B or better through the long term with the addition of site-generated traffic.

Misty Acres Boulevard/Access B

All individual turning movements and approaches are projected to operate at LOS A through the long term with the addition of site-generated traffic.

Misty Acres Boulevard/Access C

All individual turning movements and approaches are projected to operate at LOS B or better through the long term with the addition of site-generated traffic.

Misty Acres Boulevard/Monument Hill Road

LSC has accounted for changes to existing traffic patterns that would likely change following the realignment of Monument Hill Boulevard and extension of Misty Acres Boulevard. All individual turning movements and approaches are projected to operate at LOS B or better through the long term.

Misty Acres Boulevard/Old Antlers Way

All individual turning movements and approaches are projected to operate at LOS B or better through the long term, with or without the addition of site-generated traffic.

ROADWAY IMPROVEMENTS

Auxiliary Turn-Lane Thresholds and Design Parameters

Section 2.3.7.D of the *ECM* lists ingress/egress volume thresholds in which exclusive right- or left-turn lanes would be required, by classification. Prescribed auxiliary turn lanes would be required to meet design criteria outlined in Section 2.3.7.E of the *ECM*.

At the intersection of Misty Acres Boulevard/County Line Road, the **Colorado State Highway Access Code** criteria (Section 4.8) would apply.

Based on the classification, the **design speed** of Misty Acres Boulevard is 40 mph. LSC has based future **posted speed** of 40 mph on County Line Road

Provide reasoning/justification for the future speed as criteria for a minor arterial is 60/55 mph and 30mph is identified above as the existing posted speed, and 45mph is listed beyond to the east.

also indicate the design speed used for the Aux. lane analysis

ge and the I-25 Interchange (i.e., through the Misty Acres Boulevard
in in speed at the Monument Hill Road study-area intersections are noted
fo

please identify if this
is downgrade or
upgrade and indicate
the factor used.

Auxiliary Turn-Lane Needs Analysis

Please refer to Figure 11 and Figure 12 for preliminary recommendations for auxiliary turn lanes
at the study-area intersections.

Please identify the ECM criteria and identify if it has
been met.
Also northbound left turn lane is meeting thresholds
per the volumes provided. Please include.

County Line Road/Misty Acres Boulevard

The following auxiliary turn lanes would be required at the future County Line Road/Misty Acres
Boulevard intersection. The turn lanes on County Line Road are based on County Line Road
grades of between five and seven percent. Please refer to the site plan, which depicts the
following laneage at this intersection. LSC provided the laneage recommendations for inclusion
on the site plan.

- Northbound Right Turn Deceleration Lane
 - 175 feet of full-width lane (including storage) + 80- foot bay taper = 255 feet total
- Westbound-Left Turn Deceleration Lane
 - 176 feet of full-width lane + 50 feet of storage + 162-foot taper = 388 feet total
- Eastbound-Right-Turn Deceleration Lane
 - 140 feet of full-width lane + 75-foot taper = 215 feet total
 - Will require a design waiver from CDOT, as based on SHAC criteria, a 356-foot lane plus 144-foot taper is prescribed for a total of 500 feet. This waiver would be requested due to the challenging topography to the west of the intersection. The plans show a larger corner radius on the southwest corner as mitigation for the shorter lane which would allow for right turns at a higher speed, thus reducing the speed differential between eastbound through traffic and right-turning traffic.

An eastbound-left-turn deceleration lane would not be required based on projected turning
volumes and the threshold requirement for a turn lane. However, in this situation LSC
recommends a short eastbound-left-turn bay for vehicle storage. The space will be available to
stripe this lane between the eastbound and westbound through lanes on the west leg of this
intersection.

- Eastbound-left-Turn-Storage-Bay
 - 75 feet of full-width lane for vehicle storage + 120-foot taper = 195 feet total
 - Not required based on projected volumes but recommended by LSC.

Misty Acres Boulevard/Access C

Based on projected total volumes, auxiliary turn lanes would **not** be required on any approach at the intersection of Monument Hill Road/Access C.

Although the projected left-turn volume does not exceed the *ECM* threshold requiring a northbound-left-turn lane on Misty Acres Boulevard, the proposed major collector cross section of Misty Acres Boulevard includes a striped median for left-turning movements at intersections/access points.

Misty Acres Boulevard/Access A

Based on projected total volumes, auxiliary turn lanes would **not** be **required** on any approach at the intersection of Misty Acres Boulevard/Access A.

Although the projected left-turn volume does not exceed the *ECM* threshold requiring a northbound-left-turn lane on Misty Acres Boulevard, the proposed major collector cross section of Misty Acres Boulevard includes a striped median for left-turning movements at intersections/access points.

Misty Acres Boulevard/Old Antlers Way/South Site Access

Based on projected total volumes, auxiliary turn lanes would **not** be required on any approach at the intersection of Misty Acres Boulevard/Old Antlers Way.

Although the projected left-turn volume does not exceed the *ECM* threshold requiring a northbound-left-turn lane on Misty Acres Boulevard, the proposed major collector cross section of Misty Acres Boulevard includes a striped median for left-turning movements at intersections/access points.

Monument Hill Road (Realigned) /Misty Acres Boulevard/Site Access (New proposed Intersection)

A 315-foot southbound-right-turn lane would be required on Misty Acres Boulevard approaching Monument Hill Road. This 315-foot turn lane would consist of 155 feet of deceleration length plus a 160-foot taper. Based on projected total volumes, other auxiliary turn lanes would **not** be required at the intersection of Misty Acres Boulevard/Monument Hill Road. The width that would otherwise be six-foot paved shoulder in the southbound direction (as part of the overall Misty Acres Boulevard cross section) could be utilized as part of the 12-foot right-turn lane width.

Although the projected left-turn volume does not exceed the *ECM* threshold requiring a northbound-left-turn lane on Misty Acres Boulevard, the proposed major collector cross section

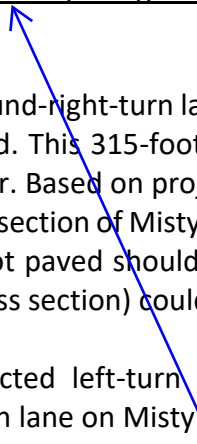

it appears that a eastbound left turn is meeting thresholds also. Please provide recommendations.

of Misty Acres Boulevard includes a striped median for left-turning movements at intersections/access points.

Monument Hill Road/Access B

Based on projected total volumes, auxiliary turn lanes would **not** be required on any approach at the intersection of Monument Hill Road/Access B. Based on the recommended classification of this new segment/new north terminus of Monument Hill Road (Urban Local), the design speed will be 25 mph.

Monument Hill Road/Misty Acres Boulevard (South/Existing Intersection)

No modifications would be required by the applicant at the intersection of Monument Hill Road/Misty Acres Boulevard despite additional site-generated traffic from this development.

Intersection Configuration and Traffic Control

All proposed site-access points would be two-way, stop-sign-controlled intersections.

Regarding the intersection of County Line Road and Misty Acres Boulevard, the project team has determined that a roundabout option for traffic control would not be feasible. The following are a list of pros and cons comparing a modern roundabout intersection to a conventional intersection with two-way, stop-sign control and the potential for future signalization once MUTCD warrant(s) are met.

Roundabout Intersection

Cons:

- Grades would not meet the established guidelines for grades. The following is criteria from the *Wisconsin DOT Roundabout Design Manual* (used by El Paso County, Colorado):
 - *Entry grade profiles (approximately 2 car lengths from the ICD) are not to exceed 4%, with 2% being the typical maximum.*
 - *Roundabouts typically should be constructed on relatively flat or rolling terrain with an approach grade that is typically less than 3%, but not greater than 5%. Grades approaching 4% and steeper terrain may require greater transitions to provide an appropriate grade through the intersection. The profile grades along the central island should generally not exceed 4%, (typically 3% or less).*
- A roundabout centered on the existing County Line Road would force realignment of the existing north leg [at the current County Line Road/Monument Hill Road intersection] into conservation easement on the north side of County Line Road, which is prohibited.
- If a roundabout circle were shifted south to avoid the conservation easement, then the grading for the roundabout footprint would encroach into the wetlands located southeast of the intersection, which would also not be feasible.

- Projected volumes are higher on County Line Road than Misty Acres approach. Balanced volumes are ideal for roundabouts.

Pros:

- Generally, roundabouts are self-regulating and offer safety advantages over conventional intersections.
- The LOS would potentially be better than the conventional intersection for the northbound approach before a signal warrant is met, and potentially after signalization as well.

Conventional Intersection

Pros:

- The intersection would be similar to the existing intersection, will little modification needed on the north leg.
- A signal would not likely need to be installed in the short term – could remain TWSC.
- The LOS is shown to be D or better, based on the short-term scenario.
- There are likely more precedent cases for signal installation at intersections with grades over 4 percent than with roundabout grades over 4 percent.

Cons:

- Installation of a signal at an intersection with approach grades over 4 percent is not ideal, and would require a deviation (county intersection maximum intersection grade is 4 percent)
- Generally, El Paso County staff has indicated that an intersection cannot be signalized until warrants are met. The LOS would potentially be worse with the conventional intersection for the northbound approach before a signal warrant is met. The short term shows LOS D for the northbound approach.
- The conventional intersection would require auxiliary turn lanes on the intersection legs as shown on Figure 11,

The intersection of Misty Acres Boulevard/County Line Road will likely need to be signalized in the future. Based on projected volumes the volumes for the AM and PM peak hours would meet the Warrant No. 2 (Four-Hour Volume) threshold. The volume threshold would need to be met for two other hours of the day, such as the afternoon “school” peak hour and two hours during the late afternoon/evening peak hour.

Please indicate whether crash warrants would be met.

Other Recommendations

LSC recommends MUTCD horizontal curve warning signage be installed on Monument Hill Road for traffic on the northbound approach to the proposed curve to the east adjacent to the site. The specific signs and sign placement can be included for review as part of the construction plans.

ROADWAY CLASSIFICATIONS

indicate whether these are based on 2044 or short term volumes

Based on the projected traffic volumes, roadway continuity, length, the *MTCP*, and other factors, LSC recommends roadway classifications for the study-area roadways. These are presented in Table 4 below and are shown on a roadway map in Figure 13.

Table 4: Roadway Classifications at Proposed Site Access Points

Roadway	Direction from Intersecting Road	Intersecting Road	Projected ADT	Recommended Classification
County Line Rd	West	Misty Acres Blvd	10,972	Rural Minor Arterial (but under CDOT Access Control)
County Line Rd	East	Misty Acres Blvd	8,378	Rural Minor Arterial
Misty Acres Blvd	South	County Line Rd	4,000	Major Collector (Urban Non-Residential Collector)
Misty Acres Blvd	South	Old Antlers Way*	4,000	Major Collector (Hybrid Cross Section)
Access A	East	Misty Acres Blvd	298	Urban Local
Access A	West	Misty Acres Blvd	510	Local (Private Street)
Monument Hill Rd	East (for 1,000 feet)	Misty Acres Blvd	119	Urban Local
Monument Hill Rd	South	725 feet west of Access B	119	Rural Major Collector
Access B	South	Monument Hill Rd	404	Local (Private Street)
Old Antlers Way	West	Misty Acres Blvd	947	Local (Private Street)

*More precisely, south of the south site boundary on the east side of Misty Acres, which is 175' north of Old Antlers Way

use County nomenclature (i.e. urban local)

COUNTY ROAD IMPROVEMENT FEE PROGRAM

Transportation Impact Fees

Per *ECM* Appendix B:

State what the current applicable Transportation Impact Fees are and what option the developer will be selecting for payment.

The applicant will be required to participate in this program.

The applicant will notify staff of the selected PID option prior to scheduling for public hearing this TIS will be updated accordingly once the option is confirmed.

Reimbursable Improvements

The following roadway improvement projects have been identified as being needed by the year 2040 per Map 13 and Table 4 of El Paso County's 2016 *MTCP*:

- U18 – Monument Hill Road from Woodmoor Drive to County Line Road (\$5,224,000)
 - Existing conditions – 2-lane Unimproved County Road
 - Future conditions – 2-lane Collector
- U20 -- This roadway improvement project has been identified as being needed by the year 2040 per Map 13 and Table 4 of El Paso County's 2016 *MTCP*.

MULTI-MODAL TRANSPORTATION AND TDM OPPORTUNITIES

No multi-modal roadway improvement projects have been identified as being needed by the year 2040 per Map 15 and Table 5 of El Paso County's 2016 *MTCP*.

CDOT ACCESS PERMITTING

Prior access permits for County Line Road/Monument Hill Road are under Colorado State Highway Access Permit numbers 204054 and 204055. Newer permits may have been issued.

The previous access permits identified a requirement to construct a westbound-left-turn deceleration lane on County Line Road. This would also include widening for redirect tapers just west of the intersection that would tie into the recent road widening associated with the interchange improvements.

The previous permit terms and conditions identified that, "an eastbound right turn deceleration lane is required however, due to topography, the Permittee may elect to submit a design waiver." This design waiver would likely accompany the submittal of a new access permit application.

revise to deviations
that may be required
since no actual plan
has been submitted
nor is it required with
a rezone

CDOT will require a new access permit for Monument Hill Road, County Line Road/Misty Acres Boulevard. The permit application will be submitted as part of the design waiver request. The final permit, once issued, will identify the resolution of the above design waivers and will identify the requirements of this development at this intersection. CDOT will not require an access permit for the current intersection adjacent to the site on Monument Hill Road, as jurisdictional control of Monument Hill Road has been transferred to El Paso County.

DEVIATIONS, DESIGN WAIVERS, AND LDC WAIVERS

Deviations to EPC ECM Criteria

- **Major Collector Intersection Centerline Spacing:** A deviation may be required for the intersection of Misty Acres Boulevard/Access C for intersection spacing less than 660' along an Urban Non-Residential Collector.
- **Intersection Grades:** The approach grades on County Line Road approaching the proposed Misty Acres Boulevard intersection would exceed *ECM* criteria. Although this is an existing condition, a deviation may be required.

CDOT Design Waivers

- Right Turn Deceleration Lane Length (CDOT Design Waiver – to be submitted as part of the access permit process)

EPC Land Development Code (LDC) Waivers

- Local (Private) Streets shown on the site plan areas west of Misty Acres Boulevard connecting to Access points C, A, B and the Misty Acres/Old Antlers Way intersection would likely need waivers to the LDC to allow for private streets.

POTENTIAL ESCROW FOR FUTURE INTERSECTION SIGNALIZATION

- Following the realignment of Monument Hill Road, County Line Road/Misty Acres Boulevard has the potential to warrant signalization in the future. El Paso County may require a fair-share escrow amount toward this future traffic signal, unless this intersection is determined to be an “eligible” intersection under the El Paso County Roadway Impact Fee program.

FYI: Please submit the deviation at the subdivision state. Deviation file may be submitted separately for review.

FINDINGS AND CONCLUSIONS

- The site is projected to generate about 2,525 new driveway vehicle-trips on the average weekday.
- During the weekday morning peak hour of adjacent street traffic, 51 vehicles would enter the site while 121 vehicles would exit.
- During the weekday afternoon peak hour of adjacent street traffic, 122 vehicles would enter the site while 86 vehicles would exit.
- Please refer to the “Level of Service” section above for detailed LOS results and discussion regarding all study-area intersections.
- Please refer to the “Auxiliary Turn-Lane Analysis” section for evaluation of turn-lane needs at the study-area intersections.
- A list of potential deviations, CDOT design waivers and/or LDC waivers is included above.

* * * * *

Please contact me if you have any questions regarding this report.

Respectfully Submitted,

LSC TRANSPORTATION CONSULTANTS, INC.

FYI: Please discuss any traffic improvements with trigger points for the construction at the subdivision stage.

By: Jeffrey C. Hodsdon, P.E.
Principal

JCH/JAB:jas

Enclosures: Table 2
Figure 1 - Figure 13
Traffic Count Reports
Synchro LOS Reports

Tables



Table 2: Detailed Trip Generation Estimate

ITE		Value Units ¹		Trip Generation Rates ²				Total Driveway Trips Generated					
Code	Description			Average	A.M.		P.M.		Average	A.M.		P.M.	
				Weekday	In	Out	In	Out	Weekday	In	Out	In	Out
210	Single-Family (Detached) Housing	37	DU	9.43	0.18	0.52	0.59	0.35	349	7	20	22	13
215	Single-Family (Attached) Housing	261	DU	7.20	0.15	0.33	0.32	0.25	1879	39	87	85	64
220	Multi-Family Housing (Low-Rise)	44	DU	6.74	0.10	0.30	0.32	0.19	297	5	14	15	9
								Total	2525	51	121	122	86

¹ DU = dwelling units

² Source: *Trip Generation, 11th Edition (2021)* by the Institute of Transportation Engineers (ITE)

Updated: 02/20/2024

Figures





Figure 1

Vicinity

Monument Ridge East (LSC# S234450)





Approximate Scale
1" = 500'

860' 825'

Existing Monument Hill Rd Alignment (to be removed)

County Line Rd

Access C

Access A

Monument Hill Rd

270

Access B

Old Antlers Way

Dewwood Dr

FYI: this does not meet intersection spacing per ECM table 2-7. Access location are not approved at this rezone stage and would need to be in compliance once the development plan is submitted at the subdivision stage.

Note: Please refer to Figure 3 for an exhibit showing road realignments and changes.

Interstate 25

Monument Hill Rd

Misty Acres Blvd

Figure 2

Site Plan

Monument Ridge East (LSC# S234450)





Approximate Scale
1" = 500'

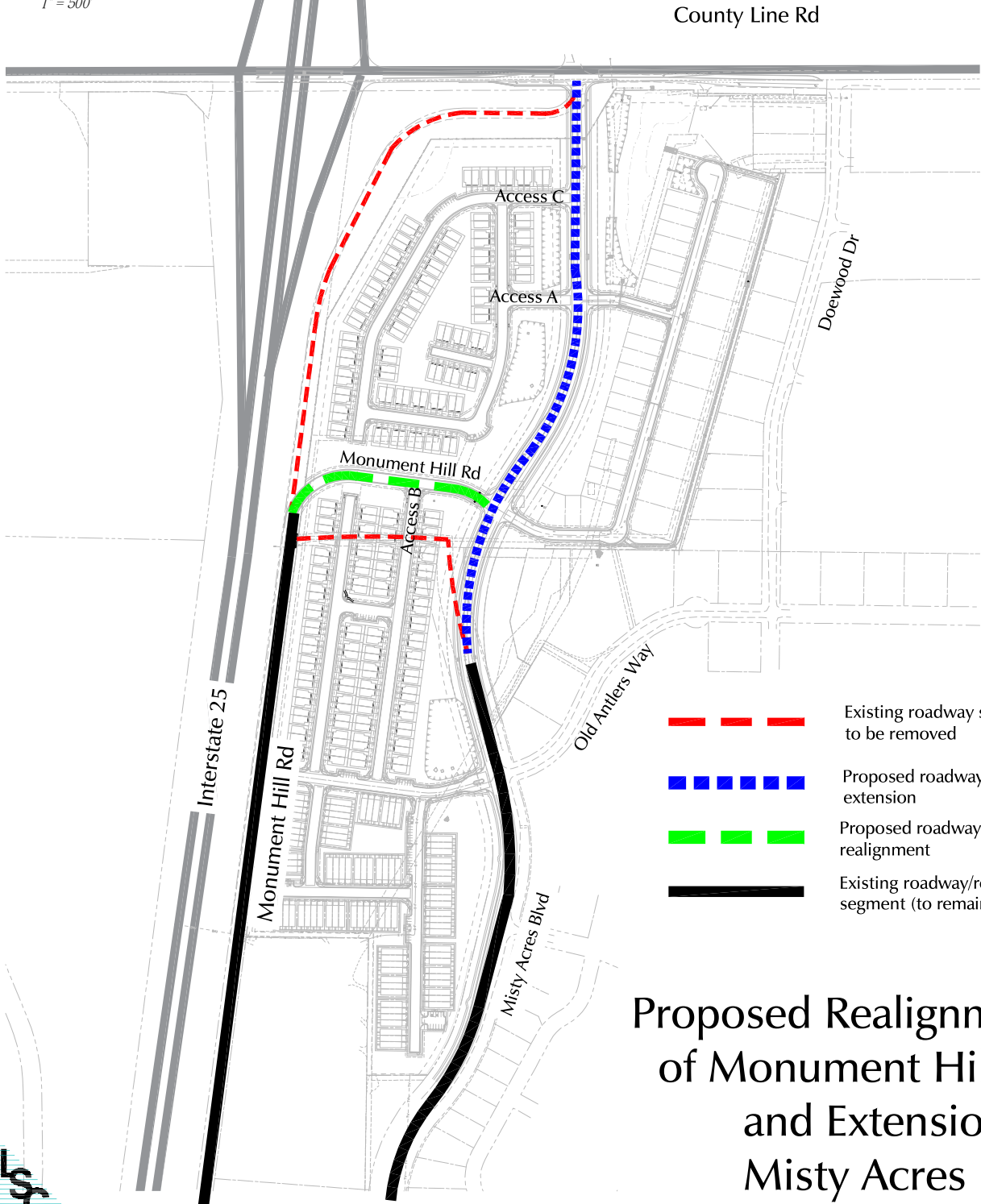





-  Existing roadway segment - to be removed
-  Proposed roadway extension
-  Proposed roadway realignment
-  Existing roadway/roadway segment (to remain)

Figure 3
**Proposed Realignment
of Monument Hill Rd
and Extension of
Misty Acres Blvd**

Monument Ridge East (LSC# S234450)



Approximate Scale
Scale: 1" = 3,000'

Please include the existing Average Daily Traffic (ADT) on road segments that the project could impact.

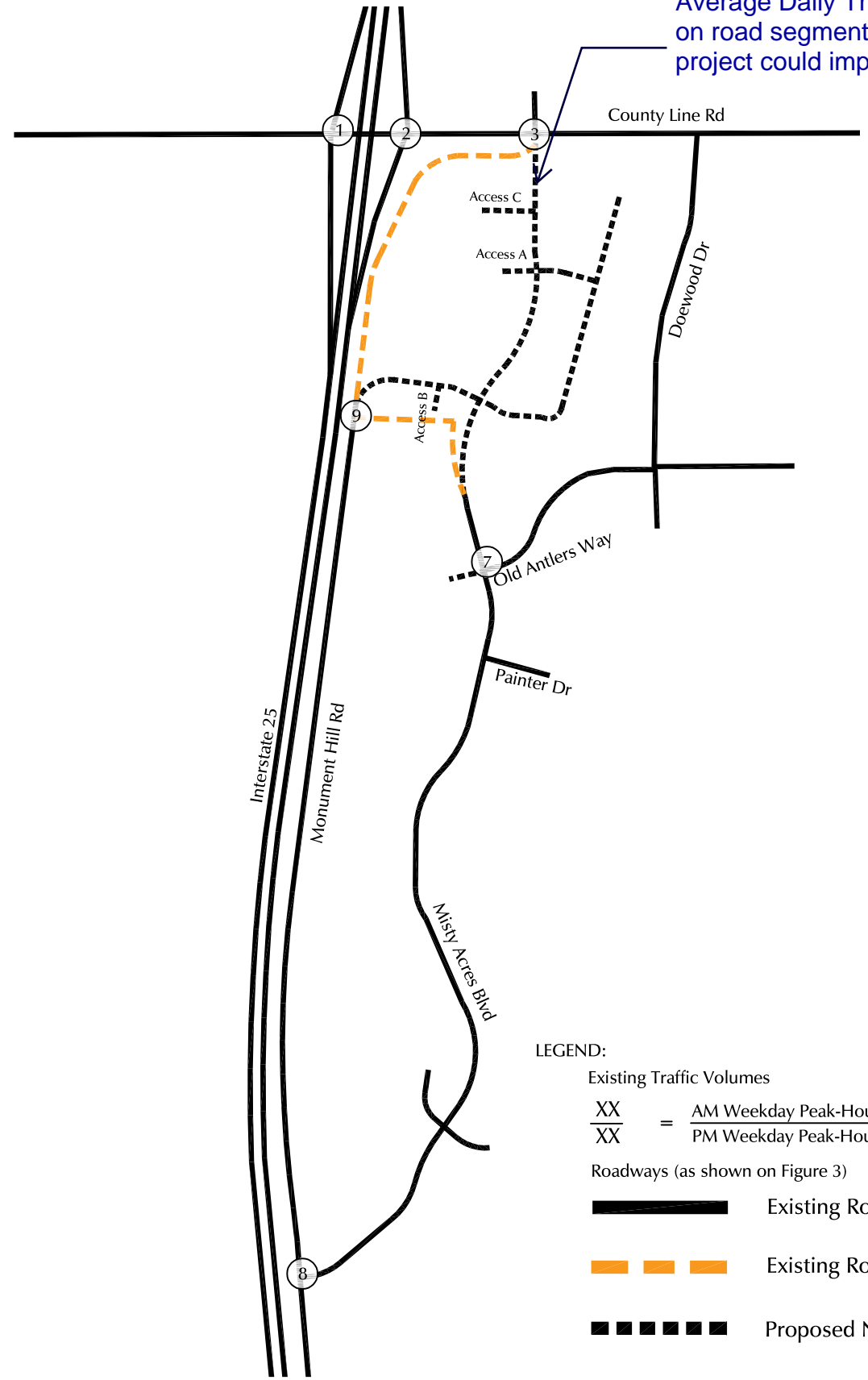
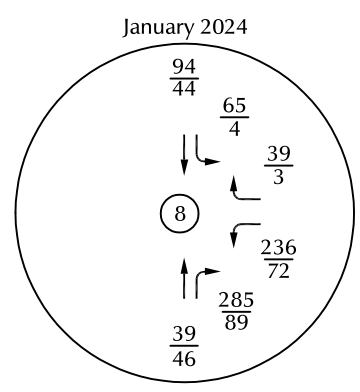
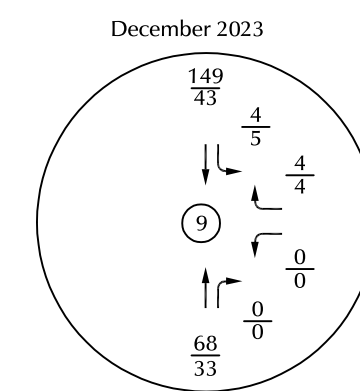
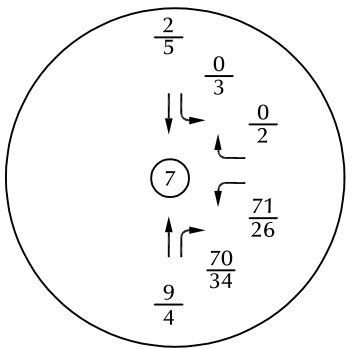
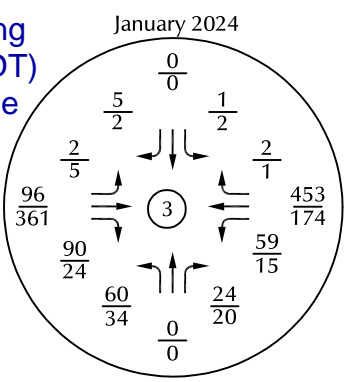
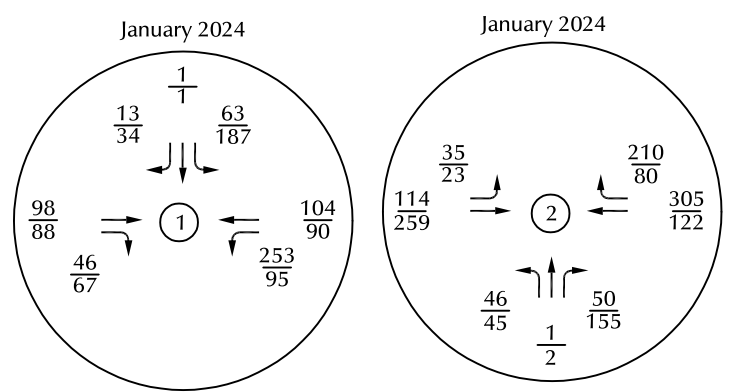

LEGEND:

Existing Traffic Volumes
 $\frac{XX}{XX}$ = AM Weekday Peak-Hour Traffic (vehicles per hour)
 = PM Weekday Peak-Hour Traffic (vehicles per hour)

Roadways (as shown on Figure 3)

- Existing Roadway segments (to remain)
- Existing Roadway Segments (to be removed)
- Proposed New Roadway Segments



Figure 4
Existing Traffic Counts
Monument Ridge East (LSC# S234450)

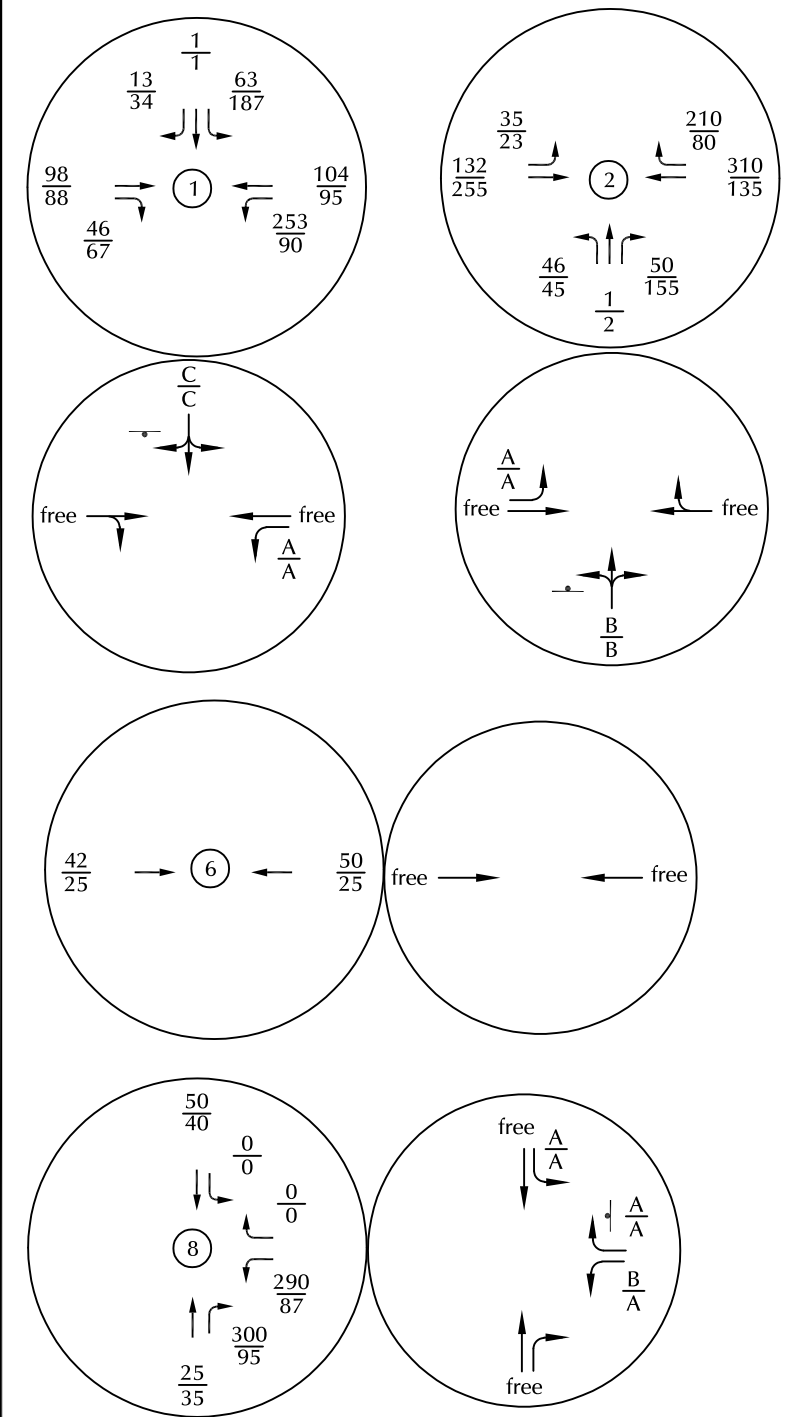

Please clearly label the year of projection for the short range. This comment is applied to all projected condition figures.

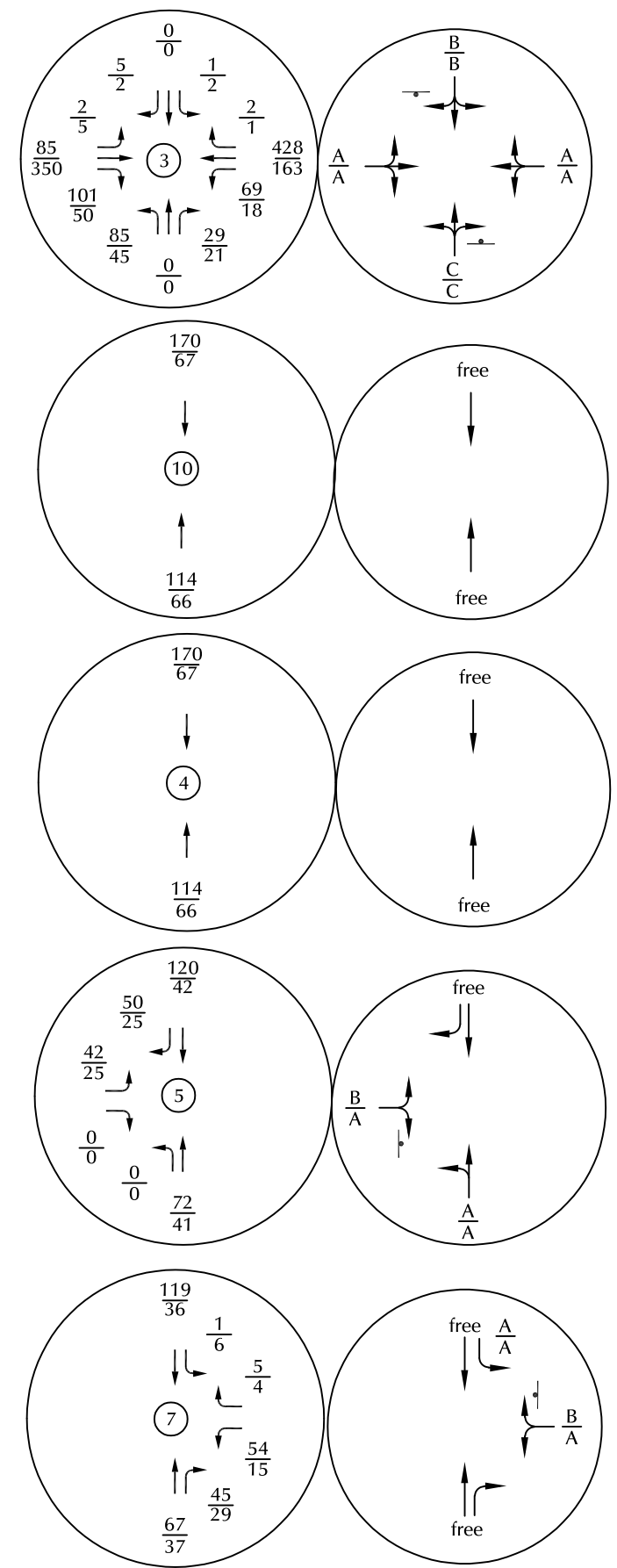
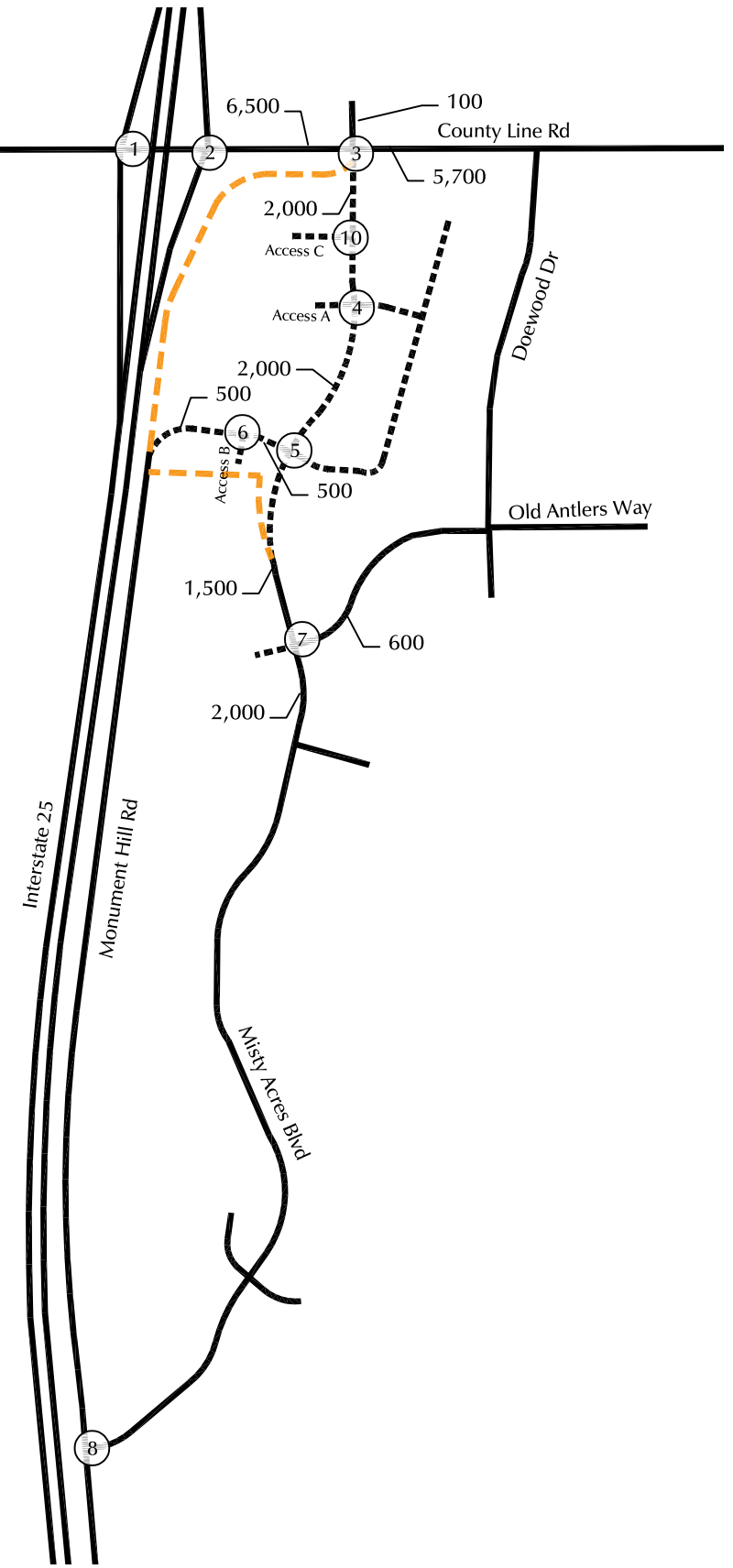

Approximate Scale
Scale: 1" = 3,000'

LEGEND:
 XX = AM Weekday Peak-Hour Traffic (vehicles per hour)
 XX = PM Weekday Peak-Hour Traffic (vehicles per hour) X,XXX = Average Daily Traffic (vehicles per day)
 X = AM Individual Movement Peak-Hour LOS
 X = PM Individual Movement Peak-Hour LOS
 † = Stop Sign

Roadways (as shown on Figure 3)
 Existing Roadway segments (to remain)
 Existing Roadway Segments (to be removed)
 Proposed New Roadway Segments



Estimated Short-Term Baseline Conditions (Adjusted Existing Traffic)

Figure 5

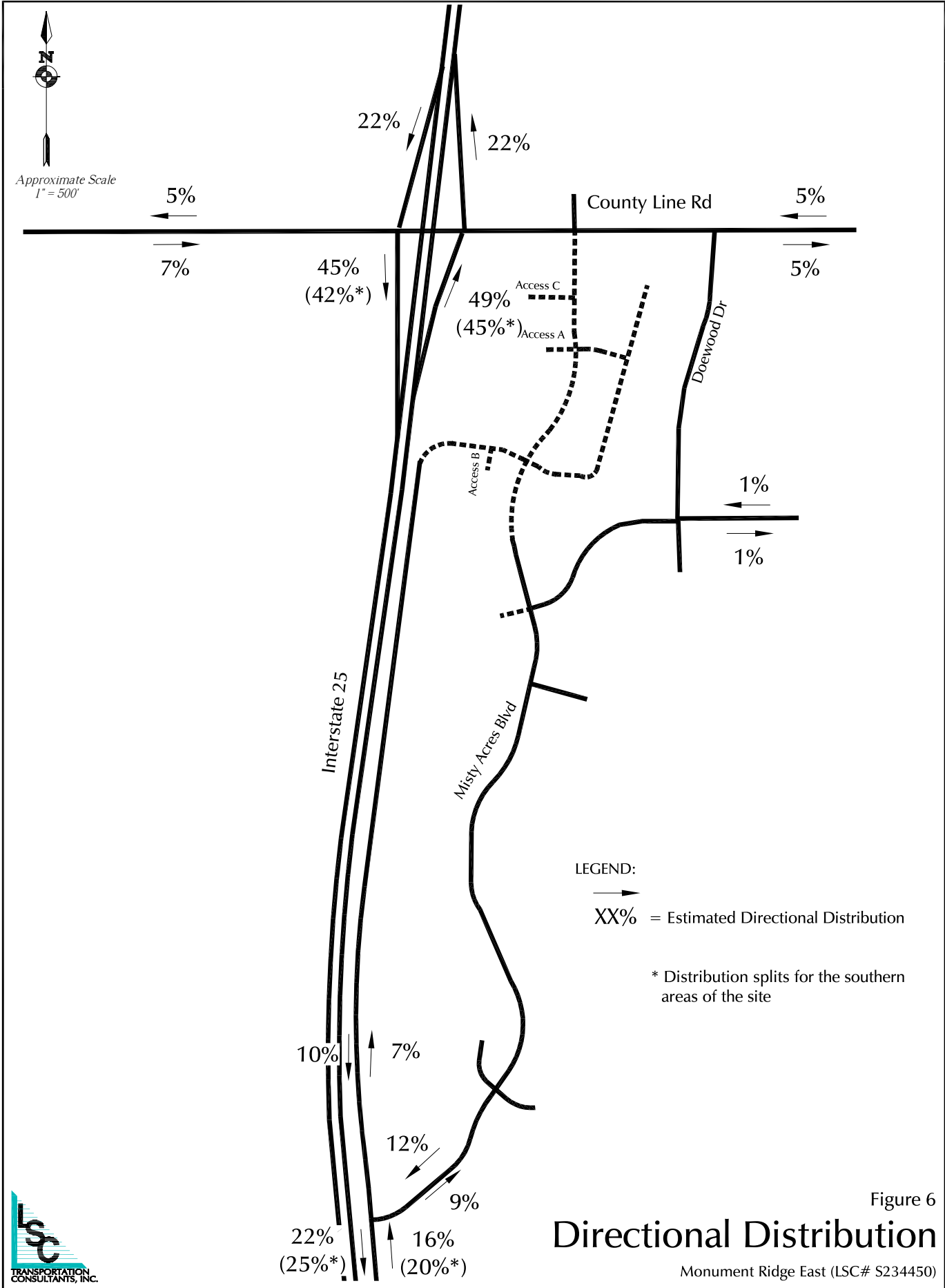
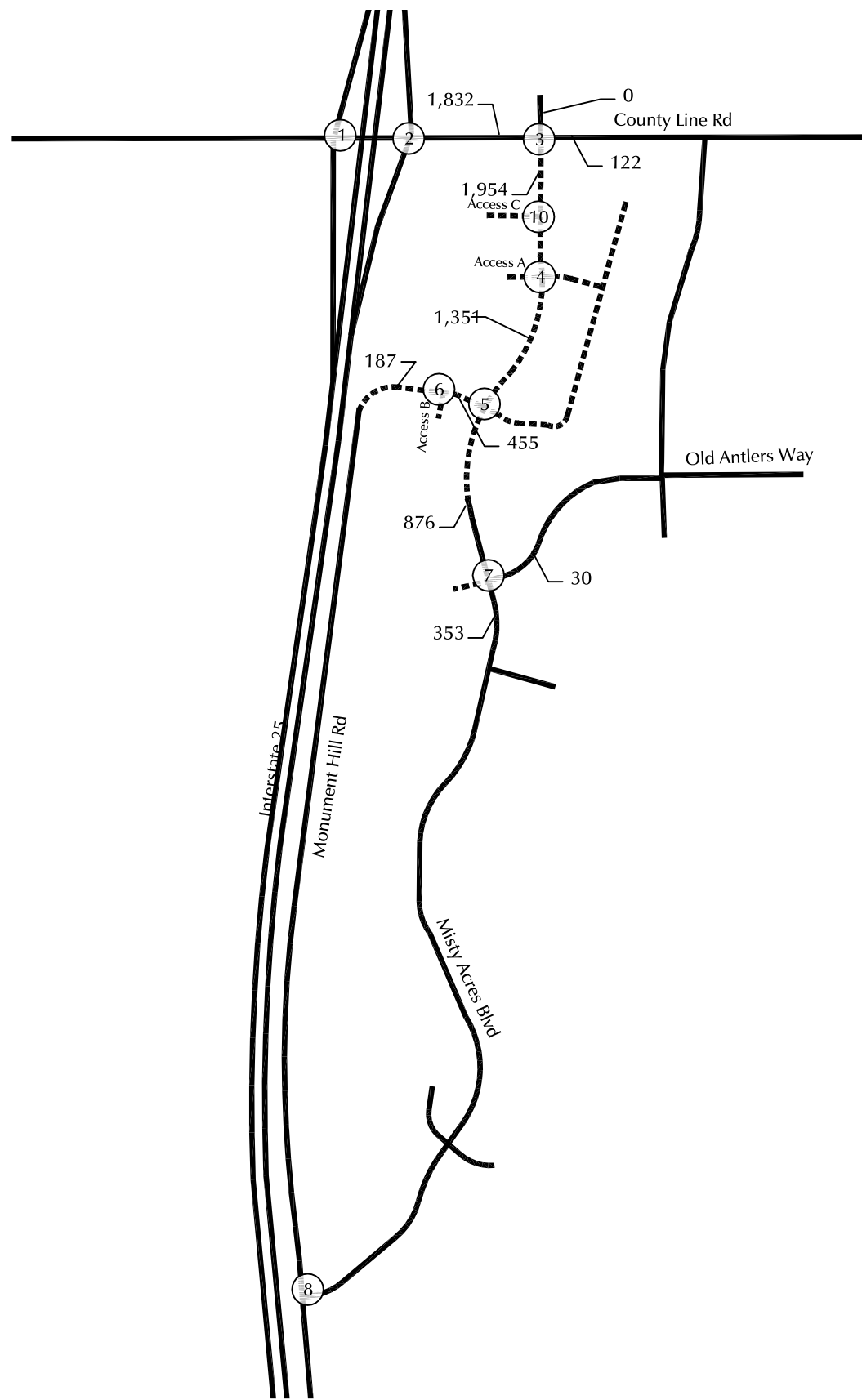
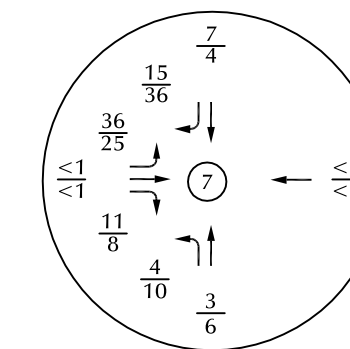
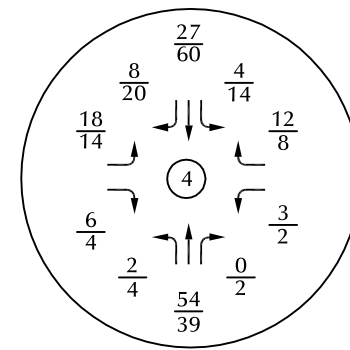
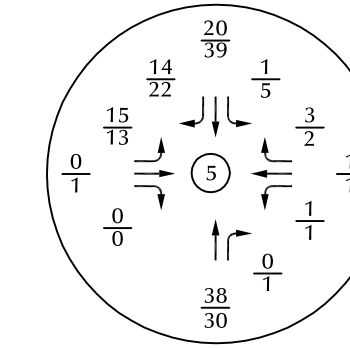
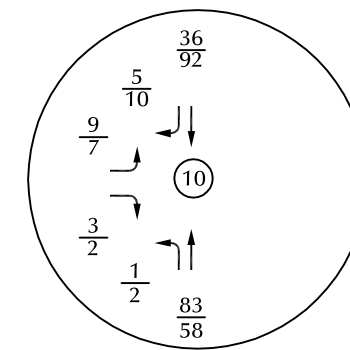
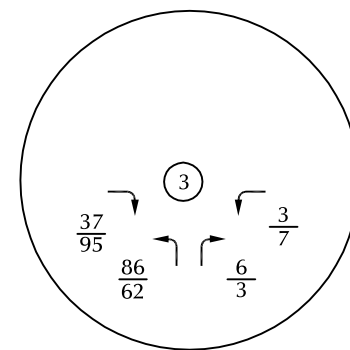
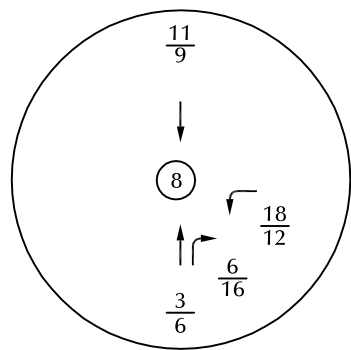
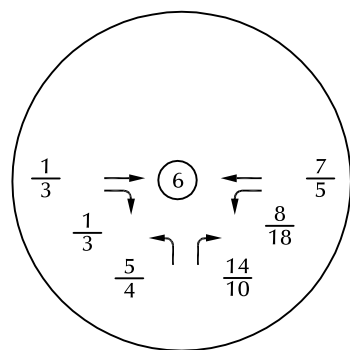
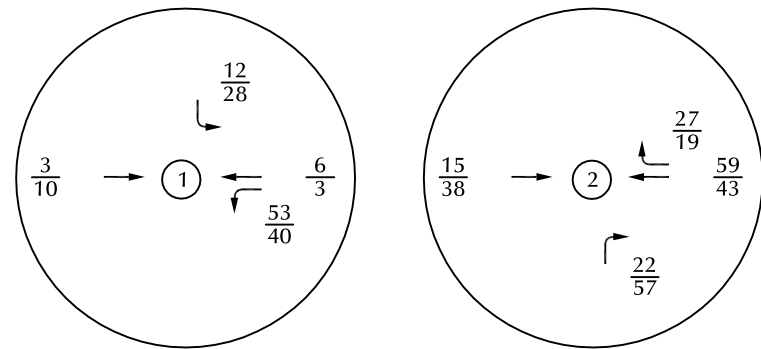

Figure 6
Directional Distribution

Monument Ridge East (LSC# S234450)



Approximate Scale
Scale: 1" = 3,000'

LEGEND:

$\frac{XX}{XX}$ = $\frac{\text{AM Weekday Peak-Hour Traffic (vehicles per hour)}}{\text{PM Weekday Peak-Hour Traffic (vehicles per hour)}}$

X,XXX = Average Daily Traffic (vehicles per day)

Roadways (as shown on Figure 3)

Existing Roadway segments (to remain)

Proposed New Roadway Segments



Figure 7
Site-Generated Traffic

Monument Ridge East (LSC# S234450)

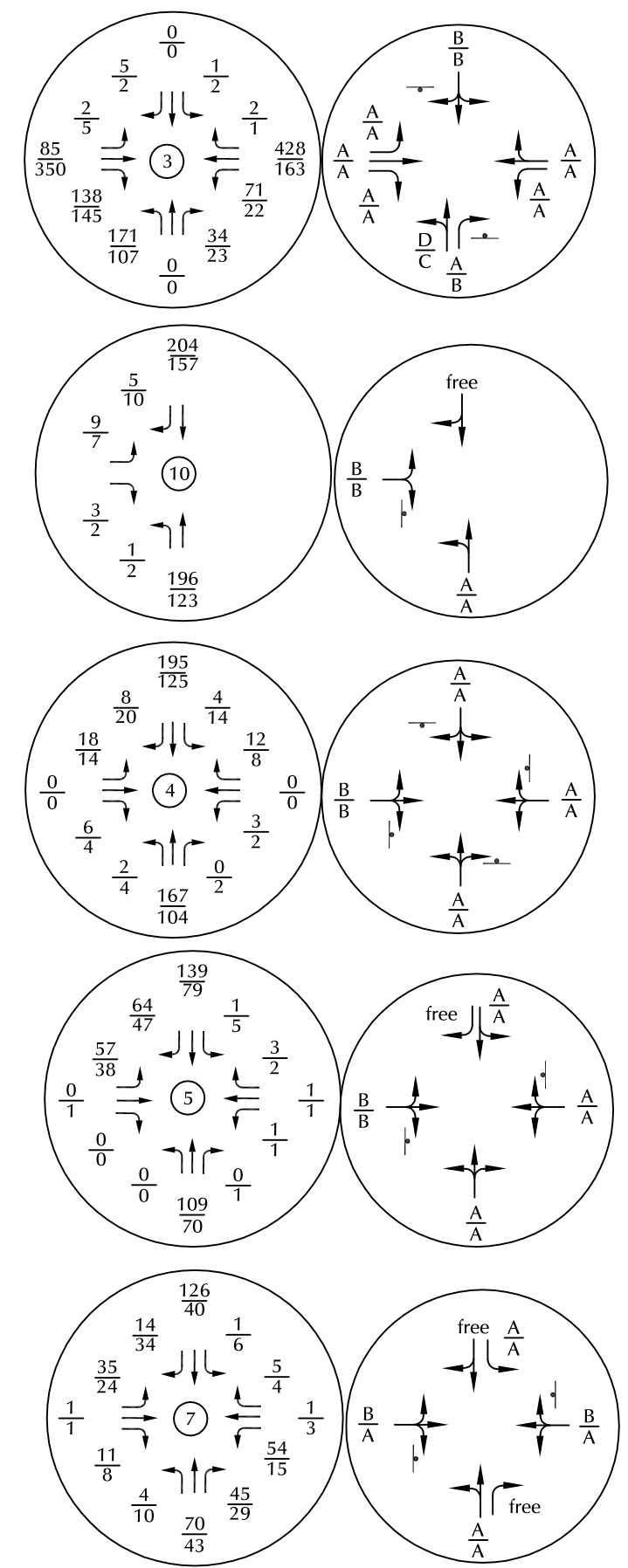
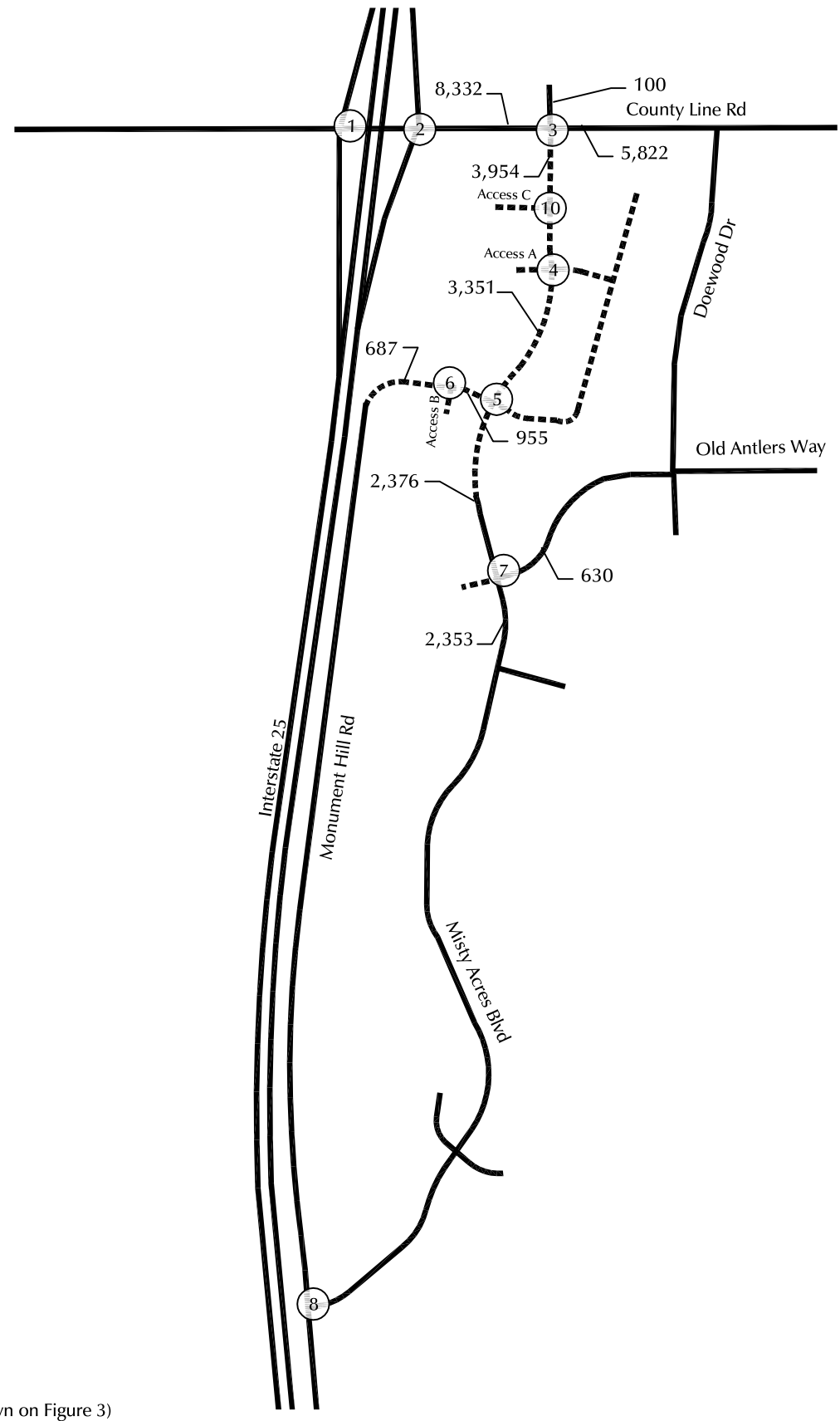
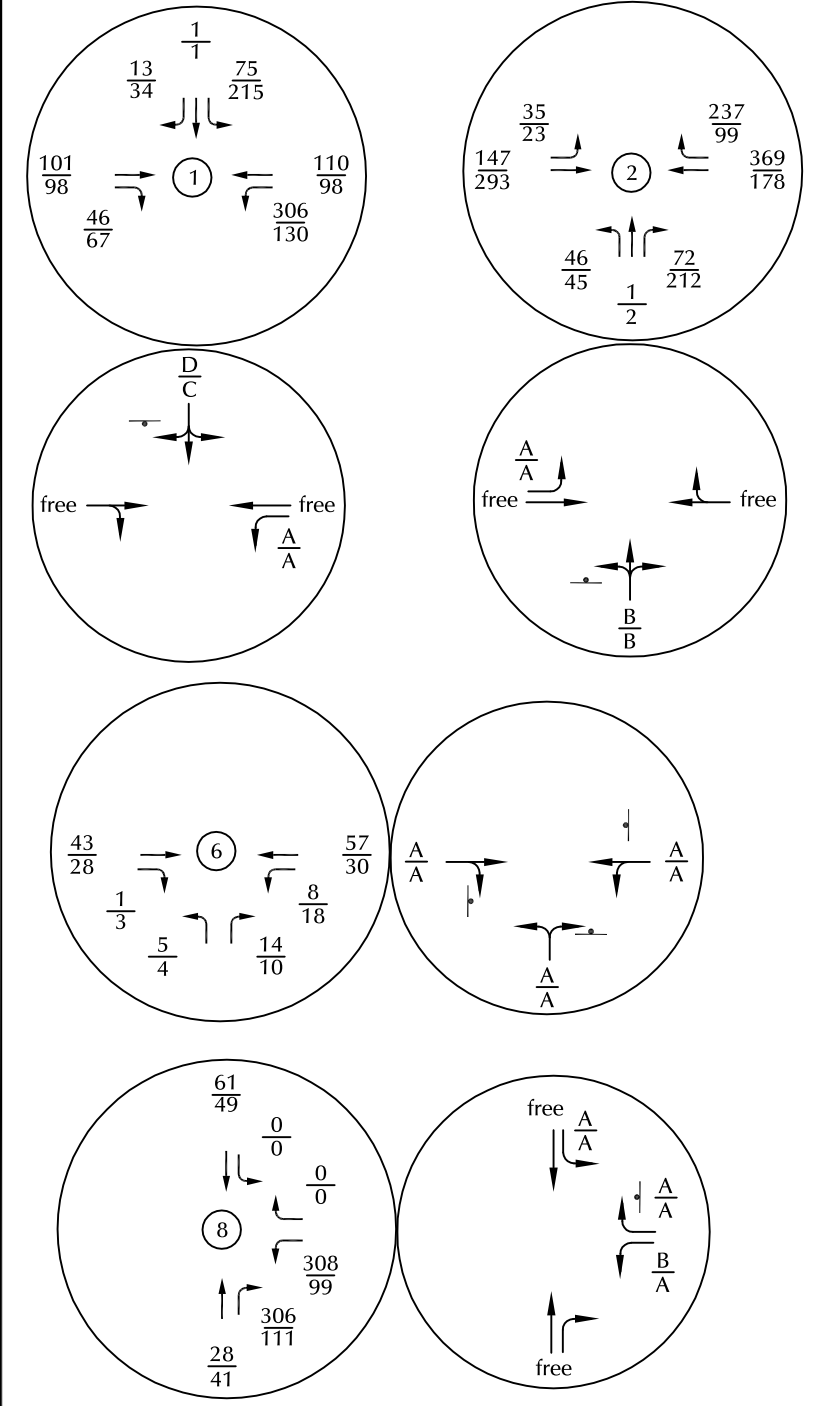

Approximate Scale
Scale: 1" = 3,000'

LEGEND:

X,XXX = Average Daily Traffic (vehicles per day)

$\frac{XX}{XX}$ = AM Weekday Peak-Hour Traffic (vehicles per hour)
PM Weekday Peak-Hour Traffic (vehicles per hour)

$\frac{X}{X}$ = AM Individual Movement Peak-Hour LOS
PM Individual Movement Peak-Hour LOS

$\frac{X}{X}$ = AM Entire Intersection Peak-Hour LOS
PM Entire Intersection Peak-Hour LOS

= Traffic Signal = Stop Sign

Roadways (as shown on Figure 3)

Existing Roadway segments (to remain)

Proposed New Roadway Segments

Short-Term Baseline + Site-Generated Traffic

Figure 8



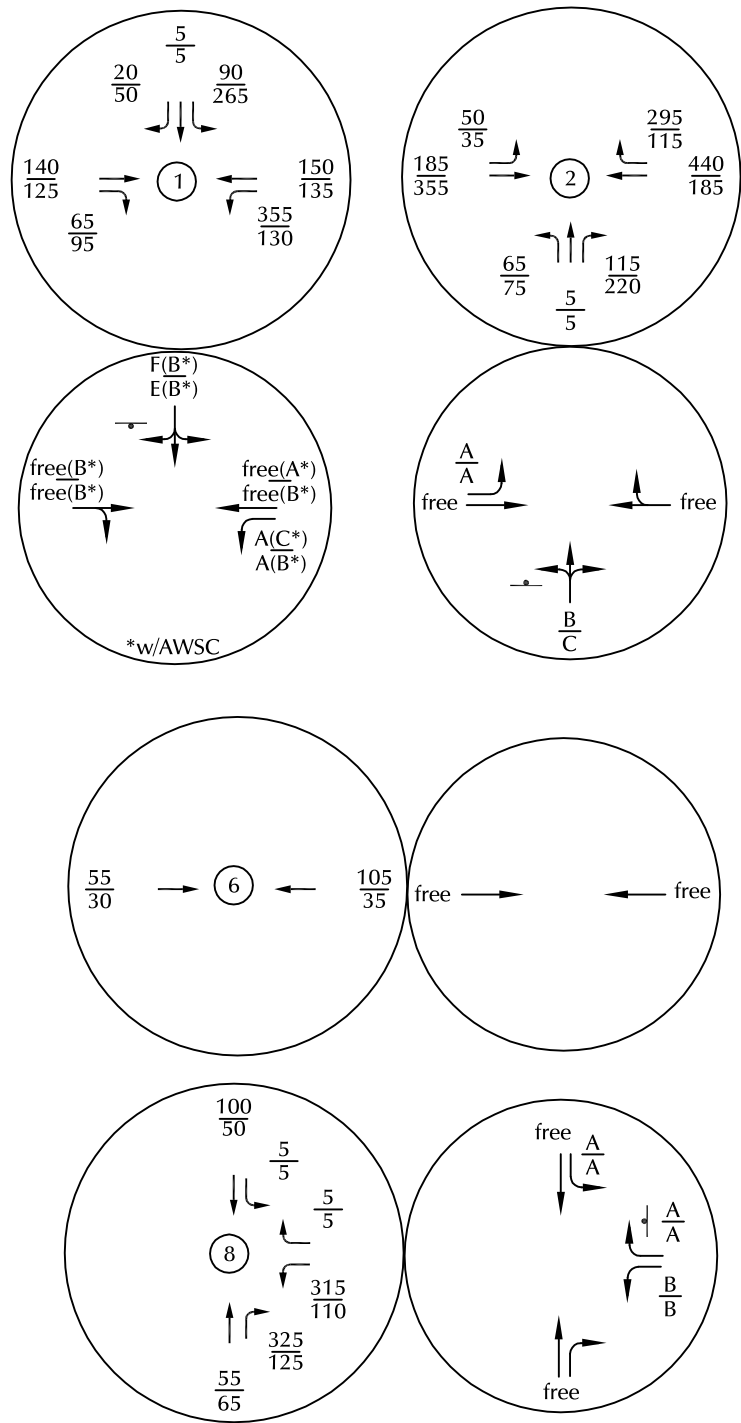

LEGEND:

- $\frac{XX}{XX}$ = AM Weekday Peak-Hour Traffic (vehicles per hour)
- $\frac{XX}{XX}$ = PM Weekday Peak-Hour Traffic (vehicles per hour)
- $\frac{X}{X}$ = AM Individual Movement Peak-Hour LOS
- $\frac{X}{X}$ = PM Individual Movement Peak-Hour LOS
- X,XXX = Average Daily Traffic (vehicles per day)
- ⊥ = Stop Sign

- Roadways (as shown on Figure 3)
- Existing Roadway segments (to remain)
 - Proposed New Roadway Segments

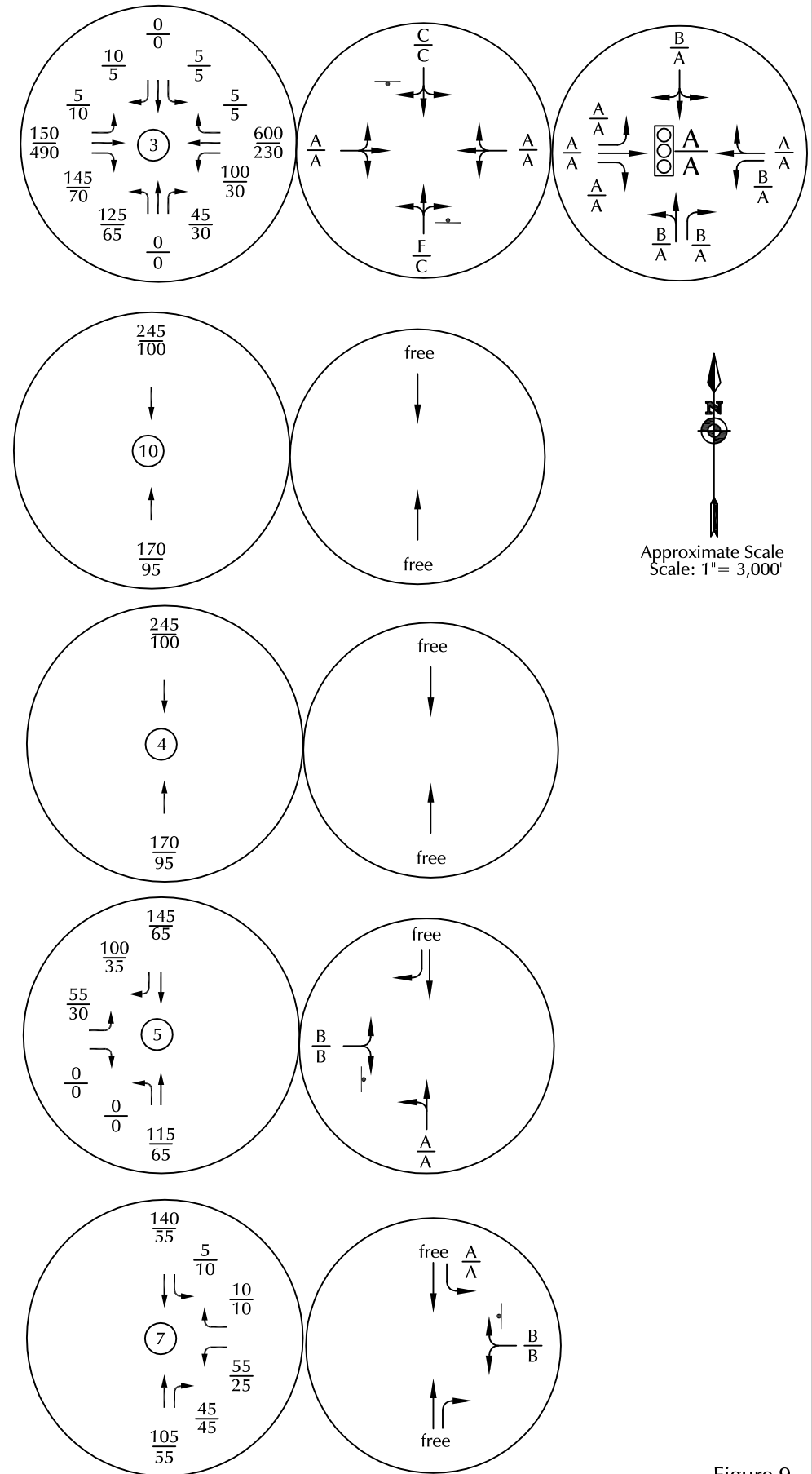
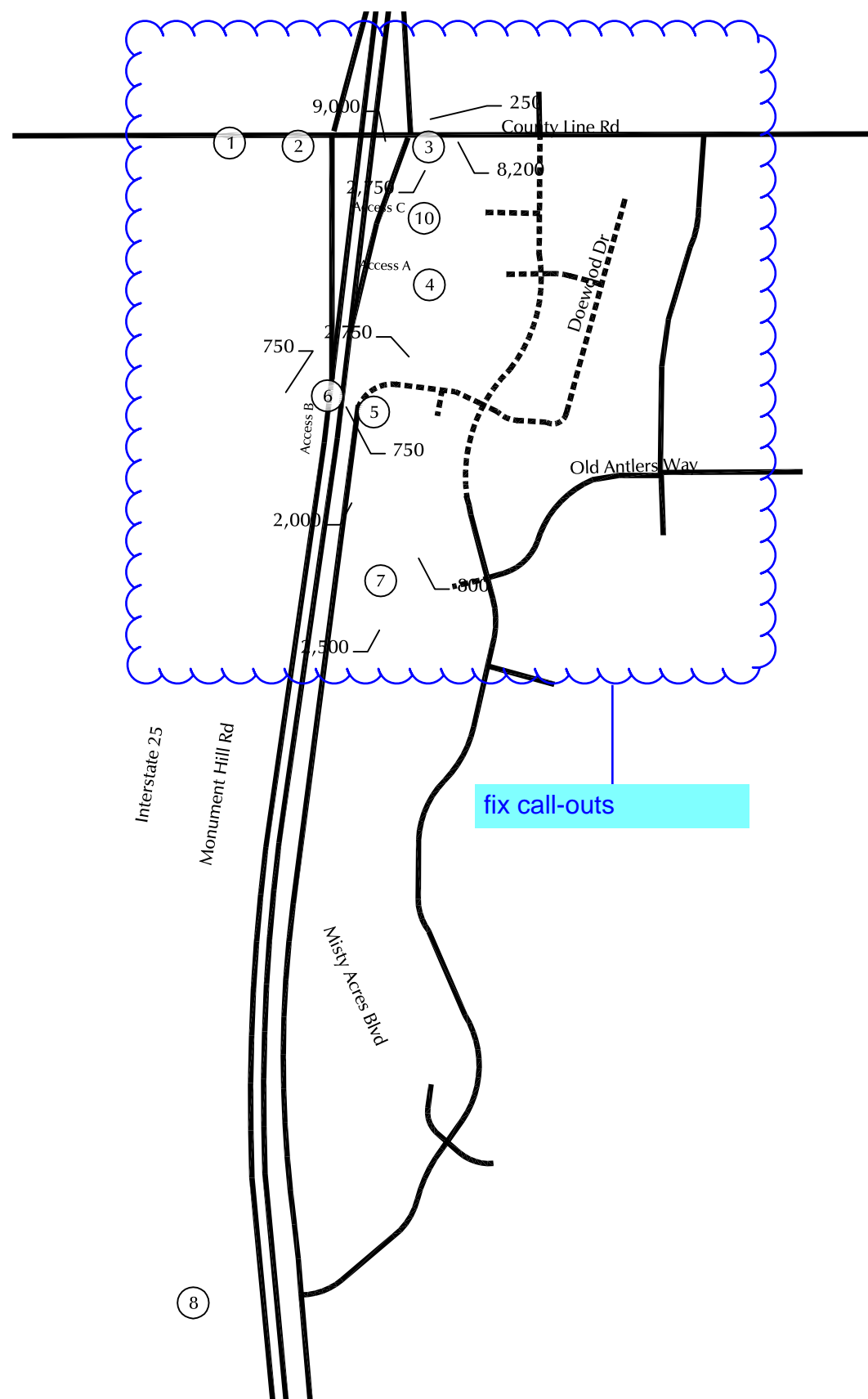
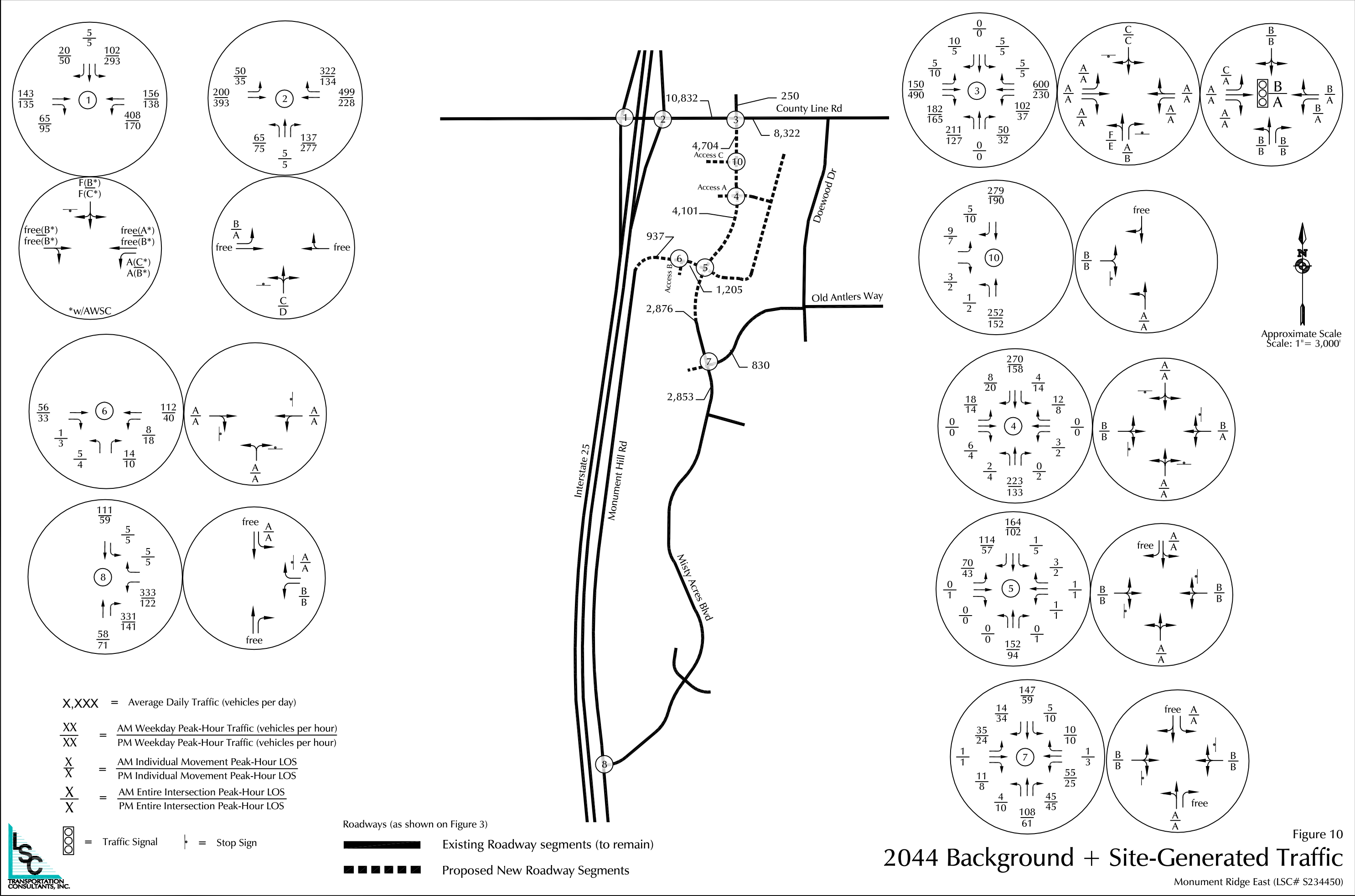

Figure 9
2044 Background Traffic
 Monument Ridge East (LSC# S234450)



X,XXX = Average Daily Traffic (vehicles per day)

$\frac{XX}{XX}$ = $\frac{\text{AM Weekday Peak-Hour Traffic (vehicles per hour)}}{\text{PM Weekday Peak-Hour Traffic (vehicles per hour)}}$

$\frac{X}{X}$ = $\frac{\text{AM Individual Movement Peak-Hour LOS}}{\text{PM Individual Movement Peak-Hour LOS}}$

$\frac{X}{X}$ = $\frac{\text{AM Entire Intersection Peak-Hour LOS}}{\text{PM Entire Intersection Peak-Hour LOS}}$

= Traffic Signal = Stop Sign

Roadways (as shown on Figure 3)

Existing Roadway segments (to remain)

Proposed New Roadway Segments

2044 Background + Site-Generated Traffic

Figure 10

Monument Ridge East (LSC# S234450)



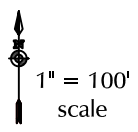
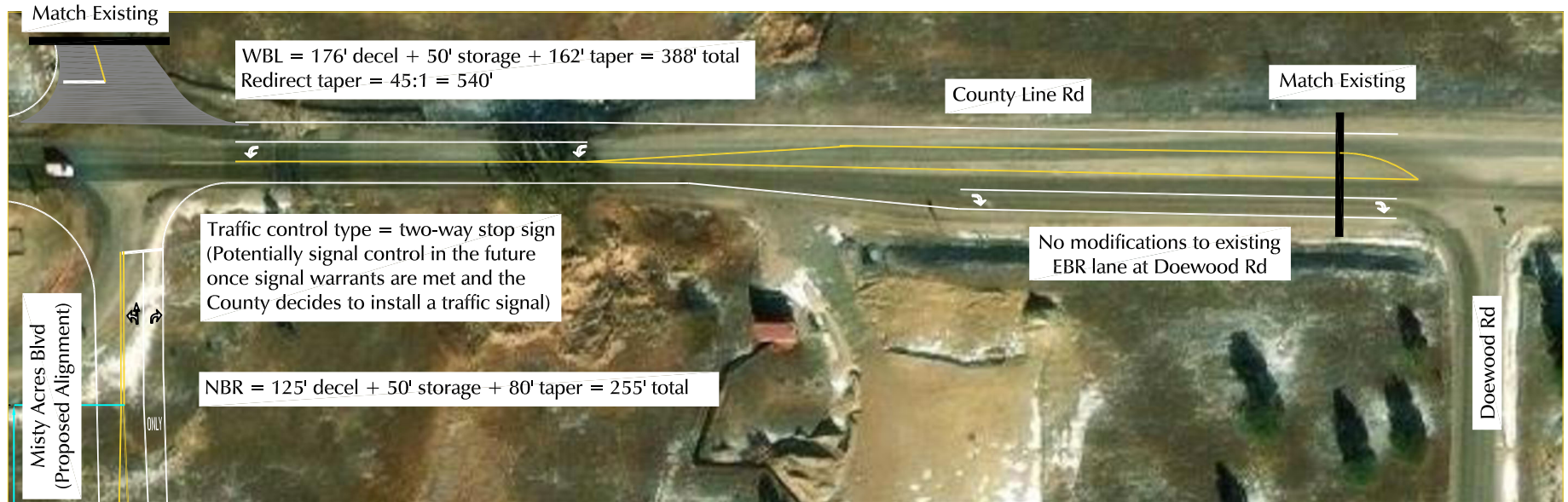
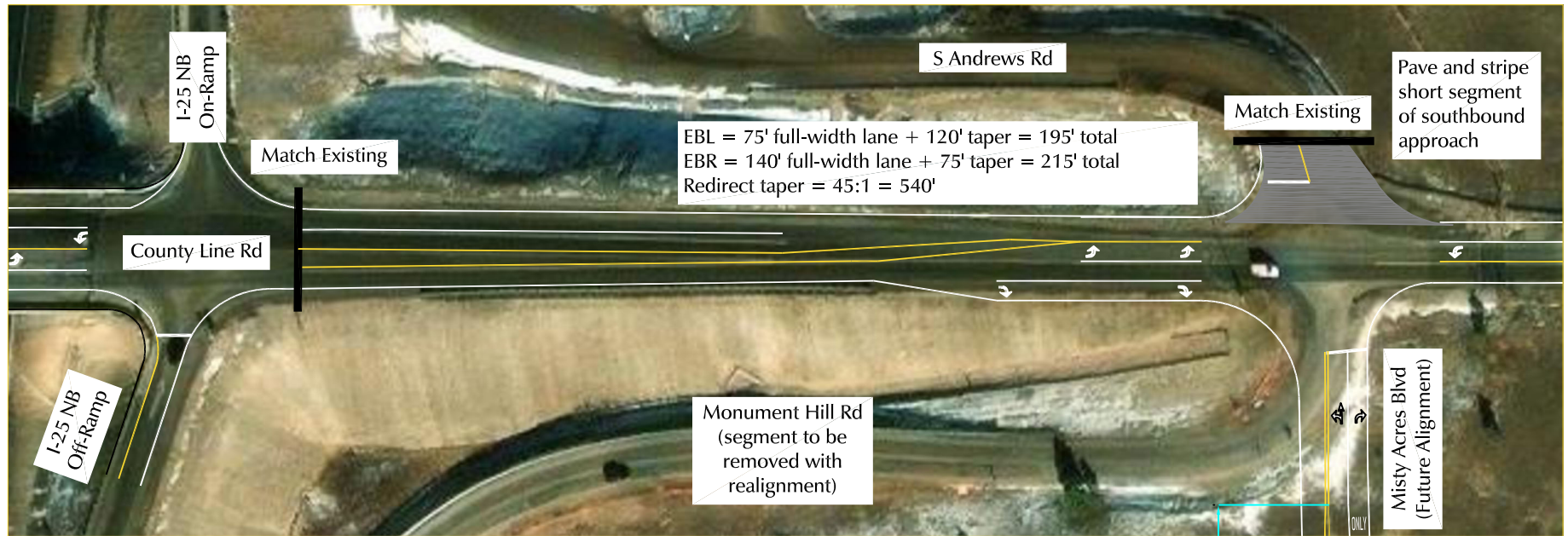

Figure 11
Proposed Laneage on County Line Rd
 Monument Ridge East (LSC# S234450)



1" = 100'
scale

Figure 12

Proposed Laneage on Misty Acres Boulevard







Monument Ridge East (LSC# S234450)

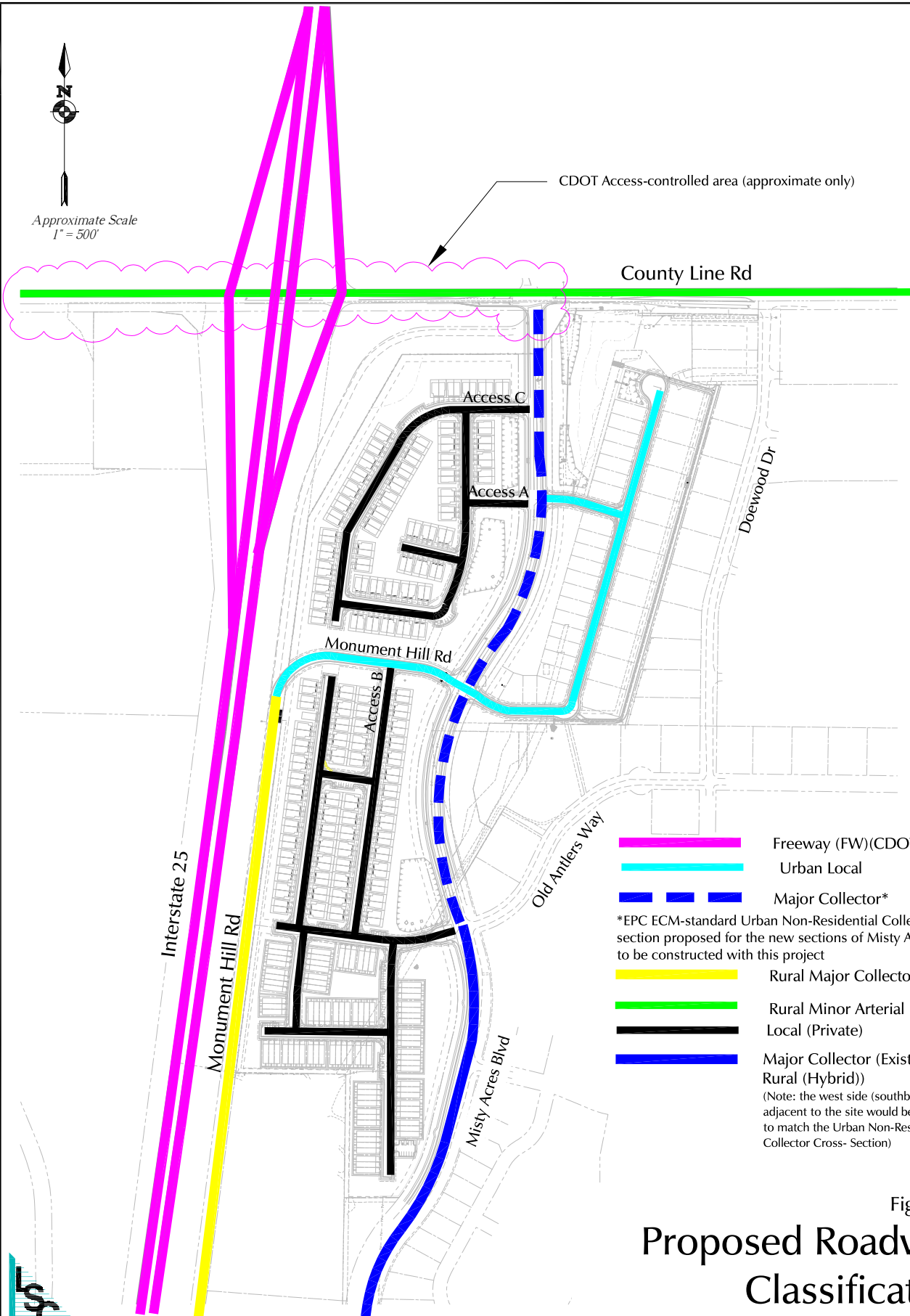

Approximate Scale
1" = 500'

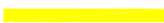
CDOT Access-controlled area (approximate only)



-  Freeway (FW)(CDOT)
-  Urban Local
-  Major Collector*
-  Rural Major Collector
-  Rural Minor Arterial
-  Local (Private)
-  Major Collector (Existing Rural (Hybrid))

*EPC ECM-standard Urban Non-Residential Collector cross section proposed for the new sections of Misty Acres Blvd to be constructed with this project

(Note: the west side (southbound side) adjacent to the site would be improved to match the Urban Non-Residential Collector Cross- Section)

Figure 13

Proposed Roadway Classification

Monument Ridge East (LSC# S234450)



Traffic Counts



LSC Transportation Consultants, Inc.

2504 E. Pikes Peak Ave, Suite 304
 Colorado Springs, CO 80909
 719-633-2868

File Name : Monument Hill Rd - County Line Rd AM
 Site Code : S234450
 Start Date : 1/10/2024
 Page No : 1

Groups Printed- Unshifted

Start Time	S Andrews Rd Southbound					County Line Rd Westbound					Monument Hill Rd Northbound					County Line Rd Eastbound					Int. Total
	Right	Thru	Left	Peds	App. Total	Right	Thru	Left	Peds	App. Total	Right	Thru	Left	Peds	App. Total	Right	Thru	Left	Peds	App. Total	
06:30	0	0	0	0	0	0	30	0	0	30	0	0	4	0	4	1	4	0	0	5	39
06:35	0	0	0	0	0	0	33	1	0	34	0	0	2	0	2	2	6	0	0	8	44
06:40	0	0	0	0	0	0	37	1	0	38	1	0	1	0	2	3	2	0	0	5	45
06:45	1	0	0	0	1	0	34	0	0	34	0	0	1	0	1	2	5	1	0	8	44
06:50	0	0	0	0	0	0	16	0	0	16	0	0	2	0	2	5	3	0	0	8	26
06:55	0	0	0	0	0	0	27	2	0	29	1	0	2	0	3	6	6	1	0	13	45
Total	1	0	0	0	1	0	177	4	0	181	2	0	12	0	14	19	26	2	0	47	243
07:00	2	0	0	0	2	1	35	1	0	37	0	0	2	0	2	9	1	0	0	10	51
07:05	0	0	0	0	0	0	30	3	0	33	2	0	4	0	6	8	5	0	0	13	52
07:10	0	0	0	0	0	0	34	5	0	39	1	0	4	0	5	11	7	1	0	19	63
07:15	0	0	0	0	0	0	33	6	0	39	3	0	10	0	13	9	7	0	0	16	68
07:20	0	0	0	0	0	0	43	14	0	57	2	0	3	0	5	19	17	0	0	36	98
07:25	1	0	0	0	1	0	45	13	0	58	4	0	6	0	10	12	10	0	0	22	91
07:30	0	0	0	0	0	0	46	9	0	55	3	0	10	0	13	11	7	0	0	18	86
07:35	0	0	0	0	0	0	43	2	0	45	3	0	11	0	14	3	9	0	0	12	71
07:40	0	0	0	0	0	1	35	3	0	39	4	0	7	0	11	3	9	0	0	12	62
07:45	0	0	1	0	1	0	42	0	0	42	0	0	1	0	1	4	11	0	0	15	59
07:50	0	0	0	0	0	0	35	1	0	36	1	0	1	0	2	0	6	1	0	7	45
07:55	2	0	0	0	2	0	32	2	0	34	1	0	1	0	2	1	7	0	0	8	46
Total	5	0	1	0	6	2	453	59	0	514	24	0	60	0	84	90	96	2	0	188	792
08:00	0	0	0	0	0	0	27	1	0	28	1	0	4	0	5	2	7	1	0	10	43
08:05	0	0	0	0	0	1	39	0	0	40	0	0	3	0	3	0	12	0	0	12	55
08:10	1	0	0	0	1	0	35	1	0	36	1	0	1	0	2	0	7	0	0	7	46
08:15	1	0	0	0	1	0	20	0	0	20	1	0	0	0	1	1	9	0	0	10	32
08:20	1	0	0	0	1	0	30	0	0	30	0	0	0	0	0	4	13	1	0	18	49
08:25	0	0	0	0	0	0	26	0	0	26	1	0	0	0	1	2	8	0	0	10	37
Grand Total	9	0	1	0	10	3	807	65	0	875	30	0	80	0	110	118	178	6	0	302	1297
Apprch %	90	0	10	0		0.3	92.2	7.4	0		27.3	0	72.7	0		39.1	58.9	2	0		
Total %	0.7	0	0.1	0	0.8	0.2	62.2	5	0	67.5	2.3	0	6.2	0	8.5	9.1	13.7	0.5	0	23.3	

LSC Transportation Consultants, Inc.

2504 E. Pikes Peak Ave, Suite 304
 Colorado Springs, CO 80909
 719-633-2868

File Name : Monument Hill Rd - County Line Rd AM
 Site Code : S234450
 Start Date : 1/10/2024
 Page No : 2

Start Time	S Andrews Rd Southbound					County Line Rd Westbound					Monument Hill Rd Northbound					County Line Rd Eastbound					Int. Total
	Right	Thru	Left	Peds	App. Total	Right	Thru	Left	Peds	App. Total	Right	Thru	Left	Peds	App. Total	Right	Thru	Left	Peds	App. Total	
Peak Hour Analysis From 06:30 to 08:25 - Peak 1 of 1																					
Peak Hour for Entire Intersection Begins at 07:00																					
07:00	2	0	0	0	2	1	35	1	0	37	0	0	2	0	2	9	1	0	0	10	51
07:05	0	0	0	0	0	0	30	3	0	33	2	0	4	0	6	8	5	0	0	13	52
07:10	0	0	0	0	0	0	34	5	0	39	1	0	4	0	5	11	7	1	0	19	63
07:15	0	0	0	0	0	0	33	6	0	39	3	0	10	0	13	9	7	0	0	16	68
07:20	0	0	0	0	0	0	43	14	0	57	2	0	3	0	5	19	17	0	0	36	98
07:25	1	0	0	0	1	0	45	13	0	58	4	0	6	0	10	12	10	0	0	22	91
07:30	0	0	0	0	0	0	46	9	0	55	3	0	10	0	13	11	7	0	0	18	86
07:35	0	0	0	0	0	0	43	2	0	45	3	0	11	0	14	3	9	0	0	12	71
07:40	0	0	0	0	0	1	35	3	0	39	4	0	7	0	11	3	9	0	0	12	62
07:45	0	0	1	0	1	0	42	0	0	42	0	0	1	0	1	4	11	0	0	15	59
07:50	0	0	0	0	0	0	35	1	0	36	1	0	1	0	2	0	6	1	0	7	45
07:55	2	0	0	0	2	0	32	2	0	34	1	0	1	0	2	1	7	0	0	8	46
Total Volume	5	0	1	0	6	2	453	59	0	514	24	0	60	0	84	90	96	2	0	188	792
% App. Total	83.3	0	16.7	0		0.4	88.1	11.5	0		28.6	0	71.4	0		47.9	51.1	1.1	0		
PHF	.208	.000	.083	.000	.250	.167	.821	.351	.000	.739	.500	.000	.455	.000	.500	.395	.471	.167	.000	.435	.673

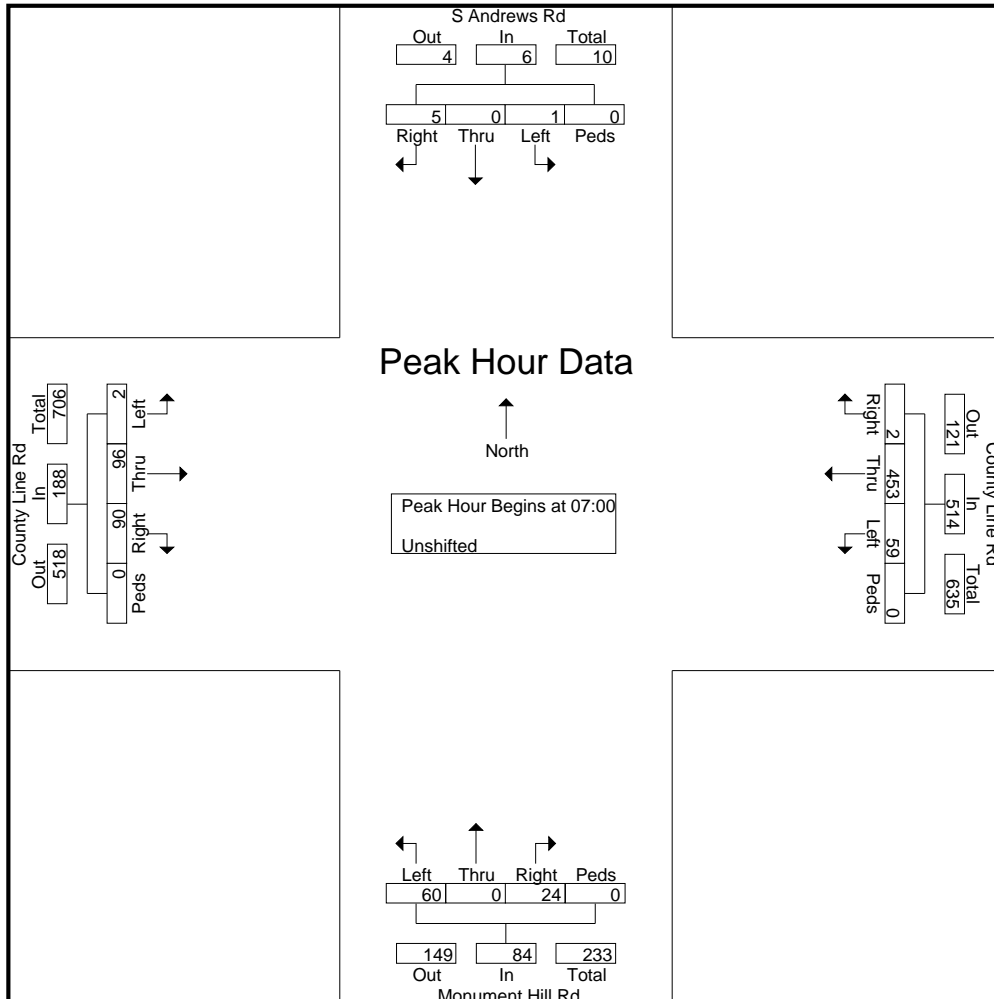

LSC Transportation Consultants, Inc.

2504 E. Pikes Peak Ave, Suite 304
 Colorado Springs, CO 80909
 719-633-2868

File Name : Monument Hill Rd - County Line Rd AM
 Site Code : S234450
 Start Date : 1/10/2024
 Page No : 3

Start Time	S Andrews Rd Southbound					County Line Rd Westbound					Monument Hill Rd Northbound					County Line Rd Eastbound					Int. Total
	Right	Thru	Left	Peds	App. Total	Right	Thru	Left	Peds	App. Total	Right	Thru	Left	Peds	App. Total	Right	Thru	Left	Peds	App. Total	
Peak Hour Analysis From 06:30 to 08:25 - Peak 1 of 1																					
Peak Hour for Each Approach Begins at:																					
	07:25					07:00					07:05					06:50					
+0 mins.	1	0	0	0	1	1	35	1	0	37	2	0	4	0	6	5	3	0	0	8	
+5 mins.	0	0	0	0	0	0	30	3	0	33	1	0	4	0	5	6	6	1	0	13	
+10 mins.	0	0	0	0	0	0	34	5	0	39	3	0	10	0	13	9	1	0	0	10	
+15 mins.	0	0	0	0	0	0	33	6	0	39	2	0	3	0	5	8	5	0	0	13	
+20 mins.	0	0	1	0	1	0	43	14	0	57	4	0	6	0	10	11	7	1	0	19	
+25 mins.	0	0	0	0	0	0	45	13	0	58	3	0	10	0	13	9	7	0	0	16	
+30 mins.	2	0	0	0	2	0	46	9	0	55	3	0	11	0	14	19	17	0	0	36	
+35 mins.	0	0	0	0	0	0	43	2	0	45	4	0	7	0	11	12	10	0	0	22	
+40 mins.	0	0	0	0	0	1	35	3	0	39	0	0	1	0	1	11	7	0	0	18	
+45 mins.	1	0	0	0	1	0	42	0	0	42	1	0	1	0	2	3	9	0	0	12	
+50 mins.	1	0	0	0	1	0	35	1	0	36	1	0	1	0	2	3	9	0	0	12	
+55 mins.	1	0	0	0	1	0	32	2	0	34	1	0	4	0	5	4	11	0	0	15	
Total Volume	6	0	1	0	7	2	453	59	0	514	25	0	62	0	87	100	92	2	0	194	
% App. Total	85.7	0	14.3	0		0.4	88.1	11.5	0		28.7	0	71.3	0		51.5	47.4	1	0		
PHF	.250	.000	.083	.000	.292	.167	.821	.351	.000	.739	.521	.000	.470	.000	.518	.439	.451	.167	.000	.449	

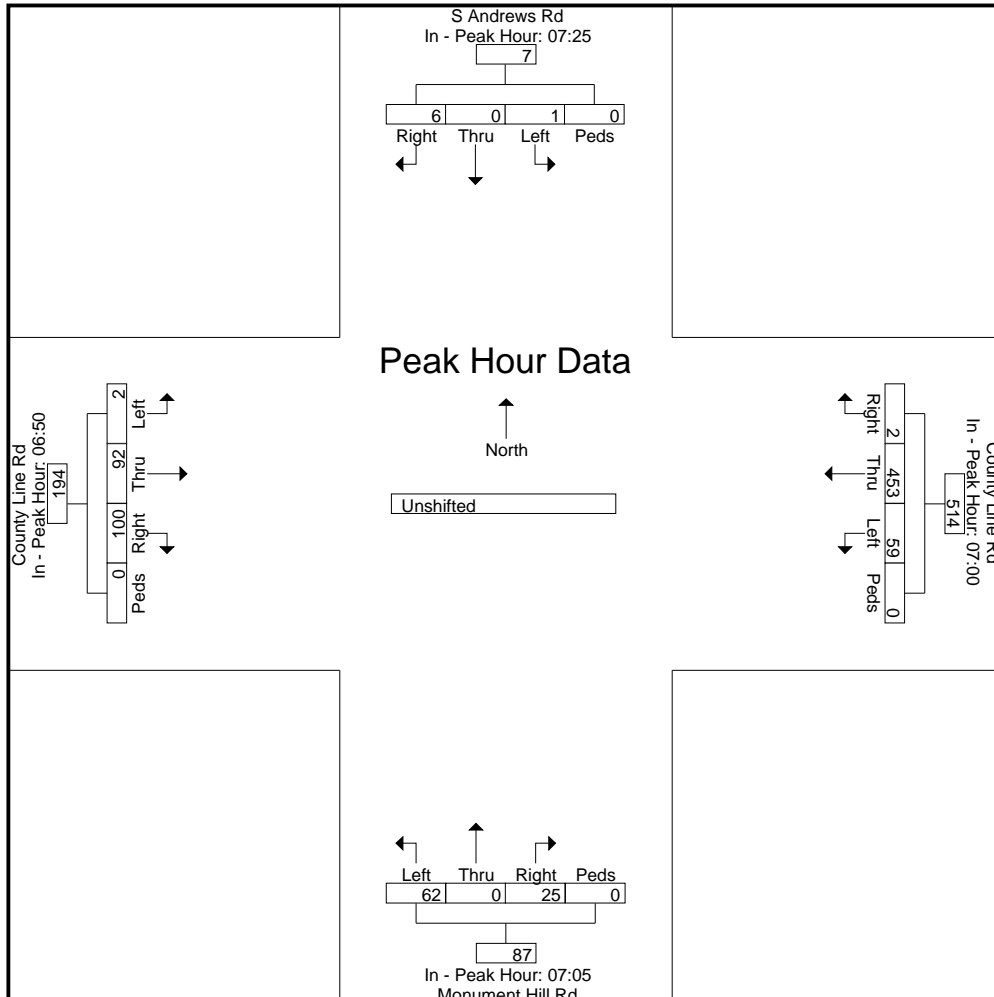

LSC Transportation Consultants, Inc.

2504 E. Pikes Peak Ave, Suite 304
 Colorado Springs, CO 80909
 719-633-2868

File Name : Monument Hill Rd - County Line Rd PM
 Site Code : S234450
 Start Date : 1/9/2024
 Page No : 1

Groups Printed- Unshifted

Start Time	S Andrews Rd Southbound					County Line Rd Westbound					Monument Hill Rd Northbound					County Line Rd Eastbound					Int. Total
	Right	Thru	Left	Peds	App. Total	Right	Thru	Left	Peds	App. Total	Right	Thru	Left	Peds	App. Total	Right	Thru	Left	Peds	App. Total	
16:00	0	0	0	0	0	0	18	2	0	20	0	0	0	0	0	0	22	0	0	22	42
16:05	0	0	0	0	0	0	16	1	0	17	0	0	0	0	0	0	19	0	0	19	36
16:10	0	0	1	0	1	0	19	2	0	21	2	0	0	0	2	2	21	0	0	23	47
16:15	0	0	0	0	0	0	20	1	0	21	1	0	1	0	2	3	27	0	0	30	53
16:20	0	0	0	0	0	1	20	0	0	21	1	0	3	0	4	4	33	0	0	37	62
16:25	0	0	0	0	0	0	17	0	0	17	1	0	2	0	3	2	25	0	0	27	47
16:30	0	0	0	0	0	0	15	1	0	16	1	0	1	0	2	4	29	0	0	33	51
16:35	0	0	0	0	0	0	12	3	0	15	0	0	3	0	3	4	27	2	0	33	51
16:40	0	0	0	0	0	0	18	1	0	19	4	0	3	0	7	0	37	0	0	37	63
16:45	1	0	0	0	1	0	17	3	0	20	3	0	7	0	10	1	27	0	0	28	59
16:50	0	0	0	0	0	0	16	2	0	18	3	0	2	0	5	1	26	1	0	28	51
16:55	0	0	0	0	0	0	10	0	0	10	2	0	1	0	3	3	39	0	0	42	55
Total	1	0	1	0	2	1	198	16	0	215	18	0	23	0	41	24	332	3	0	359	617
17:00	0	0	0	0	0	0	15	1	0	16	0	0	4	0	4	0	25	1	0	26	46
17:05	0	0	1	0	1	1	13	0	0	14	4	0	1	0	5	5	22	0	0	27	47
17:10	0	0	0	0	0	0	17	0	0	17	0	0	0	0	0	1	32	0	0	33	50
17:15	1	0	0	0	1	0	12	0	0	12	2	0	3	0	5	0	32	0	0	32	50
17:20	0	0	0	0	0	0	14	3	0	17	2	0	1	0	3	5	31	0	0	36	56
17:25	0	0	1	0	1	0	9	2	0	11	0	0	4	0	4	2	36	0	0	38	54
17:30	0	0	0	0	0	0	21	0	0	21	0	0	5	0	5	2	27	1	0	30	56
17:35	1	0	0	0	1	1	12	0	0	13	1	0	6	0	7	3	27	0	0	30	51
17:40	0	0	0	0	0	0	10	0	0	10	6	0	1	0	7	0	39	0	0	39	56
17:45	0	0	0	0	0	0	9	0	0	9	4	0	3	0	7	2	25	2	0	29	45
17:50	0	0	0	0	0	0	5	0	0	5	0	0	3	0	3	2	21	0	0	23	31
17:55	2	0	0	0	2	0	18	1	0	19	1	0	1	0	2	3	19	0	0	22	45
Total	4	0	2	0	6	2	155	7	0	164	20	0	32	0	52	25	336	4	0	365	587
Grand Total	5	0	3	0	8	3	353	23	0	379	38	0	55	0	93	49	668	7	0	724	1204
Apprch %	62.5	0	37.5	0		0.8	93.1	6.1	0		40.9	0	59.1	0		6.8	92.3	1	0		
Total %	0.4	0	0.2	0	0.7	0.2	29.3	1.9	0	31.5	3.2	0	4.6	0	7.7	4.1	55.5	0.6	0	60.1	

LSC Transportation Consultants, Inc.

2504 E. Pikes Peak Ave, Suite 304
 Colorado Springs, CO 80909
 719-633-2868

File Name : Monument Hill Rd - County Line Rd PM
 Site Code : S234450
 Start Date : 1/9/2024
 Page No : 2

Start Time	S Andrews Rd Southbound					County Line Rd Westbound					Monument Hill Rd Northbound					County Line Rd Eastbound					Int. Total
	Right	Thru	Left	Peds	App. Total	Right	Thru	Left	Peds	App. Total	Right	Thru	Left	Peds	App. Total	Right	Thru	Left	Peds	App. Total	
Peak Hour Analysis From 16:00 to 17:55 - Peak 1 of 1																					
Peak Hour for Entire Intersection Begins at 16:35																					
16:35	0	0	0	0	0	0	12	3	0	15	0	0	3	0	3	4	27	2	0	33	51
16:40	0	0	0	0	0	0	18	1	0	19	4	0	3	0	7	0	37	0	0	37	63
16:45	1	0	0	0	1	0	17	3	0	20	3	0	7	0	10	1	27	0	0	28	59
16:50	0	0	0	0	0	0	16	2	0	18	3	0	2	0	5	1	26	1	0	28	51
16:55	0	0	0	0	0	0	10	0	0	10	2	0	1	0	3	3	39	0	0	42	55
17:00	0	0	0	0	0	0	15	1	0	16	0	0	4	0	4	0	25	1	0	26	46
17:05	0	0	1	0	1	1	13	0	0	14	4	0	1	0	5	5	22	0	0	27	47
17:10	0	0	0	0	0	0	17	0	0	17	0	0	0	0	0	1	32	0	0	33	50
17:15	1	0	0	0	1	0	12	0	0	12	2	0	3	0	5	0	32	0	0	32	50
17:20	0	0	0	0	0	0	14	3	0	17	2	0	1	0	3	5	31	0	0	36	56
17:25	0	0	1	0	1	0	9	2	0	11	0	0	4	0	4	2	36	0	0	38	54
17:30	0	0	0	0	0	0	21	0	0	21	0	0	5	0	5	2	27	1	0	30	56
Total Volume	2	0	2	0	4	1	174	15	0	190	20	0	34	0	54	24	361	5	0	390	638
% App. Total	50	0	50	0		0.5	91.6	7.9	0		37	0	63	0		6.2	92.6	1.3	0		
PHF	.167	.000	.167	.000	.333	.083	.690	.417	.000	.754	.417	.000	.405	.000	.450	.400	.771	.208	.000	.774	.844

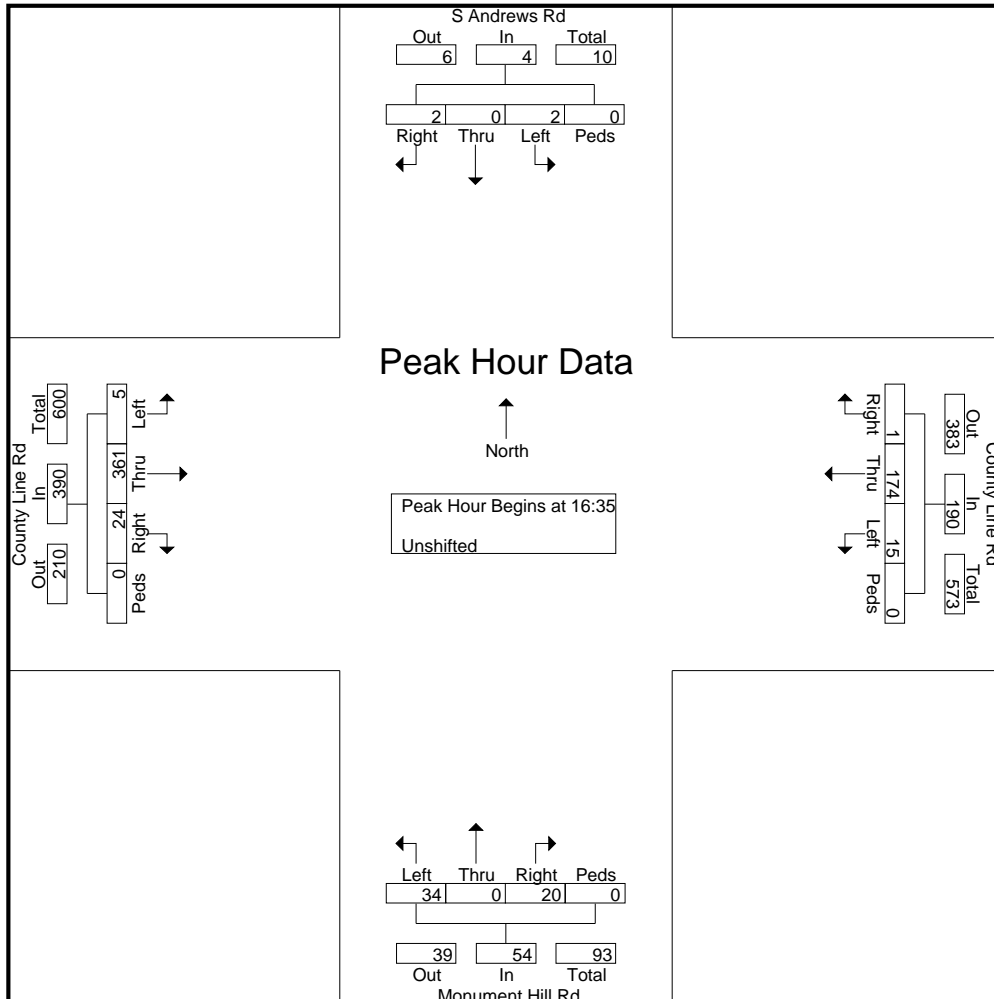

LSC Transportation Consultants, Inc.

2504 E. Pikes Peak Ave, Suite 304
 Colorado Springs, CO 80909
 719-633-2868

File Name : Monument Hill Rd - County Line Rd PM
 Site Code : S234450
 Start Date : 1/9/2024
 Page No : 3

Start Time	S Andrews Rd Southbound					County Line Rd Westbound					Monument Hill Rd Northbound					County Line Rd Eastbound					Int. Total
	Right	Thru	Left	Peds	App. Total	Right	Thru	Left	Peds	App. Total	Right	Thru	Left	Peds	App. Total	Right	Thru	Left	Peds	App. Total	
Peak Hour Analysis From 16:00 to 17:55 - Peak 1 of 1																					
Peak Hour for Each Approach Begins at:																					
	17:00					16:00					16:40					16:30					
+0 mins.	0	0	0	0	0	0	18	2	0	20	4	0	3	0	7	4	29	0	0	33	
+5 mins.	0	0	1	0	1	0	16	1	0	17	3	0	7	0	10	4	27	2	0	33	
+10 mins.	0	0	0	0	0	0	19	2	0	21	3	0	2	0	5	0	37	0	0	37	
+15 mins.	1	0	0	0	1	0	20	1	0	21	2	0	1	0	3	1	27	0	0	28	
+20 mins.	0	0	0	0	0	1	20	0	0	21	0	0	4	0	4	1	26	1	0	28	
+25 mins.	0	0	1	0	1	0	17	0	0	17	4	0	1	0	5	3	39	0	0	42	
+30 mins.	0	0	0	0	0	0	15	1	0	16	0	0	0	0	0	0	25	1	0	26	
+35 mins.	1	0	0	0	1	0	12	3	0	15	2	0	3	0	5	5	22	0	0	27	
+40 mins.	0	0	0	0	0	0	18	1	0	19	2	0	1	0	3	1	32	0	0	33	
+45 mins.	0	0	0	0	0	0	17	3	0	20	0	0	4	0	4	0	32	0	0	32	
+50 mins.	0	0	0	0	0	0	16	2	0	18	0	0	5	0	5	5	31	0	0	36	
+55 mins.	2	0	0	0	2	0	10	0	0	10	1	0	6	0	7	2	36	0	0	38	
Total Volume	4	0	2	0	6	1	198	16	0	215	21	0	37	0	58	26	363	4	0	393	
% App. Total	66.7	0	33.3	0		0.5	92.1	7.4	0		36.2	0	63.8	0		6.6	92.4	1	0		
PHF	.167	.000	.167	.000	.250	.083	.825	.444	.000	.853	.438	.000	.440	.000	.483	.433	.776	.167	.000	.780	

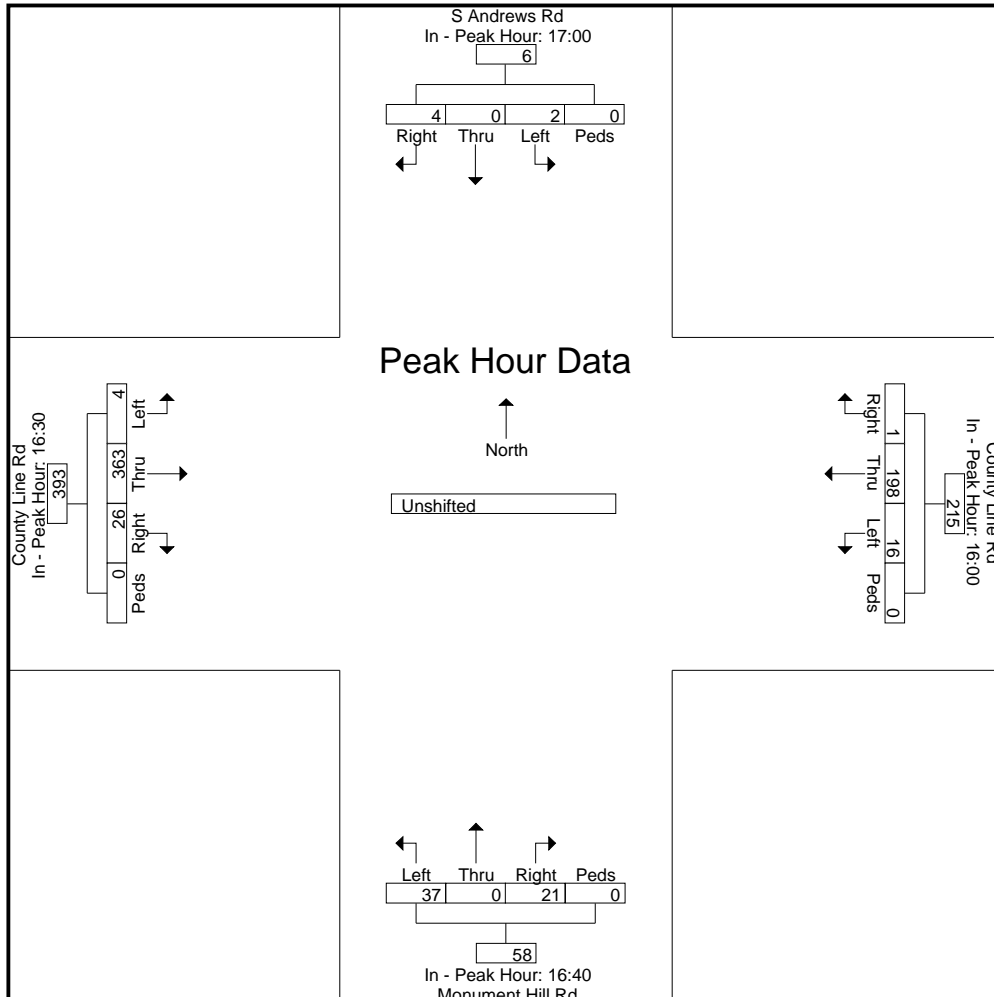

LSC Transportation Consultants, Inc.

2504 E. Pikes Peak Ave, Suite 304
 Colorado Springs, CO 80909
 719-633-2868

File Name : Monument Hill Rd - N Misty Acres Blvd AM 1-24-24

Site Code : S234450

Start Date : 1/24/2024

Page No : 1

Groups Printed- Unshifted

Start Time	Monument Hill Rd Southbound					N Misty Acres Blvd Westbound					Monument Hill Rd Northbound					Eastbound					Int. Total	
	Right	Thru	Left	Peds	App. Total	Right	Thru	Left	Peds	App. Total	Right	Thru	Left	Peds	App. Total	Right	Thru	Left	Peds	App. Total		
06:30	0	1	0	0	1	0	0	0	0	0	0	1	0	0	1	0	0	0	0	0	0	2
06:35	0	3	0	0	3	0	0	0	0	0	0	2	0	0	2	0	0	0	0	0	0	5
06:40	0	2	0	0	2	0	0	0	0	0	0	0	0	0	0	0	0	0	0	0	0	2
06:45	0	5	0	0	5	0	0	0	0	0	0	2	0	0	2	0	0	0	0	0	0	7
06:50	0	7	1	0	8	0	0	0	0	0	0	1	0	0	1	0	0	0	0	0	0	9
06:55	0	3	0	0	3	0	0	0	0	0	0	6	0	0	6	0	0	0	0	0	0	9
Total	0	21	1	0	22	0	0	0	0	0	0	12	0	0	12	0	0	0	0	0	0	34
07:00	0	6	0	0	6	0	0	0	0	0	0	1	0	0	1	0	0	0	0	0	0	7
07:05	0	9	0	0	9	0	0	0	0	0	0	5	0	0	5	0	0	0	0	0	0	14
07:10	0	26	1	0	27	2	0	0	0	2	0	8	0	0	8	0	0	0	0	0	0	37
07:15	0	18	0	0	18	0	0	0	0	0	0	12	0	0	12	0	0	0	0	0	0	30
07:20	0	17	0	0	17	0	0	0	0	0	0	5	0	0	5	0	0	0	0	0	0	22
07:25	0	26	2	0	28	1	0	0	0	1	0	6	0	0	6	0	0	0	0	0	0	35
07:30	0	22	0	0	22	0	0	0	0	0	0	6	0	0	6	0	0	0	0	0	0	28
07:35	0	6	0	0	6	1	0	0	0	1	0	11	0	0	11	0	0	0	0	0	0	18
07:40	0	4	0	0	4	0	0	0	0	0	0	5	0	0	5	0	0	0	0	0	0	9
07:45	0	2	0	0	2	0	0	0	0	0	0	4	0	0	4	0	0	0	0	0	0	6
07:50	0	2	0	0	2	0	0	0	0	0	0	1	0	0	1	0	0	0	0	0	0	3
07:55	0	5	0	0	5	1	0	0	0	1	0	1	0	0	1	0	0	0	0	0	0	7
Total	0	143	3	0	146	5	0	0	0	5	0	65	0	0	65	0	0	0	0	0	0	216
08:00	0	1	0	0	1	0	0	0	0	0	1	5	0	0	6	0	0	0	0	0	0	7
08:05	0	4	0	0	4	0	0	0	0	0	0	1	0	0	1	0	0	0	0	0	0	5
08:10	0	4	0	0	4	0	0	0	0	0	0	1	0	0	1	0	0	0	0	0	0	5
08:15	0	1	0	0	1	0	0	0	0	0	0	2	0	0	2	0	0	0	0	0	0	3
08:20	0	4	1	0	5	0	0	0	0	0	0	3	0	0	3	0	0	0	0	0	0	8
08:25	0	2	0	0	2	0	0	0	0	0	0	3	0	0	3	0	0	0	0	0	0	5
Grand Total	0	180	5	0	185	5	0	0	0	5	1	92	0	0	93	0	0	0	0	0	0	283
Apprch %	0	97.3	2.7	0		100	0	0	0		1.1	98.9	0	0		0	0	0	0	0	0	
Total %	0	63.6	1.8	0	65.4	1.8	0	0	0	1.8	0.4	32.5	0	0	32.9	0	0	0	0	0	0	

LSC Transportation Consultants, Inc.

2504 E. Pikes Peak Ave, Suite 304
 Colorado Springs, CO 80909
 719-633-2868

File Name : Monument Hill Rd - N Misty Acres Blvd AM 1-24-24
 Site Code : S234450
 Start Date : 1/24/2024
 Page No : 2

Start Time	Monument Hill Rd Southbound					N Misty Acres Blvd Westbound					Monument Hill Rd Northbound					Eastbound					Int. Total
	Right	Thru	Left	Peds	App. Total	Right	Thru	Left	Peds	App. Total	Right	Thru	Left	Peds	App. Total	Right	Thru	Left	Peds	App. Total	
Peak Hour Analysis From 06:30 to 08:25 - Peak 1 of 1																					
Peak Hour for Entire Intersection Begins at 06:45																					
06:45	0	5	0	0	5	0	0	0	0	0	0	2	0	0	2	0	0	0	0	0	7
06:50	0	7	1	0	8	0	0	0	0	0	0	1	0	0	1	0	0	0	0	0	9
06:55	0	3	0	0	3	0	0	0	0	0	0	6	0	0	6	0	0	0	0	0	9
07:00	0	6	0	0	6	0	0	0	0	0	0	1	0	0	1	0	0	0	0	0	7
07:05	0	9	0	0	9	0	0	0	0	0	0	5	0	0	5	0	0	0	0	0	14
07:10	0	26	1	0	27	2	0	0	0	2	0	8	0	0	8	0	0	0	0	0	37
07:15	0	18	0	0	18	0	0	0	0	0	0	12	0	0	12	0	0	0	0	0	30
07:20	0	17	0	0	17	0	0	0	0	0	0	5	0	0	5	0	0	0	0	0	22
07:25	0	26	2	0	28	1	0	0	0	1	0	6	0	0	6	0	0	0	0	0	35
07:30	0	22	0	0	22	0	0	0	0	0	0	6	0	0	6	0	0	0	0	0	28
07:35	0	6	0	0	6	1	0	0	0	1	0	11	0	0	11	0	0	0	0	0	18
07:40	0	4	0	0	4	0	0	0	0	0	0	5	0	0	5	0	0	0	0	0	9
Total Volume	0	149	4	0	153	4	0	0	0	4	0	68	0	0	68	0	0	0	0	0	225
% App. Total	0	97.4	2.6	0		100	0	0	0		0	100	0	0		0	0	0	0		
PHF	.000	.478	.167	.000	.455	.167	.000	.000	.000	.167	.000	.472	.000	.000	.472	.000	.000	.000	.000	.000	.507

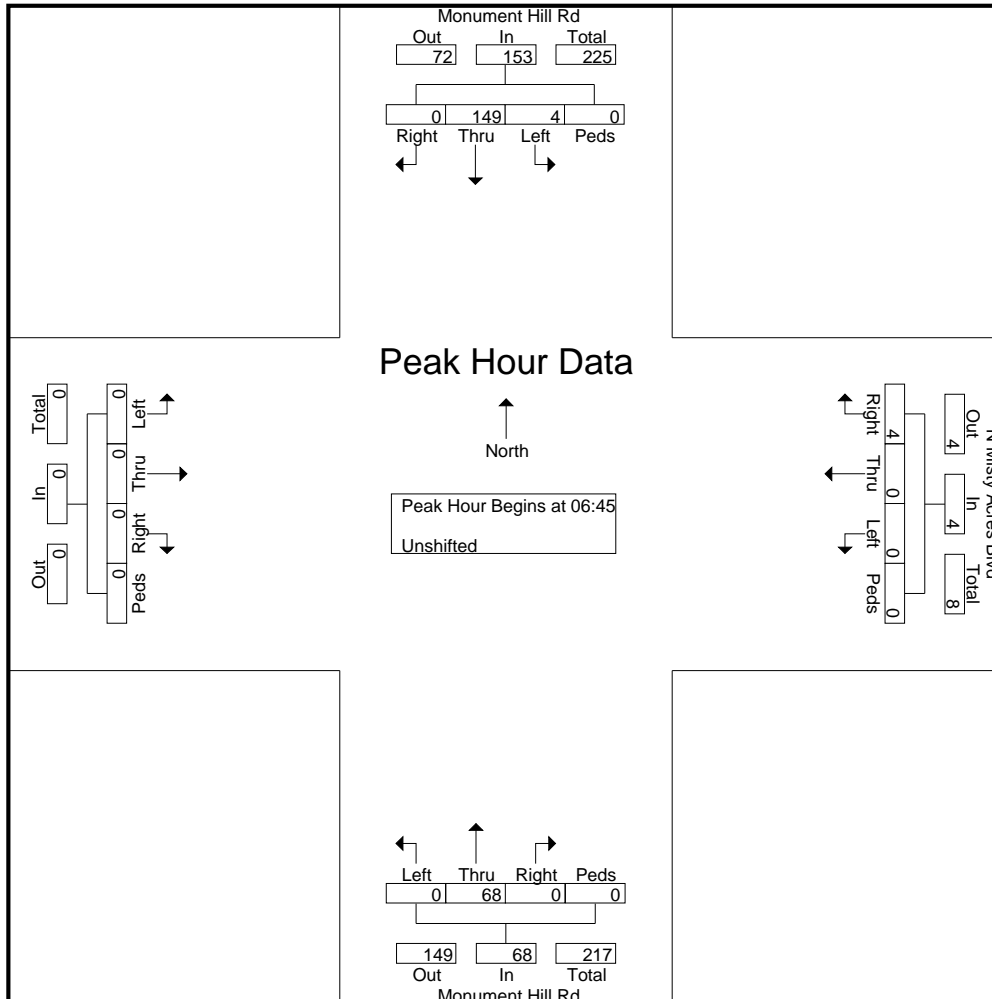

LSC Transportation Consultants, Inc.

2504 E. Pikes Peak Ave, Suite 304
 Colorado Springs, CO 80909
 719-633-2868

File Name : Monument Hill Rd - N Misty Acres Blvd AM 1-24-24
 Site Code : S234450
 Start Date : 1/24/2024
 Page No : 3

Start Time	Monument Hill Rd Southbound					N Misty Acres Blvd Westbound					Monument Hill Rd Northbound					Eastbound					Int. Total
	Right	Thru	Left	Peds	App. Total	Right	Thru	Left	Peds	App. Total	Right	Thru	Left	Peds	App. Total	Right	Thru	Left	Peds	App. Total	

Peak Hour Analysis From 06:30 to 08:25 - Peak 1 of 1
 Peak Hour for Each Approach Begins at:

	06:45					07:00					06:50					06:30				
+0 mins.	0	5	0	0	5	0	0	0	0	0	0	1	0	0	1	0	0	0	0	0
+5 mins.	0	7	1	0	8	0	0	0	0	0	0	6	0	0	6	0	0	0	0	0
+10 mins.	0	3	0	0	3	2	0	0	0	2	0	1	0	0	1	0	0	0	0	0
+15 mins.	0	6	0	0	6	0	0	0	0	0	0	5	0	0	5	0	0	0	0	0
+20 mins.	0	9	0	0	9	0	0	0	0	0	0	8	0	0	8	0	0	0	0	0
+25 mins.	0	26	1	0	27	1	0	0	0	1	0	12	0	0	12	0	0	0	0	0
+30 mins.	0	18	0	0	18	0	0	0	0	0	0	5	0	0	5	0	0	0	0	0
+35 mins.	0	17	0	0	17	1	0	0	0	1	0	6	0	0	6	0	0	0	0	0
+40 mins.	0	26	2	0	28	0	0	0	0	0	0	6	0	0	6	0	0	0	0	0
+45 mins.	0	22	0	0	22	0	0	0	0	0	0	11	0	0	11	0	0	0	0	0
+50 mins.	0	6	0	0	6	0	0	0	0	0	0	5	0	0	5	0	0	0	0	0
+55 mins.	0	4	0	0	4	1	0	0	0	1	0	4	0	0	4	0	0	0	0	0
Total Volume	0	149	4	0	153	5	0	0	0	5	0	70	0	0	70	0	0	0	0	0
% App. Total	0	97.4	2.6	0		100	0	0	0		0	100	0	0		0	0	0	0	
PHF	.000	.478	.167	.000	.455	.208	.000	.000	.000	.208	.000	.486	.000	.000	.486	.000	.000	.000	.000	.000

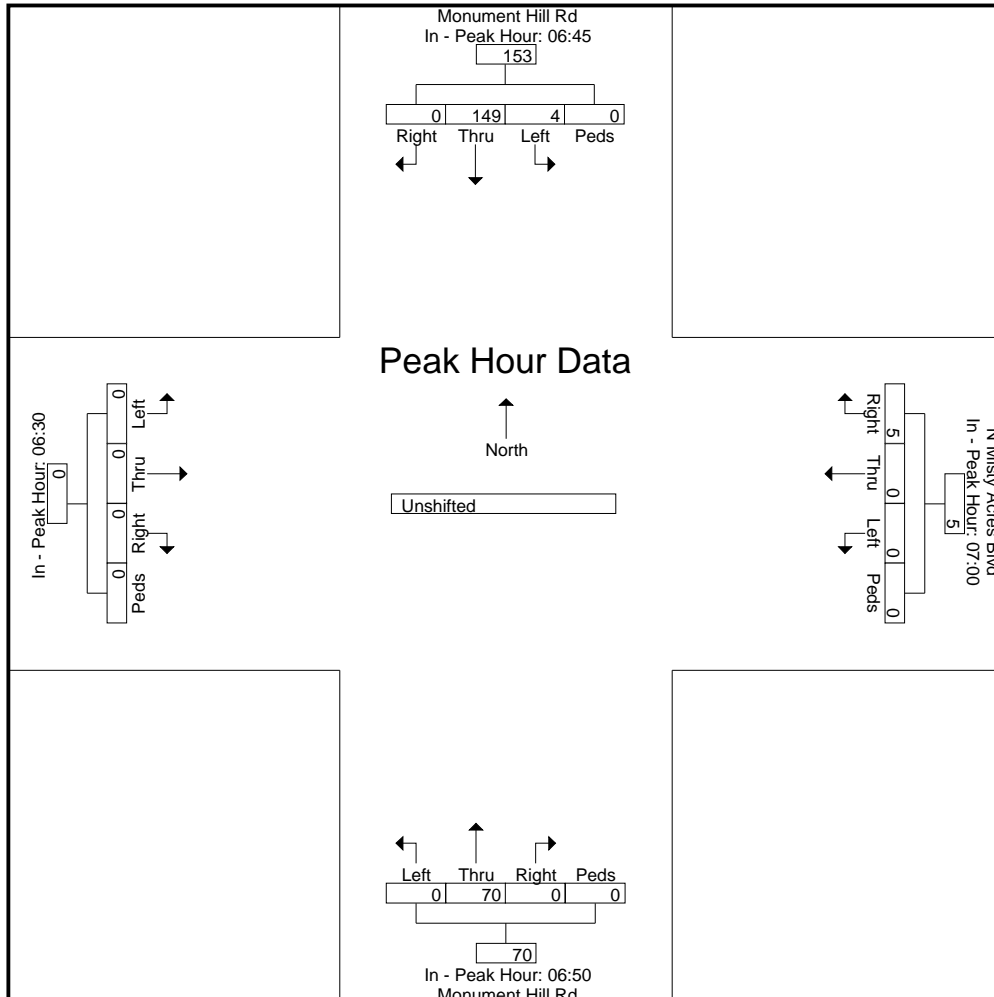

LSC Transportation Consultants, Inc.

2504 E. Pikes Peak Ave, Suite 304
 Colorado Springs, CO 80909
 719-633-2868

File Name : Monument Hill Rd - Misty Acres Blvd Mid 12-12-23

Site Code : S234450

Start Date : 12/12/2023

Page No : 1

Groups Printed- Unshifted

Start Time	Monument Hill Rd Southbound					Misty Acres Blvd Westbound					Monument Hill Rd Northbound					Eastbound					Int. Total	
	Right	Thru	Left	Peds	App. Total	Right	Thru	Left	Peds	App. Total	Right	Thru	Left	Peds	App. Total	Right	Thru	Left	Peds	App. Total		
13:45	0	3	0	0	3	0	0	0	0	0	0	2	0	0	2	0	0	0	0	0	0	5
13:50	0	2	0	0	2	0	0	0	0	0	0	3	0	0	3	0	0	0	0	0	0	5
13:55	0	2	0	0	2	0	0	0	0	0	0	3	0	0	3	0	0	0	0	0	0	5
Total	0	7	0	0	7	0	0	0	0	0	0	8	0	0	8	0	0	0	0	0	0	15
14:00	0	2	0	0	2	1	0	0	0	1	1	1	0	0	2	0	0	0	0	0	0	5
14:05	0	2	0	0	2	0	0	0	0	0	0	0	0	0	0	0	0	0	0	0	0	2
14:10	0	6	0	0	6	0	0	0	0	0	0	4	0	0	4	0	0	0	0	0	0	10
14:15	0	4	0	0	4	0	0	0	0	0	0	2	0	0	2	0	0	0	0	0	0	6
14:20	0	5	0	0	5	0	0	0	0	0	0	2	0	0	2	0	0	0	0	0	0	7
14:25	0	5	0	0	5	0	0	0	0	0	0	3	0	0	3	0	0	0	0	0	0	8
14:30	0	9	1	0	10	0	0	0	0	0	0	3	0	0	3	0	0	0	0	0	0	13
14:35	0	6	0	0	6	0	0	1	0	1	0	6	0	0	6	0	0	0	0	0	0	13
14:40	0	3	0	0	3	0	0	0	0	0	0	9	0	0	9	0	0	0	0	0	0	12
14:45	0	3	0	0	3	0	0	0	0	0	0	11	0	0	11	0	0	0	0	0	0	14
14:50	0	2	0	0	2	0	0	0	0	0	0	10	0	0	10	0	0	0	0	0	0	12
14:55	0	7	2	0	9	0	0	0	0	0	0	6	0	0	6	0	0	0	0	0	0	15
Total	0	54	3	0	57	1	0	1	0	2	1	57	0	0	58	0	0	0	0	0	0	117
15:00	0	2	0	0	2	1	0	0	0	1	0	7	0	0	7	0	0	0	0	0	0	10
15:05	0	3	0	0	3	0	0	0	0	0	0	5	0	0	5	0	0	0	0	0	0	8
15:10	0	1	0	0	1	0	0	0	0	0	0	4	0	0	4	0	0	0	0	0	0	5
15:15	0	5	0	0	5	0	0	0	0	0	0	9	0	0	9	0	0	0	0	0	0	14
15:20	0	2	0	0	2	0	0	0	0	0	0	3	0	0	3	0	0	0	0	0	0	5
15:25	0	5	0	0	5	0	0	0	0	0	0	5	0	0	5	0	0	0	0	0	0	10
15:30	0	3	0	0	3	0	0	0	0	0	0	4	0	0	4	0	0	0	0	0	0	7
15:35	0	4	0	0	4	0	0	0	0	0	0	4	0	0	4	0	0	0	0	0	0	8
15:40	0	6	0	0	6	0	0	0	0	0	1	2	0	0	3	0	0	0	0	0	0	9
Grand Total	0	92	3	0	95	2	0	1	0	3	2	108	0	0	110	0	0	0	0	0	0	208
Apprch %	0	96.8	3.2	0		66.7	0	33.3	0		1.8	98.2	0	0		0	0	0	0	0	0	
Total %	0	44.2	1.4	0	45.7	1	0	0.5	0	1.4	1	51.9	0	0	52.9	0	0	0	0	0	0	

LSC Transportation Consultants, Inc.

2504 E. Pikes Peak Ave, Suite 304
 Colorado Springs, CO 80909
 719-633-2868

File Name : Monument Hill Rd - Misty Acres Blvd Mid 12-12-23

Site Code : S234450

Start Date : 12/12/2023

Page No : 2

Start Time	Monument Hill Rd Southbound					Misty Acres Blvd Westbound					Monument Hill Rd Northbound					Eastbound					Int. Total
	Right	Thru	Left	Peds	App. Total	Right	Thru	Left	Peds	App. Total	Right	Thru	Left	Peds	App. Total	Right	Thru	Left	Peds	App. Total	
Peak Hour Analysis From 13:45 to 15:40 - Peak 1 of 1																					
Peak Hour for Entire Intersection Begins at 14:20																					
14:20	0	5	0	0	5	0	0	0	0	0	0	2	0	0	2	0	0	0	0	0	7
14:25	0	5	0	0	5	0	0	0	0	0	0	3	0	0	3	0	0	0	0	0	8
14:30	0	9	1	0	10	0	0	0	0	0	0	3	0	0	3	0	0	0	0	0	13
14:35	0	6	0	0	6	0	0	1	0	1	0	6	0	0	6	0	0	0	0	0	13
14:40	0	3	0	0	3	0	0	0	0	0	0	9	0	0	9	0	0	0	0	0	12
14:45	0	3	0	0	3	0	0	0	0	0	0	11	0	0	11	0	0	0	0	0	14
14:50	0	2	0	0	2	0	0	0	0	0	0	10	0	0	10	0	0	0	0	0	12
14:55	0	7	2	0	9	0	0	0	0	0	0	6	0	0	6	0	0	0	0	0	15
15:00	0	2	0	0	2	1	0	0	0	1	0	7	0	0	7	0	0	0	0	0	10
15:05	0	3	0	0	3	0	0	0	0	0	0	5	0	0	5	0	0	0	0	0	8
15:10	0	1	0	0	1	0	0	0	0	0	0	4	0	0	4	0	0	0	0	0	5
15:15	0	5	0	0	5	0	0	0	0	0	0	9	0	0	9	0	0	0	0	0	14
Total Volume	0	51	3	0	54	1	0	1	0	2	0	75	0	0	75	0	0	0	0	0	131
% App. Total	0	94.4	5.6	0		50	0	50	0		0	100	0	0		0	0	0	0		
PHF	.000	.472	.125	.000	.450	.083	.000	.083	.000	.167	.000	.568	.000	.000	.568	.000	.000	.000	.000	.000	.728

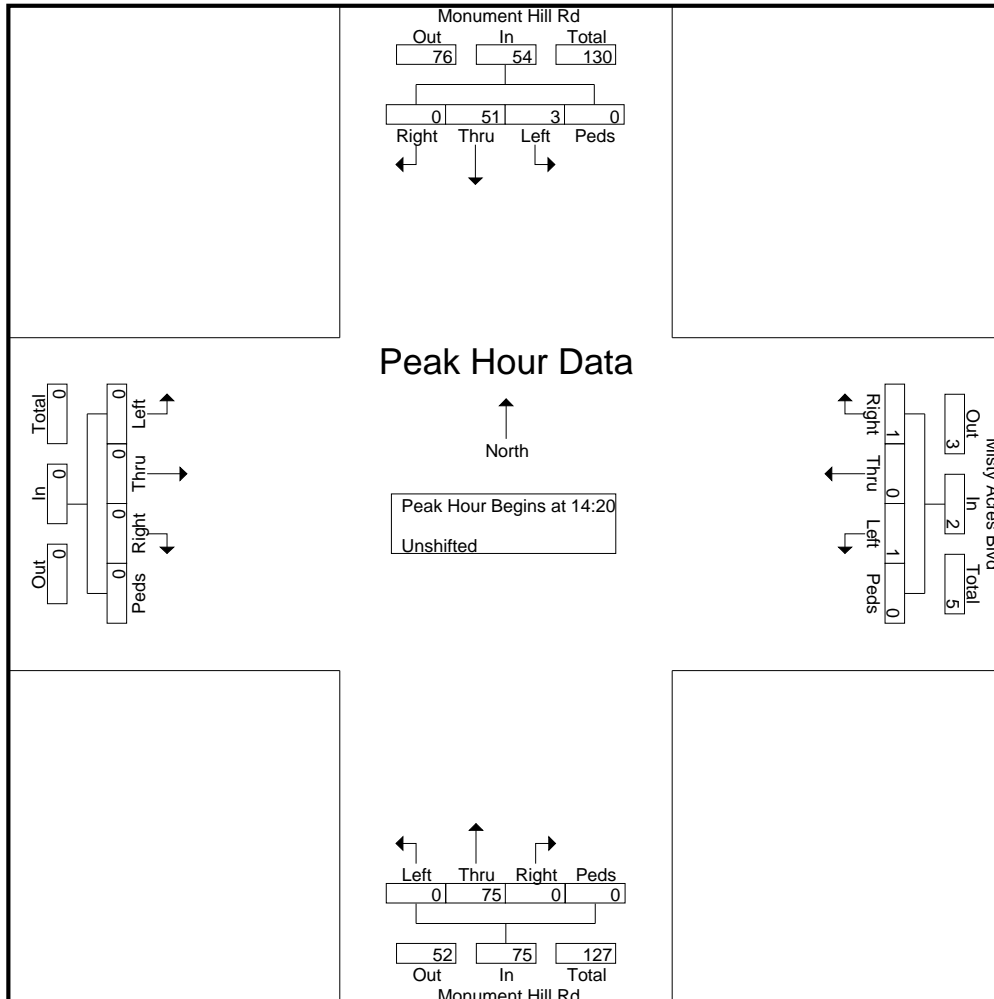

LSC Transportation Consultants, Inc.

2504 E. Pikes Peak Ave, Suite 304
 Colorado Springs, CO 80909
 719-633-2868

File Name : Monument Hill Rd - Misty Acres Blvd Mid 12-12-23
 Site Code : S234450
 Start Date : 12/12/2023
 Page No : 3

Start Time	Monument Hill Rd Southbound					Misty Acres Blvd Westbound					Monument Hill Rd Northbound					Eastbound					Int. Total
	Right	Thru	Left	Peds	App. Total	Right	Thru	Left	Peds	App. Total	Right	Thru	Left	Peds	App. Total	Right	Thru	Left	Peds	App. Total	

Peak Hour Analysis From 13:45 to 15:40 - Peak 1 of 1
 Peak Hour for Each Approach Begins at:

	14:10					13:45					14:35					13:45				
+0 mins.	0	6	0	0	6	0	0	0	0	0	0	6	0	0	6	0	0	0	0	0
+5 mins.	0	4	0	0	4	0	0	0	0	0	0	9	0	0	9	0	0	0	0	0
+10 mins.	0	5	0	0	5	0	0	0	0	0	0	11	0	0	11	0	0	0	0	0
+15 mins.	0	5	0	0	5	1	0	0	0	1	0	10	0	0	10	0	0	0	0	0
+20 mins.	0	9	1	0	10	0	0	0	0	0	0	6	0	0	6	0	0	0	0	0
+25 mins.	0	6	0	0	6	0	0	0	0	0	0	7	0	0	7	0	0	0	0	0
+30 mins.	0	3	0	0	3	0	0	0	0	0	0	5	0	0	5	0	0	0	0	0
+35 mins.	0	3	0	0	3	0	0	0	0	0	0	4	0	0	4	0	0	0	0	0
+40 mins.	0	2	0	0	2	0	0	0	0	0	0	9	0	0	9	0	0	0	0	0
+45 mins.	0	7	2	0	9	0	0	0	0	0	0	3	0	0	3	0	0	0	0	0
+50 mins.	0	2	0	0	2	0	0	1	0	1	0	5	0	0	5	0	0	0	0	0
+55 mins.	0	3	0	0	3	0	0	0	0	0	0	4	0	0	4	0	0	0	0	0
Total Volume	0	55	3	0	58	1	0	1	0	2	0	79	0	0	79	0	0	0	0	0
% App. Total	0	94.8	5.2	0		50	0	50	0		0	100	0	0		0	0	0	0	
PHF	.000	.509	.125	.000	.483	.083	.000	.083	.000	.167	.000	.598	.000	.000	.598	.000	.000	.000	.000	.000

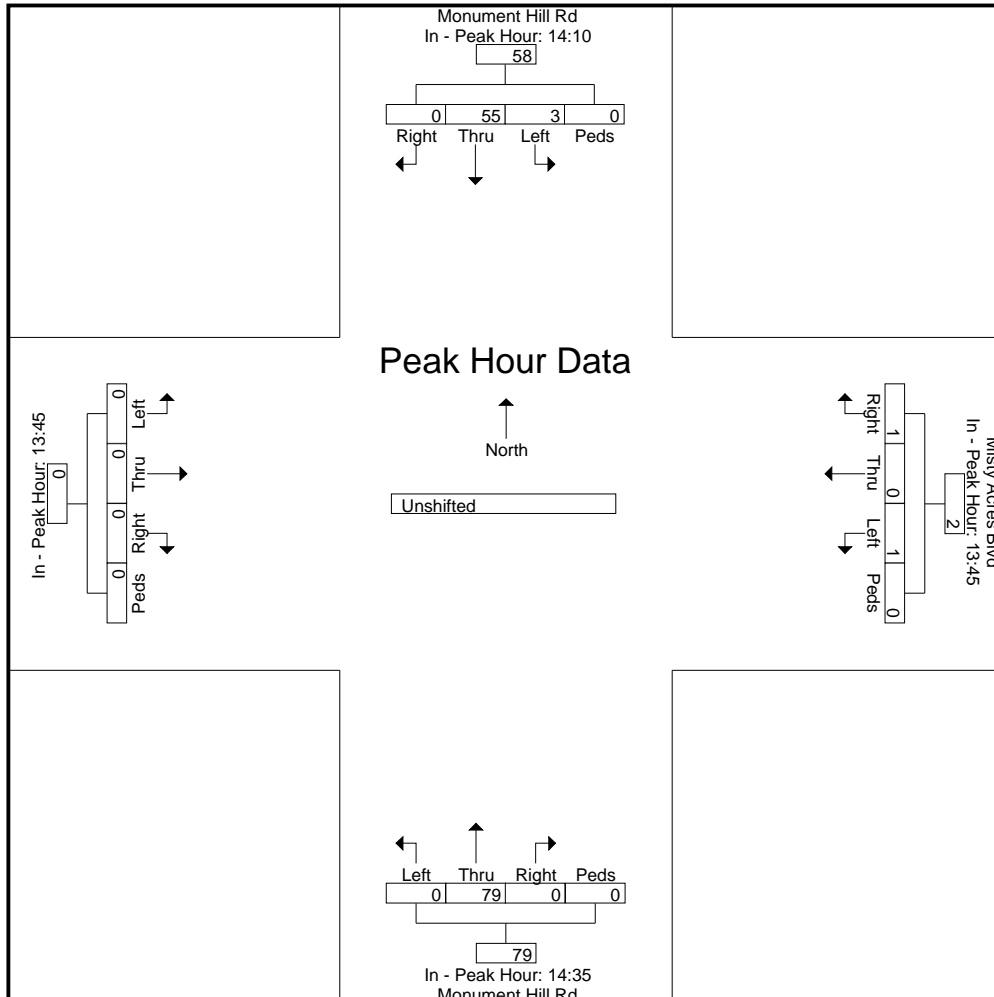

LSC Transportation Consultants, Inc.

2504 E. Pikes Peak Ave, Suite 304
 Colorado Springs, CO 80909
 719-633-2868

File Name : Monument Hill Rd - Misty Acres Blvd PM 12-12-23

Site Code : S234450

Start Date : 12/12/2023

Page No : 1

Groups Printed- Unshifted

Start Time	Monument Hill Rd Southbound					Misty Acres Blvd Westbound					Monument Hill Rd Northbound					Eastbound					Int. Total	
	Right	Thru	Left	Peds	App. Total	Right	Thru	Left	Peds	App. Total	Right	Thru	Left	Peds	App. Total	Right	Thru	Left	Peds	App. Total		
15:45	0	3	0	0	3	0	0	0	0	0	0	2	0	0	2	0	0	0	0	0	0	5
15:50	0	2	0	0	2	0	0	0	0	0	0	3	0	0	3	0	0	0	0	0	0	5
15:55	0	2	0	0	2	0	0	0	0	0	0	3	0	0	3	0	0	0	0	0	0	5
Total	0	7	0	0	7	0	0	0	0	0	0	8	0	0	8	0	0	0	0	0	0	15
16:00	0	4	0	0	4	0	0	0	0	0	0	1	0	0	1	0	0	0	0	0	0	5
16:05	0	2	0	0	2	0	0	0	0	0	0	2	0	0	2	0	0	0	0	0	0	4
16:10	0	2	0	0	2	1	0	0	0	1	1	3	0	0	4	0	0	0	0	0	0	7
16:15	0	5	0	0	5	0	0	0	0	0	0	1	0	0	1	0	0	0	0	0	0	6
16:20	0	3	0	0	3	0	0	0	0	0	1	1	0	0	2	0	0	0	0	0	0	5
16:25	0	5	1	0	6	1	0	0	0	1	0	5	0	0	5	0	0	0	0	0	0	12
16:30	0	4	1	0	5	0	0	0	0	0	0	3	0	0	3	0	0	0	0	0	0	8
16:35	0	3	1	0	4	0	0	0	0	0	0	3	0	0	3	0	0	0	0	0	0	7
16:40	0	6	1	0	7	1	0	0	0	1	0	3	0	0	3	0	0	0	0	0	0	11
16:45	0	2	1	0	3	0	0	0	0	0	0	0	0	0	0	0	0	0	0	0	0	3
16:50	0	2	0	0	2	0	0	0	0	0	0	6	0	0	6	0	0	0	0	0	0	8
16:55	0	1	0	0	1	1	0	0	0	1	0	1	0	0	1	0	0	0	0	0	0	3
Total	0	39	5	0	44	4	0	0	0	4	2	29	0	0	31	0	0	0	0	0	0	79
17:00	0	3	0	0	3	0	0	0	0	0	0	1	0	0	1	0	0	0	0	0	0	4
17:05	0	6	0	0	6	0	0	0	0	0	0	1	0	0	1	0	0	0	0	0	0	7
17:10	0	4	0	0	4	0	0	0	0	0	0	4	0	0	4	0	0	0	0	0	0	8
17:15	0	3	0	0	3	0	0	0	0	0	0	3	0	0	3	0	0	0	0	0	0	6
17:20	0	4	0	0	4	1	0	0	0	1	0	3	0	0	3	0	0	0	0	0	0	8
17:25	0	7	1	0	8	0	0	0	0	0	0	1	0	0	1	0	0	0	0	0	0	9
17:30	0	2	0	0	2	0	0	0	0	0	0	4	0	0	4	0	0	0	0	0	0	6
17:35	0	2	0	0	2	0	0	0	0	0	0	2	0	0	2	0	0	0	0	0	0	4
17:40	0	2	0	0	2	0	0	0	0	0	0	3	0	0	3	0	0	0	0	0	0	5
Grand Total	0	79	6	0	85	5	0	0	0	5	2	59	0	0	61	0	0	0	0	0	0	151
Apprch %	0	92.9	7.1	0		100	0	0	0		3.3	96.7	0	0		0	0	0	0	0	0	
Total %	0	52.3	4	0	56.3	3.3	0	0	0	3.3	1.3	39.1	0	0	40.4	0	0	0	0	0	0	

LSC Transportation Consultants, Inc.

2504 E. Pikes Peak Ave, Suite 304
 Colorado Springs, CO 80909
 719-633-2868

File Name : Monument Hill Rd - Misty Acres Blvd PM 12-12-23
 Site Code : S234450
 Start Date : 12/12/2023
 Page No : 2

Start Time	Monument Hill Rd Southbound					Misty Acres Blvd Westbound					Monument Hill Rd Northbound					Eastbound					Int. Total
	Right	Thru	Left	Peds	App. Total	Right	Thru	Left	Peds	App. Total	Right	Thru	Left	Peds	App. Total	Right	Thru	Left	Peds	App. Total	
Peak Hour Analysis From 15:45 to 17:40 - Peak 1 of 1																					
Peak Hour for Entire Intersection Begins at 16:25																					
16:25	0	5	1	0	6	1	0	0	0	1	0	5	0	0	5	0	0	0	0	0	12
16:30	0	4	1	0	5	0	0	0	0	0	0	3	0	0	3	0	0	0	0	0	8
16:35	0	3	1	0	4	0	0	0	0	0	0	3	0	0	3	0	0	0	0	0	7
16:40	0	6	1	0	7	1	0	0	0	1	0	3	0	0	3	0	0	0	0	0	11
16:45	0	2	1	0	3	0	0	0	0	0	0	0	0	0	0	0	0	0	0	0	3
16:50	0	2	0	0	2	0	0	0	0	0	0	6	0	0	6	0	0	0	0	0	8
16:55	0	1	0	0	1	1	0	0	0	1	0	1	0	0	1	0	0	0	0	0	3
17:00	0	3	0	0	3	0	0	0	0	0	0	1	0	0	1	0	0	0	0	0	4
17:05	0	6	0	0	6	0	0	0	0	0	0	1	0	0	1	0	0	0	0	0	7
17:10	0	4	0	0	4	0	0	0	0	0	0	4	0	0	4	0	0	0	0	0	8
17:15	0	3	0	0	3	0	0	0	0	0	0	3	0	0	3	0	0	0	0	0	6
17:20	0	4	0	0	4	1	0	0	0	1	0	3	0	0	3	0	0	0	0	0	8
Total Volume	0	43	5	0	48	4	0	0	0	4	0	33	0	0	33	0	0	0	0	0	85
% App. Total	0	89.6	10.4	0		100	0	0	0		0	100	0	0		0	0	0	0		
PHF	.000	.597	.417	.000	.571	.333	.000	.000	.000	.333	.000	.458	.000	.000	.458	.000	.000	.000	.000	.000	.590

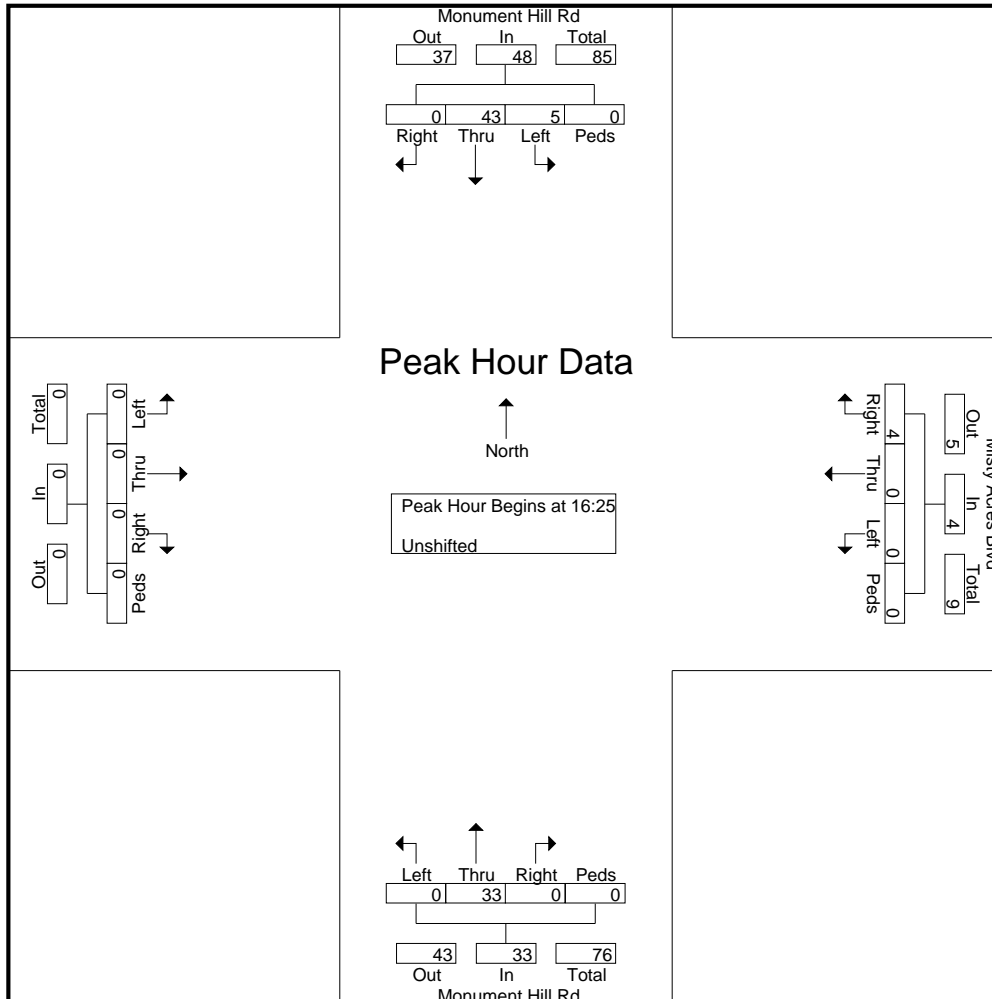

LSC Transportation Consultants, Inc.

2504 E. Pikes Peak Ave, Suite 304
 Colorado Springs, CO 80909
 719-633-2868

File Name : Monument Hill Rd - Misty Acres Blvd PM 12-12-23
 Site Code : S234450
 Start Date : 12/12/2023
 Page No : 3

Start Time	Monument Hill Rd Southbound					Misty Acres Blvd Westbound					Monument Hill Rd Northbound					Eastbound					Int. Total
	Right	Thru	Left	Peds	App. Total	Right	Thru	Left	Peds	App. Total	Right	Thru	Left	Peds	App. Total	Right	Thru	Left	Peds	App. Total	

Peak Hour Analysis From 15:45 to 17:40 - Peak 1 of 1
 Peak Hour for Each Approach Begins at:

	16:30					16:00					15:55					15:45				
+0 mins.	0	4	1	0	5	0	0	0	0	0	0	3	0	0	3	0	0	0	0	0
+5 mins.	0	3	1	0	4	0	0	0	0	0	0	1	0	0	1	0	0	0	0	0
+10 mins.	0	6	1	0	7	1	0	0	0	1	0	2	0	0	2	0	0	0	0	0
+15 mins.	0	2	1	0	3	0	0	0	0	0	1	3	0	0	4	0	0	0	0	0
+20 mins.	0	2	0	0	2	0	0	0	0	0	0	1	0	0	1	0	0	0	0	0
+25 mins.	0	1	0	0	1	1	0	0	0	1	1	1	0	0	2	0	0	0	0	0
+30 mins.	0	3	0	0	3	0	0	0	0	0	0	5	0	0	5	0	0	0	0	0
+35 mins.	0	6	0	0	6	0	0	0	0	0	0	3	0	0	3	0	0	0	0	0
+40 mins.	0	4	0	0	4	1	0	0	0	1	0	3	0	0	3	0	0	0	0	0
+45 mins.	0	3	0	0	3	0	0	0	0	0	0	3	0	0	3	0	0	0	0	0
+50 mins.	0	4	0	0	4	0	0	0	0	0	0	0	0	0	0	0	0	0	0	0
+55 mins.	0	7	1	0	8	1	0	0	0	1	0	6	0	0	6	0	0	0	0	0
Total Volume	0	45	5	0	50	4	0	0	0	4	2	31	0	0	33	0	0	0	0	0
% App. Total	0	90	10	0		100	0	0	0		6.1	93.9	0	0		0	0	0	0	
PHF	.000	.536	.417	.000	.521	.333	.000	.000	.000	.333	.167	.431	.000	.000	.458	.000	.000	.000	.000	.000

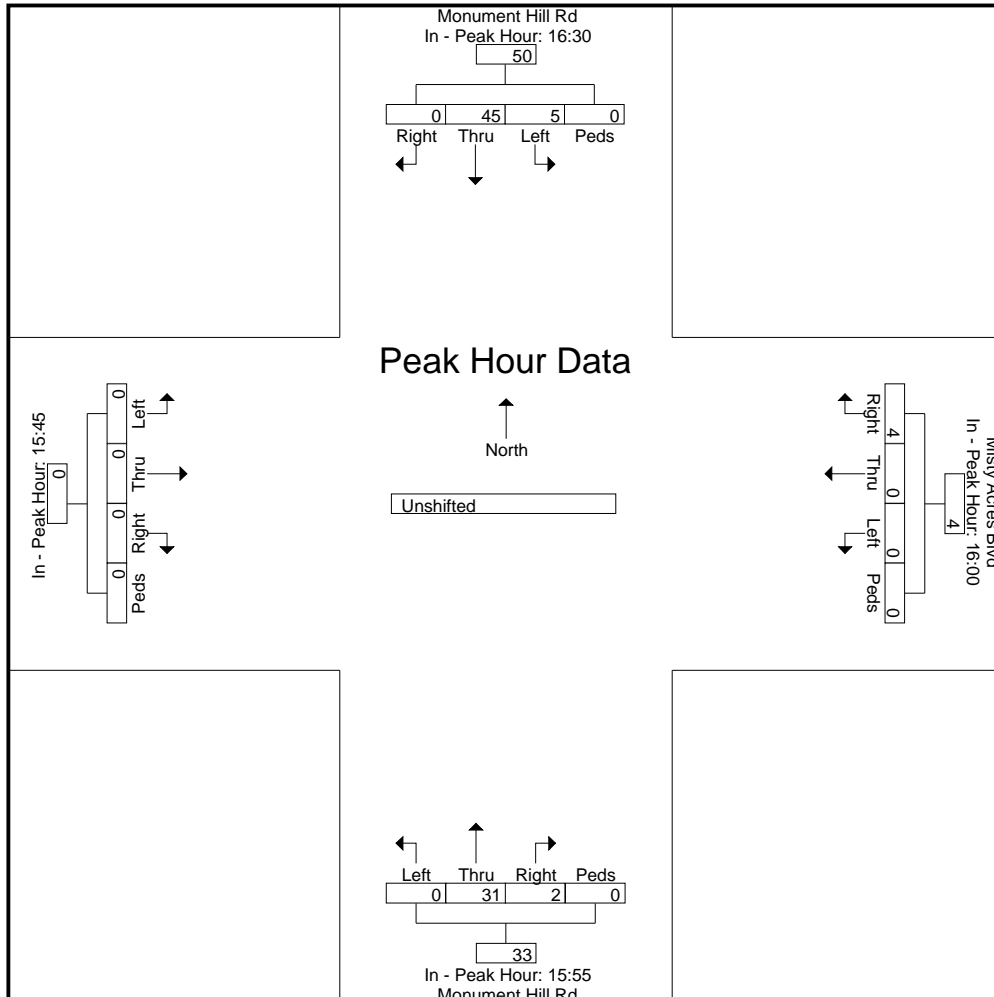

LSC Transportation Consultants, Inc.

2504 E. Pikes Peak Ave, Suite 304
 Colorado Springs, CO 80909
 719-633-2868

File Name : Monument Hill Rd - S Misty Acres Blvd AM 1-10-24

Site Code : S234450

Start Date : 1/10/2024

Page No : 1

Groups Printed- Unshifted

Start Time	Monument Hill Rd Southbound					S Misty Acres Blvd Westbound					Monument Hill Rd Northbound					Eastbound					Int. Total	
	Right	Thru	Left	Peds	App. Total	Right	Thru	Left	Peds	App. Total	Right	Thru	Left	Peds	App. Total	Right	Thru	Left	Peds	App. Total		
06:30	0	0	1	0	1	0	0	0	0	0	2	1	0	0	3	0	0	0	0	0	0	4
06:35	0	4	0	0	4	0	0	1	0	1	1	1	0	0	2	0	0	0	0	0	0	7
06:40	0	3	0	0	3	0	0	2	0	2	6	3	0	0	9	0	0	0	0	0	0	14
06:45	0	2	0	0	2	0	0	2	0	2	4	0	0	0	4	0	0	0	0	0	0	8
06:50	0	4	0	0	4	0	0	3	0	3	5	3	0	0	8	0	0	0	0	0	0	15
06:55	0	5	0	0	5	0	0	8	0	8	10	2	0	0	12	0	0	0	0	0	0	25
Total	0	18	1	0	19	0	0	16	0	16	28	10	0	0	38	0	0	0	0	0	0	73
07:00	0	7	3	0	10	1	0	14	0	15	26	2	0	0	28	0	0	0	0	0	0	53
07:05	0	7	4	0	11	2	0	16	0	18	16	3	0	0	19	0	0	0	0	0	0	48
07:10	0	8	9	0	17	1	0	17	0	18	27	4	0	0	31	0	0	0	0	0	0	66
07:15	0	5	8	0	13	6	0	24	0	30	40	7	0	0	47	0	0	0	0	0	0	90
07:20	0	16	8	0	24	4	0	27	0	31	31	1	0	0	32	0	0	0	0	0	0	87
07:25	0	11	10	0	21	7	0	30	0	37	40	4	0	0	44	0	0	0	0	0	0	102
07:30	0	13	15	0	28	4	0	26	0	30	50	7	0	0	57	0	0	0	0	0	0	115
07:35	0	9	6	0	15	9	0	39	0	48	28	5	0	0	33	0	0	0	0	0	0	96
07:40	0	4	1	0	5	3	0	20	0	23	3	1	0	0	4	0	0	0	0	0	0	32
07:45	0	5	1	0	6	2	0	12	0	14	9	0	0	0	9	0	0	0	0	0	0	29
07:50	0	2	0	0	2	0	0	11	0	11	2	0	0	0	2	0	0	0	0	0	0	15
07:55	0	1	0	0	1	2	0	4	0	6	5	2	0	0	7	0	0	0	0	0	0	14
Total	0	88	65	0	153	41	0	240	0	281	277	36	0	0	313	0	0	0	0	0	0	747
08:00	0	2	1	0	3	0	0	9	0	9	3	3	0	0	6	0	0	0	0	0	0	18
08:05	0	2	0	0	2	0	0	5	0	5	4	2	0	0	6	0	0	0	0	0	0	13
08:10	0	1	0	0	1	0	0	6	0	6	4	3	0	0	7	0	0	0	0	0	0	14
08:15	0	0	0	0	0	0	0	2	0	2	1	0	0	0	1	0	0	0	0	0	0	3
08:20	0	3	0	0	3	0	0	5	0	5	1	1	0	0	2	0	0	0	0	0	0	10
08:25	0	2	0	0	2	0	0	2	0	2	1	0	0	0	1	0	0	0	0	0	0	5
Grand Total	0	116	67	0	183	41	0	285	0	326	319	55	0	0	374	0	0	0	0	0	0	883
Apprch %	0	63.4	36.6	0		12.6	0	87.4	0		85.3	14.7	0	0		0	0	0	0	0	0	
Total %	0	13.1	7.6	0	20.7	4.6	0	32.3	0	36.9	36.1	6.2	0	0	42.4	0	0	0	0	0	0	

LSC Transportation Consultants, Inc.

2504 E. Pikes Peak Ave, Suite 304
 Colorado Springs, CO 80909
 719-633-2868

File Name : Monument Hill Rd - S Misty Acres Blvd AM 1-10-24
 Site Code : S234450
 Start Date : 1/10/2024
 Page No : 2

Start Time	Monument Hill Rd Southbound					S Misty Acres Blvd Westbound					Monument Hill Rd Northbound					Eastbound					Int. Total
	Right	Thru	Left	Peds	App. Total	Right	Thru	Left	Peds	App. Total	Right	Thru	Left	Peds	App. Total	Right	Thru	Left	Peds	App. Total	
Peak Hour Analysis From 06:30 to 08:25 - Peak 1 of 1																					
Peak Hour for Entire Intersection Begins at 06:50																					
06:50	0	4	0	0	4	0	0	3	0	3	5	3	0	0	8	0	0	0	0	0	15
06:55	0	5	0	0	5	0	0	8	0	8	10	2	0	0	12	0	0	0	0	0	25
07:00	0	7	3	0	10	1	0	14	0	15	26	2	0	0	28	0	0	0	0	0	53
07:05	0	7	4	0	11	2	0	16	0	18	16	3	0	0	19	0	0	0	0	0	48
07:10	0	8	9	0	17	1	0	17	0	18	27	4	0	0	31	0	0	0	0	0	66
07:15	0	5	8	0	13	6	0	24	0	30	40	7	0	0	47	0	0	0	0	0	90
07:20	0	16	8	0	24	4	0	27	0	31	31	1	0	0	32	0	0	0	0	0	87
07:25	0	11	10	0	21	7	0	30	0	37	40	4	0	0	44	0	0	0	0	0	102
07:30	0	13	15	0	28	4	0	26	0	30	50	7	0	0	57	0	0	0	0	0	115
07:35	0	9	6	0	15	9	0	39	0	48	28	5	0	0	33	0	0	0	0	0	96
07:40	0	4	1	0	5	3	0	20	0	23	3	1	0	0	4	0	0	0	0	0	32
07:45	0	5	1	0	6	2	0	12	0	14	9	0	0	0	9	0	0	0	0	0	29
Total Volume	0	94	65	0	159	39	0	236	0	275	285	39	0	0	324	0	0	0	0	0	758
% App. Total	0	59.1	40.9	0		14.2	0	85.8	0		88	12	0	0		0	0	0	0		
PHF	.000	.490	.361	.000	.473	.361	.000	.504	.000	.477	.475	.464	.000	.000	.474	.000	.000	.000	.000	.000	.549

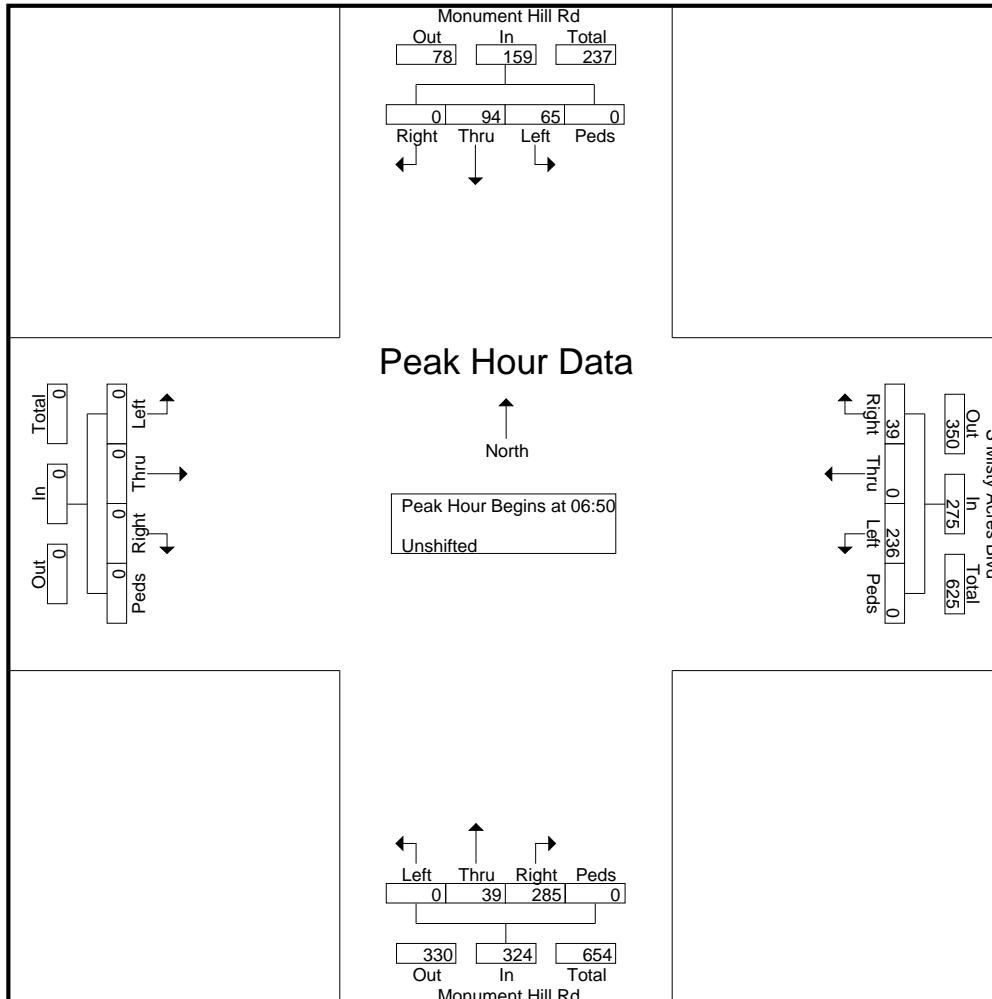

LSC Transportation Consultants, Inc.

2504 E. Pikes Peak Ave, Suite 304
 Colorado Springs, CO 80909
 719-633-2868

File Name : Monument Hill Rd - S Misty Acres Blvd AM 1-10-24
 Site Code : S234450
 Start Date : 1/10/2024
 Page No : 3

Start Time	Monument Hill Rd Southbound					S Misty Acres Blvd Westbound					Monument Hill Rd Northbound					Eastbound					Int. Total
	Right	Thru	Left	Peds	App. Total	Right	Thru	Left	Peds	App. Total	Right	Thru	Left	Peds	App. Total	Right	Thru	Left	Peds	App. Total	

Peak Hour Analysis From 06:30 to 08:25 - Peak 1 of 1
 Peak Hour for Each Approach Begins at:

	06:50					06:55					06:40					06:30				
+0 mins.	0	4	0	0	4	0	0	8	0	8	6	3	0	0	9	0	0	0	0	0
+5 mins.	0	5	0	0	5	1	0	14	0	15	4	0	0	0	4	0	0	0	0	0
+10 mins.	0	7	3	0	10	2	0	16	0	18	5	3	0	0	8	0	0	0	0	0
+15 mins.	0	7	4	0	11	1	0	17	0	18	10	2	0	0	12	0	0	0	0	0
+20 mins.	0	8	9	0	17	6	0	24	0	30	26	2	0	0	28	0	0	0	0	0
+25 mins.	0	5	8	0	13	4	0	27	0	31	16	3	0	0	19	0	0	0	0	0
+30 mins.	0	16	8	0	24	7	0	30	0	37	27	4	0	0	31	0	0	0	0	0
+35 mins.	0	11	10	0	21	4	0	26	0	30	40	7	0	0	47	0	0	0	0	0
+40 mins.	0	13	15	0	28	9	0	39	0	48	31	1	0	0	32	0	0	0	0	0
+45 mins.	0	9	6	0	15	3	0	20	0	23	40	4	0	0	44	0	0	0	0	0
+50 mins.	0	4	1	0	5	2	0	12	0	14	50	7	0	0	57	0	0	0	0	0
+55 mins.	0	5	1	0	6	0	0	11	0	11	28	5	0	0	33	0	0	0	0	0
Total Volume	0	94	65	0	159	39	0	244	0	283	283	41	0	0	324	0	0	0	0	0
% App. Total	0	59.1	40.9	0		13.8	0	86.2	0		87.3	12.7	0	0		0	0	0	0	
PHF	.000	.490	.361	.000	.473	.361	.000	.521	.000	.491	.472	.488	.000	.000	.474	.000	.000	.000	.000	.000

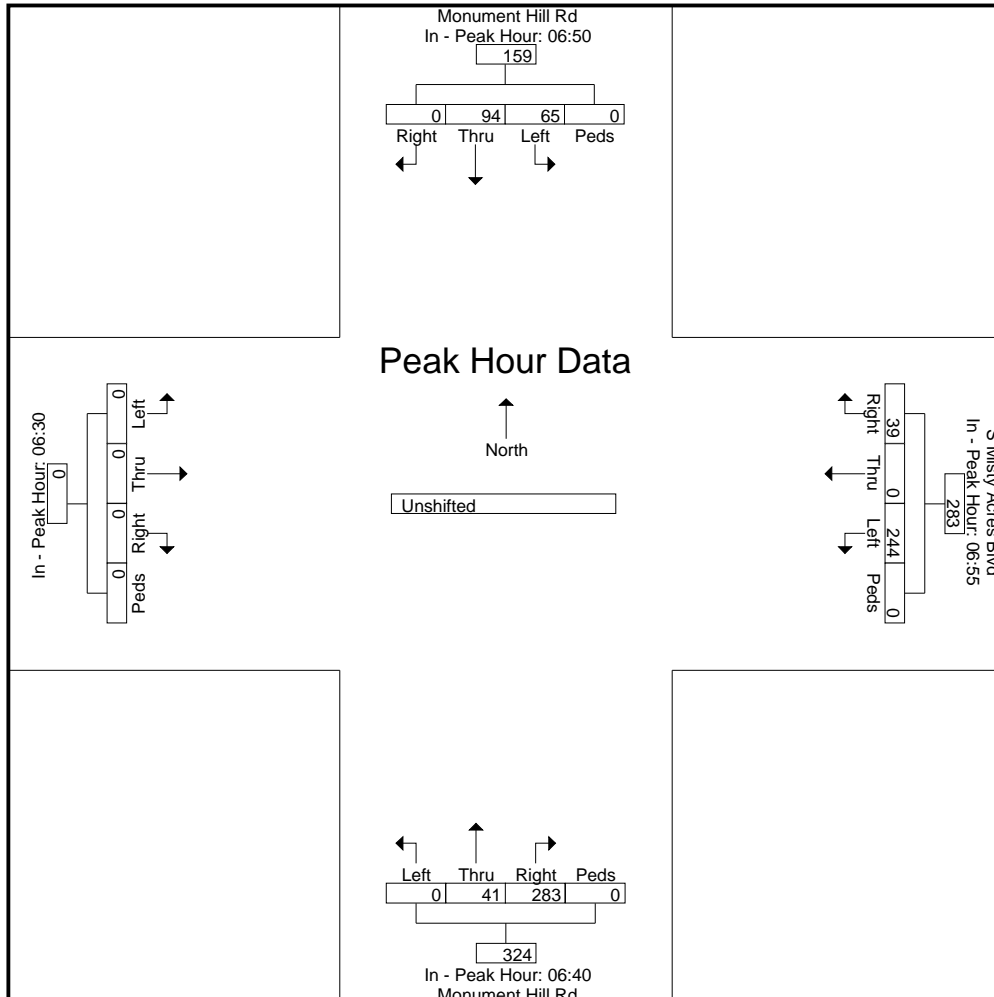

LSC Transportation Consultants, Inc.

2504 E. Pikes Peak Ave, Suite 304
 Colorado Springs, CO 80909
 719-633-2868

File Name : Monument Hill Rd - S Misty Acres Blvd PM 1-9-24
 Site Code : S234450
 Start Date : 1/9/2024
 Page No : 2

Start Time	Monument Hill Rd Southbound					S Misty Acres Blvd Westbound					Monument Hill Rd Northbound					Eastbound					Int. Total
	Right	Thru	Left	Peds	App. Total	Right	Thru	Left	Peds	App. Total	Right	Thru	Left	Peds	App. Total	Right	Thru	Left	Peds	App. Total	
Peak Hour Analysis From 16:00 to 17:55 - Peak 1 of 1																					
Peak Hour for Entire Intersection Begins at 16:10																					
16:10	0	4	0	0	4	0	0	1	0	1	13	3	0	0	16	0	0	0	0	0	21
16:15	0	6	0	0	6	0	0	13	0	13	7	1	0	0	8	0	0	0	0	0	27
16:20	0	5	0	0	5	0	0	4	0	4	7	5	0	0	12	0	0	0	0	0	21
16:25	0	2	0	0	2	0	0	7	0	7	5	4	0	0	9	0	0	0	0	0	18
16:30	0	3	1	0	4	0	0	2	0	2	5	1	0	0	6	0	0	0	0	0	12
16:35	0	2	1	0	3	0	0	12	0	12	3	3	0	0	6	0	0	0	0	0	21
16:40	0	5	0	0	5	2	0	7	0	9	7	8	0	0	15	0	0	0	0	0	29
16:45	0	3	0	0	3	0	0	3	0	3	10	6	0	0	16	0	0	0	0	0	22
16:50	0	5	0	0	5	0	0	5	0	5	6	5	0	0	11	0	0	0	0	0	21
16:55	0	2	0	0	2	1	0	5	0	6	9	2	0	0	11	0	0	0	0	0	19
17:00	0	3	1	0	4	0	0	9	0	9	4	4	0	0	8	0	0	0	0	0	21
17:05	0	4	1	0	5	0	0	4	0	4	11	4	0	0	15	0	0	0	0	0	24
Total Volume	0	44	4	0	48	3	0	72	0	75	87	46	0	0	133	0	0	0	0	0	256
% App. Total	0	91.7	8.3	0		4	0	96	0		65.4	34.6	0	0		0	0	0	0		
PHF	.000	.611	.333	.000	.667	.125	.000	.462	.000	.481	.558	.479	.000	.000	.693	.000	.000	.000	.000	.000	.736

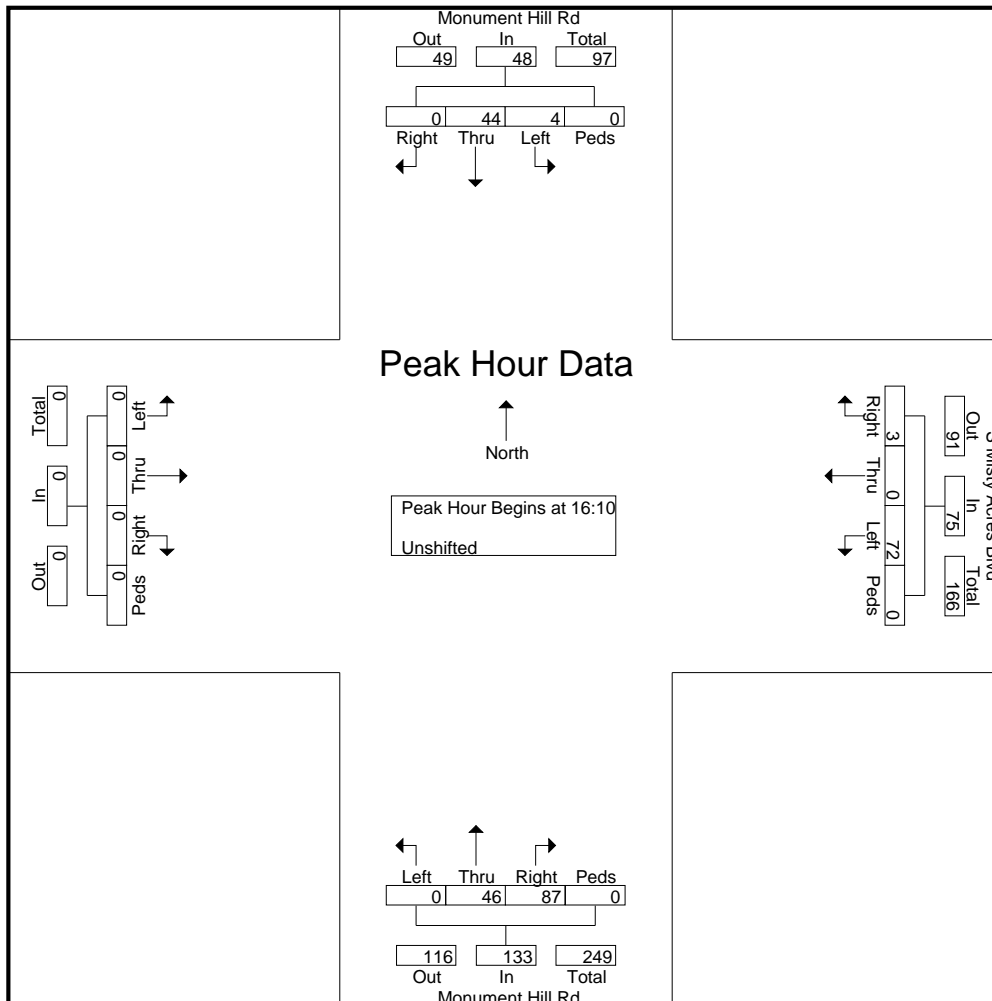

LSC Transportation Consultants, Inc.

2504 E. Pikes Peak Ave, Suite 304
 Colorado Springs, CO 80909
 719-633-2868

File Name : Monument Hill Rd - S Misty Acres Blvd PM 1-9-24
 Site Code : S234450
 Start Date : 1/9/2024
 Page No : 3

Start Time	Monument Hill Rd Southbound					S Misty Acres Blvd Westbound					Monument Hill Rd Northbound					Eastbound					Int. Total
	Right	Thru	Left	Peds	App. Total	Right	Thru	Left	Peds	App. Total	Right	Thru	Left	Peds	App. Total	Right	Thru	Left	Peds	App. Total	

Peak Hour Analysis From 16:00 to 17:55 - Peak 1 of 1
 Peak Hour for Each Approach Begins at:

	16:10					16:15					16:45					16:00				
+0 mins.	0	4	0	0	4	0	0	13	0	13	10	6	0	0	16	0	0	0	0	0
+5 mins.	0	6	0	0	6	0	0	4	0	4	6	5	0	0	11	0	0	0	0	0
+10 mins.	0	5	0	0	5	0	0	7	0	7	9	2	0	0	11	0	0	0	0	0
+15 mins.	0	2	0	0	2	0	0	2	0	2	4	4	0	0	8	0	0	0	0	0
+20 mins.	0	3	1	0	4	0	0	12	0	12	11	4	0	0	15	0	0	0	0	0
+25 mins.	0	2	1	0	3	2	0	7	0	9	6	1	0	0	7	0	0	0	0	0
+30 mins.	0	5	0	0	5	0	0	3	0	3	8	6	0	0	14	0	0	0	0	0
+35 mins.	0	3	0	0	3	0	0	5	0	5	5	3	0	0	8	0	0	0	0	0
+40 mins.	0	5	0	0	5	1	0	5	0	6	6	3	0	0	9	0	0	0	0	0
+45 mins.	0	2	0	0	2	0	0	9	0	9	9	9	0	0	18	0	0	0	0	0
+50 mins.	0	3	1	0	4	0	0	4	0	4	3	4	0	0	7	0	0	0	0	0
+55 mins.	0	4	1	0	5	0	0	3	0	3	9	9	0	0	18	0	0	0	0	0
Total Volume	0	44	4	0	48	3	0	74	0	77	86	56	0	0	142	0	0	0	0	0
% App. Total	0	91.7	8.3	0		3.9	0	96.1	0		60.6	39.4	0	0		0	0	0	0	
PHF	.000	.611	.333	.000	.667	.125	.000	.474	.000	.494	.652	.519	.000	.000	.657	.000	.000	.000	.000	.000

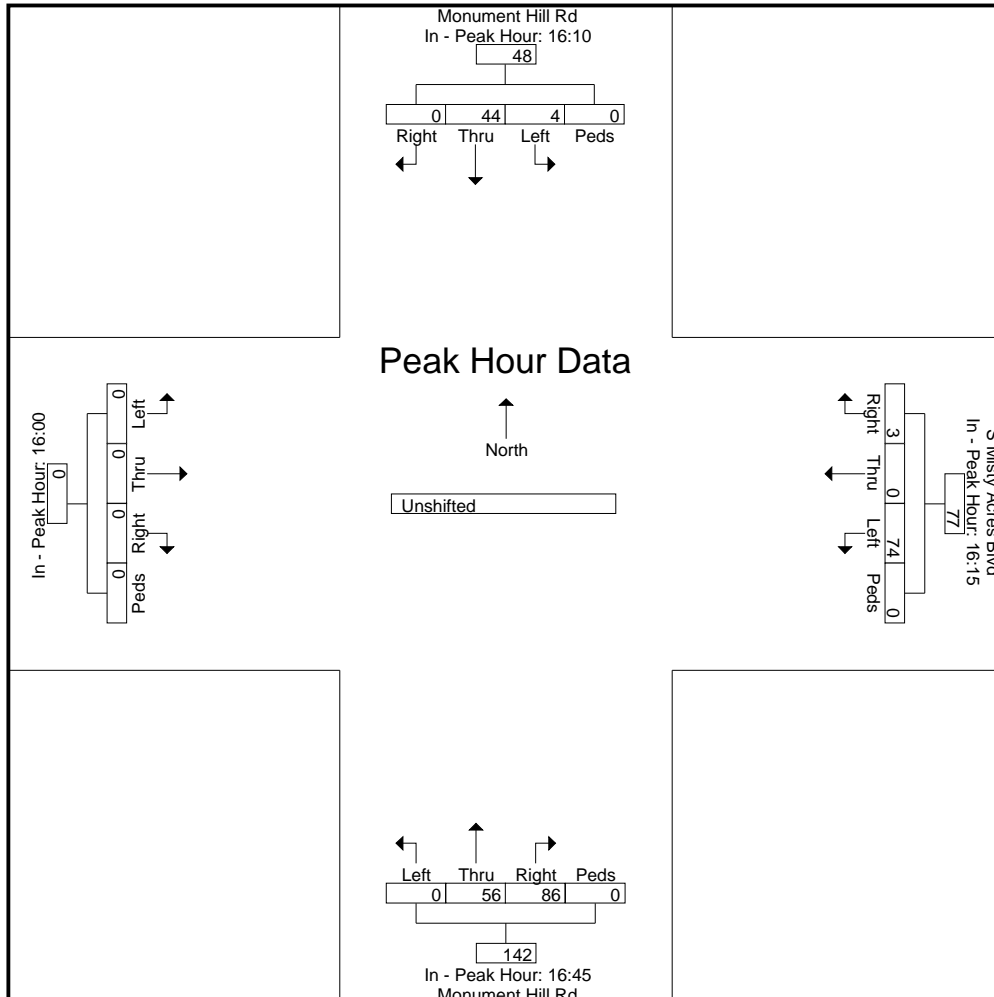

LSC Transportation Consultants, Inc.

2504 E. Pikes Peak Ave, Suite 304
 Colorado Springs, CO 80909
 719-633-2868

File Name : I-25 NB Ramps - County Line Rd AM
 Site Code : S234450
 Start Date : 1/18/2024
 Page No : 1

Groups Printed- Unshifted

Start Time	I-25 NB On Ramp Southbound					County Line Rd Westbound					I-25 NB Off Ramp Northbound					County Line Rd Eastbound					Int. Total
	Right	Thru	Left	Peds	App. Total	Right	Thru	Left	Peds	App. Total	Right	Thru	Left	Peds	App. Total	Right	Thru	Left	Peds	App. Total	
06:30	0	0	0	0	0	14	21	0	0	35	0	1	0	0	1	0	3	5	0	8	44
06:35	0	0	0	0	0	21	13	0	0	34	1	0	2	0	3	0	4	9	0	13	50
06:40	0	0	0	0	0	21	13	0	0	34	4	0	0	0	4	0	4	4	0	8	46
06:45	0	0	0	0	0	19	14	0	0	33	0	0	3	0	3	0	6	3	0	9	45
06:50	0	0	0	0	0	15	5	0	0	20	2	0	2	0	4	0	5	3	0	8	32
06:55	0	0	0	0	0	22	10	0	0	32	3	0	3	0	6	0	13	2	0	15	53
Total	0	0	0	0	0	112	76	0	0	188	10	1	10	0	21	0	35	26	0	61	270
07:00	0	0	0	0	0	19	13	0	0	32	1	0	1	0	2	0	8	5	0	13	47
07:05	0	0	0	0	0	17	26	0	0	43	2	0	0	0	2	0	12	4	0	16	61
07:10	0	0	0	0	0	24	20	0	0	44	3	0	3	0	6	0	7	2	0	9	59
07:15	0	0	0	0	0	10	19	0	0	29	7	0	6	0	13	0	12	5	0	17	59
07:20	0	0	0	0	0	18	32	0	0	50	3	0	3	0	6	0	13	0	0	13	69
07:25	0	0	0	0	0	18	26	0	0	44	2	0	3	0	5	0	15	3	0	18	67
07:30	0	0	0	0	0	24	42	0	0	66	1	1	1	0	3	0	8	1	0	9	78
07:35	0	0	0	0	0	16	24	0	0	40	2	0	2	0	4	0	9	3	0	12	56
07:40	0	0	0	0	0	18	30	0	0	48	1	0	6	0	7	0	10	3	0	13	68
07:45	0	0	0	0	0	20	32	0	0	52	7	0	2	0	9	0	9	4	0	13	74
07:50	0	0	0	0	0	19	19	0	0	38	7	0	3	0	10	0	10	6	0	16	64
07:55	0	0	0	0	0	11	14	0	0	25	7	0	6	0	13	0	9	3	0	12	50
Total	0	0	0	0	0	214	297	0	0	511	43	1	36	0	80	0	122	39	0	161	752
08:00	0	0	0	0	0	18	18	0	0	36	5	0	4	0	9	0	7	2	0	9	54
08:05	0	0	0	0	0	14	29	0	0	43	5	0	7	0	12	0	5	3	0	8	63
08:10	0	0	0	0	0	21	19	0	0	40	5	0	3	0	8	0	10	1	0	11	59
08:15	0	0	0	0	0	10	11	0	0	21	5	0	4	0	9	0	5	8	0	13	43
08:20	0	0	0	0	0	14	14	0	0	28	9	1	5	0	15	0	8	4	0	12	55
08:25	0	0	0	0	0	21	20	0	0	41	10	0	4	0	14	0	4	3	0	7	62
Grand Total	0	0	0	0	0	424	484	0	0	908	92	3	73	0	168	0	196	86	0	282	1358
Apprch %	0	0	0	0	0	46.7	53.3	0	0		54.8	1.8	43.5	0		0	69.5	30.5	0		
Total %	0	0	0	0	0	31.2	35.6	0	0	66.9	6.8	0.2	5.4	0	12.4	0	14.4	6.3	0	20.8	

LSC Transportation Consultants, Inc.

2504 E. Pikes Peak Ave, Suite 304
 Colorado Springs, CO 80909
 719-633-2868

File Name : I-25 NB Ramps - County Line Rd AM
 Site Code : S234450
 Start Date : 1/18/2024
 Page No : 2

Start Time	I-25 NB On Ramp Southbound					County Line Rd Westbound					I-25 NB Off Ramp Northbound					County Line Rd Eastbound					Int. Total
	Right	Thru	Left	Peds	App. Total	Right	Thru	Left	Peds	App. Total	Right	Thru	Left	Peds	App. Total	Right	Thru	Left	Peds	App. Total	
Peak Hour Analysis From 06:30 to 08:25 - Peak 1 of 1																					
Peak Hour for Entire Intersection Begins at 07:10																					
07:10	0	0	0	0	0	24	20	0	0	44	3	0	3	0	6	0	7	2	0	9	59
07:15	0	0	0	0	0	10	19	0	0	29	7	0	6	0	13	0	12	5	0	17	59
07:20	0	0	0	0	0	18	32	0	0	50	3	0	3	0	6	0	13	0	0	13	69
07:25	0	0	0	0	0	18	26	0	0	44	2	0	3	0	5	0	15	3	0	18	67
07:30	0	0	0	0	0	24	42	0	0	66	1	1	1	0	3	0	8	1	0	9	78
07:35	0	0	0	0	0	16	24	0	0	40	2	0	2	0	4	0	9	3	0	12	56
07:40	0	0	0	0	0	18	30	0	0	48	1	0	6	0	7	0	10	3	0	13	68
07:45	0	0	0	0	0	20	32	0	0	52	7	0	2	0	9	0	9	4	0	13	74
07:50	0	0	0	0	0	19	19	0	0	38	7	0	3	0	10	0	10	6	0	16	64
07:55	0	0	0	0	0	11	14	0	0	25	7	0	6	0	13	0	9	3	0	12	50
08:00	0	0	0	0	0	18	18	0	0	36	5	0	4	0	9	0	7	2	0	9	54
08:05	0	0	0	0	0	14	29	0	0	43	5	0	7	0	12	0	5	3	0	8	63
Total Volume	0	0	0	0	0	210	305	0	0	515	50	1	46	0	97	0	114	35	0	149	761
% App. Total	0	0	0	0	0	40.8	59.2	0	0		51.5	1	47.4	0		0	76.5	23.5	0		
PHF	.000	.000	.000	.000	.000	.729	.605	.000	.000	.650	.595	.083	.548	.000	.622	.000	.633	.486	.000	.690	.813

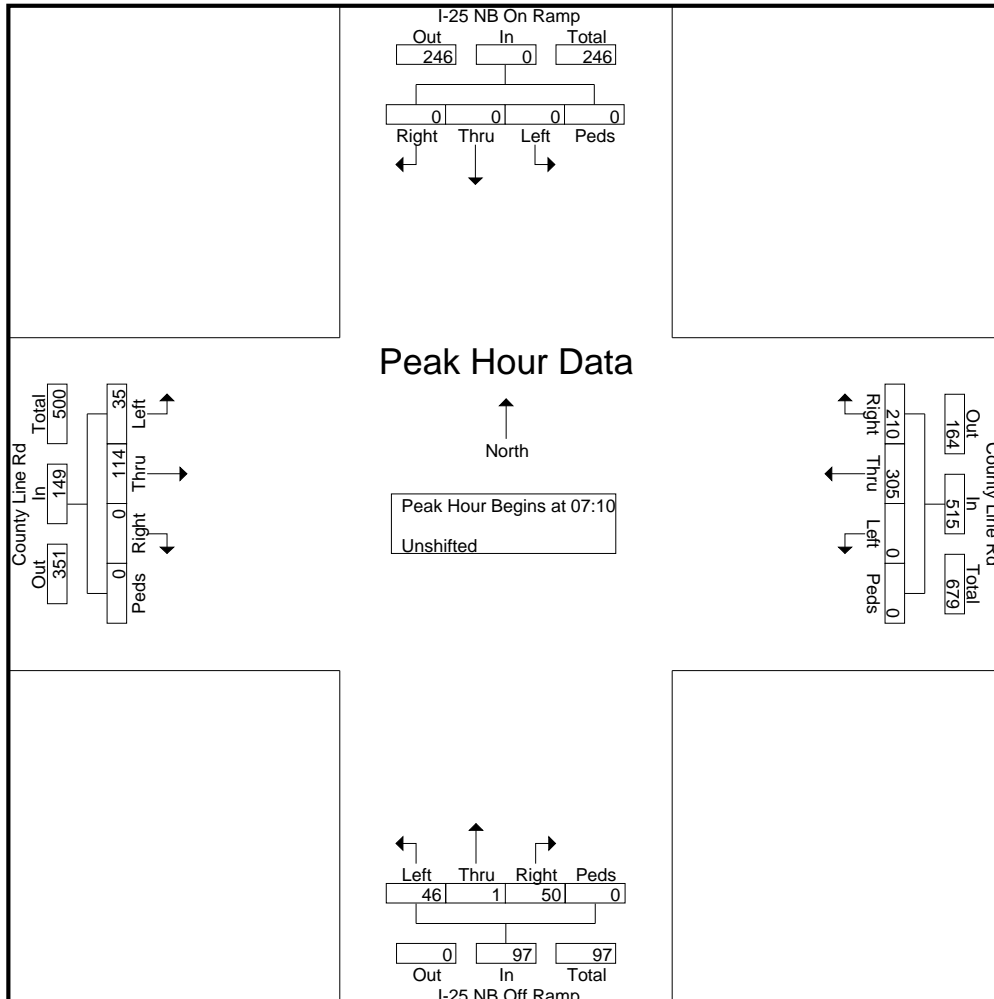

LSC Transportation Consultants, Inc.

2504 E. Pikes Peak Ave, Suite 304
 Colorado Springs, CO 80909
 719-633-2868

File Name : I-25 NB Ramps - County Line Rd AM
 Site Code : S234450
 Start Date : 1/18/2024
 Page No : 3

Start Time	I-25 NB On Ramp Southbound					County Line Rd Westbound					I-25 NB Off Ramp Northbound					County Line Rd Eastbound					Int. Total
	Right	Thru	Left	Peds	App. Total	Right	Thru	Left	Peds	App. Total	Right	Thru	Left	Peds	App. Total	Right	Thru	Left	Peds	App. Total	
Peak Hour Analysis From 06:30 to 08:25 - Peak 1 of 1																					
Peak Hour for Each Approach Begins at:																					
	06:30					06:55					07:30					06:55					
+0 mins.	0	0	0	0	0	22	10	0	0	32	1	1	1	0	3	0	13	2	0	15	
+5 mins.	0	0	0	0	0	19	13	0	0	32	2	0	2	0	4	0	8	5	0	13	
+10 mins.	0	0	0	0	0	17	26	0	0	43	1	0	6	0	7	0	12	4	0	16	
+15 mins.	0	0	0	0	0	24	20	0	0	44	7	0	2	0	9	0	7	2	0	9	
+20 mins.	0	0	0	0	0	10	19	0	0	29	7	0	3	0	10	0	12	5	0	17	
+25 mins.	0	0	0	0	0	18	32	0	0	50	7	0	6	0	13	0	13	0	0	13	
+30 mins.	0	0	0	0	0	18	26	0	0	44	5	0	4	0	9	0	15	3	0	18	
+35 mins.	0	0	0	0	0	24	42	0	0	66	5	0	7	0	12	0	8	1	0	9	
+40 mins.	0	0	0	0	0	16	24	0	0	40	5	0	3	0	8	0	9	3	0	12	
+45 mins.	0	0	0	0	0	18	30	0	0	48	5	0	4	0	9	0	10	3	0	13	
+50 mins.	0	0	0	0	0	20	32	0	0	52	9	1	5	0	15	0	9	4	0	13	
+55 mins.	0	0	0	0	0	19	19	0	0	38	10	0	4	0	14	0	10	6	0	16	
Total Volume	0	0	0	0	0	225	293	0	0	518	64	2	47	0	113	0	126	38	0	164	
% App. Total	0	0	0	0	0	43.4	56.6	0	0		56.6	1.8	41.6	0		0	76.8	23.2	0		
PHF	.000	.000	.000	.000	.000	.781	.581	.000	.000	.654	.533	.167	.560	.000	.628	.000	.700	.528	.000	.759	

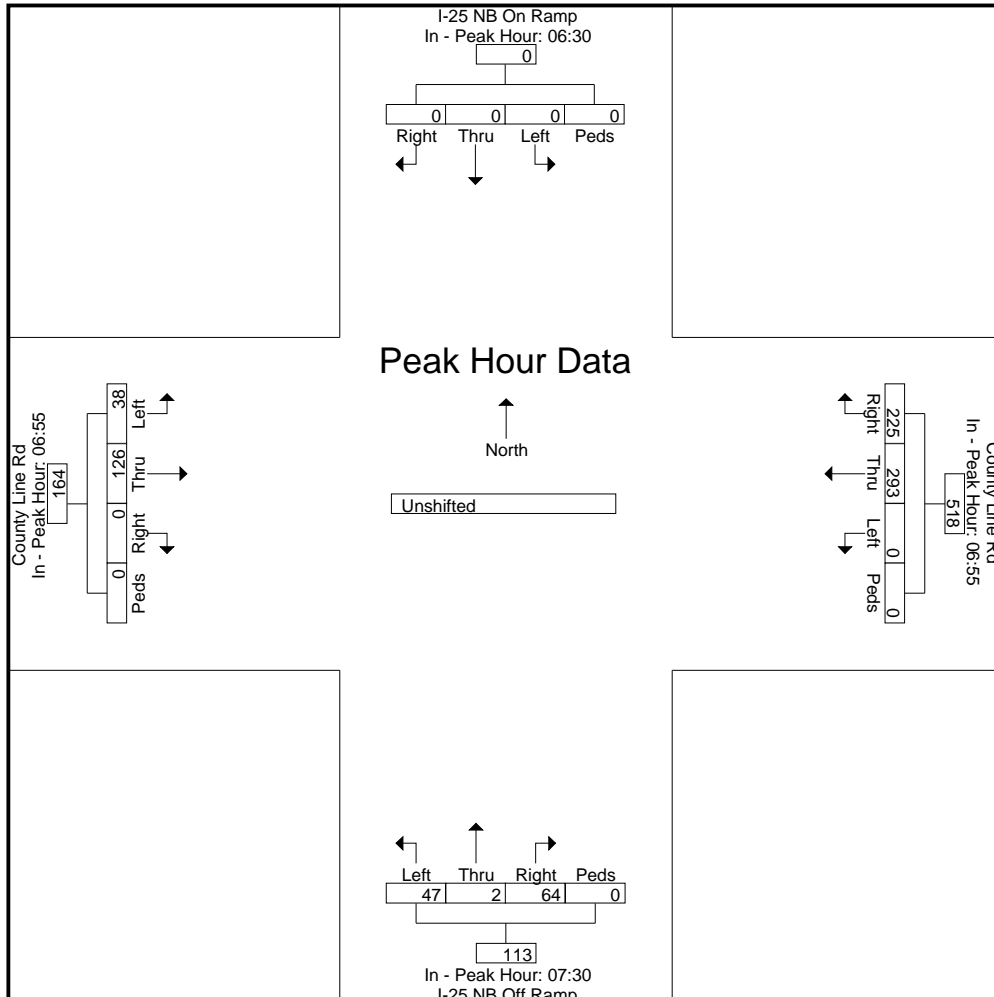

LSC Transportation Consultants, Inc.

2504 E. Pikes Peak Ave, Suite 304
 Colorado Springs, CO 80909
 719-633-2868

File Name : I-25 NB Ramps - County Line Rd PM
 Site Code : S234450
 Start Date : 1/17/2024
 Page No : 1

Groups Printed- Unshifted

Start Time	I-25 NB On Ramp Southbound					County Line Rd Westbound					I-25 NB Off Ramp Northbound					County Line Rd Eastbound					Int. Total
	Right	Thru	Left	Peds	App. Total	Right	Thru	Left	Peds	App. Total	Right	Thru	Left	Peds	App. Total	Right	Thru	Left	Peds	App. Total	
16:00	0	0	0	0	0	5	14	0	0	19	14	0	4	0	18	0	12	0	0	12	49
16:05	0	0	0	0	0	6	16	0	0	22	11	0	4	0	15	0	21	2	0	23	60
16:10	0	0	0	0	0	2	10	0	0	12	11	0	4	0	15	0	16	2	0	18	45
16:15	0	0	0	0	0	8	15	0	0	23	15	0	5	0	20	0	15	3	0	18	61
16:20	0	0	0	0	0	3	18	0	0	21	9	0	8	0	17	0	18	1	0	19	57
16:25	0	0	0	0	0	5	8	0	0	13	8	0	1	0	9	0	35	2	0	37	59
16:30	0	0	0	0	0	5	5	0	0	10	7	0	3	0	10	0	16	1	0	17	37
16:35	0	0	0	0	0	3	14	0	0	17	13	0	5	0	18	0	19	3	0	22	57
16:40	0	0	0	0	0	6	15	0	0	21	15	0	5	0	20	0	18	2	0	20	61
16:45	0	0	0	0	0	8	8	0	0	16	17	1	3	0	21	0	24	5	0	29	66
16:50	0	0	0	0	0	7	7	0	0	14	19	0	5	0	24	0	23	1	0	24	62
16:55	0	0	0	0	0	2	9	0	0	11	9	0	0	0	9	0	21	1	0	22	42
Total	0	0	0	0	0	60	139	0	0	199	148	1	47	0	196	0	238	23	0	261	656
17:00	0	0	0	0	0	4	12	0	0	16	13	0	6	0	19	0	22	0	0	22	57
17:05	0	0	0	0	0	8	18	0	0	26	9	0	2	0	11	0	25	1	0	26	63
17:10	0	0	0	0	0	12	9	0	0	21	8	0	6	0	14	0	20	3	0	23	58
17:15	0	0	0	0	0	5	7	0	0	12	14	0	3	0	17	0	12	3	0	15	44
17:20	0	0	0	0	0	8	6	0	0	14	13	0	2	0	15	0	30	2	0	32	61
17:25	0	0	0	0	0	11	9	0	0	20	15	1	4	0	20	0	20	1	0	21	61
17:30	0	0	0	0	0	6	8	0	0	14	10	0	4	1	15	0	25	1	0	26	55
17:35	0	0	0	0	0	7	8	0	0	15	8	0	11	0	19	0	21	1	0	22	56
17:40	0	0	0	0	0	1	10	0	0	11	17	0	3	0	20	0	17	1	0	18	49
17:45	0	0	0	0	0	9	3	0	0	12	21	0	3	0	24	0	16	1	0	17	53
17:50	0	0	0	0	0	8	10	0	0	18	9	0	7	0	16	0	23	2	0	25	59
17:55	0	0	0	0	0	9	12	0	0	21	6	0	3	0	9	0	29	2	0	31	61
Total	0	0	0	0	0	88	112	0	0	200	143	1	54	1	199	0	260	18	0	278	677
Grand Total	0	0	0	0	0	148	251	0	0	399	291	2	101	1	395	0	498	41	0	539	1333
Apprch %	0	0	0	0	0	37.1	62.9	0	0		73.7	0.5	25.6	0.3		0	92.4	7.6	0		
Total %	0	0	0	0	0	11.1	18.8	0	0	29.9	21.8	0.2	7.6	0.1	29.6	0	37.4	3.1	0	40.4	

LSC Transportation Consultants, Inc.

2504 E. Pikes Peak Ave, Suite 304
 Colorado Springs, CO 80909
 719-633-2868

File Name : I-25 NB Ramps - County Line Rd PM
 Site Code : S234450
 Start Date : 1/17/2024
 Page No : 2

Start Time	I-25 NB On Ramp Southbound					County Line Rd Westbound					I-25 NB Off Ramp Northbound					County Line Rd Eastbound					Int. Total
	Right	Thru	Left	Peds	App. Total	Right	Thru	Left	Peds	App. Total	Right	Thru	Left	Peds	App. Total	Right	Thru	Left	Peds	App. Total	
Peak Hour Analysis From 16:00 to 17:55 - Peak 1 of 1																					
Peak Hour for Entire Intersection Begins at 16:35																					
16:35	0	0	0	0	0	3	14	0	0	17	13	0	5	0	18	0	19	3	0	22	57
16:40	0	0	0	0	0	6	15	0	0	21	15	0	5	0	20	0	18	2	0	20	61
16:45	0	0	0	0	0	8	8	0	0	16	17	1	3	0	21	0	24	5	0	29	66
16:50	0	0	0	0	0	7	7	0	0	14	19	0	5	0	24	0	23	1	0	24	62
16:55	0	0	0	0	0	2	9	0	0	11	9	0	0	0	9	0	21	1	0	22	42
17:00	0	0	0	0	0	4	12	0	0	16	13	0	6	0	19	0	22	0	0	22	57
17:05	0	0	0	0	0	8	18	0	0	26	9	0	2	0	11	0	25	1	0	26	63
17:10	0	0	0	0	0	12	9	0	0	21	8	0	6	0	14	0	20	3	0	23	58
17:15	0	0	0	0	0	5	7	0	0	12	14	0	3	0	17	0	12	3	0	15	44
17:20	0	0	0	0	0	8	6	0	0	14	13	0	2	0	15	0	30	2	0	32	61
17:25	0	0	0	0	0	11	9	0	0	20	15	1	4	0	20	0	20	1	0	21	61
17:30	0	0	0	0	0	6	8	0	0	14	10	0	4	1	15	0	25	1	0	26	55
Total Volume	0	0	0	0	0	80	122	0	0	202	155	2	45	1	203	0	259	23	0	282	687
% App. Total	0	0	0	0	0	39.6	60.4	0	0		76.4	1	22.2	0.5		0	91.8	8.2	0		
PHF	.000	.000	.000	.000	.000	.556	.565	.000	.000	.647	.680	.167	.625	.083	.705	.000	.719	.383	.000	.734	.867

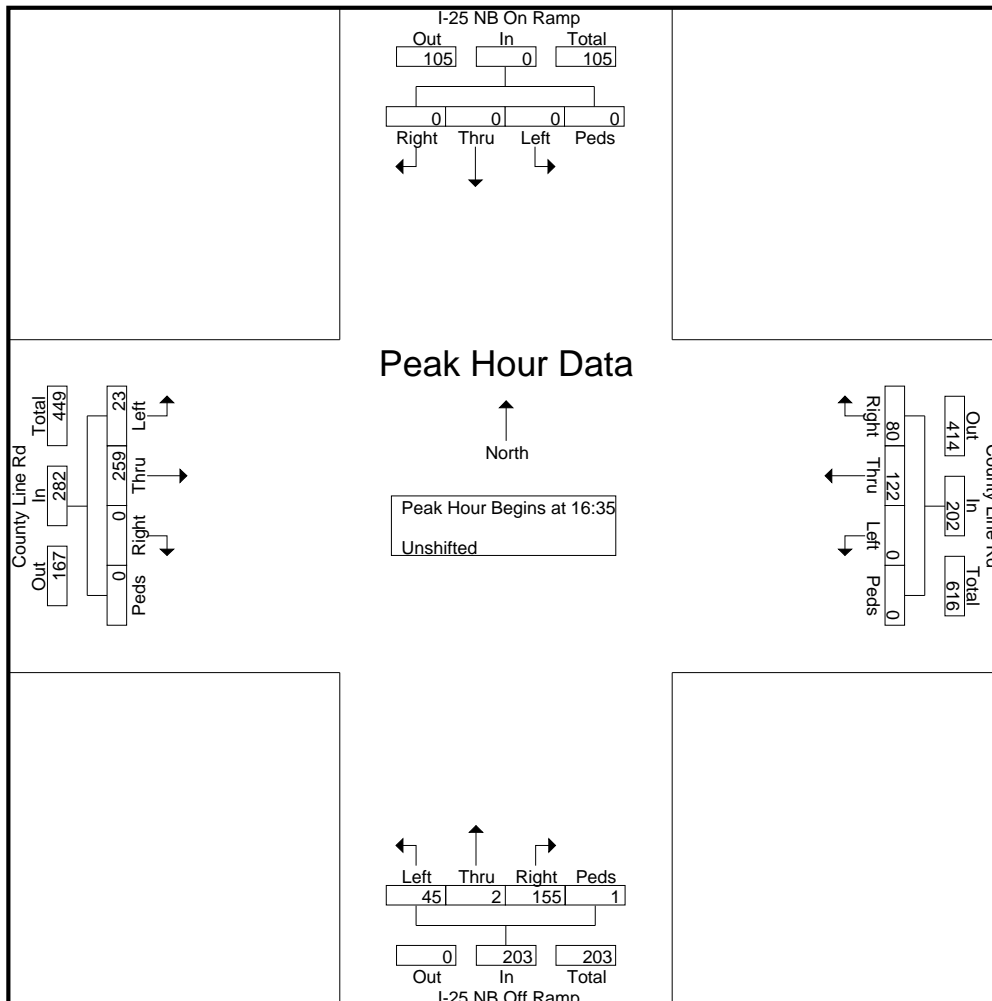

LSC Transportation Consultants, Inc.

2504 E. Pikes Peak Ave, Suite 304
 Colorado Springs, CO 80909
 719-633-2868

File Name : I-25 NB Ramps - County Line Rd PM
 Site Code : S234450
 Start Date : 1/17/2024
 Page No : 3

Start Time	I-25 NB On Ramp Southbound					County Line Rd Westbound					I-25 NB Off Ramp Northbound					County Line Rd Eastbound					Int. Total
	Right	Thru	Left	Peds	App. Total	Right	Thru	Left	Peds	App. Total	Right	Thru	Left	Peds	App. Total	Right	Thru	Left	Peds	App. Total	

Peak Hour Analysis From 16:00 to 17:55 - Peak 1 of 1
 Peak Hour for Each Approach Begins at:

	16:00					16:15					16:50					16:25				
+0 mins.	0	0	0	0	0	8	15	0	0	23	19	0	5	0	24	0	35	2	0	37
+5 mins.	0	0	0	0	0	3	18	0	0	21	9	0	0	0	9	0	16	1	0	17
+10 mins.	0	0	0	0	0	5	8	0	0	13	13	0	6	0	19	0	19	3	0	22
+15 mins.	0	0	0	0	0	5	5	0	0	10	9	0	2	0	11	0	18	2	0	20
+20 mins.	0	0	0	0	0	3	14	0	0	17	8	0	6	0	14	0	24	5	0	29
+25 mins.	0	0	0	0	0	6	15	0	0	21	14	0	3	0	17	0	23	1	0	24
+30 mins.	0	0	0	0	0	8	8	0	0	16	13	0	2	0	15	0	21	1	0	22
+35 mins.	0	0	0	0	0	7	7	0	0	14	15	1	4	0	20	0	22	0	0	22
+40 mins.	0	0	0	0	0	2	9	0	0	11	10	0	4	1	15	0	25	1	0	26
+45 mins.	0	0	0	0	0	4	12	0	0	16	8	0	11	0	19	0	20	3	0	23
+50 mins.	0	0	0	0	0	8	18	0	0	26	17	0	3	0	20	0	12	3	0	15
+55 mins.	0	0	0	0	0	12	9	0	0	21	21	0	3	0	24	0	30	2	0	32
Total Volume	0	0	0	0	0	71	138	0	0	209	156	1	49	1	207	0	265	24	0	289
% App. Total	0	0	0	0	0	34	66	0	0	75.4	0.5	23.7	0.5	0	91.7	8.3	0	0	0	651
PHF	.000	.000	.000	.000	.000	.493	.639	.000	.000	.670	.619	.083	.371	.083	.719	.000	.631	.400	.000	.651

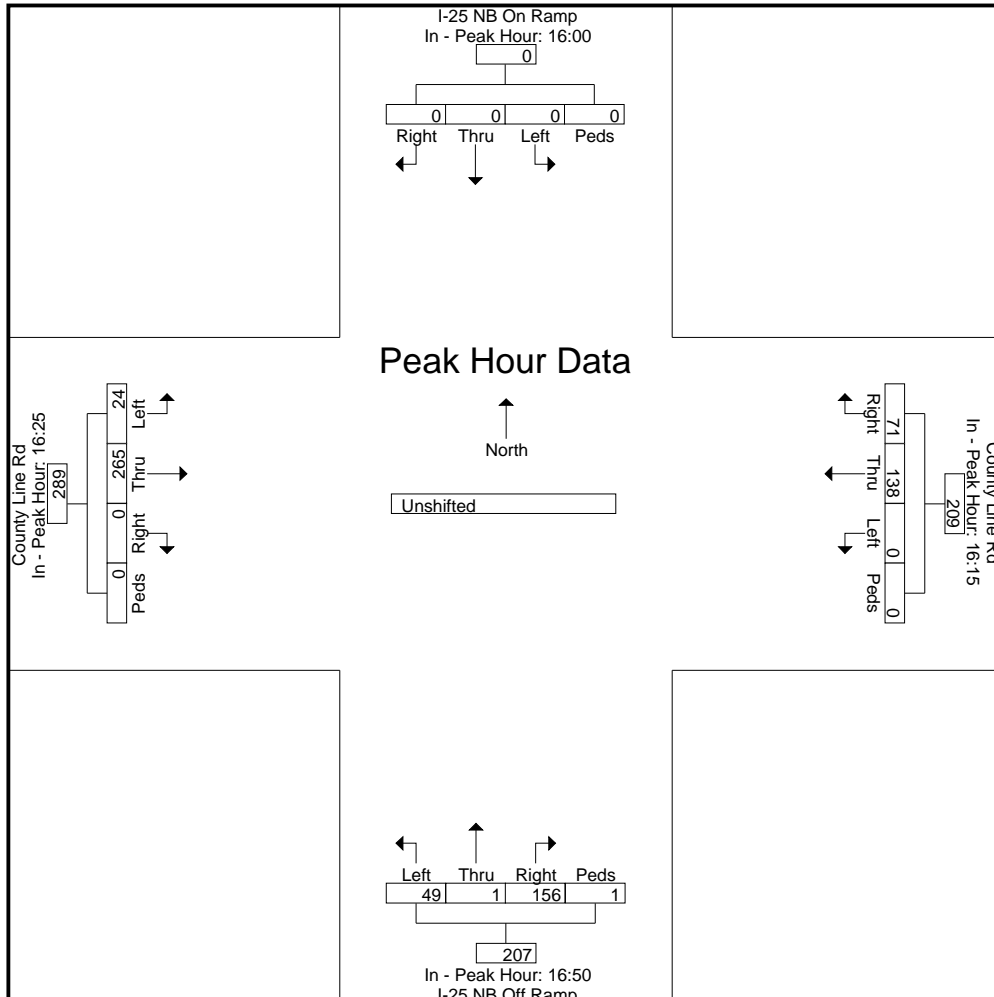

LSC Transportation Consultants, Inc.

2504 E. Pikes Peak Ave, Suite 304
 Colorado Springs, CO 80909
 719-633-2868

File Name : I-25 SB Ramps - County Line Rd AM
 Site Code : S234450
 Start Date : 1/18/2024
 Page No : 1

Groups Printed- Bank 1

Start Time	I-25 SB Off Ramp Southbound					County Line Rd Westbound					I-25 SB On Ramp Northbound					County Line Rd Eastbound					Int. Total
	Right	Thru	Left	Peds	App. Total	Right	Thru	Left	Peds	App. Total	Right	Thru	Left	Peds	App. Total	Right	Thru	Left	Peds	App. Total	
06:30	0	0	3	0	3	0	4	14	0	18	0	0	0	0	0	2	6	0	0	8	29
06:35	0	0	3	0	3	0	3	13	0	16	0	0	0	0	0	2	9	0	0	11	30
06:40	0	0	3	0	3	0	2	11	0	13	0	0	0	0	0	3	5	0	0	8	24
06:45	1	0	6	0	7	0	3	13	0	16	0	0	0	0	0	5	2	0	0	7	30
06:50	0	0	1	0	1	0	2	5	0	7	0	0	0	0	0	2	6	0	0	8	16
06:55	0	0	7	0	7	0	3	9	0	12	0	0	0	0	0	2	9	0	0	11	30
Total	1	0	23	0	24	0	17	65	0	82	0	0	0	0	0	16	37	0	0	53	159
07:00	1	1	2	0	4	0	2	11	0	13	0	0	0	0	0	2	9	0	0	11	28
07:05	0	0	6	0	6	0	3	23	0	26	0	0	0	0	0	4	11	0	0	15	47
07:10	0	0	4	0	4	0	6	17	0	23	0	0	0	0	0	2	3	0	0	5	32
07:15	2	1	3	0	6	0	6	17	0	23	0	0	0	0	0	3	14	0	0	17	46
07:20	0	0	3	0	3	0	6	30	0	36	0	0	0	0	0	5	14	0	0	19	58
07:25	0	0	6	0	6	0	13	20	0	33	0	0	0	0	0	4	17	0	0	21	60
07:30	1	0	7	0	8	0	10	34	0	44	0	0	0	0	0	6	3	0	0	9	61
07:35	1	0	5	0	6	0	9	20	0	29	0	0	0	0	0	3	8	0	0	11	46
07:40	1	0	8	0	9	0	11	24	0	35	0	0	0	0	0	10	6	0	0	16	60
07:45	1	0	6	0	7	0	7	25	0	32	0	0	0	0	0	3	8	0	0	11	50
07:50	1	0	8	0	9	0	9	14	0	23	0	0	0	0	0	2	7	0	0	9	41
07:55	1	0	9	0	10	0	10	10	0	20	0	0	0	0	0	1	3	0	0	4	34
Total	9	2	67	0	78	0	92	245	0	337	0	0	0	0	0	45	103	0	0	148	563
08:00	1	0	2	0	3	0	7	15	0	22	0	0	0	0	0	4	8	0	0	12	37
08:05	3	0	2	0	5	0	11	26	0	37	0	0	0	0	0	4	4	0	0	8	50
08:10	1	0	4	0	5	0	5	18	0	23	0	0	0	0	0	1	6	0	0	7	35
08:15	1	0	3	0	4	0	7	7	0	14	0	0	0	0	0	4	6	0	0	10	28
08:20	1	1	4	0	6	0	8	10	0	18	0	0	0	0	0	4	7	0	0	11	35
08:25	0	0	2	0	2	0	7	17	0	24	0	0	0	0	0	3	6	0	0	9	35
Grand Total	17	3	107	0	127	0	154	403	0	557	0	0	0	0	0	81	177	0	0	258	942
Apprch %	13.4	2.4	84.3	0		0	27.6	72.4	0		0	0	0	0		31.4	68.6	0	0		
Total %	1.8	0.3	11.4	0	13.5	0	16.3	42.8	0	59.1	0	0	0	0	0	8.6	18.8	0	0	27.4	

LSC Transportation Consultants, Inc.

2504 E. Pikes Peak Ave, Suite 304
 Colorado Springs, CO 80909
 719-633-2868

File Name : I-25 SB Ramps - County Line Rd AM
 Site Code : S234450
 Start Date : 1/18/2024
 Page No : 2

Start Time	I-25 SB Off Ramp Southbound					County Line Rd Westbound					I-25 SB On Ramp Northbound					County Line Rd Eastbound					Int. Total
	Right	Thru	Left	Peds	App. Total	Right	Thru	Left	Peds	App. Total	Right	Thru	Left	Peds	App. Total	Right	Thru	Left	Peds	App. Total	
Peak Hour Analysis From 06:30 to 08:25 - Peak 1 of 1																					
Peak Hour for Entire Intersection Begins at 07:15																					
07:15	2	1	3	0	6	0	6	17	0	23	0	0	0	0	0	3	14	0	0	17	46
07:20	0	0	3	0	3	0	6	30	0	36	0	0	0	0	0	5	14	0	0	19	58
07:25	0	0	6	0	6	0	13	20	0	33	0	0	0	0	0	4	17	0	0	21	60
07:30	1	0	7	0	8	0	10	34	0	44	0	0	0	0	0	6	3	0	0	9	61
07:35	1	0	5	0	6	0	9	20	0	29	0	0	0	0	0	3	8	0	0	11	46
07:40	1	0	8	0	9	0	11	24	0	35	0	0	0	0	0	10	6	0	0	16	60
07:45	1	0	6	0	7	0	7	25	0	32	0	0	0	0	0	3	8	0	0	11	50
07:50	1	0	8	0	9	0	9	14	0	23	0	0	0	0	0	2	7	0	0	9	41
07:55	1	0	9	0	10	0	10	10	0	20	0	0	0	0	0	1	3	0	0	4	34
08:00	1	0	2	0	3	0	7	15	0	22	0	0	0	0	0	4	8	0	0	12	37
08:05	3	0	2	0	5	0	11	26	0	37	0	0	0	0	0	4	4	0	0	8	50
08:10	1	0	4	0	5	0	5	18	0	23	0	0	0	0	0	1	6	0	0	7	35
Total Volume	13	1	63	0	77	0	104	253	0	357	0	0	0	0	0	46	98	0	0	144	578
% App. Total	16.9	1.3	81.8	0		0	29.1	70.9	0		0	0	0	0		31.9	68.1	0	0		
PHF	.361	.083	.583	.000	.642	.000	.667	.620	.000	.676	.000	.000	.000	.000	.000	.383	.480	.000	.000	.571	.790

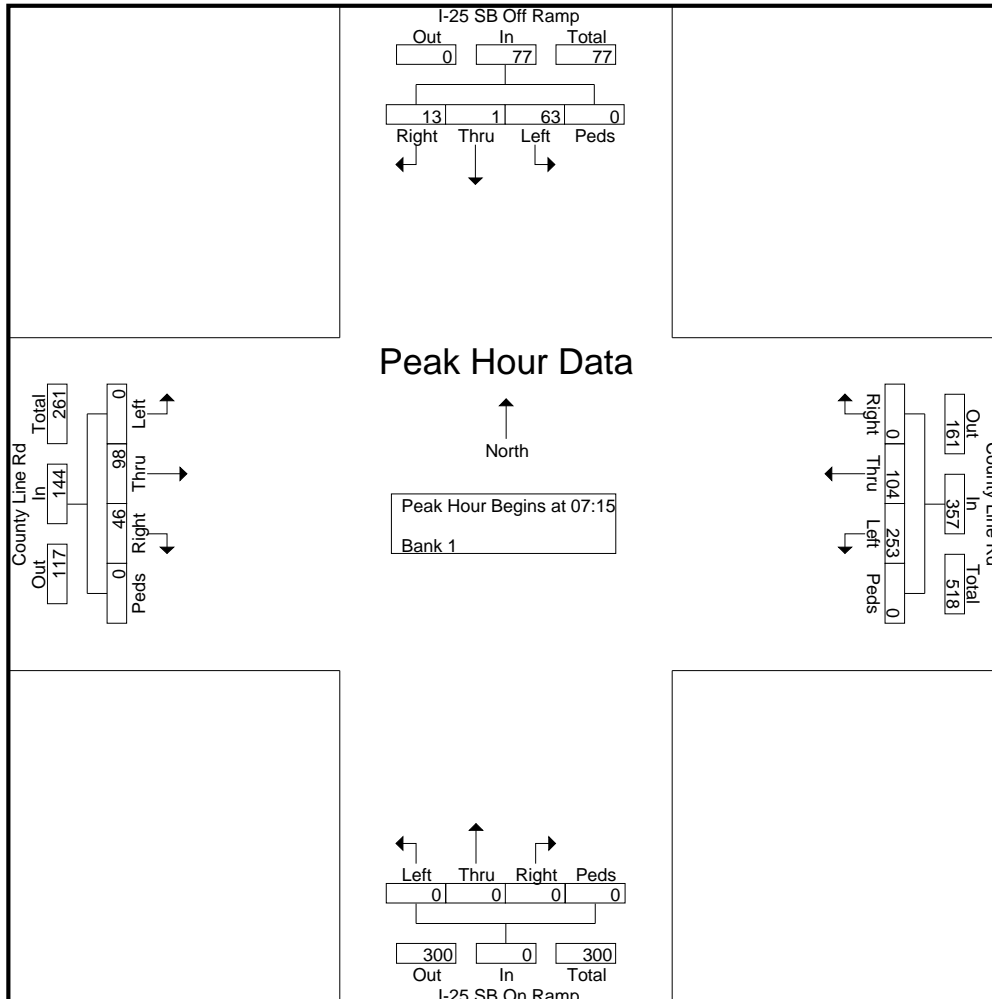

LSC Transportation Consultants, Inc.

2504 E. Pikes Peak Ave, Suite 304
 Colorado Springs, CO 80909
 719-633-2868

File Name : I-25 SB Ramps - County Line Rd AM
 Site Code : S234450
 Start Date : 1/18/2024
 Page No : 3

Start Time	I-25 SB Off Ramp Southbound					County Line Rd Westbound					I-25 SB On Ramp Northbound					County Line Rd Eastbound					Int. Total
	Right	Thru	Left	Peds	App. Total	Right	Thru	Left	Peds	App. Total	Right	Thru	Left	Peds	App. Total	Right	Thru	Left	Peds	App. Total	
Peak Hour Analysis From 06:30 to 08:25 - Peak 1 of 1																					
Peak Hour for Each Approach Begins at:																					
	07:00					07:10					06:30					06:55					
+0 mins.	1	1	2	0	4	0	6	17	0	23	0	0	0	0	0	2	9	0	0	11	
+5 mins.	0	0	6	0	6	0	6	17	0	23	0	0	0	0	0	2	9	0	0	11	
+10 mins.	0	0	4	0	4	0	6	30	0	36	0	0	0	0	0	4	11	0	0	15	
+15 mins.	2	1	3	0	6	0	13	20	0	33	0	0	0	0	0	2	3	0	0	5	
+20 mins.	0	0	3	0	3	0	10	34	0	44	0	0	0	0	0	3	14	0	0	17	
+25 mins.	0	0	6	0	6	0	9	20	0	29	0	0	0	0	0	5	14	0	0	19	
+30 mins.	1	0	7	0	8	0	11	24	0	35	0	0	0	0	0	4	17	0	0	21	
+35 mins.	1	0	5	0	6	0	7	25	0	32	0	0	0	0	0	6	3	0	0	9	
+40 mins.	1	0	8	0	9	0	9	14	0	23	0	0	0	0	0	3	8	0	0	11	
+45 mins.	1	0	6	0	7	0	10	10	0	20	0	0	0	0	0	10	6	0	0	16	
+50 mins.	1	0	8	0	9	0	7	15	0	22	0	0	0	0	0	3	8	0	0	11	
+55 mins.	1	0	9	0	10	0	11	26	0	37	0	0	0	0	0	2	7	0	0	9	
Total Volume	9	2	67	0	78	0	105	252	0	357	0	0	0	0	0	46	109	0	0	155	
% App. Total	11.5	2.6	85.9	0		0	29.4	70.6	0		0	0	0	0		29.7	70.3	0	0		
PHF	.375	.167	.620	.000	.650	.000	.673	.618	.000	.676	.000	.000	.000	.000	.000	.383	.534	.000	.000	.615	

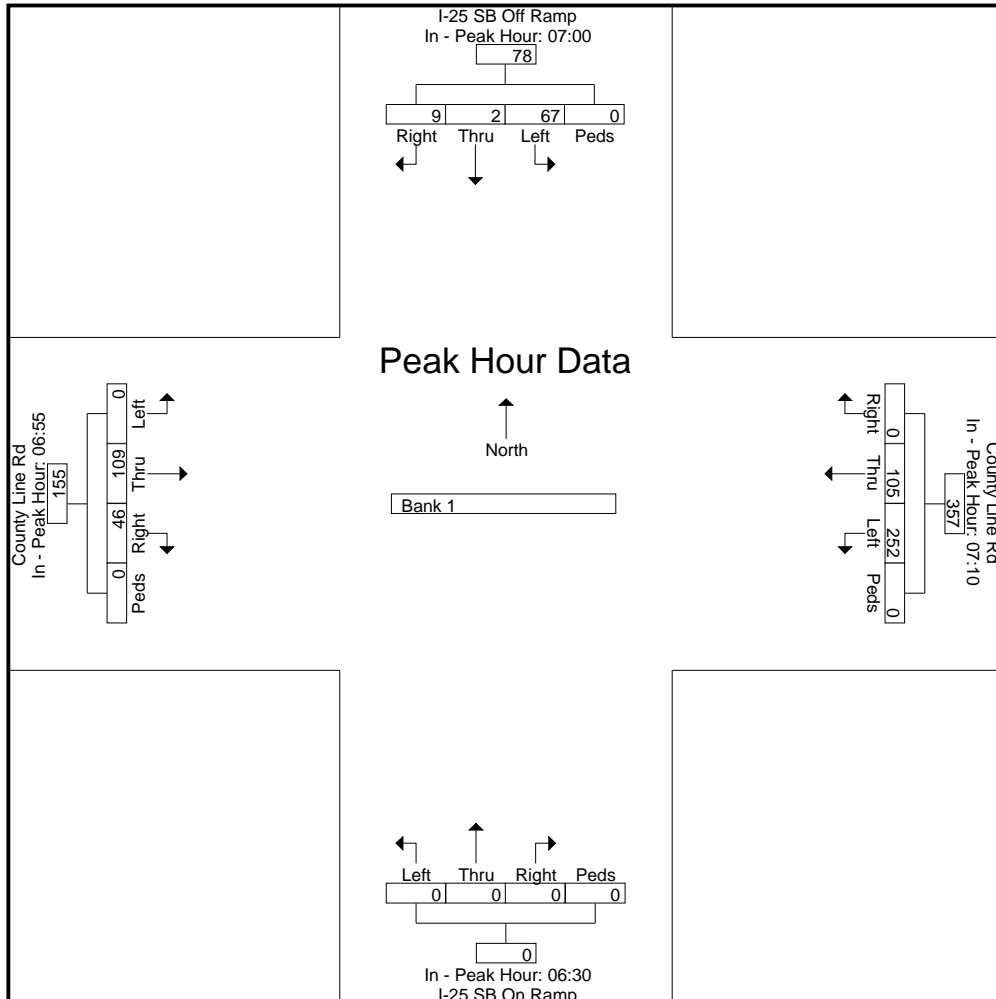

LSC Transportation Consultants, Inc.

2504 E. Pikes Peak Ave, Suite 304
 Colorado Springs, CO 80909
 719-633-2868

File Name : I-25 SB Ramps - County Line Rd PM
 Site Code : S234450
 Start Date : 1/17/2024
 Page No : 1

Groups Printed- Bank 1

Start Time	I-25 SB Off Ramp Southbound					County Line Rd Westbound					I-25 SB On Ramp Northbound					County Line Rd Eastbound					Int. Total
	Right	Thru	Left	Peds	App. Total	Right	Thru	Left	Peds	App. Total	Right	Thru	Left	Peds	App. Total	Right	Thru	Left	Peds	App. Total	
16:00	1	0	10	0	11	0	9	7	0	16	0	0	0	0	0	3	5	0	0	8	35
16:05	5	0	15	0	20	0	6	12	0	18	0	0	0	0	0	6	12	1	0	19	57
16:10	1	0	15	0	16	0	6	10	0	16	0	0	0	0	0	3	4	1	0	8	40
16:15	2	0	12	0	14	0	8	12	0	20	0	0	0	0	0	3	5	0	0	8	42
16:20	4	0	18	0	22	0	14	10	0	24	0	0	0	0	0	8	5	0	0	13	59
16:25	3	0	25	0	28	0	7	6	0	13	0	0	0	0	0	10	6	0	0	16	57
16:30	3	0	12	0	15	0	6	6	0	12	0	0	0	0	0	8	8	0	0	16	43
16:35	3	0	13	0	16	0	9	10	0	19	0	0	0	0	0	4	8	0	0	12	47
16:40	1	0	16	0	17	0	10	8	0	18	0	0	0	0	0	5	4	0	0	9	44
16:45	3	0	13	0	16	0	7	4	0	11	0	0	0	0	0	6	14	0	0	20	47
16:50	4	0	19	0	23	0	5	5	0	10	0	0	0	0	0	5	3	0	0	8	41
16:55	2	0	15	0	17	0	5	6	0	11	0	0	0	0	0	4	6	0	0	10	38
Total	32	0	183	0	215	0	92	96	0	188	0	0	0	0	0	65	80	2	0	147	550
17:00	2	1	16	0	19	0	6	9	0	15	0	0	0	0	0	4	3	0	0	7	41
17:05	3	0	13	0	16	0	9	9	0	18	0	0	0	0	0	5	18	0	0	23	57
17:10	4	0	15	0	19	0	9	5	0	14	0	0	0	0	0	5	8	0	0	13	46
17:15	3	0	11	0	14	0	5	6	0	11	0	0	0	0	0	6	4	0	0	10	35
17:20	4	0	26	0	30	0	6	4	0	10	0	0	0	0	0	2	5	0	0	7	47
17:25	3	0	17	0	20	0	6	6	0	12	0	0	0	0	0	5	3	0	0	8	40
17:30	7	0	21	0	28	0	5	7	0	12	0	0	0	0	0	2	7	0	0	9	49
17:35	3	0	16	0	19	0	12	6	0	18	0	0	0	0	0	7	6	0	0	13	50
17:40	3	0	11	0	14	0	8	7	0	15	0	0	0	0	0	1	7	0	0	8	37
17:45	2	0	10	0	12	0	5	4	0	9	0	0	0	0	0	2	5	0	0	7	28
17:50	6	0	15	0	21	0	9	7	0	16	0	0	0	0	0	1	9	0	0	10	47
17:55	2	0	18	0	20	0	4	10	0	14	0	0	0	0	0	3	12	0	0	15	49
Total	42	1	189	0	232	0	84	80	0	164	0	0	0	0	0	43	87	0	0	130	526
Grand Total	74	1	372	0	447	0	176	176	0	352	0	0	0	0	0	108	167	2	0	277	1076
Apprch %	16.6	0.2	83.2	0		0	50	50	0		0	0	0	0		39	60.3	0.7	0		
Total %	6.9	0.1	34.6	0	41.5	0	16.4	16.4	0	32.7	0	0	0	0	0	10	15.5	0.2	0	25.7	

LSC Transportation Consultants, Inc.

2504 E. Pikes Peak Ave, Suite 304
 Colorado Springs, CO 80909
 719-633-2868

File Name : I-25 SB Ramps - County Line Rd PM
 Site Code : S234450
 Start Date : 1/17/2024
 Page No : 2

Start Time	I-25 SB Off Ramp Southbound					County Line Rd Westbound					I-25 SB On Ramp Northbound					County Line Rd Eastbound					Int. Total
	Right	Thru	Left	Peds	App. Total	Right	Thru	Left	Peds	App. Total	Right	Thru	Left	Peds	App. Total	Right	Thru	Left	Peds	App. Total	
Peak Hour Analysis From 16:00 to 17:55 - Peak 1 of 1																					
Peak Hour for Entire Intersection Begins at 16:15																					
16:15	2	0	12	0	14	0	8	12	0	20	0	0	0	0	0	3	5	0	0	8	42
16:20	4	0	18	0	22	0	14	10	0	24	0	0	0	0	0	8	5	0	0	13	59
16:25	3	0	25	0	28	0	7	6	0	13	0	0	0	0	0	10	6	0	0	16	57
16:30	3	0	12	0	15	0	6	6	0	12	0	0	0	0	0	8	8	0	0	16	43
16:35	3	0	13	0	16	0	9	10	0	19	0	0	0	0	0	4	8	0	0	12	47
16:40	1	0	16	0	17	0	10	8	0	18	0	0	0	0	0	5	4	0	0	9	44
16:45	3	0	13	0	16	0	7	4	0	11	0	0	0	0	0	6	14	0	0	20	47
16:50	4	0	19	0	23	0	5	5	0	10	0	0	0	0	0	5	3	0	0	8	41
16:55	2	0	15	0	17	0	5	6	0	11	0	0	0	0	0	4	6	0	0	10	38
17:00	2	1	16	0	19	0	6	9	0	15	0	0	0	0	0	4	3	0	0	7	41
17:05	3	0	13	0	16	0	9	9	0	18	0	0	0	0	0	5	18	0	0	23	57
17:10	4	0	15	0	19	0	9	5	0	14	0	0	0	0	0	5	8	0	0	13	46
Total Volume	34	1	187	0	222	0	95	90	0	185	0	0	0	0	0	67	88	0	0	155	562
% App. Total	15.3	0.5	84.2	0		0	51.4	48.6	0		0	0	0	0		43.2	56.8	0	0		
PHF	.708	.083	.623	.000	.661	.000	.565	.625	.000	.642	.000	.000	.000	.000	.000	.558	.407	.000	.000	.562	.794

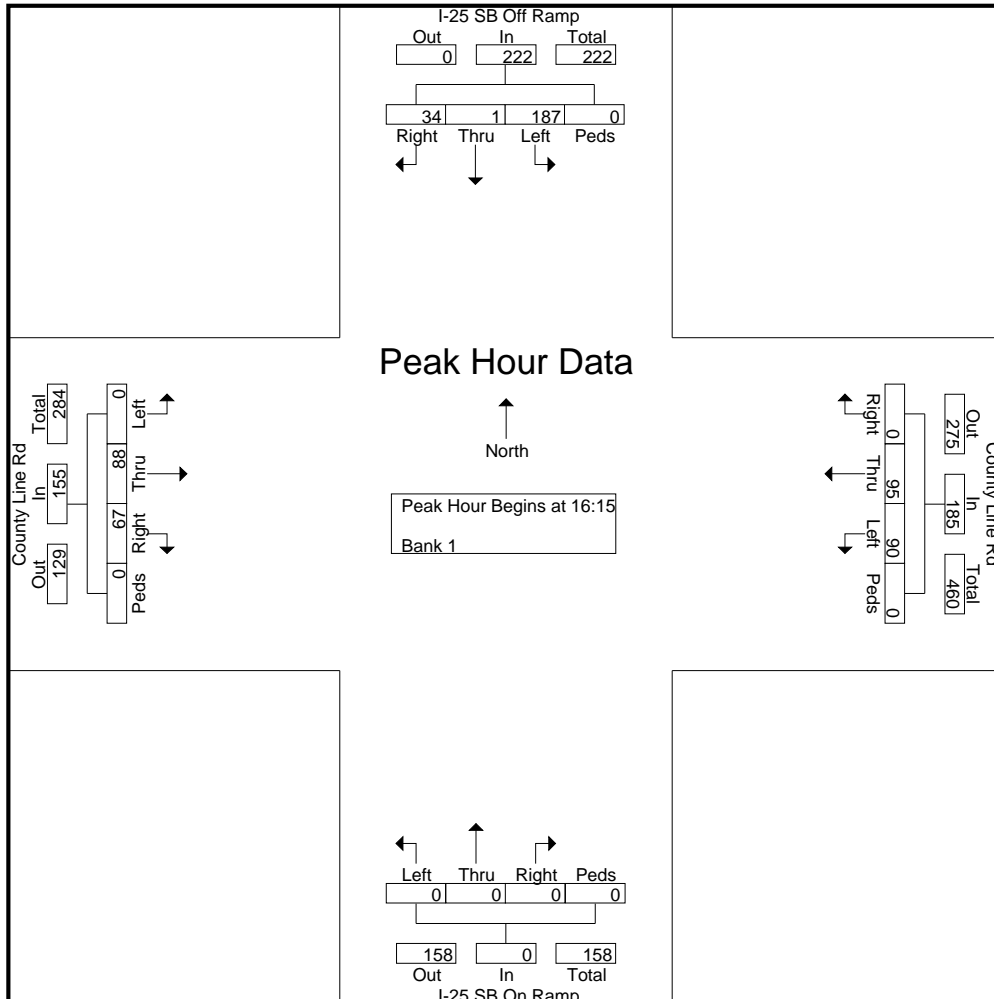

LSC Transportation Consultants, Inc.

2504 E. Pikes Peak Ave, Suite 304
 Colorado Springs, CO 80909
 719-633-2868

File Name : I-25 SB Ramps - County Line Rd PM
 Site Code : S234450
 Start Date : 1/17/2024
 Page No : 3

	I-25 SB Off Ramp Southbound					County Line Rd Westbound					I-25 SB On Ramp Northbound					County Line Rd Eastbound					Int. Total
	Right	Thru	Left	Peds	App. Total	Right	Thru	Left	Peds	App. Total	Right	Thru	Left	Peds	App. Total	Right	Thru	Left	Peds	App. Total	
Peak Hour Analysis From 16:00 to 17:55 - Peak 1 of 1																					
Peak Hour for Each Approach Begins at:																					
	16:40					16:00					16:00					16:20					
+0 mins.	1	0	16	0	17	0	9	7	0	16	0	0	0	0	0	8	5	0	0	13	
+5 mins.	3	0	13	0	16	0	6	12	0	18	0	0	0	0	0	10	6	0	0	16	
+10 mins.	4	0	19	0	23	0	6	10	0	16	0	0	0	0	0	8	8	0	0	16	
+15 mins.	2	0	15	0	17	0	8	12	0	20	0	0	0	0	0	4	8	0	0	12	
+20 mins.	2	1	16	0	19	0	14	10	0	24	0	0	0	0	0	5	4	0	0	9	
+25 mins.	3	0	13	0	16	0	7	6	0	13	0	0	0	0	0	6	14	0	0	20	
+30 mins.	4	0	15	0	19	0	6	6	0	12	0	0	0	0	0	5	3	0	0	8	
+35 mins.	3	0	11	0	14	0	9	10	0	19	0	0	0	0	0	4	6	0	0	10	
+40 mins.	4	0	26	0	30	0	10	8	0	18	0	0	0	0	0	4	3	0	0	7	
+45 mins.	3	0	17	0	20	0	7	4	0	11	0	0	0	0	0	5	18	0	0	23	
+50 mins.	7	0	21	0	28	0	5	5	0	10	0	0	0	0	0	5	8	0	0	13	
+55 mins.	3	0	16	0	19	0	5	6	0	11	0	0	0	0	0	6	4	0	0	10	
Total Volume	39	1	198	0	238	0	92	96	0	188	0	0	0	0	0	70	87	0	0	157	
% App. Total	16.4	0.4	83.2	0		0	48.9	51.1	0		0	0	0	0		44.6	55.4	0	0		
PHF	.464	.083	.635	.000	.661	.000	.548	.667	.000	.653	.000	.000	.000	.000	.000	.583	.403	.000	.000	.569	

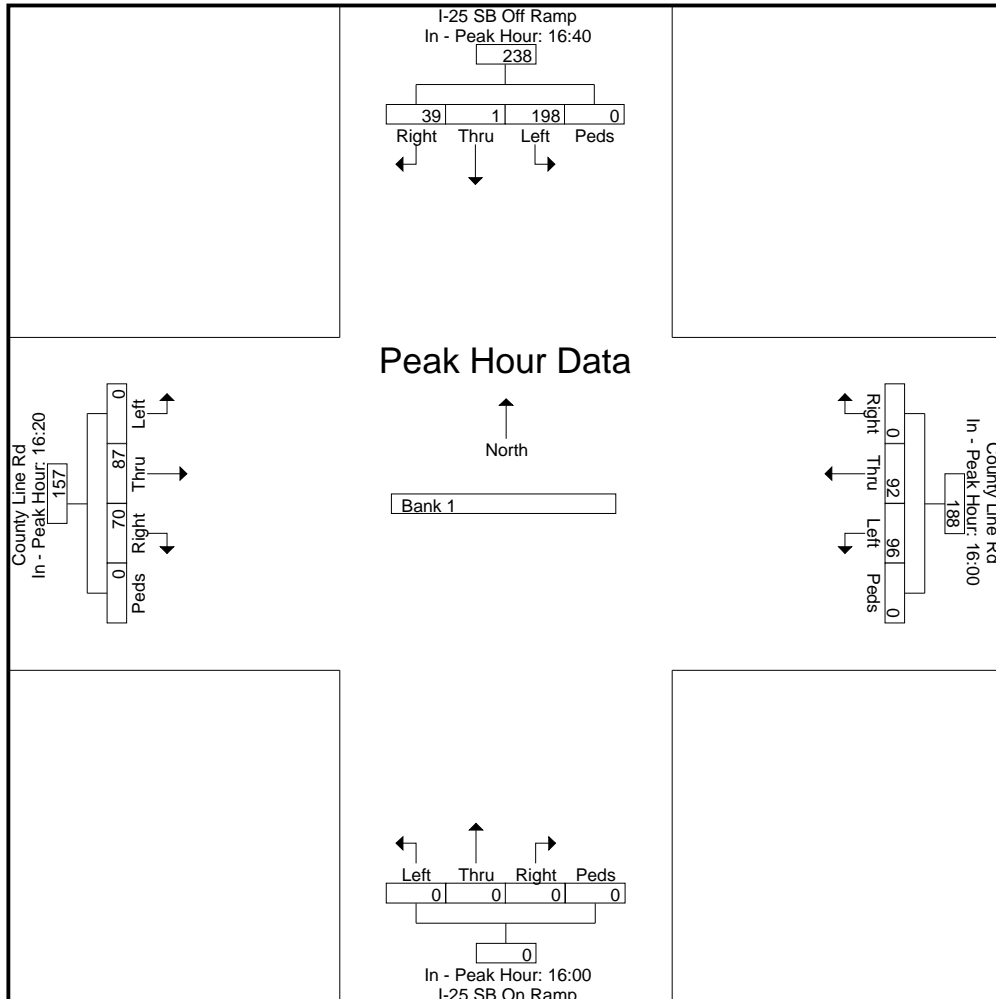

Level of Service Reports



HCM 6th TWSC
1: County Line Rd & I-25 SB Ramps

Adjusted Existing
AM

Intersection												
Int Delay, s/veh	6.8											
Movement	EBL	EBT	EBR	WBL	WBT	WBR	NBL	NBT	NBR	SBL	SBT	SBR
Lane Configurations		↕		↕	↑						↕	
Traffic Vol, veh/h	0	98	46	253	104	0	0	0	0	63	1	13
Future Vol, veh/h	0	98	46	253	104	0	0	0	0	63	1	13
Conflicting Peds, #/hr	0	0	0	0	0	0	0	0	0	0	0	0
Sign Control	Free	Free	Free	Free	Free	Free	Stop	Stop	Stop	Stop	Stop	Stop
RT Channelized	-	-	Free	-	-	None	-	-	None	-	-	None
Storage Length	-	-	-	0	-	-	-	-	-	-	-	-
Veh in Median Storage, #	-	0	-	-	0	-	-	0	-	-	0	-
Grade, %	-	0	-	-	0	-	-	0	-	-	0	-
Peak Hour Factor	83	83	83	92	92	92	92	92	92	83	83	83
Heavy Vehicles, %	2	2	2	2	2	2	2	2	2	2	2	2
Mvmt Flow	0	118	55	275	113	0	0	0	0	76	1	16

Major/Minor	Major1			Major2			Minor2			
Conflicting Flow All	113	0	-	118	0	0		781	781	113
Stage 1	-	-	-	-	-	-		663	663	-
Stage 2	-	-	-	-	-	-		118	118	-
Critical Hdwy	4.12	-	-	4.12	-	-		6.42	6.52	6.22
Critical Hdwy Stg 1	-	-	-	-	-	-		5.42	5.52	-
Critical Hdwy Stg 2	-	-	-	-	-	-		5.42	5.52	-
Follow-up Hdwy	2.218	-	-	2.218	-	-		3.518	4.018	3.318
Pot Cap-1 Maneuver	1476	-	0	1470	-	0		363	326	940
Stage 1	-	-	0	-	-	0		512	459	-
Stage 2	-	-	0	-	-	0		907	798	-
Platoon blocked, %		-			-					
Mov Cap-1 Maneuver	1476	-	-	1470	-	-		295	0	940
Mov Cap-2 Maneuver	-	-	-	-	-	-		295	0	-
Stage 1	-	-	-	-	-	-		512	0	-
Stage 2	-	-	-	-	-	-		737	0	-

Approach	EB	WB	SB
HCM Control Delay, s	0	5.7	19.9
HCM LOS			C

Minor Lane/Major Mvmt	EBL	EBT	WBL	WBT	SBLn1
Capacity (veh/h)	1476	-	1470	-	334
HCM Lane V/C Ratio	-	-	0.187	-	0.278
HCM Control Delay (s)	0	-	8	-	19.9
HCM Lane LOS	A	-	A	-	C
HCM 95th %tile Q(veh)	0	-	0.7	-	1.1

HCM 6th TWSC
2: I-25 NB Ramps & County Line Rd

Adjusted Existing
AM

Intersection												
Int Delay, s/veh	2.1											
Movement	EBL	EBT	EBR	WBL	WBT	WBR	NBL	NBT	NBR	SBL	SBT	SBR
Lane Configurations	↙	↑			↘			↕				
Traffic Vol, veh/h	35	132	0	0	310	210	46	1	50	0	0	0
Future Vol, veh/h	35	132	0	0	310	210	46	1	50	0	0	0
Conflicting Peds, #/hr	0	0	0	0	0	0	0	0	0	0	0	0
Sign Control	Free	Free	Free	Free	Free	Free	Stop	Stop	Stop	Stop	Stop	Stop
RT Channelized	-	-	None	-	-	None	-	-	None	-	-	None
Storage Length	0	-	-	-	-	-	-	-	-	-	-	-
Veh in Median Storage, #	-	0	-	-	0	-	-	0	-	-	0	-
Grade, %	-	0	-	-	0	-	-	0	-	-	0	-
Peak Hour Factor	87	87	87	92	92	92	83	83	83	92	92	92
Heavy Vehicles, %	2	2	2	2	2	2	2	2	2	2	2	2
Mvmt Flow	40	152	0	0	337	228	55	1	60	0	0	0

Major/Minor	Major1	Major2	Minor1
Conflicting Flow All	565	0	-
Stage 1	-	-	-
Stage 2	-	-	-
Critical Hdwy	4.12	-	-
Critical Hdwy Stg 1	-	-	-
Critical Hdwy Stg 2	-	-	-
Follow-up Hdwy	2.218	-	-
Pot Cap-1 Maneuver	1007	-	-
Stage 1	-	-	-
Stage 2	-	-	-
Platoon blocked, %	-	-	-
Mov Cap-1 Maneuver	1007	-	-
Mov Cap-2 Maneuver	-	-	-
Stage 1	-	-	-
Stage 2	-	-	-

Approach	EB	WB	NB
HCM Control Delay, s	1.8	0	13.1
HCM LOS			B

Minor Lane/Major Mvmt	NBLn1	EBL	EBT	WBT	WBR
Capacity (veh/h)	560	1007	-	-	-
HCM Lane V/C Ratio	0.209	0.04	-	-	-
HCM Control Delay (s)	13.1	8.7	-	-	-
HCM Lane LOS	B	A	-	-	-
HCM 95th %tile Q(veh)	0.8	0.1	-	-	-

HCM 6th TWSC
 8: Monument Hill Rd & Misty Acres Blvd

Adjusted Existing
 AM

Intersection						
Int Delay, s/veh	4.8					
Movement	WBL	WBR	NBT	NBR	SBL	SBT
Lane Configurations	↙	↗	↑	↗	↙	↑
Traffic Vol, veh/h	290	0	25	300	0	50
Future Vol, veh/h	290	0	25	300	0	50
Conflicting Peds, #/hr	0	0	0	0	0	0
Sign Control	Stop	Stop	Free	Free	Free	Free
RT Channelized	-	None	-	None	-	None
Storage Length	250	0	-	0	280	-
Veh in Median Storage, #	0	-	0	-	-	0
Grade, %	0	-	0	-	-	0
Peak Hour Factor	92	92	92	92	83	83
Heavy Vehicles, %	2	2	2	2	2	2
Mvmt Flow	315	0	27	326	0	60

Major/Minor	Minor1	Major1	Major2			
Conflicting Flow All	87	27	0	0	353	0
Stage 1	27	-	-	-	-	-
Stage 2	60	-	-	-	-	-
Critical Hdwy	6.42	6.22	-	-	4.12	-
Critical Hdwy Stg 1	5.42	-	-	-	-	-
Critical Hdwy Stg 2	5.42	-	-	-	-	-
Follow-up Hdwy	3.518	3.318	-	-	2.218	-
Pot Cap-1 Maneuver	914	1048	-	-	1206	-
Stage 1	996	-	-	-	-	-
Stage 2	963	-	-	-	-	-
Platoon blocked, %			-	-		-
Mov Cap-1 Maneuver	914	1048	-	-	1206	-
Mov Cap-2 Maneuver	914	-	-	-	-	-
Stage 1	996	-	-	-	-	-
Stage 2	963	-	-	-	-	-

Approach	WB	NB	SB
HCM Control Delay, s	11	0	0
HCM LOS	B		

Minor Lane/Major Mvmt	NBT	NBRWBLn1WBLn2	SBL	SBT
Capacity (veh/h)	-	- 914	- 1206	-
HCM Lane V/C Ratio	-	- 0.345	-	-
HCM Control Delay (s)	-	- 11	0	0
HCM Lane LOS	-	- B	A	A
HCM 95th %tile Q(veh)	-	- 1.5	-	0

HCM 6th TWSC
1: County Line Rd & I-25 SB Ramps

Adjusted Existing
PM

Intersection												
Int Delay, s/veh	8.4											
Movement	EBL	EBT	EBR	WBL	WBT	WBR	NBL	NBT	NBR	SBL	SBT	SBR
Lane Configurations		↕		↕	↑						↕	
Traffic Vol, veh/h	0	88	67	90	95	0	0	0	0	187	1	34
Future Vol, veh/h	0	88	67	90	95	0	0	0	0	187	1	34
Conflicting Peds, #/hr	0	0	0	0	0	0	0	0	0	0	0	0
Sign Control	Free	Free	Free	Free	Free	Free	Stop	Stop	Stop	Stop	Stop	Stop
RT Channelized	-	-	Free	-	-	None	-	-	None	-	-	None
Storage Length	-	-	-	0	-	-	-	-	-	-	-	-
Veh in Median Storage, #	-	0	-	-	0	-	-	0	-	-	0	-
Grade, %	-	0	-	-	0	-	-	0	-	-	0	-
Peak Hour Factor	87	87	87	87	87	87	92	92	92	87	87	87
Heavy Vehicles, %	2	2	2	2	2	2	2	2	2	2	2	2
Mvmt Flow	0	101	77	103	109	0	0	0	0	215	1	39

Major/Minor	Major1			Major2			Minor2				
Conflicting Flow All	109	0	-	101	0	0			416	416	109
Stage 1	-	-	-	-	-	-			315	315	-
Stage 2	-	-	-	-	-	-			101	101	-
Critical Hdwy	4.12	-	-	4.12	-	-			6.42	6.52	6.22
Critical Hdwy Stg 1	-	-	-	-	-	-			5.42	5.52	-
Critical Hdwy Stg 2	-	-	-	-	-	-			5.42	5.52	-
Follow-up Hdwy	2.218	-	-	2.218	-	-			3.518	4.018	3.318
Pot Cap-1 Maneuver	1481	-	0	1491	-	0			593	527	945
Stage 1	-	-	0	-	-	0			740	656	-
Stage 2	-	-	0	-	-	0			923	811	-
Platoon blocked, %		-			-						
Mov Cap-1 Maneuver	1481	-	-	1491	-	-			552	0	945
Mov Cap-2 Maneuver	-	-	-	-	-	-			552	0	-
Stage 1	-	-	-	-	-	-			740	0	-
Stage 2	-	-	-	-	-	-			859	0	-

Approach	EB	WB	SB
HCM Control Delay, s	0	3.7	15.7
HCM LOS			C

Minor Lane/Major Mvmt	EBL	EBT	WBL	WBT	SBLn1
Capacity (veh/h)	1481	-	1491	-	590
HCM Lane V/C Ratio	-	-	0.069	-	0.432
HCM Control Delay (s)	0	-	7.6	-	15.7
HCM Lane LOS	A	-	A	-	C
HCM 95th %tile Q(veh)	0	-	0.2	-	2.2

HCM 6th TWSC
2: I-25 NB Ramps & County Line Rd

Adjusted Existing
PM

Intersection												
Int Delay, s/veh	4.1											
Movement	EBL	EBT	EBR	WBL	WBT	WBR	NBL	NBT	NBR	SBL	SBT	SBR
Lane Configurations	↙	↑			↘			↕				
Traffic Vol, veh/h	23	255	0	0	135	80	45	2	155	0	0	0
Future Vol, veh/h	23	255	0	0	135	80	45	2	155	0	0	0
Conflicting Peds, #/hr	0	0	0	0	0	0	0	0	0	0	0	0
Sign Control	Free	Free	Free	Free	Free	Free	Stop	Stop	Stop	Stop	Stop	Stop
RT Channelized	-	-	None	-	-	None	-	-	None	-	-	None
Storage Length	0	-	-	-	-	-	-	-	-	-	-	-
Veh in Median Storage, #	-	0	-	-	0	-	-	0	-	-	0	-
Grade, %	-	0	-	-	0	-	-	0	-	-	0	-
Peak Hour Factor	92	92	92	87	87	87	87	87	87	92	92	92
Heavy Vehicles, %	2	2	2	2	2	2	2	2	2	2	2	2
Mvmt Flow	25	277	0	0	155	92	52	2	178	0	0	0

Major/Minor	Major1	Major2	Minor1
Conflicting Flow All	247	0	0
Stage 1	-	-	-
Stage 2	-	-	-
Critical Hdwy	4.12	-	-
Critical Hdwy Stg 1	-	-	-
Critical Hdwy Stg 2	-	-	-
Follow-up Hdwy	2.218	-	-
Pot Cap-1 Maneuver	1319	0	0
Stage 1	-	0	0
Stage 2	-	0	0
Platoon blocked, %	-	-	-
Mov Cap-1 Maneuver	1319	-	-
Mov Cap-2 Maneuver	-	-	-
Stage 1	-	-	-
Stage 2	-	-	-

Approach	EB	WB	NB
HCM Control Delay, s	0.6	0	13
HCM LOS			B

Minor Lane/Major Mvmt	NBLn1	EBL	EBT	WBT	WBR
Capacity (veh/h)	682	1319	-	-	-
HCM Lane V/C Ratio	0.34	0.019	-	-	-
HCM Control Delay (s)	13	7.8	-	-	-
HCM Lane LOS	B	A	-	-	-
HCM 95th %tile Q(veh)	1.5	0.1	-	-	-

HCM 6th TWSC
 8: Monument Hill Rd & Misty Acres Blvd

Adjusted Existing
 PM

Intersection						
Int Delay, s/veh	3.3					
Movement	WBL	WBR	NBT	NBR	SBL	SBT
Lane Configurations	↖	↗	↕	↕	↖	↗
Traffic Vol, veh/h	87	0	35	95	0	40
Future Vol, veh/h	87	0	35	95	0	40
Conflicting Peds, #/hr	0	0	0	0	0	0
Sign Control	Stop	Stop	Free	Free	Free	Free
RT Channelized	-	None	-	None	-	None
Storage Length	250	0	-	0	280	-
Veh in Median Storage, #	0	-	0	-	-	0
Grade, %	0	-	0	-	-	0
Peak Hour Factor	83	83	87	87	78	78
Heavy Vehicles, %	2	2	2	2	2	2
Mvmt Flow	105	0	40	109	0	51

Major/Minor	Minor1	Major1	Major2		
Conflicting Flow All	91	40	0	0	149
Stage 1	40	-	-	-	-
Stage 2	51	-	-	-	-
Critical Hdwy	6.42	6.22	-	-	4.12
Critical Hdwy Stg 1	5.42	-	-	-	-
Critical Hdwy Stg 2	5.42	-	-	-	-
Follow-up Hdwy	3.518	3.318	-	-	2.218
Pot Cap-1 Maneuver	909	1031	-	-	1432
Stage 1	982	-	-	-	-
Stage 2	971	-	-	-	-
Platoon blocked, %			-	-	-
Mov Cap-1 Maneuver	909	1031	-	-	1432
Mov Cap-2 Maneuver	909	-	-	-	-
Stage 1	982	-	-	-	-
Stage 2	971	-	-	-	-

Approach	WB	NB	SB
HCM Control Delay, s	9.5	0	0
HCM LOS	A		

Minor Lane/Major Mvmt	NBT	NBRWBLn1	WBLn2	SBL	SBT
Capacity (veh/h)	-	-	909	-	1432
HCM Lane V/C Ratio	-	-	0.115	-	-
HCM Control Delay (s)	-	-	9.5	0	0
HCM Lane LOS	-	-	A	A	A
HCM 95th %tile Q(veh)	-	-	0.4	-	0

Intersection												
Int Delay, s/veh	4.1											
Movement	EBL	EBT	EBR	WBL	WBT	WBR	NBL	NBT	NBR	SBL	SBT	SBR
Lane Configurations		↕			↕			↕			↕	
Traffic Vol, veh/h	2	85	101	69	428	2	85	0	29	1	0	5
Future Vol, veh/h	2	85	101	69	428	2	85	0	29	1	0	5
Conflicting Peds, #/hr	0	0	0	0	0	0	0	0	0	0	0	0
Sign Control	Free	Free	Free	Free	Free	Free	Stop	Stop	Stop	Stop	Stop	Stop
RT Channelized	-	-	None	-	-	None	-	-	None	-	-	None
Storage Length	-	-	-	-	-	-	-	-	-	-	-	-
Veh in Median Storage, #	-	0	-	-	0	-	-	0	-	-	0	-
Grade, %	-	-7	-	-	4	-	-	0	-	-	0	-
Peak Hour Factor	87	87	87	92	92	92	83	83	83	78	78	78
Heavy Vehicles, %	2	2	2	2	2	2	2	2	2	2	2	2
Mvmt Flow	2	98	116	75	465	2	102	0	35	1	0	6

Major/Minor	Major1			Major2			Minor1			Minor2		
Conflicting Flow All	467	0	0	214	0	0	779	777	156	794	834	466
Stage 1	-	-	-	-	-	-	160	160	-	616	616	-
Stage 2	-	-	-	-	-	-	619	617	-	178	218	-
Critical Hdwy	4.12	-	-	4.12	-	-	7.12	6.52	6.22	7.12	6.52	6.22
Critical Hdwy Stg 1	-	-	-	-	-	-	6.12	5.52	-	6.12	5.52	-
Critical Hdwy Stg 2	-	-	-	-	-	-	6.12	5.52	-	6.12	5.52	-
Follow-up Hdwy	2.218	-	-	2.218	-	-	3.518	4.018	3.318	3.518	4.018	3.318
Pot Cap-1 Maneuver	1094	-	-	1356	-	-	313	328	890	306	304	597
Stage 1	-	-	-	-	-	-	842	766	-	478	482	-
Stage 2	-	-	-	-	-	-	476	481	-	824	723	-
Platoon blocked, %		-	-		-	-						
Mov Cap-1 Maneuver	1094	-	-	1356	-	-	291	303	890	277	281	597
Mov Cap-2 Maneuver	-	-	-	-	-	-	291	303	-	277	281	-
Stage 1	-	-	-	-	-	-	840	764	-	477	446	-
Stage 2	-	-	-	-	-	-	436	445	-	790	722	-

Approach	EB			WB			NB			SB		
HCM Control Delay, s	0.1			1.1			21.7			12.3		
HCM LOS							C			B		

Minor Lane/Major Mvmt	NBLn1	EBL	EBT	EBR	WBL	WBT	WBR	SBLn1
Capacity (veh/h)	351	1094	-	-	1356	-	-	501
HCM Lane V/C Ratio	0.391	0.002	-	-	0.055	-	-	0.015
HCM Control Delay (s)	21.7	8.3	0	-	7.8	0	-	12.3
HCM Lane LOS	C	A	A	-	A	A	-	B
HCM 95th %tile Q(veh)	1.8	0	-	-	0.2	-	-	0

HCM 6th TWSC
51: Misty Acres Blvd & Monument Hill Rd

Adjusted Existing
AM

Intersection						
Int Delay, s/veh	1.6					
Movement	EBL	EBR	NBL	NBT	SBT	SBR
Lane Configurations						
Traffic Vol, veh/h	42	0	0	72	120	50
Future Vol, veh/h	42	0	0	72	120	50
Conflicting Peds, #/hr	0	0	0	0	0	0
Sign Control	Stop	Stop	Free	Free	Free	Free
RT Channelized	-	None	-	None	-	None
Storage Length	0	-	-	-	-	186
Veh in Median Storage, #	0	-	-	0	0	-
Grade, %	0	-	-	0	0	-
Peak Hour Factor	78	78	83	83	87	87
Heavy Vehicles, %	2	2	2	2	2	2
Mvmt Flow	54	0	0	87	138	57

Major/Minor	Minor2	Major1	Major2			
Conflicting Flow All	225	138	195	0	-	0
Stage 1	138	-	-	-	-	-
Stage 2	87	-	-	-	-	-
Critical Hdwy	6.42	6.22	4.12	-	-	-
Critical Hdwy Stg 1	5.42	-	-	-	-	-
Critical Hdwy Stg 2	5.42	-	-	-	-	-
Follow-up Hdwy	3.518	3.318	2.218	-	-	-
Pot Cap-1 Maneuver	763	910	1378	-	-	-
Stage 1	889	-	-	-	-	-
Stage 2	936	-	-	-	-	-
Platoon blocked, %				-	-	-
Mov Cap-1 Maneuver	763	910	1378	-	-	-
Mov Cap-2 Maneuver	763	-	-	-	-	-
Stage 1	889	-	-	-	-	-
Stage 2	936	-	-	-	-	-

Approach	EB	NB	SB
HCM Control Delay, s	10.1	0	0
HCM LOS	B		

Minor Lane/Major Mvmt	NBL	NBT	EBLn1	SBT	SBR
Capacity (veh/h)	1378	-	763	-	-
HCM Lane V/C Ratio	-	-	0.071	-	-
HCM Control Delay (s)	0	-	10.1	-	-
HCM Lane LOS	A	-	B	-	-
HCM 95th %tile Q(veh)	0	-	0.2	-	-

Intersection						
Int Delay, s/veh	2.1					
Movement	WBL	WBR	NBT	NBR	SBL	SBT
Lane Configurations	Y		↑	↑	↑	↑
Traffic Vol, veh/h	54	5	67	45	1	119
Future Vol, veh/h	54	5	67	45	1	119
Conflicting Peds, #/hr	0	0	0	0	0	0
Sign Control	Stop	Stop	Free	Free	Free	Free
RT Channelized	-	None	-	None	-	None
Storage Length	0	-	-	100	120	-
Veh in Median Storage, #	0	-	0	-	-	0
Grade, %	0	-	0	-	-	0
Peak Hour Factor	83	83	83	83	83	83
Heavy Vehicles, %	2	2	2	2	2	2
Mvmt Flow	65	6	81	54	1	143

Major/Minor	Minor1	Major1	Major2		
Conflicting Flow All	226	81	0	0	135
Stage 1	81	-	-	-	-
Stage 2	145	-	-	-	-
Critical Hdwy	6.42	6.22	-	-	4.12
Critical Hdwy Stg 1	5.42	-	-	-	-
Critical Hdwy Stg 2	5.42	-	-	-	-
Follow-up Hdwy	3.518	3.318	-	-	2.218
Pot Cap-1 Maneuver	762	979	-	-	1449
Stage 1	942	-	-	-	-
Stage 2	882	-	-	-	-
Platoon blocked, %			-	-	-
Mov Cap-1 Maneuver	761	979	-	-	1449
Mov Cap-2 Maneuver	761	-	-	-	-
Stage 1	942	-	-	-	-
Stage 2	881	-	-	-	-

Approach	WB	NB	SB
HCM Control Delay, s	10.1	0	0.1
HCM LOS	B		

Minor Lane/Major Mvmt	NBT	NBRWBLn1	SBL	SBT
Capacity (veh/h)	-	-	776	1449
HCM Lane V/C Ratio	-	-	0.092	0.001
HCM Control Delay (s)	-	-	10.1	7.5
HCM Lane LOS	-	-	B	A
HCM 95th %tile Q(veh)	-	-	0.3	0

HCM 6th TWSC
46: Monument Hill Rd/Andrews Rd & County Line Rd

Adjusted Existing
PM

Intersection												
Int Delay, s/veh	2											
Movement	EBL	EBT	EBR	WBL	WBT	WBR	NBL	NBT	NBR	SBL	SBT	SBR
Lane Configurations		↕			↕			↕			↕	
Traffic Vol, veh/h	5	350	50	18	163	1	45	0	21	2	0	2
Future Vol, veh/h	5	350	50	18	163	1	45	0	21	2	0	2
Conflicting Peds, #/hr	0	0	0	0	0	0	0	0	0	0	0	0
Sign Control	Free	Free	Free	Free	Free	Free	Stop	Stop	Stop	Stop	Stop	Stop
RT Channelized	-	-	None	-	-	None	-	-	None	-	-	None
Storage Length	-	-	-	-	-	-	-	-	-	-	-	-
Veh in Median Storage, #	-	0	-	-	0	-	-	0	-	-	0	-
Grade, %	-	-7	-	-	4	-	-	0	-	-	0	-
Peak Hour Factor	92	92	92	87	87	87	83	83	83	78	78	78
Heavy Vehicles, %	2	2	2	2	2	2	2	2	2	2	2	2
Mvmt Flow	5	380	54	21	187	1	54	0	25	3	0	3

Major/Minor	Major1			Major2			Minor1			Minor2		
Conflicting Flow All	188	0	0	434	0	0	648	647	407	660	674	188
Stage 1	-	-	-	-	-	-	417	417	-	230	230	-
Stage 2	-	-	-	-	-	-	231	230	-	430	444	-
Critical Hdwy	4.12	-	-	4.12	-	-	7.12	6.52	6.22	7.12	6.52	6.22
Critical Hdwy Stg 1	-	-	-	-	-	-	6.12	5.52	-	6.12	5.52	-
Critical Hdwy Stg 2	-	-	-	-	-	-	6.12	5.52	-	6.12	5.52	-
Follow-up Hdwy	2.218	-	-	2.218	-	-	3.518	4.018	3.318	3.518	4.018	3.318
Pot Cap-1 Maneuver	1386	-	-	1126	-	-	383	390	644	376	376	854
Stage 1	-	-	-	-	-	-	613	591	-	773	714	-
Stage 2	-	-	-	-	-	-	772	714	-	603	575	-
Platoon blocked, %		-	-		-	-						
Mov Cap-1 Maneuver	1386	-	-	1126	-	-	374	380	644	354	366	854
Mov Cap-2 Maneuver	-	-	-	-	-	-	374	380	-	354	366	-
Stage 1	-	-	-	-	-	-	610	588	-	769	699	-
Stage 2	-	-	-	-	-	-	754	699	-	576	572	-

Approach	EB			WB			NB			SB		
HCM Control Delay, s	0.1			0.8			15.2			12.3		
HCM LOS							C			B		

Minor Lane/Major Mvmt	NBLn1	EBL	EBT	EBR	WBL	WBT	WBR	SBLn1
Capacity (veh/h)	432	1386	-	-	1126	-	-	501
HCM Lane V/C Ratio	0.184	0.004	-	-	0.018	-	-	0.01
HCM Control Delay (s)	15.2	7.6	0	-	8.3	0	-	12.3
HCM Lane LOS	C	A	A	-	A	A	-	B
HCM 95th %tile Q(veh)	0.7	0	-	-	0.1	-	-	0

HCM 6th TWSC
 51: Misty Acres Blvd & Monument Hill Rd

Adjusted Existing
 PM

Intersection						
Int Delay, s/veh	1.8					
Movement	EBL	EBR	NBL	NBT	SBT	SBR
Lane Configurations	Y			4	↑	↑
Traffic Vol, veh/h	25	0	0	41	42	25
Future Vol, veh/h	25	0	0	41	42	25
Conflicting Peds, #/hr	0	0	0	0	0	0
Sign Control	Stop	Stop	Free	Free	Free	Free
RT Channelized	-	None	-	None	-	None
Storage Length	0	-	-	-	-	186
Veh in Median Storage, #	0	-	-	0	0	-
Grade, %	0	-	-	0	0	-
Peak Hour Factor	78	78	78	78	83	83
Heavy Vehicles, %	2	2	2	2	2	2
Mvmt Flow	32	0	0	53	51	30

Major/Minor	Minor2	Major1		Major2	
Conflicting Flow All	104	51	81	0	0
Stage 1	51	-	-	-	-
Stage 2	53	-	-	-	-
Critical Hdwy	6.42	6.22	4.12	-	-
Critical Hdwy Stg 1	5.42	-	-	-	-
Critical Hdwy Stg 2	5.42	-	-	-	-
Follow-up Hdwy	3.518	3.318	2.218	-	-
Pot Cap-1 Maneuver	894	1017	1517	-	-
Stage 1	971	-	-	-	-
Stage 2	970	-	-	-	-
Platoon blocked, %				-	-
Mov Cap-1 Maneuver	894	1017	1517	-	-
Mov Cap-2 Maneuver	894	-	-	-	-
Stage 1	971	-	-	-	-
Stage 2	970	-	-	-	-

Approach	EB	NB	SB
HCM Control Delay, s	9.2	0	0
HCM LOS	A		

Minor Lane/Major Mvmt	NBL	NBT	EBLn1	SBT	SBR
Capacity (veh/h)	1517	-	894	-	-
HCM Lane V/C Ratio	-	-	0.036	-	-
HCM Control Delay (s)	0	-	9.2	-	-
HCM Lane LOS	A	-	A	-	-
HCM 95th %tile Q(veh)	0	-	0.1	-	-

Intersection						
Int Delay, s/veh	1.8					
Movement	WBL	WBR	NBT	NBR	SBL	SBT
Lane Configurations	↘↗		↑	↗↘	↘↗	↑
Traffic Vol, veh/h	15	4	37	29	6	36
Future Vol, veh/h	15	4	37	29	6	36
Conflicting Peds, #/hr	0	0	0	0	0	0
Sign Control	Stop	Stop	Free	Free	Free	Free
RT Channelized	-	None	-	None	-	None
Storage Length	0	-	-	100	120	-
Veh in Median Storage, #	0	-	0	-	-	0
Grade, %	0	-	0	-	-	0
Peak Hour Factor	78	78	83	83	78	78
Heavy Vehicles, %	2	2	2	2	2	2
Mvmt Flow	19	5	45	35	8	46

Major/Minor	Minor1	Major1	Major2		
Conflicting Flow All	107	45	0	0	80
Stage 1	45	-	-	-	-
Stage 2	62	-	-	-	-
Critical Hdwy	6.42	6.22	-	-	4.12
Critical Hdwy Stg 1	5.42	-	-	-	-
Critical Hdwy Stg 2	5.42	-	-	-	-
Follow-up Hdwy	3.518	3.318	-	-	2.218
Pot Cap-1 Maneuver	891	1025	-	-	1518
Stage 1	977	-	-	-	-
Stage 2	961	-	-	-	-
Platoon blocked, %			-	-	-
Mov Cap-1 Maneuver	887	1025	-	-	1518
Mov Cap-2 Maneuver	887	-	-	-	-
Stage 1	977	-	-	-	-
Stage 2	956	-	-	-	-

Approach	WB	NB	SB
HCM Control Delay, s	9.1	0	1.1
HCM LOS	A		

Minor Lane/Major Mvmt	NBT	NBRWBLn1	SBL	SBT
Capacity (veh/h)	-	-	913	1518
HCM Lane V/C Ratio	-	-	0.027	0.005
HCM Control Delay (s)	-	-	9.1	7.4
HCM Lane LOS	-	-	A	A
HCM 95th %tile Q(veh)	-	-	0.1	0

HCM 6th TWSC
1: County Line Rd & I-25 SB Ramps

Adjusted Existing + Site
AM

Intersection												
Int Delay, s/veh	8.3											
Movement	EBL	EBT	EBR	WBL	WBT	WBR	NBL	NBT	NBR	SBL	SBT	SBR
Lane Configurations		↕		↕	↑						↕	
Traffic Vol, veh/h	0	101	46	306	110	0	0	0	0	75	1	13
Future Vol, veh/h	0	101	46	306	110	0	0	0	0	75	1	13
Conflicting Peds, #/hr	0	0	0	0	0	0	0	0	0	0	0	0
Sign Control	Free	Free	Free	Free	Free	Free	Stop	Stop	Stop	Stop	Stop	Stop
RT Channelized	-	-	Free	-	-	None	-	-	None	-	-	None
Storage Length	-	-	-	0	-	-	-	-	-	-	-	-
Veh in Median Storage, #	-	0	-	-	0	-	-	0	-	-	0	-
Grade, %	-	0	-	-	0	-	-	0	-	-	0	-
Peak Hour Factor	87	87	87	92	92	92	92	92	92	83	83	83
Heavy Vehicles, %	2	2	2	2	2	2	2	2	2	2	2	2
Mvmt Flow	0	116	53	333	120	0	0	0	0	90	1	16

Major/Minor	Major1			Major2			Minor2			
Conflicting Flow All	120	0	-	116	0	0		902	902	120
Stage 1	-	-	-	-	-	-		786	786	-
Stage 2	-	-	-	-	-	-		116	116	-
Critical Hdwy	4.12	-	-	4.12	-	-		6.42	6.52	6.22
Critical Hdwy Stg 1	-	-	-	-	-	-		5.42	5.52	-
Critical Hdwy Stg 2	-	-	-	-	-	-		5.42	5.52	-
Follow-up Hdwy	2.218	-	-	2.218	-	-		3.518	4.018	3.318
Pot Cap-1 Maneuver	1468	-	0	1473	-	0		308	277	931
Stage 1	-	-	0	-	-	0		449	403	-
Stage 2	-	-	0	-	-	0		909	800	-
Platoon blocked, %		-			-					
Mov Cap-1 Maneuver	1468	-	-	1473	-	-		238	0	931
Mov Cap-2 Maneuver	-	-	-	-	-	-		238	0	-
Stage 1	-	-	-	-	-	-		449	0	-
Stage 2	-	-	-	-	-	-		704	0	-

Approach	EB	WB	SB
HCM Control Delay, s	0	6	27.2
HCM LOS			D

Minor Lane/Major Mvmt	EBL	EBT	WBL	WBT	SBLn1
Capacity (veh/h)	1468	-	1473	-	267
HCM Lane V/C Ratio	-	-	0.226	-	0.402
HCM Control Delay (s)	0	-	8.2	-	27.2
HCM Lane LOS	A	-	A	-	D
HCM 95th %tile Q(veh)	0	-	0.9	-	1.8

HCM 6th TWSC
2: I-25 NB Ramps & County Line Rd

Adjusted Existing + Site
AM

Intersection												
Int Delay, s/veh	2.3											
Movement	EBL	EBT	EBR	WBL	WBT	WBR	NBL	NBT	NBR	SBL	SBT	SBR
Lane Configurations	↙	↑			↘			↕				
Traffic Vol, veh/h	35	147	0	0	369	237	46	1	72	0	0	0
Future Vol, veh/h	35	147	0	0	369	237	46	1	72	0	0	0
Conflicting Peds, #/hr	0	0	0	0	0	0	0	0	0	0	0	0
Sign Control	Free	Free	Free	Free	Free	Free	Stop	Stop	Stop	Stop	Stop	Stop
RT Channelized	-	-	None	-	-	None	-	-	None	-	-	None
Storage Length	0	-	-	-	-	-	-	-	-	-	-	-
Veh in Median Storage, #	-	0	-	-	0	-	-	0	-	-	0	-
Grade, %	-	0	-	-	0	-	-	0	-	-	0	-
Peak Hour Factor	87	87	87	93	93	93	83	83	83	92	92	92
Heavy Vehicles, %	2	2	2	2	2	2	2	2	2	2	2	2
Mvmt Flow	40	169	0	0	397	255	55	1	87	0	0	0

Major/Minor	Major1	Major2	Minor1
Conflicting Flow All	652	0	-
Stage 1	-	-	-
Stage 2	-	-	-
Critical Hdwy	4.12	-	-
Critical Hdwy Stg 1	-	-	-
Critical Hdwy Stg 2	-	-	-
Follow-up Hdwy	2.218	-	-
Pot Cap-1 Maneuver	935	0	0
Stage 1	-	0	0
Stage 2	-	0	0
Platoon blocked, %	-	-	-
Mov Cap-1 Maneuver	935	-	-
Mov Cap-2 Maneuver	-	-	-
Stage 1	-	-	-
Stage 2	-	-	-

Approach	EB	WB	NB
HCM Control Delay, s	1.7	0	13.8
HCM LOS			B

Minor Lane/Major Mvmt	NBLn1	EBL	EBT	WBT	WBR
Capacity (veh/h)	553	935	-	-	-
HCM Lane V/C Ratio	0.259	0.043	-	-	-
HCM Control Delay (s)	13.8	9	-	-	-
HCM Lane LOS	B	A	-	-	-
HCM 95th %tile Q(veh)	1	0.1	-	-	-

HCM 6th TWSC
 8: Monument Hill Rd & Misty Acres Blvd

Adjusted Existing + Site
 AM

Intersection						
Int Delay, s/veh	4.9					
Movement	WBL	WBR	NBT	NBR	SBL	SBT
Lane Configurations	↙	↗	↑	↗	↙	↑
Traffic Vol, veh/h	308	0	28	306	0	61
Future Vol, veh/h	308	0	28	306	0	61
Conflicting Peds, #/hr	0	0	0	0	0	0
Sign Control	Stop	Stop	Free	Free	Free	Free
RT Channelized	-	None	-	None	-	None
Storage Length	250	0	-	0	280	-
Veh in Median Storage, #	0	-	0	-	-	0
Grade, %	0	-	0	-	-	0
Peak Hour Factor	92	92	92	92	83	83
Heavy Vehicles, %	2	2	2	2	2	2
Mvmt Flow	335	0	30	333	0	73

Major/Minor	Minor1	Major1	Major2			
Conflicting Flow All	103	30	0	0	363	0
Stage 1	30	-	-	-	-	-
Stage 2	73	-	-	-	-	-
Critical Hdwy	6.42	6.22	-	-	4.12	-
Critical Hdwy Stg 1	5.42	-	-	-	-	-
Critical Hdwy Stg 2	5.42	-	-	-	-	-
Follow-up Hdwy	3.518	3.318	-	-	2.218	-
Pot Cap-1 Maneuver	895	1044	-	-	1196	-
Stage 1	993	-	-	-	-	-
Stage 2	950	-	-	-	-	-
Platoon blocked, %			-	-		-
Mov Cap-1 Maneuver	895	1044	-	-	1196	-
Mov Cap-2 Maneuver	895	-	-	-	-	-
Stage 1	993	-	-	-	-	-
Stage 2	950	-	-	-	-	-

Approach	WB	NB	SB
HCM Control Delay, s	11.4	0	0
HCM LOS	B		

Minor Lane/Major Mvmt	NBT	NBRWBLn1WBLn2	SBL	SBT
Capacity (veh/h)	-	- 895	- 1196	-
HCM Lane V/C Ratio	-	- 0.374	-	-
HCM Control Delay (s)	-	- 11.4	0	0
HCM Lane LOS	-	- B	A	A
HCM 95th %tile Q(veh)	-	- 1.7	-	0

HCM 6th TWSC
1: County Line Rd & I-25 SB Ramps

Adjusted Existing + Site
PM

Intersection												
Int Delay, s/veh	10.5											
Movement	EBL	EBT	EBR	WBL	WBT	WBR	NBL	NBT	NBR	SBL	SBT	SBR
Lane Configurations		↕		↕	↑						↕	
Traffic Vol, veh/h	0	98	67	130	98	0	0	0	0	215	1	34
Future Vol, veh/h	0	98	67	130	98	0	0	0	0	215	1	34
Conflicting Peds, #/hr	0	0	0	0	0	0	0	0	0	0	0	0
Sign Control	Free	Free	Free	Free	Free	Free	Stop	Stop	Stop	Stop	Stop	Stop
RT Channelized	-	-	Free	-	-	None	-	-	None	-	-	None
Storage Length	-	-	-	0	-	-	-	-	-	-	-	-
Veh in Median Storage, #	-	0	-	-	0	-	-	0	-	-	0	-
Grade, %	-	0	-	-	0	-	-	0	-	-	0	-
Peak Hour Factor	87	87	87	87	87	87	92	92	92	92	92	92
Heavy Vehicles, %	2	2	2	2	2	2	2	2	2	2	2	2
Mvmt Flow	0	113	77	149	113	0	0	0	0	234	1	37

Major/Minor	Major1			Major2			Minor2			
Conflicting Flow All	113	0	-	113	0	0		524	524	113
Stage 1	-	-	-	-	-	-		411	411	-
Stage 2	-	-	-	-	-	-		113	113	-
Critical Hdwy	4.12	-	-	4.12	-	-		6.42	6.52	6.22
Critical Hdwy Stg 1	-	-	-	-	-	-		5.42	5.52	-
Critical Hdwy Stg 2	-	-	-	-	-	-		5.42	5.52	-
Follow-up Hdwy	2.218	-	-	2.218	-	-		3.518	4.018	3.318
Pot Cap-1 Maneuver	1476	-	0	1476	-	0		514	458	940
Stage 1	-	-	0	-	-	0		669	595	-
Stage 2	-	-	0	-	-	0		912	802	-
Platoon blocked, %		-			-					
Mov Cap-1 Maneuver	1476	-	-	1476	-	-		462	0	940
Mov Cap-2 Maneuver	-	-	-	-	-	-		462	0	-
Stage 1	-	-	-	-	-	-		669	0	-
Stage 2	-	-	-	-	-	-		820	0	-

Approach	EB	WB	SB
HCM Control Delay, s	0	4.4	20.7
HCM LOS			C

Minor Lane/Major Mvmt	EBL	EBT	WBL	WBT	SBLn1
Capacity (veh/h)	1476	-	1476	-	496
HCM Lane V/C Ratio	-	-	0.101	-	0.548
HCM Control Delay (s)	0	-	7.7	-	20.7
HCM Lane LOS	A	-	A	-	C
HCM 95th %tile Q(veh)	0	-	0.3	-	3.3

HCM 6th TWSC
2: I-25 NB Ramps & County Line Rd

Adjusted Existing + Site
PM

Intersection												
Int Delay, s/veh	4.7											
Movement	EBL	EBT	EBR	WBL	WBT	WBR	NBL	NBT	NBR	SBL	SBT	SBR
Lane Configurations	↙	↑			↘			↕				
Traffic Vol, veh/h	23	293	0	0	178	99	45	2	212	0	0	0
Future Vol, veh/h	23	293	0	0	178	99	45	2	212	0	0	0
Conflicting Peds, #/hr	0	0	0	0	0	0	0	0	0	0	0	0
Sign Control	Free	Free	Free	Free	Free	Free	Stop	Stop	Stop	Stop	Stop	Stop
RT Channelized	-	-	None	-	-	None	-	-	None	-	-	None
Storage Length	0	-	-	-	-	-	-	-	-	-	-	-
Veh in Median Storage, #	-	0	-	-	0	-	-	0	-	-	0	-
Grade, %	-	0	-	-	0	-	-	0	-	-	0	-
Peak Hour Factor	92	92	92	92	92	92	92	92	92	92	92	92
Heavy Vehicles, %	2	2	2	2	2	2	2	2	2	2	2	2
Mvmt Flow	25	318	0	0	193	108	49	2	230	0	0	0

Major/Minor	Major1	Major2	Minor1
Conflicting Flow All	301	0	0
Stage 1	-	-	-
Stage 2	-	-	-
Critical Hdwy	4.12	-	-
Critical Hdwy Stg 1	-	-	-
Critical Hdwy Stg 2	-	-	-
Follow-up Hdwy	2.218	-	-
Pot Cap-1 Maneuver	1260	0	0
Stage 1	-	0	0
Stage 2	-	0	0
Platoon blocked, %	-	-	-
Mov Cap-1 Maneuver	1260	-	-
Mov Cap-2 Maneuver	-	-	-
Stage 1	-	-	-
Stage 2	-	-	-

Approach	EB	WB	NB
HCM Control Delay, s	0.6	0	14.7
HCM LOS			B

Minor Lane/Major Mvmt	NBLn1	EBL	EBT	WBT	WBR
Capacity (veh/h)	652	1260	-	-	-
HCM Lane V/C Ratio	0.432	0.02	-	-	-
HCM Control Delay (s)	14.7	7.9	-	-	-
HCM Lane LOS	B	A	-	-	-
HCM 95th %tile Q(veh)	2.2	0.1	-	-	-

Intersection						
Int Delay, s/veh	3.2					
Movement	WBL	WBR	NBT	NBR	SBL	SBT
Lane Configurations	↙	↗	↑	↗	↙	↑
Traffic Vol, veh/h	99	0	41	111	0	49
Future Vol, veh/h	99	0	41	111	0	49
Conflicting Peds, #/hr	0	0	0	0	0	0
Sign Control	Stop	Stop	Free	Free	Free	Free
RT Channelized	-	None	-	None	-	None
Storage Length	250	0	-	0	280	-
Veh in Median Storage, #	0	-	0	-	-	0
Grade, %	0	-	0	-	-	0
Peak Hour Factor	83	83	87	87	78	78
Heavy Vehicles, %	2	2	2	2	2	2
Mvmt Flow	119	0	47	128	0	63

Major/Minor	Minor1	Major1	Major2		
Conflicting Flow All	110	47	0	0	175
Stage 1	47	-	-	-	-
Stage 2	63	-	-	-	-
Critical Hdwy	6.42	6.22	-	-	4.12
Critical Hdwy Stg 1	5.42	-	-	-	-
Critical Hdwy Stg 2	5.42	-	-	-	-
Follow-up Hdwy	3.518	3.318	-	-	2.218
Pot Cap-1 Maneuver	887	1022	-	-	1401
Stage 1	975	-	-	-	-
Stage 2	960	-	-	-	-
Platoon blocked, %			-	-	-
Mov Cap-1 Maneuver	887	1022	-	-	1401
Mov Cap-2 Maneuver	887	-	-	-	-
Stage 1	975	-	-	-	-
Stage 2	960	-	-	-	-

Approach	WB	NB	SB
HCM Control Delay, s	9.7	0	0
HCM LOS	A		

Minor Lane/Major Mvmt	NBT	NBRWBLn1	WBLn2	SBL	SBT
Capacity (veh/h)	-	-	887	-	1401
HCM Lane V/C Ratio	-	-	0.134	-	-
HCM Control Delay (s)	-	-	9.7	0	0
HCM Lane LOS	-	-	A	A	A
HCM 95th %tile Q(veh)	-	-	0.5	-	0

HCM 6th TWSC
4: Misty Acres Blvd & Access A

Adjusted Existing + Site
AM

Intersection												
Int Delay, s/veh	1.2											
Movement	EBL	EBT	EBR	WBL	WBT	WBR	NBL	NBT	NBR	SBL	SBT	SBR
Lane Configurations		↕			↕			↕			↕	
Traffic Vol, veh/h	18	0	6	3	0	12	2	167	0	4	195	8
Future Vol, veh/h	18	0	6	3	0	12	2	167	0	4	195	8
Conflicting Peds, #/hr	0	0	0	0	0	0	0	0	0	0	0	0
Sign Control	Stop	Stop	Stop	Stop	Stop	Stop	Free	Free	Free	Free	Free	Free
RT Channelized	-	-	None	-	-	None	-	-	None	-	-	None
Storage Length	-	-	-	-	-	-	-	-	-	-	-	-
Veh in Median Storage, #	-	0	-	-	0	-	-	0	-	-	0	-
Grade, %	-	0	-	-	0	-	-	0	-	-	0	-
Peak Hour Factor	78	78	78	78	78	78	87	87	87	87	87	87
Heavy Vehicles, %	2	2	2	2	2	2	2	2	2	2	2	2
Mvmt Flow	23	0	8	4	0	15	2	192	0	5	224	9

Major/Minor	Minor2		Minor1		Major1		Major2					
Conflicting Flow All	443	435	229	439	439	192	233	0	0	192	0	0
Stage 1	239	239	-	196	196	-	-	-	-	-	-	-
Stage 2	204	196	-	243	243	-	-	-	-	-	-	-
Critical Hdwy	7.12	6.52	6.22	7.12	6.52	6.22	4.12	-	-	4.12	-	-
Critical Hdwy Stg 1	6.12	5.52	-	6.12	5.52	-	-	-	-	-	-	-
Critical Hdwy Stg 2	6.12	5.52	-	6.12	5.52	-	-	-	-	-	-	-
Follow-up Hdwy	3.518	4.018	3.318	3.518	4.018	3.318	2.218	-	-	2.218	-	-
Pot Cap-1 Maneuver	525	514	810	528	512	850	1335	-	-	1381	-	-
Stage 1	764	708	-	806	739	-	-	-	-	-	-	-
Stage 2	798	739	-	761	705	-	-	-	-	-	-	-
Platoon blocked, %								-	-	-	-	-
Mov Cap-1 Maneuver	513	511	810	521	509	850	1335	-	-	1381	-	-
Mov Cap-2 Maneuver	513	511	-	521	509	-	-	-	-	-	-	-
Stage 1	762	705	-	804	738	-	-	-	-	-	-	-
Stage 2	782	738	-	751	702	-	-	-	-	-	-	-

Approach	EB		WB		NB		SB	
HCM Control Delay, s	11.7		9.9		0.1		0.1	
HCM LOS	B		A					

Minor Lane/Major Mvmt	NBL	NBT	NBR	EBLn1	WBLn1	SBL	SBT	SBR
Capacity (veh/h)	1335	-	-	565	755	1381	-	-
HCM Lane V/C Ratio	0.002	-	-	0.054	0.025	0.003	-	-
HCM Control Delay (s)	7.7	0	-	11.7	9.9	7.6	0	-
HCM Lane LOS	A	A	-	B	A	A	A	-
HCM 95th %tile Q(veh)	0	-	-	0.2	0.1	0	-	-

HCM 6th TWSC
5: Misty Acres Blvd & Monument Hill Rd

Adjusted Existing + Site
AM

Intersection												
Int Delay, s/veh	1.9											
Movement	NBL	NBT	NBR	SBL	SBT	SBR	SEL	SET	SER	NWL	NWT	NWR
Lane Configurations		↕			↕	↕		↕			↕	
Traffic Vol, veh/h	0	109	0	1	139	64	57	0	1	1	1	3
Future Vol, veh/h	0	109	0	1	139	64	57	0	1	1	1	3
Conflicting Peds, #/hr	0	0	0	0	0	0	0	0	0	0	0	0
Sign Control	Free	Free	Free	Free	Free	Free	Stop	Stop	Stop	Stop	Stop	Stop
RT Channelized	-	-	None	-	-	None	-	-	None	-	-	None
Storage Length	-	-	-	-	-	186	-	-	-	-	-	-
Veh in Median Storage, #	-	0	-	-	0	-	-	0	-	-	0	-
Grade, %	-	0	-	-	0	-	-	0	-	-	0	-
Peak Hour Factor	83	83	83	87	87	87	83	83	83	78	78	78
Heavy Vehicles, %	2	2	2	2	2	2	2	2	2	2	2	2
Mvmt Flow	0	131	0	1	160	74	69	0	1	1	1	4

Major/Minor	Major1			Major2			Minor2			Minor1		
Conflicting Flow All	234	0	0	131	0	0	296	293	160	331	367	131
Stage 1	-	-	-	-	-	-	162	162	-	131	131	-
Stage 2	-	-	-	-	-	-	134	131	-	200	236	-
Critical Hdwy	4.12	-	-	4.12	-	-	7.12	6.52	6.22	7.12	6.52	6.22
Critical Hdwy Stg 1	-	-	-	-	-	-	6.12	5.52	-	6.12	5.52	-
Critical Hdwy Stg 2	-	-	-	-	-	-	6.12	5.52	-	6.12	5.52	-
Follow-up Hdwy	2.218	-	-	2.218	-	-	3.518	4.018	3.318	3.518	4.018	3.318
Pot Cap-1 Maneuver	1333	-	-	1454	-	-	656	618	885	622	562	919
Stage 1	-	-	-	-	-	-	840	764	-	873	788	-
Stage 2	-	-	-	-	-	-	869	788	-	802	710	-
Platoon blocked, %	-	-	-	-	-	-	-	-	-	-	-	-
Mov Cap-1 Maneuver	1333	-	-	1454	-	-	651	617	885	621	561	919
Mov Cap-2 Maneuver	-	-	-	-	-	-	651	617	-	621	561	-
Stage 1	-	-	-	-	-	-	840	763	-	873	788	-
Stage 2	-	-	-	-	-	-	864	788	-	800	709	-

Approach	NB			SB			SE			NW		
HCM Control Delay, s	0			0			11.2			9.8		
HCM LOS							B			A		

Minor Lane/Major Mvmt	NBL	NBT	NBR	NWLn1	SELn1	SBL	SBT	SBR
Capacity (veh/h)	1333	-	-	751	654	1454	-	-
HCM Lane V/C Ratio	-	-	-	0.009	0.107	0.001	-	-
HCM Control Delay (s)	0	-	-	9.8	11.2	7.5	0	-
HCM Lane LOS	A	-	-	A	B	A	A	-
HCM 95th %tile Q(veh)	0	-	-	0	0.4	0	-	-

Intersection						
Int Delay, s/veh	1.8					
Movement	EBT	EBR	WBL	WBT	NBL	NBR
Lane Configurations						
Traffic Vol, veh/h	43	1	8	57	5	14
Future Vol, veh/h	43	1	8	57	5	14
Conflicting Peds, #/hr	0	0	0	0	0	0
Sign Control	Free	Free	Free	Free	Stop	Stop
RT Channelized	-	None	-	None	-	None
Storage Length	-	-	-	-	0	-
Veh in Median Storage, #	0	-	-	0	0	-
Grade, %	0	-	-	0	0	-
Peak Hour Factor	78	78	83	83	78	78
Heavy Vehicles, %	2	2	2	2	2	2
Mvmt Flow	55	1	10	69	6	18

Major/Minor	Major1	Major2	Minor1		
Conflicting Flow All	0	0	56	0	145 56
Stage 1	-	-	-	-	56 -
Stage 2	-	-	-	-	89 -
Critical Hdwy	-	-	4.12	-	6.42 6.22
Critical Hdwy Stg 1	-	-	-	-	5.42 -
Critical Hdwy Stg 2	-	-	-	-	5.42 -
Follow-up Hdwy	-	-	2.218	-	3.518 3.318
Pot Cap-1 Maneuver	-	-	1549	-	847 1011
Stage 1	-	-	-	-	967 -
Stage 2	-	-	-	-	934 -
Platoon blocked, %	-	-	-	-	-
Mov Cap-1 Maneuver	-	-	1549	-	841 1011
Mov Cap-2 Maneuver	-	-	-	-	841 -
Stage 1	-	-	-	-	967 -
Stage 2	-	-	-	-	927 -

Approach	EB	WB	NB
HCM Control Delay, s	0	0.9	8.8
HCM LOS			A

Minor Lane/Major Mvmt	NBLn1	EBT	EBR	WBL	WBT
Capacity (veh/h)	960	-	-	1549	-
HCM Lane V/C Ratio	0.025	-	-	0.006	-
HCM Control Delay (s)	8.8	-	-	7.3	0
HCM Lane LOS	A	-	-	A	A
HCM 95th %tile Q(veh)	0.1	-	-	0	-

Intersection												
Int Delay, s/veh	3.3											
Movement	EBL	EBT	EBR	WBL	WBT	WBR	NBL	NBT	NBR	SBL	SBT	SBR
Lane Configurations		↕			↕			↕	↕	↕	↕	
Traffic Vol, veh/h	35	1	11	54	1	5	4	70	45	1	126	14
Future Vol, veh/h	35	1	11	54	1	5	4	70	45	1	126	14
Conflicting Peds, #/hr	0	0	0	0	0	0	0	0	0	0	0	0
Sign Control	Stop	Stop	Stop	Stop	Stop	Stop	Free	Free	Free	Free	Free	Free
RT Channelized	-	-	None	-	-	None	-	-	None	-	-	None
Storage Length	-	-	-	-	-	-	-	-	100	120	-	-
Veh in Median Storage, #	-	0	-	-	0	-	-	0	-	-	0	-
Grade, %	-	0	-	-	0	-	-	0	-	-	0	-
Peak Hour Factor	78	78	78	83	83	83	83	83	83	83	83	83
Heavy Vehicles, %	2	2	2	2	2	2	2	2	2	2	2	2
Mvmt Flow	45	1	14	65	1	6	5	84	54	1	152	17

Major/Minor	Minor2		Minor1		Major1		Major2					
Conflicting Flow All	288	311	161	264	265	84	169	0	0	138	0	0
Stage 1	163	163	-	94	94	-	-	-	-	-	-	-
Stage 2	125	148	-	170	171	-	-	-	-	-	-	-
Critical Hdwy	7.12	6.52	6.22	7.12	6.52	6.22	4.12	-	-	4.12	-	-
Critical Hdwy Stg 1	6.12	5.52	-	6.12	5.52	-	-	-	-	-	-	-
Critical Hdwy Stg 2	6.12	5.52	-	6.12	5.52	-	-	-	-	-	-	-
Follow-up Hdwy	3.518	4.018	3.318	3.518	4.018	3.318	2.218	-	-	2.218	-	-
Pot Cap-1 Maneuver	664	604	884	689	640	975	1409	-	-	1446	-	-
Stage 1	839	763	-	913	817	-	-	-	-	-	-	-
Stage 2	879	775	-	832	757	-	-	-	-	-	-	-
Platoon blocked, %								-	-	-	-	-
Mov Cap-1 Maneuver	657	601	884	675	637	975	1409	-	-	1446	-	-
Mov Cap-2 Maneuver	657	601	-	675	637	-	-	-	-	-	-	-
Stage 1	836	762	-	909	814	-	-	-	-	-	-	-
Stage 2	869	772	-	817	756	-	-	-	-	-	-	-

Approach	EB	WB	NB	SB
HCM Control Delay, s	10.6	10.8	0.3	0.1
HCM LOS	B	B		

Minor Lane/Major Mvmt	NBL	NBT	NBR	EBLn1	WBLn1	SBL	SBT	SBR
Capacity (veh/h)	1409	-	-	698	692	1446	-	-
HCM Lane V/C Ratio	0.003	-	-	0.086	0.104	0.001	-	-
HCM Control Delay (s)	7.6	0	-	10.6	10.8	7.5	0	-
HCM Lane LOS	A	A	-	B	B	A	A	-
HCM 95th %tile Q(veh)	0	-	-	0.3	0.3	0	-	-

Intersection						
Int Delay, s/veh	0.4					
Movement	EBL	EBR	NBL	NBT	SBT	SBR
Lane Configurations	T			T		T
Traffic Vol, veh/h	9	3	1	196	204	5
Future Vol, veh/h	9	3	1	196	204	5
Conflicting Peds, #/hr	0	0	0	0	0	0
Sign Control	Stop	Stop	Free	Free	Free	Free
RT Channelized	-	None	-	None	-	None
Storage Length	0	-	-	-	-	-
Veh in Median Storage, #	0	-	-	0	0	-
Grade, %	0	-	-	0	0	-
Peak Hour Factor	78	78	87	87	87	87
Heavy Vehicles, %	2	2	2	2	2	2
Mvmt Flow	12	4	1	225	234	6

Major/Minor	Minor2	Major1	Major2			
Conflicting Flow All	464	237	240	0	-	0
Stage 1	237	-	-	-	-	-
Stage 2	227	-	-	-	-	-
Critical Hdwy	6.42	6.22	4.12	-	-	-
Critical Hdwy Stg 1	5.42	-	-	-	-	-
Critical Hdwy Stg 2	5.42	-	-	-	-	-
Follow-up Hdwy	3.518	3.318	2.218	-	-	-
Pot Cap-1 Maneuver	556	802	1327	-	-	-
Stage 1	802	-	-	-	-	-
Stage 2	811	-	-	-	-	-
Platoon blocked, %				-	-	-
Mov Cap-1 Maneuver	555	802	1327	-	-	-
Mov Cap-2 Maneuver	555	-	-	-	-	-
Stage 1	801	-	-	-	-	-
Stage 2	811	-	-	-	-	-

Approach	EB	NB	SB
HCM Control Delay, s	11.1	0	0
HCM LOS	B		

Minor Lane/Major Mvmt	NBL	NBT	EBLn1	SBT	SBR
Capacity (veh/h)	1327	-	601	-	-
HCM Lane V/C Ratio	0.001	-	0.026	-	-
HCM Control Delay (s)	7.7	0	11.1	-	-
HCM Lane LOS	A	A	B	-	-
HCM 95th %tile Q(veh)	0	-	0.1	-	-

HCM 6th TWSC
 41: Misty Acres Blvd/S Andrews Rd & County Line Rd

Adjusted Existing + Site
 AM

Intersection												
Int Delay, s/veh	6.9											
Movement	EBL	EBT	EBR	WBL	WBT	WBR	NBL	NBT	NBR	SBL	SBT	SBR
Lane Configurations												
Traffic Vol, veh/h	2	96	138	71	453	2	161	0	34	1	0	5
Future Vol, veh/h	2	96	138	71	453	2	161	0	34	1	0	5
Conflicting Peds, #/hr	0	0	0	0	0	0	0	0	0	0	0	0
Sign Control	Free	Free	Free	Free	Free	Free	Stop	Stop	Stop	Stop	Stop	Stop
RT Channelized	-	-	None	-	-	None	-	-	None	-	-	None
Storage Length	232	-	182	172	-	-	-	-	155	-	-	-
Veh in Median Storage, #	-	0	-	-	0	-	-	0	-	-	0	-
Grade, %	-	0	-	-	0	-	-	0	-	-	0	-
Peak Hour Factor	87	87	87	92	92	92	87	87	87	78	78	78
Heavy Vehicles, %	2	2	2	2	2	2	2	2	2	2	2	2
Mvmt Flow	2	110	159	77	492	2	185	0	39	1	0	6

Major/Minor	Major1			Major2			Minor1			Minor2		
Conflicting Flow All	494	0	0	269	0	0	764	762	110	860	920	493
Stage 1	-	-	-	-	-	-	114	114	-	647	647	-
Stage 2	-	-	-	-	-	-	650	648	-	213	273	-
Critical Hdwy	4.12	-	-	4.12	-	-	7.12	6.52	6.22	7.12	6.52	6.22
Critical Hdwy Stg 1	-	-	-	-	-	-	6.12	5.52	-	6.12	5.52	-
Critical Hdwy Stg 2	-	-	-	-	-	-	6.12	5.52	-	6.12	5.52	-
Follow-up Hdwy	2.218	-	-	2.218	-	-	3.518	4.018	3.318	3.518	4.018	3.318
Pot Cap-1 Maneuver	1070	-	-	1295	-	-	321	335	943	276	271	576
Stage 1	-	-	-	-	-	-	891	801	-	460	467	-
Stage 2	-	-	-	-	-	-	458	466	-	789	684	-
Platoon blocked, %	-	-	-	-	-	-	-	-	-	-	-	-
Mov Cap-1 Maneuver	1070	-	-	1295	-	-	303	315	943	252	254	576
Mov Cap-2 Maneuver	-	-	-	-	-	-	303	315	-	252	254	-
Stage 1	-	-	-	-	-	-	889	799	-	459	439	-
Stage 2	-	-	-	-	-	-	426	439	-	755	683	-

Approach	EB			WB			NB			SB		
HCM Control Delay, s	0.1			1.1			29.6			12.7		
HCM LOS							D			B		

Minor Lane/Major Mvmt	NBLn1	NBLn2	EBL	EBT	EBR	WBL	WBT	WBR	SBLn1
Capacity (veh/h)	303	943	1070	-	-	1295	-	-	474
HCM Lane V/C Ratio	0.611	0.041	0.002	-	-	0.06	-	-	0.016
HCM Control Delay (s)	33.9	9	8.4	-	-	8	-	-	12.7
HCM Lane LOS	D	A	A	-	-	A	-	-	B
HCM 95th %tile Q(veh)	3.8	0.1	0	-	-	0.2	-	-	0

HCM 6th TWSC
4: Misty Acres Blvd & Access A

Adjusted Existing + Site
PM

Intersection												
Int Delay, s/veh	1.5											
Movement	EBL	EBT	EBR	WBL	WBT	WBR	NBL	NBT	NBR	SBL	SBT	SBR
Lane Configurations		↕			↕			↕			↕	
Traffic Vol, veh/h	14	0	4	2	0	8	4	104	2	14	125	20
Future Vol, veh/h	14	0	4	2	0	8	4	104	2	14	125	20
Conflicting Peds, #/hr	0	0	0	0	0	0	0	0	0	0	0	0
Sign Control	Stop	Stop	Stop	Stop	Stop	Stop	Free	Free	Free	Free	Free	Free
RT Channelized	-	-	None	-	-	None	-	-	None	-	-	None
Storage Length	-	-	-	-	-	-	-	-	-	-	-	-
Veh in Median Storage, #	-	0	-	-	0	-	-	0	-	-	0	-
Grade, %	-	0	-	-	0	-	-	0	-	-	0	-
Peak Hour Factor	78	78	78	78	78	78	83	83	83	87	87	87
Heavy Vehicles, %	2	2	2	2	2	2	2	2	2	2	2	2
Mvmt Flow	18	0	5	3	0	10	5	125	2	16	144	23

Major/Minor	Minor2		Minor1		Major1		Major2					
Conflicting Flow All	329	325	156	326	335	126	167	0	0	127	0	0
Stage 1	188	188	-	136	136	-	-	-	-	-	-	-
Stage 2	141	137	-	190	199	-	-	-	-	-	-	-
Critical Hdwy	7.12	6.52	6.22	7.12	6.52	6.22	4.12	-	-	4.12	-	-
Critical Hdwy Stg 1	6.12	5.52	-	6.12	5.52	-	-	-	-	-	-	-
Critical Hdwy Stg 2	6.12	5.52	-	6.12	5.52	-	-	-	-	-	-	-
Follow-up Hdwy	3.518	4.018	3.318	3.518	4.018	3.318	2.218	-	-	2.218	-	-
Pot Cap-1 Maneuver	624	593	890	627	585	924	1411	-	-	1459	-	-
Stage 1	814	745	-	867	784	-	-	-	-	-	-	-
Stage 2	862	783	-	812	736	-	-	-	-	-	-	-
Platoon blocked, %								-	-	-	-	-
Mov Cap-1 Maneuver	610	584	890	616	576	924	1411	-	-	1459	-	-
Mov Cap-2 Maneuver	610	584	-	616	576	-	-	-	-	-	-	-
Stage 1	811	736	-	864	781	-	-	-	-	-	-	-
Stage 2	849	780	-	798	727	-	-	-	-	-	-	-

Approach	EB	WB	NB	SB
HCM Control Delay, s	10.7	9.4	0.3	0.7
HCM LOS	B	A		

Minor Lane/Major Mvmt	NBL	NBT	NBR	EBLn1	WBLn1	SBL	SBT	SBR
Capacity (veh/h)	1411	-	-	656	840	1459	-	-
HCM Lane V/C Ratio	0.003	-	-	0.035	0.015	0.011	-	-
HCM Control Delay (s)	7.6	0	-	10.7	9.4	7.5	0	-
HCM Lane LOS	A	A	-	B	A	A	A	-
HCM 95th %tile Q(veh)	0	-	-	0.1	0	0	-	-

HCM 6th TWSC
5: Misty Acres Blvd & Monument Hill Rd

Adjusted Existing + Site
PM

Intersection												
Int Delay, s/veh	2											
Movement	NBL	NBT	NBR	SBL	SBT	SBR	SEL	SET	SER	NWL	NWT	NWR
Lane Configurations		↕			↕	↕		↕			↕	
Traffic Vol, veh/h	0	77	1	5	79	47	38	1	0	1	1	2
Future Vol, veh/h	0	77	1	5	79	47	38	1	0	1	1	2
Conflicting Peds, #/hr	0	0	0	0	0	0	0	0	0	0	0	0
Sign Control	Free	Free	Free	Free	Free	Free	Stop	Stop	Stop	Stop	Stop	Stop
RT Channelized	-	-	None	-	-	None	-	-	None	-	-	None
Storage Length	-	-	-	-	-	186	-	-	-	-	-	-
Veh in Median Storage, #	-	0	-	-	0	-	-	0	-	-	0	-
Grade, %	-	0	-	-	0	-	-	0	-	-	0	-
Peak Hour Factor	83	83	83	83	83	83	78	78	78	78	78	78
Heavy Vehicles, %	2	2	2	2	2	2	2	2	2	2	2	2
Mvmt Flow	0	93	1	6	95	57	49	1	0	1	1	3

Major/Minor	Major1			Major2			Minor2			Minor1		
Conflicting Flow All	152	0	0	94	0	0	203	201	95	230	258	94
Stage 1	-	-	-	-	-	-	107	107	-	94	94	-
Stage 2	-	-	-	-	-	-	96	94	-	136	164	-
Critical Hdwy	4.12	-	-	4.12	-	-	7.12	6.52	6.22	7.12	6.52	6.22
Critical Hdwy Stg 1	-	-	-	-	-	-	6.12	5.52	-	6.12	5.52	-
Critical Hdwy Stg 2	-	-	-	-	-	-	6.12	5.52	-	6.12	5.52	-
Follow-up Hdwy	2.218	-	-	2.218	-	-	3.518	4.018	3.318	3.518	4.018	3.318
Pot Cap-1 Maneuver	1429	-	-	1500	-	-	755	695	962	725	646	963
Stage 1	-	-	-	-	-	-	898	807	-	913	817	-
Stage 2	-	-	-	-	-	-	911	817	-	867	762	-
Platoon blocked, %	-	-	-	-	-	-	-	-	-	-	-	-
Mov Cap-1 Maneuver	1429	-	-	1500	-	-	750	692	962	722	643	963
Mov Cap-2 Maneuver	-	-	-	-	-	-	750	692	-	722	643	-
Stage 1	-	-	-	-	-	-	898	804	-	913	817	-
Stage 2	-	-	-	-	-	-	907	817	-	862	759	-

Approach	NB	SB	SE	NW
HCM Control Delay, s	0	0.3	10.2	9.5
HCM LOS			B	A

Minor Lane/Major Mvmt	NBL	NBT	NBRNWLn1	SELn1	SBL	SBT	SBR
Capacity (veh/h)	1429	-	-	797	748	1500	-
HCM Lane V/C Ratio	-	-	-	0.006	0.067	0.004	-
HCM Control Delay (s)	0	-	-	9.5	10.2	7.4	0
HCM Lane LOS	A	-	-	A	B	A	A
HCM 95th %tile Q(veh)	0	-	-	0	0.2	0	-

Intersection						
Int Delay, s/veh	2.7					
Movement	EBT	EBR	WBL	WBT	NBL	NBR
Lane Configurations						
Traffic Vol, veh/h	28	3	18	30	4	10
Future Vol, veh/h	28	3	18	30	4	10
Conflicting Peds, #/hr	0	0	0	0	0	0
Sign Control	Free	Free	Free	Free	Stop	Stop
RT Channelized	-	None	-	None	-	None
Storage Length	-	-	-	-	0	-
Veh in Median Storage, #	0	-	-	0	0	-
Grade, %	0	-	-	0	0	-
Peak Hour Factor	78	78	78	78	78	78
Heavy Vehicles, %	2	2	2	2	2	2
Mvmt Flow	36	4	23	38	5	13

Major/Minor	Major1	Major2	Minor1	Minor2	Minor3
Conflicting Flow All	0	0	40	0	122 38
Stage 1	-	-	-	-	38 -
Stage 2	-	-	-	-	84 -
Critical Hdwy	-	-	4.12	-	6.42 6.22
Critical Hdwy Stg 1	-	-	-	-	5.42 -
Critical Hdwy Stg 2	-	-	-	-	5.42 -
Follow-up Hdwy	-	-	2.218	-	3.518 3.318
Pot Cap-1 Maneuver	-	-	1570	-	873 1034
Stage 1	-	-	-	-	984 -
Stage 2	-	-	-	-	939 -
Platoon blocked, %	-	-	-	-	-
Mov Cap-1 Maneuver	-	-	1570	-	860 1034
Mov Cap-2 Maneuver	-	-	-	-	860 -
Stage 1	-	-	-	-	984 -
Stage 2	-	-	-	-	925 -

Approach	EB	WB	NB
HCM Control Delay, s	0	2.7	8.8
HCM LOS			A

Minor Lane/Major Mvmt	NBLn1	EBT	EBR	WBL	WBT
Capacity (veh/h)	977	-	-	1570	-
HCM Lane V/C Ratio	0.018	-	-	0.015	-
HCM Control Delay (s)	8.8	-	-	7.3	0
HCM Lane LOS	A	-	-	A	A
HCM 95th %tile Q(veh)	0.1	-	-	0	-

HCM 6th TWSC
7: Misty Acres Blvd & Old Antlers Way

Adjusted Existing + Site
PM

Intersection												
Int Delay, s/veh	3.1											
Movement	EBL	EBT	EBR	WBL	WBT	WBR	NBL	NBT	NBR	SBL	SBT	SBR
Lane Configurations		↕			↕			↕	↕	↕	↕	
Traffic Vol, veh/h	24	1	8	15	3	4	10	43	29	6	40	34
Future Vol, veh/h	24	1	8	15	3	4	10	43	29	6	40	34
Conflicting Peds, #/hr	0	0	0	0	0	0	0	0	0	0	0	0
Sign Control	Stop	Stop	Stop	Stop	Stop	Stop	Free	Free	Free	Free	Free	Free
RT Channelized	-	-	None	-	-	None	-	-	None	-	-	None
Storage Length	-	-	-	-	-	-	-	-	100	120	-	-
Veh in Median Storage, #	-	0	-	-	0	-	-	0	-	-	0	-
Grade, %	-	0	-	-	0	-	-	0	-	-	0	-
Peak Hour Factor	78	78	78	78	78	78	83	83	83	83	83	83
Heavy Vehicles, %	2	2	2	2	2	2	2	2	2	2	2	2
Mvmt Flow	31	1	10	19	4	5	12	52	35	7	48	41

Major/Minor	Minor2		Minor1		Major1		Major2					
Conflicting Flow All	181	194	69	164	179	52	89	0	0	87	0	0
Stage 1	83	83	-	76	76	-	-	-	-	-	-	-
Stage 2	98	111	-	88	103	-	-	-	-	-	-	-
Critical Hdwy	7.12	6.52	6.22	7.12	6.52	6.22	4.12	-	-	4.12	-	-
Critical Hdwy Stg 1	6.12	5.52	-	6.12	5.52	-	-	-	-	-	-	-
Critical Hdwy Stg 2	6.12	5.52	-	6.12	5.52	-	-	-	-	-	-	-
Follow-up Hdwy	3.518	4.018	3.318	3.518	4.018	3.318	2.218	-	-	2.218	-	-
Pot Cap-1 Maneuver	781	701	994	801	715	1016	1506	-	-	1509	-	-
Stage 1	925	826	-	933	832	-	-	-	-	-	-	-
Stage 2	908	804	-	920	810	-	-	-	-	-	-	-
Platoon blocked, %								-	-	-	-	-
Mov Cap-1 Maneuver	766	692	994	784	706	1016	1506	-	-	1509	-	-
Mov Cap-2 Maneuver	766	692	-	784	706	-	-	-	-	-	-	-
Stage 1	918	822	-	926	825	-	-	-	-	-	-	-
Stage 2	892	798	-	905	806	-	-	-	-	-	-	-

Approach	EB		WB		NB		SB	
HCM Control Delay, s	9.7		9.6		0.9		0.6	
HCM LOS	A		A					

Minor Lane/Major Mvmt	NBL	NBT	NBR	EBLn1	WBLn1	SBL	SBT	SBR
Capacity (veh/h)	1506	-	-	808	805	1509	-	-
HCM Lane V/C Ratio	0.008	-	-	0.052	0.035	0.005	-	-
HCM Control Delay (s)	7.4	0	-	9.7	9.6	7.4	0	-
HCM Lane LOS	A	A	-	A	A	A	A	-
HCM 95th %tile Q(veh)	0	-	-	0.2	0.1	0	-	-

Intersection												
Int Delay, s/veh	3.4											
Movement	EBL	EBT	EBR	WBL	WBT	WBR	NBL	NBT	NBR	SBL	SBT	SBR
Lane Configurations	↙	↑	↗	↙	↑	↗		↙	↗		↔	
Traffic Vol, veh/h	5	361	144	22	174	1	108	0	23	2	0	2
Future Vol, veh/h	5	361	144	22	174	1	108	0	23	2	0	2
Conflicting Peds, #/hr	0	0	0	0	0	0	0	0	0	0	0	0
Sign Control	Free	Free	Free	Free	Free	Free	Stop	Stop	Stop	Stop	Stop	Stop
RT Channelized	-	-	None	-	-	None	-	-	None	-	-	None
Storage Length	232	-	182	172	-	-	-	-	155	-	-	-
Veh in Median Storage, #	-	0	-	-	0	-	-	0	-	-	0	-
Grade, %	-	0	-	-	0	-	-	0	-	-	0	-
Peak Hour Factor	92	92	92	87	87	87	83	83	83	78	78	78
Heavy Vehicles, %	2	2	2	2	2	2	2	2	2	2	2	2
Mvmt Flow	5	392	157	25	200	1	130	0	28	3	0	3

Major/Minor	Major1			Major2			Minor1			Minor2		
Conflicting Flow All	201	0	0	549	0	0	654	653	392	746	810	201
Stage 1	-	-	-	-	-	-	402	402	-	251	251	-
Stage 2	-	-	-	-	-	-	252	251	-	495	559	-
Critical Hdwy	4.12	-	-	4.12	-	-	7.12	6.52	6.22	7.12	6.52	6.22
Critical Hdwy Stg 1	-	-	-	-	-	-	6.12	5.52	-	6.12	5.52	-
Critical Hdwy Stg 2	-	-	-	-	-	-	6.12	5.52	-	6.12	5.52	-
Follow-up Hdwy	2.218	-	-	2.218	-	-	3.518	4.018	3.318	3.518	4.018	3.318
Pot Cap-1 Maneuver	1371	-	-	1021	-	-	380	387	657	330	314	840
Stage 1	-	-	-	-	-	-	625	600	-	753	699	-
Stage 2	-	-	-	-	-	-	752	699	-	556	511	-
Platoon blocked, %	-	-	-	-	-	-	-	-	-	-	-	-
Mov Cap-1 Maneuver	1371	-	-	1021	-	-	371	376	657	309	305	840
Mov Cap-2 Maneuver	-	-	-	-	-	-	371	376	-	309	305	-
Stage 1	-	-	-	-	-	-	623	598	-	750	682	-
Stage 2	-	-	-	-	-	-	731	682	-	531	509	-

Approach	EB	WB	NB	SB
HCM Control Delay, s	0.1	1	18.3	13.1
HCM LOS			C	B

Minor Lane/Major Mvmt	NBLn1	NBLn2	EBL	EBT	EBR	WBL	WBT	WBR	SBLn1
Capacity (veh/h)	371	657	1371	-	-	1021	-	-	452
HCM Lane V/C Ratio	0.351	0.042	0.004	-	-	0.025	-	-	0.011
HCM Control Delay (s)	19.9	10.7	7.6	-	-	8.6	-	-	13.1
HCM Lane LOS	C	B	A	-	-	A	-	-	B
HCM 95th %tile Q(veh)	1.5	0.1	0	-	-	0.1	-	-	0

HCM 6th Signalized Intersection Summary
 3: Misty Acres Blvd/Andrews Rd & County Line Rd

2044 Background
 AM



Movement	EBL	EBT	EBR	WBL	WBT	WBR	NBL	NBT	NBR	SBL	SBT	SBR
Lane Configurations												
Traffic Volume (veh/h)	5	150	145	100	600	5	125	0	45	5	0	10
Future Volume (veh/h)	5	150	145	100	600	5	125	0	45	5	0	10
Initial Q (Qb), veh	0	0	0	0	0	0	0	0	0	0	0	0
Ped-Bike Adj(A_pbT)	1.00		1.00	1.00		1.00	1.00		1.00	1.00		1.00
Parking Bus, Adj	1.00	1.00	1.00	1.00	1.00	1.00	1.00	1.00	1.00	1.00	1.00	1.00
Work Zone On Approach		No			No			No			No	
Adj Sat Flow, veh/h/ln	2145	2145	2145	1817	1817	1817	1870	1870	1870	1870	1870	1870
Adj Flow Rate, veh/h	5	163	158	109	652	5	136	0	49	5	0	11
Peak Hour Factor	0.92	0.92	0.92	0.92	0.92	0.92	0.92	0.92	0.92	0.92	0.92	0.92
Percent Heavy Veh, %	2	2	2	2	2	2	2	2	2	2	2	2
Cap, veh/h	453	1104	936	728	927	7	457	0	215	188	28	128
Arrive On Green	0.51	0.51	0.51	0.51	0.51	0.51	0.14	0.00	0.14	0.14	0.00	0.14
Sat Flow, veh/h	891	2145	1818	1029	1801	14	1603	0	1585	222	207	944
Grp Volume(v), veh/h	5	163	158	109	0	657	136	0	49	16	0	0
Grp Sat Flow(s),veh/h/ln	891	2145	1818	1029	0	1815	1603	0	1585	1373	0	0
Q Serve(g_s), s	0.1	1.2	1.4	1.9	0.0	8.3	0.0	0.0	0.8	0.0	0.0	0.0
Cycle Q Clear(g_c), s	8.4	1.2	1.4	3.1	0.0	8.3	2.1	0.0	0.8	2.2	0.0	0.0
Prop In Lane	1.00		1.00	1.00		0.01	1.00		1.00	0.31		0.69
Lane Grp Cap(c), veh/h	453	1104	936	728	0	934	457	0	215	343	0	0
V/C Ratio(X)	0.01	0.15	0.17	0.15	0.00	0.70	0.30	0.00	0.23	0.05	0.00	0.00
Avail Cap(c_a), veh/h	930	2252	1908	1279	0	1905	1109	0	951	1043	0	0
HCM Platoon Ratio	1.00	1.00	1.00	1.00	1.00	1.00	1.00	1.00	1.00	1.00	1.00	1.00
Upstream Filter(I)	1.00	1.00	1.00	1.00	0.00	1.00	1.00	0.00	1.00	1.00	0.00	0.00
Uniform Delay (d), s/veh	8.7	3.8	3.9	4.6	0.0	5.5	12.1	0.0	11.6	11.3	0.0	0.0
Incr Delay (d2), s/veh	0.0	0.1	0.1	0.1	0.0	1.0	0.4	0.0	0.5	0.1	0.0	0.0
Initial Q Delay(d3),s/veh	0.0	0.0	0.0	0.0	0.0	0.0	0.0	0.0	0.0	0.0	0.0	0.0
%ile BackOfQ(50%),veh/ln	0.0	0.2	0.2	0.2	0.0	1.4	0.7	0.0	0.2	0.1	0.0	0.0
Unsig. Movement Delay, s/veh												
LnGrp Delay(d),s/veh	8.7	3.9	4.0	4.7	0.0	6.5	12.5	0.0	12.1	11.4	0.0	0.0
LnGrp LOS	A	A	A	A	A	A	B	A	B	B	A	A
Approach Vol, veh/h		326			766			185				16
Approach Delay, s/veh		4.0			6.3			12.4				11.4
Approach LOS		A			A			B				B
Timer - Assigned Phs		2		4		6		8				
Phs Duration (G+Y+Rc), s		9.1		20.9		9.1		20.9				
Change Period (Y+Rc), s		5.0		5.5		5.0		5.5				
Max Green Setting (Gmax), s		18.0		31.5		18.0		31.5				
Max Q Clear Time (g_c+I1), s		4.1		10.4		4.2		10.3				
Green Ext Time (p_c), s		0.7		1.4		0.0		5.2				
Intersection Summary												
HCM 6th Ctrl Delay				6.6								
HCM 6th LOS				A								

HCM 6th Signalized Intersection Summary
 3: Misty Acres Blvd/Andrews Rd & County Line Rd

2044 Background
 PM



Movement	EBL	EBT	EBR	WBL	WBT	WBR	NBL	NBT	NBR	SBL	SBT	SBR
Lane Configurations												
Traffic Volume (veh/h)	10	490	70	30	230	5	35	0	30	5	0	5
Future Volume (veh/h)	10	490	70	30	230	5	35	0	30	5	0	5
Initial Q (Qb), veh	0	0	0	0	0	0	0	0	0	0	0	0
Ped-Bike Adj(A_pbT)	1.00		1.00	1.00		1.00	1.00		1.00	1.00		1.00
Parking Bus, Adj	1.00	1.00	1.00	1.00	1.00	1.00	1.00	1.00	1.00	1.00	1.00	1.00
Work Zone On Approach		No			No			No			No	
Adj Sat Flow, veh/h/ln	2145	2145	2145	1817	1817	1817	1870	1870	1870	1870	1870	1870
Adj Flow Rate, veh/h	11	533	76	33	250	5	38	0	33	5	0	5
Peak Hour Factor	0.92	0.92	0.92	0.92	0.92	0.92	0.92	0.92	0.92	0.92	0.92	0.92
Percent Heavy Veh, %	2	2	2	2	2	2	2	2	2	2	2	2
Cap, veh/h	701	903	766	461	748	15	523	0	271	291	52	133
Arrive On Green	0.42	0.42	0.42	0.42	0.42	0.42	0.17	0.00	0.17	0.17	0.00	0.17
Sat Flow, veh/h	1290	2145	1818	789	1775	36	1422	0	1585	474	305	780
Grp Volume(v), veh/h	11	533	76	33	0	255	38	0	33	10	0	0
Grp Sat Flow(s),veh/h/ln	1290	2145	1818	789	0	1811	1422	0	1585	1560	0	0
Q Serve(g_s), s	0.1	4.9	0.6	0.9	0.0	2.4	0.4	0.0	0.5	0.0	0.0	0.0
Cycle Q Clear(g_c), s	2.6	4.9	0.6	5.8	0.0	2.4	0.6	0.0	0.5	0.1	0.0	0.0
Prop In Lane	1.00		1.00	1.00		0.02	1.00		1.00	0.50		0.50
Lane Grp Cap(c), veh/h	701	903	766	461	0	763	523	0	271	476	0	0
V/C Ratio(X)	0.02	0.59	0.10	0.07	0.00	0.33	0.07	0.00	0.12	0.02	0.00	0.00
Avail Cap(c_a), veh/h	1687	2543	2155	1064	0	2147	1324	0	1171	1313	0	0
HCM Platoon Ratio	1.00	1.00	1.00	1.00	1.00	1.00	1.00	1.00	1.00	1.00	1.00	1.00
Upstream Filter(I)	1.00	1.00	1.00	1.00	0.00	1.00	1.00	0.00	1.00	1.00	0.00	0.00
Uniform Delay (d), s/veh	5.9	5.7	4.5	8.0	0.0	5.0	9.1	0.0	9.0	8.9	0.0	0.0
Incr Delay (d2), s/veh	0.0	0.6	0.1	0.1	0.0	0.3	0.1	0.0	0.2	0.0	0.0	0.0
Initial Q Delay(d3),s/veh	0.0	0.0	0.0	0.0	0.0	0.0	0.0	0.0	0.0	0.0	0.0	0.0
%ile BackOfQ(50%),veh/ln	0.0	1.0	0.1	0.1	0.0	0.4	0.1	0.0	0.1	0.0	0.0	0.0
Unsig. Movement Delay, s/veh												
LnGrp Delay(d),s/veh	5.9	6.4	4.6	8.0	0.0	5.3	9.1	0.0	9.2	8.9	0.0	0.0
LnGrp LOS	A	A	A	A	A	A	A	A	A	A	A	A
Approach Vol, veh/h		620			288			71				10
Approach Delay, s/veh		6.1			5.6			9.2				8.9
Approach LOS		A			A			A				A
Timer - Assigned Phs		2		4		6		8				
Phs Duration (G+Y+Rc), s		9.4		16.3		9.4		16.3				
Change Period (Y+Rc), s		5.0		5.5		5.0		5.5				
Max Green Setting (Gmax), s		19.0		30.5		19.0		30.5				
Max Q Clear Time (g_c+I1), s		2.6		6.9		2.1		7.8				
Green Ext Time (p_c), s		0.2		3.9		0.0		1.7				
Intersection Summary												
HCM 6th Ctrl Delay				6.2								
HCM 6th LOS				A								

Intersection												
Int Delay, s/veh	13.8											
Movement	EBL	EBT	EBR	WBL	WBT	WBR	NBL	NBT	NBR	SBL	SBT	SBR
Lane Configurations		↕		↕	↑						↕	
Traffic Vol, veh/h	0	140	65	355	150	0	0	0	0	90	5	20
Future Vol, veh/h	0	140	65	355	150	0	0	0	0	90	5	20
Conflicting Peds, #/hr	0	0	0	0	0	0	0	0	0	0	0	0
Sign Control	Free	Free	Free	Free	Free	Free	Stop	Stop	Stop	Stop	Stop	Stop
RT Channelized	-	-	None	-	-	None	-	-	None	-	-	None
Storage Length	-	-	-	0	-	-	-	-	-	-	-	-
Veh in Median Storage, #	-	0	-	-	0	-	-	0	-	-	0	-
Grade, %	-	0	-	-	0	-	-	0	-	-	0	-
Peak Hour Factor	83	83	83	92	92	92	92	92	92	83	83	83
Heavy Vehicles, %	2	2	2	2	2	2	2	2	2	2	2	2
Mvmt Flow	0	169	78	386	163	0	0	0	0	108	6	24

Major/Minor	Major1			Major2			Minor2		
Conflicting Flow All	163	0	0	247	0	0	1143	1182	163
Stage 1	-	-	-	-	-	-	935	935	-
Stage 2	-	-	-	-	-	-	208	247	-
Critical Hdwy	4.12	-	-	4.12	-	-	6.42	6.52	6.22
Critical Hdwy Stg 1	-	-	-	-	-	-	5.42	5.52	-
Critical Hdwy Stg 2	-	-	-	-	-	-	5.42	5.52	-
Follow-up Hdwy	2.218	-	-	2.218	-	-	3.518	4.018	3.318
Pot Cap-1 Maneuver	1416	-	-	1319	-	0	221	190	882
Stage 1	-	-	-	-	-	0	382	344	-
Stage 2	-	-	-	-	-	0	827	702	-
Platoon blocked, %	-	-	-	-	-	-	-	-	-
Mov Cap-1 Maneuver	1416	-	-	1319	-	-	156	0	882
Mov Cap-2 Maneuver	-	-	-	-	-	-	156	0	-
Stage 1	-	-	-	-	-	-	382	0	-
Stage 2	-	-	-	-	-	-	585	0	-

Approach	EB	WB	SB
HCM Control Delay, s	0	6.2	68.5
HCM LOS			F

Minor Lane/Major Mvmt	EBL	EBT	EBR	WBL	WBT	SBLn1
Capacity (veh/h)	1416	-	-	1319	-	183
HCM Lane V/C Ratio	-	-	-	0.293	-	0.757
HCM Control Delay (s)	0	-	-	8.9	-	68.5
HCM Lane LOS	A	-	-	A	-	F
HCM 95th %tile Q(veh)	0	-	-	1.2	-	4.9

Intersection												
Int Delay, s/veh	3.8											
Movement	EBL	EBT	EBR	WBL	WBT	WBR	NBL	NBT	NBR	SBL	SBT	SBR
Lane Configurations	↙	↑			↘			↕				
Traffic Vol, veh/h	50	185	0	0	440	295	65	5	115	0	0	0
Future Vol, veh/h	50	185	0	0	440	295	65	5	115	0	0	0
Conflicting Peds, #/hr	0	0	0	0	0	0	0	0	0	0	0	0
Sign Control	Free	Free	Free	Free	Free	Free	Stop	Stop	Stop	Stop	Stop	Stop
RT Channelized	-	-	None	-	-	None	-	-	None	-	-	None
Storage Length	0	-	-	-	-	-	-	-	-	-	-	-
Veh in Median Storage, #	-	0	-	-	0	-	-	0	-	-	0	-
Grade, %	-	0	-	-	0	-	-	0	-	-	0	-
Peak Hour Factor	87	87	87	92	92	92	83	83	83	92	92	92
Heavy Vehicles, %	2	2	2	2	2	2	2	2	2	2	2	2
Mvmt Flow	57	213	0	0	478	321	78	6	139	0	0	0

Major/Minor	Major1	Major2	Minor1
Conflicting Flow All	799	0	-
Stage 1	-	-	-
Stage 2	-	-	-
Critical Hdwy	4.12	-	-
Critical Hdwy Stg 1	-	-	-
Critical Hdwy Stg 2	-	-	-
Follow-up Hdwy	2.218	-	-
Pot Cap-1 Maneuver	824	0	0
Stage 1	-	0	0
Stage 2	-	0	0
Platoon blocked, %	-	-	-
Mov Cap-1 Maneuver	824	-	-
Mov Cap-2 Maneuver	-	-	-
Stage 1	-	-	-
Stage 2	-	-	-

Approach	EB	WB	NB
HCM Control Delay, s	2.1	0	19.6
HCM LOS			C

Minor Lane/Major Mvmt	NBLn1	EBL	EBT	WBT	WBR
Capacity (veh/h)	466	824	-	-	-
HCM Lane V/C Ratio	0.478	0.07	-	-	-
HCM Control Delay (s)	19.6	9.7	-	-	-
HCM Lane LOS	C	A	-	-	-
HCM 95th %tile Q(veh)	2.5	0.2	-	-	-

Intersection						
Int Delay, s/veh	5.1					
Movement	WBL	WBR	NBT	NBR	SBL	SBT
Lane Configurations	↘	↗	↑	↗	↘	↑
Traffic Vol, veh/h	315	5	55	325	5	100
Future Vol, veh/h	315	5	55	325	5	100
Conflicting Peds, #/hr	0	0	0	0	0	0
Sign Control	Stop	Stop	Free	Free	Free	Free
RT Channelized	-	None	-	None	-	None
Storage Length	250	0	-	0	280	-
Veh in Median Storage, #	0	-	0	-	-	0
Grade, %	0	-	0	-	-	0
Peak Hour Factor	92	92	92	92	83	83
Heavy Vehicles, %	2	2	2	2	2	2
Mvmt Flow	342	5	60	353	6	120

Major/Minor	Minor1	Major1	Major2		
Conflicting Flow All	192	60	0	0	413
Stage 1	60	-	-	-	-
Stage 2	132	-	-	-	-
Critical Hdwy	6.42	6.22	-	-	4.12
Critical Hdwy Stg 1	5.42	-	-	-	-
Critical Hdwy Stg 2	5.42	-	-	-	-
Follow-up Hdwy	3.518	3.318	-	-	2.218
Pot Cap-1 Maneuver	797	1005	-	-	1146
Stage 1	963	-	-	-	-
Stage 2	894	-	-	-	-
Platoon blocked, %			-	-	-
Mov Cap-1 Maneuver	793	1005	-	-	1146
Mov Cap-2 Maneuver	793	-	-	-	-
Stage 1	963	-	-	-	-
Stage 2	890	-	-	-	-

Approach	WB	NB	SB
HCM Control Delay, s	12.8	0	0.4
HCM LOS	B		

Minor Lane/Major Mvmt	NBT	NBR	WBLn1	WBLn2	SBL	SBT
Capacity (veh/h)	-	-	793	1005	1146	-
HCM Lane V/C Ratio	-	-	0.432	0.005	0.005	-
HCM Control Delay (s)	-	-	12.9	8.6	8.2	-
HCM Lane LOS	-	-	B	A	A	-
HCM 95th %tile Q(veh)	-	-	2.2	0	0	-

Intersection												
Int Delay, s/veh	16.2											
Movement	EBL	EBT	EBR	WBL	WBT	WBR	NBL	NBT	NBR	SBL	SBT	SBR
Lane Configurations		↕		↕	↑						↕	
Traffic Vol, veh/h	0	125	95	130	135	0	0	0	0	265	5	50
Future Vol, veh/h	0	125	95	130	135	0	0	0	0	265	5	50
Conflicting Peds, #/hr	0	0	0	0	0	0	0	0	0	0	0	0
Sign Control	Free	Free	Free	Free	Free	Free	Stop	Stop	Stop	Stop	Stop	Stop
RT Channelized	-	-	None	-	-	None	-	-	None	-	-	None
Storage Length	-	-	-	0	-	-	-	-	-	-	-	-
Veh in Median Storage, #	-	0	-	-	0	-	-	0	-	-	0	-
Grade, %	-	0	-	-	0	-	-	0	-	-	0	-
Peak Hour Factor	87	87	87	92	92	92	92	92	92	92	92	92
Heavy Vehicles, %	2	2	2	2	2	2	2	2	2	2	2	2
Mvmt Flow	0	144	109	141	147	0	0	0	0	288	5	54

Major/Minor	Major1			Major2			Minor2		
Conflicting Flow All	147	0	0	253	0	0	628	682	147
Stage 1	-	-	-	-	-	-	429	429	-
Stage 2	-	-	-	-	-	-	199	253	-
Critical Hdwy	4.12	-	-	4.12	-	-	6.42	6.52	6.22
Critical Hdwy Stg 1	-	-	-	-	-	-	5.42	5.52	-
Critical Hdwy Stg 2	-	-	-	-	-	-	5.42	5.52	-
Follow-up Hdwy	2.218	-	-	2.218	-	-	3.518	4.018	3.318
Pot Cap-1 Maneuver	1435	-	-	1312	-	0	447	372	900
Stage 1	-	-	-	-	-	0	657	584	-
Stage 2	-	-	-	-	-	0	835	698	-
Platoon blocked, %	-	-	-	-	-	-	-	-	-
Mov Cap-1 Maneuver	1435	-	-	1312	-	-	399	0	900
Mov Cap-2 Maneuver	-	-	-	-	-	-	399	0	-
Stage 1	-	-	-	-	-	-	657	0	-
Stage 2	-	-	-	-	-	-	746	0	-

Approach	EB	WB	SB
HCM Control Delay, s	0	4	38.2
HCM LOS			E

Minor Lane/Major Mvmt	EBL	EBT	EBR	WBL	WBT	SBLn1
Capacity (veh/h)	1435	-	-	1312	-	438
HCM Lane V/C Ratio	-	-	-	0.108	-	0.794
HCM Control Delay (s)	0	-	-	8.1	-	38.2
HCM Lane LOS	A	-	-	A	-	E
HCM 95th %tile Q(veh)	0	-	-	0.4	-	7.1

Intersection												
Int Delay, s/veh	6.4											
Movement	EBL	EBT	EBR	WBL	WBT	WBR	NBL	NBT	NBR	SBL	SBT	SBR
Lane Configurations	↙	↑			↘			↕				
Traffic Vol, veh/h	35	355	0	0	185	115	75	5	220	0	0	0
Future Vol, veh/h	35	355	0	0	185	115	75	5	220	0	0	0
Conflicting Peds, #/hr	0	0	0	0	0	0	0	0	0	0	0	0
Sign Control	Free	Free	Free	Free	Free	Free	Stop	Stop	Stop	Stop	Stop	Stop
RT Channelized	-	-	None	-	-	None	-	-	None	-	-	None
Storage Length	0	-	-	-	-	-	-	-	-	-	-	-
Veh in Median Storage, #	-	0	-	-	0	-	-	0	-	-	0	-
Grade, %	-	0	-	-	0	-	-	0	-	-	0	-
Peak Hour Factor	92	92	92	92	92	92	92	92	92	92	92	92
Heavy Vehicles, %	2	2	2	2	2	2	2	2	2	2	2	2
Mvmt Flow	38	386	0	0	201	125	82	5	239	0	0	0

Major/Minor	Major1	Major2	Minor1
Conflicting Flow All	326	0	-
Stage 1	-	-	-
Stage 2	-	-	-
Critical Hdwy	4.12	-	-
Critical Hdwy Stg 1	-	-	-
Critical Hdwy Stg 2	-	-	-
Follow-up Hdwy	2.218	-	-
Pot Cap-1 Maneuver	1234	0	0
Stage 1	-	0	0
Stage 2	-	0	0
Platoon blocked, %	-	-	-
Mov Cap-1 Maneuver	1234	-	-
Mov Cap-2 Maneuver	-	-	-
Stage 1	-	-	-
Stage 2	-	-	-

Approach	EB	WB	NB
HCM Control Delay, s	0.7	0	20.2
HCM LOS			C

Minor Lane/Major Mvmt	NBLn1	EBL	EBT	WBT	WBR
Capacity (veh/h)	556	1234	-	-	-
HCM Lane V/C Ratio	0.586	0.031	-	-	-
HCM Control Delay (s)	20.2	8	-	-	-
HCM Lane LOS	C	A	-	-	-
HCM 95th %tile Q(veh)	3.8	0.1	-	-	-

Intersection						
Int Delay, s/veh	3.4					
Movement	WBL	WBR	NBT	NBR	SBL	SBT
Lane Configurations	↘	↗	↑	↗	↘	↑
Traffic Vol, veh/h	110	5	65	125	5	50
Future Vol, veh/h	110	5	65	125	5	50
Conflicting Peds, #/hr	0	0	0	0	0	0
Sign Control	Stop	Stop	Free	Free	Free	Free
RT Channelized	-	None	-	None	-	None
Storage Length	250	0	-	0	280	-
Veh in Median Storage, #	0	-	0	-	-	0
Grade, %	0	-	0	-	-	0
Peak Hour Factor	83	83	87	87	78	78
Heavy Vehicles, %	2	2	2	2	2	2
Mvmt Flow	133	6	75	144	6	64

Major/Minor	Minor1	Major1	Major2		
Conflicting Flow All	151	75	0	0	219
Stage 1	75	-	-	-	-
Stage 2	76	-	-	-	-
Critical Hdwy	6.42	6.22	-	-	4.12
Critical Hdwy Stg 1	5.42	-	-	-	-
Critical Hdwy Stg 2	5.42	-	-	-	-
Follow-up Hdwy	3.518	3.318	-	-	2.218
Pot Cap-1 Maneuver	841	986	-	-	1350
Stage 1	948	-	-	-	-
Stage 2	947	-	-	-	-
Platoon blocked, %			-	-	-
Mov Cap-1 Maneuver	838	986	-	-	1350
Mov Cap-2 Maneuver	838	-	-	-	-
Stage 1	948	-	-	-	-
Stage 2	943	-	-	-	-

Approach	WB	NB	SB
HCM Control Delay, s	10	0	0.7
HCM LOS	B		

Minor Lane/Major Mvmt	NBT	NBR	WBLn1	WBLn2	SBL	SBT
Capacity (veh/h)	-	-	838	986	1350	-
HCM Lane V/C Ratio	-	-	0.158	0.006	0.005	-
HCM Control Delay (s)	-	-	10.1	8.7	7.7	-
HCM Lane LOS	-	-	B	A	A	-
HCM 95th %tile Q(veh)	-	-	0.6	0	0	-

Intersection	
Intersection Delay, s/veh	12.9
Intersection LOS	B

Movement	EBL	EBT	EBR	WBL	WBT	WBR	NBL	NBT	NBR	SBL	SBT	SBR
Lane Configurations		↕		↕	↑						↕	
Traffic Vol, veh/h	0	140	65	355	150	0	0	0	0	90	5	20
Future Vol, veh/h	0	140	65	355	150	0	0	0	0	90	5	20
Peak Hour Factor	0.83	0.83	0.83	0.92	0.92	0.92	0.92	0.92	0.92	0.83	0.83	0.83
Heavy Vehicles, %	2	2	2	2	2	2	2	2	2	2	2	2
Mvmt Flow	0	169	78	386	163	0	0	0	0	108	6	24
Number of Lanes	0	1	0	1	1	0	0	0	0	0	1	0

Approach	EB	WB	SB
Opposing Approach	WB	EB	
Opposing Lanes	2	1	0
Conflicting Approach Left	SB		WB
Conflicting Lanes Left	1	0	2
Conflicting Approach Right		SB	EB
Conflicting Lanes Right	0	1	1
HCM Control Delay	10.4	14.6	10.5
HCM LOS	B	B	B

Lane	EBLn1	WBLn1	WBLn2	SBLn1
Vol Left, %	0%	100%	0%	78%
Vol Thru, %	68%	0%	100%	4%
Vol Right, %	32%	0%	0%	17%
Sign Control	Stop	Stop	Stop	Stop
Traffic Vol by Lane	205	355	150	115
LT Vol	0	355	0	90
Through Vol	140	0	150	5
RT Vol	65	0	0	20
Lane Flow Rate	247	386	163	139
Geometry Grp	4a	5	5	2
Degree of Util (X)	0.333	0.605	0.233	0.221
Departure Headway (Hd)	4.853	5.644	5.141	5.749
Convergence, Y/N	Yes	Yes	Yes	Yes
Cap	736	637	695	619
Service Time	2.922	3.409	2.905	3.827
HCM Lane V/C Ratio	0.336	0.606	0.235	0.225
HCM Control Delay	10.4	16.8	9.5	10.5
HCM Lane LOS	B	C	A	B
HCM 95th-tile Q	1.5	4.1	0.9	0.8

Intersection	
Intersection Delay, s/veh	12.3
Intersection LOS	B

Movement	EBL	EBT	EBR	WBL	WBT	WBR	NBL	NBT	NBR	SBL	SBT	SBR
Lane Configurations		↕		↕	↕						↕	
Traffic Vol, veh/h	0	125	95	130	135	0	0	0	0	265	5	50
Future Vol, veh/h	0	125	95	130	135	0	0	0	0	265	5	50
Peak Hour Factor	0.87	0.87	0.87	0.92	0.92	0.92	0.92	0.92	0.92	0.92	0.92	0.92
Heavy Vehicles, %	2	2	2	2	2	2	2	2	2	2	2	2
Mvmt Flow	0	144	109	141	147	0	0	0	0	288	5	54
Number of Lanes	0	1	0	1	1	0	0	0	0	0	1	0

Approach	EB	WB	SB
Opposing Approach	WB	EB	
Opposing Lanes	2	1	0
Conflicting Approach Left	SB		WB
Conflicting Lanes Left	1	0	2
Conflicting Approach Right		SB	EB
Conflicting Lanes Right	0	1	1
HCM Control Delay	11.3	10.9	14.3
HCM LOS	B	B	B

Lane	EBLn1	WBLn1	WBLn2	SBLn1
Vol Left, %	0%	100%	0%	83%
Vol Thru, %	57%	0%	100%	2%
Vol Right, %	43%	0%	0%	16%
Sign Control	Stop	Stop	Stop	Stop
Traffic Vol by Lane	220	130	135	320
LT Vol	0	130	0	265
Through Vol	125	0	135	5
RT Vol	95	0	0	50
Lane Flow Rate	253	141	147	348
Geometry Grp	4a	5	5	2
Degree of Util (X)	0.368	0.251	0.24	0.523
Departure Headway (Hd)	5.237	6.389	5.882	5.418
Convergence, Y/N	Yes	Yes	Yes	Yes
Cap	688	564	612	668
Service Time	3.265	4.117	3.61	3.447
HCM Lane V/C Ratio	0.368	0.25	0.24	0.521
HCM Control Delay	11.3	11.3	10.5	14.3
HCM Lane LOS	B	B	B	B
HCM 95th-tile Q	1.7	1	0.9	3.1

Intersection												
Int Delay, s/veh	21.4											
Movement	EBL	EBT	EBR	WBL	WBT	WBR	NBL	NBT	NBR	SBL	SBT	SBR
Lane Configurations		↕			↕			↕			↕	
Traffic Vol, veh/h	5	150	145	100	600	5	125	0	45	5	0	10
Future Vol, veh/h	5	150	145	100	600	5	125	0	45	5	0	10
Conflicting Peds, #/hr	0	0	0	0	0	0	0	0	0	0	0	0
Sign Control	Free	Free	Free	Free	Free	Free	Stop	Stop	Stop	Stop	Stop	Stop
RT Channelized	-	-	None	-	-	None	-	-	None	-	-	None
Storage Length	-	-	-	-	-	-	-	-	-	-	-	-
Veh in Median Storage, #	-	0	-	-	0	-	-	0	-	-	0	-
Grade, %	-	-7	-	-	4	-	-	0	-	-	0	-
Peak Hour Factor	87	87	87	92	92	92	83	83	83	78	78	78
Heavy Vehicles, %	2	2	2	2	2	2	2	2	2	2	2	2
Mvmt Flow	6	172	167	109	652	5	151	0	54	6	0	13

Major/Minor	Major1			Major2			Minor1			Minor2		
Conflicting Flow All	657	0	0	339	0	0	1147	1143	256	1168	1224	655
Stage 1	-	-	-	-	-	-	268	268	-	873	873	-
Stage 2	-	-	-	-	-	-	879	875	-	295	351	-
Critical Hdwy	4.12	-	-	4.12	-	-	7.12	6.52	6.22	7.12	6.52	6.22
Critical Hdwy Stg 1	-	-	-	-	-	-	6.12	5.52	-	6.12	5.52	-
Critical Hdwy Stg 2	-	-	-	-	-	-	6.12	5.52	-	6.12	5.52	-
Follow-up Hdwy	2.218	-	-	2.218	-	-	3.518	4.018	3.318	3.518	4.018	3.318
Pot Cap-1 Maneuver	931	-	-	1220	-	-	176	200	783	170	179	466
Stage 1	-	-	-	-	-	-	738	687	-	345	368	-
Stage 2	-	-	-	-	-	-	342	367	-	713	632	-
Platoon blocked, %		-	-		-	-						
Mov Cap-1 Maneuver	931	-	-	1220	-	-	152	170	783	140	153	466
Mov Cap-2 Maneuver	-	-	-	-	-	-	152	170	-	140	153	-
Stage 1	-	-	-	-	-	-	732	682	-	342	316	-
Stage 2	-	-	-	-	-	-	286	315	-	658	627	-

Approach	EB			WB			NB			SB		
HCM Control Delay, s	0.1			1.2			132.8			19.8		
HCM LOS							F			C		

Minor Lane/Major Mvmt	NBLn1	EBL	EBT	EBR	WBL	WBT	WBR	SBLn1
Capacity (veh/h)	193	931	-	-	1220	-	-	262
HCM Lane V/C Ratio	1.061	0.006	-	-	0.089	-	-	0.073
HCM Control Delay (s)	132.8	8.9	0	-	8.2	0	-	19.8
HCM Lane LOS	F	A	A	-	A	A	-	C
HCM 95th %tile Q(veh)	9.5	0	-	-	0.3	-	-	0.2

Intersection						
Int Delay, s/veh	1.4					
Movement	EBL	EBR	NBL	NBT	SBT	SBR
Lane Configurations						
Traffic Vol, veh/h	55	0	0	115	145	100
Future Vol, veh/h	55	0	0	115	145	100
Conflicting Peds, #/hr	0	0	0	0	0	0
Sign Control	Stop	Stop	Free	Free	Free	Free
RT Channelized	-	None	-	None	-	None
Storage Length	0	-	-	-	-	186
Veh in Median Storage, #	0	-	-	0	0	-
Grade, %	0	-	-	0	0	-
Peak Hour Factor	92	92	92	92	92	92
Heavy Vehicles, %	2	2	2	2	2	2
Mvmt Flow	60	0	0	125	158	109

Major/Minor	Minor2	Major1	Major2			
Conflicting Flow All	283	158	267	0	-	0
Stage 1	158	-	-	-	-	-
Stage 2	125	-	-	-	-	-
Critical Hdwy	6.42	6.22	4.12	-	-	-
Critical Hdwy Stg 1	5.42	-	-	-	-	-
Critical Hdwy Stg 2	5.42	-	-	-	-	-
Follow-up Hdwy	3.518	3.318	2.218	-	-	-
Pot Cap-1 Maneuver	707	887	1297	-	-	-
Stage 1	871	-	-	-	-	-
Stage 2	901	-	-	-	-	-
Platoon blocked, %				-	-	-
Mov Cap-1 Maneuver	707	887	1297	-	-	-
Mov Cap-2 Maneuver	707	-	-	-	-	-
Stage 1	871	-	-	-	-	-
Stage 2	901	-	-	-	-	-

Approach	EB	NB	SB
HCM Control Delay, s	10.6	0	0
HCM LOS	B		

Minor Lane/Major Mvmt	NBL	NBT	EBLn1	SBT	SBR
Capacity (veh/h)	1297	-	707	-	-
HCM Lane V/C Ratio	-	-	0.085	-	-
HCM Control Delay (s)	0	-	10.6	-	-
HCM Lane LOS	A	-	B	-	-
HCM 95th %tile Q(veh)	0	-	0.3	-	-

Intersection						
Int Delay, s/veh	2.1					
Movement	WBL	WBR	NBT	NBR	SBL	SBT
Lane Configurations	↘↙		↑	↗↘	↘	↑
Traffic Vol, veh/h	55	10	105	45	5	140
Future Vol, veh/h	55	10	105	45	5	140
Conflicting Peds, #/hr	0	0	0	0	0	0
Sign Control	Stop	Stop	Free	Free	Free	Free
RT Channelized	-	None	-	None	-	None
Storage Length	0	-	-	100	120	-
Veh in Median Storage, #	0	-	0	-	-	0
Grade, %	0	-	0	-	-	0
Peak Hour Factor	83	83	83	83	83	83
Heavy Vehicles, %	2	2	2	2	2	2
Mvmt Flow	66	12	127	54	6	169

Major/Minor	Minor1	Major1	Major2		
Conflicting Flow All	308	127	0	0	181
Stage 1	127	-	-	-	-
Stage 2	181	-	-	-	-
Critical Hdwy	6.42	6.22	-	-	4.12
Critical Hdwy Stg 1	5.42	-	-	-	-
Critical Hdwy Stg 2	5.42	-	-	-	-
Follow-up Hdwy	3.518	3.318	-	-	2.218
Pot Cap-1 Maneuver	684	923	-	-	1394
Stage 1	899	-	-	-	-
Stage 2	850	-	-	-	-
Platoon blocked, %			-	-	-
Mov Cap-1 Maneuver	681	923	-	-	1394
Mov Cap-2 Maneuver	681	-	-	-	-
Stage 1	899	-	-	-	-
Stage 2	847	-	-	-	-

Approach	WB	NB	SB
HCM Control Delay, s	10.7	0	0.3
HCM LOS	B		

Minor Lane/Major Mvmt	NBT	NBRWBLn1	SBL	SBT
Capacity (veh/h)	-	-	710	1394
HCM Lane V/C Ratio	-	-	0.11	0.004
HCM Control Delay (s)	-	-	10.7	7.6
HCM Lane LOS	-	-	B	A
HCM 95th %tile Q(veh)	-	-	0.4	0

Intersection												
Int Delay, s/veh	3.3											
Movement	EBL	EBT	EBR	WBL	WBT	WBR	NBL	NBT	NBR	SBL	SBT	SBR
Lane Configurations		↕			↕			↕			↕	
Traffic Vol, veh/h	10	490	70	30	230	5	65	0	30	5	0	5
Future Vol, veh/h	10	490	70	30	230	5	65	0	30	5	0	5
Conflicting Peds, #/hr	0	0	0	0	0	0	0	0	0	0	0	0
Sign Control	Free	Free	Free	Free	Free	Free	Stop	Stop	Stop	Stop	Stop	Stop
RT Channelized	-	-	None	-	-	None	-	-	None	-	-	None
Storage Length	-	-	-	-	-	-	-	-	-	-	-	-
Veh in Median Storage, #	-	0	-	-	0	-	-	0	-	-	0	-
Grade, %	-	-7	-	-	4	-	-	0	-	-	0	-
Peak Hour Factor	93	93	93	92	92	92	83	83	83	78	78	78
Heavy Vehicles, %	2	2	2	2	2	2	2	2	2	2	2	2
Mvmt Flow	11	527	75	33	250	5	78	0	36	6	0	6

Major/Minor	Major1			Major2			Minor1			Minor2		
Conflicting Flow All	255	0	0	602	0	0	909	908	565	924	943	253
Stage 1	-	-	-	-	-	-	587	587	-	319	319	-
Stage 2	-	-	-	-	-	-	322	321	-	605	624	-
Critical Hdwy	4.12	-	-	4.12	-	-	7.12	6.52	6.22	7.12	6.52	6.22
Critical Hdwy Stg 1	-	-	-	-	-	-	6.12	5.52	-	6.12	5.52	-
Critical Hdwy Stg 2	-	-	-	-	-	-	6.12	5.52	-	6.12	5.52	-
Follow-up Hdwy	2.218	-	-	2.218	-	-	3.518	4.018	3.318	3.518	4.018	3.318
Pot Cap-1 Maneuver	1310	-	-	975	-	-	256	275	524	250	263	786
Stage 1	-	-	-	-	-	-	496	497	-	693	653	-
Stage 2	-	-	-	-	-	-	690	652	-	485	478	-
Platoon blocked, %		-	-		-	-						
Mov Cap-1 Maneuver	1310	-	-	975	-	-	244	261	524	224	250	786
Mov Cap-2 Maneuver	-	-	-	-	-	-	244	261	-	224	250	-
Stage 1	-	-	-	-	-	-	490	491	-	684	628	-
Stage 2	-	-	-	-	-	-	658	627	-	446	472	-

Approach	EB	WB	NB	SB
HCM Control Delay, s	0.1	1	24.8	15.7
HCM LOS			C	C

Minor Lane/Major Mvmt	NBLn1	EBL	EBT	EBR	WBL	WBT	WBR	SBLn1
Capacity (veh/h)	294	1310	-	-	975	-	-	349
HCM Lane V/C Ratio	0.389	0.008	-	-	0.033	-	-	0.037
HCM Control Delay (s)	24.8	7.8	0	-	8.8	0	-	15.7
HCM Lane LOS	C	A	A	-	A	A	-	C
HCM 95th %tile Q(veh)	1.8	0	-	-	0.1	-	-	0.1

Intersection						
Int Delay, s/veh	1.5					
Movement	EBL	EBR	NBL	NBT	SBT	SBR
Lane Configurations	Y			4	↑	↑
Traffic Vol, veh/h	30	0	0	65	65	35
Future Vol, veh/h	30	0	0	65	65	35
Conflicting Peds, #/hr	0	0	0	0	0	0
Sign Control	Stop	Stop	Free	Free	Free	Free
RT Channelized	-	None	-	None	-	None
Storage Length	0	-	-	-	-	186
Veh in Median Storage, #	0	-	-	0	0	-
Grade, %	0	-	-	0	0	-
Peak Hour Factor	78	78	83	83	83	83
Heavy Vehicles, %	2	2	2	2	2	2
Mvmt Flow	38	0	0	78	78	42

Major/Minor	Minor2	Major1		Major2	
Conflicting Flow All	156	78	120	0	0
Stage 1	78	-	-	-	-
Stage 2	78	-	-	-	-
Critical Hdwy	6.42	6.22	4.12	-	-
Critical Hdwy Stg 1	5.42	-	-	-	-
Critical Hdwy Stg 2	5.42	-	-	-	-
Follow-up Hdwy	3.518	3.318	2.218	-	-
Pot Cap-1 Maneuver	835	983	1468	-	-
Stage 1	945	-	-	-	-
Stage 2	945	-	-	-	-
Platoon blocked, %				-	-
Mov Cap-1 Maneuver	835	983	1468	-	-
Mov Cap-2 Maneuver	835	-	-	-	-
Stage 1	945	-	-	-	-
Stage 2	945	-	-	-	-

Approach	EB	NB	SB
HCM Control Delay, s	9.5	0	0
HCM LOS	A		

Minor Lane/Major Mvmt	NBL	NBT	EBLn1	SBT	SBR
Capacity (veh/h)	1468	-	835	-	-
HCM Lane V/C Ratio	-	-	0.046	-	-
HCM Control Delay (s)	0	-	9.5	-	-
HCM Lane LOS	A	-	A	-	-
HCM 95th %tile Q(veh)	0	-	0.1	-	-

Intersection						
Int Delay, s/veh	2.1					
Movement	WBL	WBR	NBT	NBR	SBL	SBT
Lane Configurations	Y		↑	↑	↑	↑
Traffic Vol, veh/h	25	10	55	45	10	55
Future Vol, veh/h	25	10	55	45	10	55
Conflicting Peds, #/hr	0	0	0	0	0	0
Sign Control	Stop	Stop	Free	Free	Free	Free
RT Channelized	-	None	-	None	-	None
Storage Length	0	-	-	100	120	-
Veh in Median Storage, #	0	-	0	-	-	0
Grade, %	0	-	0	-	-	0
Peak Hour Factor	78	78	83	83	83	83
Heavy Vehicles, %	2	2	2	2	2	2
Mvmt Flow	32	13	66	54	12	66





















Major/Minor	Minor1	Major1	Major2			
Conflicting Flow All	156	66	0	0	120	0
Stage 1	66	-	-	-	-	-
Stage 2	90	-	-	-	-	-
Critical Hdwy	6.42	6.22	-	-	4.12	-
Critical Hdwy Stg 1	5.42	-	-	-	-	-
Critical Hdwy Stg 2	5.42	-	-	-	-	-
Follow-up Hdwy	3.518	3.318	-	-	2.218	-
Pot Cap-1 Maneuver	835	998	-	-	1468	-
Stage 1	957	-	-	-	-	-
Stage 2	934	-	-	-	-	-
Platoon blocked, %			-	-		-
Mov Cap-1 Maneuver	828	998	-	-	1468	-
Mov Cap-2 Maneuver	828	-	-	-	-	-
Stage 1	957	-	-	-	-	-
Stage 2	927	-	-	-	-	-

Approach	WB	NB	SB
HCM Control Delay, s	9.4	0	1.1
HCM LOS	A		

Minor Lane/Major Mvmt	NBT	NBRWBLn1	SBL	SBT
Capacity (veh/h)	-	-	870	1468
HCM Lane V/C Ratio	-	-	0.052	0.008
HCM Control Delay (s)	-	-	9.4	7.5
HCM Lane LOS	-	-	A	A
HCM 95th %tile Q(veh)	-	-	0.2	0

HCM 6th Signalized Intersection Summary
 3: Misty Acres Blvd/Andrews Rd & County Line Rd

2044 Background + Site
 AM

												
Movement	EBL	EBT	EBR	WBL	WBT	WBR	NBL	NBT	NBR	SBL	SBT	SBR
Lane Configurations												
Traffic Volume (veh/h)	5	150	182	102	600	5	211	0	50	5	0	10
Future Volume (veh/h)	5	150	182	102	600	5	211	0	50	5	0	10
Initial Q (Qb), veh	0	0	0	0	0	0	0	0	0	0	0	0
Ped-Bike Adj(A_pbT)	1.00		1.00	1.00		1.00	1.00		1.00	1.00		1.00
Parking Bus, Adj	1.00	1.00	1.00	1.00	1.00	1.00	1.00	1.00	1.00	1.00	1.00	1.00
Work Zone On Approach		No			No			No			No	
Adj Sat Flow, veh/h/ln	2145	2145	2145	1817	1817	1817	1870	1870	1870	1870	1870	1870
Adj Flow Rate, veh/h	5	163	198	110	645	5	243	0	57	6	0	13
Peak Hour Factor	0.92	0.92	0.92	0.93	0.93	0.93	0.87	0.87	0.87	0.78	0.78	0.78
Percent Heavy Veh, %	2	2	2	2	2	2	2	2	2	2	2	2
Cap, veh/h	236	912	773	513	766	6	414	0	542	108	43	127
Arrive On Green	0.43	0.43	0.43	0.43	0.43	0.43	0.34	0.00	0.34	0.34	0.00	0.34
Sat Flow, veh/h	897	2145	1818	992	1801	14	802	0	1585	46	124	370
Grp Volume(v), veh/h	5	163	198	110	0	650	243	0	57	19	0	0
Grp Sat Flow(s),veh/h/ln	897	2145	1818	992	0	1815	802	0	1585	540	0	0
Q Serve(g_s), s	0.3	2.4	3.6	4.0	0.0	16.6	0.5	0.0	1.3	0.2	0.0	0.0
Cycle Q Clear(g_c), s	16.6	2.4	3.6	6.5	0.0	16.6	16.3	0.0	1.3	16.1	0.0	0.0
Prop In Lane	1.00		1.00	1.00		0.01	1.00		1.00	0.32		0.68
Lane Grp Cap(c), veh/h	236	912	773	513	0	772	414	0	542	277	0	0
V/C Ratio(X)	0.02	0.18	0.26	0.21	0.00	0.84	0.59	0.00	0.11	0.07	0.00	0.00
Avail Cap(c_a), veh/h	359	1205	1021	648	0	1019	450	0	583	315	0	0
HCM Platoon Ratio	1.00	1.00	1.00	1.00	1.00	1.00	1.00	1.00	1.00	1.00	1.00	1.00
Upstream Filter(I)	1.00	1.00	1.00	1.00	0.00	1.00	1.00	0.00	1.00	1.00	0.00	0.00
Uniform Delay (d), s/veh	20.6	9.2	9.6	11.3	0.0	13.3	16.7	0.0	11.6	12.7	0.0	0.0
Incr Delay (d2), s/veh	0.0	0.1	0.2	0.2	0.0	5.0	1.7	0.0	0.1	0.1	0.0	0.0
Initial Q Delay(d3),s/veh	0.0	0.0	0.0	0.0	0.0	0.0	0.0	0.0	0.0	0.0	0.0	0.0
%ile BackOfQ(50%),veh/ln	0.1	1.0	1.2	0.8	0.0	6.5	2.5	0.0	0.4	0.1	0.0	0.0
Unsig. Movement Delay, s/veh												
LnGrp Delay(d),s/veh	20.7	9.3	9.7	11.5	0.0	18.3	18.4	0.0	11.7	12.8	0.0	0.0
LnGrp LOS	C	A	A	B	A	B	B	A	B	B	A	A
Approach Vol, veh/h		366			760			300				19
Approach Delay, s/veh		9.7			17.3			17.2				12.8
Approach LOS		A			B			B				B
Timer - Assigned Phs		2		4		6		8				
Phs Duration (G+Y+Rc), s		23.9		28.1		23.9		28.1				
Change Period (Y+Rc), s		6.0		6.0		6.0		6.0				
Max Green Setting (Gmax), s		19.0		29.0		19.0		29.0				
Max Q Clear Time (g_c+I1), s		18.1		18.6		18.3		18.6				
Green Ext Time (p_c), s		0.0		3.7		0.1		1.2				
Intersection Summary												
HCM 6th Ctrl Delay				15.3								
HCM 6th LOS				B								

HCM 6th Signalized Intersection Capacity Analysis
3: Misty Acres Blvd/Andrews Rd & County Line Rd

2044 Background + Site
PM

Movement	EBL	EBT	EBR	WBL	WBT	WBR	NBL	NBT	NBR	SBL	SBT	SBR
Lane Configurations												
Traffic Volume (veh/h)	10	490	165	37	230	5	127	0	32	5	0	5
Future Volume (veh/h)	10	490	165	37	230	5	127	0	32	5	0	5
Number	3	8	18	7	4	14	1	6	16	5	2	12
Initial Q, veh	0	0	0	0	0	0	0	0	0	0	0	0
Ped-Bike Adj (A_pbT)	1.00		1.00	1.00		1.00	1.00		1.00	1.00		1.00
Parking Bus Adj	1.00	1.00	1.00	1.00	1.00	1.00	1.00	1.00	1.00	1.00	1.00	1.00
Work Zone On Approach		No			No			No			No	
Lanes Open During Work Zone												
Adj Sat Flow, veh/h/ln	2145	2145	2145	1817	1817	1817	1870	1870	1870	1870	1870	1870
Adj Flow Rate, veh/h	11	527	177	40	250	5	146	0	37	6	0	6
Peak Hour Factor	0.93	0.93	0.93	0.92	0.92	0.92	0.87	0.87	0.87	0.78	0.78	0.78
Percent Heavy Veh, %	2	2	2	2	2	2	2	2	2	2	2	2
Opposing Right Turn Influence	Yes			Yes			Yes			Yes		
Cap, veh/h	746	1148	973	431	950	19	459	0	312	208	35	127
HCM Platoon Ratio	1.00	1.00	1.00	1.00	1.00	1.00	1.00	1.00	1.00	1.00	1.00	1.00
Prop Arrive On Green	0.54	0.54	0.54	0.54	0.54	0.54	0.20	0.00	0.20	0.20	0.00	0.20
Unsig. Movement Delay												
Ln Grp Delay, s/veh	6.9	7.0	5.7	9.5	0.0	6.0	16.8	0.0	15.6	15.2	0.0	0.0
Ln Grp LOS	A	A	A	A	A	A	B	A	B	B	A	A
Approach Vol, veh/h		715			295			183			12	
Approach Delay, s/veh		6.6			6.5			16.5			15.2	
Approach LOS		A			A			B			B	
Timer:		1	2	3	4	5	6	7	8			
Assigned Phs			2		4		6		8			
Case No			8.0		6.0		7.0		5.0			
Phs Duration (G+Y+Rc), s			15.2		31.5		15.2		31.5			
Change Period (Y+Rc), s			* 6		6.5		6.0		6.5			
Max Green (Gmax), s			* 17		31.5		16.0		31.5			
Max Allow Headway (MAH), s			5.6		5.4		4.9		4.9			
Max Q Clear (g_c+I1), s			5.4		10.8		5.3		9.1			
Green Ext Time (g_e), s			0.0		1.7		0.6		4.2			
Prob of Phs Call (p_c)			0.92		1.00		0.92		1.00			
Prob of Max Out (p_x)			0.00		0.00		0.04		0.03			
Left-Turn Movement Data												
Assigned Mvmt			5		7		1		3			
Mvmt Sat Flow, veh/h			468		722		1545		1290			
Through Movement Data												
Assigned Mvmt			2		4		6		8			
Mvmt Sat Flow, veh/h			179		1775		0		2145			
Right-Turn Movement Data												
Assigned Mvmt			12		14		16		18			
Mvmt Sat Flow, veh/h			646		36		1585		1818			
Left Lane Group Data												
Assigned Mvmt		0	5	0	7	0	1	0	3			
Lane Assignment			L+T+R		L		L+T		L			

HCM 6th Signalized Intersection Capacity Analysis
 3: Misty Acres Blvd/Andrews Rd & County Line Rd

2044 Background + Site
 PM

Lanes in Grp	0	1	0	1	0	1	0	1
Grp Vol (v), veh/h	0	12	0	40	0	146	0	11
Grp Sat Flow (s), veh/h/ln	0	1293	0	722	0	1545	0	1290
Q Serve Time (g_s), s	0.0	0.0	0.0	1.7	0.0	0.0	0.0	0.2
Cycle Q Clear Time (g_c), s	0.0	3.4	0.0	8.8	0.0	3.3	0.0	3.8
Perm LT Sat Flow (s_l), veh/h/ln	0	1393	0	722	0	1432	0	1290
Shared LT Sat Flow (s_sh), veh/h/ln	0	0	0	0	0	1781	0	0
Perm LT Eff Green (g_p), s	0.0	9.2	0.0	25.0	0.0	9.2	0.0	25.0
Perm LT Serve Time (g_u), s	0.0	5.9	0.0	17.9	0.0	5.8	0.0	21.4
Perm LT Q Serve Time (g_ps), s	0.0	0.0	0.0	1.7	0.0	0.0	0.0	0.2
Time to First Blk (g_f), s	0.0	1.9	0.0	0.0	0.0	0.0	0.0	0.0
Serve Time pre Blk (g_fs), s	0.0	0.3	0.0	0.0	0.0	0.0	0.0	0.0
Prop LT Inside Lane (P_L)	0.00	0.50	0.00	1.00	0.00	1.00	0.00	1.00
Lane Grp Cap (c), veh/h	0	370	0	431	0	459	0	746
V/C Ratio (X)	0.00	0.03	0.00	0.09	0.00	0.32	0.00	0.01
Avail Cap (c_a), veh/h	0	600	0	532	0	664	0	926
Upstream Filter (I)	0.00	1.00	0.00	1.00	0.00	1.00	0.00	1.00
Uniform Delay (d1), s/veh	0.0	15.2	0.0	9.4	0.0	16.4	0.0	6.9
Incr Delay (d2), s/veh	0.0	0.0	0.0	0.1	0.0	0.4	0.0	0.0
Initial Q Delay (d3), s/veh	0.0	0.0	0.0	0.0	0.0	0.0	0.0	0.0
Control Delay (d), s/veh	0.0	15.2	0.0	9.5	0.0	16.8	0.0	6.9
1st-Term Q (Q1), veh/ln	0.0	0.1	0.0	0.2	0.0	1.2	0.0	0.0
2nd-Term Q (Q2), veh/ln	0.0	0.0	0.0	0.0	0.0	0.1	0.0	0.0
3rd-Term Q (Q3), veh/ln	0.0	0.0	0.0	0.0	0.0	0.0	0.0	0.0
%ile Back of Q Factor (f_B%)	0.00	1.00	0.00	1.00	0.00	1.00	0.00	1.00
%ile Back of Q (50%), veh/ln	0.0	0.1	0.0	0.2	0.0	1.2	0.0	0.0
%ile Storage Ratio (RQ%)	0.00	0.01	0.00	0.03	0.00	0.12	0.00	0.01
Initial Q (Qb), veh	0.0	0.0	0.0	0.0	0.0	0.0	0.0	0.0
Final (Residual) Q (Qe), veh	0.0	0.0	0.0	0.0	0.0	0.0	0.0	0.0
Sat Delay (ds), s/veh	0.0	0.0	0.0	0.0	0.0	0.0	0.0	0.0
Sat Q (Qs), veh	0.0	0.0	0.0	0.0	0.0	0.0	0.0	0.0
Sat Cap (cs), veh/h	0	0	0	0	0	0	0	0
Initial Q Clear Time (tc), h	0.0	0.0	0.0	0.0	0.0	0.0	0.0	0.0
Middle Lane Group Data								
Assigned Mvmt	0	2	0	4	0	6	0	8
Lane Assignment								T
Lanes in Grp	0	0	0	0	0	0	0	1
Grp Vol (v), veh/h	0	0	0	0	0	0	0	527
Grp Sat Flow (s), veh/h/ln	0	0	0	0	0	0	0	2145
Q Serve Time (g_s), s	0.0	0.0	0.0	0.0	0.0	0.0	0.0	7.1
Cycle Q Clear Time (g_c), s	0.0	0.0	0.0	0.0	0.0	0.0	0.0	7.1
Lane Grp Cap (c), veh/h	0	0	0	0	0	0	0	1148
V/C Ratio (X)	0.00	0.00	0.00	0.00	0.00	0.00	0.00	0.46
Avail Cap (c_a), veh/h	0	0	0	0	0	0	0	1447
Upstream Filter (I)	0.00	0.00	0.00	0.00	0.00	0.00	0.00	1.00
Uniform Delay (d1), s/veh	0.0	0.0	0.0	0.0	0.0	0.0	0.0	6.7
Incr Delay (d2), s/veh	0.0	0.0	0.0	0.0	0.0	0.0	0.0	0.3
Initial Q Delay (d3), s/veh	0.0	0.0	0.0	0.0	0.0	0.0	0.0	0.0
Control Delay (d), s/veh	0.0	0.0	0.0	0.0	0.0	0.0	0.0	7.0
1st-Term Q (Q1), veh/ln	0.0	0.0	0.0	0.0	0.0	0.0	0.0	2.2
2nd-Term Q (Q2), veh/ln	0.0	0.0	0.0	0.0	0.0	0.0	0.0	0.1

HCM 6th Signalized Intersection Capacity Analysis
3: Misty Acres Blvd/Andrews Rd & County Line Rd

2044 Background + Site
PM

3rd-Term Q (Q3), veh/ln	0.0	0.0	0.0	0.0	0.0	0.0	0.0	0.0
%ile Back of Q Factor (f_B%)	0.00	1.00	0.00	1.00	0.00	1.00	0.00	1.00
%ile Back of Q (50%), veh/ln	0.0	0.0	0.0	0.0	0.0	0.0	0.0	2.3
%ile Storage Ratio (RQ%)	0.00	0.00	0.00	0.00	0.00	0.00	0.00	0.09
Initial Q (Qb), veh	0.0	0.0	0.0	0.0	0.0	0.0	0.0	0.0
Final (Residual) Q (Qe), veh	0.0	0.0	0.0	0.0	0.0	0.0	0.0	0.0
Sat Delay (ds), s/veh	0.0	0.0	0.0	0.0	0.0	0.0	0.0	0.0
Sat Q (Qs), veh	0.0	0.0	0.0	0.0	0.0	0.0	0.0	0.0
Sat Cap (cs), veh/h	0	0	0	0	0	0	0	0
Initial Q Clear Time (tc), h	0.0	0.0	0.0	0.0	0.0	0.0	0.0	0.0

Right Lane Group Data

Assigned Mvmt	0	12	0	14	0	16	0	18
Lane Assignment				T+R		R		R
Lanes in Grp	0	0	0	1	0	1	0	1
Grp Vol (v), veh/h	0	0	0	255	0	37	0	177
Grp Sat Flow (s), veh/h/ln	0	0	0	1811	0	1585	0	1818
Q Serve Time (g_s), s	0.0	0.0	0.0	3.6	0.0	0.9	0.0	2.3
Cycle Q Clear Time (g_c), s	0.0	0.0	0.0	3.6	0.0	0.9	0.0	2.3
Prot RT Sat Flow (s_R), veh/h/ln	0.0	0.0	0.0	0.0	0.0	0.0	0.0	0.0
Prot RT Eff Green (g_R), s	0.0	0.0	0.0	0.0	0.0	0.0	0.0	0.0
Prop RT Outside Lane (P_R)	0.00	0.50	0.00	0.02	0.00	1.00	0.00	1.00
Lane Grp Cap (c), veh/h	0	0	0	969	0	312	0	973
V/C Ratio (X)	0.00	0.00	0.00	0.26	0.00	0.12	0.00	0.18
Avail Cap (c_a), veh/h	0	0	0	1221	0	543	0	1226
Upstream Filter (I)	0.00	0.00	0.00	1.00	0.00	1.00	0.00	1.00
Uniform Delay (d1), s/veh	0.0	0.0	0.0	5.9	0.0	15.4	0.0	5.6
Incr Delay (d2), s/veh	0.0	0.0	0.0	0.1	0.0	0.2	0.0	0.1
Initial Q Delay (d3), s/veh	0.0	0.0	0.0	0.0	0.0	0.0	0.0	0.0
Control Delay (d), s/veh	0.0	0.0	0.0	6.0	0.0	15.6	0.0	5.7
1st-Term Q (Q1), veh/ln	0.0	0.0	0.0	0.9	0.0	0.3	0.0	0.6
2nd-Term Q (Q2), veh/ln	0.0	0.0	0.0	0.0	0.0	0.0	0.0	0.0
3rd-Term Q (Q3), veh/ln	0.0	0.0	0.0	0.0	0.0	0.0	0.0	0.0
%ile Back of Q Factor (f_B%)	0.00	1.00	0.00	1.00	0.00	1.00	0.00	1.00
%ile Back of Q (50%), veh/ln	0.0	0.0	0.0	1.0	0.0	0.3	0.0	0.6
%ile Storage Ratio (RQ%)	0.00	0.00	0.00	0.03	0.00	0.05	0.00	0.09
Initial Q (Qb), veh	0.0	0.0	0.0	0.0	0.0	0.0	0.0	0.0
Final (Residual) Q (Qe), veh	0.0	0.0	0.0	0.0	0.0	0.0	0.0	0.0
Sat Delay (ds), s/veh	0.0	0.0	0.0	0.0	0.0	0.0	0.0	0.0
Sat Q (Qs), veh	0.0	0.0	0.0	0.0	0.0	0.0	0.0	0.0
Sat Cap (cs), veh/h	0	0	0	0	0	0	0	0
Initial Q Clear Time (tc), h	0.0	0.0	0.0	0.0	0.0	0.0	0.0	0.0

Intersection Summary

HCM 6th Ctrl Delay	8.2
HCM 6th LOS	A

Notes

* HCM 6th Edition computational engine requires equal clearance times for the phases crossing the barrier.

Intersection												
Int Delay, s/veh	4.1											
Movement	EBL	EBT	EBR	WBL	WBT	WBR	NBL	NBT	NBR	SBL	SBT	SBR
Lane Configurations	↙	↑			↘			↕				
Traffic Vol, veh/h	50	200	0	0	499	322	65	5	137	0	0	0
Future Vol, veh/h	50	200	0	0	499	322	65	5	137	0	0	0
Conflicting Peds, #/hr	0	0	0	0	0	0	0	0	0	0	0	0
Sign Control	Free	Free	Free	Free	Free	Free	Stop	Stop	Stop	Stop	Stop	Stop
RT Channelized	-	-	None	-	-	None	-	-	None	-	-	None
Storage Length	0	-	-	-	-	-	-	-	-	-	-	-
Veh in Median Storage, #	-	0	-	-	0	-	-	0	-	-	0	-
Grade, %	-	0	-	-	0	-	-	0	-	-	0	-
Peak Hour Factor	87	87	87	93	93	93	87	87	87	92	92	92
Heavy Vehicles, %	2	2	2	2	2	2	2	2	2	2	2	2
Mvmt Flow	57	230	0	0	537	346	75	6	157	0	0	0

Major/Minor	Major1	Major2	Minor1
Conflicting Flow All	883	0	- - - 0 1054 1227 230
Stage 1	-	-	- - - 344 344 -
Stage 2	-	-	- - - 710 883 -
Critical Hdwy	4.12	-	- - - 6.42 6.52 6.22
Critical Hdwy Stg 1	-	-	- - - 5.42 5.52 -
Critical Hdwy Stg 2	-	-	- - - 5.42 5.52 -
Follow-up Hdwy	2.218	-	- - - 3.518 4.018 3.318
Pot Cap-1 Maneuver	766	- 0 0	- - 250 178 809
Stage 1	-	- 0 0	- - 718 637 -
Stage 2	-	- 0 0	- - 487 364 -
Platoon blocked, %	-	-	- -
Mov Cap-1 Maneuver	766	- - -	- - 232 0 809
Mov Cap-2 Maneuver	-	- - -	- - 232 0 -
Stage 1	-	- - -	- - 665 0 -
Stage 2	-	- - -	- - 487 0 -

Approach	EB	WB	NB
HCM Control Delay, s	2	0	21.7
HCM LOS			C

Minor Lane/Major Mvmt	NBLn1	EBL	EBT	WBT	WBR
Capacity (veh/h)	449	766	-	-	-
HCM Lane V/C Ratio	0.53	0.075	-	-	-
HCM Control Delay (s)	21.7	10.1	-	-	-
HCM Lane LOS	C	B	-	-	-
HCM 95th %tile Q(veh)	3	0.2	-	-	-

Intersection						
Int Delay, s/veh	5.4					
Movement	WBL	WBR	NBT	NBR	SBL	SBT
Lane Configurations	↘	↗	↑	↗	↘	↑
Traffic Vol, veh/h	333	5	58	331	5	111
Future Vol, veh/h	333	5	58	331	5	111
Conflicting Peds, #/hr	0	0	0	0	0	0
Sign Control	Stop	Stop	Free	Free	Free	Free
RT Channelized	-	None	-	None	-	None
Storage Length	250	0	-	0	280	-
Veh in Median Storage, #	0	-	0	-	-	0
Grade, %	0	-	0	-	-	0
Peak Hour Factor	92	92	92	92	83	83
Heavy Vehicles, %	2	2	2	2	2	2
Mvmt Flow	362	5	63	360	6	134

Major/Minor	Minor1	Major1	Major2		
Conflicting Flow All	209	63	0	0	423
Stage 1	63	-	-	-	-
Stage 2	146	-	-	-	-
Critical Hdwy	6.42	6.22	-	-	4.12
Critical Hdwy Stg 1	5.42	-	-	-	-
Critical Hdwy Stg 2	5.42	-	-	-	-
Follow-up Hdwy	3.518	3.318	-	-	2.218
Pot Cap-1 Maneuver	779	1002	-	-	1136
Stage 1	960	-	-	-	-
Stage 2	881	-	-	-	-
Platoon blocked, %			-	-	-
Mov Cap-1 Maneuver	775	1002	-	-	1136
Mov Cap-2 Maneuver	775	-	-	-	-
Stage 1	960	-	-	-	-
Stage 2	877	-	-	-	-

Approach	WB	NB	SB
HCM Control Delay, s	13.5	0	0.4
HCM LOS	B		

Minor Lane/Major Mvmt	NBT	NBR	WBLn1	WBLn2	SBL	SBT
Capacity (veh/h)	-	-	775	1002	1136	-
HCM Lane V/C Ratio	-	-	0.467	0.005	0.005	-
HCM Control Delay (s)	-	-	13.6	8.6	8.2	-
HCM Lane LOS	-	-	B	A	A	-
HCM 95th %tile Q(veh)	-	-	2.5	0	0	-

Intersection												
Int Delay, s/veh	38											
Movement	EBL	EBT	EBR	WBL	WBT	WBR	NBL	NBT	NBR	SBL	SBT	SBR
Lane Configurations		↕			↕						↕	
Traffic Vol, veh/h	0	135	95	170	138	0	0	0	0	293	5	50
Future Vol, veh/h	0	135	95	170	138	0	0	0	0	293	5	50
Conflicting Peds, #/hr	0	0	0	0	0	0	0	0	0	0	0	0
Sign Control	Free	Free	Free	Free	Free	Free	Stop	Stop	Stop	Stop	Stop	Stop
RT Channelized	-	-	None	-	-	None	-	-	None	-	-	None
Storage Length	-	-	-	-	-	-	-	-	-	-	-	-
Veh in Median Storage, #	-	0	-	-	0	-	-	0	-	-	0	-
Grade, %	-	0	-	-	0	-	-	0	-	-	0	-
Peak Hour Factor	87	87	87	92	92	92	92	92	92	92	92	92
Heavy Vehicles, %	2	2	2	2	2	2	2	2	2	2	2	2
Mvmt Flow	0	155	109	185	150	0	0	0	0	318	5	54

Major/Minor	Major1			Major2			Minor2			
Conflicting Flow All	150	0	0	264	0	0		730	784	150
Stage 1	-	-	-	-	-	-		520	520	-
Stage 2	-	-	-	-	-	-		210	264	-
Critical Hdwy	4.12	-	-	4.12	-	-		6.42	6.52	6.22
Critical Hdwy Stg 1	-	-	-	-	-	-		5.42	5.52	-
Critical Hdwy Stg 2	-	-	-	-	-	-		5.42	5.52	-
Follow-up Hdwy	2.218	-	-	2.218	-	-		3.518	4.018	3.318
Pot Cap-1 Maneuver	1431	-	-	1300	-	-		389	325	896
Stage 1	-	-	-	-	-	-		597	532	-
Stage 2	-	-	-	-	-	-		825	690	-
Platoon blocked, %		-	-	-	-	-				
Mov Cap-1 Maneuver	1431	-	-	1300	-	-		329	0	896
Mov Cap-2 Maneuver	-	-	-	-	-	-		329	0	-
Stage 1	-	-	-	-	-	-		597	0	-
Stage 2	-	-	-	-	-	-		697	0	-

Approach	EB	WB	SB
HCM Control Delay, s	0	4.5	94.2
HCM LOS			F

Minor Lane/Major Mvmt	EBL	EBT	EBR	WBL	WBT	WBR	SBLn1
Capacity (veh/h)	1431	-	-	1300	-	-	362
HCM Lane V/C Ratio	-	-	-	0.142	-	-	1.045
HCM Control Delay (s)	0	-	-	8.2	0	-	94.2
HCM Lane LOS	A	-	-	A	A	-	F
HCM 95th %tile Q(veh)	0	-	-	0.5	-	-	13

Intersection												
Int Delay, s/veh	9.1											
Movement	EBL	EBT	EBR	WBL	WBT	WBR	NBL	NBT	NBR	SBL	SBT	SBR
Lane Configurations	↙	↑			↘			↕				
Traffic Vol, veh/h	35	393	0	0	228	134	75	5	277	0	0	0
Future Vol, veh/h	35	393	0	0	228	134	75	5	277	0	0	0
Conflicting Peds, #/hr	0	0	0	0	0	0	0	0	0	0	0	0
Sign Control	Free	Free	Free	Free	Free	Free	Stop	Stop	Stop	Stop	Stop	Stop
RT Channelized	-	-	None	-	-	None	-	-	None	-	-	None
Storage Length	0	-	-	-	-	-	-	-	-	-	-	-
Veh in Median Storage, #	-	0	-	-	0	-	-	0	-	-	0	-
Grade, %	-	0	-	-	0	-	-	0	-	-	0	-
Peak Hour Factor	92	92	92	92	92	92	92	92	92	92	92	92
Heavy Vehicles, %	2	2	2	2	2	2	2	2	2	2	2	2
Mvmt Flow	38	427	0	0	248	146	82	5	301	0	0	0

Major/Minor	Major1	Major2	Minor1
Conflicting Flow All	394	0	-
Stage 1	-	-	-
Stage 2	-	-	-
Critical Hdwy	4.12	-	-
Critical Hdwy Stg 1	-	-	-
Critical Hdwy Stg 2	-	-	-
Follow-up Hdwy	2.218	-	-
Pot Cap-1 Maneuver	1165	0	0
Stage 1	-	0	0
Stage 2	-	0	0
Platoon blocked, %	-	-	-
Mov Cap-1 Maneuver	1165	-	-
Mov Cap-2 Maneuver	-	-	-
Stage 1	-	-	-
Stage 2	-	-	-

Approach	EB	WB	NB
HCM Control Delay, s	0.7	0	28.4
HCM LOS			D

Minor Lane/Major Mvmt	NBLn1	EBL	EBT	WBT	WBR
Capacity (veh/h)	528	1165	-	-	-
HCM Lane V/C Ratio	0.735	0.033	-	-	-
HCM Control Delay (s)	28.4	8.2	-	-	-
HCM Lane LOS	D	A	-	-	-
HCM 95th %tile Q(veh)	6.2	0.1	-	-	-

Intersection						
Int Delay, s/veh	3.3					
Movement	WBL	WBR	NBT	NBR	SBL	SBT
Lane Configurations	↘	↗	↑	↗	↘	↑
Traffic Vol, veh/h	122	5	71	141	5	59
Future Vol, veh/h	122	5	71	141	5	59
Conflicting Peds, #/hr	0	0	0	0	0	0
Sign Control	Stop	Stop	Free	Free	Free	Free
RT Channelized	-	None	-	None	-	None
Storage Length	250	0	-	0	280	-
Veh in Median Storage, #	0	-	0	-	-	0
Grade, %	0	-	0	-	-	0
Peak Hour Factor	87	87	87	87	83	83
Heavy Vehicles, %	2	2	2	2	2	2
Mvmt Flow	140	6	82	162	6	71

Major/Minor	Minor1	Major1	Major2		
Conflicting Flow All	165	82	0	0	244
Stage 1	82	-	-	-	-
Stage 2	83	-	-	-	-
Critical Hdwy	6.42	6.22	-	-	4.12
Critical Hdwy Stg 1	5.42	-	-	-	-
Critical Hdwy Stg 2	5.42	-	-	-	-
Follow-up Hdwy	3.518	3.318	-	-	2.218
Pot Cap-1 Maneuver	826	978	-	-	1322
Stage 1	941	-	-	-	-
Stage 2	940	-	-	-	-
Platoon blocked, %			-	-	-
Mov Cap-1 Maneuver	822	978	-	-	1322
Mov Cap-2 Maneuver	822	-	-	-	-
Stage 1	941	-	-	-	-
Stage 2	935	-	-	-	-

Approach	WB	NB	SB
HCM Control Delay, s	10.2	0	0.6
HCM LOS	B		

Minor Lane/Major Mvmt	NBT	NBR	WBLn1	WBLn2	SBL	SBT
Capacity (veh/h)	-	-	822	978	1322	-
HCM Lane V/C Ratio	-	-	0.171	0.006	0.005	-
HCM Control Delay (s)	-	-	10.3	8.7	7.7	-
HCM Lane LOS	-	-	B	A	A	-
HCM 95th %tile Q(veh)	-	-	0.6	0	0	-

Intersection	
Intersection Delay, s/veh	14.8
Intersection LOS	B

Movement	EBL	EBT	EBR	WBL	WBT	WBR	NBL	NBT	NBR	SBL	SBT	SBR
Lane Configurations		↕		↕	↑						↕	
Traffic Vol, veh/h	0	143	65	408	156	0	0	0	0	102	5	20
Future Vol, veh/h	0	143	65	408	156	0	0	0	0	102	5	20
Peak Hour Factor	0.87	0.87	0.87	0.93	0.93	0.93	0.92	0.92	0.92	0.83	0.83	0.83
Heavy Vehicles, %	2	2	2	2	2	2	2	2	2	2	2	2
Mvmt Flow	0	164	75	439	168	0	0	0	0	123	6	24
Number of Lanes	0	1	0	1	1	0	0	0	0	0	1	0

Approach	EB	WB	SB
Opposing Approach	WB	EB	
Opposing Lanes	2	1	0
Conflicting Approach Left	SB		WB
Conflicting Lanes Left	1	0	2
Conflicting Approach Right		SB	EB
Conflicting Lanes Right	0	1	1
HCM Control Delay	10.5	17.5	10.9
HCM LOS	B	C	B

Lane	EBLn1	WBLn1	WBLn2	SBLn1
Vol Left, %	0%	100%	0%	80%
Vol Thru, %	69%	0%	100%	4%
Vol Right, %	31%	0%	0%	16%
Sign Control	Stop	Stop	Stop	Stop
Traffic Vol by Lane	208	408	156	127
LT Vol	0	408	0	102
Through Vol	143	0	156	5
RT Vol	65	0	0	20
Lane Flow Rate	239	439	168	153
Geometry Grp	4a	5	5	2
Degree of Util (X)	0.33	0.694	0.242	0.249
Departure Headway (Hd)	4.971	5.693	5.19	5.869
Convergence, Y/N	Yes	Yes	Yes	Yes
Cap	715	632	686	606
Service Time	3.055	3.47	2.966	3.959
HCM Lane V/C Ratio	0.334	0.695	0.245	0.252
HCM Control Delay	10.5	20.5	9.6	10.9
HCM Lane LOS	B	C	A	B
HCM 95th-tile Q	1.4	5.5	0.9	1

Intersection	
Intersection Delay, s/veh	13.7
Intersection LOS	B

Movement	EBL	EBT	EBR	WBL	WBT	WBR	NBL	NBT	NBR	SBL	SBT	SBR
Lane Configurations		↕		↕	↑						↕	
Traffic Vol, veh/h	0	135	95	170	138	0	0	0	0	293	5	50
Future Vol, veh/h	0	135	95	170	138	0	0	0	0	293	5	50
Peak Hour Factor	0.87	0.87	0.87	0.92	0.92	0.92	0.92	0.92	0.92	0.92	0.92	0.92
Heavy Vehicles, %	2	2	2	2	2	2	2	2	2	2	2	2
Mvmt Flow	0	155	109	185	150	0	0	0	0	318	5	54
Number of Lanes	0	1	0	1	1	0	0	0	0	0	1	0

Approach	EB	WB	SB
Opposing Approach	WB	EB	
Opposing Lanes	2	1	0
Conflicting Approach Left	SB		WB
Conflicting Lanes Left	1	0	2
Conflicting Approach Right		SB	EB
Conflicting Lanes Right	0	1	1
HCM Control Delay	12.1	11.8	16.4
HCM LOS	B	B	C

Lane	EBLn1	WBLn1	WBLn2	SBLn1
Vol Left, %	0%	100%	0%	84%
Vol Thru, %	59%	0%	100%	1%
Vol Right, %	41%	0%	0%	14%
Sign Control	Stop	Stop	Stop	Stop
Traffic Vol by Lane	230	170	138	348
LT Vol	0	170	0	293
Through Vol	135	0	138	5
RT Vol	95	0	0	50
Lane Flow Rate	264	185	150	378
Geometry Grp	4a	5	5	2
Degree of Util (X)	0.401	0.336	0.252	0.588
Departure Headway (Hd)	5.456	6.555	6.047	5.597
Convergence, Y/N	Yes	Yes	Yes	Yes
Cap	658	549	594	643
Service Time	3.496	4.296	3.788	3.634
HCM Lane V/C Ratio	0.401	0.337	0.253	0.588
HCM Control Delay	12.1	12.6	10.8	16.4
HCM Lane LOS	B	B	B	C
HCM 95th-tile Q	1.9	1.5	1	3.8

Intersection												
Int Delay, s/veh	1.1											
Movement	EBL	EBT	EBR	WBL	WBT	WBR	NBL	NBT	NBR	SBL	SBT	SBR
Lane Configurations		↕			↕			↕			↕	
Traffic Vol, veh/h	18	0	6	3	0	12	2	223	0	4	270	8
Future Vol, veh/h	18	0	6	3	0	12	2	223	0	4	270	8
Conflicting Peds, #/hr	0	0	0	0	0	0	0	0	0	0	0	0
Sign Control	Stop	Stop	Stop	Stop	Stop	Stop	Free	Free	Free	Free	Free	Free
RT Channelized	-	-	None	-	-	None	-	-	None	-	-	None
Storage Length	-	-	-	-	-	-	-	-	-	-	-	-
Veh in Median Storage, #	-	0	-	-	0	-	-	0	-	-	0	-
Grade, %	-	0	-	-	0	-	-	0	-	-	0	-
Peak Hour Factor	78	78	78	78	78	78	87	87	87	92	92	92
Heavy Vehicles, %	2	2	2	2	2	2	2	2	2	2	2	2
Mvmt Flow	23	0	8	4	0	15	2	256	0	4	293	9

Major/Minor	Minor2		Minor1		Major1		Major2					
Conflicting Flow All	574	566	298	570	570	256	302	0	0	256	0	0
Stage 1	306	306	-	260	260	-	-	-	-	-	-	-
Stage 2	268	260	-	310	310	-	-	-	-	-	-	-
Critical Hdwy	7.12	6.52	6.22	7.12	6.52	6.22	4.12	-	-	4.12	-	-
Critical Hdwy Stg 1	6.12	5.52	-	6.12	5.52	-	-	-	-	-	-	-
Critical Hdwy Stg 2	6.12	5.52	-	6.12	5.52	-	-	-	-	-	-	-
Follow-up Hdwy	3.518	4.018	3.318	3.518	4.018	3.318	2.218	-	-	2.218	-	-
Pot Cap-1 Maneuver	430	434	741	432	431	783	1259	-	-	1309	-	-
Stage 1	704	662	-	745	693	-	-	-	-	-	-	-
Stage 2	738	693	-	700	659	-	-	-	-	-	-	-
Platoon blocked, %								-	-	-	-	-
Mov Cap-1 Maneuver	420	431	741	426	428	783	1259	-	-	1309	-	-
Mov Cap-2 Maneuver	420	431	-	426	428	-	-	-	-	-	-	-
Stage 1	703	659	-	744	692	-	-	-	-	-	-	-
Stage 2	722	692	-	690	656	-	-	-	-	-	-	-

Approach	EB		WB		NB		SB	
HCM Control Delay, s	13.2		10.5		0.1		0.1	
HCM LOS	B		B					

Minor Lane/Major Mvmt	NBL	NBT	NBR	EBLn1	WBLn1	SBL	SBT	SBR
Capacity (veh/h)	1259	-	-	471	671	1309	-	-
HCM Lane V/C Ratio	0.002	-	-	0.065	0.029	0.003	-	-
HCM Control Delay (s)	7.9	0	-	13.2	10.5	7.8	0	-
HCM Lane LOS	A	A	-	B	B	A	A	-
HCM 95th %tile Q(veh)	0	-	-	0.2	0.1	0	-	-

Intersection												
Int Delay, s/veh	1.9											
Movement	NBL	NBT	NBR	SBL	SBT	SBR	SEL	SET	SER	NWL	NWT	NWR
Lane Configurations		↕			↕	↕		↕			↕	
Traffic Vol, veh/h	0	152	0	1	164	114	70	0	0	1	1	3
Future Vol, veh/h	0	152	0	1	164	114	70	0	0	1	1	3
Conflicting Peds, #/hr	0	0	0	0	0	0	0	0	0	0	0	0
Sign Control	Free	Free	Free	Free	Free	Free	Stop	Stop	Stop	Stop	Stop	Stop
RT Channelized	-	-	None	-	-	None	-	-	None	-	-	None
Storage Length	-	-	-	-	-	186	-	-	-	-	-	-
Veh in Median Storage, #	-	0	-	-	0	-	-	0	-	-	0	-
Grade, %	-	0	-	-	0	-	-	0	-	-	0	-
Peak Hour Factor	83	83	83	92	92	92	83	83	83	78	78	78
Heavy Vehicles, %	2	2	2	2	2	2	2	2	2	2	2	2
Mvmt Flow	0	183	0	1	178	124	84	0	0	1	1	4

Major/Minor	Major1		Major2		Minor2			Minor1				
Conflicting Flow All	302	0	0	183	0	0	366	363	178	425	487	183
Stage 1	-	-	-	-	-	-	180	180	-	183	183	-
Stage 2	-	-	-	-	-	-	186	183	-	242	304	-
Critical Hdwy	4.12	-	-	4.12	-	-	7.12	6.52	6.22	7.12	6.52	6.22
Critical Hdwy Stg 1	-	-	-	-	-	-	6.12	5.52	-	6.12	5.52	-
Critical Hdwy Stg 2	-	-	-	-	-	-	6.12	5.52	-	6.12	5.52	-
Follow-up Hdwy	2.218	-	-	2.218	-	-	3.518	4.018	3.318	3.518	4.018	3.318
Pot Cap-1 Maneuver	1259	-	-	1392	-	-	590	565	865	540	481	859
Stage 1	-	-	-	-	-	-	822	750	-	819	748	-
Stage 2	-	-	-	-	-	-	816	748	-	762	663	-
Platoon blocked, %		-	-	-	-	-						
Mov Cap-1 Maneuver	1259	-	-	1392	-	-	586	564	865	539	481	859
Mov Cap-2 Maneuver	-	-	-	-	-	-	586	564	-	539	481	-
Stage 1	-	-	-	-	-	-	822	749	-	819	748	-
Stage 2	-	-	-	-	-	-	811	748	-	761	662	-

Approach	NB	SB	SE	NW
HCM Control Delay, s	0	0	12.2	10.4
HCM LOS			B	B

Minor Lane/Major Mvmt	NBL	NBT	NBRNWLn1	SELn1	SBL	SBT	SBR
Capacity (veh/h)	1259	-	-	673	586	1392	-
HCM Lane V/C Ratio	-	-	-	0.01	0.144	0.001	-
HCM Control Delay (s)	0	-	-	10.4	12.2	7.6	0
HCM Lane LOS	A	-	-	B	B	A	A
HCM 95th %tile Q(veh)	0	-	-	0	0.5	0	-

Intersection						
Int Delay, s/veh	1.2					
Movement	EBT	EBR	WBL	WBT	NBL	NBR
Lane Configurations						
Traffic Vol, veh/h	56	1	8	112	5	14
Future Vol, veh/h	56	1	8	112	5	14
Conflicting Peds, #/hr	0	0	0	0	0	0
Sign Control	Free	Free	Free	Free	Stop	Stop
RT Channelized	-	None	-	None	-	None
Storage Length	-	-	-	-	0	-
Veh in Median Storage, #	0	-	-	0	0	-
Grade, %	0	-	-	0	0	-
Peak Hour Factor	83	83	83	83	78	78
Heavy Vehicles, %	2	2	2	2	2	2
Mvmt Flow	67	1	10	135	6	18

Major/Minor	Major1	Major2	Minor1			
Conflicting Flow All	0	0	68	0	223	68
Stage 1	-	-	-	-	68	-
Stage 2	-	-	-	-	155	-
Critical Hdwy	-	-	4.12	-	6.42	6.22
Critical Hdwy Stg 1	-	-	-	-	5.42	-
Critical Hdwy Stg 2	-	-	-	-	5.42	-
Follow-up Hdwy	-	-	2.218	-	3.518	3.318
Pot Cap-1 Maneuver	-	-	1533	-	765	995
Stage 1	-	-	-	-	955	-
Stage 2	-	-	-	-	873	-
Platoon blocked, %	-	-	-	-	-	-
Mov Cap-1 Maneuver	-	-	1533	-	760	995
Mov Cap-2 Maneuver	-	-	-	-	760	-
Stage 1	-	-	-	-	955	-
Stage 2	-	-	-	-	867	-

Approach	EB	WB	NB
HCM Control Delay, s	0	0.5	9
HCM LOS			A

Minor Lane/Major Mvmt	NBLn1	EBT	EBR	WBL	WBT
Capacity (veh/h)	920	-	-	1533	-
HCM Lane V/C Ratio	0.026	-	-	0.006	-
HCM Control Delay (s)	9	-	-	7.4	0
HCM Lane LOS	A	-	-	A	A
HCM 95th %tile Q(veh)	0.1	-	-	0	-

Intersection												
Int Delay, s/veh	3.3											
Movement	EBL	EBT	EBR	WBL	WBT	WBR	NBL	NBT	NBR	SBL	SBT	SBR
Lane Configurations		↕			↕			↕	↕	↕	↕	
Traffic Vol, veh/h	35	1	11	55	1	10	4	108	45	5	147	14
Future Vol, veh/h	35	1	11	55	1	10	4	108	45	5	147	14
Conflicting Peds, #/hr	0	0	0	0	0	0	0	0	0	0	0	0
Sign Control	Stop	Stop	Stop	Stop	Stop	Stop	Free	Free	Free	Free	Free	Free
RT Channelized	-	-	None	-	-	None	-	-	None	-	-	None
Storage Length	-	-	-	-	-	-	-	-	100	120	-	-
Veh in Median Storage, #	-	0	-	-	0	-	-	0	-	-	0	-
Grade, %	-	0	-	-	0	-	-	0	-	-	0	-
Peak Hour Factor	78	78	78	83	83	83	87	87	87	87	87	87
Heavy Vehicles, %	2	2	2	2	2	2	2	2	2	2	2	2
Mvmt Flow	45	1	14	66	1	12	5	124	52	6	169	16

Major/Minor	Minor2		Minor1		Major1		Major2					
Conflicting Flow All	356	375	177	331	331	124	185	0	0	176	0	0
Stage 1	189	189	-	134	134	-	-	-	-	-	-	-
Stage 2	167	186	-	197	197	-	-	-	-	-	-	-
Critical Hdwy	7.12	6.52	6.22	7.12	6.52	6.22	4.12	-	-	4.12	-	-
Critical Hdwy Stg 1	6.12	5.52	-	6.12	5.52	-	-	-	-	-	-	-
Critical Hdwy Stg 2	6.12	5.52	-	6.12	5.52	-	-	-	-	-	-	-
Follow-up Hdwy	3.518	4.018	3.318	3.518	4.018	3.318	2.218	-	-	2.218	-	-
Pot Cap-1 Maneuver	599	556	866	622	588	927	1390	-	-	1400	-	-
Stage 1	813	744	-	869	785	-	-	-	-	-	-	-
Stage 2	835	746	-	805	738	-	-	-	-	-	-	-
Platoon blocked, %								-	-	-	-	-
Mov Cap-1 Maneuver	586	552	866	607	583	927	1390	-	-	1400	-	-
Mov Cap-2 Maneuver	586	552	-	607	583	-	-	-	-	-	-	-
Stage 1	810	741	-	866	782	-	-	-	-	-	-	-
Stage 2	820	743	-	787	735	-	-	-	-	-	-	-

Approach	EB	WB	NB	SB
HCM Control Delay, s	11.3	11.4	0.2	0.2
HCM LOS	B	B		

Minor Lane/Major Mvmt	NBL	NBT	NBR	EBLn1	WBLn1	SBL	SBT	SBR
Capacity (veh/h)	1390	-	-	633	640	1400	-	-
HCM Lane V/C Ratio	0.003	-	-	0.095	0.124	0.004	-	-
HCM Control Delay (s)	7.6	0	-	11.3	11.4	7.6	0	-
HCM Lane LOS	A	A	-	B	B	A	A	-
HCM 95th %tile Q(veh)	0	-	-	0.3	0.4	0	-	-

Intersection						
Int Delay, s/veh	0.3					
Movement	EBL	EBR	NBL	NBT	SBT	SBR
Lane Configurations	T			T		T
Traffic Vol, veh/h	9	3	1	252	279	5
Future Vol, veh/h	9	3	1	252	279	5
Conflicting Peds, #/hr	0	0	0	0	0	0
Sign Control	Stop	Stop	Free	Free	Free	Free
RT Channelized	-	None	-	None	-	None
Storage Length	0	-	-	-	-	-
Veh in Median Storage, #	0	-	-	0	0	-
Grade, %	0	-	-	0	0	-
Peak Hour Factor	78	78	87	87	92	92
Heavy Vehicles, %	2	2	2	2	2	2
Mvmt Flow	12	4	1	290	303	5

Major/Minor	Minor2	Major1		Major2	
Conflicting Flow All	598	306	308	0	0
Stage 1	306	-	-	-	-
Stage 2	292	-	-	-	-
Critical Hdwy	6.42	6.22	4.12	-	-
Critical Hdwy Stg 1	5.42	-	-	-	-
Critical Hdwy Stg 2	5.42	-	-	-	-
Follow-up Hdwy	3.518	3.318	2.218	-	-
Pot Cap-1 Maneuver	465	734	1253	-	-
Stage 1	747	-	-	-	-
Stage 2	758	-	-	-	-
Platoon blocked, %				-	-
Mov Cap-1 Maneuver	465	734	1253	-	-
Mov Cap-2 Maneuver	465	-	-	-	-
Stage 1	746	-	-	-	-
Stage 2	758	-	-	-	-

Approach	EB	NB	SB
HCM Control Delay, s	12.2	0	0
HCM LOS	B		

Minor Lane/Major Mvmt	NBL	NBT	EBLn1	SBT	SBR
Capacity (veh/h)	1253	-	512	-	-
HCM Lane V/C Ratio	0.001	-	0.03	-	-
HCM Control Delay (s)	7.9	0	12.2	-	-
HCM Lane LOS	A	A	B	-	-
HCM 95th %tile Q(veh)	0	-	0.1	-	-

Intersection												
Int Delay, s/veh	30.6											
Movement	EBL	EBT	EBR	WBL	WBT	WBR	NBL	NBT	NBR	SBL	SBT	SBR
Lane Configurations	↙	↑	↗	↙	↗			↖	↗		↕	
Traffic Vol, veh/h	5	135	182	102	635	5	191	0	50	5	0	10
Future Vol, veh/h	5	135	182	102	635	5	191	0	50	5	0	10
Conflicting Peds, #/hr	0	0	0	0	0	0	0	0	0	0	0	0
Sign Control	Free	Free	Free	Free	Free	Free	Stop	Stop	Stop	Stop	Stop	Stop
RT Channelized	-	-	None	-	-	None	-	-	None	-	-	None
Storage Length	232	-	182	172	-	-	-	-	155	-	-	-
Veh in Median Storage, #	-	0	-	-	0	-	-	0	-	-	0	-
Grade, %	-	0	-	-	0	-	-	0	-	-	0	-
Peak Hour Factor	92	92	92	93	93	93	87	87	87	78	78	78
Heavy Vehicles, %	2	2	2	2	2	2	2	2	2	2	2	2
Mvmt Flow	5	147	198	110	683	5	220	0	57	6	0	13

Major/Minor	Major1			Major2			Minor1			Minor2		
Conflicting Flow All	688	0	0	345	0	0	1069	1065	147	1191	1261	686
Stage 1	-	-	-	-	-	-	157	157	-	906	906	-
Stage 2	-	-	-	-	-	-	912	908	-	285	355	-
Critical Hdwy	4.12	-	-	4.12	-	-	7.12	6.52	6.22	7.12	6.52	6.22
Critical Hdwy Stg 1	-	-	-	-	-	-	6.12	5.52	-	6.12	5.52	-
Critical Hdwy Stg 2	-	-	-	-	-	-	6.12	5.52	-	6.12	5.52	-
Follow-up Hdwy	2.218	-	-	2.218	-	-	3.518	4.018	3.318	3.518	4.018	3.318
Pot Cap-1 Maneuver	906	-	-	1214	-	-	~ 199	223	900	164	170	447
Stage 1	-	-	-	-	-	-	845	768	-	331	355	-
Stage 2	-	-	-	-	-	-	328	354	-	722	630	-
Platoon blocked, %		-	-		-	-						
Mov Cap-1 Maneuver	906	-	-	1214	-	-	~ 179	202	900	142	154	447
Mov Cap-2 Maneuver	-	-	-	-	-	-	~ 179	202	-	142	154	-
Stage 1	-	-	-	-	-	-	840	763	-	329	323	-
Stage 2	-	-	-	-	-	-	290	322	-	672	626	-

Approach	EB	WB	NB	SB
HCM Control Delay, s	0.1	1.1	155	19.9
HCM LOS			F	C

Minor Lane/Major Mvmt	NBLn1	NBLn2	EBL	EBT	EBR	WBL	WBT	WBR	SBLn1
Capacity (veh/h)	179	900	906	-	-	1214	-	-	260
HCM Lane V/C Ratio	1.226	0.064	0.006	-	-	0.09	-	-	0.074
HCM Control Delay (s)	193.1	9.3	9	-	-	8.3	-	-	19.9
HCM Lane LOS	F	A	A	-	-	A	-	-	C
HCM 95th %tile Q(veh)	12	0.2	0	-	-	0.3	-	-	0.2

Notes
 ~: Volume exceeds capacity \$: Delay exceeds 300s +: Computation Not Defined *: All major volume in platoon

Intersection												
Int Delay, s/veh	1.3											
Movement	EBL	EBT	EBR	WBL	WBT	WBR	NBL	NBT	NBR	SBL	SBT	SBR
Lane Configurations		↕			↕			↕			↕	
Traffic Vol, veh/h	14	0	4	2	0	8	4	133	2	14	158	20
Future Vol, veh/h	14	0	4	2	0	8	4	133	2	14	158	20
Conflicting Peds, #/hr	0	0	0	0	0	0	0	0	0	0	0	0
Sign Control	Stop	Stop	Stop	Stop	Stop	Stop	Free	Free	Free	Free	Free	Free
RT Channelized	-	-	None	-	-	None	-	-	None	-	-	None
Storage Length	-	-	-	-	-	-	-	-	-	-	-	-
Veh in Median Storage, #	-	0	-	-	0	-	-	0	-	-	0	-
Grade, %	-	0	-	-	0	-	-	0	-	-	0	-
Peak Hour Factor	78	78	78	78	78	78	83	83	83	87	87	87
Heavy Vehicles, %	2	2	2	2	2	2	2	2	2	2	2	2
Mvmt Flow	18	0	5	3	0	10	5	160	2	16	182	23

Major/Minor	Minor2		Minor1		Major1		Major2					
Conflicting Flow All	402	398	194	399	408	161	205	0	0	162	0	0
Stage 1	226	226	-	171	171	-	-	-	-	-	-	-
Stage 2	176	172	-	228	237	-	-	-	-	-	-	-
Critical Hdwy	7.12	6.52	6.22	7.12	6.52	6.22	4.12	-	-	4.12	-	-
Critical Hdwy Stg 1	6.12	5.52	-	6.12	5.52	-	-	-	-	-	-	-
Critical Hdwy Stg 2	6.12	5.52	-	6.12	5.52	-	-	-	-	-	-	-
Follow-up Hdwy	3.518	4.018	3.318	3.518	4.018	3.318	2.218	-	-	2.218	-	-
Pot Cap-1 Maneuver	559	540	847	561	533	884	1366	-	-	1417	-	-
Stage 1	777	717	-	831	757	-	-	-	-	-	-	-
Stage 2	826	756	-	775	709	-	-	-	-	-	-	-
Platoon blocked, %								-	-	-	-	-
Mov Cap-1 Maneuver	546	531	847	550	524	884	1366	-	-	1417	-	-
Mov Cap-2 Maneuver	546	531	-	550	524	-	-	-	-	-	-	-
Stage 1	774	708	-	828	754	-	-	-	-	-	-	-
Stage 2	813	753	-	760	700	-	-	-	-	-	-	-

Approach	EB		WB		NB		SB	
HCM Control Delay, s	11.3		9.6		0.2		0.6	
HCM LOS	B		A					

Minor Lane/Major Mvmt	NBL	NBT	NBR	EBLn1	WBLn1	SBL	SBT	SBR
Capacity (veh/h)	1366	-	-	593	788	1417	-	-
HCM Lane V/C Ratio	0.004	-	-	0.039	0.016	0.011	-	-
HCM Control Delay (s)	7.6	0	-	11.3	9.6	7.6	0	-
HCM Lane LOS	A	A	-	B	A	A	A	-
HCM 95th %tile Q(veh)	0	-	-	0.1	0.1	0	-	-

Intersection												
Int Delay, s/veh	1.9											
Movement	NBL	NBT	NBR	SBL	SBT	SBR	SEL	SET	SER	NWL	NWT	NWR
Lane Configurations		↕			↕	↕		↕			↕	
Traffic Vol, veh/h	0	94	1	5	102	57	43	1	0	1	1	2
Future Vol, veh/h	0	94	1	5	102	57	43	1	0	1	1	2
Conflicting Peds, #/hr	2	0	0	0	0	0	0	0	0	0	0	0
Sign Control	Free	Free	Free	Free	Free	Free	Stop	Stop	Stop	Stop	Stop	Stop
RT Channelized	-	-	None	-	-	None	-	-	None	-	-	None
Storage Length	-	-	-	-	-	186	-	-	-	-	-	-
Veh in Median Storage, #	-	0	-	-	0	-	-	0	-	-	0	-
Grade, %	-	0	-	-	0	-	-	0	-	-	0	-
Peak Hour Factor	83	83	83	87	87	87	78	78	78	78	78	78
Heavy Vehicles, %	2	2	2	2	2	2	2	2	2	2	2	2
Mvmt Flow	0	113	1	6	117	66	55	1	0	1	1	3

Major/Minor	Major1			Major2			Minor2			Minor1		
Conflicting Flow All	185	0	0	114	0	0	247	245	119	277	311	114
Stage 1	-	-	-	-	-	-	131	131	-	114	114	-
Stage 2	-	-	-	-	-	-	116	114	-	163	197	-
Critical Hdwy	4.12	-	-	4.12	-	-	7.12	6.52	6.22	7.12	6.52	6.22
Critical Hdwy Stg 1	-	-	-	-	-	-	6.12	5.52	-	6.12	5.52	-
Critical Hdwy Stg 2	-	-	-	-	-	-	6.12	5.52	-	6.12	5.52	-
Follow-up Hdwy	2.218	-	-	2.218	-	-	3.518	4.018	3.318	3.518	4.018	3.318
Pot Cap-1 Maneuver	1390	-	-	1475	-	-	707	657	933	675	604	939
Stage 1	-	-	-	-	-	-	873	788	-	891	801	-
Stage 2	-	-	-	-	-	-	889	801	-	839	738	-
Platoon blocked, %		-	-		-	-						
Mov Cap-1 Maneuver	1387	-	-	1475	-	-	700	652	931	672	600	939
Mov Cap-2 Maneuver	-	-	-	-	-	-	700	652	-	672	600	-
Stage 1	-	-	-	-	-	-	871	782	-	891	801	-
Stage 2	-	-	-	-	-	-	885	801	-	833	733	-

Approach	NB			SB			SE			NW		
HCM Control Delay, s	0			0.2			10.6			9.8		
HCM LOS							B			A		

Minor Lane/Major Mvmt	NBL	NBT	NBR	NWLn1	SELn1	SBL	SBT	SBR
Capacity (veh/h)	1387	-	-	757	699	1475	-	-
HCM Lane V/C Ratio	-	-	-	0.007	0.081	0.004	-	-
HCM Control Delay (s)	0	-	-	9.8	10.6	7.5	0	-
HCM Lane LOS	A	-	-	A	B	A	A	-
HCM 95th %tile Q(veh)	0	-	-	0	0.3	0	-	-

Intersection						
Int Delay, s/veh	2.4					
Movement	EBT	EBR	WBL	WBT	NBL	NBR
Lane Configurations						
Traffic Vol, veh/h	33	3	18	40	4	10
Future Vol, veh/h	33	3	18	40	4	10
Conflicting Peds, #/hr	0	0	0	0	0	0
Sign Control	Free	Free	Free	Free	Stop	Stop
RT Channelized	-	None	-	None	-	None
Storage Length	-	-	-	-	0	-
Veh in Median Storage, #	0	-	-	0	0	-
Grade, %	0	-	-	0	0	-
Peak Hour Factor	78	78	83	83	78	78
Heavy Vehicles, %	2	2	2	2	2	2
Mvmt Flow	42	4	22	48	5	13

Major/Minor	Major1	Major2	Minor1	Minor2	Minor3
Conflicting Flow All	0	0	46	0	136
Stage 1	-	-	-	-	44
Stage 2	-	-	-	-	92
Critical Hdwy	-	-	4.12	-	6.42
Critical Hdwy Stg 1	-	-	-	-	5.42
Critical Hdwy Stg 2	-	-	-	-	5.42
Follow-up Hdwy	-	-	2.218	-	3.518
Pot Cap-1 Maneuver	-	-	1562	-	857
Stage 1	-	-	-	-	978
Stage 2	-	-	-	-	932
Platoon blocked, %	-	-	-	-	-
Mov Cap-1 Maneuver	-	-	1562	-	845
Mov Cap-2 Maneuver	-	-	-	-	845
Stage 1	-	-	-	-	978
Stage 2	-	-	-	-	919

Approach	EB	WB	NB
HCM Control Delay, s	0	2.3	8.8
HCM LOS			A

Minor Lane/Major Mvmt	NBLn1	EBT	EBR	WBL	WBT
Capacity (veh/h)	967	-	-	1562	-
HCM Lane V/C Ratio	0.019	-	-	0.014	-
HCM Control Delay (s)	8.8	-	-	7.3	0
HCM Lane LOS	A	-	-	A	A
HCM 95th %tile Q(veh)	0.1	-	-	0	-

Intersection												
Int Delay, s/veh	3.1											
Movement	EBL	EBT	EBR	WBL	WBT	WBR	NBL	NBT	NBR	SBL	SBT	SBR
Lane Configurations		↕			↕			↕	↕	↕	↕	
Traffic Vol, veh/h	24	1	8	25	3	10	10	61	45	10	59	34
Future Vol, veh/h	24	1	8	25	3	10	10	61	45	10	59	34
Conflicting Peds, #/hr	0	0	0	0	0	0	0	0	0	0	0	0
Sign Control	Stop	Stop	Stop	Stop	Stop	Stop	Free	Free	Free	Free	Free	Free
RT Channelized	-	-	None	-	-	None	-	-	None	-	-	None
Storage Length	-	-	-	-	-	-	-	-	100	120	-	-
Veh in Median Storage, #	-	0	-	-	0	-	-	0	-	-	0	-
Grade, %	-	0	-	-	0	-	-	0	-	-	0	-
Peak Hour Factor	78	78	78	78	78	78	83	83	83	83	83	83
Heavy Vehicles, %	2	2	2	2	2	2	2	2	2	2	2	2
Mvmt Flow	31	1	10	32	4	13	12	73	54	12	71	41

Major/Minor	Minor2		Minor1		Major1		Major2					
Conflicting Flow All	249	267	92	218	233	73	112	0	0	127	0	0
Stage 1	116	116	-	97	97	-	-	-	-	-	-	-
Stage 2	133	151	-	121	136	-	-	-	-	-	-	-
Critical Hdwy	7.12	6.52	6.22	7.12	6.52	6.22	4.12	-	-	4.12	-	-
Critical Hdwy Stg 1	6.12	5.52	-	6.12	5.52	-	-	-	-	-	-	-
Critical Hdwy Stg 2	6.12	5.52	-	6.12	5.52	-	-	-	-	-	-	-
Follow-up Hdwy	3.518	4.018	3.318	3.518	4.018	3.318	2.218	-	-	2.218	-	-
Pot Cap-1 Maneuver	705	639	965	738	667	989	1478	-	-	1459	-	-
Stage 1	889	800	-	910	815	-	-	-	-	-	-	-
Stage 2	870	772	-	883	784	-	-	-	-	-	-	-
Platoon blocked, %								-	-	-	-	-
Mov Cap-1 Maneuver	684	628	965	720	656	989	1478	-	-	1459	-	-
Mov Cap-2 Maneuver	684	628	-	720	656	-	-	-	-	-	-	-
Stage 1	881	794	-	902	808	-	-	-	-	-	-	-
Stage 2	847	765	-	865	778	-	-	-	-	-	-	-

Approach	EB	WB	NB	SB
HCM Control Delay, s	10.2	10	0.6	0.7
HCM LOS	B	B		

Minor Lane/Major Mvmt	NBL	NBT	NBR	EBLn1	WBLn1	SBL	SBT	SBR
Capacity (veh/h)	1478	-	-	734	769	1459	-	-
HCM Lane V/C Ratio	0.008	-	-	0.058	0.063	0.008	-	-
HCM Control Delay (s)	7.5	0	-	10.2	10	7.5	0	-
HCM Lane LOS	A	A	-	B	B	A	A	-
HCM 95th %tile Q(veh)	0	-	-	0.2	0.2	0	-	-

Intersection						
Int Delay, s/veh	0.3					
Movement	EBL	EBR	NBL	NBT	SBT	SBR
Lane Configurations						
Traffic Vol, veh/h	7	2	2	152	10	190
Future Vol, veh/h	7	2	2	152	10	190
Conflicting Peds, #/hr	0	0	0	0	0	0
Sign Control	Stop	Stop	Free	Free	Free	Free
RT Channelized	-	None	-	None	-	None
Storage Length	0	-	-	-	-	-
Veh in Median Storage, #	0	-	-	0	0	-
Grade, %	0	-	-	0	0	-
Peak Hour Factor	78	78	87	87	87	87
Heavy Vehicles, %	2	2	2	2	2	2
Mvmt Flow	9	3	2	175	11	218

Major/Minor	Minor2	Major1	Major2			
Conflicting Flow All	299	120	229	0	-	0
Stage 1	120	-	-	-	-	-
Stage 2	179	-	-	-	-	-
Critical Hdwy	6.42	6.22	4.12	-	-	-
Critical Hdwy Stg 1	5.42	-	-	-	-	-
Critical Hdwy Stg 2	5.42	-	-	-	-	-
Follow-up Hdwy	3.518	3.318	2.218	-	-	-
Pot Cap-1 Maneuver	692	931	1339	-	-	-
Stage 1	905	-	-	-	-	-
Stage 2	852	-	-	-	-	-
Platoon blocked, %				-	-	-
Mov Cap-1 Maneuver	691	931	1339	-	-	-
Mov Cap-2 Maneuver	691	-	-	-	-	-
Stage 1	903	-	-	-	-	-
Stage 2	852	-	-	-	-	-

Approach	EB	NB	SB
HCM Control Delay, s	10	0.1	0
HCM LOS	B		

Minor Lane/Major Mvmt	NBL	NBT	EBLn1	SBT	SBR
Capacity (veh/h)	1339	-	733	-	-
HCM Lane V/C Ratio	0.002	-	0.016	-	-
HCM Control Delay (s)	7.7	0	10	-	-
HCM Lane LOS	A	A	B	-	-
HCM 95th %tile Q(veh)	0	-	0	-	-

Intersection												
Int Delay, s/veh	5.6											
Movement	EBL	EBT	EBR	WBL	WBT	WBR	NBL	NBT	NBR	SBL	SBT	SBR
Lane Configurations	↔	↑	↗	↖	↗	↖		↖	↗		↔	
Traffic Vol, veh/h	10	510	165	34	245	5	127	0	32	5	0	5
Future Vol, veh/h	10	510	165	34	245	5	127	0	32	5	0	5
Conflicting Peds, #/hr	0	0	0	0	0	0	0	0	0	0	0	0
Sign Control	Free	Free	Free	Free	Free	Free	Stop	Stop	Stop	Stop	Stop	Stop
RT Channelized	-	-	None	-	-	None	-	-	None	-	-	None
Storage Length	232	-	182	172	-	-	-	-	155	-	-	-
Veh in Median Storage, #	-	0	-	-	0	-	-	0	-	-	0	-
Grade, %	-	0	-	-	0	-	-	0	-	-	0	-
Peak Hour Factor	93	93	93	92	92	92	87	87	87	78	78	78
Heavy Vehicles, %	2	2	2	2	2	2	2	2	2	2	2	2
Mvmt Flow	11	548	177	37	266	5	146	0	37	6	0	6

Major/Minor	Major1			Major2			Minor1			Minor2		
Conflicting Flow All	271	0	0	725	0	0	916	915	548	1020	1090	269
Stage 1	-	-	-	-	-	-	570	570	-	343	343	-
Stage 2	-	-	-	-	-	-	346	345	-	677	747	-
Critical Hdwy	4.12	-	-	4.12	-	-	7.12	6.52	6.22	7.12	6.52	6.22
Critical Hdwy Stg 1	-	-	-	-	-	-	6.12	5.52	-	6.12	5.52	-
Critical Hdwy Stg 2	-	-	-	-	-	-	6.12	5.52	-	6.12	5.52	-
Follow-up Hdwy	2.218	-	-	2.218	-	-	3.518	4.018	3.318	3.518	4.018	3.318
Pot Cap-1 Maneuver	1292	-	-	878	-	-	253	273	536	215	215	770
Stage 1	-	-	-	-	-	-	506	505	-	672	637	-
Stage 2	-	-	-	-	-	-	670	636	-	443	420	-
Platoon blocked, %	-	-	-	-	-	-	-	-	-	-	-	-
Mov Cap-1 Maneuver	1292	-	-	878	-	-	241	259	536	193	204	770
Mov Cap-2 Maneuver	-	-	-	-	-	-	241	259	-	193	204	-
Stage 1	-	-	-	-	-	-	501	500	-	666	610	-
Stage 2	-	-	-	-	-	-	636	609	-	409	416	-

Approach	EB			WB			NB			SB		
HCM Control Delay, s	0.1			1.1			34.8			17.2		
HCM LOS							D			C		

Minor Lane/Major Mvmt	NBLn1	NBLn2	EBL	EBT	EBR	WBL	WBT	WBR	SBLn1
Capacity (veh/h)	241	536	1292	-	-	878	-	-	309
HCM Lane V/C Ratio	0.606	0.069	0.008	-	-	0.042	-	-	0.041
HCM Control Delay (s)	40.5	12.2	7.8	-	-	9.3	-	-	17.2
HCM Lane LOS	E	B	A	-	-	A	-	-	C
HCM 95th %tile Q(veh)	3.5	0.2	0	-	-	0.1	-	-	0.1