

INTERMEDIATE TRAFFIC IMPACT STUDY

For

Iron Ridge
El Paso County, Colorado
PCD File No. P2511 and SP253

August 2025
Revised November 2025

Prepared for:

Atticus Land, LLC
PO Box 88010
Colorado Springs, Colorado 80908

Prepared by:



SM ROCHA, LLC

TRAFFIC & TRANSPORTATION ENGINEERING CONSULTANTS

8700 Turnpike Drive, Suite 240
Westminster, Colorado 80031
(303) 458-9798

6 South Tejon Street, Suite 618
Colorado Springs, Colorado 80903
(719) 203-6639

Project Manager:
Brandon Wilson, EIT

Project Engineer:
Zac Trotter, EIT

Engineer in Responsible Charge:
Fred Lantz, PE

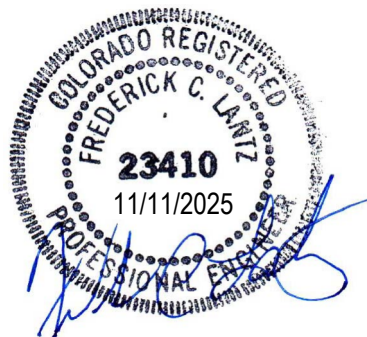

25-052409

Traffic Engineer's Statement

The attached traffic report and supporting information were prepared under my responsible charge and they comport with the standard of care. So far as is consistent with the standard of care, said report was prepared in general conformance with the criteria established by the County for traffic reports.



11/11/2025

Fred Lantz, P.E. #23410

Date

Developer's Statement

I, the Developer, have read and will comply with all commitments made on my behalf within this report.

Jake Decoto
Atticus Land, LLC
PO Box 88010
Colorado Springs, Colorado 80908

Date

Table of Contents

I. Introduction 1

 Project Overview..... 1

 Study Area Boundaries 1

 Site Description..... 1

 Existing and Committed Surface Transportation Network.....4

II. Existing Traffic Conditions 5

 Peak Hour Intersection Levels of Service – Existing Traffic.....7

 Existing Traffic Analysis Results7

III. Future Traffic Conditions Without Proposed Development.....8

 Peak Hour Intersection Levels of Service – Background Traffic 10

 Background Traffic Analysis Results – Year 2027 10

IV. Proposed Project Traffic 11

 Trip Generation..... 11

 Adjustments to Trip Generation Rates 12

 Trip Distribution..... 12

 Trip Assignment..... 12

V. Future Traffic Conditions With Proposed Development..... 14

 Total Traffic Auxiliary Lane Analysis 14

 Peak Hour Intersection Levels of Service – Total Traffic 16

 Total Traffic Analysis Results Upon Development Build-Out 16

VI. Project Impacts 17

 Queue Length Analysis..... 17

 Sight Distance Analysis 18

 Development Impacts 18

 Recommended Improvements 18

VII. Conclusion 19

List of Figures

Figure 1 – Location.....2
Figure 2 – Preliminary Land Plan3
Figure 3 – Existing Traffic Volumes & Intersection Geometry6
Figure 4 – Background Traffic Volumes & Intersection Geometry – Year 2027.....9
Figure 5 – Distribution and Site-Generated Assignment..... 13
Figure 6 – Total Traffic Volumes & Intersection Geometry – Year 2027 15

List of Tables

Table 1 – Intersection Capacity Analysis Summary – Existing Traffic7
Table 2 – Intersection Capacity Analysis Summary – Background Traffic – Year 2027 10
Table 3 – Trip Generation Rates 11
Table 4 – Trip Generation Summary 11
Table 5 – Intersection Capacity Analysis Summary – Total Traffic – Year 2027 16
Table 6 – Turn Lane Queues and Storage Requirements – Total Traffic – Year 2027 17

Appendices

APPENDIX A TRAFFIC COUNT DATA
APPENDIX B LEVEL OF SERVICE DEFINITIONS
APPENDIX C CAPACITY WORKSHEETS
APPENDIX D SIGHT DISTANCE EXHIBIT

I. Introduction

Project Overview

This Intermediate Traffic Impact Study is provided as a planning document and addresses the capacity, geometric, and control requirements associated with the development entitled Iron Ridge. This analysis was prepared in accordance with Appendix B of the County's Engineering Criteria Manual (ECM)¹.

This traffic impact study has been revised to address County review comments made to the August 2025 version of this study regarding a sight distance evaluation, discussion of Stepler Road, and updates to study text, tables, and figures throughout.

This proposed residential development is located south of Walker Road and west of Thompson Road in El Paso County, Colorado.

Study Area Boundaries

The study area to be examined in this analysis encompasses the Walker Road intersections bounded by Brown Road east to Thompson Road.

Figure 1 illustrates location of the site and study intersections.

Site Description

Land for the development is currently vacant and surrounded by residential land uses.

The proposed development is understood to entail the new construction of 30 single-family detached homes.

Access to the development is provided at the following locations: one proposed full-movement access onto Walker Road aligning with Brown Road (referred to as Access A) and one existing full-movement access onto Walker Road via an extension of Colt Court. This extension will also provide access to the adjacent out-parcel. Both access drives will operate independently from the other and each provide access to 15 residential lots.

For purposes of this study, it is anticipated that development construction would be completed by end of Year 2027.

General site and access locations are shown on Figure 1. A preliminary land plan, as prepared by All Terrain Engineering, is shown in Figure 2. This plan is provided for illustrative purposes only.

¹ El Paso County Engineering Criteria Manual, El Paso County, January 9, 2025.

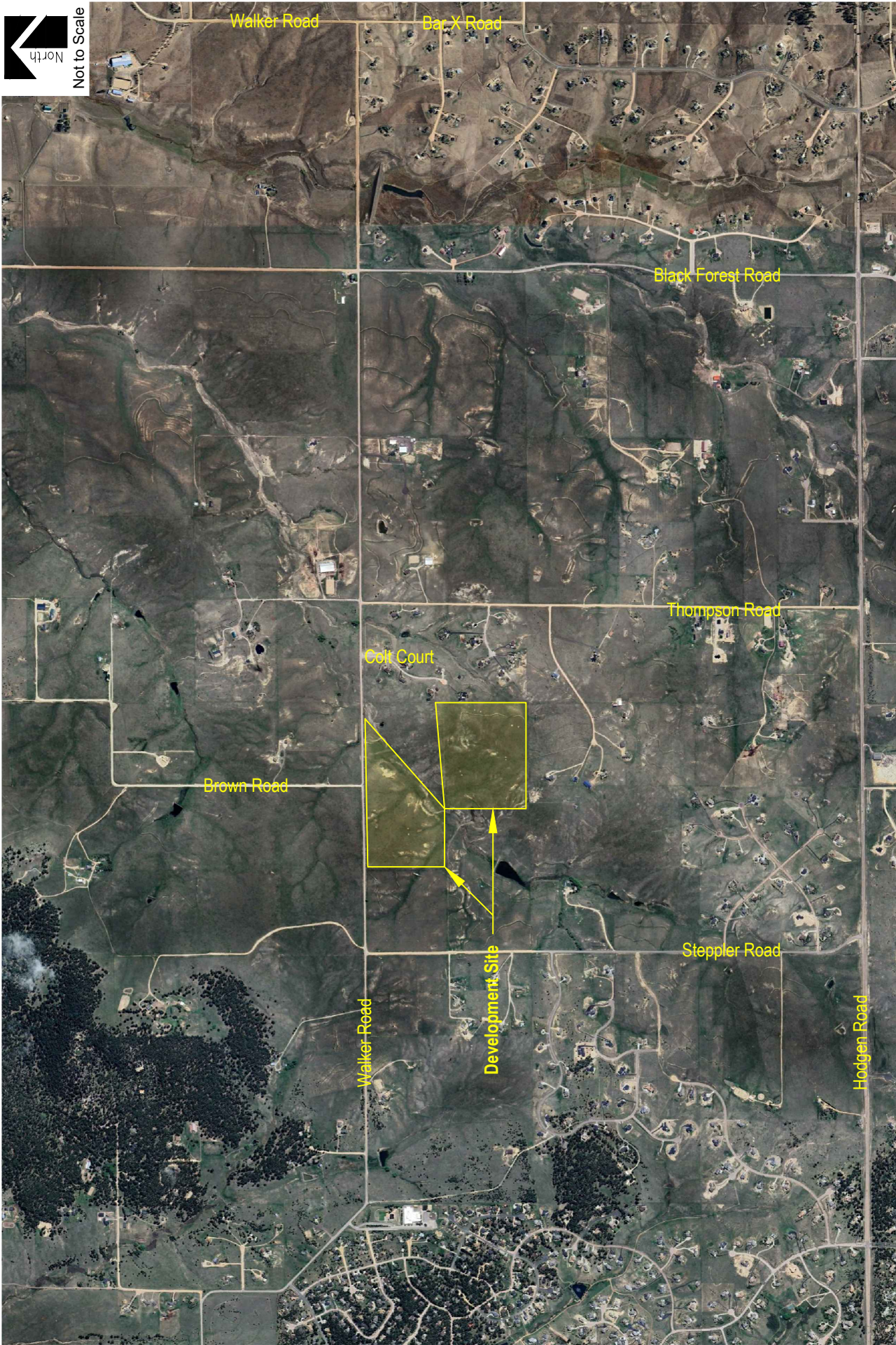

Figure 1
SITE LOCATION



Existing and Committed Surface Transportation Network

Within the study area, regional access to the proposed development area is provided by way of Walker Road and Thompson Road while local access is provided via Colt Court and Brown Road. A brief description of each roadway, based on the County's Master Transportation Corridor Plan (MTCP)² and the County's ECM, is provided below:

Walker Road is an east-west rural major collector roadway having two through lanes (one lane in each direction) with shared turn lanes at the intersections within the study area. Walker Road provides a posted speed limit of 45 MPH.

Thompson Road is a north-south rural local roadway having two through lanes (one lane in each direction) with shared turn lanes at the intersection within the study area. Thompson Road provides a posted speed limit of 30 MPH.

Colt Court is a north-south rural local roadway having two through lanes (one lane in each direction) with shared turn lanes at the intersection within the study area. Pursuant to Section 2.3.2 of the County's ECM, Colt Court is assumed to provide a posted speed limit of 30 MPH.

Brown Road is a north-south rural local roadway having two through lanes (one lane in each direction) with shared turn lanes at the intersection within the study area. Pursuant to Section 2.3.2 of the County's ECM, Brown Road is assumed to provide a posted speed limit of 30 MPH.

Steppler Road is a north-south rural local roadway having two through lanes (one lane in each direction) with shared turn lanes. Pursuant to Section 2.3.2 of the County's ECM, Steppler Road is assumed to provide a posted speed limit of 30 mph. Steppler Road is unpaved for an approximate ½ mile stretch south of Walker Road while the remainder of Steppler Road is paved.

All study intersections operate under a stop-controlled condition. A stop-controlled intersection is defined as a roadway intersection where vehicle rights-of-way are controlled by one or more "STOP" signs.

No regional or specific improvements for the above-described roadways are known to be planned or committed at this time. The study area roadways appear to be built to their ultimate cross-sections.

² El Paso County Major Transportation Corridors Plan, Felsburg Holt & Ullevig, July 18, 2024.

II. Existing Traffic Conditions

Morning (AM) and afternoon (PM) peak hour traffic counts were collected at the Walker Road intersections with Thompson Road, Colt Court, and Brown Road. Average daily traffic (ADT) volumes were collected over a 24-hour period on Walker Road. Counts were collected on Tuesday July 15, 2025, with AM peak hour counts being collected during the period of 7:00 a.m. to 9:00 a.m. and PM peak hour counts being collected during the period of 4:00 p.m. to 6:00 p.m.

Existing volumes and intersection geometry are shown in Figure 3. Traffic count data is included for reference in Appendix A.



Not to Scale

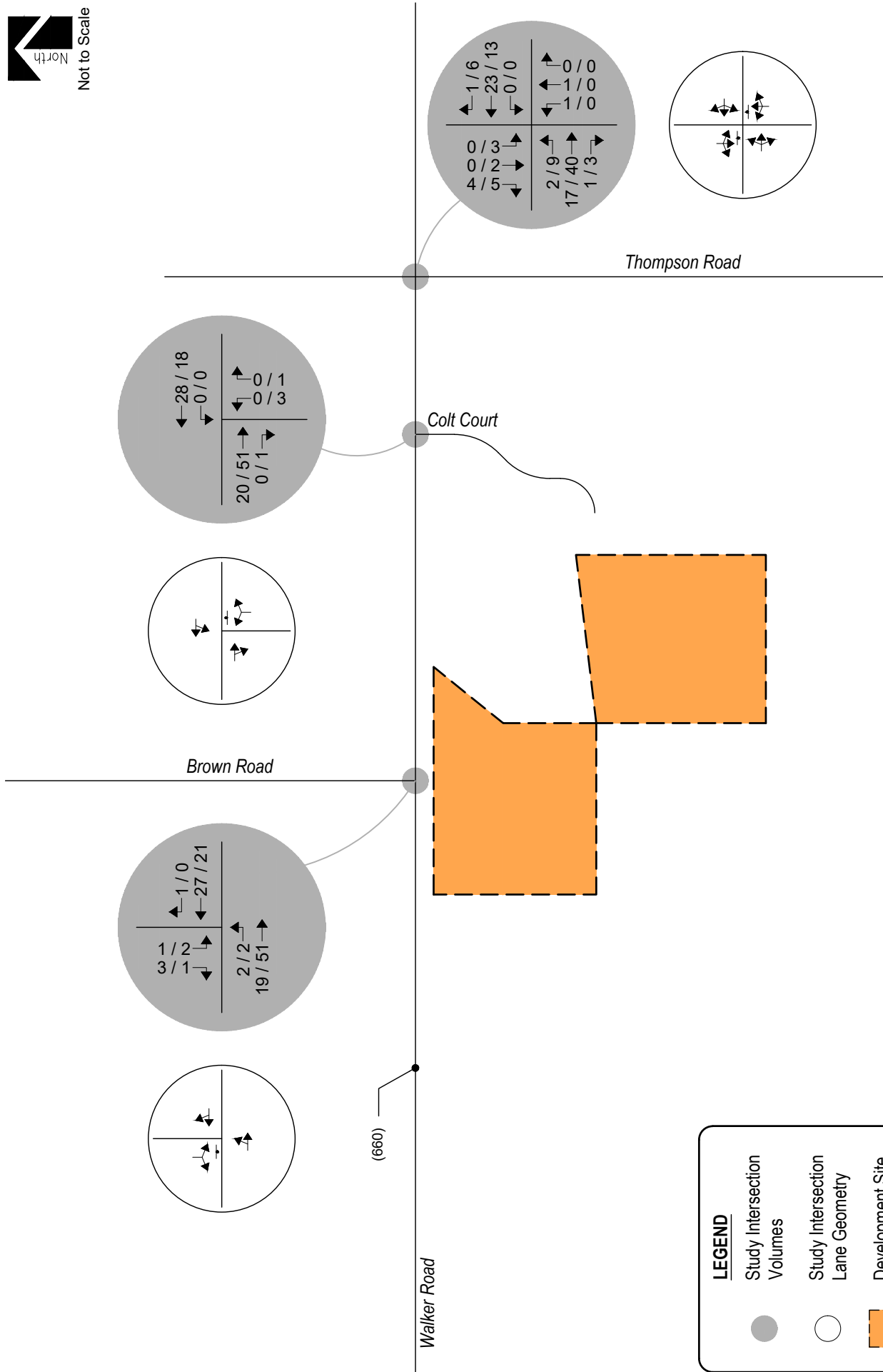

LEGEND

- Study Intersection Volumes
- Study Intersection Lane Geometry
- Development Site

Figure 3
EXISTING TRAFFIC
 Volumes & Intersection Geometry
 AM / PM Peak Traffic Hour
 (ADT) : Average Daily Traffic

IRON RIDGE
 Intermediate Traffic Impact Study



SM ROCHA, LLC
 Traffic & Transportation Engineering Consultants

Peak Hour Intersection Levels of Service – Existing Traffic

The Unsignalized Intersection Analysis technique, as published in the Highway Capacity Manual (HCM), 7th Edition, by the Transportation Research Board and as incorporated into the SYNCHRO computer program, was used to analyze the study intersections for existing and future traffic conditions. This nationally accepted technique allows for the determination of intersection level of service (LOS) based on the congestion and delay of each traffic movement.

Pursuant to Section B.4.1.A of the County’s ECM, the design objective for each scenario of this study shall be level of service “D”. Level of service is a method of measurement used by transportation professionals to quantify a driver’s perception of travel conditions that include travel time, number of stops, and total amount of stopped delay experienced on a roadway network. The HCM categorizes level of service into a range from “A” which indicates little, if any, vehicle delay, to “F” which indicates a level of operation considered unacceptable to most drivers. These levels of service grades with brief descriptions of the operating condition, for unsignalized and signalized intersections, are included for reference in Appendix B and have been used throughout this study.

The level of service analyses results for existing conditions are summarized in Table 1.

Intersection capacity worksheets developed for this study are provided in Appendix C.

Table 1 – Intersection Capacity Analysis Summary – Existing Traffic

| INTERSECTION LANE GROUPS | LEVEL OF SERVICE | |
|---|------------------|------------------|
| | AM PEAK HOUR | PM PEAK HOUR |
| Walker Road / Thompson Road (Stop-Controlled) Eastbound Left, Through and Right Westbound Left, Through and Right Northbound Left, Through and Right Southbound Left, Through and Right | A A A A | A A A A |
| Walker Road / Colt Court (Stop-Controlled) Westbound Left and Through Northbound Left and Right | A A | A A |
| Walker Road / Brown Road (Stop-Controlled) Eastbound Left and Through Southbound Left and Right | A A | A A |

Key: Stop-Controlled Intersection: Level of Service

Existing Traffic Analysis Results

Under existing conditions, operational analysis shows the unsignalized intersections within the study area have turning movement operations at LOS A during the morning and afternoon peak traffic hours.

III. Future Traffic Conditions Without Proposed Development

Background traffic is the traffic projected to be on area roadways without consideration of the proposed development. Background traffic includes traffic generated by development of vacant parcels in the area.

To account for projected increases in background traffic for Year 2027, a compounded annual growth rate was determined using population growth estimates provided by El Paso County's MTCP which anticipates a 10-year growth rate between one and two percent. Therefore, an annual growth rate of two percent was applied to existing traffic volumes. This annual growth rate provides for a conservative analysis.

It is important to note that ingress and egress traffic volumes at the Walker Road intersections with Colt Court and Brown Road are not subject to annual growth patterns since these access drives do not provide connection to other roadways, therefore do not serve regional traffic.

Pursuant to the area roadway improvements discussed in Section I, Year 2027 background traffic conditions assume no roadway improvements to accommodate regional transportation demands.

Projected background traffic volumes and intersection geometry for Year 2027 are shown in Figure 4.



Not to Scale

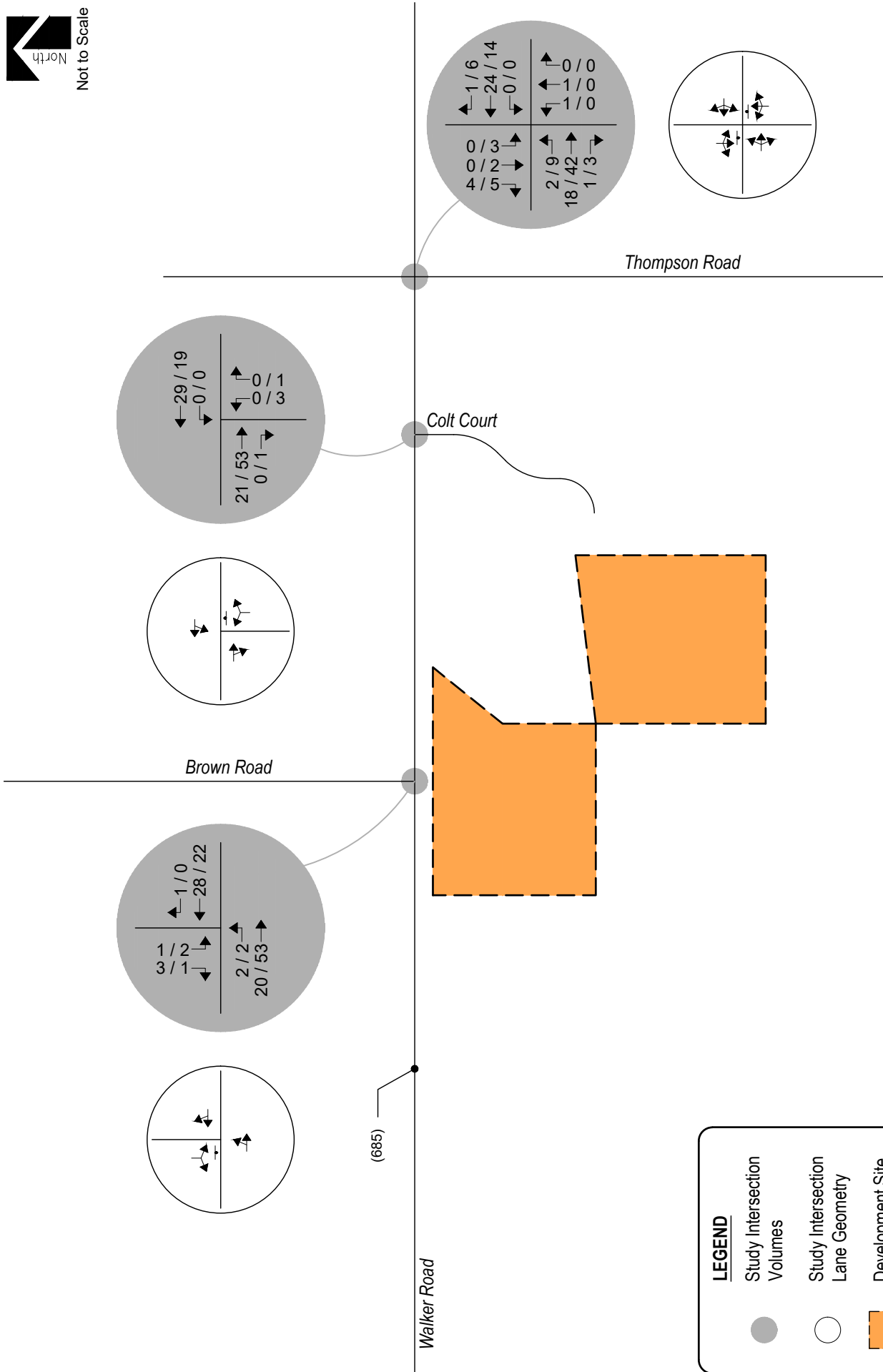

LEGEND

- Study Intersection Volumes
- Study Intersection Lane Geometry
- ▭ Development Site

Figure 4
BACKGROUND TRAFFIC - YEAR 2027
 Volumes & Intersection Geometry
 AM / PM Peak Traffic Hour
 (ADT) : Average Daily Traffic

IRON RIDGE
 Intermediate Traffic Impact Study



SM ROCHA, LLC
 Traffic & Transportation Engineering Consultants

Peak Hour Intersection Levels of Service – Background Traffic

As with existing traffic conditions, the operations of study intersections were analyzed under background conditions, without the proposed development, using the SYNCHRO computer program.

Background traffic level of service analysis results for Year 2027 are listed in Table 2.

Definitions of levels of service are given in Appendix B. Intersection capacity worksheets are provided in Appendix C.

Table 2 – Intersection Capacity Analysis Summary – Background Traffic – Year 2027

| INTERSECTION LANE GROUPS | LEVEL OF SERVICE | |
|---|------------------|------------------|
| | AM PEAK HOUR | PM PEAK HOUR |
| Walker Road / Thompson Road (Stop-Controlled) Eastbound Left, Through and Right Westbound Left, Through and Right Northbound Left, Through and Right Southbound Left, Through and Right | A A A A | A A A A |
| Walker Road / Colt Court (Stop-Controlled) Westbound Left and Through Northbound Left and Right | A A | A A |
| Walker Road / Brown Road (Stop-Controlled) Eastbound Left and Through Southbound Left and Right | A A | A A |

Key: Stop-Controlled Intersection: Level of Service

Background Traffic Analysis Results – Year 2027

Year 2027 background traffic analysis indicates that the unsignalized intersections within the study area are expected to provide turning movement operations at LOS A during the morning and afternoon peak traffic hours.

These intersection operations are similar to existing conditions.

IV. Proposed Project Traffic

Trip Generation

Standard traffic generation characteristics compiled by the Institute of Transportation Engineers (ITE) in their report entitled Trip Generation Manual, 11th Edition, were applied to the proposed land use in order to estimate average daily traffic (ADT), AM Peak Hour, and PM Peak Hour vehicle trips. A vehicle trip is defined as a one-way vehicle movement from a point of origin to a point of destination.

The ITE land use code 210 (Single-Family Detached Housing) was used for estimating trip generation because of its conservative rates and best fit to the proposed land use description.

Trip generation rates used in this study are presented in Table 3.

Table 3 – Trip Generation Rates

| ITE CODE | LAND USE | UNIT | TRIP GENERATION RATES | | | | | | |
|----------|--------------------------------|------|-----------------------|--------------|------|-------|--------------|------|-------|
| | | | 24 HOUR | AM PEAK HOUR | | | PM PEAK HOUR | | |
| | | | | ENTER | EXIT | TOTAL | ENTER | EXIT | TOTAL |
| 210 | Single-Family Detached Housing | DU | 9.43 | 0.18 | 0.53 | 0.70 | 0.59 | 0.35 | 0.94 |

Key: DU = Dwelling Units.

Note: All data and calculations above are subject to being rounded to nearest value.

Table 4 illustrates projected ADT, AM Peak Hour, and PM Peak Hour traffic volumes likely generated by the proposed development upon build-out.

Table 4 – Trip Generation Summary

| ITE CODE | LAND USE | SIZE | TOTAL TRIPS GENERATED | | | | | | |
|---------------|--------------------------------|-------|-----------------------|--------------|------|-------|--------------|------|-------|
| | | | 24 HOUR | AM PEAK HOUR | | | PM PEAK HOUR | | |
| | | | | ENTER | EXIT | TOTAL | ENTER | EXIT | TOTAL |
| 210 | Single-Family Detached Housing | 30 DU | 283 | 5 | 16 | 21 | 18 | 10 | 28 |
| <i>Total:</i> | | | 283 | 5 | 16 | 21 | 18 | 10 | 28 |

Key: DU = Dwelling Units.

Note: All data and calculations above are subject to being rounded to nearest value.

Upon build-out, Table 4 illustrates that the proposed development has the potential to generate approximately 283 daily vehicle trips with 21 of those occurring during the morning peak hour and 28 during the afternoon peak hour.

Adjustments to Trip Generation Rates

A development of this type is not likely to attract trips from within area land uses nor pass-by or diverted link trips from the adjacent roadway system, therefore no trip reduction was taken in this analysis.

Trip Distribution

The overall directional distribution of site-generated traffic was determined based on the location of development site within the County, proposed and existing area land uses, allowed turning movements, available roadway network, and in reference to historical traffic count data provided by the Colorado Department of Transportation’s (CDOT) Traffic Count Database System³ (TCDS).

Overall trip distribution patterns for the development are shown on Figure 5.

Trip Assignment

Trip assignment is how generated and distributed vehicle trips are expected to be loaded onto the available roadway network.

Applying trip distribution patterns to site-generated traffic provides the overall site-generated trip assignments shown on Figure 5.

³ Transportation Data Management System, MS2, 2022.



Not to Scale

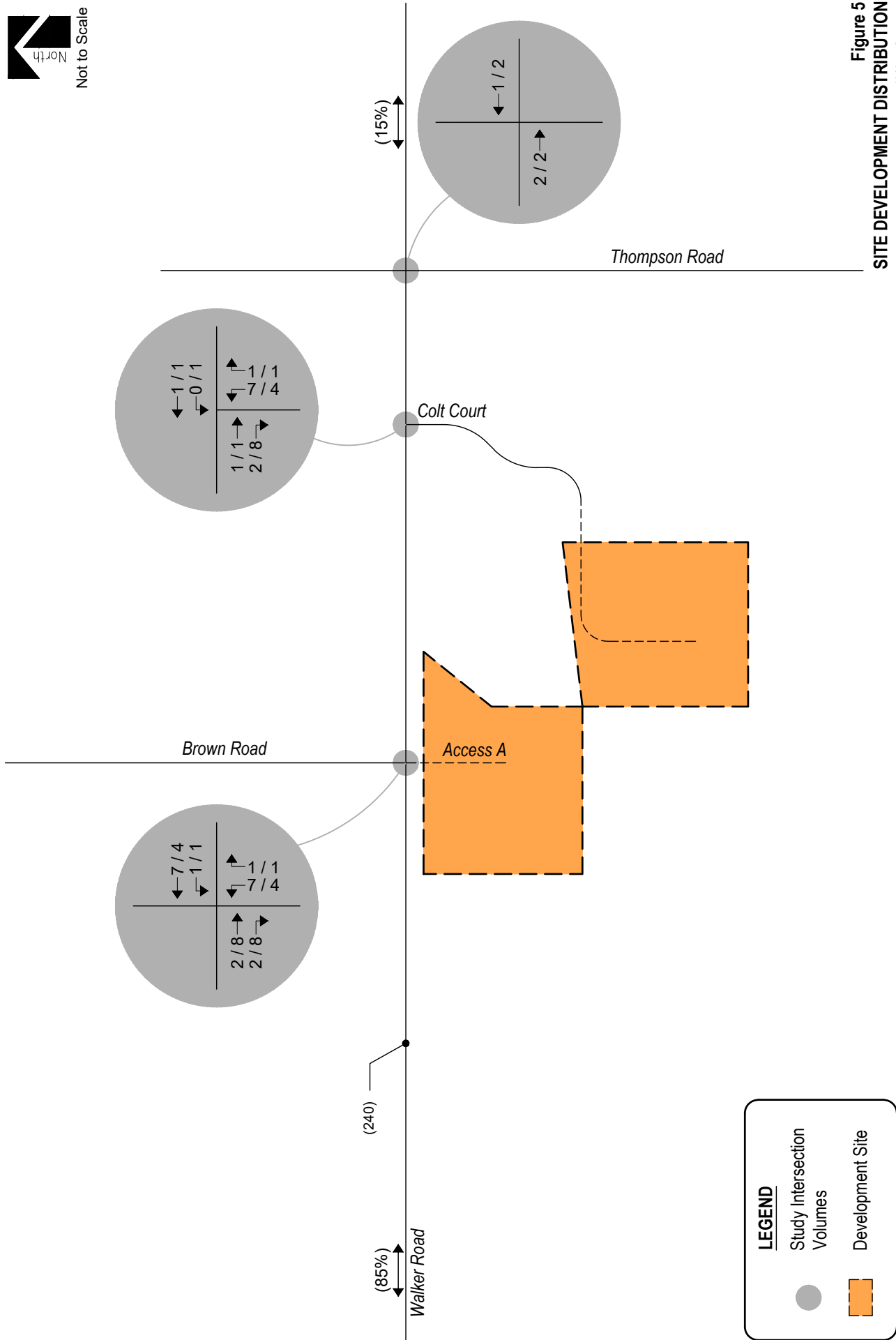

LEGEND

- Study Intersection
- Volumes
- Development Site

Figure 5
SITE DEVELOPMENT DISTRIBUTION

(%) : Overall

SITE-GENERATED TRIPS

AM / PM Peak Hour

(ADT) : Average Daily Traffic

IRON RIDGE
Intermediate Traffic Impact Study



SM ROCHA, LLC

Traffic & Transportation Engineering Consultants

V. Future Traffic Conditions With Proposed Development

Total traffic is the traffic projected to be on area roadways with consideration of the proposed development. Total traffic includes background traffic projections for Year 2027 with consideration of site-generated traffic. For analysis purposes, it was assumed that development construction would be completed by end of Year 2027.

Pursuant to area roadway improvement discussions provided in Section III, Year 2027 total traffic conditions assume no roadway improvements to accommodate regional transportation demands. This assumption provides for a conservative analysis. Roadway improvements associated with site development are expected to be limited to site access and frontage as required by the governing agency.

Total Traffic Auxiliary Lane Analysis

Auxiliary lanes for site development access drives were evaluated and are to be based on the County's ECM.

Considering development build-out, an evaluation of auxiliary lane requirements, pursuant to Section 2.3.7.D of the County's ECM indicates that westbound left turn deceleration lanes are not required along Walker Road at Colt Court nor Access A since the development projected peak hour left turn ingress volume does not exceed the County's threshold of 25 vehicles per hour (vph). Additionally, eastbound right turn deceleration lanes are not required along Walker Road at Colt Court nor Access A since the development's projected peak hour right turn ingress volume does not exceed the County's threshold of 50 vph.

Projected Year 2027 total traffic volumes and intersection geometry are shown in Figure 6.



Not to Scale

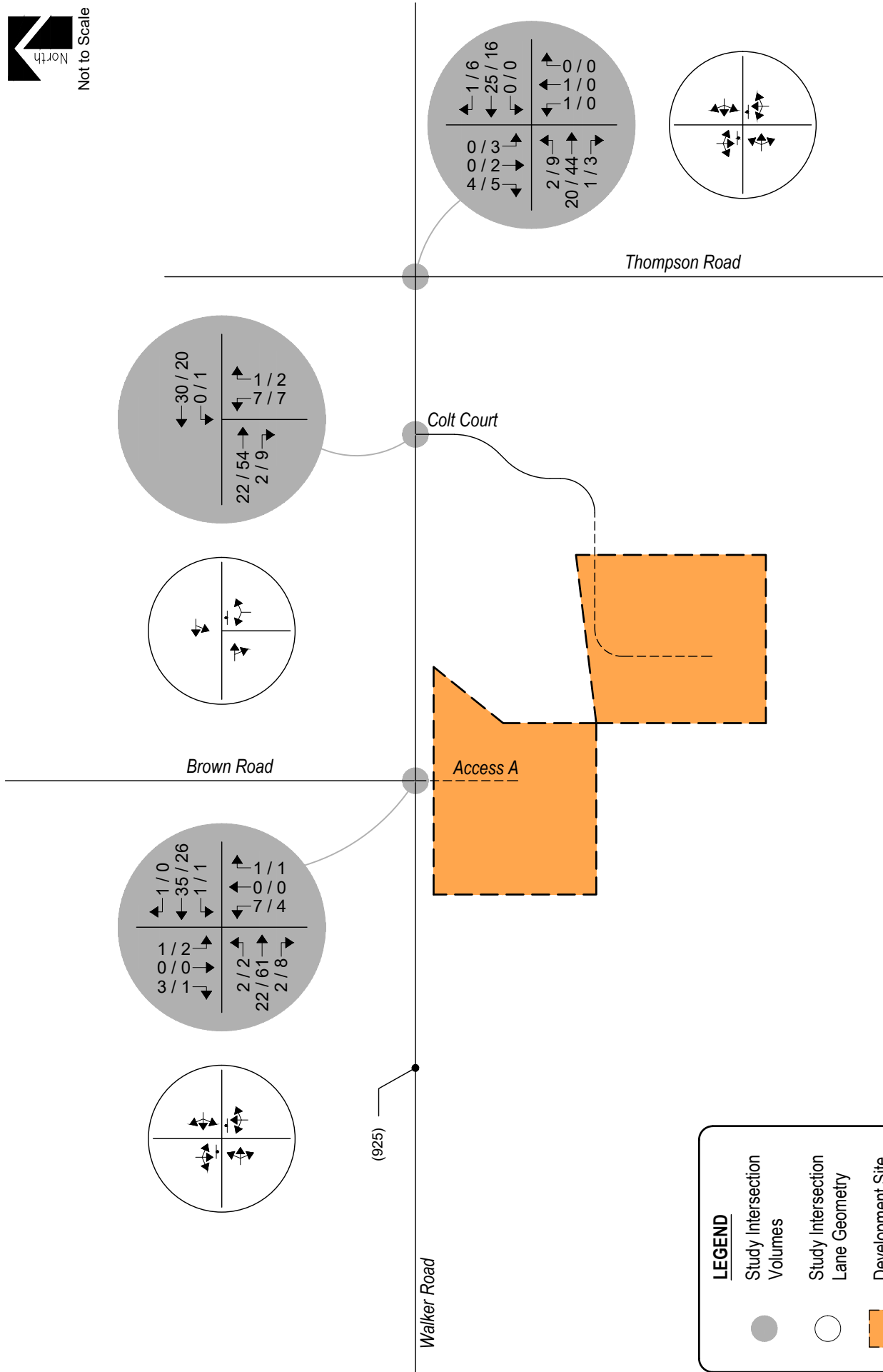

LEGEND

- Study Intersection Volumes
- Study Intersection Lane Geometry
- Development Site

Figure 6
TOTAL TRAFFIC - YEAR 2027
 Volumes & Intersection Geometry
 AM / PM Peak Traffic Hour
 (ADT) : Average Daily Traffic

IRON RIDGE
 Intermediate Traffic Impact Study



SM ROCHA, LLC
 Traffic & Transportation Engineering Consultants

Peak Hour Intersection Levels of Service – Total Traffic

As with background traffic, the operations of the study intersections were analyzed under projected total traffic conditions using the SYNCHRO computer program. The analyses and procedures were performed in accordance with the latest HCM and are based upon the worst-case conditions that occur during a typical weekday upon build-out of site development and analyzed land uses. Therefore, study intersections are likely to operate with traffic conditions better than those described within this study, which represent the peak hours of weekday operations only.

Total traffic level of service analysis results for Years 2027 are summarized in Table 5.

Definitions of levels of service are given in Appendix B. Intersection capacity worksheets are provided in Appendix C.

Table 5 – Intersection Capacity Analysis Summary – Total Traffic – Year 2027

| INTERSECTION LANE GROUPS | LEVEL OF SERVICE | |
|---|------------------|--------------|
| | AM PEAK HOUR | PM PEAK HOUR |
| Walker Road / Thompson Road (Stop-Controlled) | | |
| Eastbound Left, Through and Right | A | A |
| Westbound Left, Through and Right | A | A |
| Northbound Left, Through and Right | A | A |
| Southbound Left, Through and Right | A | A |
| Walker Road / Colt Court (Stop-Controlled) | | |
| Westbound Left and Through | A | A |
| Northbound Left and Right | A | A |
| Walker Road / Brown Road (Stop-Controlled) | | |
| Eastbound Left and Through | A | A |
| Southbound Left and Right | A | A |

Key: Stop-Controlled Intersection: Level of Service

Total Traffic Analysis Results Upon Development Build-Out

Table 5 illustrates how, by Year 2027 and upon development build-out, the unsignalized intersections within the study area are expected to maintain turning movement operations at LOS A during the morning and afternoon peak traffic hours.

These intersection operations are similar to background conditions.

VI. Project Impacts

It is emphasized that the analyses and procedures described in this study were performed in accordance with the latest HCM and are based upon the worst-case conditions that occur during a typical weekday upon build-out of site development and analyzed land uses. Therefore, study intersections are likely to operate with traffic conditions better than those described within this study, which represent the peak hours of weekday operations only.

Queue Length Analysis

Queue lengths for the study intersections were analyzed using Year 2027 background and total traffic conditions. The analysis yields estimate of 95th percentile queue lengths, which have only a five percent probability of being exceeded during the analysis time period. An average vehicle length of 25 feet was assumed. Queue lengths were modeled and are included with the Synchro worksheets in Appendix C.

Table 6 summarizes the 95th percentile queue results in comparison to the projected storage requirements for turn movements within study area for Year 2027.

Table 6 – Turn Lane Queues and Storage Requirements – Total Traffic – Year 2027

| Intersection | Turn Movement | | Existing Turn Lane Length (feet) | Background 2027 | | Total 2027 | | Recommended Turn Lane Length (feet) |
|-------------------------------------|---------------|-------|----------------------------------|---------------------|---------------------|---------------------|---------------------|-------------------------------------|
| | | | | AM Peak Hour (feet) | PM Peak Hour (feet) | AM Peak Hour (feet) | PM Peak Hour (feet) | |
| Stop-Controlled Intersections | | | | | | | | |
| Walker Road / Thompson Road | EB | L,T,R | - | 0' | 0' | 0' | 0' | - |
| | WB | L,T,R | - | 0' | 0' | 0' | 0' | - |
| | NB | L,T,R | - | 0' | 0' | 0' | 0' | - |
| | SB | L,T,R | - | 0' | 0' | 0' | 0' | - |
| Walker Road / Colt Court | EB | L,T | - | 0' | 0' | 0' | 0' | - |
| | WB | T,R | - | 0' | 0' | 0' | 0' | - |
| | NB | L,R | - | 0' | 0' | 0' | 0' | - |
| Walker Road / Brown Road / Access A | EB | L,T,R | - | 0' | 0' | 0' | 0' | - |
| | WB | L,T,R | - | 0' | 0' | 0' | 0' | - |
| | NB | L,T,R | - | - | - | 0' | 0' | - |
| | SB | L,T,R | - | 0' | 0' | 0' | 0' | - |

Note: Turn Lane Length does not include taper length.

As Table 6 shows, no vehicular queues are projected at the study area intersections.

Sight Distance Analysis

Sight distance lengths for Access A and Colt Court were analyzed using Section 2.3, Table 2-21 of the County's ECM.

Considering the land use of the proposed development, the posted speed limit along Walker Road, and the roadway geometry along Walker Road, Access A must provide an entering sight distance of 555 feet. A sight distance exhibit is provided for reference in Appendix D.

Development Impacts

Analysis of future traffic conditions indicates that the addition of site-generated traffic is expected to create no negative impact to traffic operations for the existing and surrounding roadway system upon roadway and intersection control improvements assumed within this analysis. With all conservative assumptions defined in this analysis, the study intersections are projected to operate at future levels of service comparable to Year 2027 background traffic conditions.

Recommended Improvements

Roadway and intersection improvement recommendations were assessed pursuant to roadway descriptions discussed in Section I, projected peak hour traffic volumes, level of service results, projected 95th percentile queue lengths, and per requirements defined within the County's ECM.

In review of the future ADT along Walker Road, as illustrated in Figure 6 (925 vehicles trips per day), it is recommended that Walker Road continue to provide its rural major collector classification with a 90-foot right-of-way (ROW).

When considering Year 2027 total traffic conditions, no public improvements to the surrounding roadway network were identified to be needed, therefore none are being recommended with this development.

Pursuant to Section B.8 of the County's ECM, below is a list of traffic and/or transportation related deviation requests associated with the proposed Iron Ridge development:

1. Section 2.3.8 describes how cul-de-sacs shall have a minimum radius of 50 feet and a maximum length of 1,600 feet for rural conditions be designed in conformance with Figure 2-31. The maximum length of cul-de-sac shall be measured from the right-of-way of the intersecting street to the center of the cul-de-sac bulb. Hammerhead turnarounds are not permitted as permanent roadway terminations.

The proposed extension of Colt Court is proposed to be approximately 2,647 feet in length.

VII. Conclusion

This Intermediate Traffic Impact Study addressed the capacity, geometric, and control requirements associated with the development entitled Iron Ridge. This proposed residential development consists of 30 single-family detached homes. The development is located south of Walker Road and west of Thompson Road in El Paso County, Colorado.

The study area to be examined in this analysis encompassed the Walker Road intersections bounded by Brown Road east to Thompson Road.

Analysis was conducted for critical AM Peak Hour and PM Peak Hour traffic operations for existing traffic conditions, Year 2027 background traffic conditions, and Year 2027 total traffic conditions.

Analysis of existing traffic conditions indicates that all unsignalized intersections provide turning movement operations at LOS A.

Under Year 2027 background traffic conditions, operational analysis shows that all stop-controlled intersections anticipate turn movement operations at than LOS A during their respective peak traffic periods.

Analysis of future traffic conditions indicates that the addition of site-generated traffic is expected to create no negative impact to traffic operations for the existing and surrounding roadway system upon roadway and intersection control improvements assumed within this analysis. With all conservative assumptions defined in this analysis, the study intersections are projected to operate at future levels of service comparable to Year 2027 background traffic conditions. Proposed site accesses have long-term operations at LOS A during peak traffic periods and upon build-out.

APPENDIX A

Traffic Count Data

Location: 1 BROWN RD & WALKER RD AM

Date: Tuesday, July 15, 2025

Peak Hour: 07:45 AM - 08:45 AM

Peak 15-Minutes: 07:45 AM - 08:00 AM

Peak Hour - Motorized Vehicles

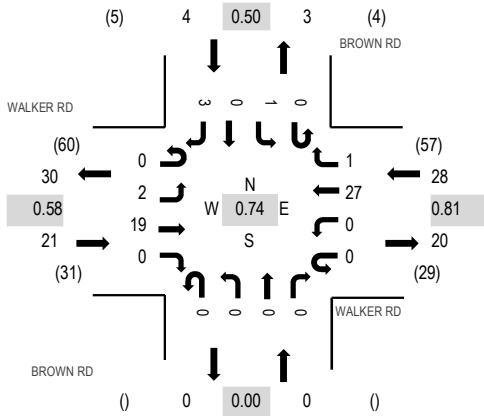

Peak Hour - Bicycles

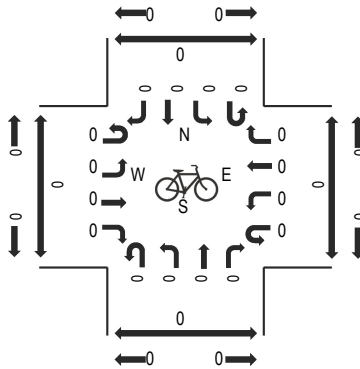

Peak Hour - Pedestrians

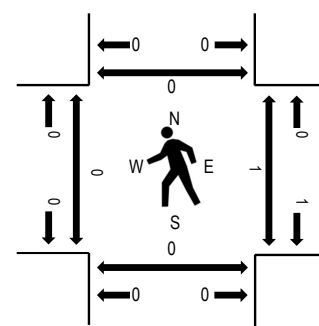

Note: Total study counts contained in parentheses.

Traffic Counts - Motorized Vehicles

| Interval Start Time | WALKER RD Eastbound | | | | WALKER RD Westbound | | | | BROWN RD Northbound | | | | BROWN RD Southbound | | | | Total | Rolling Hour | Pedestrian Crossings | | | |
|------------------------|------------------------|------|------|-------|------------------------|------|------|-------|------------------------|------|------|-------|------------------------|------|------|-------|-------|-----------------|----------------------|------|-------|-------|
| | U-Turn | Left | Thru | Right | U-Turn | Left | Thru | Right | U-Turn | Left | Thru | Right | U-Turn | Left | Thru | Right | | | West | East | South | North |
| 7:00 AM | 0 | 0 | 1 | 0 | 0 | 0 | 7 | 0 | 0 | 0 | 0 | 0 | 0 | 0 | 0 | 1 | 9 | 47 | 0 | 0 | 0 | 0 |
| 7:15 AM | 0 | 0 | 3 | 0 | 0 | 0 | 9 | 0 | 0 | 0 | 0 | 0 | 0 | 0 | 0 | 0 | 12 | 46 | 0 | 0 | 0 | 0 |
| 7:30 AM | 0 | 0 | 3 | 0 | 0 | 0 | 5 | 0 | 0 | 0 | 0 | 0 | 0 | 0 | 0 | 0 | 8 | 50 | 0 | 0 | 0 | 0 |
| 7:45 AM | 0 | 0 | 9 | 0 | 0 | 0 | 8 | 0 | 0 | 0 | 0 | 0 | 0 | 0 | 0 | 1 | 18 | 53 | 0 | 0 | 0 | 0 |
| 8:00 AM | 0 | 0 | 2 | 0 | 0 | 0 | 4 | 1 | 0 | 0 | 0 | 0 | 0 | 0 | 0 | 1 | 8 | 46 | 0 | 0 | 0 | 0 |
| 8:15 AM | 0 | 1 | 4 | 0 | 0 | 0 | 9 | 0 | 0 | 0 | 0 | 0 | 0 | 1 | 0 | 1 | 16 | | 0 | 0 | 0 | 0 |
| 8:30 AM | 0 | 1 | 4 | 0 | 0 | 0 | 6 | 0 | 0 | 0 | 0 | 0 | 0 | 0 | 0 | 0 | 11 | | 0 | 1 | 0 | 0 |
| 8:45 AM | 0 | 1 | 2 | 0 | 0 | 0 | 8 | 0 | 0 | 0 | 0 | 0 | 0 | 0 | 0 | 0 | 11 | | 0 | 0 | 0 | 0 |
| Count Total | 0 | 3 | 28 | 0 | 0 | 0 | 56 | 1 | 0 | 0 | 0 | 0 | 0 | 1 | 0 | 4 | 93 | | 0 | 1 | 0 | 0 |
| Peak Hour | 0 | 2 | 19 | 0 | 0 | 0 | 27 | 1 | 0 | 0 | 0 | 0 | 0 | 1 | 0 | 3 | 53 | | 0 | 1 | 0 | 0 |

Location: 1 BROWN RD & WALKER RD PM

Date: Tuesday, July 15, 2025

Peak Hour: 04:15 PM - 05:15 PM

Peak 15-Minutes: 04:45 PM - 05:00 PM

Peak Hour - Motorized Vehicles

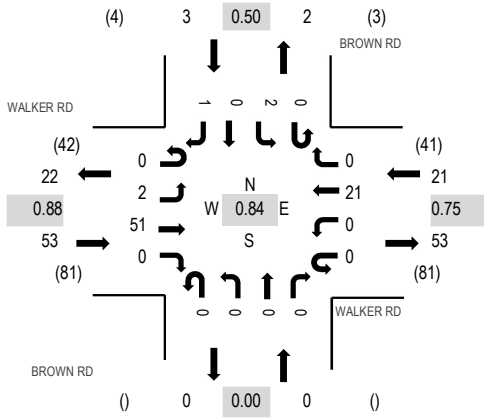

Peak Hour - Bicycles

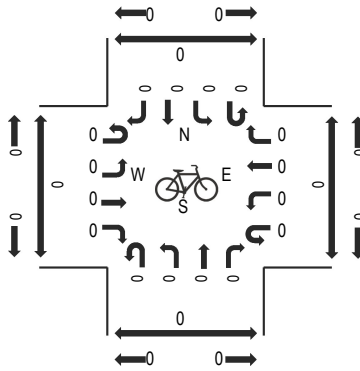

Peak Hour - Pedestrians

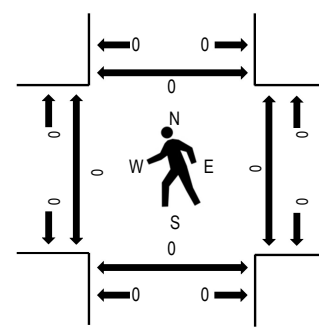

Note: Total study counts contained in parentheses.

Traffic Counts - Motorized Vehicles

| Interval Start Time | WALKER RD Eastbound | | | | WALKER RD Westbound | | | | BROWN RD Northbound | | | | BROWN RD Southbound | | | | Total | Rolling Hour | Pedestrian Crossings | | | |
|------------------------|------------------------|------|------|-------|------------------------|------|------|-------|------------------------|------|------|-------|------------------------|------|------|-------|-------|-----------------|----------------------|------|-------|-------|
| | U-Turn | Left | Thru | Right | U-Turn | Left | Thru | Right | U-Turn | Left | Thru | Right | U-Turn | Left | Thru | Right | | | West | East | South | North |
| 4:00 PM | 0 | 0 | 6 | 0 | 0 | 0 | 7 | 0 | 0 | 0 | 0 | 0 | 0 | 0 | 0 | 0 | 13 | 70 | 0 | 0 | 0 | 0 |
| 4:15 PM | 0 | 1 | 12 | 0 | 0 | 0 | 6 | 0 | 0 | 0 | 0 | 0 | 0 | 0 | 0 | 0 | 19 | 77 | 0 | 0 | 0 | 0 |
| 4:30 PM | 0 | 0 | 10 | 0 | 0 | 0 | 3 | 0 | 0 | 0 | 0 | 0 | 0 | 2 | 0 | 0 | 15 | 67 | 0 | 0 | 0 | 0 |
| 4:45 PM | 0 | 1 | 14 | 0 | 0 | 0 | 8 | 0 | 0 | 0 | 0 | 0 | 0 | 0 | 0 | 0 | 23 | 65 | 0 | 0 | 0 | 0 |
| 5:00 PM | 0 | 0 | 15 | 0 | 0 | 0 | 4 | 0 | 0 | 0 | 0 | 0 | 0 | 0 | 0 | 1 | 20 | 56 | 0 | 0 | 0 | 0 |
| 5:15 PM | 0 | 1 | 4 | 0 | 0 | 0 | 3 | 0 | 0 | 0 | 0 | 0 | 0 | 1 | 0 | 0 | 9 | | 0 | 0 | 0 | 0 |
| 5:30 PM | 0 | 0 | 7 | 0 | 0 | 0 | 6 | 0 | 0 | 0 | 0 | 0 | 0 | 0 | 0 | 0 | 13 | | 0 | 0 | 0 | 0 |
| 5:45 PM | 0 | 0 | 10 | 0 | 0 | 0 | 4 | 0 | 0 | 0 | 0 | 0 | 0 | 0 | 0 | 0 | 14 | | 0 | 0 | 0 | 0 |
| Count Total | 0 | 3 | 78 | 0 | 0 | 0 | 41 | 0 | 0 | 0 | 0 | 0 | 0 | 3 | 0 | 1 | 126 | | 0 | 0 | 0 | 0 |
| Peak Hour | 0 | 2 | 51 | 0 | 0 | 0 | 21 | 0 | 0 | 0 | 0 | 0 | 0 | 2 | 0 | 1 | 77 | | 0 | 0 | 0 | 0 |

Location: 2 COLT CT & WALKER RD AM

Date: Tuesday, July 15, 2025

Peak Hour: 07:45 AM - 08:45 AM

Peak 15-Minutes: 07:45 AM - 08:00 AM

Peak Hour - Motorized Vehicles

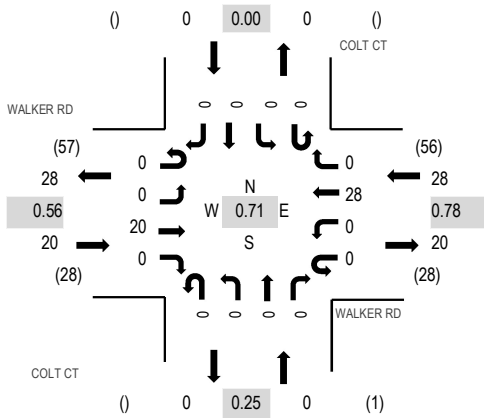

Peak Hour - Bicycles

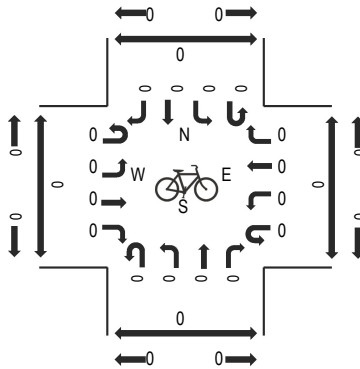

Peak Hour - Pedestrians

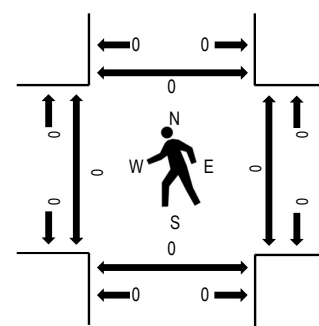

Note: Total study counts contained in parentheses.

Traffic Counts - Motorized Vehicles

| Interval Start Time | WALKER RD Eastbound | | | | WALKER RD Westbound | | | | COLT CT Northbound | | | | COLT CT Southbound | | | | Total | Rolling Hour | Pedestrian Crossings | | | | | | | | |
|---------------------|---------------------|------|------|-------|---------------------|------|------|-------|--------------------|------|------|-------|--------------------|------|------|-------|-------|--------------|----------------------|------|-------|-------|----|---|---|---|---|
| | U-Turn | Left | Thru | Right | U-Turn | Left | Thru | Right | U-Turn | Left | Thru | Right | U-Turn | Left | Thru | Right | | | West | East | South | North | | | | | |
| 7:00 AM | 0 | 0 | 1 | 0 | 0 | 0 | 6 | 0 | 0 | 1 | 0 | 0 | 0 | 0 | 0 | 0 | 0 | 0 | 0 | 0 | 0 | 8 | 45 | 0 | 0 | 0 | 0 |
| 7:15 AM | 0 | 0 | 3 | 0 | 0 | 0 | 9 | 0 | 0 | 0 | 0 | 0 | 0 | 0 | 0 | 0 | 0 | 0 | 0 | 0 | 0 | 12 | 44 | 0 | 0 | 0 | 0 |
| 7:30 AM | 0 | 0 | 3 | 0 | 0 | 0 | 5 | 0 | 0 | 0 | 0 | 0 | 0 | 0 | 0 | 0 | 0 | 0 | 0 | 0 | 0 | 8 | 46 | 0 | 0 | 0 | 0 |
| 7:45 AM | 0 | 0 | 9 | 0 | 0 | 0 | 8 | 0 | 0 | 0 | 0 | 0 | 0 | 0 | 0 | 0 | 0 | 0 | 0 | 0 | 0 | 17 | 48 | 0 | 0 | 0 | 0 |
| 8:00 AM | 0 | 0 | 2 | 0 | 0 | 0 | 5 | 0 | 0 | 0 | 0 | 0 | 0 | 0 | 0 | 0 | 0 | 0 | 0 | 0 | 0 | 7 | 40 | 0 | 0 | 0 | 0 |
| 8:15 AM | 0 | 0 | 5 | 0 | 0 | 0 | 9 | 0 | 0 | 0 | 0 | 0 | 0 | 0 | 0 | 0 | 0 | 0 | 0 | 0 | 0 | 14 | | 0 | 0 | 0 | 0 |
| 8:30 AM | 0 | 0 | 4 | 0 | 0 | 0 | 6 | 0 | 0 | 0 | 0 | 0 | 0 | 0 | 0 | 0 | 0 | 0 | 0 | 0 | 0 | 10 | | 0 | 0 | 0 | 0 |
| 8:45 AM | 0 | 0 | 1 | 0 | 0 | 0 | 8 | 0 | 0 | 0 | 0 | 0 | 0 | 0 | 0 | 0 | 0 | 0 | 0 | 0 | 0 | 9 | | 0 | 0 | 0 | 0 |
| Count Total | 0 | 0 | 28 | 0 | 0 | 0 | 56 | 0 | 0 | 1 | 0 | 0 | 0 | 0 | 0 | 0 | 0 | 0 | 0 | 0 | 0 | 85 | | 0 | 0 | 0 | 0 |
| Peak Hour | 0 | 0 | 20 | 0 | 0 | 0 | 28 | 0 | 0 | 0 | 0 | 0 | 0 | 0 | 0 | 0 | 0 | 0 | 0 | 0 | 0 | 48 | | 0 | 0 | 0 | 0 |

Location: 2 COLT CT & WALKER RD PM

Date: Tuesday, July 15, 2025

Peak Hour: 04:15 PM - 05:15 PM

Peak 15-Minutes: 04:45 PM - 05:00 PM

Peak Hour - Motorized Vehicles

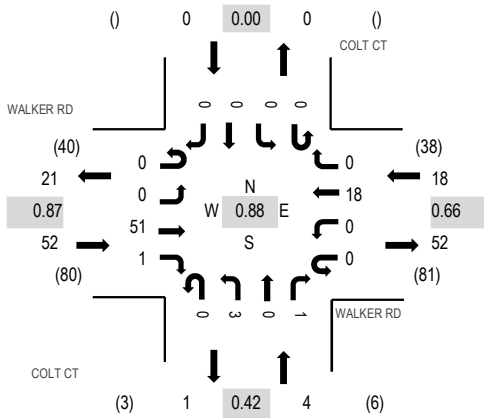

Peak Hour - Bicycles

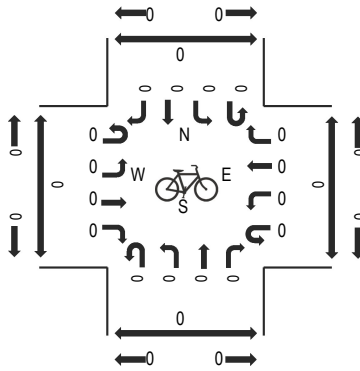

Peak Hour - Pedestrians

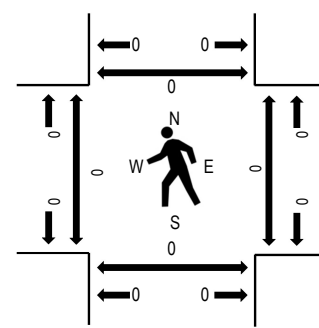

Note: Total study counts contained in parentheses.

Traffic Counts - Motorized Vehicles

| Interval Start Time | WALKER RD Eastbound | | | | WALKER RD Westbound | | | | COLT CT Northbound | | | | COLT CT Southbound | | | | Total | Rolling Hour | Pedestrian Crossings | | | |
|------------------------|------------------------|------|------|-------|------------------------|------|------|-------|-----------------------|------|------|-------|-----------------------|------|------|-------|-------|-----------------|----------------------|------|-------|-------|
| | U-Turn | Left | Thru | Right | U-Turn | Left | Thru | Right | U-Turn | Left | Thru | Right | U-Turn | Left | Thru | Right | | | West | East | South | North |
| 4:00 PM | 0 | 0 | 6 | 0 | 0 | 0 | 6 | 0 | 0 | 0 | 0 | 1 | 0 | 0 | 0 | 0 | 13 | 69 | 0 | 0 | 0 | 0 |
| 4:15 PM | 0 | 0 | 12 | 0 | 0 | 0 | 3 | 0 | 0 | 3 | 0 | 0 | 0 | 0 | 0 | 0 | 18 | 74 | 0 | 0 | 0 | 0 |
| 4:30 PM | 0 | 0 | 12 | 0 | 0 | 0 | 4 | 0 | 0 | 0 | 0 | 1 | 0 | 0 | 0 | 0 | 17 | 66 | 0 | 0 | 0 | 0 |
| 4:45 PM | 0 | 0 | 12 | 1 | 0 | 0 | 8 | 0 | 0 | 0 | 0 | 0 | 0 | 0 | 0 | 0 | 21 | 63 | 0 | 0 | 0 | 0 |
| 5:00 PM | 0 | 0 | 15 | 0 | 0 | 0 | 3 | 0 | 0 | 0 | 0 | 0 | 0 | 0 | 0 | 0 | 18 | 55 | 0 | 0 | 0 | 0 |
| 5:15 PM | 0 | 0 | 6 | 0 | 0 | 1 | 3 | 0 | 0 | 0 | 0 | 0 | 0 | 0 | 0 | 0 | 10 | | 0 | 0 | 0 | 0 |
| 5:30 PM | 0 | 0 | 7 | 0 | 0 | 1 | 5 | 0 | 0 | 1 | 0 | 0 | 0 | 0 | 0 | 0 | 14 | | 0 | 0 | 0 | 0 |
| 5:45 PM | 0 | 0 | 9 | 0 | 0 | 0 | 4 | 0 | 0 | 0 | 0 | 0 | 0 | 0 | 0 | 0 | 13 | | 0 | 0 | 0 | 0 |
| Count Total | 0 | 0 | 79 | 1 | 0 | 2 | 36 | 0 | 0 | 4 | 0 | 2 | 0 | 0 | 0 | 0 | 124 | | 0 | 0 | 0 | 0 |
| Peak Hour | 0 | 0 | 51 | 1 | 0 | 0 | 18 | 0 | 0 | 3 | 0 | 1 | 0 | 0 | 0 | 0 | 74 | | 0 | 0 | 0 | 0 |

Location: 3 THOMPSON RD & WALKER RD AM

Date: Tuesday, July 15, 2025

Peak Hour: 07:45 AM - 08:45 AM

Peak 15-Minutes: 07:45 AM - 08:00 AM

Peak Hour - Motorized Vehicles

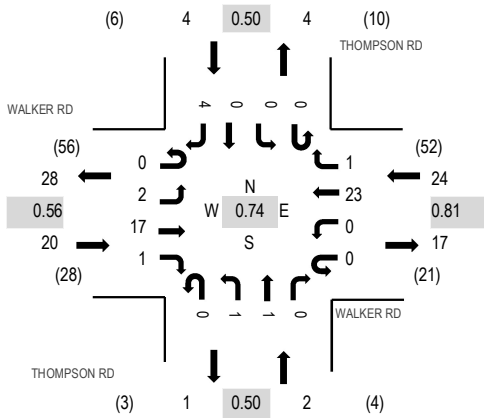

Peak Hour - Bicycles

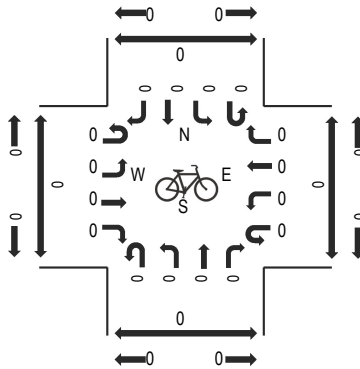

Peak Hour - Pedestrians

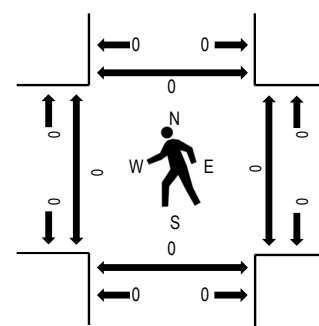

Note: Total study counts contained in parentheses.

Traffic Counts - Motorized Vehicles

| Interval Start Time | WALKER RD Eastbound | | | | WALKER RD Westbound | | | THOMPSON RD Northbound | | | | THOMPSON RD Southbound | | | | Total | Rolling Hour | Pedestrian Crossings | | | | |
|------------------------|------------------------|------|------|-------|------------------------|------|------|---------------------------|--------|------|------|---------------------------|--------|------|------|-------|-----------------|----------------------|------|------|-------|-------|
| | U-Turn | Left | Thru | Right | U-Turn | Left | Thru | Right | U-Turn | Left | Thru | Right | U-Turn | Left | Thru | | | Right | West | East | South | North |
| 7:00 AM | 0 | 0 | 1 | 0 | 0 | 1 | 5 | 1 | 0 | 1 | 0 | 0 | 0 | 0 | 0 | 0 | 9 | 48 | 0 | 0 | 0 | 0 |
| 7:15 AM | 0 | 1 | 2 | 0 | 0 | 0 | 8 | 0 | 0 | 1 | 0 | 0 | 0 | 0 | 1 | 0 | 13 | 47 | 0 | 0 | 0 | 0 |
| 7:30 AM | 0 | 2 | 1 | 0 | 0 | 0 | 4 | 1 | 0 | 0 | 0 | 0 | 0 | 0 | 0 | 1 | 9 | 49 | 0 | 0 | 0 | 0 |
| 7:45 AM | 0 | 1 | 8 | 0 | 0 | 0 | 6 | 0 | 0 | 0 | 0 | 0 | 0 | 0 | 0 | 2 | 17 | 50 | 0 | 0 | 0 | 0 |
| 8:00 AM | 0 | 0 | 2 | 0 | 0 | 0 | 5 | 0 | 0 | 0 | 1 | 0 | 0 | 0 | 0 | 0 | 8 | 42 | 0 | 0 | 0 | 0 |
| 8:15 AM | 0 | 0 | 5 | 0 | 0 | 0 | 7 | 1 | 0 | 1 | 0 | 0 | 0 | 0 | 0 | 1 | 15 | | 0 | 0 | 0 | 0 |
| 8:30 AM | 0 | 1 | 2 | 1 | 0 | 0 | 5 | 0 | 0 | 0 | 0 | 0 | 0 | 0 | 0 | 1 | 10 | | 0 | 0 | 0 | 0 |
| 8:45 AM | 0 | 1 | 0 | 0 | 0 | 0 | 8 | 0 | 0 | 0 | 0 | 0 | 0 | 0 | 0 | 0 | 9 | | 0 | 0 | 0 | 0 |
| Count Total | 0 | 6 | 21 | 1 | 0 | 1 | 48 | 3 | 0 | 3 | 1 | 0 | 0 | 0 | 1 | 5 | 90 | | 0 | 0 | 0 | 0 |
| Peak Hour | 0 | 2 | 17 | 1 | 0 | 0 | 23 | 1 | 0 | 1 | 1 | 0 | 0 | 0 | 0 | 4 | 50 | | 0 | 0 | 0 | 0 |

Location: 3 THOMPSON RD & WALKER RD PM

Date: Tuesday, July 15, 2025

Peak Hour: 04:15 PM - 05:15 PM

Peak 15-Minutes: 04:45 PM - 05:00 PM

Peak Hour - Motorized Vehicles

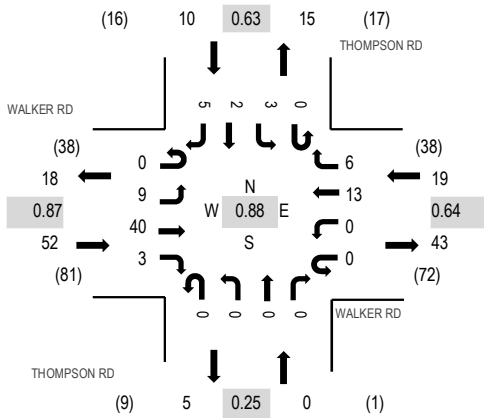

Peak Hour - Bicycles

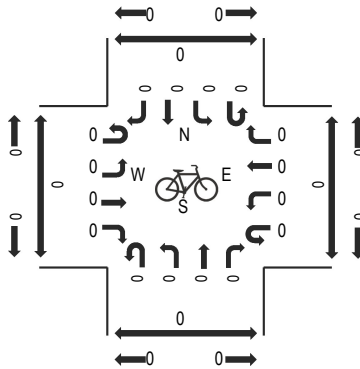

Peak Hour - Pedestrians

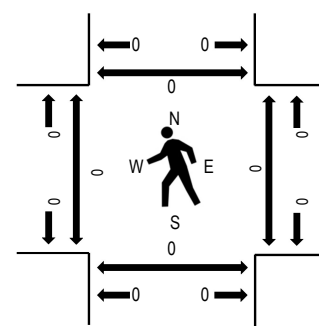

Note: Total study counts contained in parentheses.

Traffic Counts - Motorized Vehicles

| Interval Start Time | WALKER RD Eastbound | | | | WALKER RD Westbound | | | | THOMPSON RD Northbound | | | | THOMPSON RD Southbound | | | | Total | Rolling Hour | Pedestrian Crossings | | | |
|------------------------|------------------------|------|------|-------|------------------------|------|------|-------|---------------------------|------|------|-------|---------------------------|------|------|-------|-------|-----------------|----------------------|------|-------|-------|
| | U-Turn | Left | Thru | Right | U-Turn | Left | Thru | Right | U-Turn | Left | Thru | Right | U-Turn | Left | Thru | Right | | | West | East | South | North |
| 4:00 PM | 0 | 2 | 5 | 0 | 0 | 1 | 6 | 0 | 0 | 0 | 0 | 0 | 0 | 0 | 0 | 0 | 14 | 74 | 0 | 0 | 0 | 0 |
| 4:15 PM | 0 | 4 | 8 | 0 | 0 | 0 | 3 | 2 | 0 | 0 | 0 | 0 | 0 | 1 | 0 | 0 | 18 | 81 | 0 | 0 | 0 | 0 |
| 4:30 PM | 0 | 3 | 10 | 0 | 0 | 0 | 1 | 1 | 0 | 0 | 0 | 0 | 0 | 0 | 1 | 3 | 19 | 73 | 0 | 0 | 0 | 0 |
| 4:45 PM | 0 | 1 | 9 | 2 | 0 | 0 | 7 | 2 | 0 | 0 | 0 | 0 | 0 | 0 | 1 | 1 | 23 | 69 | 0 | 0 | 0 | 0 |
| 5:00 PM | 0 | 1 | 13 | 1 | 0 | 0 | 2 | 1 | 0 | 0 | 0 | 0 | 0 | 2 | 0 | 1 | 21 | 62 | 0 | 0 | 0 | 0 |
| 5:15 PM | 0 | 0 | 4 | 2 | 0 | 0 | 4 | 0 | 0 | 0 | 0 | 0 | 0 | 0 | 0 | 0 | 10 | | 0 | 0 | 0 | 0 |
| 5:30 PM | 0 | 0 | 7 | 0 | 0 | 0 | 5 | 0 | 0 | 0 | 0 | 0 | 0 | 2 | 0 | 1 | 15 | | 0 | 0 | 0 | 0 |
| 5:45 PM | 0 | 0 | 9 | 0 | 0 | 0 | 3 | 0 | 0 | 0 | 1 | 0 | 1 | 1 | 1 | 1 | 16 | | 0 | 0 | 0 | 0 |
| Count Total | 0 | 11 | 65 | 5 | 0 | 1 | 31 | 6 | 0 | 0 | 1 | 0 | 6 | 3 | 7 | 136 | | 0 | 0 | 0 | 0 | 0 |
| Peak Hour | 0 | 9 | 40 | 3 | 0 | 0 | 13 | 6 | 0 | 0 | 0 | 0 | 3 | 2 | 5 | 81 | | 0 | 0 | 0 | 0 | 0 |



All Traffic Data Services

4 - WALKER RD WEST OF BROWN RD

| Time | EB | WB | Total |
|-----------------------|----------------|----------------|----------------|
| 7/15/2025 | 1 | 1 | 2 |
| 7/15/2025 12:15:00 AM | 0 | 0 | 0 |
| 7/15/2025 12:30:00 AM | 0 | 0 | 0 |
| 7/15/2025 12:45:00 AM | 0 | 0 | 0 |
| 7/15/2025 1:00:00 AM | 1 | 0 | 1 |
| 7/15/2025 1:15:00 AM | 0 | 0 | 0 |
| 7/15/2025 1:30:00 AM | 0 | 0 | 0 |
| 7/15/2025 1:45:00 AM | 0 | 0 | 0 |
| 7/15/2025 2:00:00 AM | 0 | 0 | 0 |
| 7/15/2025 2:15:00 AM | 1 | 0 | 1 |
| 7/15/2025 2:30:00 AM | 0 | 0 | 0 |
| 7/15/2025 2:45:00 AM | 0 | 0 | 0 |
| 7/15/2025 3:00:00 AM | 0 | 0 | 0 |
| 7/15/2025 3:15:00 AM | 0 | 0 | 0 |
| 7/15/2025 3:30:00 AM | 0 | 0 | 0 |
| 7/15/2025 3:45:00 AM | 0 | 0 | 0 |
| 7/15/2025 4:00:00 AM | 0 | 2 | 2 |
| 7/15/2025 4:15:00 AM | 0 | 0 | 0 |
| 7/15/2025 4:30:00 AM | 0 | 1 | 1 |
| 7/15/2025 4:45:00 AM | 1 | 0 | 1 |
| 7/15/2025 5:00:00 AM | 0 | 6 | 6 |
| 7/15/2025 5:15:00 AM | 3 | 1 | 4 |
| 7/15/2025 5:30:00 AM | 0 | 1 | 1 |
| 7/15/2025 5:45:00 AM | 2 | 3 | 5 |
| 7/15/2025 6:00:00 AM | 3 | 6 | 9 |
| 7/15/2025 6:15:00 AM | 1 | 3 | 4 |
| 7/15/2025 6:30:00 AM | 0 | 6 | 6 |
| 7/15/2025 6:45:00 AM | 0 | 5 | 5 |
| 7/15/2025 7:00:00 AM | 1 | 8 | 9 |
| 7/15/2025 7:15:00 AM | 3 | 9 | 12 |
| 7/15/2025 7:30:00 AM | 3 | 5 | 8 |
| 7/15/2025 7:45:00 AM | 9 | 9 | 18 |
| 7/15/2025 8:00:00 AM | 2 | 5 | 7 |
| 7/15/2025 8:15:00 AM | 5 | 10 | 15 |
| 7/15/2025 8:30:00 AM | 5 | 6 | 11 |
| 7/15/2025 8:45:00 AM | 3 | 8 | 11 |
| 7/15/2025 9:00:00 AM | 2 | 10 | 12 |
| 7/15/2025 9:15:00 AM | 2 | 8 | 10 |
| 7/15/2025 9:30:00 AM | 2 | 2 | 4 |
| 7/15/2025 9:45:00 AM | 7 | 3 | 10 |
| 7/15/2025 10:00:00 AM | 5 | 7 | 12 |
| 7/15/2025 10:15:00 AM | 2 | 6 | 8 |
| 7/15/2025 10:30:00 AM | 5 | 4 | 9 |
| 7/15/2025 10:45:00 AM | 4 | 3 | 7 |
| 7/15/2025 11:00:00 AM | 3 | 6 | 9 |
| 7/15/2025 11:15:00 AM | 3 | 5 | 8 |
| 7/15/2025 11:30:00 AM | 8 | 4 | 12 |
| 7/15/2025 11:45:00 AM | 4 | 9 | 13 |
| Total | 91 | 162 | 253 |
| Percentage | 36.0% | 64.0% | |
| Peak Hour | 7:45 AM | 8:15 AM | 7:45 AM |
| Volume | 21 | 34 | 51 |
| PHF | 0.583 | 0.850 | 0.708 |



All Traffic Data Services

4 - WALKER RD WEST OF BROWN RD

| Time | EB | WB | Total |
|-----------------------|----------------|----------------|----------------|
| 7/15/2025 12:00:00 PM | 5 | 4 | 9 |
| 7/15/2025 12:15:00 PM | 5 | 7 | 12 |
| 7/15/2025 12:30:00 PM | 5 | 2 | 7 |
| 7/15/2025 12:45:00 PM | 3 | 4 | 7 |
| 7/15/2025 1:00:00 PM | 8 | 4 | 12 |
| 7/15/2025 1:15:00 PM | 2 | 5 | 7 |
| 7/15/2025 1:30:00 PM | 4 | 4 | 8 |
| 7/15/2025 1:45:00 PM | 10 | 3 | 13 |
| 7/15/2025 2:00:00 PM | 8 | 5 | 13 |
| 7/15/2025 2:15:00 PM | 10 | 5 | 15 |
| 7/15/2025 2:30:00 PM | 8 | 8 | 16 |
| 7/15/2025 2:45:00 PM | 4 | 3 | 7 |
| 7/15/2025 3:00:00 PM | 9 | 4 | 13 |
| 7/15/2025 3:15:00 PM | 8 | 1 | 9 |
| 7/15/2025 3:30:00 PM | 6 | 7 | 13 |
| 7/15/2025 3:45:00 PM | 10 | 7 | 17 |
| 7/15/2025 4:00:00 PM | 6 | 7 | 13 |
| 7/15/2025 4:15:00 PM | 13 | 6 | 19 |
| 7/15/2025 4:30:00 PM | 10 | 3 | 13 |
| 7/15/2025 4:45:00 PM | 15 | 8 | 23 |
| 7/15/2025 5:00:00 PM | 15 | 5 | 20 |
| 7/15/2025 5:15:00 PM | 5 | 3 | 8 |
| 7/15/2025 5:30:00 PM | 7 | 6 | 13 |
| 7/15/2025 5:45:00 PM | 10 | 4 | 14 |
| 7/15/2025 6:00:00 PM | 11 | 3 | 14 |
| 7/15/2025 6:15:00 PM | 4 | 5 | 9 |
| 7/15/2025 6:30:00 PM | 1 | 2 | 3 |
| 7/15/2025 6:45:00 PM | 6 | 1 | 7 |
| 7/15/2025 7:00:00 PM | 3 | 5 | 8 |
| 7/15/2025 7:15:00 PM | 10 | 4 | 14 |
| 7/15/2025 7:30:00 PM | 5 | 2 | 7 |
| 7/15/2025 7:45:00 PM | 8 | 1 | 9 |
| 7/15/2025 8:00:00 PM | 4 | 2 | 6 |
| 7/15/2025 8:15:00 PM | 4 | 1 | 5 |
| 7/15/2025 8:30:00 PM | 0 | 3 | 3 |
| 7/15/2025 8:45:00 PM | 2 | 2 | 4 |
| 7/15/2025 9:00:00 PM | 1 | 1 | 2 |
| 7/15/2025 9:15:00 PM | 2 | 3 | 5 |
| 7/15/2025 9:30:00 PM | 2 | 0 | 2 |
| 7/15/2025 9:45:00 PM | 1 | 1 | 2 |
| 7/15/2025 10:00:00 PM | 0 | 1 | 1 |
| 7/15/2025 10:15:00 PM | 2 | 0 | 2 |
| 7/15/2025 10:30:00 PM | 1 | 0 | 1 |
| 7/15/2025 10:45:00 PM | 1 | 0 | 1 |
| 7/15/2025 11:00:00 PM | 1 | 1 | 2 |
| 7/15/2025 11:15:00 PM | 0 | 0 | 0 |
| 7/15/2025 11:30:00 PM | 0 | 0 | 0 |
| 7/15/2025 11:45:00 PM | 1 | 0 | 1 |
| Total | 256 | 153 | 409 |
| Percentage | 62.6% | 37.4% | |
| Peak Hour | 4:15 PM | 3:30 PM | 4:15 PM |
| Volume | 53 | 27 | 75 |
| PHF | 0.883 | 0.964 | 0.815 |
| Grand Total | 347 | 315 | 662 |
| Percentage | 52.4% | 47.6% | |

APPENDIX B

Level of Service Definitions

The following information is referenced from the Highway Capacity Manual: A Guide for Multimodal Mobility Analysis, 7th Edition, Transportation Research Board, 2022: Chapter 19 – Signalized Intersections.

Motorized Vehicle Level of Service (LOS) for Signalized Intersections

Levels of service are defined to represent reasonable ranges in control delay.

LOS A Describes operations with a control delay of 10 s/veh or less and a volume-to-capacity ratio no greater than 1.0. This level is typically assigned when the volume-to-capacity ratio is low and either progression is exceptionally favorable or the cycle length is very short. If it is due to favorable progression, most vehicles arrive during the green indication and travel through the intersection without stopping.

LOS B Describes operations with control delay between 10 and 20 s/veh and a volume-to-capacity ratio no greater than 1.0. This level is typically assigned when the volume-to-capacity ratio is low and either progression is highly favorable or the cycle length is short. More vehicles stop than with LOS A.

LOS C Describes operations with control delay between 20 and 35 s/veh and a volume-to-capacity ratio no greater than 1.0. This level is typically assigned when progression is favorable or the cycle length is moderate. Individual *cycle failures* (i.e., one or more queued vehicles are not able to depart as a result of insufficient capacity during the cycle) may begin to appear at this level. The number of vehicles stopping is significant, although many vehicles still pass through the intersection without stopping.

LOS D Describes operations with control delay between 35 and 55 s/veh and a volume-to-capacity ratio no greater than 1.0. This level is typically assigned when the volume-to-capacity ratio is high and either progression is ineffective or the cycle length is long. Many vehicles stop and individual cycle failures are noticeable.

LOS E Describes operations with control delay between 55 and 80 s/veh and a volume-to-capacity ratio no greater than 1.0. This level is typically assigned when the volume-to-capacity ratio is high, progression is unfavorable, and the cycle length is long. Individual cycle failures are frequent.

LOS F Describes operations with control delay exceeding 80 s/veh or a volume-to-capacity ratio greater than 1.0. This level is typically assigned when the volume-to-capacity ratio is very high, progression is very poor, and the cycle length is long. Most cycles fail to clear the queue.

| Control Delay (s/veh) | LOS by Volume-to-Capacity Ratio ^a | |
|--------------------------|--|-------------|
| | $v/c \leq 1.0$ | $v/c > 1.0$ |
| ≤ 10 | A | F |
| > 10 – 20 | B | F |
| > 20 – 35 | C | F |
| > 35 – 55 | D | F |
| > 55 – 80 | E | F |
| > 80 | F | F |

Note: ^a For approach-based and intersectionwide assessments, LOS is defined solely by control delay.

The following information is referenced from the Highway Capacity Manual: A Guide for Multimodal Mobility Analysis, 7th Edition, Transportation Research Board, 2022: Chapter 20 – Two-Way Stop-Controlled Intersections, Chapter 21 – All-Way Stop-Controlled Intersections, and Chapter 22 - Roundabouts.

Motorized Vehicle Level of Service (LOS) for Unsignalized & Roundabout Intersections

LOS is a quantitative stratification of performance measure(s) representing quality of service. Quality of service describes how well a transportation facility or service operates from a traveler’s perspective. LOS is measured on an A – F scale, with LOS A representing the best operating conditions from a traveler’s perspective.

| Control Delay (s/veh) | LOS by Volume-to-Capacity Ratio ^a | |
|--------------------------|--|-----------|
| | v/c ≤ 1.0 | v/c > 1.0 |
| 0 – 10 | A | F |
| > 10 – 15 | B | F |
| > 15 – 25 | C | F |
| > 25 – 35 | D | F |
| > 35 – 50 | E | F |
| > 50 | F | F |

Note: The LOS criteria apply to each lane on a given approach and to each approach on the minor street. LOS is not calculated for major-street approaches or for the intersection as a whole.

^a For approaches and intersectionwide assessment, LOS is defined solely by control delay.

APPENDIX C

Capacity Worksheets

Intersection

Int Delay, s/veh 1.3

| Movement | EBL | EBT | EBR | WBL | WBT | WBR | NBL | NBT | NBR | SBL | SBT | SBR |
|--------------------------|------|------|------|------|------|------|------|------|------|------|------|------|
| Lane Configurations | | ↕ | | | ↕ | | | ↕ | | | ↕ | |
| Traffic Vol, veh/h | 2 | 17 | 1 | 0 | 23 | 1 | 1 | 1 | 0 | 0 | 0 | 4 |
| Future Vol, veh/h | 2 | 17 | 1 | 0 | 23 | 1 | 1 | 1 | 0 | 0 | 0 | 4 |
| Conflicting Peds, #/hr | 0 | 0 | 0 | 0 | 0 | 0 | 0 | 0 | 0 | 0 | 0 | 0 |
| Sign Control | Free | Free | Free | Free | Free | Free | Stop | Stop | Stop | Stop | Stop | Stop |
| RT Channelized | - | - | None | - | - | None | - | - | None | - | - | None |
| Storage Length | - | - | - | - | - | - | - | - | - | - | - | - |
| Veh in Median Storage, # | - | 0 | - | - | 0 | - | - | 0 | - | - | 0 | - |
| Grade, % | - | 0 | - | - | 0 | - | - | 0 | - | - | 0 | - |
| Peak Hour Factor | 92 | 92 | 92 | 92 | 92 | 92 | 92 | 92 | 92 | 92 | 92 | 92 |
| Heavy Vehicles, % | 2 | 2 | 2 | 2 | 2 | 2 | 2 | 2 | 2 | 2 | 2 | 2 |
| Mvmt Flow | 2 | 18 | 1 | 0 | 25 | 1 | 1 | 1 | 0 | 0 | 0 | 4 |

| Major/Minor | Major1 | | | Major2 | | | Minor1 | | | Minor2 | | |
|----------------------|--------|---|---|--------|---|---|--------|-------|-------|--------|-------|-------|
| Conflicting Flow All | 26 | 0 | 0 | 20 | 0 | 0 | 48 | 49 | 19 | 49 | 49 | 26 |
| Stage 1 | - | - | - | - | - | - | 23 | 23 | - | 26 | 26 | - |
| Stage 2 | - | - | - | - | - | - | 25 | 26 | - | 23 | 24 | - |
| Critical Hdwy | 4.12 | - | - | 4.12 | - | - | 7.12 | 6.52 | 6.22 | 7.12 | 6.52 | 6.22 |
| Critical Hdwy Stg 1 | - | - | - | - | - | - | 6.12 | 5.52 | - | 6.12 | 5.52 | - |
| Critical Hdwy Stg 2 | - | - | - | - | - | - | 6.12 | 5.52 | - | 6.12 | 5.52 | - |
| Follow-up Hdwy | 2.218 | - | - | 2.218 | - | - | 3.518 | 4.018 | 3.318 | 3.518 | 4.018 | 3.318 |
| Pot Cap-1 Maneuver | 1588 | - | - | 1597 | - | - | 952 | 842 | 1059 | 951 | 842 | 1050 |
| Stage 1 | - | - | - | - | - | - | 995 | 876 | - | 992 | 874 | - |
| Stage 2 | - | - | - | - | - | - | 993 | 873 | - | 995 | 875 | - |
| Platoon blocked, % | | - | - | - | - | - | | | | | | |
| Mov Cap-1 Maneuver | 1588 | - | - | 1597 | - | - | 947 | 841 | 1059 | 949 | 841 | 1050 |
| Mov Cap-2 Maneuver | - | - | - | - | - | - | 947 | 841 | - | 949 | 841 | - |
| Stage 1 | - | - | - | - | - | - | 993 | 875 | - | 992 | 874 | - |
| Stage 2 | - | - | - | - | - | - | 989 | 873 | - | 992 | 874 | - |

| Approach | EB | | | WB | | | NB | | | SB | | |
|-------------------|------|--|--|----|--|--|------|--|--|------|--|--|
| HCM Ctrl Dly, s/v | 0.73 | | | 0 | | | 9.05 | | | 8.44 | | |
| HCM LOS | | | | | | | A | | | A | | |

| Minor Lane/Major Mvmt | NBLn1 | EBL | EBT | EBR | WBL | WBT | WBR | SBLn1 |
|-----------------------|-------|-------|-----|-----|------|-----|-----|-------|
| Capacity (veh/h) | 891 | 178 | - | - | 1597 | - | - | 1050 |
| HCM Lane V/C Ratio | 0.002 | 0.001 | - | - | - | - | - | 0.004 |
| HCM Ctrl Dly (s/v) | 9.1 | 7.3 | 0 | - | 0 | - | - | 8.4 |
| HCM Lane LOS | A | A | A | - | A | - | - | A |
| HCM 95th %tile Q(veh) | 0 | 0 | - | - | 0 | - | - | 0 |

Intersection

Int Delay, s/veh 0

| Movement | EBT | EBR | WBL | WBT | NBL | NBR |
|--------------------------|------|------|------|------|------|------|
| Lane Configurations | ↔ | | | ↕ | ↕ | |
| Traffic Vol, veh/h | 20 | 0 | 0 | 28 | 0 | 0 |
| Future Vol, veh/h | 20 | 0 | 0 | 28 | 0 | 0 |
| Conflicting Peds, #/hr | 0 | 0 | 0 | 0 | 0 | 0 |
| Sign Control | Free | Free | Free | Free | Stop | Stop |
| RT Channelized | - | None | - | None | - | None |
| Storage Length | - | - | - | - | 0 | - |
| Veh in Median Storage, # | 0 | - | - | 0 | 0 | - |
| Grade, % | 0 | - | - | 0 | 0 | - |
| Peak Hour Factor | 92 | 92 | 92 | 92 | 92 | 92 |
| Heavy Vehicles, % | 2 | 2 | 2 | 2 | 2 | 2 |
| Mvmt Flow | 22 | 0 | 0 | 30 | 0 | 0 |

| Major/Minor | Major1 | Major2 | Minor1 | Minor2 | Minor3 |
|----------------------|--------|--------|--------|--------|--------|
| Conflicting Flow All | 0 | 0 | 22 | 0 | 52 |
| Stage 1 | - | - | - | - | 22 |
| Stage 2 | - | - | - | - | 30 |
| Critical Hdwy | - | - | 4.12 | - | 6.42 |
| Critical Hdwy Stg 1 | - | - | - | - | 5.42 |
| Critical Hdwy Stg 2 | - | - | - | - | 5.42 |
| Follow-up Hdwy | - | - | 2.218 | - | 3.518 |
| Pot Cap-1 Maneuver | - | - | 1594 | - | 956 |
| Stage 1 | - | - | - | - | 1001 |
| Stage 2 | - | - | - | - | 992 |
| Platoon blocked, % | - | - | - | - | - |
| Mov Cap-1 Maneuver | - | - | 1594 | - | 956 |
| Mov Cap-2 Maneuver | - | - | - | - | 956 |
| Stage 1 | - | - | - | - | 1001 |
| Stage 2 | - | - | - | - | 992 |

| Approach | EB | WB | NB |
|-------------------|----|----|----|
| HCM Ctrl Dly, s/v | 0 | 0 | 0 |
| HCM LOS | | | A |

| Minor Lane/Major Mvmt | NBLn1 | EBT | EBR | WBL | WBT |
|-----------------------|-------|-----|-----|------|-----|
| Capacity (veh/h) | - | - | - | 1594 | - |
| HCM Lane V/C Ratio | - | - | - | - | - |
| HCM Ctrl Dly (s/v) | 0 | - | - | 0 | - |
| HCM Lane LOS | A | - | - | A | - |
| HCM 95th %tile Q(veh) | - | - | - | 0 | - |

Intersection

Int Delay, s/veh 0.9

| Movement | EBL | EBT | WBT | WBR | SBL | SBR |
|--------------------------|------|------|------|------|------|------|
| Lane Configurations | | ↕ | ↕ | | ↕ | |
| Traffic Vol, veh/h | 2 | 19 | 27 | 1 | 1 | 3 |
| Future Vol, veh/h | 2 | 19 | 27 | 1 | 1 | 3 |
| Conflicting Peds, #/hr | 0 | 0 | 0 | 0 | 0 | 0 |
| Sign Control | Free | Free | Free | Free | Stop | Stop |
| RT Channelized | - | None | - | None | - | None |
| Storage Length | - | - | - | - | 0 | - |
| Veh in Median Storage, # | - | 0 | 0 | - | 0 | - |
| Grade, % | - | 0 | 0 | - | 0 | - |
| Peak Hour Factor | 92 | 92 | 92 | 92 | 92 | 92 |
| Heavy Vehicles, % | 2 | 2 | 2 | 2 | 2 | 2 |
| Mvmt Flow | 2 | 21 | 29 | 1 | 1 | 3 |

| Major/Minor | Major1 | Major2 | Minor2 |
|----------------------|--------|--------|--------|
| Conflicting Flow All | 30 | 0 | 0 |
| Stage 1 | - | - | - |
| Stage 2 | - | - | - |
| Critical Hdwy | 4.12 | - | - |
| Critical Hdwy Stg 1 | - | - | - |
| Critical Hdwy Stg 2 | - | - | - |
| Follow-up Hdwy | 2.218 | - | - |
| Pot Cap-1 Maneuver | 1582 | - | - |
| Stage 1 | - | - | - |
| Stage 2 | - | - | - |
| Platoon blocked, % | - | - | - |
| Mov Cap-1 Maneuver | 1582 | - | - |
| Mov Cap-2 Maneuver | - | - | - |
| Stage 1 | - | - | - |
| Stage 2 | - | - | - |

| Approach | EB | WB | SB |
|-------------------|------|----|------|
| HCM Ctrl Dly, s/v | 0.69 | 0 | 8.55 |
| HCM LOS | | | A |

| Minor Lane/Major Mvmt | EBL | EBT | WBT | WBR | SBLn1 |
|-----------------------|-------|-----|-----|-----|-------|
| Capacity (veh/h) | 171 | - | - | - | 1020 |
| HCM Lane V/C Ratio | 0.001 | - | - | - | 0.004 |
| HCM Ctrl Dly (s/v) | 7.3 | 0 | - | - | 8.5 |
| HCM Lane LOS | A | A | - | - | A |
| HCM 95th %tile Q(veh) | 0 | - | - | - | 0 |

| Intersection | | | | | | | | | | | | |
|--------------------------|------|------|------|------|------|------|------|------|------|------|------|------|
| Int Delay, s/veh | 1.9 | | | | | | | | | | | |
| Movement | EBL | EBT | EBR | WBL | WBT | WBR | NBL | NBT | NBR | SBL | SBT | SBR |
| Lane Configurations | | ↕ | | | ↕ | | | ↕ | | | ↕ | |
| Traffic Vol, veh/h | 9 | 40 | 3 | 0 | 13 | 6 | 0 | 0 | 0 | 3 | 2 | 5 |
| Future Vol, veh/h | 9 | 40 | 3 | 0 | 13 | 6 | 0 | 0 | 0 | 3 | 2 | 5 |
| Conflicting Peds, #/hr | 0 | 0 | 0 | 0 | 0 | 0 | 0 | 0 | 0 | 0 | 0 | 0 |
| Sign Control | Free | Free | Free | Free | Free | Free | Stop | Stop | Stop | Stop | Stop | Stop |
| RT Channelized | - | - | None | - | - | None | - | - | None | - | - | None |
| Storage Length | - | - | - | - | - | - | - | - | - | - | - | - |
| Veh in Median Storage, # | - | 0 | - | - | 0 | - | - | 0 | - | - | 0 | - |
| Grade, % | - | 0 | - | - | 0 | - | - | 0 | - | - | 0 | - |
| Peak Hour Factor | 92 | 92 | 92 | 92 | 92 | 92 | 92 | 92 | 92 | 92 | 92 | 92 |
| Heavy Vehicles, % | 2 | 2 | 2 | 2 | 2 | 2 | 2 | 2 | 2 | 2 | 2 | 2 |
| Mvmt Flow | 10 | 43 | 3 | 0 | 14 | 7 | 0 | 0 | 0 | 3 | 2 | 5 |

| Major/Minor | Major1 | | | Major2 | | | Minor1 | | | Minor2 | | |
|----------------------|--------|---|---|--------|---|---|--------|-------|-------|--------|-------|-------|
| Conflicting Flow All | 21 | 0 | 0 | 47 | 0 | 0 | 80 | 85 | 45 | 80 | 84 | 17 |
| Stage 1 | - | - | - | - | - | - | 65 | 65 | - | 17 | 17 | - |
| Stage 2 | - | - | - | - | - | - | 15 | 21 | - | 63 | 66 | - |
| Critical Hdwy | 4.12 | - | - | 4.12 | - | - | 7.12 | 6.52 | 6.22 | 7.12 | 6.52 | 6.22 |
| Critical Hdwy Stg 1 | - | - | - | - | - | - | 6.12 | 5.52 | - | 6.12 | 5.52 | - |
| Critical Hdwy Stg 2 | - | - | - | - | - | - | 6.12 | 5.52 | - | 6.12 | 5.52 | - |
| Follow-up Hdwy | 2.218 | - | - | 2.218 | - | - | 3.518 | 4.018 | 3.318 | 3.518 | 4.018 | 3.318 |
| Pot Cap-1 Maneuver | 1595 | - | - | 1561 | - | - | 908 | 805 | 1025 | 908 | 806 | 1061 |
| Stage 1 | - | - | - | - | - | - | 946 | 841 | - | 1002 | 881 | - |
| Stage 2 | - | - | - | - | - | - | 1005 | 878 | - | 948 | 840 | - |
| Platoon blocked, % | | - | - | | - | - | | | | | | |
| Mov Cap-1 Maneuver | 1595 | - | - | 1561 | - | - | 896 | 800 | 1025 | 902 | 801 | 1061 |
| Mov Cap-2 Maneuver | - | - | - | - | - | - | 896 | 800 | - | 902 | 801 | - |
| Stage 1 | - | - | - | - | - | - | 940 | 836 | - | 1002 | 881 | - |
| Stage 2 | - | - | - | - | - | - | 997 | 878 | - | 942 | 834 | - |

| Approach | EB | | | WB | | | NB | | | SB | | |
|-------------------|------|--|--|----|--|--|----|--|--|------|--|--|
| HCM Ctrl Dly, s/v | 1.26 | | | 0 | | | 0 | | | 8.84 | | |
| HCM LOS | | | | | | | A | | | A | | |

| Minor Lane/Major Mvmt | NBLn1 | EBL | EBT | EBR | WBL | WBT | WBR | SBLn1 |
|-----------------------|-------|-------|-----|-----|------|-----|-----|-------|
| Capacity (veh/h) | - | 307 | - | - | 1561 | - | - | 949 |
| HCM Lane V/C Ratio | - | 0.006 | - | - | - | - | - | 0.011 |
| HCM Ctrl Dly (s/v) | 0 | 7.3 | 0 | - | 0 | - | - | 8.8 |
| HCM Lane LOS | A | A | A | - | A | - | - | A |
| HCM 95th %tile Q(veh) | - | 0 | - | - | 0 | - | - | 0 |

| Intersection | | | | | | |
|--------------------------|------|------|------|------|------|------|
| Int Delay, s/veh | 0.5 | | | | | |
| Movement | EBT | EBR | WBL | WBT | NBL | NBR |
| Lane Configurations | ↔ | | | ↕ | ↕ | |
| Traffic Vol, veh/h | 51 | 1 | 0 | 18 | 3 | 1 |
| Future Vol, veh/h | 51 | 1 | 0 | 18 | 3 | 1 |
| Conflicting Peds, #/hr | 0 | 0 | 0 | 0 | 0 | 0 |
| Sign Control | Free | Free | Free | Free | Stop | Stop |
| RT Channelized | - | None | - | None | - | None |
| Storage Length | - | - | - | - | 0 | - |
| Veh in Median Storage, # | 0 | - | - | 0 | 0 | - |
| Grade, % | 0 | - | - | 0 | 0 | - |
| Peak Hour Factor | 92 | 92 | 92 | 92 | 92 | 92 |
| Heavy Vehicles, % | 2 | 2 | 2 | 2 | 2 | 2 |
| Mvmt Flow | 55 | 1 | 0 | 20 | 3 | 1 |

| Major/Minor | Major1 | Major2 | Minor1 | Minor2 | Minor3 |
|----------------------|--------|--------|--------|--------|--------|
| Conflicting Flow All | 0 | 0 | 57 | 0 | 76 |
| Stage 1 | - | - | - | - | 56 |
| Stage 2 | - | - | - | - | 20 |
| Critical Hdwy | - | - | 4.12 | - | 6.42 |
| Critical Hdwy Stg 1 | - | - | - | - | 5.42 |
| Critical Hdwy Stg 2 | - | - | - | - | 5.42 |
| Follow-up Hdwy | - | - | 2.218 | - | 3.518 |
| Pot Cap-1 Maneuver | - | - | 1548 | - | 928 |
| Stage 1 | - | - | - | - | 967 |
| Stage 2 | - | - | - | - | 1003 |
| Platoon blocked, % | - | - | - | - | - |
| Mov Cap-1 Maneuver | - | - | 1548 | - | 928 |
| Mov Cap-2 Maneuver | - | - | - | - | 928 |
| Stage 1 | - | - | - | - | 967 |
| Stage 2 | - | - | - | - | 1003 |

| Approach | EB | WB | NB |
|-------------------|----|----|------|
| HCM Ctrl Dly, s/v | 0 | 0 | 8.82 |
| HCM LOS | | | A |

| Minor Lane/Major Mvmt | NBLn1 | EBT | EBR | WBL | WBT |
|-----------------------|-------|-----|-----|------|-----|
| Capacity (veh/h) | 947 | - | - | 1548 | - |
| HCM Lane V/C Ratio | 0.005 | - | - | - | - |
| HCM Ctrl Dly (s/v) | 8.8 | - | - | 0 | - |
| HCM Lane LOS | A | - | - | A | - |
| HCM 95th %tile Q(veh) | 0 | - | - | 0 | - |

Intersection

Int Delay, s/veh 0.5

| Movement | EBL | EBT | WBT | WBR | SBL | SBR |
|--------------------------|------|------|------|------|------|------|
| Lane Configurations | | ↕ | ↕ | | ↕ | |
| Traffic Vol, veh/h | 2 | 51 | 21 | 0 | 2 | 1 |
| Future Vol, veh/h | 2 | 51 | 21 | 0 | 2 | 1 |
| Conflicting Peds, #/hr | 0 | 0 | 0 | 0 | 0 | 0 |
| Sign Control | Free | Free | Free | Free | Stop | Stop |
| RT Channelized | - | None | - | None | - | None |
| Storage Length | - | - | - | - | 0 | - |
| Veh in Median Storage, # | - | 0 | 0 | - | 0 | - |
| Grade, % | - | 0 | 0 | - | 0 | - |
| Peak Hour Factor | 92 | 92 | 92 | 92 | 92 | 92 |
| Heavy Vehicles, % | 2 | 2 | 2 | 2 | 2 | 2 |
| Mvmt Flow | 2 | 55 | 23 | 0 | 2 | 1 |

| Major/Minor | Major1 | Major2 | Minor2 |
|----------------------|--------|--------|---------------|
| Conflicting Flow All | 23 | 0 | 0 83 23 |
| Stage 1 | - | - | - 23 - |
| Stage 2 | - | - | - 60 - |
| Critical Hdwy | 4.12 | - | - 6.42 6.22 |
| Critical Hdwy Stg 1 | - | - | - 5.42 - |
| Critical Hdwy Stg 2 | - | - | - 5.42 - |
| Follow-up Hdwy | 2.218 | - | - 3.518 3.318 |
| Pot Cap-1 Maneuver | 1592 | - | - 919 1054 |
| Stage 1 | - | - | - 1000 - |
| Stage 2 | - | - | - 963 - |
| Platoon blocked, % | | - | - |
| Mov Cap-1 Maneuver | 1592 | - | - 918 1054 |
| Mov Cap-2 Maneuver | - | - | - 918 - |
| Stage 1 | - | - | - 998 - |
| Stage 2 | - | - | - 963 - |

| Approach | EB | WB | SB |
|-------------------|------|----|------|
| HCM Ctrl Dly, s/v | 0.27 | 0 | 8.77 |
| HCM LOS | | | A |

| Minor Lane/Major Mvmt | EBL | EBT | WBT | WBR | SBLn1 |
|-----------------------|-------|-----|-----|-----|-------|
| Capacity (veh/h) | 68 | - | - | - | 959 |
| HCM Lane V/C Ratio | 0.001 | - | - | - | 0.003 |
| HCM Ctrl Dly (s/v) | 7.3 | 0 | - | - | 8.8 |
| HCM Lane LOS | A | A | - | - | A |
| HCM 95th %tile Q(veh) | 0 | - | - | - | 0 |

Intersection

Int Delay, s/veh 1.3

| Movement | EBL | EBT | EBR | WBL | WBT | WBR | NBL | NBT | NBR | SBL | SBT | SBR |
|--------------------------|------|------|------|------|------|------|------|------|------|------|------|------|
| Lane Configurations | | ↕ | | | ↕ | | | ↕ | | | ↕ | |
| Traffic Vol, veh/h | 2 | 18 | 1 | 0 | 24 | 1 | 1 | 1 | 0 | 0 | 0 | 4 |
| Future Vol, veh/h | 2 | 18 | 1 | 0 | 24 | 1 | 1 | 1 | 0 | 0 | 0 | 4 |
| Conflicting Peds, #/hr | 0 | 0 | 0 | 0 | 0 | 0 | 0 | 0 | 0 | 0 | 0 | 0 |
| Sign Control | Free | Free | Free | Free | Free | Free | Stop | Stop | Stop | Stop | Stop | Stop |
| RT Channelized | - | - | None | - | - | None | - | - | None | - | - | None |
| Storage Length | - | - | - | - | - | - | - | - | - | - | - | - |
| Veh in Median Storage, # | - | 0 | - | - | 0 | - | - | 0 | - | - | 0 | - |
| Grade, % | - | 0 | - | - | 0 | - | - | 0 | - | - | 0 | - |
| Peak Hour Factor | 92 | 92 | 92 | 92 | 92 | 92 | 92 | 92 | 92 | 92 | 92 | 92 |
| Heavy Vehicles, % | 2 | 2 | 2 | 2 | 2 | 2 | 2 | 2 | 2 | 2 | 2 | 2 |
| Mvmt Flow | 2 | 20 | 1 | 0 | 26 | 1 | 1 | 1 | 0 | 0 | 0 | 4 |

| Major/Minor | Major1 | Major2 | Minor1 | Minor2 |
|----------------------|--------|--------|--------|--------|
| Conflicting Flow All | 27 | 0 | 0 | 21 |
| Stage 1 | - | - | - | - |
| Stage 2 | - | - | - | - |
| Critical Hdwy | 4.12 | - | - | 4.12 |
| Critical Hdwy Stg 1 | - | - | - | - |
| Critical Hdwy Stg 2 | - | - | - | - |
| Follow-up Hdwy | 2.218 | - | - | 2.218 |
| Pot Cap-1 Maneuver | 1587 | - | - | 1595 |
| Stage 1 | - | - | - | - |
| Stage 2 | - | - | - | - |
| Platoon blocked, % | - | - | - | - |
| Mov Cap-1 Maneuver | 1587 | - | - | 1595 |
| Mov Cap-2 Maneuver | - | - | - | - |
| Stage 1 | - | - | - | - |
| Stage 2 | - | - | - | - |

| Approach | EB | WB | NB | SB |
|-------------------|------|----|------|------|
| HCM Ctrl Dly, s/v | 0.69 | 0 | 9.06 | 8.45 |
| HCM LOS | | | A | A |

| Minor Lane/Major Mvmt | NBLn1 | EBL | EBT | EBR | WBL | WBT | WBR | SBLn1 |
|-----------------------|-------|-------|-----|-----|------|-----|-----|-------|
| Capacity (veh/h) | 888 | 170 | - | - | 1595 | - | - | 1049 |
| HCM Lane V/C Ratio | 0.002 | 0.001 | - | - | - | - | - | 0.004 |
| HCM Ctrl Dly (s/v) | 9.1 | 7.3 | 0 | - | 0 | - | - | 8.4 |
| HCM Lane LOS | A | A | A | - | A | - | - | A |
| HCM 95th %tile Q(veh) | 0 | 0 | - | - | 0 | - | - | 0 |

Intersection

Int Delay, s/veh 0

| Movement | EBT | EBR | WBL | WBT | NBL | NBR |
|--------------------------|------|------|------|------|------|------|
| Lane Configurations | ↔ | | | ↕ | ↕ | |
| Traffic Vol, veh/h | 21 | 0 | 0 | 29 | 0 | 0 |
| Future Vol, veh/h | 21 | 0 | 0 | 29 | 0 | 0 |
| Conflicting Peds, #/hr | 0 | 0 | 0 | 0 | 0 | 0 |
| Sign Control | Free | Free | Free | Free | Stop | Stop |
| RT Channelized | - | None | - | None | - | None |
| Storage Length | - | - | - | - | 0 | - |
| Veh in Median Storage, # | 0 | - | - | 0 | 0 | - |
| Grade, % | 0 | - | - | 0 | 0 | - |
| Peak Hour Factor | 92 | 92 | 92 | 92 | 92 | 92 |
| Heavy Vehicles, % | 2 | 2 | 2 | 2 | 2 | 2 |
| Mvmt Flow | 23 | 0 | 0 | 32 | 0 | 0 |

| Major/Minor | Major1 | Major2 | Minor1 | Minor2 | Minor3 |
|----------------------|--------|--------|--------|--------|--------|
| Conflicting Flow All | 0 | 0 | 23 | 0 | 54 |
| Stage 1 | - | - | - | - | 23 |
| Stage 2 | - | - | - | - | 32 |
| Critical Hdwy | - | - | 4.12 | - | 6.42 |
| Critical Hdwy Stg 1 | - | - | - | - | 5.42 |
| Critical Hdwy Stg 2 | - | - | - | - | 5.42 |
| Follow-up Hdwy | - | - | 2.218 | - | 3.518 |
| Pot Cap-1 Maneuver | - | - | 1592 | - | 954 |
| Stage 1 | - | - | - | - | 1000 |
| Stage 2 | - | - | - | - | 991 |
| Platoon blocked, % | - | - | - | - | - |
| Mov Cap-1 Maneuver | - | - | 1592 | - | 954 |
| Mov Cap-2 Maneuver | - | - | - | - | 954 |
| Stage 1 | - | - | - | - | 1000 |
| Stage 2 | - | - | - | - | 991 |

| Approach | EB | WB | NB |
|-------------------|----|----|----|
| HCM Ctrl Dly, s/v | 0 | 0 | 0 |
| HCM LOS | | | A |

| Minor Lane/Major Mvmt | NBLn1 | EBT | EBR | WBL | WBT |
|-----------------------|-------|-----|-----|------|-----|
| Capacity (veh/h) | - | - | - | 1592 | - |
| HCM Lane V/C Ratio | - | - | - | - | - |
| HCM Ctrl Dly (s/v) | 0 | - | - | 0 | - |
| HCM Lane LOS | A | - | - | A | - |
| HCM 95th %tile Q(veh) | - | - | - | 0 | - |

| Intersection | | | | | | |
|--------------------------|------|------|------|------|------|------|
| Int Delay, s/veh | 0.9 | | | | | |
| Movement | EBL | EBT | WBT | WBR | SBL | SBR |
| Lane Configurations | | ↕ | ↕ | | ↕ | |
| Traffic Vol, veh/h | 2 | 20 | 28 | 1 | 1 | 3 |
| Future Vol, veh/h | 2 | 20 | 28 | 1 | 1 | 3 |
| Conflicting Peds, #/hr | 0 | 0 | 0 | 0 | 0 | 0 |
| Sign Control | Free | Free | Free | Free | Stop | Stop |
| RT Channelized | - | None | - | None | - | None |
| Storage Length | - | - | - | - | 0 | - |
| Veh in Median Storage, # | - | 0 | 0 | - | 0 | - |
| Grade, % | - | 0 | 0 | - | 0 | - |
| Peak Hour Factor | 92 | 92 | 92 | 92 | 92 | 92 |
| Heavy Vehicles, % | 2 | 2 | 2 | 2 | 2 | 2 |
| Mvmt Flow | 2 | 22 | 30 | 1 | 1 | 3 |

| Major/Minor | Major1 | Major2 | Minor2 | | |
|----------------------|--------|--------|--------|---|-------------|
| Conflicting Flow All | 32 | 0 | - | 0 | 57 31 |
| Stage 1 | - | - | - | - | 31 - |
| Stage 2 | - | - | - | - | 26 - |
| Critical Hdwy | 4.12 | - | - | - | 6.42 6.22 |
| Critical Hdwy Stg 1 | - | - | - | - | 5.42 - |
| Critical Hdwy Stg 2 | - | - | - | - | 5.42 - |
| Follow-up Hdwy | 2.218 | - | - | - | 3.518 3.318 |
| Pot Cap-1 Maneuver | 1581 | - | - | - | 950 1043 |
| Stage 1 | - | - | - | - | 992 - |
| Stage 2 | - | - | - | - | 996 - |
| Platoon blocked, % | | - | - | - | |
| Mov Cap-1 Maneuver | 1581 | - | - | - | 949 1043 |
| Mov Cap-2 Maneuver | - | - | - | - | 949 - |
| Stage 1 | - | - | - | - | 990 - |
| Stage 2 | - | - | - | - | 996 - |

| Approach | EB | WB | SB |
|-------------------|------|----|------|
| HCM Ctrl Dly, s/v | 0.66 | 0 | 8.55 |
| HCM LOS | | | A |

| Minor Lane/Major Mvmt | EBL | EBT | WBT | WBR | SBLn1 |
|-----------------------|-------|-----|-----|-----|-------|
| Capacity (veh/h) | 164 | - | - | - | 1018 |
| HCM Lane V/C Ratio | 0.001 | - | - | - | 0.004 |
| HCM Ctrl Dly (s/v) | 7.3 | 0 | - | - | 8.6 |
| HCM Lane LOS | A | A | - | - | A |
| HCM 95th %tile Q(veh) | 0 | - | - | - | 0 |

| Intersection | | | | | | | | | | | | |
|--------------------------|------|------|------|------|------|------|------|------|------|------|------|------|
| Int Delay, s/veh | 1.8 | | | | | | | | | | | |
| Movement | EBL | EBT | EBR | WBL | WBT | WBR | NBL | NBT | NBR | SBL | SBT | SBR |
| Lane Configurations | | ↕ | | | ↕ | | | ↕ | | | ↕ | |
| Traffic Vol, veh/h | 9 | 42 | 3 | 0 | 14 | 6 | 0 | 0 | 0 | 3 | 2 | 5 |
| Future Vol, veh/h | 9 | 42 | 3 | 0 | 14 | 6 | 0 | 0 | 0 | 3 | 2 | 5 |
| Conflicting Peds, #/hr | 0 | 0 | 0 | 0 | 0 | 0 | 0 | 0 | 0 | 0 | 0 | 0 |
| Sign Control | Free | Free | Free | Free | Free | Free | Stop | Stop | Stop | Stop | Stop | Stop |
| RT Channelized | - | - | None | - | - | None | - | - | None | - | - | None |
| Storage Length | - | - | - | - | - | - | - | - | - | - | - | - |
| Veh in Median Storage, # | - | 0 | - | - | 0 | - | - | 0 | - | - | 0 | - |
| Grade, % | - | 0 | - | - | 0 | - | - | 0 | - | - | 0 | - |
| Peak Hour Factor | 92 | 92 | 92 | 92 | 92 | 92 | 92 | 92 | 92 | 92 | 92 | 92 |
| Heavy Vehicles, % | 2 | 2 | 2 | 2 | 2 | 2 | 2 | 2 | 2 | 2 | 2 | 2 |
| Mvmt Flow | 10 | 46 | 3 | 0 | 15 | 7 | 0 | 0 | 0 | 3 | 2 | 5 |

| Major/Minor | Major1 | | | Major2 | | | Minor1 | | | Minor2 | | |
|----------------------|--------|---|---|--------|---|---|--------|-------|-------|--------|-------|-------|
| Conflicting Flow All | 22 | 0 | 0 | 49 | 0 | 0 | 83 | 89 | 47 | 84 | 87 | 18 |
| Stage 1 | - | - | - | - | - | - | 67 | 67 | - | 18 | 18 | - |
| Stage 2 | - | - | - | - | - | - | 16 | 22 | - | 65 | 68 | - |
| Critical Hdwy | 4.12 | - | - | 4.12 | - | - | 7.12 | 6.52 | 6.22 | 7.12 | 6.52 | 6.22 |
| Critical Hdwy Stg 1 | - | - | - | - | - | - | 6.12 | 5.52 | - | 6.12 | 5.52 | - |
| Critical Hdwy Stg 2 | - | - | - | - | - | - | 6.12 | 5.52 | - | 6.12 | 5.52 | - |
| Follow-up Hdwy | 2.218 | - | - | 2.218 | - | - | 3.518 | 4.018 | 3.318 | 3.518 | 4.018 | 3.318 |
| Pot Cap-1 Maneuver | 1594 | - | - | 1558 | - | - | 904 | 802 | 1022 | 903 | 803 | 1060 |
| Stage 1 | - | - | - | - | - | - | 944 | 839 | - | 1001 | 880 | - |
| Stage 2 | - | - | - | - | - | - | 1003 | 877 | - | 945 | 838 | - |
| Platoon blocked, % | | - | - | - | - | - | | | | | | |
| Mov Cap-1 Maneuver | 1594 | - | - | 1558 | - | - | 891 | 796 | 1022 | 897 | 798 | 1060 |
| Mov Cap-2 Maneuver | - | - | - | - | - | - | 891 | 796 | - | 897 | 798 | - |
| Stage 1 | - | - | - | - | - | - | 938 | 834 | - | 1001 | 880 | - |
| Stage 2 | - | - | - | - | - | - | 996 | 877 | - | 939 | 833 | - |

| Approach | EB | | | WB | | | NB | | | SB | | |
|-------------------|------|--|--|----|--|--|----|--|--|------|--|--|
| HCM Ctrl Dly, s/v | 1.21 | | | 0 | | | 0 | | | 8.85 | | |
| HCM LOS | | | | | | | A | | | A | | |

| Minor Lane/Major Mvmt | NBLn1 | EBL | EBT | EBR | WBL | WBT | WBR | SBLn1 |
|-----------------------|-------|-------|-----|-----|------|-----|-----|-------|
| Capacity (veh/h) | - | 296 | - | - | 1558 | - | - | 946 |
| HCM Lane V/C Ratio | - | 0.006 | - | - | - | - | - | 0.011 |
| HCM Ctrl Dly (s/v) | 0 | 7.3 | 0 | - | 0 | - | - | 8.8 |
| HCM Lane LOS | A | A | A | - | A | - | - | A |
| HCM 95th %tile Q(veh) | - | 0 | - | - | 0 | - | - | 0 |

| Intersection | | | | | | |
|--------------------------|------|------|------|------|------|------|
| Int Delay, s/veh | 0.5 | | | | | |
| Movement | EBT | EBR | WBL | WBT | NBL | NBR |
| Lane Configurations | ↔ | | | ↕ | ↕ | |
| Traffic Vol, veh/h | 53 | 1 | 0 | 19 | 3 | 1 |
| Future Vol, veh/h | 53 | 1 | 0 | 19 | 3 | 1 |
| Conflicting Peds, #/hr | 0 | 0 | 0 | 0 | 0 | 0 |
| Sign Control | Free | Free | Free | Free | Stop | Stop |
| RT Channelized | - | None | - | None | - | None |
| Storage Length | - | - | - | - | 0 | - |
| Veh in Median Storage, # | 0 | - | - | 0 | 0 | - |
| Grade, % | 0 | - | - | 0 | 0 | - |
| Peak Hour Factor | 92 | 92 | 92 | 92 | 92 | 92 |
| Heavy Vehicles, % | 2 | 2 | 2 | 2 | 2 | 2 |
| Mvmt Flow | 58 | 1 | 0 | 21 | 3 | 1 |

| Major/Minor | Major1 | Major2 | Minor1 | Minor2 | Minor3 |
|----------------------|--------|--------|--------|--------|--------|
| Conflicting Flow All | 0 | 0 | 59 | 0 | 79 |
| Stage 1 | - | - | - | - | 58 |
| Stage 2 | - | - | - | - | 21 |
| Critical Hdwy | - | - | 4.12 | - | 6.42 |
| Critical Hdwy Stg 1 | - | - | - | - | 5.42 |
| Critical Hdwy Stg 2 | - | - | - | - | 5.42 |
| Follow-up Hdwy | - | - | 2.218 | - | 3.518 |
| Pot Cap-1 Maneuver | - | - | 1545 | - | 924 |
| Stage 1 | - | - | - | - | 964 |
| Stage 2 | - | - | - | - | 1002 |
| Platoon blocked, % | - | - | - | - | - |
| Mov Cap-1 Maneuver | - | - | 1545 | - | 924 |
| Mov Cap-2 Maneuver | - | - | - | - | 924 |
| Stage 1 | - | - | - | - | 964 |
| Stage 2 | - | - | - | - | 1002 |

| Approach | EB | WB | NB |
|-------------------|----|----|------|
| HCM Ctrl Dly, s/v | 0 | 0 | 8.83 |
| HCM LOS | | | A |

| Minor Lane/Major Mvmt | NBLn1 | EBT | EBR | WBL | WBT |
|-----------------------|-------|-----|-----|------|-----|
| Capacity (veh/h) | 943 | - | - | 1545 | - |
| HCM Lane V/C Ratio | 0.005 | - | - | - | - |
| HCM Ctrl Dly (s/v) | 8.8 | - | - | 0 | - |
| HCM Lane LOS | A | - | - | A | - |
| HCM 95th %tile Q(veh) | 0 | - | - | 0 | - |

| Intersection | | | | | | |
|--------------------------|------|------|------|------|------|------|
| Int Delay, s/veh | 0.5 | | | | | |
| Movement | EBL | EBT | WBT | WBR | SBL | SBR |
| Lane Configurations | | ↕ | ↕ | | ↕ | |
| Traffic Vol, veh/h | 2 | 53 | 22 | 0 | 2 | 1 |
| Future Vol, veh/h | 2 | 53 | 22 | 0 | 2 | 1 |
| Conflicting Peds, #/hr | 0 | 0 | 0 | 0 | 0 | 0 |
| Sign Control | Free | Free | Free | Free | Stop | Stop |
| RT Channelized | - | None | - | None | - | None |
| Storage Length | - | - | - | - | 0 | - |
| Veh in Median Storage, # | - | 0 | 0 | - | 0 | - |
| Grade, % | - | 0 | 0 | - | 0 | - |
| Peak Hour Factor | 92 | 92 | 92 | 92 | 92 | 92 |
| Heavy Vehicles, % | 2 | 2 | 2 | 2 | 2 | 2 |
| Mvmt Flow | 2 | 58 | 24 | 0 | 2 | 1 |

| Major/Minor | Major1 | Major2 | Minor2 | | |
|----------------------|--------|--------|--------|---|-------------|
| Conflicting Flow All | 24 | 0 | - | 0 | 86 24 |
| Stage 1 | - | - | - | - | 24 - |
| Stage 2 | - | - | - | - | 62 - |
| Critical Hdwy | 4.12 | - | - | - | 6.42 6.22 |
| Critical Hdwy Stg 1 | - | - | - | - | 5.42 - |
| Critical Hdwy Stg 2 | - | - | - | - | 5.42 - |
| Follow-up Hdwy | 2.218 | - | - | - | 3.518 3.318 |
| Pot Cap-1 Maneuver | 1591 | - | - | - | 915 1053 |
| Stage 1 | - | - | - | - | 999 - |
| Stage 2 | - | - | - | - | 961 - |
| Platoon blocked, % | | - | - | - | |
| Mov Cap-1 Maneuver | 1591 | - | - | - | 914 1053 |
| Mov Cap-2 Maneuver | - | - | - | - | 914 - |
| Stage 1 | - | - | - | - | 997 - |
| Stage 2 | - | - | - | - | 961 - |

| Approach | EB | WB | SB |
|-------------------|------|----|------|
| HCM Ctrl Dly, s/v | 0.26 | 0 | 8.78 |
| HCM LOS | | | A |

| Minor Lane/Major Mvmt | EBL | EBT | WBT | WBR | SBLn1 |
|-----------------------|-------|-----|-----|-----|-------|
| Capacity (veh/h) | 65 | - | - | - | 956 |
| HCM Lane V/C Ratio | 0.001 | - | - | - | 0.003 |
| HCM Ctrl Dly (s/v) | 7.3 | 0 | - | - | 8.8 |
| HCM Lane LOS | A | A | - | - | A |
| HCM 95th %tile Q(veh) | 0 | - | - | - | 0 |

Intersection

Int Delay, s/veh 1.2

| Movement | EBL | EBT | EBR | WBL | WBT | WBR | NBL | NBT | NBR | SBL | SBT | SBR |
|--------------------------|------|------|------|------|------|------|------|------|------|------|------|------|
| Lane Configurations | | ↕ | | | ↕ | | | ↕ | | | ↕ | |
| Traffic Vol, veh/h | 2 | 20 | 1 | 0 | 25 | 1 | 1 | 1 | 0 | 0 | 0 | 4 |
| Future Vol, veh/h | 2 | 20 | 1 | 0 | 25 | 1 | 1 | 1 | 0 | 0 | 0 | 4 |
| Conflicting Peds, #/hr | 0 | 0 | 0 | 0 | 0 | 0 | 0 | 0 | 0 | 0 | 0 | 0 |
| Sign Control | Free | Free | Free | Free | Free | Free | Stop | Stop | Stop | Stop | Stop | Stop |
| RT Channelized | - | - | None | - | - | None | - | - | None | - | - | None |
| Storage Length | - | - | - | - | - | - | - | - | - | - | - | - |
| Veh in Median Storage, # | - | 0 | - | - | 0 | - | - | 0 | - | - | 0 | - |
| Grade, % | - | 0 | - | - | 0 | - | - | 0 | - | - | 0 | - |
| Peak Hour Factor | 92 | 92 | 92 | 92 | 92 | 92 | 92 | 92 | 92 | 92 | 92 | 92 |
| Heavy Vehicles, % | 2 | 2 | 2 | 2 | 2 | 2 | 2 | 2 | 2 | 2 | 2 | 2 |
| Mvmt Flow | 2 | 22 | 1 | 0 | 27 | 1 | 1 | 1 | 0 | 0 | 0 | 4 |

| Major/Minor | Major1 | Major2 | Minor1 | Minor2 |
|----------------------|--------|--------|--------|--------|
| Conflicting Flow All | 28 | 0 | 0 | 23 |
| Stage 1 | - | - | - | - |
| Stage 2 | - | - | - | - |
| Critical Hdwy | 4.12 | - | - | 4.12 |
| Critical Hdwy Stg 1 | - | - | - | - |
| Critical Hdwy Stg 2 | - | - | - | - |
| Follow-up Hdwy | 2.218 | - | - | 2.218 |
| Pot Cap-1 Maneuver | 1585 | - | - | 1592 |
| Stage 1 | - | - | - | - |
| Stage 2 | - | - | - | - |
| Platoon blocked, % | - | - | - | - |
| Mov Cap-1 Maneuver | 1585 | - | - | 1592 |
| Mov Cap-2 Maneuver | - | - | - | - |
| Stage 1 | - | - | - | - |
| Stage 2 | - | - | - | - |

| Approach | EB | WB | NB | SB |
|-------------------|------|----|------|------|
| HCM Ctrl Dly, s/v | 0.63 | 0 | 9.08 | 8.45 |
| HCM LOS | | | A | A |

| Minor Lane/Major Mvmt | NBLn1 | EBL | EBT | EBR | WBL | WBT | WBR | SBLn1 |
|-----------------------|-------|-------|-----|-----|------|-----|-----|-------|
| Capacity (veh/h) | 884 | 155 | - | - | 1592 | - | - | 1048 |
| HCM Lane V/C Ratio | 0.002 | 0.001 | - | - | - | - | - | 0.004 |
| HCM Ctrl Dly (s/v) | 9.1 | 7.3 | 0 | - | 0 | - | - | 8.5 |
| HCM Lane LOS | A | A | A | - | A | - | - | A |
| HCM 95th %tile Q(veh) | 0 | 0 | - | - | 0 | - | - | 0 |

Intersection

Int Delay, s/veh 1.1

| Movement | EBT | EBR | WBL | WBT | NBL | NBR |
|--------------------------|------|------|------|------|------|------|
| Lane Configurations | ↔ | | | ↕ | ↕ | |
| Traffic Vol, veh/h | 22 | 2 | 0 | 30 | 7 | 1 |
| Future Vol, veh/h | 22 | 2 | 0 | 30 | 7 | 1 |
| Conflicting Peds, #/hr | 0 | 0 | 0 | 0 | 0 | 0 |
| Sign Control | Free | Free | Free | Free | Stop | Stop |
| RT Channelized | - | None | - | None | - | None |
| Storage Length | - | - | - | - | 0 | - |
| Veh in Median Storage, # | 0 | - | - | 0 | 0 | - |
| Grade, % | 0 | - | - | 0 | 0 | - |
| Peak Hour Factor | 92 | 92 | 92 | 92 | 92 | 92 |
| Heavy Vehicles, % | 2 | 2 | 2 | 2 | 2 | 2 |
| Mvmt Flow | 24 | 2 | 0 | 33 | 8 | 1 |

| Major/Minor | Major1 | Major2 | Minor1 | Minor2 | Minor3 |
|----------------------|--------|--------|--------|--------|--------|
| Conflicting Flow All | 0 | 0 | 26 | 0 | 58 |
| Stage 1 | - | - | - | - | 25 |
| Stage 2 | - | - | - | - | 33 |
| Critical Hdwy | - | - | 4.12 | - | 6.42 |
| Critical Hdwy Stg 1 | - | - | - | - | 5.42 |
| Critical Hdwy Stg 2 | - | - | - | - | 5.42 |
| Follow-up Hdwy | - | - | 2.218 | - | 3.518 |
| Pot Cap-1 Maneuver | - | - | 1588 | - | 950 |
| Stage 1 | - | - | - | - | 998 |
| Stage 2 | - | - | - | - | 990 |
| Platoon blocked, % | - | - | - | - | - |
| Mov Cap-1 Maneuver | - | - | 1588 | - | 950 |
| Mov Cap-2 Maneuver | - | - | - | - | 950 |
| Stage 1 | - | - | - | - | 998 |
| Stage 2 | - | - | - | - | 990 |

| Approach | EB | WB | NB |
|-------------------|----|----|------|
| HCM Ctrl Dly, s/v | 0 | 0 | 8.78 |
| HCM LOS | | | A |

| Minor Lane/Major Mvmt | NBLn1 | EBT | EBR | WBL | WBT |
|-----------------------|-------|-----|-----|------|-----|
| Capacity (veh/h) | 961 | - | - | 1588 | - |
| HCM Lane V/C Ratio | 0.009 | - | - | - | - |
| HCM Ctrl Dly (s/v) | 8.8 | - | - | 0 | - |
| HCM Lane LOS | A | - | - | A | - |
| HCM 95th %tile Q(veh) | 0 | - | - | 0 | - |

Intersection

Int Delay, s/veh 1.7

| Movement | EBL | EBT | EBR | WBL | WBT | WBR | NBL | NBT | NBR | SBL | SBT | SBR |
|--------------------------|------|------|------|------|------|------|------|------|------|------|------|------|
| Lane Configurations | | ↕ | | | ↕ | | | ↕ | | | ↕ | |
| Traffic Vol, veh/h | 2 | 22 | 2 | 1 | 35 | 1 | 7 | 0 | 1 | 1 | 0 | 3 |
| Future Vol, veh/h | 2 | 22 | 2 | 1 | 35 | 1 | 7 | 0 | 1 | 1 | 0 | 3 |
| Conflicting Peds, #/hr | 0 | 0 | 0 | 0 | 0 | 0 | 0 | 0 | 0 | 0 | 0 | 0 |
| Sign Control | Free | Free | Free | Free | Free | Free | Stop | Stop | Stop | Stop | Stop | Stop |
| RT Channelized | - | - | None | - | - | None | - | - | None | - | - | None |
| Storage Length | - | - | - | - | - | - | - | - | - | - | - | - |
| Veh in Median Storage, # | - | 0 | - | - | 0 | - | - | 0 | - | - | 0 | - |
| Grade, % | - | 0 | - | - | 0 | - | - | 0 | - | - | 0 | - |
| Peak Hour Factor | 92 | 92 | 92 | 92 | 92 | 92 | 92 | 92 | 92 | 92 | 92 | 92 |
| Heavy Vehicles, % | 2 | 2 | 2 | 2 | 2 | 2 | 2 | 2 | 2 | 2 | 2 | 2 |
| Mvmt Flow | 2 | 24 | 2 | 1 | 38 | 1 | 8 | 0 | 1 | 1 | 0 | 3 |

| Major/Minor | Major1 | | | Major2 | | | Minor1 | | | Minor2 | | |
|----------------------|--------|---|---|--------|---|---|--------|-------|-------|--------|-------|-------|
| Conflicting Flow All | 39 | 0 | 0 | 26 | 0 | 0 | 70 | 71 | 25 | 69 | 71 | 39 |
| Stage 1 | - | - | - | - | - | - | 29 | 29 | - | 41 | 41 | - |
| Stage 2 | - | - | - | - | - | - | 40 | 41 | - | 28 | 30 | - |
| Critical Hdwy | 4.12 | - | - | 4.12 | - | - | 7.12 | 6.52 | 6.22 | 7.12 | 6.52 | 6.22 |
| Critical Hdwy Stg 1 | - | - | - | - | - | - | 6.12 | 5.52 | - | 6.12 | 5.52 | - |
| Critical Hdwy Stg 2 | - | - | - | - | - | - | 6.12 | 5.52 | - | 6.12 | 5.52 | - |
| Follow-up Hdwy | 2.218 | - | - | 2.218 | - | - | 3.518 | 4.018 | 3.318 | 3.518 | 4.018 | 3.318 |
| Pot Cap-1 Maneuver | 1571 | - | - | 1588 | - | - | 922 | 820 | 1051 | 923 | 819 | 1033 |
| Stage 1 | - | - | - | - | - | - | 988 | 871 | - | 974 | 861 | - |
| Stage 2 | - | - | - | - | - | - | 975 | 861 | - | 989 | 870 | - |
| Platoon blocked, % | | - | - | - | - | - | | | | | | |
| Mov Cap-1 Maneuver | 1571 | - | - | 1588 | - | - | 918 | 818 | 1051 | 920 | 818 | 1033 |
| Mov Cap-2 Maneuver | - | - | - | - | - | - | 918 | 818 | - | 920 | 818 | - |
| Stage 1 | - | - | - | - | - | - | 986 | 869 | - | 973 | 860 | - |
| Stage 2 | - | - | - | - | - | - | 971 | 860 | - | 986 | 869 | - |

| Approach | EB | | | WB | | | NB | | | SB | | |
|-------------------|------|--|--|-----|--|--|-----|--|--|------|--|--|
| HCM Ctrl Dly, s/v | 0.56 | | | 0.2 | | | 8.9 | | | 8.61 | | |
| HCM LOS | | | | | | | A | | | A | | |

| Minor Lane/Major Mvmt | NBLn1 | EBL | EBT | EBR | WBL | WBT | WBR | SBLn1 |
|-----------------------|-------|-------|-----|-----|-------|-----|-----|-------|
| Capacity (veh/h) | 932 | 136 | - | - | 48 | - | - | 1002 |
| HCM Lane V/C Ratio | 0.009 | 0.001 | - | - | 0.001 | - | - | 0.004 |
| HCM Ctrl Dly (s/v) | 8.9 | 7.3 | 0 | - | 7.3 | 0 | - | 8.6 |
| HCM Lane LOS | A | A | A | - | A | A | - | A |
| HCM 95th %tile Q(veh) | 0 | 0 | - | - | 0 | - | - | 0 |

| Intersection | | | | | | | | | | | | |
|--------------------------|------|------|------|------|------|------|------|------|------|------|------|------|
| Int Delay, s/veh | 1.8 | | | | | | | | | | | |
| Movement | EBL | EBT | EBR | WBL | WBT | WBR | NBL | NBT | NBR | SBL | SBT | SBR |
| Lane Configurations | | ↕ | | | ↕ | | | ↕ | | | ↕ | |
| Traffic Vol, veh/h | 9 | 44 | 3 | 0 | 16 | 6 | 0 | 0 | 0 | 3 | 2 | 5 |
| Future Vol, veh/h | 9 | 44 | 3 | 0 | 16 | 6 | 0 | 0 | 0 | 3 | 2 | 5 |
| Conflicting Peds, #/hr | 0 | 0 | 0 | 0 | 0 | 0 | 0 | 0 | 0 | 0 | 0 | 0 |
| Sign Control | Free | Free | Free | Free | Free | Free | Stop | Stop | Stop | Stop | Stop | Stop |
| RT Channelized | - | - | None | - | - | None | - | - | None | - | - | None |
| Storage Length | - | - | - | - | - | - | - | - | - | - | - | - |
| Veh in Median Storage, # | - | 0 | - | - | 0 | - | - | 0 | - | - | 0 | - |
| Grade, % | - | 0 | - | - | 0 | - | - | 0 | - | - | 0 | - |
| Peak Hour Factor | 92 | 92 | 92 | 92 | 92 | 92 | 92 | 92 | 92 | 92 | 92 | 92 |
| Heavy Vehicles, % | 2 | 2 | 2 | 2 | 2 | 2 | 2 | 2 | 2 | 2 | 2 | 2 |
| Mvmt Flow | 10 | 48 | 3 | 0 | 17 | 7 | 0 | 0 | 0 | 3 | 2 | 5 |

| Major/Minor | Major1 | | | Major2 | | | Minor1 | | | Minor2 | | |
|----------------------|--------|---|---|--------|---|---|--------|-------|-------|--------|-------|-------|
| Conflicting Flow All | 24 | 0 | 0 | 51 | 0 | 0 | 88 | 93 | 49 | 88 | 91 | 21 |
| Stage 1 | - | - | - | - | - | - | 69 | 69 | - | 21 | 21 | - |
| Stage 2 | - | - | - | - | - | - | 18 | 24 | - | 67 | 71 | - |
| Critical Hdwy | 4.12 | - | - | 4.12 | - | - | 7.12 | 6.52 | 6.22 | 7.12 | 6.52 | 6.22 |
| Critical Hdwy Stg 1 | - | - | - | - | - | - | 6.12 | 5.52 | - | 6.12 | 5.52 | - |
| Critical Hdwy Stg 2 | - | - | - | - | - | - | 6.12 | 5.52 | - | 6.12 | 5.52 | - |
| Follow-up Hdwy | 2.218 | - | - | 2.218 | - | - | 3.518 | 4.018 | 3.318 | 3.518 | 4.018 | 3.318 |
| Pot Cap-1 Maneuver | 1591 | - | - | 1555 | - | - | 898 | 797 | 1019 | 897 | 799 | 1057 |
| Stage 1 | - | - | - | - | - | - | 941 | 837 | - | 998 | 878 | - |
| Stage 2 | - | - | - | - | - | - | 1001 | 875 | - | 943 | 836 | - |
| Platoon blocked, % | | - | - | - | - | - | | | | | | |
| Mov Cap-1 Maneuver | 1591 | - | - | 1555 | - | - | 885 | 792 | 1019 | 892 | 794 | 1057 |
| Mov Cap-2 Maneuver | - | - | - | - | - | - | 885 | 792 | - | 892 | 794 | - |
| Stage 1 | - | - | - | - | - | - | 935 | 832 | - | 998 | 878 | - |
| Stage 2 | - | - | - | - | - | - | 993 | 875 | - | 937 | 831 | - |

| Approach | EB | | | WB | | | NB | | | SB | | |
|-------------------|------|--|--|----|--|--|----|--|--|------|--|--|
| HCM Ctrl Dly, s/v | 1.17 | | | 0 | | | 0 | | | 8.87 | | |
| HCM LOS | | | | | | | A | | | A | | |

| Minor Lane/Major Mvmt | NBLn1 | EBL | EBT | EBR | WBL | WBT | WBR | SBLn1 |
|-----------------------|-------|-------|-----|-----|------|-----|-----|-------|
| Capacity (veh/h) | - | 286 | - | - | 1555 | - | - | 942 |
| HCM Lane V/C Ratio | - | 0.006 | - | - | - | - | - | 0.012 |
| HCM Ctrl Dly (s/v) | 0 | 7.3 | 0 | - | 0 | - | - | 8.9 |
| HCM Lane LOS | A | A | A | - | A | - | - | A |
| HCM 95th %tile Q(veh) | - | 0 | - | - | 0 | - | - | 0 |

Intersection

Int Delay, s/veh 0.9

| Movement | EBT | EBR | WBL | WBT | NBL | NBR |
|--------------------------|------|------|------|------|------|------|
| Lane Configurations | ↔ | | | ↕ | ↕ | |
| Traffic Vol, veh/h | 54 | 9 | 1 | 20 | 7 | 2 |
| Future Vol, veh/h | 54 | 9 | 1 | 20 | 7 | 2 |
| Conflicting Peds, #/hr | 0 | 0 | 0 | 0 | 0 | 0 |
| Sign Control | Free | Free | Free | Free | Stop | Stop |
| RT Channelized | - | None | - | None | - | None |
| Storage Length | - | - | - | - | 0 | - |
| Veh in Median Storage, # | 0 | - | - | 0 | 0 | - |
| Grade, % | 0 | - | - | 0 | 0 | - |
| Peak Hour Factor | 92 | 92 | 92 | 92 | 92 | 92 |
| Heavy Vehicles, % | 2 | 2 | 2 | 2 | 2 | 2 |
| Mvmt Flow | 59 | 10 | 1 | 22 | 8 | 2 |

| Major/Minor | Major1 | Major2 | Minor1 | Minor2 | Minor3 |
|----------------------|--------|--------|--------|--------|--------|
| Conflicting Flow All | 0 | 0 | 68 | 0 | 88 |
| Stage 1 | - | - | - | - | 64 |
| Stage 2 | - | - | - | - | 24 |
| Critical Hdwy | - | - | 4.12 | - | 6.42 |
| Critical Hdwy Stg 1 | - | - | - | - | 5.42 |
| Critical Hdwy Stg 2 | - | - | - | - | 5.42 |
| Follow-up Hdwy | - | - | 2.218 | - | 3.518 |
| Pot Cap-1 Maneuver | - | - | 1533 | - | 913 |
| Stage 1 | - | - | - | - | 959 |
| Stage 2 | - | - | - | - | 999 |
| Platoon blocked, % | - | - | - | - | - |
| Mov Cap-1 Maneuver | - | - | 1533 | - | 913 |
| Mov Cap-2 Maneuver | - | - | - | - | 913 |
| Stage 1 | - | - | - | - | 959 |
| Stage 2 | - | - | - | - | 998 |

| Approach | EB | WB | NB |
|-------------------|----|------|------|
| HCM Ctrl Dly, s/v | 0 | 0.35 | 8.91 |
| HCM LOS | | | A |

| Minor Lane/Major Mvmt | NBLn1 | EBT | EBR | WBL | WBT |
|-----------------------|-------|-----|-----|-------|-----|
| Capacity (veh/h) | 931 | - | - | 86 | - |
| HCM Lane V/C Ratio | 0.011 | - | - | 0.001 | - |
| HCM Ctrl Dly (s/v) | 8.9 | - | - | 7.4 | 0 |
| HCM Lane LOS | A | - | - | A | A |
| HCM 95th %tile Q(veh) | 0 | - | - | 0 | - |

Intersection

Int Delay, s/veh 0.9

| Movement | EBL | EBT | EBR | WBL | WBT | WBR | NBL | NBT | NBR | SBL | SBT | SBR |
|--------------------------|------|------|------|------|------|------|------|------|------|------|------|------|
| Lane Configurations | | ↕ | | | ↕ | | | ↕ | | | ↕ | |
| Traffic Vol, veh/h | 2 | 61 | 8 | 1 | 26 | 0 | 4 | 0 | 1 | 2 | 0 | 1 |
| Future Vol, veh/h | 2 | 61 | 8 | 1 | 26 | 0 | 4 | 0 | 1 | 2 | 0 | 1 |
| Conflicting Peds, #/hr | 0 | 0 | 0 | 0 | 0 | 0 | 0 | 0 | 0 | 0 | 0 | 0 |
| Sign Control | Free | Free | Free | Free | Free | Free | Stop | Stop | Stop | Stop | Stop | Stop |
| RT Channelized | - | - | None | - | - | None | - | - | None | - | - | None |
| Storage Length | - | - | - | - | - | - | - | - | - | - | - | - |
| Veh in Median Storage, # | - | 0 | - | - | 0 | - | - | 0 | - | - | 0 | - |
| Grade, % | - | 0 | - | - | 0 | - | - | 0 | - | - | 0 | - |
| Peak Hour Factor | 92 | 92 | 92 | 92 | 92 | 92 | 92 | 92 | 92 | 92 | 92 | 92 |
| Heavy Vehicles, % | 2 | 2 | 2 | 2 | 2 | 2 | 2 | 2 | 2 | 2 | 2 | 2 |
| Mvmt Flow | 2 | 66 | 9 | 1 | 28 | 0 | 4 | 0 | 1 | 2 | 0 | 1 |

| Major/Minor | Major1 | | | Major2 | | | Minor1 | | | Minor2 | | |
|----------------------|--------|---|---|--------|---|---|--------|-------|-------|--------|-------|-------|
| Conflicting Flow All | 28 | 0 | 0 | 75 | 0 | 0 | 105 | 105 | 71 | 101 | 110 | 28 |
| Stage 1 | - | - | - | - | - | - | 75 | 75 | - | 30 | 30 | - |
| Stage 2 | - | - | - | - | - | - | 30 | 30 | - | 71 | 79 | - |
| Critical Hdwy | 4.12 | - | - | 4.12 | - | - | 7.12 | 6.52 | 6.22 | 7.12 | 6.52 | 6.22 |
| Critical Hdwy Stg 1 | - | - | - | - | - | - | 6.12 | 5.52 | - | 6.12 | 5.52 | - |
| Critical Hdwy Stg 2 | - | - | - | - | - | - | 6.12 | 5.52 | - | 6.12 | 5.52 | - |
| Follow-up Hdwy | 2.218 | - | - | 2.218 | - | - | 3.518 | 4.018 | 3.318 | 3.518 | 4.018 | 3.318 |
| Pot Cap-1 Maneuver | 1585 | - | - | 1524 | - | - | 874 | 785 | 992 | 880 | 780 | 1047 |
| Stage 1 | - | - | - | - | - | - | 934 | 833 | - | 986 | 870 | - |
| Stage 2 | - | - | - | - | - | - | 986 | 870 | - | 939 | 829 | - |
| Platoon blocked, % | | - | - | - | - | - | | | | | | |
| Mov Cap-1 Maneuver | 1585 | - | - | 1524 | - | - | 871 | 783 | 992 | 877 | 779 | 1047 |
| Mov Cap-2 Maneuver | - | - | - | - | - | - | 871 | 783 | - | 877 | 779 | - |
| Stage 1 | - | - | - | - | - | - | 933 | 831 | - | 986 | 869 | - |
| Stage 2 | - | - | - | - | - | - | 984 | 869 | - | 937 | 828 | - |

| Approach | EB | | | WB | | | NB | | | SB | | |
|-------------------|-----|--|--|------|--|--|------|--|--|-----|--|--|
| HCM Ctrl Dly, s/v | 0.2 | | | 0.27 | | | 9.06 | | | 8.9 | | |
| HCM LOS | | | | | | | A | | | A | | |

| Minor Lane/Major Mvmt | NBLn1 | EBL | EBT | EBR | WBL | WBT | WBR | SBLn1 |
|-----------------------|-------|-------|-----|-----|-------|-----|-----|-------|
| Capacity (veh/h) | 893 | 50 | - | - | 67 | - | - | 927 |
| HCM Lane V/C Ratio | 0.006 | 0.001 | - | - | 0.001 | - | - | 0.004 |
| HCM Ctrl Dly (s/v) | 9.1 | 7.3 | 0 | - | 7.4 | 0 | - | 8.9 |
| HCM Lane LOS | A | A | A | - | A | A | - | A |
| HCM 95th %tile Q(veh) | 0 | 0 | - | - | 0 | - | - | 0 |

APPENDIX D

Sight Distance Exhibit

IRON RIDGE SUBDIVISION

SITE DISTANCE

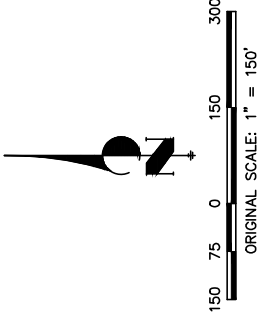
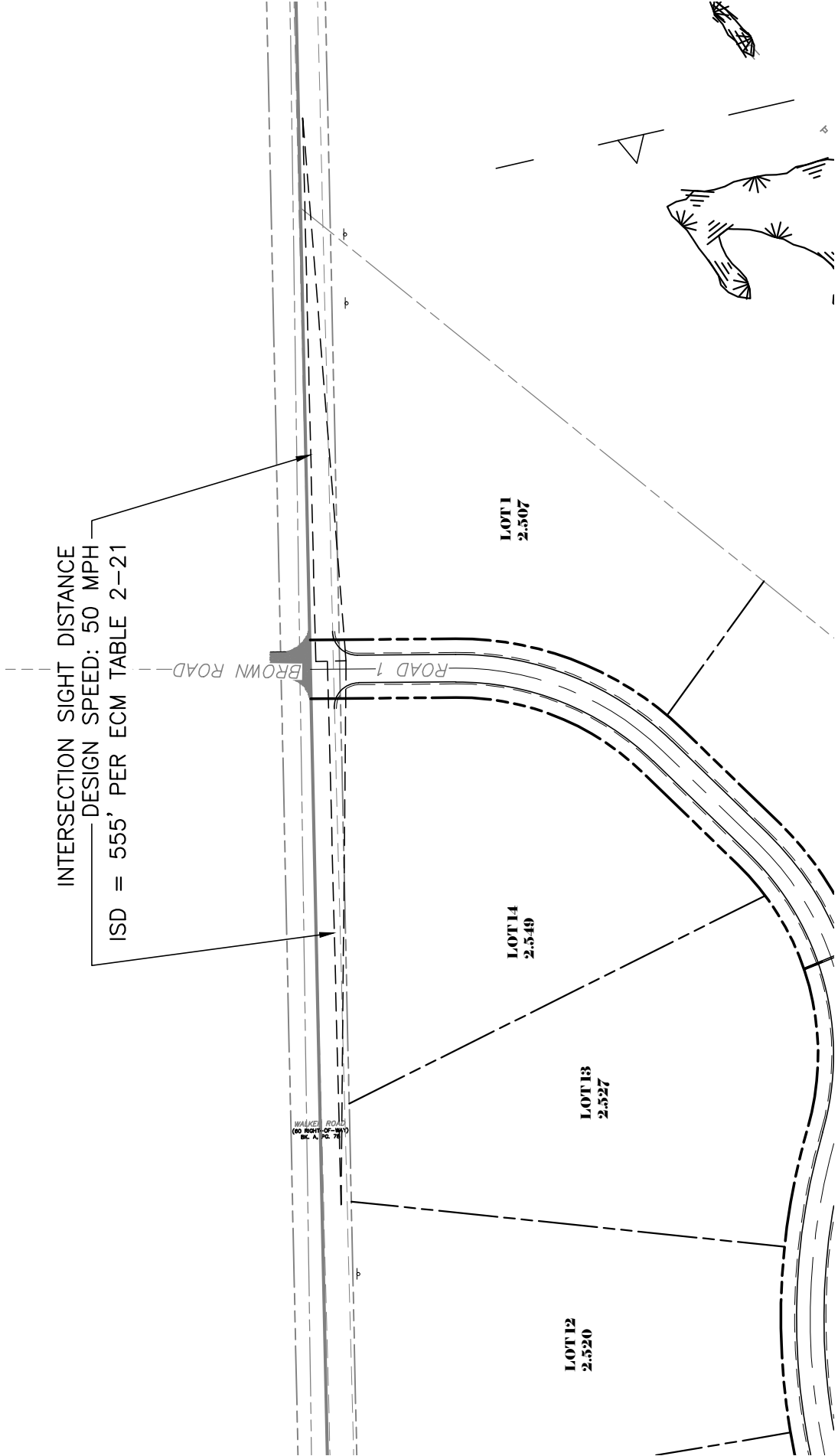

| | |
|-----------------|-------|
| SITE DISTANCE | |
| IRON RIDGE SUB. | |
| JOB NO. 25009 | |
| LOCATION: EPC | SHEET |
| 11/04/2025 | |

