

TRI-LAKES MONUMENT FIRE PROTECTION DISTRICT

15455 Gleneagle Drive, Suite 230
Colorado Springs, CO 80921
Bus: (719) 484-0911 Fax (719) 481-3456



Jamey Bumgarner, Fire Marshal

June 22 2017

El Paso County Development Review
Attention: Raimere Fitzpatrick
File Number: SF-17-015

Applicant: The Beach at Woodmoor

Tri-Lakes Monument Fire Protection District (TLMFPD) upon review of the proposed building has determined that the proposed design appears to meet the minimum requirements established by the International Fire Code-2009 (IFC-09) and the TLMFPD Local Amendments to the IFC-09.

This site and future structure shall be designed and constructed in accordance with the IFC-09 as adopted and amended locally by the TLMFPD.

Some items of note are:

1. Construction Plans: Approved drawings shall be submitted to this district for review and approval after receiving a preliminary review by the Pikes Peak Regional Building Department.
2. Fire hydrant(s) spacing/location per Appendix B. Additional hydrant(s) required.
3. Hazardous Materials: IFC-09/Appendix H has been adopted and shall be completed and submitted with the construction permit drawings as necessary.
4. IFC-09/Appendix J (Emergency Responder Radio Coverage) is mandatory and adopted by TLMFPD. Building owner must show documentation that emergency responder radios will work inside this building or a radio coverage system must be installed prior to fire final.
5. Fire Protection System(s) shall be reviewed and approved by Colorado Springs Fire Department (CSFD) Construction Services. If applicable.
6. All partials and fire finals are conducted by CSFD and TLMFPD. If applicable.
7. Contractor/Building Owner shall submit a "Contractor's Material & Test Certificate" for all Underground Piping for Water-Based Fire Systems, Per NFPA 25.
8. Coordination with this site and possible development of nearby site(s) should be considered for fire hydrant placement and spacing.

TRI-LAKES MONUMENT FIRE PROTECTION DISTRICT

15455 Gleneagle Drive, Suite 230
Colorado Springs, CO 80921
Bus: (719) 484-0911 Fax (719) 481-3456



Jamey Bumgarner, Fire Marshal

Chapter 1 – Administration

Chapter 5 – Fire Service Features

Chapter 9 – Fire Protection Systems

Chapter 10 – Means of Egress

Chapter 14 – Fire Safety During Construction & Demolition

Chapter 23 – High-Pile Combustible Storage

Chapter 30 – Compressed Gas

Chapter 46 – Construction Requirements for Existing Buildings

Appendix D – Fire Apparatus Access Roads

Appendix E – Hazard Categories

Appendix F – Hazard Rankings

Appendix G – Cryogenic Fluids – Weight and Volume Equivalents

Appendix H – HMMP and HMIS

Appendix J – Emergency Responder Radio Coverage

Appendix K – Wildland-Urban Interface Requirements

TRI-LAKES MONUMENT FIRE PROTECTION DISTRICT

15455 Gleneagle Drive, Suite 230
Colorado Springs, CO 80921
Bus: (719) 484-0911 Fax (719) 481-3456



Jamey Bumgarner, Fire Marshal

Administration chapter 1

Section 101 – General

Section 101.1. Title. Amend Section 101.1 by adding the following: These regulations shall be known as the *Fire Code* of the Tri-Lakes Monument Fire Protection District, as applicable, hereinafter referred to as “this code”

Section 101.2.1. Appendices. Delete Section 101.2.1 and replace with the following: 101.2.1 Appendices. In conjunction with the adoption of the 2009 International Fire Code, the above mentioned Authority Having Jurisdiction (AHJ) also adopts Appendixes B, C, D, E, F, G, H, J and K as amended, as part of the provisions and requirements of this code.

Section 102 – Applicability

Section 102.7. Referenced Codes and Standards. Amend Section 102.7 to read as follows: “102.7. Referenced Codes and Standards. The codes and standards referenced in this code shall be those that are listed in Chapter 47 and such codes and standards shall be considered part of the requirements of this code to the prescribed extent of each such reference. Where differences occur between the provisions of this code and the referenced standards, the provisions of this code shall apply.” The current edition shall become effective on January 1 of the year following the NFPA’s effective date for the standard.

Section 105 – Permits

Section 105.1.4. Permit Fees. Add a new section 105.1.4 to read as follows: “105.1.4 Permit Fees. A permit fee shall be paid to the (AHJ) at a rate established and adjusted by the AHJ Board of Directors. These fees recover costs associated with inspection related activities, such as plan reviews, physical inspections, and associated administrative activities. All permit fees shall be paid directly to the AHJ.”

TRI-LAKES MONUMENT FIRE PROTECTION DISTRICT

15455 Gleneagle Drive, Suite 230
Colorado Springs, CO 80921
Bus: (719) 484-0911 Fax (719) 481-3456



Jamey Bumgarner, Fire Marshal

Fire Service Features chapter 5

Section 505 – Premises Identification

Section 505.1. Address Identification. Amend Section 505.1 as follows: Address Identification shall be per Pikes Peak Regional Building Code 2011, Section RBC312.11 Address Numbers on Buildings.

Section 505.1.1. Suite Numbers. Add a new section 505.1.1 to read as follows:
505.1.1 Suite Numbers. Any area occupied by tenants of a mall or shopping center, the main entrance to which is from the inside of the mall or shopping center, or any area used for other than single-unit or multi-unit residential occupancy that abuts a public courtyard or other public space shall be identified by numbers that are a minimum of four (4) inches in height with no less than one half (1/2) inch stroke so as to be plainly visible and legible from a distance of at least fifty (50) feet from the main entrance to the area.”

Section 505.1.2. Addressing of Rear Doors. Add a new section 505.1.2 to read as follows: “505.1.2 Addressing of Rear Doors. The rear entrance or access doors of all malls, strip center, commercial center buildings, and other areas with multi-tenant spaces shall be identified with the appropriate address numbers. The address numbers/letters shall be at least four (4) inches high with a minimum stroke width of one half (1/2) inch. The AHJ may require the installation of address numbers/letters on other locations to prevent confusion in the event of an emergency.

Section 510 Emergency Responder Radio Coverage

Section 510.3. Emergency Responder Radio Coverage in Existing Buildings. Delete Section 510.3 in its entirety.

Fire Protection Systems chapter 9

Section 901- General

Section 901.3.1. Relocation and Additions to Fire Sprinklers in Existing Buildings. Add a new section 901.3.1 to read as follows. “901.3.1 Relocations and Additions to Fire Sprinklers in Existing Buildings:

- 1). Any additions or remodeling to existing commercial sprinkler systems that involve 20 sprinkler heads or less, 5 or less fire alarm devices will not require a

TRI-LAKES MONUMENT FIRE PROTECTION DISTRICT

15455 Gleneagle Drive, Suite 230
Colorado Springs, CO 80921
Bus: (719) 484-0911 Fax (719) 481-3456



Jamey Bumgarner, Fire Marshal

permit through the AHJ; however a letter from a PPRBD licensed sprinkler contractor shall be submitted to the AHJ. The letter shall be on the sprinkler contractor's letterhead long with a set of plans. Electronic submittal of the information is authorized.

2). This does not apply to spray booths, NFPA 13D or 13R systems, special hazard systems, or other special stipulations previously mandated and required by the AHJ.

3). All systems with more than 20 heads or more than 5 fire alarm devices must conform to all local and state standards including plan submittal, permits, and other requirements.

Section 901 .10. Clear Space Around Fire Protection Equipment. Add a new Section 901.10 to read as follows: "901.10 Clear Space Around Fire Protection Equipment. A three (3) foot circumference clear space shall be maintained around all fire protection equipment. This clear space shall include an unobstructed path of travel and access to all fire protection equipment.

Section 904 – Alternative Automatic Fire-Extinguishing Systems

Section 904.11.6.4. Ventilation System Interconnection. Add a new Section 904.11.6.4 to read as follows: "904.11.6.4 Ventilation System Interconnection. Upon activation of the fire suppression systems, the exhaust for the hood shall remain on.

Section 905 – Standpipe Systems

Section 905.3.1. Building Height. Delete all exceptions and Amend Section 905.3.1 to read as follows: "905.3.1 Building Height. Class I automatic wet standpipe system shall be installed throughout buildings where the floor level of the highest story is located more than 30 feet above the lowest level of the fire department vehicle access, or where the floor level of the lowest story is located more than 30 below the highest level of fire department vehicle access.

Exception: "Manual dry standpipes are allowed in open parking garages that are subject to freezing temperatures, provided that the hose connections are located so that all portions of the building are within 30 feet of a nozzle attached to 100 feet of hose."

Section 905.3.4.1. Hose and Cabinet. Delete Section 905.3.4.1 in its entirety.



Jamey Bumgarner, Fire Marshal

Section 905.4. Location of Class I Standpipe Hose Connections. Amend Section 905.4 Location of Class I Standpipe Hose Connections, by adding an exception to subsection number 1, to read as follows:

1. In every required stairway, a hose connection shall be provided for each floor level above or below grade. Hose connections shall be located at an intermediate floor level landing between floors, unless otherwise approved by the fire code official.

Exception: When stairways are constructed with a vestibule in accordance with the International Building Code, the hose connection shall be installed inside the floor level vestibule, not in the stairway.

Section 907 – Fire Alarm and Detection Systems

Section 907.2.6.2.1. Alternative Designs. Add a new Section 907.2.6.2.1 to read as follows: “907.2.6.2.1 Alternative Design. As an alternative design, addressable system smoke detectors may be used in patient rooms. In such case, a visual notification in the corridor shall not be required and the patient room detector shall initiate the building alarm. A remote Annunciator shall be located at the respective nurse’s station.”

Section 907.2.8.3. Smoke Alarms. Amend Section 907.2.8.3 to read as follows: “907.2.8.3 Smoke Alarms. Single and multiple station smoke alarms shall be installed in accordance with Section 907.2.11. Smoke alarms provided in guest rooms may be annunciated at the fire alarm control panel as supervisory only.”

Section 907.2.9.2. Smoke Alarms. Amend Section 907.2.9.2 to read as follows: “907.2.9.2. Smoke Alarms single and multiple station smoke alarms shall be installed in accordance with Section 907.2.11. Smoke alarms provided in guest rooms may be annunciated at the fire alarm control panel as supervisory only.”

Section 910 – Smoke and Heat Vents

Section 910.1. General. Amend Section 910.1 by deleting number 2.

Section 910.3.2.2. Sprinklered Buildings. Amend Section 910.3.2.2 to read as follows: “910.3.2.2 Sprinklered Buildings. Where installed in buildings equipped with an approved automatic sprinkler system, smoke and heat vents shall be designed to operate automatically by activation of a heat-responsive device rated at least 100 degrees above the operating temperature of the fire sprinkler heads in the immediate vicinity of the vent. Vents shall also be manually operable from the exterior by an approved means.

TRI-LAKES MONUMENT FIRE PROTECTION DISTRICT

15455 Gleneagle Drive, Suite 230
Colorado Springs, CO 80921
Bus: (719) 484-0911 Fax (719) 481-3456



Jamey Bumgarner, Fire Marshal

Section 912 – Fire Department Connections

Section 912.1.2. Inlets. Add a new Section 912.1.2 to read as follows: “912.1.2 Inlets. There shall be a minimum of one 2.5” connection for every 250 gallons per minute (GPM) of system demand.

Section 912.1.3. Multiple Fire Department Connections. Add a new Section 912.1.3 to read as follows: “912.1.3 Multiple Fire Department Connections (FDC’s). When demand of sprinkler system exceeds 1500 GPM’s, additional FDC’s shall be provided and located as specified by the fire code official. Multiple FDC’s shall be of equal capacity.”

Section 912.1.1. Indicating Device. Add a new Section 912.2.1.1 to read as follows: “912.2.1.1 indicating Device. A listed horn and strobe, activated by the sprinkler water-flow switch, shall be located within 20 feet of the FDC, and shall be highly visible to emergency responders along their normally anticipated arrival route.”

Means of Egress Chapter 10

Section 1029 – Emergency Escape and Rescue

Section 1029.6. Emergency Escape Openings Below Horizontal Projections. Add a new Section 1029.6 to read as follows: “1029.6 Emergency Escape Openings Below Horizontal Projections. Emergency escape openings may be located below decks, porches, cantilevers and similar horizontal projections provided one of the following exists:

1. The location of the projection allows the emergency escape opening to be fully opened and provides a path not less than 36 inches in height and width to a yard or court.
2. The minimum horizontal area of 9 square feet is provided clear of the projection and the horizontal projection of the operable portion of the egress window and ladder, if required, remain clear of the projection.”

TRI-LAKES MONUMENT FIRE PROTECTION DISTRICT

15455 Gleneagle Drive, Suite 230

Colorado Springs, CO 80921

Bus: (719) 484-0911 Fax (719) 481-3456



Jamey Bumgarner, Fire Marshal

Fire Safety During Construction & Demolition Chapter 14

Section 1402 – Definitions

Section 1402.1. Temporary Fire Access Road. Add a new section 1402.2 to read as follows: “1402.2 Temporary Fire Access Road. Temporary access roads shall be an all weather surface comprised of either the first lift of asphalt or concrete and/or compacted gravel to a thickness capable of supporting the imposed loads of fire department apparatus. A 20 foot minimum width shall be maintained unless the permanent road is designed less than 20 feet, in which case the temporary road shall be the intended width of the permanent road. Adequate street signs and fire lane signs shall be installed where applicable. Temporary access roads must be maintained in accordance with this section. Temporary roads serving as fire lanes shall not be in place more than 6 months without special approval from the fire district.”

Compressed Gas Chapter 30

Section 3003 – General Requirements

Section 3003.7.12. Location. Add a new Section 3003.7.12 to read as follows: “3003.7.12 Location. Portable or manifold cylinders located inside of a building shall be stored in a well-ventilated, dry location at least 20 feet from combustible material and at least 10 feet from elevators, stairways, corridors, exits or in areas normally used, as a means of egress.”

TRI-LAKES MONUMENT FIRE PROTECTION DISTRICT

15455 Gleneagle Drive, Suite 230
Colorado Springs, CO 80921
Bus: (719) 484-0911 Fax (719) 481-3456



Jamey Bumgarner, Fire Marshal

Construction Requirements for Existing Buildings Chapter 46

Section 4603 – Fire Safety Requirements for Existing Buildings

Section 4603.1. Required Construction. Amend Section 4603.1 to read as follows:
“4603.1 Required Construction. Existing buildings shall comply as enumerated in Sections 4603.6 through 4603.7.3”

The provisions of this chapter shall not be construed to allow the elimination of fire protection systems or a reduction in the level of fire safety provided in buildings constructed in accordance with previously adopted codes.

Exception: Group U Occupancies.

Table 4603.1 Occupancy and Use Requirements. Delete Table 4603.1 in its entirety.

Section 4603.2 Elevator Operation. Delete Section 4603.2 in its entirety.

Section 4603.3 Vertical Openings. Delete Section 4603.3 in its entirety.

Section 4603.4 Sprinkler Systems. Delete Section 4603.4 in its entirety.

Section 4603.5 Standpipes. Delete Section 4603.5 in its entirety.

Section 4603.6.5 Group R-1. Delete Section 4603.6.5 in its entirety.

Section 4603.6.5.1 Group R-1 Hotel and Motel Manual Fire Alarm System. Delete Section 4603.6.5.1 in its entirety.

Section 4603.6.5.1.1 Group R-1 Hotel and Motel Automatic Smoke Detection System. Delete Section 4603.6.5.1.1 in its entirety.

Section 4603.6.5.2 Group R-1 Boarding and Rooming Houses Manual Fire Alarm System. Delete Section 4603.6.5.2 in its entirety.

Section 4603.6.5.2.1 Group R-1 Boarding and Rooming Houses Automatic Smoke Detection System. Delete Section 4603.6.5.2.1 in its entirety.

Section 4603.6.6 Group R-2. Delete Section 4603.6.6 in its entirety.

Section 4604.23 Egress Path Markings. Delete Section 4604.23 in its entirety.



Jamey Bumgarner, Fire Marshal

High Pile Storage Chapter 23

Section 4606. Existing High-Piled Storage Facilities. Create a new Section as follows: “Section 4606 Existing High-Piled Storage Facilities.”

Section 4606.1. Scope. This Section is applicable to all high-piled combustible storage in buildings that meet at least one of the following criteria:

1. Any existing building built prior to January 1, 1988, containing the same occupant, original occupant, and utilizing high pile storage defined by the Chapter.
2. Any existing, non-conforming, building utilizing high pile storage, defined by this chapter, in which no official records such as certificate of occupancy, fire department records or similar verifying the occupancy of the current tenant.

Section 4606.2. Storage of Class I-IV and High Hazard Commodities. The storage of class I-IV and high hazard commodities shall meet the provisions of this section as set forth.

Section 4606.2.2. Smoke/Heat Vents/Draft Curtains. Smoke and heat vents shall be provided in accordance with Section 2306.7. When required, a vent area to floor area ratio of 1:200 shall be utilized. Draft curtains, when required, may only be used in non-sprinklered buildings and in accordance with Section 2306.7

Appendix D Fire Apparatus Roads

SECTION D102 – REQUIRED ACCESS

Section D102.1. Access and Loading. Amend Section D102.1 to read as follows: “D102.1.

Access and Loading. Facilities, buildings or portions of buildings hereafter constructed shall be accessible to fire department apparatus by way of an approved fire apparatus access road with an asphalt, concrete or other approved driving surface capable of supporting the imposed load of fire apparatus weighing at least 75,000 pounds with a minimum single axle weight of 27,000 pounds.”



Jamey Bumgarner, Fire Marshal

Section D103.1. Access Road Width with a Hydrant. Delete Section D103.1 in its entirety.

Figure D103.1. Dead-End Fire Apparatus Access Road Turnaround. Delete Figure D103.1 and replace with the following:

FIGURE D103.1 MINIMUM DEAD-END FIRE APPARATUS ACCESS ROAD TURNAROUND.

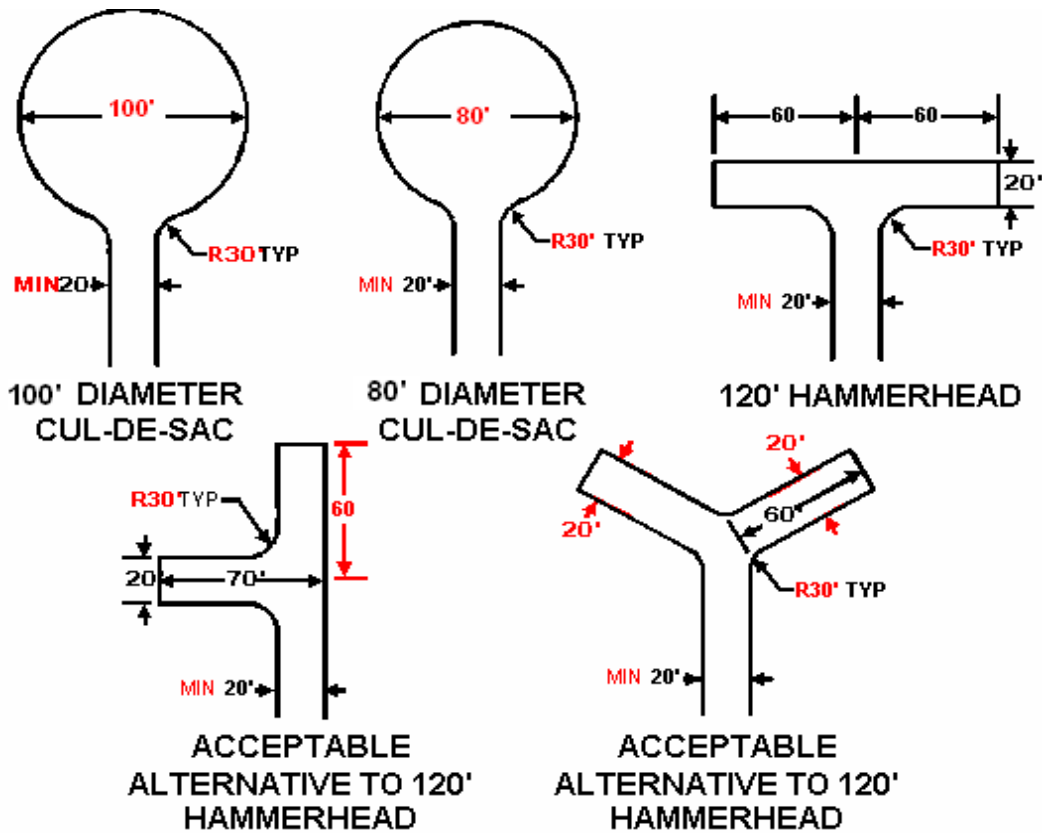

TRI-LAKES MONUMENT FIRE PROTECTION DISTRICT

15455 Gleneagle Drive, Suite 230

Colorado Springs, CO 80921

Bus: (719) 484-0911 Fax (719) 481-3456



Jamey Bumgarner, Fire Marshal

Table D103.4. Requirements for Dead-End Fire Apparatus Access Roads. Delete Table D103.4 and replace with the following:

FIGURE D103.4 MINIMUM REQUIREMENTS FOR DEAD-END FIRE APPARATUS ACCESS ROADS

DEAD-END LENGTH (FEET)	MINIMUM ROAD WIDTH (FEET)	APPROVED TURNAROUND OPTIONS (See Figure D103.1)
0 - 150	20	NONE REQUIRED
151 – 500	20	1) 120-FOOT HAMMERHEAD 2) 60-FOOT "Y" 3) 80- FOOT DIAMETER CUL-DE-SAC FOR DEAD-ENDS WITH CURB AND GUTTER 4) 100-FOOT DIAMETER CUL-DE-SAC FOR DEAD-ENDSWITHOUT CURB AND GUTTER
501 – 750	20	100-FOOTDIAMETER CUL-DE-SAC (ADDITIONAL INTERMEDIATE TURNAROUNDS MAY BE REQUIRED)
OVER 750		SPECIAL AHJ APPROVAL IS REQUIRED

Section D103.6. Signs. Amend Section D103.6 to read as follows: "D103.6. Fire Apparatus Access Road Marking. Where required by the fire code official, fire apparatus access roads shall be marked with permanent NO PARKING – FIRE LANE markings consisting of signage complying with Section D103.8 and/or striping complying with Section D103.7. Approved markings shall be posted on one or both sides of the fire apparatus road as required by Sections D103.6.1 through D103.6.3 (all amended Sections, below)."

Figure D103.6. Fire Lane Signs. Delete Figure D103.6. Fire Lane Signs. See new Figure D103.8.

Section D103.6.1. Roads Less Than 28 Feet in Width. Amend Section D103.6.1 to read as follows: "D103.6.1. Roads Less Than 28 Feet in Width. Fire apparatus access roads less than 28 feet in width shall be posted on both sides as a fire lane."

Section D103.6.2. Roads More Than 28 Feet and Less Than 34 Feet in Width. Amend Section D103.6.2 to read as follows: "D103.6.2. Roads more than 28 feet and less than 34 feet in width. Fire apparatus access roads more than 28 feet and less than 34 feet wide shall be posted on one side of the road as a fire lane."

TRI-LAKES MONUMENT FIRE PROTECTION DISTRICT

15455 Gleneagle Drive, Suite 230

Colorado Springs, CO 80921

Bus: (719) 484-0911 Fax (719) 481-3456



Jamey Bumgarner, Fire Marshal

Section D103.6.3. Roads 34 Feet in Width or Greater. Add a new Section D103.6.3 to read as follows: "D103.6.3. Roads 34 feet in width or greater. Fire apparatus access roads 34 feet in width or greater do not require marking as a fire lane."

Section D103.7. Striping. Add a new Section D103.7 to read as follows: "D103.7. Striping. When striping is used to identify fire apparatus access roads, the striping shall comply with this Section and Figure D103.7. Striping shall consist of painted lines of red traffic paint six inches in width to show the boundaries of the fire lane. The words "NO PARKING FIRE LANE" shall appear in four inch high white reflective letters having a 3/4 inch stroke and spacing in 25 feet intervals on the red traffic paint. Striping shall be located along one or both sides of the fire lane as required by Section D103.6. Where a curb is available, the striping shall be on the vertical face of the curb."

Figure D103.7. Fire Lane Striping. Add a new Figure D103.7. Fire Lane Striping. As follows:



Amend the subtitle of Appendix E to read as follows:

"This appendix is adopted for information purposes."

Amend the subtitle of Appendix F to read as follows:

"This appendix is adopted for information purposes."

Amend the subtitle of Appendix G to read as follows:

"This appendix is adopted for information purposes."

TRI-LAKES MONUMENT FIRE PROTECTION DISTRICT

15455 Gleneagle Drive, Suite 230

Colorado Springs, CO 80921

Bus: (719) 484-0911 Fax (719) 481-3456



Jamey Bumgarner, Fire Marshal

Amend the subtitle of Appendix H to read as follows:

“The provisions of this appendix are mandatory and adopted.”

Amend the subtitle of Appendix J to read as follows:

“The provisions of this appendix are mandatory and adopted.”

Section K101 – General

Section K101.2. Objective. The objective of this appendix is to develop minimum regulations consistent with nationally recognized good practice for the safeguarding of life and property within the designated Wildland-Urban Interface Zone. Sections within this appendix are intended to mitigate the risk to life and structures from intrusion of fire from Wildland exposures and fire exposures from spreading to Wildland fuels.

Section K104.1. Grade. Driveways shall not exceed 10 percent grade.

Section K105 – Signs and Address Markers

Section K105.1. Residential Structures. The remote address sign for residential structures shall be placed at the driveway entrance. The address numbers shall be visible from both the intended and opposite directions of travel.

Section K107 – Building Construction

Section K107.1. Roofing. All structures re-roofed or constructed after the adoption of this code and located within the Wildland-Urban Interface shall be roofed with a Class A roof covering or a Class A roof assembly (solid wood roofing materials, i.e. wood shakes and wood shingles shall not be used).

Section K107.2. Replacement or Repair of Roof Coverings. The roof covering on buildings or structures in existence prior to the adoption of this section that are replaced or have 25 percent or more replaced in a 12 month period shall be replaced with a Class A roof covering or a Class A roof Assembly (excluding solid wood roofing, i.e. wood shakes and wood shingles).

TRI-LAKES MONUMENT FIRE PROTECTION DISTRICT

15455 Gleneagle Drive, Suite 230

Colorado Springs, CO 80921

Bus: (719) 484-0911 Fax (719) 481-3456



Jamey Bumgarner, Fire Marshal

Section K108 – Defensible Space Requirement for New Construction

Section K 108.1. Defensible Space. Structures located in the Wildland-Urban interface area shall be clear of all vegetation by a distance of not less than 10 feet. This distance may be increased by the AHJ, upon reviewing site specific conditions. In addition to the 10 feet of clear space a safety zone of not less than 30 feet in all directions from the structure shall be maintained. The safety zone consists of small brush patches, not exceeding 100 square feet and 15 lineal feet in any direction.

All vegetation shall be placed in a fire safe manner to include pruning limbs located less than 6 feet above ground surface. Adequate thinning shall occur so that trees do not have overlapping limbs.

Tree branches shall not extend over or under roof eaves or decks and shall not be within 15 feet of a wood burning appliance.

Jamey Bumgarner
Fire Marshal