

**DRAINAGE LETTER
FOR
7886 RANNOCH MOOR WAY
EL PASO COUNTY, COLORADO
VR262**

DESIGN ENGINEER'S STATEMENT:

The attached drainage plan and report were prepared under my direction and supervision and are correct to the best of my knowledge and belief. Said drainage report has been prepared according to the criteria established by the County for drainage reports and said report is in conformity with the applicable master plan of the drainage basin. I accept responsibility for any liability caused by any negligent acts, errors or omissions on my part in preparing this report.



John Fornander, P.E. 66415
On behalf of Terra Nova Engineering, Inc.

Date

OWNER/DEVELOPER'S STATEMENT:

I, the owner/developer have read and will comply with all of the requirements specified in this drainage report and plan.



Authorized Signature

05/12/2026

Date

Scott E Strate, Owner

Printed Name, Title

Aspen Valley Custom Homes

Business Name

25 Misty Creek Drive, Monument, Co 80132

Address

EL PASO COUNTY:

Filed in accordance with the requirements of the Drainage Criteria Manual, Volumes 1 and 2, El Paso County Engineering Criteria Manual and Land Development Code as amended.

Joshua J Palmer, P.E.
County Engineer / ECM Administrator

Date

Conditions:

May 10, 2026

RE: 7886 Rannoch Moor Way
Colorado Springs, CO 80908
PCD #: VR262

To Whom It May Concern:

We have reviewed the previously approved "Preliminary/Final Drainage Report for Highland Park Filing No. 3 (File No.: SF08013)" prepared by Law & Mariotti Consultants, Inc. revised May 5 2016, relating to 7886 Rannoch Moor Way (AKA Lot 151 Rannoch Moor Way) and have gathered information from aerial views and on site visits. Terra Nova Engineering is of the opinion that stormwater drainage will be in an acceptable condition after the alteration of the existing drainage channel per the grading and erosion control plan that I have submitted along with this letter. See the attached GEC plan below. The 100-year flow of 29.8 cfs will be maintained inside of the new drainage easement with 1 foot of freeboard as shown by the calculations included in this submittal. The channel design and calculations from the previously approved report are included with this letter to show compliance. The flow path is to be altered from the existing path in order to make use of the lot for a residence at a future date. A revised plat is also included with this submittal. The area of disturbance on this site is 1.73 acres. This site is excluded from PCM applicability because it meets the "Large Lot Exclusion" per ECM App 1.7.1.B.5. Therefore, no water quality treatment will be required. The changes will not affect the drainage as prescribed in the approved drainage report and will not affect any other neighboring or downstream sites.

Maintenance responsibility for the existing drainage easement will not change from the current conditions and will be the responsibility of the lot owner.

In an effort to protect receiving water and as part of the "four-step process to minimize adverse impacts of urbanization" this site was analyzed in the following manner:

1. Reduce Runoff- The proposed site will be covered in vegetation which will reduce runoff through infiltration.
2. Stabilize Drainageways- The proposed drainageway will be stabilized temporarily through the use of check dams and permanently through the establishment of vegetation.
3. Provide Water Quality Capture Volume (WQCV)- This site is excluded from PCM applicability because it meets the "Large Lot Exclusion" per ECM App 1.7.1.B.5. Therefore, no water quality treatment will be required.
4. Consider Need for Industrial and Commercial BMPs- No Industrial and Commercial BMPs have been deemed necessary for this project.

If you require any additional information, please feel free to contact me directly.

Sincerely,

Terra Nova Engineering, Inc.

John Fornander, P.E.

Project Engineer

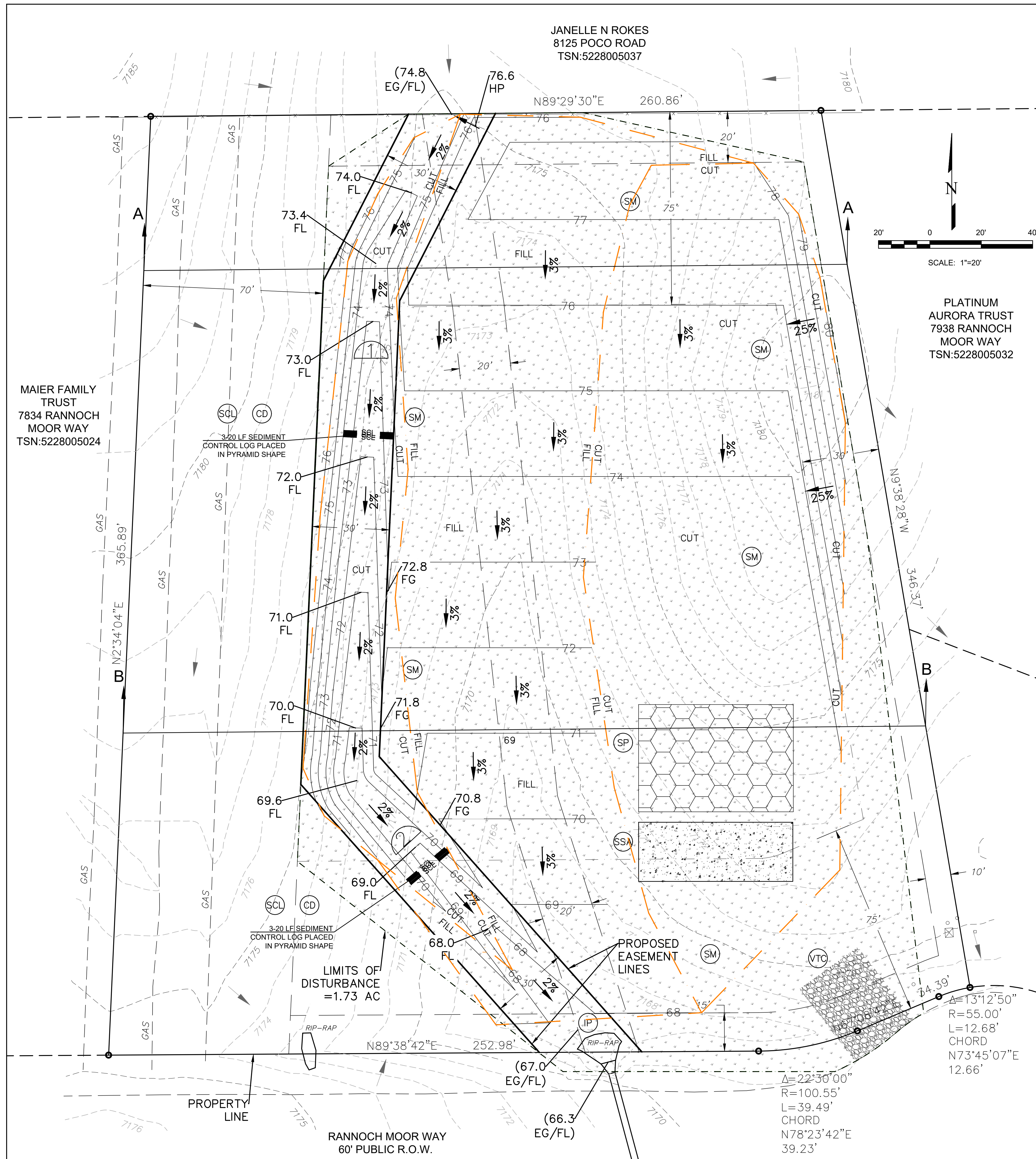

LEGEND

- - - - - EXISTING CONTOUR-MAJOR
- - - - - EXISTING CONTOUR-MINOR
- EXISTING FLOW DIRECTION
- EXISTING PROPERTY LINE/ROW
- - - - - EXISTING EASEMENT
- - - - - LIMITS OF DISTURBANCE/CONSTRUCTION
- PROPOSED EASEMENT
- - - - - ADJACENT PROPERTY LINE/ROW
- CUT/FILL BOUNDARY

EROSION CONTROL LEGEND

KEY	TITLE	SYMBOL
FINAL (SM)	PERMANENT SEEDING AND MULCHING (FINAL)	[Symbol]
INTERIM (SSA)	STABILIZED STAGING AREA (INTERIM)	[Symbol]
INTERIM (VTC)	VEHICLE TRACKING CONTROL (INTERIM)	[Symbol]
INTERIM (SP)	STOCKPILE PROTECTION (INTERIM)	[Symbol]
INITIAL & INTERIM (SCL)	SEDIMENT CONTROL LOG (INITIAL & INTERIM)	[Symbol]
INITIAL & INTERIM (CD)	CHECK DAM (INITIAL & INTERIM)	[Symbol]
INITIAL & INTERIM (IP)	INLET PROTECTION (INITIAL & INTERIM)	[Symbol]

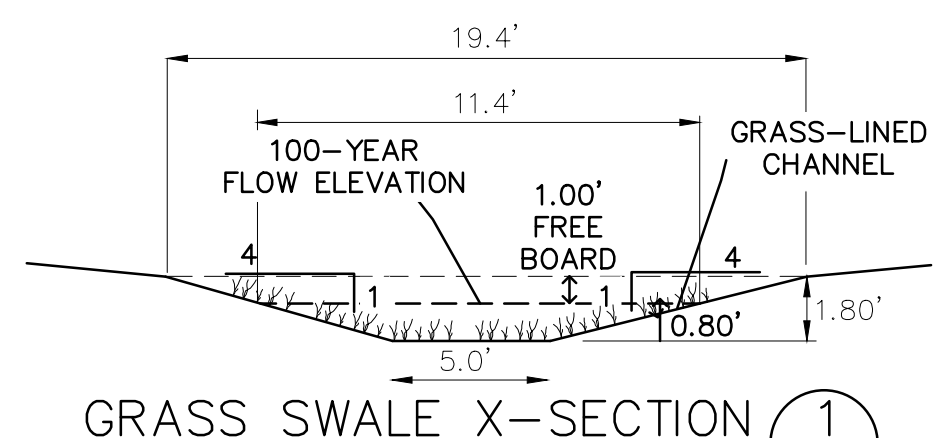

SCALE : NTS
 Q (100-YEAR) = 29.8 CFS
 SLOPE = 2.0%
 n VALUE = 0.030
 DEPTH = 0.80'
 VELOCITY = 4.8 FT/S

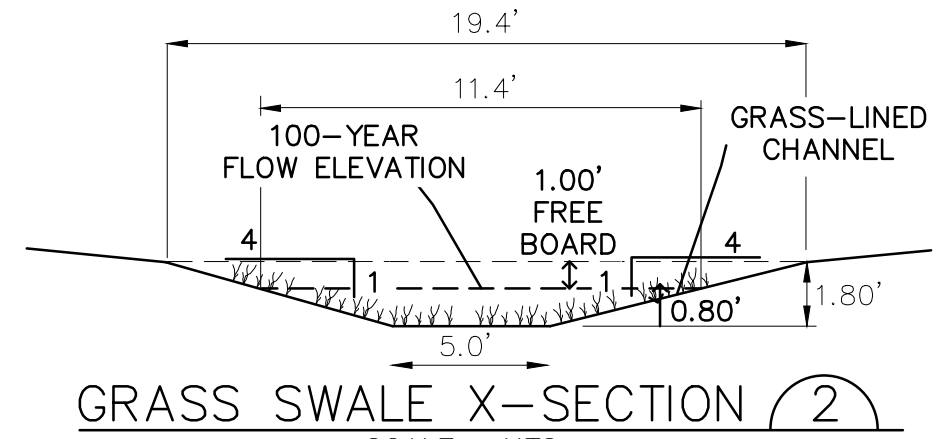

SCALE : NTS
 Q (100-YEAR) = 29.8 CFS
 SLOPE = 2.0%
 n VALUE = 0.030
 DEPTH = 0.80'
 VELOCITY = 4.8 FT/S

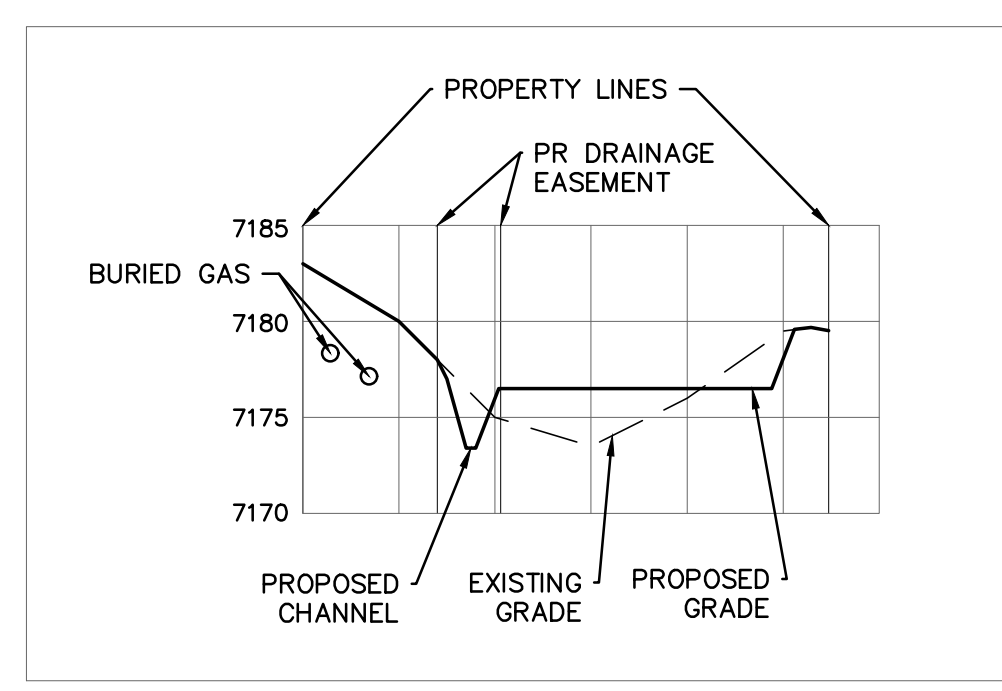

ENTIRE LOT CROSS SECTION A-A



SCALE: 1"=100' HORIZ
 1"=10' VERT

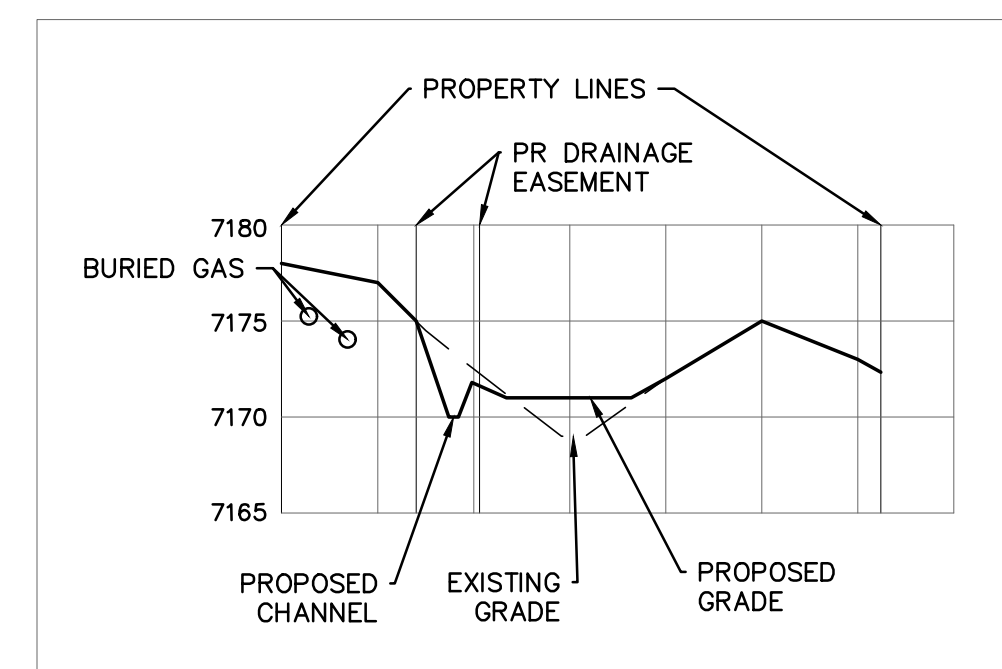

ENTIRE LOT CROSS SECTION B-B

GENERAL NOTES

- CONTRACTOR TO MARK UP PLAN SHOWING ACTUAL FIELD INSTALLATION OF EROSION CONTROL BMPs.
- BROADCAST SEEDING SHALL BE PLACED OVER DISTURBED AREAS ONCE THE CONSTRUCTION IS DONE.
- TOTAL LIMITS OF DISTURBANCE ESTIMATED TO BE APPROXIMATELY 1.73 AC.
- WHEN WORK HAS BEEN COMPLETED, CONTRACTOR SHALL RETURN ANY DISTURBED AREAS TO THEIR ORIGINAL GRADES ON AREAS THAT ARE NOT RE-GRADED PER THESE PLANS. USE SURFACE ROUGHENING OR TRACK WHEELING ON SLOPES AND SWALE WITHIN DRAINAGE EASEMENT.
- MAX ALLOWABLE EXCAVATED/STOCKPILED SLOPE IS 3:1.
- VEGETATIVE COVER IS APPROXIMATELY 70% CONSISTING OF NATIVE GRASSES.
- GEOTECH REPORT SHALL BE DONE PRIOR TO OBTAINING BUILDING PERMIT. GEOTECH RECOMMENDATIONS MUST BE FOLLOWED.

THIS DESIGN WAS PREPARED UNDER MY DIRECT SUPERVISION FOR AND ON BEHALF OF TERRA NOVA ENGINEERING, INC.

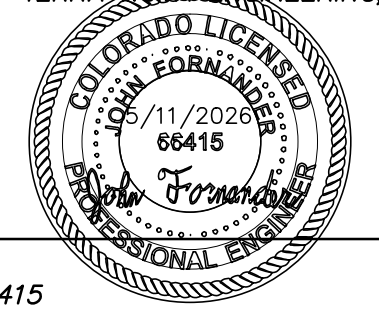

JOHN FORWANDER, P.E.
 COLORADO P.E. NO. 66415

NO.	REVISIONS	DESCRIPTION	DATE

UNTIL SUCH TIME AS THESE DRAWINGS ARE APPROVED BY THE APPROPRIATE REVIEWING AGENCIES, INCORPORATING THEIR USE ONLY FOR THEIR USE FOR PURPOSES DESIGNATED BY WRITTEN AUTHORIZATION.

PREPARED FOR:
 ASPEN VALLEY CUSTOM HOMES
 ATTN: SCOTT STRATE
 PO BOX 49
 MONUMENT, CO 80132
 (719) 314-9830

721 S. 23RD STREET
 COLORADO SPRINGS, CO 80904
 OFFICE: 719-635-6422
 FAX: 719-635-6426
 www.tnove.com

Terra Nova
 Engineering, Inc.
 "Creating the City" Engineering Inc.

7886 RANNOCH MOOR WAY

GRADING, EROSION, & SEDIMENT CONTROL PLAN

DESIGNED BY	JF
DRAWN BY	JF
CHECKED BY	
H-SCALE	AS SHOWN
V-SCALE	NA
JOB NO.	2602.00
DATE ISSUED	5/11/26
SHEET NO.	2 OF 4

RELEVANT EXCERPTS FROM PREVIOUS
DRAINAGE REPORT

Normal Flow Analysis - Trapezoidal Channel

Project: **Highland Park Fil 3**
 Channel ID: **CH-10 (6B) =29.8 CFS**

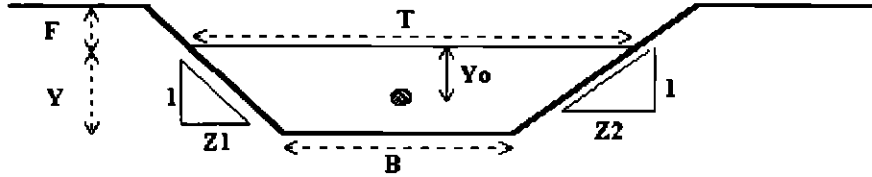

Design Information (Input)

Channel Invert Slope	So =	0.0200 ft/ft
Channel Manning's N	N =	0.040
Bottom Width	B =	5.0 ft
Left Side Slope	Z1 =	10.0 ft/ft
Right Side Slope	Z2 =	10.0 ft/ft
Freeboard Height	F =	0.0 ft
Design Water Depth	Y =	0.75 ft

Normal Flow Condition (Calculated)

Discharge	Q =	29.7 cfs
Froude Number	Fr =	0.82
Flow Velocity	V =	3.2 fps
Flow Area	A =	9.4 sq ft
Top Width	T =	20.0 ft
Wetted Perimeter	P =	20.1 ft
Hydraulic Radius	R =	0.5 ft
Hydraulic Depth	D =	0.5 ft
Specific Energy	Es =	0.9 ft
Centroid of Flow Area	Yo =	0.3 ft
Specific Force	Fs =	0.4 kip

Design Point OS-1 – This represents the total flow from off-site sub-basin OS-A12 having a 100-year flow of 127.4 cfs which enters and exits the property along its extreme North West corner.

Developed Conditions

Design Point 1 – This represents the total flow from on-site sub-basin D-1 having a 5-year flow of 10.6 cfs and a 100-year flow of 45.2 cfs which will exit the property along its westerly boundary via surface flow and enter a tributary of Cottonwood Creek.

Design Point 2 – This represents the total flow from on-site sub-basin D-2 having a 5-year flow of 2.7 cfs and a 100-year flow of 11.6 cfs will collect in roadside ditches and convey south under proposed Culloden Court via a proposed 24" RCP at the roadway intersection. Flow then conveys via roadside ditch to DP-4.

Design Point 3 – This represents the total flow from on-site sub-basin D-3 having a 5-year flow of 4.9 cfs and a 100-year flow of 21.2 cfs which will convey overland south, collect into a roadside ditch and convey to a proposed 24" RCP under proposed Rannoch Way. Flow then conveys south. A drainage easement is provided to convey this flow through lot 134 and to the proposed ditch along the future alignment of Briargate Parkway.

Design Point 4 – On-site sub-basins D-2 and D-4 combine for a 5-year flow of 3.8 cfs and a 100-year flow of 10.3 cfs which will collect in a roadside ditch and convey south under proposed Rannoch Way via a proposed 24" RCP at the roadway intersection. Flow then conveys south via ditch flow to DP-9.

Design Point 5A – This represents the total flow from off-site sub-basin OSD-1 having a 5-year flow of 2.5 cfs and a 100-year flow of 19.2 cfs which will enter the property along its northerly boundary via overland flow.

Design Point 5B – Combined flow from on-site sub-basin D-5 and off-site sub-basin OSD-1 produce a 5-year flow of 9.0 cfs and a 100 year flow of 49.5 cfs will collect in roadside ditches and convey south under proposed Rannoch Way via twin proposed 30" RCP culverts at the roadway intersection. Flow then conveys via ditch flow to DP 8.

Design Point 6A – This represents the total flow from off-site sub-basin OSD-2 having a 5-year flow of 3.2 cfs and a 100-year flow of 24.6 cfs which will enter the property along its northerly boundary via overland flow.

Design Point 6B – Combined flow from on-site sub-basin D-6A and off-site sub-basin OSD-2 produce a 5-year flow of 4.4 cfs and a 100 year flow of 29.8 cfs which will be conveyed south via a proposed 30" RCP culvert under the

proposed Rannoch Moor Way. The low area that currently exists downstream of the proposed inlet is proposed to be regarded. Flow then conveys south via ditch flow to DP 6C.

Design Point 6C – Combined flow from on-site sub-basin D-6B and Design Point 6B produce a 5-year flow of 9.4 cfs and a 100 year flow of 49.8 cfs which will be conveyed south via a proposed 36" RCP culvert under the proposed Briargate Parkway Extended. Flow then conveys south via ditch flow to DP 12.

Design Point 6D – This represents the total flow from off-site sub-basin OSD-4 having a 5-year flow of 0.8 cfs and a 100-year flow of 6.4 cfs which will enter the property along its northerly boundary via overland flow.

Design Point 7 – This represents the total flow from on-site sub-basin D-7 having a 5-year flow of 1.2 cfs and a 100-year flow of 4.7 cfs which will exit the property eastward at historical patterns and volume.

Design Point 8 – Combined flow from Design Point 5B and on-site sub-basin D-8 produce a 5-year flow of 12.5 cfs and a 100-year flow of 62.5 cfs, which will be conveyed westward via a proposed 48" RCP culvert at the roadway intersection under Lochwinnoch Lane. Flow then conveys via ditch flow to DP 9.

Design Point 9 – Flow from Design Points 3, 4, and 8 combine with on-site sub-basin D-9 to produce a 5-year flow of 19.5 cfs and a 100-year flow of 90.5 cfs, which will be conveyed westward via ditch flow to Cottonwood Creek. A D-9 ditch inlet and 36" storm sewer is proposed to convey flow to Cottonwood Creek. A rip-rap dissipation structure is proposed to dissipate the energy from this flow. The 36" storm sewer is intended to be permanent and should connect to the future drainage structure once Briargate Boulevard is extended.

Design Point 10 – This represents the total flow from on-site sub-basin D-10 having a 5-year flow of 4.9 cfs and a 100-year flow of 10.4 cfs which will be conveyed westward via ditch flow to Cottonwood Creek.

Design Point 11 – This represents the total flow from on-site sub-basin D-11A having a 5-year flow of 1.3 cfs and a 100-year flow of 5.2 cfs which will be conveyed south via a proposed 18" RCP at the roadway intersection under Bannoch Burn Trail. Flow then conveys via ditch flow to DP-16 to a point being the existing roadside ditch of Lochwinnoch Lane.

Design Point 12 – Combined flow from Design Point 6C and on-site sub-basin D-12 produce a 5-year flow of 9.4 cfs and a 100-year flow of 50.0 cfs. A small detention facility is proposed to provide water quality and storm water detention. See drainage plan for details. Out flow of 5.2 cfs and 32.0 cfs will then be conveyed south via a proposed 30" RCP culvert under the proposed Bannoch Burn Trail. Flow then conveys via ditch flow to DP 13.