



# EL PASO COUNTY PLANNING & COMMUNITY DEVELOPMENT SIGN APPLICATION

DATE: 8/21/2017

**Business**

Name: Service King  
Address: 6110 Southmoor Dr.

Zone: N/A  
Legal Description: LOT 2 BROWN SUB

**Type of Sign**

**Wall**

Illuminated: YES  
Non-Illuminated: NO  
Valuation: 4,500.00

Storefront Length &/or Width: 150.67'

Proposed Sign Sq. Ft. 48.95

Existing Sign Sq. Ft. 33

Total Sign Sq. Ft. 81.95

**Contractor Information**

Name: Sign Shop Illuminated

Address: 3505 E. Platte Ave. Colorado Springs, CO

Phone: 719.573.1567

Type of License: D5A

Contractor ID# 13325

**Vicinity Map**  
Tax Schedule # 6514401002  
Please show major intersections.

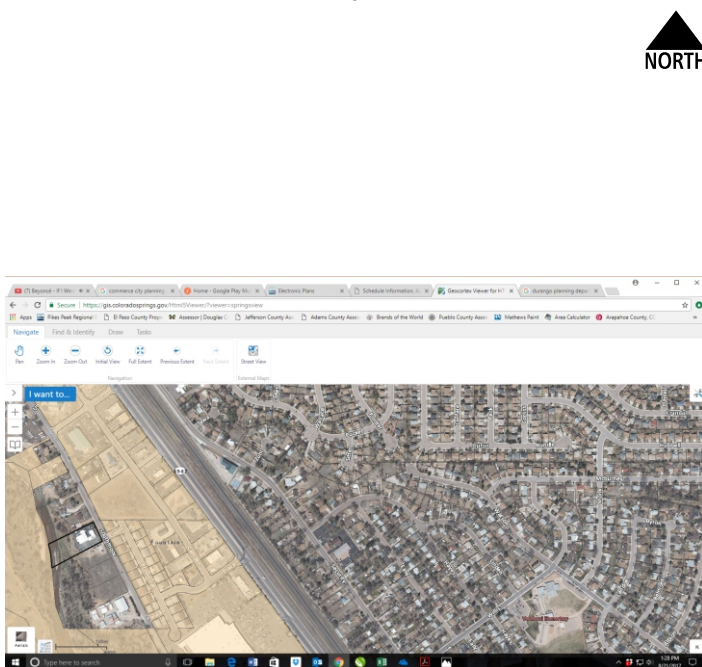

**Elevation Drawing**  
Indicate storefront length & placement of sign

**Inventory Recommendation Detail**

N01

RECOMMENDATION	Proposed Action	New Install
	Proposed Sign Type	Wall Sign
	Sign ID	WC-OVF-Sx12
	Dimensions	Illuminated 5'2" x 12'w
	Flex Face Oval Wall Sign	
	Signage Text	Service King Collision Repair Center
	Wall Repair	N/A
	Comments	Install new 5'-2"x12' Flex Face wall sign and run new electrical to the new sign location.

**Sign Plan**  
(Please indicate dimensions and sign copy)

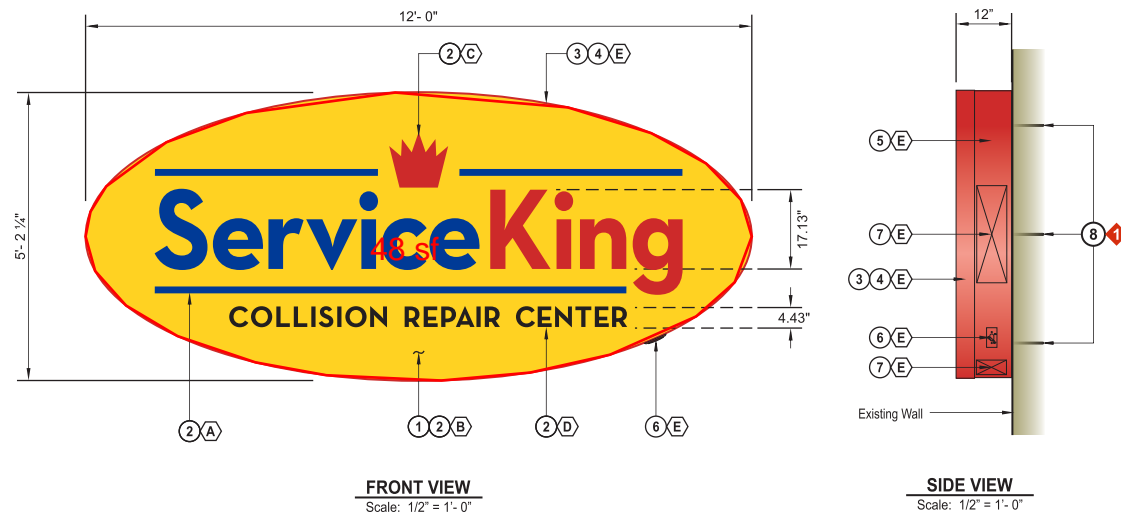

**Approx. Total Weight: 595 Lbs.**  
This is Only Estimated Weight, Actual Weight May Vary Significantly

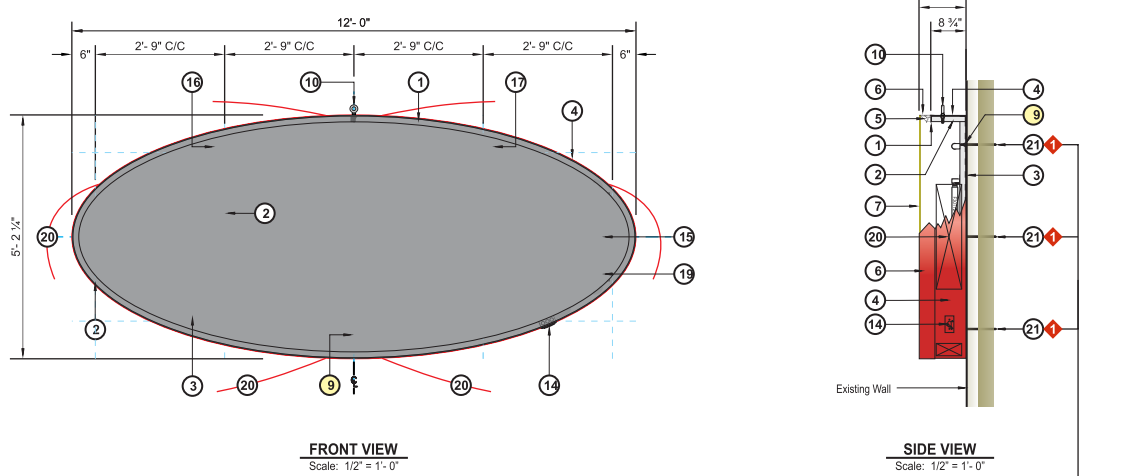

**Approx. Total Weight: 595 Lbs.**  
This is Only Estimated Weight, Actual Weight May Vary Significantly

**INSTALLATION NOTE:**  
- 3/8"-16 Nuts Welded Inside Sign For Mounting Flush to Wall  
- Access Through Face of Sign is Not Necessary.

SER9S1F1002	
5-2 x 12-0 - SF WALL CABINET FLEX FACE - 62 SQ. FT.	
Installation:	<input type="checkbox"/> Interior: <input checked="" type="checkbox"/> Exterior:
Electrical Specifications:	
Volts:	120 Amp.: 5.70 Circ.: 1
# Descriptions:	
1	ARLON DPF-390 WHITE FLEX FACE MATERIAL (6'-6" ROLL)
2	ARLON TRANSLUCENT VINYL APPLIED TO 1st SURFACE
3	SIGNCOMP #2104 RETRO BLEED FRAME
4	SIGNCOMP #2121 RETRO BLEED FRAME COVER
5	.080" THK ALUM. WELDED RETURNS
6	DISCONNECT SWITCH w/ WEATHERPROOF COVER
7	HINGED SERVICE DOOR (TYP.)
8	3/8"-16 HARDWARE FOR MOUNTING
*	T12 DAYLIGHT HIGH OUTPUT FLUORESCENT LAMPS
*	120V ELECTRONIC SIGN BALLASTS
*	120V / 20A / 60HZ DEDICATED CIRCUIT - REQUIRED

SER9S1F1002	
5-2 x 12-0 - SF WALL CABINET FLEX FACE - 62 SQ. FT.	
Installation:	<input type="checkbox"/> Interior: <input checked="" type="checkbox"/> Exterior:
Electrical Specifications:	
Volts:	120 Amp.: 5.70 Circ.: 1
# Descriptions:	
1	.125" ALUM. CABINET FLANGE RING
2	1 1/2" x 1 1/2" x .188" ALUM. ANGLE VERTICAL BRACING
3	.125" ALUM. BACK PANEL
4	.080" THK ALUM. WELDED RETURNS
5	SIGNCOMP #2104 RETRO BLEED FRAME
6	SIGNCOMP #2121 RETRO BLEED FRAME COVER
7	ARLON DPF-390 WHITE FLEX FACE MATERIAL (6'-6" ROLL)
8	ARLON TRANSLUCENT VINYL APPLIED TO 1st SURFACE
9	(8) 3/8"-16 ALUM. WELDED NUTS FOR MOUNTING
10	2" x 12" DIA. EYE BOLT FOR PICK-UP
11	(2) F72T12/DLHO FLUORESCENT LAMPS (HORIZ.)
12	(3) F108T12/DLHO FLUORESCENT LAMPS (HORIZ.)
13	(2) F30T12/DLHO FLUORESCENT LAMPS (VERT.)
14	DISCONNECT SWITCH w/ WEATHERPROOF COVER
15	(2) ESB-104C-14 BALLASTS (1-LAMP/510°-40°) @ 2.85 AMPS EA.
16	(7) 530.2KIS SPRING-LOADED TOMBSTONE SOCKETS (TYP.)
17	(7) 530.2KIS STATIONARY TOMBSTONE SOCKETS (TYP.)
18	RW-3 SOCKET WIREWAY (TYP.)
19	RW-4 BALLAST WIREWAY (TYP.)
20	HINGED SERVICE DOOR (TYP.)
21	3/8"-16 HARDWARE FOR MOUNTING
*	120V / 20A / 60HZ DEDICATED CIRCUIT - REQUIRED

**For Planning & Community Development Use Only**

Approved Date: RF 9/5/2017 Resubmittal? Yes  No

Denied Date: \_\_\_\_\_

Comments: Approved wall sign of approximately 48.95 SF wall sign as depicted.