

Stormwater Management Plan

for:

Super Star Carwash (Meadowbrook)
Colorado Springs, CO

Operator(s):

Super Star Carwash
1830 N 95th Ave, Suite 106
Phoenix, AZ 85037
801-651-1748
Tim Varley

SWMP Preparer

Ayres Associates
3665 JFK Parkway, Bldg, Suite 100
Fort Collins, CO 80525
262-522-4901
Scott Maier P.E.

Site Contact/Qualified Stormwater Manager

Name _____
Address _____
City, State _____
Contact # _____
Contact Name _____

Site Contractor:

Name _____
Address _____
City, State _____
Contact # _____
Contact Name _____

SWPPP Preparation Date: **October 2023**

Estimated Project Dates:

Project Start Date: October, 2023
Project Completion Date: August, 2024

Contents

SECTION 1: SITE EVALUATION, ASSESSMENT, AND PLANNING	1
1.1 Project/Site Information.....	1
1.2 Contact Information/Responsible Parties.....	2
1.2 Nature and Sequence of Construction Activity.....	3
1.3 Existing Soils, Slopes, Vegetation, and Current Drainage Patterns	3
1.4 Receiving Waters.....	4
1.5 Potential Sources of Pollution and Erosion Potential	4
1.6 Endangered Species Certification.....	5
SECTION 2: EROSION AND SEDIMENT CONTROL BMPS	5
2.1 Phase Construction Activity.....	5
SECTION 3: GOOD HOUSEKEEPING BMPS	7
3.1 Material Handling and Waste Management.....	10
SWPPP APPENDICES	21
Appendix A – General Location Map	
Appendix B – Site Maps	
Appendix C – Construction General Permit	
Appendix D – NOI and Acknowledgement Letter from EPA/State	
Appendix E – Inspection Reports	
Appendix F – Corrective Action Log (or in Part 5.3)	
Appendix G – SWPPP Amendment Log (or in Part 6.2)	
Appendix H – Subcontractor Certifications/Agreements	
Appendix I – Grading and Stabilization Activities Log (or in Part 6.1)	
Appendix J – Training Log	
Appendix K – Delegation of Authority	

SECTION 1: SITE EVALUATION, ASSESSMENT, AND PLANNING

1.1 Project/Site Information

Project/Site Name: Super Star Carwash

Project Street/Location: Meadowbrook Parkway and El Jefe Dr.

Municipality: El Paso County (Colorado Springs) State: CO ZIP Code: 80910

County or Similar Subdivision: El Paso County

Is the project located in Indian country? Yes No

If yes, name of Reservation, or if not part of a Reservation, indicate "not applicable." _____

Is this project considered a federal facility? Yes No

NPDES project or permit tracking number*: (Insert Permit Number Here Once Obtained)

**(This is the unique identifying number assigned to your project by your permitting authority after you have applied for coverage under the appropriate National Pollutant Discharge Elimination System (NPDES) construction general permit.)*

1.2 Contact Information/Responsible Parties

Operator(s):

Super Star Carwash
1830 N 95th Ave, Suite 106
Phoenix, AZ 85037
801-651-1748
Tim Varley

SWMP Preparer

Ayres Associates
3665 JFK Parkway, Bldg, Suite 100
Fort Collins, CO 80525
262-522-4901
Scott Maier P.E.

Site Contact(s):

Super Star Carwash
1830 N 95th Ave, Suite 106
Phoenix, AZ 85037
801-651-1748
Tim Varley

Site Contractor(s):

Name _____
Address _____
City, State _____
Contact # _____
Contact Name _____

Site Contact/Qualified Stormwater Manager:

Name _____
Address _____
City, State _____
Contact # _____
Contact Name _____

1.2 Nature and Sequence of Construction Activity

Describe the general scope of the work for the project, major phases of construction, etc:

Super Star Carwash is planning to develop a Carwash on an approximate 1.5+/- acre vacant site located at the southeast corner of Meadowbrook Parkway and El Jefe Heights in Colorado Springs, CO. The site will be accessed by an internal private drive (El Jefe Heights).

The sequence of construction will be follow:

The following is an anticipated phasing and sequence of construction activities:

- Mobilization and erosion control installation
- Site preparation, construction entrance, clearing and grubbing
- Earthwork and site grading
- Building construction
- Concrete curb and gutter
- Base course surfacing and asphalt surfacing construction
- Site restoration/seeding
- Erosion control removal and demobilization

Estimate Disturbance Area: 1.5+/- Acres

What is the function of the construction activity?

- Residential Commercial Industrial Road Construction Linear Utility
 Other (please specify):

Estimated Project Start Date: October 2023

Estimated Stabilization Date: June 2024

Estimated Project Completion Date: August 2024

1.3 Existing Soils, Slopes, Vegetation, and Current Drainage Patterns

The site is currently approximately 60%+/- vegetated with native seeding based on on-site visual observation. The native seeding was installed when the site was originally overlot graded by a previous construction activity. Some areas of the site did not establish well and are void of vegetation.

The existing site is vegetated with grass and generally drains from the northeast to the southwest where the runoff is collected within a storm sewer that will be constructed at the southwest corner of the site. The site slopes average 2% across the site based on as-built survey.

The soils are generally sandy loams based on NRCS soil data and are part of a Group A and B. These soils have a moderate to high rate of water infiltration. These soils thus have a moderate potential for erosion. These soils consist chiefly of moderately deep or deep, moderately well

drained or well drained soils that have moderately fine texture to moderately coarse texture.

This site will have limited non-stormwater discharge (landscape irrigation) that is considered CDPHE low risk runoff. The runoff from the irrigation will drain to proposed stormwater inlets and drain to the proposed rain garden that will provide the required water quality. Potential allowable non-stormwater discharge may include minimal runoff from the vehicles exiting the car wash. Since the carwash has a dryer, the runoff will be minimal. The water used in the carwash will be recycled and reused. After the water is used, it is discharged into a sanitary sewer system.

1.4 Receiving Waters

Local RCP storm sewer within adjacent private street to a common stormwater detention facility. Ultimate outfall to East Fork of Sand Creek. There are no streams that cross the project area.

1.5 Potential Sources of Pollution and Erosion Potential

Potential sources of sediment to stormwater runoff include:

- Clearing, grading, and excavating activities, primarily un-stabilized areas, paving operations, demolition and debris disposal, dewatering operations, drilling, material delivery, concrete washouts, portable toilets, storage and use, and landscaping/dust control operations.
- Portable toilets will be located a minimum of 10' from stormwater inlets and 50ft from state waters. They will be secured at all four corners to prevent overturning and cleaned on a weekly basis. They need to be inspected daily for spills.

Potential pollutants other than sediment include the following materials and substances that could be expected to be present on-site during construction:

- Heavy Metals – from concrete additives, concrete washout, material delivery, storage and use, and hazardous substance/waste spills
- pH (Acids and Bases) – from concrete washout, painting and cleaning, drilling and blasting operations, material delivery, storage and use, hazardous waste spills, and sanitary/septic waste.
- Paints and Solvents – from concrete washout and waste, painting, concrete polishing, cleaning products, material delivery and use, hazardous waste spills, and sanitary/septic waste
- Trash, Debris and Solids – from clearing and grading, paving, concrete wash waste, construction painting and cleaning, demolition, drilling and blasting, material delivery storage and use, landscaping, and general construction

- Petroleum Based Products – from material delivery storage and use, hazardous waste spills, vehicle and equipment use on site, and vehicle and equipment fueling and maintenance and storage
- Pesticides/Herbicides – from material delivery, storage and use, hazardous waste spills, vehicle use, storage, service and maintenance
- Fertilizers/Nutrients – from painting, cleaning products, dewatering, material delivery and storage, spills during landscaping operation, sanitary/septic waste

1.6 Endangered Species Certification

Are endangered or threatened species and critical habitats on or near the project area?

Yes No

SECTION 2: EROSION AND SEDIMENT CONTROL BMPS

See plan references for installation instructions. All BMPs will be installed according to the installation instructions and Sequence of Construction Activities and inspected by the Qualified Inspector at the inspection. Any deficiency, required maintenance or ineffectiveness shall be reported by the Qualified Inspector. The Qualified Inspection must be sufficiently qualified for the required duties per the State and Local requirements. Corrective action will commence within 24 hours and be completed within 48 hours of report.

2.1 Phase Construction Activity

The General Contractor will be responsible for implementing the following Erosion and Sediment Control and Storm Water Management control measures. The General Contractor may designate these tasks to specific Subcontractors as necessary, but the ultimate responsibility for implementing these controls and ensuring their proper functioning remains with the General Contractor.

Structural Practices

A vehicle traffic control pad will be installed at the entrance/exit of the site to reduce sediment tracking off-site. Practices may include, but are not limited to: straw bales, wattles/sediment control logs, silt fences, earth dikes, drainage swales, sediment traps, subsurface drains, pipe slope drains, and temporary or permanent sediment basins. All roads will be inspected to ensure that sediment from on-site construction activity is not being discharged with the stormwater. Sediment and debris that have been tracked off site should be removed daily by shoveling or sweeping.

Non-Structural Practices

Surface roughening may be used to reduce the amount of runoff and wind erosion from any given areas. Once the existing vegetation is cleared, watering should occur to help control fugitive dust. Disturbed areas where work is temporarily halted shall be temporarily stabilized within 21 calendar days after activity has ceased unless work is to be resumed within 30 calendar days after the activity has ceased. Other Non-Structural Practices may include soils erosion control measures for all slopes, channels, ditches, or any disturbed land area and shall be completed within 21 calendar days after final grade, or final earth disturbance, has been completed. Disturbed areas and stockpiles, which are not at final grade but will remain dormant for longer than 30 days, shall also be mulched within 21 days after interim grading. An area that is going to remain in an interim state for more than 60 days shall also be seeded. All temporary soil erosion control measures and BMPs shall be maintained until permanent soil erosion control measures are implemented.

PHASE ONE

- a) A pre-construction meeting shall be held by the General Contractor and the Operator's Engineer prior to land disturbing activities.
- b) Construct temporary construction exits at locations shown on the SWPPP plan sheet.
- c) Install perimeter protection silt fence in the locations shown on the SWPPP plan sheet.
- d) Begin clearing and grubbing operations. Clearing and grubbing shall be done only in areas where earthwork will be performed and only in areas where building is planned to commence within 14 days after clearing and grubbing.
- e) Implement temporary or permanent stabilization for all areas of the site where grading activity has ceased for more than 14 days.

PHASE TWO

- a) Commence site grading.
- b) Implement temporary or permanent stabilization for all areas of the site where grading activity has ceased for more than 14 days.
- c) Install inlet/outlet protection at the locations of all grate inlets, curb inlets, and at the ends of all exposed storm sewer pipes.
- d) Finalize pavement sub-grade preparation.

- e) Construct all curb and gutter, curb inlets, area inlets, and storm drainage manholes, as shown on the plans.
- f) Remove inlet protection around inlets and manholes no more than 48 hours prior to placing stabilized base course. Inlet protection is to remain at all inlets until contributing area achieves Final Stabilization and/or all potential pollutant sources are eliminated.
- g) Install base material as required for pavement.
- h) Complete final grading and seeding, planting and mulching stabilization.
- i) Inspect and clean storm drainage system
- j) BMP inspections, maintenance, record keeping and site posting shall continue until Final Stabilization.
- k) Remove perimeter protection measures (sediment fencing) only after all paving is complete and all exposed surfaces are stabilized.
- l) Remove temporary construction exits only prior to pavement construction in these areas (These areas are to be paved last).

FINAL STABILIZATION AND LONG-TERM STORMWATER QUALITY

- a) Final Stabilization is considered complete once 70% of the final vegetation has been established.
- b) A rain garden is part of this project to support the water quality of the site. A separate operation and maintenance plan has been prepared for the long-term maintenance of the rain garden. There are no other stormwater control measures offsite that this property is responsible for if onsite treatment for this site is maintained properly.

SECTION 3: GOOD HOUSEKEEPING BMPS

SITE MAP (PROGRESS DRAWING)

A SITE MAP (Progress Drawing) usually consisting of a print of the Phase I and Phase II Erosion and Sediment Control Plans will be used to record the locations of the Job Trailer, Sanitary Waste Facilities, Solid Waste Facilities, Fixed Fuel Storage Areas, Equipment Service Areas, Material Storage Areas, Petroleum Fueled Equipment, and Concrete Washout. The SITE MAP will also be used to record construction progress and current site conditions; which BMP's are

currently in use and which are no longer in use. The SITE MAP will be updated daily to record where site stabilization has occurred. The SITE MAP will be updated to record and document any plan amendments or modifications and will be used to visually depict all modifications. The SITE MAP (Progress Drawing) shall be posted inside the job trailer wall. The SITE MAP posted shall agree with the current phase of the work.

Revising BMP's and SWMP

The plans must be amended, by the contractor whenever there is a change in design, construction operation, or maintenance that could have a significant change to the approved designed plan. Changes are allowable as needed; however, they must be documented. Amendments are also allowed, and needed, if the BMP is found to be ineffective in controlling pollutants.

Permittees are required to amend, adapt, and adjust their SWMP to accurately reflect phased construction changes and current conditions at the site. Plan modifications are broken into major and minor modifications which have differing requirements:

Major Modifications: Major modifications are changes to the SWMP that remove or add area to the project, modify the final hydrology or drainage of the final design, replace approved SWMP, or otherwise expand or contract the scope of the approved project. A revised SWMP and any revised supporting documents require review and approval of the local agency.

Minor Modifications: Minor modifications are changes to the SWMP that do not increase the scope or change hydrology of the project but; modify or improve specific BMPs in use at the site, indicate progression in phasing of the project, or specify relocation of previously approved BMPs within the project. Minor modifications can be made in the field by the permittee if the permittee can demonstrate that the modified soil erosion controls are equivalent to, or better than, the originally approved BMPs. Minor modifications must be thoroughly documented in the permittee's SWMP narrative, drawings and specifications.

The SWMP should be viewed as a "living document" throughout the lifetime of the project. The inspection forms, amendment logs, permit forms, etc. are located in the appendix of this report. The forms shall be signed as noted on the inspection forms and kept on file on-site. This SWMP shall be kept on-site in the construction trailer or in a designated area onsite that is accessible and the location is noted with the permit sign posting. These forms shall be filled out and kept on file with this report. The report shall be kept onsite during operating hours and must be available for inspectors to review.

OTHER CONTROLS

Off-Site Vehicle Tracking

A stabilized construction entrance/exit will be provided at each entrance used for construction access to help reduce vehicle tracking of sediments and the generation of dust. The paved streets adjacent to the site entrance will be inspected daily and swept as necessary to remove any excess mud, dirt, or rock tracked from the site. Dump trucks hauling material from the construction site will be covered with a tarpaulin. The job Contractor's Superintendent will be responsible for seeing that these procedures are followed.

Dust Control

Minimizing wind erosion and controlling dust will be accomplished by one or more of the following methods

- Covering 30% or more of the soil surface with a non-erodible material.
- Roughening the soil to produce ridges perpendicular to the prevailing wind. Ridges should be about six (6) inches in height.
- Frequent watering of excavation and fill areas.
- Providing gravel or paving at entrance/exit drives, parking areas and transit paths.

Material Stockpiles

Stormwater runoff to and from material stockpiles shall be controlled to prevent materials from creating a Diversion of surface water to disturbed soils or from entering the surface water. Topsoil stockpiles shall be surrounded with perimeter sediment control measures and be covered with non-erosive material as soon as practicable but no longer than 14 days after completion of the pile. Non-erosive material may include temporary seeding with straw mulch and tackifier, Mulch, or other material providing suitable cover. Topsoil stockpile heights shall not exceed 35 feet and side slopes shall not exceed 3:1.

Masonry Mixing Area

Non-stormwater discharges into storm drainage systems or waterways containing slurries from concrete or mortar mixing operations shall not be permitted. Masonry mixing areas shall be located a minimum distance of 100 linear feet from drainage ways, inlets and surface waters and all storm water runoff from these areas shall be contained by a berm or other measures. Run-on water to these areas will be diverted to prevent mixing of clean water and water contaminated with concrete slurry.

3.1 Material Handling and Waste Management

A. MATERIALS COVERED

The following materials or substances are expected to be present onsite during construction:

Concrete/Additives/Wastes	Cleaning solvents
Detergents	Petroleum based products
Paints/Solvents	Pesticides
Acids	Fertilizers
Solid and construction wastes	Sanitary wastes
Soil stabilization additives	

B. MATERIALS MANAGEMENT PRACTICES

The following are the material management practices that will be used to reduce the risk of spills or other accidental exposure of materials and substances to stormwater runoff. The Contractor's Superintendent will be responsible for ensuring that these procedures are followed:

1. Good Housekeeping

The following good housekeeping practices will be followed onsite during construction:

- a) An effort will be made to store only enough products required to do the job.
- b) All materials stored onsite will be stored in a neat, orderly manner and, if possible, under a roof or in a containment area. The Contractor will be responsible for showing the location of all materials storage areas on the Site Map. At a minimum, all containers will be stored with their lids on when not in use. Drip pans shall be provided under all dispensers.
- c) Products will be kept in their original containers with the original manufacturer's label in legible condition.
- d) Substances will not be mixed with one another unless recommended by the manufacturer.
- e) Whenever possible, all of a product will be used up before disposing of the container.
- f) Manufacturer's recommendations for proper use and disposal will be followed.
- g) The Contractor's Superintendent will be responsible for daily inspections to ensure proper use and disposal of materials.

2. Hazardous Substances

These practices will be used to reduce the risks associated with Hazardous Substances. Material Safety Data Sheets (MSDSs) for each product with hazardous properties that is used at the Project will be obtained and used for the

proper management of potential wastes that may result from these products. An MSDS will be posted in the immediate area where such product is stored and/or used and another copy of each MSDS will be maintained in the job trailer at the Project. Each employee who must handle a Hazardous Substance will be instructed on the use of MSDS sheets and the specific information in the applicable MSDS for the product he/she is using, particularly regarding spill control techniques.

- a) Products will be kept in original containers with the original labels in legible condition.
- b) Original labels and MSDSs will be procured and used for each product.
- c) If surplus product must be disposed manufacturer's and local/state/federal required methods for proper disposal must be followed.

3. Hazardous Waste

It is imperative that all Hazardous Waste be properly identified and handled in accordance with all applicable Hazardous Waste Standards, including the storage, transport and disposal of the Hazardous Wastes. The General Contractor's Superintendent is responsible for properly identifying and handling or seeking assistance in properly identifying or handling any Hazardous Waste. There are significant penalties for the improper handling of Hazardous Wastes. Hazardous Waste may include certain Hazardous Substances, as well as pesticides, paints, paint solvents, cleaning solvents, pesticides, contaminated soils, and other materials, substances or chemicals that have been discarded (or are to be discarded) as being out-of-date, contaminated, or otherwise unusable, and can include the containers for those substances; other materials and substances can also be or become Hazardous Wastes.. The Contractor's Superintendent is also responsible for ensuring that all site personnel are instructed as to these Hazardous Waste requirements and also that the requirements are being followed.

4. Product Specific Practices

The following product specific practices will be followed on the job site:

a) Petroleum Products

The following practices shall be followed in relation to petroleum products:

- 1. Inspections: All petroleum tanks and fueling areas shall be inspected at the inspection frequency required by law.
- 2. Secondary Containment: Petroleum products will be stored in tightly sealed containers which are clearly labeled and provided with secondary containment.
 - a. Any petroleum storage tanks stored onsite will be located within a containment area that is designed with an impervious surface between

- the tank and ground. Containment shall be sufficiently impervious to contain oil. Impervious surface shall be defined as a surface containing any spill for a minimum of 48 hours without penetration to any environmental media (soil, groundwater, etc...). All containment systems must be capable of containing oil and must be constructed so that any discharge from a primary containment system, such as a tank or pipe, will not escape the system before cleanup occurs.
- b. The secondary containment must be designed to provide a volume of 110% of the volume of the largest tank.
 - c. Any mobile petroleum tank shall be parked in a vehicular service area surrounded by a berm, with an impervious surface between the tank(s) and ground that provides a containment volume equal to 110% of the largest tank.
 - d. Accumulated rainwater in any secondary containment areas or other areas where petroleum is stored should be collected, inspected and/or tested so that It can be characterized properly and the rainwater can be properly and economically disposed or released on-site. Rainwater contaminated with fuel or spills from contaminated containment areas are to be promptly disposed of by a licensed hazardous waste transporter.
 - e. Drip pans shall be provided for all dispensers. Any asphalt substances used onsite will be applied according to the manufacturer's recommendations. Asphalt paving machines shall not be cleaned on the Project site.
 - f. Spill diversion ponds and retention ponds will not be used for spill or secondary containment.
3. Location: Petroleum storage tanks shall be located at minimum 100 linear feet from drainage ways, inlets and surface waters to prevent surface drainage from reaching culverts, gutters, surface waters or other drainage systems.
 4. SITE MAP: All fixed petroleum storage tanks shall be located on the SITE MAP.
 5. Spill Kit: A petroleum spill kit shall be included on the site. The spill kit shall include: Personal Safety Wear (Apron (2), Shoe Booties (2), Chemical Goggles (2), Solvent Resistant Gloves (2)), Absorbents (Durasorb 40 lbs., 10' Booms (3), Static Resistant Pads (12 each), Sump Booms (2 each)), Clean Up Equipment (55 Gallon Steel Drum, Drum Liner, Broom, Solvent Resistant, Shovel, Non-Spark and Solvent Resistant, Residue Bags (50 each)). The Spill Kit shall be located in the construction trailer and shall be accessible at all times by trained personnel. The Spill Kit provides an active countermeasure that will be quickly and immediately deployed after discovery of a small volume spill or any discharge of petroleum.
 6. Petroleum Fueled Equipment (stationary non-self-propelled): Petroleum fueled equipment such as pumps and generators are to be provided with secondary containment for the entire footprint of the equipment sufficient

to contain 110% of the volume of the largest tank serving the equipment. This requirement is for all stationary non-self-propelled equipment including hand-held equipment when not in use.

b) Fertilizers

Fertilizers will be applied only in the minimum amounts recommended by the manufacturer. Once applied, fertilizer will be worked in the soil to limit exposure to storm water. Storage will be in a covered shed. The contents of any partially used bags of fertilizer will be transferred to a sealable plastic bin to avoid spills.

c) Paints, Paint Solvents, and Cleaning Solvents

All containers will be tightly sealed and stored when not in use. Excess paint and solvents will not be discharged to the storm sewer system but will be properly disposed of according to manufacturer's instructions or state and federal regulations.

d) Concrete Wastes

The Project may require the use of multiple concrete wash out areas. These concrete wash out areas are to be made available to all trades and subcontractors working on the Project. The Contractor may designate certain wash out areas for particular trades or subcontractors, but the Contractor is responsible for the management of all concrete washout areas on the Project. All concrete wash out areas will be located in an area where the likelihood of the area contributing to storm water discharges is negligible. If required, additional BMPs must be implemented to prevent concrete wastes from contributing to storm water discharges. The location of concrete wash out area(s) must be identified on the SITE MAP by the Contractor once the locations have been determined.

Concrete trucks will be allowed to wash out or discharge surplus concrete or drum wash water on the site, but only in specifically designated diked and impervious washouts which have been prepared to prevent contact between the concrete wash and storm water. Waste generated from concrete wash water shall not be allowed to be discharged into drainage ways, inlets, receiving waters or highway right of ways, or any location other than the designated concrete washout. Proper signage designating the "Concrete Washout" shall be placed near the facility. Concrete Washouts shall be located at minimum 100 linear feet from drainage ways, inlets and surface waters. Waste concrete may be poured into forms to make riprap or other useful concrete products.

The hardened residue from the concrete wash out diked areas will be disposed of in the same manner as other non-hazardous construction waste materials or may be broken up and used on site as deemed appropriate by the Contractor. Maintenance of the washout is to include removal of hardened concrete. Facility shall have sufficient volume to contain all the concrete waste resulting from washout and a minimum freeboard of 12 inches. Facility shall not be filled beyond 95% capacity and shall be cleaned out once 75% full unless a new facility is constructed. The Contractor's Superintendent will be responsible for seeing that these procedures are followed.

Saw-cut Portland Cement Concrete (PCC) slurry shall not be allowed to enter storm drains or Watercourses. Saw-cut residue should not be left on the surface of pavement or be allowed to flow over and off pavement. Residue from saw-cutting and grinding shall be collected by vacuum and disposed of in the concrete washout facility.

e) Reserved

1. Solid and Construction Wastes

All waste materials will be collected and stored in an appropriately covered container and/or securely contained metal dumpster rented from a local waste management company which must be a licensed solid waste management company. The dumpster will comply with all local and state solid waste management regulations.

All trash and construction debris from the site will be deposited in the dumpster. The dumpster will be emptied a minimum of once per week or more often if necessary. Once building construction has commenced, the dumpster will be emptied a minimum of once per week or when 95% full, or more often if necessary to prevent overflow and the trash will be hauled to a landfill. No construction waste materials will be buried on site. All personnel will be instructed by the Qualified Inspector regarding the correct procedures for waste disposal.

All waste dumpsters and roll-off containers will be located in an area where the likelihood of the containers contributing to storm water discharges is negligible. Solid waste containers shall be located no less than 50 feet from any storm inlet, drainage way, or surface water. If required, additional BMPs must be implemented, such as gravel bags, wattles, Dikes, berms, and fences around the base, to prevent wastes from contributing to storm water discharges. The location of waste dumpsters and roll-off containers must be identified on the SITE MAP by the Contractor once the locations have been determined.

2. Sanitary Wastes

A minimum of one portable sanitary unit will be provided for every ten (10) workers on the site. All sanitary waste will be collected from the portable units a minimum of one time per week by a licensed portable facility provider in complete compliance with local and state regulations.

All sanitary waste units will be located in an area where the likelihood of the unit contributing to storm water discharges is negligible. Additional containment BMPs must be implemented, such as gravel bags or specially designed plastic skid containers around the base, to prevent wastes from contributing to storm water discharges. The location of sanitary waste units must be identified on the PROGRESS DRAWING by the contractor once the locations have been determined

3. Contaminated Soils

Any contaminated soils (resulting from spills of Hazardous Substances or Oil or discovered during the course of construction) which may result from Construction Activities will be contained and cleaned up immediately in accordance with the SWPPP and in accordance with applicable state and federal regulations. Contaminated soils not resulting from Construction Activities, or which pre-existed Construction Activities, but which are discovered by virtue of Construction Activities, should be reported in the same manner as spills (see Section 819.C below), but with sufficient information to indicate that the discovery of an existing condition is being reported. If there is a release that occurs by virtue of the discovery of existing contamination, this should be reported as a spill, if it otherwise meets the requirements for a reportable spill.

C. SPILL PREVENTION AND RESPONSE PROCEDURES

The Contractor will train all personnel in the proper handling and cleanup of spilled Hazardous Substances or Oil. No spilled Hazardous Substances or Oil will be allowed to come in contact with storm water discharges. If such contact occurs, the storm water discharge will be contained on site by measures such as, but not limited to absorbents, booms, static resistant pads, sump booms and other clean up equipment (see Spill Kit contents) until appropriate measures in compliance with state and federal regulations are taken to dispose of such contaminated storm water. It shall be the responsibility of the Contractor's Superintendent to be properly trained, and to train all personnel in spill prevention and clean up procedures.

Note: No dedicated batch plant is proposed on this project.

SPILL PREVENTION AND MINIMIZATION MEASURES:

In order to prevent or minimize the potential for a spill of Hazardous Substances or Oil to come into contact with storm water, the following general steps will be implemented:

- All Hazardous Substances or Oil (such as pesticides, petroleum products, fertilizers, detergents, construction chemicals, acids, paints, paint solvents, cleaning solvents, additives for soil stabilization, concrete curing compounds and additives, etc.) will be stored in a secure location, with their lids on, preferably under cover, when not in use.
- The minimum practical quantity of all such materials will be kept at the Project.
- Manufacturer's recommended methods for spill cleanup will be clearly posted inside the job trailer wall and site personnel will be trained regarding these procedures and the location of the information and cleanup supplies.
- It is the Contractor's responsibility to ensure that all Hazardous Waste discovered or generated at the Project site is disposed of properly by a licensed hazardous material disposal company. The Contractor is responsible for not exceeding Hazardous Waste storage requirements mandated by the EPA or state and local authority.
- Train key employees in plan and provide clear, common-sense spill prevention practices and clean-up procedures to be strictly followed.
- Identify equipment that is exposed to precipitation, pollutants that may be generated and possible sources of leaks or discharges.
- Perform inspections and preventative maintenance of equipment for proper operation and to check for leaks or evidence of discharge (stains). Ensure repairs are completed or provide temporary leak containment until such repairs can be made.
- Drain used motor oil and other automotive fluids in a designated area away from storm inlets. Collect spent fluids and recycle or dispose of properly. Never dispose into storm or sanitary sewer.
- In fueling areas, clean up spills with dry methods (absorbents) and use damp cloths on gas pumps and damp mops on paved surfaces.
- Never hose down a spill or absorbent materials into the storm drain, or down into an interior floor drain which leads to the sanitary sewer system.
- Reduce stormwater contact with equipment and materials by implementing covered storage, reduce stormwater run-on and follow good housekeeping practices.
- Post signs at critical locations with Spill Prevention and Response Plan information.

Material Handling Procedures: From a water quality perspective, the primary principle behind effective material handling practices is to minimize exposure to precipitation. Store the material indoors, otherwise implement the following outdoor materials handling procedures:

- Divert stormwater around materials storage areas.
- Keep bulk solid materials (raw materials, sand, gravel, topsoil, compost, concrete, packing materials, metal products, etc) covered and protected from stormwater.
- When practical, store materials on impermeable surfaces.
- Store hazardous materials according to federal, state, and local requirements.
- Adopt procedures to reduce spills or leaks during filling or transfer of materials.
- Substitute less toxic or nontoxic materials for toxic materials.
- Store containers that are easily punctured or damaged away from high traffic areas.
- Add waste-capture containers such as collection pans for lubricating fluids.

- **Spill Response Procedures:** Tailor spill response procedures to site-specific conditions and industry-specific regulatory requirements. Follow procedures:
 - Contain and cleanup spills promptly after the spill is discovered.
 - Sweep up small quantities of pollutants to reduce exposure to runoff.
 - Place absorbents at fueling areas or areas susceptible to spills.
 - Wipe up small spills with a rag, store rags in appropriate containers, dispose of rags properly or use a professional industrial cleaning service.
 - Contain medium-sized spills with absorbents and use berms or absorbent "snakes" as temporary booms for the spill. Store and dispose of absorbents properly. Wet/dry vacuums may be used, but not for volatile fluids.
 - Install drip pans below minor equipment leaks until a repair can be made.
 - For large spills, first contain the spill and plug storm inlet where the liquid may migrate off-site, then clean up the spill.
 - Excavation of spill areas to removed contaminated material may be required where large liquid spills occur on unpaved surfaces.
 - Maintain an inventory of cleanup materials onsite and strategically locate them based on the types and quantities of chemicals present.
 - Records of spills, leaks, or overflows that result in the discharge of pollutants must be documented and maintained.
- Two approaches are used when implementing spill containment measures: 1) Design system to contain the entire spill; or 2) Use curbing to route spilled material to a collection basin. Both containment berming and curbing should be sized to safely contain or convey to a collection basin a spill from the largest storage tank, tanker truck, or other containment device in the possible spill area. The spill containment area must have an impermeable surface (impermeable liner, asphalt or concrete) to prevent groundwater contamination. Design containment system to enable collection and removal of spilled material through a pump or vacuum trucks, sorbent or gelling material, etc. Material removed must be disposed of or recycled according to local,

state, and federal standards. If the capacity of the spill containment is exceeded, supplemental measures should be available such as a portable containment device, sorbent materials, or gelling agents to solidify the material. Water that collects within containment areas due to rainfall or snowmelt must be appropriately treated before release from the spill area.

Spill Reporting Procedures:

Notification procedures:

- a. In the event of an accident or spill the SWMP administrator shall be notified.
- b. Depending on the nature of the spill material involved, the Colorado Department of Public Health and Environment (24- hour spill reporting line: 887-518-5608), downstream water users, or other agencies may also need to be notified.
- c. Any spill of oil which 1) violates water quality standards, 2) produces a “sheen” on a surface water, or 3) causes a sludge or emulsion, or any hazardous substance release, or hazardous waste release which exceeds the reportable quantity, must be reported immediately by telephone to the National Response Center Hotline at (800) 424-8802.

Any discharge of pollutants to waters of the state (which include surface water, groundwater, or features like dry gullies or storm sewers leading to surface water) must be reported to 1-877-518-5608 within 24-hours of discovery. The notification must describe, at a minimum:

- a. The date, time, estimated length of time, and approximate volume of the discharge.
- b. The cause of the discharge.
- c. The level of wastewater in the discharging impoundment(s).
- d. Whether the discharge entered, or could enter, waters of the United States.
- e. A spill which does not reach surface water does not have to be reported, but will likely require clean up and mitigation. Contact your Ag Program representative to determine what actions are necessary.

Spill Kit Recommendations:

A Spill Kit is recommended to be onsite and contain: Personal Safety Wear (Apron (2), Shoe Booties (2), Chemical Goggles (2), Solvent Resistant Gloves (2)), Absorbents (Durasorb 40 lbs., 10’ Booms (3), Static Resistant Pads (12 each), Sump Booms (2 each)), Clean Up Equipment (55 Gallon Steel Drum, Drum Liner, Broom, Solvent Resistant, Shovel, Non-Spark and Solvent Resistant, Residue Bags (50 each)). The Spill Kit shall be located in the construction trailer and shall be accessible at all times by trained personnel. The Spill Kit provides an active countermeasure that will be quickly and immediately deployed after discovery of a small volume spill or any discharge of petroleum.

CONTROL OF NON-STORM WATER DISCHARGES

Only specifically authorized non-stormwater discharges are allowed and all allowed non-stormwater discharges shall be eliminated or reduced to the extent practicable.

The following non-stormwater discharges are allowable under the Construction General Permit, and may be associated with the project:

- Discharge from fire fighting activities;
- Fire hydrant flushing;
- Waters used to control dust;
- Potable water including uncontaminated water line flushing;
- Pavement wash waters where spills or leaks of toxic or hazardous materials have not occurred (unless all spilled material has been removed) and where detergents are not used;
- Landscape Irrigation.

Appropriate BMPs shall be used to minimize the discharge of pollutants. Such control measures (some of which have been mentioned previously in this SWPPP) will be strictly followed to ensure any impacts from non-stormwater discharges are reduced or eliminated. Appropriate BMPs are:

Discharge from fire fighting activities

Fire hydrant flushing

Concentrated flow is to be directed toward protected areas such as sediment basins and landscaped areas to minimize potential erosion and to allow chlorine in water to dissipate. Provide suitable sediment control measures such as wattles or sediment fence where flows will be directed to denuded areas. Provide storm inlet protection to protect against sediment or chlorine discharge. Super-chlorinated wastewaters (water containing chlorine above residual levels acceptable in drinking water systems) is to be retained on-site until the chlorine dissipates or shall be de-chlorinated or if acceptable to the local sanitary sewer authority discharged to the sanitary sewer. Suitable BMPs to treat chlorine include de-chlorination mats and bags at inlets, treatment with ascorbic acid for low levels of chlorine <2mg/L, and treatment with sodium ascorbate for high levels of chlorine up to 100 mg/L. Manufacturer's recommendations should be followed closely to prevent over-treatment or chemical reaction.

Waters used to control dust

Water used to control dust will be limited to the quantity needed to suppress dust without producing runoff. Any runoff produced in addition with the volume necessary to wet disturbed soil will be directed to suitable sediment control measures such as sediment fence, sediment basins and traps, wattles and inlet protection measures. Chlorinated water shall not be allowed to leave the site

unless suitable BMPs are implemented to reduce the amount of chlorine entering the storm drain system.

Potable water including uncontaminated water line flushing

Concentrated flow is to be directed toward protected areas such as sediment basins and landscaped areas to minimize potential erosion and to allow chlorine in water to dissipate. Provide suitable sediment control measures such as wattles or sediment fence where flows will be directed to denuded areas. Provide storm inlet protection to protect against sediment or chlorine discharge. Super-chlorinated wastewaters (water containing chlorine above residual levels acceptable in drinking water systems) is to be retained on-site until the chlorine dissipates or shall be de-chlorinated or if acceptable to the local sanitary sewer authority discharged to the sanitary sewer. Suitable BMPs to treat chlorine include de-chlorination mats and bags at inlets, treatment with ascorbic acid for low levels of chlorine <2mg/L, and treatment with sodium ascorbate for high levels of chlorine up to 100 mg/L. Manufacturer's recommendations should be followed closely to prevent over-treatment or chemical reaction.

Landscape Irrigation

Volume of water used for irrigation prior to establishment of vegetation shall be controlled to prevent excess runoff and erosion. Temporary sediment control measures shall remain in place until all upstream disturbed areas are stabilized. Sediment loss will be controlled through the use of sediment control measures such as wattles, sediment fence, and vegetative buffers.

SWPPP APPENDICES

Attach the following documentation to the SWPPP:

Appendix A – General Location Map

Appendix B – Site Maps

Appendix C – Construction General Permit

Appendix D – NOI and Acknowledgement Letter from EPA/State

Appendix E – Inspection Reports

Appendix F – Corrective Action Log

Appendix G – SWPPP Amendment Log

Appendix H – Subcontractor Certifications/Agreements

Appendix I – Grading and Stabilization Activities Log

Appendix J – Training Log

Appendix K – Delegation of Authority

Appendix A – General Location Map

LOCATION MAP

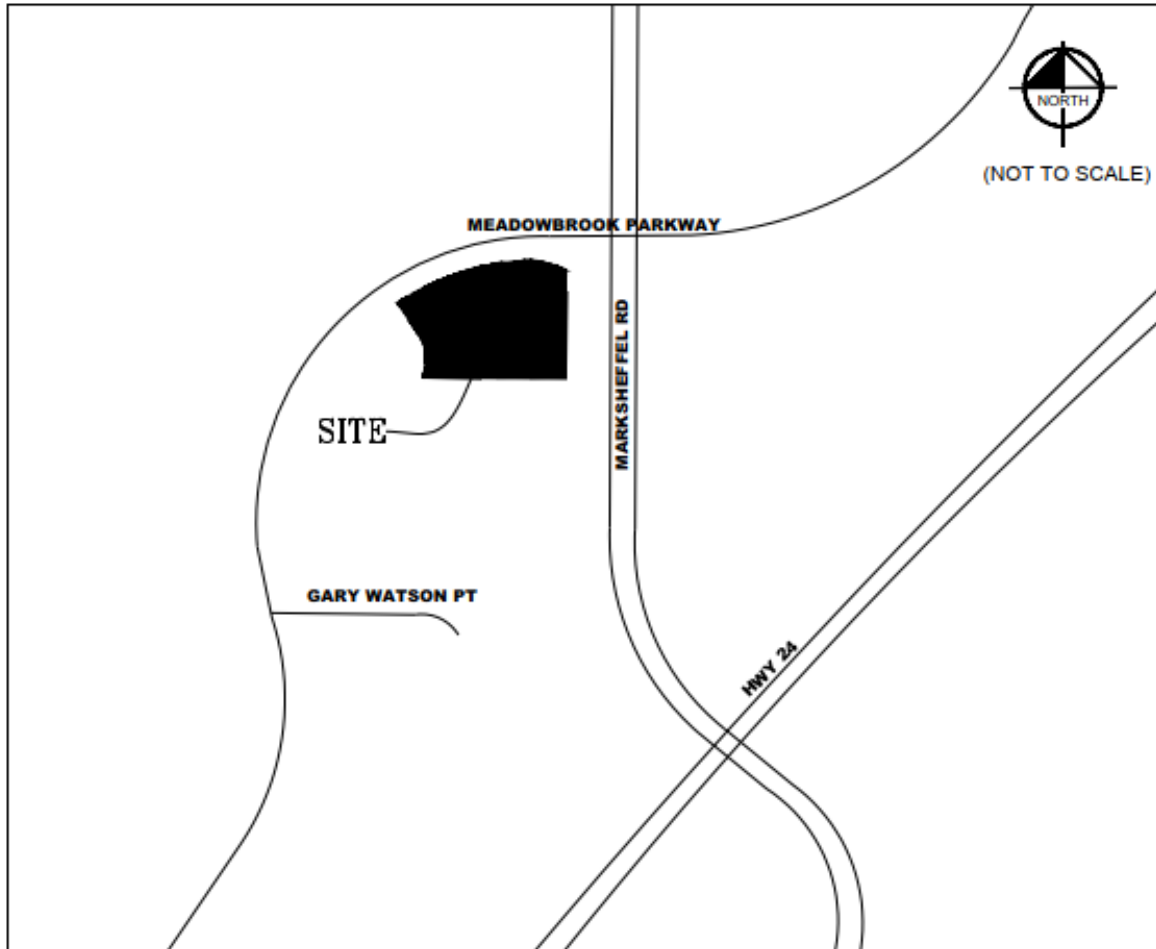

Appendix B – Site Map

EROSION CONTROL AND GRADING PLAN

SUPERSTAR CARWASH

MEADOWBROOK PKWY

COLORADO SPRINGS, CO 80915

AYRES ASSOCIATES

3665 JFK PARKWAY
BUILDING 2, SUITE 100
FORT COLLINS, CO
80525
262.522.4901
www.AyresAssociates.com



LOCATION MAP

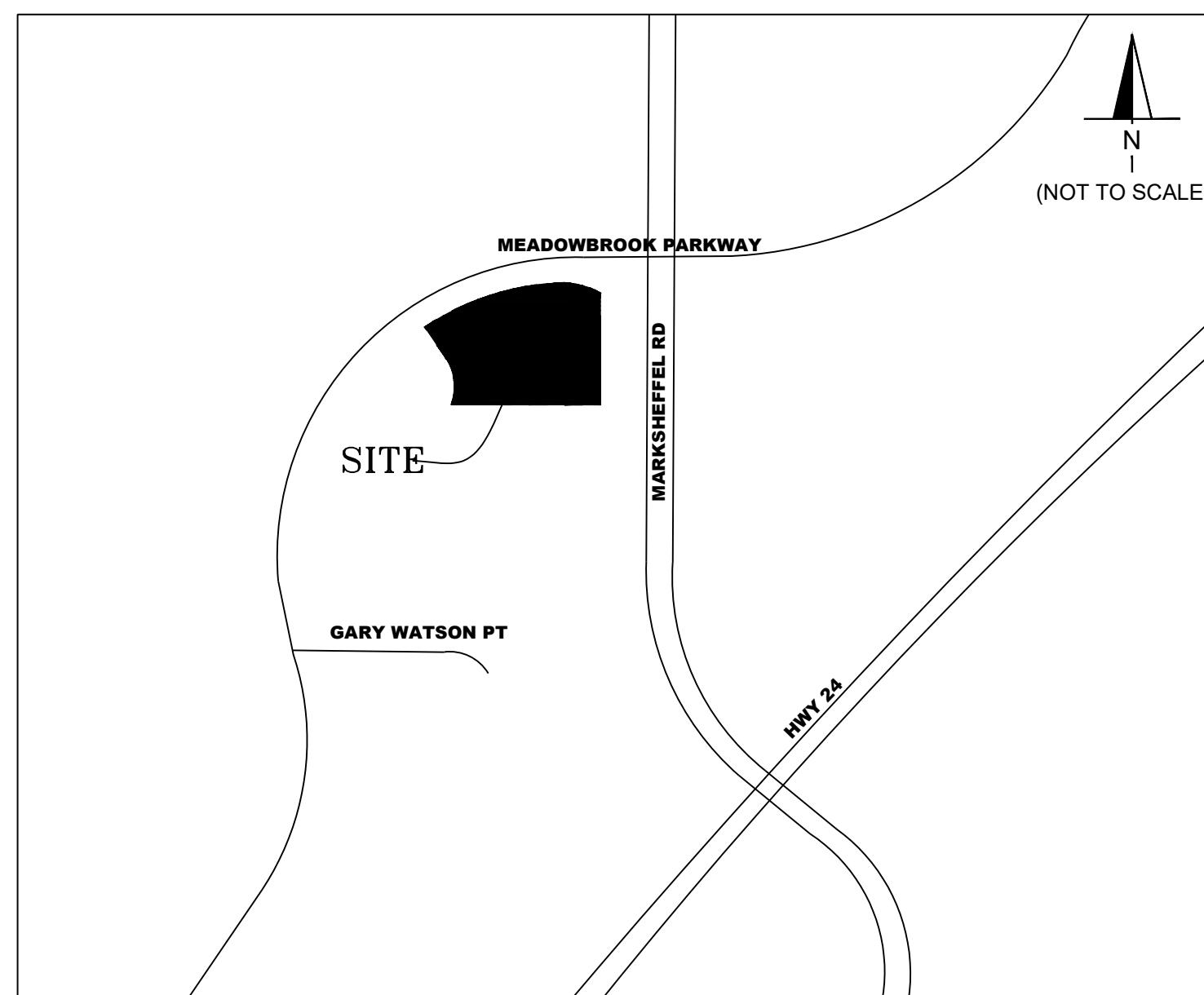

SHEET LIST TABLE	
SHEET NUMBER	SHEET TITLE
E1.0	COVER SHEET
E2.0	EROSION CONTROL PLAN
E2.1	EROSION CONTROL DETAILS
E2.2	EROSION CONTROL DETAILS
E2.3	EROSION CONTROL DETAILS
E2.4	EROSION CONTROL DETAILS
E3.0	GRADING PLAN
E3.1	RAIN GARDEN

PROJECT TEAM

OWNER
SUPER STAR CAR WASH
1830 N 95TH AVE, SUITE 106
PHOENIX, AZ, 85037
CONTACT: TIM VARLEY
TEL: 801-651-1748
EMAIL: TVARLEY@SSCWAZ.COM

ENGINEER
AYRES ASSOCIATES
3665 JFK PARKWAY BLDG. 2 SUITE 100
FORT COLLINS, CO 80525
CONTACT: SCOTT MAIER
TEL: (262)-522-4901
EMAIL: MAIERS@AYRESASSOCIATES.COM

LANDSCAPE ARCHITECT
AYRES ASSOCIATES
3665 JFK PARKWAY BLDG. 2 SUITE 100
FORT COLLINS, CO 80525
CONTACT: DAVID LAND
TEL: (303)-548-2870
EMAIL: LANDD@AYRESASSOCIATES.COM

ARCHITECT
AO ARCHITECTS
144 N ORANGE STREET
ORANGE CA 92866
CONTACT: DUC HUYNH
TEL: (714)-639-9860
EMAIL: DUCH@AOARCHITECTS.COM

Design Engineer's Statement:

This Grading and Erosion Control Plan was prepared under my direction and supervision and is correct to the best of my knowledge and belief. Said Plan has been prepared according to the criteria established by the County for Grading and Erosion Control Plans. I accept responsibility for any liability caused by any negligent acts, errors or omissions on my part in preparing this plan.



10/19/23
Date

Scot Maier, PE # _____

Owner/Developer's Statement:

I, the owner/developer have read and will comply with all of the requirements specified in these detailed plans and specifications.

10/20/2023
Date

TVarley
Tim Varley
Super Star Car Wash
1830 N 95th Ave, Suite 106
Phoenix, AZ, 85037

EL PASO COUNTY

County plan review is provided only for general conformance with County Design Criteria. The County is not responsible for the accuracy and adequacy of the design, dimensions, and/or elevations which shall be confirmed at the job site. The County through the approval of this document assumes no responsibility for completeness and/or accuracy of this document.

Filed in accordance with the requirements of the El Paso County Land Development Code, Drainage Criteria Manual Volumes 1 and 2, and Engineering Criteria Manual, as amended.

In accordance with ECM Section 1.12, these construction documents will be valid for construction for a period of 2 years from the date signed by the El Paso County Engineer. If construction has not started within those 2 years, the plans will need to be resubmitted for approval, including payment of review fees at the Planning and Community Development Director's discretion.

County Engineer/ECM Administrator Date

EPC - EDARP FILE NUMBER: PPR2315

CONTRACTOR NOTE

CONTRACTOR SHALL KEEP A COPY OF EL PASO COUNTY STAMPED/APPROVED PLANS ON-SITE AT ALL TIMES FOR GENERAL CONTRACTOR AND MUNICIPAL INSPECTOR REFERENCE.



PROPERTY LEGAL DESCRIPTION

LOT 1. BEING A TRACT OF LAND IN THE SOUTHEAST QUARTER OF THE SOUTHEAST QUARTER (SE 1/4, SE 1/4) OF SECTION 5 AND NORTHEAST QUARTER OF THE NORTHEAST QUARTER (NE 1/4, NE 1/4) OF SECTION 8, T14S, R65W, OF THE 6TH P.M., EL PASO COUNTY, COLORADO

DATE
9/18/23

REVISION
RESUBMITTAL

SUPERSTAR CARWASH
 MEADOWBROOK PKWY
 COLORADO SPRING, CO 80915
COVER SHEET

Drawn By: AJJ
Checked By: SEM
Date: 06/23/2023
Project No. 24-0409
Sheet Number

E1.0



REVISION	DATE
RESUBMITTAL #1	7/25/2023
RESUBMITTAL #2	9/18/2023
RESUBMITTAL #3	10/20/2023

SUPERSTAR CARWASH
MEADOWBROOK PKWY
COLORADO SPRING, CO 80915

EROSION CONTROL PLAN

Drawn By: AJJ
Checked By: SEM
Date: 10/20/2023
Project No. 24-0409
Sheet Number

E2.0

EROSION CONTROL NOTES

- STORMWATER DISCHARGES FROM CONSTRUCTION SITES SHALL NOT CAUSE OR THREATEN TO CAUSE POLLUTION, CONTAMINATION, OR DEGRADATION OF STATE WATERS. ALL WORK AND EARTH DISTURBANCE SHALL BE DONE IN A MANNER THAT MINIMIZES POLLUTION OF ANY ON-SITE OR OFF-SITE WATERS, INCLUDING WETLANDS.
- NOTWITHSTANDING ANYTHING DEPICTED IN THESE PLANS IN WORDS OR GRAPHIC REPRESENTATION, ALL DESIGN AND CONSTRUCTION RELATED TO ROADS, STORM DRAINAGE AND EROSION CONTROL SHALL CONFORM TO THE STANDARDS AND REQUIREMENTS OF THE MOST RECENT VERSION OF THE RELEVANT ADOPTED EL PASO COUNTY STANDARDS, INCLUDING THE LAND DEVELOPMENT CODE, THE ENGINEERING CRITERIA MANUAL, THE DRAINAGE CRITERIA MANUAL, AND THE DRAINAGE CRITERIA MANUAL VOLUME 2. ANY DEVIATIONS FROM REGULATIONS AND STANDARDS MUST BE REQUESTED, AND APPROVED, IN WRITING.
- A SEPARATE STORMWATER MANAGEMENT PLAN (SWMP) FOR THIS PROJECT SHALL BE COMPLETED AND AN EROSION AND STORMWATER QUALITY CONTROL PERMIT (EQCQP) ISSUED PRIOR TO COMMENCING CONSTRUCTION. MANAGEMENT OF THE SWMP DURING CONSTRUCTION IS THE RESPONSIBILITY OF THE DESIGNATED QUALIFIED STORMWATER MANAGER OR CERTIFIED EROSION CONTROL INSPECTOR. THE SWMP SHALL BE LOCATED ON-SITE AT ALL TIMES DURING CONSTRUCTION AND SHALL BE KEPT UP TO DATE WITH WORK PROGRESS AND CHANGES IN THE FIELD.
- ONCE THE EQCQP IS APPROVED AND A NOTICE TO PROCEED HAS BEEN ISSUED, THE CONTRACTOR MAY INSTALL THE INITIAL STAGE EROSION AND SEDIMENT CONTROL MEASURES AS INDICATED ON THE APPROVED EQC. A PRECONSTRUCTION MEETING BETWEEN THE CONTRACTOR, ENGINEER, AND EL PASO COUNTY WILL BE HELD PRIOR TO ANY CONSTRUCTION. IT IS THE RESPONSIBILITY OF THE APPLICANT TO COORDINATE THE MEETING TIME AND PLACE WITH COUNTY STAFF.
- CONTROL MEASURES MUST BE INSTALLED PRIOR TO COMMENCEMENT OF ACTIVITIES THAT COULD CONTRIBUTE POLLUTANTS TO STORMWATER. CONTROL MEASURES FOR ALL SLOPES, CHANNELS, DITCHES, AND DISTURBED LAND AREAS SHALL BE INSTALLED IMMEDIATELY UPON COMPLETION OF THE DISTURBANCE.
- ALL TEMPORARY SEDIMENT AND EROSION CONTROL MEASURES SHALL BE MAINTAINED AND REMAIN IN EFFECTIVE OPERATING CONDITION UNTIL PERMANENT SOIL EROSION CONTROL MEASURES ARE IMPLEMENTED AND FINAL STABILIZATION IS ESTABLISHED. ALL PERSONS ENGAGED IN LAND DISTURBANCE ACTIVITIES SHALL ASSESS THE ADEQUACY OF CONTROL MEASURES AT THE SITE AND IDENTIFY IF CHANGES TO THOSE CONTROL MEASURES ARE NEEDED TO ENSURE THE CONTINUED EFFECTIVE PERFORMANCE OF THE CONTROL MEASURES. ALL CHANGES TO TEMPORARY SEDIMENT AND EROSION CONTROL MEASURES MUST BE INCORPORATED INTO THE STORMWATER MANAGEMENT PLAN.
- TEMPORARY STABILIZATION SHALL BE IMPLEMENTED ON DISTURBED AREAS AND STOCKPILES WHERE GROUND DISTURBING CONSTRUCTION ACTIVITY HAS PERMANENTLY CEASED OR TEMPORARILY CEASED FOR LONGER THAN 14 DAYS.
- FINAL STABILIZATION MUST BE IMPLEMENTED AT ALL APPLICABLE CONSTRUCTION SITES. FINAL STABILIZATION IS ACHIEVED WHEN ALL GROUND DISTURBING ACTIVITIES ARE COMPLETE AND ALL DISTURBED AREAS EITHER HAVE A UNIFORM VEGETATIVE COVER WITH INDIVIDUAL PLANT DENSITY OF 70 PERCENT OF PRE-DISTURBANCE LEVELS ESTABLISHED OR EQUIVALENT PERMANENT ALTERNATIVE STABILIZATION METHOD IS IMPLEMENTED. ALL TEMPORARY SEDIMENT AND EROSION CONTROL MEASURES SHALL BE REMOVED UPON FINAL STABILIZATION AND BEFORE PERMIT CLOSURE.
- ALL PERMANENT STORMWATER MANAGEMENT FACILITIES SHALL BE INSTALLED AS DESIGNED IN THE APPROVED PLANS. ANY PROPOSED CHANGES THAT EFFECT THE DESIGN OR FUNCTION OF PERMANENT STORMWATER MANAGEMENT STRUCTURES MUST BE APPROVED BY THE EGM ADMINISTRATOR PRIOR TO IMPLEMENTATION.
- EARTH DISTURBANCES SHALL BE CONDUCTED IN SUCH A MANNER SO AS TO EFFECTIVELY MINIMIZE ACCELERATED SOIL EROSION AND RESULTING SEDIMENTATION. ALL DISTURBANCES SHALL BE DESIGNED, CONSTRUCTED, AND COMPLETED SO THAT THE EXPOSED AREA OF ANY DISTURBED LAND SHALL BE LIMITED TO THE SHORTEST PRACTICAL PERIOD OF TIME. PRE-EXISTING VEGETATION SHALL BE PROTECTED AND MAINTAINED WITHIN 50 HORIZONTAL FEET OF A WATERS OF THE STATE UNLESS SHOWN TO BE INFEASIBLE AND SPECIFICALLY REQUESTED AND APPROVED.
- COMPACTION OF SOIL MUST BE PREVENTED IN AREAS DESIGNATED FOR INFILTRATION CONTROL MEASURES OR WHERE FINAL STABILIZATION WILL BE ACHIEVED BY VEGETATIVE COVER. AREAS DESIGNATED FOR INFILTRATION CONTROL MEASURES SHALL ALSO BE PROTECTED FROM SEDIMENTATION DURING CONSTRUCTION UNTIL FINAL STABILIZATION IS ACHIEVED. IF COMPACTION PREVENTION IS NOT FEASIBLE DUE TO SITE CONSTRAINTS, ALL AREAS DESIGNATED FOR INFILTRATION AND VEGETATION CONTROL MEASURES MUST BE LOOSENEED PRIOR TO INSTALLATION OF THE CONTROL MEASURE(S).
- ANY TEMPORARY OR PERMANENT FACILITY DESIGNED AND CONSTRUCTED FOR THE CONVEYANCE OF STORMWATER AROUND, THROUGH, OR FROM THE EARTH DISTURBANCE AREA SHALL BE A STABILIZED CONVEYANCE DESIGNED TO MINIMIZE EROSION AND THE DISCHARGE OF SEDIMENT OFF-SITE.
- CONCRETE WASH WATER SHALL BE CONTAINED AND DISPOSED OF IN ACCORDANCE WITH THE SWMP. NO WASH WATER SHALL BE DISCHARGED TO OR ALLOWED TO ENTER STATE WATERS, INCLUDING ANY SURFACE OR SUBSURFACE STORM DRAINAGE SYSTEM OR FACILITIES. CONCRETE WASHOUTS SHALL NOT BE LOCATED IN AN AREA WHERE SHALLOW GROUNDWATER MAY BE PRESENT, OR WITHIN 50 FEET OF A SURFACE WATER BODY, CREEK OR STREAM.
- DURING DEWATERING OPERATIONS, UNCONTAMINATED GROUNDWATER MAY BE DISCHARGED ON-SITE, BUT SHALL NOT LEAVE THE SITE IN THE FORM OF SURFACE RUNOFF UNLESS AN APPROVED STATE DEWATERING PERMIT IS IN PLACE.
- EROSION CONTROL BLANKETING OR OTHER PROTECTIVE COVERING SHALL BE USED ON SLOPES STEEPER THAN 3:1.
- CONTRACTOR SHALL BE RESPONSIBLE FOR THE REMOVAL OF ALL WASTES FROM THE CONSTRUCTION SITE FOR DISPOSAL IN ACCORDANCE WITH LOCAL AND STATE REGULATORY REQUIREMENTS. NO CONSTRUCTION DEBRIS, TREE SLASH, BUILDING MATERIAL, WASTES OR UNUSED BUILDING MATERIALS SHALL BE BURIED, DUMPED, OR DISCHARGED AT THE SITE.
- WASTE MATERIALS SHALL NOT BE TEMPORARILY PLACED OR STORED IN THE STREET, ALLEY, OR OTHER PUBLIC WAY, UNLESS IN ACCORDANCE WITH AN APPROVED TRAFFIC CONTROL PLAN. CONTROL MEASURES MAY BE REQUIRED BY EL PASO COUNTY ENGINEERING IF DEEMED NECESSARY, BASED ON SPECIFIC CONDITIONS AND CIRCUMSTANCES.
- TRACKING OF SOILS AND CONSTRUCTION DEBRIS OFF-SITE SHALL BE MINIMIZED. MATERIALS TRACKED OFF-SITE SHALL BE CLEANED UP AND PROPERLY DISPOSED OF IMMEDIATELY.
- THE OWNER/DEVELOPER SHALL BE RESPONSIBLE FOR THE REMOVAL OF ALL CONSTRUCTION DEBRIS, DIRT, TRASH, ROCK, SEDIMENT, SOIL, AND SAND THAT MAY ACCUMULATE IN ROADS, STORM DRAINS AND OTHER DRAINAGE CONVEYANCE SYSTEMS AND STORMWATER APPURTENANCES AS A RESULT OF SITE DEVELOPMENT.
- THE QUANTITY OF MATERIALS STORED ON THE PROJECT SITE SHALL BE LIMITED, AS MUCH AS PRACTICAL, TO THAT QUANTITY REQUIRED TO PERFORM THE WORK IN AN ORDERLY SEQUENCE. ALL MATERIALS STORED ON-SITE SHALL BE STORED IN A NEAT, ORDERLY MANNER, IN THEIR ORIGINAL CONTAINERS, WITH ORIGINAL MANUFACTURER'S LABELS.
- NO CHEMICAL(S) HAVING THE POTENTIAL TO BE RELEASED TO THE ENVIRONMENT OR STORED OR USED ON-SITE UNLESS PERMISSION FOR THE USE OF SUCH CHEMICAL(S) IS GRANTED IN WRITING BY THE EGM ADMINISTRATOR. IN GRANTING APPROVAL FOR THE USE OF SUCH CHEMICAL(S), SPECIAL CONDITIONS AND MONITORING MAY BE REQUIRED.
- BULK STORAGE OF ALLOWED PETROLEUM PRODUCTS OR OTHER ALLOWED LIQUID CHEMICALS IN EXCESS OF 55 GALLONS SHALL REQUIRE ADEQUATE SECONDARY CONTAINMENT PROTECTION TO CONTAIN ALL SPILLS ON-SITE AND TO PREVENT ANY SPILLED MATERIALS FROM ENTERING STATE WATERS. ANY SURFACE OR SUBSURFACE STORM DRAINAGE SYSTEM OR OTHER FACILITIES.
- NO PERSON SHALL CAUSE THE IMPEDIMENT OF STORMWATER FLOW IN THE CURB AND GUTTER OR DITCH EXCEPT WITH APPROVED SEDIMENT CONTROL MEASURES.
- OWNER/DEVELOPER AND THEIR AGENTS SHALL COMPLY WITH THE "COLORADO WATER QUALITY CONTROL ACT" (TITLE 25, ARTICLE 8, CRS), AND THE "CLEAN WATER ACT" (33 USC 1344), IN ADDITION TO THE REQUIREMENTS OF THE LAND DEVELOPMENT CODE, DCM VOLUME II AND THE EGM APPENDIX I. ALL APPROPRIATE PERMITS MUST BE OBTAINED BY THE CONTRACTOR PRIOR TO CONSTRUCTION (1041, 1042, FLOODPLAIN, 404, FUGITIVE DUST, ETC.). IN THE EVENT OF CONFLICTS BETWEEN THESE REQUIREMENTS AND OTHER LAWS, RULES, OR REGULATIONS OF OTHER FEDERAL, STATE, LOCAL, OR COUNTY AGENCIES, THE MOST RESTRICTIVE LAWS, RULES, OR REGULATIONS SHALL APPLY.
- ALL CONSTRUCTION TRAFFIC MUST ENTER/EXIT THE SITE ONLY AT APPROVED CONSTRUCTION ACCESS POINTS.
- PRIOR TO CONSTRUCTION THE PERMITTEE SHALL VERIFY THE LOCATION OF EXISTING UTILITIES.
- A WATER SOURCE SHALL BE AVAILABLE ON-SITE DURING EARTHWORK OPERATIONS AND SHALL BE UTILIZED AS REQUIRED TO MINIMIZE DUST FROM EARTHWORK EQUIPMENT AND WIND.
- THE SOILS REPORT FOR THIS SITE HAS BEEN PREPARED BY PARTNER ENGINEERING AND SCIENCE, DATE: 7/13/2023 AND SHALL BE CONSIDERED A PART OF THESE PLANS.
- THERE ARE NO DEDICATED ASPHALT OR CONCRETE PLANS DEDICATED FOR THIS SITE.
- AT LEAST TEN (10) DAYS PRIOR TO THE ANTICIPATED START OF CONSTRUCTION, FOR PROJECTS THAT WILL DISTURB ONE (1) ACRE OR MORE, THE OWNER OR OPERATOR OF CONSTRUCTION ACTIVITY SHALL SUBMIT A PERMIT APPLICATION FOR STORMWATER DISCHARGE TO THE COLORADO DEPARTMENT OF PUBLIC HEALTH AND ENVIRONMENT, WATER QUALITY DIVISION. THE APPLICATION CONTAINS CERTIFICATION OF COMPLETION OF A STORMWATER MANAGEMENT PLAN (SWMP), OF WHICH THIS GRADING AND EROSION CONTROL PLAN MAY BE A PART. FOR INFORMATION OR APPLICATION MATERIALS CONTACT:
COLORADO DEPARTMENT OF PUBLIC HEALTH AND ENVIRONMENT
WATER QUALITY CONTROL DIVISION
WQCD - PERMITS
4300 CHERRY CREEK DRIVE SOUTH
DENVER, CO 80246-1530
ATTN: PERMITS UNIT

CONSTRUCTION NOTES

THERE ARE NO DEDICATED ASPHALT OR CONCRETE BACH PLANS

SITE AREA

LOT AREA = 1.48 ACRES
DISTURBED AREA = 1.47 ACRES

SEQUENCE OF ACTIVITIES

- CONSTRUCT SILT FENCE
- ALL DISTURBED AREAS SHALL BE STABILIZED AND VEGETATED
- STRAW BALE BARRIER INLET PROTECTION SHALL BE CONSTRUCTED AT ALL EXISTING INLETS UPON COMPLETION OF CONSTRUCTION.
- STRAW BALE BARRIERS SHALL BE REPLACED WITH GRAVEL FILTERS AT ALL INLETS UPON COMPLETION OF PAVING
- ALL TEMPORARY EROSION CONTROL MEASURES SHALL BE IN PLACE UNTIL PERMANENT EROSION CONTROL MEASURES ARE ESTABLISHED.

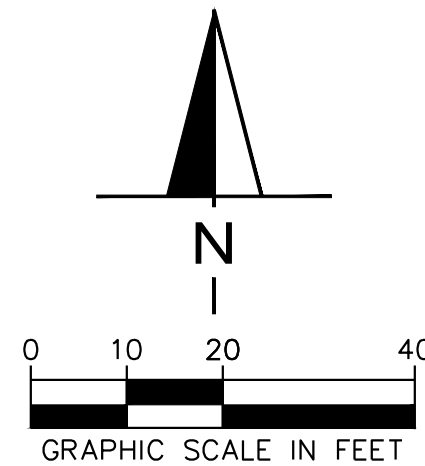

MEADOWBROOK PARKWAY

PROPERTY LINE

EL JEFE HEIGHTS

LOT 3
PARCEL #5405412006

LOT 2
PARCEL #5405412005

EROSION CONTROL LEGEND

	EXISTING CONTOUR
	PROPOSED CONTOUR (DATUM = 6300)
	SILT FENCE (INITIAL THROUGH FINAL) (SEE EROSION CONTROL DETAILS)
	LIMITS OF DISTURBANCE/CONSTRUCTION LIMITS (1.5+/- ACRES)
	CONSTRUCTION ENTRANCE (INITIAL THROUGH FINAL) (SEE EROSION CONTROL DETAILS)
	INLET PROTECTION (INTERIM THROUGH FINAL) (SEE EROSION CONTROL DETAILS)
	CONCRETE WASHOUT (INTERIM) (TO BE DETERMINED BY CONTRACTOR)
	AREA FOR STAGING, STORAGE OF MATERIALS, AND SOIL STOCKPILES OR WASTE (INITIAL THROUGH FINAL)
	PROPOSED LANDSCAPE AREAS (TEMP SEED IF PERMANENT LANDSCAPING CANNOT BE INSTALLED AFTER 14 DAYS OF INACTIVITY (INTERIM AND FINAL) SEE LANDSCAPE PLANS FOR FINAL STABILIZATION)

OUTFALL FROM THIS SITE IS TO STORM SEWER WITHIN EL JEFE HEIGHTS AND ULTIMATE OUTFALL TO EAST FORK OF SAND CREEK.

THE EXISTING SITE IS APPROXIMATELY 60% VEGETATED BASED ON VISUAL OBSERVATION

File: I:\24\24-0409_Super Star Colorado Springs\4_Production\Civil\3D\PlanSheets\C4.0_EROSION_CONTROL_PLAN.dwg Layout: C4.0_EROSION_CONTROL_PLAN User: johndia Plotted: Oct 19, 2023 - 4:51pm



DATE	7/25/2023
REVISION	
RESUBMITTAL #1	9/18/2023
RESUBMITTAL #2	10/20/2023
RESUBMITTAL #3	

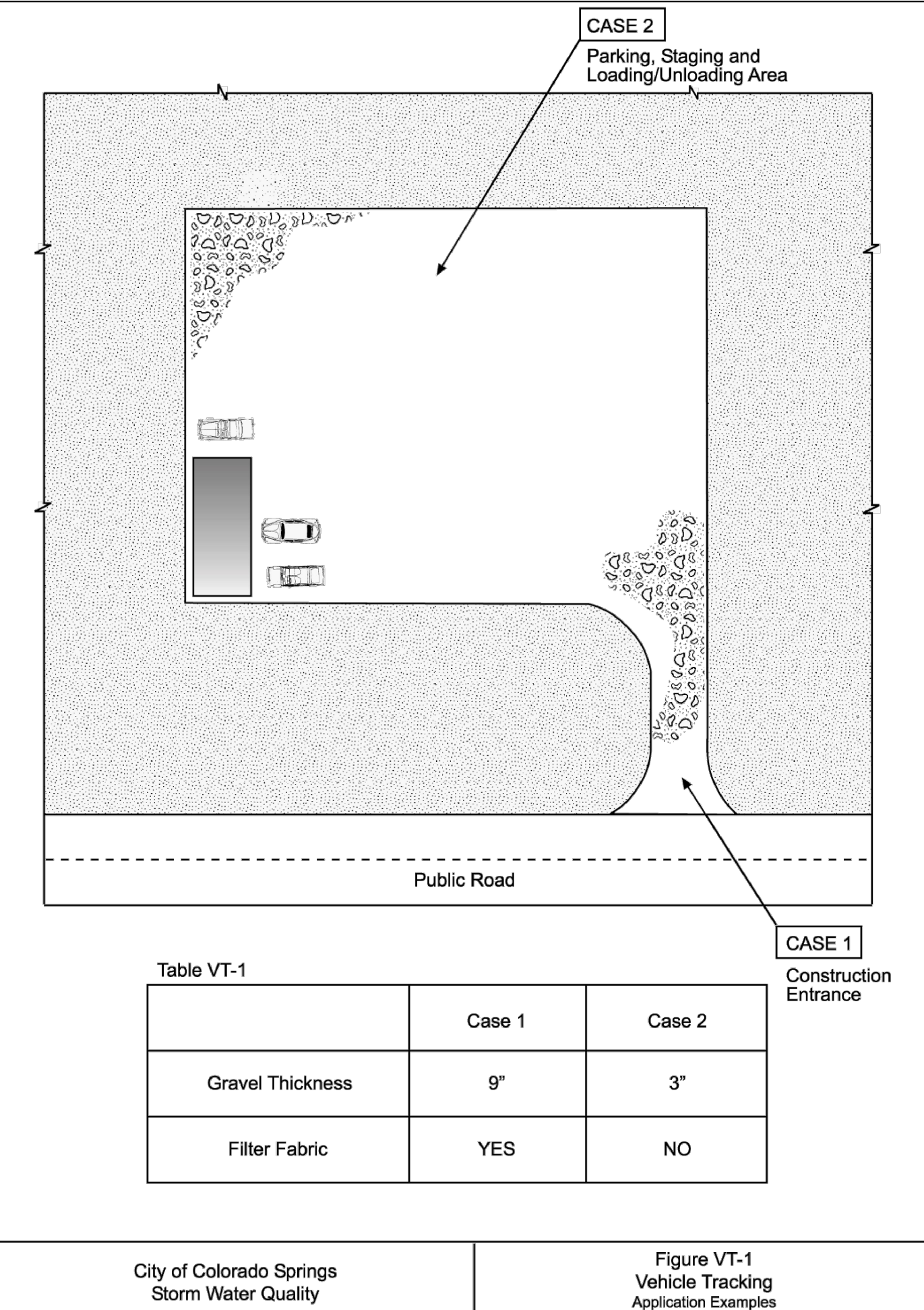
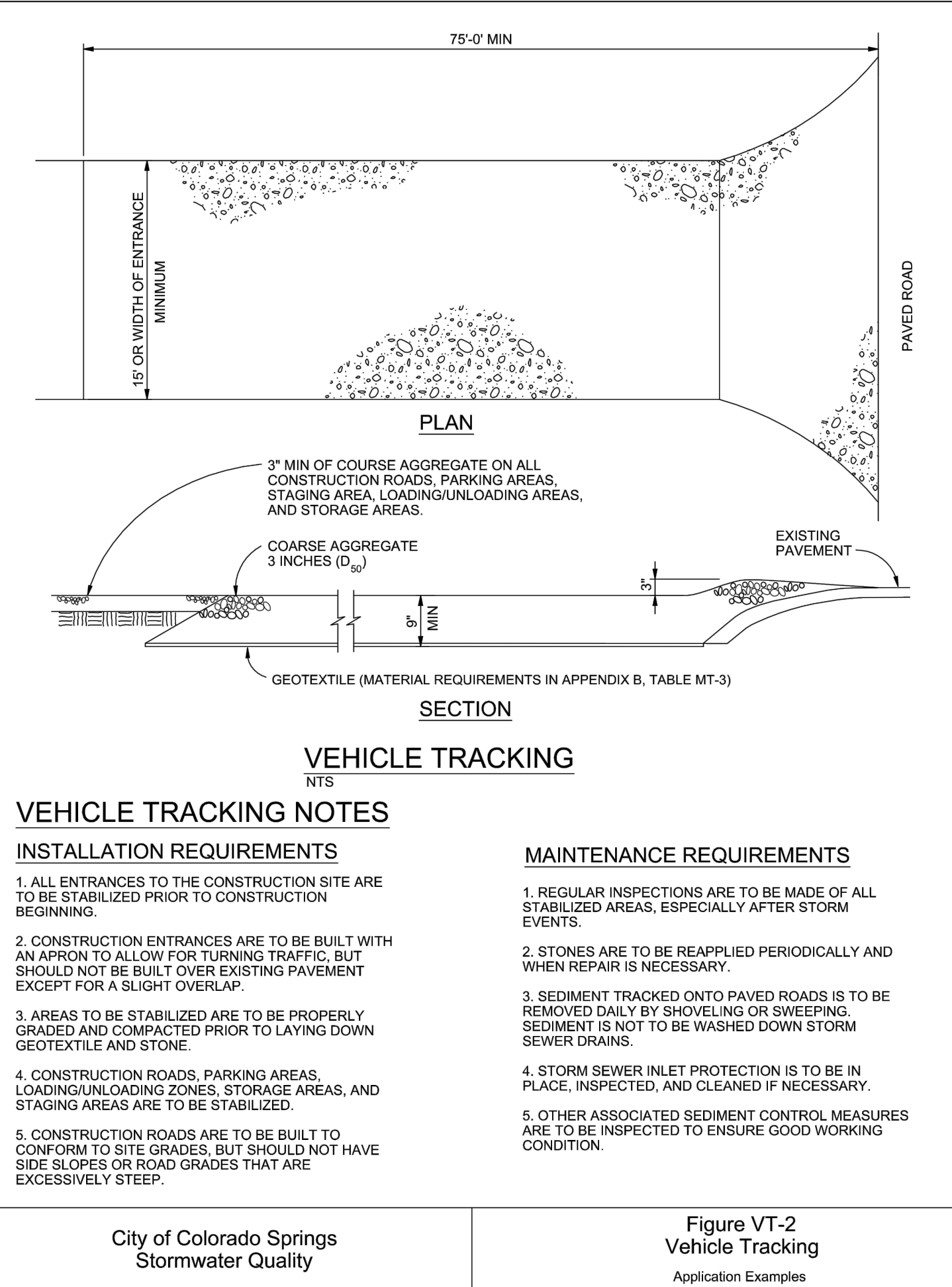
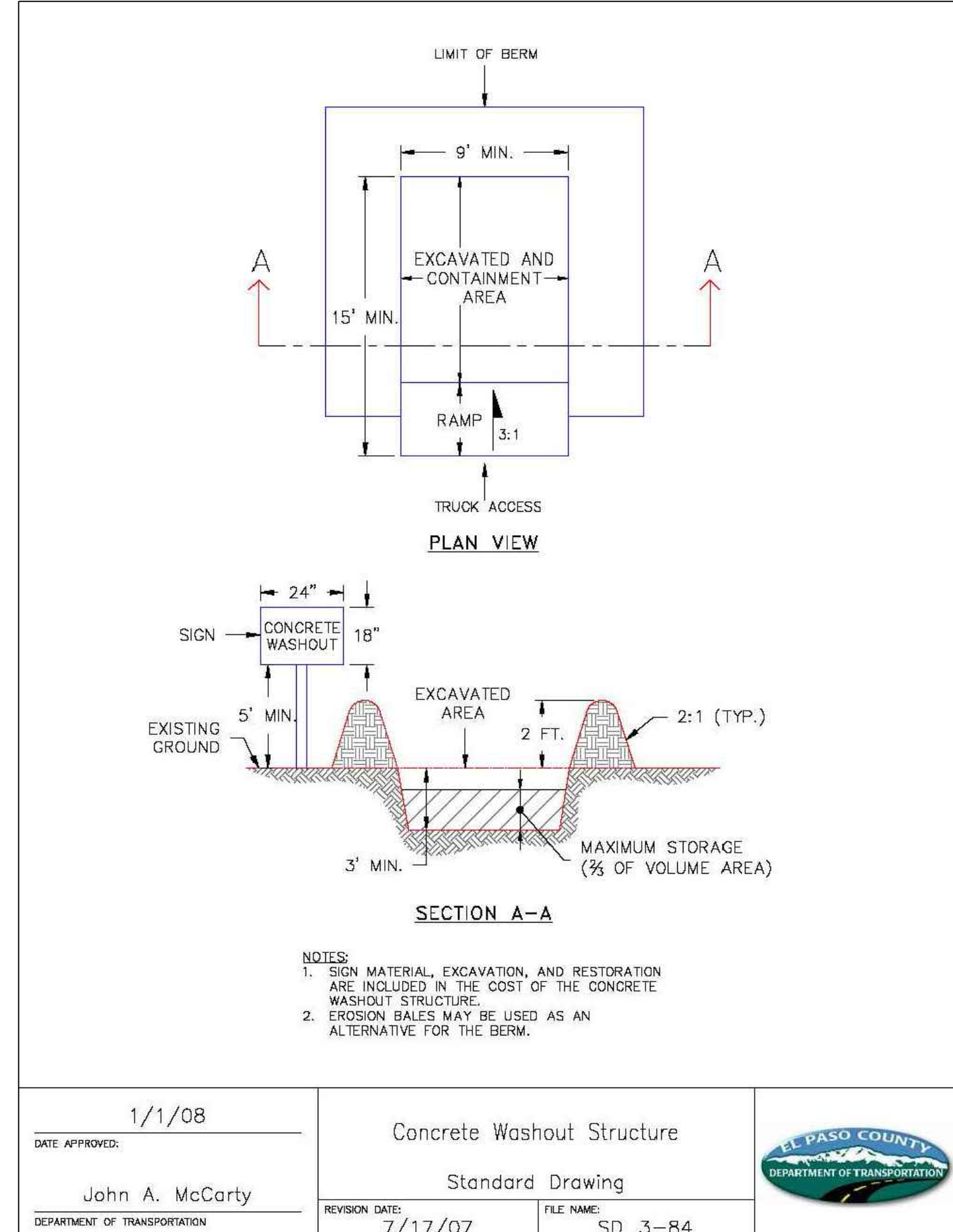

Silt Fence (SF) SC-1

Description
 A silt fence is a woven geotextile fabric attached to wooden posts and trenched into the ground. It is designed as a sediment barrier to intercept sheet flow runoff from disturbed areas.

Appropriate Uses
 A silt fence can be used where runoff is conveyed from a disturbed area as sheet flow. Silt fence is not designed to receive concentrated flow or to be used as a filter fabric. Typical uses include:

- Down slope of a disturbed area to accept sheet flow.
- Along the perimeter of a receiving water such as a stream, pond or wetland.
- At the perimeter of a construction site.

Design and Installation
 Silt fence should be installed along the contour of slopes so that it intercepts sheet flow. The maximum recommended tributary drainage area per 100 lineal feet of silt fence, installed along the contour, is approximately 0.25 acres with a disturbed slope length of up to 150 feet and a tributary slope gradient no steeper than 3:1. Longer and steeper slopes require additional measures. This recommendation only applies to silt fence installed along the contour. Silt fence installed for other uses, such as perimeter control, should be installed in a way that will not produce concentrated flows. For example, a "J-hook" installation may be appropriate to force runoff to pond and evaporate or infiltrate in multiple areas rather than concentrate and cause erosive conditions parallel to the silt fence.

See Detail SF-1 for proper silt fence installation, which involves proper trenching, staking, securing the fabric to the stakes, and backfilling the silt fence. Properly installed silt fence should not be easily pulled out by hand and there should be no gaps between the ground and the fabric.

Silt fence must meet the minimum allowable strength requirements, depth of installation requirement, and other specifications in the design details. Improper installation of silt fence is a common reason for silt fence failure; however, when properly installed and used for the appropriate purposes, it can be highly effective.

Silt Fence	
Functions	
Erosion Control	No
Sediment Control	Yes
Site/Material Management	No

November 2010 Urban Drainage and Flood Control District Urban Storm Drainage Criteria Manual Volume 3 SF-1

SC-1 Silt Fence (SF)

Maintenance and Removal
 Inspection of silt fence includes observing the material for tears or holes and checking for slumping fence and undercut areas bypassing flows. Repair of silt fence typically involves replacing the damaged section with a new section. Sediment accumulated behind silt fence should be removed, as needed to maintain BMP effectiveness, typically before it reaches a depth of 6 inches.

Silt fence may be removed when the upstream area has reached final stabilization.

Photograph SF-2. When silt fence is not installed along the contour, a "J-hook" installation may be appropriate to ensure that the BMP does not create concentrated flow parallel to the silt fence. Photo courtesy of Tom Gore.

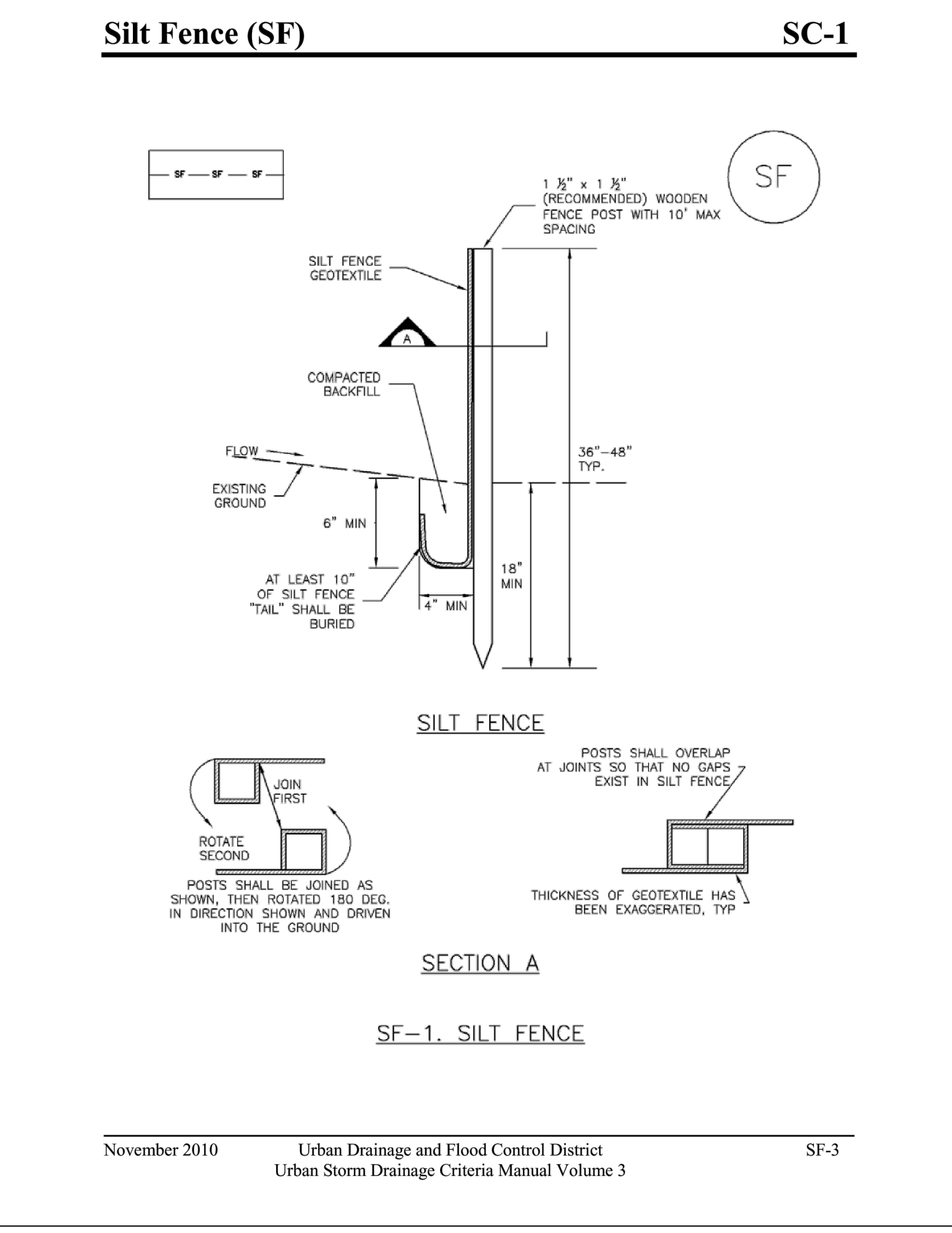

SUPERSTAR CARWASH
 MEADOWBROOK PKWY
 COLORADO SPRING, CO 80915

EROSION CONTROL DETAILS

Drawn By: AJJ
 Checked By: SEM
 Date: 10/20/2023
 Project No. 24-0409
 Sheet Number

E2.1

File: I:\24-0409-Super Star Colorado Springs\4-Production\Civil\3D\PlanSheets\C4.1 EROSION CONTROL DETAILS.dwg Layout: C4.1 EROSION CONTROL DETAILS User: johndraida Plotted: Oct 19, 2023 4:52pm



REVISION	DATE
RESUBMITTAL #1	7/25/2023
RESUBMITTAL #2	9/18/2023
RESUBMITTAL #3	10/20/2023

SUPERSTAR CARWASH
MEADOWBROOK PKWY
COLORADO SPRING, CO 80915
EROSION CONTROL DETAILS

Drawn By: AJJ
Checked By: SEM
Date: 10/20/2023
Project No. 24-0409
Sheet Number

Stockpile Management (SP) MM-2

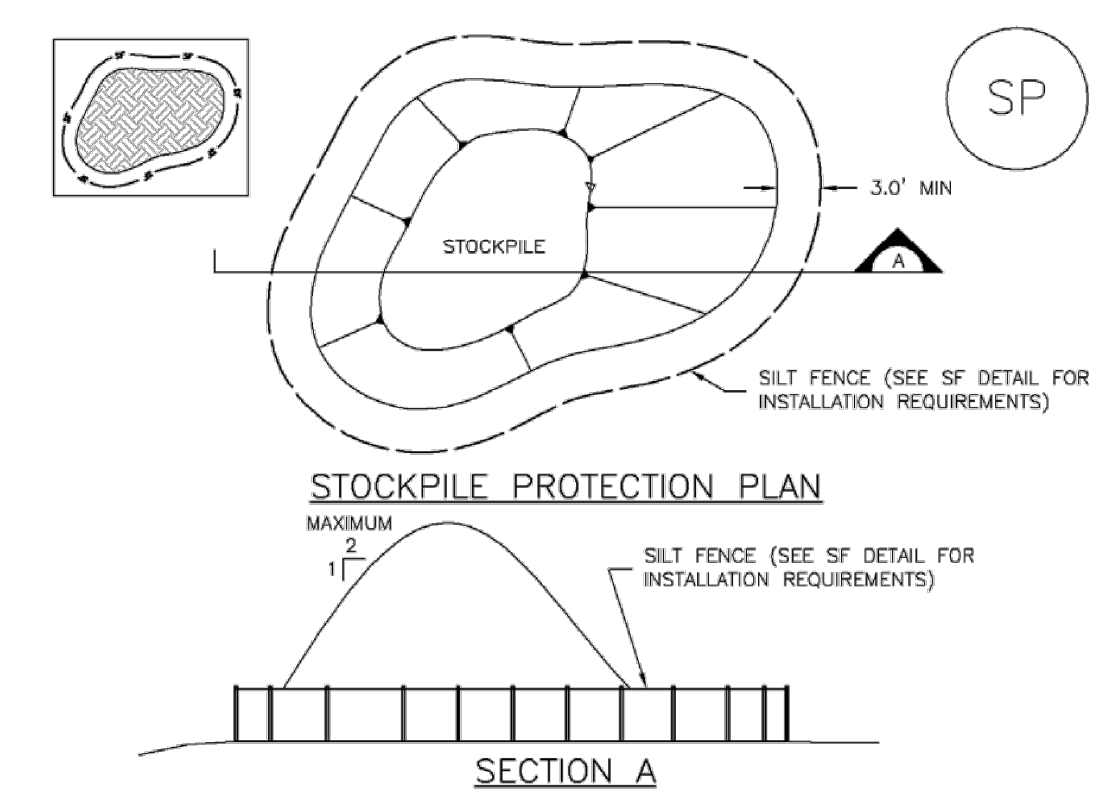

SP-1. STOCKPILE PROTECTION

- STOCKPILE PROTECTION INSTALLATION NOTES**
- SEE PLAN VIEW FOR:
-LOCATION OF STOCKPILES.
-TYPE OF STOCKPILE PROTECTION.
 - INSTALL PERIMETER CONTROLS IN ACCORDANCE WITH THEIR RESPECTIVE DESIGN DETAILS. SILT FENCE IS SHOWN IN THE STOCKPILE PROTECTION DETAILS; HOWEVER, OTHER TYPES OF PERIMETER CONTROLS INCLUDING SEDIMENT CONTROL LOGS OR ROCK SOCKS MAY BE SUITABLE IN SOME CIRCUMSTANCES. CONSIDERATIONS FOR DETERMINING THE APPROPRIATE TYPE OF PERIMETER CONTROL FOR A STOCKPILE INCLUDE WHETHER THE STOCKPILE IS LOCATED ON A PERVIOUS OR IMPERVIOUS SURFACE, THE RELATIVE HEIGHTS OF THE PERIMETER CONTROL AND STOCKPILE, THE ABILITY OF THE PERIMETER CONTROL TO CONTAIN THE STOCKPILE, WITHOUT FAILING IN THE EVENT THAT MATERIAL FROM THE STOCKPILE SHIFTS OR SLUMPS AGAINST THE PERIMETER, AND OTHER FACTORS.
 - STABILIZE THE STOCKPILE SURFACE WITH SURFACE ROUGHENING, TEMPORARY SEEDING AND MULCHING, EROSION CONTROL BLANKETS, OR SOIL BINDERS. SOILS STOCKPILED FOR AN EXTENDED PERIOD (TYPICALLY FOR MORE THAN 60 DAYS) SHOULD BE SEEDED AND MULCHED WITH A TEMPORARY GRASS COVER ONCE THE STOCKPILE IS PLACED (TYPICALLY WITHIN 14 DAYS). USE OF MULCH ONLY OR A SOIL BINDER IS ACCEPTABLE IF THE STOCKPILE WILL BE IN PLACE FOR A MORE LIMITED TIME PERIOD (TYPICALLY 30-60 DAYS).
 - FOR TEMPORARY STOCKPILES ON THE INTERIOR PORTION OF A CONSTRUCTION SITE, WHERE OTHER DOWNGRADE CONTROLS, INCLUDING PERIMETER CONTROL, ARE IN PLACE, STOCKPILE PERIMETER CONTROLS MAY NOT BE REQUIRED.

November 2010 Urban Drainage and Flood Control District SP-3
Urban Storm Drainage Criteria Manual Volume 3

MM-2 Stockpile Management (SM)

When the stockpile is no longer needed, properly dispose of excess materials and revegetate or otherwise stabilize the ground surface where the stockpile was located.

SP-2 Urban Drainage and Flood Control District November 2010
Urban Storm Drainage Criteria Manual Volume 3

Stockpile Management (SP) MM-2

Description

Stockpile management includes measures to minimize erosion and sediment transport from soil stockpiles.

Appropriate Uses

Stockpile management should be used when soils or other erodible materials are stored at the construction site. Special attention should be given to stockpiles in close proximity to natural or manmade storm systems.

Design and Installation

Locate stockpiles away from all drainage system components including storm sewer inlets. Where practical, choose stockpile locations that that will remain undisturbed for the longest period of time as the phases of construction progress. Place sediment control BMPs around the perimeter of the stockpile, such as sediment control logs, rock socks, silt fence, straw bales and sand bags. See Detail SP-1 for guidance on proper establishment of perimeter controls around a stockpile. For stockpiles in active use, provide a stabilized designated access point on the upgradient side of the stockpile.

Stabilize the stockpile surface with surface roughening, temporary seeding and mulching, erosion control blankets, or soil binders. Soils stockpiled for an extended period (typically for more than 60 days) should be seeded and mulched with a temporary grass cover once the stockpile is placed (typically within 14 days). Use of mulch only or a soil binder is acceptable if the stockpile will be in place for a more limited time period (typically 30-60 days). Timeframes for stabilization of stockpiles noted in this fact sheet are "typical" guidelines. Check permit requirements for specific federal, state, and/or local requirements that may be more prescriptive.

Stockpiles should not be placed in streets or paved areas unless no other practical alternative exists. See the Stabilized Staging Area Fact Sheet for guidance when staging in roadways is unavoidable due to space or right-of-way constraints. For paved areas, rock socks must be used for perimeter control and all inlets with the potential to receive sediment from the stockpile (even from vehicle tracking) must be protected.

Maintenance and Removal

Inspect perimeter controls and inlet protection in accordance with their respective BMP Fact Sheets. Where seeding, mulch and/or soil binders are used, reseeding or reapplication of soil binder may be necessary.

When temporary removal of a perimeter BMP is necessary to access a stockpile, ensure BMPs are reinstalled in accordance with their respective design detail section.

Stockpile Management	
Functions	
Erosion Control	Yes
Sediment Control	Yes
Site/Material Management	Yes

November 2010 Urban Drainage and Flood Control District SP-1
Urban Storm Drainage Criteria Manual Volume 3



MM-2 Stockpile Management (SM)

STOCKPILE PROTECTION MAINTENANCE NOTES

- INSPECT BMPs EACH WORKDAY, AND MAINTAIN THEM IN EFFECTIVE OPERATING CONDITION. MAINTENANCE OF BMPs SHOULD BE PROACTIVE, NOT REACTIVE. INSPECT BMPs AS SOON AS POSSIBLE (AND ALWAYS WITHIN 24 HOURS) FOLLOWING A STORM THAT CAUSES SURFACE EROSION, AND PERFORM NECESSARY MAINTENANCE.
- FREQUENT OBSERVATIONS AND MAINTENANCE ARE NECESSARY TO MAINTAIN BMPs IN EFFECTIVE OPERATING CONDITION. INSPECTIONS AND CORRECTIVE MEASURES SHOULD BE DOCUMENTED THOROUGHLY.
- WHERE BMPs HAVE FAILED, REPAIR OR REPLACEMENT SHOULD BE INITIATED UPON DISCOVERY OF THE FAILURE.
- IF PERIMETER PROTECTION MUST BE MOVED TO ACCESS SOIL STOCKPILE, REPLACE PERIMETER CONTROLS BY THE END OF THE WORKDAY.
- STOCKPILE PERIMETER CONTROLS CAN BE REMOVED ONCE ALL THE MATERIAL FROM THE STOCKPILE HAS BEEN USED.

STOCKPILE PROTECTION MAINTENANCE NOTES

- INSPECT BMPs EACH WORKDAY, AND MAINTAIN THEM IN EFFECTIVE OPERATING CONDITION. MAINTENANCE OF BMPs SHOULD BE PROACTIVE, NOT REACTIVE. INSPECT BMPs AS SOON AS POSSIBLE (AND ALWAYS WITHIN 24 HOURS) FOLLOWING A STORM THAT CAUSES SURFACE EROSION, AND PERFORM NECESSARY MAINTENANCE.
- FREQUENT OBSERVATIONS AND MAINTENANCE ARE NECESSARY TO MAINTAIN BMPs IN EFFECTIVE OPERATING CONDITION. INSPECTIONS AND CORRECTIVE MEASURES SHOULD BE DOCUMENTED THOROUGHLY.
- WHERE BMPs HAVE FAILED, REPAIR OR REPLACEMENT SHOULD BE INITIATED UPON DISCOVERY OF THE FAILURE.
- IF PERIMETER PROTECTION MUST BE MOVED TO ACCESS SOIL STOCKPILE, REPLACE PERIMETER CONTROLS BY THE END OF THE WORKDAY.
- STOCKPILE PERIMETER CONTROLS CAN BE REMOVED ONCE ALL THE MATERIAL FROM THE STOCKPILE HAS BEEN USED.

SP-4 Urban Drainage and Flood Control District November 2010
Urban Storm Drainage Criteria Manual Volume 3

MM-2 Stockpile Management (SM)

MATERIALS STAGING IN ROADWAY MAINTENANCE NOTES

- INSPECT BMPs EACH WORKDAY, AND MAINTAIN THEM IN EFFECTIVE OPERATING CONDITION. MAINTENANCE OF BMPs SHOULD BE PROACTIVE, NOT REACTIVE. INSPECT BMPs AS SOON AS POSSIBLE (AND ALWAYS WITHIN 24 HOURS) FOLLOWING A STORM THAT CAUSES SURFACE EROSION, AND PERFORM NECESSARY MAINTENANCE.
- FREQUENT OBSERVATIONS AND MAINTENANCE ARE NECESSARY TO MAINTAIN BMPs IN EFFECTIVE OPERATING CONDITION. INSPECTIONS AND CORRECTIVE MEASURES SHOULD BE DOCUMENTED THOROUGHLY.
- WHERE BMPs HAVE FAILED, REPAIR OR REPLACEMENT SHOULD BE INITIATED UPON DISCOVERY OF THE FAILURE.
- INSPECT PVC PIPE ALONG CURB LINE FOR CLOGGING AND DEBRIS. REMOVE OBSTRUCTIONS PROMPTLY.
- CLEAN MATERIAL FROM PAVED SURFACES BY SWEEPING OR VACUUMING.

NOTE: MANY JURISDICTIONS HAVE BMP DETAILS THAT VARY FROM UDFCD STANDARD DETAILS. CONSULT WITH LOCAL JURISDICTIONS AS TO WHICH DETAIL SHOULD BE USED WHEN DIFFERENCES ARE NOTED.

(DETAILS ADAPTED FROM AURORA, COLORADO)

SP-6 Urban Drainage and Flood Control District November 2010
Urban Storm Drainage Criteria Manual Volume 3

Stockpile Management (SP) MM-2

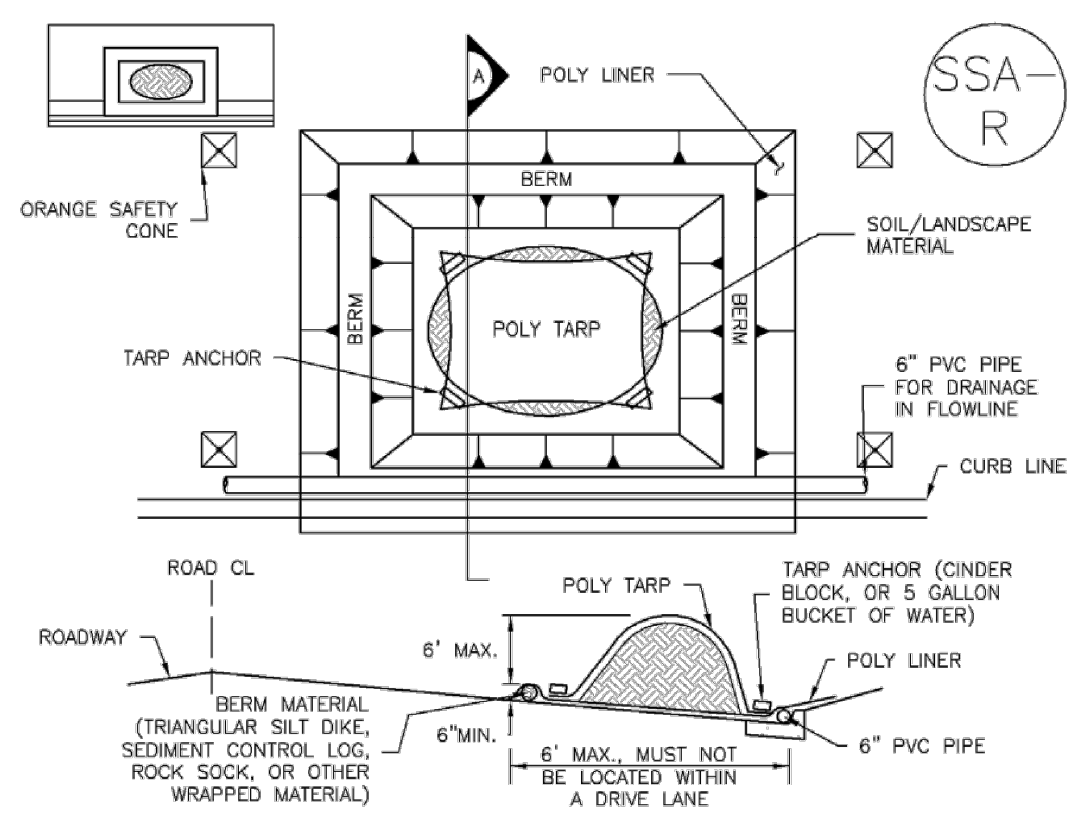

SP-2. MATERIALS STAGING IN ROADWAY

MATERIALS STAGING IN ROADWAYS INSTALLATION NOTES

- SEE PLAN VIEW FOR:
-LOCATION OF MATERIAL STAGING AREA(S).
-CONTRACTOR MAY ADJUST LOCATION AND SIZE OF STAGING AREA WITH APPROVAL FROM THE LOCAL JURISDICTION.
- FEATURE MUST BE INSTALLED PRIOR TO EXCAVATION, EARTHWORK OR DELIVERY OF MATERIALS.
- MATERIALS MUST BE STATIONED ON THE POLY LINER. ANY INCIDENTAL MATERIALS DEPOSITED ON PAVED SECTION OR ALONG CURB LINE MUST BE CLEANED UP PROMPTLY.
- POLY LINER AND TARP COVER SHOULD BE OF SIGNIFICANT THICKNESS TO PREVENT DAMAGE OR LOSS OF INTEGRITY.
- SAND BAGS MAY BE SUBSTITUTED TO ANCHOR THE COVER TARP OR PROVIDE BERMING UNDER THE BASE LINER.
- FEATURE IS NOT INTENDED FOR USE WITH WET MATERIAL THAT WILL BE DRAINING AND/OR SPREADING OUT ON THE POLY LINER OR FOR DEMOLITION MATERIALS.
- THIS FEATURE CAN BE USED FOR:
-UTILITY REPAIRS.
-WHEN OTHER STAGING LOCATIONS AND OPTIONS ARE LIMITED.
-OTHER LIMITED APPLICATION AND SHORT DURATION STAGING.

November 2010 Urban Drainage and Flood Control District SP-5
Urban Storm Drainage Criteria Manual Volume 3

Inlet Protection (IP)

SC-6

Description

Inlet protection consists of permeable barriers installed around an inlet to filter runoff and remove sediment prior to entering a storm drain inlet. Inlet protection can be constructed from rock socks, sediment control logs, silt fence, block and rock socks, or other materials approved by the local jurisdiction. Area inlets can also be protected by over-excavating around the inlet to form a sediment trap.



Photograph IP-1. Inlet protection for a curb opening inlet.

Appropriate Uses

Install protection at storm sewer inlets that are operable during construction. Consider the potential for tracked-out sediment or temporary stockpile areas to contribute sediment to inlets when determining which inlets must be protected. This may include inlets in the general proximity of the construction area, not limited to downgradient inlets. Inlet protection is not a stand-alone BMP and should be used in conjunction with other upgradient BMPs.

Design and Installation

To function effectively, inlet protection measures must be installed to ensure that flows do not bypass the inlet protection and enter the storm drain without treatment. However, designs must also enable the inlet to function without completely blocking flows into the inlet in a manner that causes localized flooding. When selecting the type of inlet protection, consider factors such as type of inlet (e.g., curb or area, sump or on-grade conditions), traffic, anticipated flows, ability to secure the BMP properly, safety and other site-specific conditions. For example, block and rock socks will be better suited to a curb and gutter along a roadway, as opposed to silt fence or sediment control logs, which cannot be properly secured in a curb and gutter setting, but are effective area inlet protection measures.

Several inlet protection designs are provided in the Design Details. Additionally, a variety of proprietary products are available for inlet protection that may be approved for use by local governments. If proprietary products are used, design details and installation procedures from the manufacturer must be followed. Regardless of the type of inlet protection selected, inlet protection is most effective when combined with other BMPs such as curb socks and check dams. Inlet protection is often the last barrier before runoff enters the storm sewer or receiving water.

Design details with notes are provided for these forms of inlet protection:

Inlet Protection (various forms)	
Functions	
Erosion Control	No
Sediment Control	Yes
Site/Material Management	No

- IP-1. Block and Rock Sock Inlet Protection for Sump or On-grade Inlets
- IP-2. Curb (Rock) Socks Upstream of Inlet Protection, On-grade Inlets

August 2013 Urban Drainage and Flood Control District Urban Storm Drainage Criteria Manual Volume 3 IP-1

Inlet Protection (IP)

SC-6

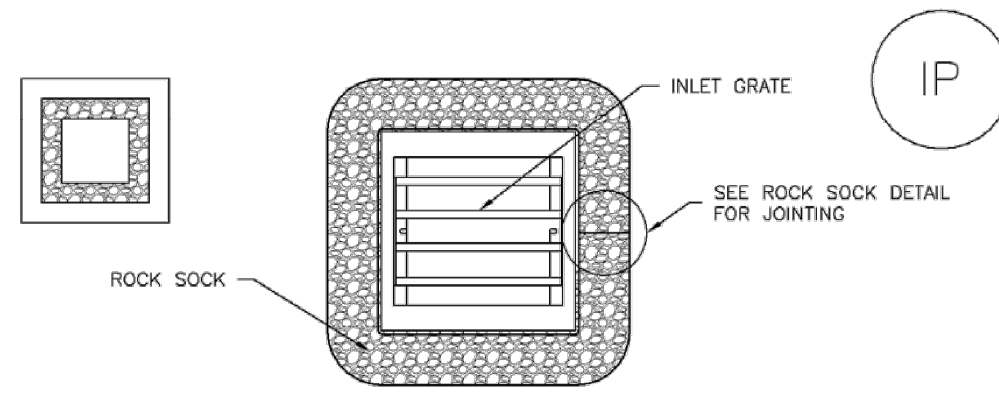

IP-3. ROCK SOCK SUMP/AREA INLET PROTECTION

ROCK SOCK SUMP/AREA INLET PROTECTION INSTALLATION NOTES
 1. SEE ROCK SOCK DESIGN DETAIL FOR INSTALLATION REQUIREMENTS.
 2. STRAW WATTLES/SEDIMENT CONTROL LOGS MAY BE USED IN PLACE OF ROCK SOCKS FOR INLETS IN PERVIOUS AREAS. INSTALL PER SEDIMENT CONTROL LOG DETAIL.

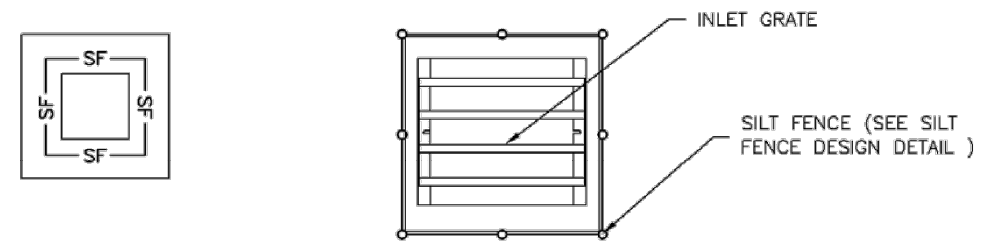

IP-4. SILT FENCE FOR SUMP INLET PROTECTION

SILT FENCE INLET PROTECTION INSTALLATION NOTES
 1. SEE SILT FENCE DESIGN DETAIL FOR INSTALLATION REQUIREMENTS.
 2. POSTS SHALL BE PLACED AT EACH CORNER OF THE INLET AND AROUND THE EDGES AT A MAXIMUM SPACING OF 3 FEET.
 3. STRAW WATTLES/SEDIMENT CONTROL LOGS MAY BE USED IN PLACE OF SILT FENCE FOR INLETS IN PERVIOUS AREAS. INSTALL PER SEDIMENT CONTROL LOG DETAIL.

August 2013 Urban Drainage and Flood Control District Urban Storm Drainage Criteria Manual Volume 3 IP-5

SC-6

Inlet Protection (IP)

- IP-3. Rock Sock Inlet Protection for Sump/Area Inlet
- IP-4. Silt Fence Inlet Protection for Sump/Area Inlet
- IP-5. Over-excavation Inlet Protection
- IP-6. Straw Bale Inlet Protection for Sump/Area Inlet
- CIP-1. Culvert Inlet Protection

Proprietary inlet protection devices should be installed in accordance with manufacturer specifications. More information is provided below on selecting inlet protection for sump and on-grade locations.

Inlets Located in a Sump

When applying inlet protection in sump conditions, it is important that the inlet continue to function during larger runoff events. For curb inlets, the maximum height of the protective barrier should be lower than the top of the curb opening to allow overflow into the inlet during larger storms without excessive localized flooding. If the inlet protection height is greater than the curb elevation, particularly if the filter becomes clogged with sediment, runoff will not enter the inlet and may bypass it, possibly causing localized flooding, public safety issues, and downstream erosion and damage from bypassed flows.

Area inlets located in a sump setting can be protected through the use of silt fence, concrete block and rock socks (on paved surfaces), sediment control logs/straw wattles embedded in the adjacent soil and stacked around the area inlet (on pervious surfaces), over-excavation around the inlet, and proprietary products providing equivalent functions.

Inlets Located on a Slope

For curb and gutter inlets on paved sloping streets, block and rock sock inlet protection is recommended in conjunction with curb socks in the gutter leading to the inlet. For inlets located along unpaved roads, also see the Check Dam Fact Sheet.

Maintenance and Removal

Inspect inlet protection frequently. Inspection and maintenance guidance includes:

- Inspect for tears that can result in sediment directly entering the inlet, as well as result in the contents of the BMP (e.g., gravel) washing into the inlet.
- Check for improper installation resulting in untreated flows bypassing the BMP and directly entering the inlet or bypassing to an unprotected downstream inlet. For example, silt fence that has not been properly trenched around the inlet can result in flows under the silt fence and directly into the inlet.
- Look for displaced BMPs that are no longer protecting the inlet. Displacement may occur following larger storm events that wash away or reposition the inlet protection. Traffic or equipment may also crush or displace the BMP.
- Monitor sediment accumulation upgradient of the inlet protection.

IP-2 Urban Drainage and Flood Control District Urban Storm Drainage Criteria Manual Volume 3 August 2013

SC-6

Inlet Protection (IP)

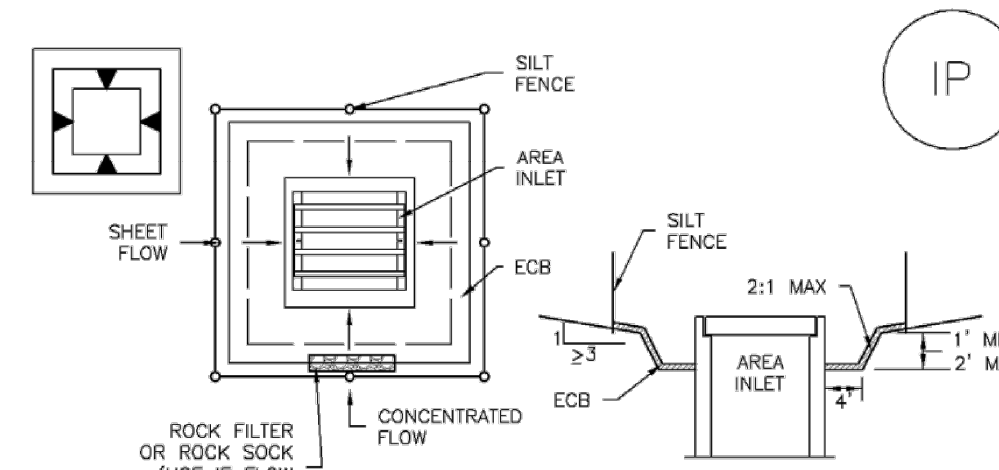

IP-5. OVEREXCAVATION INLET PROTECTION

OVEREXCAVATION INLET PROTECTION INSTALLATION NOTES
 1. THIS FORM OF INLET PROTECTION IS PRIMARILY APPLICABLE FOR SITES THAT HAVE NOT YET REACHED FINAL GRADE AND SHOULD BE USED ONLY FOR INLETS WITH A RELATIVELY SMALL CONTRIBUTING DRAINAGE AREA.
 2. WHEN USING FOR CONCENTRATED FLOWS, SHAPE BASIN IN 2:1 RATIO WITH LENGTH ORIENTED TOWARDS DIRECTION OF FLOW.
 3. SEDIMENT MUST BE PERIODICALLY REMOVED FROM THE OVEREXCAVATED AREA.

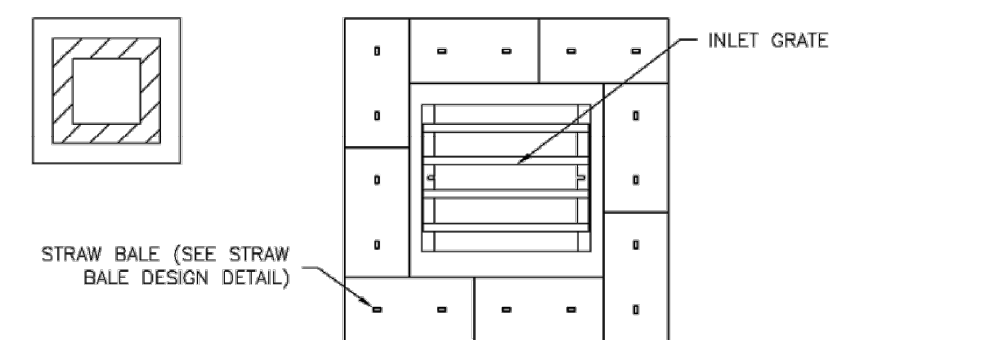

IP-6. STRAW BALE FOR SUMP INLET PROTECTION

STRAW BALE BARRIER INLET PROTECTION INSTALLATION NOTES
 1. SEE STRAW BALE DESIGN DETAIL FOR INSTALLATION REQUIREMENTS.
 2. BALES SHALL BE PLACED IN A SINGLE ROW AROUND THE INLET WITH ENDS OF BALES TIGHTLY ABUTTING ONE ANOTHER.

IP-6 Urban Drainage and Flood Control District Urban Storm Drainage Criteria Manual Volume 3 August 2013

Inlet Protection (IP)

SC-6

- Remove sediment accumulation from the area upstream of the inlet protection, as needed to maintain BMP effectiveness, typically when it reaches no more than half the storage capacity of the inlet protection. For silt fence, remove sediment when it accumulates to a depth of no more than 6 inches. Remove sediment accumulation from the area upstream of the inlet protection as needed to maintain the functionality of the BMP.
- Proprietary inlet protection devices should be inspected and maintained in accordance with manufacturer specifications. If proprietary inlet insert devices are used, sediment should be removed in a timely manner to prevent devices from breaking and spilling sediment into the storm drain.

Inlet protection must be removed and properly disposed of when the drainage area for the inlet has reached final stabilization.

August 2013 Urban Drainage and Flood Control District Urban Storm Drainage Criteria Manual Volume 3 IP-3

Inlet Protection (IP)

SC-6

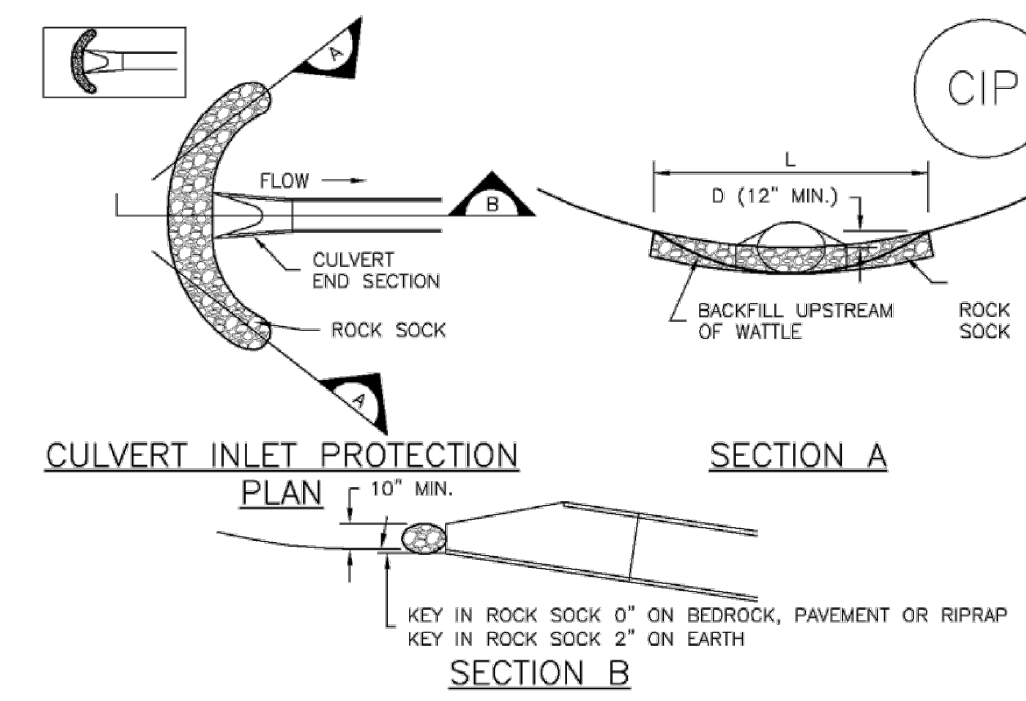

CIP-1. CULVERT INLET PROTECTION

CULVERT INLET PROTECTION INSTALLATION NOTES
 1. SEE PLAN VIEW FOR -LOCATION OF CULVERT INLET PROTECTION.
 2. SEE ROCK SOCK DESIGN DETAIL FOR ROCK GRADATION REQUIREMENTS AND JOINTING DETAIL.

CULVERT INLET PROTECTION MAINTENANCE NOTES
 1. INSPECT BMPs EACH WORKDAY, AND MAINTAIN THEM IN EFFECTIVE OPERATING CONDITION. MAINTENANCE OF BMPs SHOULD BE PROACTIVE, NOT REACTIVE. INSPECT BMPs AS SOON AS POSSIBLE (AND ALWAYS WITHIN 24 HOURS) FOLLOWING A STORM THAT CAUSES SURFACE EROSION, AND PERFORM NECESSARY MAINTENANCE.

2. FREQUENT OBSERVATIONS AND MAINTENANCE ARE NECESSARY TO MAINTAIN BMPs IN EFFECTIVE OPERATING CONDITION. INSPECTIONS AND CORRECTIVE MEASURES SHOULD BE DOCUMENTED THOROUGHLY.
 3. WHERE BMPs HAVE FAILED, REPAIR OR REPLACEMENT SHOULD BE INITIATED UPON DISCOVERY OF THE FAILURE.

4. SEDIMENT ACCUMULATED UPSTREAM OF THE CULVERT SHALL BE REMOVED WHEN THE SEDIMENT DEPTH IS 1/2 THE HEIGHT OF THE ROCK SOCK.
 5. CULVERT INLET PROTECTION SHALL REMAIN IN PLACE UNTIL THE UPSTREAM DISTURBED AREA IS PERMANENTLY STABILIZED AND APPROVED BY THE LOCAL JURISDICTION.

(DETAILS ADAPTED FROM AURORA, COLORADO, NOT AVAILABLE IN AUTOCAD)
 NOTE: MANY JURISDICTIONS HAVE BMP DETAILS THAT VARY FROM UDFCD STANDARD DETAILS. CONSULT WITH LOCAL JURISDICTIONS AS TO WHICH DETAIL SHOULD BE USED WHEN DIFFERENCES ARE NOTED.

August 2013 Urban Drainage and Flood Control District Urban Storm Drainage Criteria Manual Volume 3 IP-7

SC-6

Inlet Protection (IP)

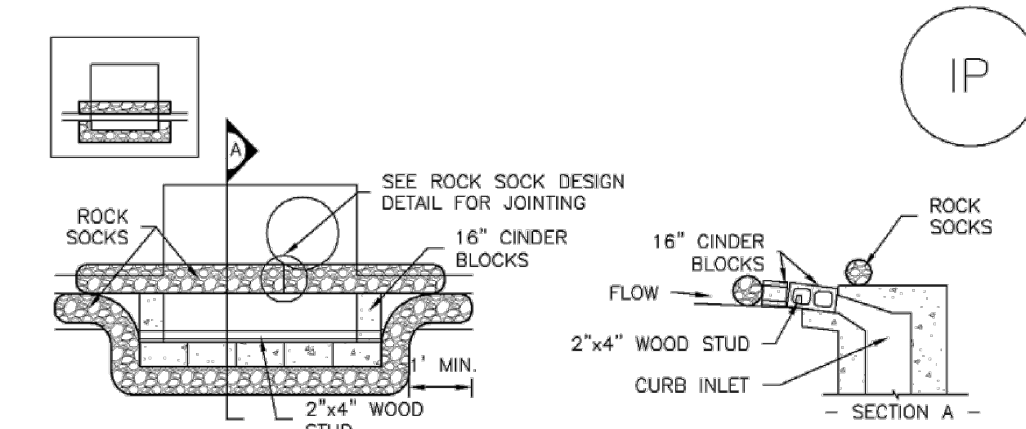

IP-1. BLOCK AND ROCK SOCK SUMP OR ON GRADE INLET PROTECTION

BLOCK AND CURB SOCK INLET PROTECTION INSTALLATION NOTES
 1. SEE ROCK SOCK DESIGN DETAIL FOR INSTALLATION REQUIREMENTS.
 2. CONCRETE "CINDER" BLOCKS SHALL BE LAID ON THEIR SIDES AROUND THE INLET IN A SINGLE ROW, ABUTTING ONE ANOTHER WITH THE OPEN END FACING AWAY FROM THE CURB.
 3. GRAVEL BAGS SHALL BE PLACED AROUND CONCRETE BLOCKS, CLOSELY ABUTTING ONE ANOTHER AND JOINTED TOGETHER IN ACCORDANCE WITH ROCK SOCK DESIGN DETAIL.

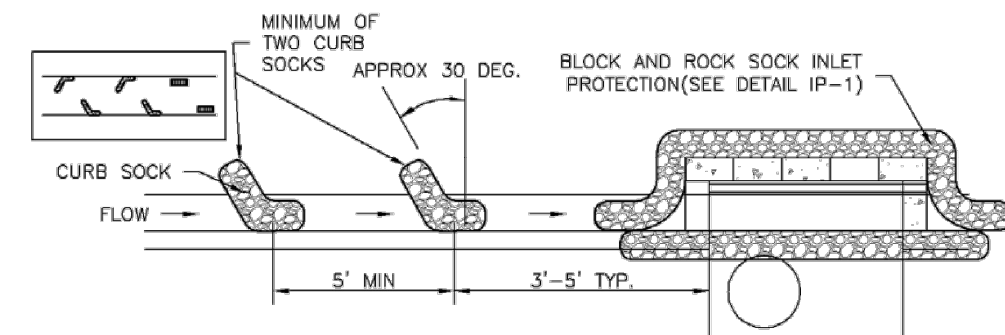

IP-2. CURB ROCK SOCKS UPSTREAM OF INLET PROTECTION

CURB ROCK SOCK INLET PROTECTION INSTALLATION NOTES
 1. SEE ROCK SOCK DESIGN DETAIL INSTALLATION REQUIREMENTS.
 2. PLACEMENT OF THE SOCK SHALL BE APPROXIMATELY 30 DEGREES FROM PERPENDICULAR IN THE OPPOSITE DIRECTION OF FLOW.
 3. SOCKS ARE TO BE FLUSH WITH THE CURB AND SPACED A MINIMUM OF 5 FEET APART.
 4. AT LEAST TWO CURB SOCKS IN SERIES ARE REQUIRED UPSTREAM OF ON-GRADE INLETS.

IP-4 Urban Drainage and Flood Control District Urban Storm Drainage Criteria Manual Volume 3 August 2013

SC-6

Inlet Protection (IP)

GENERAL INLET PROTECTION INSTALLATION NOTES
 1. SEE PLAN VIEW FOR:
 -LOCATION OF INLET PROTECTION.
 -TYPE OF INLET PROTECTION (IP-1, IP-2, IP-3, IP-4, IP-5, IP-6)
 2. INLET PROTECTION SHALL BE INSTALLED PROMPTLY AFTER INLET CONSTRUCTION OR PAVING IS COMPLETE (TYPICALLY WITHIN 48 HOURS). IF A RAINFALL/RUNOFF EVENT IS FORECAST, INSTALL INLET PROTECTION PRIOR TO ONSET OF EVENT.
 3. MANY JURISDICTIONS HAVE BMP DETAILS THAT VARY FROM UDFCD STANDARD DETAILS. CONSULT WITH LOCAL JURISDICTIONS AS TO WHICH DETAIL SHOULD BE USED WHEN DIFFERENCES ARE NOTED.

INLET PROTECTION MAINTENANCE NOTES
 1. INSPECT BMPs EACH WORKDAY, AND MAINTAIN THEM IN EFFECTIVE OPERATING CONDITION. MAINTENANCE OF BMPs SHOULD BE PROACTIVE, NOT REACTIVE. INSPECT BMPs AS SOON AS POSSIBLE (AND ALWAYS WITHIN 24 HOURS) FOLLOWING A STORM THAT CAUSES SURFACE EROSION, AND PERFORM NECESSARY MAINTENANCE.
 2. FREQUENT OBSERVATIONS AND MAINTENANCE ARE NECESSARY TO MAINTAIN BMPs IN EFFECTIVE OPERATING CONDITION. INSPECTIONS AND CORRECTIVE MEASURES SHOULD BE DOCUMENTED THOROUGHLY.
 3. WHERE BMPs HAVE FAILED, REPAIR OR REPLACEMENT SHOULD BE INITIATED UPON DISCOVERY OF THE FAILURE.
 4. SEDIMENT ACCUMULATED UPSTREAM OF INLET PROTECTION SHALL BE REMOVED AS NECESSARY TO MAINTAIN BMP EFFECTIVENESS, TYPICALLY WHEN STORAGE VOLUME REACHES 50% OF CAPACITY, A DEPTH OF 6" WHEN SILT FENCE IS USED, OR 1/4 OF THE HEIGHT FOR STRAW BALES.

5. INLET PROTECTION IS TO REMAIN IN PLACE UNTIL THE UPSTREAM DISTURBED AREA IS PERMANENTLY STABILIZED, UNLESS THE LOCAL JURISDICTION APPROVES EARLIER REMOVAL OF INLET PROTECTION IN STREETS.
 6. WHEN INLET PROTECTION AT AREA INLETS IS REMOVED, THE DISTURBED AREA SHALL BE COVERED WITH TOP SOIL, SEEDS, MULCH, OR OTHERWISE STABILIZED IN A MANNER APPROVED BY THE LOCAL JURISDICTION.

(DETAILS ADAPTED FROM TOWN OF PARKER, COLORADO AND CITY OF AURORA, COLORADO, NOT AVAILABLE IN AUTOCAD)
 NOTE: MANY JURISDICTIONS HAVE BMP DETAILS THAT VARY FROM UDFCD STANDARD DETAILS. CONSULT WITH LOCAL JURISDICTIONS AS TO WHICH DETAIL SHOULD BE USED WHEN DIFFERENCES ARE NOTED.
 NOTE: SOME MUNICIPALITIES DISCOURAGE OR PROHIBIT THE USE OF STRAW BALES FOR INLET PROTECTION. CHECK WITH LOCAL JURISDICTION TO DETERMINE IF STRAW BALE INLET PROTECTION IS ACCEPTABLE.

IP-8 Urban Drainage and Flood Control District Urban Storm Drainage Criteria Manual Volume 3 August 2013

AYRES ASSOCIATES
 3665 JFK PARKWAY
 BUILDING 2, SUITE 100
 FORT COLLINS, CO
 80525
 262.522.4901
 www.AyresAssociates.com

SUPER STAR CAR WASH

REVISION	DATE
RESUBMITTAL #1	7/25/2023
RESUBMITTAL #2	9/18/2023
RESUBMITTAL #3	10/20/2023

SUPERSTAR CARWASH
 MEADOWBROOK PKWY
 COLORADO SPRING, CO 80915
EROSION CONTROL DETAILS

Drawn By: AJJ
 Checked By: SEM
 Date: 10/20/2023
 Project No. 24-0409

Sheet Number
E2.3

Temporary and Permanent Seeding (TS/PS) EC-2

Description

Temporary seeding can be used to stabilize disturbed areas that will be inactive for an extended period. Permanent seeding should be used to stabilize areas at final grade that will not be otherwise stabilized. Effective seeding includes preparing a seedbed, selecting an appropriate seed mixture, using proper planting techniques, and protecting the seeded area with mulch, geotextiles, or other appropriate measures.



Photograph TS/PS-1. Equipment used to drill seed. Photo courtesy of Douglas County.

Appropriate Uses

When the soil surface is disturbed and will remain inactive for an extended period (typically determined by local government requirements), proactive stabilization measures, including planting a temporary seed mix, should be implemented. If the inactive period is short-lived (on the order of two weeks), techniques such as surface roughening may be appropriate. For longer periods of inactivity of up to one year, temporary seeding and mulching can provide effective erosion control. Permanent seeding should be used on finished areas that have not been otherwise stabilized.

The USDCM Volume 2 *Revegetation* Chapter contains suggested annual grains and native seed mixes to use for temporary seeding. Alternatively, local governments may have their own seed mixes and timelines for seeding. Check jurisdictional requirements for seeding and temporary stabilization.

Design and Installation

Effective seeding requires proper seedbed preparation, selecting an appropriate seed mixture, using appropriate seeding equipment to ensure proper coverage and density, and protecting seeded areas with mulch or fabric until plants are established.

The USDCM Volume 2 *Revegetation* Chapter contains detailed seed mixes, soil preparation practices, and seeding and mulching recommendations that should be referenced to supplement this Fact Sheet.

Drill seeding is the preferred seeding method. Hydroseeding is not recommended except in areas where steep slopes prevent use of drill seeding equipment, and even in these instances it is preferable to hand seed and mulch. Some jurisdictions do not allow hydroseeding or hydromulching.

Seedbed Preparation

Prior to seeding, ensure that areas to be revegetated have soil conditions capable of supporting vegetation. Overlot grading can result in loss of topsoil and compaction, resulting in poor quality subsoils at the ground surface that

Temporary and Permanent Seeding	
Functions	
Erosion Control	Yes
Sediment Control	No
Site/Material Management	No

January 2021 Urban Drainage and Flood Control District Urban Storm Drainage Criteria Manual Volume 3 TS/PS-1

EC-2 Temporary and Permanent Seeding (TS/PS)

have low nutrient value, little organic matter content, few soil microorganisms, rooting restrictions, and conditions less conducive to infiltration of precipitation. As a result, it is typically necessary to provide stockpiled topsoil, compost, or other soil amendments and rototill them into the soil to a depth of 6 inches or more.

Topsoil should be salvaged during grading operations for use and spread on areas to be revegetated later. Topsoil should be viewed as an important resource to be utilized for vegetation establishment, due to its water-holding capacity, structure, texture, organic matter content, biological activity, and nutrient content. The rooting depth of most native grasses in the semi-arid Denver metropolitan area is 6 to 18 inches. If present, at a minimum of the upper 6 inches of topsoil should be stripped, stockpiled, and ultimately respread across areas that will be revegetated.

Where topsoil is not available, subsoils should be amended to provide an appropriate plant-growth medium. Organic matter, such as well digested compost, can be added to improve soil characteristics conducive to plant growth. Other treatments can be used to adjust soil pH conditions when needed. Soil testing, which is typically inexpensive, should be completed to determine and optimize the types and amounts of amendments that are required.

If the disturbed ground surface is compacted, rip or rototill the upper 12 inches of the surface prior to placing topsoil. If adding compost to the existing soil surface, rototilling is necessary. Surface roughening will assist in placing a stable topsoil layer on steeper slopes, and allow infiltration and root penetration to greater depth. Topsoil should not be placed when either the salvaged topsoil or receiving ground are frozen or snow covered.

Prior to seeding, the soil surface should be rough and the seedbed should be firm, but neither too loose nor compacted. The upper layer of soil should be in a condition suitable for seeding at the proper depth and conducive to plant growth. Seed-to-soil contact is the key to good germination.

Refer to MHFD's Topsoil Management Guidance for detailed information on topsoil assessment, design, and construction.

Temporary Vegetation

To provide temporary vegetative cover on disturbed areas which will not be paved, built upon, or fully landscaped or worked for an extended period (typically 30 days or more), plant an annual grass appropriate for the time of planting and mulch the planted areas. Temporary grain seed mixes suitable for the Denver metropolitan area are listed in Table TS/PS-1. Native temporary seed mixes are provided in USDCM Volume 2, Chapter 13, Appendix A. These are to be considered only as general recommendations when specific design guidance for a particular site is not available. Local governments typically specify seed mixes appropriate for their jurisdiction.

Permanent Revegetation

To provide vegetative cover on disturbed areas that have reached final grade, a perennial grass mix should be established. Permanent seeding should be performed promptly (typically within 14 days) after reaching final grade. Each site will have different characteristics and a landscape professional or the local jurisdiction should be contacted to determine the most suitable seed mix for a specific site. In lieu of a specific recommendation, one of the perennial grass mixes appropriate for site conditions and growth season listed in seed mix tables in the USDCM Volume 2 *Revegetation* Chapter can be used. The pure live seed (PLS) rates of application recommended in these tables are considered to be absolute minimum rates for seed applied using proper drill-seeding equipment. These are to be considered only as general

TS/PS-2 Urban Drainage and Flood Control District Urban Storm Drainage Criteria Manual Volume 3 January 2021

Temporary and Permanent Seeding (TS/PS) EC-2

recommendations when specific design guidance for a particular site is not available. Local governments typically specify seed mixes appropriate for their jurisdiction.

If desired for wildlife habitat or landscape diversity, shrubs such as rubber rabbitbrush (*Chrysothamnus nauseosus*), fourwing saltbush (*Atriplex canescens*) and skunkbrush sumac (*Rhus trilobata*) could be added to the upland seed mixes at 0.25, 0.5 and 1 pound PLS/acre, respectively. In riparian zones, planting root stock of such species as American plum (*Prunus americana*), woods rose (*Rosa woodsii*), plains cottonwood (*Populus sargentii*), and willow (*Salix spp.*) may be considered. On non-topsoiled upland sites, a legume such as Ladak alfalfa at 1 pound PLS/acre can be included as a source of nitrogen for perennial grasses.

Timing of seeding is an important aspect of the revegetation process. For upland and riparian areas on the Colorado Front Range, the suitable timing for seeding is from October through May. The most favorable time to plant non-irrigated areas is during the fall, so that seed can take advantage of winter and spring moisture. Seed should not be planted if the soil is frozen, snow covered, or wet.

Seeding dates for the highest success probability of perennial species along the Front Range are generally in the spring from April through early May and in the fall after the first of September until the ground freezes. If the area is irrigated, seeding may occur in summer months, as well. See Table TS/PS-2 for appropriate seeding dates.

January 2021 Urban Drainage and Flood Control District Urban Storm Drainage Criteria Manual Volume 3 TS/PS-3

AYRES ASSOCIATES
 3665 JFK PARKWAY
 BUILDING 2, SUITE 100
 FORT COLLINS, CO
 80525
 262.522.4901
 www.AyresAssociates.com



REVISION	DATE
RESUBMITTAL #1	7/25/2023
RESUBMITTAL #2	9/18/2023
RESUBMITTAL #3	10/20/2023

EC-2 Temporary and Permanent Seeding (TS/PS)

Table TS/PS-1. Minimum Drill Seeding Rates for Various Temporary Annual Grasses

Species* (Common name)	Growth Season*	Pounds of Pure Live Seed (PLS)/acre ^c	Planting Depth (inches)
1. Oats	Cool	35 - 50	1 - 2
2. Spring wheat	Cool	25 - 35	1 - 2
3. Spring barley	Cool	25 - 35	1 - 2
4. Annual ryegrass	Cool	10 - 15	½
5. Millet	Warm	3 - 15	½ - ¾
6. Winter wheat	Cool	20-35	1 - 2
7. Winter barley	Cool	20-35	1 - 2
8. Winter rye	Cool	20-35	1 - 2
9. Triticale	Cool	25-40	1 - 2

^a Successful seeding of annual grass resulting in adequate plant growth will usually produce enough dead-plant residue to provide protection from wind and water erosion for an additional year. This assumes that the cover is not disturbed or mowed closer than 8 inches.

Hydraulic seeding may be substituted for drilling only where slopes are steeper than 3:1 or where access limitations exist. When hydraulic seeding is used, hydraulic mulching should be applied as a separate operation, when practical, to prevent the seeds from being encapsulated in the mulch.

^b See Table TS/PS-2 for seeding dates. Irrigation, if consistently applied, may extend the use of cool season species during the summer months.

^c Seeding rates should be doubled if seed is broadcast, or increased by 50 percent if done using a Brillion Drill or by hydraulic seeding.

TS/PS-4 Urban Drainage and Flood Control District Urban Storm Drainage Criteria Manual Volume 3 January 2021

Temporary and Permanent Seeding (TS/PS) EC-2

Table TS/PS-2. Seeding Dates for Annual and Perennial Grasses

Seeding Dates	Annual Grasses (Numbers in table reference species in Table TS/PS-1)		Perennial Grasses	
	Warm	Cool	Warm	Cool
January 1–March 15			✓	✓
March 16–April 30		1,2,3	✓	✓
May 1–May 15			✓	
May 16–June 30	5			
July 1–July 15	5			
July 16–August 31				
September 1–September 30		6, 7, 8, 9		
October 1–December 31			✓	✓

Mulch

Cover seeded areas with mulch or an appropriate rolled erosion control product to promote establishment of vegetation. Anchor mulch by crimping, netting or use of a non-toxic tackifier. See the USDCM Volume 2 *Revegetation* Chapter and Volume 3 Mulching BMP Fact Sheet (EC-04) for additional guidance.

Maintenance and Removal

Monitor and observe seeded areas to identify areas of poor growth or areas that fail to germinate. Reseed and mulch these areas, as needed.

If a temporary annual seed was planted, the area should be reseeded with the desired perennial mix when there will be no further work in the area. To minimize competition between annual and perennial species, the annual mix needs time to mature and die before seeding the perennial mix. To increase success of the perennial mix, it should be seeded during the appropriate seeding dates the second year after the temporary annual mix was seeded. Alternatively, if this timeline is not feasible, the annual mix seed heads should be removed and then the area seeded with the perennial mix.

An area that has been permanently seeded should have a good stand of vegetation within one growing season if irrigated and within three growing seasons without irrigation in Colorado. Reseed portions of the site that fail to germinate or remain bare after the first growing season.

Seeded areas may require irrigation, particularly during extended dry periods. Targeted weed control may also be necessary.

Protect seeded areas from construction equipment and vehicle access.

January 2021 Urban Drainage and Flood Control District Urban Storm Drainage Criteria Manual Volume 3 TS/PS-5

SUPERSTAR CARWASH
 MEADOWBROOK PKWY
 COLORADO SPRING, CO 80915
EROSION CONTROL DETAILS

Drawn By: AJJ
 Checked By: SEM
 Date: 10/20/2023
 Project No. 24-0409
 Sheet Number

E2.4



REVISION	DATE
RESUBMITTAL #1	7/25/2023
RESUBMITTAL #2	9/18/2023
RESUBMITTAL #3	10/20/2023

SUPERSTAR CARWASH
MEADOWBROOK PKWY
COLORADO SPRING, CO 80915

GRADING AND DRAINAGE PLAN

Drawn By: AJJ
Checked By: SEM
Date: 10/20/2023
Project No. 24-0409
Sheet Number

E3.0

GRADING NOTES

- CONTRACTOR TO VERIFY ALL EXISTING TOPOGRAPHY AND STRUCTURES ON THE SITE AND IMMEDIATELY NOTIFY THE ENGINEER OF ANY DISCREPANCIES PRIOR TO STARTING WORK. THE CONTRACTOR SHALL ENSURE THAT POSITIVE DRAINAGE OCCURS AT ALL JOINTS WITH EXISTING CONDITIONS.
- ALL PAVEMENT SPOT GRADE ELEVATIONS AND RIM ELEVATIONS WITHIN OR ALONG CURB AND GUTTER REFER TO FLOW LINE ELEVATIONS UNLESS OTHERWISE NOTED.
- ALL ELEVATIONS SHOWN DEPICT FINISHED GRADE UNLESS OTHERWISE NOTED. GENERAL CONTRACTOR TO COORDINATE WITH EXCAVATION, LANDSCAPE AND PAVING SUBCONTRACTORS REGARDING TOPSOIL THICKNESS FOR LANDSCAPE AREAS AND PAVEMENT SECTION THICKNESS FOR PAVED AREAS TO PROPERLY ENSURE ADEQUATE CUT TO ESTABLISH SUBGRADE ELEVATIONS.
- MAXIMUM SLOPE IN ACCESSIBLE PARKING SPACES AND LOADING ZONES SHALL NOT EXCEED 2.0% IN ALL DIRECTIONS.
- MAXIMUM RUNNING SLOPE SHALL NOT EXCEED 5% AND CROSS SLOPE SHALL NOT EXCEED 2.0% ON ALL SIDEWALKS AND ACCESSIBLE ROUTES.
- WHEN NATURAL FLOW OF DRAINAGE IS AWAY FROM CURB, CONTRACTOR TO INSTALL REVERSE GUTTER PITCH.
- MATCH EXISTING ELEVATIONS AT THE PROPERTY LINE.
- NO GRADING SLOPES SHALL EXCEED 4:1 SLOPES.
- WATER TRUCK CALLED FOR BY THE CITY INSPECTOR WILL BE PROVIDED TO KEEP WIND EROSION IN CHECK.
- ANY SETTLEMENT OR SOIL ACCUMULATIONS BEYOND THE PROPERTY LIMITS DUE TO GRADING OR EROSION SHALL BE REPAIRED IMMEDIATELY BY THE CONTRACTOR.
- ANY CONSTRUCTION DEBRIS OR MUD TRACKING IN THE PUBLIC RIGHT-OF-WAY RESULTING FROM THIS DEVELOPMENT SHALL BE REMOVED IMMEDIATELY BY THE CONTRACTOR. THE CONTRACTOR SHALL IMMEDIATELY FIX ANY EXCAVATIONS OR EXCESSIVE PAVEMENT FAILURES CAUSED BY THE DEVELOPMENT AND SHALL PROPERLY BARRICADE THE SITE UNTIL CONSTRUCTION IS COMPLETE. FAILURE BY THE CONTRACTOR TO CORRECT ANY OF THE ABOVE WITHIN 48 HOURS OF WRITTEN NOTICE BY THE COUNTY SHALL CAUSE THE COUNTY TO ISSUE A STOP WORK ORDER (RED TAG) AND/OR DO THE WORK AND MAKE A CLAIM AGAINST THE LETTER OF CREDIT FOR ANY COST INCURRED BY THE CITY.
- AREAS BEING DISTURBED BY THE GRADING SHALL BE RESEED WITH NATIVE VEGETATION OR AS APPROVED ON THE DEVELOPMENT PLAN.
- THE CONTRACTOR SHALL BE SOLELY AND COMPLETELY RESPONSIBLE FOR CONDITIONS AT AND ADJACENT TO THE JOB SITE, INCLUDING SAFETY OF ALL PERSONS AND PROPERTY DURING PERFORMANCE OF THE WORK. THIS REQUEST SHALL APPLY CONTINUOUSLY AND NOT BE LIMITED TO NORMAL WORKING HOURS.
- THE DUTY OF THE COUNTY TO CONDUCT CONSTRUCTION REVIEW OF THE CONTRACTOR'S PERFORMANCE IS NOT INTENDED TO INCLUDE REVIEW OF THE ADEQUACY OF THE CONTRACTOR'S SAFETY MEASURE IN, ON, OR NEAR THE CONSTRUCTION SITE.
- CONTRACTOR SHALL CONTACT UTILITY NOTIFICATION CENTER OF COLORADO (1-800-922-1967) FOR LOCATION OF UNDERGROUND GAS, ELECTRIC, AND TELEPHONE UTILITIES AT LEAST 48 HOURS PRIOR TO COMMENCEMENT OF CONSTRUCTION.
- CONTRACTOR SHALL REFERENCE GEOTECHNICAL SOILS REPORT FOR GRADING DESIGN OF SLOPES, EMBANKMENTS, MATERIALS, MITIGATION, ETC.

GRADING LEGEND

	BW = BOTTOM OF WALL
	TC = TOP OF CURB
	ME = MATCH EXISTING ELEVATION
	LP = LOW POINT
	FG = FINISHED GRADE
	SLOPE AND FLOW DIRECTION
	EXISTING CONTOUR
	PROPOSED CONTOUR (DATUM = 6300)
	LIMITS OF DISTURBANCE
	SPECIAL CURB
	RETAINING WALL

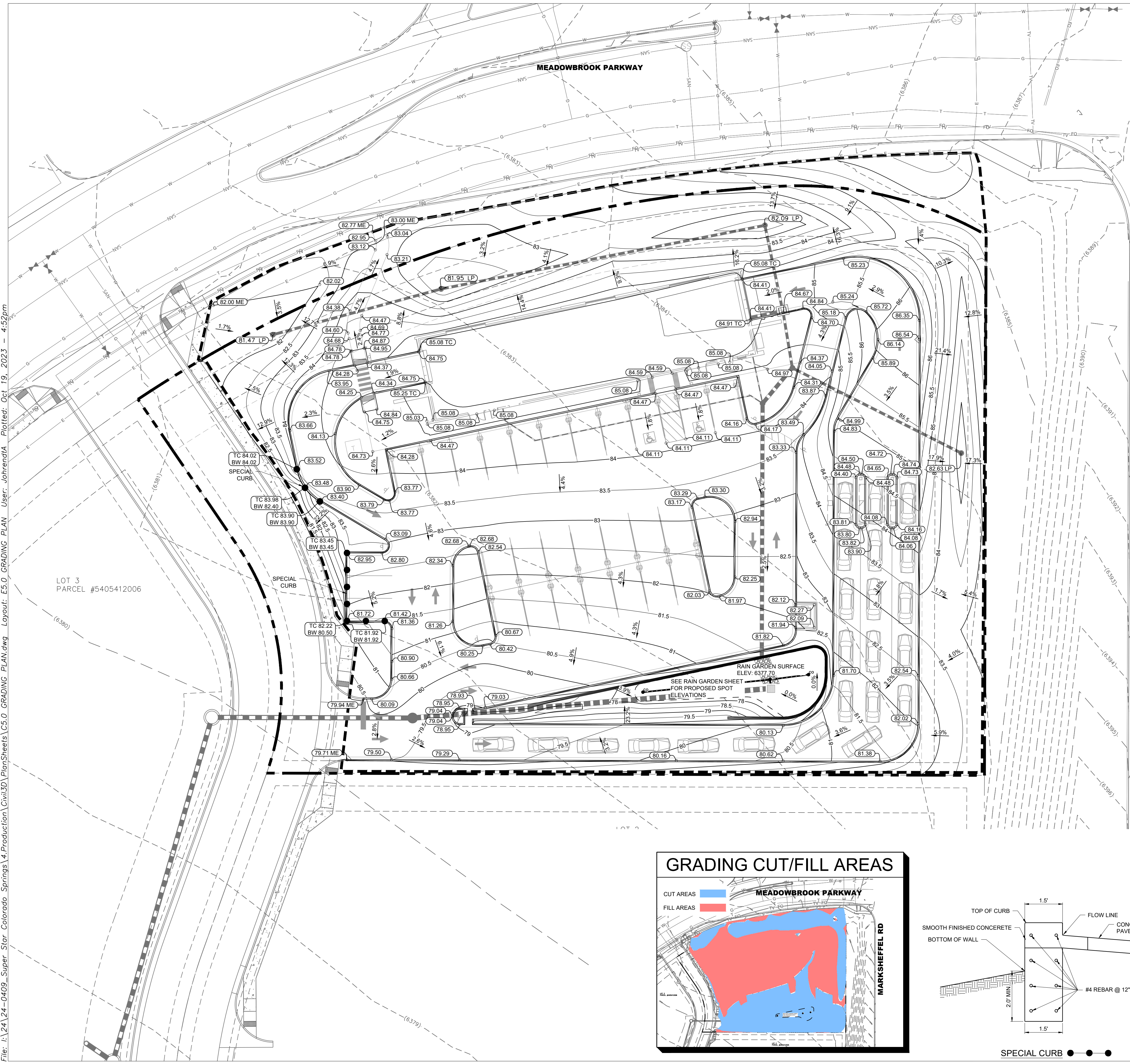

GRADING CUT/FILL AREAS

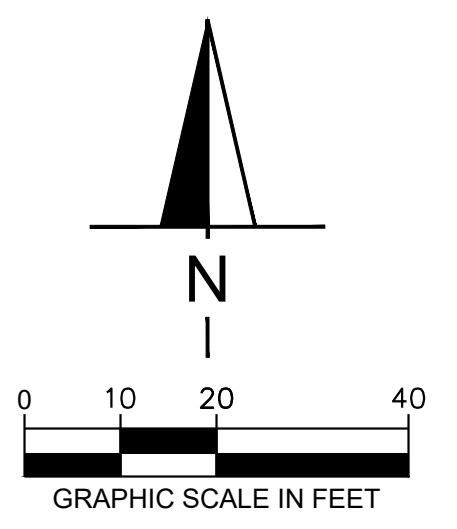
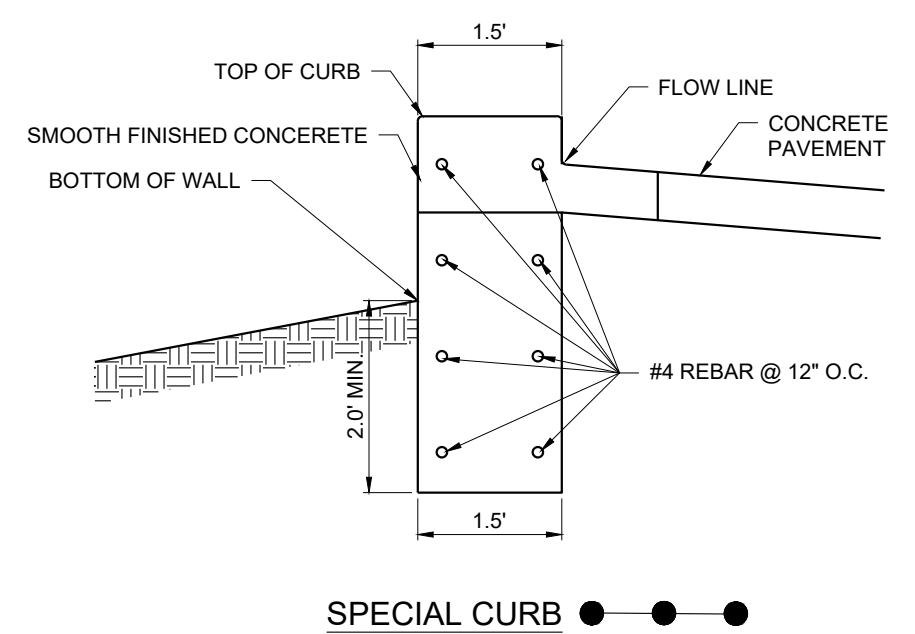
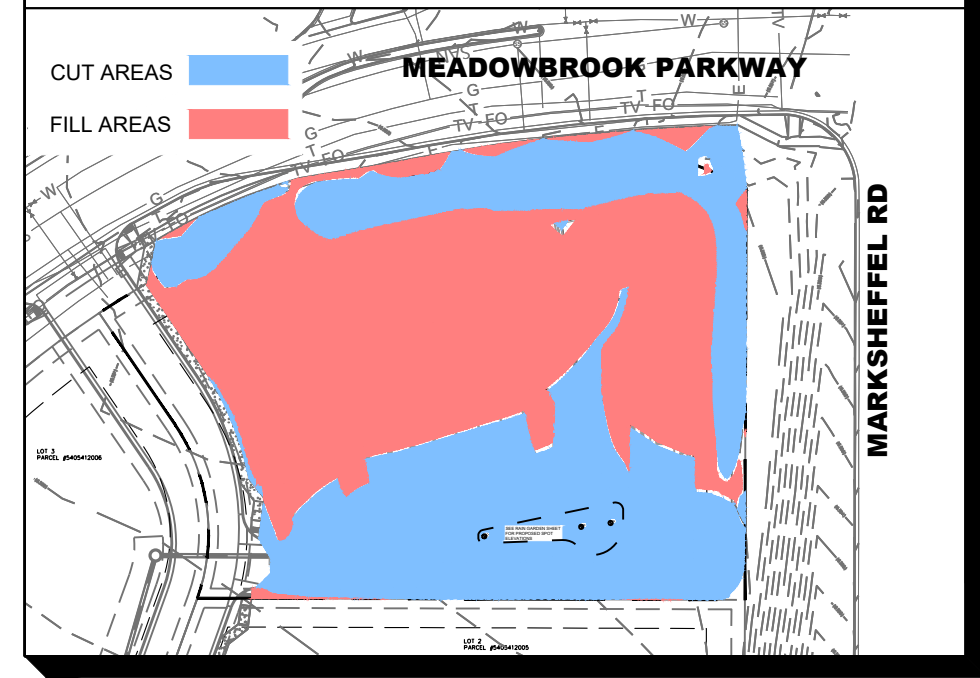

File: I:\24-0409_Super Star Colorado Springs\4.Production\Civil\3D\PlanSheets\C5.0 GRADING PLAN.dwg Layout: E3.0 GRADING PLAN User: Jorrendia Plotted: Oct 19, 2023 4:52pm



REVISION	DATE
RESUBMITTAL #1	7/25/2023
RESUBMITTAL #2	9/18/2023
RESUBMITTAL #3	10/20/2023

SUPERSTAR CARWASH
MEADOWBROOK PKWY
COLORADO SPRING, CO 80915
RAIN GARDEN

Drawn By: **AJJ**
Checked By: **SEM**
Date: **10/20/2023**
Project No. **24-0409**
Sheet Number

MATERIAL SPECIFICATION FOR RAIN GARDEN

Material	Specification	Submittals	Testing	Notes
Bioretention Growing Media (soil + organics)	Bioretention soil Particle Size Distribution 80-90% sand (0.05-2.0 mm diameter) 3-17% silt (0.002-0.5 mm diameter) 3-17% clay (<0.002 diameter) Chemical attribute and nutrient analysis: pH 6.8 - 7.5 organic matter > 15% nitrogen < 15 ppm phosphorus < 15 pp salinity < 6 mmhos/cm			Percentages are in weight
	Bioretention organics 3 to 5% shredded mulch (by weight of growing media)			bioretention soil required. Aged 6 months (minimum). Aged 6 months (minimum). No weed fabric allowed.
Landscape mulch	Shredded hardwood			
Underdrain aggregate (Class B or C as specified)	Sieve Size	Max Percent Passing Square Mesh	Particle Size Distribution Required	
	37.5 mm (1.5")	Class B: 100 Class C: 100		
	4.75 mm (No. 4)	20-60		
	1.18 mm (No. 16)	30-Oct		
	300 um (No. 50)	0-10		
	150 um (No. 100)	0-10		
Underdrain Pipe	Pipe diameter and type	Maximum slot width (inches)	Minimum open area (per foot)	Required Pipe must conform to requirements of ASTM designation F949. There shall be no evidence of splitting, cracking or breaking when the pipe is tested per ASTM test method D2412 in accordance with F949 section 7.5 and ASTM F794 section 8.5.
	4-inch slotted PVC	0.032	1.90 in ²	
Impermeable Liner	Thickness	0.76 mm (30 mil)	Test Method	Required Thermal welding required for fully lined facilities (no a curtain). Leaktesting in the field required.
	Thickness % Tolerance	+/- 5	ASTM D 1593	
	Tensile Strength, kNm (lb/in)	12.25 (70)	ASTM D8 82, Method B	
	Modulus at 100% elongation, kN/m	55.25 (30)	ASTM D8 82, Method B	
	Ultimate elongation %	350	ASTM D8 82, Method A	
	Tear Resistance (N/lbs)	38 (8.5)	ASTM D 1004	
Underdrain aggregate	Low Temperature Impact °C (°F)	-29 (-20)	ASTM D 1790	
	Volatile loss % maximum	0.7	ASTM D8 82, Method A	
	Pinholes, no. per 8 m ² (no. per 10 yd ²)	1(max)	N/A	
	Bonded seam strength, % of tensile	80	N/A	

GRADING LEGEND

BW = BOTTOM OF WALL
TC = TOP OF CURB
ME = MATCH EXISTING ELEVATION
LP = LOW POINT
FG = FINISHED GRADE
SLOPE AND FLOW DIRECTION
EXISTING CONTOUR
PROPOSED CONTOUR (DATUM = 6300)
LIMITS OF DISTURBANCE
SPECIAL CURB
RETAINING WALL
RAIN GARDEN AREA

RAIN GARDEN SEED MIX

Common Name	Scientific Name	Variety	PLS ² lbs per Acre	Ounces per Acre
Sand Bluestem	Andropogon hallii	Garden	3.5	
Sideoats grama	Bouteloua curtipendula	Butte	3	
Prairie sandreed	Calamovilfa longifolia	Goshen	3	
Indian ricegrass	Oryzopsis hymenoides	Paloma	3	
Switchgrass	Panicum virgatum	Blackwell	4	
Western Wheatgrass	Pascopyrum smithii	Ariba	3	
Little Bluestem	Schizachyrium scoparium	Patara	3	
Alkali Sacaton	Sporobolus airoides		3	
Sand Dropseed	Sporobolus cryptandrus		3	
Pasture Sage ¹	Artemisia frigida			2
Blue Aster ¹	Aster laevis			4
Blanket Flower ¹	Gaillardia aristata			8
Prairie Coneflower ¹	Ratibida columnifera			4
Purple Prairieclover ¹	Dalea (Petalostemum) purpurea			4
Sub-Totals			27.5	22
Total lbs per acre:				28.9

¹ Wildflower seed (optional) for a more diverse and natural look
² PLS = Pure Live Seed

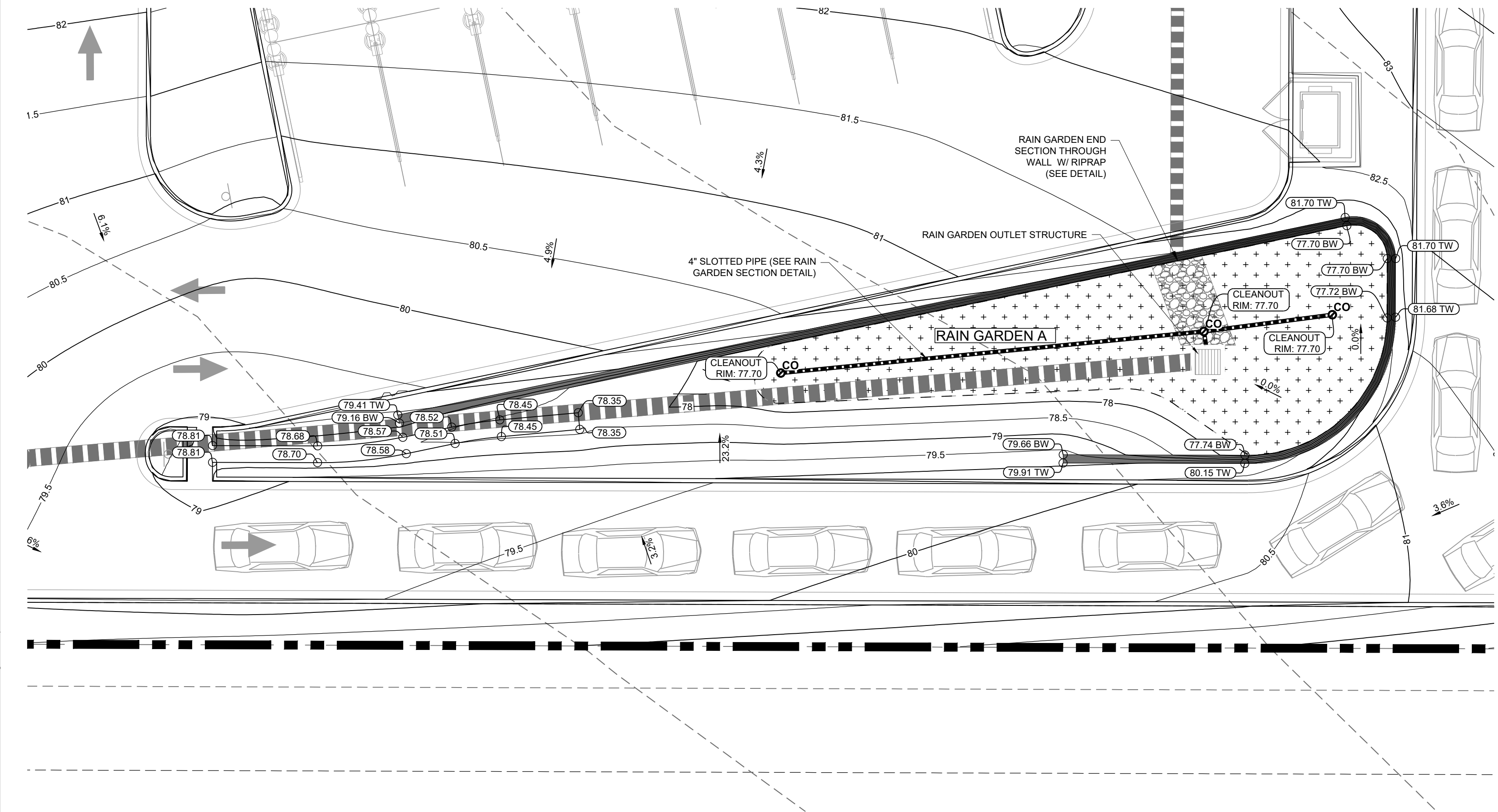

RAIN GARDEN A END SECTION THRU WALL

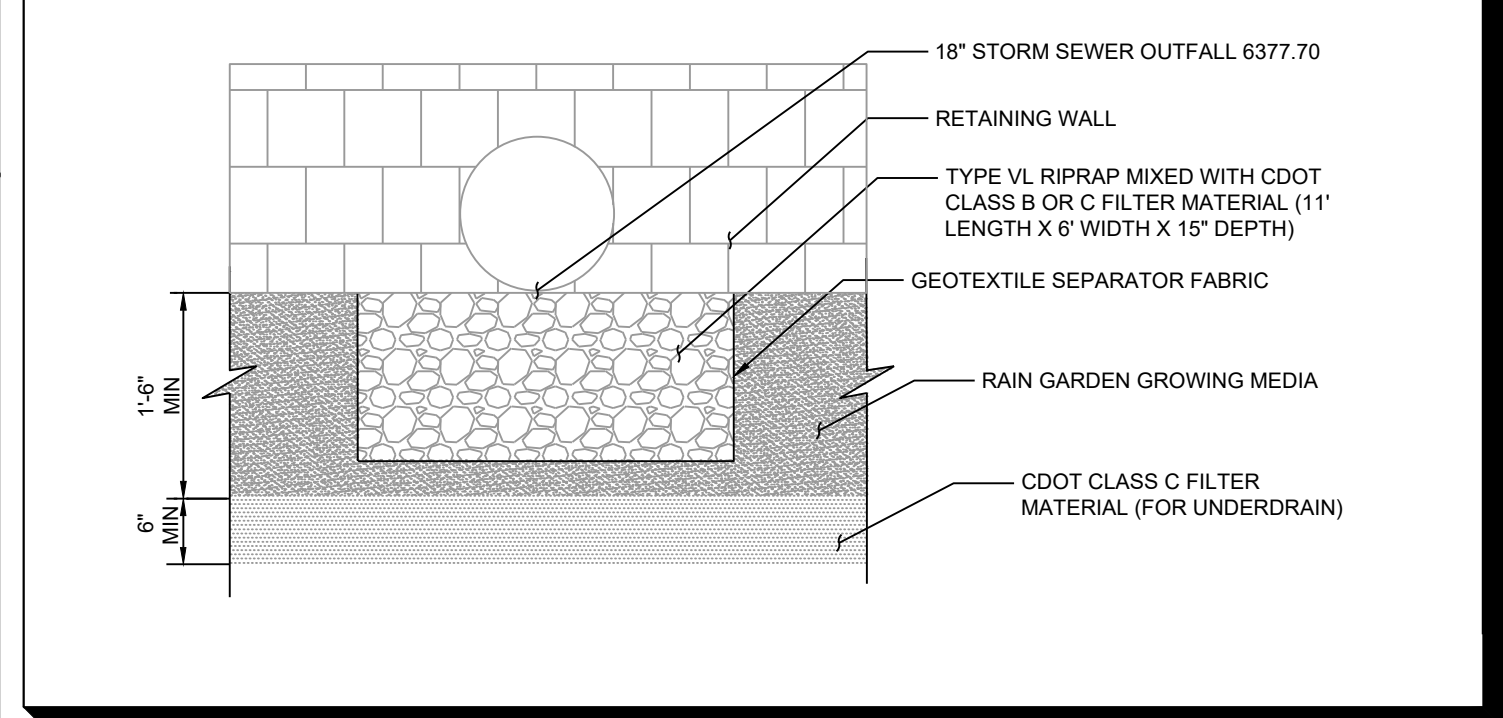

RAIN GARDEN A SECTION

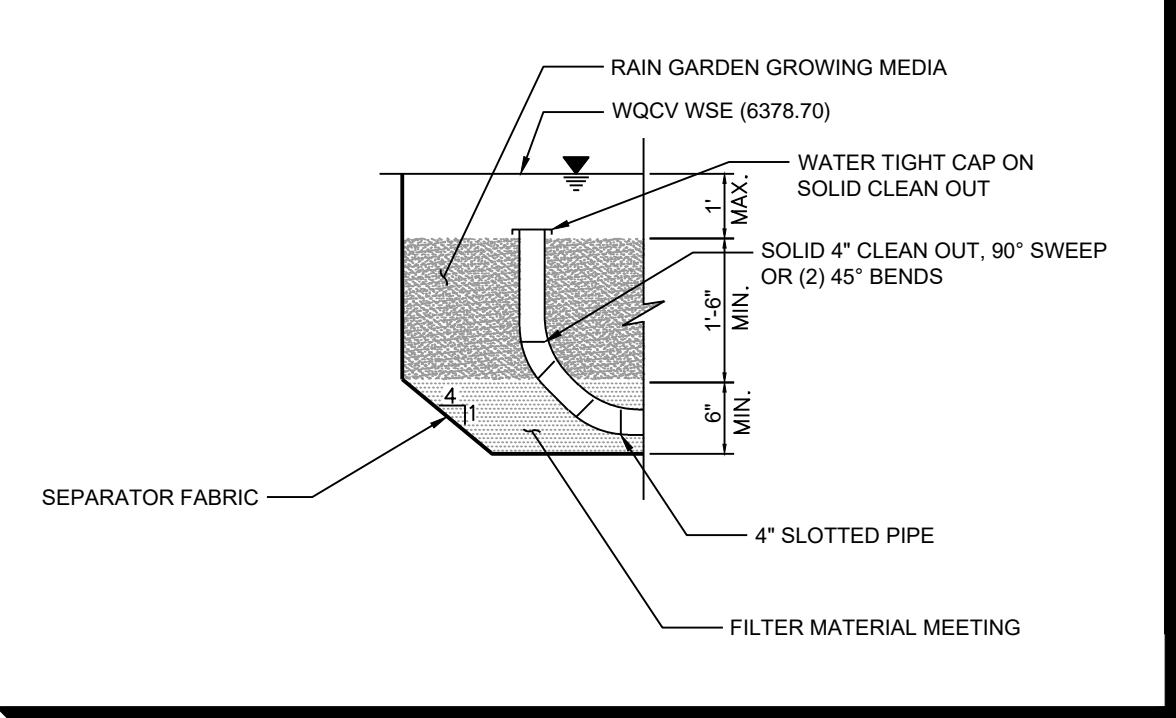

RAIN GARDEN A OUTLET STRUCTURE

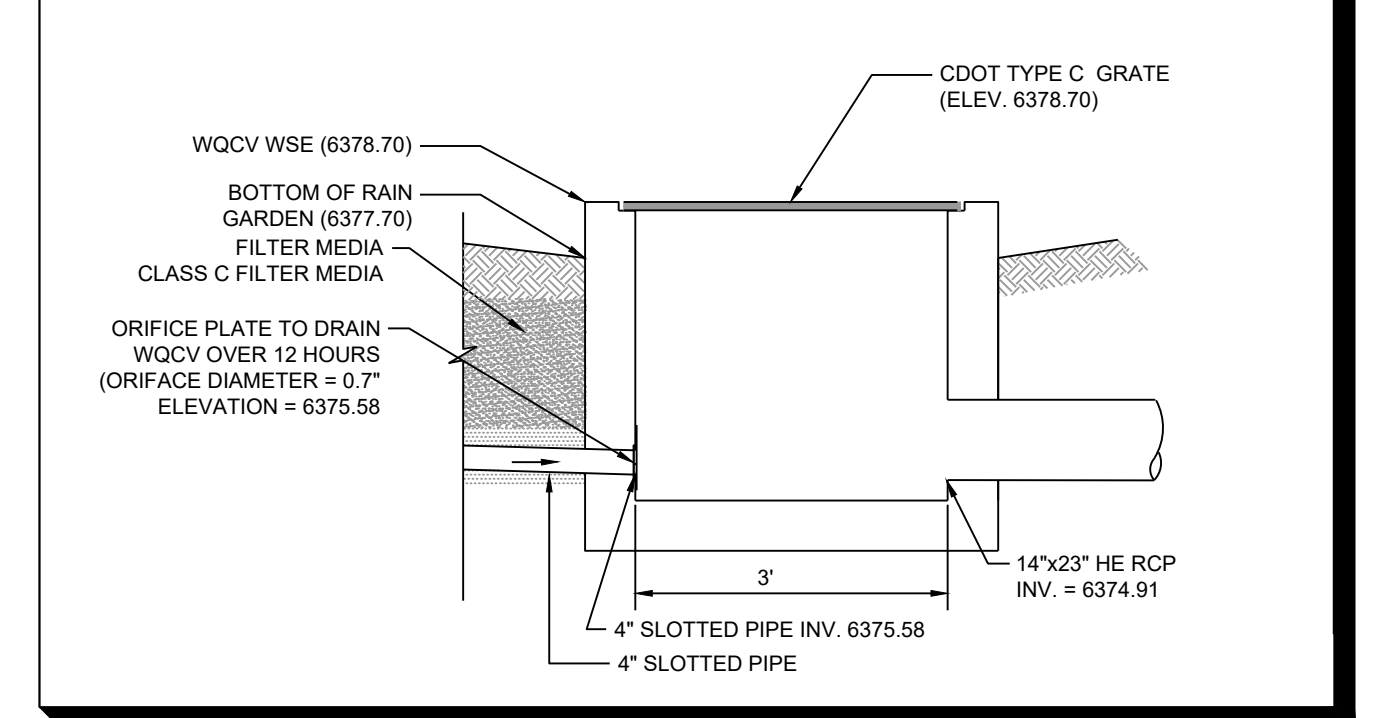

SEPARATOR FABRIC

Property	Class B		Test Method
	Elongation <50% ²	Elongation >50% ²	
Grab Strength, N (lbs.)	800 (180)		ASTM D 4632
Puncture Resistance, N (lbs.)	310 (70)		ASTM D 4833
Trapezoidal Tear Strength, N (lbs.)	310 (70)		ASTM D 4533
Apparent Opening Size, mm (US Sieve Size)	AOS < 0.3 mm (US Sieve Size No. 50)		ASTM D 4751
Permittivity, sec ⁻¹	0.02 default value, must also be greater than that of soil		ASTM D 4491
Permeability cm/sec	k fabric > k soil for all classes		ASTM D 4491
Ultraviolet Degradation at 500 hours	50% strength retained for all classes		ASTM D 4355

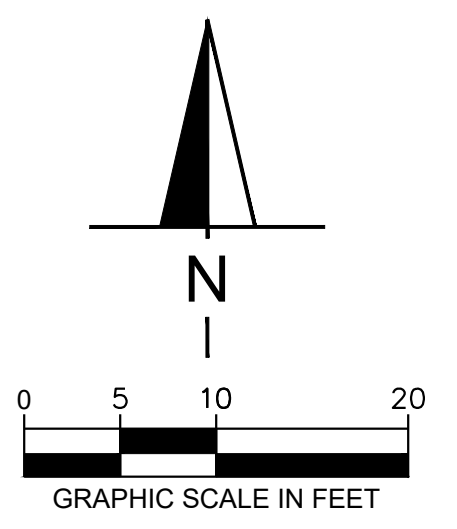

Appendix C – Construction General Permit



STATE OF COLORADO

COLORADO DEPARTMENT OF PUBLIC HEALTH AND ENVIRONMENT

Water Quality Control Division

CDPS GENERAL PERMIT STORMWATER DISCHARGES ASSOCIATED WITH
CONSTRUCTION ACTIVITY AUTHORIZATION TO DISCHARGE UNDER THE COLORADO DISCHARGE PERMIT SYSTEM (CDPS)
COR400000

In compliance with the provisions of the Colorado Water Quality Control Act, (25-8-101 et seq., CRS, 1973 as amended) and the Federal Water Pollution Control Act, as amended (33 U.S.C. 1251 et seq.; the "Act"), this permit authorizes the discharge of stormwater associated with construction activities (and specific allowable non-stormwater discharges in accordance with Part I.A.1. of the permit) certified under this permit, from those locations specified throughout the State of Colorado to specified waters of the State.

Such discharges shall be in accordance with the conditions of this permit. This permit specifically authorizes the facility listed on the certification to discharge in accordance with permit requirements and conditions set forth in Parts I and II hereof. All discharges authorized herein shall be consistent with the terms and conditions of this permit.

This permit becomes effective on April 1, 2019, and shall expire at midnight March 31, 2024.

Issued and signed this 28th day of January, 2021.

Meg Parish

Meg Parish, Permits Section Manager Water Quality Control Division

COLORADO DEPARTMENT OF PUBLIC HEALTH AND ENVIRONMENT

Permit History

Minor Modification Issued January 28, 2021 Effective February 1, 2021

Modification Issued December 31, 2020 Effective February 1, 2021

Originally signed and issued October 31, 2018; effective April 1, 2019

Table of Contents

PART I 3

 A. COVERAGE UNDER THIS PERMIT 3

 1. Authorized Discharges..... 3

 2. Limitations on Coverage 3

 3. Permit Certification and Submittal Procedures 4

 B. EFFLUENT LIMITATIONS 8

 1. Requirements for Control Measures Used to Meet Effluent Limitations..... 8

 2. Discharges to an Impaired Waterbody..... 11

 3. General Requirements 12

 C. STORMWATER MANAGEMENT PLAN (SWMP) REQUIREMENTS..... 12

 1. SWMP General Requirements 12

 2. SWMP Content 13

 3. SWMP Review and Revisions..... 15

 4. SWMP Availability 16

 D. SITE INSPECTIONS 16

 1. Person Responsible for Conducting Inspections 16

 2. Inspection Frequency..... 16

 3. Inspection Frequency for Discharges to Outstanding Waters..... 17

 4. Reduced Inspection Frequency 17

 5. Inspection Scope 17

 E. DEFINITIONS..... 19

 F. MONITORING 22

 G. OIL AND GAS CONSTRUCTION 22

PART II: STANDARD PERMIT CONDITIONS 24

 A. DUTY TO COMPLY 24

 B. DUTY TO REAPPLY 24

 C. NEED TO HALT OR REDUCE ACTIVITY NOT A DEFENSE..... 24

 D. DUTY TO MITIGATE 24

 E. PROPER OPERATION AND MAINTENANCE 24

 F. PERMIT ACTIONS..... 24

 G. PROPERTY RIGHTS 24

 H. DUTY TO PROVIDE INFORMATION 25

 I. INSPECTION AND ENTRY 25

 J. MONITORING AND RECORDS 25

 K. SIGNATORY REQUIREMENTS 26

 1. Authorization to Sign: 26

 2. Electronic Signatures 26

3. Change in Authorization to Sign	26
L. REPORTING REQUIREMENTS	27
1. Planned Changes	27
2. Anticipated Non-Compliance.....	27
3. Transfer of Ownership or Control	27
4. Monitoring reports	27
5. Compliance Schedules	27
6. Twenty-four Hour Reporting	28
7. Other Non-Compliance	28
8. Other Information.....	28
M. BYPASS.....	28
1. Bypass Not Exceeding Limitations.....	28
2. Notice of Bypass.....	28
3. Prohibition of Bypass	28
N. UPSET	29
1. Effect of an upset.....	29
2. Conditions Necessary for Demonstration of an Upset	29
3. Burden of Proof	29
O. RETENTION OF RECORDS	29
1. Post-Expiration or Termination Retention.....	29
2. On-site Retention	29
P. REOPENER CLAUSE	30
1. Procedures for Modification or Revocation.....	30
2. Water Quality Protection	30
Q. SEVERABILITY	30
R. NOTIFICATION REQUIREMENTS.....	30
1. Notification to Parties	30
S. RESPONSIBILITIES	30
1. Reduction, Loss, or Failure of Treatment Facility	30
T. OIL AND HAZARDOUS SUBSTANCE LIABILITY.....	30
U. EMERGENCY POWERS	31
V. CONFIDENTIALITY	31
W. FEES	31
X. DURATION OF PERMIT	31
Y. SECTION 307 TOXICS.....	31

Part I

Note: At the first mention of terminology that has a specific connotation for the purposes of this permit, the terminology is electronically linked to the definitions section of the permit in Part I.E.

A. COVERAGE UNDER THIS PERMIT

1. Authorized Discharges

This general permit authorizes permittee(s) to discharge the following to state waters: stormwater associated with construction activity and specified non-stormwater associated with construction activity. The following types of stormwater and non-stormwater discharges are authorized under this permit:

a. Allowable Stormwater Discharges

- i. Stormwater discharges associated with construction activity.
- ii. Stormwater discharges associated with producing earthen materials, such as soils, sand, and gravel dedicated to providing material to a single contiguous site, or within ¼ mile of a construction site (e.g. borrow or fill areas).
- iii. Stormwater discharges associated with [dedicated asphalt](#), [concrete batch plants](#) and [masonry mixing stations](#) (Coverage under this permit is not required if alternative coverage has been obtained.)

b. Allowable Non-Stormwater Discharges

The following non-stormwater discharges are allowable under this permit if the discharges are identified in the stormwater management plan in accordance with [Part I.C](#) and if they have appropriate [control measures](#) in accordance with [Part I.B.1](#).

- i. Discharges from uncontaminated springs that do not originate from an area of land disturbance.
- ii. Discharges to the ground of concrete washout water associated with the washing of concrete tools and concrete mixer chutes. Discharges of concrete washout water must not leave the site as surface runoff or reach [receiving waters](#) as defined by this permit. Concrete on-site waste disposal is not authorized by this permit except in accordance with [Part I.B.1.a.ii\(b\)](#).
- iii. Discharges of landscape irrigation return flow.
- iv. Discharges from [diversions](#) of state waters within the permitted site.

c. Emergency Fire Fighting

Discharges resulting from emergency firefighting activities during the active emergency response are authorized by this permit.

2. Limitations on Coverage

Discharges not authorized by this permit include, but are not limited to, the discharges and activities listed below. Permittees may seek individual or alternate general permit coverage for the discharges, as appropriate and available.

a. Discharges of Non-Stormwater

Discharges of non-stormwater, except the authorized non-stormwater discharges listed in Part

I.A.1.b., are not eligible for coverage under this permit.

- b. Discharges Currently Covered by another Individual or General Permit
- c. Discharges Currently Covered by a Water Quality Control Division (division) Low Risk Guidance Document

3. Permit Certification and Submittal Procedures

a. Duty to Apply

The following activities shall apply for coverage under this permit:

- i. Construction activity that will disturb one acre or more; or
- ii. Construction activity that is part of a [common plan of development or sale](#); or
- iii. Stormwater discharges that are designated by the division as needing a stormwater permit because the discharge:
 - (a) Contributes to a violation of a water quality standard; or
 - (b) Is a significant contributor of [pollutants](#) to state waters.

b. Application Requirements

To obtain authorization to discharge under this permit, applicants applying for coverage following the effective date of the renewal permit shall meet the following requirements:

- i. Owners and operators submitting an application for permit coverage will be co-permittees subject to the same benefits, duties, and obligations under this permit.
- ii. Signature requirements: Both the [owner](#) and [operator](#) (permittee) of the construction site, as defined in Part I.E., must agree to the terms and conditions of the permit and submit a completed application that includes the signature of both the owner and the operator. In cases where the duties of the owner and operator are managed by the owner, both application signatures may be completed by the owner. Both the owner and operator are responsible for ensuring compliance with all terms and conditions of the permit, including implementation of the stormwater management plan.
- iii. The applicant(s) must develop a stormwater management plan (SWMP) in accordance with the requirements of Part I.C. The applicant(s) must also certify that the SWMP is complete, or will be complete, prior to commencement of any construction activity.
- iv. In order to apply for certification under this general permit, the applicant(s) must submit a complete, accurate, and signed permit application form as provided by the division by electronic delivery at least 10 days prior to the commencement of construction activity, except those construction activities that are in response to a [public emergency related site](#); [public emergency related sites](#) shall apply for coverage no later than 14 days after the commencement of construction activities. The provisions of this part in no way remove a violation of the Colorado Water Quality Control Act if a [point source](#) discharge occurs prior to the issuance of a CDPS permit.
- v. The application in its entirety must be submitted via the division's online permitting system unless a waiver is granted by the division. If a waiver is granted, the application in its entirety, including signatures by both the owner and operator, must be submitted to:

Colorado Department of Public Health and Environment
Water Quality Control Division
Permits Section, WQCD-PS-B2
4300 Cherry Creek Drive South
Denver, CO 80246

- vi. The applicant(s) must receive written notification that the division granted permit coverage prior to conducting construction activities except for construction activities that are in response to a public emergency related site.

c. Division Review of Permit Application

Within 10 days of receipt of the application, and following review of the application, the division may:

- i. Issue a certification of coverage;
- ii. Request additional information necessary to evaluate the discharge;
- iii. Delay the authorization to discharge pending further review;
- iv. Notify the applicant that additional terms and conditions are necessary; or
- v. Deny the authorization to discharge under this general permit.

d. Alternative Permit Coverage

i. Division Required Alternative Permit Coverage:

The division may require an applicant or permittee to apply for an individual permit or an alternative general permit if it determines the discharge does not fall under the scope of this general permit, including if any additional terms and conditions are necessary in order to ensure that discharges authorized by this permit shall not cause, have the reasonable potential to cause, or measurably contribute to an exceedance of any applicable water quality standard, including narrative standards for water quality. In this case, the division will notify the applicant or permittee that an individual permit application is required.

ii. Permittee Request for Alternative Permit Coverage:

A permittee authorized to discharge stormwater under this permit may request to be excluded from coverage under this general permit by applying for an individual permit. In this case, the permittee must submit an individual application, with reasons supporting the request, to the division at least 180 days prior to any discharge. When an individual permit is issued, the permittee's authorization to discharge under this permit is terminated on the effective date of the individual permit.

e. Submittal Signature Requirements

Documents required for submittal to the division in accordance with this permit, including applications for permit coverage and other documents as requested by the division, must include signatures by **both** the owner and the operator, except for instances where the duties of the owner and operator are managed by the owner.

Signatures on all documents submitted to the division as required by this permit must meet the Standard Signatory Requirements in [Part II.K](#) of this permit in accordance with 40 C.F.R. 122.41(k).

i. Signature Certification

Any person(s) signing documents required for submittal to the division must make the following

certification:

“I certify under penalty of law that this document and all attachments were prepared under my direction or supervision in accordance with a system designed to assure that qualified personnel properly gather and evaluate the information submitted. Based on my inquiry of the person or persons who manage the system, or those persons directly responsible for gathering the information, the information submitted is, to the best of my knowledge and belief, true, accurate, and complete. I am aware that there are significant penalties for submitting false information, including the possibility of fine and imprisonment for knowing violations.”

f. Compliance Document Signature Requirements

Documents which are required for compliance with the permit, but for which submittal to the division is not required unless specifically requested by the division, must be signed by the individual(s) designated as the [Qualified Stormwater Manager](#), as defined in Part I.E.

- i. Any person(s) signing inspection documents required for compliance with the permit per [Part I.D.5.c.xiii](#) must make the following statement and provide the date of the statement:

“I verify that, to the best of my knowledge and belief, that if any corrective action items were identified during the inspection, those corrective actions are complete, and the site is currently in compliance with the permit.”

g. Field Wide Permit Coverage for Oil and Gas Construction

At the discretion of the division, a single permit certification may be issued to a single oil and gas permittee to cover construction activity related discharges from an oil and gas field at multiple locations that are not necessarily contiguous.

h. Permit Coverage without Application

Qualifying Local Program: When a small construction site is within the jurisdiction of a qualifying local program, the owner and operator of the construction activity are authorized to discharge stormwater associated with **small construction activity** under this general permit without the submittal of an application to the division. Sites covered by a qualifying local program are exempt from the following sections of this general permit: Part I.A.3.a.; Part I.A.3.b.; Part I.A.3.c.; Part I.A.3.d.; Part I.A.3.g.; Part I.A.3.i.; Part I.A.3.j.; Part I.A.3.k.

Sites covered by a qualifying local program are subject to the following requirements:

- i. **Local Agency Authority:** This permit does not pre-empt or supersede the authority of local agencies to prohibit, restrict, or control discharges of stormwater to storm drain systems or other water courses within their jurisdiction.
- ii. **Permit Coverage Termination:** When a site under a Qualifying Local Program is finally stabilized, coverage under this permit is automatically terminated.
- iii. **Compliance with Qualifying Local Program:** Qualifying Local Program requirements that are equivalent to the requirements of this permit are incorporated by reference. Permittees authorized to discharge under this permit, must comply with the equivalent requirements of the Qualifying Local Program that has jurisdiction over the site as a condition of this permit.
- iv. **Compliance with Remaining Permit Conditions.** Requirements of this permit that are in addition to or more stringent than the requirements of the Qualifying Local Program apply in addition to the requirements of the Qualifying Local Program.
- v. **Written Authorization of Coverage:** The division or local municipality may require any permittee within the jurisdiction of a Qualifying Local Program covered under this permit to

apply for, and obtain written authorization of coverage under this permit. The permittee must be notified in writing that an application for written authorization of coverage is required.

i. Permittee Initiated Permit Actions

Permittee initiated permit actions, including but not limited to modifications, contact changes, transfers, and terminations, shall be conducted following [Part II.L](#), division guidance and using appropriate division-provided forms.

j. Sale of Residence to Homeowner

Residential construction sites only: The permittee may remove residential lots from permit coverage once the lot meets the following criteria:

- i. The residential lot has been sold to the homeowner(s) for private residential use;
- ii. A certificate of occupancy, or equivalent, is maintained on-site and is available during division inspections;
- iii. The lot is less than one acre of disturbance;
- iv. All construction activity conducted on the lot by the permittee is complete;
- v. The permittee is not responsible for final stabilization of the lot; and
- vi. The SWMP was modified to indicate the lot is no longer part of the construction activity.

If the residential lot meets the criteria listed above then activities occurring on the lot are no longer considered to be construction activities with a duty to apply and maintain permit coverage. Therefore, the permittee is not required to meet the final stabilization requirements and may terminate permit coverage for the lot.

k. Permit Expiration and Continuation of Permit Coverage

Authorization to discharge under this general permit shall expire at midnight on March 31, 2024. While Regulation 61.4 requires a permittee to submit an application for continuing permit coverage 180 days before the permit expires, the division is requiring that permittees desiring continued coverage under this general permit must reapply at least 90 days in advance of this permit expiration. The division will determine if the permittee may continue to discharge stormwater under the terms of the general permit. An individual permit may be required for any facility not reauthorized to discharge under the reissued general permit.

If this permit is not reissued or replaced prior to the expiration date, it will be administratively continued and remain in force and effect. For permittees that have applied for continued permit coverage, discharges authorized under this permit prior to the expiration date will automatically remain covered by this permit until the earliest of:

- i. An authorization to discharge under a reissued permit, or a replacement of this permit, following the timely and appropriate submittal of a complete application requesting authorization to discharge under the new permit and compliance with the requirements of the new permit; or
- ii. The issuance and effect of a termination issued by the division; or
- iii. The issuance or denial of an individual permit for the facility's discharges; or
- iv. A formal permit decision by the division not to reissue this general permit, at which time the division will identify a reasonable time period for covered dischargers to seek coverage under

an alternative general permit or an individual permit. Coverage under this permit will cease when coverage under another permit is granted/authorized; or

- v. The division has informed the permittee that discharges previously authorized under this permit are no longer covered under this permit.

B. EFFLUENT LIMITATIONS

1. Requirements for Control Measures Used to Meet Effluent Limitations

The permittee must implement control measures to [minimize](#) the discharge of pollutants from all potential pollutant sources at the site. Control measures must be installed prior to commencement of construction activities. Control measures must be selected, designed, installed and maintained in accordance with [good engineering, hydrologic and pollution control practices](#). Control measures implemented at the site must be designed to prevent pollution or degradation of state waters.

a. Stormwater Pollution Prevention

The permittee must implement structural and/or nonstructural control measures that effectively minimize erosion, sediment transport, and the release of other pollutants related to construction activity.

i. Control Measures for Erosion and Sediment Control

Control measures for erosion and sediment control may include, but are not limited to, wattles/sediment control logs, silt fences, earthen dikes, drainage swales, sediment traps, subsurface drains, pipe slope drains, inlet protection, outlet protection, gabions, sediment basins, temporary vegetation, permanent vegetation, mulching, geotextiles, sod stabilization, slope roughening, maintaining existing vegetation, protection of trees, and preservation of mature vegetation.

Specific control measures must meet the requirements listed below.

- (a) Structural and nonstructural vehicle tracking controls shall be implemented to minimize vehicle tracking of sediment from disturbed areas and may include tracking pads, minimizing site access, wash racks, graveled parking areas, maintaining vehicle traffic to paved areas, street sweeping and sediment control measures.
- (b) Stormwater runoff from all disturbed areas and soil storage areas must utilize or flow to one or more control measures to minimize erosion or sediment in the discharge. The control measure(s) must be selected, designed, installed and adequately sized in accordance with good engineering, hydrologic and pollution control practices for the intended application. The control measure(s) must contain or filter flows in order to prevent the [bypass](#) of flows without treatment and must be appropriate for stormwater runoff from disturbed areas and for the expected flow rate, duration, and flow conditions (e.g. sheet or concentrated flow).
- (c) Selection of control measures should prioritize the use of structural and nonstructural control measures that minimize the potential for erosion (i.e. covering materials). Selection should also prioritize phasing construction activities to minimize the amount of soil disturbance at any point in time throughout the duration of construction.
- (d) Outlets that withdraw water from or near the surface shall be installed when discharging from basins and impoundments, unless [infeasible](#).
- (e) Maintain pre-existing vegetation or equivalent control measures for areas within 50 horizontal feet of receiving waters as defined by this permit, unless infeasible.

- (f) Soil compaction must be minimized for areas where infiltration control measures will occur or where [final stabilization](#) will be achieved through vegetative cover.
 - (g) Unless infeasible, topsoil shall be preserved for those areas of a site that will utilize vegetative final stabilization.
 - (h) Minimize the amount of soil exposed during construction activity, including the disturbance of [steep slopes](#).
 - (i) Diversion control measures must minimize soil transport and erosion within the entire diversion, minimize erosion during discharge, and minimize run-on into the diversion. The permittee must minimize the discharge of pollutants throughout the installation, implementation and removal of the diversion. Diversions must meet one or more of the following conditions:
 - (1) Lined or piped structures that result in no erosion in all flow conditions.
 - (2) Diversion channels, berms, and coffer dams must be lined or composed of a material that minimizes potential for soil loss in the entire wetted perimeter during anticipated flow conditions (e.g. vegetated swale, non-erosive soil substrate). The entire length of the diversion channel must be designed with all of the following considerations: maximum flow velocity for the type of material(s) exposed to the anticipated flows to ensure that the calculated maximum shear stress of flows in the channel is not expected to result in physical damage to the channel or liner and result in discharge of pollutants. Additionally, the conditions relied on to minimize soil loss must be maintained for the projected life of the diversion (i.e. a vegetated swale must be limited to a period of time that ensures vegetative growth, minimizes erosion and maintains stable conditions).
 - (3) An alternative diversion criteria, approved by the division prior to implementation. The diversion method must be designed to minimize the discharge of pollutants and to prevent the potential for pollution or degradation to state waters as a result of the diverted flow through the diversion structure. In addition, the alternative diversion method must minimize the discharge of pollutants throughout the installation, implementation and removal of the diversion.
- ii. Practices for Other Common Pollutants
- (a) Bulk storage, individual containers of 55 gallons or greater, for petroleum products and other liquid chemicals must have secondary containment, or equivalent protection, in order to contain [spills](#) and to prevent spilled material from entering state waters.
 - (b) Control measures designed for concrete washout waste must be implemented. This includes washout waste discharged to the ground as authorized under this permit and washout waste from concrete trucks and masonry operations contained on site. The permittee must ensure the washing activities do not contribute pollutants to stormwater runoff, or receiving waters in accordance [Part I.A.1.b.ii](#). Discharges that may reach groundwater must flow through soil that has buffering capacity prior to reaching groundwater, as necessary to meet the effluent limits in this permit, including [Part I.B.3.a](#). The concrete washout location must not be located in an area where shallow groundwater may be present and would result in buffering capacity not being adequate, such as near natural drainages, springs, or wetlands. This permit authorizes discharges to the ground of concrete washout waste, but does not authorize on-site waste disposal per [Part I.B.3.d](#).
 - (c) In the event that water remains onsite and contains pollutants either from the

firefighting activities or picked up from the site (i.e. in a gutter, sediment basin, etc.) after active emergency response is complete, the permittee must ensure the remaining water containing pollutants is properly removed and disposed of in order to minimize pollutants from discharging from the site, unless infeasible.

iii. Stabilization Requirements

The following requirements must be implemented for each site.

- (a) Temporary stabilization must be implemented for earth disturbing activities on any portion of the site where ground disturbing construction activity has permanently ceased, or temporarily ceased for more than 14 calendar days. Temporary stabilization methods may include, but are not limited to, tarps, soil tackifier, and hydroseed. The permittee may exceed the 14-day schedule when either the function of the specific area of the site requires it to remain disturbed or physical characteristics of the terrain and climate prevent stabilization. The SWMP must document the constraints necessitating the alternative schedule, provide the alternate stabilization schedule, and identify all locations where the alternative schedule is applicable on the site map. Minimum inspection frequency and scope, as directed in Part I.D., must be followed for temporarily stabilized areas.
- (b) Final stabilization must be implemented for all construction sites covered under this permit. Final stabilization is reached when (1), (2), and (3) below are complete:
 - (1) All construction activities are complete.
 - (2) Permanent stabilization methods are complete. Permanent stabilization methods include, but are not limited to, permanent pavement or concrete, hardscape, xeriscape, stabilized driving surfaces, vegetative cover, or equivalent permanent alternative stabilization methods. The division may approve alternative final stabilization criteria for specific operations. Vegetative cover must meet the following criteria:
 - a. Evenly distributed perennial vegetation, and
 - b. Coverage, at a minimum, equal to 70 percent of what would have been provided by native vegetation in a local, undisturbed area or adequate reference site, and
 - (3) The permittee must ensure all temporary control measures are removed from the construction site once final stabilization is achieved, except when the control measure specifications allow the control measure to be left in place (i.e. bio-degradable control measures).
- (c) Final stabilization must be designed and installed as a permanent feature. Final stabilization measures for obtaining a vegetative cover or alternative stabilization methods include, but are not limited to, the following as appropriate:
 - (1) Seed mix selection and application methods;
 - (2) Soil preparation and amendments;
 - (3) Soil stabilization methods to provide adequate protection to minimize erosion (e.g. crimped straw, hydro mulch or rolled erosion control products);
 - (4) Appropriate sediment control measures as needed until final stabilization is achieved;

(5) Permanent pavement, hardscape, xeriscape, stabilized driving surfaces;

(d) Other alternative stabilization practices as applicable.

b. Maintenance

The permittee must ensure that all control measures remain in effective operating condition and are protected from activities that would reduce their effectiveness. Control measures must be maintained in accordance with good engineering, hydrologic and pollution control practices. Observations leading to the required maintenance of control measures can be made during a site inspection, or during general observations of site conditions. The necessary repairs or modifications to a [control measure requiring routine maintenance](#), as defined in Part I.E., must be conducted to maintain an effective operating condition. This section is not subject to the requirements in [Part I.B.1.c](#) below.

c. Corrective Actions

The permittee must assess the adequacy of control measures at the site, and the need for changes to those control measures, to ensure continued effective performance.

When an [inadequate control measure](#), as defined in Part I.E., is identified (i.e., new or replacement control measures become necessary), the following corrective action requirements apply. The permittee is in noncompliance with the permit until the inadequate control measure is replaced or corrected and returned to effective operating condition in compliance with [Part I.B.1](#) and the general requirements in [Part I.B.3](#). If the inadequate control measure results in noncompliance that meets the conditions of Part II.L., the permittee must also meet the requirements of that section.

i. The permittee must take all necessary steps to minimize or prevent the discharge of pollutants from the permitted area and manage any stormwater run-on onto the site until a control measure is implemented and made operational and/or an inadequate control measure is replaced or corrected and returned to effective operating condition. If it is infeasible to install or repair the control measure immediately after discovering the deficiency, the following must be documented in the SWMP in [Part I.D.5.c](#) and kept on record in accordance with the recordkeeping requirements in Part II.

(a) Describe why it is infeasible to initiate the installation or repair immediately; and

(b) Provide a schedule for installing or repairing the control measure and returning it to an effective operating condition as soon as possible.

ii. If applicable, the permittee must remove and properly dispose of any unauthorized release or discharge within and from the permitted area (e.g., discharge of non-stormwater, untreated stormwater containing pollutants, spill, or leak not authorized by this permit.) The permittee must also clean up any contaminated surfaces, if feasible, to minimize discharges of the material in subsequent storm events, including water remaining from the response that contains pollutants after active emergency firefighting response is complete.

2. Discharges to an Impaired Waterbody

a. [Total Maximum Daily Load](#) (TMDL)

If the discharge from the site of permit coverage flows to or could reasonably be expected to flow to any water body for which a TMDL has been approved, and stormwater discharges associated with construction activity were assigned a pollutant-specific Wasteload Allocation (WLA) under the TMDL, the division may:

i. Ensure the WLA is implemented properly through alternative local requirements, such as by a

municipal stormwater permit; or

- ii. Notify the permittee of the WLA and amend the permittee's certification to add specific effluent limits and other requirements, as appropriate. The permittee may be required to do the following:
 - (a) Under the permittee's SWMP, implement specific control measures based on requirements of the WLA, and evaluate whether the requirements are met through implementation of existing stormwater control measures or if additional control measures are necessary. Document the calculations or other evidence demonstrating that the requirements are expected to be met; and
 - (b) If the evaluation shows that additional or modified control measures are necessary, describe the type and schedule for the control measure additions or modifications.
- iii. Discharge monitoring may also be required. The permittee may maintain coverage under the general permit provided they comply with the applicable requirements outlined above. The division reserves the right to require individual or alternate general permit coverage.

3. General Requirements

- a. Discharges authorized by this permit shall not cause, have the reasonable potential to cause, or measurably contribute to an exceedance of any applicable water quality standard, including narrative standards for water quality.
- b. The division may require sampling and testing, on a case-by-case basis, in the event that there is reason to suspect that the SWMP is not adequately minimizing pollutants in stormwater or in order to measure the effectiveness of the control measures in removing pollutants in the effluent. Such monitoring may include Whole Effluent Toxicity testing.
- c. The permittee must comply with the lawful requirements of federal agencies, municipalities, counties, drainage districts and other local agencies including applicable requirements in [Municipal Stormwater Management Programs](#) developed to comply with CDPS permits. The permittee must comply with local stormwater management requirements, policies and guidelines including those for erosion and sediment control.
- d. All construction site wastes must be properly managed to prevent potential pollution of state waters. This permit does not authorize on-site waste disposal.
- e. This permit does not relieve the permittee of the reporting requirements in 40 CFR 110, 40 CFR 117 or 40 CFR 302. Any discharge of hazardous material must be handled in accordance with the division's Noncompliance Notification Requirements (see [Part II.L](#) of the permit).

C. STORMWATER MANAGEMENT PLAN (SWMP) REQUIREMENTS

1. SWMP General Requirements

- a. A SWMP shall be developed for each construction site listed under [Part I.A.3.a](#), including but not limited to, construction activity that will disturb one acre or more and/or are part of a common plan of development or sale covered by this permit. The SWMP must be prepared in accordance with good engineering, hydrologic and pollution control practices.
 - i. For public emergency related sites, a SWMP shall be created no later than 14 days after the commencement of construction activities.
- b. The permittee must implement the provisions of the SWMP as written and updated, from commencement of construction activity until final stabilization is complete. The division may review the SWMP.

- c. A copy of the SWMP must be retained onsite or be onsite when construction activities are occurring at the site unless the permittee specifies another location and obtains approval from the division.

2. SWMP Content

- a. The SWMP, at a minimum, must include the following elements.
 - i. Qualified Stormwater Manager. The SWMP must list individual(s) by title and name who are designated as responsible for implementing the SWMP in its entirety and meet the definition of a Qualified Stormwater Manager. This role may be filled by more than one individual.
 - ii. Spill Prevention and Response Plan. The SWMP must have a spill prevention and response plan. The plan may incorporate by reference any part of a Spill Prevention Control and Countermeasure (SPCC) plan under section 311 of the Clean Water Act (CWA) or a Spill Prevention Plan required by a separate CDPS permit. The relevant sections of any referenced plans must be available as part of the SWMP consistent with Part I.C.4.
 - iii. Other CDPS Permits. The SWMP must list the applicable CDPS permits associated with the permitted site and the activities occurring on the permitted site (e.g. a CDPS Dewatering Permit).
 - iv. Materials Handling. The SWMP must describe handling procedures of all control measures implemented at the site to minimize impacts from handling significant materials that could contribute pollutants to runoff. These handling procedures can include control measures for pollutants and activities such as, exposed storage of building materials, paints and solvents, landscape materials, fertilizers or chemicals, sanitary waste material, trash and equipment maintenance or fueling procedures.
 - v. Potential Sources of Pollution. The SWMP must list all potential sources of pollution which may reasonably be expected to affect the quality of stormwater discharges associated with construction activity from the site. This may include, but is not limited to, the following pollutant sources:
 - (a) Disturbed and stored soils;
 - (b) Vehicle tracking of sediments;
 - (c) Management of contaminated soils, if known to be present, or if contaminated soils are found during construction;
 - (d) Loading and unloading operations;
 - (e) Outdoor storage activities (erodible building materials, fertilizers, chemicals, etc.);
 - (f) Vehicle and equipment maintenance and fueling;
 - (g) Significant dust or particulate generating processes (e.g., saw cutting material, including dust);
 - (h) Routine maintenance activities involving fertilizers, pesticides, herbicides, detergents, fuels, solvents, oils, etc.;
 - (i) On-site waste management practices (waste piles, liquid wastes, dumpsters);
 - (j) Concrete truck/equipment washing, including washing of the concrete truck chute and associated fixtures and equipment;
 - (k) Dedicated asphalt, concrete batch plants and masonry mixing stations;

(l) Non-industrial waste sources such as worker trash and portable toilets.

- vi. Implementation of Control Measures. The SWMP must include design specifications that contain information on the implementation of all the structural and nonstructural control measures in use on the site in accordance with good engineering, hydrologic and pollution control practices; including, as applicable, drawings, dimensions, installation information, materials, implementation processes, control measure-specific inspection expectations, and maintenance requirements.

The SWMP must include a documented use agreement between the permittee and the owner or operator of any control measures located outside of the permitted area, that are utilized by the permittee's construction site for compliance with this permit, but not under the direct control of the permittee. The permittee is responsible for ensuring that all control measures located outside of their permitted area, that are being utilized by the permittee's construction site, are properly maintained and in compliance with all terms and conditions of the permit. The SWMP must include all information required of and relevant to any such control measures located outside the permitted area, including location, installation specifications, design specifications and maintenance requirements.

- vii. Site Description. The SWMP must include a site description which includes, at a minimum, the following:
- (a) The nature of the construction activity at the site;
 - (b) The proposed schedule for the sequence for major construction activities and the planned implementation of control measures for each phase. (e.g. clearing, grading, utilities, vertical, etc.);
 - (c) Estimates of the total acreage of the site, and the acreage expected to be disturbed by clearing, excavation, grading, or any other construction activities;
 - (d) A summary of any existing data and sources used in the development of the construction site plans or SWMP that describe the soil types found in the permitted area and the erodibility of the identified soil types;
 - (e) A description of the percent cover of native vegetation on the site if the site is undisturbed, or the percent cover of native vegetation in a similar, local undisturbed area or adequate reference area if the site is disturbed. Include the source or methodology for determining the percentage. If a percent cover is not appropriate for the site location (i.e. arid), describe the technique and justification for the identified cover of native vegetation;
 - (f) A description of any allowable non-stormwater discharges at the site, including those being discharged under a separate CDPS permit or a division low risk discharge guidance policy, and applicable control measures installed;
 - (g) A description of the drainage patterns from the site, including a description of the immediate source receiving the discharge and the receiving water(s) of the discharge, if different than the immediate source. If the stormwater discharge is to a [municipal separate storm sewer system](#), include the name of the entity owning that system, the location(s) of the stormwater discharge, and the receiving water(s);
 - (h) A description of all stream crossings located within the construction site boundary; and
 - (i) A description of the alternate temporary stabilization schedule, if applicable ([Part I.B.1.a.iii\(a\)](#)).

- (j) A description of the alternative diversion criteria as approved by the division, if applicable ([Part I.B.1.a.i\(i\)\(3\)](#)).

viii. Site Map. The SWMP must include a site map which includes, at a minimum, the following:

- (a) Construction site boundaries;
- (b) Flow arrows that depict stormwater flow directions on-site and runoff direction;
- (c) All areas of ground disturbance including areas of borrow and fill;
- (d) Areas used for storage of soil;
- (e) Locations of all waste accumulation areas, including areas for liquid, concrete, masonry, and asphalt;
- (f) Locations of dedicated asphalt, concrete batch plants and masonry mixing stations;
- (g) Locations of all structural control measures;
- (h) Locations of all non-structural control measures (e.g. temporary stabilization);
- (i) Locations of springs, streams, wetlands, diversions and other state waters, including areas that require pre-existing vegetation be maintained within 50 feet of a receiving water, where determined feasible in accordance with [Part I.B.1.a.i\(e\)](#);
- (j) Locations of all stream crossings located within the construction site boundary; and
- (k) Locations where alternative temporary stabilization schedules apply.

ix. Temporary Stabilization, Final Stabilization and Long Term Stormwater Management.

- (a) The SWMP must document the constraints necessitating an alternative temporary stabilization schedule, as referenced in [Part I.B.1.a.iii\(a\)](#), provide the alternate stabilization schedule, and identify all locations where the alternative schedule is applicable on the site map.
- (b) The SWMP must describe and locate the methods used to achieve final stabilization of all disturbed areas at the site, as listed in [Part I.B.1.a.iii\(b\)](#).
- (c) The SWMP must describe the measures used to establish final stabilization through vegetative cover or alternative stabilization method, as referenced in [Part I.B.1.a.iii\(c\)](#), and describe and locate any temporary control measures in place during the process of final stabilization.
- (d) The SWMP must describe and locate any planned permanent control measures to control pollutants in stormwater discharges that will occur after construction operations are completed, including but not limited to, detention/retention ponds, rain gardens, stormwater vaults, etc.

x. Inspection Reports. The SWMP must include documented inspection reports in accordance with [Part I.D.5.c](#).

3. SWMP Review and Revisions

Permittees must keep a record of SWMP changes made that includes the date and identification of the changes. The SWMP must be amended when the following occurs:

- a. A change in design, construction, operation, or maintenance of the site requiring implementation

of new or revised control measures;

- b. The SWMP proves ineffective in controlling pollutants in stormwater runoff in compliance with the permit conditions;
- c. Control measures identified in the SWMP are no longer necessary and are removed; and
- d. Corrective actions are taken onsite that result in a change to the SWMP.
- e. The site or areas of the site qualifying for reduced frequency inspections under [Part I.D.4](#).

For SWMP revisions made prior to or following a change(s) onsite, including revisions to sections addressing site conditions and control measures, a notation must be included in the SWMP that identifies the date of the site change, the control measure removed, or modified, the location(s) of those control measures, and any changes to the control measure(s). The permittee must ensure the site changes are reflected in the SWMP. The permittee is noncompliant with the permit until the SWMP revisions have been made.

4. SWMP Availability

A copy of the SWMP must be provided upon request to the division, EPA, and any local agency with authority for approving sediment and erosion plans, grading plans or stormwater management plans within the time frame specified in the request. If the SWMP is required to be submitted to any of these entities, the submission must include a signed certification in accordance with [Part I.A.3.e](#), certifying that the SWMP is complete and compliant with all terms and conditions of the permit.

All SWMPs required under this permit are considered reports that must be available to the public under Section 308(b) of the CWA and Section 61.5(4) of the CDPS regulations. The permittee must make plans available to members of the public upon request. However, the permittee may claim any portion of a SWMP as confidential in accordance with 40 CFR Part 2.

D. SITE INSPECTIONS

Site inspections must be conducted in accordance with the following requirements. The required inspection schedules are a minimum frequency and do not affect the permittee's responsibility to implement control measures in effective operating condition as prescribed in the SWMP, [Part I.C.2.a.vi](#), as proper maintenance of control measures may require more frequent inspections. Site inspections shall start within 7 calendar days of the commencement of construction activities on site.

1. Person Responsible for Conducting Inspections

The person(s) inspecting the site may be on the permittee's staff or a third party hired to conduct stormwater inspections under the direction of the permittee(s). The permittee is responsible for ensuring that the inspector meets the definition of a Qualified Stormwater Manager. The inspector may be different than the individual(s) listed in [Part I.C.2.a.i](#).

2. Inspection Frequency

Permittees must conduct site inspections in accordance with on the following minimum frequencies, unless the site meets the requirements of [Part I.D.3](#). All inspections must be recorded per [Part I.D.5.c](#).

- a. At least one inspection every 7 calendar days; or
- b. At least one inspection every 14 calendar days, if post-storm event inspections are conducted within 24 hours after the end of any precipitation or snowmelt event that causes surface erosion. Post-storm inspections may be used to fulfill the 14-day routine inspection requirement.
- c. When site conditions make the schedule required in this section impractical, the permittee may

petition the division to grant an alternate inspection schedule. The alternative inspection schedule must not be implemented prior to written approval by the division and incorporation into the SWMP.

3. Inspection Frequency for Discharges to Outstanding Waters

Permittees must conduct site inspections at least once every 7 calendar days for sites that discharge to a water body designated as an Outstanding Water by the Water Quality Control Commission.

4. Reduced Inspection Frequency

The permittee may perform site inspections at the following reduced frequencies when one of the following conditions exists:

a. Post-Storm Inspections at Temporarily Idle Sites

For permittees choosing an inspection frequency pursuant to [Part I.D.2.b](#) and if no construction activities will occur following a storm event, post-storm event inspections must be conducted prior to re-commencing construction activities, and no later than 72 hours following the storm event. If the post-storm event inspection qualifies under this section, the inspection delay must be documented in the inspection record per [Part I.D.5.c](#). Routine inspections must still be conducted at least every 14 calendar days.

b. Inspections at Completed Sites/Areas

When the site, or portions of a site, are awaiting establishment of a vegetative ground cover and final stabilization, the permittee must conduct a thorough inspection of the stormwater management system at least once every 30 days. Post-storm event inspections are not required under this schedule. This reduced inspection schedule is allowed if all of the following criteria are met:

- i. All construction activities resulting in ground disturbance are complete;
- ii. All activities required for final stabilization, in accordance with [Part I.B.1.a.iii\(b\) & \(c\)](#) and with the SWMP, have been completed, with the exception of the application of seed that has not occurred due to seasonal conditions or the necessity for additional seed application to augment previous efforts; and
- iii. The SWMP has been amended to locate those areas to be inspected in accordance with the reduced schedule allowed for in this paragraph.

c. Winter Conditions Inspections Exclusion

Inspections are not required for sites that meet all of the following conditions: construction activities are temporarily halted, snow cover exists over the entire site for an extended period, and melting conditions posing a risk of surface erosion do not exist. This inspection exception is applicable only during the period where melting conditions do not exist, and applies to the routine 7-day, 14-day and monthly inspections, as well as the post-storm-event inspections. When this inspection exclusion is implemented, the following information must be documented in accordance with the requirements in [Part I.C.3](#) and [Part I.D.5.c](#):

- i. Dates when snow cover existed;
- ii. Date when construction activities ceased; and
- iii. Date melting conditions began.

5. Inspection Scope

a. Areas to Be Inspected

When conducting a site inspection the following areas, if applicable, must be inspected for evidence of, or the potential for, pollutants leaving the construction site boundaries, entering the stormwater drainage system or discharging to state waters:

- i. Construction site perimeter;
- ii. All disturbed areas;
- iii. Locations of installed control measures;
- iv. Designated haul routes;
- v. Material and waste storage areas exposed to precipitation;
- vi. Locations where stormwater has the potential to discharge offsite; and
- vii. Locations where vehicles exit the site.

b. Inspection Requirements

- i. Visually verify whether all implemented control measures are in effective operational condition and are working as designed in their specifications to minimize pollutant discharges.
- ii. Determine if there are new potential sources of pollutants.
- iii. Assess the adequacy of control measures at the site to identify areas requiring new or modified control measures to minimize pollutant discharges.
- iv. Identify all areas of non-compliance with the permit requirements and, if necessary, implement corrective action(s) in accordance with [Part I.B.1.c](#).

c. Inspection Reports

The permittee must keep a record of all inspections conducted for each permitted site. Inspection reports must identify any incidents of noncompliance with the terms and conditions of this permit. All inspection reports must be signed and dated in accordance with [Part I.A.3.f](#). Inspection records must be retained in accordance with [Part II.O](#). At a minimum, the inspection report must include:

- i. The inspection date;
- ii. Name(s) and title(s) of personnel conducting the inspection;
- iii. Weather conditions at the time of inspection;
- iv. Phase of construction at the time of inspection;
- v. Estimated acreage of disturbance at the time of inspection;
- vi. Location(s) and identification of control measures requiring routine maintenance;
- vii. Location(s) and identification of discharges of sediment or other pollutants from the site;
- viii. Location(s) and identification of inadequate control measures;
- ix. Location(s) and identification of additional control measures needed that were not in place at the time of inspection;

- x. Description of corrective action(s) for items vii, viii, ix, above, dates corrective action(s) were completed, including requisite changes to the SWMP, as necessary;
- xi. Description of the minimum inspection frequency (either in accordance with [Part I.D.2](#), [Part I.D.3](#) or [Part I.D.4.](#)) utilized when conducting each inspection.
- xii. Deviations from the minimum inspection schedule as required in [Part I.D.2](#). This would include documentation of division approval for an alternate inspection schedule outlined in [Part I.D.2.c](#);
- xiii. After adequate corrective action(s) have been taken, or where a report does not identify any incidents requiring corrective action, the report shall contain a statement as required in [Part I.A.3.f](#).

E. DEFINITIONS

For the purposes of this permit:

- (1) Bypass the intentional diversion of waste streams from any portion of a treatment facility in accordance with 40 CFR 122.41(m)(1)(i) and Regulation 61.2(12).
- (2) Common Plan of Development or Sale - A contiguous area where multiple separate and distinct construction activities may be taking place at different times on different schedules, but remain related. The division has determined that “contiguous” means construction activities located in close proximity to each other (within ¼ mile). Construction activities are considered to be “related” if they share the same development plan, builder or contractor, equipment, storage areas, etc. “Common plan of development or sale” includes construction activities that are associated with the construction of field wide oil and gas permits for facilities that are related.
- (3) Construction Activity - Ground surface disturbing and associated activities (land disturbance), which include, but are not limited to, clearing, grading, excavation, demolition, installation of new or improved haul roads and access roads, staging areas, stockpiling of fill materials, and borrow areas. Construction does not include routine maintenance to maintain the original line and grade, hydraulic capacity, or original purpose of the facility. Activities to conduct repairs that are not part of routine maintenance or for replacement are construction activities and are not routine maintenance. Repaving activities where underlying and/or surrounding soil is exposed as part of the repaving operation are considered construction activities. Construction activity is from initial ground breaking to final stabilization regardless of ownership of the construction activities.
- (4) Control Measure - Any best management practice or other method used to prevent or reduce the discharge of pollutants to state waters. Control measures include, but are not limited to, best management practices. Control measures can include other methods such as the installation, operation, and maintenance of structural controls and treatment devices.
- (5) Control Measure Requiring Routine Maintenance - Any control measure that is still operating in accordance with its design and the requirements of this permit, but requires maintenance to prevent a breach of the control measure. See also inadequate control measure.
- (6) Dedicated Asphalt, Concrete Batch Plants and Masonry Mixing Stations - Are batch plants or mixing stations located on, or within ¼ mile of, a construction site and that provide materials only to that specific construction site.
- (7) Diversion - Discharges of state waters that are temporarily routed through channels or structures (e.g. in-stream, uncontaminated springs, non-pumped groundwater, temporary rerouting of surface waters).
- (8) Final Stabilization - The condition reached when construction activities at the site have been

- completed, permanent stabilization methods are complete, and temporary control measures are removed. Areas being stabilized with a vegetative cover must have evenly distributed perennial vegetation. The vegetation coverage must be, at a minimum, equal to 70 percent of what would have been provided by native vegetation in a local, undisturbed area or adequate reference site.
- (9) Good Engineering, Hydrologic and Pollution Control Practices: are methods, procedures, and practices that:
- a. Are based on basic scientific fact(s).
 - b. Reflect best industry practices and standards.
 - c. Are appropriate for the conditions and pollutant sources.
 - d. Provide appropriate solutions to meet the associated permit requirements, including practice based effluent limits.
- (10) Inadequate Control Measure - Any control measure that is not designed or implemented in accordance with the requirements of the permit and/or any control measure that is not implemented to operate in accordance with its design. See also Control Measure Requiring Routine Maintenance.
- (11) Infeasible - Not technologically possible, or not economically practicable and achievable in light of best industry practices.
- (12) Minimize - reduce or eliminate to the extent achievable using control measures that are technologically available and economically practicable and achievable in light of best industry practice.
- (13) Municipality - A city, town, county, district, association, or other public body created by, or under, State law and having jurisdiction over disposal of sewage, industrial wastes, or other wastes, or a designated and approved management agency under section 208 of CWA (1987).
- (14) Municipal Separate Storm Sewer System (MS4) - A conveyance or system of conveyances (including roads with drainage systems, municipal streets, catch basins, curbs, gutters, ditches, man-made channels, or storm drains):
- a. Owned or operated by a State, city, town, county, district, association, or other public body (created by or pursuant to State law) having jurisdiction over disposal of sewage, industrial wastes, stormwater, or other wastes, including special districts under State law such as a sewer district, flood control district or drainage district, or similar entity, or a designated and approved management agency under section 208 of the CWA that discharges to state waters;
 - i. Designed or used for collecting or conveying stormwater;
 - ii. Are not a combined sewer; and
 - iii. Are not part of a Publicly Owned Treatment Works (POTW). See 5 CCR 1002-61.2(62).
- (15) Municipal Stormwater Management Program - A stormwater program operated by a municipality, typically to meet the requirements of the municipalities MS4 discharge certification.
- (16) Operator - The party that has operational control over day-to-day activities at a project site which are necessary to ensure compliance with the permit. This party is authorized to direct individuals at a site to carry out activities required by the permit (i.e. the general contractor).

- (17) Outstanding Waters - Waters designated as outstanding waters pursuant to Regulation 31, Section 31.8(2)(a). The highest level of water quality protection applies to certain waters that constitute an outstanding state or national resource.
- (18) Owner - The party that has overall control of the activities and that has funded the implementation of the construction plans and specifications. This is the party that may have ownership of, a long term lease of, or easements on the property on which the construction activity is occurring (e.g. the developer).
- (19) Permittee(s) - The owner and operator named in the discharge certification issued under this permit for the construction site specified in the certification.
- (20) Point Source - Any discernible, confined, and discrete conveyance, including, but not limited to, any pipe, ditch, channel, tunnel, conduit, well, discrete fissure, container, rolling stock, concentrated animal feeding operation, or vessel or other floating craft, from which pollutants are or may be discharged. Point source does not include irrigation return flow. See 5 CCR 102-61.2(75).
- (21) Pollutant - Dredged spoil, dirt, slurry, solid waste, incinerator residue, sewage, sewage sludge, garbage, trash, chemical waste, biological nutrient, biological material, radioactive material, heat, wrecked or discarded equipment, rock, sand, or any industrial, municipal or agricultural waste. See 5 CCR 1002-61.2(76).
- (22) Presentation of credentials - a government issued form of identification, if in person; or (ii) providing name, position and purpose of inspection if request to enter is made via telephone, email or other form of electronic communication. A Permittee's non-response to a request to enter upon presentation of credentials constitutes a denial to such request, and may result in violation of the Permit.
- (23) Process Water - Any water which, during manufacturing or processing, comes into contact with or results from the production of any raw material, intermediate product, finished product, by product or waste product.
- (24) Public Emergency Related Site - a project initiated in response to an unanticipated emergency (e.g., mud slides, earthquake, extreme flooding conditions, disruption in essential public services), for which the related work requires immediate authorization to avoid imminent endangerment to human health or the environment, or to reestablish essential public services.
- (25) Qualified Stormwater Manager - An individual knowledgeable in the principles and practices of erosion and sediment control and pollution prevention, and with the skills to assess conditions at construction sites that could impact stormwater quality and to assess the effectiveness of stormwater controls implemented to meet the requirements of this permit.
- (26) Qualifying Local Program - A municipal program for stormwater discharges associated with small construction activity that was formally approved by the division as a qualifying local program.
- (27) Receiving Water - Any classified or unclassified surface water segment (including tributaries) in the State of Colorado into which stormwater associated with construction activities discharges. This definition includes all water courses, even if they are usually dry, such as borrow ditches, arroyos, and other unnamed waterways.
- (28) Severe Property Damage - substantial physical damage to property, damage to the treatment facilities which causes them to become inoperable, or substantial and permanent loss of natural resources which can reasonably be expected to occur in the absence of a bypass. Severe property damage does not mean economic loss caused by delays in production. See 40 CFR 122.41(m)(1)(ii).
- (29) Significant Materials - Include, but not limited to, raw materials; fuels; materials such as solvents, detergents, and plastic pellets; finished materials such as metallic products; raw materials used in

- food processing or production; hazardous substances designated under section 101(14) of CERCLA; any chemical the permittee is required to report under section 313 of Title III of the Superfund Amendments and Reauthorization Act (SARA); fertilizers; pesticides; and waste products such as ashes, slag and sludge that have the potential to be released with stormwater discharges.
- (30) Small Construction Activity - The discharge of stormwater from construction activities that result in land disturbance of equal to, or greater than, one acre and less than five acres. Small construction activity also includes the disturbance of less than one acre of total land area that is part of a larger common plan of development or sale, if the larger common plan ultimately disturbs equal to, or greater than, one acre and less than five acres.
 - (31) Spill - An unintentional release of solid or liquid material which may pollute state waters.
 - (32) State Waters - means any and all surface and subsurface waters which are contained in or flow in or through this state, but does not include waters in sewage systems, waters in treatment works of disposal systems, waters in potable water distribution systems, and all water withdrawn for use until use and treatment have been completed.
 - (33) Steep Slopes: where a local government, or industry technical manual (e.g. stormwater BMP manual) has defined what is to be considered a "steep slope", this permit's definition automatically adopts that definition. Where no such definition exists, steep slopes are automatically defined as those that are 3:1 or greater.
 - (34) Stormwater - Precipitation runoff, snow melt runoff, and surface runoff and drainage. See 5 CCR 1002-61.2(103).
 - (35) Total Maximum Daily Loads (TMDLs) -The sum of the individual wasteload allocations (WLA) for point sources and load allocations (LA) for nonpoint sources and natural background. For the purposes of this permit, a TMDL is a calculation of the maximum amount of a pollutant that a waterbody can receive and still meet water quality standards, and an allocation of that amount to the pollutant's sources. A TMDL includes WLAs, LAs, and must include a margin of safety (MOS), and account for seasonal variations. See section 303(d) of the CWA and 40 C.F.R. 130.2 and 130.7.
 - (36) Upset - an exceptional incident in which there is unintentional and temporary noncompliance with permit effluent limitations because of factors beyond the reasonable control of the permittee. An upset does not include noncompliance to the extent caused by operational error, improperly designed treatment facilities, inadequate treatment facilities, lack of preventative maintenance, or careless or improper operation in accordance with 40 CFR 122.41(n) and Regulation 61.2(114).

F. MONITORING

The division may require sampling and testing, on a case-by-case basis. If the division requires sampling and testing, the division will send a notification to the permittee. Reporting procedures for any monitoring data collected will be included in the notification.

If monitoring is required, the following applies:

1. The thirty (30) day average must be determined by the arithmetic mean of all samples collected during a thirty (30) consecutive-day period; and
2. A grab sample, for monitoring requirements, is a single "dip and take" sample.

G. OIL AND GAS CONSTRUCTION

Stormwater discharges associated with construction activities directly related to oil and gas exploration, production, processing, and treatment operations or transmission facilities are regulated under the Colorado Discharge Permit System Regulations (5 CCR 1002-61), and require coverage under this permit in accordance with that regulation. However, references in this permit to specific authority under the CWA do not apply to

stormwater discharges associated with these oil and gas related construction activities, to the extent that the references are limited by the federal Energy Policy Act of 2005.

Part II: Standard Permit Conditions

A. DUTY TO COMPLY

The permittee must comply with all conditions of this permit. Any permit noncompliance constitutes a violation of the Water Quality Control Act and is grounds for:

1. Enforcement action;
2. Permit termination, revocation and reissuance, or modification; or
3. Denial of a permit renewal application.

B. DUTY TO REAPPLY

If the permittee wishes to continue an activity regulated by this permit after the expiration date of this permit, the permittee must apply for and obtain authorization as required by Part I.A.3.k. of the permit.

C. NEED TO HALT OR REDUCE ACTIVITY NOT A DEFENSE

It shall not be a defense for a permittee in an enforcement action that it would have been necessary to halt or reduce the permitted activity in order to maintain compliance with the conditions of this permit.

D. DUTY TO MITIGATE

A permittee must take all reasonable steps to minimize or prevent any discharge in violation of this permit which has a reasonable likelihood of adversely affecting human health or the environment.

E. PROPER OPERATION AND MAINTENANCE

A permittee must at all times properly operate and maintain all facilities and systems of treatment and control (and related appurtenances) that are installed or used by the permittee to achieve compliance with the conditions of this permit. Proper operation and maintenance also includes adequate laboratory controls and appropriate quality assurance procedures. This provision requires the operation of backup or auxiliary facilities or similar systems which are installed by the permittee only when the operation is necessary to achieve compliance with the conditions of this permit. This requirement can be met by meeting the requirements for Part I.B., I.C., and I.D. above. See also 40 C.F.R. § 122.41(e).

F. PERMIT ACTIONS

This permit may be modified, revoked and reissued, or terminated for cause. The permittee request for a permit modification, revocation and reissuance, or termination, or a notification of planned changes or anticipated noncompliance does not stay any permit condition. Any request for modification, revocation, reissuance, or termination under this permit must comply with all terms and conditions of Regulation 61.8(8).

G. PROPERTY RIGHTS

In accordance with 40 CFR 122.41(g) and 5 CCR 1002-61, 61.8(9):

1. The issuance of a permit does not convey any property or water rights in either real or personal property, or stream flows or any exclusive privilege.
2. The issuance of a permit does not authorize any injury to person or property or any invasion of personal rights, nor does it authorize the infringement of federal, state, or local laws or regulations.
3. Except for any toxic effluent standard or prohibition imposed under Section 307 of the Federal act or any standard for sewage sludge use or disposal under Section 405(d) of the Federal act, compliance with a permit during its term constitutes compliance, for purposes of enforcement, with Sections 301,

302, 306, 318, 403, and 405(a) and (b) of the Federal act. However, a permit may be modified, revoked and reissued, or terminated during its term for cause as set forth in Section 61.8(8) of the Colorado Discharge Permit System Regulations.

H. DUTY TO PROVIDE INFORMATION

The permittee shall furnish to the division, within a reasonable time, any information which the division may request to determine whether cause exists for modifying, revoking and reissuing, or terminating this permit, or to determine compliance with this permit. The permittee shall also furnish to the division, upon request, copies of records required to be kept by this permit in accordance with 40 CFR 122.41(h) and/or Regulation 61.8(3)(q).

I. INSPECTION AND ENTRY

The permittee shall allow the division and the authorized representative, upon the [presentation of credentials](#) as required by law, to allow for inspections to be conducted in accordance with 40 CFR 122.41(i), Regulation 61.8(3), and Regulation 61.8(4):

1. To enter upon the permittee's premises where a regulated facility or activity is located or in which any records are required to be kept under the terms and conditions of this permit;
2. At reasonable times to have access to and copy any records required to be kept under the terms and conditions of this permit;
3. At reasonable times, inspect any monitoring equipment or monitoring method required in the permit; and
4. To enter upon the permittee's premises in a reasonable manner and at a reasonable time to inspect or investigate, any actual, suspected, or potential source of water pollution, or any violation of the Colorado Water Quality Control Act. The investigation may include: sampling of any discharges, stormwater or [process water](#), taking of photographs, interviewing site staff on alleged violations and other matters related to the permit, and assessing any and all facilities or areas within the site that may affect discharges, the permit, or an alleged violation.

The permittee shall provide access to the division or other authorized representatives upon presentation of proper credentials. A permittee's non-response to a request to enter upon presentation of credentials constitutes a denial of such request, and may result in a violation of the permit.

J. MONITORING AND RECORDS

1. Samples and measurements taken for the purpose of monitoring must be representative of the volume and nature of the monitored activity.
2. The permittee must retain records of all monitoring information, including all calibration and maintenance records and all original strip chart recordings for continuous monitoring instrumentation, copies of all reports required by this permit, and records of all data used to complete the application for this permit, for a period of at least three years from the date the permit expires or the date the permittee's authorization is terminated. This period may be extended by request of the division at any time.
3. Records of monitoring information must include:
 - a. The date, exact place, and time of sampling or measurements;
 - b. The individual(s) who performed the sampling or measurements;
 - c. The date(s) analyses were performed

- d. The individual(s) who performed the analyses;
 - e. The analytical techniques or methods used; and
 - f. The results of such analyses.
4. Monitoring must be conducted according to test procedures approved under 40 CFR Part 136, unless other test procedures have been specified in the permit.

K. SIGNATORY REQUIREMENTS

1. Authorization to Sign:

All documents required to be submitted to the division by the permit must be signed in accordance with the following criteria:

- a. For a corporation: by a responsible corporate officer. For the purpose of this subsection, a responsible corporate officer means:
 - i. A president, secretary, treasurer, or vice president of the corporation in charge of a principal business function, or any other person who performs similar policy- or decision-making functions for the corporation, or
 - ii. The manager of one or more manufacturing, production, or operating facilities, provided, the manager is authorized to make management decisions which govern the operation of the regulated facility including having the explicit or implicit duty of making major capital investment recommendations, and initiating and directing other comprehensive measures to assure long term environmental compliance with environmental laws and regulations; the manager can ensure that the necessary systems are established or actions taken to gather complete and accurate information for permit application requirements; and where authority to sign documents has been assigned or delegated to the manager in accordance with corporate procedures.
- b. For a partnership or sole proprietorship: by a general partner or the proprietor, respectively; or
- c. For a [municipality](#), state, federal, or other public agency: By either a principal executive officer or ranking elected official. For purposes of this subsection, a principal executive officer of a federal agency includes
 - i. The chief executive officer of the agency, or
 - ii. A senior executive officer having responsibility for the overall operations of a principal geographic unit of the agency. (e.g. Regional Administrator of EPA)

2. Electronic Signatures

For persons signing applications for coverage under this permit electronically, in addition to meeting other applicable requirements stated above, such signatures must meet the same signature, authentication, and identity-proofing standards set forth at 40 CFR § 3.2000(b) for electronic reports (including robust second-factor authentication). Compliance with this requirement can be achieved by submitting the application using the Colorado Environmental Online Service (CEOS) system.

3. Change in Authorization to Sign

If an authorization is no longer accurate because a different individual or position has responsibility for the overall operation of the facility, a new authorization must be submitted to the division, prior to the re-authorization, or together with any reports, information, or applications to be signed by an authorized representative.

L. REPORTING REQUIREMENTS

1. Planned Changes

The permittee shall give advance notice to the division, in writing, of any planned physical alterations or additions to the permitted facility in accordance with 40 CFR 122.41(l) and Regulation 61.8(5)(a). Notice is required only when:

- a. The alteration or addition to a permitted facility may meet one of the criteria for determining whether a facility is a new source in 40 CFR 122.29(b); or
- b. The alteration or addition could significantly change the nature or increase the quantity of pollutants discharged. This notification applies to pollutants which are subject neither to effluent limitations in the permit, nor to notification requirements under 40 CFR 122.41(a)(1).

2. Anticipated Non-Compliance

The permittee shall give advance notice to the division, in writing, of any planned changes in the permitted facility or activity that may result in noncompliance with permit requirements. The timing of notification requirements differs based on the type of non-compliance as described in subparagraphs 5, 6, 7, and 8 below.

3. Transfer of Ownership or Control

The permittee shall notify the division, in writing, ten (10) calendar days in advance of a proposed transfer of the permit. This permit is not transferable to any person except after notice is given to the division.

- a. Where a facility wants to change the name of the permittee, the original permittee (the first owner or operators) must submit a Notice of Termination.
- b. The new owner or operator must submit an application. See also signature requirements in Part II.K, above.
- c. A permit may be automatically transferred to a new permittee if:
 - i. The current permittee notifies the division in writing 30 calendar days in advance of the proposed transfer date; and
 - ii. The notice includes a written agreement between the existing and new permittee(s) containing a specific date for transfer of permit responsibility, coverage and liability between them; and
 - iii. The division does not notify the existing permittee and the proposed new permittee of its intent to modify, or revoke and reissue the permit.
 - iv. Fee requirements of the Colorado Discharge Permit System Regulations, Section 61.15, have been met.

4. Monitoring reports

Monitoring results must be reported at the intervals specified in this permit per the requirements of 40 CFR 122.41(l)(4).

5. Compliance Schedules

Reports of compliance or noncompliance with, or any progress reports on, interim and final requirements contained in any compliance schedule in the permit, shall be submitted on the date listed

in the compliance schedule section. The fourteen (14) calendar day provision in Regulation 61.8(4)(n)(i) has been incorporated into the due date.

6. Twenty-four Hour Reporting

In addition to the reports required elsewhere in this permit, the permittee shall report the following circumstances orally within twenty-four (24) hours from the time the permittee becomes aware of the circumstances, and shall mail to the division a written report containing the information requested within five (5) working days after becoming aware of the following circumstances:

- a. Circumstances leading to any noncompliance which may endanger health or the environment regardless of the cause of the incident;
- b. Circumstances leading to any unanticipated bypass which exceeds any effluent limitations in the permit;
- c. Circumstances leading to any upset which causes an exceedance of any effluent limitation in the permit;
- d. Daily maximum violations for any of the pollutants limited by Part I of this permit. This includes any toxic pollutant or hazardous substance or any pollutant specifically identified as the method to control any toxic pollutant or hazardous substance.
- e. The division may waive the written report required under subparagraph 6 of this section if the oral report has been received within 24 hours.

7. Other Non-Compliance

A permittee must report all instances of noncompliance at the time monitoring reports are due. If no monitoring reports are required, these reports are due at least annually in accordance with Regulation 61.8(4)(p). The annual report must contain all instances of non-compliance required under either subparagraph 5 or subparagraph 6 of this subsection.

8. Other Information

Where a permittee becomes aware that it failed to submit any relevant facts in a permit application, or submitted incorrect information in a permit application, or in any report to the Permitting Authority, it has a duty to promptly submit such facts or information.

M. BYPASS

1. Bypass Not Exceeding Limitations

The permittees may allow any bypass to occur which does not cause effluent limitations to be exceeded, but only if it also is for essential maintenance to assure efficient operation. These bypasses are not subject to the provisions of Part II.M.2 of this permit. See 40 CFR 122.41(m)(2).

2. Notice of Bypass

- a. Anticipated bypass. If the permittee knows in advance of the need for a bypass, the permittee must submit prior notice, if possible at least ten days before the date of the bypass. See 40 CFR §122.41(m)(3)(i) and/or Regulation 61.9(5)(c).
- b. Unanticipated bypass. The permittee must submit notice of an unanticipated bypass in accordance with Part II.L.6. See 40 CFR §122.41(m)(3)(ii).

3. Prohibition of Bypass

Bypasses are prohibited and the division may take enforcement action against the permittee for bypass, unless:

- a. The bypass is unavoidable to prevent loss of life, personal injury, or severe property damage;
- b. There were no feasible alternatives to the bypass, such as the use of auxiliary treatment facilities, retention of untreated wastes, or maintenance during normal periods of equipment downtime. This condition is not satisfied if adequate backup equipment should have been installed in the exercise of reasonable engineering judgment to prevent a bypass which occurred during normal periods of equipment downtime or preventive maintenance; and
- c. Proper notices were submitted to the division.

N. UPSET

1. Effect of an upset

An upset constitutes an affirmative defense to an action brought for noncompliance with permit effluent limitations if the requirements of Part II.N.2. of this permit are met. No determination made during administrative review of claims that noncompliance was caused by upset, and before an action for noncompliance, is final administrative action subject to judicial review in accordance with Regulation 61.8(3)(j).

2. Conditions Necessary for Demonstration of an Upset

A permittee who wishes to establish the affirmative defense of upset shall demonstrate through properly signed contemporaneous operating logs, or other relevant evidence that:

- a. An upset occurred and the permittee can identify the specific cause(s) of the upset;
- b. The permitted facility was at the time being properly operated and maintained; and
- c. The permittee submitted proper notice of the upset as required in Part II.L.6. (24- hour notice); and
- d. The permittee complied with any remedial measure necessary to minimize or prevent any discharge or sludge use or disposal in violation of this permit which has a reasonable likelihood of adversely affecting human health or the environment. In addition to the demonstration required above, a permittee who wishes to establish the affirmative defense of upset for a violation of effluent limitations based upon water quality standards shall also demonstrate through monitoring, modeling or other methods that the relevant standards were achieved in the receiving water.

3. Burden of Proof

In any enforcement proceeding, the permittee seeking to establish the occurrence of an upset has the burden of proof.

O. RETENTION OF RECORDS

1. Post-Expiration or Termination Retention

Copies of documentation required by this permit, including records of all data used to complete the application for permit coverage to be covered by this permit, must be retained for at least three years from the date that permit coverage expires or is terminated. This period may be extended by request of EPA at any time.

2. On-site Retention

The permittee must retain an electronic version or hardcopy of the SWMP at the construction site from

the date of the initiation of construction activities to the date of expiration or inactivation of permit coverage; unless another location, specified by the permittee, is approved by the division.

P. REOPENER CLAUSE

1. Procedures for Modification or Revocation

Permit modification or revocation of this permit or coverage under this permit will be conducted according to Regulation 61.8(8).

2. Water Quality Protection

If there is evidence indicating that the stormwater discharges authorized by this permit cause, have the reasonable potential to cause or contribute to an excursion above any applicable water quality standard, the permittee may be required to obtain an individual permit, or the permit may be modified to include different limitations and/or requirements.

Q. SEVERABILITY

The provisions of this permit are severable. If any provisions or the application of any provision of this permit to any circumstances, is held invalid, the application of such provision to other circumstances and the application of the remainder of this permit shall not be affected.

R. NOTIFICATION REQUIREMENTS

1. Notification to Parties

All notification requirements, excluding information submitted using the CEOS portal, shall be directed as follows:

- a. Oral Notifications, during normal business hours shall be to:
Clean Water Compliance Section
Water Quality Control Division
Telephone: (303) 692-3500
- b. Written notification shall be to:
Clean Water Compliance Section
Water Quality Control Division
Colorado Department of Public Health and Environment
WQCD-WQP-B2
4300 Cherry Creek Drive South
Denver, CO 80246-1530

S. RESPONSIBILITIES

1. Reduction, Loss, or Failure of Treatment Facility

The permittee has the duty to halt or reduce any activity if necessary to maintain compliance with the effluent limitations of the permit. It shall not be a defense for a permittee in an enforcement action that it would be necessary to halt or reduce the permitted activity in order to maintain compliance with the conditions of this permit.

T. OIL AND HAZARDOUS SUBSTANCE LIABILITY

Nothing in this permit shall be construed to preclude the institution of any legal action or relieve the permittee from any responsibilities, liabilities, or penalties to which the permittee is or may be subject to under Section 311 (Oil and Hazardous Substance Liability) of the CWA.

U. EMERGENCY POWERS

Nothing in this permit shall be construed to prevent or limit application of any emergency power of the division.

V. CONFIDENTIALITY

Any information relating to any secret process, method of manufacture or production, or sales or marketing data which has been declared confidential by the permittee, and which may be acquired, ascertained, or discovered, whether in any sampling investigation, emergency investigation, or otherwise, shall not be publicly disclosed by any member, officer, or employee of the Water Quality Control Commission or the division, but shall be kept confidential. Any person seeking to invoke the protection of this section shall bear the burden of proving its applicability. This section shall never be interpreted as preventing full disclosure of effluent data.

W. FEES

The permittee is required to submit payment of an annual fee as set forth in the 2016 amendments to the Water Quality Control Act. Section 25-8-502 (1.1) (b), and the Colorado Discharge Permit System Regulations 5 CCR 1002-61, Section 61.15 as amended. Failure to submit the required fee when due and payable is a violation of the permit and will result in enforcement action pursuant to Section 25-8-601 et. seq., C.R.S.1973 as amended.

X. DURATION OF PERMIT

The duration of a permit shall be for a fixed term and shall not exceed five (5) years. If the permittee desires to continue to discharge, a permit renewal application shall be submitted at least ninety (90) calendar days before this permit expires. Filing of a timely and complete application shall cause the expired permit to continue in force to the effective date of the new permit. The permit's duration may be extended only through administrative extensions and not through interim modifications. If the permittee anticipates there will be no discharge after the expiration date of this permit, the division should be promptly notified so that it can terminate the permit in accordance with Part I.A.3.i.

Y. SECTION 307 TOXICS

If a toxic effluent standard or prohibition, including any applicable schedule of compliance specified, is established by regulation pursuant to Section 307 of the Federal Act for a toxic pollutant which is present in the permittee's discharge and such standard or prohibition is more stringent than any limitation upon such pollutant in the discharge permit, the division shall institute proceedings to modify or revoke and reissue the permit to conform to the toxic effluent standard or prohibition

***Appendix D – NOI and Acknowledgement Letter from EPA/State
(Insert copy of permits here once obtained)***

Appendix E – Inspection Report

Stormwater Inspection Report Template

Facility Name		Permittee					
Date of Inspection		Weather Conditions					
Permit Certification #		Disturbed Acreage					
Phase of Construction		Inspector Title					
Inspector Name							
Is the above inspector a qualified stormwater manager? (permittee is responsible for ensuring that the inspector is a qualified stormwater manager)			<table border="1"> <tr> <td>YES</td> <td>NO</td> </tr> <tr> <td><input type="checkbox"/></td> <td><input type="checkbox"/></td> </tr> </table>	YES	NO	<input type="checkbox"/>	<input type="checkbox"/>
YES	NO						
<input type="checkbox"/>	<input type="checkbox"/>						

INSPECTION FREQUENCY					
Check the box that describes the minimum inspection frequency utilized when conducting each inspection					
At least one inspection every 7 calendar days	<input type="checkbox"/>				
At least one inspection every 14 calendar days, with post-storm event inspections conducted within 24 hours after the end of any precipitation or snowmelt event that causes surface erosions	<input type="checkbox"/>				
<ul style="list-style-type: none"> This is this a post-storm event inspection. Event Date: _____ 	<input type="checkbox"/>				
Reduced inspection frequency - Include site conditions that warrant reduced inspection frequency	<input type="checkbox"/>				
<ul style="list-style-type: none"> Post-storm inspections at temporarily idle sites 	<input type="checkbox"/>				
<ul style="list-style-type: none"> Inspections at completed sites/area 	<input type="checkbox"/>				
<ul style="list-style-type: none"> Winter conditions exclusion 	<input type="checkbox"/>				
Have there been any deviations from the minimum inspection schedule? If yes, describe below.	<table border="1"> <tr> <td>YES</td> <td>NO</td> </tr> <tr> <td><input type="checkbox"/></td> <td><input type="checkbox"/></td> </tr> </table>	YES	NO	<input type="checkbox"/>	<input type="checkbox"/>
YES	NO				
<input type="checkbox"/>	<input type="checkbox"/>				

INSPECTION REQUIREMENTS*
i. Visually verify all implemented control measures are in effective operational condition and are working as designed in the specifications
ii. Determine if there are new potential sources of pollutants
iii. Assess the adequacy of control measures at the site to identify areas requiring new or modified control measures to minimize pollutant discharges
iv. Identify all areas of non-compliance with the permit requirements, and if necessary, implement corrective action
*Use the attached Control Measures Requiring Routine Maintenance and Inadequate Control Measures Requiring Corrective Action forms to document results of this assessment that trigger either maintenance or corrective actions

AREAS TO BE INSPECTED			
Is there evidence of, or the potential for, pollutants leaving the construction site boundaries, entering the stormwater drainage system or discharging to state waters at the following locations?			
	NO	YES	If "YES" describe discharge or potential for discharge below. Document related maintenance, inadequate control measures and corrective actions Inadequate Control Measures Requiring Corrective Action form
Construction site perimeter	<input type="checkbox"/>	<input type="checkbox"/>	
All disturbed areas	<input type="checkbox"/>	<input type="checkbox"/>	
Designated haul routes	<input type="checkbox"/>	<input type="checkbox"/>	
Material and waste storage areas exposed to precipitation	<input type="checkbox"/>	<input type="checkbox"/>	
Locations where stormwater has the potential to discharge offsite	<input type="checkbox"/>	<input type="checkbox"/>	
Locations where vehicles exit the site	<input type="checkbox"/>	<input type="checkbox"/>	
Locations of installed control measures	<input type="checkbox"/>	<input type="checkbox"/>	

REPORTING REQUIREMENTS

The permittee shall report the following circumstances orally within twenty-four (24) hours from the time the permittee becomes aware of the circumstances, and shall mail to the division a written report containing the information requested within five (5) working days after becoming aware of the following circumstances. The division may waive the written report required if the oral report has been received within 24 hours.

<p>All Noncompliance Requiring 24-Hour Notification per Part II.L.6 of the Permit</p> <p>a. Endangerment to Health or the Environment Circumstances leading to any noncompliance which may endanger health or the environment regardless of the cause of the incident (See Part II.L.6.a of the Permit) <i>This category would primarily result from the discharge of pollutants in violation of the permit</i></p> <p>b. Numeric Effluent Limit Violations <input type="checkbox"/> Circumstances leading to any unanticipated bypass which exceeds any effluent limitations (See Part II.L.6.b of the Permit) <input type="checkbox"/> Circumstances leading to any upset which causes an exceedance of any effluent limitation (See Part II.L.6.c of the Permit) <input type="checkbox"/> Daily maximum violations (See Part II.L.6.d of the Permit) <i>Numeric effluent limits are very uncommon in certifications under the COR400000 general permit. This category of noncompliance only applies if numeric effluent limits are included in a permit certification.</i></p>
--

Has there been an incident of noncompliance requiring 24-hour notification?	NO	YES	
	<input type="checkbox"/>	<input type="checkbox"/>	If "YES" document below

Date and Time of Incident	Location	Description of Noncompliance	Description of Corrective Action	Date and Time of 24 Hour Oral Notification	Date of 5 Day Written Notification *

*Attach copy of 5 day written notification to report. Indicate if written notification was waived, including the name of the division personnel who granted waiver.

"I verify that, to the best of my knowledge and belief, all corrective action identified during the inspection are complete, and the site is currently in compliance with the permit."

Name of Qualified Stormwater Manager

Title of Qualified Stormwater Manager

Signature of Qualified Stormwater Manager

Date

Notes/Comments

Appendix H –Subcontractor Certifications/Agreements

SUBCONTRACTOR CERTIFICATION STORMWATER POLLUTION PREVENTION PLAN

Project Number: _____

Project Title: _____

Operator(s): _____

As a subcontractor, you are required to comply with the Stormwater Pollution Prevention Plan (SWPPP) for any work that you perform on-site. Any person or group who violates any condition of the SWPPP may be subject to substantial penalties or loss of contract. You are encouraged to advise each of your employees working on this project of the requirements of the SWPPP. A copy of the SWPPP is available for your review at the office trailer.

Each subcontractor engaged in activities at the construction site that could impact stormwater must be identified and sign the following certification statement:

I certify under the penalty of law that I have read and understand the terms and conditions of the SWPPP for the above designated project and agree to follow the BMPs and practices described in the SWPPP.

This certification is hereby signed in reference to the above named project:

Company: _____

Address: _____

Telephone Number: _____

Type of construction service to be provided: _____

Signature: _____

Title: _____

Date: _____

Appendix J –SWPPP Training Log

Stormwater Pollution Prevention Training Log

Project Name:

Project Location:

Instructor's Name(s):

Instructor's Title(s):

Course Location: _____ Date: _____

Course Length (hours): _____

Stormwater Training Topic: *(check as appropriate)*

- Erosion Control BMPs Emergency Procedures
- Sediment Control BMPs Good Housekeeping BMPs
- Non-Stormwater BMPs

Specific Training Objective: _____

Attendee Roster: *(attach additional pages as necessary)*

No.	Name of Attendee	Company
1		
2		
3		
4		
5		
6		
7		
8		
9		
10		

Appendix K – Delegation of Authority Form

Delegation of Authority

I, _____ (name), hereby designate the person or specifically described position below to be a duly authorized representative for the purpose of overseeing compliance with environmental requirements, including the Construction General Permit, at the _____ construction site. The designee is authorized to sign any reports, stormwater pollution prevention plans and all other documents required by the permit.

_____ (name of person or position)
_____ (company)
_____ (address)
_____ (Village, state, zip)
_____ (phone)

By signing this authorization, I confirm that I meet the requirements to make such a designation as set forth in _____ (Reference State Permit), and that the designee above meets the definition of a “duly authorized representative” as set forth in _____ (Reference State Permit).

I certify under penalty of law that this document and all attachments were prepared under my direction or supervision in accordance with a system designed to assure that qualified personnel properly gathered and evaluated the information submitted. Based on my inquiry of the person or persons who manage the system, or those persons directly responsible for gathering the information, the information submitted is, to the best of my knowledge and belief, true, accurate, and complete. I am aware that there are significant penalties for submitting false information, including the possibility of fine and imprisonment for knowing violations.

Name: _____

Company: _____

Title: _____

Signature: _____

Date: _____