

MEMORANDUM

To: El Paso County - Stormwater

From: Scott Maier, PE (Ayres Associates)

Date: September 11, 2023

EPC Project No.: PPR2315

Re: Super Star Carwash – Claremont Business Park 2 – Drainage Compliance Letter

Background

Super Star Carwash is planning to construct a carwash located within the Claremont Business Park 2 located at the southwest corner of Marksheffel Road and Meadowbrook Parkway. The site is currently vacant and is 1.5+/- acres.

The proposed development will consist of a 5,000+/- square foot carwash building with access drives, parking areas with vacuum bays, patio areas, and landscaping. This lot was initially contemplated for development as part of the overall development of the Claremont Business Park 2, Filing No. 2 VR 233. The onsite runoff will be collected via onsite private storm sewers and curb and gutter. The runoff is conveyed to an onsite rain garden to provide water quality treatment. Peak runoff detention is not required for this project. The overall development will construct the storm sewer conveyance system to convey runoff from this site to the downstream outfall into the east fork of Sand Creek located southwest of this site and across Meadowbrook Parkway. The purpose of this letter is to demonstrate that the proposed development of the Super Star Carwash is in compliance with the assumptions of Claremont Business Park 2 Filing No. 2. The proposed development will discharge to an 18" RCP storm sewer system along El Jefe Heights that will be constructed as part of the overall development.

Onsite Basins

Basins A1 and A2 are primarily the parking lot for the carwash. The flows from these basins will be collected via curb and gutter to storm sewer inlets and curb cuts that run to the water quality basin. These basins are primarily impervious except for the minor landscape areas.

Basin B1 is the carwash building. The flows from this basin will run (via roof drains to storm sewer) to the water quality basin. This basin is 100% impervious.

Basins A3, A4, A5, and A6 are landscape areas. These landscape areas are collected in area drains that convey the water to the water quality pond. These basins are pervious landscape areas.

Basin OFF is primarily the El Jefe Heights road. This basin is accounted for, and is part of, Basin E1 of the Claremont Business Park 2, Filing No. 2 drainage report.

Runoff Comparison

The proposed development for the Super Star Carwash is part of Basin B within the Claremont Business Park 2 Filing No. 2 prepared by MS Civil Consultants, dated 6/11/23 as shown in the supporting documents. Below is a summary of the anticipated runoff from the overall drainage report.

Comparison Studies	Basin Area (acres)	Time of Concentration (min.)	Design Runoff Coefficient 5-yr	Design Runoff Coefficient 100-yr	Runoff (5 year) (CFS)	Runoff (100 year) (CFS)
Claremont Business Park 2 Filing No. 2 Basins A+B***	1.71	5.0	0.81	0.88	5.9	11.2
Super Star Carwash	1.8	5.0	C=0.44	C=0.67	2.95	10.09

***Runoff noted is for design point 1 within the Claremont Business Park 2 Filing No. 2 drainage study (Not including Basin E1). Basin OFF of the superstar carwash plan is included in the calculations above; however, the runoff from basin off runs into Basin E1 of the Claremont Business Park 2 Filing No. 2. The

The proposed development for the Super Star Carwash will have less designed runoff than those contemplated in the Claremont Business Park 2 Filing No. 2 drainage studies even after adding in the offsite areas along Marksheffel Rd and Meadowbrook Parkway.

Water Quality

Water Quality was not included as part of the improvements for the Claremont Business Park 2 Filing No. 2 overall development and is required to be constructed upon development. The Super Star Carwash proposes to construct a rain garden to serve the water quality requirements for it's development. A rain garden is an acceptable method of providing water quality treatment.

	WQCV Required	WQCV Provided	Method
Super Star Carwash Parking Lot and Building	0.023 Ac-Ft	0.023	Rain Garden

The rain garden is designed to have an underdrain system and an outfall to the west. As part of the proposed improvements, the site will drain a rain garden in the southern portion of the site. After treatment the rain garden will enter the overall development storm sewer system to the west and ultimately discharge into the east fork of Sand Creek.

Super Star Carwash will follow the “Four-Step Process” as defined below:

Step 1: Employ Runoff Reduction Practices

The proposed development utilizes reduced pavement areas with the implementation of landscaped islands in the parking lot and around the building.

Step 2: Stabilize Drainage Ways

Proposed drainage ways have been stabilized through the implementation of a concrete drainage pan for water entering the rain garden. A grass drainage swale is located along the east side of the property to capture offsite runoff that enters the property.

Step 3: Provide Water Quality Capture Volume (WQCV)

WQCV is achieved through a rain garden that treats onsite runoff. The rain garden is located at the southern portion of the property and treats building and parking lot runoff as well as offsite runoff that enters the site from the east.

Step 4: Consider Need for Industrial and Commercial BMP's

The proposed site will implement silt fence, construction entrance, concrete washout area and inlet protection to limit erosion and sediment runoff across the site.

Low Impact Development

This development will propose to construct a rain garden as part of the development. The rain garden will provide water quality benefits by providing filtration and some infiltration. The engineered media within the rain garden will provide filtration of the runoff from the site. In addition to the filtration for smaller rain events infiltration will also be a benefit of the rain garden.

Conclusion

The proposed Super Star Carwash development complies with the Claremont Business Park 2 overall drainage study. The Super Star Carwash development will install the proposed rain garden to meet the water quality requirements of the onsite development.

In summary, the Super Star Carwash is in general compliance with the original development assumptions and no additional improvements to the storm sewer system beyond those noted is necessary.

Design Engineer's Statement:

The attached drainage plan and report were prepared under my direction and supervision and are correct to the best of my knowledge and belief. Said drainage report has been prepared according to the criteria established by the County for drainage reports and said report is in conformity with the applicable master plan of the drainage basin. I accept responsibility for any liability caused by any negligent acts, errors or omissions on my part in preparing this report.

[Scott Maier, P.E. #



9/11/23

Date

Owner/Developer Statement:

I, the Owner/Developer had read and will comply with all of the requirements specific in the is drainage report and Plan

Luke Eid - Senior Project Manager
[Name, Title]

9/15/23

Date

SSCW 22712 Meadowbrook LLC
Business Name

960 W Behrend Dr, Suite 2, Phoenix, AZ 85027
Address

El Paso County:

Filed in accordance with the requirements of the Drainage Criteria Manual, Volume 1 and 2, El Paso County Engineering Criteria Manual and Land Development Code as amended.

County Engineer/ECM Administrator

Date

Conditions:

Bromley Park Filing 5 – Supporting Documents

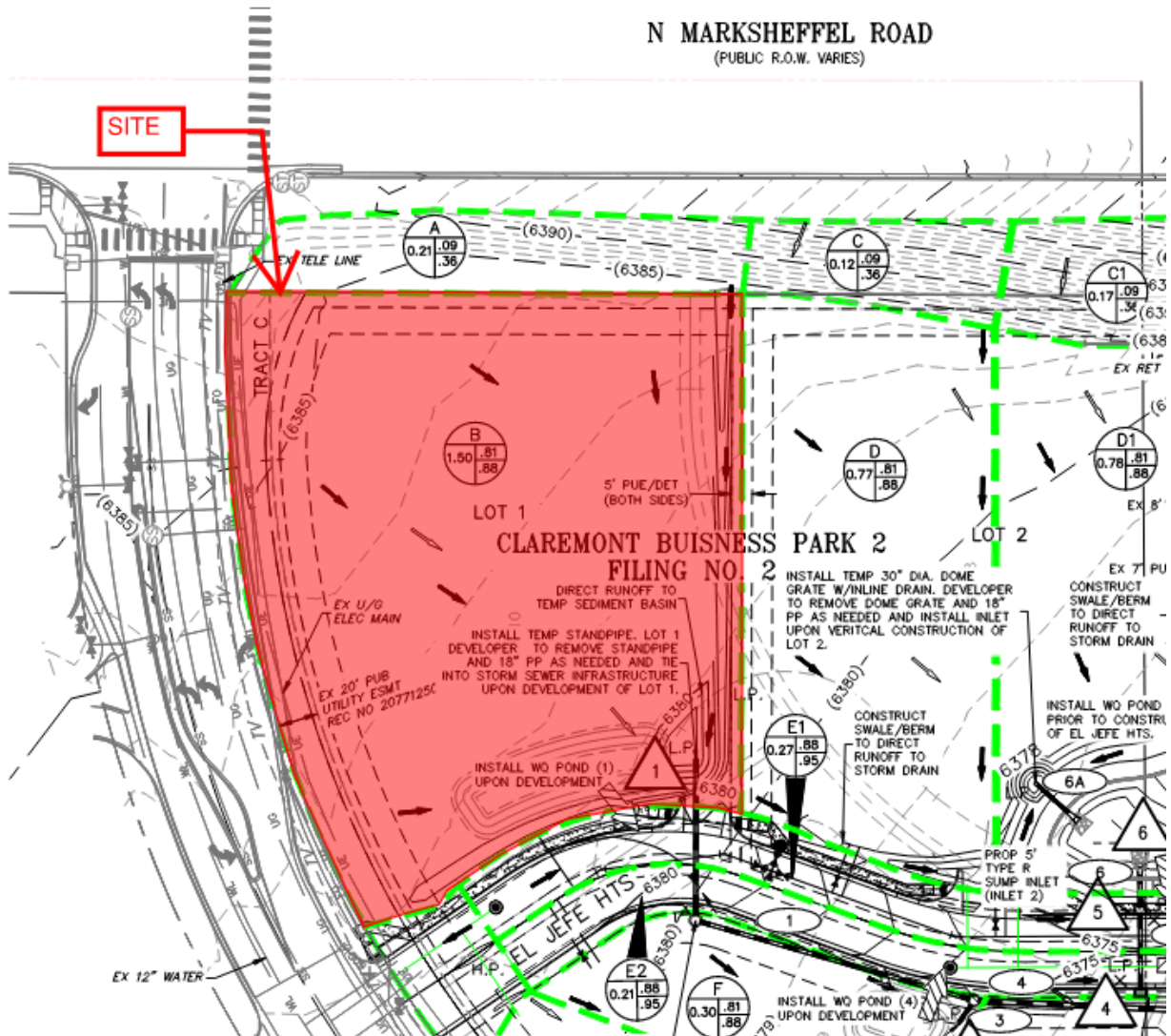

(EXHIBIT ABOVE IS PORTION OF Claremont Business Park 2 Filing No. 2 DRAINAGE PLAN)

FINAL DRAINAGE REPORT FOR CLAREMONT BUSINESS PARK 2 FILING NO.1 COUNTY OF EL PASO, STATE OF COLORADO PROPOSED CONDITIONS DRAINAGE MAP

MAY 2023

LEGEND

- BASIN DESIGNATION
- PIPE RUN REFERENCE LABEL
- SURFACE DESIGN POINT
- BASIN BOUNDARY
- EXISTING CONTOUR
- PROP CONTOUR
- UGE - UNDERGROUND ELECTRICAL
- EXISTING GAS LINE
- STORM SEWER PIPE
- EXISTING STORM SEWER PIPE
- CROSSSPAN
- INLET
- EXISTING FLOW DIRECTION ARROW
- EMERGENCY OVERFLOW DIRECTION
- FLOW DIRECTION
- FLARED END SECTION
- HIGH POINT
- LOW POINT

BASIN SUMMARY			
BASIN	AREA (ACRES)	Q ₅	Q ₁₀₀
A	0.21	0.1	0.7
B	1.50	6.0	10.9
C	0.12	0.1	0.4
C1	0.17	0.1	0.5
D	0.77	3.2	5.9
D1	0.78	3.3	6.0
E1	0.27	1.2	2.2
E2	0.21	1.0	1.7
F	0.30	1.2	2.3
G1	0.27	0.4	1.2
G2	1.15	4.3	7.8
H1	0.16	0.1	0.5
H2	0.40	0.2	1.1
H3	0.04	0.0	0.1
H4	0.10	0.0	0.3
I1	0.55	2.3	4.3
I2	0.48	2.0	3.6
I3	0.45	1.8	3.3
I4	0.55	2.3	4.2
I5	0.23	0.9	1.7
I6	0.19	0.6	1.2
I7	0.23	0.9	1.6
J1	0.69	2.7	5.1
J2	0.25	1.0	1.8
J3	0.01	0.0	0.1
K1	0.17	0.7	1.3
K2	0.05	0.2	0.4
K3	0.15	0.6	1.1
K4	0.05	0.2	0.4
L	1.32	5.3	9.7
M1	0.28	1.2	2.2
M2	0.24	0.8	1.5
M3	0.37	1.6	2.9
M4	0.98	3.5	6.6
N1	0.06	0.3	0.5
N2	0.41	0.2	1.1
O1	0.12	0.1	0.4
O2	0.06	0.1	0.3
P	0.11	0.0	0.3

DESIGN POINT SUMMARY				
DESIGN POINT	Q ₅	Q ₁₀₀	BASIN	STRUCTURE
1	5.9	11.2	A, B	18" PP
2				OMITTED
3	1.2	2.3	F	18" PP
4	1.0	1.7	E2	PROP 5" INLET
5	1.2	2.2	E1	PROP 5" INLET
6	7.8	14.6	C, D, C1, D1, PR6	WO POND 3
7	4.7	8.7	G2	EX STREET
8	2.2	4.3	H1, I1	EX STREET
9	1.8	4.1	H2, I2	EX STREET
10	0.8	1.6	H3, I7	EX STREET
11	8.4	16.7	DP3-5, I3-16	EX 15" INLETS
12	2.8	8.1	FB INLETS, J1	EX 15" INLET
13	1.0	5.0	FB INLETS, J2, J3	EX 15" INLET
14	3.8	9.7	H4, L, M4	EX SWALE
15	5.3	12.3	DP9, M2, M3	EX SWALE/RD
16	1.4	2.5	M1, K4	EX CONC. RD
17	1.1	2.0	K2, K3, N1	EX CONC. RD
18	0.7	1.3	K1	EX AREA INLET
19	19.3	43.7	DP15-17, N2, PR14, PR17	EX FSD POND 2

STORM SEWER SUMMARY				
PIPE RUN	Q ₅	Q ₁₀₀	PIPE SIZE	CONTRIBUTING DP/BASIN/PIPES
1	2.4	5.7	18"	FUT POND 1 OUTFALL
2			NOT USED	
3	0.4	1.0	18"	FUT POND 4 OUTFALL
4	3.9	6.7	24"	PR1-PR3
5	1.0	1.7	18"	DP4
6	2.2	3.9	18"	PR5, DP5
6A	6.0	11.6	18"	C, C1, 90% D, D1
7	3.3	4.0	18"	POND 3 OUTFALL
8	6.1	10.7	24"	PR4, PR7
9	1.3	3.0	18"	FUT POND 5 OUTFALL
10	7.4	13.8	24"	PR8, PR9
11	7.4	13.8	24"/EX24"	PR10
12	7.4	13.8	EX 24"	PR11
13	4.2	8.0	EX 15"	INLET 3
14	8.4	16.0	EX 24"	PR13, INLET 4
15	2.8	7.8	EX 18"	INLET 5
16	3.7	12.6	EX 24"	PR15, INLET 6
17	4.4	13.8	EX 24"	PR16, DP18
18	13.7	23.8	EX 30"	EX POND 2 OUTFALL
19	21.1	37.6	EX 42"	DP18, PR12

SF WQCV FUTURE PONDS SUMMARY	
EPC/URBAN DRAINAGE SAND FILTER BASIN-SEE STD. DET.	
POND 1 AREA REQUIRED	773 SF
POND 4 AREA PROVIDED	288 SF
POND 5 AREA PROVIDED	565 SF

SF WQCV POND 3 SUMMARY	
EPC/URBAN DRAINAGE SAND FILTER BASIN-SEE STD. DET.	
AREA REQUIRED	1,014 SF
AREA PROVIDED	1,045 SF

SF ELEV = 6370.35

POND 3 SAND FILTER DETENTION BASIN DATA	
WO WATER SURFACE EL = 6371.78	
WO VOLUME=0.051 AC-FT	
100-YR WATER SURFACE EL=6373.36	
100-YR VOLUME=0.153 AC-FT	
SPILLWAY CREST EL=6375.30	
TOP OF EMBANKMENT EL=6376.55	
RATIONAL 100-YR INFLOW=14.8 CFS	
MHFD 100-YR INFLOW = 9.0 CFS	
MHFD 100-YR RELEASE = 4.0 CFS	

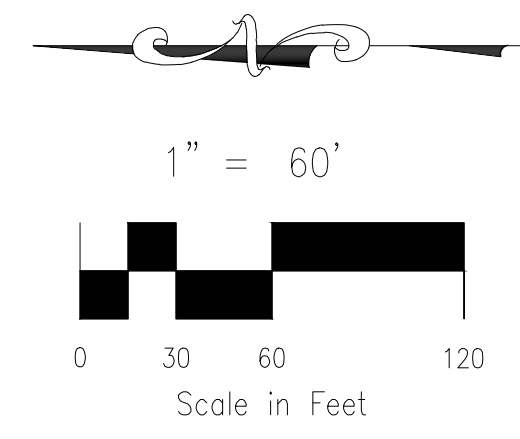

102 E. PIKES PEAK AVE., 5TH FLOOR
COLORADO SPRINGS, CO 80903
PHONE: 719.955.5485

CLAREMONT BUSINESS PARK 2 FIL. NO.2
PROP. CONDITIONS DRAINAGE MAP

PROJECT NO. 10-022A FILE: \dwg\Eng Exhibits\10020 PDM.dwg

DESIGNED BY: DLM	SCALE:	DATE: 05-17-2023
DRAWN BY: DLM	HORIZ: 1"=60'	
CHECKED BY: VAS	VERT: N/A	

SHEET 1 OF 1 PDM01

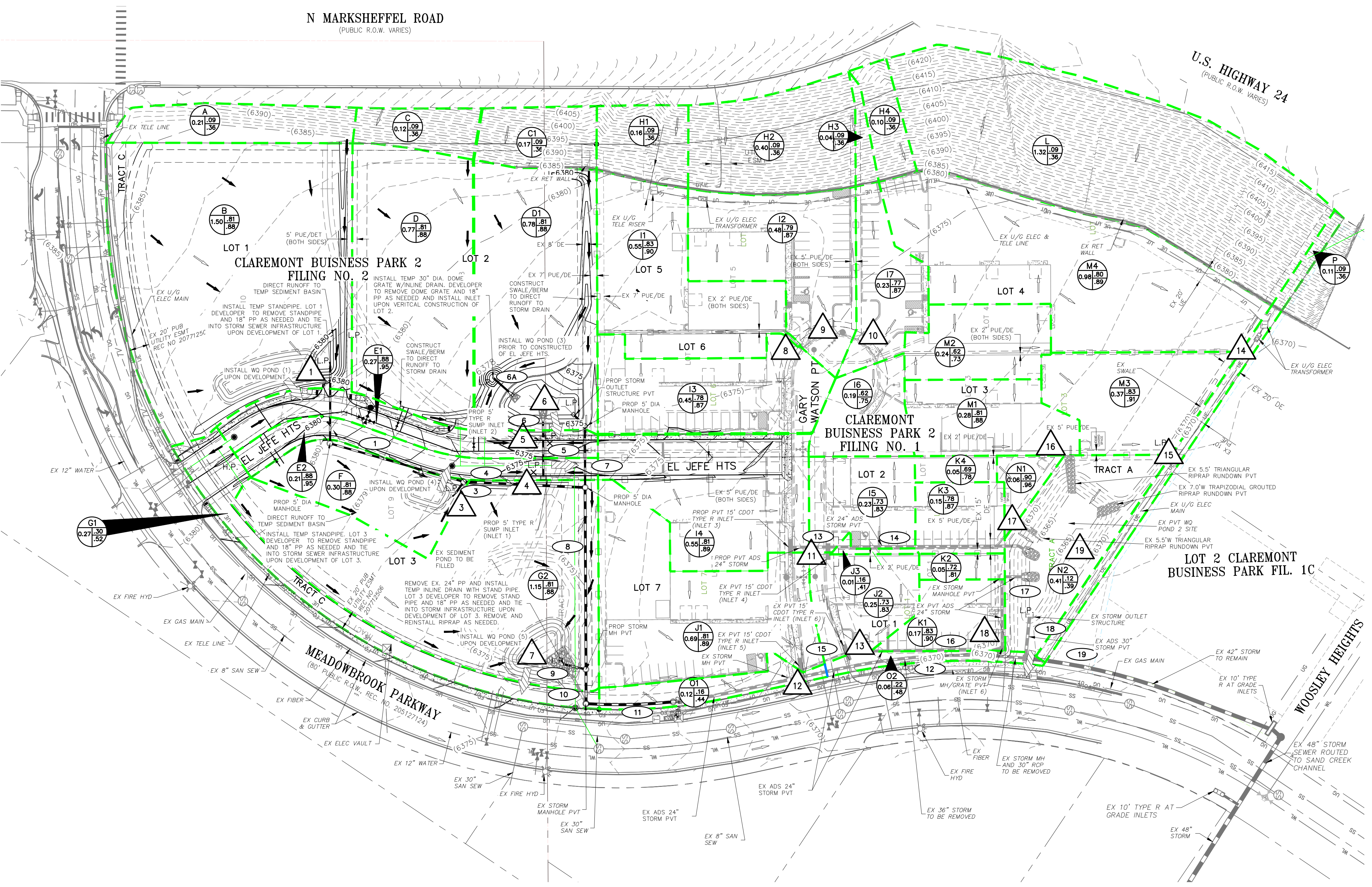

File: C:\10020-2-CB-Drainage\Map\10020-PDM.dwg Plotstamp: 5/24/2023 10:39 AM

FOR LOCATING & MARKING GAS, ELECTRIC, WATER & TELEPHONE LINES
FOR BURIED UTILITY INFORMATION 48 HRS BEFORE YOU DIG CALL 1-800-922-1987

FINAL DRAINAGE REPORT FOR CLAREMONT BUSINESS PARK 2 FILING NO.2
PROPOSED DRAINAGE CALCULATIONS
(Area Runoff Coefficient Summary)

BASIN	TOTAL AREA (SF)	TOTAL AREA (Acres)	ROOFS 0.73-0.81 0.81-0.88 ASPHALT DRIVES 0.90-0.96				LANDSCAPED AREAS 0.16-0.41 GRAVEL STORAGE YARD 0.30-0.50 LIGHT INDUST AREAS 0.39-0.70				PARKS 0.12-0.39 GREENBELTS/AGRI. 0.09-0.36				WEIGHTED			
			AREA (Acres)	C ₁	C ₃	C ₁₀₀	AREA (Acres)	C ₃	C ₅	C ₁₀₀	AREA (Acres)	C ₂	C ₅	C ₁₀₀	C ₂	C ₅	C ₁₀₀	
A	9300.8	0.21	0.10	0.89	0.00	0.00	0.07	0.41	0.21	0.03	0.09	0.36	0.03	0.09	0.36			
B	65284.4	1.50	1.30	0.79	0.81	0.33	0.34	0.30	0.10	0.05	0.12	0.39	0.09	0.36	0.36			
C	5372.3	0.12	0.00	0.89	0.90	0.00	0.07	0.41	0.12	0.03	0.09	0.36	0.03	0.09	0.36			
CT	7457.3	0.17	0.00	0.89	0.90	0.00	0.07	0.41	0.17	0.03	0.09	0.36	0.03	0.09	0.36			
Σ	18658.4	0.43	0.77	0.70	0.82	0.00	0.21	0.23	0.00	0.05	0.15	0.30	0.05	0.15	0.30			

(EXHIBIT ABOVE IS PORTION OF Claremont Business Park 2 Filing No. 2 Proposed Drainage Calculations-Area Runoff Coefficient Summary)

**FINAL DRAINAGE REPORT FOR CLAREMONT BUSINESS PARK 2 FILING NO.2
PROPOSED DRAINAGE CALCULATIONS
(Area Drainage Summary)**

BASIN	Flow Area Based Coefficient Summary				OVERLAND				STREET / CHANNEL FLOW				Time of Travel (T _t)				INTENSITY *				TOTAL FLOWS	
	AREA (Acres)	C ₁	C ₂	C ₃	C ₁₀₀	Length (ft)	Height (ft)	T _c (min)	Slope (%)	Velocity (ft/s)	T _t (min)	CHECK (min)	I ₁ (ft/hr)	I ₂ (ft/hr)	I ₃ (ft/hr)	I ₁₀₀ (ft/hr)	Q ₁ (cfs)	Q ₂ (cfs)	Q ₃ (cfs)	Q ₁₀₀ (cfs)		
A	0.21	0.03	0.79	0.81	0.36	40	5.0	5.0	0.0%	0.0	0.0	10.2	4.1	5.2	8.7	8.7	0.0	0.0	0.0	0.7		
B	1.50	0.79	0.81	0.88	0.36	80	1.0	4.4	1.7%	2.6	1.5	5.0	3.3	4.9	8.3	8.3	4.4	4.4	6.0	10.9		
C	0.12	0.03	0.09	0.36	0.09	40	16.0	3.4	0	0.0	0.0	5.0	4.1	5.2	8.7	8.7	0.0	0.0	0.0	0.4		
C1	0.17	0.03	0.09	0.36	0.09	60	22.6	4.3	0	0.0	0.0	5.0	10.3	5.2	8.7	8.7	0.0	0.0	0.0	0.7		
D	0.77	0.79	0.81	0.88	0.81	60	1.2	3.2	2.6%	2.5	1.6	5.0	11.7	4.1	5.2	8.7	2.5	2.5	3.2	5.9		
D1	0.78	0.79	0.81	0.88	0.81	60	1.2	3.2	2.6%	2.5	1.6	5.0	11.7	4.1	5.2	8.7	2.5	2.5	3.1	6.0		
E1	0.27	0.87	0.88	0.95	0.88	30	0.6	1.7	2.0%	2.8	1.7	5.0	11.7	4.1	5.2	8.7	1.0	1.0	1.2	2.2		
E2	0.21	0.87	0.88	0.95	0.88	30	0.6	1.7	2.0%	2.8	1.7	5.0	11.7	4.1	5.2	8.7	0.7	0.7	1.0	1.7		
F	0.30	0.79	0.81	0.88	0.81	60	1.2	3.2	1.3%	2.3	1.1	5.0	11.2	4.1	5.2	8.7	1.0	1.0	1.2	2.3		
G1	0.27	0.25	0.30	0.32	0.30	30	1.0	5.3	0	0.0	0.0	5.3	10.2	4.1	5.1	8.5	0.4	0.4	0.4	1.2		
G2	1.15	0.79	0.81	0.88	0.81	60	0.6	4.1	1.0%	2.0	3.3	7.4	12.6	3.7	4.6	7.7	2.3	2.3	4.3	7.8		
H1	0.16	0.03	0.04	0.36	0.09	76	20.0	5.4	0	0.0	0.0	5.4	10.4	4.0	5.1	8.5	0.0	0.0	0.1	0.5		
H2	0.40	0.03	0.09	0.36	0.09	100	17.0	7.2	0	0.0	0.0	7.2	10.6	3.7	4.6	7.8	0.0	0.0	0.2	1.1		
H3	0.04	0.03	0.04	0.36	0.09	100	17.0	7.2	0	0.0	0.0	7.2	10.6	3.7	4.6	7.8	0.0	0.0	0.0	0.1		
H4	0.10	0.03	0.04	0.36	0.09	100	17.0	7.2	0	0.0	0.0	7.2	10.6	3.7	4.6	7.8	0.0	0.0	0.0	0.2		
H5	0.56	0.82	0.83	0.90	0.87	100	3.0	3.4	2.1%	3.2	1.1	5.0	11.8	4.1	5.2	8.7	1.0	1.0	2.1	4.3		
I1	0.48	0.77	0.78	0.87	0.78	60	7.0	5.5	1.0%	5.0	5.3	5.0	11.7	4.1	5.3	8.7	1.4	1.4	3.0	7.4		

(EXHIBIT ABOVE IS PORTION OF Claremont Business Park 2 Filing No. 2 Proposed Drainage Calculations-Area Drainage Summary)

Super Star Carwash Onsite Drainage Calculations

PBMP SUMMARY TABLE

BASINS	PBMP TRIBUTARY AREA (AC)	PBMP
A1.1	1.43	RG-A1.1
A3.1	1.87	RG-A3.1
B1,B2	8.60	EDB-B
OA2,A2	0.95	EXCLUDED*

* EXCLUDED BASED ON < 1-ACRE OF DEVELOPED ROADWAY AREA PER ECM APP. 17.C.1.0

Please add Q Design Point to the drainage map and summary table
Label storm pipe and inlets sizes on the drainage map and the GEC Plan sheets
The drainage report and GEC plan set are approved by the County Engineer so must include those details. They seem to be reflect on the utility plan sheet within the SDP set.

Please label the runoff summary (cfs) and be consistent with the drainage legend as they show 10yr and the runoff summary as 5yr

RUNOFF SUMMARY

BASIN	AREA (AC)	5-YR RUNOFF	100-YR RUNOFF
A1	0.03	0.10	0.23
A2	0.94	2.15	6.30
A3	0.29	0.00	0.86
A4	0.11	0.00	0.33
A5	0.10	0.00	0.31
A6	0.07	0.01	0.23
B1	0.11	0.34	0.82
OFF	0.15	0.35	1.01

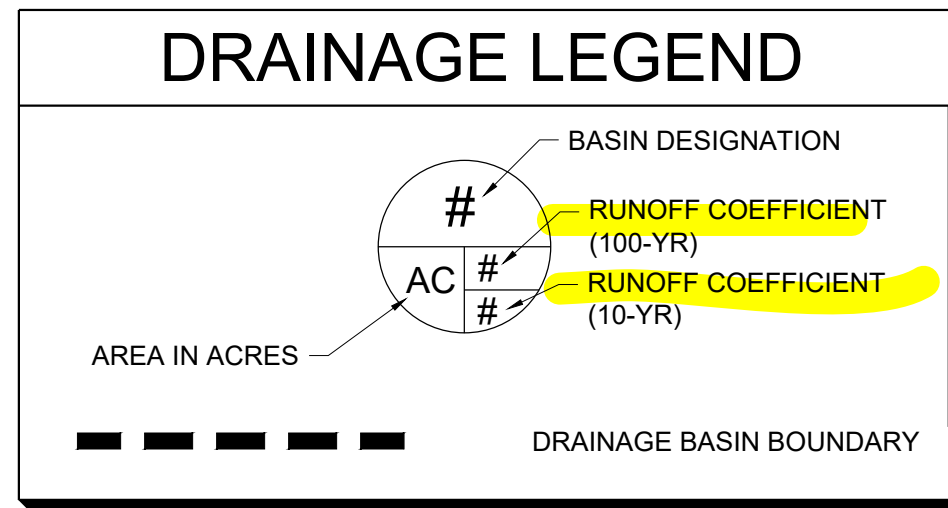

DATE
REVISION

SUPERSTAR CAR WASH
MEADOWBROOK PKWY
COLORADO SPRING, CO 80915
DRAINAGE PLAN

Drawn By: AJJ
Checked By: SEM
Date: 06/23/2023
Project No. 24-0409
Sheet Number

C5.2

Unresolved from Submittal 1, 2 - We need to know how much disturbed area is untreated and if there are any exclusions that apply to those areas. So please create a basic overview map (or modify an existing drainage map) with color shading/hatching that shows areas tributary to each PBMP (pond, runoff reduction, etc.) and those disturbed areas that are not treated by a PBMP, with the applicable exclusion labeled (ex: 20% up to 1ac of development can be excluded per ECM App 17.1.C.1 and exclusions listed in ECM App 17.1.B.#). An accompanying summary table on this map would also be very helpful (example provided):

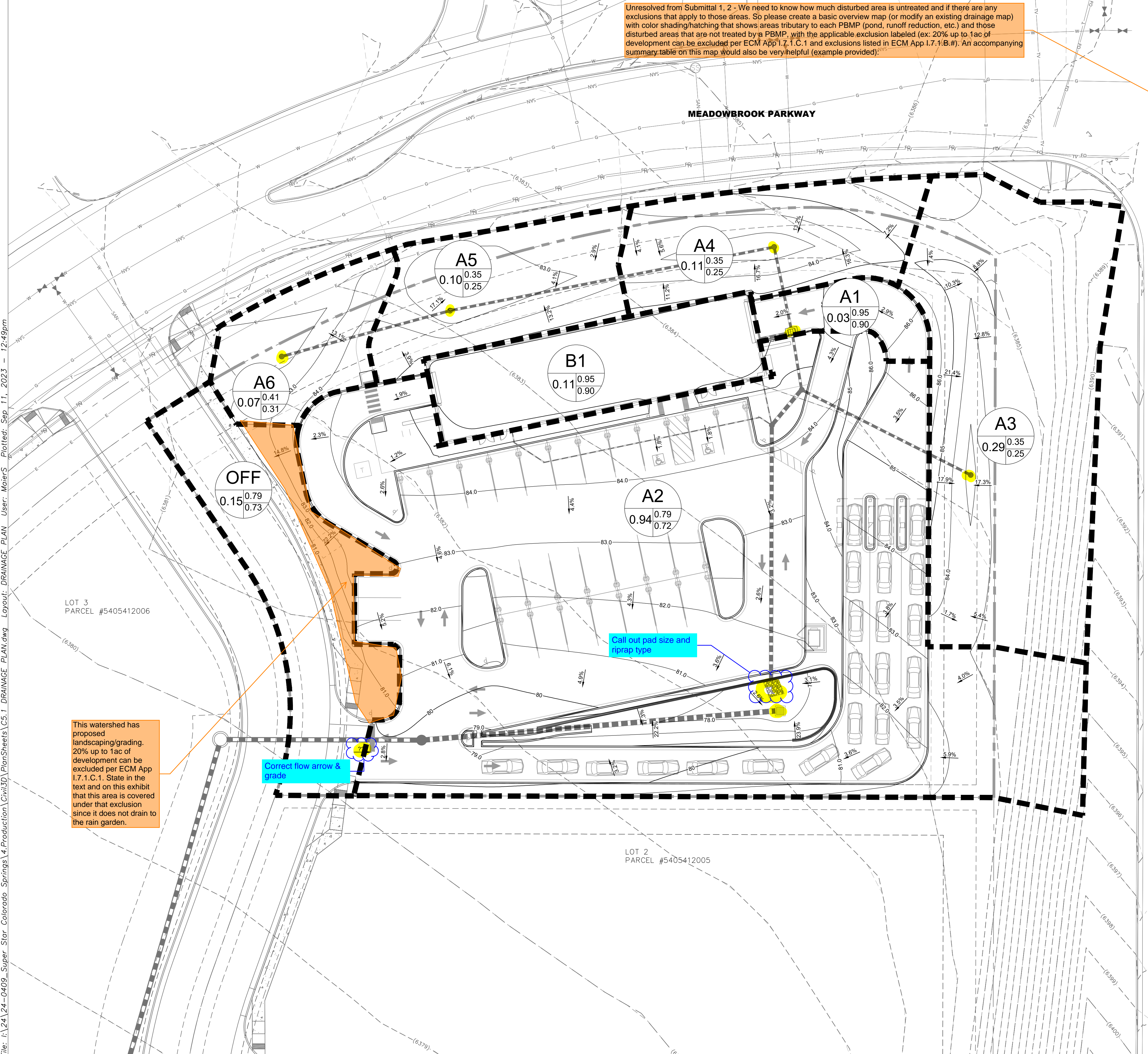

This watershed has proposed landscaping/grading. 20% up to 1ac of development can be excluded per ECM App 17.1.C.1. State in the text and on this exhibit that this area is covered under that exclusion since it does not drain to the rain garden.

File: I:\24-0409-Super Star Colorado Springs\4.Production\Civil\3D\PlanSheets\C5.1.DRAINAGE_PLAN.dwg Layout: DRAINAGE_PLAN User: MaierS Plotted: Sep 11, 2023 - 12:49pm

Design Engineer's Statement:

This grading and erosion control plan was prepared under my direction and supervision and is correct to the best of my knowledge and belief. Said plan has been prepared according to the criteria established by the County for grading and erosion control plans. I accept responsibility for any liability caused by any negligent acts, errors or omissions on my part in preparing this plan.

[Name, P.E. #] _____

Date _____

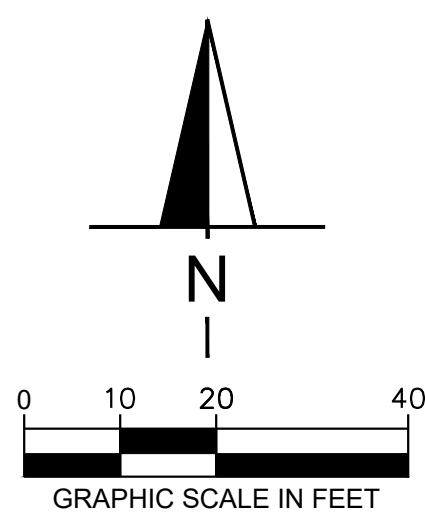

Area-Weighted Runoff Coefficient Calculations

Version 2.00 released May 2017

Designer: Scott Maier

Company: Ayres Associates

Date: 9/11/2023

Project: SUPER STAR CAR WASH

Location: MEADOWBROOK, Mesa County

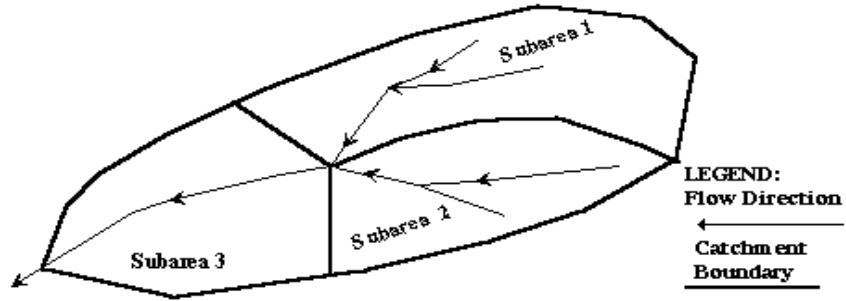

Subcatchment Name

Cells of this color are for required user-input
Cells of this color are for optional override values
Cells of this color are for calculated results based on overrides

See sheet "Design Info" for imperviousness-based runoff coefficient values.

Sub-Area ID	Area (ac)	NRCS Hydrologic Soil Group	Percent Imperviousness	Runoff Coefficient, C						
				2-yr	5-yr	10-yr	25-yr	50-yr	100-yr	500-yr
Basin A1	0.03	B	100.0	0.84	0.86	0.86	0.88	0.89	0.89	0.90
Basin A2	0.94	B	73.0	0.58	0.61	0.65	0.71	0.74	0.77	0.80
Basin A3	0.29	B	0.0	0.00	0.00	0.06	0.25	0.33	0.43	0.54
Basin A4	0.11	B	0.0	0.00	0.00	0.06	0.25	0.33	0.43	0.54
Basin A5	0.10	B	0.0	0.00	0.00	0.06	0.25	0.33	0.43	0.54
Basin A6	0.07	B	0.0	0.00	0.00	0.06	0.25	0.33	0.43	0.54
Basin B1	0.11	B	100.0	0.84	0.86	0.86	0.88	0.89	0.89	0.90
OFF	0.15	B	74.0	0.59	0.62	0.65	0.71	0.74	0.77	0.81
Total Area (ac)	1.80	Area-Weighted C		0.42	0.44	0.48	0.58	0.62	0.67	0.73
		Area-Weighted Override C		0.42	0.44	0.48	0.58	0.62	0.67	0.73

Calculation of Peak Runoff using Rational Method

Designer: Scott Maier
 Company: Ayres Associates
 Date: 9/11/2023
 Project: SUPER STAR CAR WASH
 Location: MEADOWBROOK, Mea County

Version 2.00 released May 2017

Cells of this color are for required user-input
 Cells of this color are for optional override values
 Cells of this color are for calculated results based on overrides

$$t_1 = \frac{0.395(1.1 - C_s)\sqrt{L_1}}{S^{0.33}}$$

$$t_2 = \frac{L_2}{60K\sqrt{S_2}} = \frac{L_2}{60V_2}$$

Computed $t_c = t_1 + t_2$

Regional $t_c = (26 - 17i) + \frac{L_2}{60(14i + 9)\sqrt{S_2}}$

$t_{\text{minimum}} = 5$ (urban)
 $t_{\text{minimum}} = 10$ (non-urban)

Selected $t_c = \max\{t_{\text{minimum}}, \min(\text{Computed } t_c, \text{Regional } t_c)\}$

Select UDFCD location for NOAA Atlas 14 Rainfall Depths from the pull-down list OR enter your own depths obtained from the NOAA website (click this link)

1-hour rainfall depth, P1 (in) =

2-yr	5-yr	10-yr	25-yr	50-yr	100-yr	500-yr
0.83	1.11	1.38	1.69	2.17	2.58	3.14

Rainfall Intensity Equation Coefficients =

a	b	c
28.50	10.00	0.786

$I(\text{in/hr}) = \frac{a + P_1}{(b + t_c)^c}$

$Q(\text{cfs}) = CIA$

Subcatchment Name	Area (ac)	NRCS Hydrologic Soil Group	Percent Imperviousness	Runoff Coefficient, C							Overland (Initial) Flow Time				Channelized (Travel) Flow Time				Time of Concentration			Rainfall Intensity, I (in/hr)							Peak Flow, Q (cfs)										
				2-yr	5-yr	10-yr	25-yr	50-yr	100-yr	500-yr	Overland Flow Length L ₁ (ft)	U/S Elevation (ft) (Optional)	D/S Elevation (ft) (Optional)	Overland Flow Slope S ₁ (ft/ft)	Overland Flow Time t ₁ (min)	Channelized Flow Length L ₂ (ft)	U/S Elevation (ft) (Optional)	D/S Elevation (ft) (Optional)	Channelized Flow Slope S ₂ (ft/ft)	NRCS Conveyance Factor K	Channelized Flow Velocity V ₂ (ft/sec)	Channelized Flow Time t ₂ (min)	Computed t _c (min)	Regional t _c (min)	Selected t _c (min)	2-yr	5-yr	10-yr	25-yr	50-yr	100-yr	500-yr	2-yr	5-yr	10-yr	25-yr	50-yr	100-yr	500-yr
Basin A1	0.03	B	100.0	0.84	0.86	0.86	0.88	0.89	0.89	0.90	10.00			0.250	0.48	20.00			0.010	20	2.00	0.17	0.65	9.14	5.00	2.80	3.76	4.68	5.73	7.36	8.75	10.65	0.07	0.10	0.12	0.15	0.20	0.23	0.29
Basin A2	0.94	B	73.0	0.58	0.61	0.65	0.71	0.74	0.77	0.80	20.00			0.050	2.33	200.00			0.015	20	2.45	1.36	3.69	15.01	5.00	2.80	3.76	4.68	5.73	7.36	8.75	10.65	1.52	2.15	2.84	3.81	5.09	6.30	8.04
Basin A3	0.29	B	0.0	0.00	0.00	0.06	0.25	0.33	0.43	0.54	20.00			0.020	7.07	100.00			0.010	15	1.50	1.11	8.18	27.85	10.00	2.23	3.00	3.73	4.57	5.87	6.98	8.50	0.00	0.00	0.06	0.33	0.56	0.86	1.32
Basin A4	0.11	B	0.0	0.00	0.00	0.06	0.25	0.33	0.43	0.54	20.00			0.020	7.07	30.00			0.020	15	2.12	0.24	7.30	26.39	10.00	2.23	3.00	3.73	4.57	5.87	6.98	8.50	0.00	0.00	0.02	0.13	0.21	0.33	0.50
Basin A5	0.10	B	0.0	0.00	0.00	0.06	0.25	0.33	0.43	0.54	20.00			0.250	3.07	30.00			0.030	15	2.60	0.19	3.26	26.32	10.00	2.23	3.00	3.73	4.57	5.87	6.98	8.50	0.00	0.00	0.02	0.12	0.20	0.31	0.47
Basin A6	0.07	B	9.0	0.05	0.06	0.13	0.31	0.38	0.47	0.57	20.00			0.050	4.93	10.00			0.043	15	3.11	0.05	4.98	24.55	10.00	2.23	3.00	3.73	4.57	5.87	6.98	8.50	0.01	0.01	0.03	0.10	0.16	0.23	0.34
Basin B1	0.11	B	100.0	0.84	0.86	0.86	0.88	0.89	0.89	0.90	20.00			0.020	1.56	50.00			0.020	20	2.83	0.29	1.86	9.26	5.00	2.80	3.76	4.68	5.73	7.36	8.75	10.65	0.25	0.34	0.42	0.53	0.68	0.82	1.01
OFF	0.15	B	74.0	0.59	0.62	0.65	0.71	0.74	0.77	0.81	10.00					150.00			0.020	20	2.63	0.88		14.33	5.00	2.80	3.76	4.68	5.73	7.36	8.75	10.65	0.25	0.35	0.46	0.61	0.82	1.01	1.29

Please update these values to be consistent with the drainage map and the DCM Vol 1 Table 6-6. Runoff Coefficients for Rational Method

Unresolved - dotschoenheit
 10/03/2023 11:14:23 AM

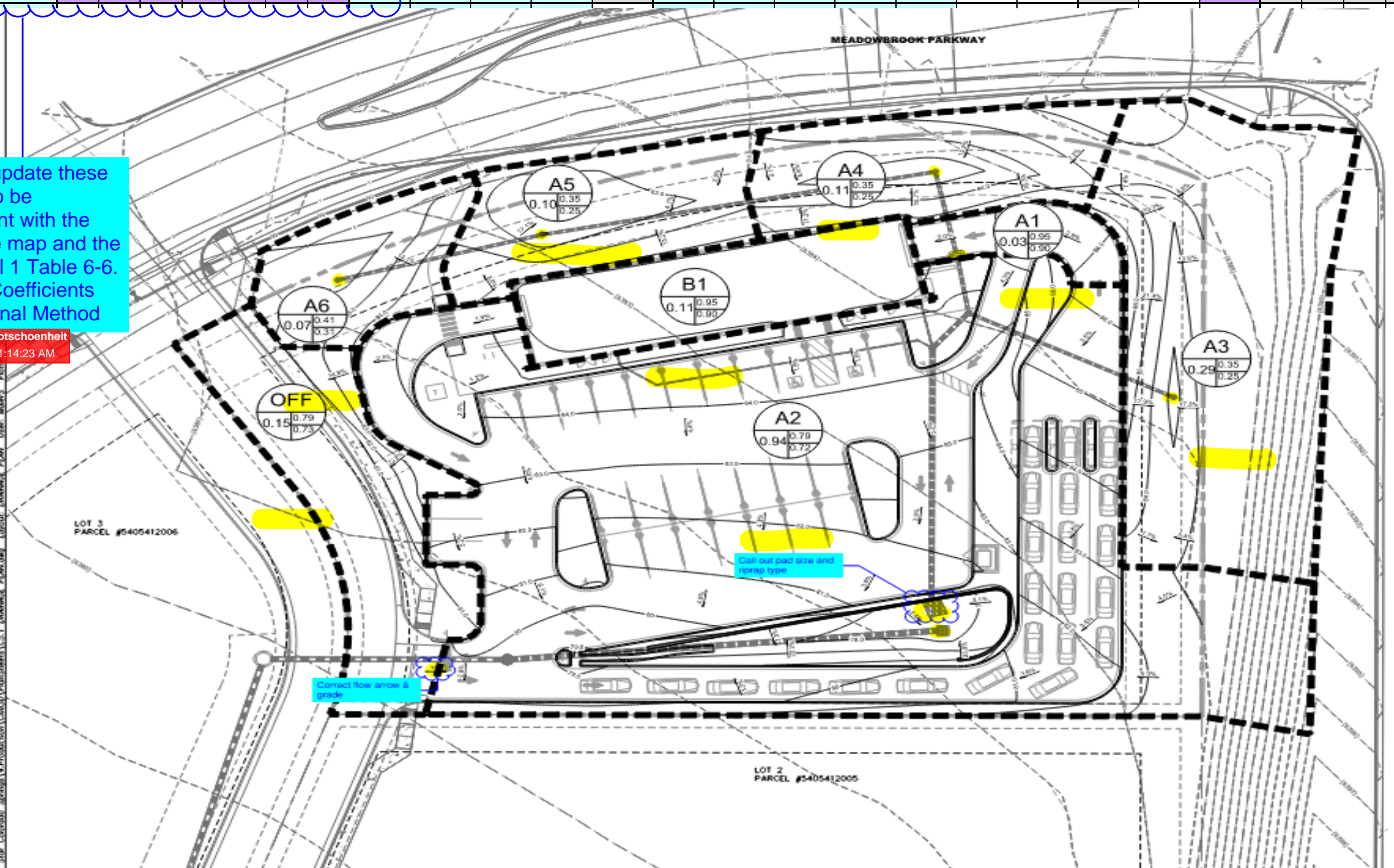

Super Star Carwash Soil Information

Hydrologic Soil Group—El Paso County Area, Colorado
(Super Star Car Wash)

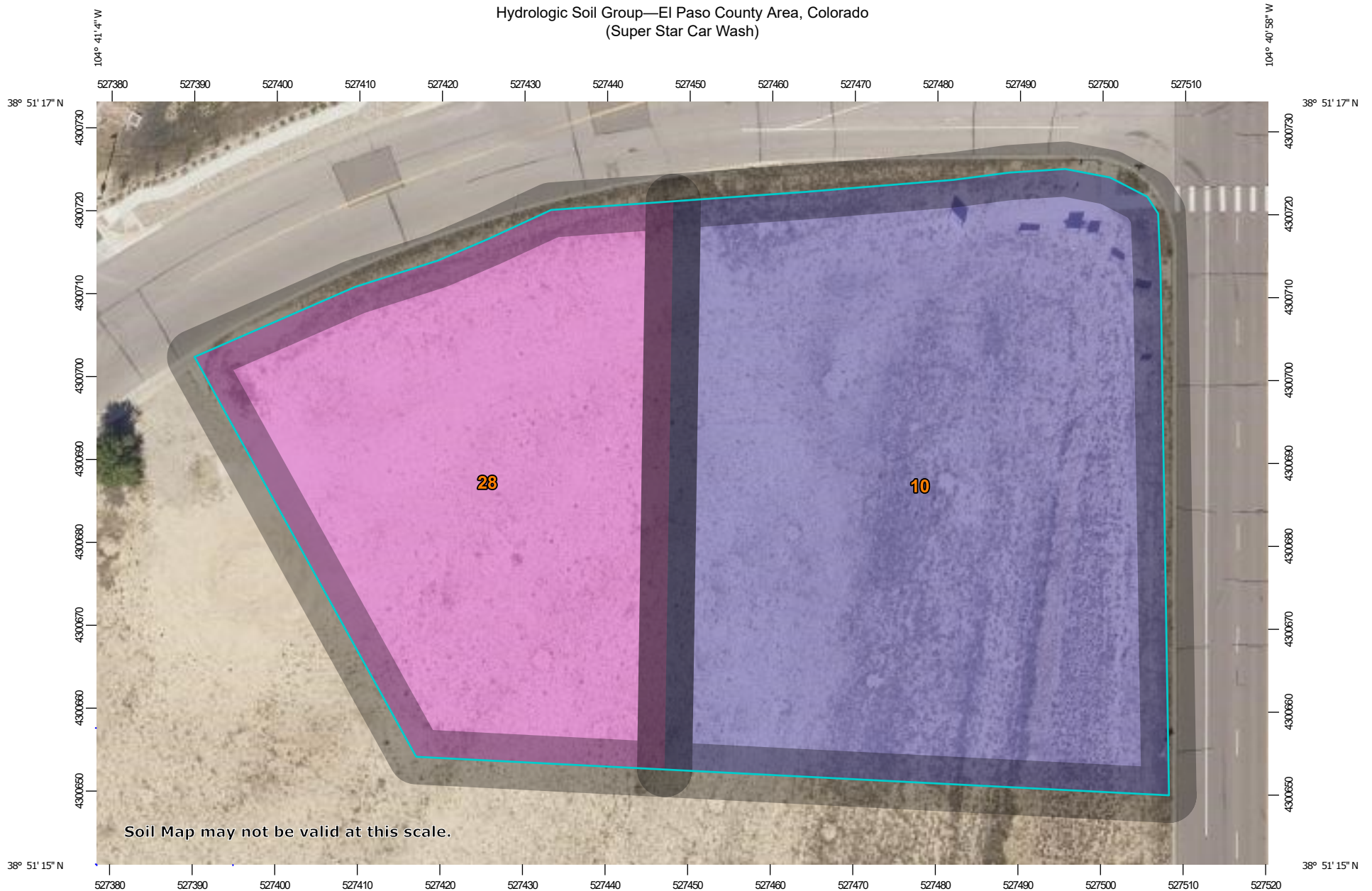

Map Scale: 1:649 if printed on A landscape (11" x 8.5") sheet.

Meters

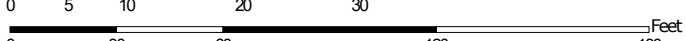

Map projection: Web Mercator Corner coordinates: WGS84 Edge tics: UTM Zone 13N WGS84

Hydrologic Soil Group—El Paso County Area, Colorado
(Super Star Car Wash)

MAP LEGEND

Area of Interest (AOI)









 Area of Interest (AOI)

Soils

Soil Rating Polygons





-  A
-  A/D
-  B
-  B/D
-  C
-  C/D
-  D
-  Not rated or not available

Soil Rating Lines

-  A
-  A/D
-  B
-  B/D
-  C
-  C/D
-  D
-  Not rated or not available

Soil Rating Points



-  A
-  A/D
-  B
-  B/D

-  C
-  C/D
-  D
-  Not rated or not available

Water Features

 Streams and Canals

Transportation

-  Rails
-  Interstate Highways
-  US Routes
-  Major Roads
-  Local Roads

Background

 Aerial Photography

MAP INFORMATION

The soil surveys that comprise your AOI were mapped at 1:24,000.

Warning: Soil Map may not be valid at this scale.

Enlargement of maps beyond the scale of mapping can cause misunderstanding of the detail of mapping and accuracy of soil line placement. The maps do not show the small areas of contrasting soils that could have been shown at a more detailed scale.

Please rely on the bar scale on each map sheet for map measurements.

Source of Map: Natural Resources Conservation Service
Web Soil Survey URL:
Coordinate System: Web Mercator (EPSG:3857)

Maps from the Web Soil Survey are based on the Web Mercator projection, which preserves direction and shape but distorts distance and area. A projection that preserves area, such as the Albers equal-area conic projection, should be used if more accurate calculations of distance or area are required.

This product is generated from the USDA-NRCS certified data as of the version date(s) listed below.

Soil Survey Area: El Paso County Area, Colorado
Survey Area Data: Version 20, Sep 2, 2022

Soil map units are labeled (as space allows) for map scales 1:50,000 or larger.

Date(s) aerial images were photographed: Aug 19, 2018—Sep 23, 2018

The orthophoto or other base map on which the soil lines were compiled and digitized probably differs from the background imagery displayed on these maps. As a result, some minor shifting of map unit boundaries may be evident.

Hydrologic Soil Group

Map unit symbol	Map unit name	Rating	Acres in AOI	Percent of AOI
10	Blendon sandy loam, 0 to 3 percent slopes	B	1.1	60.7%
28	Ellicott loamy coarse sand, 0 to 5 percent slopes	A	0.7	39.3%
Totals for Area of Interest			1.8	100.0%

Description

Hydrologic soil groups are based on estimates of runoff potential. Soils are assigned to one of four groups according to the rate of water infiltration when the soils are not protected by vegetation, are thoroughly wet, and receive precipitation from long-duration storms.

The soils in the United States are assigned to four groups (A, B, C, and D) and three dual classes (A/D, B/D, and C/D). The groups are defined as follows:

Group A. Soils having a high infiltration rate (low runoff potential) when thoroughly wet. These consist mainly of deep, well drained to excessively drained sands or gravelly sands. These soils have a high rate of water transmission.

Group B. Soils having a moderate infiltration rate when thoroughly wet. These consist chiefly of moderately deep or deep, moderately well drained or well drained soils that have moderately fine texture to moderately coarse texture. These soils have a moderate rate of water transmission.

Group C. Soils having a slow infiltration rate when thoroughly wet. These consist chiefly of soils having a layer that impedes the downward movement of water or soils of moderately fine texture or fine texture. These soils have a slow rate of water transmission.

Group D. Soils having a very slow infiltration rate (high runoff potential) when thoroughly wet. These consist chiefly of clays that have a high shrink-swell potential, soils that have a high water table, soils that have a claypan or clay layer at or near the surface, and soils that are shallow over nearly impervious material. These soils have a very slow rate of water transmission.

If a soil is assigned to a dual hydrologic group (A/D, B/D, or C/D), the first letter is for drained areas and the second is for undrained areas. Only the soils that in their natural condition are in group D are assigned to dual classes.

Rating Options

Aggregation Method: Dominant Condition

Component Percent Cutoff: None Specified

Tie-break Rule: Higher

Super Star Carwash Onsite Water Quality Basin Calculations

DETENTION BASIN STAGE-STORAGE TABLE BUILDER

MHFD-Detention, Version 4.06 (July 2022)

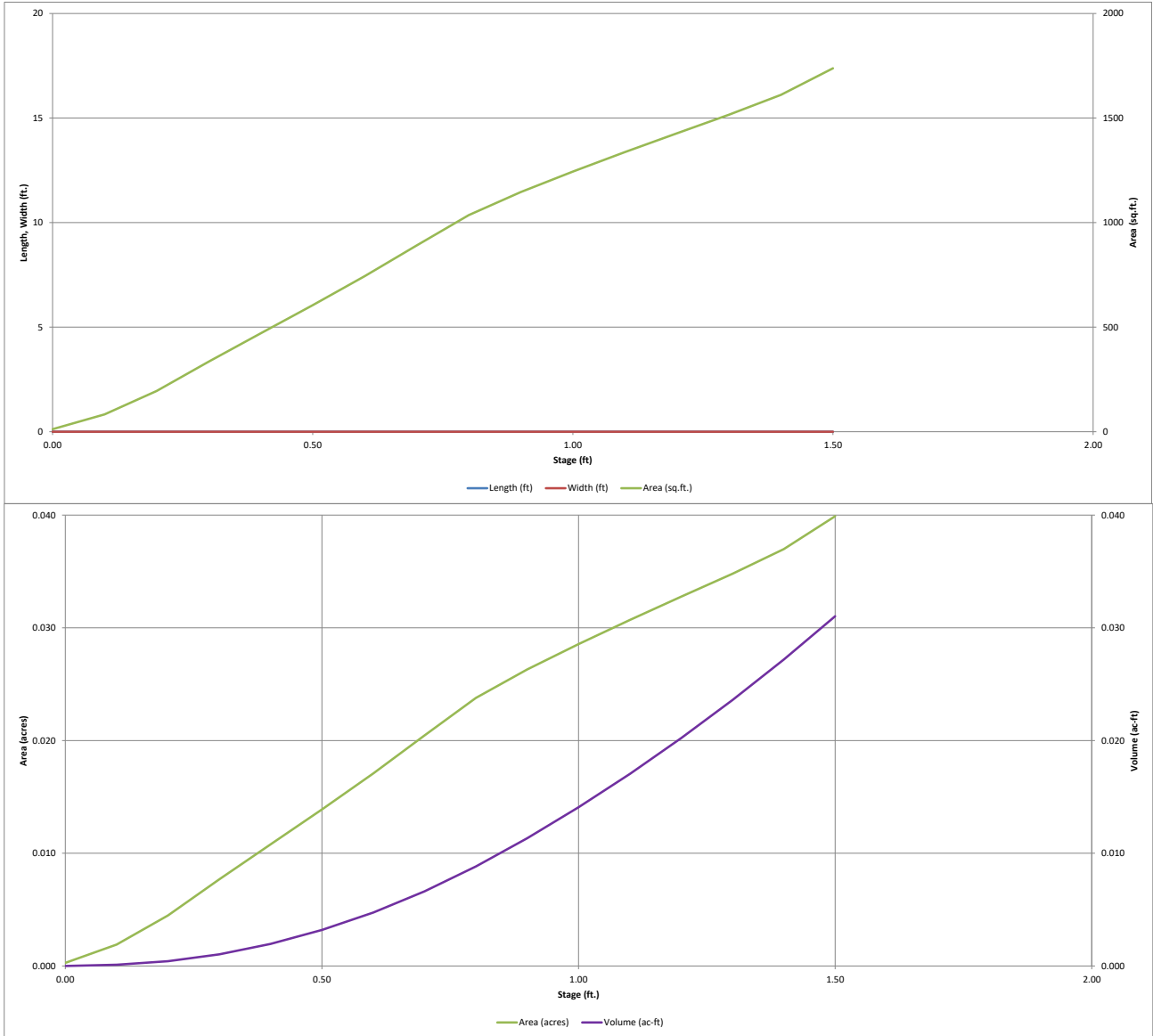

DETENTION BASIN OUTLET STRUCTURE DESIGN

MHFD-Detention, Version 4.06 (July 2022)

Project: Super Star Carwash
Basin ID: Water Quality Basin

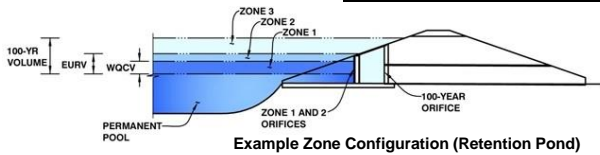

Example Zone Configuration (Retention Pond)

	Estimated Stage (ft)	Estimated Volume (ac-ft)	Outlet Type
Zone 1 (WQCV)	1.28	0.023	Filtration Media
Zone 2			Not Utilized
Zone 3			
Total (all zones)		0.023	

User Input: Orifice at Underdrain Outlet (typically used to drain WQCV in a Filtration BMP)

Underdrain Orifice Invert Depth = ft (distance below the filtration media surface)
 Underdrain Orifice Diameter = inches

Calculated Parameters for Underdrain
 Underdrain Orifice Area = ft²
 Underdrain Orifice Centroid = feet

User Input: Orifice Plate with one or more orifices or Elliptical Slot Weir (typically used to drain WQCV and/or EURV in a sedimentation BMP)

Centroid of Lowest Orifice = ft (relative to basin bottom at Stage = 0 ft)
 Depth at top of Zone using Orifice Plate = ft (relative to basin bottom at Stage = 0 ft)
 Orifice Plate: Orifice Vertical Spacing = inches
 Orifice Plate: Orifice Area per Row = sq. inches

Calculated Parameters for Plate
 WQ Orifice Area per Row = ft²
 Elliptical Half-Width = feet
 Elliptical Slot Centroid = feet
 Elliptical Slot Area = ft²

User Input: Stage and Total Area of Each Orifice Row (numbered from lowest to highest)

	Row 1 (optional)	Row 2 (optional)	Row 3 (optional)	Row 4 (optional)	Row 5 (optional)	Row 6 (optional)	Row 7 (optional)	Row 8 (optional)
Stage of Orifice Centroid (ft)	<input type="text" value="N/A"/>	<input type="text" value="N/A"/>	<input type="text" value="N/A"/>	<input type="text" value="N/A"/>	<input type="text" value="N/A"/>	<input type="text" value="N/A"/>	<input type="text" value="N/A"/>	<input type="text" value="N/A"/>
Orifice Area (sq. inches)	<input type="text" value="N/A"/>	<input type="text" value="N/A"/>	<input type="text" value="N/A"/>	<input type="text" value="N/A"/>	<input type="text" value="N/A"/>	<input type="text" value="N/A"/>	<input type="text" value="N/A"/>	<input type="text" value="N/A"/>

	Row 9 (optional)	Row 10 (optional)	Row 11 (optional)	Row 12 (optional)	Row 13 (optional)	Row 14 (optional)	Row 15 (optional)	Row 16 (optional)
Stage of Orifice Centroid (ft)	<input type="text" value="N/A"/>	<input type="text" value="N/A"/>	<input type="text" value="N/A"/>	<input type="text" value="N/A"/>	<input type="text" value="N/A"/>	<input type="text" value="N/A"/>	<input type="text" value="N/A"/>	<input type="text" value="N/A"/>
Orifice Area (sq. inches)	<input type="text" value="N/A"/>	<input type="text" value="N/A"/>	<input type="text" value="N/A"/>	<input type="text" value="N/A"/>	<input type="text" value="N/A"/>	<input type="text" value="N/A"/>	<input type="text" value="N/A"/>	<input type="text" value="N/A"/>

User Input: Vertical Orifice (Circular or Rectangular)

Invert of Vertical Orifice = ft (relative to basin bottom at Stage = 0 ft)
 Depth at top of Zone using Vertical Orifice = ft (relative to basin bottom at Stage = 0 ft)
 Vertical Orifice Diameter = inches

Calculated Parameters for Vertical Orifice
 Vertical Orifice Area = ft²
 Vertical Orifice Centroid = feet

User Input: Overflow Weir (Dropbox with Flat or Sloped Grate and Outlet Pipe OR Rectangular/Trapezoidal Weir and No Outlet Pipe)

Overflow Weir Front Edge Height, H_o = ft (relative to basin bottom at Stage = 0 ft)
 Overflow Weir Front Edge Length = feet
 Overflow Weir Grate Slope = H:V
 Horiz. Length of Weir Sides = feet
 Overflow Grate Type =
 Debris Clogging % = %

Calculated Parameters for Overflow Weir
 Height of Grate Upper Edge, H_u = feet
 Overflow Weir Slope Length = feet
 Grate Open Area / 100-yr Orifice Area =
 Overflow Grate Open Area w/o Debris = ft²
 Overflow Grate Open Area w/ Debris = ft²

User Input: Outlet Pipe w/ Flow Restriction Plate (Circular Orifice, Restrictor Plate, or Rectangular Orifice)

Depth to Invert of Outlet Pipe = ft (distance below basin bottom at Stage = 0 ft)
 Circular Orifice Diameter = inches

Calculated Parameters for Outlet Pipe w/ Flow Restriction Plate
 Outlet Orifice Area = ft²
 Outlet Orifice Centroid = feet
 Half-Central Angle of Restrictor Plate on Pipe = radians

User Input: Emergency Spillway (Rectangular or Trapezoidal)

Spillway Invert Stage = ft (relative to basin bottom at Stage = 0 ft)
 Spillway Crest Length = feet
 Spillway End Slopes = H:V
 Freeboard above Max Water Surface = feet

Calculated Parameters for Spillway
 Spillway Design Flow Depth = feet
 Stage at Top of Freeboard = feet
 Basin Area at Top of Freeboard = acres
 Basin Volume at Top of Freeboard = acre-ft

Routed Hydrograph Results

The user can override the default CUHP hydrographs and runoff volumes by entering new values in the Inflow Hydrographs table (Columns W through AF).

	WQCV	EURV	2 Year	5 Year	10 Year	25 Year	50 Year	100 Year	500 Year
Design Storm Return Period	N/A	N/A	1.19	1.50	1.75	2.00	2.25	2.52	3.14
One-Hour Rainfall Depth (in)	0.023	0.095	0.068	0.091	0.108	0.137	0.164	0.199	0.275
CUHP Runoff Volume (acre-ft)	N/A	N/A	0.068	0.091	0.108	0.137	0.164	0.199	0.275
Inflow Hydrograph Volume (acre-ft)	N/A	N/A	0.0	0.0	0.0	0.3	0.6	1.1	1.9
CUHP Predevelopment Peak Q (cfs)	N/A	N/A							
OPTIONAL Override Predevelopment Peak Q (cfs)	N/A	N/A							
Predevelopment Unit Peak Flow, q (cfs/acre)	N/A	N/A	0.01	0.02	0.02	0.20	0.39	0.64	1.14
Peak Inflow Q (cfs)	N/A	N/A	1.1	1.4	1.7	2.3	2.8	3.5	4.8
Peak Outflow Q (cfs)	0.0	0.0	0.0	0.0	0.0	0.0	0.0	0.0	0.0
Ratio Peak Outflow to Predevelopment Q	N/A	N/A	N/A	1.0	0.7	0.1	0.0	0.0	0.0
Structure Controlling Flow	Filtration Media	N/A	N/A	N/A	N/A	N/A	N/A	N/A	N/A
Max Velocity through Grate 1 (fps)	N/A	N/A	N/A	N/A	N/A	N/A	N/A	N/A	N/A
Max Velocity through Grate 2 (fps)	N/A	N/A	N/A	N/A	N/A	N/A	N/A	N/A	N/A
Time to Drain 97% of Inflow Volume (hours)	12	44	32	43	51	63	76	92	>120
Time to Drain 99% of Inflow Volume (hours)	12	45	33	44	52	65	78	94	>120
Maximum Ponding Depth (ft)	1.29	1.50	1.50	1.50	1.50	1.50	1.50	1.50	1.50
Area at Maximum Ponding Depth (acres)	0.03	0.04	0.04	0.04	0.04	0.04	0.04	0.04	0.04
Maximum Volume Stored (acre-ft)	0.023	0.031	0.031	0.031	0.031	0.031	0.031	0.031	0.031

DETENTION BASIN OUTLET STRUCTURE DESIGN

MHFD-Detention, Version 4.06 (July 2022)

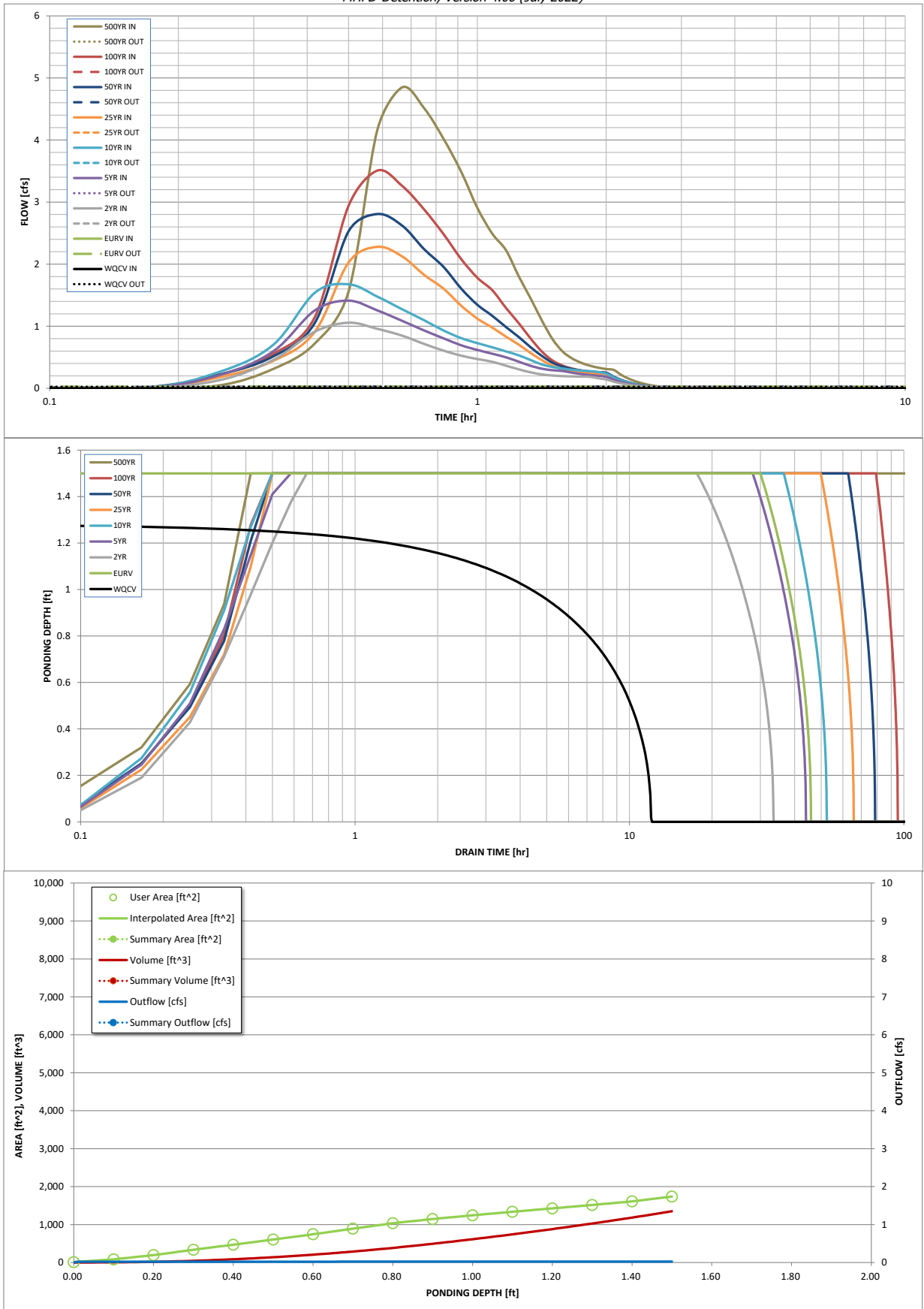

S-A-V-D Chart Axis Override	X-axis	Left Y-Axis	Right Y-Axis
minimum bound			
maximum bound			

DETENTION BASIN OUTLET STRUCTURE DESIGN

Outflow Hydrograph Workbook Filename: _____

Inflow Hydrographs

The user can override the calculated inflow hydrographs from this workbook with inflow hydrographs developed in a separate program.

Time Interval	SOURCE	CUHP	CUHP	CUHP	CUHP	CUHP	CUHP	CUHP	CUHP	CUHP	
	TIME	WQCV [cfs]	EURV [cfs]	2 Year [cfs]	5 Year [cfs]	10 Year [cfs]	25 Year [cfs]	50 Year [cfs]	100 Year [cfs]	500 Year [cfs]	
5.00 min	0:00:00	0.00	0.00	0.00	0.00	0.00	0.00	0.00	0.00	0.00	
	0:05:00	0.00	0.00	0.00	0.00	0.00	0.00	0.00	0.00	0.00	
	0:10:00	0.00	0.00	0.00	0.00	0.00	0.00	0.00	0.02	0.00	0.05
	0:15:00	0.00	0.00	0.13	0.21	0.27	0.18	0.22	0.22	0.22	0.31
	0:20:00	0.00	0.00	0.46	0.60	0.70	0.44	0.51	0.55	0.55	0.72
	0:25:00	0.00	0.00	0.91	1.25	1.54	0.91	1.05	1.15	1.15	1.56
	0:30:00	0.00	0.00	1.06	1.41	1.68	2.03	2.53	2.94	2.94	4.16
	0:35:00	0.00	0.00	0.96	1.26	1.48	2.28	2.81	3.51	3.51	4.85
	0:40:00	0.00	0.00	0.85	1.09	1.27	2.13	2.62	3.26	3.26	4.52
	0:45:00	0.00	0.00	0.72	0.93	1.10	1.83	2.24	2.88	2.88	4.02
	0:50:00	0.00	0.00	0.61	0.81	0.93	1.61	1.96	2.48	2.48	3.49
	0:55:00	0.00	0.00	0.53	0.69	0.81	1.33	1.61	2.08	2.08	2.91
	1:00:00	0.00	0.00	0.47	0.62	0.73	1.12	1.34	1.78	1.78	2.49
	1:05:00	0.00	0.00	0.43	0.56	0.66	0.98	1.17	1.58	1.58	2.22
	1:10:00	0.00	0.00	0.36	0.50	0.59	0.83	0.99	1.29	1.29	1.80
	1:15:00	0.00	0.00	0.31	0.43	0.53	0.70	0.83	1.05	1.05	1.44
	1:20:00	0.00	0.00	0.26	0.36	0.45	0.57	0.66	0.80	0.80	1.09
	1:25:00	0.00	0.00	0.22	0.31	0.38	0.45	0.52	0.59	0.59	0.79
	1:30:00	0.00	0.00	0.21	0.29	0.34	0.36	0.41	0.45	0.45	0.59
	1:35:00	0.00	0.00	0.20	0.28	0.32	0.31	0.35	0.37	0.37	0.48
	1:40:00	0.00	0.00	0.19	0.25	0.30	0.28	0.31	0.32	0.32	0.41
	1:45:00	0.00	0.00	0.19	0.23	0.29	0.25	0.29	0.29	0.29	0.36
	1:50:00	0.00	0.00	0.19	0.21	0.28	0.24	0.27	0.26	0.26	0.33
	1:55:00	0.00	0.00	0.16	0.20	0.26	0.23	0.26	0.25	0.25	0.31
	2:00:00	0.00	0.00	0.14	0.19	0.24	0.22	0.25	0.24	0.24	0.30
	2:05:00	0.00	0.00	0.11	0.14	0.18	0.17	0.19	0.18	0.18	0.22
	2:10:00	0.00	0.00	0.08	0.10	0.13	0.12	0.14	0.13	0.13	0.16
	2:15:00	0.00	0.00	0.06	0.07	0.09	0.09	0.10	0.09	0.09	0.12
	2:20:00	0.00	0.00	0.04	0.05	0.07	0.06	0.07	0.07	0.07	0.08
	2:25:00	0.00	0.00	0.03	0.04	0.05	0.05	0.05	0.05	0.05	0.06
	2:30:00	0.00	0.00	0.02	0.03	0.03	0.03	0.04	0.03	0.03	0.04
	2:35:00	0.00	0.00	0.01	0.02	0.02	0.02	0.02	0.02	0.02	0.03
	2:40:00	0.00	0.00	0.01	0.01	0.01	0.01	0.02	0.01	0.01	0.02
	2:45:00	0.00	0.00	0.00	0.01	0.01	0.01	0.01	0.01	0.01	0.01
	2:50:00	0.00	0.00	0.00	0.00	0.00	0.00	0.00	0.00	0.00	0.00
	2:55:00	0.00	0.00	0.00	0.00	0.00	0.00	0.00	0.00	0.00	0.00
	3:00:00	0.00	0.00	0.00	0.00	0.00	0.00	0.00	0.00	0.00	0.00
	3:05:00	0.00	0.00	0.00	0.00	0.00	0.00	0.00	0.00	0.00	0.00
	3:10:00	0.00	0.00	0.00	0.00	0.00	0.00	0.00	0.00	0.00	0.00
	3:15:00	0.00	0.00	0.00	0.00	0.00	0.00	0.00	0.00	0.00	0.00
	3:20:00	0.00	0.00	0.00	0.00	0.00	0.00	0.00	0.00	0.00	0.00
	3:25:00	0.00	0.00	0.00	0.00	0.00	0.00	0.00	0.00	0.00	0.00
	3:30:00	0.00	0.00	0.00	0.00	0.00	0.00	0.00	0.00	0.00	0.00
	3:35:00	0.00	0.00	0.00	0.00	0.00	0.00	0.00	0.00	0.00	0.00
	3:40:00	0.00	0.00	0.00	0.00	0.00	0.00	0.00	0.00	0.00	0.00
	3:45:00	0.00	0.00	0.00	0.00	0.00	0.00	0.00	0.00	0.00	0.00
	3:50:00	0.00	0.00	0.00	0.00	0.00	0.00	0.00	0.00	0.00	0.00
	3:55:00	0.00	0.00	0.00	0.00	0.00	0.00	0.00	0.00	0.00	0.00
	4:00:00	0.00	0.00	0.00	0.00	0.00	0.00	0.00	0.00	0.00	0.00
	4:05:00	0.00	0.00	0.00	0.00	0.00	0.00	0.00	0.00	0.00	0.00
	4:10:00	0.00	0.00	0.00	0.00	0.00	0.00	0.00	0.00	0.00	0.00
	4:15:00	0.00	0.00	0.00	0.00	0.00	0.00	0.00	0.00	0.00	0.00
	4:20:00	0.00	0.00	0.00	0.00	0.00	0.00	0.00	0.00	0.00	0.00
	4:25:00	0.00	0.00	0.00	0.00	0.00	0.00	0.00	0.00	0.00	0.00
	4:30:00	0.00	0.00	0.00	0.00	0.00	0.00	0.00	0.00	0.00	0.00
	4:35:00	0.00	0.00	0.00	0.00	0.00	0.00	0.00	0.00	0.00	0.00
	4:40:00	0.00	0.00	0.00	0.00	0.00	0.00	0.00	0.00	0.00	0.00
	4:45:00	0.00	0.00	0.00	0.00	0.00	0.00	0.00	0.00	0.00	0.00
	4:50:00	0.00	0.00	0.00	0.00	0.00	0.00	0.00	0.00	0.00	0.00
	4:55:00	0.00	0.00	0.00	0.00	0.00	0.00	0.00	0.00	0.00	0.00
5:00:00	0.00	0.00	0.00	0.00	0.00	0.00	0.00	0.00	0.00	0.00	
5:05:00	0.00	0.00	0.00	0.00	0.00	0.00	0.00	0.00	0.00	0.00	
5:10:00	0.00	0.00	0.00	0.00	0.00	0.00	0.00	0.00	0.00	0.00	
5:15:00	0.00	0.00	0.00	0.00	0.00	0.00	0.00	0.00	0.00	0.00	
5:20:00	0.00	0.00	0.00	0.00	0.00	0.00	0.00	0.00	0.00	0.00	
5:25:00	0.00	0.00	0.00	0.00	0.00	0.00	0.00	0.00	0.00	0.00	
5:30:00	0.00	0.00	0.00	0.00	0.00	0.00	0.00	0.00	0.00	0.00	
5:35:00	0.00	0.00	0.00	0.00	0.00	0.00	0.00	0.00	0.00	0.00	
5:40:00	0.00	0.00	0.00	0.00	0.00	0.00	0.00	0.00	0.00	0.00	
5:45:00	0.00	0.00	0.00	0.00	0.00	0.00	0.00	0.00	0.00	0.00	
5:50:00	0.00	0.00	0.00	0.00	0.00	0.00	0.00	0.00	0.00	0.00	
5:55:00	0.00	0.00	0.00	0.00	0.00	0.00	0.00	0.00	0.00	0.00	
6:00:00	0.00	0.00	0.00	0.00	0.00	0.00	0.00	0.00	0.00	0.00	

Unresolved from Submittal 1, 2: Provide storm drain and swale calculations as well as inlet calcs

Super Star Carwash Onsite Inlet Calculations

INLET MANAGEMENT

Worksheet Protected

INLET NAME	Basin A1	Rain Garden Outlet Structure	Basin A4
Site Type (Urban or Rural)	URBAN	URBAN	URBAN
Inlet Application (Street or Area)	STREET	AREA	AREA
Hydraulic Condition	On Grade	Swale	Swale
Inlet Type	CDOT Type C Grate	CDOT Type C (Depressed)	User-Defined

USER-DEFINED INPUT

User-Defined Design Flows			
Minor Q_{known} (cfs)	0.10	2.59	0.00
Major Q_{known} (cfs)	0.23	9.08	0.33
Bypass (Carry-Over) Flow from Upstream			
Receive Bypass Flow from:	User-Defined	No Bypass Flow Received	No Bypass Flow Received
Minor Bypass Flow Received, Q_b (cfs)	0.0	0.0	0.0
Major Bypass Flow Received, Q_b (cfs)	0.0	0.0	0.0
Watershed Characteristics			
Subcatchment Area (acres)			
Percent Impervious			
NRCS Soil Type			
Watershed Profile			
Overland Slope (ft/ft)			
Overland Length (ft)			
Channel Slope (ft/ft)			
Channel Length (ft)			
Minor Storm Rainfall Input			
Design Storm Return Period, T_r (years)			
One-Hour Precipitation, P_1 (inches)			
Major Storm Rainfall Input			
Design Storm Return Period, T_r (years)			
One-Hour Precipitation, P_1 (inches)			

CALCULATED OUTPUT

Minor Total Design Peak Flow, Q (cfs)	0.12	2.59	0.00
Major Total Design Peak Flow, Q (cfs)	0.23	9.08	0.33
Minor Flow Bypassed Downstream, Q_b (cfs)	0.1	0.0	0.0
Major Flow Bypassed Downstream, Q_b (cfs)	0.1	0.0	0.0

INLET MANAGEMENT

Worksheet Protected

INLET NAME	Basin A5	Basin A3	Basin A6
Site Type (Urban or Rural)	URBAN	URBAN	URBAN
Inlet Application (Street or Area)	AREA	AREA	AREA
Hydraulic Condition	Swale	Swale	Swale
Inlet Type	User-Defined	User-Defined	User-Defined

USER-DEFINED INPUT

User-Defined Design Flows			
Minor Q_{known} (cfs)	0.00	0.00	0.00
Major Q_{known} (cfs)	0.31	0.86	0.23
Bypass (Carry-Over) Flow from Upstream			
Receive Bypass Flow from:	No Bypass Flow Received	No Bypass Flow Received	No Bypass Flow Received
Minor Bypass Flow Received, Q_b (cfs)	0.0	0.0	0.0
Major Bypass Flow Received, Q_b (cfs)	0.0	0.0	0.0
Watershed Characteristics			
Subcatchment Area (acres)			
Percent Impervious			
NRCS Soil Type			
Watershed Profile			
Overland Slope (ft/ft)			
Overland Length (ft)			
Channel Slope (ft/ft)			
Channel Length (ft)			
Minor Storm Rainfall Input			
Design Storm Return Period, T_r (years)			
One-Hour Precipitation, P_1 (inches)			
Major Storm Rainfall Input			
Design Storm Return Period, T_r (years)			
One-Hour Precipitation, P_1 (inches)			

CALCULATED OUTPUT

Minor Total Design Peak Flow, Q (cfs)	0.00	0.00	0.00
Major Total Design Peak Flow, Q (cfs)	0.31	0.86	0.23
Minor Flow Bypassed Downstream, Q_b (cfs)	0.0	0.0	0.0
Major Flow Bypassed Downstream, Q_b (cfs)	0.0	0.0	0.0

ALLOWABLE CAPACITY FOR ONE-HALF OF STREET (Minor & Major Storm)

(Based on Regulated Criteria for Maximum Allowable Flow Depth and Spread)

Project: Super Star Car Wash - Meadowbrook
 Inlet ID: Basin A1

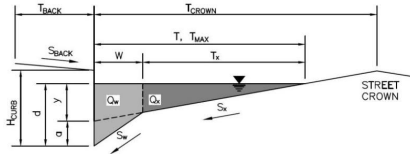

Gutter Geometry:

Maximum Allowable Width for Spread Behind Curb
 Side Slope Behind Curb (leave blank for no conveyance credit behind curb)
 Manning's Roughness Behind Curb (typically between 0.012 and 0.020)
 Height of Curb at Gutter Flow Line
 Distance from Curb Face to Street Crown
 Gutter Width
 Street Transverse Slope
 Gutter Cross Slope (typically 2 inches over 24 inches or 0.083 ft/ft)
 Street Longitudinal Slope - Enter 0 for sump condition
 Manning's Roughness for Street Section (typically between 0.012 and 0.020)

T _{BACK} =	10.0	ft
S _{BACK} =		ft/ft
n _{BACK} =	0.013	
H _{CURB} =	6.00	inches
T _{CROWN} =	10.0	ft
W =	1.00	ft
S _X =	0.048	ft/ft
S _W =	0.083	ft/ft
S _O =	0.007	ft/ft
n _{STREET} =	0.013	

Max. Allowable Spread for Minor & Major Storm
 Max. Allowable Depth at Gutter Flowline for Minor & Major Storm
 Allow Flow Depth at Street Crown (check box for yes, leave blank for no)

	Minor Storm	Major Storm	
T _{MAX} =	10.0	10.0	ft
d _{MAX} =	6.0	6.0	inches
	<input type="checkbox"/>	<input type="checkbox"/>	

Maximum Capacity for 1/2 Street based On Allowable Spread

Water Depth without Gutter Depression (Eq. ST-2)
 Vertical Depth between Gutter Lip and Gutter Flowline (usually 2")
 Gutter Depression (d_c - (W * S_x * 12))
 Water Depth at Gutter Flowline
 Allowable Spread for Discharge outside the Gutter Section W (T - W)
 Gutter Flow to Design Flow Ratio by FHWA HEC-22 method (Eq. ST-7)
 Discharge outside the Gutter Section W, carried in Section T_X
 Discharge within the Gutter Section W (Q_T - Q_X)
 Discharge Behind the Curb (e.g., sidewalk, driveways, & lawns)
 Maximum Flow Based On Allowable Spread
 Flow Velocity within the Gutter Section
 V*d Product: Flow Velocity times Gutter Flowline Depth

	Minor Storm	Major Storm	
y =	5.76	5.76	inches
d _c =	1.0	1.0	inches
a =	0.42	0.42	inches
d =	6.18	6.18	inches
T _X =	9.0	9.0	ft
E _O =	0.257	0.257	
Q _X =	8.0	8.0	cfs
Q _W =	2.8	2.8	cfs
Q _{BACK} =	0.0	0.0	cfs
Q _T =	10.8	10.8	cfs
V =	1.5	1.5	fps
V*d =	0.8	0.8	

Maximum Capacity for 1/2 Street based on Allowable Depth

Theoretical Water Spread
 Theoretical Spread for Discharge outside the Gutter Section W (T - W)
 Gutter Flow to Design Flow Ratio by FHWA HEC-22 method (Eq. ST-7)
 Theoretical Discharge outside the Gutter Section W, carried in Section T_{X TH}
 Actual Discharge outside the Gutter Section W, (limited by distance T_{CROWN})
 Discharge within the Gutter Section W (Q_d - Q_X)
 Discharge Behind the Curb (e.g., sidewalk, driveways, & lawns)
 Total Discharge for Major & Minor Storm (Pre-Safety Factor)
 Average Flow Velocity Within the Gutter Section
 V*d Product: Flow Velocity Times Gutter Flowline Depth
 Slope-Based Depth Safety Reduction Factor for Major & Minor (d ≥ 6") Storm
 Max Flow Based on Allowable Depth (Safety Factor Applied)
 Resultant Flow Depth at Gutter Flowline (Safety Factor Applied)
 Resultant Flow Depth at Street Crown (Safety Factor Applied)

	Minor Storm	Major Storm	
T _{TH} =	9.7	9.7	ft
T _{X TH} =	8.7	8.7	ft
E _O =	0.265	0.265	
Q _{X TH} =	7.3	7.3	cfs
Q _X =	7.3	7.3	cfs
Q _W =	2.6	2.6	cfs
Q _{BACK} =	0.0	0.0	cfs
Q =	9.9	9.9	cfs
V =	1.4	1.4	fps
V*d =	0.7	0.7	
R =	1.00	1.00	
Q _d =	9.9	9.9	cfs
d =	6.00	6.00	inches
d _{CROWN} =	0.00	0.00	inches

MINOR STORM Allowable Capacity is based on Depth Criterion
 MAJOR STORM Allowable Capacity is based on Depth Criterion

	Minor Storm	Major Storm	
Q _{allow} =	9.9	9.9	cfs

Minor storm max. allowable capacity GOOD - greater than the design flow given on sheet 'Inlet Management'
 Major storm max. allowable capacity GOOD - greater than the design flow given on sheet 'Inlet Management'

INLET ON A CONTINUOUS GRADE

MHFD-Inlet, Version 5.01 (April 2021)

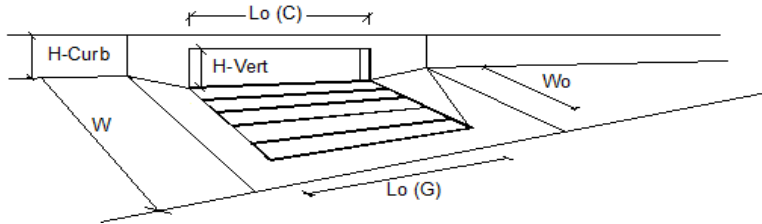

Design Information (Input)	MINOR	MAJOR	
Type of Inlet	CDOT Type C Grate		
Local Depression (additional to continuous gutter depression 'a')	0.0	0.0	inches
Total Number of Units in the Inlet (Grate or Curb Opening)	1	1	
Length of a Single Unit Inlet (Grate or Curb Opening)	2.92	2.92	ft
Width of a Unit Grate (cannot be greater than W, Gutter Width)	2.92	2.92	ft
Clogging Factor for a Single Unit Grate (typical min. value = 0.5)	0.50	0.50	
Clogging Factor for a Single Unit Curb Opening (typical min. value = 0.1)	N/A	N/A	
Street Hydraulics: OK - O < Allowable Street Capacity			
Design Discharge for Half of Street (from <i>Inlet Management</i>)	0.1	0.2	cfs
Water Spread Width	1.6	2.1	ft
Water Depth at Flowline (outside of local depression)	1.3	1.7	inches
Water Depth at Street Crown (or at T _{MAX})	0.0	0.0	inches
Ratio of Gutter Flow to Design Flow	0.968	0.867	
Discharge outside the Gutter Section W _x , carried in Section T _x	0.0	0.0	cfs
Discharge within the Gutter Section W	0.1	0.2	cfs
Discharge Behind the Curb Face	0.0	0.0	cfs
Flow Area within the Gutter Section W	0.07	0.10	sq ft
Velocity within the Gutter Section W	1.7	2.1	fps
Water Depth for Design Condition	1.3	1.7	inches
Grate Analysis (Calculated)			
Total Length of Inlet Grate Opening	2.92	2.92	ft
Ratio of Grate Flow to Design Flow	-0.487	0.422	
Under No-Clogging Condition			
Minimum Velocity Where Grate Splash-Over Begins	9.94	9.94	fps
Interception Rate of Frontal Flow	1.00	1.00	
Interception Rate of Side Flow	0.61	0.56	
Interception Capacity	0.1	0.2	cfs
Under Clogging Condition			
Clogging Coefficient for Multiple-unit Grate Inlet	1.00	1.00	
Clogging Factor for Multiple-unit Grate Inlet	0.50	0.50	
Effective (unclogged) Length of Multiple-unit Grate Inlet	1.46	1.46	ft
Minimum Velocity Where Grate Splash-Over Begins	6.91	6.91	fps
Interception Rate of Frontal Flow	1.00	1.00	
Interception Rate of Side Flow	0.24	0.20	
Actual Interception Capacity	0.0	0.1	cfs
Carry-Over Flow = Q _o - Q _i (to be applied to curb opening or next d/s inlet)	0.1	0.1	cfs
Curb or Slotted Inlet Opening Analysis (Calculated)			
Equivalent Slope S _a (based on grate carry-over)	N/A	N/A	ft/ft
Required Length L _T to Have 100% Interception	N/A	N/A	ft
Under No-Clogging Condition			
Effective Length of Curb Opening or Slotted Inlet (minimum of L, L _T)	N/A	N/A	ft
Interception Capacity	N/A	N/A	cfs
Under Clogging Condition			
Clogging Coefficient	N/A	N/A	
Clogging Factor for Multiple-unit Curb Opening or Slotted Inlet	N/A	N/A	
Effective (Unclogged) Length	N/A	N/A	ft
Actual Interception Capacity	N/A	N/A	cfs
Carry-Over Flow = Q _o - Q _i	N/A	N/A	cfs
Summary			
Total Inlet Interception Capacity	0.0	0.1	cfs
Total Inlet Carry-Over Flow (flow bypassing inlet)	0.1	0.1	cfs
Capture Percentage = Q _i /Q _o =	-12	54	%

AREA INLET IN A SWALE

Super Star Car Wash - Meadowbrook
Rain Garden Outlet Structure

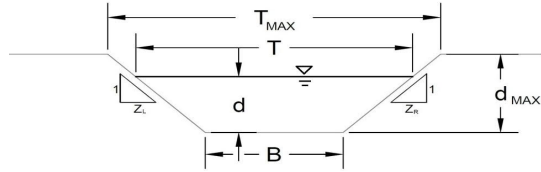

This worksheet uses the NRCS vegetal retardance method to determine Manning's n.

For more information see Section 7.2.3 of the USDCM.

Analysis of Trapezoidal Grass-Lined Channel Using SCS Method

NRCS Vegetal Retardance (A, B, C, D, or E)
Manning's n (Leave cell D16 blank to manually enter an n value)
Channel Invert Slope
Bottom Width
Left Side Slope
Right Side Slope

Check one of the following soil types:

Soil Type:	Max. Velocity (V _{MAX})	Max. Froude No. (F _{MAX})
Non-Cohesive	5.0 fps	0.60
Cohesive	7.0 fps	0.80
Paved	N/A	N/A

A, B, C, D, or E =

n =	0.013
S ₀ =	0.0050 ft/ft
B =	75.00 ft
Z1 =	100.00 ft/ft
Z2 =	100.00 ft/ft

Choose One:

Non-Cohesive

Cohesive

Paved

Maximum Allowable Top Width of Channel for Minor & Major Storm
Maximum Allowable Water Depth in Channel for Minor & Major Storm

	Minor Storm	Major Storm	
T _{MAX} =	100.00	100.00	ft
d _{MAX} =	0.20	0.70	ft

Maximum Channel Capacity Based On Allowable Top Width

Maximum Allowable Top Width
Water Depth
Flow Area
Wetted Perimeter
Hydraulic Radius
Manning's n
Flow Velocity
Velocity-Depth Product
Hydraulic Depth
Froude Number
Maximum Flow Based on Allowable Water Depth

	Minor Storm	Major Storm	
T _{MAX} =	100.00	100.00	ft
d =	0.13	0.13	ft
A =	10.94	10.94	sq ft
P =	100.00	100.00	ft
R =	0.11	0.11	ft
n =	0.013	0.013	
V =	1.85	1.85	fps
VR =	0.20	0.20	ft ² /s
D =	0.11	0.11	ft
Fr =	0.99	0.99	
Q _T =	20.3	20.3	cfs

Maximum Channel Capacity Based On Allowable Water Depth

Maximum Allowable Water Depth
Top Width
Flow Area
Wetted Perimeter
Hydraulic Radius
Manning's n
Flow Velocity
Velocity-Depth Product
Hydraulic Depth
Froude Number
Maximum Flow Based on Allowable Water Depth

	Minor Storm	Major Storm	
d _{MAX} =	0.20	0.70	ft
T =	115.00	215.00	ft
A =	19.00	101.50	sq ft
P =	115.00	215.01	ft
R =	0.17	0.47	ft
n =	0.013	0.013	
V =	2.44	4.91	fps
VR =	0.40	2.32	ft ² /s
D =	0.17	0.47	ft
Fr =	1.06	1.26	
Q _d =	46.4	498.7	cfs

Allowable Channel Capacity Based On Channel Geometry

MINOR STORM Allowable Capacity is based on Top Width Criterion
MAJOR STORM Allowable Capacity is based on Top Width Criterion

	Minor Storm	Major Storm	
Q _{allow} =	20.3	20.3	cfs
d _{allow} =	0.13	0.13	ft

Water Depth in Channel Based On Design Peak Flow

Design Peak Flow
Water Depth
Top Width
Flow Area
Wetted Perimeter
Hydraulic Radius
Manning's n
Flow Velocity
Velocity-Depth Product
Hydraulic Depth
Froude Number

	Minor Storm	Major Storm	
Q _o =	2.6	9.1	cfs
d =	0.04	0.08	ft
T =	82.48	90.68	ft
A =	2.95	6.50	sq ft
P =	82.48	90.68	ft
R =	0.04	0.07	ft
n =	0.013	0.013	
V =	0.88	1.40	fps
VR =	0.03	0.10	ft ² /s
D =	0.04	0.07	ft
Fr =	0.82	0.92	

Minor storm max. allowable capacity GOOD - greater than the design flow given on sheet 'Inlet Management'
Major storm max. allowable capacity GOOD - greater than the design flow given on sheet 'Inlet Management'

MHFD-Inlet, Version 5.01 (April 2021)
AREA INLET IN A SWALE

Super Star Car Wash - Meadowbrook
 Rain Garden Outlet Structure

Inlet Design Information (Input)	
Type of Inlet	CDOT Type C (Depressed)
Inlet Type =	CDOT Type C (Depressed)
Angle of Inclined Grate (must be ≤ 30 degrees)	$\theta = 0.00$ degrees
Width of Grate	$W = 3.00$ ft
Length of Grate	$L = 3.00$ ft
Open Area Ratio	$A_{RATIO} = 0.70$
Height of Inclined Grate	$H_B = 0.00$ ft
Clogging Factor	$C_f = 0.50$
Grate Discharge Coefficient	$C_d = 0.84$
Orifice Coefficient	$C_o = 0.56$
Weir Coefficient	$C_w = 1.81$

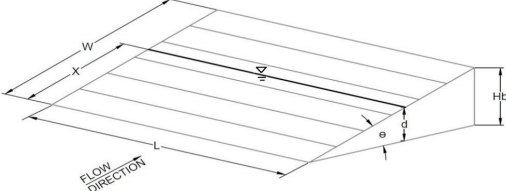

	MINOR	MAJOR
$d =$	1.04	1.08

	MINOR	MAJOR
$X =$	3.00	3.00
$Q_{ws} =$	10.0	10.6
$Q_{wb} =$	14.3	15.2
$Q_{wi} =$	34.4	36.4
$Q_{wa} =$	17.2	18.2

	MINOR	MAJOR
$Q_{oi} =$	29.0	29.5
$Q_{oa} =$	14.5	14.8

Total Inlet Interception Capacity (assumes clogged condition)	$Q_a = 14.5$	14.8	cfs
Bypassed Flow	$Q_b = 0.0$	0.0	cfs
Capture Percentage = Q_a/Q_o	$C\% = 100$	100	%

MHFD-Inlet, Version 5.01 (April 2021)
AREA INLET IN A SWALE

Super Star Car Wash - Meadowbrook
 Basin A4

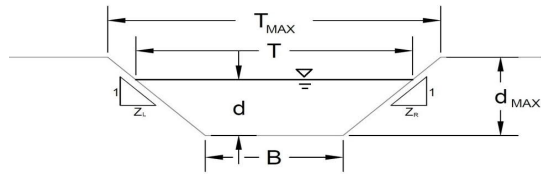

This worksheet uses the NRCS vegetal retardance method to determine Manning's n.
 For more information see Section 7.2.3 of the USDCM.

Analysis of Trapezoidal Grass-Lined Channel Using SCS Method				
NRCS Vegetal Retardance (A, B, C, D, or E)				
Manning's n (Leave cell D16 blank to manually enter an n value)				
Channel Invert Slope				
Bottom Width				
Left Side Slope				
Right Side Slope				
Check one of the following soil types:				
Soil Type:	Max. Velocity (V _{MAX})	Max. Froude No. (F _{MAX})		
Non-Cohesive	5.0 fps	0.60		
Cohesive	7.0 fps	0.80		
Paved	N/A	N/A		
A, B, C, D, or E = <table border="1"><tr><td>B</td></tr></table>			B	
B				
n = <table border="1"><tr><td>see details below</td></tr></table>			see details below	
see details below				
S ₀ = <table border="1"><tr><td>0.0200</td><td>ft/ft</td></tr></table>			0.0200	ft/ft
0.0200	ft/ft			
B = <table border="1"><tr><td>4.00</td><td>ft</td></tr></table>			4.00	ft
4.00	ft			
Z1 = <table border="1"><tr><td>10.00</td><td>ft/ft</td></tr></table>			10.00	ft/ft
10.00	ft/ft			
Z2 = <table border="1"><tr><td>20.00</td><td>ft/ft</td></tr></table>			20.00	ft/ft
20.00	ft/ft			
Choose One:				
<input type="radio"/> Non-Cohesive				
<input type="radio"/> Cohesive				
<input type="radio"/> Paved				
Maximum Allowable Top Width of Channel for Minor & Major Storm				
Maximum Allowable Water Depth in Channel for Minor & Major Storm				
T _{MAX} =	<table border="1"><tr><td>15.00</td><td>15.00</td></tr></table>	15.00	15.00	ft
15.00	15.00			
d _{MAX} =	<table border="1"><tr><td>0.50</td><td>0.50</td></tr></table>	0.50	0.50	ft
0.50	0.50			
Allowable Channel Capacity Based On Channel Geometry				
MINOR STORM Allowable Capacity is based on Top Width Criterion				
MAJOR STORM Allowable Capacity is based on Top Width Criterion				
Q _{allow} =	<table border="1"><tr><td>0.9</td><td>0.9</td></tr></table>	0.9	0.9	cfs
0.9	0.9			
d _{allow} =	<table border="1"><tr><td>0.37</td><td>0.37</td></tr></table>	0.37	0.37	ft
0.37	0.37			
Water Depth in Channel Based On Design Peak Flow				
Design Peak Flow				
Water Depth				
Q _o =	<table border="1"><tr><td>0.0</td><td>0.3</td></tr></table>	0.0	0.3	cfs
0.0	0.3			
d =	<table border="1"><tr><td>0.00</td><td>0.23</td></tr></table>	0.00	0.23	ft
0.00	0.23			
Minor storm max. allowable capacity GOOD - greater than the design flow given on sheet 'Inlet Management'				
Major storm max. allowable capacity GOOD - greater than the design flow given on sheet 'Inlet Management'				

MHFD-Inlet, Version 5.01 (April 2021)
AREA INLET IN A SWALE

Super Star Car Wash - Meadowbrook
 Basin A4

Inlet Design Information (Input)																					
Type of Inlet	User-Defined																				
Inlet Type =	User-Defined																				
Angle of Inclined Grate (must be <= 30 degrees)	$\theta = 0.00$ degrees																				
Width of Grate	$W = 2.00$ ft																				
Length of Grate	$L = 2.00$ ft																				
Open Area Ratio	$A_{RATIO} = 0.70$																				
Height of Inclined Grate	$H_B = 0.00$ ft																				
Clogging Factor	$C_f = 0.50$																				
Grate Discharge Coefficient	$C_d = N/A$																				
Orifice Coefficient	$C_o = 0.64$																				
Weir Coefficient	$C_w = 2.05$																				
	<table border="1"> <thead> <tr> <th></th> <th>MINOR</th> <th>MAJOR</th> <th></th> </tr> </thead> <tbody> <tr> <td>$d =$</td> <td>0.00</td> <td>0.23</td> <td></td> </tr> <tr> <td>$Q_a =$</td> <td>0.0</td> <td>1.4</td> <td>cfs</td> </tr> <tr> <td>$Q_b =$</td> <td>0.0</td> <td>0.0</td> <td>cfs</td> </tr> <tr> <td>$C\% =$</td> <td>100</td> <td>100</td> <td>%</td> </tr> </tbody> </table>		MINOR	MAJOR		$d =$	0.00	0.23		$Q_a =$	0.0	1.4	cfs	$Q_b =$	0.0	0.0	cfs	$C\% =$	100	100	%
	MINOR	MAJOR																			
$d =$	0.00	0.23																			
$Q_a =$	0.0	1.4	cfs																		
$Q_b =$	0.0	0.0	cfs																		
$C\% =$	100	100	%																		
Water Depth at Inlet (for depressed inlets, 1 foot is added for depression)																					
Total Inlet Interception Capacity (assumes clogged condition)																					
Bypassed Flow																					
Capture Percentage = Q_a/Q_o																					

MHFD-Inlet, Version 5.01 (April 2021)
AREA INLET IN A SWALE

Super Star Car Wash - Meadowbrook
 Basin A5

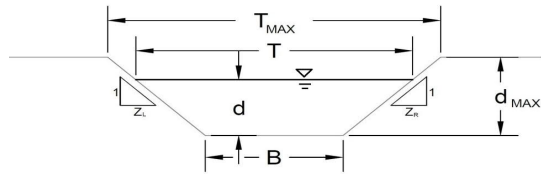

This worksheet uses the NRCS vegetal retardance method to determine Manning's n.
 For more information see Section 7.2.3 of the USDCM.

Analysis of Trapezoidal Grass-Lined Channel Using SCS Method					
NRCS Vegetal Retardance (A, B, C, D, or E)					
Manning's n (Leave cell D16 blank to manually enter an n value)					
Channel Invert Slope					
Bottom Width					
Left Side Slope					
Right Side Slope					
Check one of the following soil types:					
Soil Type:	Max. Velocity (V_{MAX})	Max. Froude No. (F_{MAX})			
Non-Cohesive	5.0 fps	0.60			
Cohesive	7.0 fps	0.80			
Paved	N/A	N/A			
A, B, C, D, or E = <table border="1"><tr><td>B</td></tr></table>			B		
B					
n = <table border="1"><tr><td>see details below</td></tr></table>			see details below		
see details below					
S_0 = <table border="1"><tr><td>0.0200</td><td>ft/ft</td></tr></table>			0.0200	ft/ft	
0.0200	ft/ft				
B = <table border="1"><tr><td>4.00</td><td>ft</td></tr></table>			4.00	ft	
4.00	ft				
Z_1 = <table border="1"><tr><td>10.00</td><td>ft/ft</td></tr></table>			10.00	ft/ft	
10.00	ft/ft				
Z_2 = <table border="1"><tr><td>10.00</td><td>ft/ft</td></tr></table>			10.00	ft/ft	
10.00	ft/ft				
Choose One:					
<input type="radio"/> Non-Cohesive					
<input type="radio"/> Cohesive					
<input type="radio"/> Paved					
Maximum Allowable Top Width of Channel for Minor & Major Storm					
T_{MAX} = <table border="1"><tr><td>10.00</td><td>10.00</td><td>ft</td></tr></table>			10.00	10.00	ft
10.00	10.00	ft			
Maximum Allowable Water Depth in Channel for Minor & Major Storm					
d_{MAX} = <table border="1"><tr><td>0.50</td><td>0.50</td><td>ft</td></tr></table>			0.50	0.50	ft
0.50	0.50	ft			
Allowable Channel Capacity Based On Channel Geometry					
MINOR STORM Allowable Capacity is based on Top Width Criterion					
MAJOR STORM Allowable Capacity is based on Top Width Criterion					
Q_{allow} = <table border="1"><tr><td>0.5</td><td>0.5</td><td>cfs</td></tr></table>			0.5	0.5	cfs
0.5	0.5	cfs			
d_{allow} = <table border="1"><tr><td>0.30</td><td>0.30</td><td>ft</td></tr></table>			0.30	0.30	ft
0.30	0.30	ft			
Water Depth in Channel Based On Design Peak Flow					
Design Peak Flow					
Water Depth					
Q_o = <table border="1"><tr><td>0.0</td><td>0.3</td><td>cfs</td></tr></table>			0.0	0.3	cfs
0.0	0.3	cfs			
d = <table border="1"><tr><td>0.00</td><td>0.24</td><td>ft</td></tr></table>			0.00	0.24	ft
0.00	0.24	ft			
Minor storm max. allowable capacity GOOD - greater than the design flow given on sheet 'Inlet Management'					
Major storm max. allowable capacity GOOD - greater than the design flow given on sheet 'Inlet Management'					

MHFD-Inlet, Version 5.01 (April 2021)
AREA INLET IN A SWALE

Super Star Car Wash - Meadowbrook
 Basin A5

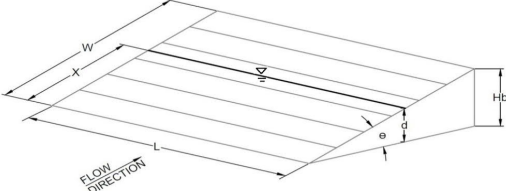
Inlet Design Information (Input)																					
Type of Inlet	User-Defined																				
Inlet Type =	User-Defined																				
Angle of Inclined Grate (must be ≤ 30 degrees)	$\theta = 0.00$ degrees																				
Width of Grate	$W = 2.00$ ft																				
Length of Grate	$L = 2.00$ ft																				
Open Area Ratio	$A_{RATIO} = 0.70$																				
Height of Inclined Grate	$H_B = 0.00$ ft																				
Clogging Factor	$C_f = 0.50$																				
Grate Discharge Coefficient	$C_d = N/A$																				
Orifice Coefficient	$C_o = 0.64$																				
Weir Coefficient	$C_w = 2.05$																				
																					
Water Depth at Inlet (for depressed inlets, 1 foot is added for depression)	<table border="1"> <thead> <tr> <th></th> <th>MINOR</th> <th>MAJOR</th> <th></th> </tr> </thead> <tbody> <tr> <td>$d =$</td> <td>0.00</td> <td>0.24</td> <td></td> </tr> <tr> <td>$Q_a =$</td> <td>0.0</td> <td>1.4</td> <td>cfs</td> </tr> <tr> <td>$Q_b =$</td> <td>0.0</td> <td>0.0</td> <td>cfs</td> </tr> <tr> <td>$C\% =$</td> <td>100</td> <td>100</td> <td>%</td> </tr> </tbody> </table>		MINOR	MAJOR		$d =$	0.00	0.24		$Q_a =$	0.0	1.4	cfs	$Q_b =$	0.0	0.0	cfs	$C\% =$	100	100	%
	MINOR	MAJOR																			
$d =$	0.00	0.24																			
$Q_a =$	0.0	1.4	cfs																		
$Q_b =$	0.0	0.0	cfs																		
$C\% =$	100	100	%																		
Total Inlet Interception Capacity (assumes clogged condition)																					
Bypassed Flow																					
Capture Percentage = Q_a/Q_o																					

MHFD-Inlet, Version 5.01 (April 2021)
AREA INLET IN A SWALE

Super Star Car Wash - Meadowbrook
 Basin A3

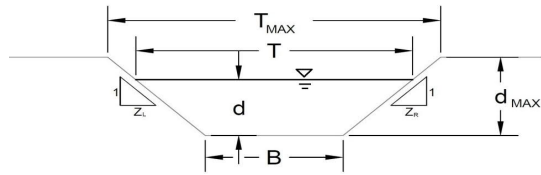

This worksheet uses the NRCS vegetal retardance method to determine Manning's n.
 For more information see Section 7.2.3 of the USDCM.

Analysis of Trapezoidal Grass-Lined Channel Using SCS Method		
NRCS Vegetal Retardance (A, B, C, D, or E)	A, B, C, D, or E =	B
Manning's n (Leave cell D16 blank to manually enter an n value)	n =	see details below
Channel Invert Slope	S ₀ =	0.0200 ft/ft
Bottom Width	B =	4.00 ft
Left Side Slope	Z1 =	5.00 ft/ft
Right Side Slope	Z2 =	5.00 ft/ft
Check one of the following soil types:		
Soil Type:	Max. Velocity (V _{max})	Max. Froude No. (F _{max})
Non-Cohesive	5.0 fps	0.60
Cohesive	7.0 fps	0.80
Paved	N/A	N/A
Choose One:		
<input type="radio"/> Non-Cohesive		
<input type="radio"/> Cohesive		
<input type="radio"/> Paved		
Maximum Allowable Top Width of Channel for Minor & Major Storm	T _{MAX} =	Minor Storm: 10.00 ft, Major Storm: 10.00 ft
Maximum Allowable Water Depth in Channel for Minor & Major Storm	d _{MAX} =	Minor Storm: 0.50 ft, Major Storm: 0.50 ft
Allowable Channel Capacity Based On Channel Geometry		
MINOR STORM Allowable Capacity is based on Depth Criterion		
MAJOR STORM Allowable Capacity is based on Depth Criterion		
Water Depth in Channel Based On Design Peak Flow	Q _{allow} =	Minor Storm: 1.1 cfs, Major Storm: 1.1 cfs
Design Peak Flow	d _{allow} =	Minor Storm: 0.50 ft, Major Storm: 0.50 ft
Water Depth	Q _o =	0.0 cfs, 0.9 cfs
	d =	0.00 ft, 0.44 ft
Minor storm max. allowable capacity GOOD - greater than the design flow given on sheet 'Inlet Management'		
Major storm max. allowable capacity GOOD - greater than the design flow given on sheet 'Inlet Management'		

MHFD-Inlet, Version 5.01 (April 2021)
AREA INLET IN A SWALE

Super Star Car Wash - Meadowbrook
 Basin A3

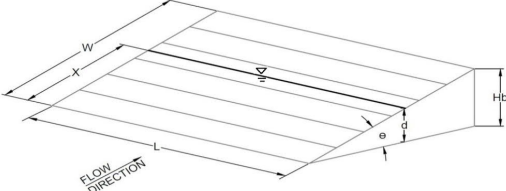
Inlet Design Information (Input)																					
Type of Inlet	User-Defined																				
Inlet Type =	User-Defined																				
Angle of Inclined Grate (must be ≤ 30 degrees)	$\theta = 0.00$ degrees																				
Width of Grate	$W = 2.00$ ft																				
Length of Grate	$L = 2.00$ ft																				
Open Area Ratio	$A_{RATIO} = 0.70$																				
Height of Inclined Grate	$H_B = 0.00$ ft																				
Clogging Factor	$C_f = 0.50$																				
Grate Discharge Coefficient	$C_d = N/A$																				
Orifice Coefficient	$C_o = 0.64$																				
Weir Coefficient	$C_w = 2.05$																				
																					
Water Depth at Inlet (for depressed inlets, 1 foot is added for depression)																					
Total Inlet Interception Capacity (assumes clogged condition)																					
Bypassed Flow																					
Capture Percentage = Q_a/Q_o																					
	<table border="1"> <thead> <tr> <th></th> <th>MINOR</th> <th>MAJOR</th> <th></th> </tr> </thead> <tbody> <tr> <td>$d =$</td> <td>0.00</td> <td>0.44</td> <td></td> </tr> <tr> <td>$Q_a =$</td> <td>0.0</td> <td>3.6</td> <td>cfs</td> </tr> <tr> <td>$Q_b =$</td> <td>0.0</td> <td>0.0</td> <td>cfs</td> </tr> <tr> <td>$C\% =$</td> <td>100</td> <td>100</td> <td>%</td> </tr> </tbody> </table>		MINOR	MAJOR		$d =$	0.00	0.44		$Q_a =$	0.0	3.6	cfs	$Q_b =$	0.0	0.0	cfs	$C\% =$	100	100	%
	MINOR	MAJOR																			
$d =$	0.00	0.44																			
$Q_a =$	0.0	3.6	cfs																		
$Q_b =$	0.0	0.0	cfs																		
$C\% =$	100	100	%																		

AREA INLET IN A SWALE

Super Star Car Wash - Meadowbrook
Basin A6

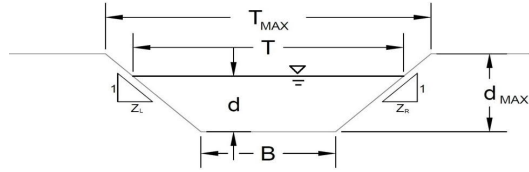

This worksheet uses the NRCS vegetative retardance method to determine Manning's n.
For more information see Section 7.2.3 of the USDCM.

Analysis of Trapezoidal Grass-Lined Channel Using SCS Method		
NRCS Vegetal Retardance (A, B, C, D, or E)		
Manning's n (Leave cell D16 blank to manually enter an n value)		
Channel Invert Slope		
Bottom Width		
Left Side Slope		
Right Side Slope		
Check one of the following soil types:		
Soil Type:	Max. Velocity (V_{MAX})	Max Froude No. (F_{MAX})
Non-Cohesive	5.0 fps	0.60
Cohesive	7.0 fps	0.80
Paved	N/A	N/A
Maximum Allowable Top Width of Channel for Minor & Major Storm		
Maximum Allowable Water Depth in Channel for Minor & Major Storm		
Allowable Channel Capacity Based On Channel Geometry		
MINOR STORM Allowable Capacity is based on Depth Criterion		
MAJOR STORM Allowable Capacity is based on Depth Criterion		
Water Depth in Channel Based On Design Peak Flow		
Design Peak Flow		
Water Depth		

A, B, C, D, or E =	B			
n =	see details below			
S_0 =	0.0200	ft/ft		
B =	4.00	ft		
Z1 =	5.00	ft/ft		
Z2 =	5.00	ft/ft		
Choose One:				
<input type="radio"/> Non-Cohesive <input type="radio"/> Cohesive <input type="radio"/> Paved				
<table border="1" style="border-collapse: collapse; width: 100%;"> <tr> <td style="padding: 2px;">Minor Storm</td> <td style="padding: 2px;">Major Storm</td> </tr> </table>			Minor Storm	Major Storm
Minor Storm	Major Storm			
T_{MAX} =	10.00	10.00	ft	
d_{MAX} =	0.50	0.50	ft	
<table border="1" style="border-collapse: collapse; width: 100%;"> <tr> <td style="padding: 2px;">Minor Storm</td> <td style="padding: 2px;">Major Storm</td> </tr> </table>			Minor Storm	Major Storm
Minor Storm	Major Storm			
Q_{allow} =	1.1	1.1	cfs	
d_{allow} =	0.50	0.50	ft	
<table border="1" style="border-collapse: collapse; width: 100%;"> <tr> <td style="padding: 2px;">0.0</td> <td style="padding: 2px;">0.2</td> </tr> </table>			0.0	0.2
0.0	0.2			
Q_o =	0.0	0.2	cfs	
d =	0.00	0.22	ft	

Minor storm max. allowable capacity GOOD - greater than the design flow given on sheet 'Inlet Management'

Major storm max. allowable capacity GOOD - greater than the design flow given on sheet 'Inlet Management'

MHFD-Inlet, Version 5.01 (April 2021)
AREA INLET IN A SWALE

Super Star Car Wash - Meadowbrook
 Basin A6

Inlet Design Information (Input)

Type of Inlet: Inlet Type =

Angle of Inclined Grate (must be ≤ 30 degrees)

Width of Grate

Length of Grate

Open Area Ratio

Height of Inclined Grate

Clogging Factor

Grate Discharge Coefficient

Orifice Coefficient

Weir Coefficient

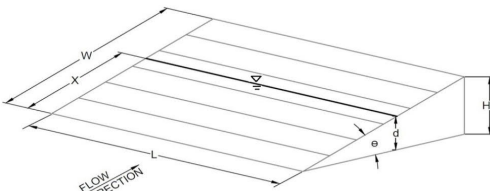

θ =	0.00	degrees
W =	2.00	ft
L =	2.00	ft
A _{RATIO} =	0.70	
H _B =	0.00	ft
C _r =	0.50	
C _d =	N/A	
C _o =	0.64	
C _w =	2.05	

	MINOR	MAJOR	
d =	0.00	0.22	
Q _a =	0.0	1.2	cfs
Q _b =	0.0	0.0	cfs
C% =	100	100	%

Water Depth at Inlet (for depressed inlets, 1 foot is added for depression)

Total Inlet Interception Capacity (assumes clogged condition)

Bypassed Flow

Capture Percentage = Q_a/Q_o