



**DEVIATION REQUEST** (Attach diagrams, figures, and other documentation to clarify request)

A deviation from the standards of or in Section **2.6 Structure Design** of the Engineering Criteria Manual (ECM) is requested.

Identify the specific ECM standard which a deviation is requested:

ECM Section 2.6.9.G

G. Multiple pipe crossings. Due to maintenance issues, parallel culverts (a.k.a. culvert batteries) are not permitted except in areas where low headwater is unavoidable, areas where approach velocity is supercritical, or in the vicinity of a bend immediately upstream. Refer to Chapter 9 of the CDOT Drainage Design Manual for additional information.

State the reason for the requested deviation:

A request allow for multiple pipe crossing (i.e. parallel culverts) for Culvert B6-A, triple 36-inch RCP culverts to allow for the proposed roadway to cross over a shallow and wide natural drainageway.

Explain the proposed alternative and compare to the ECM standards (May provide applicable regional or national standards used as basis):

The request proposes allowing for triple 36-inch RCP culverts in place of a single larger culvert. Allowing for multiple culverts (parallel culverts) is a standard practice allowed by CDOT and other jurisdictions that allows for flexibility in design for more constraining locations. This multiple pipe crossing proposes to follow the CDOT standards as outlined in Section 9.2.3-Design Features of Chapter 9 of the CDOT Drainage Design Manual. The pipes will be spaced at the minimum spacing identified in the CDOT Standard Detail M-206-1. An exhibit showing the design and location is provided attached to this deviation request.

**LIMITS OF CONSIDERATION**

(At least one of the conditions listed below must be met for this deviation request to be considered.)

- The ECM standard is inapplicable to the particular situation.
- Topography, right-of-way, or other geographical conditions or impediments impose an undue hardship and an equivalent alternative that can accomplish the same design objective is available and does not compromise public safety or accessibility.
- A change to a standard is required to address a specific design or construction problem, and if not modified, the standard will impose an undue hardship on the applicant with little or no material benefit to the public.

Provide justification:

The following reasons provide justification for why a modified cross section is being requested:

- The existing drainage way is wide and shallow. At the location of the culvert, the drainageway starts to transition from a small concentrated drainageway to an approximate 100' wide natural channel way, in more a sheet flow type condition. Crossing a shallow and wider channel lends to a design with a smaller culvert diameter to avoid large amounts of fill.
- Proposed design maintaining the 2-foot minimum cover over the proposed pipe.
- Without a triple barrel, a 54" pipe would be required, causing 1.5' feet of additional fill to the roadway.
- Meet the criteria outlined in the CDOT Drainage Design Manual outlined in Section 9.2.3
- The pipes will be spaced at the minimum spacing identified in the CDOT Standard Detail M-206-1.
- Upstream riprap is being placed on the inlet side to help dissipate any energy prior to entering the culvert.

**CRITERIA FOR APPROVAL**

Per ECM section 5.8.7 the request for a deviation may be considered if the request is **not based exclusively on financial considerations**. The deviation must not be detrimental to public safety or surrounding property. The applicant must include supporting information demonstrating compliance with **all of the following criteria**:

The deviation will achieve the intended result with a comparable or superior design and quality of improvement.

The multiple pipes are design to have the same capacity as the larger single pipe/ culvert. Section 2.6.9.G of the ECM references Chapter 9 of the CDOT Drainage Design Manual, within the section. This design follows the criteria of the CDOT Drainage Design Manual which allows for a multiple pipe application. The pipes will be spaced at the minimum spacing identified in the CDOT Standard Detail M-206-1.

The deviation will not adversely affect safety or operations.

Designs with multiple pipe applications are common and do not adversely affect safety or operations. The multiple pipes are design to have the same capacity as the larger single pipe/ culvert. 36-inch culverts are also large enough to maintain and clear debris without much more difficulty than a 54-inch pipe.

The deviation will not adversely affect maintenance and its associated cost.

The deviation will not adversely affect maintenance and cost. The modification doesn't not include any component or features which require specialized maintenance activities and/or equipment.

The deviation will not adversely affect aesthetic appearance.

The multiple pipe design will not adversely affect aesthetic appearance. Without a multiple pipe design, the roadway would have 1.5 feet of additional fill which would not allow the roadway to blend into the hillside in a balanced cut/fill condition and look aesthetically unpleasing.

The deviation meets the design intent and purpose of the ECM standards.

Section 2.6.9.G of the ECM references Chapter 9 of the CDOT Drainage Design Manual, within the section. This design follows the criteria of the CDOT Drainage Design Manual which allows for a multiple pipe application. So, even though the ECM and the CDOT manuals seem to contradict each other, the intent is that multiple barrel/ pipe applications are generally allowed if the conditions listed within the CDOT Drainage Manual are met.

The deviation meets the control measure requirements of Part I.E.3 and Part I.E.4 of the County's MS4 permit, as applicable.

The proposed design modifications do not change the ability to remain consistent with the control measure requirements of the County MS4 permit. All the runoff from the proposed roadways will be captured and receive water quality treatment provided by an existing detention pond.

**REVIEW AND RECOMMENDATION:**

**Approved by the ECM Administrator**

This request has been determined to have met the criteria for approval. A deviation from Section \_\_\_\_\_ of the ECM is hereby granted based on the justification provided.

Γ Γ

L J

**Denied by the ECM Administrator**

This request has been determined not to have met criteria for approval. A deviation from Section \_\_\_\_\_ of the ECM is hereby denied.

Γ Γ

L J

**ECM ADMINISTRATOR COMMENTS/CONDITIONS:**

## **1.1. PURPOSE**

The purpose of this resource is to provide a form for documenting the findings and decision by the ECM Administrator concerning a deviation request. The form is used to document the review and decision concerning a requested deviation. The request and decision concerning each deviation from a specific section of the ECM shall be recorded on a separate form.

## **1.2. BACKGROUND**

A deviation is a critical aspect of the review process and needs to be documented to ensure that the deviations granted are applied to a specific development application in conformance with the criteria for approval and that the action is documented as such requests can point to potential needed revisions to the ECM.

## **1.3. APPLICABLE STATUTES AND REGULATIONS**

Section 5.8 of the ECM establishes a mechanism whereby an engineering design standard can be modified when if strictly adhered to, would cause unnecessary hardship or unsafe design because of topographical or other conditions particular to the site, and that a departure may be made without destroying the intent of such provision.

## **1.4. APPLICABILITY**

All provisions of the ECM are subject to deviation by the ECM Administrator provided that one of the following conditions is met:

- The ECM standard is inapplicable to a particular situation.
- Topography, right-of-way, or other geographical conditions or impediments impose an undue hardship on the applicant, and an equivalent alternative that can accomplish the same design objective is available and does not compromise public safety or accessibility.
- A change to a standard is required to address a specific design or construction problem, and if not modified, the standard will impose an undue hardship on the applicant with little or no material benefit to the public.

## **1.5. TECHNICAL GUIDANCE**

The review shall ensure all criteria for approval are adequately considered and that justification for the deviation is properly documented.

## **1.6. LIMITS OF APPROVAL**

Whether a request for deviation is approved as proposed or with conditions, the approval is for project-specific use and shall not constitute a precedent or general deviation from these Standards.

## **1.7. REVIEW FEES**

A Deviation Review Fee shall be paid in full at the time of submission of a request for deviation. The fee for Deviation Review shall be as determined by resolution of the BoCC.



K:\COS\_Civil\196239003\_Overlook\CADD\PlanSheets\CDs\196239003\_CD\_OV\_SP.dwg Kofford, Kevin 11/13/2024 9:54 PM

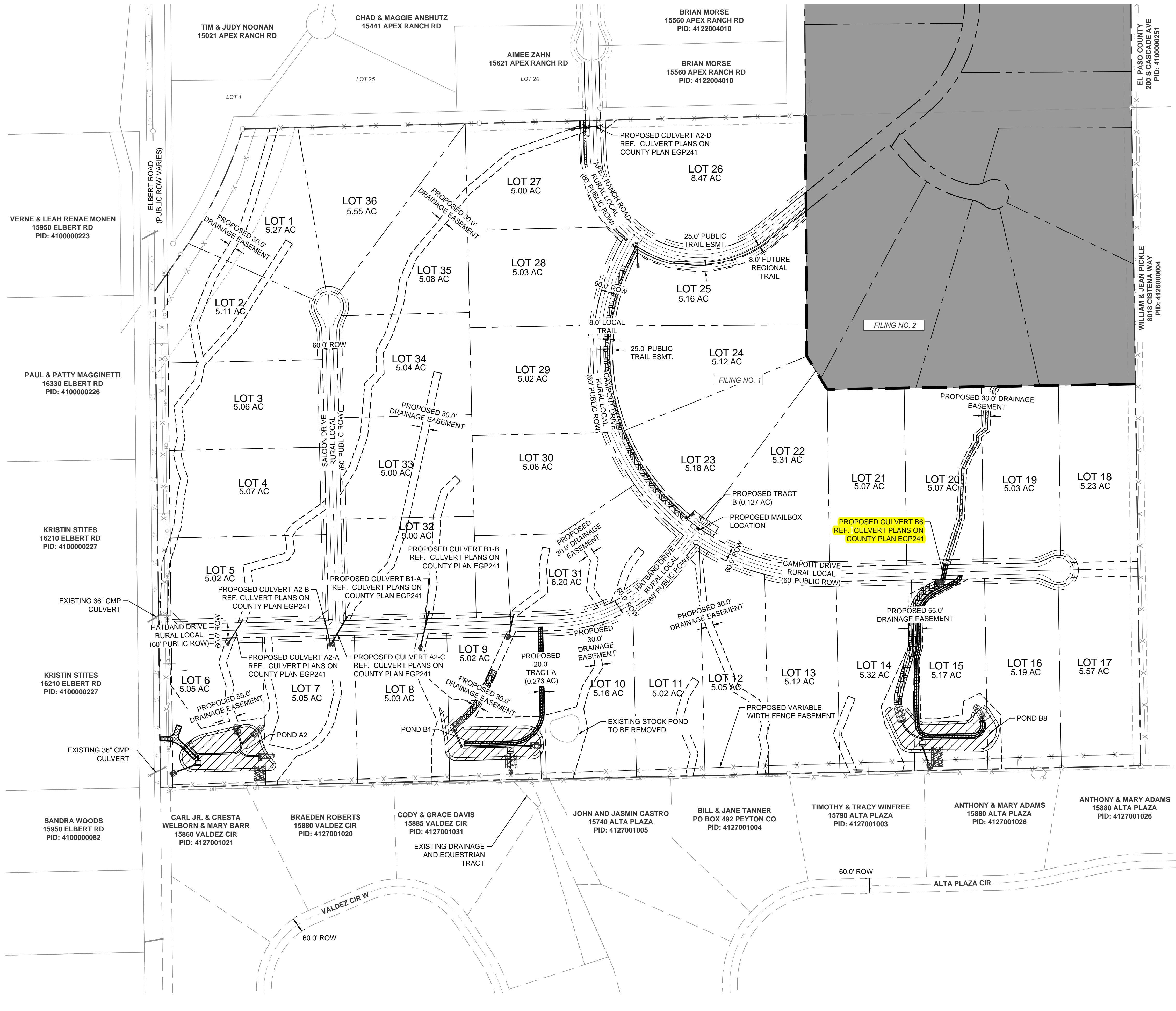

**LEGEND:**

- PROPERTY LINE
- ROW LINE
- LOT LINE
- CENTER LINE
- EASEMENT LINE
- GRADE BREAK LINE
- DITCH LINE
- x-x- EXISTING FENCE
- PUBLIC IMPROVEMENTS EASEMENT
- PUBLIC UTILITY EASEMENT

NO.	REVISION	BY	DATE	APPR.

**Kimley»Horn**  
 2024 KIMLEY-HORN AND ASSOCIATES, INC.  
 2 North Nevada Avenue Suite 900  
 Colorado Springs, Colorado 80903 (719) 453-0180

DESIGNED BY: KRK  
 DRAWN BY: A.J.L.  
 CHECKED BY: KRK  
 DATE: 06/14/2024

**OVERLOOK AT HOMESTEAD FILING NO. 1**  
 EL PASO COUNTY, COLORADO  
 CONSTRUCTION DOCUMENTS  
 OVERALL SITE PLAN

PRELIMINARY  
 FOR REVIEW ONLY  
 NOT FOR  
 CONSTRUCTION  
**Kimley»Horn**  
 Kimley-Horn and Associates, Inc.

PROJECT NO.  
 196239003

SHEET

**C1.4**

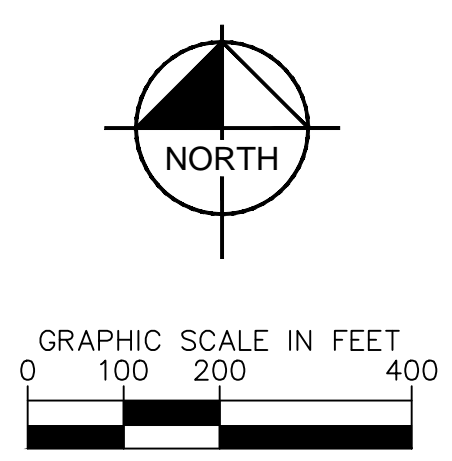

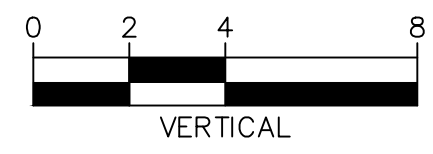
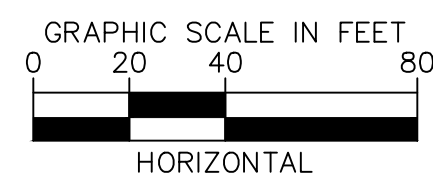
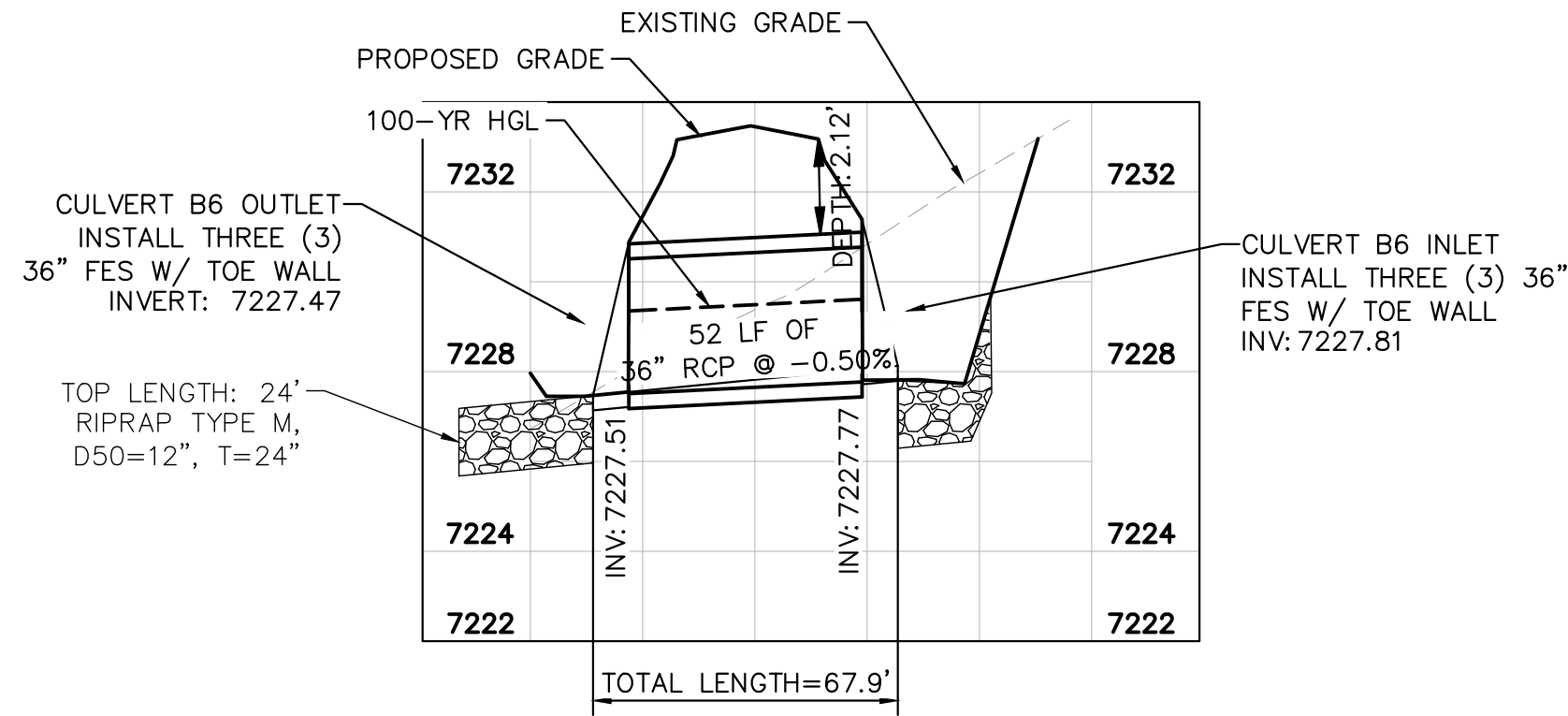
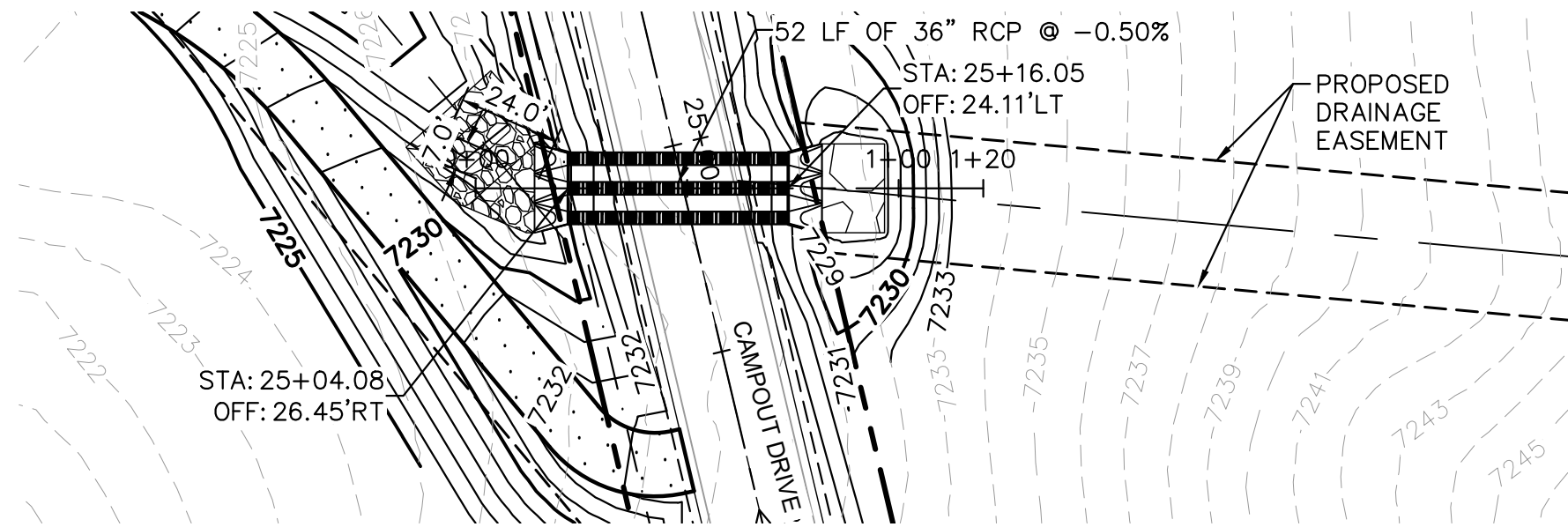

OVERLOOK AT HOMESTEAD FILING NO. 1  
EL PASO COUNTY, COLORADO  
PRE DEVELOPMENT GESC PLAN  
CULVERT PLAN

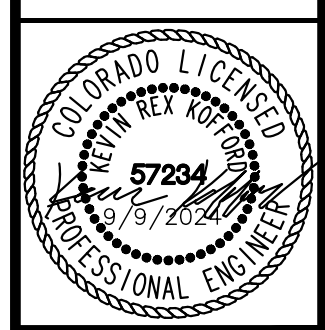

PROJECT NO.  
196239003

SHEET

1.16

CULVERT B6-A PLAN AND PROFILE