



Final Drainage Report

Lot 4, Barbarick Subdivision El Paso County, Colorado

Prepared for:

Vollmer Road Partners, LLLP.
6035 Erin Parkway Drive, Suite 101
Colorado Springs, CO 80918
Contact: Richard Graham

Prepared by:

Kimley-Horn and Associates, Inc.
2 North Nevada Avenue, Suite 900
Colorado Springs, Colorado 80903
(719) 453-0180
Contact: Eric Gunderson, P.E.

Project #: 196489000

Prepared: May 7, 2024

PCD File Number: COM2346

Kimley»Horn



CERTIFICATION

DESIGN ENGINEER'S STATEMENT

The attached drainage plan and report were prepared under my direction and supervision and are correct to the best of my knowledge and belief. Said drainage report has been prepared according to the criteria established by the County for drainage reports and said report is in conformity with the master plan of the drainage basin. I accept responsibility for any liability caused by any negligent acts, errors or omissions on my part in preparation of this report.



SIGNATURE (Affix Seal): Eric Gundersen 05/07/2024
Colorado P.E. No. 49487 Date

OWNER/DEVELOPER'S STATEMENT

I, the developer, have read and will comply with all of the requirements specified in this Drainage Report and Plan.

Vollmer Road Partners, LLLP
Name of Developer

[Signature]
Authorized Signature Date

Richard A. Graham Jr
Printed Name

General Partner
Title

6305 Elm Park Dr, #101 Colo. Spgs. CO 80918
Address:

EL PASO COUNTY

Filed in accordance with the requirements of the Drainage Criteria Manual, Volumes 1 and 2, El Paso County Engineering Criteria Manual and Land Development Code as amended.

Josh Palmer, P.E. Date
County Engineer/ ECM Administrator

Conditions:

TABLE OF CONTENTS

CERTIFICATION2

 DESIGN ENGINEER’S STATEMENT2

 OWNER/DEVELOPER’S STATEMENT2

 EL PASO COUNTY.....2

TABLE OF CONTENTS3

INTRODUCTION5

 GENERAL PROJECT DESCRIPTION5

 PURPOSE AND SCOPE OF STUDY5

 LOCATION5

 DESCRIPTION OF PROPERTY5

DRAINAGE BASINS6

 MAJOR BASIN DESCRIPTIONS6

 EXISTING SUB-BASIN DESCRIPTIONS.....6

Sub-Basin E1.....6

Sub-Basin E2.....6

Sub-Basin OE1.....6

Sub-Basin OE2.....7

Sub-Basin OE3.....7

Sub-Basin OE4.....7

Sub-Basin OE5.....7

 PROPOSED SUB-BASIN DESCRIPTIONS7

Sub-Basin P1.....8

Sub-Basin P2.....8

Sub-Basin P3.....8

Sub-Basin P4.....8

Sub-Basin P5.....9

Sub-Basin P6.....9

Sub-Basin R19

Sub-Basin R29

Sub-Basin O110

Sub-Basin O210

Sub-Basin O3.....10

Sub-Basin O4.....10

Sub-Basin O5.....10

Sub-Basin O6.....11

Sub-Basin O7.....11

Sub-Basin O8.....11

DRAINAGE DESIGN CRITERIA.....11

 DEVELOPMENT CRITERIA REFERENCE11

 HYDROLOGIC CRITERIA11

 HYDRAULIC CRITERIA.....12

THE FOUR STEP PROCESS13

DRAINAGE FACILITY DESIGN14

GENERAL CONCEPT	14
SPECIFIC DETAILS	14
GEOTECHNICAL RECOMMENDATIONS	15
COMPLIANCE WITH PREVIOUS STUDIES	15
SUMMARY	16
REFERENCES	16
APPENDIX	17
APPENDIX A: VICINITY MAP	18
APPENDIX B: NRCS SOIL STUDY	19
APPENDIX C: FEMA FIRM MAP	20
APPENDIX D: HYDROLOGIC ANALYSIS	21
APPENDIX E: HYDRAULIC ANALYSIS	22
APPENDIX F: EX. FINAL DRAINAGE REPORT FOR BARBARICK SUBDIVISION.....	23
APPENDIX G: COST ESTIMATE / FINANCIAL ASSURANCES ESTIMATE	24
APPENDIX H: DRAINAGE MAPS	25

INTRODUCTION

GENERAL PROJECT DESCRIPTION

The Property is approximately 3.93± acres total and 2.31± acres are anticipated to be disturbed. The Project includes a proposed recycling and refuse transfer station building and attendant structure. Water quality and 100-year detention is required for the site and is achieved with the existing full spectrum detention pond to the south of the property. The existing detention pond is adequately sized for the proposed improvements. Minor modifications to the outlet structure are proposed to ensure that water quality detention requirements are met.

PURPOSE AND SCOPE OF STUDY

The purpose of this Final Drainage Report (FDR) is to provide the hydrologic and hydraulic calculations and to document and finalize the drainage design methodology in support of the proposed Project. The Project is located within the jurisdictional limits of El Paso County (“the County”). Thus, the guidelines for the hydrologic and hydraulic design components were based on the criteria for the County and City of Colorado Springs, described below.

LOCATION

The Project is located at Lot 4 (TSN: 5233002013) of the Barbarick Subdivision, just east of Vollmer Rd and northeast of the major intersection of Black Forest Rd and Woodmen Rd. Lot 4 is 5.29 acres. The Project is within a 3.93 acre leased boundary within Lot 4 (Site). More specifically the project location exists within a portion of the southwest Quarter of Section 33, Township 12 South, Range 65 West of the 6th Principal Meridian, County of El Paso, State of Colorado. The Site is bounded by industrial lots zoned I-2 (BWH Properties LLC) & I-3 (HW Diesel Enterprises LLC) to the north and west, respectively. The Site is bounded by existing residential zoned lots to the east, and an undeveloped residential lot to the south. A vicinity map has been provided in the **Appendix A** of this report.

DESCRIPTION OF PROPERTY

The Site is mostly undeveloped and gravel in landcover. Lot 4 is an existing business, which is outside of the limits of the Project and will remain. The purpose of this Project is to construct a recycling and refuse transfer facility which includes a building enclosure, scale house with ground scales, detention pond outlet structure modification, and landscape buffering as required for County code compliance. Lot 4 of the Barbarick Subdivision is inclusive of an existing full spectrum extended detention basin (“EDB”). The Site currently provides water quality and 100-year detention for the Project Area. The existing EDB serving the site is functioning as intended today, though, is in need of maintenance.

The existing topography generally slopes from north to south at approximately 3.0%.

NRCS soil data is available for this Site and it has been noted that soils onsite are generally USCS Type A/B. The NRCS soil data can be found in **Appendix B**. There are no major drainage ways or irrigation facilities within the Site.

DRAINAGE BASINS

MAJOR BASIN DESCRIPTIONS

The Site improvements are located in Zone X, as determined by the Flood Insurance Rate Map (FIRM) number 08041C0533G effective date, December 7, 2018 (see **Appendix C**).

The Project is located within El Paso County's Sand Creek Drainage Basin (FOFO4000).

EXISTING SUB-BASIN DESCRIPTIONS

Historic and existing drainage patterns are described in detail in the FDR for the Barbarick Subdivision, by Matrix Design Group, dated June 6, 2016. In the existing condition, runoff flows from north to south via sheet and concentrated flow over developed and undeveloped land to the existing EDB located to the south of the Site. Below is a description of the existing onsite and off-site sub-basins. For the existing condition, the total weighted basin imperviousness is 86.3% and the cumulative direct runoff for the 5-year and 100-year storm events are 40.22 cfs and 75.42 cfs, respectively.

Sub-Basin E1

Sub-Basin E1 consists of the entrance to the Site, beginning at the dead end of Cliff Allen Pt. E1 is 0.39 acres in size and yields an impervious value of 55.3%. This Sub-Basin accepts flows from the adjacent off-site basin, OE1, to the north. The central section of this Sub-Basin directs flows from the adjacent offsite Sub-Basins and runoff generated within, westwards via vegetated swale. Runoff during the 5-year and 100-year storm events are 0.70 and 1.62 cfs, respectively. Concentrated flows in this Sub-Basin outfall into an existing culvert at design point E1, which runs southwards to the existing EDB to the south of the Site. See **Appendix H** for the Existing Conditions Drainage Map.

Sub-Basin E2

Sub-Basin E2 consists of the rest of the Site, including the existing EDB to the south of the Site. E2 is approximately 2.59 acres in size and yields an impervious value of 62.1%. This Sub-Basin accepts flows from adjacent off-site basins OE2, OE3, and OE4, to the north and west. Flows accepted from off-site and generated on-site flow into the existing EDB at design point E2 via sheet flow with minimal concentrated flows. Runoff during the 5-year and 100-year storm events are 5.56 and 12.19 cfs, respectively. The required storage volume in the existing EDB is 1.76 ac-ft to the spillway (Elev: 7023.20). The provided storage volume of the existing EDB is 2.89 ac-ft. Flows are detained within the EDB and are released downstream at design point ED and outfall to the south, into Sand Creek. See **Appendix H** for the Existing Conditions Drainage Map.

Sub-Basin OE1

Sub-Basin OE1 is the offsite sub-basin just to the north of sub-basin E1. OE1 is approximately 2.34 acres in size and yields an impervious value of 96.8%. Existing land cover for this basin can be described as compacted gravel with asphalt millings. The existing land-use for this sub-basin is vehicular and modular storage. Runoff during the 5-year and 100-year storm events are 10.55 and 19.07 cfs respectively. Flows generated within OE1 flow into sub-basin E1 at design

point OE1 and ultimately outfall into the EDB to the south of the Site. See **Appendix H** for the Existing Conditions Drainage Map.

Sub-Basin OE2

Sub-Basin OE2 is the offsite sub-basin just to the north of sub-basin E2. OE2 is approximately 2.48 acres in size and yields an impervious value of 100%. Existing land cover for this basin can be described as compacted gravel. The existing land-use for this sub-basin is vehicular and modular storage. Runoff during the 5-year and 100-year storm events are 11.54 and 20.67 cfs respectively. Flows generated within the OE2 flow into sub-basin E2 and ultimately sheet flow into the EDB to the south of the Site. See **Appendix H** for the Existing Conditions Drainage Map.

Sub-Basin OE3

Sub-Basin OE2 is the offsite sub-basin just to the northwest of sub-basin E2. OE3 is approximately 1.14 acres in size and yields an impervious value of 100%. Existing land cover for this basin can be described as compacted gravel. Land-use for this sub-basin is vehicular and modular storage. Runoff during the 5-year and 100-year storm events are 5.32 and 9.54 cfs respectively. Flows generated within the OE3 flow into sub-basin E2 at design point OE3 and ultimately sheet flow into the EDB to the south of the Site. See **Appendix H** for the Existing Conditions Drainage Map.

Sub-Basin OE4

Sub-Basin OE4 is the offsite sub-basin just to the west of sub-basin E2. OE4 is approximately 0.82 acres in size and yields an impervious value of 100%. Existing land cover for this basin can be described as compacted gravel. Land-use for this sub-basin is vehicular and modular storage. Runoff during the 5-year and 100-year storm events are 3.80 and 6.81 cfs respectively. Flows generated within the OE4 flow into sub-basin E2 at design point OE4 and enter the EDB as concentrated flow to the southwest of the Site. See **Appendix H** for the Existing Conditions Drainage Map.

Sub-Basin OE5

Sub-Basin OE5 is the offsite sub-basin just to the east of sub-basin E2 and south of E1. OE5 is approximately 0.97 acres in size and yields an impervious value of 75.3%. Existing land cover for this basin can be described as compacted gravel. Land-use for this sub-basin is an existing diesel mechanic shop. Runoff during the 5-year and 100-year storm events are 2.73 and 5.51 cfs respectively. Flows generated within the OE5 flow into sub-basin E2 at design point OE5 and enter the EDB as concentrated flow to the southeast of the Site. See **Appendix H** for the Existing Conditions Drainage Map.

PROPOSED SUB-BASIN DESCRIPTIONS

In the proposed condition, runoff flows from north to south via sheet and concentrated flows over developed land and within proposed storm sewer infrastructure to the existing EDB. Below are descriptions for the proposed on-site and off-site sub-basins. For the proposed condition, the total weighted basin imperviousness is 88.0% and the cumulative direct runoff for the 5-year and 100-year storm events are 41.26 and 76.63 cfs, respectively.

Sub-Basin P1

Sub-Basin P1 consists of the entrance to the Site, beginning at the dead end of Cliff Allen Pt. P1 is 0.31 acres in size and yields an impervious value of 81.7%. This Sub-Basin accepts flows from the adjacent off-site basin, O1, to the north. The central section of this Sub-Basin is subject to a portion of the Site improvements including truck scales and a 250 sf attendant shelter for facility operation. This sub-basin directs flows from the adjacent offsite sub-basins and runoff generated within, centrally, towards the proposed CDOT Type C grated area inlet at design point P1. Runoff during the 5-year and 100-year storm events are 0.98 and 1.92 cfs, respectively. These flows are then conveyed through a proposed 18" PVC pipe, tying into the existing 30" HDPE pipe to the east. These flows are discharged into the pond along with the bypass flows from Woodmen View Storage, as shown in the existing drainage report by Matrix Design Group dated June 6, 2016. See **Appendix F** for the existing drainage report and **Appendix H** for the Proposed Conditions Drainage Map.

Sub-Basin P2

Sub-Basin P2 consists of the area just west of sub-basin P1. P2 is 0.15 acres in size and yields an impervious value of 76.4%. P2 accepts flows from the adjacent off-site sub-basin, O2, to the north. This sub-basin is subject to a portion of the Site improvements including the truck scales, attendant shelter, and vegetated swale. Runoff during the 5-year and 100-year storm events are 0.44 and 0.88 cfs, respectively. Flows in this sub-basin are routed towards and into the proposed vegetated swale which conveys flows into the existing storm inlet and 24" CPP at design point P2. These flows are discharged into the existing pond as they do in the existing condition, but at a lesser quantity due to the decrease in tributary area. See **Appendix H** for the Proposed Conditions Drainage Map.

Sub-Basin P3

Sub-Basin P3 consists of the area just west of sub-basin P2 and a portion of the proposed drive isle, to the north of the proposed transfer station. P3 is 0.11 acres in size and yields an impervious value of 82.2%. P3 accepts flows from the adjacent off-site sub-basin, O4, to the north. Site improvements proposed within sub-basin P3 are the 4' concrete drainage pan and CDOT Double Type C grated area inlet. Runoff during the 5-year and 100-year storm events are 0.36 and 0.70 cfs, respectively. Flows in this sub-basin are routed towards and into the proposed inlet at design point P3. These flows are then routed westerly and southwardly within the proposed 24" PVC storm sewer pipe, into the existing detention pond to the south. See **Appendix E** for Inlet Capacity Calculations and for StormCAD Modeling, and **Appendix H** for the Proposed Conditions Drainage Map.

Sub-Basin P4

Sub-Basin P4 consists of the area just west of sub-basin P3 and a portion of the proposed drive isle, to the north of the proposed transfer station. P4 is 0.11 acres in size and yields an impervious value of 82.3%. P3 accepts flows from the adjacent off-site sub-basin, O5, to the north. Site improvements proposed within sub-basin P4 are the 4' concrete drainage pan and CDOT Double Type C grated area inlet. Runoff during the 5-year and 100-year storm events are 0.35 and 0.70 cfs, respectively. Flows in this sub-basin are routed towards and into the proposed inlet at design point P4. These flows are then routed westerly and southwardly within the proposed 24" PVC storm sewer pipe, into the existing detention pond to the south. See **Appendix E** for Inlet Capacity Calculations and for StormCAD Modeling, and **Appendix H** for

the Proposed Conditions Drainage Map.

Sub-Basin P5

Sub-Basin P5 consists of the area just west of sub-basin P4 and includes proposed drive isle, to the west of the proposed transfer station. P5 is 0.13 acres in size and yields an impervious value of 82.0%. P5 accepts flows from the adjacent off-site sub-basin, O6, to the north and west. Site improvements proposed within sub-basin P5 are the 4' concrete drainage pan and CDOT Type C grated area inlet. Runoff during the 5-year and 100-year storm events are 0.43 and 0.84 cfs, respectively. Flows in this sub-basin are routed towards and into the proposed inlet at design point P5. These flows are then routed southwardly within the proposed 24" PVC storm sewer pipe, into the existing detention pond to the south. Any flows bypassing the proposed inlet will surface flow into the existing detention pond to the south. See **Appendix E** for Inlet Capacity Calculations and for StormCAD Modeling, and **Appendix H** for the Proposed Conditions Drainage Map.

Sub-Basin P6

Sub-Basin P6 consists of the majority of the Site. Improvements within this sub-basin include the proposed transfer station building and paved access, numerous concrete drainage pans, and outlets of the proposed storm infrastructure. P6 also consists of the existing detention pond and outlets of the existing storm infrastructure. Sub-basin P6 is 2.04 acres in size and yields an impervious value of 58.9%. P6 accepts surface flows from the adjacent off-site sub-basin, O3, to the north as well as flows from sub-basins P1-P5 via existing and proposed stormwater infrastructure. All existing and proposed storm pipes daylight into the existing detention facility. Runoff during the 5-year and 100-year storm events are 4.14 and 8.96 cfs, respectively. These flows are then routed via surface flows southwardly into the existing detention pond. A portion of these flows will channelize within the proposed concrete drainage pan and discharge into the existing pond as well. The existing detention pond is sized adequately to meet the required water quality and detention requirements. See **Appendix E** for the Pond Capacity and Outlet Structure Design spreadsheet calculations, **Appendix E** for StormCAD Modeling, and **Appendix H** for the Proposed Conditions Drainage Map.

Sub-Basin R1

Sub-Basin R1 consists of the westerly half of the proposed transfer station building and associated roof drain system. R1 is 0.14 acres in size and yields an impervious value of 90%. Runoff during the 5-year and 100-year storm events are 0.43 and 0.80 cfs, respectively. These flows are captured within the gutter and routed into three evenly spaced downspouts. The downspouts are then tied into the proposed 24" PVC storm sewer pipe to the west, and eventually discharging into the existing detention facility. See **Appendix E** for Inlet Capacity Calculations and for StormCAD Modeling, and **Appendix H** for the Proposed Conditions Drainage Map.

Sub-Basin R2

Sub-Basin R2 consists of the easterly half of the proposed transfer station building and associated roof drain system. R2 is 0.14 acres in size and yields an impervious value of 90%. Runoff during the 5-year and 100-year storm events are 0.43 and 0.80 cfs, respectively. These flows are captured within the gutter and routed into three evenly spaced downspouts. The downspouts are then tied into the proposed 24" PVC storm sewer pipe to the north, and

eventually discharging into the existing detention facility. See **Appendix E** for Inlet Capacity Calculations and for StormCAD Modeling, and **Appendix H** for the Proposed Conditions Drainage Map.

Sub-Basin O1

Sub-Basin O1 is the offsite sub-basin just to the north of sub-basin P1. O1 is approximately 1.51 acres in size and yields an impervious value of 95.1%. Existing land cover for this basin can be described as compacted gravel. The existing land-use for this sub-basin is vehicular and modular storage. Runoff during the 5-year and 100-year storm events are 6.73 and 12.23 cfs respectively. Flows generated within O1 flow into sub-basin E1 at design point O1 and ultimately outfall into the EDB to the south of the Site, along with the flows generated within E1. See **Appendix H** for the Proposed Conditions Drainage Map.

Sub-Basin O2

Sub-Basin O2 is the offsite sub-basin just to the north of sub-basin P2. O2 is approximately 0.74 acres in size and yields an impervious value of 100.0%. Existing land cover for this basin can be described as compacted gravel. The existing land-use for this sub-basin is vehicular and modular storage. Runoff during the 5-year and 100-year storm events are 3.46 and 6.20 cfs respectively. Flows generated within O2 flow into sub-basin E2 at design point O2 and ultimately outfall into the EDB to the south of the Site, along with the flows generated within E2. See **Appendix H** for the Proposed Conditions Drainage Map.

Sub-Basin O3

Sub-Basin O3 is the offsite sub-basin just to the north of sub-basin P6. O3 is approximately 0.44 acres in size and yields an impervious value of 100.0%. Existing land cover for this basin can be described as compacted gravel. The existing land-use for this sub-basin is vehicular and modular storage. Runoff during the 5-year and 100-year storm events are 2.04 and 3.65 cfs respectively. Flows generated within O3 flow into sub-basin E3 at design point O3 and ultimately outfall into the EDB to the south of the Site, along with the flows generated within P6. See **Appendix H** for the Proposed Conditions Drainage Map.

Sub-Basin O4

Sub-Basin O4 is the offsite sub-basin just to the north of sub-basin P3. O4 is approximately 1.05 acres in size and yields an impervious value of 100.0%. Existing land cover for this basin can be described as compacted gravel. The existing land-use for this sub-basin is vehicular and modular storage. Runoff during the 5-year and 100-year storm events are 4.86 and 8.71 cfs respectively. Flows generated within O4 flow into sub-basin P3 at design point O4 and ultimately outfall into the EDB to the south of the Site, along with the flows generated within P3. See **Appendix H** for the Proposed Conditions Drainage Map.

Sub-Basin O5

Sub-Basin O5 is the offsite sub-basin just to the north of sub-basin P4. O5 is approximately 1.08 acres in size and yields an impervious value of 100.0%. Existing land cover for this basin can be described as compacted gravel. The existing land-use for this sub-basin is vehicular and modular storage. Runoff during the 5-year and 100-year storm events are 5.00 and 8.96 cfs respectively. Flows generated within O5 flow into sub-basin P4 at design point O5 and

ultimately outfall into the EDB to the south of the Site, along with the flows generated within P4. See **Appendix H** for the Proposed Conditions Drainage Map.

Sub-Basin O6

Sub-Basin O6 is the offsite sub-basin just to the north and west of sub-basins P4 and P5. O6 is approximately 1.14 acres in size and yields an impervious value of 100.0%. Existing land cover for this basin can be described as compacted gravel. The existing land-use for this sub-basin is vehicular and modular storage. Runoff during the 5-year and 100-year storm events are 5.32 and 8.96 cfs respectively. Flows generated within O6 flow into sub-basin P5 at design point O6 and ultimately outfall into the EDB to the south of the Site, along with the flows generated within P5. See **Appendix H** for the Proposed Conditions Drainage Map.

Sub-Basin O7

Sub-Basin O7 is the offsite sub-basin just to the west of sub-basins P5 and P6. O7 is approximately 0.82 acres in size and yields an impervious value of 100.00%. Existing land cover for this basin can be described as compacted gravel. Land-use for this sub-basin is vehicular and modular storage. Runoff during the 5-year and 100-year storm events are 3.80 and 6.81 cfs respectively. Flows generated within the O7 flow into sub-basin P6 at design point O7 and enter the EDB as concentrated flow to the southwest of the Site. See **Appendix H** for the Proposed Conditions Drainage Map.

Sub-Basin O8

Sub-Basin O8 is the offsite sub-basin just to the south of sub-basins P1 and P2 and east of P6. O8 is approximately 0.82 acres in size and yields an impervious value of 76.7%. Existing land cover for this basin can be described as compacted gravel. This sub-basin consists of the existing Diesel Mechanic Shop: Dirt Road Diesel. Runoff during the 5-year and 100-year storm events are 2.48 and 4.94 cfs respectively. Flows generated within the O8 flow into sub-basin P6 at design point O8 and enter the EDB as concentrated flow to the south of the Site. See **Appendix H** for the Existing Conditions Drainage Map.

DRAINAGE DESIGN CRITERIA

DEVELOPMENT CRITERIA REFERENCE

The proposed storm facilities are designed to be in compliance with the City of Colorado Springs and El Paso County “Drainage Criteria Manual (DCM)” dated October 2018 (“the MANUAL”), El Paso County “Engineering Criteria Manual” (“the Engineering Manual”), Chapter 6 and Section 3.2.1 of Chapter 13 of the City of Colorado Springs Drainage Criteria Manual dated May 2014 (“the Colorado Springs MANUAL”).

There are no known master plans or studies for the Site.

HYDROLOGIC CRITERIA

The 5-year and 100-year design storm events were used in determining rainfall and runoff for the existing and proposed condition drainage analysis per the MANUAL and DCM. The rainfall depths for the Site were determined from Table 6-2 from the DCM. Refer to **Table 1** below for the rainfall depths utilized for the Site and **Appendix D** for the hydrologic calculations for the

Site.

Table 1: Rainfall Depths (IN)

	Duration (HRS)
Storm Event	1 HR
5 Year	1.50 IN
100 Year	2.52 IN

Calculations for the runoff coefficients and percent imperviousness are included in the **Appendix D**. The rational method was used to determine the peak flows for the Project. These flows were used to determine the size of the proposed inlets, culvert, storm drain system and on-site swales.

The proposed impervious values in Table 6-6 of the DCM were utilized in this report for the final design.

The existing Site provides one full spectrum extended detention basin. The Site is maintaining the historic drainage patterns as much as possible.

There are no additional provisions selected or deviations from the criteria in both the MANUAL and Colorado Springs MANUAL.

HYDRAULIC CRITERIA

Applicable design methods were utilized to confirm the size of the EDB, which includes the use of the UD-Detention spreadsheet and rational calculations spreadsheet. Storm sewer sizing and hydraulic grade line calculations were computed using StormCAD implementing the standard step method. Bentley FlowMaster (Edition Update 3) was used for the sizing and analysis of the western drive isle/drainage pan, proposed roof drains, and proposed 18” PVC storm pipe connecting to the existing 30” HDPE storm pipe to the east of the Site.

Proposed drainage features on-site have been analyzed and sized for the following storm events:

- Major Storm: 100-year Storm Event

One EDB is exists on Site and provides the required water quality capture volume, EURV volume and 100-year detention. The existing EDB is located to the south of the Site with an existing volume of 2.89 ac-ft and designed for the 100-year storm event. The minimum required volume for the EDB, in the proposed condition, is 1.758 ac-ft. Developed flows from the Site will be released at controlled rates from the EDB and is ultimately tributary to Sand Creek. Flows that are discharged from the pond will continue south through rip rap, low-tailwater basin for energy dissipation before continuing south. As flows continue south via historic drainage patterns, they will channelize and be conveyed through a 24” corrugated metal pipe (per ALTA Survey by LDC, Inc dated 10/20/2021), running beneath the existing gravel road. It is stated in the existing FDR for the Barbarick Subdivision that this pipe is 12” and that flows in excess of 5.7 cfs would overtop the gravel road, creating a tailwater elevation of 7018.0. This gravel road and corrugated metal pipe will be eliminated in the development of Sterling Ranch.

Proposed improvements to the EDB are associated with the outlet structure. The overflow weir dropbox shall be raised from a total height of 3.01 ft to 4.10 ft. The orifice plate and outlet restrictor plate shall both be replaced per the pond details provided in the Barbarick Transfer Station Construction Documents (COM-2346) as well as MHFD-Detention Spreadsheet in **Appendix E**. The EDB is designed to release the 5-year and 100-year flow rates below the pre-development flow rate as well as in the existing site condition. The existing EDB as-built certification document “*Pond As-Built Verification for Barabrick Subdivision Lots 1-4 Construction*”, prepared by Matrix Design Group, dated January 16, 2017, was utilized for EDB storage calculations and design of the outlet structure modification. The EDB as-built certification is included in the **Appendix F**. See the “Compliance with Previous Studies” section of this report for specific flow rates and compliance details.

Concrete drainage pans, area inlets, grass lined swales, and storm sewer pipes are designed to carry flows to the EDB. Calculations for the proposed improvements are provided in the **Appendix E** and the design points are provided in the Proposed Drainage Map located in **Appendix H**.

Emergency overflows will be routed over the southern embankment of the pond through the emergency spillway. It will follow the historic drainage patterns that conveys drainage southward towards Sand Creek.

THE FOUR STEP PROCESS

The Project was designed in accordance with the four-step process to minimize adverse impacts of urbanization, as outlined in the County’s “Four-Step Process” for selecting structural BMPs (ECM Section I.7.2 BMP Selection).

Step 1. Employ Runoff Reduction Practices - The Project is proposing a recycling and refuse transfer station. Although the proposed site increases in imperviousness by 1.7%, the cumulative direct runoff for the 100-year storm decreases by 3.23 cfs. The proposed grading and underground storm system were designed to broadly distribute on-site and off-site flows and slow the runoff velocity and reduce runoff peaks. The existing full spectrum detention pond will be used to capture and maintain flows discharging off Site at or below historic levels. The existing pond is sized adequately for the proposed improvements and only requires a modification of the outlet structure’s restrictor plate.

Step 2. Stabilize Drainageways – Proposed drainage ways are stabilized by designing them with slopes that control the flow rates. Concrete drainage pans are utilized in areas of concentrated flow to better convey flows to the proposed inlets or discharge points. Discharge points feature adequately sized rip rap pads which will be constructed to reduce the velocities of runoff entering the pond. It is anticipated this will minimize erosion.

Step 3. Provide Water Quality Capture Volume (WQCV) – Permanent water quality measures and detention facilities will be provided with the Project via the existing Full Spectrum EDB. More specifically, this Project proposes a modification to the existing outlet structure’s restrictor plate, to effectively meet water quality and detention requirements.

Step 4. Consider Need for Industrial and Commercial BMPs – The Project is proposing a fully enclosed recycling and refuse transfer station facility. The Project

responds to the covering of storage and handling areas by providing a building enclosure where all physical transfer operations will take place.

DRAINAGE FACILITY DESIGN

GENERAL CONCEPT

The existing condition of the Site consists of flows draining from the north to the south with an approximate average slope of 3%, all discharging into the existing full spectrum EDB to the south of the Site. The existing runoff conditions for the Site were developed utilizing the Rational Method described in the Hydrologic Criteria section of this report.

The proposed drainage patterns will match the overall historic patterns for the Barabrick Subdivision. To maintain historic flows, all flows will be routed to the existing full spectrum EDB which will capture and control the release of flows from the Site. Site drainage will be conveyed to the EDB via a series of swales, surface flow, and a storm sewer system.

Provided in the **Appendix D** are hydrologic calculations utilizing the Rational Method for the existing and proposed conditions. Provided in **Appendix E** are the hydraulic calculations for the proposed conditions, including the proposed detention basin sizing. As previously mentioned, the existing drainage map and proposed drainage map can be found in **Appendix H**.

SPECIFIC DETAILS

Sub-basins P1-P6 are subject to Site improvements including the transfer building, attendant shelter, and entrance/exit scales. In the proposed condition flows are routed to CDOT Type C grated area inlets, drainage pans, or swales laid out to effectively control flows as they are conveyed to the existing EDB. Flows captured by the existing EDB are released via the existing 30" CPP which conveying flows southwardly towards Sand Creek at a rate less than in the historic conditions from the existing FDR: "Final Drainage Report for Barbarick Subdivision, Portions of Lots 1, 2, and Lots 3 & 4" prepared by Matrix Design Group on June 6, 2016. (Existing FDR for the Barbarick Subdivision). Improvements to the pond include a new orifice plate, new outlet restrictor plate, and a cast-in-place increase in outlet structure weir-box height.

A forebay is not proposed for the existing EDB because the tributary area for any given sub-basin is less than 1-acre. This tributary area was determined by adding together the impervious area at 100%, roof area at 90%, and gravel area at 80%, per their respective impervious rates as shown in the DCM. The maximum total tributary area entering the existing EDB at a single point is 41,798 s.f. or 0.96 acres. Proposed at this entrance point to the EDB is an adequately sized riprap pad: 24.0'x5.0' type M riprap, 12" depth. The purpose of this riprap pad is for the dissipation of runoff velocity and erosive forces.

Modeling of the existing pond, in the as built condition, and associated discharge calculations were done using the MHFD-Detention Spreadsheet, Version 4.06: Detention Basin Design Workbook (**Appendix E**) and AutoCAD Civil 3D. The staged storage calculations for the EDB were modeled using the design survey for the site. Per these staged storage calculations, the existing EDB has a capacity of 2.89 ac-ft. Outlet structure dimensions and elevations were referenced from the pond's As-Built Verification performed by Matrix Design Group on January 16, 2017. (**Appendix F**). In the proposed condition, the EDB is designed to release the 5-year and 100-year on-site flows at a discharge rate of 0.3 cfs and 7.7cfs, respectively. This is a reduction from the 5-year and 100-year on-site discharge rate of 0.3 cfs and 45.9 cfs as shown in the existing FDR for the Barbarick Subdivision, page 19 of the report (**Appendix F**).

Therefore, impact to downstream infrastructure is not anticipated and planned release rates are in compliance with the Existing FDR for the Barbarick Subdivision.

All proposed storm sewer infrastructure and the existing detention facility is located within the private property's boundary and will be owned and maintained by the property owner and will require maintenance consisting of routine inspections, removal of debris from the detention area, and bi-annual inspections for hydraulic performance of the basin. Refer to the DCM for exact maintenance criteria and for other Best Management Practices.

The hydrologic calculations, hydraulic calculations, and Drainage Maps are included in **Appendix D**, **Appendix E**, and **Appendix H**, respectively, of this report for reference.

The Site will disturb more than 1 acre and will require a Colorado Discharge Permit System (CDPS) General Permit for Stormwater Discharge Associated with Construction Activities from the Colorado Department of Public Health and Environment (CDPHE).

Since the Site was previously platted, there are no associated drainage and bridge fees due at this time. A cost estimate for the proposed private storm drain improvements is included in **Appendix G** of this report for reference.

GEOTECHNICAL RECOMMENDATIONS

Per the Geotechnical Subsurface Investigation by RMG – Rocky Mountain Group, dated October 23, 2023, it was determined that the soil is generally anticipated to be well draining, however groundwater was encountered at depths anticipated to impact the proposed construction. A subsurface perimeter drain and underslab drain are recommended and are included in the design. Geotechnical recommendations do not impact the existing detention facility to the south of the Site.

COMPLIANCE WITH PREVIOUS STUDIES

The Site area was previously included and studied as part of the existing FDR for the Barbarick Subdivision (*Final Drainage Report for Barbarick Subdivision, Portions of Lots 1,2 and Lots 3 & 4*) prepared by Matrix Design Group on June 6, 2016. The Site lies within sub-basins H1 and D1 of the historic and previously planned drainage conditions. Design points H3 and D2 correspond to Design Point P8, the proposed discharge from the existing detention pond, in the proposed condition. The existing FDR for the Barbarick Subdivision is provided in **Appendix F**.

HISTORIC CONDITION:

- Design Point H3 experiences flows of 21.3 cfs and 56.7 cfs for the 5-year and 100-year storm events, respectively.

EXISTION CONDITION:

- Design Point D2 experiences a flow of 0.3 cfs and 45.9 cfs (16.5 cfs+29.4 cfs_{bypass}) for the 5-year and 100-year storm event.
- EDB Capacity Provided: 2.64 ac-ft (Appendix F, Lot 3 FSD Pond)

PROPOSED CONDITION:

- Design Point P8 experiences a flow of 0.3 cfs and 7.7 cfs for the 5-year and 100-year storm event.
- EDB Capacity Required: 1.758 ac-ft
- EDB Capacity Provided per staged storage calculations: 2.85 ac-ft (Appendix E, EDB Modification – Proposed Condition)

The existing EDB, in the proposed condition, will release the 5-year and 100-year storm events at 0.3 and 7.7 cfs respectively. These values are less than the historic flow rates at this design point. With the proposed modified outlet structure overflow weir, orifice plate, and outlet restrictor plate, the flows will be further controlled for the 100-year storm event than that of the existing condition at design point D2. Therefore, impact to downstream infrastructure is not anticipated and the planned release rates are in compliance with the Existing FDR for the Barbarick Subdivision.

SUMMARY

The proposed drainage design is to maintain the historic drainage patterns and release rates for the Site. Runoff from the Site will flow through a proposed storm sewer system to an existing full spectrum extended detention basin. The existing EDB is currently functioning properly, ultimately discharges to Sand Creek. The drainage design presented within this report conforms to the criteria presented in both the MANUAL and the Colorado Springs MANUAL. The proposed modifications to the pond outlet structure will adequately manage the increase in flows associated with the proposed site improvements. Additionally, the Site runoff and storm drain facilities will not adversely affect the downstream and surrounding developments, including Sand Creek.

It is known that the existing EDB is in need of maintenance, and that maintenance of the pond must be completed prior to Preliminary Acceptance of this project.

REFERENCES

1. El Paso County “Drainage Criteria Manual”, dated October 31, 2018
2. City of Colorado Springs “Drainage Criteria Manual (DCM) Volume 1”, dated May, 2014
3. El Paso County “Engineering Criteria Manual” Revision 6, dated December 13, 2016
4. Chapter 6 and Section 3.2.1. of Chapter 13-City of Colorado Springs Drainage Criteria Manual, May 2014.
5. Urban Drainage and Flood Control District Drainage Criteria Manual (UDFCDCM), Vol. 1, prepared by Wright-McLaughlin Engineers, June 2001, with latest revisions.
6. Flood Insurance Rate Map, El Paso County, Colorado and Incorporated Areas, Map Number 08041C0533G, Effective Date December 7, 2018, prepared by the Federal Emergency Management Agency (FEMA).
7. “Final Drainage Report for Barbarick Subdivision, Portions of Lots 1,2 and Lots 3 &4” prepared by Matrix Design Group. (June 6, 2016)
8. “Geotechnical Subsurface Soil Investigation” prepared by RMG – Rocky Mountain Group. (October 23, 2023).

APPENDIX

APPENDIX A: VICINITY MAP

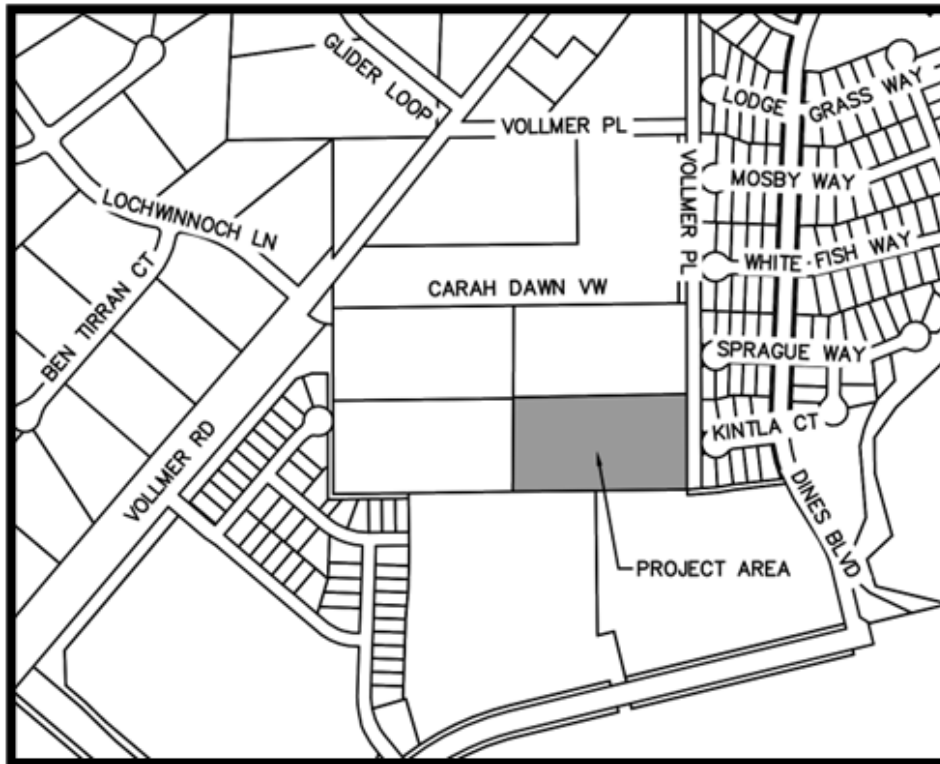

Figure 1: Vicinity Map (Not to Scale)

APPENDIX B: NRCS SOIL STUDY



United States
Department of
Agriculture

NRCS

Natural
Resources
Conservation
Service

A product of the National
Cooperative Soil Survey,
a joint effort of the United
States Department of
Agriculture and other
Federal agencies, State
agencies including the
Agricultural Experiment
Stations, and local
participants

Custom Soil Resource Report for **El Paso County Area, Colorado**

Barbarick Transfer Station

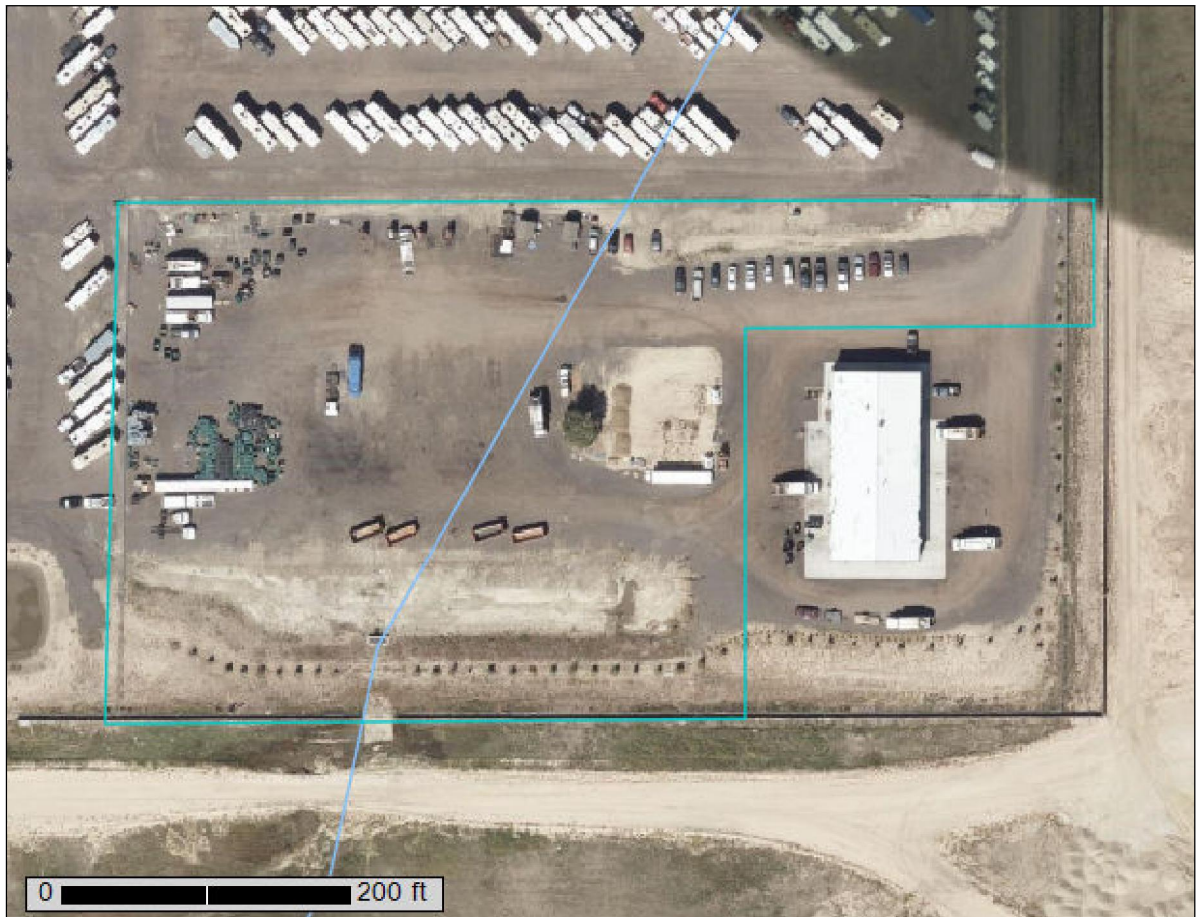

December 5, 2023

Preface

Soil surveys contain information that affects land use planning in survey areas. They highlight soil limitations that affect various land uses and provide information about the properties of the soils in the survey areas. Soil surveys are designed for many different users, including farmers, ranchers, foresters, agronomists, urban planners, community officials, engineers, developers, builders, and home buyers. Also, conservationists, teachers, students, and specialists in recreation, waste disposal, and pollution control can use the surveys to help them understand, protect, or enhance the environment.

Various land use regulations of Federal, State, and local governments may impose special restrictions on land use or land treatment. Soil surveys identify soil properties that are used in making various land use or land treatment decisions. The information is intended to help the land users identify and reduce the effects of soil limitations on various land uses. The landowner or user is responsible for identifying and complying with existing laws and regulations.

Although soil survey information can be used for general farm, local, and wider area planning, onsite investigation is needed to supplement this information in some cases. Examples include soil quality assessments (<http://www.nrcs.usda.gov/wps/portal/nrcs/main/soils/health/>) and certain conservation and engineering applications. For more detailed information, contact your local USDA Service Center (<https://offices.sc.egov.usda.gov/locator/app?agency=nrcs>) or your NRCS State Soil Scientist (http://www.nrcs.usda.gov/wps/portal/nrcs/detail/soils/contactus/?cid=nrcs142p2_053951).

Great differences in soil properties can occur within short distances. Some soils are seasonally wet or subject to flooding. Some are too unstable to be used as a foundation for buildings or roads. Clayey or wet soils are poorly suited to use as septic tank absorption fields. A high water table makes a soil poorly suited to basements or underground installations.

The National Cooperative Soil Survey is a joint effort of the United States Department of Agriculture and other Federal agencies, State agencies including the Agricultural Experiment Stations, and local agencies. The Natural Resources Conservation Service (NRCS) has leadership for the Federal part of the National Cooperative Soil Survey.

Information about soils is updated periodically. Updated information is available through the NRCS Web Soil Survey, the site for official soil survey information.

The U.S. Department of Agriculture (USDA) prohibits discrimination in all its programs and activities on the basis of race, color, national origin, age, disability, and where applicable, sex, marital status, familial status, parental status, religion, sexual orientation, genetic information, political beliefs, reprisal, or because all or a part of an individual's income is derived from any public assistance program. (Not all prohibited bases apply to all programs.) Persons with disabilities who require

alternative means for communication of program information (Braille, large print, audiotape, etc.) should contact USDA's TARGET Center at (202) 720-2600 (voice and TDD). To file a complaint of discrimination, write to USDA, Director, Office of Civil Rights, 1400 Independence Avenue, S.W., Washington, D.C. 20250-9410 or call (800) 795-3272 (voice) or (202) 720-6382 (TDD). USDA is an equal opportunity provider and employer.

Contents

Preface	2
How Soil Surveys Are Made	5
Soil Map	8
Soil Map (Barbarick WTS).....	9
Legend.....	10
Map Unit Legend (Barbarick WTS).....	11
Map Unit Descriptions (Barbarick WTS).....	11
El Paso County Area, Colorado.....	13
9—Blakeland-Fluvaquentic Haplaquolls.....	13
71—Pring coarse sandy loam, 3 to 8 percent slopes.....	14
Soil Information for All Uses	16
Soil Properties and Qualities.....	16
Soil Erosion Factors.....	16
Wind Erodibility Index (Barbarick WTS).....	16
K Factor, Whole Soil (Barbarick WTS).....	19
Soil Qualities and Features.....	22
Hydrologic Soil Group (Barbarick WTS).....	22
References	27

How Soil Surveys Are Made

Soil surveys are made to provide information about the soils and miscellaneous areas in a specific area. They include a description of the soils and miscellaneous areas and their location on the landscape and tables that show soil properties and limitations affecting various uses. Soil scientists observed the steepness, length, and shape of the slopes; the general pattern of drainage; the kinds of crops and native plants; and the kinds of bedrock. They observed and described many soil profiles. A soil profile is the sequence of natural layers, or horizons, in a soil. The profile extends from the surface down into the unconsolidated material in which the soil formed or from the surface down to bedrock. The unconsolidated material is devoid of roots and other living organisms and has not been changed by other biological activity.

Currently, soils are mapped according to the boundaries of major land resource areas (MLRAs). MLRAs are geographically associated land resource units that share common characteristics related to physiography, geology, climate, water resources, soils, biological resources, and land uses (USDA, 2006). Soil survey areas typically consist of parts of one or more MLRA.

The soils and miscellaneous areas in a survey area occur in an orderly pattern that is related to the geology, landforms, relief, climate, and natural vegetation of the area. Each kind of soil and miscellaneous area is associated with a particular kind of landform or with a segment of the landform. By observing the soils and miscellaneous areas in the survey area and relating their position to specific segments of the landform, a soil scientist develops a concept, or model, of how they were formed. Thus, during mapping, this model enables the soil scientist to predict with a considerable degree of accuracy the kind of soil or miscellaneous area at a specific location on the landscape.

Commonly, individual soils on the landscape merge into one another as their characteristics gradually change. To construct an accurate soil map, however, soil scientists must determine the boundaries between the soils. They can observe only a limited number of soil profiles. Nevertheless, these observations, supplemented by an understanding of the soil-vegetation-landscape relationship, are sufficient to verify predictions of the kinds of soil in an area and to determine the boundaries.

Soil scientists recorded the characteristics of the soil profiles that they studied. They noted soil color, texture, size and shape of soil aggregates, kind and amount of rock fragments, distribution of plant roots, reaction, and other features that enable them to identify soils. After describing the soils in the survey area and determining their properties, the soil scientists assigned the soils to taxonomic classes (units). Taxonomic classes are concepts. Each taxonomic class has a set of soil characteristics with precisely defined limits. The classes are used as a basis for comparison to classify soils systematically. Soil taxonomy, the system of taxonomic classification used in the United States, is based mainly on the kind and character of soil properties and the arrangement of horizons within the profile. After the soil

Custom Soil Resource Report

scientists classified and named the soils in the survey area, they compared the individual soils with similar soils in the same taxonomic class in other areas so that they could confirm data and assemble additional data based on experience and research.

The objective of soil mapping is not to delineate pure map unit components; the objective is to separate the landscape into landforms or landform segments that have similar use and management requirements. Each map unit is defined by a unique combination of soil components and/or miscellaneous areas in predictable proportions. Some components may be highly contrasting to the other components of the map unit. The presence of minor components in a map unit in no way diminishes the usefulness or accuracy of the data. The delineation of such landforms and landform segments on the map provides sufficient information for the development of resource plans. If intensive use of small areas is planned, onsite investigation is needed to define and locate the soils and miscellaneous areas.

Soil scientists make many field observations in the process of producing a soil map. The frequency of observation is dependent upon several factors, including scale of mapping, intensity of mapping, design of map units, complexity of the landscape, and experience of the soil scientist. Observations are made to test and refine the soil-landscape model and predictions and to verify the classification of the soils at specific locations. Once the soil-landscape model is refined, a significantly smaller number of measurements of individual soil properties are made and recorded. These measurements may include field measurements, such as those for color, depth to bedrock, and texture, and laboratory measurements, such as those for content of sand, silt, clay, salt, and other components. Properties of each soil typically vary from one point to another across the landscape.

Observations for map unit components are aggregated to develop ranges of characteristics for the components. The aggregated values are presented. Direct measurements do not exist for every property presented for every map unit component. Values for some properties are estimated from combinations of other properties.

While a soil survey is in progress, samples of some of the soils in the area generally are collected for laboratory analyses and for engineering tests. Soil scientists interpret the data from these analyses and tests as well as the field-observed characteristics and the soil properties to determine the expected behavior of the soils under different uses. Interpretations for all of the soils are field tested through observation of the soils in different uses and under different levels of management. Some interpretations are modified to fit local conditions, and some new interpretations are developed to meet local needs. Data are assembled from other sources, such as research information, production records, and field experience of specialists. For example, data on crop yields under defined levels of management are assembled from farm records and from field or plot experiments on the same kinds of soil.

Predictions about soil behavior are based not only on soil properties but also on such variables as climate and biological activity. Soil conditions are predictable over long periods of time, but they are not predictable from year to year. For example, soil scientists can predict with a fairly high degree of accuracy that a given soil will have a high water table within certain depths in most years, but they cannot predict that a high water table will always be at a specific level in the soil on a specific date.

After soil scientists located and identified the significant natural bodies of soil in the survey area, they drew the boundaries of these bodies on aerial photographs and

Custom Soil Resource Report

identified each as a specific map unit. Aerial photographs show trees, buildings, fields, roads, and rivers, all of which help in locating boundaries accurately.







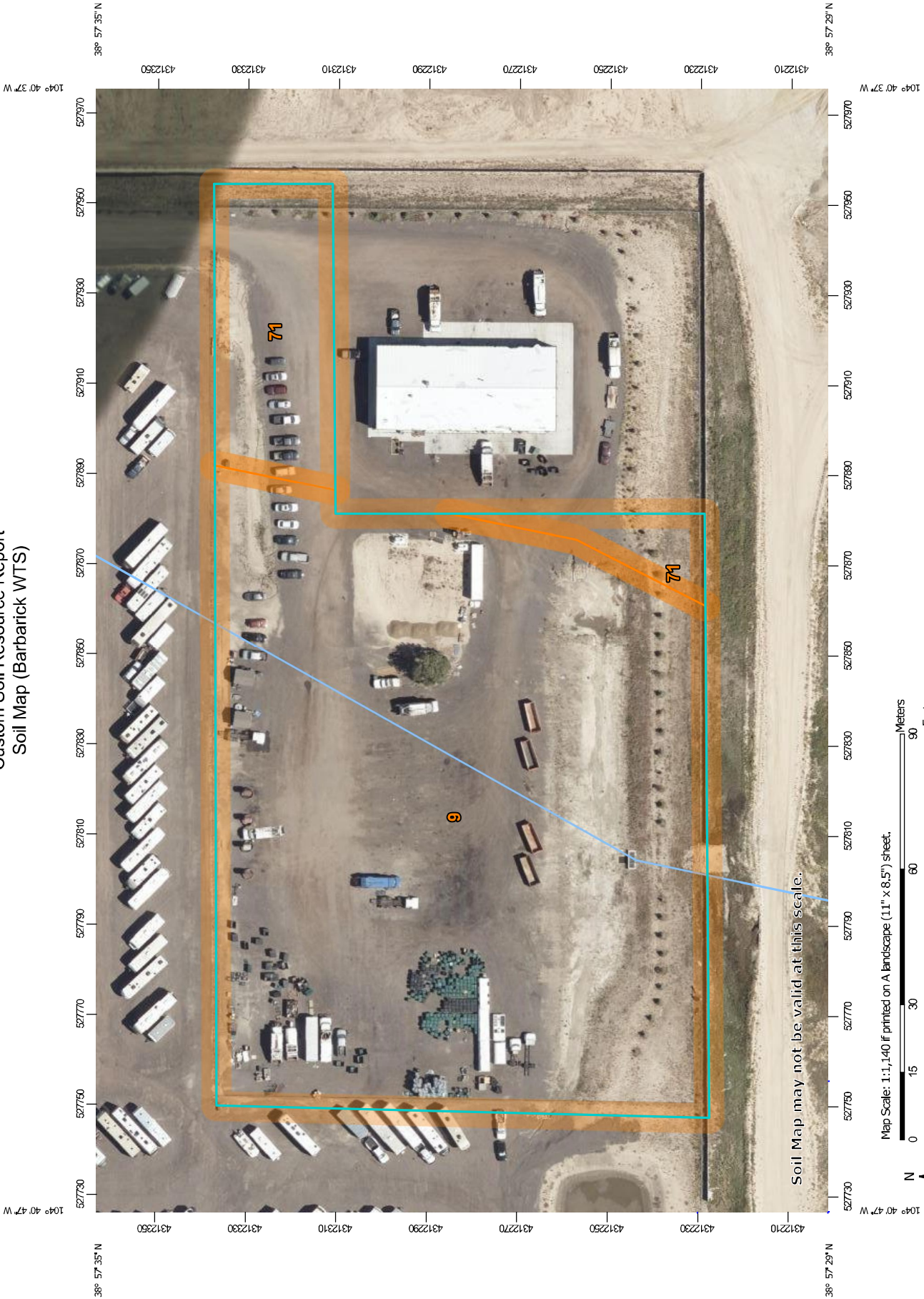































Soil Map

The soil map section includes the soil map for the defined area of interest, a list of soil map units on the map and extent of each map unit, and cartographic symbols displayed on the map. Also presented are various metadata about data used to produce the map, and a description of each soil map unit.

Custom Soil Resource Report
Soil Map (Barbarick WTS)



MAP LEGEND

-  Area of Interest (AOI)
-  Area of Interest (AOI)
- Soils**
-  Soil Map Unit Polygons
-  Soil Map Unit Lines
-  Soil Map Unit Points
-  Soil Map Unit Points
- Special Point Features**
-  Blowout
-  Borrow Pit
-  Clay Spot
-  Closed Depression
-  Gravel Pit
-  Gravelly Spot
-  Landfill
-  Lava Flow
-  Marsh or swamp
-  Mine or Quarry
-  Miscellaneous Water
-  Perennial Water
-  Rock Outcrop
-  Saline Spot
-  Sandy Spot
-  Severely Eroded Spot
-  Sinkhole
-  Slide or Slip
-  Sodic Spot
-  Spoil Area
-  Stony Spot
-  Very Stony Spot
-  Wet Spot
-  Other
-  Special Line Features
- Water Features**
-  Streams and Canals
- Transportation**
-  Rails
-  Interstate Highways
-  US Routes
-  Major Roads
-  Local Roads
- Background**
-  Aerial Photography

MAP INFORMATION

The soil surveys that comprise your AOI were mapped at 1:24,000.

Warning: Soil Map may not be valid at this scale.

Enlargement of maps beyond the scale of mapping can cause misunderstanding of the detail of mapping and accuracy of soil line placement. The maps do not show the small areas of contrasting soils that could have been shown at a more detailed scale.

Please rely on the bar scale on each map sheet for map measurements.

Source of Map: Natural Resources Conservation Service
 Web Soil Survey URL:
 Coordinate System: Web Mercator (EPSG:3857)

Maps from the Web Soil Survey are based on the Web Mercator projection, which preserves direction and shape but distorts distance and area. A projection that preserves area, such as the Albers equal-area conic projection, should be used if more accurate calculations of distance or area are required.

This product is generated from the USDA-NRCS certified data as of the version date(s) listed below.

Soil Survey Area: El Paso County Area, Colorado
 Survey Area Data: Version 21, Aug 24, 2023

Soil map units are labeled (as space allows) for map scales 1:50,000 or larger.

Date(s) aerial images were photographed: Aug 19, 2018—Oct 20, 2018

The orthophoto or other base map on which the soil lines were compiled and digitized probably differs from the background imagery displayed on these maps. As a result, some minor shifting of map unit boundaries may be evident.

Map Unit Legend (Barbarick WTS)

Map Unit Symbol	Map Unit Name	Acres in AOI	Percent of AOI
9	Blakeland-Fluvaquentic Haplaquolls	3.5	86.7%
71	Pring coarse sandy loam, 3 to 8 percent slopes	0.5	13.3%
Totals for Area of Interest		4.1	100.0%

Map Unit Descriptions (Barbarick WTS)

The map units delineated on the detailed soil maps in a soil survey represent the soils or miscellaneous areas in the survey area. The map unit descriptions, along with the maps, can be used to determine the composition and properties of a unit.

A map unit delineation on a soil map represents an area dominated by one or more major kinds of soil or miscellaneous areas. A map unit is identified and named according to the taxonomic classification of the dominant soils. Within a taxonomic class there are precisely defined limits for the properties of the soils. On the landscape, however, the soils are natural phenomena, and they have the characteristic variability of all natural phenomena. Thus, the range of some observed properties may extend beyond the limits defined for a taxonomic class. Areas of soils of a single taxonomic class rarely, if ever, can be mapped without including areas of other taxonomic classes. Consequently, every map unit is made up of the soils or miscellaneous areas for which it is named and some minor components that belong to taxonomic classes other than those of the major soils.

Most minor soils have properties similar to those of the dominant soil or soils in the map unit, and thus they do not affect use and management. These are called noncontrasting, or similar, components. They may or may not be mentioned in a particular map unit description. Other minor components, however, have properties and behavioral characteristics divergent enough to affect use or to require different management. These are called contrasting, or dissimilar, components. They generally are in small areas and could not be mapped separately because of the scale used. Some small areas of strongly contrasting soils or miscellaneous areas are identified by a special symbol on the maps. If included in the database for a given area, the contrasting minor components are identified in the map unit descriptions along with some characteristics of each. A few areas of minor components may not have been observed, and consequently they are not mentioned in the descriptions, especially where the pattern was so complex that it was impractical to make enough observations to identify all the soils and miscellaneous areas on the landscape.

The presence of minor components in a map unit in no way diminishes the usefulness or accuracy of the data. The objective of mapping is not to delineate pure taxonomic classes but rather to separate the landscape into landforms or landform segments that have similar use and management requirements. The delineation of such segments on the map provides sufficient information for the development of resource plans. If intensive use of small areas is planned, however,

Custom Soil Resource Report

onsite investigation is needed to define and locate the soils and miscellaneous areas.

An identifying symbol precedes the map unit name in the map unit descriptions. Each description includes general facts about the unit and gives important soil properties and qualities.

Soils that have profiles that are almost alike make up a *soil series*. Except for differences in texture of the surface layer, all the soils of a series have major horizons that are similar in composition, thickness, and arrangement.

Soils of one series can differ in texture of the surface layer, slope, stoniness, salinity, degree of erosion, and other characteristics that affect their use. On the basis of such differences, a soil series is divided into *soil phases*. Most of the areas shown on the detailed soil maps are phases of soil series. The name of a soil phase commonly indicates a feature that affects use or management. For example, Alpha silt loam, 0 to 2 percent slopes, is a phase of the Alpha series.

Some map units are made up of two or more major soils or miscellaneous areas. These map units are complexes, associations, or undifferentiated groups.

A *complex* consists of two or more soils or miscellaneous areas in such an intricate pattern or in such small areas that they cannot be shown separately on the maps. The pattern and proportion of the soils or miscellaneous areas are somewhat similar in all areas. Alpha-Beta complex, 0 to 6 percent slopes, is an example.

An *association* is made up of two or more geographically associated soils or miscellaneous areas that are shown as one unit on the maps. Because of present or anticipated uses of the map units in the survey area, it was not considered practical or necessary to map the soils or miscellaneous areas separately. The pattern and relative proportion of the soils or miscellaneous areas are somewhat similar. Alpha-Beta association, 0 to 2 percent slopes, is an example.

An *undifferentiated group* is made up of two or more soils or miscellaneous areas that could be mapped individually but are mapped as one unit because similar interpretations can be made for use and management. The pattern and proportion of the soils or miscellaneous areas in a mapped area are not uniform. An area can be made up of only one of the major soils or miscellaneous areas, or it can be made up of all of them. Alpha and Beta soils, 0 to 2 percent slopes, is an example.

Some surveys include *miscellaneous areas*. Such areas have little or no soil material and support little or no vegetation. Rock outcrop is an example.

El Paso County Area, Colorado

9—Blakeland-Fluvaquentic Haplaquolls

Map Unit Setting

National map unit symbol: 36b6
Elevation: 3,500 to 5,800 feet
Mean annual precipitation: 13 to 17 inches
Mean annual air temperature: 46 to 55 degrees F
Frost-free period: 110 to 165 days
Farmland classification: Not prime farmland

Map Unit Composition

Blakeland and similar soils: 60 percent
Fluvaquentic haplaquolls and similar soils: 38 percent
Minor components: 2 percent
Estimates are based on observations, descriptions, and transects of the mapunit.

Description of Blakeland

Setting

Landform: Hills, flats
Landform position (three-dimensional): Side slope, tal
Down-slope shape: Linear
Across-slope shape: Linear
Parent material: Sandy alluvium derived from arkose and/or eolian deposits
derived from arkose

Typical profile

A - 0 to 11 inches: loamy sand
AC - 11 to 27 inches: loamy sand
C - 27 to 60 inches: sand

Properties and qualities

Slope: 1 to 9 percent
Depth to restrictive feature: More than 80 inches
Drainage class: Somewhat excessively drained
Runoff class: Low
Capacity of the most limiting layer to transmit water (Ksat): High to very high (5.95
to 19.98 in/hr)
Depth to water table: More than 80 inches
Frequency of flooding: None
Frequency of ponding: None
Calcium carbonate, maximum content: 5 percent
Available water supply, 0 to 60 inches: Low (about 4.5 inches)

Interpretive groups

Land capability classification (irrigated): 3e
Land capability classification (nonirrigated): 6e
Hydrologic Soil Group: A
Ecological site: R049XB210CO - Sandy Foothill
Hydric soil rating: No

Description of Fluvaquentic Haplaquolls

Setting

Landform: Swales
Down-slope shape: Linear
Across-slope shape: Linear
Parent material: Alluvium

Typical profile

H1 - 0 to 12 inches: variable
H2 - 12 to 60 inches: stratified very gravelly sand to loam

Properties and qualities

Slope: 1 to 2 percent
Depth to restrictive feature: More than 80 inches
Drainage class: Poorly drained
Runoff class: Very high
Capacity of the most limiting layer to transmit water (Ksat): Moderately high to high
(0.20 to 6.00 in/hr)
Depth to water table: About 0 to 24 inches
Frequency of flooding: Occasional
Frequency of ponding: None
Maximum salinity: Nonsaline to slightly saline (0.0 to 4.0 mmhos/cm)
Available water supply, 0 to 60 inches: Moderate (about 6.2 inches)

Interpretive groups

Land capability classification (irrigated): 6w
Land capability classification (nonirrigated): 6w
Hydrologic Soil Group: D
Ecological site: R048AY241CO - Mountain Meadow
Hydric soil rating: Yes

Minor Components

Other soils

Percent of map unit: 1 percent
Hydric soil rating: No

Pleasant

Percent of map unit: 1 percent
Landform: Depressions
Hydric soil rating: Yes

71—Pring coarse sandy loam, 3 to 8 percent slopes

Map Unit Setting

National map unit symbol: 369k
Elevation: 6,800 to 7,600 feet
Farmland classification: Not prime farmland

Map Unit Composition

Pring and similar soils: 85 percent
Estimates are based on observations, descriptions, and transects of the mapunit.

Description of Pring

Setting

Landform: Hills
Landform position (three-dimensional): Side slope
Down-slope shape: Linear
Across-slope shape: Linear
Parent material: Arkosic alluvium derived from sedimentary rock

Typical profile

A - 0 to 14 inches: coarse sandy loam
C - 14 to 60 inches: gravelly sandy loam

Properties and qualities

Slope: 3 to 8 percent
Depth to restrictive feature: More than 80 inches
Drainage class: Well drained
Runoff class: Low
Capacity of the most limiting layer to transmit water (Ksat): High (2.00 to 6.00 in/hr)
Depth to water table: More than 80 inches
Frequency of flooding: None
Frequency of ponding: None
Available water supply, 0 to 60 inches: Low (about 6.0 inches)

Interpretive groups

Land capability classification (irrigated): None specified
Land capability classification (nonirrigated): 3e
Hydrologic Soil Group: B
Ecological site: R048AY222CO - Loamy Park
Hydric soil rating: No

Minor Components

Pleasant

Percent of map unit:
Landform: Depressions
Hydric soil rating: Yes

Other soils

Percent of map unit:
Hydric soil rating: No

Soil Information for All Uses

Soil Properties and Qualities

The Soil Properties and Qualities section includes various soil properties and qualities displayed as thematic maps with a summary table for the soil map units in the selected area of interest. A single value or rating for each map unit is generated by aggregating the interpretive ratings of individual map unit components. This aggregation process is defined for each property or quality.

Soil Erosion Factors

Soil Erosion Factors are soil properties and interpretations used in evaluating the soil for potential erosion. Example soil erosion factors can include K factor for the whole soil or on a rock free basis, T factor, wind erodibility group and wind erodibility index.

Wind Erodibility Index (Barbarick WTS)

The wind erodibility index is a numerical value indicating the susceptibility of soil to wind erosion, or the tons per acre per year that can be expected to be lost to wind erosion. There is a close correlation between wind erosion and the texture of the surface layer, the size and durability of surface clods, rock fragments, organic matter, and a calcareous reaction. Soil moisture and frozen soil layers also influence wind erosion.

Custom Soil Resource Report
 Map—Wind Erodibility Index (Barbarick WTS)



Map Scale: 1:1,140 if printed on A landscape (11" x 8.5") sheet.
 0 15 30 60 90 Meters
 0 50 100 200 300 Feet
 Map projection: Web Mercator Corner coordinates: WGS84 Edge tics: UTM Zone 13N WGS84

MAP LEGEND

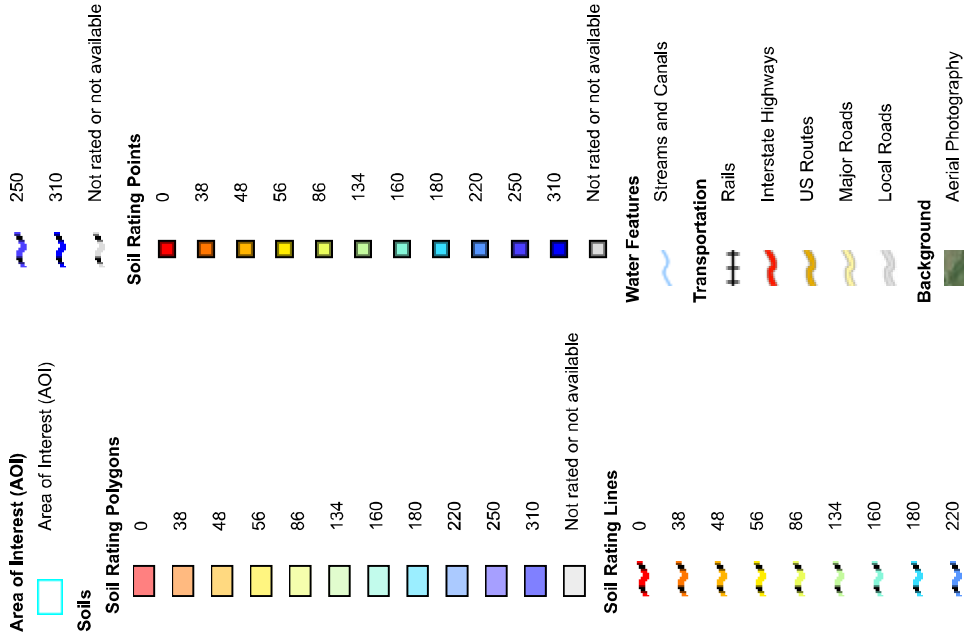

MAP INFORMATION

The soil surveys that comprise your AOI were mapped at 1:24,000.

Warning: Soil Map may not be valid at this scale.

Enlargement of maps beyond the scale of mapping can cause misunderstanding of the detail of mapping and accuracy of soil line placement. The maps do not show the small areas of contrasting soils that could have been shown at a more detailed scale.

Please rely on the bar scale on each map sheet for map measurements.

Source of Map: Natural Resources Conservation Service
 Web Soil Survey URL:
 Coordinate System: Web Mercator (EPSG:3857)

Maps from the Web Soil Survey are based on the Web Mercator projection, which preserves direction and shape but distorts distance and area. A projection that preserves area, such as the Albers equal-area conic projection, should be used if more accurate calculations of distance or area are required.

This product is generated from the USDA-NRCS certified data as of the version date(s) listed below.

Soil Survey Area: El Paso County Area, Colorado
 Survey Area Data: Version 21, Aug 24, 2023

Soil map units are labeled (as space allows) for map scales 1:50,000 or larger.

Date(s) aerial images were photographed: Aug 19, 2018—Oct 20, 2018

The orthophoto or other base map on which the soil lines were compiled and digitized probably differs from the background imagery displayed on these maps. As a result, some minor shifting of map unit boundaries may be evident.

Table—Wind Erodibility Index (Barbarick WTS)

Map unit symbol	Map unit name	Rating (tons per acre per year)	Acres in AOI	Percent of AOI
9	Blakeland-Fluvaquentic Haplaquolls	134	3.5	86.7%
71	Pring coarse sandy loam, 3 to 8 percent slopes	86	0.5	13.3%
Totals for Area of Interest			4.1	100.0%

Rating Options—Wind Erodibility Index (Barbarick WTS)

Units of Measure: tons per acre per year

Aggregation Method: Dominant Condition

Component Percent Cutoff: None Specified

Tie-break Rule: Higher

K Factor, Whole Soil (Barbarick WTS)

Erosion factor K indicates the susceptibility of a soil to sheet and rill erosion by water. Factor K is one of six factors used in the Universal Soil Loss Equation (USLE) and the Revised Universal Soil Loss Equation (RUSLE) to predict the average annual rate of soil loss by sheet and rill erosion in tons per acre per year. The estimates are based primarily on percentage of silt, sand, and organic matter and on soil structure and saturated hydraulic conductivity (Ksat). Values of K range from 0.02 to 0.69. Other factors being equal, the higher the value, the more susceptible the soil is to sheet and rill erosion by water.

"Erosion factor Kw (whole soil)" indicates the erodibility of the whole soil. The estimates are modified by the presence of rock fragments.

Factor K does not apply to organic horizons and is not reported for those layers.

Custom Soil Resource Report
Map—K Factor, Whole Soil (Barbarick WTS)



Map Scale: 1:1,140 if printed on A landscape (11" x 8.5") sheet.
0 15 30 60 90 Meters
0 50 100 200 300 Feet
Map projection: Web Mercator Corner coordinates: WGS84 Edge tics: UTM Zone 13N WGS84

MAP LEGEND

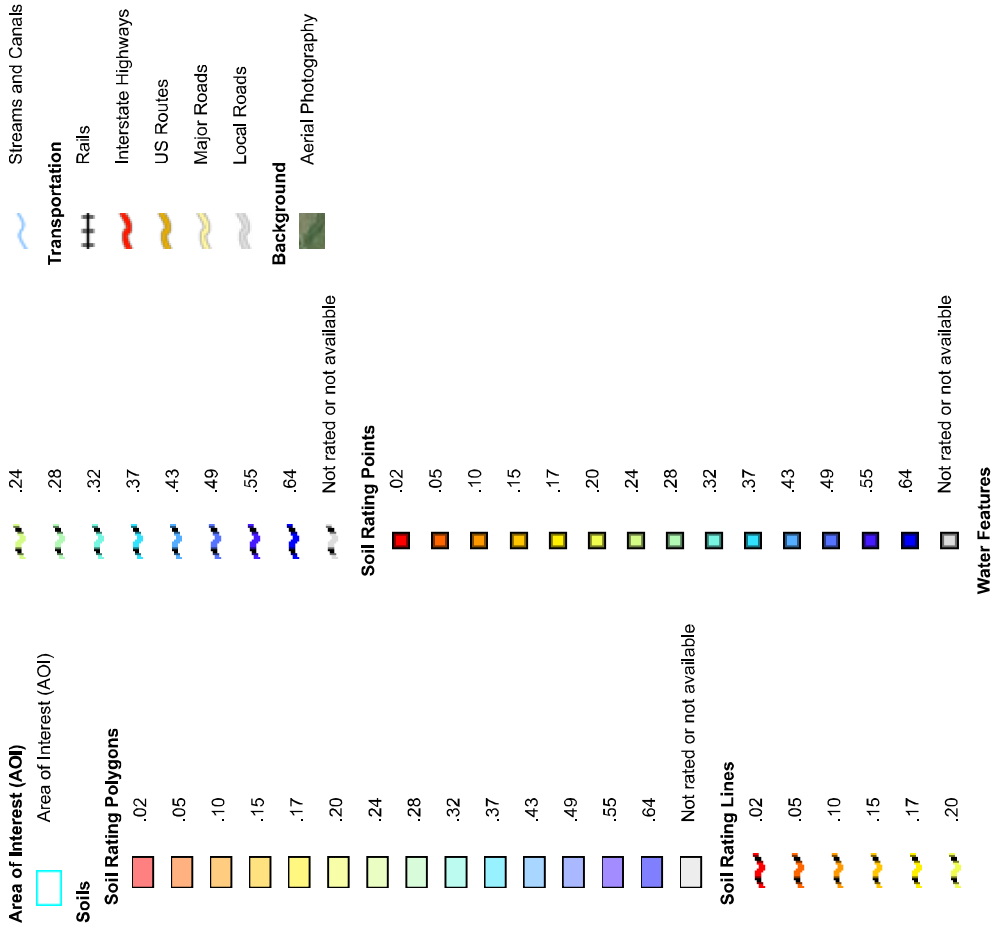

MAP INFORMATION

The soil surveys that comprise your AOI were mapped at 1:24,000.

Warning: Soil Map may not be valid at this scale.

Enlargement of maps beyond the scale of mapping can cause misunderstanding of the detail of mapping and accuracy of soil line placement. The maps do not show the small areas of contrasting soils that could have been shown at a more detailed scale.

Please rely on the bar scale on each map sheet for map measurements.

Source of Map: Natural Resources Conservation Service
 Web Soil Survey URL:
 Coordinate System: Web Mercator (EPSG:3857)

Maps from the Web Soil Survey are based on the Web Mercator projection, which preserves direction and shape but distorts distance and area. A projection that preserves area, such as the Albers equal-area conic projection, should be used if more accurate calculations of distance or area are required.

This product is generated from the USDA-NRCS certified data as of the version date(s) listed below.

Soil Survey Area: El Paso County Area, Colorado
 Survey Area Data: Version 21, Aug 24, 2023

Soil map units are labeled (as space allows) for map scales 1:50,000 or larger.

Date(s) aerial images were photographed: Aug 19, 2018—Oct 20, 2018

The orthophoto or other base map on which the soil lines were compiled and digitized probably differs from the background imagery displayed on these maps. As a result, some minor shifting of map unit boundaries may be evident.

Table—K Factor, Whole Soil (Barbarick WTS)

Map unit symbol	Map unit name	Rating	Acres in AOI	Percent of AOI
9	Blakeland-Fluvaquentic Haplaquolls	.10	3.5	86.7%
71	Pring coarse sandy loam, 3 to 8 percent slopes	.17	0.5	13.3%
Totals for Area of Interest			4.1	100.0%

Rating Options—K Factor, Whole Soil (Barbarick WTS)

Aggregation Method: Dominant Condition

Component Percent Cutoff: None Specified

Tie-break Rule: Higher

Layer Options (Horizon Aggregation Method): Surface Layer (Not applicable)

Soil Qualities and Features

Soil qualities are behavior and performance attributes that are not directly measured, but are inferred from observations of dynamic conditions and from soil properties. Example soil qualities include natural drainage, and frost action. Soil features are attributes that are not directly part of the soil. Example soil features include slope and depth to restrictive layer. These features can greatly impact the use and management of the soil.

Hydrologic Soil Group (Barbarick WTS)

Hydrologic soil groups are based on estimates of runoff potential. Soils are assigned to one of four groups according to the rate of water infiltration when the soils are not protected by vegetation, are thoroughly wet, and receive precipitation from long-duration storms.

The soils in the United States are assigned to four groups (A, B, C, and D) and three dual classes (A/D, B/D, and C/D). The groups are defined as follows:

Group A. Soils having a high infiltration rate (low runoff potential) when thoroughly wet. These consist mainly of deep, well drained to excessively drained sands or gravelly sands. These soils have a high rate of water transmission.

Group B. Soils having a moderate infiltration rate when thoroughly wet. These consist chiefly of moderately deep or deep, moderately well drained or well drained

Custom Soil Resource Report

soils that have moderately fine texture to moderately coarse texture. These soils have a moderate rate of water transmission.

Group C. Soils having a slow infiltration rate when thoroughly wet. These consist chiefly of soils having a layer that impedes the downward movement of water or soils of moderately fine texture or fine texture. These soils have a slow rate of water transmission.

Group D. Soils having a very slow infiltration rate (high runoff potential) when thoroughly wet. These consist chiefly of clays that have a high shrink-swell potential, soils that have a high water table, soils that have a claypan or clay layer at or near the surface, and soils that are shallow over nearly impervious material. These soils have a very slow rate of water transmission.

If a soil is assigned to a dual hydrologic group (A/D, B/D, or C/D), the first letter is for drained areas and the second is for undrained areas. Only the soils that in their natural condition are in group D are assigned to dual classes.

Custom Soil Resource Report
Map—Hydrologic Soil Group (Barbarick WTS)



Map Scale: 1:1,140 if printed on A landscape (11" x 8.5") sheet.
0 15 30 60 90 Meters
0 50 100 200 300 Feet
Map projection: Web Mercator Corner coordinates: WGS84 Edge tics: UTM Zone 13N WGS84

MAP LEGEND

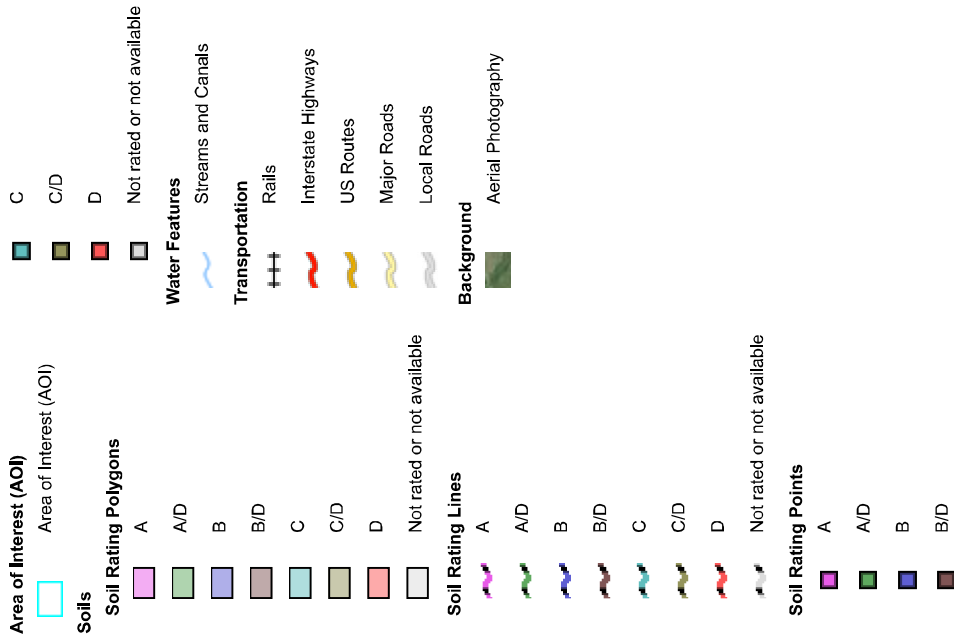

MAP INFORMATION

The soil surveys that comprise your AOI were mapped at 1:24,000.

Warning: Soil Map may not be valid at this scale.

Enlargement of maps beyond the scale of mapping can cause misunderstanding of the detail of mapping and accuracy of soil line placement. The maps do not show the small areas of contrasting soils that could have been shown at a more detailed scale.

Please rely on the bar scale on each map sheet for map measurements.

Source of Map: Natural Resources Conservation Service
 Web Soil Survey URL:
 Coordinate System: Web Mercator (EPSG:3857)

Maps from the Web Soil Survey are based on the Web Mercator projection, which preserves direction and shape but distorts distance and area. A projection that preserves area, such as the Albers equal-area conic projection, should be used if more accurate calculations of distance or area are required.

This product is generated from the USDA-NRCS certified data as of the version date(s) listed below.

Soil Survey Area: El Paso County Area, Colorado
 Survey Area Data: Version 21, Aug 24, 2023

Soil map units are labeled (as space allows) for map scales 1:50,000 or larger.

Date(s) aerial images were photographed: Aug 19, 2018—Oct 20, 2018

The orthophoto or other base map on which the soil lines were compiled and digitized probably differs from the background imagery displayed on these maps. As a result, some minor shifting of map unit boundaries may be evident.

Table—Hydrologic Soil Group (Barbarick WTS)

Map unit symbol	Map unit name	Rating	Acres in AOI	Percent of AOI
9	Blakeland-Fluvaquentic Haplaquolls	A	3.5	86.7%
71	Pring coarse sandy loam, 3 to 8 percent slopes	B	0.5	13.3%
Totals for Area of Interest			4.1	100.0%

Rating Options—Hydrologic Soil Group (Barbarick WTS)

Aggregation Method: Dominant Condition

Component Percent Cutoff: None Specified

Tie-break Rule: Higher

References

- American Association of State Highway and Transportation Officials (AASHTO). 2004. Standard specifications for transportation materials and methods of sampling and testing. 24th edition.
- American Society for Testing and Materials (ASTM). 2005. Standard classification of soils for engineering purposes. ASTM Standard D2487-00.
- Cowardin, L.M., V. Carter, F.C. Golet, and E.T. LaRoe. 1979. Classification of wetlands and deep-water habitats of the United States. U.S. Fish and Wildlife Service FWS/OBS-79/31.
- Federal Register. July 13, 1994. Changes in hydric soils of the United States.
- Federal Register. September 18, 2002. Hydric soils of the United States.
- Hurt, G.W., and L.M. Vasilas, editors. Version 6.0, 2006. Field indicators of hydric soils in the United States.
- National Research Council. 1995. Wetlands: Characteristics and boundaries.
- Soil Survey Division Staff. 1993. Soil survey manual. Soil Conservation Service. U.S. Department of Agriculture Handbook 18. http://www.nrcs.usda.gov/wps/portal/nrcs/detail/national/soils/?cid=nrcs142p2_054262
- Soil Survey Staff. 1999. Soil taxonomy: A basic system of soil classification for making and interpreting soil surveys. 2nd edition. Natural Resources Conservation Service, U.S. Department of Agriculture Handbook 436. http://www.nrcs.usda.gov/wps/portal/nrcs/detail/national/soils/?cid=nrcs142p2_053577
- Soil Survey Staff. 2010. Keys to soil taxonomy. 11th edition. U.S. Department of Agriculture, Natural Resources Conservation Service. http://www.nrcs.usda.gov/wps/portal/nrcs/detail/national/soils/?cid=nrcs142p2_053580
- Tiner, R.W., Jr. 1985. Wetlands of Delaware. U.S. Fish and Wildlife Service and Delaware Department of Natural Resources and Environmental Control, Wetlands Section.
- United States Army Corps of Engineers, Environmental Laboratory. 1987. Corps of Engineers wetlands delineation manual. Waterways Experiment Station Technical Report Y-87-1.
- United States Department of Agriculture, Natural Resources Conservation Service. National forestry manual. http://www.nrcs.usda.gov/wps/portal/nrcs/detail/soils/home/?cid=nrcs142p2_053374
- United States Department of Agriculture, Natural Resources Conservation Service. National range and pasture handbook. <http://www.nrcs.usda.gov/wps/portal/nrcs/detail/national/landuse/rangepasture/?cid=stelp2db1043084>

Custom Soil Resource Report

United States Department of Agriculture, Natural Resources Conservation Service. National soil survey handbook, title 430-VI. http://www.nrcs.usda.gov/wps/portal/nrcs/detail/soils/scientists/?cid=nrcs142p2_054242

United States Department of Agriculture, Natural Resources Conservation Service. 2006. Land resource regions and major land resource areas of the United States, the Caribbean, and the Pacific Basin. U.S. Department of Agriculture Handbook 296. http://www.nrcs.usda.gov/wps/portal/nrcs/detail/national/soils/?cid=nrcs142p2_053624

United States Department of Agriculture, Soil Conservation Service. 1961. Land capability classification. U.S. Department of Agriculture Handbook 210. http://www.nrcs.usda.gov/Internet/FSE_DOCUMENTS/nrcs142p2_052290.pdf

APPENDIX C: FEMA FIRM MAP

NOTES TO USERS

This map is for use in administering the National Flood Insurance Program. It does not necessarily identify all areas subject to flooding, particularly from local drainage sources of small size. The community map repository should be consulted for possible updated or additional flood hazard information.

To obtain more detailed information in areas where **Base Flood Elevations (BFEs)** and/or **floodways** have been determined, users are encouraged to consult the Flood Profiles and Floodway Data and/or Summary of Stillwater Elevations tables contained within the Flood Insurance Study (FIS) report that accompanies this FIRM. Users should be aware that BFEs shown on the FIRM represent rounded whole-foot elevations. These BFEs are intended for flood insurance rating purposes only and should not be used as the sole source of flood elevation information. Accordingly, flood elevation data presented in the FIS report should be utilized in conjunction with the FIRM for purposes of construction and/or floodplain management.

Coastal Base Flood Elevations shown on this map apply only landward of 0.0' North American Vertical Datum of 1988 (NAVD88). Users of this FIRM should be aware that coastal flood elevations are also provided in the Summary of Stillwater Elevations table in the Flood Insurance Study report for this jurisdiction. Elevations shown in the Summary of Stillwater Elevations table should be used for construction and/or floodplain management purposes when they are higher than the elevations shown on this FIRM.

Boundaries of the **floodways** were computed at cross sections and interpolated between cross sections. The floodways were based on hydraulic considerations with regard to requirements of the National Flood Insurance Program. Floodway widths and other pertinent floodway data are provided in the Flood Insurance Study report for this jurisdiction.

Certain areas not in Special Flood Hazard Areas may be protected by **flood control structures**. Refer to section 2.4 "Flood Protection Measures" of the Flood Insurance Study report for information on flood control structures for this jurisdiction.

The **projection** used in the preparation of this map was Universal Transverse Mercator (UTM) zone 13. The **horizontal datum** was NAD83, GRS80 spheroid. Differences in datum, spheroid, projection or UTM zones zones used in the production of FIRMs for adjacent jurisdictions may result in slight positional differences in map features across jurisdiction boundaries. These differences do not affect the accuracy of this FIRM.

Flood elevations on this map are referenced to the **North American Vertical Datum of 1988 (NAVD88)**. These flood elevations must be compared to structure and ground elevations referenced to the same **vertical datum**. For information regarding conversion between the National Geodetic Vertical Datum of 1929 and the North American Vertical Datum of 1988, visit the National Geodetic Survey website at <http://www.ngs.noaa.gov/> or contact the National Geodetic Survey at the following address:

NGS Information Services
NOAA, NIMS12
National Geodetic Survey
SSMC-3, #9202
1315 East-West Highway
Silver Spring, MD 20910-3282

To obtain current elevation, description, and/or location information for **bench marks** shown on this map, please contact the Information Services Branch of the National Geodetic Survey at (301) 713-3242 or visit its website at <http://www.ngs.noaa.gov/>.

Base Map information shown on this FIRM was provided in digital format by El Paso County, Colorado Springs Utilities, and Anderson Consulting Engineers, Inc. These data are current as of 2008.

This map reflects more detailed and up-to-date **stream channel configurations and floodplain delineations** than those shown on the previous FIRM for this jurisdiction. The floodplains and floodways that were transferred from the previous FIRM may have been adjusted to conform to these new stream channel configurations. As a result, the Flood Profiles and Floodway Data tables in the Flood Insurance Study Report (which contains authoritative hydraulic data) may reflect stream channel distances that differ from what is shown on this map. The profile baselines depicted on this map represent the hydraulic modeling baselines that match the flood profiles and Floodway Data Tables if applicable, in the FIS report. As a result, the profile baselines may deviate significantly from the new base map channel representation and may appear outside of the floodplain.

Corporate limits shown on this map are based on the best data available at the time of publication. Because changes due to annexations or de-annexations may have occurred after this map was published, map users should contact appropriate community officials to verify current corporate limit locations.

Please refer to the separately printed **Map Index** for an overview map of the county showing the layout of map panels; community map repository addresses; and a Listing of Communities table containing National Flood Insurance Program dates for each community as well as a listing of the panels on which each community is located.

Contact **FEMA Map Service Center (MSC)** via the FEMA Map Information eXchange (FIRM) 1-877-336-2627 for information on available products associated with this FIRM. Available products may include previously issued Letters of Map Change, a Flood Insurance Study Report, and/or digital versions of this map. The MSC may also be reached by Fax at 1-800-358-9620 and its website at <http://www.msc.fema.gov/>.

If you have **questions about this map** or questions concerning the National Flood Insurance Program in general, please call **1-877-FEMA MAP (1-877-336-2627)** or visit the FEMA website at <http://www.fema.gov/business/nfp>.

El Paso County Vertical Datum Offset Table

Flooding Source	Vertical Datum Offset (ft)
REFER TO SECTION 3.3 OF THE EL PASO COUNTY FLOOD INSURANCE STUDY FOR STREAM BY STREAM VERTICAL DATUM CONVERSION INFORMATION	

Panel Location Map

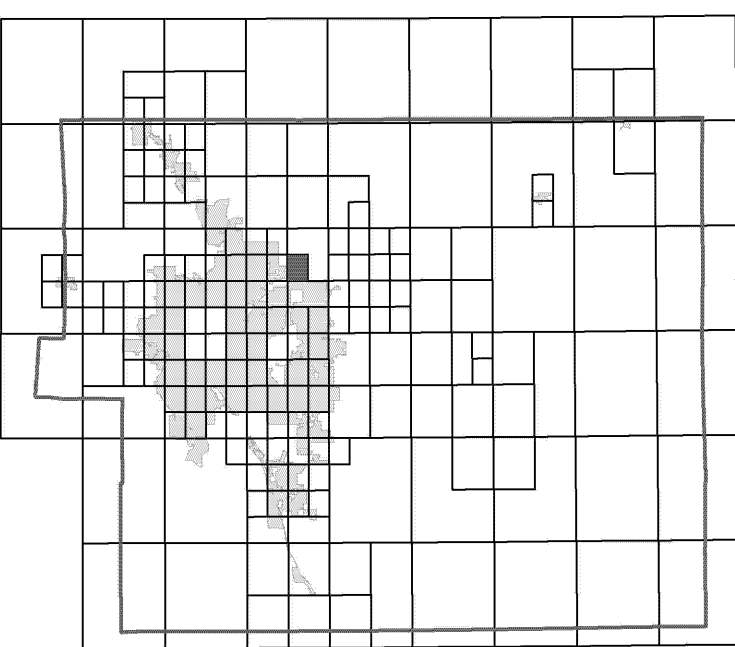

This Digital Flood Insurance Rate Map (DFIRM) was produced through a Cooperating Technical Partner (CTP) agreement between the State of Colorado Water Conservation Board (CWCB) and the Federal Emergency Management Agency (FEMA).



Additional Flood Hazard information and resources are available from local communities and the Colorado Water Conservation Board.

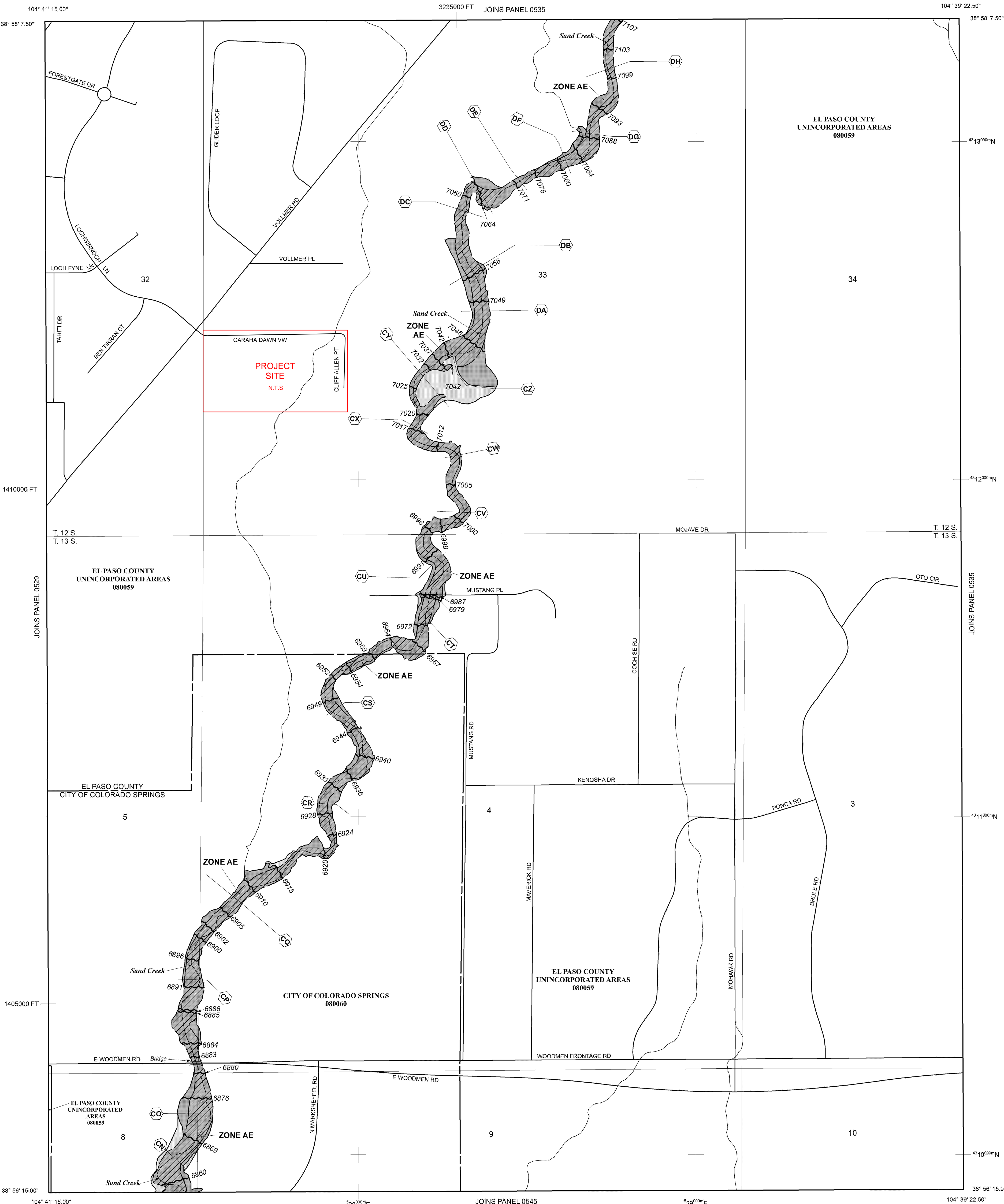

NOTE: MAP AREA SHOWN ON THIS PANEL IS LOCATED WITHIN TOWNSHIP 12 SOUTH, RANGE 65 WEST, AND TOWNSHIP 13 SOUTH, RANGE 65 WEST.

LEGEND

SPECIAL FLOOD HAZARD AREAS (SFHAS) SUBJECT TO INUNDATION BY THE 1% ANNUAL CHANCE FLOOD

The 1% annual chance flood (100-year flood), also known as the base flood, is the flood that has a 1% chance of being equalled or exceeded in any given year. The Special Flood Hazard Area is the area subject, to flooding by the 1% annual chance flood. Areas of Special Flood Hazard include Zones A, AE, AH, AO, AR, A99, V, and VE. The Base Flood Elevation is the water-surface elevation of the 1% annual chance flood.

- ZONE A** No Base Flood Elevations determined.
- ZONE AE** Base Flood Elevations determined.
- ZONE AH** Flood depths of 1 to 3 feet (usually areas of ponding); Base Flood Elevations determined.
- ZONE AO** Flood depths of 1 to 3 feet (usually sheet flow on sloping terrain); average depths determined. For areas of alluvial fan flooding, velocities also determined.
- ZONE AR** Special Flood Hazard Area Formerly protected from the 1% annual chance flood by a flood control system that was subsequently decertified. Zone AR indicates that the former flood control system is being restored to provide protection from the 1% annual chance or greater flood.
- ZONE A99** Area to be protected from 1% annual chance flood by a Federal flood protection system under construction; no Base Flood Elevations determined.
- ZONE V** Coastal flood zone with velocity hazard (wave action); no Base Flood Elevations determined.
- ZONE VE** Coastal flood zone with velocity hazard (wave action); Base Flood Elevations determined.

FLOODWAY AREAS IN ZONE AE

The floodway is the channel of a stream plus any adjacent floodplain areas that must be kept free of encroachment so that the 1% annual chance flood can be carried without substantial increases in flood heights.

OTHER FLOOD AREAS

ZONE X Areas of 0.2% annual chance flood; areas of 1% annual chance flood with average depths of less than 1 foot or with drainage areas less than 1 square mile; and areas protected by levees from 1% annual chance flood.

OTHER AREAS

ZONE X Areas determined to be outside the 0.2% annual chance floodplain.

ZONE D Areas in which flood hazards are undetermined, but possible.

COASTAL BARRIER RESOURCES SYSTEM (CBRS) AREAS

OTHERWISE PROTECTED AREAS (OPAs)

CBRS areas and OPAs are normally located within or adjacent to Special Flood Hazard Areas.

- Floodplain boundary
- Floodway boundary
- Zone D Boundary
- CBRS and OPA boundary
- Boundary dividing Special Flood Hazard Areas of different Base Flood Elevations, flood depths or flood velocities.
- (EL 987) Base Flood Elevation value where uniform within zone; elevation in feet*
- 513 Base Flood Elevation line and value; elevation in feet*

* Referenced to the North American Vertical Datum of 1988 (NAVD 88)

A Cross section line

23 Transsect line

97° 07' 30.00" Datum of 1983 (NAD 83)

4750000N 1000-meter Universal Transverse Mercator grid ticks, zone 13

6000000 FT 5000-foot grid ticks; Colorado State Plane coordinate system, central zone (EPSG:3023), Lambert Conformal Conic Projection

DX5510 Bench mark (see explanation in Notes to Users section of this FIRM panel)

M1.5 River Mile

MAP REPOSITORIES Refer to Map Repositories list on Map Index

EFFECTIVE DATE OF COUNTYWIDE FLOOD INSURANCE RATE MAP MARCH 17, 1997

EFFECTIVE DATE(S) OF REVISION(S) TO THIS PANEL DECEMBER 7, 2018 - to update corporate limits, to change Base Flood Elevations and Special Flood Hazard Areas, to update map format, to add roads and road names, and to incorporate previously issued Letters of Map Revision.

For community map revision history prior to countywide mapping, refer to the Community Map History Table located in the Flood Insurance Study report for this jurisdiction.

To determine if flood insurance is available in this community, contact your insurance agent or call the National Flood Insurance Program at 1-800-638-6620.

MAP SCALE 1" = 500'

250 0 500 1000 FEET

150 0 150 300 METERS

NFIP **PANEL 0533G**

FIRM
FLOOD INSURANCE RATE MAP
EL PASO COUNTY,
COLORADO
AND INCORPORATED AREAS

PANEL 533 OF 1300
(SEE MAP INDEX FOR FIRM PANEL LAYOUT)

CONTAINS:

COMMUNITY	NUMBER	PANEL	SUFFIX
COLORADO SPRINGS, CITY OF	08060	0533	G
EL PASO COUNTY	08059	0533	G

Notice to User: The Map Number shown below should be used when placing map orders. The Community Number shown above should be used on insurance applications for the subject community.

MAP NUMBER
08041C0533G

MAP REVISED
DECEMBER 7, 2018
Federal Emergency Management Agency

APPENDIX D: HYDROLOGIC ANALYSIS

Weighted Imperviousness Calculations - Existing Conditions

SUB-BASIN	AREA (SF)	AREA (Acres)	GRAVEL AREA	GRAVEL IMP.	GRAVEL				LANDSCAPE AREA	LANDSCAPE IMP.	LANDSCAPE				PAVEMENT AREA	TOTAL IMP.	PAVEMENT / MILLINGS				ROOF AREA	TOTAL IMP.	ROOF				WEIGHTED IMP.	WEIGHTED COEFFICIENTS			
					C2	C5	C10	C100			C2	C5	C10	C100			C2	C5	C10	C100			C2	C5	C10	C100					
E1	16,873	0.39	11,670	80%	0.57	0.59	0.63	0.7	5,204	0%	0.02	0.08	0.15	0.35	0	100%	0.89	0.9	0.92	0.96	0	90%	0.71	0.73	0.75	0.81	55.3%	0.40	0.43	0.48	0.59
E2	112,891	2.59	87,610	80%	0.57	0.59	0.63	0.7	25,281	0%	0.02	0.08	0.15	0.35	0	100%	0.89	0.9	0.92	0.96	0	90%	0.71	0.73	0.75	0.81	62.1%	0.45	0.48	0.52	0.62
OE1	101,771	2.34	0	80%	0.57	0.59	0.63	0.7	3,243	0%	0.02	0.08	0.15	0.35	98,528	100%	0.89	0.9	0.92	0.96	0	90%	0.71	0.73	0.75	0.81	96.8%	0.86	0.87	0.90	0.94
OE2	108,087	2.48	0	80%	0.57	0.59	0.63	0.7	0	0%	0.02	0.08	0.15	0.35	108,087	100%	0.89	0.9	0.92	0.96	0	90%	0.71	0.73	0.75	0.81	100.0%	0.89	0.90	0.92	0.96
OE3	49,856	1.14	0	80%	0.57	0.59	0.63	0.7	0	0%	0.02	0.08	0.15	0.35	49,856	100%	0.89	0.9	0.92	0.96	0	90%	0.71	0.73	0.75	0.81	100.0%	0.89	0.90	0.92	0.96
OE4	35,615	0.82	0	80%	0.57	0.59	0.63	0.7	0	0%	0.02	0.08	0.15	0.35	35,615	100%	0.89	0.9	0.92	0.96	0	90%	0.71	0.73	0.75	0.81	100.0%	0.89	0.90	0.92	0.96
OE5	42,290	0.97	31,640	80%	0.57	0.59	0.63	0.7	3,715	0%	0.02	0.08	0.15	0.35	2,959	100%	0.89	0.9	0.92	0.96	3,977	90%	0.71	0.73	0.75	0.81	75.3%	0.56	0.58	0.62	0.70
TOTAL	467,384	10.73	130,919	80%	0.57	0.59	0.63	0.70	37,443	0%	0.02	0.08	0.15	0.35	295,045	100%	0.89	0.90	0.92	0.96	3,977	90%	0.71	0.73	0.75	0.81	86.3%	0.73	0.75	0.78	0.84

DESIGN POINT		SUB-BASIN DATA			INITIAL / OVERLAND* TIME			TRAVEL TIME T(t)					T(c) CHECK (URBANIZED BASINS)			FINAL T@* min.	
		DRAIN BASIN	AREA sq. ft.	AREA ac.	C(5)	Length ft.	Slope %	T(i) min	Length ft.	Slope %	Coeff.	Velocity fps	T(t) min.	COMP. T(c)	TOTAL LENGTH		L/180+10
					Forest & Meadow 2.50			Short Grass Pasture & Lawns 7.00					Grassed Waterway 15.00				
					Fallow or Cultivation 5.00			Nearly Bare Ground 10.00					Paved Area & Shallow Gutter 20.00				
E1		E1	16,873	0.39	0.43	100	4.0%	7.7	145	1.8%	10.00	1.3	1.8	9.5	245	11.4	9.5
E2		E2	112,891	2.59	0.48	100	3.2%	7.8	0	0.0%	10.00	0.0	0.0	7.8	100	10.6	7.8
OE1		OE1	101,771	2.34	0.87	100	2.0%	3.3	0	0.0%	10.00	0.0	0.0	5.0	100	10.6	5.0
OE2		OE2	108,087	2.48	0.90	100	2.5%	2.7	0	0.0%	10.00	0.0	0.0	5.0	100	10.6	5.0
OE3		OE3	49,856	1.14	0.90	100	3.5%	2.4	0	0.0%	10.00	0.0	0.0	5.0	100	10.6	5.0
OE4		OE4	35,615	0.82	0.90	100	3.0%	2.5	35	13.0%	10.00	3.6	0.2	5.0	135	10.8	5.0
OE5		OE5	42,290	0.97	0.58	100	3.8%	6.1	30	25.0%	10.00	5.0	0.1	6.2	130	10.7	6.2
TOTAL		TOTAL	467,384	10.73													

*Note: El Paso County Drainage Manual Chapter 6 indicates that the maximum overland flow length is 100ft for urbanized areas and 300ft for rural areas. The minimum time of concentration is 5 min for developed conditions, 10 min for undeveloped conditions.

Barbarick Transfer Station Time of Concentration - Existing Conditions Design Storm 5 Year Storm Event (Rational Method Procedure)												
BASIN INFORMATION				DIRECT RUNOFF				CUMMULATIVE RUNOFF				NOTES
DESIGN POINT	DRAIN BASIN	AREA ac.	RUNOFF COEFF	T(c) min	C x A	I in/hr	Q cfs	T(c) min	C x A	I in/hr	Q cfs	
E1	E1	0.39	0.43	9.5	0.17	4.20	0.70	9.5	2.0	4.20	8.58	
E2	E2	2.59	0.48	7.8	1.23	4.51	5.56	7.8	2.23	4.51	10.07	
OE1	OE1	2.34	0.87	5.0	2.04	5.17	10.55					
OE2	OE2	2.48	0.90	5.0	2.23	5.17	11.54					
OE3	OE3	1.14	0.90	5.0	1.03	5.17	5.32					
OE4	OE4	0.82	0.90	5.0	0.74	5.17	3.80					
OE5	OE5	0.97	0.58	6.2	0.56	4.84	2.73					
TOTAL	TOTAL	10.73	0.75				40.22					

Barbarick Transfer Station Time of Concentration - Existing Conditions (Rational Method Procedure)												
Design Storm <i>100 Year Storm Event</i>												
BASIN INFORMATION				DIRECT RUNOFF				CUMMULATIVE RUNOFF				NOTES
DESIGN POINT	DRAIN BASIN	AREA ac.	RUNOFF COEFF	T(c) min	C x A	I in/hr	Q cfs	T(c) min	C x A	I in/hr	Q cfs	
E1	E1	0.39	0.59	9.5	0.23	7.06	1.62	9.5	2.2	7.06	15.51	
E2	E2	2.59	0.62	7.8	1.61	7.57	12.19	7.8	2.38	7.57	18.03	
OE1	OE1	2.34	0.94	5.0	2.20	8.68	19.07					
OE2	OE2	2.48	0.96	5.0	2.38	8.68	20.67					
OE3	OE3	1.14	0.96	5.0	1.10	8.68	9.54					
OE4	OE4	0.82	0.96	5.0	0.78	8.68	6.81					
OE5	OE5	0.97	0.70	6.2	0.68	8.13	5.51					
TOTAL	TOTAL	10.73	0.84				75.42					

SUMMARY - EXISTING RUNOFF TABLE					
DESIGN POINT	BASIN DESIGNATION	BASIN AREA (ACRES)	BASIN IMPERVIOUSNESS (%)	DIRECT 5-YR RUNOFF (CFS)	DIRECT 100-YR RUNOFF (CFS)
E1	E1	0.39	55.3%	0.70	1.62
E2	E2	2.59	62.1%	5.56	12.19
OE1	OE1	2.34	96.8%	10.55	19.07
OE2	OE2	2.48	100.0%	11.54	20.67
OE3	OE3	1.14	100.0%	5.32	9.54
OE4	OE4	0.82	100.0%	3.80	6.81
OE5	OE5	0.97	75.3%	2.73	5.51
TOTAL		10.73	86.3%	40.22	75.42

Weighted Imperviousness Calculations - Proposed Conditions

SUB-BASIN	AREA	AREA	GRAVEL	GRAVEL	GRAVEL				LANDSCAPE	LANDSCAPE	LANDSCAPE				PAVEMENT	TOTAL	PAVEMENT / MILLINGS				ROOF	TOTAL	ROOF				WEIGHTED	WEIGHTED COEFFICIENTS			
	(SF)	(Acres)			AREA	IMP.	C2	C5			C10	C100	AREA	IMP			C2	C5	C10	C100			AREA	IMP	C2	C5		C10	C100	AREA	IMP
P1	13,663	0.31	12,504	80%	0.57	0.59	0.63	0.7	0	0%	0.02	0.08	0.15	0.35	1,159	100%	0.89	0.9	0.92	0.96	0	90%	0.71	0.73	0.75	0.81	81.7%	0.60	0.62	0.65	0.72
P2	6,602	0.15	5,123	80%	0.57	0.59	0.63	0.7	509	0%	0.02	0.08	0.15	0.35	720	100%	0.89	0.9	0.92	0.96	250	90%	0.71	0.73	0.75	0.81	76.4%	0.57	0.59	0.63	0.71
P3	4,792	0.11	4,258	80%	0.57	0.59	0.63	0.7	0	0%	0.02	0.08	0.15	0.35	534	100%	0.89	0.9	0.92	0.96	0	90%	0.71	0.73	0.75	0.81	82.2%	0.61	0.62	0.66	0.73
P4	4,781	0.11	4,235	80%	0.57	0.59	0.63	0.7	0	0%	0.02	0.08	0.15	0.35	547	100%	0.89	0.9	0.92	0.96	0	90%	0.71	0.73	0.75	0.81	82.3%	0.61	0.63	0.66	0.73
P5	5,806	0.13	5,237	80%	0.57	0.59	0.63	0.7	0	0%	0.02	0.08	0.15	0.35	569	100%	0.89	0.9	0.92	0.96	0	90%	0.71	0.73	0.75	0.81	82.0%	0.60	0.62	0.66	0.73
P6	88,931	2.04	28,161	80%	0.57	0.59	0.63	0.7	30,941	0%	0.02	0.08	0.15	0.35	29,829	100%	0.89	0.9	0.92	0.96	0	90%	0.71	0.73	0.75	0.81	58.9%	0.49	0.52	0.56	0.67
R1	5,882	0.14	0	80%	0.57	0.59	0.63	0.7	0	0%	0.02	0.08	0.15	0.35	0	100%	0.89	0.9	0.92	0.96	5,882	90%	0.71	0.73	0.75	0.81	90.0%	0.71	0.73	0.75	0.81
R2	5,882	0.14	0	80%	0.57	0.59	0.63	0.7	0	0%	0.02	0.08	0.15	0.35	0	100%	0.89	0.9	0.92	0.96	5,882	90%	0.71	0.73	0.75	0.81	90.0%	0.71	0.73	0.75	0.81
O1	65,975	1.51	0	80%	0.57	0.59	0.63	0.7	3,243	0%	0.02	0.08	0.15	0.35	62,732	100%	0.89	0.9	0.92	0.96	0	90%	0.71	0.73	0.75	0.81	95.1%	0.85	0.86	0.88	0.93
O2	32,389	0.74	0	80%	0.57	0.59	0.63	0.7	0	0%	0.02	0.08	0.15	0.35	32,389	100%	0.89	0.9	0.92	0.96	0	90%	0.71	0.73	0.75	0.81	100.0%	0.89	0.90	0.92	0.96
O3	19,087	0.44	0	80%	0.57	0.59	0.63	0.7	0	0%	0.02	0.08	0.15	0.35	19,087	100%	0.89	0.9	0.92	0.96	0	90%	0.71	0.73	0.75	0.81	100.0%	0.89	0.90	0.92	0.96
O4	45,546	1.05	0	80%	0.57	0.59	0.63	0.7	0	0%	0.02	0.08	0.15	0.35	45,546	100%	0.89	0.9	0.92	0.96	0	90%	0.71	0.73	0.75	0.81	100.0%	0.89	0.90	0.92	0.96
O5	46,861	1.08	0	80%	0.57	0.59	0.63	0.7	0	0%	0.02	0.08	0.15	0.35	46,861	100%	0.89	0.9	0.92	0.96	0	90%	0.71	0.73	0.75	0.81	100.0%	0.89	0.90	0.92	0.96
O6	49,856	1.14	0	80%	0.57	0.59	0.63	0.7	0	0%	0.02	0.08	0.15	0.35	49,856	100%	0.89	0.9	0.92	0.96	0	90%	0.71	0.73	0.75	0.81	100.0%	0.89	0.90	0.92	0.96
O7	35,615	0.82	0	80%	0.57	0.59	0.63	0.7	0	0%	0.02	0.08	0.15	0.35	35,615	100%	0.89	0.9	0.92	0.96	0	90%	0.71	0.73	0.75	0.81	100.0%	0.89	0.90	0.92	0.96
O8	35,714	0.82	20,976	80%	0.57	0.59	0.63	0.7	3,715	0%	0.02	0.08	0.15	0.35	6,935	100%	0.89	0.9	0.92	0.96	4,088	90%	0.71	0.73	0.75	0.81	76.7%	0.59	0.61	0.65	0.73
TOTAL	467,384	10.73	80,494	80%	0.57	0.59	0.63	0.70	38,408	0%	0.02	0.08	0.15	0.35	332,379	100%	0.89	0.90	0.92	0.96	16,102	90%	0.71	0.73	0.75	0.81	88.0%	0.76	0.77	0.80	0.86

Barbarick Transfer Station																
Time of Concentration - Proposed Conditions																
					Forest & Meadow		2.50	Short Grass Pasture & Lawns		7.00		Grassed Waterway			15.00	
					Fallow or Cultivation		5.00	Nearly Bare Ground		10.00		Paved Area & Shallow Gutter			20.00	
DESIGN POINT	SUB-BASIN DATA				INITIAL / OVERLAND* TIME			TRAVEL TIME T(t)					T(c) CHECK (URBANIZED BASINS)			FINAL T@* min.
	DRAIN BASIN	AREA sq. ft.	AREA ac.	C(5)	Length ft.	Slope %	T(i) min	Length ft.	Slope %	Coeff.	Velocity fps	T(t) min.	COMP. T(c)	TOTAL LENGTH	L/180+10	
P1	P1	13,663	0.31	0.62	52	2.0%	5.1	30	2.5%	10.00	1.6	0.3	5.4	82	10.5	5.4
P2	P2	6,602	0.15	0.59	72	2.6%	5.8	42	3.5%	15.00	2.8	0.2	6.0	114	10.6	6.0
P3	P3	4,792	0.11	0.62	31	2.8%	3.4	25	1.6%	20.00	2.5	0.2	5.0	56	10.3	5.0
P4	P4	4,781	0.11	0.63	40	1.6%	4.7	26	1.2%	20.00	2.2	0.2	5.0	66	10.4	5.0
P5	P5	5,806	0.13	0.62	33	4.4%	3.1	136	1.9%	20.00	2.8	0.8	5.0	169	10.9	5.0
P6	P6	88,931	2.04	0.52	100	2.6%	7.8	438	1.0%	20.00	2.0	3.7	11.4	538	13.0	11.4
R1	R1	5,882	0.14	0.73	100	0.5%	8.5	0	0.0%	20.00	0.0	0.0	8.5	100	10.6	8.5
R2	R2	5,882	0.14	0.73	100	0.5%	8.5	0	0.0%	20.00	0.0	0.0	8.5	100	10.6	8.5
O1	O1	65,975	1.51	0.86	100	2.0%	3.5	0	0.0%	10.00	0.0	0.0	5.0	100	10.6	5.0
O2	O2	32,389	0.74	0.90	100	2.5%	2.7	0	0.0%	10.00	0.0	0.0	5.0	100	10.6	5.0
O3	O3	19,087	0.44	0.90	100	2.5%	2.7	0	0.0%	10.00	0.0	0.0	5.0	100	10.6	5.0
O4	O4	45,546	1.05	0.90	100	3.0%	2.5	0	0.0%	10.00	0.0	0.0	5.0	100	10.6	5.0
O5	O5	46,861	1.08	0.90	100	3.0%	2.5	0	0.0%	10.00	0.0	0.0	5.0	100	10.6	5.0
O6	O6	49,856	1.14	0.90	100	3.5%	2.4	0	0.0%	10.00	0.0	0.0	5.0	100	10.6	5.0
O7	O7	35,615	0.82	0.90	100	3.0%	2.5	35	13.0%	10.00	3.6	0.2	5.0	135	10.8	5.0
O8	O8	35,714	0.82	0.61	100	3.8%	5.7	30	25.0%	10.00	5.0	0.1	5.8	130	10.7	5.8
TOTAL	TOTAL	467,384	10.73													

*Note: El Paso County Drainage Manual Chapter 6 indicates that the maximum overland flow length is 100ft for urbanized areas and 300ft for rural areas. The minimum time of concentration is 5 min for developed conditions, 10 min for undeveloped conditions.

Barbarick Transfer Station Time of Concentration - Proposed Conditions Design Storm 5 Year Storm Event (Rational Method Procedure)												
BASIN INFORMATION				DIRECT RUNOFF				CUMMULATIVE RUNOFF				NOTES
DESIGN POINT	DRAIN BASIN	AREA ac.	RUNOFF COEFF	T(c) min	C x A	I in/hr	Q cfs	T(c) min	C x A	I in/hr	Q cfs	
P1	P1	0.31	0.62	5.4	0.19	5.06	0.98	10.4	1.3	4.07	5.30	O1 is tributary to P1
P2	P2	0.15	0.59	6.0	0.09	4.89	0.44					
P3	P3	0.11	0.62	5.0	0.07	5.17	0.36	5.0	1.0	5.17	5.22	O4 is tributary to P3
P4	P4	0.11	0.63	5.0	0.07	5.17	0.35	5.0	1.0	5.17	5.36	O5 is tributary to P4
P5	P5	0.13	0.62	5.0	0.08	5.17	0.43	5.0	1.1	5.17	5.75	O6 is tributary to P5
P6	P6	2.04	0.52	11.4	1.05	3.93	4.14					
R1	R1	0.14	0.73	8.5	0.10	4.36	0.43					
R2	R2	0.14	0.73	8.5	0.10	4.36	0.43					
O1	O1	1.51	0.86	5.0	1.30	5.17	6.73					
O2	O2	0.74	0.90	5.0	0.67	5.17	3.46					
O3	O3	0.44	0.90	5.0	0.39	5.17	2.04					
O4	O4	1.05	0.90	5.0	0.94	5.17	4.86					
O5	O5	1.08	0.90	5.0	0.97	5.17	5.00					
O6	O6	1.14	0.90	5.0	1.03	5.17	5.32					
O7	O7	0.82	0.90	5.0	0.74	5.17	3.80					
O8	O8	0.82	0.61	5.8	0.50	4.94	2.48					
TOTAL	TOTAL	10.73	0.77				41.26					

Barbarick Transfer Station Time of Concentration - Proposed Conditions (Rational Method Procedure)												
BASIN INFORMATION				DIRECT RUNOFF				CUMMULATIVE RUNOFF				NOTES
DESIGN POINT	DRAIN BASIN	AREA ac.	RUNOFF COEFF	T(c) min	C x A	I in/hr	Q cfs	T(c) min	C x A	I in/hr	Q cfs	
P1	P1	0.31	0.72	5.4	0.23	8.49	1.92	5.4	1.4	8.49	11.96	O1 is tributary to P1
P2	P2	0.15	0.71	6.0	0.11	8.21	0.88					
P3	P3	0.11	0.73	5.0	0.08	8.68	0.70	5.0	1.1	8.68	9.41	O4 is tributary to P3
P4	P4	0.11	0.73	5.0	0.08	8.68	0.70	5.0	1.1	8.68	9.66	O5 is tributary to P4
P5	P5	0.13	0.73	5.0	0.10	8.68	0.84	5.0	1.1	8.68	9.54	O6 is tributary to P5
P6	P6	2.04	0.67	11.4	1.36	6.60	8.96					
R1	R1	0.14	0.81	8.5	0.11	7.33	0.80					
R2	R2	0.14	0.81	8.5	0.11	7.33	0.80					
O1	O1	1.51	0.93	5.0	1.41	8.68	12.23					
O2	O2	0.74	0.96	5.0	0.71	8.68	6.20					
O3	O3	0.44	0.96	5.0	0.42	8.68	3.65					
O4	O4	1.05	0.96	5.0	1.00	8.68	8.71					
O5	O5	1.08	0.96	5.0	1.03	8.68	8.96					
O6	O6	1.14	0.96	5.0	1.10	8.68	9.54					
O7	O7	0.82	0.96	5.0	0.78	8.68	6.81					
O8	O8	0.82	0.73	5.8	0.60	8.30	4.94					
TOTAL	TOTAL	10.73	0.86				76.63					

SUMMARY - PROPOSED RUNOFF TABLE					
DESIGN POINT	BASIN DESIGNATION	BASIN AREA (ACRES)	BASIN IMPERVIOUSNESS (%)	DIRECT 5-YR RUNOFF (CFS)	DIRECT 100-YR RUNOFF (CFS)
P1	P1	0.31	81.7%	0.98	1.92
P2	P2	0.15	76.4%	0.44	0.88
P3	P3	0.11	82.2%	0.36	0.70
P4	P4	0.11	82.3%	0.35	0.70
P5	P5	0.13	82.0%	0.43	0.84
P6	P6	2.04	58.9%	4.14	8.96
R1	R1	0.14	90.0%	0.43	0.80
R2	R2	0.14	90.0%	0.43	0.80
O1	O1	1.51	95.1%	6.73	12.23
O2	O2	0.74	100.0%	3.46	6.20
O3	O3	0.44	100.0%	2.04	3.65
O4	O4	1.05	100.0%	4.86	8.71
O5	O5	1.08	100.0%	5.00	8.96
O6	O6	1.14	100.0%	5.32	9.54
O7	O7	0.82	100.0%	3.80	6.81
O8	O8	0.82	76.7%	2.48	4.94
TOTAL		10.73	88.0%	41.26	76.63

APPENDIX E: HYDRAULIC ANALYSIS

DETENTION BASIN STAGE-STORAGE TABLE BUILDER

MHFD-Detention, Version 4.06 (July 2022)

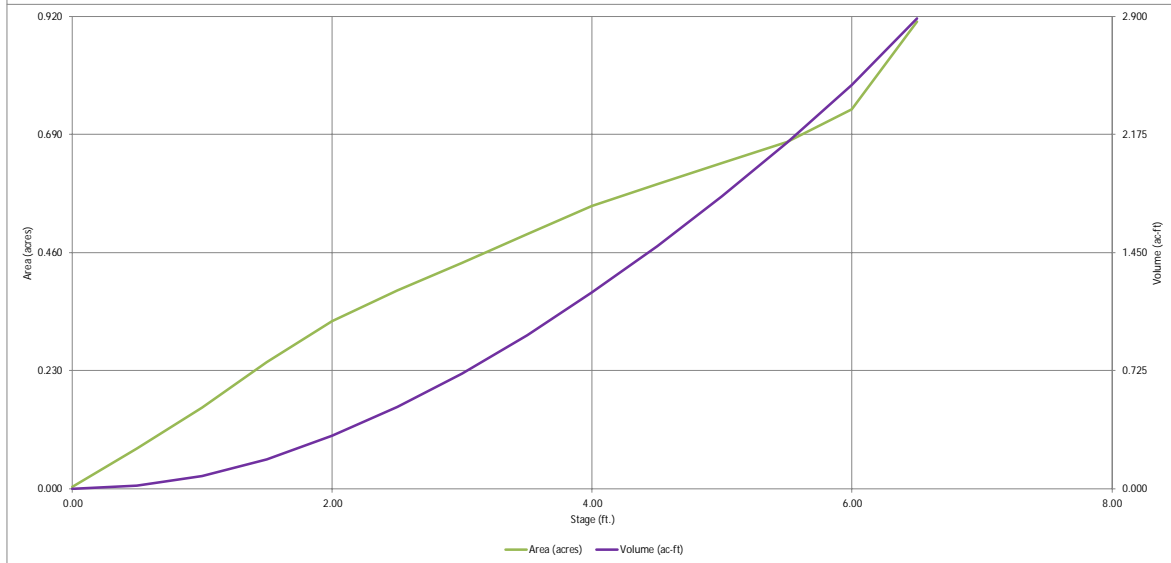
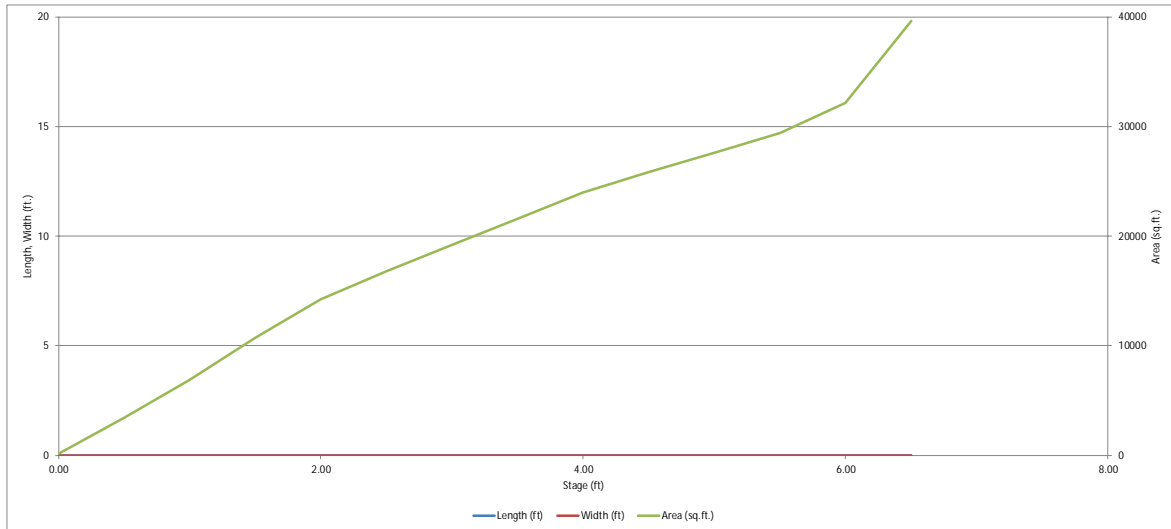

DETENTION BASIN OUTLET STRUCTURE DESIGN

MHFD- Detention, Version 4.06 (July 2022)

Project: Barbarick Transfer Station
 Basin ID: EDB Modification - Proposed Condition

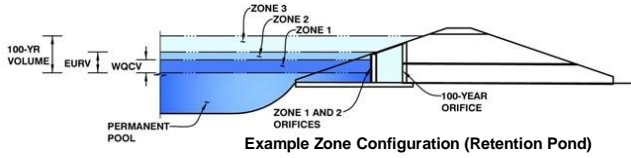

	Estimated Stage (ft)	Estimated Volume (ac-ft)	Outlet Type
Zone 1 (WOCV)	2.07	0.344	Orifice Plate
Zone 2 (EURV)	4.08	0.903	Orifice Plate
Zone 3 (100-year)	4.94	0.511	Weir&Pipe (Restrict)
Total (all zones)		1.758	

User Input: Orifice at Underdrain Outlet (typically used to drain WOCV in a Filtration BMP)

Underdrain Orifice Invert Depth = ft (distance below the filtration media surface)
 Underdrain Orifice Diameter = inches

Calculated Parameters for Underdrain
 Underdrain Orifice Area = ft²
 Underdrain Orifice Centroid = feet

User Input: Orifice Plate with one or more orifices or Elliptical Slot Weir (typically used to drain WOCV and/or EURV in a sedimentation BMP)

Centroid of Lowest Orifice = ft (relative to basin bottom at Stage = 0 ft)
 Depth at top of Zone using Orifice Plate = ft (relative to basin bottom at Stage = 0 ft)
 Orifice Plate: Orifice Vertical Spacing = inches
 Orifice Plate: Orifice Area per Row = sq. inches

Calculated Parameters for Plate
 WO Orifice Area per Row = ft²
 Elliptical Half-Width = feet
 Elliptical Slot Centroid = feet
 Elliptical Slot Area = ft²

User Input: Stage and Total Area of Each Orifice Row (numbered from lowest to highest)

	Row 1 (required)	Row 2 (optional)	Row 3 (optional)	Row 4 (optional)	Row 5 (optional)	Row 6 (optional)	Row 7 (optional)	Row 8 (optional)
Stage of Orifice Centroid (ft)	0.00	2.00	2.75					
Orifice Area (sq. inches)	2.75	3.00	1.00					

	Row 9 (optional)	Row 10 (optional)	Row 11 (optional)	Row 12 (optional)	Row 13 (optional)	Row 14 (optional)	Row 15 (optional)	Row 16 (optional)
Stage of Orifice Centroid (ft)								
Orifice Area (sq. inches)								

User Input: Vertical Orifice (Circular or Rectangular)

Invert of Vertical Orifice = ft (relative to basin bottom at Stage = 0 ft)
 Depth at top of Zone using Vertical Orifice = ft (relative to basin bottom at Stage = 0 ft)
 Vertical Orifice Diameter = inches

Calculated Parameters for Vertical Orifice
 Vertical Orifice Area = ft²
 Vertical Orifice Centroid = feet

User Input: Overflow Weir (Dropbox with Flat or Sloped Gate and Outlet Pipe OR Rectangular/Trapezoidal Weir and No Outlet Pipe)

	Zone 3 Weir	Not Selected	
Overflow Weir Front Edge Height, Ho =	4.10	N/A	ft (relative to basin bottom at Stage = 0 ft)
Overflow Weir Front Edge Length =	12.00	N/A	feet
Overflow Weir Gate Slope =	0.00	N/A	H:V
Horiz. Length of Weir Sides =	4.00	N/A	feet
Overflow Gate Type =	Type C Gate	N/A	
Debris Clogging % =	50%	N/A	%

Calculated Parameters for Overflow Weir
 Height of Gate Upper Edge, H₁ = ft
 Overflow Weir Slope Length = feet
 Gate Open Area / 100-yr Orifice Area =
 Overflow Gate Open Area w/o Debris =
 Overflow Gate Open Area w/ Debris =

User Input: Outlet Pipe w/ Flow Restriction Plate (Circular Orifice, Restrictor Plate, or Rectangular Orifice)

	Zone 3 Restrictor	Not Selected	
Depth to Invert of Outlet Pipe =	1.08	N/A	ft (distance below basin bottom at Stage = 0 ft)
Outlet Pipe Diameter =	30.00	N/A	inches
Restrictor Plate Height Above Pipe Invert =	5.00	N/A	inches

Calculated Parameters for Outlet Pipe w/ Flow Restriction Plate
 Outlet Orifice Area = ft²
 Outlet Orifice Centroid = feet
 Half-Central Angle of Restrictor Plate on Pipe = degrees

User Input: Emergency Spillway (Rectangular or Trapezoidal)

Spillway Invert Stage = ft (relative to basin bottom at Stage = 0 ft)
 Spillway Crest Length = feet
 Spillway End Slopes = H:V
 Freeboard above Max Water Surface = feet

Calculated Parameters for Spillway
 Spillway Design Flow Depth = feet
 Stage at Top of Freeboard = feet
 Basin Area at Top of Freeboard = acres
 Basin Volume at Top of Freeboard = acre-ft

Routed Hydrograph Results

The user can override the default CUHP hydrographs and runoff volumes by entering new values in the Inflow Hydrographs table (Columns W through AF).

	WOCV	EURV	2 Year	5 Year	10 Year	25 Year	50 Year	100 Year
Design Storm Return Period =	N/A	N/A	1.19	1.50	1.75	2.00	2.25	2.52
One-Hour Rainfall Depth (in) =	0.344	1.247	0.865	1.116	1.320	1.551	1.770	2.018
CUHP Runoff Volume (acre-ft) =	N/A	N/A	0.865	1.116	1.320	1.551	1.770	2.018
Inflow Hydrograph Volume (acre-ft) =	N/A	N/A	0.1	0.2	0.3	4.0	6.4	9.5
CUHP Predevelopment Peak Q (cfs) =	N/A	N/A	N/A	N/A	N/A	N/A	N/A	N/A
OPTIONAL Override Predevelopment Peak Q (cfs) =	N/A	N/A	N/A	N/A	N/A	N/A	N/A	N/A
Predevelopment Unit Peak Flow, q (cfs/acre) =	N/A	N/A	0.01	0.02	0.03	0.38	0.60	0.89
Peak Inflow Q (cfs) =	N/A	N/A	17.8	23.0	27.1	32.6	37.2	41.3
Peak Outflow Q (cfs) =	0.2	0.4	0.3	0.3	0.4	3.0	5.7	7.3
Ratio Peak Outflow to Predevelopment Q =	N/A	N/A	N/A	1.5	1.4	0.7	0.9	0.8
Structure Controlling Flow =	Plate	Plate	Plate	Plate	Overflow Weir 1	Overflow Weir 1	Outlet Plate 1	Spillway
Max Velocity through Gate 1 (fps) =	N/A	N/A	N/A	N/A	0.0	0.1	0.2	0.2
Max Velocity through Gate 2 (fps) =	N/A	N/A	N/A	N/A	N/A	N/A	N/A	N/A
Time to Drain 97% of Inflow Volume (hours) =	39	74	63	71	77	76	75	74
Time to Drain 99% of Inflow Volume (hours) =	41	79	67	75	81	82	81	81
Maximum Ponding Depth (ft) =	2.07	4.08	3.25	3.74	4.11	4.24	4.32	4.58
Area at Maximum Ponding Depth (acres) =	0.33	0.56	0.47	0.52	0.56	0.57	0.58	0.60
Maximum Volume Stored (acre-ft) =	0.347	1.248	0.822	1.064	1.265	1.333	1.384	1.538

BARBARICK WTS - STORMCAD LAYOUT

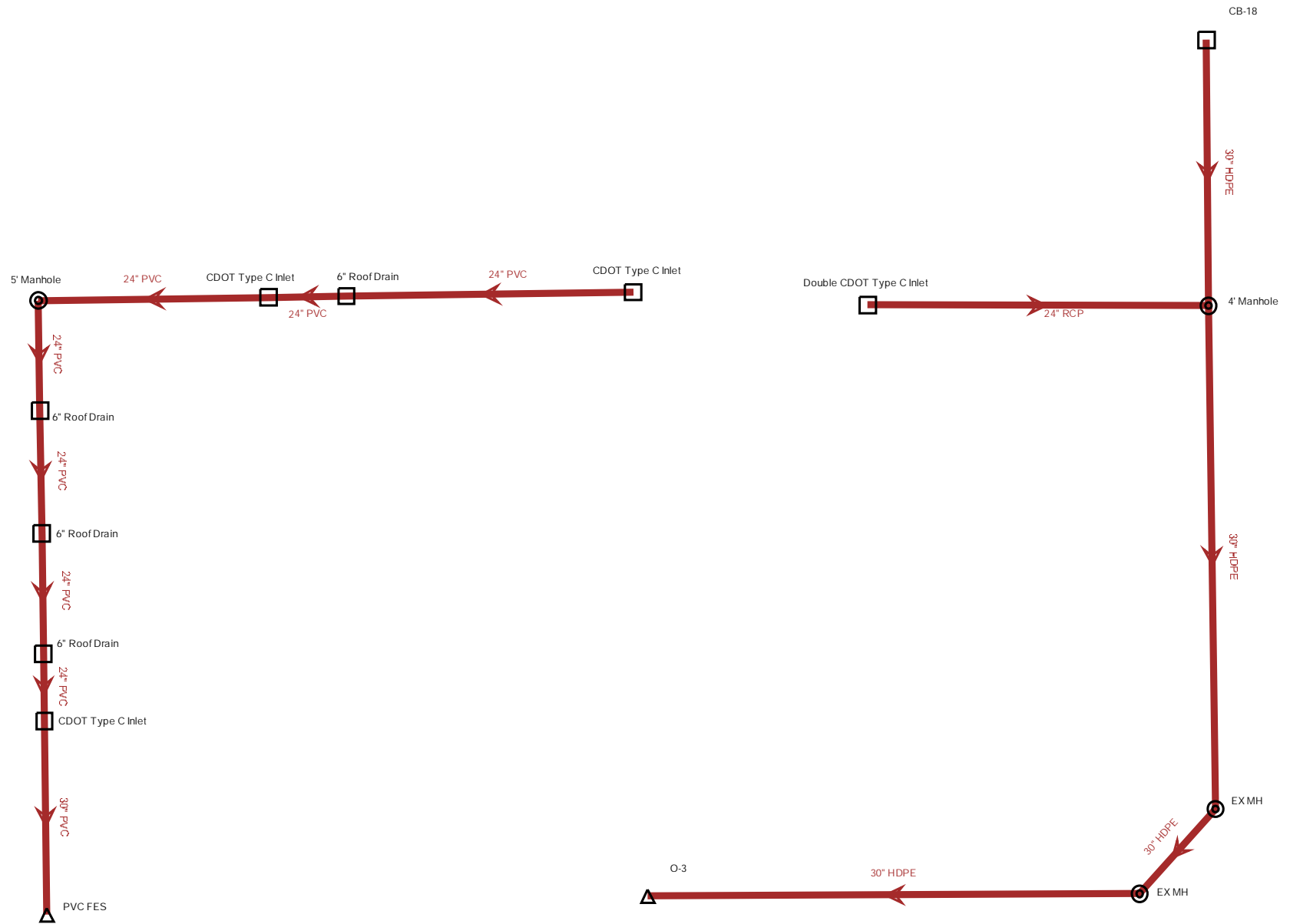

100-Year Profile Report

Engineering Profile - Barbarick WTS - Storm Sewer Profile (Barbarick WTS.stsw)

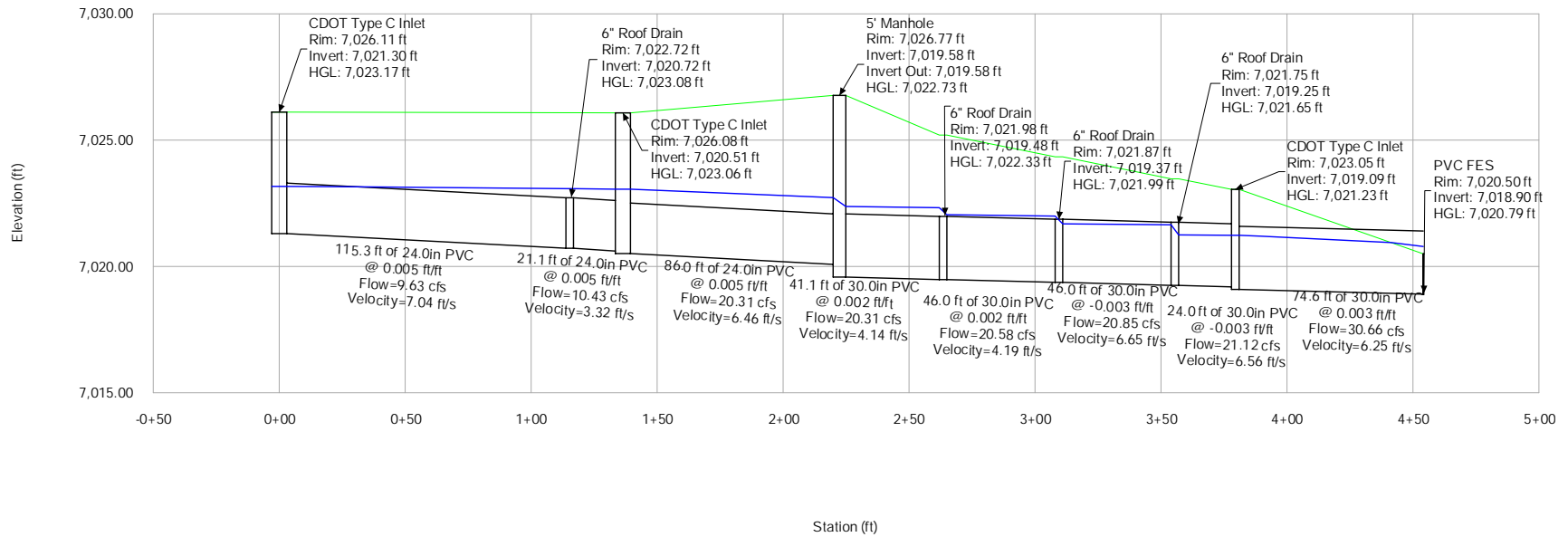

5-Year Profile Report

Engineering Profile - Barbarick WTS - Storm Sewer Profile (Barbarick WTS.stsw)

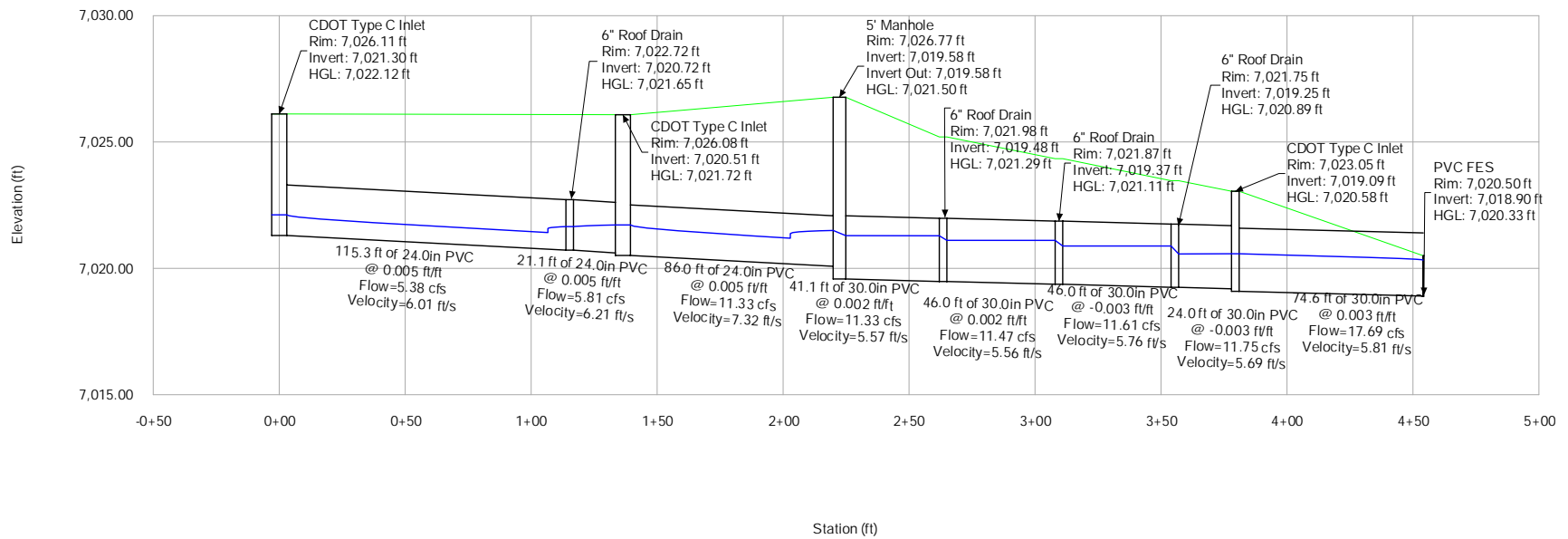

100-Year
Profile Report

Engineering Profile - Barbarick WTS - Entrance Storm Sewer Profile (Barbarick WTS.stsw)

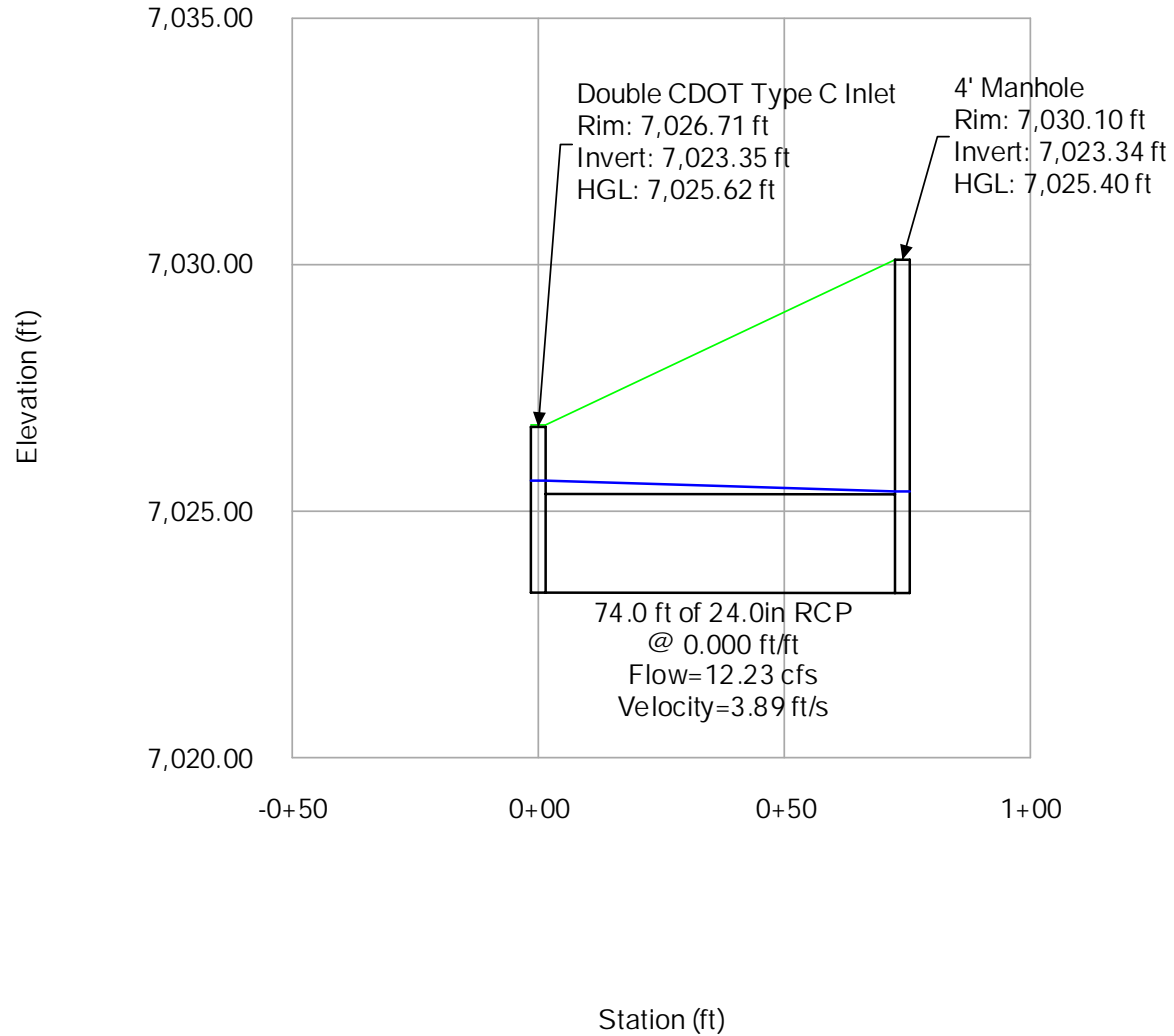

5-Year
Profile Report

Engineering Profile - Barbarick WTS - Entrance Storm Sewer Profile (Barbarick WTS.stsw)

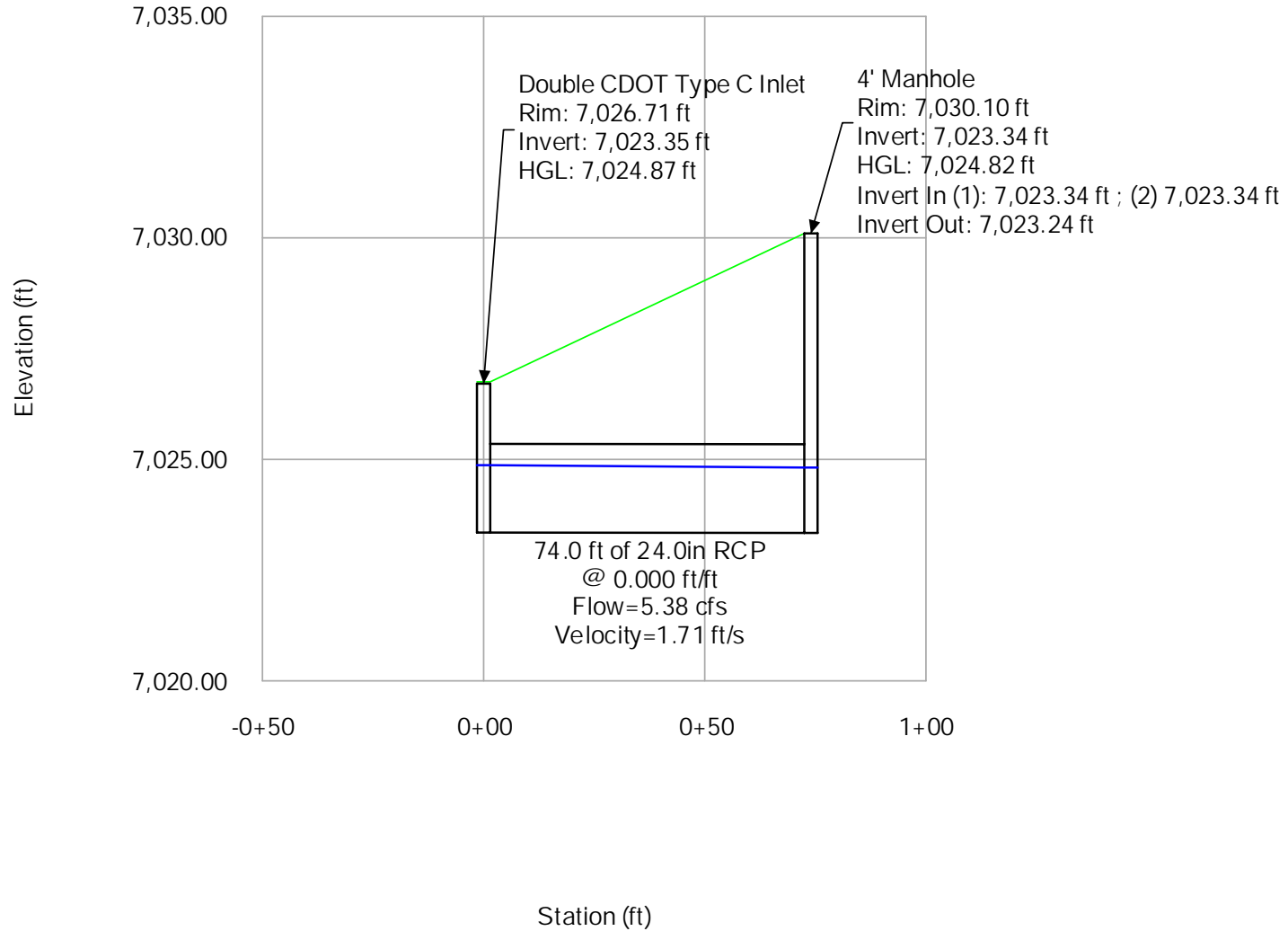

ALLOWABLE CAPACITY FOR ONE-HALF OF STREET (Minor & Major Storm)
 (Based on Regulated Criteria for Maximum Allowable Flow Depth and Spread)

Project: Barbarick Transfer Station
Inlet ID: Inlet P1

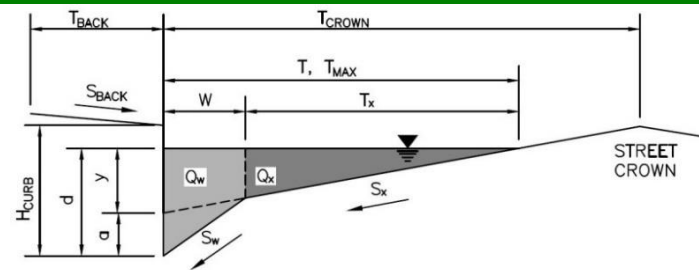

Gutter Geometry:					
Maximum Allowable Width for Spread Behind Curb	$T_{BACK} = 0.0$ ft				
Side Slope Behind Curb (leave blank for no conveyance credit behind curb)	$S_{BACK} =$ ft/ft				
Manning's Roughness Behind Curb (typically between 0.012 and 0.020)	$n_{BACK} =$				
Height of Curb at Gutter Flow Line	$H_{CURB} = 10.80$ inches				
Distance from Curb Face to Street Crown	$T_{CROWN} = 71.0$ ft				
Gutter Width	$W = 3.00$ ft				
Street Transverse Slope	$S_X = 0.010$ ft/ft				
Gutter Cross Slope (typically 2 inches over 24 inches or 0.083 ft/ft)	$S_W = 0.083$ ft/ft				
Street Longitudinal Slope - Enter 0 for sump condition	$S_O = 0.000$ ft/ft				
Manning's Roughness for Street Section (typically between 0.012 and 0.020)	$n_{STREET} = 0.020$				
Max. Allowable Spread for Minor & Major Storm	$T_{MAX} =$ <table border="1"><tr><th>Minor Storm</th><th>Major Storm</th></tr><tr><td>71.0</td><td>71.0</td></tr></table> ft	Minor Storm	Major Storm	71.0	71.0
Minor Storm	Major Storm				
71.0	71.0				
Max. Allowable Depth at Gutter Flowline for Minor & Major Storm	$d_{MAX} =$ <table border="1"><tr><th>Minor Storm</th><th>Major Storm</th></tr><tr><td>10.8</td><td>10.8</td></tr></table> inches	Minor Storm	Major Storm	10.8	10.8
Minor Storm	Major Storm				
10.8	10.8				
Check boxes are not applicable in SUMP conditions	<input type="checkbox"/> <input type="checkbox"/>				
MINOR STORM Allowable Capacity is not applicable to Sump Condition					
MAJOR STORM Allowable Capacity is not applicable to Sump Condition					
$Q_{allow} =$	<table border="1"><tr><th>Minor Storm</th><th>Major Storm</th></tr><tr><td>SUMP</td><td>SUMP</td></tr></table> cfs	Minor Storm	Major Storm	SUMP	SUMP
Minor Storm	Major Storm				
SUMP	SUMP				

INLET IN A SUMP OR SAG LOCATION

MHFD-Inlet, Version 5.03 (August 2023)

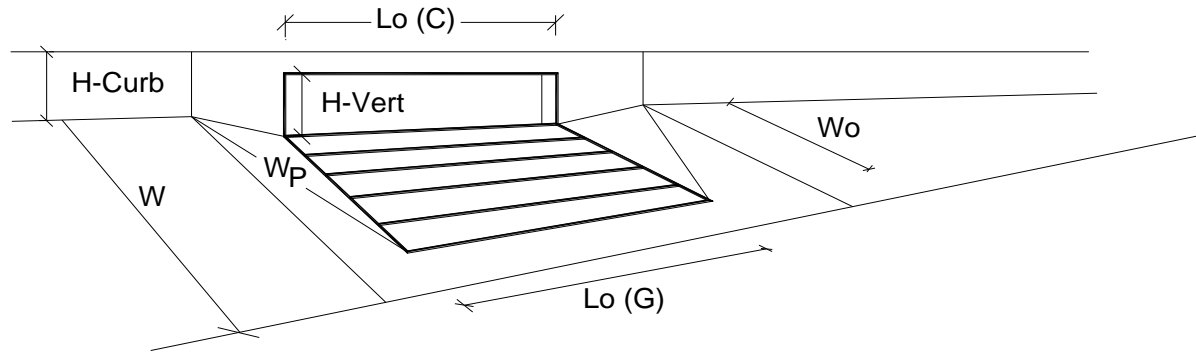

Warning 1

Design Information (Input)		MINOR		MAJOR	
Type of Inlet	CDOT Type C Grate	Type =	CDOT Type C Grate		
Local Depression (additional to continuous gutter depression 'a' from above)		a_{local} =	3.00	3.00	inches
Number of Unit Inlets (Grate or Curb Opening)		No =	2	2	
Water Depth at Flowline (outside of local depression)		Ponding Depth =	9.5	9.5	inches
Grate Information			MINOR	MAJOR	<input checked="" type="checkbox"/> Override Depths
Length of a Unit Grate		L_o (G) =	2.92	2.92	feet
Width of a Unit Grate		W_o =	2.92	2.92	feet
Open Area Ratio for a Grate (typical values 0.15-0.90)		A_{ratio} =	0.70	0.70	
Clogging Factor for a Single Grate (typical value 0.50 - 0.70)		C_f (G) =	0.50	0.50	
Grate Weir Coefficient (typical value 2.15 - 3.60)		C_w (G) =	3.00	3.00	
Grate Orifice Coefficient (typical value 0.60 - 0.80)		C_o (G) =	0.70	0.70	
Curb Opening Information			MINOR	MAJOR	
Length of a Unit Curb Opening		L_o (C) =	N/A	N/A	feet
Height of Vertical Curb Opening in Inches		H_{vert} =	N/A	N/A	inches
Height of Curb Orifice Throat in Inches		H_{throat} =	N/A	N/A	inches
Angle of Throat		Theta =	N/A	N/A	degrees
Side Width for Depression Pan (typically the gutter width of 2 feet)		W_p =	N/A	N/A	feet
Clogging Factor for a Single Curb Opening (typical value 0.10)		C_f (C) =	N/A	N/A	
Curb Opening Weir Coefficient (typical value 2.3-3.7)		C_w (C) =	N/A	N/A	
Curb Opening Orifice Coefficient (typical value 0.60 - 0.70)		C_o (C) =	N/A	N/A	
Low Head Performance Reduction (Calculated)			MINOR	MAJOR	
Depth for Grate Midwidth		d_{Grate} =	0.80	0.80	ft
Depth for Curb Opening Weir Equation		d_{Curb} =	N/A	N/A	ft
Grated Inlet Performance Reduction Factor for Long Inlets		RF_{Grate} =	N/A	N/A	
Curb Opening Performance Reduction Factor for Long Inlets		RF_{Curb} =	N/A	N/A	
Combination Inlet Performance Reduction Factor for Long Inlets		$RF_{Combination}$ =	N/A	N/A	
Total Inlet Interception Capacity (assumes clogged condition)			MINOR	MAJOR	
		Q_a =	13.1	13.1	cfs
		$Q_{PEAK REQUIRED}$ =	5.3	12.0	cfs

Warning 1: Dimension entered is not a typical dimension for inlet type specified.

ALLOWABLE CAPACITY FOR ONE-HALF OF STREET (Minor & Major Storm)
 (Based on Regulated Criteria for Maximum Allowable Flow Depth and Spread)

Project: **Barbarick Transfer Station**
 Inlet ID: **Inlet P3**

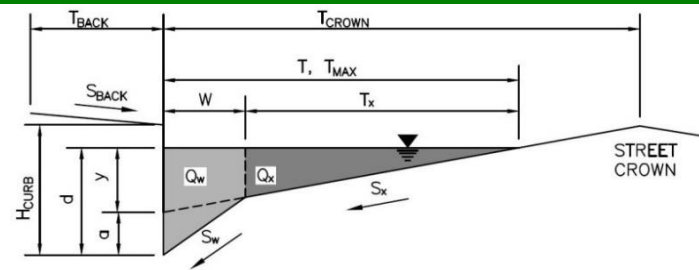

Gutter Geometry:					
Maximum Allowable Width for Spread Behind Curb	$T_{BACK} = 0.0$ ft				
Side Slope Behind Curb (leave blank for no conveyance credit behind curb)	$S_{BACK} =$ ft/ft				
Manning's Roughness Behind Curb (typically between 0.012 and 0.020)	$n_{BACK} =$				
Height of Curb at Gutter Flow Line	$H_{CURB} = 10.98$ inches				
Distance from Curb Face to Street Crown	$T_{CROWN} = 68.0$ ft				
Gutter Width	$W = 6.00$ ft				
Street Transverse Slope	$S_X = 0.010$ ft/ft				
Gutter Cross Slope (typically 2 inches over 24 inches or 0.083 ft/ft)	$S_W = 0.083$ ft/ft				
Street Longitudinal Slope - Enter 0 for sump condition	$S_O = 0.000$ ft/ft				
Manning's Roughness for Street Section (typically between 0.012 and 0.020)	$n_{STREET} = 0.020$				
Max. Allowable Spread for Minor & Major Storm	$T_{MAX} =$ <table border="1"><tr><td>Minor Storm</td><td>Major Storm</td></tr><tr><td>68.0</td><td>68.0</td></tr></table> ft	Minor Storm	Major Storm	68.0	68.0
Minor Storm	Major Storm				
68.0	68.0				
Max. Allowable Depth at Gutter Flowline for Minor & Major Storm	$d_{MAX} =$ <table border="1"><tr><td>Minor Storm</td><td>Major Storm</td></tr><tr><td>11.0</td><td>11.0</td></tr></table> inches	Minor Storm	Major Storm	11.0	11.0
Minor Storm	Major Storm				
11.0	11.0				
Check boxes are not applicable in SUMP conditions	<input type="checkbox"/> <input type="checkbox"/>				
MINOR STORM Allowable Capacity is not applicable to Sump Condition					
MAJOR STORM Allowable Capacity is not applicable to Sump Condition					
$Q_{allow} =$	<table border="1"><tr><td>Minor Storm</td><td>Major Storm</td></tr><tr><td>SUMP</td><td>SUMP</td></tr></table> cfs	Minor Storm	Major Storm	SUMP	SUMP
Minor Storm	Major Storm				
SUMP	SUMP				

INLET IN A SUMP OR SAG LOCATION

MHFD-Inlet, Version 5.03 (August 2023)

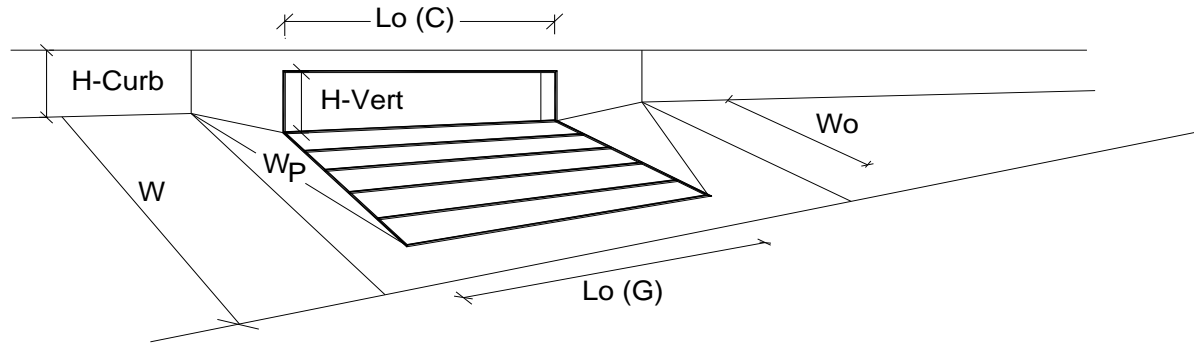

Warning 1

Design Information (Input)		MINOR		MAJOR	
Type of Inlet	CDOT Type C Grate				
Local Depression (additional to continuous gutter depression 'a' from above)		Type =	CDOT Type C Grate		
Number of Unit Inlets (Grate or Curb Opening)		a_{local} =	6.00	6.00	inches
Water Depth at Flowline (outside of local depression)		No =	1	1	
Grate Information		Ponding Depth =	11.0	11.0	inches
Length of a Unit Grate		<input type="checkbox"/> Override Depths			
Width of a Unit Grate		MINOR		MAJOR	
Open Area Ratio for a Grate (typical values 0.15-0.90)		L_o (G) =	2.92	2.92	feet
Clogging Factor for a Single Grate (typical value 0.50 - 0.70)		W_o =	2.92	2.92	feet
Grate Weir Coefficient (typical value 2.15 - 3.60)		A_{ratio} =	0.70	0.70	
Grate Orifice Coefficient (typical value 0.60 - 0.80)		C_f (G) =	0.50	0.50	
Curb Opening Information		C_w (G) =	3.00	3.00	
Length of a Unit Curb Opening		C_o (G) =	0.70	0.70	
Height of Vertical Curb Opening in Inches		MINOR		MAJOR	
Height of Curb Orifice Throat in Inches		L_o (C) =	N/A	N/A	feet
Angle of Throat		H_{vert} =	N/A	N/A	inches
Side Width for Depression Pan (typically the gutter width of 2 feet)		H_{throat} =	N/A	N/A	inches
Clogging Factor for a Single Curb Opening (typical value 0.10)		Theta =	N/A	N/A	degrees
Curb Opening Weir Coefficient (typical value 2.3-3.7)		W_p =	N/A	N/A	feet
Curb Opening Orifice Coefficient (typical value 0.60 - 0.70)		C_f (C) =	N/A	N/A	
Low Head Performance Reduction (Calculated)		C_w (C) =	N/A	N/A	
Depth for Grate Midwidth		C_o (C) =	N/A	N/A	
Depth for Curb Opening Weir Equation		MINOR		MAJOR	
Grated Inlet Performance Reduction Factor for Long Inlets		d_{Grate} =	1.17	1.17	ft
Curb Opening Performance Reduction Factor for Long Inlets		d_{Curb} =	N/A	N/A	ft
Combination Inlet Performance Reduction Factor for Long Inlets		RF_{Grate} =	N/A	N/A	
		RF_{Curb} =	N/A	N/A	
		$RF_{Combination}$ =	N/A	N/A	
Total Inlet Interception Capacity (assumes clogged condition)		MINOR		MAJOR	
Inlet Capacity IS GOOD for Minor and Major Storms (>Q Peak)		Q_a =	14.0	14.0	cfs
		$Q_{PEAK REQUIRED}$ =	5.2	9.4	cfs

Warning 1: Dimension entered is not a typical dimension for inlet type specified.

ALLOWABLE CAPACITY FOR ONE-HALF OF STREET (Minor & Major Storm)
 (Based on Regulated Criteria for Maximum Allowable Flow Depth and Spread)

Project: **Barbarick Transfer Station**
 Inlet ID: **Inlet P4**

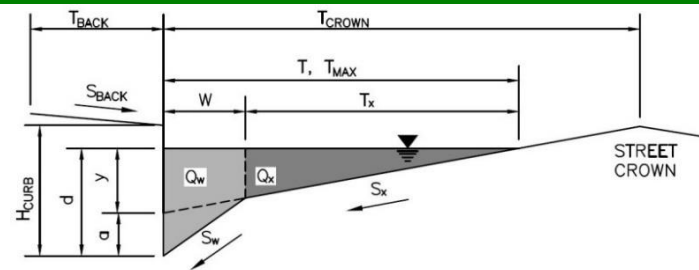

Gutter Geometry:					
Maximum Allowable Width for Spread Behind Curb	$T_{BACK} = 0.0$ ft				
Side Slope Behind Curb (leave blank for no conveyance credit behind curb)	$S_{BACK} =$ ft/ft				
Manning's Roughness Behind Curb (typically between 0.012 and 0.020)	$n_{BACK} =$				
Height of Curb at Gutter Flow Line	$H_{CURB} = 10.80$ inches				
Distance from Curb Face to Street Crown	$T_{CROWN} = 68.0$ ft				
Gutter Width	$W = 4.50$ ft				
Street Transverse Slope	$S_X = 0.010$ ft/ft				
Gutter Cross Slope (typically 2 inches over 24 inches or 0.083 ft/ft)	$S_W = 0.083$ ft/ft				
Street Longitudinal Slope - Enter 0 for sump condition	$S_O = 0.000$ ft/ft				
Manning's Roughness for Street Section (typically between 0.012 and 0.020)	$n_{STREET} = 0.020$				
Max. Allowable Spread for Minor & Major Storm	$T_{MAX} =$ <table border="1"><tr><th>Minor Storm</th><th>Major Storm</th></tr><tr><td>68.0</td><td>68.0</td></tr></table> ft	Minor Storm	Major Storm	68.0	68.0
Minor Storm	Major Storm				
68.0	68.0				
Max. Allowable Depth at Gutter Flowline for Minor & Major Storm	$d_{MAX} =$ <table border="1"><tr><th>Minor Storm</th><th>Major Storm</th></tr><tr><td>10.8</td><td>10.8</td></tr></table> inches	Minor Storm	Major Storm	10.8	10.8
Minor Storm	Major Storm				
10.8	10.8				
Check boxes are not applicable in SUMP conditions	<input type="checkbox"/> <input type="checkbox"/>				
MINOR STORM Allowable Capacity is not applicable to Sump Condition					
MAJOR STORM Allowable Capacity is not applicable to Sump Condition					
$Q_{allow} =$	<table border="1"><tr><th>Minor Storm</th><th>Major Storm</th></tr><tr><td>SUMP</td><td>SUMP</td></tr></table> cfs	Minor Storm	Major Storm	SUMP	SUMP
Minor Storm	Major Storm				
SUMP	SUMP				

INLET IN A SUMP OR SAG LOCATION

MHFD-Inlet, Version 5.03 (August 2023)

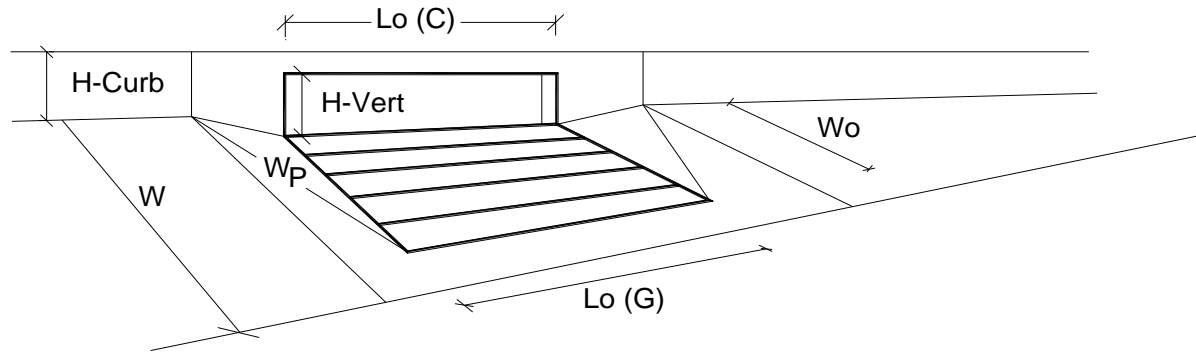

Warning 1

Design Information (Input)		MINOR		MAJOR																																					
Type of Inlet	CDOT Type C Grate	Type = CDOT Type C Grate																																							
Local Depression (additional to continuous gutter depression 'a' from above)		a_{local} =	6.00	6.00	inches																																				
Number of Unit Inlets (Grate or Curb Opening)		No =	1	1																																					
Water Depth at Flowline (outside of local depression)		Ponding Depth =	10.8	10.8	inches																																				
Grate Information		<table border="1" style="width: 100%; border-collapse: collapse;"> <thead> <tr> <th></th> <th style="text-align: center;">MINOR</th> <th style="text-align: center;">MAJOR</th> <th></th> </tr> </thead> <tbody> <tr> <td>L_o (G) =</td> <td style="text-align: center;">2.92</td> <td style="text-align: center;">2.92</td> <td>feet</td> </tr> <tr> <td>W_o =</td> <td style="text-align: center;">2.92</td> <td style="text-align: center;">2.92</td> <td>feet</td> </tr> <tr> <td>A_{ratio} =</td> <td style="text-align: center;">0.70</td> <td style="text-align: center;">0.70</td> <td></td> </tr> <tr> <td>C_f (G) =</td> <td style="text-align: center;">0.50</td> <td style="text-align: center;">0.50</td> <td></td> </tr> <tr> <td>C_w (G) =</td> <td style="text-align: center;">3.00</td> <td style="text-align: center;">3.00</td> <td></td> </tr> <tr> <td>C_o (G) =</td> <td style="text-align: center;">0.70</td> <td style="text-align: center;">0.70</td> <td></td> </tr> </tbody> </table>					MINOR	MAJOR		L_o (G) =	2.92	2.92	feet	W_o =	2.92	2.92	feet	A_{ratio} =	0.70	0.70		C_f (G) =	0.50	0.50		C_w (G) =	3.00	3.00		C_o (G) =	0.70	0.70									
	MINOR	MAJOR																																							
L_o (G) =	2.92	2.92	feet																																						
W_o =	2.92	2.92	feet																																						
A_{ratio} =	0.70	0.70																																							
C_f (G) =	0.50	0.50																																							
C_w (G) =	3.00	3.00																																							
C_o (G) =	0.70	0.70																																							
Length of a Unit Grate		<input type="checkbox"/> Override Depths																																							
Width of a Unit Grate																																									
Open Area Ratio for a Grate (typical values 0.15-0.90)																																									
Clogging Factor for a Single Grate (typical value 0.50 - 0.70)																																									
Grate Weir Coefficient (typical value 2.15 - 3.60)																																									
Grate Orifice Coefficient (typical value 0.60 - 0.80)																																									
Curb Opening Information		<table border="1" style="width: 100%; border-collapse: collapse;"> <thead> <tr> <th></th> <th style="text-align: center;">MINOR</th> <th style="text-align: center;">MAJOR</th> <th></th> </tr> </thead> <tbody> <tr> <td>L_o (C) =</td> <td style="text-align: center;">N/A</td> <td style="text-align: center;">N/A</td> <td>feet</td> </tr> <tr> <td>H_{vert} =</td> <td style="text-align: center;">N/A</td> <td style="text-align: center;">N/A</td> <td>inches</td> </tr> <tr> <td>H_{throat} =</td> <td style="text-align: center;">N/A</td> <td style="text-align: center;">N/A</td> <td>inches</td> </tr> <tr> <td>Theta =</td> <td style="text-align: center;">N/A</td> <td style="text-align: center;">N/A</td> <td>degrees</td> </tr> <tr> <td>W_p =</td> <td style="text-align: center;">N/A</td> <td style="text-align: center;">N/A</td> <td>feet</td> </tr> <tr> <td>C_f (C) =</td> <td style="text-align: center;">N/A</td> <td style="text-align: center;">N/A</td> <td></td> </tr> <tr> <td>C_w (C) =</td> <td style="text-align: center;">N/A</td> <td style="text-align: center;">N/A</td> <td></td> </tr> <tr> <td>C_o (C) =</td> <td style="text-align: center;">N/A</td> <td style="text-align: center;">N/A</td> <td></td> </tr> </tbody> </table>					MINOR	MAJOR		L_o (C) =	N/A	N/A	feet	H_{vert} =	N/A	N/A	inches	H_{throat} =	N/A	N/A	inches	Theta =	N/A	N/A	degrees	W_p =	N/A	N/A	feet	C_f (C) =	N/A	N/A		C_w (C) =	N/A	N/A		C_o (C) =	N/A	N/A	
	MINOR	MAJOR																																							
L_o (C) =	N/A	N/A	feet																																						
H_{vert} =	N/A	N/A	inches																																						
H_{throat} =	N/A	N/A	inches																																						
Theta =	N/A	N/A	degrees																																						
W_p =	N/A	N/A	feet																																						
C_f (C) =	N/A	N/A																																							
C_w (C) =	N/A	N/A																																							
C_o (C) =	N/A	N/A																																							
Length of a Unit Curb Opening																																									
Height of Vertical Curb Opening in Inches																																									
Height of Curb Orifice Throat in Inches																																									
Angle of Throat																																									
Side Width for Depression Pan (typically the gutter width of 2 feet)																																									
Clogging Factor for a Single Curb Opening (typical value 0.10)																																									
Curb Opening Weir Coefficient (typical value 2.3-3.7)																																									
Curb Opening Orifice Coefficient (typical value 0.60 - 0.70)																																									
Low Head Performance Reduction (Calculated)		<table border="1" style="width: 100%; border-collapse: collapse;"> <thead> <tr> <th></th> <th style="text-align: center;">MINOR</th> <th style="text-align: center;">MAJOR</th> <th></th> </tr> </thead> <tbody> <tr> <td>d_{Grate} =</td> <td style="text-align: center;">1.12</td> <td style="text-align: center;">1.12</td> <td>ft</td> </tr> <tr> <td>d_{Curb} =</td> <td style="text-align: center;">N/A</td> <td style="text-align: center;">N/A</td> <td>ft</td> </tr> <tr> <td>RF_{Grate} =</td> <td style="text-align: center;">N/A</td> <td style="text-align: center;">N/A</td> <td></td> </tr> <tr> <td>RF_{Curb} =</td> <td style="text-align: center;">N/A</td> <td style="text-align: center;">N/A</td> <td></td> </tr> <tr> <td>$RF_{Combination}$ =</td> <td style="text-align: center;">N/A</td> <td style="text-align: center;">N/A</td> <td></td> </tr> </tbody> </table>					MINOR	MAJOR		d_{Grate} =	1.12	1.12	ft	d_{Curb} =	N/A	N/A	ft	RF_{Grate} =	N/A	N/A		RF_{Curb} =	N/A	N/A		$RF_{Combination}$ =	N/A	N/A													
	MINOR	MAJOR																																							
d_{Grate} =	1.12	1.12	ft																																						
d_{Curb} =	N/A	N/A	ft																																						
RF_{Grate} =	N/A	N/A																																							
RF_{Curb} =	N/A	N/A																																							
$RF_{Combination}$ =	N/A	N/A																																							
Depth for Grate Midwidth																																									
Depth for Curb Opening Weir Equation																																									
Grated Inlet Performance Reduction Factor for Long Inlets																																									
Curb Opening Performance Reduction Factor for Long Inlets																																									
Combination Inlet Performance Reduction Factor for Long Inlets																																									
Total Inlet Interception Capacity (assumes clogged condition)		<table border="1" style="width: 100%; border-collapse: collapse;"> <thead> <tr> <th></th> <th style="text-align: center;">MINOR</th> <th style="text-align: center;">MAJOR</th> <th></th> </tr> </thead> <tbody> <tr> <td>Q_a =</td> <td style="text-align: center;">13.0</td> <td style="text-align: center;">13.0</td> <td>cfs</td> </tr> <tr> <td>$Q_{PEAK REQUIRED}$ =</td> <td style="text-align: center;">5.4</td> <td style="text-align: center;">9.7</td> <td>cfs</td> </tr> </tbody> </table>					MINOR	MAJOR		Q_a =	13.0	13.0	cfs	$Q_{PEAK REQUIRED}$ =	5.4	9.7	cfs																								
	MINOR	MAJOR																																							
Q_a =	13.0	13.0	cfs																																						
$Q_{PEAK REQUIRED}$ =	5.4	9.7	cfs																																						
Inlet Capacity IS GOOD for Minor and Major Storms (>Q Peak)																																									

Warning 1: Dimension entered is not a typical dimension for inlet type specified.

ALLOWABLE CAPACITY FOR ONE-HALF OF STREET (Minor & Major Storm)
 (Based on Regulated Criteria for Maximum Allowable Flow Depth and Spread)

Project: Barbarick Transfer Station
Inlet ID: Inlet P5

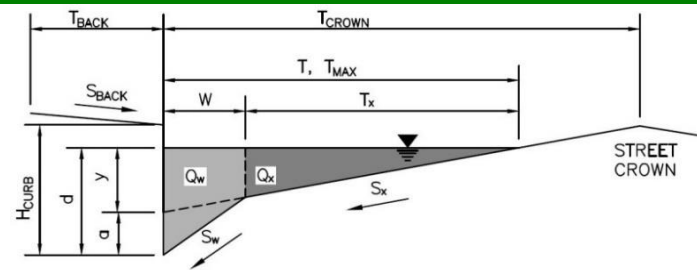

Gutter Geometry:					
Maximum Allowable Width for Spread Behind Curb	$T_{BACK} = 0.0$ ft				
Side Slope Behind Curb (leave blank for no conveyance credit behind curb)	$S_{BACK} =$ ft/ft				
Manning's Roughness Behind Curb (typically between 0.012 and 0.020)	$n_{BACK} =$				
Height of Curb at Gutter Flow Line	$H_{CURB} = 7.44$ inches				
Distance from Curb Face to Street Crown	$T_{CROWN} = 18.0$ ft				
Gutter Width	$W = 3.00$ ft				
Street Transverse Slope	$S_X = 0.050$ ft/ft				
Gutter Cross Slope (typically 2 inches over 24 inches or 0.083 ft/ft)	$S_W = 0.083$ ft/ft				
Street Longitudinal Slope - Enter 0 for sump condition	$S_O = 0.019$ ft/ft				
Manning's Roughness for Street Section (typically between 0.012 and 0.020)	$n_{STREET} = 0.020$				
Max. Allowable Spread for Minor & Major Storm	$T_{MAX} =$ <table border="1"><tr><th>Minor Storm</th><th>Major Storm</th></tr><tr><td>18.0</td><td>18.0</td></tr></table> ft	Minor Storm	Major Storm	18.0	18.0
Minor Storm	Major Storm				
18.0	18.0				
Max. Allowable Depth at Gutter Flowline for Minor & Major Storm	$d_{MAX} =$ <table border="1"><tr><th>Minor Storm</th><th>Major Storm</th></tr><tr><td>7.4</td><td>7.4</td></tr></table> inches	Minor Storm	Major Storm	7.4	7.4
Minor Storm	Major Storm				
7.4	7.4				
Allow Flow Depth at Street Crown (check box for yes, leave blank for no)	<input type="checkbox"/> <input type="checkbox"/>				
MINOR STORM Allowable Capacity is based on Depth Criterion					
MAJOR STORM Allowable Capacity is based on Depth Criterion					
Minor storm max. allowable capacity GOOD - greater than the design peak flow of 5.75 cfs on sheet 'Inlet Management'					
Major storm max. allowable capacity GOOD - greater than the design peak flow of 9.54 cfs on sheet 'Inlet Management'					
	$Q_{allow} =$ <table border="1"><tr><th>Minor Storm</th><th>Major Storm</th></tr><tr><td>15.1</td><td>15.1</td></tr></table> cfs	Minor Storm	Major Storm	15.1	15.1
Minor Storm	Major Storm				
15.1	15.1				

INLET ON A CONTINUOUS GRADE

MHFD-Inlet, Version 5.03 (August 2023)

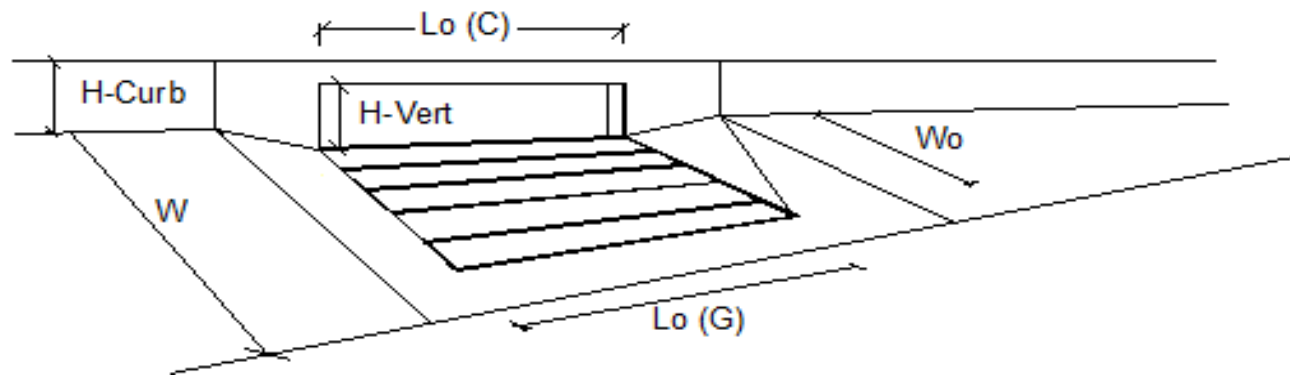

Warning 1

Design Information (Input)		MINOR		MAJOR	
Type of Inlet	CDOT Type C Grate	Type = CDOT Type C Grate			
Local Depression (additional to continuous gutter depression 'a')		6.0	6.0	inches	
Total Number of Units in the Inlet (Grate or Curb Opening)		1	1		
Length of a Single Unit Inlet (Grate or Curb Opening)		2.92	2.92	ft	
Width of a Unit Grate (cannot be greater than W, Gutter Width)		2.92	2.92	ft	
Clogging Factor for a Single Unit Grate (typical min. value = 0.5)		0.50	0.50		
Clogging Factor for a Single Unit Curb Opening (typical min. value = 0.1)		N/A	N/A		
Street Hydraulics: OK - $Q < \text{Allowable Street Capacity}$					
Total Inlet Interception Capacity		4.8	7.0	cfs	
Total Inlet Carry-Over Flow (flow bypassing inlet)		1.0	2.6	cfs	
Capture Percentage = Q_a/Q_o		83	73	%	

Warning 1: Dimension entered is not a typical dimension for inlet type specified.

Inlet P5 - 100-YR Storm

Project Description	
Friction Method	Manning Formula
Solve For	Normal Depth

Input Data	
Channel Slope	0.018 ft/ft
Normal Depth	4.9 in
Discharge	9.54 cfs

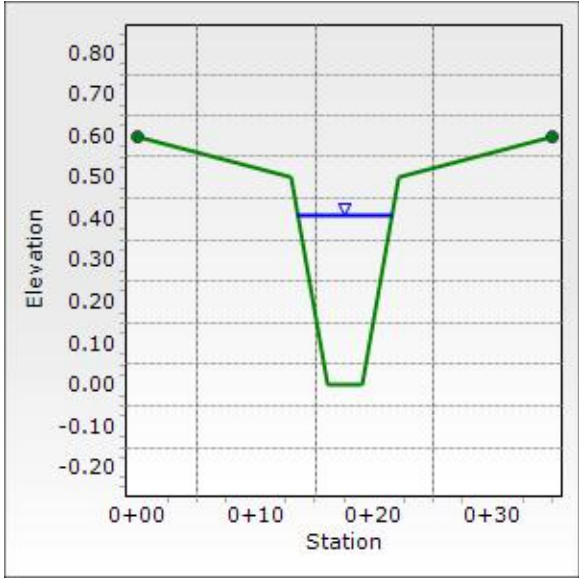

Rip-Rap Calculation

100-Year Outflow

100-Year Storm System Discharge Into Existing EDB

Applicable Equations:

$L_p = (1/2 \tan \theta)(A_t / Y_t - D)$	Equation 9-11 per USDCM
$A_t = Q/V$	Equation 9-12 per USDCM
$\theta = \tan^{-1}(1/(2 * \text{ExpansionFactor}))$	Equation 9-13 per USDCM
$W = 2(L_p \tan \theta) + D$	Equation 9-14 per USDCM
$T = 2D_{50}$	Equation 9-15 per USDCM

Assumptions

Acceptable major event velocity is 5 ft/s due to HSG B soils

Input parameters:

Description	Variable	Input	Unit
Width of the conduit (use diameter for circular conduits),	D:	2.50	ft
HGL Elevation	INV to TOP	2.53	ft
Invert Elevation		1.00	ft
Tailwater depth (ft),	Y_t :	1.53	ft
Expansion angle of the culvert flow	θ :	0.07	radians
Design discharge (cfs)*	Q:	30.66	cfs
Froude Number	F_r	0.89	Subcritical
Unitless Variables for Tables:			
	For Figure 9-35	$Q/D^{2.5}$	3.10
	For Figure 9-35	Y_t/D	0.61
	For Figure 9-38	$Q/D^{1.5}$	7.76
	For Figure 9-38	Y_t/D	0.61
Allowable non-eroding velocity in the downstream channel (ft/sec)	V:	3	ft/sec
Expansion Factor (Figure 9-35), $1/(2 \tan(\theta))$		7.13	

Solve for:

Description	Variable	Output	Unit
1. Required area of flow at allowable velocity (ft ²)	A_t :	10.22	ft ²
2. Length of Protection	L_p :	29.80	ft
	$L_p < 3D$?	No	
	$L_p > 10D$?	Yes	
	$L_p > 10D$ & $F_r > 6$?	No	
	L_{pmin} :	25.00	ft
3. Width of downstream riprap protection	W:	6.00	ft
4. Rip Rap Type (Figure 9-38)	-	M	
5. Rip Rap Size (Figure 8-34)	D_{50} :	12	inches

Rip Rap Summary

Length	L_p	25.00	ft
Width	W_{min}	6.00	ft
Size	D_{50}	12	inches
Type	-	M	-
Thickness	T	24	inches

Rip-Rap Calculation

100-Year Outflow

100-Year Discharge Into Existing 24" CPP (P2)

Applicable Equations:

$L_p = (1/2 \tan \theta)(A_t / Y_t - D)$	Equation 9-11 per USDCM
$A_t = Q/V$	Equation 9-12 per USDCM
$\theta = \tan^{-1}(1/(2 * \text{ExpansionFactor}))$	Equation 9-13 per USDCM
$W = 2(L_p \tan \theta) + D$	Equation 9-14 per USDCM
$T = 2D_{50}$	Equation 9-15 per USDCM

Assumptions

Acceptable major event velocity is 5 ft/s due to HSG B soils

Input parameters:

Description	Variable	Input	Unit
Width of the conduit (use diameter for circular conduits),	D:	2.00	ft
HGL Elevation	INV to TOP	2.03	ft
Invert Elevation		1.00	ft
Tailwater depth (ft),	Y_t :	1.03	ft
Expansion angle of the culvert flow	θ :	0.07	radians
Design discharge (cfs)*	Q:	5.86	cfs
Froude Number	F_r	0.32	Subcritical
Unitless Variables for Tables:			
	For Figure 9-35 $Q/D^{2.5}$	1.04	
	For Figure 9-35 Y_t/D	0.52	
	For Figure 9-38 $Q/D^{1.5}$	2.07	
	For Figure 9-38 Y_t/D	0.52	
Allowable non-eroding velocity in the downstream channel (ft/sec)	V:	3	ft/sec
Expansion Factor (Figure 9-35), $1/(2 \tan(\theta))$		7.13	

Solve for:

Description	Variable	Output	Unit
1. Required area of flow at allowable velocity (ft ²)	A_t :	1.95	ft ²
2. Length of Protection	L_p :	-0.74	ft
	$L_p < 3D$?	Yes	
	$L_p > 10D$?	No	
	$L_p > 10D$ & $F_r > 6$?	No	
	L_{pmin} :	6.00	ft
3. Width of downstream riprap protection	W:	3.00	ft
4. Rip Rap Type (Figure 9-38)	-	M	
5. Rip Rap Size (Figure 8-34)	D_{50} :	12	inches

Rip Rap Summary

Length	L_p	6.00	ft
Width	W_{min}	3.00	ft
Size	D_{50}	12	inches
Type	-	M	-
Thickness	T	24	inches

APPENDIX F: EX. FINAL DRAINAGE REPORT FOR BARBARICK SUBDIVISION

**FINAL DRAINAGE REPORT**

For

**BARBARICK SUBDIVISION,
PORTIONS OF LOTS 1, 2 and LOTS 3 & 4
El Paso County, Colorado****Sand Creek Drainage Basin**

Prepared for:
**El Paso County Development Services
Engineering Division**

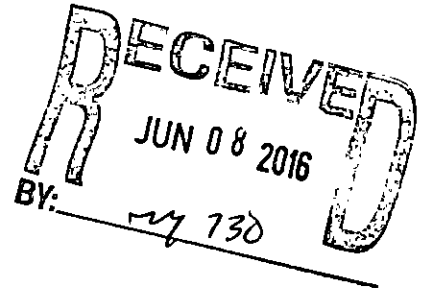

On Behalf of:
Wykota Construction
430 Beacon Light Road, Suite 130
Monument, CO 80132

Prepared by:



2435 Research Parkway, Suite 300
Colorado Springs, CO 80920
(719) 575-0100
Fax (719) 572-0208

June 6, 2016

15.789.001

Engineer's Statement:

The attached drainage plan and report were prepared under my direction and supervision and are correct to the best of my knowledge and belief. Said drainage report has been prepared according to the criteria established by the County for drainage reports and said report is in conformity with the master plan of the drainage basin.

Gregory G. Shaner
Registered Professional Engineer
State of Colorado No. 036307



SEAL

Developer's Statement:

I, the developer have read and will comply with all of the requirements specified in this drainage report and plan.

Wykota Construction

Business Name

By: _____

Justin Ballard
Justin Ballard

Title: _____
President

Address: _____
430 Beacon Light Road, Suite 130

Monument, CO 80132

El Paso County:

Filed in accordance with the requirements of the Drainage Criteria Manual, Volumes 1 and 2, El Paso County Engineering Criteria Manual and Land Development Code as amended.

Print Name — ~~FORE TENUERLE TRU~~ Date
County Engineer / ECM Administrator

9 JUNE 2016

TABLE of CONTENTS

GENERAL LOCATION AND DESCRIPTION 1
 Background 1
 Location 1
 Property Description 3
 Soil Description 5
HYDROLOGIC AND HYDRAULIC ANALYSIS 6
 Basin Description 6
 Design Criteria 6
EXISTING DRAINAGE DISCUSSION 10
EXISTING DRAINAGE DISCUSSION (continued) 15
PROPOSED DRAINAGE DISCUSSION 16
RECOMMENDED DESIGN 18
DRAINAGE, BRIDGE, AND POND FEES 22
MAINTENANCE 22
EROSION CONTROL 22
Cost Estimate 24
REFERENCES 24

Page Missing or Blank
on EDARP

Surrounding Developments. The following are the existing or planned general land uses adjacent to the property.

North: Un-platted parcels that contain commercial/industrial uses. Carah Dawn View is on the north side of the property.

East and South: Although this adjacent area is currently undeveloped, the Sterling Ranch Master Planned area is in the process of developing this area (future single family development).

West: This is an undeveloped, un-platted lot. Across Vollmer Road is a low density single family development (Highland Park, Fil 2).

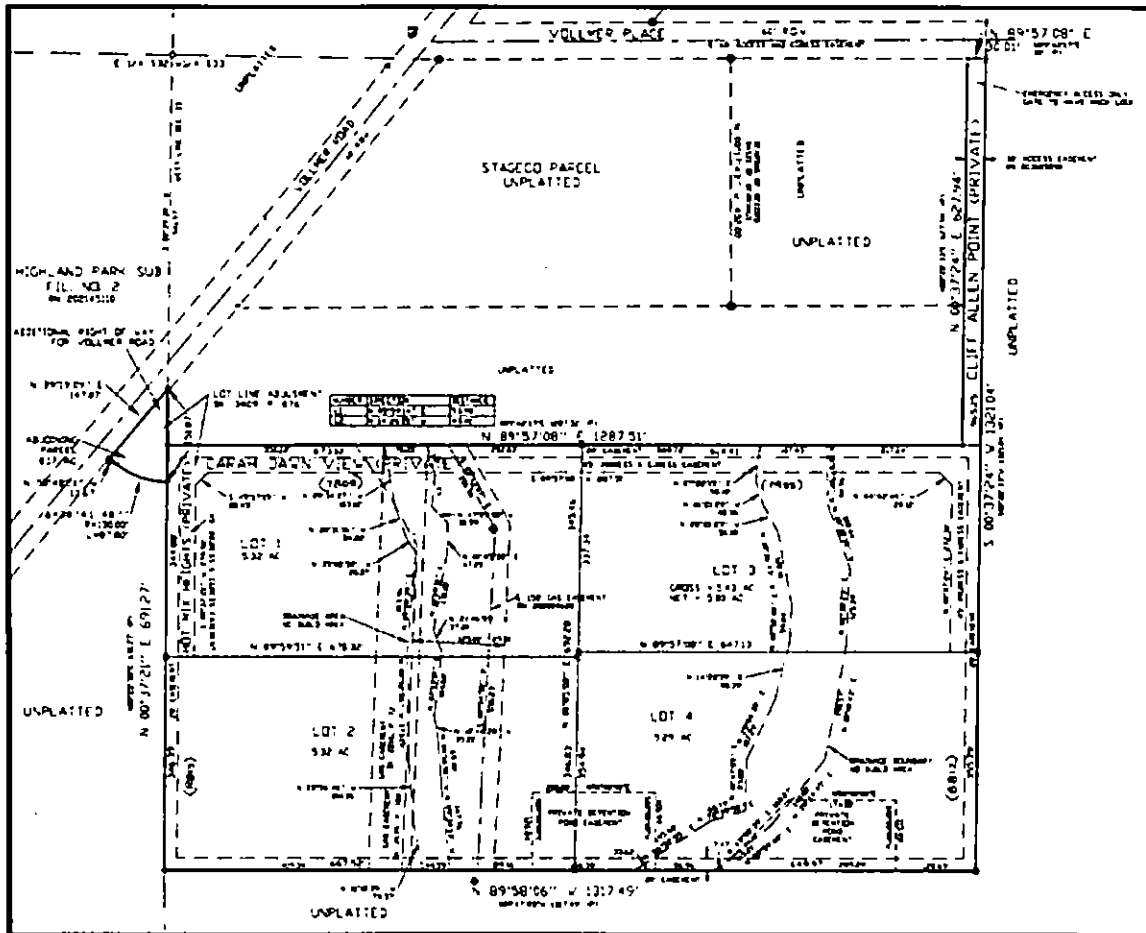

Barbarick Subdivision Plat

Property Description

1. **Major Drainage Way:** The entire site is located within the Sand Creek Drainage Basin. The Main Fork of Sand Creek is located about 1500 feet to the east. The site currently drains to the south into natural drainage ways that direct runoff to Sand Creek. The Sand Creek Drainage Basin is located in the northeastern portion of the City of Colorado Springs and El Paso County. The general drainage pattern of this larger basin flows to the southwest and ultimately feeds into Fountain Creek.
2. **Project Site Area:** This site is approximately 21.37 acres in area.
3. **Ground Cover:** This site is covered with native grasses.
4. **General Topography:** The site drains from north to the south with average grades ranging from 1% to 5%. There are two natural drainage ways that drain through these lots.
5. **Irrigation Facilities:** No known functioning irrigation facilities are located on the site. A small detention pond does exist to the northeast of the property; however, the outfall of this pond will be re-routed in order to direct runoff around the perimeter of the proposed development.
6. **Utilities:** Utilities in the project area include; but are not limited to, telephone, high pressure gas/petroleum and electrical lines. Water & wastewater service is provided through wells & individual septic systems. These utilities will be examined on a case-by-case basis and avoided where feasible, or they will be relocated. Any relocation of these utilities will be coordinated with the respective utility contact. Utility services will be extended into the site as necessary. There are large gas easements that run north-south through these lots. These easements contain one 6 inch and two 20 inch high pressure gas/petroleum pipelines. These Utility Easements will be no-build zones and grading will be fill only.
7. **On-Site Drainage Ways:** The plat shows two “Drainage Boundary – No Build Area(s)” draining through the subdivision. These are not regulated FEMA floodplains. The site development will include the installation of pass through culverts for offsite flows, and regraded. An amended plat has been completed for the removal of the no build areas, identification of new drainage easements, and relocation of water quality ponds.

8. **Floodplain Statement:** Review of the Flood Insurance Rate Map (FIRM) 535 (08041CO535 F), effective date March 17, 1997, published by the Federal Emergency Management Agency (FEMA) reveals that no portion of Barbaric Subdivision lie within any designated 100-year floodplain.

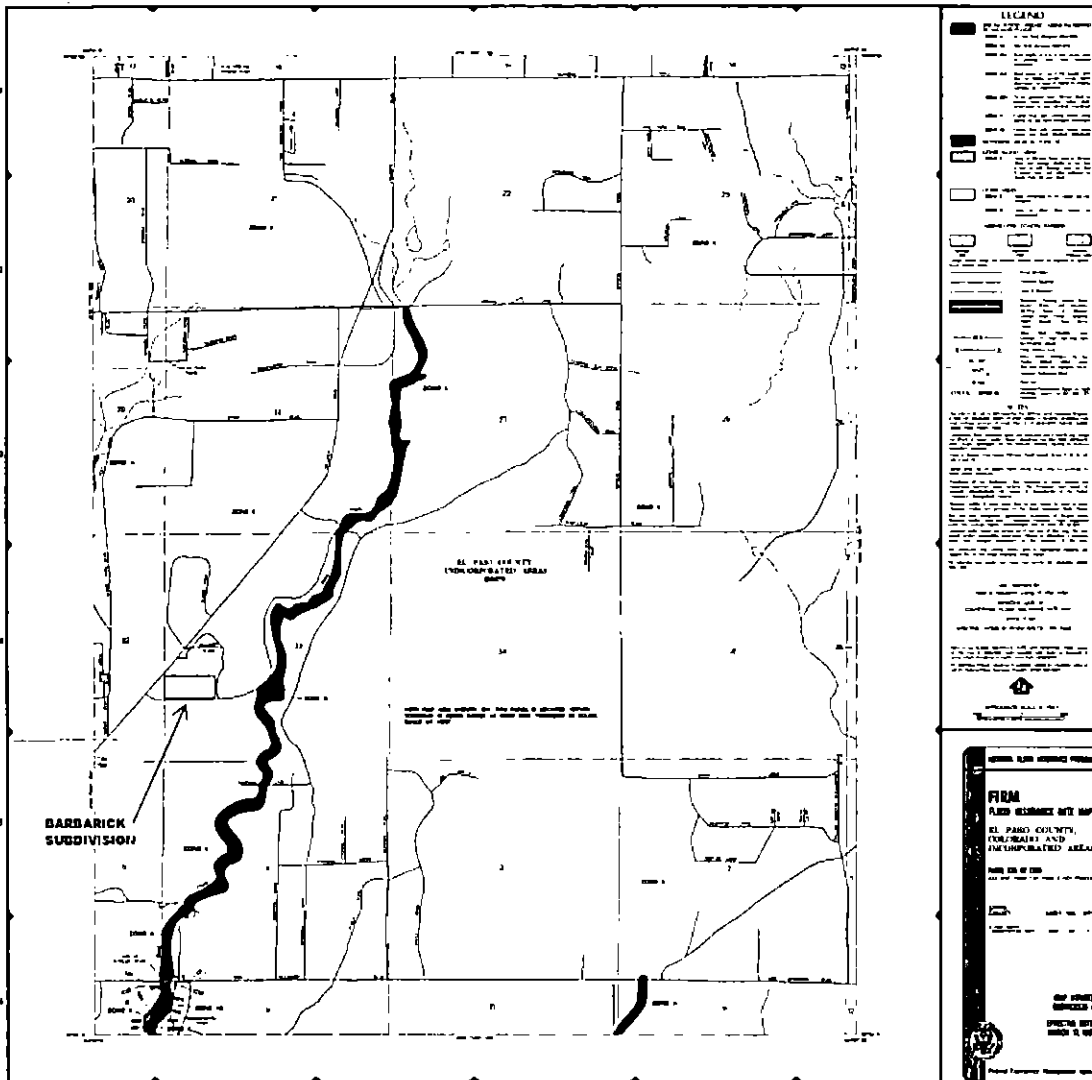

FEMA - Flood Insurance Rate Map (FIRM)

HYDROLOGIC AND HYDRAULIC ANALYSIS

Basin Description

The Barbarick Subdivision is located within the Sand Creek Drainage Basin. The tributary area that drains through the Barbarick Subdivision is developed, which includes large lot single-family parcels and some commercial/industrial land uses. Sub-basins were delineated using surveyed information, proposed contours and field observations. See the Drainage Basin Maps in the Appendix.

This study is in conformance with the following two approved Drainage Reports:

1. ***Preliminary Drainage Report for Sterling Ranch-Phase 1, Sand Creek Drainage Basin***, M & S Civil Consultants, Inc., May 2015 AKA: "SR-PDR"
2. ***Woodmen Storage Final Drainage Report, El Paso County***, Calibre Engineering, Inc., July 2004; Revised February, 2010; Revised May, 2010; Revised July, 2010 AKA: "WS-FDR"

This study is *not* in conformance with the following approved Drainage Report due to changes from the approved recent reports cited above that supercede the original report:

1. ***Preliminary and Final Drainage Plan and Report, Barbarick Subdivision a Replat of Lot "D", McClintock Subdivision, El Paso County***, Oliver E. Watts, Consulting Engineer, Inc., August 15, 2007 AKA: "BS-FDR"

Design Criteria

This report has been prepared in accordance to the criteria set forth in the ***City of Colorado Springs & El Paso County Drainage Criteria Manual, Volumes I and II***, dated November 1991 including subsequent updates. El Paso County has also adopted Chapter 6 and Section 3.2.1 of Chapter 13 in the ***City of Colorado Springs & El Paso County Drainage Criteria Manual, Volumes I and II***, dated May 2014 (Appendix I of the El Paso County's Engineering Criteria Manual (ECM), 2008). In addition to the ECM, the ***Urban Storm Drainage Criteria Manuals, Volumes 1-3***, published by the Urban Drainage and Flood Control District, (Volumes 1 & 2 dated January 2016, Volume 3 dated November 2010 with some sections update November 2015), has also been used to supplement the ECM.

Hydrologic Criteria

Hydrologic analyses for the site have been completed using the Rational Method for on-site basins. The SCS Method was used in the referenced studies for the larger off-site basins (greater than 100 acres). The design storms for each method are:

- Initial Storm = 5-Year Storm
- Major Storm = 100-Year Storm

Rational Method: The Rational Method will be utilized to evaluate smaller basins (under 100 acres). This methodology is used for the design of localized facilities such as inlets, storm drain, drainage swales and detention:

Rational Method peak flow rate equation (cfs): $Q=C*I*A$

- Where: Q = Maximum runoff rate in cubic feet per second (cfs)
- C = Runoff coefficient
- I = Average rainfall intensity in inches per hour
- A = Area of drainage sub-basin in acres

Runoff Coefficient

Rational Method coefficients are derived from UDFCD Vol 1 (Chapter 6 – Runoff, 2016-01 Rev) for the various land uses, including parking areas, drives, walks, roofs, lawns and open space areas. The Runoff Coefficients associated with these land uses also have a corresponding impervious value that is used in the detention calculations. The Rational Method Coefficients used in this study include:

<u>Land Use or Surface Type</u>	<u>% Impervious</u>	<u>Runoff Coefficient (B Soils)</u>	
		<u>(5-Year)</u>	<u>(100-Year)</u>
Greenbelts/Agricultural	2%	.03	.46
Gravel (packed)	40%	.37	.65
Drives & Walks	90%	.84	.90

Table 6-3. Recommended percentage imperviousness values

Land Use or Surface Characteristics	Percentage Imperviousness (%)
Business:	
Downtown Areas	95
Suburban Areas	75
Residential:	
Single-family	
2.5 acres or larger	12
0.75 – 2.5 acres	20
0.25 – 0.75 acres	30
0.25 acres or less	45
Apartments	75
Industrial:	
Light areas	80
Heavy areas	90
Parks, cemeteries	10
Playgrounds	25
Schools	55
Railroad yard areas	50
Undeveloped Areas:	
Historic flow analysis	2
Greenbelts, agricultural	2
Off-site flow analysis (when land use not defined)	45
Streets:	
Paved	100
Gravel (packed)	40
Drive and walks	90
Roofs	90
Lawns, sandy soil	2
Lawns, clayey soil	2

Table 6-5. Runoff coefficients, c

Total or Effective % Imperviousness	NRCS Hydrologic Soil Group A					
	2-yr	5-yr	10-yr	25-yr	50-yr	100-yr
2%	0.02	0.02	0.02	0.02	0.02	0.17
5%	0.04	0.05	0.05	0.05	0.05	0.19
10%	0.09	0.09	0.09	0.09	0.1	0.23
15%	0.13	0.14	0.14	0.14	0.14	0.28
20%	0.18	0.19	0.19	0.19	0.19	0.32
25%	0.22	0.23	0.24	0.24	0.24	0.36
30%	0.27	0.28	0.28	0.28	0.29	0.4
35%	0.31	0.33	0.33	0.33	0.33	0.44
40%	0.36	0.37	0.38	0.38	0.38	0.48
45%	0.4	0.42	0.42	0.42	0.43	0.52
50%	0.45	0.47	0.47	0.47	0.48	0.56
55%	0.49	0.51	0.52	0.52	0.52	0.6
60%	0.53	0.56	0.56	0.57	0.57	0.64
65%	0.58	0.6	0.61	0.61	0.62	0.68
70%	0.62	0.65	0.66	0.66	0.67	0.72
75%	0.67	0.7	0.71	0.71	0.71	0.76
80%	0.71	0.74	0.75	0.76	0.76	0.8
85%	0.76	0.79	0.8	0.8	0.81	0.84
90%	0.8	0.84	0.85	0.85	0.86	0.88
95%	0.85	0.88	0.89	0.9	0.9	0.92
100%	0.89	0.93	0.94	0.94	0.95	0.96
Total or Effective % Imperviousness	NRCS Hydrologic Soil Group B					
2%	0.02	0.02	0.14	0.24	0.38	0.46
5%	0.04	0.05	0.17	0.27	0.39	0.48
10%	0.09	0.09	0.21	0.3	0.42	0.5
15%	0.13	0.14	0.25	0.34	0.45	0.53
20%	0.18	0.19	0.29	0.37	0.48	0.55
25%	0.22	0.23	0.33	0.41	0.51	0.58
30%	0.27	0.28	0.37	0.44	0.54	0.6
35%	0.31	0.33	0.41	0.48	0.57	0.63
40%	0.36	0.37	0.45	0.51	0.6	0.65
45%	0.4	0.42	0.49	0.55	0.63	0.67
50%	0.45	0.47	0.53	0.58	0.66	0.7
55%	0.49	0.51	0.57	0.62	0.69	0.72
60%	0.53	0.56	0.61	0.65	0.72	0.75
65%	0.58	0.6	0.65	0.69	0.75	0.77
70%	0.62	0.65	0.69	0.72	0.78	0.8
75%	0.67	0.7	0.73	0.76	0.81	0.82
80%	0.71	0.74	0.77	0.79	0.84	0.85
85%	0.76	0.79	0.81	0.83	0.87	0.87
90%	0.8	0.84	0.85	0.86	0.89	0.9
95%	0.85	0.88	0.89	0.9	0.92	0.92
100%	0.89	0.93	0.94	0.94	0.95	0.94

Time of Concentration

The time of concentration (T_c) for the Rational Method was calculated by methods derived from the UDFCD. The time of concentration consists of an initial time or overland flow time (t_i) plus the travel time (t_t) in the storm sewer, paved gutter, roadside drainage ditch, or drainage channel. For non-urban areas, the time of concentration consists of an initial time or overland flow time (t_i)

plus the time of travel (t_t) in concentrated form, such as a swale or drainageway. A minimum T_c of 5 minutes and 10 minutes were used for the final calculations in developed and undeveloped conditions, respectively.

Storm Drain Systems

All proposed storm drain infrastructure will be located within private property and will be owned and maintained by the property owner.

The storm drain hydraulics is analyzed using *Bentley's FlowMaster*, *CulvertMaster* & *StormCAD* design software. Colorado Department of Transportation (CDOT) type inlets will be used where necessary.

The designated outfall locations for the proposed on-site storm drains are the natural drainage ways at the south end of the property. The proposed storm drain infrastructure will be discussed in more detail below.

EXISTING DRAINAGE REPORT DISCUSSION

The approved Barbarick Subdivision Final Drainage Report (BS-FDR) and the approved Woodmen Storage Final Drainage Report (WS-FDR) both apply to the existing general drainage conditions for this site. The off-site basins and general flow patterns in the BS-FDR and WS-FDR still apply. Excerpts from these reports are provided below for reference.

On-site and Off-Site Basin Descriptions from the BS-FDR and WS-FDR:

The following summary is taken from the Barbarick Subdivision Final Drainage Report (BS-FDR):

Off-site:

Off-site Basin O3 This basin encompasses approximately 7.03 acres and represents the area north and northwest of Lot 1. This basin drains into Lot 1 through a series of (2) 24" CMP pipes which control the flow of 14/36 cfs in the 5/100 year storm events.

Lots 1 & 2 – these lots are considered fully developed lots and drain north to south collecting at the existing concrete settling pond on Lot 2. This developed flow (20.8 cfs /57.2 cfs) combines with Off-site Basin O3 to total 30.5 cfs / 80.8 cfs in the greenbelt offsite south of Lot 2. At the time of development permit for these developed lots, a detention pond for water quality will be required, probably in the area of the existing concrete settling pond, that will accommodate Lots 1 and 2 west of the gas easement and flood plain area.

On-site:

On-site Basins A1 and B1 (for portions of Lots 1 and 2, and Lots 3 & 4)

These basins encompass approximately 5.3 & 3.8 acres and represent the buildable portions of the property as described in the BS-FDR (see Basin Map from BS-FDR below). These basins were slated (in the BS-FDR) to drain into small detention ponds that would release to historic rates. These discharge rates were calculated to be 2.9/7.3 and 2.2/5.4 cfs (5/100 year). The BS-FDR does not include the drainage ways in any hydrology calculations due to the fact that this no-build drainage area was not planned on being developed. This drainage way allowed off-site flows from O1+O2 to pass-through Lots 3 & 4. The drainage way to the west of A1 passes through flows from offsite O3. Since the approval of this report, offsite tributary basins O1+O2 have been changed, and the development of the property encompasses the whole property, including the previously determined no-build area.

The following summary is taken from the Woodmen Storage Final Drainage Report (WS-FDR):

Off-site:

Design Point 5 - This design point encompasses approximately 19.69 acres and represents the tributary area north of the project site. This basin drains into a proposed detention pond near the northeast corner of the property and generates 57.4/92.7 cfs in the 10/100 year storm events, historic flows are 16.7/30.3 cfs. The releases rates from this pond are lower than historic 16.1 cfs/29.4 cfs in the 10/100-year storm events. These flows are conveyed along the east property line of the site and into the eastern natural drainage way that leaves the property to the south.

Review of the Sterling Ranch Preliminary Drainage Report (SR-PDR):

The Barbarick Subdivision is surrounded on three sides by the planned Sterling Ranch Development. The approved Sterling Ranch PDR was prepared by M&S Civil Consultants in May of 2015. This Sterling Ranch PDR re-analyzes runoff from Barbarick Subdivision and plans for storm drain improvements to convey this runoff to a full spectrum detention and water quality pond to be located down stream of Barbarick Subdivision as part of Sterling Ranch Phase One.

In summary; the Sterling Ranch PDR is planning on receiving 73.3/139.2 cfs (5/100 year) from Basin OS3. A 54" RCP is planned to convey this flow through Sterling Ranch. The Sterling Ranch PDR is planning on receiving 45/86 cfs (5/100 year) from OS2, encompasses Lots 1 & 2 and OS3 encompasses Lots 3 & 4 and the Basin north of Lot 3. A 48" RCP is planned to convey this flow through Sterling Ranch. The cumulative runoff from the northerly property and Lots 1 through 4 does not exceed the anticipated rates in the SR-PDR.

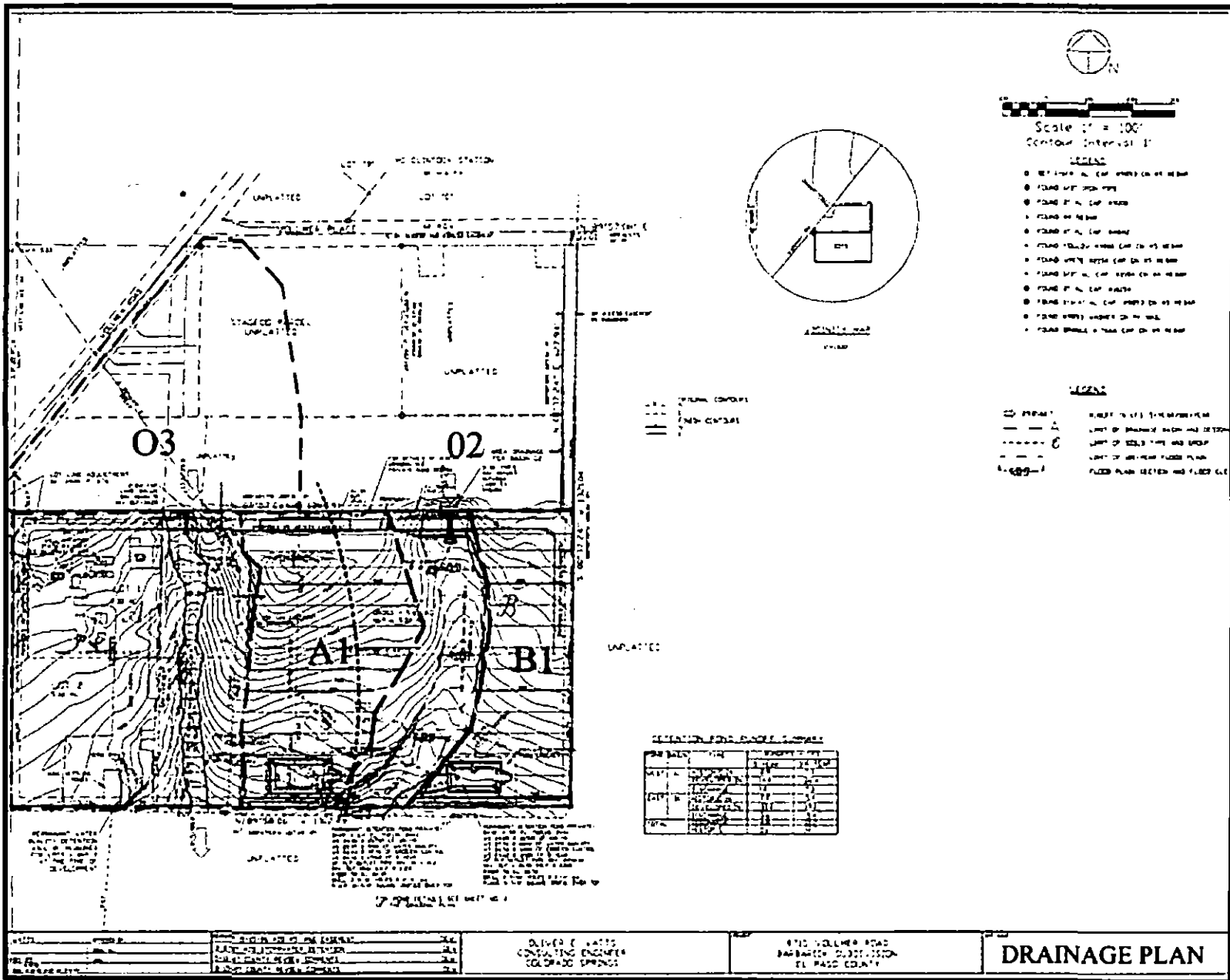

Basin Map - from the Barbarick Subdivision FDR

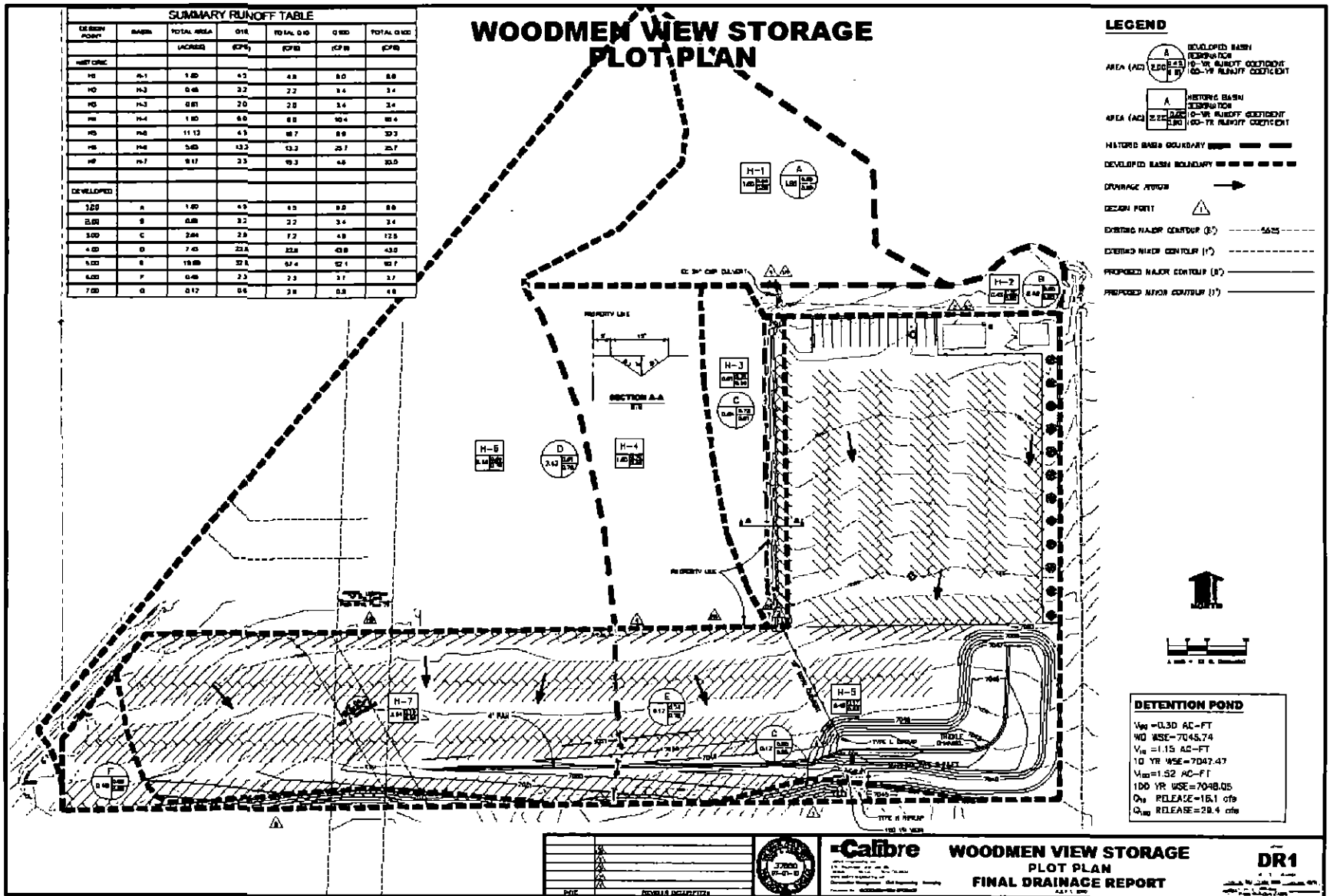

Basin Map - from the FDR

 <p>CIVIL CONSULTANTS, INC. 102 E. Pikes Peak Ave. Ste 306 Colorado Springs, CO 80903 (719) 955-5485, FAX (719) 448-8427</p>	STERLING RANCH PHASE 1		
	PROPOSED - DRAINAGE MAP (OVERALL)		
	PROJECT NO. 09-001	SCALE	DATE: 5/08/15
	DESIGNED BY: DLM	HORIZ: 1" = 200'	SHEET 1 of 1
DRAWN BY: DLM	VERT: N/A	D2	
CHECKED BY: VAS			

Basin Map from the Sterling Ranch PDR

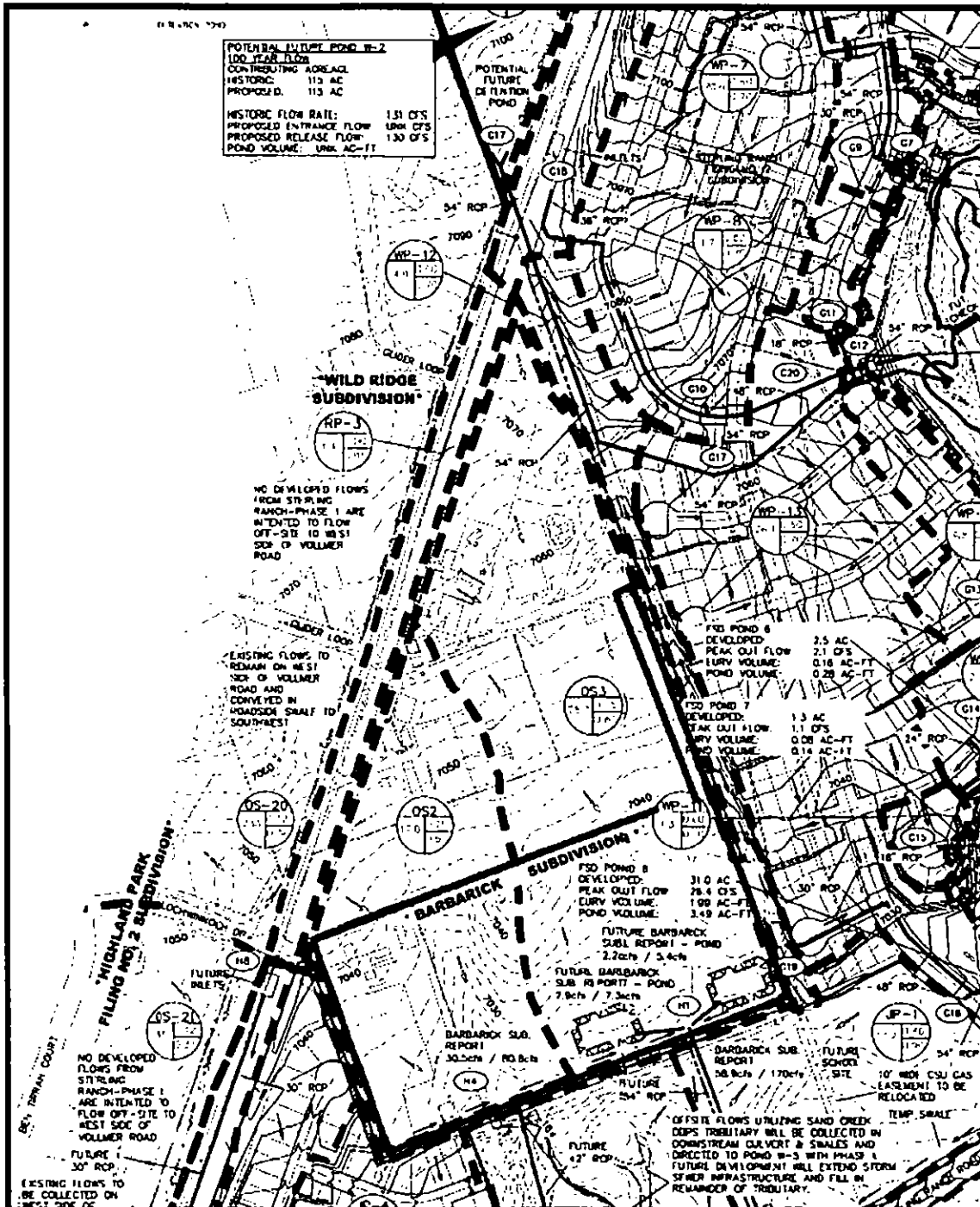

STORM SEWER ROUTING SUMMARY			
DESIGN POINT	Q _s (cfs)	Q ₁₀₀ (cfs)	
G4A	640	1584	
G5	78	146	
G6	32	66	
G7	82	157	
G8	20	42	
G9	14	29	
G10	47	97	
G11	4	9	
G12	72	144	
G13	12	25	
G14	7	14	
G15	3	7	
G16	60	125	
G17	80	130	
G18	29	54	
G19	11	23	
G20	69	138	
G21	1044	1767	
G22	5	10	
G23	64	133	
G25	1056	1795	
H1	73	139	
H2	46	92	
H3	103	200	
H4	45	86	
H5	30	61	
H6	68	134	
H8	16	29	
H11	22	45	
H12	31	62	
H13	57	118	
H14	196	382	
H16	31	65	
H17	26	54	
H18	224	441	

BASIN SUMMARY			
BASIN	AREA (ACRES)	Q _s (cfs)	Q ₁₀₀ (cfs)
OS1	110.1	68	167
OS2	17.0	45	86
OS3	28.7	73	139
OS4	5.0	5	11

Flow Summary from the Sterling Ranch PDR

EXISTING SITE DRAINAGE DISCUSSION:

On-Site (Existing Conditions):

On-site Basin H1 This basin covers approximately 10.7 acres and represents the majority of Lots 3 & 4. This basin is modeled as good condition undeveloped rangeland. This drains to the south and generates 2.6/23.7 cfs in the 5/100 year storm events.

On-site Basin H2 This existing basin covers approximately 3.70 acres and represents the eastern half of Lots 1 & 2. This basin is modeled as good condition rangeland and generates 0.9/8.2 cfs in the 5/100 year storm events.

On-site Basin H3 This existing basin covers 1.1 acres and represents the a small portion of lots 3 & 4 that drains south easterly. This basin is modeled as good

condition rangeland and generates 0.3/2.7 cfs in the 5/100 year storm events. This basin sheet flows offsite where it is captured in a small swale between the site and existing roadway and conveyed westerly to the low point south of the outfall of Basin H1.

These existing basins encompass the previously unmodelled drainage area from the BS-FDR. The total historic flow from the site is 3.8/34.6 cfs in the 5/100 year storm events. The following design point table is for combined allowable discharge rates from the property at respective locations including historic flows from the tributary upstream basins:

<u>Design Point</u>	<u>5/100 Release</u>	<u>Comments</u>
DP H1	16.7*/30.3 cfs	DP H5 WS-FDR - * is 10year
DP H2	13.7/35.5 cfs	O3 BS-FDR
DP H3	56.7 cfs	DPH1+H1+H3 (100-year)
DP H4	14.6/43.7 cfs	DPH2 + H2

Design Point H3 will release a flow lower than previously anticipated within the BS-FDR (52.9/170 cfs). It is the introduction of development within the Sterling Ranch site that has eliminated offsite flows from BS-FDR Basin O1 that significantly changed the drainage pattern. The historic release is now contained solely to the historic flows from WS-FDR design point H5 and the proposed onsite historic flows.

Design Point H4 will combine with the western half of Lots 1&2. Per the BS-FDR the combined portions of Lots 1&2 and O3 to release a combined flow of 30.5/80.8 cfs downstream. The flow anticipated in the BS-FDR appears consistent with the smaller basin analysis of this report and should be used for downstream analysis.

PROPOSED DRAINAGE DISCUSSION

Introduction

The proposed site will be developed differently than anticipated in the previous BS-FDR. The previous plan for this site maintained the existing native drainage way down the middle of Lots 1 & 2 and 3 & 4, thereby splitting the buildable area into the outer thirds of these lots. The native drainage way and "Drainage Boundary – No Build Area" (as shown on the Plat & FDR) will be eliminated with the proposed development. The proposed site and proposed drainage improvements will allow this native drainage way to be eliminated while maintaining the pass through of major flows. These modifications to the site and to the drainage patterns will allow a larger buildable area.

The existing retention pond, located just north of Lot 3, will be modified by others to become a water quality/detention pond pursuant to the WS-FDR. A new outlet works and a storm drain pipe will convey runoff from this detention pond (16.1/29.4 cfs in the 10/100 year storm events) discharging at the property line. This development is proposing a CDOT Type D inlet to capture the discharged flow and pipe it downstream along the east side of Lots 3 & 4 to discharge into the proposed Full Spectrum Extended

Detention Basin (EDB) in Lot 4. The EDB is designed to pass through, and not treat or detain, these offsite flows.

A new EDB will be provided in Lot 4. This detention basin will provide water quality treatment for portions of Lots 1 & 2, and Lots 3 & 4. In the approved Barbarick FDR there were to be two separate ponds. The new site development has been planned for a single pond to treat the developed flows. Tributary water sheet flow across the site to shallow swales that will direct runoff to the proposed EDB. The EDB will have a forebay at the confluence of the two pipe outfalls, a concrete trickle channel that terminates at a micropool structure, and is designed to treat the WQCV, EURV and 100-year detention.

A second SFB water quality with detention catchment basin will be provided at the south east/downstream end of Lot 2. This SFB will not have an outlet structure to release flows due to requirements from the gas main utility ownership of no structure to be built within the existing easements. There will be a small spillway to allow the release of large storm events. Runoff will be directed to the proposed SFB where possible.

Flow from the area north of Lot 1 (Basin O3) will pass through the site via two 24" culverts and will be discharged at the southern boundary of Lot 2, as historically done. An earthen channel will run north-south along the east side of the existing Lot 1 and Lot 2 developments. The channel is approximately 1-ft deep with 4:1 side slopes and will capture and convey any westerly flowing nuisance runoff from the proposed improvements to the sand filter detention pond as discussed in the original Barbarick Subdivision FDR, instead of the existing Lot 1 and 2 improved areas.

Runoff from the property is at historic flows and will not exceed the anticipated runoff as determined in the Sterling Ranch PDR. This is described in more detail below. The Sterling Ranch PDR includes an analysis of future drainage conditions and includes recommended infrastructure to convey this runoff. Since the Sterling Ranch surrounds the Barbarick Subdivision, it is appropriate to include the recommendations from the SR-PDR in this Proposed Drainage Discussion.

Proposed On-Site Basin Descriptions: (See Basin Map in the pocket)

On-site Basin D1 (D for Developed condition) - This developed basin encompasses approximately 11.4 acres - the majority of Lots 3 & 4 and small portions of Lots 1 & 2. This basin generates 19.7/56.0 cfs in the 5/100 year storm events and sheet flows into shallow swales that direct the runoff into the proposed EDB to be located in Lot 4. Lot 3 is based on Owner provided information for a gravel parking/vehicle storage area, and Lot 4 has been based on proposed building site improvements as identified in the rezoning application. Any changes to the land use will require an update to the Final Drainage Report; much like the original Barbarick Subdivision Final Drainage Report is being updated with the grading and Lot 4 development application.

On-site Basin D2 This undeveloped basin encompasses 1.2 acres and represents the south portion of Lot 4, below and south of the two detention ponds. This basin is historic in nature and generates 0.8/3.0 cfs and drains directly into a road side ditch within the Sterling Ranch development.

On-site Basin D3 This developed basin encompasses approximately 3.13 acres - the remaining proposed infill portions of Lots 1 and 2 (east of the currently built out Lots 1&2). As discussed in the original Barbarick Subdivision FDR, development of these areas will require a detention water quality pond. This basin generates 4.1/11.6 cfs in the 5/100 year storm events and sheet flows southerly to the proposed SFB located at the southern-most portion of Lot 2.

The following design point table is for combined allowable discharge rates from the property at respective locations including historic flows from the tributary upstream basins:

<u>Design Point</u>	<u>5/100 Year</u>	<u>Comments</u>
DP D1	85.4 cfs (100)	D1+O2 Pass Through
DP D2	48.9 cfs (100)	Pond Release+D2
DP D3	4.1/11.6 cfs	D3
DP D4	13.8/39.1 cfs	Pond Release +O3 Pass Through

All release flows downstream are at or below historic levels.

RECOMMENDED DESIGN

Off-site Detention Facility:

This shallow pond will be modified for the proposed development to the north as part of the WS-FDR. This will eliminate the retention properties in this pond, will provide detention for off-site flows, will provide a suitable outlet structure, and will remove accumulated sediment. The modified pond will store up to 1.52 acft (66,211 cuft) to the principal spillway (elevation = 7048.05). A summary of flows into and out of this pond:

<u>Off-site Pond Flow Summary (cfs)</u>	<u>5 year</u>	<u>100 year</u>
Proposed Flow into offsite pond (Basin G/DP 5)	<u>57.4</u>	<u>92.7</u>
Increase in peak flow due to development	46.2	51.3
Proposed flow out of modified pond	<u>16.1</u>	<u>29.4</u>
Reduction in peak flow	41.3	63.3

For complete pond design, refer to the WS-FDR.

Proposed 30” HDPE Storm Drain from Modified Off-site Detention Pond:

This storm drain will capture flows from the discharged offsite pond and route them along the perimeter of the property daylighting into the EDB in Lot 4. 4’ precast concrete manholes will be used for maintenance access at all bends and grade breaks. A grouted riprap forebay will help dissipate energy at the outlet of the pipe, and allow for settling prior to entering the pond. See the Appendix for the hydraulic analysis of this storm drain (StormCAD).

In the event of an emergency and the offsite pond fails, developed flow (Q100=93.0 cfs) will overtop the pond and be collected between the proposed roadway and pond berm.. Flow not captured by the proposed inlet will bypass easterly to the proposed offsite swale between this property and the Sterling Ranch property and conveyed southerly.

Proposed 18” HDPE Storm Drain Culvert:

A 18” HDPE culvert will convey collected runoff from Lot 3 (Developed Q100 = 15.90cfs) through Lot 4 to the FSD Pond and join sheet flow from Lot 4 and the 30” piped bypass flow from basin O2. This culvert will be privately owned and maintained by the property owners. See the Appendix for open channel calculations.

On-site FSD - EDB Pond in Lot 4 (Basin D1):

This On-site Full Spectrum Extended Detention Basin Pond provides water quality, EURV and 100-year detention. Onsite flows will combine with the 30-inch bypass flows from the north and pass through the EDB. The pond has been sized for the release of historic flows from Basin D1, as well as provides capacity for pass through conveyance of historic flows from the north.

The following table outlines the onsite existing and developed flow, required detention, and modifications to required detention utilizing the upstream over detention.

<u>On-site Basin Flow Summary (cfs)</u>	<u>5 year</u>	<u>100 year</u>
Existing On-site Flow at Pond	2.2	16.5
Developed On-site Flow (Basin D1)	19.7	56.0
Increase in peak flow due to development	17.5	39.5
Proposed Pass Through Flow from Off-Site Pond	16.1*	29.4
Proposed total flow out of EDB pond	0.3	45.9**

*Includes 10 year from WS-FDR

**Includes Pass Through flow of 29.4 cfs

Water Quality Benefits:

Stormwater from Lots 3 & 4, and portions of 1 & 2 will drain directly to the proposed Full Spectrum Extended Detention Pond. This pond will be privately maintained and provide water quality treatment to approximately 11.4 acres of developed land.

The proposed Water Quality facility is sized using the methods derived from the UDFCD Stormwater FSD Design Workbook (UD-FSD 1.11) (see Appendix). The Water Quality Capture Volume (WQCV) will be provided in this EDB, where the “initial flush” of storm water will be drained over a 40-hour time period.

The impervious area ratio is used in the UDFCD workbook to calculate the WQCV. An adjusted impervious ratio of 57% to correlate with the land use charts and Runoff Coefficients (provided above) is being utilized for the sizing of the facility.

The EDB Pond will have a forebay, concrete trickle channel and micro-pool within the outlet structure (per UDFCD). This outlet structure will have a bar screen and an orifice plate containing 3 rows outlets (1.55 sq in orifices for the first two, and 3.8 sq in for the last row). The EURV has been designed to an elevation of 7021.50. The top of the inlet will have a grate to allow flows that exceed the WQCV and EURV to drain through the outlet works without overtopping the spillway, with an internal orifice plate of 2.37-ft diameter constricting flows to historic release rates ($Q_{100 \text{ Onsite}} = 16.5 \text{ cfs} + Q_{100 \text{ bypass}} = 29.4$ Total Release = 45.9 cfs) .

The EDB pond can store up to 64,904 cuft (1.49 acft) to the principal spillway (7023.20). The pond bottom elevation will be at 7018.50 and the top of the embankment will be at elevation 7025.10. Should the outlet works become fully blocked; the 36' spillway will have the capacity to pass the combined 100 year peak developed runoff and northerly bypass with a flow depth = 0.90' ($55.0 + 29.4 = 84.4 \text{ cfs}$) maintaining 1-ft of freeboard. .

Summary results include:

- WQCV Volume = 0.203 ac-ft depth 1.53-ft (40 hour release)
- EURV Volume Stored = 0.677 ac-ft at depth 2.98 ft (72 hour release)
- 5 Year Volume Stored = 0.673 ac-ft at depth 2.98 ft (72 hour release)
- 100 Year Volume Stored = 1.261 ac-ft depth 4.26-ft (77 hour release)
- Emergency Spillway Volume at Crest = 1.49 ac-ft at depth 4.7ft.

A 30" HDPE pipe will drain this outlet structure. A Low-Tailwater basin will be provided at the outlet for energy dissipation. This storm drain will daylight into the open channel just south of Lot 4 near the entrance of an existing 12" CMP. This existing 12" CMP drains under a dirt road. This dirt road will be eliminated upon development of the Sterling Ranch. Due to the limited capacity of this existing 12" CMP, runoff in excess of 5.7 cfs will overtop this dirt road, creating tail water to 7018.0. See the Appendix for the calculation results (CulvertMaster).

On-site Sand Filter Basin w/ Detention in Lot 2 (Basin D3):

A sand filter basin detention pond is being proposed to treat runoff from the proposed gravel parking portions of Lots 1 and 2 prior to discharging from the site. Due to the high pressure gas mains within this basin, grading is limited to fill only and no structures are allowed within the gas easement, so this pond will have underdrain design with partial infiltration and a controlled overflow design for the 100-year event.

The following table outlines the onsite existing and developed flow, required detention, and modifications to required detention utilizing the upstream over detention.

<u>On-site Basin Flow Summary (cfs)</u>	<u>5 year</u>	<u>100 year</u>
Existing On-site Flow at Pond	0.5	4.2
Developed On-site Flow (Basin D3)	4.1	11.6
Increase in peak flow due to development	3.6	7.4
Proposed total flow out of Sand Filter pond	<u>0.1</u>	<u>3.6</u>

Water Quality Benefits:

Stormwater from portions of 1 & 2 will drain directly to the proposed Sand Filter Pond. This pond will be privately maintained and provide water quality treatment to approximately 3.13 acres of developed land.

The proposed Water Quality facility is sized using the methods derived from the UDFCD Stormwater Detention Design Workbook (UD-Detention 3.04) (see Appendix). The Water Quality Capture Volume (WQCV) will be provided in this SFB, where the "initial flush" of storm water will be drained over a 12-hour time period.

The impervious area ratio is used in the UDFCD workbook to calculate the WQCV. An adjusted impervious ratio of 57% to correlate with the land use charts and Runoff Coefficients (provided above) is being utilized for the sizing of the facility.

The sand filter will contain a 4" underdrain beneath 18" of CDOT Class C material. The underdrain will contain a 1.27" diameter orifice to control the outflow time in accordance with UDFCD.

The SFB pond can store up to 16,247 cu ft (0.373 acft) to the principal spillway (7025.50). The pond bottom elevation will be at 7023.00 and the top of the embankment will be at elevation 7027.37. Because the spillway acts as the 100-year control structure and notched weir design is proposed. The spillway is 5-ft wide for a depth of 10-inches for the release of the 100-year flow (3.6 cfs which is less than the 4.2 historic) then the spillway widens to 10ft for a depth of 18-inches which will have the capacity to pass the combined 100 year peak developed runoff (11.6cfs) with a flow depth = 0.5' maintaining 1-ft of freeboard.

Summary results include:

- WQCV Volume = 0.039 ac-ft depth 0.37-ft (12 hour release)
- EURV Volume Stored = 0.181 ac-ft at depth 1.52 ft (42 hour release)
- 5 Year Volume Stored = 0.181 ac-ft at depth 1.52 ft (42 hour release)
- 100 Year Volume Stored = 0.394 ac-ft depth 2.83-ft (68 hour release)

Proposed (2) 24" HDPE Storm Drain Culvert:

Two 24" pipes will convey offsite flows through Lots 1 and 2 discharging to the south. The culverts will connect to a pair of existing 24" culverts entering the property and will discharge to a riprap settling basing prior to the released downstream. These culverts will be privately owned and maintained by the property owners. See the Appendix for the hydraulic analysis of this storm drain (CulvertMaster). Flow from these pipes will join the flow from the Sand Filter and discharge at Design Point 4 (combined 39.4 cfs in the 100-year event). Per the BS-FDR this flow combines with the westerly portions of Lots 1 & 2 offsite for a total release of 30.5/80.8 cfs in the 5/100 year events.

As stated above in the summary from the Sterling Ranch PDR, the anticipated runoff from this proposed discharge point (aka: SR-PDR Basin H4) is 30.5/80.8 cfs (5/100 year) due to the large pass through flow. A 42" RCP is planned to convey this flow through Sterling Ranch.

DRAINAGE, BRIDGE, AND POND FEES

This subdivision has already been platted. No additional Drainage, Bridge or Pond fees are required.

MAINTENANCE

All proposed storm drain infrastructure will be located within private property and will be owned and maintained by the property owner. The detention pond will be owned and maintained by the property owner and will require maintenance consisting of routine inspections, removal of debris from the detention area, and bi-annual inspections for hydraulic performance of the basin. Refer to the DCM for exact maintenance criteria and for other Best Management Practices (BMP).

EROSION CONTROL

Best Management Practices (BMPs) will be utilized to minimize erosion during construction and will be shown on the construction drawings. These will be in accordance with will be utilized as deemed necessary by the contractor and/or engineer. The contractor shall minimize the amount of area disturbed during all construction activities.

In general, the following shall be applied in developing the sequence of major activities;

1. Install down slope and side slope perimeter BMPs before the land disturbing activity occurs.
2. Do not disturb area until it is necessary for the construction activity to proceed.
3. Cover or stabilize exposed areas as soon as possible.
4. Time the construction activities to reduce the impacts from seasonal climatic changes or weather events.
5. The construction of permanent filtration BMPs should wait until the end of the construction project when drainage areas have been stabilized.
6. Do not remove the temporary erosion controls until after all areas are stabilized.

Slopes

Erosion control soil retention blankets shall be installed where noted on slopes 3:1 or steeper. At a minimum, coconut/straw blend fiber material blankets should be used. The silt fence or erosion logs shall be installed at the toe of fill slopes where noted on a level contour. Erosion logs shall also be installed on slopes greater than ten feet in height where noted to reduce runoff length. The erosion logs shall be installed on a level contour. Disturbed surfaces shall be left in a roughened condition at all times when horizontal depressions approximately 2" to 4" deep, spaced 4" to 6" apart. Silt fence and erosion logs shall remain in place until all construction is complete and/or "finally stabilized", after which the silt fence and erosion logs shall be removed from the slopes. All material shall be installed per manufacturer's installation instructions.

Stockpiles/Mobilization/Winter Shutdown

Soils stockpiled for more than 30 days shall be mulched with mulch tackifier and native seeding within 14 days of stockpile construction. After mobilization and prior to winter shutdown, all disturbed slopes not completed shall be mulched with mulch tackifier and native seeding.

Inlet and Outlet Protection

Storm Drain Inlet Protection shall be provided at all storm inlets. Outlet protection shall be provided at all pipe outlet and runoff / rundown treatment locations. All materials shall be installed per manufacturer's installation instructions.

Concrete Washout

Concrete washout structures shall be installed for cleaning concrete trucks. The concrete washout structure shall be constructed such that water can only evaporate or infiltrate from the structure. Residue and concrete from the washout structure shall be periodically cleaned out and properly disposed.

Erosion Control Supervisor and Maintenance

The erosion control supervisor shall be a person other than the superintendent. The erosion control supervisor shall inspect at least every 14 days and after any precipitation or snowmelt event that causes surface erosion. At sites where construction has been completed but a vegetative cover has not been established, these inspections must occur at least once per month.

All erosion control measures shall remain in place until all construction is complete and final stabilization has been achieved. "Final stabilization" is where all disturbed areas

have been built on, paved, or germinated with a uniform vegetative cover with a density of at least 70% of pre-disturbance levels. Equivalent permanent, physical erosion reduction methods may also be employed. Any areas not meeting this standard shall be repaired according to the BMP guidelines. Accumulated sediment and debris shall be removed when the sediment level reaches one half the height of the BMP or when the sediment/debris adversely impacts the functionality of the BMP. The Contractor shall remove all sediment, mud, and construction debris that may accumulate in public right of ways not designated before-hand as a result of this construction project. All repairs, removals, and replacements stated above shall be conducted in a timely manner.

Cost Estimate

The proposed drainage system to be constructed will be privately owned and maintained. The developer will be responsible for constructing the proposed improvements.

An engineer's estimate of probable construction costs has been provided for the proposed improvements. The storm sewer systems will be located in the Sand Creek Drainage Basin. The construction cost for the improvements are not eligible for reimbursement.

**Engineer's Estimate of Probable Construction Costs
Tri-Lakes Construction - Sand Creek Drainage Basin
Non-Reimbursable Private Improvements**

Item	Unit	Quantity	Unit Cost	Total Cost
Precast Manhole	EA	4	\$2,500	\$10,000
18" HDPE Pipe	LF	231	\$45	\$10,395
24" HDPE Pipe	LF	1212	\$60	\$72,720
30" HDPE Pipe	LF	1128	\$72	\$81,216
18" Flared End	EA	2	\$225	\$450
24" Flared End	EA	2	\$250	\$500
24" CMP-HDPE	EA	2	\$200	\$400
30" Flared End	EA	1	\$350	\$350
CDOT Type D Inlet	EA	1	\$4,000	\$4,000
EDB Pond Outlet	EA	1	\$35,000	\$35,000
			SubTotal	\$215,031.00
			15% Contingency	\$32,254.65
			Total Estimate	\$247,285.65

REFERENCES

1. **City of Colorado Springs & El Paso County Drainage Criteria Manual, Volumes I and II**, dated May 2014 including subsequent updates
2. **City of Colorado Springs & El Paso County Drainage Criteria Manual, Volumes I and II**, dated November 1991 including subsequent updates
3. **Appendix I of the El Paso County's Engineering Criteria Manual (ECM)**, (2008).
4. **Urban Storm Drainage Criteria Manuals, Volumes 1-3**, published by the Urban Drainage and Flood Control District, (Volumes 1 & 2 dated 2016, Volume 3 dated 2015)
5. **Preliminary Drainage Report for Sterling Ranch-Phase 1, Sand Creek Drainage Basin**, M & S Civil Consultants, Inc., May 2015
6. **Woodmen Storage Final Drainage Report, El Paso County**, Calibre Engineering, Inc., July 2004; Revised February, 2010; Revised May, 2010; Revised July, 2010
7. **Preliminary and Final Drainage Plan and Report for Barbarick Subdivision, El Paso County**, Oliver E. Watts Consulting Engineer Inc., January 2005; Revised October 2005; Revised December 2006; Revised May 2007; Revised August 15, 2007
8. **NOAA Atlas 14, Volume 8 Version 2** U.S. Department of Commerce, National Oceanic and Atmospheric Administration, National Weather Service, Hydrometeorological Design Studies Center.
9. FEMA Map Service Center: <http://msc.fema.gov>
10. NRCS Web Soil Survey. <http://websoilsurvey.nrcs.usda.gov>

APPENDIX A

HYDROLOGIC AND HYDRAULIC CALCULATIONS

CALCULATION OF A PEAK RUNOFF USING RATIONAL METHOD

Project Title: Barbarick Subdivision
 Catchment ID: H-1 5 Year

I. Catchment Hydrologic Data

Catchment ID = H1
 Area = 10.70 Acres
 Percent Imperviousness = 2.00 %
 NRCS Soil Type = B A, B, C, or D

II. Rainfall Information $I (\text{inch/hr}) = C1 * P1 / (C2 + Td)^{C3}$

Design Storm Return Period, T_r = 5 years (input return period for design storm)
 $C1$ = 28.50 (input the value of $C1$)
 $C2$ = 10.00 (input the value of $C2$)
 $C3$ = 0.786 (input the value of $C3$)
 $P1$ = 1.23 inches (input one-hr precipitation--see Sheet "Design Info")

III. Analysis of Flow Time (Time of Concentration) for a Catchment

Runoff Coefficient, C = 0.08
 Override Runoff Coefficient, C = _____ (enter an override C value if desired, or leave blank to accept calculated C .)
 5-yr. Runoff Coefficient, $C-5$ = 0.08
 Override 5-yr. Runoff Coefficient, $C-5$ = _____ (enter an override $C-5$ value if desired, or leave blank to accept calculated $C-5$.)

Illustration

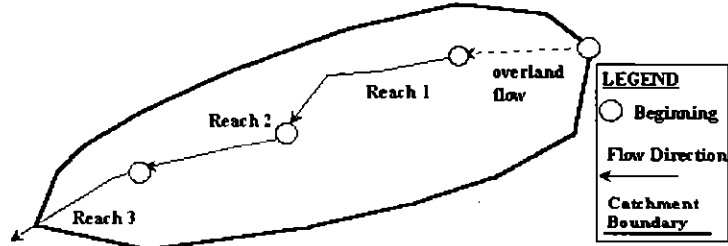

NRCS Land Type	Heavy Meadow	Tillage/Field	Short Pasture/Lawns	Nearly Bare Ground	Grassed Swales/Waterways	Paved Areas & Shallow Paved Swales (Sheet Flow)
Conveyance	2.5	5	7	10	15	20

Calculations:

Reach ID	Slope S ft/ft input	Length L ft input	5-yr Runoff Coeff C-5 output	NRCS Convey- ance input	Flow Velocity V fps output	Flow Time Tf minutes output
1	0.0300	338		10.00	1.73	3.25
2						
3						
4						
5						
Sum		638				

Computed T_c = 25.42
 Regional T_c = 13.54
 User-Entered T_c = 13.54

IV. Peak Runoff Prediction

Rainfall Intensity at Computed T_c , I = 2.12 inch/hr
 Rainfall Intensity at Regional T_c , I = 2.93 inch/hr
 Rainfall Intensity at User-Defined T_c , I = 2.93 inch/hr

Peak Flowrate, Q_p = 1.85 cfs
 Peak Flowrate, Q_p = 2.56 cfs
 Peak Flowrate, Q_p = 2.56 cfs

CALCULATION OF A PEAK RUNOFF USING RATIONAL METHOD

Project Title: Barbarick Subdivision
 Catchment ID: H-1 100 Year

I. Catchment Hydrologic Data

Catchment ID = H1
 Area = 10.70 Acres
 Percent Imperviousness = 2.00 %
 NRCS Soil Type = B A, B, C, or D

II. Rainfall Information I (inch/hr) = $C1 * P1 / (C2 + Td)^{C3}$

Design Storm Return Period, T_r = 100 years (input return period for design storm)
 $C1$ = 28.50 (input the value of $C1$)
 $C2$ = 10.00 (input the value of $C2$)
 $C3$ = 0.786 (input the value of $C3$)
 $P1$ = 2.57 inches (input one-hr precipitation--see Sheet "Design Info")

III. Analysis of Flow Time (Time of Concentration) for a Catchment

Runoff Coefficient, C = 0.36
 Override Runoff Coefficient, C = _____ (enter an override C value if desired, or leave blank to accept calculated C .)
 5-yr. Runoff Coefficient, $C-5$ = 0.08
 Override 5-yr. Runoff Coefficient, $C-5$ = _____ (enter an override $C-5$ value if desired, or leave blank to accept calculated $C-5$.)

Illustration

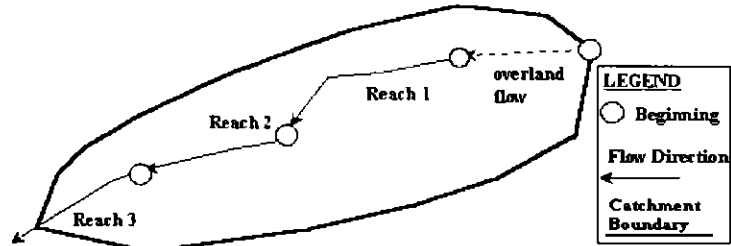

NRCS Land Type	Heavy Meadow	Tillage/ Field	Short Pasture/ Lawns	Nearly Bare Ground	Grassed Swales/ Waterways	Paved Areas & Shallow Paved Swales (Sheet Flow)
Conveyance	2.5	5	7	10	15	20

Calculations:

Reach ID	Slope S ft/ft	Length L ft	5-yr Runoff Coeff		NRCS Conveyance	Flow Velocity		Flow Time	
			C-5 input	C-5 output		V input	V output	Tf input	Tf output
Overland	0.0300	300		0.08	N/A	0.23		22.16	
1	0.0300	338			10.00	1.73		3.25	
2									
3									
4									
5									
Sum		638							
								Computed T_c =	25.42
								Regional T_c =	13.54
								User-Entered T_c =	13.54

IV. Peak Runoff Prediction

Rainfall Intensity at Computed T_c , I = 4.44 inch/hr
 Rainfall Intensity at Regional T_c , I = 6.12 inch/hr
 Rainfall Intensity at User-Defined T_c , I = 6.12 inch/hr

Peak Flowrate, Q_p = 17.20 cfs
 Peak Flowrate, Q_p = 23.71 cfs
 Peak Flowrate, Q_p = 23.71 cfs

CALCULATION OF A PEAK RUNOFF USING RATIONAL METHOD

Project Title: Barbarick Subdivision
 Catchment ID: H-2 5 Year

I. Catchment Hydrologic Data

Catchment ID = H2
 Area = 3.70 Acres
 Percent Imperviousness = 2.00 %
 NRCS Soil Type = B A, B, C, or D

II. Rainfall Information $I (\text{inch/hr}) = C1 * P1 / (C2 + Td)^{C3}$

Design Storm Return Period, T_r = 5 years (input return period for design storm)
 $C1$ = 28.50 (input the value of $C1$)
 $C2$ = 10.00 (input the value of $C2$)
 $C3$ = 0.786 (input the value of $C3$)
 $P1$ = 1.23 inches (input one-hr precipitation--see Sheet "Design Info")

III. Analysis of Flow Time (Time of Concentration) for a Catchment

Runoff Coefficient, C = 0.08
 Override Runoff Coefficient, C = _____ (enter an override C value if desired, or leave blank to accept calculated C .)
 5-yr. Runoff Coefficient, $C-5$ = 0.08
 Override 5-yr. Runoff Coefficient, C = _____ (enter an override $C-5$ value if desired, or leave blank to accept calculated $C-5$.)

Illustration

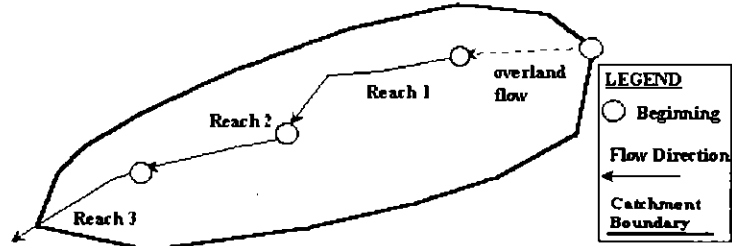

NRCS Land Type	Heavy Meadow	Tillage/Field	Short Pasture/Lawns	Nearly Bare Ground	Grassed Swales/Waterways	Paved Areas & Shallow Paved Swales (Sheet Flow)
Conveyance	2.5	5	7	10	15	20

Calculations:

Reach ID	Slope S ft/ft input	Length L ft input	5-yr Runoff Coeff C-5 output	NRCS Convey- ance input	Flow Velocity V fps output	Flow Time Tf minutes output
1	0.0350	515		10.00	1.87	4.59
2						
3						
4						
5						
Sum		670				

Computed T_c = 19.32
 Regional T_c = 13.72
 User-Entered T_c = 13.72

IV. Peak Runoff Prediction

Rainfall Intensity at Computed T_c , I = 2.46 inch/hr
 Rainfall Intensity at Regional T_c , I = 2.91 inch/hr
 Rainfall Intensity at User-Defined T_c , I = 2.91 inch/hr

Peak Flowrate, Q_p = 0.74 cfs
 Peak Flowrate, Q_p = 0.88 cfs
 Peak Flowrate, Q_p = 0.88 cfs

CALCULATION OF A PEAK RUNOFF USING RATIONAL METHOD

Project Title: Barbarick Subdivision
 Catchment ID: H-2 100 Year

I. Catchment Hydrologic Data

Catchment ID = H2
 Area = 3.70 Acres
 Percent Imperviousness = 2.00 %
 NRCS Soil Type = B A, B, C, or D

II. Rainfall Information $I (\text{inch/hr}) = C1 * P1 / (C2 + Td)^{C3}$

Design Storm Return Period, T_r = 100 years (input return period for design storm)
 $C1$ = 28.50 (input the value of $C1$)
 $C2$ = 10.00 (input the value of $C2$)
 $C3$ = 0.786 (input the value of $C3$)
 $P1$ = 2.57 inches (input one-hr precipitation--see Sheet "Design Info")

III. Analysis of Flow Time (Time of Concentration) for a Catchment

Runoff Coefficient, C = 0.36
 Override Runoff Coefficient, C = _____ (enter an override C value if desired, or leave blank to accept calculated C .)
 5-yr. Runoff Coefficient, $C-5$ = 0.08
 Override 5-yr. Runoff Coefficient, $C-5$ = _____ (enter an override $C-5$ value if desired, or leave blank to accept calculated $C-5$.)

Illustration

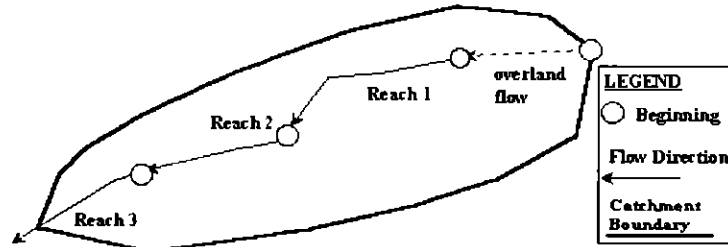

NRCS Land Type	Heavy Meadow	Tillage/ Field	Short Pasture/ Lawns	Nearly Bare Ground	Grassed Swales/ Waterways	Paved Areas & Shallow Paved Swales (Sheet Flow)
Conveyance	2.5	5	7	10	15	20

Calculations:

Reach ID	Slope S	Length L	5-yr Runoff Coeff C-5	NRCS Conveyance	Flow Velocity V	Flow Time Tf
	ft/ft input	ft input	output		fps output	minutes output
Overland	0.0380	155	0.08	N/A	0.18	14.74
1	0.0350	515		10.00	1.87	4.59
2						
3						
4						
5						
Sum		670				

Computed T_c = 19.32
 Regional T_c = 13.72
 User-Entered T_c = 13.72

IV. Peak Runoff Prediction

Rainfall Intensity at Computed T_c , I = 5.15 inch/hr
 Rainfall Intensity at Regional T_c , I = 6.08 inch/hr
 Rainfall Intensity at User-Defined T_c , I = 6.08 inch/hr

Peak Flowrate, Q_p = 6.90 cfs
 Peak Flowrate, Q_p = 8.15 cfs
 Peak Flowrate, Q_p = 8.15 cfs

CALCULATION OF A PEAK RUNOFF USING RATIONAL METHOD

Project Title: Barbarick Subdivision
 Catchment ID: H-3 5 year

I. Catchment Hydrologic Data

Catchment ID = H3
 Area = 1.11 Acres
 Percent Imperviousness = 2.00 %
 NRCS Soil Type = B A, B, C, or D

II. Rainfall Information $I (\text{inch/hr}) = C1 * P1 / (C2 + Td)^{C3}$

Design Storm Return Period, T_r = 5 years (input return period for design storm)
 $C1$ = 28.50 (input the value of C1)
 $C2$ = 10.00 (input the value of C2)
 $C3$ = 0.786 (input the value of C3)
 $P1$ = 1.23 inches (input one-hr precipitation--see Sheet "Design Info")

III. Analysis of Flow Time (Time of Concentration) for a Catchment

Runoff Coefficient, C = 0.08
 Override Runoff Coefficient, C = _____ (enter an override C value if desired, or leave blank to accept calculated C.)
 5-yr. Runoff Coefficient, $C-5$ = 0.08
 Override 5-yr. Runoff Coefficient, C = _____ (enter an override C-5 value if desired, or leave blank to accept calculated C-5.)

Illustration

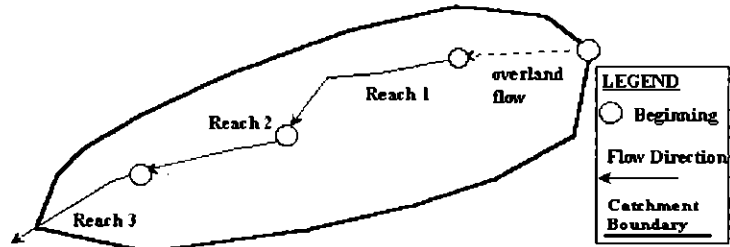

NRCS Land Type	Heavy Meadow	Tillage/Field	Short Pasture/Lawns	Nearly Bare Ground	Grassed Swales/Waterways	Paved Areas & Shallow Paved Swales (Sheet Flow)
Conveyance	2.5	5	7	10	15	20

Calculations:

Reach ID	Slope S	Length L	5-yr Runoff Coeff C-5	NRCS Conveyance	Flow Velocity V	Flow Time Tf
	ft/ft input	ft input	output		fps output	minutes output
Overland	0.0250	338	0.08	N/A	0.23	24.98
1						
2						
3						
4						
5						
	Sum	338				

Computed T_c = 24.98
 Regional T_c = 11.88
 User-Entered T_c = 11.88

IV. Peak Runoff Prediction

Rainfall Intensity at Computed T_c , I = 2.14 inch/hr
 Rainfall Intensity at Regional T_c , I = 3.10 inch/hr
 Rainfall Intensity at User-Defined T_c , I = 3.10 inch/hr

Peak Flowrate, Q_p = 0.19 cfs
 Peak Flowrate, Q_p = 0.28 cfs
 Peak Flowrate, Q_p = 0.28 cfs

CALCULATION OF A PEAK RUNOFF USING RATIONAL METHOD

Project Title: Barbarick Subdivision
 Catchment ID: H-3 100 year

I. Catchment Hydrologic Data

Catchment ID = H3
 Area = 1.11 Acres
 Percent Imperviousness = 2.00 %
 NRCS Soil Type = B A, B, C, or D

II. Rainfall Information I (inch/hr) = $C1 * P1 / (C2 + Td)^{C3}$

Design Storm Return Period, T_r = 100 years (input return period for design storm)
 $C1$ = 28.50 (input the value of $C1$)
 $C2$ = 10.00 (input the value of $C2$)
 $C3$ = 0.786 (input the value of $C3$)
 $P1$ = 2.67 inches (input one-hr precipitation--see Sheet "Design Info")

III. Analysis of Flow Time (Time of Concentration) for a Catchment

Runoff Coefficient, C = 0.36
 Override Runoff Coefficient, C = _____ (enter an override C value if desired, or leave blank to accept calculated C .)
 5-yr. Runoff Coefficient, $C-5$ = 0.08
 Override 5-yr. Runoff Coefficient, $C-5$ = _____ (enter an override $C-5$ value if desired, or leave blank to accept calculated $C-5$.)

Illustration

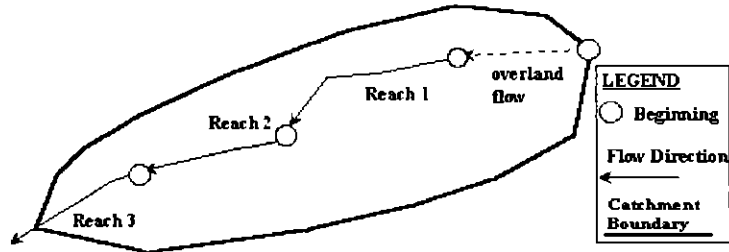

NRCS Land Type	Heavy Meadow	Tillage/ Field	Short Pasture/ Lawns	Nearly Bare Ground	Grassed Swales/ Waterways	Paved Areas & Shallow Paved Swales (Sheet Flow)
Conveyance	2.5	5	7	10	15	20

Calculations:

Reach ID	Slope S	Length L	5-yr Runoff Coeff C-5	NRCS Conveyance	Flow Velocity V	Flow Time T _f
	ft/ft input	ft input	output	input	fps output	minutes output
Overland	0.0250	338	0.08	N/A	0.23	24.98
1						
2						
3						
4						
5						
Sum		338				

Computed T_c = 24.98
 Regional T_c = 11.88
 User-Entered T_c = 11.88

IV. Peak Runoff Prediction

Rainfall Intensity at Computed T_c, I = 4.65 inch/hr
 Rainfall Intensity at Regional T_c, I = 6.73 inch/hr
 Rainfall Intensity at User-Defined T_c, I = 6.73 inch/hr

Peak Flowrate, Q_p = 1.87 cfs
 Peak Flowrate, Q_p = 2.71 cfs
 Peak Flowrate, Q_p = 2.71 cfs

CALCULATION OF A PEAK RUNOFF USING RATIONAL METHOD

Project Title: Barbarick Subdivision
 Catchment ID: D-2 5 Year

I. Catchment Hydrologic Data

Catchment ID = D2
 Area = 1.20 Acres
 Percent Imperviousness = 2.00 %
 NRCS Soil Type = B A, B, C, or D

II. Rainfall Information $I(\text{inch/hr}) = C1 * P1 / (C2 + Td)^{C3}$

Design Storm Return Period, T_r = 5 years (input return period for design storm)
 $C1$ = 28.50 (input the value of $C1$)
 $C2$ = 10.00 (input the value of $C2$)
 $C3$ = 0.786 (input the value of $C3$)
 $P1$ = 1.23 inches (input one-hr precipitation--see Sheet "Design Info")

III. Analysis of Flow Time (Time of Concentration) for a Catchment

Runoff Coefficient, C = 0.08
 Override Runoff Coefficient, C = _____ (enter an override C value if desired, or leave blank to accept calculated C .)
 5-yr. Runoff Coefficient, $C-5$ = 0.08
 Override 5-yr. Runoff Coefficient, C = _____ (enter an override $C-5$ value if desired, or leave blank to accept calculated $C-5$.)

Illustration

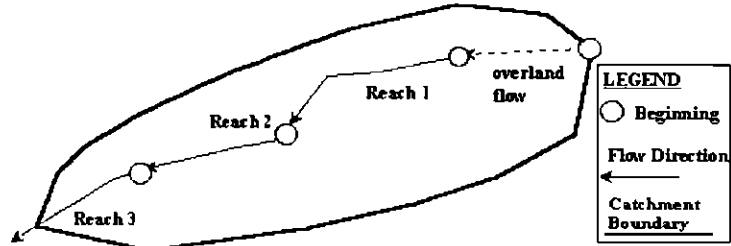

NRCS Land Type	Heavy Meadow	Tillage/ Field	Short Pasture/ Lawns	Nearly Bare Ground	Grassed Swales/ Waterways	Paved Areas & Shallow Paved Swales (Sheet Flow)
Conveyance	2.5	5	7	10	15	20

Calculations:

Reach ID	Slope S	Length L	5-yr Runoff Coeff C-5	NRCS Conveyance	Flow Velocity V	Flow Time T _f
	ft/ft input	ft input	output		fps output	minutes output
Overland	0.0200	155	0.08	N/A	0.14	18.21
1						
2						
3						
4						
5						
	Sum	155				

Computed T_c = 18.21
 Regional T_c = 10.86
 User-Entered T_c = 10.86

IV. Peak Runoff Prediction

Rainfall Intensity at Computed T_c, I = 2.54 inch/hr
 Rainfall Intensity at Regional T_c, I = 3.22 inch/hr
 Rainfall Intensity at User-Defined T_c, I = 3.22 inch/hr

Peak Flowrate, Q_p = 0.25 cfs
 Peak Flowrate, Q_p = 0.32 cfs
 Peak Flowrate, Q_p = 0.32 cfs

CALCULATION OF A PEAK RUNOFF USING RATIONAL METHOD

Project Title: Barbarick Subdivision
 Catchment ID: D2 - 100yr

I. Catchment Hydrologic Data

Catchment ID = D2
 Area = 1.20 Acres
 Percent Imperviousness = 2.00 %
 NRCS Soil Type = B A, B, C, or D

II. Rainfall Information I (inch/hr) = $C1 * P1 / (C2 + Td)^{C3}$

Design Storm Return Period, T_r = 100 years (input return period for design storm)
 $C1$ = 28.50 (input the value of $C1$)
 $C2$ = 10.00 (input the value of $C2$)
 $C3$ = 0.786 (input the value of $C3$)
 $P1$ = 2.57 inches (input one-hr precipitation--see Sheet "Design Info")

III. Analysis of Flow Time (Time of Concentration) for a Catchment

Runoff Coefficient, C = 0.36
 Override Runoff Coefficient, C = _____ (enter an override C value if desired, or leave blank to accept calculated C .)
 5-yr. Runoff Coefficient, $C-5$ = 0.08
 Override 5-yr. Runoff Coefficient, $C-5$ = _____ (enter an override $C-5$ value if desired, or leave blank to accept calculated $C-5$.)

Illustration

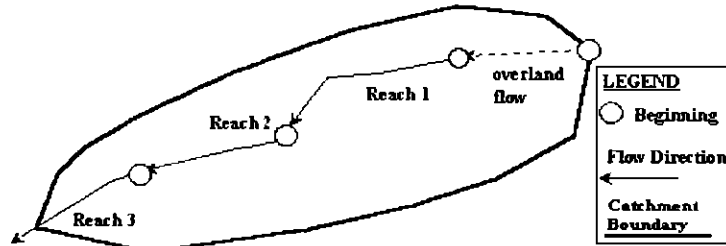

NRCS Land Type	Heavy Meadow	Tillage/ Field	Short Pasture/ Lawns	Nearly Bare Ground	Grassed Swales/ Waterways	Paved Areas & Shallow Paved Swales (Sheet Flow)
Conveyance	2.5	5	7	10	15	20

Calculations:

Reach ID	Slope S	Length L	5-yr Runoff Coeff C-5	NRCS Conveyance	Flow Velocity V	Flow Time T _f
	ft/ft input	ft input	output		fps output	minutes output
Overland	0.0200	85	0.08	N/A	0.11	13.49
1						
2						
3						
4						
5						
	Sum	85				

Computed T_c = 13.49
 Regional T_c = 10.47
 User-Entered T_c = 10.47

IV. Peak Runoff Prediction

Rainfall Intensity at Computed T_c, I = 6.13 inch/hr
 Rainfall Intensity at Regional T_c, I = 6.83 inch/hr
 Rainfall Intensity at User-Defined T_c, I = 6.83 inch/hr

Peak Flowrate, Q_p = 2.66 cfs
 Peak Flowrate, Q_p = 2.97 cfs
 Peak Flowrate, Q_p = 2.97 cfs

CALCULATION OF A PEAK RUNOFF USING RATIONAL METHOD

Project Title: Barbarick Subdivision
 Catchment ID: Lot3-Culvert 100yr

I. Catchment Hydrologic Data

Catchment ID = Lot 3
 Area = 4.86 Acres
 Percent Imperviousness = 57.00 %
 NRCS Soil Type = B A, B, C, or D

II. Rainfall Information $I (\text{inch/hr}) = C1 * P1 / (C2 + Td)^{C3}$

Design Storm Return Period, $T_r =$ 100 years (input return period for design storm)
 $C1 =$ 28.50 (input the value of C1)
 $C2 =$ 10.00 (input the value of C2)
 $C3 =$ 0.786 (input the value of C3)
 $P1 =$ 2.57 inches (input one-hr precipitation--see Sheet "Design Info")

III. Analysis of Flow Time (Time of Concentration) for a Catchment

Runoff Coefficient, $C =$ 0.55
 Override Runoff Coefficient, $C =$ _____ (enter an override C value if desired, or leave blank to accept calculated C.)
 5-yr. Runoff Coefficient, $C-5 =$ 0.39
 Override 5-yr. Runoff Coefficient, $C =$ _____ (enter an override C-5 value if desired, or leave blank to accept calculated C-5.)

Illustration

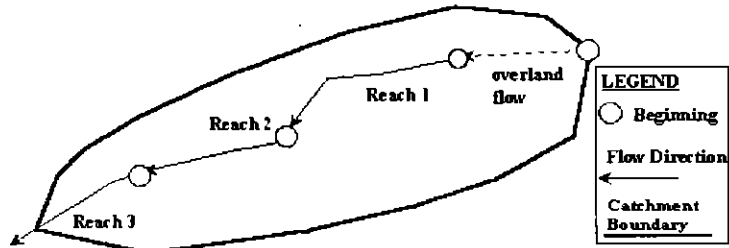

NRCS Land Type	Heavy Meadow	Tillage/Field	Short Pasture/Lawns	Nearly Bare Ground	Grassed Swales/Waterways	Paved Areas & Shallow Paved Swales (Sheet Flow)
Conveyance	2.5	5	7	10	15	20

Calculations:

Reach ID	Slope S	Length L	5-yr Runoff Coeff C-5	NRCS Conveyance	Flow Velocity V	Flow Time T _f
	f/ft input	ft input	output	input	fps output	minutes output
Overland	0.0300	300	0.39	N/A	0.32	15.41
1	0.0100	500		10.00	1.00	8.33
2						
3						
4						
5						
Sum		800				

Computed T_c = 23.74
 Regional T_c = 14.44
 User-Entered T_c = 14.44

IV. Peak Runoff Prediction

Rainfall Intensity at Computed T_c, $I =$ 4.61 inch/hr
 Rainfall Intensity at Regional T_c, $I =$ 5.94 inch/hr
 Rainfall Intensity at User-Defined T_c, $I =$ 5.94 inch/hr

Peak Flowrate, $Q_p =$ 12.34 cfs
 Peak Flowrate, $Q_p =$ 15.90 cfs
 Peak Flowrate, $Q_p =$ 15.90 cfs

Page Missing or Blank
on EDARP

DETENTION BASIN STAGE-STORAGE TABLE BUILDER

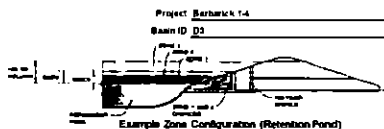

Required Volume Calculation

Selected BMP Type	BF
Watershed Area	3.13 acres
Watershed Length	648 ft
Watershed Slope	0.030 ft/ft
Watershed Imperviousness	57.00% percent
Percentage Hydrologic Soil Group A	5.0% percent
Percentage Hydrologic Soil Group B	95.0% percent
Percentage Hydrologic Soil Group C/D	0.0% percent
Desired WQCV Drain Time	12.0 hours
Location for 1-yr Rainfall Depth	Lower Input
Water Quality Capture Volume (WQCV)	0.047 acre-feet
Excess Urban Runoff Volume (EURV)	0.194 acre-feet
2-yr Runoff Volume (P1 = 0.95 in.)	0.128 acre-feet
5-yr Runoff Volume (P1 = 1.23 in.)	0.194 acre-feet
10-yr Runoff Volume (P1 = 1.48 in.)	0.253 acre-feet
25-yr Runoff Volume (P1 = 1.88 in.)	0.363 acre-feet
50-yr Runoff Volume (P1 = 2.21 in.)	0.452 acre-feet
100-yr Runoff Volume (P1 = 2.57 in.)	0.554 acre-feet
500-yr Runoff Volume (P1 = 0 in.)	0.000 acre-feet
Approximate 2-yr Detention Volume	0.122 acre-feet
Approximate 5-yr Detention Volume	0.178 acre-feet
Approximate 10-yr Detention Volume	0.204 acre-feet
Approximate 25-yr Detention Volume	0.237 acre-feet
Approximate 50-yr Detention Volume	0.273 acre-feet
Approximate 100-yr Detention Volume	0.338 acre-feet

Stage-Storage Calculation

Zone 1 Volume (WQCV)	0.047 acre-feet
Zone 2 Volume (100-yr - Zone 1)	0.289 acre-feet
Select Zone 3 Storage Volume (Optional)	0.000 acre-feet
Total Detention Basin Volume	0.336 acre-feet
Initial Surge Volume (SV)	NA ft ³
Initial Surge Depth (ISD)	NA ft
Total Available Detention Depth (H _{av})	2.50 ft
Depth of Trickle Channel (H _{tc})	NA ft
Slope of Trickle Channel (S _{tc})	NA ft/ft
Steps of Main Basin Sides (S _{ms})	0 ft
Basin Length-to-Width Ratio (R _{bw})	1.5 ft
Initial Surge Area (A _{sv})	0 ft ²
Surcharge Volume Length (V _{sl})	0.0 ft
Surcharge Volume Width (V _{sw})	0.0 ft
Depth of Basin Floor (V _{df})	0.0 ft
Length of Basin Floor (V _{lf})	81.0 ft
Width of Basin Floor (V _{wf})	94.0 ft
Area of Basin Floor (V _{af})	4370 ft ²
Volume of Basin Floor (V _{vf})	0 ft ³
Depth of Main Basin (V _{dm})	2.50 ft
Length of Main Basin (V _{lm})	101.0 ft
Width of Main Basin (V _{wm})	74.0 ft
Area of Main Basin (V _{am})	7488 ft ²
Volume of Main Basin (V _{vm})	14826 ft ³
Calculated Total Basin Volume (V _{tb})	0.336 acre-feet

Depth Increment	0.1	0.2	0.3	0.4	0.5	0.6	0.7	0.8	0.9	1.0	1.1	1.2	1.3	1.4	1.5	1.6	1.7	1.8	1.9	2.0	2.1	2.2	2.3	2.4	2.5
Stage - Storage Description	Stage (ft)	Optional Overflow Stage (ft)	Length (ft)	Width (ft)	Area (ft ²)	Optional Overflow Area (ft ²)	Area (acres)	Volume (ft ³)	Volume (ac-ft)																
Media Surface	0.00		81.0	94.0	4370		0.103																		
	0.10		81.8	94.8	4478		0.103	442	0.010																
	0.20		82.5	95.5	4577		0.105	850	0.020																
	0.30		83.3	96.3	4688		0.108	1313	0.030																
	0.40		84.1	97.1	4801		0.110	1788	0.041																
Zone 1 (WQCV)	0.45		84.6	97.6	4889		0.112	2078	0.048																
	0.50		84.9	97.9	4914		0.113	2273	0.052																
	0.60		85.7	98.7	5029		0.115	2770	0.064																
	0.70		86.5	99.5	5145		0.118	3279	0.075																
	0.80		87.3	100.3	5263		0.121	3800	0.087																
	0.90		88.1	101.1	5381		0.124	4332	0.099																
	1.00		88.9	101.9	5501		0.126	4876	0.112																
	1.10		89.7	102.7	5622		0.129	5432	0.125																
	1.20		90.5	103.5	5745		0.132	6000	0.138																
	1.30		91.3	104.3	5869		0.135	6581	0.151																
	1.40		92.1	105.1	5994		0.138	7174	0.165																
	1.50		92.9	105.9	6120		0.141	7780	0.179																
	1.60		93.7	106.7	6248		0.143	8398	0.193																
	1.70		94.5	107.5	6377		0.146	9030	0.207																
	1.80		95.3	108.3	6507		0.149	9674	0.222																
	1.90		96.1	109.1	6639		0.152	10331	0.237																
	2.00		96.9	109.9	6771		0.155	11001	0.253																
	2.10		97.7	110.7	6904		0.158	11784	0.270																
	2.20		98.5	111.5	7038		0.162	12583	0.286																
	2.30		99.4	112.4	7171		0.165	13400	0.303																
	2.40		100.2	113.2	7305		0.168	14234	0.319																
Zone 2 (100-yr)	2.50		101.0	114.0	7440		0.171	14831	0.336																
	2.60		101.8	114.8	7576		0.175	15385	0.353																
	2.70		102.6	115.6	7713		0.178	16053	0.371																
	2.80		103.4	116.4	7854		0.181	16835	0.388																
	2.90		104.2	117.2	8000		0.185	17732	0.407																
	3.00		105.0	118.0	8154		0.188	18643	0.426																
	3.10		105.8	118.8	8313		0.191	19569	0.445																
	3.20		106.6	119.6	8480		0.195	20509	0.464																
	3.30		107.4	120.4	8652		0.198	21465	0.484																
	3.40		108.2	121.2	8829		0.202	22436	0.504																
	3.50		109.0	122.0	9012		0.205	23421	0.524																
	3.60		109.8	122.8	9200		0.209	24421	0.545																
	3.70		110.6	123.6	9394		0.212	25436	0.566																
	3.80		111.4	124.4	9594		0.216	26466	0.587																
	3.90		112.2	125.2	9800		0.219	27511	0.608																
	4.00		113.0	126.0	9912		0.223	27480	0.631																
	4.10		113.8	126.8	10030		0.227	28480	0.653																
	4.20		114.6	127.6	10154		0.230	29505	0.676																
	4.30		115.4	128.4	10284		0.234	30495	0.699																
	4.40		116.2	129.2	10420		0.238	31494	0.723																
	4.50		117.0	130.0	10562		0.242	32536	0.747																
	4.60		117.8	130.8	10710		0.245	33589	0.771																
	4.70		118.6	131.6	10864		0.249	34676	0.795																
	4.80		119.4	132.4	11024		0.253	35770	0.821																
	4.90		120.2	133.2	11190		0.257	36881	0.847																
	5.00		121.0	134.0	11362		0.261	38009	0.873																
	5.10		121.8	134.8	11540		0.265	39155	0.899																
	5.20		122.6	135.6	11714		0.269	40317	0.926																
	5.30		123.4	136.4	11896		0.273	41495	0.953																
	5.40		124.2	137.2	12076		0.277	42689	0.980																
	5.50		125.0	138.0	12262		0.281	43899	1.008																
	5.60		125.8	138.8	12454		0.285	45114	1.036																
	5.70		126.6	139.6	12652		0.289	46345	1.065																
	5.80		127.4	140.4	12854		0.293	47594	1.094																
	5.90		128.2	141.2	13062		0.298	48860	1.124																
	6.00		129.0	142.0	13276		0.302	50142	1.154																
	6.10		129.8	142.8	13496		0.306	51441	1.184																
	6.20		130.6	143.6	13722		0.310	52757	1.215																
	6.30		131.4	144.4	13954		0.315	54089	1.246																
	6.40		132.2	145.2	14192		0.319	55437	1.278																
	6.50		133.0	146.0	14436		0.323	57000	1.310																
	6.60		133.8	146.8	14686		0.328	58499	1.343																
	6.70		134.6	147.6	14942		0.332	59933	1.376																
	6.80		135.4	148.4	15204		0.337	61403	1.409																
	6.90		136.2	149.2	15472		0.341	62917	1.443																
	7.00		137.0	150.0	15746		0.346	64465	1.477																
	7.10		137.8	150.8	16026		0.350	66047	1.511																
	7.20		138.6	151.6	16312		0.355	67663	1.547																
	7.30		139.4	152.4	16604		0.360	69313	1.583																
	7.40		140.2	153.2	16902		0.364	70997	1.619																
	7.50		141.0	154.0	17206		0.369	72714	1.656																
	7.60		141.8	154.8	17516		0.374	74464	1.693																
	7.70		142.6	155.6	17832		0.378	76247	1.731																
	7.80		143.4	156.4	18154		0.383	78063	1.769																
	7.90		144.2	157.2	18482		0.388	79913	1.807																
	8.00		145.0	158.0	18816		0.393	81797	1.846																
	8.10		145.8	158.8	19156		0.397	83715	1.885																
	8.20		146.6	159.6	19502		0.402	85667	1.924																
	8.30		147.4	160.4	19854		0.407	87653	1.964																
	8.40		148.2	161.2	20212		0.412	89673	2.004																
	8.50		149.0	162.0	20576		0.417	91727	2.044																
	8.60		149.8	162.8	20946		0.422	93805	2.084																
	8.70		150.6	163.6	21322		0.427	95907	2.124																
	8.80		151.4	164.4	21704		0.432	98033	2.176																
	8.90		152.2	165.2	22092		0.437	100183	2.220																
	9.00		153.0	166.0	22486		0.442	102357	2.264																
	9.10		153.8	166.8	22886		0.447	104555	2.308																
	9.20		154.6	167.6	23292		0.453	106777	2.353																
	9.30		155.4	168.4	23704		0.458	109023	2.399																
	9.40		156.2	169.2	24122		0.463	111293	2.445																
	9.50		157.0	170.0	24546		0.469	113587	2.491																
	9.60		157.8	170.8	24976		0.474	115905	2.538																
	9.70		158.6	171.6	25412		0.479	118247	2.586																

Detention Basin Outlet Structure Design

Project: **Barbarick Subdivision**
 Basin ID: **D3**

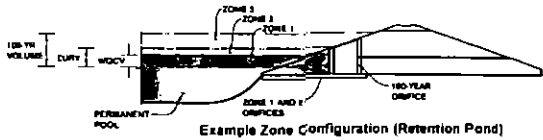

	Stage (ft)	Zone Volume (ac-ft)	Outlet Type
Zone 1 (WQCV)	0.45	0.047	Filtration Media
Zone 2 (100-year)	2.50	0.289	Not Utilized
Zone 3			
		0.336	Total

User Input: Orifice at Underdrain Outlet (typically used to drain WQCV in a Filtration BMP)

Underdrain Orifice Invert Depth =	1.00	ft (distance below the filtration media surface)
Underdrain Orifice Diameter =	1.27	inches

Calculated Parameters for Underdrain

Underdrain Orifice Area =	0.0	ft ²
Underdrain Orifice Centroid =	0.05	feet

User Input: Orifice Plate with one or more orifices of Elliptical Slot Weir (typically used to drain WQCV and/or EURV in a sedimentation BMP)

Invert of Lowest Orifice =	N/A	ft (relative to basin bottom at Stage = 0 ft)
Depth at top of Zone using Orifice Plate =	N/A	ft (relative to basin bottom at Stage = 0 ft)
Orifice Plate Orifice Vertical Spacing =	N/A	inches
Orifice Plate Orifice Area per Row =	N/A	inches

Calculated Parameters for Plate

WQ Orifice Area per Row =	N/A	ft ²
Elliptical Half-Width =	N/A	feet
Elliptical Slot Centroid =	N/A	feet
Elliptical Slot Area =	N/A	ft ²

User Input: Stage and Total Area of Each Orifice Row (numbered from lowest to highest)

	Row 1 (optional)	Row 2 (optional)	Row 3 (optional)	Row 4 (optional)	Row 5 (optional)	Row 6 (optional)	Row 7 (optional)	Row 8 (optional)
Stage of Orifice Centroid (ft)	N/A	N/A	N/A	N/A	N/A	N/A	N/A	N/A
Orifice Area (sq inches)	N/A	N/A	N/A	N/A	N/A	N/A	N/A	N/A

	Row 9 (optional)	Row 10 (optional)	Row 11 (optional)	Row 12 (optional)	Row 13 (optional)	Row 14 (optional)	Row 15 (optional)	Row 16 (optional)
Stage of Orifice Centroid (ft)	N/A	N/A	N/A	N/A	N/A	N/A	N/A	N/A
Orifice Area (sq inches)	N/A	N/A	N/A	N/A	N/A	N/A	N/A	N/A

User Input: Vertical Orifice (Circular or Rectangular)

	Not Selected	Not Selected	
Invert of Vertical Orifice =			ft (relative to basin bottom at Stage = 0 ft)
Depth at top of Zone using Vertical Orifice =			ft (relative to basin bottom at Stage = 0 ft)
Vertical Orifice Diameter =			inches

Calculated Parameters for Vertical Orifice

	Not Selected	Not Selected	
Vertical Orifice Area =			ft ²
Vertical Orifice Centroid =			feet

User Input: Overflow Weir (Dropbox) and Grate (Flat or Sloped)

	Not Selected	Not Selected	
Overflow Weir Front Edge Height, H _o =			ft (relative to basin bottom at Stage = 0 ft)
Overflow Weir Front Edge Length =			feet
Overflow Weir Slope =			H/V (enter zero for flat grate)
Horiz. Length of Weir Sides =			feet
Overflow Grate Open Area % =			% grate open area/total area
Debris Clogging % =			%

Calculated Parameters for Overflow Weir

	Not Selected	Not Selected	
Height of Grate Upper Edge, H ₁ =			feet
Over Flow Weir Slope Length =			feet
Grate Open Area / 100-yr Orifice Area =			should be ≥ 4
Overflow Grate Open Area w/o Debris =			ft ²
Overflow Grate Open Area w/ Debris =			ft ²

User Input: Outlet Pipe w/ Flow Restriction Plate (Circular Orifice, Restrictor Plate, or Rectangular Orifice)

	Not Selected	Not Selected	
Depth to Invert of Outlet Pipe =			ft (distance below basin bottom at Stage = 0 ft)
Circular Orifice Diameter =			inches

Calculated Parameters for Outlet Pipe w/ Flow Restriction Plate

	Not Selected	Not Selected	
Outlet Orifice Area =			ft ²
Outlet Orifice Centroid =			feet
Half-Central Angle of Restrictor Plate on Pipe =	N/A	N/A	radians

User Input: Emergency Spillway (Rectangular or Trapezoidal)

Spillway Invert Stage =	2.50	ft (relative to basin bottom at Stage = 0 ft)
Spillway Crest Length =	5.00	feet
Spillway End Slopes =	4.00	H/V
Freeboard above Max Water Surface =	1.00	feet

Calculated Parameters for Spillway

Spillway Design Flow Depth =	0.66	feet
Stage at Top of Freeboard =	4.16	feet
Basin Area at Top of Freeboard =	0.23	acres

Routed Hydrograph Results

	WQCV	EURV	2 Year	5 Year	10 Year	25 Year	50 Year	100 Year	500 Year
Design Storm Return Period =	0.53	1.07	0.95	1.23	1.48	1.88	2.21	2.57	0.00
One-Hour Rainfall Depth (in) =	0.047	0.194	0.128	0.194	0.253	0.363	0.452	0.554	0.000
OPTIONAL Override Runoff Volume (acre-ft) =									
Inflow Hydrograph Volume (acre-ft) =	0.047	0.194	0.127	0.194	0.253	0.363	0.451	0.553	#N/A
Predevelopment Unit Peak Flow, q (cfs/acre) =	0.00	0.00	0.01	0.17	0.34	0.80	1.04	1.33	1.89
Predevelopment Peak Q (cfs) =	0.0	0.0	0.0	0.5	1.1	2.5	3.2	4.2	5.9
Peak Inflow Q (cfs) =	1.0	4.1	2.7	4.1	5.3	7.6	9.4	11.6	#N/A
Peak Outflow Q (cfs) =	0.0	0.1	0.1	0.1	0.1	0.2	1.7	3.6	#N/A
Ratio Peak Outflow to Predevelopment Q =	N/A	N/A	N/A	0.1	0.1	0.1	0.5	0.9	#N/A
Structure Controlling Flow =	Filtration Media	Filtration Media	Filtration Media	Filtration Media	Filtration Media	Spillway	Spillway	Spillway	#N/A
Max Velocity through Grate 1 (fps) =	N/A	N/A	N/A	N/A	N/A	N/A	N/A	N/A	#N/A
Max Velocity through Grate 2 (fps) =	N/A	N/A	N/A	N/A	N/A	N/A	N/A	N/A	#N/A
Time to Drain 97% of Inflow Volume (hours) =	12	41	29	41	51	66	65	65	#N/A
Time to Drain 99% of Inflow Volume (hours) =	13	42	30	42	52	68	68	68	#N/A
Maximum Ponding Depth (ft) =	0.37	1.52	1.04	1.52	1.91	2.55	2.71	2.83	#N/A
Area at Maximum Ponding Depth (acres) =	0.11	0.14	0.13	0.14	0.15	0.17	0.18	0.18	#N/A
Maximum Volume Stored (acre-ft) =	0.039	0.181	0.117	0.181	0.240	0.343	0.371	0.394	#N/A

Page Missing or Blank
on EDARP

APPENDIX B

STORMCAD INFORMATION

Culvert Calculator Report Twin 24" Culvert

Solve For: Headwater Elevation

Culvert Summary			
Allowable HW Elevation	2.00 ft	Headwater Depth/Height	1.32
Computed Headwater Elev.	7,038.15 ft	Discharge	35.50 cfs
Inlet Control HW Elev.	7,038.10 ft	Tailwater Elevation	0.00 ft
Outlet Control HW Elev.	7,038.15 ft	Control Type	Entrance Control
Grades			
Upstream Invert	7,035.51 ft	Downstream Invert	7,020.00 ft
Length	606.00 ft	Constructed Slope	0.025594 ft/ft
Hydraulic Profile			
Profile	S2	Depth, Downstream	0.94 ft
Slope Type	Steep	Normal Depth	0.94 ft
Flow Regime	Supercritical	Critical Depth	1.52 ft
Velocity Downstream	12.17 ft/s	Critical Slope	0.006140 ft/ft
Section			
Section Shape	Circular	Mannings Coefficient	0.012
Section Material	Concrete	Span	2.00 ft
Section Size	24 inch	Rise	2.00 ft
Number Sections	2		
Outlet Control Properties			
Outlet Control HW Elev.	7,038.15 ft	Upstream Velocity Head	0.75 ft
Ke	0.50	Entrance Loss	0.37 ft
Inlet Control Properties			
Inlet Control HW Elev.	7,038.10 ft	Flow Control	Transition
Inlet Type	Square edge w/headwall	Area Full	6.3 ft ²
K	0.00980	HDS 5 Chart	1
M	2.00000	HDS 5 Scale	1
C	0.03980	Equation Form	1
Y	0.67000		

Culvert Calculator Report Outlet Pipe

Solve For: Discharge

Culvert Summary			
Allowable HW Elevation	7,023.10 ft	Headwater Depth/Height	2.07
Computed Headwater Elev.	7,023.10 ft	Discharge	55.60 cfs
Inlet Control HW Elev.	7,023.10 ft	Tailwater Elevation	0.00 ft
Outlet Control HW Elev.	7,022.97 ft	Control Type	Inlet Control
Grades			
Upstream Invert	7,017.92 ft	Downstream Invert	7,017.52 ft
Length	40.00 ft	Constructed Slope	0.010000 ft/ft
Hydraulic Profile			
Profile	CompositeM2PressureProfile	Depth, Downstream	2.36 ft
Slope Type	Mild	Normal Depth	N/A ft
Flow Regime	Subcritical	Critical Depth	2.36 ft
Velocity Downstream	11.58 ft/s	Critical Slope	0.013538 ft/ft
Section			
Section Shape	Circular	Mannings Coefficient	0.012
Section Material	Concrete	Span	2.50 ft
Section Size	30 inch	Rise	2.50 ft
Number Sections	1		
Outlet Control Properties			
Outlet Control HW Elev.	7,022.97 ft	Upstream Velocity Head	1.99 ft
Ke	0.20	Entrance Loss	0.40 ft
Inlet Control Properties			
Inlet Control HW Elev.	7,023.10 ft	Flow Control	Submerged
Inlet Type	Beveled ring, 33.7° bevels	Area Full	4.9 ft ²
K	0.00180	HDS 5 Chart	3
M	2.50000	HDS 5 Scale	B
C	0.02430	Equation Form	1
Y	0.83000		

O2-Overflow Channel

Project Description

Friction Method Manning Formula
Solve For Discharge

Input Data

Roughness Coefficient	0.050	
Channel Slope	0.02000	ft/ft
Normal Depth	2.00	ft
Left Side Slope	3.00	ft/ft (H:V)
Right Side Slope	3.00	ft/ft (H:V)
Bottom Width	4.00	ft

Results

Discharge	94.99	ft ³ /s
Flow Area	20.00	ft ²
Wetted Perimeter	16.65	ft
Hydraulic Radius	1.20	ft
Top Width	16.00	ft
Critical Depth	1.73	ft
Critical Slope	0.03707	ft/ft
Velocity	4.75	ft/s
Velocity Head	0.35	ft
Specific Energy	2.35	ft
Froude Number	0.75	
Flow Type	Subcritical	

GVF Input Data

Downstream Depth	0.00	ft
Length	0.00	ft
Number Of Steps	0	

GVF Output Data

Upstream Depth	0.00	ft
Profile Description		
Profile Headloss	0.00	ft
Downstream Velocity	Infinity	ft/s
Upstream Velocity	Infinity	ft/s
Normal Depth	2.00	ft
Critical Depth	1.73	ft
Channel Slope	0.02000	ft/ft

O2-Overflow Channel

GVF Output Data

Critical Slope

0.03707 ft/ft

Worksheet for Open Channel Culvert Lot 3

Project Description

Friction Method Manning Formula
Solve For Normal Depth

Input Data

Roughness Coefficient	0.012	
Channel Slope	0.03000	ft/ft
Diameter	1.50	ft
Discharge	15.90	ft ³ /s

Results

Normal Depth	1.02	ft
Flow Area	1.28	ft ²
Wetted Perimeter	2.91	ft
Hydraulic Radius	0.44	ft
Top Width	1.40	ft
Critical Depth	1.42	ft
Percent Full	68.1	%
Critical Slope	0.01690	ft/ft
Velocity	12.41	ft/s
Velocity Head	2.39	ft
Specific Energy	3.41	ft
Froude Number	2.29	
Maximum Discharge	21.20	ft ³ /s
Discharge Full	19.71	ft ³ /s
Slope Full	0.01952	ft/ft
Flow Type	SuperCritical	

GVF Input Data

Downstream Depth	0.00	ft
Length	0.00	ft
Number Of Steps	0	

GVF Output Data

Upstream Depth	0.00	ft
Profile Description		
Profile Headloss	0.00	ft
Average End Depth Over Rise	0.00	%
Normal Depth Over Rise	68.08	%
Downstream Velocity	Infinity	ft/s

Worksheet for Open Channel Culvert Lot 3

GVF Output Data

Upstream Velocity	Infinity	ft/s
Normal Depth	1.02	ft
Critical Depth	1.42	ft
Channel Slope	0.03000	ft/ft
Critical Slope	0.01690	ft/ft

Worksheet for Outlet with Passthrough-Weir

Project Description

Solve For Discharge

Input Data

Headwater Elevation	1.40	ft
Crest Elevation	0.00	ft
Tailwater Elevation	0.00	ft
Weir Coefficient	3.00	US
Crest Length	32.00	ft
Number Of Contractions	0	

Results

Discharge	159.02	ft ³ /s
Headwater Height Above Crest	1.40	ft
Tailwater Height Above Crest	0.00	ft
Flow Area	44.80	ft ²
Velocity	3.55	ft/s
Wetted Perimeter	34.80	ft
Top Width	32.00	ft

Weir is more restrictive than Orifice.
159.02 cfs
70% Gate Opening
50% Closing
= 55.66 cfs > 45.9 tributary
→ Install orifice Restrictor on outlet pipe.

Worksheet for Type D Inlet - Weir

Project Description

Solve For Discharge

Input Data

Headwater Elevation	1.50	ft
Crest Elevation	0.00	ft
Weir Coefficient	3.00	US
Crest Length	17.17	ft

Results

Discharge	94.61	ft ³ /s
Headwater Height Above Crest	1.50	ft
Flow Area	25.75	ft ²
Velocity	3.67	ft/s
Wetted Perimeter	20.17	ft
Top Width	17.17	ft

Type D Weir is most restrictive

94.61 cfs

70% Grate Opening

50% Clogging

= 33.11 cfs > 29.4 cfs tributary

Worksheet for Type D Inlet - Orifice

Project Description

Solve For Discharge

Input Data

Headwater Elevation	1.50	ft
Centroid Elevation	0.00	ft
Tailwater Elevation	0.00	ft
Discharge Coefficient	0.60	
Opening Width	2.92	ft
Opening Height	5.67	ft

Results

Discharge	97.50	ft ³ /s
Headwater Height Above Centroid	1.50	ft
Tailwater Height Above Centroid	0.00	ft
Flow Area	16.54	ft ²
Velocity	5.89	ft/s

*Type Δ Weir is more restrictive
→ Use Weir Calculations*

Worksheet for Western Channel Capacity

Project Description

Friction Method Manning Formula
Solve For Discharge

Input Data

Roughness Coefficient	0.030
Channel Slope	0.02000 ft/ft
Normal Depth	1.00 ft
Left Side Slope	4.00 ft/ft (H:V)
Right Side Slope	4.00 ft/ft (H:V)

Results

Discharge	17.30 ft ³ /s
Flow Area	4.00 ft ²
Wetted Perimeter	8.25 ft
Hydraulic Radius	0.49 ft
Top Width	8.00 ft
Critical Depth	1.03 ft
Critical Slope	0.01703 ft/ft
Velocity	4.32 ft/s
Velocity Head	0.29 ft
Specific Energy	1.29 ft
Froude Number	1.08
Flow Type	Supercritical

GVF Input Data

Downstream Depth	0.00 ft
Length	0.00 ft
Number Of Steps	0

GVF Output Data

Upstream Depth	0.00 ft
Profile Description	
Profile Headloss	0.00 ft
Downstream Velocity	Infinity ft/s
Upstream Velocity	Infinity ft/s
Normal Depth	1.00 ft
Critical Depth	1.03 ft
Channel Slope	0.02000 ft/ft
Critical Slope	0.01703 ft/ft

Page Missing or Blank
on EDARP

Label	Start Node	Stop Node	Branch ID	Branch Element ID	Length (Unified) (ft)	Upstream Inlet C	Upstream Intensity (in/h)	Upstream Inlet Area (acres)	System Intensity (in/h)
CO-1	CB-1	MH-1	1	1	255.4 (N/A)		8 (N/A)		8
CO-2	MH-1	MH-2	1	2	295.1 (N/A)		8 (N/A)		8
CO-3	MH-2	MH-3	1	3	295.1 (N/A)		8 (N/A)		8
CO-4	MH-3	MH-4	1	4	44.9 (N/A)		8 (N/A)		8
CO-5	MH-4	OF-1	1	5	198.3 (N/A)		8 (N/A)		8

	System		Rise	Capacity (Full	Velocity	Invert	Invert	
	Rational Flow	Total Flow	(Unified)	Flow) (ft ³ /s)	(Average)	(Upstream	(Downstream	Slope (ft/ft)
	(ft ³ /s)	(ft ³ /s)	(in)		(ft/s)	m) (ft)) (ft)	
CO-1	0	29.4	30	44.49	9.68	7032.21	7029.65	0.01
CO-2	0	29.4	30	44.43	9.67	7029.35	7026.4	0.01
CO-3	0	29.4	30	38.97	8.72	7026.2	7023.93	0.008
CO-4	0	29.4	30	57.43	11.77	7023.63	7022.88	0.017
CO-5	0	29.4	30	44.4	9.67	7022.88	7020.9	0.01

APPENDIX C

STANDARD DESIGN CHARTS AND TABLES



NOAA Atlas 14, Volume 8, Version 2
Location name: Colorado Springs, Colorado, US*
Latitude: 38.9514°, Longitude: -104.6905°
Elevation: 6984 ft*
 * source: Google Maps



POINT PRECIPITATION FREQUENCY ESTIMATES

Sanja Penca, Deborah Martin, Sandra Pavlovic, Ishani Roy, Michael St. Laurent, Carl Trypaluk,
 Date Unruh, Michael Yekta, Geoffrey Bonnin

NOAA, National Weather Service, Silver Spring, Maryland

[PF tabular](#) | [PF graphical](#) | [Maps & aerals](#)

PF tabular

PDS-based point precipitation frequency estimates with 90% confidence intervals (in inches)¹										
Duration	Average recurrence interval (years)									
	1	2	5	10	25	50	100	200	500	1000
5-min	0.237 (0.195-0.290)	0.289 (0.238-0.355)	0.380 (0.311-0.467)	0.460 (0.374-0.568)	0.577 (0.456-0.746)	0.674 (0.517-0.880)	0.775 (0.573-1.04)	0.883 (0.625-1.21)	1.03 (0.701-1.46)	1.15 (0.759-1.65)
10-min	0.347 (0.285-0.425)	0.424 (0.348-0.520)	0.556 (0.455-0.684)	0.673 (0.548-0.832)	0.846 (0.667-1.09)	0.987 (0.757-1.29)	1.14 (0.839-1.52)	1.29 (0.914-1.78)	1.51 (1.03-2.14)	1.69 (1.11-2.41)
15-min	0.423 (0.348-0.519)	0.516 (0.424-0.634)	0.678 (0.555-0.834)	0.821 (0.668-1.01)	1.03 (0.814-1.33)	1.20 (0.924-1.57)	1.38 (1.02-1.85)	1.58 (1.11-2.17)	1.84 (1.25-2.61)	2.06 (1.35-2.94)
30-min	0.613 (0.504-0.751)	0.747 (0.614-0.917)	0.980 (0.802-1.21)	1.19 (0.965-1.47)	1.49 (1.17-1.92)	1.74 (1.33-2.27)	2.00 (1.48-2.67)	2.27 (1.61-3.13)	2.66 (1.80-3.76)	2.97 (1.95-4.24)
60-min	0.795 (0.654-0.974)	0.948 (0.779-1.16)	1.23 (1.00-1.51)	1.48 (1.21-1.83)	1.88 (1.49-2.44)	2.21 (1.70-2.90)	2.57 (1.91-3.46)	2.96 (2.10-4.09)	3.52 (2.39-4.99)	3.97 (2.61-5.67)
2-hr	0.977 (0.809-1.19)	1.15 (0.951-1.40)	1.47 (1.22-1.80)	1.78 (1.46-2.19)	2.27 (1.82-2.94)	2.68 (2.09-3.51)	3.14 (2.35-4.21)	3.65 (2.61-5.02)	4.38 (3.00-6.18)	4.98 (3.30-7.06)
3-hr	1.08 (0.897-1.31)	1.25 (1.04-1.51)	1.58 (1.31-1.93)	1.92 (1.57-2.34)	2.45 (1.98-3.19)	2.92 (2.29-3.83)	3.45 (2.60-4.62)	4.04 (2.91-5.55)	4.90 (3.39-6.92)	5.62 (3.75-7.95)
6-hr	1.26 (1.05-1.51)	1.44 (1.20-1.73)	1.81 (1.51-2.18)	2.19 (1.81-2.65)	2.81 (2.30-3.64)	3.37 (2.66-4.39)	4.00 (3.04-5.34)	4.71 (3.43-6.45)	5.77 (4.02-8.09)	6.65 (4.46-9.33)
12-hr	1.45 (1.23-1.74)	1.68 (1.41-2.00)	2.12 (1.78-2.54)	2.55 (2.13-3.07)	3.26 (2.68-4.19)	3.89 (3.10-5.03)	4.59 (3.52-6.08)	5.38 (3.94-7.31)	6.54 (4.59-9.11)	7.51 (5.08-10.5)
24-hr	1.68 (1.43-1.99)	1.97 (1.67-2.33)	2.50 (2.12-2.98)	3.01 (2.53-3.60)	3.80 (3.13-4.80)	4.48 (3.58-5.72)	5.23 (4.02-6.83)	6.04 (4.45-8.11)	7.23 (5.09-9.96)	8.20 (5.58-11.4)
2-day	1.95 (1.67-2.29)	2.31 (1.97-2.72)	2.95 (2.51-3.48)	3.53 (2.99-4.18)	4.39 (3.62-5.46)	5.11 (4.10-6.44)	5.88 (4.55-7.59)	6.71 (4.96-8.91)	7.89 (5.59-10.8)	8.83 (6.07-12.2)
3-day	2.15 (1.85-2.51)	2.54 (2.18-2.97)	3.22 (2.75-3.78)	3.83 (3.26-4.52)	4.74 (3.92-5.87)	5.50 (4.42-6.88)	6.30 (4.89-8.09)	7.16 (5.31-9.45)	8.37 (5.96-11.4)	9.34 (6.45-12.8)
4-day	2.31 (2.00-2.70)	2.72 (2.34-3.17)	3.42 (2.94-4.01)	4.06 (3.46-4.78)	5.00 (4.15-6.16)	5.78 (4.67-7.21)	6.61 (5.14-8.46)	7.50 (5.58-9.87)	8.75 (6.25-11.8)	9.76 (6.75-13.3)
7-day	2.74 (2.38-3.18)	3.17 (2.75-3.68)	3.92 (3.39-4.57)	4.60 (3.95-5.38)	5.60 (4.67-6.86)	6.43 (5.23-7.97)	7.32 (5.73-9.30)	8.27 (6.19-10.8)	9.60 (6.90-12.9)	10.7 (7.44-14.5)
10-day	3.11 (2.71-3.60)	3.58 (3.11-4.14)	4.39 (3.80-5.09)	5.11 (4.40-5.95)	6.17 (5.17-7.51)	7.05 (5.75-8.69)	7.98 (6.27-10.1)	8.97 (6.75-11.7)	10.4 (7.47-13.9)	11.5 (8.03-15.5)
20-day	4.18 (3.67-4.79)	4.79 (4.20-5.50)	5.83 (5.09-6.71)	6.72 (5.84-7.77)	7.99 (6.71-9.59)	9.01 (7.38-11.0)	10.0 (7.94-12.6)	11.1 (8.42-14.3)	12.6 (9.17-16.7)	13.8 (9.73-18.6)
30-day	5.05 (4.46-5.77)	5.80 (5.11-6.63)	7.04 (6.18-8.07)	8.08 (7.05-9.30)	9.51 (8.01-11.3)	10.6 (8.73-12.8)	11.8 (9.32-14.6)	12.9 (9.79-16.5)	14.4 (10.5-19.0)	15.6 (11.1-20.9)
45-day	6.14 (5.44-6.98)	7.06 (6.25-8.03)	8.54 (7.53-9.74)	9.75 (8.55-11.2)	11.4 (9.60-13.4)	12.6 (10.4-15.1)	13.8 (11.0-17.0)	15.0 (11.4-19.1)	16.6 (12.1-21.7)	17.7 (12.6-23.7)
60-day	7.05 (6.27-7.99)	8.12 (7.20-9.20)	9.80 (8.66-11.1)	11.1 (9.80-12.7)	12.9 (10.9-15.2)	14.2 (11.8-17.0)	15.5 (12.4-19.0)	16.7 (12.8-21.1)	18.3 (13.4-23.8)	19.4 (13.9-25.8)

¹ Precipitation frequency (PF) estimates in this table are based on frequency analysis of partial duration series (PDS). Numbers in parenthesis are PF estimates at lower and upper bounds of the 90% confidence interval. The probability that precipitation frequency estimates (for a given duration and average recurrence interval) will be greater than the upper bound (or less than the lower bound) is 5%. Estimates at upper bounds are not checked against probable maximum precipitation (PMP) estimates and may be higher than currently valid PMP values. Please refer to NOAA Atlas 14 document for more information.

[Back to Top](#)

Page Missing or Blank
on EDARP

Page Missing or Blank
on EDARP

Page Missing or Blank
on EDARP

Page Missing or Blank
on EDARP

Page Missing or Blank
on EDARP

Map Unit Legend

El Paso County Area, Colorado (CO625)			
Map Unit Symbol	Map Unit Name	Acres in AOI	Percent of AOI
9	Blakeland-Fluvaquentic Haplaquolls	12.5	76.4%
71	Pring coarse sandy loam, 3 to 8 percent slopes	3.9	23.6%
Totals for Area of Interest		16.4	100.0%

El Paso County Area, Colorado

9—Blakeland-Fluvaquentic Haplaquolls

Map Unit Setting

National map unit symbol: 36b6
Elevation: 3,500 to 5,800 feet
Mean annual precipitation: 13 to 17 inches
Mean annual air temperature: 46 to 55 degrees F
Frost-free period: 110 to 165 days
Farmland classification: Not prime farmland

Map Unit Composition

Blakeland and similar soils: 60 percent
Fluvaquentic haplaquolls and similar soils: 30 percent
Estimates are based on observations, descriptions, and transects of the mapunit.

Description of Blakeland

Setting

Landform: Flats, hills
Landform position (three-dimensional): Side slope, talf
Down-slope shape: Linear
Across-slope shape: Linear
Parent material: Sandy alluvium derived from arkose and/or eolian deposits derived from arkose

Typical profile

A - 0 to 11 inches: loamy sand
AC - 11 to 27 inches: loamy sand
C - 27 to 60 inches: sand

Properties and qualities

Slope: 1 to 9 percent
Depth to restrictive feature: More than 80 inches
Natural drainage class: Somewhat excessively drained
Runoff class: Low
Capacity of the most limiting layer to transmit water (Ksat): High to very high (5.95 to 19.98 in/hr)
Depth to water table: More than 80 inches
Frequency of flooding: None
Frequency of ponding: None
Calcium carbonate, maximum in profile: 5 percent
Available water storage in profile: Low (about 4.5 inches)

Interpretive groups

Land capability classification (irrigated): 3e
Land capability classification (nonirrigated): 6e
Hydrologic Soil Group: A
Ecological site: Sandy Foothill (R049BY210CO)

Description of Fluvaquentic Haplaquolls

Setting

Landform: Swales
Down-slope shape: Linear
Across-slope shape: Linear
Parent material: Alluvium

Typical profile

H1 - 0 to 12 inches: variable

Properties and qualities

Slope: 1 to 2 percent
Depth to restrictive feature: More than 80 inches
Natural drainage class: Poorly drained
Runoff class: Very high
Capacity of the most limiting layer to transmit water (Ksat):
Moderately high to high (0.20 to 6.00 in/hr)
Depth to water table: About 0 to 24 inches
Frequency of flooding: Occasional
Frequency of ponding: None
Salinity, maximum in profile: Nonsaline to slightly saline (0.0 to 4.0 mmhos/cm)

Interpretive groups

Land capability classification (irrigated): 6w
Land capability classification (nonirrigated): 6w
Hydrologic Soil Group: D

Minor Components

Other soils

Percent of map unit:

Pleasant

Percent of map unit:
Landform: Depressions

Data Source Information

Soil Survey Area: El Paso County Area, Colorado
Survey Area Data: Version 13, Sep 22, 2015

El Paso County Area, Colorado

71—Pring coarse sandy loam, 3 to 8 percent slopes

Map Unit Setting

National map unit symbol: 369k
Elevation: 6,800 to 7,600 feet
Farmland classification: Not prime farmland

Map Unit Composition

Pring and similar soils: 85 percent
Estimates are based on observations, descriptions, and transects of the mapunit.

Description of Pring

Setting

Landform: Hills
Landform position (three-dimensional): Side slope
Down-slope shape: Linear
Across-slope shape: Linear
Parent material: Arkosic alluvium derived from sedimentary rock

Typical profile

A - 0 to 14 inches: coarse sandy loam
C - 14 to 60 inches: gravelly sandy loam

Properties and qualities

Slope: 3 to 8 percent
Depth to restrictive feature: More than 80 inches
Natural drainage class: Well drained
Runoff class: Low
Capacity of the most limiting layer to transmit water (Ksat): High (2.00 to 6.00 in/hr)
Depth to water table: More than 80 inches
Frequency of flooding: None
Frequency of ponding: None
Available water storage in profile: Low (about 6.0 inches)

Interpretive groups

Land capability classification (irrigated): None specified
Land capability classification (nonirrigated): 3e
Hydrologic Soil Group: B
Ecological site: Loamy Park (R048AY222CO)

Minor Components

Other soils

Percent of map unit:

Pleasant

Percent of map unit:

Landform: Depressions

Data Source Information

Soil Survey Area: El Paso County Area, Colorado
Survey Area Data: Version 13, Sep 22, 2015

APPENDIX D

MAPS



Know what's below. Call before you dig.

UNPLATTEL (STERLING RANCH)

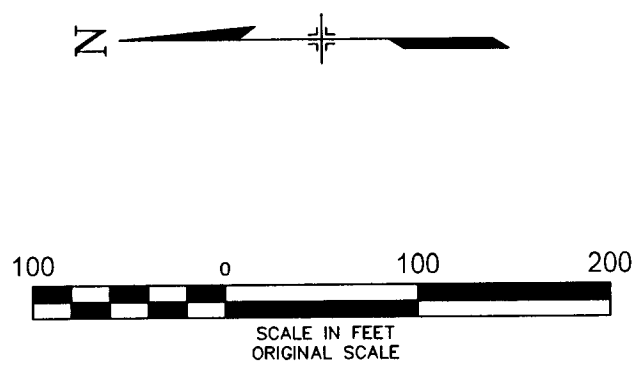
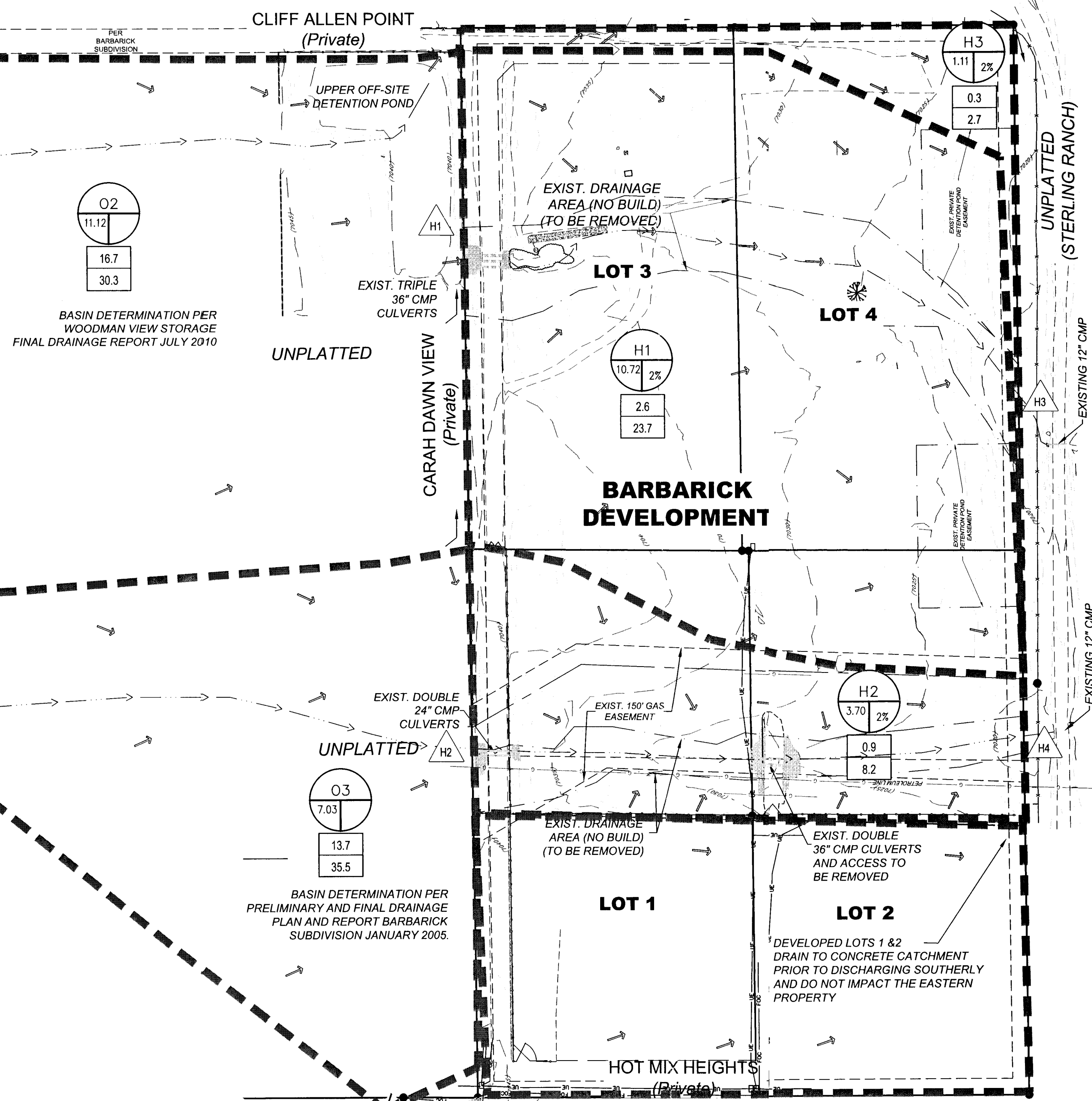

PROJECT SITE

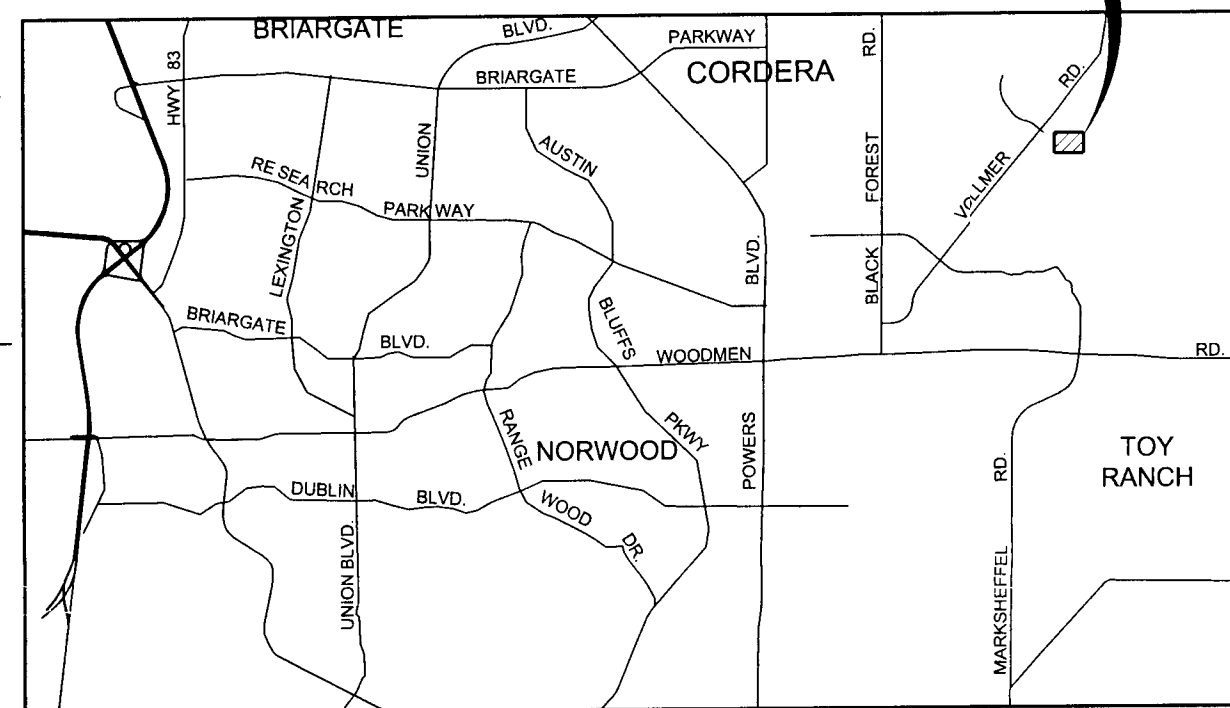

VICINITY MAP N.T.S.

LEGEND

- Legend items: SUB-BASIN BOUNDARY, EXISTING CONTOUR, PHASE 3A FILING LIMITS, TEMPORARY DIVERSION SWALE, LOT LINE, DESIGN POINT, SUB BASIN DESIGNATION, SUB BASIN PERCENT IMPERVIOUS, SUB BASIN AREA (AC.), 5-YEAR STORM EVENT PEAK FLOW (CFS), 100-YEAR STORM EVENT PEAK FLOW (CFS), PROPOSED FLOW DIRECTION, EXISTING FLOW DIRECTION.

BARBARICK DRAINAGE SUMMARY TABLE

Table with columns: BASIN, AREA (AC.), Q(5) (CFS), Q(100) (CFS), COMMENT. Includes rows for H1, H2, H3, O2, O3 and design points H1-H4.

**EXISTING CONDITIONS

Table with columns: NO., DATE, DESCRIPTION, BY. Includes a section for REVISIONS and a section for BENCHMARK DATA (ELEV.) and DATUM.

VERTICAL BENCHMARK: THE VERTICAL INFORMATION ON THIS MAP IS BASED ON THE NATIONAL GEODETIC VERTICAL DATUM OF 1929... BASIS OF BEARING: THE BASIS OF BEARINGS FOR THIS MAP IS THE NORTH LINE OF BARBARICK SUBDIVISION...

PREPARED UNDER MY DIRECT SUPERVISION, FOR AND ON BEHALF OF MATRIX DESIGN GROUP, INC.



2435 Research Parkway, Suite 300 Colorado Springs, CO 80920 Phone 719-575-0100 Fax 719-575-0208

BARBARICK SUBDIVISION LOTS 1-4

EXISTING CONDITIONS DRAINAGE PLAN

Table with columns: DESIGNED BY, DRAWN BY, CHECKED BY, SCALE, DATE ISSUED, SHEET NO. OF SHEETS, DP01.

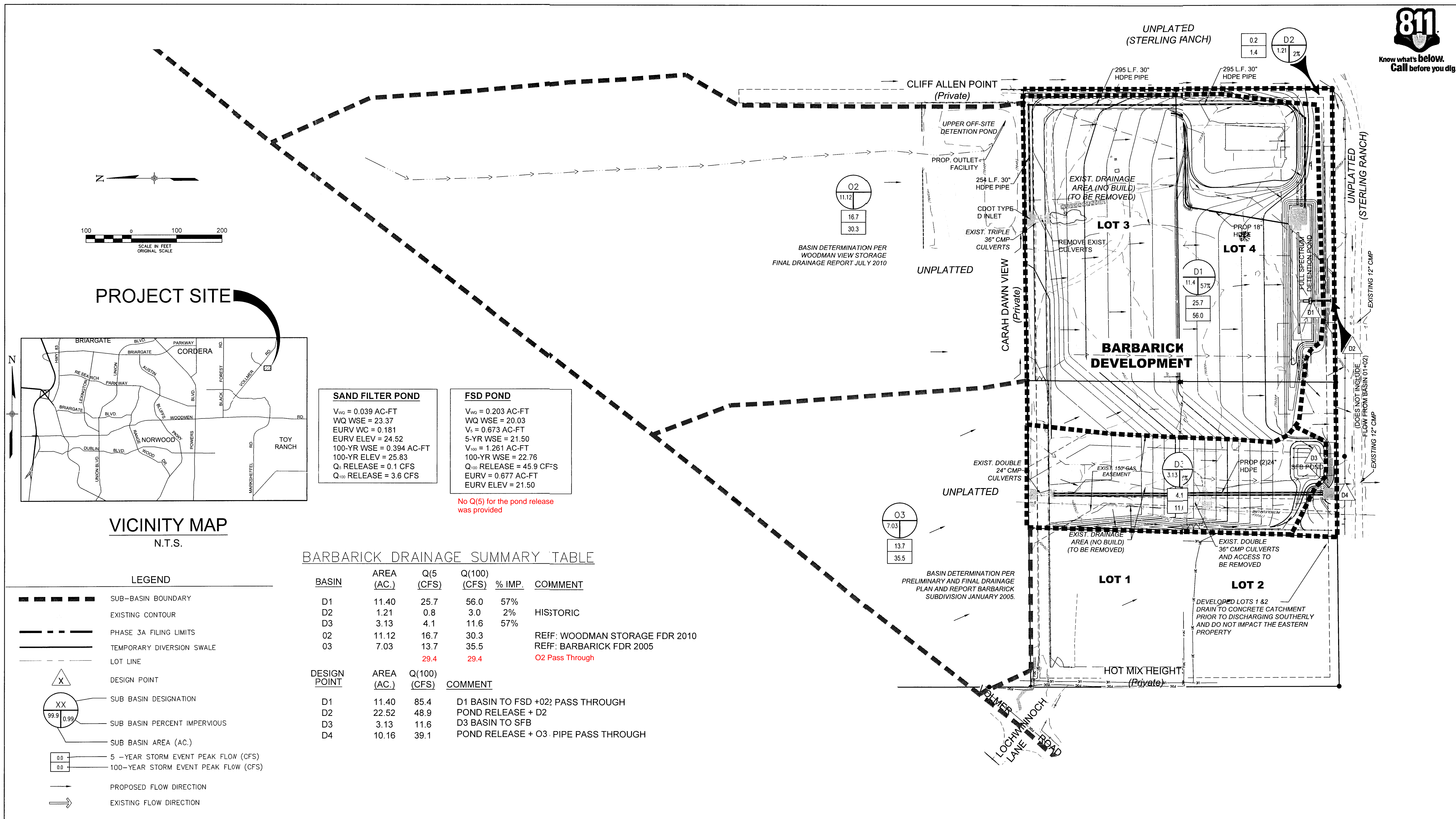

PROJECT SITE

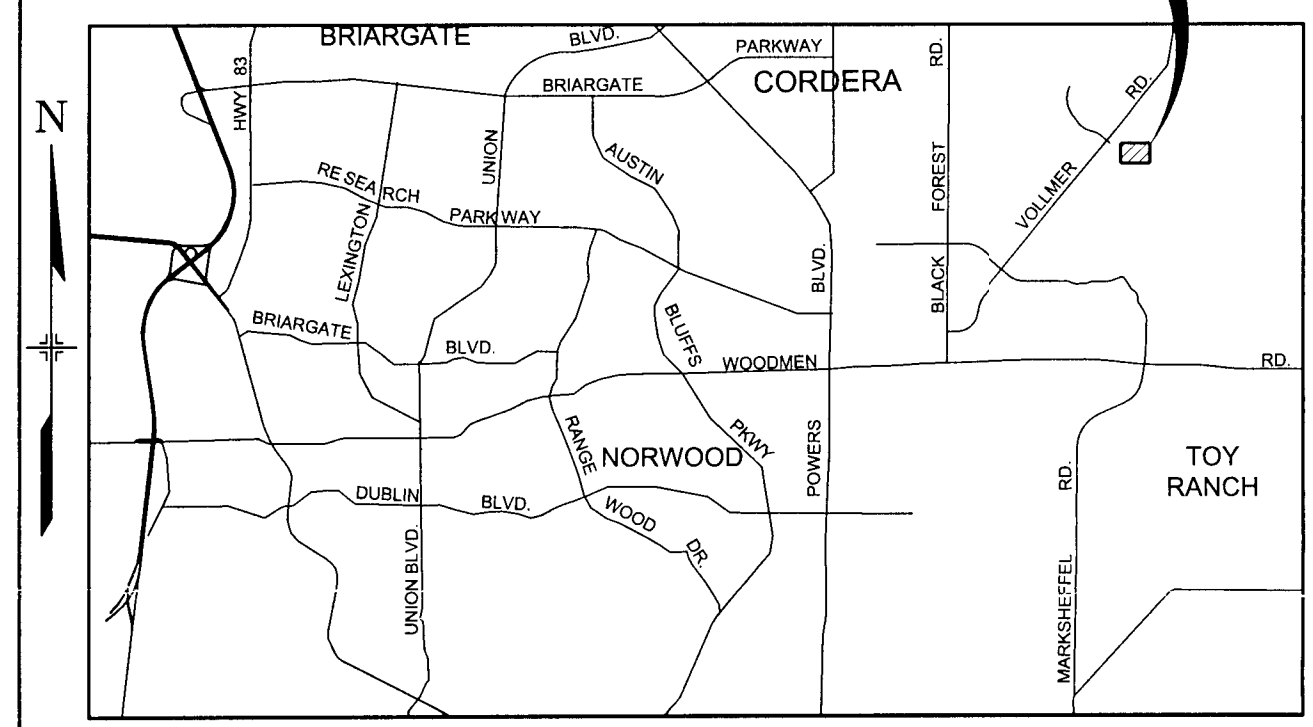

VICINITY MAP
N.T.S.

SAND FILTER POND
 $V_{100} = 0.039$ AC-FT
 WQ WSE = 23.37
 EURV WC = 0.181
 EURV ELEV = 24.52
 100-YR WSE = 0.394 AC-FT
 100-YR ELEV = 25.83
 Q_5 RELEASE = 0.1 CFS
 Q_{100} RELEASE = 3.6 CFS

FSD POND
 $V_{100} = 0.203$ AC-FT
 WQ WSE = 20.03
 $V_5 = 0.673$ AC-FT
 5-YR WSE = 21.50
 $V_{100} = 1.261$ AC-FT
 100-YR WSE = 22.76
 Q_{100} RELEASE = 45.9 CFS
 EURV = 0.677 AC-FT
 EURV ELEV = 21.50

No Q(5) for the pond release was provided

BARBARICK DRAINAGE SUMMARY TABLE

BASIN	AREA (AC.)	Q(5) (CFS)	Q(100) (CFS)	% IMP.	COMMENT
D1	11.40	25.7	56.0	57%	
D2	1.21	0.8	3.0	2%	HISTORIC
D3	3.13	4.1	11.6	57%	
O2	11.12	16.7	30.3		REF: WOODMAN STORAGE FDR 2010
O3	7.03	13.7	35.5		REF: BARBARICK FDR 2005
		29.4	29.4		O2 Pass Through

DESIGN POINT	AREA (AC.)	Q(100) (CFS)	COMMENT
D1	11.40	85.4	D1 BASIN TO FSD +O2: PASS THROUGH
D2	22.52	48.9	POND RELEASE + D2
D3	3.13	11.6	D3 BASIN TO SFB
D4	10.16	39.1	POND RELEASE + O3: PIPE PASS THROUGH

- LEGEND**
- SUB-BASIN BOUNDARY
 - EXISTING CONTOUR
 - PHASE 3A FILING LIMITS
 - TEMPORARY DIVERSION SWALE
 - LOT LINE
 - DESIGN POINT
 - SUB BASIN DESIGNATION
 - SUB BASIN PERCENT IMPERVIOUS
 - SUB BASIN AREA (AC.)
 - 5 - YEAR STORM EVENT PEAK FLOW (CFS)
 - 100-YEAR STORM EVENT PEAK FLOW (CFS)
 - PROPOSED FLOW DIRECTION
 - EXISTING FLOW DIRECTION

NO.	DATE	DESCRIPTION	BY
REVISIONS			
BENCHMARK DATA(ELEV.)			
(DATUM)			
(DESCRIPTION/LOCATION)			

VERTICAL BENCHMARK:
 THE VERTICAL INFORMATION ON THIS MAP IS BASED ON THE NATIONAL GEODETIC VERTICAL DATUM OF 1929 AND THE 1960 SUPPLEMENTARY ADJUSTMENT BEING A FOUND 3.25" ALUMINUM CAP IN A ROAD BOX DESIGNATED AS FACILITIES INFORMATION MANAGEMENT SYSTEM (FIMS) MONUMENT "T-69" AND HAVING PUBLISHED ELEVATION OF 6975.62 FEET WAS USED TO REFERENCE THIS VERTICAL DATUM. THE BENCHMARK IS LOCATED ON THE WEST SIDE OF BLACK FOREST ROAD, ABOUT 1.95 MILES SOUTH OF OLD RANCH ROAD, JUST SOUTH OF THE SCHMIDT CONSTRUCTION COMPANY DRIVEWAY. A CORNER FENCE POST IS 28.1 FEET TO THE SOUTHWEST, AND THE MOST SOUTHERLY GUARD RAIL POST IS 25.7 FEET TO THE NORTH.

BASIS OF BEARING:
 THE BASIS OF BEARINGS FOR THIS MAP IS THE NORTH LINE OF BARBARICK SUBDIVISION ACCORDING TO THE OFFICIAL MAP THEREOF RECORDED FEBRUARY 12, 2009 IN THE OFFICE OF THE EL PASO COUNTY CLERK AND RECORDER UNDER RECEPTION NUMBER 208712754, SAID LINE MONUMENTED ON THE WEST END BY A FOUND 5/8" REBAR AND ON THE EAST BY A FOUND 4/8" REBAR WITH 1" ALUMINUM CAP STAMPED "LS 2154" BEING A POINT ON THE NORTH LINE BEARING NORTH 89°12'41" EAST 1287.35 FEET FROM THE WEST END THEREOF.

PREPARED UNDER MY DIRECT SUPERVISION, FOR AND ON BEHALF OF MATRIX DESIGN GROUP, INC.



2435 Research Parkway, Suite 300
 Colorado Springs, CO 80920
 Phone 719-575-0100
 Fax 719-575-0208

BARBARICK SUBDIVISION LOTS 1-4

PROPOSED DRAINAGE PLAN

DESIGNED BY: BJH	SCALE: 1"=100'	DATE ISSUED: April 2016	DP02
DRAWN BY: BJH	HORIZ: N/A	SHEET NO. 1 OF 2 SHEETS	
CHECKED BY: ES	VERT: N/A		



2435 Research Parkway, Suite 300
Colorado Springs, Colorado 80920
Phone: 719-575-0100
www.matrixdesigngroup.com

Justin Ballard
Wykota Construction
430 Beacon Light Road
Monument, CO 80132

January 16, 2017

Subject: Pond As-Built Verification for Barbarick Subdivision Lots 1-4 Construction

Dear Mr. Ballard,

Please accept this letter as certification of the post-construction measurements and volume calculations of the subject sand filter pond and the full spectrum pond. The table below depicts the design elevations and volumes from the construction plans with the post-construction measured elevations and volumes. The as-built survey was completed by Matrix Design Group on January 12, 2017 and the criteria shown below was compiled from this survey data. The benchmark used for this survey is a found 3-1/4" aluminum cap in road box designated as FIMS F_69 and having a published NGVD 29 elevation of 6975.62 feet.

Full Spectrum Detention Pond Outlet Structure Elevations			
	Design Elevation	As Built Elevation	Delta Elevation
bottom of micropool	7016.00	7016.14	0.14
orifice slot1 CL	7018.50	7018.89	0.39
orifice slot2 CL	7019.50	7019.87	0.37
orifice slot3 CL	7020.50	7020.87	0.37
micropool wall top	7018.50	7018.60	0.10
orifice plate wall top	7021.00	7021.35	0.35
Trash Rack wall Top	7021.80	7021.90	0.10
invert 30" cpp	7017.80	7017.87	0.07

Full Spectrum Detention Pond Elevations & Volumes			
	Design Elevation	As Built Elevation	Delta Elevation
WQ WSE	7020.03	7020.17	0.14
5-Year WSE	7021.50	7021.64	0.14
100-Year (weir)	7022.76	7022.92	0.16
EURV	7021.50	7021.64	0.14
	Design Volume	As Built Volume	Delta Volume
WQ volume	0.203 ac-ft	0.182 ac-ft	(-)0.021 ac-ft
5-Year volume	0.673 ac-ft	0.695 ac-ft	0.002 ac-ft
100-Year (weir)	1.261 ac-ft	1.286 ac-ft	0.025 ac-ft
EURV	0.677 ac-ft	0.695 ac-ft	0.018 ac-ft

Sand Filter Pond Elevations & Volumes			
	<u>Design Elevation</u>	<u>As Built Elevation</u>	<u>Delta Elevation</u>
WQ WSE	7023.38	7023.37	-0.01
100-Year (weir)	7025.83	7025.02	-0.81
EURV	7024.52	7024.52	0.00
	<u>Design Volume</u>	<u>As Built Volume</u>	<u>Delta Volume</u>
WQ volume	0.039 ac-ft	0.258 ac-ft	0.219 ac-ft
100-Year (weir)	0.394 ac-ft	0.517 ac-ft	0.123 ac-ft
EURV	0.181 ac-ft	0.429 ac-ft	0.248 ac-ft

I, Justin A. Conner, a Colorado licensed Professional Land Surveyor, certify on behalf of Matrix Design Group that the above as-built elevations and volumes were derived from a field survey performed on January 12, 2017 under my direct supervision and is true and correct to the best of my knowledge and belief.

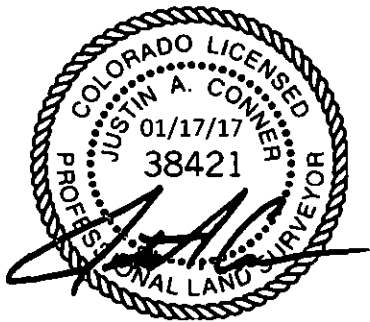

Justin A. Conner, PLS 38421
 Prepared for and on behalf of Matrix Design Group, Inc.

APPENDIX G: COST ESTIMATE / FINANCIAL ASSURANCES ESTIMATE

Kimley»Horn

2 North Nevada, Suite 900
 Colorado Springs, Colorado 80903

Project: Barbarick Transfer Station - COM-2346
 Project Number: 196489000
 Date: March 5, 2024

Prepared By: RES
 Checked By: EJK

COS Bid Item #	Item Description	Unit	Unit Cost	Quantity	Extended Cost	
1	1	EARTHWORK	CY	\$5.00	8,606	\$43,030
2	2	PERMANENT SEEDING	AC	\$1,875.00	1	\$2,250
3	3	CONCRETE WASHOUT BASIN	EA	\$1,090.00	1	\$1,090
4	4	INLET PROTECTION	EA	\$202.00	8	\$1,616
5	5	SAFETY FENCE (CONSTRUCTION FENCE)	LF	\$3.00	960	\$2,880
6	6	SILT FENCE	LF	\$3.00	841	\$2,523
7	7	SEDIMENT BASIN (EXISTING DETENTION POND)	EA	\$2,135.00	1	\$1,068
8	8	STRAW WATTLE/ROCK SOCK	LF	\$7.00	601	\$4,207
9	9	TEMPORARY EROSION CONTROL BLANKET	SY	\$3.00	32	\$96
10	10	VEHICLE TRACKING CONTROL	EA	\$2,870.00	1.0	\$2,870
11	11	AGGREGATE BASE COURSE (135LB/CF)	TON	\$34.00	962	\$32,708
12	12	ASPHALT PAVEMENT (147LB/CF)	TON	\$106.00	872	\$92,432
13	13	EPOXY PAVEMENT MARKING	SF	\$16.00	233	\$3,728
14	14	THERMOPLASTIC PAVEMENT MARKING	SF	\$28.00	12	\$336
15	15	ELECTRICAL CONDUIT (1-INCH)	LF	\$20.00	1,030	\$20,600
16	16	ELECTRICAL CONDUIT (2-INCH)	LF	\$20.00	910	\$18,200
17	17	MSE BLOCK RETAINING WALL (8' MAX)	SF	\$50.00	1,400	\$70,000
18	18	CONCRETE RETAINING WALL (8' MAX)	SF	\$80.00	985	\$78,800
19	19	GRADED INLET (CDOT TYPE C)(DEPTH < 5')	EA	\$6,000.00	5	\$30,000
20	20	STORM SEWER MANHOLE, BOX BASE	EA	\$14,061.00	2	\$28,122
21	21	4" PERFORATED PVC PIPE	LF	\$70.00	941	\$65,870
22	22	6" PVC PIPE	LF	\$75.00	205	\$15,375
23	23	24" PVC PIPE	LF	\$80.00	371	\$29,680
24	24	30" PVC PIPE	LF	\$90.00	70	\$6,300
25	25	30" PVC FES	EA	\$800.00	1	\$800
26	26	24" RCP Pipe	LF	\$100.00	71	\$7,100
27	27	4' CONCRETE DRAINAGE PAN (6", FIBERMESH REINFORCED)	LF	\$100.00	848	\$84,800
28	28	RIP RAP (TYPE M, 12 INCH DEPTH)	TON	\$97.00	21	\$2,037
29	29	WATER SERVICE LINE (INCLUDING TAP AND VALVES)	EA	\$1,601.00	2	\$3,202
30	30	SANITARY SERVICE LINE	EA	\$1,696.00	1	\$1,696
31	31	TREES (PONDEROSA PINE)	EA	\$600.00	34	\$20,400
32	32	SEEDING (EPC LOW GROW MIX)	SF	\$0.50	50,413	\$25,207
PROJECT CONSTRUCTION BID ITEMS COST					B	\$699,022
Contingencies (Construction Items)			(0 - 25%) of B	10.0%	\$69,902	
Total Project Cost						\$768,924

Conceptual Opinion of Probable Construction Cost

The Engineer has no control over the cost of labor, materials, equipment, or over the Contractor's methods of determining prices or over competitive bidding or market conditions. Opinions of probable costs provided herein are based on the information known to Engineer at this time and represent only the Engineer's judgment as a design professional familiar with the construction industry. The Engineer cannot and does not guarantee that proposals, bids, or actual construction costs will not vary from its opinions of probable costs.

APPENDIX H: DRAINAGE MAPS

K:\COS_Civil\196489000_Barbarick Waste Transfer\CADD\PlanSheets\DR\DR_PP_196489000.dwg Schneibach, Ryan 4/2/2024 3:39 PM

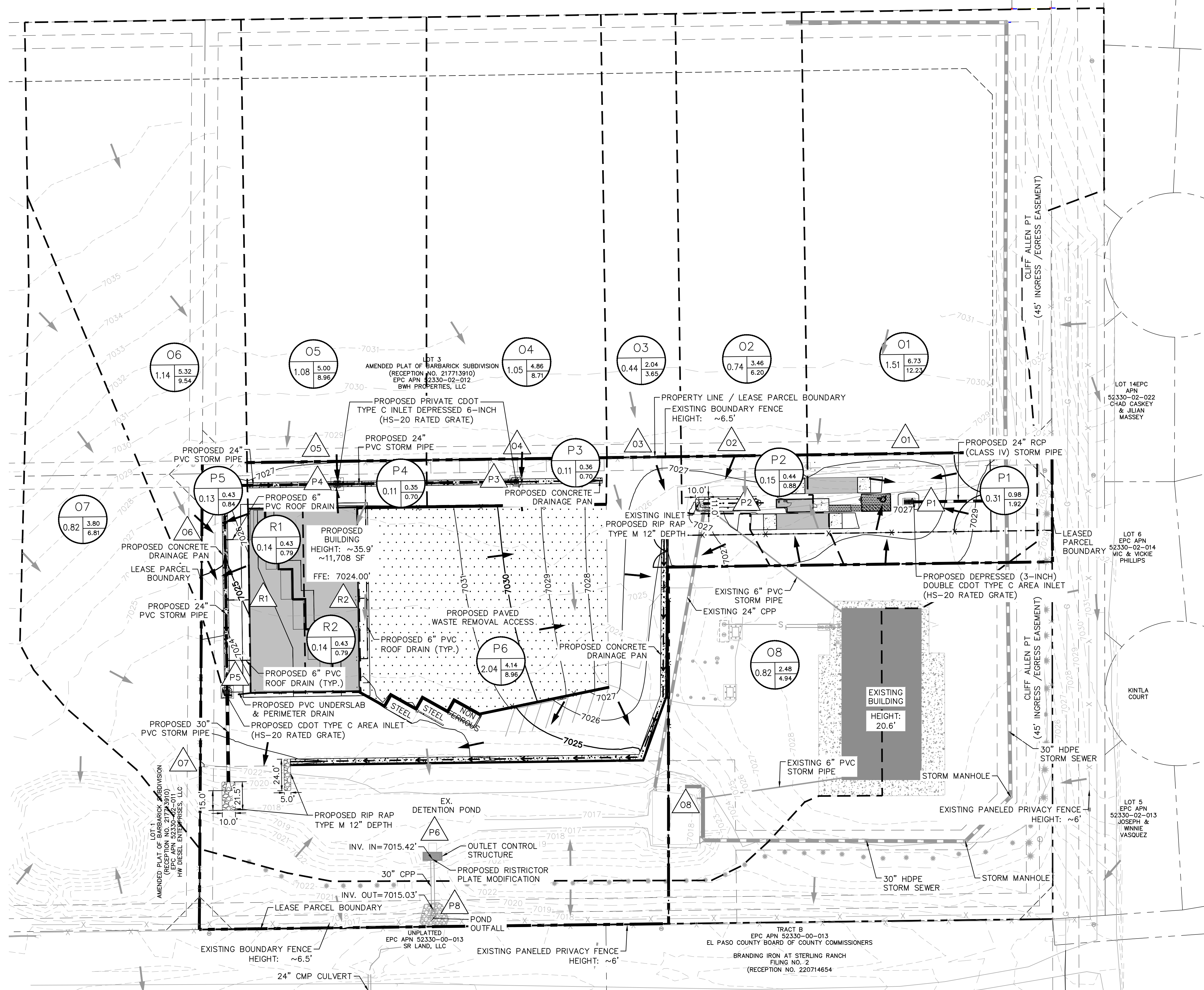

LEGEND

- PROPERTY LINE
- LEASED PARCEL BOUNDARY
- EXISTING UTILITY & DRAINAGE EASEMENT
- EXISTING FENCE
- EXISTING STORM SEWER
- EXISTING GAS MAIN
- EXISTING VEGETATION
- EXISTING TRANSFORMER
- PROPOSED UNDERGROUND ELECTRIC
- PROPOSED STORM SEWER
- PROPOSED STORM INLET
- PROPOSED ASPHALT
- PROPOSED CONCRETE
- EXISTING MAJOR CONTOUR
- EXISTING MINOR CONTOUR
- PROPOSED MAJOR CONTOUR
- PROPOSED MINOR CONTOUR
- PROPOSED BASIN BOUNDARY

	A = SUB-BASIN NAME
	B = BASIN SIZE (ACRE)
	C = 5-YEAR RUNOFF
	D = 100-YEAR RUNOFF

-

- EXISTING FLOW ARROW
- PROPOSED FLOW ARROW

SUMMARY - PROPOSED RUNOFF TABLE

DESIGN POINT	BASIN DESIGNATION	BASIN AREA (ACRES)	BASIN IMPERVIOUSNESS (%)	DIRECT 5-YR RUNOFF (CFS)	DIRECT 100-YR RUNOFF (CFS)
P1	P1	0.31	81.7%	0.98	1.92
P2	P2	0.15	76.4%	0.44	0.88
P3	P3	0.11	82.2%	0.36	0.70
P4	P4	0.11	82.3%	0.35	0.70
P5	P5	0.13	82.0%	0.43	0.84
P6	P6	2.04	58.9%	4.14	8.96
R1	R1	0.14	90.0%	0.43	0.80
R2	R2	0.14	90.0%	0.43	0.80
O1	O1	1.51	95.1%	6.73	12.23
O2	O2	0.74	100.0%	3.46	6.20
O3	O3	0.44	100.0%	2.04	3.65
O4	O4	1.05	100.0%	4.86	8.71
O5	O5	1.08	100.0%	5.00	8.96
O6	O6	1.14	100.0%	5.32	9.54
O7	O7	0.82	100.0%	3.80	6.81
O8	O8	0.82	76.7%	2.48	4.94
TOTAL		10.73	88.0%	41.26	76.63

POND DISCHARGE

(DESIGN POINT P8)

5-YEAR: 0.3 CFS 100-YEAR: 7.7 CFS

GRAPHIC SCALE IN FEET: 0, 20, 40, 80

811 Know what's below. Call before you dig.

CALL UTILITY NOTIFICATION CENTER OF COLORADO 1-800-922-1987

CALL 2-BUSINESS DAYS IN ADVANCE BEFORE YOU DIG, GRADE, OR EXCAVATE FOR THE MARKING OF UNDERGROUND MEMBER UTILITIES.

Kimley»Horn

2024 KIMLEY-HORN AND ASSOCIATES, INC.
2 North Nevada Avenue Suite 900
Colorado Springs, Colorado 80903 (719) 453-0180

DESIGNED BY: EUG
DRAWN BY: RES
CHECKED BY: EUG
DATE: 4/2/2024

BARBARICK WASTE TRANSFER STATION
EL PASO COUNTY, COLORADO
DRAINAGE MAP
PROPOSED CONDITIONS

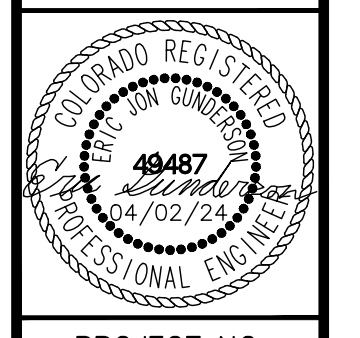

PROJECT NO. 196489000
SHEET DR-2

PCD FILE NO. COM2346