

PRELIMINARY SITE GRADING CONSTRUCTION PLANS
FOR
HILLSIDE AT LORSON RANCH
EARLY OVERLOT GRADING / EROSION CONTROL PLANS

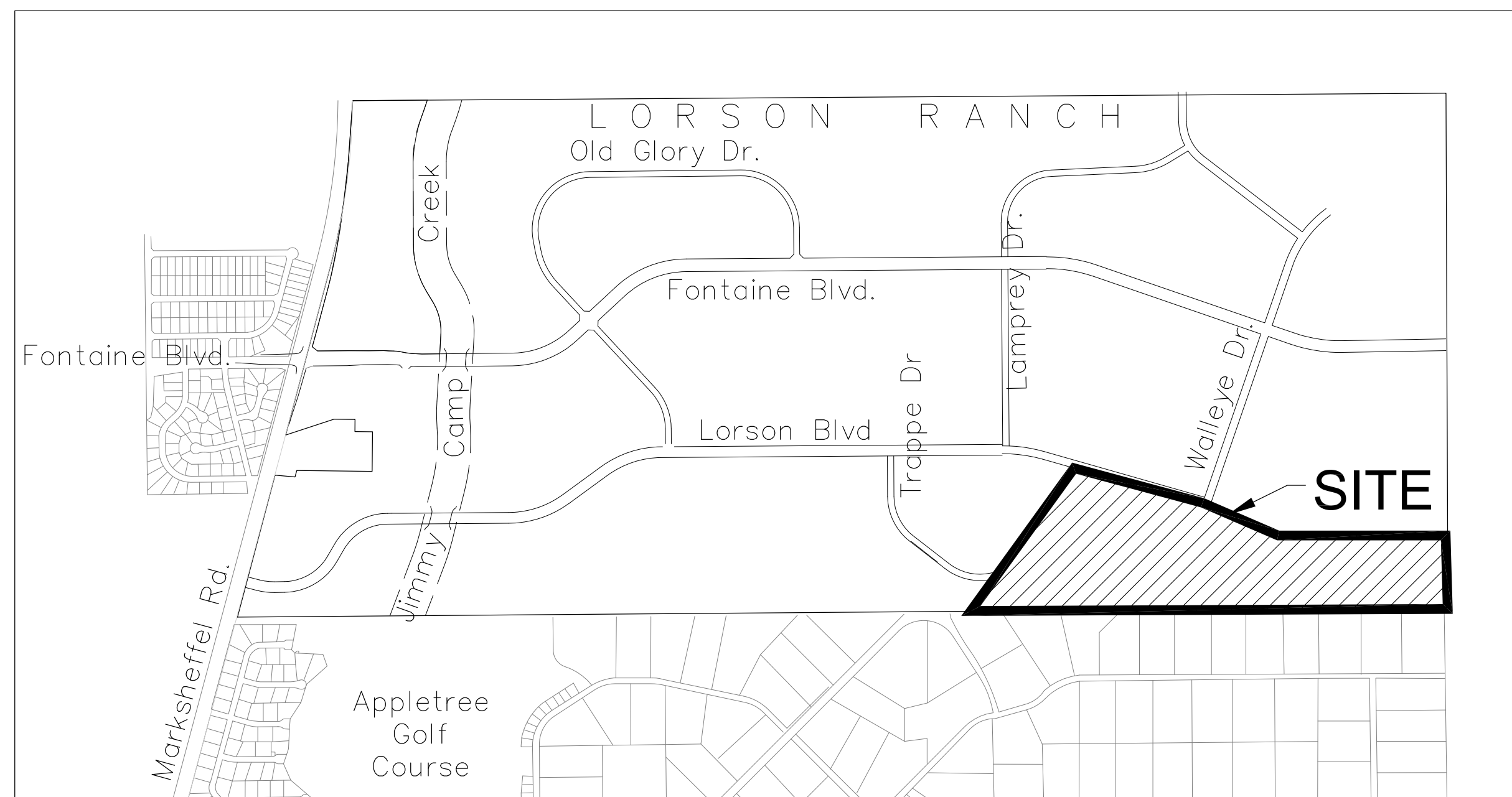

Know what's below.
Call before you dig.

CALL 2-BUSINESS DAYS IN ADVANCE
BEFORE YOU DIG, GRADE OR
EXCAVATE FOR THE MARKING OF
UNDERGROUND MEMBER UTILITIES



VICINITY MAP
NO SCALE

SHEET INDEX	
SHEET NO.	SHEET DESCRIPTION
C0.1	COVER SHEET
C0.2	NOTES (GENERAL, GRADING, EROSION CONTROL)
C0.3	TYPICAL SECTIONS
C4.1 ~ C4.5	GRADING AND EROSION CONTROL PLAN
C9.1 ~ C9.8	PONDS E1, G, & H, OUTLET STRUCTURES, AND DETAILS
C12.1 ~ C12.4	DETAILS

DEVELOPER'S STATEMENT

I, THE OWNER/DEVELOPER HAVE READ AND WILL COMPLY WITH THE REQUIREMENTS OF THE GRADING AND EROSION CONTROL PLAN.

FEB 5, 2022

DATE

CONSTRUCTION APPROVAL

COUNTY PLAN REVIEW IS PROVIDED ONLY FOR GENERAL CONFORMANCE WITH COUNTY DESIGN CRITERIA. THE COUNTY IS NOT RESPONSIBLE FOR THE ACCURACY AND ADEQUACY OF THE DESIGN, DIMENSIONS, AND/OR ELEVATIONS WHICH SHALL BE CONFIRMED AT THE JOB SITE. THE COUNTY THROUGH THE APPROVAL OF THIS DOCUMENT ASSUMES NO RESPONSIBILITY FOR COMPLETENESS AND/OR ACCURACY OF THIS DOCUMENT. FILED IN ACCORDANCE WITH THE REQUIREMENTS OF THE EL PASO COUNTY LAND DEVELOPMENT CODE, DRAINAGE CRITERIA MANUAL VOLUMES 1 AND 2, AND ENGINEERING CRITERIA MANUAL, AS AMENDED.

IN ACCORDANCE WITH ECM SECTION 1.12, THESE CONSTRUCTION DOCUMENTS WILL BE VALID FOR CONSTRUCTION FOR A PERIOD OF 2 YEARS FROM THE DATE SIGNED BY THE EL PASO COUNTY ENGINEER. IF CONSTRUCTION HAS NOT STARTED WITHIN THOSE 2 YEARS, THE PLANS WILL NEED TO BE RESUBMITTED FOR APPROVAL, INCLUDING PAYMENT OF REVIEW FEES AT THE PLANNING AND COMMUNITY DEVELOPMENT DIRECTOR'S DISCRETION.

JENNIFER IRVINE, P.E., COUNTY ENGINEER/ECM ADMINISTRATOR DATE
CONDITIONS:

ENGINEER'S APPROVAL

THIS GRADING AND EROSION CONTROL PLAN WAS PREPARED UNDER MY DIRECTION AND SUPERVISION AND IS CORRECT TO THE BEST OF MY KNOWLEDGE AND BELIEF. SAID PLAN HAS BEEN PREPARED ACCORDING TO THE CRITERIA ESTABLISHED BY THE COUNTY FOR GRADING AND EROSION CONTROL PLANS. I ACCEPT RESPONSIBILITY FOR ANY LIABILITY CAUSED BY NEGLIGENT ACTS, ERRORS, OR OMISSIONS ON MY PART IN PREPARING THIS PLAN

RICHARD L. SCHINDLER, P.E. # 33997
FOR AND ON BEHALF OF CORE ENGINEERING GROUP

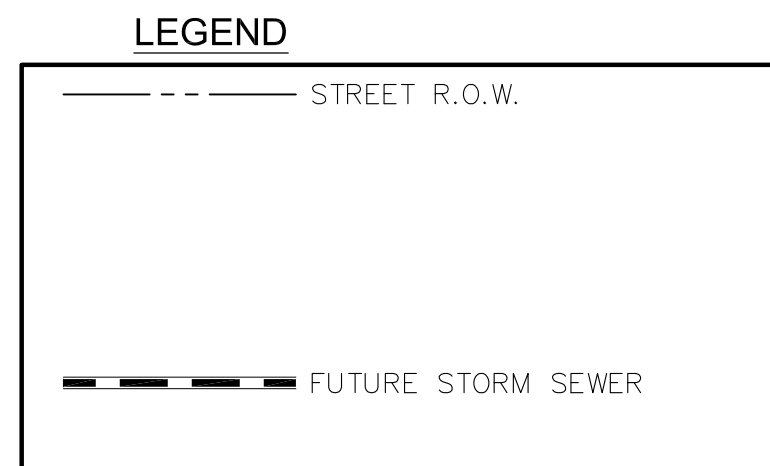

WATER / SANITARY
WIDEFIELD WATER AND SANITATION DISTRICT
8495 FONTAINE BLVD.
COLORADO SPRINGS, CO 80925
719-390-7111

CABLE
COMCAST
P.O. BOX 173838
DENVER, CO 80217
970-641-4774

ELECTRIC
MOUNTAIN VIEW ELECTRIC
11140 E. WOODMEN RD.
COLORADO SPRINGS, CO 80831
719-495-2283

SECURITY FIRE PROTECTION DISTRICT
400 SECURITY BOULEVARD
SECURITY, CO 80911
719-392-7121

PREPARED FOR:
LORSON, LLC
N. WAHSATCH AVE., SUITE 301
COLORADO SPRINGS, CO 80903
719-635-3200
CONTACT: JEFF MARK

PREPARED BY:
CORE ENGINEERING GROUP
15004 1ST AVENUE S.
BURNSVILLE, MN 55306
719-570-1100
CONTACT: RICHARD L. SCHINDLER P.E.

TELEPHONE
CENTURYLINK
7925 INDUSTRY ROAD
COLORADO SPRINGS, CO 80939
719-278-4651

GAS
BLACK HILLS ENGERGY
7060 ALLEGRE ST.
FOUNTAIN, CO 80817
719-393-6639

EL PASO COUNTY
PLANNING AND COMMUNITY DEVELOPMENT
2880 INTERNATIONAL CIRCLE
COLORADO SPRINGS, CO 80910
719-520-6300

BASIS OF BEARING

BEARINGS ARE BASED ON THE SOUTH LINE OF THE NORTH HALF OF SECTION 23, TOWNSHIP 15 SOUTH, RANGE 65 WEST OF THE 6TH PRINCIPAL MERIDIAN AS BEING SOUTH 8941'52" WEST. THE EAST QUARTER CORNER OF SAID SECTION 23 IS A FOUND 3-1/2" ALUMINUM CAP MONUMENT AND THE WEST QUARTER CORNER OF SAID SECTION 23 IS A FOUND 2-1/2" ALUMINUM CAP MONUMENT

BENCHMARK

FIMS MONUMENT F204 LOCATED AT THE NORTHWEST CORNER OF FONTAINE BLVD AND COTTONWOOD GROVE DR. ELEVATION 5724.072 (N.G.V.D. 29)

TRAFFIC CONTROL NOTE

THE CONTRACTOR SHALL PROVIDE ALL TRAFFIC CONTROL DEVICES AND MONITORING NECESSARY TO SAFELY COMPLETE THE WORK SHOWN IN THESE CONSTRUCTION DOCUMENTS IN CONFORMANCE WITH M.U.T.C.D. GUIDELINES. THE CONTRACTOR SHALL COMPLETE ALL NECESSARY WORK FOR PLAN REVIEW, PERMITS AND PROCESSING. TRAFFIC CONTROL WILL NOT BE PAID SEPARATELY BUT IS INCLUDED IN THE COST OF THE PROJECT.

PUD/SP 22-001

CORE ENGINEERING GROUP
15004 1ST AVENUE S.
BURNSVILLE, MN 55306
PH: 719.570.1100
CONTACT: RICHARD L. SCHINDLER, P.E.
EMAIL: Rich@cog1.com

DATE: _____
DESCRIPTION: _____
NO. _____

PREPARED FOR:
LORSON, LLC
212 N. WAHSATCH AVE, SUITE 301
COLORADO SPRINGS, COLORADO 80903
(719) 635-3200
CONTACT: JEFF MARK

PROJECT:
HILLSIDE AT LORSON RANCH
LORSON BLVD AND WALLEYE DR
COLORADO SPRINGS, COLORADO

DRAWN: RLS
DESIGNED: RLS
CHECKED: RLS

**COVER SHEET
EARLY GRADING AND
EROSION CONTROL PLAN**

DATE:
APRIL 15, 2022

PROJECT NO.
100.065

SHEET NUMBER
C0.1

TOTAL SHEETS: 20

CONSTRUCTION NOTES

- ALL WORK SHALL COMPLY WITH THE CODES AND POLICIES FOR EL PASO COUNTY.
- EXISTING TOPOGRAPHIC INFORMATION SHOWN ON THIS GRADING PLAN WAS OBTAINED FROM AERIAL CONTOURS AND PREVIOUS CONSTRUCTION DOCUMENTS. THE CONTRACTOR SHALL BE RESPONSIBLE TO EXAMINE THE SITE AND BE FAMILIAR WITH THE EXISTING CONDITIONS.
- DEPTH OF MOISTURE-DENSITY CONTROL FOR THIS PROJECT SHALL BE AS FOLLOWS:
BASE OF ALL CUTS AND FILLS - 12 INCHES,
FULL DEPTH OF ALL EMBANKMENTS
- THE CONTRACTOR IS RESPONSIBLE FOR THE RE-ESTABLISHMENT OF ALL SURVEY MONUMENTS DISTURBED WITHIN THE PROJECT LIMITS.
- THE CONTRACTOR SHALL PROTECT ALL WORK AREAS AND FACILITIES FROM FLOODING AT ALL TIMES. AREAS AND FACILITIES SUBJECTED TO FLOODING, REGARDLESS OF THE SOURCE OF WATER, SHALL BE PROMPTLY DEWATERED AND RESTORED.
- PRIOR TO PAVING OPERATIONS, THE ENTIRE SUBGRADE SHALL BE PROOF-ROLLED WITH A LOADED 988 FRONT-END LOADER OR SIMILAR HEAVY RUBBER Tired VEHICLE (GVW OF 50,000 POUNDS WITH 18 KIP PER AXLE AT TIRE PRESSURES OF 90 PSI) TO DETECT ANY SOFT OR LOOSE AREAS. IN AREAS WHERE SOFT OR LOOSE SOILS, PUMPING OR EXCESSIVE MOVEMENT IS OBSERVED, THE EXPOSED MATERIALS SHALL BE OVER-EXCAVATED TO A MINIMUM DEPTH OF TWO FEET BELOW PROPOSED FINAL GRADE OR TO A DEPTH AT WHICH SOILS ARE STABLE. AFTER THIS HAS BEEN COMPLETED, THE EXPOSED MATERIALS SHALL BE SCARIFIED TO A DEPTH OF 12 INCHES AND MOISTURE CONDITIONED. THE SUBGRADE SHALL THEN BE UNIFORMLY COMPACTED TO A MINIMUM OF 95% OF STANDARD PROCTOR DENSITY (ASTM D-698) AT 0 TO +4.0% OF OPTIMUM MOISTURE CONTENT FOR A-6 AND A-7-6 SOILS ENCOUNTERED. OTHER SUBGRADE TYPES SHALL BE UNIFORMLY COMPACTED TO A MINIMUM OF 95% OF MODIFIED PROCTOR DENSITY (ASTM D-1557) AT PLUS OR MINUS 2.0% OF OPTIMUM MOISTURE CONTENT. AREAS WHERE STABLE NATURAL SOILS ARE ENCOUNTERED AT PROPOSED SUBGRADE ELEVATION SHALL ALSO BE SCARIFIED (18 INCHES FOR A-7-6 SOILS BELOW FULL-DEPTH ASPHALT CONCRETE) AND COMPACTED AS OUTLINED ABOVE PRIOR TO PAVING OPERATIONS. SUBGRADE FILL SHALL BE PLACED IN SIX-INCH LIFTS AND UNIFORMLY COMPACTED, MEETING THE REQUIREMENTS AS PREVIOUSLY DESCRIBED.
- SUBGRADE MATERIALS DEEMED UNSUITABLE BY THE ENGINEER SHALL BE EXCAVATED, DISPOSED OF AND REPLACED WITH APPROVED MATERIALS.
- FILL SHALL BE PLACED IN 8-INCH MAXIMUM LOOSE LIFTS AND SHALL BE COMPACTED PRIOR TO SUCCESSIVE LIFTS.
- THE CONTRACTOR IS RESPONSIBLE FOR PREVENTING AND CONTROLLING EROSION DURING CONSTRUCTION ACTIVITIES AT ALL TIMES DURING GRADING AND CONSTRUCTION. THE CONTRACTOR SHALL PROVIDE THE FOLLOWING EROSION AND SEDIMENT CONTROL MEASURES:
 - HAY BALE BARRIERS WHERE NEEDED AND/OR AS DIRECTED BY THE ENGINEER.
 - SILT FENCE WHERE NEEDED AND/OR AS DIRECTED BY THE ENGINEER.
 - TEMPORARY SEDIMENTATION BASINS WHERE NEEDED AND/OR AS DIRECTED BY THE ENGINEER.
 - MULCHING AND SEEDING OF EXCESSIVE SLOPED AREAS AS NEEDED OR AS DIRECTED BY THE ENGINEER.
 - TEMPORARY VEHICLE TRACKING CONTROL AS NEEDED AND/OR DIRECTED BY THE ENGINEER.
 - CONCRETE WASH AREAS.
 - INLET PROTECTION.
 THESE AND ALL EROSION CONTROL BEST MANAGEMENT PRACTICES AS SHOWN IN THE GRADING AND EROSION CONTROL PLANS SHALL BE STRICTLY ADHERED TO.
- FINISHED CONTOURS/SPOT ELEVATIONS SHOWN HEREON REPRESENT FINISHED GRADES. ALL PAVEMENT SUBGRADES ARE BASED ON THE COMPOSITE ASPHALT PAVEMENT RECOMMENDATIONS MADE IN THE "GEOTECHNICAL STUDY" FOR THIS PROJECT.
- THERE MAY BE SOME TOPSOIL WITHIN LORSON RANCH EAST THAT IS NOT SUITABLE FOR RE-USE. CONTRACTOR SHALL AMEND THE TOPSOIL AS NECESSARY AND RE-SPREAD IN ACCORDANCE WITH THE GEOTECHNICAL RECOMMENDATIONS. IF TOPSOIL CANNOT BE AMENDED IT SHALL BE USED AS FILL WHERE NO FUTURE STRUCTURES OR ROADS WILL BE BUILT.

EL PASO COUNTY STANDARD CONSTRUCTION NOTES:

- ALL DRAINAGE AND ROADWAY CONSTRUCTION SHALL MEET THE STANDARDS AND SPECIFICATIONS OF THE CITY OF COLORADO SPRINGS/EL PASO COUNTY DRAINAGE CRITERIA MANUAL, VOLUMES 1 AND 2, AND THE EL PASO COUNTY ENGINEERING CRITERIA MANUAL.
- CONTRACTOR SHALL BE RESPONSIBLE FOR THE NOTIFICATION AND FIELD NOTIFICATION OF ALL EXISTING UTILITIES, WHETHER SHOWN ON THE PLANS OR NOT, BEFORE BEGINNING CONSTRUCTION. LOCATION OF EXISTING UTILITIES SHALL BE VERIFIED BY THE CONTRACTOR PRIOR TO CONSTRUCTION. CALL 811 TO CONTACT THE UTILITY NOTIFICATION CENTER OF COLORADO (UNCC).
- CONTRACTOR SHALL KEEP A COPY OF THESE APPROVED PLANS, THE GRADING AND EROSION CONTROL PLAN, THE STORMWATER MANAGEMENT PLAN (SWMP), THE SOILS AND GEOTECHNICAL REPORT, AND THE APPROPRIATE DESIGN AND CONSTRUCTION STANDARDS AND SPECIFICATIONS AT THE JOB SITE AT ALL TIMES, INCLUDING THE FOLLOWING:
 - EL PASO COUNTY ENGINEERING CRITERIA MANUAL (ECM)
 - CITY OF COLORADO SPRINGS/EL PASO COUNTY DRAINAGE CRITERIA MANUAL, VOLUMES 1 AND 2
 - COLORADO DEPARTMENT OF TRANSPORTATION (CDOT) STANDARD SPECIFICATIONS FOR ROAD AND BRIDGE CONSTRUCTION
 - CDOT M & S STANDARDS
- NOTWITHSTANDING ANYTHING DEPICTED IN THESE PLANS OR GRAPHIC REPRESENTATION, ALL DESIGN AND CONSTRUCTION RELATED TO ROADS, STORM DRAINAGE AND EROSION CONTROL SHALL CONFORM TO THE STANDARDS AND REQUIREMENTS OF THE MOST RECENT VERSION OF THE RELEVANT ADOPTED EL PASO COUNTY STANDARDS, INCLUDING THE LAND DEVELOPMENT CODE, THE ENGINEERING CRITERIA MANUAL, THE DRAINAGE CRITERIA MANUAL, AND THE DRAINAGE CRITERIA MANUAL VOLUME 2. ANY DEVIATIONS FROM REGULATIONS AND STANDARDS MUST BE REQUESTED, AND APPROVED, IN WRITING. ANY MODIFICATIONS NECESSARY TO MEET CRITERIA AFTER-THE-FACT WILL BE ENTIRELY THE DEVELOPER'S RESPONSIBILITY TO RECTIFY.
- IT IS THE DESIGN ENGINEER'S RESPONSIBILITY TO ACCURATELY SHOW EXISTING CONDITIONS, BOTH ONSITE AND OFFSITE, ON THE CONSTRUCTION PLANS. ANY MODIFICATIONS NECESSARY DUE TO CONFLICTS, OMISSIONS, OR CHANGED CONDITIONS WILL BE ENTIRELY THE DEVELOPER'S RESPONSIBILITY TO RECTIFY.
- CONTRACTOR SHALL SCHEDULE A PRE-CONSTRUCTION MEETING WITH EL PASO COUNTY PLANNING AND COMMUNITY DEVELOPMENT (PCD) - INSPECTIONS, PRIOR TO STARTING CONSTRUCTION.
- IT IS THE CONTRACTOR'S RESPONSIBILITY TO UNDERSTAND THE REQUIREMENTS OF ALL JURISDICTIONAL AGENCIES AND TO OBTAIN ALL REQUIRED PERMITS, INCLUDING BUT NOT LIMITED TO EL PASO COUNTY EROSION AND STORMWATER QUALITY CONTROL PERMIT (ESQCP), REGIONAL BUILDING FLOODPLAIN DEVELOPMENT PERMIT, U.S. ARMY CORPS OF ENGINEERS-ISSUED 401 AND/OR 404 PERMITS, AND COUNTY AND STATE FUGITIVE DUST PERMITS.
- CONTRACTOR SHALL NOT DEVIATE FROM THE PLANS WITHOUT FIRST OBTAINING WRITTEN APPROVAL FROM THE DESIGN ENGINEER AND DSD. CONTRACTOR SHALL NOTIFY THE DESIGN ENGINEER IMMEDIATELY UPON DISCOVERY OF ANY ERRORS OR INCONSISTENCIES.
- ALL STORM DRAIN PIPE SHALL BE CLASS III RCP UNLESS OTHERWISE NOTED AND APPROVED BY PCD.
- CONTRACTOR SHALL COORDINATE GEOTECHNICAL TESTING PER ECM STANDARDS. PAVEMENT DESIGN SHALL BE APPROVED BY EL PASO COUNTY PCD PRIOR TO PLACEMENT OF CURB AND GUTTER AND PAVEMENT.
- ALL CONSTRUCTION TRAFFIC MUST ENTER/EXIT THE SITE AT APPROVED CONSTRUCTION ACCESS POINTS.
- SIGHT VISIBILITY TRIANGLES AS IDENTIFIED IN THE PLANS SHALL BE PROVIDED AT ALL INTERSECTIONS. OBSTRUCTIONS GREATER THAN 18 INCHES ABOVE FLOWLINE ARE NOT ALLOWED WITHIN SIGHT TRIANGLES.
- SIGNING AND STRIPING SHALL COMPLY WITH EL PASO COUNTY PUBLIC WORK DEPARTMENT AND MUTCD CRITERIA.
- CONTRACTOR SHALL OBTAIN ANY PERMITS REQUIRED BY EL PASO COUNTY PWD, INCLUDING WORK WITHIN THE RIGHT-OF-WAY AND SPECIAL TRANSPORT PERMITS.
- THE LIMITS OF CONSTRUCTION SHALL REMAIN WITHIN THE PROPERTY LINE UNLESS OTHERWISE NOTED. THE OWNER/DEVELOPER SHALL OBTAIN WRITTEN PERMISSION AND EASEMENTS, WHERE REQUIRED, FROM ADJOINING PROPERTY OWNER(S) PRIOR TO ANY OFF-SITE DISTURBANCE, GRADING, OR CONSTRUCTION.

GEOTECHNICAL REPORT NOTE

- ALL GRADING SHALL CONFORM TO THE GEOTECHNICAL RECOMMENDATIONS PREPARED BY RMG, " SOILS AND GEOLOGY FOR HILLSIDE AT LORSON RANCH", DATED JANUARY 3, 2022, JOB NO. 181988.

↑
Revised May 20, 2022

ADDITIONAL SWMP PLAN CONTRACTOR NOTES:

- CONTRACTOR MUST ADD THEIR CONTACT INFORMATION TO THE SWMP PLANS PRIOR TO CONSTRUCTION
- IF THE GRADING IS TO BE PHASED THE CONTRACTOR MUST PROVIDE PHASING MAPS FOR INSERTION INTO THE SWMP PLANS.
- THE CONTRACTOR MUST PROVIDE THE CLIENT THE LOCATION OF ANY POTENTIAL SOURCES OF POLLUTIONS SUCH AS FUELING AREAS, ETC TO BE INSERTED INTO THE SWMP PLANS.
- THE ON-SITE SWMP PLAN SHALL BE LOCATED AT THE SE CORNER OF FONTAINE BLVD AND MARKSHEFFEL ROAD UNLESS OTHERWISE DOCUMENTED.
- EXISTING VEGETATION WITHIN THE LIMITS OF CONSTRUCTION CONSISTS OF NATIVE GRASSES AND WEEDS. GROUND COVER IS ESTIMATED AT 70% DENSITY. EXISTING VEGETATION WILL BE VERIFIED VISUALLY IN THE FIELD PRIOR TO STARTING WORK.

STANDARD NOTES FOR EL PASO COUNTY GRADING AND EROSION CONTROL PLANS

- Stormwater discharges from construction sites shall not cause or threaten to cause pollution, contamination, or degradation of State Waters. All work and earth disturbance shall be done in a manner that minimizes pollution of any on-site or off-site waters, including wetlands.
- Notwithstanding anything depicted in these plans in words or graphic representation, all design and construction related to roads, storm drainage and erosion control shall conform to the standards and requirements of the most recent version of the relevant adopted El Paso County standards, including the Land Development Code, the Engineering Criteria Manual, the Drainage Criteria Manual, and the Drainage Criteria Manual Volume 2. Any deviations from regulations and standards must be requested, and approved, in writing.
- A separate Stormwater Management Plan (SWMP) for this project shall be completed and an Erosion and Stormwater Quality Control Permit (ESQCP) issued prior to commencing construction. Management of the SWMP during construction is the responsibility of the designated Qualified Stormwater Manager or Certified Erosion Control Inspector. The SWMP shall be located on site at all times during construction and shall be kept up to date with work progress and changes in the field.
- Once the ESQCP is approved and a "Notice to Proceed" has been issued, the contractor may install the initial stage erosion and sediment control measures as indicated on the approved GEC. A Preconstruction Meeting between the contractor, engineer, and El Paso County will be held prior to any construction. It is the responsibility of the applicant to coordinate the meeting time and place with County staff.
- Control measures must be installed prior to commencement of activities that could contribute pollutants to stormwater. Control measures for all slopes, channels, ditches, and disturbed land areas shall be installed immediately upon completion of the disturbance.
- All temporary sediment and erosion control measures shall be maintained and remain in effective operating condition until permanent soil erosion control measures are implemented and final stabilization is established. All persons engaged in land disturbance activities shall assess the adequacy of control measures at the site and identify if changes to those control measures are needed to ensure the continued effective performance of the control measures. All changes to temporary sediment and erosion control measures must be incorporated into the Stormwater Management Plan.
- Temporary stabilization shall be implemented on disturbed areas and stockpiles where ground disturbing construction activity has permanently ceased or temporarily ceased for longer than 14 days.
- Final stabilization must be implemented at all applicable construction sites. Final stabilization is achieved when all ground disturbing activities are complete and all disturbed areas either have a uniform vegetative cover with individual plant density of 70 percent of pre-disturbance levels established or equivalent permanent alternative stabilization method is implemented. All temporary sediment and erosion control measures shall be removed upon final stabilization and before permit closure.
- All permanent stormwater management facilities shall be installed as designed in the approved plans. Any proposed changes that effect the design or function of permanent stormwater management structures must be approved by the ECM Administrator prior to implementation.
- Earth disturbances shall be conducted in such a manner so as to effectively minimize accelerated soil erosion and resulting sedimentation. All disturbances shall be designed, constructed, and completed so that the exposed area of any disturbed land shall be limited to the shortest practical period of time. Pre-existing vegetation shall be protected and maintained within 50 horizontal feet of a waters of the state unless shown to be infeasible and specifically requested and approved.
- Compaction of soil must be prevented in areas designated for infiltration control measures or where final stabilization will be achieved by vegetative cover. Areas designated for infiltration control measures shall also be protected from sedimentation during construction until final stabilization is achieved. If compaction prevention is not feasible due to site constraints, all areas designated for infiltration and vegetation control measures must be loosened prior to installation of the control measure(s).
- Any temporary or permanent facility designed and constructed for the conveyance of stormwater around, through, or from the earth disturbance area shall be a stabilized conveyance designed to minimize erosion and the discharge of sediment off site.
- Concrete wash water shall be contained and disposed of in accordance with the SWMP. No wash water shall be discharged to or allowed to enter State Waters, including any surface or subsurface storm drainage system or facilities. Concrete washouts shall not be located in an area where shallow groundwater may be present, or within 50 feet of a surface water body, creek or stream.
- During dewatering operations of uncontaminated ground water may be discharged on site, but shall not leave the site in the form of surface runoff unless an approved State dewatering permit is in place.
- Erosion control blanketing or other protective covering shall be used on slopes steeper than 3:1.
- Contractor shall be responsible for the removal of all wastes from the construction site for disposal in accordance with local and State regulatory requirements. No construction debris, tree slash, building material wastes or unused building materials shall be buried, dumped, or discharged at the site.
- Waste materials shall not be temporarily placed or stored in the street, alley, or other public way, unless in accordance with an approved Traffic Control Plan. Control measures may be required by El Paso County Engineering if deemed necessary, based on specific conditions and circumstances.
- Tracking of soils and construction debris off-site shall be minimized. Materials tracked off-site shall be cleaned up and properly disposed of immediately.
- The owner/developer shall be responsible for the removal of all construction debris, dirt, trash, rock, sediment, soil, and sand that may accumulate in roads, storm drains and other drainage conveyance systems and stormwater appurtenances as a result of site development.
- The quantity of materials stored on the project site shall be limited, as much as practical, to that quantity required to perform the work in an orderly sequence. All materials stored on-site shall be stored in a neat, orderly manner, in their original containers, with original manufacturer's labels.
- No chemical(s) having the potential to be released in stormwater are to be stored or used onsite unless permission for the use of such chemical(s) is granted in writing by the ECM Administrator. In granting approval for the use of such chemical(s), special conditions and monitoring may be required.
- Bulk storage of allowed petroleum products or other allowed liquid chemicals in excess of 55 gallons shall require adequate secondary containment protection to contain all spills onsite and to prevent any spilled materials from entering State Waters, any surface or subsurface storm drainage system or other facilities.
- No person shall cause the impediment of stormwater flow in the curb and gutter or ditch except with approved sediment control measures.
- Owner/developer and their agents shall comply with the "Colorado Water Quality Control Act" (Title 25, Article 8, CRS), and the "Clean Water Act" (33 USC 1344), in addition to the requirements of the Land Development Code, DCM Volume II and the ECM Appendix I. All appropriate permits must be obtained by the contractor prior to construction (1041, NPDES, Floodplain, 404, fugitive dust, etc.). In the event of conflicts between these requirements and other laws, rules, or regulations of other Federal, State, local, or County agencies, the most restrictive laws, rules, or regulations shall apply.
- All construction traffic must enter/exit the site only at approved construction access points.
- Prior to construction the permittee shall verify the location of existing utilities.
- A water source shall be available on site during earthwork operations and shall be utilized as required to minimize dust from earthwork equipment and wind.
- The soils report for this site has been prepared by RMG and shall be considered a part of these plans. See Geotechnical Report Note.
- At least ten (10) days prior to the anticipated start of construction, for projects that will disturb one (1) acre or more, the owner or operator of construction activity shall submit a permit application for stormwater discharge to the Colorado Department of Public Health and Environment, Water Quality Division. The application contains certification of completion of a stormwater management plan (SWMP), of which this Grading and Erosion Control Plan may be a part. For information or application materials contact:

Colorado Department of Public Health and Environment
Water Quality Control Division
WQCD - Permits
4300 Cherry Creek Drive South
Denver, CO 80246-1530
Attn: Permits Unit

CORE ENGINEERING GROUP
1500 WEST AVENUE, SUITE 5506
BOULDER, CO 80502
PHONE: 719.570.1100
CONTACT: RICHARD L. SCHINDLER, P.E.
EMAIL: Rich@ceg1.com

NO.	DESCRIPTION	DATE

PREPARED FOR: **LORSON, LLC**
212 N. WAHSATCH AVE, SUITE 301
COLORADO SPRINGS, COLORADO 80903
(719) 635-3200
CONTACT: JEFF MARK

PROJECT: **HILLSIDE AT LORSON RANCH**
LORSON BLVD. WALLEYE DR.
COLORADO SPRINGS, COLORADO

DRAWN: **RLS**
DESIGNED: **RLS**
CHECKED: **RLS**

OVERLOT EARLY SITE GRADING PLAN NOTES

DATE: **APRIL 15, 2022**

PROJECT NO. **100.065**

SHEET NUMBER **C0.2**

TOTAL SHEETS: **20**

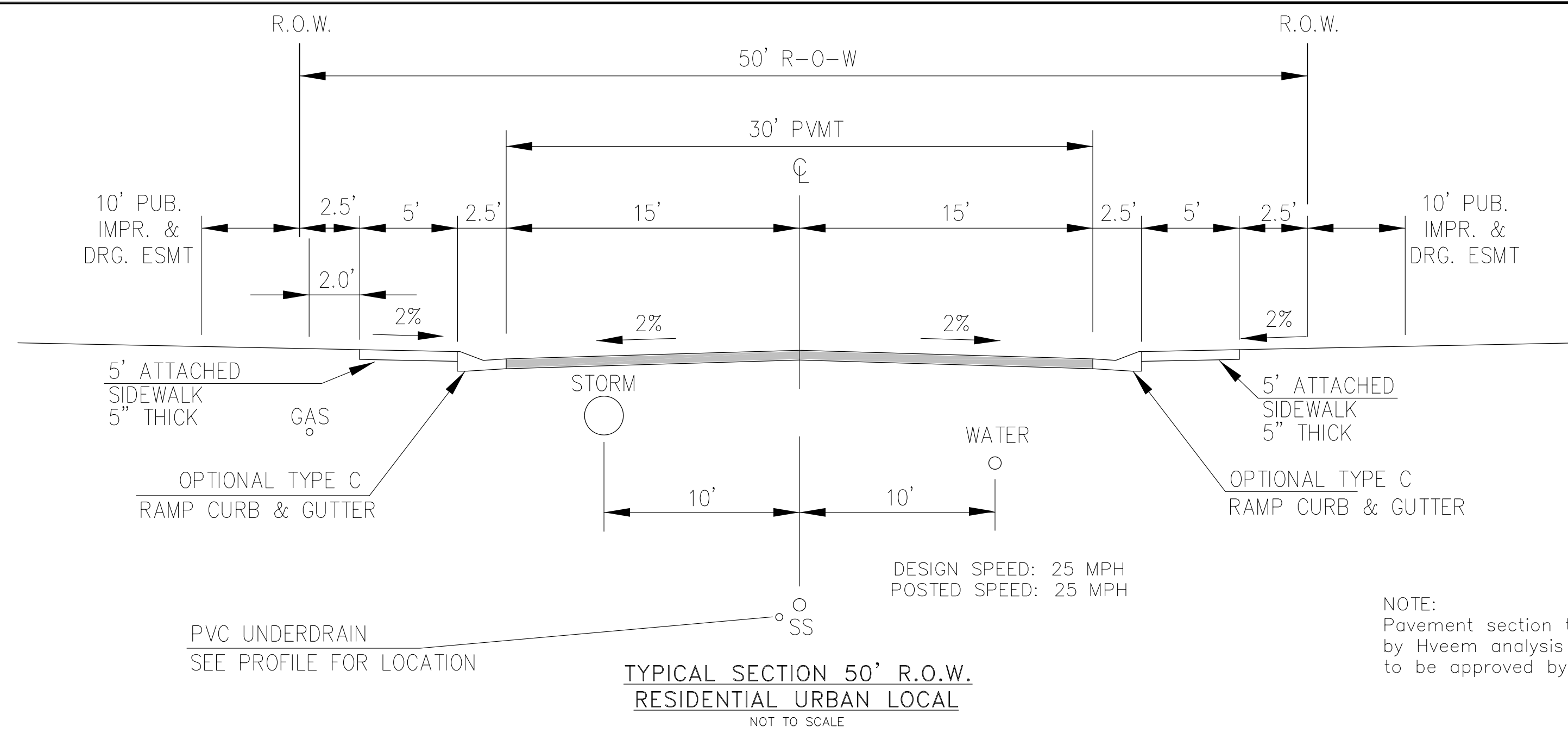

KINGSTON PEAK PL, WAHLUKE DR, HACKBERRY HILL ST, TIN MOUNTAIN TR,
YAMSAY WY, HOCKING TR, SALT SPRING WY, WHISKEY HILL LN, SHUKSAN LN
SPERRY TER, SAWTOOTH RIDGE WY, ELK HILLS DR, CRAFTON CT,
TRAPPE DR, LONG RIDGE CT, KEYNOT CT, BEACON BUTTE PL, SOLOMON TR.

NOTE:
Pavement section to be determined
by Hveem analysis and design. Design
to be approved by El Paso County PCD Engineering

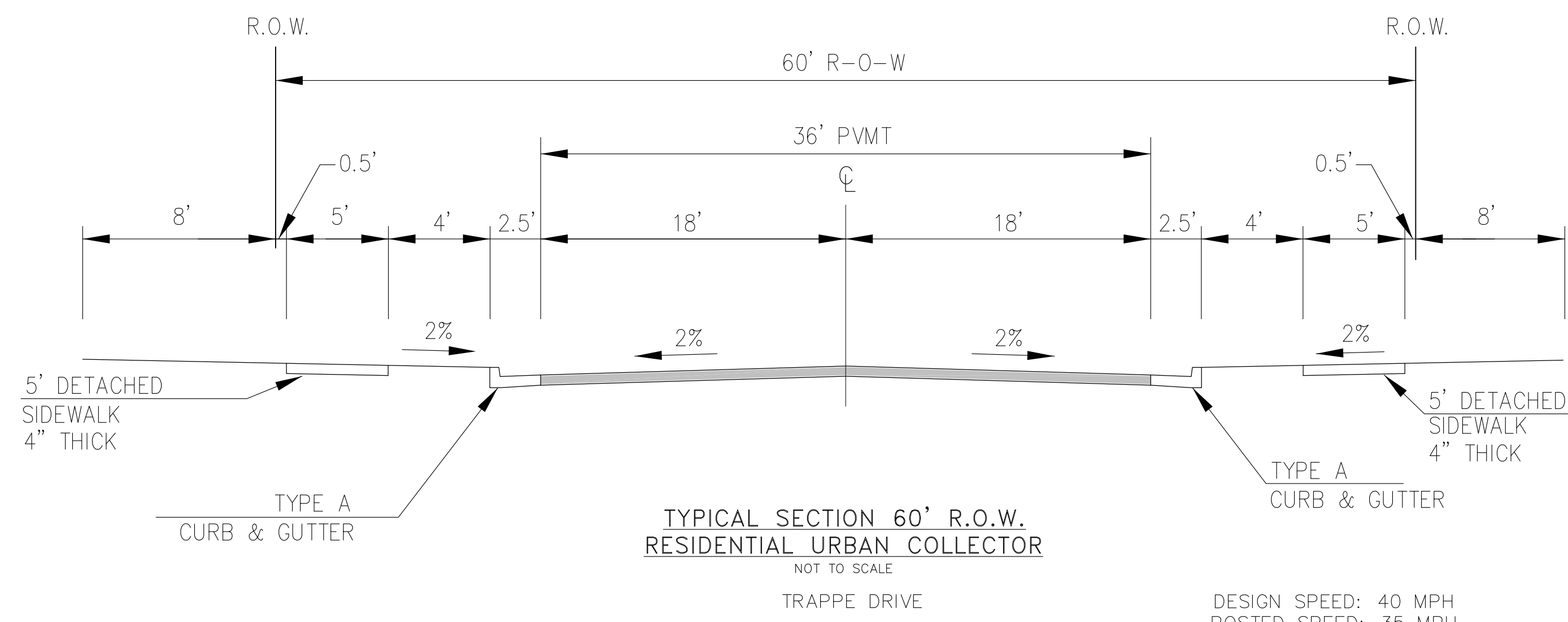

NOTE:
Pavement section to be determined
by Hveem analysis and design. Design
to be approved by PCD Engineering

**CORE
ENGINEERING GROUP**
15004 1ST AVENUE S.
BURNSVILLE, MN 55306
PH: 719.570.1100
CONTACT: RICHARD L. SCHINDLER, P.E.
EMAIL: Rich@cegi.com

DATE: _____
DESCRIPTION: _____
NO. _____

PREPARED FOR:
LORSON, LLC
212 N. WAHSATCH AVE, SUITE 301
COLORADO SPRINGS, COLORADO 80903
(719) 635-3200
CONTACT: JEFF MARK

PROJECT:
**HILL SIDE AT LORSON
RANCH**
LORSON BLVD - WALLEYE DR
COLORADO SPRINGS, COLORADO

DRAWN: RLS
DESIGNED: RLS
CHECKED: RLS

**OVERLOT EARLY
SITE GRADING
TYPICAL ROADWAY SECTIONS**

DATE:
APRIL 15, 2022

PROJECT NO.
100.065

SHEET NUMBER
C0.3

TOTAL SHEETS: 20

LEGEND

- 5721----- EXISTING MINOR CONTOUR
- 5720----- EXISTING MAJOR CONTOUR
- PROPOSED CONTOUR
- EXISTING STORM SEWER
- PROPOSED STORM SEWER, INLETS, MANHOLES
- (SF)----- PERIMETER EROSION CONTROL
SILT FENCE, EROSION LOG, OR EARTH BERM
- SUBDIVISION BOUNDARY
- CONSTRUCTION BOUNDARY/LIMITS OF DISTURBANCE
- P/L----- PROPERTY LINE OR TRACT LINE
- ROW LINE
- STORMWATER RUNOFF DIRECTION
- X%----- SLOPE DIRECTION AND GRADE
- CUT/FILL LINE
- (VTC)----- VEHICLE TRACKING CONTROL
- COMPACTED EARTHEN BERM OR ROUGH CUT STREET CONTROL PLAN OR STRAW BALE CHECK DAM
- (T) (G) (WO)----- LOT TYPE
TRANSITION, GARDEN, WALK-OUT
SEE DETAIL SHEET
- (PS)----- PERMANENT SEEDING
- (IP)----- INLET PROTECTION
- (MU)----- MULCH
- (DS2)----- UNLINED EARTHEN BERM
BY CUT/FILL

NOTE:

1. SLOPES SHALL BE 4:1 UNLESS OTHERWISE NOTED
2. POND SLOPES SHALL BE 4:1
3. STRAW ECB SHALL BE PLACED ON ALL SIDE SLOPES AND PERMANENT SLOPES 3:1 OR STEEPER
- (TS) 4. TEMPORARY SEEDING REQUIRED ON DISTURBED AREAS AND STOCKPILES WHICH ARE NOT AT FINAL GRADE BUT WILL REMAIN DORMANT FOR LONGER THAN 30 DAYS SHALL ALSO BE MULCHED AND SEEDED WITHIN 21 DAYS AFTER INTERIM GRADING.
5. THERE ARE NO ASPHALT BATCH PLANTS OR CONSTRUCTION OFFICE TRAILERS PLANNED FOR THIS SITE OR CONTRACTOR SHALL OBTAIN PERMIT IF DESIRED.
6. CONTRACTOR TO DETERMINE STOCKPILE AREAS, CONCRETE WASHOUT AREAS, AND STAGING AREAS AND SHOW THEM ON THE WORKING MAPS.
7. EXISTING VEGETATION CONSISTS OF GRASSES AND WEEDS. GROUND COVER ESTIMATED AT 65% DENSITY AND WILL BE FIELD VERIFIED AT THE TIME OF CONSTRUCTION
8. THE STAGING AREA WILL BE DETERMINED IN THE FIELD PRIOR TO CONSTRUCTION AND WILL BE DEPICTED ON THE SWMP PLAN AT THAT TIME
9. THE SWMP MANUAL IS LOCATED AT THE SE CORNER OF MARKSHEFFEL ROAD AND FONTAINE BOULEVARD.
10. THERE ARE NO STREAMS OR WETLANDS WITHIN THE LIMITS OF CONSTRUCTION

INITIAL BMP'S:

1. PERIMETER SILT FENCE
2. VEHICLE TRACKING CONTROL PADS
3. SEDIMENT BASIN IN POND E1
4. INLET PROTECTION FOR EXISTING INLETS
5. PLACEMENT OF ON-SITE SWMP MANUAL

INTERIM BMP'S:

1. TEMPORARY SEDIMENT TRAPS AS GRADING PROGRESSES
2. TEMPORARY SEEDING/MULCHING AS NEEDED
3. STRAW BALE CHECKS AS NEEDED DURING GRADING
4. SEDIMENT BASIN IN POND H

FINAL BMP'S:

1. FINAL SEEDING AND MULCHING
2. STRAW ECB ON PERMANENT SLOPES 3:1 OR STEEPER.
3. POND OUTLET STRUCTURES

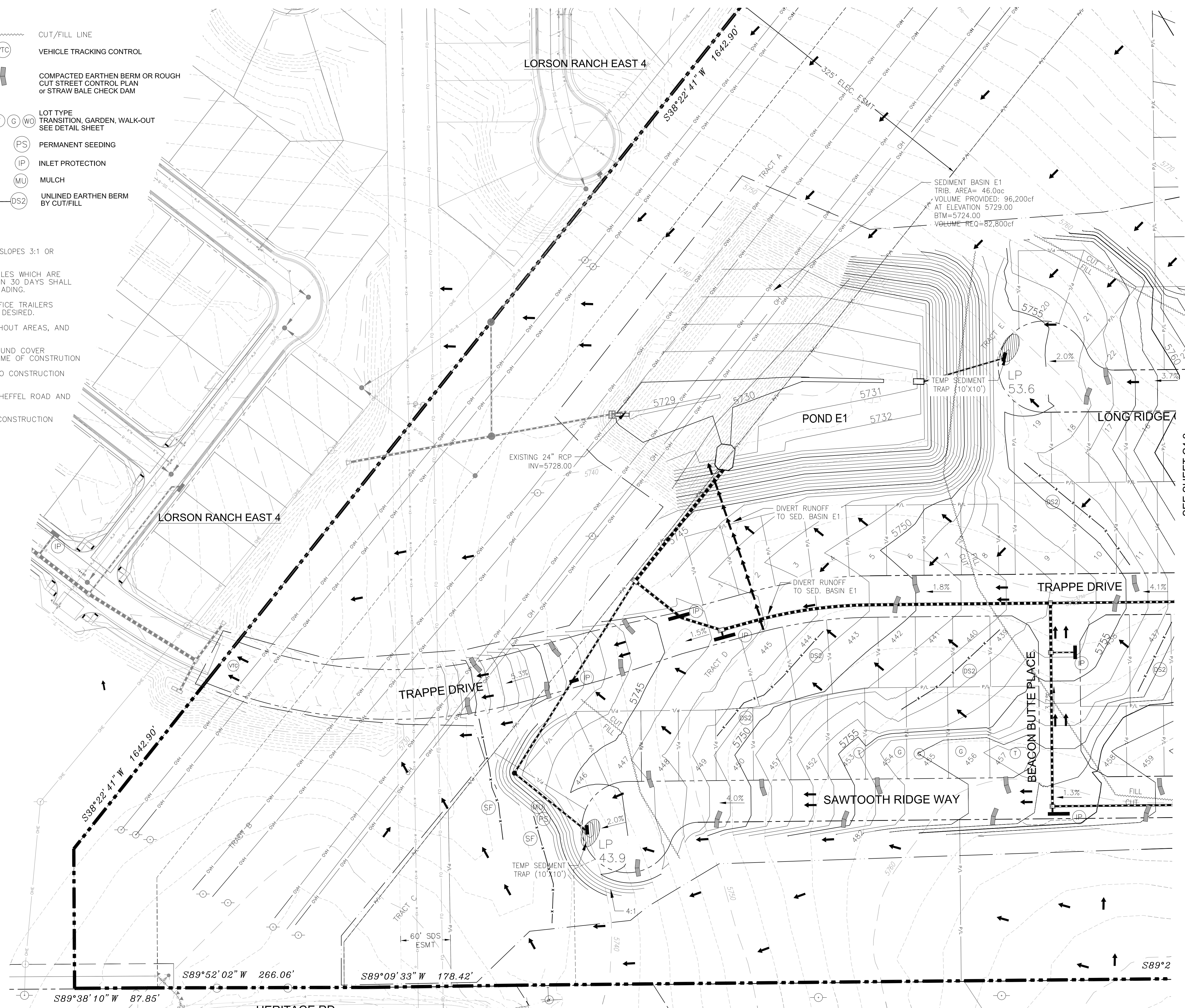
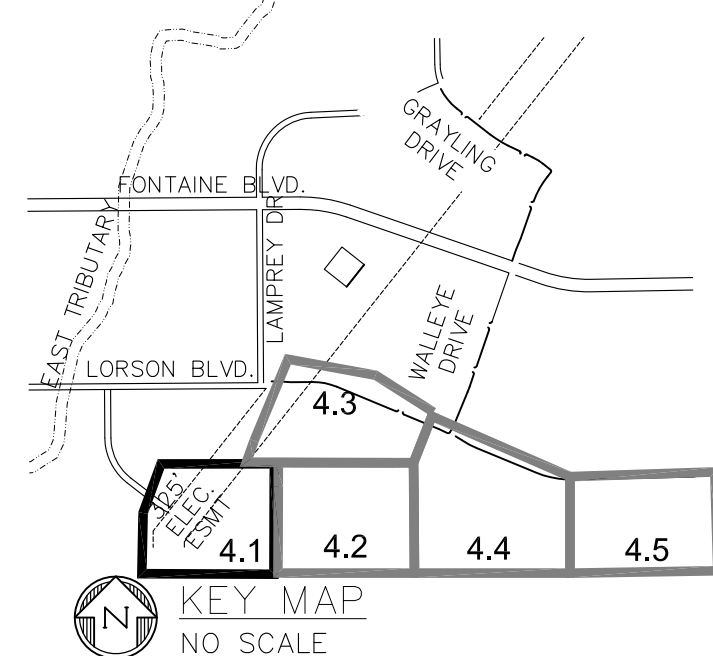
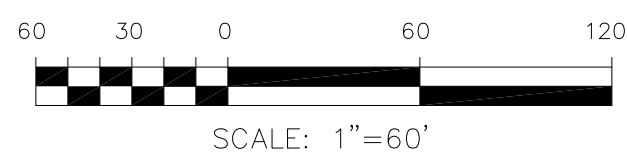
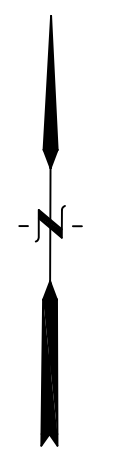

SEE SHEET C4.2

CORE ENGINEERING GROUP
 1500S 151ST AVENUE, SUITE 50506
 PH: 719.570.1100
 CONTACT: RICHARD L. SCHINDLER, P.E.
 EMAIL: Rich@ceg1.com

DATE: _____
 DESCRIPTION: _____
 NO: _____
 PREPARED FOR: **LORSON, LLC**
 212 N. WAHSATCH AVE, SUITE 301
 COLORADO SPRINGS, COLORADO 80903
 CONTACT: JEFF MARK
 PROJECT: **HILLSIDE AT LORSON RANCH**
 LORSON BLVD. - WALLEYE DR.
 COLORADO SPRINGS, COLORADO

DRAWN: RLS
 DESIGNED: RLS
 CHECKED: RLS

**HILLSIDE AT LORSON RANCH
 OVERLOT EARLY GRADING AND
 EROSION CONTROL PLAN**

DATE: APRIL 15, 2022

PROJECT NO. 100.065

SHEET NUMBER C4.1

TOTAL SHEETS: 20

SEE SHEET C4.3

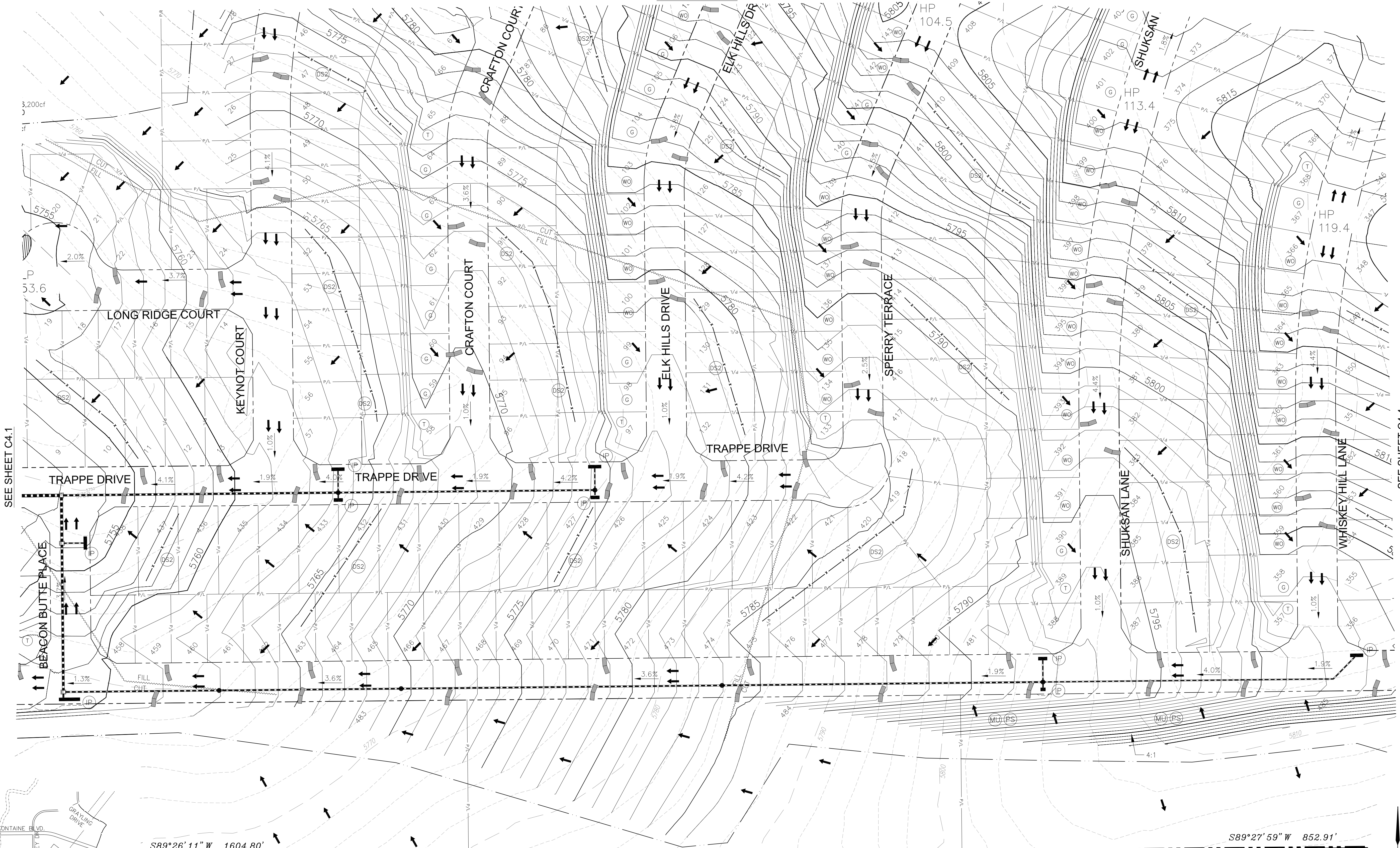

SEE SHEET C4.1

SEE SHEET C4.4

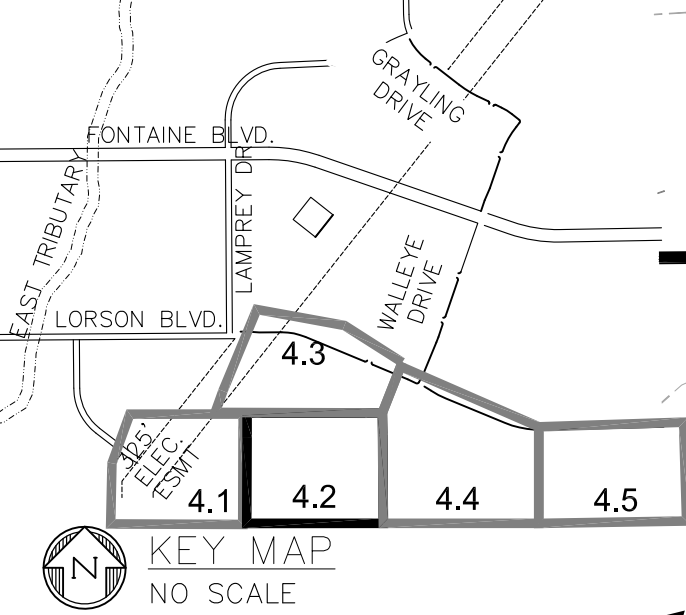

S89°26'11" W 1604.80'

S89°27'59" W 852.91'

PEACEFUL VALLEY LAKE ESTATES
HECTOR VEGA
5524001011

PEACEFUL VALLEY LAKE ESTATES
DAVID BIBER
5524001020

PEACEFUL VALLEY LAKE ESTATES
YURIY LASHCHUK
5524001019

PEACEFUL VALLEY LAKE ESTATES
JOSEPH LEVINE
5524001008

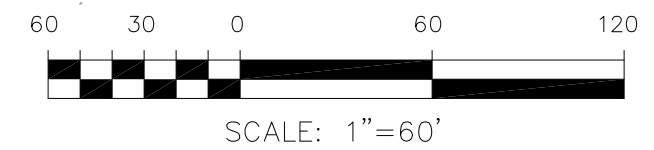

CORE
ENGINEERING GROUP
1500S 151ST AVENUE, SUITE 301
LORSON, CO 80903
PH: 719.570.1100
CONTACT: RICHARD L. SCHINDLER, P.E.
EMAIL: Rich@ceg1.com

DATE: _____
DESCRIPTION: _____
NO. _____
PROJECT: HILLSIDE AT LORSON RANCH
PREPARED FOR: LORSON, LLC
212 N. WAHSATCH AVE, SUITE 301
COLORADO SPRINGS, COLORADO 80903
LORSON BLVD. - WALLEYE DR.
COLORADO SPRINGS, COLORADO
CONTACT: JEFF MARK

DRAWN: RLS
DESIGNED: RLS
CHECKED: RLS

**HILLSIDE AT LORSON RANCH
OVERLOT EARLY GRADING AND
EROSION CONTROL PLAN**

DATE:
APRIL 15, 2022

PROJECT NO.
100.065

SHEET NUMBER
C4.2

TOTAL SHEETS: 20

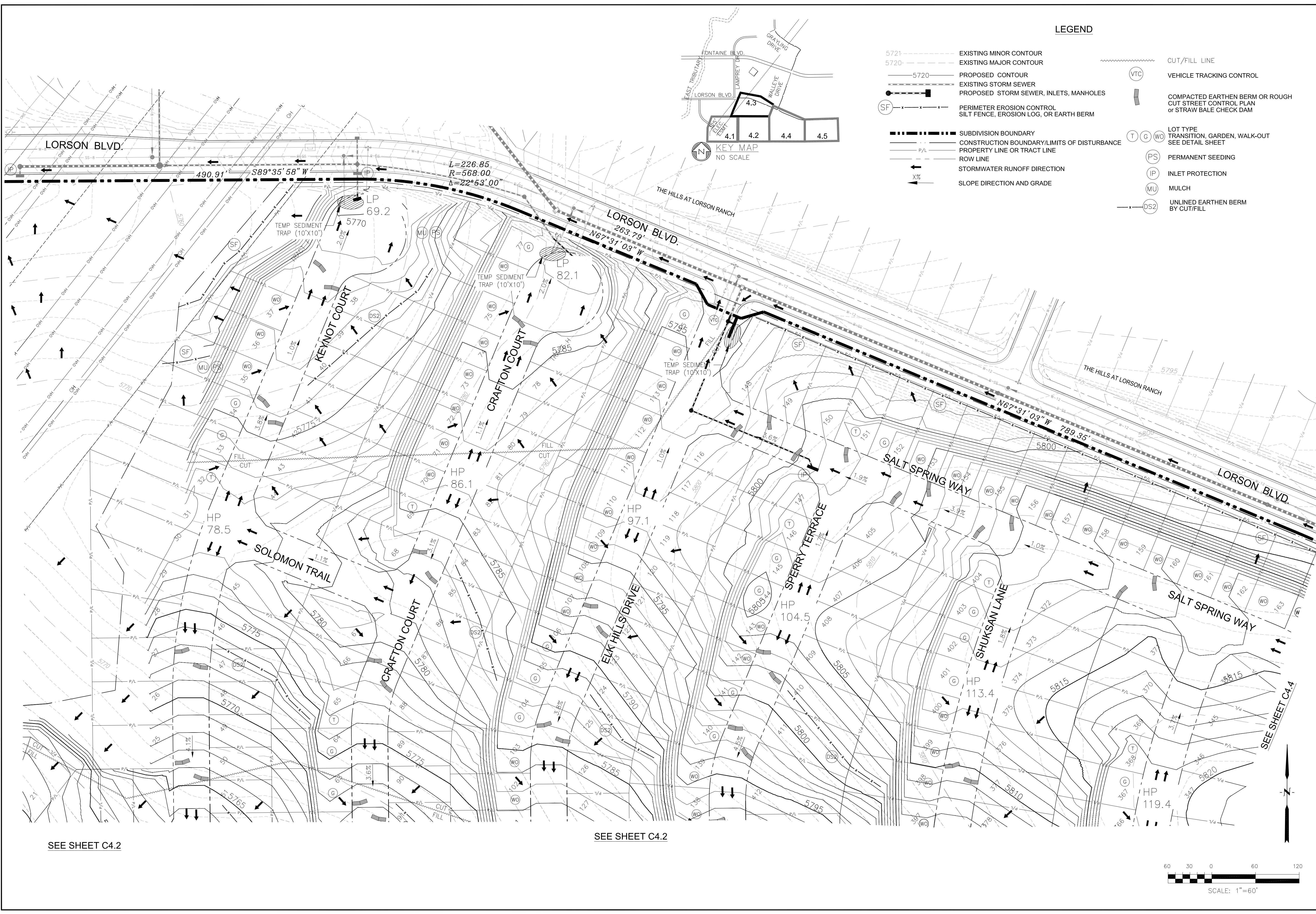

LEGEND

- 5721----- EXISTING MINOR CONTOUR
- 5720----- EXISTING MAJOR CONTOUR
- 5720----- PROPOSED CONTOUR
- EXISTING STORM SEWER
- PROPOSED STORM SEWER, INLETS, MANHOLES
- (SF)----- PERIMETER EROSION CONTROL
SILT FENCE, EROSION LOG, OR EARTH BERM
- SUBDIVISION BOUNDARY
- CONSTRUCTION BOUNDARY/LIMITS OF DISTURBANCE
- P/L----- PROPERTY LINE OR TRACT LINE
- ROW LINE
- STORMWATER RUNOFF DIRECTION
- X%----- SLOPE DIRECTION AND GRADE
- CUT/FILL LINE
- (VTC)----- VEHICLE TRACKING CONTROL
- COMPACTED EARTHEN BERM OR ROUGH CUT STREET CONTROL PLAN OR STRAW BALE CHECK DAM
- (T) (G) (WO)----- LOT TYPE
TRANSITION, GARDEN, WALK-OUT
SEE DETAIL SHEET
- (PS)----- PERMANENT SEEDING
- (IP)----- INLET PROTECTION
- (MU)----- MULCH
- (DS2)----- UNLINED EARTHEN BERM
BY CUT/FILL

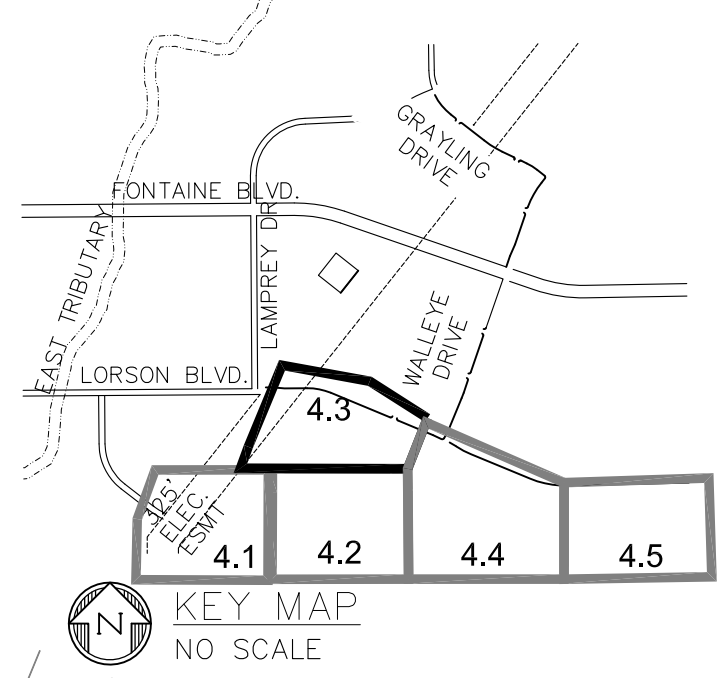

LORSON BLVD.

LORSON BLVD.

SALT SPRING WAY

LORSON BLVD.

SOLOMON TRAIL

CRAFFTON COURT

CRAFFTON COURT

ELK HILLS DRIVE

SPERRY TERRACE

SHUKSAN LANE

SALT SPRING WAY

SEE SHEET C4.2

SEE SHEET C4.2

SEE SHEET C4.4

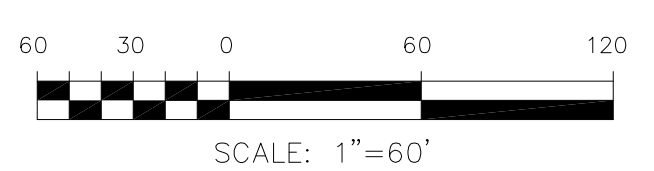

CORE
ENGINEERING GROUP
1500 S. 151ST AVENUE, SUITE 300
DENVER, CO 80232
PH: 719.570.1100
CONTACT: RICHARD L. SCHINDLER, P.E.
EMAIL: Rich@ceg1.com

DATE: _____
DESCRIPTION: _____
NO. _____
PROJECT: HILLSIDE AT LORSON RANCH
PREPARED FOR: LORSON, LLC
212 N. WAHSATCH AVE, SUITE 301
COLORADO SPRINGS, COLORADO 80903
LORSON BLVD. - WALLEYE DR.
COLORADO SPRINGS, COLORADO
CONTACT: JEFF MARK

DRAWN: RLS
DESIGNED: RLS
CHECKED: RLS

**HILLSIDE AT LORSON RANCH
OVERLOT EARLY GRADING AND
EROSION CONTROL PLAN**

DATE:
APRIL 15, 2022

PROJECT NO.
100.065

SHEET NUMBER
C4.3

TOTAL SHEETS: 20

SEE SHEET C4.3

SEE SHEET C4.2

LEGEND

- 5721 - - - - - EXISTING MINOR CONTOUR
- 5720 - - - - - EXISTING MAJOR CONTOUR
- 5720 ——— PROPOSED CONTOUR
- EXISTING STORM SEWER
- PROPOSED STORM SEWER, INLETS, MANHOLES
- (SF) ——— PERIMETER EROSION CONTROL
SILT FENCE, EROSION LOG, OR EARTH BERM
- CUT/FILL LINE
- (VTC) VEHICLE TRACKING CONTROL
- COMPACTED EARTHEN BERM OR ROUGH
CUT STREET CONTROL PLAN
OR STRAW BALE CHECK DAM
- (T) (G) (WO) LOT TYPE
TRANSITION, GARDEN, WALK-OUT
SEE DETAIL SHEET
- (PS) PERMANENT SEEDING
- (IP) INLET PROTECTION
- (MU) MULCH
- (DS2) UNLINED EARTHEN BERM
BY CUT/FILL
- SUBDIVISION BOUNDARY
- CONSTRUCTION BOUNDARY/LIMITS OF DISTURBANCE
- P/L PROPERTY LINE OR TRACT LINE
- ROW LINE
- STORMWATER RUNOFF DIRECTION
- X% SLOPE DIRECTION AND GRADE

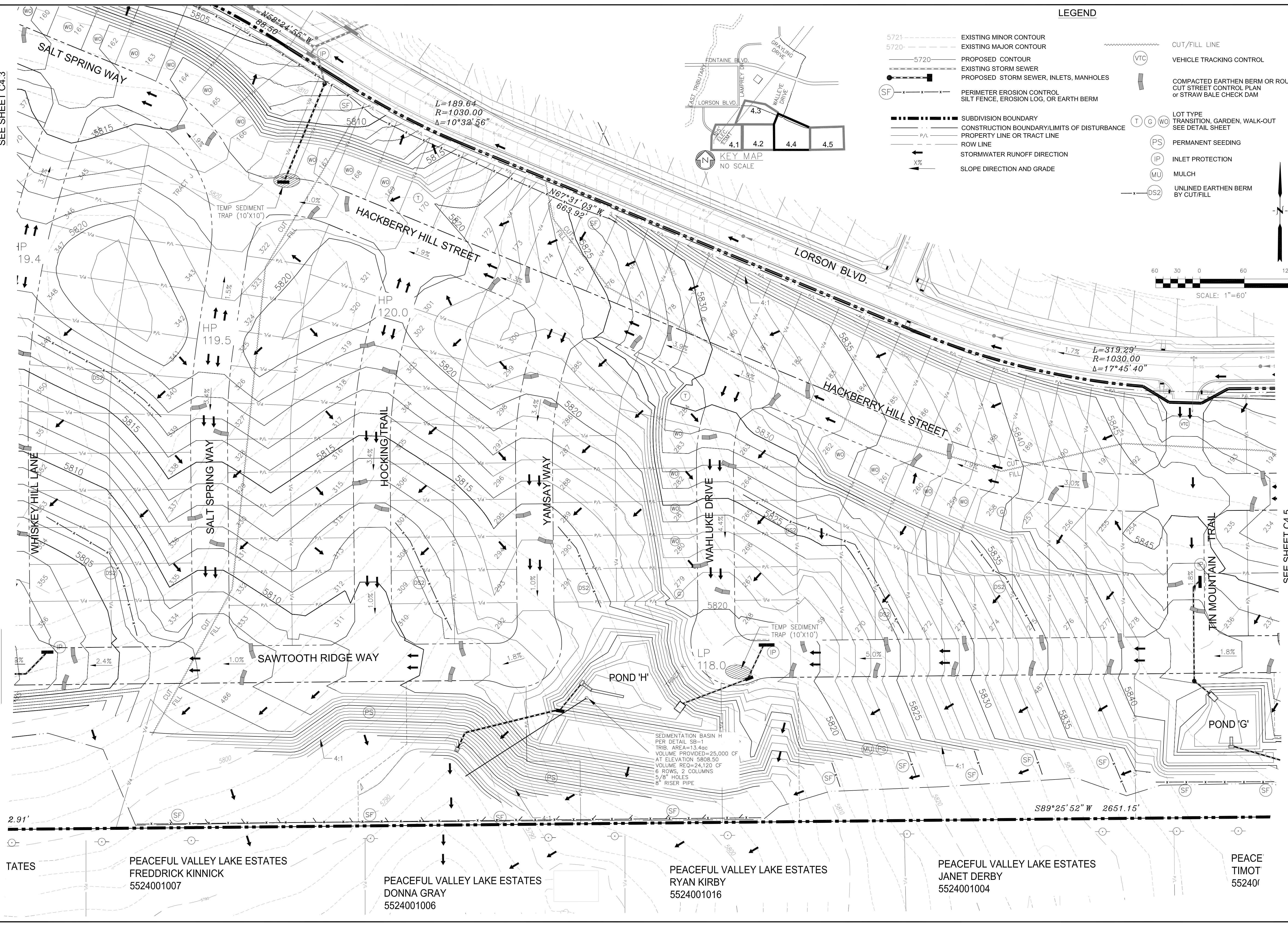
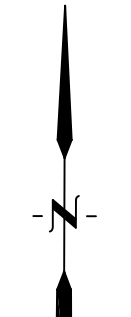
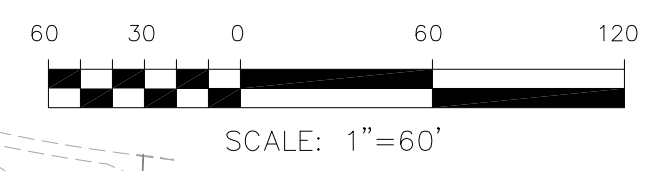
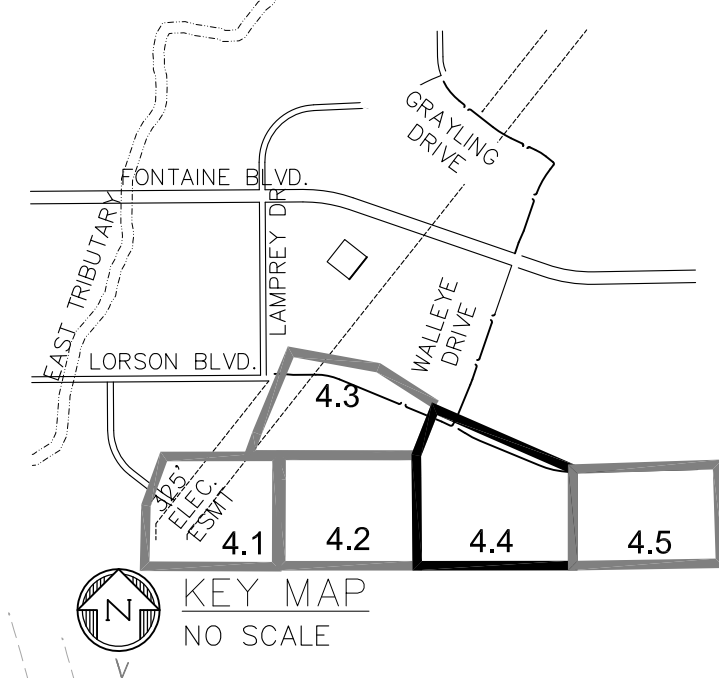

SEDIMENTATION BASIN H
 PER DETAIL S3-1
 TRIB. AREA=13.4ac
 VOLUME PROVIDED=25,000 CF
 AT ELEVATION 5808.50
 VOLUME REQ=24,120 CF
 6 ROWS, 2 COLUMNS
 5/8" HOLES
 8" RISER PIPE

CORE ENGINEERING GROUP
 1500R 151st AVENUE, S.
 BOULDER, CO 80506
 PH: 719.570.1100
 CONTACT: RICHARD L. SCHINDLER, P.E.
 EMAIL: Rich@ceg1.com

DATE: _____
 DESCRIPTION: _____
 NO: _____
 PREPARED FOR:
LORSON, LLC
 212 N. WAHSATCH AVE, SUITE 301
 COLORADO SPRINGS, COLORADO 80903
 LORSON BLVD. - WALLEYE DR.
 COLORADO SPRINGS, COLORADO
 CONTACT: JEFF MARK

DRAWN: RLS
 DESIGNED: RLS
 CHECKED: RLS

**HILLSIDE AT LORSON RANCH
 OVERLOT EARLY GRADING AND
 EROSION CONTROL PLAN**

DATE:
 APRIL 15, 2022
 PROJECT NO.
 100.065
 SHEET NUMBER
C4.4
 TOTAL SHEETS: 20

TATES
 PEACEFUL VALLEY LAKE ESTATES
 FREDRICK KINNICK
 5524001007
 PEACEFUL VALLEY LAKE ESTATES
 DONNA GRAY
 5524001006
 PEACEFUL VALLEY LAKE ESTATES
 RYAN KIRBY
 5524001016
 PEACEFUL VALLEY LAKE ESTATES
 JANET DERBY
 5524001004
 PEACE
 TIMOT
 552401

LEGEND

- 5721----- EXISTING MINOR CONTOUR
- 5720----- EXISTING MAJOR CONTOUR
- PROPOSED CONTOUR
- EXISTING STORM SEWER
- PROPOSED STORM SEWER, INLETS, MANHOLES
- (SF)----- PERIMETER EROSION CONTROL
SILT FENCE, EROSION LOG, OR EARTH BERM
- SUBDIVISION BOUNDARY
- CONSTRUCTION BOUNDARY/LIMITS OF DISTURBANCE
- P/L----- PROPERTY LINE OR TRACT LINE
- ROW LINE
- STORMWATER RUNOFF DIRECTION
- X%----- SLOPE DIRECTION AND GRADE
- CUT/FILL LINE
- (VTC)----- VEHICLE TRACKING CONTROL
- COMPACTED EARTHEN BERM OR ROUGH CUT STREET CONTROL PLAN or STRAW BALE CHECK DAM
- (T) (G) (WO)----- LOT TYPE
TRANSITION, GARDEN, WALK-OUT
SEE DETAIL SHEET
- (PS)----- PERMANENT SEEDING
- (IP)----- INLET PROTECTION
- (MU)----- MULCH
- (DS2)----- UNLINED EARTHEN BERM
BY CUT/FILL

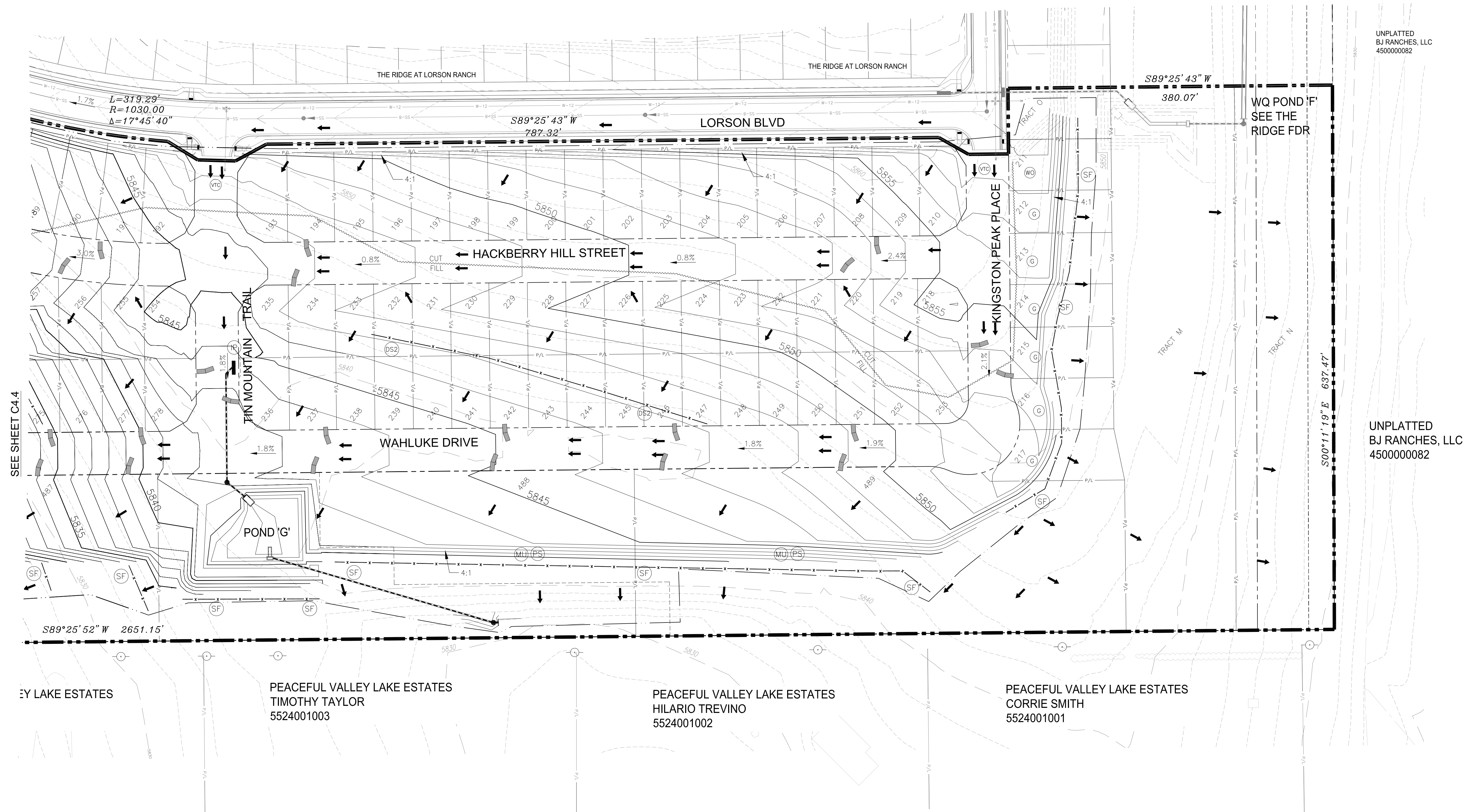
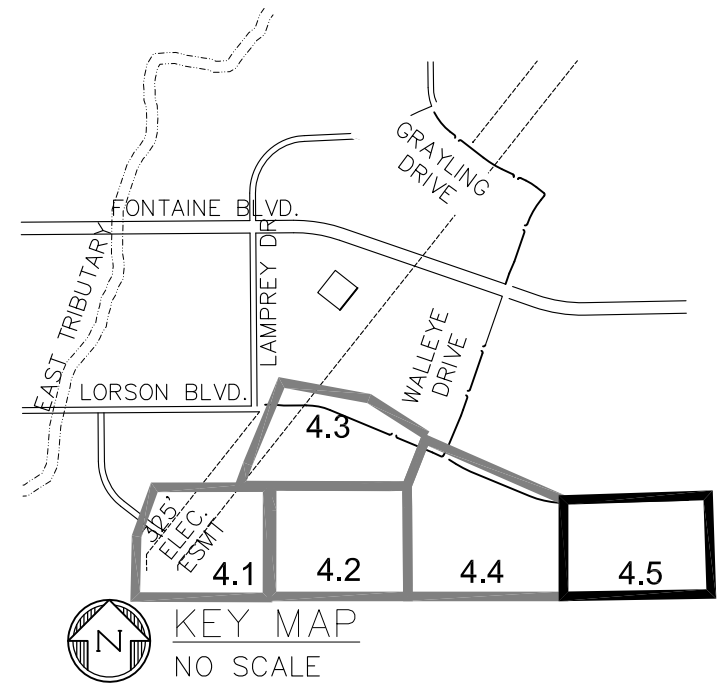
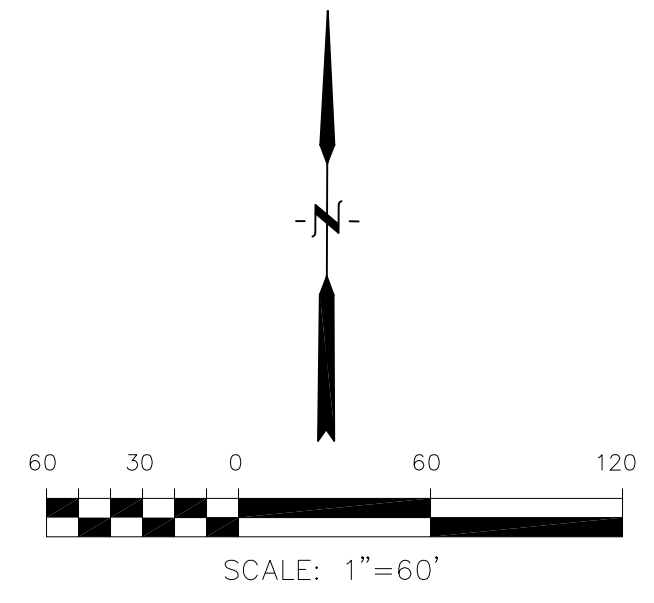

CORE ENGINEERING GROUP
 1500 S. 151ST AVENUE, SUITE 100
 BOULDER, CO 80506
 PH: 719.570.1100
 CONTACT: RICHARD L. SCHINDLER, P.E.
 EMAIL: Rich@ceg1.com

DATE: _____
 DESCRIPTION: _____
 NO. _____
 PREPARED FOR: **LORSON, LLC**
 212 N. WAHSATCH AVE, SUITE 301
 COLORADO SPRINGS, COLORADO 80903
 PROJECT: **HILLSIDE AT LORSON RANCH**
 LORSON BLVD - WALLEYE DR
 COLORADO SPRINGS, COLORADO
 CONTACT: JEFF MARK

DRAWN: RLS
 DESIGNED: RLS
 CHECKED: RLS

**HILLSIDE AT LORSON RANCH
 OVERLOT EARLY GRADING AND
 EROSION CONTROL PLAN**

DATE: APRIL 15, 2022
 PROJECT NO. 100.065
 SHEET NUMBER **C4.5**
 TOTAL SHEETS: 20

PEACEFUL VALLEY LAKE ESTATES

PEACEFUL VALLEY LAKE ESTATES
 TIMOTHY TAYLOR
 5524001003

PEACEFUL VALLEY LAKE ESTATES
 HILARIO TREVINO
 5524001002

PEACEFUL VALLEY LAKE ESTATES
 CORRIE SMITH
 5524001001

UNPLATTED
 BJ RANGES, LLC
 4500000082

UNPLATTED
 BJ RANGES, LLC
 4500000082

NOTE:
 1. POND SLOPES SHALL BE 3:1 UNLESS OTHERWISE NOTED
 2. STRAW ECB SHALL BE PLACED ON ALL POND SIDE SLOPES UNLESS NOTED OTHERWISE

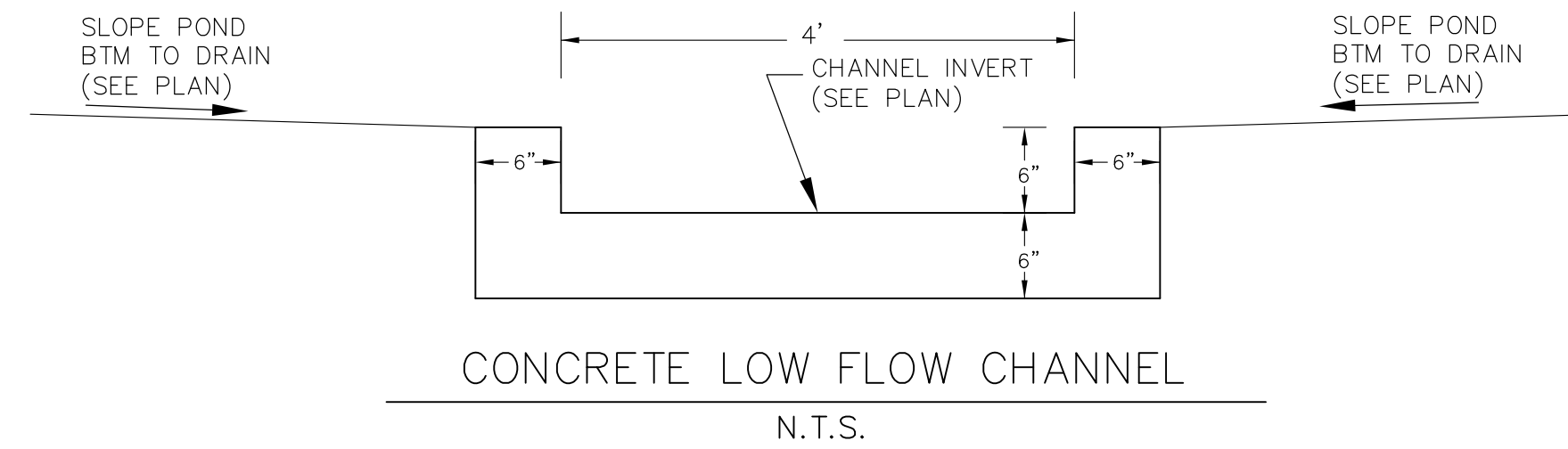
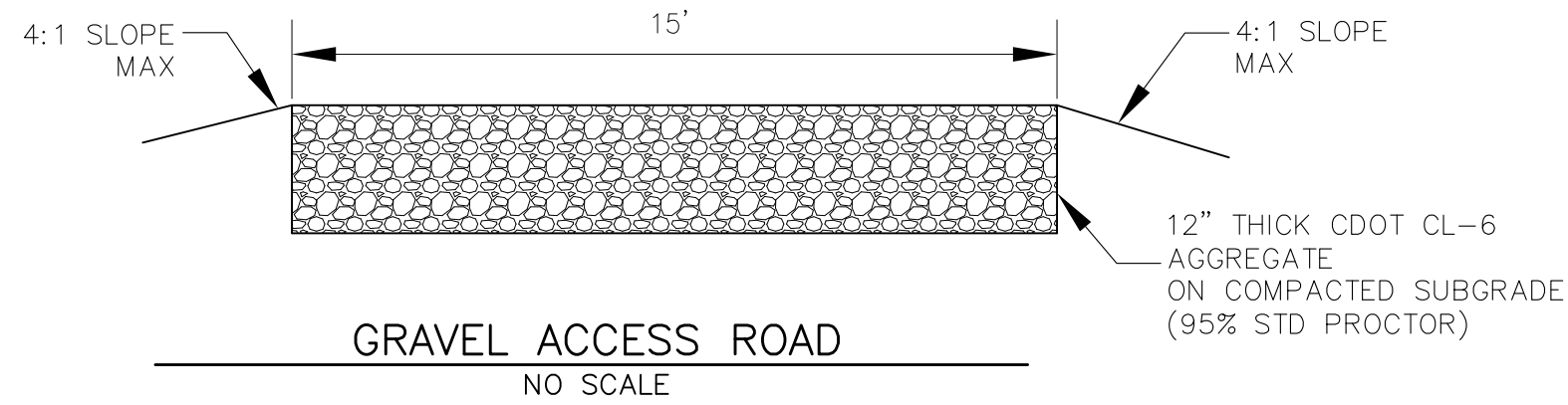

Unresolved comment from Review #1:
 show emergency spillway and accompanying details.

Rich's response:
 there is no spillway since the pond was cut below existing grade. the overflow is spread out over a large area and will not erode the downstream areas.

My thoughts:
 I still don't think it's acceptable to not have a spillway. MHFD criteria recommends directing overflow through a spillway.

label emergency spillway

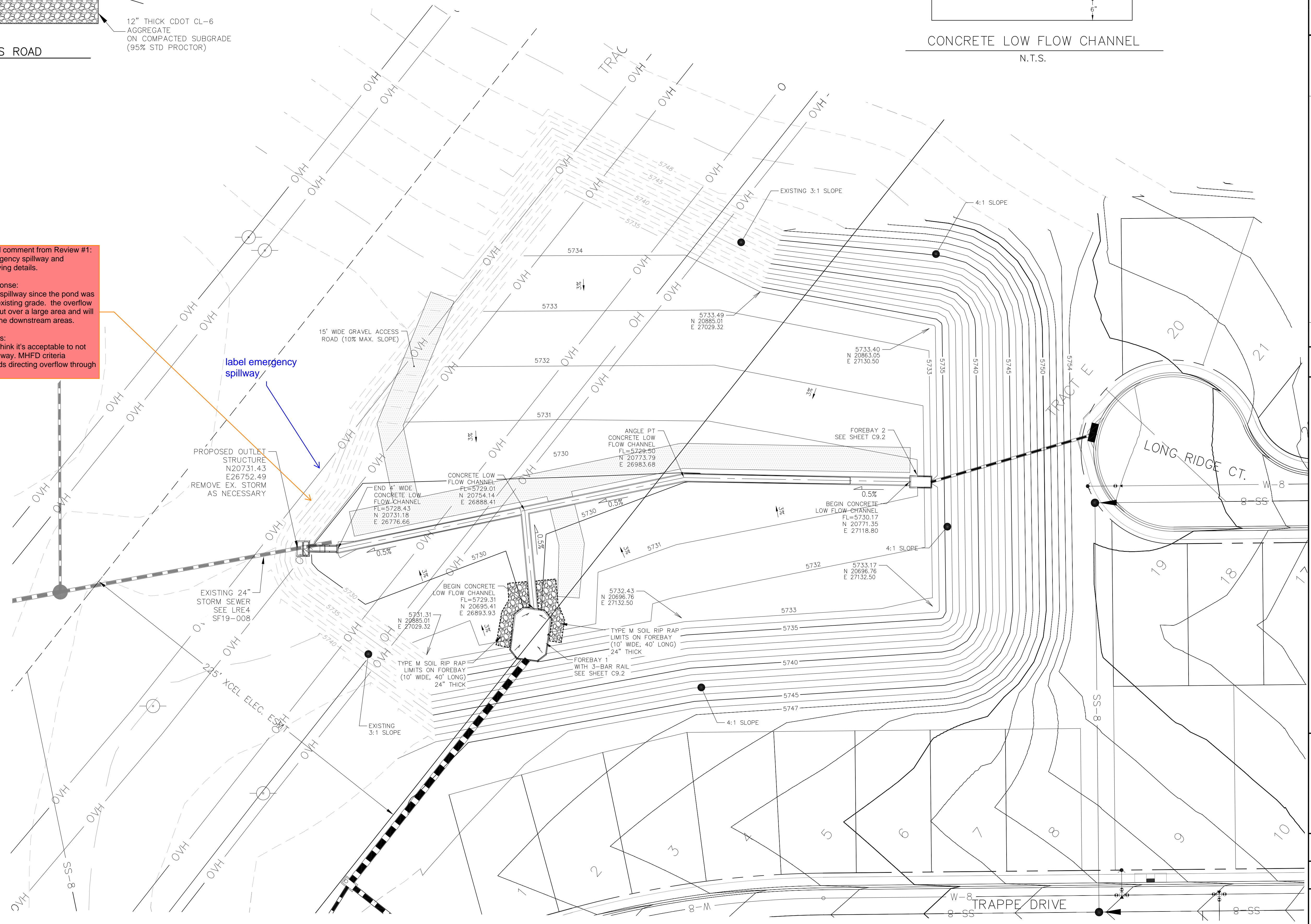
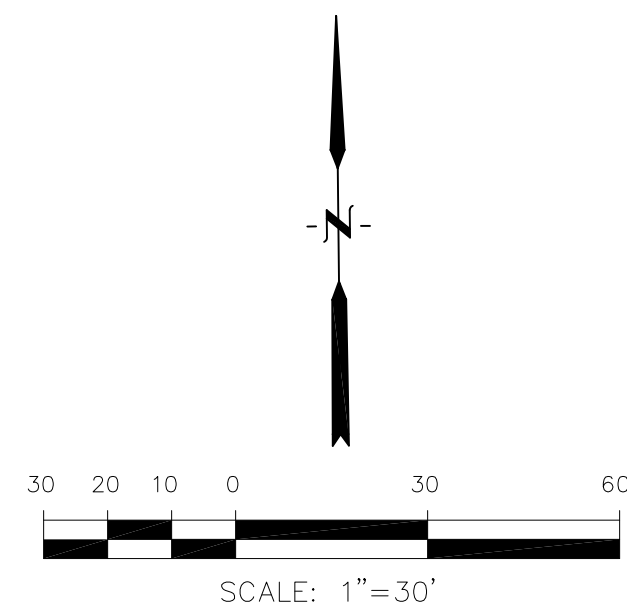

CORE ENGINEERING GROUP 15004 1ST AVENUE S. DENVER, CO 80202 PHONE: 719.570.1100 CONTACT: RICHARD L. SCHINDLER, P.E. EMAIL: Rich@ceg1.com	
DATE:	
DESCRIPTION:	
NO.:	
PREPARED FOR:	LORSON, LLC 212 N. WAHSATCH AVE, SUITE 301 COLORADO SPRINGS, COLORADO 80903 (719) 635-3200 CONTACT: JEFF MARK
PROJECT:	HILLSIDE AT LORSON RANCH LORSON BLVD. - WALLEYE DR. COLORADO SPRINGS, COLORADO
DRAWN:	RLS
DESIGNED:	RLS
CHECKED:	RLS
POND E1 POND GRADING AND TRICKLE CHANNEL	
DATE:	APRIL 15, 2022
PROJECT NO.:	100.065
SHEET NUMBER:	C9.1
TOTAL SHEETS:	20

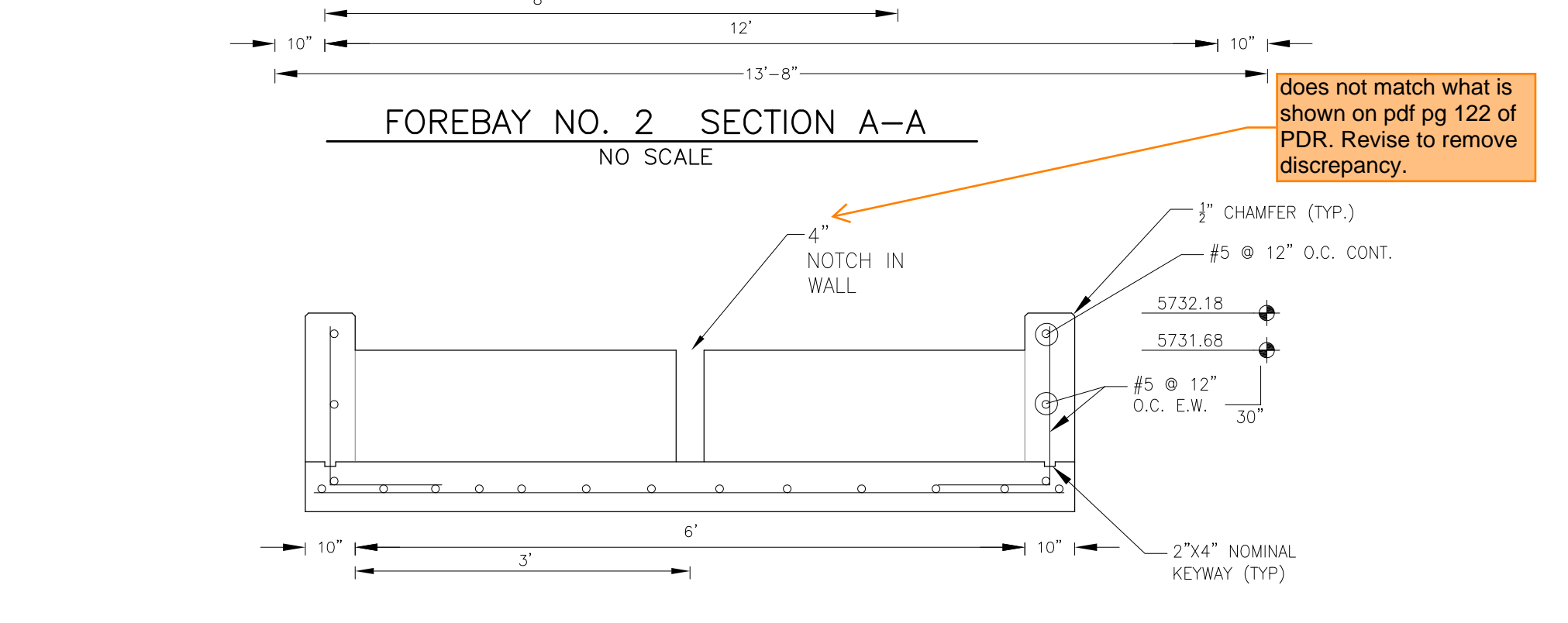
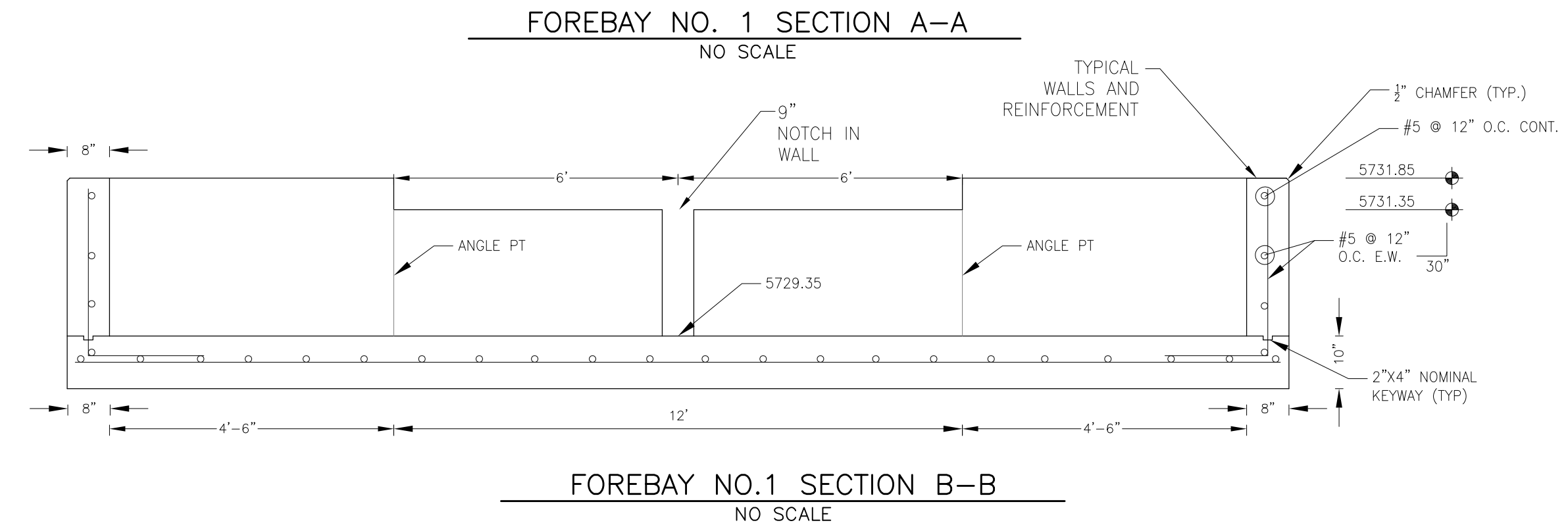
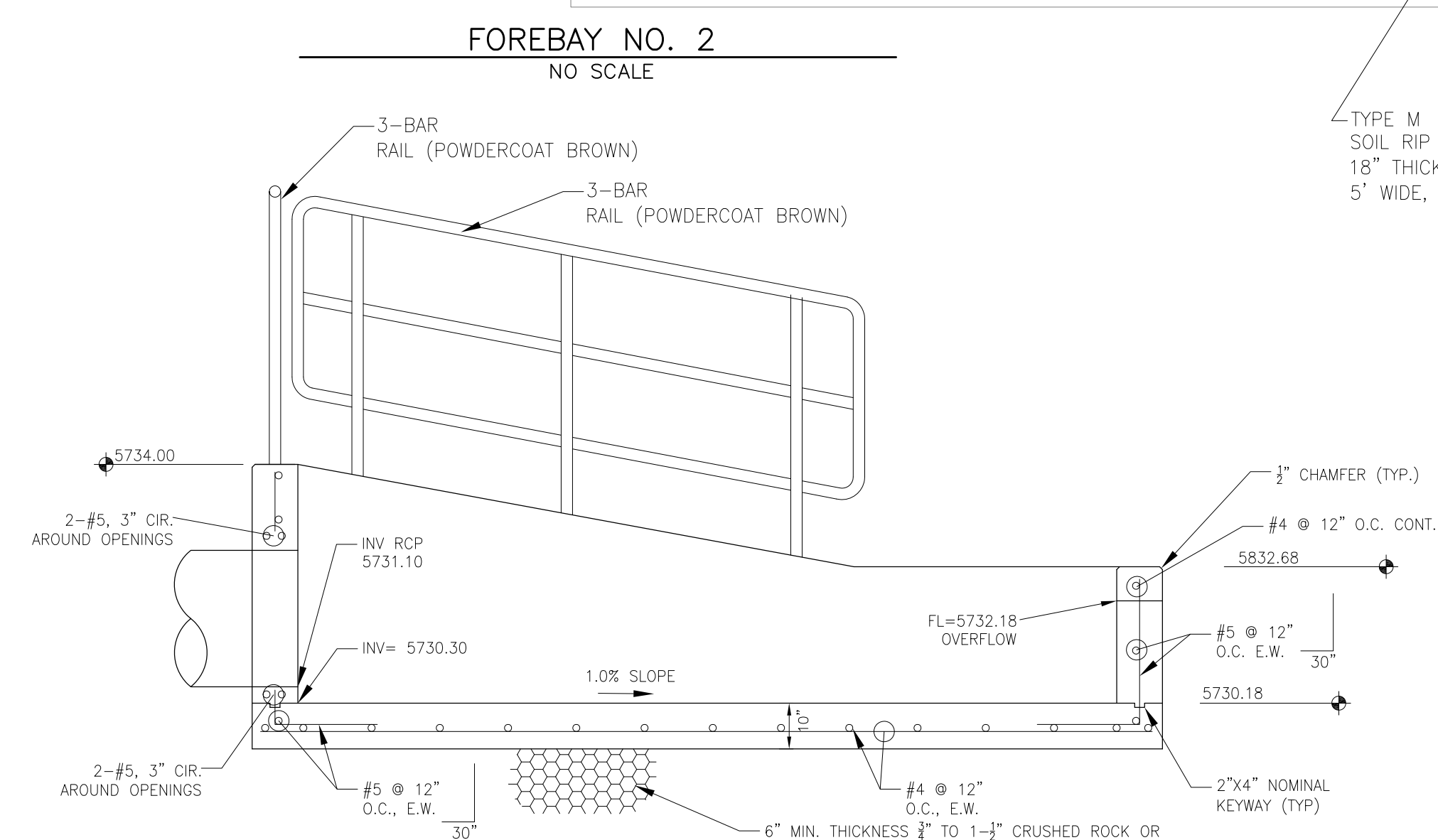
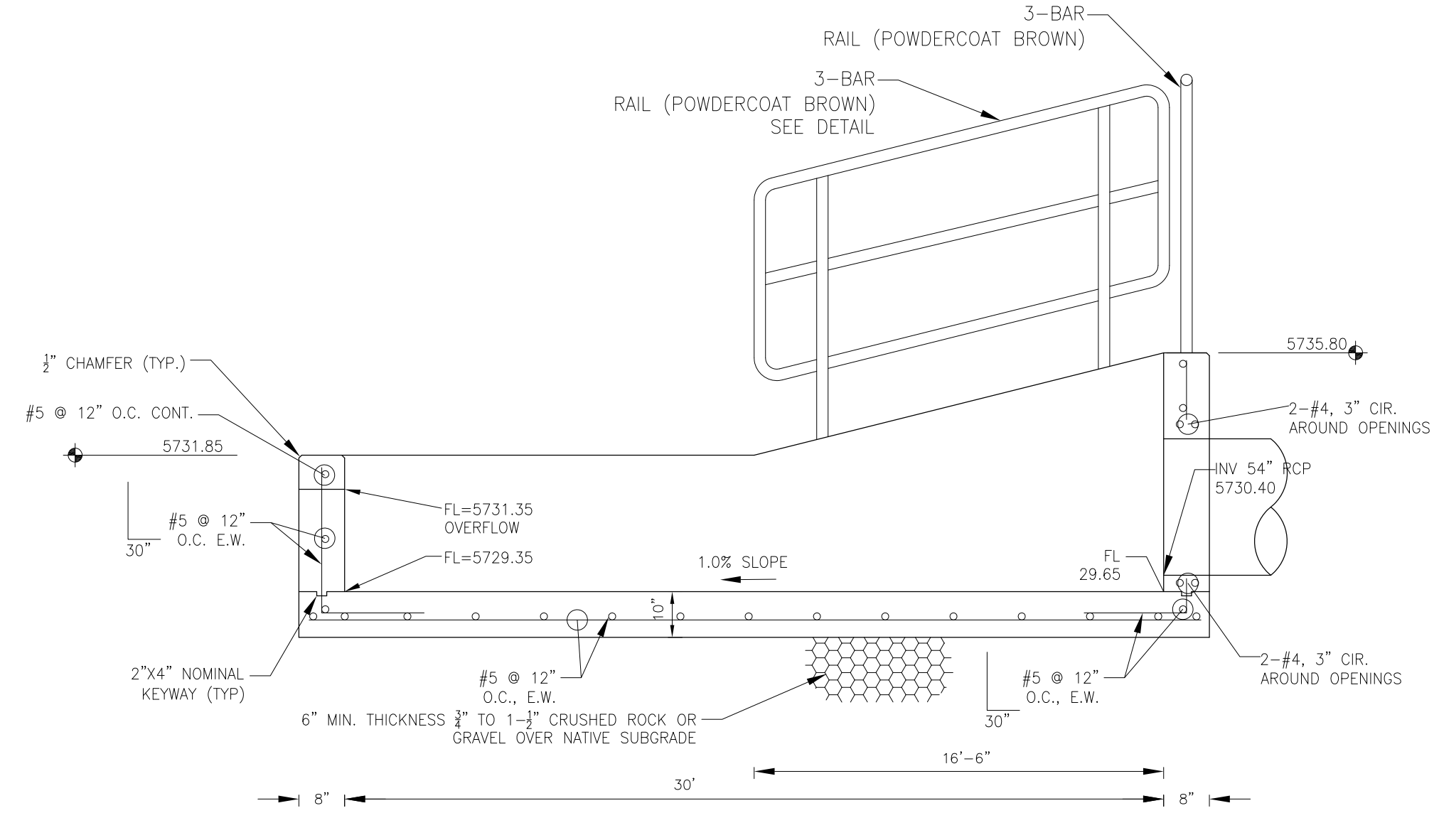
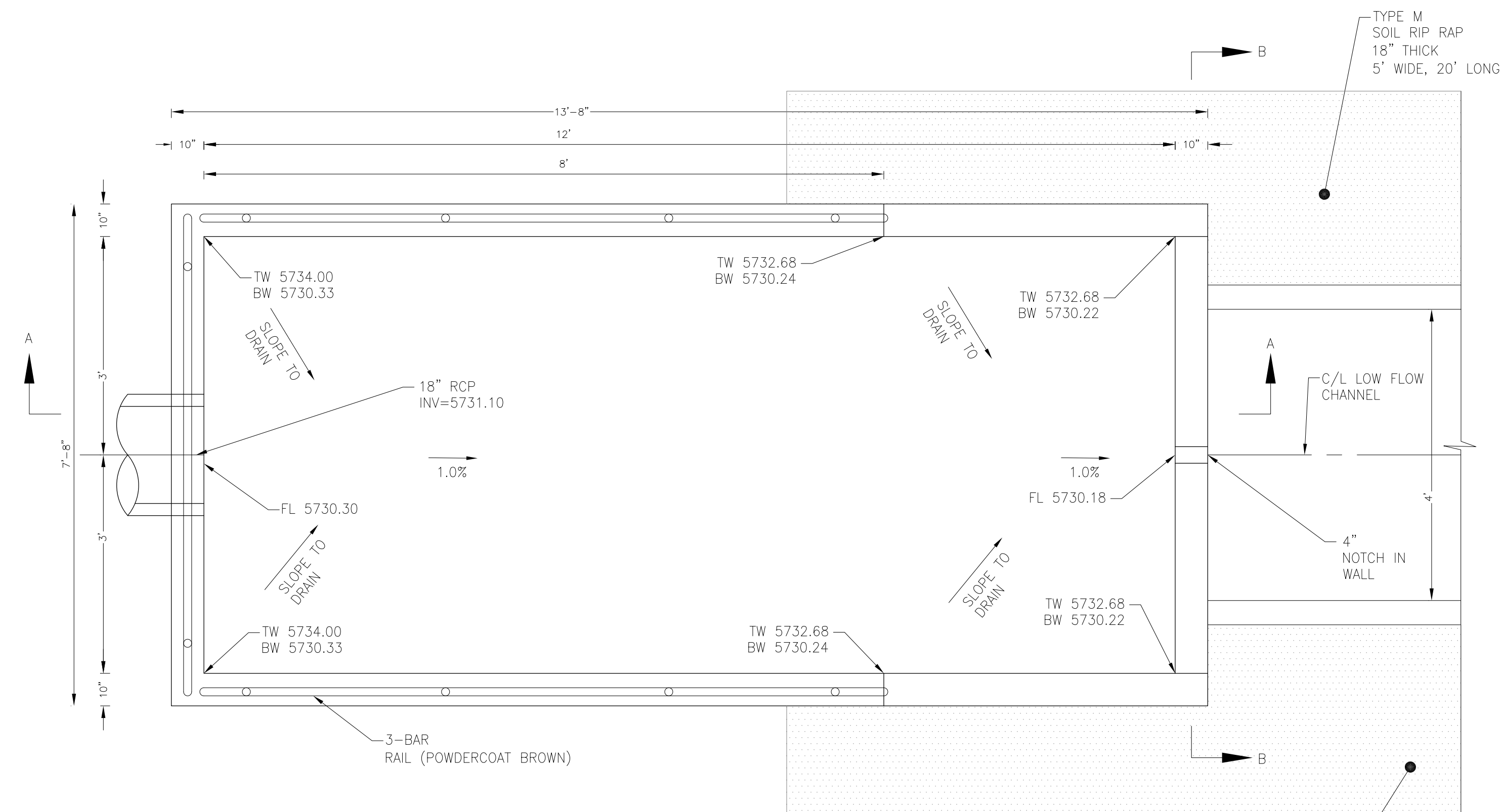
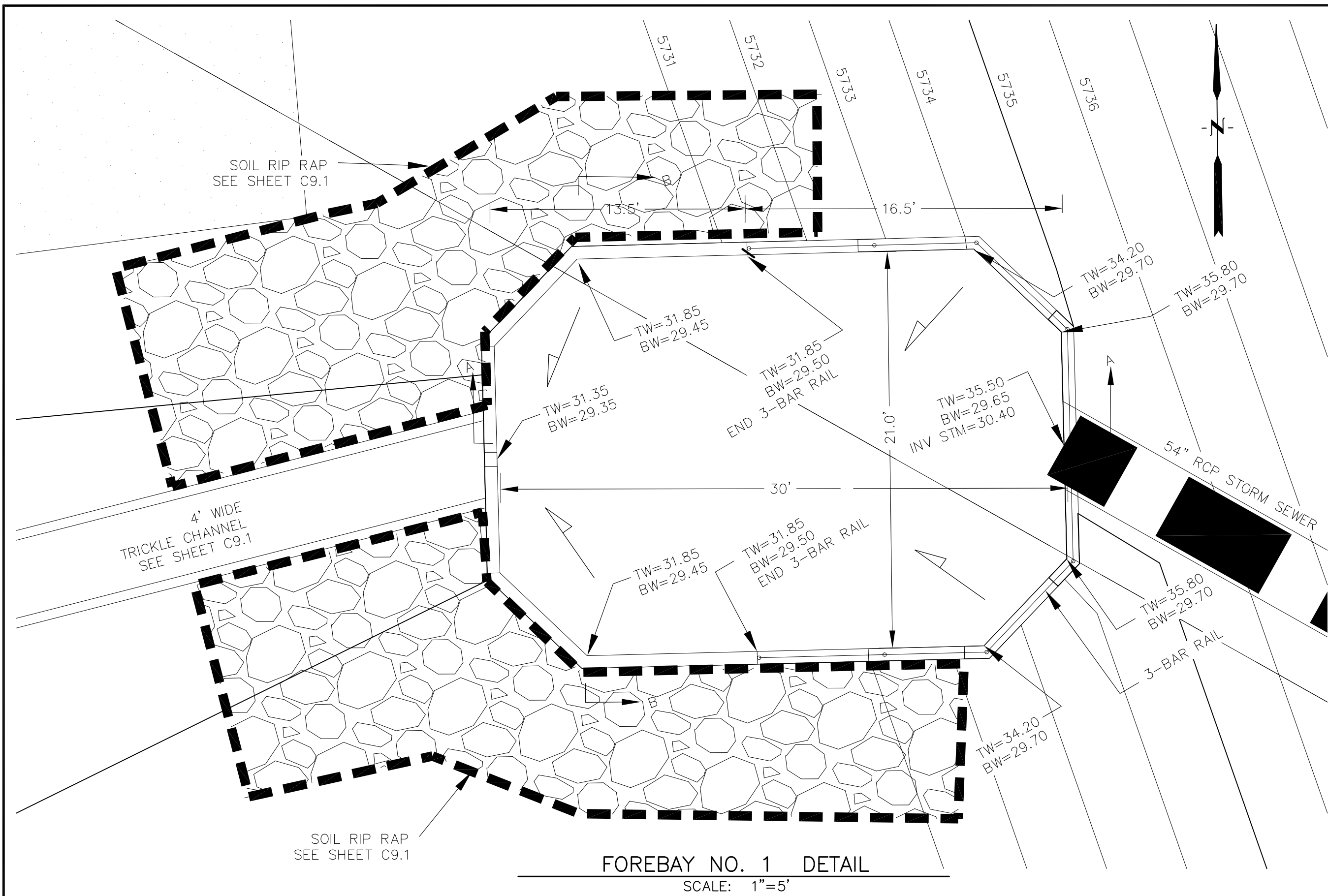

does not match what is shown on pdf pg 122 of PDR. Revise to remove discrepancy.

CORE ENGINEERING GROUP
15004 1ST AVENUE S.
DENVER, CO 80202
PH: 719.570.1100
CONTACT: RICHARD L. SCHINDLER, P.E.
EMAIL: Rich@cegi.com

DATE: _____
DESCRIPTION: _____
NO: _____

PREPARED FOR:
LORSON, LLC
212 N. WAHSATCH AVE, SUITE 301
COLORADO SPRINGS, COLORADO 80903
LORSON BLVD. - WALLEYE DR.
COLORADO SPRINGS, COLORADO (719) 635-3200
CONTACT: JEFF MARK

PROJECT:
HILLSIDE AT LORSON RANCH

DRAWN: RLS
DESIGNED: RLS
CHECKED: RLS

**POND E1
POND FOREBAY DETAILS**

DATE:
APRIL 15, 2022

PROJECT NO.
100.065

SHEET NUMBER
C9.2

TOTAL SHEETS: 20

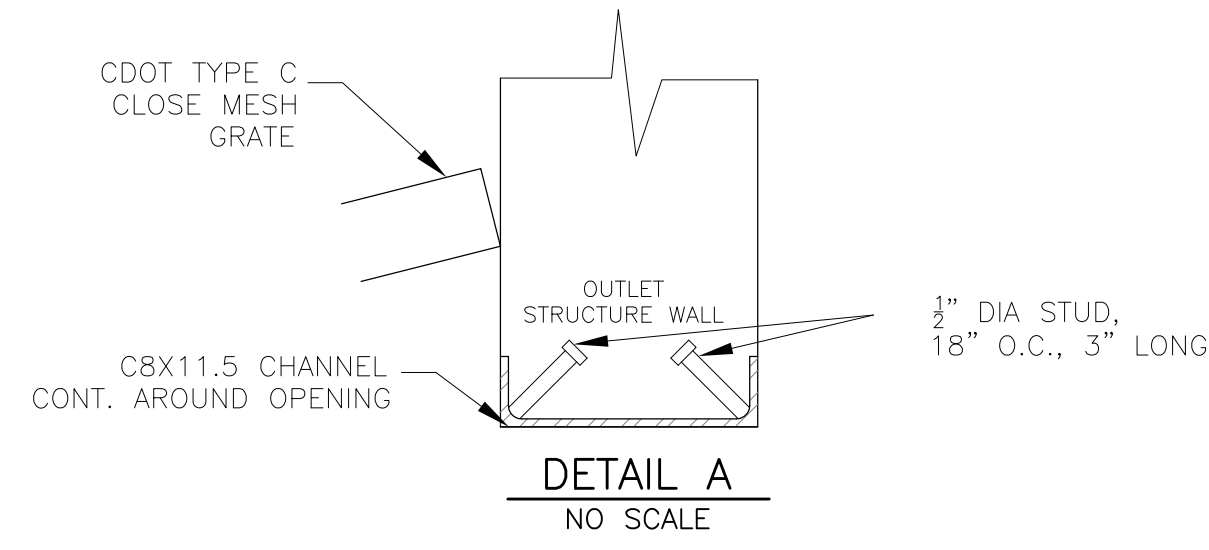

NOTE:
AFTER CONCRETE STRUCTURE HAS BEEN POURED
ALL GRATE DIMENSIONS SHALL BE FIELD VERIFIED
PRIOR TO GRATE CONSTRUCTION

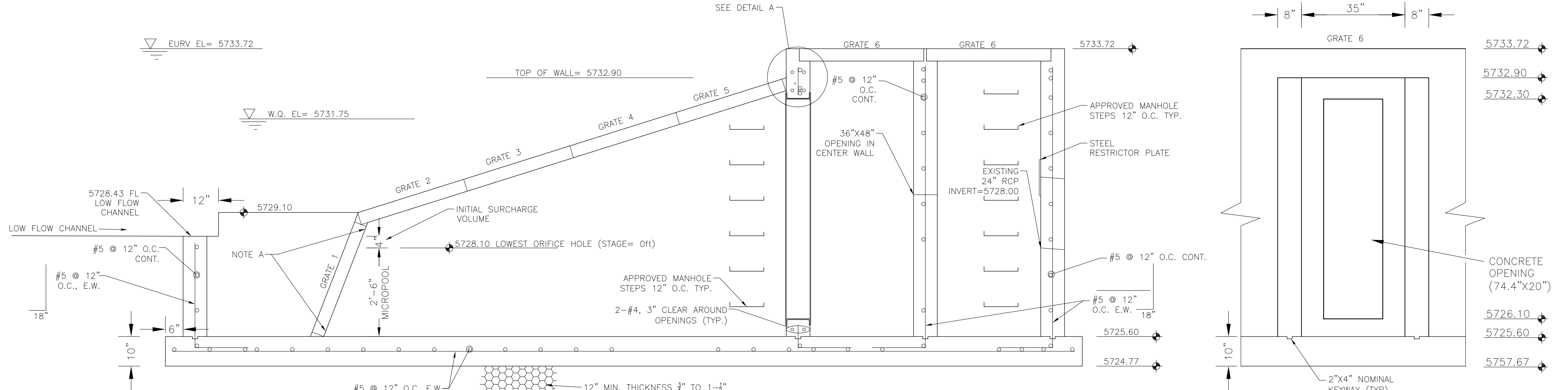
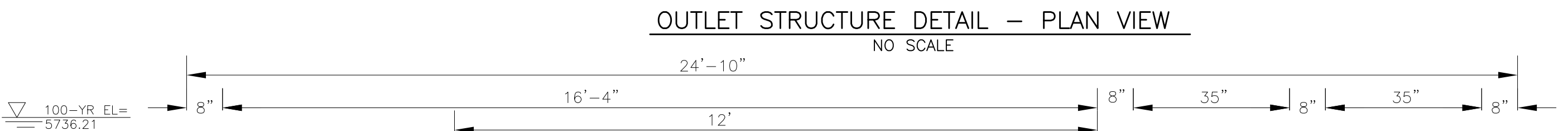
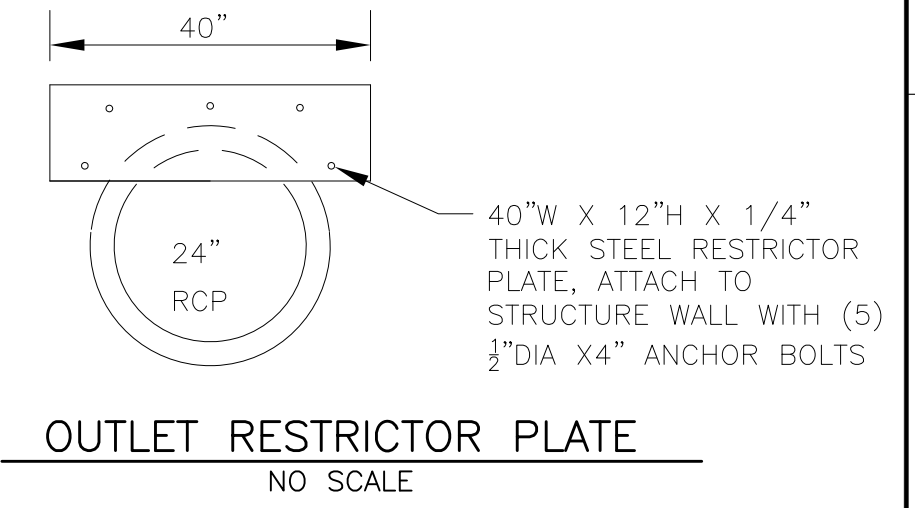
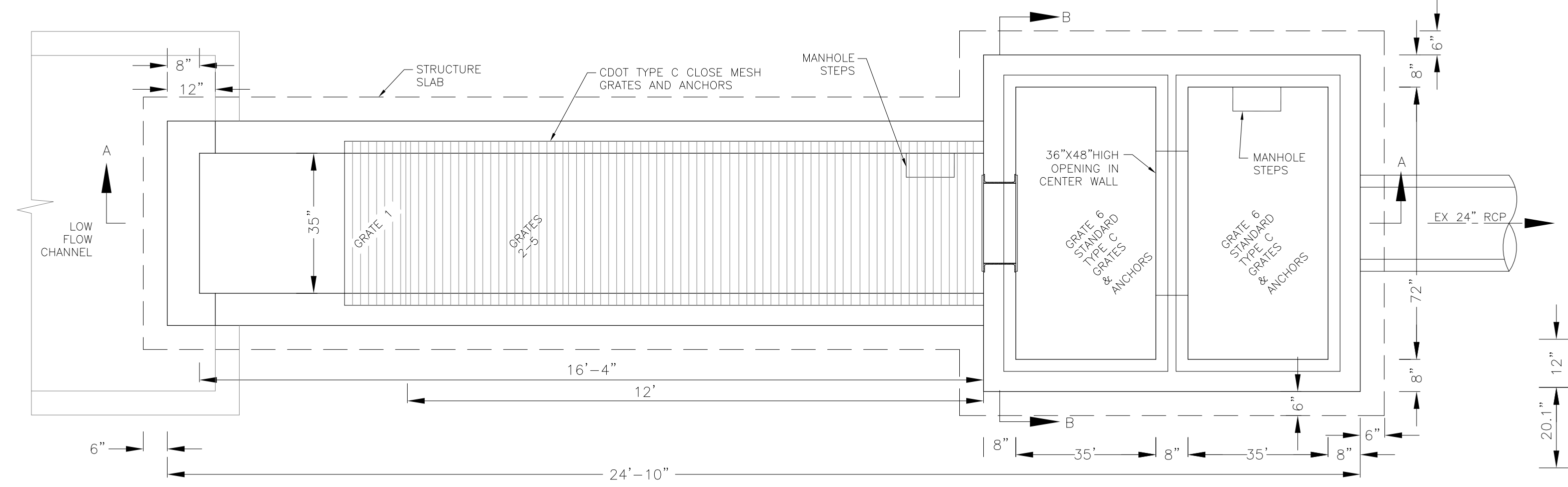
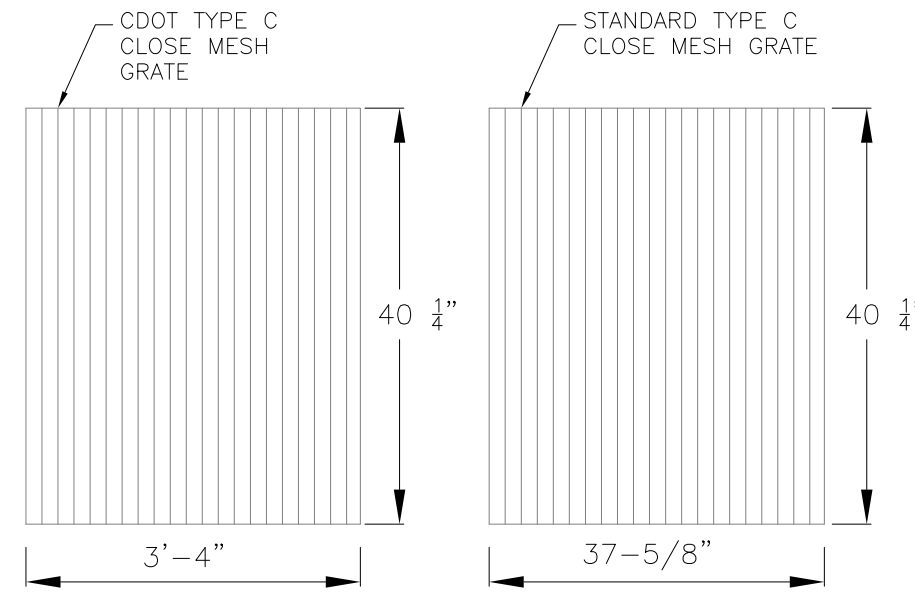

OUTLET STRUCTURE DETAIL - SECTION B-B
NO SCALE

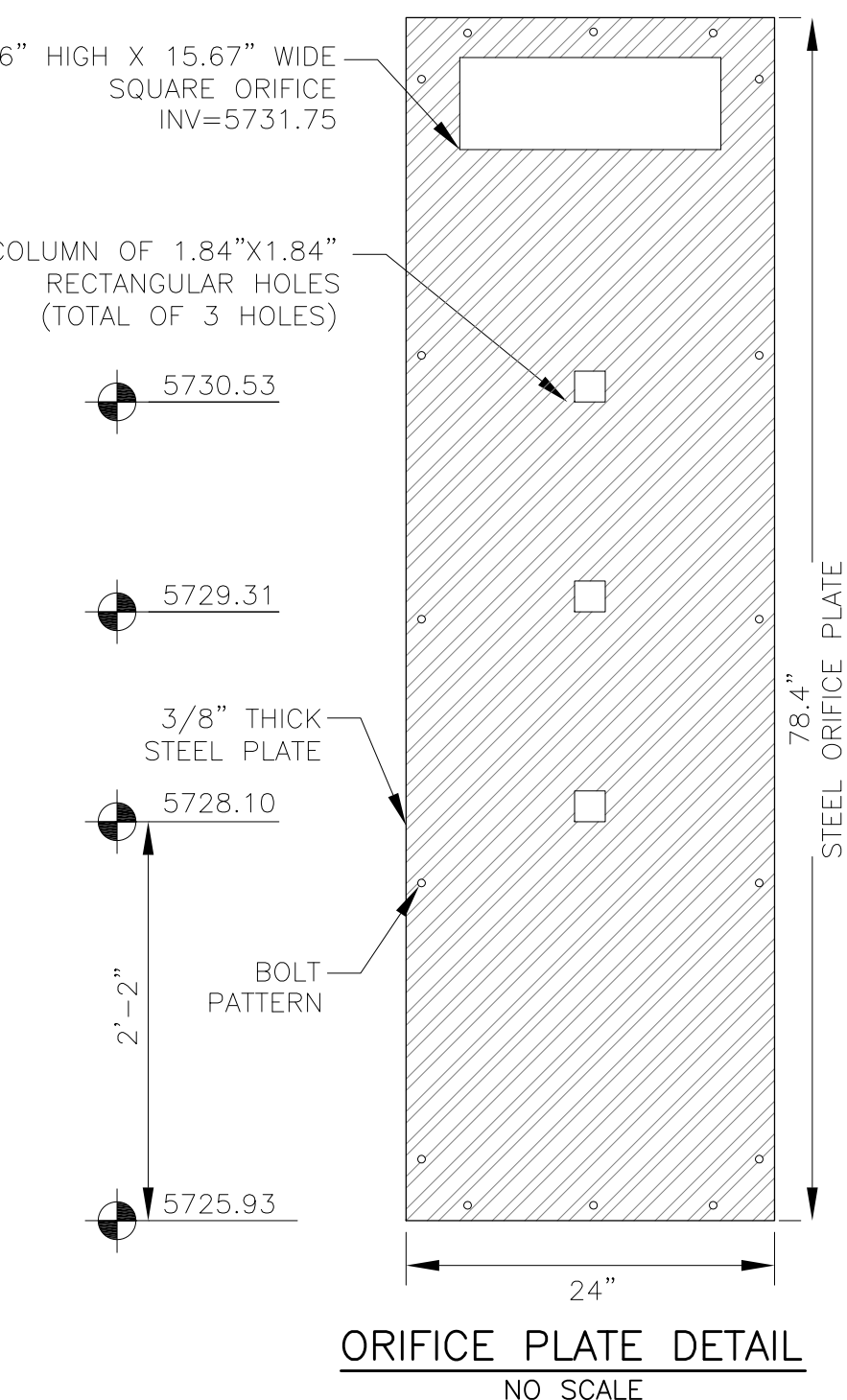
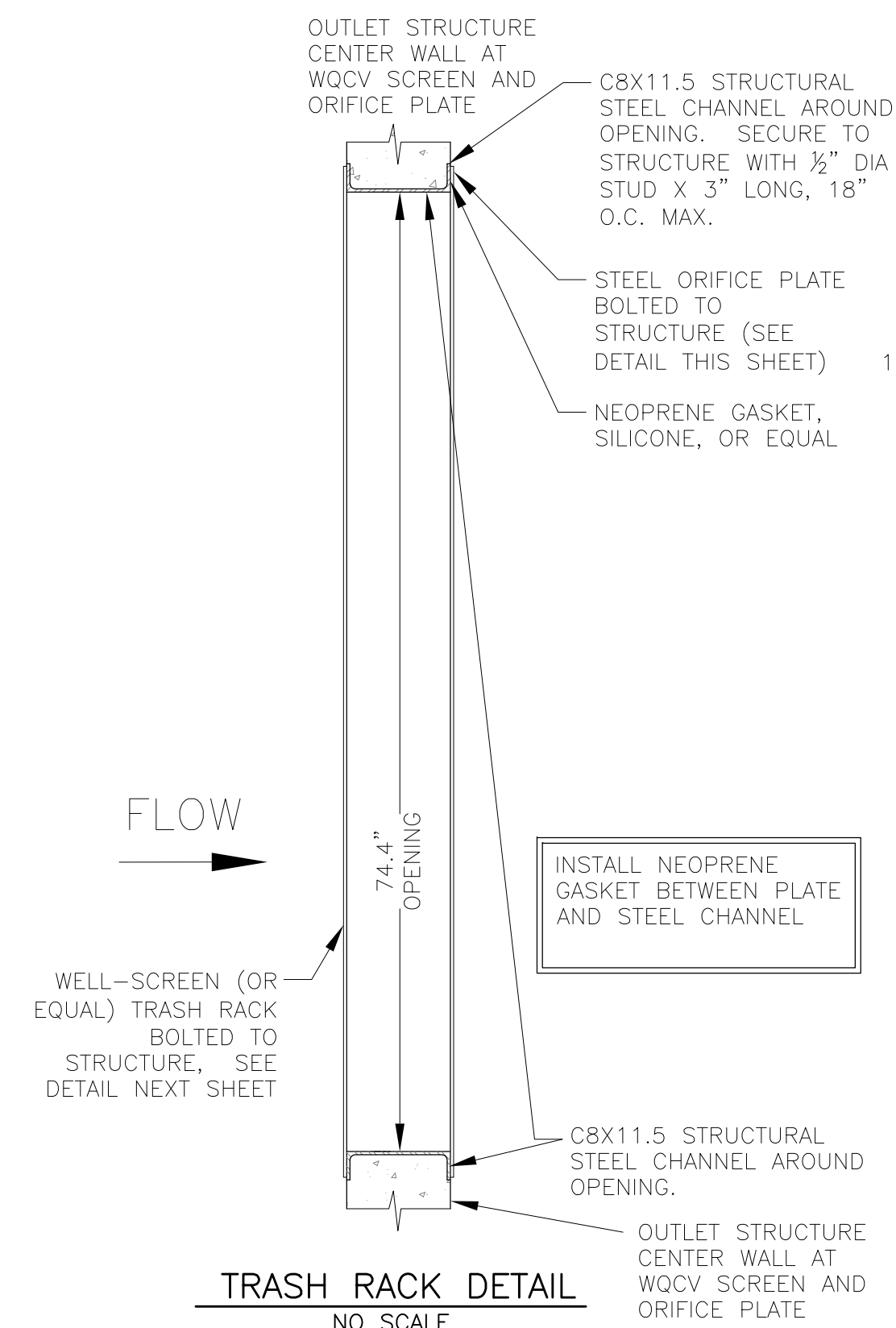

OUTLET STRUCTURE DETAIL - SECTION A-A
NO SCALE

OUTLET STRUCTURE, FOREBAY, AND DRAIN CHANNEL NOTES:

- PRIOR TO CONSTRUCTION, CONTRACTOR SHALL PROVIDE SHOP DRAWINGS FOR ALL COMPONENTS OF THE OUTLET STRUCTURE.
- GRADE 60 REINFORCING STEEL REQUIRED. SEE TABLE FOR THE MINIMUM LAP SPLICE LENGTH FOR REINFORCING BARS. ALL REINFORCING STEEL SHALL HAVE A TWO-INCH MINIMUM CLEARANCE FROM EDGE OF CONCRETE, UNLESS OTHERWISE NOTED.
- CONCRETE FOR THE OUTLET STRUCTURE AND FOREBAY SHALL BE CDOT CLASS D CONCRETE.
- CONCRETE FOR DRAIN CHANNELS SHALL BE CDOT CLASS B CONCRETE
- EXPANSION JOINT MATERIAL SHALL MEET AASHTO SPECIFICATION M-213. EXPANSION JOINT MATERIAL SHALL BE 1/2" THICK, SHALL EXTEND THE FULL DEPTH OF CONTACT SURFACE AND THE JOINT SHALL BE SEALED, REFER TO DETAILS.
- ALL EXPOSED CONCRETE CORNERS SHALL HAVE A 3/8" CHAMFER UNLESS OTHERWISE NOTED.
- SUBGRADE TO BE 12" THICK CLEAN FILL COMPACTED TO 95% STANDARD PROCTOR DENSITY PER ASTM M698 UNDER STRUCTURE.
- REFER TO POND DETAILS FOR PRESEDIMENTATION/FOREBAY DESIGN.
- ENGINEER SHALL BE NOTIFIED PRIOR TO BEGINNING CONSTRUCTION OF OUTLET STRUCTURE TO SCHEDULE OBSERVATION VISITS FOR STRUCTURES.

BAR SIZE	#4	#5	#6
MIN. SPLICE LENGTH	1'-3"	1'-7"	2'-0"

WQCV WELL-SCREEN NOTES:

- Well-Screen shall be stainless steel and attached by stainless steel bolts along edge of the mounting frame.
- WQCV Well Screen
 - Type of Screen: Stainless steel #93 Vee Wire (Johnson Vee Wire (tm) Stainless Steel Screen or equivalent with 60% open area)
 - Screen slot opening dimension: 0.139" (Screen #93 Vee Wire Slot Opening)
 - Type and Size of Support Rod: TE 0.074"x0.50"
 - Spacing of Support Rod (O.C.): 1.0 Inch
 - Total Screen Thickness: 0.655"
 - Carbon Steel Holding Frame Type: 3/4" x 1.0" angle

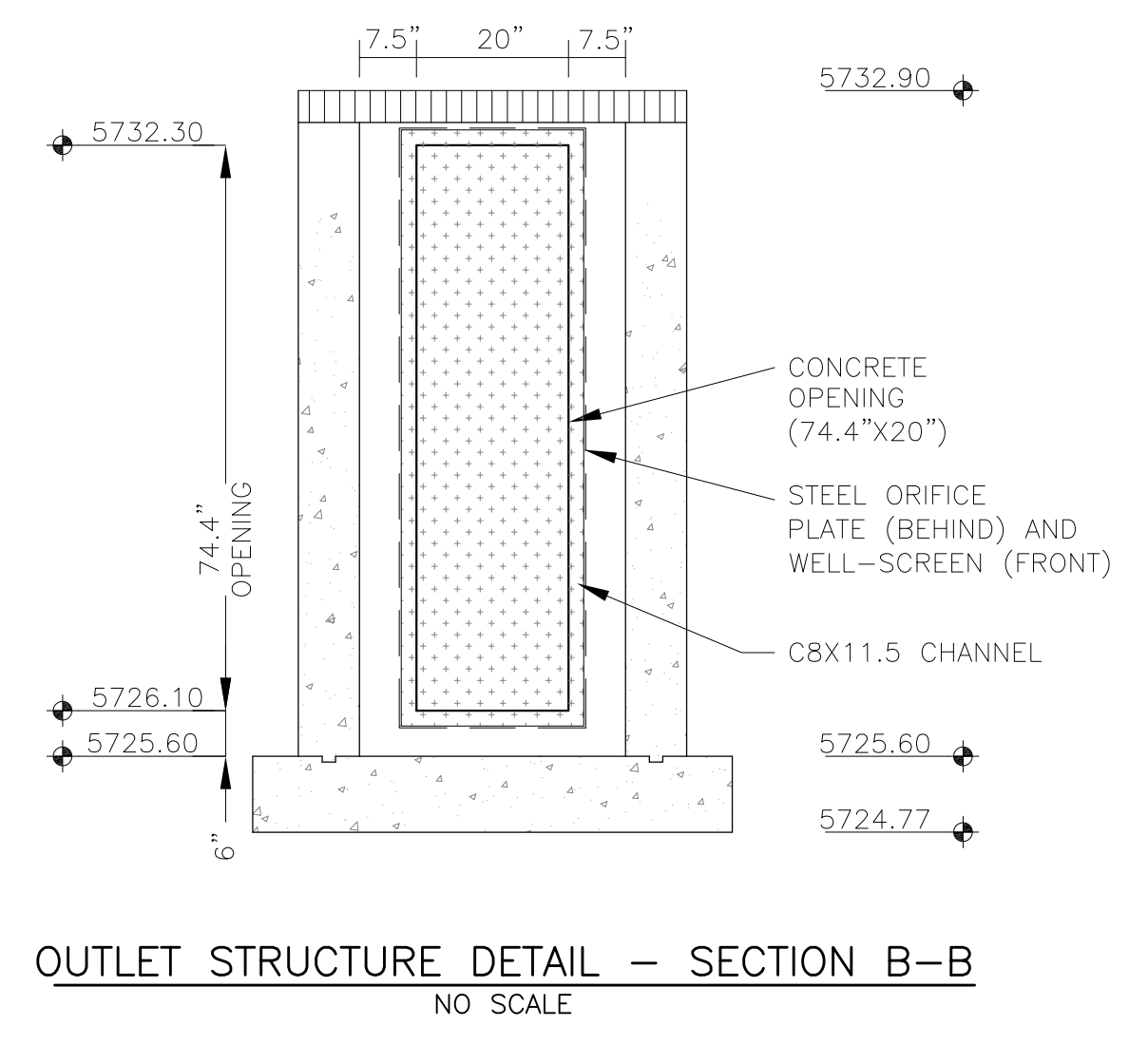

OUTLET STRUCTURE DETAIL - SECTION B-B
NO SCALE

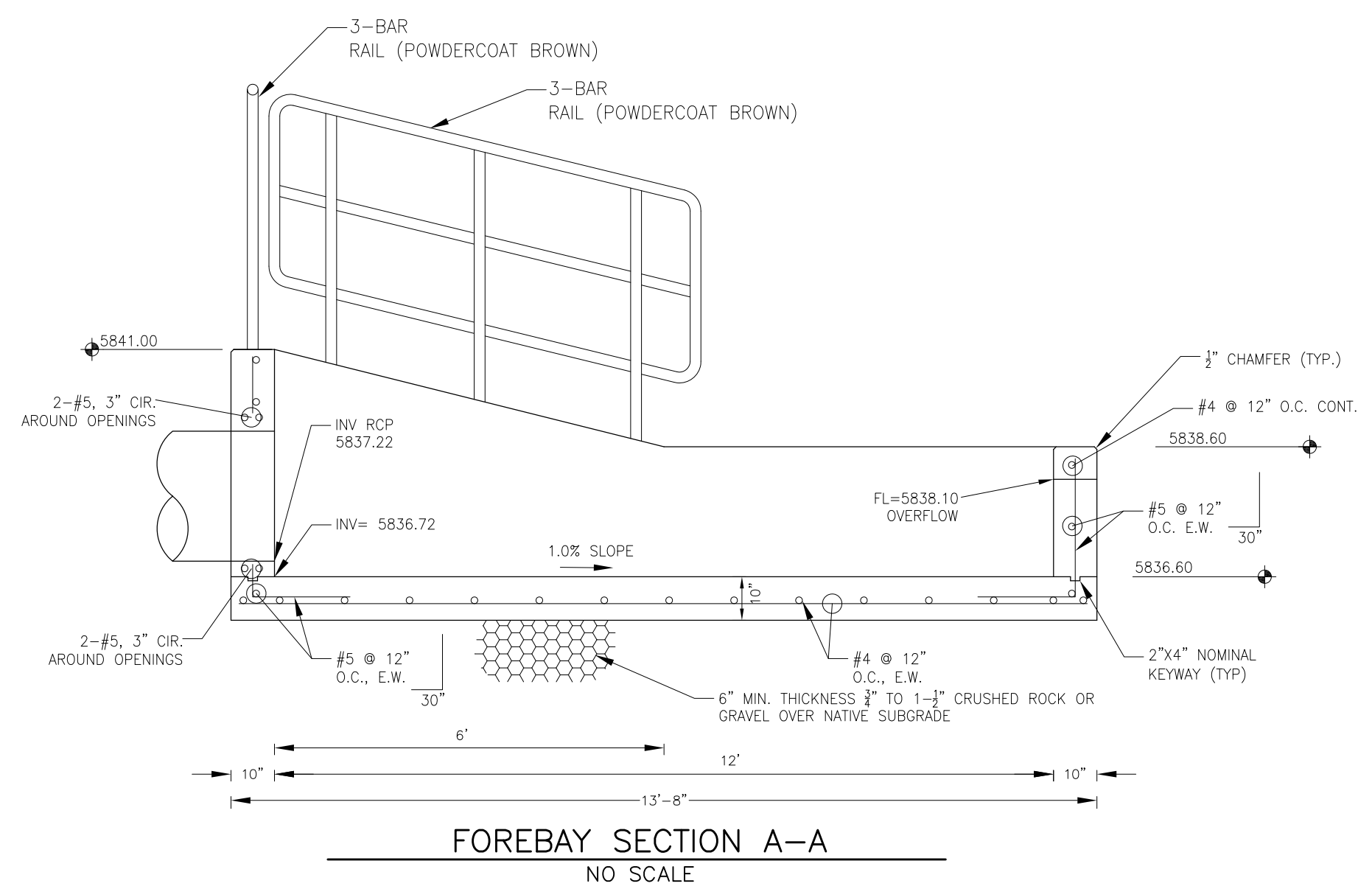

FOREBAY SECTION A-A
NO SCALE

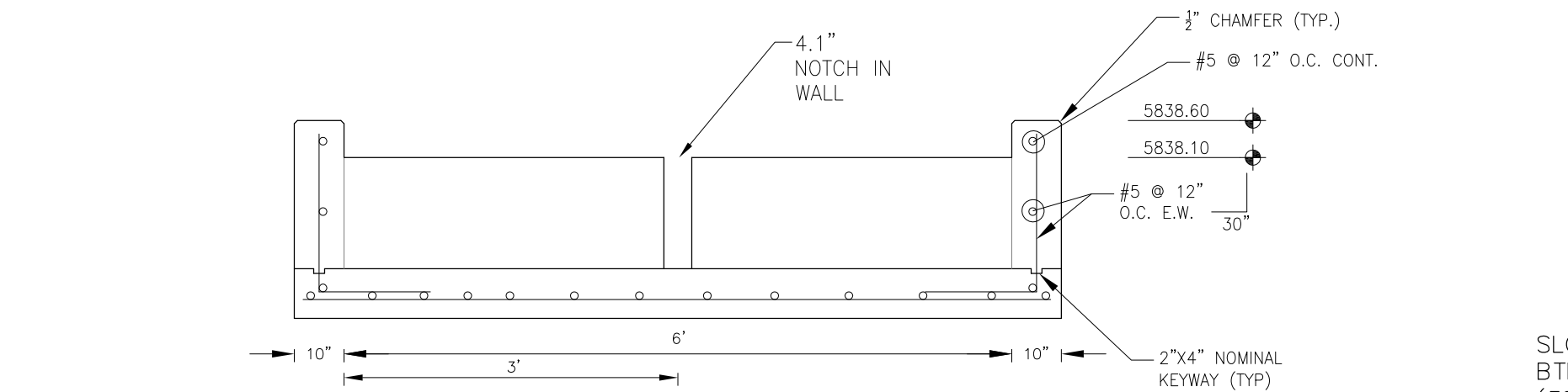

FOREBAY SECTION B-B
NO SCALE

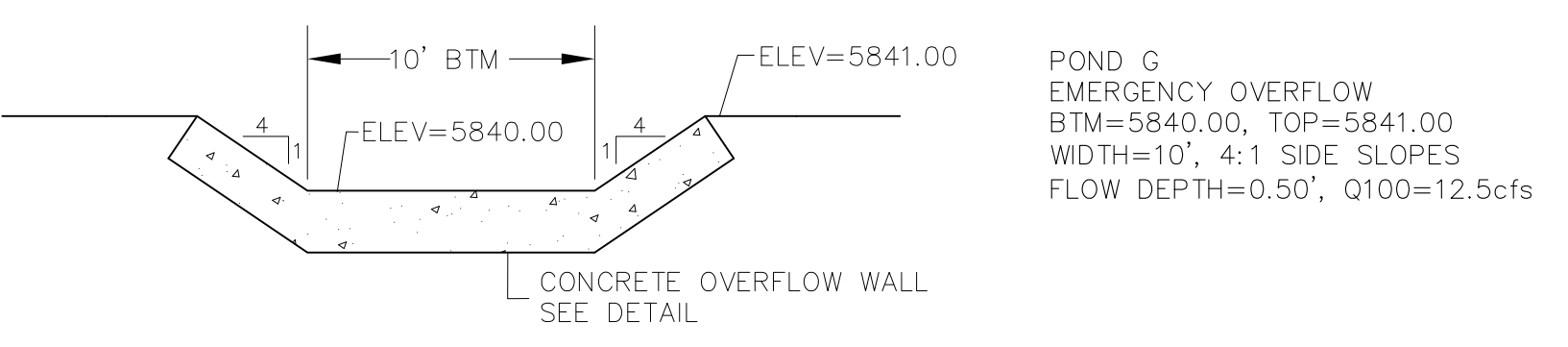

WQ POND G
EMERGENCY OVERFLOW
PROFILE
SCALE: NTS

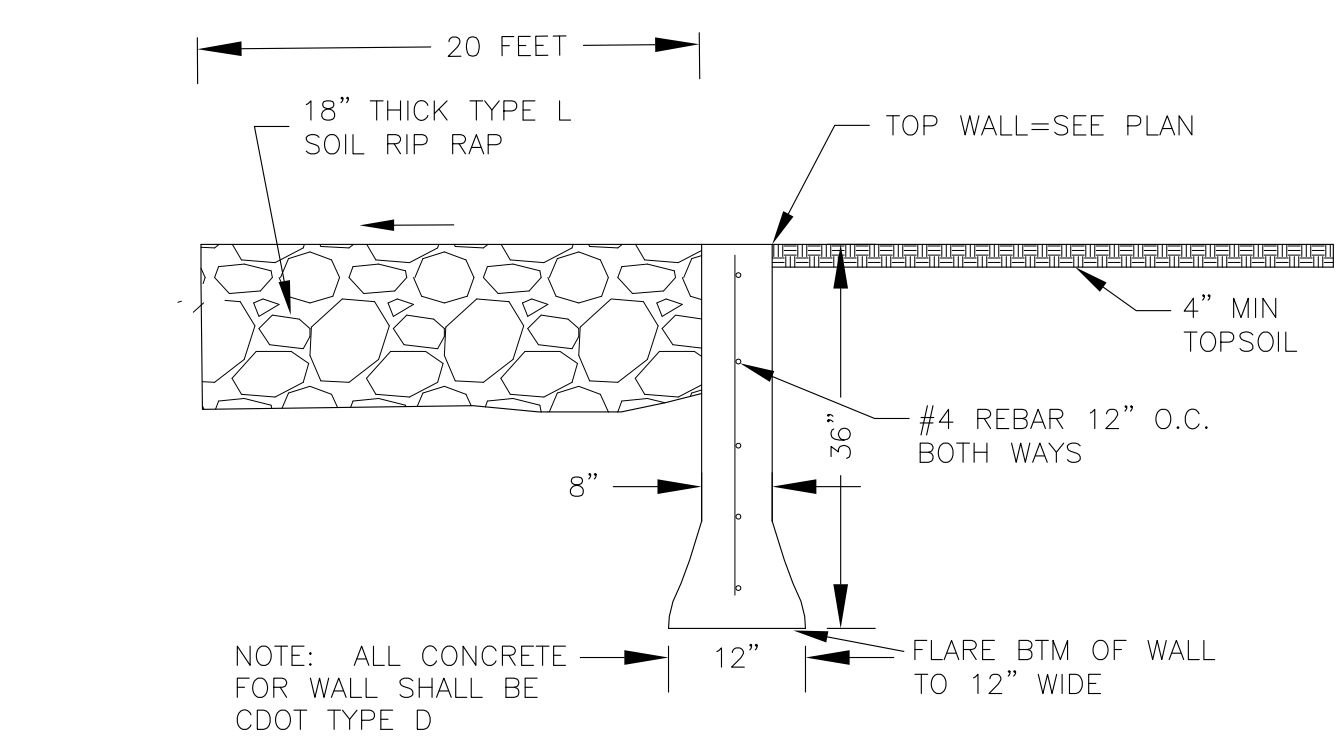

POND CONCRETE OVERFLOW WALL
NO SCALE

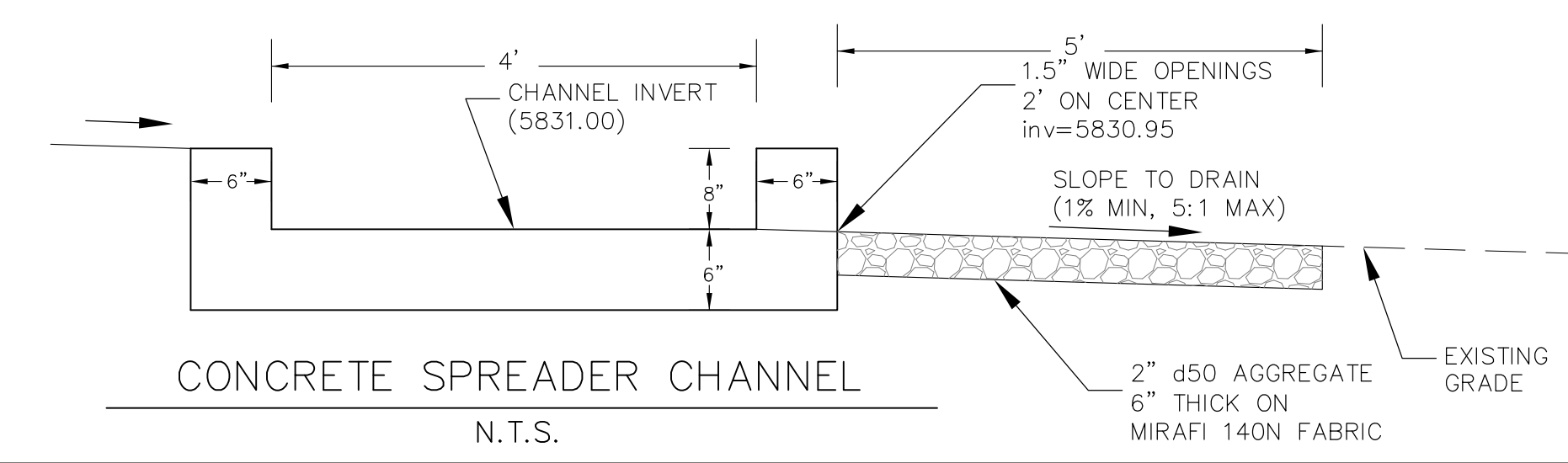

CONCRETE SPREADER CHANNEL
N.T.S.

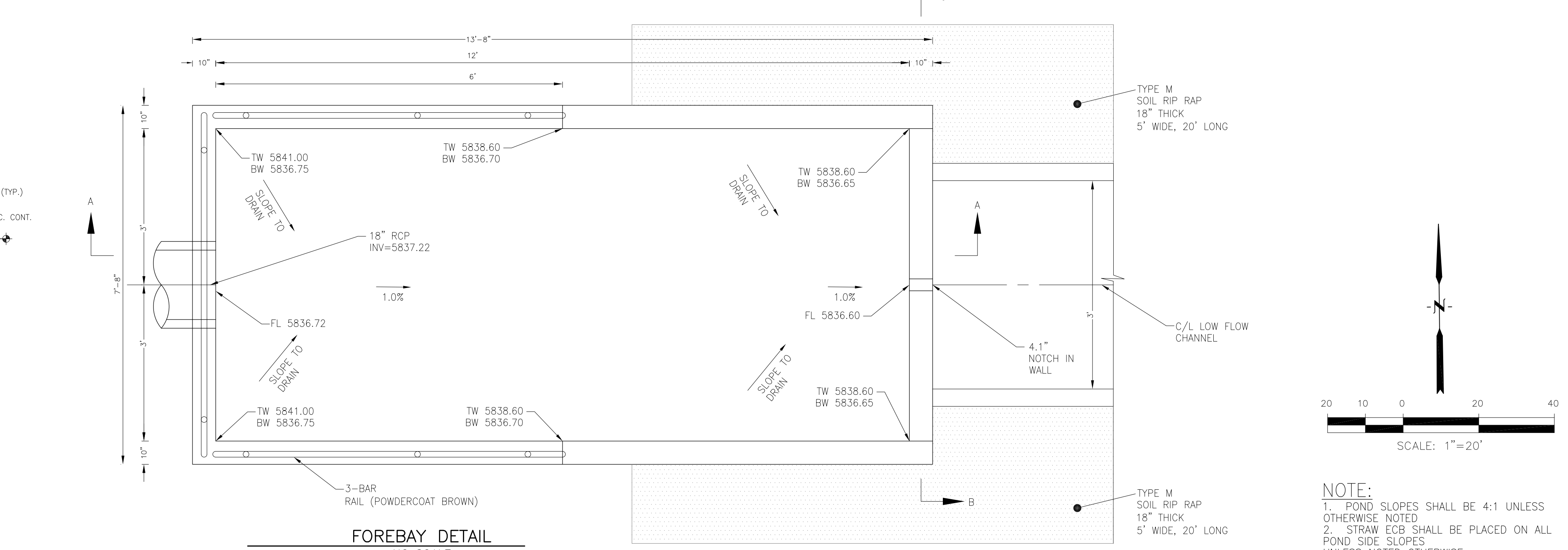

FOREBAY DETAIL
NO SCALE

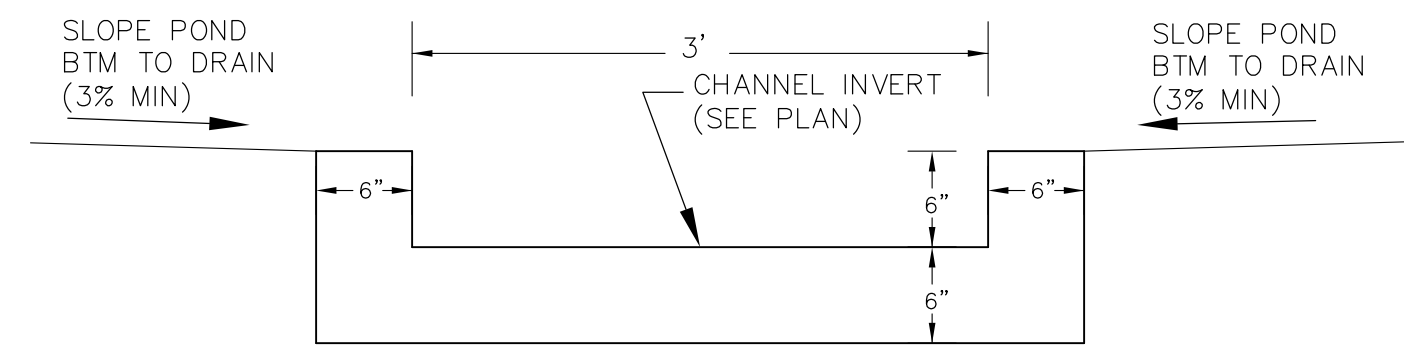

CONCRETE LOW FLOW CHANNEL
N.T.S.

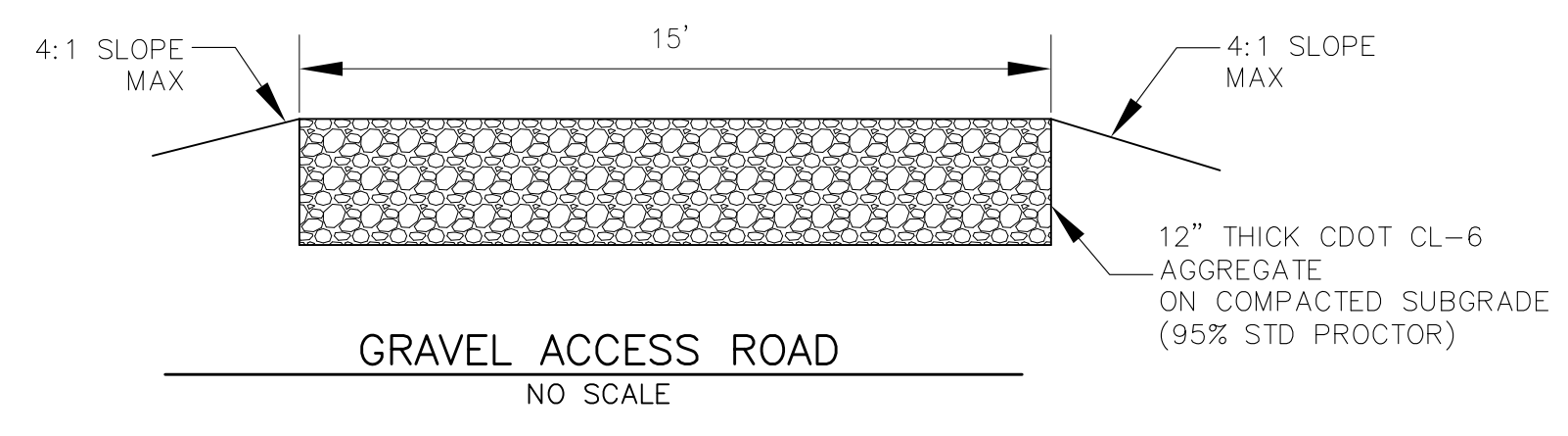

GRAVEL ACCESS ROAD
NO SCALE

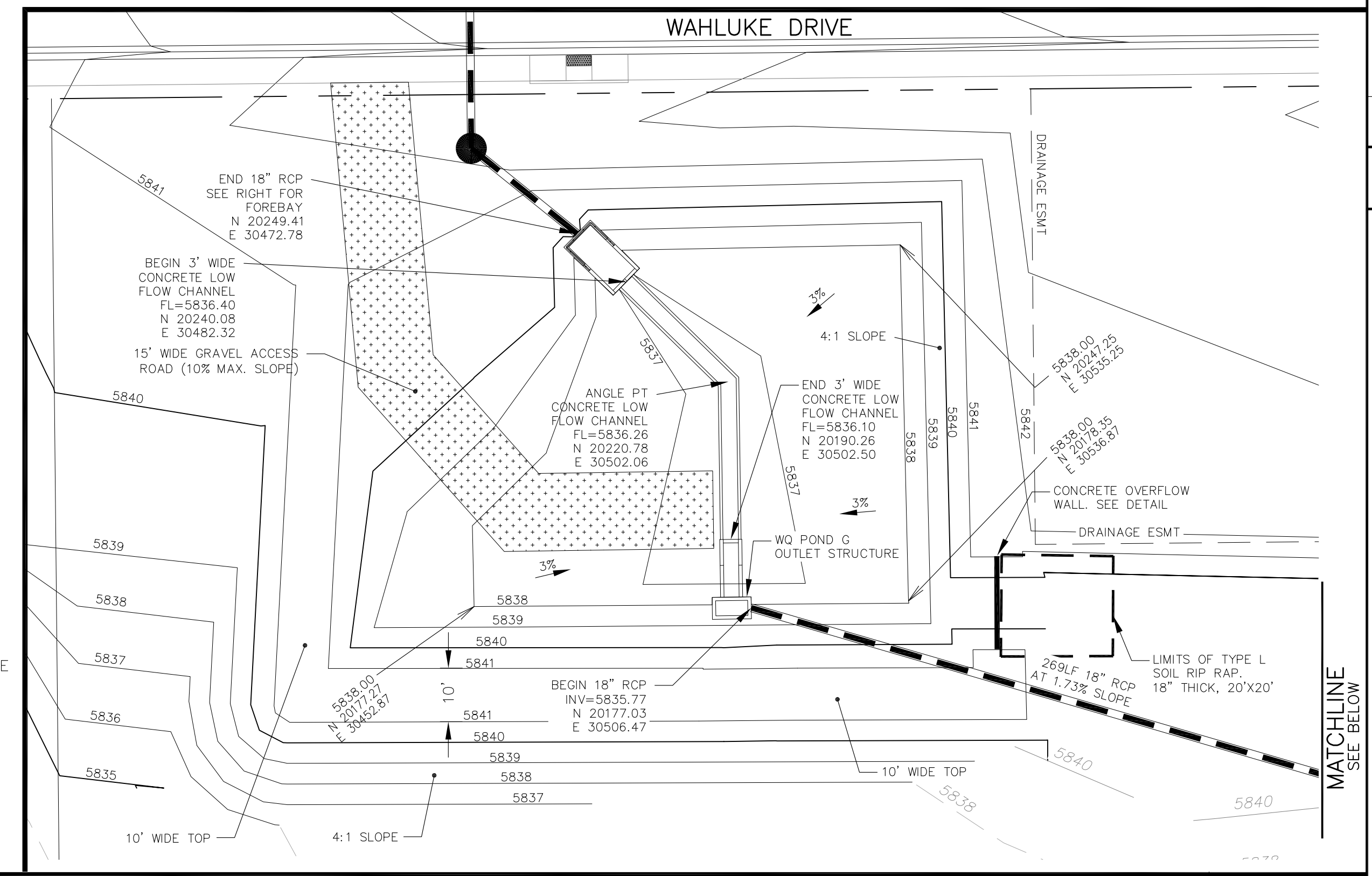

POND G
POND DETAILS
AND TRICKLE CHANNEL

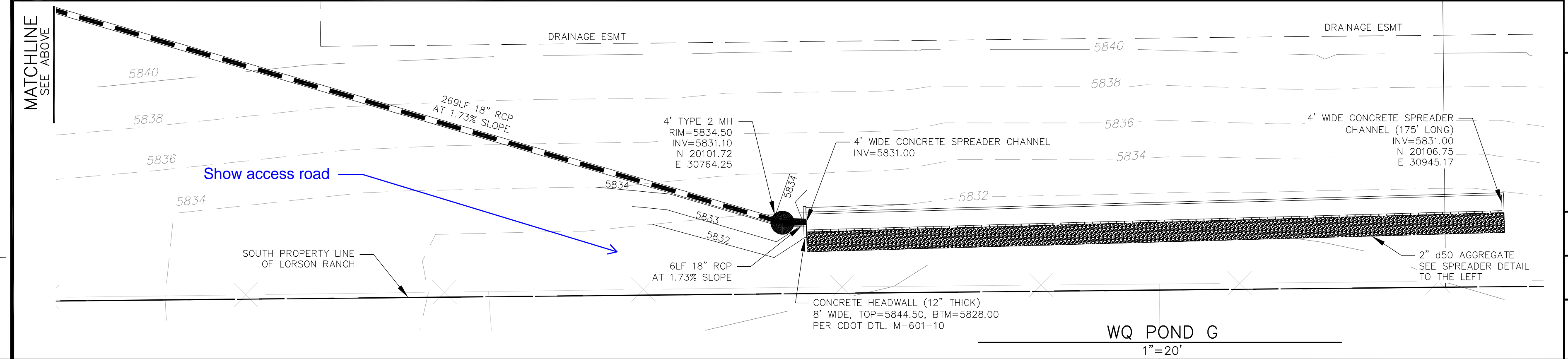

WQ POND G
1"=20'

NO.	DESCRIPTION	DATE
		NOV. 30, 2021
1.	MODIFY CONCRETE SPREADER CHANNEL	
PREPARED FOR: LORSON, LLC 212 N. WAHSATCH AVE, SUITE 301 COLORADO SPRINGS, COLORADO 80903 CONTACT: RICHARD L. SCHINDLER, P.E. EMAIL: Rich@eg1.com		
PROJECT: HILLSIDE AT LORSON RANCH LORSON BLVD. - WALLEYE DR. COLORADO SPRINGS, COLORADO CONTACT: JEFF MARK		
DRAWN:	RLS	
DESIGNED:	RLS	
CHECKED:	RLS	

DATE:	APRIL 15, 2022
PROJECT NO.	100.065
SHEET NUMBER	C9.4
TOTAL SHEETS:	20

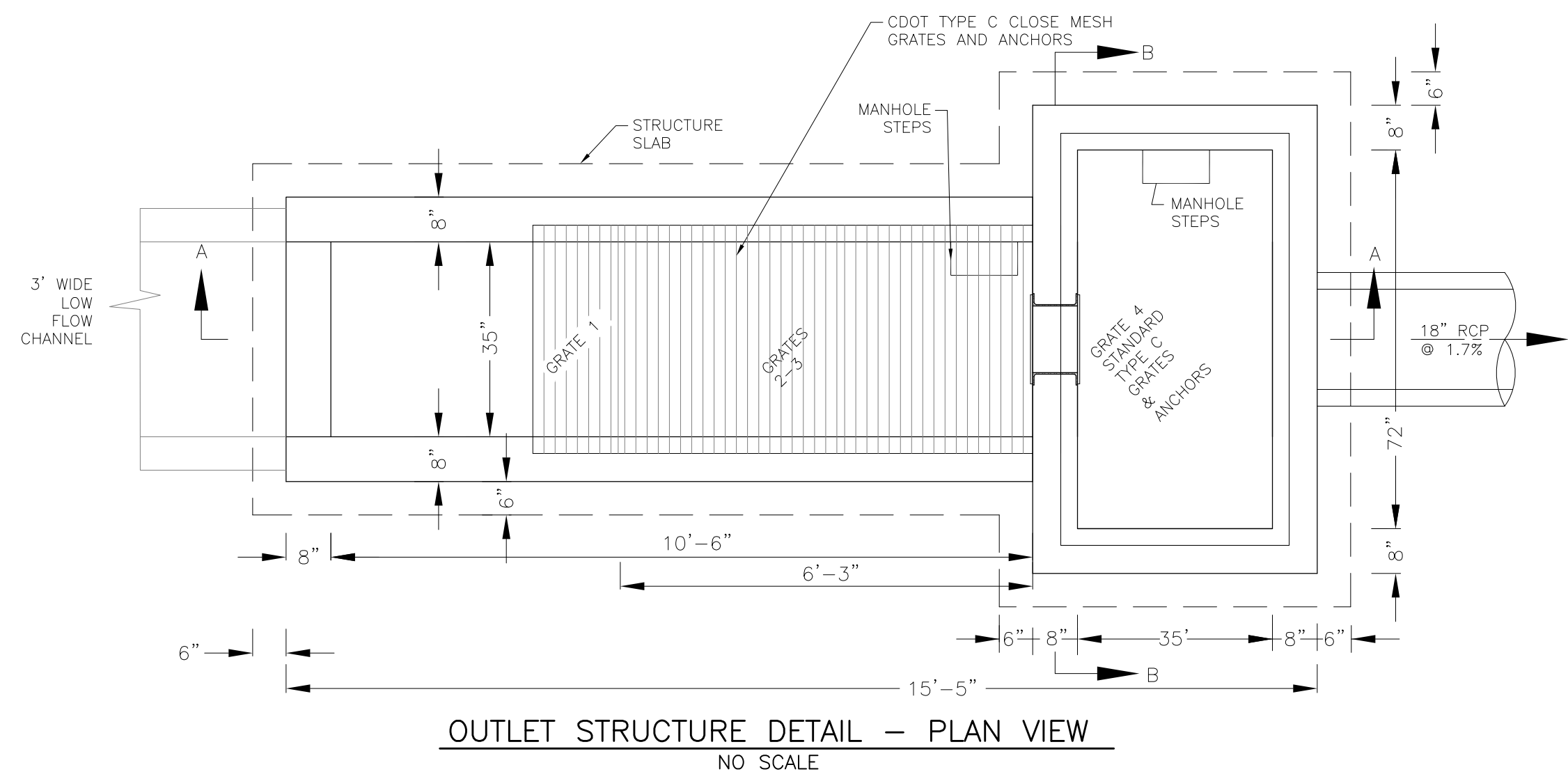
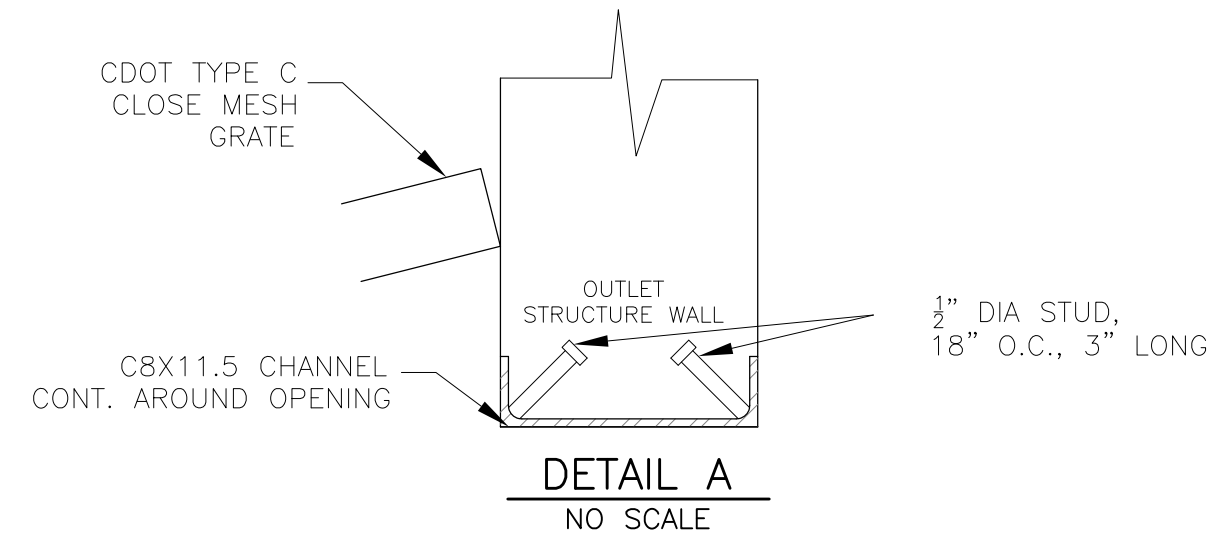

NOTE:
AFTER CONCRETE STRUCTURE HAS BEEN POURED
ALL GRATE DIMENSIONS SHALL BE FIELD VERIFIED
PRIOR TO GRATE CONSTRUCTION

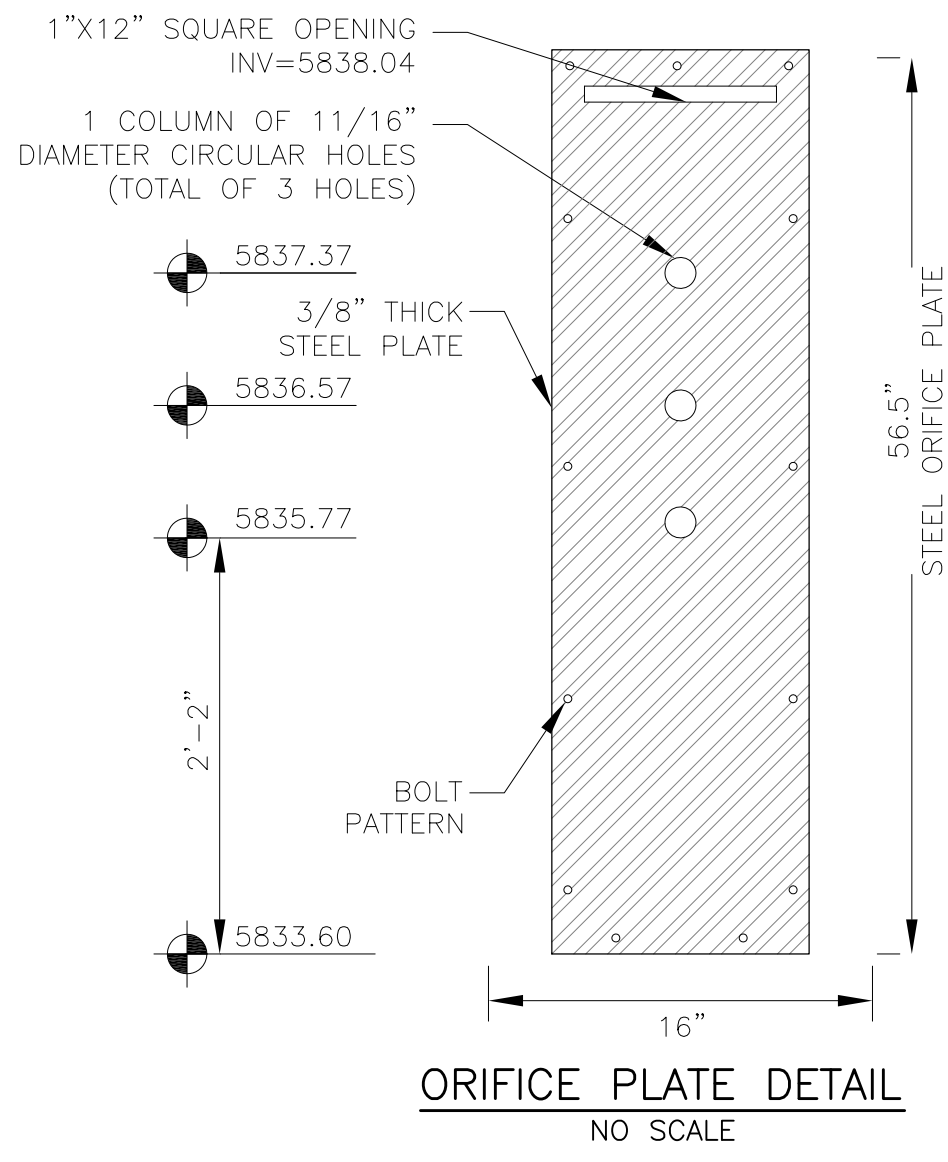
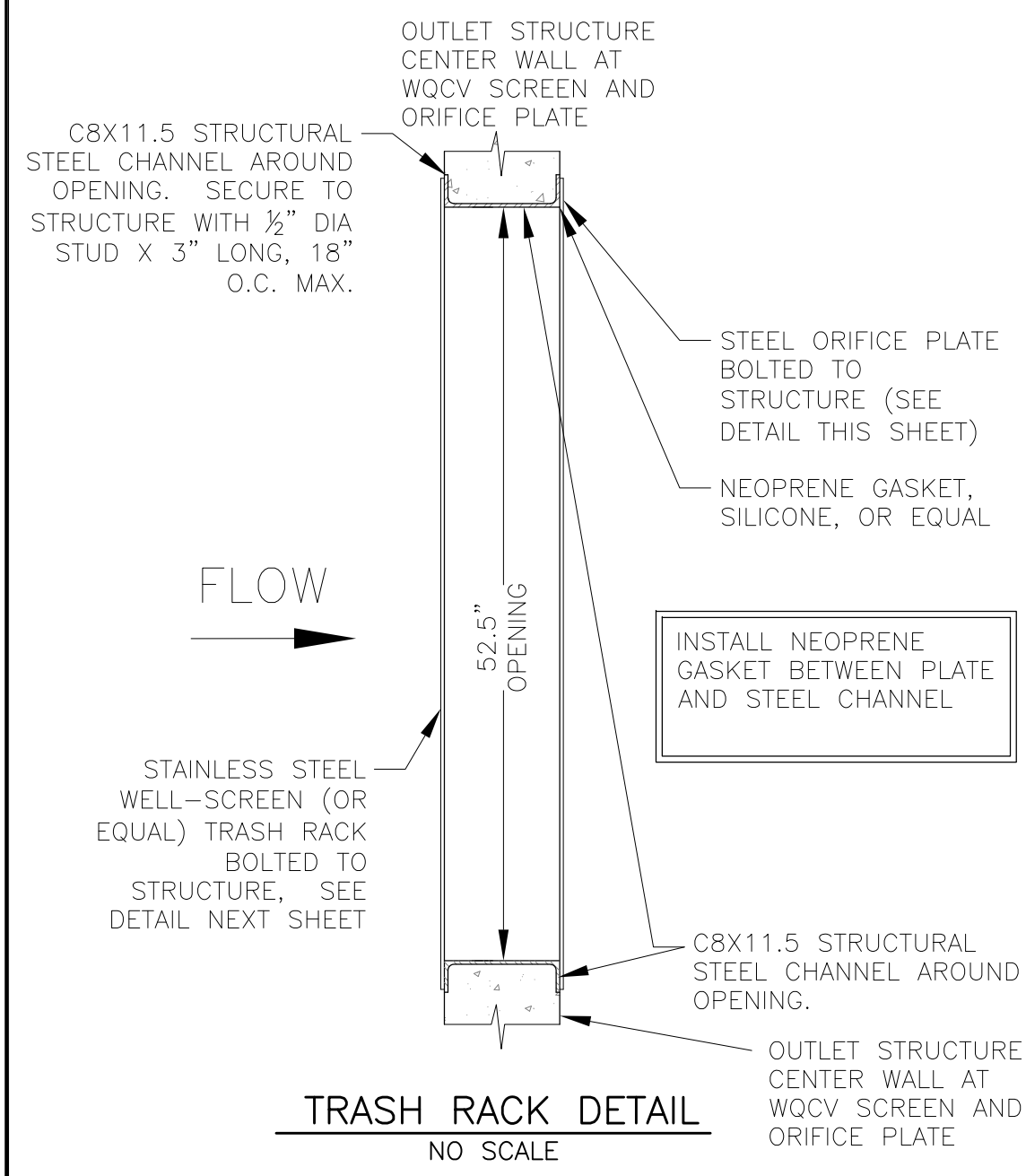
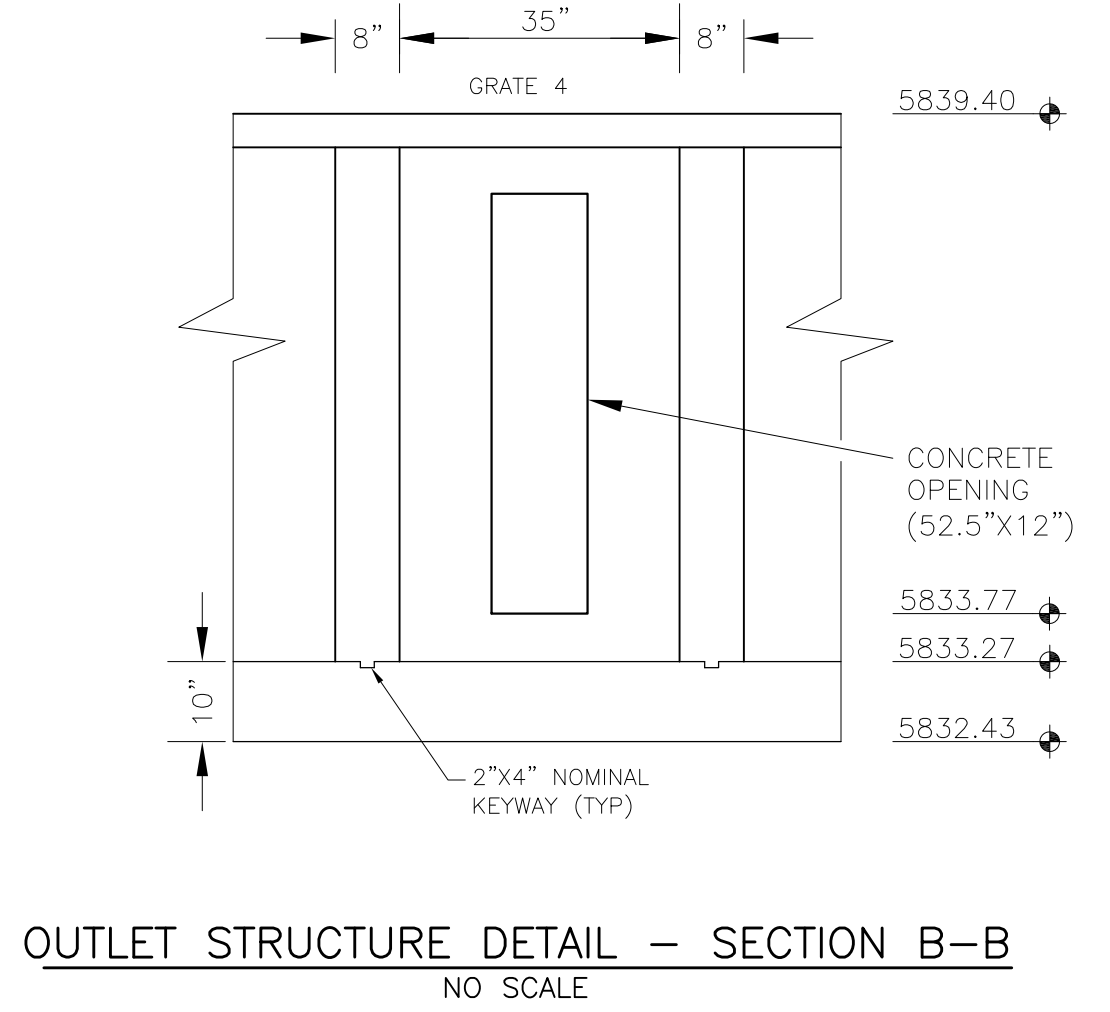
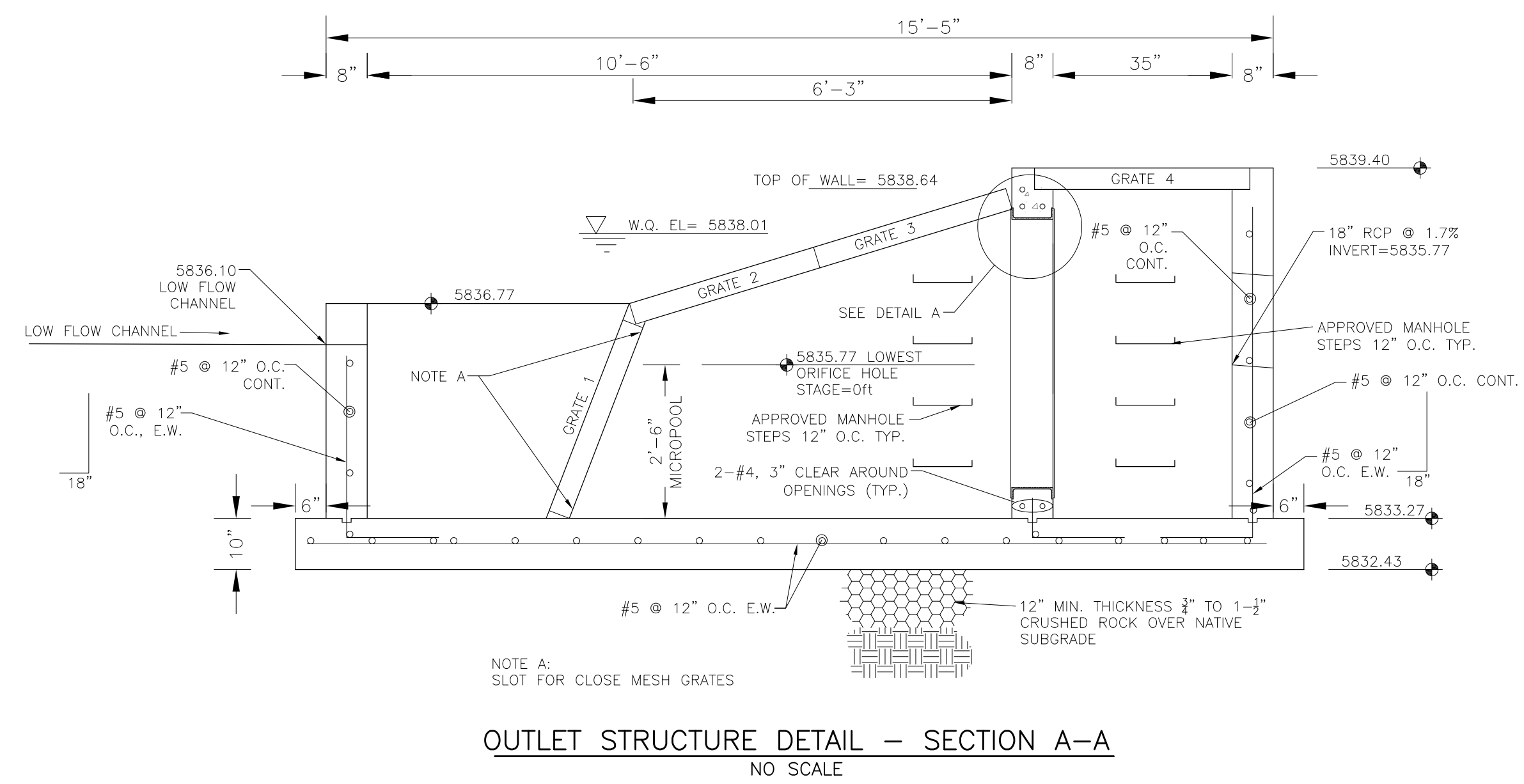
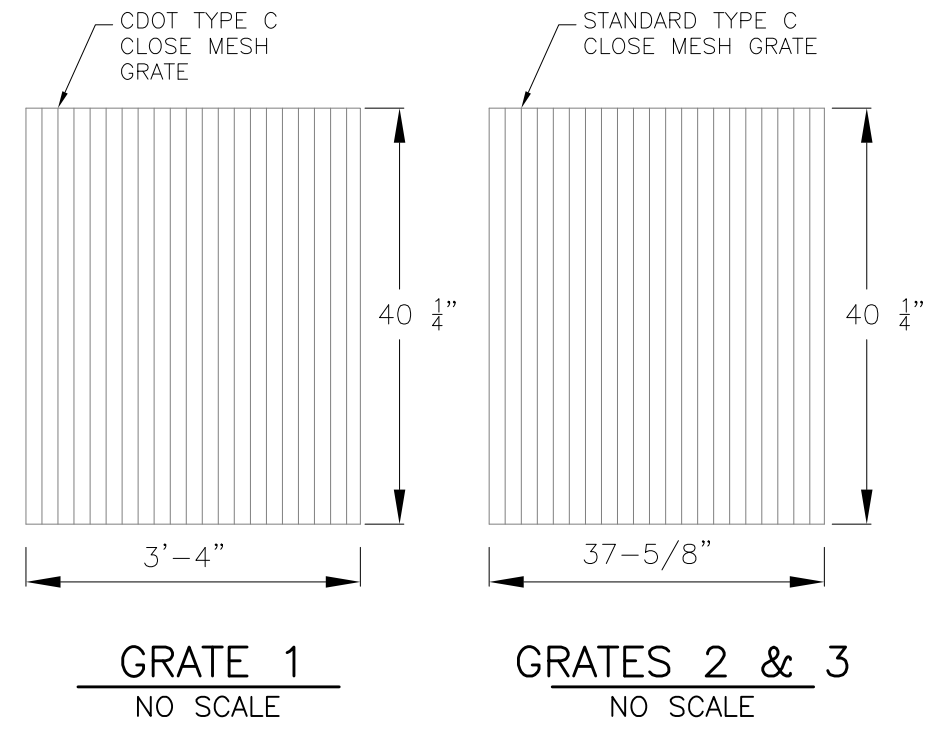

OUTLET STRUCTURE, FOREBAY, AND DRAIN CHANNEL NOTES:

- PRIOR TO CONSTRUCTION, CONTRACTOR SHALL PROVIDE SHOP DRAWINGS FOR ALL COMPONENTS OF THE OUTLET STRUCTURE.
 - GRADE 60 REINFORCING STEEL REQUIRED. SEE TABLE FOR THE MINIMUM LAP SPLICE LENGTH FOR REINFORCING BARS. ALL REINFORCING STEEL SHALL HAVE A TWO-INCH MINIMUM CLEARANCE FROM EDGE OF CONCRETE, UNLESS OTHERWISE NOTED.
- | BAR SIZE | #4 | #5 | #6 |
|--------------------|-------|-------|-------|
| MIN. SPLICE LENGTH | 1'-3" | 1'-7" | 2'-0" |
- CONCRETE FOR THE OUTLET STRUCTURE AND FOREBAY SHALL BE CDOT CLASS D CONCRETE.
 - CONCRETE FOR DRAIN CHANNELS SHALL BE CDOT CLASS B CONCRETE
 - EXPANSION JOINT MATERIAL SHALL MEET AASHTO SPECIFICATION M-213. EXPANSION JOINT MATERIAL SHALL BE 1/2" THICK, SHALL EXTEND THE FULL DEPTH OF CONTACT SURFACE AND THE JOINT SHALL BE SEALED, REFER TO DETAILS.
 - ALL EXPOSED CONCRETE CORNERS SHALL HAVE A 3/8" CHAMFER UNLESS OTHERWISE NOTED.
 - SUBGRADE TO BE 12" THICK CLEAN FILL COMPACTED TO 95% STANDARD PROCTOR DENSITY PER ASTM M698 UNDER STRUCTURE.
 - REFER TO POND DETAILS FOR PRESEDIMENTATION/FOREBAY DESIGN.
 - ENGINEER SHALL BE NOTIFIED PRIOR TO BEGINNING CONSTRUCTION OF OUTLET STRUCTURE TO SCHEDULE OBSERVATION VISITS FOR STRUCTURES.

- WQCV WELL-SCREEN NOTES:
- Well-Screen shall be stainless steel and attached by stainless steel bolts along edge of the mounting frame.
 - WQCV Well Screen
 - Type of Screen: Stainless steel #93 Vee Wire (Johnson Vee Wire (tm) Stainless Steel Screen or equivalent with 60% open area)
 - Screen slot opening dimension: 0.139" (Screen #93 Vee Wire Slot Opening)
 - Type and Size of Support Rod: 1E 0.074"x0.50"
 - Spacing of Support Rod (O.C.): 1.0 Inch
 - Total Screen Thickness: 0.655"
 - Carbon Steel Holding Frame Type: 3/4" x 1.0" angle

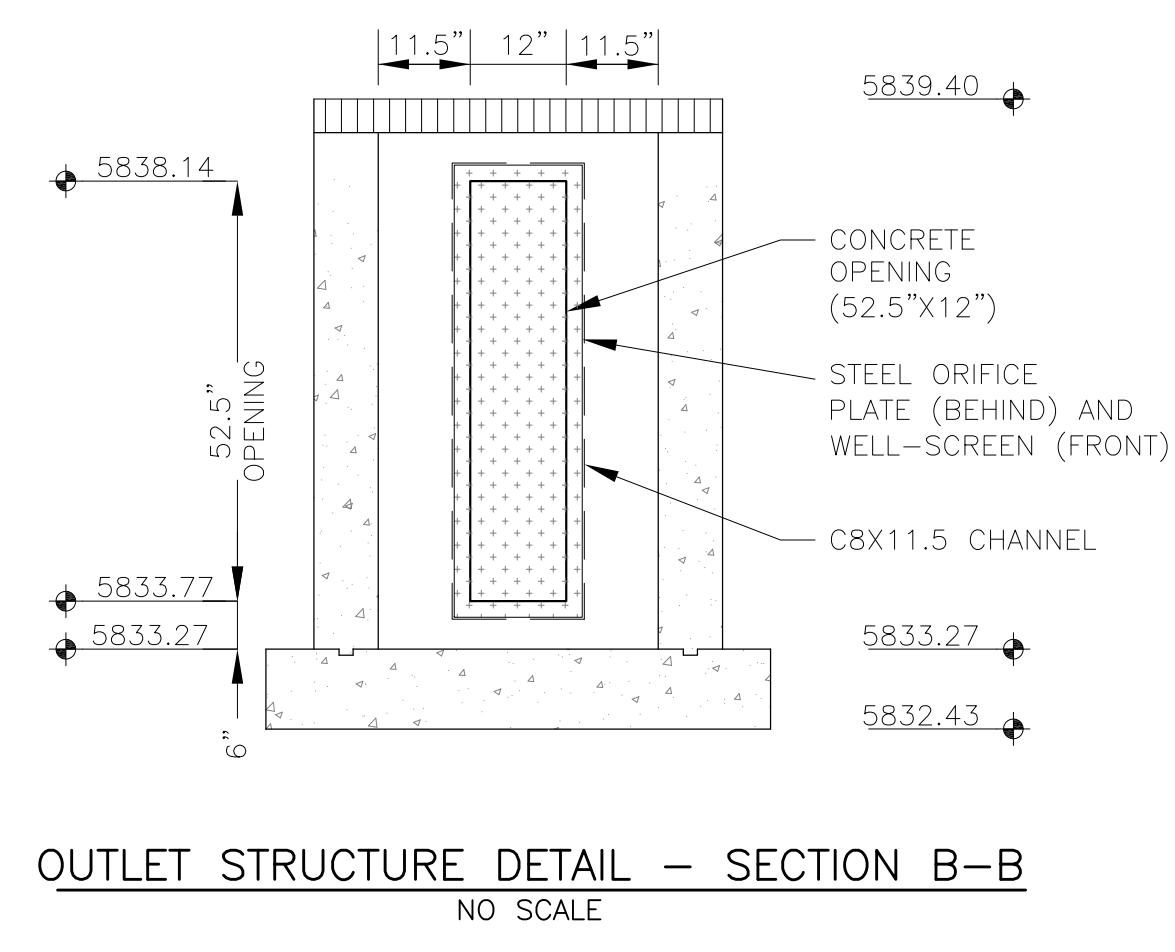

CORE
ENGINEERING GROUP
15004 1ST AVENUE S.
DENVER, CO 80202
PH: 719.570.1100
CONTACT: RICHARD L. SCHINDLER, P.E.
EMAIL: Rich@cog1.com

DATE: NOV 30, 2021
DESCRIPTION: MODIFY CIRCULAR HOLES IN ORIFICE PLATE
NO. 1.
PREPARED FOR: LORSON, LLC
212 N. WAHSATCH AVE, SUITE 301
COLORADO SPRINGS, COLORADO 80903
CONTACT: JEFF MARK

PROJECT: HILLSIDE AT LORSON RANCH
LORSON BLVD. - WALLEYE DR.
COLORADO SPRINGS, COLORADO

DRAWN: RLS
DESIGNED: RLS
CHECKED: RLS

POND G
FULL SPECTRUM / WQ POND
OUTLET STRUCTURE DETAILS

DATE: APRIL 15, 2022

PROJECT NO. 100.065

SHEET NUMBER **C9.5**
TOTAL SHEETS: 20

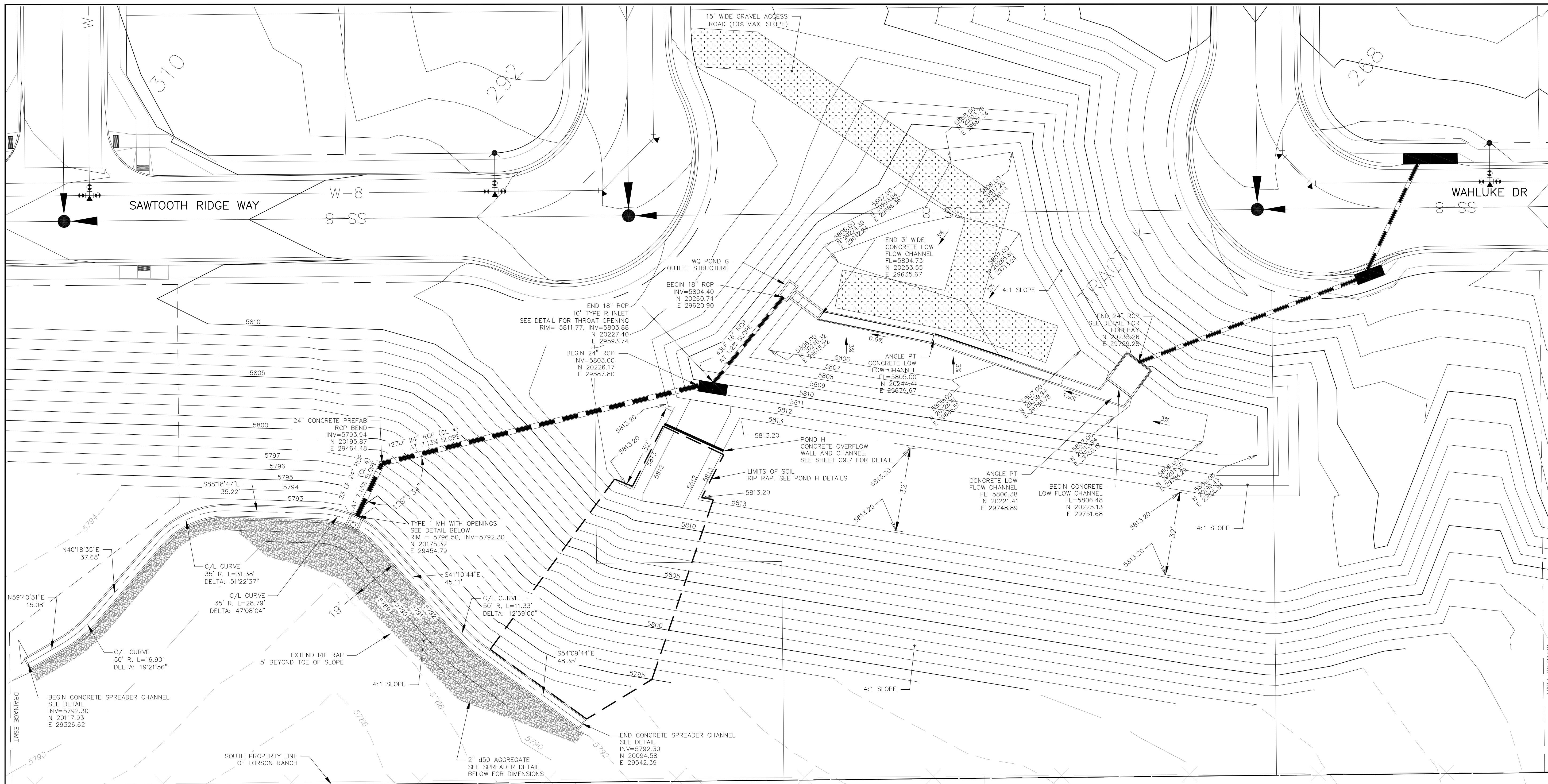

WQ POND H
1"=20'

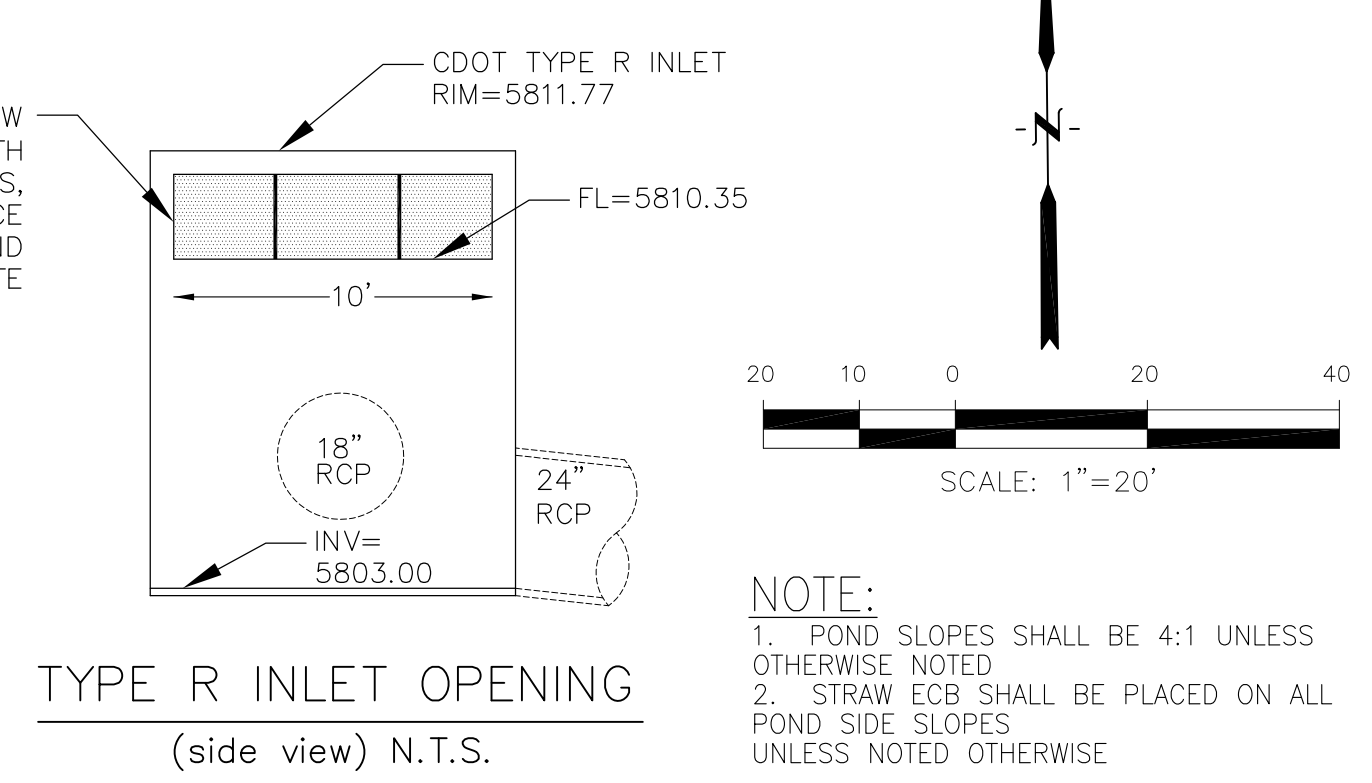
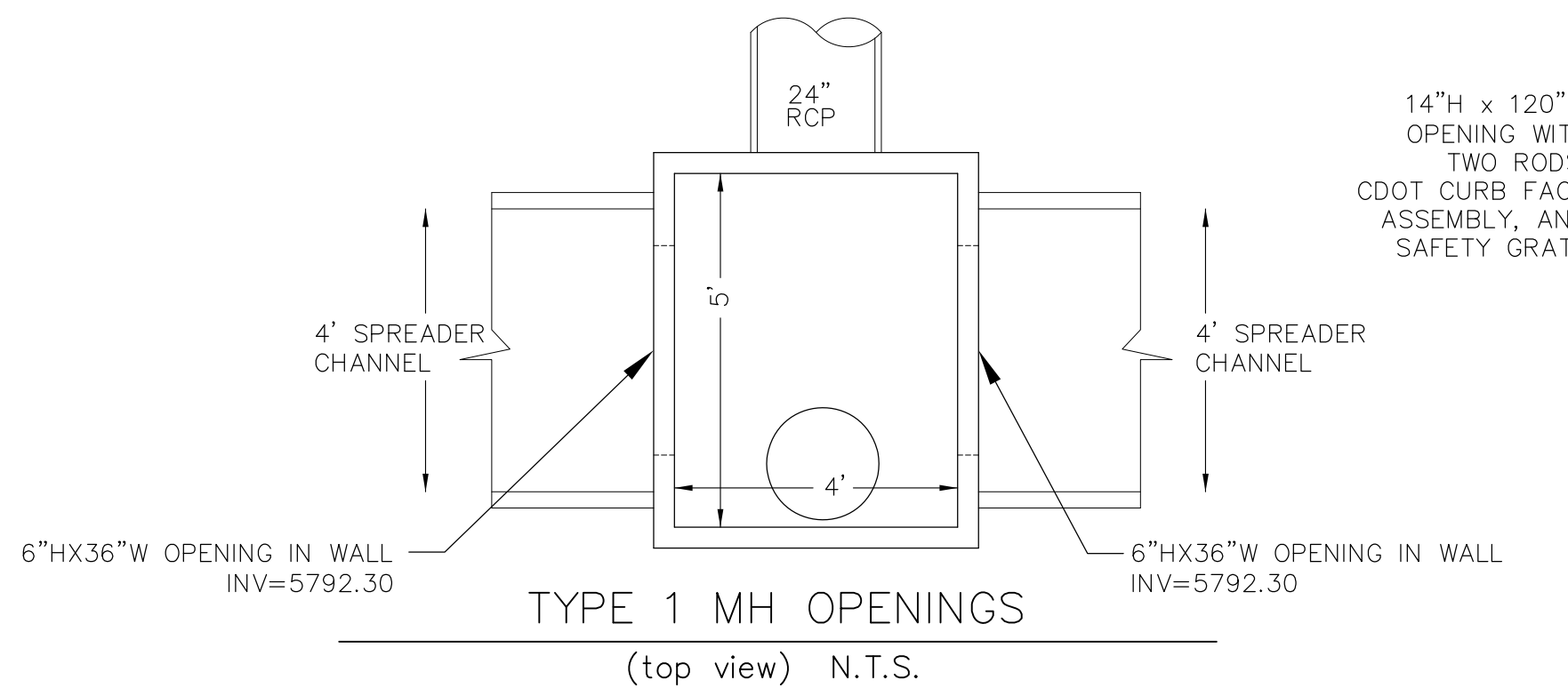
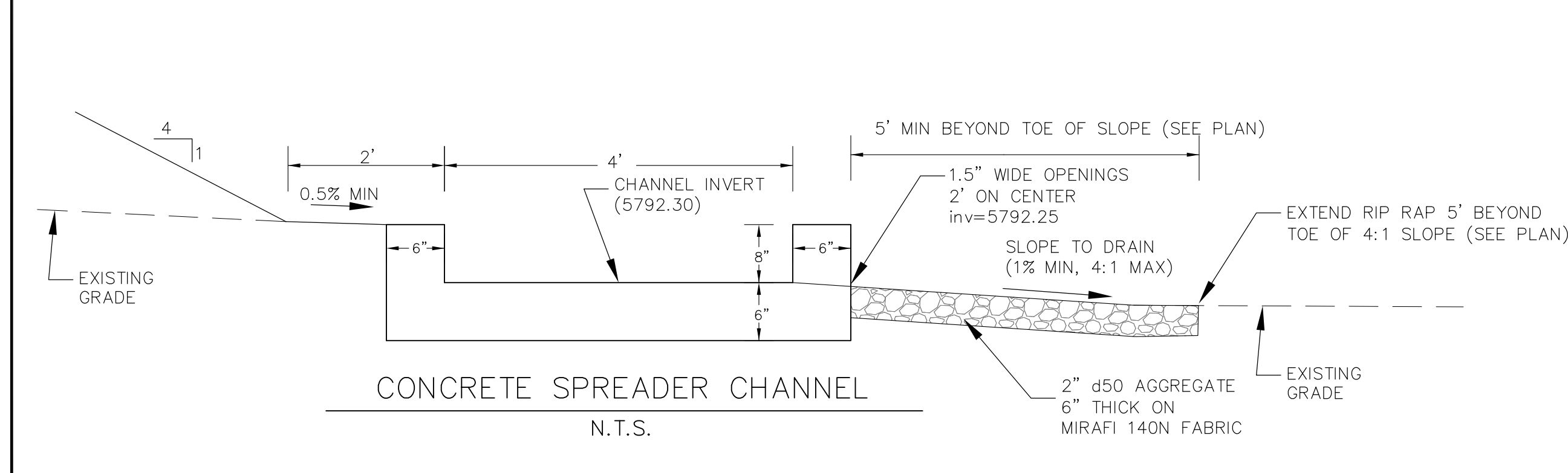

NOTE:
1. POND SLOPES SHALL BE 4:1 UNLESS OTHERWISE NOTED
2. STRAW COG SHALL BE PLACED ON ALL POND SIDE SLOPES UNLESS NOTED OTHERWISE

CORE
ENGINEERING GROUP
15004 1ST AVENUE S.
FLORENCE, CO 81226
PH: 719.570.1100
CONTACT: RICHARD L. SCHINDLER, P.E.
EMAIL: Rich@ceg1.com

DATE: _____
DESCRIPTION: _____
NO: _____
DRAWN: RLS
DESIGNED: RLS
CHECKED: RLS

PREPARED FOR:
LORSON, LLC
212 N. WAHSATCH AVE, SUITE 301
COLORADO SPRINGS, COLORADO 80903
LORSON BLDG. - WALLEYE DR.
COLORADO SPRINGS, COLORADO
CONTACT: JEFF MARK

PROJECT:
HILLSIDE AT LORSON RANCH

DATE: _____
DESCRIPTION: _____
NO: _____

POND H
POND GRADING AND
CONCRETE SPREADER CHANNEL

DATE:
APRIL 15, 2022

PROJECT NO.
100.065

SHEET NUMBER
C9.6

TOTAL SHEETS: 20

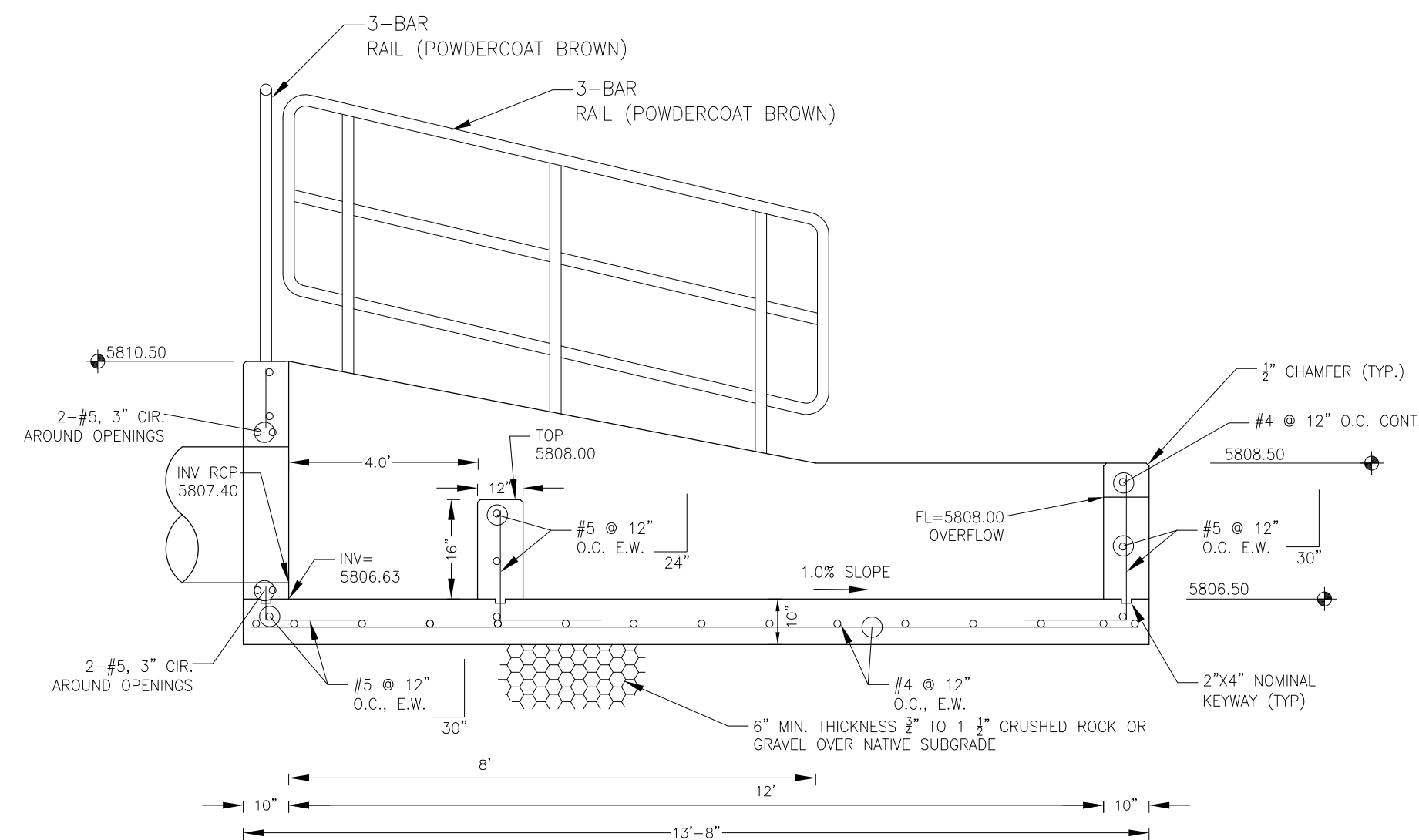

FOREBAY SECTION A-A
NO SCALE

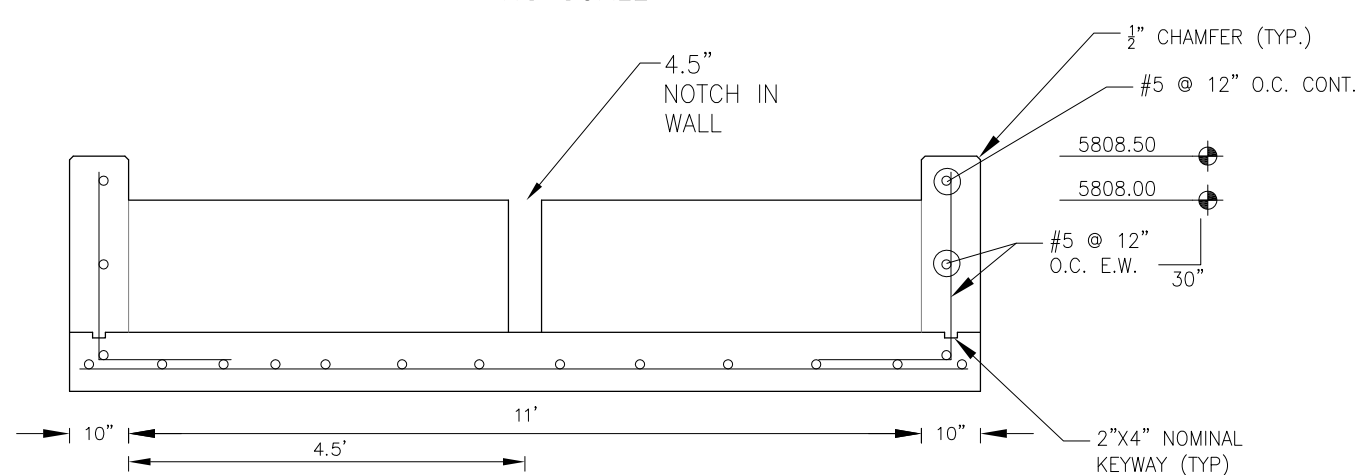

FOREBAY SECTION B-B
NO SCALE

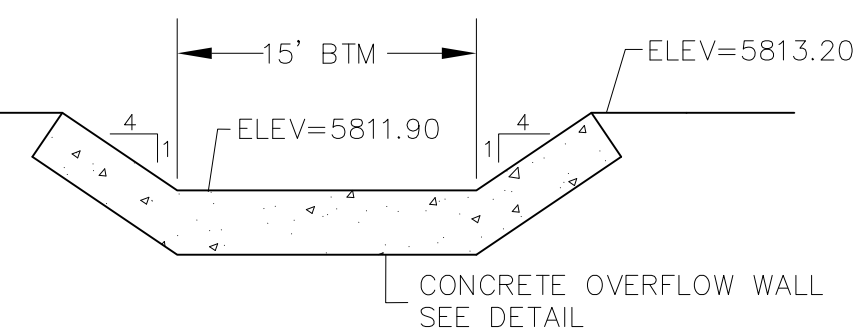

**WQ POND H
EMERGENCY OVERFLOW
PROFILE**
SCALE: NTS

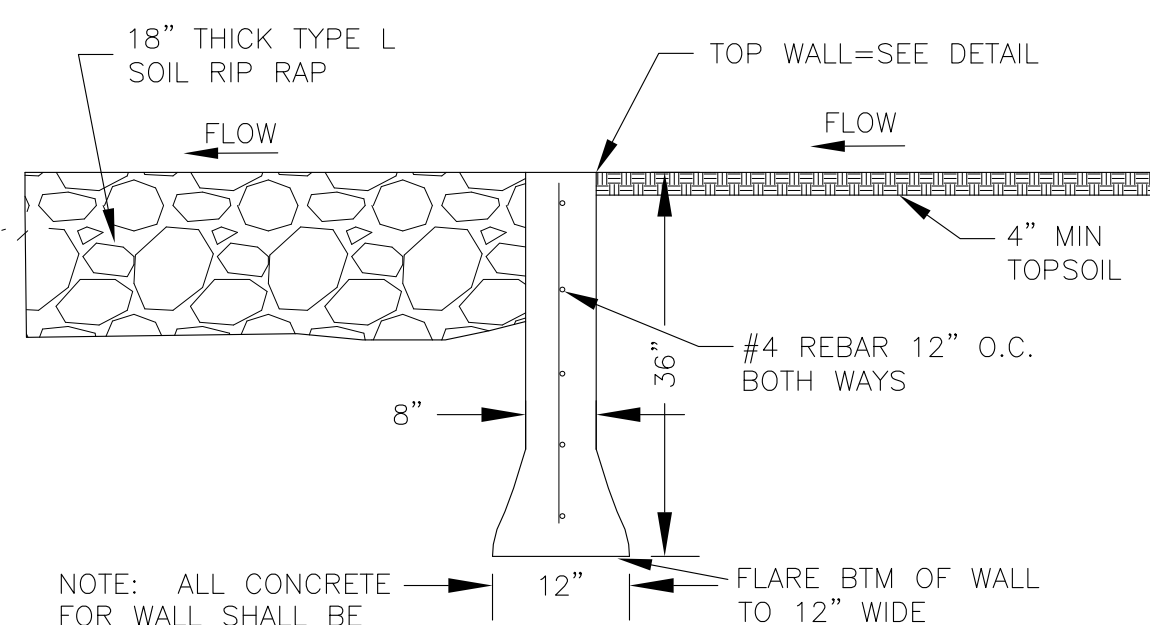

POND CONCRETE OVERFLOW WALL
NO SCALE

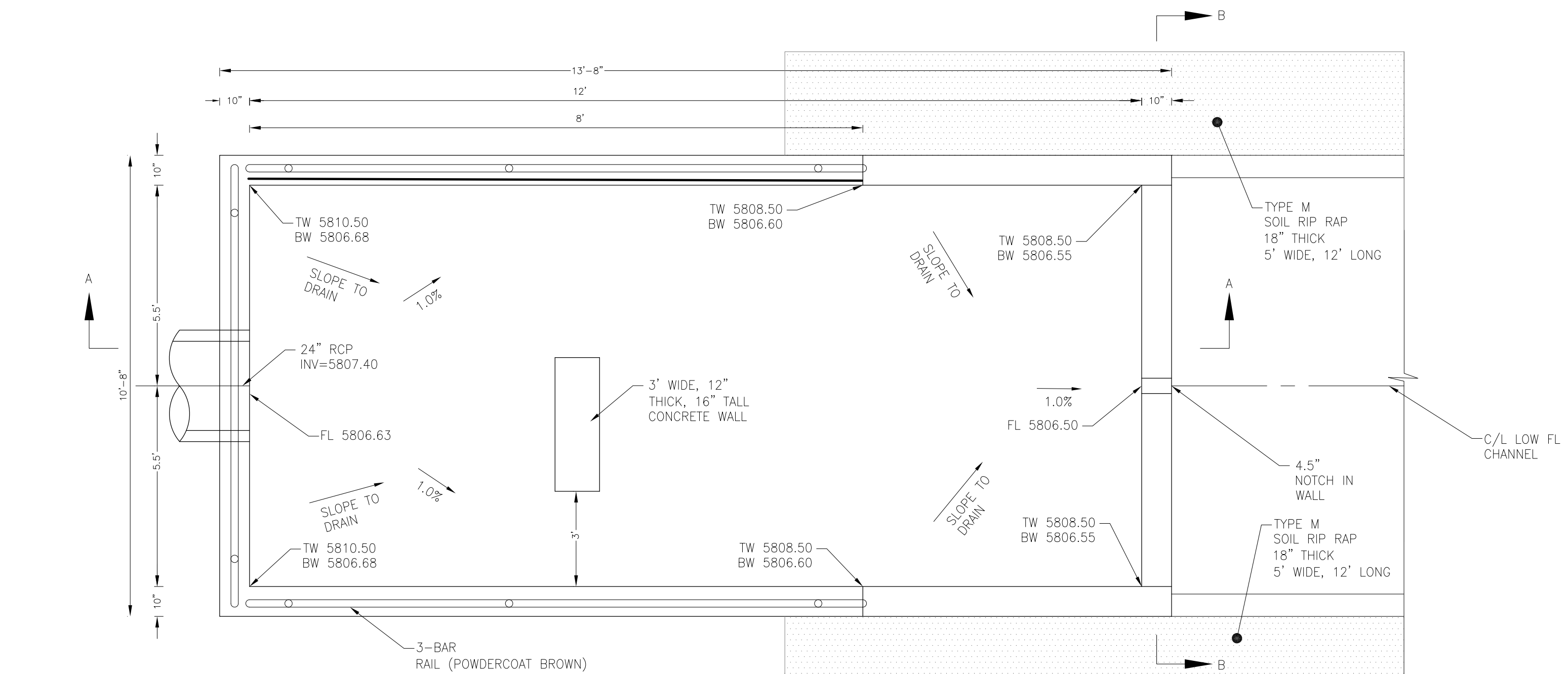

FOREBAY DETAIL
NO SCALE

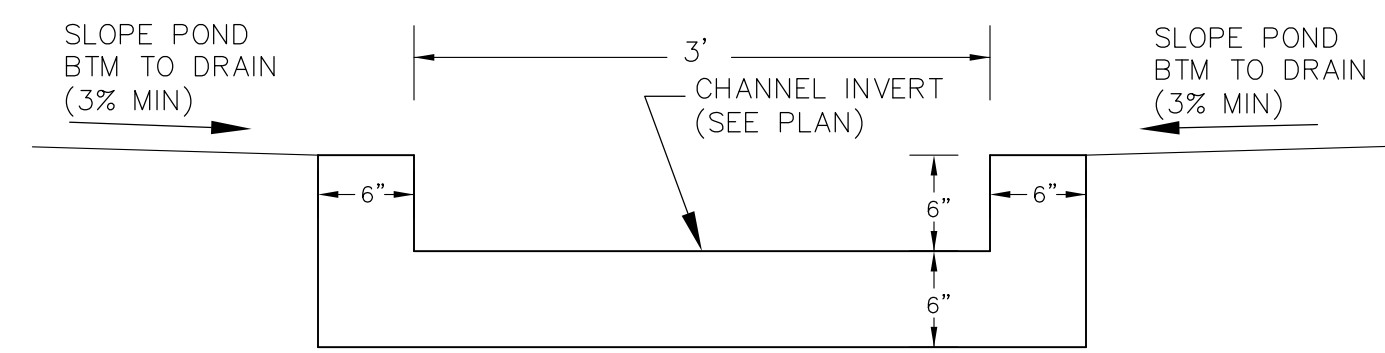

CONCRETE LOW FLOW CHANNEL
N.T.S.

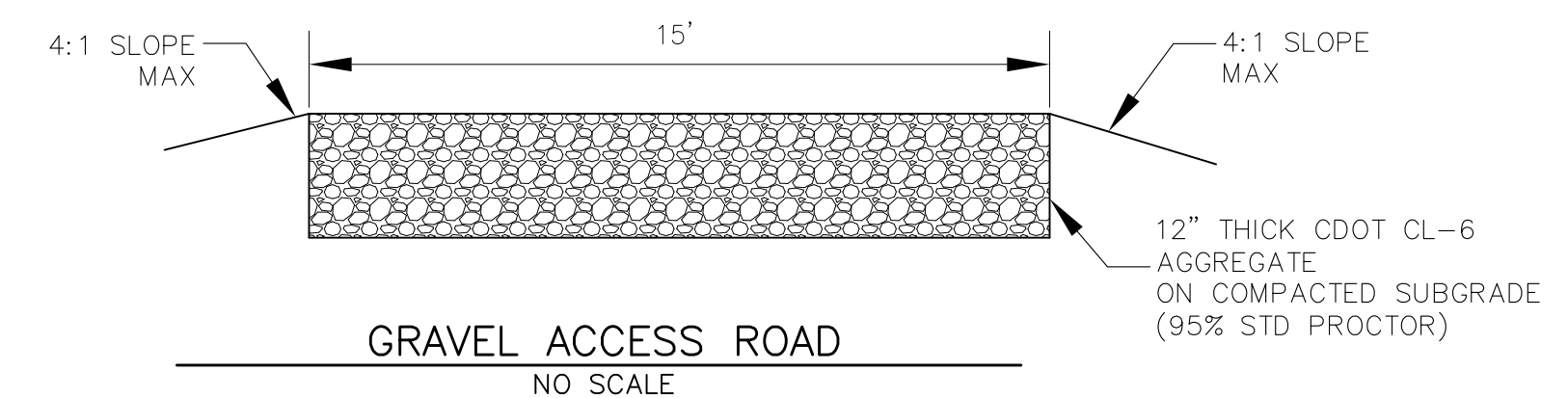

GRAVEL ACCESS ROAD
NO SCALE

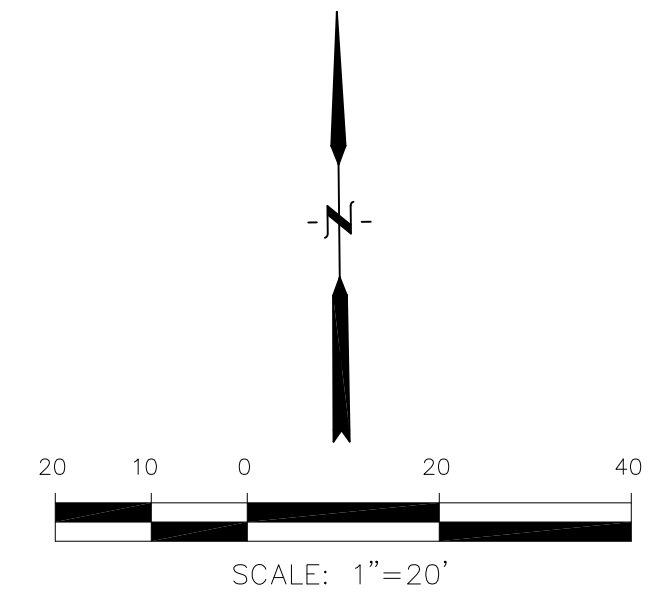

NOTE:
1. POND SLOPES SHALL BE 4:1 UNLESS OTHERWISE NOTED
2. STRAW ECB SHALL BE PLACED ON ALL POND SIDE SLOPES UNLESS NOTED OTHERWISE

**CORE
ENGINEERING GROUP**
15004 1ST AVENUE, S.
DENVER, CO 80202
PHONE: 719.570.1100
CONTACT: RICHARD L. SCHINDLER, P.E.
EMAIL: Rich@cegi.com

DATE: NOV 30, 2021
DESCRIPTION: MODIFY CONCRETE SPREADER CHANNEL
NO. 1.
PROJECT: HILLSIDE AT LORSON RANCH
PREPARED FOR: LORSON, LLC
212 N. WAHSATCH AVE, SUITE 301
COLORADO SPRINGS, COLORADO 80903
LORSON BLVD. - WALLEYE DR.
COLORADO SPRINGS, COLORADO
CONTACT: JEFF MARK

DRAWN: RLS
DESIGNED: RLS
CHECKED: RLS

DRAWN: RLS
DESIGNED: RLS
CHECKED: RLS

**POND H
POND DETAILS
AND TRICKLE CHANNEL**

DATE: APRIL 15, 2022

PROJECT NO. 100.065

SHEET NUMBER C9.7

TOTAL SHEETS: 20

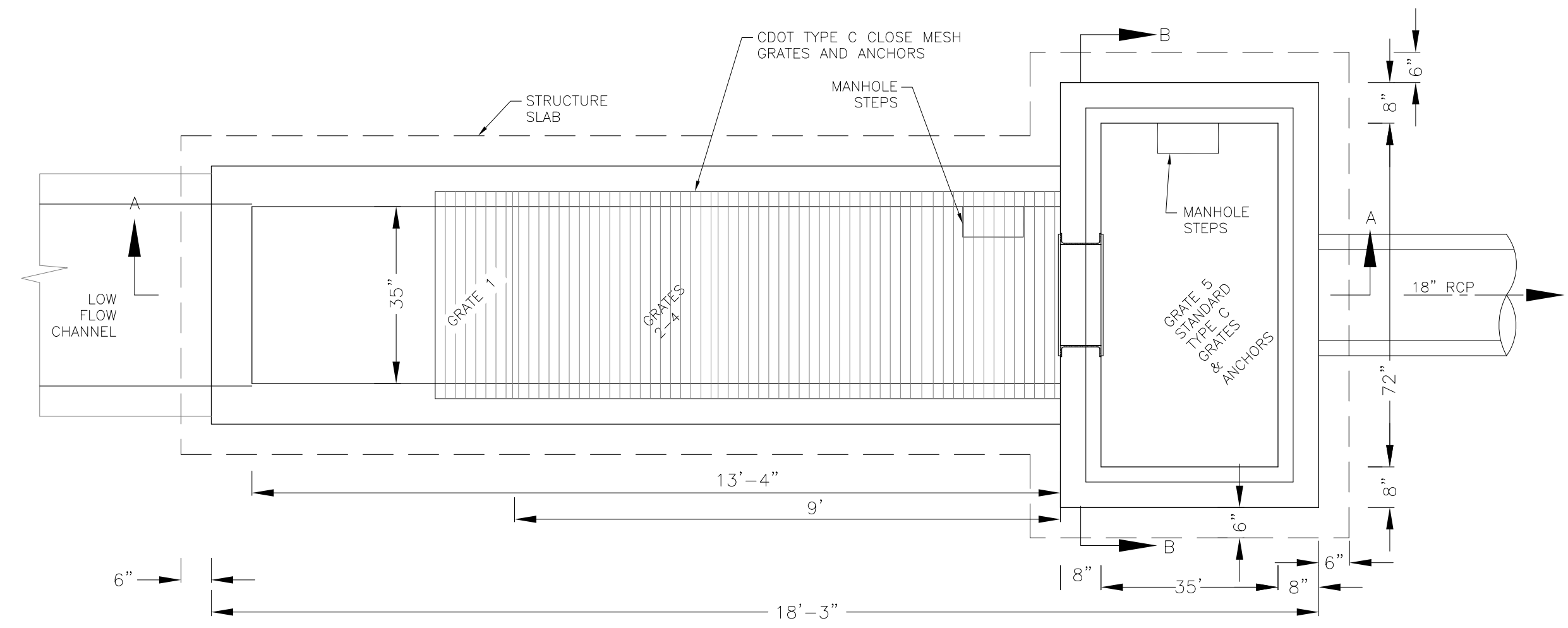
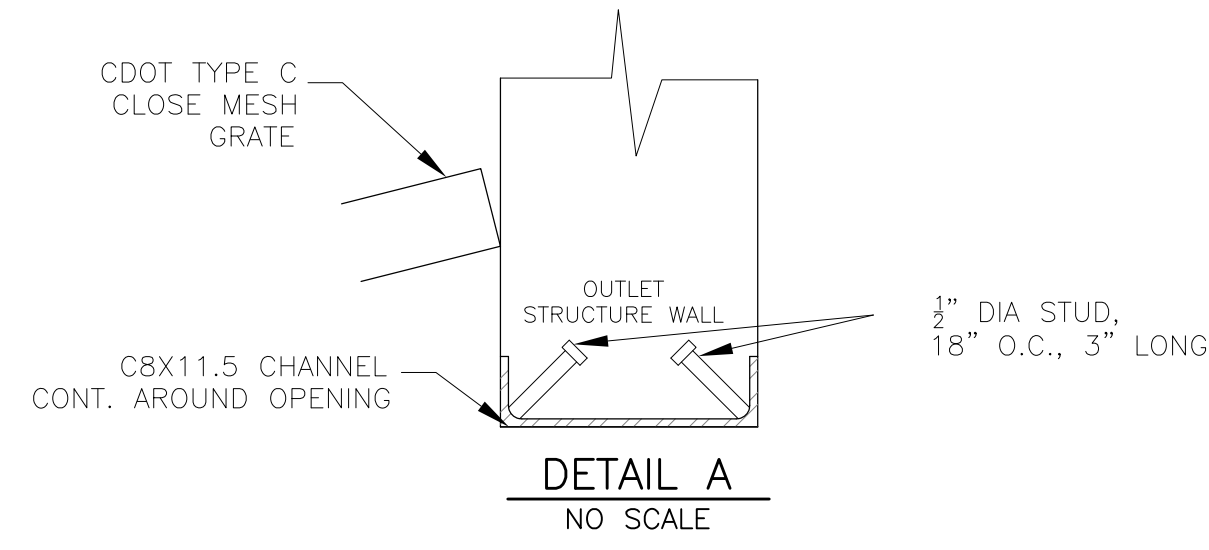

NOTE:
AFTER CONCRETE STRUCTURE HAS BEEN POURED
ALL GRATE DIMENSIONS SHALL BE FIELD VERIFIED
PRIOR TO GRATE CONSTRUCTION

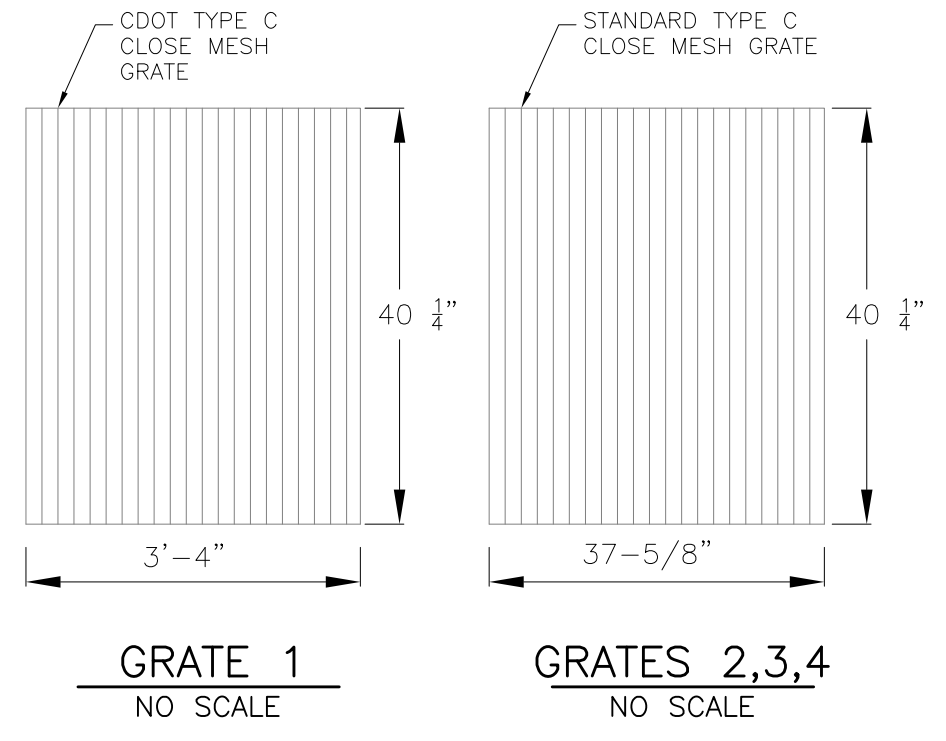

OUTLET STRUCTURE DETAIL - PLAN VIEW
NO SCALE

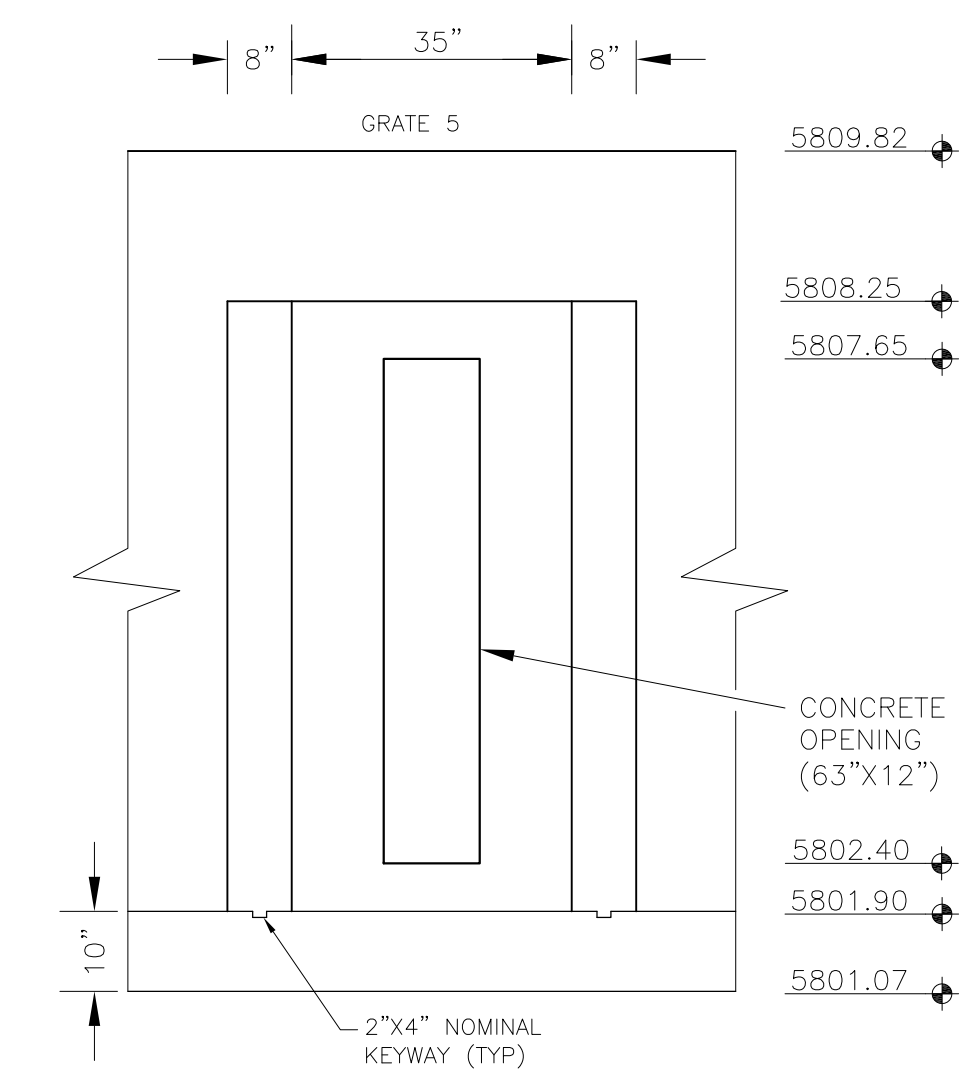
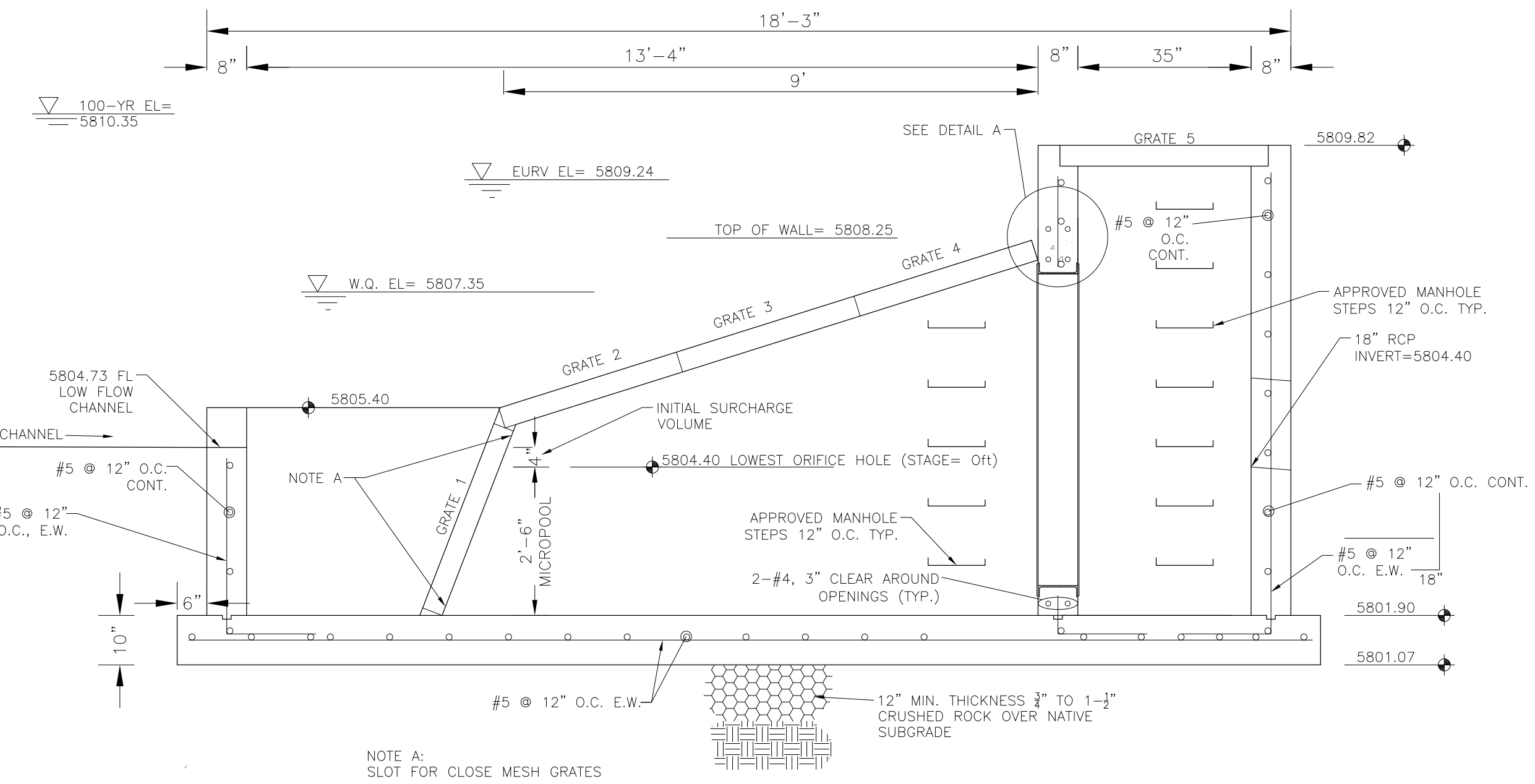

OUTLET STRUCTURE DETAIL - SECTION B-B
NO SCALE

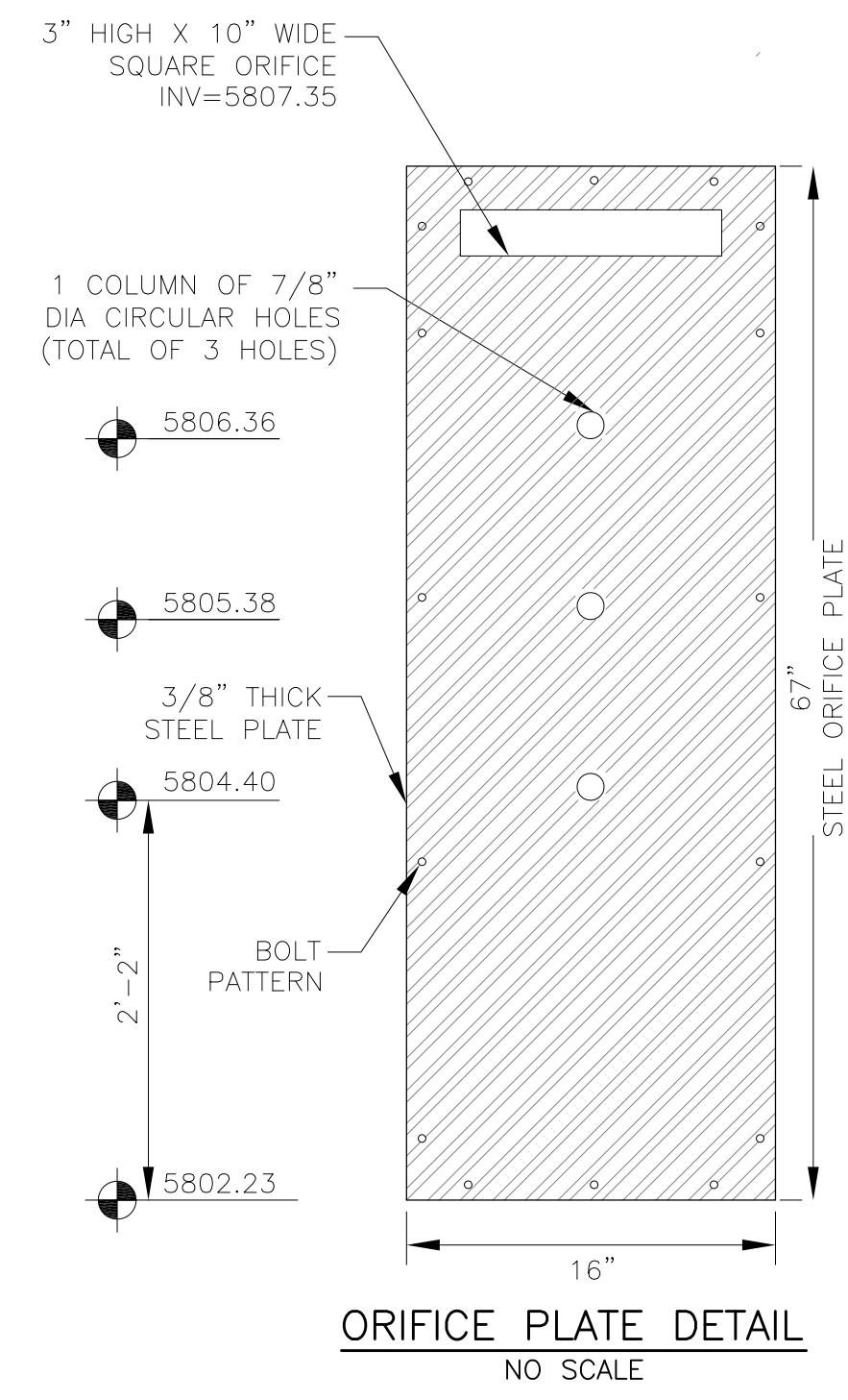
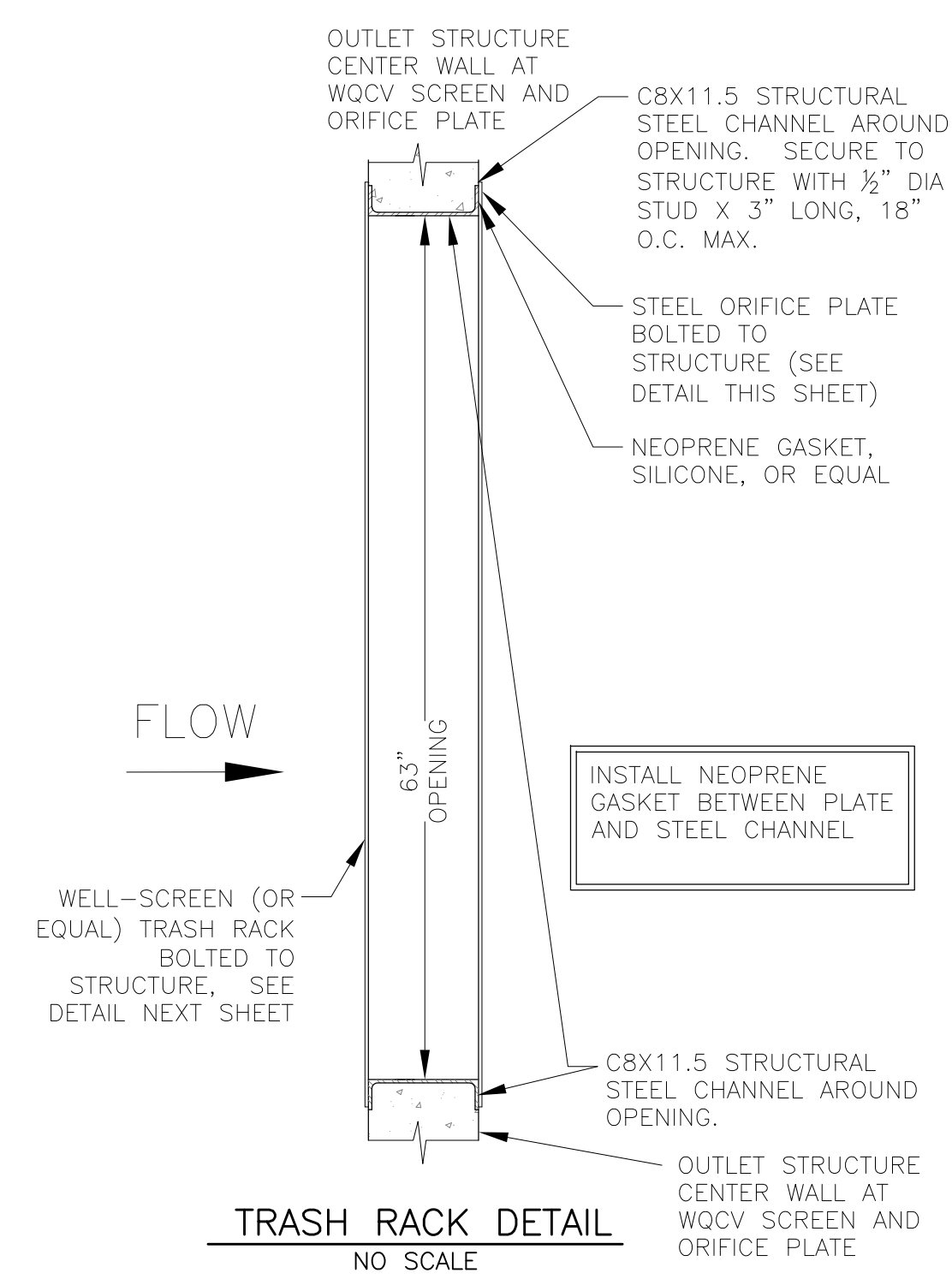

OUTLET STRUCTURE, FOREBAY, AND DRAIN CHANNEL NOTES:

- PRIOR TO CONSTRUCTION, CONTRACTOR SHALL PROVIDE SHOP DRAWINGS FOR ALL COMPONENTS OF THE OUTLET STRUCTURE.
 - GRADE 60 REINFORCING STEEL REQUIRED. SEE TABLE FOR THE MINIMUM LAP SPLICE LENGTH FOR REINFORCING BARS. ALL REINFORCING STEEL SHALL HAVE A TWO-INCH MINIMUM CLEARANCE FROM EDGE OF CONCRETE, UNLESS OTHERWISE NOTED.
- | BAR SIZE | #4 | #5 | #6 |
|--------------------|-------|-------|-------|
| MIN. SPLICE LENGTH | 1'-3" | 1'-7" | 2'-0" |
- CONCRETE FOR THE OUTLET STRUCTURE AND FOREBAY SHALL BE CDOT CLASS D CONCRETE.
 - CONCRETE FOR DRAIN CHANNELS SHALL BE CDOT CLASS B CONCRETE.
 - EXPANSION JOINT MATERIAL SHALL MEET AASHTO SPECIFICATION M-213. EXPANSION JOINT MATERIAL SHALL BE 1/2" THICK, SHALL EXTEND THE FULL DEPTH OF CONTACT SURFACE AND THE JOINT SHALL BE SEALED, REFER TO DETAILS.
 - ALL EXPOSED CONCRETE CORNERS SHALL HAVE A 3/8" CHAMFER UNLESS OTHERWISE NOTED.
 - SUBGRADE TO BE 12" THICK CLEAN FILL COMPACTED TO 95% STANDARD PROCTOR DENSITY PER ASTM M698 UNDER STRUCTURE.
 - REFER TO POND DETAILS FOR PRESEDIMENTATION/FOREBAY DESIGN.
 - ENGINEER SHALL BE NOTIFIED PRIOR TO BEGINNING CONSTRUCTION OF OUTLET STRUCTURE TO SCHEDULE OBSERVATION VISITS FOR STRUCTURES.

WQCV WELL-SCREEN NOTES:

- Well-Screen shall be stainless steel and attached by stainless steel bolts along edge of the mounting frame.
- WQCV Well Screen
 - Type of Screen: Stainless steel #93 Vee Wire (Johnson Vee Wire (tm) Stainless Steel Screen or equivalent with 60% open area)
 - Screen slot opening dimension: 0.139" (Screen #93 Vee Wire Slot Opening)
 - Type and Size of Support Rod: TE 0.074"x0.50"
 - Spacing of Support Rod (O.C.): 1.0 Inch
 - Total Screen Thickness: 0.655"
 - Carbon Steel Holding Frame Type: 3/4" x 1.0" angle

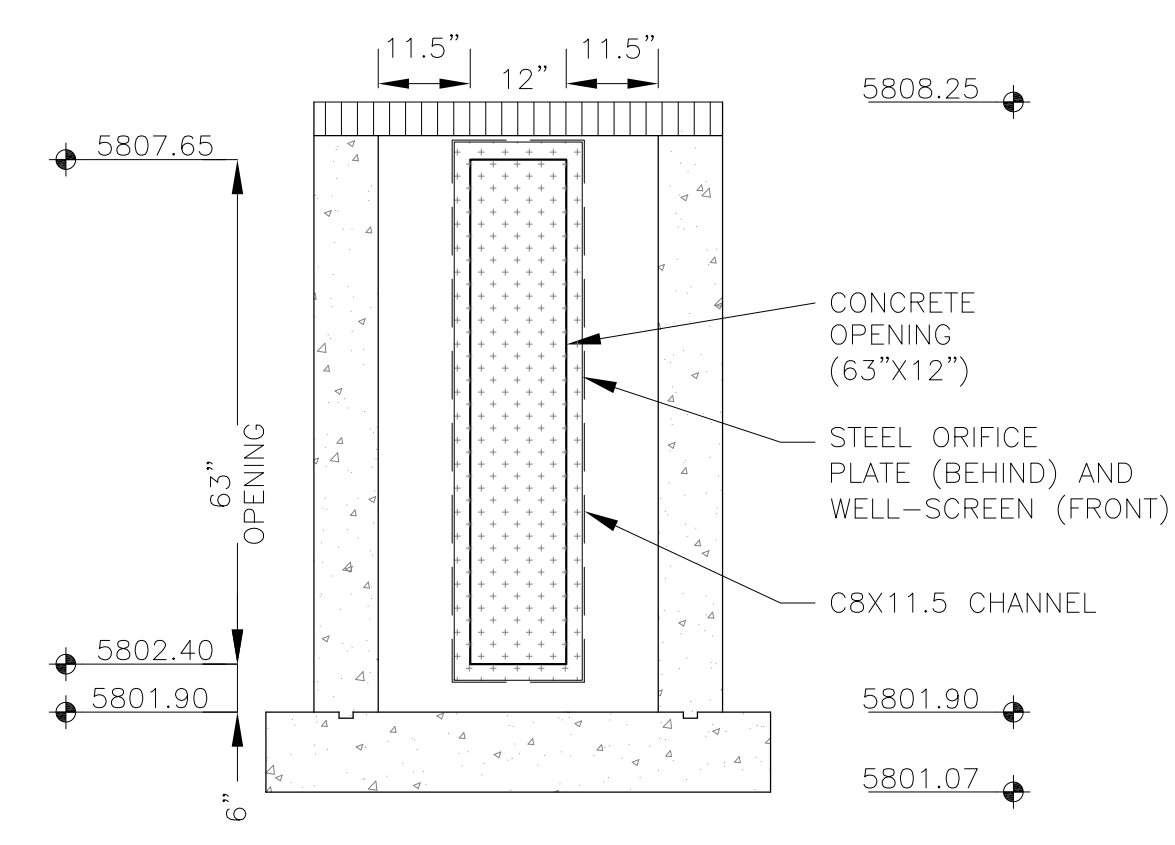

OUTLET STRUCTURE DETAIL - SECTION B-B
NO SCALE

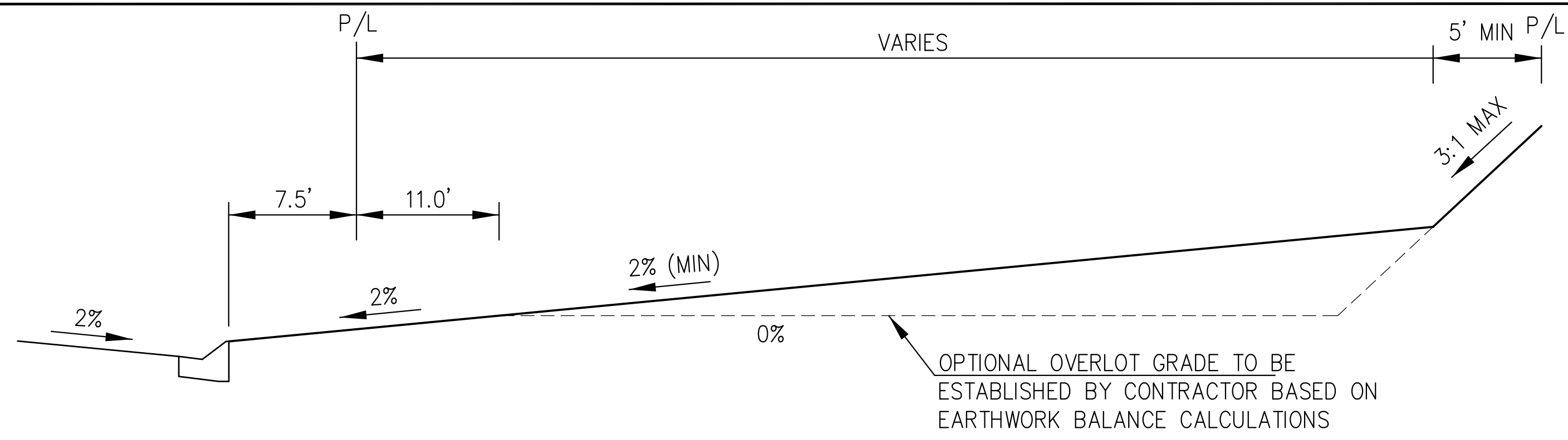

TYPICAL "A" LOT

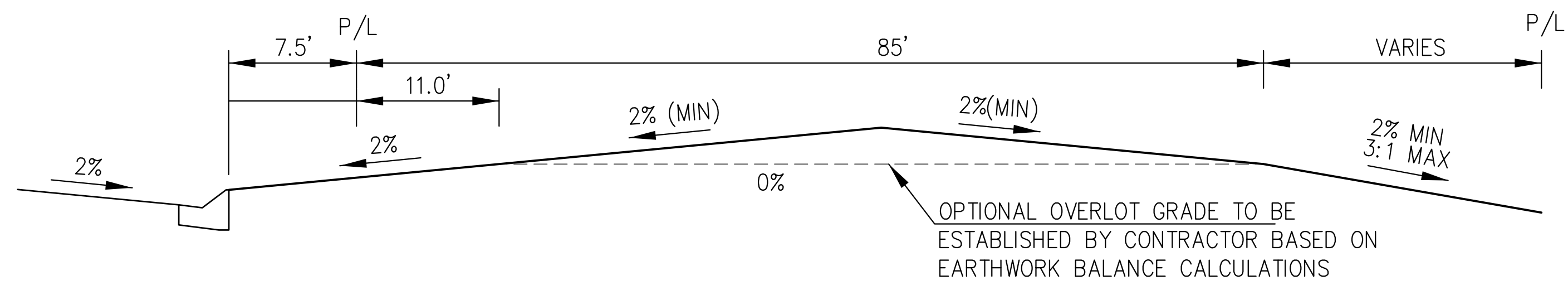

TYPICAL "B" LOT

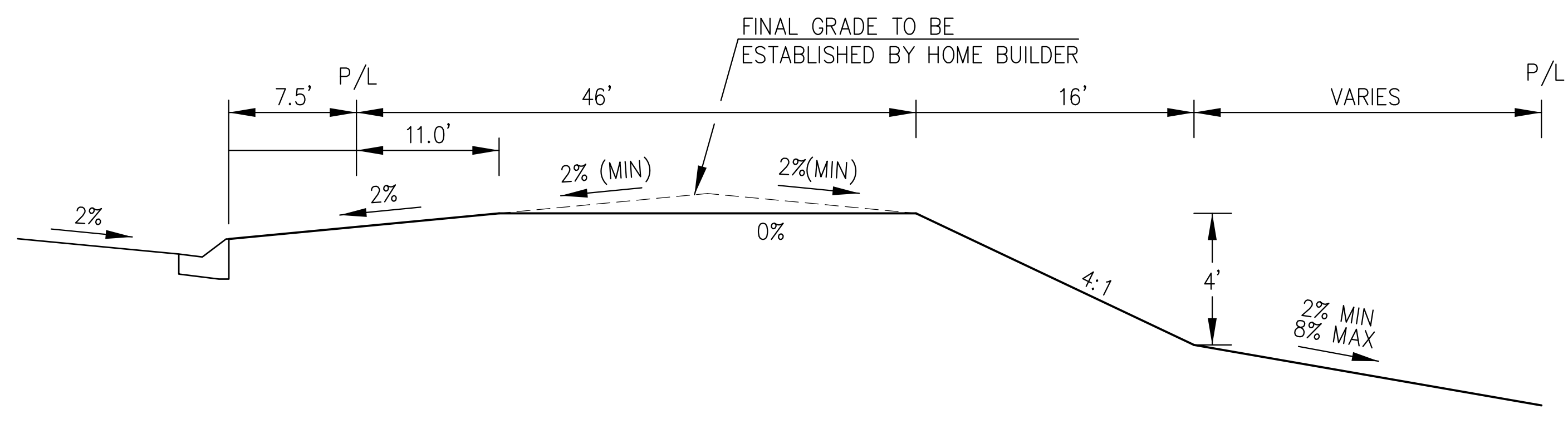

TYPICAL "GARDEN" LOT

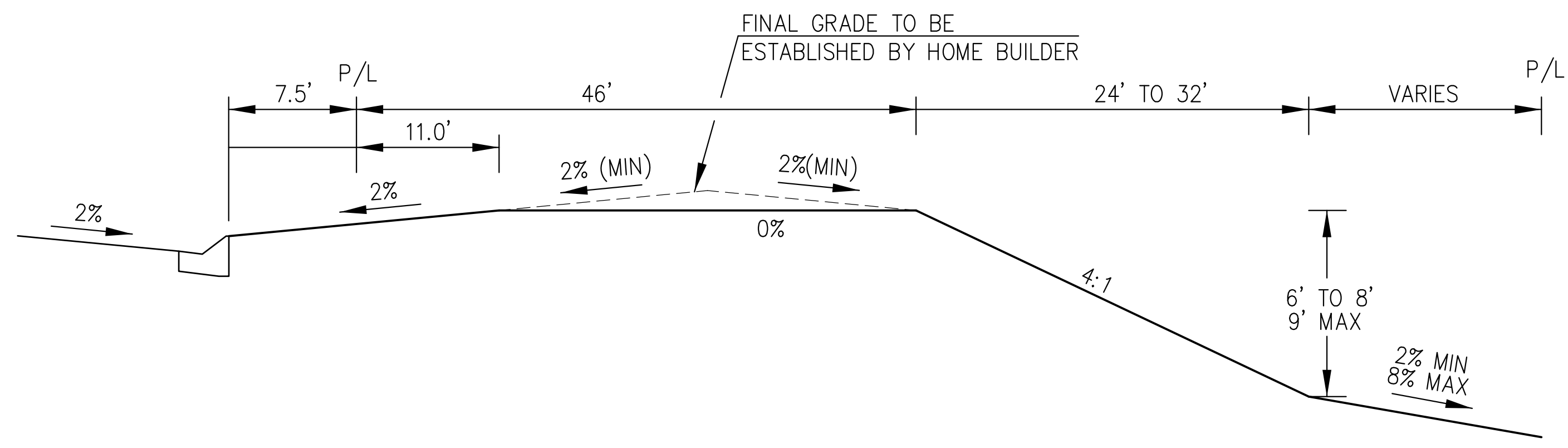

TYPICAL "WALKOUT" LOT

Sediment Control Log (SCL) SC-2

SEDIMENT CONTROL LOG

NOTE: LARGER DIAMETER SEDIMENT CONTROL LOGS MAY NEED TO BE EMBEDDED DEEPER.

SECTION A

SEDIMENT CONTROL LOG JOINTS

SCL-1. SEDIMENT CONTROL LOG

November 2010 Urban Drainage and Flood Control District Urban Storm Drainage Criteria Manual Volume 3 SCL-3

EC-9 Rough Cut Street Control (RCS)

ROUGH CUT STREET CONTROL PLAN

SECTION A

SECTION B

W (FT)	X (FT)
20-30	5
31-40	7
41-50	9
51-60	10.5
61-70	12

LONGITUDINAL STREET SLOPE (%)	SPACING (FT)
<2	NOT TYPICALLY NEEDED
3	200
4	150
5	100
6	50
7	25
8	25

RCS-2 Urban Drainage and Flood Control District Urban Storm Drainage Criteria Manual Volume 3 November 2010

STRAW BALE INLET PROTECTION

STRAW BALE INLET PROTECTION NOTES

INSTALLATION REQUIREMENTS

- INLET PROTECTION SHALL BE INSTALLED IMMEDIATELY AFTER CONSTRUCTION OF INLET.
- BALES ARE TO BE PLACED IN A SINGLE ROW AROUND THE INLET WITH THE END OF THE BALES TIGHTLY ABUTTING ONE ANOTHER.
- SEE STRAW BALE BARRIER FIGURE 8BB-2 FOR INSTALLATION REQUIREMENTS.

MAINTENANCE REQUIREMENTS

- CONTRACTOR SHALL INSPECT STRAW BALE INLET PROTECTION IMMEDIATELY AFTER EACH RAINFALL AT LEAST DAILY DURING PROLONGED RAINFALL, AND WEEKLY DURING PERIODS NO RAINFALL.
- DAMAGED OR INEFFECTIVE INLET PROTECTION SHALL PROMPTLY BE REPAIRED, REPLACING BALES IF NECESSARY, AND UNREINFORCED BALES NEED TO BE REPAIRED WITH COMPACTED BACKFILL MATERIAL.
- SEDIMENT SHALL BE REMOVED FROM BEHIND STRAW BALES WHEN IT ACCUMULATES TO APPROXIMATELY 1/3 THE HEIGHT OF THE BARRIER.
- INLET PROTECTION SHALL BE REMOVED WHEN ADEQUATE VEGETATIVE COVER IS ATTAINED WITHIN THE DRAINAGE AREA AS APPROVED BY THE CITY.

City of Colorado Springs Stormwater Quality Figure IP-2 Straw Bale Inlet Protection Construction Detail and Maintenance Requirements 3-26

Concrete Washout Structure

PLAN VIEW

SECTION A-A

NOTES:

- SIGN MATERIAL, EXCAVATION, AND RESTORATION ARE INCLUDED IN THE COST OF THE CONCRETE WASHOUT STRUCTURE.
- EROSION BALES MAY BE USED AS AN ALTERNATIVE FOR THE BERM.

DATE APPROVED: 1/1/08
 DEPARTMENT OF TRANSPORTATION: John A. McCarty
 STANDARD DRAWING: Concrete Washout Structure
 REVISION DATE: 7/17/07
 FILE NAME: SD_3-84

CORE ENGINEERING GROUP
 1500 S. 1ST AVENUE, SUITE 35506
 P.O. BOX 179, FLORENCE, CO 81226
 CONTACT: RICHARD L. SCHINDLER, P.E.
 EMAIL: Rich@cegi.com

PREPARED FOR: LORSON, LLC
 212 N. WAHSATCH AVE, SUITE 301
 COLORADO SPRINGS, COLORADO 80903
 (719) 635-3200
 CONTACT: JEFF MARK

PROJECT: HILLSIDE AT LORSON RANCH
 LORSON BLVD. - WALLEYE DR.
 COLORADO SPRINGS, COLORADO

DATE: APRIL 15, 2022

PROJECT NO.: 100.065

SHEET NUMBER: C12.1

TOTAL SHEETS: 20

GRADING AND EROSION CONTROL DETAILS

Vehicle Tracking Control (VTC)

SM-4

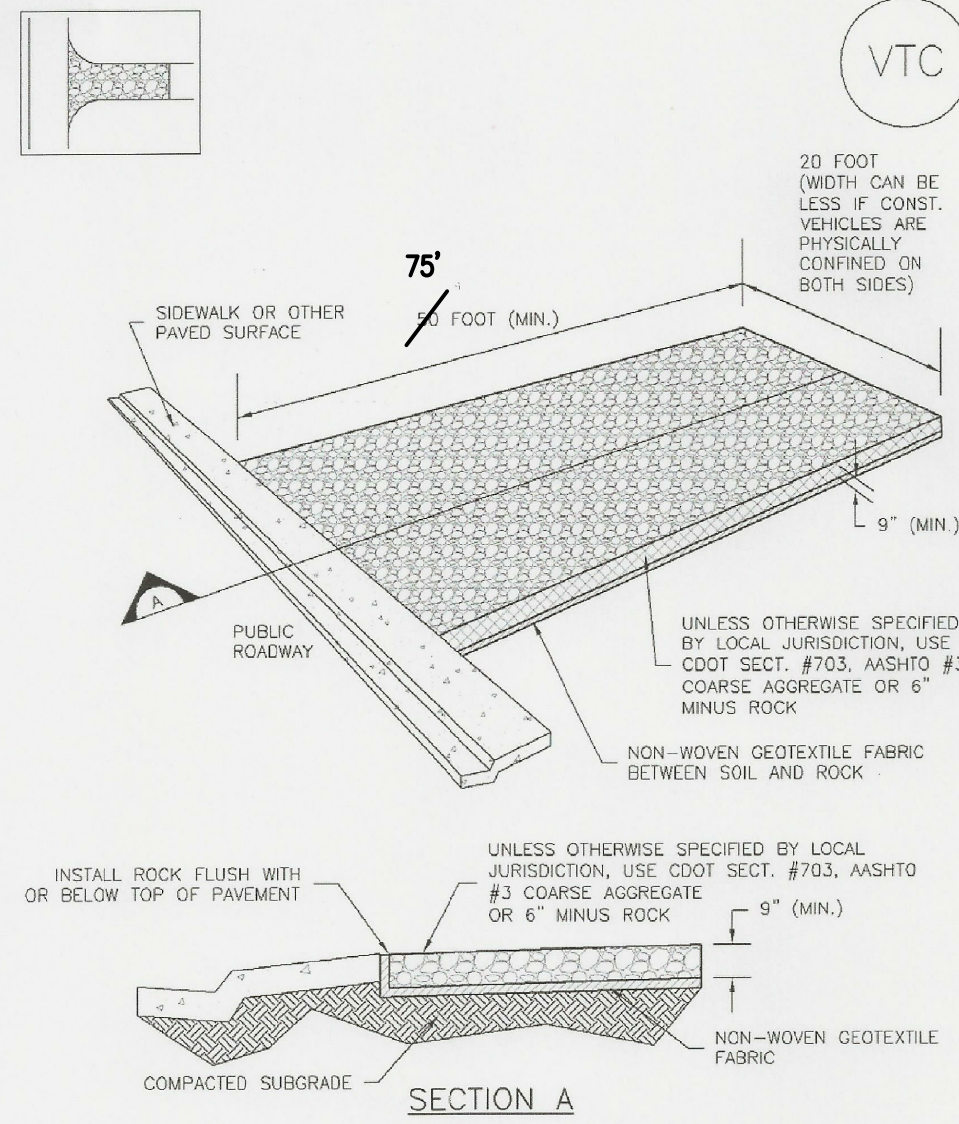

VTC-1. AGGREGATE VEHICLE TRACKING CONTROL

November 2010 Urban Drainage and Flood Control District Urban Storm Drainage Criteria Manual Volume 3 VTC-3

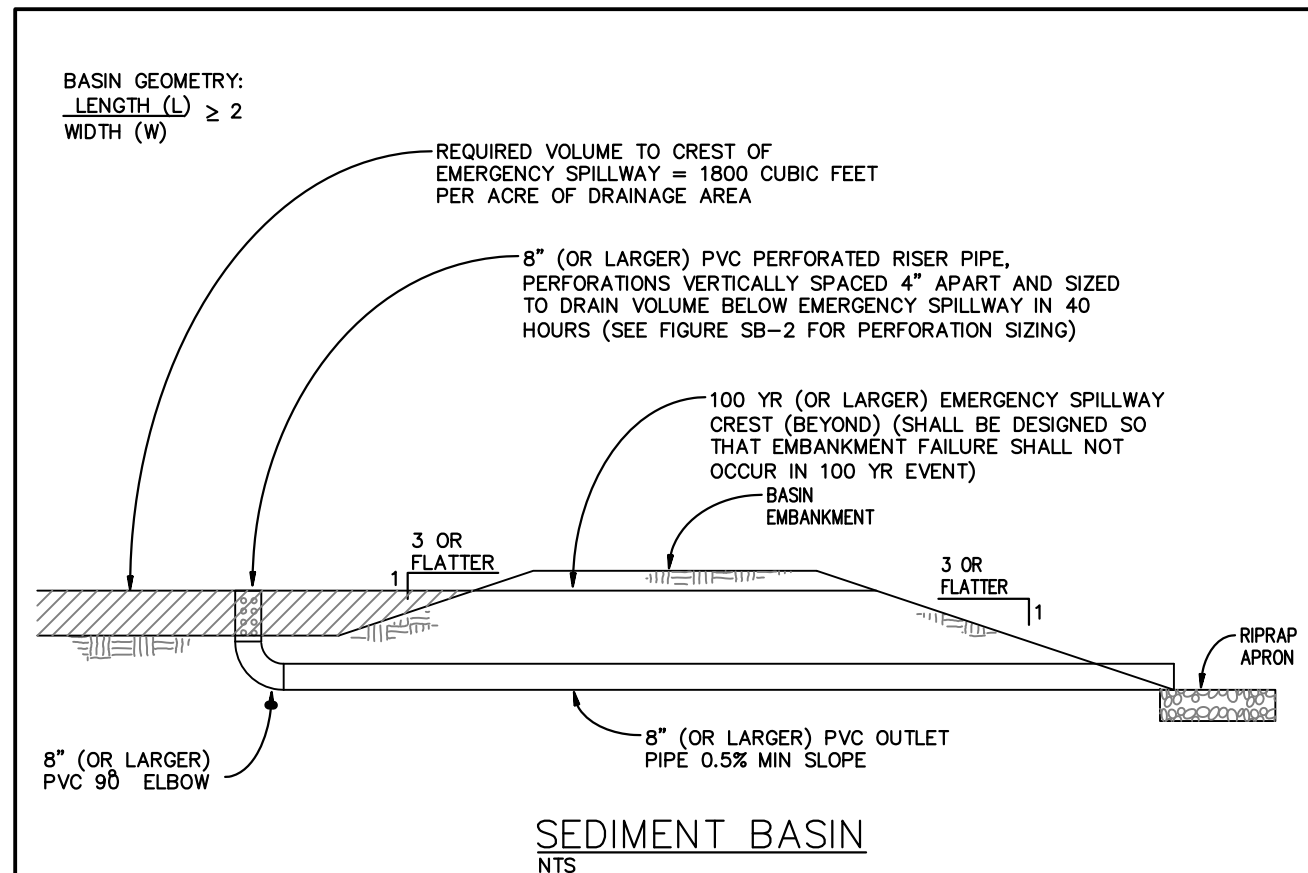

SEDIMENT BASIN NOTES

INSTALLATION REQUIREMENTS

1. SEDIMENT BASINS SHALL BE INSTALLED BEFORE ANY CLEARING AND/OR GRADING IS UNDERTAKEN.
2. THE AREA UNDER WHICH THE EMBANKMENT IS TO BE INSTALLED SHALL BE CLEARED, GRUBBED, AND STRIPPED OF ALL VEGETATION AND ROOT MAT.
3. THE OUTLET OF THE BASIN SHALL BE DESIGNED TO DRAIN ITS VOLUME IN 40 HOURS.
4. THE OUTLET IS TO BE LOCATED AT THE FURTHEST DISTANCE FROM THE INLET OF THE BASIN. BATTLES MAY BE NEEDED TO INCREASE THE FLOW LENGTH AND SETTLING TIME.
5. EMBANKMENT MATERIAL SHALL CONSIST OF SOIL WITH A MINIMUM OF 15% PASSING A #200 SIEVE. EXCAVATED SOIL CAN BE USED IF IT MEETS THIS REQUIREMENT.
6. EMBANKMENT IS TO BE COMPACTED TO AT LEAST 90% OF MAXIMUM DENSITY AND WITHIN 2% OF OPTIMUM MOISTURE CONTENT ACCORDING TO ASTM D 698.
7. WHEN A BASIN IS INSTALLED NEAR A RESIDENTIAL AREA, FOR SAFETY REASONS, A SIGN SHALL BE POSTED AND THE AREA SECURED WITH A FENCE.

MAINTENANCE REQUIREMENTS

1. CONTRACTOR SHALL INSPECT SEDIMENT BASINS AFTER EACH RAINFALL, AT LEAST DAILY DURING PROLONGED RAINFALL, AND WEEKLY DURING PERIODS OF NO RAINFALL.
2. SEDIMENT BASINS SHALL BE CLEANED OUT BEFORE SEDIMENT HAS FILLED HALF THE VOLUME OF THE BASIN.
3. SEDIMENT BASINS SHALL REMAIN OPERATIONAL AND PROPERLY MAINTAINED UNTIL THE SITE AREA IS PERMANENTLY STABILIZED WITH ADEQUATE VEGETATIVE COVER AND/OR OTHER PERMANENT STRUCTURE AS APPROVED BY THE CITY.

City of Colorado Springs Stormwater Quality

Figure SB-1 Sediment Basin Construction Detail and Maintenance Requirements

3-32

EC-6 Rolled Erosion Control Products (RECP)

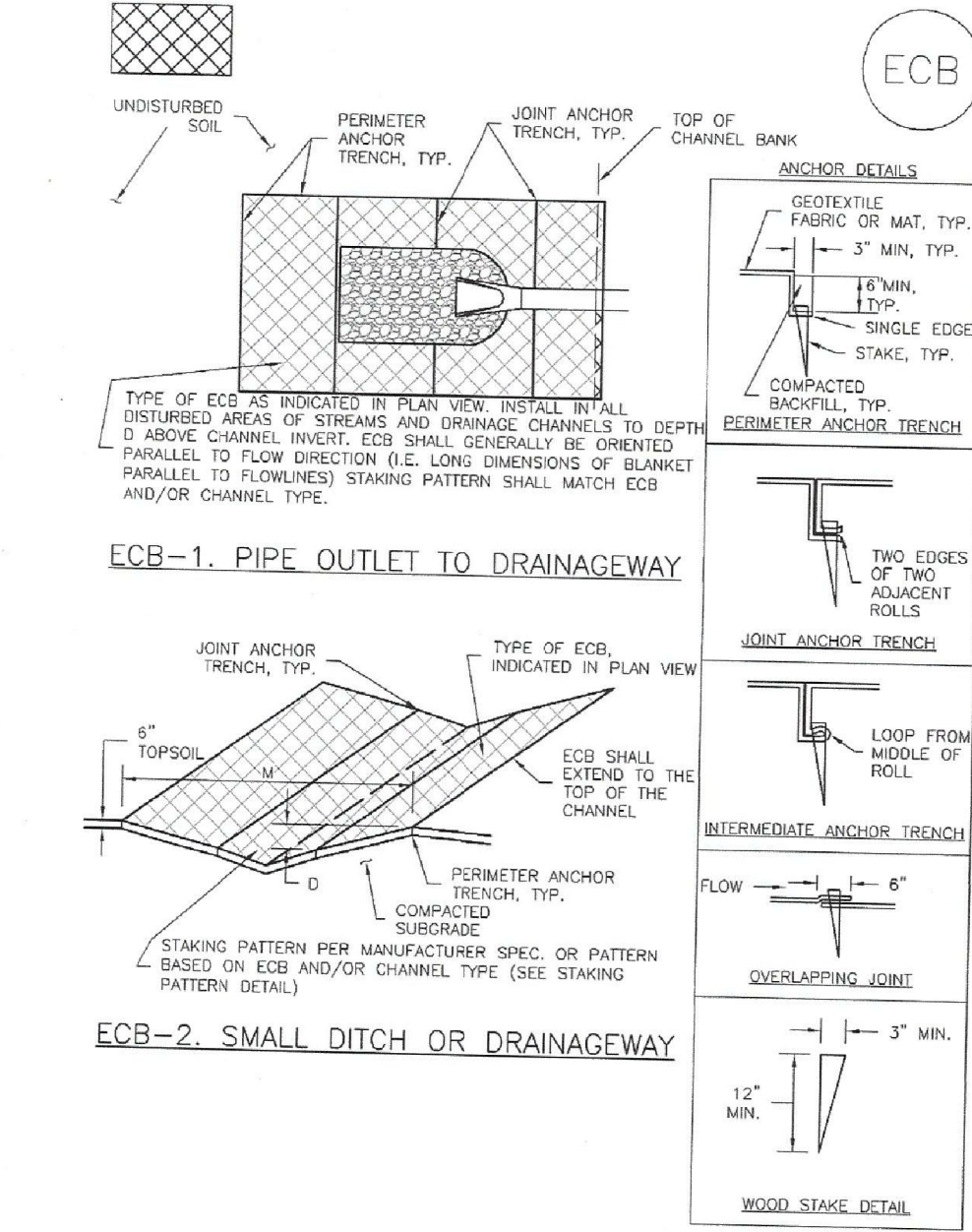

RECP-6 Urban Drainage and Flood Control District Urban Storm Drainage Criteria Manual Volume 3 November 2010

CORE ENGINEERING GROUP
1500 S. 1ST AVENUE, SUITE 3506
PH: 719.570.1100
CONTACT: RICHARD L. SCHINDLER, P.E.
EMAIL: Rich@cegi.com

PREPARED FOR: **LORSON, LLC**
212 N. WAHSATCH AVE, SUITE 301
COLORADO SPRINGS, COLORADO 80903
(719) 635-3200
CONTACT: JEFF MARK

PROJECT: **HILLSIDE AT LORSON RANCH**
LORSON BLVD. - WALLEYE DR.
COLORADO SPRINGS, COLORADO

DRAWN: RLS
DESIGNED: RLS
CHECKED: RLS

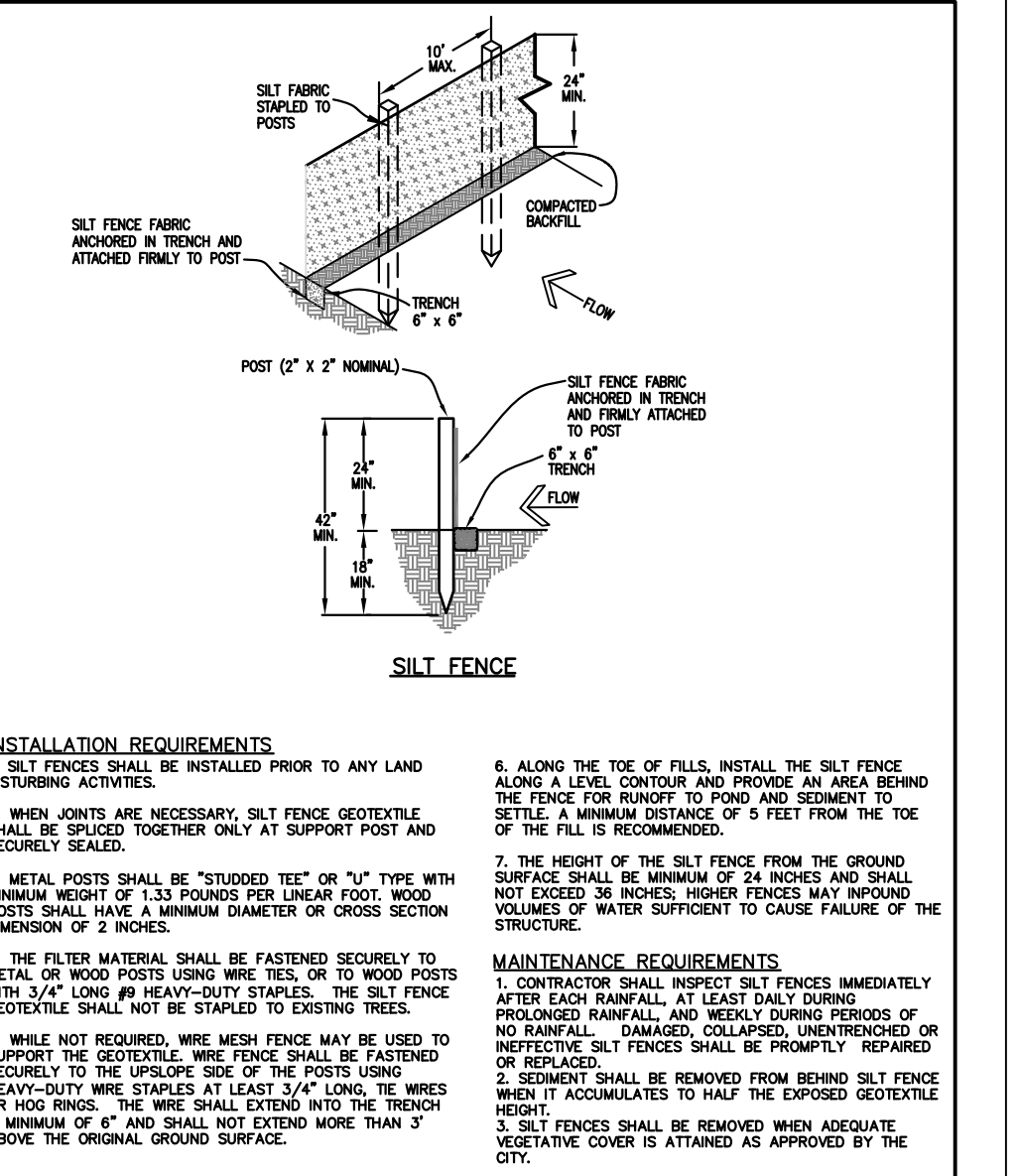

Figure SF-2 Silt Fence Construction Detail and Maintenance Requirements

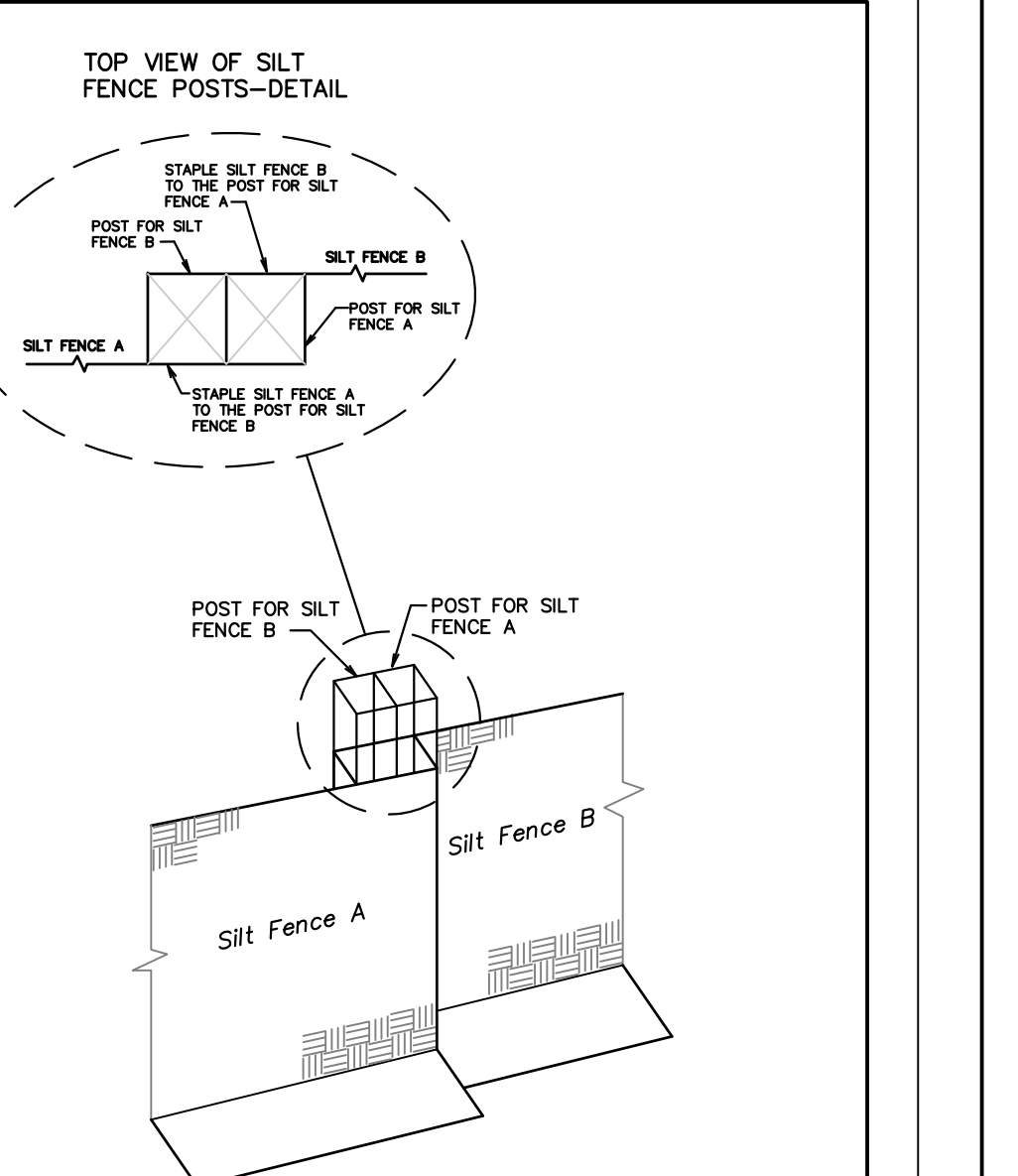

Figure SF-3 Silt Fence Joint Tying Construction Detail and Maintenance Requirements

Required Area per Row (ft²)

Depth at Outlet (ft)	Depth at Outlet (ft)									
	1.0	1.5	2.0	2.5	3.0	3.5	4.0	4.5	5.0	5.5
0.2	15.64	7.71	5.10	3.78	2.89	2.41	2.02	1.73	1.50	1.33
0.4	7.92	3.86	2.55	1.88	1.40	1.21	1.01	0.87	0.75	0.67
0.6	4.91	2.31	1.53	1.13	0.89	0.72	0.61	0.52	0.45	0.40
0.8	3.61	1.84	1.02	0.75	0.59	0.48	0.40	0.35	0.30	0.27
1.0	2.75	1.39	0.77	0.51	0.38	0.30	0.24	0.20	0.17	0.15
1.2	2.25	1.12	0.62	0.40	0.29	0.22	0.17	0.14	0.12	0.10
1.5	1.50	0.77	0.45	0.28	0.19	0.15	0.12	0.10	0.09	0.08
2.0	0.90	0.45	0.23	0.15	0.11	0.09	0.07	0.06	0.05	0.05
2.5	0.54	0.28	0.15	0.10	0.08	0.06	0.05	0.04	0.03	0.03
3.0	0.36	0.18	0.09	0.06	0.04	0.03	0.02	0.02	0.02	0.02
4.0	0.22	0.11	0.05	0.03	0.02	0.01	0.01	0.01	0.01	0.01

TABLE SB-1

Circular Perforation Sizing (in)	Area per Row (ft ²)	
	n = 1	n = 2
1/4	0.290	0.05
5/16	0.313	0.08
3/8	0.375	0.11
7/16	0.438	0.15
1/2	0.500	0.20
9/16	0.563	0.25
5/8	0.625	0.31
11/16	0.688	0.37
3/4	0.750	0.44
7/8	0.875	0.60
1.000	1.000	0.79
1.125	1.125	0.99
1.14	1.250	1.23
1.375	1.375	1.48
1.12	1.500	1.77
1.50	1.625	2.07
1.34	1.750	2.41
1.75	1.875	2.78
2	2.000	3.14

n = Number of columns of perforations

Figure SB-2 Outlet Sizing Application Techniques and Maintenance Requirements

City of Colorado Springs Stormwater Quality

3-33

EC-6 Rolled Erosion Control Products (RECP)

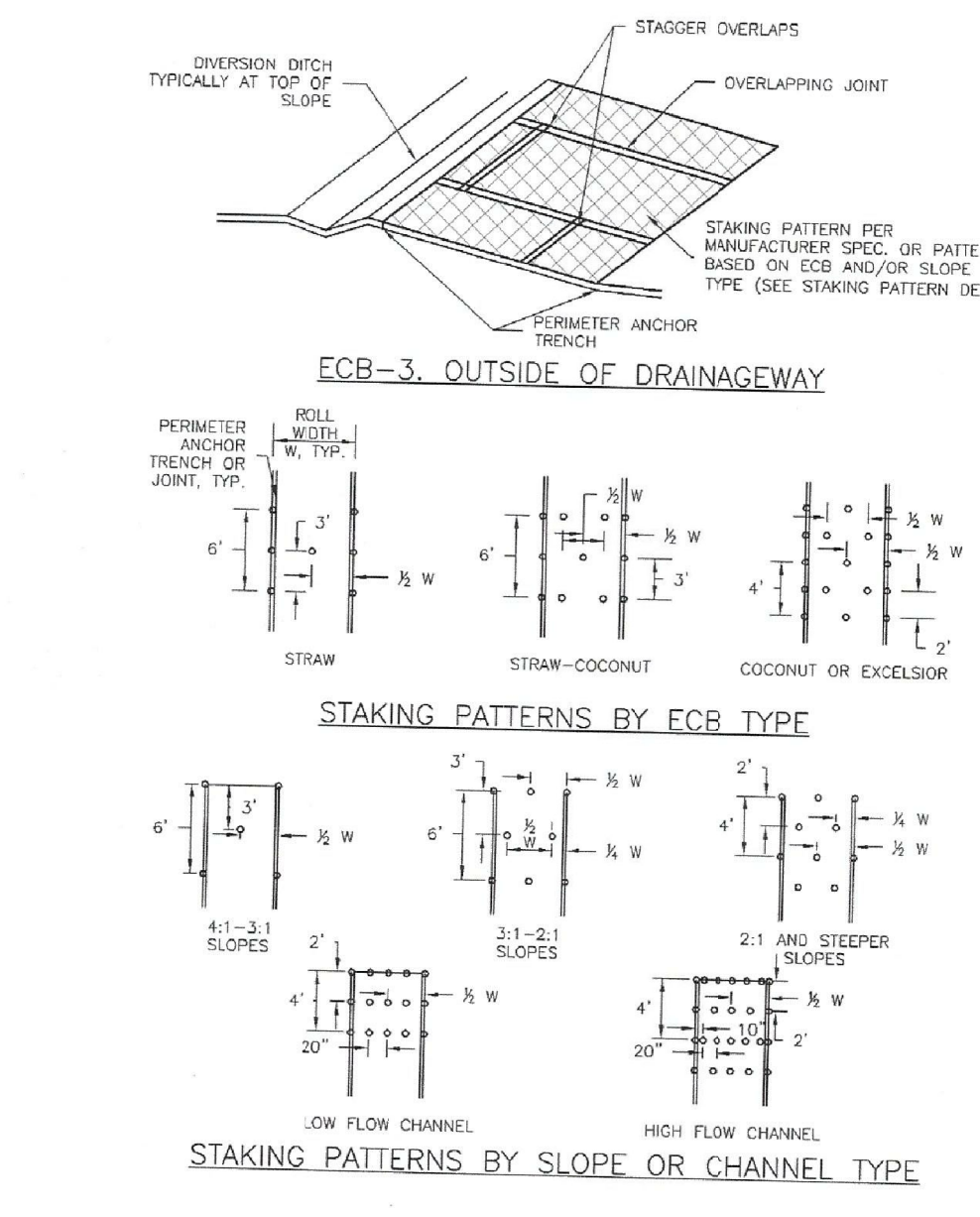

RECP-7 Urban Drainage and Flood Control District Urban Storm Drainage Criteria Manual Volume 3 November 2010

GRADING AND EROSION CONTROL DETAILS

DATE: **APRIL 15, 2022**
PROJECT NO. **100.065**
SHEET NUMBER **C12.2**
TOTAL SHEETS: **20**

EC-2 Temporary and Permanent Seeding (TS/PS)

Table TS/PS-2. Minimum Drill Seeding Rates for Perennial Grasses. Table with 5 columns: Common Name, Botanical Name, Growth Season, Growth Form, Seeds/Pound, Pounds of PLS/acre. Includes sections for Alkali Soil Seed Mix, Fertile Loamy Soil Seed Mix, and High Water Table Soil Seed Mix.

TS/PS-4 Urban Drainage and Flood Control District Urban Storm Drainage Criteria Manual Volume 3 June 2012

Temporary and Permanent Seeding (TS/PS) EC-2

Table TS/PS-2. Minimum Drill Seeding Rates for Perennial Grasses (cont.). Table with 5 columns: Common Name, Botanical Name, Growth Season, Growth Form, Seeds/Pound, Pounds of PLS/acre. Includes sections for Sandy Soil Seed Mix and Heavy Clay, Rocky Foothill Seed Mix.

June 2012 Urban Drainage and Flood Control District Urban Storm Drainage Criteria Manual Volume 3 TS/PS-5

Temporary and Permanent Seeding (TS/PS) EC-2

Seeding dates for the highest success probability of perennial species along the Front Range are generally in the spring from April through early May and in the fall after the first of September until the ground freezes.

Table TS/PS-1. Minimum Drill Seeding Rates for Various Temporary Annual Grasses. Table with 4 columns: Species (Common name), Growth Season, Pounds of Pure Live Seed (PLS)/acre, Planting Depth (inches).

June 2012 Urban Drainage and Flood Control District Urban Storm Drainage Criteria Manual Volume 3 TS/PS-3

EC-2 Temporary and Permanent Seeding (TS/PS)

Table TS/PS-3. Seeding Dates for Annual and Perennial Grasses

Table with 5 columns: Seeding Dates, Annual Grasses (Warm, Cool), Perennial Grasses (Warm, Cool). Rows include dates from January 1-March 15 to October 1-December 31.

Mulch Cover seeded areas with mulch or an appropriate rolled erosion control product to promote establishment of vegetation. Anchor mulch by crimping, netting or use of a non-toxic tackifier.

Maintenance and Removal Monitor and observe seeded areas to identify areas of poor growth or areas that fail to germinate. Reseed and mulch these areas, as needed.

An area that has been permanently seeded should have a good stand of vegetation within one growing season if irrigated and within three growing seasons without irrigation in Colorado. Reseed portions of the site that fail to germinate or remain bare after the first growing season.

Seeded areas may require irrigation, particularly during extended dry periods. Targeted weed control may also be necessary. Protect seeded areas from construction equipment and vehicle access.

TS/PS-6 Urban Drainage and Flood Control District Urban Storm Drainage Criteria Manual Volume 3 June 2012

Earth Dikes and Drainage Swales (ED/DS) EC-10

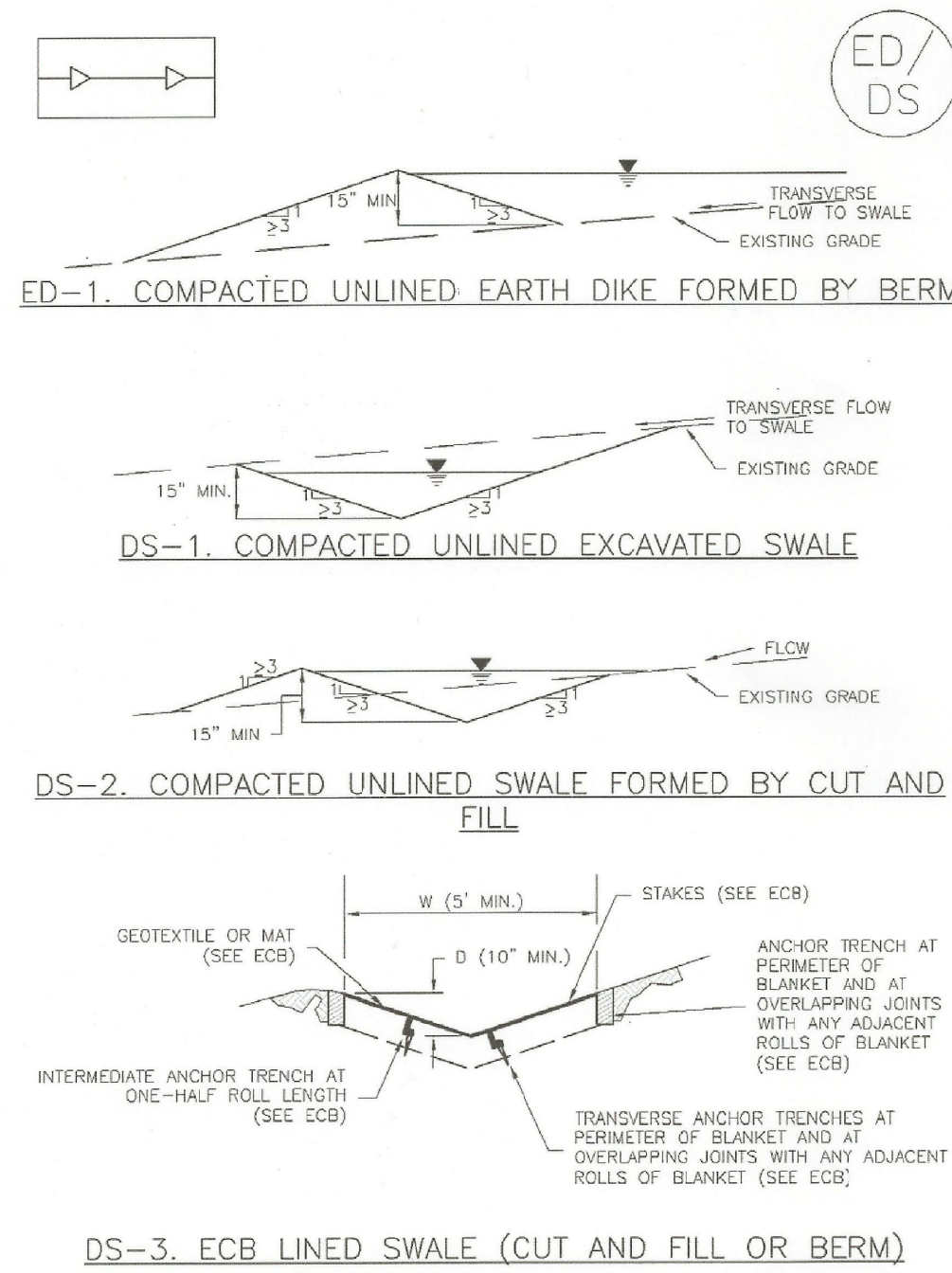

November 2010 Urban Drainage and Flood Control District Urban Storm Drainage Criteria Manual Volume 3 ED/DS-3

Sediment Trap (ST) ST-8

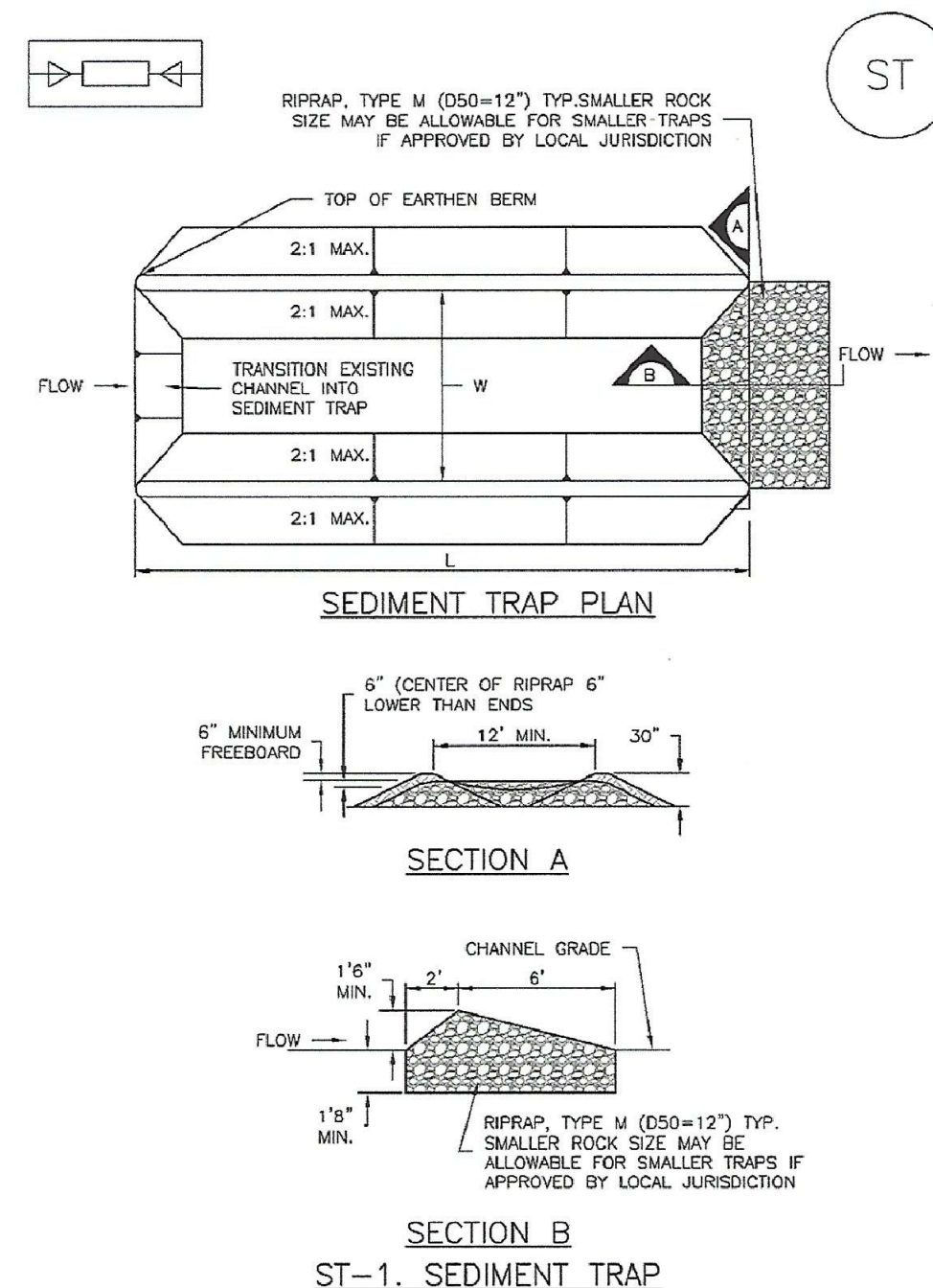

ST-2 Urban Drainage and Flood Control District Urban Storm Drainage Criteria Manual Volume 3 November 2010

Stockpile Management (SP) MM-2

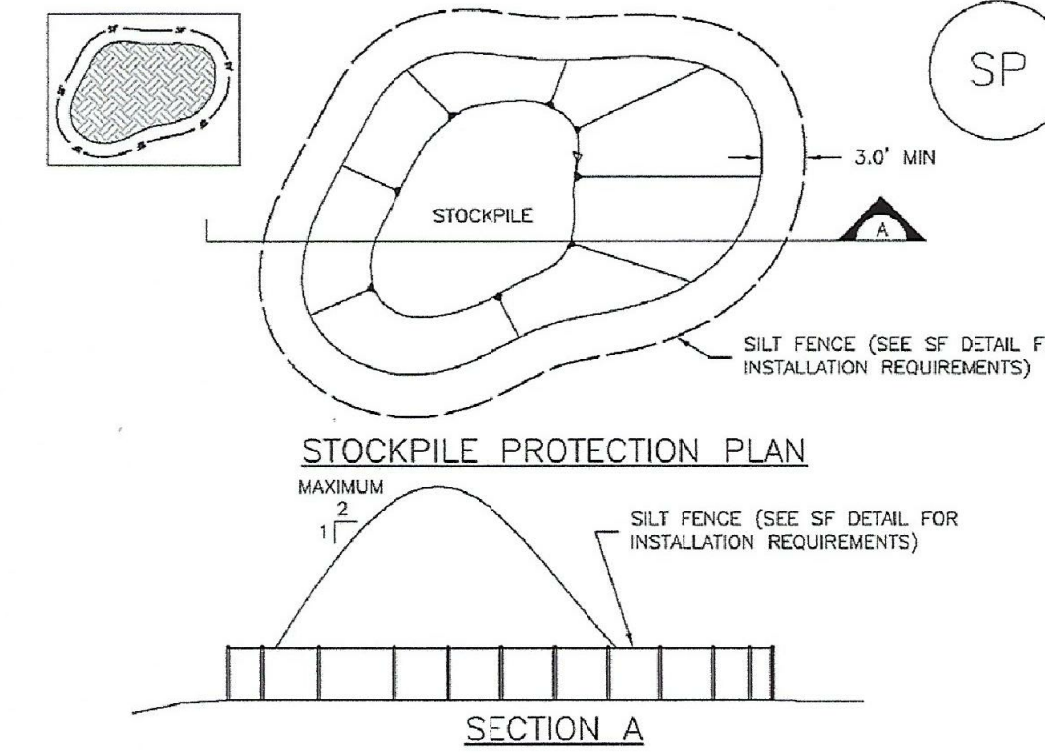

Stockpile Protection Installation Notes. 1. See plan view for location of stockpiles... 2. Install perimeter controls in accordance with their respective design details...

November 2010 Urban Drainage and Flood Control District Urban Storm Drainage Criteria Manual Volume 3 SP-3

Stabilized Staging Area (SSA) SM-6

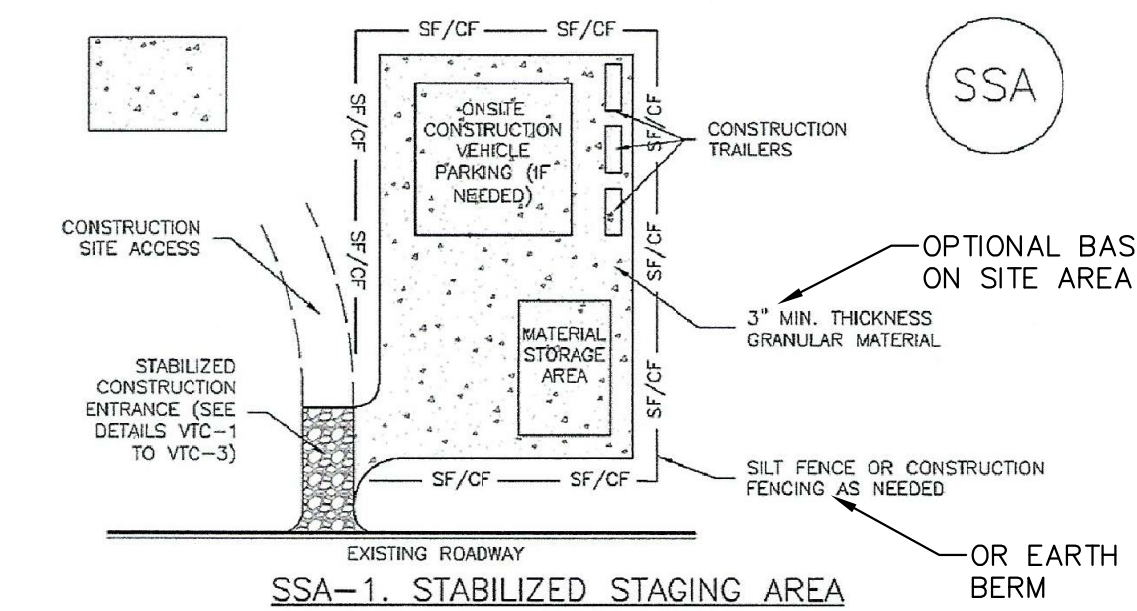

Stabilized Staging Area Installation Notes

- 1. See plan view for location of staging area(s). 2. Stabilized staging area should be appropriate for the needs of the site. 3. Staging area shall be stabilized prior to other operations on the site. 4. The stabilized staging area shall consist of a minimum 3" thick granular material.

Stabilized Staging Area Maintenance Notes

- 1. Inspect BMPs each workday, and maintain them in effective operating condition. 2. Frequent observations and maintenance are necessary to maintain BMPs in effective operating condition.

November 2010 Urban Drainage and Flood Control District Urban Storm Drainage Criteria Manual Volume 3 SSA-3

CORE ENGINEERING GROUP logo and contact information: 1500 S. JAY AVENUE, SUITE 3500, P.O. BOX 79, FORT COLLINS, CO 80504. CONTACT: RICHARD L. SCHINDLER, P.E. EMAIL: Rich@egi.com

DRAWN: RLS, DESIGNED: RLS, CHECKED: RLS

DATE: APRIL 15, 2012. PROJECT NO: 100.065. SHEET NUMBER: C12.3. TOTAL SHEETS: 20.

GRADING AND EROSION CONTROL DETAILS

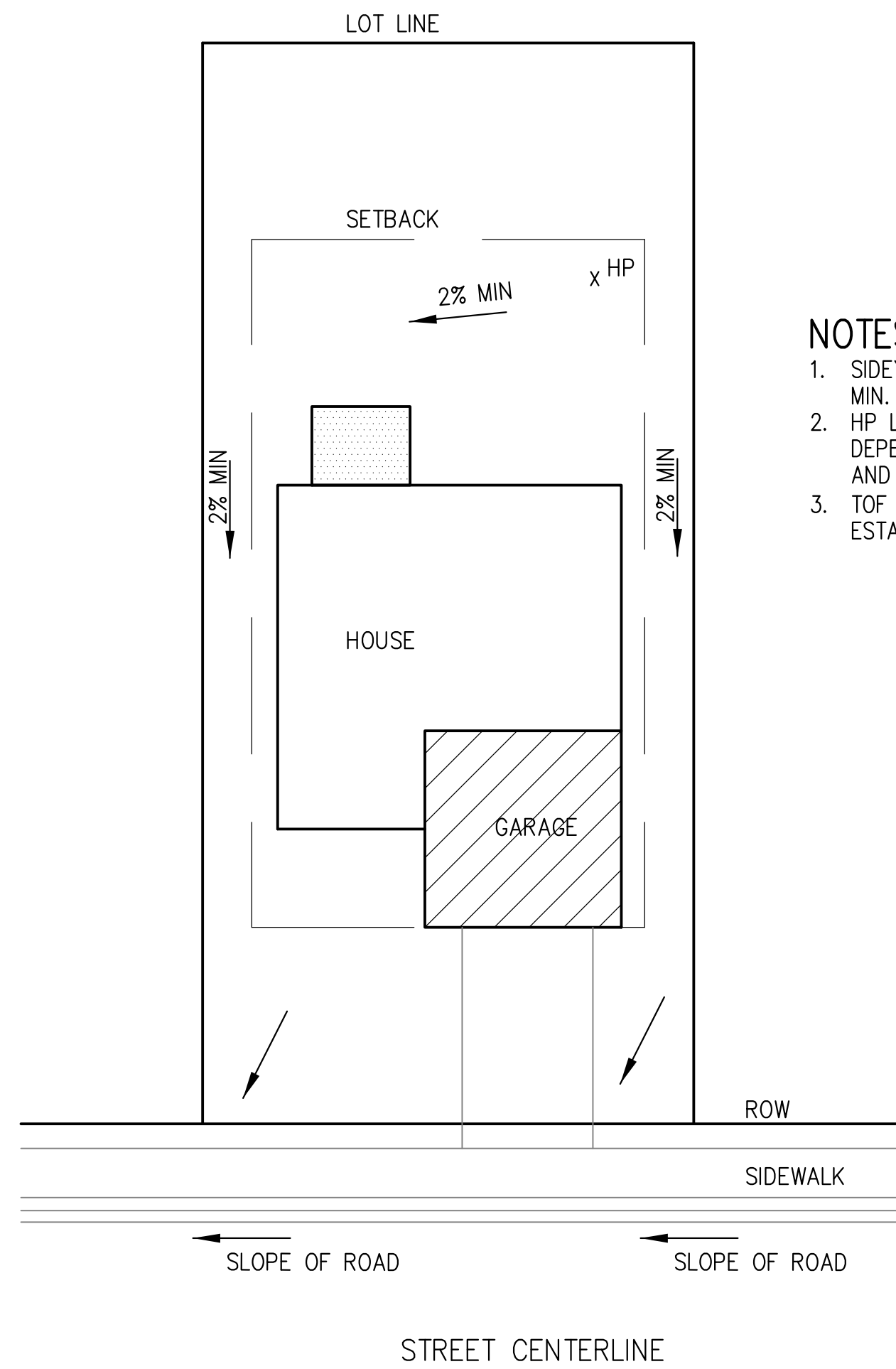

TYPICAL "A" LOT DRAINAGE PATTERN
N.T.S.

NOTES:

1. SIDEYARD SWALE TO BE CONSTRUCTED AT 2% MIN. SLOPE.
2. HP LOCATION ON EACH LOT WILL VARY DEPENDING UPON EXACT HOUSE FOOTPRINT AND LOCATION
3. TOF ELEVATION MUST BE MIN. 18" HIGHER THAN ESTABLISHED HP.

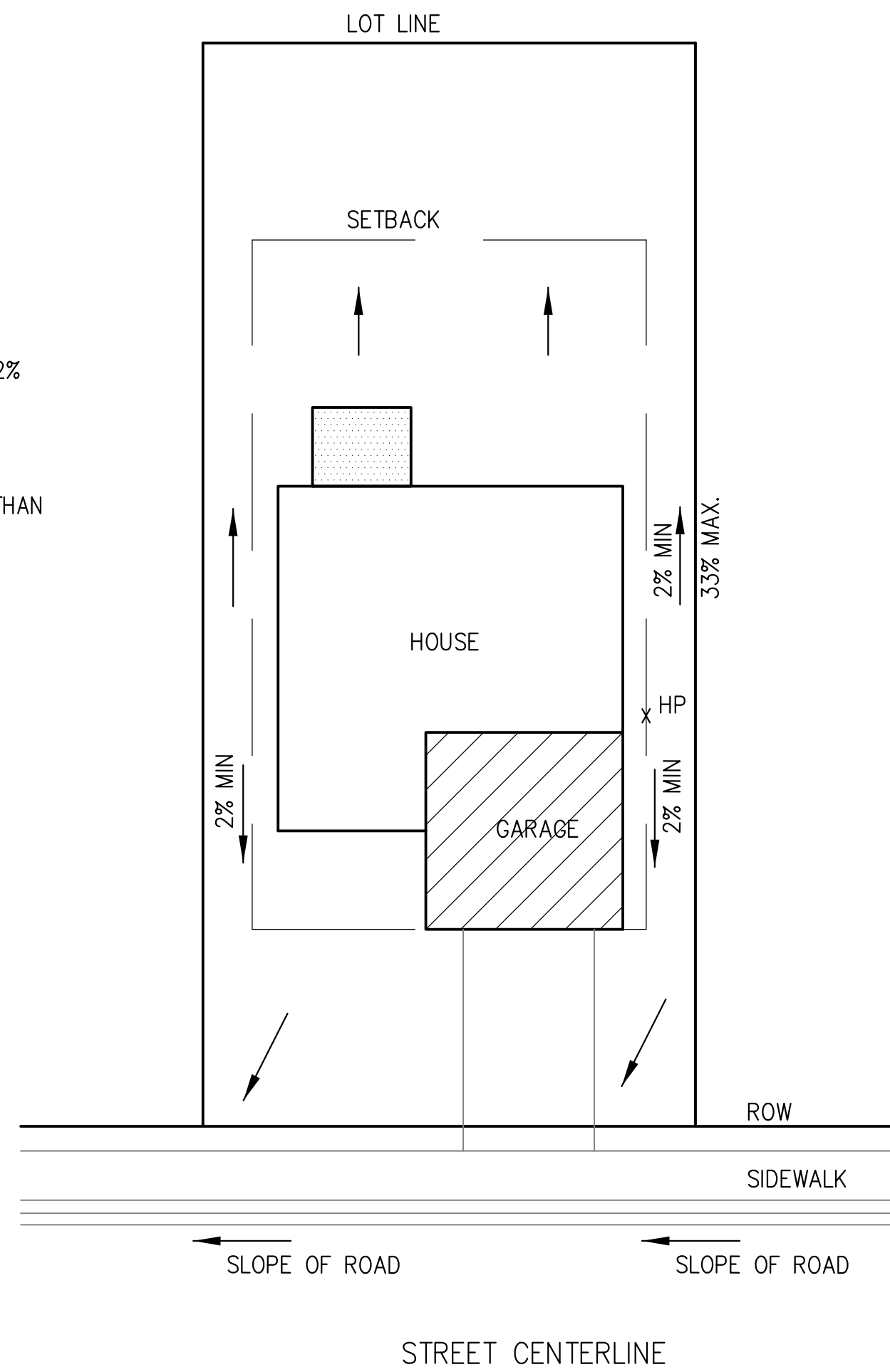

TYPICAL "B", "G", "W/O" LOT DRAINAGE PATTERN
N.T.S.

MULCHING NOTES

INSTALLATION REQUIREMENTS

1. ALL DISTURBED AREAS MUST BE MULCHED WITHIN 21 DAYS AFTER FINAL GRADE AND SEEDING AREAS ARE TO BE MULCHED WITHIN 24 HOURS AFTER SEEDING.
2. MATERIAL USED FOR MULCH CAN BE CERTIFIED CLEAN, WEED- AND SEED-FREE: LONG-STEMMED FIELD OR MARSH HAY, OR STRAW OF OATS, BARLEY, WHEAT, RYE, OR TRITICALE CERTIFIED BY THE COLORADO DEPARTMENT OF AGRICULTURE WEED FREE FORAGE CERTIFICATION PROGRAM.
3. HYDRAULIC MULCHING MATERIAL SHALL CONSIST OF VIRGIN WOOD FIBER MANUFACTURED FROM CLEAN WHOLE WOOD CHIPS. WOOD CHIPS CANNOT CONTAIN ANY GROWTH OR GERMINATION INHIBITORS OR BE PRODUCED FROM RECYCLED MATERIAL. GRAVEL CAN ALSO BE USED.
4. MULCH IS TO BE APPLIED EVENLY AT A RATE OF 2 TONS PER ACRE.
5. MULCH IS TO BE ANCHORED EITHER BY GRIPPING (TUCKING MULCH FIBERS 4 INCHES INTO THE SOIL) USING NETTING (USED ON SMALL AREAS WITH STEEP SLOPES), OR WITH A TACKIFIER.
6. HYDRAULIC MULCHING AND TACKIFIERS ARE NOT TO BE USED IN THE PRESENCE OF FREE SURFACE WATER.

MAINTENANCE REQUIREMENTS

1. REGULAR INSPECTIONS ARE TO BE MADE OF ALL MULCHED AREAS.
2. MULCH IS TO BE REPLACED IMMEDIATELY IN THOSE AREAS IT HAS BEEN REMOVED, AND IF NECESSARY THE AREA SHOULD BE RESEEDING.

City of Colorado Springs
Stormwater Quality

Figure MU-1
Mulching
Construction Detail and Maintenance
Requirements

SC-3

Straw Bale Barrier (SBB)

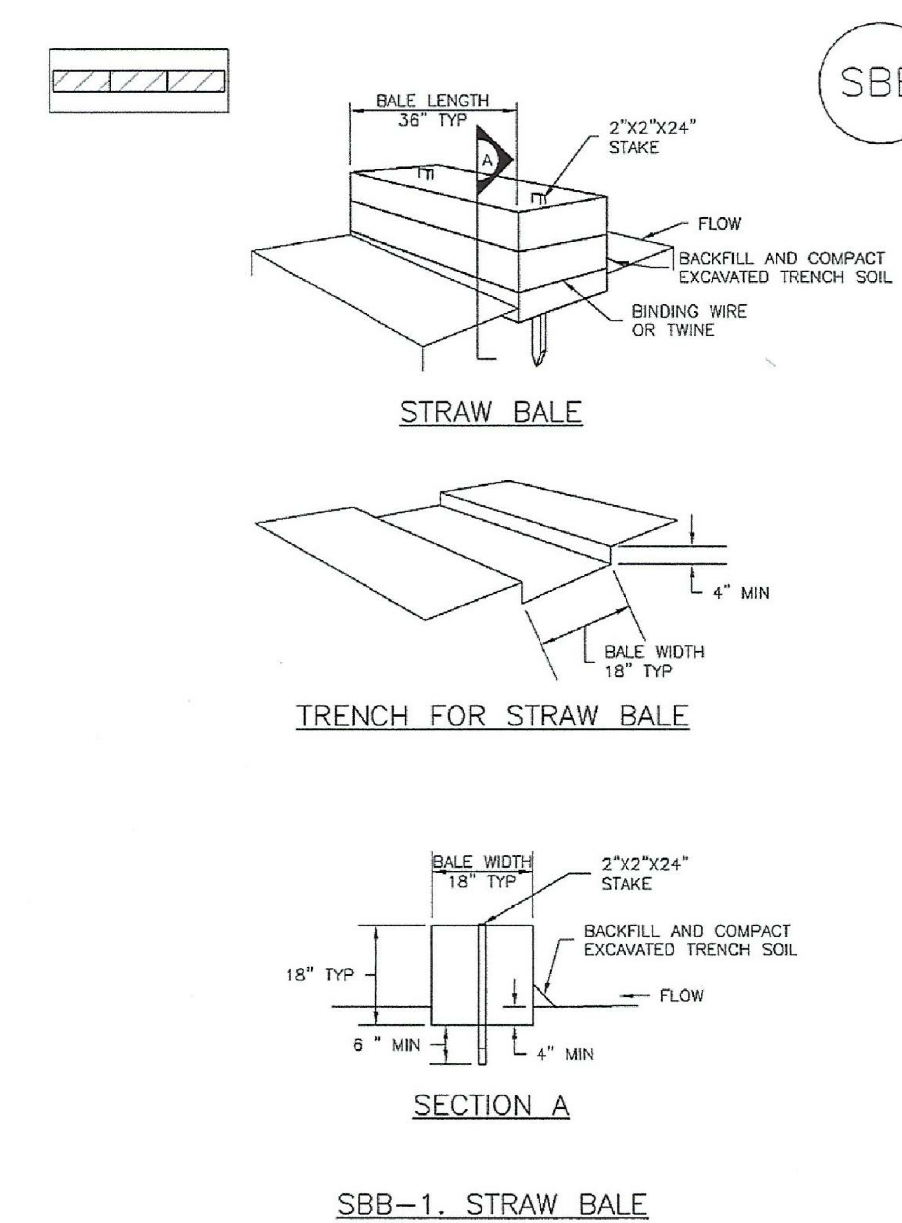

SBB-1. STRAW_BALE

SBB-2

Urban Drainage and Flood Control District
Urban Storm Drainage Criteria Manual Volume 3

November 2010

CORE ENGINEERING GROUP
1500 S. 1ST AVENUE, SUITE 100
DENVER, CO 80202
PHONE: 719.570.1100
CONTACT: RICHARD L. SCHINDLER, P.E.
EMAIL: Rich@cegi.com

DATE: _____
DESCRIPTION: _____
NO: _____
PROJECT: HILLSIDE AT LORSON RANCH
PREPARED FOR: LORSON, LLC
212 N. WAHSATCH AVE, SUITE 301
COLORADO SPRINGS, COLORADO 80903
LORSON BLVD. - WALLEYE DR.
COLORADO SPRINGS, COLORADO
CONTACT: JEFF MARK

DRAWN: RLS
DESIGNED: RLS
CHECKED: RLS

GRADING AND EROSION CONTROL DETAILS

DATE:
APRIL 15, 2022

PROJECT NO.
100.065

SHEET NUMBER
C12.4

TOTAL SHEETS: 20