

STATE OF COLORADO
DEPARTMENT OF TRANSPORTATION
CITY OF COLORADO SPRINGS
Parks, Recreation and Cultural Services Department
CAPITAL IMPROVEMENT PROJECT
TRAIL IMPROVEMENT PROGRAM
COMBINED FEDERAL AID PROJECT No. TAP M240-162, SubAccT. No.20391
STREET IMPROVEMENTS
PLAN of the ROCK ISLAND MULTI-USE TRAIL
SAND CREEK TO CONSTITUTION AVENUE
COLORADO SPRINGS & EL PASO COUNTY, COLORADO

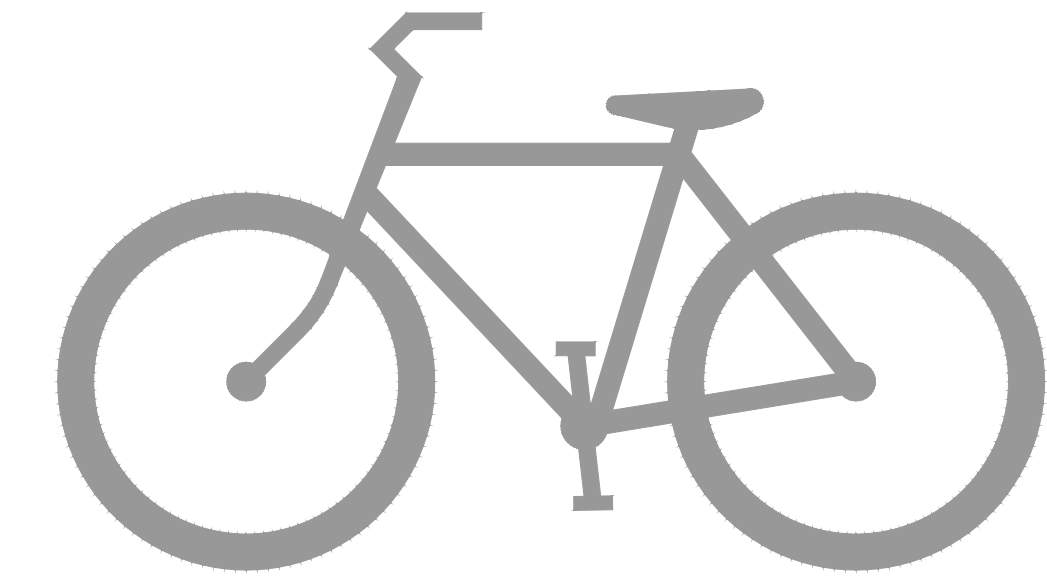

21 JULY 2024

SHEET INDEX		
C000	TITLE SHEET	
C001	SUMMARY OF QUANTITIES	
C002	GENERAL NOTES	
C101	ROCK ISLAND STA 08+00	TO STA 17+50
C102	ROCK ISLAND STA 17+50	TO STA 21+50
C103	ROCK ISLAND STA 21+50	TO STA 27+00
C104	ROCK ISLAND STA 27+00	TO STA 32+50
C105	ROCK ISLAND STA 32+50	TO STA 38+00
C106	ROCK ISLAND STA 38+00	TO STA 43+50
C107	ROCK ISLAND STA 43+50	TO STA 49+00
C108	ROCK ISLAND STA 49+00	TO STA 54+50
C109	ROCK ISLAND STA 54+50	TO STA 60+00
C110	ROCK ISLAND STA 60+00	TO STA 65+50
C111	ROCK ISLAND STA 65+50	TO STA 71+00
C112	ROCK ISLAND STA 71+00	TO STA 76+50
C113	ROCK ISLAND STA 76+50	TO STA 82+00
C114	ROCK ISLAND STA 82+00	TO STA 87+50
C115	ROCK ISLAND STA 87+50	TO STA 93+00
C116	ROCK ISLAND STA 93+00	TO STA 98+50
C117	ROCK ISLAND STA 98+50	TO STA 104+00
C118	ROCK ISLAND STA 104+00	TO STA 109+50
C119	ROCK ISLAND STA 109+50	TO STA 115+00
C120	ROCK ISLAND STA 115+00	TO STA 117+50
C200	PEDESTRIAN BRIDGE GENERAL INFORMATION	
C201	PEDESTRIAN BRIDGE BORING LOG	
C202	PEDESTRIAN BRIDGE HYDRAULICS	
C203	PEDESTRIAN BRIDGE LAYOUT AND GRADING PLAN	
C204	PEDESTRIAN BRIDGE SECTION	
C205	PEDESTRIAN BRIDGE ABUTMENT DETAILS	
C501	TYPICAL STANDARD DETAILS	
C502	TYPICAL MISCELLANEOUS DETAILS	
C503	TYPICAL HANDRAIL AND FENCE DETAILS	
C504	SITE SPECIFIC DETAILS	
C511	SIGNAGE & STRIPING PLAN - PETERSON ROAD	

APPROVAL SIGNATURES			
TITLE	NAME	SIGNATURE	DATE
DIRECTOR, PARKS, REC. & CULT. SVS PARKS OPERATION & DEVELOPMENT MANAGER	BRITT HALEY	_____	_____
CITY FORESTER		_____	_____
REG. SUPERVISOR, PARKS, TRAILS & OPEN SPACE	SCOTT ABBOTT	_____	_____
CONSTRUCTION PROJECT MANAGER	EMILY DUNCAN	_____	_____
COLORADO DEPARTMENT OF TRANSPORTATION		_____	_____
EL PASO COUNTY DEPARTMENT OF PUBLIC WORKS	JENNIFER IRVINE, PE	_____	_____

TRAIL DATA DESIGN	
BEGIN STATION ROCK ISLAND TRAIL	10+00
END STATION ROCK ISLAND TRAIL	106+25
MAXIMUM GRADE	8.33%
MINIMUM HORIZONTAL CURVE	25'
MINIMUM WIDTH 8'	8'
TYPICAL WIDTH	10'
CROSS-SLOPE	2%
LENGTH ROCK ISLAND TRAIL	XX LF
AREA OF DISTURBANCE	XX ACRES
CONSTRUCTION AREA	22.8 ACRES
ANTICIPATED START	09/01/2024
ANTICIPATED CONSTRUCTION END	08/01/2024
ANTICIPATED STABILIZATION	10/01/2025
RECEIVING WATER	SAND CREEK
SITE IS NATIVE GRASS AND WILL REMAIN NATIVE GRASS.	
BENCHMARK: FIMS MONUMENT SR10 IS A 2-INCH DIAMETER ALUMINUM CAP STAMPED "CSU FIMS CONTROL SR10" ON TOP OF THE NORTH CURB OF CONSTITUTION AVENUE AT THE NORTHWEST CORNER OF THE BRIDGE OVER SAND CREEK.	

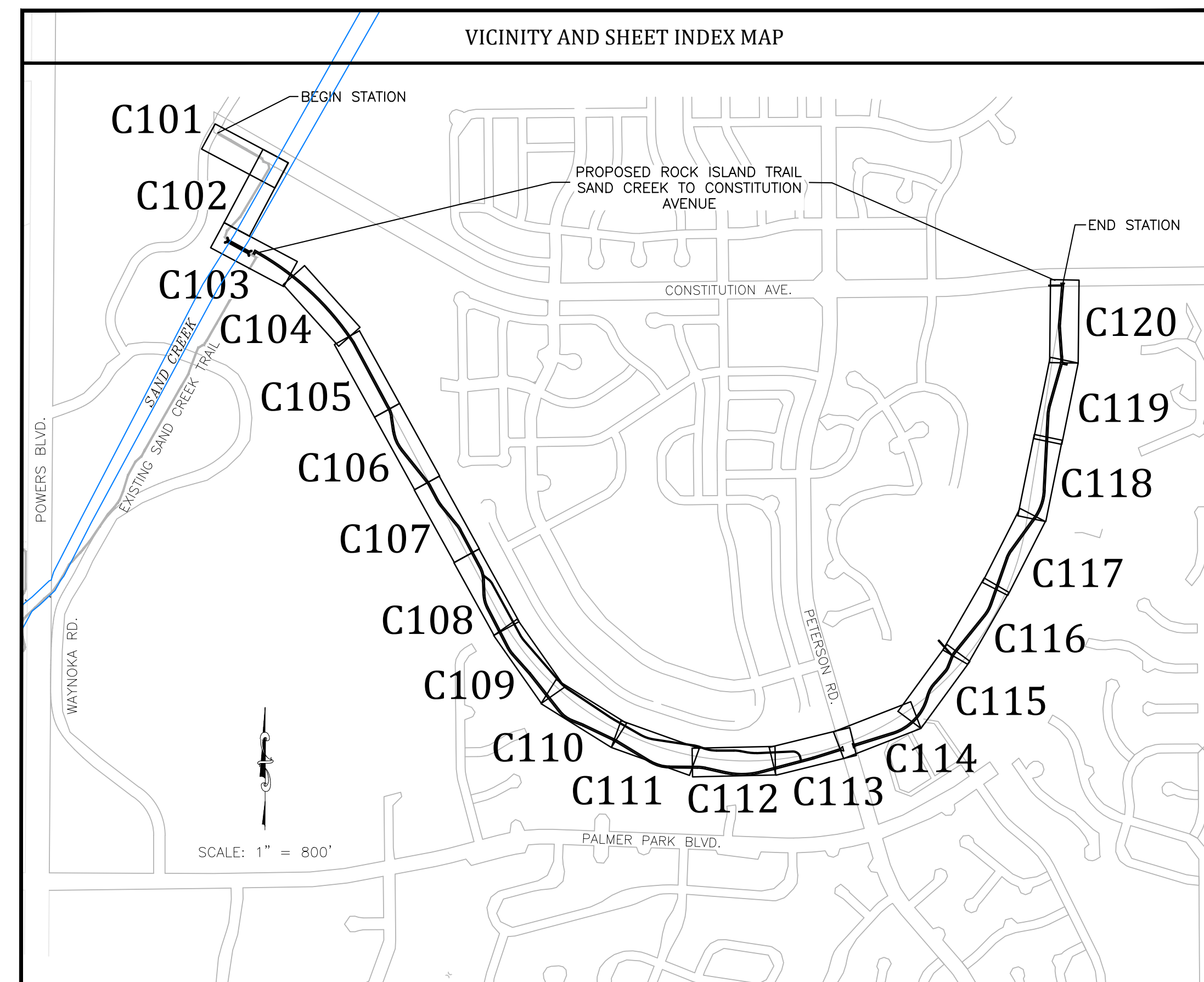

STATEMENTS	
Engineer's Statement:	
This Street Improvement Plan was prepared under my direction and supervision and is correct to the best of my knowledge and belief. Said Plan has been prepared according to the criteria established by the County for Street Improvement Plans. I accept responsibility for any liability caused by any negligent acts or omissions on my part in preparing this Plan.	
Engineer of Record signature	Date
Owner's Statement:	
I, the owner/developer have read and will comply with the requirements of this Street Improvement Plan.	
Signature	Date
El Paso County:	
County Plan review is provided only for general conformance with County Design Criteria. The County is not responsible for the accuracy and adequacy of the design, dimensions, and/or elevations which shall be confirmed at the job site. The County through the approval of this document assumes no responsibility for completeness and/or accuracy of this document.	
Filed in accordance with the requirements of the El Paso County Land Development Code, Drainage Criteria Manual Volumes 1 and 2, and Engineering Criteria Manual as amended.	
In accordance with ECM Section 1.12, these construction documents will be valid for construction for a period of 2 years from the date signed by the El Paso County Engineer. If construction has not started within those 2 years, the Plans will need to be resubmitted for approval, including payment of review fees at the Planning and Community Development Director's discretion.	
County Engineer/ECM Administrator	Date

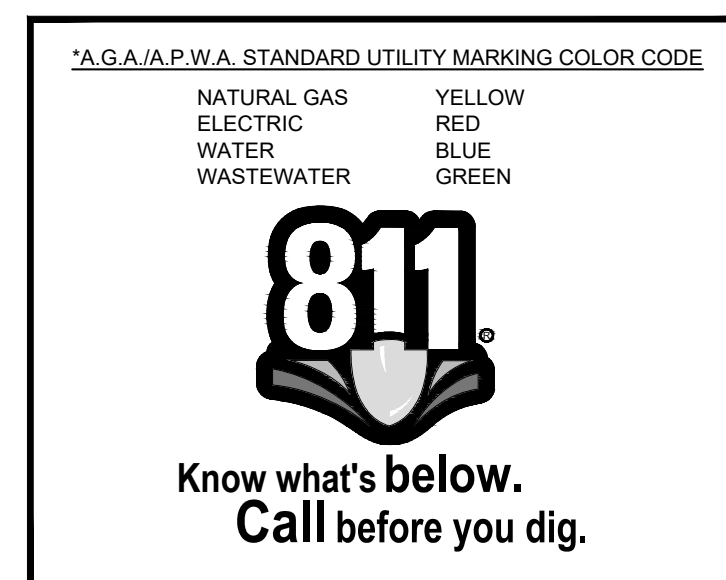

IN PROGRESS
NOT FOR CONSTRUCTION



Sheet Revisions

90% BID SET

No Revisions:

Revised:

Void:

ROCK ISLAND TRAIL
Sand Creek to Constitution Avenue
COVER SHEET

Designer: RNW
Detailer: RNW
Date: 08/06/2024

Kiowa Proj. No. 16028

TAP M240-162

SubAcct No. 20391

Sheet Number C000

Please remove this note before approval. Signatures and Stamp are required on each plan sheet.

For and on Behalf of
Kiowa Engineering Corporation Date

SUMMARY OF APPROXIMATE QUANTITIES			
CONTRACT ITEM NO.	CONTRACT ITEM	PROJECT TOTALS	
Item No.	Description	Quantity	Units
201	Clearing and grubbing	1	EA
202.1	Remove and dispose concrete curb and gutter	80	LF
202.2	Remove and dispose concrete sidewalk	80	LF
202.3	Remove concrete bridge abutment	1	EA
202.4	Remove and dispose trees	12	EA
203.1	Excavation- cut to fill on site	2,000	CY
203.2	Scarify, rake and revegetate existing trails, 5-foot avg width	9,337	LF
207	Topsoil	950	CY
208.1	Storm Drain/Inlet protection	2	EA
208.2	Silt Fencing	11,500	LF
208.3	Concrete wash out area	2	EA
208.4	Vehicle tracking control	3	EA
208.5	Stabilized staging area	1	EA
212.1	Permanent seeding	3	AC
212.2	Mulching	3	AC
212.3	Sanitary facility	2	EA
304	Aggregate base course, Class 6	510	CY
406	Hot Mix Asphalt Pavement, 6-inch thick	91	SY
506	18-inch Type L soil riprap	10	CY
514	Smooth rail fence	104	LF
604	CDoT std. Type C inlet	2	EA
608.1	Concrete trail section A	9,449	LF
608.2	Breeze trail section, 4-feet wide	2,695	LF
608.3	EPC std. pedestrian ramps	3	EA
608.4	EPC Type A curb and gutter	32	LF
608.5	EPC Type B median curb and gutter	172	LF
608.6	EPC Std sidewalk, 4-inch thick	1,900	SF
608.7	Patterned and colored median concrete, 4-inch thick	504	SF
608.8	Concrete refuge island, 6-inch thick	144	SF
617.1	18-inch HDPE	80	LF
617.2	18-inch HDPE flared end section	2	EA
625	Construction staking	1	EA
627	Epoxy coated pavement markings	240	SF
630.1	Construction zone traffic control signs, 30" x 30"	4	EA
630.2	Trail signage, panel size 12" x 18"	6	EA
630.3	Traffic signage 12" x 18"	2	EA
630.4	Traffic signage 24" x 30"	2	EA
630.5	Traffic signage 24" x 24"	2	EA
630.6	Traffic signage 30" x 30"	2	EA
630.7	Traffic signage 12" x 36"	2	EA
712.1	Removable locking steel posts	3	EA
712.2	MSE retaining wall	390	SF

STANDARD GRADING AND EROSION CONTROL PLAN NOTES
1. No clearing, grading, excavation, or other land disturbing activities shall be allowed (except for work directly related to the installation of Initial Control Measures) until a City GEC Permit has been issued.
2. All land disturbing activities must be performed in accordance with and the approved GEC Plan and CSWMP.
3. Initial Control Measures shall be installed and inspected prior to any land disturbance activities taking place. An initial site inspection will not be scheduled until a City GEC Permit has been "conditionally approved." Call City Stormwater Inspections, 385-5980, at least 48 hours prior to construction to schedule an initial inspection and obtain full permit approval.
4. Individuals shall comply with the "Colorado Water Quality Control Act" (Title 25, Article 8, CRS) and the "Clean Water Act" (33 USC 1344), including regulations promulgated and certifications or permits issued, in addition to the requirements included in the City's MS4 Permit, Stormwater Construction Manual. In the event of conflicts between these requirements and water quality control laws, rules, or regulations of other Federal or State agencies, the more restrictive laws, rules, or regulations shall apply.
5. Stormwater discharges from construction sites shall not cause or threaten to cause pollution, contamination, or degradation of State Waters.
6. All Construction Control Measures shall be maintained until permanent stabilization measures are implemented. Temporary Construction Control Measures must be removed prior to permit closeout.
7. Concrete wash water shall not be discharged to or allowed to runoff to State Waters or any surface or subsurface storm drainage system or facilities.
8. Building, construction, excavation, or other waste materials shall not be temporarily placed or stored in the street, alley, or other public way, unless in accordance with an approved Traffic Control Plan. Construction Control Measures may be required by the GEC Inspector if deemed necessary based on specific conditions and circumstances (e.g., estimated time of exposure, season of the year, etc.).
9. All wastes composed of building materials must be removed from the construction site for disposal in accordance with local and state regulatory requirements. No building material wastes or unused building materials shall be buried, dumped, or discharged at the site.
10. The permittee shall be responsible for the removal of all construction debris, dirt, trash, rock, sediment, and sand that may accumulate in the storm sewer or other drainage conveyance system as a result of construction activities.
11. The quantity of materials stored on the project site shall be limited, as much as practical, to that quantity required to perform the work in an orderly sequence. All materials stored on-site shall be stored in a neat, orderly manner, in their original containers, with original manufacturer's labels. Materials shall not be stored in a location where they may be carried by stormwater runoff into the storm sewer system at any time.
12. Spill prevention and containment measures shall be used at all storage, equipment fueling, and equipment servicing areas so as to contain all spills and prevent any spilled material from entering the MS4, including any surface or subsurface storm drainage system or facility. Bulk storage structures for petroleum products and other chemicals shall have secondary containment or equivalent adequate protection. All spills shall be cleaned up immediately after discovery, or contained until appropriate cleanup methods can be employed. Manufacturer's recommended methods for spill cleanup shall be followed, along with proper disposal methods.
13. Sediment (mud and dirt) transported onto a public road, regardless of the size of the site, shall be cleaned as soon as possible after discovery.
14. No chemicals are to be added to the discharge unless permission for the use of a specific chemical is granted by the State. In granting the use of such chemicals, special conditions and monitoring may be required.
15. Control Measures for all slopes, channels, ditches, or any disturbed land area shall be completed within fourteen (14) calendar days after final grading or final land disturbance has been completed. Disturbed areas which are not at final grade but will remain dormant for longer than fourteen (14) days shall be roughened, mulched, tackified, or stabilized with tarps within fourteen (14) days after interim grading. An area that is going to remain in an interim state for more than sixty (60) days shall also be seeded, unless an alternative stabilization measure is accepted at the inspector's discretion. All temporary Construction Control Measures shall be maintained until final stabilization is achieved.
16. The GEC Plan will be subject to re-review and re-acceptance by the Stormwater Enterprise should any of the following occur: grading does not commence within twelve (12) months of the City's acceptance of the plan, the construction site is idle for twelve (12) consecutive months, a change in property ownership occurs, the planned development changes, or any other major modifications are proposed as defined in the Stormwater Construction Manual.
17. It is not permissible for any person to modify the grade of the earth on any utility easement or utility right-of-way without written approval from the utility owner. City acceptance of the GEC Plan and CSWMP does not satisfy this requirement. The plan shall not increase or divert water towards utility facilities. Any changes to existing utility facilities to accommodate the plan must be approved by the affected utility owner prior to implementing the plan. The cost to relocate or protect existing utilities or to provide interim access shall be at the applicant's expense.
18. Applicant represents and warrants that they have the legal authority to grade and/or construct improvements on adjacent property. The City has not reviewed the developer's authority to modify adjacent property. An approved GEC Permit does not provide approval for the Applicant to perform work on adjacent property.



IN PROGRESS
NOT FOR CONSTRUCTION

For and on Behalf of
Kiowa Engineering Corporation Date



1604 South 21st Street
Colorado Springs, Colorado 80904
(719) 630-7342

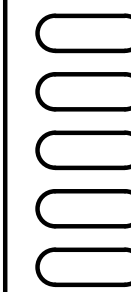

Sheet Revisions

90% BID SET

No Revisions:

Revised:

Void:

ROCK ISLAND TRAIL Sand
Creek to Constitution Avenue
SUMMARY OF QUANTITIES

Designer: RNW
Detailer: RNW
Date: 08/06/2024

Kiowa Proj. No. 16028

TAP M240-162

SubAcct No. 20391

Sheet Number C001

GENERAL NOTES

- ALL MATERIALS AND WORKMANSHIP SHALL BE IN CONFORMANCE WITH THE LATEST VERSION OF COLORADO DEPARTMENT OF TRANSPORTATION (CDOT) STANDARD SPECIFICATIONS FOR ROAD AND BRIDGE CONSTRUCTION AND SUPPLEMENTED WITH THE CITY OF COLORADO SPRINGS STANDARD SPECIFICATIONS.
- THE CONTRACTOR SHALL NOTIFY THE OWNER (CITY) AND ENGINEER OF ANY PROBLEM IN CONFORMING TO THE APPROVED PLANS FOR ANY ELEMENT OF THE PROPOSED IMPROVEMENTS PRIOR TO ITS CONSTRUCTION.
- THE CONTRACTOR SHALL PROTECT ALL EXISTING FACILITIES IN THE GENERAL AREA OF CONSTRUCTION. THE CONTRACTOR SHALL REPAIR ANY DAMAGE CAUSED BY CONSTRUCTION OPERATIONS AT NO COST TO THE PROJECT.
- UTILITY LINES AS SHOWN ON THESE DRAWINGS ARE PLOTTED FROM THE BEST AVAILABLE INFORMATION. THE CONTRACTOR SHALL CALL 811 FOR UTILITY LOCATIONS AT LEAST TWO WORKING DAYS PRIOR TO ANY DIGGING. THE CONTRACTOR SHALL DETERMINE THE EXACT LOCATION OF ALL UTILITIES PRIOR TO CONSTRUCTION AND SHALL PROTECT THEM FROM DAMAGE DURING CONSTRUCTION.
- SURVEYING FOR THIS PROJECT SHALL BE CONDUCTED IN ACCORDANCE WITH CDOT STANDARDS.
- BENCHMARK: FIMS MONUMENT SR10 IS A 2-INCH DIAMETER ALUMINUM CAP STAMPED "CSU FIMS CONTROL SR10" ON TOP OF THE NORTH CURB OF CONSTITUTION AVENUE AT THE NORTHWEST CORNER OF THE BRIDGE OVER SAND CREEK.
- ALL EXISTING MANHOLES TO BE MARKED WITH T-POSTS AND CAUTION TAPE PRIOR TO COMMENCING WITH THE CONSTRUCTION.
- WATER SHALL BE USED AS A DUST PALLIATIVE WHERE REQUIRED. LOCATIONS SHALL BE AS DIRECTED BY THE ENGINEER. WATER WILL NOT BE PAID FOR SEPARATELY, BUT WILL BE SUBSIDIARY TO THE EXCAVATION ITEM.
- ALL REMOVED ASPHALT WILL BECOME THE PROPERTY OF THE CONTRACTOR AND WILL BE DISPOSED OF OUTSIDE PROJECT LIMITS.
- THE SOIL TO BE PLACED AS TOPSOIL MATERIAL SHALL BE FREE OF REFUSE, STUMPS, ROOTS, ROCKS, BRUSH, WEEDS, HARD CLOUDS, TOXIC SUBSTANCES OR OTHER MATERIAL WHICH WOULD BE DETRIMENTAL TO ITS USE ON THE PROJECT. IT SHALL HAVE A MINIMUM P.I. OF 5 BUT SHALL NOT BE SUCH HEAVY CLAY AS TO PRECLUDE PLACEMENT WITH A SHOULDER MACHINE.
- SALVAGEABLE MATERIAL: MATERIAL THAT CAN BE SAVED OR SALVAGED. UNLESS OTHERWISE SPECIFIED IN THE CONTRACT, ALL SALVABLE MATERIAL SHALL BECOME THE PROPERTY OF THE CONTRACTOR.
- TOPOGRAPHIC DATA INDICATED ON THESE DRAWINGS WAS COMPILED FROM FIELD SURVEYS. CONTRACTOR MUST VERIFY EXTENT OF WORK WITHIN THESE AREAS. DIMENSIONS, ELEVATIONS, AND LOCATIONS OF EXISTING STRUCTURES, PIPELINES, AND UTILITIES ARE APPROXIMATE. WHERE SUCH DIMENSIONS OR LOCATIONS DETERMINE THE LIMITS OF THE WORK, SUCH DIMENSIONS OR LOCATIONS SHALL BE VERIFIED IN THE FIELD PRIOR TO CONSTRUCTION.
- THE LOCATIONS OF EXISTING STRUCTURES, PIPELINES, UTILITIES, ETC., SHOWN ON THE DRAWINGS HAVE BEEN APPROXIMATED. THERE MAY BE OTHER STRUCTURES, PIPELINES, UTILITIES, ETC., NOT SHOWN ON THE DRAWINGS WHICH PRESENTLY EXIST IN THE AREA OF CONSTRUCTION. THE ENGINEER AND/OR OWNER ASSUMES NO RESPONSIBILITY FOR THE ACCURACY OR COMPLETENESS OF THE INFORMATION SHOWN. THE CONTRACTOR WILL BE RESPONSIBLE FOR LOCATING AND PROTECTING ALL IMPACTED EXISTING STRUCTURES, PIPELINES, UTILITIES, ETC., IN THE PROJECT SITE.
- THE CONTRACTOR SHALL CAREFULLY PRESERVE ALL MONUMENTS, BENCHMARKS, PROPERTY MARKERS, REFERENCE POINTS, AND STAKES. IN CASE OF HIS DESTRUCTION OF THESE, THE CONTRACTOR WILL BE RESPONSIBLE FOR RESETTling SAME, AT NO COST TO THE OWNER, AND SHALL BE RESPONSIBLE FOR ANY LOSS OF TIME THAT MAY BE CAUSED.
- THE CONTRACTOR SHALL NOTIFY THE ENGINEER WHERE UTILITIES CONFLICT WITH THE WORK IN CONFORMANCE WITH THE SPECIFICATIONS. WHERE FIELD VERIFICATION IS NOTED ON THE PLANS, THIS SHALL REQUIRE THE CONTRACTOR TO DETERMINE THE LOCATION OF THE FACILITY IN QUESTION PRIOR TO CONSTRUCTION. A DETERMINATION SHALL BE MADE BY THE CONTRACTOR IF THE CURRENT DESIGN WILL CONFLICT WITH THE EXISTING FACILITY AND NOTIFY THE ENGINEER IN WRITING.
- ALL EXISTING AREAS DISTURBED OUTSIDE THE LIMITS OF CONSTRUCTION ACTIVITIES SHALL BE REVEGETATED IN CONFORMANCE WITH THE SPECIFICATIONS AT NO ADDITIONAL COST TO THE PROJECT. ALL EXISTING ROADWAYS AND SIDEWALKS DAMAGED DURING CONSTRUCTION SHALL BE REPAIRED OR RECONSTRUCTED IN CONFORMANCE WITH THE SPECIFICATIONS.
- SIGNAGE SHALL FOLLOW THE "MANUAL ON UNIFORM TRAFFIC CONTROL DEVICES" LATEST EDITION AND THE CITY OF COLORADO SPRINGS TRAFFIC ENGINEERING SIGNAGE & PAVEMENT MARKING STANDARDS. CONTRACTOR SHALL SUBMIT TO THE COUNTY A TRAFFIC CONTROL PLAN PRIOR TO COMMENCING WITH THE WORK.
- CONTRACTOR SHALL ESTABLISH TRAIL CORRIDOR WITH STAKES. THE OWNER WILL THEN MARK ALL TREES TO BE SAVED IN A WALKTHROUGH OF THE TRAIL CORRIDOR WITH THE CONTRACTOR.
- ALL DISCHARGES TO DRAINAGE COURSES AND STORM SEWER SYSTEMS MUST COMPLY WITH THE APPLICABLE PROVISIONS OF THE COLORADO WATER QUALITY CONTROL ACT AND THE COLORADO DISCHARGE PERMIT REGULATIONS, AND ARE SUBJECT TO INSPECTION BY EL PASO COUNTY AND CDPHE. EL PASO HAS A MS-4 PERMIT. CONTRACTOR SHALL DEVISE AND IMPLEMENT A PERMANENT PLAN FOR PERIODIC REMOVAL AND DISPOSAL OF SEDIMENT FROM EROSION CONTROL FACILITIES AND FOR MAINTENANCE OF EROSION CONTROL FACILITIES.
- THE CONTRACTOR SHALL OBTAIN CONSTRUCTION STORMWATER DISCHARGE PERMIT FROM CDPHE.

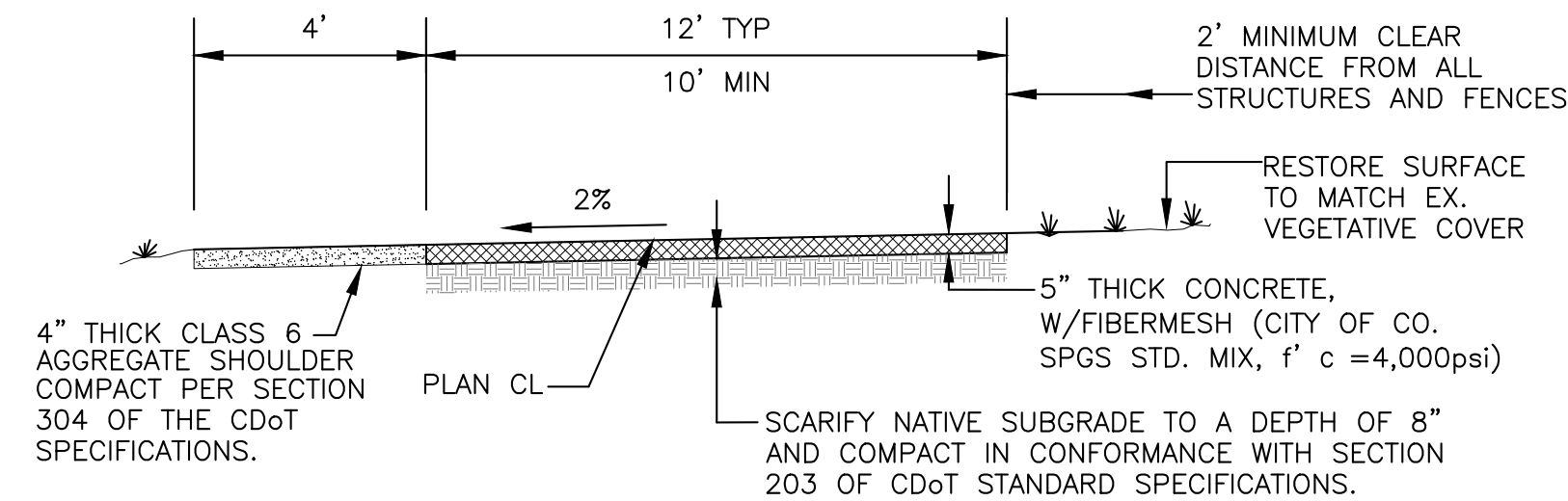

TRAIL SECTION A
NOT TO SCALE

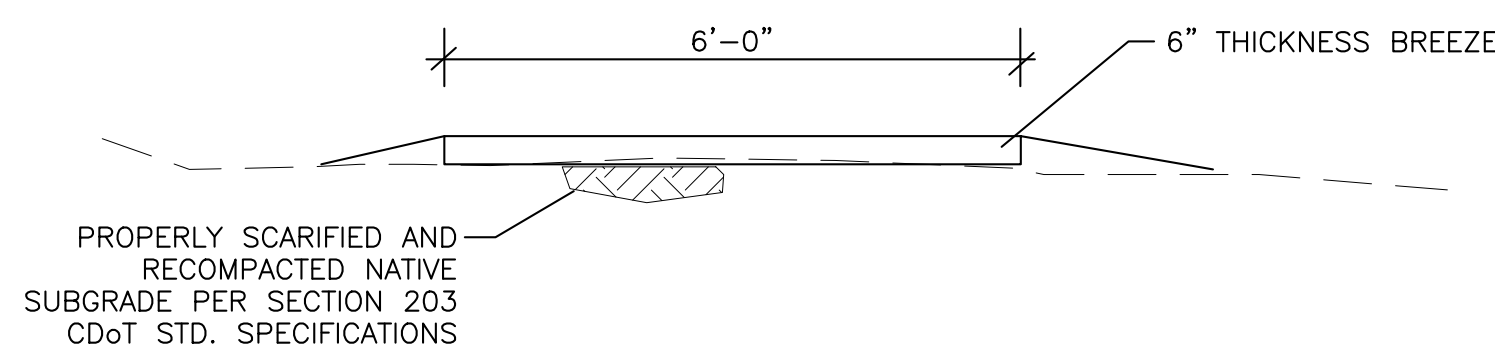

TRAIL SECTION B - 6' BREEZE TRAIL
SCALE: 1"=2'

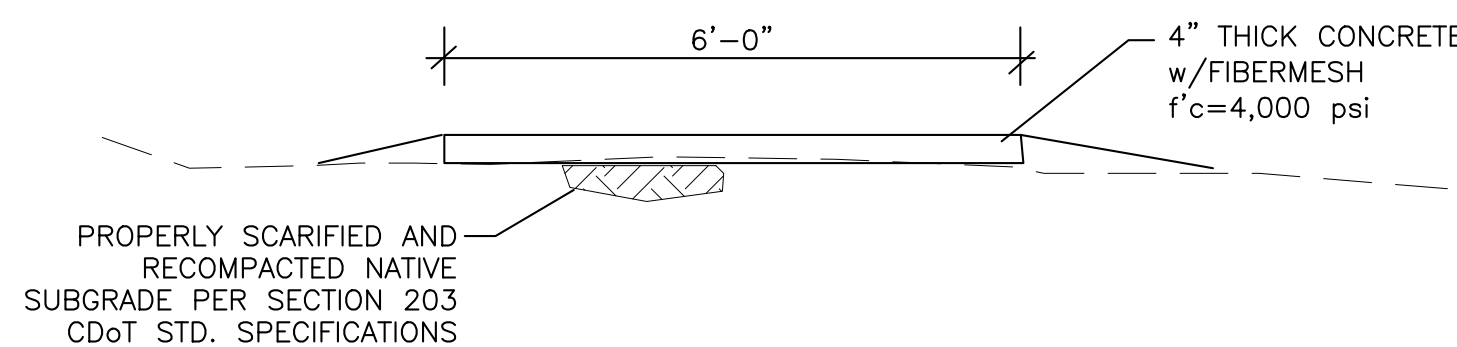

TRAIL SECTION C
SCALE: 1"=2'

KNOWN UTILITIES WITHIN PROJECT LIMITS

CONTRACTOR MUST VERIFY ALL UTILITIES PRIOR TO EXCAVATION

- CITY OF COLORADO SPRINGS DEPT. OF UTILITIES: ELECTRIC & GAS DIVISIONS
- CENTURY LINK
- LEVEL 3 COMMUNICATIONS
- CIMMARON WATER AND SANITATION DISTRICT

PRE-EXCAVATION CHECKLIST

- GAS AND OTHER UTILITY LINES OF RECORD SHOWN ON PLANS.
- UTILITIES CENTRAL LOCATING CALLED AT LEAST 2 BUSINESS DAYS AHEAD. (811)
- UTILITIES LOCATED AND MARKED.
- EMPLOYEES BRIEFED ON MARKING AND COLOR CODES.*
- EMPLOYEES TRAINED ON EXCAVATION AND SAFETY PROCEDURES FOR NATURAL GAS LINES.
- WHEN EXCAVATION APPROACHES GAS LINES, EMPLOYEES EXPOSE LINES BY CAREFUL PROBING AND HAND DIGGING.

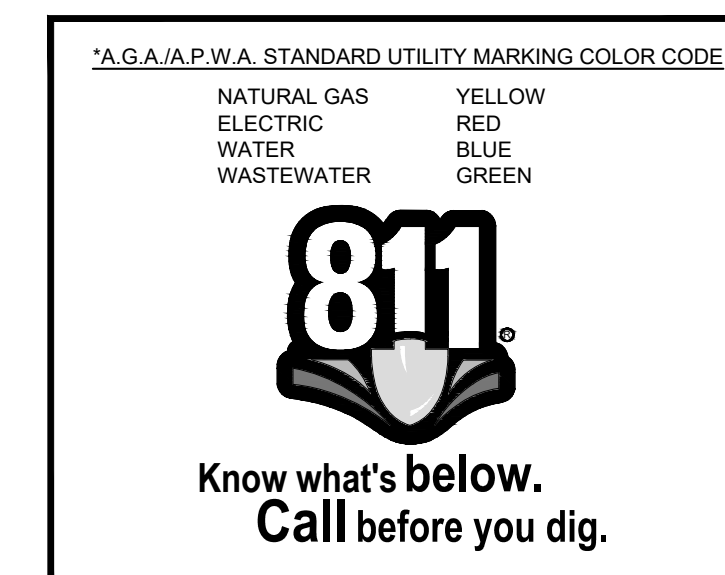

LEGEND

○	BOLLARD
—x—x—	FENCE
— — —	GUARDRAIL
—T—	SIGN
—P—	ELECTRIC POWER POLE
—E—	ELECTRIC LINE
—E—	ELECTRIC VAULT
—G—	GAS MAIN
—GV—	GAS VENT
—SS—	SANITARY SEWER MAIN
—O—	SANITARY SEWER MANHOLE
—T—	TELEPHONE MAIN
—Φ—	TELEPHONE MANHOLE
—□—	TELEPHONE RISER
— —	WATER MAIN
—V—	WATER VALVE



IN PROGRESS
NOT FOR CONSTRUCTION

For and on Behalf of
Kiowa Engineering Corporation Date



1604 South 21st Street
Colorado Springs, Colorado 80904
(719) 630-7342



Sheet Revisions

90% BID SET

No Revisions:

Revised:

Void:

ROCK ISLAND TRAIL Sand Creek to Constitution Avenue GENERAL NOTES

Designer: RNW

Detailer: RNW

Date: 08/06/2024

Kiowa Proj. No. 16028

TAP M240-162

SubAcct No. 20391

Sheet Number C002

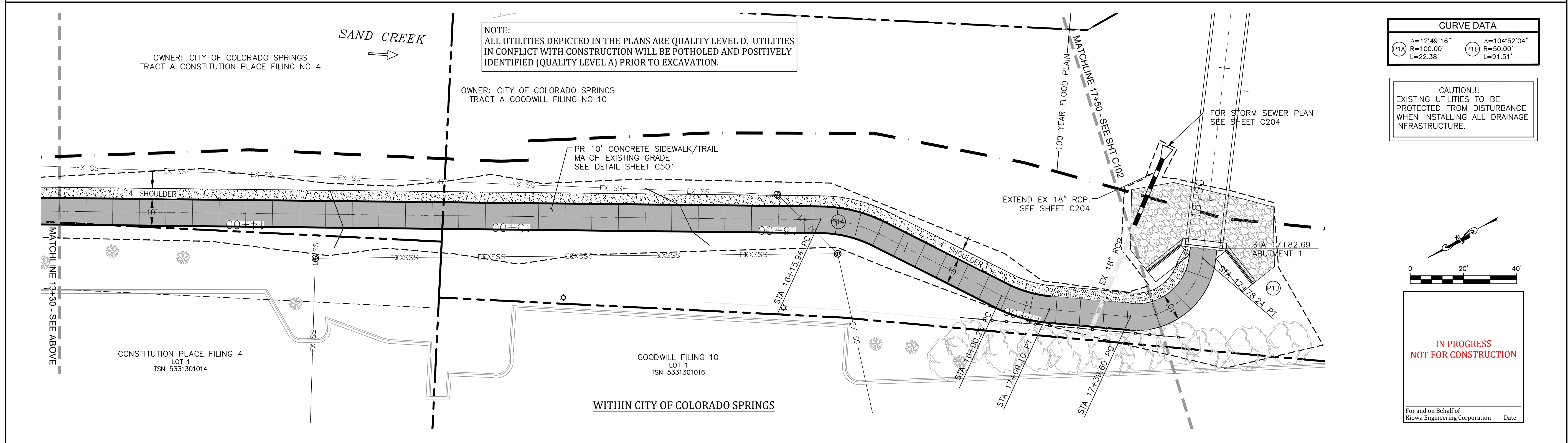
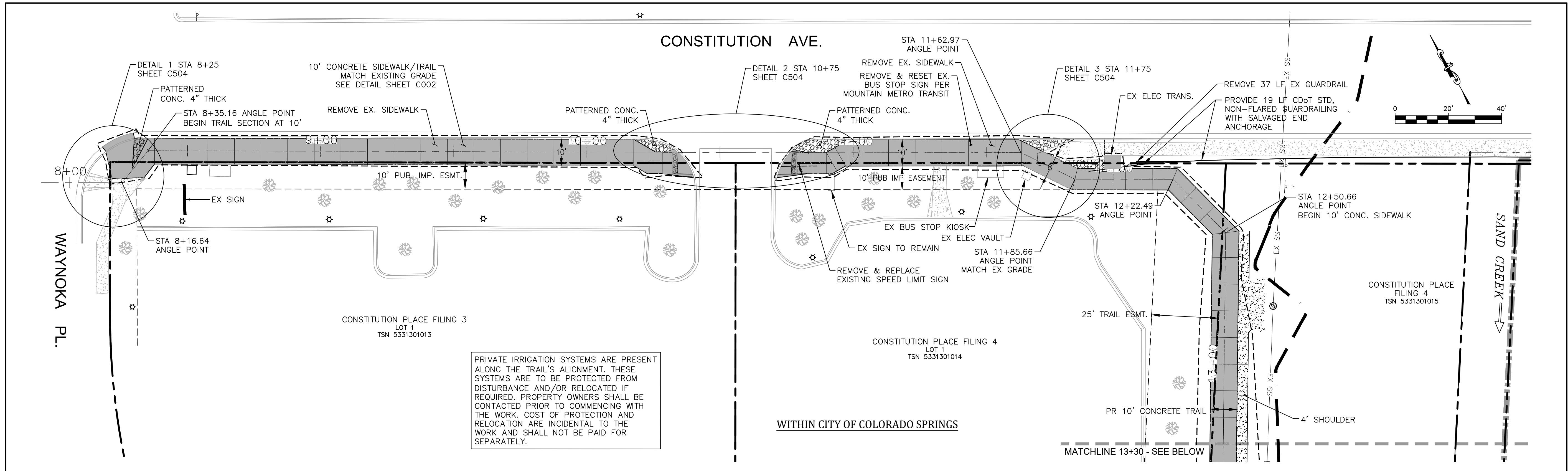

CURVE DATA	
Δ=12°49'16"	Δ=104°52'04"
Ⓟ1A R=100.00'	Ⓟ1B R=50.00'
L=22.38'	L=91.51'

**IN PROGRESS
NOT FOR CONSTRUCTION**

For and on Behalf of
Kiowa Engineering Corporation Date

	<p style="color: red;">IN PROGRESS NOT FOR CONSTRUCTION</p> <p>For and on Behalf of Kiowa Engineering Corporation Date</p>	<p>1604 South 21st Street Colorado Springs, Colorado 80904 (719) 630-7342</p>	Sheet Revisions	90% BID SET	ROCK ISLAND TRAIL		Kiowa Proj. No. 16028		
			Sand Creek to Constitution Avenue		FINAL TRAIL PLAN STA 8+00 TO STA 17+50			TAP M240-162	
			No Revisions:		Designer: RNW	SubAcct No. 20391			
			Revised:		Detailer: RNW				
Void:		Date: 08/06/2024	Sheet Number C101						

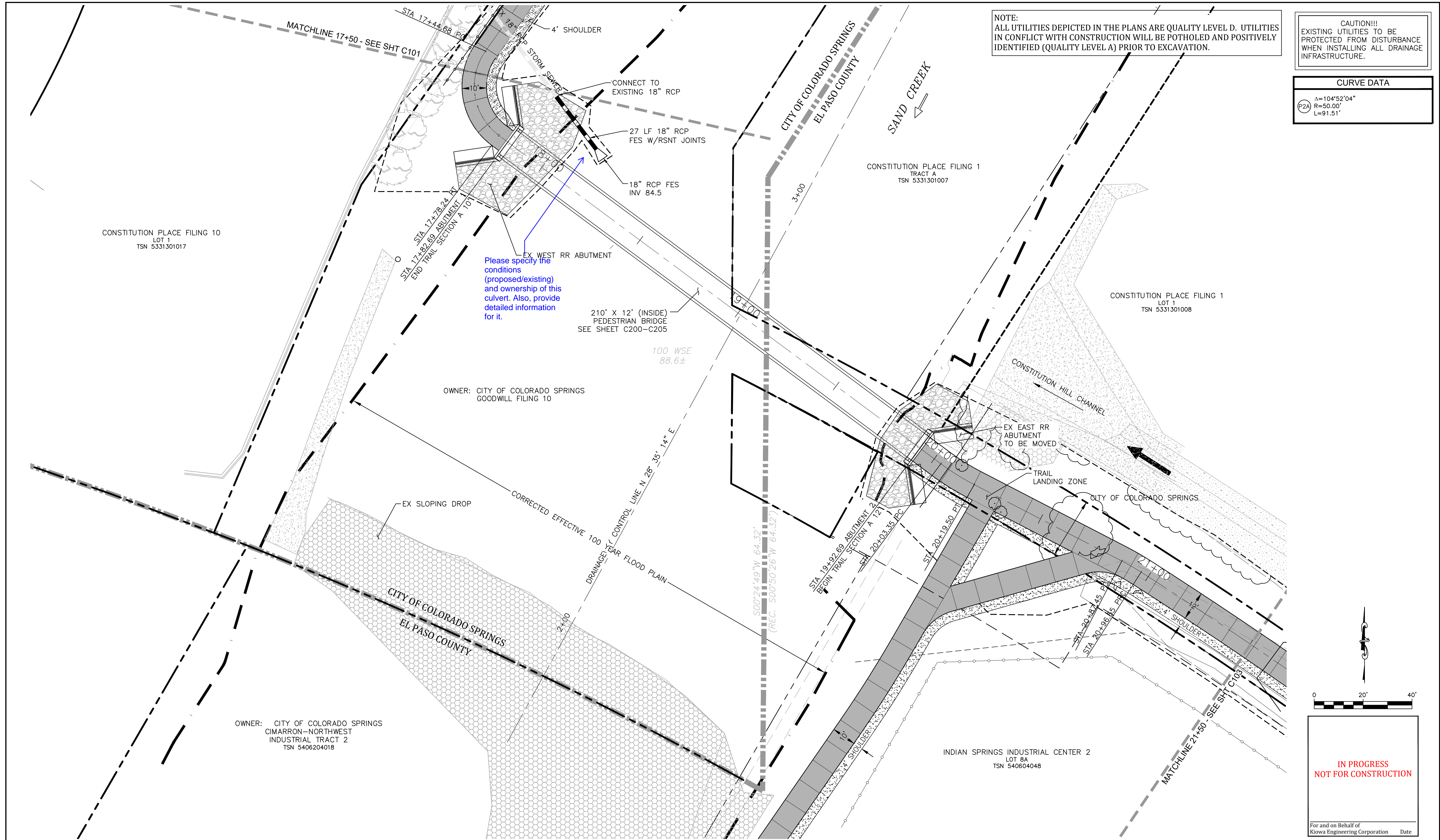

CONSTITUTION PLACE FILING 10
LOT 1
TSN 5331301017

OWNER: CITY OF COLORADO SPRINGS
GOODWILL FILING 10

OWNER: CITY OF COLORADO SPRINGS
CIMARRON-NORTHWEST
INDUSTRIAL TRACT 2
TSN 5406204018

NOTE:
ALL UTILITIES DEPICTED IN THE PLANS ARE QUALITY LEVEL D. UTILITIES
IN CONFLICT WITH CONSTRUCTION WILL BE POTHOLED AND POSITIVELY
IDENTIFIED (QUALITY LEVEL A) PRIOR TO EXCAVATION.

CAUTION!!!
EXISTING UTILITIES TO BE
PROTECTED FROM DISTURBANCE
WHEN INSTALLING ALL DRAINAGE
INFRASTRUCTURE.

CURVE DATA	
Δ=104°52'04"	
R=50.00'	
L=91.51'	



**IN PROGRESS
NOT FOR CONSTRUCTION**

For and on Behalf of
Kiowa Engineering Corporation Date



**IN PROGRESS
NOT FOR CONSTRUCTION**

Celebrating 30 years
Kiowa
Engineering Corporation
1604 South 21st Street
Colorado Springs, Colorado 80904
(719) 630-7342



Sheet Revisions

90% BID SET

No Revisions:
Revised:
Void:

ROCK ISLAND TRAIL
Sand Creek to Constitution Avenue
FINAL TRAIL PLAN STA 17+50 TO STA 21+50

Designer: RNW
Detailer: RNW
Date: 08/06/2024

Kiowa Proj. No. 16028
TAP M240-162
SubAcct No. 20391
Sheet Number C102

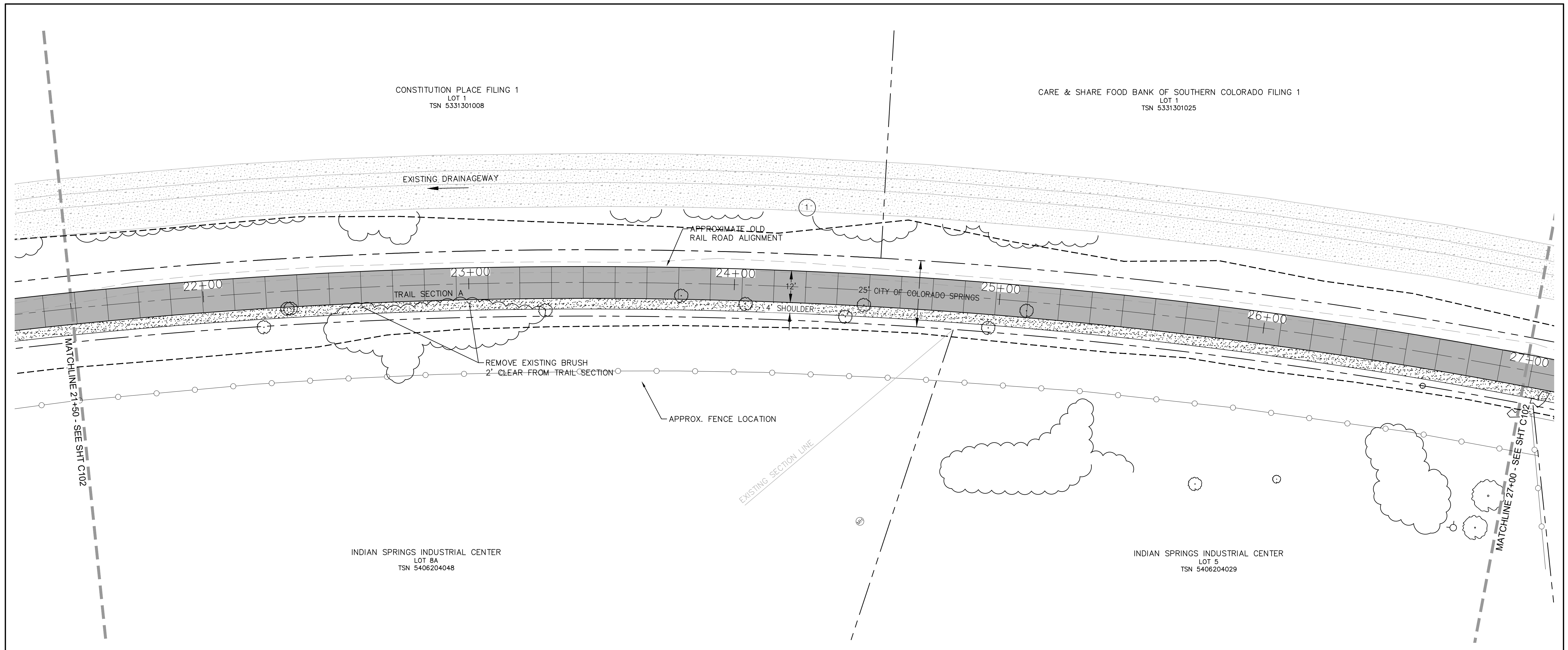

NOTE:
 ALL UTILITIES DEPICTED IN THE PLANS ARE QUALITY LEVEL D.
 UTILITIES IN CONFLICT WITH CONSTRUCTION WILL BE
 POTHOLED AND POSITIVELY IDENTIFIED (QUALITY LEVEL A)
 PRIOR TO EXCAVATION.

PT#	N	COORDINATES		DESCRIPTION	ELEVATION
		E			
100	1378591.13	3224761.21		BEGIN TRAIL	6394.8
101	1388610.98	3224772.35		PC	6394.9

CURVE DATA
 ① R=1910.00'
 L=916.54'
 Δ=27°29'39"

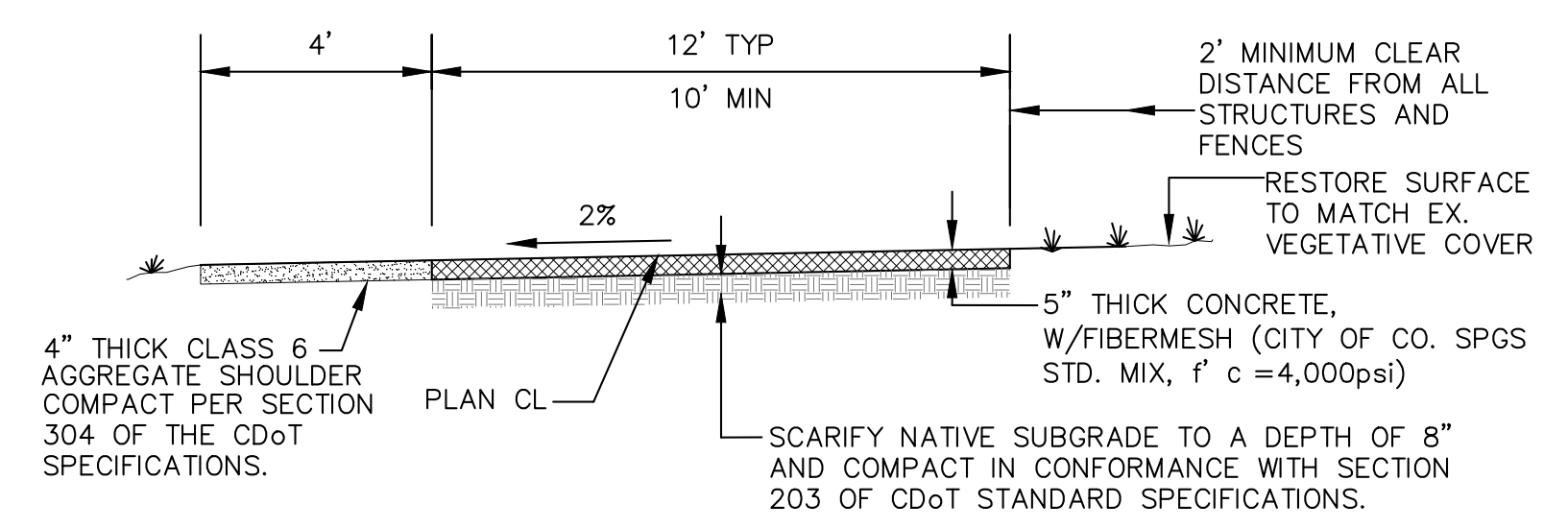

TRAIL SECTION A
 NOT TO SCALE

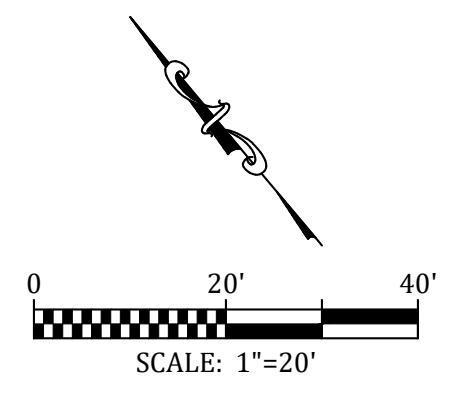

	<p style="color: red; text-align: center;">IN PROGRESS NOT FOR CONSTRUCTION</p>	<p style="font-size: small;">1604 South 21st Street Colorado Springs, Colorado 80904 (719) 630-7342</p>	<p style="text-align: center;">Sheet Revisions</p>	<p style="text-align: center;">90% BID SET</p>	<p style="text-align: center;">ROCK ISLAND TRAIL Sand Creek to Constitution Avenue</p>		Kiowa Proj. No. 16028
			<p style="text-align: center;">No Revisions:</p>	<p style="text-align: center;">Revised:</p>	<p style="text-align: center;">Void:</p>	<p style="text-align: center;">FINAL TRAIL PLAN STA 21+50 TO STA 27+00</p>	
<p style="font-size: x-small;">For and on Behalf of Kiowa Engineering Corporation Date</p>					Designer: RNW	SubAcct No. 20391	Sheet Number C103
					Date: 08/06/2024		

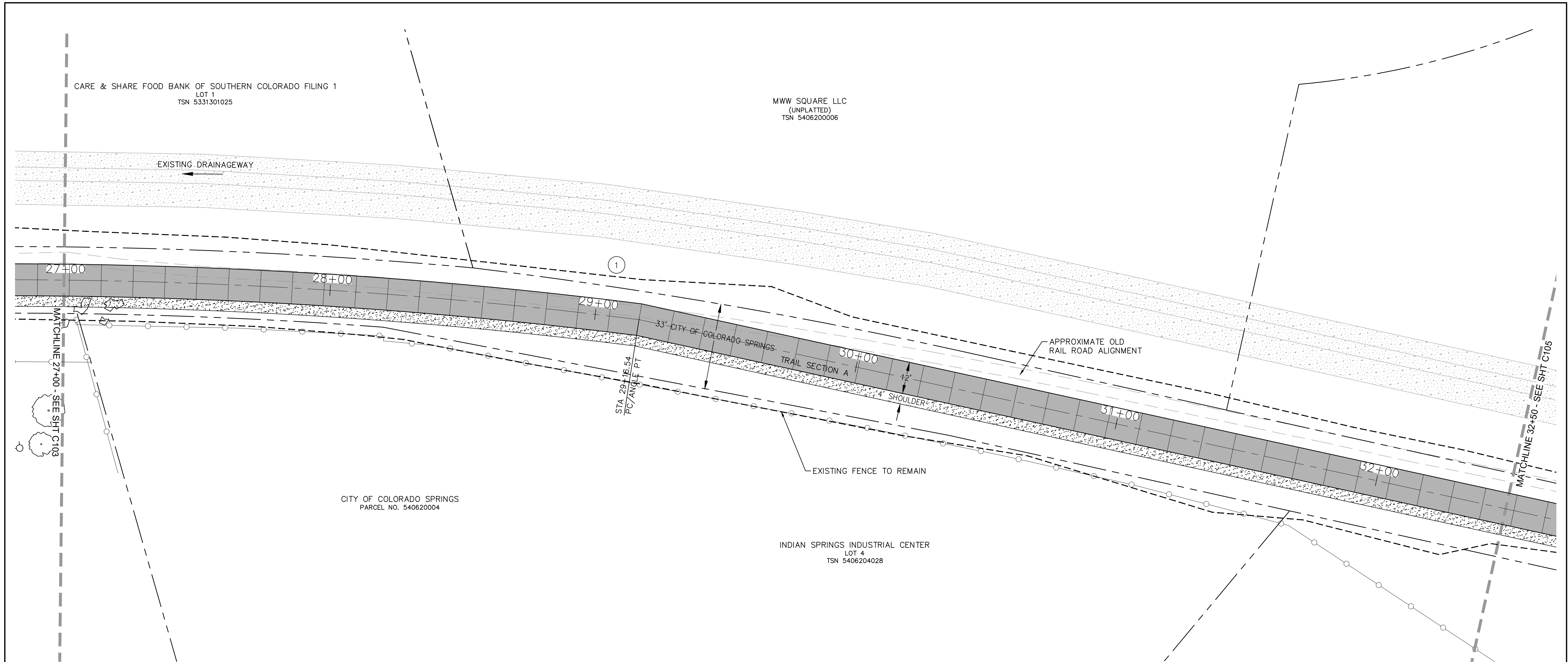



COORDINATES				
PT#	N	E	DESCRIPTION	ELEVATION
102	1377992.88	3225437.19	PC/ANGLE PT	6411.2

CURVE DATA	
①	R=1910.00' L=916.54' Δ=27°29'39"

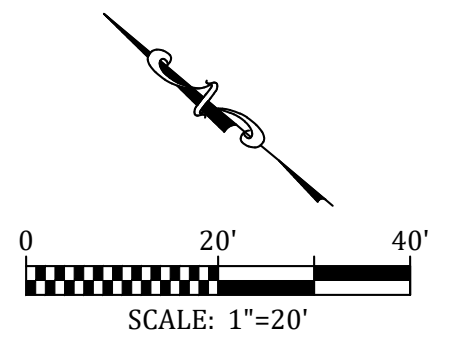
NOTE:
ALL UTILITIES DEPICTED IN THE PLANS ARE QUALITY LEVEL D.
UTILITIES IN CONFLICT WITH CONSTRUCTION WILL BE
POTHOLED AND POSITIVELY IDENTIFIED (QUALITY LEVEL A)
PRIOR TO EXCAVATION.

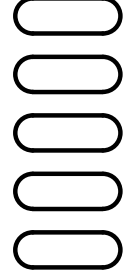

	IN PROGRESS NOT FOR CONSTRUCTION	 <small>Celebrating 30 years</small> 1604 South 21st Street Colorado Springs, Colorado 80904 (719) 630-7342		Sheet Revisions	90% BID SET	ROCK ISLAND TRAIL Sand Creek to Constitution Avenue FINAL TRAIL PLAN STA 27+00 TO STA 32+50		Kiowa Proj. No. 16028
				No Revisions:	Revised:	Void:	Designer: RNW Detailer: RNW Date: 08/06/2024	TAP M240-162 SubAcct No. 20391 Sheet Number C104

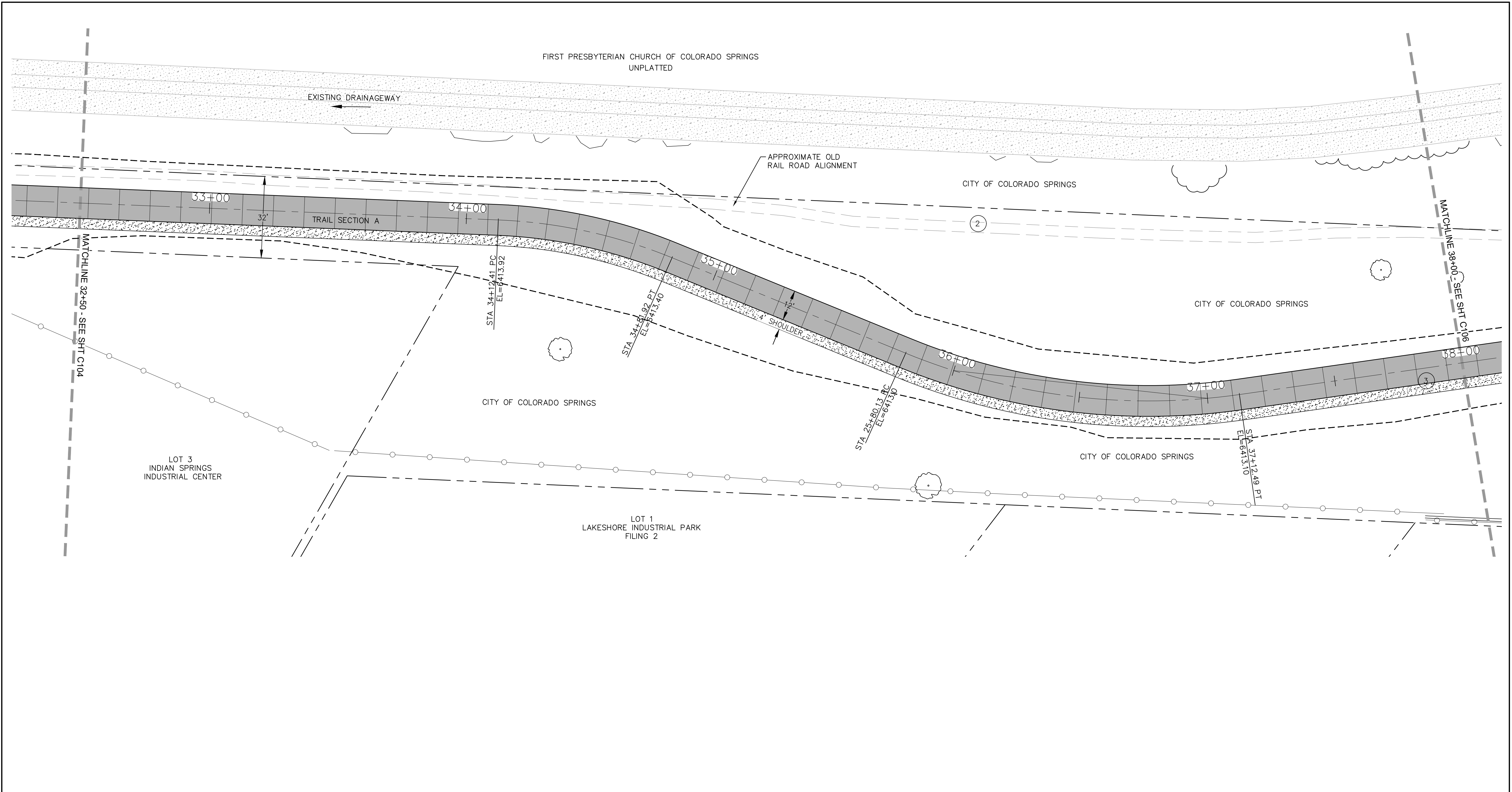



COORDINATES				
PT#	N	E	DESCRIPTION	ELEVATION
103	1377555.89	3225671.54	PC	6413.92
104	1377490.20	3225693.19	PT	6413.40
105	1375707.35	3225707.35	PC	6413.10

CURVE DATA		
②	R=200.00'	L=69.51'
		$\Delta = 19^{\circ}54'52''$
③	R=250.00'	L=132.27'
		$\Delta = 30^{\circ}20'11''$

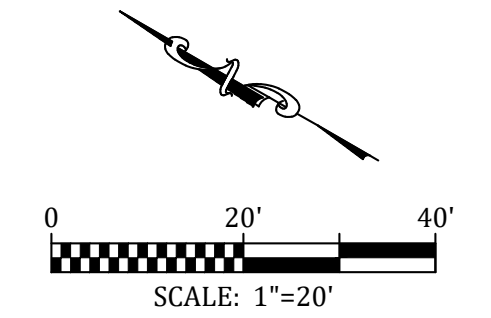
NOTE:
 ALL UTILITIES DEPICTED IN THE PLANS ARE QUALITY LEVEL D.
 UTILITIES IN CONFLICT WITH CONSTRUCTION WILL BE
 POTHOLED AND POSITIVELY IDENTIFIED (QUALITY LEVEL A)
 PRIOR TO EXCAVATION.



 COLORADO SPRINGS	IN PROGRESS NOT FOR CONSTRUCTION	 Kiowa Engineering Corporation <small>1604 South 21st Street Colorado Springs, Colorado 80904 (719) 630-7342</small>	Sheet Revisions 0000 0000 0000 0000	90% BID SET	ROCK ISLAND TRAIL Sand Creek to Constitution Avenue FINAL TRAIL PLAN STA 32+50 TO STA 38+00	Kiowa Proj. No. 16028 TAP M240-162 SubAcct No. 20391 Sheet Number C105
			No Revisions: Revised: Void:	Designer: RNW Detailer: RNW Date: 08/06/2024		

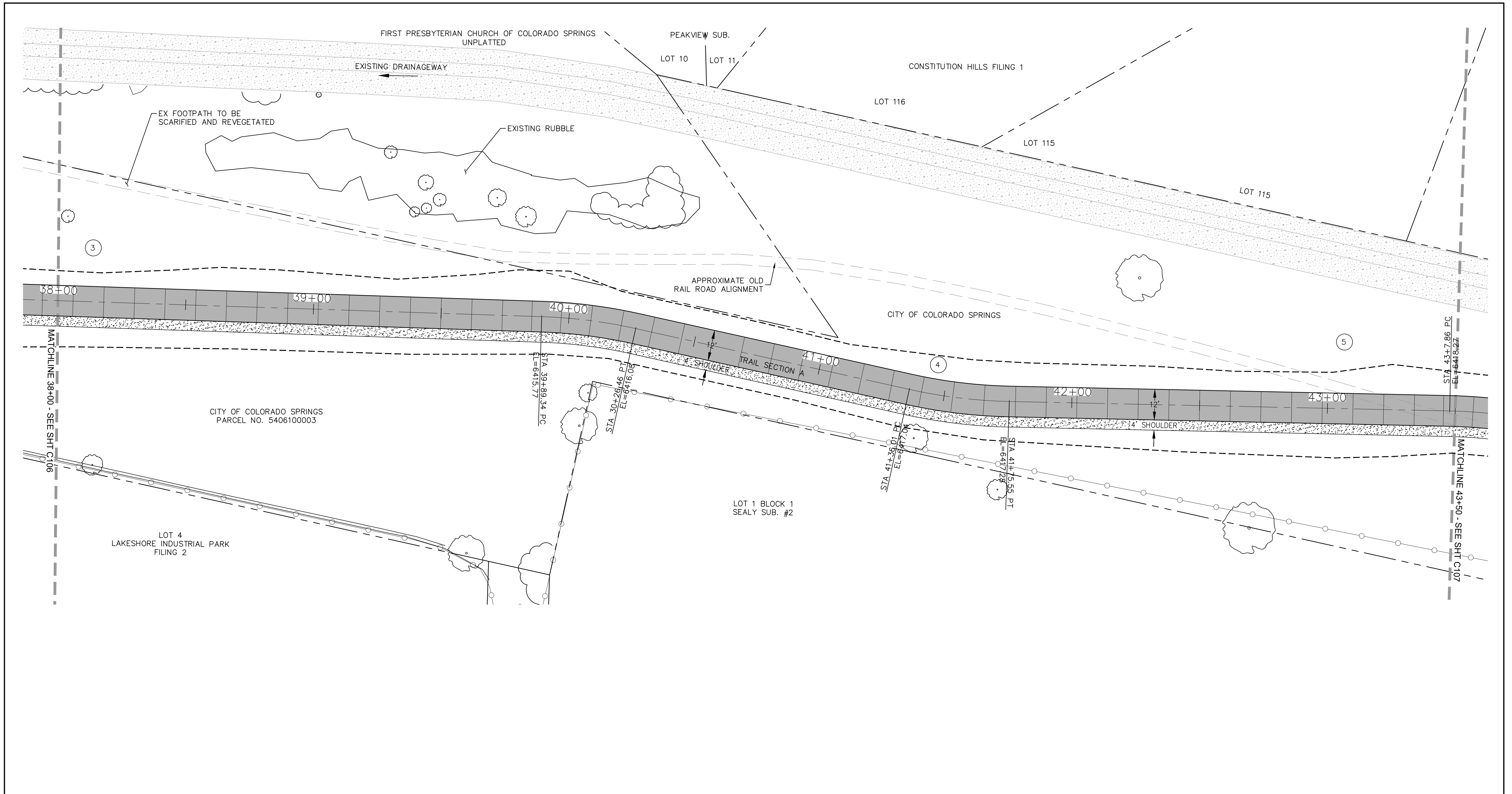



COORDINATES				
PT#	N	E	DESCRIPTION	ELEVATION
106	1377272.22	3225760.05	PT	6413.10
107	1377056.72	3225932.24	PC	6415.77
108	1377026.62	3225952.13	PT	6416.08
109	1376928.93	3226004.06	PC	6417.04
110	1376896.14	3226025.87	PT	6417.28

CURVE DATA		
3	R=250.00' L=132.27' Δ=30°20'11"	
4	R=200.00' L=37.13' Δ=10°38'09"	
5	R=200.00' L=39.45' Δ=11°18'04"	

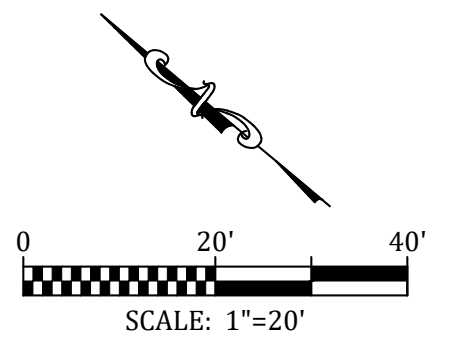
NOTE:
ALL UTILITIES DEPICTED IN THE PLANS ARE QUALITY LEVEL D.
UTILITIES IN CONFLICT WITH CONSTRUCTION WILL BE
POTHOLED AND POSITIVELY IDENTIFIED (QUALITY LEVEL A)
PRIOR TO EXCAVATION.



 COLORADO SPRINGS	IN PROGRESS NOT FOR CONSTRUCTION	 Kiowa Engineering Corporation 1604 South 21st Street Colorado Springs, Colorado 80904 (719) 630-7342	Sheet Revisions 000000	90% BID SET No Revisions: Revised: Void:	ROCK ISLAND TRAIL Sand Creek to Constitution Avenue FINAL TRAIL PLAN STA 38+00 TO STA 43+50	Kiowa Proj. No. 16028 TAP M240-162 SubAcct No. 20391 Sheet Number C106
			For and on Behalf of Kiowa Engineering Corporation Date	Designer: RNW Detailer: RNW Date: 08/06/2024		

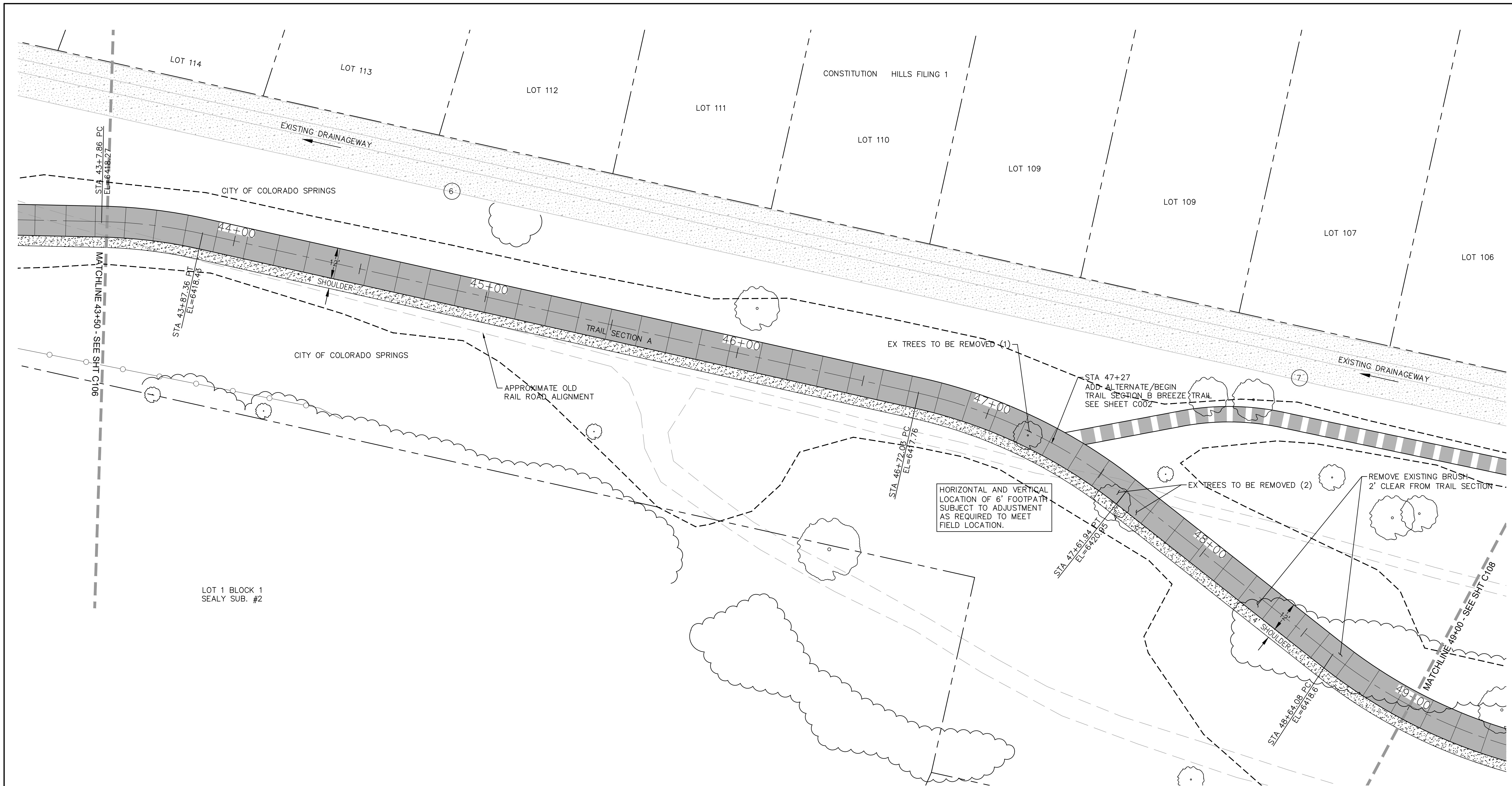

COORDINATES				
PT#	N	E	DESCRIPTION	ELEVATION
111	1376762.79	3226134.99	PC	6418.25
112	1376729.95	3226156.83	PT	6418.45
113	1376478.54	3226290.37	PC	6419.71
114	1376393.46	3226313.55	PT	6420.95

CURVE DATA		
6	R=200.00'	L=39.50'
	$\Delta=11^{\circ}18'58''$	
7	R=200.00'	L=89.91'
	$\Delta=25^{\circ}45'27''$	

NOTE:
 ALL UTILITIES DEPICTED IN THE PLANS ARE QUALITY LEVEL D.
 UTILITIES IN CONFLICT WITH CONSTRUCTION WILL BE
 POTHOLED AND POSITIVELY IDENTIFIED (QUALITY LEVEL A)
 PRIOR TO EXCAVATION.

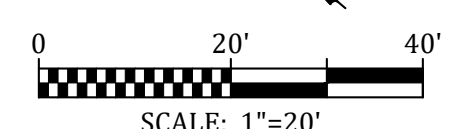

**IN PROGRESS
 NOT FOR CONSTRUCTION**



Sheet Revisions	90% BID SET
	No Revisions:
	Revised:
	Void:

ROCK ISLAND TRAIL Sand Creek to Constitution Avenue FINAL TRAIL PLAN STA 43+50 TO STA 49+00	
Designer:	RNW
Detailer:	RNW
Date:	08/06/2024

Kiowa Proj. No. 16028
TAP M240-162
SubAcct No. 20391
Sheet Number C107

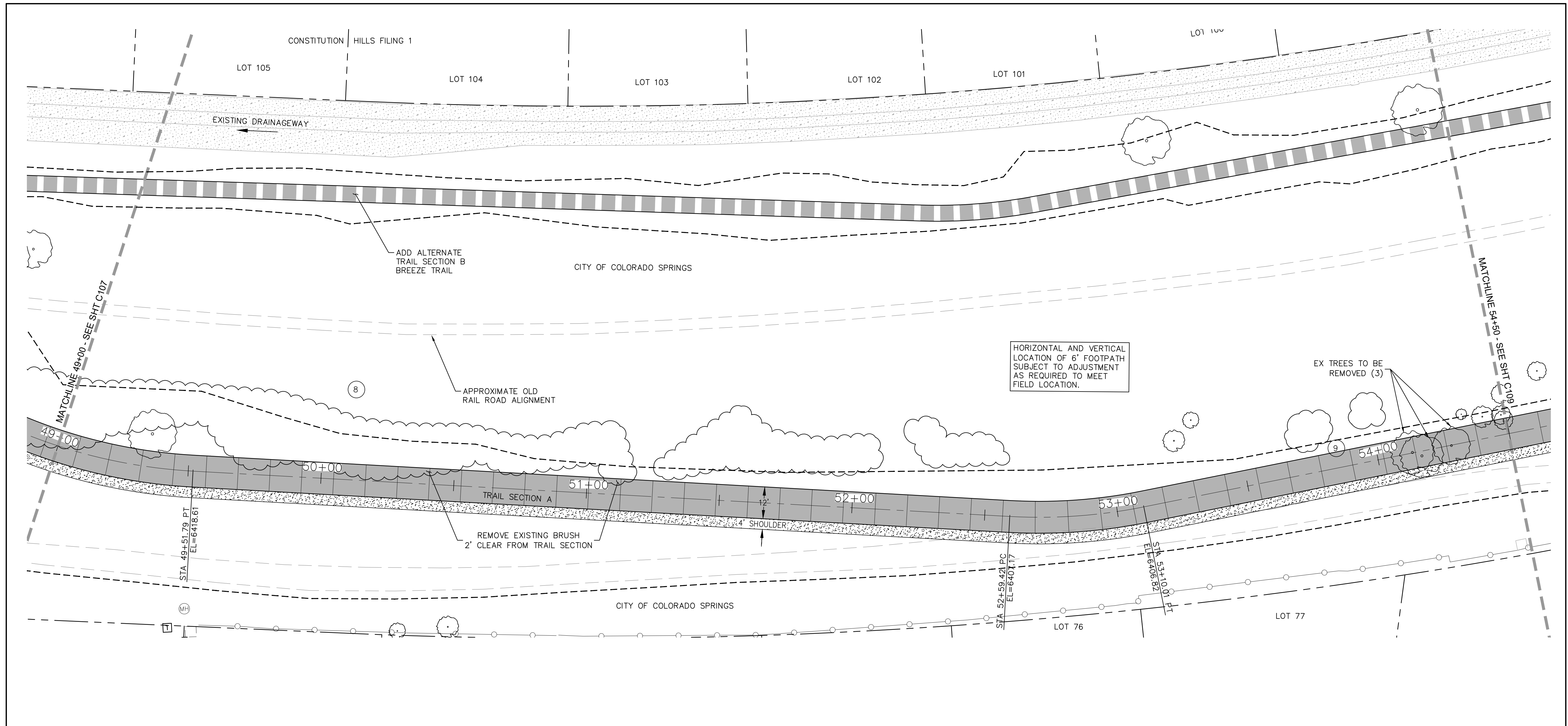

HORIZONTAL AND VERTICAL LOCATION OF 6' FOOTPATH SUBJECT TO ADJUSTMENT AS REQUIRED TO MEET FIELD LOCATION.

EX TREES TO BE REMOVED (3)

NOTE:
ALL UTILITIES DEPICTED IN THE PLANS ARE QUALITY LEVEL D. UTILITIES IN CONFLICT WITH CONSTRUCTION WILL BE POTHOLED AND POSITIVELY IDENTIFIED (QUALITY LEVEL A) PRIOR TO EXCAVATION.

PT#	N	E	DESCRIPTION	ELEVATION
115	1376290.41	3226317.15	PC	6418.82
116	1376206.27	3226339.74	PT	6415.40
117	1375933.01	3226481.05	PC	6407.15
118	1375891.41	3226509.75	PT	6406.82

CURVE DATA

8	R=200.00'	9	R=200.00'
	L=87.71'		L=50.68'
	$\Delta=25^{\circ}7'38''$		$\Delta=14^{\circ}31'08''$

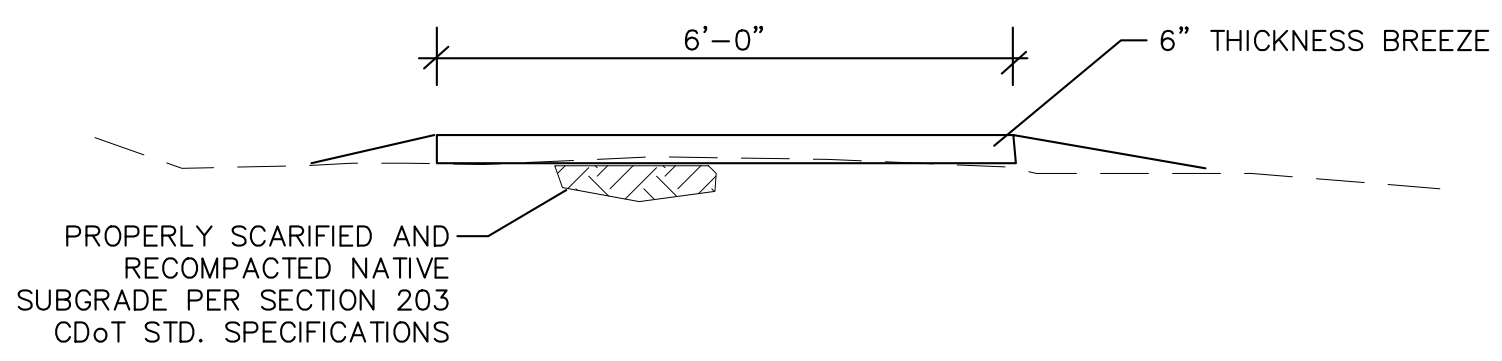

TRAIL SECTION B - 6' BREEZE TRAIL
SCALE: 1"=2'

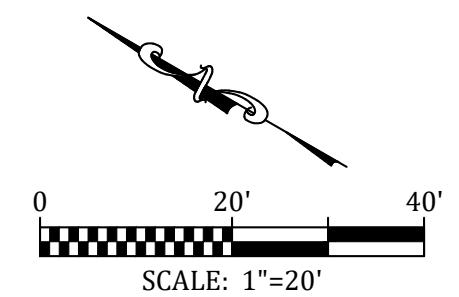

IN PROGRESS
NOT FOR CONSTRUCTION

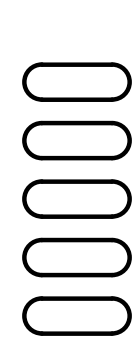

Sheet Revisions	90% BID SET	ROCK ISLAND TRAIL Sand Creek to Constitution Avenue		Kiowa Proj. No. 16028
	No Revisions:	FINAL TRAIL PLAN STA 49+00 TO STA 54+50		TAP M240-162
	Revised:	Designer: RNW		SubAcct No. 20391
	Void:	Detailer: RNW		Sheet Number C108
		Date: 08/06/2024		

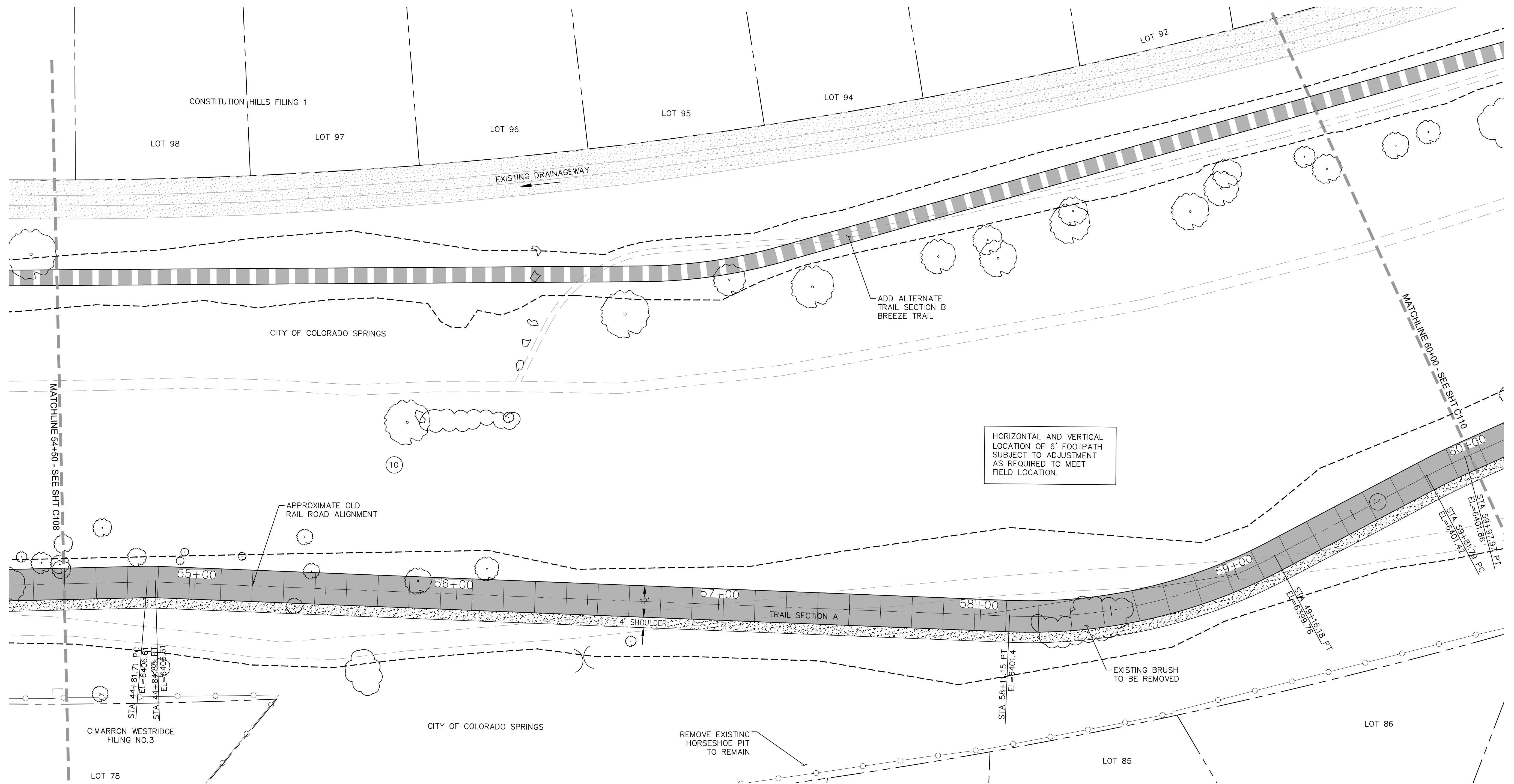

COORDINATES				
PT#	N	E	DESCRIPTION	ELEVATION
119	1375763.61	3226624.28	PC	6406.18
120	1375761.18	3226626.32	PT	6406.13
121	1376828.23	3225504.85	PC	6401.42

CURVE DATA	
⑩	R=50.00' L=3.17' Δ=3°37'52"
⑪	R=200.00' L=105.03' Δ=3°05'19"

NOTE:
ALL UTILITIES DEPICTED IN THE PLANS ARE QUALITY LEVEL D.
UTILITIES IN CONFLICT WITH CONSTRUCTION WILL BE
POTHOLED AND POSITIVELY IDENTIFIED (QUALITY LEVEL A)
PRIOR TO EXCAVATION.

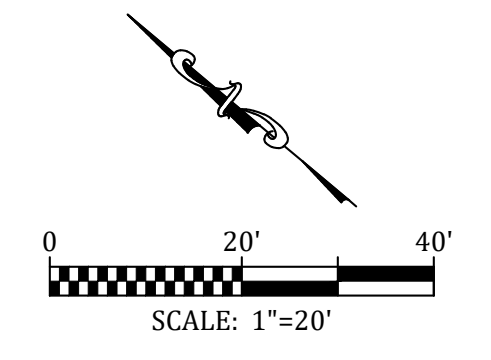

**IN PROGRESS
NOT FOR CONSTRUCTION**



Sheet Revisions	

90% BID SET	
No Revisions:	
Revised:	
Void:	

ROCK ISLAND TRAIL Sand Creek to Constitution Avenue	
FINAL TRAIL PLAN STA 54+50 TO STA 60+00	
Designer:	RNW
Detailer:	RNW
Date:	08/06/2024

Kiowa Proj. No. 16028
TAP M240-162
SubAcct No. 20391
Sheet Number C109

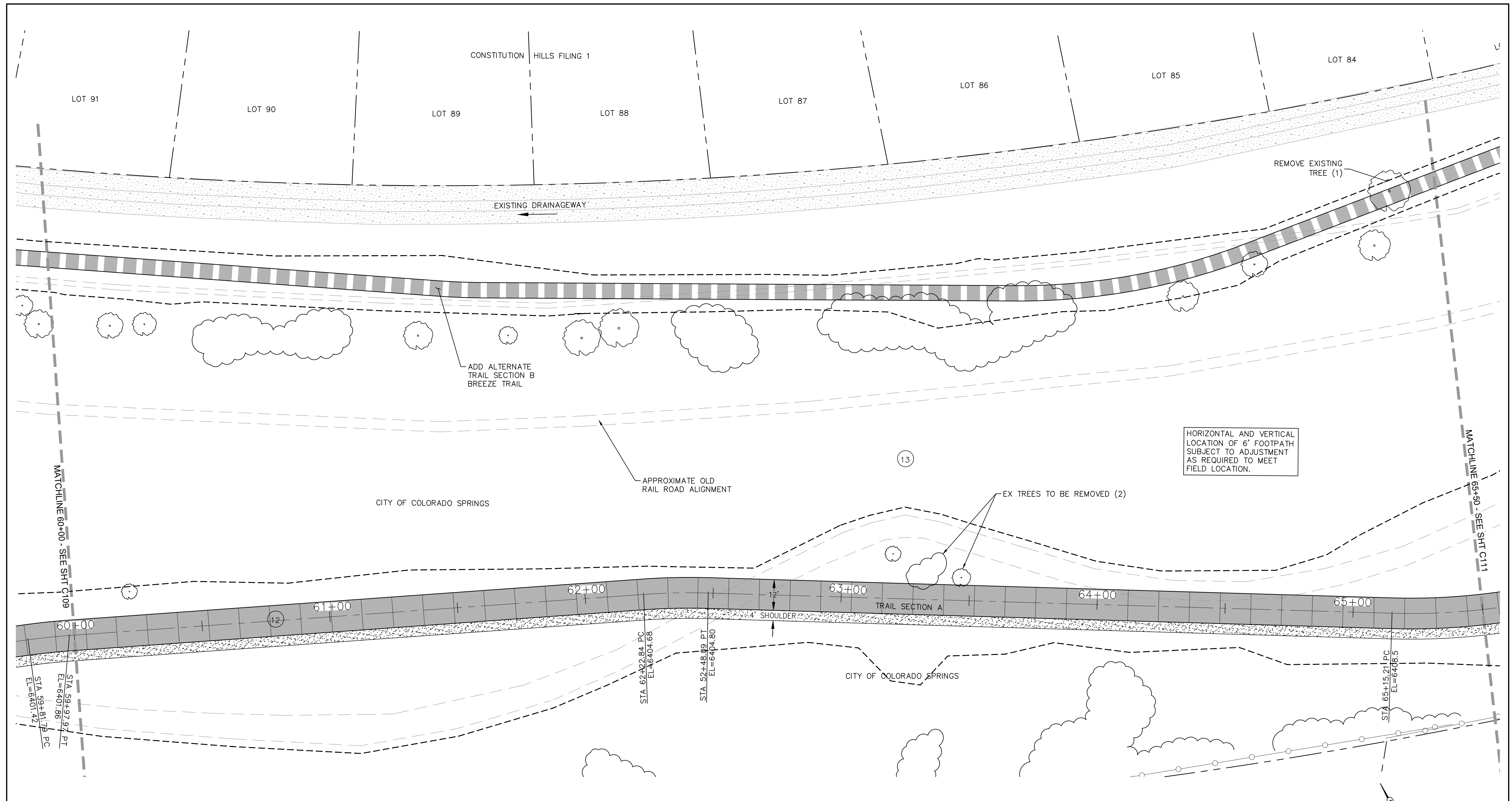

HORIZONTAL AND VERTICAL LOCATION OF 6' FOOTPATH SUBJECT TO ADJUSTMENT AS REQUIRED TO MEET FIELD LOCATION.

NOTE:
ALL UTILITIES DEPICTED IN THE PLANS ARE QUALITY LEVEL D. UTILITIES IN CONFLICT WITH CONSTRUCTION WILL BE POTHOLED AND POSITIVELY IDENTIFIED (QUALITY LEVEL A) PRIOR TO EXCAVATION.

COORDINATES				
PT#	N	E	DESCRIPTION	ELEVATION
122	1375442.81	3226911.45	PT	6399.76
123	1375418.57	3226972.42	PC	6401.42
124	1375412.12	3226987.25	PT	6401.85
125	1375315.71	3227190.40	PC	6404.68
126	1375303.75	3227212.63	PT	6404.80

CURVE DATA	
(12)	R=250.00' L=16.18' $\Delta = 3^{\circ}42'29''$
(13)	R=250.00' L=25.25' $= 5^{\circ}47'11''$

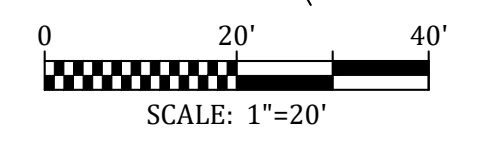

**IN PROGRESS
NOT FOR CONSTRUCTION**

For and on Behalf of
Kiowa Engineering Corporation Date

Celebrating 30 years
Kiowa
Engineering Corporation
1604 South 21st Street
Colorado Springs, Colorado 80904
(719) 630-7342

Sheet Revisions	

90% BID SET	
No Revisions:	
Revised:	
Void:	

ROCK ISLAND TRAIL
Sand Creek to Constitution Avenue
FINAL TRAIL PLAN STA 60+00 TO STA 65+50

Designer: RNW
Detailer: RNW
Date: 08/06/2024

Kiowa Proj. No. 16028
TAP M240-162
SubAcct No. 20391
Sheet Number C110

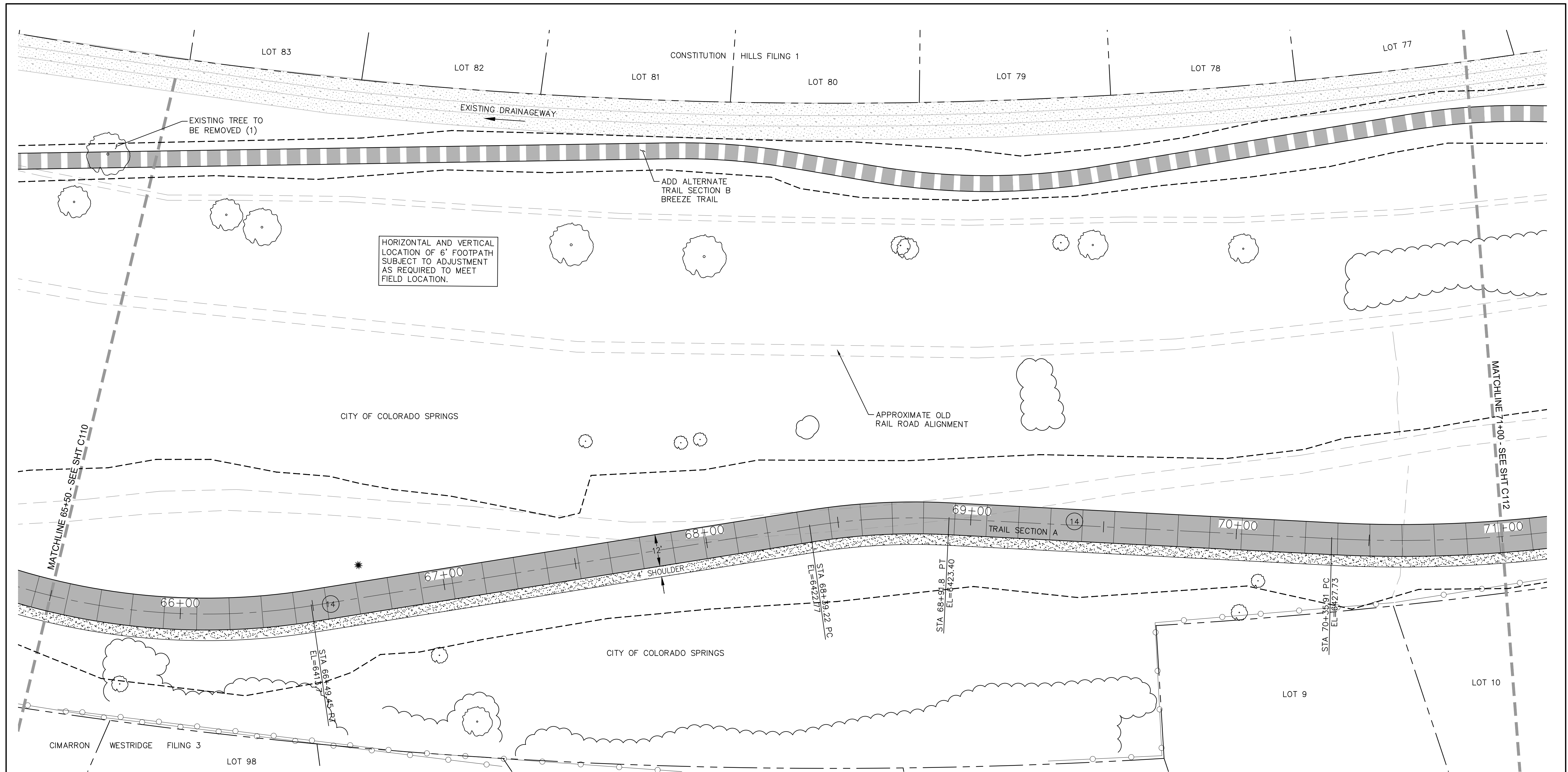

HORIZONTAL AND VERTICAL LOCATION OF 6' FOOTPATH SUBJECT TO ADJUSTMENT AS REQUIRED TO MEET FIELD LOCATION.

NOTE:
ALL UTILITIES DEPICTED IN THE PLANS ARE QUALITY LEVEL D. UTILITIES IN CONFLICT WITH CONSTRUCTION WILL BE POTHOLED AND POSITIVELY IDENTIFIED (QUALITY LEVEL A) PRIOR TO EXCAVATION.

PT#	COORDINATES		DESCRIPTION	ELEVATION
	N	E		
127	1375165.48	3227441.18	PC	6408.0
128	1375129.39	3227568.81	PT	6413.93
129	1375128.03	3227758.58	PC	6422.41
130	1375122.15	3227810.73	PT	6423.56

CURVE DATA	
14	R=250.00' L=134.24' Δ=30°45'53"
15	R=250.00' L=52.58' Δ=12°3'2"

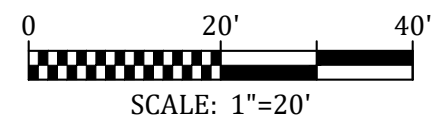

**IN PROGRESS
NOT FOR CONSTRUCTION**

For and on Behalf of
Kiowa Engineering Corporation Date

Celebrating 30 years
Kiowa
Engineering Corporation

1604 South 21st Street
Colorado Springs, Colorado 80904
(719) 630-7342

Sheet Revisions	90% BID SET
	No Revisions:
	Revised:
	Void:

ROCK ISLAND TRAIL Sand Creek to Constitution Avenue	
FINAL TRAIL PLAN STA 65+50 TO STA 71+00	
Designer:	RNW
Detailer:	RNW
Date:	08/06/2024

Kiowa Proj. No. 16028
TAP M240-162
SubAcct No. 20391
Sheet Number C111

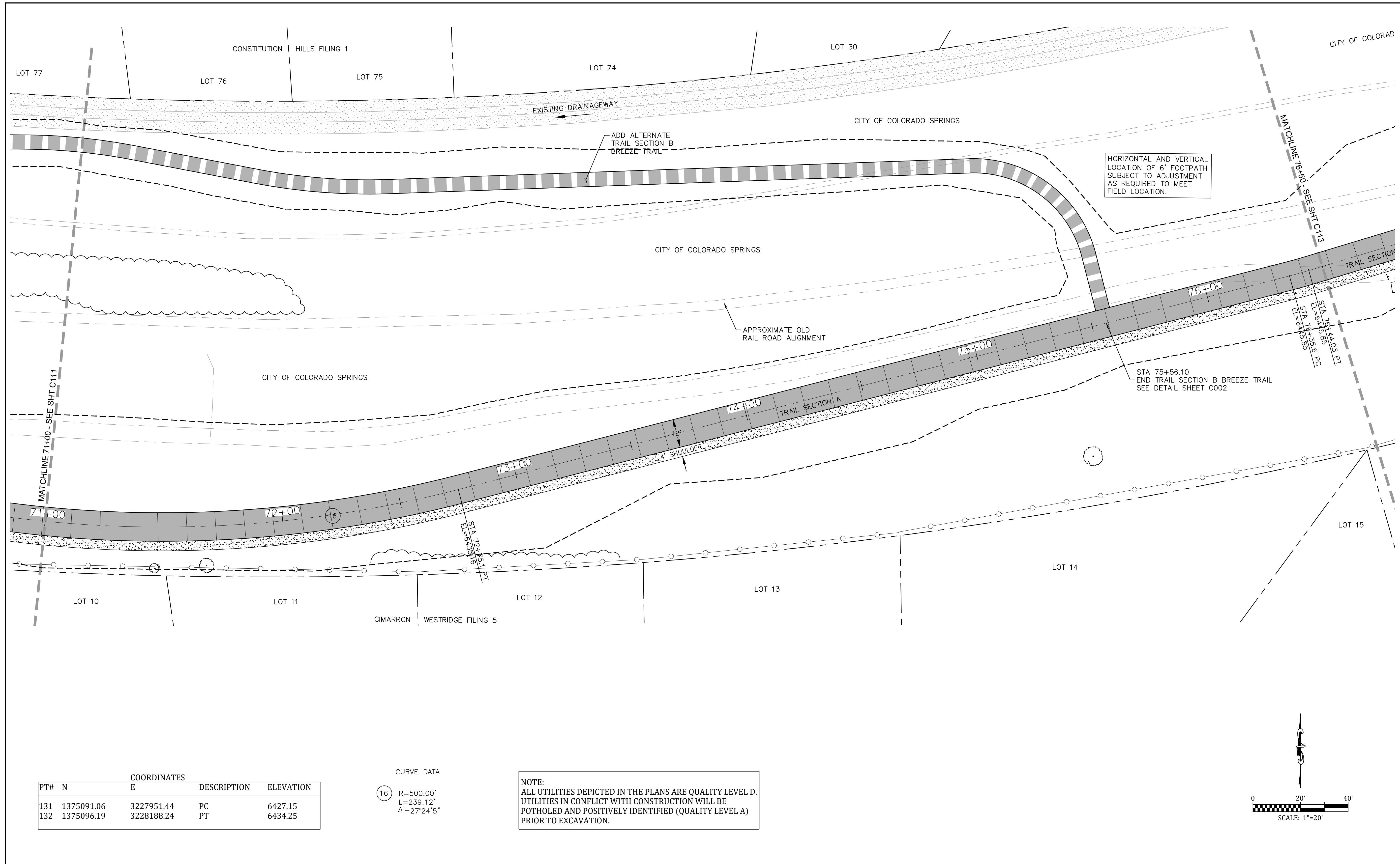



PT#	COORDINATES		DESCRIPTION	ELEVATION
	N	E		
131	1375091.06	3227951.44	PC	6427.15
132	1375096.19	3228188.24	PT	6434.25

CURVE DATA
 (16) R=500.00'
 L=239.12'
 $\Delta=27^{\circ}24'5''$

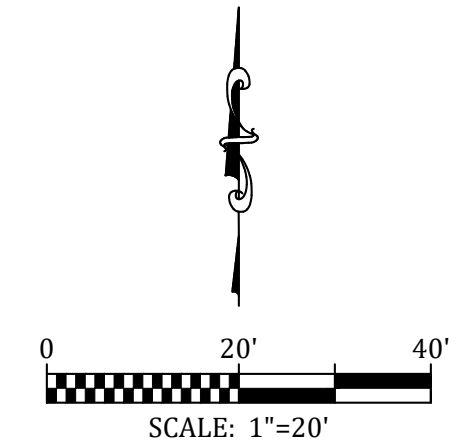
NOTE:
 ALL UTILITIES DEPICTED IN THE PLANS ARE QUALITY LEVEL D.
 UTILITIES IN CONFLICT WITH CONSTRUCTION WILL BE
 POTHOLED AND POSITIVELY IDENTIFIED (QUALITY LEVEL A)
 PRIOR TO EXCAVATION.

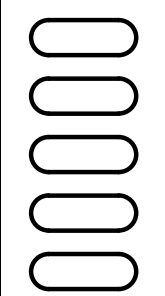

	IN PROGRESS NOT FOR CONSTRUCTION	 <small>1604 South 21st Street Colorado Springs, Colorado 80904 (719) 630-7342</small>		Sheet Revisions	90% BID SET	ROCK ISLAND TRAIL Sand Creek to Constitution Avenue FINAL TRAIL PLAN STA 71+00 TO STA 76+50	Kiowa Proj. No. 16028 TAP M240-162
			<small>For and on Behalf of Kiowa Engineering Corporation Date</small>	No Revisions: Revised: Void:	Designer: RNW Detailer: RNW Date: 08/06/2024	SubAcct No. 20391 Sheet Number C112	

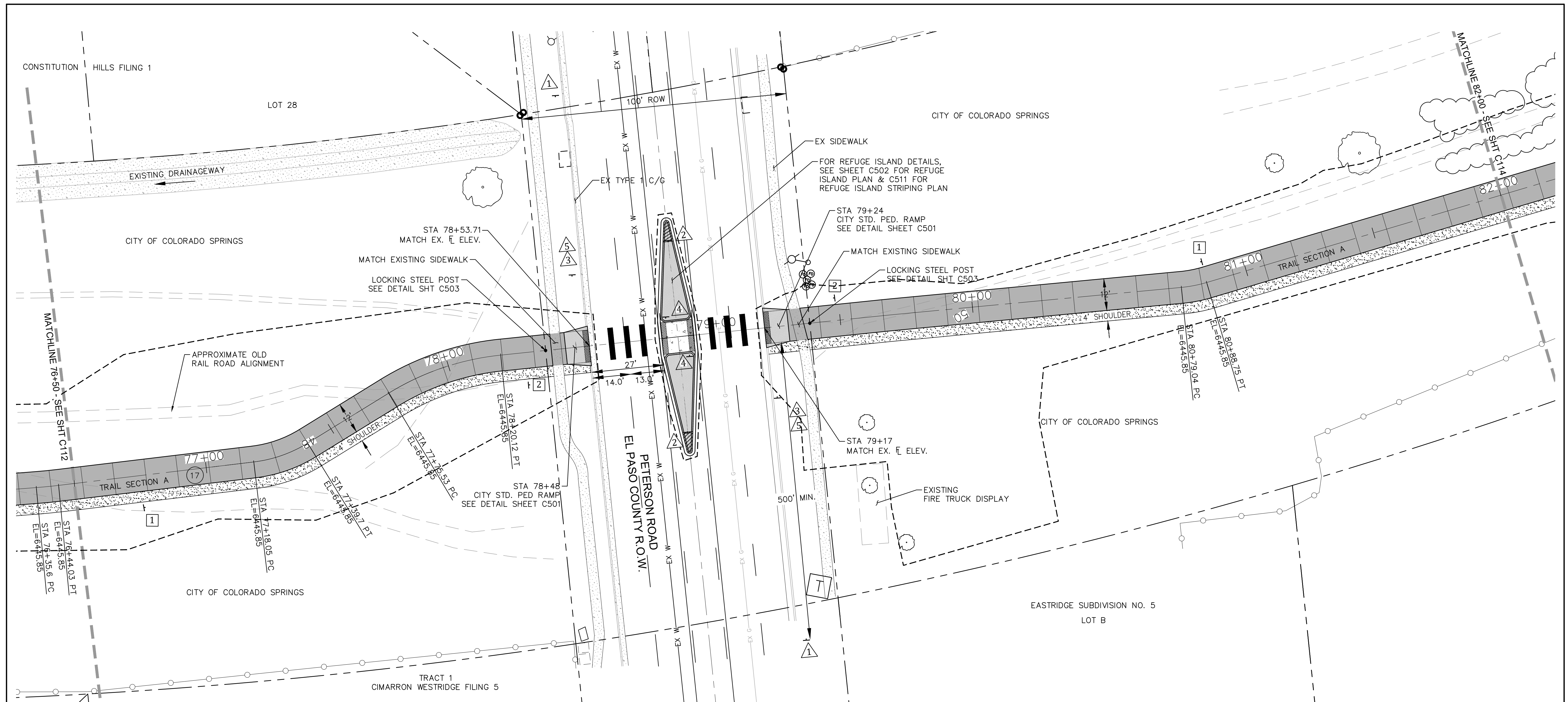

NOTE:
 ALL UTILITIES DEPICTED IN THE PLANS ARE QUALITY LEVEL D.
 UTILITIES IN CONFLICT WITH CONSTRUCTION WILL BE
 POTHOLED AND POSITIVELY IDENTIFIED (QUALITY LEVEL A)
 PRIOR TO EXCAVATION.

PT#	N	E	DESCRIPTION	ELEVATION
133	1375189.16	3228536.61	PC	6444.85
134	1375191.51	3228544.71	PT	6446.0
135	1375252.48	3228739.76	EX. WEST FL	MATCH EX.
136	1375271.64	3228803.12	EX. EAST FL	MATCH EX.
137	1375277.35	3228822.28	ANGLE PT	6451.4

CURVE DATA
 (17) R=200.00'
 L=8.23'
 $\Delta=2'24'54''$

TRAIL SIGNAGE		
SIGNAGE	#	PANEL SIZE
1	2	12x18
2	2	12x18

TRAFFIC SIGNAGE		
SIGNAGE	#	PANEL SIZE
1	2	30x30 W11-1
2	2	24x30 R4-7
3	2	24x24 W11A-2
4	2	12x36 R1-6
5	2	12X18 W16-7P

NOTES:
 1. CONTRACTOR TO OBTAIN EPC-DPW ROAD CUT WORK PERMIT FOR WORK IN RIGHT-OF-WAY.
 2. CONTRACTOR TO SUPPLY TO EPC-DPW CONSTRUCTION TRAFFIC CONTROL PLAN FOR REVIEW AND APPROVAL PRIOR TO COMMENCING WITH ANY WORK WITHIN THE PETERSON ROAD RIGHT-OF-WAY.

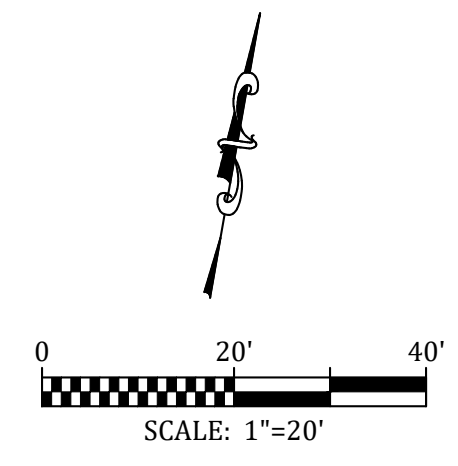

 COLORADO SPRINGS	IN PROGRESS NOT FOR CONSTRUCTION	 Celebrating 30 years Kiowa Engineering Corporation <small>1604 South 21st Street Colorado Springs, Colorado 80904 (719) 630-7342</small>	Sheet Revisions No Revisions: Revised: Void:	90% BID SET	ROCK ISLAND TRAIL Sand Creek to Constitution Avenue FINAL TRAIL PLAN STA 76+50 TO STA 82+00	Kiowa Proj. No. 16028 TAP M240-162 SubAcct No. 20391 Sheet Number C113
			<small>For and on Behalf of Kiowa Engineering Corporation Date</small>	<small>Designer: RNW Detailer: RNW Date: 08/06/2024</small>		

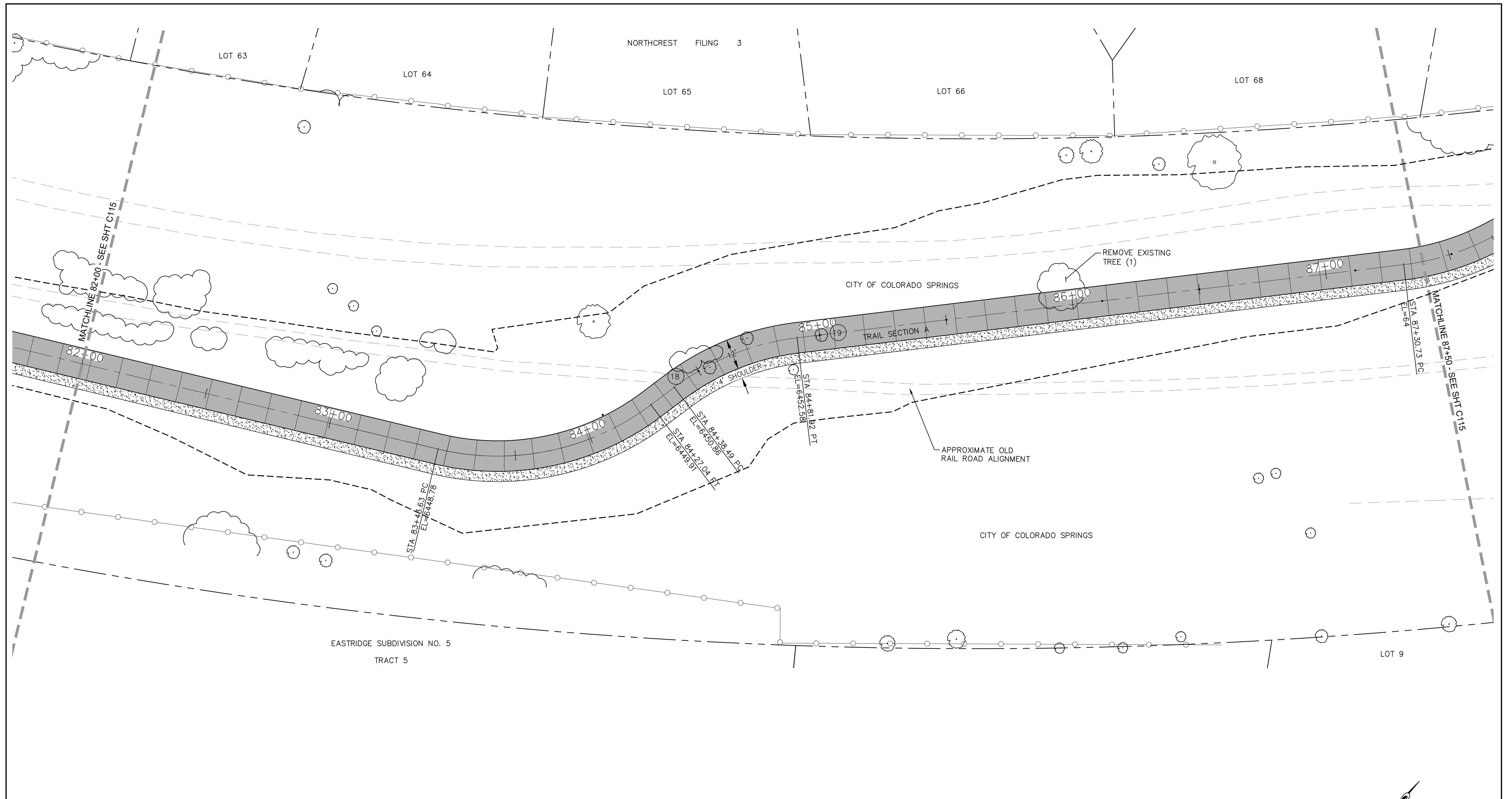

COORDINATES				
PT#	N	E	DESCRIPTION	ELEVATION
138	1375475.97	3229211.44	PC	6448.78
139	1375522.69	3229258.66	PT	6449.91
140	1375536.62	3229238.05	PC	6450.75
141	1375572.64	3229251.20	PT	6452.20

CURVE DATA

18	R=50.00' L=57.13' Δ=65°27'56"	19	R=50.00' L=39.36' Δ=45°6'10"
----	-------------------------------------	----	------------------------------------

NOTE:
ALL UTILITIES DEPICTED IN THE PLANS ARE QUALITY LEVEL D.
UTILITIES IN CONFLICT WITH CONSTRUCTION WILL BE
POTHOLED AND POSITIVELY IDENTIFIED (QUALITY LEVEL A)
PRIOR TO EXCAVATION.

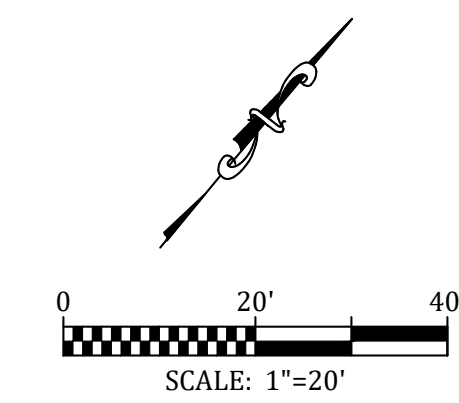

**IN PROGRESS
NOT FOR CONSTRUCTION**

For and on Behalf of
Kiowa Engineering Corporation Date

Celebrating 30 years

Kiowa
Engineering Corporation

1604 South 21st Street
Colorado Springs, Colorado 80904
(719) 630-7342

Sheet Revisions	90% BID SET
	No Revisions:
	Revised:
	Void:

ROCK ISLAND TRAIL Sand Creek to Constitution Avenue	
FINAL TRAIL PLAN STA 82+00 TO STA 87+50	
Designer:	RNW
Detailer:	RNW
Date:	08/06/2024

Kiowa Proj. No. 16028
TAP M240-162
SubAcct No. 20391
Sheet Number C114

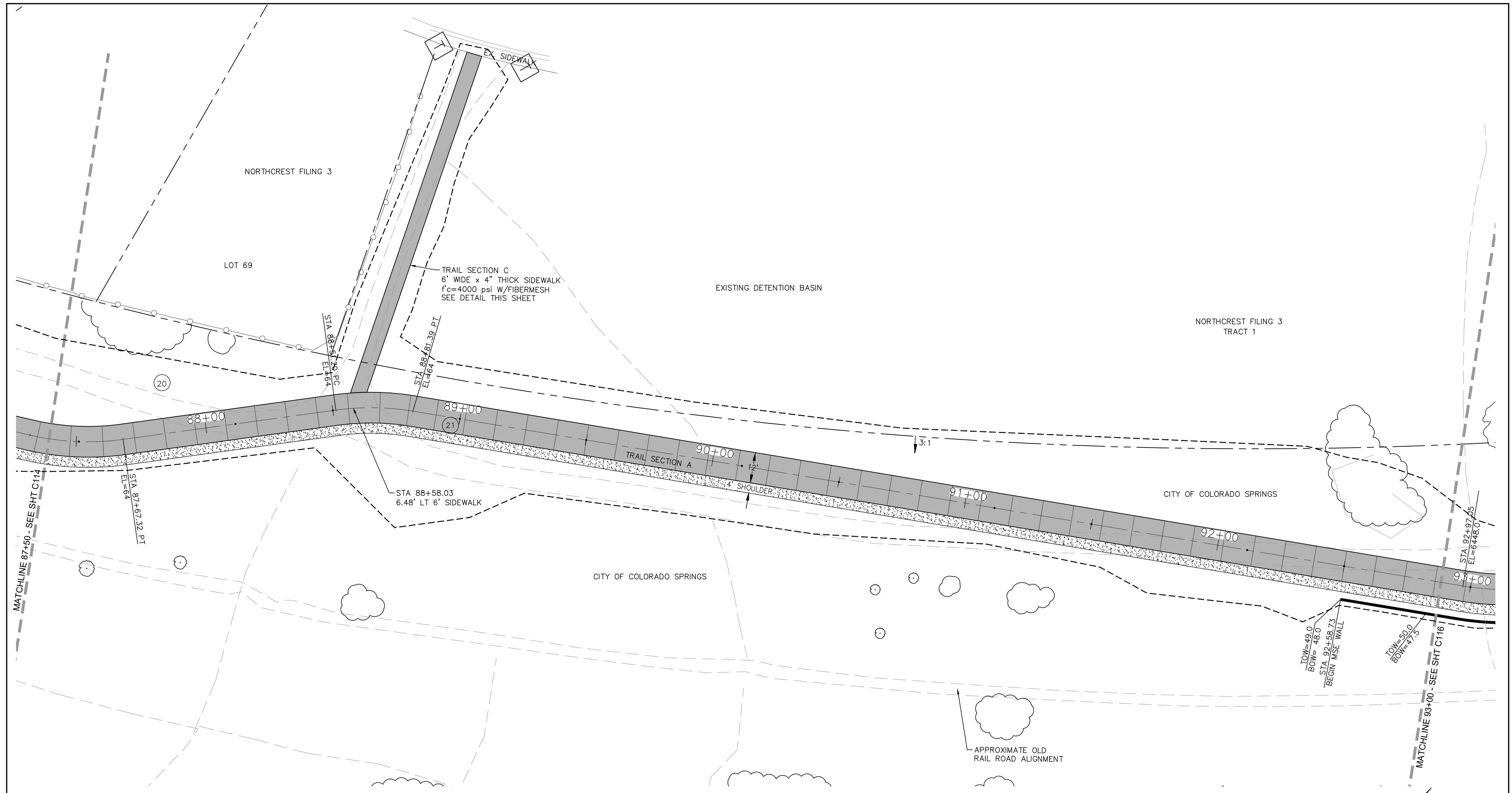

NOTE:
 ALL UTILITIES DEPICTED IN THE PLANS ARE QUALITY LEVEL D.
 UTILITIES IN CONFLICT WITH CONSTRUCTION WILL BE
 POTHOLED AND POSITIVELY IDENTIFIED (QUALITY LEVEL A)
 PRIOR TO EXCAVATION.

COORDINATES				
PT#	N	E	DESCRIPTION	ELEVATION
142	1375764.36	3229427.48	PC	6447.66
143	1375795.19	3229446.82	PT	6447.46
144	1375873.15	3229477.74	PC	6446.68
145	1375899.13	3229492.91	PT	6445.13

CURVE DATA	
(20) R=100.00' L=36.59' Δ=20°58'0"	(21) R=100.00' L=30.20' Δ=17°18'4"

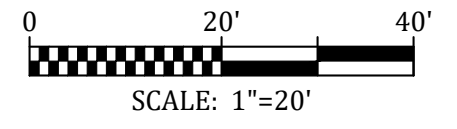
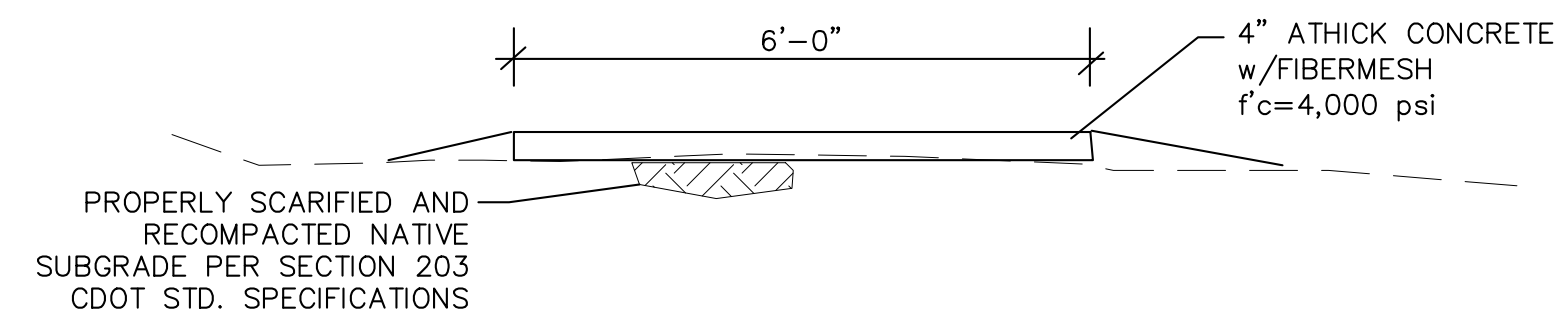

**IN PROGRESS
 NOT FOR CONSTRUCTION**

For and on Behalf of
 Kiowa Engineering Corporation Date



Sheet Revisions	90% BID SET
	No Revisions:
	Revised:
	Void:

ROCK ISLAND TRAIL Sand Creek to Constitution Avenue	
FINAL TRAIL PLAN STA 87+50 TO STA 93+00	
Designer:	RNW
Detailer:	RNW
Date:	08/06/2024

Kiowa Proj. No. 16028
TAP M240-162
SubAcct No. 20391
Sheet Number C115

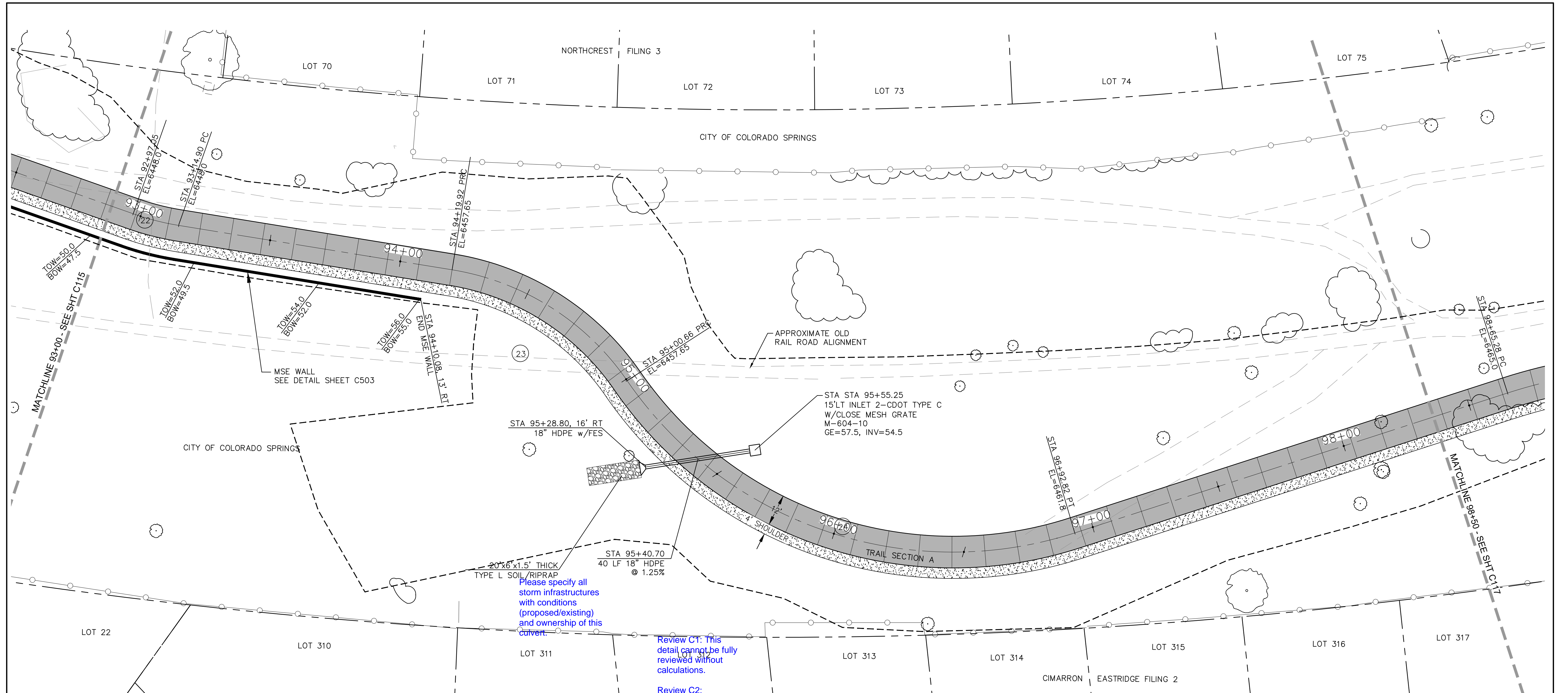

NOTE:
ALL UTILITIES DEPICTED IN THE PLANS ARE QUALITY LEVEL D.
UTILITIES IN CONFLICT WITH CONSTRUCTION WILL BE
POTHOLED AND POSITIVELY IDENTIFIED (QUALITY LEVEL A)
PRIOR TO EXCAVATION.

PT#	N	E	COORDINATES	DESCRIPTION	ELEVATION
146	1376222.47	3229754.11	PC		6448.21
147	1376237.28	3229764.03	PT		6449.20
148	1376349.33	3229825.39	PC		6456.0
149	1376373.35	3229857.16	PT		6457.90
150	1376376.78	3229871.63	PC		6458.30
151	1376393.39	3229913.16	CL 18" HDPE		6457.8
152	1376518.71	3229987.26	PT		6461.78
153	1376691.11	3229991.97	PC		6464.95

CURVE DATA

22	R=100.00' L=17.85' $\Delta=10^{\circ}13'45''$	23	R=50.00' L=41.87' $\Delta=47^{\circ}58'28''$
24	R=150.00' L=196.65' $\Delta=75^{\circ}6'53''$		

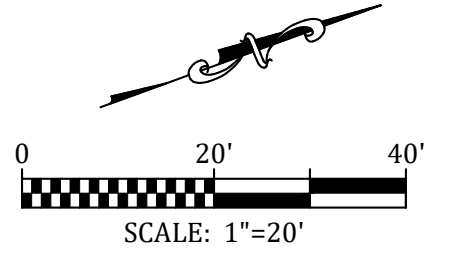
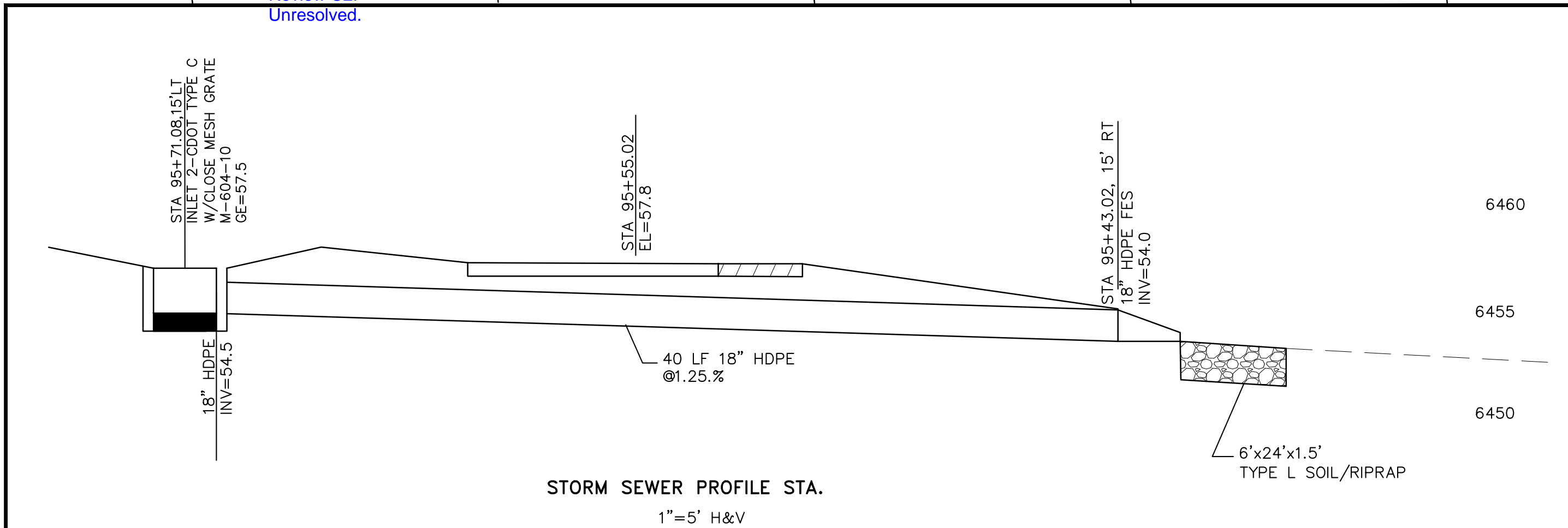

Please specify all storm infrastructures with conditions (proposed/existing) and ownership of this curvnt.

Review C1: This detail cannot be fully reviewed without calculations.

Review C2: Unresolved.



**IN PROGRESS
NOT FOR CONSTRUCTION**



Sheet Revisions	

90% BID SET	
No Revisions:	
Revised:	
Void:	

ROCK ISLAND TRAIL Sand Creek to Constitution Avenue	
FINAL TRAIL PLAN STA 93+00 TO STA 98+50	
Designer:	RNW
Detailer:	RNW
Date:	08/06/2024

Kiowa Proj. No. 16028
TAP M240-162
SubAcct No. 20391
Sheet Number C116

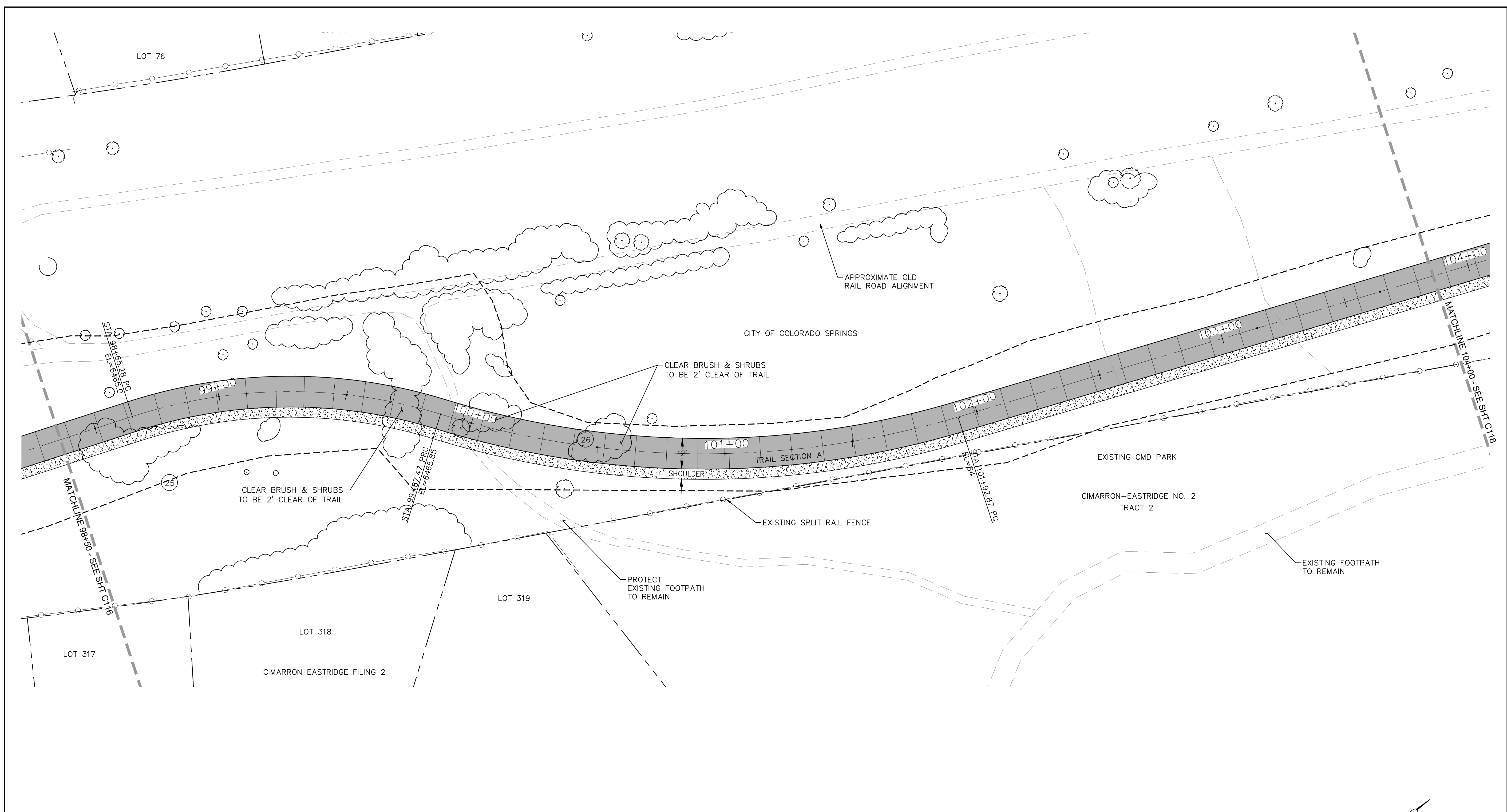

COORDINATES				
PT#	N	E	DESCRIPTION	ELEVATION
154	1376804.80	3220031.26	PRC	6465.10
155	1376995.36	3220099.68	PT	6465.68

CURVE DATA	
(25)	R=200.00' L=122.18' Δ=35°0'7"
(26)	R=350.00' L=205.40' Δ=33°37'30"

NOTE:
ALL UTILITIES DEPICTED IN THE PLANS ARE QUALITY LEVEL D.
UTILITIES IN CONFLICT WITH CONSTRUCTION WILL BE
POTHOLED AND POSITIVELY IDENTIFIED (QUALITY LEVEL A)
PRIOR TO EXCAVATION.

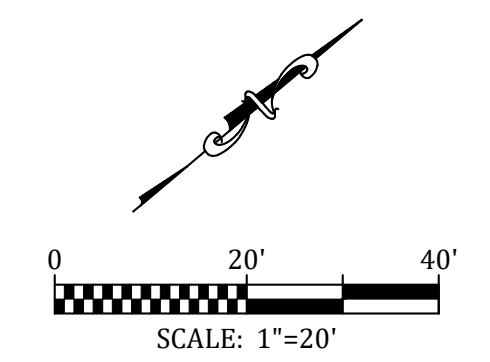

**IN PROGRESS
NOT FOR CONSTRUCTION**

For and on Behalf of
Kiowa Engineering Corporation Date

Celebrating 30 years
Kiowa
Engineering Corporation

1604 South 21st Street
Colorado Springs, Colorado 80904
(719) 630-7342

Sheet Revisions	90% BID SET
	No Revisions:
	Revised:
	Void:

ROCK ISLAND TRAIL
Sand Creek to Constitution Avenue
FINAL TRAIL PLAN STA 98+50 TO STA 104+00

Designer: RNW
Detailer: RNW
Date: 08/06/2024

Kiowa Proj. No. 16028
TAP M240-162
SubAcct No. 20391
Sheet Number C117

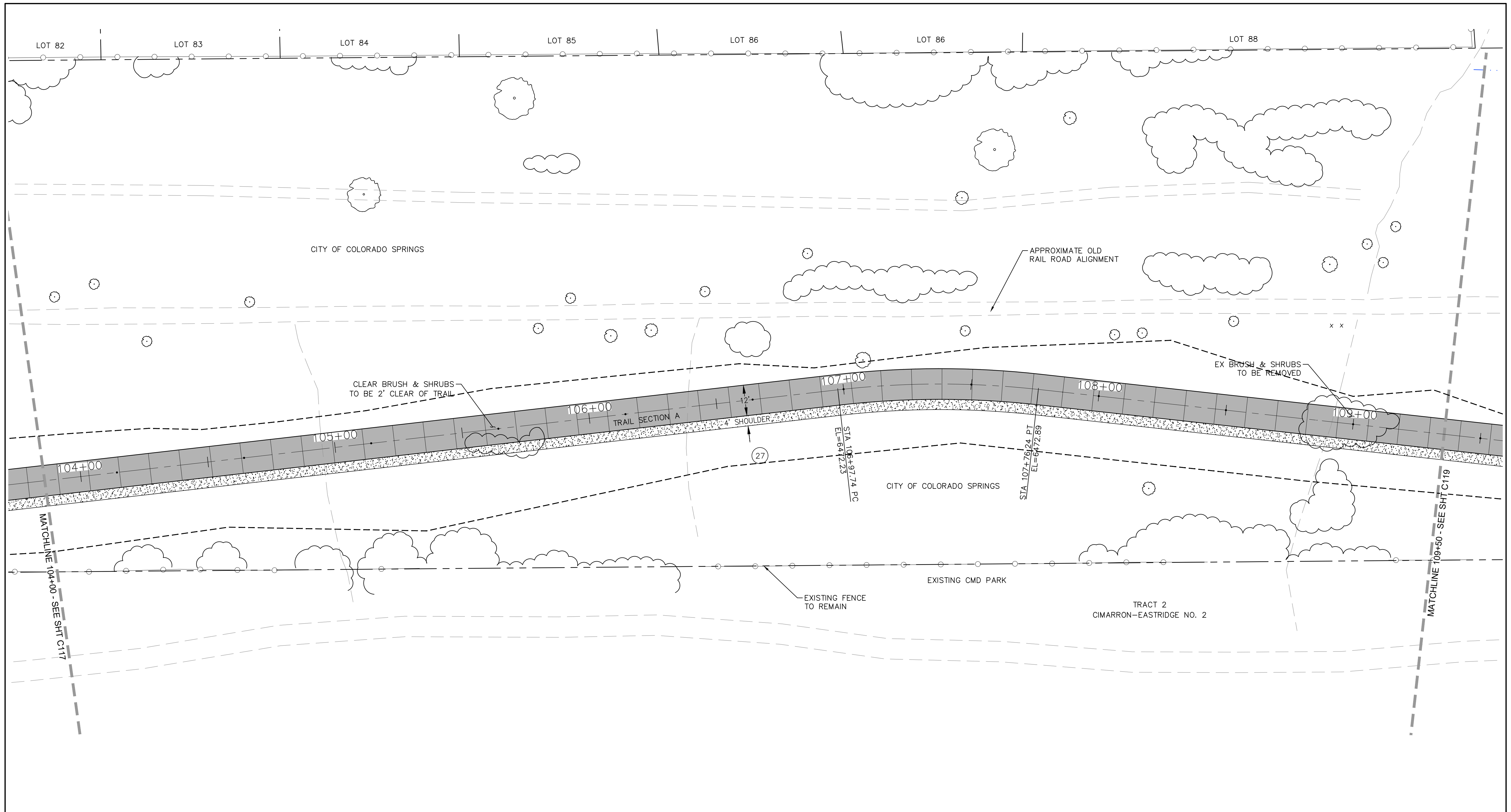



COORDINATES				
PT#	N	E	DESCRIPTION	ELEVATION
156	1377499.57	322012557	PC	6472.05
157	1377576.86	3220138.32	PT	6473.05

CURVE DATA
 (27) R=350.00'
 L=78.50'
 $\Delta=12^{\circ}51'33''$

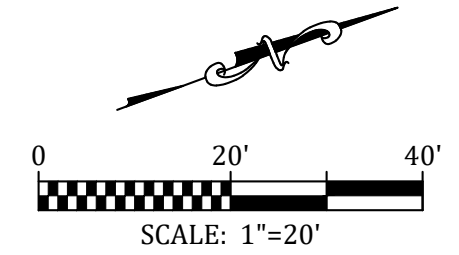
NOTE:
 ALL UTILITIES DEPICTED IN THE PLANS ARE QUALITY LEVEL D.
 UTILITIES IN CONFLICT WITH CONSTRUCTION WILL BE
 POTHOLED AND POSITIVELY IDENTIFIED (QUALITY LEVEL A)
 PRIOR TO EXCAVATION.



 COLORADO SPRINGS	IN PROGRESS NOT FOR CONSTRUCTION	 Celebrating 30 years Kiowa Engineering Corporation 1604 South 21st Street Colorado Springs, Colorado 80904 (719) 630-7342	Sheet Revisions	90% BID SET	ROCK ISLAND TRAIL Sand Creek to Constitution Avenue FINAL TRAIL PLAN STA 104+00 TO STA 109+50	Kiowa Proj. No. 16028 TAP M240-162
			For and on Behalf of Kiowa Engineering Corporation Date	No Revisions: Revised: Void:	Designer: RNW Detailer: RNW Date: 08/06/2024	SubAcct No. 20391 Sheet Number C118

NORTHCREST FILING 4
LOT 3

TRAIL SIGNAGE			
SIGNAGE	#	PANEL SIZE	
1	TRAIL ENDS AHEAD	1	12x18
2	TRAIL USERS CROSS AT CONSTITUTION AVE & PIROS DRIVE	1	12x18

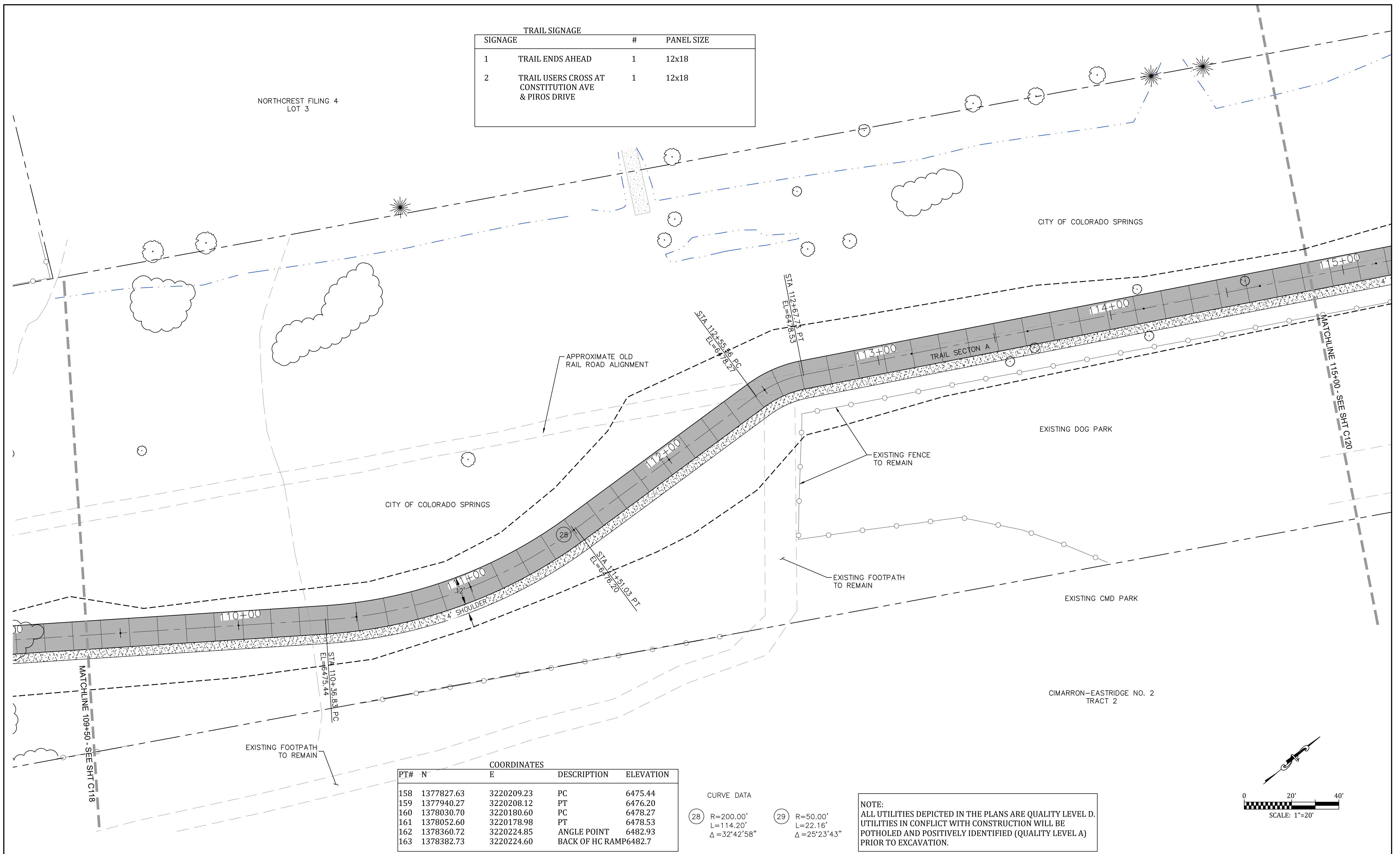

PT#	N	E	DESCRIPTION	ELEVATION
158	1377827.63	3220209.23	PC	6475.44
159	1377940.27	3220208.12	PT	6476.20
160	1378030.70	3220180.60	PC	6478.27
161	1378052.60	3220178.98	PT	6478.53
162	1378360.72	3220224.85	ANGLE POINT	6482.93
163	1378382.73	3220224.60	BACK OF HC RAMP	6482.7

CURVE DATA	
28	R=200.00' L=114.20' Δ=32°42'58"
29	R=50.00' L=22.16' Δ=25°23'43"

NOTE:
ALL UTILITIES DEPICTED IN THE PLANS ARE QUALITY LEVEL D.
UTILITIES IN CONFLICT WITH CONSTRUCTION WILL BE
POTHOLED AND POSITIVELY IDENTIFIED (QUALITY LEVEL A)
PRIOR TO EXCAVATION.

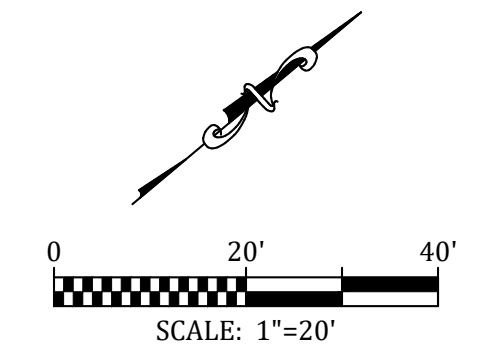

**IN PROGRESS
NOT FOR CONSTRUCTION**

Celebrating 30 years
Kiowa
Engineering Corporation
1604 South 21st Street
Colorado Springs, Colorado 80904
(719) 630-7342

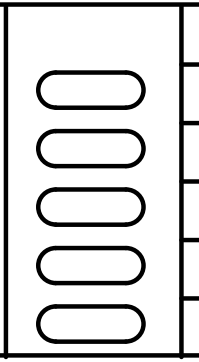

Sheet Revisions

90% BID SET

ROCK ISLAND TRAIL
Sand Creek to Constitution Avenue
FINAL TRAIL PLAN STA 109+50 TO STA 115+00
Designer: RNW
Detailer: RNW
Date: 08/06/2024

Kiowa Proj. No. 16028
TAP M240-162
SubAcct No. 20391
Sheet Number C119

TRAIL SIGNAGE			
SIGNAGE		#	PANEL SIZE
1	TRAIL ENDS AHEAD	1	12x18
2	TRAIL USERS CROSS AT CONSTITUTION AVE & PIROS DRIVE	1	12x18

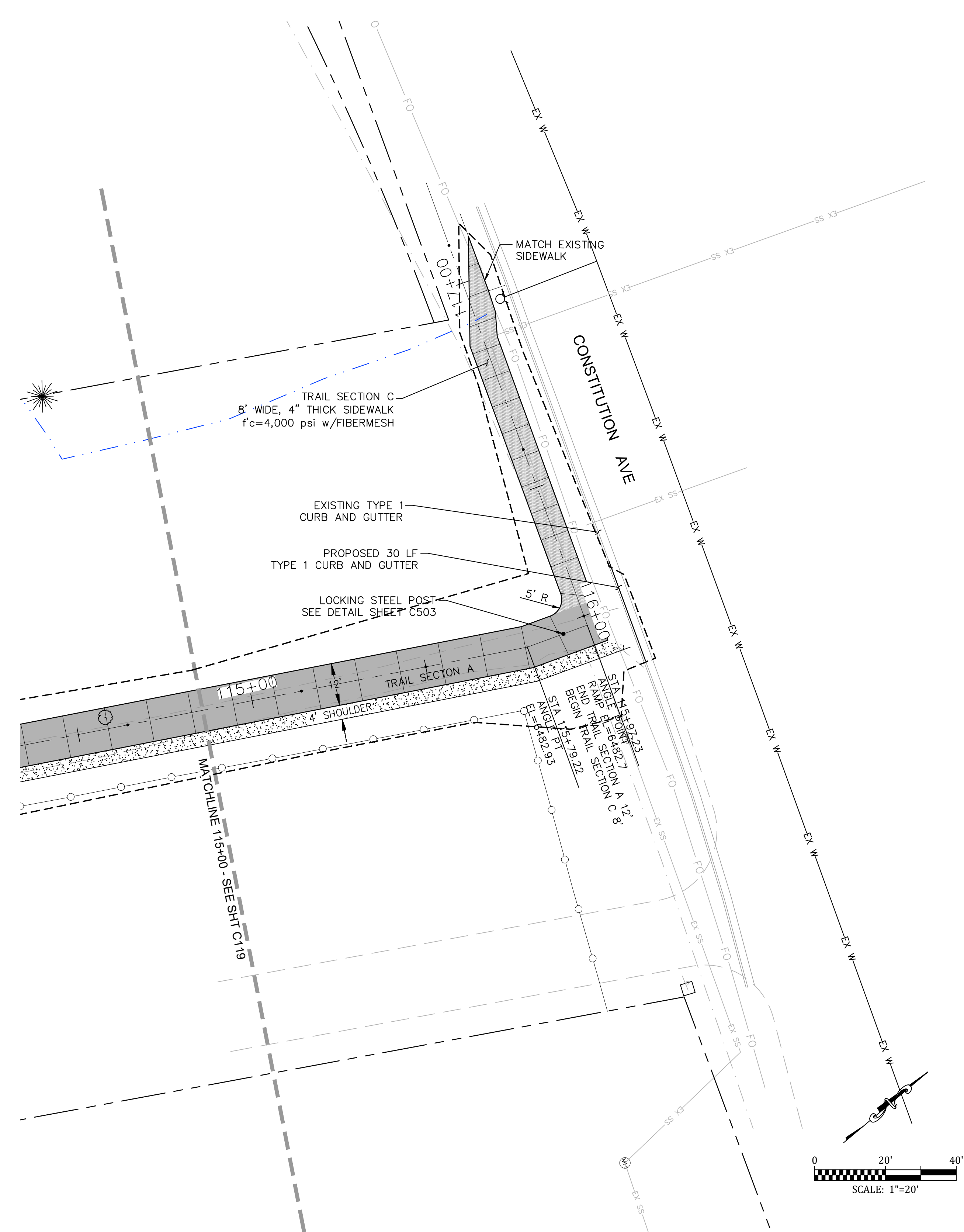

NOTE:
 ALL UTILITIES DEPICTED IN THE PLANS ARE QUALITY LEVEL D.
 UTILITIES IN CONFLICT WITH CONSTRUCTION WILL BE
 POTHOLED AND POSITIVELY IDENTIFIED (QUALITY LEVEL A)
 PRIOR TO EXCAVATION.

PT#	COORDINATES			DESCRIPTION	ELEVATION
	N	E			
158	1377827.63	3220209.23		PC	6475.44
159	1377940.27	3220208.12		PT	6476.20
160	1378030.70	3220180.60		PC	6478.27
161	1378052.60	3220178.98		PT	6478.53
162	1378360.72	3220224.85		ANGLE POINT	6482.93
163	1378382.73	3220224.60		BACK OF HC RAMP6482.7	

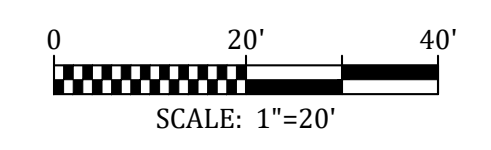

IN PROGRESS
NOT FOR CONSTRUCTION



For and on Behalf of
 Kiowa Engineering Corporation Date

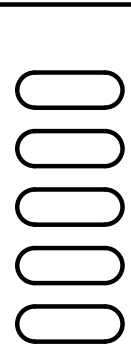

Sheet Revisions

90% BID SET

ROCK ISLAND TRAIL
 Sand Creek to Constitution Avenue
FINAL TRAIL PLAN STA 115+00 TO STA 117+50

Kiowa Proj. No. 16028

Designer: RNW
 Detailer: RNW
 Date: 08/06/2024

TAP M240-162

SubAcct No. 20391

Sheet Number C120

PEDESTRIAN BRIDGE GENERAL INFORMATION

SPECIFICATIONS FOR BRIDGE GIRDER AND DECK UNIT (ITEM 628)

GENERAL

IT IS THE CONTRACTOR'S RESPONSIBILITY TO INSTALL AND ERECT A FULLY ENGINEERED, PREFABRICATED BRIDGE GIRDER AND DECK UNIT. THIS WORK SHALL CONSIST OF ALL LABOR, MATERIALS, AND EQUIPMENT FOR INSTALLATION OF THE SUPERSTRUCTURE AS SHOWN ON THE PLANS. FABRICATION AND DELIVERY OF THE BRIDGE GIRDER AND DECK UNIT SHALL BE FURNISHED BY THE CITY OF COLORADO SPRINGS. FABRICATION AND CONSTRUCTION OF THE BRIDGE AND ITS COMPONENTS SHALL COMPLY WITH ALL APPLICABLE PROVISIONS OF AASHTO STANDARD SPECIFICATIONS FOR HIGHWAY BRIDGES. THE CONTRACTOR IS RESPONSIBLE FOR VERIFYING ALL DIMENSIONS AND ELEVATIONS ON THE PLANS.

GEOMETRY

SPAN LENGTHS, DECK WIDTH AND ELEVATIONS SHALL BE IN ACCORDANCE WITH BRIDGE PLANS.

REQUIREMENTS FOR PEDESTRIAN AND BICYCLE RAILING SHALL BE IN ACCORDANCE WITH THE LATEST EDITION OF AASHTO STANDARD SPECIFICATIONS FOR HIGHWAY BRIDGES.

DESIGN DATA

THE SUPERSTRUCTURE SHALL BE DESIGNED FOR A MINIMUM PEDESTRIAN LOAD OF 90 psf
THE SUPERSTRUCTURE SHALL ALSO BE DESIGNED FOR A VEHICLE LOAD OF 20,000 POUNDS (H10 TRUCK).

OTHER LOADS FOR SUPERSTRUCTURE DESIGN SHALL BE IN ACCORDANCE WITH THE LATEST EDITION OF AASHTO GUIDE SPECIFICATIONS FOR DESIGN OF PEDESTRIAN BRIDGES.

MATERIALS

THE BRIDGE SHALL BE FABRICATED FROM HIGH STRENGTH, SELF-WEATHERING, LOW ALLOY, ATMOSPHERIC CORROSION RESISTANT ASTM A847 COLD-FORMED WELDED SQUARE AND RECTANGULAR TUBING AND ASTM A588, ASTM A606, OR ASTM A 242 PLATE AND STRUCTURAL STEEL SHAPES (fy=50,000 psi). ALL BOLTS SHALL BE ASTM A325 HIGH STRENGTH BOLTS. DECK SHALL BE 6" THICK CDOT CLASS D REINFORCED CONCRETE OVER 20 GAGE GALVANIZED STEEL FORM DECKING. REINFORCING STEEL SHALL BE GRADE 60 STEEL REBAR.

EXPANSION JOINT MATERIAL SHALL MEET AASHTO M-213.

SHOP DRAWINGS

THE CONTRACTOR SHALL SUBMIT SHOP FABRICATION DRAWINGS AND DESIGN CALCULATIONS TO THE CITY OF COLORADO SPRINGS FOR APPROVAL. ALL DRAWINGS AND CALCULATIONS THAT ARE SUBMITTED SHALL BE APPROVED, SIGNED, AND SEALED BY A PROFESSIONAL ENGINEER REGISTRATED IN THE STATE OF COLORADO.

DESIGN DATA







- UNIFORM PEDESTRIAN LOAD = 85 psf
- VEHICLE LOAD = 10,000 lbs (H5 TRUCK)
- REINFORCED CONCRETE CLASS BZ: fc=4,000psi
- ABUTMENT STRUCTURAL STEEL: AASHTO M-183 (ASTM A-36)

BRIDGE DESCRIPTION

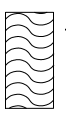
- PRE-FABRICATED SINGLE SPAN PEDESTRIAN BRIDGE
- WITH SELF-WEATHERING STEEL AND WITH CONCRETE DECKING CDOT CLASS D
- LENGTH = 210 FEET (STA 18+87)
- WIDTH = 12 FEET
- RAILING HEIGHT = 54 INCHES (MINIMUM)

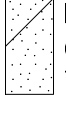
SOILS LEGEND

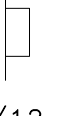
LEGEND

-  TOPSOIL.
-  FILL: POORLY TO WELL-GRADED SAND WITH SILT (SP-SM, SW-SM) WITH OCCASIONAL CLAYEY TO SILTY SAND LAYERS, SLIGHTLY MOIST TO MOIST, TAN TO BROWN. OCCASIONAL ASPHALT DEBRIS IN BORING 4.
-  POORLY TO WELL-GRADED SAND WITH SILT (SP-SM, SW-SM) WITH OCCASIONAL POORLY GRADED SAND (SP) AND SILTY TO CLAYEY LAYERS, MEDIUM DENSE TO VERY DENSE, MOIST TO WET, TAN TO GRAY.
-  CLAYSTONE BEDROCK, VERY HARD, MOIST, DARK GRAY.
-  DRIVE SAMPLE, 2-INCH I.D. CALIFORNIA LINER SAMPLE.
- 25/12 DRIVE SAMPLE BLOW COUNT. INDICATES THAT 25 BLOWS OF A 140-POUND HAMMER FALLING 30 INCHES WERE REQUIRED TO DRIVE THE SAMPLER 12 INCHES.
-  DEPTH TO WATER LEVEL AND NUMBER OF DAYS AFTER DRILLING MEASUREMENT WAS MADE.
-  DEPTH AT WHICH BORING CAVED.

NOTES

- THE EXPLORATORY BORINGS WERE DRILLED ON MARCH 17, 2011 WITH A 4-INCH DIAMETER CONTINUOUS FLIGHT POWER AUGER.
- THE LOCATIONS OF THE EXPLORATORY BORINGS WERE MEASURED APPROXIMATELY BY TAPING FROM FEATURES SHOWN ON THE SITE PLAN PROVIDED.
- THE ELEVATIONS OF THE EXPLORATORY BORINGS WERE OBTAINED BY INTERPOLATION BETWEEN CONTOURS ON THE SITE PLAN PROVIDED.
- THE EXPLORATORY BORING LOCATIONS AND ELEVATIONS SHOULD BE CONSIDERED ACCURATE ONLY TO THE DEGREE IMPLIED BY THE METHOD USED.
- THE LINES BETWEEN MATERIALS SHOWN ON THE EXPLORATORY BORING LOGS REPRESENT THE APPROXIMATE BOUNDARIES BETWEEN MATERIAL TYPES AND THE TRANSITIONS MAY BE GRADUAL.
- GROUND WATER LEVELS SHOWN ON THE LOGS WERE MEASURED AT THE TIME AND UNDER CONDITIONS INDICATED. FLUCTUATIONS IN THE WATER LEVEL MAY OCCUR WITH TIME.
- LABORATORY TEST RESULTS:
WC = WATER CONTENT (%) (ASTM D 2216);
DD = DRY DENSITY (pcf) (ASTM D 2216);
+4 = PERCENTAGE RETAINED ON NO. 4 SIEVE (ASTM D 422);
-200 = PERCENTAGE PASSING NO. 200 SIEVE (ASTM D 1140);
LL = LIQUID LIMIT (ASTM D 4318);
PI = PLASTICITY INDEX (ASTM D 4318);
NP = NON-PLASTIC (ASTM D 4318);
WSS = WATER SOLUBLE SULFATES (%) (AASHTO T 290).

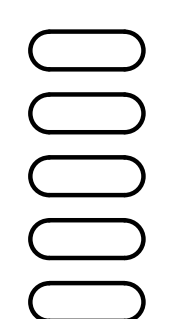

Sheet Revisions

90% BID SET

No Revisions:

Revised:

Void:

ROCK ISLAND TRAIL Sand Creek to Constitution Avenue Pedestrian Bridge General Information	
Designer:	RNW
Detailer:	RNW
Date:	08/06/2024

Kiowa Proj. No. 16028

TAP M240-162

SubAcct No. 20391

Sheet Number C200

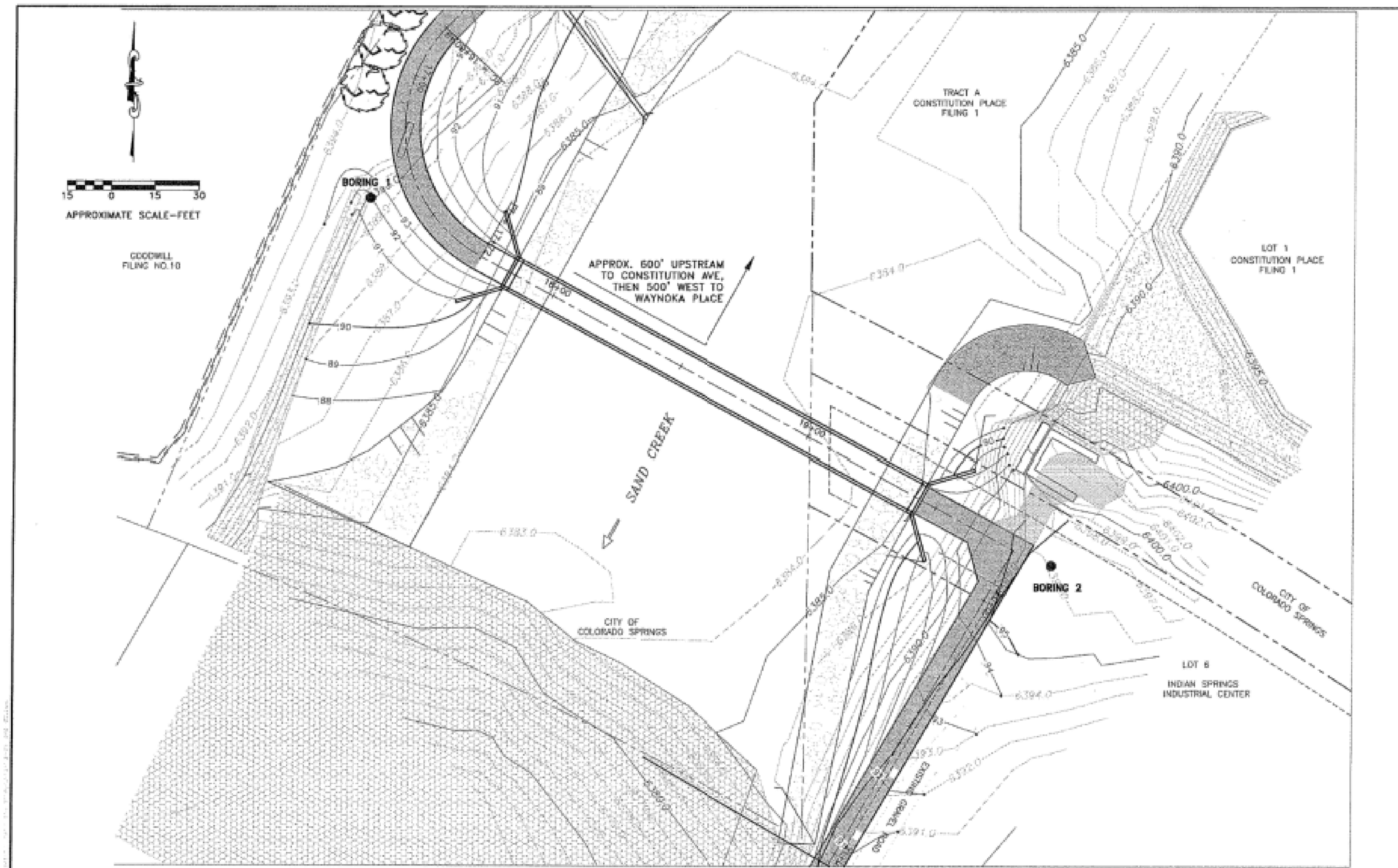

11-2-116 Kumar & Associates CHICAGO ROCK ISLAND BRIDGE LOCATION OF EXPLORATORY BORINGS Fig. 1

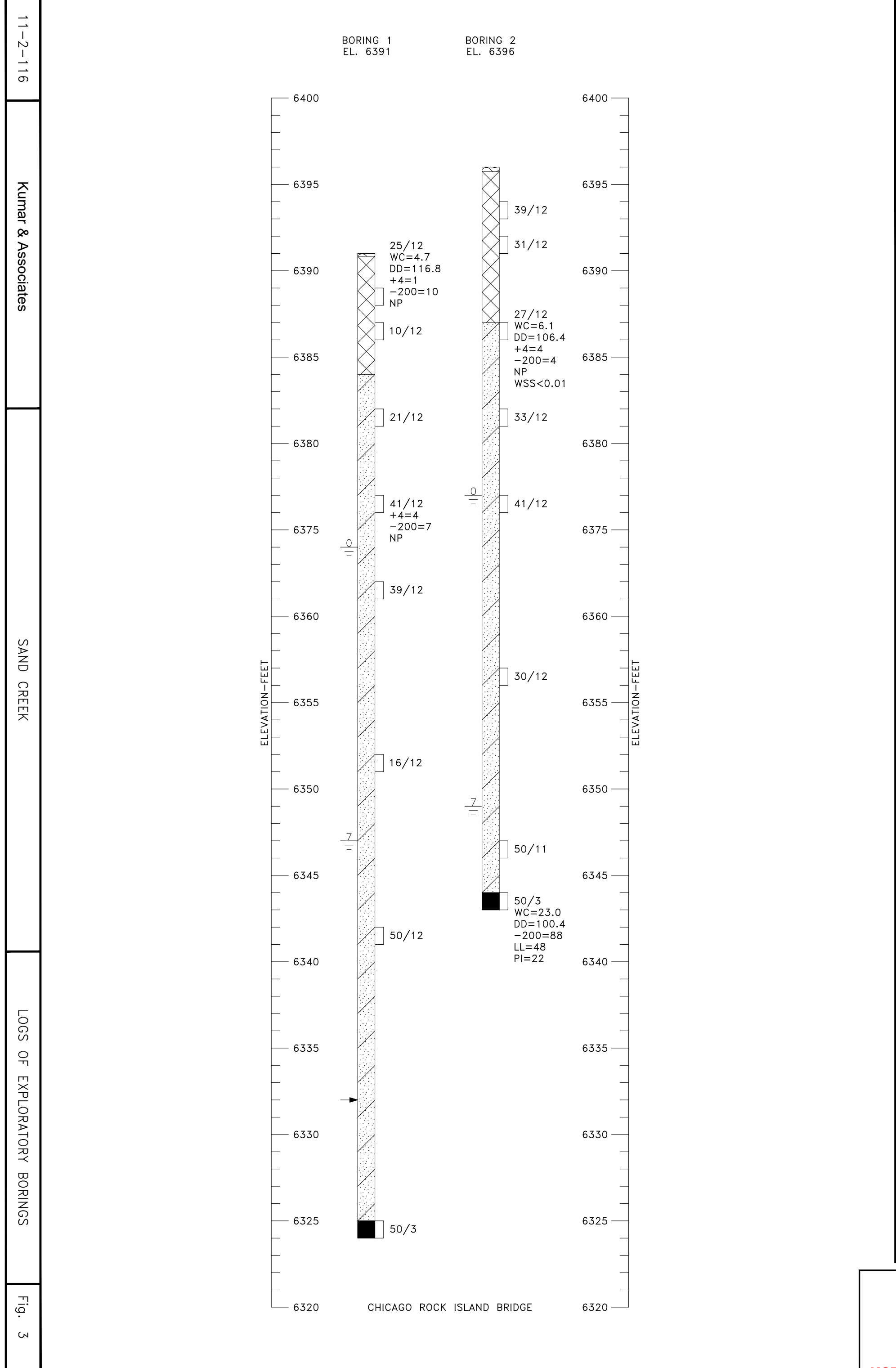

11-2-116 Kumar & Associates SAND CREEK LOGS OF EXPLORATORY BORINGS Fig. 3

SOILS BORINGS
FOR BORING LEGEND SEE SHEET C200

IN PROGRESS
NOT FOR CONSTRUCTION

For and on Behalf of
Kiowa Engineering Corporation Date



<input type="checkbox"/> <input type="checkbox"/> <input type="checkbox"/> <input type="checkbox"/>	Sheet Revisions	90% BID SET	ROCK ISLAND TRAIL Sand Creek to Constitution Avenue Pedestrian Bridge Boring Log		Kiowa Proj. No. 16028
		No Revisions:	Designer: RNW		TAP M240-162
		Revised:	Detailer: RNW		SubAcct No. 20391
		Void:	Date: 08/06/2024		Sheet Number C201

RECURRENCE INTERVAL IN YEARS

SOURCE: FINAL AS-BUILT
HYDROLOGY SAND CREEK
DETENTION BASIN NO. 1
PREPARED BY KIOWA ENGINEERING

CHANNEL DESCRIPTION

BOTTOM MATERIAL - COHESIVE NON-COHESIVE
 BOTTOM MATERIAL SIZE - CLAY SILT SAND
 GRAVEL COBBLES OTHER
 STREAM FORM - STRAIGHT MEANDERING BRAIDED
 MANNINGS 'n' FOR DESIGN - CHANNEL .03 OVERBANK .04
 DEBRIS - BRUSH TREES/LOGS ICE OTHER

COMPARISON OF HYDRAULICS (100-YEAR)

	VELOCITY	FREEBOARD	MAX. BACKWATER
HEATHERCREST BRIDGE			
① EXISTING	7.1 fps	4.0± ft	0.0 ft
② PROPOSED	7.1 fps	4.0± ft(1)	0.0 ft
CHICAGO ROCK ISLAND BRIDGE			
① EXISTING	6.2 fps	3.2 ft	0.0 ft
② PROPOSED	6.5 fps	2.5 ft(1)	0.0 ft

COMMENTS

(1) DISTANCE TO LOW STEEL OF BRIDGE

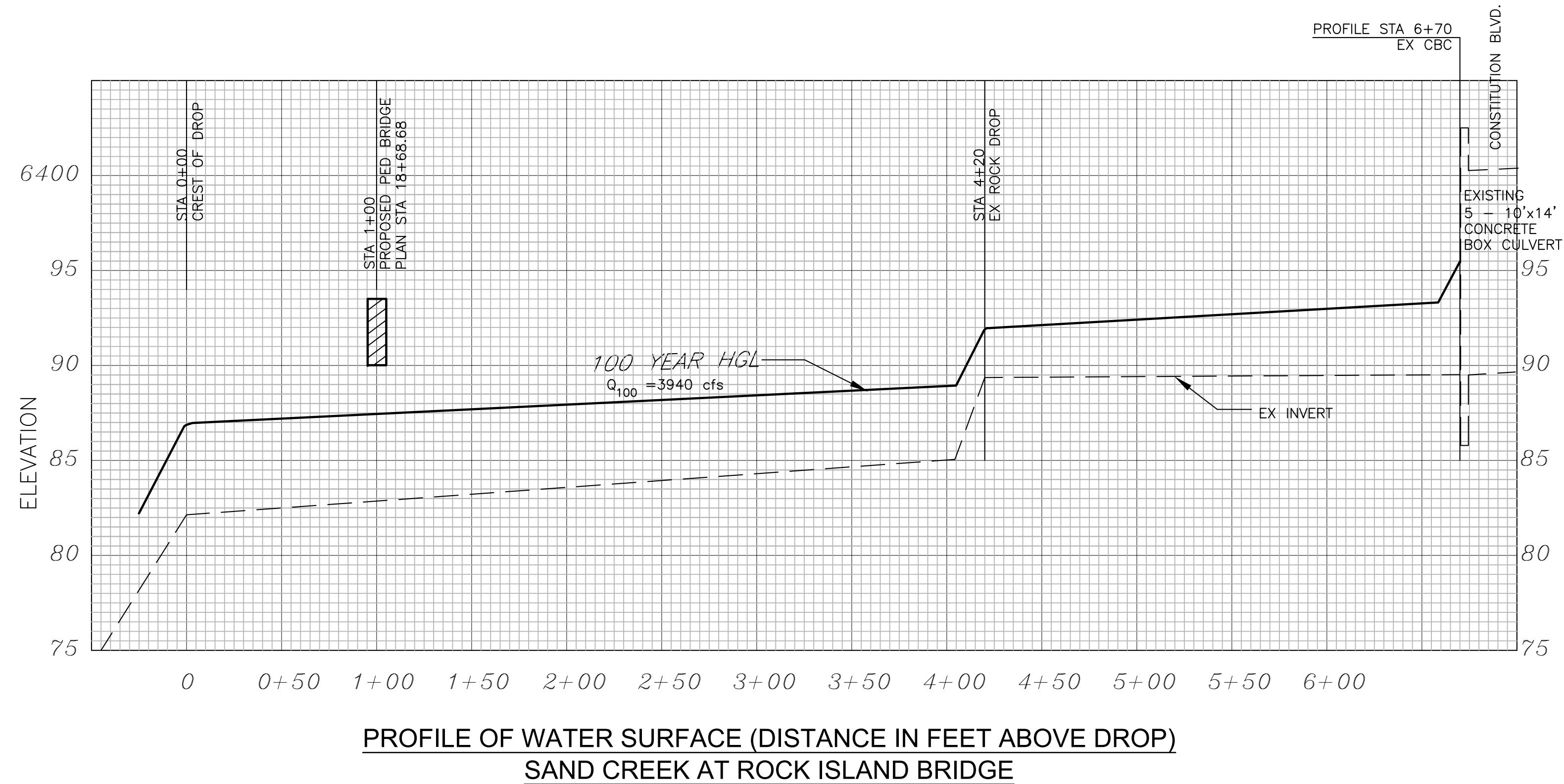
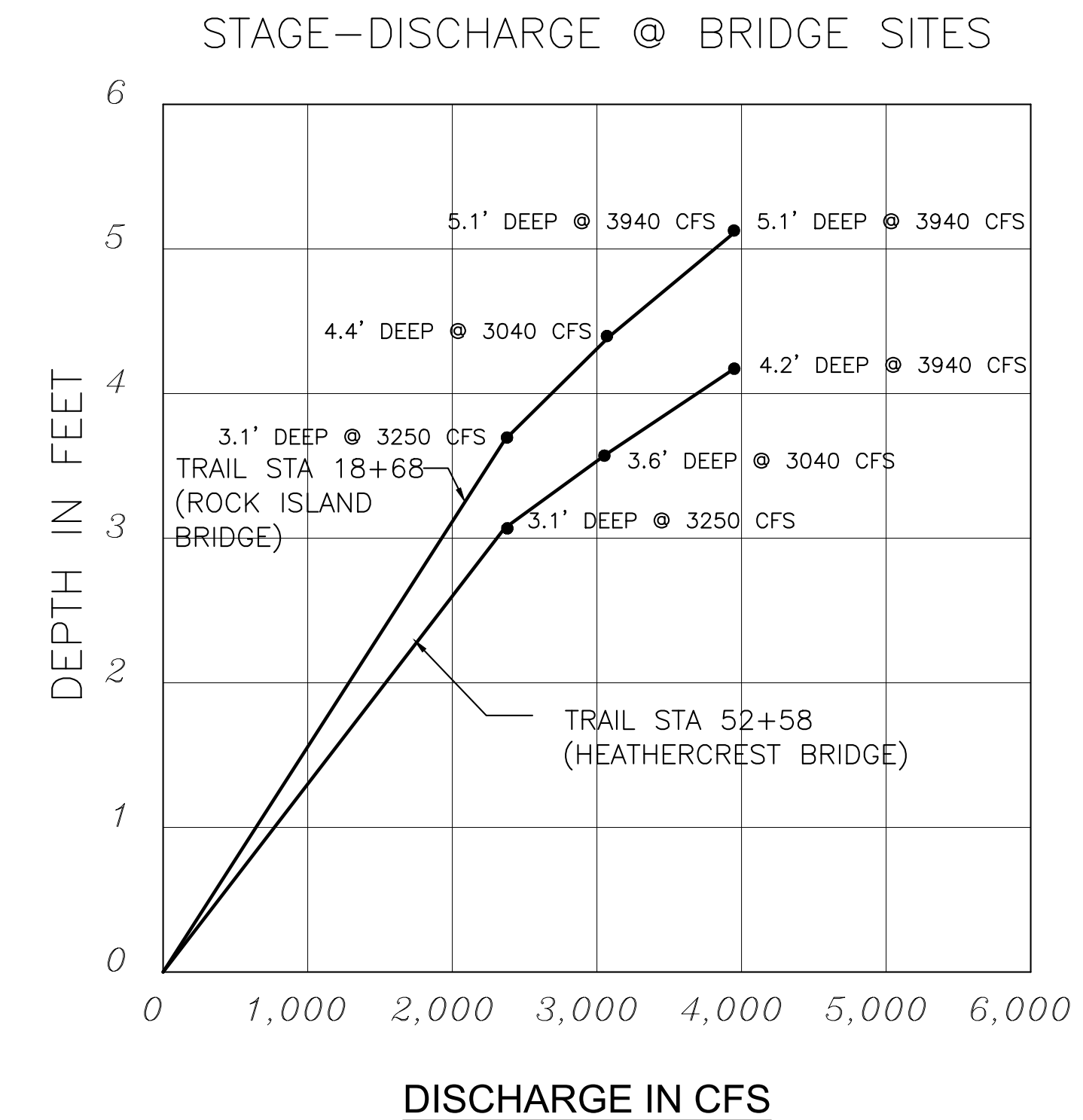
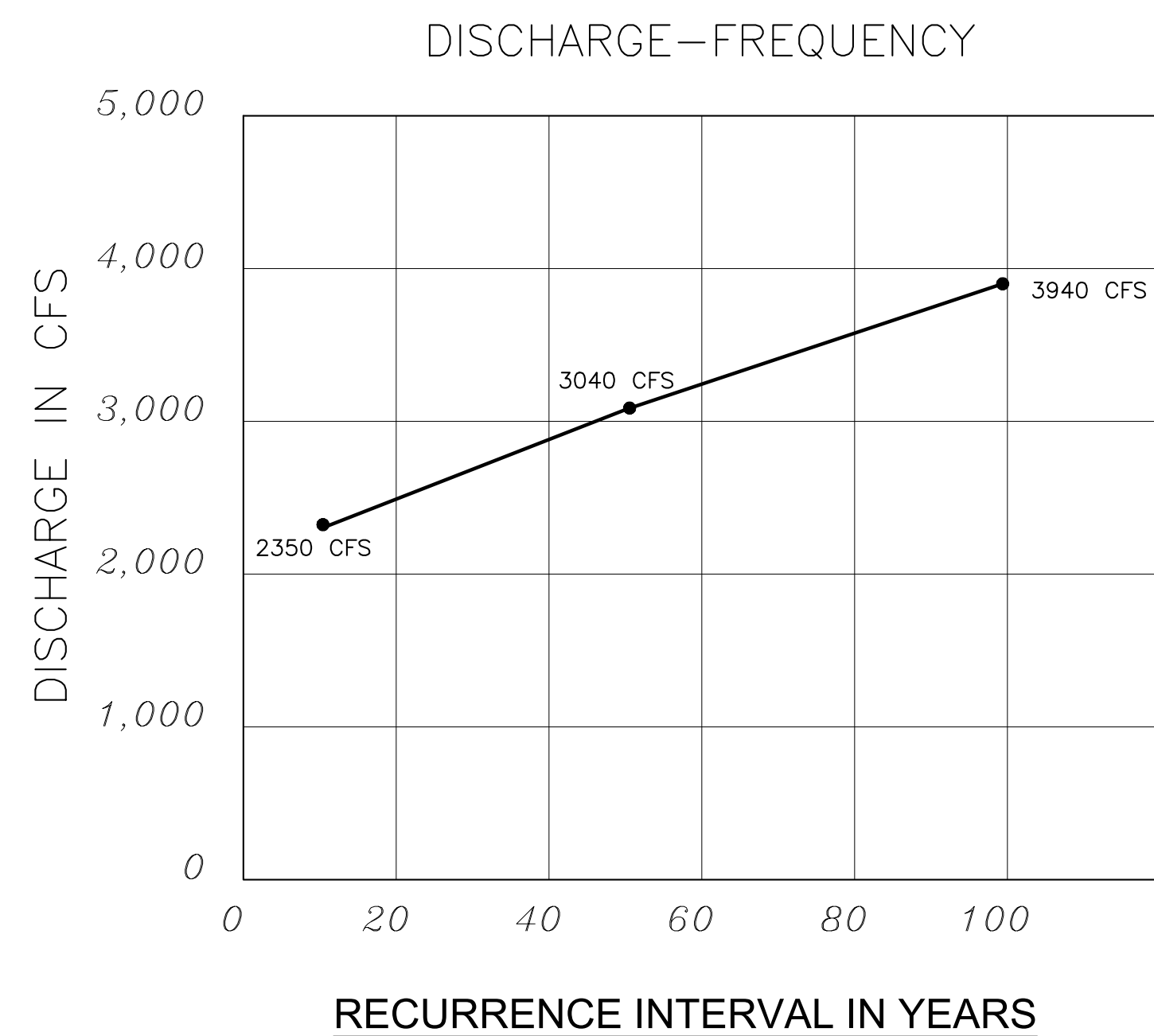

IN PROGRESS
NOT FOR CONSTRUCTION

For and on Behalf of
Kiowa Engineering Corporation Date



Sheet Revisions 0000 0000 0000 0000	90% BID SET	ROCK ISLAND TRAIL Sand Creek to Constitution Avenue Pedestrian Bridge Hydraulics		Kiowa Proj. No. 16028
	No Revisions:	Designer: RNW		TAP M240-162
	Revised:	Detailer: RNW		SubAcct No. 20391
	Void:	Date: 08/06/2024		Sheet Number C202

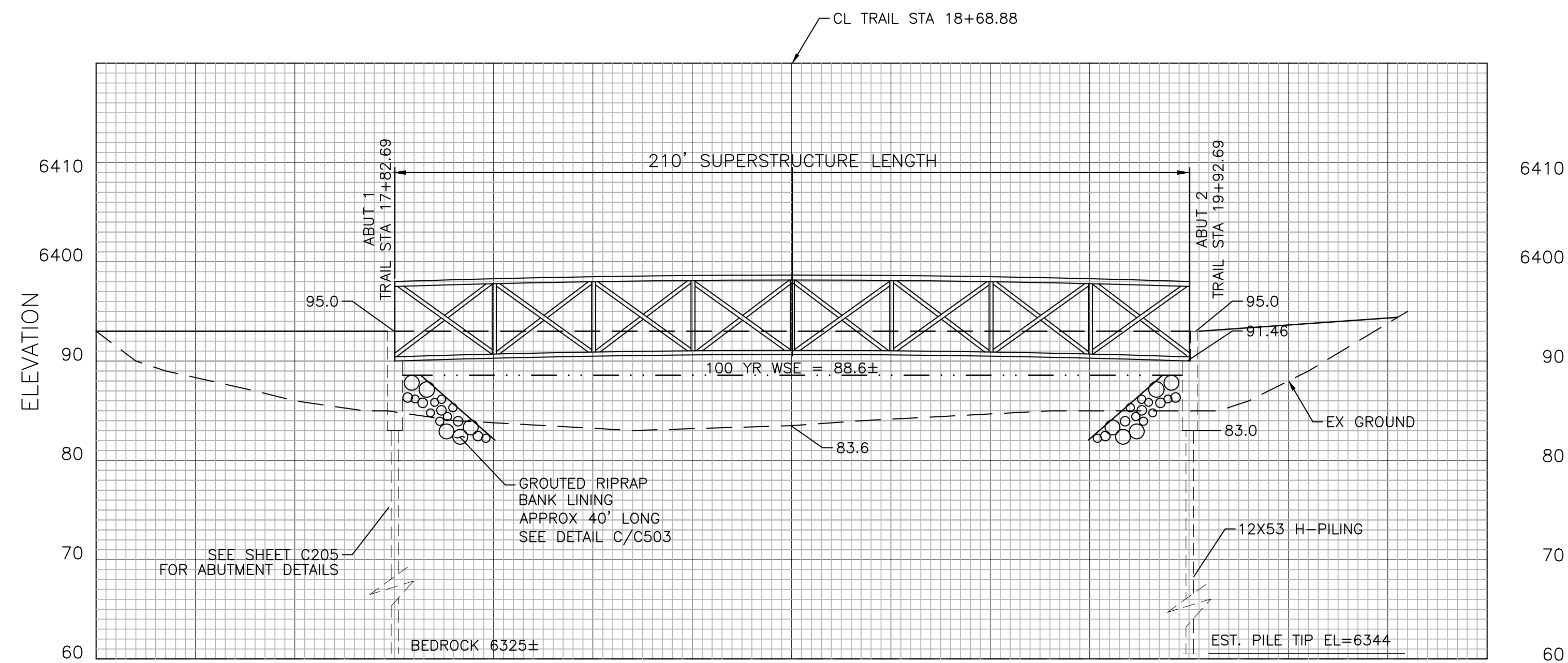

CHICAGO, ROCK ISLAND & PACIFIC PEDESTRIAN BRIDGE
LONGITUDINAL SECTION LOOKING NORTHEAST
 SCALE: 1" = 20' (H) & 1" = 10' (V)

PAY ITEM 628 SHALL INCLUDE THE INSTALLATION OF THE BRIDGE GIRDER, DECK UNIT, BEARING PLATES AND BEARING PADS. FABRICATION AND DELIVERY OF THE BRIDGE, DECK UNIT, BEARING PLATE AND BEARING PADS SHALL BE PROVIDED BY THE CITY OF COLORADO SPRINGS.

IN PROGRESS
 NOT FOR CONSTRUCTION

For and on Behalf of
 Kiowa Engineering Corporation Date

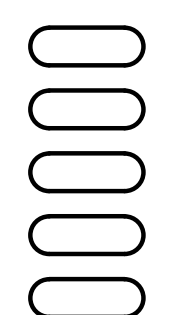

Sheet Revisions

90% BID SET

No Revisions:

Revised:

Void:

ROCK ISLAND TRAIL
 Sand Creek to Constitution Avenue
 Pedestrian Bridge Section

Designer: RNW

Detailer: RNW

Date: 08/06/2024

Kiowa Proj. No. 16028

TAP M240-162

SubAcct No. 20391

Sheet Number C204

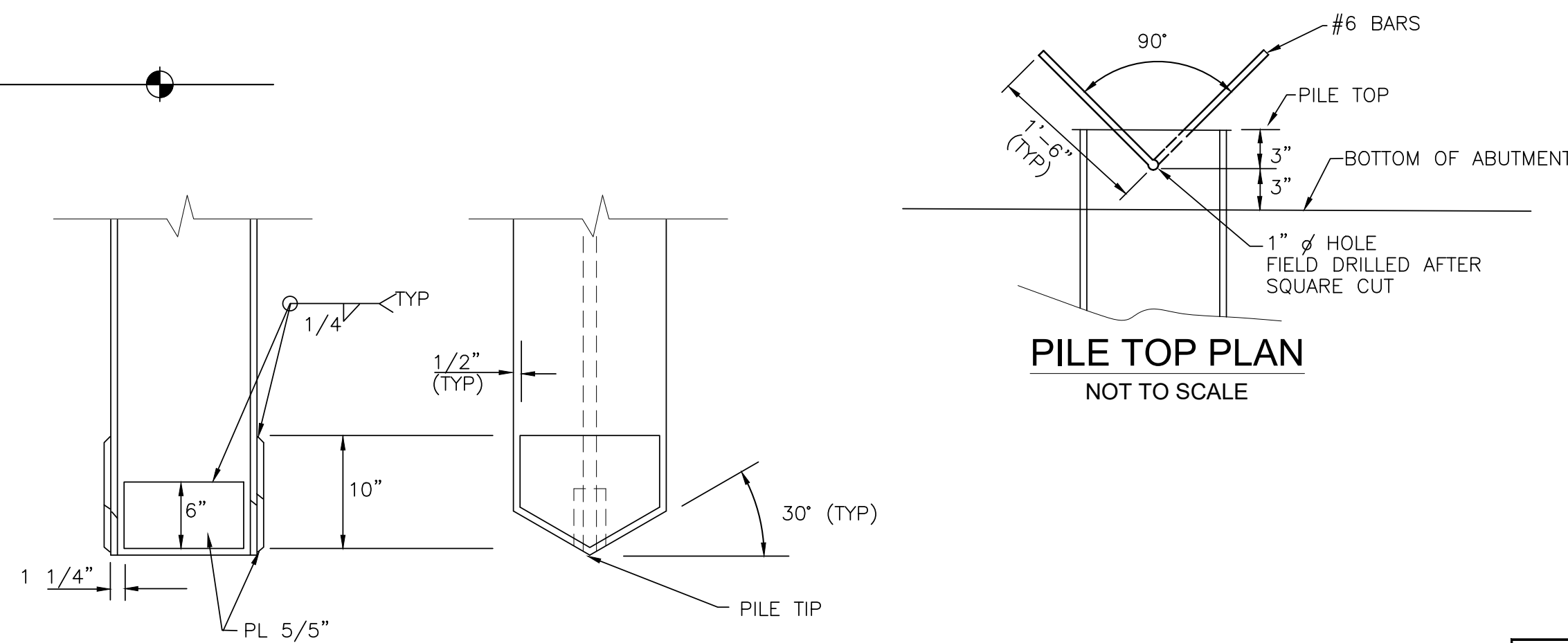
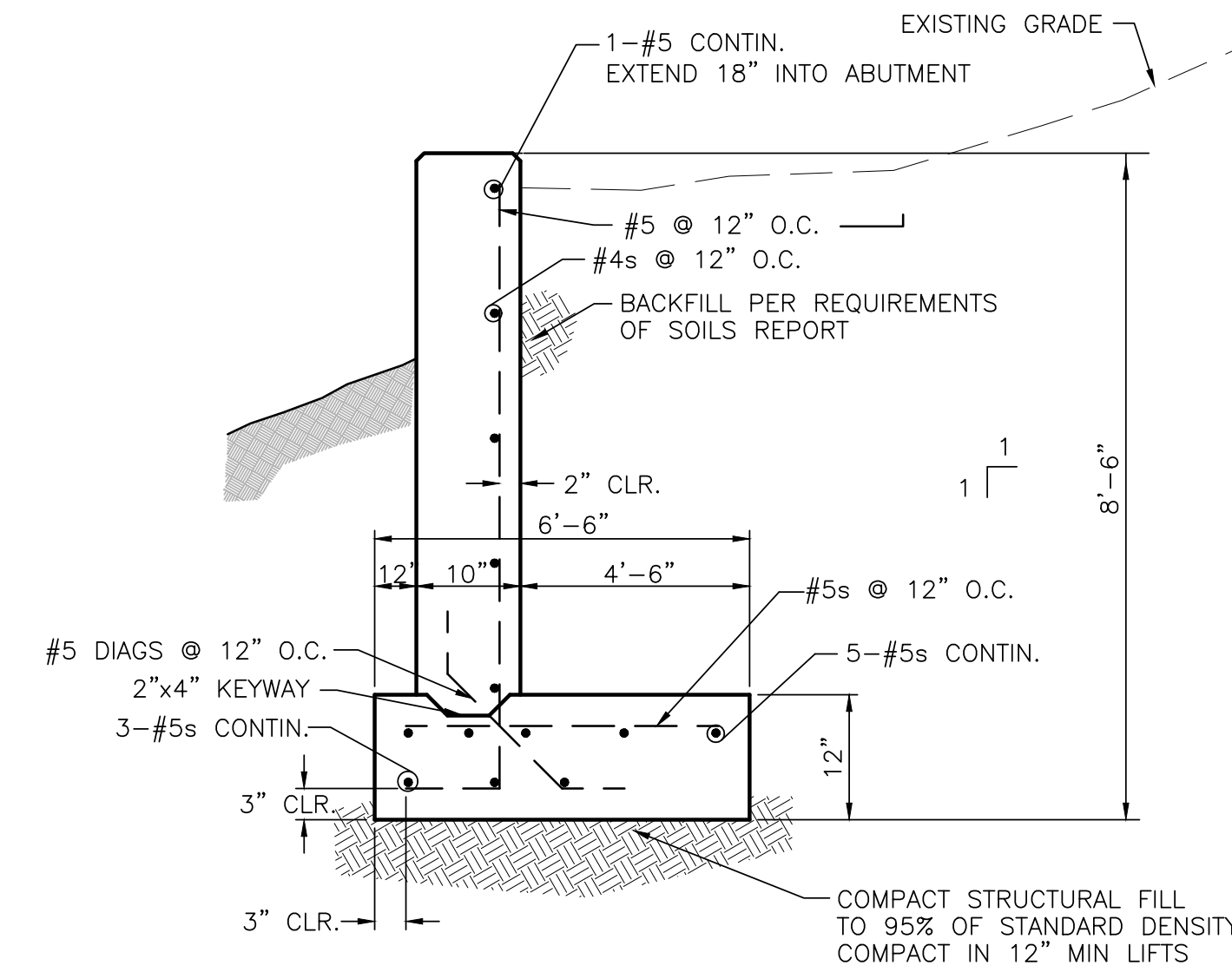
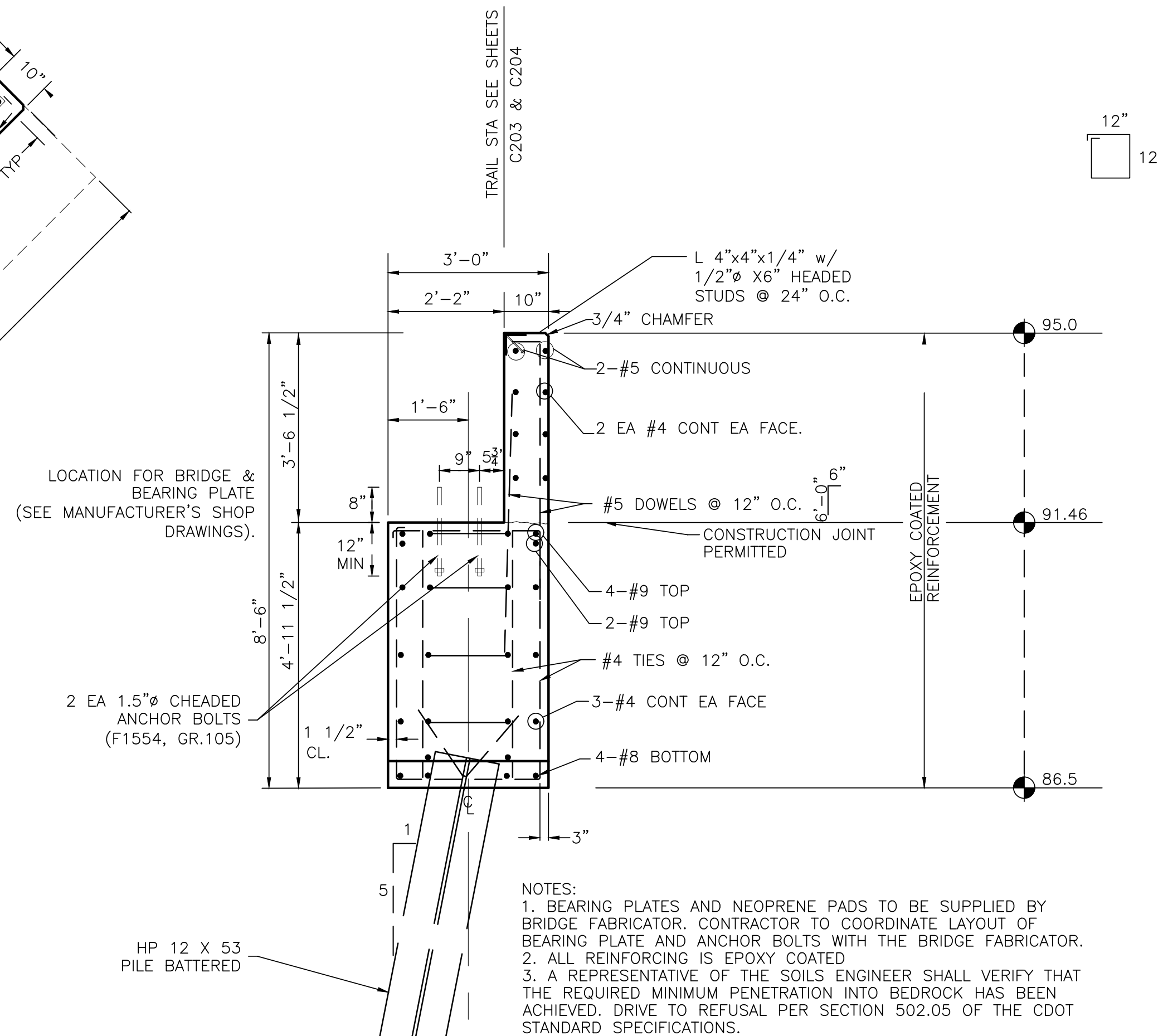
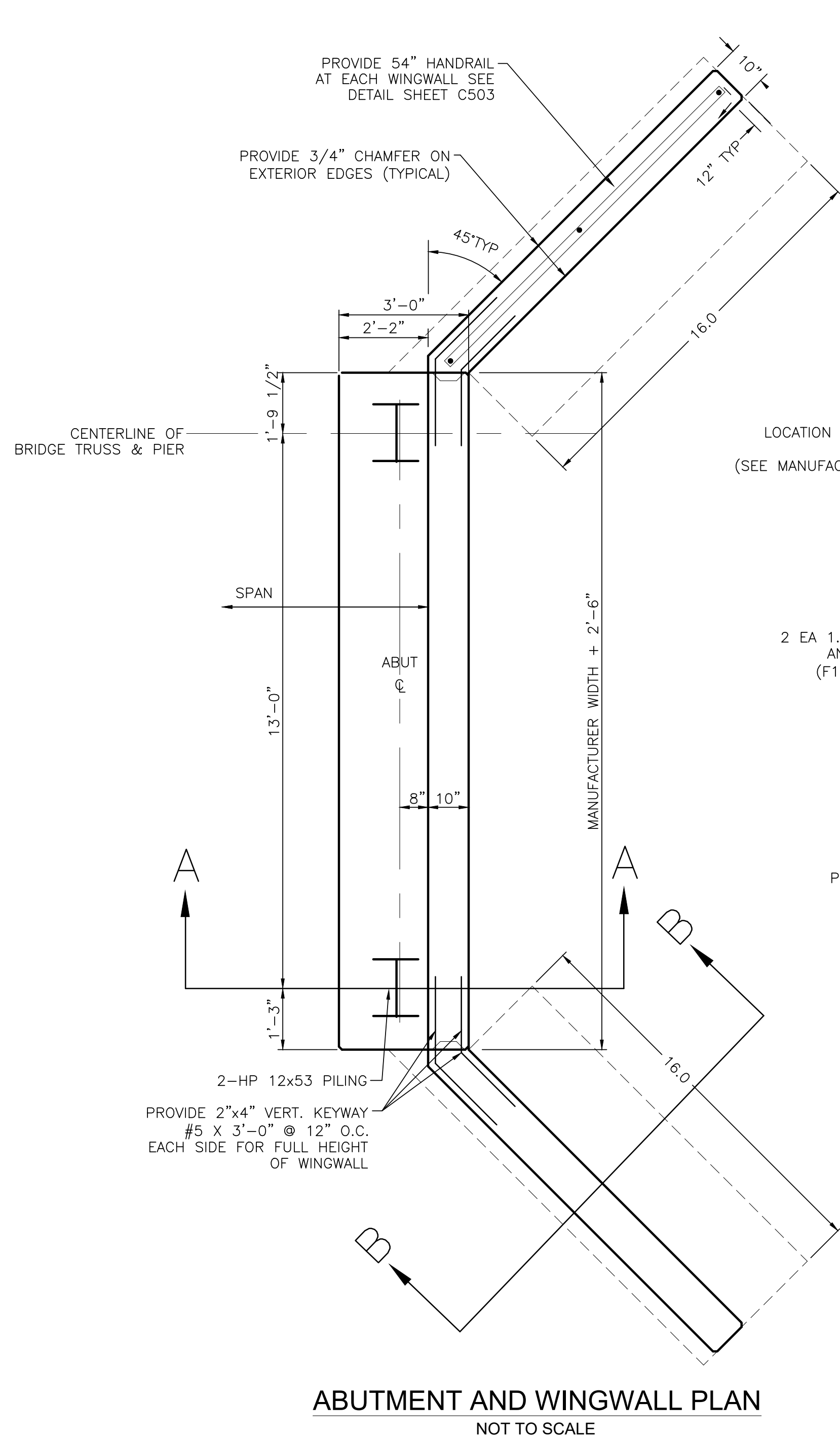

IN PROGRESS
NOT FOR CONSTRUCTION

For and on Behalf of
Kiowa Engineering Corporation Date



Sheet Revisions		90% BID SET	ROCK ISLAND TRAIL Sand Creek to Constitution Avenue Pedestrian Bridge Abutment Details		Kiowa Proj. No. 16028
○		No Revisions:	Designer: RNW		TAP M240-162
○		Revised:	Detailer: RNW		SubAcct No. 20391
○		Void:	Date: 08/06/2024		Sheet Number C205

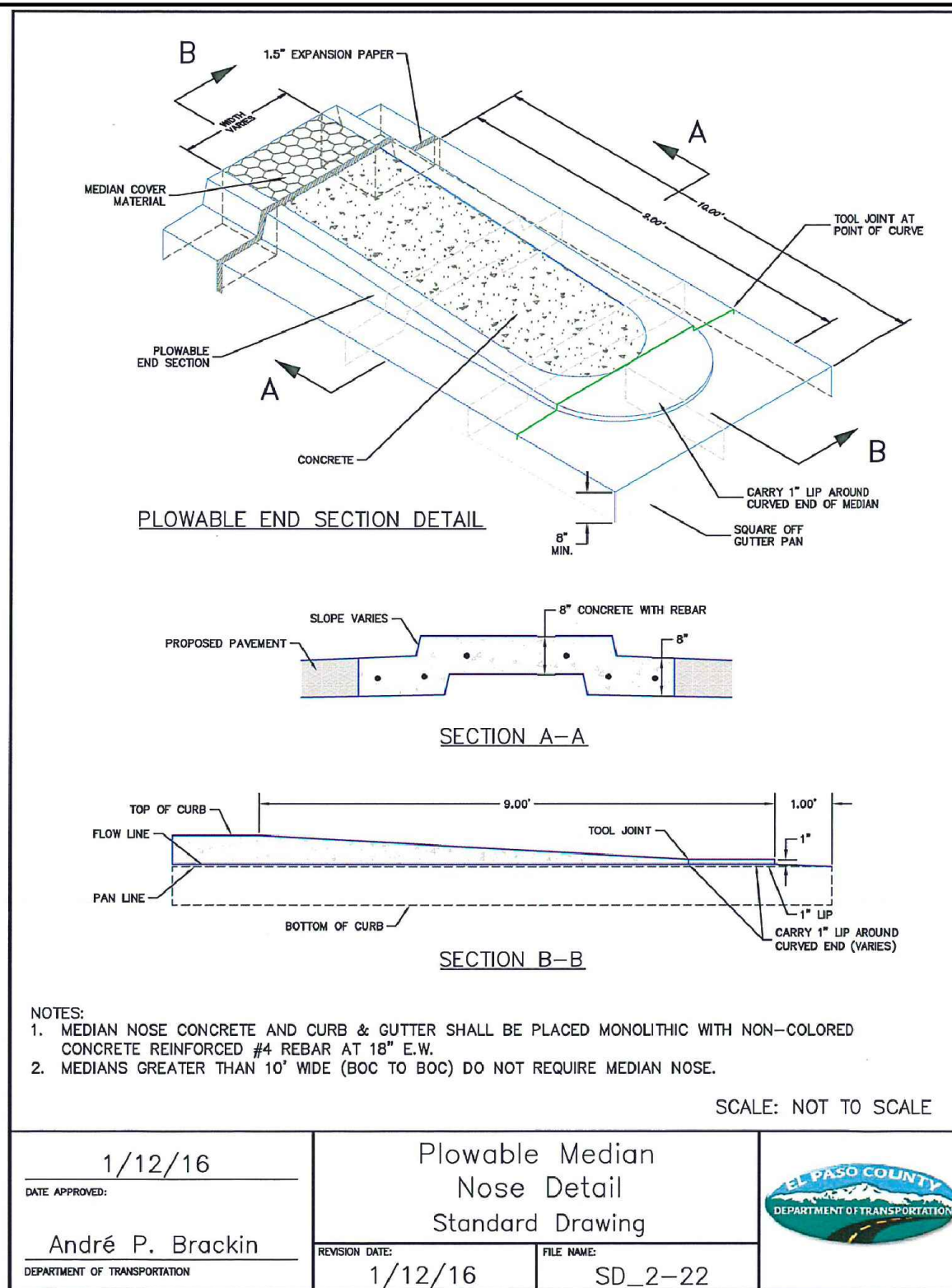

MEDIAN DETAIL

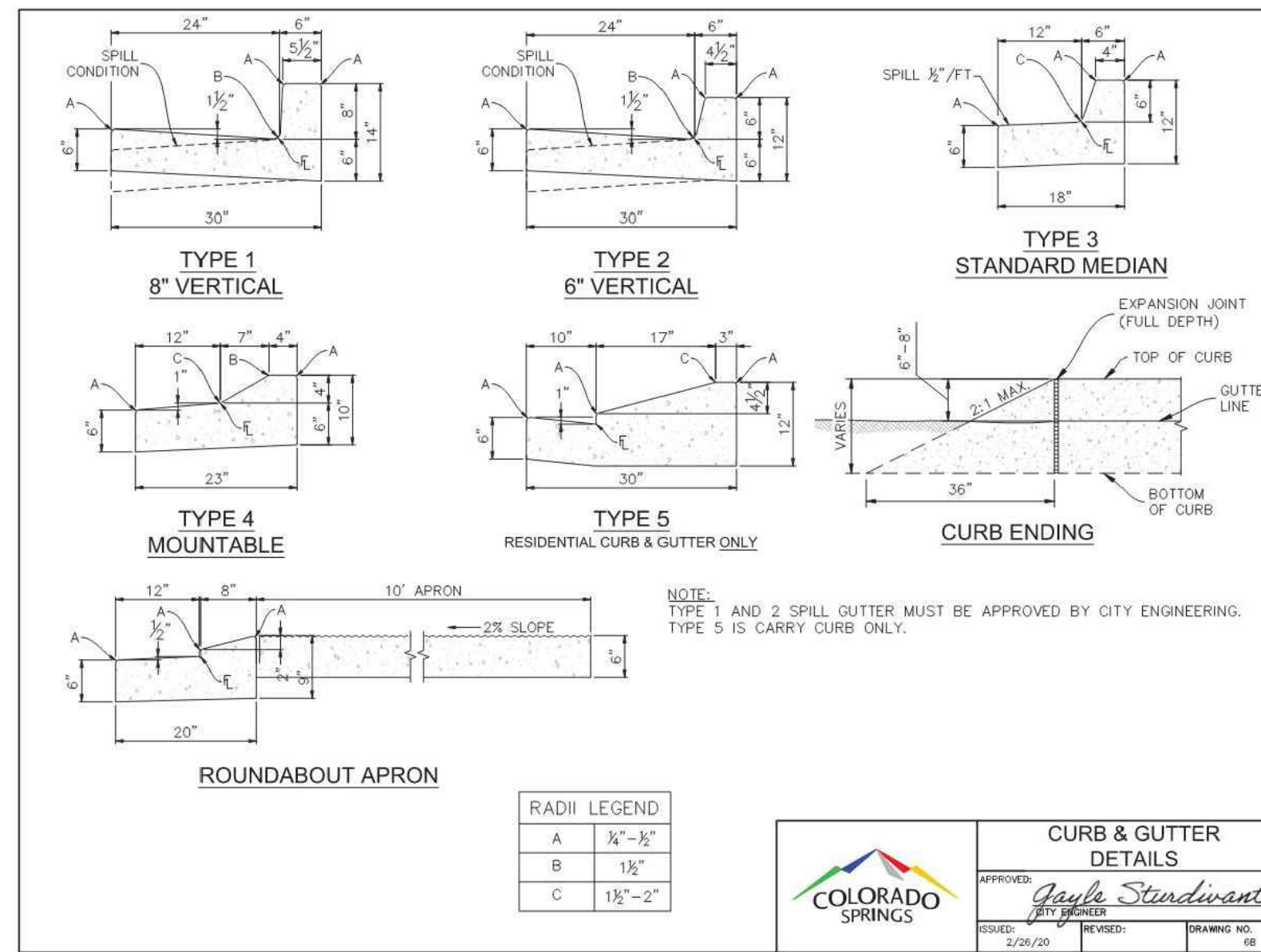

STANDARD CURB AND GUTTER

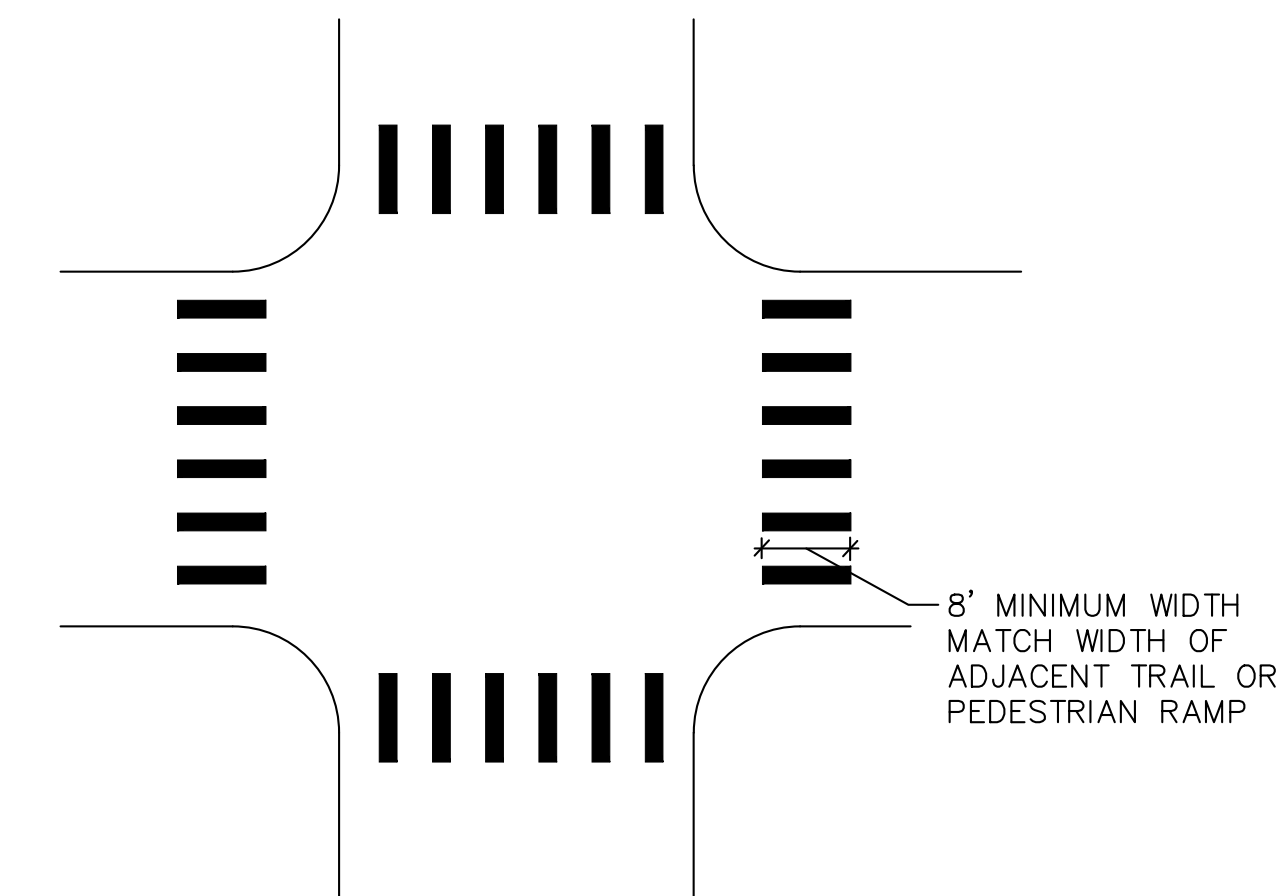

CROSSWALK MARKING DETAIL

NOT TO SCALE

NOTES:
CENTER CROSSWALK MARKINGS ON PEDESTRIAN RAMPS.
CROSSWALK MARKINGS SHALL BE 24" WIDE AND SPACED 12" TO 24" APART.
MARKINGS SHALL BE MADE WITH EPOXY PAINT.
REFER TO CDOT STANDARD S-627-1 FOR LAYOUT OF MARKINGS.

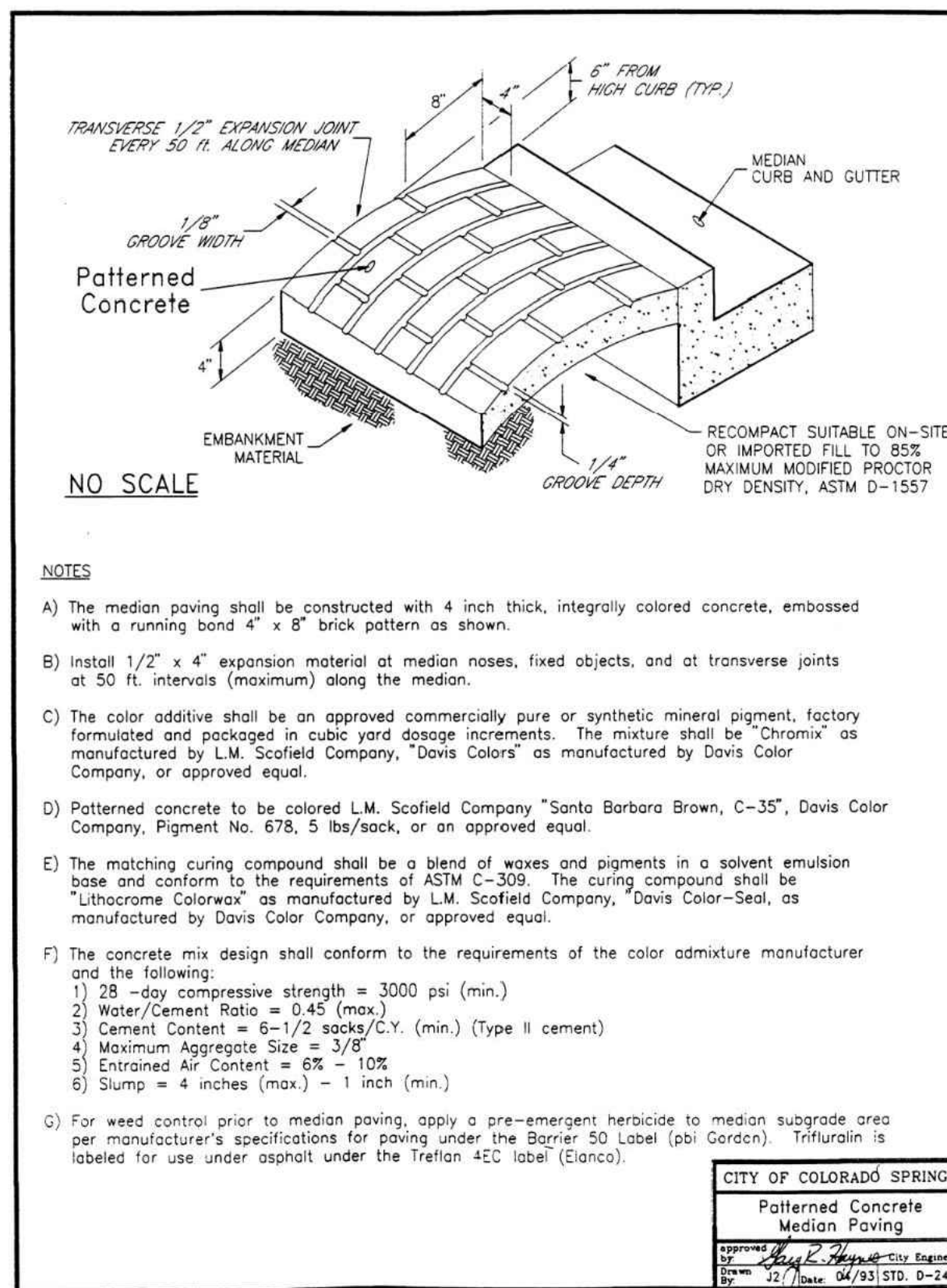

MEDIAN DETAIL

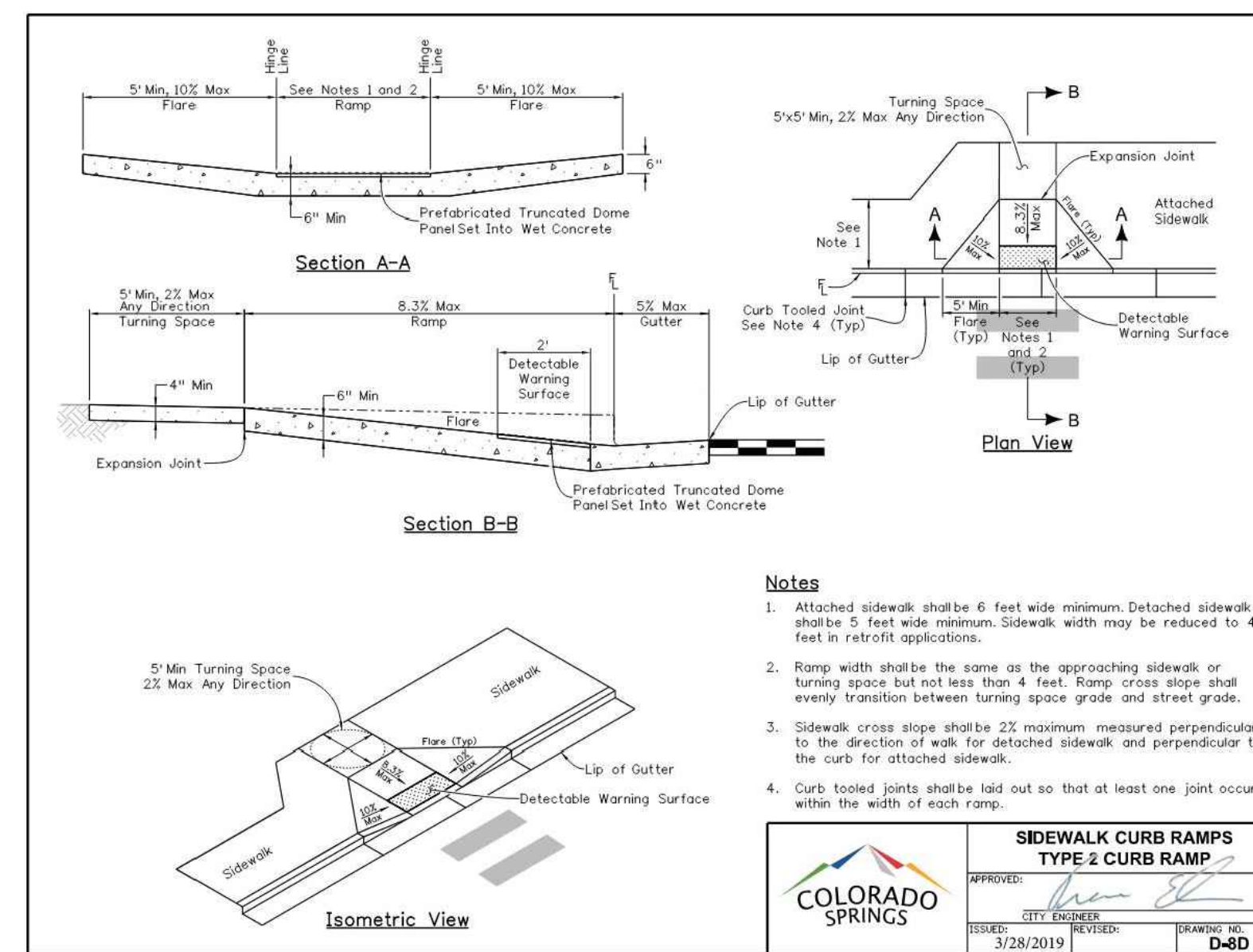

EPC STANDARD RAMP DETAIL



IN PROGRESS
NOT FOR CONSTRUCTION

For and on Behalf of
Kiowa Engineering Corporation Date

Kiowa
Engineering Corporation
1604 South 21st Street
Colorado Springs, Colorado 80904
(719) 630-7342



Sheet Revisions

90% BID SET

No Revisions:

Revised:

Void:

ROCK ISLAND TRAIL
Sand Creek to Constitution Avenue
STANDARD DETAILS

Designer: RNW

Detailer: RNW

Date: 08/06/2024

Kiowa Proj. No. 16028

TAP M240-162

SubAcct No. 20391

Sheet Number C501

SOIL RIPRAP

THE SOIL MATERIAL SHALL BE NATIVE OR TOPSOIL AND MIXED WITH SIXTY FIVE PERCENT (65%) RIPRAP AND THIRTY FIVE PERCENT (35%) SOIL BY VOLUME.
 SOIL RIPRAP SHALL CONSIST OF A UNIFORM MIXTURE OF SOIL AND RIPRAP WITHOUT VOIDS.
 CONTRACTOR SHALL COOPERATE WITH ENGINEER IN OBTAINING AND PROVIDING SAMPLES OF ALL SPECIFIED MATERIALS.
 CONTRACTOR SHALL SUBMIT CERTIFIED LABORATORY TEST CERTIFICATES FOR ALL ITEMS REQUIRED FOR SOIL RIPRAP.
 RIPRAP USED SHALL BE THE TYPE DESIGNATED ON THE DRAWINGS AND SHALL CONFORM TO TABLE SHOWN TO THE RIGHT.
 THE RIPRAP DESIGNATION AND TOTAL THICKNESS OF RIPRAP SHALL BE AS SHOWN ON THE DRAWINGS. THE MAXIMUM STONE SIZE SHALL NOT LARGER THAN THE THICKNESS OF THE RIPRAP.
 NEITHER WIDTH NOR THICKNESS OF A SINGLE STONE OF RIPRAP SHALL BE LESS THAN ONE-THIRD (1/3) OF ITS LENGTH.
 THE SPECIFIC GRAVITY OF THE RIPRAP SHALL BE TWO AND ONE-HALF (2.5) OR GREATER.
 MINIMUM DENSITY FOR ACCEPTABLE RIPRAP SHALL BE ONE HUNDRED AND SIXTY FIVE (165) POUNDS PER CUBIC FOOT.
 RIPRAP SPECIFIC GRAVITY SHALL BE ACCORDING TO THE BULK-SATURATED, SURFACE-DRY BASIS, IN ACCORDANCE WITH AASHTO T85.
 THE RIPRAP SHALL HAVE A PERCENTAGE LOSS OF NOT MORE THAN FORTY PERCENT (40%) AFTER FIVE HUNDRED (500) REVOLUTIONS WHEN TESTED IN ACCORDANCE WITH AASHTO T96.
 THE RIPRAP SHALL HAVE A PERCENTAGE LOSS OF NOT MORE THAN TEN (10%) AFTER FIVE (5) CYCLES WHEN TESTED IN ACCORDANCE WITH AASHTO T104 FOR LEDGE ROCK USING SODIUM SULFATE.
 THE RIPRAP SHALL HAVE A PERCENTAGE LOSS OF NOT MORE THAN TEN PERCENT (10%) AFTER TWELVE (12) CYCLES OF FREEZING AND THAWING WHEN TESTED IN ACCORDANCE WITH AASHTO T103 FOR LEDGE ROCK, PROCEDURE A. ROCK SHALL BE FREE FROM CALCITE INTRUSIONS.
 RUBBLE FOR USE AS SOIL/RIPRAP SHALL BE GRADED TO MEET THE EQUIVALENT ROCK RIPRAP GRADATION. RUBBLE PROPOSED FOR USE IN PLACE OF ROCK RIPRAP SHALL BE STOCKPILED FOR OBSERVATION BY THE ENGINEER PRIOR TO THE COMMENCEMENT OF THE WORK
GRADATION:
 A. EACH LOAD OF RIPRAP SHALL BE REASONABLY WELL GRADED FROM THE SMALLEST TO THE LARGEST SIZE SPECIFIED.
 B. STONES SMALLER THAN THE TWO TO TEN PERCENT (2%-10%) SIZE WILL NOT BE PERMITTED IN AN AMOUNT EXCEEDING TEN PERCENT (10%) BY WEIGHT OF EACH LOAD.
 C. CONTROL OF GRADATION SHALL BE BY VISUAL INSPECTION. HOWEVER IN THE EVENT THE ENGINEER DETERMINES THE RIPRAP TO BE UNACCEPTABLE, THE ENGINEER SHALL PICK TWO (2) RANDOM TRUCKLOADS TO BE DUMPED AND CHECKED FOR GRADATION.
 1) MECHANICAL EQUIPMENT AND LABOR NEEDED TO ASSIST IN CHECKING GRADATION SHALL BE PROVIDED BY THE CONTRACTOR AT NO ADDITIONAL COST.
 BROKEN ASPHALT PAVEMENT SHALL NOT BE ACCEPTABLE FOR USE IN THE WORK.
 ROUNDED RIPRAP (RIVER ROCK) IS NOT ACCEPTABLE, UNLESS SPECIFICALLY DESIGNATED ON THE DRAWINGS.

CLASSIFICATION AND GRADATION OF RIPRAP			
RIPRAP DESIGNATION	% SMALLER THAN GIVEN SIZE BY WEIGHT	INTERMEDIATE ROCK DIMENSION (INCHES)	d50* (INCHES)
TYPE VL	70-100	12	6**
	50-70	9	
	35-50	6	
	2-10	2	
TYPE L	70-100	15	9**
	50-70	12	
	35-50	9	
	2-10	3	
TYPE M	70-100	21	12**
	50-70	18	
	35-50	12	
	2-10	4	
TYPE H	100	30	18
	50-70	24	
	35-50	18	
	2-10	6	
TYPE VH	100	42	24
	50-70	33	
	35-50	24	
	2-10	9	

* d50=MEAN PARTICLE SIZE (INTERMEDIATE DIMENSION) BY WEIGHT.
 ** MIX VL, L AND M RIPRAP WITH 35% TOPSOIL (BY VOLUME) AND BURY WITH 4-6 INCHES OF TOPSOIL, ALL VIBRATION COMPACTED & REVEGETATE.
 (TABLE MD-7: CLASSIFICATION AND GRADATION OF ORDINARY RIPRAP. UDFCD, DRAINAGE CRITERIA MANUAL, VOL. 1)

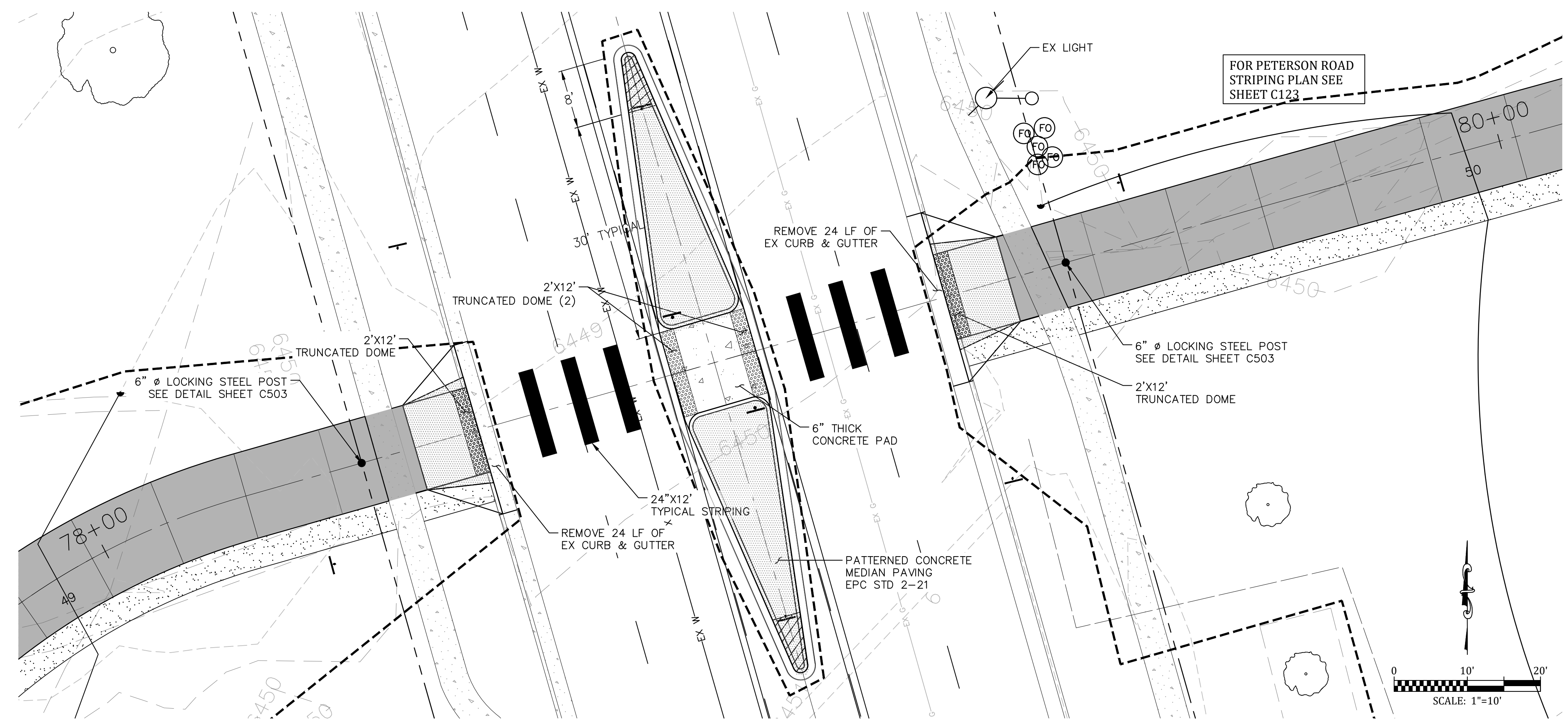
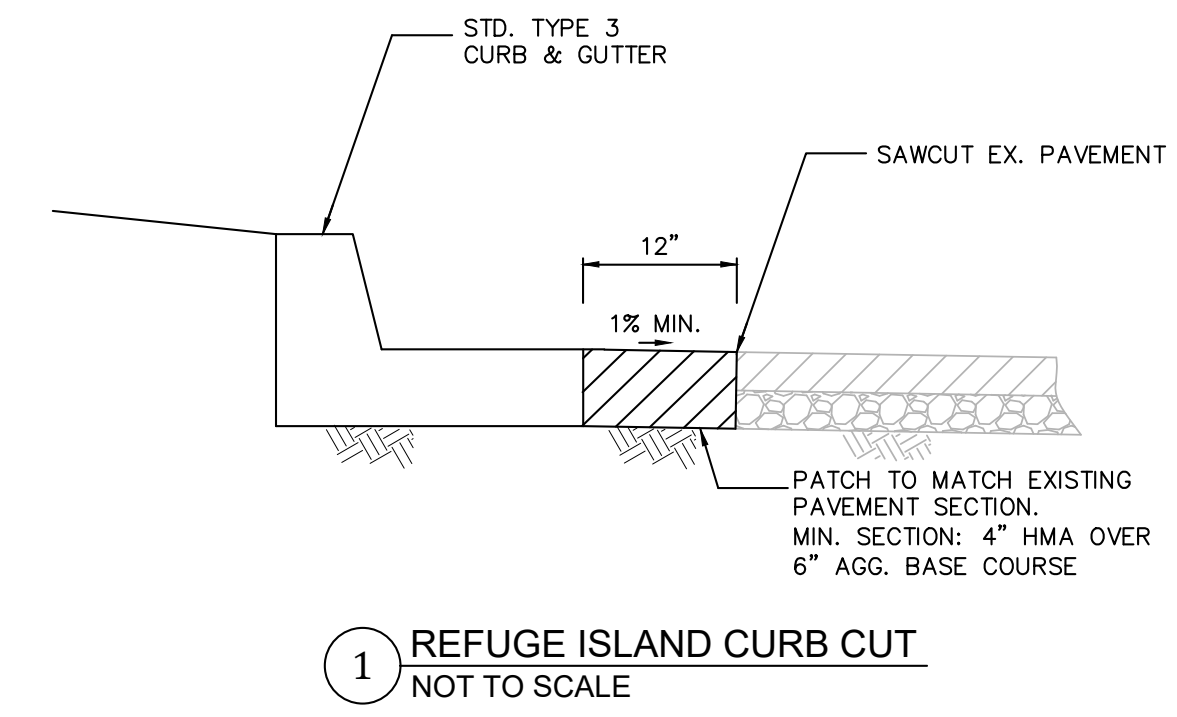

IN PROGRESS
NOT FOR CONSTRUCTION



Sheet Revisions	90% BID SET
	No Revisions:
	Revised:
	Void:

ROCK ISLAND TRAIL
 Sand Creek to Constitution Avenue
TYPICAL MISCELLANEOUS DETAILS
 Designer: RNW
 Detailer: RNW
 Date: 08/06/2024

Kiowa Proj. No. 16028
 TAP M240-162
 SubAcct No. 20391
 Sheet Number C502

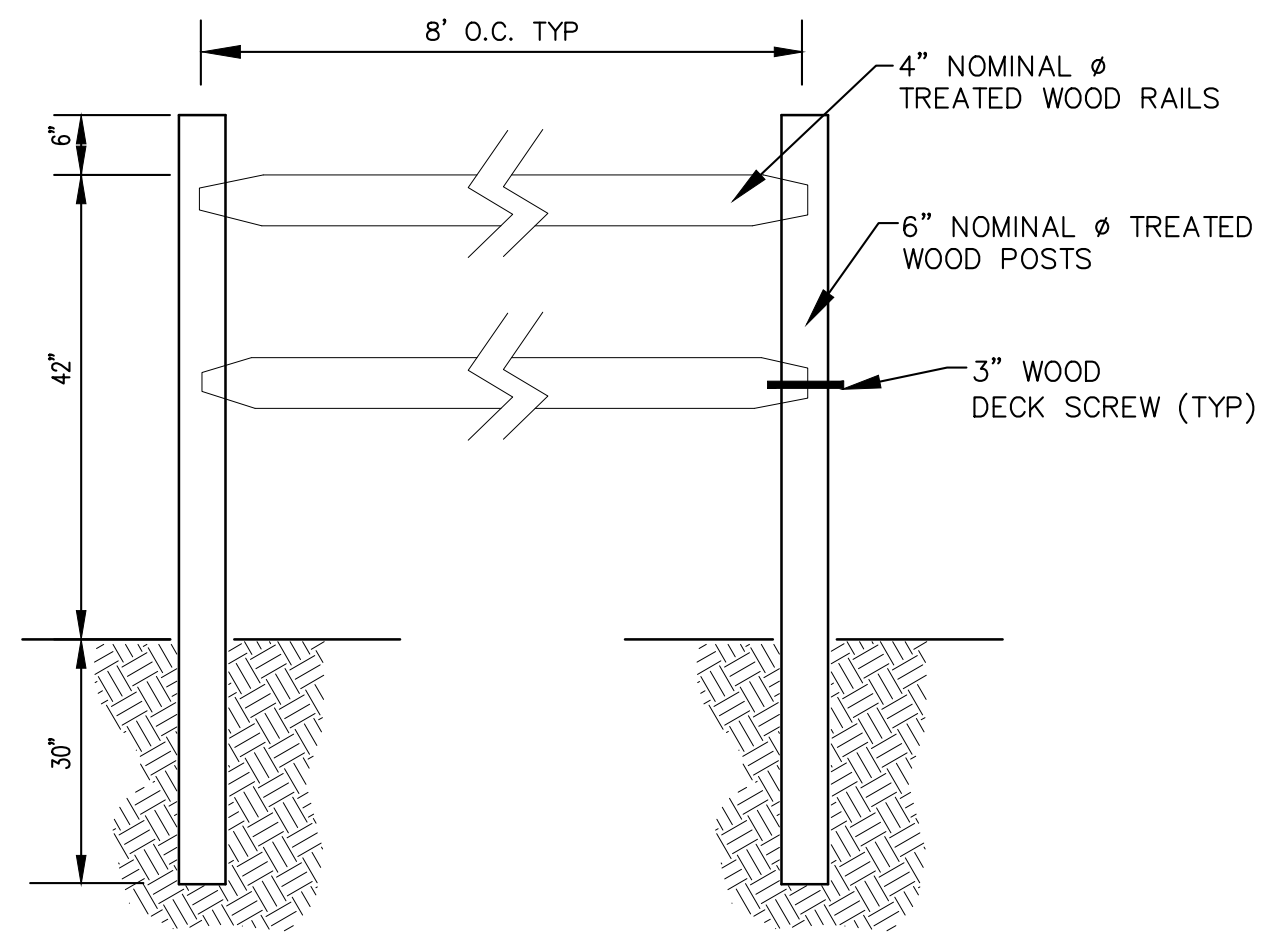

A FENCE WOOD SMOOTH DOWEL
C503 NOT TO SCALE

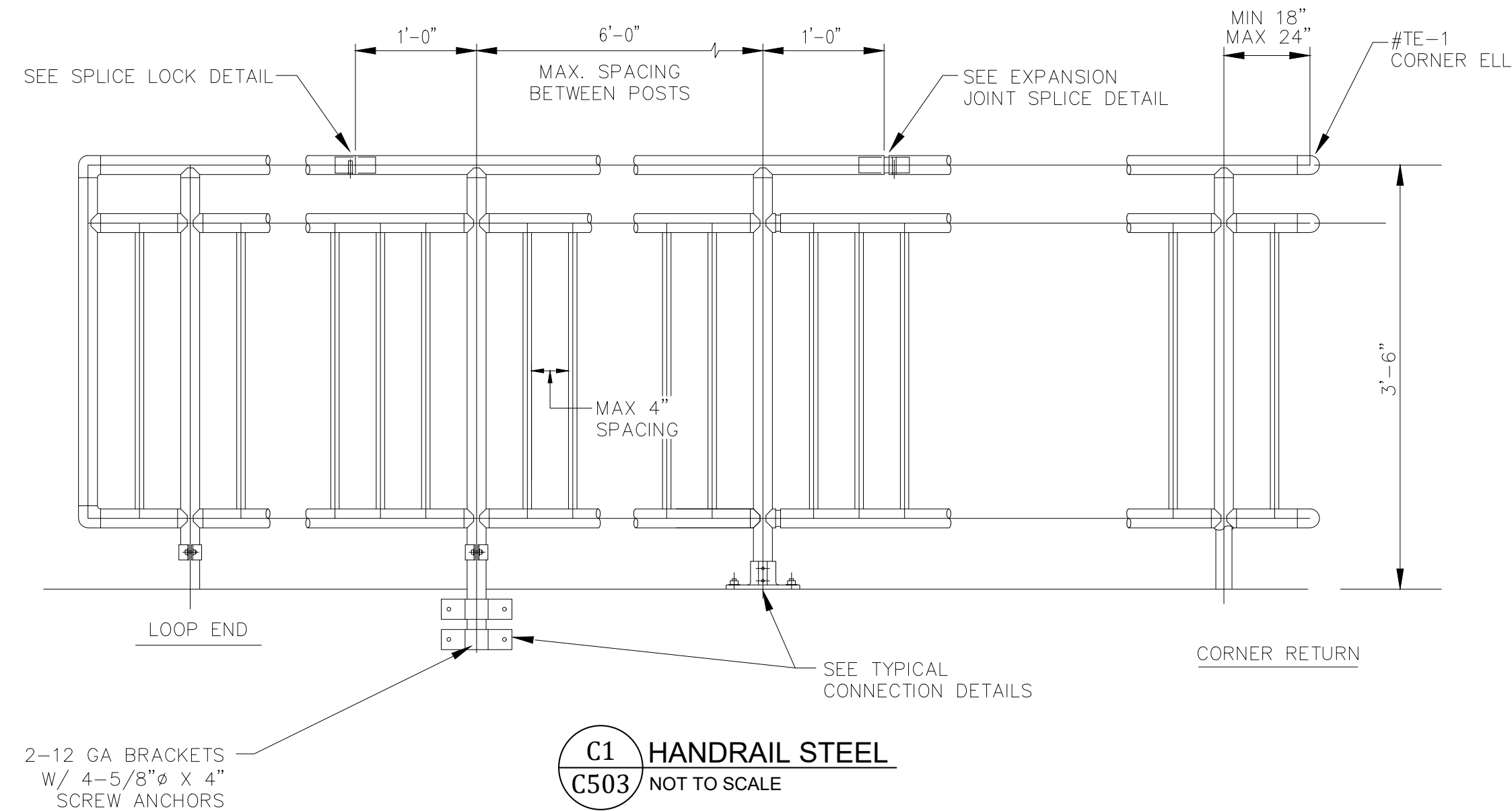

C1 HANDRAIL STEEL
C503 NOT TO SCALE

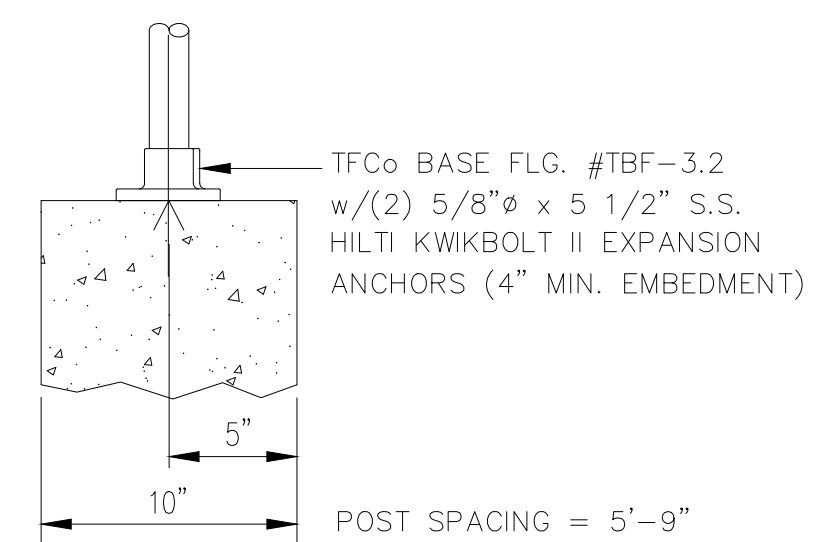

TYPICAL TOP MOUNT CONNECTION TO CONCRETE WALL

C2 STEEL HANDRAIL CONNECTION DETAIL
C503 NOT TO SCALE

- NOTES:
1. HANDRAIL SHALL BE TOP MOUNTED OR SIDE MOUNTED.
2. 2 HANDRAILS SHALL BE PAINTED OXFORD BROWN OR EQUIVALENT APPROVED BY PM, POWDER COATED.

2-12 GA BRACKETS
W/ 4-5/8" Ø X 4"
SCREW ANCHORS

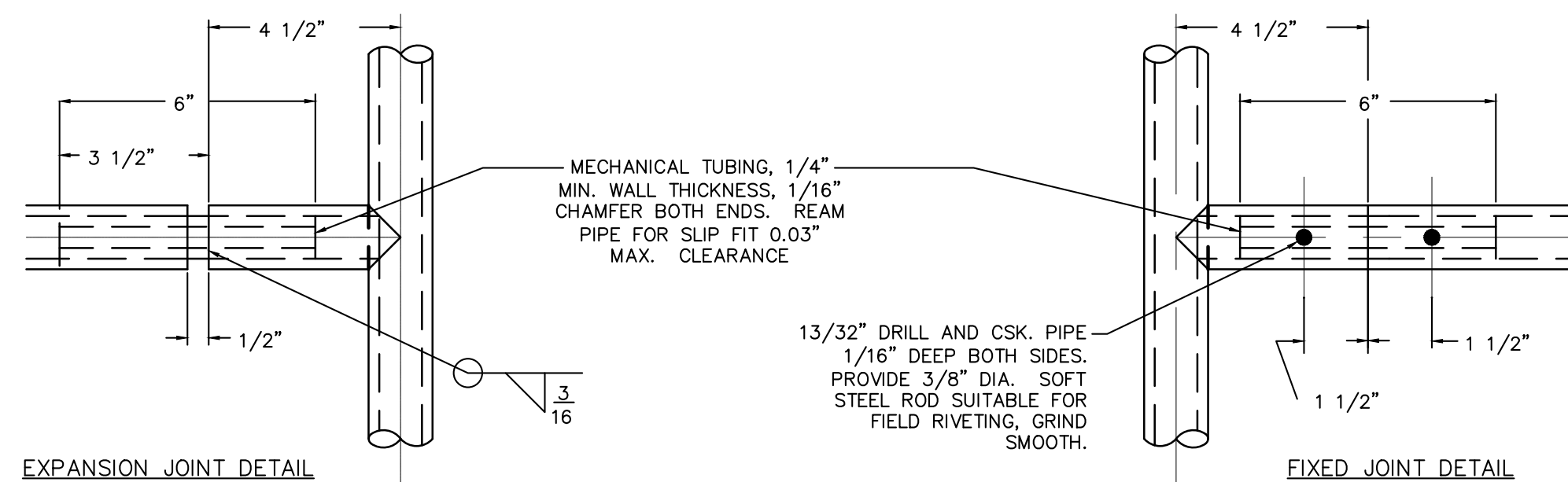

C3 STEEL HANDRAIL JOINT DETAIL
C503 NOT TO SCALE

- NOTES:
1. EXPANSION JOINTS SHALL BE A MAXIMUM OF 20' APART.

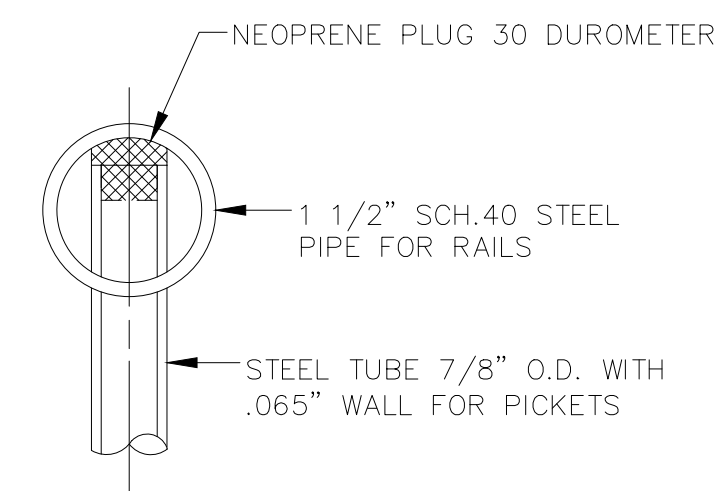

C4 STEEL HANDRAIL CONNECTION
C503 NOT TO SCALE

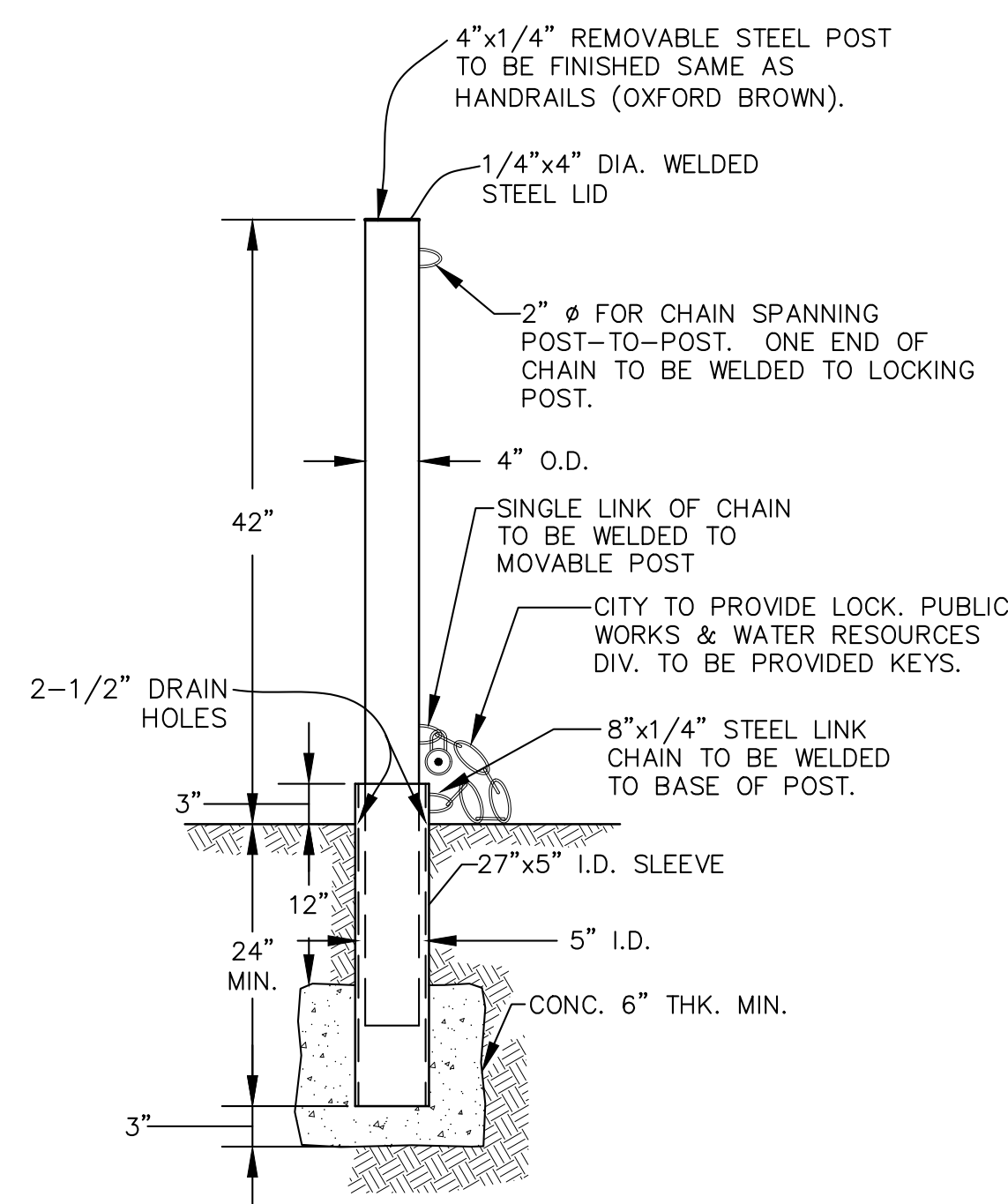

B LOCKING STEEL POST DETAIL
C503 NOT TO SCALE

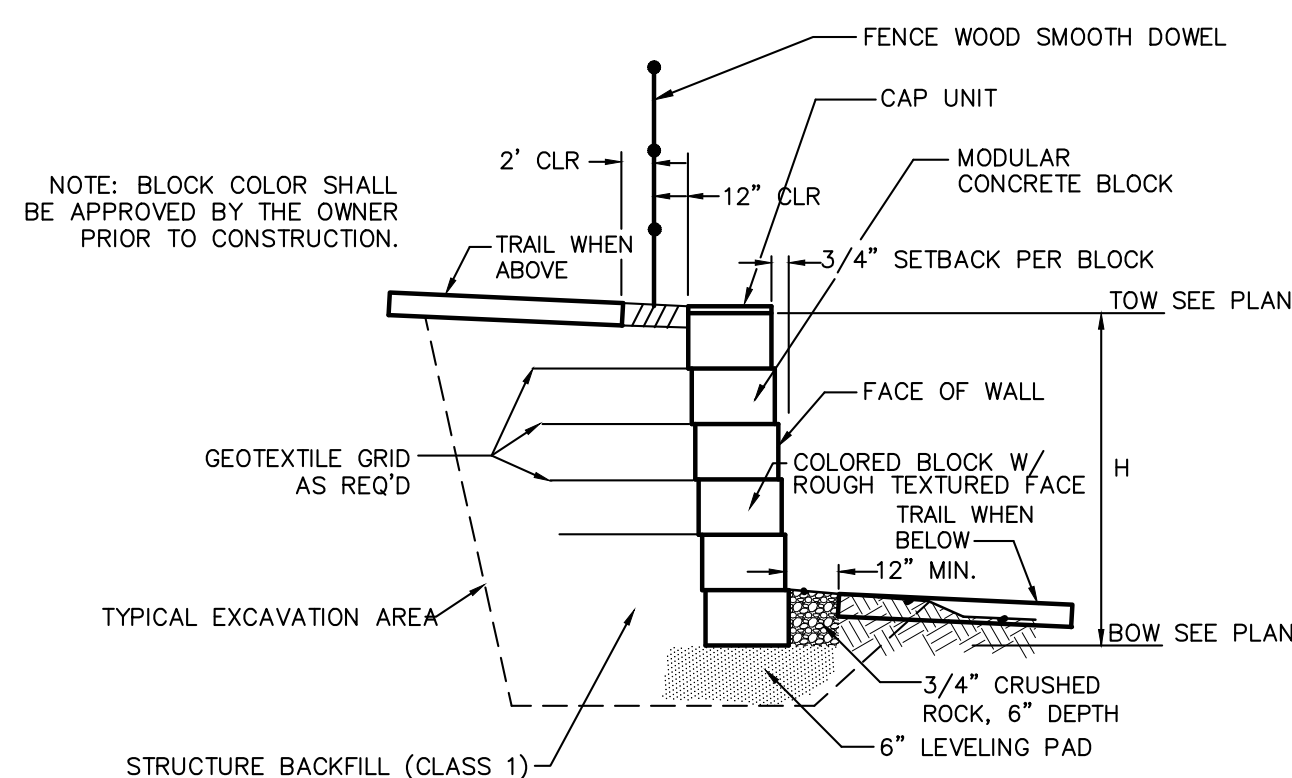

D CONCRETE BLOCK FACING MSE WALL CROSS SECTION
C503 NOT TO SCALE

- WALL NOTES:
1. SHOP DRAWINGS DEPICTING THE DESIGN OF BLOCK WALL SHALL BE SUBMITTED TO ENGINEER PRIOR TO CONSTRUCTION PER THE PROJECT SPECIFICATIONS. DESIGN SHALL BE COMPLETED UNDER THE DIRECT SUPERVISION OF A PROPERLY REGISTERED PROFESSIONAL ENGINEER WITH THE STATE OF COLORADO. FINAL CONSTRUCTION DRAWINGS SHALL BEAR HIS/HER SEAL AND SIGNATURE.
2. CONTRACTOR TO OBTAIN EPC-DPW ROAD CUT WORK PERMIT FOR WORK IN RIGHT-OF-WAY.
3. CONTRACTOR TO SUPPLY TO EPC-DPW CONSTRUCTION TRAFFIC CONTROL PLAN FOR REVIEW AND APPROVAL PRIOR TO COMMENCING WITH ANY WORK WITHIN THE PETERSON ROAD RIGHT-OF-WAY.

**IN PROGRESS
NOT FOR CONSTRUCTION**

For and on Behalf of
Kiowa Engineering Corporation Date



**IN PROGRESS
NOT FOR CONSTRUCTION**



Sheet Revisions	

90% BID SET
No Revisions:
Revised:
Void:

ROCK ISLAND TRAIL	
Sand Creek to Constitution Avenue	
TYPICAL HANDRAIL & FENCE DETAILS	
Designer:	RNW
Detailer:	RNW
Date:	08/06/2024

Kiowa Proj. No. 16028
TAP M240-162
SubAcct No. 20391
Sheet Number C503

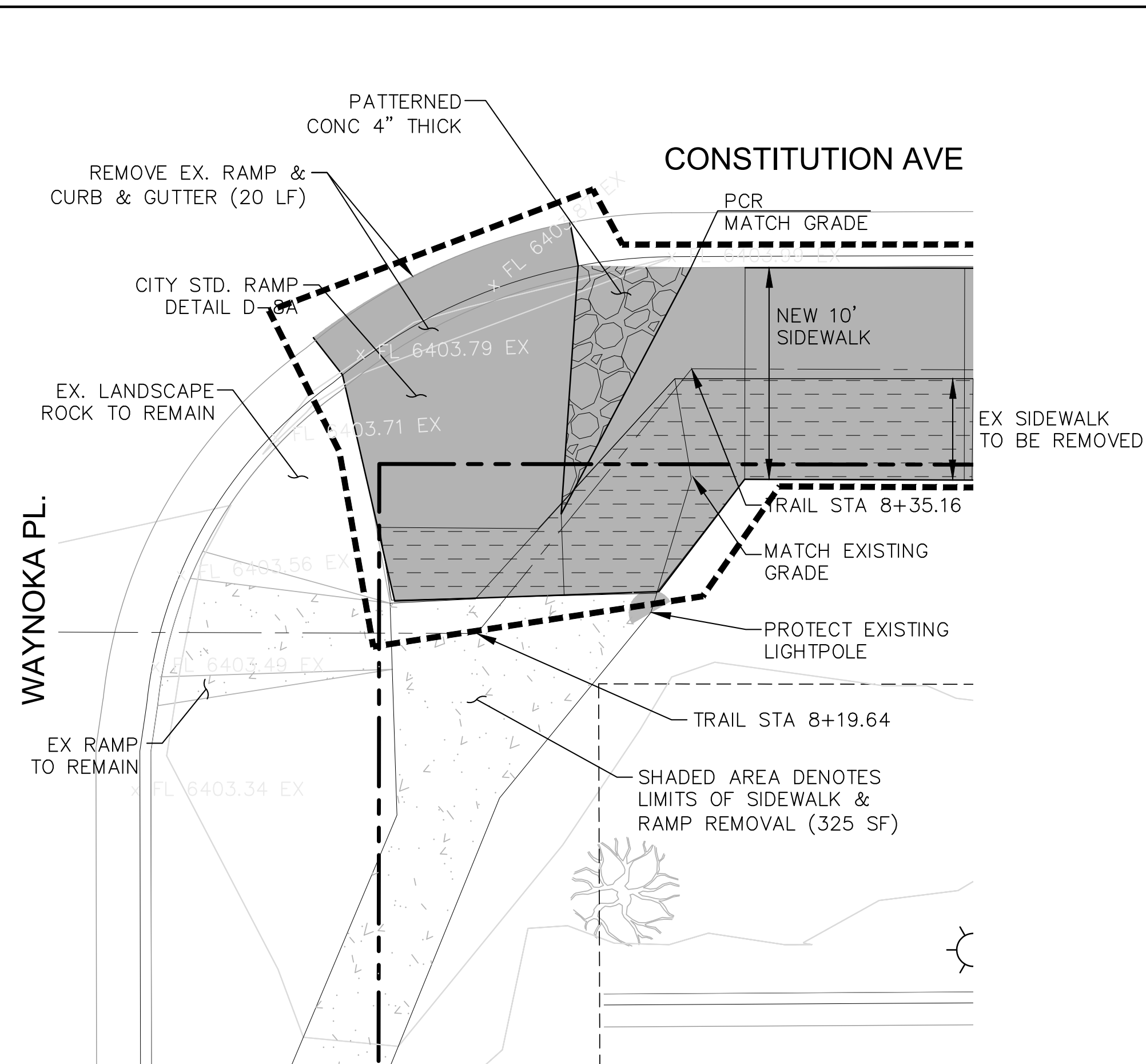

DETAIL 1: STA 8+25
SCALE: 1" = 5'

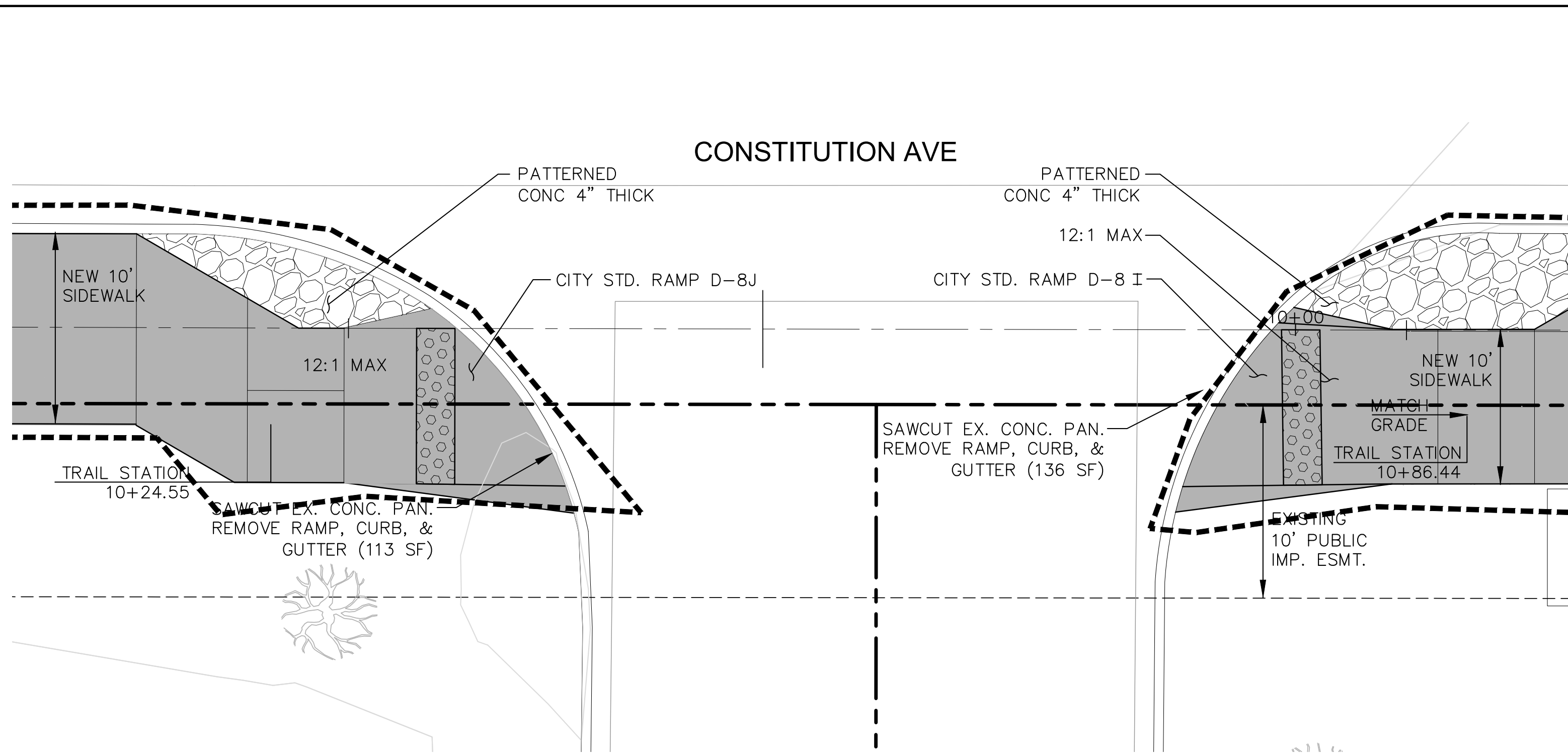

DETAIL 2: STA 10+75
SCALE: 1" = 5'

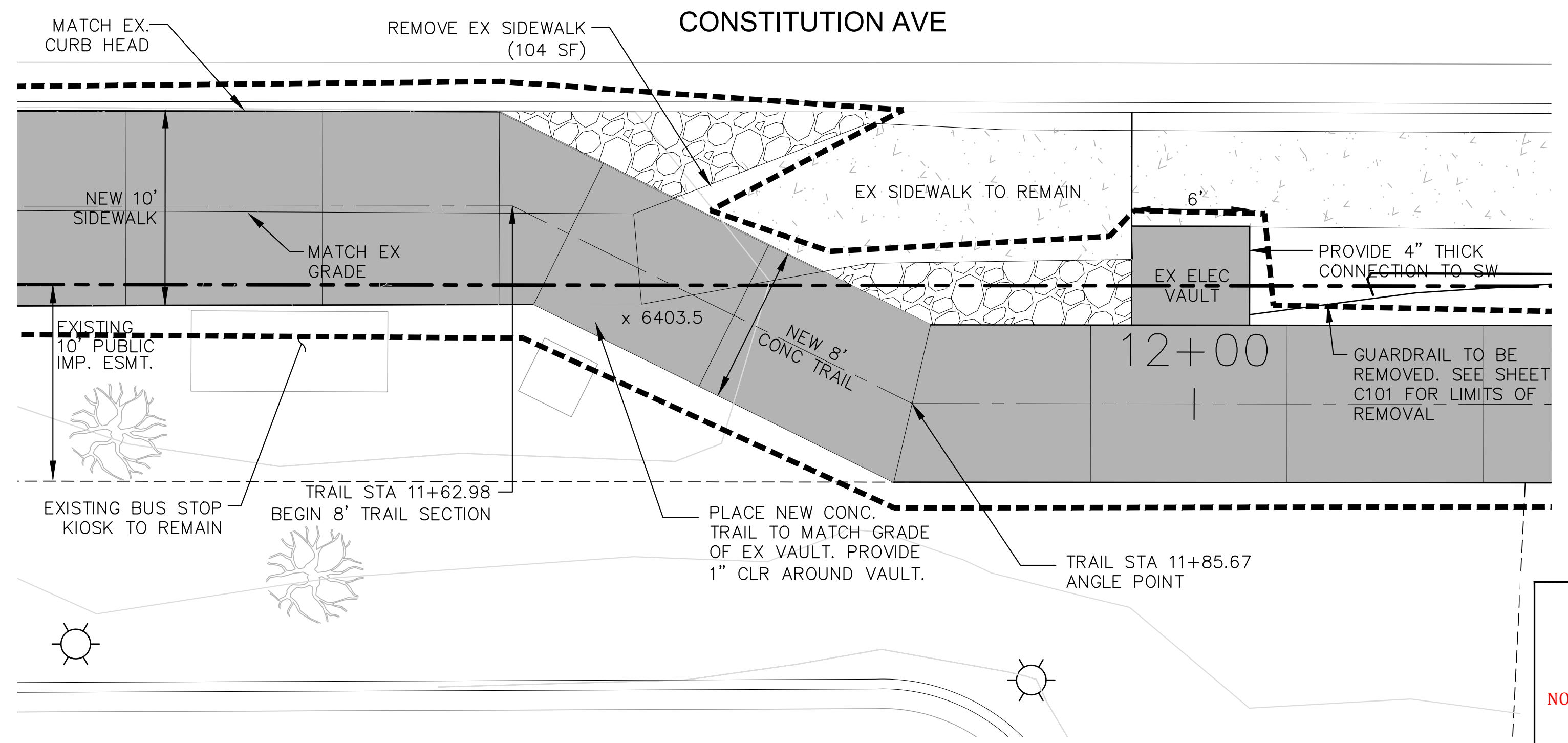

DETAIL 3: STA 11+75
SCALE: 1" = 5'

**IN PROGRESS
NOT FOR CONSTRUCTION**

For and on Behalf of
Kiowa Engineering Corporation Date



**IN PROGRESS
NOT FOR CONSTRUCTION**



Sheet Revisions		90% BID SET
0000		No Revisions:
0001		Revised:
0002		Void:

ROCK ISLAND TRAIL Sand Creek to Constitution Avenue SITE SPECIFIC DETAILS	
Designer: RNW	
Detailer: RNW	
Date: 08/06/2024	

Kiowa Proj. No. 16028
TAP M240-162
SubAcct No. 20391
Sheet Number C504

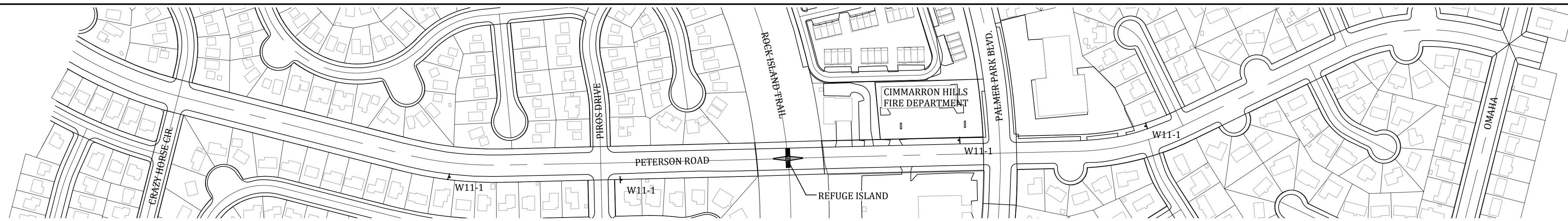

PETERSON ROAD SIGNAGE PLAN

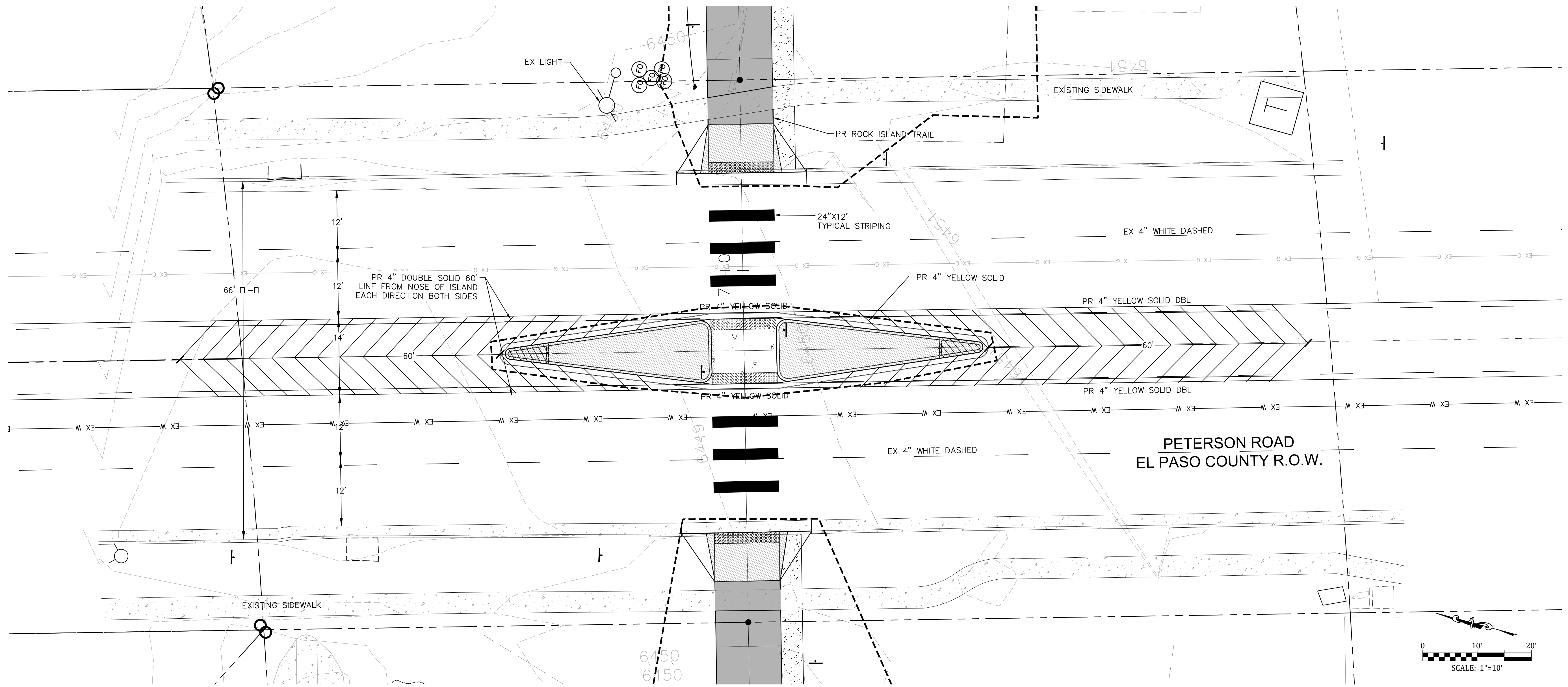

REFUGE ISLAND STRIPING PLAN

PETERSON ROAD IS A
MINOR ARTERIAL ROADWAY.

FOR REFUGE ISLAND
SIGNAGE, SEE SHEET C111



IN PROGRESS
NOT FOR CONSTRUCTION

For and on Behalf of
Kiowa Engineering Corporation Date



1604 South 21st Street
Colorado Springs, Colorado 80904
(719) 630-7342

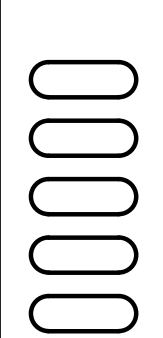

Sheet Revisions	90% BID SET
	No Revisions:
	Revised:
	Void:

ROCK ISLAND TRAIL Sand Creek to Constitution Avenue	
SIGNAGE & STRIPING PLAN - PETERSON ROAD	
Designer:	RNW
Detailer:	RNW
Date:	08/06/2024

Kiowa Proj. No. 16028
TAP M240-162
SubAcct No. 20391
Sheet Number C511