

Traffic Impact Study

Barbarick Waste Transfer Station

El Paso County, Colorado

PCD File No. AL2310

Prepared for:

Graham Construction Management

Kimley»Horn

T R A F F I C I M P A C T S T U D Y

Traffic Engineer's Statement

The attached traffic report and supporting information were prepared under my responsible charge and they comport with the standard of care. So far as is consistent with the standard of care, said report was prepared in general conformance with the criteria established by the County for traffic reports.

Jeffrey R. Planck

July 7, 2023

Jeffrey R. Planck, P.E., PE #53006

Date

Developer's Statement

I, the Developer, have read and will comply with all commitments made on my behalf within this report.

Mr. Richard Graham, Jr.
Graham Construction Management
4615 Northpark Drive
Colorado Springs, CO 80918

Unresolved
Review 1
Comment: Provide
signature and date

Resolved - dothernandez
08/10/2023 7:23:42 AM

Barbarick Waste Transfer Station

PCD File No. AL2310

El Paso County, Colorado

Prepared for
Graham Construction Management
4615 Northpark Drive
Colorado Springs, CO 80918

Prepared by
Kimley-Horn and Associates, Inc.
2 North Nevada Avenue
Suite 300
Colorado Springs, Colorado 80903
(719) 453-0180

July 2023



This document, together with the concepts and designs presented herein, as an instrument of service, is intended only for the specific purpose and client for which it was prepared. Reuse of and improper reliance on this document without written authorization and adaptation by Kimley-Horn and Associates, Inc. shall be without liability to Kimley-Horn and Associates, Inc.

TABLE OF CONTENTS

TABLE OF CONTENTS	i
LIST OF TABLES	ii
LIST OF FIGURES	ii
1.0 EXECUTIVE SUMMARY	1
2.0 INTRODUCTION	1
3.0 EXISTING AND FUTURE CONDITIONS	3
3.1 Existing Study Area	3
3.2 Existing Roadway Network	3
3.3 Existing Traffic Volumes	6
3.4 Unspecified Development Traffic Growth	6
4.0 PROJECT TRAFFIC CHARACTERISTICS	10
4.1 Trip Generation	10
4.2 Trip Distribution	11
4.3 Traffic Assignment	11
4.4 Total (Background Plus Project) Traffic	11
5.0 TRAFFIC OPERATIONS ANALYSIS	16
5.1 Analysis Methodology	16
5.2 Key Intersection Operational Analysis	17
5.3 El Paso County Turn Lane Requirement Analysis	19
5.4 Vehicle Queuing Analysis	20
5.5 Roadway Classifications	20
5.6 Sight Distance Evaluation	22
5.7 Bicycle and Pedestrian Access	22
5.8 Road Impact Fees	23
5.9 Heavy Vehicle Assessment	23
5.10 Improvement Summary	24
6.0 CONCLUSIONS AND RECOMMENDATIONS	26

APPENDICES

- Appendix A – Traffic Impact Study Checklist
- Appendix B – Intersection Count Sheets
- Appendix C – Future Traffic Projections
- Appendix D – Background Traffic Study
- Appendix E – Intersection Analysis Worksheets
- Appendix F – Conceptual Site Plan

LIST OF TABLES

Table 1 – Barbarick Waste Transfer Station Traffic Generation.....	11
Table 2 – Level of Service Definitions	16
Table 3 – Lochwinnoch Lane/Carah Dawn View & Vollmer Road LOS Results.....	17
Table 4 – Turn Lane Queuing Analysis Results.....	20
Table 5 – Road Impact Fees	23

LIST OF FIGURES

Figure 1 – Vicinity Map.....	2
Figure 2 – Existing Geometry and Control.....	5
Figure 3 – 2022 Existing Traffic Volumes	7
Figure 4 – 2025 Background Traffic Volumes.....	8
Figure 5 – 2045 Background Traffic Volumes.....	9
Figure 6 – Project Trip Distribution	12
Figure 7 – Project Traffic Assignment	13
Figure 8 – 2025 Total Traffic Volumes	14
Figure 9 – 2045 Total Traffic Volumes	15
Figure 10 – Roadway Classification Map	21
Figure 11 – 2045 Recommended Geometry and Control	25

1.0 EXECUTIVE SUMMARY

This report has been prepared to document the results of a Traffic Impact Study for the Barbarick Waste Transfer Station project proposed at 8812 Cliff Allen Point in El Paso County, Colorado. Specifically, the project is located near the southeast corner of the Lochwinnoch Lane/Carah Dawn View and Vollmer Road intersection. For the purposes of this study, Barbarick Waste Transfer Station is anticipated to include an intermediate transfer facility. It is expected that Barbarick Waste Transfer Station will be completed in the next several years; therefore, analysis was conducted for the 2025 short-term horizon as well as the 2045 long-term horizon.

The purpose of this traffic study is to identify project traffic generation characteristics to determine potential project traffic related impacts on the local street system and to develop the necessary mitigation measures required for the identified traffic impacts. The intersection of Vollmer Road and Lochwinnoch Lane/Carah Dawn View was incorporated into this traffic study in accordance with El Paso County standards and requirements.

Regional access to Barbarick Waste Transfer Station will be provided by SH-21 and US-24. Primary access will be provided by Vollmer Road. Direct access will be provided by the existing east leg at the intersection of Lochwinnoch Lane/Carah Dawn View and Vollmer Road.

Barbarick Waste Transfer Station is expected to generate approximately 280 weekday daily trips, with 36 of trips occurring during both the morning and afternoon peak hours. Of the 280 daily trips, 10 are anticipated to be heavy vehicle trips with two (2) truck trips during both peak hours.

Based on the analysis presented in this report, Kimley-Horn believes Barbarick Waste Transfer Station will be successfully incorporated into the existing and future roadway network with the existing geometry and control. The intersection of Vollmer Road and Lochwinnoch Lane/Carah Dawn View is anticipated to operate acceptably throughout 2025 and all vehicle queues are anticipated to be maintained within the existing storage lengths. If future 2045 traffic volume projections are realized, northbound and southbound left turn lanes with 245 feet of length plus 180-foot tapers may be needed at the intersection of Lochwinnoch Lane/Carah Dawn View and Vollmer Road to meet El Paso County Standards. The road impact fee associated with the project is expected to be \$43,812.

2.0 INTRODUCTION

Kimley-Horn and Associates, Inc. has prepared this report to document the results of a Traffic Impact Study for the Barbarick Waste Transfer Station project proposed at 8812 Cliff Allen Point in El Paso County, Colorado. Specifically, the project is located near the southeast corner of the Lochwinnoch Lane/Carah Dawn View and Vollmer Road intersection. A vicinity map illustrating the Barbarick Waste Transfer Station development location is shown in **Figure 1**. For the purposes of this study, Barbarick Waste Transfer Station is anticipated to include an intermediate transfer facility. A conceptual site plan is attached in **Appendix F**. It is expected that Barbarick Waste Transfer Station will be completed in the next couple years; therefore, analysis was conducted for the 2025 short-term buildout horizon as well as the 2045 long-term twenty-year planning horizon. The Traffic Impact Study Checklist is attached in **Appendix A**.

The purpose of this traffic study is to identify project traffic generation characteristics to determine potential project traffic related impacts on the local street system and to develop the necessary mitigation measures required for the identified traffic impacts. The intersection of Vollmer Road and Lochwinnoch Lane/Carah Dawn View was incorporated into this traffic study in accordance with El Paso County standards and requirements.

Regional access to Barbarick Waste Transfer Station will be provided by SH-21 and US-24. Primary access will be provided by Vollmer Road. Direct access will be provided by the existing east leg at the intersection of Lochwinnoch Lane/Carah Dawn View and Vollmer Road.

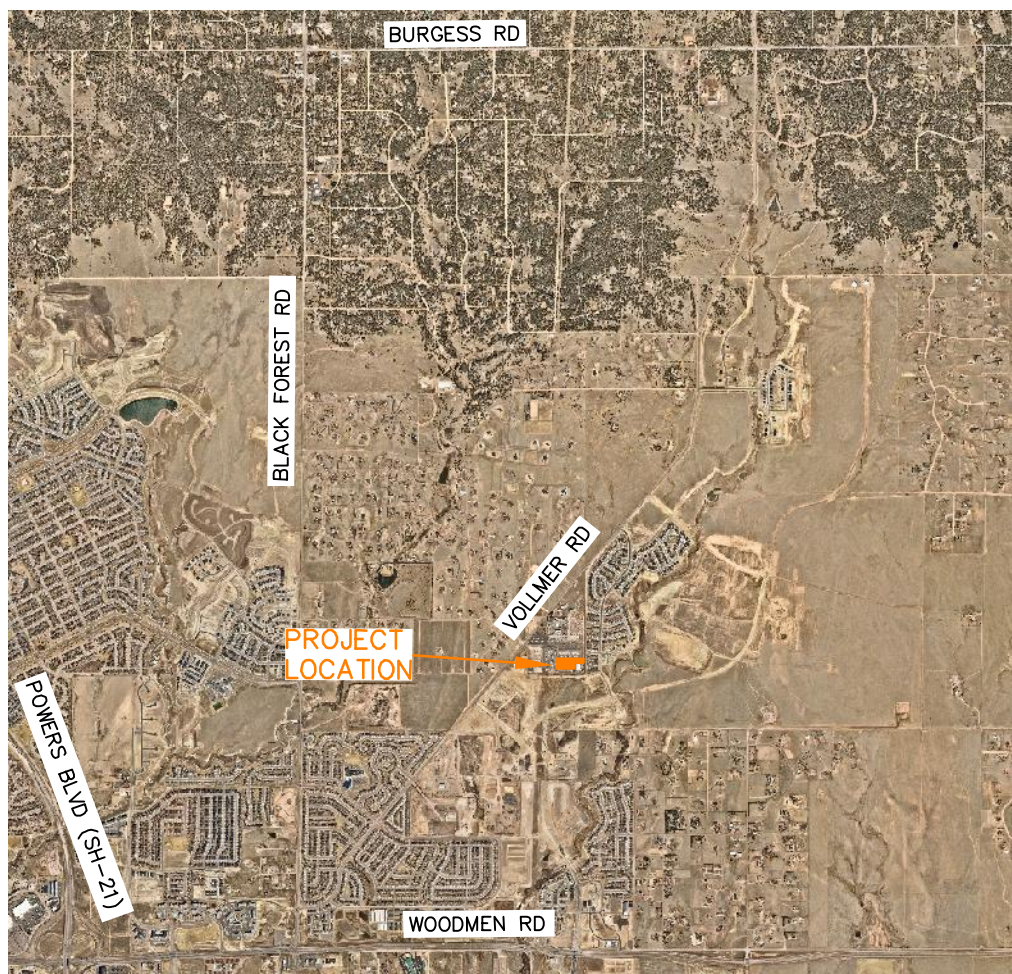

BARBARICK WASTE TRANSFER STATION
EL PASO COUNTY, COLORADO
VICINITY MAP

FIGURE 1

3.0 EXISTING AND FUTURE CONDITIONS

3.1 Existing Study Area

The existing site is comprised of a diesel engine repair service. West of the site are single family homes. East of the site is vacant land that is currently being developed. Vacant land, industrial uses, and single-family homes are located to the south. An RV and boat storage facility is located to the north of the site. Access to the project site is currently provided by Cliff Allen Point on the south side of Carah Dawn View.

3.2 Existing Roadway Network

Vollmer Road provides one through lane of travel in each direction, northeastbound and southwestbound, with a 45 mile per hour speed limit through the study area. Lochwinnoch Lane/Carah Dawn View consists of one through lane in each direction extending primarily eastbound and westbound at the study area key intersection.

The unsignalized intersection of Lochwinnoch Lane/Carah Dawn View and Vollmer Road operates with stop-control on the eastbound Lochwinnoch Lane/Carah Dawn View and westbound Carah Dawn View approaches. For the purposes of this analysis, Vollmer Road is considered a north/south roadway while Lochwinnoch Lane/Carah Dawn View is considered an east/west roadway. The northbound and westbound approaches provide a shared left turn/through lane and a separate right turn lane. The southbound and eastbound approaches provide one shared lane for all movements. An aerial photo of the existing intersection configuration is below (north is up - typical).



Lochwinnoch Lane/Carah Dawn View & Vollmer Road

The intersection lane configuration and control for the study area intersection are shown in **Figure 2**.

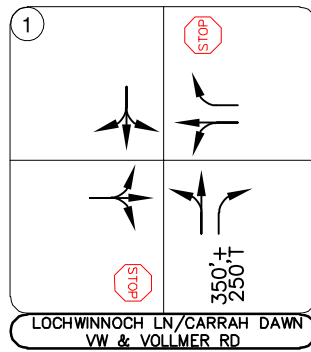

LEGEND	
	Study Area Key Intersection
	Stop Controlled Approach
	Roadway Speed Limit
	100' Turn Lane Length (feet)

BARBARICK WASTE TRANSFER STATION
 EL PASO COUNTY, COLORADO
 EXISTING GEOMETRY AND CONTROL

FIGURE 2

3.3 Existing Traffic Volumes

Existing turning movement counts were conducted at the study intersection on Thursday, August 25, 2022, during the morning and afternoon peak hours. The counts were conducted during the morning and afternoon peak hours of adjacent street traffic in 15-minute intervals from 7:00 AM to 9:00 AM and 4:00 PM to 6:00 PM on this count date. The existing intersection traffic volumes are shown in **Figure 3** with count sheets provided in **Appendix B**.

3.4 Unspecified Development Traffic Growth

According to the 2040 traffic projections from the El Paso County Major Transportation Corridor Plan (MTCP) traffic model compared to the existing traffic volumes, the area surrounding the site is expected to have an average 18-year growth factor of 1.43. This growth factor equates to an annual growth rate of 1.99 percent. Future traffic volume projections and growth rate calculations are provided in **Appendix C**. Therefore, a 1.99 percent annual growth rate was used to calculate future traffic volumes at the study area intersection. This annual growth rate was used to estimate short-term 2025 and long-term 2045 traffic volume projections at the key intersection. Additionally, project traffic volumes for the proposed Sterling Ranch development were added to the background volumes for the 2045 horizon. Applicable documents from the Sterling Ranch Master Traffic Impact Study are included in **Appendix D**. Sterling Ranch is the only known traffic study completed in the last five years within the study limits. The calculated background traffic volumes for 2025 and 2045 are shown in **Figure 4** and **Figure 5**, respectively.

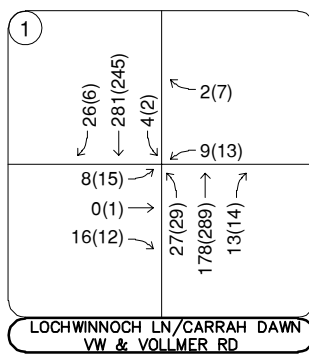

Thursday, August 25, 2022
7:00 to 8:00AM (4:15 to 5:15PM)

LEGEND

- (X) Study Area Key Intersection
- XXX(XXX) Weekday AM(PM)
Peak Hour Traffic Volumes
- XX,X00 Estimated Daily Traffic Volume

BARBARICK WASTE TRANSFER STATION
EL PASO COUNTY, COLORADO
2022 EXISTING TRAFFIC VOLUMES

FIGURE 3

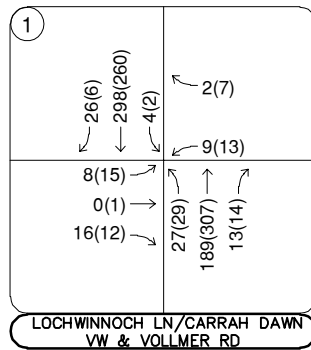
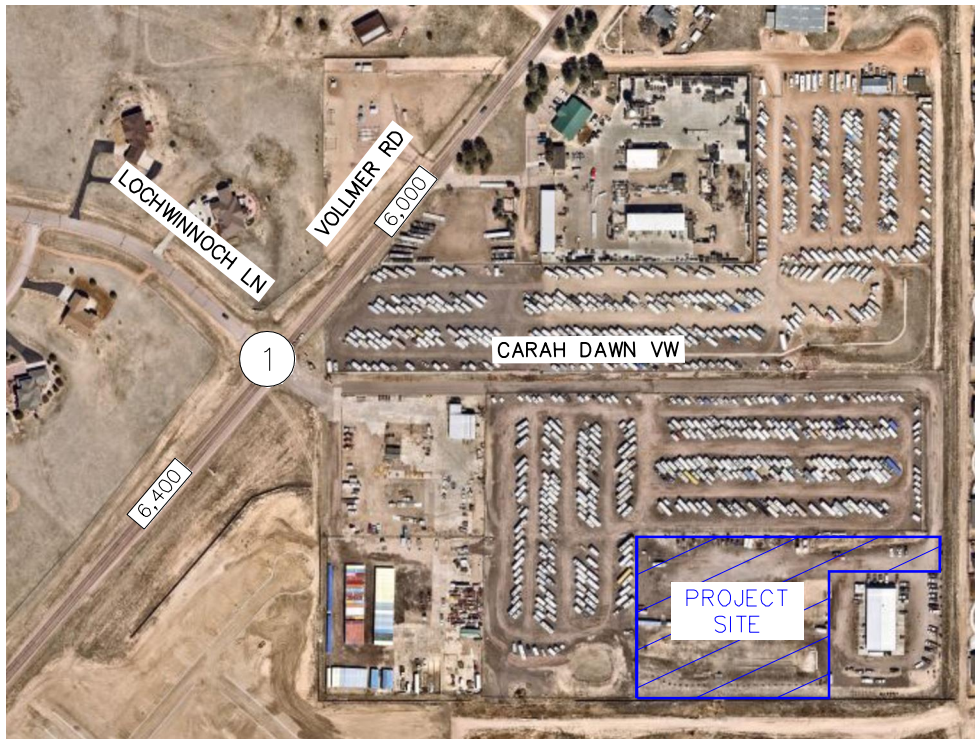

LEGEND

⊗ Study Area Key Intersection

XXX(XXX) Weekday AM(PM)
Peak Hour Traffic Volumes

XX,X00 Estimated Daily Traffic Volume

BARBARICK WASTE TRANSFER STATION
 EL PASO COUNTY, COLORADO
 2025 BACKGROUND TRAFFIC VOLUMES

FIGURE 4

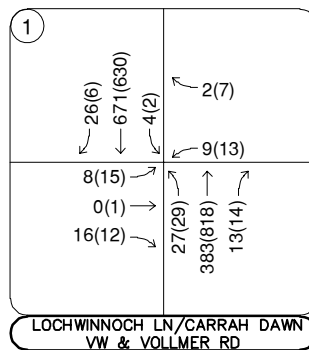

LEGEND

- (X) Study Area Key Intersection
- XXX(XXX) Weekday AM(PM)
Peak Hour Traffic Volumes
- XX,X00 Estimated Daily Traffic Volume

BARBARICK WASTE TRANSFER STATION
EL PASO COUNTY, COLORADO
2045 BACKGROUND TRAFFIC VOLUMES

FIGURE 5

4.0 PROJECT TRAFFIC CHARACTERISTICS

4.1 Trip Generation

Site-generated traffic estimates are determined through a process known as trip generation. Rates and equations are applied to the proposed land use to estimate traffic generated by the development during a specific time interval. The acknowledged source for trip generation rates is the *Trip Generation Manual*¹ published by the Institute of Transportation Engineers (ITE). ITE has established trip rates in nationwide studies of similar land uses. However, for this study, Kimley-Horn used user-specific trip generation based on trips at a similar Peak Disposal and Recycling facility located at 856 Washington Street in Monument, Colorado, for traffic associated with the development. Further, steel recycling collection data from Colorado Industrial Recycling located at 2730 E. Las Vegas Street in Colorado Springs as well as data from the Green for Life trash collection facility were used for site generated traffic. Trips at the existing site were collected daily from August 2018 to July 2022. To be conservative, the month with highest number of trips, June 2022, was used for the trip generation. Of note, operations significantly decrease during the winter season and colder months. The operations primarily consist of personal vehicles utilizing the site to unload waste or recycle steel materials while trucks with 40-yard dumpster containers will haul out recycled steel and waste. The peak month for waste trucks occurred in June 2022 with 73 trucks collecting waste from the facility and hauling off-site. Likewise, the peak month for steel recycling trucks occurred in June 2022 with 7 trucks collecting recycled steel and hauling off-site. Further, trips generated on the existing diesel engine repair site were not subtracted from the existing counts to conservatively evaluate the key intersection.

Barbarick Waste Transfer Station is expected to generate approximately 280 weekday daily trips, with 36 of these trips occurring during both the morning and afternoon peak hours. Of the 280, weekday daily trips, 10 trips are anticipated to be heavy vehicle trips with two (2) heavy vehicle trips during both peak hours. **Table 1** summarizes the estimated trip generation for the Barbarick Waste Transfer Station.

¹ Institute of Transportation Engineers, *Trip Generation Manual*, Eleventh Edition, Washington DC, 2021.

Table 1 – Barbarick Waste Transfer Station Traffic Generation

Vehicle and Trip Type	Weekday Vehicle Trips						
	Daily	AM Peak Hour			PM Peak Hour		
		In	Out	Total	In	Out	Total
Passenger Vehicle Trash/Recycle Drop-off	270	17	17	34	17	17	34
Truck - GFL Boxes Picked up	8	1	1	2	1	1	2
Truck - Recycled Steel Pick up	2	0	0	0	0	0	0
Total Site Generated Trips	280	18	18	36	18	18	36

4.2 Trip Distribution

Distribution of site traffic on the street system was based on the area street system characteristics, existing traffic patterns, existing and anticipated surrounding demographic information, and the proposed access system for the project. The directional distribution of traffic is a means to quantify the percentage of site-generated traffic that approaches the site from a given direction and departs the site back to the original source. The project trip distribution for the proposed development is illustrated in **Figure 6**.

4.3 Traffic Assignment

Barbarick Waste Transfer Station traffic assignment was obtained by applying the project trip distribution to the estimated traffic generation of the development shown in **Table 1**. Traffic assignment is shown in **Figure 7**.

4.4 Total (Background Plus Project) Traffic

Site traffic volumes were added to the background volumes to represent estimated traffic conditions for the short-term 2025 buildout horizon and long-term 2045 twenty-year planning horizon. These total traffic volumes for the study area are illustrated for the 2025 and 2045 horizon years in **Figures 8** and **9**, respectively.

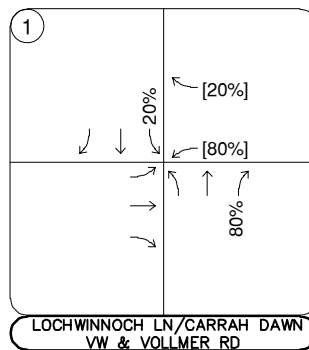

LEGEND

(X) Study Area Key Intersection

XX% External Trip Distribution Percentage

XX%[XX%] Entering[Exiting] Trip Distribution Percentage

BARBARICK WASTE TRANSFER STATION
 EL PASO COUNTY, COLORADO
 PROJECT TRIP DISTRIBUTION

FIGURE 6

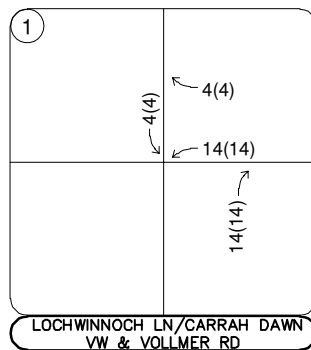
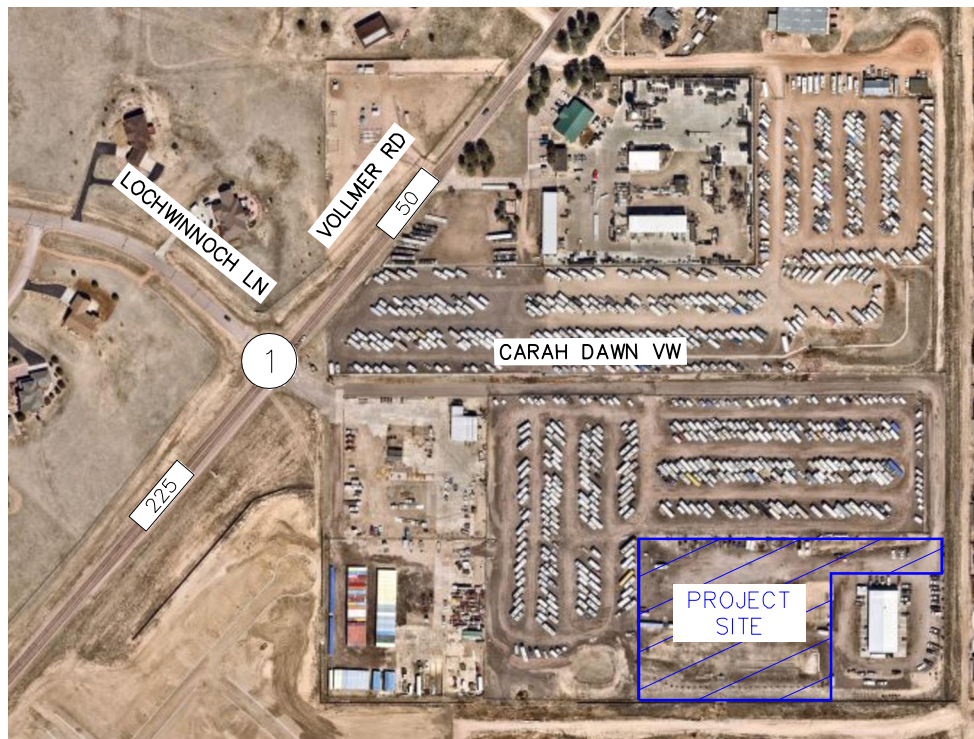

LEGEND

⊗ Study Area Key Intersection

XXX(XXX) Weekday AM(PM)
Peak Hour Traffic Volumes

ⓧ,X00 Estimated Daily Traffic Volume

BARBARICK WASTE TRANSFER STATION
EL PASO COUNTY, COLORADO
PROJECT TRAFFIC ASSIGNMENT

FIGURE 7

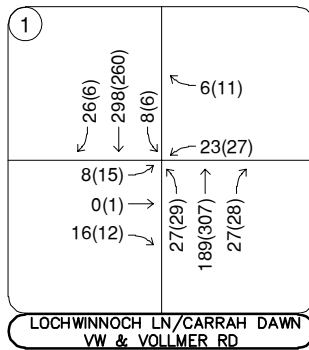

LEGEND

⊗ Study Area Key Intersection

XXX(XXX) Weekday AM(PM)
Peak Hour Traffic Volumes

XX,X00 Estimated Daily Traffic Volume

BARBARICK WASTE TRANSFER STATION
EL PASO COUNTY, COLORADO
2025 TOTAL TRAFFIC VOLUMES

FIGURE 8

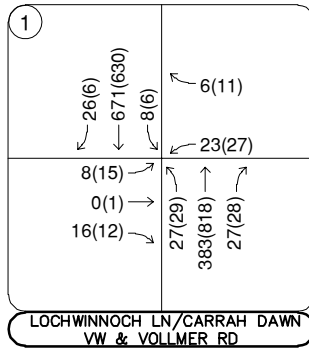
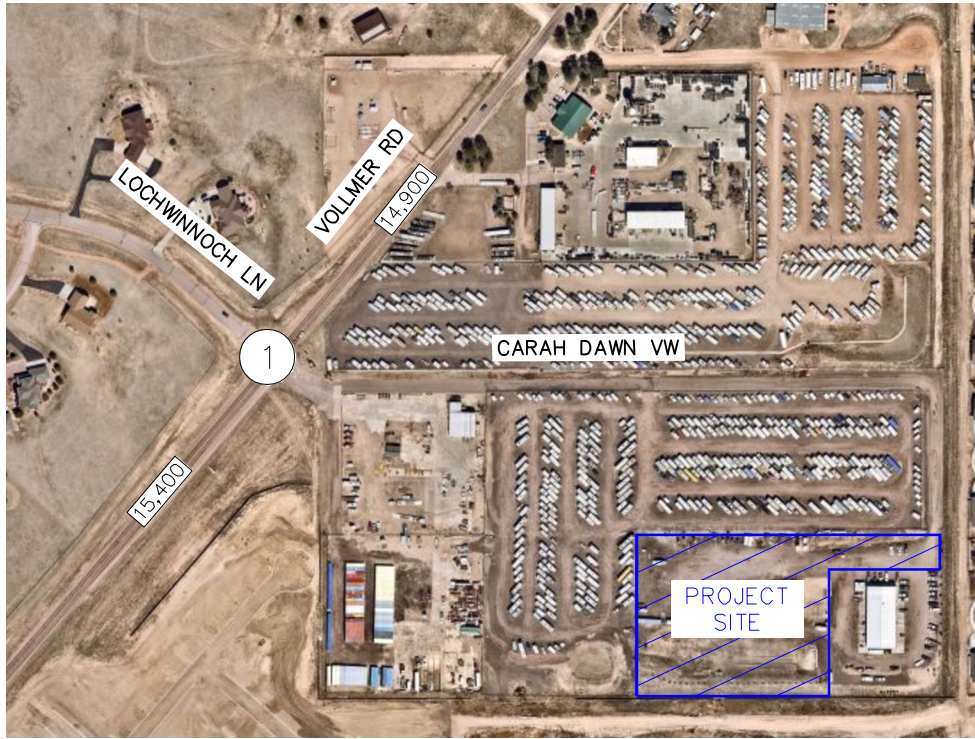

LEGEND

⊗ Study Area Key Intersection

XXX(XXX) Weekday AM(PM)
Peak Hour Traffic Volumes

XX,X00 Estimated Daily Traffic Volume

BARBARICK WASTE TRANSFER STATION
EL PASO COUNTY, COLORADO
2045 TOTAL TRAFFIC VOLUMES

FIGURE 9

5.0 TRAFFIC OPERATIONS ANALYSIS

Kimley-Horn’s analysis of traffic operations in the site vicinity was conducted to determine potential capacity deficiencies in the 2025 and 2045 development horizons at the identified key intersection. The acknowledged source for determining overall capacity is the current edition of the *Highway Capacity Manual (HCM)*².

5.1 Analysis Methodology

Capacity analysis results are listed in terms of Level of Service (LOS). LOS is a qualitative term describing operating conditions a driver will experience while traveling on a particular street or highway during a specific time interval. It ranges from A (very little delay) to F (long delays and congestion). Based on El Paso County standards, the threshold for acceptable LOS is not less than LOS D during peak hours. **Table 2** shows the definition of level of service for signalized and unsignalized intersections.

Table 2 – Level of Service Definitions

Level of Service	Signalized Intersection Average Total Delay (sec/veh)	Unsignalized Intersection Average Total Delay (sec/veh)
A	≤ 10	≤ 10
B	> 10 and ≤ 20	> 10 and ≤ 15
C	> 20 and ≤ 35	> 15 and ≤ 25
D	> 35 and ≤ 55	> 25 and ≤ 35
E	> 55 and ≤ 80	> 35 and ≤ 50
F	> 80	> 50

Definitions provided from the Highway Capacity Manual, Sixth Edition, Transportation Research Board, 2016.

The study area intersection was analyzed based on average total delay analysis for unsignalized intersections. Under the unsignalized analysis, the LOS for a two-way stop-controlled intersection is determined by the computed or measured control delay and is defined for each minor movement.

² Transportation Research Board, *Highway Capacity Manual*, Sixth Edition, Washington DC, 2016.

5.2 Key Intersection Operational Analysis

Calculations for the operational level of service at the key intersection for the study area are provided in **Appendix E**. The existing year analysis is based on the lane geometry and intersection control shown in **Figure 2**. Existing peak hour factors were used for all horizons. Additionally, truck percentages were used for all horizons. Synchro traffic analysis software was used to analyze the unsignalized key intersection for HCM level of service.

Lochwinnoch Lane/Carah Dawn View & Vollmer Road

The unsignalized intersection of Lochwinnoch Lane/Carah Dawn View and Vollmer Road operates with stop-control on the eastbound and westbound Vollmer Road approaches. The intersection movements operate acceptably at LOS C or better during both peak hours under existing conditions. With project traffic, all movements are anticipated to continue operating at an acceptable level of service throughout the 2025 horizon. With the standard growth rate and addition of project traffic, this intersection is anticipated to operate acceptably throughout 2045. However, Sterling Ranch is proposed to be constructed adjacent to this project by 2045. With Sterling Ranch traffic volumes, some movements are anticipated to operate poorly without the addition of project traffic in the 2045 horizon. Therefore, if future traffic volumes are realized northbound and southbound left turn lanes may be needed at this intersection with or without the addition of project traffic by 2045. Of note, the Sterling Ranch Traffic Impact Study recommended two northbound and southbound through lanes along Vollmer Road. If Vollmer Road is ever improved to a five-lane roadway, this intersection will operate with less vehicle delays than reported in this study. However, it is believed that this intersection can operate acceptably as a three-lane section by 2045. **Table 3** provides the results of the LOS analysis conducted at this intersection.

Table 3 – Lochwinnoch Lane/Carah Dawn View & Vollmer Road LOS Results

Scenario	AM Peak Hour		PM Peak Hour	
	Delay (sec/veh)	LOS	Delay (sec/veh)	LOS
2022 Existing				
Northbound Left	8.2	A	7.9	A
Eastbound Approach	12.6	B	13.3	B
Westbound Through/Left	16.1	C	15.5	C
Westbound Right	9.5	A	10.0	B
Southbound Left	7.8	A	8.0	A
2025 Background				
Northbound Left	8.3	A	7.9	A
Eastbound Approach	12.9	B	13.7	B
	16.8	C	16.2	C

Scenario	AM Peak Hour		PM Peak Hour	
	Delay (sec/veh)	LOS	Delay (sec/veh)	LOS
Westbound Through/Left	9.6	A	10.2	B
Westbound Right	7.8	A	8.0	A
Southbound Left				
2025 Background Plus Project				
Northbound Left	8.3	A	7.9	A
Eastbound Approach	13.1	B	14.0	B
Westbound Through/Left	17.8	C	16.9	C
Westbound Right	9.6	A	10.2	B
Southbound Left	7.9	A	8.1	A
2045 Background (without Sterling Ranch)				
Northbound Left	8.3	A	8.3	A
Eastbound Approach	12.9	B	18.6	C
Westbound Through/Left	16.8	C	23.3	C
Westbound Right	9.6	A	11.4	B
Southbound Left	7.8	A	8.5	A
2045 Background (with Sterling Ranch)				
Northbound Left	10.0	B	9.2	A
Eastbound Approach	27.1	D	48.7	E
Westbound Through/Left	47.5	E	67.9	F
Westbound Right	11.3	B	15.9	C
Southbound Left	8.5	A	9.9	A
2045 Background Plus Project (without Sterling Ranch)				
Northbound Left	8.9	A	8.3	A
Eastbound Approach	17.0	C	19.0	C
Westbound Through/Left	27.1	D	25.4	D
Westbound Right	10.3	B	11.4	B
Southbound Left	8.2	A	8.5	A
2045 Background Plus Project (with Sterling Ranch) #				
Northbound Left	10.0	B	8.3	A
Eastbound Approach	19.0	C	14.4	B
Westbound Through/Left	26.2	D	16.9	C
Westbound Right	11.4	B	11.4	B
Southbound Left	8.5	A	8.5	A

= Northbound and southbound left turn lanes

5.3 El Paso County Turn Lane Requirement Analysis

The El Paso County Engineering Criteria Manual (ECM) was used to determine if left and right turn lanes are warranted along Vollmer Road. El Paso County classifies Vollmer Road as a Minor Arterial roadway. According to El Paso County ECM guidelines for Minor Arterials, a left turn lane is required for any access with a projected peak hour left turning volume of 25 vehicles per hour or greater, a right turn lane is required for any access with a projected peak hour right turning volume of 50 vehicles per hour or greater, and a right turn acceleration lane is generally not required.

Based on Vollmer Road providing a posted speed limit of 45 miles per hour, the turn lane requirements that the project traffic contributes to are as follows:

Lochwinnoch Lane/Carah Dawn View and Vollmer Road:

- A southbound left turn lane **is not** warranted at this intersection based on projected 2045 total traffic volumes being eight (8) southbound left turns during the peak hour and the threshold being 25 vehicles per hour.
- A northbound right turn lane exists but **is not** warranted at this intersection based on projected 2045 total traffic volumes being 28 northbound right turns during the peak hour and the threshold being 50 vehicles per hour.

5.4 Vehicle Queuing Analysis

A vehicle queuing analysis was conducted for the study area intersection. The queuing analysis was performed using Synchro presenting the results of the 95th percentile queue lengths. Results are shown in the following **Table 4** with calculations provided within the level of service operational sheets of **Appendix E**.

Table 4 – Turn Lane Queuing Analysis Results

Intersection Turn Lane	Existing Turn Lane Length (feet)	2025 Calculated Queue (feet)	2025 Recommended Length (feet)	2045 Calculated Queue (feet)	2045 Recommended Length (feet)
Lochwinnoch Ln/Carah Dawn View & Vollmer Rd					
Northbound Left	DNE	-	-	25'	245'+180'T
Northbound Right	350'	25'	350'	25'	350'
Southbound Left	DNE	-	-	25'	245'+180'T
Westbound Left/Through	100'	25'	100'	25'	100'
Westbound Right	C	25'	C	25'	C

DNE = Does Not Exist; C = Continuous Lane; **Blue** Text = Recommendation

As shown in the table above, vehicle queues are all anticipated to remain within the existing turn lane lengths through 2045. If future traffic volumes are realized by 2045, northbound and southbound left turn lanes could be needed at the intersection of Lochwinnoch Lane/Carah Dawn View and Vollmer Road and should be designated to a length of 245 feet with a 180 foot taper to meet El Paso County Standards.

5.5 Roadway Classifications

According to El Paso County 2016 Major Transportation Corridors Plan Update, Vollmer Road is classified as a Minor Arterial, and Lochwinnoch Lane/Carah Dawn View is not explicitly classified which typically indicates a local street classification. It is believed that the roadway segments meet the cross section standards for the designated classifications. **Figure 10** illustrates the circulation plan and street classification map for roadways internal and external to the Barbarick Waste Transfer Station project.

Based on the project's percentage of southbound left turning traffic (8/14=57%), escrow for the southbound left turn lane should be provided and conditions of approval will be provided regarding design and construction of the turn lane when warranted. Describe how this is proposed to be addressed.

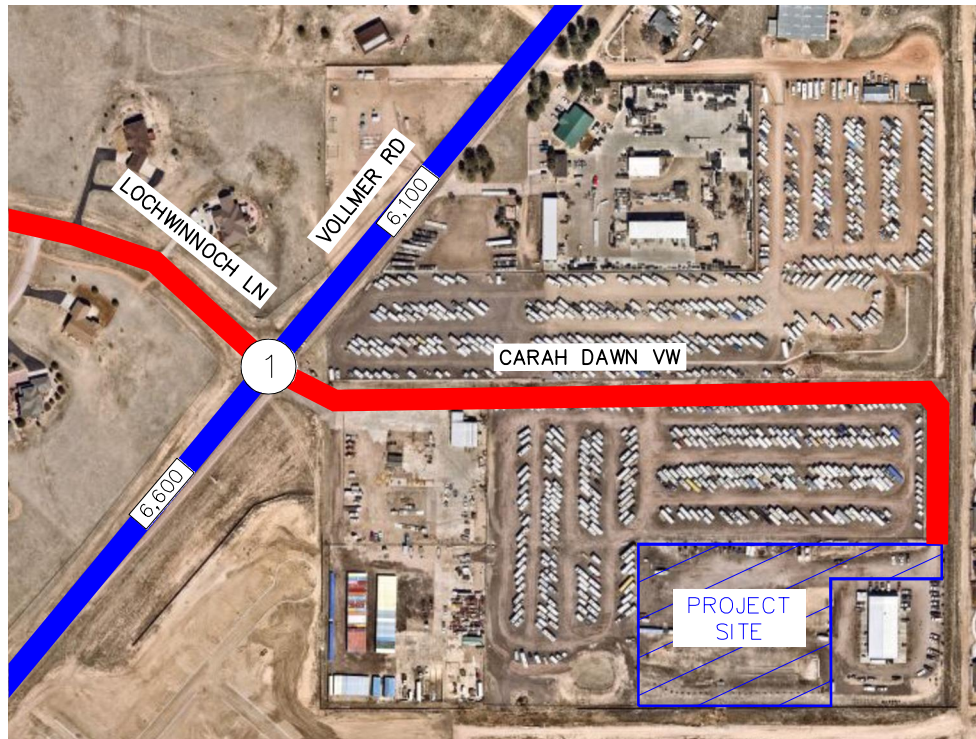

BARBARICK WASTE TRANSFER STATION
 EL PASO COUNTY, COLORADO
 ROADWAY CLASSIFICATION MAP

FIGURE 10

5.6 Sight Distance Evaluation

It is recommended that sight triangles be provided at all site access points to give drivers exiting the site a clear view of oncoming traffic. Landscaping and objects within sight triangles must not obstruct drivers' views of the adjacent travel lanes. ECM design sight distances for left turn from stop from public street intersections (Table 2-21) was evaluated at the intersection of Vollmer Road and Lochwinnoch Lane/Carah Dawn View. ECM does not provide sight distances for right-turning vehicles from stop for public street intersections; therefore, AASHTO standards were used for right-turn from stop distances at the intersection of Vollmer Road and Lochwinnoch Lane/Carah Dawn View.

According to Table 2-21 from ECM and a roadway design speed of 45 miles per hour along Vollmer Road, the intersection sight distance for a vehicle turning left from stop is 500 feet for a two-lane roadway. With AASHTO standards, the sight distance for a vehicle turning right from stop is 430 feet. Therefore, all obstructions for left turning vehicles from stop should be clear to the right within the triangle created with a vertex point located 10 feet from the edge of the major road traveled way (typical position of the minor road driver's eye when stopped) and a line-of-sight distance of 500 feet located in the middle of the nearest southbound through lane along Vollmer Road. Likewise, all obstructions for right turning vehicles from stop should be clear to the left within the triangle created with a vertex point located 10 feet from the edge of the major road traveled way and a line-of-sight distance of 430 feet located in the middle of the nearest northbound through lane along Vollmer Road. It is believed that the intersection of Vollmer Road and Lochwinnoch Lane/Carah Dawn View is appropriately located to provide necessary sight distances.

5.7 Bicycle and Pedestrian Access

Sidewalks are not present on either side of the Vollmer Road and Lochwinnoch Lane/Carah Dawn View intersection. Sidewalks and bicycle lanes are not provided along Vollmer Road or Lochwinnoch Lane/Carah Dawn View.

Please revise statement. The property is already platted and the project does not appear to be going through a replat process. Road Impact Fees are due at the time of building permit approval or land use approval whichever comes first.

5.8 Road Impact Fees

Road impact fees were evaluated based on the El Paso County Road Impact Fee Schedule. Based on these fee schedule guidelines, the fee per 1,000 square feet of industrial space is \$3,651. Therefore, the road impact fee for the proposed 12,000 square foot building is expected to be \$43,812. Road impact fee calculations are shown in **Table 5**.

Table 5 – Road Impact Fees

Use	Units	Fee / Unit	Total Fee
Industrial	12.00 KSF	\$3,651	\$43,812

During the final plat process, the project team will determine if the impact fees are paid up front or if the property will be included in one of the available public improvement districts with reduced upfront costs. The project team will determine payment methods with the final plat.

5.9 Heavy Vehicle Assessment

The heavy vehicle percentage adjacent to the intersection of Lochwinnoch Lane/Carah Dawn View and Vollmer Road is currently 6.2 percent during the morning peak hour and 4.4 percent during the afternoon peak hour. An industry standard 10 percent K-factor was utilized to estimate an average daily traffic volume of 6,100 vehicles per day along Vollmer Road. The afternoon heavy vehicle percentage of 4.4 percent was utilized to estimate a daily heavy vehicle estimate of 268 trucks (6,100 x 0.044). The project is anticipated to add 10 daily truck trips during the peak day of the peak month. This equates to a 3.7 percent (10/268) increase in the overall number of daily trucks along Vollmer Road. However, the heavy vehicle usage of 4.4 percent along Vollmer Road remains the same due to the small number of trucks added daily by this project. This is due to passenger vehicles generated by the project being added to Vollmer Road as well as trucks and the overall truck percentage along Vollmer Road remaining the same ((268 existing trucks + 10 project trucks) / (6,100 existing vehicles + 280 project vehicles)). It should also be noted that this is calculated with the highest project generated volume day in the entire calendar year and the not the average project generation. Therefore, an approximate total of five heavy vehicles (10 trips) are expected to be added to the roadway network on a peak day, and this is expected to have a negligible impact to the surrounding roadway.

5.10 Improvement Summary

Based on the results of the intersection operational, turn lane evaluations, and vehicle queuing analysis, the key intersection recommended improvements and control are shown in **Figure 11** for the 2045 horizon. Of note, the existing geometry and control is anticipated to operate acceptably in the 2025 horizon. Therefore, no improvements are anticipated to be needed for the short term 2025 horizon.

Unresolved Review 1 Comment:

Address the ownership and condition of Carah Dawn View and Cliff Allen Point to the site, width, shoulders, pavement condition and thickness, etc. access and sight distance requirements at the site. Does it meet minimum ECM requirements for the volume and type of traffic proposed? If maintenance or improvements need to be done on the road, who will do it?

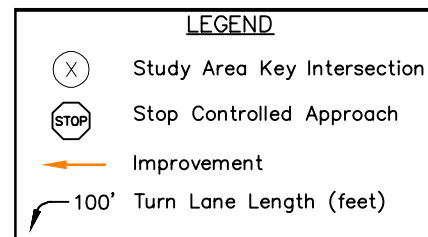
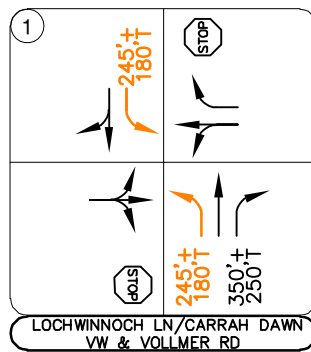
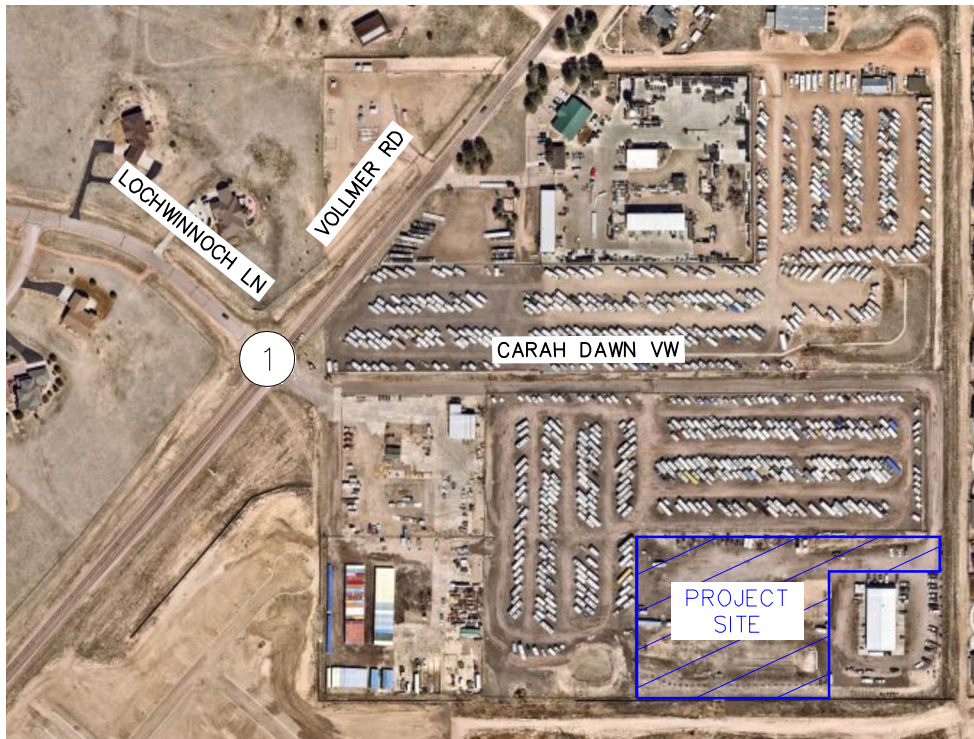

BARBARICK WASTE TRANSFER STATION
 EL PASO COUNTY, COLORADO
 2045 RECOMMENDED GEOMETRY AND
 CONTROL

FIGURE 11

6.0 CONCLUSIONS AND RECOMMENDATIONS

Based on the analysis presented in this report, Kimley-Horn believes Barbarick Waste Transfer Station will be successfully incorporated into the existing and future roadway network with the existing geometry and control. The intersection of Vollmer Road and Lochwinnoch Lane/Carah Dawn View is anticipated to operate acceptably throughout 2025 and all vehicle queues are anticipated to be maintained within the existing storage lengths. If future 2045 traffic volume projections are realized, northbound and southbound left turn lanes with 245 feet of length plus 180-foot tapers may be needed at the intersection of Lochwinnoch Lane/Carah Dawn View and Vollmer Road to meet El Paso County Standards. The road impact fee associated with the project is expected to be \$43,812.

APPENDICES

APPENDIX A

Traffic Impact Study Checklist



2880 International Circle, Suite 110
 Colorado Springs, CO 80910
 Phone 719-520-6300
 Fax 719-520-6695
 www.elpasoco.com

**EL PASO COUNTY PLANNING AND
 COMMUNITY DEVELOPMENT
 DEPARTMENT**

TRAFFIC IMPACT STUDY

Revised: January 2022

Traffic Impact Study Report

The purpose of the traffic impact study is to provide detailed recommendations for the preparation of plans for all necessary transportation facility improvements and adequate access to those facilities for proposed development. The facilities include roadways and their structures, as well as extrinsic structures that support the use of the transportation facility. El Paso County standards and technical criteria shall be used to plan, design, construct, choose materials, locate, repair, maintain, reconstruct, and use roadways and other transportation facilities and the associated extrinsic structures. The Traffic Impact Study shall be prepared by a qualified professional engineer and shall be tailored to the stage of development application and the stage of subdivision-related construction.

The report preparer shall verify type and level of TIS/memorandum required in accordance with ECM Section B.1.

		Applicant	PCD
Please confirm each item below has been included by placing a check mark in the "Applicant" column. See right for an example. The "PCD" column is for office use only.		✓	Office use only
1	Signature Page (ECM B.8)	✓	
2	Table of contents, pages numbered	✓	
3	Existing/background conditions narrative to include at a minimum:	✓	
	Vicinity map showing the subdivision in relation to section lines and existing or proposed arterial or collector roadways.	✓	
	Label all roads discussed in the report	✓	
	Graphically indicate all intersections evaluated	✓	
	Accurately depict the site location and boundaries	✓	
	Study Area – Provide calculations showing that the study area includes all affected intersections, address ECM B.2.3 requirements	✓	
	Background traffic	✓	
	Clearly explain how background traffic was derived	✓	
	List other traffic studies in the area of study within the past five years identified by County staff or that the applicant is aware of. State whether the current study is consistent with those studies and explain any discrepancies.	✓	
	Excerpts from studies of those developments are included in the appendices.	✓	
	Sketch diagrams of all existing intersections evaluated in the study showing widths of all approach lanes and lengths of auxiliary lanes and tapers.	✓	
	Description, classification, and link ADT of major roads in the study area (collector classification and higher).	✓	
	Specify MTCP functional and corridor preservation classifications	✓	
	Description of intersections evaluated in the study including existing controls	✓	
	Do existing road segments meet cross section standards for designated classifications?	✓	
	Traffic Count Data	✓	
	24 Hour Counts for ADT for major road segments K-factor estimates	✓	
	Peak-hour counts for all intersections evaluated in the study	✓	
4	Proposed development and trip generation narrative shall include at a minimum:	✓	
	Site Plan	✓	
	Land Use – Type and extent correspond with associated application documents	✓	



2880 International Circle, Suite 110
 Colorado Springs, CO 80910
 Phone 719-520-6300
 Fax 719-520-6695
 www.elpasoco.com

**EL PASO COUNTY PLANNING AND
 COMMUNITY DEVELOPMENT
 DEPARTMENT**

TRAFFIC IMPACT STUDY

Revised: January 2022

	Discussion of applicable ITE land use type(s) (including ITE code(s)) and comparison between the proposed use(s) and the codified use Client provided trip gen	✓	
	Total traffic generated by the proposed development using ITE trip generation; provide footnotes on the methods used (equation/chart/interpolation) Client provided trip gen	✓	
	Adjustments to trip generation including pass-by trips and internal trip capture	N/A	
	Trip distribution assumptions and map	✓	
	Specify expected year of completion (build-out) and intermediate years if phasing is proposed	✓	
	On-site road classification figure including ADT numbers	✓	
	On-site Traffic control recommendations (particularly stop controls at intersections)	✓	
	Evaluation of intersection spacing along all interior roads, and new intersections on adjacent or off-site roads, and confirmation that the spacing meet criteria No new access	✓	
	List ECM criteria for stacking, storage, and taper for every affected auxiliary lane and access and state whether this access can be met. If it cannot be met, state the required modifications so that it can be met.	✓	
	State what the sight distance is for every affected access and whether it can be met. If it cannot be met, state the required modifications so that it can be met.	✓	
5	Evaluation and Mitigation of Impacts shall include a minimum:	✓	
	Short-term, intermediate and long-term analysis horizon years are clearly stated and years are labeled on the corresponding figures.	✓	
	Capacity analysis of major road segments. Results presented in a figure or table showing short-term and long-term ADTs against maximum allowable ADT		
	Capacity analysis of all existing intersections evaluated in the study and all proposed access locations onto existing public roads	✓	
	For capacity analysis of signalized intersections, provide discussion of the following parameters:	✓	
	Cycle length	✓	
	Provisions for left turns ~ permissive/protected; lead/lag	✓	
	Free right turns	✓	
	Identification of any sub-standard LOS situations and discussion of recommendations for mitigation.	✓	
	Evaluation of safety-based warrants for turn lanes at unsignalized intersections (speed change lanes).	✓	
	Weaving analysis if applicable	N/A	
	Summary table of necessary turn lane improvements including design speed, taper rates and taper lengths, storage lengths, deceleration or acceleration lengths, and the resulting full-width lane lengths.	✓	
	Signal warrant analysis; estimated projected need if not currently warranted	N/A	
	Graphical depiction of improvements required to meet level-of-service standards No improvements	✓	
	Trigger points for the construction of all required future improvements including but not limited to turn lanes, signals, widenings, and openings or closings of accesses. ("Trigger points" are the conditions that, when met, will call for the construction of said improvements.)	✓	
	Summary of accident history within the study area.	N/A	
	Accident history data presented in tabular form by location and including annual vehicle use volume and accident rate calculations	N/A	
	Discussion of pedestrian/bicyclist needs and provisions.	✓	



2880 International Circle, Suite 110
 Colorado Springs, CO 80910
 Phone 719-520-6300
 Fax 719-520-6695
 www.elpasoco.com

**EL PASO COUNTY PLANNING AND
 COMMUNITY DEVELOPMENT
 DEPARTMENT**

TRAFFIC IMPACT STUDY

Revised: January 2022

	School and pedestrian routing plans	N/A	
	School traffic analysis per North Carolina DOT MSTA https://connect.ncdot.gov/municipalities/School/pages/default.aspx	N/A	
	Master-planned trails	N/A	
	Project Traffic modeling and figures	✓	
	Short Term Background Plus Project Traffic lanes, intersection control and LOS modeling and figures for all affected intersection movements	✓	
	Long Term Background Plus Project Traffic lanes, intersection control and LOS modeling and figures for all affected intersection movements	✓	
	Assess and summarize all project impacts (roadways, intersections, pedestrians, bicycles, etc.)	✓	
	Describe proposed mitigation measures	✓	
	Specifically address all deviations requested (separate form(s) required)	✓	
	Address any special studies that apply (access management plan, neighborhood impact evaluation, sight distance evaluation, traffic speed study, etc.)	✓	
6	Recommendations and Report Conclusions shall include a minimum of:	✓	
	Narrative recommendations and conclusions	✓	
	For final plats, state definitively what improvements the developer will be constructing with the project.	✓	
	State whether or not any improvements affected by the project are reimbursable under the current Major Transportation Corridors Plan (MTCP) and Road Fee program.	✓	
	State whether the MTCP or other approved corridor study calls for the construction of improvements in the immediate area.		
	State what the current applicable Road Impact Fees are and what option the developer will be selecting for payment. If the site is in a special district, so state and summarize the applicable fees.	✓	
	Provide a description of how transportation improvements will be financed (responsibility) and a Recommended Improvements Summary Table per ECM section B.6.1.D.	✓	
	List of References.	✓	
7	A minimum of the following appendices:	✓	
	Complete modeling for all existing and proposed development horizons	✓	
	Modeled lanes match improvements table and CDs	✓	

APPENDIX B

Intersection Count Sheets

Vollmer Rd Lochwinnoch Ln



Date: 08/25/2022
Count Period: 7:00 AM to 9:00 AM
Peak Hour: 7:00 AM to 8:00 AM

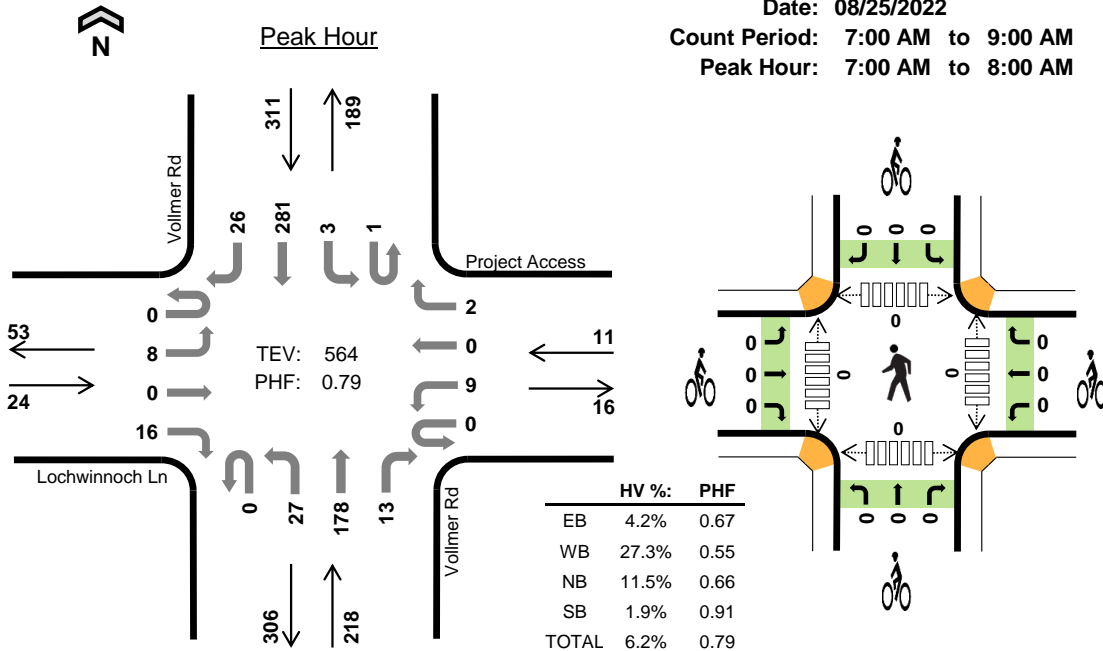

Two-Hour Count Summaries

Interval Start	Lochwinnoch Ln				Project Access				Vollmer Rd				Vollmer Rd				15-min Total	Rolling One Hour	
	Eastbound		Westbound		Northbound		Southbound		UT	LT	TH	RT	UT	LT	TH	RT			
7:00 AM	0	1	0	3	0	1	0	0	0	5	36	3	0	0	70	7	126	0	
7:15 AM	0	2	0	7	0	3	0	2	0	5	47	0	1	1	76	2	146	0	
7:30 AM	0	1	0	4	0	1	0	0	0	4	29	6	0	0	65	4	114	0	
7:45 AM	0	4	0	2	0	4	0	0	0	13	66	4	0	2	70	13	178	564	
8:00 AM	0	5	0	3	0	1	0	0	0	3	53	2	0	0	43	9	119	557	
8:15 AM	0	1	0	5	0	2	0	0	0	1	40	5	0	0	32	2	88	499	
8:30 AM	0	2	0	2	0	4	0	1	0	3	42	3	0	1	47	0	105	490	
8:45 AM	0	2	0	6	0	3	0	0	0	4	43	0	0	0	51	1	110	422	
Count Total	0	18	0	32	0	19	0	3	0	38	356	23	1	4	454	38	986	0	
Peak Hour	All	0	8	0	16	0	9	0	2	0	27	178	13	1	3	281	26	564	0
	HV	0	1	0	0	0	3	0	0	0	2	21	2	0	1	4	1	35	0
	HV%	-	13%	-	0%	-	33%	-	0%	-	7%	12%	15%	0%	33%	1%	4%	6%	0

Note: Two-hour count summary volumes include heavy vehicles but exclude bicycles in overall count.

Interval Start	Heavy Vehicle Totals					Bicycles					Pedestrians (Crossing Leg)				
	EB	WB	NB	SB	Total	EB	WB	NB	SB	Total	East	West	North	South	Total
7:00 AM	0	0	5	1	6	0	0	0	0	0	0	0	0	0	0
7:15 AM	1	0	8	2	11	0	0	0	0	0	0	0	0	0	0
7:30 AM	0	1	7	2	10	0	0	0	0	0	0	0	0	0	0
7:45 AM	0	2	5	1	8	0	0	0	0	0	0	0	0	0	0
8:00 AM	0	1	7	1	9	0	0	0	0	0	0	0	0	0	0
8:15 AM	1	1	5	1	8	0	0	0	0	0	0	0	0	0	0
8:30 AM	0	2	3	2	7	0	0	0	0	0	0	0	0	0	0
8:45 AM	0	0	3	1	4	0	0	0	0	0	0	0	0	0	0
Count Total	2	7	43	11	63	0	0	0	0	0	0	0	0	0	0
Peak Hour	1	3	25	6	35	0	0	0	0	0	0	0	0	0	0

Two-Hour Count Summaries - Heavy Vehicles																		
Interval Start	Lochwinnoch Ln				Project Access				Vollmer Rd				Vollmer Rd				15-min Total	Rolling One Hour
	Eastbound				Westbound				Northbound				Southbound					
	UT	LT	TH	RT	UT	LT	TH	RT	UT	LT	TH	RT	UT	LT	TH	RT		
7:00 AM	0	0	0	0	0	0	0	0	0	0	5	0	0	0	0	1	6	0
7:15 AM	0	1	0	0	0	0	0	0	0	0	8	0	0	1	1	0	11	0
7:30 AM	0	0	0	0	0	1	0	0	0	0	2	4	1	0	0	2	10	0
7:45 AM	0	0	0	0	0	2	0	0	0	0	0	4	1	0	0	1	8	35
8:00 AM	0	0	0	0	0	1	0	0	0	0	0	6	1	0	0	1	9	38
8:15 AM	0	0	0	1	0	1	0	0	0	0	0	4	1	0	0	1	8	35
8:30 AM	0	0	0	0	0	1	0	1	0	0	0	3	0	0	1	1	7	32
8:45 AM	0	0	0	0	0	0	0	0	0	0	0	3	0	0	0	1	4	28
Count Total	0	1	0	1	0	6	0	1	0	2	37	4	0	2	8	1	63	0
Peak Hour	0	1	0	0	0	3	0	0	0	2	21	2	0	1	4	1	35	0
Two-Hour Count Summaries - Bikes																		
Interval Start	Lochwinnoch Ln			Project Access			Vollmer Rd			Vollmer Rd			15-min Total	Rolling One Hour				
	Eastbound			Westbound			Northbound			Southbound								
	LT	TH	RT	LT	TH	RT	LT	TH	RT	LT	TH	RT						
7:00 AM	0	0	0	0	0	0	0	0	0	0	0	0	0	0	0	0	0	0
7:15 AM	0	0	0	0	0	0	0	0	0	0	0	0	0	0	0	0	0	0
7:30 AM	0	0	0	0	0	0	0	0	0	0	0	0	0	0	0	0	0	0
7:45 AM	0	0	0	0	0	0	0	0	0	0	0	0	0	0	0	0	0	0
8:00 AM	0	0	0	0	0	0	0	0	0	0	0	0	0	0	0	0	0	0
8:15 AM	0	0	0	0	0	0	0	0	0	0	0	0	0	0	0	0	0	0
8:30 AM	0	0	0	0	0	0	0	0	0	0	0	0	0	0	0	0	0	0
8:45 AM	0	0	0	0	0	0	0	0	0	0	0	0	0	0	0	0	0	0
Count Total	0	0	0	0	0	0	0	0	0	0	0	0	0	0	0	0	0	0
Peak Hour	0	0	0	0	0	0	0	0	0	0	0	0	0	0	0	0	0	0
<i>Note: U-Turn volumes for bikes are included in Left-Turn, if any.</i>																		

Vollmer Rd Lochwinnoch Ln



Date: 08/25/2022
Count Period: 4:00 PM to 6:00 PM
Peak Hour: 4:15 PM to 5:15 PM

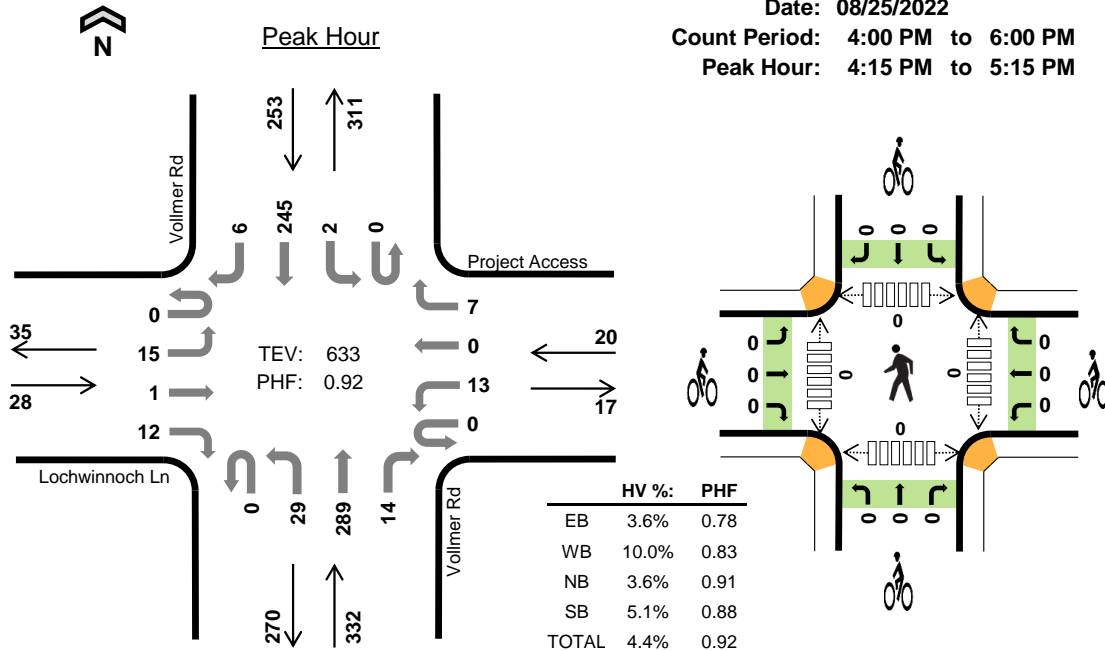

Two-Hour Count Summaries

Interval Start	Lochwinnoch Ln				Project Access				Vollmer Rd				Vollmer Rd				15-min Total	Rolling One Hour	
	Eastbound		Westbound		Northbound		Southbound		UT	LT	TH	RT	UT	LT	TH	RT			
4:00 PM	0	1	0	5	0	3	0	1	0	7	52	2	0	0	51	1	123	0	
4:15 PM	0	3	0	3	0	3	0	2	0	5	68	3	0	0	63	3	153	0	
4:30 PM	0	3	0	6	0	2	0	4	0	6	80	3	0	0	59	1	164	0	
4:45 PM	0	2	1	2	0	4	0	0	0	10	78	3	0	2	69	1	172	612	
5:00 PM	0	7	0	1	0	4	0	1	0	8	63	5	0	0	54	1	144	633	
5:15 PM	0	1	1	3	0	2	0	0	0	8	63	2	0	0	68	1	149	629	
5:30 PM	0	2	0	4	0	5	2	2	0	6	62	1	0	1	41	4	130	595	
5:45 PM	0	1	1	1	0	1	0	1	0	3	89	1	0	0	44	3	145	568	
Count Total	0	20	3	25	0	24	2	11	0	53	555	20	0	3	449	15	1,180	0	
Peak Hour	All	0	15	1	12	0	13	0	7	0	29	289	14	0	2	245	6	633	0
	HV	0	0	0	1	0	1	0	1	0	0	11	1	0	1	11	1	28	0
	HV%	-	0%	0%	8%	-	8%	-	14%	-	0%	4%	7%	-	50%	4%	17%	4%	0

Note: Two-hour count summary volumes include heavy vehicles but exclude bicycles in overall count.

Interval Start	Heavy Vehicle Totals					Bicycles					Pedestrians (Crossing Leg)				
	EB	WB	NB	SB	Total	EB	WB	NB	SB	Total	East	West	North	South	Total
4:00 PM	0	1	1	6	8	0	0	0	0	0	0	0	0	0	0
4:15 PM	1	1	6	2	10	0	0	0	0	0	0	0	0	0	0
4:30 PM	0	1	3	1	5	0	0	0	0	0	0	0	0	0	0
4:45 PM	0	0	1	6	7	0	0	0	0	0	0	0	0	0	0
5:00 PM	0	0	2	4	6	0	0	0	0	0	0	0	0	0	0
5:15 PM	0	0	0	2	2	0	0	0	0	0	0	0	0	0	0
5:30 PM	0	0	1	3	4	0	0	0	0	0	0	0	0	0	0
5:45 PM	0	0	0	3	3	0	0	0	0	0	0	0	0	0	0
Count Total	1	3	14	27	45	0	0	0	0	0	0	0	0	0	0
Peak Hour	1	2	12	13	28	0	0	0	0	0	0	0	0	0	0

Two-Hour Count Summaries - Heavy Vehicles																			
Interval Start	Lochwinnoch Ln				Project Access				Vollmer Rd				Vollmer Rd				15-min Total	Rolling One Hour	
	Eastbound				Westbound				Northbound				Southbound						
	UT	LT	TH	RT	UT	LT	TH	RT	UT	LT	TH	RT	UT	LT	TH	RT			
4:00 PM	0	0	0	0	0	1	0	0	0	1	0	0	0	0	6	0	8	0	
4:15 PM	0	0	0	1	0	1	0	0	0	0	0	6	0	0	0	2	0	10	0
4:30 PM	0	0	0	0	0	0	0	1	0	0	2	1	0	0	1	0	5	0	
4:45 PM	0	0	0	0	0	0	0	0	0	0	1	0	0	1	4	1	7	30	
5:00 PM	0	0	0	0	0	0	0	0	0	0	2	0	0	0	4	0	6	28	
5:15 PM	0	0	0	0	0	0	0	0	0	0	0	0	0	0	2	0	2	20	
5:30 PM	0	0	0	0	0	0	0	0	0	0	1	0	0	0	3	0	4	19	
5:45 PM	0	0	0	0	0	0	0	0	0	0	0	0	0	0	3	0	3	15	
Count Total	0	0	0	1	0	2	0	1	0	1	12	1	0	1	25	1	45	0	
Peak Hour	0	0	0	1	0	1	0	1	0	0	11	1	0	1	11	1	28	0	
Two-Hour Count Summaries - Bikes																			
Interval Start	Lochwinnoch Ln			Project Access			Vollmer Rd			Vollmer Rd			15-min Total	Rolling One Hour					
	Eastbound			Westbound			Northbound			Southbound									
	LT	TH	RT	LT	TH	RT	LT	TH	RT	LT	TH	RT							
4:00 PM	0	0	0	0	0	0	0	0	0	0	0	0	0	0	0	0	0	0	
4:15 PM	0	0	0	0	0	0	0	0	0	0	0	0	0	0	0	0	0	0	
4:30 PM	0	0	0	0	0	0	0	0	0	0	0	0	0	0	0	0	0	0	
4:45 PM	0	0	0	0	0	0	0	0	0	0	0	0	0	0	0	0	0	0	
5:00 PM	0	0	0	0	0	0	0	0	0	0	0	0	0	0	0	0	0	0	
5:15 PM	0	0	0	0	0	0	0	0	0	0	0	0	0	0	0	0	0	0	
5:30 PM	0	0	0	0	0	0	0	0	0	0	0	0	0	0	0	0	0	0	
5:45 PM	0	0	0	0	0	0	0	0	0	0	0	0	0	0	0	0	0	0	
Count Total	0	0	0	0	0	0	0	0	0	0	0	0	0	0	0	0	0	0	
Peak Hour	0	0	0	0	0	0	0	0	0	0	0	0	0	0	0	0	0	0	
<i>Note: U-Turn volumes for bikes are included in Left-Turn, if any.</i>																			

APPENDIX C

Future Traffic Projections

MTCP Growth Rate: Barbarick Waste Transfer Station

Location	2022 AADT	2040 AADT	Growth Factor	Growth Rate
Vollmer Rd S/O Burgess Rd	6100	8700	1.43	1.99%

APPENDIX D

Background Traffic Study



LSC TRANSPORTATION CONSULTANTS, INC.
 2504 East Pikes Peak Avenue, Suite 304
 Colorado Springs, CO 80909
 (719) 633-2868
 FAX (719) 633-5430
 E-mail: lsc@lscstrans.com
 Website: <http://www.lscstrans.com>

Condition:
 The applicant/developer and/or property owner(s) shall be required to participate in a fair and equitable manner in the onsite and offsite transportation improvements required by the Sterling Ranch development's traffic impacts as identified in each subsequent TIS. This includes but is not limited to potential roadway and intersection upgrades to and construction of Briargate Parkway, Vollmer Road, Marksheffel Road, Woodmen Road, and Banning-Lewis Parkway. Participation shall be through construction of specified improvements and inclusion in El Paso County's Road Impact Fee program. Specific responsibilities and obligations of the development shall be determined with rezoning, preliminary plan, and final plat approvals.

ACCEPTED for FILE
 Engineering Review
 04/04/2023 1:30:31 PM
 Elizabeth Nijkamp, PE
 EPC Department of Public Works
 See condition at left.

Sterling Ranch Sketch Plan Amendment Master Traffic Impact Study

SKP-22-004
 (LSC #S224440)
 March 17, 2023

Traffic Engineer's Statement

This traffic report and supporting information were prepared under my responsible charge and they comport with the standard of care. So far as is consistent with the standard of care, said report was prepared in general conformance with the criteria established by the County for traffic reports.



Developer's Statement

I, the Developer, have read and will comply with all commitments made on my behalf within this report.

3/25/2023
 Date

Sterling Ranch Sketch Plan Amendment Master Traffic Impact Study

Prepared for:
Loren J. Moreland
Vice President/ Project Manager
Classic SRJ
2138 Flying Horse Club Drive
Colorado Springs, CO 80921

MARCH 17, 2023

LSC Transportation Consultants
Prepared by: Kirstin D. Ferrin, P.E.
Reviewed by: Jeffrey C. Hodsdon, P.E.

LSC #S224440

PCD File No.: SKP-22-004



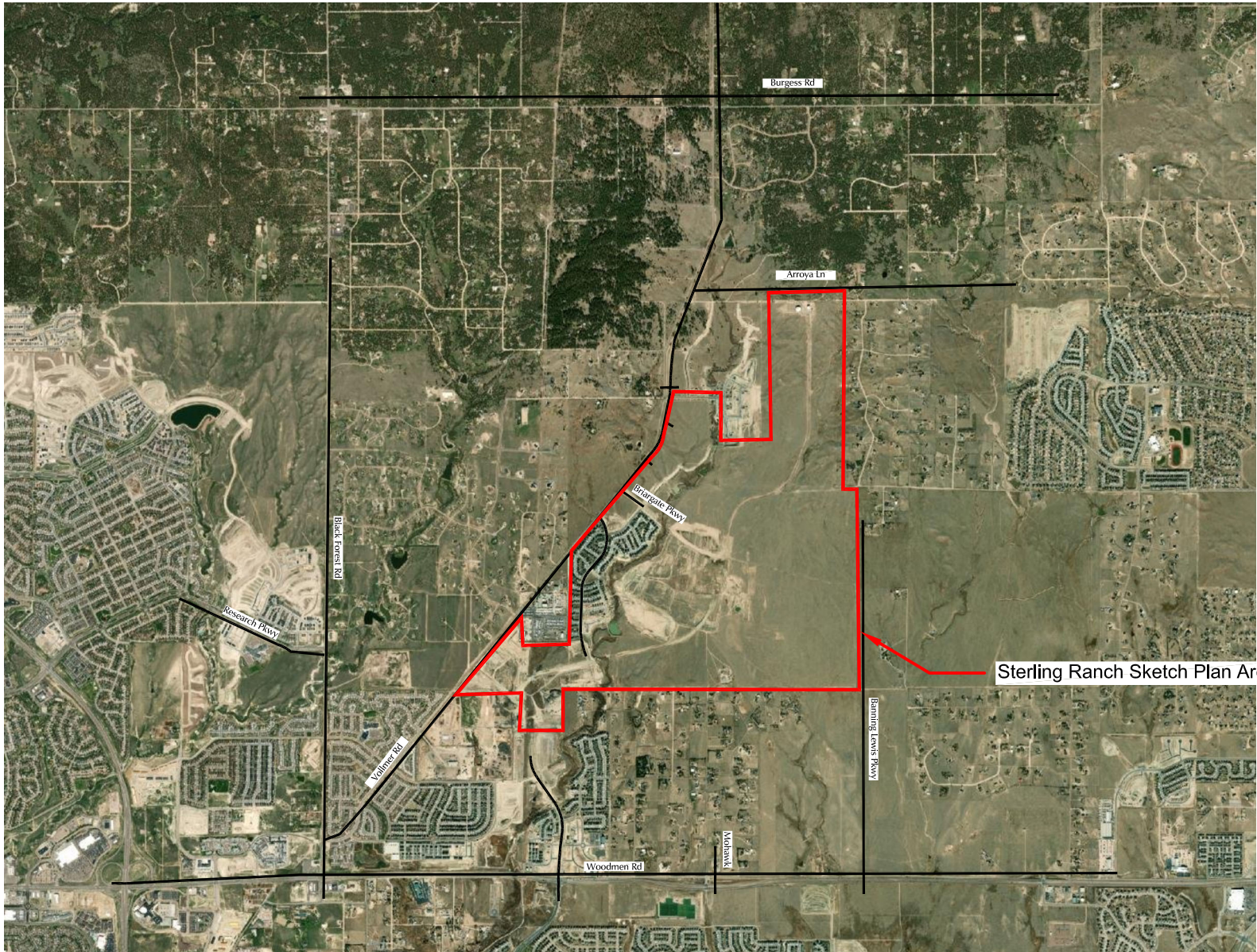
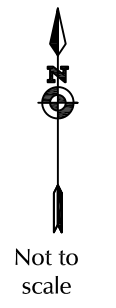
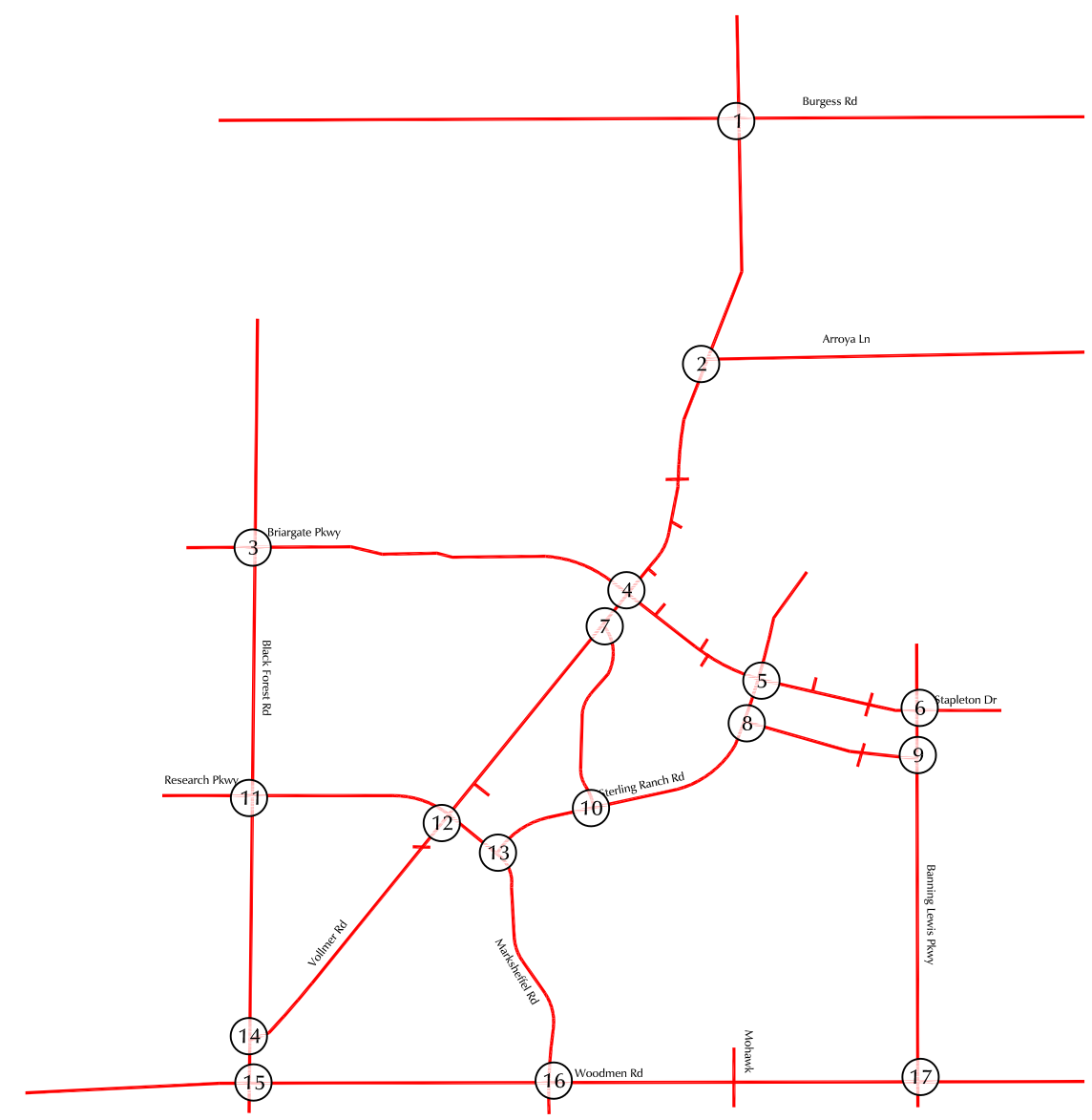
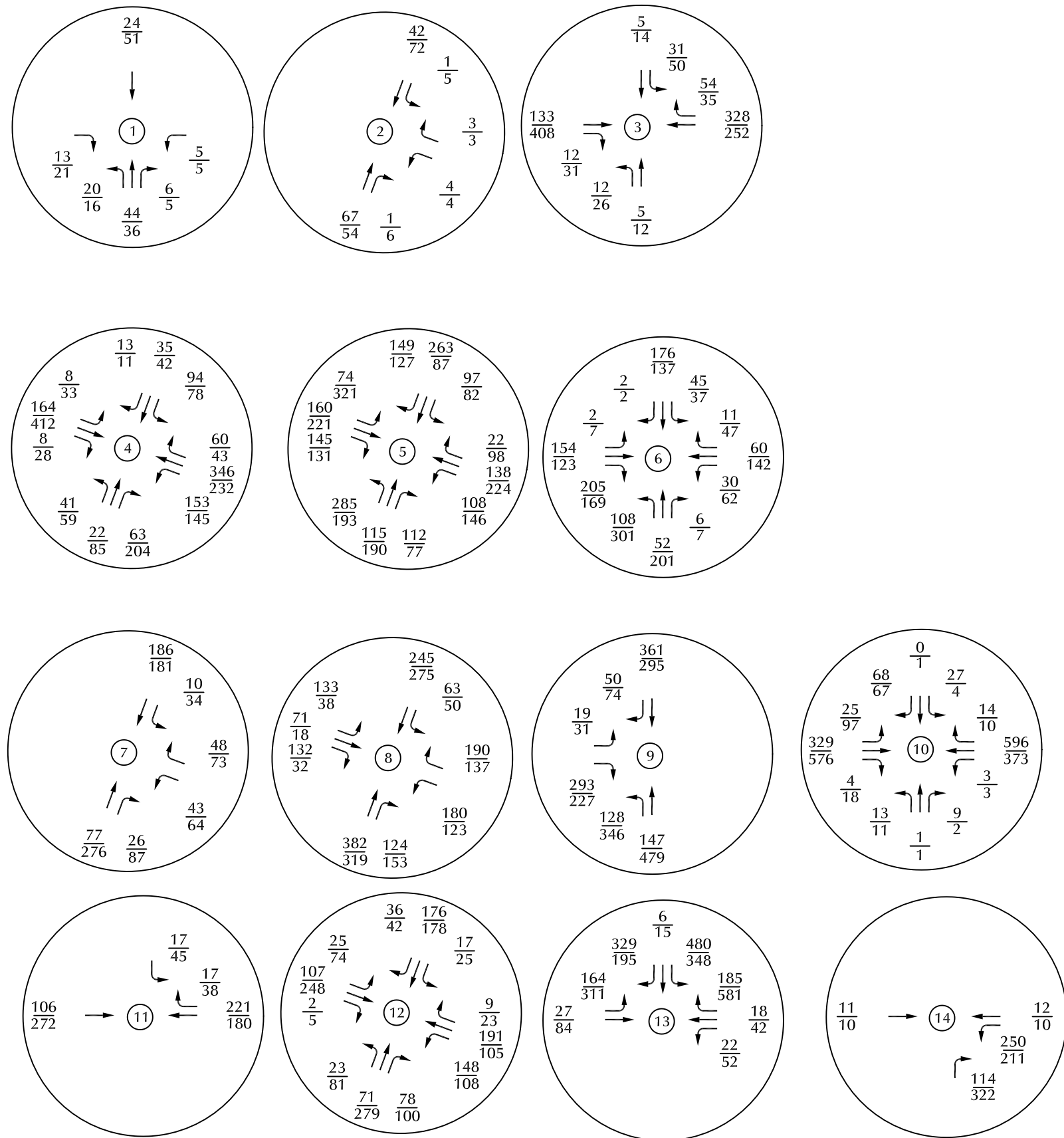

Figure 1

Vicinity

Sterling Ranch East Rezoning and Preliminary Plan (LSC# S224440)





LEGEND: $\frac{XX}{XX} = \frac{\text{AM Peak-Hour Traffic (veh/hr)}}{\text{PM Peak-Hour Traffic (veh/hr)}}$

Figure 9b
Site-Generated Peak-Hour Traffic

Sterling Ranch Sketch Plan - 2022 Amendment (LSC# S224440)

LAND USE LEGEND:

44 AC. RESIDENTIAL: 0.2 DU/AC	9 D.U.
33 AC. RESIDENTIAL: 0.4 DU/AC	13 D.U.
35 AC. RESIDENTIAL: 1 DU/AC	35 D.U.
163 AC. RESIDENTIAL: 2 DU/AC	326 D.U.
790 AC. RESIDENTIAL: 3-5 DU/AC	3,642 D.U.
86 AC. RESIDENTIAL: 5-8 DU/AC	600 D.U.
47 AC. MIXED USE 8-25 DU/AC *	600 D.U.
57 AC. ELEMENTARY / K-8 SCHOOL	
18 AC. NEIGHBORHOOD PARK	
25 AC. COMMUNITY PARK	
62 AC. OPEN SPACE / PARK / GREENWAY	
43 AC. OPEN SPACE / BUFFER	
9 AC. UTILITY PARCEL	
5 AC. INDUSTRIAL	

TOTAL: 1,444 AC. TOTAL: 4,800 D.U. Max
 * COMMERCIAL/MULTIFAMILY UP TO 25 DU/AC

LEGAL DESCRIPTION:

THE WEST HALF OF THE WEST HALF OF THE EAST HALF AND EAST HALF OF THE WEST HALF AND THE SOUTHWEST QUARTER OF THE SOUTHWEST QUARTER OF SECTION 27; THE EAST HALF OF THE SOUTHWEST QUARTER AND THAT PORTION OF THE SOUTHWEST QUARTER OF THE SOUTHWEST QUARTER LYING SOUTH AND EAST OF THE COUNTY ROAD KNOWN AS VOLLMER ROAD, OF SECTION 28; THE WEST HALF OF THE EAST HALF AND THE WEST HALF OF SECTION 34; THE EAST HALF AND THE EAST HALF OF THE SOUTHWEST QUARTER AND THE SOUTHWEST QUARTER OF THE SOUTHWEST QUARTER OF SECTION 33, AND ALL THAT PART OF THE NORTHWEST QUARTER OF SECTION 33 LYING SOUTH AND EAST OF THE COUNTY ROAD KNOWN AS VOLLMER ROAD, EXCEPT THAT PORTION OF THE SOUTHWEST QUARTER OF THE NORTHWEST QUARTER OF SAID SECTION 33 LYING SOUTH AND EAST OF SAID COUNTY ROAD AS DEEDED TO COLORADO INTERSTATE GAS COMPANY BY WARRANTY DEED RECORDED IN BOOK 1173 AT PAGE 359; AND THAT PORTION OF THE NORTHEAST QUARTER OF THE SOUTHWEST QUARTER AND THE SOUTHWEST QUARTER OF THE SOUTHWEST QUARTER LYING SOUTHWEST OF THE COUNTY ROAD KNOWN AS VOLLMER ROAD, OF SECTION 32, EXCEPT THAT PORTION OF THE NORTHEAST QUARTER OF THE SOUTHWEST QUARTER OF SAID SECTION 32 DEEDED TO J. MARCUS BROWN BY TRUSTEES' DEED RECORDED IN BOOK 3292 AT PAGE 168; ALL IN TOWNSHIP 12 SOUTH, RANGE 65 WEST OF THE 6TH P.M., EL PASO COUNTY, COLORADO. ALL THAT PORTION OF THE NORTHWEST QUARTER OF THE SOUTHWEST QUARTER OF SECTION 28, TOWNSHIP 12 SOUTH, RANGE 65 WEST OF THE 6TH P.M., EL PASO COUNTY, COLORADO LYING SOUTH AND EAST OF THE COUNTY ROAD (VOLLMER ROAD), ALSO; THE NORTHWEST QUARTER OF THE NORTHWEST QUARTER OF SECTION 4, TOWNSHIP 13 SOUTH, RANGE 65 WEST OF THE SIXTH PRINCIPAL MERIDIAN, LYING SOUTHERLY OF AN EXISTING EAST-WEST FENCE AS DESCRIBED IN SPECIAL WARRANTY DEED RECORDED DECEMBER 23, 2004 AT RECEPTION NO. 204209417, COUNTY OF EL PASO, STATE OF COLORADO, ALSO; THE SOUTHWEST QUARTER OF THE SOUTHWEST QUARTER OF THE SOUTHWEST QUARTER OF SECTION 32, TOWNSHIP 12 SOUTH, RANGE 65 WEST OF THE 6TH P.M., LYING SOUTHEASTERLY OF THE PUBLIC ROAD KNOWN AS VOLLMER ROAD, EL PASO COUNTY, COLORADO, AND CONTAINING 1443.695 ACRES MORE OR LESS.

OWNERS:

SR LAND, LLC.
20 BOULDER CRESCENT STREET, SUITE 102
COLORADO SPRINGS, CO 80903-3300

CLASSIC SRJ LAND, LLC
2138 FLYING HORSE CLUB DRIVE
COLORADO SPRINGS, CO 80921

CHALLENGER COMMUNITIES, LLC.
8605 EXPLORER DRIVE, SUITE 250
COLORADO SPRINGS, CO 80920-1013

STERLING RANCH SKETCH PLAN AMENDMENT

SYMBOL LEGEND:

- ROAD
- FULL MOVEMENT ACCESS POINT
- 3/4 MOVEMENT
- R/W/O
- 100-YEAR FLOODPLAIN
- TRAIL
- BUFFER / OS TRAIL CORRIDOR / EASEMENT
- NEIGHBORHOOD PARK
- ACCESS SPACING (FEET)

VICINITY MAP:

Overall Development Dwelling Unit Table

Dwelling Units	Homestead Fil 1 SF 04-029	Banding Iron Fil 1 SF-06-017	Homestead Fil 2 SF 19-004	Banding Iron Fil 2 SF-19-018	Sterling Ranch Fil 2 SF-20-015	Total Entitled Units	Remaining Developable Units	Maximum Dwelling Units
72	51	104	75	49	351	449	4800	

ROAD CLASSIFICATION TABLE

Roadway	Existing	2040 MTC/P	2060 MTC/CP	Sterling Ranch Proposed
Voller Road	2 lane Collector - 60'	4 lane Minor - 100'	4 lane Minor - 100'	4 lane Minor - 100'
Briargate Parkway	4 lane Principal - 130'	4 lane Principal - 130'	4 lane Principal - 130'	4 lane Principal - 130'
Banning Lewis Ranch Parkway	4 lane Principal - 130'	4 lane Principal - 130'	4 lane Principal - 130'	4 lane Principal - 130'
Marksheffel Road	4 lane Principal - 130'	4 lane Principal - 130'	4 lane Principal - 130'	4 lane Principal - 130'

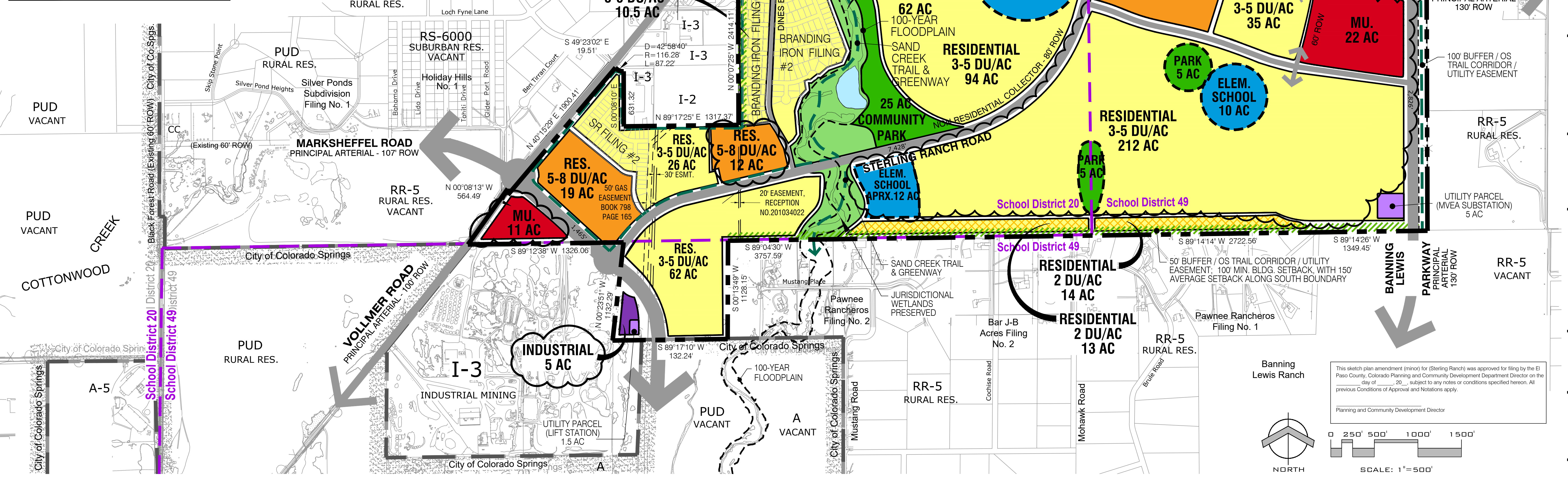
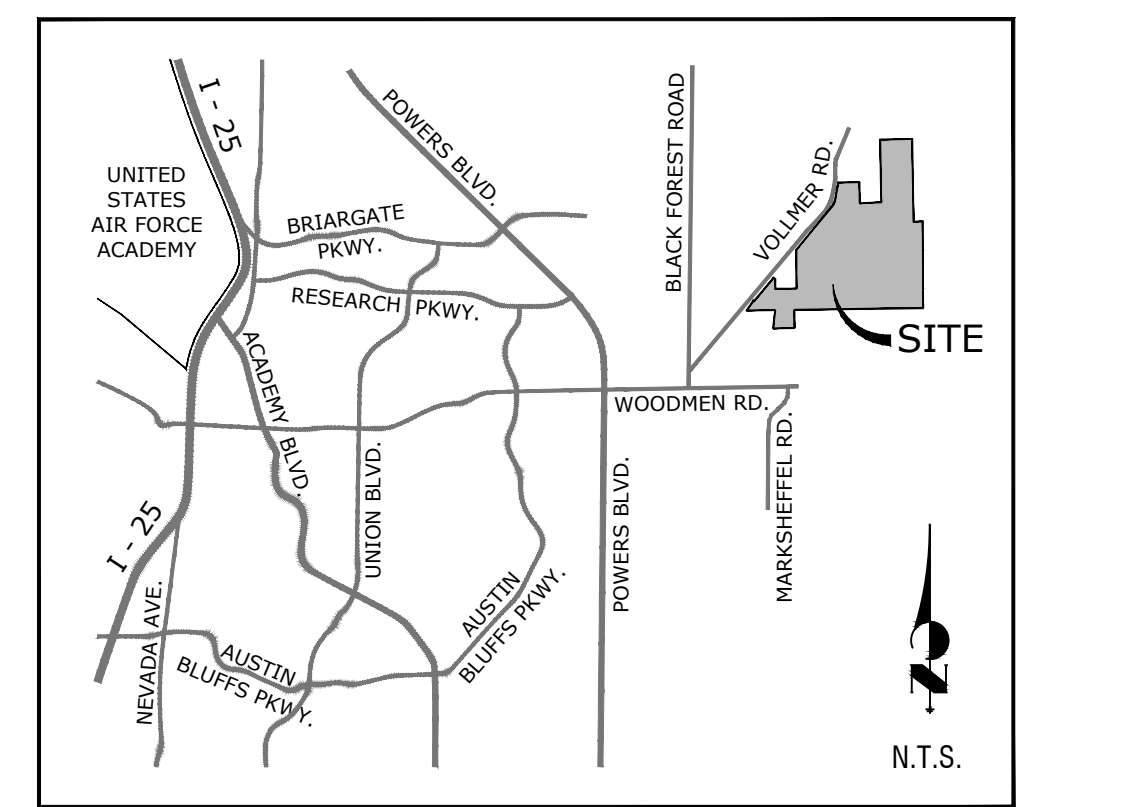

Land Planning
Landscape Architecture
Urban Design

NES

N.E.S. Inc.
619 N. Cascade Avenue, Suite 200
Colorado Springs, CO 80903

Tel. 719.471.0073
Fax 719.471.0267

www.nescolorado.com

© 2012. All Rights Reserved.

STERLING RANCH SKETCH PLAN AMENDMENT

MORLEY-BENTLEY INVESTMENTS, LLC.

DATE: OCTOBER 29, 2007
 PROJECT MGR: J. MANNING ROMERO
 PREPARED BY: J. KUHNEL/M. SWIFT

REVISIONS:

DATE	BY	DESCRIPTION
05.22.2009	JK	APPROVED SKETCH PLAN PER COUNTY - NOV. 2008
12.05.2018	BE	APPROVED SKETCH PLAN AMENDMENT - DEC. 2018
07.01.2022	BE	SKETCH PLAN AMEND 2022
08.30.2022	AL	SKETCH PLAN AMEND 2022
12.22.2022	JS	SKETCH PLAN AMEND 2022

This sketch plan amendment (minor) for (Sterling Ranch) was approved for filing by the El Paso County, Colorado Planning and Community Development Department Director on the day of _____, 20____, subject to any notes or conditions specified hereon. All previous Conditions of Approval and Notations apply.

Planning and Community Development Director

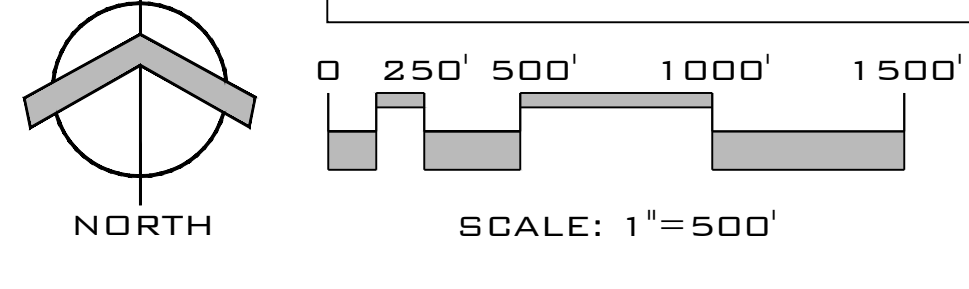

APPENDIX E

Intersection Analysis Worksheets

Intersection												
Int Delay, s/veh	1.3											
Movement	EBL	EBT	EBR	WBL	WBT	WBR	NBL	NBT	NBR	SBL	SBT	SBR
Lane Configurations		↕			↕	↕		↕	↕		↕	
Traffic Vol, veh/h	8	0	16	9	0	2	27	178	13	4	281	26
Future Vol, veh/h	8	0	16	9	0	2	27	178	13	4	281	26
Conflicting Peds, #/hr	0	0	0	0	0	0	0	0	0	0	0	0
Sign Control	Stop	Stop	Stop	Stop	Stop	Stop	Free	Free	Free	Free	Free	Free
RT Channelized	-	-	None	-	-	None	-	-	None	-	-	None
Storage Length	-	-	-	-	-	0	-	-	350	-	-	-
Veh in Median Storage, #	-	0	-	-	0	-	-	0	-	-	0	-
Grade, %	-	0	-	-	0	-	-	0	-	-	0	-
Peak Hour Factor	79	79	79	79	79	79	79	79	79	79	79	79
Heavy Vehicles, %	6	6	6	6	6	6	6	6	6	6	6	6
Mvmt Flow	10	0	20	11	0	3	34	225	16	5	356	33

Major/Minor	Minor2		Minor1		Major1		Major2					
Conflicting Flow All	686	692	373	686	692	225	389	0	0	241	0	0
Stage 1	383	383	-	293	293	-	-	-	-	-	-	-
Stage 2	303	309	-	393	399	-	-	-	-	-	-	-
Critical Hdwy	7.16	6.56	6.26	7.16	6.56	6.26	4.16	-	-	4.16	-	-
Critical Hdwy Stg 1	6.16	5.56	-	6.16	5.56	-	-	-	-	-	-	-
Critical Hdwy Stg 2	6.16	5.56	-	6.16	5.56	-	-	-	-	-	-	-
Follow-up Hdwy	3.554	4.054	3.354	3.554	4.054	3.354	2.254	-	-	2.254	-	-
Pot Cap-1 Maneuver	356	362	664	356	362	805	1148	-	-	1302	-	-
Stage 1	632	605	-	707	663	-	-	-	-	-	-	-
Stage 2	698	652	-	624	595	-	-	-	-	-	-	-
Platoon blocked, %								-	-	-	-	-
Mov Cap-1 Maneuver	344	348	664	335	348	805	1148	-	-	1302	-	-
Mov Cap-2 Maneuver	344	348	-	335	348	-	-	-	-	-	-	-
Stage 1	611	602	-	683	640	-	-	-	-	-	-	-
Stage 2	672	630	-	602	592	-	-	-	-	-	-	-

Approach	EB		WB		NB		SB	
HCM Control Delay, s	12.6		14.9		1		0.1	
HCM LOS	B		B					

Minor Lane/Major Mvmt	NBL	NBT	NBR	EBLn1	WBLn1	WBLn2	SBL	SBT	SBR
Capacity (veh/h)	1148	-	-	507	335	805	1302	-	-
HCM Lane V/C Ratio	0.03	-	-	0.06	0.034	0.003	0.004	-	-
HCM Control Delay (s)	8.2	0	-	12.6	16.1	9.5	7.8	0	-
HCM Lane LOS	A	A	-	B	C	A	A	A	-
HCM 95th %tile Q(veh)	0.1	-	-	0.2	0.1	0	0	-	-

Intersection												
Int Delay, s/veh	1.4											
Movement	EBL	EBT	EBR	WBL	WBT	WBR	NBL	NBT	NBR	SBL	SBT	SBR
Lane Configurations		↕			↕	↕		↕	↕		↕	
Traffic Vol, veh/h	15	1	12	13	0	7	29	289	14	2	245	6
Future Vol, veh/h	15	1	12	13	0	7	29	289	14	2	245	6
Conflicting Peds, #/hr	0	0	0	0	0	0	0	0	0	0	0	0
Sign Control	Stop	Stop	Stop	Stop	Stop	Stop	Free	Free	Free	Free	Free	Free
RT Channelized	-	-	None	-	-	None	-	-	None	-	-	None
Storage Length	-	-	-	-	-	0	-	-	350	-	-	-
Veh in Median Storage, #	-	0	-	-	0	-	-	0	-	-	0	-
Grade, %	-	0	-	-	0	-	-	0	-	-	0	-
Peak Hour Factor	92	92	92	92	92	92	92	92	92	92	92	92
Heavy Vehicles, %	4	4	4	4	4	4	4	4	4	4	4	4
Mvmt Flow	16	1	13	14	0	8	32	314	15	2	266	7

Major/Minor	Minor2		Minor1		Major1			Major2				
Conflicting Flow All	664	667	270	659	655	314	273	0	0	329	0	0
Stage 1	274	274	-	378	378	-	-	-	-	-	-	-
Stage 2	390	393	-	281	277	-	-	-	-	-	-	-
Critical Hdwy	7.14	6.54	6.24	7.14	6.54	6.24	4.14	-	-	4.14	-	-
Critical Hdwy Stg 1	6.14	5.54	-	6.14	5.54	-	-	-	-	-	-	-
Critical Hdwy Stg 2	6.14	5.54	-	6.14	5.54	-	-	-	-	-	-	-
Follow-up Hdwy	3.536	4.036	3.336	3.536	4.036	3.336	2.236	-	-	2.236	-	-
Pot Cap-1 Maneuver	371	377	764	374	383	722	1279	-	-	1219	-	-
Stage 1	728	680	-	640	612	-	-	-	-	-	-	-
Stage 2	630	602	-	721	678	-	-	-	-	-	-	-
Platoon blocked, %								-	-	-	-	-
Mov Cap-1 Maneuver	358	365	764	358	370	722	1279	-	-	1219	-	-
Mov Cap-2 Maneuver	358	365	-	358	370	-	-	-	-	-	-	-
Stage 1	705	679	-	620	593	-	-	-	-	-	-	-
Stage 2	604	583	-	706	677	-	-	-	-	-	-	-

Approach	EB		WB		NB			SB		
HCM Control Delay, s	13.3		13.6		0.7			0.1		
HCM LOS	B		B							

Minor Lane/Major Mvmt	NBL	NBT	NBR	EBLn1	WBLn1	WBLn2	SBL	SBT	SBR
Capacity (veh/h)	1279	-	-	464	358	722	1219	-	-
HCM Lane V/C Ratio	0.025	-	-	0.066	0.039	0.011	0.002	-	-
HCM Control Delay (s)	7.9	0	-	13.3	15.5	10	8	0	-
HCM Lane LOS	A	A	-	B	C	B	A	A	-
HCM 95th %tile Q(veh)	0.1	-	-	0.2	0.1	0	0	-	-

Intersection												
Int Delay, s/veh	1.3											
Movement	EBL	EBT	EBR	WBL	WBT	WBR	NBL	NBT	NBR	SBL	SBT	SBR
Lane Configurations		↕			↕	↕		↕	↕		↕	
Traffic Vol, veh/h	8	0	16	9	0	2	27	189	13	4	298	26
Future Vol, veh/h	8	0	16	9	0	2	27	189	13	4	298	26
Conflicting Peds, #/hr	0	0	0	0	0	0	0	0	0	0	0	0
Sign Control	Stop	Stop	Stop	Stop	Stop	Stop	Free	Free	Free	Free	Free	Free
RT Channelized	-	-	None	-	-	None	-	-	None	-	-	None
Storage Length	-	-	-	-	-	0	-	-	350	-	-	-
Veh in Median Storage, #	-	0	-	-	0	-	-	0	-	-	0	-
Grade, %	-	0	-	-	0	-	-	0	-	-	0	-
Peak Hour Factor	79	79	79	79	79	79	79	79	79	79	79	79
Heavy Vehicles, %	6	6	6	6	6	6	6	6	6	6	6	6
Mvmt Flow	10	0	20	11	0	3	34	239	16	5	377	33

Major/Minor	Minor2		Minor1		Major1			Major2				
Conflicting Flow All	721	727	394	721	727	239	410	0	0	255	0	0
Stage 1	404	404	-	307	307	-	-	-	-	-	-	-
Stage 2	317	323	-	414	420	-	-	-	-	-	-	-
Critical Hdwy	7.16	6.56	6.26	7.16	6.56	6.26	4.16	-	-	4.16	-	-
Critical Hdwy Stg 1	6.16	5.56	-	6.16	5.56	-	-	-	-	-	-	-
Critical Hdwy Stg 2	6.16	5.56	-	6.16	5.56	-	-	-	-	-	-	-
Follow-up Hdwy	3.554	4.054	3.354	3.554	4.054	3.354	2.254	-	-	2.254	-	-
Pot Cap-1 Maneuver	337	346	646	337	346	790	1128	-	-	1287	-	-
Stage 1	615	592	-	694	654	-	-	-	-	-	-	-
Stage 2	686	643	-	608	583	-	-	-	-	-	-	-
Platoon blocked, %								-	-	-	-	-
Mov Cap-1 Maneuver	326	332	646	316	332	790	1128	-	-	1287	-	-
Mov Cap-2 Maneuver	326	332	-	316	332	-	-	-	-	-	-	-
Stage 1	593	589	-	670	631	-	-	-	-	-	-	-
Stage 2	660	620	-	586	580	-	-	-	-	-	-	-

Approach	EB		WB		NB		SB	
HCM Control Delay, s	12.9		15.5		1		0.1	
HCM LOS	B		C					

Minor Lane/Major Mvmt	NBL	NBT	NBR	EBLn1	WBLn1	WBLn2	SBL	SBT	SBR
Capacity (veh/h)	1128	-	-	487	316	790	1287	-	-
HCM Lane V/C Ratio	0.03	-	-	0.062	0.036	0.003	0.004	-	-
HCM Control Delay (s)	8.3	0	-	12.9	16.8	9.6	7.8	0	-
HCM Lane LOS	A	A	-	B	C	A	A	A	-
HCM 95th %tile Q(veh)	0.1	-	-	0.2	0.1	0	0	-	-

Intersection												
Int Delay, s/veh	1.4											
Movement	EBL	EBT	EBR	WBL	WBT	WBR	NBL	NBT	NBR	SBL	SBT	SBR
Lane Configurations		↕			↕	↕		↕	↕		↕	
Traffic Vol, veh/h	15	1	12	13	0	7	29	307	14	2	260	6
Future Vol, veh/h	15	1	12	13	0	7	29	307	14	2	260	6
Conflicting Peds, #/hr	0	0	0	0	0	0	0	0	0	0	0	0
Sign Control	Stop	Stop	Stop	Stop	Stop	Stop	Free	Free	Free	Free	Free	Free
RT Channelized	-	-	None	-	-	None	-	-	None	-	-	None
Storage Length	-	-	-	-	-	0	-	-	350	-	-	-
Veh in Median Storage, #	-	0	-	-	0	-	-	0	-	-	0	-
Grade, %	-	0	-	-	0	-	-	0	-	-	0	-
Peak Hour Factor	92	92	92	92	92	92	92	92	92	92	92	92
Heavy Vehicles, %	4	4	4	4	4	4	4	4	4	4	4	4
Mvmt Flow	16	1	13	14	0	8	32	334	15	2	283	7

Major/Minor	Minor2		Minor1			Major1			Major2			
Conflicting Flow All	701	704	287	696	692	334	290	0	0	349	0	0
Stage 1	291	291	-	398	398	-	-	-	-	-	-	-
Stage 2	410	413	-	298	294	-	-	-	-	-	-	-
Critical Hdwy	7.14	6.54	6.24	7.14	6.54	6.24	4.14	-	-	4.14	-	-
Critical Hdwy Stg 1	6.14	5.54	-	6.14	5.54	-	-	-	-	-	-	-
Critical Hdwy Stg 2	6.14	5.54	-	6.14	5.54	-	-	-	-	-	-	-
Follow-up Hdwy	3.536	4.036	3.336	3.536	4.036	3.336	2.236	-	-	2.236	-	-
Pot Cap-1 Maneuver	351	359	747	353	365	703	1260	-	-	1199	-	-
Stage 1	713	668	-	624	599	-	-	-	-	-	-	-
Stage 2	615	590	-	706	666	-	-	-	-	-	-	-
Platoon blocked, %								-	-	-	-	-
Mov Cap-1 Maneuver	338	347	747	337	353	703	1260	-	-	1199	-	-
Mov Cap-2 Maneuver	338	347	-	337	353	-	-	-	-	-	-	-
Stage 1	690	667	-	604	580	-	-	-	-	-	-	-
Stage 2	589	571	-	691	665	-	-	-	-	-	-	-

Approach	EB		WB			NB			SB		
HCM Control Delay, s	13.7		14.1			0.7			0.1		
HCM LOS	B		B								

Minor Lane/Major Mvmt	NBL	NBT	NBR	EBLn1	WBLn1	WBLn2	SBL	SBT	SBR
Capacity (veh/h)	1260	-	-	442	337	703	1199	-	-
HCM Lane V/C Ratio	0.025	-	-	0.069	0.042	0.011	0.002	-	-
HCM Control Delay (s)	7.9	0	-	13.7	16.2	10.2	8	0	-
HCM Lane LOS	A	A	-	B	C	B	A	A	-
HCM 95th %tile Q(veh)	0.1	-	-	0.2	0.1	0	0	-	-

Intersection												
Int Delay, s/veh	1.7											
Movement	EBL	EBT	EBR	WBL	WBT	WBR	NBL	NBT	NBR	SBL	SBT	SBR
Lane Configurations		↕			↕	↕		↕	↕		↕	
Traffic Vol, veh/h	8	0	16	23	0	6	27	189	27	8	298	26
Future Vol, veh/h	8	0	16	23	0	6	27	189	27	8	298	26
Conflicting Peds, #/hr	0	0	0	0	0	0	0	0	0	0	0	0
Sign Control	Stop	Stop	Stop	Stop	Stop	Stop	Free	Free	Free	Free	Free	Free
RT Channelized	-	-	None	-	-	None	-	-	None	-	-	None
Storage Length	-	-	-	-	-	0	-	-	350	-	-	-
Veh in Median Storage, #	-	0	-	-	0	-	-	0	-	-	0	-
Grade, %	-	0	-	-	0	-	-	0	-	-	0	-
Peak Hour Factor	79	79	79	79	79	79	79	79	79	79	79	79
Heavy Vehicles, %	6	6	6	6	6	6	6	6	6	6	6	6
Mvmt Flow	10	0	20	29	0	8	34	239	34	10	377	33

Major/Minor	Minor2		Minor1		Major1			Major2				
Conflicting Flow All	742	755	394	731	737	239	410	0	0	273	0	0
Stage 1	414	414	-	307	307	-	-	-	-	-	-	-
Stage 2	328	341	-	424	430	-	-	-	-	-	-	-
Critical Hdwy	7.16	6.56	6.26	7.16	6.56	6.26	4.16	-	-	4.16	-	-
Critical Hdwy Stg 1	6.16	5.56	-	6.16	5.56	-	-	-	-	-	-	-
Critical Hdwy Stg 2	6.16	5.56	-	6.16	5.56	-	-	-	-	-	-	-
Follow-up Hdwy	3.554	4.054	3.354	3.554	4.054	3.354	2.254	-	-	2.254	-	-
Pot Cap-1 Maneuver	327	333	646	332	341	790	1128	-	-	1267	-	-
Stage 1	608	586	-	694	654	-	-	-	-	-	-	-
Stage 2	676	632	-	600	577	-	-	-	-	-	-	-
Platoon blocked, %								-	-	-	-	-
Mov Cap-1 Maneuver	313	318	646	310	325	790	1128	-	-	1267	-	-
Mov Cap-2 Maneuver	313	318	-	310	325	-	-	-	-	-	-	-
Stage 1	586	580	-	669	630	-	-	-	-	-	-	-
Stage 2	645	609	-	575	571	-	-	-	-	-	-	-

Approach	EB		WB		NB		SB	
HCM Control Delay, s	13.1		16.1		0.9		0.2	
HCM LOS	B		C					

Minor Lane/Major Mvmt	NBL	NBT	NBR	EBLn1	WBLn1	WBLn2	SBL	SBT	SBR
Capacity (veh/h)	1128	-	-	477	310	790	1267	-	-
HCM Lane V/C Ratio	0.03	-	-	0.064	0.094	0.01	0.008	-	-
HCM Control Delay (s)	8.3	0	-	13.1	17.8	9.6	7.9	0	-
HCM Lane LOS	A	A	-	B	C	A	A	A	-
HCM 95th %tile Q(veh)	0.1	-	-	0.2	0.3	0	0	-	-

Intersection												
Int Delay, s/veh	1.8											
Movement	EBL	EBT	EBR	WBL	WBT	WBR	NBL	NBT	NBR	SBL	SBT	SBR
Lane Configurations		↕			↕	↕		↕	↕		↕	
Traffic Vol, veh/h	15	1	12	27	0	11	29	307	28	6	260	6
Future Vol, veh/h	15	1	12	27	0	11	29	307	28	6	260	6
Conflicting Peds, #/hr	0	0	0	0	0	0	0	0	0	0	0	0
Sign Control	Stop	Stop	Stop	Stop	Stop	Stop	Free	Free	Free	Free	Free	Free
RT Channelized	-	-	None	-	-	None	-	-	None	-	-	None
Storage Length	-	-	-	-	-	0	-	-	350	-	-	-
Veh in Median Storage, #	-	0	-	-	0	-	-	0	-	-	0	-
Grade, %	-	0	-	-	0	-	-	0	-	-	0	-
Peak Hour Factor	92	92	92	92	92	92	92	92	92	92	92	92
Heavy Vehicles, %	4	4	4	4	4	4	4	4	4	4	4	4
Mvmt Flow	16	1	13	29	0	12	32	334	30	7	283	7

Major/Minor	Minor2		Minor1		Major1			Major2				
Conflicting Flow All	720	729	287	706	702	334	290	0	0	364	0	0
Stage 1	301	301	-	398	398	-	-	-	-	-	-	-
Stage 2	419	428	-	308	304	-	-	-	-	-	-	-
Critical Hdwy	7.14	6.54	6.24	7.14	6.54	6.24	4.14	-	-	4.14	-	-
Critical Hdwy Stg 1	6.14	5.54	-	6.14	5.54	-	-	-	-	-	-	-
Critical Hdwy Stg 2	6.14	5.54	-	6.14	5.54	-	-	-	-	-	-	-
Follow-up Hdwy	3.536	4.036	3.336	3.536	4.036	3.336	2.236	-	-	2.236	-	-
Pot Cap-1 Maneuver	341	347	747	348	360	703	1260	-	-	1184	-	-
Stage 1	704	661	-	624	599	-	-	-	-	-	-	-
Stage 2	608	581	-	698	659	-	-	-	-	-	-	-
Platoon blocked, %								-	-	-	-	-
Mov Cap-1 Maneuver	325	333	747	331	346	703	1260	-	-	1184	-	-
Mov Cap-2 Maneuver	325	333	-	331	346	-	-	-	-	-	-	-
Stage 1	681	656	-	604	580	-	-	-	-	-	-	-
Stage 2	579	562	-	680	654	-	-	-	-	-	-	-

Approach	EB		WB		NB		SB	
HCM Control Delay, s	14		15		0.6		0.2	
HCM LOS	B		C					

Minor Lane/Major Mvmt	NBL	NBT	NBR	EBLn1	WBLn1	WBLn2	SBL	SBT	SBR
Capacity (veh/h)	1260	-	-	429	331	703	1184	-	-
HCM Lane V/C Ratio	0.025	-	-	0.071	0.089	0.017	0.006	-	-
HCM Control Delay (s)	7.9	0	-	14	16.9	10.2	8.1	0	-
HCM Lane LOS	A	A	-	B	C	B	A	A	-
HCM 95th %tile Q(veh)	0.1	-	-	0.2	0.3	0.1	0	-	-

Intersection												
Int Delay, s/veh	1.3											
Movement	EBL	EBT	EBR	WBL	WBT	WBR	NBL	NBT	NBR	SBL	SBT	SBR
Lane Configurations		↕			↕	↕		↕	↕		↕	
Traffic Vol, veh/h	8	0	16	9	0	2	27	189	13	4	298	26
Future Vol, veh/h	8	0	16	9	0	2	27	189	13	4	298	26
Conflicting Peds, #/hr	0	0	0	0	0	0	0	0	0	0	0	0
Sign Control	Stop	Stop	Stop	Stop	Stop	Stop	Free	Free	Free	Free	Free	Free
RT Channelized	-	-	None	-	-	None	-	-	None	-	-	None
Storage Length	-	-	-	-	-	0	-	-	350	-	-	-
Veh in Median Storage, #	-	0	-	-	0	-	-	0	-	-	0	-
Grade, %	-	0	-	-	0	-	-	0	-	-	0	-
Peak Hour Factor	79	79	79	79	79	79	79	79	79	79	79	79
Heavy Vehicles, %	6	6	6	6	6	6	6	6	6	6	6	6
Mvmt Flow	10	0	20	11	0	3	34	239	16	5	377	33

Major/Minor	Minor2		Minor1		Major1			Major2				
Conflicting Flow All	721	727	394	721	727	239	410	0	0	255	0	0
Stage 1	404	404	-	307	307	-	-	-	-	-	-	-
Stage 2	317	323	-	414	420	-	-	-	-	-	-	-
Critical Hdwy	7.16	6.56	6.26	7.16	6.56	6.26	4.16	-	-	4.16	-	-
Critical Hdwy Stg 1	6.16	5.56	-	6.16	5.56	-	-	-	-	-	-	-
Critical Hdwy Stg 2	6.16	5.56	-	6.16	5.56	-	-	-	-	-	-	-
Follow-up Hdwy	3.554	4.054	3.354	3.554	4.054	3.354	2.254	-	-	2.254	-	-
Pot Cap-1 Maneuver	337	346	646	337	346	790	1128	-	-	1287	-	-
Stage 1	615	592	-	694	654	-	-	-	-	-	-	-
Stage 2	686	643	-	608	583	-	-	-	-	-	-	-
Platoon blocked, %								-	-	-	-	-
Mov Cap-1 Maneuver	326	332	646	316	332	790	1128	-	-	1287	-	-
Mov Cap-2 Maneuver	326	332	-	316	332	-	-	-	-	-	-	-
Stage 1	593	589	-	670	631	-	-	-	-	-	-	-
Stage 2	660	620	-	586	580	-	-	-	-	-	-	-

Approach	EB		WB		NB		SB	
HCM Control Delay, s	12.9		15.5		1		0.1	
HCM LOS	B		C					

Minor Lane/Major Mvmt	NBL	NBT	NBR	EBLn1	WBLn1	WBLn2	SBL	SBT	SBR
Capacity (veh/h)	1128	-	-	487	316	790	1287	-	-
HCM Lane V/C Ratio	0.03	-	-	0.062	0.036	0.003	0.004	-	-
HCM Control Delay (s)	8.3	0	-	12.9	16.8	9.6	7.8	0	-
HCM Lane LOS	A	A	-	B	C	A	A	A	-
HCM 95th %tile Q(veh)	0.1	-	-	0.2	0.1	0	0	-	-

Intersection												
Int Delay, s/veh	1.2											
Movement	EBL	EBT	EBR	WBL	WBT	WBR	NBL	NBT	NBR	SBL	SBT	SBR
Lane Configurations		↕			↕	↕		↕	↕		↕	
Traffic Vol, veh/h	15	1	12	13	0	7	29	455	14	2	385	6
Future Vol, veh/h	15	1	12	13	0	7	29	455	14	2	385	6
Conflicting Peds, #/hr	0	0	0	0	0	0	0	0	0	0	0	0
Sign Control	Stop	Stop	Stop	Stop	Stop	Stop	Free	Free	Free	Free	Free	Free
RT Channelized	-	-	None	-	-	None	-	-	None	-	-	None
Storage Length	-	-	-	-	-	0	-	-	350	-	-	-
Veh in Median Storage, #	-	0	-	-	0	-	-	0	-	-	0	-
Grade, %	-	0	-	-	0	-	-	0	-	-	0	-
Peak Hour Factor	92	92	92	92	92	92	92	92	92	92	92	92
Heavy Vehicles, %	4	4	4	4	4	4	4	4	4	4	4	4
Mvmt Flow	16	1	13	14	0	8	32	495	15	2	418	7

Major/Minor	Minor2		Minor1		Major1			Major2				
Conflicting Flow All	997	1000	422	992	988	495	425	0	0	510	0	0
Stage 1	426	426	-	559	559	-	-	-	-	-	-	-
Stage 2	571	574	-	433	429	-	-	-	-	-	-	-
Critical Hdwy	7.14	6.54	6.24	7.14	6.54	6.24	4.14	-	-	4.14	-	-
Critical Hdwy Stg 1	6.14	5.54	-	6.14	5.54	-	-	-	-	-	-	-
Critical Hdwy Stg 2	6.14	5.54	-	6.14	5.54	-	-	-	-	-	-	-
Follow-up Hdwy	3.536	4.036	3.336	3.536	4.036	3.336	2.236	-	-	2.236	-	-
Pot Cap-1 Maneuver	221	241	627	223	245	571	1124	-	-	1045	-	-
Stage 1	602	582	-	510	508	-	-	-	-	-	-	-
Stage 2	502	500	-	597	581	-	-	-	-	-	-	-
Platoon blocked, %								-	-	-	-	-
Mov Cap-1 Maneuver	211	231	627	211	234	571	1124	-	-	1045	-	-
Mov Cap-2 Maneuver	211	231	-	211	234	-	-	-	-	-	-	-
Stage 1	578	580	-	490	488	-	-	-	-	-	-	-
Stage 2	475	480	-	582	579	-	-	-	-	-	-	-

Approach	EB		WB		NB		SB	
HCM Control Delay, s	18.6		19.1		0.5		0	
HCM LOS	C		C					

Minor Lane/Major Mvmt	NBL	NBT	NBR	EBLn1	WBLn1	WBLn2	SBL	SBT	SBR
Capacity (veh/h)	1124	-	-	296	211	571	1045	-	-
HCM Lane V/C Ratio	0.028	-	-	0.103	0.067	0.013	0.002	-	-
HCM Control Delay (s)	8.3	0	-	18.6	23.3	11.4	8.5	0	-
HCM Lane LOS	A	A	-	C	C	B	A	A	-
HCM 95th %tile Q(veh)	0.1	-	-	0.3	0.2	0	0	-	-

Intersection												
Int Delay, s/veh	1.2											
Movement	EBL	EBT	EBR	WBL	WBT	WBR	NBL	NBT	NBR	SBL	SBT	SBR
Lane Configurations		↕			↕	↕		↕	↕		↕	
Traffic Vol, veh/h	8	0	16	9	0	2	27	383	13	4	671	26
Future Vol, veh/h	8	0	16	9	0	2	27	383	13	4	671	26
Conflicting Peds, #/hr	0	0	0	0	0	0	0	0	0	0	0	0
Sign Control	Stop	Stop	Stop	Stop	Stop	Stop	Free	Free	Free	Free	Free	Free
RT Channelized	-	-	None	-	-	None	-	-	None	-	-	None
Storage Length	-	-	-	-	-	0	-	-	350	-	-	-
Veh in Median Storage, #	-	0	-	-	0	-	-	0	-	-	0	-
Grade, %	-	0	-	-	0	-	-	0	-	-	0	-
Peak Hour Factor	79	79	79	79	79	79	79	79	79	79	79	79
Heavy Vehicles, %	6	6	6	6	6	6	6	6	6	6	6	6
Mvmt Flow	10	0	20	11	0	3	34	485	16	5	849	33

Major/Minor	Minor2		Minor1		Major1		Major2					
Conflicting Flow All	1439	1445	866	1439	1445	485	882	0	0	501	0	0
Stage 1	876	876	-	553	553	-	-	-	-	-	-	-
Stage 2	563	569	-	886	892	-	-	-	-	-	-	-
Critical Hdwy	7.16	6.56	6.26	7.16	6.56	6.26	4.16	-	-	4.16	-	-
Critical Hdwy Stg 1	6.16	5.56	-	6.16	5.56	-	-	-	-	-	-	-
Critical Hdwy Stg 2	6.16	5.56	-	6.16	5.56	-	-	-	-	-	-	-
Follow-up Hdwy	3.554	4.054	3.354	3.554	4.054	3.354	2.254	-	-	2.254	-	-
Pot Cap-1 Maneuver	108	129	347	108	129	574	750	-	-	1043	-	-
Stage 1	338	361	-	510	508	-	-	-	-	-	-	-
Stage 2	504	499	-	334	355	-	-	-	-	-	-	-
Platoon blocked, %								-	-	-	-	-
Mov Cap-1 Maneuver	102	120	347	96	120	574	750	-	-	1043	-	-
Mov Cap-2 Maneuver	102	120	-	96	120	-	-	-	-	-	-	-
Stage 1	317	358	-	478	476	-	-	-	-	-	-	-
Stage 2	470	468	-	312	352	-	-	-	-	-	-	-

Approach	EB		WB		NB		SB	
HCM Control Delay, s	27.1		40.9		0.6		0	
HCM LOS	D		E					

Minor Lane/Major Mvmt	NBL	NBT	NBR	EBLn1	WBLn1	WBLn2	SBL	SBT	SBR
Capacity (veh/h)	750	-	-	193	96	574	1043	-	-
HCM Lane V/C Ratio	0.046	-	-	0.157	0.119	0.004	0.005	-	-
HCM Control Delay (s)	10	0	-	27.1	47.5	11.3	8.5	0	-
HCM Lane LOS	B	A	-	D	E	B	A	A	-
HCM 95th %tile Q(veh)	0.1	-	-	0.5	0.4	0	0	-	-

Intersection												
Int Delay, s/veh	1.7											
Movement	EBL	EBT	EBR	WBL	WBT	WBR	NBL	NBT	NBR	SBL	SBT	SBR
Lane Configurations		↕			↕	↕		↕	↕		↕	
Traffic Vol, veh/h	15	1	12	13	0	7	29	818	14	2	630	6
Future Vol, veh/h	15	1	12	13	0	7	29	818	14	2	630	6
Conflicting Peds, #/hr	0	0	0	0	0	0	0	0	0	0	0	0
Sign Control	Stop	Stop	Stop	Stop	Stop	Stop	Free	Free	Free	Free	Free	Free
RT Channelized	-	-	None	-	-	None	-	-	None	-	-	None
Storage Length	-	-	-	-	-	0	-	-	350	-	-	-
Veh in Median Storage, #	-	0	-	-	0	-	-	0	-	-	0	-
Grade, %	-	0	-	-	0	-	-	0	-	-	0	-
Peak Hour Factor	92	92	92	92	92	92	92	92	92	92	92	92
Heavy Vehicles, %	4	4	4	4	4	4	4	4	4	4	4	4
Mvmt Flow	16	1	13	14	0	8	32	889	15	2	685	7

Major/Minor	Minor2		Minor1		Major1		Major2					
Conflicting Flow All	1658	1661	689	1653	1649	889	692	0	0	904	0	0
Stage 1	693	693	-	953	953	-	-	-	-	-	-	-
Stage 2	965	968	-	700	696	-	-	-	-	-	-	-
Critical Hdwy	7.14	6.54	6.24	7.14	6.54	6.24	4.14	-	-	4.14	-	-
Critical Hdwy Stg 1	6.14	5.54	-	6.14	5.54	-	-	-	-	-	-	-
Critical Hdwy Stg 2	6.14	5.54	-	6.14	5.54	-	-	-	-	-	-	-
Follow-up Hdwy	3.536	4.036	3.336	3.536	4.036	3.336	2.236	-	-	2.236	-	-
Pot Cap-1 Maneuver	77	96	442	78	98	339	894	-	-	744	-	-
Stage 1	430	442	-	309	335	-	-	-	-	-	-	-
Stage 2	304	330	-	427	440	-	-	-	-	-	-	-
Platoon blocked, %								-	-	-	-	-
Mov Cap-1 Maneuver	71	89	442	71	91	339	894	-	-	744	-	-
Mov Cap-2 Maneuver	71	89	-	71	91	-	-	-	-	-	-	-
Stage 1	399	440	-	287	311	-	-	-	-	-	-	-
Stage 2	276	306	-	412	438	-	-	-	-	-	-	-

Approach	EB		WB		NB		SB	
HCM Control Delay, s	48.7		49.7		0.3		0	
HCM LOS	E		E					

Minor Lane/Major Mvmt	NBL	NBT	NBR	EBLn1	WBLn1	WBLn2	SBL	SBT	SBR
Capacity (veh/h)	894	-	-	112	71	339	744	-	-
HCM Lane V/C Ratio	0.035	-	-	0.272	0.199	0.022	0.003	-	-
HCM Control Delay (s)	9.2	0	-	48.7	67.9	15.9	9.9	0	-
HCM Lane LOS	A	A	-	E	F	C	A	A	-
HCM 95th %tile Q(veh)	0.1	-	-	1	0.7	0.1	0	-	-

Intersection												
Int Delay, s/veh	1.6											
Movement	EBL	EBT	EBR	WBL	WBT	WBR	NBL	NBT	NBR	SBL	SBT	SBR
Lane Configurations		↕			↕	↕		↕	↕		↕	
Traffic Vol, veh/h	8	0	16	23	0	6	27	280	27	8	442	26
Future Vol, veh/h	8	0	16	23	0	6	27	280	27	8	442	26
Conflicting Peds, #/hr	0	0	0	0	0	0	0	0	0	0	0	0
Sign Control	Stop	Stop	Stop	Stop	Stop	Stop	Free	Free	Free	Free	Free	Free
RT Channelized	-	-	None	-	-	None	-	-	None	-	-	None
Storage Length	-	-	-	-	-	0	-	-	350	-	-	-
Veh in Median Storage, #	-	0	-	-	0	-	-	0	-	-	0	-
Grade, %	-	0	-	-	0	-	-	0	-	-	0	-
Peak Hour Factor	79	79	79	79	79	79	79	79	79	79	79	79
Heavy Vehicles, %	6	6	6	6	6	6	6	6	6	6	6	6
Mvmt Flow	10	0	20	29	0	8	34	354	34	10	559	33

Major/Minor	Minor2		Minor1			Major1			Major2			
Conflicting Flow All	1039	1052	576	1028	1034	354	592	0	0	388	0	0
Stage 1	596	596	-	422	422	-	-	-	-	-	-	-
Stage 2	443	456	-	606	612	-	-	-	-	-	-	-
Critical Hdwy	7.16	6.56	6.26	7.16	6.56	6.26	4.16	-	-	4.16	-	-
Critical Hdwy Stg 1	6.16	5.56	-	6.16	5.56	-	-	-	-	-	-	-
Critical Hdwy Stg 2	6.16	5.56	-	6.16	5.56	-	-	-	-	-	-	-
Follow-up Hdwy	3.554	4.054	3.354	3.554	4.054	3.354	2.254	-	-	2.254	-	-
Pot Cap-1 Maneuver	205	223	509	209	228	681	964	-	-	1149	-	-
Stage 1	483	486	-	602	581	-	-	-	-	-	-	-
Stage 2	586	561	-	477	478	-	-	-	-	-	-	-
Platoon blocked, %								-	-	-	-	-
Mov Cap-1 Maneuver	194	210	509	192	215	681	964	-	-	1149	-	-
Mov Cap-2 Maneuver	194	210	-	192	215	-	-	-	-	-	-	-
Stage 1	461	480	-	575	555	-	-	-	-	-	-	-
Stage 2	553	536	-	452	472	-	-	-	-	-	-	-

Approach	EB		WB			NB			SB		
HCM Control Delay, s	17		23.6			0.7			0.1		
HCM LOS	C		C								

Minor Lane/Major Mvmt	NBL	NBT	NBR	EBLn1	WBLn1	WBLn2	SBL	SBT	SBR
Capacity (veh/h)	964	-	-	330	192	681	1149	-	-
HCM Lane V/C Ratio	0.035	-	-	0.092	0.152	0.011	0.009	-	-
HCM Control Delay (s)	8.9	0	-	17	27.1	10.3	8.2	0	-
HCM Lane LOS	A	A	-	C	D	B	A	A	-
HCM 95th %tile Q(veh)	0.1	-	-	0.3	0.5	0	0	-	-

Intersection												
Int Delay, s/veh	1.7											
Movement	EBL	EBT	EBR	WBL	WBT	WBR	NBL	NBT	NBR	SBL	SBT	SBR
Lane Configurations		↔			↔	↔		↔	↔		↔	
Traffic Vol, veh/h	15	1	12	27	0	11	29	455	28	6	385	6
Future Vol, veh/h	15	1	12	27	0	11	29	455	28	6	385	6
Conflicting Peds, #/hr	0	0	0	0	0	0	0	0	0	0	0	0
Sign Control	Stop	Stop	Stop	Stop	Stop	Stop	Free	Free	Free	Free	Free	Free
RT Channelized	-	-	None	-	-	None	-	-	None	-	-	None
Storage Length	-	-	-	-	-	0	-	-	350	-	-	-
Veh in Median Storage, #	-	0	-	-	0	-	-	0	-	-	0	-
Grade, %	-	0	-	-	0	-	-	0	-	-	0	-
Peak Hour Factor	92	92	92	92	92	92	92	92	92	92	92	92
Heavy Vehicles, %	4	4	4	4	4	4	4	4	4	4	4	4
Mvmt Flow	16	1	13	29	0	12	32	495	30	7	418	7

Major/Minor	Minor2		Minor1		Major1			Major2				
Conflicting Flow All	1016	1025	422	1002	998	495	425	0	0	525	0	0
Stage 1	436	436	-	559	559	-	-	-	-	-	-	-
Stage 2	580	589	-	443	439	-	-	-	-	-	-	-
Critical Hdwy	7.14	6.54	6.24	7.14	6.54	6.24	4.14	-	-	4.14	-	-
Critical Hdwy Stg 1	6.14	5.54	-	6.14	5.54	-	-	-	-	-	-	-
Critical Hdwy Stg 2	6.14	5.54	-	6.14	5.54	-	-	-	-	-	-	-
Follow-up Hdwy	3.536	4.036	3.336	3.536	4.036	3.336	2.236	-	-	2.236	-	-
Pot Cap-1 Maneuver	215	233	627	219	242	571	1124	-	-	1032	-	-
Stage 1	595	576	-	510	508	-	-	-	-	-	-	-
Stage 2	497	492	-	590	575	-	-	-	-	-	-	-
Platoon blocked, %								-	-	-	-	-
Mov Cap-1 Maneuver	203	222	627	206	230	571	1124	-	-	1032	-	-
Mov Cap-2 Maneuver	203	222	-	206	230	-	-	-	-	-	-	-
Stage 1	571	571	-	490	488	-	-	-	-	-	-	-
Stage 2	467	472	-	571	570	-	-	-	-	-	-	-

Approach	EB		WB		NB		SB	
HCM Control Delay, s	19		21.3		0.5		0.1	
HCM LOS	C		C					

Minor Lane/Major Mvmt	NBL	NBT	NBR	EBLn1	WBLn1	WBLn2	SBL	SBT	SBR
Capacity (veh/h)	1124	-	-	287	206	571	1032	-	-
HCM Lane V/C Ratio	0.028	-	-	0.106	0.142	0.021	0.006	-	-
HCM Control Delay (s)	8.3	0	-	19	25.4	11.4	8.5	0	-
HCM Lane LOS	A	A	-	C	D	B	A	A	-
HCM 95th %tile Q(veh)	0.1	-	-	0.4	0.5	0.1	0	-	-

Intersection												
Int Delay, s/veh	1.2											
Movement	EBL	EBT	EBR	WBL	WBT	WBR	NBL	NBT	NBR	SBL	SBT	SBR
Lane Configurations		↔			↔	↔	↔	↔	↔	↔	↔	↔
Traffic Vol, veh/h	8	0	16	23	0	6	27	383	27	8	671	26
Future Vol, veh/h	8	0	16	23	0	6	27	383	27	8	671	26
Conflicting Peds, #/hr	0	0	0	0	0	0	0	0	0	0	0	0
Sign Control	Stop	Stop	Stop	Stop	Stop	Stop	Free	Free	Free	Free	Free	Free
RT Channelized	-	-	None	-	-	None	-	-	None	-	-	None
Storage Length	-	-	-	-	-	0	0	-	350	0	-	-
Veh in Median Storage, #	-	1	-	-	1	-	-	0	-	-	0	-
Grade, %	-	0	-	-	0	-	-	0	-	-	0	-
Peak Hour Factor	79	79	79	79	79	79	79	79	79	79	79	79
Heavy Vehicles, %	6	6	6	6	6	6	6	6	6	6	6	6
Mvmt Flow	10	0	20	29	0	8	34	485	34	10	849	33

Major/Minor	Minor2		Minor1		Major1		Major2					
Conflicting Flow All	1460	1473	866	1449	1455	485	882	0	0	519	0	0
Stage 1	886	886	-	553	553	-	-	-	-	-	-	-
Stage 2	574	587	-	896	902	-	-	-	-	-	-	-
Critical Hdwy	7.16	6.56	6.26	7.16	6.56	6.26	4.16	-	-	4.16	-	-
Critical Hdwy Stg 1	6.16	5.56	-	6.16	5.56	-	-	-	-	-	-	-
Critical Hdwy Stg 2	6.16	5.56	-	6.16	5.56	-	-	-	-	-	-	-
Follow-up Hdwy	3.554	4.054	3.354	3.554	4.054	3.354	2.254	-	-	2.254	-	-
Pot Cap-1 Maneuver	105	124	347	107	127	574	750	-	-	1027	-	-
Stage 1	334	357	-	510	508	-	-	-	-	-	-	-
Stage 2	497	490	-	329	351	-	-	-	-	-	-	-
Platoon blocked, %								-	-	-	-	-
Mov Cap-1 Maneuver	99	117	347	97	120	574	750	-	-	1027	-	-
Mov Cap-2 Maneuver	215	234	-	199	225	-	-	-	-	-	-	-
Stage 1	319	353	-	487	485	-	-	-	-	-	-	-
Stage 2	468	468	-	307	347	-	-	-	-	-	-	-

Approach	EB	WB	NB	SB
HCM Control Delay, s	19	23.1	0.6	0.1
HCM LOS	C	C		

Minor Lane/Major Mvmt	NBL	NBT	NBR	EBLn1	WBLn1	WBLn2	SBL	SBT	SBR
Capacity (veh/h)	750	-	-	288	199	574	1027	-	-
HCM Lane V/C Ratio	0.046	-	-	0.105	0.146	0.013	0.01	-	-
HCM Control Delay (s)	10	-	-	19	26.2	11.4	8.5	-	-
HCM Lane LOS	B	-	-	C	D	B	A	-	-
HCM 95th %tile Q(veh)	0.1	-	-	0.3	0.5	0	0	-	-

Intersection												
Int Delay, s/veh	1.3											
Movement	EBL	EBT	EBR	WBL	WBT	WBR	NBL	NBT	NBR	SBL	SBT	SBR
Lane Configurations		↔			↔	↔	↔	↔	↔	↔	↔	↔
Traffic Vol, veh/h	15	1	12	27	0	11	29	455	28	6	385	6
Future Vol, veh/h	15	1	12	27	0	11	29	455	28	6	385	6
Conflicting Peds, #/hr	0	0	0	0	0	0	0	0	0	0	0	0
Sign Control	Stop	Stop	Stop	Stop	Stop	Stop	Free	Free	Free	Free	Free	Free
RT Channelized	-	-	None	-	-	None	-	-	None	-	-	None
Storage Length	-	-	-	-	-	0	0	-	350	0	-	-
Veh in Median Storage, #	-	1	-	-	1	-	-	0	-	-	0	-
Grade, %	-	0	-	-	0	-	-	0	-	-	0	-
Peak Hour Factor	92	92	92	92	92	92	92	92	92	92	92	92
Heavy Vehicles, %	4	4	4	4	4	4	4	4	4	4	4	4
Mvmt Flow	16	1	13	29	0	12	32	495	30	7	418	7

Major/Minor	Minor2		Minor1		Major1			Major2				
Conflicting Flow All	1016	1025	422	1002	998	495	425	0	0	525	0	0
Stage 1	436	436	-	559	559	-	-	-	-	-	-	-
Stage 2	580	589	-	443	439	-	-	-	-	-	-	-
Critical Hdwy	7.14	6.54	6.24	7.14	6.54	6.24	4.14	-	-	4.14	-	-
Critical Hdwy Stg 1	6.14	5.54	-	6.14	5.54	-	-	-	-	-	-	-
Critical Hdwy Stg 2	6.14	5.54	-	6.14	5.54	-	-	-	-	-	-	-
Follow-up Hdwy	3.536	4.036	3.336	3.536	4.036	3.336	2.236	-	-	2.236	-	-
Pot Cap-1 Maneuver	215	233	627	219	242	571	1124	-	-	1032	-	-
Stage 1	595	576	-	510	508	-	-	-	-	-	-	-
Stage 2	497	492	-	590	575	-	-	-	-	-	-	-
Platoon blocked, %								-	-	-	-	-
Mov Cap-1 Maneuver	205	225	627	208	234	571	1124	-	-	1032	-	-
Mov Cap-2 Maneuver	327	337	-	331	342	-	-	-	-	-	-	-
Stage 1	578	572	-	496	494	-	-	-	-	-	-	-
Stage 2	473	478	-	573	571	-	-	-	-	-	-	-

Approach	EB		WB		NB		SB	
HCM Control Delay, s	14.4		15.3		0.5		0.1	
HCM LOS	B		C					

Minor Lane/Major Mvmt	NBL	NBT	NBR	EBLn1	WBLn1	WBLn2	SBL	SBT	SBR
Capacity (veh/h)	1124	-	-	412	331	571	1032	-	-
HCM Lane V/C Ratio	0.028	-	-	0.074	0.089	0.021	0.006	-	-
HCM Control Delay (s)	8.3	-	-	14.4	16.9	11.4	8.5	-	-
HCM Lane LOS	A	-	-	B	C	B	A	-	-
HCM 95th %tile Q(veh)	0.1	-	-	0.2	0.3	0.1	0	-	-

APPENDIX F

Conceptual Site Plan

BARBARICK WASTE TRANSFER STATION

SITE PLAN EXHIBIT - AL2310

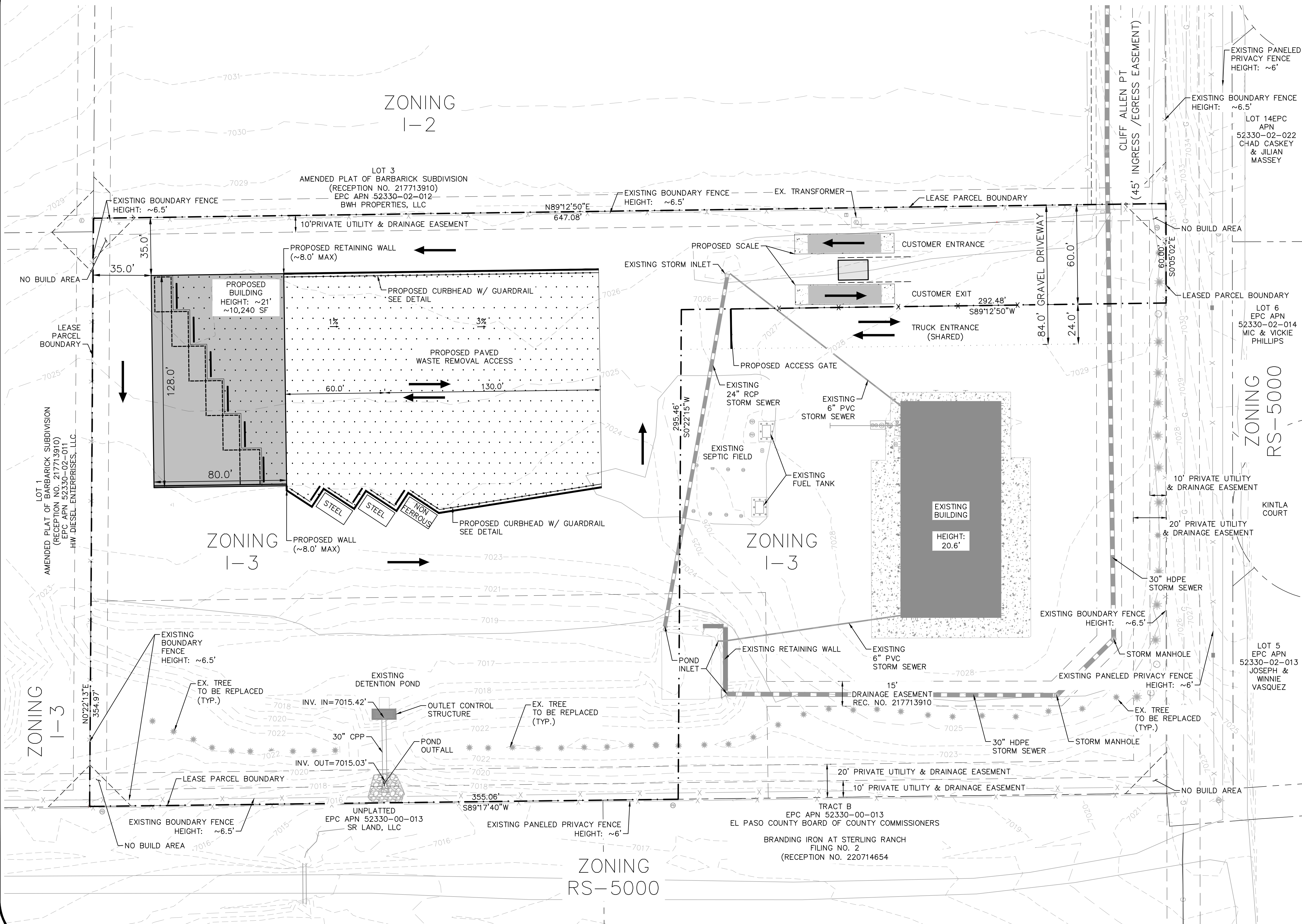

LEGEND

	EXISTING GRAVEL ROAD
	EXISTING CONTOUR (MAJOR)
	EXISTING CONTOUR (MINOR)
	EXISTING BARRIER FENCE
	STORM SEWER
	SANITARY SEWER (SEPTIC)
	WATER MAIN
	GAS MAIN
	EXISTING VEGETATION
	EXISTING BUILDING COLUMN
	PROPERTY LINE
	PRIVATE UTILITY & DRAINAGE EASEMENT
	PROPOSED RETAINING WALL
	LEASE PARCEL BOUNDARY
	TRUCK ENTRANCE (SHARED)
	ASPHALT PAVEMENT
	TRAFFIC CIRCULATION

OWNER/APPLICANT

BR 8812 CLIFF ALLEN POINT LLC
 ATTN: RICHARD GRAHAM
 EMAIL: GRAHAMINVESTMENTS@GMAIL.COM
 PHONE: 719-440-9414

LEASE PARCEL INFORMATION

PARCEL SIZE: 3.297 ACRES (143,638 S.F.)
 ZONING: 1-3 (HEAVY INDUSTRIAL)
 EXISTING LAND USE: DIESEL MECHANIC SHOP / STORAGE YARD (LARGE VEHICLES, FREIGHT CONTAINERS, ETC.)

EXISTING SITE COVERAGE: GRAVEL/ASPHALT MILLINGS AND NATURAL PASTURE/MEADOW VEGETATIVE COVER WITHIN THE EXISTING DETENTION POND EASEMENT (RECEPTION NO. 217713910)

LANDSCAPING / OPEN SPACE: ~30% (44,001 S.F. OR 1.01 ACRES)
 LOT COVERAGE (BUILDING & ACCESS): ~25% (36,461 S.F.)

