

# WINSOME FILING NO. 3 CONSTRUCTION DOCUMENTS

A PORTION OF THE SOUTHEAST QUARTER OF SECTION 13, AND A PORTION SECTION 24,  
TOWNSHIP 11 SOUTH, RANGE 65 WEST OF THE 6TH PM, COUNTY OF EL PASO, STATE OF COLORADO  
PCD FILING NO.: SF229

## CONTACTS:

**DEVELOPER:**  
WINSOME, LLC  
1884 WOODMOOR DRIVE, SUITE 100  
MONUMENT, CO 80132  
TEL: (719) 476-0800  
CONTACT: JOSEPH DESJARDIN

**SURVEY:**  
EDWARD JAMES SURVEYING, INC.  
926 ELKTON DRIVE  
COLORADO SPRINGS, CO 80907  
TEL: (719) 576-1216  
CONTACT: JONATHAN TESSIN

**EPC DPW STORMWATER TEAM:**  
CHRISTINA FURCHAK  
(719) 433-4863  
EMAIL: CHRISTINAFURCHAK@ELPASOCO.COM

**EPC PCD INSPECTIONS SUPERVISOR:**  
TEM: BRAD WALTERS  
(719) 520-6819  
EMAIL: BRADWALTERS@ELPASOCO.COM

**FALCON FIRE DEPARTMENT:**  
AREA: FAL D2  
DEPUTY CHIEF JEFF PETERSMA  
7030 OLD MERIDIAN ROAD  
PAYTON, CO 80831  
TEL: (719) 243-0651  
EMAIL: FALCONFIRE@FALCONFIREPD.ORG

**PLANNER/LANDSCAPE ARCHITECT:**  
NES, INC  
619 N CASCADE AVENUE, SUITE 200  
COLORADO SPRINGS, CO 80903  
TEL: (719) 471-0073  
EMAIL: ABARLOW@NESCOLORADO.COM  
CONTACT: ANDREA BARLOW

**EL PASO COUNTY PLANNING DEPARTMENT**  
2680 INTERNATIONAL CIRCLE, SUITE 110  
COLORADO SPRINGS, CO 80910

**PLANNING REVIEWER:**  
RYAN HOWSER  
TEL: (719) 520-6313  
EMAIL: RYANHOWSER@ELPASOCO.COM

**ENGINEERING REVIEWER:**  
GILBERT LAFORCE  
TEL: (719) 520-7945  
EMAIL: GILBERTLAFORCE@ELPASOCO.COM

**ENGINEER:**  
KIMLEY-HORN AND ASSOCIATES, INC.  
2 NORTH NEVADA, SUITE 300  
COLORADO SPRINGS, CO 80903  
(719) 453-0180  
EMAIL:  
KEVIN.KOFFORD@KIMLEY-HORN.COM  
CONTACT: KEVIN KOFFORD

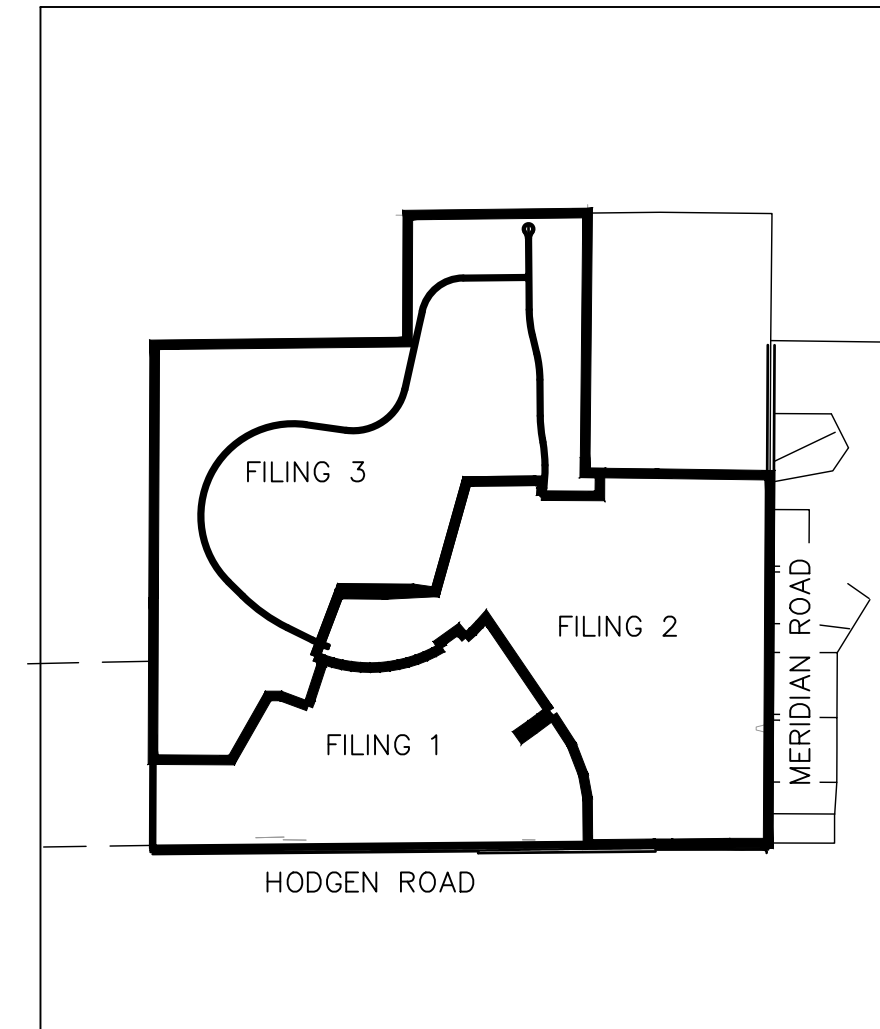

VICINITY MAP  
1" = 2,000'

## LEGAL DESCRIPTION

TRACT OF LAND BEING A PORTION OF THE SOUTHEAST QUARTER OF SECTION 13, AND A PORTION OF SECTION 24, TOWNSHIP 11 SOUTH, RANGE 65 WEST OF THE 6TH PRINCIPAL MERIDIAN, COUNTY OF EL PASO, STATE OF COLORADO, BEING MORE PARTICULARLY DESCRIBED AS FOLLOWS:

COMMENCING AT THE WEST QUARTER CORNER OF SAID SECTION 24, SAID POINT BEING THE POINT OF BEGINNING; THENCE N00°14'25"E ON THE WEST LINE OF THE NORTHWEST QUARTER OF SAID SECTION 24, SAID LINE ALSO BEING ON THE WEST BOUNDARY OF PARCEL 4, AS RECORDED UNDER RECEPTION NUMBER 218900072, A DISTANCE OF 2,636.99 FEET TO THE NORTHWEST CORNER OF SAID SECTION 24; THENCE N89°21'38"E ON THE NORTH LINE OF THE NORTHWEST QUARTER OF SAID SECTION 24, A DISTANCE OF 2,633.02 FEET TO THE NORTH QUARTER CORNER OF SAID SECTION 24; THENCE N00°10'29"E ON THE WEST LINE OF THE SOUTH HALF OF THE SOUTH EAST QUARTER OF SECTION 13, TOWNSHIP 11 SOUTH, RANGE 65 WEST, A DISTANCE OF 1,321.95 FEET TO THE NORTHWEST CORNER OF THE SOUTH HALF OF THE SOUTHEAST QUARTER OF SAID SECTION 13; THENCE N89°20'26"E ON THE NORTH LINE OF THE SOUTH HALF OF THE SOUTHEAST QUARTER OF SAID SECTION 13, A DISTANCE OF 1,873.37 FEET; THENCE S00°34'43"W, A DISTANCE OF 2,706.21 FEET; THENCE S89°15'17"E, A DISTANCE OF 155.82 FEET; THENCE S00°17'06"W, A DISTANCE OF 239.06 FEET; THENCE N89°42'54"W, A DISTANCE OF 609.60 FEET TO A POINT ON CURVE; THENCE ON THE ARC OF A CURVE TO THE LEFT, WHOSE CENTER BEARS N85°44'53"W, HAVING A DELTA OF 05°13'06", A RADIUS OF 1,710.00 FEET, A DISTANCE OF 155.74 FEET TO A POINT ON CURVE; THENCE S89°02'00"W, A DISTANCE OF 60.00 FEET; S89°29'13"W, A DISTANCE OF 722.44 FEET; THENCE S15°45'23"W, A DISTANCE OF 1,195.74 FEET; THENCE N82°21'05"W, A DISTANCE OF 229.91 FEET; THENCE N89°29'30"W, A DISTANCE OF 757.49 FEET; THENCE S20°46'13"W, A DISTANCE OF 758.90 FEET TO A POINT ON CURVE; THENCE ON THE ARC OF A CURVE TO THE LEFT, WHOSE CENTER BEARS N22°56'03"E, HAVING A DELTA OF 03°42'28", A RADIUS OF 1,470.00 FEET, A DISTANCE OF 95.13 FEET TO A POINT ON CURVE; THENCE S19°13'35"W, A DISTANCE OF 60.00 FEET; THENCE S18°06'10"W, A DISTANCE OF 383.72 FEET TO A POINT ON CURVE; THENCE ON THE ARC OF A CURVE TO THE RIGHT, HAVING A DELTA OF 02°06'44", A RADIUS OF 1,790.00 FEET, A DISTANCE OF 65.99 FEET TO A POINT ON CURVE; THENCE N69°47'06"W, A DISTANCE OF 306.30 FEET; THENCE N89°45'39"W, A DISTANCE OF 128.26 FEET; THENCE S29°41'56"W, A DISTANCE OF 768.98 FEET; THENCE N89°41'23"W, A DISTANCE OF 820.25 FEET TO A POINT ON THE WEST LINE OF THE SOUTHWEST QUARTER OF SAID SECTION 24; THENCE N00°14'17"E ON THE WEST LINE OF SOUTHWEST QUARTER OF SAID SECTION 24 A DISTANCE OF 1,684.27 FEET TO THE POINT OF BEGINNING.

CONTAINING A CALCULATED AREA OF 15,222,954 SQUARE FEET OR 349.471 ACRES.

## BENCHMARK

A 2.5" ALUMINUM CAP BEING A 30 FOOT WITNESS CORNER NORTH OF THE SOUTHWEST CORNER OF SECTION 24, TOWNSHIP 11 SOUTH, RANGE 65 WEST OF THE 6TH PRINCIPAL MERIDIAN.

## BASIS OF BEARING

THE WEST LINE OF THE NORTHWEST QUARTER OF SECTION 24, TOWNSHIP 11 SOUTH, RANGE 65 WEST OF THE 6 PRINCIPAL MERIDIAN MONUMENTED ON THE SOUTHERLY END BY A 2-1/2" ALUMINUM CAP STAMPED 'LS 28658' AND AT THE NORTHERLY END BY A 3-1/2" ALUMINUM CAP STAMPED 'LS 12103' BEING ASSUMED TO BEAR N00°14'25"E A DISTANCE OF 2636.99 FEET AS SHOWN IN LAND SURVEY PLAT RECORDED UNDER RECEPTION 218900072 RECORDS OF EL PASO COUNTY, COLORADO.

## FLOODPLAIN NOTE

FEDERAL EMERGENCY MANAGEMENT AGENCY, FLOOD INSURANCE RATE MAP, MAP NUMBER 08041C0350G, EFFECTIVE DECEMBER 7, 2018 INDICATES THE AREA IN THE VICINITY OF THIS PARCEL OF LAND TO BE IN ZONE X (AREA DETERMINED TO BE OUT OF THE 500 YEAR FLOODPLAIN). A CONDITIONAL LETTER OF MAP REVISION HAS BEEN PROCESSED AND APPROVED FOR THIS REACH OF WEST KIOWA CREEK (FEMA CASE NO: 19-08-0185R).

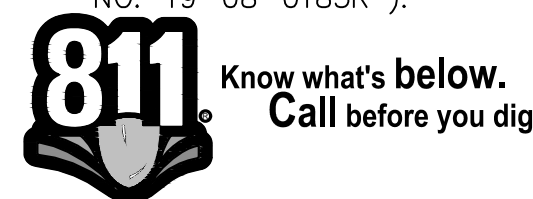

Sheet List Table	
Sheet Number	Sheet Title
C1.0	COVER SHEET
C1.1	GENERAL NOTES
C1.2	CROSS SECTIONS
C1.3	HORIZONTAL CONTROL PLAN
C1.4	GRADING PLAN
C1.5	GRADING PLAN
C1.6	GRADING PLAN
C1.7	GRADING PLAN
C1.8	ALAMAR PLAN AND PROFILE
C1.9	ALAMAR PLAN AND PROFILE
C1.10	ALAMAR PLAN AND PROFILE
C1.11	ALAMAR PLAN AND PROFILE
C1.12	ALAMAR PLAN AND PROFILE
C1.13	ALAMAR PLAN AND PROFILE
C1.14	ALAMAR PLAN AND PROFILE
C1.15	ALAMAR PLAN AND PROFILE
C1.16	TWINKLING STAR PLAN AND PROFILE
C1.17	TWINKLING STAR PLAN AND PROFILE
C1.18	TWINKLING STAR PLAN AND PROFILE
C1.19	CUL-DE-SAC PLAN AND PROFILE
C1.20	SIGNING AND STRIPING PLAN
C1.21	CUT AND FILL MAP
C1.22	GEC FINAL PLAN
C1.23	GEC FINAL PLAN
C1.24	GEC FINAL PLAN
C1.25	GEC FINAL PLAN
C1.26	GEC DETAILS
C1.27	GEC DETAILS
C1.28	GEC DETAILS
C1.29	GEC DETAILS
C1.30	FIRE CISTERN PLAN
C1.31	FIRE CISTERN DETAILS
C1.32	POND 1 OVERVIEW
C1.33	POND 1 DETAILS
C1.34	POND 1 DETAILS
C1.35	POND 2 OVERVIEW
C1.36	POND 2 DETAILS
C1.37	POND 2 DETAILS
C1.38	POND 4 OVERVIEW
C1.39	POND 4 DETAILS
C1.40	POND 4 DETAILS
C1.41	WQ POND A OVERVIEW
C1.42	WQ POND A DETAILS
C1.43	WQ POND A DETAILS
C1.44	RIPRAP DETAILS

## OWNER'S STATEMENT

I, THE OWNER/DEVELOPER HAVE READ AND WILL COMPLY WITH THE REQUIREMENTS OF THE GRADING AND EROSION CONTROL PLAN AND ALL OF THE SPECIFIED IN THESE DETAILED PLANS AND SPECIFICATIONS.

✓ *Joseph W. Desjardin*

4/28/2023

OWNER SIGNATURE

DATE

JOE DESJARDIN, DIRECTOR OF ENTITLEMENTS  
WINSOME, LLC  
1884 WOODMOOR DRIVE, SUITE 100  
MONUMENT, CO 80132

## ENGINEER'S STATEMENT

THESE DETAILED PLANS AND SPECIFICATIONS WERE PREPARED UNDER MY DIRECTION AND SUPERVISION. SAID PLANS AND SPECIFICATIONS HAVE BEEN PREPARED ACCORDING TO THE CRITERIA ESTABLISHED BY THE COUNTY FOR DETAILED ROADWAY, DRAINAGE, GRADING AND EROSION CONTROL PLANS AND SPECIFICATIONS, AND SAID PLANS AND SPECIFICATIONS ARE IN CONFORMITY WITH APPLICABLE MASTER DRAINAGE PLANS AND MASTER TRANSPORTATION PLANS. SAID PLANS AND SPECIFICATIONS MEET THE PURPOSES FOR WHICH THE PARTICULAR ROADWAY AND DRAINAGE FACILITIES ARE DESIGNED AND ARE CORRECT TO THE BEST OF MY KNOWLEDGE AND BELIEF. I ACCEPT RESPONSIBILITY FOR ANY LIABILITY CAUSED BY ANY NEGLIGENT ACTS, ERRORS OR OMISSIONS ON MY PART IN PREPARATION OF THESE DETAILED PLANS AND SPECIFICATIONS.



4/28/2023

KEVIN KOFFORD, PE (CO #57234) - KIMLEY-HORN AND ASSOCIATES, INC. DATE

## EL PASO COUNTY

COUNTY PLAN REVIEW IS PROVIDED ONLY FOR GENERAL CONFORMANCE WITH COUNTY DESIGN CRITERIA. THE COUNTY IS NOT RESPONSIBLE FOR THE ACCURACY AND ADEQUACY OF THE DESIGN, DIMENSIONS, AND/OR ELEVATIONS WHICH SHALL BE CONFIRMED AT THE JOB SITE. THE COUNTY THROUGH THE APPROVAL OF THIS DOCUMENT ASSUMES NO RESPONSIBILITY FOR COMPLETENESS AND/OR ACCURACY OF THIS DOCUMENT. FILED IN ACCORDANCE WITH THE REQUIREMENTS OF THE EL PASO COUNTY LAND DEVELOPMENT CODE, DRAINAGE CRITERIA MANUAL VOLUMES 1 AND 2, AND ENGINEERING CRITERIA MANUAL, AS AMENDED.

IN ACCORDANCE WITH ECM SECTION 1.12, THESE CONSTRUCTION DOCUMENTS WILL BE VALID FOR CONSTRUCTION FOR A PERIOD OF 2 YEARS FROM THE DATE SIGNED BY THE EL PASO COUNTY ENGINEER. IF CONSTRUCTION HAS NOT STARTED WITHIN THOSE 2 YEARS, THE PLANS WILL NEED TO BE RESUBMITTED FOR APPROVAL, INCLUDING PAYMENT OF REVIEW FEES AT THE PLANNING AND COMMUNITY DEVELOPMENT DIRECTOR'S DISCRETION.

Approved  
By: Elizabeth Nijkamp, PE  
Date: 05/31/2023



JOSHUA PALMER, PE COUNTY ENGINEER/ECM ADMINISTRATOR

NO.	REVISION	BY	DATE
2	COUNTY COMMENTS	KRK	4/28/23
1	COUNTY COMMENTS	KRK	3/10/23

**Kimley-Horn**  
2021 KIMLEY-HORN AND ASSOCIATES, INC.  
2 North Nevada Avenue Suite 300  
Colorado Springs, Colorado 80903 (719) 453-0180

DESIGNED BY: KRK  
DRAWN BY: AJL  
CHECKED BY: KRK  
DATE: 12/16/2021

WINSOME FILING NO. 3  
EL PASO COUNTY, COLORADO  
CONSTRUCTION DOCUMENTS  
COVER SHEET

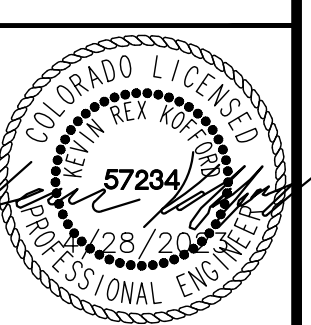

PROJECT NO.  
196106001

SHEET

C1.0

K:\COS\_Civil\196106001\_Winsome Filing No. 3\CADD\PlanSheets\Cds\196106001\_CD\_CV.dwg Kofford, Kevin 4/28/2023 10:04 AM

K:\COS\_Civil\196106001\_Winsome Filing No. 3\CADD\PlanSheets\Cds\196106001\_CD\_NOTES AND CROSS SECTIONS.dwg Koford, Kevin 4/28/2023 10:04 AM

### EL PASO COUNTY GRADING AND EROSION CONTROL PLAN NOTES

- STORMWATER DISCHARGES FROM CONSTRUCTION SITES SHALL NOT CAUSE OR THREATEN TO CAUSE POLLUTION, CONTAMINATION, OR DEGRADATION OF STATE WATERS. ALL WORK AND EARTH DISTURBANCE SHALL BE DONE IN A MANNER THAT MINIMIZES POLLUTION OF ANY ON-SITE OR OFF-SITE WATERS, INCLUDING WETLANDS.
- NOTWITHSTANDING ANYTHING DEPICTED IN THESE PLANS IN WORDS OR GRAPHIC REPRESENTATION, ALL DESIGN AND CONSTRUCTION RELATED TO ROADS, STORM DRAINAGE AND EROSION CONTROL SHALL CONFORM TO THE STANDARDS AND REQUIREMENTS OF THE MOST RECENT VERSION OF THE RELEVANT ADOPTED EL PASO COUNTY STANDARDS, INCLUDING THE LAND DEVELOPMENT CODE, THE ENGINEERING CRITERIA MANUAL, THE DRAINAGE CRITERIA MANUAL, AND THE DRAINAGE CRITERIA MANUAL VOLUME 2. ANY DEVIATIONS FROM REGULATIONS AND STANDARDS MUST BE REQUESTED, AND APPROVED, IN WRITING.
- A SEPARATE STORMWATER MANAGEMENT PLAN (SMWP) FOR THIS PROJECT SHALL BE COMPLETED AND AN EROSION AND STORMWATER QUALITY CONTROL PERMIT (ESQCP) ISSUED PRIOR TO COMMENCING CONSTRUCTION. MANAGEMENT OF THE SWMP DURING CONSTRUCTION IS THE RESPONSIBILITY OF THE DESIGNATED QUALIFIED STORMWATER MANAGER OR CERTIFIED EROSION CONTROL INSPECTOR. THE SWMP SHALL BE LOCATED ON SITE AT ALL TIMES DURING CONSTRUCTION AND SHALL BE KEPT UP TO DATE WITH WORK PROGRESS AND CHANGES IN THE FIELD.
- ONCE THE ESQCP IS APPROVED AND A "NOTICE TO PROCEED" HAS BEEN ISSUED, THE CONTRACTOR MAY INSTALL THE INITIAL STAGE EROSION AND SEDIMENT CONTROL MEASURES AS INDICATED ON THE APPROVED DEC. A PRECONSTRUCTION MEETING BETWEEN THE CONTRACTOR, ENGINEER, AND EL PASO COUNTY WILL BE HELD PRIOR TO ANY CONSTRUCTION. IT IS THE RESPONSIBILITY OF THE APPLICANT TO COORDINATE THE MEETING TIME AND PLACE WITH COUNTY STAFF.
- CONTROL MEASURES MUST BE INSTALLED PRIOR TO COMMENCEMENT OF ACTIVITIES THAT COULD CONTRIBUTE POLLUTANTS TO STORMWATER. CONTROL MEASURES FOR ALL SLOPES, CHANNELS, DITCHES, AND DISTURBED LAND AREAS SHALL BE INSTALLED IMMEDIATELY UPON COMPLETION OF THE DISTURBANCE.
- ALL TEMPORARY SEDIMENT AND EROSION CONTROL MEASURES SHALL BE MAINTAINED AND REMAIN IN EFFECTIVE OPERATING CONDITION UNTIL PERMANENT SOIL EROSION CONTROL MEASURES ARE IMPLEMENTED AND FINAL STABILIZATION IS ESTABLISHED. ALL PERSONS ENGAGED IN LAND DISTURBANCE ACTIVITIES SHALL ASSESS THE ADEQUACY OF CONTROL MEASURES AT THE SITE AND IDENTIFY IF CHANGES TO THOSE CONTROL MEASURES ARE NEEDED TO ENSURE THE CONTINUED EFFECTIVE PERFORMANCE OF THE CONTROL MEASURES. ALL CHANGES TO TEMPORARY SEDIMENT AND EROSION CONTROL MEASURES MUST BE INCORPORATED INTO THE STORMWATER MANAGEMENT PLAN.
- TEMPORARY STABILIZATION SHALL BE IMPLEMENTED ON DISTURBED AREAS AND STOCKPILES WHERE GROUND DISTURBING CONSTRUCTION ACTIVITY HAS PERMANENTLY CEASED OR TEMPORARILY CEASED FOR LONGER THAN 14 DAYS.
- FINAL STABILIZATION MUST BE IMPLEMENTED AT ALL APPLICABLE CONSTRUCTION SITES. FINAL STABILIZATION IS ACHIEVED WHEN ALL GROUND DISTURBING ACTIVITIES ARE COMPLETE AND ALL DISTURBED AREAS EITHER HAVE A UNIFORM VEGETATIVE COVER WITH INDIVIDUAL PLANT DENSITY OF 70 PERCENT OF PRE-DISTURBANCE LEVELS ESTABLISHED OR EQUIVALENT PERMANENT ALTERNATIVE STABILIZATION METHOD IS IMPLEMENTED. ALL TEMPORARY SEDIMENT AND EROSION CONTROL MEASURES SHALL BE REMOVED UPON FINAL STABILIZATION AND BEFORE PERMIT CLOSURE.
- ALL PERMANENT STORMWATER MANAGEMENT FACILITIES SHALL BE INSTALLED AS DESIGNED IN THE APPROVED PLANS. ANY PROPOSED CHANGES THAT EFFECT THE DESIGN OR FUNCTION OF PERMANENT STORMWATER MANAGEMENT STRUCTURES MUST BE APPROVED BY THE ECM ADMINISTRATOR PRIOR TO IMPLEMENTATION.
- EARTH DISTURBANCES SHALL BE CONDUCTED IN SUCH A MANNER SO AS TO EFFECTIVELY MINIMIZE ACCELERATED SOIL EROSION AND RESULTING SEDIMENTATION. ALL DISTURBANCES SHALL BE DESIGNED, CONSTRUCTED, AND COMPLETED SO THAT THE EXPOSED AREA OF ANY DISTURBED LAND SHALL BE LIMITED TO THE SHORTEST PRACTICAL PERIOD OF TIME. PRE-EXISTING VEGETATION SHALL BE PROTECTED AND MAINTAINED WITHIN 50 HORIZONTAL FEET OF A WATERS OF THE STATE UNLESS SHOWN TO BE INFESIBLE AND SPECIFICALLY REQUESTED AND APPROVED.
- COMPACTION OF SOIL MUST BE PREVENTED IN AREAS DESIGNATED FOR INFILTRATION CONTROL MEASURES OR WHERE FINAL STABILIZATION WILL BE ACHIEVED BY VEGETATIVE COVER. AREAS DESIGNATED FOR INFILTRATION CONTROL MEASURES SHALL ALSO BE PROTECTED FROM SEDIMENTATION DURING CONSTRUCTION UNTIL FINAL STABILIZATION IS ACHIEVED. IF COMPACTION PREVENTION IS NOT FEASIBLE DUE TO SITE CONSTRAINTS, ALL AREAS DESIGNATED FOR INFILTRATION AND VEGETATION CONTROL MEASURES MUST BE LOOSENED PRIOR TO INSTALLATION OF THE CONTROL MEASURE(S).
- ANY TEMPORARY OR PERMANENT FACILITY DESIGNED AND CONSTRUCTED FOR THE CONVEYANCE OF STORMWATER AROUND, THROUGH, OR FROM THE EARTH DISTURBANCE AREA SHALL BE A STABILIZED CONVEYANCE DESIGNED TO MINIMIZE EROSION AND THE DISCHARGE OF SEDIMENT OFF SITE.
- CONCRETE WASH WATER SHALL BE CONTAINED AND DISPOSED OF IN ACCORDANCE WITH THE SWMP. NO WASH WATER SHALL BE DISCHARGED TO OR ALLOWED TO ENTER STATE WATERS, INCLUDING ANY SURFACE OR SUBSURFACE STORM DRAINAGE SYSTEM OR FACILITIES. CONCRETE WASHOUTS SHALL NOT BE LOCATED IN AN AREA WHERE SHALLOW GROUNDWATER MAY BE PRESENT, OR WITHIN 50 FEET OF A SURFACE WATER BODY, CREEK OR STREAM.
- DURING DEWATERING OPERATIONS OF UNCONTAMINATED GROUND WATER MAY BE DISCHARGED ON SITE, BUT SHALL NOT LEAVE THE SITE IN THE FORM OF SURFACE RUNOFF UNLESS AN APPROVED STATE DEWATERING PERMIT IS IN PLACE.
- EROSION CONTROL BLANKETING OR OTHER PROTECTIVE COVERING SHALL BE USED ON SLOPES STEEPER THAN 3:1.
- CONTRACTOR SHALL BE RESPONSIBLE FOR THE REMOVAL OF ALL WASTES FROM THE CONSTRUCTION SITE FOR DISPOSAL IN ACCORDANCE WITH LOCAL AND STATE REGULATORY REQUIREMENTS. NO CONSTRUCTION DEBRIS, TREE SLASH, BUILDING MATERIAL WASTES OR UNUSED BUILDING MATERIALS SHALL BE BURIED, DUMPED, OR DISCHARGED AT THE SITE.
- WASTE MATERIALS SHALL NOT BE TEMPORARILY PLACED OR STORED IN THE STREET, ALLEY, OR OTHER PUBLIC WAY, UNLESS IN ACCORDANCE WITH AN APPROVED TRAFFIC CONTROL PLAN. CONTROL MEASURES MAY BE REQUIRED BY EL PASO COUNTY ENGINEERING IF DEEMED NECESSARY, BASED ON SPECIFIC CONDITIONS AND CIRCUMSTANCES.
- TRACKING OF SOILS AND CONSTRUCTION DEBRIS OFF-SITE SHALL BE MINIMIZED. MATERIALS TRACKED OFF-SITE SHALL BE CLEANED UP AND PROPERLY DISPOSED OF IMMEDIATELY.
- THE OWNER/DEVELOPER SHALL BE RESPONSIBLE FOR THE REMOVAL OF ALL CONSTRUCTION DEBRIS, DIRT, TRASH, ROCK, SEDIMENT, SOIL, AND SAND THAT MAY ACCUMULATE IN ROADS, STORM DRAINS AND OTHER DRAINAGE CONVEYANCE SYSTEMS AND STORMWATER APPURTENANCES AS A RESULT OF SITE DEVELOPMENT.
- THE QUANTITY OF MATERIALS STORED ON THE PROJECT SITE SHALL BE LIMITED, AS MUCH AS PRACTICAL, TO THAT QUANTITY REQUIRED TO PERFORM THE WORK IN AN ORDERLY SEQUENCE. ALL MATERIALS STORED ON-SITE SHALL BE STORED IN A NEAT, ORDERLY MANNER, IN THEIR ORIGINAL CONTAINERS, WITH ORIGINAL MANUFACTURER'S LABELS.
- NO CHEMICAL(S) HAVING THE POTENTIAL TO BE RELEASED IN STORMWATER ARE TO BE STORED OR USED ONSITE UNLESS PERMISSION FOR THE USE OF SUCH CHEMICAL(S) IS GRANTED IN WRITING BY THE ECM ADMINISTRATOR. IN GRANTING APPROVAL FOR THE USE OF SUCH CHEMICAL(S), SPECIAL CONDITIONS AND MONITORING MAY BE REQUIRED.
- BULK STORAGE OF ALLOWED PETROLEUM PRODUCTS OR OTHER ALLOWED LIQUID CHEMICALS IN EXCESS OF 55 GALLONS SHALL REQUIRE ADEQUATE SECONDARY CONTAINMENT PROTECTION TO CONTAIN ALL SPILLS ONSITE AND TO PREVENT ANY SPILLED MATERIALS FROM ENTERING STATE WATERS, ANY SURFACE OR SUBSURFACE STORM DRAINAGE SYSTEM OR OTHER FACILITIES.
- NO PERSON SHALL CAUSE THE IMPEDIMENT OF STORMWATER FLOW IN THE CURB AND GUTTER OR DITCH EXCEPT WITH APPROVED SEDIMENT CONTROL MEASURES.
- OWNER/DEVELOPER AND THEIR AGENTS SHALL COMPLY WITH THE "COLORADO WATER QUALITY CONTROL ACT" (TITLE 25, ARTICLE 8, CRS), AND THE "CLEAN WATER ACT" (33 USC 1344), IN ADDITION TO THE REQUIREMENTS OF THE LAND DEVELOPMENT CODE, DCM VOLUME II AND THE ECM APPENDIX I. ALL APPROPRIATE PERMITS MUST BE OBTAINED BY THE CONTRACTOR PRIOR TO CONSTRUCTION (1041, NPDES, FLOODPLAIN, 404, FUGITIVE DUST, ETC.). IN THE EVENT OF CONFLICTS BETWEEN THESE REQUIREMENTS AND OTHER LAWS, RULES, OR REGULATIONS OF OTHER FEDERAL, STATE, LOCAL, OR COUNTY AGENCIES, THE MOST RESTRICTIVE LAWS, RULES, OR REGULATIONS SHALL APPLY.

- ALL CONSTRUCTION TRAFFIC MUST ENTER/EXIT THE SITE ONLY AT APPROVED CONSTRUCTION ACCESS POINTS.
- PRIOR TO CONSTRUCTION THE PERMITTEE SHALL VERIFY THE LOCATION OF EXISTING UTILITIES.
- A WATER SOURCE SHALL BE AVAILABLE ON SITE DURING EARTHWORK OPERATIONS AND SHALL BE UTILIZED AS REQUIRED TO MINIMIZE DUST FROM EARTHWORK EQUIPMENT AND WIND.
- THE SOILS REPORT FOR THIS SITE HAS BEEN PREPARED BY ENTECH ENGINEERING, INC. DATED JANUARY 26, 2021 AND SHALL BE CONSIDERED A PART OF THESE PLANS.
- AT LEAST TEN (10) DAYS PRIOR TO THE ANTICIPATED START OF CONSTRUCTION, FOR PROJECTS THAT WILL DISTURB ONE (1) ACRE OR MORE, THE OWNER OR OPERATOR OF CONSTRUCTION ACTIVITY SHALL SUBMIT A PERMIT APPLICATION FOR STORMWATER DISCHARGE TO THE COLORADO DEPARTMENT OF PUBLIC HEALTH AND ENVIRONMENT, WATER QUALITY DIVISION. THE APPLICATION CONTAINS CERTIFICATION OF COMPLETION OF A STORMWATER MANAGEMENT PLAN (SWMP), OF WHICH THIS GRADING AND EROSION CONTROL PLAN MAY BE A PART. FOR INFORMATION OR APPLICATION MATERIALS CONTACT:

COLORADO DEPARTMENT OF PUBLIC HEALTH AND ENVIRONMENT  
 WATER QUALITY CONTROL DIVISION  
 WQCD - PERMITS  
 4300 CHERRY CREEK DRIVE SOUTH  
 DENVER, CO 80246-1530  
 ATTN: PERMITS UNIT

### STANDARD NOTES FOR EL PASO COUNTY CONSTRUCTION PLANS

- ALL DRAINAGE AND ROADWAY CONSTRUCTION SHALL MEET THE STANDARDS AND SPECIFICATIONS OF THE CITY OF COLORADO SPRINGS/EL PASO COUNTY DRAINAGE CRITERIA MANUAL, VOLUMES 1 AND 2, AND THE EL PASO COUNTY ENGINEERING CRITERIA MANUAL.
- CONTRACTOR SHALL BE RESPONSIBLE FOR THE NOTIFICATION AND FIELD NOTIFICATION OF ALL EXISTING UTILITIES, WHETHER SHOWN ON THE PLANS OR NOT, BEFORE BEGINNING CONSTRUCTION. LOCATION OF EXISTING UTILITIES SHALL BE VERIFIED BY THE CONTRACTOR PRIOR TO CONSTRUCTION. CALL 811 TO CONTACT THE UTILITY NOTIFICATION CENTER OF COLORADO (UNCC).
- CONTRACTOR SHALL KEEP A COPY OF THESE APPROVED PLANS, THE GRADING AND EROSION CONTROL PLAN, THE STORMWATER MANAGEMENT PLAN (SWMP), THE SOILS AND GEOTECHNICAL REPORT, AND THE APPROPRIATE DESIGN AND CONSTRUCTION STANDARDS AND SPECIFICATIONS AT THE JOB SITE AT ALL TIMES, INCLUDING THE FOLLOWING:
  - EL PASO COUNTY ENGINEERING CRITERIA MANUAL (ECM)
  - CITY OF COLORADO SPRINGS/EL PASO COUNTY DRAINAGE CRITERIA MANUAL, VOLUMES 1 AND 2
  - COLORADO DEPARTMENT OF TRANSPORTATION (CDOT) STANDARD SPECIFICATIONS FOR ROAD AND BRIDGE CONSTRUCTION
  - CDOT M & S STANDARDS
- NOTWITHSTANDING ANYTHING DEPICTED IN THESE PLANS IN WORDS OR GRAPHIC REPRESENTATION, ALL DESIGN AND CONSTRUCTION RELATED TO ROADS, STORM DRAINAGE AND EROSION CONTROL SHALL CONFORM TO THE STANDARDS AND REQUIREMENTS OF THE MOST RECENT VERSION OF THE RELEVANT ADOPTED EL PASO COUNTY STANDARDS, INCLUDING THE LAND DEVELOPMENT CODE, THE ENGINEERING CRITERIA MANUAL, THE DRAINAGE CRITERIA MANUAL, AND THE DRAINAGE CRITERIA MANUAL VOLUME 2. ANY DEVIATIONS FROM REGULATIONS AND STANDARDS MUST BE REQUESTED, AND APPROVED, IN WRITING. ANY MODIFICATIONS NECESSARY TO MEET CRITERIA AFTER-THE-FACT WILL BE ENTIRELY THE DEVELOPER'S RESPONSIBILITY TO RECTIFY.
- IT IS THE DESIGN ENGINEER'S RESPONSIBILITY TO ACCURATELY SHOW EXISTING CONDITIONS, BOTH ONSITE AND OFFSITE, ON THE CONSTRUCTION PLANS. ANY MODIFICATIONS NECESSARY DUE TO CONFLICTS, OMISSIONS, OR CHANGED CONDITIONS WILL BE ENTIRELY THE DEVELOPER'S RESPONSIBILITY TO RECTIFY.
- CONTRACTOR SHALL SCHEDULE A PRE-CONSTRUCTION MEETING WITH EL PASO COUNTY PLANNING AND COMMUNITY DEVELOPMENT (PCD) - INSPECTIONS, PRIOR TO STARTING CONSTRUCTION.
- IT IS THE CONTRACTOR'S RESPONSIBILITY TO UNDERSTAND THE REQUIREMENTS OF ALL JURISDICTIONAL AGENCIES AND TO OBTAIN ALL REQUIRED PERMITS, INCLUDING BUT NOT LIMITED TO EL PASO COUNTY EROSION AND STORMWATER QUALITY CONTROL PERMIT (ESQCP), REGIONAL BUILDING FLOODPLAIN DEVELOPMENT PERMIT, U.S. ARMY CORPS OF ENGINEERS-ISSUED 401 AND/OR 404 PERMITS, AND COUNTY AND STATE FUGITIVE DUST PERMITS.
- CONTRACTOR SHALL NOT DEVIATE FROM THE PLANS WITHOUT FIRST OBTAINING WRITTEN APPROVAL FROM THE DESIGN ENGINEER AND PCD. CONTRACTOR SHALL NOTIFY THE DESIGN ENGINEER IMMEDIATELY UPON DISCOVERY OF ANY ERRORS OR INCONSISTENCIES.
- ALL STORM DRAIN PIPE SHALL BE CLASS III RCP UNLESS OTHERWISE NOTED AND APPROVED BY PCD.
- CONTRACTOR SHALL COORDINATE GEOTECHNICAL TESTING PER ECM STANDARDS. PAVEMENT DESIGN SHALL BE APPROVED BY EL PASO COUNTY PCD PRIOR TO PLACEMENT OF CURB AND GUTTER AND PAVEMENT.
- ALL CONSTRUCTION TRAFFIC MUST ENTER/EXIT THE SITE AT APPROVED CONSTRUCTION ACCESS POINTS.
- SIGHT VISIBILITY TRIANGLES AS IDENTIFIED IN THE PLANS SHALL BE PROVIDED AT ALL INTERSECTIONS. OBSTRUCTIONS GREATER THAN 18 INCHES ABOVE FLOWLINE ARE NOT ALLOWED WITHIN SIGHT TRIANGLES.
- SIGNING AND STRIPING SHALL COMPLY WITH EL PASO COUNTY DOT AND MUTCD CRITERIA. [IF APPLICABLE, ADDITIONAL SIGNING AND STRIPING NOTES WILL BE PROVIDED.]
- CONTRACTOR SHALL OBTAIN ANY PERMITS REQUIRED BY EL PASO COUNTY DOT, INCLUDING WORK WITHIN THE RIGHT-OF-WAY AND SPECIAL TRANSPORT PERMITS.
- THE LIMITS OF CONSTRUCTION SHALL REMAIN WITHIN THE PROPERTY LINE UNLESS OTHERWISE NOTED. THE OWNER/DEVELOPER SHALL OBTAIN WRITTEN PERMISSION AND EASEMENTS, WHERE REQUIRED, FROM ADJOINING PROPERTY OWNER(S) PRIOR TO ANY OFF-SITE DISTURBANCE, GRADING, OR CONSTRUCTION.

NO.	REV. DATE	BY
1	3/10/23	KRK
2	4/28/23	KRK
		APPR.



DESIGNED BY: KRK  
 DRAWN BY: AUL  
 CHECKED BY: KRK  
 DATE: 12/16/2021

WINSOME FILING NO. 3  
 EL PASO COUNTY, COLORADO  
 CONSTRUCTION DOCUMENTS  
 GENERAL NOTES



PROJECT NO.  
196106001

SHEET

C1.1

**ROADWAY CROSS SECTIONS**

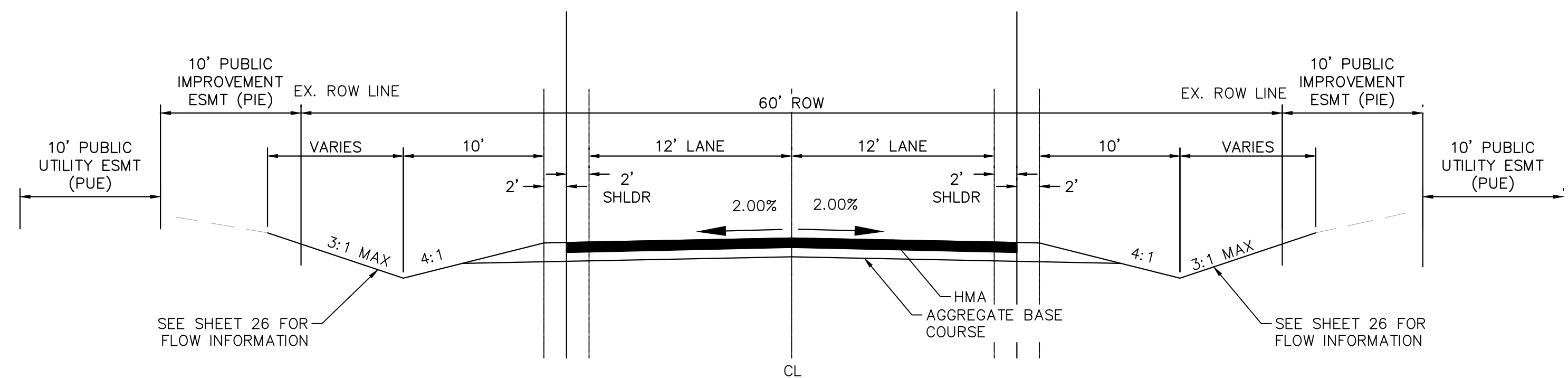

(A) RURAL LOCAL ROADWAY – ROADSIDE DITCH: LEFT AND RIGHT  
SCALE: NTS

ALAMAR WAY: 1014+50–1017+00, 1022+00–1027+00, 1035+00–1045+00, 1051+00–1054+00, 1064+00–END  
TWINKLING STAR LANE: 2000+00–2004+00, 2013+50–2023+00

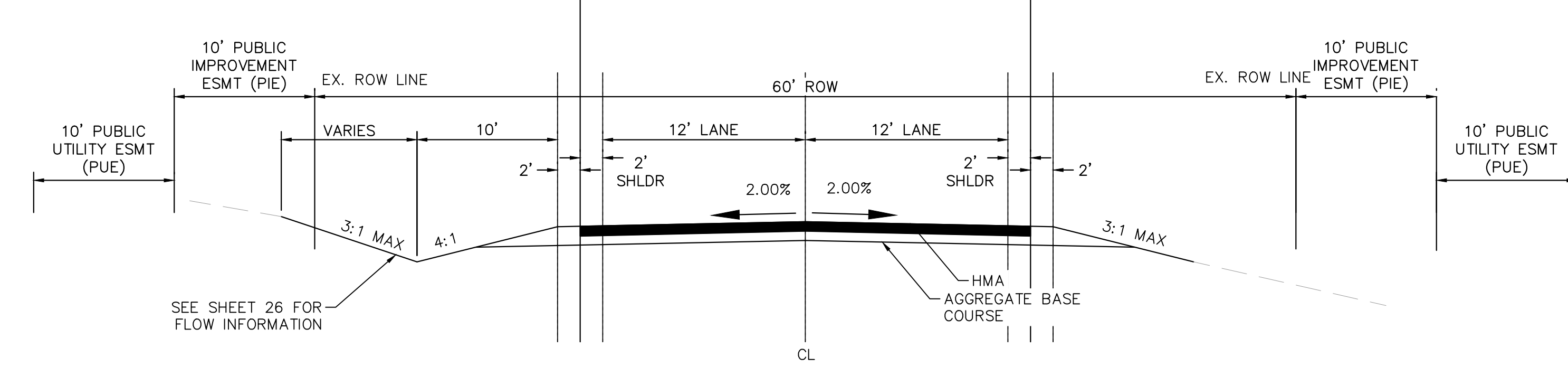

(B) RURAL LOCAL ROADWAY – ROADSIDE DITCH LEFT ONLY  
SCALE: NTS

ALAMAR WAY: 1008+50–1010+50, 1018+50–1022, 1032+00–1035+00, 1048+00–1051+00  
TWINKLING STAR LANE: 2023+00–2028+00

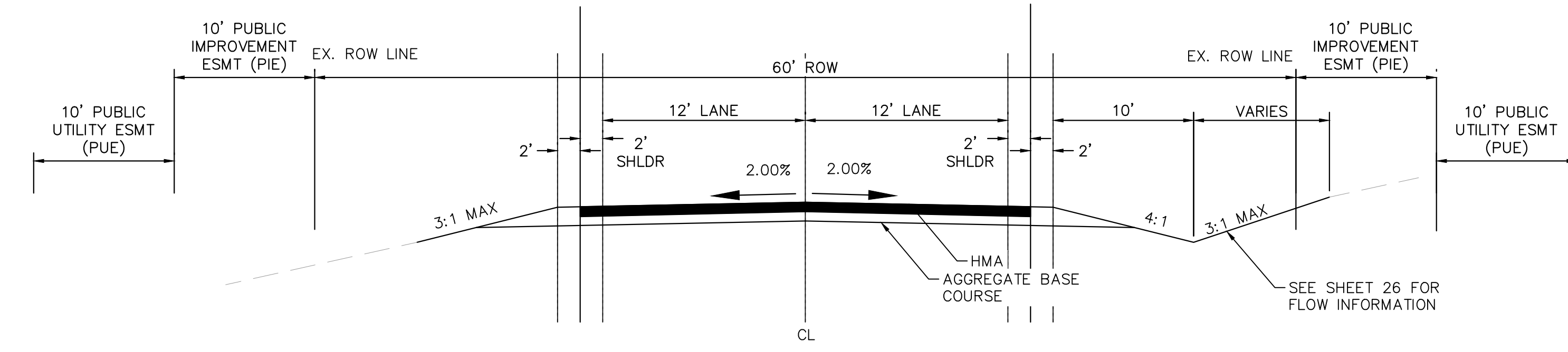

(C) RURAL LOCAL ROADWAY – ROADSIDE DITCH RIGHT ONLY  
SCALE: NTS

ALAMAR WAY: 1013+50–1014+50  
TWINKLING STAR LANE: 2004+00–207+00

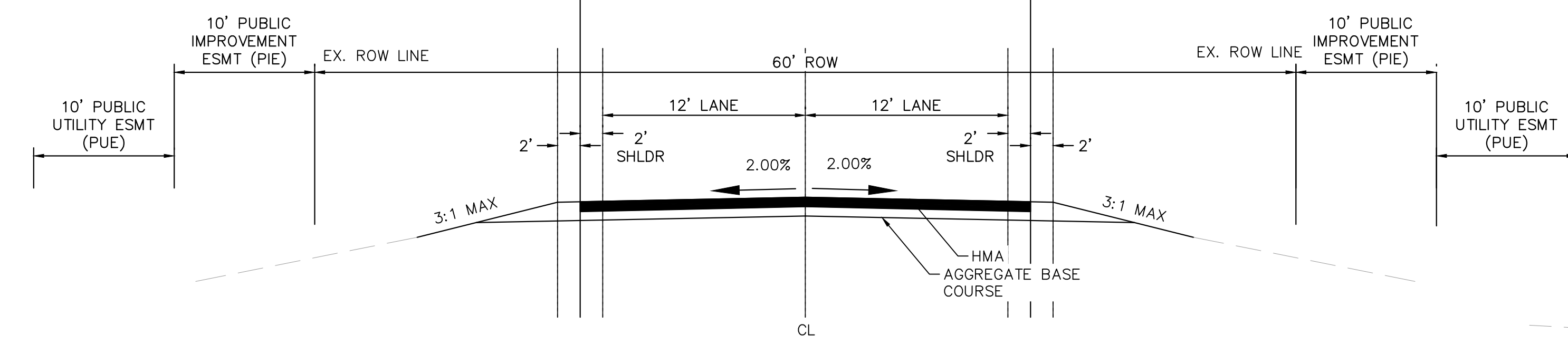

(D) RURAL LOCAL ROADWAY – NO ROADSIDE DITCH  
SCALE: NTS

ALAMAR WAY: 1000+00–1008+50, 1010+50–1013+50, 1017+00–1018+50, 1027+00–1032+00, 1045+00–1048+00, 1054+00–1064+00  
TWINKLING STAR LANE: 2007+00–2013+50

**DRAINAGE CHANNEL CROSS SECTIONS**

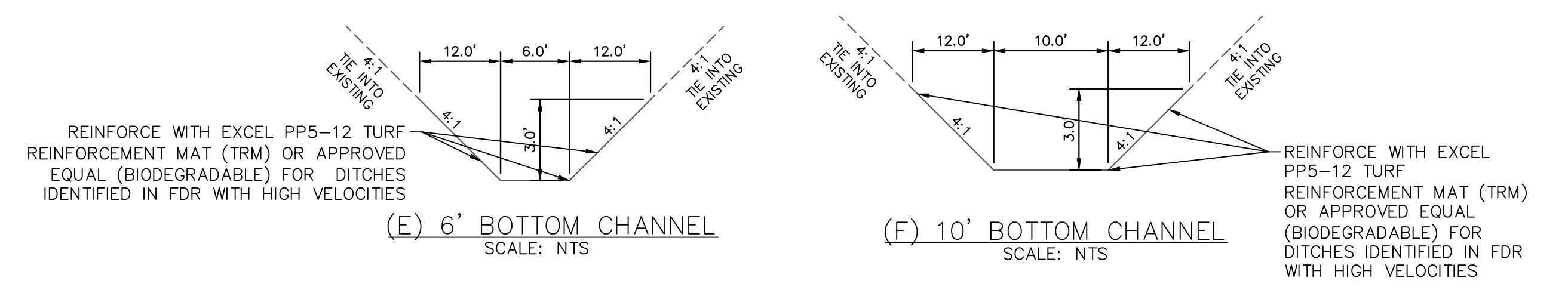

ROADWAY	FROM STA	TO STA	PROPOSED SLOPE (%)	SIDE	SIDE SLOPE	CHANNEL DEPTH (FT)	FRICTION FACTOR	BASIN	Q100 FLOW (CFS)	DITCH FLOW % OF BAS	DITCH FLOW (CFS)	Q100 DEPTH (FT)	Q100 VELOCITY (FT/S)	DITCH LINING	CHANNEL XSECTION
ALAMAR WAY	1008+50	1010+50	5.38%	LEFT	4:1/3:1	3	0.04	G2B	9.6	50%	4.8	0.6	3.8	GRASS	
ALAMAR WAY	1008+50	1010+50	5.32%	RIGHT	4:1/3:1	3	0.04	A3A & A2B	46.1	100%	46.1	1.4	6.6	GRASS/TRM*	SWALE A3A
ALAMAR WAY	1013+50	1014+50	4.45%	RIGHT	4:1/3:1	3	0.04	G2B	9.6	20%	1.9	0.4	2.8	GRASS	
ALAMAR WAY	1014+50	1017+00	5.45%	RIGHT	4:1/3:1	3	0.04	G2B	9.6	10%	1.0	0.3	2.6	GRASS	
ALAMAR WAY	1014+50	1017+00	5.16%	LEFT	4:1/3:1	3	0.04	A3A	25.8	25%	6.5	0.7	4.0	GRASS	
ALAMAR WAY	1018+50	1022+00	4.17%	LEFT	4:1/3:1	3	0.04	G1	40.1	25%	10.0	0.8	4.1	GRASS	
ALAMAR WAY	1022+00	1027+00	3.92%	RIGHT	4:1/3:1	3	0.04	H4	73.6	10%	7.4	0.8	3.7	GRASS	
ALAMAR WAY	1022+00	1027+00	3.71%	LEFT	4:1/3:1	3	0.04	G1	40.1	25%	10.0	0.9	3.9	GRASS	
ALAMAR WAY	1032+00	1035+00	2.04%	LEFT	4:1/3:1	3	0.04	H1	33.0	10%	3.3	0.6	2.4	GRASS	
ALAMAR WAY	1035+00	1045+00	5.88%	RIGHT	4:1/3:1	3	0.04	H6B	57.1	10%	5.7	0.6	4.1	GRASS	
ALAMAR WAY	1035+00	1045+00	5.79%	LEFT	4:1/3:1	3	0.04	H1 & H2	98.2	15%	14.7	0.9	5.1	GRASS	
ALAMAR WAY	1048+00	1051+00	3.45%	LEFT	4:1/3:1	3	0.04	H2	65.2	25%	16.3	0.9	5.3	GRASS	
ALAMAR WAY	1051+00	1054+00	7.02%	RIGHT	4:1/3:1	3	0.04	H6B	57.1	10%	5.7	0.6	4.4	GRASS	
ALAMAR WAY	1051+00	1054+00	6.27%	LEFT	4:1/3:1	3	0.04	H2	65.2	10%	6.5	0.7	4.3	GRASS	
ALAMAR WAY	1064+00	END	3.66%	RIGHT	4:1/3:1	3	0.04	H7A	27.1	10%	2.7	0.5	2.8	GRASS	
ALAMAR WAY	1064+00	END	3.36%	LEFT	4:1/3:1	3	0.04	I1 & H3B	27.2	44%	12.0	0.9	4.0	GRASS	SWALE H3B
TWINKLING STAR LANE	2000+00	2004+00	3.61%	RIGHT	4:1/3:1	3	0.04	E8	25.6	35%	9.0	0.8	3.8	GRASS	
TWINKLING STAR LANE	2000+00	2004+00	3.40%	LEFT	4:1/3:1	3	0.04	D6	28.1	25%	7.0	0.8	3.5	GRASS	
TWINKLING STAR LANE	2004+00	2007+00	6.14%	RIGHT	4:1/3:1	3	0.04	E8	25.6	35%	9.0	0.7	4.6	GRASS	
TWINKLING STAR LANE	2013+50	2023+00	7.84%	RIGHT	4:1/3:1	3	0.04	H8A & I1 & H3B	38.4	82%	31.5	1.1	7.0	GRASS/TRM*	SWALE I1
TWINKLING STAR LANE	2013+50	2023+00	8.17%	LEFT	4:1/3:1	3	0.04	H7A	27.1	100%	27.1	1.1	6.8	GRASS/TRM*	
TWINKLING STAR LANE	2023+00	2028+00	1.14%	LEFT	4:1/3:1	3	0.04	I1	20.3	50%	10.2	1.1	2.6	GRASS	

\*: Turf Reinforcement Matting will be installed within the final phase of the Grading, and Erosion Control plans. In the interim condition, Turf Reinforcement Mat lined channels will have seeding and mulching with straw waddle check dams.

**MAINTENANCE ROAD CROSS SECTION**

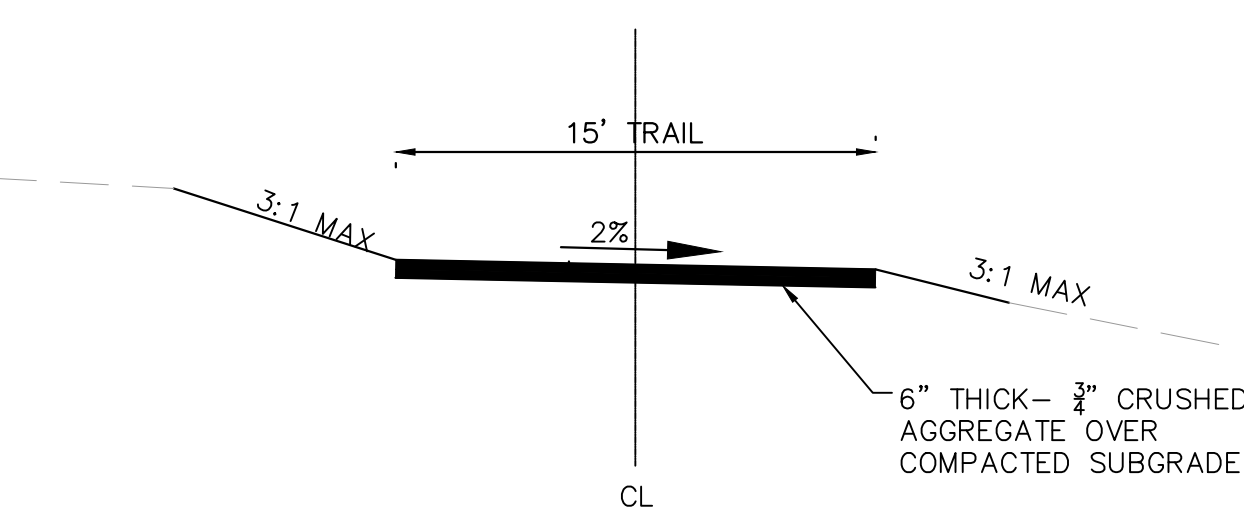

(H) MAINTENANCE ROAD  
SCALE: NTS

**TRAIL CROSS SECTION**

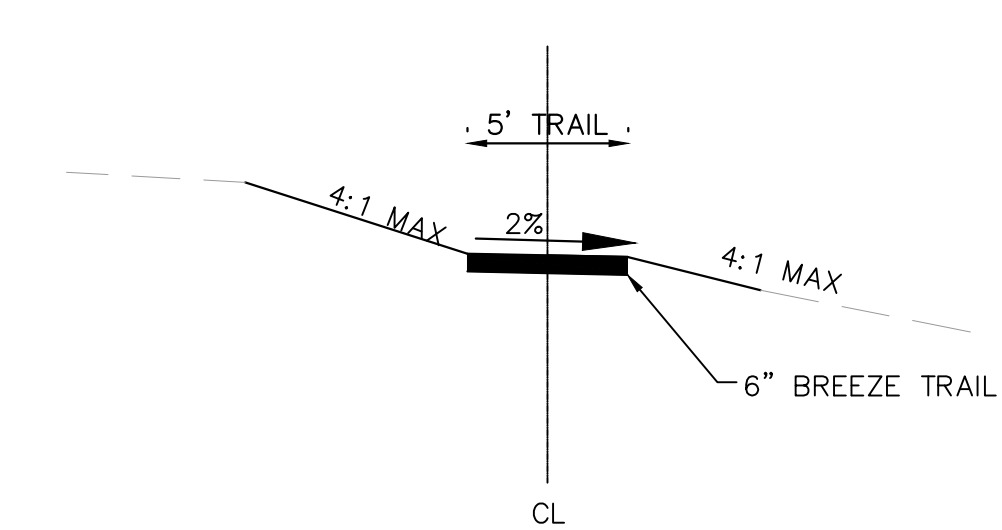

(G) GRAVEL TRAIL  
SCALE: NTS

EPC 5/30/23

K:\COS\_Civil\196106001\_Winsome Filing No. 3\CADD\PlanSheets\CDS\196106001\_CD\_NOTES AND CROSS SECTIONS.dwg Korford, Kevin 4/28/2023 10:04 AM

NO.	REVISION	DATE	BY	APPR.
1	COUNTY COMMENTS	KRK 3/10/23	KRK	
2	COUNTY COMMENTS	KRK 4/28/23	KRK	

**Kimley»Horn**  
2021 KIMLEY-HORN AND ASSOCIATES, INC.  
2 North Nevada Avenue Suite 300  
Colorado Springs, Colorado 80903 (719) 453-0180

DESIGNED BY: KRK  
DRAWN BY: AJL  
CHECKED BY: KRK  
DATE: 12/16/2021

WINSOME FILING NO. 3  
EL PASO COUNTY, COLORADO  
CONSTRUCTION DOCUMENTS  
CROSS SECTIONS

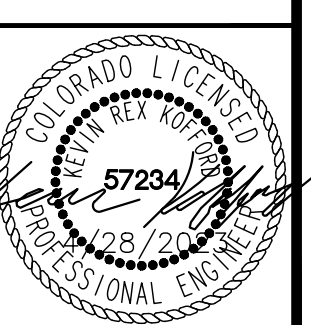

PROJECT NO.  
196106001

SHEET

**C1.2**

K:\COS\_Civil\196106001\_Winsome Filing No. 3\CADD\PlanSheets\CDS\196106001\_CD\_HC.dwg Kofford, Kevin 4/28/2023 10:05 AM

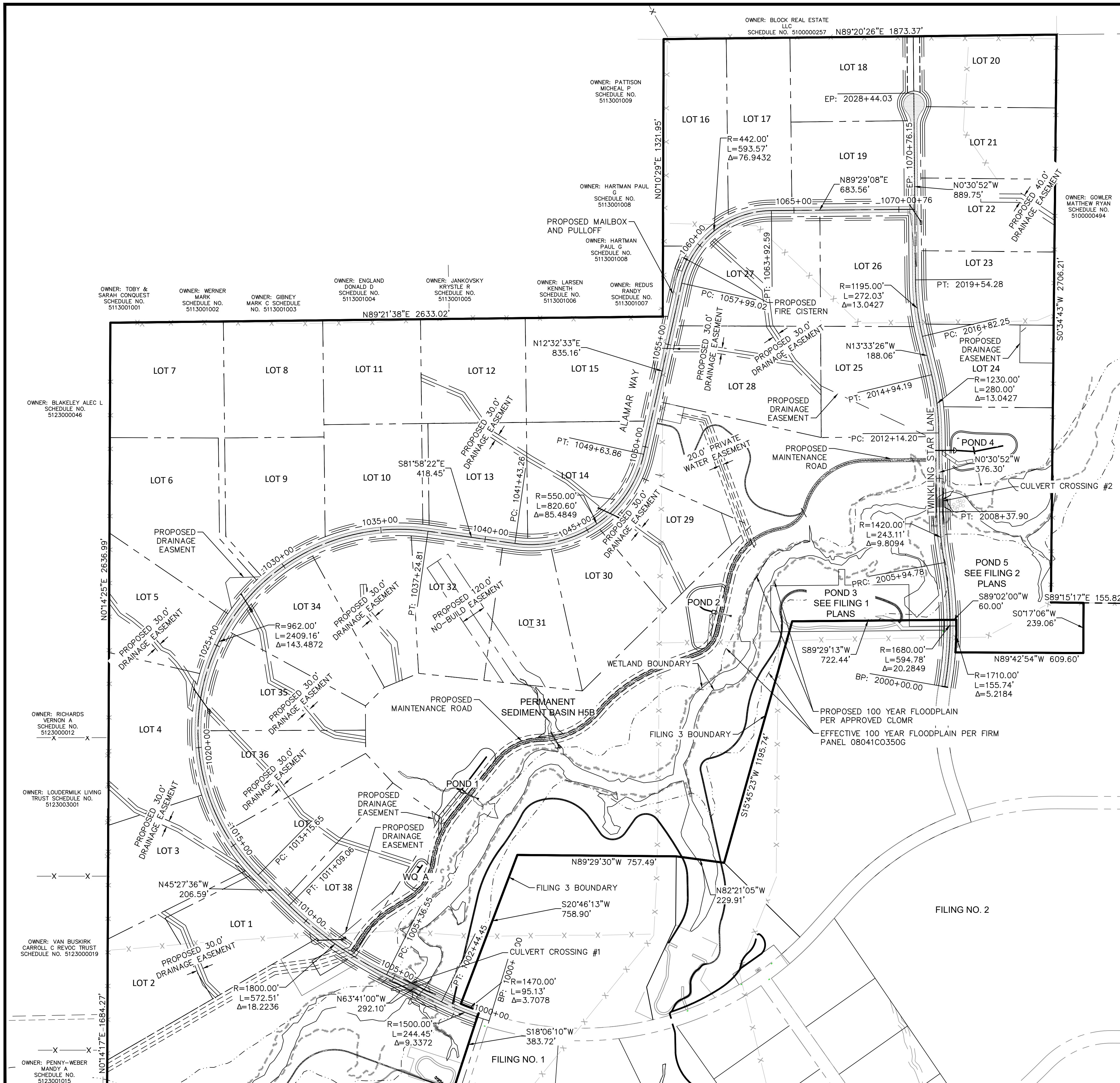

**BENCHMARK**

A 2.5" ALUMINUM CAP BEING A 30 FOOT WITNESS CORNER NORTH OF THE SOUTHWEST CORNER OF SECTION 24, TOWNSHIP 11 SOUTH, RANGE 65 WEST OF THE 6TH PRINCIPAL MERIDIAN.

**BASIS OF BEARING**

THE WEST LINE OF THE NORTHWEST QUARTER OF SECTION 24, TOWNSHIP 11 SOUTH, RANGE 65 WEST OF THE 6TH/ PRINCIPAL MERIDIAN BEING MONUMENTED ON THE SOUTHERLY END BY A 2-1/2" ALUMINUM CAP STAMPED 'LS 28658' AND AT THE NORTHERLY END BY A 3-1/2" ALUMINUM CAP STAMPED 'LS 12103' BEING ASSUMED TO BEAR N001'42'5"E A DISTANCE OF 2636.99 FEET AS SHOWN IN LAND SURVEY PLAT RECORDED UNDER RECEPTION 218900072 RECORDS OF EL PASO COUNTY.

NO.	REVISION	DATE	BY	APPR.
1	COUNTY COMMENTS	KRK 3/10/23	KRK	
2	COUNTY COMMENTS	KRK 4/26/23	KRK	

**Kimley»Horn**  
 2021 KIMLEY-HORN AND ASSOCIATES, INC.  
 2 North Nevada Avenue Suite 300  
 Colorado Springs, Colorado 80903 (719) 453-0180

DESIGNED BY: KRK  
 DRAWN BY: AJL  
 CHECKED BY: KRK  
 DATE: 12/16/2021

WINSOME FILING NO. 3  
 EL PASO COUNTY, COLORADO  
 CONSTRUCTION DOCUMENTS  
**HORIZONTAL CONTROL PLAN**

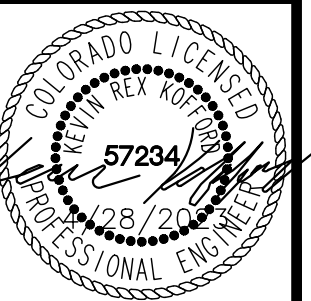
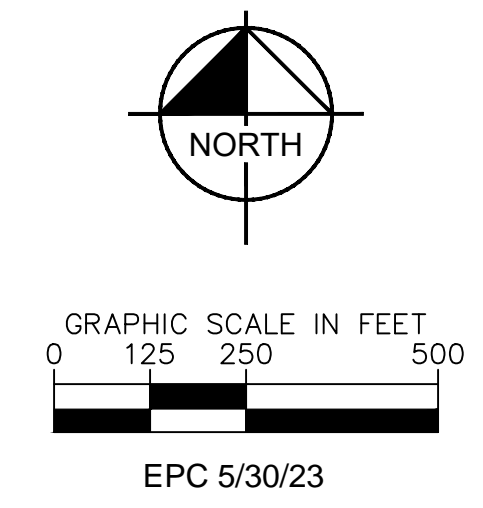

PROJECT NO.  
196106001  
 SHEET  
**C1.3**

K:\COS\_Civil\196106001\_Winsome Filing No. 3\CADD\PlanSheets\CDS\196106001\_CD\_CD.dwg Kofford, Kevin 4/28/2023 10:06 AM

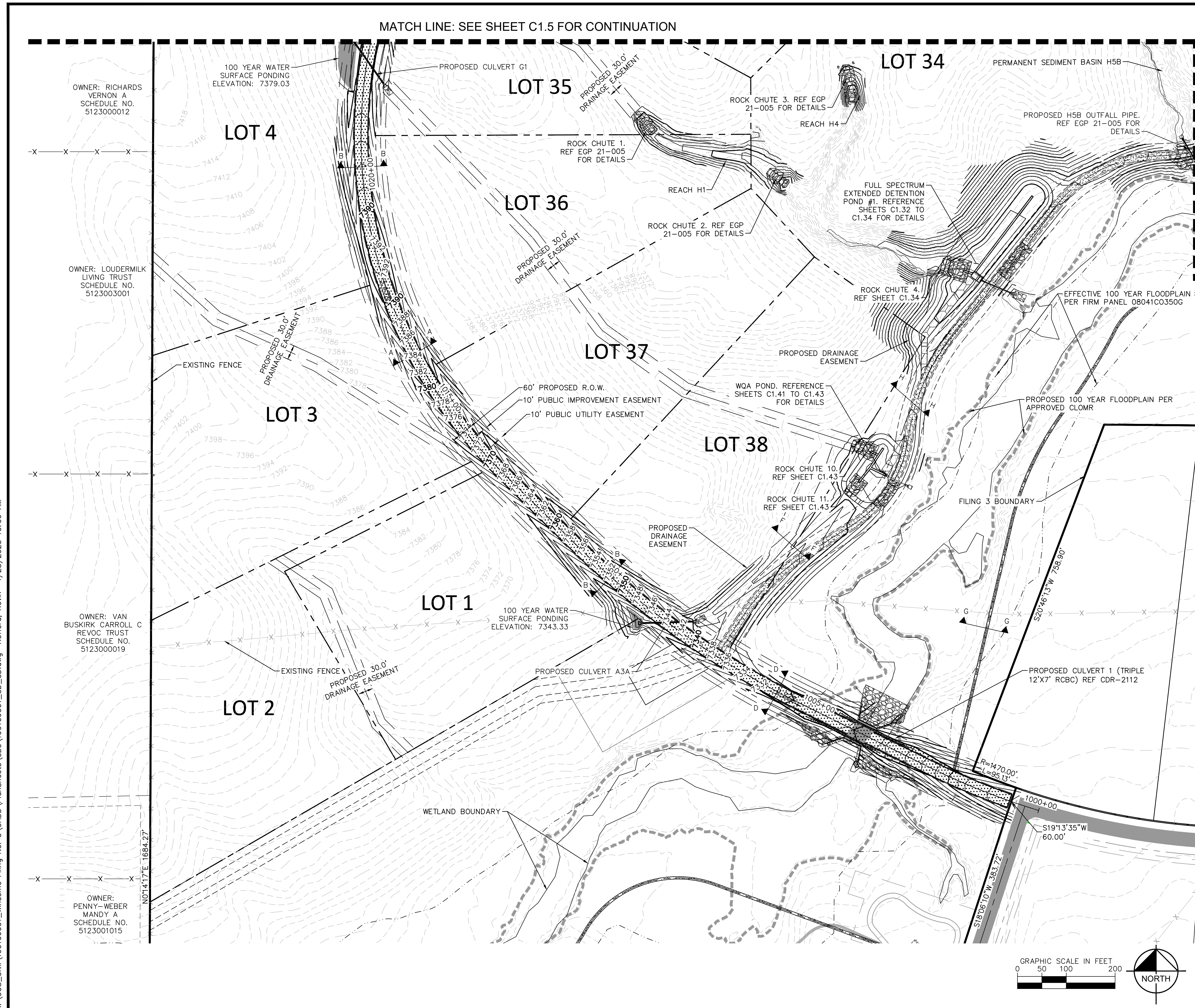

MATCH LINE: SEE SHEET C1.7 FOR CONTINUATION

**LEGEND**

	LOT BOUNDARY LINE
	EXISTING MAJOR CONTOUR
	EXISTING MINOR CONTOUR
	PROPOSED MAJOR CONTOUR
	PROPOSED MINOR CONTOUR
	STREET CROSS SECTION (SEE SHEET C1.2 FOR DETAILS)
	PROPOSED STORM LINE
	UTILITY EASEMENT
	R.O.W. LINE
	EDGE OF PAVEMENT

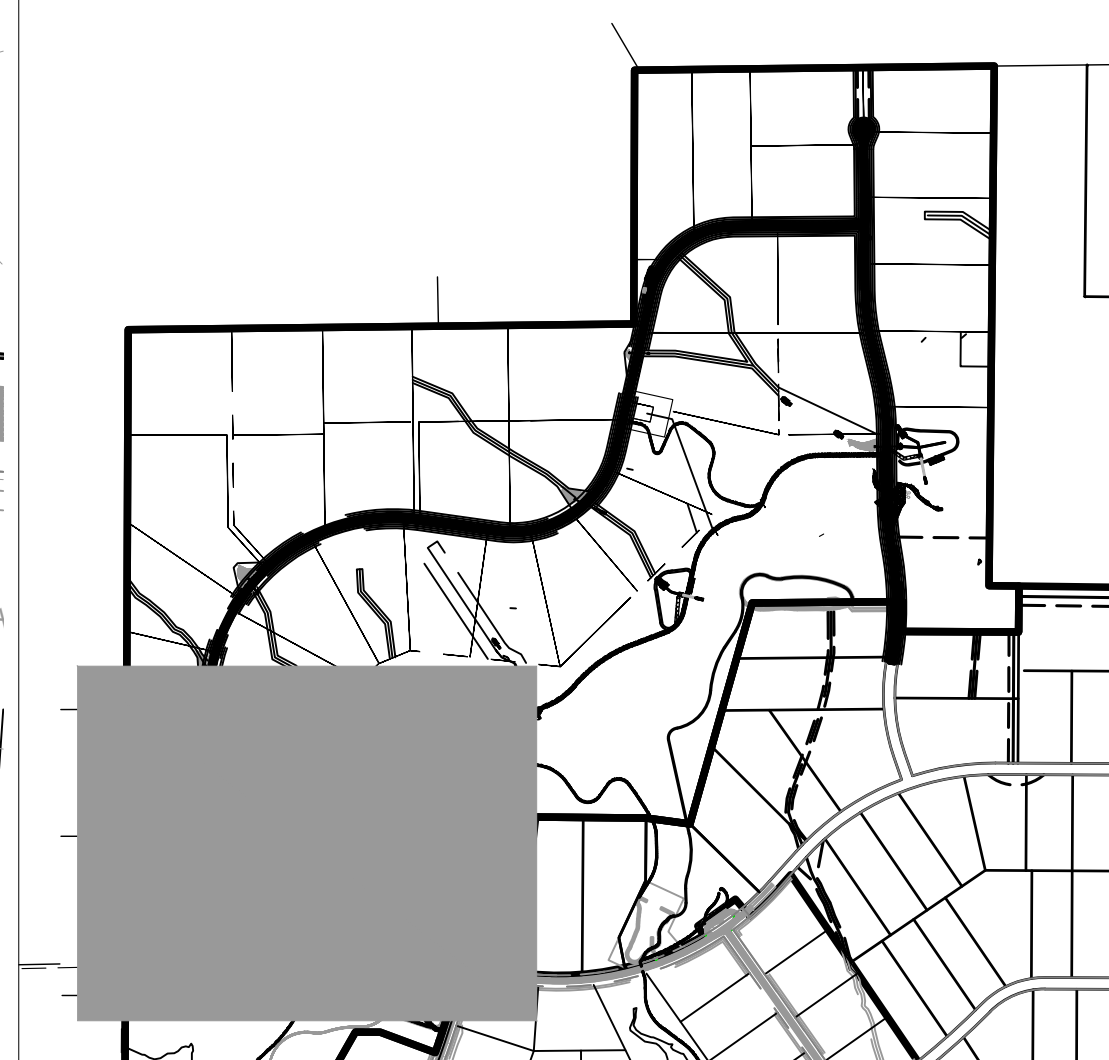
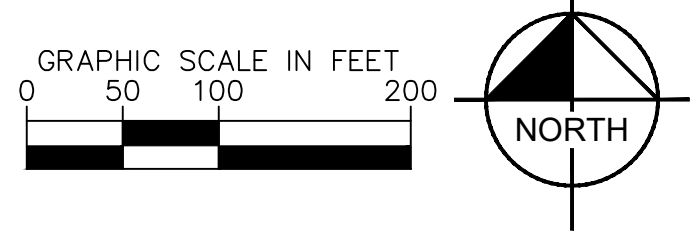
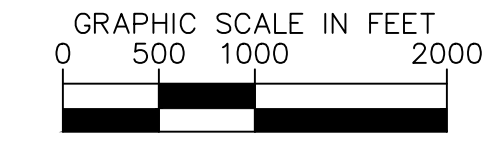

NO.	REVISION	DATE	BY	APPR.
1	COUNTY COMMENTS	KRK 3/10/23	KRK	
2	COUNTY COMMENTS	KRK 4/28/23	KRK	

**Kimley»Horn**  
 2021 KIMLEY-HORN AND ASSOCIATES, INC.  
 2 North Nevada Avenue Suite 300  
 Colorado Springs, Colorado 80903 (719) 453-0180

DESIGNED BY: KRK  
 DRAWN BY: A.J.L.  
 CHECKED BY: KRK  
 DATE: 12/16/2021

WINSOME FILING NO. 3  
 EL PASO COUNTY, COLORADO  
 CONSTRUCTION DOCUMENTS  
**GRADING PLAN**

EPC 5/30/23



PROJECT NO.  
196106001

SHEET  
**C1.4**

K:\COS\_Civil\196106001\_Winsome Filing No. 3\CADD\PlanSheets\CDS\196106001\_CD\_CD.dwg Kofford, Kevin 4/28/2023 10:06 AM

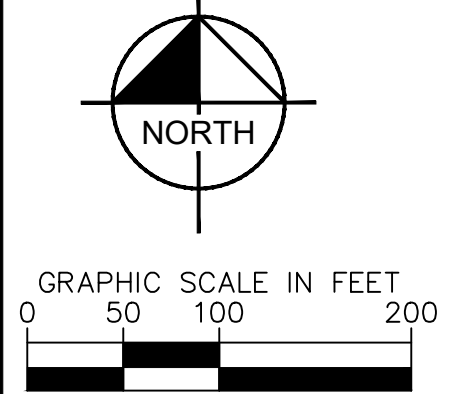
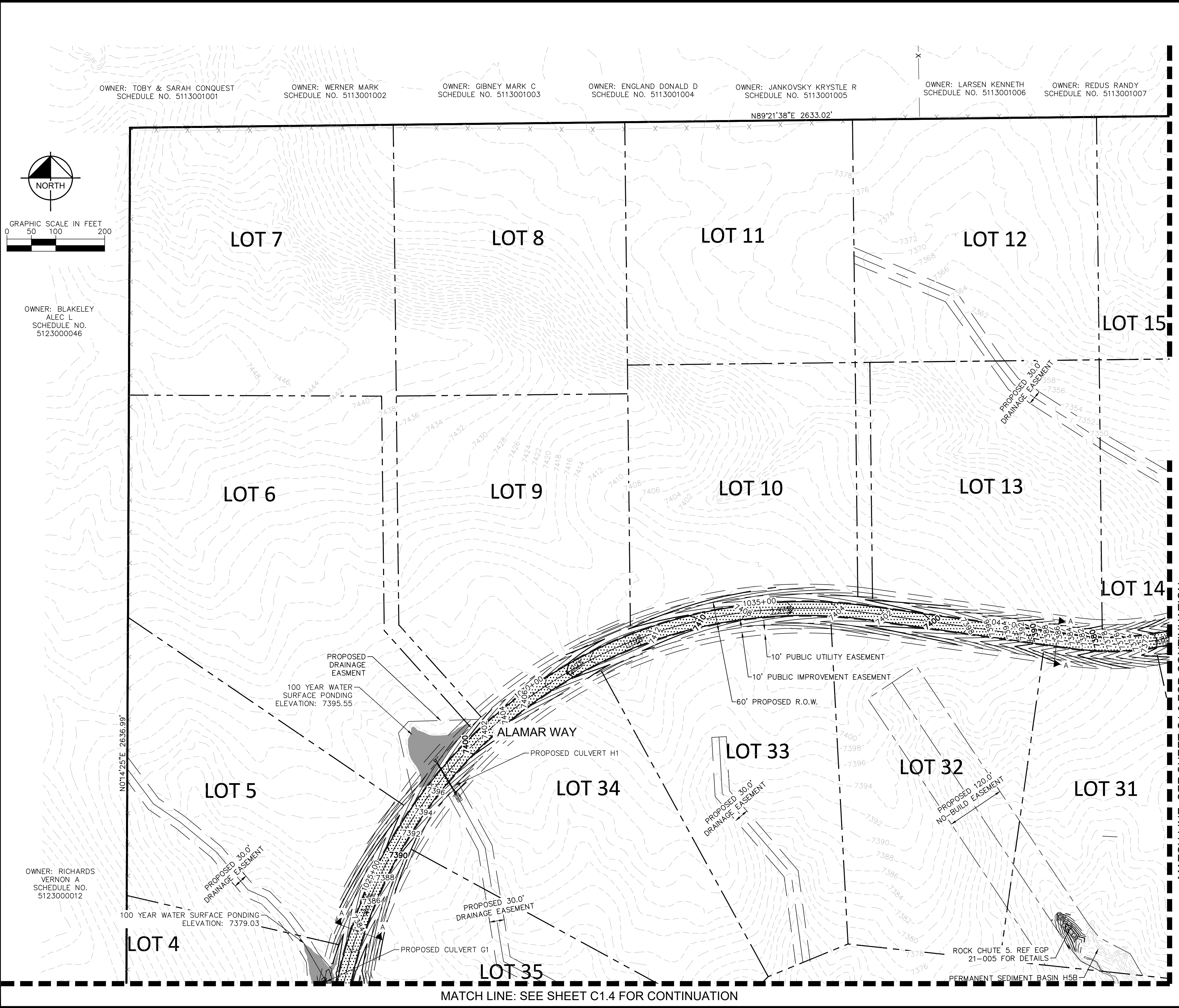

OWNER: BLAKELEY  
ALEC L  
SCHEDULE NO. 5123000046

OWNER: RICHARDS  
VERNON A  
SCHEDULE NO. 5123000012

OWNER: TOBY & SARAH CONQUEST SCHEDULE NO. 5113001001  
 OWNER: WERNER MARK SCHEDULE NO. 5113001002  
 OWNER: GIBNEY MARK C SCHEDULE NO. 5113001003  
 OWNER: ENGLAND DONALD D SCHEDULE NO. 5113001004  
 OWNER: JANKOVSKY KRISTLE R SCHEDULE NO. 5113001005  
 OWNER: LARSEN KENNETH SCHEDULE NO. 5113001006  
 OWNER: REDUS RANDY SCHEDULE NO. 5113001007

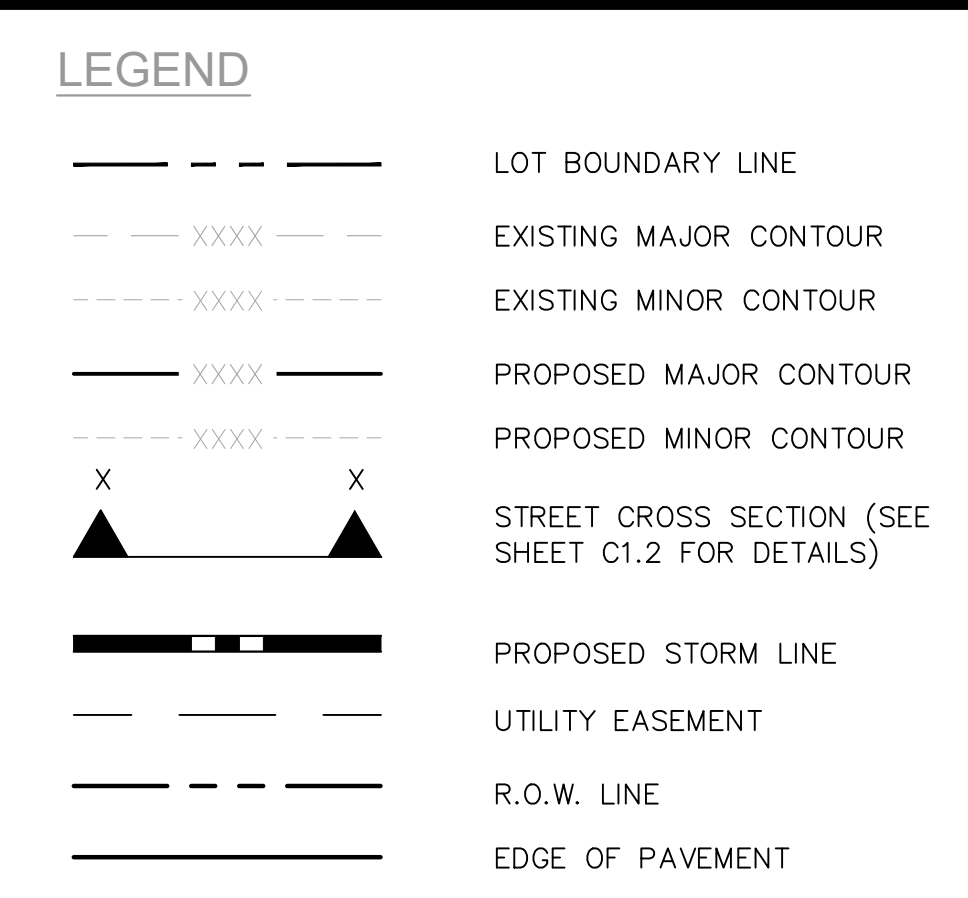

MATCH LINE: SEE SHEET C1.8 FOR CONTINUATION

MATCH LINE: SEE SHEET C1.9 FOR CONTINUATION

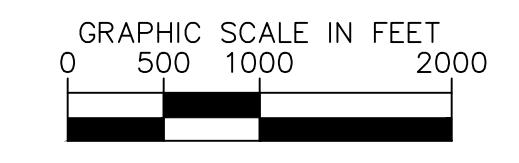

NO.	REVISION	COUNTY COMMENTS	BY	DATE	APPR.
2		COUNTY COMMENTS	KRK	4/28/23	KRK
1		COUNTY COMMENTS	KRK	3/10/23	KRK

**Kimley»Horn**  
 2021 KIMLEY-HORN AND ASSOCIATES, INC.  
 2 North Nevada Avenue Suite 300  
 Colorado Springs, Colorado 80903 (719) 453-0180

DESIGNED BY: KRK  
 DRAWN BY: AJL  
 CHECKED BY: KRK  
 DATE: 12/16/2021

WINSOME FILING NO. 3  
 EL PASO COUNTY, COLORADO  
 CONSTRUCTION DOCUMENTS  
**GRADING PLAN**

EPC 5/30/23



PROJECT NO. 196106001  
 SHEET

**C1.5**

K:\COS\_Civil\196106001\_Winsome Filing No. 3\CADD\PlanSheets\Cds\196106001\_CD\_CD.dwg Koford, Kevin 4/28/2023 10:06 AM

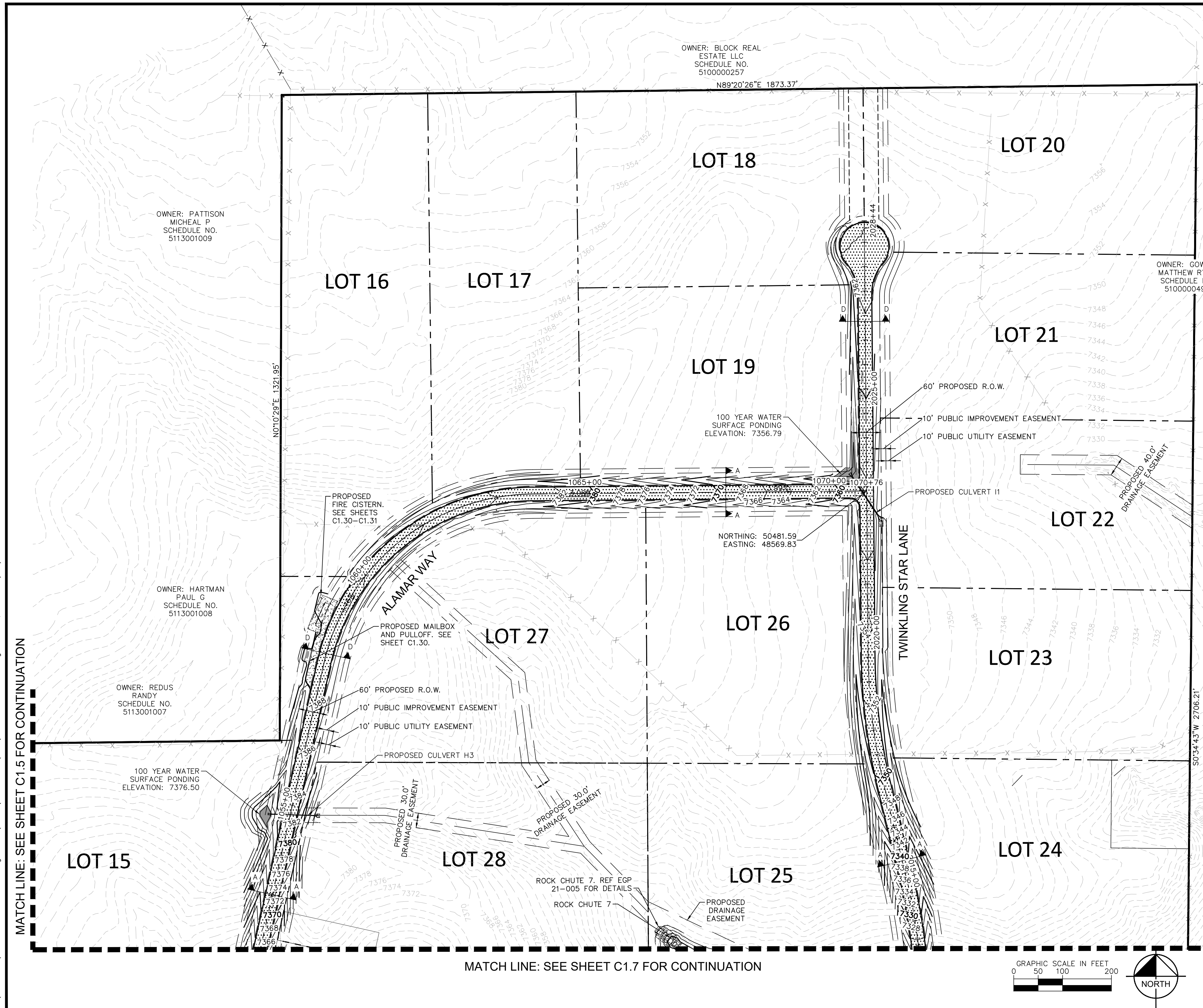

**LEGEND**

- LOT BOUNDARY LINE
- XXXX ----- EXISTING MAJOR CONTOUR
- XXXX ----- EXISTING MINOR CONTOUR
- XXXX ----- PROPOSED MAJOR CONTOUR
- XXXX ----- PROPOSED MINOR CONTOUR
- X X STREET CROSS SECTION (SEE SHEET C1.2 FOR DETAILS)
- PROPOSED STORM LINE
- UTILITY EASEMENT
- R.O.W. LINE
- EDGE OF PAVEMENT

MATCH LINE: SEE SHEET C1.5 FOR CONTINUATION

MATCH LINE: SEE SHEET C1.7 FOR CONTINUATION

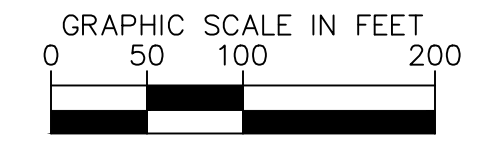
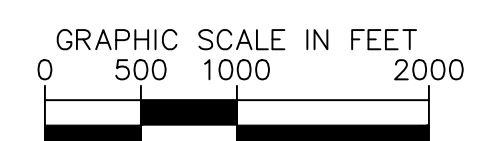

NO.	REVISION	DATE	BY	APPR.
1	COUNTY COMMENTS	KRK 3/10/23	KRK	
2	COUNTY COMMENTS	KRK 4/28/23	KRK	

**Kimley»Horn**  
 2021 KIMLEY-HORN AND ASSOCIATES, INC.  
 2 North Nevada Avenue Suite 300  
 Colorado Springs, Colorado 80903 (719) 453-0180

DESIGNED BY: KRK  
 DRAWN BY: A.JL  
 CHECKED BY: KRK  
 DATE: 12/16/2021

WINSOME FILING NO. 3  
 EL PASO COUNTY, COLORADO  
 CONSTRUCTION DOCUMENTS  
**GRADING PLAN**

EPC 5/30/23



PROJECT NO. 196106001

SHEET

C1.6

K:\COS\_Civil\196106001\_Winsome Filing No. 3\CADD\PlanSheets\Cds\196106001\_CD\_CD.dwg Kofford, Kevin 4/28/2023 10:07 AM

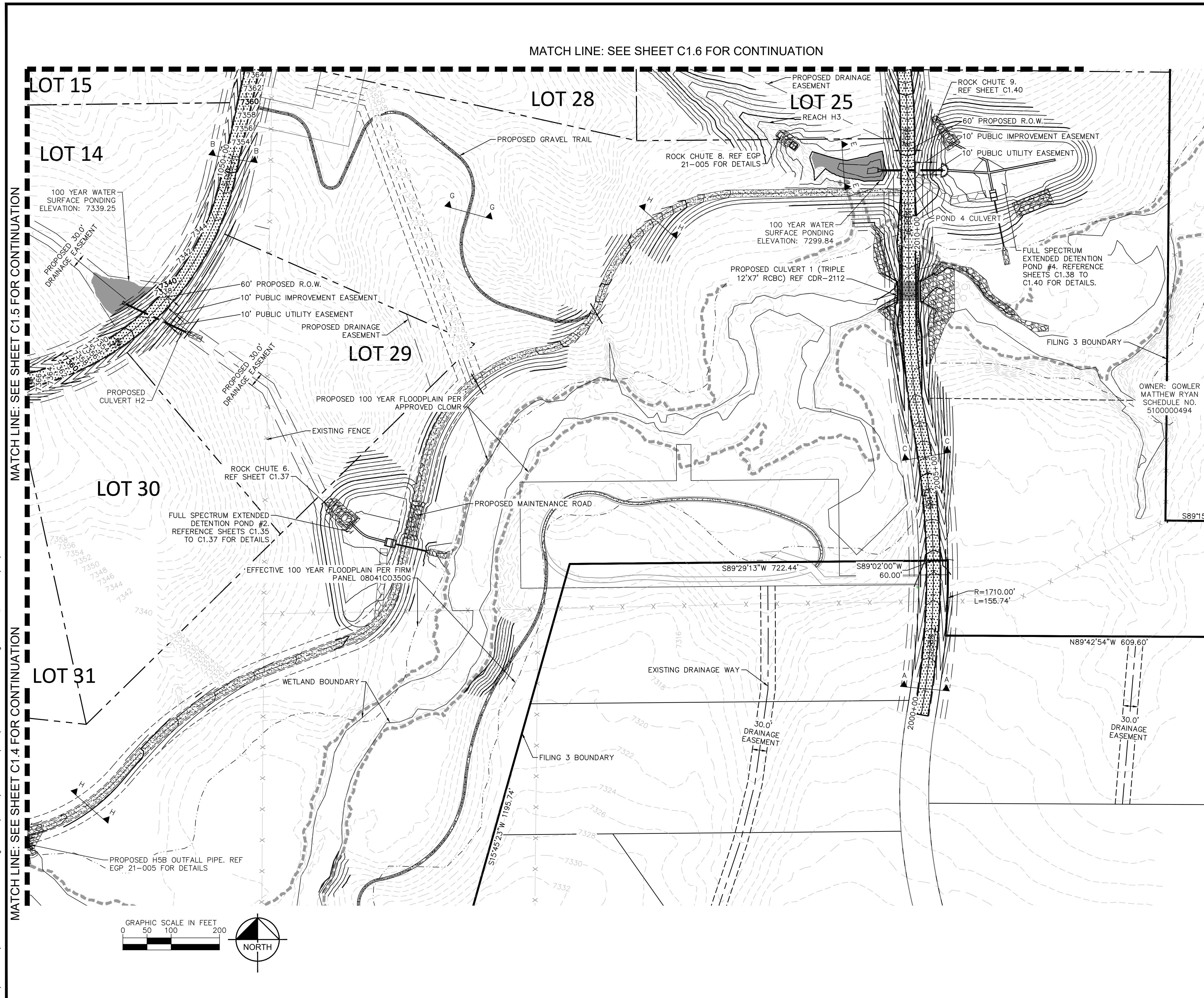

**LEGEND**

---	LOT BOUNDARY LINE
XXXX	EXISTING MAJOR CONTOUR
XXXX	EXISTING MINOR CONTOUR
XXXX	PROPOSED MAJOR CONTOUR
XXXX	PROPOSED MINOR CONTOUR
X X	STREET CROSS SECTION (SEE SHEET C1.2 FOR DETAILS)
---	PROPOSED STORM LINE
---	UTILITY EASEMENT
---	R.O.W. LINE
---	EDGE OF PAVEMENT

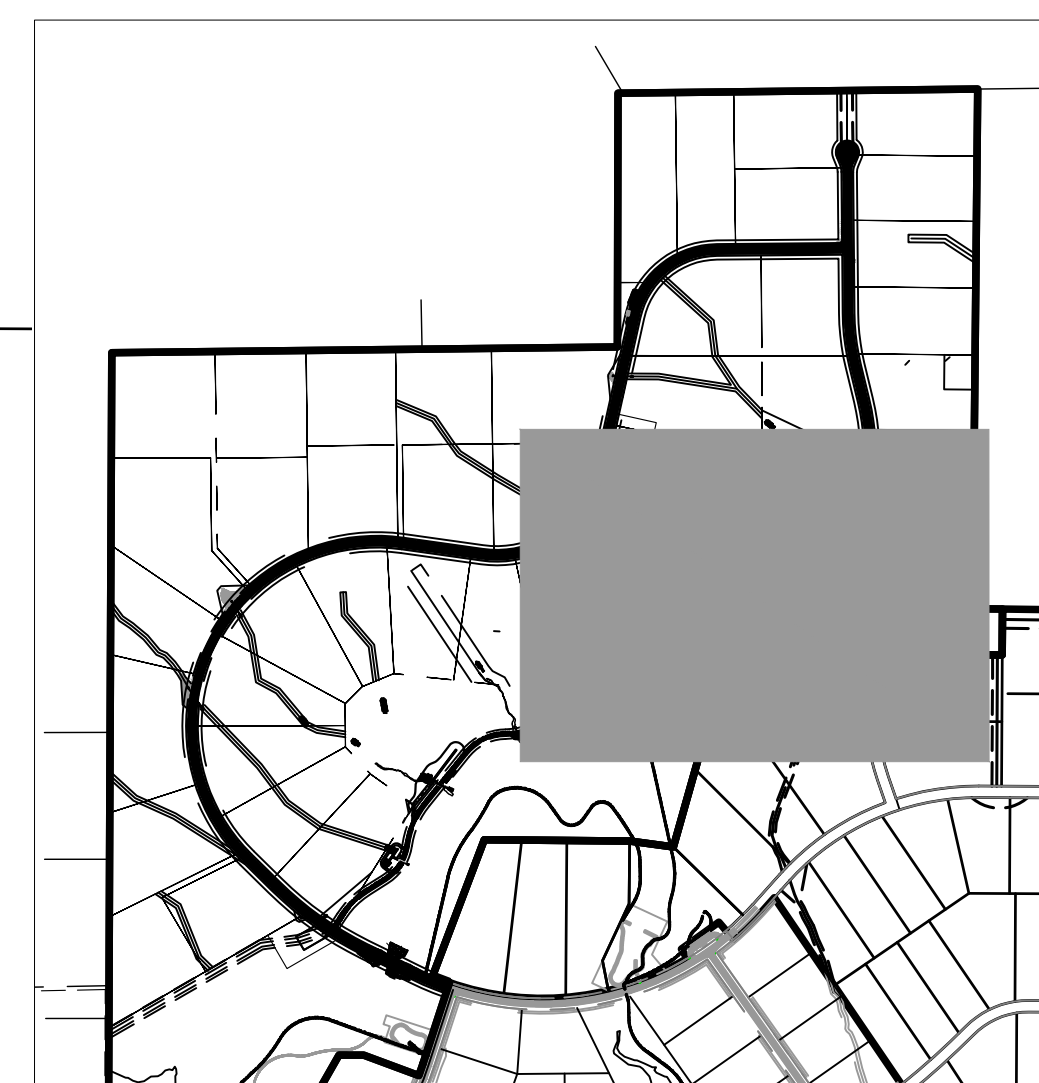
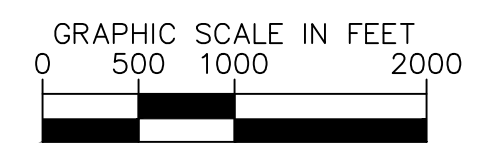

NO.	REVISION	DATE	BY	APPR.
1	COUNTY COMMENTS	KRK 3/10/23	KRK	
2	COUNTY COMMENTS	KRK 4/28/23	KRK	

**Kimley»Horn**  
 2021 KIMLEY-HORN AND ASSOCIATES, INC.  
 2 North Nevada Avenue Suite 300  
 Colorado Springs, Colorado 80903 (719) 453-0180

DESIGNED BY: KRK  
 DRAWN BY: AJL  
 CHECKED BY: KRK  
 DATE: 12/16/2021

WINSOME FILING NO. 3  
 EL PASO COUNTY, COLORADO  
 CONSTRUCTION DOCUMENTS  
**GRADING PLAN**

EPC 5/30/23



PROJECT NO.  
196106001

SHEET  
**C1.7**



K:\COS\_Civil\196106001\_Winsome Filing No. 3\CADD\PlanSheets\Cds\196106001\_P&P\_ALAMR.dwg Kofford, Kevin 4/28/2023 10:08 AM

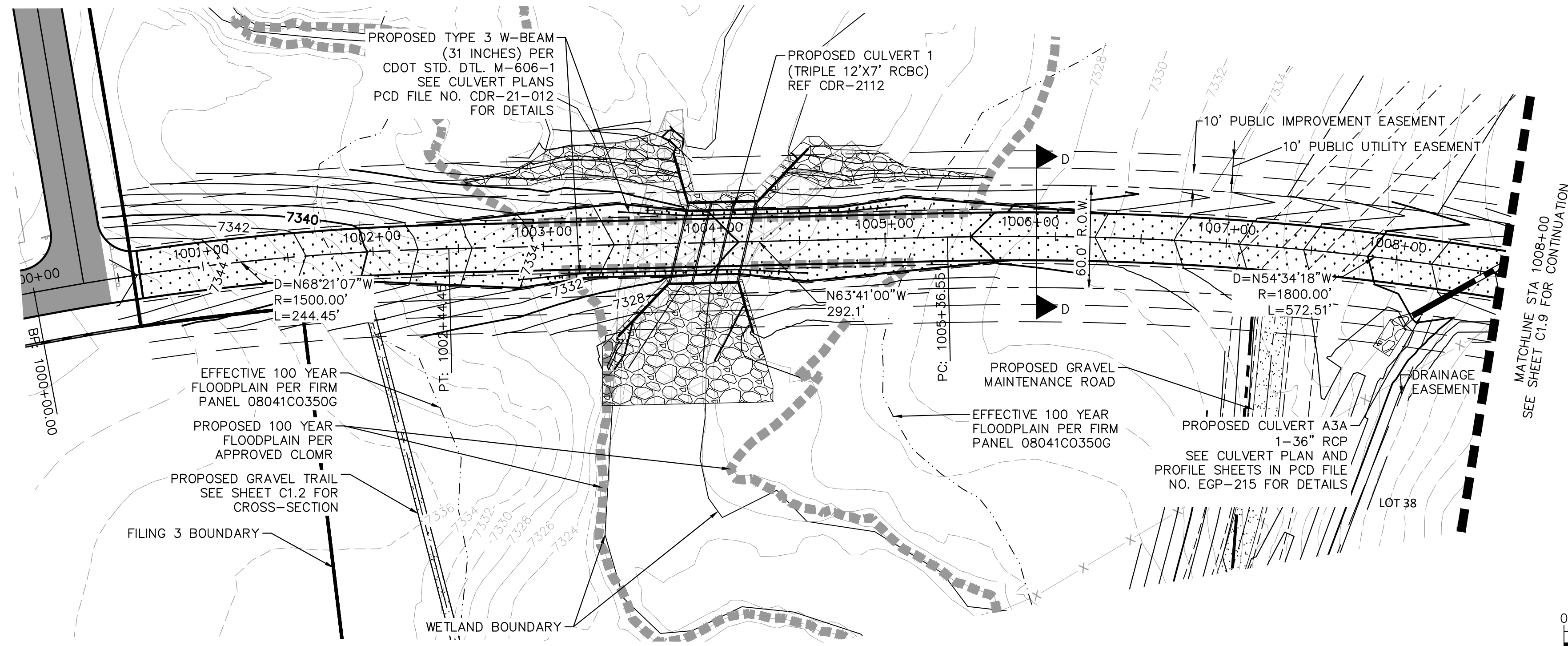

**LEGEND**

---	LOT BOUNDARY LINE
-----	EXISTING MAJOR CONTOUR
-----	EXISTING MINOR CONTOUR
-----	PROPOSED MAJOR CONTOUR
-----	PROPOSED MINOR CONTOUR
X X	STREET CROSS SECTION (SEE SHEET C1.2 FOR DETAILS)
---	PROPOSED STORM LINE
---	UTILITY EASEMENT
---	R.O.W. LINE
---	EDGE OF PAVEMENT

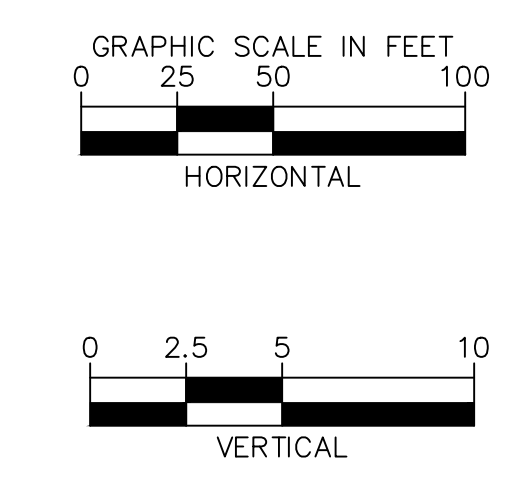
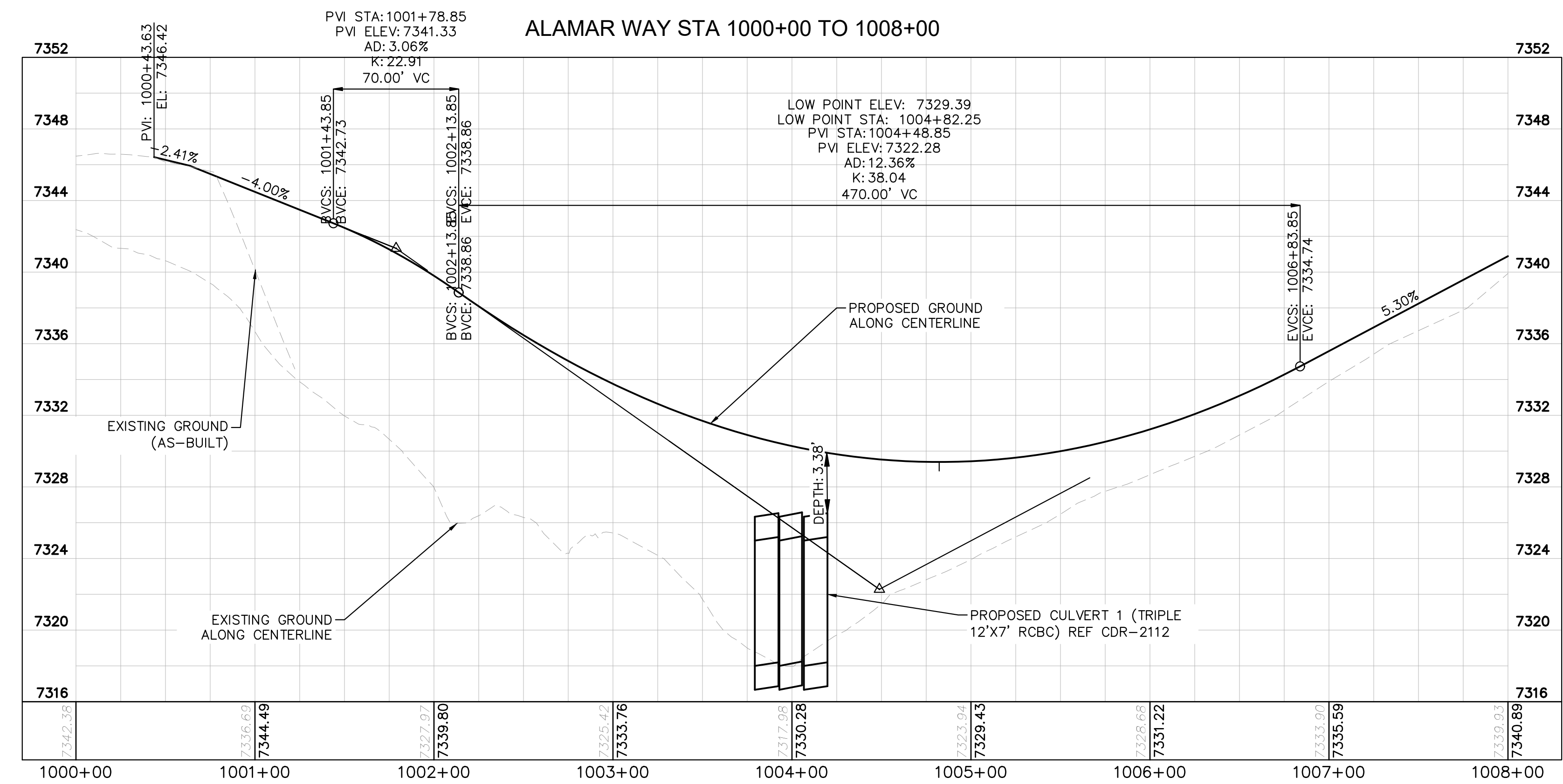
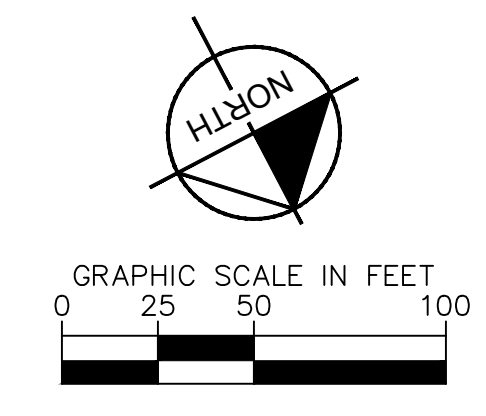

**NOTES**

- SEE SHEET C1.2 FOR TYPICAL ROADWAY SECTIONS AND ROADSIDE DITCH CONFIGURATIONS AS LABELED IN PLAN VIEW.

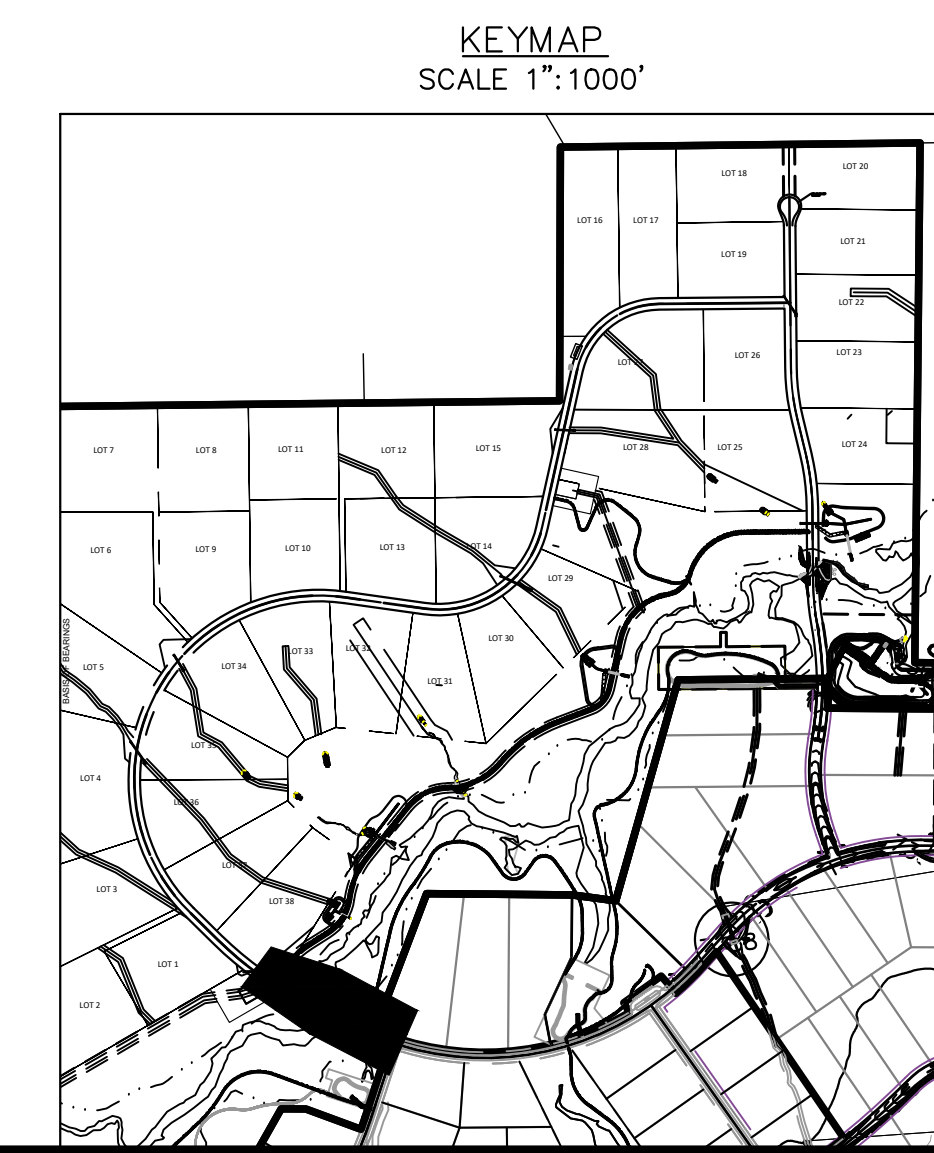

NO.	REVISION	DATE	BY	APPR.
1	COUNTY COMMENTS	KRK 3/10/23	KRK	
2	COUNTY COMMENTS	KRK 4/28/23	KRK	

**Kimley»Horn**  
 2021 KIMLEY-HORN AND ASSOCIATES, INC.  
 2 North Nevada Avenue Suite 300  
 Colorado Springs, Colorado 80903 (719) 453-0180

DESIGNED BY: KRK  
 DRAWN BY: AJL  
 CHECKED BY: KRK  
 DATE: 12/16/2021

WINSOME FILING NO. 3  
 EL PASO COUNTY, COLORADO  
 CONSTRUCTION DOCUMENTS  
**ALAMAR PLAN AND PROFILE**

EPC 5/30/23

PROJECT NO.  
196106001  
 SHEET  
**C1.8**

K:\COS\_Civil\196106001\_Winsome Filing No. 3\CADD\PlanSheets\Cds\196106001\_P&P\_ALAMR.dwg Kofford, Kevin 4/28/2023 10:08 AM

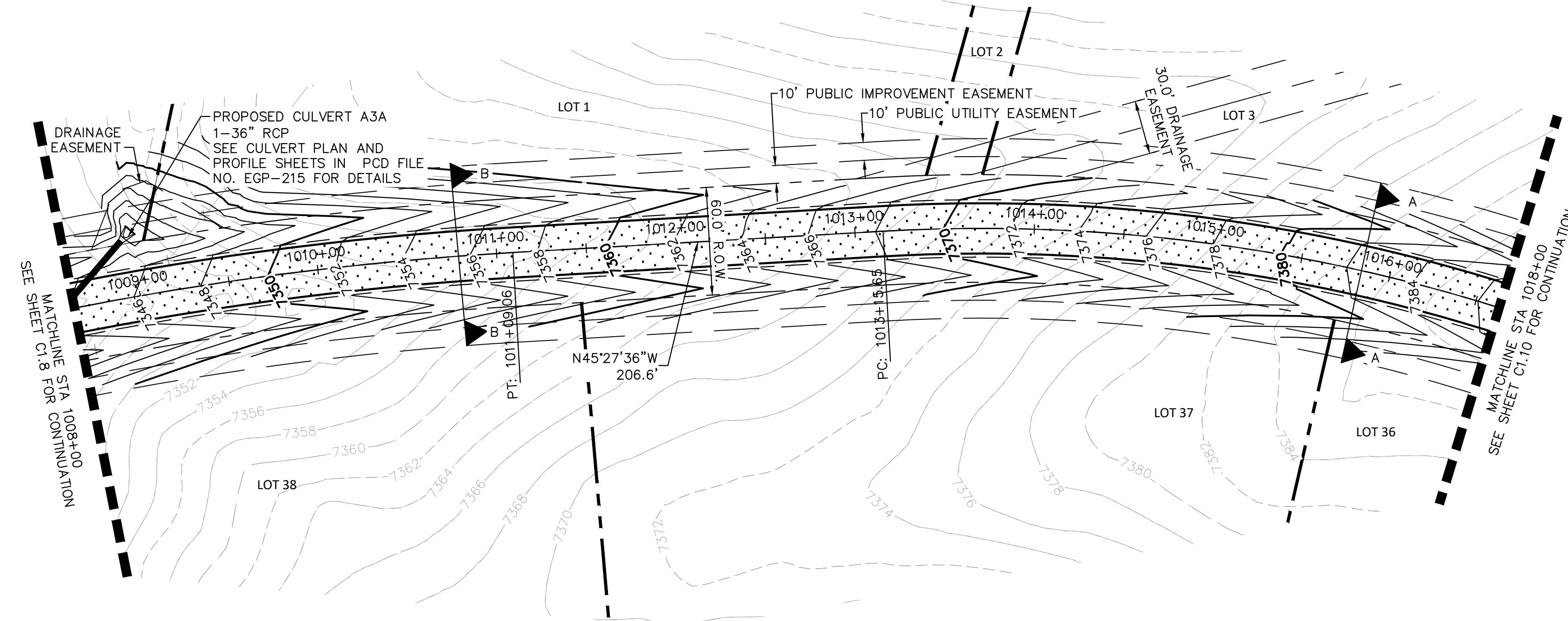

**LEGEND**

- LOT BOUNDARY LINE
- EXISTING MAJOR CONTOUR
- EXISTING MINOR CONTOUR
- PROPOSED MAJOR CONTOUR
- PROPOSED MINOR CONTOUR
- X X X X STREET CROSS SECTION (SEE SHEET C1.2 FOR DETAILS)
- PROPOSED STORM LINE
- UTILITY EASEMENT
- R.O.W. LINE
- EDGE OF PAVEMENT

**NOTES**

- SEE SHEET C1.2 FOR TYPICAL ROADWAY SECTIONS AND ROADSIDE DITCH CONFIGURATIONS AS LABELED IN PLAN VIEW.

ALAMAR WAY STA 1008+00 TO 1016+00

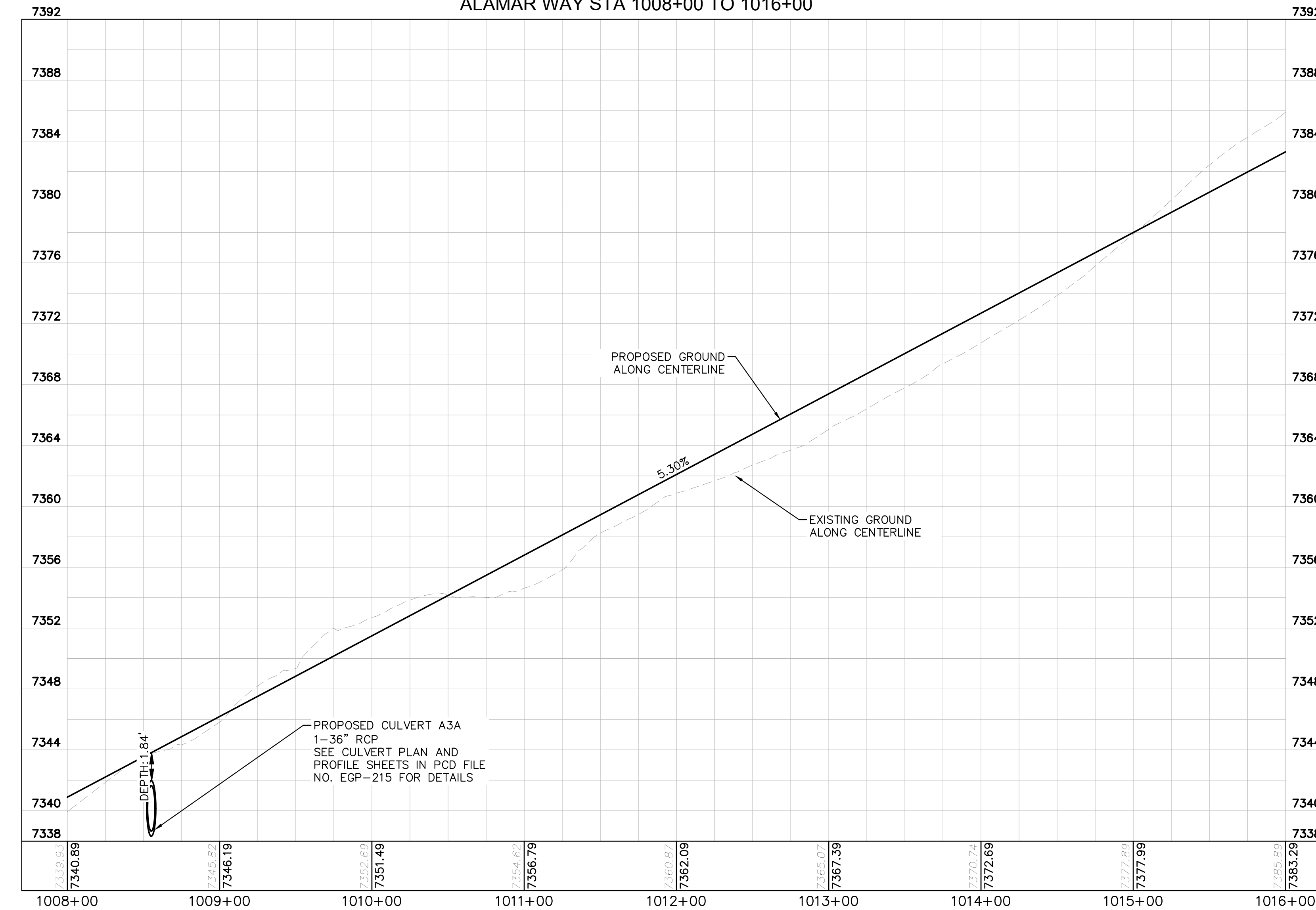

NO.	REVISION	BY	DATE	APPR.
2	COUNTY COMMENTS	KRK	4/28/23	KRK
1	COUNTY COMMENTS	KRK	3/10/23	KRK

**Kimley»Horn**  
 2021 KIMLEY-HORN AND ASSOCIATES, INC.  
 2 North Nevada Avenue Suite 300  
 Colorado Springs, Colorado 80903 (719) 453-0180

DESIGNED BY: KRK  
 DRAWN BY: AJL  
 CHECKED BY: KRK  
 DATE: 12/16/2021

WINSOME FILING NO. 3  
 EL PASO COUNTY, COLORADO  
 CONSTRUCTION DOCUMENTS  
**ALAMAR PLAN AND PROFILE**

EPC 5/30/23

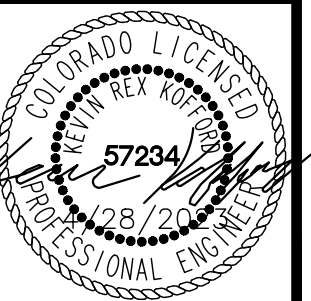

PROJECT NO.  
196106001

SHEET  
**C1.9**

K:\COS\_Civil\196106001\_Winsome Filing No. 3\CADD\PlanSheets\Cds\196106001\_P&P\_ALAMR.dwg Kofford, Kevin 4/28/2023 10:08 AM

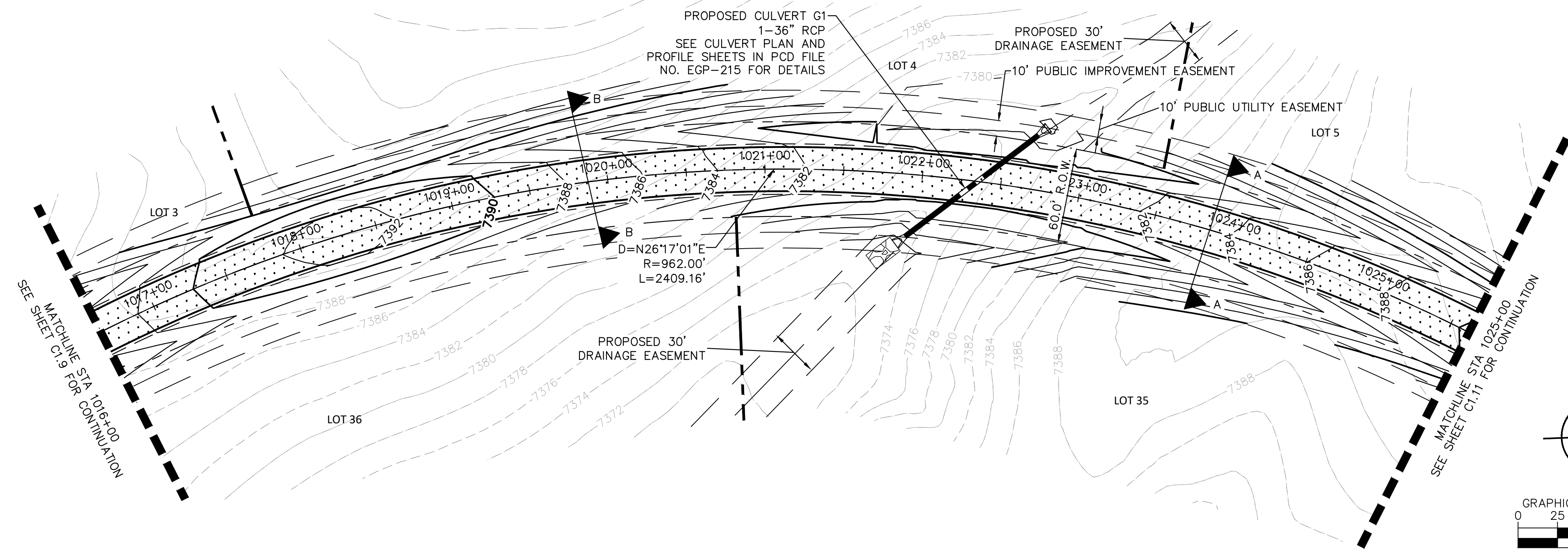

**LEGEND**

- LOT BOUNDARY LINE
- XXXX ----- EXISTING MAJOR CONTOUR
- XXXX ----- EXISTING MINOR CONTOUR
- XXXX ----- PROPOSED MAJOR CONTOUR
- XXXX ----- PROPOSED MINOR CONTOUR
- X                      X STREET CROSS SECTION (SEE SHEET C1.2 FOR DETAILS)
- PROPOSED STORM LINE
- UTILITY EASEMENT
- R.O.W. LINE
- EDGE OF PAVEMENT

**NOTES**

1. SEE SHEET C1.2 FOR TYPICAL ROADWAY SECTIONS AND ROADSIDE DITCH CONFIGURATIONS AS LABELED IN PLAN VIEW.

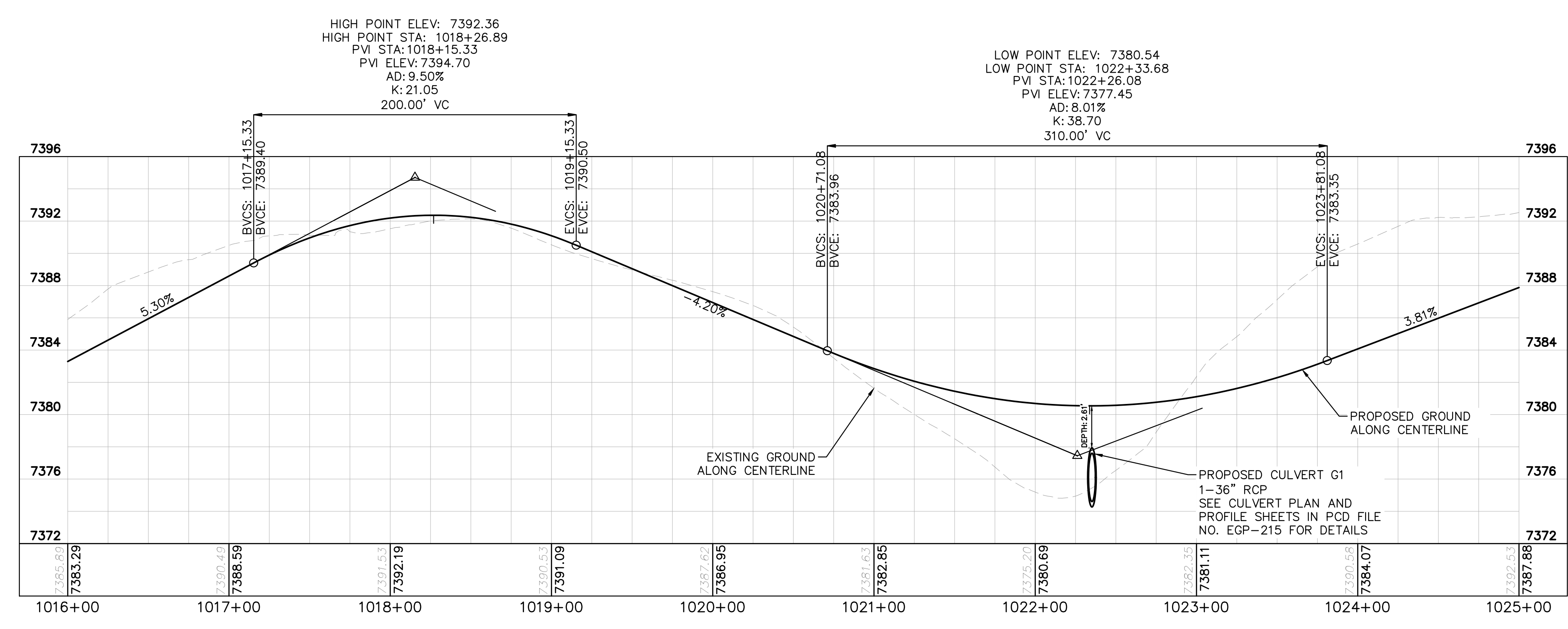

NO.	REVISION	BY	DATE	APPR.
1	COUNTY COMMENTS	KRK	3/10/23	KRK
2	COUNTY COMMENTS	KRK	4/28/23	KRK

**Kimley»Horn**  
 2021 KIMLEY-HORN AND ASSOCIATES, INC.  
 2 North Nevada Avenue Suite 300  
 Colorado Springs, Colorado 80903 (719) 453-0180

DESIGNED BY: KRK  
 DRAWN BY: A.J.L.  
 CHECKED BY: KRK  
 DATE: 12/16/2021

WINSOME FILING NO. 3  
 EL PASO COUNTY, COLORADO  
 CONSTRUCTION DOCUMENTS  
**ALAMAR PLAN AND PROFILE**

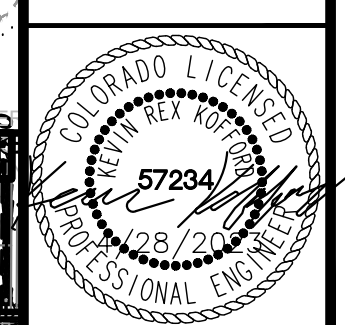

PROJECT NO.  
196106001  
 SHEET  
**C1.10**

K:\COS\_Civil\196106001\_Winsome Filing No. 3\CADD\PlanSheets\CDS\196106001\_P&P\_ALAMR.dwg Kofford, Kevin 4/28/2023 10:09 AM

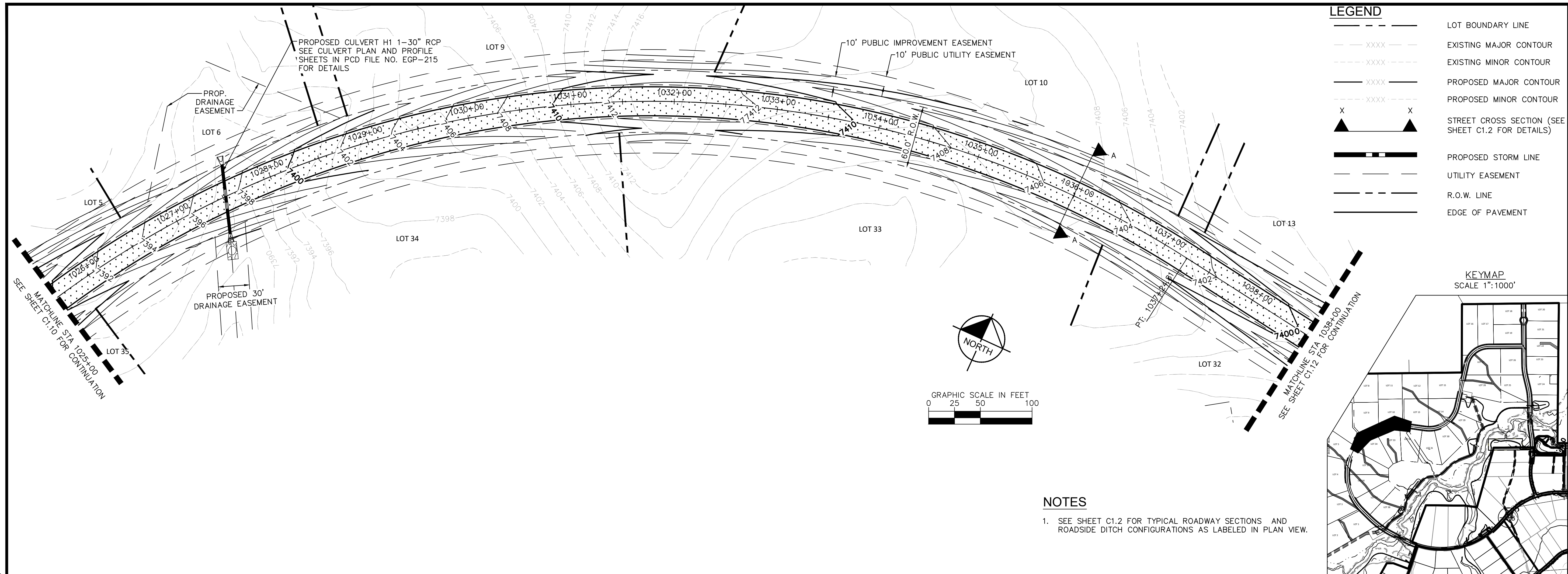

**LEGEND**

---	LOT BOUNDARY LINE
-----	EXISTING MAJOR CONTOUR
- - - - -	EXISTING MINOR CONTOUR
-----	PROPOSED MAJOR CONTOUR
- - - - -	PROPOSED MINOR CONTOUR
X      X	STREET CROSS SECTION (SEE SHEET C1.2 FOR DETAILS)
---	PROPOSED STORM LINE
---	UTILITY EASEMENT
---	R.O.W. LINE
---	EDGE OF PAVEMENT

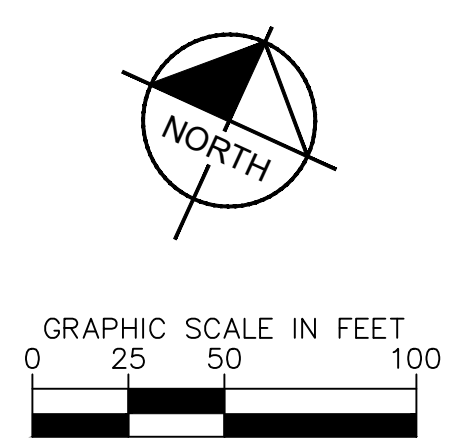

**NOTES**

1. SEE SHEET C1.2 FOR TYPICAL ROADWAY SECTIONS AND ROADSIDE DITCH CONFIGURATIONS AS LABELED IN PLAN VIEW.

NO.	REVISION	BY	DATE	APPR.
2	COUNTY COMMENTS	KRK	4/28/23	KRK
1	COUNTY COMMENTS	KRK	3/10/23	KRK

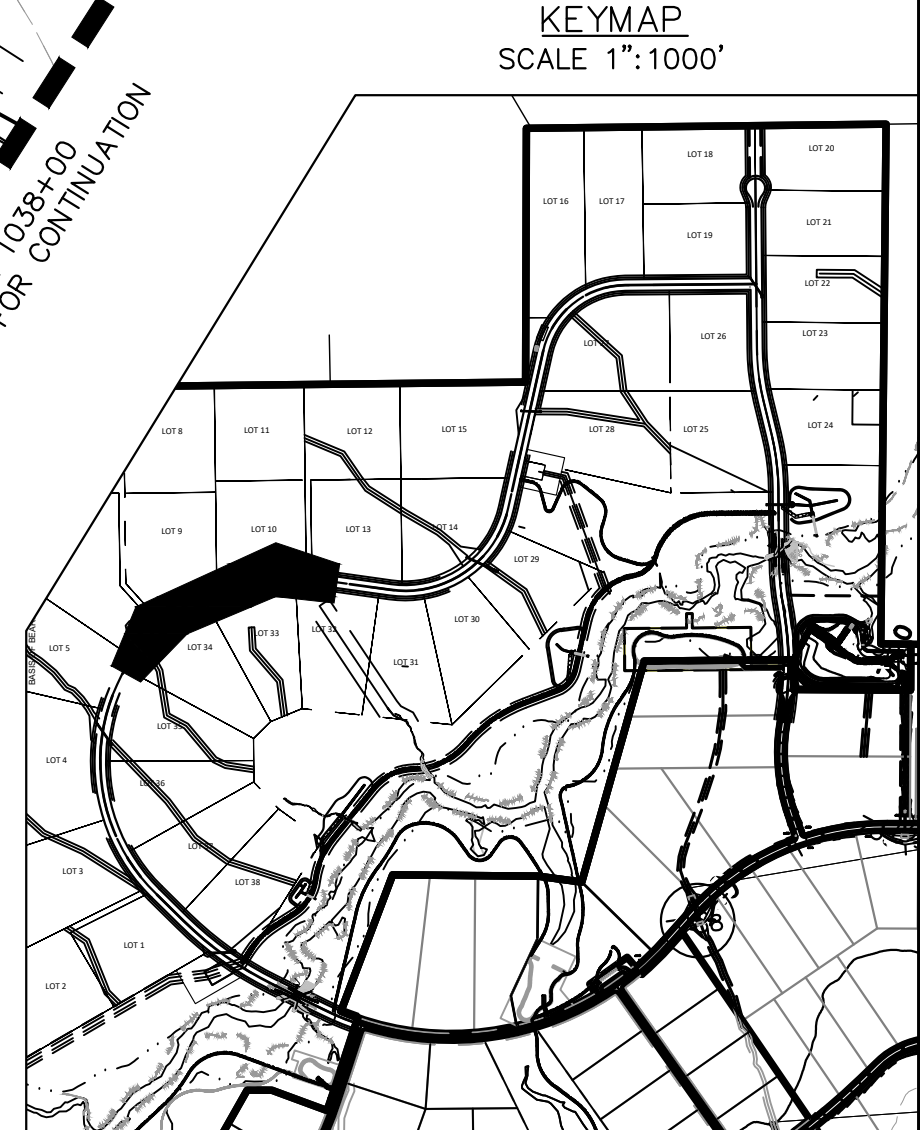

**Kimley»Horn**

2021 KIMLEY-HORN AND ASSOCIATES, INC.  
2 North Nevada Avenue Suite 300  
Colorado Springs, Colorado 80903 (719) 453-0180

DESIGNED BY: KRK  
DRAWN BY: A.J.L.  
CHECKED BY: KRK  
DATE: 12/16/2021

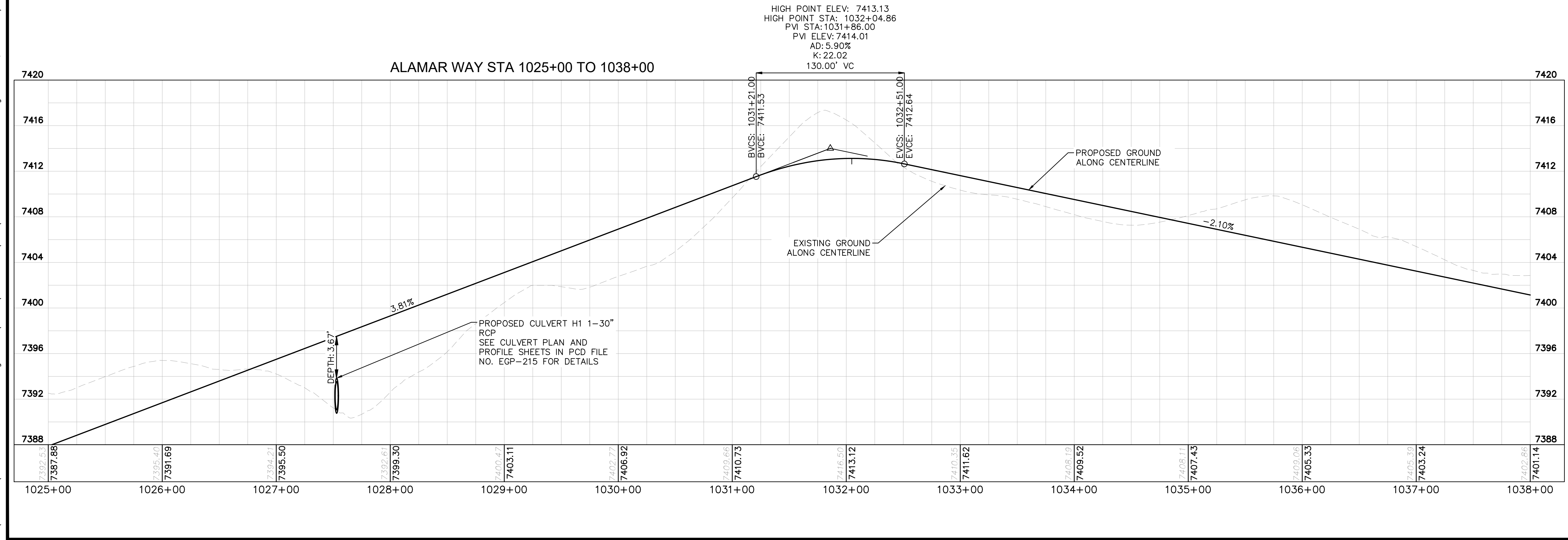

WINSOME FILING NO. 3  
EL PASO COUNTY, COLORADO  
CONSTRUCTION DOCUMENTS  
ALAMAR PLAN AND PROFILE

PROJECT NO. 196106001  
SHEET C1.11  
EPC 5/30/23

K:\COS\_Civil\196106001\_Winsome Filing No. 3\CADD\PlanSheets\CDS\196106001\_P&P\_ALAMR.dwg Kofford, Kevin 4/28/2023 10:09 AM

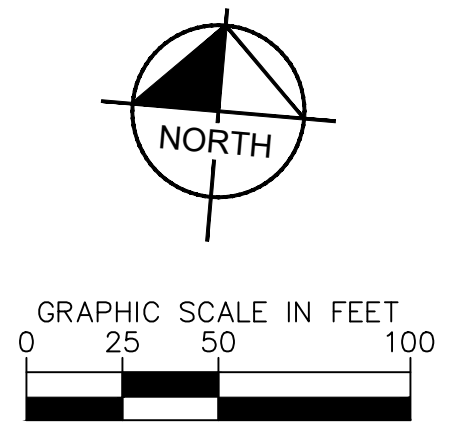
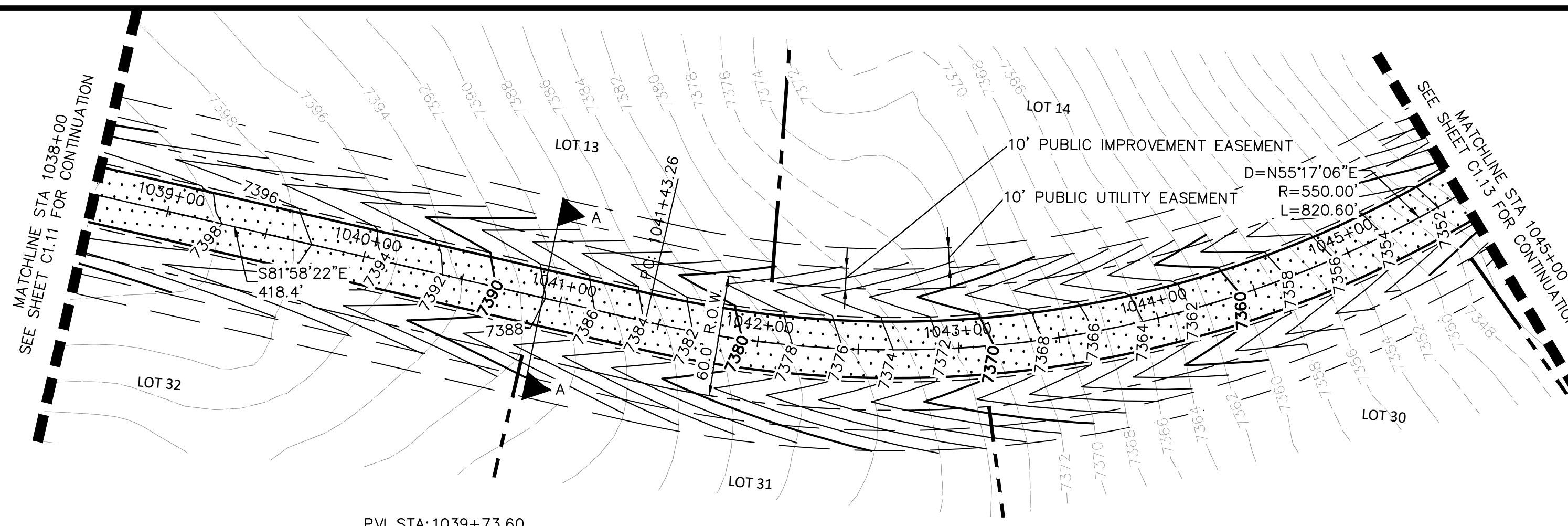

**LEGEND**

- LOT BOUNDARY LINE
- EXISTING MAJOR CONTOUR
- EXISTING MINOR CONTOUR
- PROPOSED MAJOR CONTOUR
- PROPOSED MINOR CONTOUR
- X X X X STREET CROSS SECTION (SEE SHEET C1.2 FOR DETAILS)
- PROPOSED STORM LINE
- UTILITY EASEMENT
- R.O.W. LINE
- EDGE OF PAVEMENT

PVI STA: 1039+73.60  
 PVI ELEV: 7397.50  
 AD: 5.90%  
 K: 34.72  
 205.00' VC

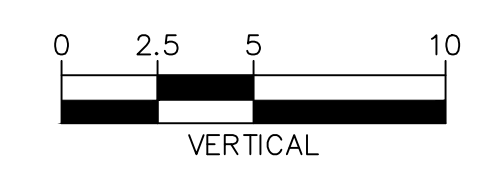
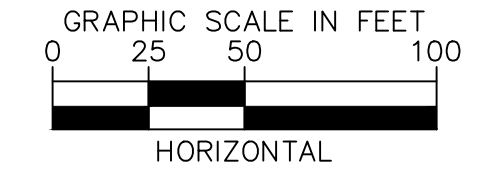
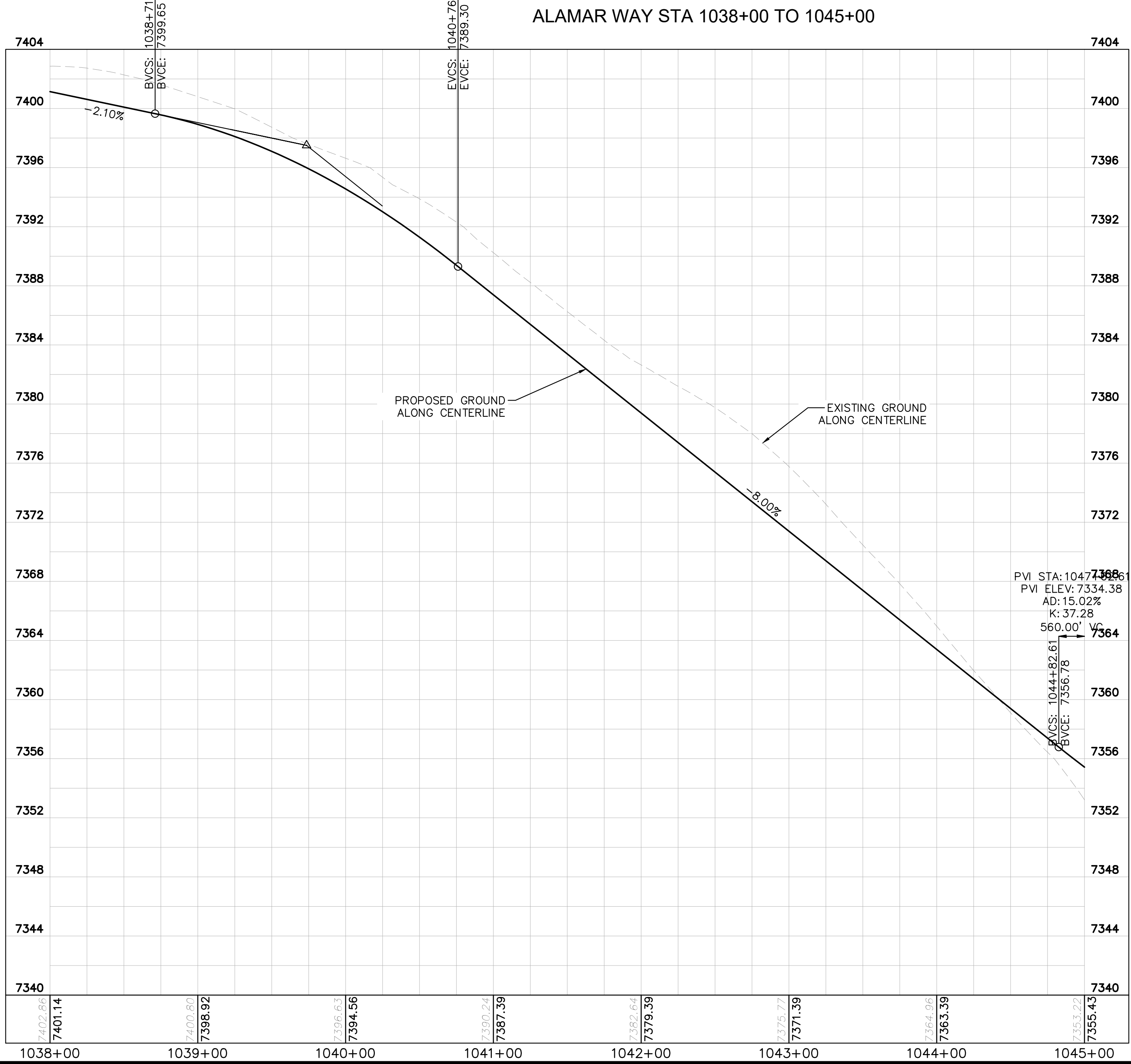

EPC 5/30/23

**NOTES**

- SEE SHEET C1.2 FOR TYPICAL ROADWAY SECTIONS AND ROADSIDE DITCH CONFIGURATIONS AS LABELED IN PLAN VIEW.



NO.	REVISION	BY	DATE	APPR.
1	COUNTY COMMENTS	KRK	3/10/23	KRK
2	COUNTY COMMENTS	KRK	4/28/23	KRK

**Kimley»Horn**  
 2021 KIMLEY-HORN AND ASSOCIATES, INC.  
 2 North Nevada Avenue Suite 300  
 Colorado Springs, Colorado 80903 (719) 453-0180

DESIGNED BY: KRK  
 DRAWN BY: AJL  
 CHECKED BY: KRK  
 DATE: 12/16/2021

WINSOME FILING NO. 3  
 EL PASO COUNTY, COLORADO  
 CONSTRUCTION DOCUMENTS  
**ALAMAR PLAN AND PROFILE**

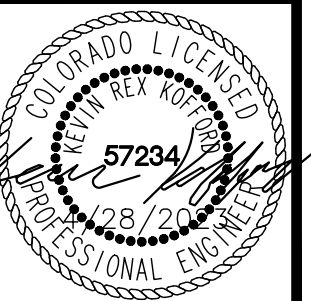

PROJECT NO.  
196106001  
 SHEET  
**C1.12**

K:\COS\_Civil\196106001\_Winsome Filing No. 3\CADD\PlanSheets\Cds\196106001\_P&P\_ALAMR.dwg Kofford, Kevin 4/28/2023 10:09 AM

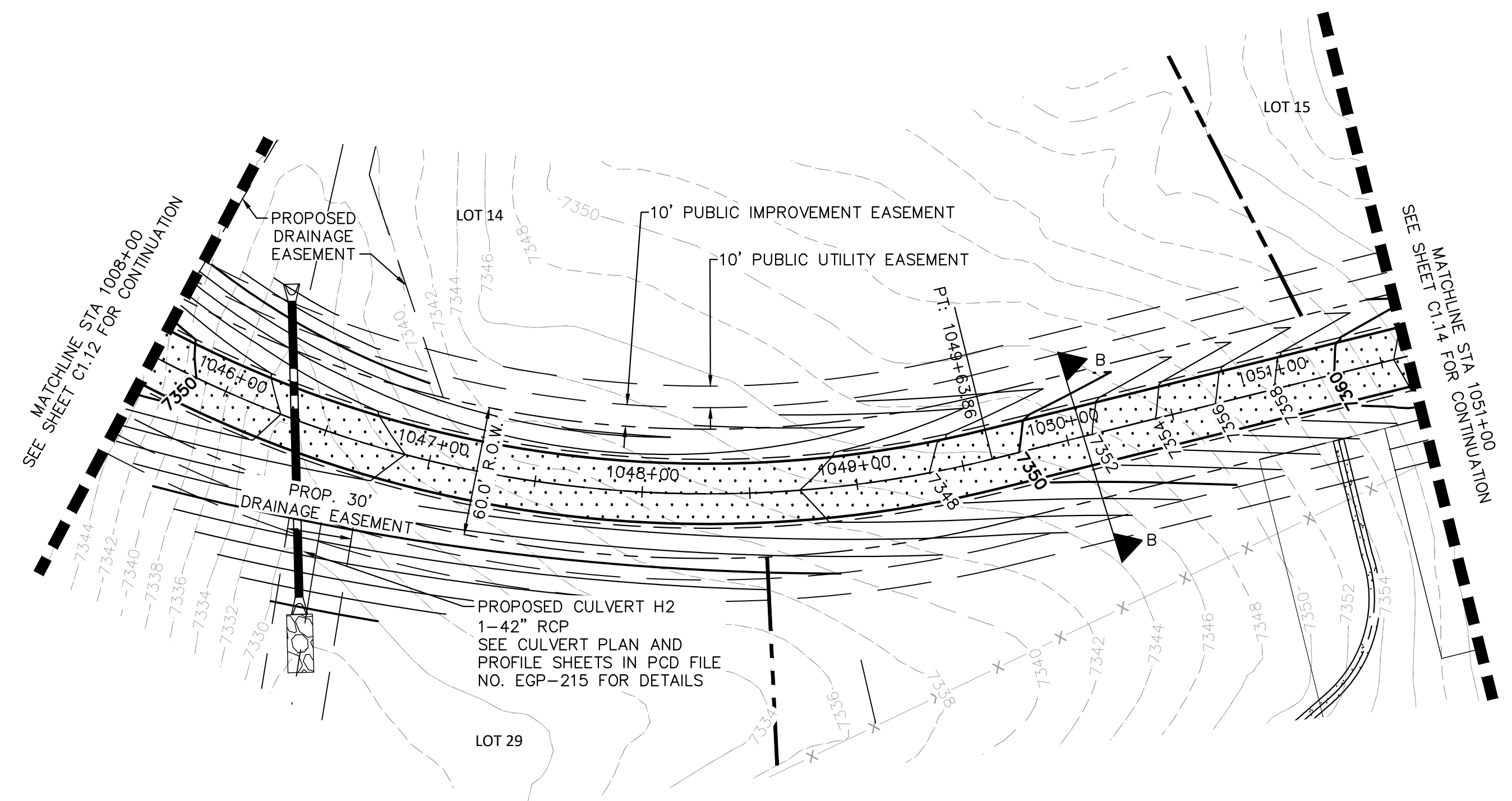

LOW POINT ELEV: 7344.85  
 LOW POINT STA: 1047+80.85  
 PVI STA: 1047+62.61  
 PVI ELEV: 7334.38  
 AD: 15.02%  
 K: 37.28  
 560.00' VC  
**ALAMAR WAY STA 1045+00 TO 1051+00**

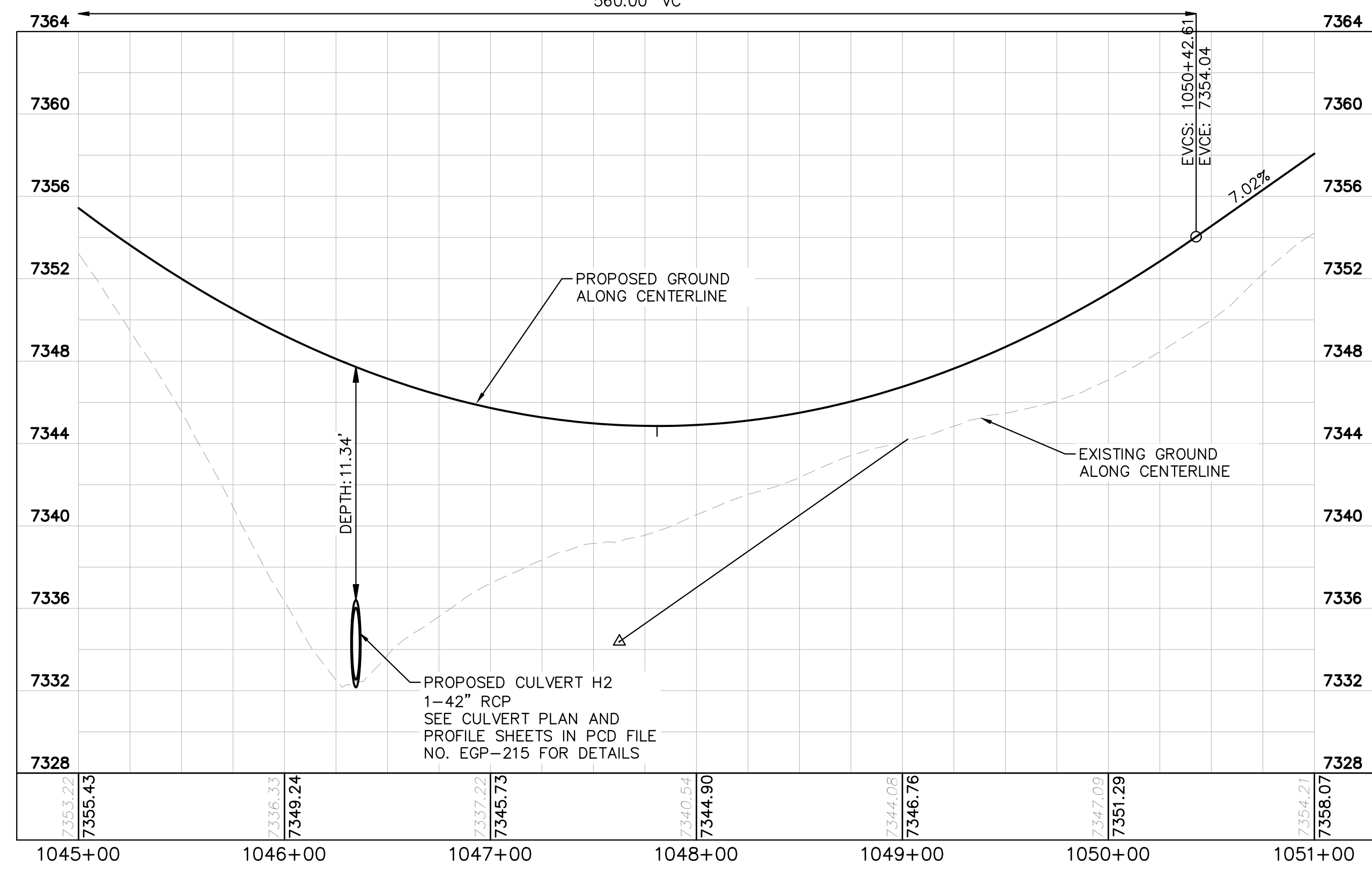

**LEGEND**

---	LOT BOUNDARY LINE
-----XXXX	EXISTING MAJOR CONTOUR
-----XXXX	EXISTING MINOR CONTOUR
-----XXXX	PROPOSED MAJOR CONTOUR
-----XXXX	PROPOSED MINOR CONTOUR
X                      X	STREET CROSS SECTION (SEE SHEET C1.2 FOR DETAILS)
---	PROPOSED STORM LINE
---	UTILITY EASEMENT
---	R.O.W. LINE
---	EDGE OF PAVEMENT

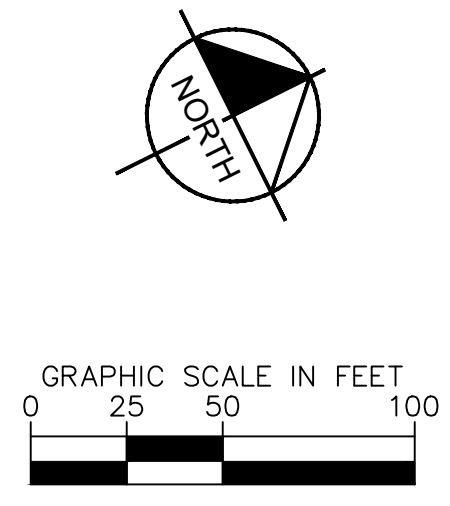

**NOTES**  
 1. SEE SHEET C1.2 FOR TYPICAL ROADWAY SECTIONS AND ROADSIDE DITCH CONFIGURATIONS AS LABELED IN PLAN VIEW.

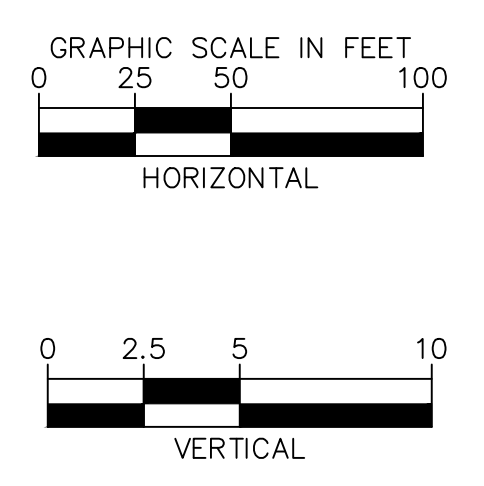

NO.	REVISION	BY	DATE	APPR.
2	COUNTY COMMENTS	KRK	4/28/23	KRK
1	COUNTY COMMENTS	KRK	3/10/23	KRK

**Kimley»Horn**  
 2021 KIMLEY-HORN AND ASSOCIATES, INC.  
 2 North Nevada Avenue Suite 300  
 Colorado Springs, Colorado 80903 (719) 453-0180

DESIGNED BY: KRK  
 DRAWN BY: A.J.L.  
 CHECKED BY: KRK  
 DATE: 12/16/2021

WINSOME FILING NO. 3  
 EL PASO COUNTY, COLORADO  
 CONSTRUCTION DOCUMENTS  
**ALAMAR PLAN AND PROFILE**

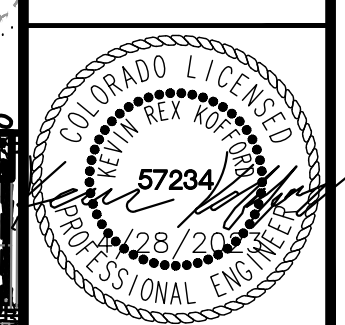

PROJECT NO.  
196106001  
 SHEET  
**C1.13**

EPC 5/30/23

K:\COS\_Civil\196106001\_Winsome Filing No. 3\CADD\PlanSheets\CDS\196106001\_P&P\_ALAMR.dwg Kofford, Kevin 4/28/2023 10:09 AM

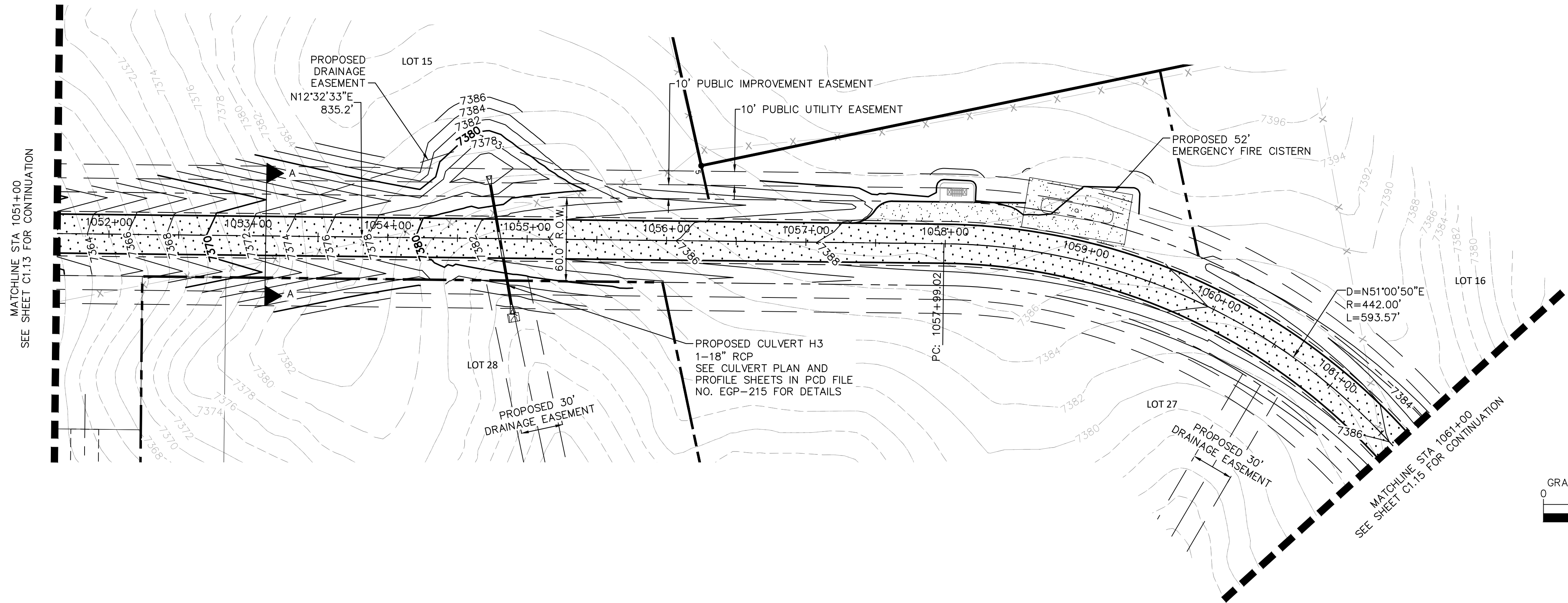

**LEGEND**

- LOT BOUNDARY LINE
- EXISTING MAJOR CONTOUR
- EXISTING MINOR CONTOUR
- PROPOSED MAJOR CONTOUR
- PROPOSED MINOR CONTOUR
- X X X X STREET CROSS SECTION (SEE SHEET C1.2 FOR DETAILS)
- PROPOSED STORM LINE
- UTILITY EASEMENT
- R.O.W. LINE
- EDGE OF PAVEMENT

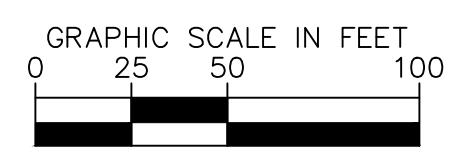
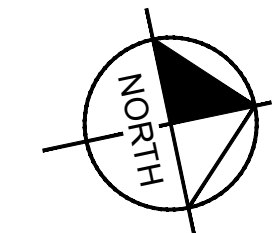

**ALAMAR WAY STA 1051+00 TO 1061+00**

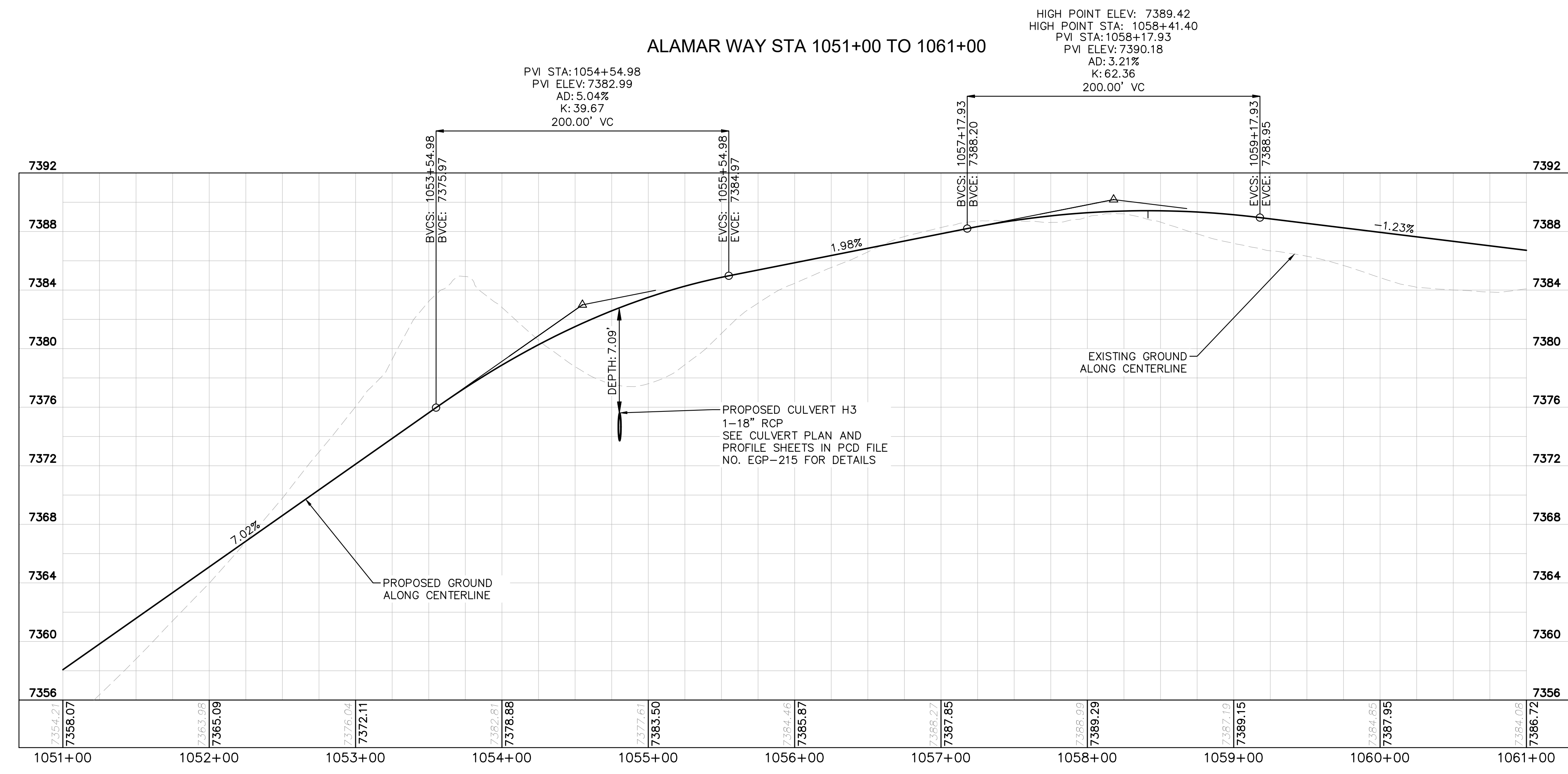

**NOTES**

- SEE SHEET C1.2 FOR TYPICAL ROADWAY SECTIONS AND ROADSIDE DITCH CONFIGURATIONS AS LABELED IN PLAN VIEW.

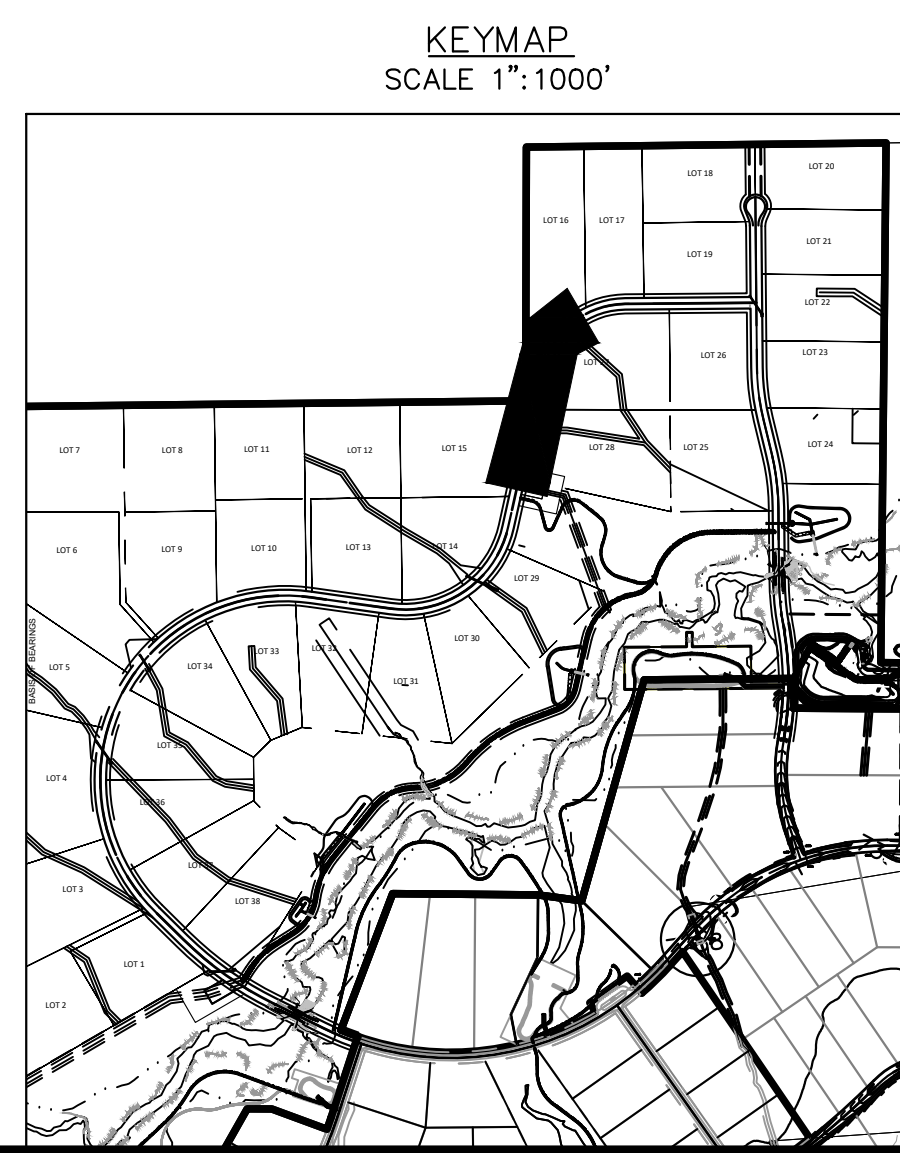
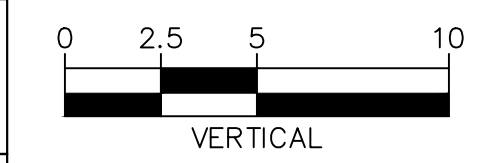
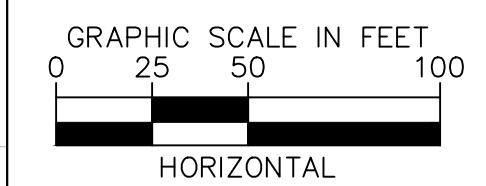

NO.	REVISION	DATE	BY	APPR.
2	COUNTY COMMENTS	KRK 4/28/23	KRK	
1	COUNTY COMMENTS	KRK 3/10/23	KRK	

**Kimley»Horn**  
 2021 KIMLEY-HORN AND ASSOCIATES, INC.  
 2 North Nevada Avenue Suite 300  
 Colorado Springs, Colorado 80903 (719) 453-0180

DESIGNED BY: KRK  
 DRAWN BY: A.J.L.  
 CHECKED BY: KRK  
 DATE: 12/16/2021

**WINSOME FILING NO. 3  
 EL PASO COUNTY, COLORADO  
 CONSTRUCTION DOCUMENTS  
 ALAMAR PLAN AND PROFILE**



PROJECT NO.  
196106001

SHEET

**C1.14**

K:\COS\_Civil\196106001\_Winsome Filing No. 3\CADD\PlanSheets\Cds\196106001\_P&P\_ALAMR.dwg Kofford, Kevin 4/28/2023 10:10 AM

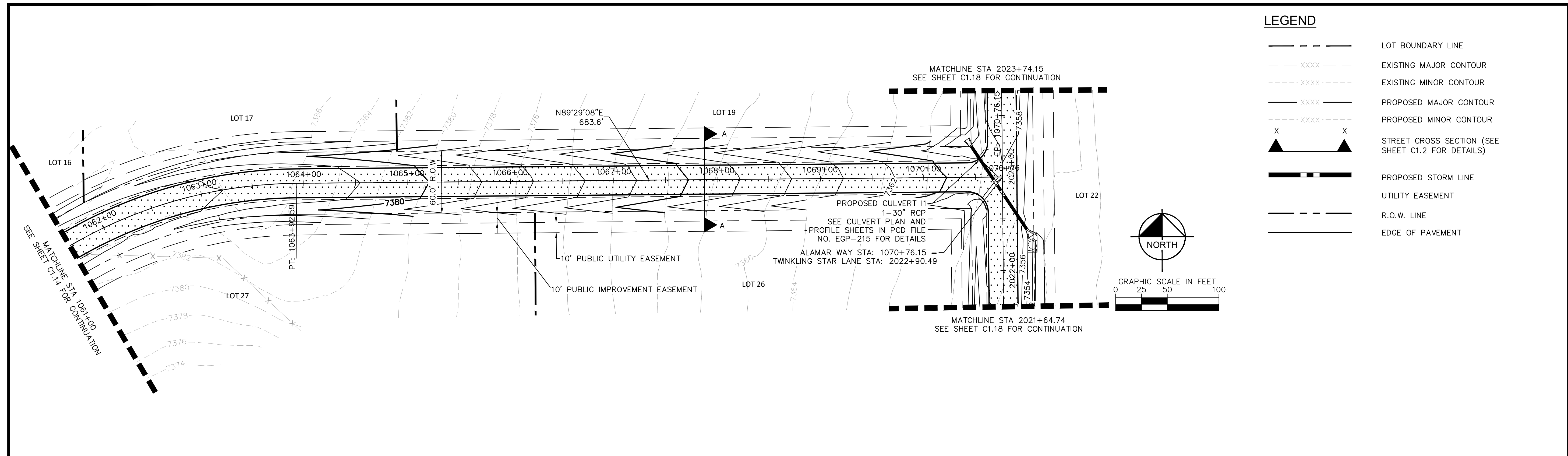

**LEGEND**

- LOT BOUNDARY LINE
- EXISTING MAJOR CONTOUR
- EXISTING MINOR CONTOUR
- PROPOSED MAJOR CONTOUR
- PROPOSED MINOR CONTOUR
- X X STREET CROSS SECTION (SEE SHEET C1.2 FOR DETAILS)
- PROPOSED STORM LINE
- UTILITY EASEMENT
- R.O.W. LINE
- EDGE OF PAVEMENT

NO.	REVISION	BY	DATE	APPR.
2	COUNTY COMMENTS	KRK	4/28/23	KRK
1	COUNTY COMMENTS	KRK	3/10/23	KRK

ALAMAR WAY STA 1061+00 TO 1070+50

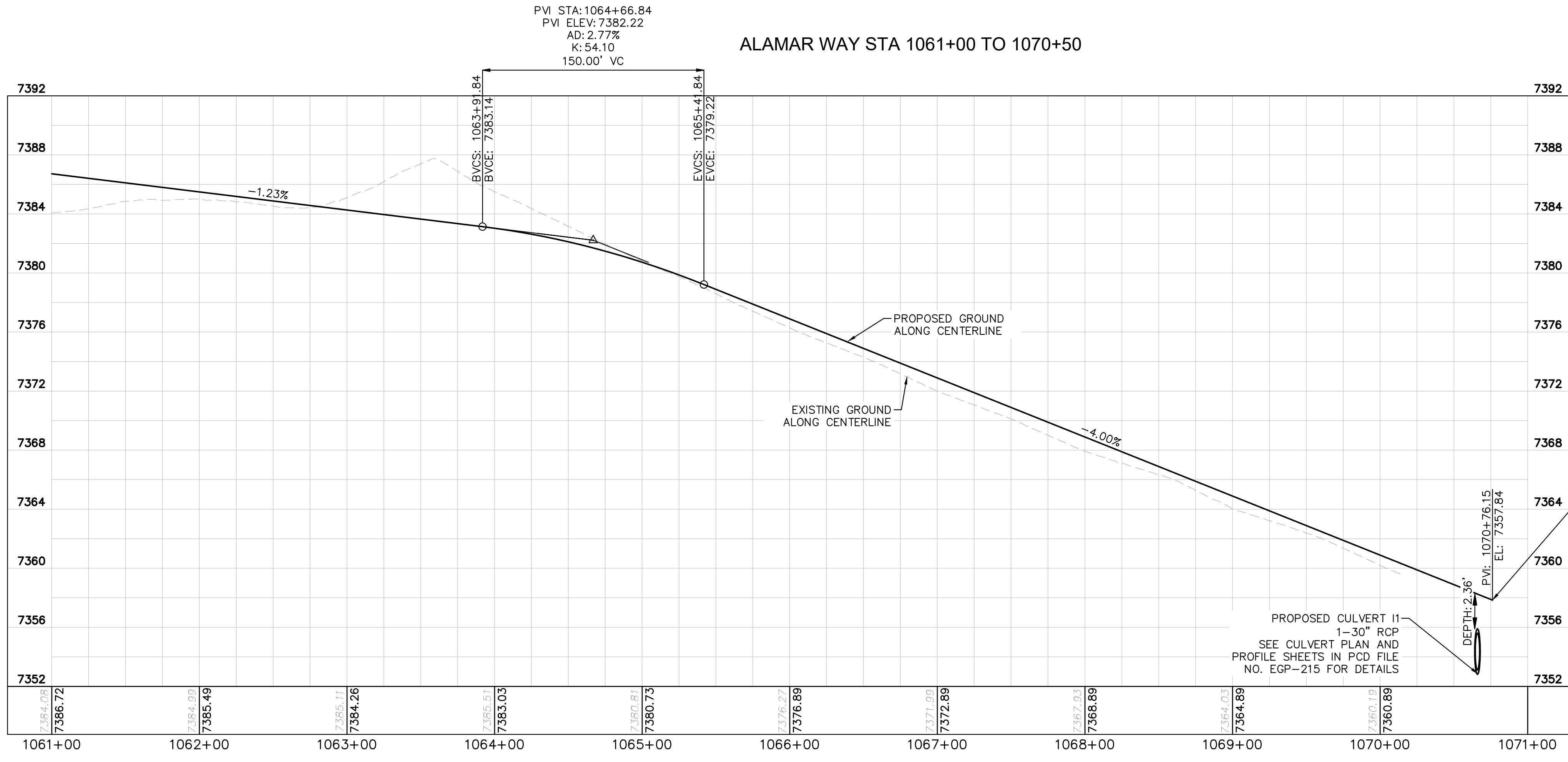

**NOTES**

- SEE SHEET C1.2 FOR TYPICAL ROADWAY SECTIONS AND ROADSIDE DITCH CONFIGURATIONS AS LABELED IN PLAN VIEW.

ALAMAR WAY STA: 1070+76.15 = TWINKLING STAR LANE STA: 2022+90.49 INTERSECTION STATION EQUATION

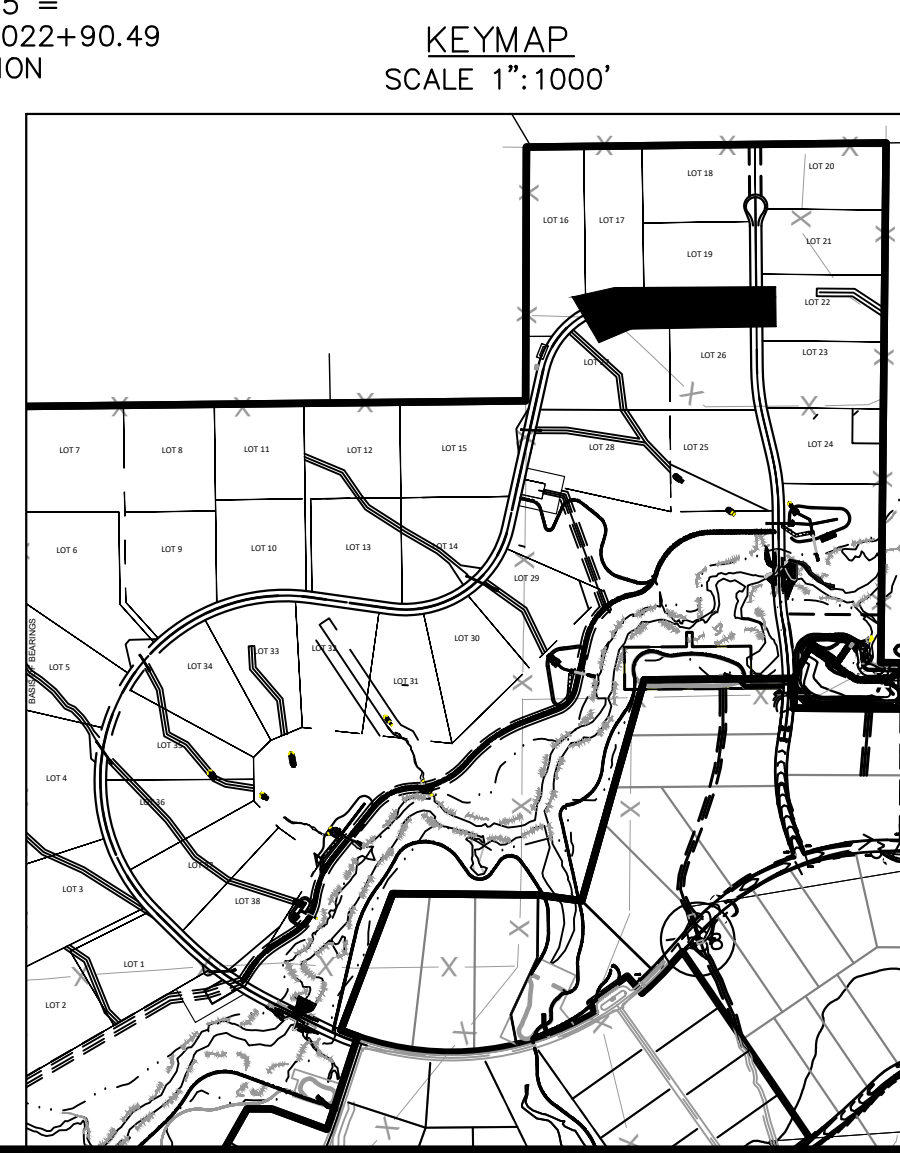
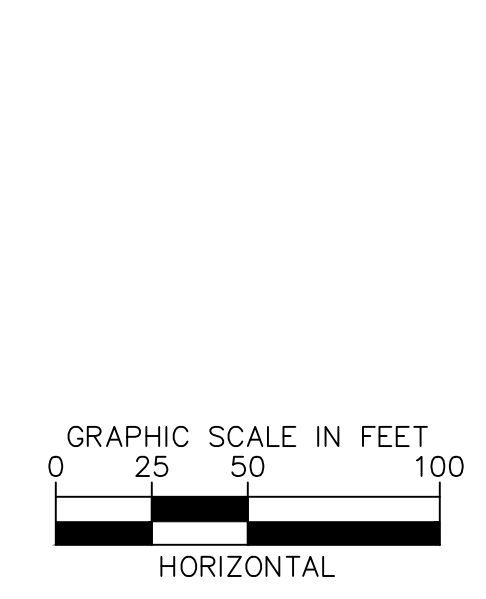

**Kimley»Horn**  
 2021 KIMLEY-HORN AND ASSOCIATES, INC.  
 2 North Nevada Avenue Suite 300  
 Colorado Springs, Colorado 80903 (719) 453-0180

DESIGNED BY: KRK  
 DRAWN BY: A.JL  
 CHECKED BY: KRK  
 DATE: 12/16/2021

WINSOME FILING NO. 3  
 EL PASO COUNTY, COLORADO  
 CONSTRUCTION DOCUMENTS  
**ALAMAR PLAN AND PROFILE**

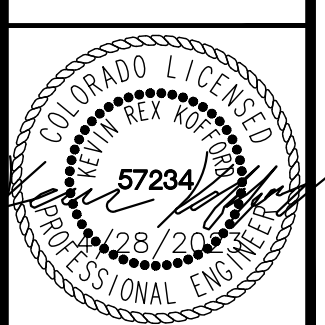

PROJECT NO.  
196106001  
 SHEET  
**C1.15**

EPC 5/30/23



K:\COS\_Civil\196106001\_Winsome Filing No. 3\CADD\PlanSheets\CDS\196106001\_P&P\_ALAMR.dwg Kofford, Kevin 4/28/2023 10:10 AM

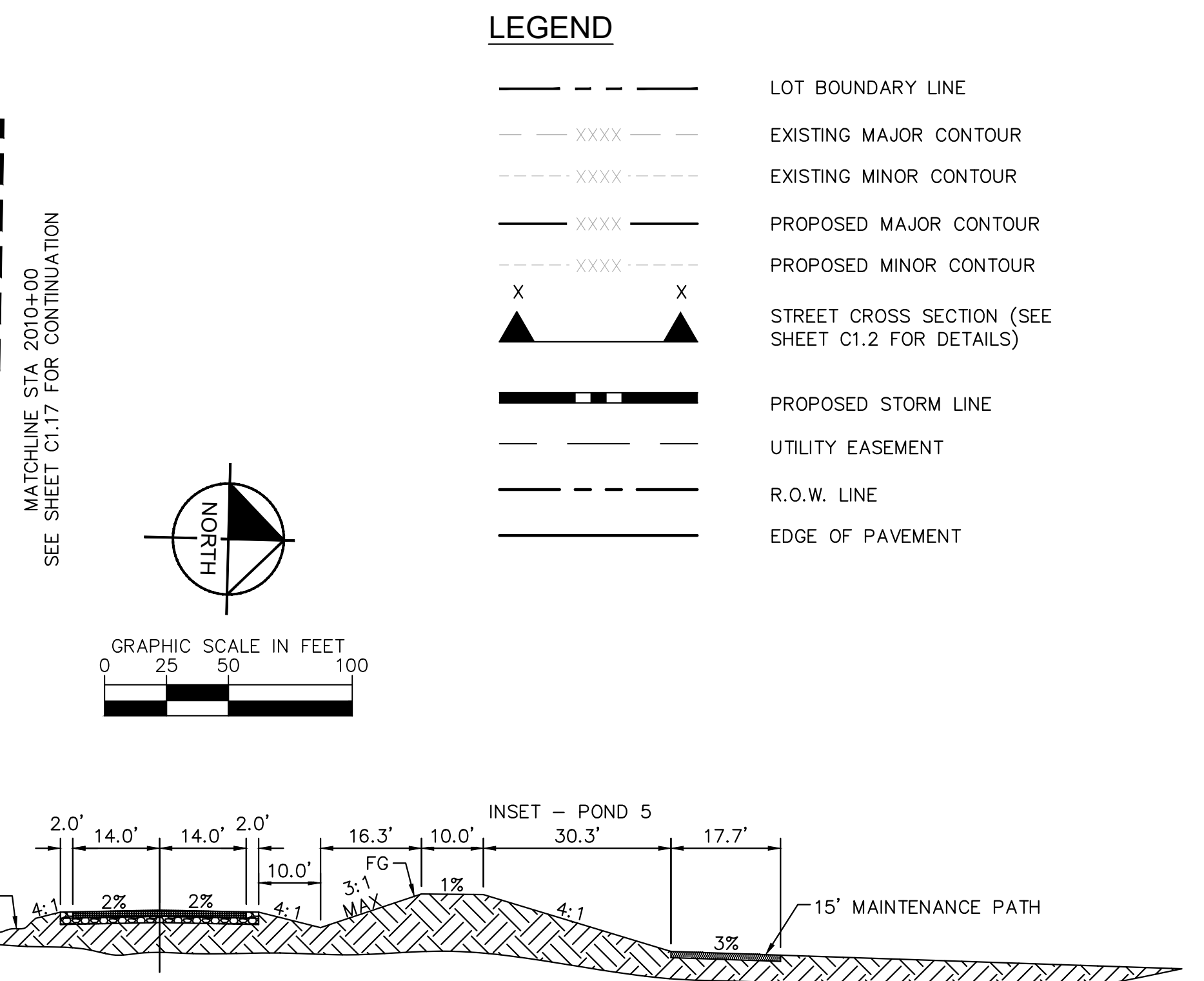
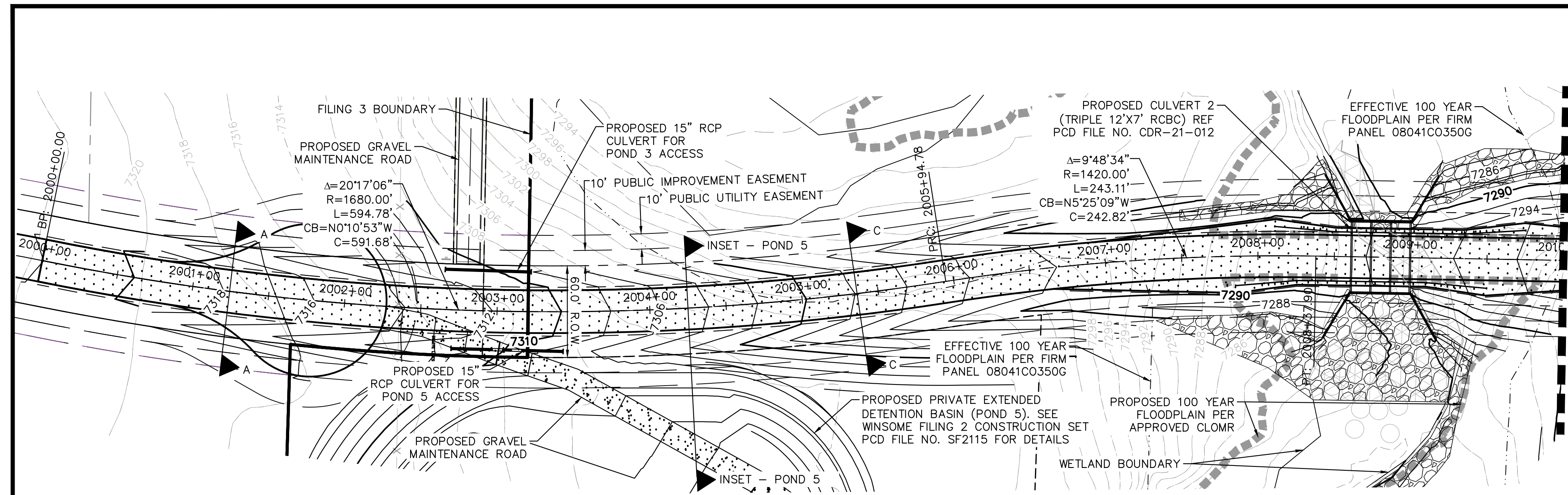

INSET - POND 5  
(WINSOME FILING 2)  
TWINKLING STAR STA: 2004+25.00  
SCALE: 1"=5'

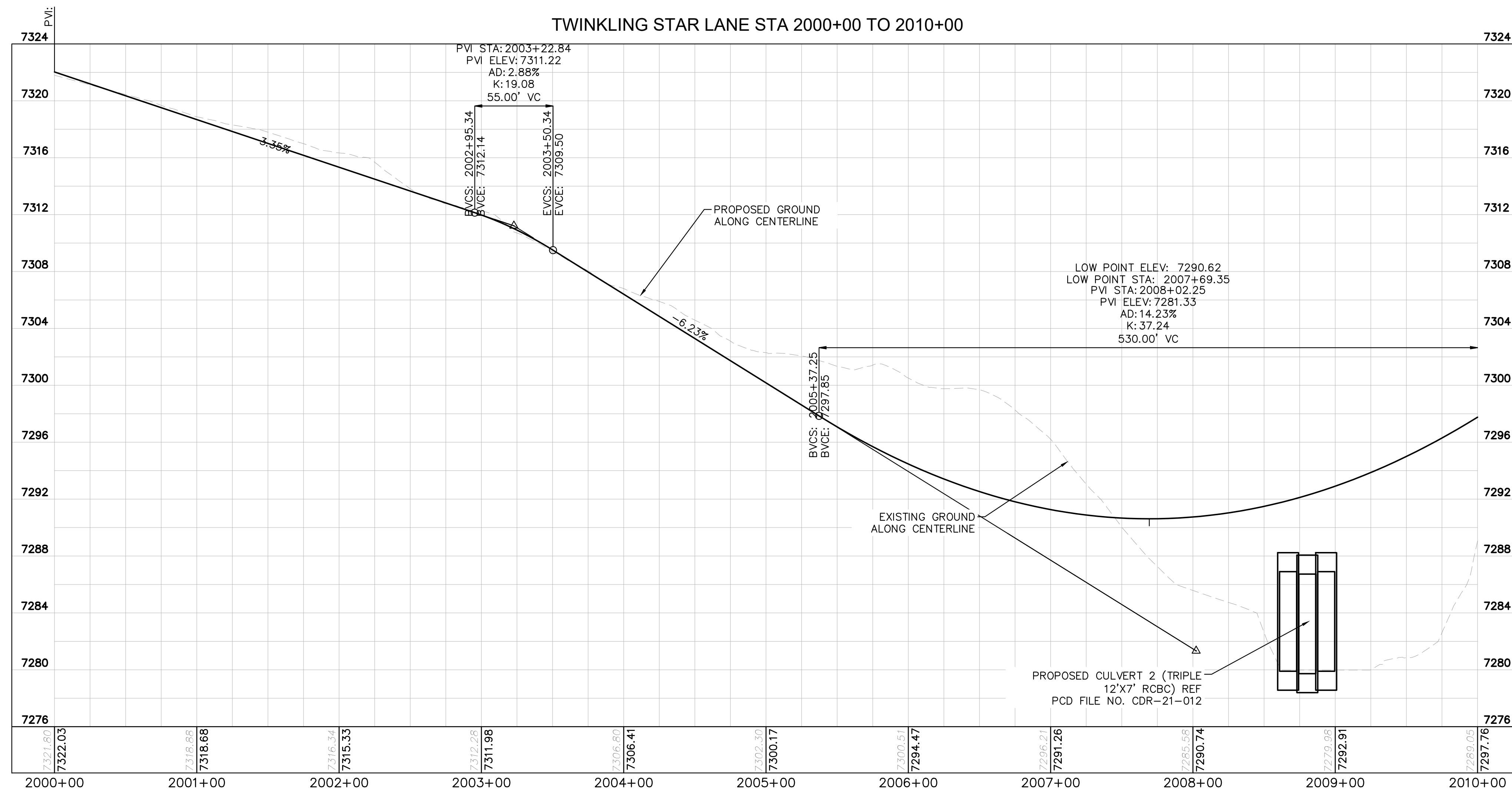

**NOTES**

- SEE SHEET C1.2 FOR TYPICAL ROADWAY SECTIONS AND ROADSIDE DITCH CONFIGURATIONS AS LABELED IN PLAN VIEW.

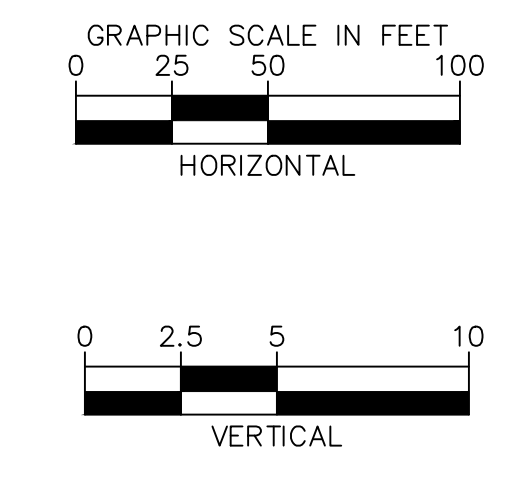

NO.	REVISION	DATE	BY	APPR.
1			KRK	KRK
2			KRK	KRK

**Kimley»Horn**  
2021 KIMLEY-HORN AND ASSOCIATES, INC.  
2 North Nevada Avenue Suite 300  
Colorado Springs, Colorado 80903 (719) 453-0180

DESIGNED BY: KRK  
DRAWN BY: AJL  
CHECKED BY: KRK  
DATE: 12/16/2021

WINSOME FILING NO. 3  
EL PASO COUNTY, COLORADO  
CONSTRUCTION DOCUMENTS  
TWINKLING STAR PLAN AND PROFILE

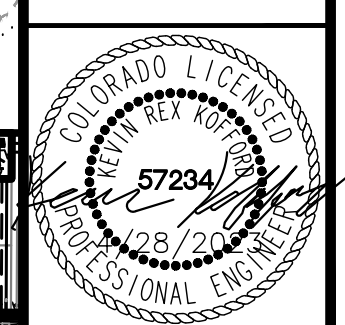

PROJECT NO. 196106001  
SHEET C1.16

EPC 5/30/23

K:\COS\_Civil\196106001\_Winsome Filing No. 3\CADD\PlanSheets\CDS\196106001\_P&P\_ALAMR.dwg Kofford, Kevin 4/28/2023 10:10 AM

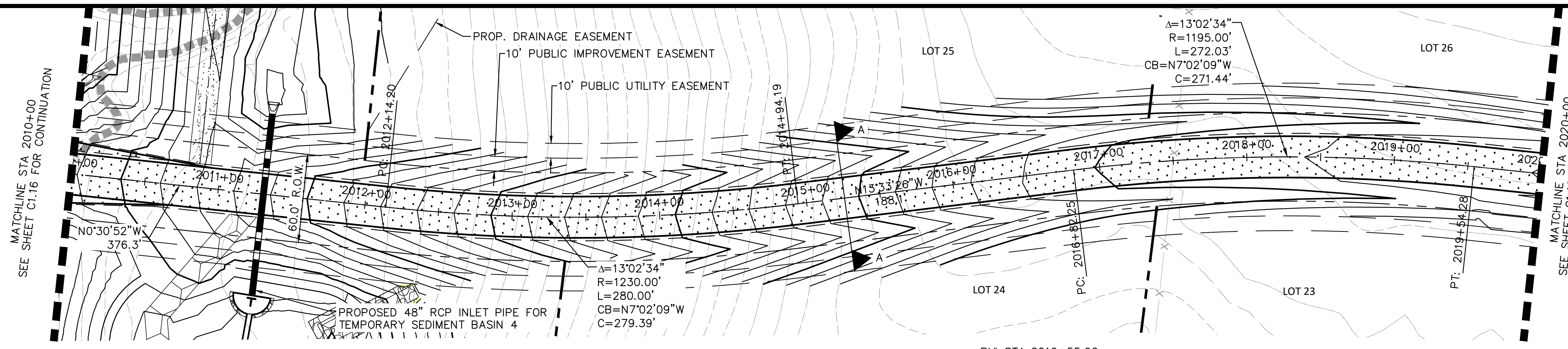

**LEGEND**

- LOT BOUNDARY LINE
- EXISTING MAJOR CONTOUR
- EXISTING MINOR CONTOUR
- PROPOSED MAJOR CONTOUR
- PROPOSED MINOR CONTOUR
- X X X X STREET CROSS SECTION (SEE SHEET C1.2 FOR DETAILS)
- PROPOSED STORM LINE
- UTILITY EASEMENT
- R.O.W. LINE
- EDGE OF PAVEMENT

GRAPHIC SCALE IN FEET  
0 25 50 100

NORTH

NO.	REVISION	DATE	BY	APPR.
1			KRK	
2	COUNTY COMMENTS	4/28/23	KRK	
	COUNTY COMMENTS	3/10/23	KRK	

TWINKLING STAR LANE STA 2010+00 TO 2020+00

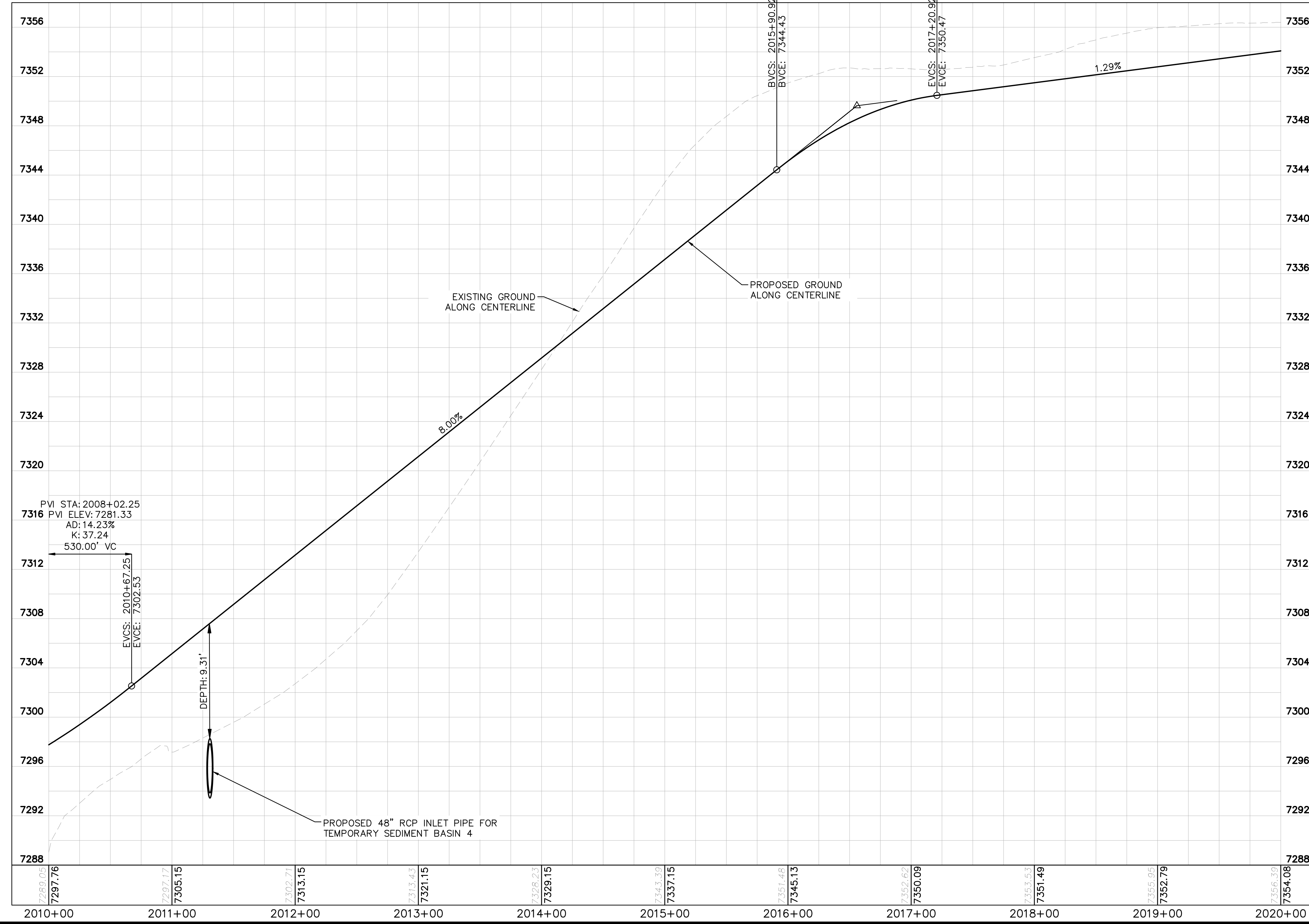

- NOTES**
- SEE SHEET C1.2 FOR TYPICAL ROADWAY SECTIONS AND ROADSIDE DITCH CONFIGURATIONS AS LABELED IN PLAN VIEW.

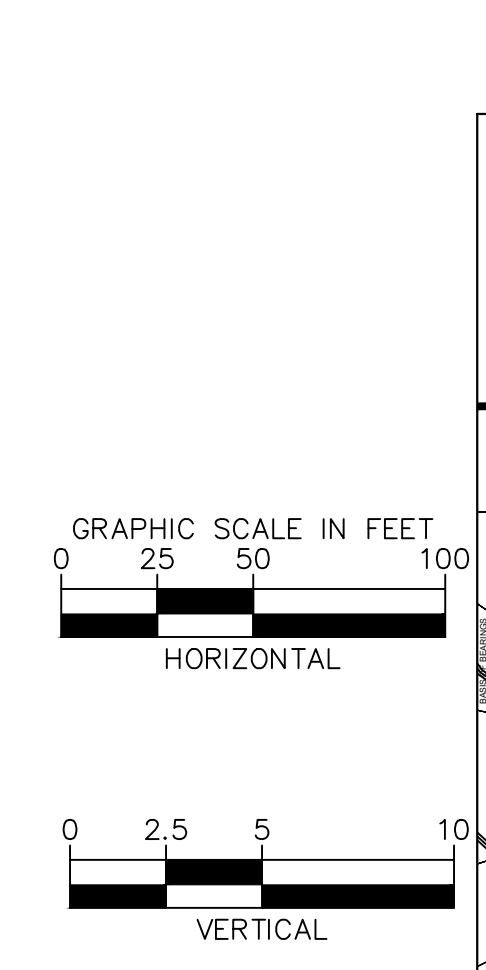

**Kimley»Horn**  
2021 KIMLEY-HORN AND ASSOCIATES, INC.  
2 North Nevada Avenue Suite 300  
Colorado Springs, Colorado 80903 (719) 453-0180

DESIGNED BY: KRK  
DRAWN BY: A.J.L.  
CHECKED BY: KRK  
DATE: 12/16/2021

WINSOME FILING NO. 3  
EL PASO COUNTY, COLORADO  
CONSTRUCTION DOCUMENTS  
**TWINKLING STAR PLAN AND PROFILE**

PROJECT NO. 196106001  
SHEET **C1.17**

EPC 5/30/23

K:\COS\_Civil\196106001\_Winsome Filing No. 3\CADD\PlanSheets\CDS\196106001\_P&P\_ALAMR.dwg Kofford, Kevin 4/28/2023 10:10 AM

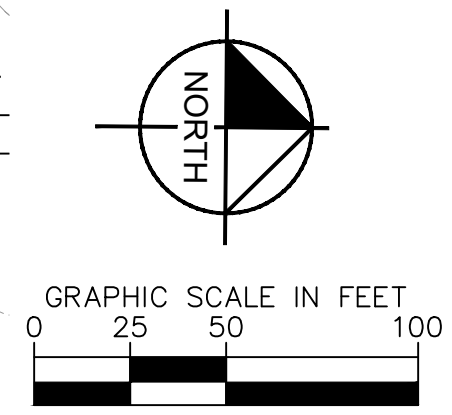
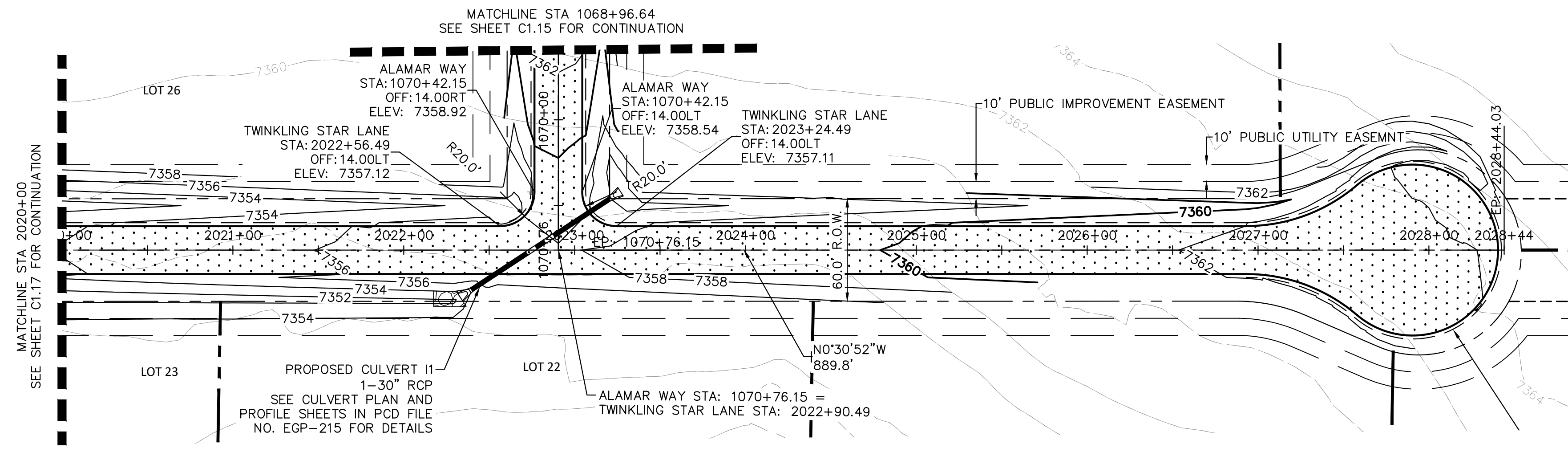

**LEGEND**

- LOT BOUNDARY LINE
- XXXX ----- EXISTING MAJOR CONTOUR
- XXXX ----- EXISTING MINOR CONTOUR
- XXXX ----- PROPOSED MAJOR CONTOUR
- XXXX ----- PROPOSED MINOR CONTOUR
- X X STREET CROSS SECTION (SEE SHEET C1.2 FOR DETAILS)
- PROPOSED STORM LINE
- UTILITY EASEMENT
- R.O.W. LINE
- EDGE OF PAVEMENT

**NOTES**

1. SEE SHEET C1.2 FOR TYPICAL ROADWAY SECTIONS AND ROADSIDE DITCH CONFIGURATIONS AS LABELED IN PLAN VIEW.

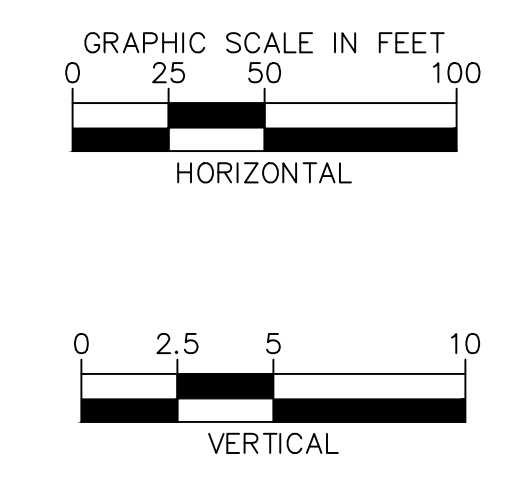
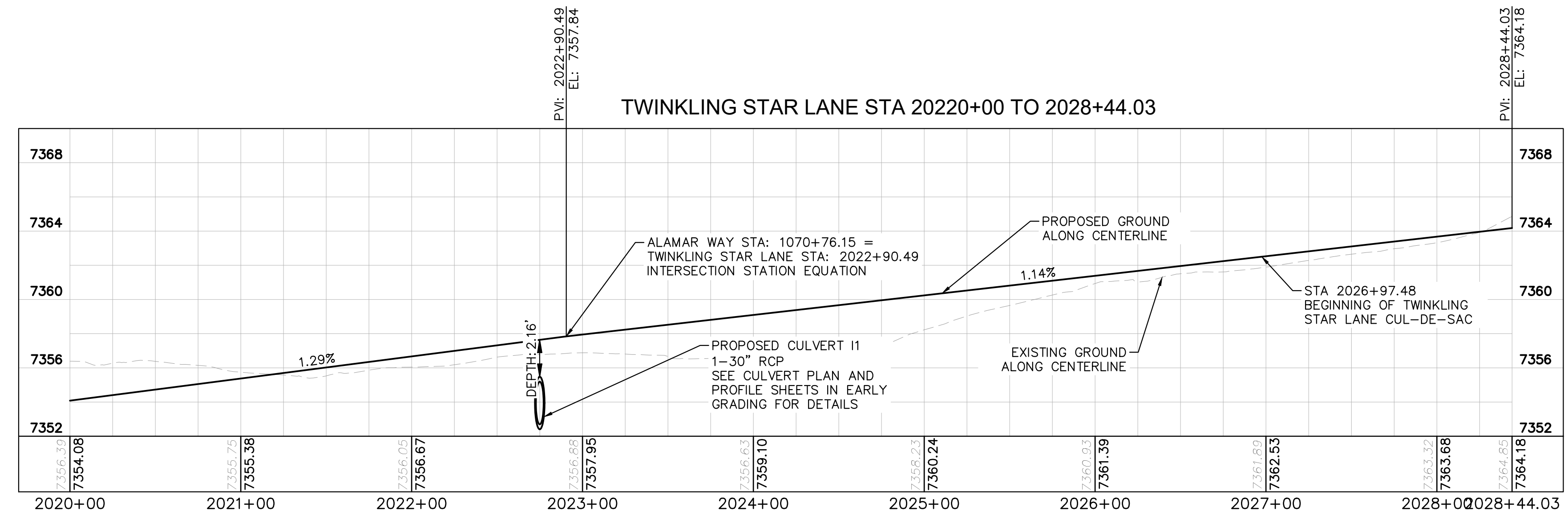

NO.	REVISION	BY	DATE	APPR.
2	COUNTY COMMENTS	KRK	4/28/23	KRK
1	COUNTY COMMENTS	KRK	3/10/23	KRK

**Kimley»Horn**

2021 KIMLEY-HORN AND ASSOCIATES, INC.  
2 North Nevada Avenue Suite 300  
Colorado Springs, Colorado 80903 (719) 453-0180

DESIGNED BY: KRK  
DRAWN BY: A.JL  
CHECKED BY: KRK  
DATE: 12/16/2021

WINSOME FILING NO. 3  
EL PASO COUNTY, COLORADO  
CONSTRUCTION DOCUMENTS  
TWINKLING STAR PLAN AND PROFILE

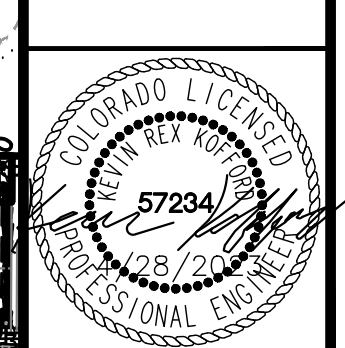

PROJECT NO.  
196106001

SHEET  
**C1.18**

K:\COS\_Civil\196106001\_Winsome Filing No. 3\CADD\PlanSheets\Cds\196106001\_P&P\_ALAMR.dwg Kofford, Kevin 4/28/2023 10:10 AM

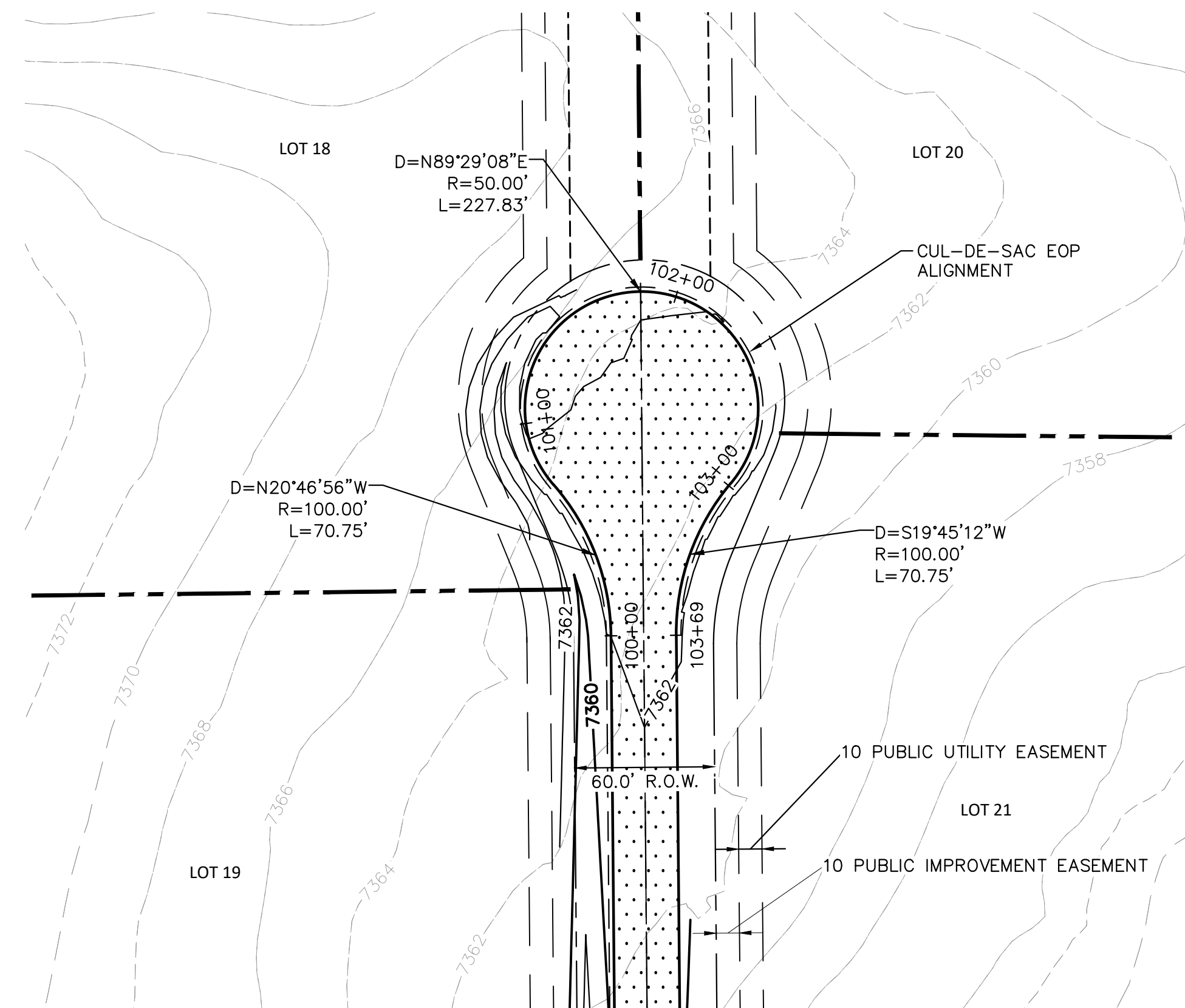

TWINKLING STAR LANE CUL-DE-SAC

LEGEND

- LOT BOUNDARY LINE
- - - - - EXISTING MAJOR CONTOUR
- - - - - EXISTING MINOR CONTOUR
- XXXX --- PROPOSED MAJOR CONTOUR
- - - - - PROPOSED MINOR CONTOUR
- X X STREET CROSS SECTION (SEE SHEET C1.2 FOR DETAILS)
- PROPOSED STORM LINE
- - - - - UTILITY EASEMENT
- - - - - R.O.W. LINE
- EDGE OF PAVEMENT

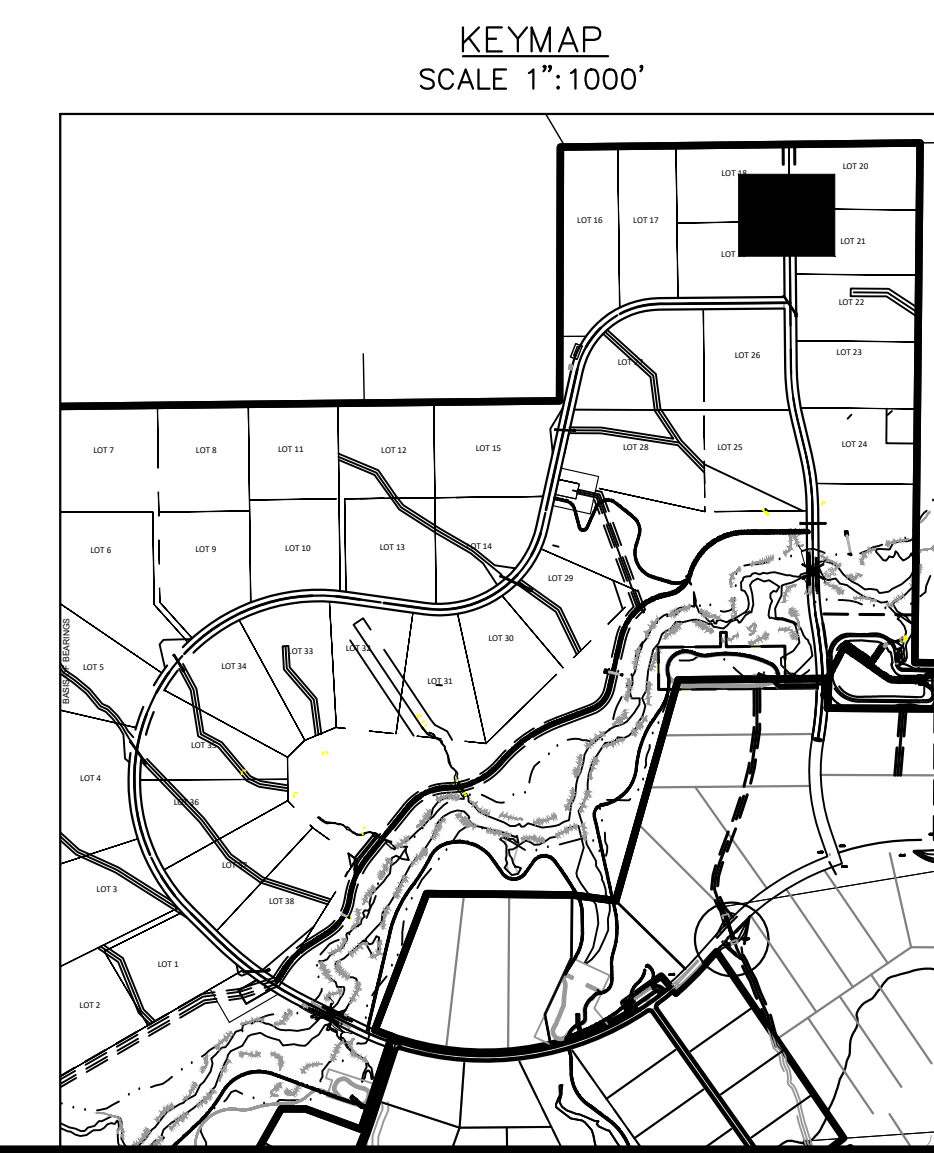
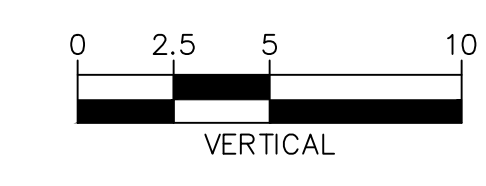
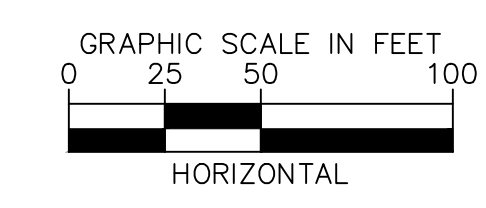
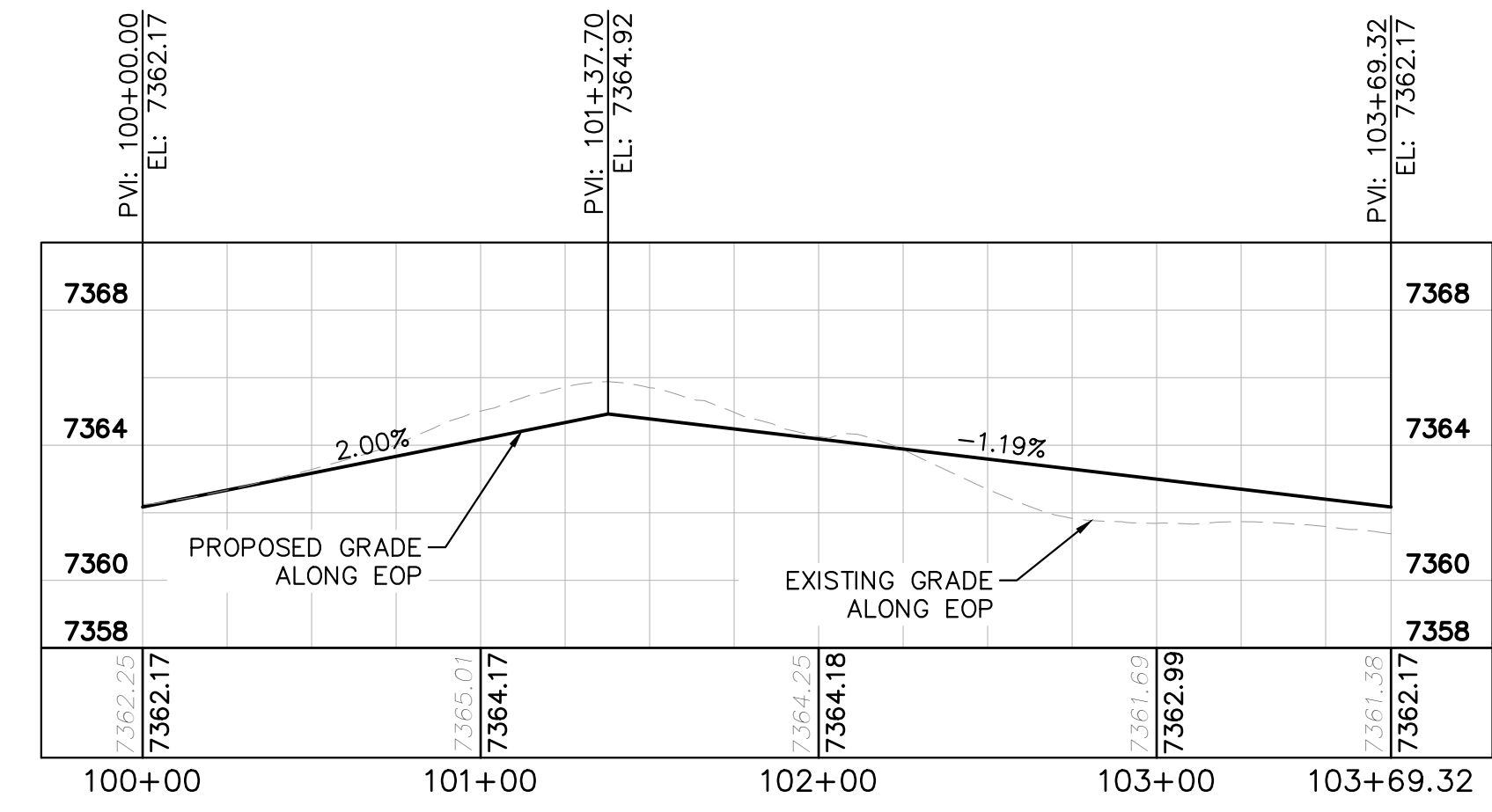
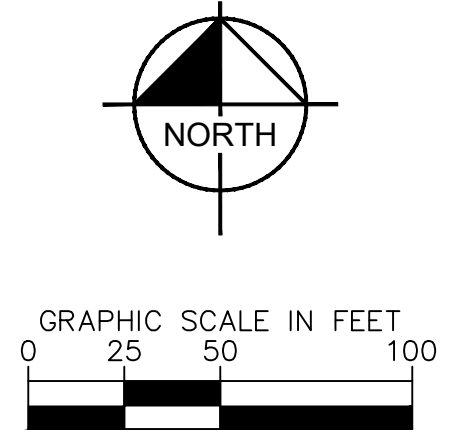

NO.	REVISION	BY	DATE
1	COUNTY COMMENTS	KRK	3/10/23
2	COUNTY COMMENTS	KRK	4/28/23

**Kimley»Horn**  
 2021 KIMLEY-HORN AND ASSOCIATES, INC.  
 2 North Nevada Avenue Suite 300  
 Colorado Springs, Colorado 80903 (719) 453-0180

DESIGNED BY: KRK  
 DRAWN BY: A.JL  
 CHECKED BY: KRK  
 DATE: 12/16/2021

WINSOME FILING NO. 3  
 EL PASO COUNTY, COLORADO  
 CONSTRUCTION DOCUMENTS  
 CUL-DE-SAC PLAN AND PROFILE

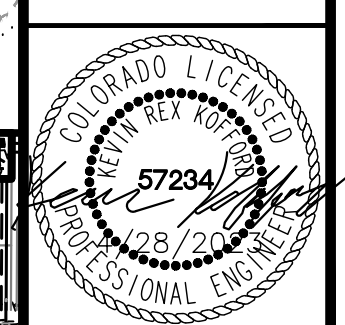

PROJECT NO. 196106001  
 SHEET

C1.19

K:\COS\_Civil\196106001\_Winsome Filing No. 3\CADD\PlanSheets\Cds\196106001\_CD\_SIGNING&STRIPING.dwg Kofford, Kevin 4/28/2023 10:11 AM

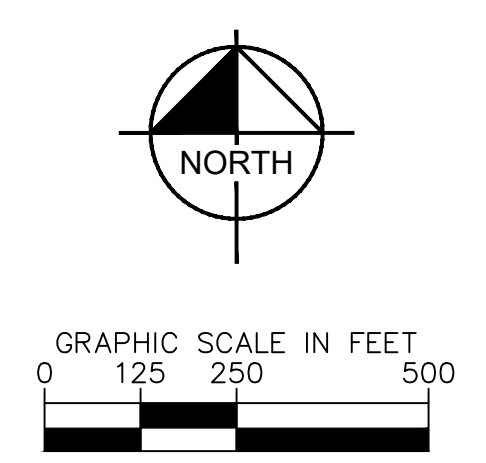
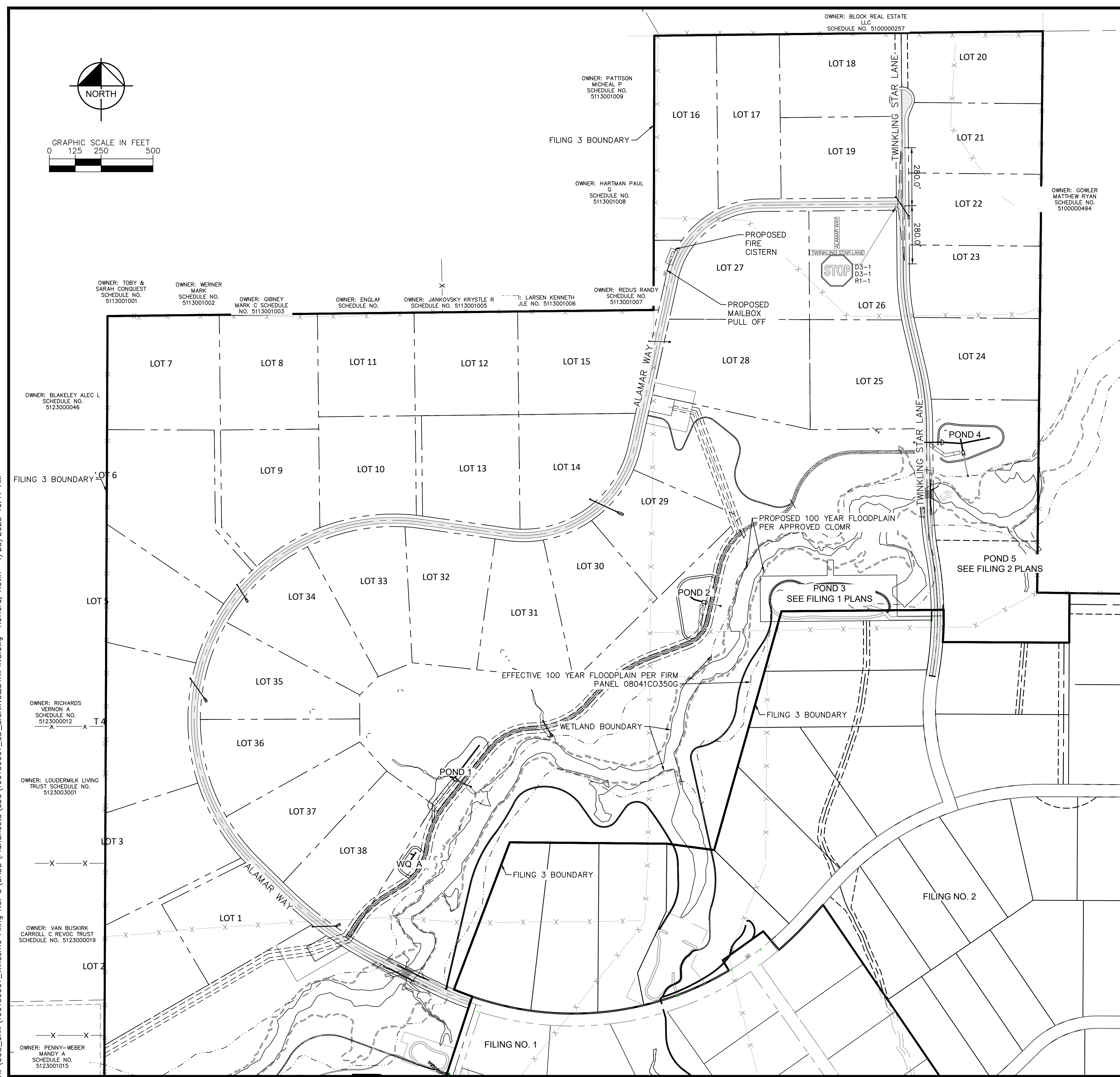

**LEGEND**

- PROPERTY LINE
- - - - - PROPOSED R.O.W.
- ▨ PROPOSED ASPHALT PAVEMENT
- ⬇ PROPOSED CLASS II GROUND MOUNT SIGN

**SIGNING AND STRIPING NOTES**

1. ALL SIGNS AND PAVEMENT MARKINGS SHALL BE IN COMPLIANCE WITH THE CURRENT MANUAL ON UNIFORM TRAFFIC CONTROL DEVICES (MUTCD).
2. REMOVAL OF EXISTING PAVEMENT MARKINGS SHALL BE ACCOMPLISHED BY A METHOD THAT DOES NOT MATERIALLY DAMAGE THE PAVEMENT. THE PAVEMENT MARKINGS SHALL BE REMOVED TO THE EXTENT THAT THEY WILL NOT BE VISIBLE UNDER DAY OR NIGHT CONDITIONS. AT NO TIME WILL IT BE ACCEPTABLE TO PAINT OVER EXISTING PAVEMENT MARKINGS.
3. ANY DEVIATION FROM THE STRIPING AND SIGNING PLAN SHALL BE APPROVED BY EL PASO COUNTY PLANNING AND COMMUNITY DEVELOPMENT.
4. ALL SIGNS SHOWN ON THE SIGNING AND STRIPING PLAN SHALL BE NEW SIGNS. EXISTING SIGNS MAY REMAIN OR BE REUSED IF THEY MEET CURRENT EL PASO COUNTY AND MUTCD STANDARDS.
5. STREET NAME AND REGULATORY STOP SIGNS SHALL BE ON THE SAME POST AT INTERSECTIONS.
6. ALL REMOVED SIGNS SHALL BE DISPOSED OF IN A PROPER MANNER BY THE CONTRACTOR.
7. ALL STREET NAME SIGNS SHALL HAVE "D" SERIES LETTERS, WITH LOCAL ROADWAY SIGNS BEING 4" UPPER-LOWER CASE LETTERING ON 8" BLANK AND NON-LOCAL ROADWAY SIGNS BEING 6" LETTERING, UPPER-LOWER CASE ON 12" BLANK, WITH A WHITE BORDER THAT IS NOT RECESSED. MULTI-LANE ROADWAYS WITH SPEED LIMITS OF 40 MPH OR HIGHER SHALL HAVE 8" UPPER-LOWER CASE LETTERING ON 18" BLANK WITH A WHITE BORDER THAT IS NOT RECESSED. THE WIDTH OF THE NON-RECESSED WHITE BORDERS SHALL MATCH PAGE 255 OF THE 2012 MUTCD "STANDARD HIGHWAY SIGNS".
8. ALL TRAFFIC SIGNS SHALL HAVE A MINIMUM HIGH INTENSITY PRISMATIC GRADE SHEETING.
9. ALL LOCAL RESIDENTIAL STREET SIGNS SHALL BE MOUNTED ON A 1.75" X 1.75" SQUARE TUBE SIGN POST AND STUB POST BASE. FOR OTHER APPLICATIONS, REFER TO THE CDOT STANDARD S-614-8 REGARDING USE OF THE P2 TUBULAR STEEL POST SLIPBASE DESIGN.
10. ALL SIGNS SHALL BE SINGLE SHEET ALUMINUM WITH 0.100" MINIMUM THICKNESS.
11. ALL LIMIT LINES/STOP LINES, CROSSWALK LINES, PAVEMENT LEGENDS, AND ARROWS SHALL BE A MINIMUM 125 MIL THICKNESS PREFORMED THERMOPLASTIC PAVEMENT MARKINGS WITH TAPERED LEADING EDGES PER CDOT STANDARD S-627-1. WORD AND SYMBOL MARKINGS SHALL BE THE NARROW TYPE. STOP BARS SHALL BE 24" IN WIDTH. CROSSWALKS LINES SHALL BE 12" WIDE AND 8' LONG PER CDOT S-627-1.
12. ALL LONGITUDINAL LINES SHALL BE A MINIMUM 15MIL THICKNESS EPOXY PAINT. ALL NON-LOCAL RESIDENTIAL ROADWAYS SHALL INCLUDE BOTH RIGHT AND LEFT EDGE LINE STRIPING AND ANY ADDITIONAL STRIPING AS REQUIRED BY CDOT S-627-1.
13. THE CONTRACTOR SHALL NOTIFY EL PASO COUNTY PLANNING AND COMMUNITY DEVELOPMENT (719) 520-6819 PRIOR TO AND UPON COMPLETION OF SIGNING AND STRIPING.
14. THE CONTRACTOR SHALL OBTAIN A WORK IN THE RIGHT OF WAY PERMIT FROM THE EL PASO COUNTY DEPARTMENT OF PUBLIC WORKS (DPW) PRIOR TO ANY SIGNAGE OR STRIPING WORK WITHIN AN EXISTING EL PASO COUNTY ROADWAY.

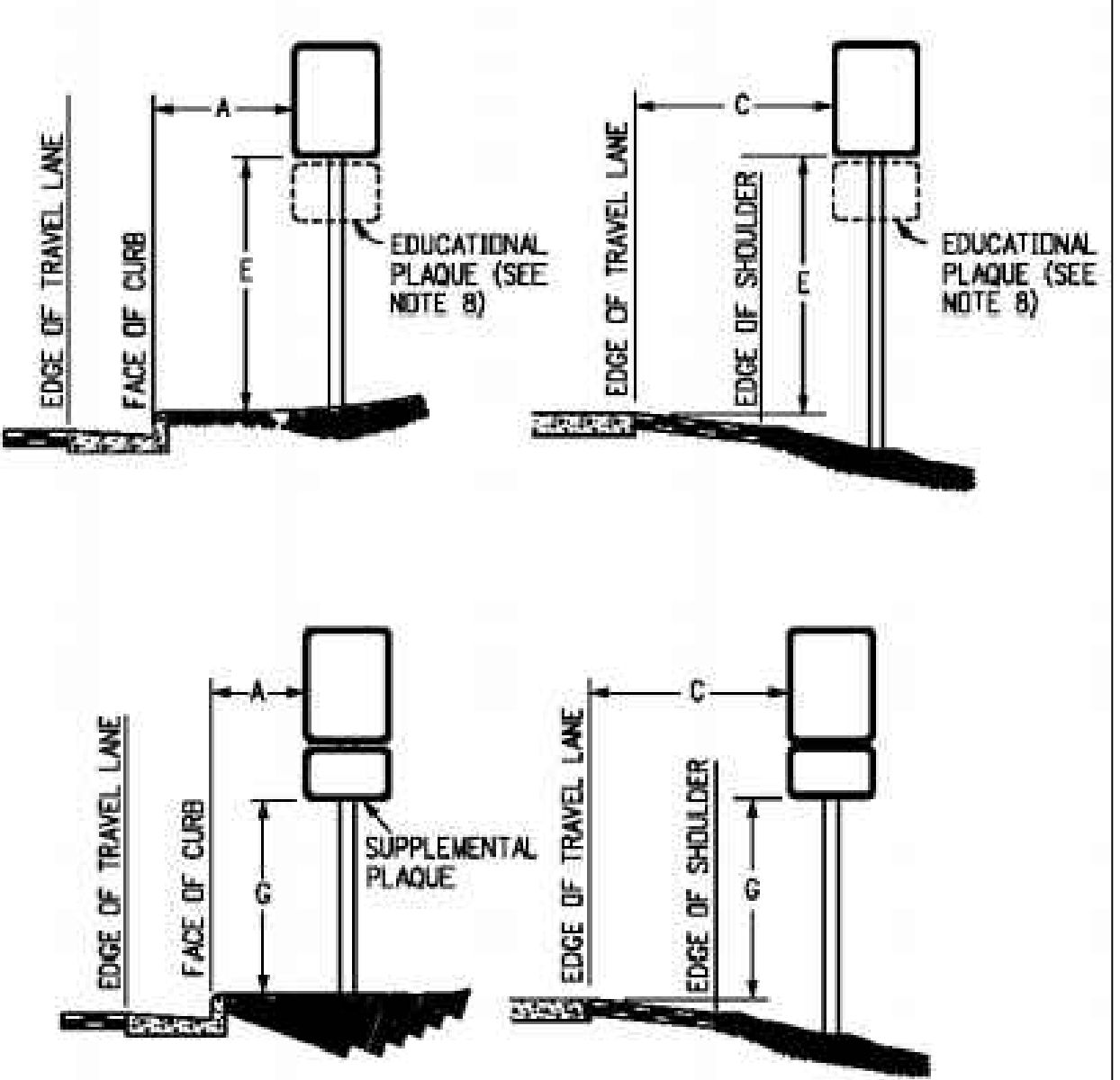

**REGULATORY, RECREATIONAL AND CULTURAL INFORMATION SIGN PLACEMENT**

**PLACEMENT TABLES**

LATERAL PLACEMENT			VERTICAL PLACEMENT						
KEY	ALL CLASSES OF STREETS AND HIGHWAYS		FREWAYS AND EXPRESSWAYS		CONVENTIONAL STREETS AND HIGHWAYS				
	MINIMUM	NORMAL	MIN.	MAX.	URBAN	RURAL	MAX.		
A	2'-0"	15'-0" PLUS CURB	D	7'-0" OR NOTE NO. 9	12'-0"	7'-0"	8'-0"	5'-0"	8'-0"
B	2'-0"	30'-0" OR MORE INCLUDES CURB	E	7'-0"	8'-0"	7'-0"	8'-0"	5'-0"	8'-0"
C	2'-0"	8'-0" PLUS EDGE OF 6'-0" WIDE SHOULDER. IF NONE, 15'-0" FROM EDGE OF TRAVEL LANE.	F	8'-0" OR NOTE NO. 9	12'-0"	8'-0"	9'-0"	5'-0"	9'-0"
			G	8'-0"	7'-0"	8'-0"	7'-0"	4'-0"	7'-0"
			H	5'-0"	10'-0"	8'-0"	7'-0"	4'-0"	7'-0"

EPC 5/30/23

NO.	REVISION	DATE	BY	APPR.
1	COUNTY COMMENTS	3/10/23	KRK	
2	COUNTY COMMENTS	4/26/23	KRK	

**Kimley»Horn**  
 2021 KIMLEY-HORN AND ASSOCIATES, INC.  
 2 North Nevada Avenue Suite 300  
 Colorado Springs, Colorado 80903 (719) 453-0180

DESIGNED BY: KRK  
 DRAWN BY: AJL  
 CHECKED BY: KRK  
 DATE: 12/16/2021

**WINSOME FILING NO. 3  
 EL PASO COUNTY, COLORADO  
 CONSTRUCTION DOCUMENTS  
 SIGNING AND STRIPING PLAN**

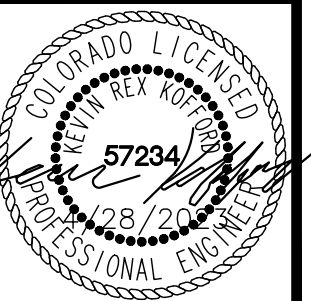

PROJECT NO.  
196106001

SHEET

**C1.20**

K:\COS\_Civil\196106001\_Winsome Filing No. 3\CADD\PlanSheets\CDS\196106001\_CD\_CUT\_FILL.dwg Kofford, Kevin 4/28/2023 10:11 AM



**LEGEND**

CUT AREA

FILL AREA

TOTAL CUT: 90,985 CY  
 TOTAL FILL: 74,730 CY  
 NET: 16,255 CY (FILL)\*  
 \*1.15 FILL FACTOR APPLIED

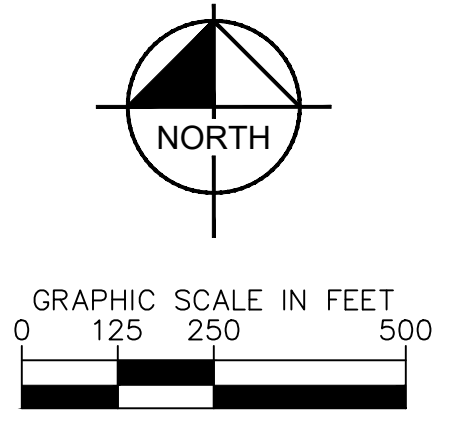

NO.	REVISION	BY	DATE	APPR.
2	RESUBMITTAL #2	KRK	11/30/22	KRK
1	RESUBMITTAL #1	KRK	8/30/22	KRK

**Kimley»Horn**  
 2022 KIMLEY-HORN AND ASSOCIATES, INC.  
 2 North Nevada Avenue Suite 300  
 Colorado Springs, Colorado 80903 (719) 453-0180

DESIGNED BY: KRK  
 DRAWN BY: A.J.L.  
 CHECKED BY: KRK  
 DATE: 12/10/2021

WINSOME FILING NO. 3  
 EL PASO COUNTY, COLORADO  
 PRE DEVELOPMENT GESC PLAN  
 CUT AND FILL MAP

**PRELIMINARY**  
 FOR REVIEW ONLY  
 NOT FOR  
 CONSTRUCTION  
 Kimley-Horn and Associates, Inc.

PROJECT NO.  
196106001

SHEET  
**C1.21**

EPC 5/30/23

MATCH LINE: SEE SHEET C1.23 FOR CONTINUATION

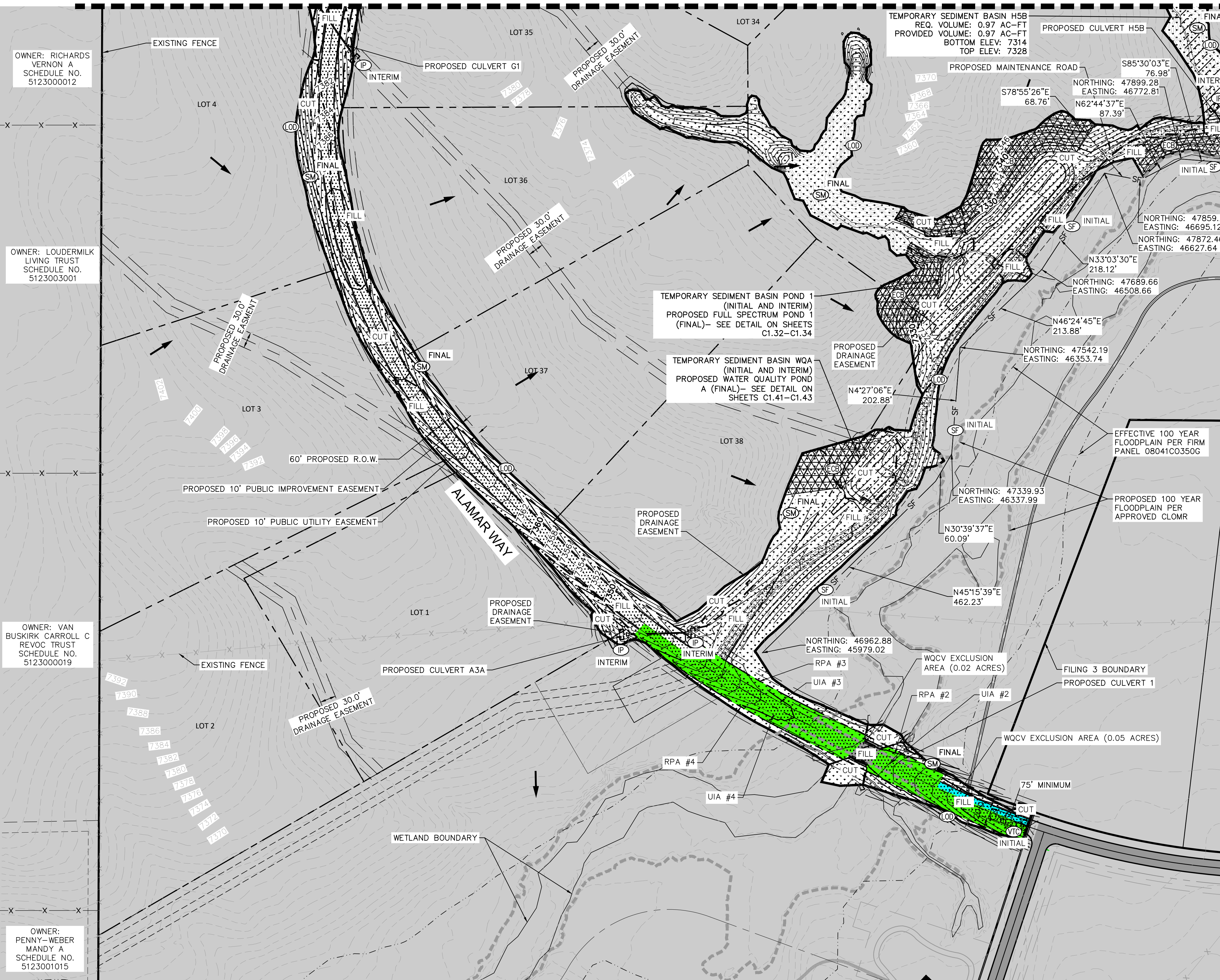

OWNER: RICHARDS  
VERNON A  
SCHEDULE NO.  
5123000012

OWNER: LOUDERMILK  
LIVING TRUST  
SCHEDULE NO.  
5123003001

OWNER: VAN  
BUSKIRK CARROLL C  
REVOC TRUST  
SCHEDULE NO.  
5123000019

OWNER:  
PENNY-WEBER  
MANDY A  
SCHEDULE NO.  
5123001015

**LEGEND**

- XXXX --- LOT BOUNDARY LINE
- XXXX --- EXISTING MAJOR CONTOUR
- XXXX --- EXISTING MINOR CONTOUR
- XXXX --- PROPOSED MAJOR CONTOUR
- XXXX --- PROPOSED MINOR CONTOUR
- LOD --- LIMITS OF CONSTRUCTION/DISTURBANCE
- CF --- CONSTRUCTION FENCE
- SF --- SILT FENCE
- CUT/FILL --- CUT/FILL DEMARCATION
- SP --- SOIL STOCKPILE
- SSA --- STABILIZED STAGING AREA
- VTC --- VEHICLE TRACKING CONTROL
- GR --- GRAVEL MAINTENANCE ROAD
- TS --- TEMPORARY SEDIMENT BASIN
- ECB --- EROSION CONTROL BLANKET
- SM --- PERMANENT SEEDING
- WA --- ASPHALT ROADWAY
- WA --- CONCRETE WASHOUT
- IP --- INLET PROTECTION
- FLD --- EXISTING FLOW DIRECTION ARROW

**NOTES**

1. THE INTENT OF THIS PLAN IS TO IDENTIFY THE EROSION CONTROL PRACTICES RECOMMENDED. THE CONTRACTOR SHALL REFERENCE ADDITIONAL CONSTRUCTION PLANS FOR DEMOLITION OF EXISTING AND CONSTRUCTION OF PROPOSED IMPROVEMENTS.
2. ADJACENT STREETS SHALL BE KEPT CLEAN AND FREE OF SEDIMENT AND/OR DEBRIS AT ALL TIMES.
3. TEMPORARY STABILIZATION (TS) SHALL BE IMPLEMENTED WITHIN THE DISTURBED PORTIONS OF THE PROJECT SITE NO LATER THAN 14 DAYS FOLLOWING THE CEASE OF CONSTRUCTION ACTIVITIES WITHIN THE DISTURBED AREAS.
4. PERMANENT STABILIZATION (PS) MAY BE USED WITHIN AREAS OF TEMPORARY STABILIZATION (TS) AT THE CONTRACTOR'S DISCRETION. STABILIZATION SHALL BE APPLIED IN ACCORDANCE WITH APPLICABLE TEMPORARY STABILIZATION SEQUENCING REQUIREMENTS.
5. CONTRACTOR SHALL UTILIZE ROLLED EROSION CONTROL PRODUCTS (STRAW-SINGLE NET EROSION CONTROL BLANKETS AND OPEN WEAVE TEXTILES) ON ALL SLOPES 3H:1V OR GREATER TO ACHIEVE REQUIRED STABILIZATION.
6. CONTRACTOR SHALL MAINTAIN ACCEPTABLE EROSION CONTROL PRACTICES WITHIN THE ANTICIPATED LIMITS OF CONSTRUCTION IDENTIFIED HEREIN. BEST MANAGEMENT PRACTICES AND STABILIZATION SHALL BE COMPLETED AS IDENTIFIED HEREIN IN ACCORDANCE WITH OWNER REQUIREMENTS.
7. ALL WORK IN THE HODGEN ROAD AND MERDIAIN ROAD ROW REQUIRES A ROW PERMIT FROM EL PASO COUNTY. CONTRACTOR IS RESPONSIBLE FOR APPLYING FOR AND OBTAINING ALL NECESSARY ROW PERMITS.
8. SILT FENCE TO BE INSTALLED PRIOR TO COMMENCEMENT OF ONSITE GRADING AND CONSTRUCTION ACTIVITIES.
9. DEMOLITION, REMOVAL, OVEREXCAVATION AND SOIL TREATMENT SHALL BE IN ACCORDANCE WITH THE GEOTECHNICAL ENGINEER RECOMMENDATIONS AS NOTED IN THE APPROVED PROJECT GEOTECHNICAL REPORT.
10. VEGETATION COVER IS ABOUT 90% CONSISTING OF NATIVE GRASSES, TREES AND SHRUBS, BASED ON VISUAL INSPECTION.
11. NO ASPHALT OR CONCRETE BATCH PLANTS SHALL BE USED FOR THIS PROJECT.
12. ROCK CHECK DAMS (CD) TO BE PLACED IN TEMPORARY AND PERMANENT DRAINAGE SWALES AND ROADSIDE DITCHES PER TABLE BELOW. ROCK CD'S TO BE SUBSTITUTED FOR SEDIMENT CONTROL LOGS (SCL) OR STRAW WADDLES. CONTRACTOR TO DETERMINE LOCATION OF CD WITHIN THE ROADSIDE DITCH (SEE TABLE FOR MIN. SPACING REQUIREMENTS) IN COORDINATION WITH COUNTY INSPECTORS.

SIZE OF SCL (STRAW WADDLE)	WADDLE SPACING PER VERTICAL FEET OF FALL
9 INCH	1.5 FEET
12 INCH	2 FEET
16 INCH	2.67 FEET

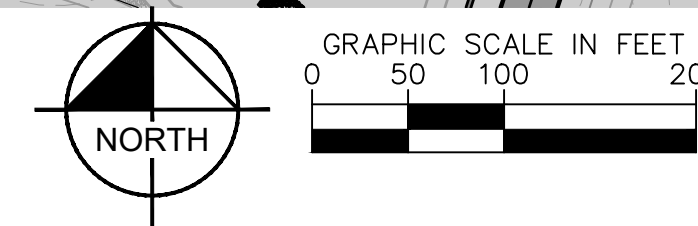
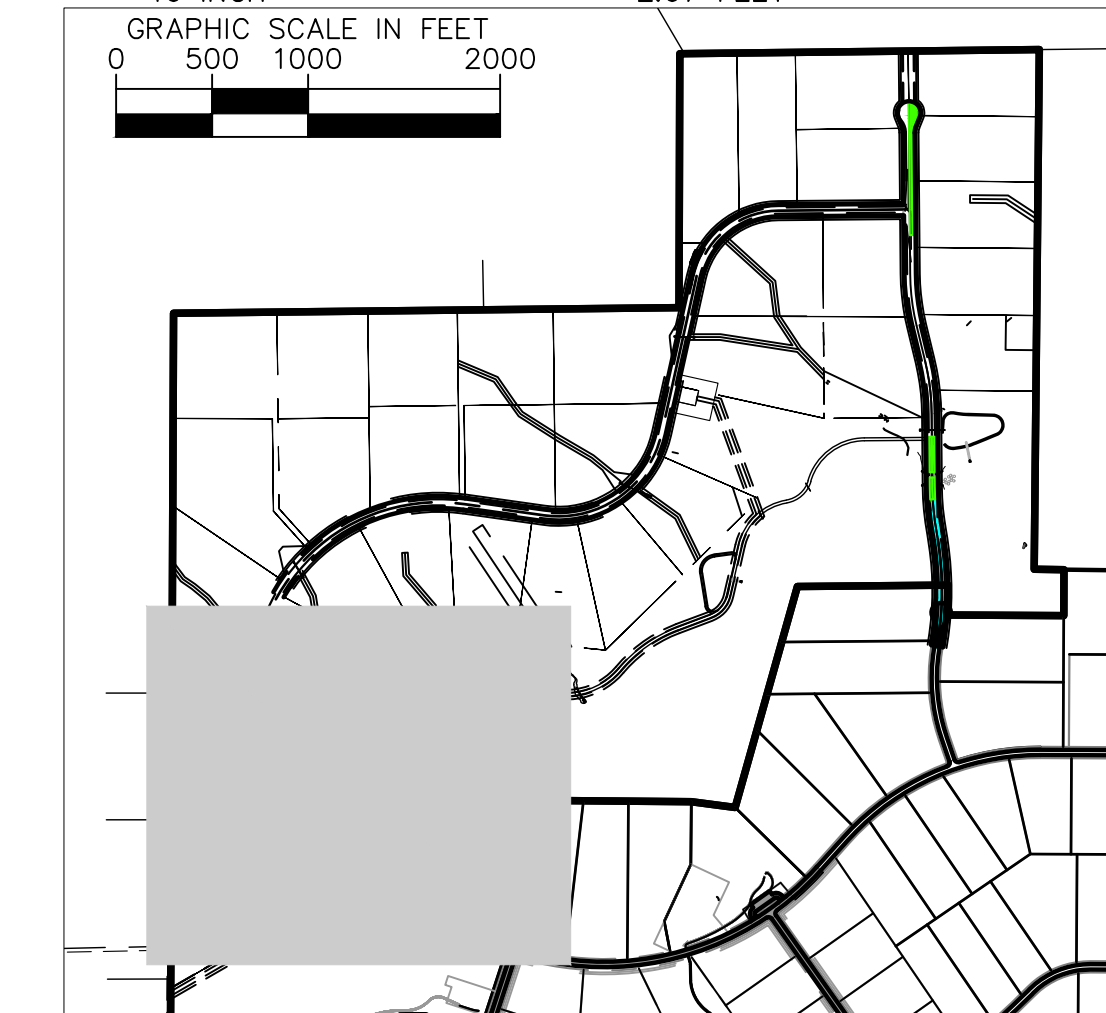
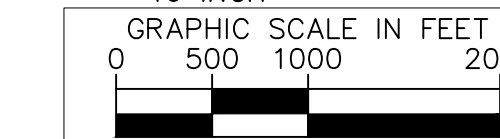

EPC 5/30/23

K:\COS\_Civil\196106001\_Winsome Filing No. 3\CADD\PlanSheets\Cds\196106001\_CD\_GEC\_FINAL.dwg Kofford, Kevin 4/28/2023 10:12 AM



DESIGNED BY: KRK  
DRAWN BY: AJL  
CHECKED BY: KRK  
DATE: 12/10/2021

WINSOME FILING NO. 3  
EL PASO COUNTY, COLORADO  
PRE DEVELOPMENT GESC PLAN  
GEC FINAL PLAN

**PRELIMINARY**  
FOR REVIEW ONLY  
NOT FOR  
CONSTRUCTION

PROJECT NO.  
196106001

SHEET

C1.22

NO.	REVISION	DATE	BY
1	RESUBMITTAL #1	KRK 8/30/22	KRK
2	RESUBMITTAL #2	KRK 11/30/22	KRK

K:\COS\_Civil\196106001\_Winsome Filing No. 3\CADD\PlanSheets\Cds\196106001\_CD\_GEC\_FINAL.dwg Kofford, Kevin 4/28/2023 10:12 AM

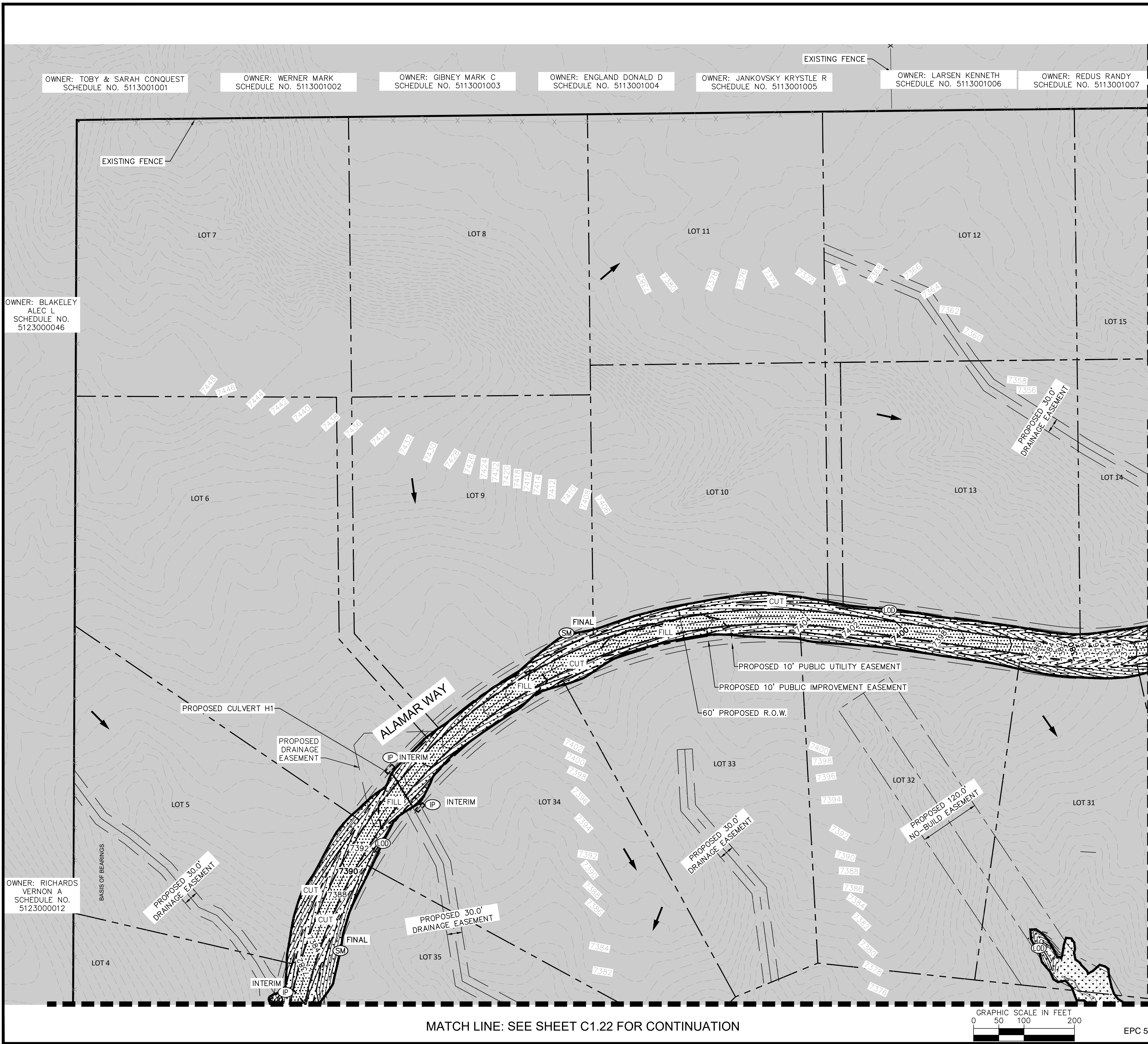

MATCH LINE: SEE SHEET C1.24 FOR CONTINUATION

MATCH LINE: SEE SHEET C1.25 FOR CONTINUATION

**LEGEND**

- LOT BOUNDARY LINE
- XXXX --- EXISTING MAJOR CONTOUR
- XXXX --- EXISTING MINOR CONTOUR
- XXXX --- PROPOSED MAJOR CONTOUR
- XXXX --- PROPOSED MINOR CONTOUR
- LOD --- LIMITS OF CONSTRUCTION/DISTURBANCE
- CF --- CONSTRUCTION FENCE
- SF --- SILT FENCE
- SF --- CUT/FILL DEMARCATION
- SP --- SOIL STOCKPILE
- SSA --- STABILIZED STAGING AREA
- VTC --- VEHICLE TRACKING CONTROL
- GR --- GRAVEL MAINTENANCE ROAD
- TS --- TEMPORARY SEDIMENT BASIN
- ECP --- EROSION CONTROL BLANKET
- SM --- PERMANENT SEEDING
- AR --- ASPHALT ROADWAY
- CWA --- CONCRETE WASHOUT
- EFD --- EXISTING FLOW DIRECTION ARROW
- IP --- INLET PROTECTION

- NOTES**
1. THE INTENT OF THIS PLAN IS TO IDENTIFY THE EROSION CONTROL PRACTICES RECOMMENDED. THE CONTRACTOR SHALL REFERENCE ADDITIONAL CONSTRUCTION PLANS FOR DEMOLITION OF EXISTING AND CONSTRUCTION OF PROPOSED IMPROVEMENTS.
  2. ADJACENT STREETS SHALL BE KEPT CLEAN AND FREE OF SEDIMENT AND/OR DEBRIS AT ALL TIMES.
  3. TEMPORARY STABILIZATION (TS) SHALL BE IMPLEMENTED WITHIN THE DISTURBED PORTIONS OF THE PROJECT SITE NO LATER THAN 14 DAYS FOLLOWING THE CEASE OF CONSTRUCTION ACTIVITIES WITHIN THE DISTURBED AREAS.
  4. PERMANENT STABILIZATION (PS) MAY BE USED WITHIN AREAS OF TEMPORARY STABILIZATION (TS) AT THE CONTRACTOR'S DISCRETION. STABILIZATION SHALL BE APPLIED IN ACCORDANCE WITH APPLICABLE TEMPORARY STABILIZATION SEQUENCING REQUIREMENTS.
  5. CONTRACTOR SHALL UTILIZE ROLLED EROSION CONTROL PRODUCTS (STRAW-SINGLE NET EROSION CONTROL BLANKETS AND OPEN WEAVE TEXTILES) ON ALL SLOPES 3H:1V OR GREATER TO ACHIEVE REQUIRED STABILIZATION.
  6. CONTRACTOR SHALL MAINTAIN ACCEPTABLE EROSION CONTROL PRACTICES WITHIN THE ANTICIPATED LIMITS OF CONSTRUCTION IDENTIFIED HEREIN. BEST MANAGEMENT PRACTICES AND STABILIZATION SHALL BE COMPLETED AS IDENTIFIED HEREIN IN ACCORDANCE WITH OWNER REQUIREMENTS.
  7. ALL WORK IN THE HODGEN ROAD AND MERDAIN ROAD ROW REQUIRES A ROW PERMIT FROM EL PASO COUNTY. CONTRACTOR IS RESPONSIBLE FOR APPLYING FOR AND OBTAINING ALL NECESSARY ROW PERMITS.
  8. SILT FENCE TO BE INSTALLED PRIOR TO COMMENCEMENT OF ONSITE GRADING AND CONSTRUCTION ACTIVITIES.
  9. DEMOLITION, REMOVAL, OVEREXCAVATION AND SOIL TREATMENT SHALL BE IN ACCORDANCE WITH THE GEOTECHNICAL ENGINEER RECOMMENDATIONS AS NOTED IN THE APPROVED PROJECT GEOTECHNICAL REPORT.
  10. VEGETATION COVER IS ABOUT 90% CONSISTING OF NATIVE GRASSES, TREES AND SHRUBS, BASED ON VISUAL INSPECTION.
  11. NO ASPHALT OR CONCRETE BATCH PLANTS SHALL BE USED FOR THIS PROJECT.
  12. ROCK CHECK DAMS (CD) TO BE PLACED IN TEMPORARY AND PERMANENT DRAINAGE SWALES AND ROADSIDE DITCHES PER TABLE BELOW. ROCK CD'S TO BE SUBSTITUTED FOR SEDIMENT CONTROL LOGS (SCL) OR STRAW WADDLES. CONTRACTOR TO DETERMINE LOCATION OF CD WITHIN THE ROADSIDE DITCH (SEE TABLE FOR MIN. SPACING REQUIREMENTS) IN COORDINATION WITH COUNTY INSPECTORS.

SIZE OF SCL (STRAW WADDLE)	WADDLE SPACING PER VERTICAL FEET OF FALL
9 INCH	1.5 FEET
12 INCH	2 FEET
16 INCH	2.67 FEET

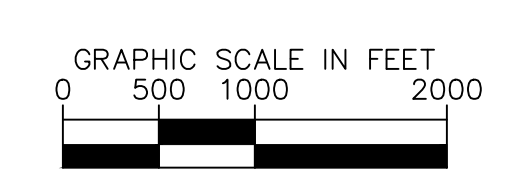

GRAPHIC SCALE IN FEET  
0 50 100 200  
EPC 5/30/23

<b>Kimley»Horn</b>													
2022 KIMLEY-HORN AND ASSOCIATES, INC. 2 North Nevada Avenue Suite 300 Colorado Springs, Colorado 80903 (719) 453-0180													
DESIGNED BY: KRK	DRAWN BY: AUL												
CHECKED BY: KRK	DATE: 12/10/2021												
<p>WINSOME FILING NO. 3 EL PASO COUNTY, COLORADO PRE DEVELOPMENT GESC PLAN GEC FINAL PLAN</p>													
<p><b>PRELIMINARY</b> FOR REVIEW ONLY NOT FOR CONSTRUCTION</p>													
<p>PROJECT NO. 196106001</p>													
<p>SHEET <b>C1.23</b></p>													
<table border="1" style="width: 100%; border-collapse: collapse; font-size: x-small;"> <tr> <th>NO.</th> <th>REVISION</th> <th>DATE</th> <th>BY</th> </tr> <tr> <td>1</td> <td>RESUBMITTAL #1</td> <td>11/30/22</td> <td>KRK</td> </tr> <tr> <td>2</td> <td>RESUBMITTAL #2</td> <td>12/22</td> <td>KRK</td> </tr> </table>	NO.	REVISION	DATE	BY	1	RESUBMITTAL #1	11/30/22	KRK	2	RESUBMITTAL #2	12/22	KRK	
NO.	REVISION	DATE	BY										
1	RESUBMITTAL #1	11/30/22	KRK										
2	RESUBMITTAL #2	12/22	KRK										



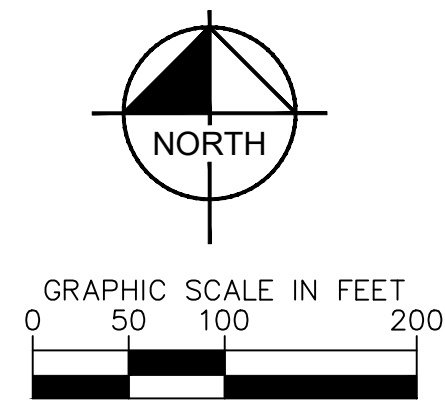

OWNER: PATTISON  
MICHAEL P.  
SCHEDULE NO.  
5113001009

OWNER: HARTMAN  
PAUL G.  
SCHEDULE NO.  
5113001008

OWNER: REDUS  
RANDY  
SCHEDULE NO.  
5113001007

OWNER: BLOCK REAL  
ESTATE LLC  
SCHEDULE NO.  
510000257

OWNER: COWLER  
MICHAEL W.  
SCHEDULE NO.  
510000494

**LEGEND**

---	LOT BOUNDARY LINE
----	EXISTING MAJOR CONTOUR
-----	EXISTING MINOR CONTOUR
- - - - -	PROPOSED MAJOR CONTOUR
- - - - -	PROPOSED MINOR CONTOUR
---	LOD LIMITS OF CONSTRUCTION/DISTURBANCE
---	CONSTRUCTION FENCE
---	SILT FENCE
---	CUT/FILL DEMARCATION
---	SOIL STOCKPILE
---	STABILIZED STAGING AREA
---	VEHICLE TRACKING CONTROL
---	GRAVEL MAINTENANCE ROAD
---	TEMPORARY SEDIMENT BASIN
---	EROSION CONTROL BLANKET
---	PERMANENT SEEDING
---	ASPHALT ROADWAY
---	CONCRETE WASHOUT
---	EXISTING FLOW DIRECTION ARROW
---	INLET PROTECTION

- NOTES**
- THE INTENT OF THIS PLAN IS TO IDENTIFY THE EROSION CONTROL PRACTICES RECOMMENDED. THE CONTRACTOR SHALL REFERENCE ADDITIONAL CONSTRUCTION PLANS FOR DEMOLITION OF EXISTING AND CONSTRUCTION OF PROPOSED IMPROVEMENTS.
  - ADJACENT STREETS SHALL BE KEPT CLEAN AND FREE OF SEDIMENT AND/OR DEBRIS AT ALL TIMES.
  - TEMPORARY STABILIZATION (TS) SHALL BE IMPLEMENTED WITHIN THE DISTURBED PORTIONS OF THE PROJECT SITE NO LATER THAN 14 DAYS FOLLOWING THE CEASE OF CONSTRUCTION ACTIVITIES WITHIN THE DISTURBED AREAS.
  - PERMANENT STABILIZATION (PS) MAY BE USED WITHIN AREAS OF TEMPORARY STABILIZATION (TS) AT THE CONTRACTOR'S DISCRETION. STABILIZATION SHALL BE APPLIED IN ACCORDANCE WITH APPLICABLE TEMPORARY STABILIZATION SEQUENCING REQUIREMENTS.
  - CONTRACTOR SHALL UTILIZE ROLLED EROSION CONTROL PRODUCTS (STRAW-SINGLE NET EROSION CONTROL BLANKETS AND OPEN WEAVE TEXTILES) ON ALL SLOPES 3H:1V OR GREATER TO ACHIEVE REQUIRED STABILIZATION.
  - CONTRACTOR SHALL MAINTAIN ACCEPTABLE EROSION CONTROL PRACTICES WITHIN THE ANTICIPATED LIMITS OF CONSTRUCTION IDENTIFIED HEREIN. BEST MANAGEMENT PRACTICES AND STABILIZATION SHALL BE COMPLETED AS IDENTIFIED HEREIN IN ACCORDANCE WITH OWNER REQUIREMENTS.
  - ALL WORK IN THE HODGEN ROAD AND MERIDIAN ROAD ROW REQUIRES A ROW PERMIT FROM EL PASO COUNTY. CONTRACTOR IS RESPONSIBLE FOR APPLYING FOR AND OBTAINING ALL NECESSARY ROW PERMITS.
  - SILT FENCE TO BE INSTALLED PRIOR TO COMMENCEMENT OF ONSITE GRADING AND CONSTRUCTION ACTIVITIES.
  - DEMOLITION, REMOVAL, OVEREXCAVATION AND SOIL TREATMENT SHALL BE IN ACCORDANCE WITH THE GEOTECHNICAL ENGINEER RECOMMENDATIONS AS NOTED IN THE APPROVED PROJECT GEOTECHNICAL REPORT.
  - VEGETATION COVER IS ABOUT 90% CONSISTING OF NATIVE GRASSES, TREES AND SHRUBS, BASED ON VISUAL INSPECTION.
  - NO ASPHALT OR CONCRETE BATCH PLANTS SHALL BE USED FOR THIS PROJECT.
  - ROCK CHECK DAMS (CD) TO BE PLACED IN TEMPORARY AND PERMANENT DRAINAGE SWALES AND ROADSIDE DITCHES PER TABLE BELOW. ROCK CD'S TO BE SUBSTITUTED FOR SEDIMENT CONTROL LOGS (SCL) OR STRAW WADDLES. CONTRACTOR TO DETERMINE LOCATION OF CD WITHIN THE ROADSIDE DITCH (SEE TABLE FOR MIN. SPACING REQUIREMENTS) IN COORDINATION WITH COUNTY INSPECTORS.

SIZE OF SCL (STRAW WADDLE)	WADDLE SPACING PER VERTICAL FEET OF FALL
9 INCH	1.5 FEET
12 INCH	2 FEET
16 INCH	2.67 FEET

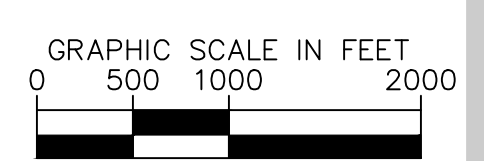

MATCH LINE: SEE SHEET C1.23 FOR CONTINUATION

MATCH LINE: SEE SHEET C1.25 FOR CONTINUATION

EPC 5/30/23

K:\COS\_Civil\196106001\_Winsome Filing No. 3\CADD\PlanSheets\Cds\196106001\_CD\_GEC\_FINAL.dwg Kofford, Kevin 4/28/2023 10:13 AM

NO.	REVISION	DATE	BY
2	RESUBMITTAL #2	KRK 11/30/22	KRK
1	RESUBMITTAL #1	KRK 8/30/22	KRK

**Kimley»Horn**  
2022 KIMLEY-HORN AND ASSOCIATES, INC.  
2 North Nevada Avenue Suite 300  
Colorado Springs, Colorado 80903 (719) 453-0180

DESIGNED BY: KRK  
DRAWN BY: AJL  
CHECKED BY: KRK  
DATE: 12/10/2021

WINSOME FILING NO. 3  
EL PASO COUNTY, COLORADO  
PRE DEVELOPMENT GESC PLAN  
GEC FINAL PLAN

PRELIMINARY  
FOR REVIEW ONLY  
NOT FOR  
CONSTRUCTION  
**Kimley»Horn**  
Kimley-Horn and Associates, Inc.

PROJECT NO.  
196106001  
SHEET  
**C1.24**

K:\COS\_Civil\196106001\_Winsome Filing No. 3\CADD\PlanSheets\Cds\196106001\_CD\_GEC\_FINAL.dwg Kofford, Kevin 4/28/2023 10:13 AM

MATCH LINE: SEE SHEET C1.23 FOR CONTINUATION

MATCH LINE: SEE SHEET C1.24 FOR CONTINUATION

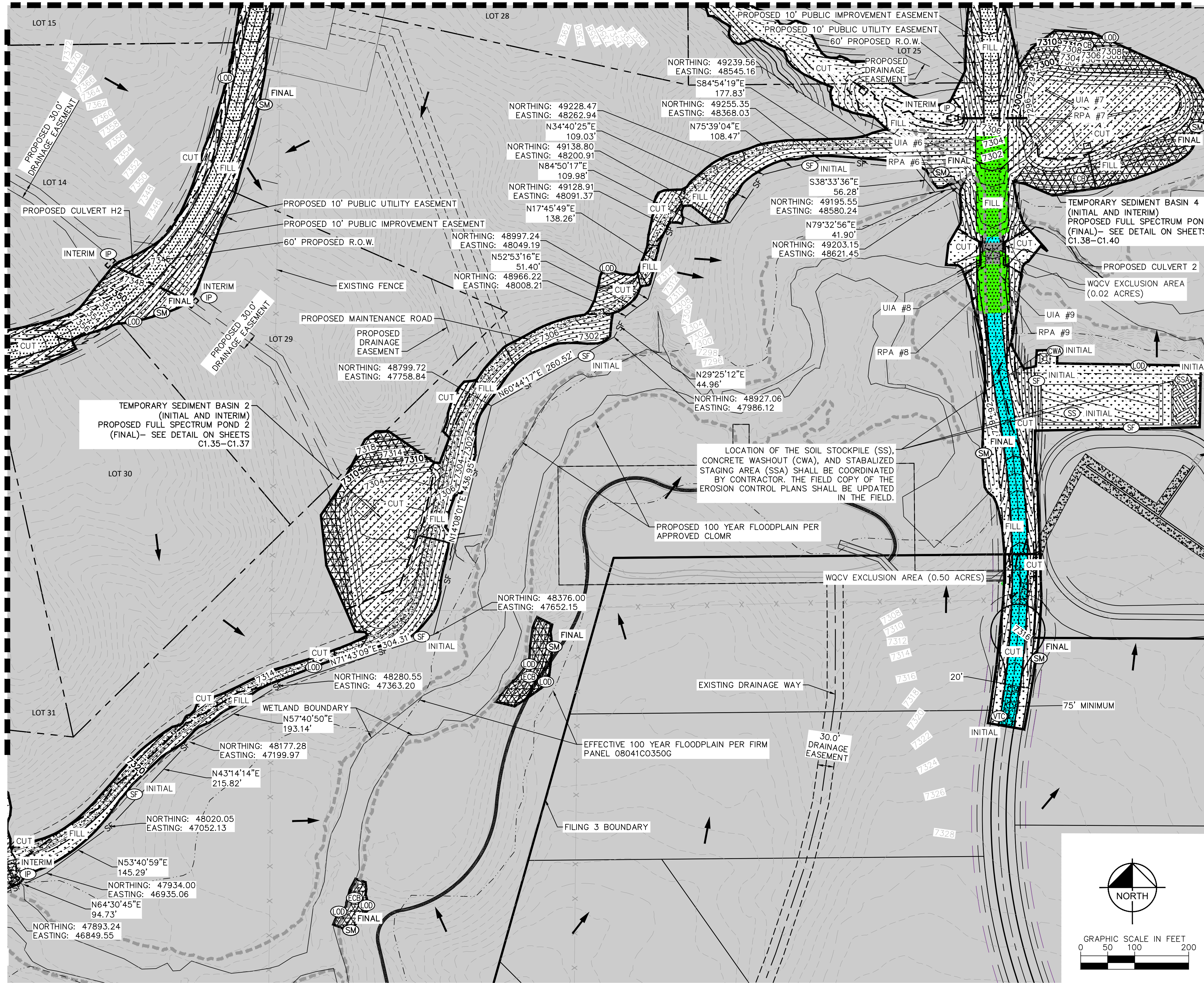

**LEGEND**

- LOT BOUNDARY LINE
- EXISTING MAJOR CONTOUR
- EXISTING MINOR CONTOUR
- PROPOSED MAJOR CONTOUR
- PROPOSED MINOR CONTOUR
- (OD)--- LIMITS OF CONSTRUCTION/DISTURBANCE
- (CF)--- CONSTRUCTION FENCE
- (SF)--- SILT FENCE
- (SF)--- CUT/FILL DEMARCATION
- (SF)--- SOIL STOCKPILE
- (SSA)--- STABILIZED STAGING AREA
- (VTC)--- VEHICLE TRACKING CONTROL
- (GR)--- GRAVEL MAINTENANCE ROAD
- (TS)--- TEMPORARY SEDIMENT BASIN
- (ECB)--- EROSION CONTROL BLANKET
- (SM)--- PERMANENT SEEDING
- (CWA)--- ASPHALT ROADWAY
- (CWA)--- CONCRETE WASHOUT
- (FD)--- EXISTING FLOW DIRECTION ARROW
- (IP)--- INLET PROTECTION

**NOTES**

1. THE INTENT OF THIS PLAN IS TO IDENTIFY THE EROSION CONTROL PRACTICES RECOMMENDED. THE CONTRACTOR SHALL REFERENCE ADDITIONAL CONSTRUCTION PLANS FOR DEMOLITION OF EXISTING AND CONSTRUCTION OF PROPOSED IMPROVEMENTS.
2. ADJACENT STREETS SHALL BE KEPT CLEAN AND FREE OF SEDIMENT AND/OR DEBRIS AT ALL TIMES.
3. TEMPORARY STABILIZATION (TS) SHALL BE IMPLEMENTED WITHIN THE DISTURBED PORTIONS OF THE PROJECT SITE NO LATER THAN 14 DAYS FOLLOWING THE CEASE OF CONSTRUCTION ACTIVITIES WITHIN THE DISTURBED AREAS.
4. PERMANENT STABILIZATION (PS) MAY BE USED WITHIN AREAS OF TEMPORARY STABILIZATION (TS) AT THE CONTRACTOR'S DISCRETION. STABILIZATION SHALL BE APPLIED IN ACCORDANCE WITH APPLICABLE TEMPORARY STABILIZATION SEQUENCING REQUIREMENTS.
5. CONTRACTOR SHALL UTILIZE ROLLED EROSION CONTROL PRODUCTS (STRAW-SINGLE NET EROSION CONTROL BLANKETS AND OPEN WEAVE TEXTILES) ON ALL SLOPES 3H:1V OR GREATER TO ACHIEVE REQUIRED STABILIZATION. CONTRACTOR SHALL MAINTAIN ACCEPTABLE EROSION CONTROL PRACTICES WITHIN THE ANTICIPATED LIMITS OF CONSTRUCTION IDENTIFIED HEREIN. BEST MANAGEMENT PRACTICES AND STABILIZATION SHALL BE COMPLETED AS IDENTIFIED HEREIN IN ACCORDANCE WITH OWNER REQUIREMENTS.
6. ALL WORK IN THE HODGEN ROAD AND MERDIAN ROAD ROW REQUIRES A ROW PERMIT FROM EL PASO COUNTY. CONTRACTOR IS RESPONSIBLE FOR APPLYING FOR AND OBTAINING ALL NECESSARY ROW PERMITS.
7. SILT FENCE TO BE INSTALLED PRIOR TO COMMENCEMENT OF ONSITE GRADING AND CONSTRUCTION ACTIVITIES.
8. DEMOLITION, REMOVAL, OVEREXCAVATION AND SOIL TREATMENT SHALL BE IN ACCORDANCE WITH THE GEOTECHNICAL ENGINEER RECOMMENDATIONS AS NOTED IN THE APPROVED PROJECT GEOTECHNICAL REPORT.
9. VEGETATION COVER IS ABOUT 90% CONSISTING OF NATIVE GRASSES, TREES AND SHRUBS, BASED ON VISUAL INSPECTION.
10. NO ASPHALT OR CONCRETE BATCH PLANTS SHALL BE USED FOR THIS PROJECT.
11. ROCK CHECK DAMS (CD) TO BE PLACED IN TEMPORARY AND PERMANENT DRAINAGE SWALES AND ROADSIDE DITCHES PER TABLE BELOW. ROCK CD'S TO BE SUBSTITUTED FOR SEDIMENT CONTROL LOGS (SCL) OR STRAW WADDLES. CONTRACTOR TO DETERMINE LOCATION OF CD WITHIN THE ROADSIDE DITCH (SEE TABLE FOR MIN. SPACING REQUIREMENTS) IN COORDINATION WITH COUNTY INSPECTORS.

SIZE OF SCL (STRAW WADDLE)	WADDLE SPACING PER VERTICAL FEET OF FALL
9 INCH	1.5 FEET
12 INCH	2 FEET
16 INCH	2.67 FEET

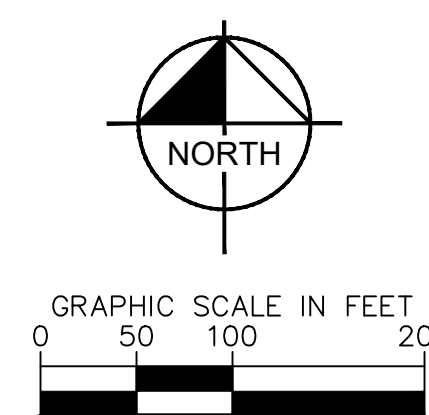
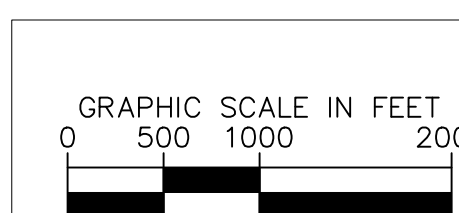

EPC 5/30/23

**Kimley»Horn**

2022 KIMLEY-HORN AND ASSOCIATES, INC.  
2 North Nevada Avenue Suite 300  
Colorado Springs, Colorado 80903 (719) 453-0180

DESIGNED BY: KRK  
DRAWN BY: AJL  
CHECKED BY: KRK  
DATE: 12/10/2021

WINSOME FILING NO. 3  
EL PASO COUNTY, COLORADO  
PRE DEVELOPMENT GESC PLAN  
GEC FINAL PLAN

PRELIMINARY  
FOR REVIEW ONLY  
NOT FOR CONSTRUCTION

PROJECT NO.  
196106001

SHEET  
C1.25

NO.	REVISION	DATE	BY
1	RESUBMITTAL #1	11/30/22	KRK
2	RESUBMITTAL #2	11/30/22	KRK

**SM-3 Construction Fence (CF)**

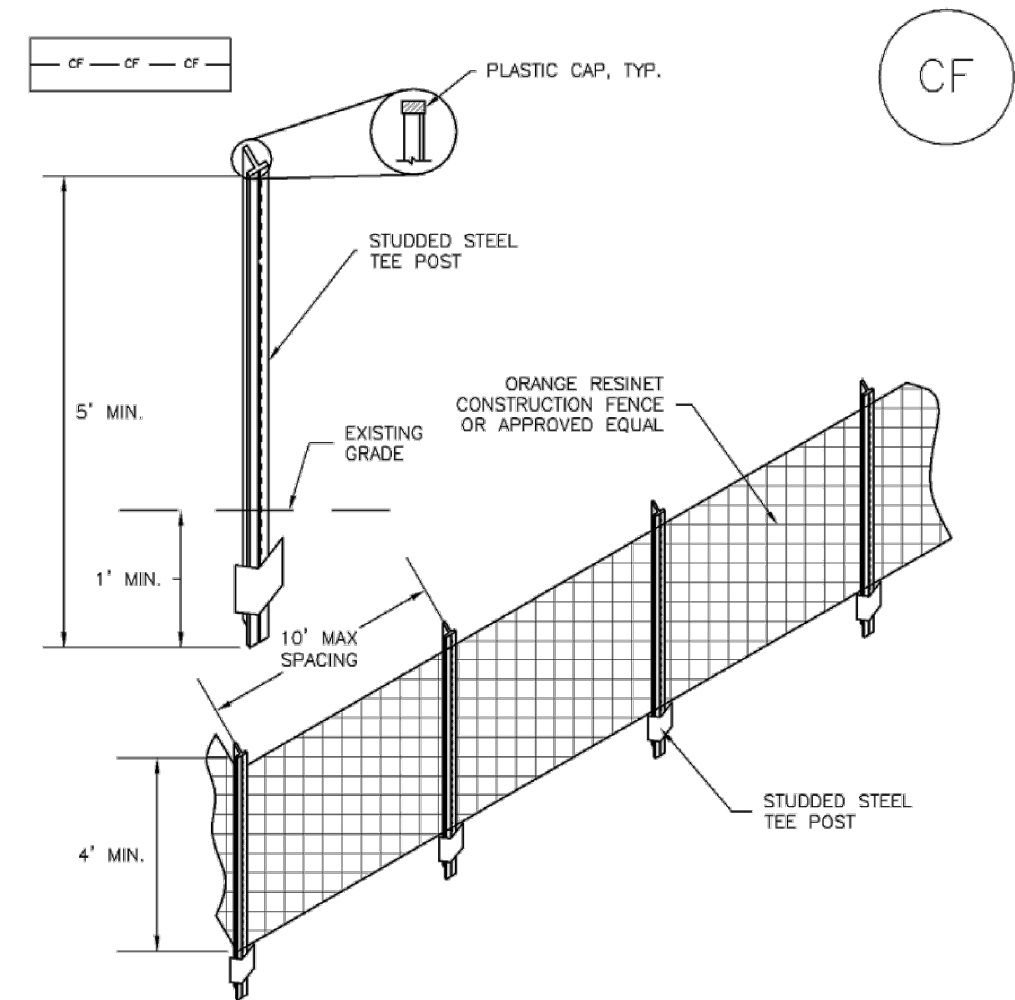

**CF-1. PLASTIC MESH CONSTRUCTION FENCE**

- CONSTRUCTION FENCE INSTALLATION NOTES**
- SEE PLAN VIEW FOR:
    - LOCATION OF CONSTRUCTION FENCE.
  - CONSTRUCTION FENCE SHOWN SHALL BE INSTALLED PRIOR TO ANY LAND DISTURBING ACTIVITIES.
  - CONSTRUCTION FENCE SHALL BE COMPOSED OF ORANGE, CONTRACTOR-GRADE MATERIAL THAT IS AT LEAST 4' HIGH. METAL POSTS SHOULD HAVE A PLASTIC CAP FOR SAFETY.
  - STUDDER STEEL TEE POSTS SHALL BE UTILIZED TO SUPPORT THE CONSTRUCTION FENCE. MAXIMUM SPACING FOR STEEL TEE POSTS SHALL BE 10'.
  - CONSTRUCTION FENCE SHALL BE SECURELY FASTENED TO THE TOP, MIDDLE, AND BOTTOM OF EACH POST.

CF-2 Urban Drainage and Flood Control District November 2010  
Urban Storm Drainage Criteria Manual Volume 3

**Construction Fence (CF) SM-3**

- CONSTRUCTION FENCE MAINTENANCE NOTES**
- INSPECT BMPs EACH WORKDAY, AND MAINTAIN THEM IN EFFECTIVE OPERATING CONDITION. MAINTENANCE OF BMPs SHOULD BE PROACTIVE, NOT REACTIVE. INSPECT BMPs AS SOON AS POSSIBLE (AND ALWAYS WITHIN 24 HOURS) FOLLOWING A STORM THAT CAUSES SURFACE EROSION, AND PERFORM NECESSARY MAINTENANCE.
  - FREQUENT OBSERVATIONS AND MAINTENANCE ARE NECESSARY TO MAINTAIN BMPs IN EFFECTIVE OPERATING CONDITION. INSPECTIONS AND CORRECTIVE MEASURES SHOULD BE DOCUMENTED THOROUGHLY.
  - WHERE BMPs HAVE FAILED, REPAIR OR REPLACEMENT SHOULD BE INITIATED UPON DISCOVERY OF THE FAILURE.
  - CONSTRUCTION FENCE SHALL BE REPAIRED OR REPLACED WHEN THERE ARE SIGNS OF DAMAGE SUCH AS RIPS OR SAGS. CONSTRUCTION FENCE IS TO REMAIN IN PLACE UNTIL THE UPSTREAM DISTURBED AREA IS STABILIZED AND APPROVED BY THE LOCAL JURISDICTION.
  - WHEN CONSTRUCTION FENCES ARE REMOVED, ALL DISTURBED AREAS ASSOCIATED WITH THE INSTALLATION, MAINTENANCE, AND/OR REMOVAL OF THE FENCE SHALL BE COVERED WITH TOPSOIL, SEEDED AND MULCHED, OR OTHERWISE STABILIZED AS APPROVED BY LOCAL JURISDICTION.
- NOTE: MANY JURISDICTIONS HAVE BMP DETAILS THAT VARY FROM UDFCD STANDARD DETAILS. CONSULT WITH LOCAL JURISDICTIONS AS TO WHICH DETAIL SHOULD BE USED WHEN DIFFERENCES ARE NOTED.
- (DETAIL ADAPTED FROM TOWN OF PARKER, COLORADO, NOT AVAILABLE IN AUTOCAD)

November 2010 Urban Drainage and Flood Control District November 2010  
Urban Storm Drainage Criteria Manual Volume 3

**Concrete Washout Area (CWA) MM-1**

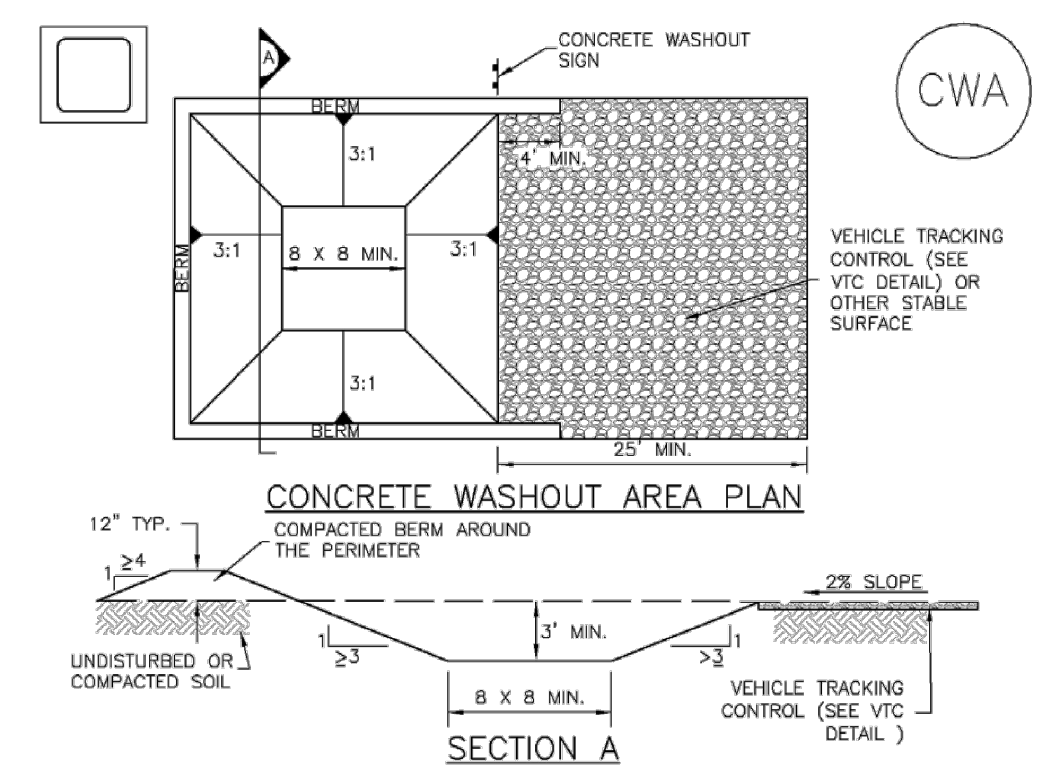

**CWA-1. CONCRETE WASHOUT AREA**

- CWA INSTALLATION NOTES**
- SEE PLAN VIEW FOR:
    - CWA INSTALLATION LOCATION.
  - DO NOT LOCATE AN UNLINED CWA WITHIN 400' OF ANY NATURAL DRAINAGE PATHWAY OR WATERBODY. DO NOT LOCATE WITHIN 1,000' OF ANY WELLS OR DRINKING WATER SOURCES. IF SITE CONSTRAINTS MAKE THIS INFEASIBLE, OR IF HIGHLY PERMEABLE SOILS EXIST ON SITE, THE CWA MUST BE INSTALLED WITH AN IMPERMEABLE LINER (1/8 MIN. THICKNESS) OR SURFACE STORAGE ALTERNATIVES USING PREFABRICATED CONCRETE WASHOUT DEVICES OR A LINED ABOVE GROUND STORAGE ARE SHOULD BE USED.
  - THE CWA SHALL BE INSTALLED PRIOR TO CONCRETE PLACEMENT ON SITE.
  - CWA SHALL INCLUDE A FLAT SUBSURFACE PIT THAT IS AT LEAST 8' BY 8' SLOPES LEADING OUT OF THE SUBSURFACE PIT SHALL BE 3:1 OR FLATTER. THE PIT SHALL BE AT LEAST 3' DEEP.
  - BERM SURROUNDING SIDES AND BACK OF THE CWA SHALL HAVE MINIMUM HEIGHT OF 1'.
  - VEHICLE TRACKING PAD SHALL BE SLOPED 2% TOWARDS THE CWA.
  - SIGNS SHALL BE PLACED AT THE CONSTRUCTION ENTRANCE, AT THE CWA AND ELSEWHERE AS NECESSARY TO CLEARLY INDICATE THE LOCATION OF THE CWA TO OPERATORS OF CONCRETE TRUCKS AND PUMP TRUCKS.
  - USE EXCAVATED MATERIAL FOR PERIMETER BERM CONSTRUCTION.

November 2010 Urban Drainage and Flood Control District November 2010  
Urban Storm Drainage Criteria Manual Volume 3

**Concrete Washout Area (CWA) MM-1**

- CWA MAINTENANCE NOTES**
- INSPECT BMPs EACH WORKDAY, AND MAINTAIN THEM IN EFFECTIVE OPERATING CONDITION. MAINTENANCE OF BMPs SHOULD BE PROACTIVE, NOT REACTIVE. INSPECT BMPs AS SOON AS POSSIBLE (AND ALWAYS WITHIN 24 HOURS) FOLLOWING A STORM THAT CAUSES SURFACE EROSION, AND PERFORM NECESSARY MAINTENANCE.
  - FREQUENT OBSERVATIONS AND MAINTENANCE ARE NECESSARY TO MAINTAIN BMPs IN EFFECTIVE OPERATING CONDITION. INSPECTIONS AND CORRECTIVE MEASURES SHOULD BE DOCUMENTED THOROUGHLY.
  - WHERE BMPs HAVE FAILED, REPAIR OR REPLACEMENT SHOULD BE INITIATED UPON DISCOVERY OF THE FAILURE.
  - THE CWA SHALL BE REPAIRED, CLEANED, OR ENLARGED AS NECESSARY TO MAINTAIN CAPACITY FOR CONCRETE WASTE, CONCRETE MATERIALS, ACCUMULATED IN PIT, SHALL BE REMOVED ONCE THE MATERIALS HAVE REACHED A DEPTH OF 2'.
  - CONCRETE WASHOUT WATER, WASTED PIECES OF CONCRETE AND ALL OTHER DEBRIS IN THE SUBSURFACE PIT SHALL BE TRANSPORTED FROM THE JOB SITE IN A WATER-TIGHT CONTAINER AND DISPOSED OF PROPERLY.
  - THE CWA SHALL REMAIN IN PLACE UNTIL ALL CONCRETE FOR THE PROJECT IS PLACED.
  - WHEN THE CWA IS REMOVED, COVER THE DISTURBED AREA WITH TOP SOIL, SEED AND MULCH OR OTHERWISE STABILIZED IN A MANNER APPROVED BY THE LOCAL JURISDICTION.
- (DETAIL ADAPTED FROM DOUGLAS COUNTY, COLORADO AND THE CITY OF PARKER, COLORADO, NOT AVAILABLE IN AUTOCAD)
- NOTE: MANY JURISDICTIONS HAVE BMP DETAILS THAT VARY FROM UDFCD STANDARD DETAILS. CONSULT WITH LOCAL JURISDICTIONS AS TO WHICH DETAIL SHOULD BE USED WHEN DIFFERENCES ARE NOTED.

CWA-4 Urban Drainage and Flood Control District November 2010  
Urban Storm Drainage Criteria Manual Volume 3

**Sediment Control Log (SCL) SC-2**

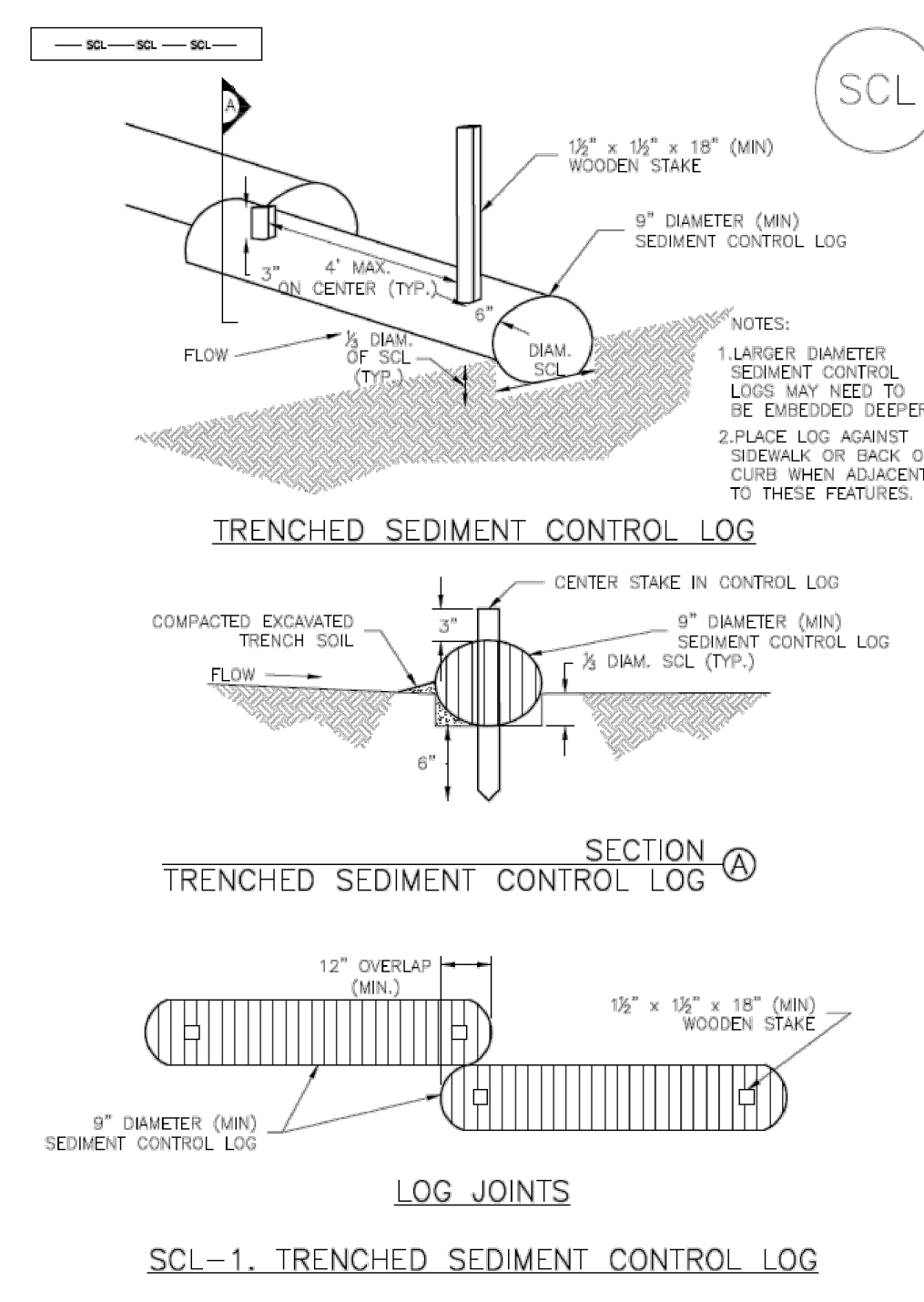

**SCL-1. TRENCHED SEDIMENT CONTROL LOG**

November 2015 Urban Drainage and Flood Control District November 2015  
Urban Storm Drainage Criteria Manual Volume 3

**Sediment Control Log (SCL) SC-2**

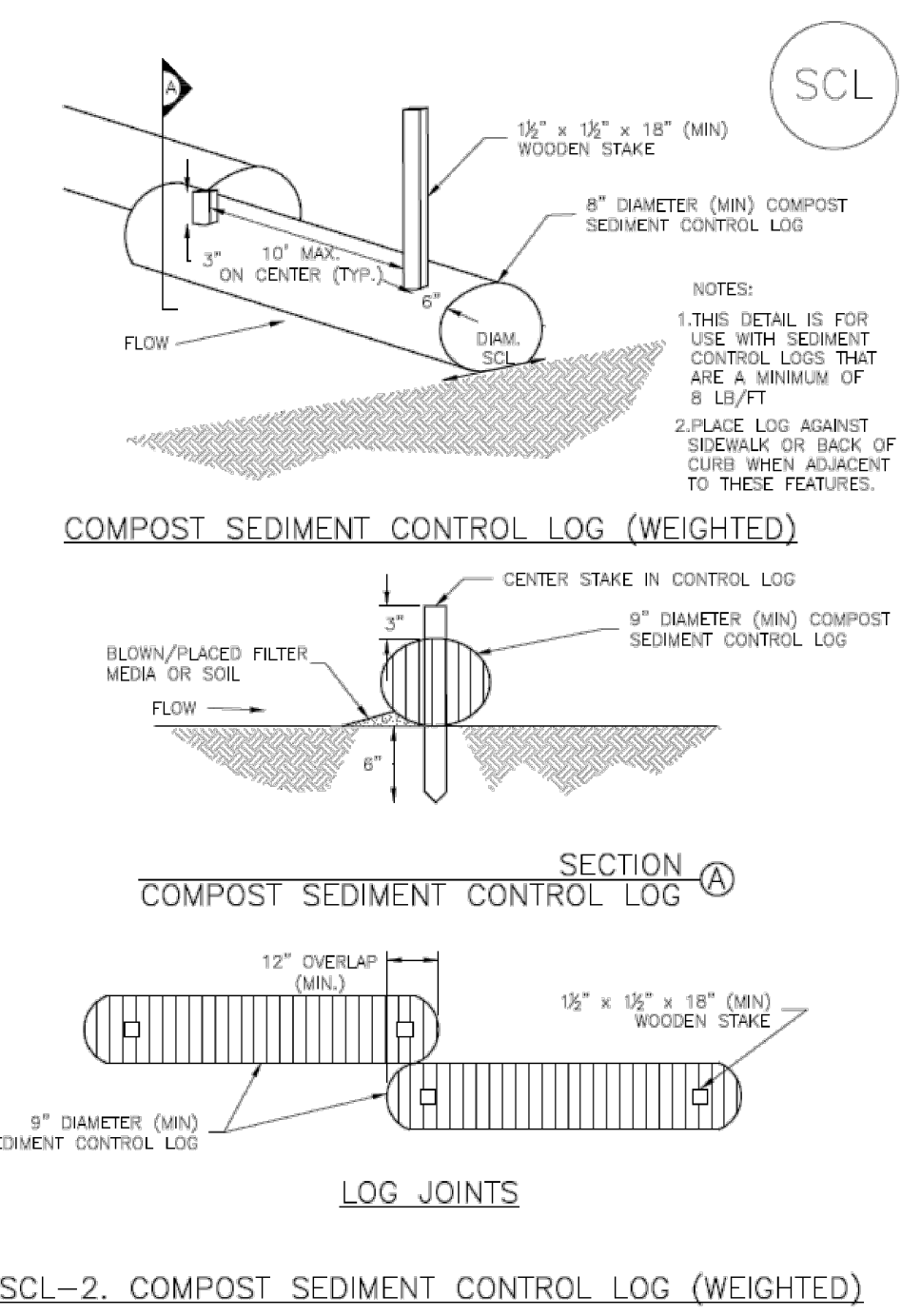

**SCL-2. COMPOST SEDIMENT CONTROL LOG (WEIGHTED)**

SCL-4 Urban Drainage and Flood Control District November 2015  
Urban Storm Drainage Criteria Manual Volume 3

**Sediment Control Log (SCL) SC-2**

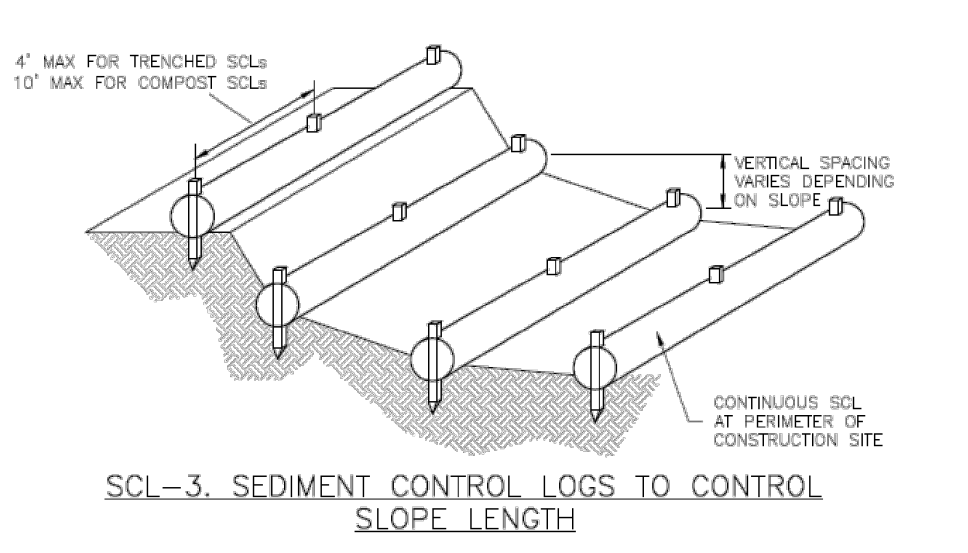

**SCL-3. SEDIMENT CONTROL LOGS TO CONTROL SLOPE LENGTH**

November 2015 Urban Drainage and Flood Control District November 2015  
Urban Storm Drainage Criteria Manual Volume 3

**Sediment Control Log (SCL) SC-2**

- SEDIMENT CONTROL LOG INSTALLATION NOTES**
- SEE PLAN VIEW FOR LOCATION AND LENGTH OF SEDIMENT CONTROL LOGS.
  - SEDIMENT CONTROL LOGS THAT ACT AS A PERIMETER CONTROL SHALL BE INSTALLED PRIOR TO ANY UPGRADE/REPAIR/REPLACEMENT OF ANY UPGRADE/REPAIR/REPLACEMENT ACTIVITIES.
  - SEDIMENT CONTROL LOGS SHALL CONSIST OF STRAW, COMPOST, EXCelsior OR COCONUT FIBER, AND SHALL BE FREE OF ANY NOXIOUS WEED SEEDS OR DEFECTS INCLUDING RIPS, HOLES AND OBVIOUS WEAR.
  - SEDIMENT CONTROL LOGS MAY BE USED AS SMALL CHECK DAMS IN DITCHES AND SWALES. HOWEVER, THEY SHOULD NOT BE USED IN PERENNIAL STREAMS.
  - IT IS RECOMMENDED THAT SEDIMENT CONTROL LOGS BE TRENCHED INTO THE GROUND TO A DEPTH OF APPROXIMATELY 1/2 OF THE DIAMETER OF THE LOG. IF TRENCHING TO THIS DEPTH IS NOT FEASIBLE AND/OR DESIRABLE (SHORT TERM INSTALLATION WITH DESIRE NOT TO DAMAGE LANDSCAPE) A LESSER TRENCHING DEPTH MAY BE ACCEPTABLE WITH MORE ROBUST STAKING. COMPOST LOGS THAT ARE 8 LB/FT DO NOT NEED TO BE TRENCHED.
  - THE UPHILL SIDE OF THE SEDIMENT CONTROL LOG SHALL BE BACKFILLED WITH SOIL OR FILTER MATERIAL THAT IS FREE OF ROCKS AND DEBRIS. THE SOIL SHALL BE TIGHTLY COMPACTED INTO THE SHAPE OF A RIGHT TRIANGLE USING A SHOVEL OR WEIGHTED LAWN ROLLER OR BLOWN IN PLACE.
  - FOLLOW MANUFACTURERS' GUIDANCE FOR STAKING. IF MANUFACTURERS' INSTRUCTIONS DO NOT SPECIFY SPACING, STAKES SHALL BE PLACED ON 4' CENTERS AND EMBEDDED A MINIMUM OF 6" INTO THE GROUND. 3" OF THE STAKE SHALL PROTRUDE FROM THE TOP OF THE LOG. STAKES THAT ARE BROKEN PRIOR TO INSTALLATION SHALL BE REPLACED. COMPOST LOGS SHOULD BE STAKED 10' ON CENTER.
- SEDIMENT CONTROL LOG MAINTENANCE NOTES**
- INSPECT BMPs EACH WORKDAY, AND MAINTAIN THEM IN EFFECTIVE OPERATING CONDITION. MAINTENANCE OF BMPs SHOULD BE PROACTIVE, NOT REACTIVE. INSPECT BMPs AS SOON AS POSSIBLE (AND ALWAYS WITHIN 24 HOURS) FOLLOWING A STORM THAT CAUSES SURFACE EROSION, AND PERFORM NECESSARY MAINTENANCE.
  - FREQUENT OBSERVATIONS AND MAINTENANCE ARE NECESSARY TO MAINTAIN BMPs IN EFFECTIVE OPERATING CONDITION. INSPECTIONS AND CORRECTIVE MEASURES SHOULD BE DOCUMENTED THOROUGHLY.
  - WHERE BMPs HAVE FAILED, REPAIR OR REPLACEMENT SHOULD BE INITIATED UPON DISCOVERY OF THE FAILURE.
  - SEDIMENT ACCUMULATED UPSTREAM OF SEDIMENT CONTROL LOG SHALL BE REMOVED AS NEEDED TO MAINTAIN FUNCTIONALITY OF THE BMP. TYPICALLY WHEN DEPTH OF ACCUMULATED SEDIMENTS IS APPROXIMATELY 1/2 OF THE HEIGHT OF THE SEDIMENT CONTROL LOG.
  - SEDIMENT CONTROL LOG SHALL BE REMOVED AT THE END OF CONSTRUCTION/COMPOST FROM COMPOST LOGS MAY BE LEFT IN PLACE AS LONG AS BAGS ARE REMOVED AND THE AREA SEEDED. IF DISTURBED AREAS EXIST AFTER REMOVAL, THEY SHALL BE COVERED WITH TOP SOIL, SEEDED AND MULCHED OR OTHERWISE STABILIZED IN A MANNER APPROVED BY THE LOCAL JURISDICTION.
- (DETAILS ADAPTED FROM TOWN OF PARKER, COLORADO, JEFFERSON COUNTY, COLORADO, DOUGLAS COUNTY, COLORADO, AND CITY OF AURORA, COLORADO, NOT AVAILABLE IN AUTOCAD)
- NOTE: MANY JURISDICTIONS HAVE BMP DETAILS THAT VARY FROM UDFCD STANDARD DETAILS. CONSULT WITH LOCAL JURISDICTIONS AS TO WHICH DETAIL SHOULD BE USED WHEN DIFFERENCES ARE NOTED.

SCL-6 Urban Drainage and Flood Control District November 2015  
Urban Storm Drainage Criteria Manual Volume 3

K:\COS\_Civil\196106001\_Winsome Filing No. 3\CADD\PlanSheets\Cds\196106001\_CD\_GEC-DTL.dwg Kofford, Kevin 4/28/2023 10:13 AM

NO.	DATE	BY	REVISION
2	KRK 4/28/23	KRK	COUNTY COMMENTS
1	KRK 3/10/23	KRK	COUNTY COMMENTS

**Kimley»Horn**  
KIMLEY-HORN AND ASSOCIATES, INC.  
2021 KIMLEY-HORN AND ASSOCIATES, INC.  
2 North Nevada Avenue Suite 300  
Colorado Springs, Colorado 80903 (719) 453-0180

DESIGNED BY: KRK  
DRAWN BY: AJL  
CHECKED BY: KRK  
DATE: 12/16/2021

WINSOME FILING NO. 3  
EL PASO COUNTY, COLORADO  
CONSTRUCTION DOCUMENTS  
GEC DETAILS

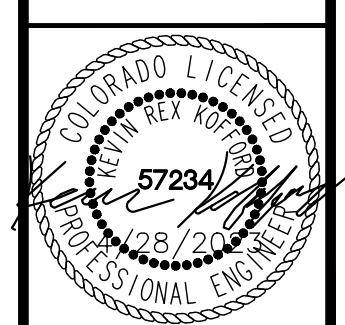

PROJECT NO.  
196106001  
SHEET  
C1.26

### Temporary and Permanent Seeding (TS/PS) EC-2

Seeding dates for the highest success probability of perennial species along the Front Range are generally in the spring from April through early May and in the fall after the first of September until the ground freezes. If the area is irrigated, seeding may occur in summer months, as well. See Table TS/PS-3 for appropriate seeding dates.

Table TS/PS-1. Minimum Drill Seeding Rates for Various Temporary Annual Grasses

Table with 4 columns: Species\* (Common name), Growth Season, Pounds of Pure Live Seed (PLS)/acre, and Planting Depth (inches). Lists 11 species like Oats, Spring barley, Annual ryegrass, etc.

\* Successful seeding of annual grass resulting in adequate plant growth will usually produce enough dead-plant residue to provide protection from wind and water erosion for an additional year. This assumes that the cover is not disturbed or mowed closer than 8 inches.

Hydraulic seeding may be substituted for drilling only where slopes are steeper than 3:1 or where access limitations exist. When hydraulic seeding is used, hydraulic mulching should be applied as a separate operation, when practical, to prevent the seeds from being encapsulated in the mulch.

† See Table TS/PS-3 for seeding dates. Irrigation, if consistently applied, may extend the use of cool season species during the summer months.

‡ Seeding rates should be doubled if seed is broadcast, or increased by 50 percent if done using a Brillion Drill or by hydraulic seeding.

### EC-2 Temporary and Permanent Seeding (TS/PS)

Table TS/PS-2. Minimum Drill Seeding Rates for Perennial Grasses

Table with 6 columns: Common Name, Botanical Name, Growth Season, Growth Form, Seeds/Pound, Pounds of PLS/acre. Divided into Alkali Soil Seed Mix, Fertile Loamy Soil Seed Mix, High Water Table Soil Seed Mix, and Transition Turf Seed Mix.

### Temporary and Permanent Seeding (TS/PS) EC-2

Table TS/PS-2. Minimum Drill Seeding Rates for Perennial Grasses (cont.)

Continuation of Table TS/PS-2 with 6 columns: Common Name, Botanical Name, Growth Season, Growth Form, Seeds/Pound, Pounds of PLS/acre. Lists species like Blue grama, Camper little bluestem, etc.

\* All of the above seeding mixes and rates are based on drill seeding followed by crimped straw mulch. These rates should be doubled if seed is broadcast and should be increased by 50 percent if the seeding is done using a Brillion Drill or is applied through hydraulic seeding.

† If site is to be irrigated, the transition turf seed rates should be doubled. ‡ Seeding rates should be doubled if seed is broadcast, or increased by 50 percent if done using a Brillion Drill or by hydraulic seeding.

### EC-2 Temporary and Permanent Seeding (TS/PS)

Table TS/PS-3. Seeding Dates for Annual and Perennial Grasses

Table with 4 columns: Seeding Dates, Annual Grasses (Warm, Cool), Perennial Grasses (Warm, Cool). Lists seeding periods from January to October.

**Mulch**
Cover seeded areas with mulch or an appropriate rolled erosion control product to promote establishment of vegetation. Anchor mulch by crimping, netting or use of a non-toxic tackifier. See the Mulching BMP Fact Sheet for additional guidance.

**Maintenance and Removal**
Monitor and observe seeded areas to identify areas of poor growth or areas that fail to germinate. Reseed and mulch these areas, as needed.

An area that has been permanently seeded should have a good stand of vegetation within one growing season if irrigated and three growing seasons without irrigation in Colorado. Reseed portions of the site that fail to germinate or remain bare after the first growing season.

Seeded areas may require irrigation, particularly during extended dry periods. Targeted weed control may also be necessary.

Protect seeded areas from construction equipment and vehicle access.

### Stockpile Management (SP) MM-2

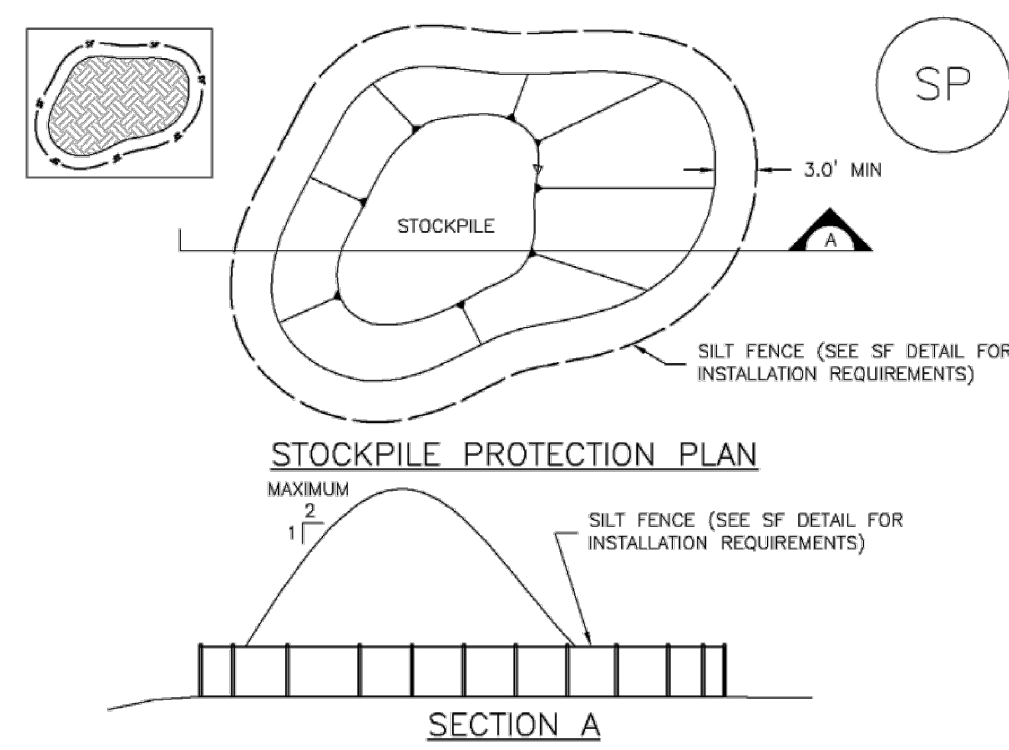

SP-1. STOCKPILE PROTECTION

STOCKPILE PROTECTION INSTALLATION NOTES
1. SEE PLAN VIEW FOR: LOCATION OF STOCKPILES; TYPE OF STOCKPILE PROTECTION.
2. INSTALL PERIMETER CONTROLS IN ACCORDANCE WITH THEIR RESPECTIVE DESIGN DETAILS.

### MM-2 Stockpile Management (SM)

STOCKPILE PROTECTION MAINTENANCE NOTES
1. INSPECT BMPs EACH WORKDAY, AND MAINTAIN THEM IN EFFECTIVE OPERATING CONDITION. MAINTENANCE OF BMPs SHOULD BE PROACTIVE, NOT REACTIVE. INSPECT BMPs AS SOON AS POSSIBLE (AND ALWAYS WITHIN 24 HOURS) FOLLOWING A STORM THAT CAUSES SURFACE EROSION...

### Rolled Erosion Control Products (RECP) EC-6

Table RECP-1. ECTC Standard Specification for Temporary Rolled Erosion Control Products (Adapted from Erosion Control Technology Council 2005)

Table with 5 columns: Product Description, Slope Applications, Channel Applications, Minimum Tensile Strength, and Expected Longevity. Lists products like Mulch Control Nets, Netless Rolled Erosion Control Blankets, etc.

\* C Factor and shear stress for mulch control nettings must be obtained with netting used in conjunction with pre-applied mulch material. (See Section 5.3 of Chapter 7 Construction BMPs for more information on the C Factor.)
† Minimum Average Roll Values, Machine direction using ECTC Mod. ASTM D 5035.

### EC-6 Rolled Erosion Control Products (RECP)

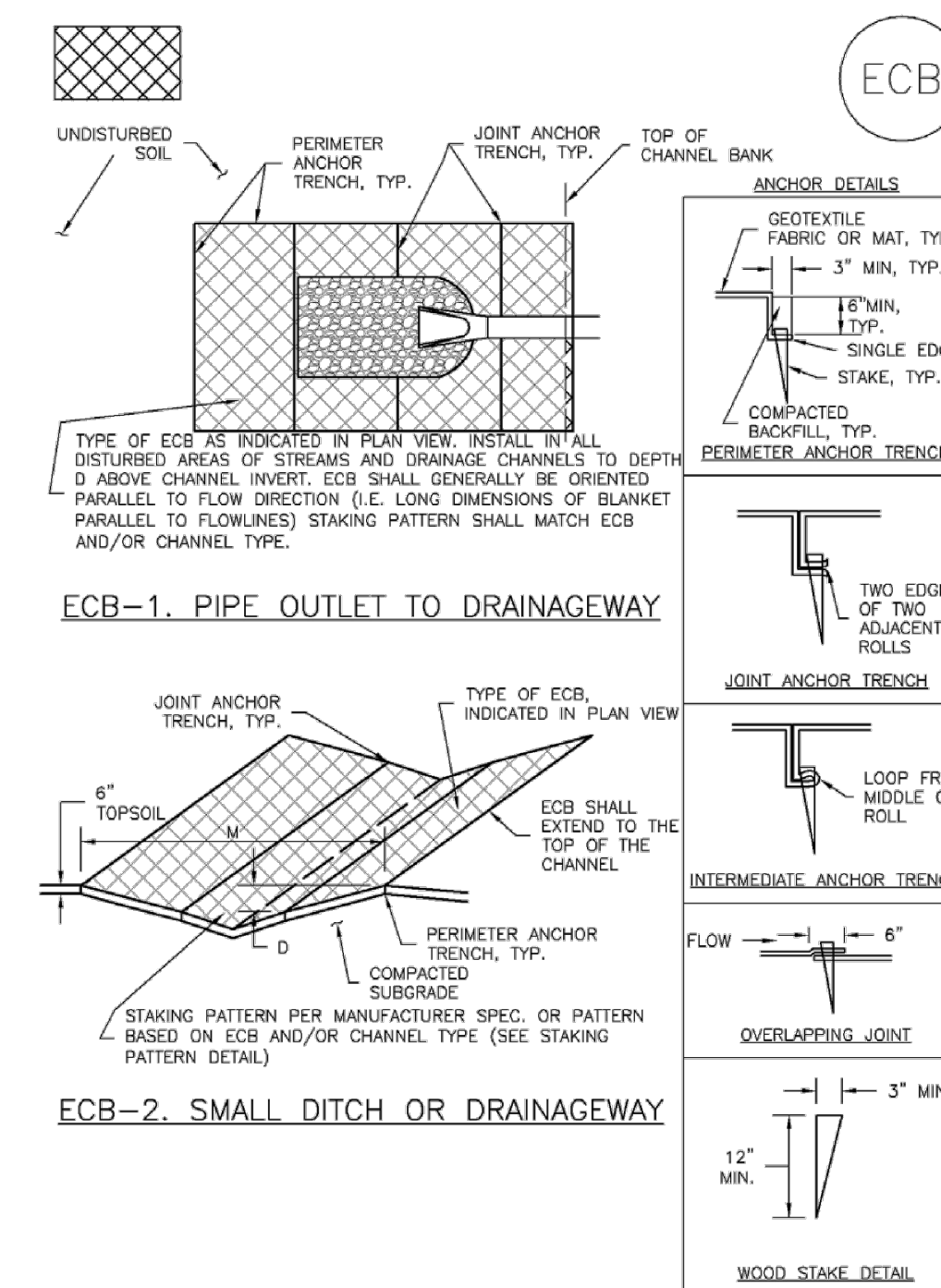

K:\COS\_Civil\196106001\_Winsome Filing No. 3\CADD\PlanSheets\CDs\196106001\_CD\_GEC-DTL.dwg Kofford, Kevin 4/28/2023 10:13 AM

Vertical sidebar containing: County/Revision table, Kimley-Horn logo and address, project filing info, and engineer's seal/signature.

Silt Fence (SF)

SC-1

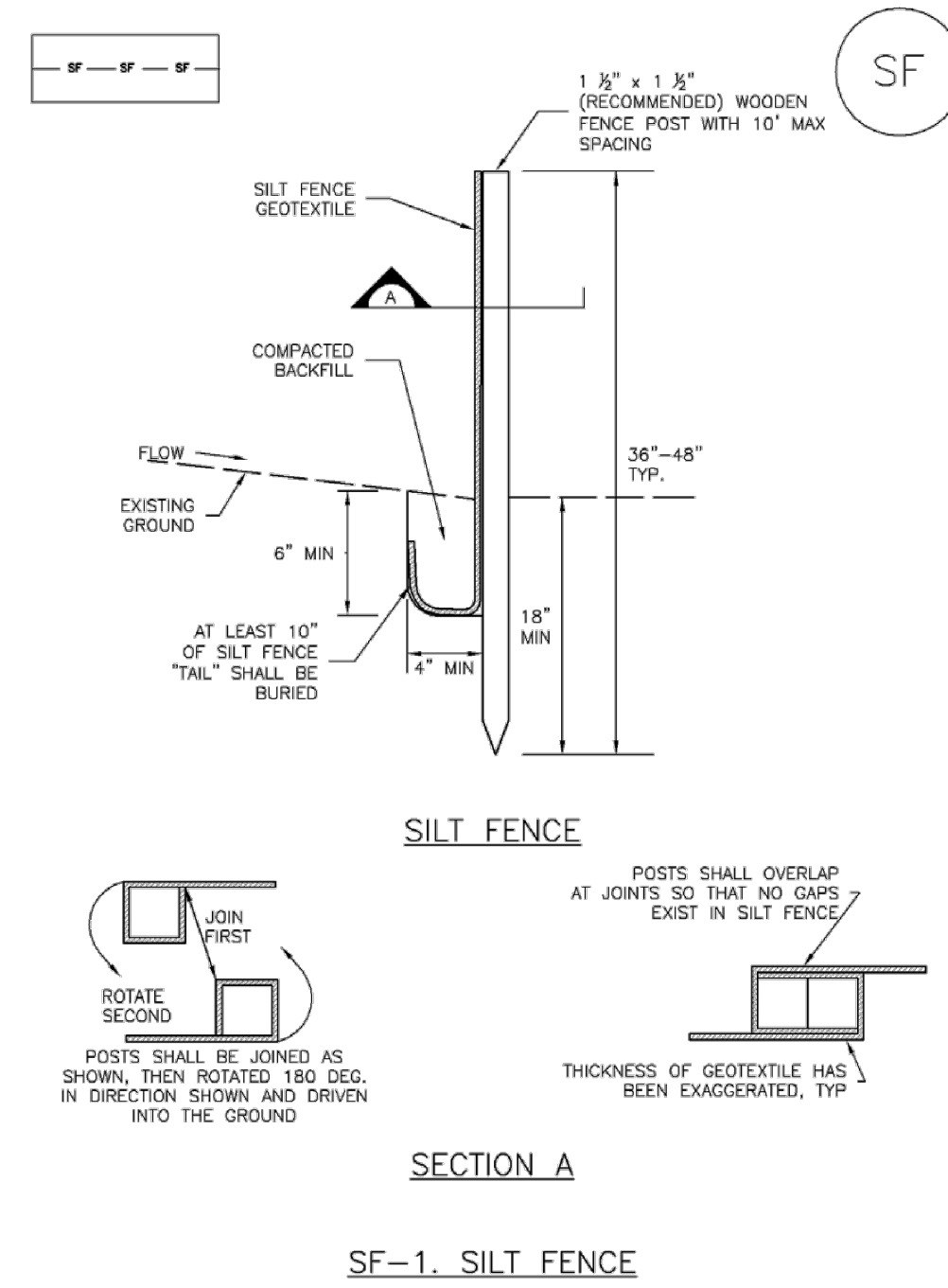

SF-1. SILT FENCE

November 2010 Urban Drainage and Flood Control District Urban Storm Drainage Criteria Manual Volume 3 SF-3

SC-1

Silt Fence (SF)

**SILT FENCE INSTALLATION NOTES**

- SILT FENCE MUST BE PLACED AWAY FROM THE TOE OF THE SLOPE TO ALLOW FOR WATER PONDING. SILT FENCE AT THE TOE OF A SLOPE SHOULD BE INSTALLED IN A FLAT LOCATION AT LEAST SEVERAL FEET (2-3 FT) FROM THE TOE OF THE SLOPE TO ALLOW ROOM FOR PONDING AND DEPOSITION.
- A UNIFORM 6" X 4" ANCHOR TRENCH SHALL BE EXCAVATED USING TRENCHER OR SILT FENCE INSTALLATION DEVICE. NO ROAD GRADERS, BACKHOES, OR SIMILAR EQUIPMENT SHALL BE USED.
- COMPACT ANCHOR TRENCH BY HAND WITH A "JUMPING JACK" OR BY WHEEL ROLLING. COMPACTION SHALL BE SUCH THAT SILT FENCE RESISTS BEING PULLED OUT OF ANCHOR TRENCH BY HAND.
- SILT FENCE SHALL BE PULLED TIGHT AS IT IS ANCHORED TO THE STAKES. THERE SHOULD BE NO NOTICEABLE SAG BETWEEN STAKES AFTER IT HAS BEEN ANCHORED TO THE STAKES.
- SILT FENCE FABRIC SHALL BE ANCHORED TO THE STAKES USING 1" HEAVY DUTY STAPLES OR NAILS WITH 1" HEADS. STAPLES AND NAILS SHOULD BE PLACED 3" ALONG THE FABRIC DOWN THE STAKE.
- AT THE END OF A RUN OF SILT FENCE TO CREATE A CONTOUR, THE SILT FENCE SHOULD BE TURNED PERPENDICULAR TO THE CONTOUR TO CREATE A "J-HOOK." THE "J-HOOK" EXTENDING PERPENDICULAR TO THE CONTOUR SHOULD BE OF SUFFICIENT LENGTH TO KEEP RUNOFF FROM FLOWING AROUND THE END OF THE SILT FENCE (TYPICALLY 10' - 20').
- SILT FENCE SHALL BE INSTALLED PRIOR TO ANY LAND DISTURBING ACTIVITIES.

**SILT FENCE MAINTENANCE NOTES**

- INSPECT BMPs EACH WORKDAY, AND MAINTAIN THEM IN EFFECTIVE OPERATING CONDITION. MAINTENANCE OF BMPs SHOULD BE PROACTIVE, NOT REACTIVE. INSPECT BMPs AS SOON AS POSSIBLE (AND ALWAYS WITHIN 24 HOURS) FOLLOWING A STORM THAT CAUSES SURFACE EROSION, AND PERFORM NECESSARY MAINTENANCE.
- FREQUENT OBSERVATIONS AND MAINTENANCE ARE NECESSARY TO MAINTAIN BMPs IN EFFECTIVE OPERATING CONDITION. INSPECTIONS AND CORRECTIVE MEASURES SHOULD BE DOCUMENTED THOROUGHLY.
- WHERE BMPs HAVE FAILED, REPAIR OR REPLACEMENT SHOULD BE INITIATED UPON DISCOVERY OF THE FAILURE.
- SEDIMENT ACCUMULATED UPSTREAM OF THE SILT FENCE SHALL BE REMOVED AS NEEDED TO MAINTAIN THE FUNCTIONALITY OF THE BMP, TYPICALLY WHEN DEPTH OF ACCUMULATED SEDIMENTS IS APPROXIMATELY 6".
- REPAIR OR REPLACE SILT FENCE WHEN THERE ARE SIGNS OF WEAR, SUCH AS SAGGING, TEARING, OR COLLAPSE.
- SILT FENCE IS TO REMAIN IN PLACE UNTIL THE UPSTREAM DISTURBED AREA IS STABILIZED AND APPROVED BY THE LOCAL JURISDICTION, OR IS REPLACED BY AN EQUIVALENT PERIMETER SEDIMENT CONTROL BMP.
- WHEN SILT FENCE IS REMOVED, ALL DISTURBED AREAS SHALL BE COVERED WITH TOPSOIL, SEED, AND MULCHED OR OTHERWISE STABILIZED AS APPROVED BY LOCAL JURISDICTION.

(DETAILS ADAPTED FROM TOWN OF PINKER, COLORADO AND CITY OF ALBUQU, NOT AVAILABLE IN AUTOCAD)

NOTE: MANY JURISDICTIONS HAVE BMP DETAILS THAT VARY FROM UDFCD STANDARD DETAILS. CONSULT WITH LOCAL JURISDICTIONS AS TO WHICH DETAIL SHOULD BE USED WHEN DIFFERENCES ARE NOTED.

SF-4 Urban Drainage and Flood Control District Urban Storm Drainage Criteria Manual Volume 3 November 2010

Stabilized Staging Area (SSA)

SM-6

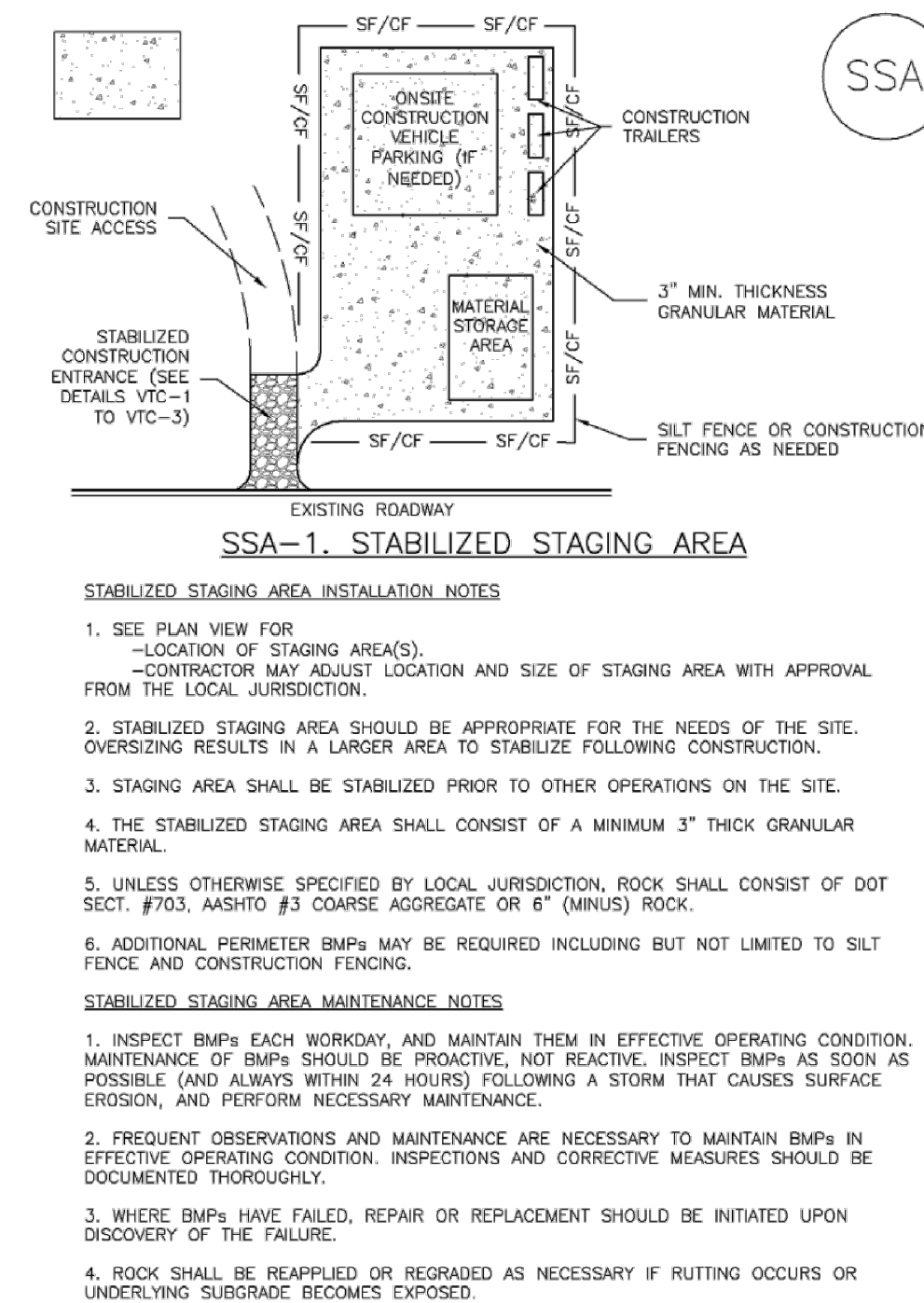

SSA-1. STABILIZED STAGING AREA

November 2010 Urban Drainage and Flood Control District Urban Storm Drainage Criteria Manual Volume 3 SSA-3

SM-6

Stabilized Staging Area (SSA)

**STABILIZED STAGING AREA MAINTENANCE NOTES**

- STABILIZED STAGING AREA SHALL BE ENLARGED IF NECESSARY TO CONTAIN PARKING, STORAGE, AND UNLOADING/LOADING OPERATIONS.
- THE STABILIZED STAGING AREA SHALL BE REMOVED AT THE END OF CONSTRUCTION. THE GRANULAR MATERIAL SHALL BE REMOVED OR, IF APPROVED BY THE LOCAL JURISDICTION, USED ON SITE, AND THE AREA COVERED WITH TOPSOIL, SEED, AND MULCHED OR OTHERWISE STABILIZED IN A MANNER APPROVED BY LOCAL JURISDICTION.

NOTE: MANY MUNICIPALITIES PROHIBIT THE USE OF RECYCLED CONCRETE AS GRANULAR MATERIAL FOR STABILIZED STAGING AREAS DUE TO DIFFICULTIES WITH RE-ESTABLISHMENT OF VEGETATION IN AREAS WHERE RECYCLED CONCRETE WAS PLACED.

NOTE: MANY JURISDICTIONS HAVE BMP DETAILS THAT VARY FROM UDFCD STANDARD DETAILS. CONSULT WITH LOCAL JURISDICTIONS AS TO WHICH DETAIL SHOULD BE USED WHEN DIFFERENCES ARE NOTED.

(DETAILS ADAPTED FROM DOUGLAS COUNTY, COLORADO, NOT AVAILABLE IN AUTOCAD)

SSA-4 Urban Drainage and Flood Control District Urban Storm Drainage Criteria Manual Volume 3 November 2010

Vehicle Tracking Control (VTC)

SM-4

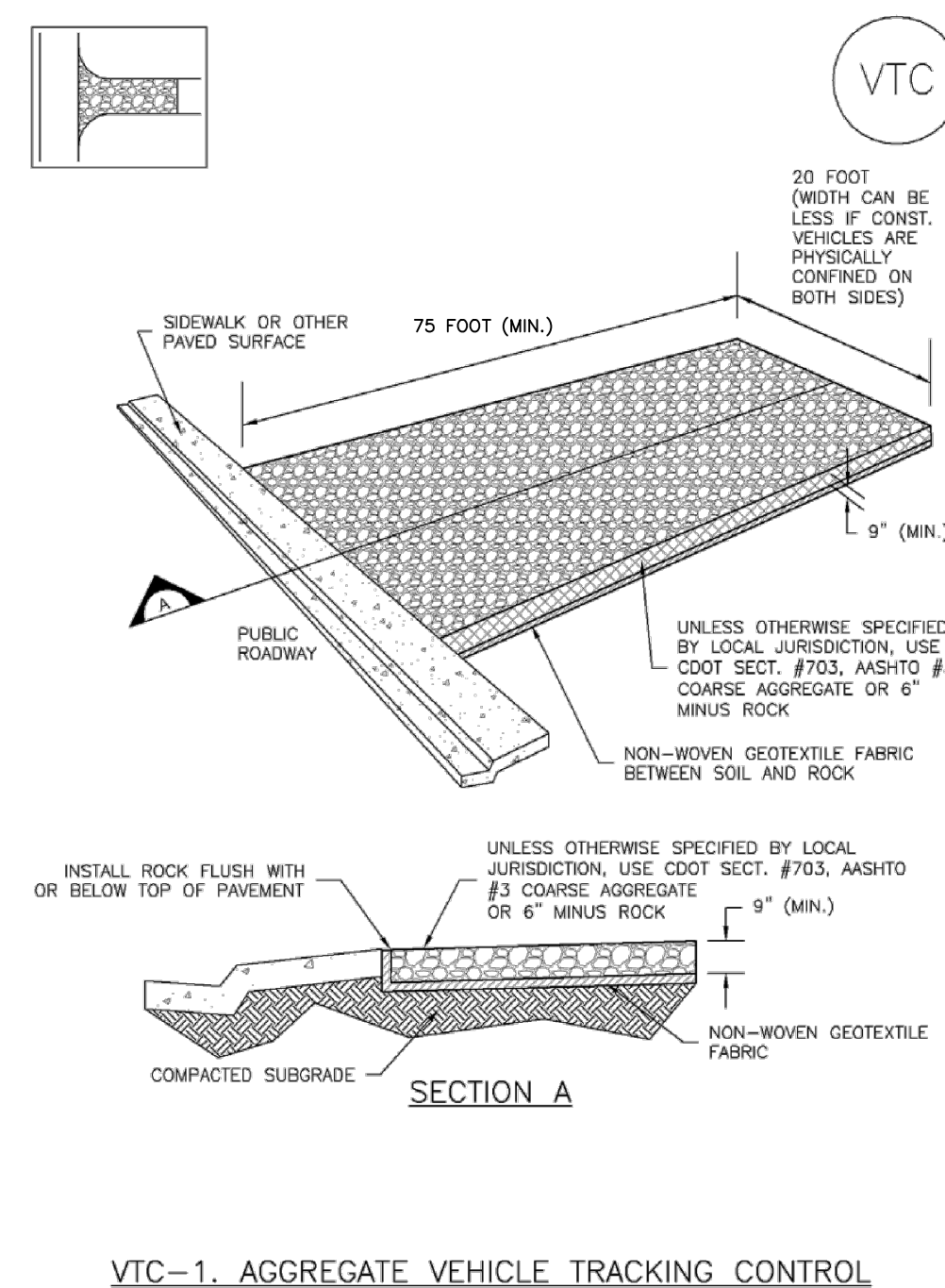

VTC-1. AGGREGATE VEHICLE TRACKING CONTROL

November 2010 Urban Drainage and Flood Control District Urban Storm Drainage Criteria Manual Volume 3 VTC-3

SM-4

Vehicle Tracking Control (VTC)

**STABILIZED CONSTRUCTION ENTRANCE/EXIT INSTALLATION NOTES**

- SEE PLAN VIEW FOR -LOCATION OF CONSTRUCTION ENTRANCE(S)/EXIT(S). -TYPE OF CONSTRUCTION ENTRANCE(S)/EXIT(S) (WITH/WITHOUT WHEEL WASH, CONSTRUCTION MAT OR TRM).
- CONSTRUCTION MAT OR TRM STABILIZED CONSTRUCTION ENTRANCES ARE ONLY TO BE USED ON SHORT DURATION PROJECTS (TYPICALLY RANGING FROM A WEEK TO A MONTH) WHERE THERE WILL BE LIMITED VEHICULAR ACCESS.
- A STABILIZED CONSTRUCTION ENTRANCE/EXIT SHALL BE LOCATED AT ALL ACCESS POINTS WHERE VEHICLES ACCESS THE CONSTRUCTION SITE FROM PAVED RIGHT-OF-WAYS.
- STABILIZED CONSTRUCTION ENTRANCE/EXIT SHALL BE INSTALLED PRIOR TO ANY LAND DISTURBING ACTIVITIES.
- A NON-WOVEN GEOTEXTILE FABRIC SHALL BE PLACED UNDER THE STABILIZED CONSTRUCTION ENTRANCE/EXIT PRIOR TO THE PLACEMENT OF ROCK.
- UNLESS OTHERWISE SPECIFIED BY LOCAL JURISDICTION, ROCK SHALL CONSIST OF DOT SECT. #703, AASHTO #3 COARSE AGGREGATE OR 6" (MINUS) ROCK.

**STABILIZED CONSTRUCTION ENTRANCE/EXIT MAINTENANCE NOTES**

- INSPECT BMPs EACH WORKDAY, AND MAINTAIN THEM IN EFFECTIVE OPERATING CONDITION. MAINTENANCE OF BMPs SHOULD BE PROACTIVE, NOT REACTIVE. INSPECT BMPs AS SOON AS POSSIBLE (AND ALWAYS WITHIN 24 HOURS) FOLLOWING A STORM THAT CAUSES SURFACE EROSION, AND PERFORM NECESSARY MAINTENANCE.
- FREQUENT OBSERVATIONS AND MAINTENANCE ARE NECESSARY TO MAINTAIN BMPs IN EFFECTIVE OPERATING CONDITION. INSPECTIONS AND CORRECTIVE MEASURES SHOULD BE DOCUMENTED THOROUGHLY.
- WHERE BMPs HAVE FAILED, REPAIR OR REPLACEMENT SHOULD BE INITIATED UPON DISCOVERY OF THE FAILURE.
- ROCK SHALL BE REAPPLIED OR REGRADED AS NECESSARY TO THE STABILIZED ENTRANCE/EXIT TO MAINTAIN A CONSISTENT DEPTH.
- SEDIMENT TRACKED ONTO PAVED ROADS IS TO BE REMOVED THROUGHOUT THE DAY AND AT THE END OF THE DAY BY SHOVELING OR SWEEEPING. SEDIMENT MAY NOT BE WASHED DOWN STORM SEWER DRAINS.

NOTE: MANY JURISDICTIONS HAVE BMP DETAILS THAT VARY FROM UDFCD STANDARD DETAILS. CONSULT WITH LOCAL JURISDICTIONS AS TO WHICH DETAIL SHOULD BE USED WHEN DIFFERENCES ARE NOTED.

(DETAILS ADAPTED FROM CITY OF BROOMFIELD, COLORADO, NOT AVAILABLE IN AUTOCAD)

VTC-6 Urban Drainage and Flood Control District Urban Storm Drainage Criteria Manual Volume 3 November 2010

Check Dams (CD)

EC-12

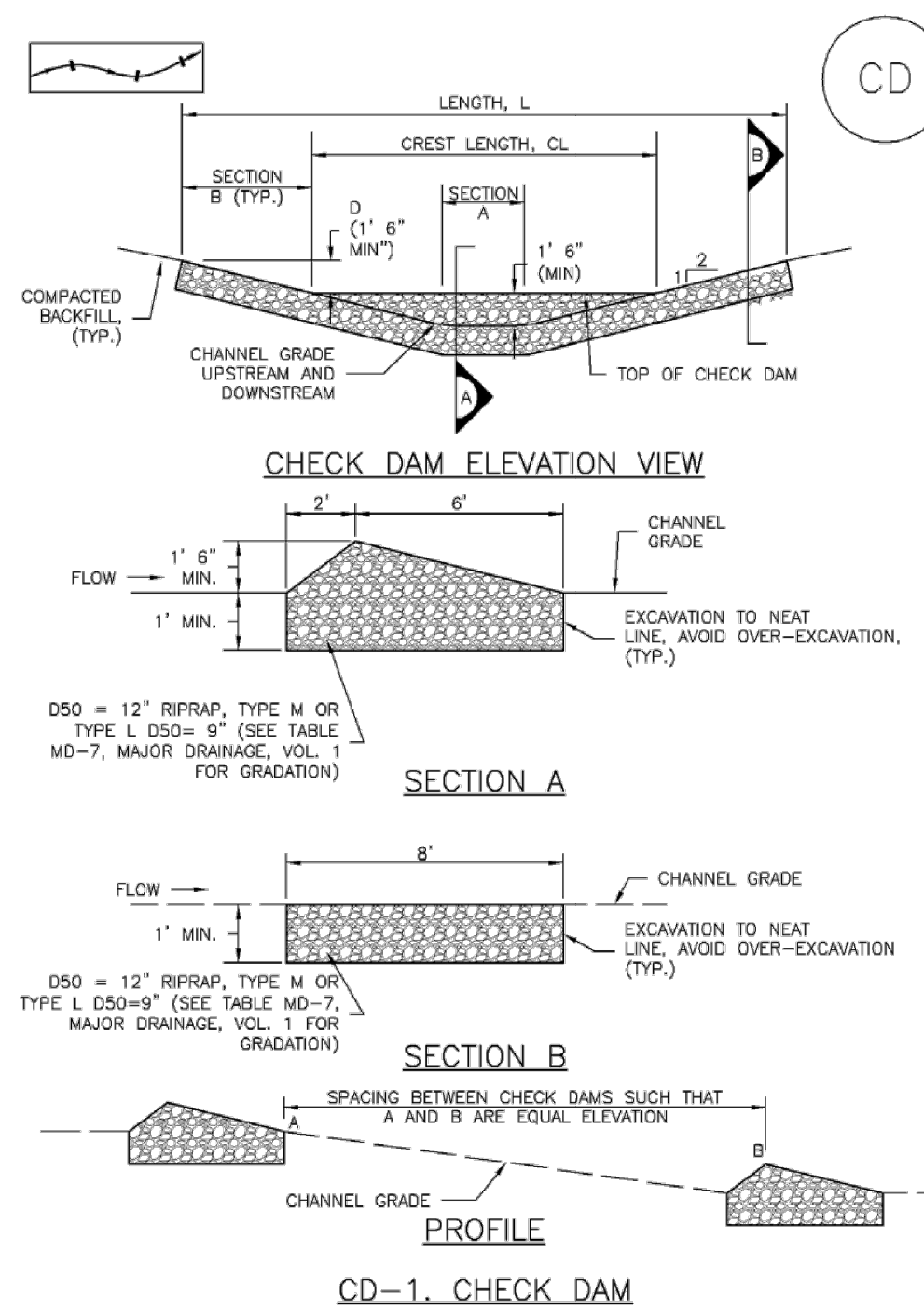

CD-1. CHECK DAM

November 2010 Urban Drainage and Flood Control District Urban Storm Drainage Criteria Manual Volume 3 CD-3

EC-12

Check Dams (CD)

**CHECK DAM INSTALLATION NOTES**

- SEE PLAN VIEW FOR -LOCATION OF CHECK DAMS. -CHECK DAM TYPE (CHECK DAM OR REINFORCED CHECK DAM). -LENGTH (L), CREST LENGTH (CL), AND DEPTH (D).
- CHECK DAMS INDICATED ON INITIAL SWMP SHALL BE INSTALLED AFTER CONSTRUCTION FENCE, BUT PRIOR TO ANY UPSTREAM LAND DISTURBING ACTIVITIES.
- RIPRAP UTILIZED FOR CHECK DAMS SHOULD BE OF APPROPRIATE SIZE FOR THE APPLICATION. TYPICAL TYPES OF RIPRAP USED FOR CHECK DAMS ARE TYPE M (D50 12") OR TYPE L (D50 9").
- RIPRAP PAD SHALL BE TRENCHED INTO THE GROUND A MINIMUM OF 1".
- THE ENDS OF THE CHECK DAM SHALL BE A MINIMUM OF 1' 6" HIGHER THAN THE CENTER OF THE CHECK DAM.

**CHECK DAM MAINTENANCE NOTES**

- INSPECT BMPs EACH WORKDAY, AND MAINTAIN THEM IN EFFECTIVE OPERATING CONDITION. MAINTENANCE OF BMPs SHOULD BE PROACTIVE, NOT REACTIVE. INSPECT BMPs AS SOON AS POSSIBLE (AND ALWAYS WITHIN 24 HOURS) FOLLOWING A STORM THAT CAUSES SURFACE EROSION, AND PERFORM NECESSARY MAINTENANCE.
- FREQUENT OBSERVATIONS AND MAINTENANCE ARE NECESSARY TO MAINTAIN BMPs IN EFFECTIVE OPERATING CONDITION. INSPECTIONS AND CORRECTIVE MEASURES SHOULD BE DOCUMENTED THOROUGHLY.
- WHERE BMPs HAVE FAILED, REPAIR OR REPLACEMENT SHOULD BE INITIATED UPON DISCOVERY OF THE FAILURE.
- SEDIMENT ACCUMULATED UPSTREAM OF THE CHECK DAMS SHALL BE REMOVED WHEN THE SEDIMENT DEPTH IS WITHIN 1/2 OF THE HEIGHT OF THE CREST.
- CHECK DAMS ARE TO REMAIN IN PLACE UNTIL THE UPSTREAM DISTURBED AREA IS STABILIZED AND APPROVED BY THE LOCAL JURISDICTION.
- WHEN CHECK DAMS ARE REMOVED, EXCAVATIONS SHALL BE FILLED WITH SUITABLE COMPACTED BACKFILL. DISTURBED AREA SHALL BE SEED, MULCHED AND COVERED WITH GEOTEXTILE OR OTHERWISE STABILIZED IN A MANNER APPROVED BY THE LOCAL JURISDICTION.

NOTE: MANY JURISDICTIONS HAVE BMP DETAILS THAT VARY FROM UDFCD STANDARD DETAILS. CONSULT WITH LOCAL JURISDICTIONS AS TO WHICH DETAIL SHOULD BE USED WHEN DIFFERENCES ARE NOTED.

(DETAILS ADAPTED FROM DOUGLAS COUNTY, COLORADO, NOT AVAILABLE IN AUTOCAD)

CD-4 Urban Drainage and Flood Control District Urban Storm Drainage Criteria Manual Volume 3 November 2010

NO.	REVISION	DATE	BY	DATE	APPR.
2	COUNTY COMMENTS	KRK 4/28/23	KRK		
1	COUNTY COMMENTS	KRK 3/10/23	KRK		

**Kimley»Horn**  
 2021 KIMLEY-HORN AND ASSOCIATES, INC.  
 2 North Nevada Avenue Suite 300  
 Colorado Springs, Colorado 80903 (719) 453-0180

DESIGNED BY: KRK  
 DRAWN BY: AJL  
 CHECKED BY: KRK  
 DATE: 12/16/2021

WINSOME FILING NO. 3  
 EL PASO COUNTY, COLORADO  
 CONSTRUCTION DOCUMENTS  
 GEC DETAILS

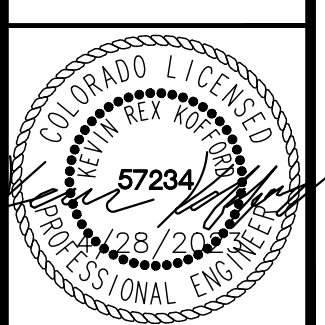

PROJECT NO. 196106001

SHEET

C1.28

K:\COS\_Civil\196106001\_Winsome Filing No. 3\CADD\PlanSheets\Cds\196106001\_CD\_GEC-DTL.dwg Kofford, Kevin 4/28/2023 10:13 AM

**Inlet Protection (IP)**

**SC-6**

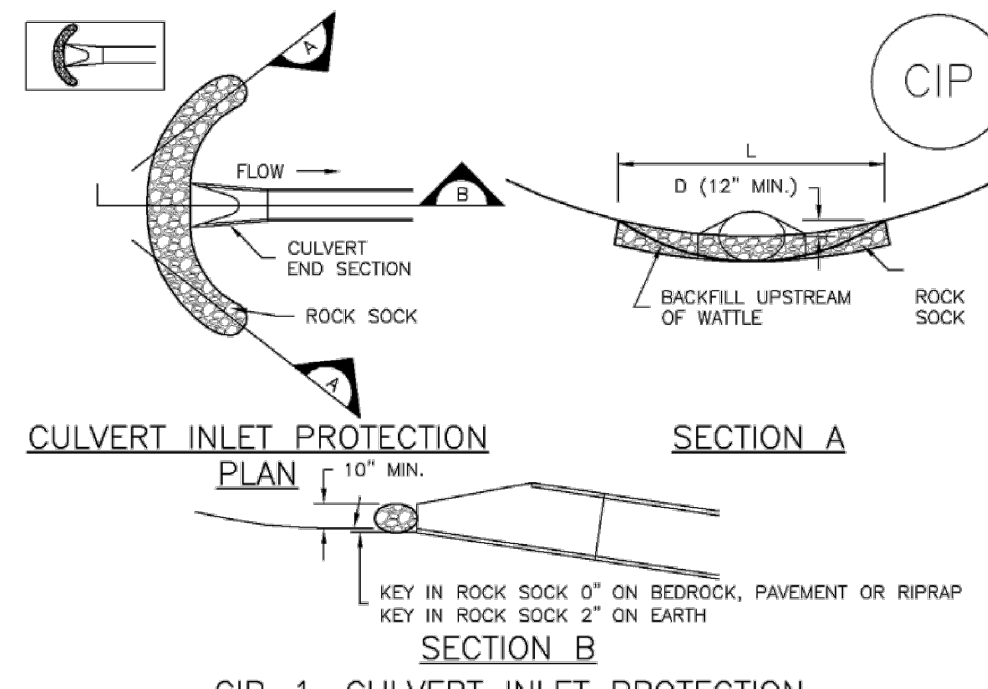

**CIP-1. CULVERT INLET PROTECTION**

**CULVERT INLET PROTECTION INSTALLATION NOTES**

- SEE PLAN VIEW FOR:
  - LOCATION OF CULVERT INLET PROTECTION.
- SEE ROCK SOCK DESIGN DETAIL FOR ROCK GRADATION REQUIREMENTS AND JOINTING DETAIL.

**CULVERT INLET PROTECTION MAINTENANCE NOTES**

- INSPECT BMPs EACH WORKDAY, AND MAINTAIN THEM IN EFFECTIVE OPERATING CONDITION. MAINTENANCE OF BMPs SHOULD BE PROACTIVE, NOT REACTIVE. INSPECT BMPs AS SOON AS POSSIBLE (AND ALWAYS WITHIN 24 HOURS) FOLLOWING A STORM THAT CAUSES SURFACE EROSION, AND PERFORM NECESSARY MAINTENANCE.
- FREQUENT OBSERVATIONS AND MAINTENANCE ARE NECESSARY TO MAINTAIN BMPs IN EFFECTIVE OPERATING CONDITION. INSPECTIONS AND CORRECTIVE MEASURES SHOULD BE DOCUMENTED THOROUGHLY.
- WHERE BMPs HAVE FAILED, REPAIR OR REPLACEMENT SHOULD BE INITIATED UPON DISCOVERY OF THE FAILURE.
- SEDIMENT ACCUMULATED UPSTREAM OF THE CULVERT SHALL BE REMOVED WHEN THE SEDIMENT DEPTH IS  $\frac{1}{2}$  THE HEIGHT OF THE ROCK SOCK.
- CULVERT INLET PROTECTION SHALL REMAIN IN PLACE UNTIL THE UPSTREAM DISTURBED AREA IS PERMANENTLY STABILIZED AND APPROVED BY THE LOCAL JURISDICTION.

(DETAILS ADAPTED FROM AURORA, COLORADO, NOT AVAILABLE IN AUTOCAD)

NOTE: MANY JURISDICTIONS HAVE BMP DETAILS THAT VARY FROM UDFCD STANDARD DETAILS. CONSULT WITH LOCAL JURISDICTIONS AS TO WHICH DETAIL SHOULD BE USED WHEN DIFFERENCES ARE NOTED.

August 2013 Urban Drainage and Flood Control District IP-7  
Urban Storm Drainage Criteria Manual Volume 3

**SC-6**

**Inlet Protection (IP)**

**GENERAL INLET PROTECTION INSTALLATION NOTES**

- SEE PLAN VIEW FOR:
  - LOCATION OF INLET PROTECTION.
  - TYPE OF INLET PROTECTION (IP.1, IP.2, IP.3, IP.4, IP.5, IP.6)
- INLET PROTECTION SHALL BE INSTALLED PROMPTLY AFTER INLET CONSTRUCTION OR PAVING IS COMPLETE (TYPICALLY WITHIN 48 HOURS). IF A RAINFALL/RUNOFF EVENT IS FORECAST, INSTALL INLET PROTECTION PRIOR TO ONSET OF EVENT.
- MANY JURISDICTIONS HAVE BMP DETAILS THAT VARY FROM UDFCD STANDARD DETAILS. CONSULT WITH LOCAL JURISDICTIONS AS TO WHICH DETAIL SHOULD BE USED WHEN DIFFERENCES ARE NOTED.

**INLET PROTECTION MAINTENANCE NOTES**

- INSPECT BMPs EACH WORKDAY, AND MAINTAIN THEM IN EFFECTIVE OPERATING CONDITION. MAINTENANCE OF BMPs SHOULD BE PROACTIVE, NOT REACTIVE. INSPECT BMPs AS SOON AS POSSIBLE (AND ALWAYS WITHIN 24 HOURS) FOLLOWING A STORM THAT CAUSES SURFACE EROSION, AND PERFORM NECESSARY MAINTENANCE.
- FREQUENT OBSERVATIONS AND MAINTENANCE ARE NECESSARY TO MAINTAIN BMPs IN EFFECTIVE OPERATING CONDITION. INSPECTIONS AND CORRECTIVE MEASURES SHOULD BE DOCUMENTED THOROUGHLY.
- WHERE BMPs HAVE FAILED, REPAIR OR REPLACEMENT SHOULD BE INITIATED UPON DISCOVERY OF THE FAILURE.
- SEDIMENT ACCUMULATED UPSTREAM OF INLET PROTECTION SHALL BE REMOVED AS NECESSARY TO MAINTAIN BMP EFFECTIVENESS, TYPICALLY WHEN STORAGE VOLUME REACHES 50% OF CAPACITY, A DEPTH OF 6" WHEN SILT FENCE IS USED, OR  $\frac{1}{4}$  OF THE HEIGHT FOR STRAW BALES.
- INLET PROTECTION IS TO REMAIN IN PLACE UNTIL THE UPSTREAM DISTURBED AREA IS PERMANENTLY STABILIZED, UNLESS THE LOCAL JURISDICTION APPROVES EARLIER REMOVAL OF INLET PROTECTION IN STREETS.
- WHEN INLET PROTECTION AT AREA INLETS IS REMOVED, THE DISTURBED AREA SHALL BE COVERED WITH TOP SOIL, SEEDED AND MULCHED, OR OTHERWISE STABILIZED IN A MANNER APPROVED BY THE LOCAL JURISDICTION.

(DETAIL ADAPTED FROM TOWN OF PARKER, COLORADO AND CITY OF AURORA, COLORADO, NOT AVAILABLE IN AUTOCAD)

NOTE: MANY JURISDICTIONS HAVE BMP DETAILS THAT VARY FROM UDFCD STANDARD DETAILS. CONSULT WITH LOCAL JURISDICTIONS AS TO WHICH DETAIL SHOULD BE USED WHEN DIFFERENCES ARE NOTED.

NOTE: THE DETAILS INCLUDED WITH THIS FACT SHEET SHOW COMMONLY USED, CONVENTIONAL METHODS OF INLET PROTECTION IN THE DENVER METROPOLITAN AREA. THERE ARE MANY PROPRIETARY INLET PROTECTION METHODS ON THE MARKET. UDFCD NEITHER ENDORSES NOR DISCOURAGES USE OF PROPRIETARY INLET PROTECTION. HOWEVER, IN THE EVENT PROPRIETARY METHODS ARE USED, THE APPROPRIATE DETAIL FROM THE MANUFACTURER MUST BE INCLUDED IN THE SWMP AND THE BMP MUST BE INSTALLED AND MAINTAINED AS SHOWN IN THE MANUFACTURER'S DETAILS.

NOTE: SOME MUNICIPALITIES DISCOURAGE OR PROHIBIT THE USE OF STRAW BALES FOR INLET PROTECTION. CHECK WITH LOCAL JURISDICTION TO DETERMINE IF STRAW BALE INLET PROTECTION IS ACCEPTABLE.

IP-8 Urban Drainage and Flood Control District August 2013  
Urban Storm Drainage Criteria Manual Volume 3

K:\COS\_Civil\196106001\_Winsome Filing No. 3\CADD\PlanSheets\CDS\196106001\_CD\_GEC\_DTL.dwg Kofford, Kevin 4/28/2023 10:13 AM

NO.	REVISION	BY	DATE	APPR.
2	COUNTY COMMENTS	KRK	4/28/23	KRK
1	COUNTY COMMENTS	KRK	3/10/23	KRK

**Kimley»Horn**  
 2021 KIMLEY-HORN AND ASSOCIATES, INC.  
 2 North Nevada Avenue Suite 300  
 Colorado Springs, Colorado 80903 (719) 453-0180

DESIGNED BY: KRK  
 DRAWN BY: AJL  
 CHECKED BY: KRK  
 DATE: 12/16/2021

WINSOME FILING NO. 3  
 EL PASO COUNTY, COLORADO  
 CONSTRUCTION DOCUMENTS  
 GEC DETAILS

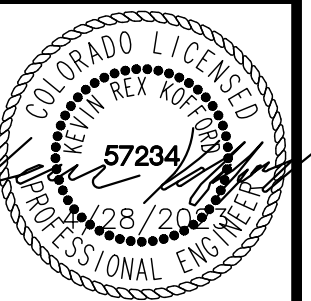

PROJECT NO.  
196106001

SHEET

**C1.29**

K:\COS\_Civil\196106001\_Winsome Filing No. 3\CADD\PlanSheets\CDS\196106001\_CD\_CISTERN.dwg Kefford, Kevin 4/28/2023 10:14 AM

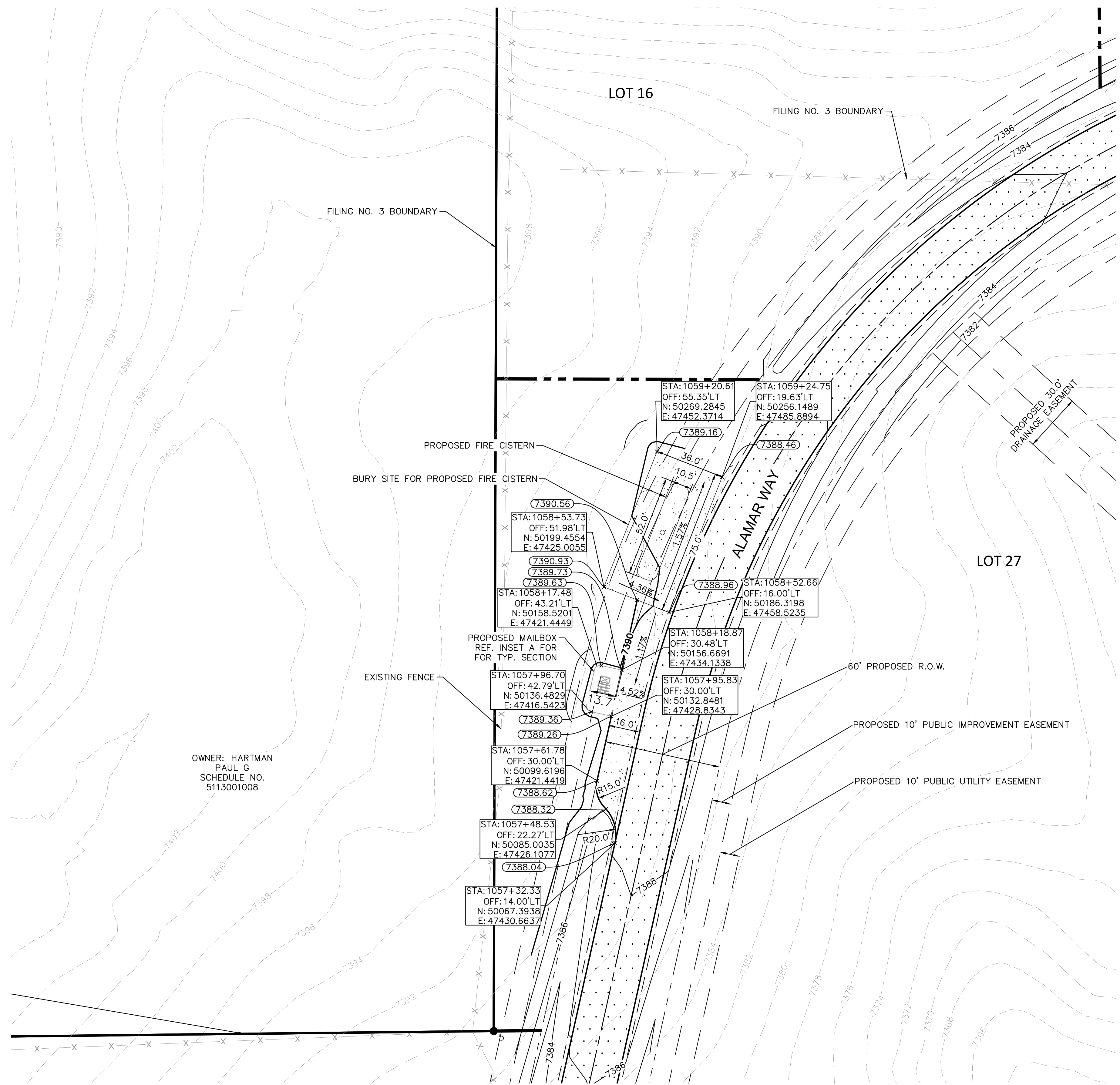

OWNER: HARTMAN  
PAUL G  
SCHEDULE NO.  
5113001008

**LEGEND**

- LOT BOUNDARY LINE
- - - - - EXISTING MAJOR CONTOUR
- - - - - EXISTING MINOR CONTOUR
- - - - - PROPOSED MAJOR CONTOUR
- - - - - PROPOSED MINOR CONTOUR
- ==== EDGE OF PAVEMENT
- ==== ROADWAY SHOULDER
- ==== PROPOSED R.O.W.
- ==== PROPOSED EASEMENTS

**NOTES**

1. PROPOSED FIRE CISTERN WILL BE DARCO 30,000 GAL FIBERGLASS TANK AS PER FALCON FIRE.
2. MINIMUM BURY DEPTH OF 36"
3. TANK WILL BE INSTALLED USING SIDE HILL BURY INSTALLATION AS PER DARCO FIBERGLASS UNDERGROUND WATER STORAGE TANK INSTALLATION MANUAL.
4. TANK AND INSTALLATION DETAILS CAN BE FOUND ON SHEET C1.31

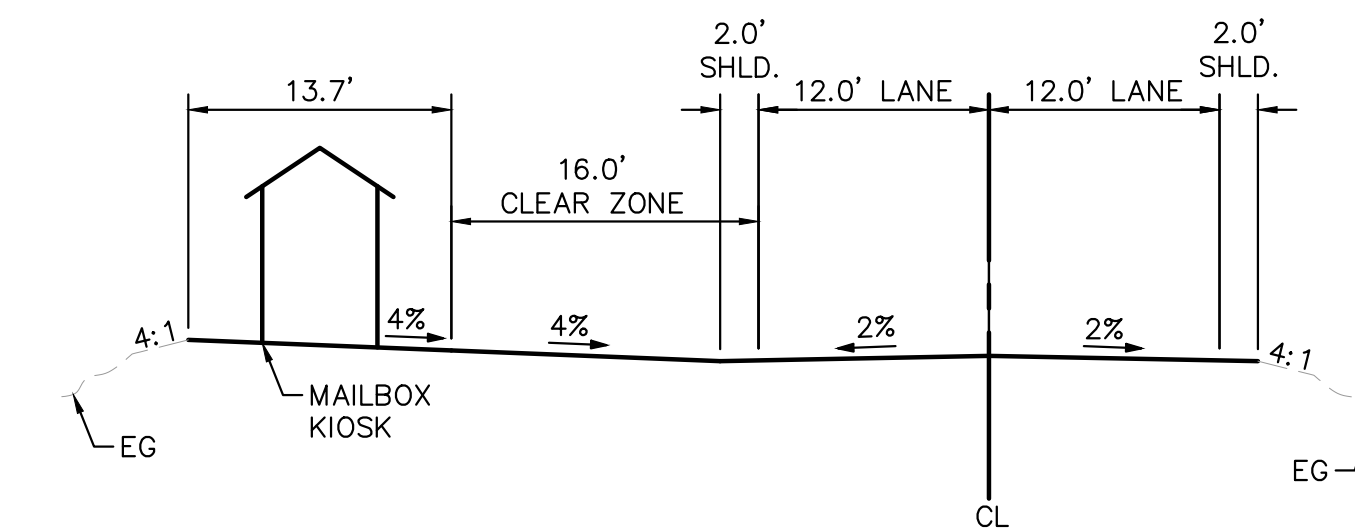

INSET A  
ALAMAR WAY  
STA: 1057+95.83 - 1058+18.87

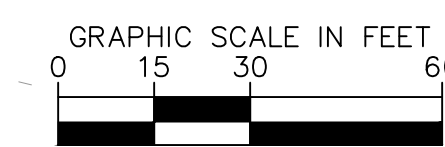
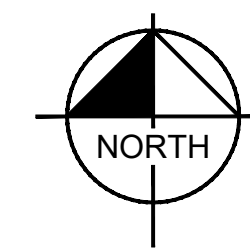

NO.	REVISION	BY	DATE
2	RESUBMITTAL #2	KRK	11/30/22
1	RESUBMITTAL #1	KRK	8/30/22

**Kimley»Horn**  
2022 KIMLEY-HORN AND ASSOCIATES, INC.  
2 North Nevada Avenue Suite 300  
Colorado Springs, Colorado 80903 (719) 453-0180

DESIGNED BY: KRK  
DRAWN BY: AJL  
CHECKED BY: KRK  
DATE: 12/10/2021

WINSOME FILING NO. 3  
EL PASO COUNTY, COLORADO  
PRE DEVELOPMENT GESC PLAN  
FIRE CISTERN PLAN

PRELIMINARY  
FOR REVIEW ONLY  
NOT FOR CONSTRUCTION  
**Kimley»Horn**  
Kimley-Horn and Associates, Inc.

PROJECT NO.  
196106001

SHEET

C1.30

K:\COS\_Civil\196106001\_Winsome Filing No. 3\CADD\PlanSheets\Cds\196106001\_CD\_CISTERN.dwg Kofford, Kevin 4/28/2023 10:14 AM

TO: FIRM Falcon Fire Protection District PROJECT Falcon FD Minimum Draft QUOTE # AD7205-R2 DATE 09.18.08  
 PHONE FAX EMAIL SITE LOCATION Falcon Fire District COUNTY El Paso  
 STANDARD D-5 NOM. CAPACITY 30,000 NOM. WEIGHT 8,000 POTABLE NON-POTABLE X USE Fire Cistern

**INCLUDED WITH THIS FIBERGLASS UNDERGROUND TANK QUOTATION**

1 - 30"x36" manway-hinged or bolted cover 19 - NFPA anti-vortex plate on draw pipe  
 6 - 4" lockable inspection hatch on manway 25 - Water level gauge (reads in inches)  
 13 - 6" PVC vent head-screens  
 15 - High water level control assembly  
 17 - Siamese refill w/2-2.5" NST-FS connections  
 18 - 6" NST-F dry hydrant head

**PREPAID PRICE**

TAX ADD 2.9% DEPOSIT 33% with order  
 FREIGHT DETAILS ESTIMATED to Falcon, CO  
 DELIVERY: 8-10 WEEKS FROM ORDER ACCEPTANCE

**EXCLUDED IN THIS PRICE QUOTATION**

1. INSPECTION, ACCEPTANCE, AND OFFLOAD  
 2. INSTALLATION MATERIALS AND LABOR  
 3. UNSPECIFIED PIPE, VALVES, AND FITTINGS  
 4. PUMPS, CONTROLS, AND LEVEL SENSORS  
 5. WIRE ROPE, CLAMPS, AND DEADMAN ANCHOR FORMS

BURY DETAILS 36" typical-rated for 60" bury depth WATER SOURCE  
 ANTIBUOYANCY APPROVALS Local Fire District

**COMMENTS:** Minimum draft design.

**NOTES:**  
 ANCHOR STRIPS (IF USED)  
 LIFTING LUGS (IF USED)  
 DEADMAN ANCHORS: 4 EACH SIDE (IF USED)  
 IMPORTANT: REVIEW DARCO STRUCTURAL SPECIFICATIONS AND LIMITED WARRANTY BEFORE APPROVAL / GRAVEL BED AND 100% GRAVEL ENCAPSULATION REQUIRED / MAXIMUM BURY DEPTH FOR STANDARD FIBERGLASS VESSELS IS 5 FEET / SEE DARCO WEB SITE FOR INSTALLATION DETAILS AND APPROVED MATERIALS / FIRE SERVICE DESIGNS MUST HAVE PRIOR FIRE DEPARTMENT APPROVAL / DARCO FACTORY QUOTES ARE HONORED FOR 30 DAYS ONLY

DARCO FIBERGLASS TANK - 10D - 30K (30,000 Gal.)  
 Rev. Date 12/12/08 Rev. No. G  
 980 Darco Drive, Bennett, Colorado 80102  
 800-232-9660 (phone) 303-644-5001 (fax)  
 www.darcoinc.com

APPROVED: DATE: PAID MANUAL RELEASE

Chief Trent Harwig / Deputy Chief Jeff Petersma

**INTRODUCTION**

2. **SIDE HILL** installations require that **no less than the bottom half** of the tank be captured in a pocket of undisturbed natural soil for proper support. If high ground water or perched water is probable, install a **sub-drain** or bed drain running down hill to daylight to relieve any water trapped in the tank bedding material.

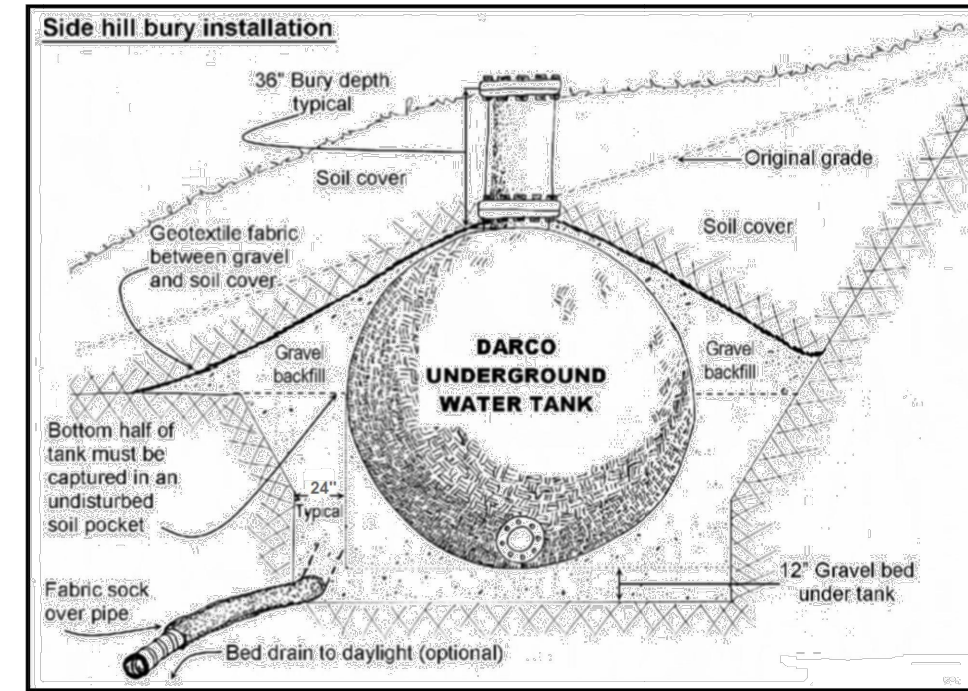

www.darcoinc.com © 2020 DARCO, INC - ALL RIGHTS RESERVED 21

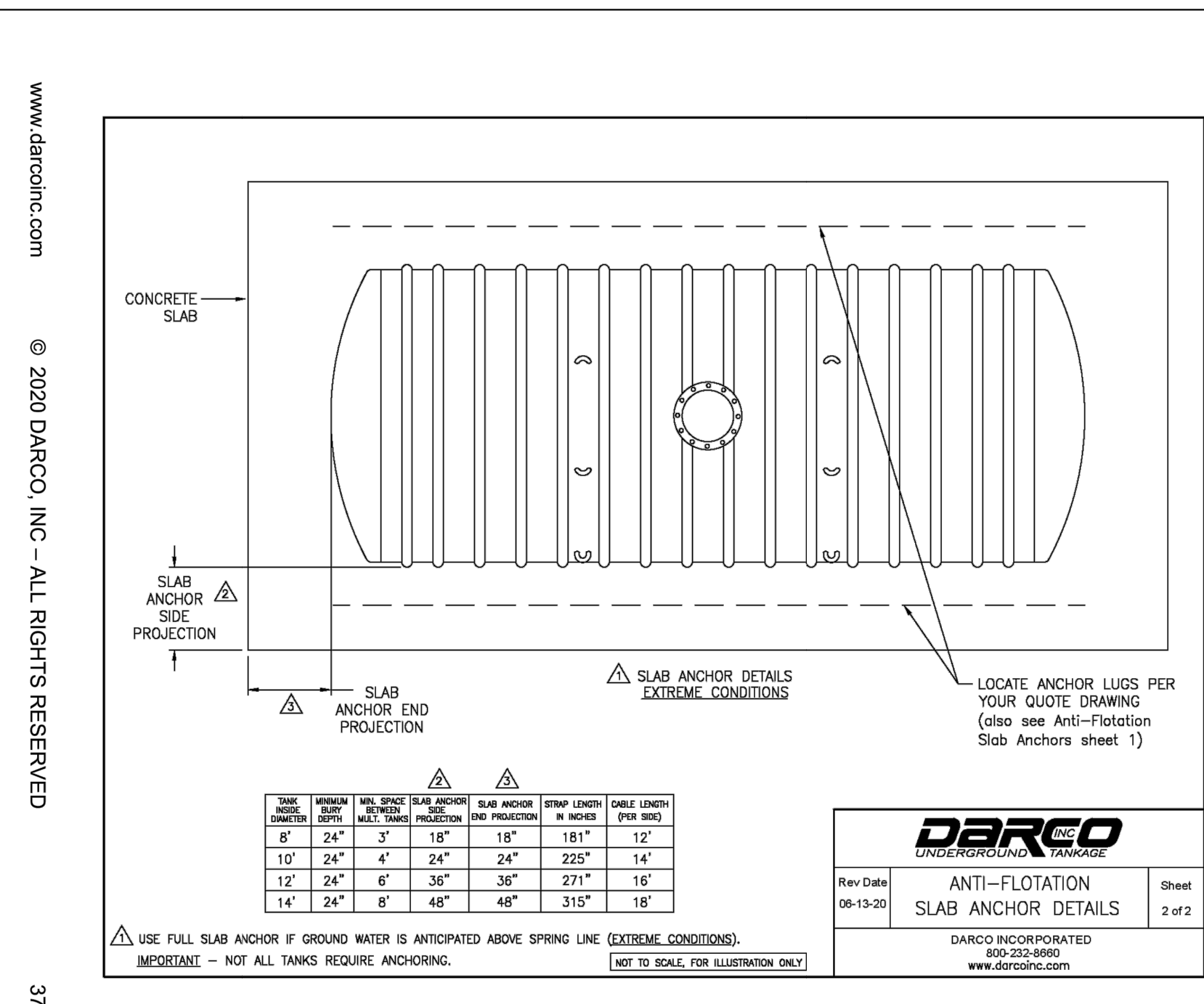

www.darcoinc.com © 2020 DARCO, INC - ALL RIGHTS RESERVED 37

**INTRODUCTION**

NO.	REVISION	DATE	BY	APPR.
1				
2				

**Kimley»Horn**  
 2022 KIMLEY-HORN AND ASSOCIATES, INC.  
 2 North Nevada Avenue Suite 300  
 Colorado Springs, Colorado 80903 (719) 453-0180

DESIGNED BY: KRK  
 DRAWN BY: A.JL  
 CHECKED BY: KRK  
 DATE: 12/10/2021

WINSOME FILING NO. 3  
 EL PASO COUNTY, COLORADO  
 PRE DEVELOPMENT GESC PLAN  
 FIRE CISTERN DETAILS

PRELIMINARY  
 FOR REVIEW ONLY  
 NOT FOR CONSTRUCTION  
**Kimley»Horn**  
 Kimley-Horn and Associates, Inc.

PROJECT NO.  
 196106001  
 SHEET

C1.31



K:\COS\_Civil\196106001\_Winsome Filing No. 3\CADD\PlanSheets\Cds\196106001\_CD\_POND\_1.dwg Kofford, Kevin 4/28/2023 12:18 PM

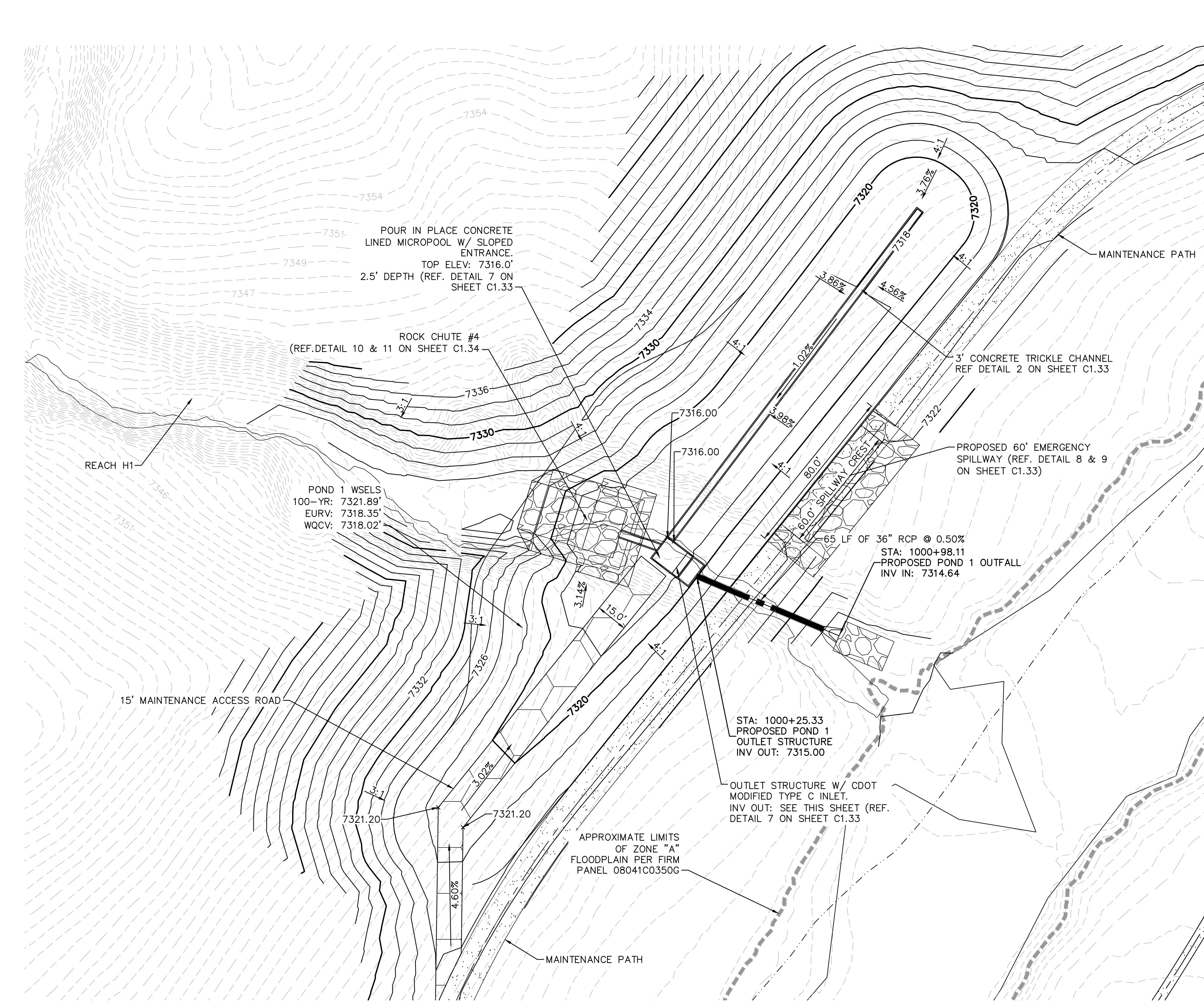

**LEGEND**

FG	FINISH GRADE
FBT	TOP OF FOREBAY AT FINISHED GRADE
FBB	BOTTOM OF FOREBAY AT FINISHED GRADE
TCT	TOP OF TRICKLE CHANNEL AT FINISHED GRADE
TCB	BOTTOM OF TRICKLE CHANNEL AT FINISHED GRADE
MPT	TOP OF MICROPOOL AT FINISHED GRADE
MPB	BOTTOM OF MICROPOOL AT FINISHED GRADE
GRATE	OUTLET STRUCTURE GRATE ELEVATION
ME	MATCH EXISTING
PT	TOP OF STEEL PLATE AT FINISHED GRADE
PB	BOTTOM OF STEEL PLATE AT FINISHED GRADE
-----	FLOODPLAIN LIMITS
=====	TOP OF POND
-----	PROPOSED STORM SEWER

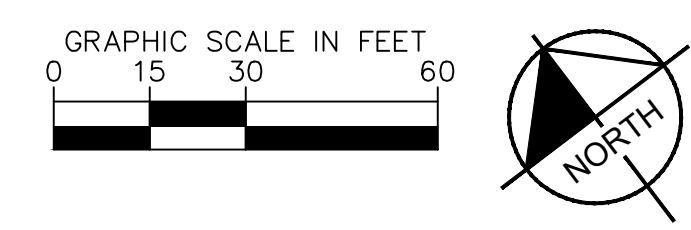
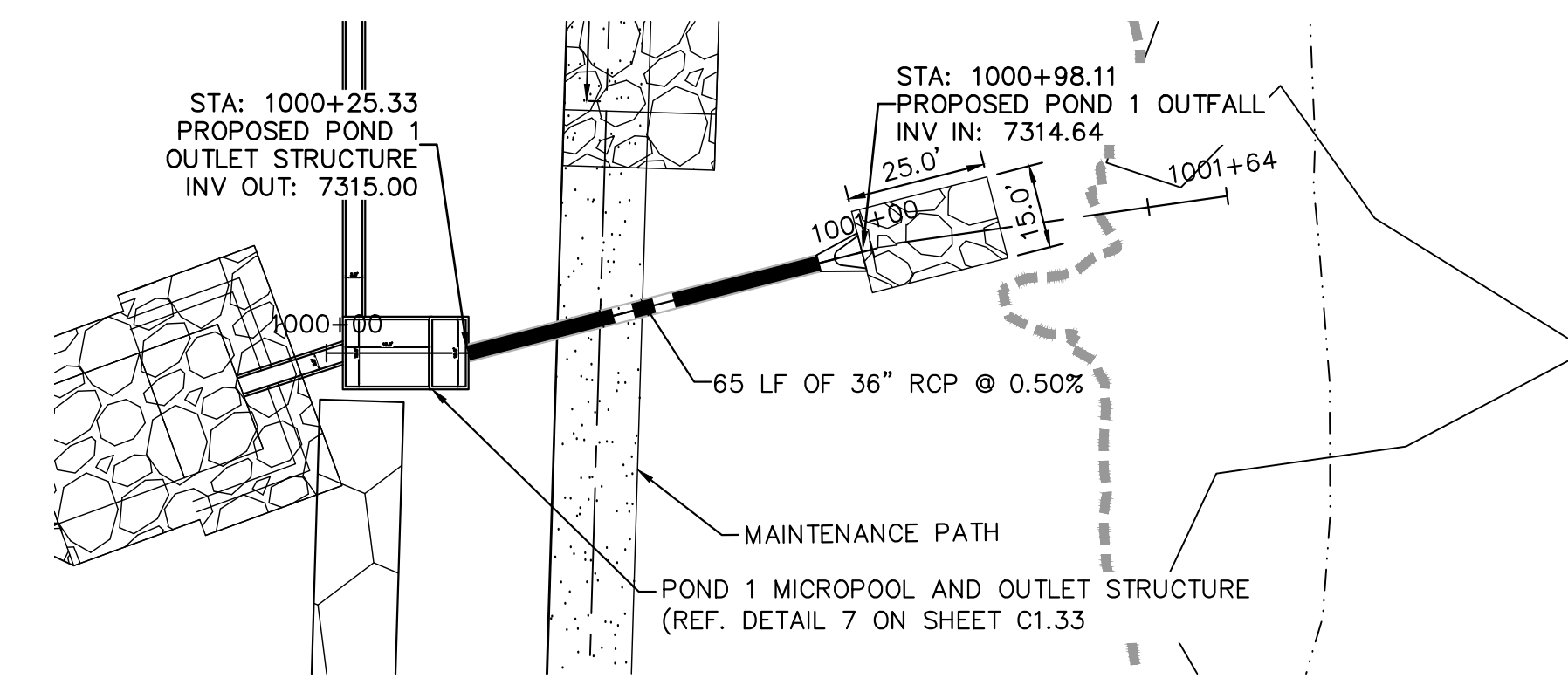

**POND 1 OUTFALL PIPE PLAN AND PROFILE**

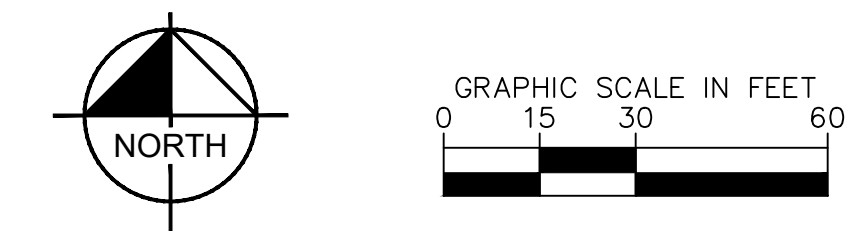
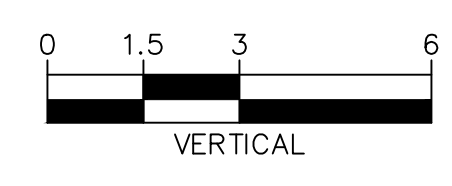
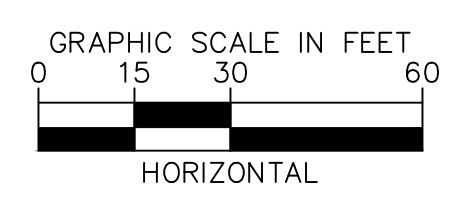
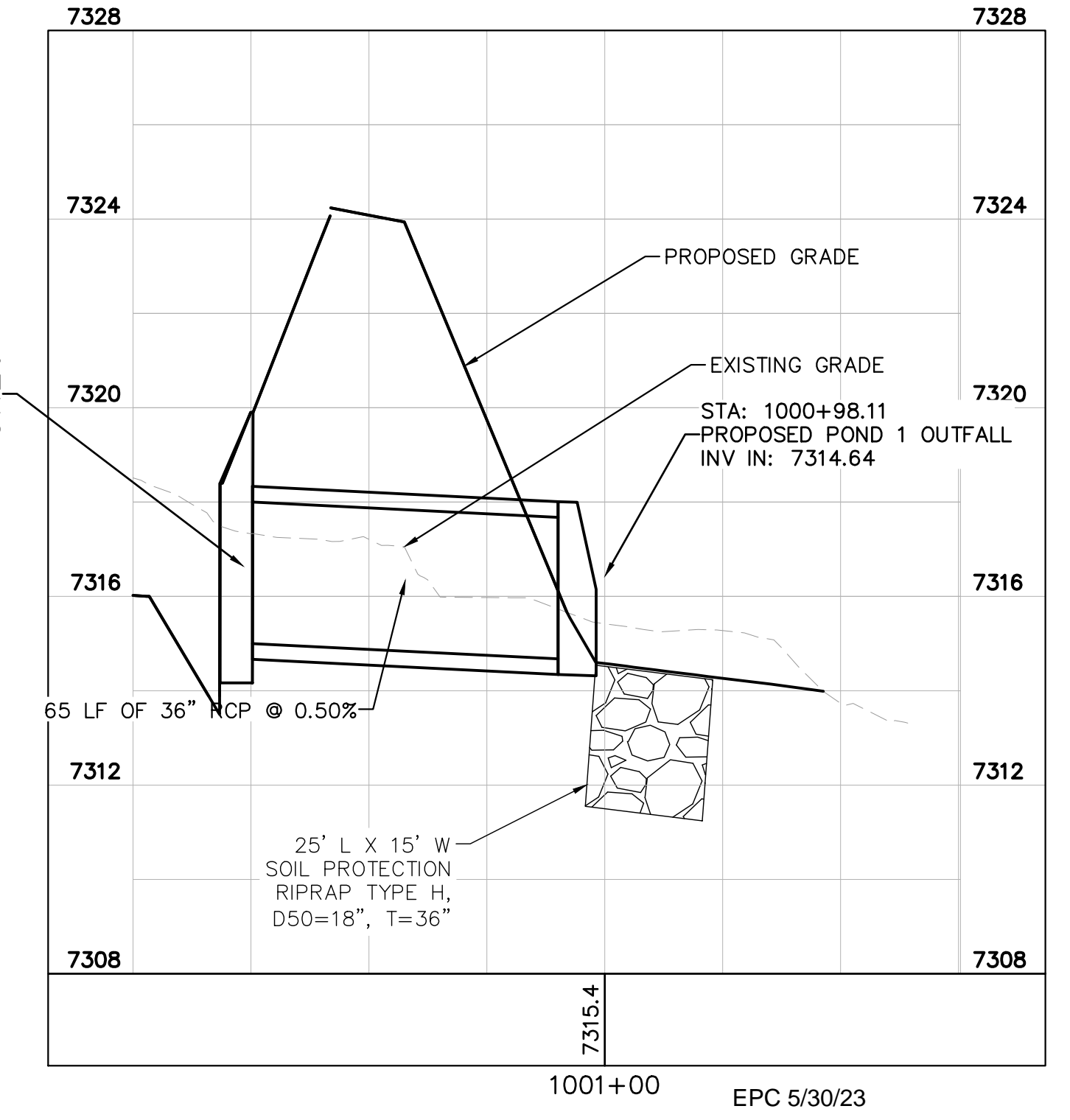

NO.	REVISION	BY	DATE	APPR.
2	COUNTY COMMENTS	KRK	4/28/23	KRK
1	COUNTY COMMENTS	KRK	3/10/23	KRK

**Kimley»Horn**  
2021 KIMLEY-HORN AND ASSOCIATES, INC.  
2 North Nevada Avenue Suite 300  
Colorado Springs, Colorado 80903 (719) 453-0180

DESIGNED BY: KRK  
DRAWN BY: AJL  
CHECKED BY: KRK  
DATE: 12/16/2021

WINSOME FILING NO. 3  
EL PASO COUNTY, COLORADO  
CONSTRUCTION DOCUMENTS  
POND 1 OVERVIEW

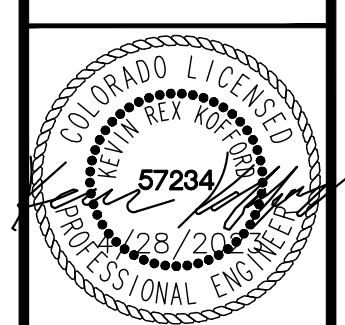

PROJECT NO.  
196106001

SHEET  
**C1.32**

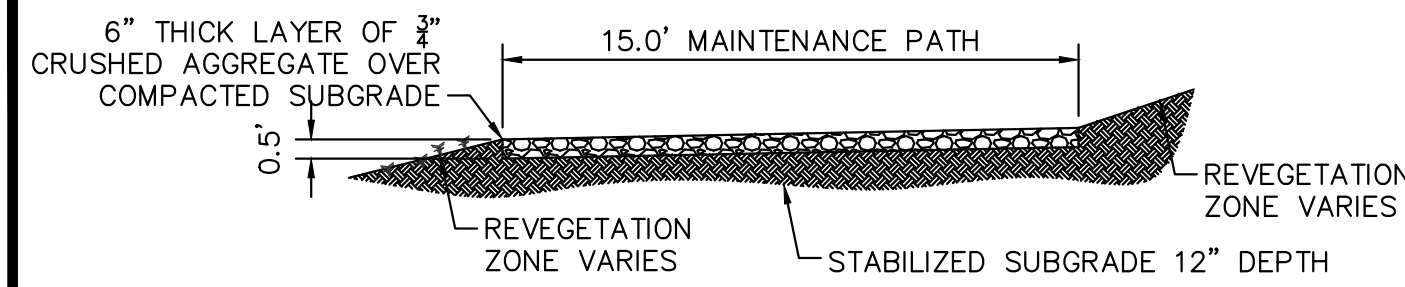

**1 MAINTENANCE ROAD**

1"=5'  
**MAINTENANCE PATH NOTES**  
 1. MAINTENANCE PATH SHALL INCLUDE SUBGRADE PREPARATION, GRAVEL BASE, AND COMPACTION.

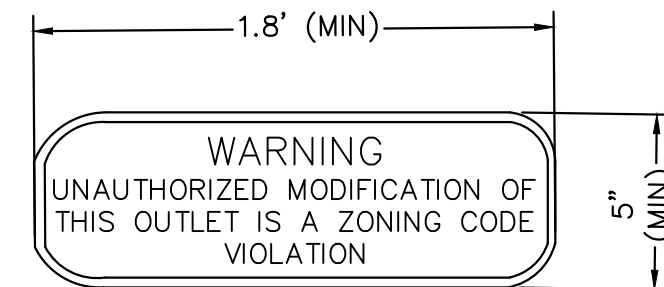
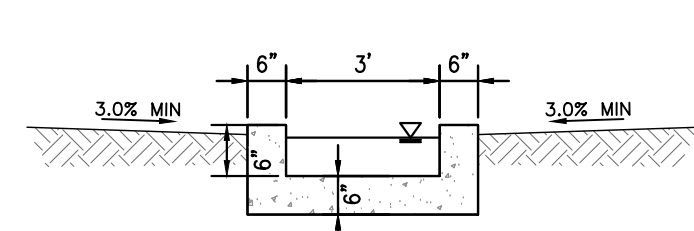

**2 CONCRETE TRICKLE CHANNEL**

N.T.S.

**3 OUTLET SIGNAGE**

N.T.S.  
**OUTLET SIGNAGE NOTES**  
 1. SIGN SHALL BE A MINIMUM OF 0.75 SQUARE FEET AND SHALL BE ATTACHED TO THE OUTLET OR POSTED NEARBY.

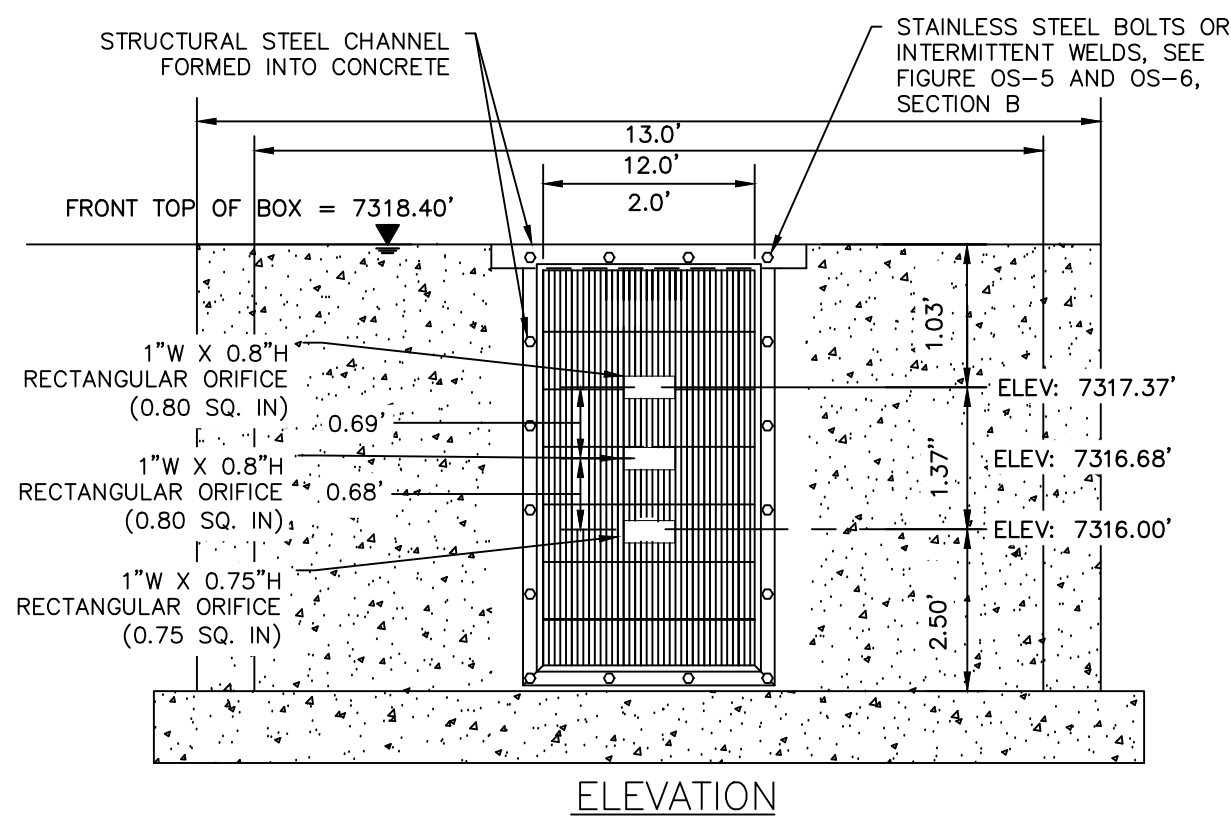

**4 ORIFICE PLATE AND TRASH RACK DETAIL**

N.T.S.  
**ORIFICE PLATE NOTES**  
 1. PROVIDE CONTINUOUS NEOPRENE GASKET MATERIAL BETWEEN THE ORIFICE PLATE AND CONCRETE.  
 2. BOLT PLATE TO CONCRETE 12" MAX. ON CENTER, WITH A PLATE THICKNESS OF 0.25".  
**EURV AND WQCV TRASH RACKS**  
 1. WELL-SCREEN TRASH RACKS SHALL BE STAINLESS STEEL AND SHALL BE ATTACHED BY INTERMITTENT WELDS ALONG THE EDGE OF THE MOUNTING FRAME.  
 2. BAR GATE TRASH RACKS SHALL BE ALUMINUM AND SHALL BE BOLTED USING STAINLESS STEEL HARDWARE.  
**OVERFLOW SAFETY GRATES**  
 1. ALL SAFETY GRATES SHALL BE MOUNTED USING STAINLESS STEEL HARDWARE AND PROVIDED WITH HINGED AND LOCKABLE OR BOLTABLE ACCESS PANELS.  
 2. SAFETY GRATES SHALL BE STAINLESS STEEL, ALUMINUM, OR STEEL. STEEL GRATES SHALL BE HOT DIP GALVANIZED AND MAY BE HOT POWDER COATED AFTER GALVANIZING.

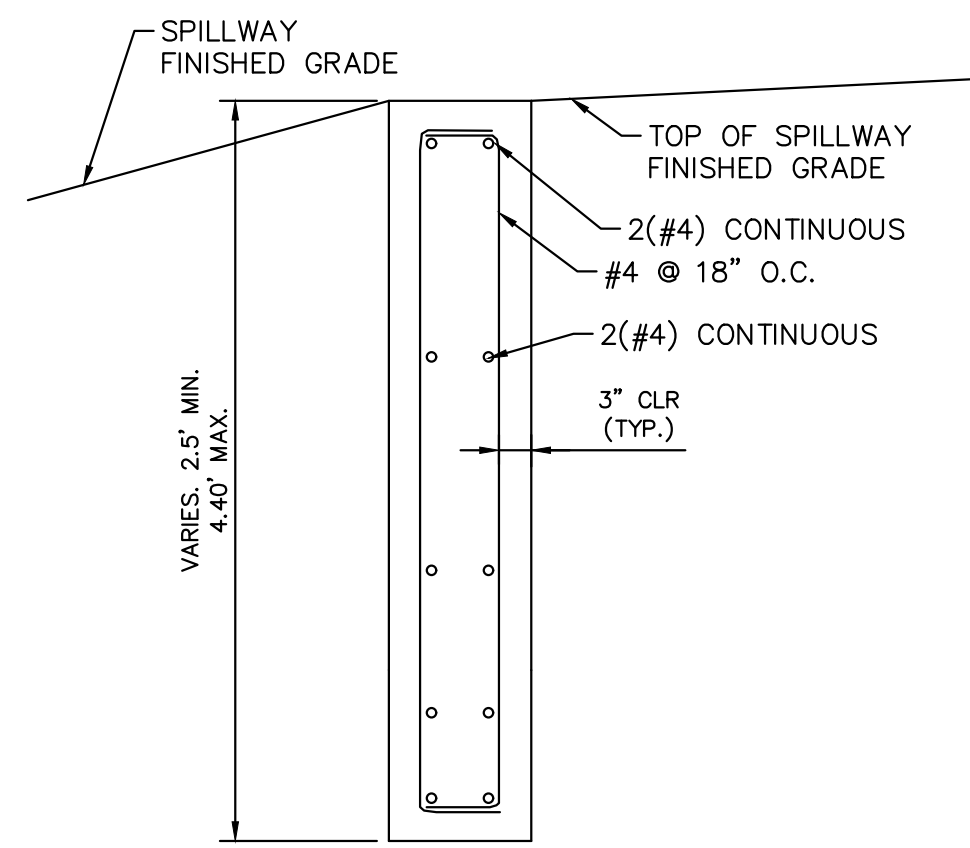

**6 SECTION CREST WALL DETAIL**

N.T.S.

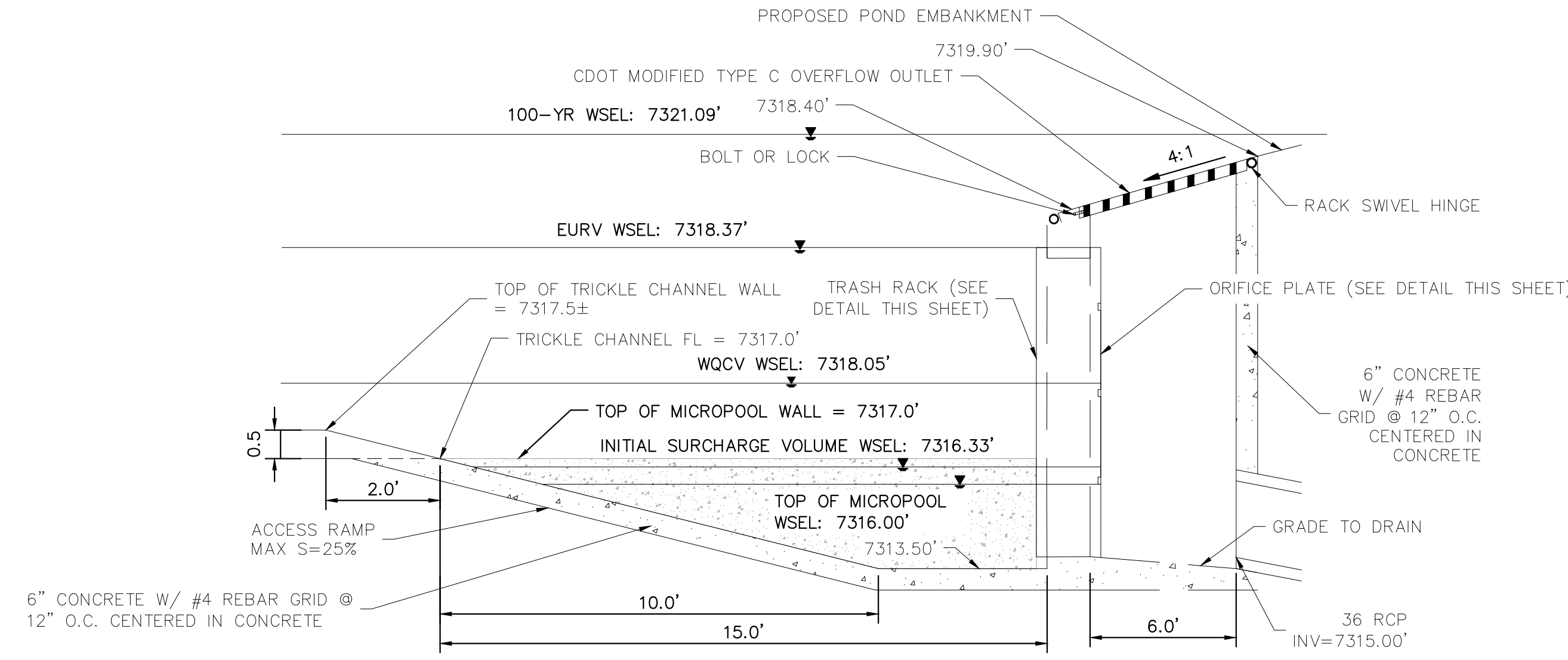

**7 OUTLET STRUCTURE DETAIL**

N.T.S.

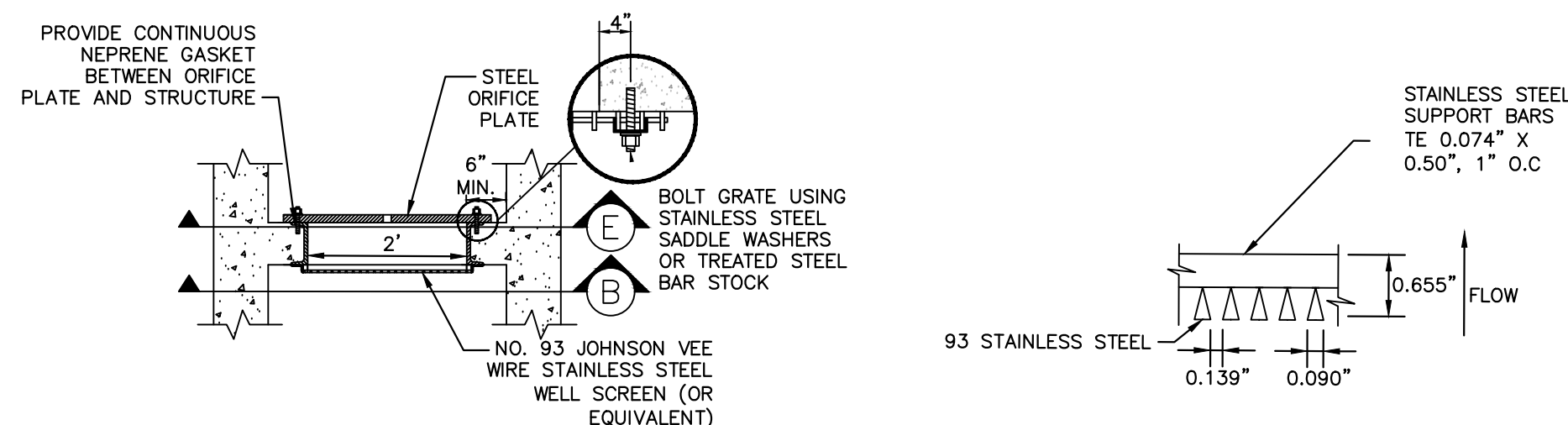

**A SECTION A**

N.T.S.

**B SECTION B**

N.T.S.

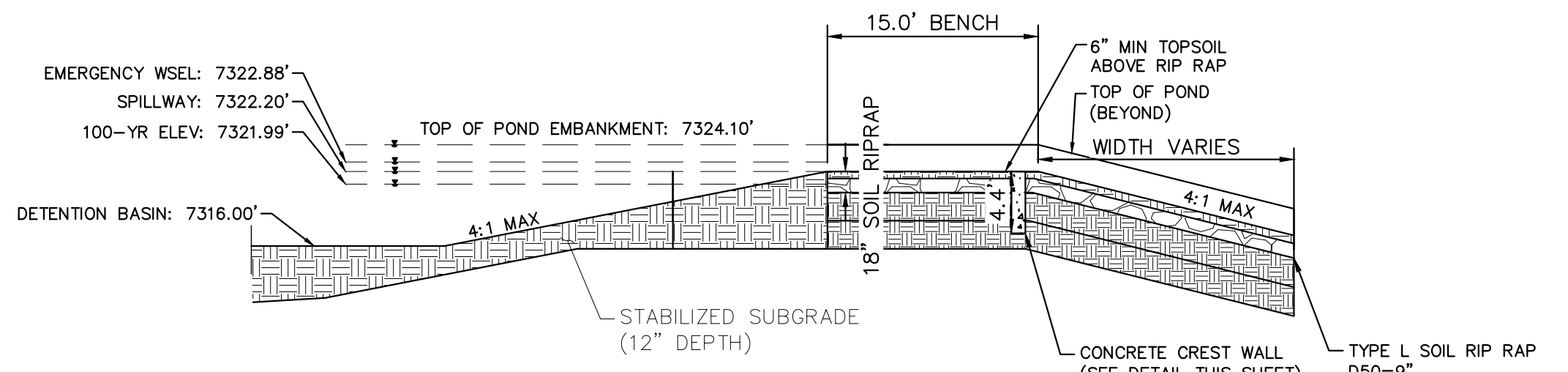

**8 EMERGENCY SPILLWAY DETAILS**

1"=10'

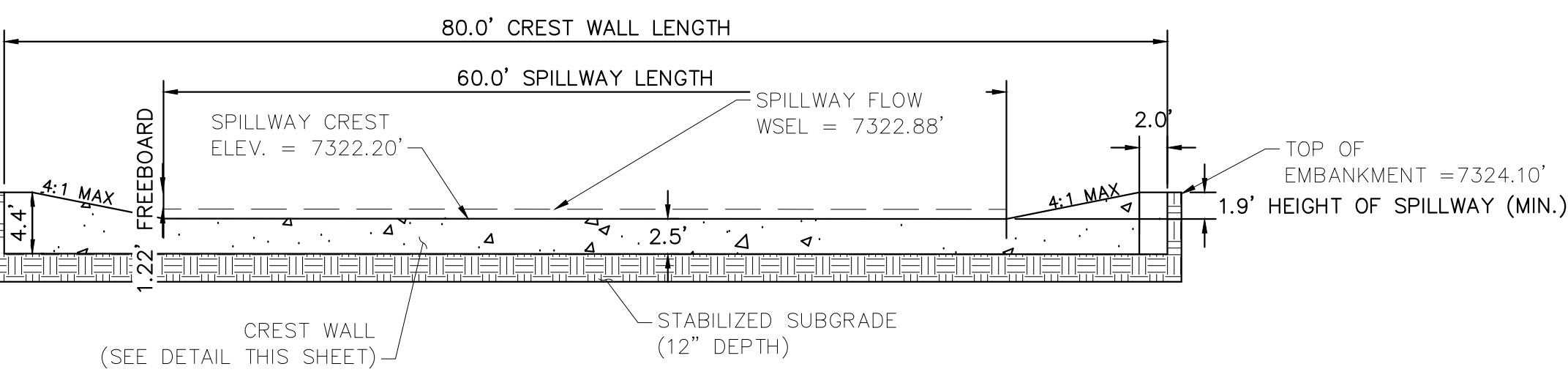

**9 EMERGENCY SPILLWAY CREST WALL**

1"=10' EPC 5/30/23

NO.	REVISION	DATE	BY
2	COUNTY COMMENTS	KRK 4/26/23	KRK
1	COUNTY COMMENTS	KRK 3/10/23	KRK

**Kimley»Horn**  
 2 NORTH NEVADA AVENUE SUITE 300  
 COLORADO SPRINGS, COLORADO 80903 (719) 453-0180

DESIGNED BY: KRK  
 DRAWN BY: A.J.L.  
 CHECKED BY: KRK  
 DATE: 12/16/2021

WINSOME FILING NO. 3  
 EL PASO COUNTY, COLORADO  
 CONSTRUCTION DOCUMENTS  
**POND 1 DETAILS**



PROJECT NO.  
 196106001

SHEET  
**C1.33**

K:\COS\_Civil\196106001\_Winsome Filing No. 3\CADD\PlanSheets\CDS\196106001\_CD\_POND\_1.dwg Kofford, Kevin 4/28/2023 12:18 PM



CALL UTILITY NOTIFICATION CENTER OF COLORADO  
 1-800-922-1987  
 CALL 2-BUSINESS DAYS IN ADVANCE BEFORE YOU DIG, GRADE, OR EXCAVATE FOR THE MARKING OF UNDERGROUND MEMBER UTILITIES

K:\COS\_Civil\196106001\_Winsome Filing No. 3\CADD\PlanSheets\Cds\196106001\_CD\_POND\_1.dwg Kofford, Kevin 4/28/2023 12:18 PM

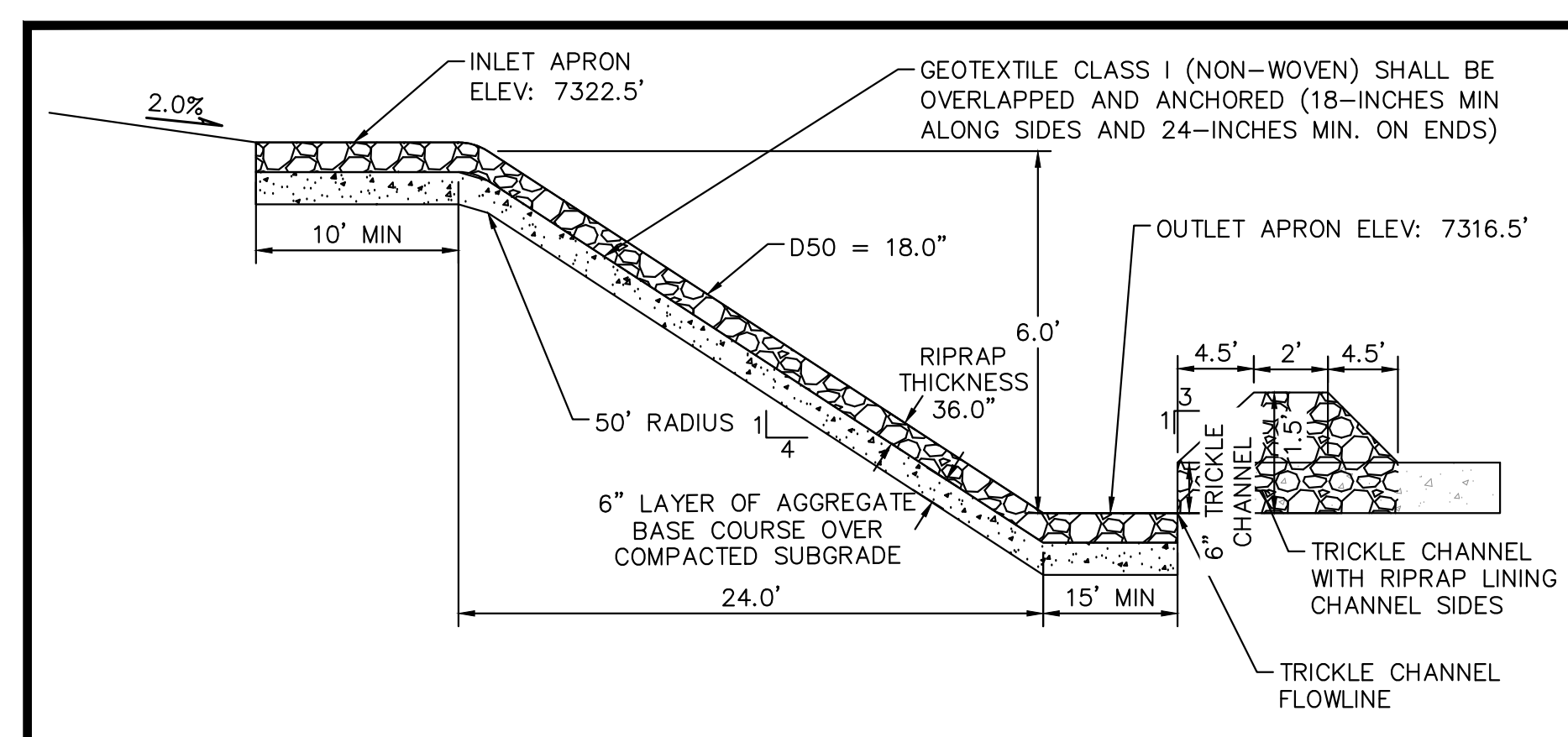

10 ROCK CHUTE #4 PROFILE- CROSS SECTION 1  
 N.T.S.

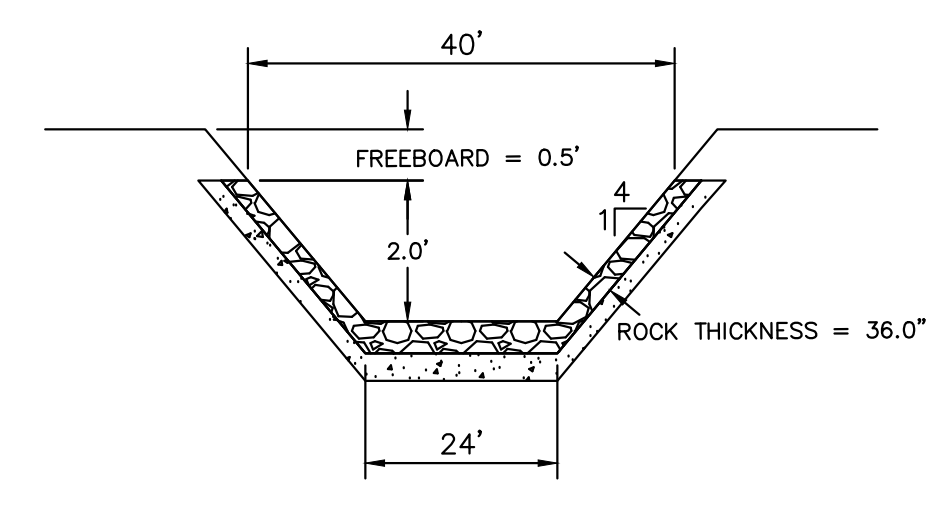

11 ROCK CHUTE #4 PROFILE- CROSS SECTION 2  
 N.T.S.

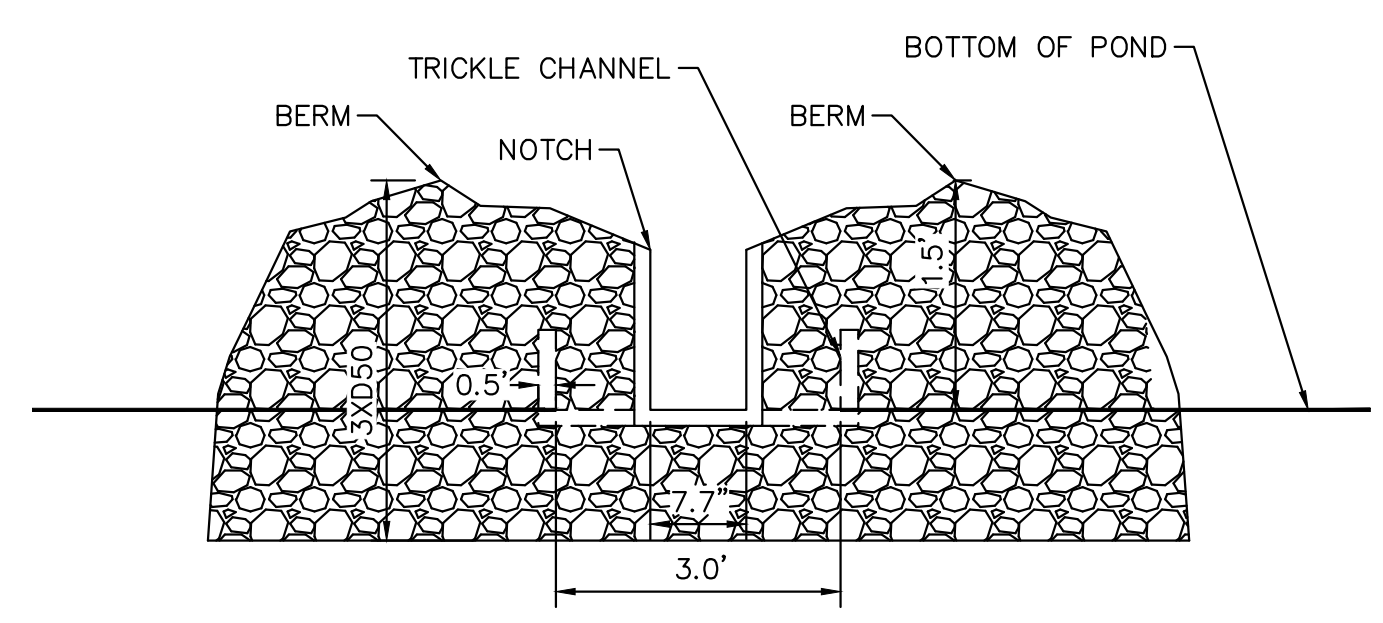

12 ROCK CHUTE #4 PROFILE- CROSS SECTION 2  
 N.T.S.

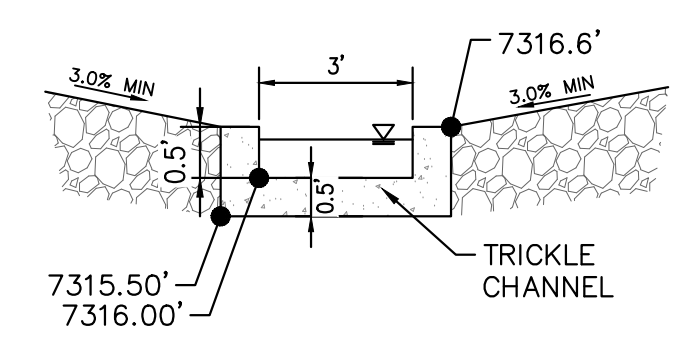

13 ROCK CHUTE TO TRICKLE CHANNEL TRANSITION  
 N.T.S.

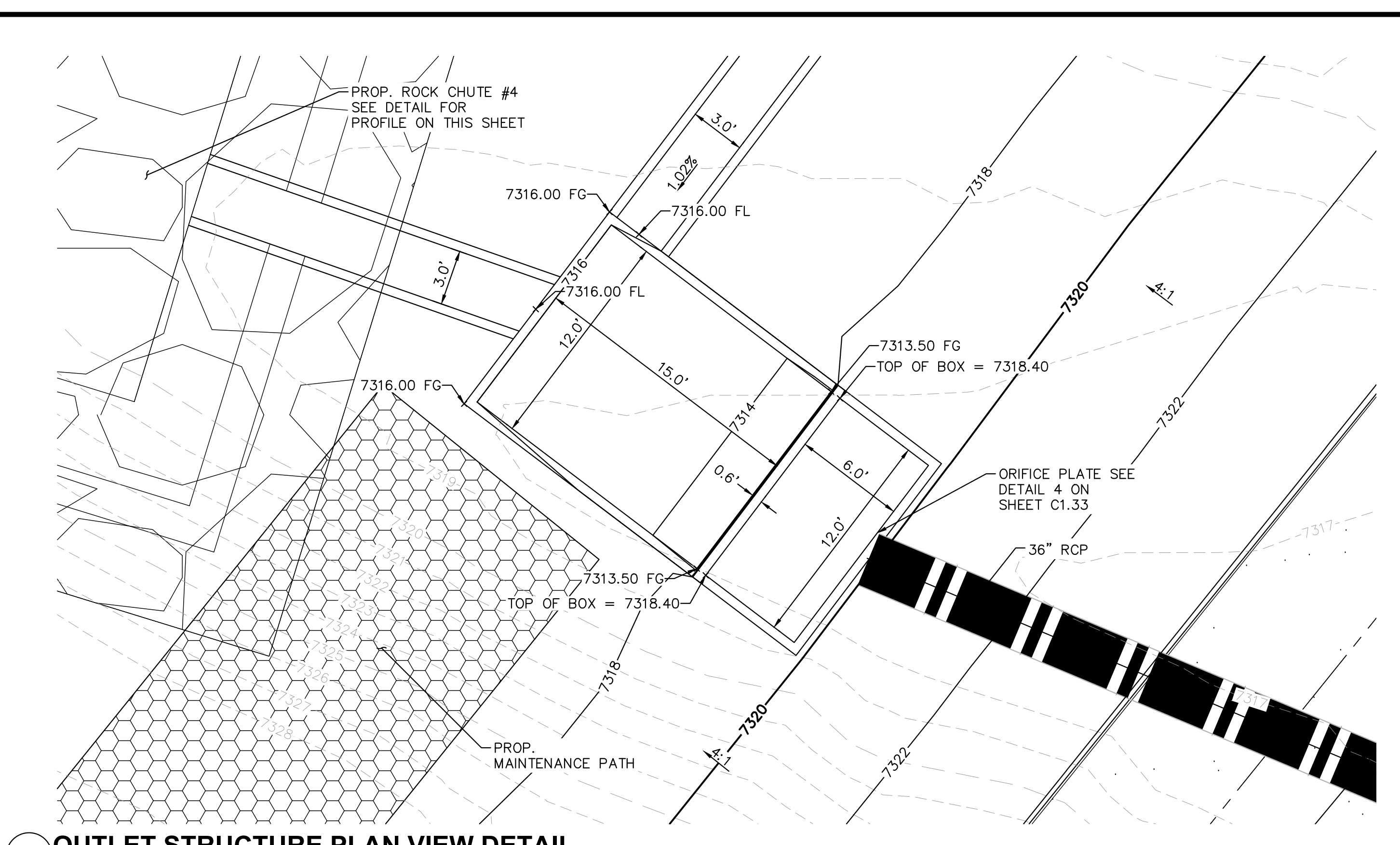

16 OUTLET STRUCTURE PLAN VIEW DETAIL  
 1"=5'

Rock Chute ID	Channel Location	Flow (cfs)	Upstream Inlet Apron Length (ft)	Drop (ft) (Inlet Apron to Outlet Apron)	Chute Length (ft)	Downstream Outlet Apron Length (ft)	Chute Width (ft)	D50 (in)	Rock Chute Thickness (in)	Radius (ft)	Min Rock Chute Depth (ft)	Rock Chute Depth (ft)	Top Chute Width (ft)
4	Pond 1	107	10	6	24	15	24	18	36	50	1.27	1.50	40
6	Pond 2	110	10	8	32	18	17	18	36	50	1.57	2.00	33
11	Pond 4	26	10	10	40	11	10	9	18	25	0.85	1.50	26
12	WQ Pond	100	11	5	20	20	12	18	36	50	1.81	2.00	28
13	WQ Pond	57	10	3	12	16	10	18	36	50	1.38	1.50	26

15 STANDARD ROCK CHUTE DIMENSION TABLE  
 N.T.S.

1. SEE GRADING PLANS FOR ROCK CHUTE LOCATIONS



NO.	REVISION	BY	DATE	APPR.
2	COUNTY COMMENTS	KRK	4/28/23	KRK
1	COUNTY COMMENTS	KRK	3/10/23	KRK

**Kimley»Horn**  
 2021 KIMLEY-HORN AND ASSOCIATES, INC.  
 2 North Nevada Avenue Suite 300  
 Colorado Springs, Colorado 80903 (719) 453-0180

DESIGNED BY: KRK  
 DRAWN BY: A.J.L.  
 CHECKED BY: KRK  
 DATE: 12/16/2021

WINSOME FILING NO. 3  
 EL PASO COUNTY, COLORADO  
 CONSTRUCTION DOCUMENTS  
 POND 1 DETAILS

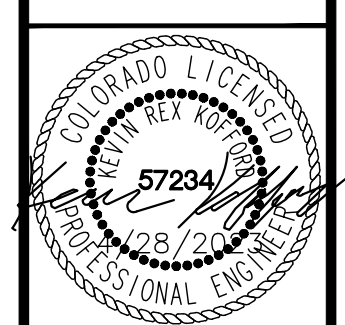

PROJECT NO.  
 196106001

SHEET  
 C1.34

K:\COS\_Civil\196106001\_Winsome Filing No. 3\CADD\PlanSheets\CDS\196106001\_CD\_POND\_2-UPDATE.dwg Kofford, Kevin 4/28/2023 12:29 PM



CALL UTILITY NOTIFICATION CENTER OF COLORADO  
1-800-922-1987  
CALL 2-BUSINESS DAYS IN ADVANCE BEFORE YOU DIG, GRADE, OR EXCAVATE FOR THE MARKING OF UNDERGROUND MEMBER UTILITIES

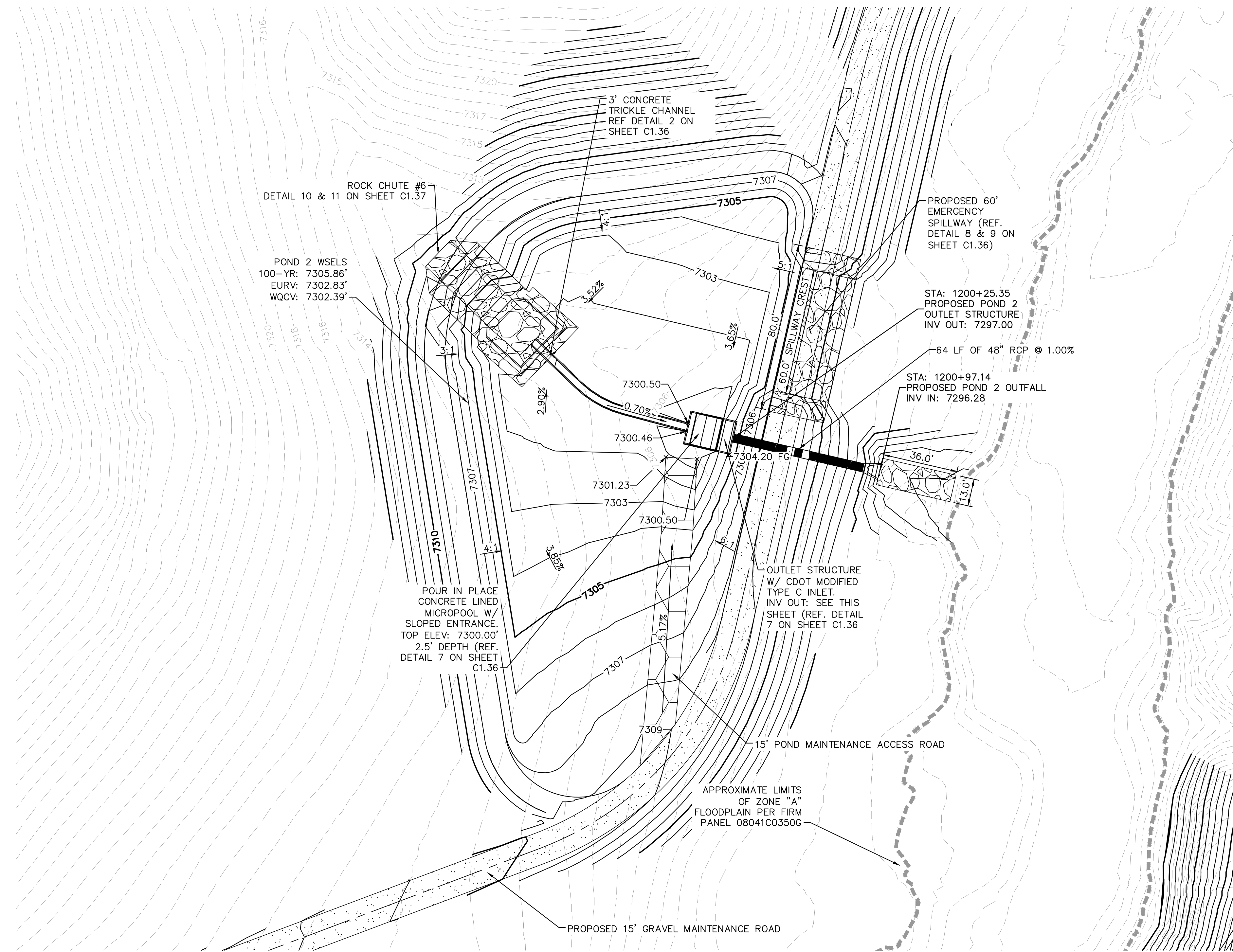
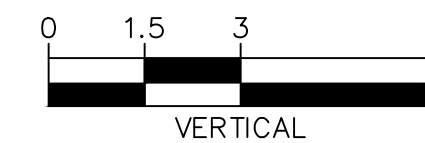
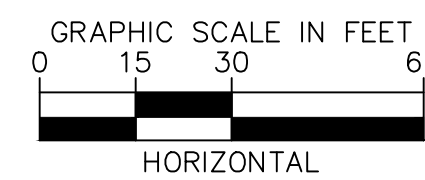
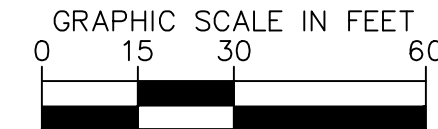
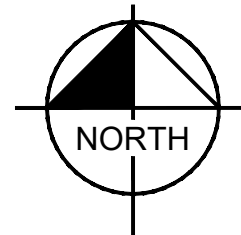

**LEGEND**

- FG FINISH GRADE
- FBT TOP OF FOREBAY AT FINISHED GRADE
- FBB BOTTOM OF FOREBAY AT FINISHED GRADE
- TCT TOP OF TRICKLE CHANNEL AT FINISHED GRADE
- TCB BOTTOM OF TRICKLE CHANNEL AT FINISHED GRADE
- MPT TOP OF MICROPOOL AT FINISHED GRADE
- MPB BOTTOM OF MICROPOOL AT FINISHED GRADE
- GRATE OUTLET STRUCTURE GRATE ELEVATION
- ME MATCH EXISTING
- PT TOP OF STEEL PLATE AT FINISHED GRADE
- PB BOTTOM OF STEEL PLATE AT FINISHED GRADE

- FLOODPLAIN LIMITS
- TOP OF POND
- PROPOSED STORM SEWER

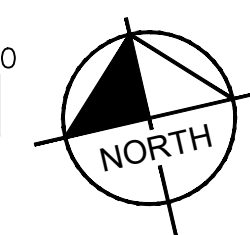
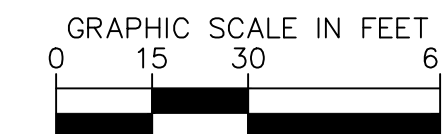
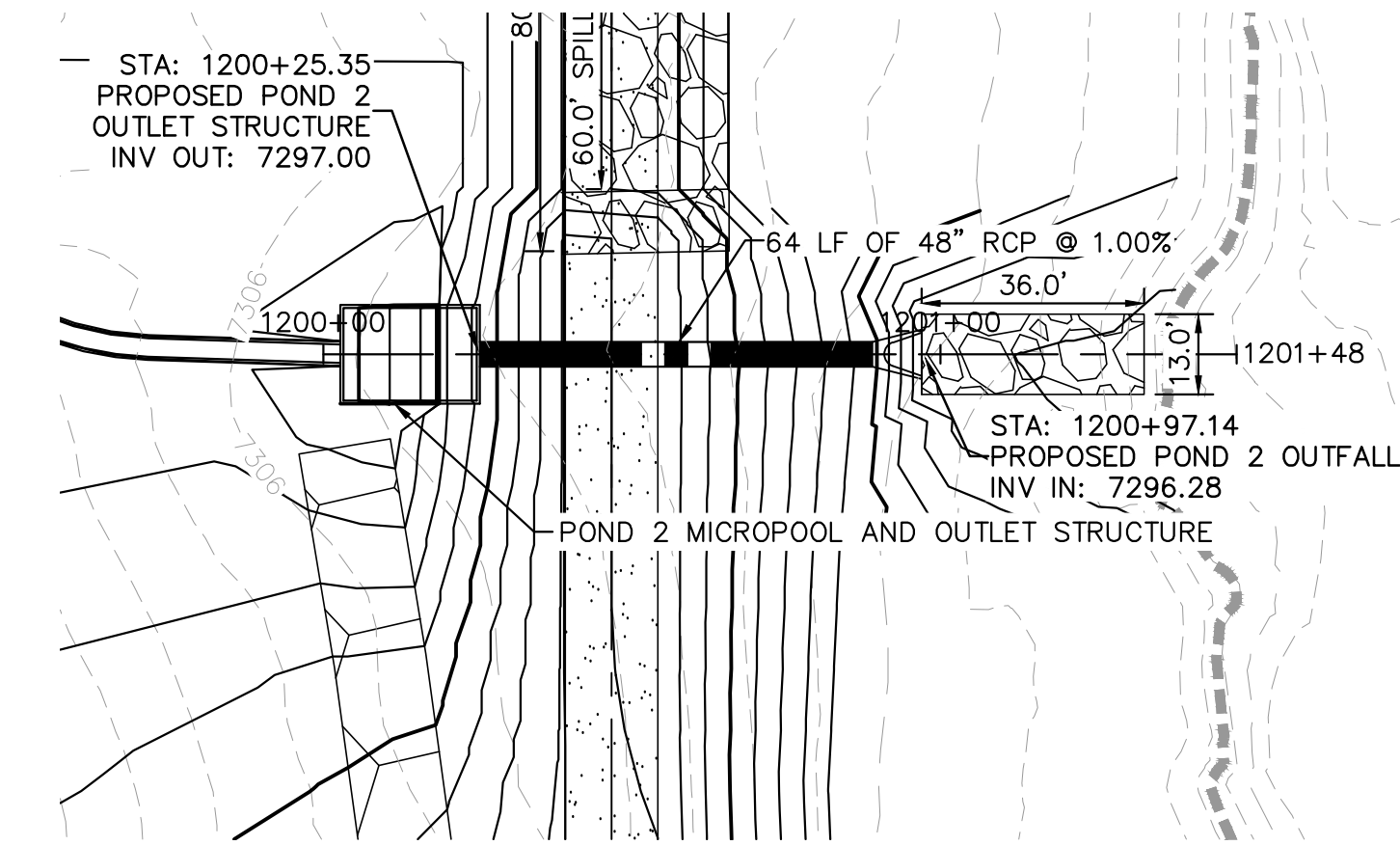

POND 2 OUTLET PIPE PLAN AND PROFILE

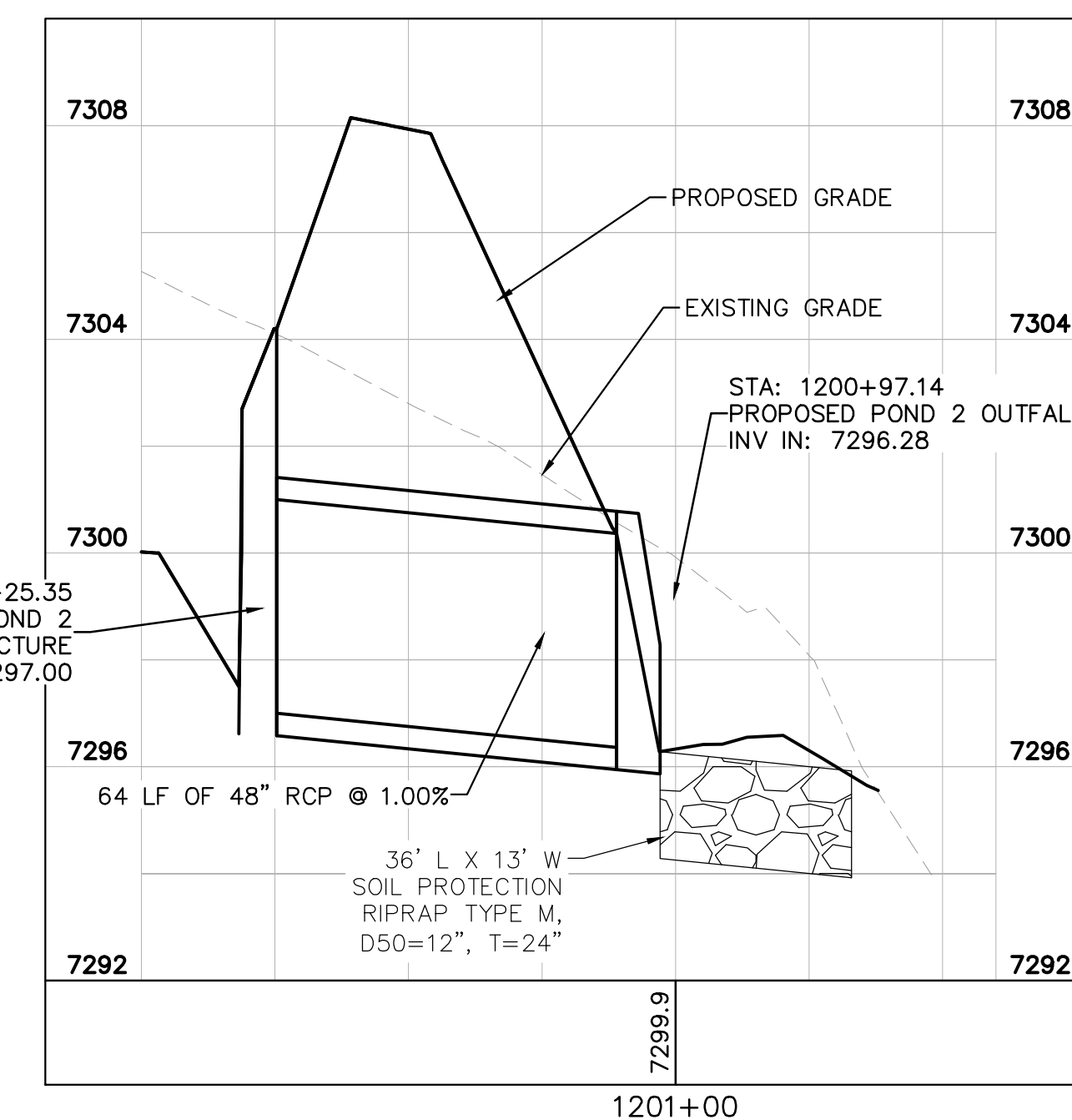

NO.	DATE	BY	REVISION
1	3/10/23	KRK	COUNTY COMMENTS
2	4/26/23	KRK	COUNTY COMMENTS

**Kimley»Horn**  
KIMLEY-HORN AND ASSOCIATES, INC.  
2021 Kimley-Horn and Associates, Inc.  
2 North Nevada Avenue Suite 300  
Colorado Springs, Colorado 80903 (719) 453-0180

DESIGNED BY: KRK  
DRAWN BY: A.J.L.  
CHECKED BY: KRK  
DATE: 12/16/2021

WINSOME FILING NO. 3  
EL PASO COUNTY, COLORADO  
CONSTRUCTION DOCUMENTS  
POND 2 OVERVIEW

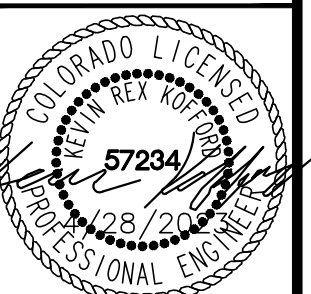

PROJECT NO.  
196106001

SHEET

C1.35

EPC 5/30/23

K:\COS\_Civil\196106001\_Winsome Filing No. 3\CADD\PlanSheets\Cds\196106001\_CD\_POND\_2--UPDATE.dwg Kofford, Kevin 4/28/2023 12:20 PM

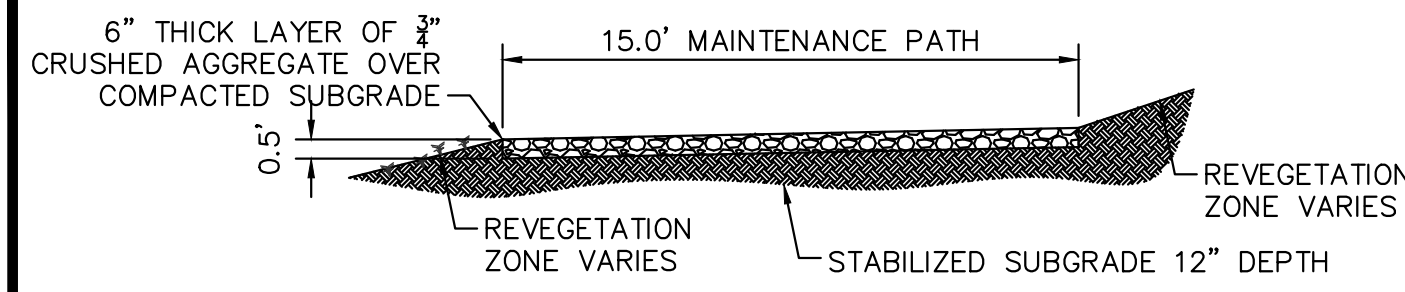

**1 MAINTENANCE ROAD**

- 1"=5'  
**MAINTENANCE PATH NOTES**  
 1. MAINTENANCE PATH SHALL INCLUDE SUBGRADE PREPARATION, GRAVEL BASE, AND COMPACTION.

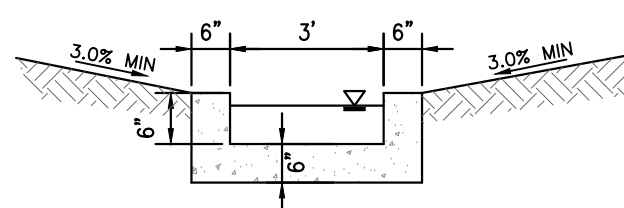

**2 CONCRETE TRICKLE CHANNEL**

N.T.S.

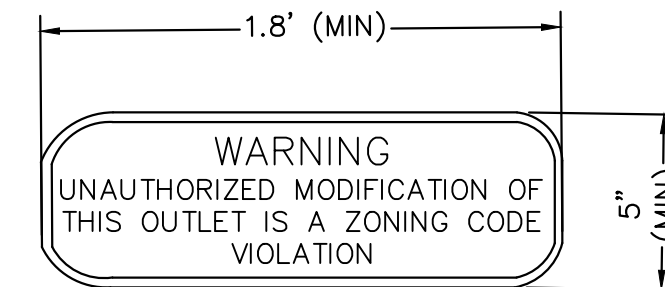

**3 OUTLET SIGNAGE**

- N.T.S.  
**OUTLET SIGNAGE NOTES**  
 1. SIGN SHALL BE A MINIMUM OF 0.75 SQUARE FEET AND SHALL BE ATTACHED TO THE OUTLET OR POSTED NEARBY.

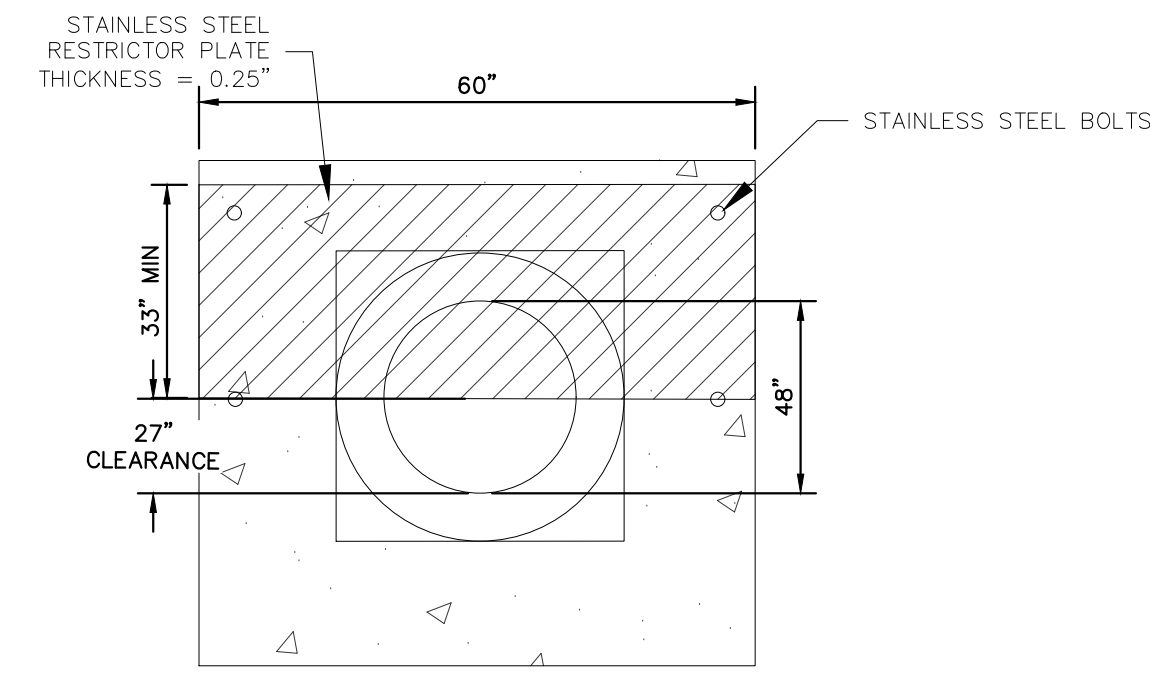

**5 100-YEAR FLOW RESTRICTOR B**

N.T.S.

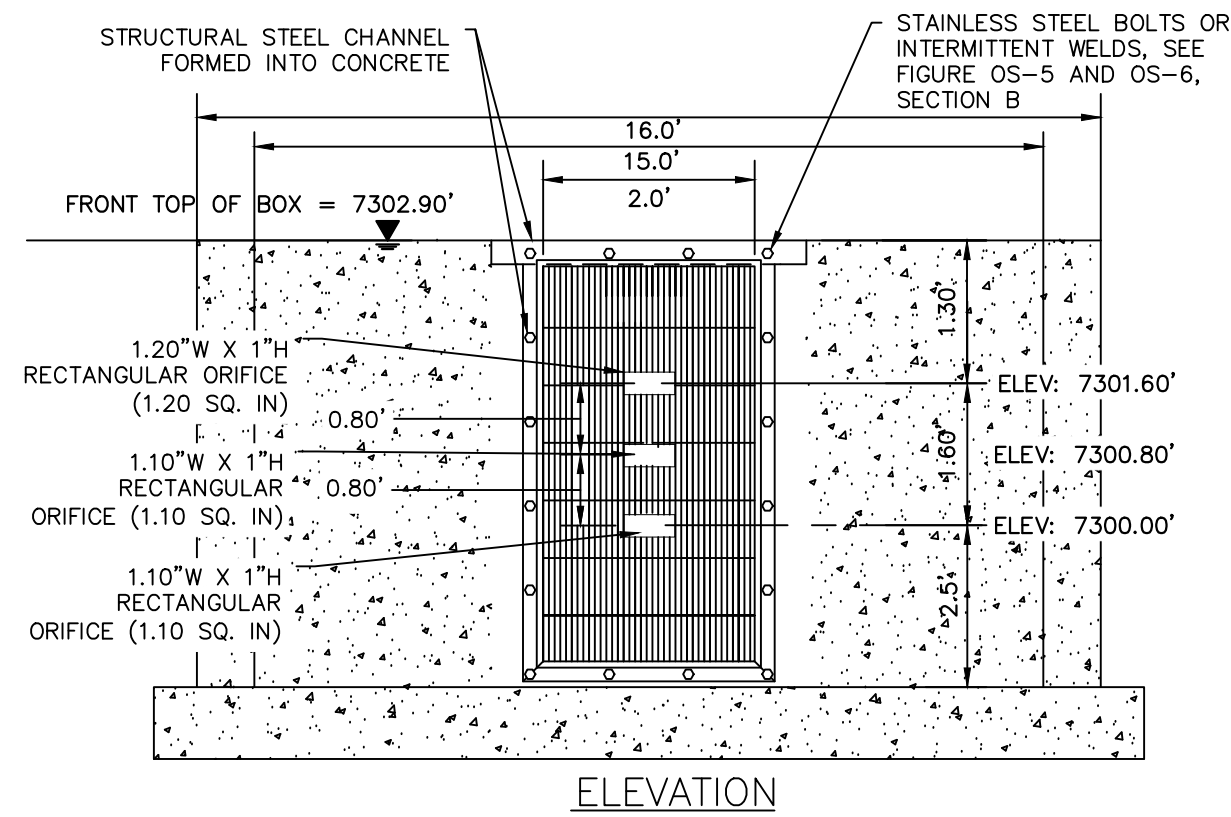

**4 ORIFICE PLATE AND TRASH RACK DETAIL**

N.T.S.

**ORIFICE PLATE NOTES**

1. PROVIDE CONTINUOUS NEOPRENE GASKET MATERIAL BETWEEN THE ORIFICE PLATE AND CONCRETE.
2. BOLT PLATE TO CONCRETE 12" MAX. ON CENTER, WITH A PLATE THICKNESS OF 0.25".

**EURV AND WQCV TRASH RACKS**

1. WELL-SCREEN TRASH RACKS SHALL BE STAINLESS STEEL AND SHALL BE ATTACHED BY INTERMITTENT WELDS ALONG THE EDGE OF THE MOUNTING FRAME.
2. BAR GATE TRASH RACKS SHALL BE ALUMINUM AND SHALL BE BOLTED USING STAINLESS STEEL HARDWARE.
3. TRASH RACK OPEN AREAS ARE FOR SPECIFIED TRASH RACK MATERIALS. TOTAL TRASH RACK SIZE MAY NEED TO BE ADJUSTED FOR MATERIALS HAVING DIFFERENT OPEN AREA/GROSS AREA RATIO (R VALUE).
4. STRUCTURAL DESIGN OF TRASH RACKS SHALL BE BASED ON FULL HYDROSTATIC HEAD WITH ZERO HEAD DOWNSTREAM OF THE RACK.

**OVERFLOW SAFETY GRATES**

1. ALL SAFETY GRATES SHALL BE MOUNTED USING STAINLESS STEEL HARDWARE AND PROVIDED WITH HINGED AND LOCKABLE OR BOLTABLE ACCESS PANELS.
2. SAFETY GRATES SHALL BE STAINLESS STEEL, ALUMINUM, OR STEEL. STEEL GRATES SHALL BE HOT DIP GALVANIZED AND MAY BE HOT POWDER COATED AFTER GALVANIZING.
3. SAFETY GRATES SHALL BE DESIGNED SUCH THAT THE DIAGONAL DIMENSION OF EACH OPENING IS SMALLER THAN THE DIAMETER OF THE OUTLET PIPE.
4. STRUCTURAL DESIGN OF SAFETY GRATES SHALL BE BASED ON FULL HYDROSTATIC HEAD WITH ZERO HEAD DOWNSTREAM OF THE RACK.

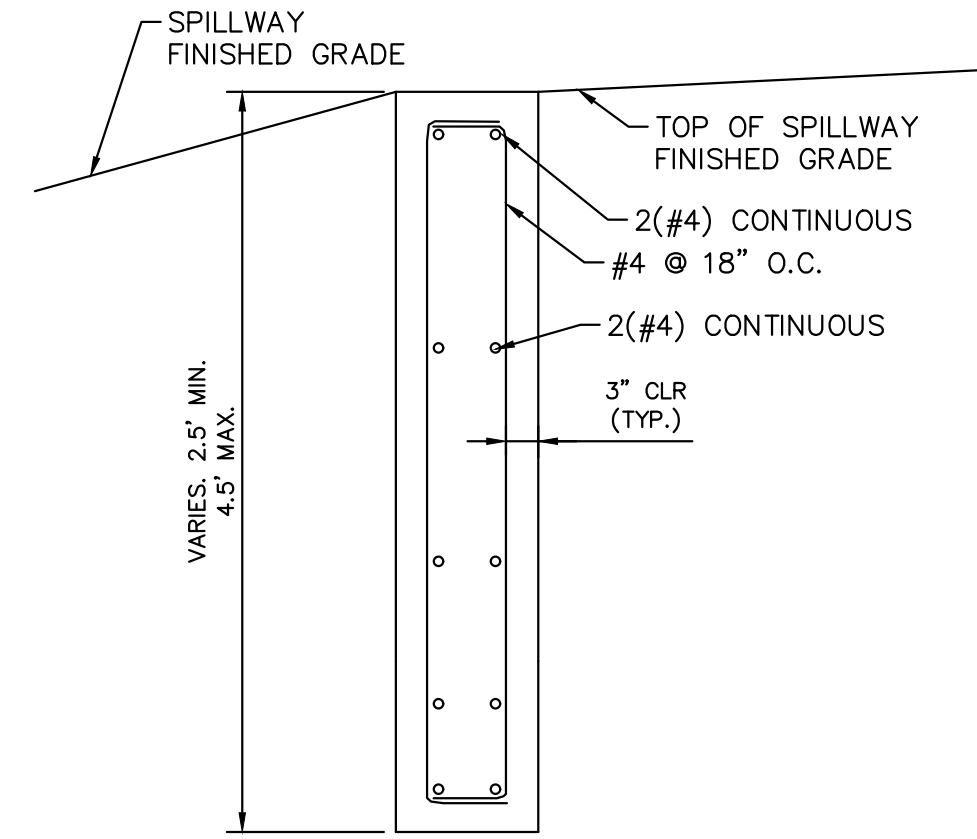

**SECTION CREST WALL DETAIL**

N.T.S.

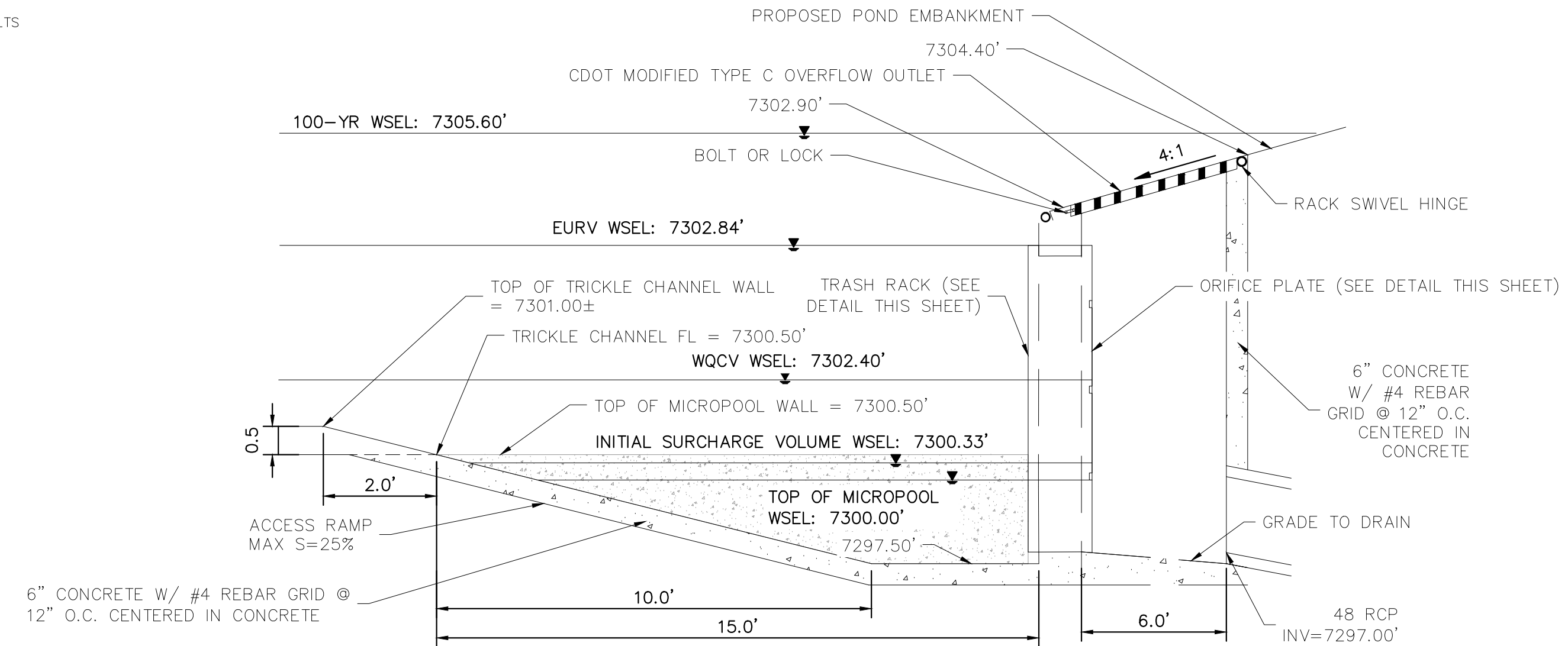

**7 OUTLET STRUCTURE DETAIL**

N.T.S.

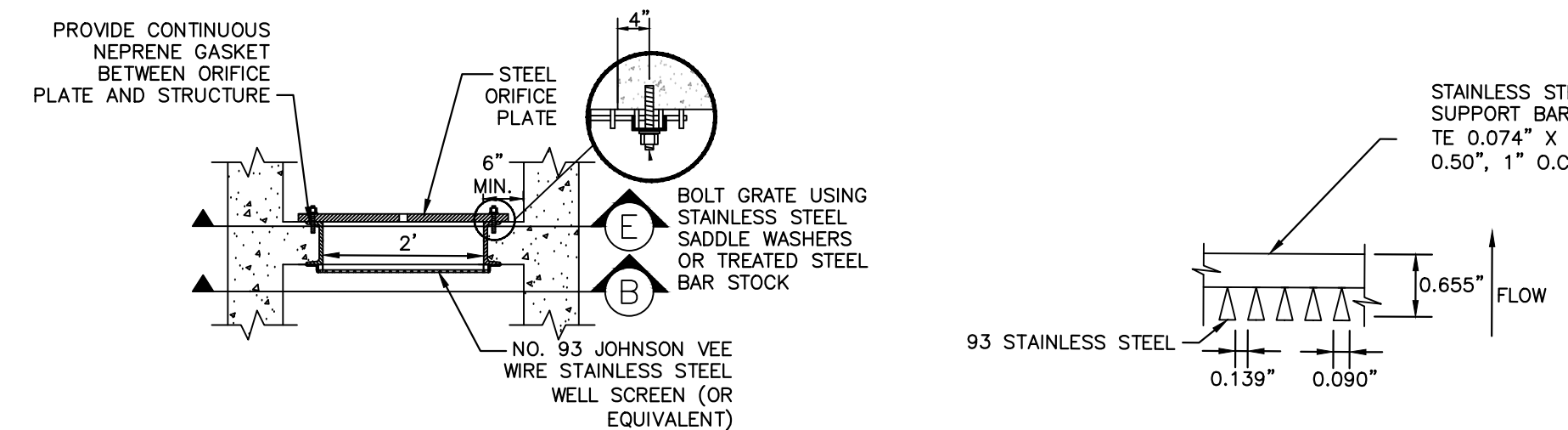

**SECTION A**

N.T.S.

**SECTION B**

N.T.S.

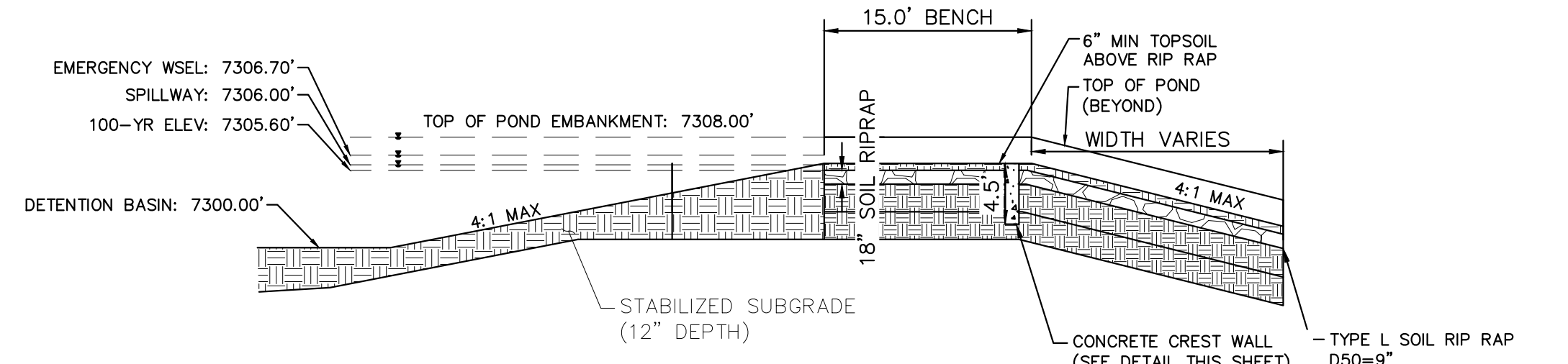

**8 EMERGENCY SPILLWAY DETAILS**

1"=10'

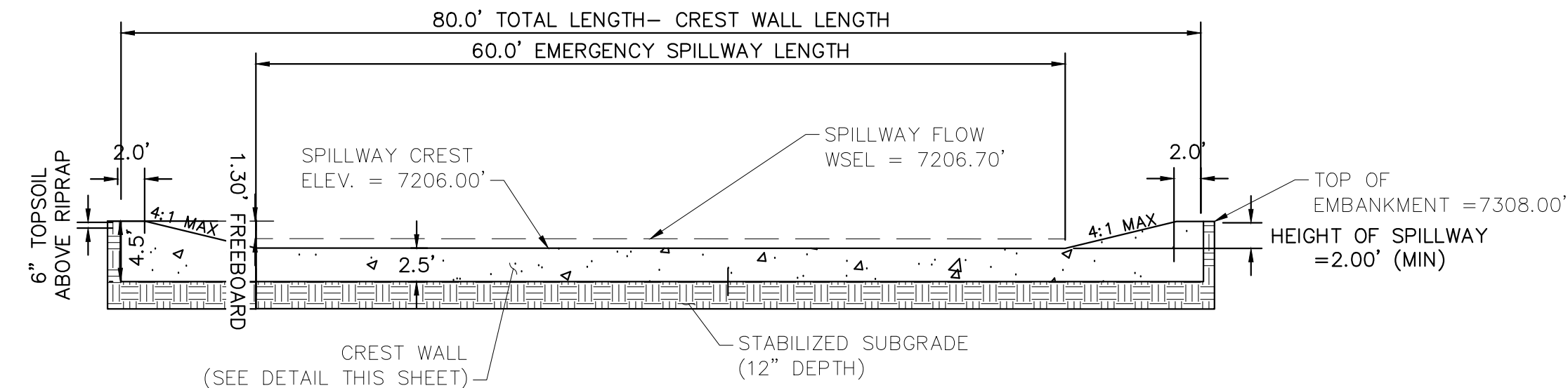

**9 EMERGENCY SPILLWAY**

1"=10'

NO.	REVISION	DATE	BY	APPR.
2	COUNTY COMMENTS	KRK 4/28/23	KRK	
1	COUNTY COMMENTS	KRK 3/10/23	KRK	

**Kimley»Horn**  
 2021 KIMLEY-HORN AND ASSOCIATES, INC.  
 2 North Nevada Avenue Suite 300  
 Colorado Springs, Colorado 80903 (719) 453-0180

DESIGNED BY: KRK  
 DRAWN BY: AUL  
 CHECKED BY: KRK  
 DATE: 12/16/2021

WINSOME FILING NO. 3  
 EL PASO COUNTY, COLORADO  
 CONSTRUCTION DOCUMENTS  
**POND 2 DETAILS**



PROJECT NO.  
 196106001  
 SHEET

**C1.36**

EPC 5/30/23



K:\COS\_Civil\196106001\_Winsome Filing No. 3\CADD\PlanSheets\Cds\196106001\_CD\_POND\_2-UPDATE.dwg Kofford, Kevin 4/28/2023 12:20 PM

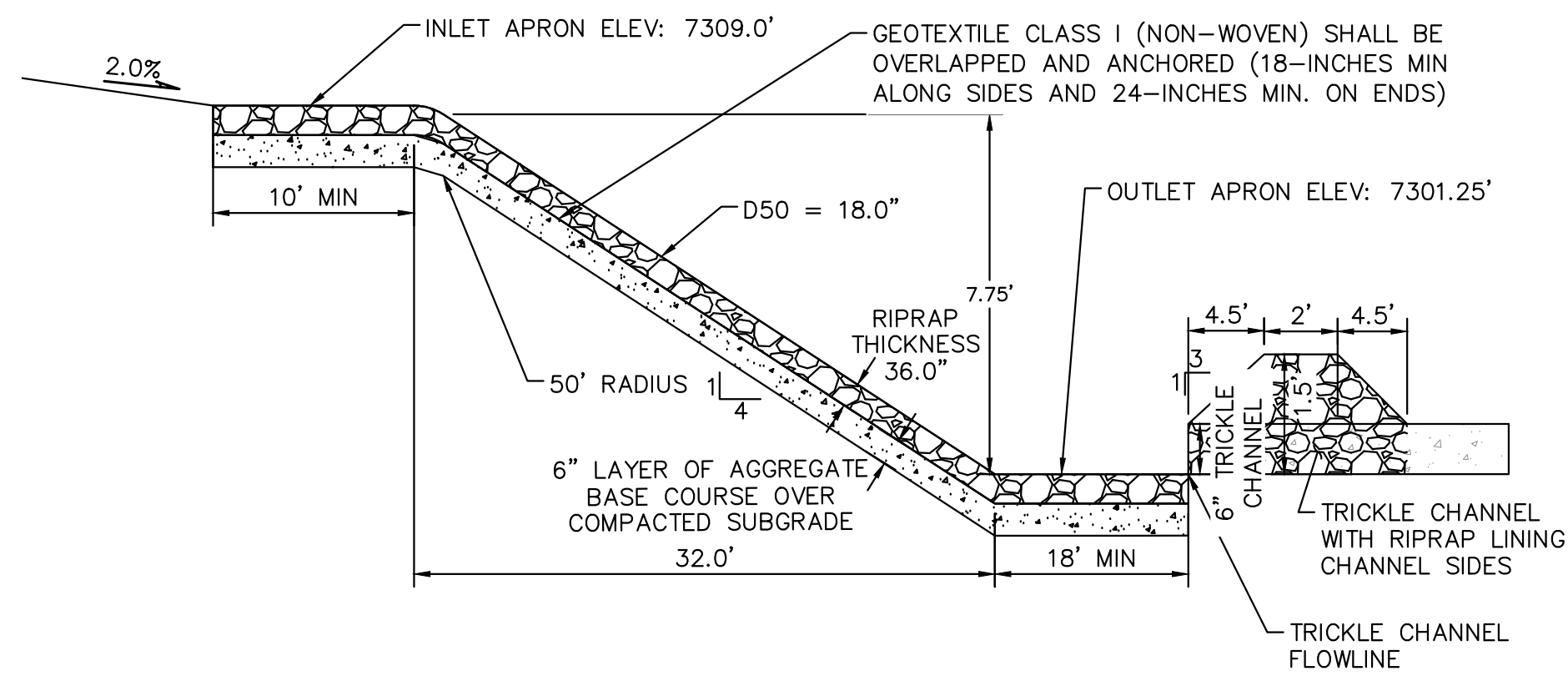

10 **ROCK CHUTE #6 PROFILE- CROSS SECTION 1**  
N.T.S.

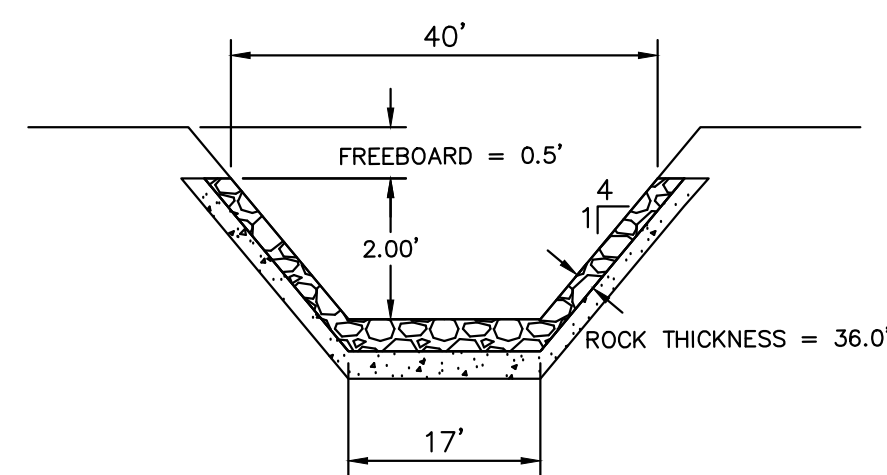

11 **ROCK CHUTE #6 PROFILE- CROSS SECTION 2**  
N.T.S.

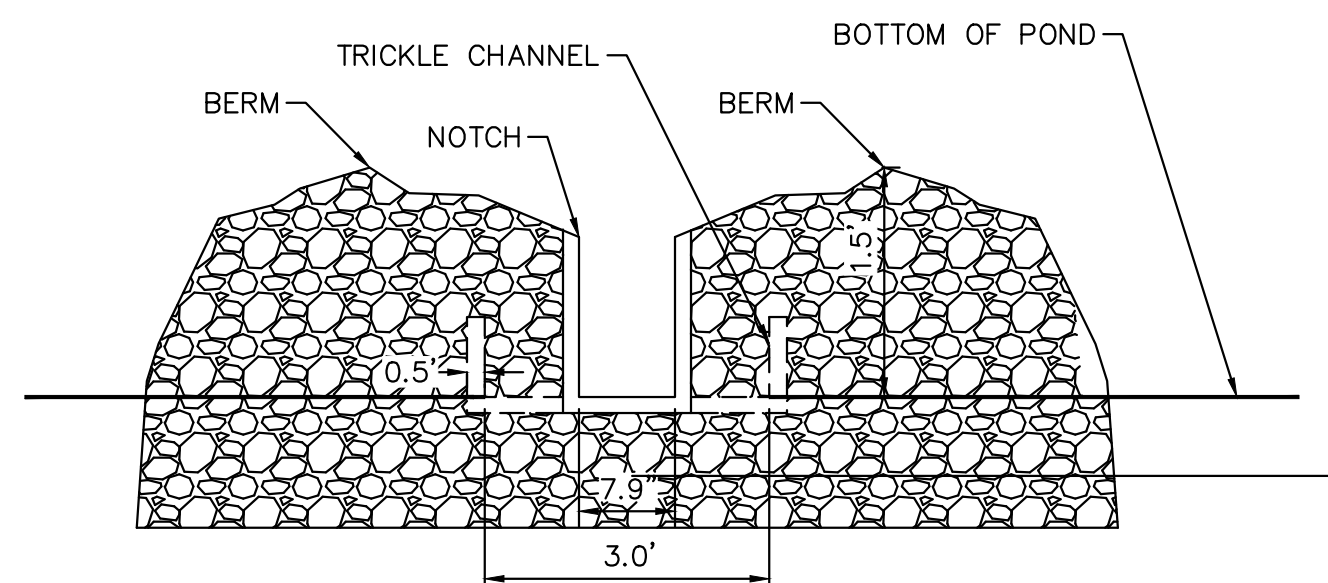

12 **ROCK CHUTE #6 NOTCH PROFILE**  
N.T.S.

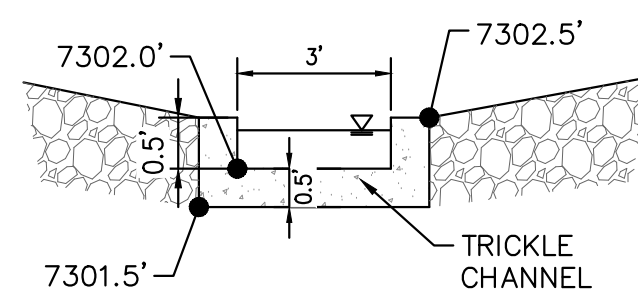

13 **ROCK CHUTE TO TRICKLE CHANNEL TRANSITION**  
N.T.S.

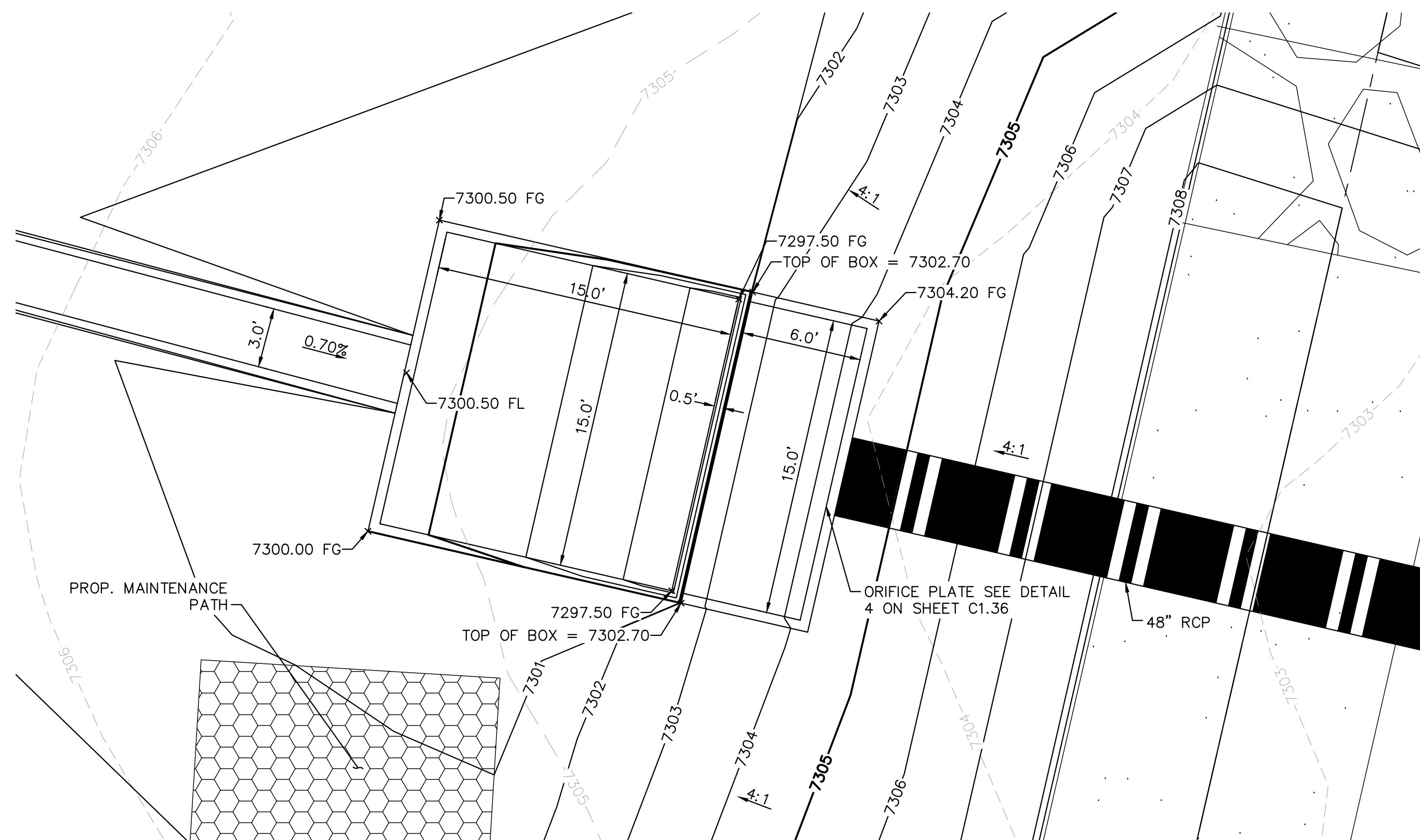

14 **OUTLET STRUCTURE PLAN VIEW DETAIL**  
1"=5'

Rock Chute ID	Channel Location	Flow (cfs)	Upstream Inlet Apron Length (ft)	Drop (ft) (Inlet Apron to Outlet Apron)	Chute Length (ft)	Downstream Outlet Apron Length (ft)	Chute Width (ft)	D50 (in)	Rock Chute Thickness (in)	Radius (ft)	Min Rock Chute Depth (ft)	Rock Chute Depth (ft)	Top Chute Width (ft)
4	Pond 1	107	10	6	24	15	24	18	36	50	1.27	1.50	40
6	Pond 2	110	10	8	32	18	17	18	36	50	1.57	2.00	33
11	Pond 4	26	10	10	40	11	10	9	18	25	0.85	1.50	26
12	WQ Pond	100	11	5	20	20	12	18	36	50	1.81	2.00	28
13	WQ Pond	57	10	3	12	16	10	18	36	50	1.38	1.50	26

15 **STANDARD ROCK CHUTE DIMENSION TABLE**  
N.T.S.

1. SEE GRADING PLANS FOR ROCK CHUTE LOCATIONS



NO.	REVISION	BY	DATE	APPR.
2	COUNTY COMMENTS	KRK	4/28/23	KRK
1	COUNTY COMMENTS	KRK	3/10/23	KRK

**Kimley»Horn**  
2021 KIMLEY-HORN AND ASSOCIATES, INC.  
2 North Nevada Avenue Suite 300  
Colorado Springs, Colorado 80903 (719) 453-0180

DESIGNED BY: KRK  
DRAWN BY: A.J.L.  
CHECKED BY: KRK  
DATE: 12/16/2021

WINSOME FILING NO. 3  
EL PASO COUNTY, COLORADO  
CONSTRUCTION DOCUMENTS  
POND 2 DETAILS

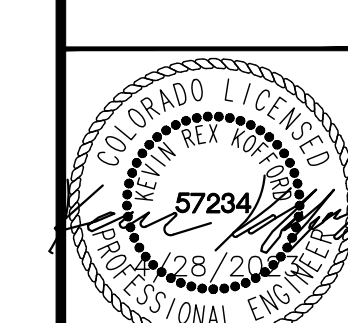

PROJECT NO.  
196106001

SHEET  
**C1.37**

EPC 5/30/23

K:\COS\_Civil\196106001\_Winsome Filing No. 3\CADD\PlanSheets\Cds\196106001\_CD\_POND\_4.dwg Kofford, Kevin 4/28/2023 12:21 PM

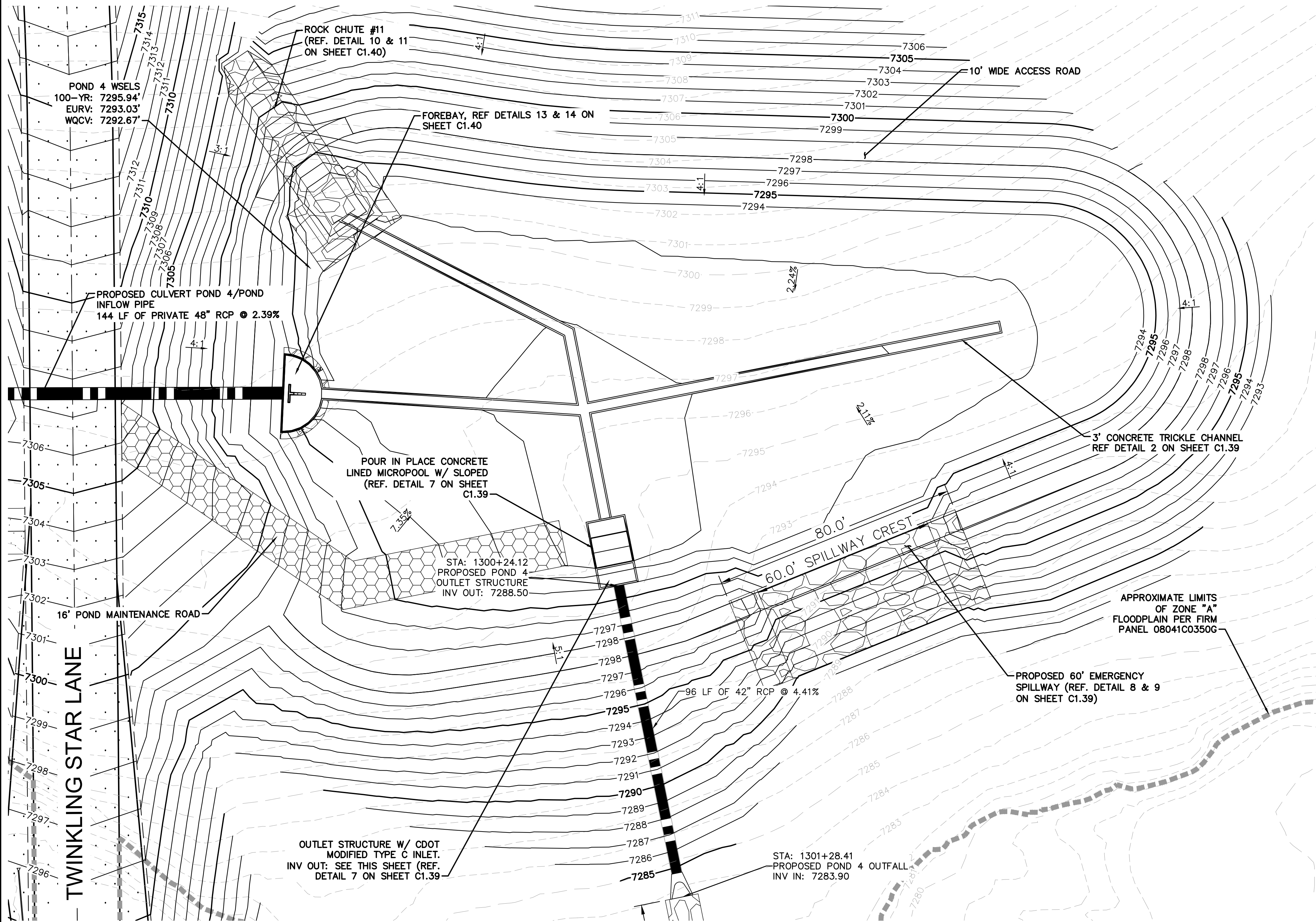

**LEGEND**

FG	FINISH GRADE
FBT	TOP OF FOREBAY AT FINISHED GRADE
FBB	BOTTOM OF FOREBAY AT FINISHED GRADE
TCT	TOP OF TRICKLE CHANNEL AT FINISHED GRADE
TCB	BOTTOM OF TRICKLE CHANNEL AT FINISHED GRADE
MPT	TOP OF MICROPOOL AT FINISHED GRADE
MPB	BOTTOM OF MICROPOOL AT FINISHED GRADE
GRATE	OUTLET STRUCTURE GRATE ELEVATION
ME	MATCH EXISTING
PT	TOP OF STEEL PLATE AT FINISHED GRADE
PB	BOTTOM OF STEEL PLATE AT FINISHED GRADE
---	FLOODPLAIN LIMITS
—	TOP OF POND
—	PROPOSED STORM SEWER

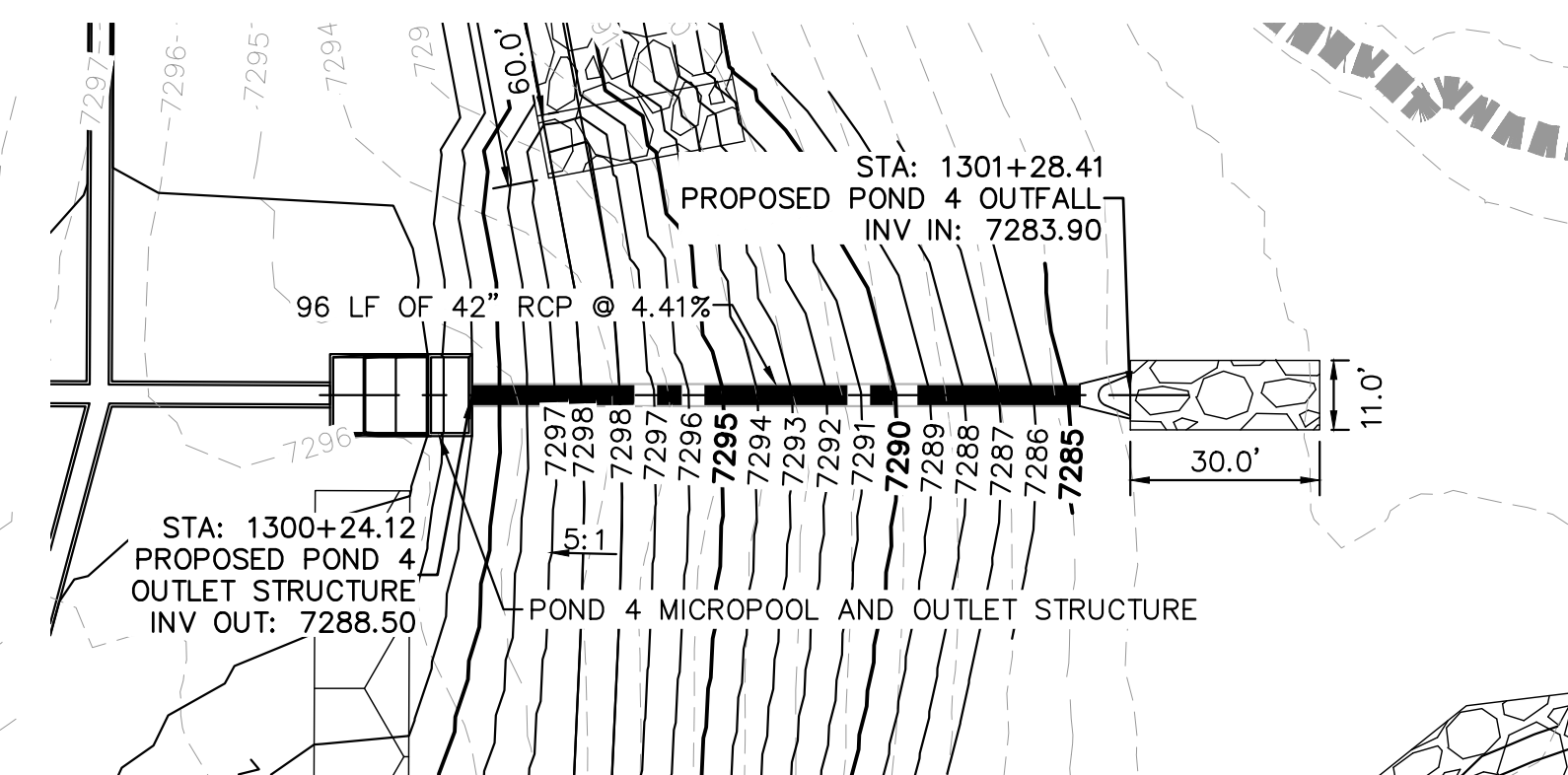

**POND 4 OUTLET PIPE PLAN AND PROFILE**

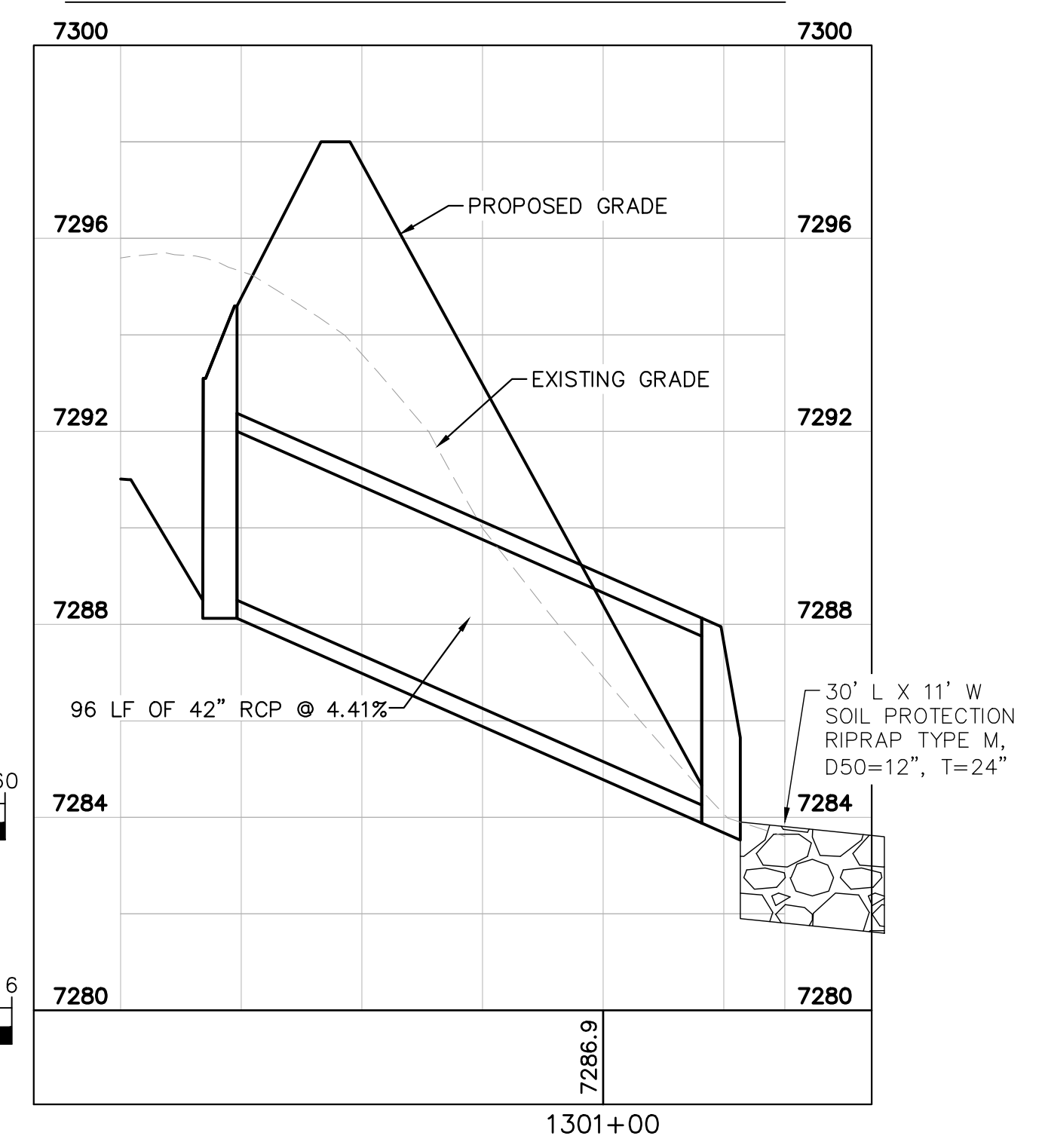

**811** Know what's below. Call before you dig.

CALL UTILITY NOTIFICATION CENTER OF COLORADO  
1-800-922-1987  
CALL 2-BUSINESS DAYS IN ADVANCE BEFORE YOU DIG, GRADE, OR EXCAVATE FOR THE MARKING OF UNDERGROUND MEMBER UTILITIES

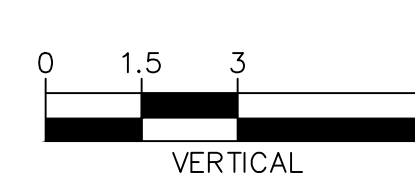
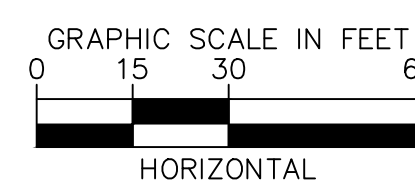
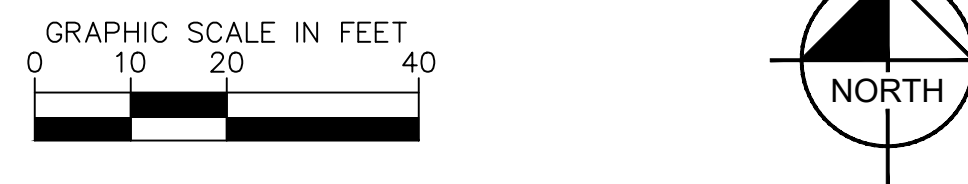

NO.	REVISION	DATE	BY	APPR.
2	COUNTY COMMENTS	KRK 4/28/23	KRK	
1	COUNTY COMMENTS	KRK 3/10/23	KRK	

**Kimley»Horn**  
2021 KIMLEY-HORN AND ASSOCIATES, INC.  
2 North Nevada Avenue Suite 300  
Colorado Springs, Colorado 80903 (719) 453-0180

DESIGNED BY: KRK  
DRAWN BY: A.J.L.  
CHECKED BY: KRK  
DATE: 12/16/2021

WINSOME FILING NO. 3  
EL PASO COUNTY, COLORADO  
CONSTRUCTION DOCUMENTS  
POND 4 OVERVIEW



PROJECT NO. 196106001  
SHEET

**C1.38**

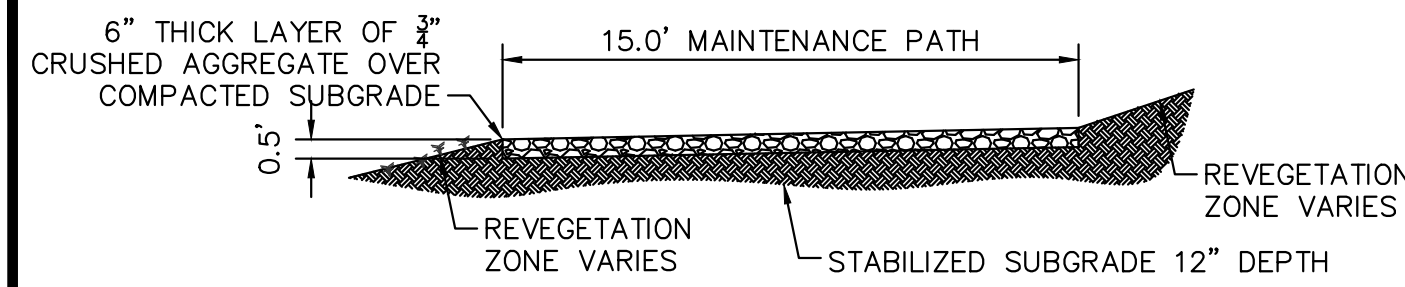

**1 MAINTENANCE ROAD**

- 1"=5'**  
**MAINTENANCE PATH NOTES**  
 1. MAINTENANCE PATH SHALL INCLUDE SUBGRADE PREPARATION, GRAVEL BASE, AND COMPACTION.

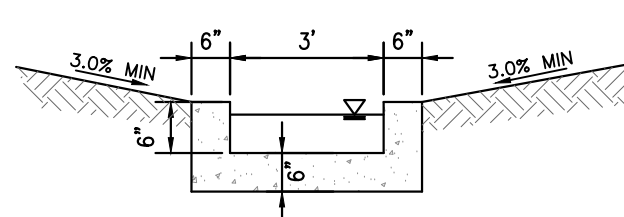

**2 CONCRETE TRICKLE CHANNEL**  
 N.T.S.

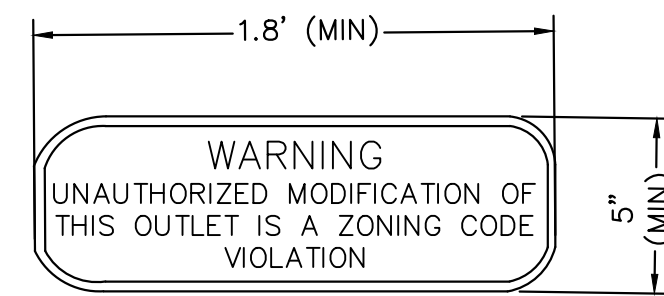

**3 OUTLET SIGNAGE**  
 N.T.S.

- OUTLET SIGNAGE NOTES**  
 1. SIGN SHALL BE A MINIMUM OF 0.75 SQUARE FEET AND SHALL BE ATTACHED TO THE OUTLET OR POSTED NEARBY.

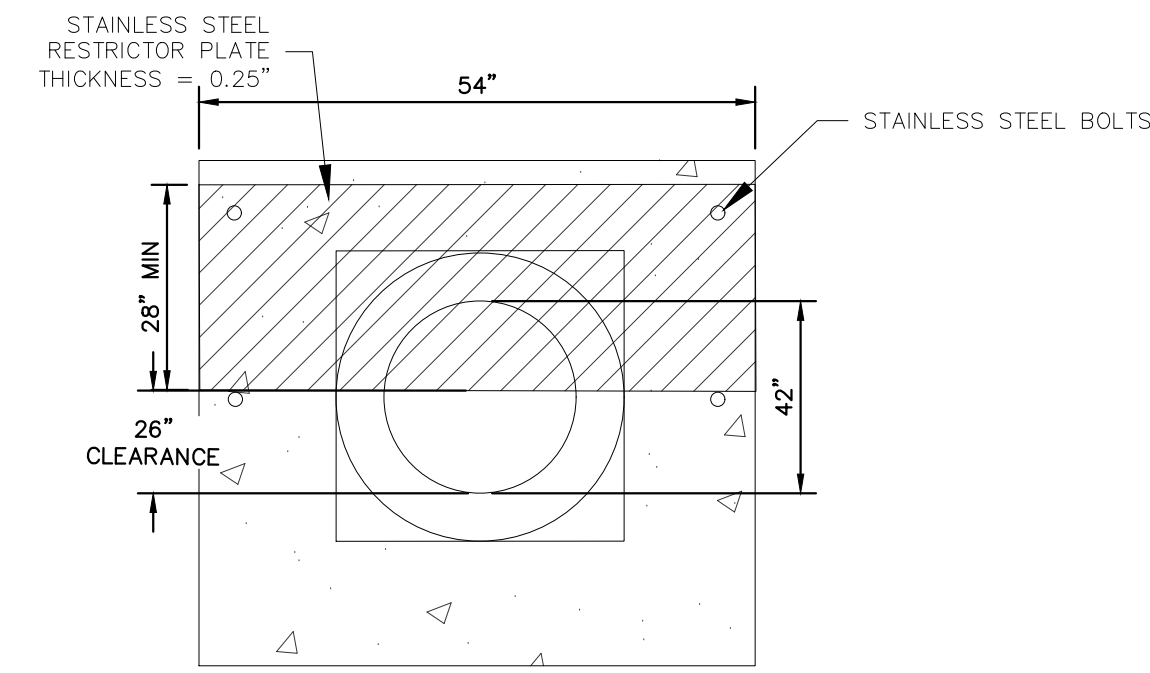

**5 100-YEAR FLOW RESTRICTOR B**  
 N.T.S.

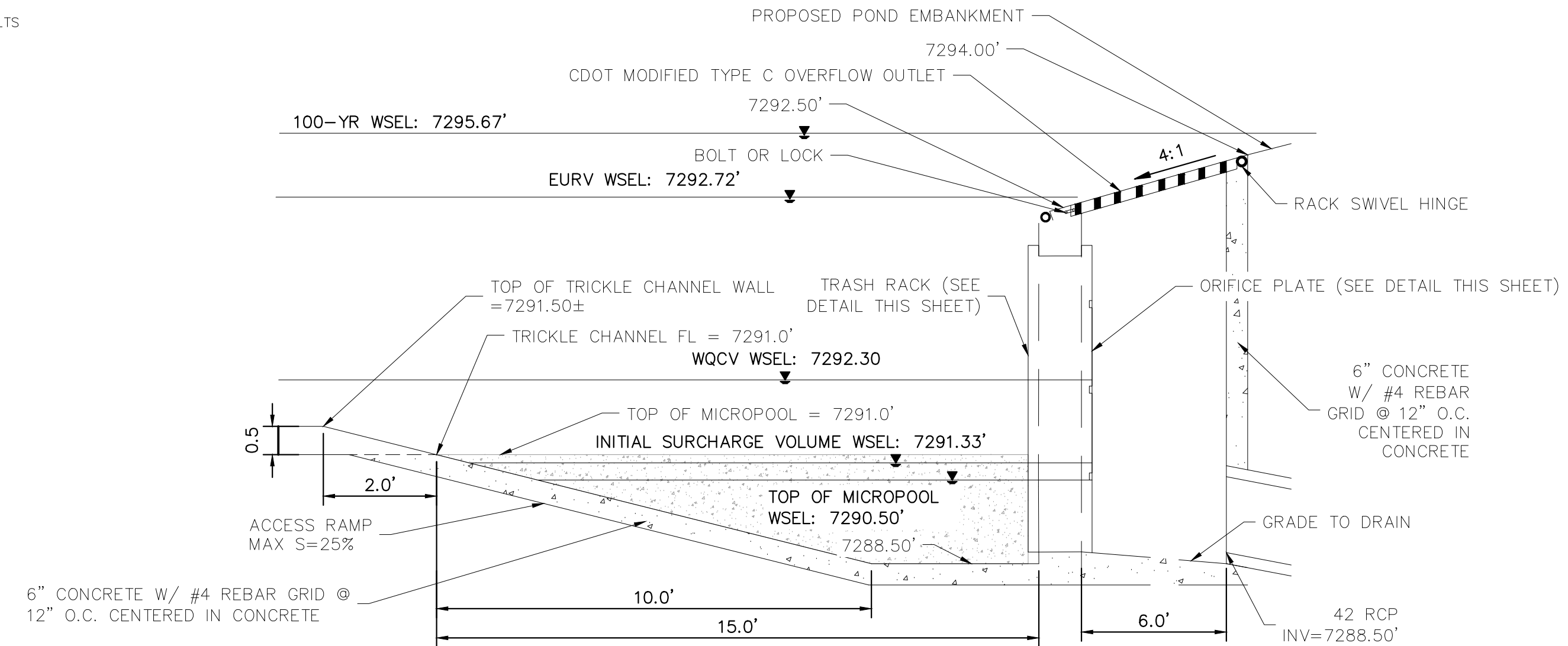

**7 OUTLET STRUCTURE DETAIL**  
 N.T.S.

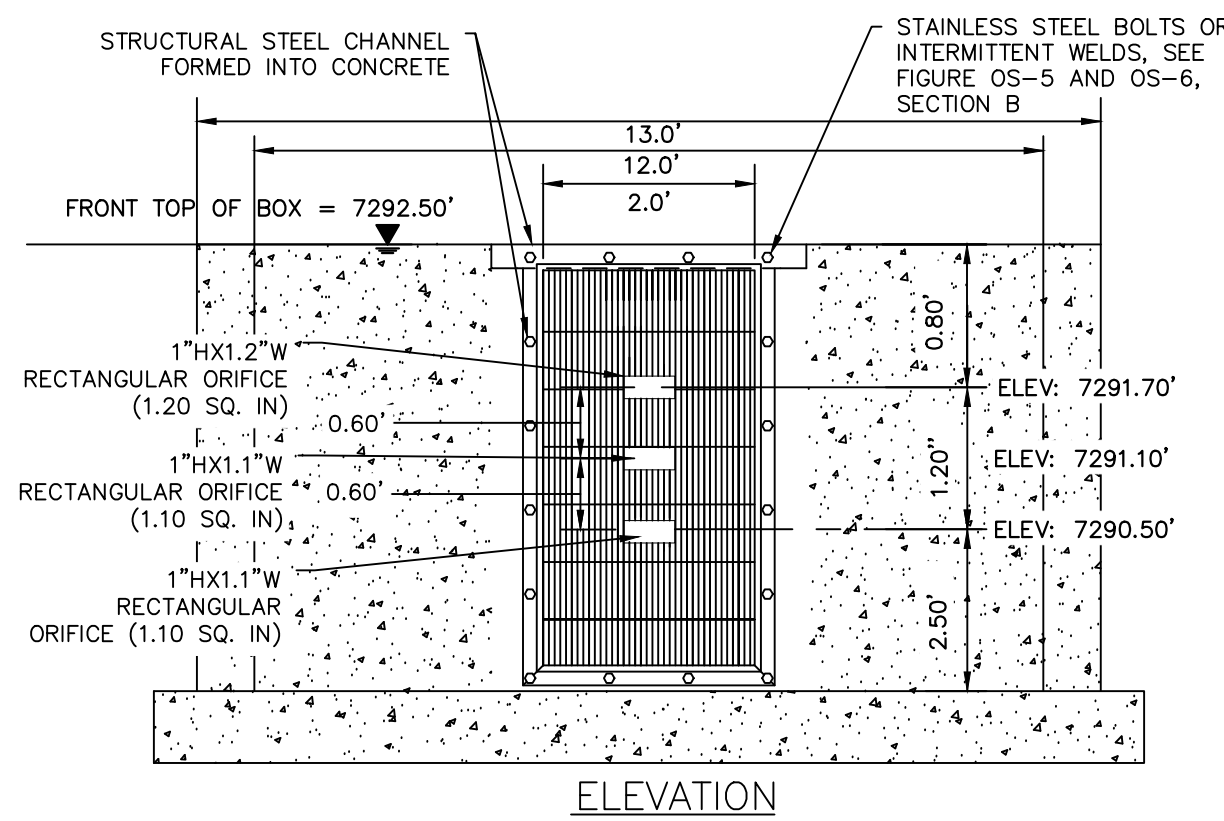

**4 ORIFICE PLATE AND TRASH RACK DETAIL**  
 N.T.S.

**ORIFICE PLATE NOTES**

1. PROVIDE CONTINUOUS NEOPRENE GASKET MATERIAL BETWEEN THE ORIFICE PLATE AND CONCRETE.
2. BOLT PLATE TO CONCRETE 12" MAX. ON CENTER, WITH A PLATE THICKNESS OF 0.25".

**EURV AND WQCV TRASH RACKS**

1. WELL-SCREEN TRASH RACKS SHALL BE STAINLESS STEEL AND SHALL BE ATTACHED BY INTERMITTENT WELDS ALONG THE EDGE OF THE MOUNTING FRAME.
2. BAR GATE TRASH RACKS SHALL BE ALUMINUM AND SHALL BE BOLTED USING STAINLESS STEEL HARDWARE.
3. TRASH RACK OPEN AREAS ARE FOR SPECIFIED TRASH RACK MATERIALS. TOTAL TRASH RACK SIZE MAY NEED TO BE ADJUSTED FOR MATERIALS HAVING DIFFERENT OPEN AREA/GROSS AREA RATIO (R VALUE).
4. STRUCTURAL DESIGN OF TRASH RACKS SHALL BE BASED ON FULL HYDROSTATIC HEAD WITH ZERO HEAD DOWNSTREAM OF THE RACK.

**OVERFLOW SAFETY GRATES**

1. ALL SAFETY GRATES SHALL BE MOUNTED USING STAINLESS STEEL HARDWARE AND PROVIDED WITH HINGED AND LOCKABLE OR BOLTABLE ACCESS PANELS.
2. SAFETY GRATES SHALL BE STAINLESS STEEL, ALUMINUM, OR STEEL. STEEL GRATES SHALL BE HOT DIP GALVANIZED AND MAY BE HOT POWDER COATED AFTER GALVANIZING.
3. SAFETY GRATES SHALL BE DESIGNED SUCH THAT THE DIAGONAL DIMENSION OF EACH OPENING IS SMALLER THAN THE DIAMETER OF THE OUTLET PIPE.
4. STRUCTURAL DESIGN OF SAFETY GRATES SHALL BE BASED ON FULL HYDROSTATIC HEAD WITH ZERO HEAD DOWNSTREAM OF THE RACK.

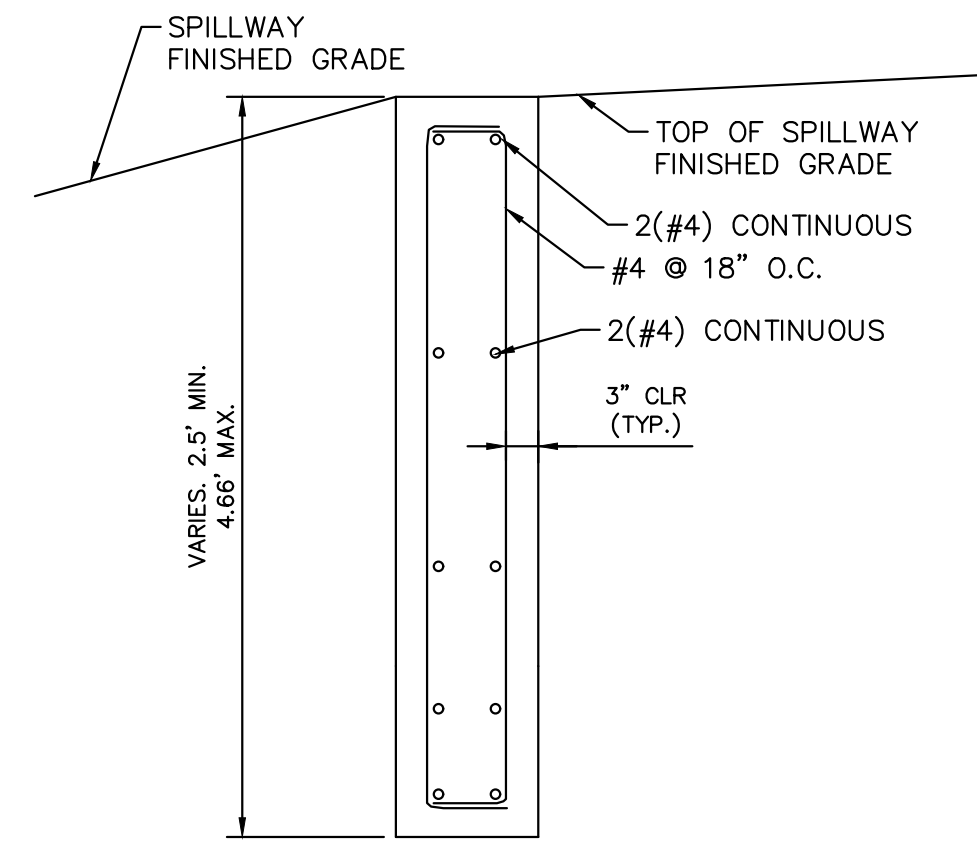

**6 SECTION CREST WALL DETAIL**  
 N.T.S.

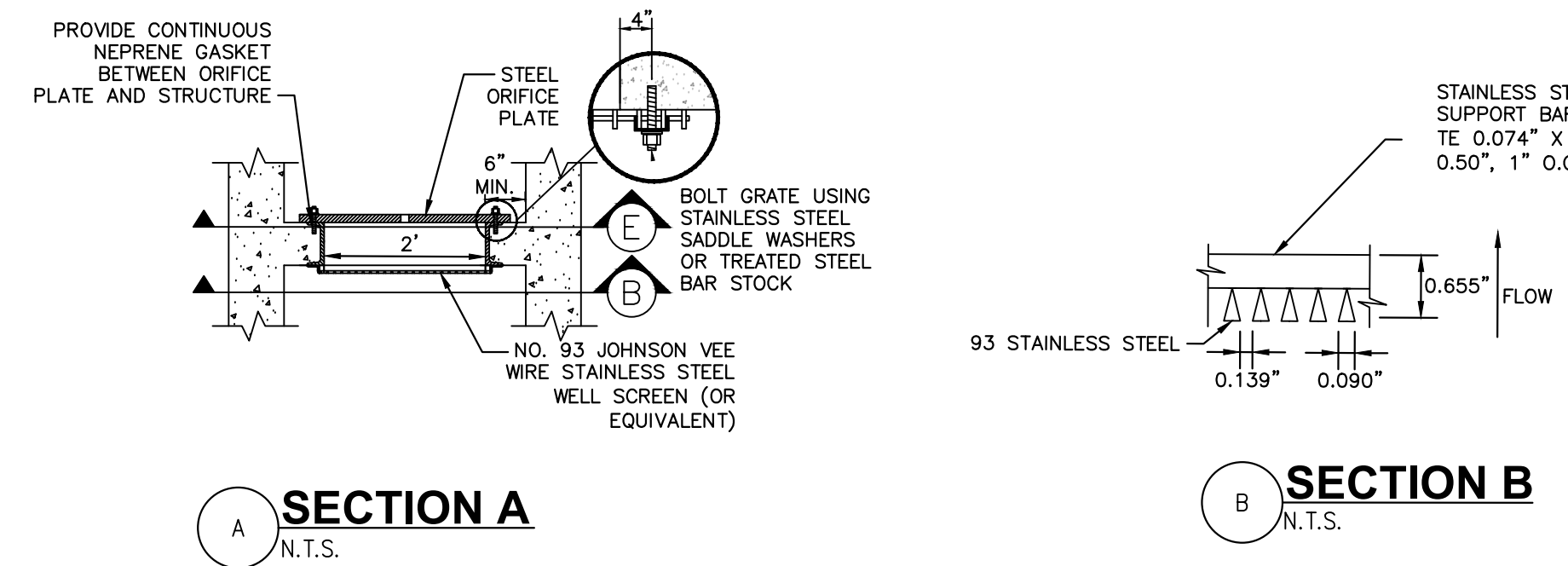

**A SECTION A**  
 N.T.S.

**B SECTION B**  
 N.T.S.

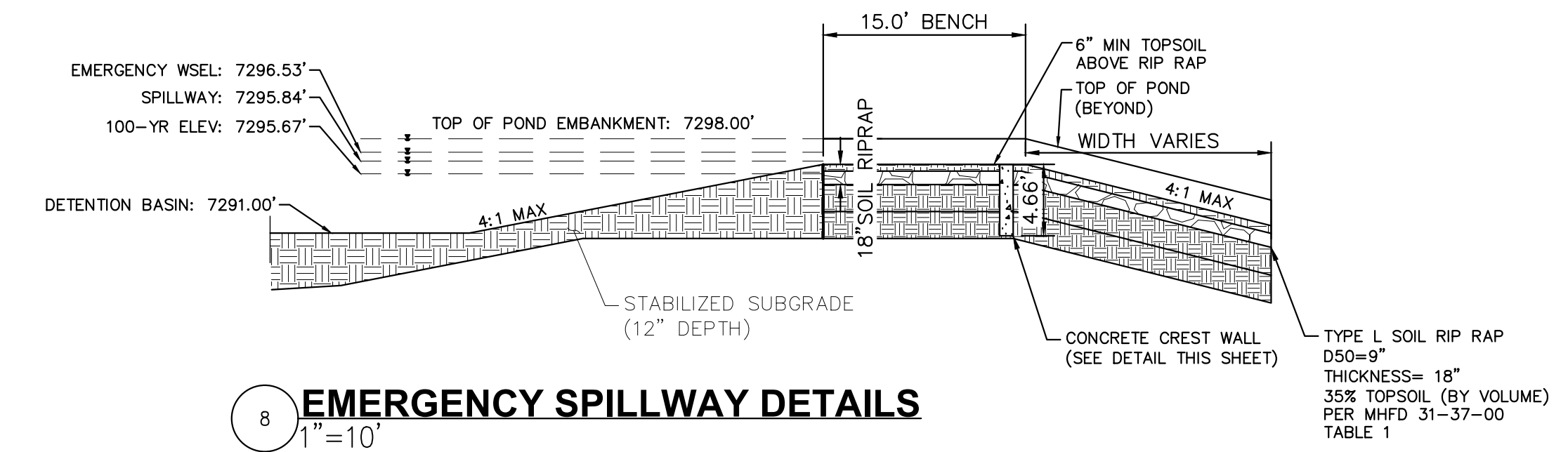

**8 EMERGENCY SPILLWAY DETAILS**  
 1"=10'

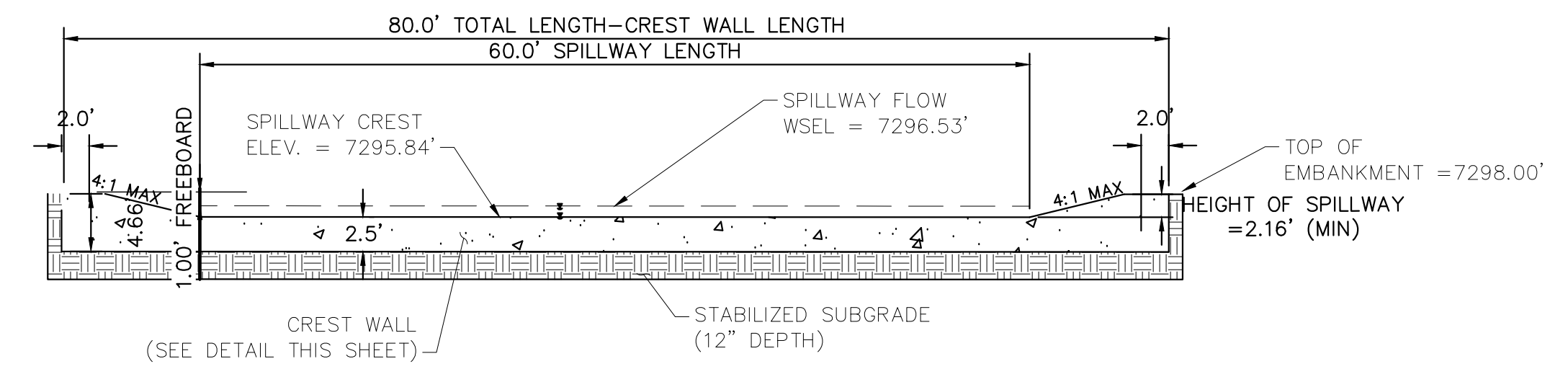

**9 EMERGENCY SPILLWAY**  
 1"=10'

EPC 5/30/23

NO.	REVISION	DATE	BY	APPR.
2	COUNTY COMMENTS	KRK 4/26/23	KRK	
1	COUNTY COMMENTS	KRK 3/10/23	KRK	

**Kimley»Horn**  
 2021 KIMLEY-HORN AND ASSOCIATES, INC.  
 2 North Nevada Avenue Suite 300  
 Colorado Springs, Colorado 80903 (719) 453-0180

DESIGNED BY: KRK  
 DRAWN BY: AUL  
 CHECKED BY: KRK  
 DATE: 12/16/2021

WINSOME FILING NO. 3  
 EL PASO COUNTY, COLORADO  
 CONSTRUCTION DOCUMENTS  
**POND 4 DETAILS**

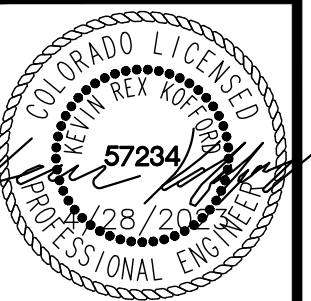

PROJECT NO.  
 196106001

SHEET

**C1.39**

K:\COS\_Civil\196106001\_Winsome Filing No. 3\CADD\PlanSheets\Cds\196106001\_CD\_POND\_4.dwg Kofford, Kevin 4/28/2023 12:21 PM





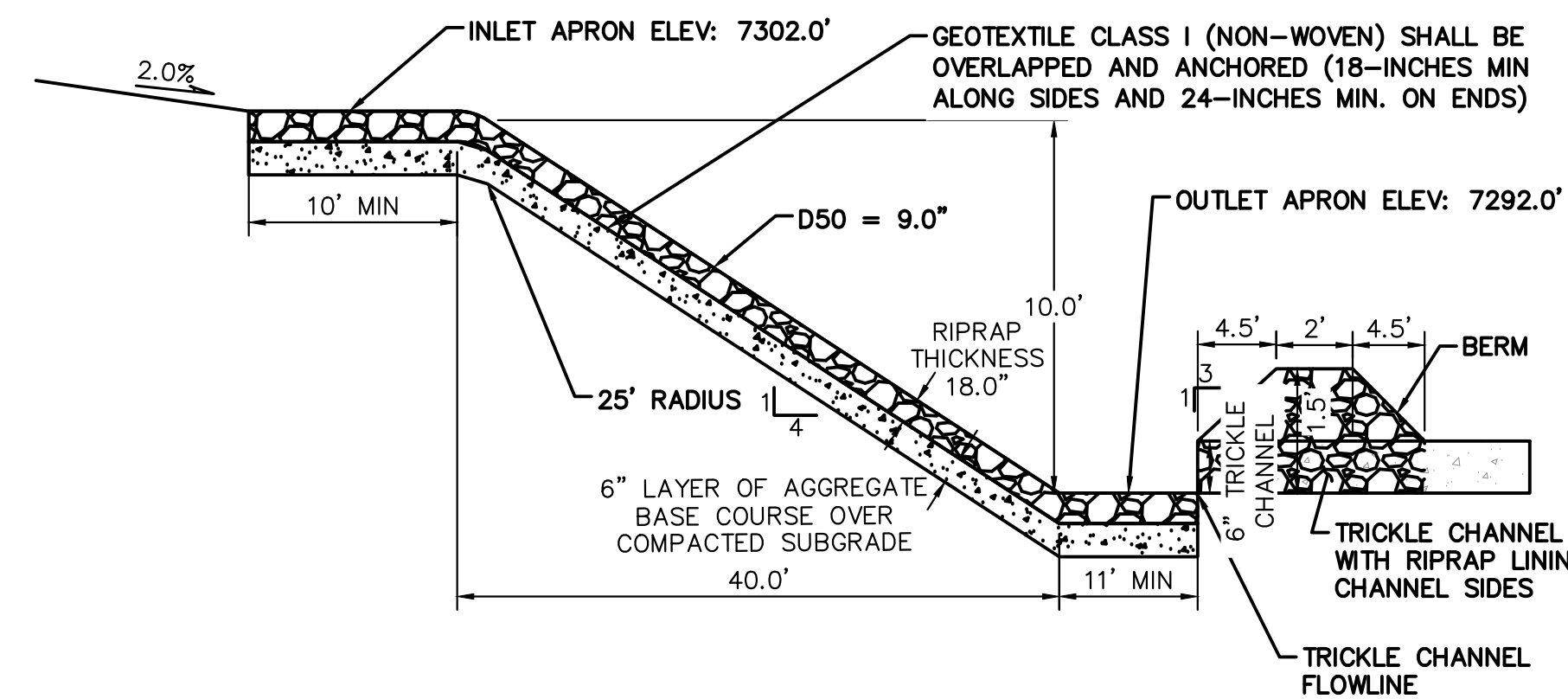

10 **ROCK CHUTE #11 PROFILE- CROSS SECTION 1**  
N.T.S.

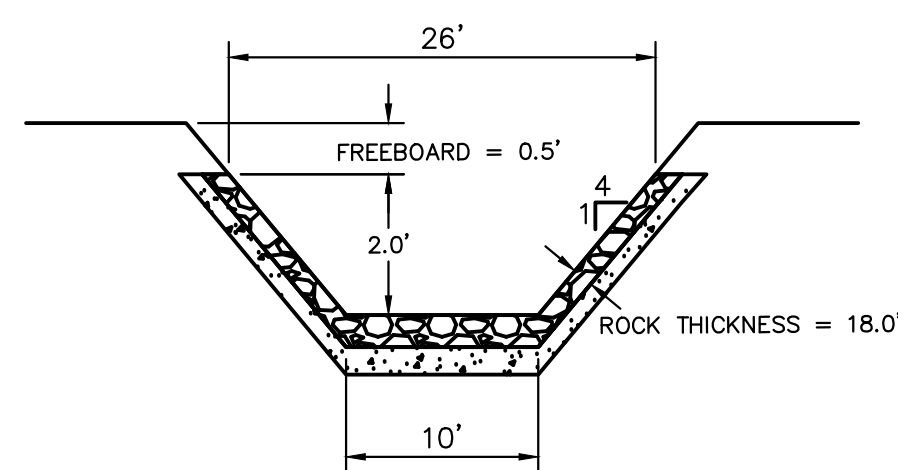

11 **ROCK CHUTE #11 PROFILE- CROSS SECTION 2**  
N.T.S.

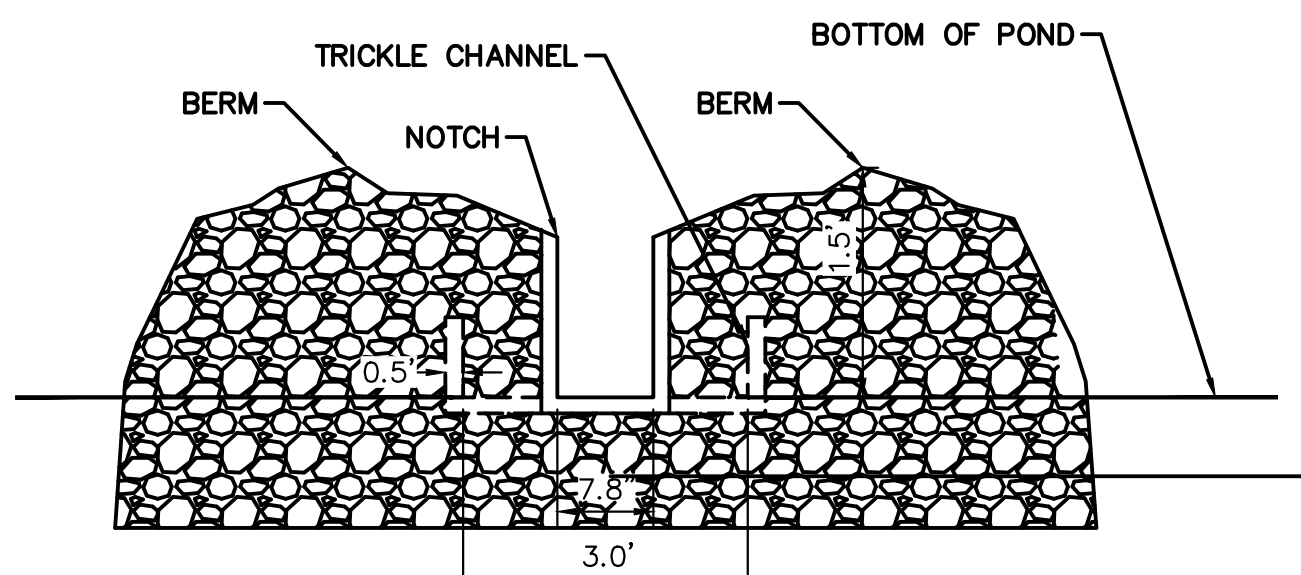

11 **ROCK CHUTE #11 PROFILE- CROSS SECTION 2**  
N.T.S.

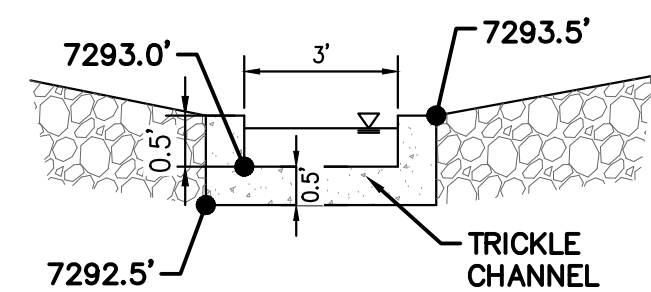

12 **ROCK CHUTE TO TRICKLE CHANNEL TRANSITION**  
N.T.S.

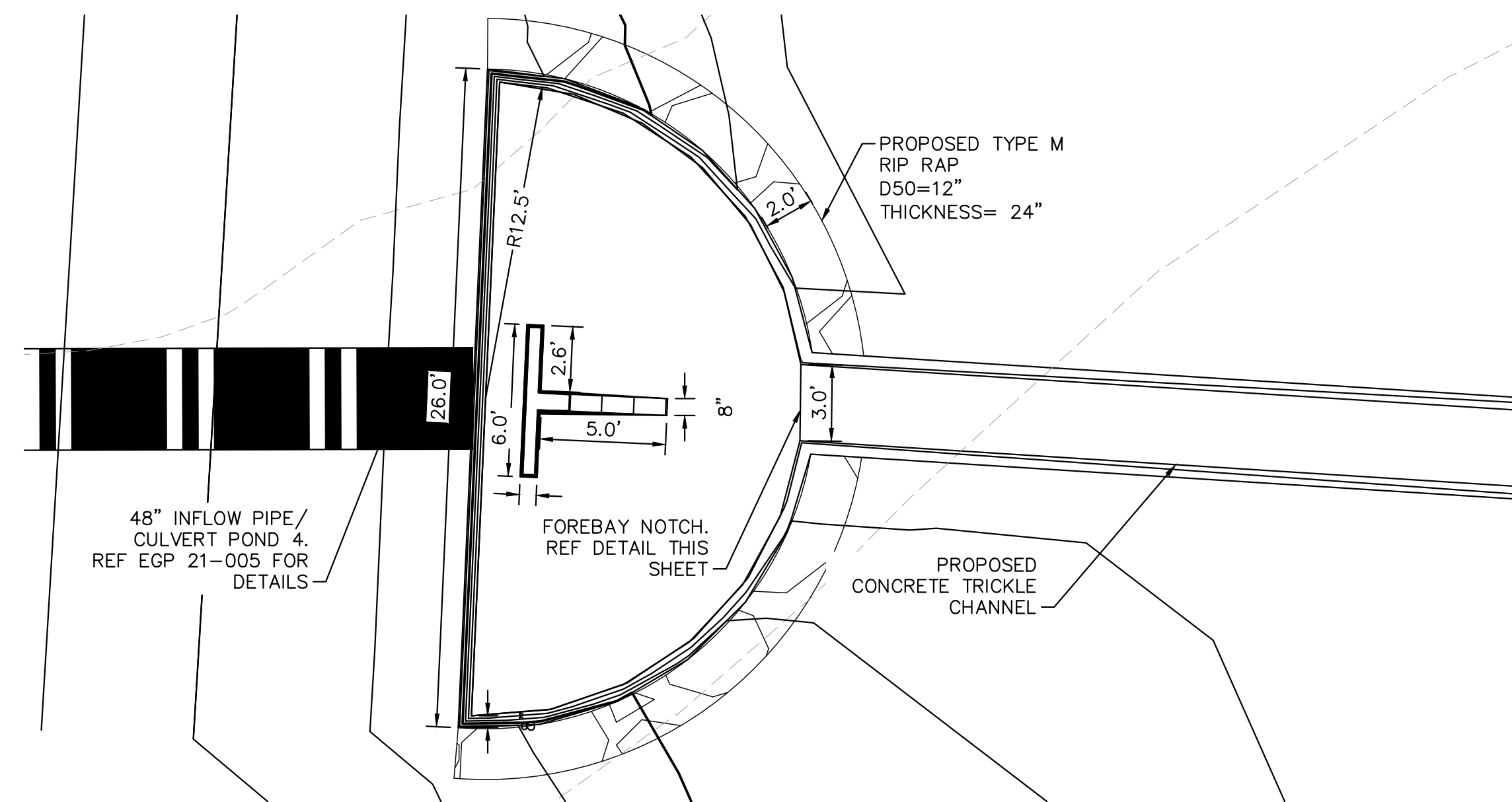

13 **FOREBAY DETAIL PLAN VIEW**  
1"=5'

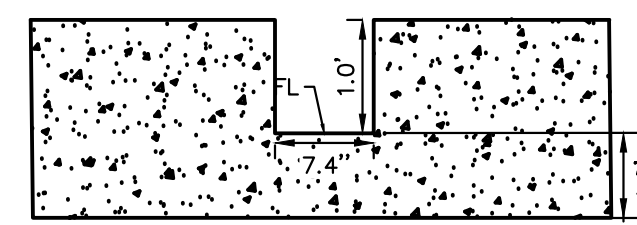

A **FOREBAY NOTCH DETAIL**  
N.T.S.

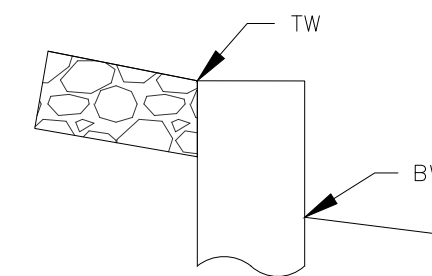

B **SECTION A-A FOREBAY WALL WITH REINFORCING**  
N.T.S.

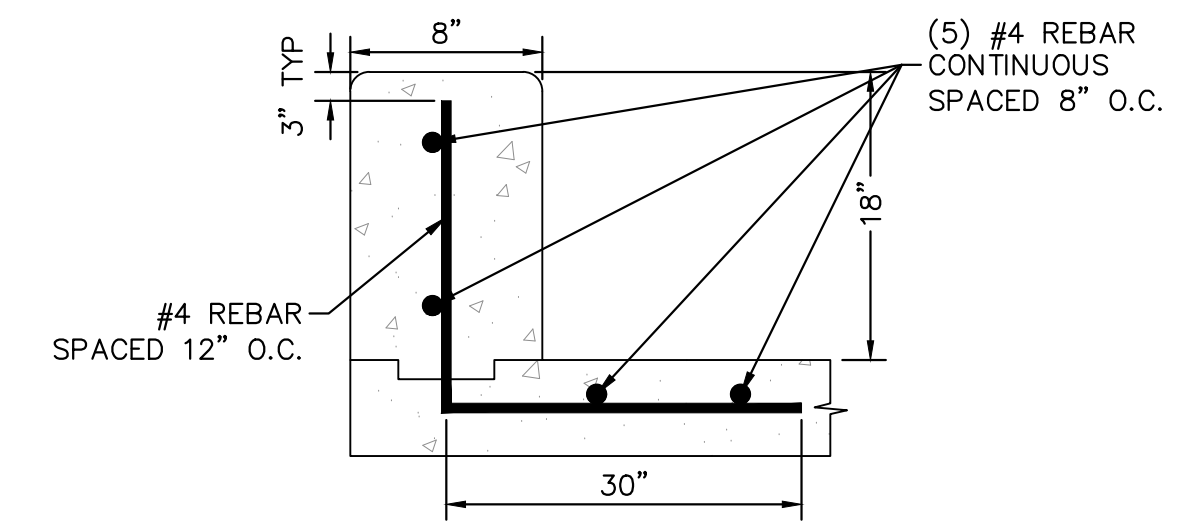

D **FOREBAY WALL CROSS SECTION**  
N.T.S.

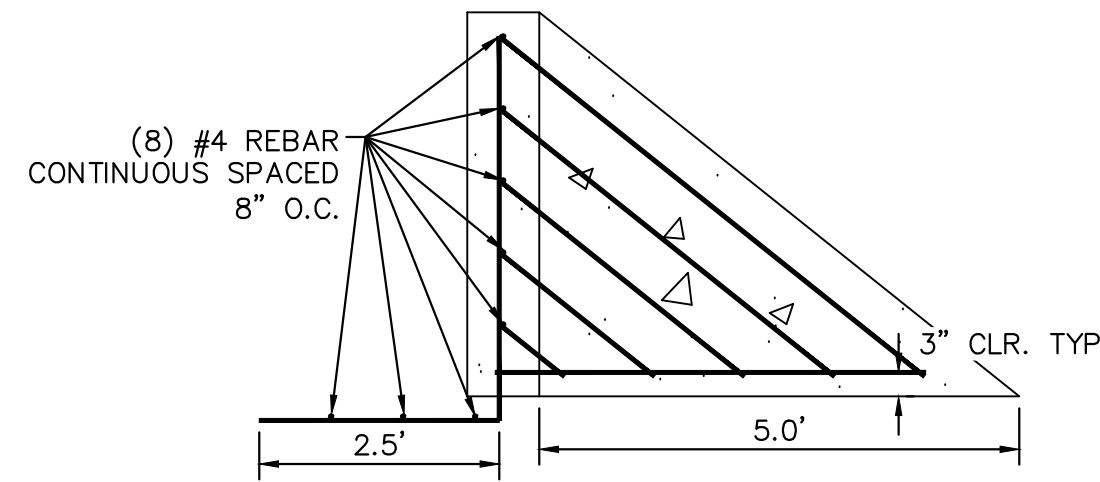
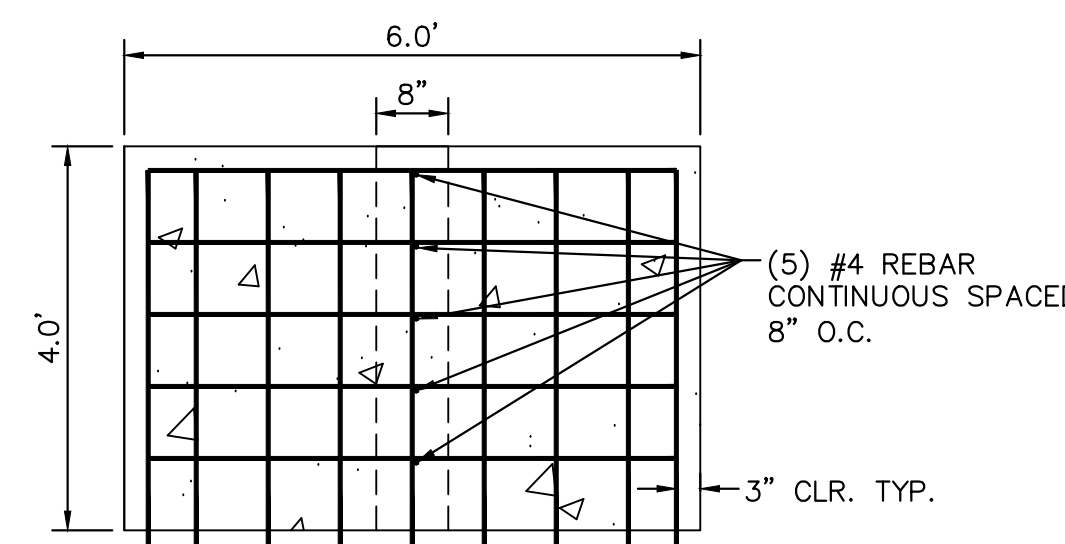

C **FOREBAY DISSIPATER DETAIL**  
1"=2'

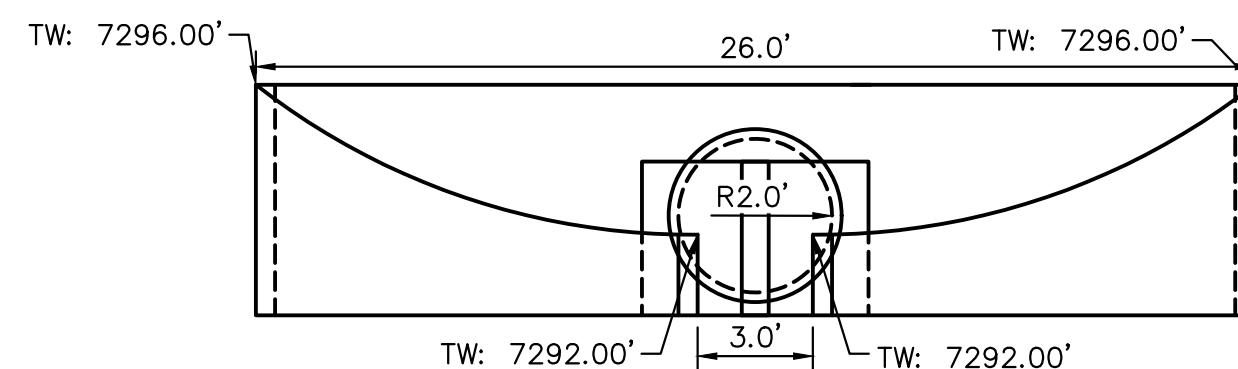

13 **FOREBAY SECTION VIEW**  
1"=5'

- RETAINING WALL NOTES**
1. TW = FINISHED GRADE AT TOP OF WALL
  2. BW = FINISHED GRADE AT BOTTOM OF WALL
  3. SEE DETAIL THIS SHEET FOR FOREBAY DIMENSIONS AND CROSS-SECTION.

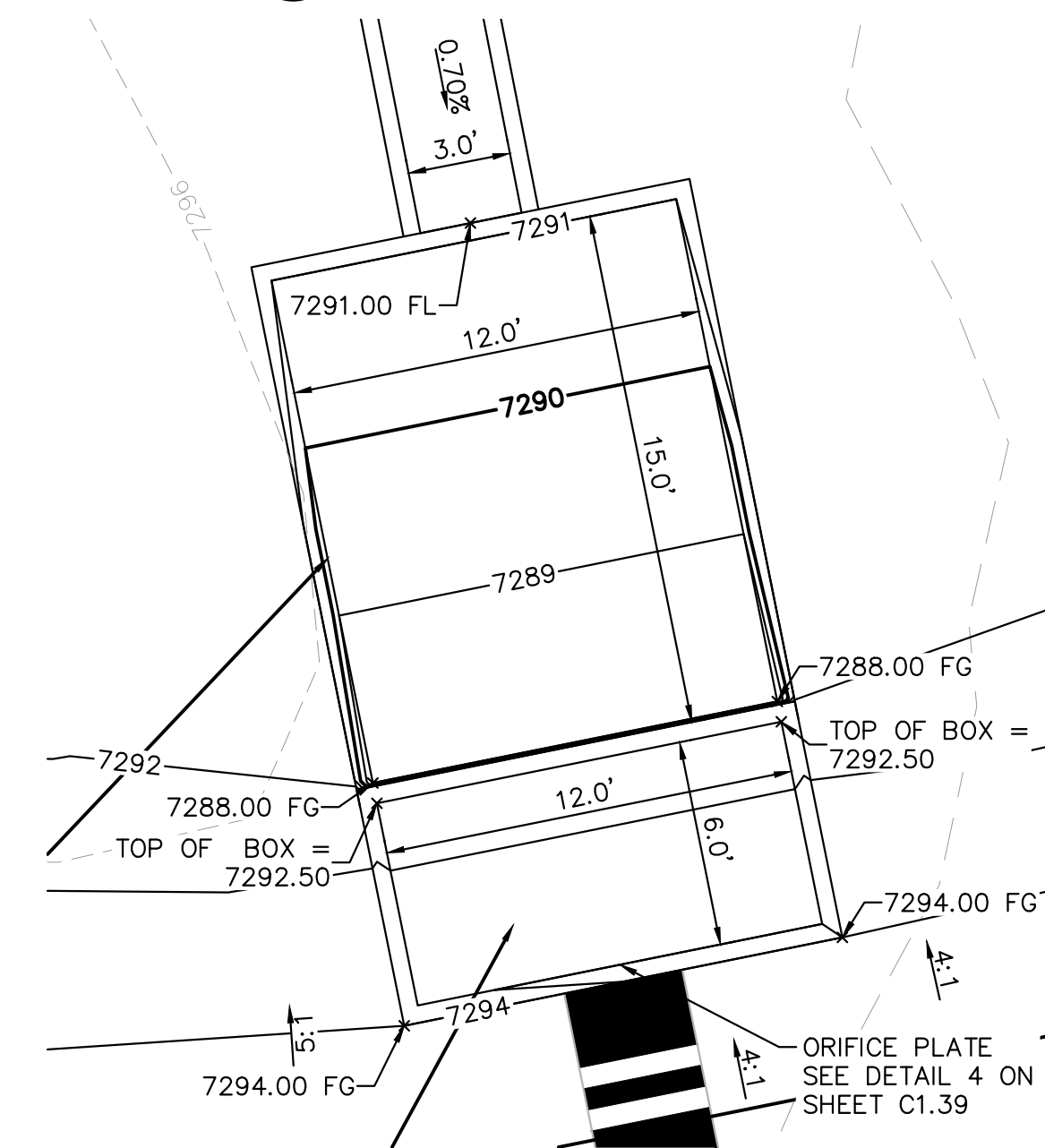

14 **OUTLET STRUCTURE PLAN VIEW DETAIL**  
1"=5'

Rock Chute ID	Channel Location	Flow (cfs)	Upstream Inlet Apron Length (ft)	Drop (ft) (Inlet Apron to Outlet Apron)	Chute Length (ft)	Downstream Outlet Apron Length (ft)	Chute Width (ft)	D50 (in)	Rock Chute Thickness (in)	Radius (ft)	Min Rock Chute Depth (ft)	Rock Chute Depth (ft)	Top Chute Width (ft)
4	Pond 1	107	10	6	24	15	24	18	36	50	1.27	1.50	40
6	Pond 2	110	10	8	32	18	17	18	36	50	1.57	2.00	33
11	Pond 4	26	10	10	40	11	10	9	18	25	0.85	1.50	26
12	WQ Pond	100	11	5	20	20	12	18	36	50	1.81	2.00	28
13	WQ Pond	57	10	3	12	16	10	18	36	50	1.38	1.50	26

15 **STANDARD ROCK CHUTE DIMENSION TABLE**  
N.T.S.

1. SEE GRADING PLANS FOR ROCK CHUTE LOCATIONS

EPC 5/30/23

NO.	REVISION	DATE	BY	APPR.
2	COUNTY COMMENTS	KRK 4/26/23	KRK	
1	COUNTY COMMENTS	KRK 3/10/23	KRK	

**Kimley»Horn**  
2021 KIMLEY-HORN AND ASSOCIATES, INC.  
2 North Nevada Avenue Suite 300  
Colorado Springs, Colorado 80903 (719) 453-0180

DESIGNED BY: KRK  
DRAWN BY: A.J.L.  
CHECKED BY: KRK  
DATE: 12/16/2021

WINSOME FILING NO. 3  
EL PASO COUNTY, COLORADO  
CONSTRUCTION DOCUMENTS  
POND 4 DETAILS

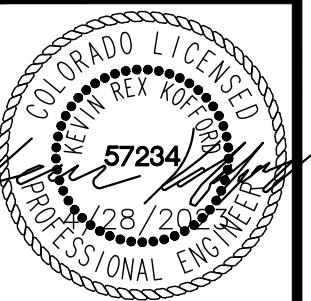

PROJECT NO.  
196106001

SHEET

C1.40

K:\COS\_Civil\196106001\_Winsome Filing No. 3\CADD\PlanSheets\Cds\196106001\_CD\_POND\_4.dwg Kofford, Kevin 4/28/2023 12:21 PM



CALL UTILITY NOTIFICATION CENTER OF COLORADO  
1-800-922-1987  
CALL 2-BUSINESS DAYS IN ADVANCE BEFORE YOU DIG, GRADE, OR EXCAVATE FOR THE MARKING OF UNDERGROUND MEMBER UTILITIES

K:\COS\_Civil\196106001\_Winsome Filing No. 3\CADD\PlanSheets\Cds\196106001\_CD\_WQ\_Pond.dwg Kofford, Kevin 4/28/2023 12:22 PM

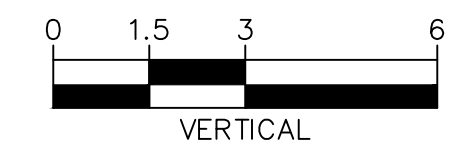
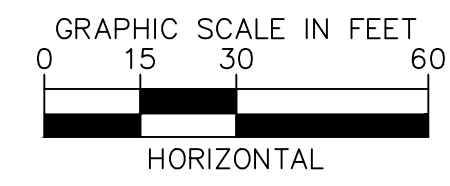
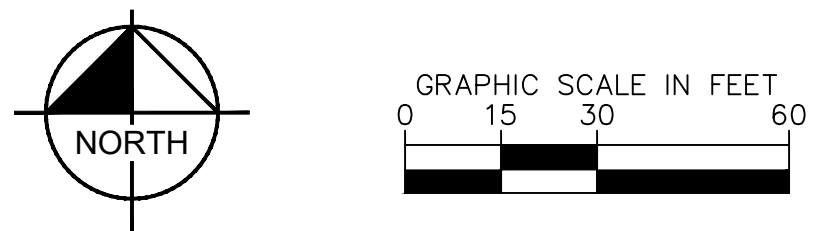
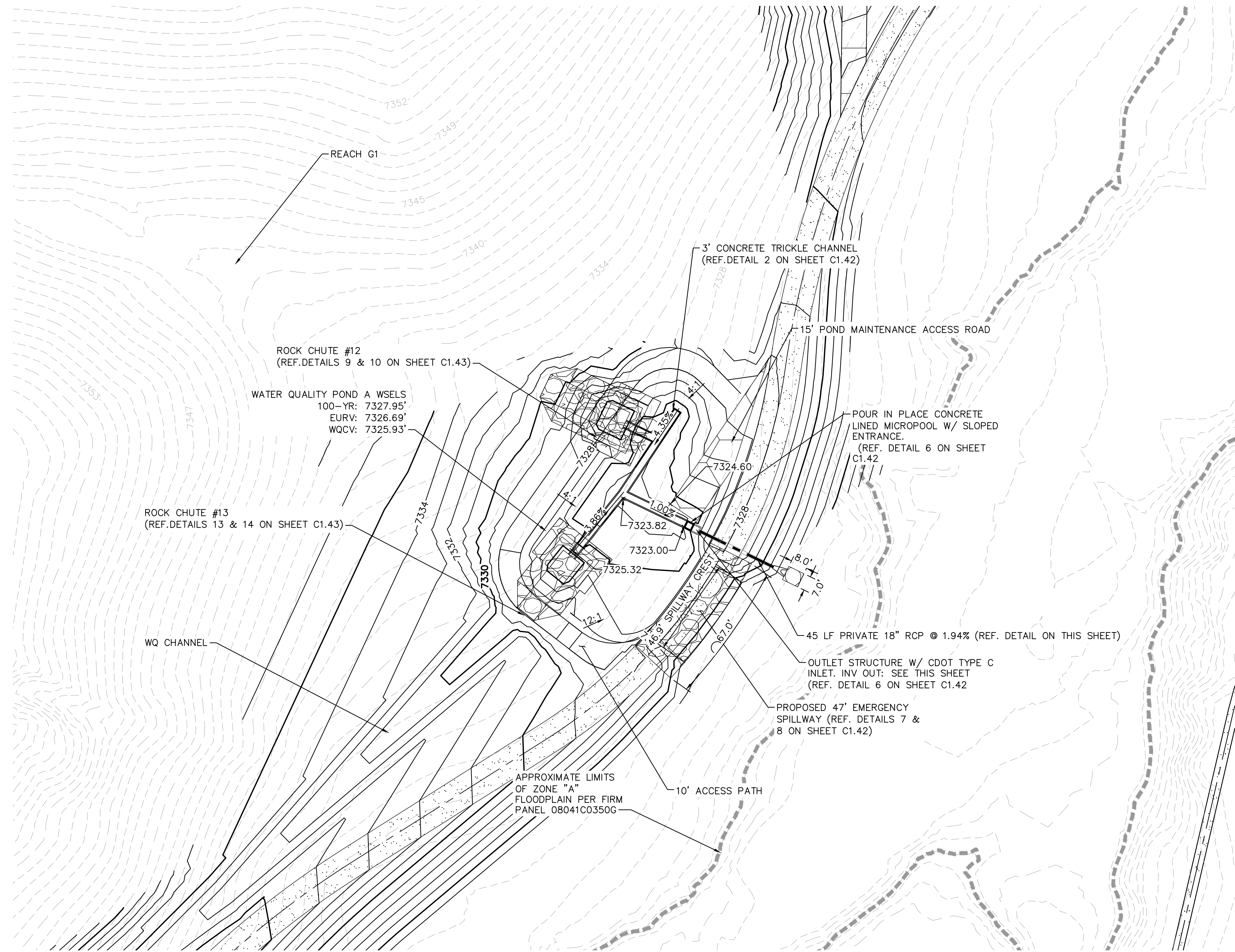

**LEGEND**

FG	FINISH GRADE
FBT	TOP OF FOREBAY AT FINISHED GRADE
FBB	BOTTOM OF FOREBAY AT FINISHED GRADE
TCT	TOP OF TRICKLE CHANNEL AT FINISHED GRADE
TCB	BOTTOM OF TRICKLE CHANNEL AT FINISHED GRADE
MPT	TOP OF MICROPOOL AT FINISHED GRADE
MPB	BOTTOM OF MICROPOOL AT FINISHED GRADE
GRATE	OUTLET STRUCTURE GRATE ELEVATION
ME	MATCH EXISTING
PT	TOP OF STEEL PLATE AT FINISHED GRADE
PB	BOTTOM OF STEEL PLATE AT FINISHED GRADE
-----	FLOODPLAIN LIMITS
=====	TOP OF POND
-----	PROPOSED STORM SEWER

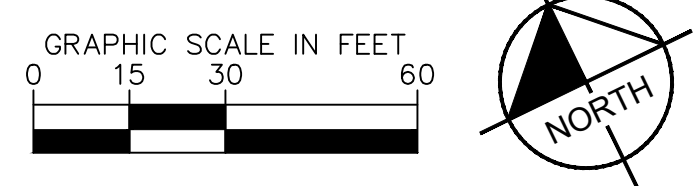
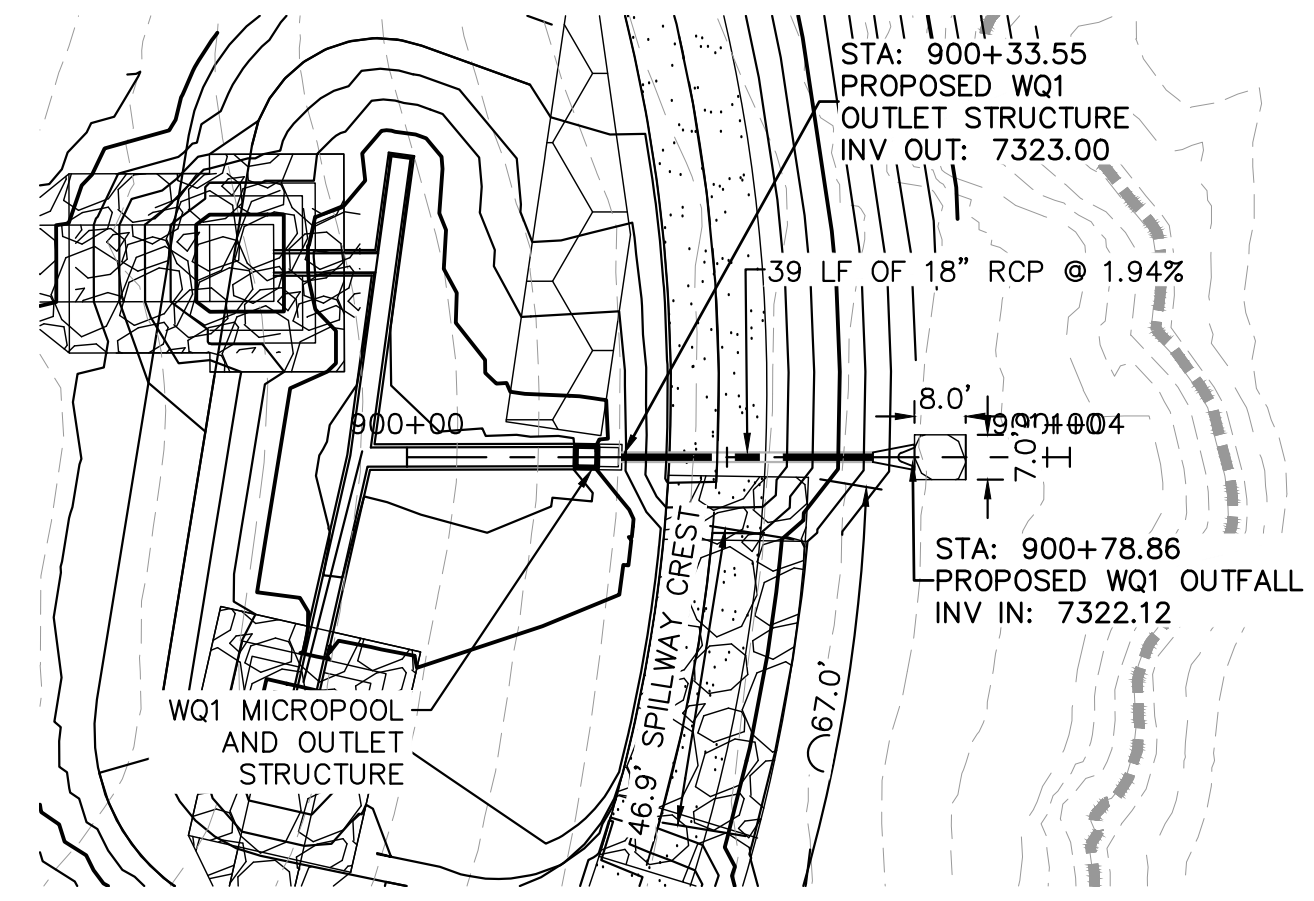

WQA POND OUTLET PIPE PLAN AND PROFILE

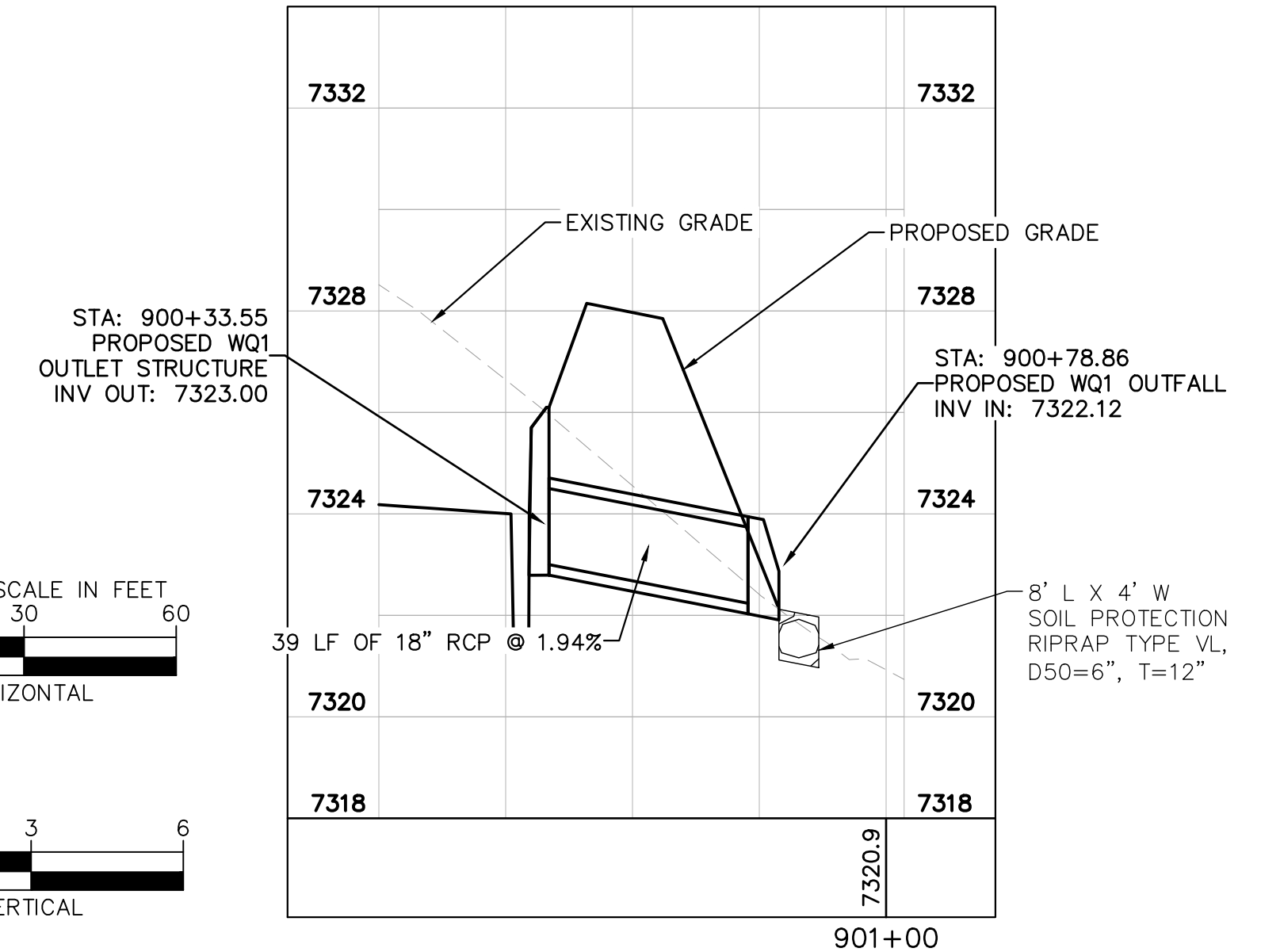

EPC 5/30/23

NO.	REVISION	BY	DATE	APPR.
2	COUNTY COMMENTS	KRK	4/28/23	KRK
1	COUNTY COMMENTS	KRK	3/10/23	KRK

**Kimley»Horn**  
2021 KIMLEY-HORN AND ASSOCIATES, INC.  
2 North Nevada Avenue Suite 300  
Colorado Springs, Colorado 80903 (719) 453-0180

DESIGNED BY: KRK  
DRAWN BY: AUL  
CHECKED BY: KRK  
DATE: 12/16/2021

WINSOME FILING NO. 3  
EL PASO COUNTY, COLORADO  
CONSTRUCTION DOCUMENTS  
WQ POND A OVERVIEW



PROJECT NO.  
196106001

SHEET

C1.41

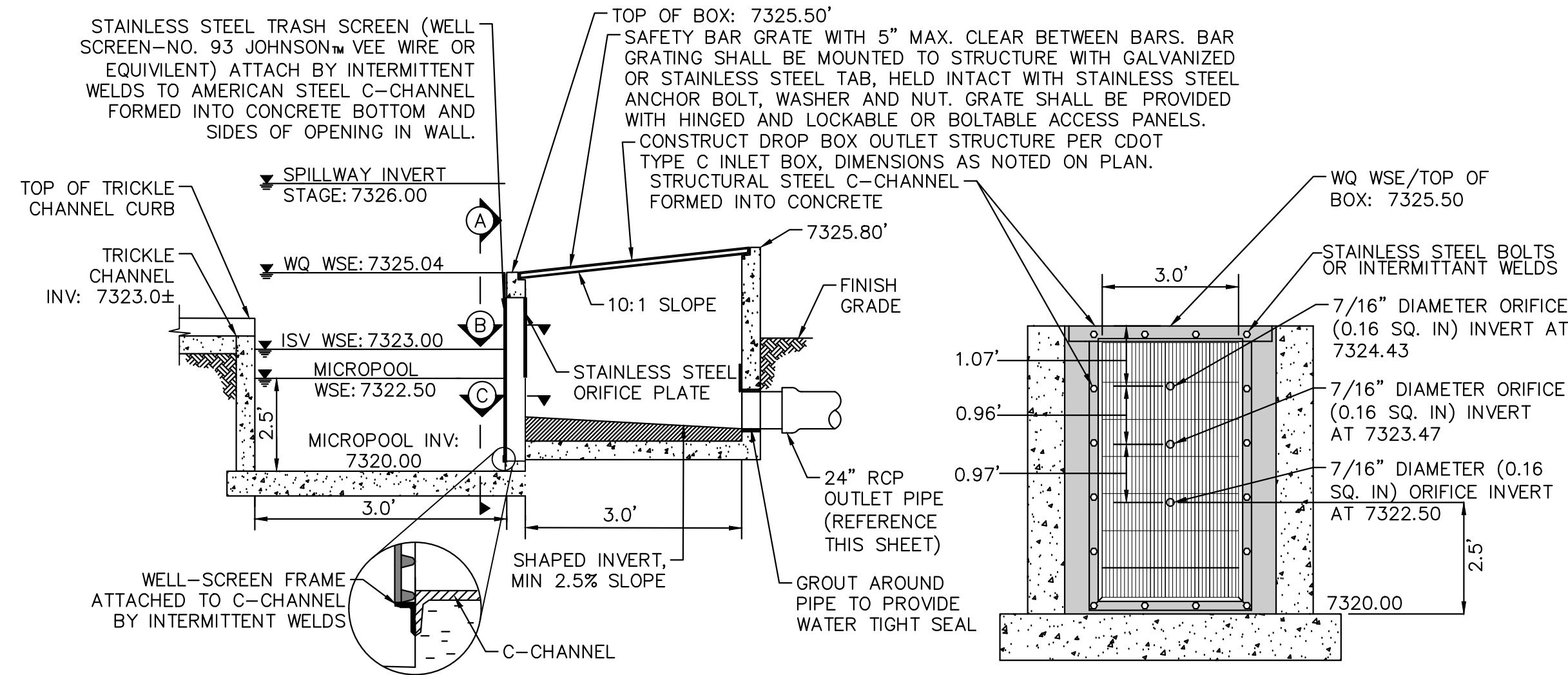

5 OUTLET STRUCTURE DETAIL  
N.T.S.

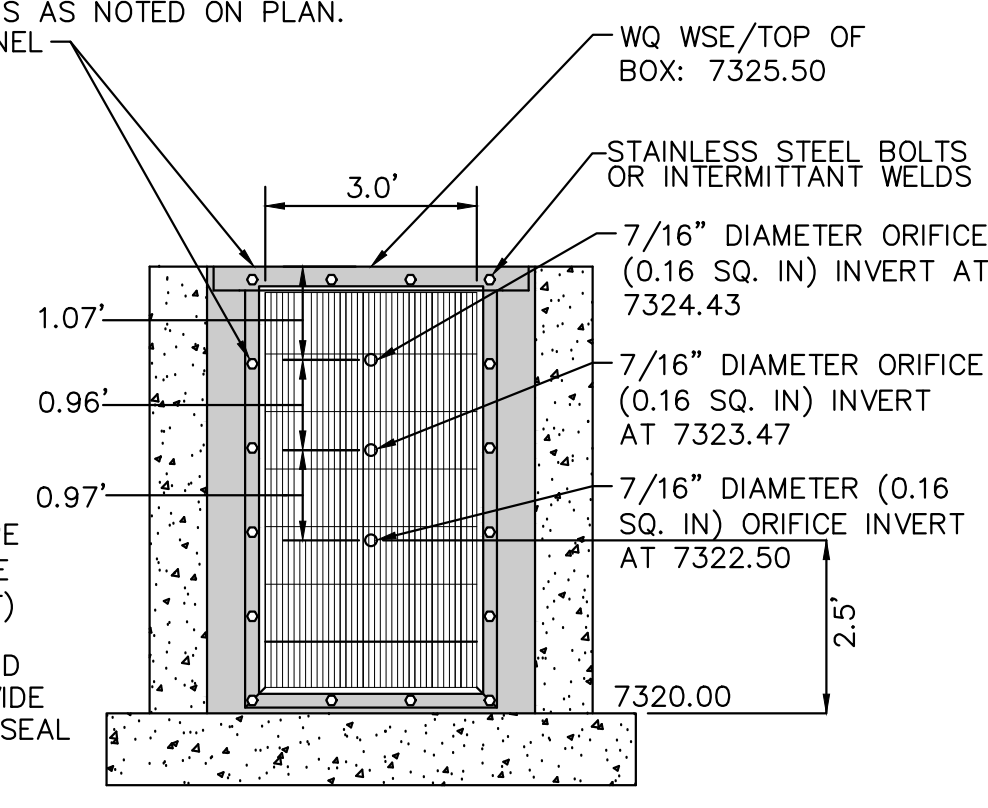

B SECTION A  
N.T.S.

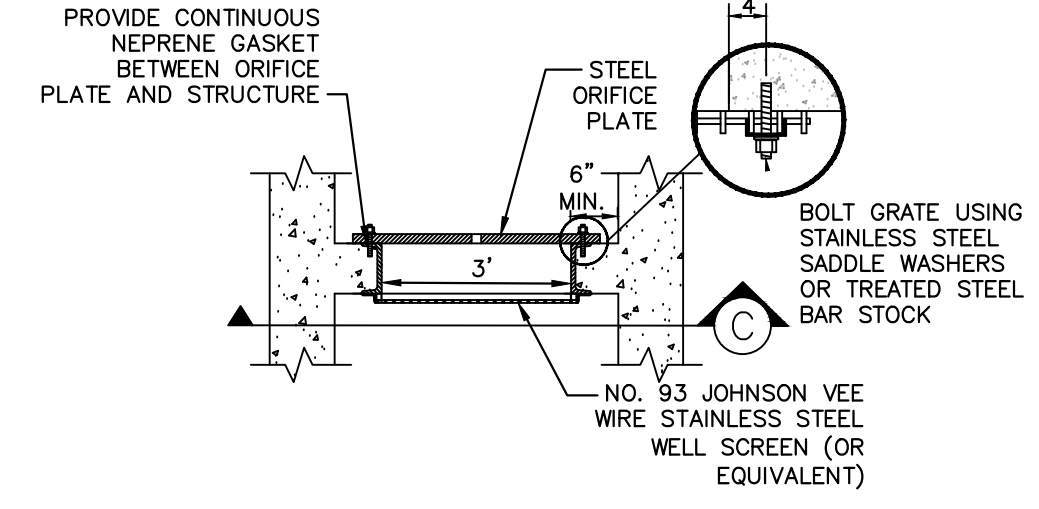

B SECTION B  
N.T.S.

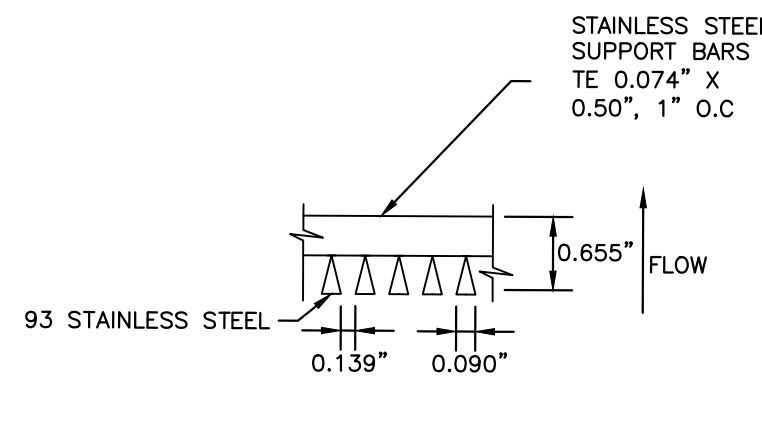

C SECTION C  
N.T.S.

4 ORIFICE PLATE AND TRASH RACK DETAIL  
N.T.S.

- ORIFICE PLATE NOTES**
1. PROVIDE CONTINUOUS NEOPRENE GASKET MATERIAL BETWEEN THE ORIFICE PLATE AND CONCRETE.
  2. BOLT PLATE TO CONCRETE 12" MAX. ON CENTER, WITH A PLATE THICKNESS OF 0.25".
- EURV AND WQCV TRASH RACKS**
1. WELL-SCREEN TRASH RACKS SHALL BE STAINLESS STEEL AND SHALL BE ATTACHED BY INTERMITTENT WELDS ALONG THE EDGE OF THE MOUNTING FRAME.
  2. BAR GATE TRASH RACKS SHALL BE ALUMINUM AND SHALL BE BOLTED USING STAINLESS STEEL HARDWARE.
  3. TRASH RACK OPEN AREAS ARE FOR SPECIFIED TRASH RACK MATERIALS. TOTAL TRASH RACK SIZE MAY NEED TO BE ADJUSTED FOR MATERIALS HAVING DIFFERENT OPEN AREA/GROSS AREA RATIO (R VALUE).
  4. STRUCTURAL DESIGN OF TRASH RACKS SHALL BE BASED ON FULL HYDROSTATIC HEAD WITH ZERO HEAD DOWNSTREAM OF THE RACK.
- OVERFLOW SAFETY GRATES**
1. ALL SAFETY GRATES SHALL BE MOUNTED USING STAINLESS STEEL HARDWARE AND PROVIDED WITH HINGED AND LOCKABLE OR BOLTABLE ACCESS PANELS.
  2. SAFETY GRATES SHALL BE STAINLESS STEEL, ALUMINUM, OR STEEL. STEEL GRATES SHALL BE HOT DIP GALVANIZED AND MAY BE HOT POWDER COATED AFTER GALVANIZING.
  3. SAFETY GRATES SHALL BE DESIGNED SUCH THAT THE DIAGONAL DIMENSION OF EACH OPENING IS SMALLER THAN THE DIAMETER OF THE OUTLET PIPE.
  4. STRUCTURAL DESIGN OF SAFETY GRATES SHALL BE BASED ON FULL HYDROSTATIC HEAD WITH ZERO HEAD DOWNSTREAM OF THE RACK.

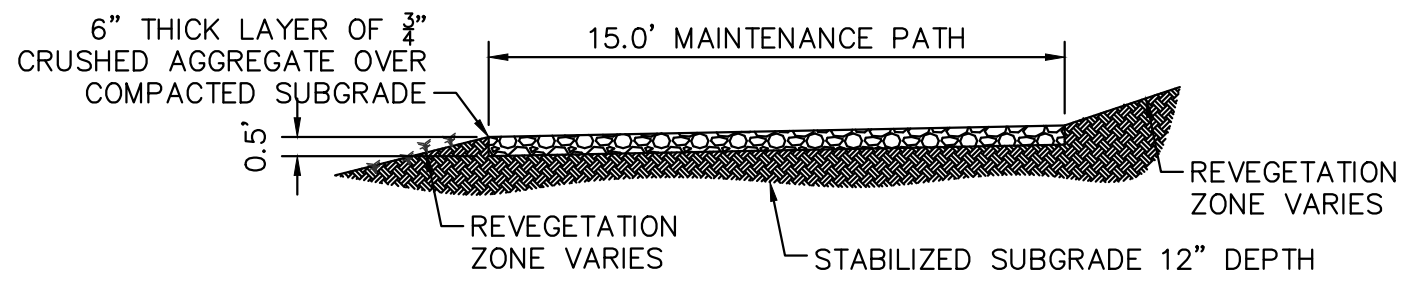

1 MAINTENANCE ROAD  
1"=5'

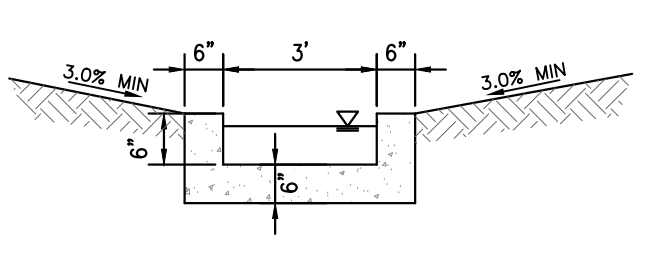

2 CONCRETE TRICKLE CHANNEL  
N.T.S.

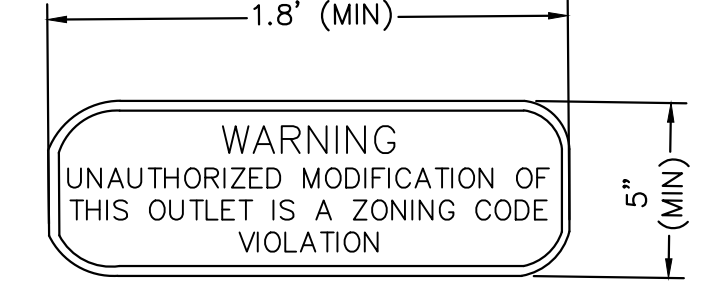

3 OUTLET SIGNAGE  
N.T.S.

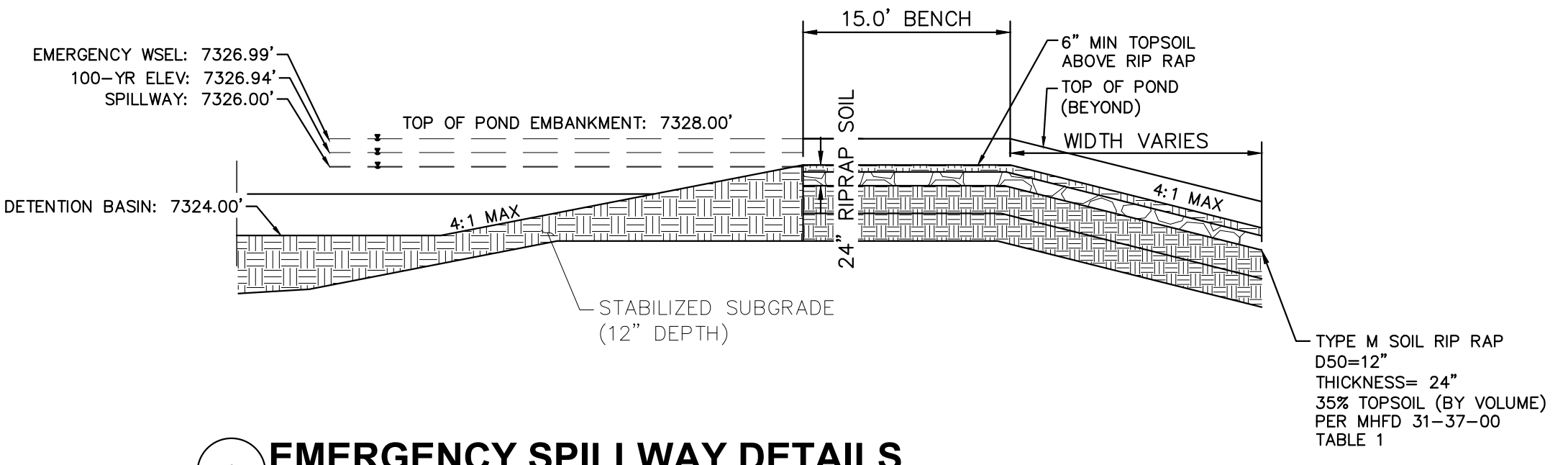

6 EMERGENCY SPILLWAY DETAILS  
1"=10'

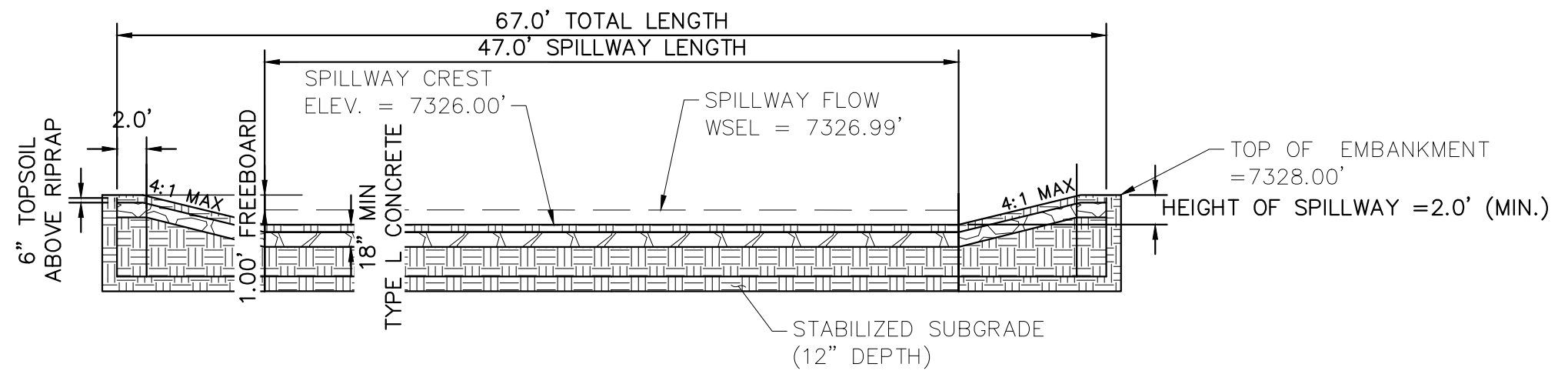

7 EMERGENCY SPILLWAY  
1"=10'



NO.	REVISION	DATE	BY	APPR.
1				
2				

**Kimley»Horn**  
2021 KIMLEY-HORN AND ASSOCIATES, INC.  
2 North Nevada Avenue Suite 300  
Colorado Springs, Colorado 80903 (719) 453-0180

DESIGNED BY: KRK  
DRAWN BY: AJL  
CHECKED BY: KRK  
DATE: 12/16/2021

WINSOME FILING NO. 3  
EL PASO COUNTY, COLORADO  
CONSTRUCTION DOCUMENTS  
WQ POND A DETAILS



PROJECT NO.  
196106001  
SHEET

C1.42

K:\COS\_Civil\196106001\_Winsome Filing No. 3\CADD\PlanSheets\Cds\196106001\_CD\_WQ\_Pond.dwg Kofford, Kevin 4/28/2023 12:22 PM

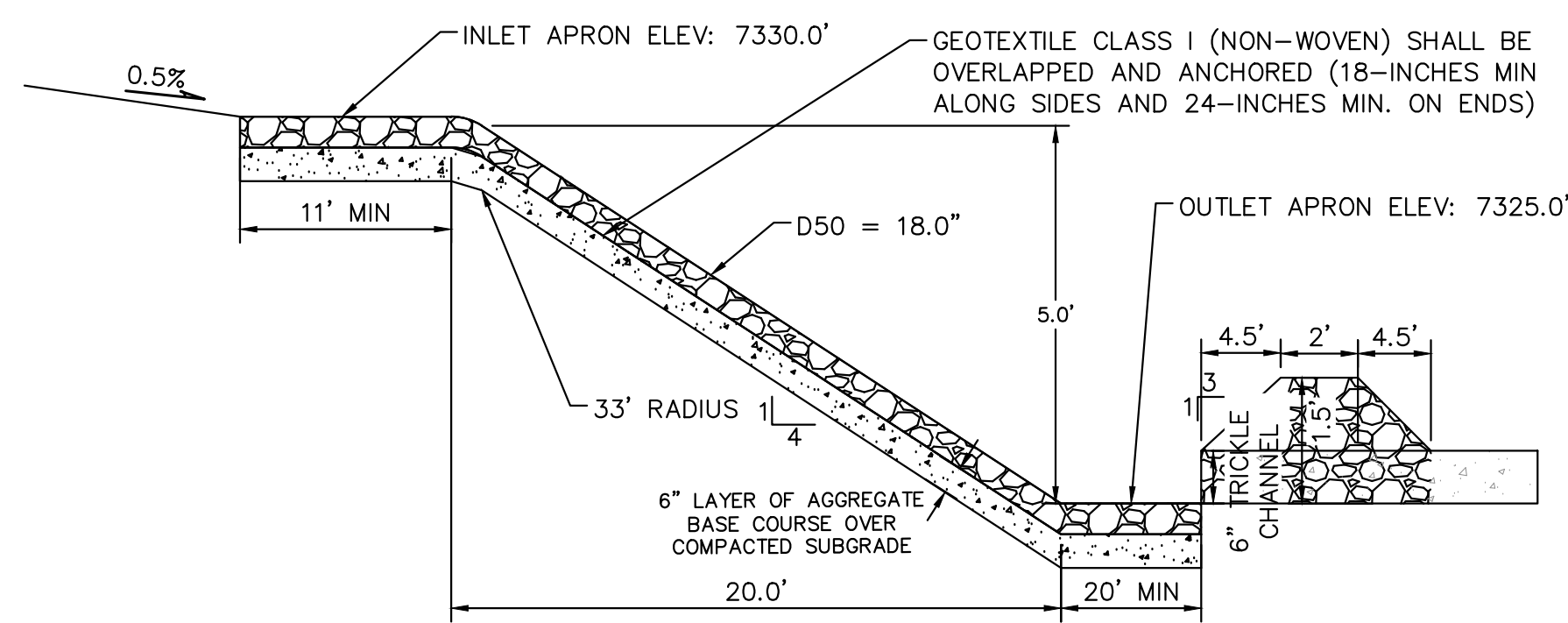

9 **ROCK CHUTE #12 PROFILE- CROSS SECTION 1**  
N.T.S.

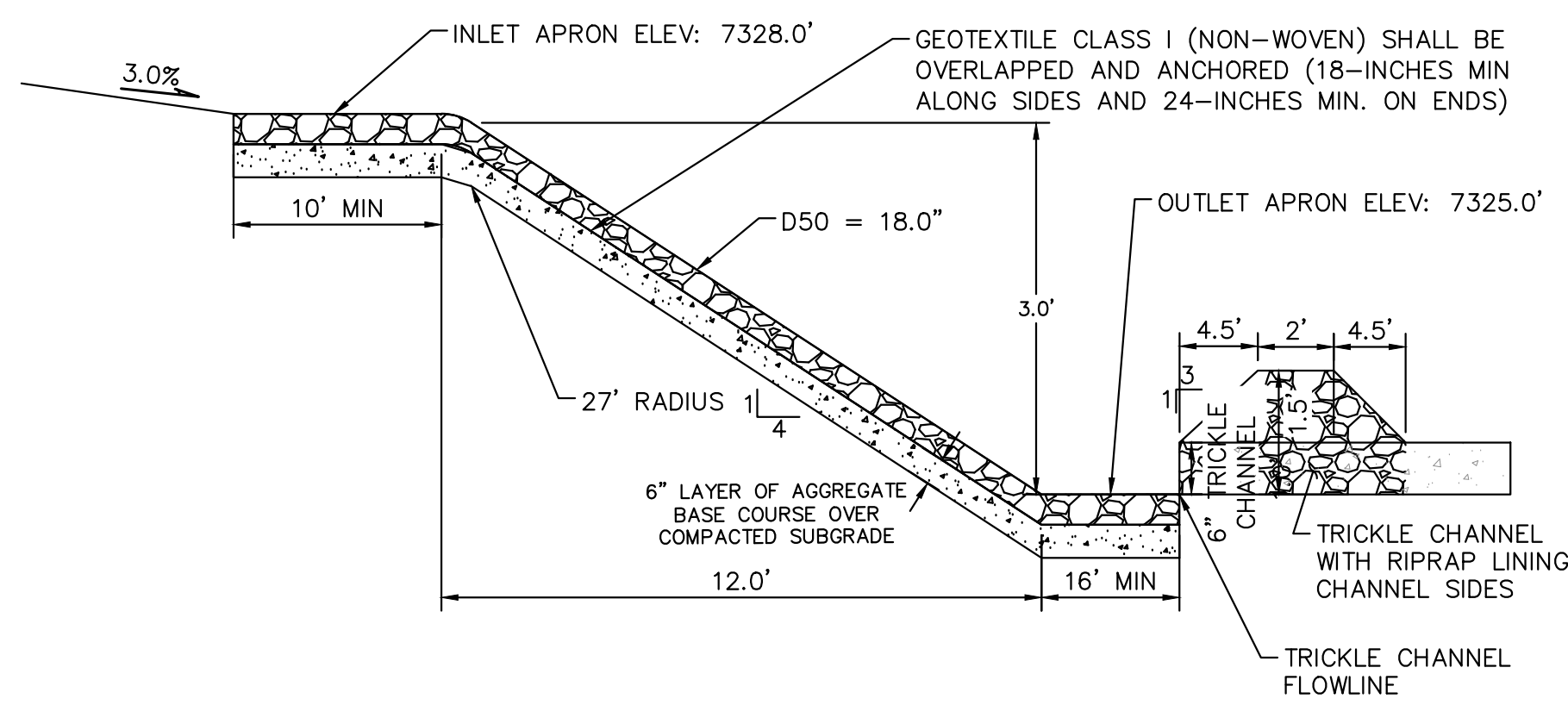

12 **ROCK CHUTE #13 PROFILE- CROSS SECTION 1**  
N.T.S.

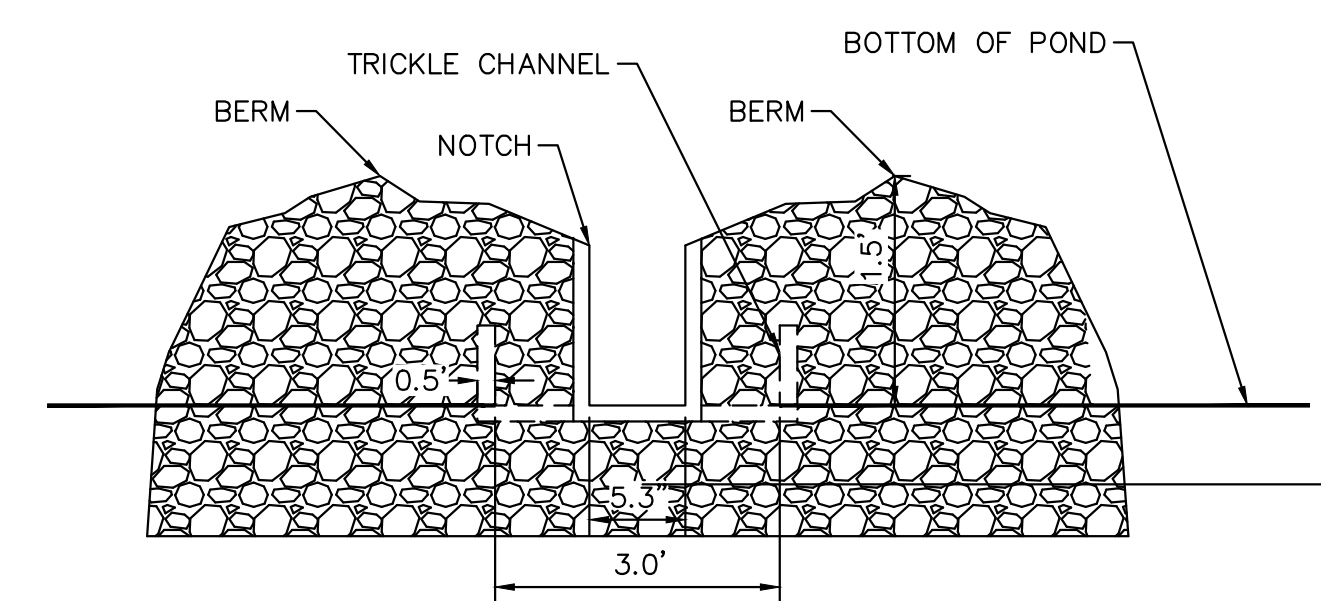

16 **ROCK CHUTE #12 PROFILE- CROSS SECTION 2**  
N.T.S.

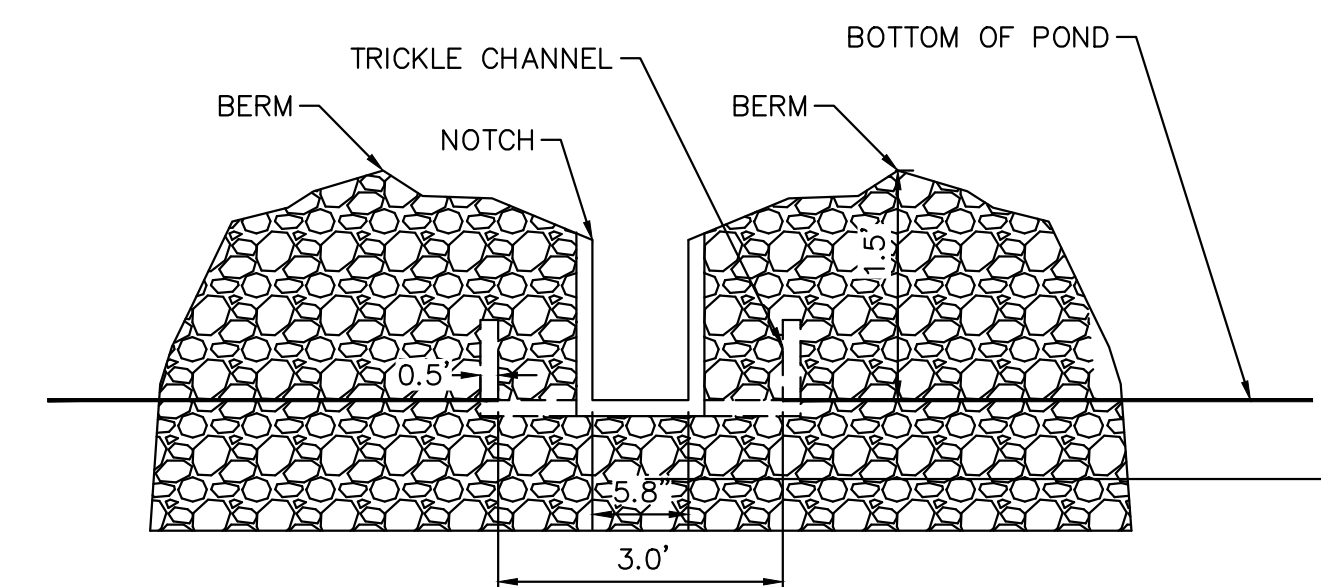

17 **ROCK CHUTE #13 PROFILE- CROSS SECTION 2**  
N.T.S.

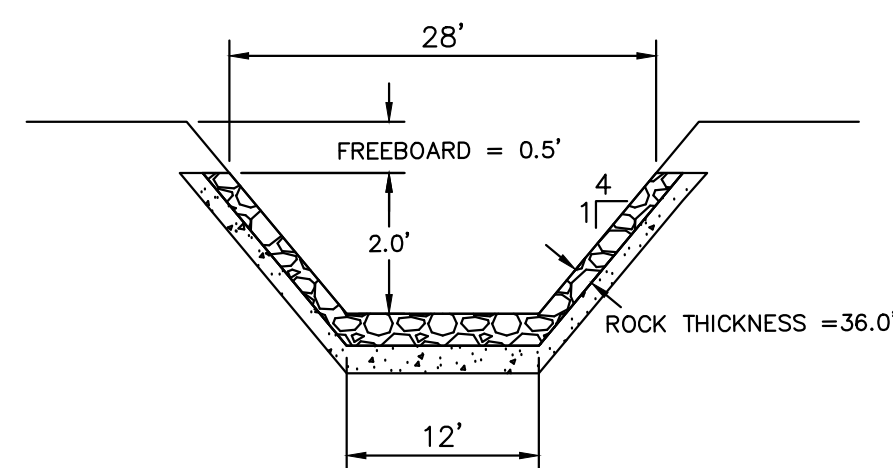

10 **ROCK CHUTE #12 PROFILE- CROSS SECTION 2**  
N.T.S.

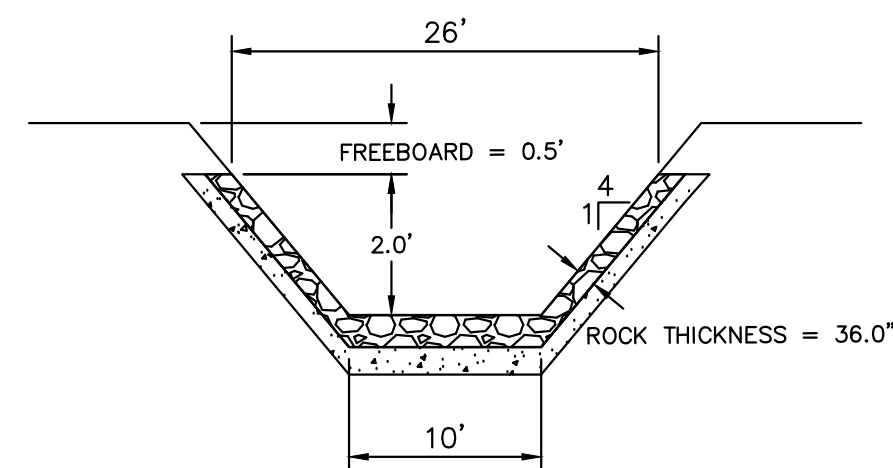

13 **ROCK CHUTE #13 PROFILE- CROSS SECTION 2**  
N.T.S.

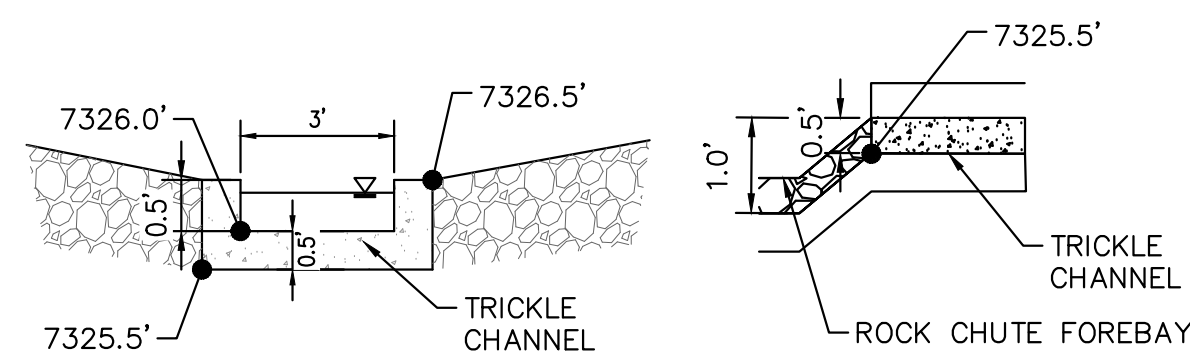

11 **ROCK CHUTE #12 TO TRICKLE CHANNEL TRANSITION**  
N.T.S.

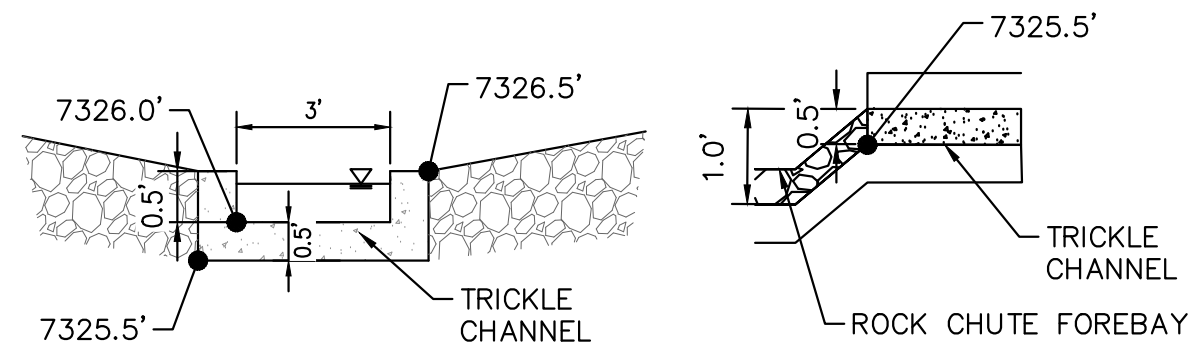

14 **ROCK CHUTE #13 TO TRICKLE CHANNEL TRANSITION**  
N.T.S.

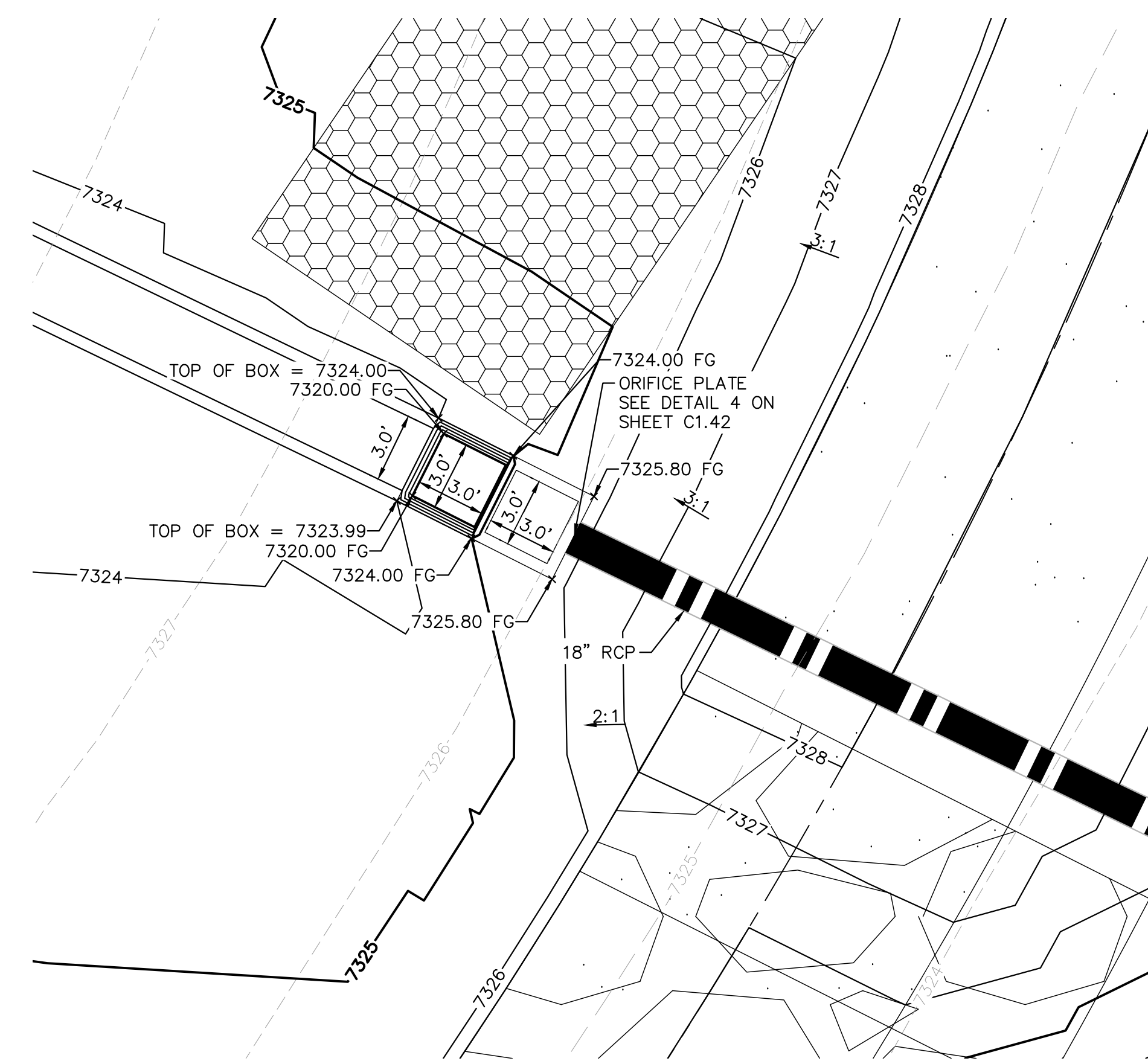

15 **OUTLET STRUCTURE PLAN VIEW DETAIL**  
1"=5'

Rock Chute ID	Channel Location	Flow (cfs)	Upstream Inlet Apron Length (ft)	Drop (ft) (Inlet Apron to Outlet Apron)	Chute Length (ft)	Downstream Outlet Apron Length (ft)	Chute Width (ft)	D50 (in)	Rock Chute Thickness (in)	Radius (ft)	Min Rock Chute Depth (ft)	Rock Chute Depth (ft)	Top Chute Width (ft)
4	Pond 1	107	10	6	24	15	24	18	36	50	1.27	1.50	40
6	Pond 2	110	10	8	32	18	17	18	36	50	1.57	2.00	33
11	Pond 4	26	10	10	40	11	10	9	18	25	0.85	1.50	26
12	WQ Pond	100	11	5	20	20	12	18	36	50	1.81	2.00	28
13	WQ Pond	57	10	3	12	16	10	18	36	50	1.38	1.50	26



NO.	REVISION	DATE	BY	DATE	APPR.
2	COUNTY COMMENTS	KRK 4/28/23	KRK		
1	COUNTY COMMENTS	KRK 3/10/23	KRK		

**Kimley»Horn**  
2021 KIMLEY-HORN AND ASSOCIATES, INC.  
2 North Nevada Avenue Suite 300  
Colorado Springs, Colorado 80903 (719) 453-0180

DESIGNED BY: KRK  
DRAWN BY: A.J.L.  
CHECKED BY: KRK  
DATE: 12/16/2021

WINSOME FILING NO. 3  
EL PASO COUNTY, COLORADO  
CONSTRUCTION DOCUMENTS  
WQ POND A DETAILS

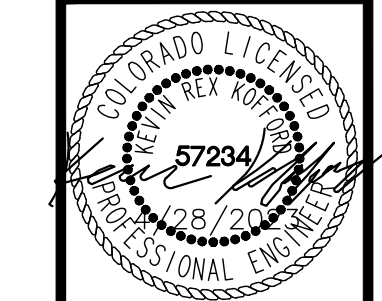

PROJECT NO.  
196106001

SHEET  
C1.43

K:\COS\_Civil\196106001\_Winsome Filing No. 3\CADD\PlanSheets\CDS\196106001\_CD\_CD.dwg Kofford, Kevin 4/28/2023 10:21 AM

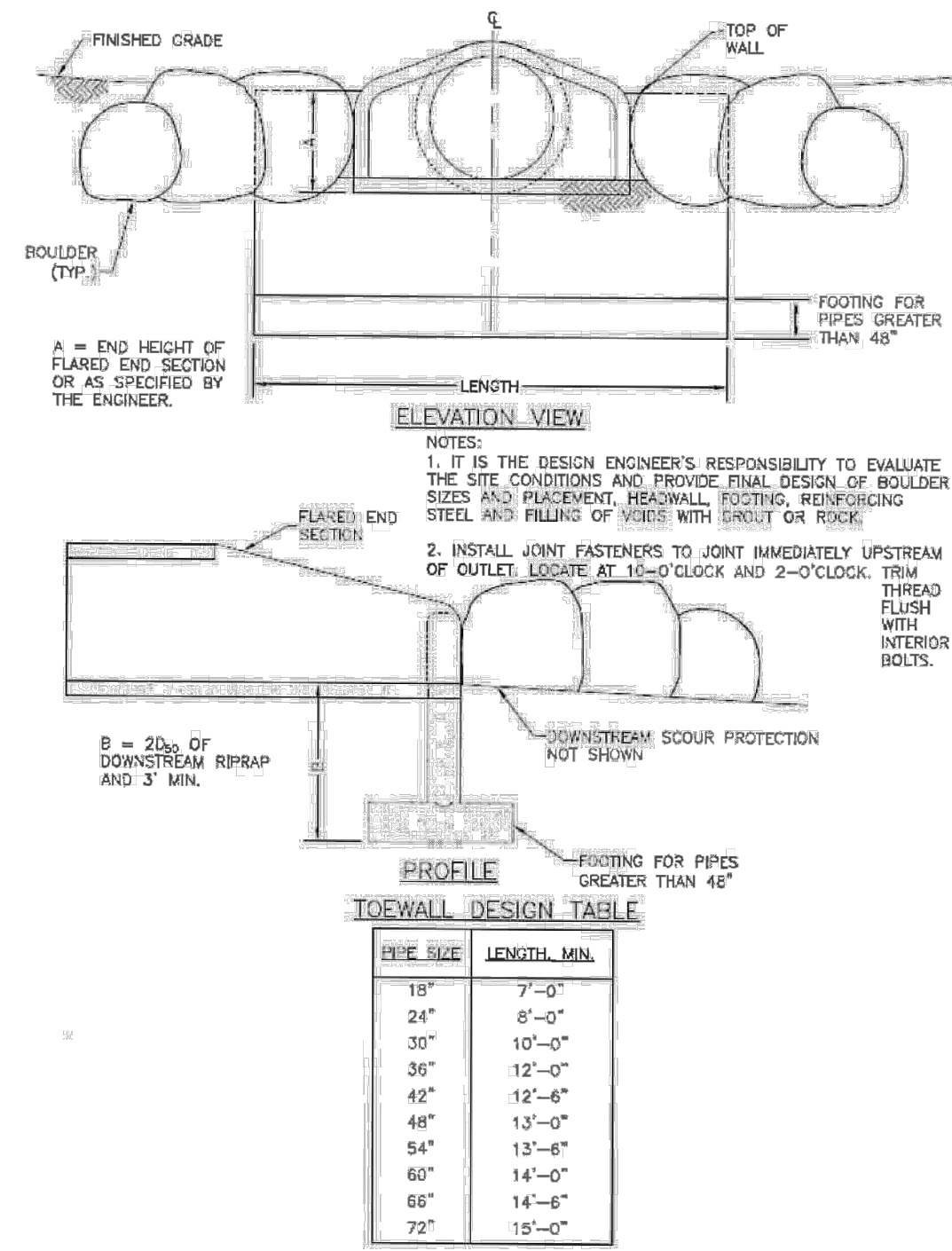

Figure 9-30. Flared end section (FES) headwall concept

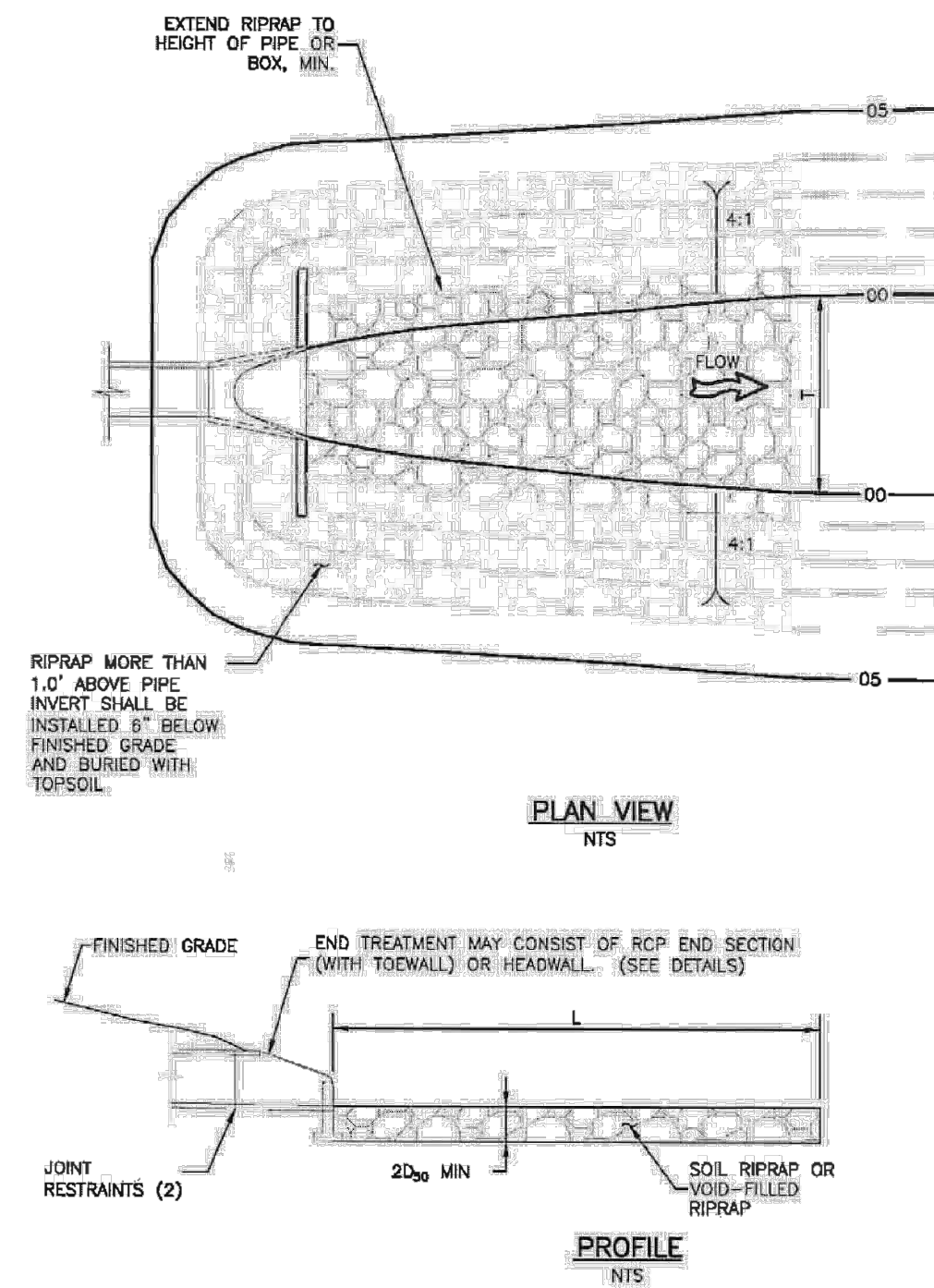
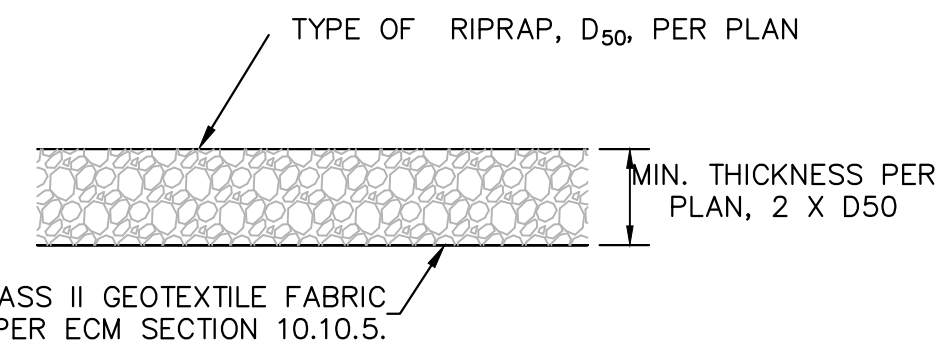

Figure 9-34. Riprap apron detail for culverts in-line with the channel



1. D50 = MEAN PARTICLE SIZE (INTERMEDIATE DIMENSION) BY WEIGHT.
2. RIP RAP SECTION THICKNESS SHALL BE 2.0 TIMES THE SPECIFIED MEAN PARTICLE SIZE (I.E. D50 X 2.0 MINIMUM) PER ECM SECTION 10.10.3.
3. ALL RIP RAP SHALL BE UNDERLAIN WITH GEOTEXTILE FILTER FABRIC FOR STABILIZATION.
4. RIP RAP SHALL WRAP AROUND AND EXTEND 2' MIN. BEHIND FLUME AND FLARED END SECTIONS.

TYPICAL RIPRAP SECTION DETAIL

Table 506-2

Pay Item	Stone Size d50 <sup>1</sup> (Inches)	Percent of Material Smaller Than Typical Stone <sup>2</sup>	Typical Stone	
			Dimensions <sup>3</sup> (Inches)	Weight <sup>4</sup> (Pounds)
Riprap	6	70-100	12	85
		50-70	9	35
		35-50	6	10
		2-10	2	0.4
Riprap	9	70-100	15	160
		50-70	12	85
		35-50	9	35
		2-10	3	1.3
Riprap	12	70-100	21	440
		50-70	18	275
		35-50	12	85
		2-10	4	3
Riprap	18	100	30	1280
		50-70	24	650
		35-50	18	275
		2-10	6	10
Riprap	24	100	42	3500
		50-70	33	1700
		35-50	24	650
		2-10	9	35

<sup>1</sup>d50 = nominal stone size  
<sup>2</sup>based on typical rock mass  
<sup>3</sup>equivalent spherical diameter  
<sup>4</sup>based on a specific gravity = 2.5

NO.	REVISION	DATE	APPR.
2	COUNTY COMMENTS	KRK 4/28/23	KRK
1	COUNTY COMMENTS	KRK 3/10/23	KRK

**Kimley»Horn**  
 2021 KIMLEY-HORN AND ASSOCIATES, INC.  
 2 North Nevada Avenue Suite 300  
 Colorado Springs, Colorado 80903 (719) 453-0180

DESIGNED BY: KRK  
 DRAWN BY: AUL  
 CHECKED BY: KRK  
 DATE: 12/16/2021

WINSOME FILING NO. 3  
 EL PASO COUNTY, COLORADO  
 CONSTRUCTION DOCUMENTS  
 RIPRAP DETAILS

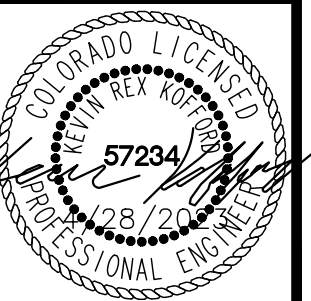

PROJECT NO.  
196106001

SHEET

C1.44