

Item Numbers refer to SWMP Checklist

STORMWATER MANAGEMENT PLAN
FOR CARRIAGE MEADOWS SOUTH AT
LORSON RANCH
FILING NO. 2
~~(EGP 19-005)~~
SF-20-011

Stormwater Permit # _____

Certification # _____

Owner:

Lorson, LLC
212 N. Wahsatch Avenue, Suite 301
Colorado Springs, Colorado 80903
Contact: Jeff Mark
(719) 635-3200

Developer:

St. Aubyn Homes
212 N. Wahsatch Avenue, Suite 201
Colorado Springs, Colorado 80903
Contact: Jared St. Aubyn
(719) 304-4919

**SWMP Administrator/
Qualified Stormwater Manager:**

TNT Landscaping, Inc
Trevor Terrill
4795 Mark Dabling Rd.
Colorado Springs, Colorado 80918
(719) 659-5619

SWMP Preparer:

Core Engineering Group, LLC
Richard L. Schindler, P.E.
15004 1st Avenue S
Burnsville, MN 55306
719-659-7800

Contractor:

Dwire Earthmoving
6799 Bismark Road, Suite C
Colorado Springs, CO 50922
Contact: Wade Fothergill
(719) 660-1058

SWMP Location

On-site (copy) and Lorson, LLC (original)

TABLE OF CONTENTS

TABLE OF CONTENTS

SWMP REPORT REVISION LOG

1.0 INTRODUCTION	1
2.0 SEQUENCE OF MAJOR ACTIVITIES	2
3.0 PRE-DEVELOPMENT CONDITIONS	3
4.0 DEVELOPED CONDITIONS	4
5.0 POTENTIAL SOURCES OF POLLUTION AND CONTROL STRATEGIES	4
6.0 BEST MANAGEMENT PRACTICES	8
7.0 SPILL PREVENTION PLAN	12
8.0 INSPECTIONS X	15
9.0 RECORDS MANAGEMENT	15
10.0 FINAL STABILIZATION	16

APPENDIX A: VICINITY MAP, FEMA FLOODPLAIN MAP

APPENDIX B (EARLY GRADING & EROSION CONTROL PLANS

- EXHIBIT 1: CARRIAGE MEADOWS SOUTH AT LORSON RANCH FILING NO. 2 GRADING PLANS, DATED FEBRUARY 12, 2020

APPENDIX C: STORMWATER INSPECTION REPORTS **(BY REFERENCE ONLY NOT ATTACHED)**

APPENDIX D: SPILL REPORT FORM

APPENDIX E: RECORD OF STABILIZATION AND CONSTRUCTION ACTIVITY DATES

APPENDIX F: FEDERAL, STATE, OR LOCAL STORM WATER OR OTHER ENVIRONMENTAL INSPECTOR SITE VISIT LOG

APPENDIX G: GENERAL PERMIT AND APPLICATION

SWMP REPORT REVISION LOG

REVISION #	DATE	BY:	COMMENTS
1.			
2.			
3.			
4.			
5.			

1.0 INTRODUCTION

The proposed **Carriage Meadows South at Lorson Ranch Filing No. 2** development is currently vacant land consisting of 5.322 acres. This SWMP report covers the residential portion of the site which will disturb approximately 5.05 acres. The property is bounded on the east by Jimmy Camp Creek, the west side by Carriage Meadows Drive, and on the south by Carriage Meadows at Lorson Ranch Filing No. 1, and the north by Fontaine Boulevard. The property drains generally southwest towards Carriage Meadows Drive where an existing inlets collect runoff. Runoff flows west and south into existing WQ/Detention ponds and eventually discharges the treated/detained runoff into Jimmy Camp Creek.

Carriage Meadows South at Lorson Ranch Filing No. 2 consists of 49 residential lots and the supporting street infrastructure that will be completed in one phase. St. Aubyn Homes is the overall developer and will construct major infrastructure (grading, roads, utilities, etc.) to serve the entire site. This Stormwater Management Plan (SWMP) will only cover construction activities that are provided as the developer. As the Lorson Ranch development progresses, this SWMP plan may need to be updated to reflect the revised scope of infrastructure.

The major infrastructure for **Carriage Meadows at Lorson Ranch Filing No. 2** includes but is not limited to construction of residential streets, onsite utilities, and grading the site for residential lots. Detention/Water quality for this development is located offsite in an existing pond (Pond G1). Pond G1 will treat and detain stormwater runoff prior to discharging into Jimmy Camp Creek.

The legal description is:

**CARRIAGE MEADOWS SOUTH AT LORSON RANCH FILING NO. 2
LEGAL DESCRIPTION**

TRACT O, CARRIAGE MEADOWS SOUTH AT LORSON RANCH FILING NO. 1

2.0 SEQUENCE OF MAJOR ACTIVITIES – Exhibit 1 Construction

The anticipated date for beginning construction activities is April, 2020 and will be complete in December, 2020. Implementation of the storm water management plan should be in place prior to initiating construction activities. The anticipated sequence of construction is as follows:

1. Installation of perimeter erosion control measures as shown on Exhibit 1.
2. Site Clearing/Grubbing and topsoil stockpiling.
3. Construct sediment ponds
4. Rough grading of the site.
5. Construct underground water/sewer/storm.
6. Construct curb/gutter and pavement.
7. Final stabilize areas outside of ROW.
8. Construct gas/electric/cable/phone in the street areas.
9. Landscape common areas

Item 6. Provide a construction schedule of anticipated starting and completion dates for each stage of land-disturbing activity.

10. Final stabilize site.
11. Final erosion control measures as areas are completed
12. Remove construction BMP's

3.0 PRE-DEVELOPMENT CONDITIONS

According to the current FEMA Flood Insurance Rate Map (FIRM) number 08041C0957 G, Dated December, 2018 this site is not located within the 100-year floodplain.

Existing Vegetation:

The site is currently undeveloped and has been vacant land for several years. Vegetation consists of native grasses. There is no brush or trees within the area to be graded. Ground cover is estimated at 70% density and shall be verified visually in the field at the time activity occurs.

Item 9. Include method used to determine ground cover (i.e., visual, aerial inspection)

Existing Slopes:

Existing slopes are around 1-10% that direct runoff southwesterly to existing inlets in the southwest corner of the site. No grading will be done in Jimmy Camp Creek under this SWMP.

Existing Drainage Patterns:

The site has moderate slopes in a south-southwesterly direction to an existing CDOT type "D" inlet in the SW corner of the site. Runoff is then directed westerly via 24" & 30" RCP's to an existing detention facility, located west side of Carriage Meadows Drive which functions as a sediment forebay. These flows then continue west and south to WQ/Detention Pond G1.

Existing Soil Types:

The following table summarizes the characteristics of the soil type.

Table 3.1: SCS Soils Survey.

Soil	Hydro. Group	Shrink/Swell Potential	Permeability	Surface Runoff Potential	Erosion Hazard
28-Ellicott Loamy Coarse Sand (1%)	A	Low	Rapid	Slow	High
52-Manzanst Clay Loam (59%)	C	Moderate to High	Slow	Medium	Moderate

The existing soil types have a moderate potential for erosion which can be mitigated by employing appropriate downstream construction BMP's before/during/after construction to limit potential impacts to discharges. Based upon the location of the different soil types and type of construction, the contractor shall employ the most appropriate method of erosion control measures based on the El Paso County/City of Colorado Springs Drainage Criteria Manual, Vol. 2 or as directed by the SWMP administrator or his representative.

The existing soil types have a moderate potential for erosion which can be mitigated by employing appropriate downstream construction BMP's before/during/after construction to limit potential impacts to stormwater discharges. The potential impacts are sediment discharge into the existing storm sewer system and the proposed storm sewer system. Sediment should not

be allowed to enter these existing and proposed facilities and can be mitigated by constructing small temporary sediment basins at low points prior to discharge into the systems. Based upon the location of the different soil types and type of construction, the contractor shall employ the most appropriate method of erosion control measures based on the El Paso County/City of Colorado Springs Drainage Criteria Manual, Vol. 2 or as directed by the SWMP administrator or his representative.

More detailed soils information can be found in the SCS soils survey for El Paso County.

4.0 DEVELOPED CONDITIONS

The overall drainage concept for **Carriage Meadows South at Lorson Ranch Filing No. 2** is to direct flow to existing storm sewer infrastructure in the southwest corner of the site.

Proper erosion protection will be installed so no sediment enters the storm sewer system or is discharged offsite.

Construction Site Estimates:

- Project Site: 5.322 acres
- Disturbed Area: 5.05acres

- Percent Impervious before Construction: 0%
- Runoff Coefficient before Construction: 0.35
- Ground Cover density prior to construction 70%

- Percent Impervious after Construction: 65%
- Runoff Coefficient after Construction: 0.65
- Final stabilization must be 70% of pre-construction density.

Receiving Waters:

- Jimmy Camp Creek.
- Description: The creek channel is a dry creek bed that flows water intermittently after significant rainfall events in the drainage basin. The creek has been armored and channelized in 2006
- Description of Storm Sewer System: There is an existing 24" storm sewer and inlet in the southwest corner of the site. All the runoff drains to this system. The existing storm sewer system outlets into existing WQ/detention ponds located south of this site and flow ultimately into Jimmy Camp Creek south of this site.
- Description of impaired waters or waters subject to TMDLs: The site contains no impaired waters or waters subject to TMDLs.
- Description of unique features that are to be preserved: There are no known protected plant species within the project limits.
- Describe measures to protect these features: There are no known protected plant species

Site Features and Sensitive Areas to be Protected:

This site is not located within waters of the state (100-year floodplain) and they contain no other sensitive areas such as wetlands or endangered species. No grading will occur in the creek.

Stream Crossings:

This site is not located within (100-year floodplain) but there will be no stream crossings with this development.

5.0 POTENTIAL SOURCES OF POLLUTION AND CONTROL STRATEGIES

Potential sources of sediment to stormwater runoff include earth moving and concrete activities associated with grading and landscaping.

Potential pollutants and sources, other than sediment, to stormwater runoff include Trash, debris, line transfer, Dewatering, fueling and equipment failure.

A dewatering permit is not required  remove

Construction activities produce many different kinds of pollutants which may cause storm water contamination problems. Grading activities remove rocks, vegetation and other erosion controlling surfaces, resulting in the exposure of underlying soil to the elements. Because the soil surface is unprotected, soil and sand particles are easily picked up by wind and/or washed away by rain or other water sources.

The following sections highlight the potential sources of pollution at the Project Site and list the “Best Management” strategies that will be used to prevent migration of pollution offsite. Chemical materials stored indoors or that have no reasonable chance of impacting storm water quality will not be discussed in this plan.

Materials of significance stored on the project site and the location to be provided by contractor include:

- Sediment
- Concrete Washout
- Cement
- Trash & Debris
- Sanitary Wastes
- Fuels & Oils

5.1 Wind Erosion & Dust Control

Pollutant: Sediment

Best Management Strategies:

- Daily inspections will occur for areas experiencing excessive winds, vehicle traffic, or precipitation events.
- Water trucks will spray down dust on the project Site as needed to not impact adjacent properties.
- Attention will be given to prevent the over use of water in dust control operations to minimize any muddying of the surface and possible sediment transportation.

5.2 Vehicular Transport

Pollutant: Sediment Tracking

Best Management Strategies:

- Construct a stabilized construction entrance to provide ingress and egress of the site.
- Restrict access to the stabilized construction entrance.
- Fencing will be erected if problems with access control are evident.
- Maintain track out pads by fluffing up the rock material or by adding additional rock as needed.
- Inspect, sweep and clean adjacent streets where track out is evident.

5.3 Stockpiles

Pollutant: Sediment

Best Management Strategies:

- Locate stockpiles clear of any water flow paths.
- Locate stockpiles within the property boundary.
- Stockpiles will have erosion control devices as needed installed around the base to prevent the migration of soil.
- Topsoil stock piles and disturbed portions of the site where construction activity temporarily ceases for at least 14 days will be stabilized with temporary seed and mulch no later than 14 days from the last construction activity in the area.

5.4 Grading, Trenching, Export/Import

Pollutant: Sediment

Best management Strategies:

- Earth moving will be minimized by the engineering balancing of the site.
- Disturbed portions of the site where construction activity temporarily ceases for at least 14 days will be stabilized with temporary seed and mulch no later than 14 days from the last construction activity in the area.
- Seed bed preparation is not required if soil is in loose condition.
- Prior to seeding, fertilizer shall be applied to each acre to be stabilized in accordance with the manufacturer's specifications.
- If required seeding areas shall be mulched with straw to a uniformed cover. The straw mulch is to be tacked into place by a disk with blades set nearly straight.
- A site specific erosion control drawing has been developed showing the location of Best Management practices to be used during site construction.
- Where indicated on the erosion control plan, Best Management Practices will be installed.
- Material shall be in accordance with the plans and specifications and all construction shall be provided in accordance with the manufacturer's specifications.
- All BMP's will be inspected bi-weekly and cleaned/maintained as required.

5.5 Waste, Residual Concrete

Pollutant: Concrete, paint, and Phosphoric Acid

Best Management Strategies:

- A cleanup and washout area will be designated and posted.
- Subcontractors will be instructed on the locations and importance of the washout and cleanup areas. No on-site disposal is allowed.

- Instruct subcontractors to remove waste for which proper onsite disposal facilities are not provided back to their own facilities for ultimate transport, storage & disposal.
- Subcontractors and subcontractor employees are held responsible for improper washout.

5.6 Sanitary Facilities, Trash Containers & Littering

Pollutant: Bacteria, Ammonia, Trash

Best Management Strategies:

- Portable facilities will be regularly serviced to prevent excessive waste containment and overflow.
- All waste materials will be collected and stored in a container which will meet all local and any state solid waste management regulations.
- Trash dumpsters will be emptied prior to becoming 90% full or when debris control becomes an issue.
- Employees will be instructed on the importance of recycling and waste management, and will be held responsible for improper waste management.

5.7 Fueling, Hazardous Materials, Equipment Leakage, Fertilizer

Pollutant: Petroleum Hydrocarbons, Ethylene Glycol, Sediment

Best Management Strategies:

- MSDS sheets will be maintained in the project trailer for all onsite materials
- All dry materials such as cement will be covered and protected from rain.
- Secondary containment will be provided for stored fuel, oil, paint and any material classified as hazardous.
- Subcontractors are responsible for hazardous waste removal back to their own facilities for ultimate transportation, storage and disposal.
- Supplies will be kept onsite as necessary to control any potential spill.
- Employees will be held responsible for any illegal dumping.
- Seals will be checked by a qualified professional on all equipment and containers containing significant materials that could contribute potential pollutants and will be replaced as necessary.
- Equipment will be inspected by a qualified professional.
- Drip pans will be available for minor leaks and during fueling operations.
- Fueling nozzles, gauges, hoses, seals, and emergency shutoff valves will be inspected for leaks prior to use.
- Under no circumstances during fueling will the fueling hose/nozzle be left unattended.
- Fertilizers used will be applied only in the minimum amounts recommended by soil tests.
- Once applied, fertilizers will be worked into the soil to limit exposure to storm water.
- Stored fertilizer will be protected from exposure to precipitation and storm water runoff.

5.8 Dewatering – not needed. This shown for information only

Pollutant: Sediment, Oil and/or Grease and Phosphoric Acid

Best Management Strategies:

- All dewatering will be filtered through rock and/or woven geo mesh fabric.
- All dewatering will be tested for Pollutants per state guidelines weekly.

Just state that dewatering is not proposed for the project. similar to Section 5.9 below

5.9 Concrete and Asphalt Batch Plant This shown for information only

There are no existing batch plants located on this project site and there are no proposed batch plants in the future.

6.0 BEST MANAGEMENT PRACTICES (BMP's)

Also refer to attached Erosion and Sediment Control notes and plans included in the site plans

6.1 – Erosion and Sediment Control BMP's

6.1.1 Minimize Disturbed Area and Protect Natural Features and Soil

All work will occur inside the limits of construction per the erosion Control Site Plan. See Exhibit 1

6.1.2 Phase Construction Activity

The sequence for the installation and removal of erosion and sediment control measures is as follows:

Perimeter control measures (silt barriers and fencing) installed at designated areas as noted on the site plans (Exhibit 1), cleaning of street surfaces during construction if applicable, site grading, installation of utilities, paving final and grading, installation of sod or other vegetation, removal of temporary practices and perimeter controls, and site cleanup.

6.1.3 Control Stormwater Flowing onto and through the Project

Narrative:

Offsite stormwater flows onto this project site from the south along Rubicon Drive. The offsite and on-site runoff will be routed in streets/proposed storm sewer west to an existing storm sewer system in Carriage Meadows Drive and then west to an existing detention pond/sediment forebay.

6.1.4 Stabilize Soils

No disturbed area which is not actively being worked shall remain denuded for more than 14 calendar days unless otherwise authorized by the director. Temporary cover by seeding or mulching should be provided on areas which will be exposed for a period greater than 14 days before permanent stabilization can be achieved. Permanent cover should be provided on all areas as soon as possible, by means of seeding and mulching, straw or hay mulch is required. All soil stock piles and borrow areas must protected with silt fence within 14 days after grading. All slopes within the project limits that are found to be eroding excessively within two years of permanent stabilization shall be provided additional slope stabilization methods such as seeding and mulching.

Water is to be used for dust control. The Contractor will prevent the escape of this water and any sediment it may carry from the construction site.

6.1.5 Protect Slopes

Temporary stabilization will include the installation of silt fences on level contours spaces at 10-20 foot intervals. Slopes will be seeded and covered with hay, straw or erosion control blankets on slopes greater than 3:1 as needed to provide for temporary stabilization until vegetation is permanently established.

All slopes within the project limits that are found to be eroding excessively within two years of permanent stabilization shall be provided additional slope stabilization methods such as seeding

and mulching. Where slopes are steeper than 3:1 erosion control blankets (per specification requirements) will be utilized for final stabilization.

6.1.6 Protect Storm Drain Inlets

Inlet protection will be installed as soon as storm drain inlets are installed and before land-disturbance activities begin in areas with existing storm drain systems.

At the Contractor's discretion, additional temporary erosion control practices to include rock bags and sand bag barriers may be installed to prevent sediment movement. Inlet protection will include rock bags erosion logs curb inlet sediment filters where an overflow capacity is necessary to prevent excessive ponding in front of the curb inlet. Concrete block and wire screen inlet protection if used detail will be included Appendix C prior to installation, will be used where heavy flows are expected and where an overflow capacity is necessary to prevent excessive ponding around the inlet.

Inlet protection devices will be inspected and accumulated sediment will be removed as needed.

6.1.7 Establish Perimeter Controls and Sediment Barriers

Temporary stabilization will include the installation of silt fences on the downslope perimeter of project area. The silt fence will be trenched in on the uphill side 6 inches deep and 6 inches wide as detailed in the silt fence exhibit. Sediment will be removed when it reaches 1/3 the height of the fence. Silt fence will be inspected and replaced or repaired as needed.

6.1.8 Retain Sediment On-Site

Temporary sediment traps shall be installed to detain sediment laden runoff from small watersheds for a period long enough to allow sediment to settle before discharge into receiving waters. For small drainage locations smaller sediment traps should be used. At a minimum, silt fences, vegetative buffer strips or equivalent sediment controls are required for all down-slope boundaries (and for those side slope boundaries deemed appropriate as dictated by individual site conditions) of the construction. The use of a combination of sediment and erosion control measures in order to achieve maximum pollutant removal will be utilized. Sediment traps will be checked regularly for sediment cleanout. Sediments shall be removed and the trap restored to its original dimensions when the sediment has accumulated to one half the design volume of the wet storage. Sediment shall be disposed in suitable areas and in such a manner that will not erode or cause sedimentation problems.

The gravel outlets will be checked regularly for sediment buildup which will prevent damage. If the gravel is clogged by sediment, it shall be removed and cleaned or replaced.

An alternate to sediment traps are temporary sediment basins.

VTC shall be 75 feet in length (DCM Vol. 2)

6.1.9 Establish Stabilized Construction Exits

The construction entrance will be established in the entry points of roads. The construction entrance will be at least 50 feet in length and approximately 12 feet wide and graded so runoff does not leave the site. The aggregate will be established at 8 inches thick on top of 4 inch minimum thick free draining material on top of geotextile and will consist of Type G dense graded material. A stabilized stone pad with a filter fabric under liner will be placed at points of vehicular ingress and egress.

6.1.10 Additional BMP's

BMP Schedule:

All Sediment and Erosion control BMP's (detailed below and only on BMP site map and details if utilized onsite) will be installed prior to any excavation or demolition and will be coordinated with the construction schedule.

As construction changes and new temporary BMP's are needed to control sediment and erosion temporary BMP's will be installed within 24 hours of inspection report.

Recommended BMP's:

ALL RECOMMENDED BMP'S WILL BE INSTALLED PRIOR TO EXCAVATION NEAR ANY SENSITIVE AREAS.

Culvert Inlet Protection will be used to protect existing and new culvert inlets. Inlet Protection Detail will be included in Appendix before using onsite. Removal of this BMP will occur only after vegetation is established to a minimum of 70% pre construction coverage and after removal of BMP all sediment builds up will be removed and the area exposed shall be seeded.

Silt Fence is to be installed in sensitive areas to protect stream channels, pond, and overland runoff. On this site it will be used to protect runoff from the slip pits. See Silt Fence Detail. Removal of this BMP will occur only after vegetation is established to a minimum of 70% pre construction coverage and after removal of BMP all sediment builds up will be removed and the area exposed shall be seeded.

Vehicle Tracking Control is needed at the main construction entrance location. Vehicle tracking control shall be installed at the edge of the construction staging area where construction vehicles regularly exit onto existing asphalt road. If sediment tracking occurs it will be cleaned within 24 hours.

See Vehicle Tracking Control Detail in Appendix C. Removal of this BMP will occur only after project is substantially complete and is ready for seeding operations; the area will then be seeded per specification with the rest of the project.

Check Dams (rip rap) will be used to reduce storm water velocities in drainage channels during construction as a temporary measure until permanent stabilization can be created and vegetation has been established. Check Dam Detail will be included in the the Appendix before using onsite. Removal of this BMP will occur only after vegetation is established to a minimum of 70% pre construction coverage and after removal of BMP all sediment build-up will be removed and the area exposed shall be seeded.

Portable Toilets: Portable toilets are brought in from a service contractor and will be maintained in accordance with standard waste disposal practices using vacuum trucks and place on stable ground to minimize risk of spillage. All portable toilets will be kept a minimum of 500' from any waterway.

Waste Disposal: If needed Roll offs will be utilized for standard construction waste. A qualified contractor will remove waste weekly and take to an appropriate dump site off this project.

6.1.11 Permanent BMP'S:

Re-vegetation:

During construction any disturbed area not being currently worked left dormant longer than 14 days will be re-vegetated per specification with native seed and mulched and crimped with weed free straw.

Final Stabilization will be considered complete when all disturbed areas have a minimum of 70% preconstruction coverage for the specification requirements. Then all temporary BMP's will be removed and the exposed areas left behind will be seeded.

Other permanent BMP's include Offsite Detention/WQ Pond G1/G2 to treat storm runoff prior to entering Jimmy Camp Creek.

6.2 Good Housekeeping BMP'S

6.2.1 Material Handling and Waste Management

The site will use a private refuse collector that will remove litter twice weekly. No less than one litter receptacle will be present at the construction site. In the event that unusual items such as tanks, cylinders, unidentified containers, etc. which could contain potentially hazardous materials are discovered or disturbed, the Fire and Rescue services will be notified.

Litter and debris will be picked up and disposed of properly daily.

Temporary toilet facilities will be located 500 feet away from any storm drain inlets and all waters of the state.

6.2.2 Establish Proper Building Material Staging Areas

A designated staging area will be used, location to be determined based on available space in the field and plans will be redline. The staging area will be contained per SWMP guidelines. All Equipment and Materials will be brought into the site as needed.

6.2.3 Designate Washout Areas

A concrete washout will be installed to detail as shown in the APPENDIX , and will be placed more than 500 feet away from any waters of the state.

6.2.4 Establish Proper Equipment/Vehicle Fueling and Maintenance Practices

During construction the site will be exposed to operation and maintenance of construction equipment. The contractor shall be responsible for all activities such as fueling, oil changing, lubrication and repair which require use of petroleum products. Such products shall be transported to and from the site in special trucks equipped for that purpose. No waste petroleum products, rags, residue, or equipment parts shall be left on site. In the event of a spill or leak, causing soil to be contaminated, that soil shall be excavated placed in sealed barrels and removed from the site for transport to an approved location for disposal.

See section 6.2.6 for the Spill Plan.

6.2.5 Control Equipment/Vehicle Washing

This activity will not be allowed onsite.

6.2.6 Any Additional BMPs

Additional BMP's will be added to this SWMP as needed.

6.2.7 Allowable Non-Stormwater Discharge Management

There are no visible natural springs or irrigation or other non-stormwater discharges anticipated to be encountered. The existing FMIC irrigation ditch was removed from this site in 2006.

6.2.8: SELECTING POST-CONSTRUCTION BMPs

Post Construction BMPs. Re-vegetation including seeding, mulching and erosion control blanket will be final BMP's. Permanent stabilization will be achieved with 70% pre construction vegetative establishment.

7.0 SPILL PREVENTION AND CONTROL PLAN

The SITE SUPERINTENDENT will act as the point of contact for any spill that occurs at this jobsite. The project manager will be responsible for implementation of prevention practices, spill containment / cleanup, worker training, reporting and complete documentation in the event of a spill. The ECO shall immediately notify the Owner, /Construction Manager, STATE and the Local Fire Department in addition to the legally required Federal, State, and Local reporting channels (including the National Response Center, 800.424.8802) if a reportable quantity is released to the environment

7.1 SPILL PREVENTION BEST MANAGEMENT PRACTICES

This section describes spill prevention methods Best Management Practices (BMP) that will be practiced to eliminate spills before they happen.

7.1.a Equipment Staging and Maintenance

Store and maintain equipment in a designated area Reduce the amount of hazardous materials and waste by substituting non-hazardous or less hazardous materials.
Use secondary containment (drain pan) to catch spills when removing or changing fluids.
Use proper equipment (pumps, funnels) to transfer fluids Keep spill kits readily accessible Check incoming vehicles for leaking oil and fluids.
Transfer used fluids and oil filters to waste or recycling drums immediately following generation.
Inspect equipment routinely for leaks and spills Repair equipment immediately, if necessary implement a preventative maintenance schedule for equipment and vehicles.

7.1.b Fueling Area

Perform fueling in designated fueling area minimum 50' away from federal waters
Use secondary containment (drain pan) to catch spills
Use proper equipment (pumps, funnels) to transfer fluids
Keep spill kits readily accessible
Inspect fueling areas routinely for leaks and spills

Hazardous Material Storage Areas

Reduce the amount of hazardous materials by substituting non-hazardous or Less hazardous materials.

7.1. c Hazardous Material Storage Areas

Minimize the quantity of hazardous materials brought onsite
Store hazardous materials in a designated area away from drainage points.

7.1. d Unexpected Contaminated Soil and Water

- Investigate historical site use
- Perform all excavation activities carefully and only after the Owner/Construction Manager directed any activities

7.2 SPILL CONTAINMENT METHODS

The following discussion identifies the types of secondary containment that will be used in the event of a spill. Table 1 summarizes the containment methods for each potential source.

- **Equipment Staging and Maintenance Area.** An equipment leak from a fuel tank, equipment seal, or hydraulic line will be contained within a spill containment cell placed beneath all stationary potential leak sources. An undetected leak from parked equipment will be cleaned up using hand shovels and containerized in a 55-gallon steel drum for offsite disposal.

- **Fueling Area.** A small spill during fueling operations will be contained using fuel absorbent pads at the nozzle. The transfer of fuel into portable equipment will be performed using a funnel and/or hand pump and a spill pad used to absorb any incidental spills/drips. Any leaking tanks or drums will have fluids removed and transferred to another tank, drum, or container for the fluids. A spill response kit will be located near the fueling area or on the fuel truck for easy access. The spill response kit will include plastic sheeting, tarps, over pack drums, absorbent litter, and shovels.

- **Hazardous Material Storage Area.** A spill from containers or cans in a hazardous material storage area will be contained within the storage cabinet these materials are kept in.

- **Unexpected Contaminated Soil.** If contaminated soil is encountered during the project, the Owner/Construction Manager will be notified immediately. Small quantities of suspected contaminated soil will be placed on a 6-mil plastic liner and covered with 6-mil plastic. A soil berm or silt fence will be used to contain the stockpile and prevent migration of contaminated liquids in the soil.

Table 1: Spill Prevention and Containment Methods

Potential Spill Source	Potential Spill Source
Equipment Staging and Maintenance Area	Spill containment pad, spill kit, pumps, funnels
Fueling Area (site equipment only)	Spill containment pad, spill kit, pumps, funnels
Hazardous Material Staging Area	Spill containment pad, spill kit, pumps, funnels
Unexpected Contaminated Soil	Plastic liner, plastic cover, soil berm, hay bales, lined super sacks

7.3 SPILL COUNTERMEASURES

Every preventative measure shall be taken to keep contaminated or hazardous materials contained. If a release occurs, the following actions shall be taken:

1. **Stop the Spill:** The severity of a spill at the site is anticipated to be minimal as large containers/quantities of Hazardous Materials (HM) are not anticipated. The type of spill

would occur while dispensing material at the HM storage facility and would likely be contained in secondary containment. Thus, the use spill kits or other available absorbent materials should stop the spill.

2. **Warn Others:** Notify co-workers and supervisory personnel of the release. Notify emergency responders if appropriate. For site personnel, an alarm system will consist of three one second blasts on an air horn sounded by the person discovering a spill or fire. In the event of any spill, the Superintendent and Project Manager shall be notified **if the spill is 5 gallons or more the STATE will be contacted along with the Fire Department.**

3. **Isolate the Area:** Prevent public access to the area and continue to minimize the spread of the material. Minimize personal exposure throughout emergency response actions.

4. **Containment:** A spill shall only be contained by trained personnel and if it is safe to do so. DO NOT PLACE YOURSELF IN DANGER. Attempt to extinguish a fire only if it is in the incipient stage; trash can size or smaller. For larger spills, wait for the arrival of emergency response personnel and provide directions to the location of the emergency.

5. **Complete a Spill and Incident Report:** For each spill of a Hazardous Material a spill and incident report shall be completed and submitted to the Owner/Construction Manager and if applicable to the Engineer and the State of Colorado Department of Public Health and Environment

8.0 INSPECTIONS

8.1 Inspections

Inspections will occur at least every 14 days and within 24 hours of a precipitation event producing runoff, which from past experience this occurs with precipitation of 1/4 inch of rain or more , the primary site for tracking weather data and rainfall measurements will be taken from Weather Underground and a rain gauge will be onsite for verification only.

1. Inspection Personnel:

The contract Stormwater Inspector will conduct the site inspections as mentioned above in Section 1.

2. Inspection Schedule and Procedures:

The inspection schedule will be routinely accomplished every 14 days and after every storm event for the entire site with all BMP's evaluated for performance and need. Any BMP found to be ineffective will be re-accomplished or replaced with a new BMP to provide the level of protection needed. BMP's found to be no longer needed will be removed. Inspections will also be accomplished as soon as practical, but within 24 hours of the end of a precipitation event causing surface erosion, over 1/4" or more.

The general procedures for correcting problems when they are identified will be to document the problem in the report, and devise a solution utilizing all resources available to formulate BMP's that will correct the problem as soon as possible.

A copy of the inspection report to be used for the site is attached. See Appendix.

3. Signatures

The contract Stormwater Inspector will be required to sign inspection forms.

8.2 Delegation of Authority

Duly Authorized Representative(s) or Position(s):

Authorized representatives for the SWMP plan will be: Jared St. Aubyn – Primary Contact

SWMP INSPECTOR – Trevor Terril

8.3 Revisions to the SWMP

The SWMP Inspector and/or the site superintendent have the authority to add/subtract/revise BMP's as necessary to accommodate construction activities. However, the engineer should be notified when any major redirection of runoff, offsite runoff, pond modifications, or other substantial changes are made to this SWMP. Changes should be documented per Section 9.0.

9.0 RECORDKEEPING AND TRAINING

9.1 Recordkeeping

Records will be retained for a minimum period of at least 3 years after the permit is terminated.

Major grading activities will start on 04.2020:

Date(s) when construction activities permanently cease on a portion of the site: 12/2020

Date(s) when an area is either temporarily or permanently stabilized: 12/2020

9.2 Changes to the SWMP

Any changes will be referenced in APPENDIX. See Section 8.3 for authority to change the SWMP.

9.3 Training

Individual(s) Responsible for Training:

All personnel on site will trained on the site specific SWMP requirements to be conducted by the SWMP Inspector and/or the site superintendent.

9.4 SWMP Location

The on-site SWMP will be located at the SW corner of this site next to Carriage Meadows Drive

10.0 FINAL STABILIZATION

Final stabilization will be accomplished by contractors to re-vegetate the area of disturbance per the approved plans and specifications. Final stabilization will include permanent seeding/mulching of disturbed areas, sediment forebays, erosion control blankets, turf reinforcement mats, and permanent BMP's.

Once 70% of the pre-development vegetative cover has been established and has been accepted, temporary BMP's will be removed and the permit will be terminated and filed.

Long term stormwater quality will be achieved by on-site full spectrum detention ponds with WQ outlet structures.

Final stabilization is anticipated to be completed in December, 2020

APPENDIX A

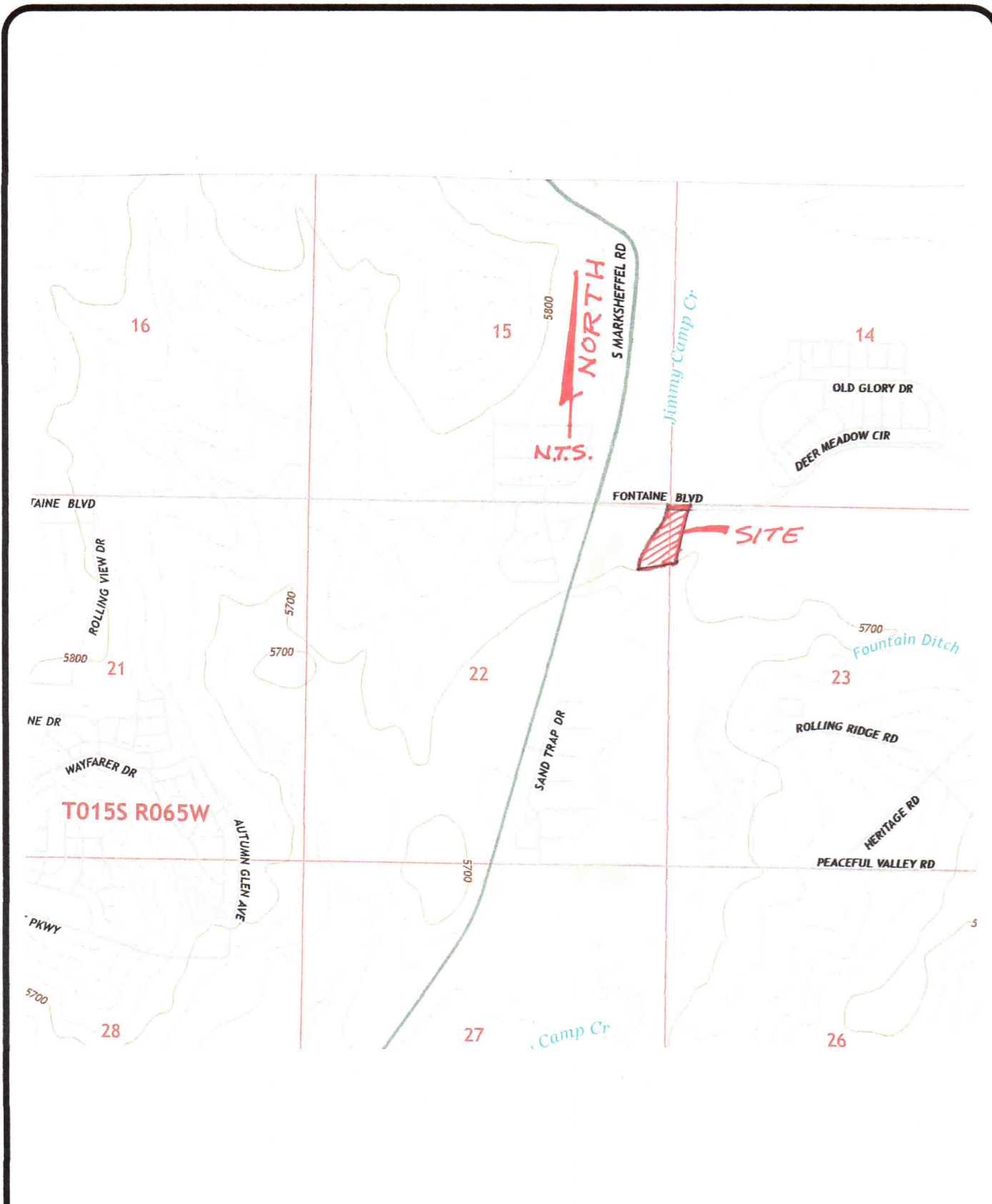

CORE
ENGINEERING GROUP

15004 1st Avenue South
Burnsville, MN 55306
PH: 719.570.1100
CONTACT: RICHARD L. SCHINDLER, P.E.
EMAIL: RichS@cegl.com

CARRIAGE MEADOWS SOUTH TOWNHOMES
VICINITY MAP

SCALE:	DATE:	FIGURE NO.
NTS	Nov. 29, 2018	1

Custom Soil Resource Report Soil Map





Map Scale: 1:1,340 if printed on A portrait (8.5" x 11") sheet.

0 15 30 60 90 Meters

0 50 100 200 300 Feet

Map projection: Web Mercator Corner coordinates: WGS84 Edge tics: UTM Zone 13N WGS84

MAP LEGEND

-  Area of Interest (AOI)
-  Area of Interest (AOI)
- Soils**
-  Soil Map Unit Polygons
-  Soil Map Unit Lines
-  Soil Map Unit Points
- Special Point Features**
-  Blowout
-  Borrow Pit
-  Clay Spot
-  Closed Depression
-  Gravel Pit
-  Gravelly Spot
-  Landfill
-  Lava Flow
-  Marsh or swamp
-  Mine or Quarry
-  Miscellaneous Water
-  Perennial Water
-  Rock Outcrop
-  Saline Spot
-  Sandy Spot
-  Severely Eroded Spot
-  Sinkhole
-  Slide or Slip
-  Sodic Spot
-  Spoil Area
-  Stony Spot
-  Very Stony Spot
-  Wet Spot
-  Other
-  Special Line Features
- Water Features**
-  Streams and Canals
- Transportation**
-  Rails
-  Interstate Highways
-  US Routes
-  Major Roads
-  Local Roads
- Background**
-  Aerial Photography

MAP INFORMATION

The soil surveys that comprise your AOI were mapped at 1:24,000.

Warning: Soil Map may not be valid at this scale.

Enlargement of maps beyond the scale of mapping can cause misunderstanding of the detail of mapping and accuracy of soil line placement. The maps do not show the small areas of contrasting soils that could have been shown at a more detailed scale.

Please rely on the bar scale on each map sheet for map measurements.

Source of Map: Natural Resources Conservation Service
 Web Soil Survey URL:
 Coordinate System: Web Mercator (EPSG:3857)

Maps from the Web Soil Survey are based on the Web Mercator projection, which preserves direction and shape but distorts distance and area. A projection that preserves area, such as the Albers equal-area conic projection, should be used if more accurate calculations of distance or area are required.

This product is generated from the USDA-NRCS certified data as of the version date(s) listed below.

Soil Survey Area: El Paso County Area, Colorado
 Survey Area Data: Version 16, Sep 10, 2018

Soil map units are labeled (as space allows) for map scales 1:50,000 or larger.

Date(s) aerial images were photographed: Apr 12, 2017—Nov 17, 2017

The orthophoto or other base map on which the soil lines were compiled and digitized probably differs from the background imagery displayed on these maps. As a result, some minor shifting of map unit boundaries may be evident.

Map Unit Legend

Map Unit Symbol	Map Unit Name	Acres in AOI	Percent of AOI
28	Ellicott loamy coarse sand, 0 to 5 percent slopes	A 3.9	75.8%
52	Manzanst clay loam, 0 to 3 percent slopes	C 1.2	24.2%
Totals for Area of Interest		5.1	100.0%

Map Unit Descriptions

The map units delineated on the detailed soil maps in a soil survey represent the soils or miscellaneous areas in the survey area. The map unit descriptions, along with the maps, can be used to determine the composition and properties of a unit.

A map unit delineation on a soil map represents an area dominated by one or more major kinds of soil or miscellaneous areas. A map unit is identified and named according to the taxonomic classification of the dominant soils. Within a taxonomic class there are precisely defined limits for the properties of the soils. On the landscape, however, the soils are natural phenomena, and they have the characteristic variability of all natural phenomena. Thus, the range of some observed properties may extend beyond the limits defined for a taxonomic class. Areas of soils of a single taxonomic class rarely, if ever, can be mapped without including areas of other taxonomic classes. Consequently, every map unit is made up of the soils or miscellaneous areas for which it is named and some minor components that belong to taxonomic classes other than those of the major soils.

Most minor soils have properties similar to those of the dominant soil or soils in the map unit, and thus they do not affect use and management. These are called noncontrasting, or similar, components. They may or may not be mentioned in a particular map unit description. Other minor components, however, have properties and behavioral characteristics divergent enough to affect use or to require different management. These are called contrasting, or dissimilar, components. They generally are in small areas and could not be mapped separately because of the scale used. Some small areas of strongly contrasting soils or miscellaneous areas are identified by a special symbol on the maps. If included in the database for a given area, the contrasting minor components are identified in the map unit descriptions along with some characteristics of each. A few areas of minor components may not have been observed, and consequently they are not mentioned in the descriptions, especially where the pattern was so complex that it was impractical to make enough observations to identify all the soils and miscellaneous areas on the landscape.

The presence of minor components in a map unit in no way diminishes the usefulness or accuracy of the data. The objective of mapping is not to delineate pure taxonomic classes but rather to separate the landscape into landforms or landform segments that have similar use and management requirements. The delineation of such segments on the map provides sufficient information for the development of resource plans. If intensive use of small areas is planned, however,

Custom Soil Resource Report

onsite investigation is needed to define and locate the soils and miscellaneous areas.

An identifying symbol precedes the map unit name in the map unit descriptions. Each description includes general facts about the unit and gives important soil properties and qualities.

Soils that have profiles that are almost alike make up a *soil series*. Except for differences in texture of the surface layer, all the soils of a series have major horizons that are similar in composition, thickness, and arrangement.

Soils of one series can differ in texture of the surface layer, slope, stoniness, salinity, degree of erosion, and other characteristics that affect their use. On the basis of such differences, a soil series is divided into *soil phases*. Most of the areas shown on the detailed soil maps are phases of soil series. The name of a soil phase commonly indicates a feature that affects use or management. For example, Alpha silt loam, 0 to 2 percent slopes, is a phase of the Alpha series.

Some map units are made up of two or more major soils or miscellaneous areas. These map units are complexes, associations, or undifferentiated groups.

A *complex* consists of two or more soils or miscellaneous areas in such an intricate pattern or in such small areas that they cannot be shown separately on the maps. The pattern and proportion of the soils or miscellaneous areas are somewhat similar in all areas. Alpha-Beta complex, 0 to 6 percent slopes, is an example.

An *association* is made up of two or more geographically associated soils or miscellaneous areas that are shown as one unit on the maps. Because of present or anticipated uses of the map units in the survey area, it was not considered practical or necessary to map the soils or miscellaneous areas separately. The pattern and relative proportion of the soils or miscellaneous areas are somewhat similar. Alpha-Beta association, 0 to 2 percent slopes, is an example.

An *undifferentiated group* is made up of two or more soils or miscellaneous areas that could be mapped individually but are mapped as one unit because similar interpretations can be made for use and management. The pattern and proportion of the soils or miscellaneous areas in a mapped area are not uniform. An area can be made up of only one of the major soils or miscellaneous areas, or it can be made up of all of them. Alpha and Beta soils, 0 to 2 percent slopes, is an example.

Some surveys include *miscellaneous areas*. Such areas have little or no soil material and support little or no vegetation. Rock outcrop is an example.

El Paso County Area, Colorado

28—Ellicott loamy coarse sand, 0 to 5 percent slopes

Map Unit Setting

National map unit symbol: 3680
Elevation: 5,500 to 6,500 feet
Mean annual precipitation: 13 to 15 inches
Mean annual air temperature: 47 to 50 degrees F
Frost-free period: 125 to 145 days
Farmland classification: Not prime farmland

Map Unit Composition

Ellicott and similar soils: 85 percent
Estimates are based on observations, descriptions, and transects of the mapunit.

Description of Ellicott

Setting

Landform: Flood plains, stream terraces
Landform position (three-dimensional): Tread
Down-slope shape: Linear
Across-slope shape: Linear
Parent material: Sandy alluvium

Typical profile

A - 0 to 4 inches: loamy coarse sand
C - 4 to 60 inches: stratified coarse sand to sandy loam

Properties and qualities

Slope: 0 to 5 percent
Depth to restrictive feature: More than 80 inches
Natural drainage class: Somewhat excessively drained
Runoff class: Very low
Capacity of the most limiting layer to transmit water (Ksat): High to very high (5.95 to 19.98 in/hr)
Depth to water table: More than 80 inches
Frequency of flooding: Frequent
Frequency of ponding: None
Available water storage in profile: Low (about 4.1 inches)

Interpretive groups

Land capability classification (irrigated): None specified
Land capability classification (nonirrigated): 7w
Hydrologic Soil Group: A
Ecological site: Sandy Bottomland LRU's A & B (R069XY031CO)
Other vegetative classification: SANDY BOTTOMLAND (069AY031CO)
Hydric soil rating: No

Minor Components

Fluvaquentic haplaquoll

Percent of map unit:
Landform: Swales
Hydric soil rating: Yes

Other soils

Percent of map unit:
Hydric soil rating: No

Pleasant

Percent of map unit:
Landform: Depressions
Hydric soil rating: Yes

52—Manzanst clay loam, 0 to 3 percent slopes

Map Unit Setting

National map unit symbol: 2w4nr
Elevation: 4,060 to 6,660 feet
Mean annual precipitation: 14 to 16 inches
Mean annual air temperature: 50 to 54 degrees F
Frost-free period: 130 to 170 days
Farmland classification: Prime farmland if irrigated

Map Unit Composition

Manzanst and similar soils: 85 percent
Minor components: 15 percent
Estimates are based on observations, descriptions, and transects of the mapunit.

Description of Manzanst

Setting

Landform: Terraces, drainageways
Landform position (three-dimensional): Tread
Down-slope shape: Linear
Across-slope shape: Linear, concave
Parent material: Clayey alluvium derived from shale

Typical profile

A - 0 to 3 inches: clay loam
Bt - 3 to 12 inches: clay
Btk - 12 to 37 inches: clay
Bk1 - 37 to 52 inches: clay
Bk2 - 52 to 79 inches: clay

Properties and qualities

Slope: 0 to 3 percent
Depth to restrictive feature: More than 80 inches
Natural drainage class: Well drained
Capacity of the most limiting layer to transmit water (Ksat): Moderately low to moderately high (0.06 to 0.20 in/hr)
Depth to water table: More than 80 inches
Frequency of flooding: None
Frequency of ponding: None
Calcium carbonate, maximum in profile: 15 percent

Custom Soil Resource Report

Gypsum, maximum in profile: 3 percent
Salinity, maximum in profile: Slightly saline (4.0 to 7.0 mmhos/cm)
Sodium adsorption ratio, maximum in profile: 10.0
Available water storage in profile: High (about 9.0 inches)

Interpretive groups

Land capability classification (irrigated): 3e
Land capability classification (nonirrigated): 4c
Hydrologic Soil Group: C
Ecological site: Saline Overflow (R067BY037CO)
Hydric soil rating: No

Minor Components

Ritoazul

Percent of map unit: 7 percent
Landform: Drainageways, interfluves
Landform position (three-dimensional): Rise
Down-slope shape: Linear
Across-slope shape: Linear
Ecological site: Clayey Plains (R067BY042CO)
Hydric soil rating: No

Arvada

Percent of map unit: 6 percent
Landform: Interfluves, drainageways
Down-slope shape: Linear
Across-slope shape: Linear
Ecological site: Salt Flat (R067XY033CO)
Hydric soil rating: No

Wiley

Percent of map unit: 2 percent
Landform: Interfluves
Down-slope shape: Linear
Across-slope shape: Linear
Ecological site: Loamy Plains (R067BY002CO)
Hydric soil rating: No

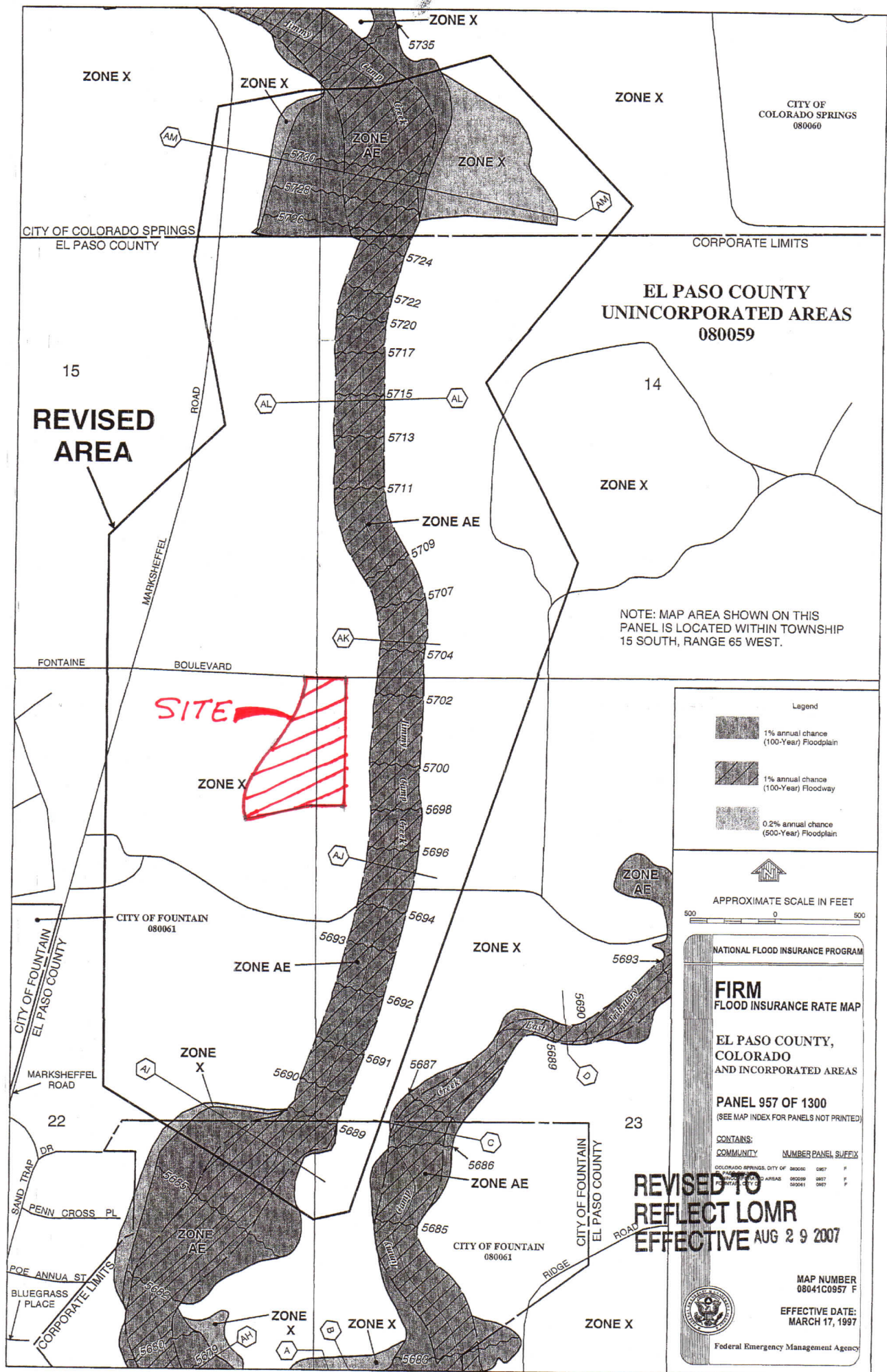

National Flood Hazard Layer FIRMette



38°44'24.77"N



Legend

SEE FIS REPORT FOR DETAILED LEGEND AND INDEX MAP FOR FIRM PANEL LAYOUT

- | | |
|------------------------------------|--|
| SPECIAL FLOOD HAZARD AREAS | Without Base Flood Elevation (BFE)
<i>Zone A, V, A99</i> |
| | With BFE or Depth <i>Zone AE, AO, AH, VE, AR</i> |
| | Regulatory Floodway |
| OTHER AREAS OF FLOOD HAZARD | 0.2% Annual Chance Flood Hazard, Areas of 1% annual chance flood with average depth less than one foot or with drainage areas of less than one square mile <i>Zone X</i> |
| | Future Conditions 1% Annual Chance Flood Hazard <i>Zone X</i> |
| | Area with Reduced Flood Risk due to Levee. See Notes. <i>Zone X</i> |
| | Area with Flood Risk due to Levee <i>Zone D</i> |
| OTHER AREAS | NO SCREEN Area of Minimal Flood Hazard <i>Zone X</i> |
| | Effective LOMRs |
| | Area of Undetermined Flood Hazard <i>Zone D</i> |
| GENERAL STRUCTURES | Channel, Culvert, or Storm Sewer |
| | Levee, Dike, or Floodwall |
| OTHER FEATURES | Cross Sections with 1% Annual Chance Water Surface Elevation |
| | Cross Sections with 1% Annual Chance Water Surface Elevation |
| | Coastal Transect |
| | Base Flood Elevation Line (BFE) |
| | Limit of Study |
| | Jurisdiction Boundary |
| | Coastal Transect Baseline |
| | Profile Baseline |
| | Hydrographic Feature |
| MAP PANELS | Digital Data Available |
| | No Digital Data Available |
| | Unmapped |



The pin displayed on the map is an approximate point selected by the user and does not represent an authoritative property location.

This map complies with FEMA's standards for the use of digital flood maps if it is not void as described below. The basemap shown complies with FEMA's basemap accuracy standards

The flood hazard information is derived directly from the authoritative NFHL web services provided by FEMA. This map was exported on 10/14/2019 at 9:45:48 AM and does not reflect changes or amendments subsequent to this date and time. The NFHL and effective information may change or become superseded by new data over time.

This map image is void if the one or more of the following map elements do not appear: basemap imagery, flood zone labels, legend, scale bar, map creation date, community identifiers, FIRM panel number, and FIRM effective date. Map images for unmapped and unmodernized areas cannot be used for regulatory purposes.

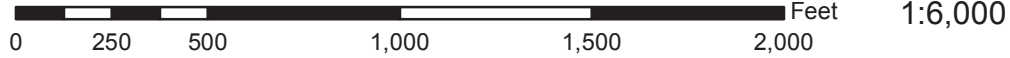

38°43'56.71"N

104°38'26.77"W

USGS The National Map: Orthoimagery. Data refreshed April, 2019.

APPENDIX B

CONSTRUCTION PLANS

CONSTRUCTION PLANS
FOR
**CARRIAGE MEADOW SOUTH AT
LORSON RANCH FILING NO. 2**
EARLY GRADING PLANS
AND DETAILED GRADING PLANS



Know what's below.
Call before you dig.

CALL 2-BUSINESS DAYS IN ADVANCE
BEFORE YOU DIG, GRADE OR
EXCAVATE FOR THE MARKING OF
UNDERGROUND MEMBER UTILITIES

SHEET INDEX	
SHEET NO.	SHEET DESCRIPTION
CO.1	COVER SHEET
CO.2	NOTES
CO.3	TYPICAL SECTIONS
C4.1 ~ C4.8	DETAILED GRADING PLANS (for information only)
C4.9 ~ C4.11	EARLY GRADING PLAN AND DETAILS



VICINITY MAP
NO SCALE

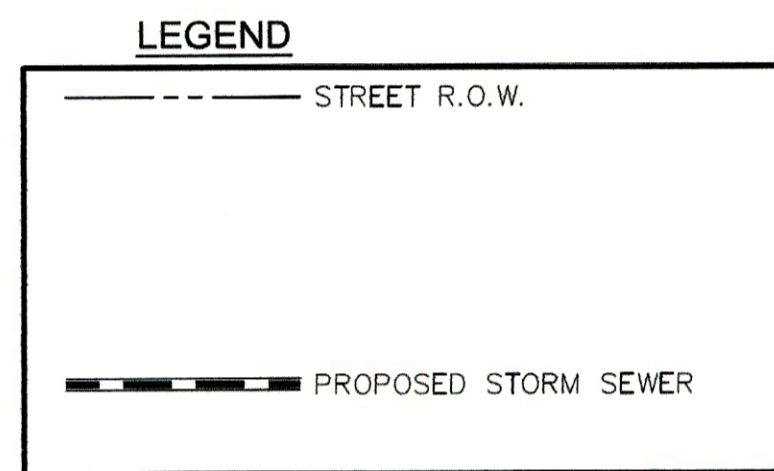

DEVELOPER'S STATEMENT

I, THE OWNER/DEVELOPER HAVE READ AND WILL COMPLY WITH THE
REQUIREMENTS OF THE GRADING AND EROSION CONTROL PLAN.

[Signature]
OWNER SIGNATURE

2/13/20
DATE

**CORE
ENGINEERING GROUP**
15004 1ST AVENUE S.
BURNSVILLE, MN 55306
PH: 719-859-7800
CONTACT: RICHARD L. SCHINDLER, P.E.
EMAIL: rich@cegi.com

DATE: _____
DESCRIPTION: _____
NO: _____
PROJECT: CARRIAGE MEADOWS
SOUTH AT LORSON
RANCH FILING NO. 2
FONTAINE BLVD.-CARRIAGE MEADOWS DR
COLORADO SPRINGS, COLORADO
PREPARED FOR:
LORSON, LLC
212 N. WAHSATCH AVE., SUITE 301
COLORADO SPRINGS, COLORADO 80903
CONTACT: JEFF MARK

DRAWN: RLS
DESIGNED: RLS
CHECKED: RLS

COVER SHEET
EARLY GRADING
AND EROSION CONTROL PLANS



DATE:
FEB 12, 2020
PROJECT NO.
100.046
SHEET NUMBER
C0.1
TOTAL SHEETS: 14

WATER / SANITARY
WIDEFIELD WATER AND SANITATION
DISTRICT
8495 FONTAINE BLVD.
COLORADO SPRINGS, CO 80925
719-390-7111

CABLE
COMCAST
P.O. BOX 173838
DENVER, CO 80217
970-641-4774

ELECTRIC
MOUNTAIN VIEW ELECTRIC
11140 E. WOODMEN RD.
COLORADO SPRINGS, CO 80831
719-495-2283

**SECURITY FIRE PROTECTION
DISTRICT**
400 SECURITY BOULEVARD
SECURITY, CO 80911
719-392-7121

PREPARED FOR:
LORSON, LLC
N. WAHSATCH AVE., SUITE 301
COLORADO SPRINGS, CO 80903
719-635-3200
CONTACT: JEFF MARK

PREPARED BY:
CORE ENGINEERING GROUP
15004 1ST AVENUE S.
BURNSVILLE, MN 55306
719-570-1100
CONTACT: RICHARD L. SCHINDLER P.E.

CONSTRUCTION APPROVAL

COUNTY PLAN REVIEW IS PROVIDED ONLY FOR GENERAL CONFORMANCE WITH
COUNTY DESIGN CRITERIA. THE COUNTY IS NOT RESPONSIBLE FOR THE
ACCURACY AND ADEQUACY OF THE DESIGN, DIMENSIONS, AND/OR ELEVATIONS
WHICH SHALL BE CONFIRMED AT THE JOB SITE. THE COUNTY THROUGH THE
APPROVAL OF THIS DOCUMENT ASSUMES NO RESPONSIBILITY FOR COMPLETENESS
AND/OR ACCURACY OF THIS DOCUMENT.

FILED IN ACCORDANCE WITH THE REQUIREMENTS OF THE EL PASO COUNTY LAND
DEVELOPMENT CODE, DRAINAGE CRITERIA MANUALS VOLUME 1 AND 2, AND
ENGINEERING CRITERIA MANUAL AS AMENDED. IN ACCORDANCE WITH ECM
SECTION 1.12, THESE CONSTRUCTION DOCUMENTS WILL BE VALID FOR
CONSTRUCTION FOR A PERIOD OF 2 YEARS FROM THE DATE SIGNED BY THE EL
PASO COUNTY ENGINEER. IF CONSTRUCTION HAS NOT STARTED WITHIN THOSE
TWO YEARS THE PLANS WILL NEED TO BE RESUBMITTED FOR APPROVAL,
INCLUDING PAYMENT OF REVIEW FEES AT THE PLANNING AND COMMUNITY
DEVELOPMENT DIRECTOR'S DISCRETION

JENNIFER IRVINE, COUNTY ENGINEER/ECM ADMINISTRATOR DATE

ENGINEER'S APPROVAL

THIS GRADING AND EROSION CONTROL PLAN WAS PREPARED UNDER MY DIRECTION
AND SUPERVISION AND IS CORRECT TO THE BEST OF MY KNOWLEDGE AND BELIEF.
SAID PLAN HAS BEEN PREPARED ACCORDING TO THE CRITERIA ESTABLISHED BY
THE COUNTY FOR GRADING AND EROSION CONTROL PLANS. I ACCEPT
RESPONSIBILITY FOR ANY LIABILITY CAUSED BY ANY NEGLIGENT ACTS, ERRORS OR
OMISSIONS ON MY PART IN PREPARATION OF THESE DETAILED PLANS AND
SPECIFICATIONS.

RICHARD L. SCHINDLER, P.E. # 33997
FOR AND ON BEHALF OF CORE ENGINEERING GROUP

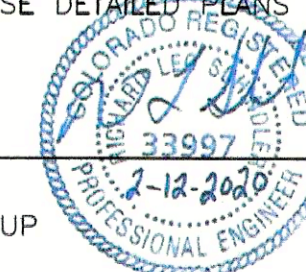

BASIS OF BEARING

BEARINGS ARE BASED ON THE SOUTH LINE OF THE NORTH HALF OF SECTION 23, TOWNSHIP 15 SOUTH, RANGE
65 WEST OF THE 6TH PRINCIPAL MERIDIAN AS BEING SOUTH 89°41'52" WEST. THE EAST QUARTER CORNER OF
SAID SECTION 23 IS A FOUND 3-1/2" ALUMINUM CAP MONUMENT AND THE WEST QUARTER CORNER OF SAID
SECTION 23 IS A FOUND 2-1/2" ALUMINUM CAP MONUMENT

BENCHMARK

FMS MONUMENT F204 LOCATED AT THE NORTHWEST CORNER OF FONTAINE BLVD AND COTTONWOOD GROVE DR.
ELEVATION 5724.072 (N.G.V.D. 29)

TRAFFIC CONTROL NOTE

THE CONTRACTOR SHALL PROVIDE ALL TRAFFIC CONTROL DEVICES AND MONITORING NECESSARY TO
SAFELY COMPLETE THE WORK SHOWN IN THESE CONSTRUCTION DOCUMENTS IN CONFORMANCE WITH
M.U.T.C.D. GUIDELINES. THE CONTRACTOR SHALL COMPLETE ALL NECESSARY WORK FOR PLAN
REVIEW, PERMITS AND PROCESSING. TRAFFIC CONTROL WILL NOT BE PAID SEPARATELY BUT IS
INCLUDED IN THE COST OF THE PROJECT.

PUDSP-19-005

CONSTRUCTION NOTES

1. ALL WORK SHALL COMPLY WITH THE CODES AND POLICIES FOR EL PASO COUNTY.
2. EXISTING TOPOGRAPHIC INFORMATION SHOWN ON THIS GRADING PLAN WAS OBTAINED FROM AERIAL CONTOURS AND PREVIOUS CONSTRUCTION DOCUMENTS. THE CONTRACTOR SHALL BE RESPONSIBLE TO EXAMINE THE SITE AND BE FAMILIAR WITH THE EXISTING CONDITIONS.
3. DEPTH OF MOISTURE-DENSITY CONTROL FOR THIS PROJECT SHALL BE AS FOLLOWS:
BASE OF ALL CUTS AND FILLS - 12 INCHES,
FULL DEPTH OF ALL EMBANKMENTS
4. THE CONTRACTOR IS RESPONSIBLE FOR THE RE-ESTABLISHMENT OF ALL SURVEY MONUMENTS DISTURBED WITHIN THE PROJECT LIMITS.
5. THE CONTRACTOR SHALL PROTECT ALL WORK AREAS AND FACILITIES FROM FLOODING AT ALL TIMES. AREAS AND FACILITIES SUBJECTED TO FLOODING, REGARDLESS OF THE SOURCE OF WATER, SHALL BE PROMPTLY DEWATERED AND RESTORED.
6. PRIOR TO PAVING OPERATIONS, THE ENTIRE SUBGRADE SHALL BE PROOF-ROLLED WITH A LOADED 988 FRONT-END LOADER OR SIMILAR HEAVY RUBBER Tired VEHICLE (GVW OF 50,000 POUNDS WITH 18 KIP PER AXLE AT TIRE PRESSURES OF 90 PSI) TO DETECT ANY SOFT OR LOOSE AREAS. IN AREAS WHERE SOFT OR LOOSE SOILS, PUMPING OR EXCESSIVE MOVEMENT IS OBSERVED, THE EXPOSED MATERIALS SHALL BE OVER-EXCAVATED TO A MINIMUM DEPTH OF TWO FEET BELOW PROPOSED FINAL GRADE OR TO A DEPTH AT WHICH SOILS ARE STABLE. AFTER THIS HAS BEEN COMPLETED, THE EXPOSED MATERIALS SHALL BE SCARIFIED TO A DEPTH OF 12 INCHES AND MOISTURE CONDITIONED. THE SUBGRADE SHALL THEN BE UNIFORMLY COMPACTED TO A MINIMUM OF 95% OF STANDARD PROCTOR DENSITY (ASTM D-698) AT 0 TO +4.0% OF OPTIMUM MOISTURE CONTENT FOR A-6 AND A-7-6 SOILS ENCOUNTERED. OTHER SUBGRADE TYPES SHALL BE UNIFORMLY COMPACTED TO A MINIMUM OF 95% OF MODIFIED PROCTOR DENSITY (ASTM D-1557) AT PLUS OR MINUS 2.0% OF OPTIMUM MOISTURE CONTENT. AREAS WHERE STABLE NATURAL SOILS ARE ENCOUNTERED AT PROPOSED SUBGRADE ELEVATION SHALL ALSO BE SCARIFIED (18 INCHES FOR A-7-6 SOILS BELOW FULL-DEPTH ASPHALT CONCRETE) AND COMPACTED AS OUTLINED ABOVE PRIOR TO PAVING OPERATIONS. SUBGRADE FILL SHALL BE PLACED IN SIX-INCH LIFTS AND UNIFORMLY COMPACTED, MEETING THE REQUIREMENTS AS PREVIOUSLY DESCRIBED.
7. SUBGRADE MATERIALS DEEMED UNSUITABLE BY THE ENGINEER SHALL BE EXCAVATED, DISPOSED OF AND REPLACED WITH APPROVED MATERIALS.
8. FILL SHALL BE PLACED IN 8-INCH MAXIMUM LOOSE LIFTS AND SHALL BE COMPACTED PRIOR TO SUCCESSIVE LIFTS.
9. THE CONTRACTOR IS RESPONSIBLE FOR PREVENTING AND CONTROLLING EROSION DURING CONSTRUCTION ACTIVITIES AT ALL TIMES DURING GRADING AND CONSTRUCTION. THE CONTRACTOR SHALL PROVIDE THE FOLLOWING EROSION AND SEDIMENT CONTROL MEASURES:
 - HAY BALE BARRIERS WHERE NEEDED AND/OR AS DIRECTED BY THE ENGINEER.
 - SILT FENCE WHERE NEEDED AND/OR AS DIRECTED BY THE ENGINEER.
 - TEMPORARY SEDIMENTATION BASINS WHERE NEEDED AND/OR AS DIRECTED BY THE ENGINEER.
 - MULCHING AND SEEDING OF EXCESSIVE SLOPED AREAS AS NEEDED OR AS DIRECTED BY THE ENGINEER.
 - TEMPORARY VEHICLE TRACKING CONTROL AS NEEDED AND/OR DIRECTED BY THE ENGINEER.
 - CONCRETE WASH AREAS.
 - INLET PROTECTION.

THESE AND ALL EROSION CONTROL BEST MANAGEMENT PRACTICES AS SHOWN IN THE GRADING AND EROSION CONTROL PLANS SHALL BE STRICTLY ADHERED TO.
10. FINISHED CONTOURS/SPOT ELEVATIONS SHOWN HEREON REPRESENT FINISHED GRADES. ALL PAVEMENT SUBGRADES ARE BASED ON THE COMPOSITE ASPHALT PAVEMENT RECOMMENDATIONS MADE IN THE "GEOTECHNICAL STUDY" FOR THIS PROJECT.

EL PASO COUNTY STANDARD CONSTRUCTION NOTES:

1. ALL DRAINAGE AND ROADWAY CONSTRUCTION SHALL MEET THE STANDARDS AND SPECIFICATIONS OF THE CITY OF COLORADO SPRINGS/EL PASO COUNTY DRAINAGE CRITERIA MANUAL, VOLUMES 1 AND 2, AND THE EL PASO COUNTY ENGINEERING CRITERIA MANUAL.
2. CONTRACTOR SHALL BE RESPONSIBLE FOR THE NOTIFICATION AND FIELD NOTIFICATION OF ALL EXISTING UTILITIES, WHETHER SHOWN ON THE PLANS OR NOT, BEFORE BEGINNING CONSTRUCTION. LOCATION OF EXISTING UTILITIES SHALL BE VERIFIED BY THE CONTRACTOR PRIOR TO CONSTRUCTION. CALL 811 TO CONTACT THE UTILITY NOTIFICATION CENTER OF COLORADO (UNCC).
3. CONTRACTOR SHALL KEEP A COPY OF THESE APPROVED PLANS, THE GRADING AND EROSION CONTROL PLAN, THE STORMWATER MANAGEMENT PLAN (SWMP), THE SOILS AND GEOTECHNICAL REPORT, AND THE APPROPRIATE DESIGN AND CONSTRUCTION STANDARDS AND SPECIFICATIONS AT THE JOB SITE AT ALL TIMES, INCLUDING THE FOLLOWING:
 - a. EL PASO COUNTY ENGINEERING CRITERIA MANUAL (ECM)
 - b. CITY OF COLORADO SPRINGS/EL PASO COUNTY DRAINAGE CRITERIA MANUAL, VOLUMES 1 AND 2
 - c. COLORADO DEPARTMENT OF TRANSPORTATION (CDOT) STANDARD SPECIFICATIONS FOR ROAD AND BRIDGE CONSTRUCTION
 - d. CDOT M & S STANDARDS
4. NOTWITHSTANDING ANYTHING DEPICTED IN THESE PLANS IN WORDS OR GRAPHIC REPRESENTATION, ALL DESIGN AND CONSTRUCTION RELATED TO ROADS, STORM DRAINAGE AND EROSION CONTROL SHALL CONFORM TO THE STANDARDS AND REQUIREMENTS OF THE MOST RECENT VERSION OF THE RELEVANT ADOPTED EL PASO COUNTY STANDARDS, INCLUDING THE LAND DEVELOPMENT CODE, THE ENGINEERING CRITERIA MANUAL, THE DRAINAGE CRITERIA MANUAL, AND THE DRAINAGE CRITERIA MANUAL VOLUME 2. ANY DEVIATIONS FROM REGULATIONS AND STANDARDS MUST BE REQUESTED, AND APPROVED, IN WRITING. ANY MODIFICATIONS NECESSARY TO MEET CRITERIA AFTER-THE-FACT WILL BE ENTIRELY THE DEVELOPER'S RESPONSIBILITY TO RECTIFY.
5. IT IS THE DESIGN ENGINEER'S RESPONSIBILITY TO ACCURATELY SHOW EXISTING CONDITIONS, BOTH ONSITE AND OFFSITE, ON THE CONSTRUCTION PLANS. ANY MODIFICATIONS NECESSARY DUE TO CONFLICTS, OMISSIONS, OR CHANGED CONDITIONS WILL BE ENTIRELY THE DEVELOPER'S RESPONSIBILITY TO RECTIFY.
6. CONTRACTOR SHALL SCHEDULE A PRE-CONSTRUCTION MEETING WITH EL PASO COUNTY PLANNING AND COMMUNITY DEVELOPMENT (PCD) - INSPECTIONS, PRIOR TO STARTING CONSTRUCTION.
7. IT IS THE CONTRACTOR'S RESPONSIBILITY TO UNDERSTAND THE REQUIREMENTS OF ALL JURISDICTIONAL AGENCIES AND TO OBTAIN ALL REQUIRED PERMITS, INCLUDING BUT NOT LIMITED TO EL PASO COUNTY EROSION AND STORMWATER QUALITY CONTROL PERMIT (ESQCP), REGIONAL BUILDING FLOODPLAIN DEVELOPMENT PERMIT, U.S. ARMY CORPS OF ENGINEERS-ISSUED 401 AND/OR 404 PERMITS, AND COUNTY AND STATE FUGITIVE DUST PERMITS.
8. CONTRACTOR SHALL NOT DEVIATE FROM THE PLANS WITHOUT FIRST OBTAINING WRITTEN APPROVAL FROM THE DESIGN ENGINEER AND DSD. CONTRACTOR SHALL NOTIFY THE DESIGN ENGINEER IMMEDIATELY UPON DISCOVERY OF ANY ERRORS OR INCONSISTENCIES.
9. ALL STORM DRAIN PIPE SHALL BE CLASS III RCP UNLESS OTHERWISE NOTED AND APPROVED BY PCD.
10. CONTRACTOR SHALL COORDINATE GEOTECHNICAL TESTING PER ECM STANDARDS. PAVEMENT DESIGN SHALL BE APPROVED BY EL PASO COUNTY PCD PRIOR TO PLACEMENT OF CURB AND GUTTER AND PAVEMENT.
11. ALL CONSTRUCTION TRAFFIC MUST ENTER/EXIT THE SITE AT APPROVED CONSTRUCTION ACCESS POINTS.
12. SIGHT VISIBILITY TRIANGLES AS IDENTIFIED IN THE PLANS SHALL BE PROVIDED AT ALL INTERSECTIONS. OBSTRUCTIONS GREATER THAN 18 INCHES ABOVE FLOWLINE ARE NOT ALLOWED WITHIN SIGHT TRIANGLES.
13. SIGNING AND STRIPING SHALL COMPLY WITH EL PASO COUNTY PUBLIC WORK DEPARTMENT AND MUTCD CRITERIA.
14. CONTRACTOR SHALL OBTAIN ANY PERMITS REQUIRED BY EL PASO COUNTY PWD, INCLUDING WORK WITHIN THE RIGHT-OF-WAY AND SPECIAL TRANSPORT PERMITS.
15. THE LIMITS OF CONSTRUCTION SHALL REMAIN WITHIN THE PROPERTY LINE UNLESS OTHERWISE NOTED. THE OWNER/DEVELOPER SHALL OBTAIN WRITTEN PERMISSION AND EASEMENTS, WHERE REQUIRED, FROM ADJOINING PROPERTY OWNER(S) PRIOR TO ANY OFF-SITE DISTURBANCE, GRADING, OR CONSTRUCTION.

STANDARD NOTES FOR EL PASO COUNTY GRADING AND EROSION CONTROL PLANS (rev. 7/02/2019)

1. Stormwater discharges from construction sites shall not cause or threaten to cause pollution, contamination, or degradation of State Waters. All work and earth disturbance shall be done in a manner that minimizes pollution of any on-site or off-site waters, including wetlands.
2. Notwithstanding anything depicted in these plans in words or graphic representation, all design and construction related to roads, storm drainage and erosion control shall conform to the standards and requirements of the most recent version of the relevant adopted El Paso County standards, including the Land Development Code, the Engineering Criteria Manual, the Drainage Criteria Manual, and the Drainage Criteria Manual Volume 2. Any deviations from regulations and standards must be requested, and approved, in writing.
3. A separate Stormwater Management Plan (SMWP) for this project shall be completed and an Erosion and Stormwater Quality Control Permit (ESQCP) issued prior to commencing construction. Management of the SWMP during construction is the responsibility of the designated Qualified Stormwater Manager or Certified Erosion Control Inspector. The SWMP shall be located on site at all times during construction and shall be kept up to date with work progress and changes in the field.
4. Once the ESQCP is approved and a "Notice to Proceed" has been issued, the contractor may install the initial stage erosion and sediment control measures as indicated on the approved GEC. A Preconstruction Meeting between the contractor, engineer, and El Paso County will be held prior to any construction. It is the responsibility of the applicant to coordinate the meeting time and place with County staff.
5. Control measures must be installed prior to commencement of activities that could contribute pollutants to stormwater. Control measures for all slopes, channels, ditches, and disturbed land areas shall be installed immediately upon completion of the disturbance.
6. All temporary sediment and erosion control measures shall be maintained and remain in effective operating condition until permanent soil erosion control measures are implemented and final stabilization is established. All persons engaged in land disturbance activities shall assess the adequacy of control measures at the site and identify if changes to those control measures are needed to ensure the continued effective performance of the control measures. All changes to temporary sediment and erosion control measures must be incorporated into the Stormwater Management Plan.
7. Temporary stabilization shall be implemented on disturbed areas and stockpiles where ground disturbing construction activity has permanently ceased or temporarily ceased for longer than 14 days.
8. Final stabilization must be implemented at all applicable construction sites. Final stabilization is achieved when all ground disturbing activities are complete and all disturbed areas either have a uniform vegetative cover with individual plant density of 70 percent of pre-disturbance levels established or equivalent permanent alternative stabilization method is implemented. All temporary sediment and erosion control measures shall be removed upon final stabilization and before permit closure.
9. All permanent stormwater management facilities shall be installed as designed in the approved plans. Any proposed changes that affect the design or function of permanent stormwater management structures must be approved by the ECM Administrator prior to implementation.
10. Earth disturbances shall be conducted in such a manner so as to effectively minimize accelerated soil erosion and resulting sedimentation. All disturbances shall be designed, constructed, and completed so that the exposed area of any disturbed land shall be limited to the shortest practical period of time. Pre-existing vegetation shall be protected and maintained within 50 horizontal feet of a waters of the state unless shown to be infeasible and specifically requested and approved.
11. Compaction of soil must be prevented in areas designated for infiltration control measures or where final stabilization will be achieved by vegetative cover. Areas designated for infiltration control measures shall also be protected from sedimentation during construction until final stabilization is achieved. If compaction prevention is not feasible due to site constraints, all areas designated for infiltration and vegetation control measures must be loosened prior to installation of the control measure(s).
12. Any temporary or permanent facility designed and constructed for the conveyance of stormwater around, through, or from the earth disturbance area shall be a stabilized conveyance designed to minimize erosion and the discharge of sediment off site.
13. Concrete wash water shall be contained and disposed of in accordance with the SWMP. No wash water shall be discharged to or allowed to enter State Waters, including any surface or subsurface storm drainage system or facilities. Concrete washouts shall not be located in an area where shallow groundwater may be present, or within 50 feet of a surface water body, creek or stream.
14. During dewatering operations of uncontaminated ground water may be discharged on site, but shall not leave the site in the form of surface runoff unless an approved State dewatering permit is in place.
15. Erosion control blanketing or other protective covering shall be used on slopes steeper than 3:1.
16. Contractor shall be responsible for the removal of all wastes from the construction site for disposal in accordance with local and State regulatory requirements. No construction debris, tree slash, building material wastes or unused building materials shall be buried, dumped, or discharged at the site.
17. Waste materials shall not be temporarily placed or stored in the street, alley, or other public way, unless in accordance with an approved Traffic Control Plan. Control measures may be required by El Paso County Engineering if deemed necessary, based on specific conditions and circumstances.
18. Tracking of soils and construction debris off-site shall be minimized. Materials tracked off-site shall be cleaned up and properly disposed of immediately.
19. The owner/developer shall be responsible for the removal of all construction debris, dirt, trash, rock, sediment, soil, and sand that may accumulate in roads, storm drains and other drainage conveyance systems and stormwater appurtenances as a result of site development.
20. The quantity of materials stored on the project site shall be limited, as much as practical, to that quantity required to perform the work in an orderly sequence. All materials stored on-site shall be stored in a neat, orderly manner, in their original containers, with original manufacturer's labels.
21. No chemical(s) having the potential to be released in stormwater are to be stored or used onsite unless permission for the use of such chemical(s) is granted in writing by the ECM Administrator. In granting approval for the use of such chemical(s), special conditions and monitoring may be required.
22. Bulk storage of allowed petroleum products or other allowed liquid chemicals in excess of 55 gallons shall require adequate secondary containment protection to contain all spills onsite and to prevent any spilled materials from entering State Waters, any surface or subsurface storm drainage system or other facilities.
23. No person shall cause the impediment of stormwater flow in the curb and gutter or ditch except with approved sediment control measures.
24. Owner/developer and their agents shall comply with the "Colorado Water Quality Control Act" (Title 25, Article 8, CRS), and the "Clean Water Act" (33 USC 1344), in addition to the requirements of the Land Development Code, DCM Volume II and the ECM Appendix I. All appropriate permits must be obtained by the contractor prior to construction (1041, NPDES, Floodplain, 404, fugitive dust, etc.). In the event of conflicts between these requirements and other laws, rules, or regulations of other Federal, State, local, or County agencies, the most restrictive laws, rules, or regulations shall apply.
25. All construction traffic must enter/exit the site only at approved construction access points.
26. Prior to construction the permittee shall verify the location of existing utilities.
27. A water source shall be available on site during earthwork operations and shall be utilized as required to minimize dust from earthwork equipment and wind.
28. The soils report for this site has been prepared by RMG, "GEOLOGY AND SOILS STUDY FOR CARRIAGE MEADOWS SOUTH AT LORSON RANCH FIL NO. 2", DATED OCTOBER 7, 2019 and shall be considered a part of these plans.
29. At least ten (10) days prior to the anticipated start of construction, for projects that will disturb one (1) acre or more, the owner or operator of construction activity shall submit a permit application for stormwater discharge to the Colorado Department of Public Health and Environment, Water Quality Division. The application contains certification of completion of a stormwater management plan (SWMP), of which this Grading and Erosion Control Plan may be a part. For information or application materials contact:

Colorado Department of Public Health and Environment
Water Quality Control Division
WQCD - Permits
4300 Cherry Creek Drive South
Denver, CO 80246-1530
Attn: Permits Unit

CORE ENGINEERING GROUP	DATE	
	DESCRIPTION	
NO.		
DRAWN: RLS		
DESIGNED: RLS		
CHECKED: RLS		

PREPARED FOR:
LORSON, LLC
212 N. WAHSATCH AVE. SUITE 301
COLORADO SPRINGS, COLORADO 80903
CONTACT: RICHARD L. SCHINDLER, P.E.
EMAIL: Rich@cgg1.com

PROJECT: **CARRIAGE MEADOWS SOUTH AT LORSON RANCH FILING NO. 2**
FONTAINE BLVD - CARRIAGE MEADOWS DR
COLORADO SPRINGS, COLORADO
CONTACT: JEFF MARK

EARLY SITE GRADING AND EROSION CONTROL PLAN NOTES



DATE:	FEB 12, 2020
PROJECT NO.	100.046
SHEET NUMBER	C0.2
TOTAL SHEETS:	14

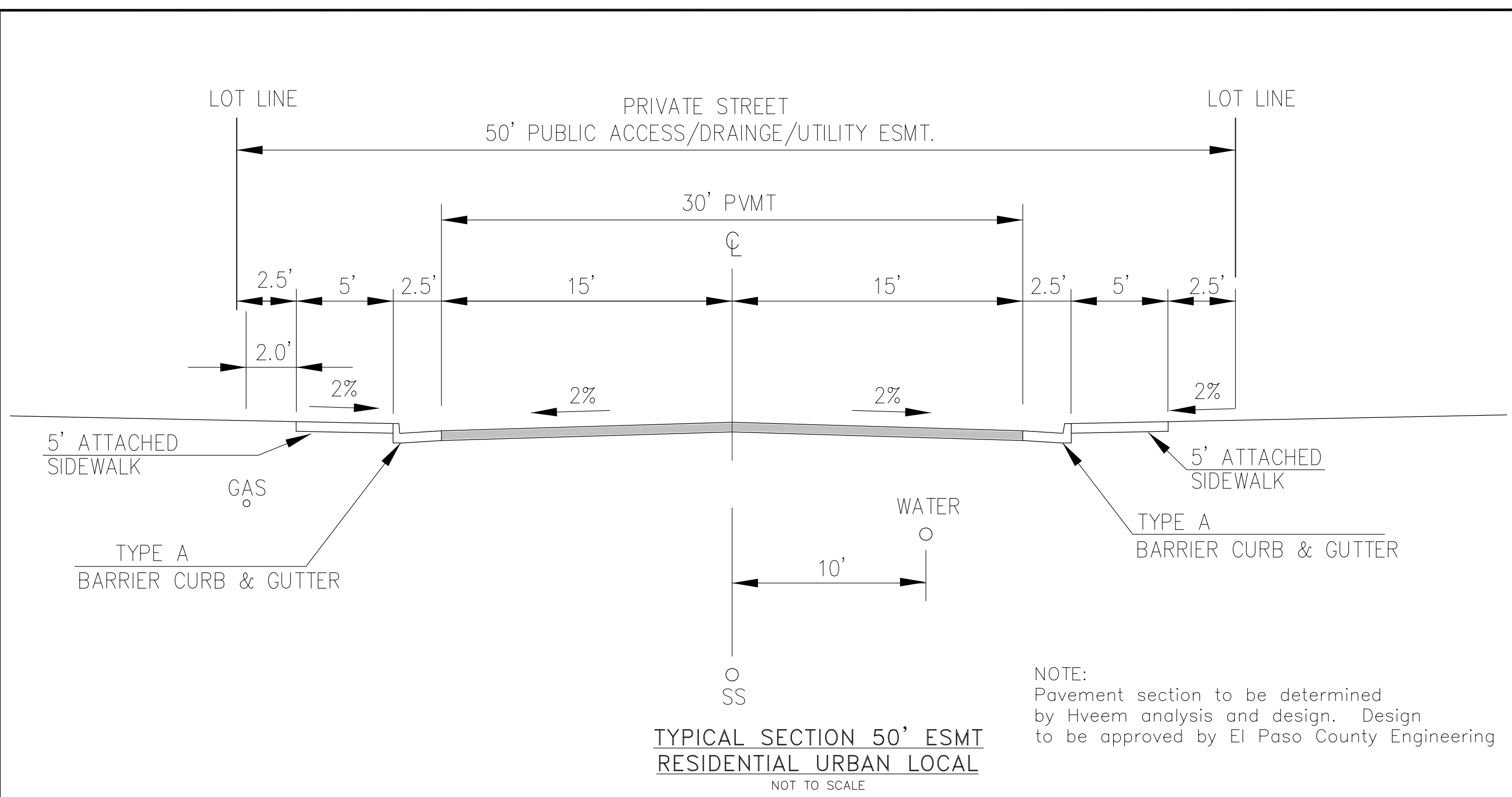

TYPICAL SECTION 50' ESMT
RESIDENTIAL URBAN LOCAL
NOT TO SCALE

RUBICON DRIVE (PUBLIC STREET) STA 0+98 TO 2+87
FIRESTEEL DRIVE (PUBLIC STREET)

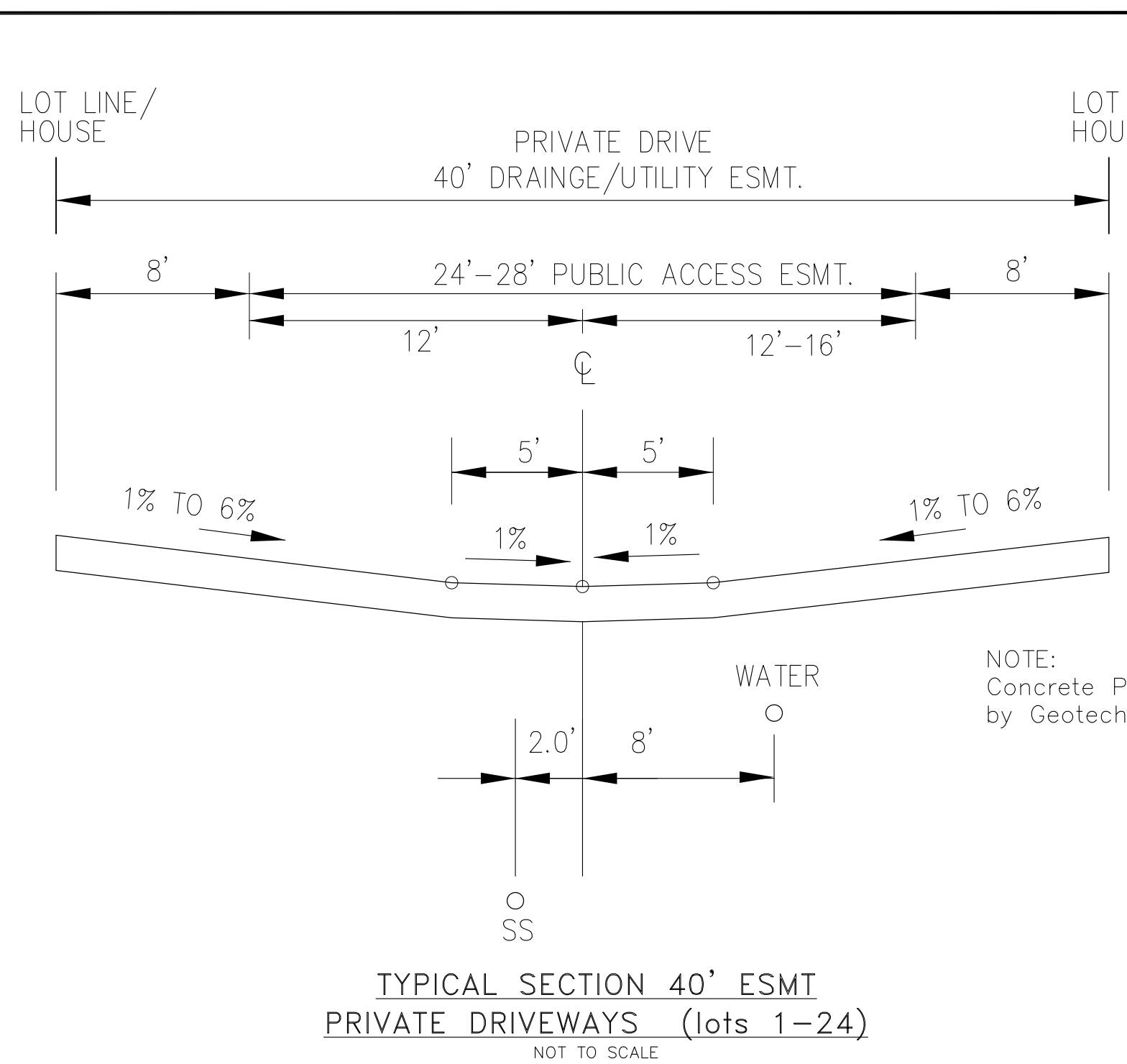

TYPICAL SECTION 40' ESMT
PRIVATE DRIVEWAYS (lots 1-24)
NOT TO SCALE

AMBLING HEIGHTS, PALUXY HEIGHTS, CHAGRIN HEIGHTS

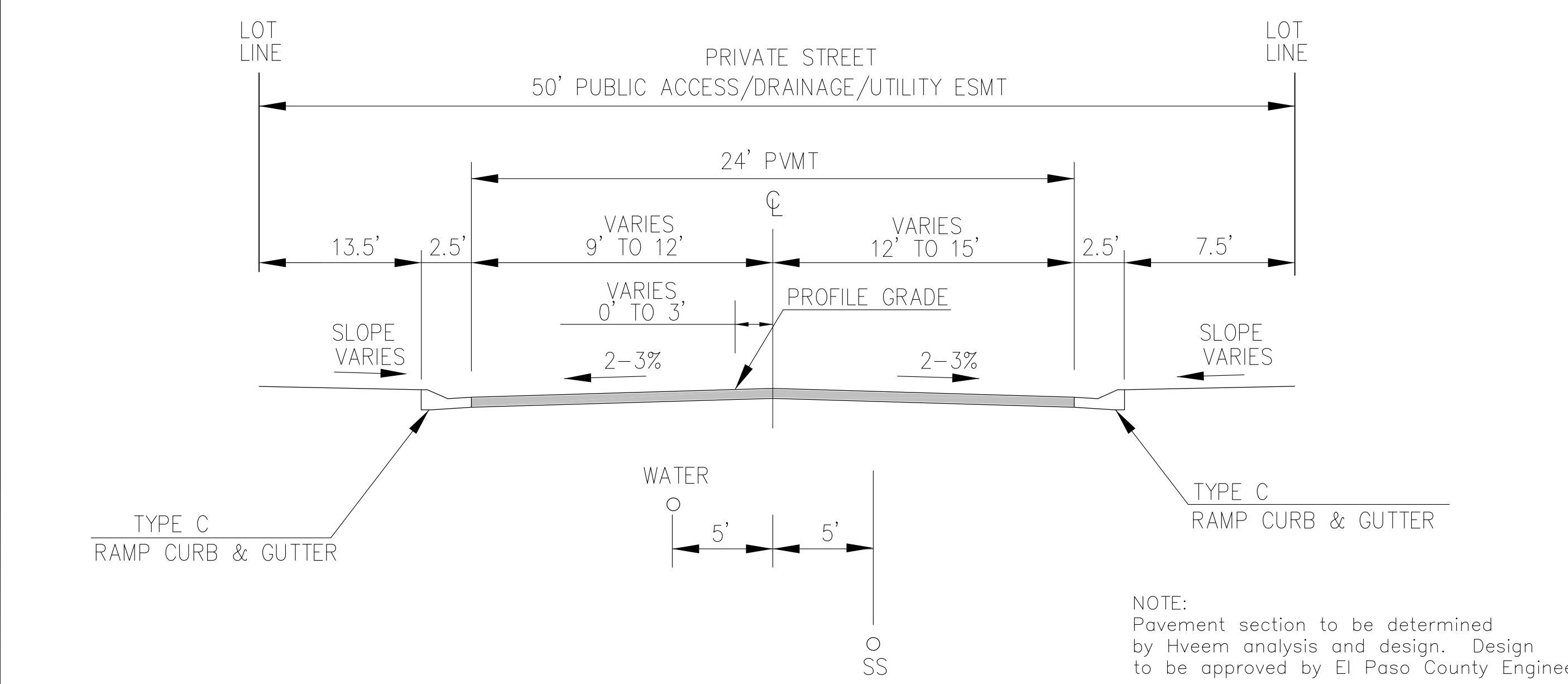

TYPICAL SECTION 50' ESMT
RESIDENTIAL URBAN LOCAL LOW VOLUME
NOT TO SCALE

RUBICON HEIGHTS (STA 2+87 TO STA 7+38)
PRIVATE STREET

CORE
ENGINEERING GROUP
15004 1ST AVENUE S.
BURNSVILLE, MN 55306
PH: 719-659-7800
CONTACT: RICHARD L. SCHINDLER, P.E.
EMAIL: Rich@cegi.com

DATE: _____
DESCRIPTION: _____
NO. _____
PREPARED FOR: LORSON, LLC
212 N. WAHSATCH AVE, SUITE 301
COLORADO SPRINGS, COLORADO 80903
PROJECT: CARRIAGE MEADOWS SOUTH AT LORSON RANCH FILING NO. 2
FONTAINE BLVD - CARRIAGE MEADOWS DR COLORADO SPRINGS, COLORADO
CONTACT: JEFF MARK

DRAWN: RLS
DESIGNED: RLS
CHECKED: RLS

TYPICAL STREET AND DRIVEWAY SECTIONS



DATE: FEB 12, 2020

PROJECT NO. 100.046

SHEET NUMBER C0.3

TOTAL SHEETS: 14

NOTE:
HOME BUILDER OR CONTRACTOR SHALL AS-BUILT ALL IMPROVEMENTS PRIOR TO CONSTRUCTING ANY BUILDINGS. THE ENGINEER SHALL BE NOTIFIED OF ANY DISCREPANCY FROM THIS PLAN PRIOR TO ANY BUILDING CONSTRUCTION.

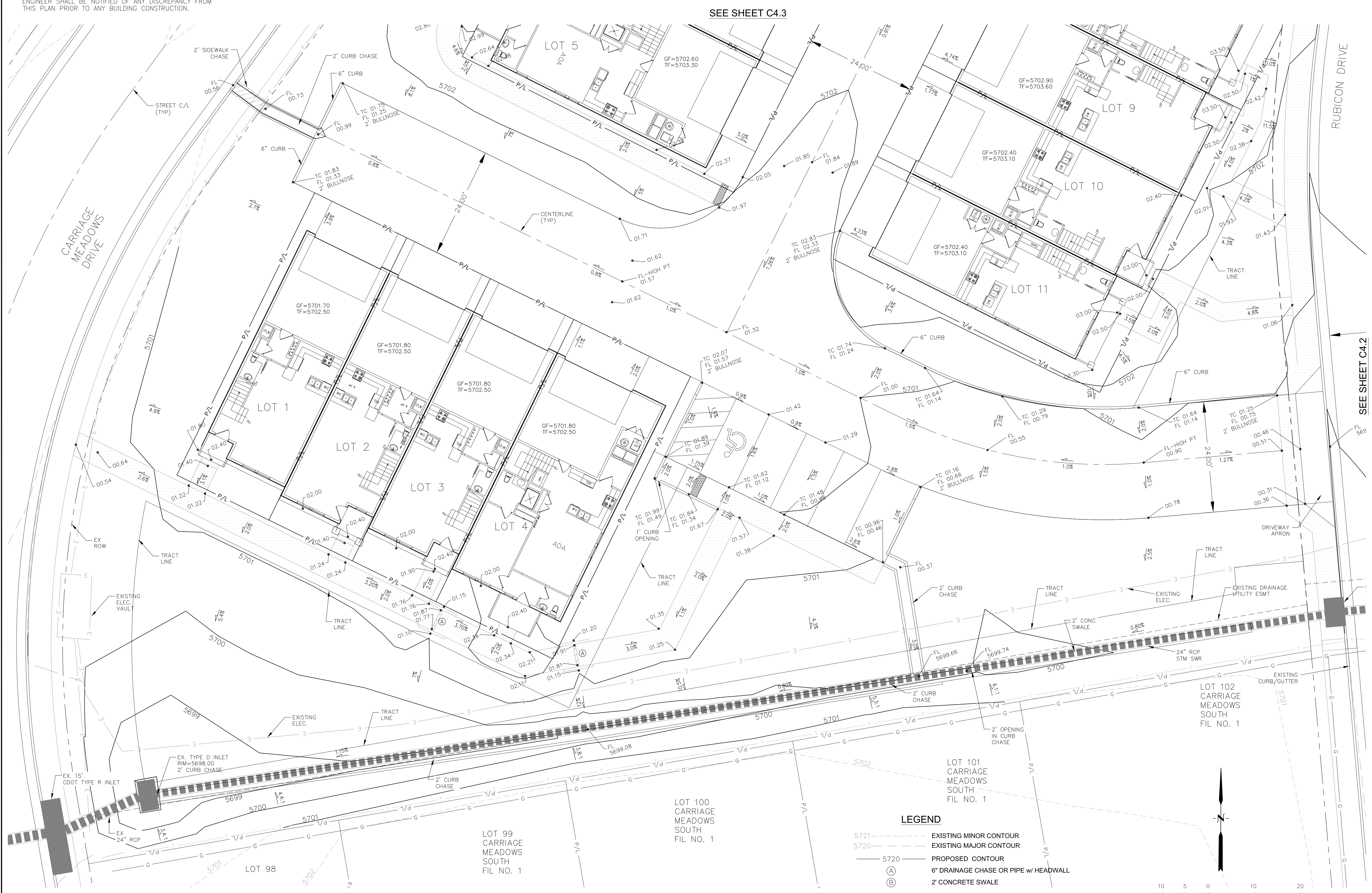

SEE SHEET C4.3

SEE SHEET C4.2

LEGEND

- 5721 - - - - - EXISTING MINOR CONTOUR
- 5720 - - - - - EXISTING MAJOR CONTOUR
- 5720 ———— PROPOSED CONTOUR
- (A) ———— 6" DRAINAGE CHASE OR PIPE w/ HEADWALL
- (B) ———— 2' CONCRETE SWALE
- FLOWLINE
- PROPERTY LINE

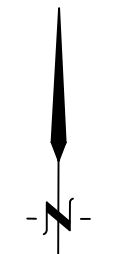
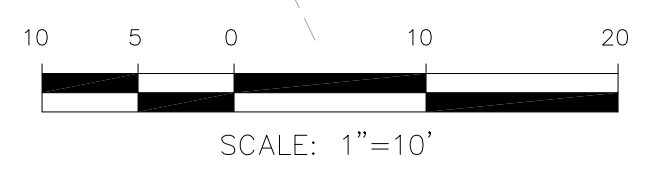

CORE ENGINEERING GROUP
1515 AVENUE S.
BOULDER, CO 80506
PH: 719-659-7800
CONTACT: RICHARD L. SCHINDLER, P.E.
EMAIL: Rich@ceg1.com

DATE: _____
NO. _____
DESCRIPTION: _____
PREPARED FOR: **LORSON, LLC**
212 N. WAHSATCH AVE, SUITE 301
COLORADO SPRINGS, COLORADO 80903
CONTACT: JEFF MARK

DRAWN: RLS
DESIGNED: RLS
CHECKED: RLS

**CARRIAGE MEADOWS SOUTH
AT LORSON RANCH FIL. NO. 2
DETAILED GRADING PLAN**



DATE: FEB 12, 2020
PROJECT NO. 100.046
SHEET NUMBER **C4.1**
TOTAL SHEETS: 14

NOTE:
HOME BUILDER OR CONTRACTOR SHALL AS-BUILT ALL IMPROVEMENTS PRIOR TO CONSTRUCTING ANY BUILDINGS. THE ENGINEER SHALL BE NOTIFIED OF ANY DISCREPANCY FROM THIS PLAN PRIOR TO ANY BUILDING CONSTRUCTION.

SEE SHEET C4.4

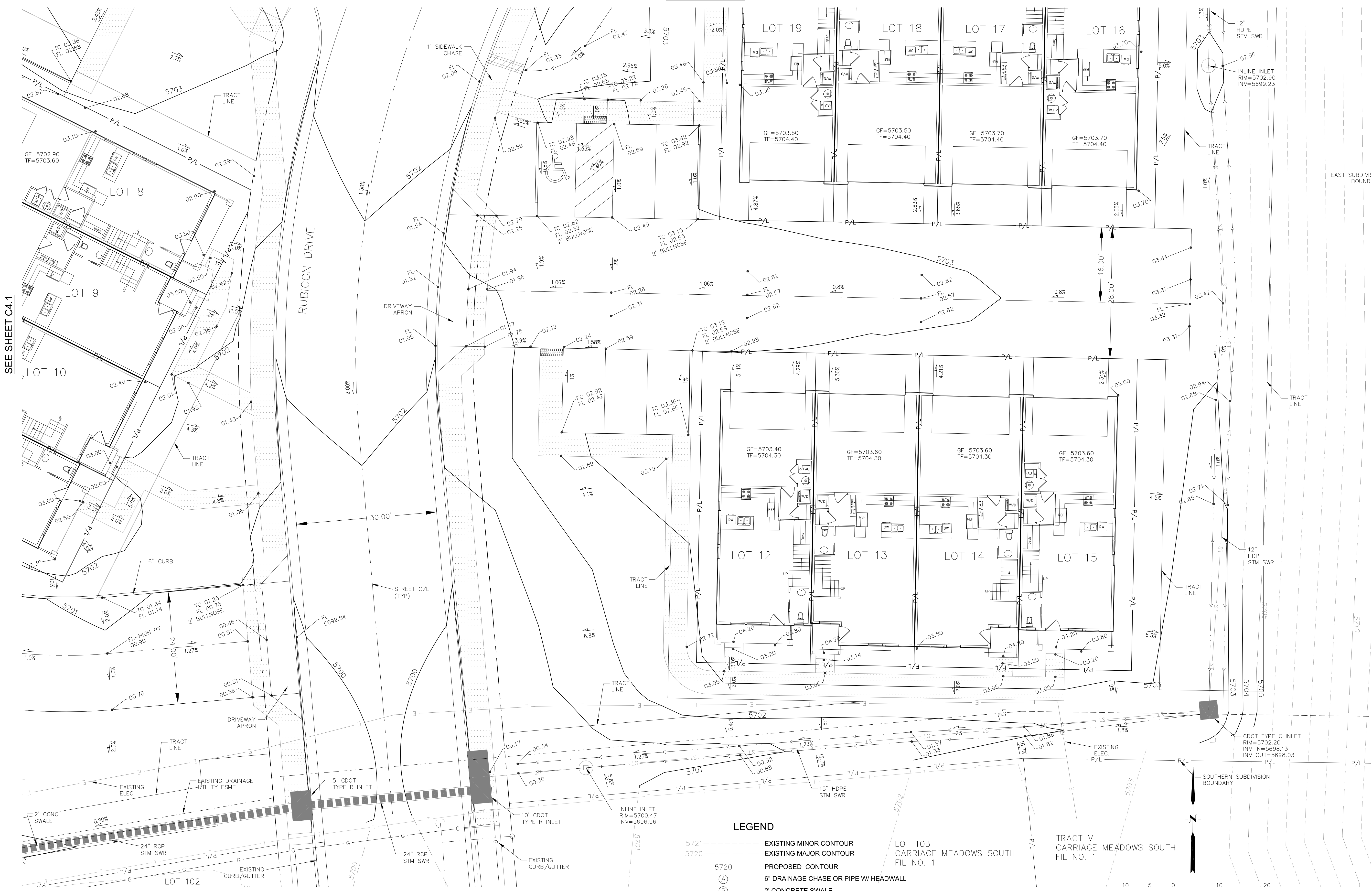

SEE SHEET C4.1

RUBICON DRIVE
SEE SF 17-011

- LEGEND**
- 5721 --- EXISTING MINOR CONTOUR
 - 5720 --- EXISTING MAJOR CONTOUR
 - PROPOSED CONTOUR
 - (A) 6" DRAINAGE CHASE OR PIPE W/ HEADWALL
 - (B) 2' CONCRETE SWALE
 - FLOWLINE
 - PROPERTY LINE



CORE ENGINEERING GROUP
1500 S. AVENUE 103
DENVER, CO 80202
PH: 719-659-7800
CONTACT: RICHARD L. SCHINDLER, P.E.
EMAIL: Rich@ceg1.com

DATE: _____
DESCRIPTION: _____
NO: _____
PROJECT: CARRIAGE MEADOWS SOUTH AT LORSON RANCH FILING NO. 2
PREPARED FOR: LORSON, LLC
212 N. WAHSATCH AVE, SUITE 301
COLORADO SPRINGS, COLORADO 80903
CONTACT: RICHARD L. SCHINDLER, P.E.
FONTANE BLVD-CARRIAGE MEADOWS DR
COLORADO SPRINGS, COLORADO
CONTACT: JEFF MARK

DRAWN: RLS
DESIGNED: RLS
CHECKED: RLS

**CARRIAGE MEADOWS SOUTH AT LORSON RANCH FIL. NO. 2
DETAILED GRADING PLAN**



DATE: FEB 12, 2020
PROJECT NO. 100.046
SHEET NUMBER C4.2
TOTAL SHEETS: 14

LEGEND

- 5721 - - - - - EXISTING MINOR CONTOUR
- 5720 - - - - - EXISTING MAJOR CONTOUR
- 5720 ——— PROPOSED CONTOUR
- (A) 6" DRAINAGE CHASE OR PIPE W/ HEADWALL
- (B) 2' CONCRETE SWALE
- FLOWLINE
- PA — PA — PROPERTY LINE

SEE SHEET C4.5

NOTE:
HOME BUILDER OR CONTRACTOR SHALL AS-BUILT ALL IMPROVEMENTS PRIOR TO CONSTRUCTING ANY BUILDINGS. THE ENGINEER SHALL BE NOTIFIED OF ANY DISCREPANCY FROM THIS PLAN PRIOR TO ANY BUILDING CONSTRUCTION.



SEE SHEET C4.1

SEE SHEET C4.4

CORE ENGINEERING GROUP
1500 S. AVENUE 103
BOULDER, CO 80506
PH: 719-659-7800
CONTACT: RICHARD L. SCHINDLER, P.E.
EMAIL: Rich@ceg1.com

DATE: _____
DESCRIPTION: _____
NO: _____
DRAWN: RLS
DESIGNED: RLS
CHECKED: RLS

PREPARED FOR:
LORSON, LLC
212 N. WAHSATCH AVE, SUITE 301
COLORADO SPRINGS, COLORADO 80903
CONTACT: (719) 635-3200
CONTACT: JEFF MARK

PROJECT: CARRIAGE MEADOWS SOUTH AT LORSON RANCH FILING NO. 2
FONTAINE BLVD-CARRIAGE MEADOWS DR
COLORADO SPRINGS, COLORADO

**CARRIAGE MEADOWS SOUTH
AT LORSON RANCH FIL. NO. 2
DETAILED GRADING PLAN**



DATE: FEB 12, 2020
PROJECT NO. 100.046
SHEET NUMBER C4.3
TOTAL SHEETS: 14

NOTE:
HOME BUILDER OR CONTRACTOR SHALL AS-BUILT ALL IMPROVEMENTS PRIOR TO CONSTRUCTING ANY BUILDINGS. THE ENGINEER SHALL BE NOTIFIED OF ANY DISCREPANCY FROM THIS PLAN PRIOR TO ANY BUILDING CONSTRUCTION.

SEE SHEET C4.5

LEGEND

- 5721----- EXISTING MINOR CONTOUR
- 5720----- EXISTING MAJOR CONTOUR
- 5720----- PROPOSED CONTOUR
- (A)----- 6" DRAINAGE CHASE OR PIPE W/ HEADWALL
- (B)----- 2' CONCRETE SWALE
- FLOWLINE
- PROPERTY LINE



SEE SHEET C4.2

CORE ENGINEERING GROUP
1515 AVENUE S.
BOULDER, CO 80506
PH: 719-659-7800
CONTACT: RICHARD L. SCHINDLER, P.E.
EMAIL: Rich@ceg1.com

DATE: _____
DESCRIPTION: _____
NO: _____
PROJECT: CARRIAGE MEADOWS SOUTH AT LORSON RANCH FILING NO. 2
PREPARED FOR: LORSON, LLC
212 N. WAHSATCH AVE, SUITE 301
COLORADO SPRINGS, COLORADO 80903
FONTAINE BLVD-CARRIAGE MEADOWS DR
COLORADO SPRINGS, COLORADO
CONTACT: JEFF MARK

DRAWN: RLS
DESIGNED: RLS
CHECKED: RLS

CARRIAGE MEADOWS SOUTH AT LORSON RANCH FIL. NO. 2 DETAILED GRADING PLAN



DATE: FEB 12, 2020
PROJECT NO: 100.046
SHEET NUMBER: C4.4
TOTAL SHEETS: 14

LEGEND

- 5721 - - - - - EXISTING MINOR CONTOUR
- 5720 - - - - - EXISTING MAJOR CONTOUR
- 5720 - - - - - PROPOSED CONTOUR
- (A) 6" DRAINAGE CHASE OR PIPE W/ HEADWALL
- (B) 2' CONCRETE SWALE
- FLOWLINE
- PROPERTY LINE

NOTE:

HOME BUILDER OR CONTRACTOR SHALL AS-BUILT ALL IMPROVEMENTS PRIOR TO CONSTRUCTING ANY BUILDINGS. THE ENGINEER SHALL BE NOTIFIED OF ANY DISCREPANCY FROM THIS PLAN PRIOR TO ANY BUILDING CONSTRUCTION.

SEE SHEET C4.6



SEE SHEET C4.3

SEE SHEET C4.4

CORE ENGINEERING GROUP
 1500 S. 151st AVENUE, SUITE 100
 BOULDER, CO 80506
 PH: 719-659-7800
 CONTACT: RICHARD L. SCHINDLER, P.E.
 EMAIL: Rich@ceg1.com

DATE: _____
 DESCRIPTION: _____
 NO. _____
 PREPARED FOR: **LORSON, LLC**
 212 N. WAHSATCH AVE, SUITE 301
 COLORADO SPRINGS, COLORADO 80903
 PROJECT: **CARRIAGE MEADOWS SOUTH AT LORSON RANCH FILING NO. 2**
 FONTAINE BLVD-CARRIAGE MEADOWS DR
 COLORADO SPRINGS, COLORADO
 CONTACT: JEFF MARK

DRAWN: RLS
 DESIGNED: RLS
 CHECKED: RLS

CARRIAGE MEADOWS SOUTH AT LORSON RANCH FIL. NO. 2 DETAILED GRADING PLANS



DATE: FEB 12, 2020
 PROJECT NO. 100.046
 SHEET NUMBER **C4.5**
 TOTAL SHEETS: 14

LEGEND

- 5721----- EXISTING MINOR CONTOUR
- 5720----- EXISTING MAJOR CONTOUR
- 5720----- PROPOSED CONTOUR
- (A)----- 6" DRAINAGE CHASE OR PIPE W/ HEADWALL
- (B)----- 2" CONCRETE SWALE
- FLOWLINE
- PROPERTY LINE

NOTE:

HOME BUILDER OR CONTRACTOR SHALL AS-BUILT ALL IMPROVEMENTS PRIOR TO CONSTRUCTING ANY BUILDINGS. THE ENGINEER SHALL BE NOTIFIED OF ANY DISCREPANCY FROM THIS PLAN PRIOR TO ANY BUILDING CONSTRUCTION.

SEE SHEET C4.7



SEE SHEET C4.5

CORE ENGINEERING GROUP
 1500 S. 151st AVENUE, SUITE 100
 COLORADO SPRINGS, CO 80906
 PH: 719-659-7800
 CONTACT: RICHARD L. SCHINDLER, P.E.
 EMAIL: Rich@c-eg1.com

DATE: _____
 DESCRIPTION: _____
 NO: _____
 PREPARED FOR: **LORSON, LLC**
 212 N. WAHSATCH AVE, SUITE 301
 COLORADO SPRINGS, COLORADO 80903
 PROJECT: **CARRIAGE MEADOWS SOUTH AT LORSON RANCH FILING NO. 2**
 FONTAINE BLVD-CARRIAGE MEADOWS DR
 COLORADO SPRINGS, COLORADO
 CONTACT: JEFF MARK

DRAWN: RLS
 DESIGNED: RLS
 CHECKED: RLS

CARRIAGE MEADOWS SOUTH AT LORSON RANCH FIL. NO. 2 DETAILED GRADING PLAN



DATE: FEB 12, 2020
 PROJECT NO: 100.046
 SHEET NUMBER: **C4.6**
 TOTAL SHEETS: 14

LEGEND

- 5721----- EXISTING MINOR CONTOUR
- 5720----- EXISTING MAJOR CONTOUR
- 5720----- PROPOSED CONTOUR
- (A) 6" DRAINAGE CHASE OR PIPE W/ HEADWALL
- (B) 2' CONCRETE SWALE
- FLOWLINE
- PROPERTY LINE

NOTE:

HOME BUILDER OR CONTRACTOR SHALL AS-BUILT ALL IMPROVEMENTS PRIOR TO CONSTRUCTING ANY BUILDINGS. THE ENGINEER SHALL BE NOTIFIED OF ANY DISCREPANCY FROM THIS PLAN PRIOR TO ANY BUILDING CONSTRUCTION.

SEE SHEET C4.8



SEE SHEET C4.6

CORE ENGINEERING GROUP
 1500 S. 151st AVENUE, SUITE 100
 COLORADO SPRINGS, CO 80906
 PH: 719-659-7800
 CONTACT: RICHARD L. SCHINDLER, P.E.
 EMAIL: Rich@ceg1.com

DATE: _____
 DESCRIPTION: _____
 NO: _____
 PREPARED FOR: **LORSON, LLC**
 212 N. WAHSATCH AVE, SUITE 301
 COLORADO SPRINGS, COLORADO 80903
 PROJECT: **CARRIAGE MEADOWS SOUTH AT LORSON RANCH FILING NO. 2**
 FONTAINE BLVD-CARRIAGE MEADOWS DR
 COLORADO SPRINGS, COLORADO
 CONTACT: JEFF MARK

DRAWN: RLS
 DESIGNED: RLS
 CHECKED: RLS

CARRIAGE MEADOWS SOUTH AT LORSON RANCH FIL. NO. 2 DETAILED GRADING PLAN



DATE: FEB 12, 2020
 PROJECT NO: 100.046
 SHEET NUMBER: C4.7
 TOTAL SHEETS: 14

LEGEND

- 5721 - - - - - EXISTING MINOR CONTOUR
- 5720 - - - - - EXISTING MAJOR CONTOUR
- 5720 - - - - - PROPOSED CONTOUR
- (A) 6" DRAINAGE CHASE OR PIPE W/ HEADWALL
- (B) 2' CONCRETE SWALE
- FLOWLINE
- PROPERTY LINE

NOTE:
HOME BUILDER OR CONTRACTOR SHALL AS-BUILT ALL IMPROVEMENTS PRIOR TO CONSTRUCTING ANY BUILDINGS. THE ENGINEER SHALL BE NOTIFIED OF ANY DISCREPANCY FROM THIS PLAN PRIOR TO ANY BUILDING CONSTRUCTION.

CARRIAGE MEADOWS DRIVE

STREET C/L (TYP)

2' SIDEWALK CHASE (PRIVATE)

LOT 36

LOT 35

LOT 34

LOT 33

LOT 32

LOT 37

LOT 38

SEE SHEET C4.7

RUBICON HEIGHTS

CORE ENGINEERING GROUP
1515 AVENUE S.S.
BOULDER, CO 80506
PH: 719-659-7800
CONTACT: RICHARD L. SCHINDLER, P.E.
EMAIL: Rich@c-eg1.com

DATE: _____
DESCRIPTION: _____
NO: _____
PROJECT: CARRIAGE MEADOWS SOUTH AT LORSON RANCH FILING NO. 2
PREPARED FOR: LORSON, LLC
212 N. WAHSATCH AVE, SUITE 301
COLORADO SPRINGS, COLORADO 80903
FONTAINE BLVD-CARRIAGE MEADOWS DR
COLORADO SPRINGS, COLORADO
CONTACT: JEFF MARK

DRAWN: RLS
DESIGNED: RLS
CHECKED: RLS

CARRIAGE MEADOWS SOUTH AT LORSON RANCH FIL. NO. 2 GRADING AND EROSION CONTROL PLAN



DATE: FEB 12, 2020
PROJECT NO. 100.046
SHEET NUMBER C4.8
TOTAL SHEETS: 14

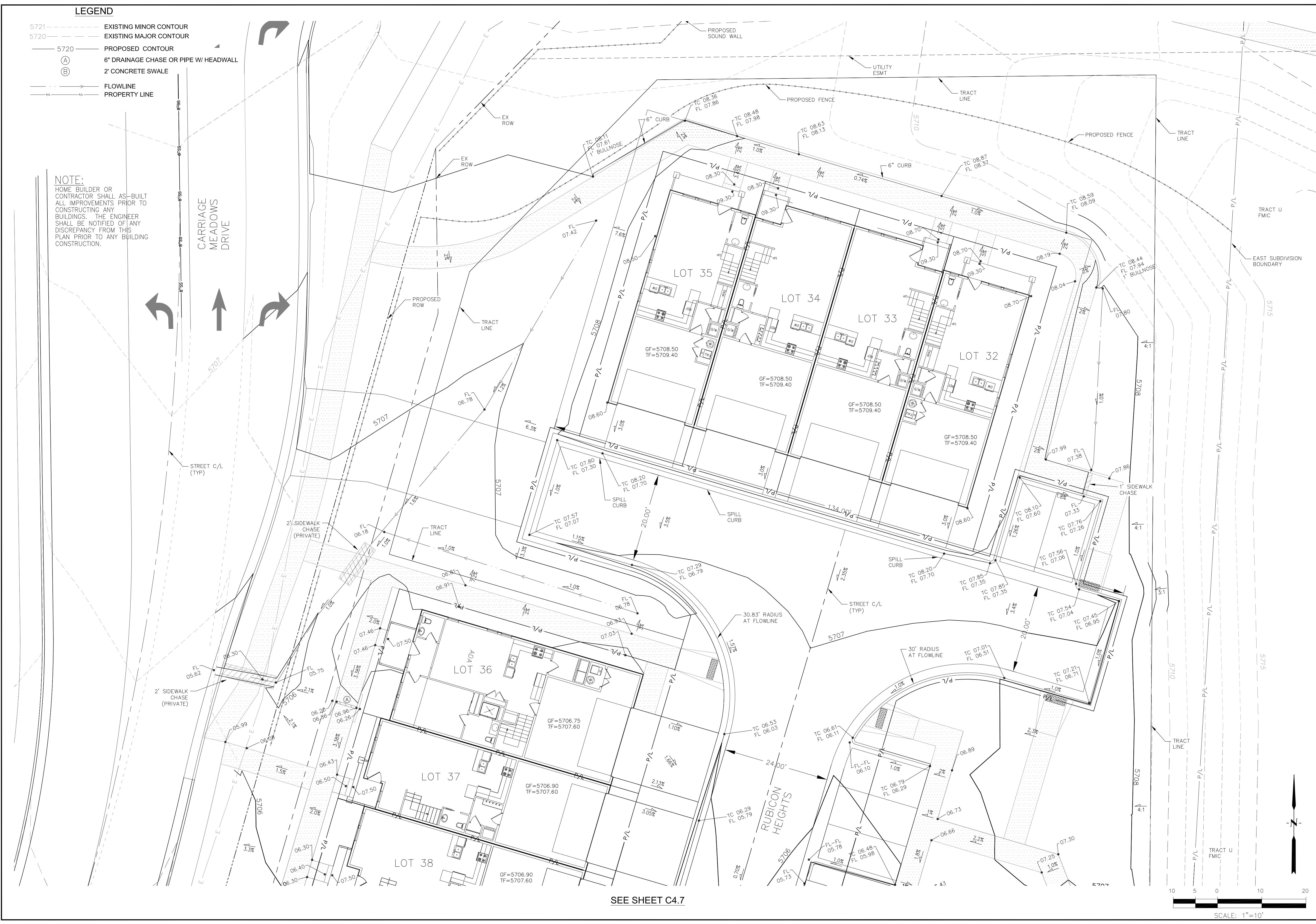
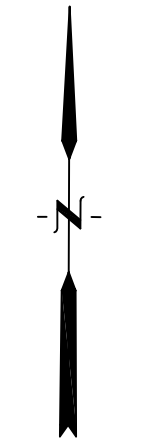
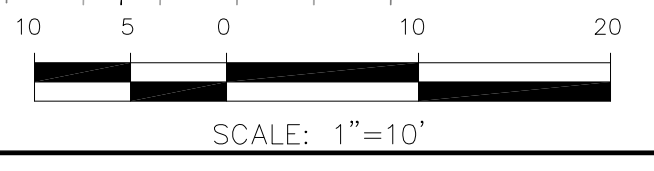

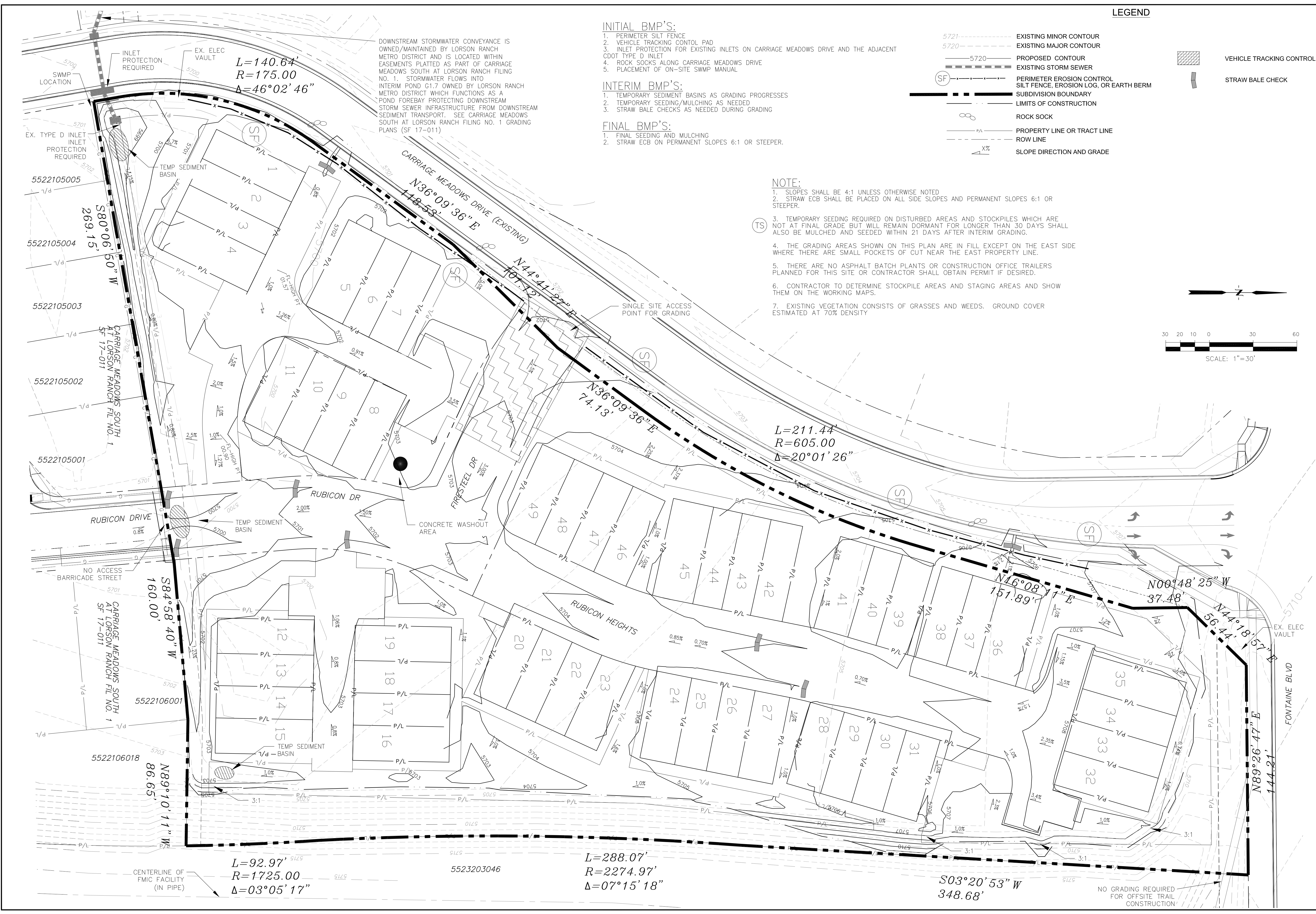

- INITIAL BMP'S:**
1. PERIMETER SILT FENCE
 2. VEHICLE TRACKING CONTROL PAD
 3. INLET PROTECTION FOR EXISTING INLETS ON CARRIAGE MEADOWS DRIVE AND THE ADJACENT CDOT TYPE D INLET
 4. ROCK SOCKS ALONG CARRIAGE MEADOWS DRIVE
 5. PLACEMENT OF ON-SITE SWMP MANUAL

- INTERIM BMP'S:**
1. TEMPORARY SEDIMENT BASINS AS GRADING PROGRESSES
 2. TEMPORARY SEEDING/MULCHING AS NEEDED
 3. STRAW BALE CHECKS AS NEEDED DURING GRADING

- FINAL BMP'S:**
1. FINAL SEEDING AND MULCHING
 2. STRAW ECB ON PERMANENT SLOPES 6:1 OR STEEPER.

LEGEND

- 5721----- EXISTING MINOR CONTOUR
- 5720----- EXISTING MAJOR CONTOUR
- PROPOSED CONTOUR
- EXISTING STORM SEWER
- (SF)----- PERIMETER EROSION CONTROL SILT FENCE, EROSION LOG, OR EARTH BERM
- SUBDIVISION BOUNDARY
- LIMITS OF CONSTRUCTION
- ∞----- ROCK SOCK
- PROPERTY LINE OR TRACT LINE
- ROW LINE
- SLOPE DIRECTION AND GRADE
- [Hatched Box]----- VEHICLE TRACKING CONTROL
- [Line with Tick]----- STRAW BALE CHECK

- NOTE:**
1. SLOPES SHALL BE 4:1 UNLESS OTHERWISE NOTED
 2. STRAW ECB SHALL BE PLACED ON ALL SIDE SLOPES AND PERMANENT SLOPES 6:1 OR STEEPER.
 3. TEMPORARY SEEDING REQUIRED ON DISTURBED AREAS AND STOCKPILES WHICH ARE NOT AT FINAL GRADE BUT WILL REMAIN DORMANT FOR LONGER THAN 30 DAYS SHALL ALSO BE MULCHED AND SEEDED WITHIN 21 DAYS AFTER INTERIM GRADING.
 4. THE GRADING AREAS SHOWN ON THIS PLAN ARE IN FILL EXCEPT ON THE EAST SIDE WHERE THERE ARE SMALL POCKETS OF CUT NEAR THE EAST PROPERTY LINE.
 5. THERE ARE NO ASPHALT BATCH PLANTS OR CONSTRUCTION OFFICE TRAILERS PLANNED FOR THIS SITE OR CONTRACTOR SHALL OBTAIN PERMIT IF DESIRED.
 6. CONTRACTOR TO DETERMINE STOCKPILE AREAS AND STAGING AREAS AND SHOW THEM ON THE WORKING MAPS.
 7. EXISTING VEGETATION CONSISTS OF GRASSES AND WEEDS. GROUND COVER ESTIMATED AT 70% DENSITY

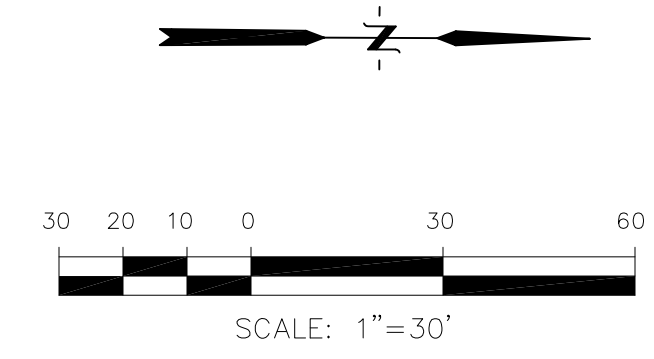

DOWNSTREAM STORMWATER CONVEYANCE IS OWNED/MAINTAINED BY LORSON RANCH METRO DISTRICT AND IS LOCATED WITHIN EASEMENTS PLATTED AS PART OF CARRIAGE MEADOWS SOUTH AT LORSON RANCH FILING NO. 1. STORMWATER FLOWS INTO INTERIM POND G1.7 OWNED BY LORSON RANCH METRO DISTRICT WHICH FUNCTIONS AS A POND FOREBAY PROTECTING DOWNSTREAM STORM SEWER INFRASTRUCTURE FROM DOWNSTREAM SEDIMENT TRANSPORT. SEE CARRIAGE MEADOWS SOUTH AT LORSON RANCH FILING NO. 1 GRADING PLANS (SF 17-011)

CORE ENGINEERING GROUP
 1515 AVENUE 15
 BOULDER, CO 80506
 PH: 719-459-7800
 CONTACT: RICHARD L. SCHINDLER, P.E.
 EMAIL: Rich@ceg1.com

DATE: _____
 DESCRIPTION: _____
 NO: _____
 PREPARED FOR: LORSON, LLC
 212 N. WAHSATCH AVE, SUITE 301
 COLORADO SPRINGS, COLORADO 80903
 PROJECT: CARRIAGE MEADOWS SOUTH AT LORSON RANCH FILING NO. 2
 FONTAINE BLVD-CARRIAGE MEADOWS DR COLORADO SPRINGS, COLORADO
 CONTACT: JEFF MARK

DRAWN: RLS
 DESIGNED: RLS
 CHECKED: RLS

CARRIAGE MEADOWS SOUTH AT LORSON RANCH FIL. NO. 2 GRADING AND EROSION CONTROL PLAN



DATE: FEB 12, 2020
 PROJECT NO: 100.046
 SHEET NUMBER: C4.9
 TOTAL SHEETS: 14

Vehicle Tracking Control (VTC)

SM-4

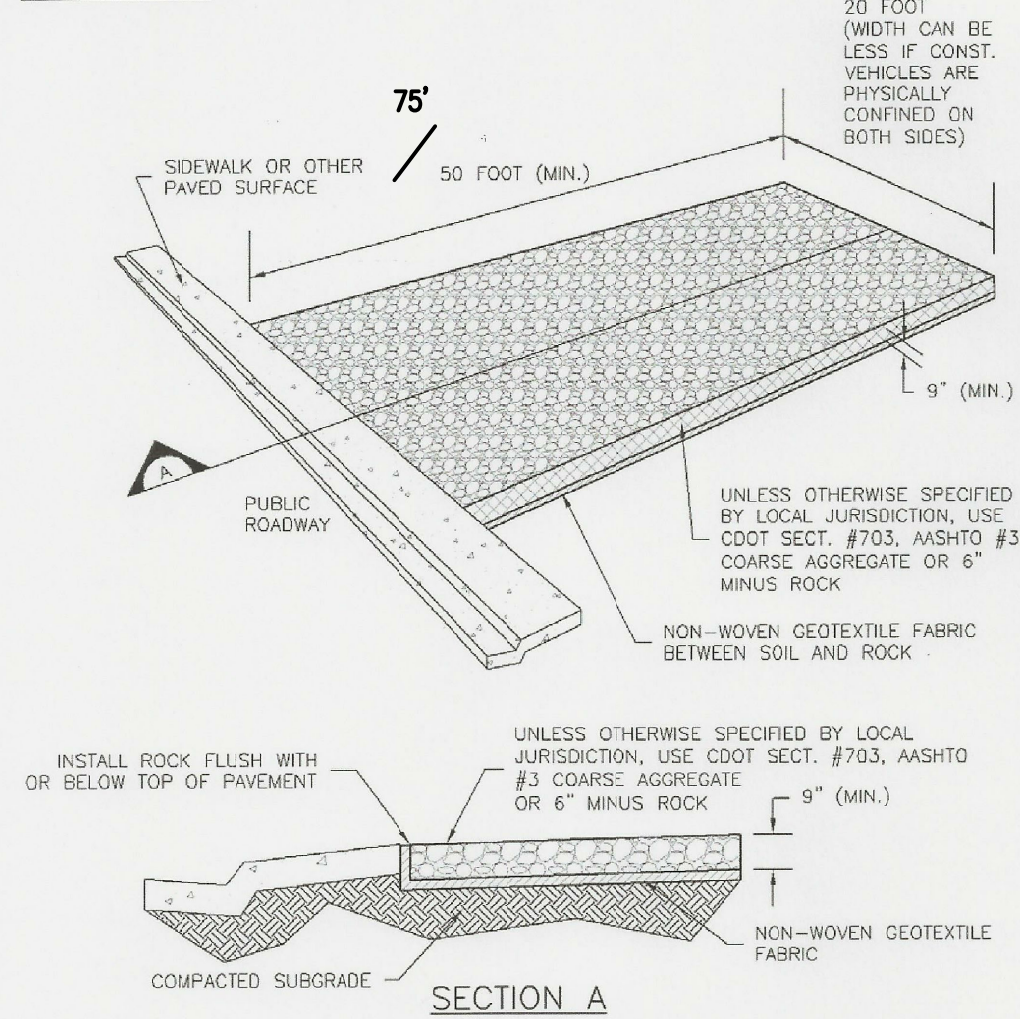

VTC-1. AGGREGATE VEHICLE TRACKING CONTROL

November 2010 Urban Drainage and Flood Control District
Urban Storm Drainage Criteria Manual Volume 3 VTC-3

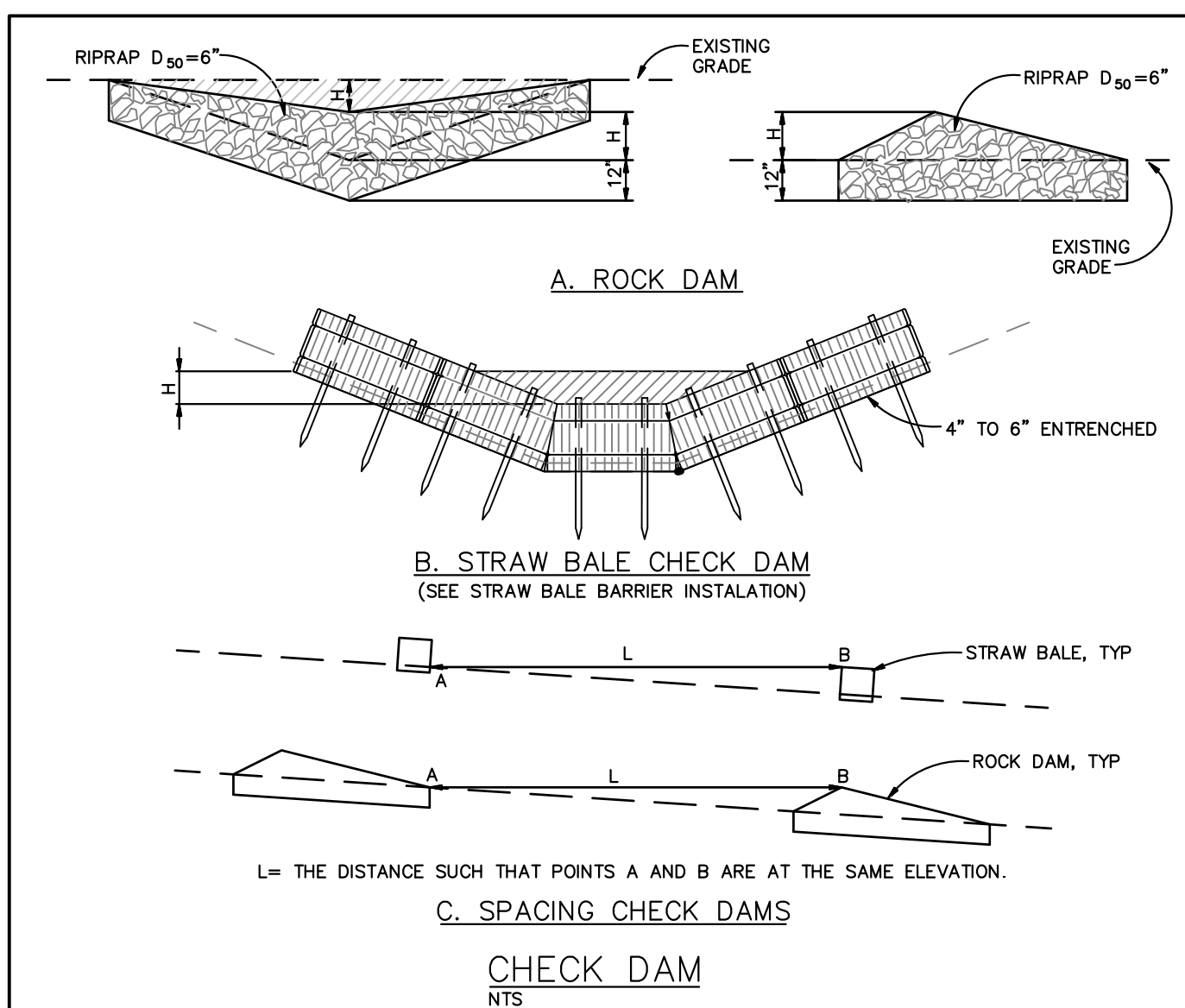

CHECK DAM NOTES

- | | |
|--|---|
| <p>INSTALLATION REQUIREMENTS</p> <ol style="list-style-type: none"> 1. STRAW BALES USED AS CHECK DAMS ARE TO MEET THE REQUIREMENTS STATED IN FIGURE SBB-2. 2. THE "H" DIMENSION SHALL BE SELECTED TO PROVIDE WEIR FLOW CONVEYANCE FOR 2-YEAR FLOW OR GREATER. | <p>MAINTENANCE REQUIREMENTS</p> <ol style="list-style-type: none"> 1. REGULAR INSPECTIONS ARE TO BE MADE OF ALL CHECK DAMS, ESPECIALLY AFTER STORM EVENTS. 2. REPLACE STONE AS NECESSARY TO MAINTAIN THE CORRECT HEIGHT OF THE DAM. 3. ACCUMULATED SEDIMENT AND DEBRIS IS TO BE REMOVED FROM BEHIND THE DAMS AFTER EACH STORM OR WHEN 1/2 OF THE ORIGINAL HEIGHT OF THE DAM IS REACHED. 3. CHECK DAMS ARE TO REMAIN IN PLACE AND OPERATIONAL UNTIL THE DRAINAGE AREA AND CHANNEL ARE PERMANENTLY STABILIZED. 4. WHEN CHECK DAMS ARE REMOVED THE CHANNEL LINING OR VEGETATION IS TO BE RESTORED. |
|--|---|

City of Colorado Springs Stormwater Quality **Figure CD-1 Check Dam**
Construction Detail and Maintenance Requirements

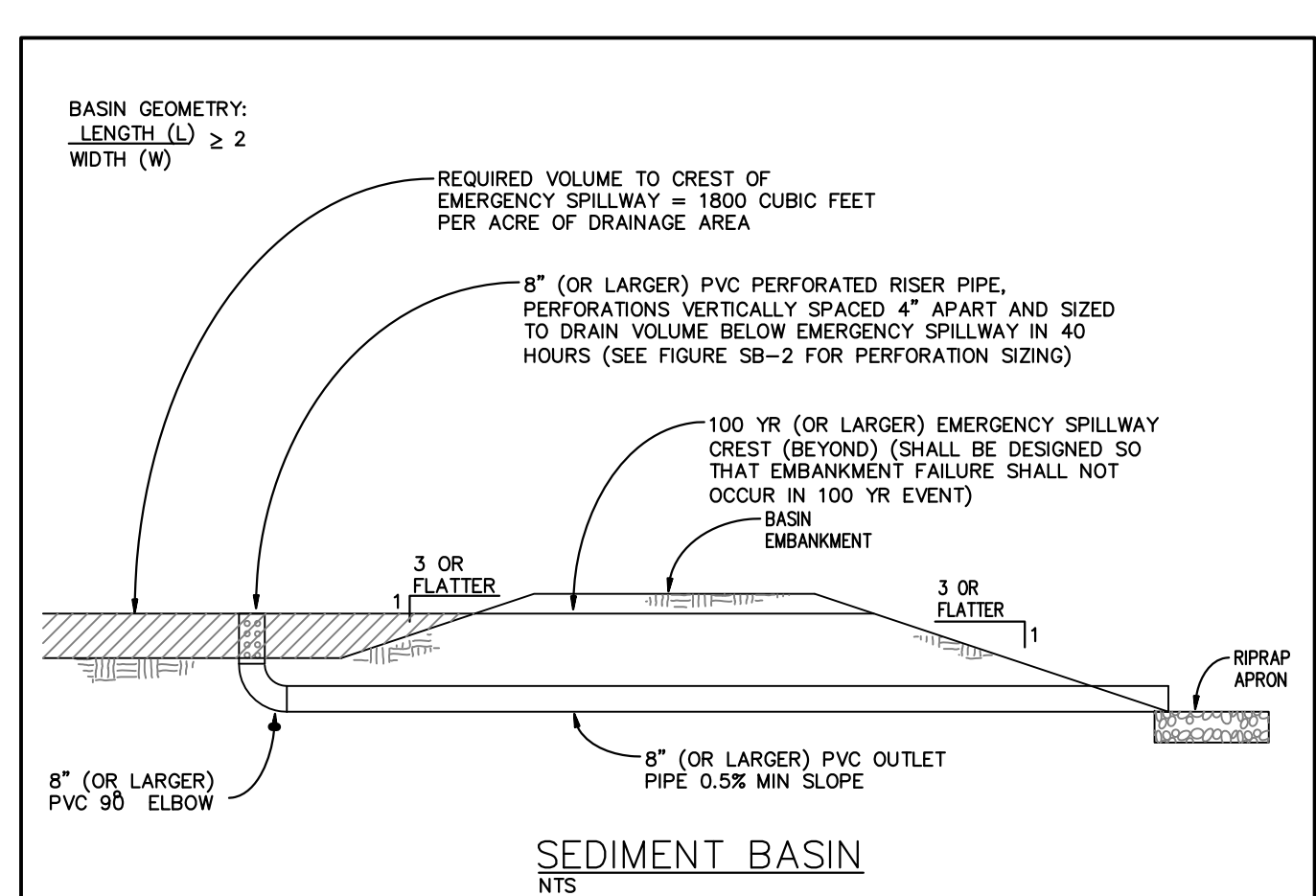

SEDIMENT BASIN NOTES

- | | |
|--|---|
| <p>INSTALLATION REQUIREMENTS</p> <ol style="list-style-type: none"> 1. SEDIMENT BASINS SHALL BE INSTALLED BEFORE ANY CLEARING AND/OR GRADING IS UNDERTAKEN. 2. THE AREA UNDER WHICH THE EMBANKMENT IS TO BE INSTALLED SHALL BE CLEARED, GRUBBED, AND STRIPPED OF ALL VEGETATION AND ROOT MAT. 3. THE OUTLET OF THE BASIN SHALL BE DESIGNED TO DRAIN ITS VOLUME IN 40 HOURS. 4. THE OUTLET IS TO BE LOCATED AT THE FURTHEST DISTANCE FROM THE INLET OF THE BASIN. Baffles MAY BE NEEDED TO INCREASE THE FLOW LENGTH AND SETTLING TIME. 5. EMBANKMENT MATERIAL SHALL CONSIST OF SOIL WITH A MINIMUM OF 15% PASSING A #200 SIEVE. EXCAVATED SOIL CAN BE USED IF IT MEETS THIS REQUIREMENT. 6. EMBANKMENT IS TO BE COMPACTED TO AT LEAST 90% OF MAXIMUM DENSITY AND WITHIN 2% OF OPTIMUM MOISTURE CONTENT ACCORDING TO ASTM D 698. 7. WHEN A BASIN IS INSTALLED NEAR A RESIDENTIAL AREA, FOR SAFETY REASONS, A SIGN SHALL BE POSTED AND THE AREA SECURED WITH A FENCE. | <p>MAINTENANCE REQUIREMENTS</p> <ol style="list-style-type: none"> 1. CONTRACTOR SHALL INSPECT SEDIMENT BASINS AFTER EACH RAINFALL, AT LEAST DAILY DURING PROLONGED RAINFALL, AND WEEKLY DURING PERIODS OF NO RAINFALL. 2. SEDIMENT BASINS SHALL BE CLEANED OUT BEFORE SEDIMENT HAS FILLED HALF THE VOLUME OF THE BASIN. 3. SEDIMENT BASINS SHALL REMAIN OPERATIONAL AND PROPERLY MAINTAINED UNTIL THE SITE AREA IS PERMANENTLY STABILIZED WITH ADEQUATE VEGETATIVE COVER AND/OR OTHER PERMANENT STRUCTURE AS APPROVED BY THE CITY. |
|--|---|

City of Colorado Springs Stormwater Quality **Figure SB-1 Sediment Basin**
Construction Detail and Maintenance Requirements

SEED MIX TABLE		
GRASS MIX FOR QUICK REVEGETATION ALL SITES:		
GRASS	VARIETY	AMOUNT IN PLS LBS PER ACRE
CRESTED WHEAT GRASS	EPHRAIM OR HYCREST	4.0
PERENNIAL RYE	LINN	2.0
WESTERN WHEAT GRASS	BARTON	3.0
SMOOTH BROME GRASS	LINCOLN OR MANCHAR	5.0
SIDEOTS GRAMA	EL RENO	2.5
		TOTAL 16.5 LBS
GRASS MIX FOR SANDY SOILS:		
GRASS	VARIETY	AMOUNT IN PLS LBS PER ACRE
SIDEOTS GRAMA	EL RENO	3.0
WESTERN WHEAT GRASS	BARTON	2.5
SLENDER WHEAT GRASS	NATIVE	2.0
LITTLE BLUESTEM	PASTURA	2.0
SAND DROPSEED	NATIVE	0.5
SWITCH GRASS	NEBRASKA 28	3.0
WEEPING LOVE GRASS	MORPHA	1.0
		TOTAL 14.0 LBS
GRASS MIX FOR HEAVIER SOIL AREAS:		
GRASS	VARIETY	AMOUNT IN PLS LBS PER ACRE
WESTERN WHEAT GRASS	BARTON	5.0
SIDEOTS GRAMA	EL RENO	3.0
SLENDER WHEAT GRASS	SODAR	2.5
SMOOTH BROME	LINCOLN OR MANCHAR	4.0
CRESTEDWHEAT GRASS	EPHRAIM	3.0
		TOTAL 17.5 LBS

CORE ENGINEERING GROUP
1500 R 1ST AVENUE, SUITE 300
DENVER, CO 80202
PHONE: 719-459-7000
CONTACT: RICHARD L. SCHINDLER, P.E.
EMAIL: Rich@cegi.com

PREPARED FOR: **LORSON, LLC**
212 N. WAHSATCH AVE, SUITE 301
COLORADO SPRINGS, COLORADO 80903
CONTACT: JEFF MARK

PROJECT: **CARRIAGE MEADOWS SOUTH AT LORSON RANCH FILING NO. 2**
FONTAINE BLVD-CARRIAGE MEADOWS DR
COLORADO SPRINGS, COLORADO

DATE: _____
DESCRIPTION: _____
NO: _____

DRAWN: RLS
DESIGNED: RLS
CHECKED: RLS

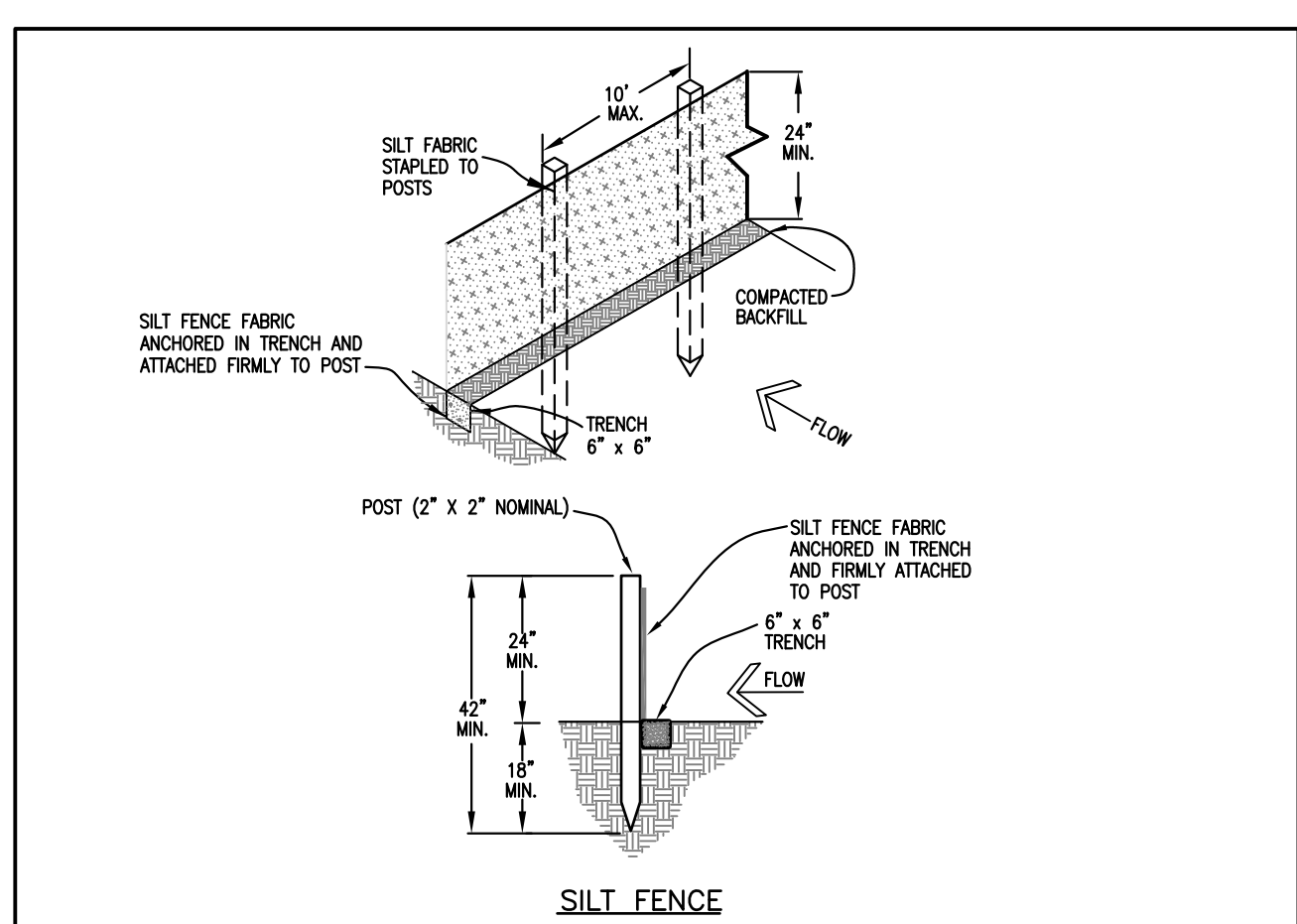

- INSTALLATION REQUIREMENTS**
1. SILT FENCES SHALL BE INSTALLED PRIOR TO ANY LAND DISTURBING ACTIVITIES.
 2. WHEN JOINTS ARE NECESSARY, SILT FENCE GEOTEXTILE SHALL BE SPICED TOGETHER ONLY AT SUPPORT POST AND SECURELY SEALED.
 3. METAL POSTS SHALL BE "STUDDED TEE" OR "U" TYPE WITH MINIMUM WEIGHT OF 1.33 POUNDS PER LINEAR FOOT. WOOD POSTS SHALL HAVE A MINIMUM DIAMETER OR CROSS SECTION DIMENSION OF 2 INCHES.
 4. THE FILTER MATERIAL SHALL BE FASTENED SECURELY TO METAL OR WOOD POSTS USING WIRE TIES, OR TO WOOD POSTS WITH 3/4" LONG #9 HEAVY-DUTY STAPLES. THE SILT FENCE GEOTEXTILE SHALL NOT BE STAPLED TO EXISTING TREES.
 5. WHILE NOT REQUIRED, WIRE MESH FENCE MAY BE USED TO SUPPORT THE GEOTEXTILE. WIRE FENCE SHALL BE FASTENED SECURELY TO THE UPSLOPE SIDE OF THE POSTS USING HEAVY-DUTY WIRE STAPLES AT LEAST 3/4" LONG. TIE WIRES OR HOG RINGS. THE WIRE SHALL EXTEND INTO THE TRENCH A MINIMUM OF 6" AND SHALL NOT EXTEND MORE THAN 3' ABOVE THE ORIGINAL GROUND SURFACE.
 6. ALONG THE TOE OF FILLS, INSTALL THE SILT FENCE ALONG A LEVEL CONTOUR AND PROVIDE AN AREA BEHIND THE FENCE FOR RUNOFF TO POND AND SEDIMENT TO SETTLE. A MINIMUM DISTANCE OF 5 FEET FROM THE TOE OF THE FILL IS RECOMMENDED.
 7. THE HEIGHT OF THE SILT FENCE FROM THE GROUND SURFACE SHALL BE MINIMUM OF 24 INCHES AND SHALL NOT EXCEED 36 INCHES. HIGHER FENCES MAY INBOUND VOLUMES OF WATER SUFFICIENT TO CAUSE FAILURE OF THE STRUCTURE.
- MAINTENANCE REQUIREMENTS**
1. CONTRACTOR SHALL INSPECT SILT FENCES IMMEDIATELY AFTER EACH RAINFALL, AT LEAST DAILY DURING PROLONGED RAINFALL, AND WEEKLY DURING PERIODS OF NO RAINFALL. DAMAGED, COLLAPSED, UNENTRENCHED OR INEFFECTIVE SILT FENCES SHALL BE PROMPTLY REPAIRED OR REPLACED.
 2. SEDIMENT SHALL BE REMOVED FROM BEHIND SILT FENCE WHEN IT ACCUMULATES TO HALF THE EXPOSED GEOTEXTILE HEIGHT.
 3. SILT FENCES SHALL BE REMOVED WHEN ADEQUATE VEGETATIVE COVER IS ATTAINED AS APPROVED BY THE CITY.

City of Colorado Springs Stormwater Quality **Figure SF-2 Silt Fence**
Construction Detail and Maintenance Requirements

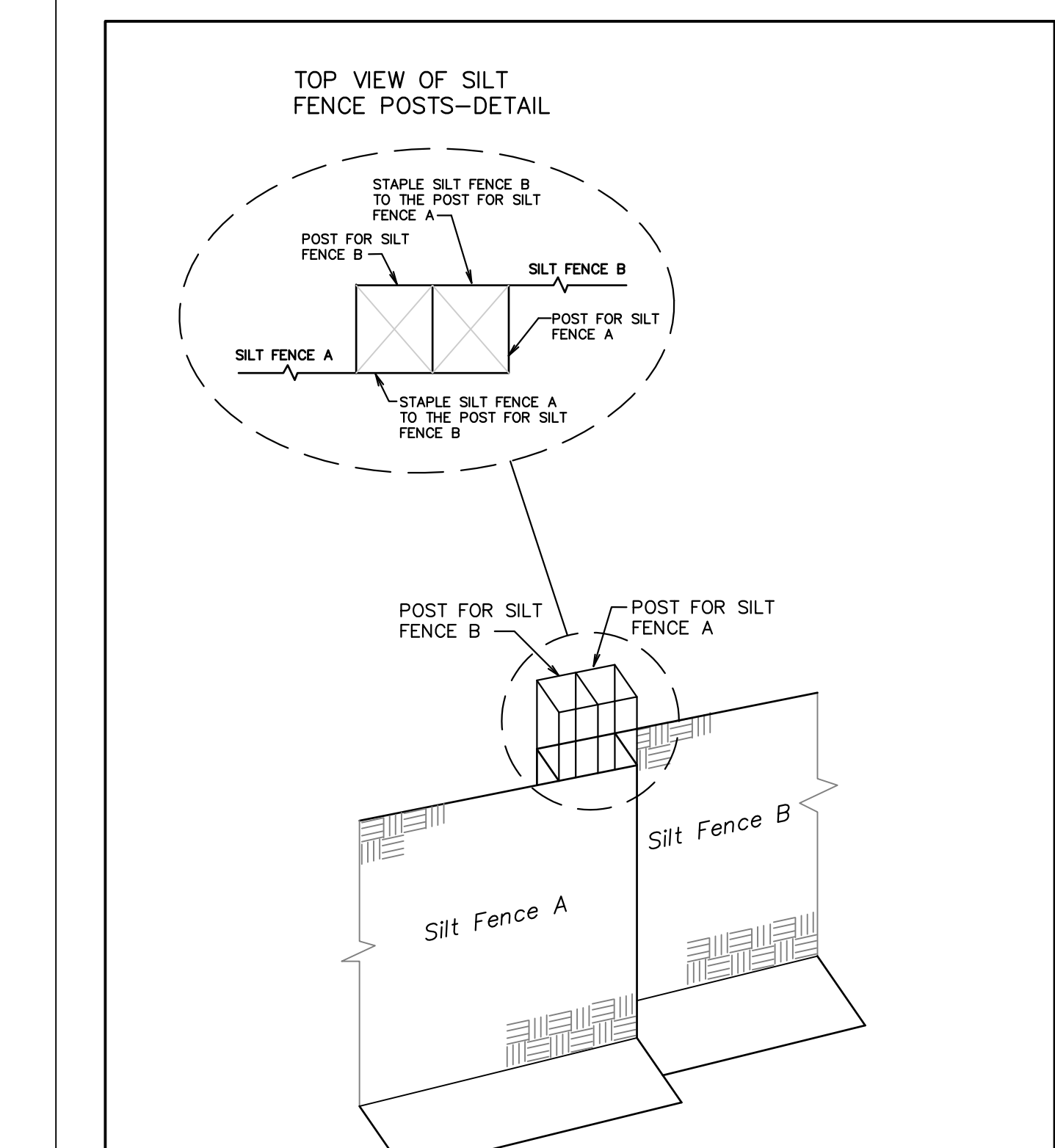

City of Colorado Springs Stormwater Quality **Figure SF-3 Silt Fence Joint Tying**
Construction Detail and Maintenance Requirements

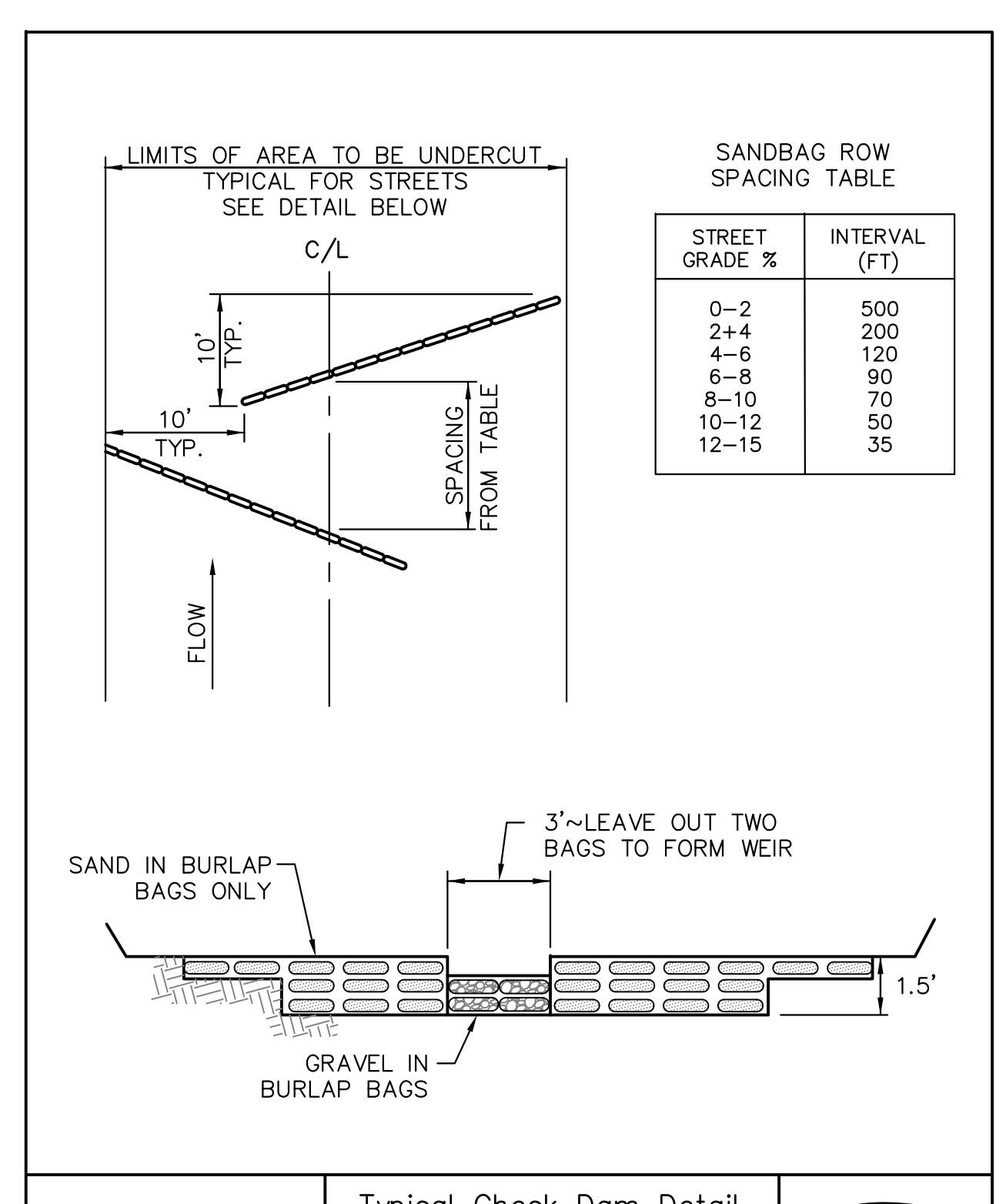

DATE APPROVED: _____
DEPARTMENT OF TRANSPORTATION
Typical Check Dam Detail
Standard Drawing
REVISION DATE: 11/10/04
FILE NAME: SD_3-62
EL PASO COUNTY DEPARTMENT OF TRANSPORTATION

GRADING AND EROSION CONTROL DETAILS

DATE: FEB 12, 2020
PROJECT NO: 100.046
SHEET NUMBER: C4.10
TOTAL SHEETS: 14

PROFESSIONAL ENGINEER
33997
2-12-2020

Sediment Control Log (SCL)

SC-2

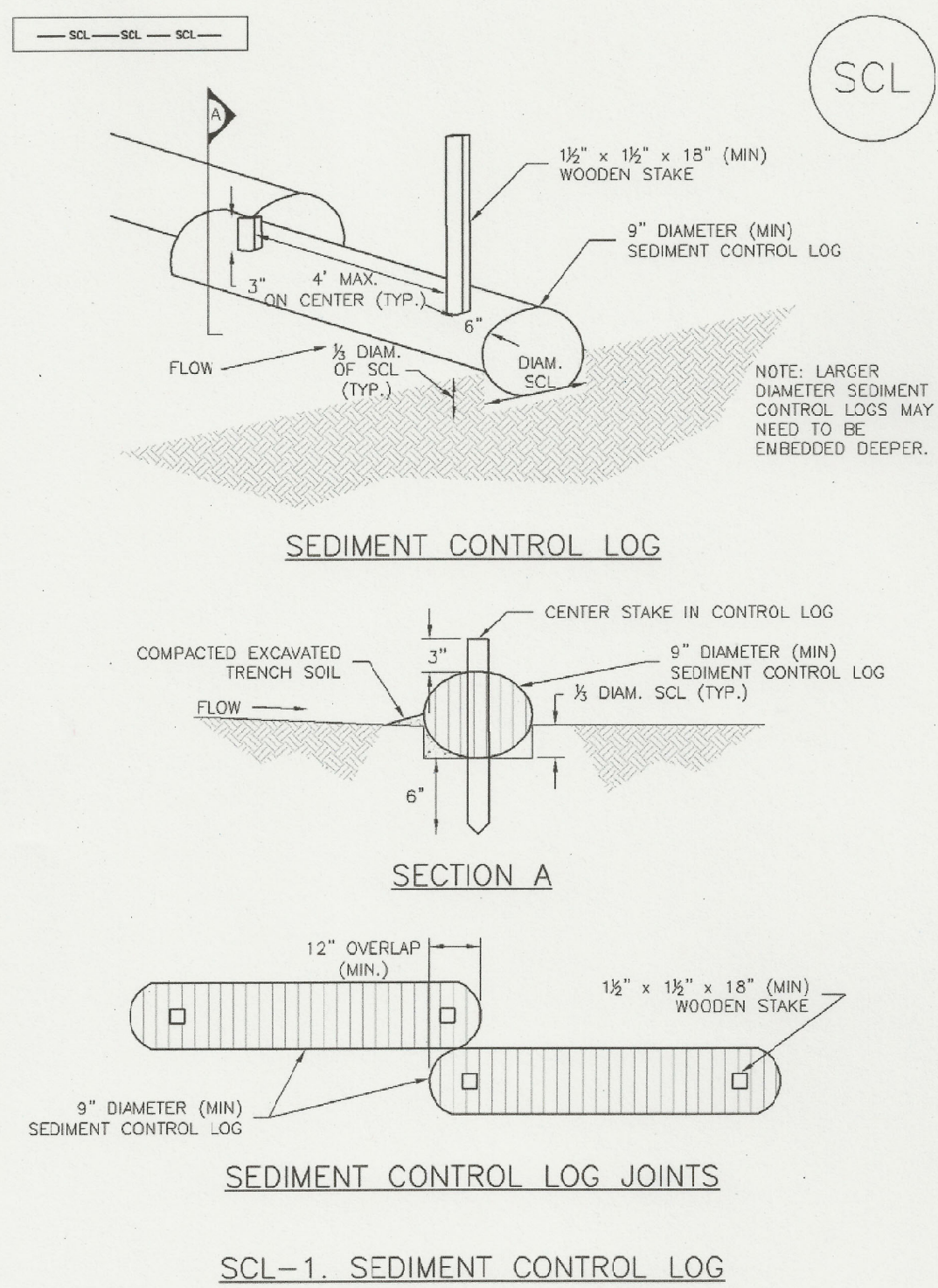

SEDIMENT CONTROL LOG

SECTION A

SEDIMENT CONTROL LOG JOINTS

SCL-1. SEDIMENT CONTROL LOG

November 2010 Urban Drainage and Flood Control District Urban Storm Drainage Criteria Manual Volume 3 SCL-3

SC-6

Inlet Protection (IP)

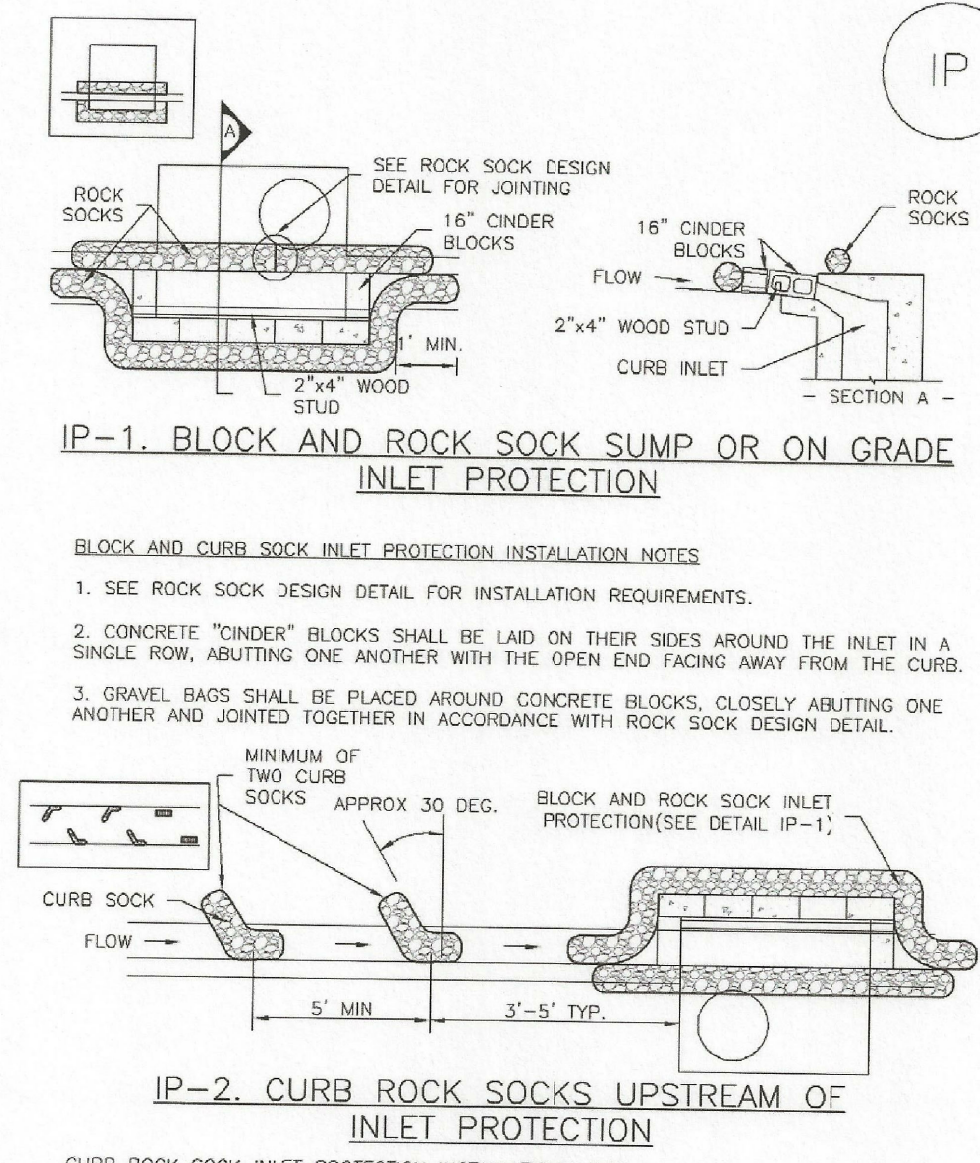

IP-1. BLOCK AND ROCK SOCK SUMP OR ON GRADE INLET PROTECTION

- BLOCK AND CURB SOCK INLET PROTECTION INSTALLATION NOTES**
- SEE ROCK SOCK DESIGN DETAIL FOR INSTALLATION REQUIREMENTS.
 - CONCRETE "CINDER" BLOCKS SHALL BE LAID ON THEIR SIDES AROUND THE INLET IN A SINGLE ROW, ABUTTING ONE ANOTHER WITH THE OPEN END FACING AWAY FROM THE CURB.
 - GRAVEL BAGS SHALL BE PLACED AROUND CONCRETE BLOCKS, CLOSELY ABUTTING ONE ANOTHER AND JOINED TOGETHER IN ACCORDANCE WITH ROCK SOCK DESIGN DETAIL.

IP-2. CURB ROCK SOCKS UPSTREAM OF INLET PROTECTION

- CURB ROCK SOCK INLET PROTECTION INSTALLATION NOTES**
- SEE ROCK SOCK DESIGN DETAIL INSTALLATION REQUIREMENTS.
 - PLACEMENT OF THE SOCK SHALL BE APPROXIMATELY 30 DEGREES FROM PERPENDICULAR IN THE OPPOSITE DIRECTION OF FLOW.
 - SOCKS ARE TO BE FLUSH WITH THE CURB AND SPACED A MINIMUM OF 5 FEET APART.
 - AT LEAST TWO CURB SOCKS IN SERIES ARE REQUIRED UPSTREAM OF ON-GRADE INLETS.

IP-4 Urban Drainage and Flood Control District Urban Storm Drainage Criteria Manual Volume 3 August 2013

SC-5

Rock Sock (RS)

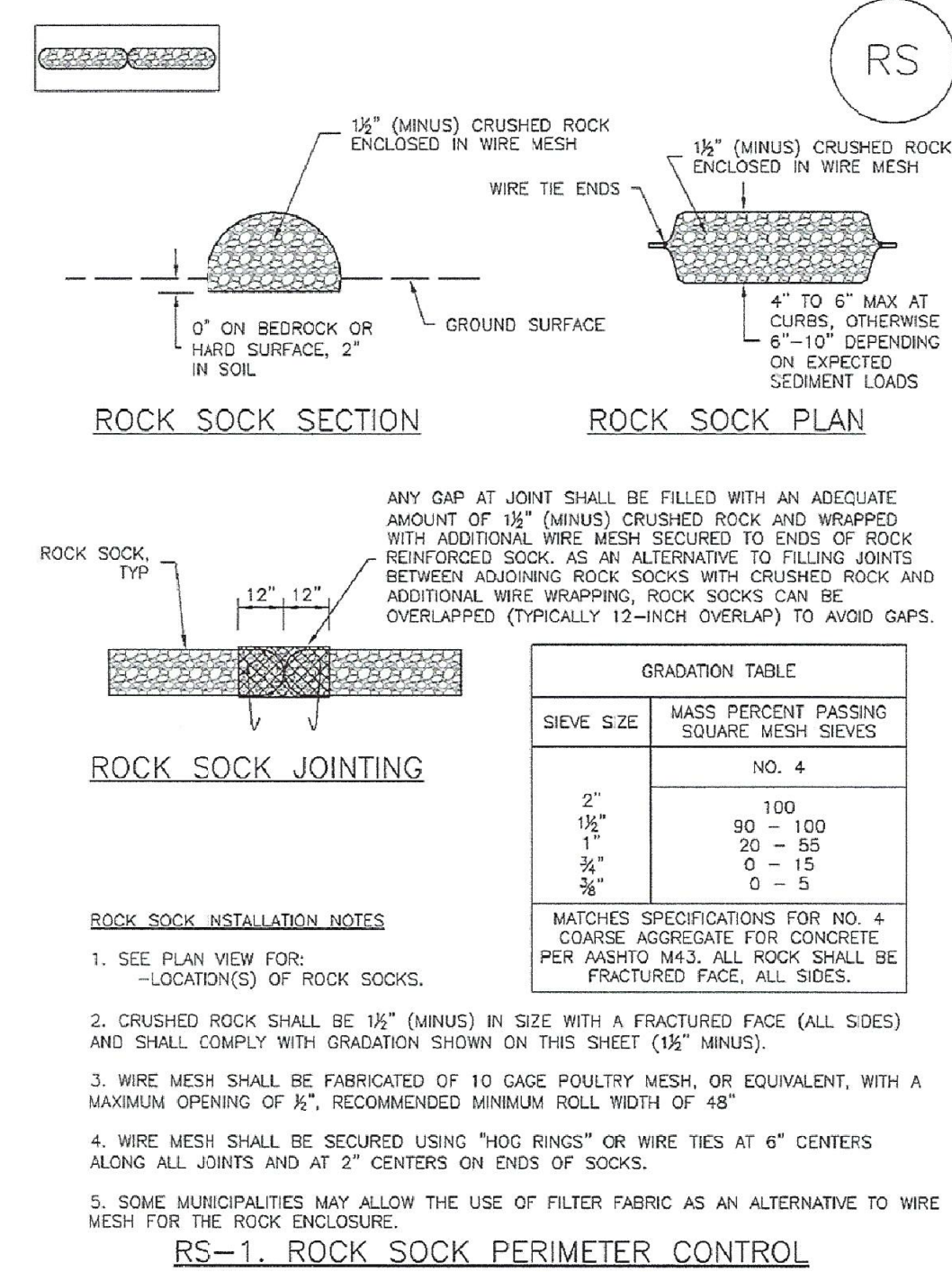

ROCK SOCK SECTION

ROCK SOCK PLAN

ROCK SOCK JOINTING

- ROCK SOCK INSTALLATION NOTES**
- SEE PLAN VIEW FOR: -LOCATION(S) OF ROCK SOCKS.
 - CRUSHED ROCK SHALL BE 1/2" (MINUS) IN SIZE WITH A FRACTURED FACE (ALL SIDES) AND SHALL COMPLY WITH GRADATION SHOWN ON THIS SHEET (1/2" MINUS).
 - WIRE MESH SHALL BE FABRICATED OF 10 GAGE POULTRY MESH, OR EQUIVALENT, WITH A MAXIMUM OPENING OF 1/2". RECOMMENDED MINIMUM ROLL WIDTH OF 48"
 - WIRE MESH SHALL BE SECURED USING "HOG RINGS" OR WIRE TIES AT 6" CENTERS ALONG ALL JOINTS AND AT 2" CENTERS ON ENDS OF SOCKS.
 - SOME MUNICIPALITIES MAY ALLOW THE USE OF FILTER FABRIC AS AN ALTERNATIVE TO WIRE MESH FOR THE ROCK ENCLOSURE.

RS-1. ROCK SOCK PERIMETER CONTROL

RS-2 Urban Drainage and Flood Control District Urban Storm Drainage Criteria Manual Volume 3 November 2010

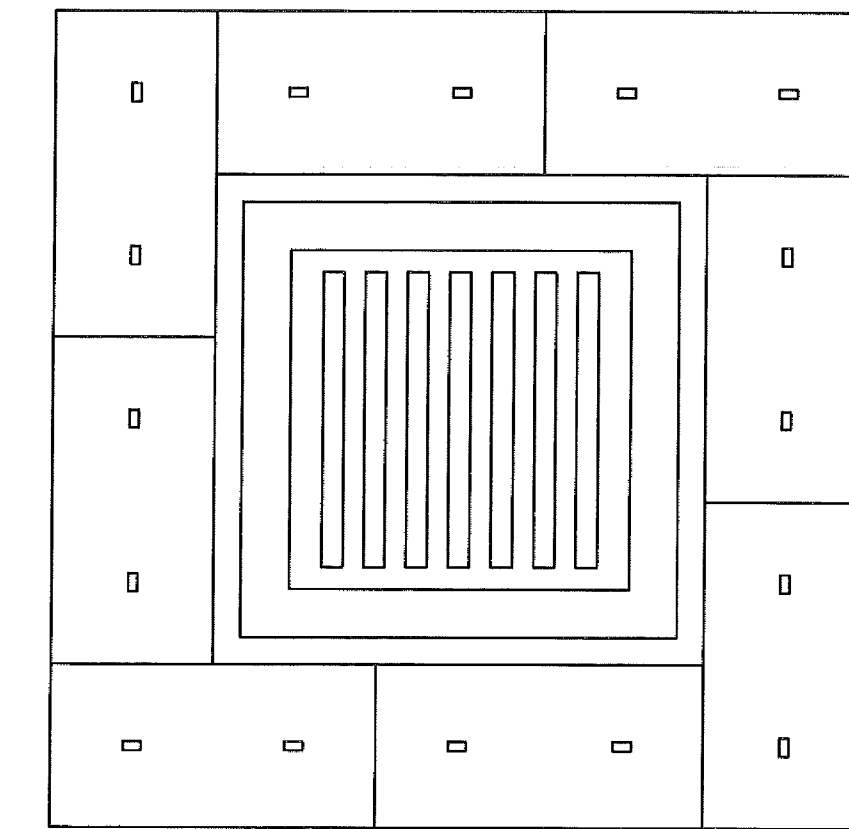

STRAW BALE INLET PROTECTION NTS

STRAW BALE INLET PROTECTION NOTES

INSTALLATION REQUIREMENTS

- INLET PROTECTION SHALL BE INSTALLED IMMEDIATELY AFTER CONSTRUCTION OF INLET.
- BALES ARE TO BE PLACED IN A SINGLE ROW AROUND THE INLET WITH THE END OF THE BALES TIGHTLY ABUTTING ONE ANOTHER.
- SEE STRAW BALE BARRIER FIGURE SBB-2 FOR INSTALLATION REQUIREMENTS.

MAINTENANCE REQUIREMENTS

- CONTRACTOR SHALL INSPECT STRAW BALE INLET PROTECTION IMMEDIATELY AFTER EACH RAINFALL, AT LEAST DAILY DURING PROLONGED RAINFALL, AND WEEKLY DURING PERIODS NO RAINFALL.
- DAMAGED OR INEFFECTIVE INLET PROTECTION SHALL PROMPTLY BE REPAIRED, REPLACING BALES IF NECESSARY, AND UNENTRENCHED BALES NEED TO BE REPAIRED WITH COMPACTED BACKFILL MATERIAL.
- SEDIMENT SHALL BE REMOVED FROM BEHIND STRAW BALES WHEN IT ACCUMULATES TO APPROXIMATELY 1/3 THE HEIGHT OF THE BARRIER.
- INLET PROTECTION SHALL BE REMOVED WHEN ADEQUATE VEGETATIVE COVER IS ATTAINED WITHIN THE DRAINAGE AREA AS APPROVED BY THE CITY.

City of Colorado Springs Stormwater Quality

Figure IP-2 Straw Bale Inlet Protection Construction Detail and Maintenance Requirements

3-26

CORE ENGINEERING GROUP
1500 S. AVENUE 103
P.O. BOX 19559-7800
CONTACT: RICHARD L. SCHINDLER, P.E.
EMAIL: Rich@cegi.com

DATE: _____
DESCRIPTION: _____
NO: _____
PREPARED FOR: **LORSON, LLC**
212 N. WAHSATCH AVE, SUITE 301
COLORADO SPRINGS, COLORADO 80903
PROJECT: **CARRIAGE MEADOWS SOUTH AT LORSON RANCH FILING NO. 2**
FONTAINE BLVD-CARRIAGE MEADOWS DR COLORADO SPRINGS, COLORADO
CONTACT: JEFF MARK

DRAWN: RLS
DESIGNED: RLS
CHECKED: RLS

GRADING AND EROSION CONTROL DETAILS



DATE: FEB 12, 2020
PROJECT NO: 100.046
SHEET NUMBER: C4.11
TOTAL SHEETS: 14

1/1/08
DATE APPROVED: _____
John A. McCarty
DEPARTMENT OF TRANSPORTATION

Concrete Washout Structure
Standard Drawing
REVISION DATE: 7/17/07
FILE NAME: SD_3-84

Vehicle Tracking Control (VTC)

SM-4

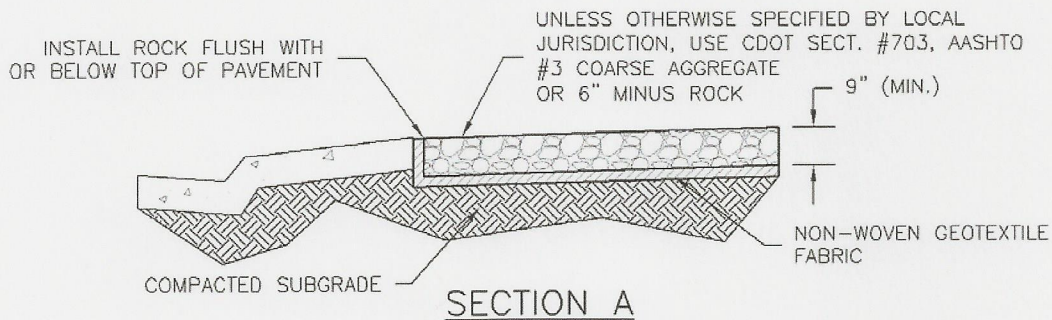
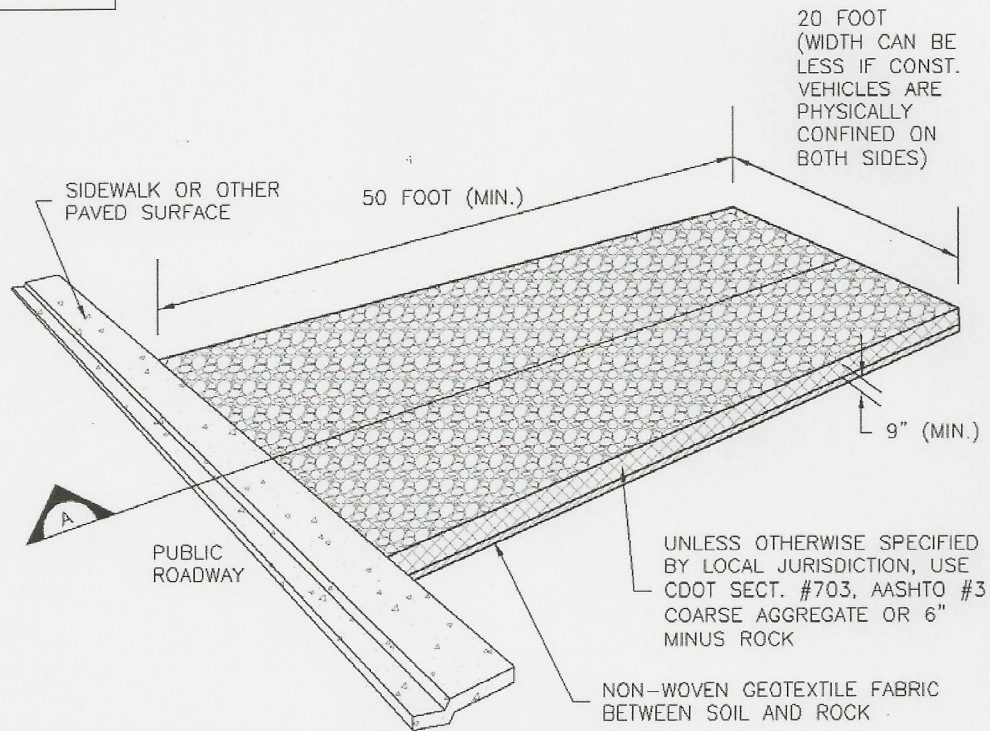
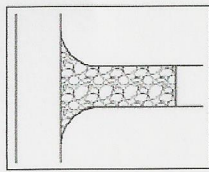

VTC-1. AGGREGATE VEHICLE TRACKING CONTROL

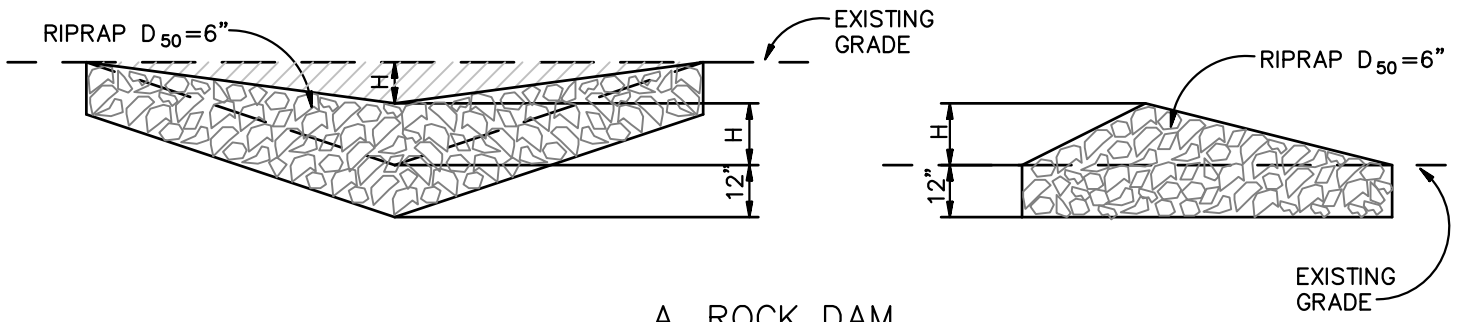

A. ROCK DAM

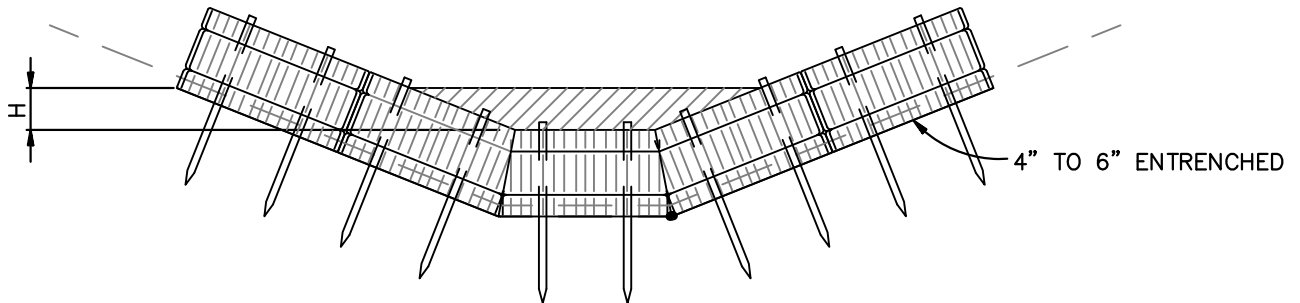

B. STRAW BALE CHECK DAM
(SEE STRAW BALE BARRIER INSTALATION)

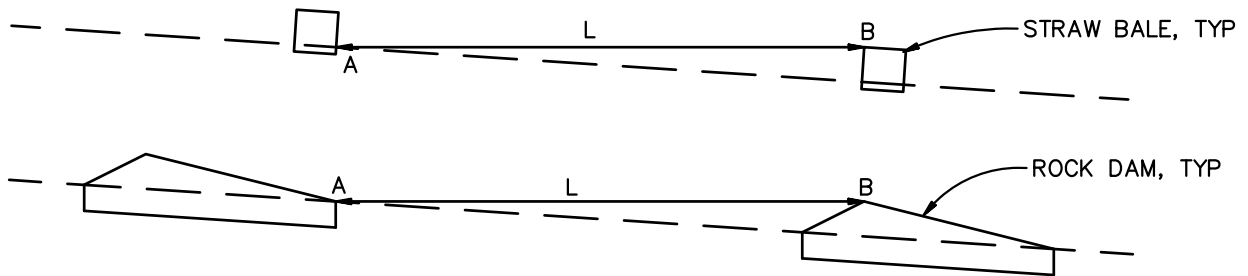

L= THE DISTANCE SUCH THAT POINTS A AND B ARE AT THE SAME ELEVATION.

C. SPACING CHECK DAMS

CHECK DAM
NTS

CHECK DAM NOTES

INSTALLATION REQUIREMENTS

1. STRAW BALES USED AS CHECK DAMS ARE TO MEET THE REQUIREMENTS STATED IN FIGURE SBB-2.
2. THE "H" DIMENSION SHALL BE SELECTED TO PROVIDE WEIR FLOW CONVEYANCE FOR 2-YEAR FLOW OR GREATER.

MAINTENANCE REQUIREMENTS

1. REGULAR INSPECTIONS ARE TO BE MADE OF ALL CHECK DAMS, ESPECIALLY AFTER STORM EVENTS.
2. REPLACE STONE AS NECESSARY TO MAINTAIN THE CORRECT HEIGHT OF THE DAM.
3. ACCUMULATED SEDIMENT AND DEBRIS IS TO BE REMOVED FROM BEHIND THE DAMS AFTER EACH STORM OR WHEN 1/2 OF THE ORIGINAL HEIGHT OF THE DAM IS REACHED.
3. CHECK DAMS ARE TO REMAIN IN PLACE AND OPERATIONAL UNTIL THE DRAINAGE AREA AND CHANNEL ARE PERMANENTLY STABILIZED.
4. WHEN CHECK DAMS ARE REMOVED THE CHANNEL LINING OR VEGETATION IS TO BE RESTORED.

BASIN GEOMETRY:

$$\frac{\text{LENGTH (L)}}{\text{WIDTH (W)}} \geq 2$$

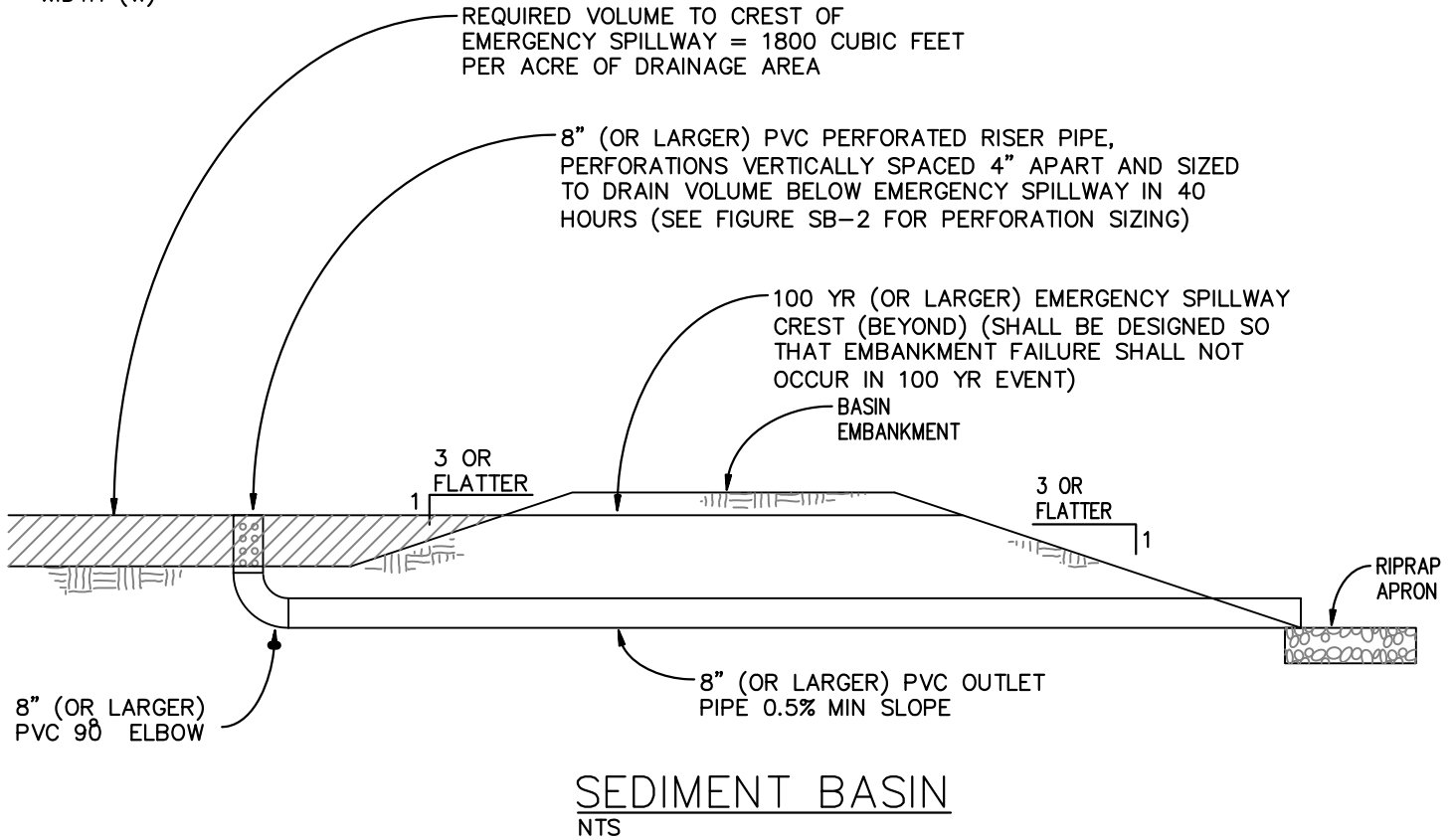

SEDIMENT BASIN NOTES

INSTALLATION REQUIREMENTS

MAINTENANCE REQUIREMENTS

1. SEDIMENT BASINS SHALL BE INSTALLED BEFORE ANY CLEARING AND/OR GRADING IS UNDERTAKEN.
2. THE AREA UNDER WHICH THE EMBANKMENT IS TO BE INSTALLED SHALL BE CLEARED, GRUBBED, AND STRIPPED OF ALL VEGETATION AND ROOT MAT.
3. THE OUTLET OF THE BASIN SHALL BE DESIGNED TO DRAIN ITS VOLUME IN 40 HOURS.
4. THE OUTLET IS TO BE LOCATED AT THE FURTHEST DISTANCE FROM THE INLET OF THE BASIN. BAFFLES MAY BE NEEDED TO INCREASE THE FLOW LENGTH AND SETTLING TIME.
5. EMBANKMENT MATERIAL SHALL CONSIST OF SOIL WITH A MINIMUM OF 15% PASSING A #200 SIEVE. EXCAVATED SOIL CAN BE USED IF IT MEETS THIS REQUIREMENT.
6. EMBANKMENT IS TO BE COMPACTED TO AT LEAST 90% OF MAXIMUM DENSITY AND WITHIN 2% OF OPTIMUM MOISTURE CONTENT ACCORDING TO ASTM D 698.
7. WHEN A BASIN IS INSTALLED NEAR A RESIDENTIAL AREA, FOR SAFETY REASONS, A SIGN SHALL BE POSTED AND THE AREA SECURED WITH A FENCE.

1. CONTRACTOR SHALL INSPECT SEDIMENT BASINS AFTER EACH RAINFALL, AT LEAST DAILY DURING PROLONGED RAINFALL, AND WEEKLY DURING PERIODS NO RAINFALL.
2. SEDIMENT BASINS SHALL BE CLEANED OUT BEFORE SEDIMENT HAS FILLED HALF THE VOLUME OF THE BASIN.
3. SEDIMENT BASINS SHALL REMAIN OPERATIONAL AND PROPERLY MAINTAINED UNTIL THE SITE AREA IS PERMANENTLY STABILIZED WITH ADEQUATE VEGETATIVE COVER AND/OR OTHER PERMANENT STRUCTURE AS APPROVED BY THE CITY.

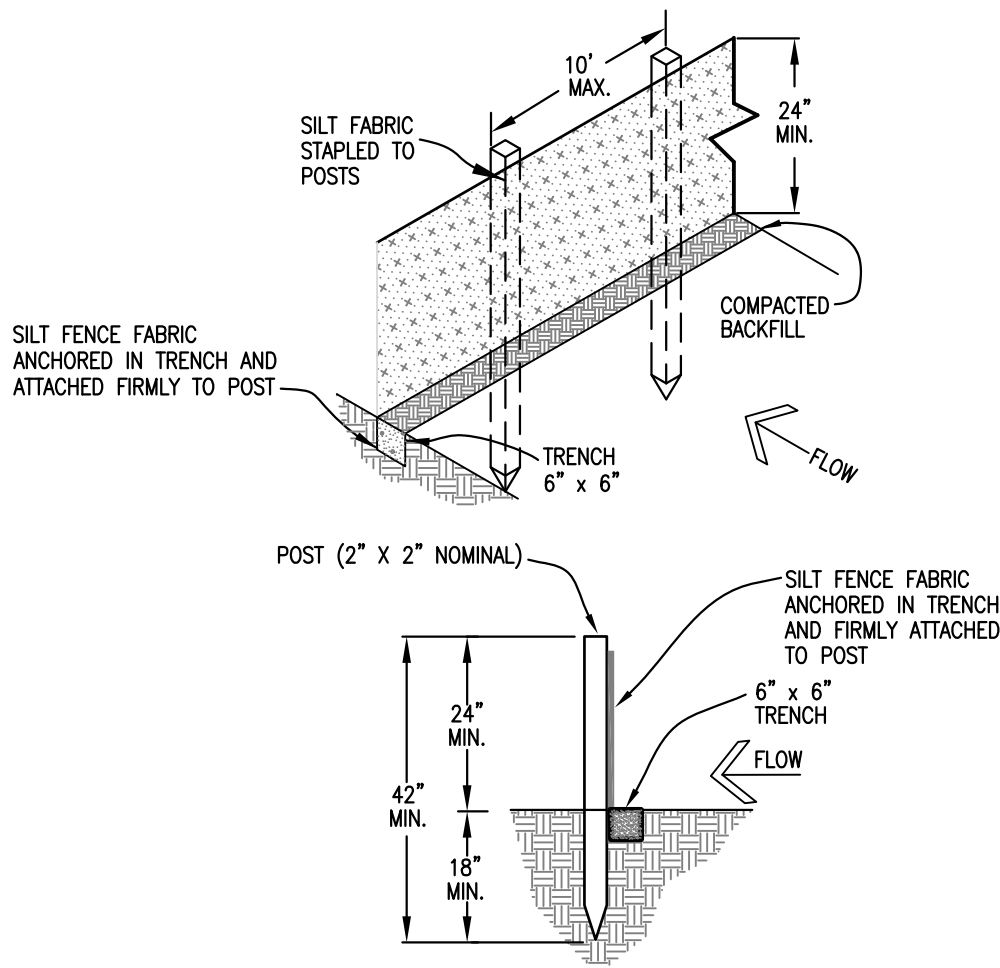

SILT FENCE

INSTALLATION REQUIREMENTS

1. SILT FENCES SHALL BE INSTALLED PRIOR TO ANY LAND DISTURBING ACTIVITIES.
2. WHEN JOINTS ARE NECESSARY, SILT FENCE GEOTEXTILE SHALL BE SPLICED TOGETHER ONLY AT SUPPORT POST AND SECURELY SEALED.
3. METAL POSTS SHALL BE "STUDDED TEE" OR "U" TYPE WITH MINIMUM WEIGHT OF 1.33 POUNDS PER LINEAR FOOT. WOOD POSTS SHALL HAVE A MINIMUM DIAMETER OR CROSS SECTION DIMENSION OF 2 INCHES.
4. THE FILTER MATERIAL SHALL BE FASTENED SECURELY TO METAL OR WOOD POSTS USING WIRE TIES, OR TO WOOD POSTS WITH 3/4" LONG #9 HEAVY-DUTY STAPLES. THE SILT FENCE GEOTEXTILE SHALL NOT BE STAPLED TO EXISTING TREES.
5. WHILE NOT REQUIRED, WIRE MESH FENCE MAY BE USED TO SUPPORT THE GEOTEXTILE. WIRE FENCE SHALL BE FASTENED SECURELY TO THE UPSLOPE SIDE OF THE POSTS USING HEAVY-DUTY WIRE STAPLES AT LEAST 3/4" LONG, TIE WIRES OR HOG RINGS. THE WIRE SHALL EXTEND INTO THE TRENCH A MINIMUM OF 6" AND SHALL NOT EXTEND MORE THAN 3' ABOVE THE ORIGINAL GROUND SURFACE.

6. ALONG THE TOE OF FILLS, INSTALL THE SILT FENCE ALONG A LEVEL CONTOUR AND PROVIDE AN AREA BEHIND THE FENCE FOR RUNOFF TO POND AND SEDIMENT TO SETTLE. A MINIMUM DISTANCE OF 5 FEET FROM THE TOE OF THE FILL IS RECOMMENDED.

7. THE HEIGHT OF THE SILT FENCE FROM THE GROUND SURFACE SHALL BE MINIMUM OF 24 INCHES AND SHALL NOT EXCEED 36 INCHES; HIGHER FENCES MAY INPOUND VOLUMES OF WATER SUFFICIENT TO CAUSE FAILURE OF THE STRUCTURE.

MAINTENANCE REQUIREMENTS

1. CONTRACTOR SHALL INSPECT SILT FENCES IMMEDIATELY AFTER EACH RAINFALL, AT LEAST DAILY DURING PROLONGED RAINFALL, AND WEEKLY DURING PERIODS OF NO RAINFALL. DAMAGED, COLLAPSED, UNENTRENCHED OR INEFFECTIVE SILT FENCES SHALL BE PROMPTLY REPAIRED OR REPLACED.
2. SEDIMENT SHALL BE REMOVED FROM BEHIND SILT FENCE WHEN IT ACCUMULATES TO HALF THE EXPOSED GEOTEXTILE HEIGHT.
3. SILT FENCES SHALL BE REMOVED WHEN ADEQUATE VEGETATIVE COVER IS ATTAINED AS APPROVED BY THE CITY.

TOP VIEW OF SILT FENCE POSTS—DETAIL

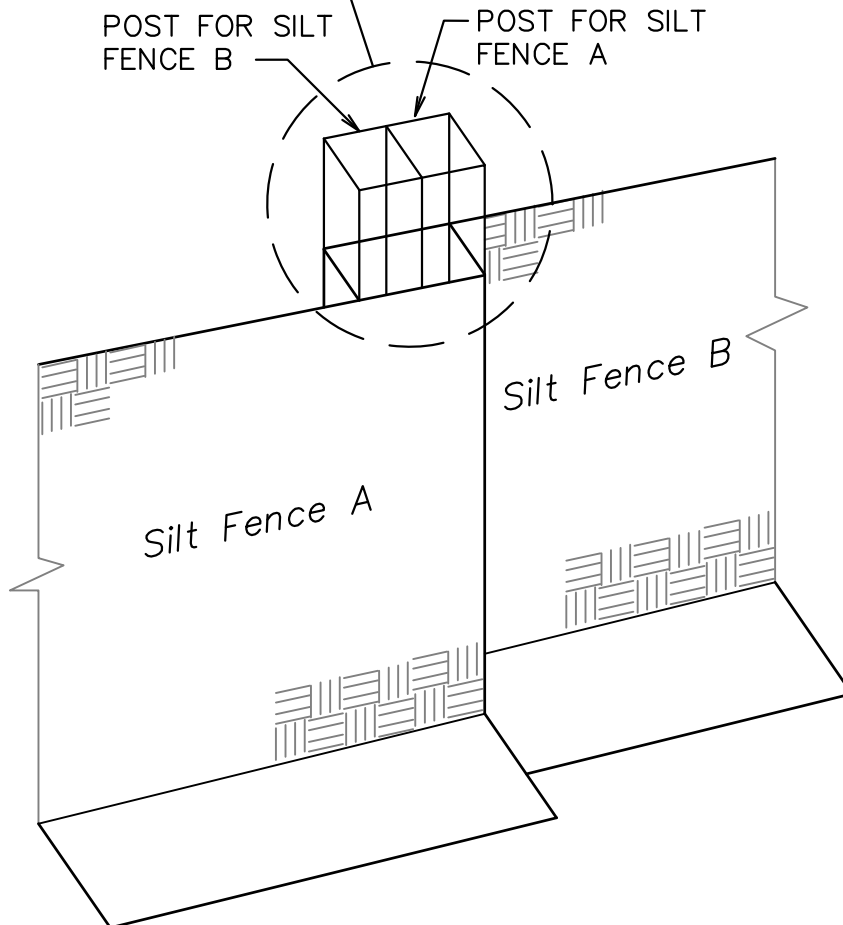
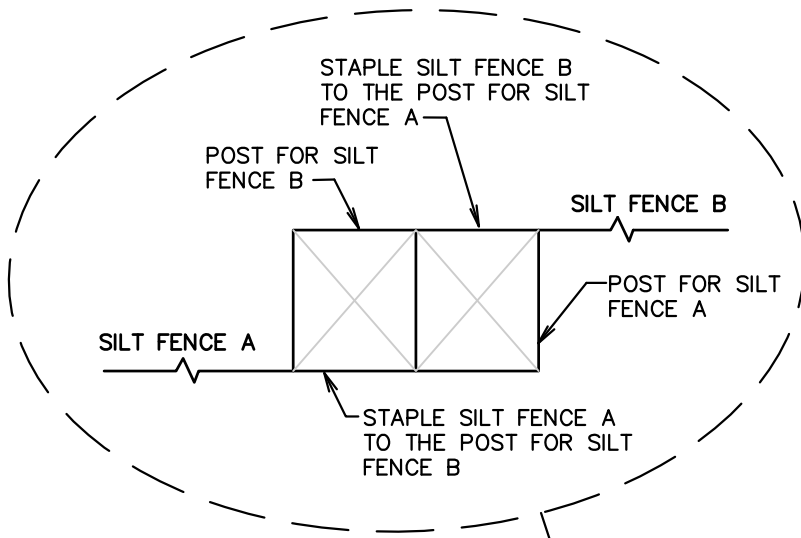

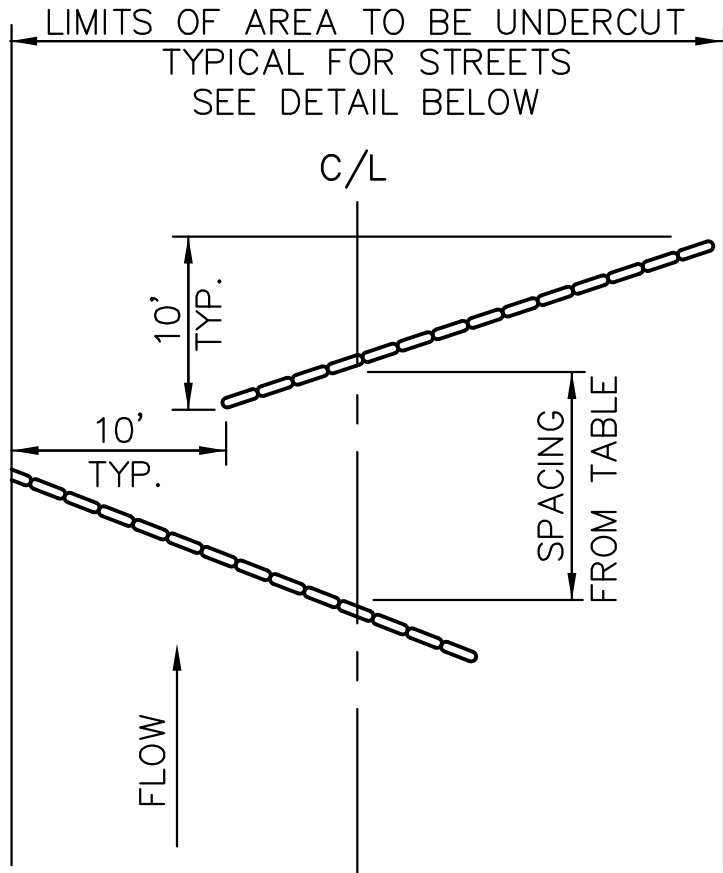

SANDBAG ROW SPACING TABLE

STREET GRADE %	INTERVAL (FT)
0-2	500
2+4	200
4-6	120
6-8	90
8-10	70
10-12	50
12-15	35

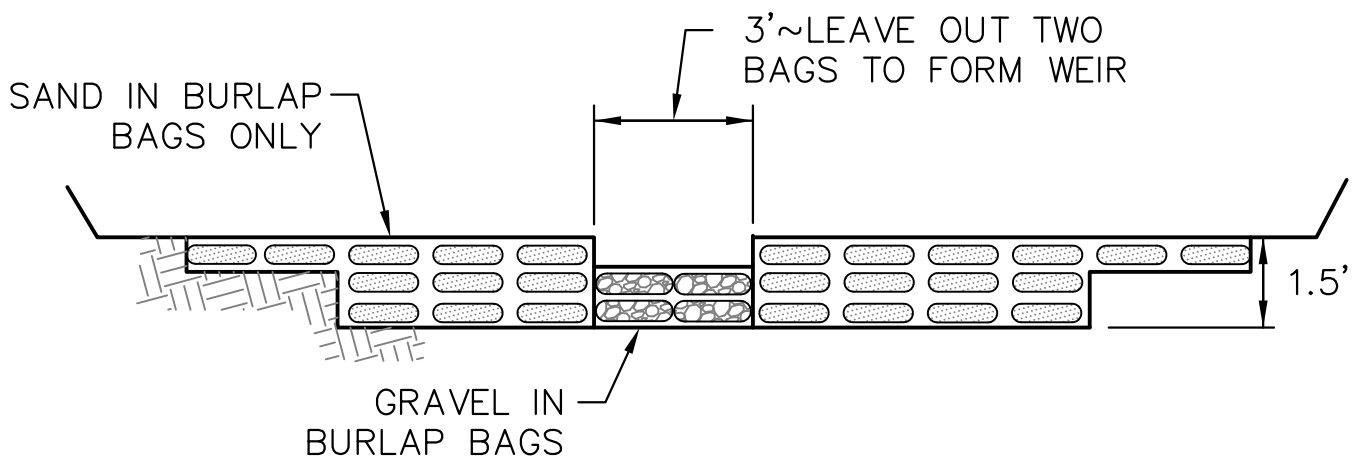

Typical Check Dam Detail

Standard Drawing

DATE: APPROVED

DEPARTMENT OF TRANSPOTATION

REVISION DATE:
11/10/04

FILE NAME:
SD_3-62

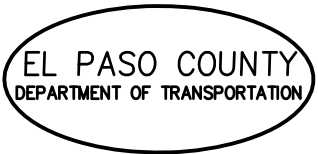

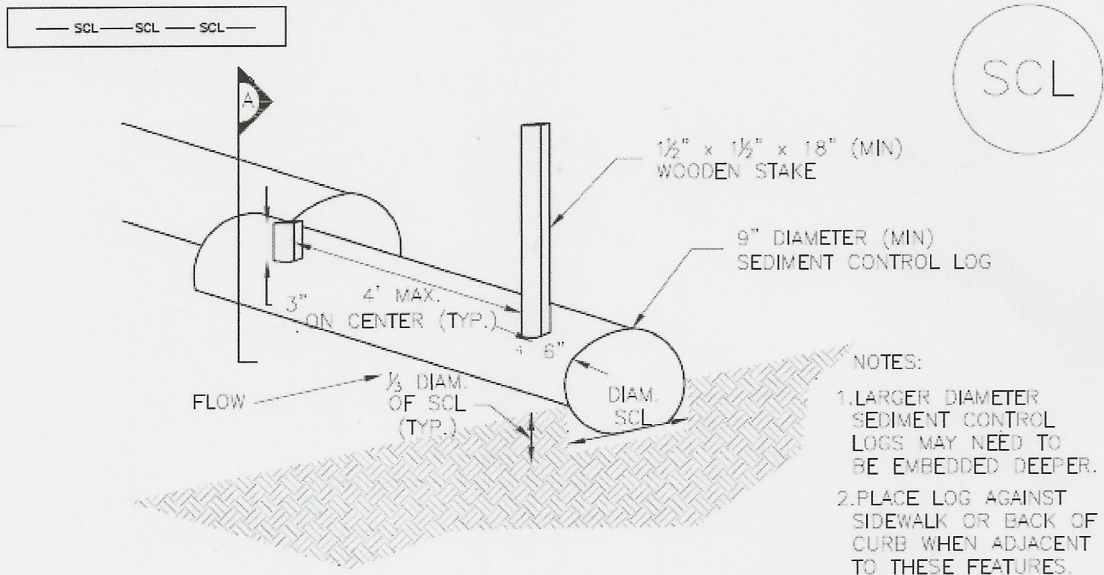

TRENCHED SEDIMENT CONTROL LOG

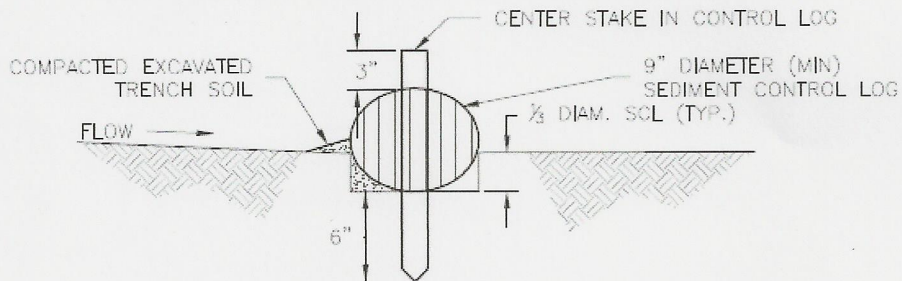

SECTION A
TRENCHED SEDIMENT CONTROL LOG (A)

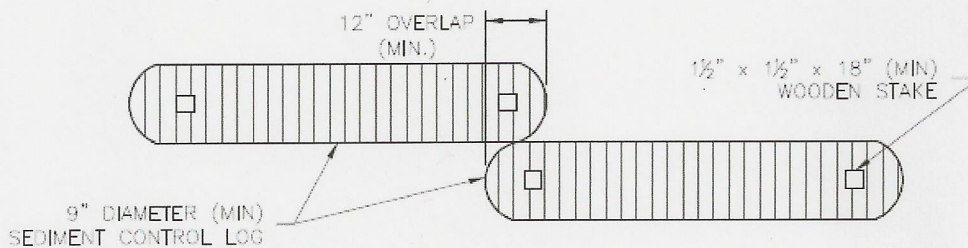

LOG JOINTS

SCL-1. TRENCHED SEDIMENT CONTROL LOG

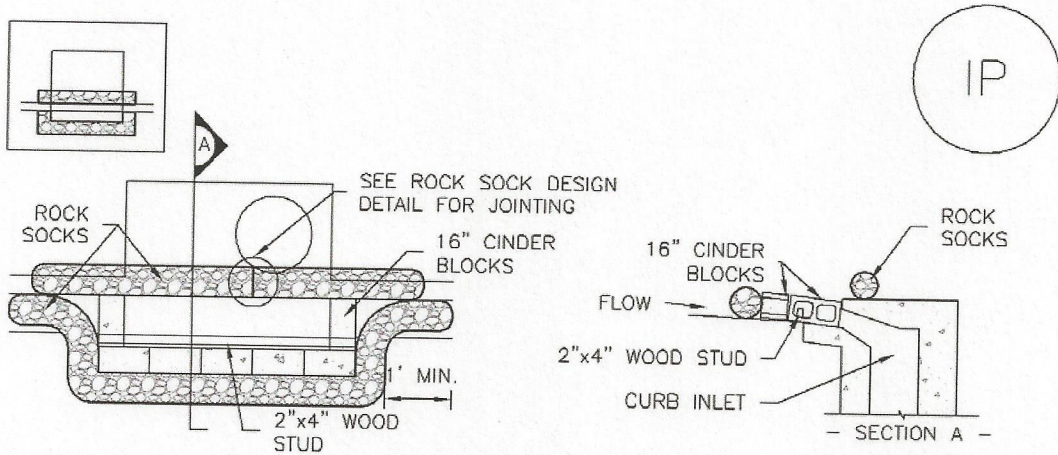

IP-1. BLOCK AND ROCK SOCK SUMP OR ON GRADE INLET PROTECTION

BLOCK AND CURB SOCK INLET PROTECTION INSTALLATION NOTES

1. SEE ROCK SOCK DESIGN DETAIL FOR INSTALLATION REQUIREMENTS.
2. CONCRETE "CINDER" BLOCKS SHALL BE LAID ON THEIR SIDES AROUND THE INLET IN A SINGLE ROW, ABUTTING ONE ANOTHER WITH THE OPEN END FACING AWAY FROM THE CURB.
3. GRAVEL BAGS SHALL BE PLACED AROUND CONCRETE BLOCKS, CLOSELY ABUTTING ONE ANOTHER AND JOINTED TOGETHER IN ACCORDANCE WITH ROCK SOCK DESIGN DETAIL.

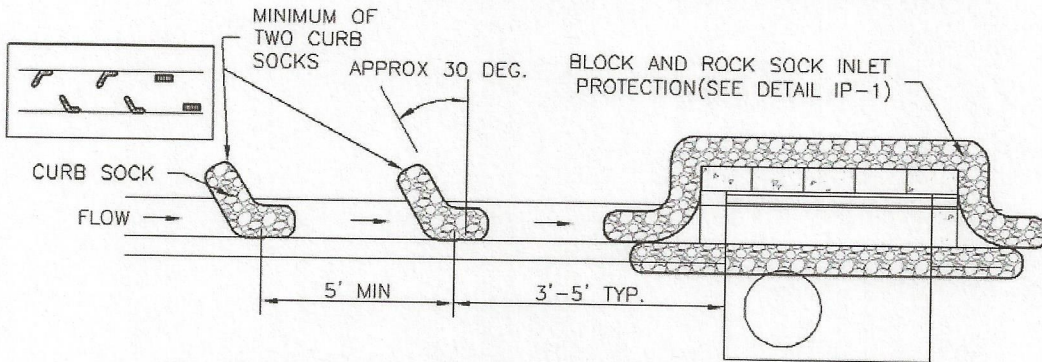

IP-2. CURB ROCK SOCKS UPSTREAM OF INLET PROTECTION

CURB ROCK SOCK INLET PROTECTION INSTALLATION NOTES

1. SEE ROCK SOCK DESIGN DETAIL INSTALLATION REQUIREMENTS.
2. PLACEMENT OF THE SOCK SHALL BE APPROXIMATELY 30 DEGREES FROM PERPENDICULAR IN THE OPPOSITE DIRECTION OF FLOW.
3. SOCKS ARE TO BE FLUSH WITH THE CURB AND SPACED A MINIMUM OF 5 FEET APART.
4. AT LEAST TWO CURB SOCKS IN SERIES ARE REQUIRED UPSTREAM OF ON-GRADE INLETS.

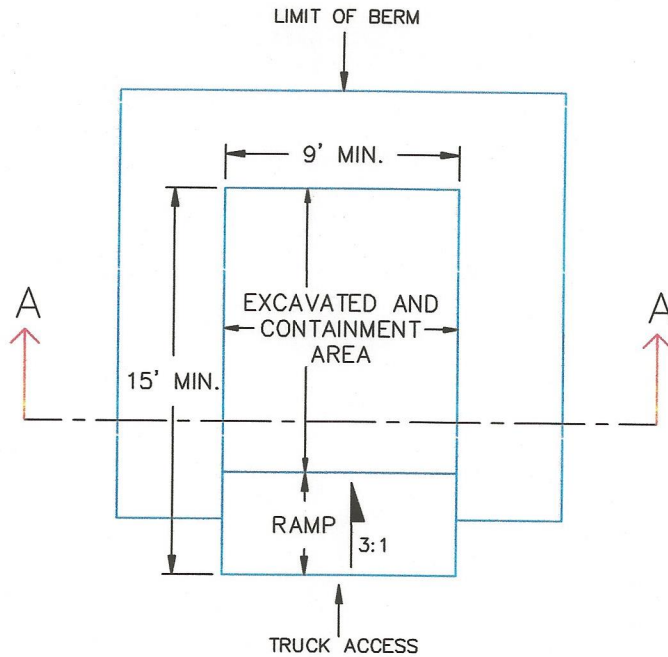

PLAN VIEW

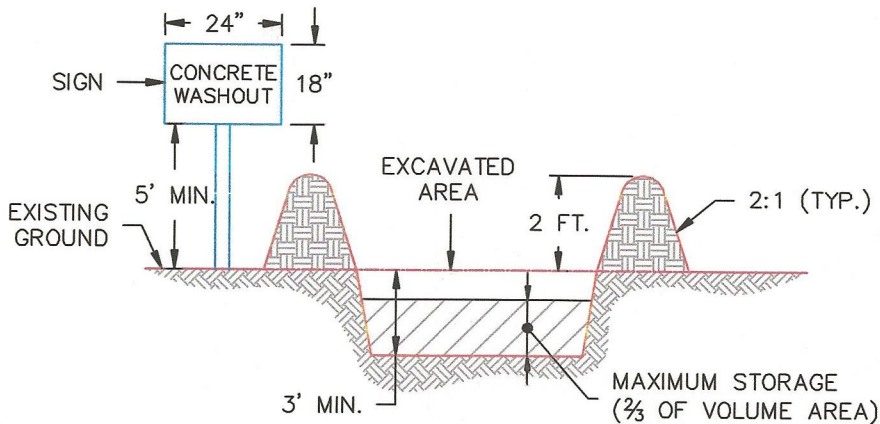

SECTION A-A

NOTES:

1. SIGN MATERIAL, EXCAVATION, AND RESTORATION ARE INCLUDED IN THE COST OF THE CONCRETE WASHOUT STRUCTURE.
2. EROSION BALES MAY BE USED AS AN ALTERNATIVE FOR THE BERM.

1/1/08

DATE APPROVED:

John A. McCarty

DEPARTMENT OF TRANSPORTATION

Concrete Washout Structure

Standard Drawing

REVISION DATE:

7/17/07

FILE NAME:

SD_3-84



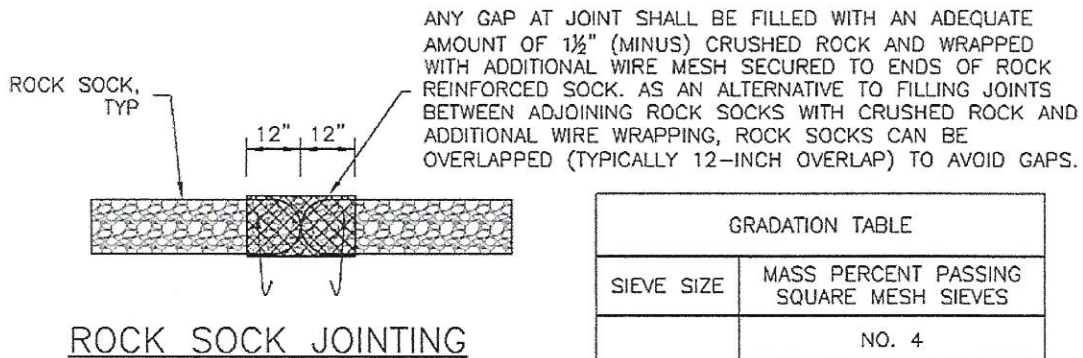
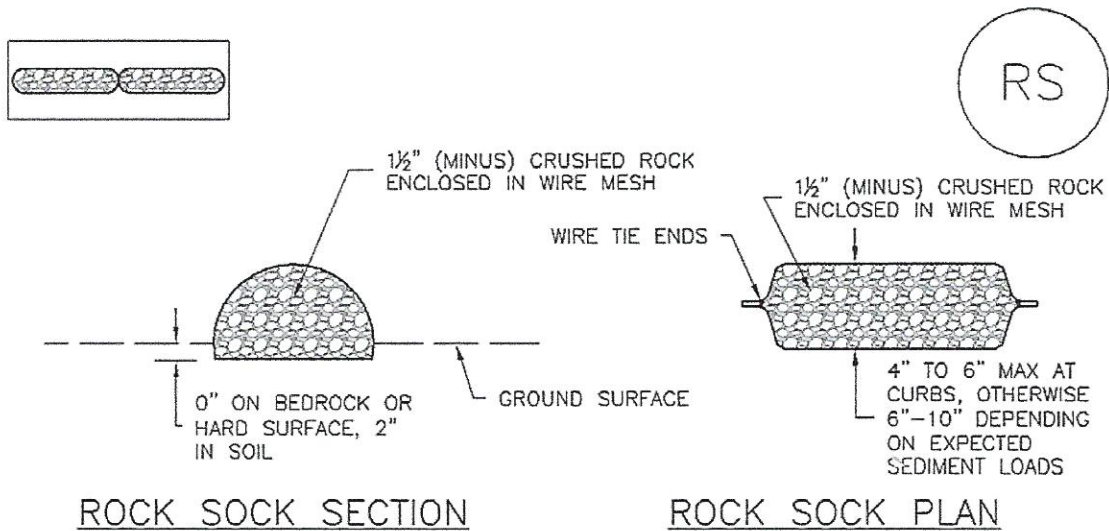

GRADATION TABLE	
SIEVE SIZE	MASS PERCENT PASSING SQUARE MESH SIEVES
	NO. 4
2"	100
1 1/2"	90 - 100
1"	20 - 55
3/4"	0 - 15
3/8"	0 - 5

MATCHES SPECIFICATIONS FOR NO. 4 COARSE AGGREGATE FOR CONCRETE PER AASHTO M43. ALL ROCK SHALL BE FRACTURED FACE, ALL SIDES.

ROCK SOCK INSTALLATION NOTES

1. SEE PLAN VIEW FOR:
-LOCATION(S) OF ROCK SOCKS.
2. CRUSHED ROCK SHALL BE 1 1/2" (MINUS) IN SIZE WITH A FRACTURED FACE (ALL SIDES) AND SHALL COMPLY WITH GRADATION SHOWN ON THIS SHEET (1 1/2" MINUS).
3. WIRE MESH SHALL BE FABRICATED OF 10 GAGE POULTRY MESH, OR EQUIVALENT, WITH A MAXIMUM OPENING OF 1/2", RECOMMENDED MINIMUM ROLL WIDTH OF 48"
4. WIRE MESH SHALL BE SECURED USING "HOG RINGS" OR WIRE TIES AT 6" CENTERS ALONG ALL JOINTS AND AT 2" CENTERS ON ENDS OF SOCKS.
5. SOME MUNICIPALITIES MAY ALLOW THE USE OF FILTER FABRIC AS AN ALTERNATIVE TO WIRE MESH FOR THE ROCK ENCLOSURE.

RS-1. ROCK SOCK PERIMETER CONTROL

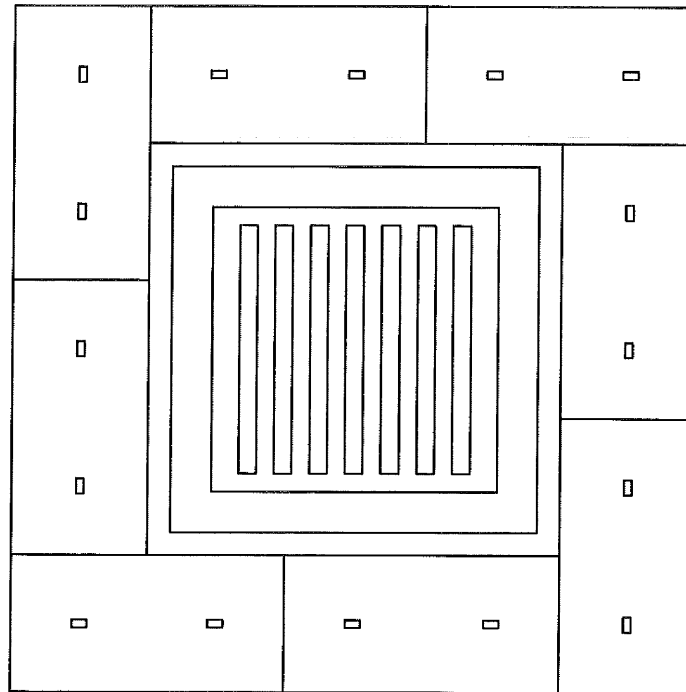

STRAW BALE
(SEE FIG. SBB-2
FOR INSTALLATION
REQUIREMENTS)

STRAW BALE INLET PROTECTION

NTS

STRAW BALE INLET PROTECTION NOTES

INSTALLATION REQUIREMENTS

1. INLET PROTECTION SHALL BE INSTALLED IMMEDIATELY AFTER CONSTRUCTION OF INLET.
2. BALES ARE TO BE PLACED IN A SINGLE ROW AROUND THE INLET WITH THE END OF THE BALES TIGHTLY ABUTTING ONE ANOTHER.
3. SEE STRAW BALE BARRIER FIGURE SBB-2 FOR INSTALLATION REQUIREMENTS.

MAINTENANCE REQUIREMENTS

1. CONTRACTOR SHALL INSPECT STRAW BALE INLET PROTECTION IMMEDIATELY AFTER EACH RAINFALL, AT LEAST DAILY DURING PROLONGED RAINFALL, AND WEEKLY DURING PERIODS NO RAINFALL.
2. DAMAGED OR INEFFECTIVE INLET PROTECTION SHALL PROMPTLY BE REPAIRED, REPLACING BALES IF NECESSARY, AND UNENTRENCHED BALES NEED TO BE REPAIRED WITH COMPACTED BACKFILL MATERIAL.
3. SEDIMENT SHALL BE REMOVED FROM BEHIND STRAW BALES WHEN IT ACCUMULATES TO APPROXIMATELY 1/3 THE HEIGHT OF THE BARRIER.
4. INLET PROTECTION SHALL BE REMOVED WHEN ADEQUATE VEGETATIVE COVER IS ATTAINED WITHIN THE DRAINAGE AREA AS APPROVED BY THE CITY.

APPENDIX C

STORMWATER INSPECTION REPORT

Stormwater Inspection Report

Project Name and Location: _____

Inspector Name and Title: _____ Director: _____

Date/Time of Inspection: _____ Weather Conditions: _____

Schedule Completion Date: _____ Construction Stage (circle all that apply):

Clearing/Grubbing Paving Rough Grading Infrastructure Building Construction Final

Grading Final Stabilization Terminate Permit _____

Type of Control	Describe status, identify problems, maintenance needs, or non-conformance with details or temporary alteration	Problem addressed (date and description of corrective action)
Structural:		
Silt Fence <input type="checkbox"/> OK <input type="checkbox"/> N/A	<input type="checkbox"/> Tears/Holes <input type="checkbox"/> Burial <input type="checkbox"/> Sed. Accum. <input type="checkbox"/> Sediment bypass	
Const. Exit <input type="checkbox"/> OK <input type="checkbox"/> N/A	<input type="checkbox"/> Voids Filled <input type="checkbox"/> Trackout	
Check Dam <input type="checkbox"/> OK <input type="checkbox"/> N/A	<input type="checkbox"/> Sediment Accumulation	
Inlet Protection <input type="checkbox"/> OK <input type="checkbox"/> N/A	<input type="checkbox"/> Sed. Accum. <input type="checkbox"/> Sed. Bypass <input type="checkbox"/> Application not appropriate	
Diversion Ditch/Berm <input type="checkbox"/> OK <input type="checkbox"/> N/A	<input type="checkbox"/> Erosion <input type="checkbox"/> Stabilization	
Sediment Trap <input type="checkbox"/> OK <input type="checkbox"/> N/A	<input type="checkbox"/> Sediment Accumulation	
Sediment Basin <input type="checkbox"/> OK <input type="checkbox"/> N/A	<input type="checkbox"/> Sed. Accumulation <input type="checkbox"/> Bank erosion <input type="checkbox"/> Stabilization	
Discharge Point <input type="checkbox"/> OK <input type="checkbox"/> N/A	<input type="checkbox"/> Erosion <input type="checkbox"/> Sediment Discharge	
Material Storage/Secondary Contain. <input type="checkbox"/> OK <input type="checkbox"/> N/A	<input type="checkbox"/> Not shown on Site Map <input type="checkbox"/> Spills <input type="checkbox"/> Out of design. area <input type="checkbox"/> Improper storage: chemicals; solvents; paint; fuels, etc.	

Other Structural Controls <input type="checkbox"/> OK <input type="checkbox"/> N/A		
Non-Structural:		
Good Housekeeping <input type="checkbox"/> OK <input type="checkbox"/> N/A	<input type="checkbox"/> Solid Waste <input type="checkbox"/> Sanitary Waste <input type="checkbox"/> Dust Control	

Project Name and Location: _____ Date: _____ Page 2

Equip. Wash/Maint. <input type="checkbox"/> OK <input type="checkbox"/> N/A	<input type="checkbox"/> Spills <input type="checkbox"/> Outside designated area	
Concrete Washout <input type="checkbox"/> OK <input type="checkbox"/> N/A	<input type="checkbox"/> Spills out of designated area <input type="checkbox"/> Not shown on Site Map	
Stabilization:		
Seed/Sod Mulching, Geotextile, Blankets <input type="checkbox"/> OK <input type="checkbox"/> N/A	<input type="checkbox"/> Need Temp. stab. <input type="checkbox"/> Need final stab. <input type="checkbox"/> Health of veg.	
Record Keeping:		
Entrance Postings <input type="checkbox"/> OK <input type="checkbox"/> N/A	<input type="checkbox"/> NOI <input type="checkbox"/> Permits <input type="checkbox"/> Construction Site Notice	
SWPPP Notebook <input type="checkbox"/> OK <input type="checkbox"/> N/A	<input type="checkbox"/> Missing Sections <input type="checkbox"/> Missing Forms	
Site Map/Details <input type="checkbox"/> OK <input type="checkbox"/> N/A	<input type="checkbox"/> Activities not up-to-date <input type="checkbox"/> Deviate from details <input type="checkbox"/> BMP Additions <input type="checkbox"/> Modifications <input type="checkbox"/> Not up-to-date	
Other <input type="checkbox"/> OK <input type="checkbox"/> N/A		

I certify under penalty of law that this document and all attachments were prepared under my direction or supervision in accordance with a system designed to assure that qualified personnel properly gathered and evaluated the information submitted. Based on my inquiry of the person or persons who manage the system, or those persons directly responsible for gathering the information, the information is, to the best of my knowledge and belief, true, accurate, and complete. I am aware that there are significant penalties for submitting false information, including the possibility of fine and imprisonment for knowing violations.

Inspector's Signature

Date

APPENDIX D

SPILL REPORT FORM

Spill Report Form

Project Type and Location: _____

Spill Reported by: _____

Date/Time Spill: _____

Describe spill location and events leading to spill: _____

Material spilled: _____

Source of spill: _____

Amount spilled: _____ Amount spilled to waterway: _____

Containment or clean up action: _____

Approximate depth of soil excavation: _____

List Injuries or Personal Contamination: _____

Action to be taken to prevent future spills: _____

Modifications to the SWPPP necessary due to this spill: _____

Agencies notified of the spill: _____

I certify under penalty of law that this document and all attachments were prepared under my direction or supervision in accordance with a system designed to assure that qualified personnel properly gather and evaluate the information submitted. Based on my inquiry of the person or persons who manage the system, or those persons directly responsible for gathering the information, the information submitted is, to the best of my knowledge and belief, true, accurate, and complete. I am aware that there are significant penalties for submitting false information, including the possibility of fine and imprisonment for knowing violations.

Contractor Superintendent

Date

APPENDIX E

**RECORD OF STABILIZATION AND
CONSTRUCTION ACTIVITY DATES**

SITE STABILIZATION and CONSTRUCTION ACTIVITY DATES

A record of dates when BMPs are installed or removed, stabilization measures are initiated, major grading activities occur, and construction activities temporarily or permanently cease on a portion of the site shall be maintained until final site stabilization is achieved.

MAJOR STABILIZATION AND GRADING ACTIVITIES

Description of Activity: _____

Site Contractor: _____ Begin (date): _____
End(date): _____

Location: _____

Description of Activity: _____

Site Contractor: _____ Begin (date): _____
End(date): _____

Location: _____

Description of Activity: _____

Site Contractor: _____ Begin (date): _____
End(date): _____

Location: _____

APPENDIX F

**FEDERAL, STATE, OR LOCAL STORM WATER OR OTHER
ENVIRONMENTAL INSPECTOR SITE VISIT LOG**

Federal, State, or Local Storm Water or other Environmental Inspector Site Visit Log

Inspectors Name: _____ Agency: _____

Contractors Representative Present: _____

Others Present: _____

Comments: _____

Time and Date: _____ Report Prepared:
Yes No

Inspectors Name: _____ Agency: _____

Contractors Representative Present: _____

Others Present: _____

Comments: _____

Time and Date: _____ Report Prepared:
Yes No

Inspectors Name: _____ Agency: _____

Contractors Representative Present: _____

Others Present: _____

Comments: _____

Time and Date: _____ Report Prepared:
Yes No

APPENDIX G
GENERAL PERMIT