

EAST FORK JIMMY CAMP CREEK CHANNEL DESIGN CREEKSIDE at LORSON RANCH FILING NO. 1

EL PASO COUNTY, COLORADO PREPARED FOR LORSON DEVELOPMENT

GENERAL NOTES

- Profile design lines are based on centerline, as shown, unless otherwise noted.
- All new construction to conform to the specifications of El Paso County Department of Public Works. Any asphalt removed is to be replaced to meet the specifications of the El Paso County Public Works Department.
- For pavement design, curb and gutter, and sidewalks see individual plan and profile sheets. Pavement design to be based on Resistance Value 'R' derived from Hveem tests and are to be approved by the Engineering Division of the El Paso County Planning and Community Development prior to work above subgrade.
- At intersections, all curb returns will have 20-foot radius unless otherwise noted.
- All existing utilities have been shown according to the best available information. The contractor is responsible for field location and verification prior to beginning work. If it appears that there could be a conflict with any utilities, whether indicated on the plans or not, the contractor is to notify the engineer and owner immediately. The contractor is responsible for the protection and repair (if necessary) of all utilities.
- A Pre-Construction meeting shall be held with the El Paso County Planning and Community Development prior to any construction.
- Approved plans, Engineering Criteria Manual, etc. is required to be on-site at all times during construction.
- All necessary permits, such as SWMP, ESQCP, Fugitive Dust, Access, C.O.E. 404, etc. shall be obtained prior to construction.
- All handicap ramps to be per El Paso County Standard SD_2-40.
- The contractor shall coordinate locations and layout with the El Paso County Planning and Community Development on the placement of any pedestrian ramps prior to construction of the curb.
- Where appropriate, neatly saw cut all existing concrete and asphalt. Repair/replace all disturbed existing items with like materials and thicknesses.
- All disturbed areas shall be revegetated with native grasses within 21 days of excavation per Erosion Control Plan.
- The prepared Erosion/Sediment Control Plan is to be considered a part of these plans and its requirements adhered to during the construction of this project.
- All storm and sanitary sewer pipe lengths and slopes are figured from center of manhole or bend. Pipe lengths are given as a horizontal length.
- All storm sewer bedding to be per CDoT Standards.
- All storm sewer pipe shall be Class III B Wall unless otherwise shown on the storm sewer plan and profile sheets.
- All wyes and bends used in construction of storm sewer facilities shall be factory fabricated, unless approved by the El Paso County Planning and Community Development.
- Construction and materials used in all storm and sanitary sewer manholes shall be per specifications. Storm sewer radial deflections to be grouted or installed per manufacturer's recommendations.
- Storm sewer manholes sizes as follows unless otherwise shown:
 - 18" thru 36" use 48" I.D. manhole
 - 42" thru 48" use 60" I.D. manhole
 - 54" thru 60" use 72" I.D. manhole
 NOTE: Manhole sizes tabulated here shall be increased, if necessary, to accommodate incoming laterals.
- All horizontal stationing is based on the 'Face of Curb', unless otherwise shown.
- All vertical design and top of curb are based on the design point shown in the typical cross section.
- The curb line design point is located at the intersection of the face and top of curb for the Type III Standard 6-inch vertical curb. See typical street section for design point locations.
- Vertical curb to be used between curb returns (CR) and at curb inlets. Transitions from ramp to vertical curb shall be 10-feet unless otherwise approved by the El Paso County Public Services Department. All other curb & gutter to be ramp curb & gutter.
- Cross pans to be per El Paso County Standard Detail SD_2-26.
- Contractor responsible for meeting all Widefield Water and Sanitation District criteria when connecting to existing stubs.
- Curb returns shall be straight graded from CR to CR unless otherwise noted.
- Inlets are Type 'R' inlets (CDOT STD M-604-12) unless otherwise noted.

BENCHMARK: Monument is located at the Northwest corner of the intersection of Powers Boulevard and Fontaine Street. The monument is a 3-inch aluminum cap (FIMS ID #206). Located 51.3 feet west of the west edge of asphalt of Powers Blvd and 65.5 feet north of the north edge of asphalt of Fontaine Street. Elevation=5897.89 feet (NGVD 1929, 1960 Adj.)
Basis of Bearing: All bearings used herein are based on an assumed bearing of N89°42'02" E, a distance of 1873.45 feet between the northeasterly corner of Pioneer Landing at Lorson Ranch Filing No. 1, as recorded under Reception No. 210713013 of the records of the El Paso County Clerk and Recorder, as monumented by a rebar and orange surveyors cap stamped "Rampart PLS 26965", from which the east one-quarter corner (E₁) of said section 14, as monumented by a 2-1/2" pipe with galvanized screw on cap only partially stamped.

EL PASO COUNTY STANDARD NOTES

- All drainage and roadway construction shall meet the standards and specifications of the City of Colorado Springs/El Paso County Drainage Criteria Manual, Volumes 1 and 2, and the El Paso County Engineering Criteria Manual.
- Contractor shall be responsible for the notification and field notification of all existing utilities, whether shown on the plans or not, before beginning construction. Location of existing utilities shall be verified by the contractor prior to construction. Call 811 to contact the Utility Notification Center of Colorado (UNCC).
- Contractor shall keep a copy of these approved plans, the Grading and Erosion Control Plan, the Stormwater Management Plan (SWMP), the soils and geotechnical report, and the appropriate design and construction standards and specifications at the job site at all times, including the following:
 - El Paso County Engineering Criteria Manual (ECM)
 - City of Colorado Springs/El Paso County Drainage Criteria Manual, Volumes 1 and 2
 - Colorado Department of Transportation (CDOT) Standard Specifications for Road and Bridge Construction
 - CDOT M & S Standards
- Notwithstanding anything depicted in these plans in words or graphic representation, all design and construction related to roads, storm drainage and erosion control shall conform to the standards and requirements of the most recent version of the relevant adopted El Paso County standards, including the Land Development Code, the Engineering Criteria Manual, the Drainage Criteria Manual, and the Drainage Criteria Manual Volume 2. Any deviations from regulations and standards must be requested, and approved, in writing. Any modifications necessary to meet criteria after-the-fact will be entirely the developer's responsibility to rectify.
- It is the design engineer's responsibility to accurately show existing conditions, both onsite and offsite, on the construction plans. Any modifications necessary due to conflicts, omissions, or changed conditions will be entirely the developer's responsibility to rectify.
- Contractor shall schedule a pre-construction meeting with El Paso County Planning and Community Development (PCD) - Inspections, prior to starting construction.
- It is the contractor's responsibility to understand the requirements of all jurisdictional agencies and to obtain all required permits, including but not limited to El Paso County Erosion and Stormwater Quality Control Permit (ESQCP), Regional Building Floodplain Development Permit, U.S. Army Corps of Engineers-issued 401 and/or 404 permits, and county and state fugitive dust permits.
- Contractor shall not deviate from the plans without first obtaining written approval from the design engineer and PCD. Contractor shall notify the design engineer immediately upon discovery of any errors or inconsistencies.
- All storm drain pipe shall be Class III RCP unless otherwise noted and approved by PCD.
- Contractor shall coordinate geotechnical testing per ECM standards. Pavement design shall be approved by El Paso County PCD prior to placement of curb and gutter and pavement.
- All construction traffic must enter/exit the site at approved construction access points.
- Sight visibility triangles as identified in the plans shall be provided at all intersections. Obstructions greater than 18 inches above flowline are not allowed within sight triangles.
- Signing and striping shall comply with El Paso County Department of Public Works and MUTCD criteria. [If applicable, additional signing and striping notes will be provided.]
- Contractor shall obtain any permits required by El Paso County Department of Public Works, including Work Within the Right-of-Way and Special Transport permits.
- The limits of construction shall remain within the property line unless otherwise noted. The owner/developer shall obtain written permission and easements, where required, from adjoining property owner(s) prior to any off-site disturbance, grading, or construction.

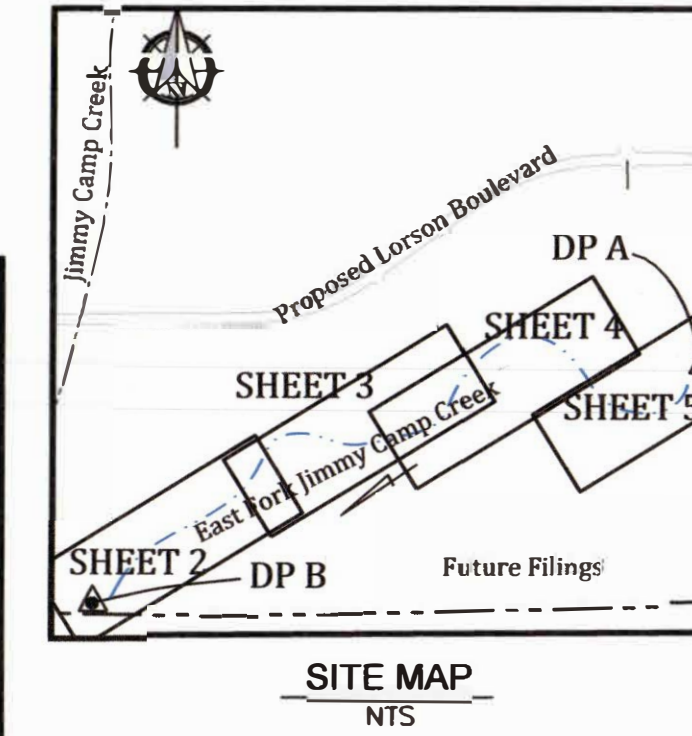

INDEX OF SHEETS	
1	Cover Sheet
2	Plan and Profile - Sta 10+00 to Sta 22+00
3	Plan and Profile - Sta 22+00 to Sta 35+00
4	Plan and Profile - Sta 35+00 to Sta 45+00
5	Plan and Profile - Sta 45+00 to Sta 50+00
6	Typical Sections and Details
7	Cross Sections
8	Grading and Erosion Control Plan
9	Grading and Erosion Control Plan
10	Grading and Erosion Control Plan Details
11	Grading and Erosion Control Plan Details

STATEMENTS

Design Engineer's Statement:

These detailed plans and specifications were prepared under my direction and supervision. Said plans and specifications have been prepared according to the criteria established by the County for detailed roadway, drainage, grading and erosion control plans and specifications, and said plans and specifications are in conformity with applicable master drainage plans and master transportation plans. Said plans and specifications meet the purposes for which the particular roadway and drainage facilities are designed and are correct to the best of my knowledge and belief. I accept responsibility for any liability caused by any negligent acts, errors or omissions on my part in preparation of these detailed plans and specifications.

Richard N. Wray
Richard N. Wray, P.E. #19310 Date: 5/18/2020
For and on behalf of Kiowa Engineering Corp.

Owner/Developer's Statement:

I, the owner/developer have read and will comply with of the requirements of the Grading and Erosion Control Plans and all of the requirements specified in these detailed plans and specifications.

Jeff Mark
Jeff Mark
Lorson Development
212 N. Wahsatch Ave. Suite 301
Colorado Springs, Colorado 80903

El Paso County:

County plan review is provided only for general conformance with County Design Criteria. The County is not responsible for the accuracy and adequacy of the design, dimensions, and/or elevations which shall be confirmed at the job site. The County through the approval of this document assumes no responsibility for completeness and/or accuracy of this document.

Filed in accordance with the requirements of the El Paso County Land Development Code, Drainage Criteria Manual, and Engineering Criteria Manual as amended.

In accordance with ECM Section 1.12, these construction documents will be valid for construction for a period of 2 years from the date signed by the El Paso County Engineer. If construction has not started within those 2 years the plans will need to be resubmitted for approval, including payment of review fees at the Planning and Community Development Directors discretion.

Jennifer Irvine, P.E., Date: _____
County Engineer / ECM Administrator *See conditions below.



ABBREVIATIONS	
ASSY = ASSEMBLY	MIN. = MINIMUM
BNDY = BOUNDARY	NTS = NOT TO SCALE
BOP = BOTTOM OF PIPE	OD = OUTSIDE DIAMETER
CL = CENTERLINE	PC = POINT OF HORIZONTAL CURVATURE
CRA = CONCRETE REVERSE ANCHOR	PP = PROPOSED
CTRB = CONCRETE THRUST BLOCK	PT = POINT OF HORIZONTAL TANGENCY
CR = POINT OF CURB RETURN	PVC = POLY VINYL CHLORIDE PIPE
DP = DUCTILE IRON PIPE	PVC = POINT OF VERTICAL CURVATURE
EL = ELEVATION	PVI = POINT OF VERTICAL INTERSECTION
ESMT = EASEMENT	PVT = POINT OF VERTICAL TANGENCY
EX. = EXISTING	RCB = REINFORCED CONCRETE BOX
FC = FACE OF CURB	RCP = REINFORCED CONCRETE PIPE
FES = FLARED END SECTION	ROW = RIGHT OF WAY
FLG = FLANGE	RT = RIGHT
FL = FLOWLINE	SHT = SHEET
GB = GRADE BREAK	SS = SANITARY SEWER
HP = HIGH POINT	STA = STATION
HORIZ = HORIZONTAL	STD = STANDARD
HYD = HYDRANT	TA = TOP OF ASPHALT
I.D. = INSIDE DIAMETER	TC = TOP OF CURB
LT = LEFT	TOP = TOP OF PIPE
LF = LINEAR FEET	TOR = TOP OF ROCK
LP = LOW POINT	TYP = TYPICAL
MAX = MAXIMUM	VC = VERTICAL CURVE
MH = MANHOLE	VERT = VERTICAL

SUMMARY OF DESIGN FLOWS (cfs)						
Design Point	EPC FIS	(1)			2014 DPBS	
		10yr	100yr	5yr	10yr	100yr
A	NR	2600	5200	100	1860	4530
B	NR	2800	5500	120	1900	4600



Kiowa Project No. 18020
May 15, 2020

The County through the approval of this document does not affirm that sufficient easements or other permissions exist for any offsite work. Construction/safety fencing shall not be placed offsite unless permission has been received from the offsite property owner.

Details of the southernmost detention pond outfall into the channel are to be verified at the time of construction.

The channel O&M Maintenance agreement shall be recorded prior to release of channel construction collateral.

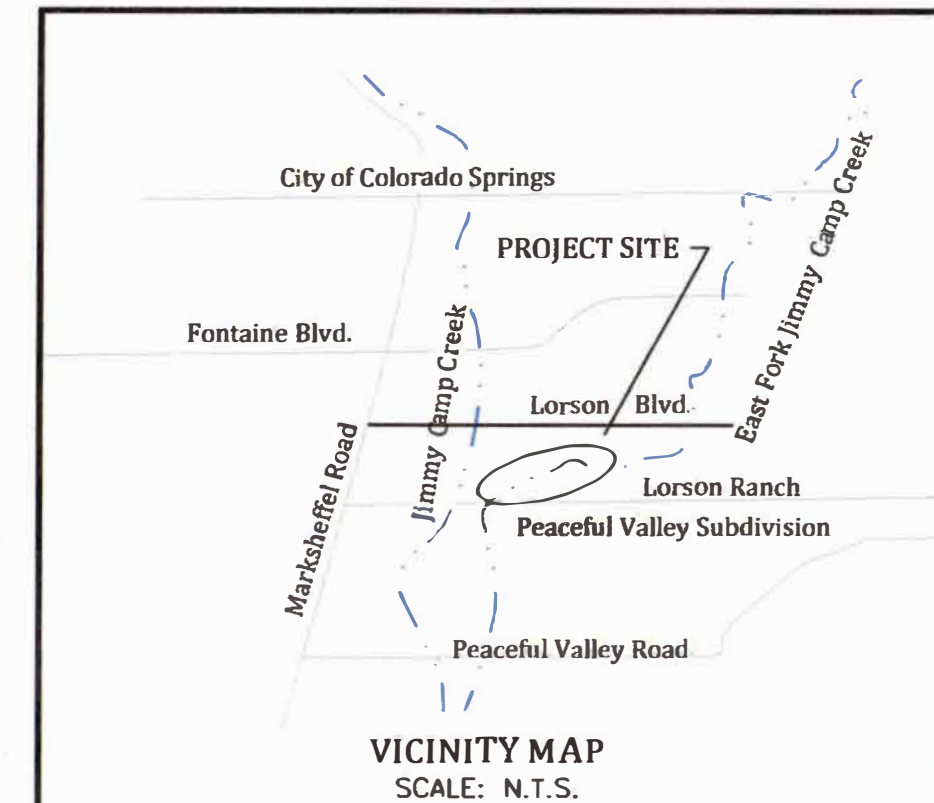

PCD FILE # CDR 192

DEVELOPER:
Lorson Development
212 N. Wahsatch #301
Colorado Springs, CO
80903

PREPARED BY:
Kiowa
Engineering Corporation
1604 South 21st Street
Colorado Springs, Colorado 80904
(719) 630-7342

FOR DESIGN OF FSD AND OUTLET WORKS, SEE FSD POND CR2 DESIGN PLANS, CREEKSIDE AT LORSON RANCH FILING NO. 1, PREPARED BY CORE ENGINEERING.

FOR PROFILE OF STORM SEWER & SPILLWAY, SEE SHEET 4.

FOR GRADING WITHIN DRAINAGEWAY, SEE SHEETS 8 AND 9.

FOR DESIGN OF SAND FILTER BASIN CR.3, SEE DESIGN PLANS, CREEKSIDE AT LORSON RANCH FILING NO. 1, PREPARED BY CORE ENGINEERING.

- LEGEND**
- EX CONTOURS
 - 100-YEAR FLOODPLAIN
 - BOULDER LOW FLOW
 - BOULDER LOW FLOW HEC RAS SECTION
 - PROPERTY LINE
 - STREAM CENTERLINE
 - EXISTING LOW FLOW CHANNEL
 - TYPE L SOIL/RIPRAP
 - TYPE VL SOIL/RIPRAP

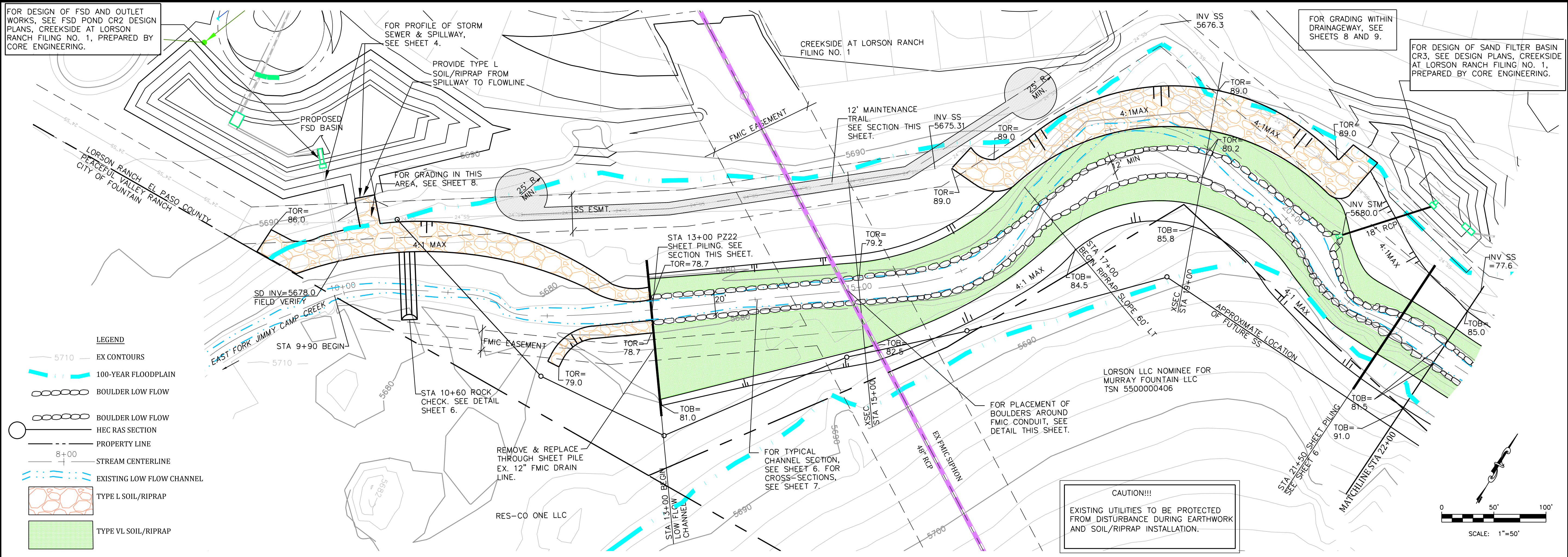

CAUTION!!!
EXISTING UTILITIES TO BE PROTECTED FROM DISTURBANCE DURING EARTHWORK AND SOIL/RIPRAP INSTALLATION.

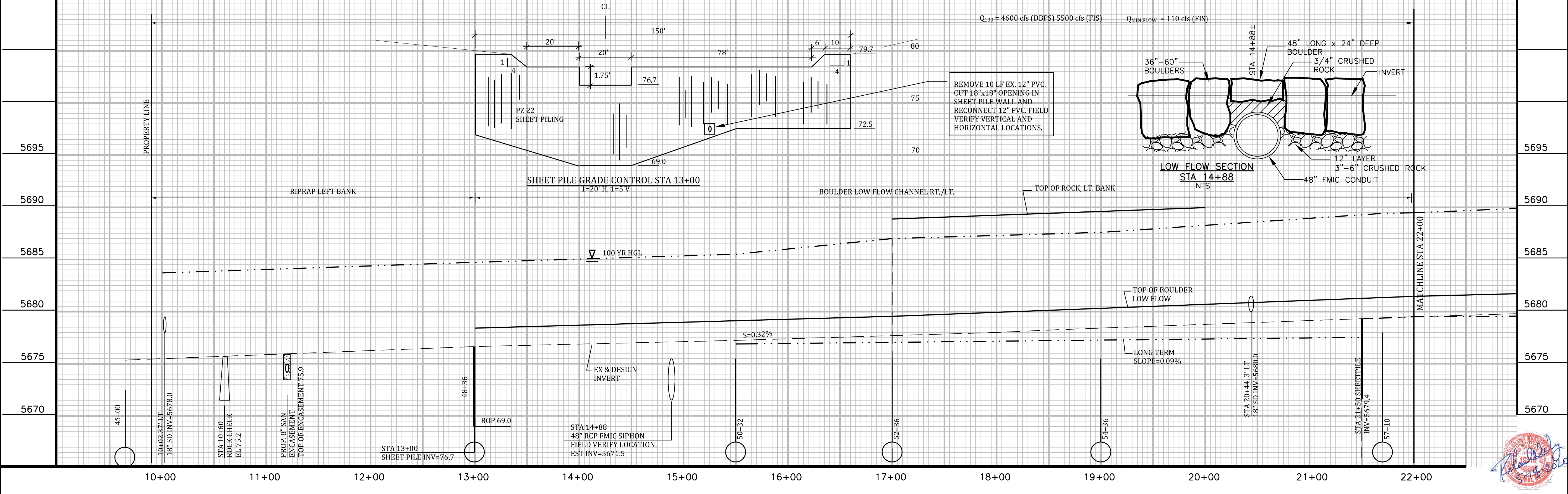
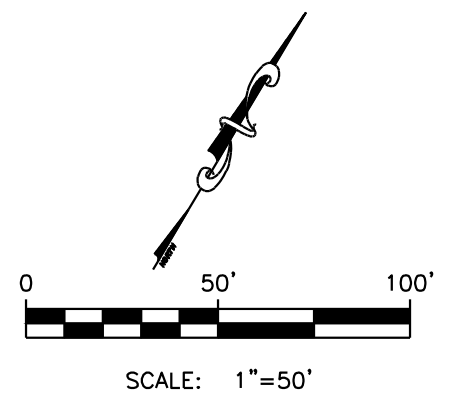

LORSON RANCH
CREEKSIDE DEVELOPMENT
EAST FORK JIMMY CAMP CREEK
CHANNEL PLAN AND PROFILE STA 10+00 TO STA 22+00
EL PASO COUNTY, COLORADO

Project No.:	18020
Date:	6/10/2020
Design:	RNW
Drawn:	EAK
Check:	RNW
Revisions:	

18020_02-11.dwg/Jun 11, 2020/11:59am

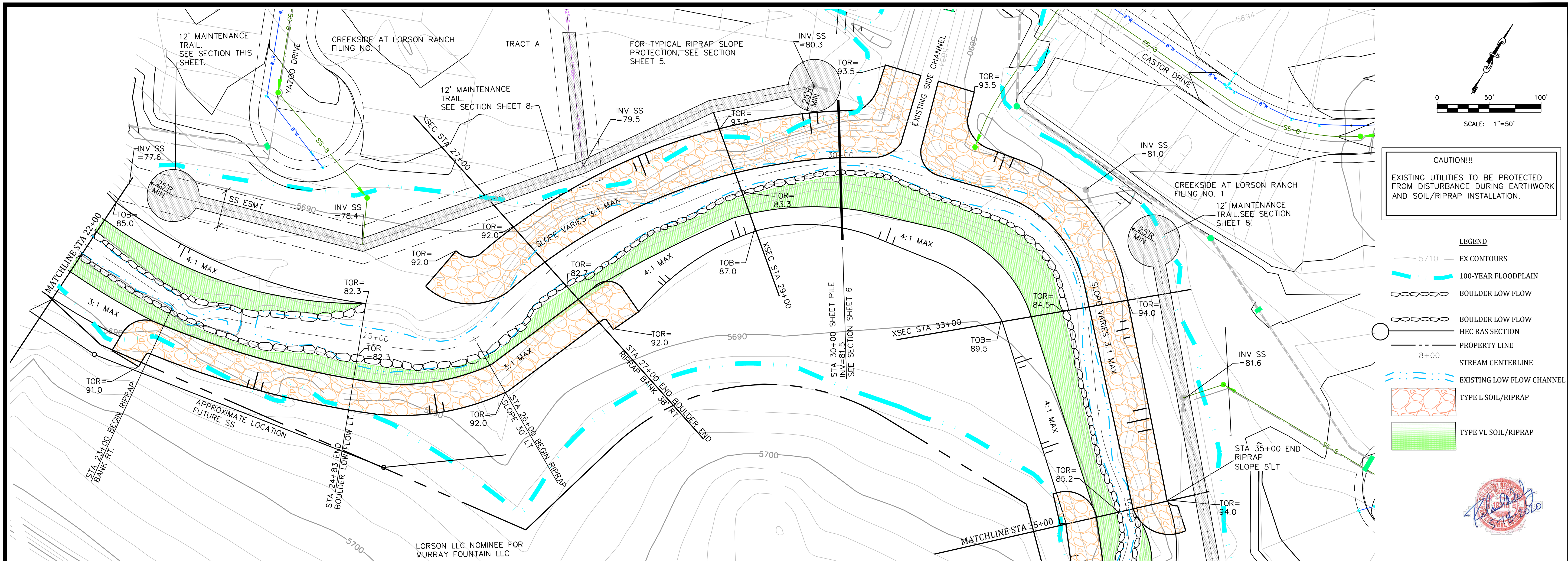

Kiowa
Engineering Corporation
1604 South 21st Street
Colorado Springs, Colorado 80904
(719) 630-7342

LORSON RANCH
CREEKSIDE DEVELOPMENT
EAST FORK JIMMY CAMP CREEK
CHANNEL PLAN AND PROFILE STA 22+00 TO STA 35+00
EL PASO COUNTY, COLORADO

Project No.:	18020
Date:	6/10/2020
Design:	RNW
Drawn:	EAK
Check:	RNW
Revisions:	

3
EPC 7/21/2020

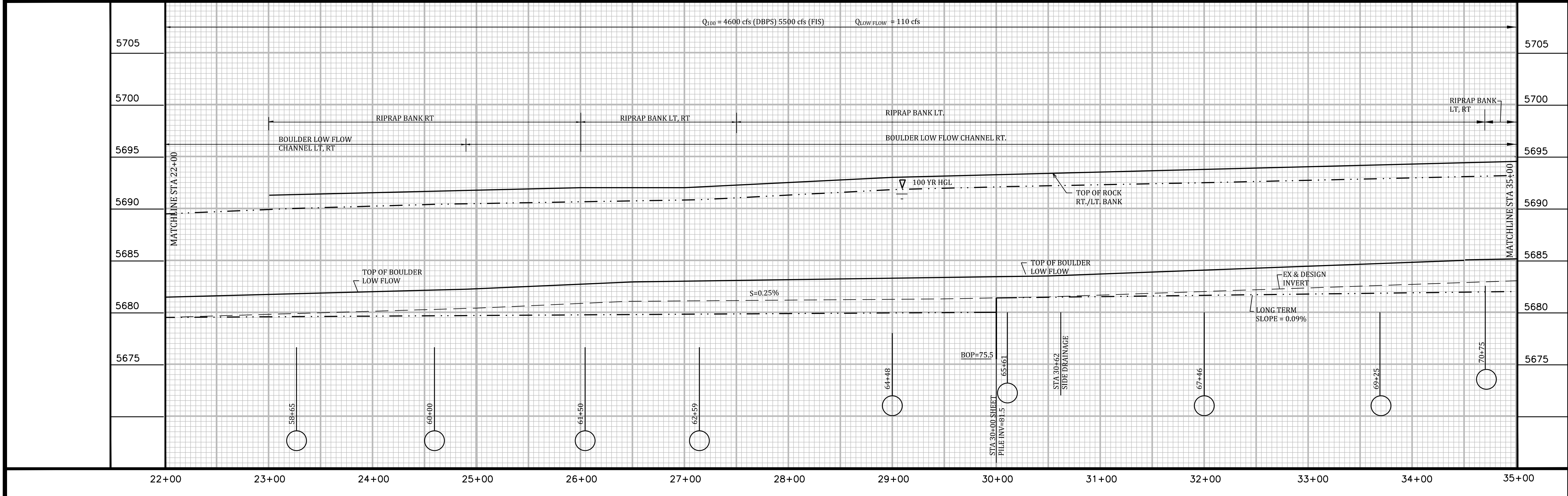

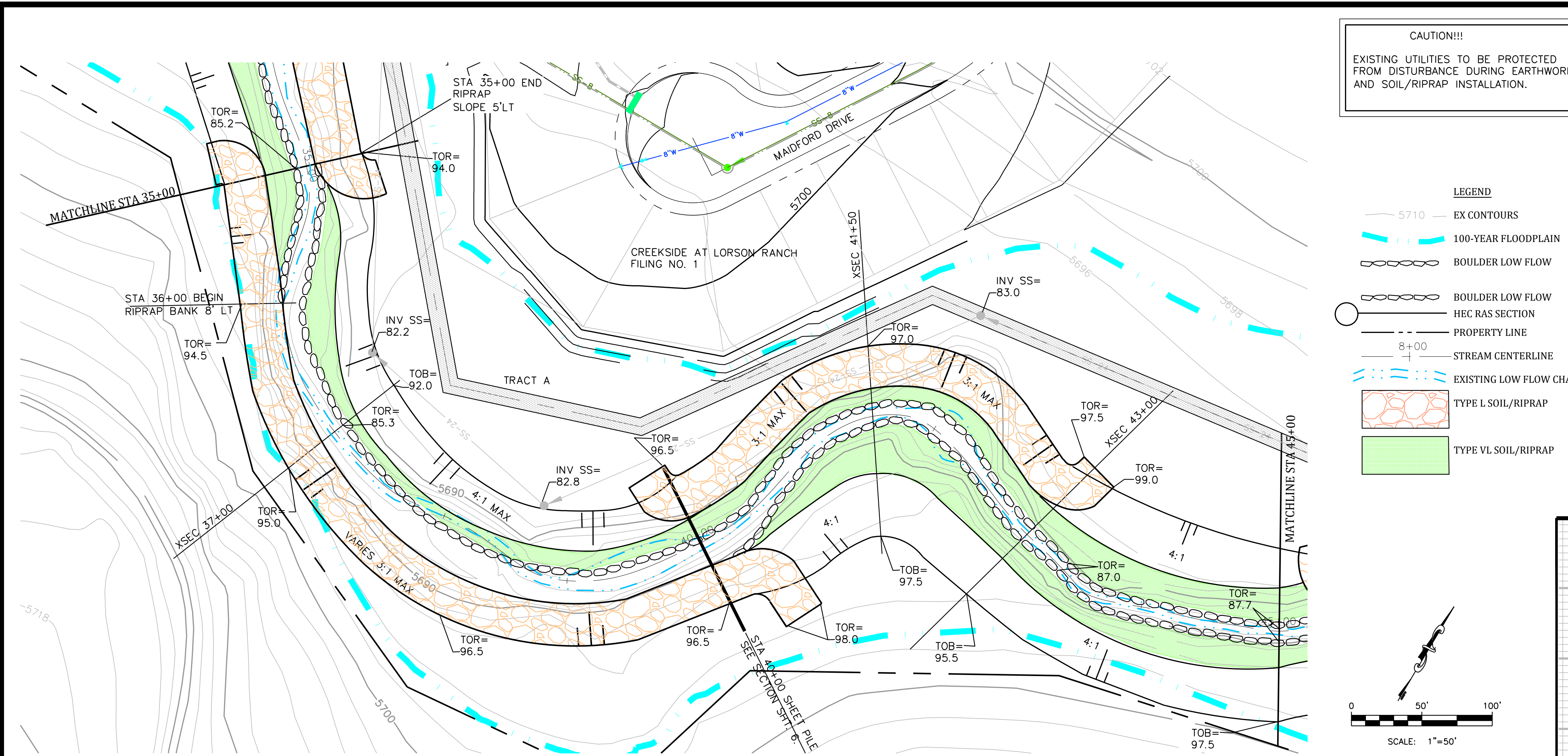

CAUTION!!!
 EXISTING UTILITIES TO BE PROTECTED FROM DISTURBANCE DURING EARTHWORK AND SOIL/RIPRAP INSTALLATION.

- LEGEND**
- 5710 EX CONTOURS
 - 100-YEAR FLOODPLAIN
 - BOULDER LOW FLOW
 - BOULDER LOW FLOW HEC RAS SECTION
 - PROPERTY LINE
 - 8+00 STREAM CENTERLINE
 - EXISTING LOW FLOW CHANNEL
 - TYPE L SOIL/RIPRAP
 - TYPE VL SOIL/RIPRAP

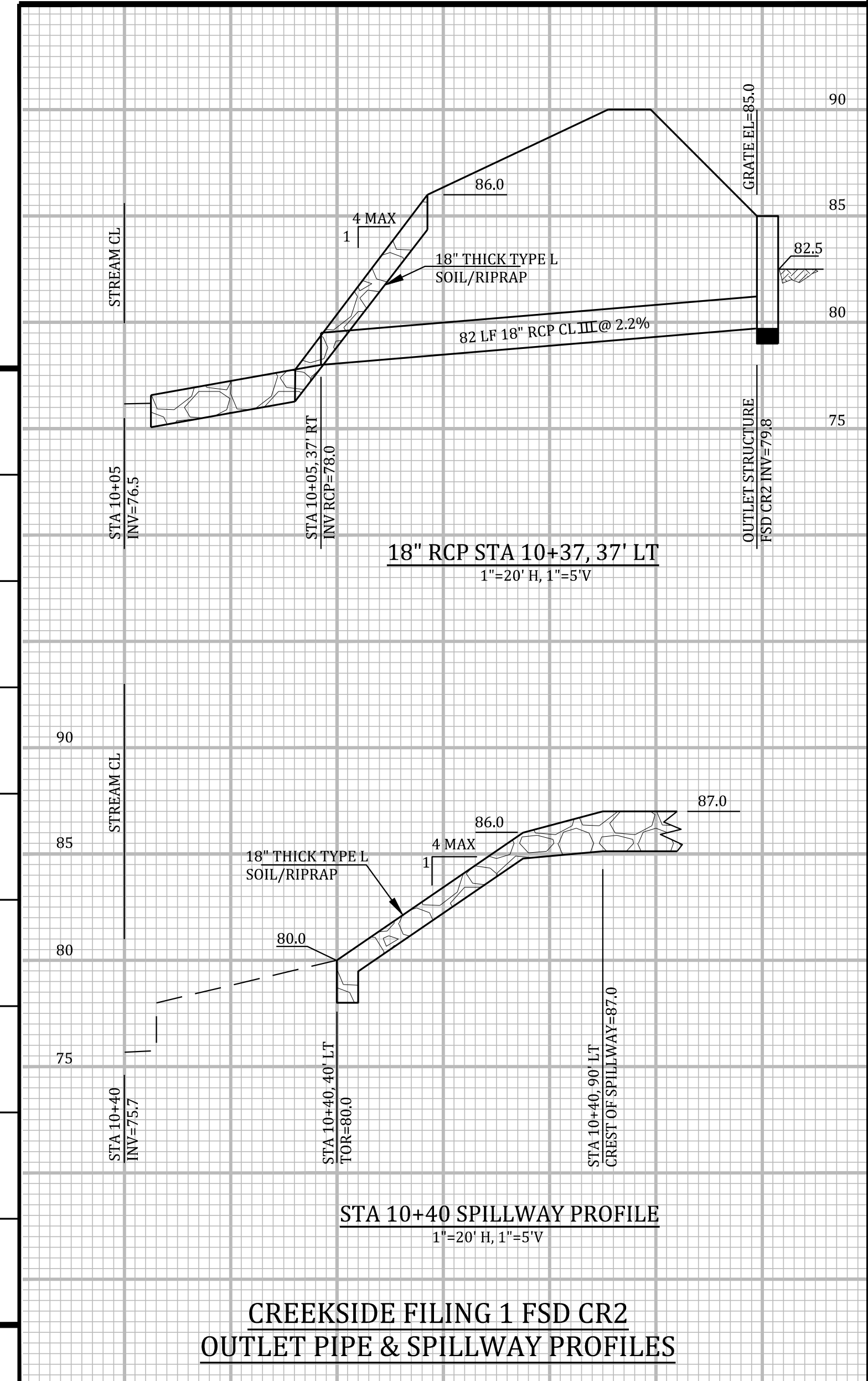
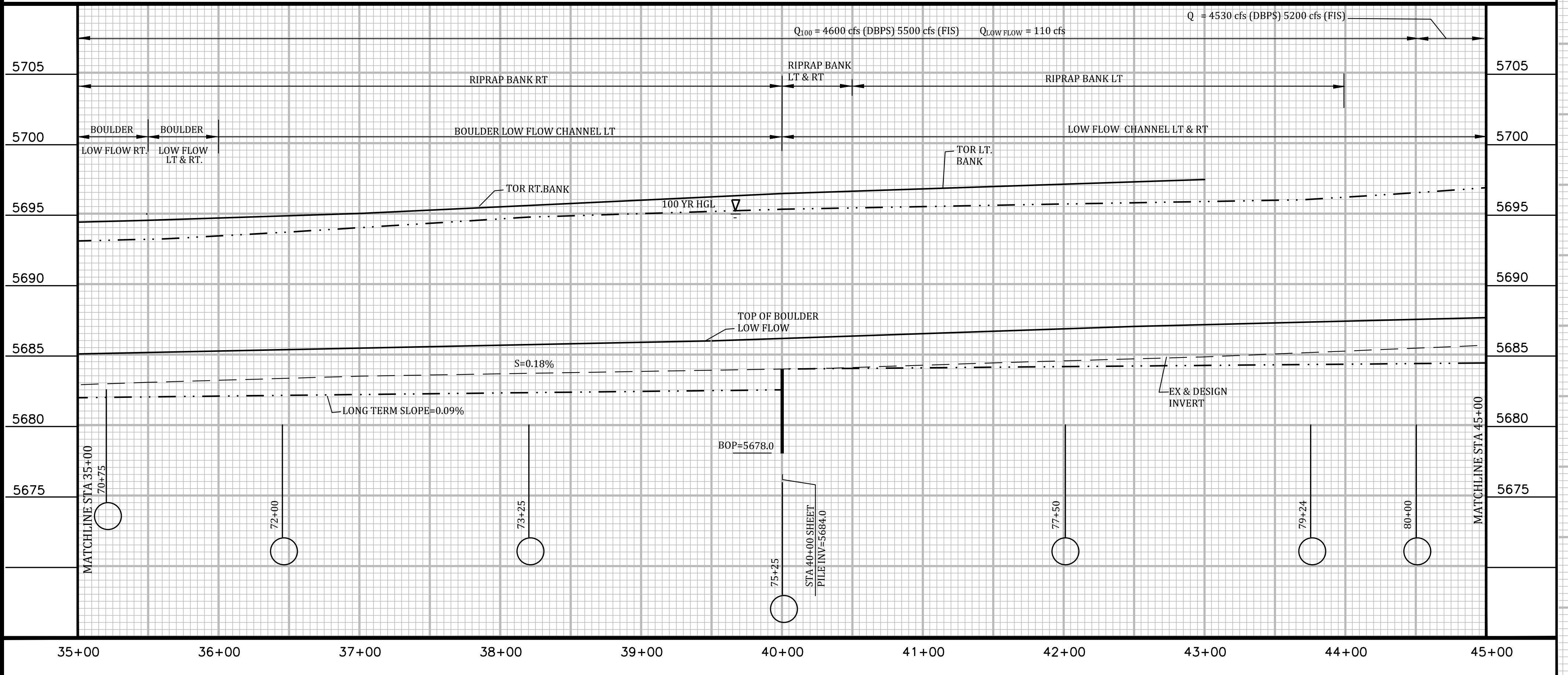
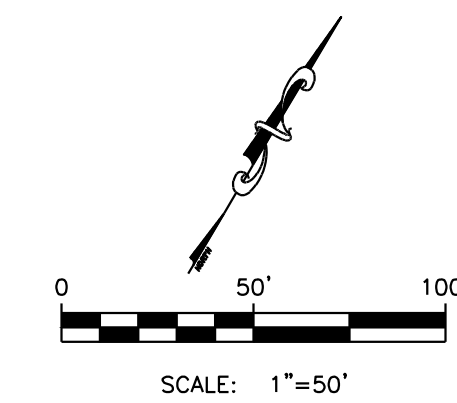

LORSON RANCH
CREEKSIDE DEVELOPMENT
EAST FORK JIMMY CAMP CREEK
CHANNEL PLAN AND PROFILE STA 35+00 TO STA 45+00
EL PASO COUNTY, COLORADO

Project No.:	18020
Date:	6/10/2020
Design:	RNW
Drawn:	EAK
Check:	RNW
Revisions:	

18020 02-11.dwg/Jun 11, 2020/1:25pm

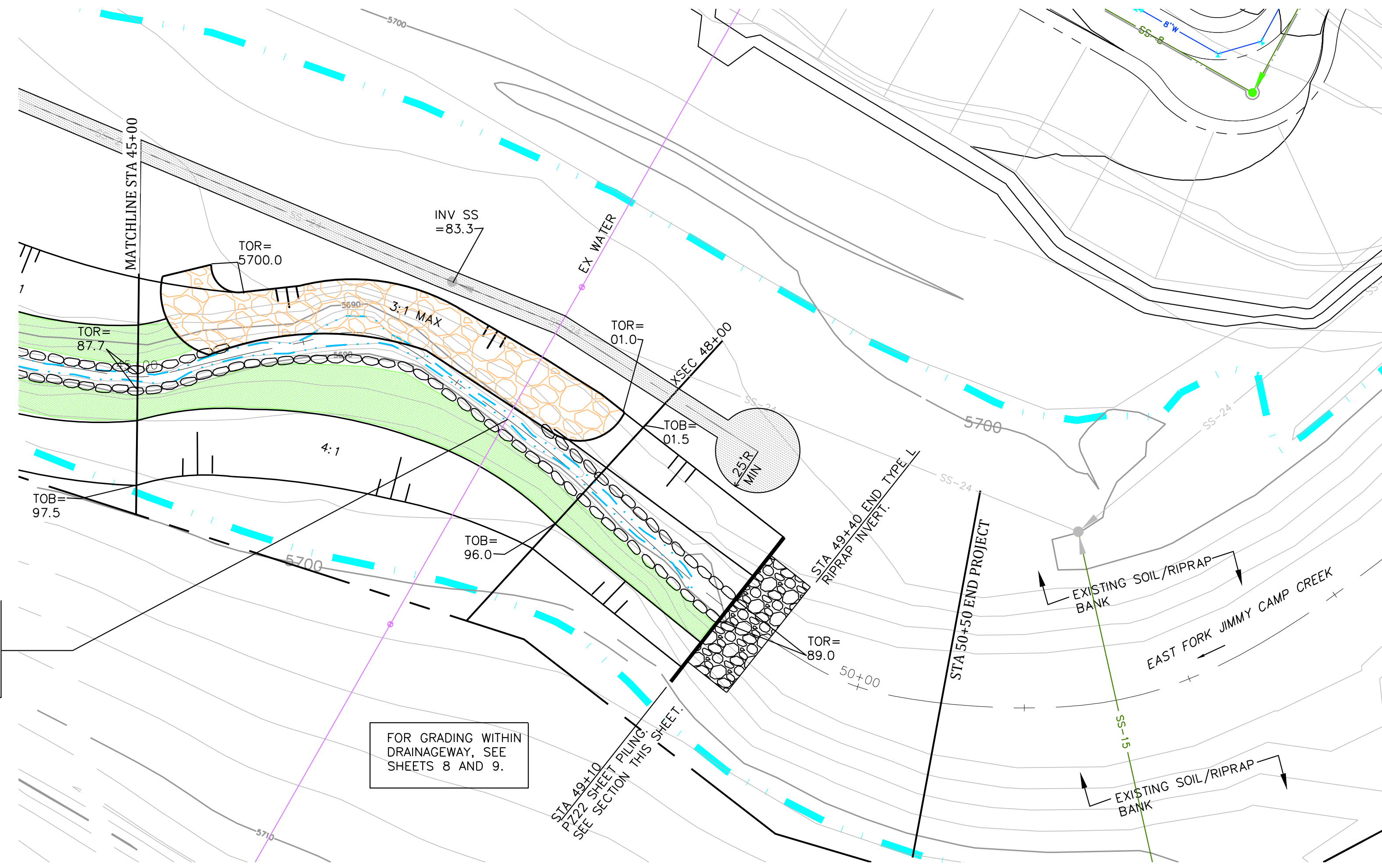

CAUTION!!!
EXISTING UTILITIES TO BE PROTECTED FROM DISTURBANCE DURING EARTHWORK AND SOIL/RIPRAP INSTALLATION.

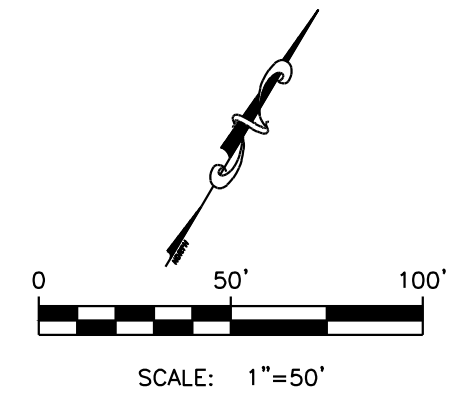

- LEGEND**
- 5710 EX CONTOURS
 - 100-YEAR FLOODPLAIN
 - BOULDER LOW FLOW
 - BOULDER LOW FLOW
 - HEC RAS SECTION
 - PROPERTY LINE
 - 8+00 STREAM CENTERLINE
 - EXISTING LOW FLOW CHANNEL
 - TYPE L SOIL/RIPRAP
 - TYPE VL SOIL/RIPRAP

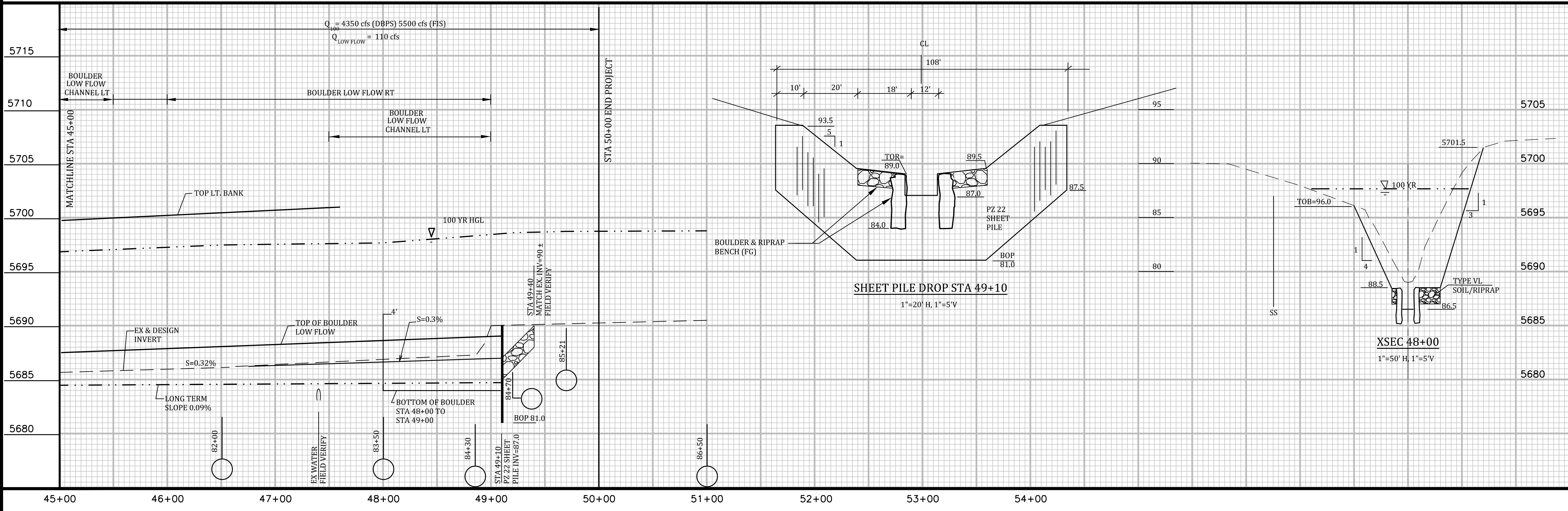

Kiowa
Engineering Corporation
1604 South 2nd Street
Colorado Springs, Colorado 80904
(719) 630-7342

LORSON RANCH
CREEKSIDE DEVELOPMENT
EAST FORK JIMMY CAMP CREEK
CHANNEL PLAN AND PROFILE STA 45+00 TO 50+00
EL PASO COUNTY, COLORADO

Project No.:	18020
Date:	6/10/2020
Design:	RNW
Drawn:	EAK
Check:	RNW
Revisions:	

5
EPC 7/21/2020

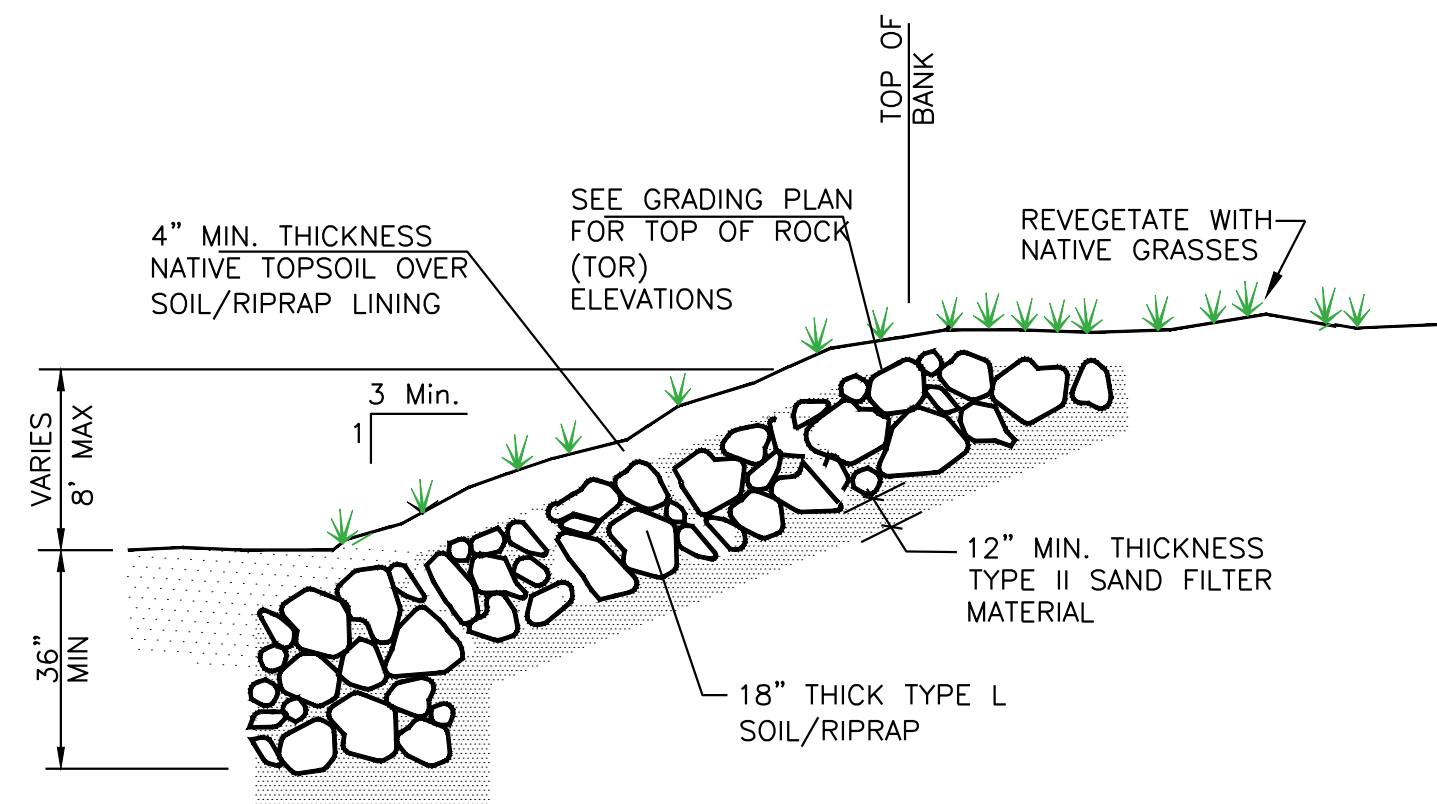
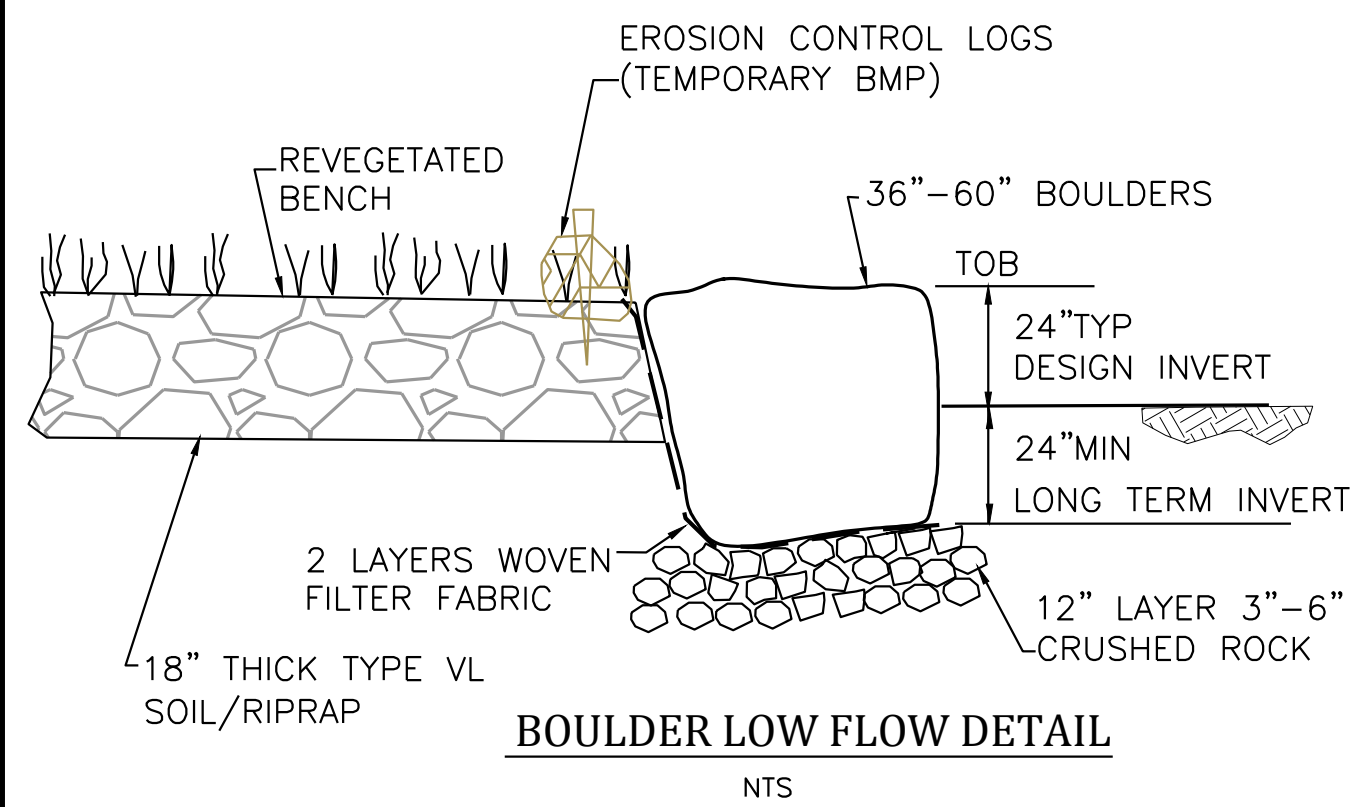

TYPICAL SOIL/RIPRAP BANK LINING
SCALE: N.T.S.

CLASSIFICATION AND GRADATION OF RIPRAP			
RIPRAP DESIGNATION	% SMALLER THAN GIVEN SIZE BY WEIGHT	INTERMEDIATE ROCK DIMENSION (INCHES)	d50* (INCHES)
TYPE VL	70-100	12	6**
	50-70	9	
	35-50	6	
	2-10	2	
TYPE L	70-100	15	9**
	50-70	12	
	35-50	9	
	2-10	3	
TYPE M	70-100	21	12**
	50-70	18	
	35-50	12	
	2-10	6	
TYPE H	100	30	18
	50-70	24	
	35-50	18	
	2-10	6	
TYPE VH	100	42	24
	50-70	33	
	35-50	24	
	2-10	9	

* d50=MEAN PARTICLE SIZE (INTERMEDIATE DIMENSION) BY WEIGHT.
 ** MIX VL, L AND M RIPRAP WITH 35% TOPSOIL (BY VOLUME) AND BURY WITH 4-6 INCHES OF TOPSOIL, ALL VIBRATION COMPACTED & REVEGETATE. (TABLE MD-7; CLASSIFICATION AND GRADATION OF ORDINARY RIPRAP. UDFCD, DRAINAGE CRITERIA MANUAL, VOL. 1)

SOIL RIPRAP

THE SOIL MATERIAL SHALL BE NATIVE OR TOPSOIL AND MIXED WITH SIXTY FIVE PERCENT (65%) RIPRAP AND THIRTY FIVE PERCENT (35%) SOIL BY VOLUME.
 SOIL RIPRAP SHALL CONSIST OF A UNIFORM MIXTURE OF SOIL AND RIPRAP WITHOUT VOIDS.
 CONTRACTOR SHALL COOPERATE WITH ENGINEER IN OBTAINING AND PROVIDING SAMPLES OF ALL SPECIFIED MATERIALS.
 CONTRACTOR SHALL SUBMIT CERTIFIED LABORATORY TEST CERTIFICATES FOR ALL ITEMS REQUIRED FOR SOIL RIPRAP.
 RIPRAP USED SHALL BE THE TYPE DESIGNATED ON THE DRAWINGS AND SHALL CONFORM TO TABLE SHOWN TO THE RIGHT.
 THE RIPRAP DESIGNATION AND TOTAL THICKNESS OF RIPRAP SHALL BE AS SHOWN ON THE DRAWINGS. THE MAXIMUM STONE SIZE SHALL NOT LARGER THAN THE THICKNESS OF THE RIPRAP.
 NEITHER WIDTH NOR THICKNESS OF A SINGLE STONE OF RIPRAP SHALL BE LESS THAN ONE-THIRD (1/3) OF ITS LENGTH.
 THE SPECIFIC GRAVITY OF THE RIPRAP SHALL BE TWO AND ONE-HALF (2.5) OR GREATER.
 MINIMUM DENSITY FOR ACCEPTABLE RIPRAP SHALL BE ONE HUNDRED AND SIXTY FIVE (165) POUNDS PER CUBIC FOOT.
 RIPRAP SPECIFIC GRAVITY SHALL BE ACCORDING TO THE BULK-SATURATED, SURFACE-DRY BASIS, IN ACCORDANCE WITH AASHTO T85.
 THE RIPRAP SHALL HAVE A PERCENTAGE LOSS OF NOT MORE THAN FORTY PERCENT (40%) AFTER FIVE HUNDRED (500) REVOLUTIONS WHEN TESTED IN ACCORDANCE WITH AASHTO T96.
 THE RIPRAP SHALL HAVE A PERCENTAGE LOSS OF NOT MORE THAN TEN (10%) AFTER FIVE (5) CYCLES WHEN TESTED IN ACCORDANCE WITH AASHTO T104 FOR LEDGE ROCK USING SODIUM SULFATE.
 THE RIPRAP SHALL HAVE A PERCENTAGE LOSS OF NOT MORE THAN TEN PERCENT (10%) AFTER TWELVE (12) CYCLES OF FREEZING AND THAWING WHEN TESTED IN ACCORDANCE WITH AASHTO T103 FOR LEDGE ROCK, PROCEDURE A. ROCK SHALL BE FREE FROM CALCITE INTRUSIONS.

RUBBLE FOR USE AS SOIL/RIPRAP SHALL BE GRADED TO MEET THE EQUIVALENT ROCK RIPRAP GRADATION. RUBBLE PROPOSED FOR USE IN PLACE OF ROCK RIPRAP SHALL BE STOCKPILED FOR OBSERVATION BY THE ENGINEER PRIOR TO THE COMMENCEMENT OF THE WORK.

GRADATION:
 A. EACH LOAD OF RIPRAP SHALL BE REASONABLY WELL GRADED FROM THE SMALLEST TO THE LARGEST SIZE SPECIFIED.
 B. STONES SMALLER THAN THE TWO TO TEN PERCENT (2%-10%) SIZE WILL NOT BE PERMITTED IN AN AMOUNT EXCEEDING TEN PERCENT (10%) BY WEIGHT OF EACH LOAD.
 C. CONTROL OF GRADATION SHALL BE BY VISUAL INSPECTION. HOWEVER IN THE EVENT THE ENGINEER DETERMINES THE RIPRAP TO BE UNACCEPTABLE, THE ENGINEER SHALL PICK TWO (2) RANDOM TRUCKLOADS TO BE DUMPED AND CHECKED FOR GRADATION.
 1) MECHANICAL EQUIPMENT AND LABOR NEEDED TO ASSIST IN CHECKING GRADATION SHALL BE PROVIDED BY THE CONTRACTOR AT NO ADDITIONAL COST.
 BROKEN ASPHALT PAVEMENT SHALL NOT BE ACCEPTABLE FOR USE IN THE WORK.
 ROUNDED RIPRAP (RIVER ROCK) IS NOT ACCEPTABLE, UNLESS SPECIFICALLY DESIGNATED ON THE DRAWINGS.

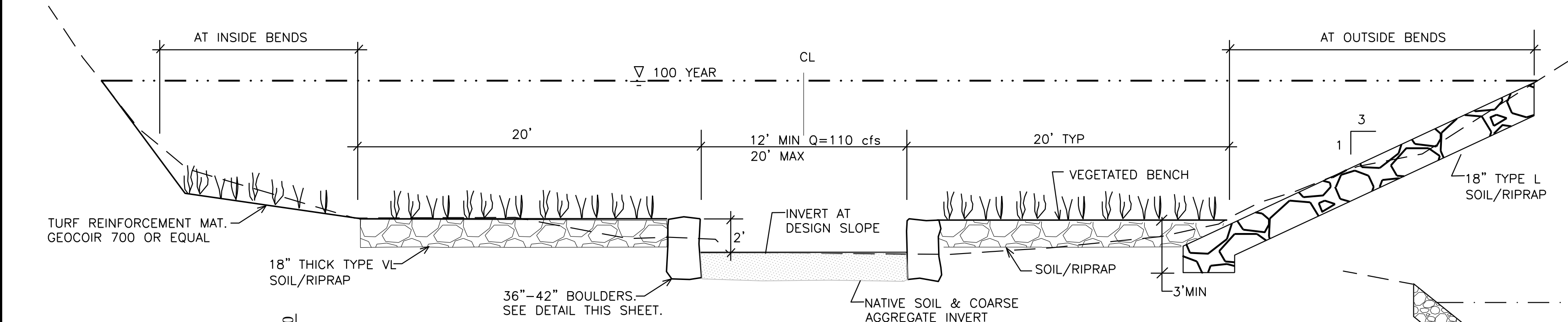

TYPICAL SECTION
SCALE: 1"=5'

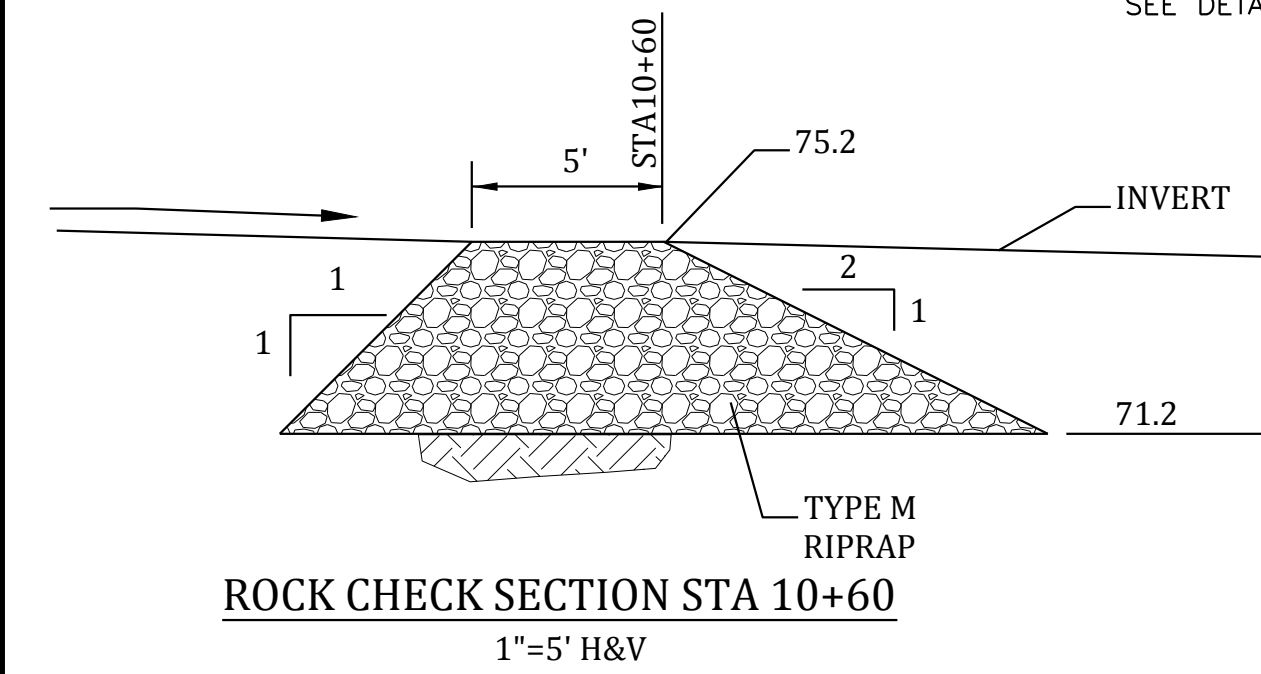

ROCK CHECK SECTION STA 10+60
1"=5' H&V

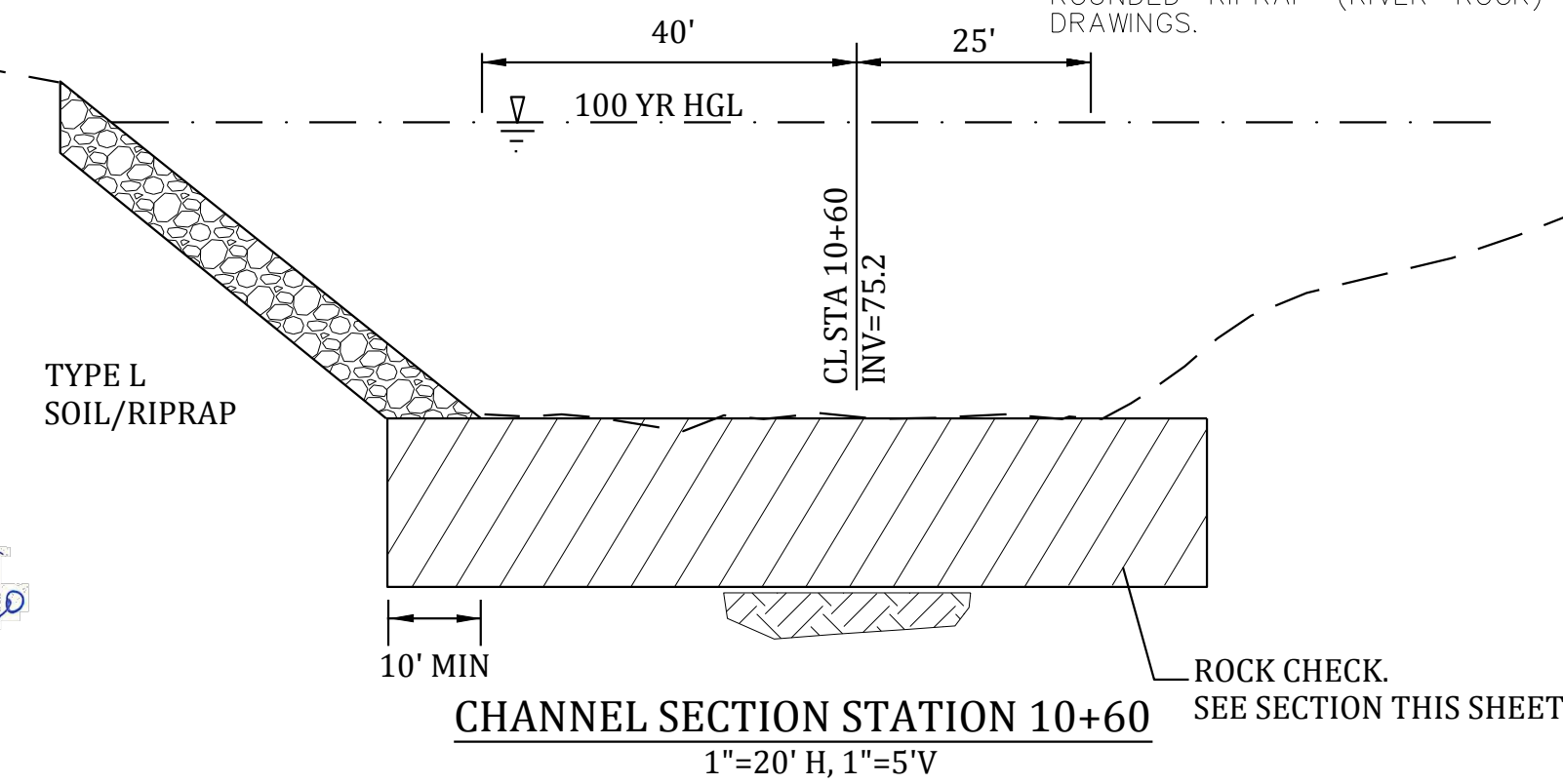

CHANNEL SECTION STATION 10+60
1"=20' H, 1"=5' V

CLASSIFICATION OF BOULDERS		
BOULDER CLASSIFICATION	NOMINAL SIZE AND RANGE IN SMALLEST DIMENSION OF INDIVIDUAL ROCK BOULDERS (INCHES)	MAXIMUM RATIO OF LARGEST TO SMALLEST ROCK DIMENSION OF INDIVIDUAL BOULDERS
B24	24 [22-26]	2.00 [44"-52" MAX.]
B30	30 [28-32]	2.00 [56"-64" MAX.]
B36	36 [34-38]	1.75 [60"-67" MAX.]
B42	42 [40-44]	1.65 [66"-73" MAX.]
B48	48 [45-51+]	1.50 [68"-77" MAX.]

(TABLE MD-8; CLASSIFICATION OF BOULDERS. UDFCD, DRAINAGE CRITERIA MANUAL, VOL. 1)

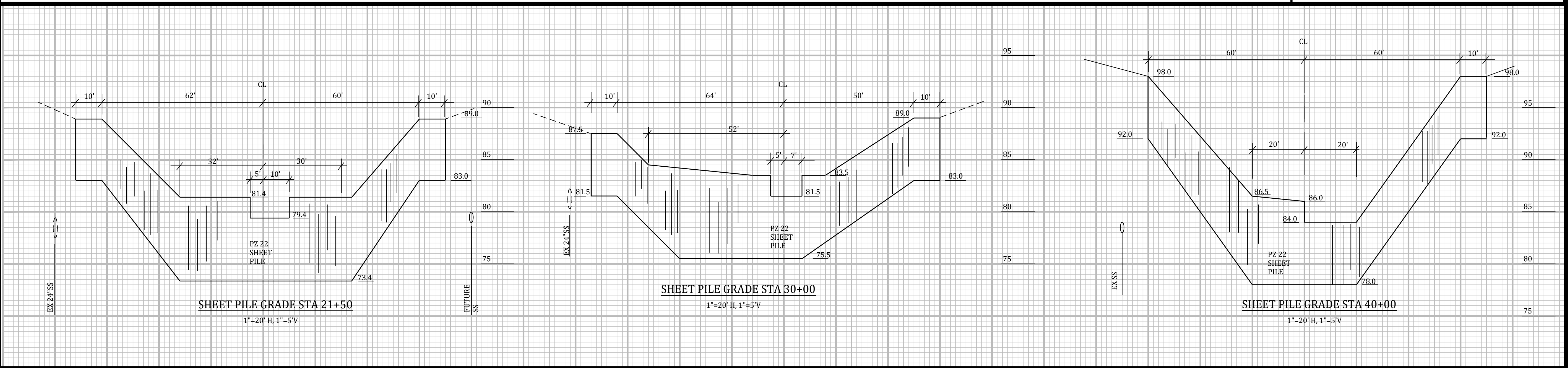

SHEET PILE GRADE STA 21+50
1"=20' H, 1"=5' V

SHEET PILE GRADE STA 30+00
1"=20' H, 1"=5' V

SHEET PILE GRADE STA 40+00
1"=20' H, 1"=5' V

**LORSON RANCH
CREEKSIDE DEVELOPMENT
EAST FORK JIMMY CAMP CREEK
CHANNEL PLAN AND PROFILE
EL PASO COUNTY, COLORADO**

Project No.:	18020
Date:	6/10/2020
Design:	RNW
Drawn:	EAK
Check:	RNW
Revisions:	

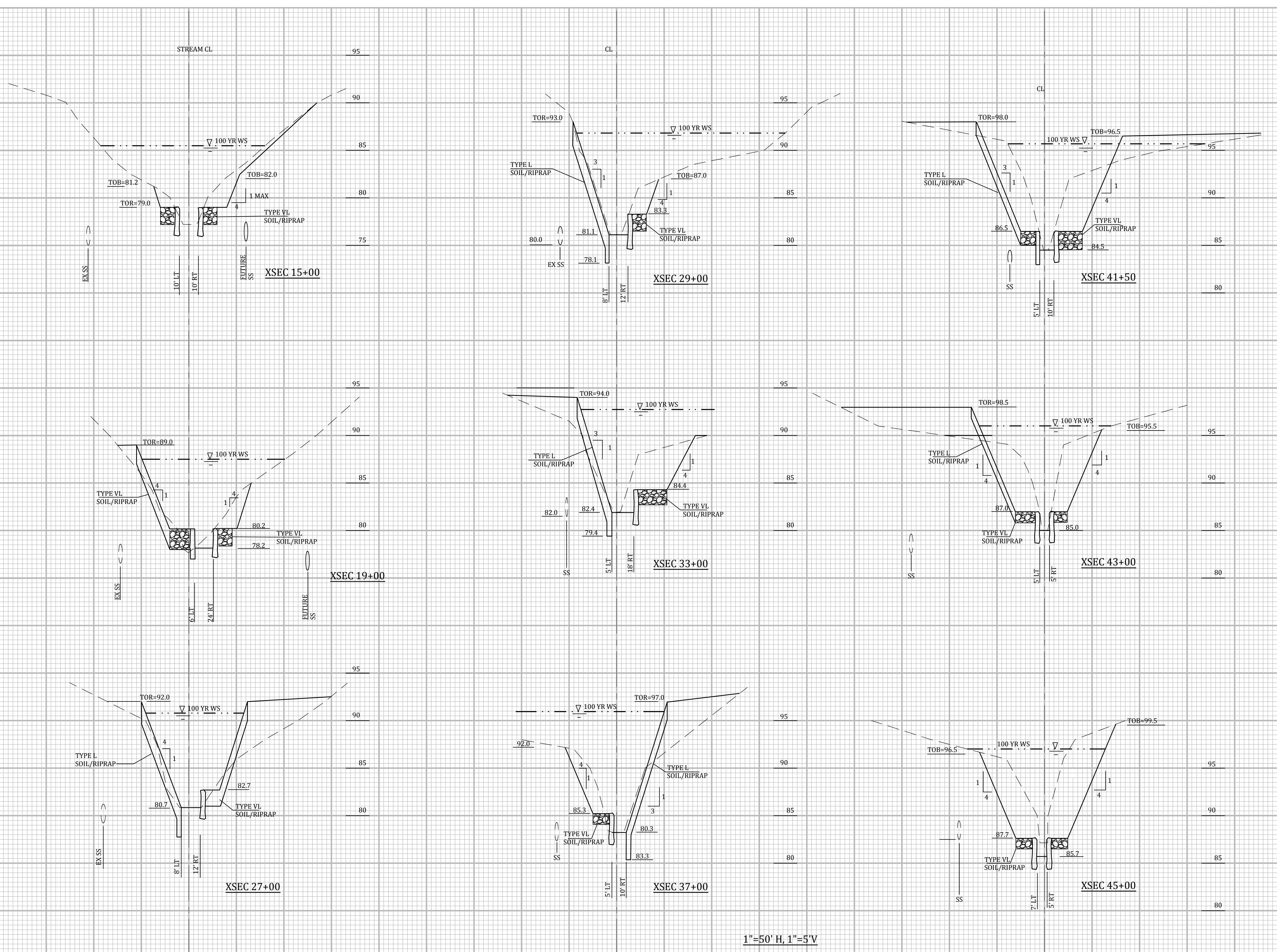

1"=50' H, 1"=5' V

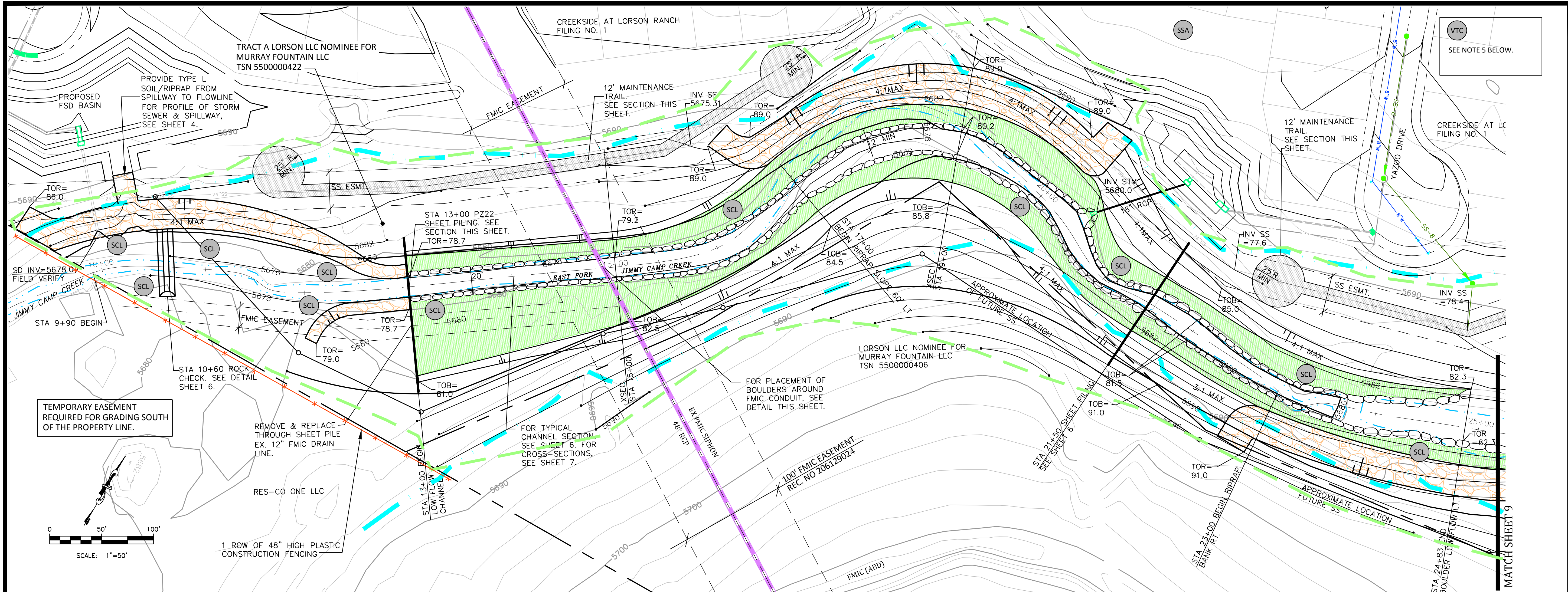

TEMPORARY EASEMENT REQUIRED FOR GRADING SOUTH OF THE PROPERTY LINE.

REMOVE & REPLACE THROUGH SHEET PILE EX. 12" FMIC DRAIN LINE.

RES-CO ONE LLC

1 ROW OF 48" HIGH PLASTIC CONSTRUCTION FENCING

FOR PLACEMENT OF BOULDERS AROUND FMIC CONDUIT, SEE DETAIL THIS SHEET.

FOR TYPICAL CHANNEL SECTION, SEE SHEET 6. FOR CROSS-SECTIONS, SEE SHEET 7.

PROJECT SPECIFIC GRADING AND EROSION CONTROL NOTES

- All earthwork required of this construction shall be completed in accordance with all applicable sections of the Project Specifications and Soil Investigation Report (Geotechnical Report).
- Rubbish including timber, concrete rubble, trees, brush, and asphalt shall not be backfilled adjacent to any of the structures or be in the placement of any unclassified fill. The Contractor shall be responsible for the removal and hauling of such materials to a suitable spoil area. Costs associated with the removal of such materials shall be paid for as documented in the Project Specifications.
- Excess excavation shall become the property of the Contractor and shall be disposed of at the Contractor's expense. The cost of haulage and spoiling of excess excavated materials shall be paid for as documented in the Project Specifications.
- Water shall be used as a dust palliative as required and shall be included in the cost for earthwork item(s). No separate payment will be made for dust control associated with the site construction.
- The road grades shall be cleared of vegetation and the topsoil stockpiled for later use.
- All grading shall be in conformance with the Geotechnical Report for the area.
- Placement of fill for roadway embankments shall be completed in conformance with the Geotechnical Report.
- Grading contours shown on this plan are to final grade.
- Compaction under filled areas, including roadway and detention basin embankments, shall be 95 percent of the maximum Standard Proctor Density (ASTM D698) at two (2) percent of optimum moisture content.
- No rubble or debris shall be placed in the backfill under any of the proposed buildings, streets, curb & gutter, sidewalk and drainage structures or within five (5) feet of a building footprint. Properly graded rubble may be used in some locations as specified and verified by the Geotechnical Engineer.
- Contractor is responsible for reviewing the site prior to bidding to verify site conditions.
- Contractor is responsible for providing erosion control measures as approved by the El Paso County PCD Engineering Division and as may be required by the El Paso County Inspector.
- All slopes equal to or greater than 3:1 shall require anchored soil retention blanket (SRB), Geocor 700 or equal.
- The Developer is responsible for maintaining erosion control measures until a mature stage of vegetation is established.
- All soils used for fill must be approved by a representative of the Geotechnical Engineer.
- All natural ground to receive fill must be properly scarified, watered and compacted prior to placing fill.
- The Contractor is solely responsible for the design, maintenance and operation of any required dewatering system. The Contractor shall perform such independent investigation as he deems necessary to satisfy himself as to the subsurface groundwater conditions and unstable soil conditions to be encountered throughout the construction. Contractor shall coordinate the dewatering system with El Paso County when associated with public facilities.
- No fill shall be placed, spread or rolled while it is frozen, thawing or during unfavorable weather conditions. When the work is interrupted by heavy rain, fill operations shall not be resumed until a representative of the Geotechnical Engineer indicates that the moisture content and density of the previously placed fill are as specified. Fill surfaces may be scarified and recompacted after rainfall if necessary, to obtain proper moisture density relation.
- Additional erosion control structures and/or grading may be required at the time of construction.
- Sediment removal for erosion control facilities shall be performed continuously for proper function.
- Base mapping was provided by Core Engineering. The date of the last survey update was January 2016.
- Proposed Construction Schedule:
 Begin Construction: August 2020
 End Construction: March 2021
 Total Site Area = 19.2 Acres
 Area to be disturbed = 14.7 Acres (est.).
 Existing 100-year runoff coefficient = 0.25
 Proposed 100-year runoff coefficient = 0.25
 Existing Hydrologic Soil Groups: B/C
 (B ASCALON SANDY LOAM)
 (C MANANST CLAY LOAM)
 24. Site is currently undeveloped and covered with native grasses on mild to moderate to steep slopes (1%-4%).
 25. Site is located in the Jimmy Camp Creek Drainage Basin.
 26. The work shown on these plans will not require the mobilization of an asphalt or concrete batch plant.

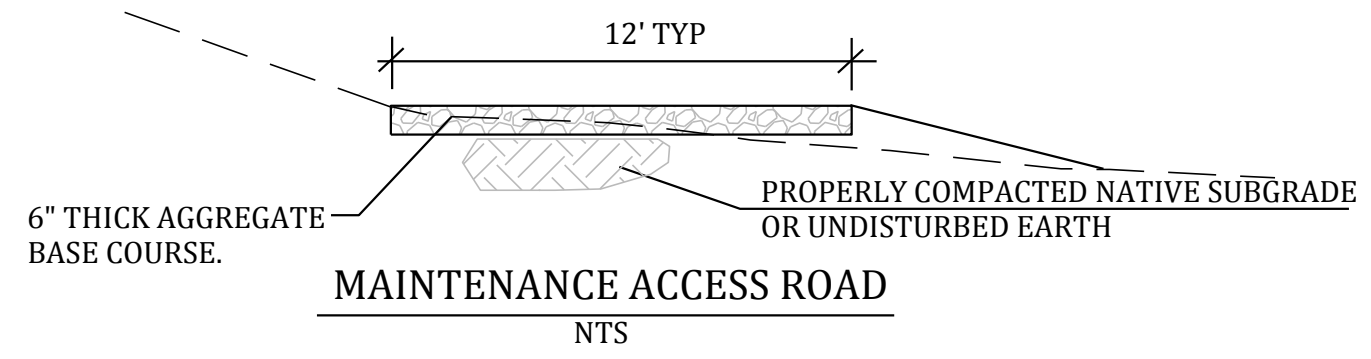

EARTHWORK SUMMARY	
CUT	28,444 CY
FILL	19,768 CY
NET HAUL	8,676 CY

① QUANTITIES SUMMARIZED ARE PROVIDED FOR INFORMATIONAL PURPOSES ONLY. CONTRACTOR SHALL INDEPENDENTLY VERIFY EARTHWORK QUANTITIES AS PART OF BIDDING THE GRADING WORK SHOWN ON THE DESIGN PLANS.

SEED MIX		
AREAS DISTURBED BY THE EARTHWORK SHALL BE PERMANENTLY REVEGETATED WITH NATIVE GRASSES. NATIVE SEED MIX FOR THIS PROJECT SHALL BE AS FOLLOWS:		
SPECIES		lbs/acre
WESTERN WHEAT GRASS	<i>Paspalum smithii</i>	3.0
SIDEWHEAT GRAMA	<i>Bouteloua curtipendula</i>	2.0
SLENDER WHEAT GRASS	<i>Elymus trachycarpus</i>	2.0
LITTLE BLUESTEM	<i>Schizachyrium scoparium</i>	2.0
BLUE GRAMA	<i>Bouteloua gracilis</i>	0.5
SWITCH GRASS	<i>Panicum virgatum</i>	2.0
JUNE GRASS	<i>Koeleria cristata</i>	0.5
SAND DROPSEED	<i>Sporobolus cryptandrus</i>	0.5
		12.5 lbs
SEEDING APPLICATION: DRILL SEED 1/4" TO 1/2" INTO TOPSOIL. IN AREAS INACCESSIBLE TO A DRILL, HAND BROADCAST AT DOUBLE THE RATE AND RAKE 1/4" TO 1/2" INTO THE TOPSOIL.		
MULCHING APPLICATION: 1-1/2 TONS NATIVE HAY PER ACRE, MECHANICALLY CRIMPED INTO THE TOPSOIL OR HYDROMULCH.		

GRADING & EROSION CONTROL BMP PHASING	
BMP	PHASE
SSA VTC	INITIAL
SM SCL SSA VTC	INTERIM
SM SCL	INTERIM / FINAL

- LEGEND**
- VTC: VEHICLE TRACKING CONTROL
 - SCL: SEDIMENT CONTROL LOGS
 - SSA: STABILIZED STAGING AREA
 - SM: SEED AND MULCH
 - TOR: TOP OF SOIL/RIPRAP
 - (Green dashed line): LIMITS OF GRADING & CONSTRUCTION
 - (Red hatched box): TYPE L SOIL/RIPRAP
 - (Green hatched box): TYPE VL SOIL/RIPRAP
 - (Blue dashed line): 100 YEAR FLOODPLAIN
 - (Black dashed line): PROPERTY LINE
 - (Black solid line): EXISTING CONTOUR
 - (Black dashed line): PROPOSED CONTOUR
 - (Blue dashed line with dots): EXISTING LOW FLOW
 - (Black dashed line with dots): EXISTING CENTERLINE
 - (Black circles): BOULDER LOW FLOW
 - (Black circles with dots): BOULDER LOW FLOW

- NOTES:**
- CONTRACTOR TO IDENTIFY MATERIAL AND SOIL STOCKPILES AREA ON THE SWMP PRIOR TO THE COMMENCEMENT OF MOBILIZATION AND PROVIDE PERIMETER CONTROL CONSTRUCTION FENCE. CONTRACTOR SHALL IDENTIFY STABILIZED STAGING AREA ON THE PLAN, THE LOCATION OF VEHICLE AND EQUIPMENT STORAGE AND MAINTENANCE, STORAGE AREAS FOR FERTILIZERS AND PESTICIDES, ON SITE WASTE MANAGEMENT MEASURES SUCH AS PORTOLETS, TRASH ROLL-OFF AND CONCRETE TRUCK AND EQUIPMENT WASHING AREA PRIOR TO THE COMMENCEMENT OF LAND DISTURBING ACTIVITIES.
 - CONTRACTOR TO IDENTIFY STABILIZED STAGING AREA PRIOR TO THE COMMENCEMENT OF MOBILIZATION.
 - CONSTRUCTION FENCING SHALL BE PROVIDED AT LIMITS OF GRADING/CONSTRUCTION AS PART OF THE INSTALLATION OF THE INITIAL BMPs.
 - CONTRACTOR SHALL PROVIDE CONSTRUCTION FENCING AROUND AREAS TO REMAIN UNDISTURBED BUT WITHIN LIMITS OF GRADING.
 - VEHICLE TRACKING BMPs FOR THIS PROJECT WILL BE LOCATED OFFSITE FROM THE WORK SHOWN ON THESE PLANS. VEHICLE TRACKING OFFSITE FROM THE PROJECT SHALL BE MAINTAINED CONTINUOUSLY THROUGHOUT THE PERIOD OF CONSTRUCTION.

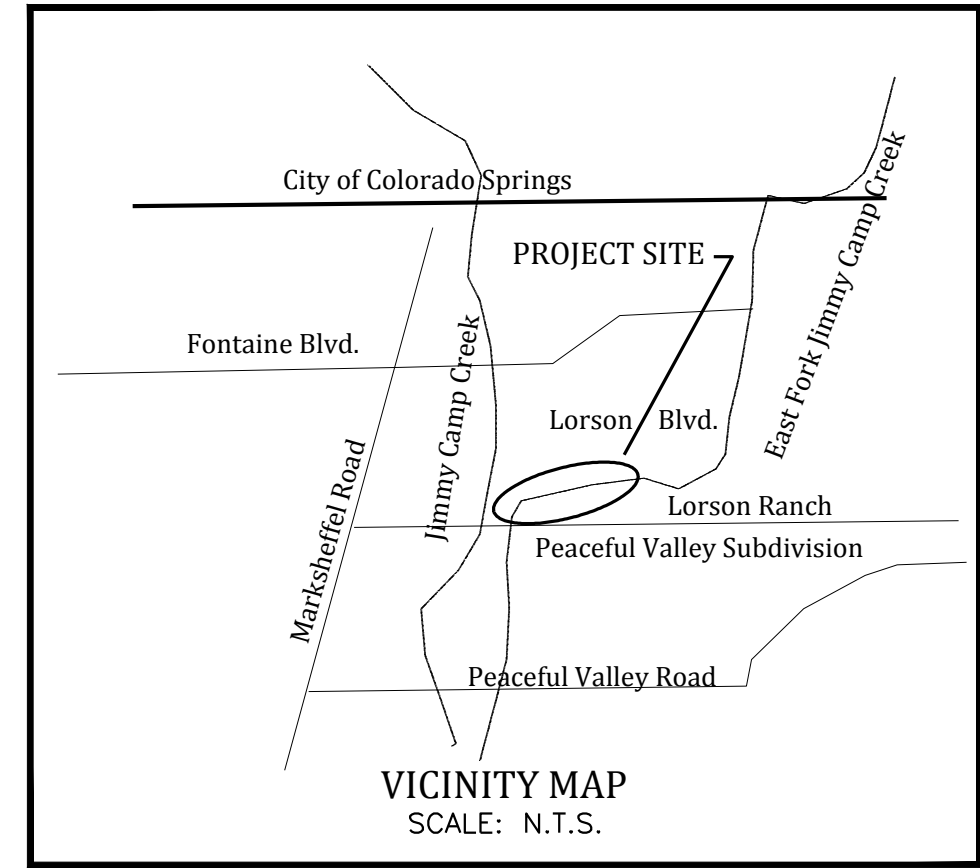

LORSON RANCH
CREEKSIDE DEVELOPMENT
EAST FORK JIMMY CAMP CREEK
GRADING AND EROSION CONTROL PLAN
EL PASO COUNTY, COLORADO

Project No.:	18020
Date:	6/10/2020
Design:	RNW
Drawn:	EAK
Check:	RNW
Revisions:	

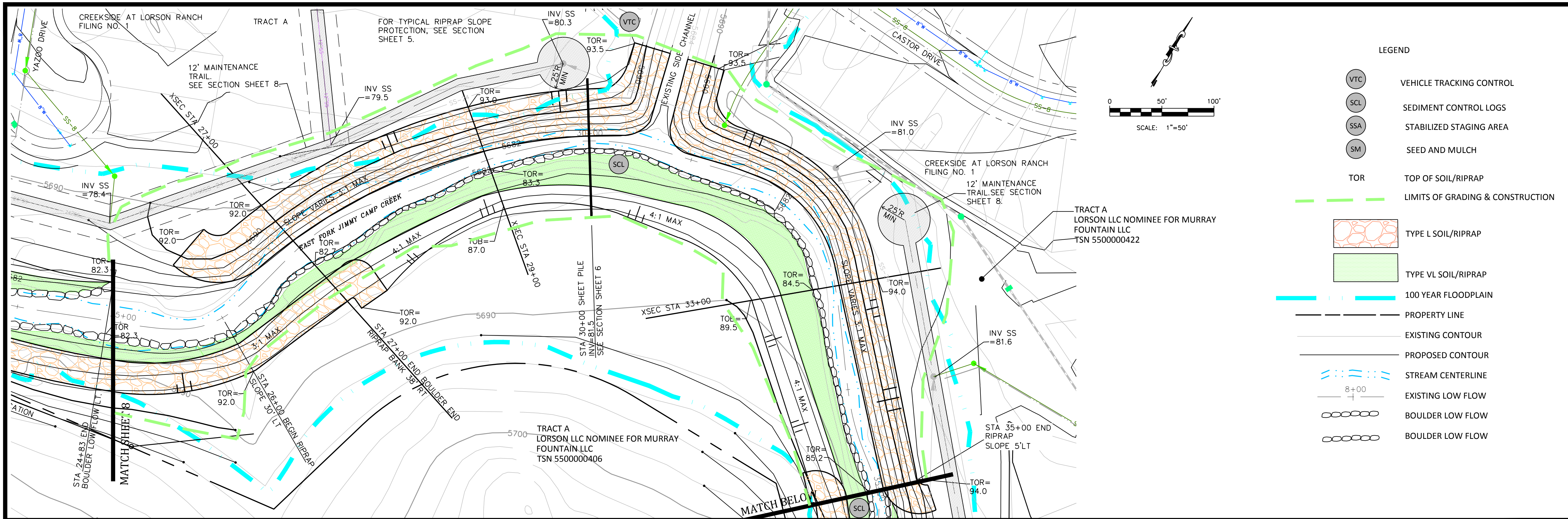

- LEGEND
- VEHICLE TRACKING CONTROL
 - SEDIMENT CONTROL LOGS
 - STABILIZED STAGING AREA
 - SEED AND MULCH
 - TOP OF SOIL/RIPRAP
 - LIMITS OF GRADING & CONSTRUCTION
 - TYPE L SOIL/RIPRAP
 - TYPE VL SOIL/RIPRAP
 - 100 YEAR FLOODPLAIN
 - PROPERTY LINE
 - EXISTING CONTOUR
 - PROPOSED CONTOUR
 - STREAM CENTERLINE
 - EXISTING LOW FLOW
 - BOULDER LOW FLOW
 - BOULDER LOW FLOW

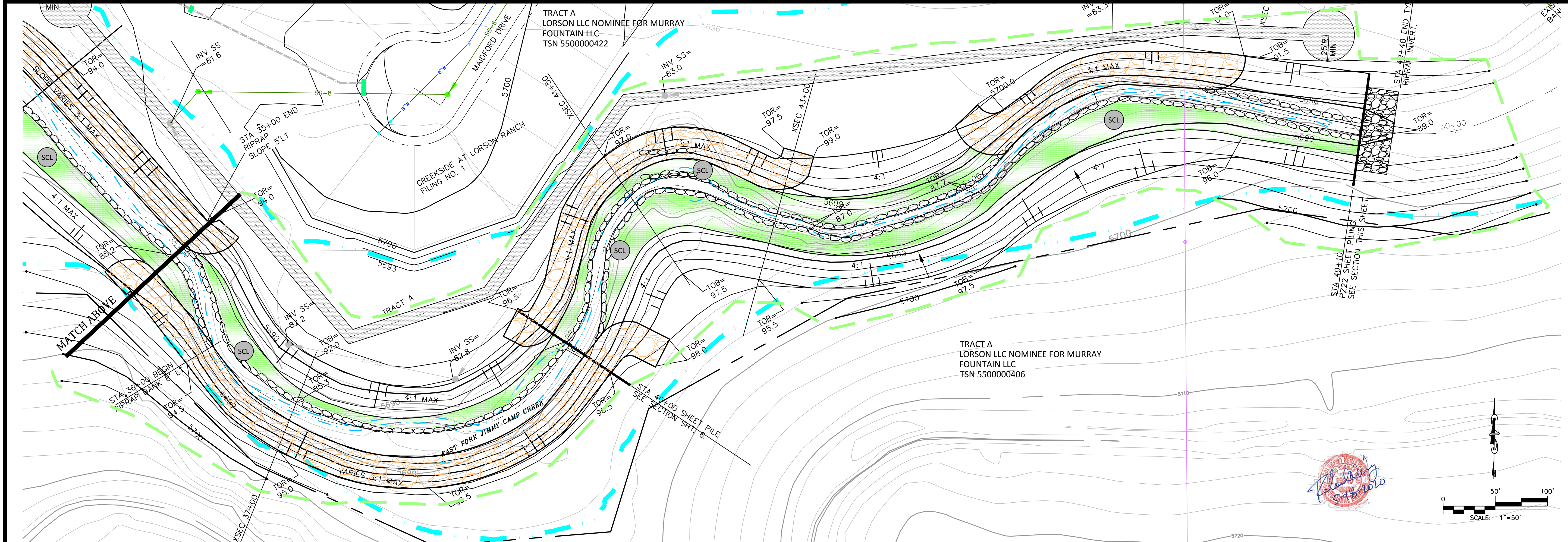

LORSON RANCH
CREEKSIDE DEVELOPMENT
EAST FORK JIMMY CAMP CREEK
GRADING AND EROSION CONTROL PLAN
EL PASO COUNTY, COLORADO

Project No.:	18020
Date:	6/10/2020
Design:	RNW
Drawn:	EAK
Check:	RNW
Revisions:	

18020 02-11.dwg/Jun 11, 2020/12:02pm

SEEDING AND MULCHING INSTALLATION NOTES

- SEE PLAN VIEW FOR:
 - AREA OF SEEDING AND MULCHING.
 - TYPE OF SEED MIX.
- ALL BRANDS FURNISHED SHALL BE FREE FROM SUCH NOXIOUS SEEDS AS RUSSIAN OR CANADIAN THISTLE, COARSE FESCUE, EUROPEAN BINDWEED, JOHNSON GRASS, KNAP WEED AND LEAFY SPURGE.
- THE SEEDER SHALL FURNISH TO THE CONTRACTOR A SIGNED STATEMENT CERTIFYING THAT THE SEED FURNISHED IS FROM A LOT THAT HAS BEEN TESTED BY A RECOGNIZED LABORATORY. SEED WHICH HAS BECOME WET, MOLDY OR OTHERWISE DAMAGED IN TRANSIT OR IN STORAGE WILL NOT BE ACCEPTABLE. SEED TICKETS SHALL BE PROVIDED TO REGULATING AGENCY UPON REQUEST.
- DRILL SEEDING MIX SHALL CONFORM TO THE TABLE ON THE RIGHT.
- IF THE SEED AVAILABLE ON THE MARKET DOES NOT MEET THE MINIMUM PURITY AND GERMINATION PERCENTAGES SPECIFIED, THE SUBCONTRACTOR MUST COMPENSATE FOR A LESSER PERCENTAGE OF PURITY OR GERMINATION BY FURNISHING SUFFICIENT ADDITIONAL SEED TO EQUAL THE SPECIFIED PRODUCT. THE TAGS FROM THE SEED MIXES MUST BE SUPPLIED TO CONTRACTOR AND FORWARDED TO THE REGULATING AGENCY'S GESC INSPECTOR.
- THE FORMULA USED FOR DETERMINING THE QUANTITY OF PURE LIVE SEED (PLS) SHALL BE (POUNDS OF SEED) X (PURITY) X (GERMINATION) = POUNDS OF PURE LIVE SEED (PLS).
- PERMANENT SEED MIX SHALL BE USED UNLESS OTHERWISE APPROVED BY THE REGULATING AGENCY.
- ALL AREAS TO BE SEED AND MULCHED SHALL HAVE NATIVE TOPSOIL OR APPROVED SOIL AMENDMENTS SPREAD TO A DEPTH OF AT LEAST 6 INCHES (LOOSE DEPTH), HALL ROADS AND OTHER COMPACTED AREAS SHALL BE LOOSENED TO A DEPTH OF 6 INCHES PRIOR TO SEEDING.
- SOIL IS TO BE THOROUGHLY LOOSENED (TILLED) TO A DEPTH OF AT LEAST 6 INCHES PRIOR TO SEEDING. THE TOP 6 INCHES OF THE SEED BED SHALL BE FREE OF ROCKS GREATER THAN 4 INCHES AND SOIL CLODS GREATER THAN 2 INCHES. SEEDING OVER ANY COMPACTED AREAS THAT HAVEN'T BEEN THOROUGHLY LOOSENED SHALL BE REJECTED.
- SEED IS TO BE APPLIED USING A MECHANICAL DRILL TO A DEPTH OF 1/4 INCH. ROW SPACINGS SHALL BE NO MORE THAN 6 INCHES. MATERIAL USED FOR MULCH SHALL CONSIST OF LONG-STEMMED STRAW, AT LEAST 50 PERCENT OF THE MULCH, BY WEIGHT, SHALL BE 10 INCHES OR MORE IN LENGTH. MULCH SHALL BE APPLIED AND MECHANICALLY ANCHORED TO A DEPTH OF AT LEAST 2 INCHES. MULCH SHALL BE APPLIED AT A RATE OF 4000 LB. OF STRAW PER ACRE.
- IF THE PERMITEE DEMONSTRATES TO THE REGULATING AGENCY THAT IT IS NOT POSSIBLE TO DRILL SEED, SEED IS TO BE UNIFORMLY BROADCAST AT TWO TIMES THE DRILLED RATE, THEN LIGHTLY HARROWED TO PROVIDE A SEED DEPTH OF APPROXIMATELY 1/4 INCH, THEN ROLLED TO COMPACT, THEN MULCHED AS SPECIFIED ABOVE.
- SEEDING AND MULCHING SHALL BE COMPLETED WITHIN 30 DAYS OF INITIAL EXPOSURE OR 7 DAYS AFTER GRADING IS SUBSTANTIALLY COMPLETE IN A GIVEN AREA (AS DEFINED BY THE REGULATING AGENCY). THIS MAY REQUIRE MULTIPLE MOBILIZATIONS FOR SEEDING AND MULCHING.
- MULCH SHALL BE APPLIED WITHIN 24 HOURS OF SEEDING.
- TACKIFIER SHOULD BE UTILIZED TO HELP WITH STRAW DISPLACEMENT.

SEEDING AND MULCH NTS

SEEDING AND MULCHING MAINTENANCE NOTES

- SEED AND MULCHED AREAS SHALL BE INSPECTED FOR REQUIRED COVERAGE MONTHLY FOR A PERIOD OF TWO YEARS FOLLOWING INITIAL SEEDING. REPAIRS AND RE-SEEDING AND MULCHING SHALL BE UNDERTAKEN AFTER THE FIRST GROWING SEASON FOR ANY AREAS FAILING TO MEET THE REQUIRED COVERAGE.
- REQUIRED COVERAGE FOR STANDARD, OPEN SPACE AND LOW GROWTH SEED MIXES SHALL BE DEFINED AS FOLLOWS:
 - THREE (3) PLANTS PER SQUARE FOOT WITH A MINIMUM HEIGHT OF 3 INCHES. THE 3 PLANTS PER SQUARE FOOT SHALL BE OF THE VARIETY AND SPECIES FOUND IN THE DOUGLAS COUNTY-APPROVED MIX.
 - NO BARE AREAS LARGER THAN 4 SQUARE FEET (TWO-FEET BY TWO-FEET OR EQUIVALENT).
 - FREE OF ERODED AREAS.
 - FREE FROM INFESTATION OF NOXIOUS WEEDS IN ACCORDANCE WITH SECTION 6.4 OF THE GESC CRITERIA MANUAL.
- REQUIRED COVERAGE FOR TURF GRASS AREAS SHALL BE DEFINED AS FOLLOWS:
 - AT LEAST 80% VEGETATIVE COVER OF GRASS SPECIES PLANTED.
 - NO BARE AREAS LARGER THAN 4 SQUARE FEET (TWO-FEET BY TWO-FEET OR EQUIVALENT).
 - FREE OF ERODED AREAS.
 - FREE FROM INFESTATION OF NOXIOUS WEEDS IN ACCORDANCE WITH SECTION 6.4 OF THE GESC CRITERIA MANUAL.
- RILL AND GULLY EROSION SHALL BE FILLED WITH TOPSOIL PRIOR TO RESEEDING. THE RESEEDING METHOD SHALL BE APPROVED BY THE COUNTY.

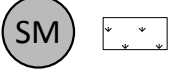

Standard Notes for El Paso County Grading and Erosion Control Plans

Revised 7/02/19

- Stormwater discharges from construction sites shall not cause or threaten to cause pollution, contamination, or degradation of State Waters. All work and earth disturbance shall be done in a manner that minimizes pollution of any on-site or off-site waters, including wetlands.
- Notwithstanding anything depicted in these plans in words or graphic representation, all design and construction related to roads, storm drainage and erosion control shall conform to the standards and requirements of the most recent version of the relevant adopted El Paso County standards, including the Land Development Code, the Engineering Criteria Manual, the Drainage Criteria Manual, and the Drainage Criteria Manual Volume 2. Any deviations from regulations and standards must be requested, and approved, in writing.
- A separate Stormwater Management Plan (SMWP) for this project shall be completed and an Erosion and Stormwater Quality Control Permit (ESQCP) issued prior to commencing construction. Management of the SMWP during construction is the responsibility of the designated Qualified Stormwater Manager or Certified Erosion Control Inspector. The SMWP shall be located on site at all times during construction and shall be kept up to date with work progress and changes in the field.
- Once the ESQCP is approved and a "Notice to Proceed" has been issued, the contractor may install the initial stage erosion and sediment control measures as indicated on the approved GEC. A Preconstruction Meeting between the contractor, engineer, and El Paso County will be held prior to any construction. It is the responsibility of the applicant to coordinate the meeting time and place with County staff.
- Control measures must be installed prior to commencement of activities that could contribute pollutants to stormwater. Control measures for all slopes, channels, ditches, and disturbed land areas shall be installed immediately upon completion of the disturbance.
- All temporary sediment and erosion control measures shall be maintained and remain in effective operating condition until permanent soil erosion control measures are implemented and final stabilization is established. All persons engaged in land disturbing activities shall assess the adequacy of control measures at the site and identify if changes to those control measures are needed to ensure the continued effective performance of the control measures. All changes to temporary sediment and erosion control measures must be incorporated into the Stormwater Management Plan.
- Temporary stabilization shall be implemented on disturbed areas and stockpiles where ground disturbing construction activity has permanently ceased or temporarily ceased for longer than 14 days.
- Final stabilization must be implemented at all applicable construction sites. Final stabilization is achieved when all ground disturbing activities are complete and all disturbed areas either have a uniform vegetative cover with individual plant density of 70 percent of pre-disturbance levels established or equivalent permanent alternative stabilization method is implemented. All temporary sediment and erosion control measures shall be removed upon final stabilization and before permit closure.
- All permanent stormwater management facilities shall be installed as designed in the approved plans. Any proposed changes that affect the design or function of permanent stormwater management structures must be approved by the ECM Administrator prior to implementation.
- Earth disturbances shall be conducted in such a manner so as to effectively minimize accelerated soil erosion and resulting sedimentation. All disturbances shall be designed, constructed, and completed so that the exposed area of any disturbed land shall be limited to the shortest practical period of time. Pre-existing vegetation shall be protected and maintained within 50 horizontal feet of a waters of the state unless shown to be infeasible and specifically requested and approved.
- Compaction of soil must be prevented in areas designated for infiltration control measures or where final stabilization will be achieved by vegetative cover. Areas designated for infiltration control measures shall also be protected from sedimentation during construction until final stabilization is achieved. If compaction prevention is not feasible due to site constraints, all areas designated for infiltration and vegetation control measures must be loosened prior to installation of the control measure(s).
- Any temporary or permanent facility designed and constructed for the conveyance of stormwater around, through, or from the earth disturbance area shall be a stabilized conveyance designed to minimize erosion and the discharge of sediment off site.
- Concrete wash water shall be contained and disposed of in accordance with the SWMP. No wash water shall be discharged to or allowed to enter State Waters, including any surface or subsurface storm drainage system or facilities. Concrete washwaters shall not be located in an area where shallow groundwater may be present, or within 50 feet of a surface water body, creek or stream.
- During dewatering operations of uncontaminated ground water may be discharged on site, but shall not leave the site in the form of surface runoff unless an approved State dewatering permit is in place.
- Erosion control blanketing or other protective covering shall be used on slopes steeper than 3:1.
- Contractor shall be responsible for the removal of all wastes from the construction site for disposal in accordance with local and State regulatory requirements. No construction debris, tree slash, building material wastes or unused building materials shall be buried, dumped, or discharged at the site.
- Waste materials shall not be temporarily placed or stored in the street, alley, or other public way, unless in accordance with an approved Traffic Control Plan. Control measures may be required by El Paso County Engineering if deemed necessary, based on specific conditions and circumstances.
- Tracking of soils and construction debris off-site shall be minimized. Materials tracked off-site shall be cleaned up and properly disposed of immediately.
- The owner/developer shall be responsible for the removal of all construction debris, dirt, trash, rock, sediment, soil, and sand that may accumulate in roads, storm drains and other drainage conveyance systems and stormwater appurtenances as a result of site development.
- The quantity of materials stored on the project site shall be limited, as much as practical, to that quantity required to perform the work in an orderly sequence. All materials stored on-site shall be stored in a neat, orderly manner, in their original containers, with original manufacturer's labels.
- No chemical(s) having the potential to be released in stormwater are to be stored or used onsite unless permission for the use of such chemical(s) is granted in writing by the ECM Administrator. In granting approval for the use of such chemical(s), special conditions and monitoring may be required.
- Bulk storage of allowed petroleum products or other allowed liquid chemicals in excess of 55 gallons shall require adequate secondary containment protection to contain all spills onsite and to prevent any spilled materials from entering State Waters, any surface or subsurface storm drainage system or other facilities.
- No person shall cause the impediment of stormwater flow in the curb and gutter or ditch except with approved sediment control measures.
- Owner/developer and their agents shall comply with the "Colorado Water Quality Control Act" (Title 25, Article 8, CRS), and the "Clean Water Act" (33 USC 1344). In addition to the requirements of the Land Development Code, DCM Volume II and the ECM Appendix I. All appropriate permits must be obtained by the contractor prior to construction (1041, NPDES, Floodplain, 404, fugitive dust, etc.). In the event of conflicts between these requirements and other laws, rules, or regulations of other Federal, State, local, or County agencies, the most restrictive laws, rules, or regulations shall apply.
- All construction traffic must enter/exit the site only at approved construction access points.
- Prior to construction the permittee shall verify the location of existing utilities
- A water source shall be available on site during earthwork operations and shall be utilized as required to minimize dust from earthwork equipment and wind.
- The soils report for this site has been prepared by RMG Engineers, dated August 2018 and shall be considered a part of these plans.
- At least ten (10) days prior to the anticipated start of construction, for projects that will disturb one (1) acre or more, the owner or operator of construction activity shall submit a permit application for stormwater discharge to the Colorado Department of Public Health and Environment, Water Quality Division. The application contains certification of completion of a stormwater management plan (SWMP), of which this Grading and Erosion Control Plan may be a part. For information or application materials contact:

Colorado Department of Public Health and Environment
Water Quality Control Division
WQCD - Permits
4300 Cherry Creek Drive South
Denver, CO 80246-1530
Attn: Permits Unit

Kiowa
Engineering Corporation
1604 South 21st Street
Colorado Springs, Colorado 80904
(719) 630-7342

LORSON RANCH
CREEKSIDE DEVELOPMENT
EAST FORK JIMMY CAMP CREEK
EROSION CONTROL PLAN DETAILS
EL PASO COUNTY, COLORADO

Project No.:	16029
Date:	6/10/2020
Design:	RNW
Drawn:	EAK
Check:	RNW
Revisions:	

10
EPC 7/21/2020

SC-2 Sediment Control Log (SCL)

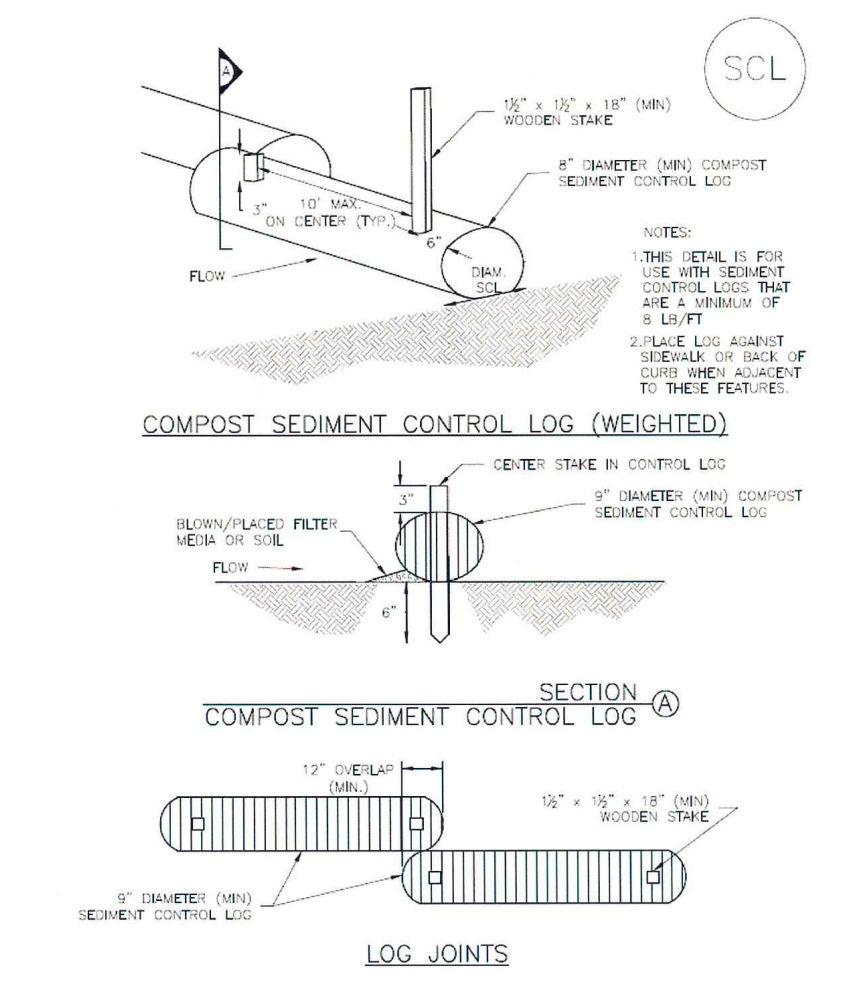

SCL-2. COMPOST SEDIMENT CONTROL LOG (WEIGHTED)

Sediment Control Log (SCL) SC-2

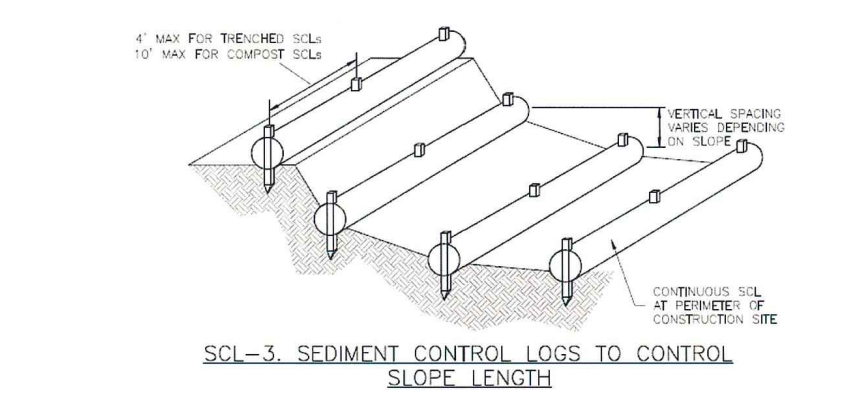

SCL-3. SEDIMENT CONTROL LOGS TO CONTROL SLOPE LENGTH

Stabilized Staging Area (SSA) SM-6

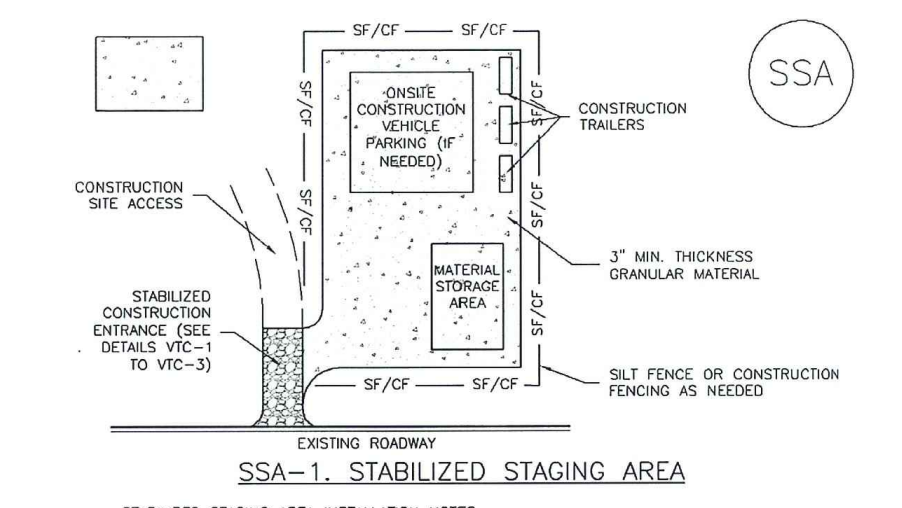

SSA-1. STABILIZED STAGING AREA

- STABILIZED STAGING AREA INSTALLATION NOTES**
- SEE PLAN VIEW FOR:
 - LOCATION OF STAGING AREAS.
 - CONTRACTOR MAY ADJUST LOCATION AND SIZE OF STAGING AREA WITH APPROVAL FROM THE LOCAL JURISDICTION.
 - STABILIZED STAGING AREA SHOULD BE APPROPRIATE FOR THE NEEDS OF THE SITE. OVERSIZING RESULTS IN A LARGER AREA TO STABILIZE FOLLOWING CONSTRUCTION.
 - STAGING AREA SHALL BE STABILIZED PRIOR TO OTHER OPERATIONS ON THE SITE.
 - THE STABILIZED STAGING AREA SHALL CONSIST OF A MINIMUM 3" THICK GRANULAR MATERIAL.
 - UNLESS OTHERWISE SPECIFIED BY LOCAL JURISDICTION, ROCK SHALL CONSIST OF DOT SECT. #703, AHSHTO #3 COARSE AGGREGATE OR 6" (MINUS) ROCK.
 - ADDITIONAL PERIMETER BMPs MAY BE REQUIRED INCLUDING BUT NOT LIMITED TO SILT FENCE AND CONSTRUCTION FENCING.
- STABILIZED STAGING AREA MAINTENANCE NOTES**
- INSPECT BMPs EACH WORKDAY, AND MAINTAIN THEM IN EFFECTIVE OPERATING CONDITION. MAINTENANCE OF BMPs SHOULD BE PROACTIVE, NOT REACTIVE. INSPECT BMPs AS SOON AS POSSIBLE (AND ALWAYS WITHIN 24 HOURS) FOLLOWING A STORM THAT CAUSES SURFACE EROSION, AND PERFORM NECESSARY MAINTENANCE.
 - FREQUENT OBSERVATIONS AND MAINTENANCE ARE NECESSARY TO MAINTAIN BMPs IN EFFECTIVE OPERATING CONDITION. INSPECTIONS AND CORRECTIVE MEASURES SHOULD BE DOCUMENTED THOROUGHLY.
 - WHERE BMPs HAVE FAILED, REPAIR OR REPLACEMENT SHOULD BE INITIATED UPON DISCOVERY OF THE FAILURE.
 - ROCK SHALL BE REAPPLIED OR REGRADED AS NECESSARY IF RUTTING OCCURS OR UNDERLYING SUBGRADE BECOMES EXPOSED.

SM-6 Stabilized Staging Area (SSA)

- STABILIZED STAGING AREA MAINTENANCE NOTES**
- STABILIZED STAGING AREA SHALL BE ENLARGED IF NECESSARY TO CONTAIN PARKING, STORAGE, AND UNCONSTRUCTED OPERATIONS.
 - THE STABILIZED STAGING AREA SHALL BE REMOVED AT THE END OF CONSTRUCTION. THE GRANULAR MATERIAL SHALL BE REMOVED OR, IF APPROVED BY THE LOCAL JURISDICTION, USED ON THE AREA COVERED WITH TOPSOIL, SEED AND MULCHED OR OTHERWISE STABILIZED IN A MANNER APPROVED BY LOCAL JURISDICTION.
 - NOTE: MANY JURISDICTIONS PROHIBIT THE USE OF RECYCLED CONCRETE AS GRANULAR MATERIAL FOR STABILIZED STAGING AREAS DUE TO DIFFICULTIES WITH RE-ESTABLISHMENT OF VEGETATION IN AREAS WHERE RECYCLED CONCRETE WAS PLACED.
 - NOTE: MANY JURISDICTIONS HAVE BMP DETAILS THAT VARY FROM LISTED STANDARD DETAILS. CONSULT WITH LOCAL JURISDICTIONS AS TO WHICH DETAIL SHOULD BE USED WHEN DIFFERENCES ARE NOTED.
- (DETAILS ADAPTED FROM TOWN OF PARKER, COLORADO, JEFFERSON COUNTY, COLORADO, DOUGLAS COUNTY, COLORADO, AND CITY OF AURORA, COLORADO, NOT AVAILABLE IN AURORA)



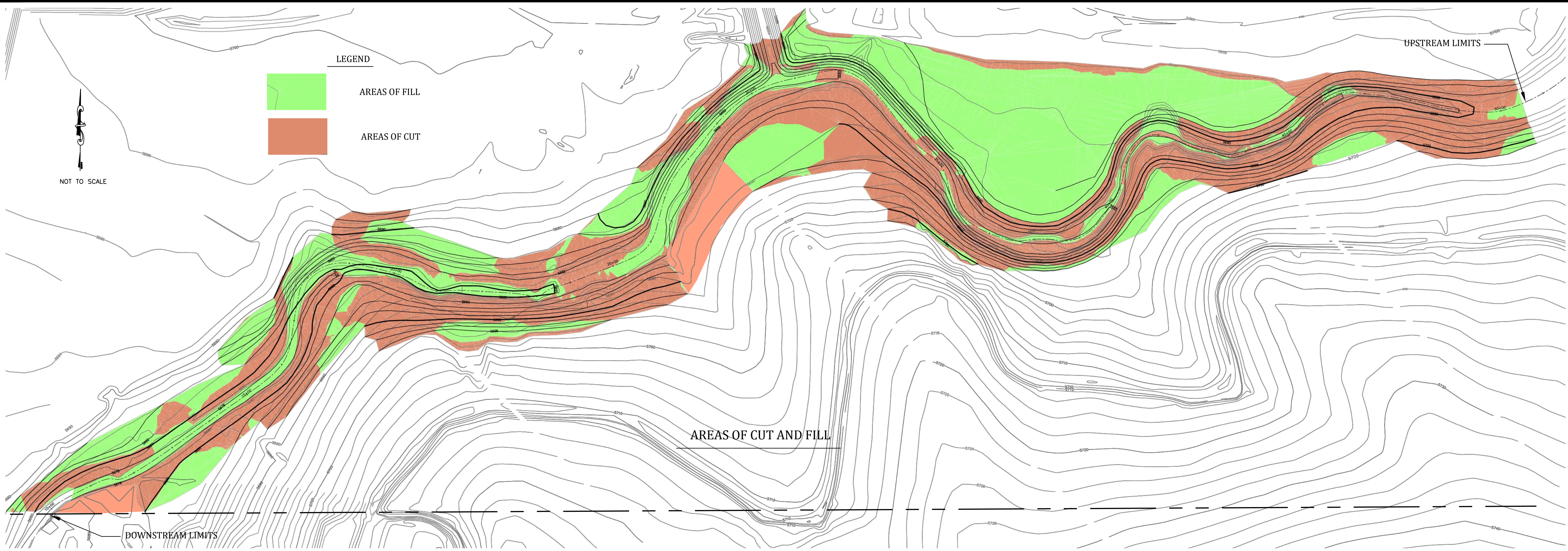

LORSON RANCH
CREEKSIDE DEVELOPMENT
EAST FORK JIMMY CAMP CREEK
GRADING AND EROSION CONTROL PLAN DETAILS
EL PASO COUNTY, COLORADO

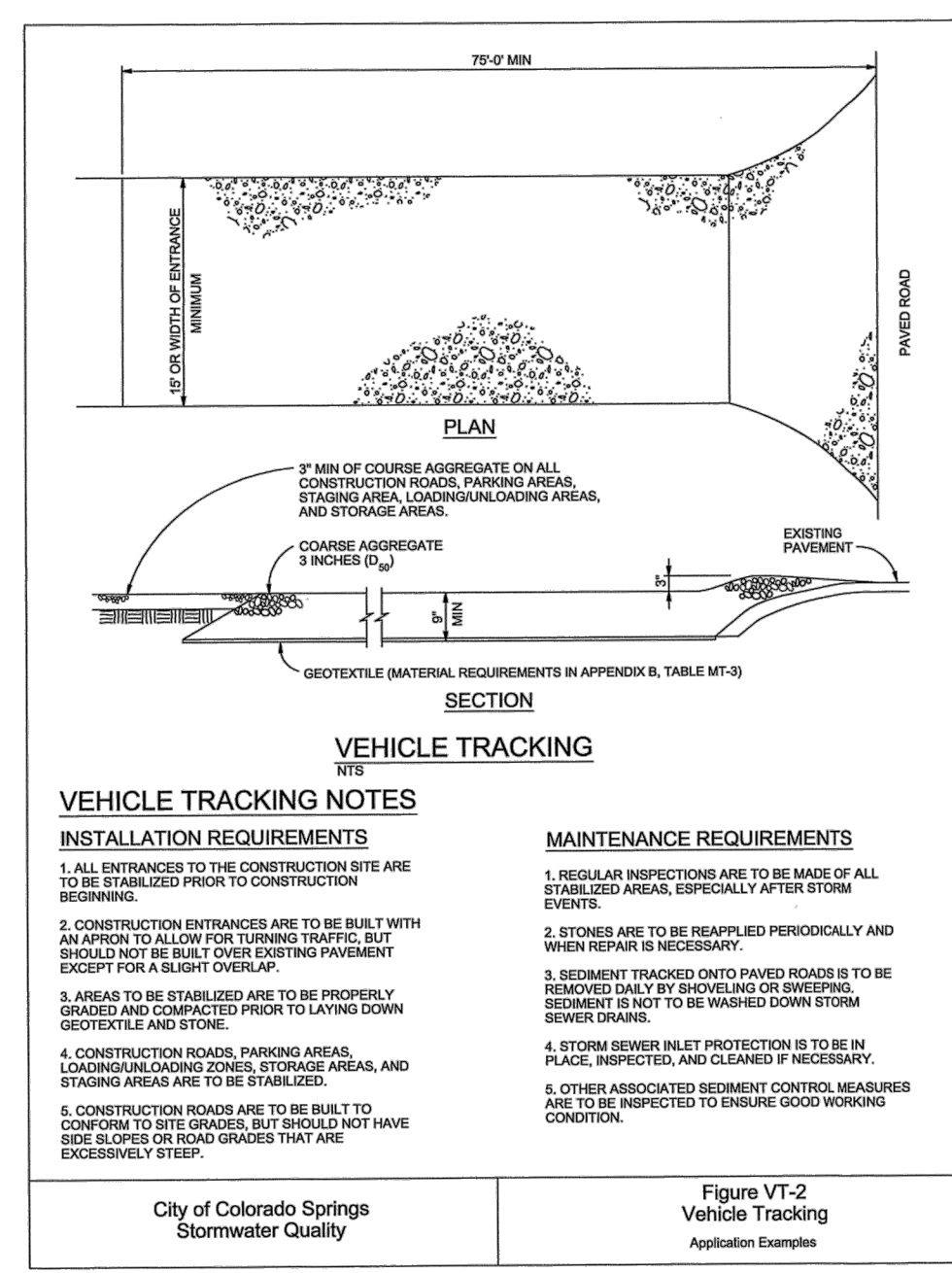

VEHICLE TRACKING CONTROL



Project No.:	18020
Date:	6/10/2020
Design:	RNW
Drawn:	EAK
Check:	RNW
Revisions:	