

## Traffic Impact Study

**To:** Bill Guman, William Guman and Associates, LTD

**From:** Eli Farney, PE, PTOE

**Date:** May 23, 2025

Project #  
CS-251

# Judge Orr Road Commercial Park

El Paso County, Colorado

Prepared By:



**Connor Beekman, Transportation Project Engineer**

**Eli Farney, Principal/Client Manager**

[efarney@jrengineering.com](mailto:efarney@jrengineering.com)

JR Engineering

7200 South Alton Way, Suite C400

Centennial, CO 80112

## Table of Contents

Executive Summary.....	3
Introduction .....	5
Existing Conditions.....	8
Traffic Volumes and Distribution .....	9
Traffic Operations Analysis .....	18
Preliminary Traffic Signal Warrant Analysis.....	23
Conclusion.....	24

## List of Figures

Figure 1: Vicinity Map .....	7
Figure 2: 2024 Existing Traffic Volumes and Lane Geometry .....	10
Figure 3: Site-Generated Traffic Volumes and Distribution .....	11
Figure 4: 2027 Opening Day Proposed Lane Geometry .....	12
Figure 5: 2027 Opening Day Background Traffic Volumes .....	13
Figure 6: 2027 Opening Day Total Traffic Volumes .....	14
Figure 7: 2045 Future Year Proposed Lane Geometry .....	15
Figure 8: 2045 Future Year Background Traffic Volumes .....	16
Figure 9: 2045 Future Year Total Traffic Volumes .....	17
Figure 10: 2027 Peak Hour Traffic Signal Warrant .....	23

## List of Tables

Table 1: 2024 Existing Levels of Service.....	18
Table 2: 2027 Opening Day Levels of Service .....	19
Table 3: 2045 Future Year Levels of Service .....	19
Table 4: 2024 Existing 95 <sup>th</sup> Percentile Queue Lengths .....	21
Table 5: 2027 Opening Day 95 <sup>th</sup> Percentile Queue Lengths.....	21
Table 6: 2045 Future Year 95 <sup>th</sup> Percentile Queue Lengths.....	22

## List of Appendices

- Appendix A: Site Plan
- Appendix B: Traffic Counts
- Appendix C: Trip Generation
- Appendix D: Synchro Reports

Provide signature page

## Executive Summary

JR Engineering (JR) has completed a review of the traffic impacts resulting from the proposed Judge Orr Road Commercial Park development (Project) in El Paso County, Colorado (County).

The objectives of this Traffic Impact Study (TIS, Study) are:

Note that newer data will most likely be needed with preliminary plan submittal

- Collect Year 2024 existing traffic count data at nearby intersections.
- Estimate site-generated traffic and route trips onto adjacent streets.
- Perform traffic operations analysis for Year 2027 Opening Day and 2045 Future Year scenarios.
- Make recommendations for roadway improvements to accommodate new traffic.

Is 2027 still viable opening day as we're already well into 2026?

The methodology, content, and findings of this TIS are consistent with the following document:

- *El Paso County Engineering Criteria Manual, Appendix B: Transportation Impact Study Guidelines*

### Key Findings of this TIS

Land Use and Trip Generation: The Judge Orr Road Commercial Park is expected to contain multiple land uses including industrial, warehousing, office, services, and retail. The total square footage of all buildings is estimated to be 275,000 square feet. Estimated site-generated traffic is 4,182 daily trips.

Levels of Service: At US 24 & Judge Orr, levels of service are C or better for all movements in the 2024 Existing condition. A few failures are expected in the 2027 Opening Day condition, but these failures may be considered temporary before the proposed roundabout is expanded to two lanes. In the 2045 Future Year condition, the double-lane roundabout is anticipated to improve traffic operations. However, the westbound approach is still expected to fail in the PM peak hour with total traffic.

At Judge Orr & Cessna, levels of service are B or better for all movements in the 2024 Existing condition. The northbound approach is expected to fail in the 2027 Opening Day condition. In the 2045 Future Year condition, traffic operations are anticipated to degrade as a result of higher traffic volumes.

Queue Lengths: At US 24 & Judge Orr, significant queuing occurs along US 24 in the 2024 Existing condition, particularly for the northbound and southbound through/right movements. In the 2027 Opening Day condition, queue lengths for some movements are anticipated to increase as a result of site-generated traffic and higher background volumes. Queuing for the northbound approach is expected to reach a length of 850 feet in the PM peak hour. In the 2045 Future Year condition, the double-lane roundabout is anticipated to reduce queuing for some movements. However, the westbound approach is expected to experience a queue length of 775 feet in the PM peak hour.

At Judge Orr & Cessna, queue lengths are minimal in the 2024 Existing condition. In the 2027 and 2045 conditions, queue lengths for some movements are anticipated to increase as a result of site-generated traffic and higher background volumes. Still, no queuing issues are identified.

Recommendations: To accommodate site-generated traffic, an eastbound left turn lane is proposed at the intersection of Judge Orr & Cessna. This intersection may need to become signalized in the future. Additionally, a northbound left turn lane may be appropriate. At the Judge Orr & US 24 intersection, the proposed roundabout is expected to improve traffic operations. An additional westbound lane may be necessary to accommodate expected future traffic.

## Introduction

JR has completed a review of the existing and forecasted traffic operations in the vicinity of the Judge Orr Road Commercial Park development. A vicinity map is included in **Figure 1**.

### Proposed Land Use

The development is anticipated to contain the following land uses, based on an assumed floor area ratio (FAR) of 25%:

- General Light Industrial (ITE 110) – 35,000 Square Feet
- Warehousing (ITE 150) – 70,000 Square Feet
- General Office Building (ITE 710) – 70,000 Square Feet
- Building Materials and Lumber Store (ITE 812) – 35,000 Square Feet
- Strip Retail Plaza (ITE 822) – 35,000 Square Feet
- Automobile Parts and Service Center (ITE 943) – 30,000 Square Feet

Land uses are subject to change and building footprints are not yet proposed, thus conservative land uses were assumed in this Study. A site plan is included in **Appendix A**.

### Study Intersections

JR analyzed two intersections as part of the Study:

1. US 24 & Judge Orr Road
2. Judge Orr Road & Cessna Drive/Range Flower Way

### US 24 PEL Study

CDOT conducted a Planning and Environmental Linkages (PEL) study along the US 24 corridor, dated March 2018. The study examined conditions and potential issues along the US 24 corridor in El Paso County, and then provided improvement alternatives to enhance traffic operations and safety. JR considered the conclusions of the PEL study in this TIS.

A concept layout in the PEL study shows a future frontage road along US 24 near the Project site. However, based on recent discussions with CDOT, the frontage road is no longer planned.

### Future Roundabout at US 24 & Judge Orr Road

The intersection of US 24 & Judge Orr Road is proposed to become a roundabout in the future. Based on discussions with CDOT, construction of the roundabout is expected to occur in 2027, coinciding with the Judge Orr Road Commercial Park. For the purposes of this Study, the intersection was assumed to be a single-lane roundabout in the 2027 Opening Day condition, and become a double-lane roundabout by Future Year 2045. The PEL study shows US 24 being widened to 4 lanes in the future.

Was there a date given for the 4-lanes to be done? If so, please provide or state that there is no planned date yet.

## Proposed Mitigations

The following mitigations are proposed in order to accommodate forecasted traffic volumes:

- Judge Orr & US 24 intersection (E1) to be converted to a roundabout by CDOT by 2027 Opening Day
- Add eastbound left turn lane at Judge Orr & Cessna intersection (E2) by 2027 Opening Day

Proposed lane geometry in 2027 and 2045 is shown in **Figure 4** and **Figure 7**, respectively.



Figure 1 - Vicinity Map



1500 750 0 1500



ORIGINAL SCALE: 1" = 1500'

7200 South Alton Way, Suite C400, Centennial, CO 80112  
303-740-9393 Fax: 303-721-9019 www.jrengineering.com



**JR ENGINEERING**

## Existing Conditions

### Existing Land Use

The Project site is mostly vacant, with one structure needing to be removed. The site does not generate a significant quantity of trips in the existing condition.

### Existing Traffic Volumes

Existing traffic volumes were obtained on Wednesday, August 21, 2024 by All Traffic Data Services for each of the Study intersections. Existing traffic volumes and lane geometry are shown in **Figure 2**. Traffic counts are included in **Appendix B**. The peak hours occurred from 7:00-8:00 AM and 4:15-5:15 PM.

# Traffic Volumes and Distribution

## Background Traffic Volumes

Jane

To determine background traffic volumes, JR considered traffic studies for other known developments in the vicinity of the Project site, as listed below. The site-generated trips from the Saddlehorn Ranch and Davis Ranch studies were considered as background traffic beginning in year 2027. The site-generated trips from the Esteban Rodriguez and BOCES Campus studies were considered as background traffic in year 2045, since these developments are not anticipated to be complete by 2027.

- *Saddlehorn Ranch Filing No. 2 TIS* by LSC Transportation Consultants, dated April 11, 2023
- *Davis Ranch Subdivision Master TIS* by LSC Transportation Consultants, dated July 7, 2023
- *Esteban Rodriguez Site TIS* by JR Engineering
- *BOCES Campus TIS* by JR Engineering

Provide exhibit that shows boundaries of these properties in relation to this project.

Additionally, JR applied a 1% annual growth rate to existing traffic volumes to account for other future regional development. Future background traffic volumes are shown in **Figure 5** (2027) and **Figure 8** (2045).

JR also considered the *Judge Orr RV Park TIS* by LSC Transportation Consultants, dated May 3, 2019. This development was complete and operational by the time traffic counts were collected for this Study. Therefore, site-generated traffic from the RV Park is captured in the existing traffic volumes.

## Site-Generated Traffic Volumes and Distribution

Site-generated traffic volumes were estimated using *ITE Trip Generation Manual*, 11<sup>th</sup> Edition. The development is expected to produce the following trips:

- Average Daily Trips: 4,182
- AM Peak Entering Site: 283
- AM Peak Exiting Site: 96
- PM Peak Entering Site: 189
- PM Peak Exiting Site: 319

Site-generated traffic volumes and directional distribution are shown in **Figure 3**. A trip generation report is included in **Appendix C**.



## Total Traffic

Total traffic is the sum of background and site-generated traffic. JR forecasted total traffic volumes at the Study intersections in 2027 (Opening Day) and 2045 (Future Year). Total traffic volumes are shown in **Figure 6** (2027) and **Figure 9** (2045).



Figure 2 - 2024 Existing Traffic Volumes and Lane Geometry

LEGEND

-  EXISTING INTERSECTION
- XX (XX) AM (PM) PEAK HOUR TRIPS
-  STOP SIGN CONTROL

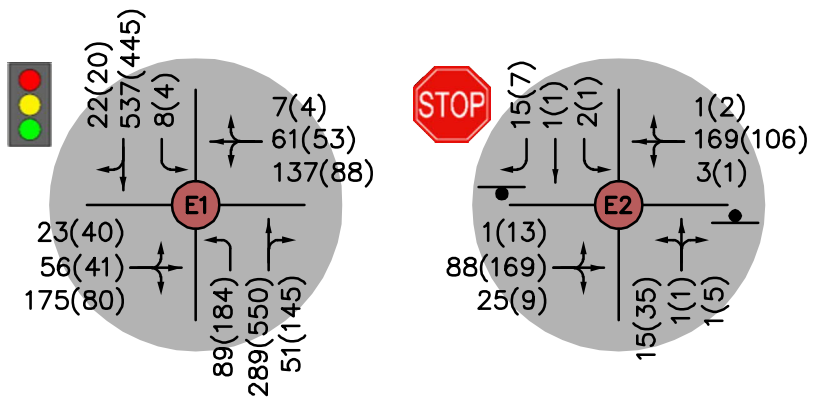

500 250 0 500



ORIGINAL SCALE: 1" = 500'

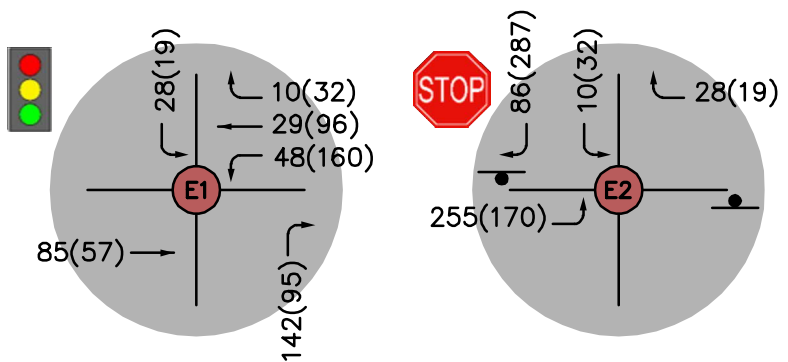



Figure 3 - Site Generated Traffic Volumes and Distribution

LEGEND

- EXISTING INTERSECTION
- XX (XX) AM (PM) PEAK HOUR TRIPS
- STOP SIGN CONTROL
- DIRECTIONAL DISTRIBUTION



500 250 0 500

ORIGINAL SCALE: 1" = 500'

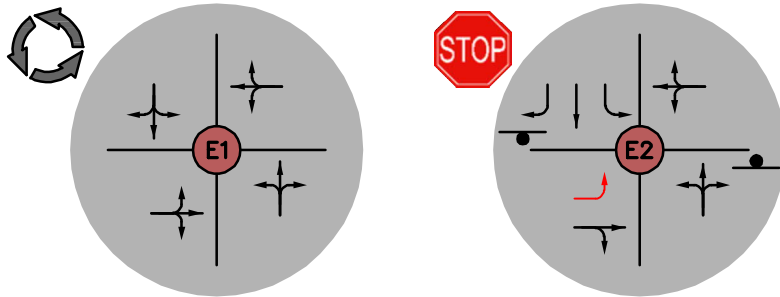



Figure 4 - 2027 Opening Day Proposed Lane Geometry

LEGEND

- EXISTING INTERSECTION
- STOP SIGN CONTROL
- PROPOSED LANE GEOMETRY
- EXISTING LANE GEOMETRY



500 250 0 500



ORIGINAL SCALE: 1" = 500'

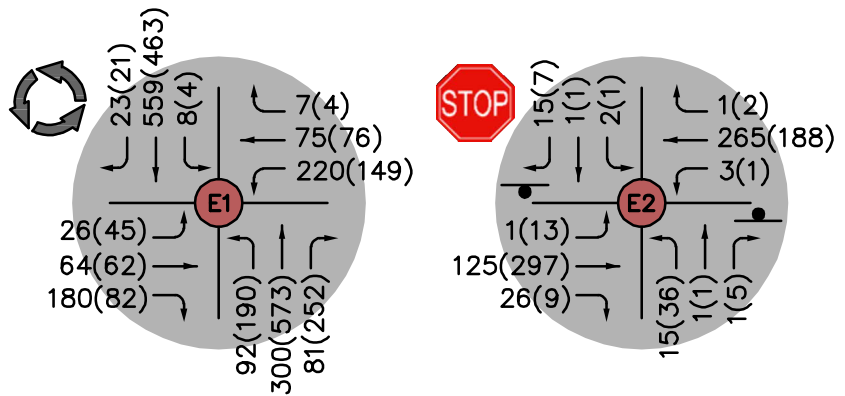



Figure 5 - 2027 Opening Day Background Traffic Volumes

LEGEND

- EXISTING INTERSECTION
- XX (XX) AM (PM) PEAK HOUR TRIPS
- STOP SIGN CONTROL



500 250 0 500





ORIGINAL SCALE: 1" = 500'





LEGEND

Figure 6 - 2027 Opening Day Total Traffic Volumes

-  EXISTING INTERSECTION
- XX (XX) AM (PM) PEAK HOUR TRIPS
-  STOP SIGN CONTROL

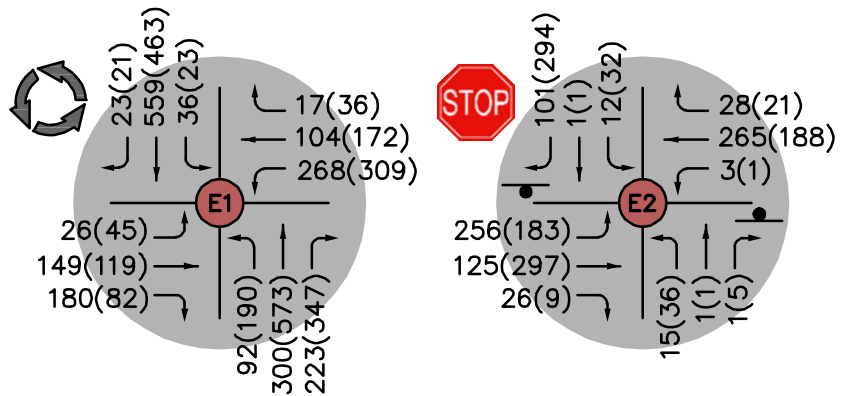

500 250 0 500

ORIGINAL SCALE: 1" = 500'

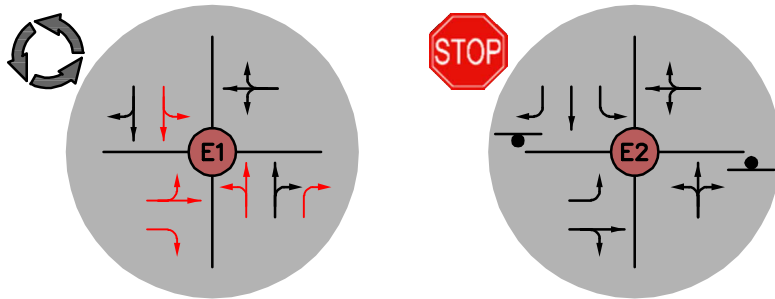



Figure 7 - 2045 Future Year Proposed Lane Geometry

LEGEND

- EXISTING INTERSECTION
- STOP SIGN CONTROL
- PROPOSED LANE GEOMETRY
- EXISTING LANE GEOMETRY



500 250 0 500





ORIGINAL SCALE: 1" = 500'

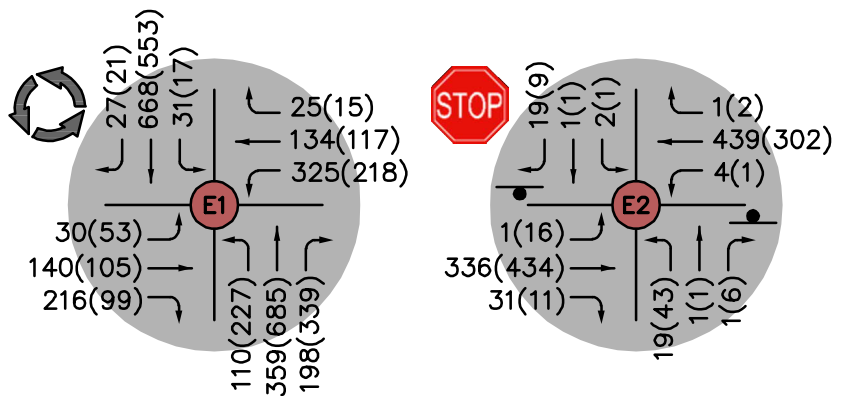



Figure 8 - 2045 Future Year Background Traffic Volumes

LEGEND

-  EXISTING INTERSECTION
- XX (XX) AM (PM) PEAK HOUR TRIPS
-  STOP SIGN CONTROL



500 250 0 500



ORIGINAL SCALE: 1" = 500'

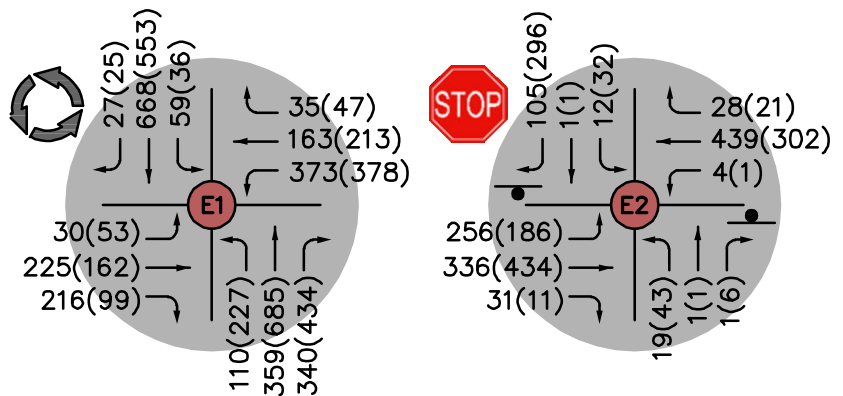



Figure 9 - 2045 Future Year Total Traffic Volumes

LEGEND

-  EXISTING INTERSECTION
- XX (XX) AM (PM) PEAK HOUR TRIPS
-  STOP SIGN CONTROL



500 250 0 500

ORIGINAL SCALE: 1" = 500'



# Traffic Operations Analysis

Traffic operations were analyzed using *Highway Capacity Manual*, 7<sup>th</sup> Edition methodology. Synchro reports are included in **Appendix D**.



## Levels of Service

JR analyzed each of the Study intersections for peak hour level of service (LOS). **Table 1** includes the LOS for each movement in the existing condition (year 2024). **Table 2** includes the forecasted LOS for background traffic and total traffic in the year 2027. **Table 3** includes the forecasted LOS for background traffic and total traffic in the year 2045. In each of these tables, seconds of delay are shown in parentheses for movements operating at LOS F.



**Table 1: 2024 Existing Levels of Service**

Intersection	Movement/Approach	AM Peak LOS	PM Peak LOS
 1: Judge Orr Road & US 24	EB Approach	C	C
	WB Approach	C	C
	NB Left	B	A
	NB Through/Right	B	B
	SB Left	B	A
	SB Through/Right	C	B
	<b>Overall</b>	<b>C</b>	<b>B</b>
 2: Judge Orr Road & Cessna Drive	EB Approach	A	A
	WB Approach	A	A
	NB Approach	B	B
	SB Left	B	B
	SB Through	B	B
	SB Right	A	A

**Table 2: 2027 Opening Day Levels of Service**

Intersection	Movement/ Approach	AM Peak LOS		PM Peak LOS	
		Background Traffic	Total Traffic	Background Traffic	Total Traffic
 1: Judge Orr Road & US 24	EB Approach	C	E	B	C
	WB Approach	A	B	C	F (102s)
	NB Approach	A	B	E	F (98s)
	SB Approach	C	D	C	E
	<b>Overall</b>	<b>B</b>	<b>C</b>	<b>D</b>	<b>F</b>
 2: Judge Orr Road & Cessna Drive	EB Left	A	A	A	A
	WB Approach	A	A	A	A
	NB Approach	B	E	B	F (54s)
	SB Left	B	D	B	D
	SB Through	B	D	B	C
	SB Right	B	B	A	B

**Table 3: 2045 Future Year Levels of Service**

Intersection	Movement/ Approach	AM Peak LOS		PM Peak LOS	
		Background Traffic	Total Traffic	Background Traffic	Total Traffic
 1: Judge Orr Road & US 24	EB Left/Through	B	C	A	B
	EB Right	A	A	A	A
	WB Approach	C	C	D	F (179s)
	NB Left/Through	A	A	A	A
	NB Through/Right	A	A	A	A
	NB Right Bypass	A	A	A	A
	SB Left/Through	B	C	B	C
	SB Through/Right	B	C	B	C
<b>Overall</b>	<b>A</b>	<b>B</b>	<b>B</b>	<b>E</b>	
 2: Judge Orr Road & Cessna Drive	EB Left	A	A	A	A
	WB Approach	A	A	A	A
	NB Approach	C	F (103s)	C	F (183s)
	SB Left	C	F (65s)	C	F (52s)
	SB Through	C	E	C	D
	SB Right	B	B	B	B

## Discussion on Levels of Service

In the 2024 Existing condition, all movements at the Study intersections operate at LOS C or better.

In the 2027 Opening Day condition, a few failures are expected in the AM and PM peak hours. At the Judge Orr & US 24 intersection, these failures may be considered temporary before the roundabout is expanded to two lanes. At the Judge Orr & Cessna intersection, two-way stop control may not operate satisfactorily in the future, particularly for the northbound approach. A northbound left turn lane may be appropriate.

In the 2045 Future Year condition, the double-lane roundabout at Judge Orr & US 24 is expected to improve traffic operations. However, the westbound approach is still expected to fail in the PM peak hour with total traffic. An additional entrance lane may be considered to improve this movement. At the Judge Orr & Cessna intersection, traffic operations are anticipated to degrade as a result of higher traffic volumes.

## Queue Lengths



JR analyzed each of the Study intersections for 95<sup>th</sup> percentile queue lengths. **Table 4** includes the queue lengths for the year 2024 with existing traffic. **Table 5** includes the queue lengths for the year 2027 with total traffic. **Table 6** includes the queue lengths for the year 2045 with total traffic.

**Table 4: 2024 Existing 95<sup>th</sup> Percentile Queue Lengths**





Intersection	Movement/Approach	AM Peak Queue (ft)	PM Peak Queue (ft)
1: Judge Orr Road & US 24	EB Approach	102	95
	WB Approach	194	117
	NB Left	40	65
	NB Through/Right	199	535
	SB Left	<25	<25
	SB Through/Right	420	280
2: Judge Orr Road & Cessna Drive	EB Approach	<25	<25
	WB Approach	<25	<25
	NB Approach	<25	<25
	SB Left	<25	<25
	SB Through	<25	<25
	SB Right	<25	<25

**Table 5: 2027 Opening Day 95<sup>th</sup> Percentile Queue Lengths**

Intersection	Movement/Approach	AM Peak Queue (ft)	PM Peak Queue (ft)
1: Judge Orr Road & US 24	EB Approach	200	75
	WB Approach	75	475
	NB Approach	150	850
	SB Approach	275	300
2: Judge Orr Road & Cessna Drive	EB Left	<25	<25
	WB Approach	<25	<25
	NB Approach	<25	48
	SB Left	<25	<25
	SB Through	<25	<25
	SB Right	<25	50

**Table 6: 2045 Future Year 95<sup>th</sup> Percentile Queue Lengths**

Intersection	Movement/Approach	AM Peak Queue (ft)	PM Peak Queue (ft)
 1: Judge Orr Road & US 24	EB Left/Through	100	50
	EB Right	<25	<25
	WB Approach	175	775
	NB Left/Through	25	75
	NB Through/Right	25	75
	NB Right Bypass	25	75
	SB Left/Through	100	100
	SB Through/Right	100	100
 2: Judge Orr Road & Cessna Drive	EB Left	28	<25
	WB Approach	<25	<25
	NB Approach	43	113
	SB Left	<25	35
	SB Through	<25	<25
	SB Right	<25	65

### Discussion on Queue Lengths

In the 2024 Existing condition, significant queuing occurs along US 24. Specifically, the SB through/right experiences a queue length of 420 feet in the AM peak hour, while the NB through/right experiences a queue length of 535 feet in the PM peak hour. Northbound queuing may block access to Blue Gill Drive.

In the 2027 Opening Day condition, queuing is anticipated to increase for some movements as a result of site-generated traffic and higher background volumes. At the roundabout, queuing for the NB approach is expected to reach a length of 850 feet in the PM peak hour. No queuing issues are identified at the intersection of Judge Orr & Cessna.

In the 2045 Future Year condition, the double-lane roundabout at Judge Orr & US 24 is anticipated to reduce queuing for some movements. However, the WB approach is expected to experience a queue length of 775 feet in the PM peak hour. No queuing issues are identified at the intersection of Judge Orr & Cessna.

## Preliminary Traffic Signal Warrant Analysis

JR conducted a preliminary traffic signal warrant analysis at the intersection of Judge Orr & Cessna. Specifically, JR considered the peak hour warrant according to the MUTCD.

In the 2027 Opening Day condition, the peak hour warrant is not expected to be met. This is based on the assumption that only half of the SBR movements are counted toward the warrant. Per the MUTCD, “Engineering judgment should be used to determine what, if any, portion of the right-turn traffic is subtracted from the minor-street traffic count when evaluating the count against the signal warrants.”

**Figure 10** shows year 2027 traffic volumes plotted on MUTCD Figure 4C-4. The 70% factor applies because the speed limit on Judge Orr Road is 45 mph.

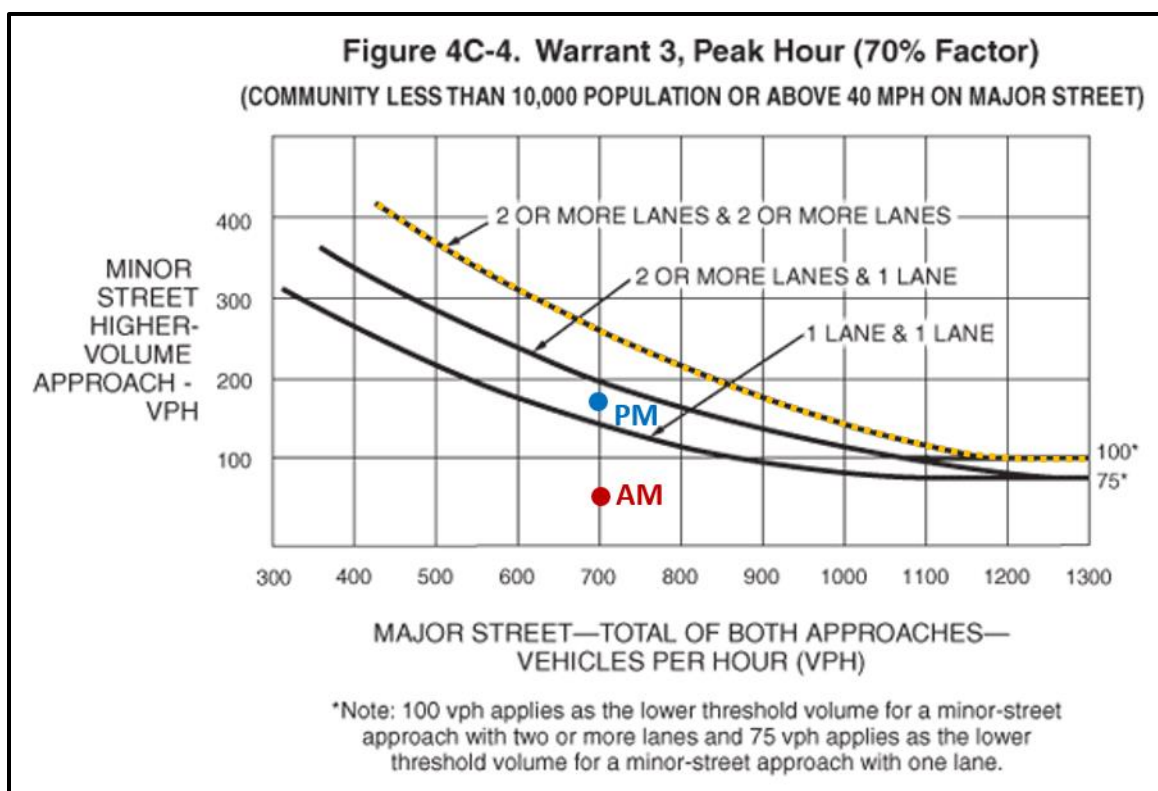

**Figure 10: 2027 Peak Hour Traffic Signal Warrant**

Based on this result, JR does not recommend a traffic signal at Judge Orr & Cessna in the 2027 Opening Day condition. The County should continue to monitor the intersection for signal warrants, which may be met in the future as other developments occur nearby.

## Conclusion

Below is a summary of the conclusions and findings of this TIS.

### Land Use and Trip Generation

The Judge Orr Road Commercial Park is expected to contain multiple land uses including industrial, warehousing, office, services, and retail. The total square footage of all buildings is estimated to be 275,000 square feet. Estimated site-generated traffic is 4,182 daily trips.

### Traffic Operational Results

At US 24 & Judge Orr, levels of service are C or better for all movements in the 2024 Existing condition. A few failures are expected in the 2027 Opening Day condition, but these failures may be considered temporary before the proposed roundabout is expanded to two lanes. In the 2045 Future Year condition, the double-lane roundabout is expected to improve traffic operations. However, the westbound approach is still expected to fail in the PM peak hour with total traffic.

At Judge Orr & Cessna, levels of service are B or better for all movements in the 2024 Existing condition. The northbound approach is expected to fail in the 2027 Opening Day condition. In the 2045 Future Year condition, traffic operations are anticipated to degrade as a result of higher traffic volumes.

At US 24 & Judge Orr, significant queuing occurs along US 24 in the 2024 Existing condition, particularly for the southbound through/right and the northbound through/right movements. In the 2027 Opening Day condition, queue lengths for some movements are anticipated to increase as a result of site-generated traffic and higher background volumes. Queuing for the northbound approach is expected to reach a length of 850 feet in the PM peak hour. In the 2045 Future Year condition, the double-lane roundabout is anticipated to reduce queuing for some movements. However, the westbound approach is expected to experience a queue length of 775 feet in the PM peak hour.

At Judge Orr & Cessna, queue lengths are minimal in the 2024 Existing condition. In the 2027 and 2045 conditions, queue lengths for some movements are anticipated to increase as a result of site-generated traffic and higher background volumes. Still, no queuing issues are identified.

### Recommendations

To accommodate site-generated traffic, an eastbound left turn lane is proposed at the intersection of Judge Orr & Cessna. This intersection may need to become signalized in the future. Additionally, a northbound left turn lane may be appropriate. At the Judge Orr & US 24 intersection, the proposed roundabout is expected to improve traffic operations. An additional westbound lane may be necessary to accommodate expected future traffic.

Note somewhere in the report that the design of this turn lane will be done at later stages of development

# Appendix A: Site Plan

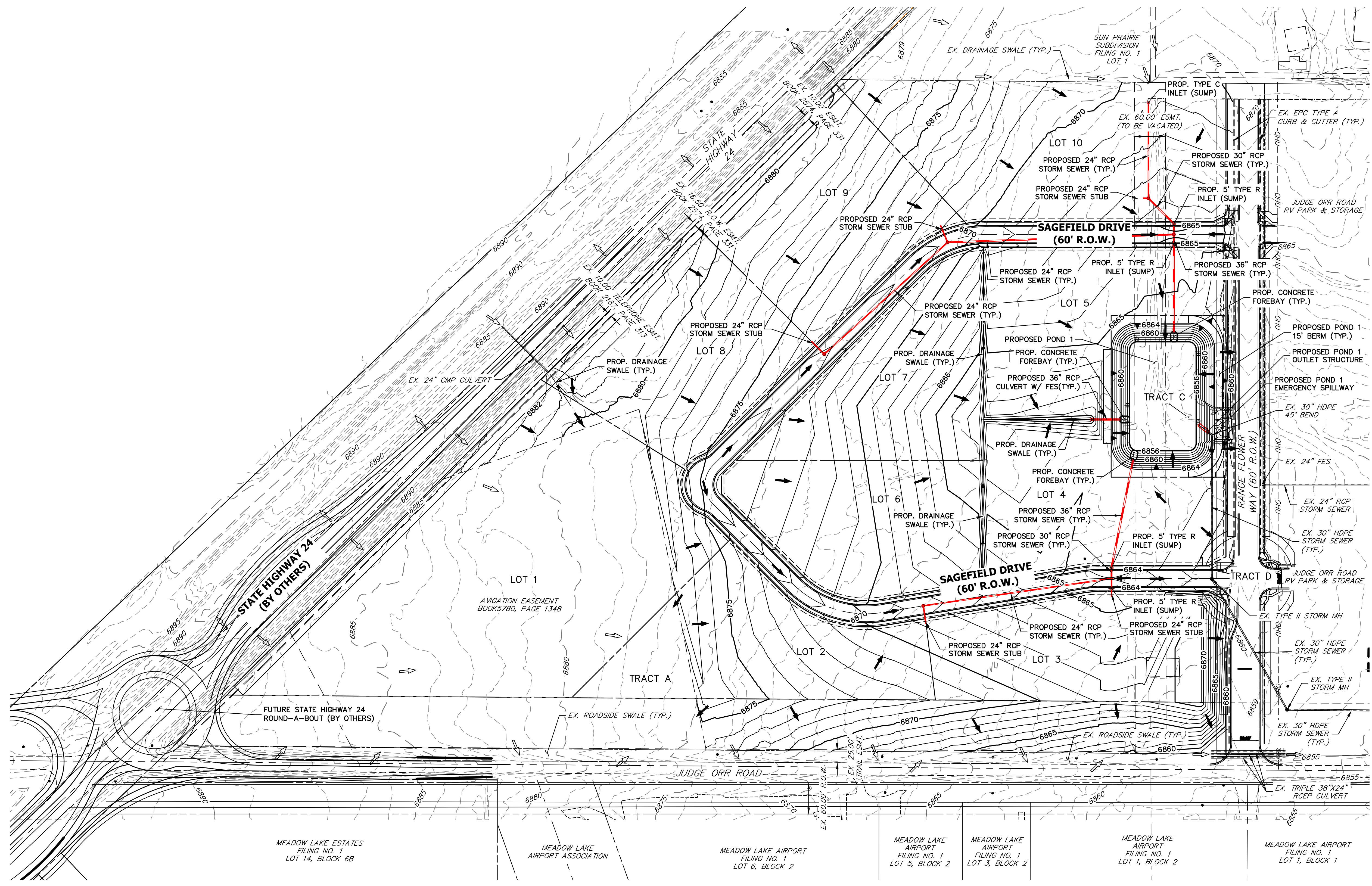

MEADOW LAKE ESTATES  
FILING NO. 1  
LOT 14, BLOCK 6B

MEADOW LAKE  
AIRPORT ASSOCIATION

MEADOW LAKE AIRPORT  
FILING NO. 1  
LOT 6, BLOCK 2

MEADOW LAKE  
AIRPORT  
FILING NO. 1  
LOT 5, BLOCK 2

MEADOW LAKE  
AIRPORT  
FILING NO. 1  
LOT 3, BLOCK 2

MEADOW LAKE  
AIRPORT  
FILING NO. 1  
LOT 1, BLOCK 2

MEADOW LAKE AIRPORT  
FILING NO. 1  
LOT 1, BLOCK 1

THE LOCATIONS OF EXISTING ABOVE GROUND AND UNDERGROUND UTILITIES ARE SHOWN IN AN APPROXIMATE WAY ONLY. THE CONTRACTOR SHALL DETERMINE THE EXACT LOCATION OF ALL EXISTING UTILITIES BEFORE COMMENCING WORK. THE CONTRACTOR SHALL BE FULLY RESPONSIBLE FOR ANY AND ALL DAMAGES WHICH MIGHT BE CAUSED BY HIS FAILURE TO EXACTLY LOCATE AND PRESERVE ANY AND ALL ABOVE GROUND AND UNDERGROUND UTILITIES.



Know what's below.  
Call before you dig.

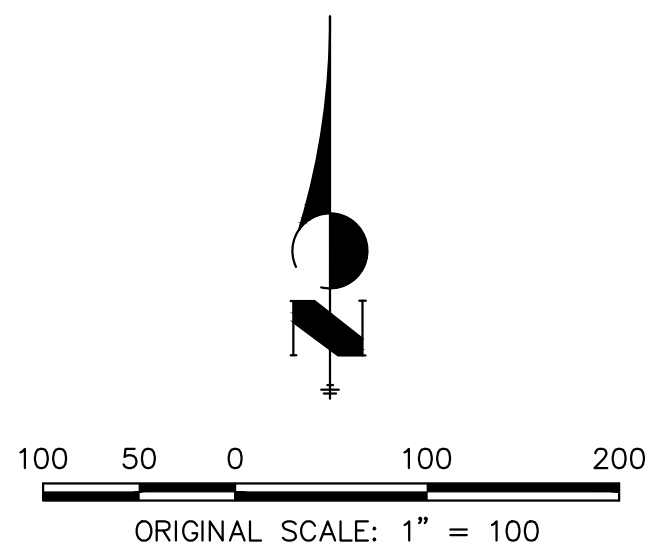

UNTIL SUCH TIME AS THESE DRAWINGS ARE APPROVED BY THE APPROPRIATE REVIEWING AGENCIES, OR ENGINEERING APPROVES THEIR USE, THESE DRAWINGS ARE DESIGNATED BY WRITTEN AUTHORIZATION.

PREPARED FOR  
CLIENT\_NAME  
CLIENT\_INFO\_1  
CLIENT\_INFO\_2  
CLIENT\_INFO\_3  
CLIENT\_INFO\_4  
CLIENT\_INFO\_5

**J.R. ENGINEERING**  
A Westman Company

Central 303-740-8888 • Colorado Springs 719-583-2583  
Fort Collins 970-491-9888 • www.jrengineering.com

H-SCALE	V-SCALE	DATE	SHEET	DATE	DESIGNED BY	DRAWN BY	CHECKED BY	No.	REVISION	BY	DATE

###  
###

SHEET --- OF #

JOB NO. PROJ. NO.

# Appendix B: Traffic Counts

### Peak Hour - Motorized Vehicles

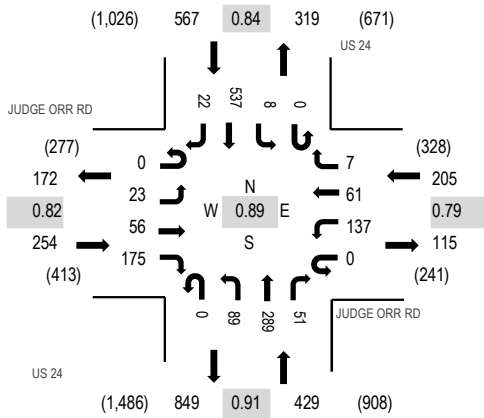

### Peak Hour - Bicycles

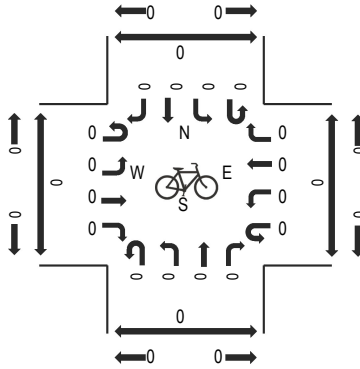

### Peak Hour - Pedestrians

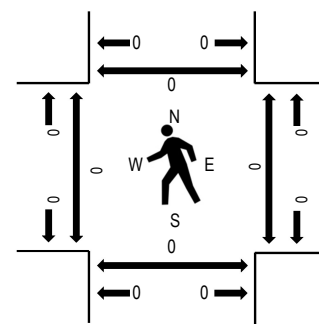

Note: Total study counts contained in parentheses.

### Traffic Counts - Motorized Vehicles

Interval Start Time	JUDGE ORR RD Eastbound				JUDGE ORR RD Westbound				US 24 Northbound			US 24 Southbound				Total	Rolling Hour	Pedestrian Crossings				
	U-Turn	Left	Thru	Right	U-Turn	Left	Thru	Right	U-Turn	Left	Thru	Right	U-Turn	Left	Thru			Right	West	East	South	North
7:00 AM	0	9	8	60	0	50	13	2	0	27	102	15	0	1	121	3	411	1,455	0	0	0	0
7:15 AM	0	5	20	36	0	31	23	0	0	26	79	9	0	5	158	9	401	1,387	0	0	0	0
7:30 AM	0	4	13	49	0	37	14	3	0	16	47	15	0	1	130	5	334	1,287	0	0	0	0
7:45 AM	0	5	15	30	0	19	11	2	0	20	61	12	0	1	128	5	309	1,249	0	0	0	0
8:00 AM	0	3	9	31	0	17	16	2	1	17	87	25	0	2	129	4	343	1,220	0	0	0	0
8:15 AM	0	4	5	32	0	20	8	2	0	10	79	19	0	2	117	3	301		0	0	0	0
8:30 AM	0	5	5	25	0	12	6	2	0	18	94	19	0	1	107	2	296		0	0	0	0
8:45 AM	0	6	8	26	0	33	4	1	0	14	67	29	0	2	87	3	280		0	0	0	0
Count Total	0	41	83	289	0	219	95	14	1	148	616	143	0	15	977	34	2,675		0	0	0	0
Peak Hour	0	23	56	175	0	137	61	7	0	89	289	51	0	8	537	22	1,455		0	0	0	0

**Peak Hour - Motorized Vehicles**

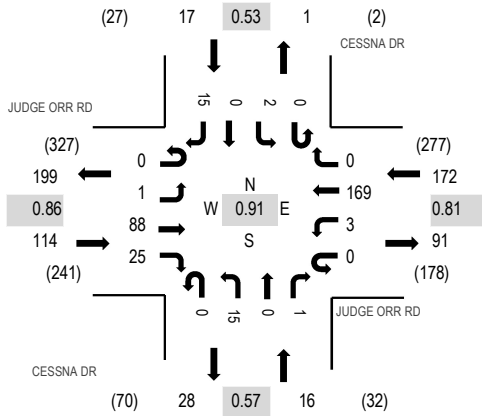

**Peak Hour - Bicycles**

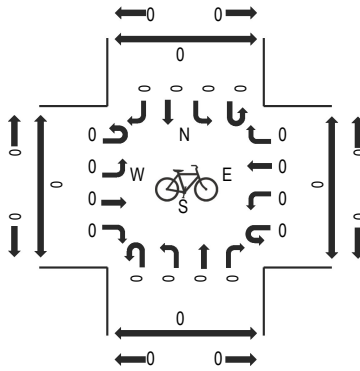

**Peak Hour - Pedestrians**

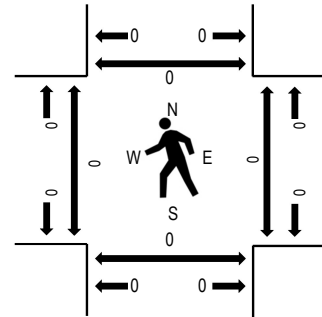

Note: Total study counts contained in parentheses.

**Traffic Counts - Motorized Vehicles**

Interval Start Time	JUDGE ORR RD Eastbound				JUDGE ORR RD Westbound				CESSNA DR Northbound				CESSNA DR Southbound				Total	Rolling Hour	Pedestrian Crossings			
	U-Turn	Left	Thru	Right	U-Turn	Left	Thru	Right	U-Turn	Left	Thru	Right	U-Turn	Left	Thru	Right			West	East	South	North
7:00 AM	0	0	15	7	0	1	52	0	0	4	0	1	0	2	0	6	88	319	0	0	0	0
7:15 AM	0	0	30	5	0	0	48	0	0	3	0	0	0	0	0	2	88	306	0	0	0	0
7:30 AM	0	1	24	3	0	1	45	0	0	5	0	0	0	0	0	3	82	274	0	0	0	0
7:45 AM	0	0	19	10	0	1	24	0	0	3	0	0	0	0	0	4	61	244	0	0	0	0
8:00 AM	0	0	23	15	0	1	32	0	0	4	0	0	0	0	0	0	75	258	0	0	0	0
8:15 AM	0	1	19	5	0	0	21	0	0	3	0	1	0	0	0	6	56		0	0	0	0
8:30 AM	0	0	20	7	0	0	20	0	0	1	0	0	0	1	0	3	52		0	0	0	0
8:45 AM	0	0	23	14	0	0	31	0	0	7	0	0	0	0	0	0	75		0	0	0	0
Count Total	0	2	173	66	0	4	273	0	0	30	0	2	0	3	0	24	577		0	0	0	0
Peak Hour	0	1	88	25	0	3	169	0	0	15	0	1	0	2	0	15	319		0	0	0	0

### Peak Hour - Motorized Vehicles

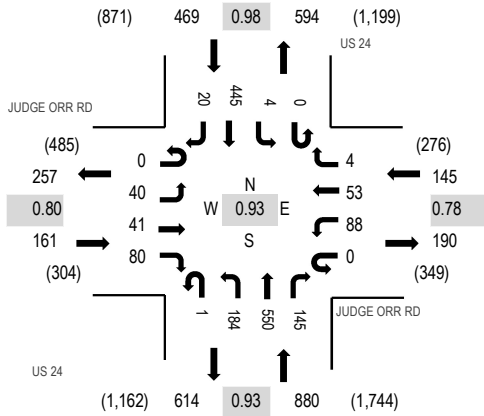

### Peak Hour - Bicycles

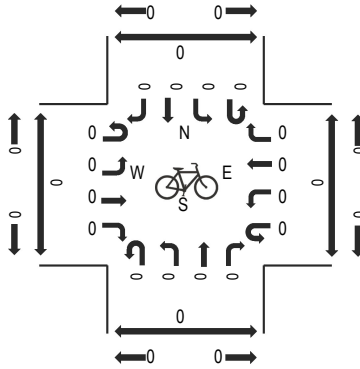

### Peak Hour - Pedestrians

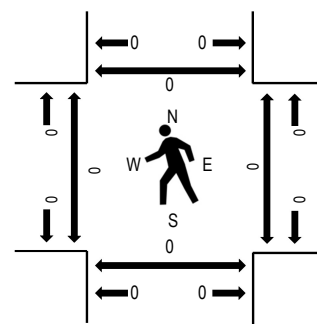

Note: Total study counts contained in parentheses.

### Traffic Counts - Motorized Vehicles

Interval Start Time	JUDGE ORR RD Eastbound				JUDGE ORR RD Westbound				US 24 Northbound			US 24 Southbound				Total	Rolling Hour	Pedestrian Crossings				
	U-Turn	Left	Thru	Right	U-Turn	Left	Thru	Right	U-Turn	Left	Thru	Right	U-Turn	Left	Thru			Right	West	East	South	North
4:00 PM	0	3	13	35	0	23	9	1	0	44	128	32	0	1	108	7	404	1,614	0	0	0	0
4:15 PM	0	12	11	15	0	23	11	1	0	42	138	40	0	2	111	3	409	1,655	0	0	0	0
4:30 PM	0	9	13	15	0	18	15	1	1	49	131	34	0	0	108	7	401	1,653	0	0	0	0
4:45 PM	0	8	7	23	0	17	8	2	0	40	143	34	0	1	111	6	400	1,616	0	0	0	0
5:00 PM	0	11	10	27	0	30	19	0	0	53	138	37	0	1	115	4	445	1,581	0	0	0	0
5:15 PM	0	5	2	12	0	29	13	1	0	59	154	28	0	0	98	6	407		0	0	0	0
5:30 PM	0	13	12	11	0	23	4	0	1	30	140	31	0	1	91	7	364		0	0	0	0
5:45 PM	0	11	13	13	0	22	6	0	0	42	149	26	0	0	82	1	365		0	0	0	0
Count Total	0	72	81	151	0	185	85	6	2	359	1,121	262	0	6	824	41	3,195		0	0	0	0
Peak Hour	0	40	41	80	0	88	53	4	1	184	550	145	0	4	445	20	1,655		0	0	0	0

Location: 2 CESSNA DR & JUDGE ORR RD PM

Date: Wednesday, August 21, 2024

Peak Hour: 04:15 PM - 05:15 PM

Peak 15-Minutes: 05:00 PM - 05:15 PM

### Peak Hour - Motorized Vehicles

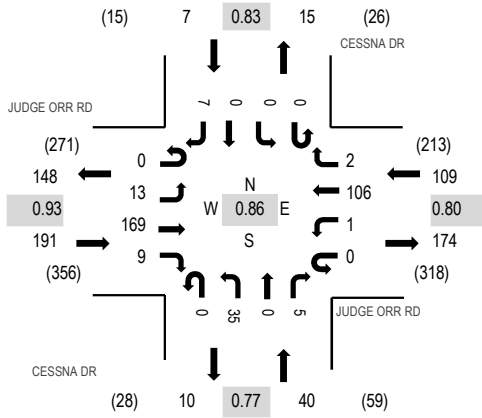

### Peak Hour - Bicycles

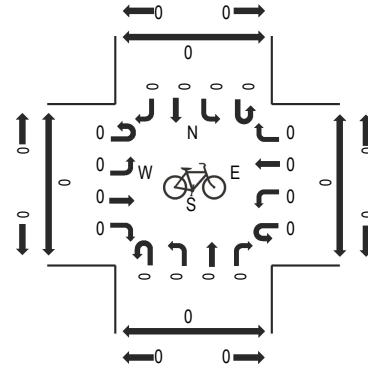

### Peak Hour - Pedestrians

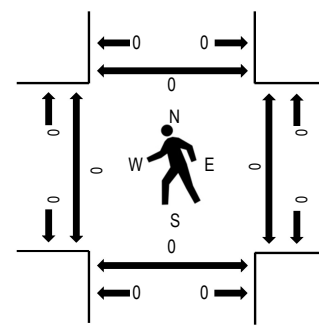

Note: Total study counts contained in parentheses.

### Traffic Counts - Motorized Vehicles

Interval Start Time	JUDGE ORR RD Eastbound				JUDGE ORR RD Westbound				CESSNA DR Northbound				CESSNA DR Southbound				Total	Rolling Hour	Pedestrian Crossings			
	U-Turn	Left	Thru	Right	U-Turn	Left	Thru	Right	U-Turn	Left	Thru	Right	U-Turn	Left	Thru	Right			West	East	South	North
4:00 PM	0	1	46	3	0	3	26	1	0	5	0	1	0	0	0	1	87	333	0	0	0	0
4:15 PM	0	5	46	1	0	0	22	0	0	9	0	0	0	0	0	2	85	347	0	0	0	0
4:30 PM	0	3	41	4	0	1	25	1	0	8	0	1	0	0	0	0	84	334	0	0	0	0
4:45 PM	0	1	42	1	0	0	21	1	0	7	0	2	0	0	0	2	77	320	0	0	0	0
5:00 PM	0	4	40	3	0	0	38	0	0	11	0	2	0	0	0	3	101	310	0	0	0	0
5:15 PM	0	0	25	6	0	1	34	0	0	2	0	1	0	0	0	3	72		0	0	0	0
5:30 PM	0	2	36	3	0	0	20	0	0	6	0	1	0	0	0	2	70		0	0	0	0
5:45 PM	0	7	34	2	0	0	19	0	0	3	0	0	0	0	0	2	67		0	0	0	0
Count Total	0	23	310	23	0	5	205	3	0	51	0	8	0	0	0	15	643		0	0	0	0
Peak Hour	0	13	169	9	0	1	106	2	0	35	0	5	0	0	0	7	347		0	0	0	0

# Appendix C: Trip Generation

## Trip Generation Summary

**Project: Judge Orr Road Commercial Park**

ITE Code	Description	Size	Units	Weekday Average Daily Trips			Weekday AM Peak Hour Trips			Weekday PM Peak Hour Trips		
				Enter	Exit	Total	Enter	Exit	Total	Enter	Exit	Total
110	General Light Industrial	35	1,000 SF	91	91	182	24	4	28	3	16	19
150	Warehousing	70	1,000 SF	75	75	150	25	7	32	10	25	35
710	General Office Building	70	1,000 SF	425	425	850	108	15	123	21	103	124
812	Building Materials and Lumber Store	35	1,000 SF	298	298	596	35	21	56	36	43	79
822	Strip Retail Plaza (<40k SF)	35	1,000 SF	953	953	1,906	50	33	83	95	94	189
943	Automobile Parts and Service Center	30	1,000 SF	249	249	498	41	16	57	24	38	62
Unadjusted Volume				2,091	2,091	4,182	283	96	379	189	319	508
Internal Capture				0%	0%	0%	0%	0%	0%	0%	0%	0%
Pass-By Trips				0%	0%	0%	0%	0%	0%	0%	0%	0%
Volume Added to Adjacent Streets				2,091	2,091	4,182	283	96	379	189	319	508

Source: Institute of Transportation Engineers, *Trip Generation Manual*, 11th Edition

# Appendix D: Synchro Reports

Lanes, Volumes, Timings  
1: US 24 & Judge Orr Road



Lane Group	EBL	EBT	EBR	WBL	WBT	WBR	NEL	NET	NER	SWL	SWT	SWR
Lane Configurations		↕			↕		↗	↘		↗	↘	
Traffic Volume (vph)	23	56	175	137	61	7	89	289	51	8	537	22
Future Volume (vph)	23	56	175	137	61	7	89	289	51	8	537	22
Ideal Flow (vphpl)	1900	1900	1900	1900	1900	1900	1900	1900	1900	1900	1900	1900
Storage Length (ft)	0		0	0		0	850		0	700		0
Storage Lanes	0		0	0		0	1		0	1		0
Taper Length (ft)	25			25			25			25		
Lane Util. Factor	1.00	1.00	1.00	1.00	1.00	1.00	1.00	1.00	1.00	1.00	1.00	1.00
Frt		0.910			0.995			0.975			0.993	
Flt Protected		0.995			0.968		0.950			0.950		
Satd. Flow (prot)	0	1687	0	0	1794	0	1770	1816	0	1770	1850	0
Flt Permitted		0.955			0.510		0.219			0.498		
Satd. Flow (perm)	0	1619	0	0	945	0	408	1816	0	928	1850	0
Right Turn on Red			Yes			Yes			Yes			Yes
Satd. Flow (RTOR)		139			3			16				4
Link Speed (mph)		45			45			55				55
Link Distance (ft)		1085			2173			1190				1114
Travel Time (s)		16.4			32.9			14.8				13.8
Peak Hour Factor	0.78	0.79	0.86	0.84	0.79	0.78	0.82	0.88	0.78	0.78	0.92	0.78
Adj. Flow (vph)	29	71	203	163	77	9	109	328	65	10	584	28
Shared Lane Traffic (%)												
Lane Group Flow (vph)	0	303	0	0	249	0	109	393	0	10	612	0
Enter Blocked Intersection	No	No	No	No	No	No	No	No	No	No	No	No
Lane Alignment	Left	Left	Right	Left	Left	Right	Left	Left	Right	Left	Left	Right
Median Width(ft)		0			0			12			12	
Link Offset(ft)		0			0			0			0	
Crosswalk Width(ft)		16			16			16			16	
Two way Left Turn Lane												
Headway Factor	1.00	1.00	1.00	1.00	1.00	1.00	1.00	1.00	1.00	1.00	1.00	1.00
Turning Speed (mph)	15		9	15		9	15		9	15		9
Number of Detectors	1	2		1	2		1	2		1	2	
Detector Template	Left	Thru		Left	Thru		Left	Thru		Left	Thru	
Leading Detector (ft)	20	100		20	100		20	100		20	100	
Trailing Detector (ft)	0	0		0	0		0	0		0	0	
Detector 1 Position(ft)	0	0		0	0		0	0		0	0	
Detector 1 Size(ft)	20	6		20	6		20	6		20	6	
Detector 1 Type	Cl+Ex	Cl+Ex		Cl+Ex	Cl+Ex		Cl+Ex	Cl+Ex		Cl+Ex	Cl+Ex	
Detector 1 Channel												
Detector 1 Extend (s)	0.0	0.0		0.0	0.0		0.0	0.0		0.0	0.0	
Detector 1 Queue (s)	0.0	0.0		0.0	0.0		0.0	0.0		0.0	0.0	
Detector 1 Delay (s)	0.0	0.0		0.0	0.0		0.0	0.0		0.0	0.0	
Detector 2 Position(ft)		94			94			94			94	
Detector 2 Size(ft)		6			6			6			6	
Detector 2 Type		Cl+Ex			Cl+Ex			Cl+Ex			Cl+Ex	
Detector 2 Channel												
Detector 2 Extend (s)		0.0			0.0			0.0			0.0	
Turn Type	Perm	NA		Perm	NA		pm+pt	NA		pm+pt	NA	
Protected Phases		4			8		5	2		1	6	
Permitted Phases	4			8			2			6		

Lanes, Volumes, Timings  
1: US 24 & Judge Orr Road



Lane Group	EBL	EBT	EBR	WBL	WBT	WBR	NEL	NET	NER	SWL	SWT	SWR
Detector Phase	4	4		8	8		5	2		1	6	
Switch Phase												
Minimum Initial (s)	5.0	5.0		5.0	5.0		5.0	5.0		5.0	5.0	
Minimum Split (s)	23.5	23.5		23.5	23.5		10.5	23.5		10.5	23.5	
Total Split (s)	28.0	28.0		28.0	28.0		10.8	36.4		10.6	36.2	
Total Split (%)	37.3%	37.3%		37.3%	37.3%		14.4%	48.5%		14.1%	48.3%	
Maximum Green (s)	22.5	22.5		22.5	22.5		5.3	30.9		5.1	30.7	
Yellow Time (s)	3.5	3.5		3.5	3.5		3.5	3.5		3.5	3.5	
All-Red Time (s)	2.0	2.0		2.0	2.0		2.0	2.0		2.0	2.0	
Lost Time Adjust (s)		0.0			0.0		0.0	0.0		0.0	0.0	
Total Lost Time (s)		5.5			5.5		5.5	5.5		5.5	5.5	
Lead/Lag							Lead	Lag		Lead	Lag	
Lead-Lag Optimize?							Yes	Yes		Yes	Yes	
Vehicle Extension (s)	3.0	3.0		3.0	3.0		3.0	3.0		3.0	3.0	
Recall Mode	None	None		None	None		None	Max		None	Max	
Walk Time (s)	7.0	7.0		7.0	7.0			7.0			7.0	
Flash Don't Walk (s)	11.0	11.0		11.0	11.0			11.0			11.0	
Pedestrian Calls (#/hr)	0	0		0	0			0			0	
Act Effct Green (s)		20.3			20.3		38.4	37.4		35.0	31.2	
Actuated g/C Ratio		0.29			0.29		0.54	0.53		0.49	0.44	
v/c Ratio		0.54			0.92		0.34	0.41		0.02	0.75	
Control Delay (s/veh)		15.6			64.4		11.0	12.6		7.9	25.8	
Queue Delay		0.0			0.0		0.0	0.0		0.0	0.0	
Total Delay (s/veh)		15.6			64.4		11.0	12.6		7.9	25.8	
LOS		B			E		B	B		A	C	
Approach Delay (s/veh)		15.6			64.4			12.3			25.5	
Approach LOS		B			E			B			C	

Intersection Summary

Area Type:	Other
Cycle Length:	75
Actuated Cycle Length:	70.8
Natural Cycle:	75
Control Type:	Actuated-Uncoordinated
Maximum v/c Ratio:	0.92
Intersection Signal Delay (s/veh):	25.5
Intersection LOS:	C
Intersection Capacity Utilization:	79.1%
ICU Level of Service:	D
Analysis Period (min):	15

Splits and Phases: 1: US 24 & Judge Orr Road

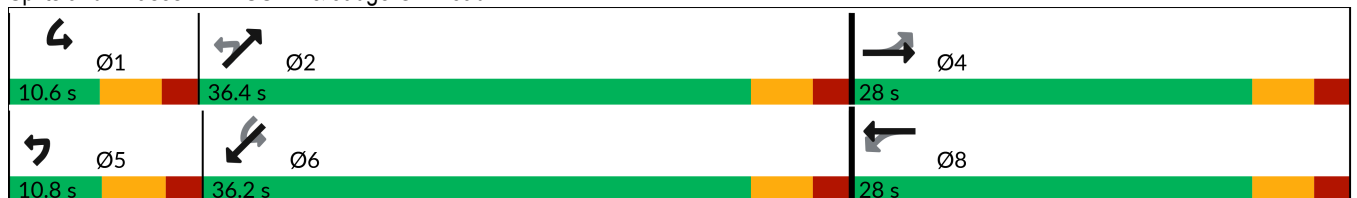



Lane Group	EBT	WBT	NEL	NET	SWL	SWT
Lane Group Flow (vph)	303	249	109	393	10	612
v/c Ratio	0.54	0.92	0.34	0.41	0.02	0.75
Control Delay (s/veh)	15.6	64.4	11.0	12.6	7.9	25.8
Queue Delay	0.0	0.0	0.0	0.0	0.0	0.0
Total Delay (s/veh)	15.6	64.4	11.0	12.6	7.9	25.8
Queue Length 50th (ft)	59	108	22	91	2	242
Queue Length 95th (ft)	102	#194	40	199	7	#420
Internal Link Dist (ft)	1005	2093		1110		1034
Turn Bay Length (ft)			850		700	
Base Capacity (vph)	616	306	324	966	521	816
Starvation Cap Reductn	0	0	0	0	0	0
Spillback Cap Reductn	0	0	0	0	0	0
Storage Cap Reductn	0	0	0	0	0	0
Reduced v/c Ratio	0.49	0.81	0.34	0.41	0.02	0.75

Intersection Summary

# 95th percentile volume exceeds capacity, queue may be longer.  
 Queue shown is maximum after two cycles.

HCM 7th Signalized Intersection Summary  
 1: US 24 & Judge Orr Road

JR Engineering  
 05/02/2025



Movement	EBL	EBT	EBR	WBL	WBT	WBR	NEL	NET	NER	SWL	SWT	SWR
Lane Configurations		↕			↕		↗	↘		↗	↘	
Traffic Volume (veh/h)	23	56	175	137	61	7	89	289	51	8	537	22
Future Volume (veh/h)	23	56	175	137	61	7	89	289	51	8	537	22
Initial Q (Qb), veh	0	0	0	0	0	0	0	0	0	0	0	0
Lane Width Adj.	1.00	1.00	1.00	1.00	1.00	1.00	1.00	1.00	1.00	1.00	1.00	1.00
Ped-Bike Adj(A_pbT)	1.00		1.00	1.00		1.00	1.00		1.00	1.00		1.00
Parking Bus, Adj	1.00	1.00	1.00	1.00	1.00	1.00	1.00	1.00	1.00	1.00	1.00	1.00
Work Zone On Approach		No			No			No			No	
Adj Sat Flow, veh/h/ln	1870	1870	1870	1870	1870	1870	1870	1870	1870	1870	1870	1870
Adj Flow Rate, veh/h	29	71	203	163	77	9	109	328	65	10	584	28
Peak Hour Factor	0.78	0.79	0.86	0.84	0.79	0.78	0.82	0.88	0.78	0.78	0.92	0.78
Percent Heavy Veh, %	2	2	2	2	2	2	2	2	2	2	2	2
Cap, veh/h	81	122	297	256	107	10	351	746	148	475	782	37
Arrive On Green	0.26	0.26	0.26	0.26	0.26	0.26	0.06	0.49	0.49	0.01	0.44	0.44
Sat Flow, veh/h	94	473	1151	659	417	40	1781	1516	300	1781	1770	85
Grp Volume(v), veh/h	303	0	0	249	0	0	109	0	393	10	0	612
Grp Sat Flow(s),veh/h/ln	1718	0	0	1116	0	0	1781	0	1816	1781	0	1855
Q Serve(g_s), s	0.0	0.0	0.0	4.2	0.0	0.0	2.2	0.0	9.8	0.2	0.0	19.1
Cycle Q Clear(g_c), s	11.1	0.0	0.0	15.3	0.0	0.0	2.2	0.0	9.8	0.2	0.0	19.1
Prop In Lane	0.10		0.67	0.65		0.04	1.00		0.17	1.00		0.05
Lane Grp Cap(c), veh/h	500	0	0	374	0	0	351	0	894	475	0	819
V/C Ratio(X)	0.61	0.00	0.00	0.67	0.00	0.00	0.31	0.00	0.44	0.02	0.00	0.75
Avail Cap(c_a), veh/h	606	0	0	458	0	0	374	0	894	583	0	819
HCM Platoon Ratio	1.00	1.00	1.00	1.00	1.00	1.00	1.00	1.00	1.00	1.00	1.00	1.00
Upstream Filter(I)	1.00	0.00	0.00	1.00	0.00	0.00	1.00	0.00	1.00	1.00	0.00	1.00
Uniform Delay (d), s/veh	23.3	0.0	0.0	24.9	0.0	0.0	12.1	0.0	11.4	10.7	0.0	16.2
Incr Delay (d2), s/veh	1.2	0.0	0.0	2.7	0.0	0.0	0.5	0.0	1.6	0.0	0.0	6.2
Initial Q Delay(d3), s/veh	0.0	0.0	0.0	0.0	0.0	0.0	0.0	0.0	0.0	0.0	0.0	0.0
%ile BackOfQ(50%),veh/ln	4.1	0.0	0.0	3.8	0.0	0.0	0.7	0.0	3.3	0.1	0.0	7.6
Unsig. Movement Delay, s/veh												
LnGrp Delay(d), s/veh	24.5	0.0	0.0	27.6	0.0	0.0	12.6	0.0	13.0	10.7	0.0	22.3
LnGrp LOS	C			C			B		B	B		C
Approach Vol, veh/h		303			249			502				622
Approach Delay, s/veh		24.5			27.6			12.9				22.2
Approach LOS		C			C			B				C
Timer - Assigned Phs	1	2		4	5	6		8				
Phs Duration (G+Y+Rc), s	6.4	39.7		23.4	9.9	36.2		23.4				
Change Period (Y+Rc), s	5.5	5.5		5.5	5.5	5.5		5.5				
Max Green Setting (Gmax), s	5.1	30.9		22.5	5.3	30.7		22.5				
Max Q Clear Time (g_c+I1), s	2.2	11.8		13.1	4.2	21.1		17.3				
Green Ext Time (p_c), s	0.0	1.9		1.1	0.0	2.4		0.6				
<b>Intersection Summary</b>												
HCM 7th Control Delay, s/veh				20.6								
HCM 7th LOS				C								

Lanes, Volumes, Timings  
2: Cessna Drive & Judge Orr Road

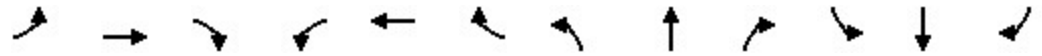

Lane Group	EBL	EBT	EBR	WBL	WBT	WBR	NBL	NBT	NBR	SBL	SBT	SBR
Lane Configurations		↕			↕			↕		↕	↕	↕
Traffic Volume (vph)	1	88	25	3	169	1	15	1	1	2	1	15
Future Volume (vph)	1	88	25	3	169	1	15	1	1	2	1	15
Ideal Flow (vphpl)	1900	1900	1900	1900	1900	1900	1900	1900	1900	1900	1900	1900
Storage Length (ft)	0		0	0		0	0		0	100		100
Storage Lanes	0		0	0		0	0		0	1		1
Taper Length (ft)	25			25			25			25		
Lane Util. Factor	1.00	1.00	1.00	1.00	1.00	1.00	1.00	1.00	1.00	1.00	1.00	1.00
Frt		0.969			0.999			0.994				0.850
Flt Protected					0.999			0.957		0.950		
Satd. Flow (prot)	0	1805	0	0	1859	0	0	1772	0	1770	1863	1583
Flt Permitted					0.999			0.957		0.950		
Satd. Flow (perm)	0	1805	0	0	1859	0	0	1772	0	1770	1863	1583
Link Speed (mph)		45			45			30				30
Link Distance (ft)		2173			1039			672				678
Travel Time (s)		32.9			15.7			15.3				15.4
Peak Hour Factor	0.78	0.82	0.78	0.78	0.86	0.78	0.78	0.78	0.78	0.78	0.78	0.78
Adj. Flow (vph)	1	107	32	4	197	1	19	1	1	3	1	19
Shared Lane Traffic (%)												
Lane Group Flow (vph)	0	140	0	0	202	0	0	21	0	3	1	19
Enter Blocked Intersection	No	No	No	No	No	No	No	No	No	No	No	No
Lane Alignment	Left	Left	Right	Left	Left	Right	Left	Left	Right	Left	Left	Right
Median Width(ft)		0			0			12				12
Link Offset(ft)		0			0			0				0
Crosswalk Width(ft)		16			16			16				16
Two way Left Turn Lane												
Headway Factor	1.00	1.00	1.00	1.00	1.00	1.00	1.00	1.00	1.00	1.00	1.00	1.00
Turning Speed (mph)	15		9	15		9	15		9	15		9
Sign Control		Free			Free			Stop				Stop

Intersection Summary

Area Type:	Other
Control Type:	Unsignalized
Intersection Capacity Utilization	25.8%
ICU Level of Service	A
Analysis Period (min)	15

Intersection												
Int Delay, s/veh	1.3											
Movement	EBL	EBT	EBR	WBL	WBT	WBR	NBL	NBT	NBR	SBL	SBT	SBR
Lane Configurations		↕			↕			↕		↗	↖	↗
Traffic Vol, veh/h	1	88	25	3	169	1	15	1	1	2	1	15
Future Vol, veh/h	1	88	25	3	169	1	15	1	1	2	1	15
Conflicting Peds, #/hr	0	0	0	0	0	0	0	0	0	0	0	0
Sign Control	Free	Free	Free	Free	Free	Free	Stop	Stop	Stop	Stop	Stop	Stop
RT Channelized	-	-	None	-	-	None	-	-	None	-	-	None
Storage Length	-	-	-	-	-	-	-	-	-	100	-	100
Veh in Median Storage, #	-	0	-	-	0	-	-	0	-	-	0	-
Grade, %	-	0	-	-	0	-	-	0	-	-	0	-
Peak Hour Factor	78	82	78	78	86	78	78	78	78	78	78	78
Heavy Vehicles, %	2	2	2	2	2	2	2	2	2	2	2	2
Mvmt Flow	1	107	32	4	197	1	19	1	1	3	1	19

Major/Minor	Major1			Major2			Minor1			Minor2		
Conflicting Flow All	198	0	0	139	0	0	331	331	123	315	347	197
Stage 1	-	-	-	-	-	-	126	126	-	205	205	-
Stage 2	-	-	-	-	-	-	205	205	-	111	142	-
Critical Hdwy	4.12	-	-	4.12	-	-	7.12	6.52	6.22	7.12	6.52	6.22
Critical Hdwy Stg 1	-	-	-	-	-	-	6.12	5.52	-	6.12	5.52	-
Critical Hdwy Stg 2	-	-	-	-	-	-	6.12	5.52	-	6.12	5.52	-
Follow-up Hdwy	2.218	-	-	2.218	-	-	3.518	4.018	3.318	3.518	4.018	3.318
Pot Cap-1 Maneuver	1375	-	-	1444	-	-	623	588	928	637	577	844
Stage 1	-	-	-	-	-	-	878	792	-	797	732	-
Stage 2	-	-	-	-	-	-	797	732	-	895	779	-
Platoon blocked, %		-	-		-	-						
Mov Cap-1 Maneuver	1375	-	-	1444	-	-	605	586	928	632	574	844
Mov Cap-2 Maneuver	-	-	-	-	-	-	605	586	-	632	574	-
Stage 1	-	-	-	-	-	-	877	791	-	795	730	-
Stage 2	-	-	-	-	-	-	775	729	-	891	779	-

Approach	EB			WB			NB			SB		
HCM Control Delay, s/v	0.07			0.14			11.06			9.62		
HCM LOS							B			A		

Minor Lane/Major Mvmt	NBLn1	EBL	EBT	EBR	WBL	WBT	WBR	SBLn1	SBLn2	SBLn3
Capacity (veh/h)	616	16	-	-	34	-	-	632	574	844
HCM Lane V/C Ratio	0.035	0.001	-	-	0.003	-	-	0.004	0.002	0.023
HCM Control Delay (s/veh)	11.1	7.6	0	-	7.5	0	-	10.7	11.3	9.4
HCM Lane LOS	B	A	A	-	A	A	-	B	B	A
HCM 95th %tile Q(veh)	0.1	0	-	-	0	-	-	0	0	0.1

Lanes, Volumes, Timings  
1: US 24 & Judge Orr Road

JR Engineering  
05/02/2025



Lane Group	EBL	EBT	EBR	WBL	WBT	WBR	NEL	NET	NER	SWL	SWT	SWR
Lane Configurations		↕			↕		↗	↘		↗	↘	
Traffic Volume (vph)	40	41	80	88	53	4	184	550	145	4	445	20
Future Volume (vph)	40	41	80	88	53	4	184	550	145	4	445	20
Ideal Flow (vphpl)	1900	1900	1900	1900	1900	1900	1900	1900	1900	1900	1900	1900
Storage Length (ft)	0		0	0		0	850		0	700		0
Storage Lanes	0		0	0		0	1		0	1		0
Taper Length (ft)	25			25			25			25		
Lane Util. Factor	1.00	1.00	1.00	1.00	1.00	1.00	1.00	1.00	1.00	1.00	1.00	1.00
Frt		0.934			0.996			0.967			0.992	
Flt Protected		0.988			0.971		0.950			0.950		
Satd. Flow (prot)	0	1719	0	0	1801	0	1770	1801	0	1770	1848	0
Flt Permitted		0.871			0.632		0.304			0.257		
Satd. Flow (perm)	0	1515	0	0	1173	0	566	1801	0	479	1848	0
Right Turn on Red			Yes			Yes			Yes			Yes
Satd. Flow (RTOR)		60			2			26			5	
Link Speed (mph)		45			45			55			55	
Link Distance (ft)		1085			2173			1190			1114	
Travel Time (s)		16.4			32.9			14.8			13.8	
Peak Hour Factor	0.78	0.78	0.81	0.82	0.78	0.78	0.86	0.92	0.85	0.78	0.91	0.78
Adj. Flow (vph)	51	53	99	107	68	5	214	598	171	5	489	26
Shared Lane Traffic (%)												
Lane Group Flow (vph)	0	203	0	0	180	0	214	769	0	5	515	0
Enter Blocked Intersection	No	No	No	No	No	No	No	No	No	No	No	No
Lane Alignment	Left	Left	Right	Left	Left	Right	Left	Left	Right	Left	Left	Right
Median Width(ft)		0			0			12			12	
Link Offset(ft)		0			0			0			0	
Crosswalk Width(ft)		16			16			16			16	
Two way Left Turn Lane												
Headway Factor	1.00	1.00	1.00	1.00	1.00	1.00	1.00	1.00	1.00	1.00	1.00	1.00
Turning Speed (mph)	15		9	15		9	15		9	15		9
Number of Detectors	1	2		1	2		1	2		1	2	
Detector Template	Left	Thru		Left	Thru		Left	Thru		Left	Thru	
Leading Detector (ft)	20	100		20	100		20	100		20	100	
Trailing Detector (ft)	0	0		0	0		0	0		0	0	
Detector 1 Position(ft)	0	0		0	0		0	0		0	0	
Detector 1 Size(ft)	20	6		20	6		20	6		20	6	
Detector 1 Type	Cl+Ex	Cl+Ex		Cl+Ex	Cl+Ex		Cl+Ex	Cl+Ex		Cl+Ex	Cl+Ex	
Detector 1 Channel												
Detector 1 Extend (s)	0.0	0.0		0.0	0.0		0.0	0.0		0.0	0.0	
Detector 1 Queue (s)	0.0	0.0		0.0	0.0		0.0	0.0		0.0	0.0	
Detector 1 Delay (s)	0.0	0.0		0.0	0.0		0.0	0.0		0.0	0.0	
Detector 2 Position(ft)		94			94			94			94	
Detector 2 Size(ft)		6			6			6			6	
Detector 2 Type		Cl+Ex			Cl+Ex			Cl+Ex			Cl+Ex	
Detector 2 Channel												
Detector 2 Extend (s)		0.0			0.0			0.0			0.0	
Turn Type	Perm	NA		Perm	NA		pm+pt	NA		pm+pt	NA	
Protected Phases		4			8		5	2		1	6	
Permitted Phases	4			8			2			6		

Lanes, Volumes, Timings  
1: US 24 & Judge Orr Road



Lane Group	EBL	EBT	EBR	WBL	WBT	WBR	NEL	NET	NER	SWL	SWT	SWR
Detector Phase	4	4		8	8		5	2		1	6	
Switch Phase												
Minimum Initial (s)	5.0	5.0		5.0	5.0		5.0	5.0		5.0	5.0	
Minimum Split (s)	23.5	23.5		23.5	23.5		10.5	23.5		10.5	23.5	
Total Split (s)	23.6	23.6		23.6	23.6		13.2	40.8		10.6	38.2	
Total Split (%)	31.5%	31.5%		31.5%	31.5%		17.6%	54.4%		14.1%	50.9%	
Maximum Green (s)	18.1	18.1		18.1	18.1		7.7	35.3		5.1	32.7	
Yellow Time (s)	3.5	3.5		3.5	3.5		3.5	3.5		3.5	3.5	
All-Red Time (s)	2.0	2.0		2.0	2.0		2.0	2.0		2.0	2.0	
Lost Time Adjust (s)		0.0			0.0		0.0	0.0		0.0	0.0	
Total Lost Time (s)		5.5			5.5		5.5	5.5		5.5	5.5	
Lead/Lag							Lead	Lag		Lead	Lag	
Lead-Lag Optimize?							Yes	Yes		Yes	Yes	
Vehicle Extension (s)	3.0	3.0		3.0	3.0		3.0	3.0		3.0	3.0	
Recall Mode	None	None		None	None		None	Max		None	Max	
Walk Time (s)	7.0	7.0		7.0	7.0			7.0			7.0	
Flash Don't Walk (s)	11.0	11.0		11.0	11.0			11.0			11.0	
Pedestrian Calls (#/hr)	0	0		0	0			0			0	
Act Effct Green (s)		14.3			14.3		45.3	43.8		37.9	32.8	
Actuated g/C Ratio		0.20			0.20		0.64	0.62		0.53	0.46	
v/c Ratio		0.58			0.76		0.44	0.69		0.01	0.60	
Control Delay (s/veh)		24.6			47.6		8.8	15.7		6.3	18.8	
Queue Delay		0.0			0.0		0.0	0.0		0.0	0.0	
Total Delay (s/veh)		24.6			47.6		8.8	15.7		6.3	18.8	
LOS		C			D		A	B		A	B	
Approach Delay (s/veh)		24.6			47.6			14.2			18.7	
Approach LOS		C			D			B			B	

Intersection Summary

Area Type:	Other
Cycle Length:	75
Actuated Cycle Length:	71.2
Natural Cycle:	75
Control Type:	Actuated-Uncoordinated
Maximum v/c Ratio:	0.76
Intersection Signal Delay (s/veh):	19.7
Intersection LOS:	B
Intersection Capacity Utilization:	72.7%
ICU Level of Service:	C
Analysis Period (min):	15

Splits and Phases: 1: US 24 & Judge Orr Road

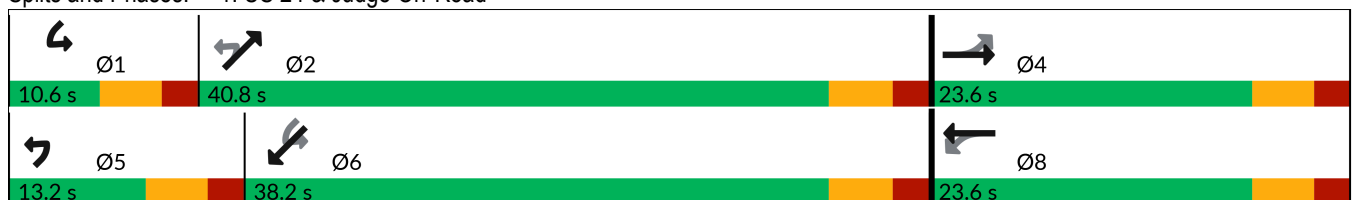



Lane Group	EBT	WBT	NEL	NET	SWL	SWT
Lane Group Flow (vph)	203	180	214	769	5	515
v/c Ratio	0.58	0.76	0.44	0.69	0.01	0.60
Control Delay (s/veh)	24.6	47.6	8.8	15.7	6.3	18.8
Queue Delay	0.0	0.0	0.0	0.0	0.0	0.0
Total Delay (s/veh)	24.6	47.6	8.8	15.7	6.3	18.8
Queue Length 50th (ft)	56	74	35	182	1	165
Queue Length 95th (ft)	95	117	65	#535	4	280
Internal Link Dist (ft)	1005	2093		1110		1034
Turn Bay Length (ft)			850		700	
Base Capacity (vph)	431	300	490	1119	347	853
Starvation Cap Reductn	0	0	0	0	0	0
Spillback Cap Reductn	0	0	0	0	0	0
Storage Cap Reductn	0	0	0	0	0	0
Reduced v/c Ratio	0.47	0.60	0.44	0.69	0.01	0.60

**Intersection Summary**

# 95th percentile volume exceeds capacity, queue may be longer.  
 Queue shown is maximum after two cycles.

HCM 7th Signalized Intersection Summary  
 1: US 24 & Judge Orr Road

JR Engineering  
 05/02/2025



Movement	EBL	EBT	EBR	WBL	WBT	WBR	NEL	NET	NER	SWL	SWT	SWR
Lane Configurations		↕			↕		↗	↘		↗	↘	
Traffic Volume (veh/h)	40	41	80	88	53	4	184	550	145	4	445	20
Future Volume (veh/h)	40	41	80	88	53	4	184	550	145	4	445	20
Initial Q (Qb), veh	0	0	0	0	0	0	0	0	0	0	0	0
Lane Width Adj.	1.00	1.00	1.00	1.00	1.00	1.00	1.00	1.00	1.00	1.00	1.00	1.00
Ped-Bike Adj(A_pbT)	1.00		1.00	1.00		1.00	1.00		1.00	1.00		1.00
Parking Bus, Adj	1.00	1.00	1.00	1.00	1.00	1.00	1.00	1.00	1.00	1.00	1.00	1.00
Work Zone On Approach		No			No			No			No	
Adj Sat Flow, veh/h/ln	1870	1870	1870	1870	1870	1870	1870	1870	1870	1870	1870	1870
Adj Flow Rate, veh/h	51	53	99	107	68	5	214	598	171	5	489	26
Peak Hour Factor	0.78	0.78	0.81	0.82	0.78	0.78	0.86	0.92	0.85	0.78	0.91	0.78
Percent Heavy Veh, %	2	2	2	2	2	2	2	2	2	2	2	2
Cap, veh/h	120	88	132	210	100	6	537	812	232	309	885	47
Arrive On Green	0.16	0.16	0.16	0.16	0.16	0.16	0.08	0.58	0.58	0.01	0.50	0.50
Sat Flow, veh/h	322	553	833	765	629	40	1781	1398	400	1781	1760	94
Grp Volume(v), veh/h	203	0	0	180	0	0	214	0	769	5	0	515
Grp Sat Flow(s),veh/h/ln	1708	0	0	1434	0	0	1781	0	1798	1781	0	1854
Q Serve(g_s), s	0.0	0.0	0.0	0.7	0.0	0.0	3.5	0.0	20.4	0.1	0.0	12.4
Cycle Q Clear(g_c), s	7.2	0.0	0.0	7.8	0.0	0.0	3.5	0.0	20.4	0.1	0.0	12.4
Prop In Lane	0.25		0.49	0.59		0.03	1.00		0.22	1.00		0.05
Lane Grp Cap(c), veh/h	341	0	0	316	0	0	537	0	1044	309	0	932
V/C Ratio(X)	0.60	0.00	0.00	0.57	0.00	0.00	0.40	0.00	0.74	0.02	0.00	0.55
Avail Cap(c_a), veh/h	528	0	0	487	0	0	598	0	1044	437	0	932
HCM Platoon Ratio	1.00	1.00	1.00	1.00	1.00	1.00	1.00	1.00	1.00	1.00	1.00	1.00
Upstream Filter(I)	1.00	0.00	0.00	1.00	0.00	0.00	1.00	0.00	1.00	1.00	0.00	1.00
Uniform Delay (d), s/veh	26.0	0.0	0.0	26.2	0.0	0.0	7.6	0.0	10.0	9.7	0.0	11.1
Incr Delay (d2), s/veh	1.7	0.0	0.0	1.6	0.0	0.0	0.5	0.0	4.6	0.0	0.0	2.4
Initial Q Delay(d3), s/veh	0.0	0.0	0.0	0.0	0.0	0.0	0.0	0.0	0.0	0.0	0.0	0.0
%ile BackOfQ(50%),veh/ln	2.8	0.0	0.0	2.5	0.0	0.0	0.8	0.0	6.1	0.0	0.0	4.2
Unsig. Movement Delay, s/veh												
LnGrp Delay(d), s/veh	27.7	0.0	0.0	27.8	0.0	0.0	8.1	0.0	14.6	9.7	0.0	13.5
LnGrp LOS	C			C			A		B	A		B
Approach Vol, veh/h		203			180			983				520
Approach Delay, s/veh		27.7			27.8			13.2				13.4
Approach LOS		C			C			B				B
Timer - Assigned Phs	1	2		4	5	6		8				
Phs Duration (G+Y+Rc), s	5.9	43.2		15.8	11.0	38.2		15.8				
Change Period (Y+Rc), s	5.5	5.5		5.5	5.5	5.5		5.5				
Max Green Setting (Gmax), s	5.1	35.3		18.1	7.7	32.7		18.1				
Max Q Clear Time (g_c+I1), s	2.1	22.4		9.2	5.5	14.4		9.8				
Green Ext Time (p_c), s	0.0	3.9		0.6	0.1	2.6		0.5				
<b>Intersection Summary</b>												
HCM 7th Control Delay, s/veh				16.2								
HCM 7th LOS				B								

Lanes, Volumes, Timings  
2: Cessna Drive & Judge Orr Road

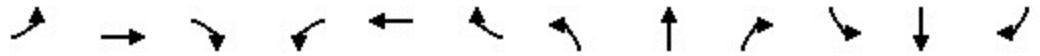

Lane Group	EBL	EBT	EBR	WBL	WBT	WBR	NBL	NBT	NBR	SBL	SBT	SBR
Lane Configurations		↕			↕			↕		↕	↕	↕
Traffic Volume (vph)	13	169	9	1	106	2	35	1	5	1	1	7
Future Volume (vph)	13	169	9	1	106	2	35	1	5	1	1	7
Ideal Flow (vphpl)	1900	1900	1900	1900	1900	1900	1900	1900	1900	1900	1900	1900
Storage Length (ft)	0		0	0		0	0		0	100		100
Storage Lanes	0		0	0		0	0		0	1		1
Taper Length (ft)	25			25			25			25		
Lane Util. Factor	1.00	1.00	1.00	1.00	1.00	1.00	1.00	1.00	1.00	1.00	1.00	1.00
Frt		0.993			0.997			0.984				0.850
Flt Protected		0.996						0.959		0.950		
Satd. Flow (prot)	0	1842	0	0	1857	0	0	1758	0	1770	1863	1583
Flt Permitted		0.996						0.959		0.950		
Satd. Flow (perm)	0	1842	0	0	1857	0	0	1758	0	1770	1863	1583
Link Speed (mph)		45			45			30				30
Link Distance (ft)		2173			1039			672				678
Travel Time (s)		32.9			15.7			15.3				15.4
Peak Hour Factor	0.78	0.86	0.78	0.78	0.83	0.78	0.78	0.78	0.78	0.78	0.78	0.78
Adj. Flow (vph)	17	197	12	1	128	3	45	1	6	1	1	9
Shared Lane Traffic (%)												
Lane Group Flow (vph)	0	226	0	0	132	0	0	52	0	1	1	9
Enter Blocked Intersection	No	No	No	No	No	No	No	No	No	No	No	No
Lane Alignment	Left	Left	Right	Left	Left	Right	Left	Left	Right	Left	Left	Right
Median Width(ft)		0			0			12				12
Link Offset(ft)		0			0			0				0
Crosswalk Width(ft)		16			16			16				16
Two way Left Turn Lane												
Headway Factor	1.00	1.00	1.00	1.00	1.00	1.00	1.00	1.00	1.00	1.00	1.00	1.00
Turning Speed (mph)	15		9	15		9	15		9	15		9
Sign Control		Free			Free			Stop				Stop

Intersection Summary

Area Type:	Other
Control Type:	Unsignalized
Intersection Capacity Utilization	32.5%
ICU Level of Service	A
Analysis Period (min)	15

Intersection												
Int Delay, s/veh	2											
Movement	EBL	EBT	EBR	WBL	WBT	WBR	NBL	NBT	NBR	SBL	SBT	SBR
Lane Configurations		↕			↕			↕		↗	↖	↗
Traffic Vol, veh/h	13	169	9	1	106	2	35	1	5	1	1	7
Future Vol, veh/h	13	169	9	1	106	2	35	1	5	1	1	7
Conflicting Peds, #/hr	0	0	0	0	0	0	0	0	0	0	0	0
Sign Control	Free	Free	Free	Free	Free	Free	Stop	Stop	Stop	Stop	Stop	Stop
RT Channelized	-	-	None	-	-	None	-	-	None	-	-	None
Storage Length	-	-	-	-	-	-	-	-	-	100	-	100
Veh in Median Storage, #	-	0	-	-	0	-	-	0	-	-	0	-
Grade, %	-	0	-	-	0	-	-	0	-	-	0	-
Peak Hour Factor	78	86	78	78	83	78	78	78	78	78	78	78
Heavy Vehicles, %	2	2	2	2	2	2	2	2	2	2	2	2
Mvmt Flow	17	197	12	1	128	3	45	1	6	1	1	9

Major/Minor	Major1			Major2			Minor1			Minor2		
Conflicting Flow All	130	0	0	208	0	0	367	368	202	362	373	129
Stage 1	-	-	-	-	-	-	236	236	-	132	132	-
Stage 2	-	-	-	-	-	-	131	133	-	230	241	-
Critical Hdwy	4.12	-	-	4.12	-	-	7.12	6.52	6.22	7.12	6.52	6.22
Critical Hdwy Stg 1	-	-	-	-	-	-	6.12	5.52	-	6.12	5.52	-
Critical Hdwy Stg 2	-	-	-	-	-	-	6.12	5.52	-	6.12	5.52	-
Follow-up Hdwy	2.218	-	-	2.218	-	-	3.518	4.018	3.318	3.518	4.018	3.318
Pot Cap-1 Maneuver	1455	-	-	1363	-	-	590	561	838	594	557	921
Stage 1	-	-	-	-	-	-	768	710	-	872	787	-
Stage 2	-	-	-	-	-	-	873	786	-	772	706	-
Platoon blocked, %		-	-		-	-						
Mov Cap-1 Maneuver	1455	-	-	1363	-	-	574	553	838	580	550	921
Mov Cap-2 Maneuver	-	-	-	-	-	-	574	553	-	580	550	-
Stage 1	-	-	-	-	-	-	758	701	-	871	787	-
Stage 2	-	-	-	-	-	-	862	786	-	755	697	-

Approach	EB			WB			NB			SB		
HCM Control Delay, s/v	0.56			0.07			11.61			9.49		
HCM LOS							B			A		

Minor Lane/Major Mvmt	NBLn1	EBL	EBT	EBR	WBL	WBT	WBR	SBLn1	SBLn2	SBLn3
Capacity (veh/h)	597	132	-	-	17	-	-	580	550	921
HCM Lane V/C Ratio	0.088	0.011	-	-	0.001	-	-	0.002	0.002	0.01
HCM Control Delay (s/veh)	11.6	7.5	0	-	7.6	0	-	11.2	11.6	8.9
HCM Lane LOS	B	A	A	-	A	A	-	B	B	A
HCM 95th %tile Q(veh)	0.3	0	-	-	0	-	-	0	0	0

Lanes, Volumes, Timings  
1: US 24 & Judge Orr Road



Lane Group	EBL	EBT	EBR	WBL	WBT	WBR	NEL	NET	NER	SWL	SWT	SWR
Lane Configurations		↕			↕			↕			↕	
Traffic Volume (vph)	26	64	180	220	75	7	92	300	81	8	559	23
Future Volume (vph)	26	64	180	220	75	7	92	300	81	8	559	23
Ideal Flow (vphpl)	1900	1900	1900	1900	1900	1900	1900	1900	1900	1900	1900	1900
Storage Length (ft)	150		0	150		0	850		0	700		0
Storage Lanes	0		0	0		0	0		0	0		0
Taper Length (ft)	25			25			25			25		
Lane Util. Factor	1.00	1.00	1.00	1.00	1.00	1.00	1.00	1.00	1.00	1.00	1.00	1.00
Frt		0.913			0.997			0.975			0.994	
Flt Protected		0.995			0.966			0.990			0.999	
Satd. Flow (prot)	0	1692	0	0	1794	0	0	1798	0	0	1850	0
Flt Permitted		0.995			0.966			0.990			0.999	
Satd. Flow (perm)	0	1692	0	0	1794	0	0	1798	0	0	1850	0
Link Speed (mph)		45			45			55			55	
Link Distance (ft)		1085			2173			1190			1114	
Travel Time (s)		16.4			32.9			14.8			13.8	
Peak Hour Factor	0.78	0.79	0.86	0.87	0.81	0.78	0.82	0.89	0.81	0.78	0.92	0.78
Adj. Flow (vph)	33	81	209	253	93	9	112	337	100	10	608	29
Shared Lane Traffic (%)												
Lane Group Flow (vph)	0	323	0	0	355	0	0	549	0	0	647	0
Enter Blocked Intersection	No	No	No	No	No	No	No	No	No	No	No	No
Lane Alignment	Left	Left	Right	Left	Left	Right	Left	Left	Right	Left	Left	Right
Median Width(ft)		12			12			0			0	
Link Offset(ft)		0			0			0			0	
Crosswalk Width(ft)		16			16			16			16	
Two way Left Turn Lane												
Headway Factor	1.00	1.00	1.00	1.00	1.00	1.00	1.00	1.00	1.00	1.00	1.00	1.00
Turning Speed (mph)	15		9	15		9	15		9	15		9
Sign Control		Yield			Yield			Yield			Yield	

Intersection Summary

Area Type:	Other
Control Type:	Roundabout
Intersection Capacity Utilization	102.8%
ICU Level of Service	G
Analysis Period (min)	15

Intersection				
Intersection Delay, s/veh	14.6			
Intersection LOS	B			
Approach	EB	WB	NE	SW
Entry Lanes	1	1	1	1
Conflicting Circle Lanes	1	1	1	1
Adj Approach Flow, veh/h	323	355	549	647
Demand Flow Rate, veh/h	330	362	560	660
Vehicles Circulating, veh/h	888	492	127	467
Vehicles Exiting, veh/h	239	195	1091	387
Ped Vol Crossing Leg, #/h	0	0	0	0
Ped Cap Adj	1.000	1.000	1.000	1.000
Approach Delay, s/veh	18.6	9.9	7.9	20.9
Approach LOS	C	A	A	C
Lane	Left	Left	Left	Left
Designated Moves	LTR	LTR	LTR	LTR
Assumed Moves	LTR	LTR	LTR	LTR
RT Channelized				
Lane Util	1.000	1.000	1.000	1.000
Follow-Up Headway, s	2.609	2.609	2.609	2.609
Critical Headway, s	4.976	4.976	4.976	4.976
A (Intercept)	1380	1380	1380	1380
B (Slope)	1.02e-3	1.02e-3	1.02e-3	1.02e-3
Entry Flow, veh/h	330	362	560	660
Cap Entry Lane, veh/h	558	835	1212	857
Entry HV Adj Factor	0.980	0.981	0.981	0.980
Flow Entry, veh/h	323	355	549	647
Cap Entry, veh/h	547	820	1189	840
V/C Ratio	0.592	0.433	0.462	0.770
Control Delay, s/veh	18.6	9.9	7.9	20.9
LOS	C	A	A	C
95th %tile Queue, veh	4	2	2	8

Lanes, Volumes, Timings  
2: Cessna Drive & Judge Orr Road

JR Engineering  
05/21/2025



Lane Group	EBL	EBT	EBR	WBL	WBT	WBR	NBL	NBT	NBR	SBL	SBT	SBR
Lane Configurations												
Traffic Volume (vph)	1	125	26	3	265	1	15	1	1	2	1	37
Future Volume (vph)	1	125	26	3	265	1	15	1	1	2	1	37
Ideal Flow (vphp)	1900	1900	1900	1900	1900	1900	1900	1900	1900	1900	1900	1900
Storage Length (ft)	150		0	150		0	100		0	100		100
Storage Lanes	1		0	0		0	0		0	1		1
Taper Length (ft)	25			25			25			25		
Lane Util. Factor	1.00	1.00	1.00	1.00	1.00	1.00	1.00	1.00	1.00	1.00	1.00	1.00
Frt		0.973						0.994				0.850
Flt Protected	0.950				0.999			0.957		0.950		
Satd. Flow (prot)	1770	1812	0	0	1861	0	0	1772	0	1770	1863	1583
Flt Permitted	0.950				0.999			0.957		0.950		
Satd. Flow (perm)	1770	1812	0	0	1861	0	0	1772	0	1770	1863	1583
Link Speed (mph)		45			45			30		30		
Link Distance (ft)		2173			1039			672		678		
Travel Time (s)		32.9			15.7			15.3		15.4		
Peak Hour Factor	0.78	0.84	0.78	0.78	0.88	0.78	0.78	0.78	0.78	0.78	0.78	0.78
Adj. Flow (vph)	1	149	33	4	301	1	19	1	1	3	1	47
Shared Lane Traffic (%)												
Lane Group Flow (vph)	1	182	0	0	306	0	0	21	0	3	1	47
Enter Blocked Intersection	No	No	No	No	No	No	No	No	No	No	No	No
Lane Alignment	Left	Left	Right	Left	Left	Right	Left	Left	Right	Left	Left	Right
Median Width(ft)		12			12			12		12		12
Link Offset(ft)		0			0			0		0		0
Crosswalk Width(ft)		16			16			16		16		16
Two way Left Turn Lane												
Headway Factor	1.00	1.00	1.00	1.00	1.00	1.00	1.00	1.00	1.00	1.00	1.00	1.00
Turning Speed (mph)	15		9	15		9	15		9	15		9
Sign Control		Free			Free			Stop				Stop

Intersection Summary

Area Type:	Other
Control Type:	Unsignalized
Intersection Capacity Utilization	30.8%
ICU Level of Service	A
Analysis Period (min)	15

Intersection												
Int Delay, s/veh	1.5											
Movement	EBL	EBT	EBR	WBL	WBT	WBR	NBL	NBT	NBR	SBL	SBT	SBR
Lane Configurations	↖	↗			↕			↕		↖	↗	↗
Traffic Vol, veh/h	1	125	26	3	265	1	15	1	1	2	1	37
Future Vol, veh/h	1	125	26	3	265	1	15	1	1	2	1	37
Conflicting Peds, #/hr	0	0	0	0	0	0	0	0	0	0	0	0
Sign Control	Free	Free	Free	Free	Free	Free	Stop	Stop	Stop	Stop	Stop	Stop
RT Channelized	-	-	None	-	-	None	-	-	None	-	-	None
Storage Length	150	-	-	-	-	-	-	-	-	100	-	100
Veh in Median Storage, #	-	0	-	-	0	-	-	0	-	-	0	-
Grade, %	-	0	-	-	0	-	-	0	-	-	0	-
Peak Hour Factor	78	84	78	78	88	78	78	78	78	78	78	78
Heavy Vehicles, %	2	2	2	2	2	2	2	2	2	2	2	2
Mvmt Flow	1	149	33	4	301	1	19	1	1	3	1	47

Major/Minor	Major1			Major2			Minor1			Minor2		
Conflicting Flow All	302	0	0	182	0	0	478	478	165	461	494	302
Stage 1	-	-	-	-	-	-	168	168	-	309	309	-
Stage 2	-	-	-	-	-	-	309	310	-	152	185	-
Critical Hdwy	4.12	-	-	4.12	-	-	7.12	6.52	6.22	7.12	6.52	6.22
Critical Hdwy Stg 1	-	-	-	-	-	-	6.12	5.52	-	6.12	5.52	-
Critical Hdwy Stg 2	-	-	-	-	-	-	6.12	5.52	-	6.12	5.52	-
Follow-up Hdwy	2.218	-	-	2.218	-	-	3.518	4.018	3.318	3.518	4.018	3.318
Pot Cap-1 Maneuver	1259	-	-	1393	-	-	498	486	879	510	476	738
Stage 1	-	-	-	-	-	-	834	759	-	701	659	-
Stage 2	-	-	-	-	-	-	701	659	-	850	747	-
Platoon blocked, %	-	-	-	-	-	-	-	-	-	-	-	-
Mov Cap-1 Maneuver	1259	-	-	1393	-	-	463	484	879	506	474	738
Mov Cap-2 Maneuver	-	-	-	-	-	-	463	484	-	506	474	-
Stage 1	-	-	-	-	-	-	833	759	-	698	657	-
Stage 2	-	-	-	-	-	-	652	657	-	847	746	-

Approach	EB		WB		NB		SB	
HCM Control Delay, s/v	0.05		0.1		12.9		10.37	
HCM LOS					B		B	

Minor Lane/Major Mvmt	NBLn1	EBL	EBT	EBR	WBL	WBT	WBR	SBLn1	SBLn2	SBLn3
Capacity (veh/h)	477	1259	-	-	23	-	-	506	474	738
HCM Lane V/C Ratio	0.046	0.001	-	-	0.003	-	-	0.005	0.003	0.064
HCM Control Delay (s/veh)	12.9	7.9	-	-	7.6	0	-	12.1	12.6	10.2
HCM Lane LOS	B	A	-	-	A	A	-	B	B	B
HCM 95th %tile Q(veh)	0.1	0	-	-	0	-	-	0	0	0.2

Lanes, Volumes, Timings  
1: US 24 & Judge Orr Road



Lane Group	EBL	EBT	EBR	WBL	WBT	WBR	NEL	NET	NER	SWL	SWT	SWR
Lane Configurations		↕			↕			↕			↕	
Traffic Volume (vph)	45	62	82	149	76	4	190	573	252	4	463	21
Future Volume (vph)	45	62	82	149	76	4	190	573	252	4	463	21
Ideal Flow (vphpl)	1900	1900	1900	1900	1900	1900	1900	1900	1900	1900	1900	1900
Storage Length (ft)	150		0	150		0	850		0	700		0
Storage Lanes	0		0	0		0	0		0	0		0
Taper Length (ft)	25			25			25			25		
Lane Util. Factor	1.00	1.00	1.00	1.00	1.00	1.00	1.00	1.00	1.00	1.00	1.00	1.00
Frt		0.942			0.998			0.966			0.993	
Flt Protected		0.988			0.969			0.990				
Satd. Flow (prot)	0	1734	0	0	1801	0	0	1781	0	0	1850	0
Flt Permitted		0.988			0.969			0.990				
Satd. Flow (perm)	0	1734	0	0	1801	0	0	1781	0	0	1850	0
Link Speed (mph)		45			45			55			55	
Link Distance (ft)		1085			2173			1190			1114	
Travel Time (s)		16.4			32.9			14.8			13.8	
Peak Hour Factor	0.78	0.79	0.81	0.85	0.81	0.78	0.87	0.92	0.88	0.78	0.92	0.78
Adj. Flow (vph)	58	78	101	175	94	5	218	623	286	5	503	27
Shared Lane Traffic (%)												
Lane Group Flow (vph)	0	237	0	0	274	0	0	1127	0	0	535	0
Enter Blocked Intersection	No	No	No	No	No	No	No	No	No	No	No	No
Lane Alignment	Left	Left	Right	Left	Left	Right	Left	Left	Right	Left	Left	Right
Median Width(ft)		12			12			0			0	
Link Offset(ft)		0			0			0			0	
Crosswalk Width(ft)		16			16			16			16	
Two way Left Turn Lane												
Headway Factor	1.00	1.00	1.00	1.00	1.00	1.00	1.00	1.00	1.00	1.00	1.00	1.00
Turning Speed (mph)	15		9	15		9	15		9	15		9
Sign Control		Yield			Yield			Yield			Yield	

Intersection Summary

Area Type:	Other
Control Type:	Roundabout
Intersection Capacity Utilization	118.5%
ICU Level of Service	H
Analysis Period (min)	15

Intersection				
Intersection Delay, s/veh	26.4			
Intersection LOS	D			
Approach	EB	WB	NE	SW
Entry Lanes	1	1	1	1
Conflicting Circle Lanes	1	1	1	1
Adj Approach Flow, veh/h	237	274	1127	535
Demand Flow Rate, veh/h	242	280	1149	546
Vehicles Circulating, veh/h	696	916	144	496
Vehicles Exiting, veh/h	346	377	795	699
Ped Vol Crossing Leg, #/h	0	0	0	0
Ped Cap Adj	1.000	1.000	1.000	1.000
Approach Delay, s/veh	10.2	16.4	37.3	15.7
Approach LOS	B	C	E	C
Lane	Left	Left	Left	Left
Designated Moves	LTR	LTR	LTR	LTR
Assumed Moves	LTR	LTR	LTR	LTR
RT Channelized				
Lane Util	1.000	1.000	1.000	1.000
Follow-Up Headway, s	2.609	2.609	2.609	2.609
Critical Headway, s	4.976	4.976	4.976	4.976
A (Intercept)	1380	1380	1380	1380
B (Slope)	1.02e-3	1.02e-3	1.02e-3	1.02e-3
Entry Flow, veh/h	242	280	1149	546
Cap Entry Lane, veh/h	679	542	1191	832
Entry HV Adj Factor	0.981	0.979	0.980	0.980
Flow Entry, veh/h	237	274	1127	535
Cap Entry, veh/h	666	531	1168	815
V/C Ratio	0.357	0.516	0.964	0.656
Control Delay, s/veh	10.2	16.4	37.3	15.7
LOS	B	C	E	C
95th %tile Queue, veh	2	3	18	5

Lanes, Volumes, Timings  
2: Cessna Drive & Judge Orr Road

JR Engineering  
05/21/2025

Lane Group	EBL	EBT	EBR	WBL	WBT	WBR	NBL	NBT	NBR	SBL	SBT	SBR
Lane Configurations												
Traffic Volume (vph)	13	297	9	1	188	2	36	1	5	1	1	7
Future Volume (vph)	13	297	9	1	188	2	36	1	5	1	1	7
Ideal Flow (vphpl)	1900	1900	1900	1900	1900	1900	1900	1900	1900	1900	1900	1900
Storage Length (ft)	150		0	150		0	100		0	100		100
Storage Lanes	1		0	0		0	0		0	1		1
Taper Length (ft)	25			25			25			25		
Lane Util. Factor	1.00	1.00	1.00	1.00	1.00	1.00	1.00	1.00	1.00	1.00	1.00	1.00
Frt		0.995			0.998			0.985				0.850
Flt Protected	0.950							0.958		0.950		
Satd. Flow (prot)	1770	1853	0	0	1859	0	0	1758	0	1770	1863	1583
Flt Permitted	0.950							0.958		0.950		
Satd. Flow (perm)	1770	1853	0	0	1859	0	0	1758	0	1770	1863	1583
Link Speed (mph)		45			45			30				30
Link Distance (ft)		2173			1039			672				678
Travel Time (s)		32.9			15.7			15.3				15.4
Peak Hour Factor	0.78	0.89	0.78	0.78	0.87	0.78	0.78	0.78	0.78	0.78	0.78	0.78
Adj. Flow (vph)	17	334	12	1	216	3	46	1	6	1	1	9
Shared Lane Traffic (%)												
Lane Group Flow (vph)	17	346	0	0	220	0	0	53	0	1	1	9
Enter Blocked Intersection	No	No	No	No	No	No	No	No	No	No	No	No
Lane Alignment	Left	Left	Right	Left	Left	Right	Left	Left	Right	Left	Left	Right
Median Width(ft)		12			12			12				12
Link Offset(ft)		0			0			0				0
Crosswalk Width(ft)		16			16			16				16
Two way Left Turn Lane												
Headway Factor	1.00	1.00	1.00	1.00	1.00	1.00	1.00	1.00	1.00	1.00	1.00	1.00
Turning Speed (mph)	15		9	15		9	15		9	15		9
Sign Control		Free			Free			Stop				Stop

Intersection Summary

Area Type:	Other
Control Type:	Unsignalized
Intersection Capacity Utilization	31.9%
ICU Level of Service	A
Analysis Period (min)	15

Intersection												
Int Delay, s/veh	1.6											
Movement	EBL	EBT	EBR	WBL	WBT	WBR	NBL	NBT	NBR	SBL	SBT	SBR
Lane Configurations												
Traffic Vol, veh/h	13	297	9	1	188	2	36	1	5	1	1	7
Future Vol, veh/h	13	297	9	1	188	2	36	1	5	1	1	7
Conflicting Peds, #/hr	0	0	0	0	0	0	0	0	0	0	0	0
Sign Control	Free	Free	Free	Free	Free	Free	Stop	Stop	Stop	Stop	Stop	Stop
RT Channelized	-	-	None	-	-	None	-	-	None	-	-	None
Storage Length	150	-	-	-	-	-	-	-	-	100	-	100
Veh in Median Storage, #	-	0	-	-	0	-	-	0	-	-	0	-
Grade, %	-	0	-	-	0	-	-	0	-	-	0	-
Peak Hour Factor	78	89	78	78	87	78	78	78	78	78	78	78
Heavy Vehicles, %	2	2	2	2	2	2	2	2	2	2	2	2
Mvmt Flow	17	334	12	1	216	3	46	1	6	1	1	9

Major/Minor	Major1			Major2			Minor1			Minor2		
Conflicting Flow All	219	0	0	345	0	0	592	594	339	588	599	217
Stage 1	-	-	-	-	-	-	373	373	-	220	220	-
Stage 2	-	-	-	-	-	-	219	221	-	368	379	-
Critical Hdwy	4.12	-	-	4.12	-	-	7.12	6.52	6.22	7.12	6.52	6.22
Critical Hdwy Stg 1	-	-	-	-	-	-	6.12	5.52	-	6.12	5.52	-
Critical Hdwy Stg 2	-	-	-	-	-	-	6.12	5.52	-	6.12	5.52	-
Follow-up Hdwy	2.218	-	-	2.218	-	-	3.518	4.018	3.318	3.518	4.018	3.318
Pot Cap-1 Maneuver	1351	-	-	1214	-	-	418	418	703	421	415	822
Stage 1	-	-	-	-	-	-	648	618	-	782	721	-
Stage 2	-	-	-	-	-	-	783	720	-	652	615	-
Platoon blocked, %	-	-	-	-	-	-	-	-	-	-	-	-
Mov Cap-1 Maneuver	1351	-	-	1214	-	-	406	412	703	410	410	822
Mov Cap-2 Maneuver	-	-	-	-	-	-	406	412	-	410	410	-
Stage 1	-	-	-	-	-	-	640	611	-	782	720	-
Stage 2	-	-	-	-	-	-	772	719	-	637	607	-

Approach	EB			WB			NB			SB		
HCM Control Delay, s/v	0.35			0.05			14.62			10.4		
HCM LOS							B			B		

Minor Lane/Major Mvmt	NBLn1	EBL	EBT	EBR	WBL	WBT	WBR	SBLn1	SBLn2	SBLn3
Capacity (veh/h)	428	1351	-	-	10	-	-	410	410	822
HCM Lane V/C Ratio	0.126	0.012	-	-	0.001	-	-	0.003	0.003	0.011
HCM Control Delay (s/veh)	14.6	7.7	-	-	8	0	-	13.8	13.8	9.4
HCM Lane LOS	B	A	-	-	A	A	-	B	B	A
HCM 95th %tile Q(veh)	0.4	0	-	-	0	-	-	0	0	0

Lanes, Volumes, Timings  
1: US 24 & Judge Orr Road



Lane Group	EBL	EBT	EBR	WBL	WBT	WBR	NEL	NET	NER	SWL	SWT	SWR
Lane Configurations		↕			↕			↕			↕	
Traffic Volume (vph)	26	149	180	268	104	17	92	300	223	36	559	23
Future Volume (vph)	26	149	180	268	104	17	92	300	223	36	559	23
Ideal Flow (vphpl)	1900	1900	1900	1900	1900	1900	1900	1900	1900	1900	1900	1900
Storage Length (ft)	150		150	150		150	850		150	700		150
Storage Lanes	0		0	0		0	0		0	0		0
Taper Length (ft)	25			25			25			25		
Lane Util. Factor	1.00	1.00	1.00	1.00	1.00	1.00	1.00	1.00	1.00	1.00	1.00	1.00
Frt		0.932			0.993			0.951			0.994	
Flt Protected		0.996			0.967			0.992			0.997	
Satd. Flow (prot)	0	1729	0	0	1789	0	0	1757	0	0	1846	0
Flt Permitted		0.996			0.967			0.992			0.997	
Satd. Flow (perm)	0	1729	0	0	1789	0	0	1757	0	0	1846	0
Link Speed (mph)		45			45			55			55	
Link Distance (ft)		1085			2173			1190			1114	
Travel Time (s)		16.4			32.9			14.8			13.8	
Peak Hour Factor	0.78	0.85	0.86	0.88	0.83	0.78	0.82	0.89	0.87	0.78	0.92	0.78
Adj. Flow (vph)	33	175	209	305	125	22	112	337	256	46	608	29
Shared Lane Traffic (%)												
Lane Group Flow (vph)	0	417	0	0	452	0	0	705	0	0	683	0
Enter Blocked Intersection	No	No	No	No	No	No	No	No	No	No	No	No
Lane Alignment	Left	Left	Right	Left	Left	Right	Left	Left	Right	Left	Left	Right
Median Width(ft)		12			12			0			0	
Link Offset(ft)		0			0			0			0	
Crosswalk Width(ft)		16			16			16			16	
Two way Left Turn Lane												
Headway Factor	1.00	1.00	1.00	1.00	1.00	1.00	1.00	1.00	1.00	1.00	1.00	1.00
Turning Speed (mph)	15		9	15		9	15		9	15		9
Sign Control		Yield			Yield			Yield			Yield	

Intersection Summary

Area Type:	Other
Control Type:	Roundabout
Intersection Capacity Utilization	113.7%
ICU Level of Service	H
Analysis Period (min)	15

Intersection				
Intersection Delay, s/veh	24.2			
Intersection LOS	C			
Approach	EB	WB	NE	SW
Entry Lanes	1	1	1	1
Conflicting Circle Lanes	1	1	1	1
Adj Approach Flow, veh/h	417	452	705	683
Demand Flow Rate, veh/h	426	461	719	697
Vehicles Circulating, veh/h	978	492	259	553
Vehicles Exiting, veh/h	272	487	1144	400
Ped Vol Crossing Leg, #/h	0	0	0	0
Ped Cap Adj	1.000	1.000	1.000	1.000
Approach Delay, s/veh	38.5	12.4	13.8	34.0
Approach LOS	E	B	B	D
Lane	Left	Left	Left	Left
Designated Moves	LTR	LTR	LTR	LTR
Assumed Moves	LTR	LTR	LTR	LTR
RT Channelized				
Lane Util	1.000	1.000	1.000	1.000
Follow-Up Headway, s	2.609	2.609	2.609	2.609
Critical Headway, s	4.976	4.976	4.976	4.976
A (Intercept)	1380	1380	1380	1380
B (Slope)	1.02e-3	1.02e-3	1.02e-3	1.02e-3
Entry Flow, veh/h	426	461	719	697
Cap Entry Lane, veh/h	509	835	1060	785
Entry HV Adj Factor	0.980	0.982	0.981	0.980
Flow Entry, veh/h	417	452	705	683
Cap Entry, veh/h	499	820	1039	769
V/C Ratio	0.837	0.552	0.679	0.888
Control Delay, s/veh	38.5	12.4	13.8	34.0
LOS	E	B	B	D
95th %tile Queue, veh	8	3	6	11

Lanes, Volumes, Timings  
2: Cessna Drive & Judge Orr Road

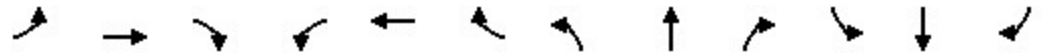

Lane Group	EBL	EBT	EBR	WBL	WBT	WBR	NBL	NBT	NBR	SBL	SBT	SBR
Lane Configurations												
Traffic Volume (vph)	256	125	26	3	265	28	15	1	1	12	1	101
Future Volume (vph)	256	125	26	3	265	28	15	1	1	12	1	101
Ideal Flow (vphpl)	1900	1900	1900	1900	1900	1900	1900	1900	1900	1900	1900	1900
Storage Length (ft)	150		0	150		0	100		0	100		100
Storage Lanes	1		0	0		0	0		0	1		1
Taper Length (ft)	25			25			25			25		
Lane Util. Factor	1.00	1.00	1.00	1.00	1.00	1.00	1.00	1.00	1.00	1.00	1.00	1.00
Frt		0.973			0.986			0.994				0.850
Flt Protected	0.950				0.999			0.957		0.950		
Satd. Flow (prot)	1770	1812	0	0	1835	0	0	1772	0	1770	1863	1583
Flt Permitted	0.950				0.999			0.957		0.950		
Satd. Flow (perm)	1770	1812	0	0	1835	0	0	1772	0	1770	1863	1583
Link Speed (mph)		45			45			30				30
Link Distance (ft)		2173			1039			672				678
Travel Time (s)		32.9			15.7			15.3				15.4
Peak Hour Factor	0.88	0.84	0.78	0.78	0.88	0.78	0.78	0.78	0.78	0.78	0.78	0.83
Adj. Flow (vph)	291	149	33	4	301	36	19	1	1	15	1	122
Shared Lane Traffic (%)												
Lane Group Flow (vph)	291	182	0	0	341	0	0	21	0	15	1	122
Enter Blocked Intersection	No	No	No	No	No	No	No	No	No	No	No	No
Lane Alignment	Left	Left	Right	Left	Left	Right	Left	Left	Right	Left	Left	Right
Median Width(ft)		12			12			12				12
Link Offset(ft)		0			0			0				0
Crosswalk Width(ft)		16			16			16				16
Two way Left Turn Lane												
Headway Factor	1.00	1.00	1.00	1.00	1.00	1.00	1.00	1.00	1.00	1.00	1.00	1.00
Turning Speed (mph)	15		9	15		9	15		9	15		9
Sign Control		Free			Free			Stop				Stop

Intersection Summary

Area Type:	Other
Control Type:	Unsignalized
Intersection Capacity Utilization	47.6%
ICU Level of Service	A
Analysis Period (min)	15

Intersection												
Int Delay, s/veh	5.4											
Movement	EBL	EBT	EBR	WBL	WBT	WBR	NBL	NBT	NBR	SBL	SBT	SBR
Lane Configurations												
Traffic Vol, veh/h	256	125	26	3	265	28	15	1	1	12	1	101
Future Vol, veh/h	256	125	26	3	265	28	15	1	1	12	1	101
Conflicting Peds, #/hr	0	0	0	0	0	0	0	0	0	0	0	0
Sign Control	Free	Free	Free	Free	Free	Free	Stop	Stop	Stop	Stop	Stop	Stop
RT Channelized	-	-	None	-	-	None	-	-	None	-	-	None
Storage Length	150	-	-	-	-	-	-	-	-	100	-	100
Veh in Median Storage, #	-	0	-	-	0	-	-	0	-	-	0	-
Grade, %	-	0	-	-	0	-	-	0	-	-	0	-
Peak Hour Factor	88	84	78	78	88	78	78	78	78	78	78	83
Heavy Vehicles, %	2	2	2	2	2	2	2	2	2	2	2	2
Mvmt Flow	291	149	33	4	301	36	19	1	1	15	1	122

Major/Minor	Major1			Major2			Minor1			Minor2		
Conflicting Flow All	337	0	0	182	0	0	1057	1092	165	1058	1091	319
Stage 1	-	-	-	-	-	-	747	747	-	327	327	-
Stage 2	-	-	-	-	-	-	309	345	-	731	764	-
Critical Hdwy	4.12	-	-	4.12	-	-	7.12	6.52	6.22	7.12	6.52	6.22
Critical Hdwy Stg 1	-	-	-	-	-	-	6.12	5.52	-	6.12	5.52	-
Critical Hdwy Stg 2	-	-	-	-	-	-	6.12	5.52	-	6.12	5.52	-
Follow-up Hdwy	2.218	-	-	2.218	-	-	3.518	4.018	3.318	3.518	4.018	3.318
Pot Cap-1 Maneuver	1222	-	-	1393	-	-	203	215	879	203	215	722
Stage 1	-	-	-	-	-	-	405	420	-	686	648	-
Stage 2	-	-	-	-	-	-	701	636	-	413	413	-
Platoon blocked, %		-	-	-	-	-						
Mov Cap-1 Maneuver	1222	-	-	1393	-	-	127	163	879	153	163	722
Mov Cap-2 Maneuver	-	-	-	-	-	-	127	163	-	153	163	-
Stage 1	-	-	-	-	-	-	308	320	-	684	646	-
Stage 2	-	-	-	-	-	-	579	634	-	313	314	-

Approach	EB			WB			NB			SB		
HCM Control Delay, s/v	5.45			0.09			36.47			13.4		
HCM LOS							E			B		

Minor Lane/Major Mvmt	NBLn1	EBL	EBT	EBR	WBL	WBT	WBR	SBLn1	SBLn2	SBLn3	
Capacity (veh/h)	136	1222	-	-	20	-	-	153	163	722	
HCM Lane V/C Ratio	0.16	0.238	-	-	0.003	-	-	0.101	0.008	0.169	
HCM Control Delay (s/veh)	36.5	8.9	-	-	7.6	0	-	31.2	27.2	11	
HCM Lane LOS		E	A	-	-	A	A	-	D	D	B
HCM 95th %tile Q(veh)	0.6	0.9	-	-	0	-	-	0.3	0	0.6	

Lanes, Volumes, Timings  
1: US 24 & Judge Orr Road



Lane Group	EBL	EBT	EBR	WBL	WBT	WBR	NEL	NET	NER	SWL	SWT	SWR
Lane Configurations		↕			↕			↕			↕	
Traffic Volume (vph)	45	119	82	309	172	36	190	573	347	23	463	21
Future Volume (vph)	45	119	82	309	172	36	190	573	347	23	463	21
Ideal Flow (vphpl)	1900	1900	1900	1900	1900	1900	1900	1900	1900	1900	1900	1900
Storage Length (ft)	150		150	150		150	850		150	700		150
Storage Lanes	0		0	0		0	0		0	0		0
Taper Length (ft)	25			25			25			25		
Lane Util. Factor	1.00	1.00	1.00	1.00	1.00	1.00	1.00	1.00	1.00	1.00	1.00	1.00
Frt		0.955			0.990			0.957			0.994	
Flt Protected		0.990			0.972			0.991			0.997	
Satd. Flow (prot)	0	1761	0	0	1792	0	0	1767	0	0	1846	0
Flt Permitted		0.990			0.972			0.991			0.997	
Satd. Flow (perm)	0	1761	0	0	1792	0	0	1767	0	0	1846	0
Link Speed (mph)		45			45			55			55	
Link Distance (ft)		1085			2173			1190			1114	
Travel Time (s)		16.4			32.9			14.8			13.8	
Peak Hour Factor	0.78	0.84	0.81	0.89	0.86	0.78	0.87	0.92	0.89	0.78	0.91	0.78
Adj. Flow (vph)	58	142	101	347	200	46	218	623	390	29	509	27
Shared Lane Traffic (%)												
Lane Group Flow (vph)	0	301	0	0	593	0	0	1231	0	0	565	0
Enter Blocked Intersection	No	No	No	No	No	No	No	No	No	No	No	No
Lane Alignment	Left	Left	Right	Left	Left	Right	Left	Left	Right	Left	Left	Right
Median Width(ft)		12			12			0			0	
Link Offset(ft)		0			0			0			0	
Crosswalk Width(ft)		16			16			16			16	
Two way Left Turn Lane												
Headway Factor	1.00	1.00	1.00	1.00	1.00	1.00	1.00	1.00	1.00	1.00	1.00	1.00
Turning Speed (mph)	15		9	15		9	15		9	15		9
Sign Control		Yield			Yield			Yield			Yield	

Intersection Summary

Area Type:	Other
Control Type:	Roundabout
Intersection Capacity Utilization	144.2%
ICU Level of Service	H
Analysis Period (min)	15

Intersection				
Intersection Delay, s/veh	78.8			
Intersection LOS	F			
Approach	EB	WB	NE	SW
Entry Lanes	1	1	1	1
Conflicting Circle Lanes	1	1	1	1
Adj Approach Flow, veh/h	301	593	1231	565
Demand Flow Rate, veh/h	307	605	1255	577
Vehicles Circulating, veh/h	903	916	234	780
Vehicles Exiting, veh/h	454	573	976	741
Ped Vol Crossing Leg, #/h	0	0	0	0
Ped Cap Adj	1.000	1.000	1.000	1.000
Approach Delay, s/veh	17.6	101.8	97.6	46.3
Approach LOS	C	F	F	E
Lane	Left	Left	Left	Left
Designated Moves	LTR	LTR	LTR	LTR
Assumed Moves	LTR	LTR	LTR	LTR
RT Channelized				
Lane Util	1.000	1.000	1.000	1.000
Follow-Up Headway, s	2.609	2.609	2.609	2.609
Critical Headway, s	4.976	4.976	4.976	4.976
A (Intercept)	1380	1380	1380	1380
B (Slope)	1.02e-3	1.02e-3	1.02e-3	1.02e-3
Entry Flow, veh/h	307	605	1255	577
Cap Entry Lane, veh/h	549	542	1087	623
Entry HV Adj Factor	0.981	0.980	0.981	0.979
Flow Entry, veh/h	301	593	1231	565
Cap Entry, veh/h	539	531	1066	610
V/C Ratio	0.559	1.116	1.155	0.926
Control Delay, s/veh	17.6	101.8	97.6	46.3
LOS	C	F	F	E
95th %tile Queue, veh	3	19	34	12

Lanes, Volumes, Timings  
2: Cessna Drive & Judge Orr Road

JR Engineering  
05/21/2025

Lane Group	EBL	EBT	EBR	WBL	WBT	WBR	NBL	NBT	NBR	SBL	SBT	SBR
Lane Configurations												
Traffic Volume (vph)	183	297	9	1	188	21	36	1	5	32	1	294
Future Volume (vph)	183	297	9	1	188	21	36	1	5	32	1	294
Ideal Flow (vphpl)	1900	1900	1900	1900	1900	1900	1900	1900	1900	1900	1900	1900
Storage Length (ft)	150		0	150		0	100		0	100		100
Storage Lanes	1		0	0		0	0		0	1		1
Taper Length (ft)	25			25			25			25		
Lane Util. Factor	1.00	1.00	1.00	1.00	1.00	1.00	1.00	1.00	1.00	1.00	1.00	1.00
Frt		0.995			0.985			0.985				0.850
Flt Protected	0.950							0.958		0.950		
Satd. Flow (prot)	1770	1853	0	0	1835	0	0	1758	0	1770	1863	1583
Flt Permitted	0.950							0.958		0.950		
Satd. Flow (perm)	1770	1853	0	0	1835	0	0	1758	0	1770	1863	1583
Link Speed (mph)		45			45			30				30
Link Distance (ft)		2173			1039			672				678
Travel Time (s)		32.9			15.7			15.3				15.4
Peak Hour Factor	0.86	0.89	0.78	0.78	0.86	0.78	0.78	0.78	0.78	0.78	0.78	0.89
Adj. Flow (vph)	213	334	12	1	219	27	46	1	6	41	1	330
Shared Lane Traffic (%)												
Lane Group Flow (vph)	213	346	0	0	247	0	0	53	0	41	1	330
Enter Blocked Intersection	No	No	No	No	No	No	No	No	No	No	No	No
Lane Alignment	Left	Left	Right	Left	Left	Right	Left	Left	Right	Left	Left	Right
Median Width(ft)		12			12			12				12
Link Offset(ft)		0			0			0				0
Crosswalk Width(ft)		16			16			16				16
Two way Left Turn Lane												
Headway Factor	1.00	1.00	1.00	1.00	1.00	1.00	1.00	1.00	1.00	1.00	1.00	1.00
Turning Speed (mph)	15		9	15		9	15		9	15		9
Sign Control		Free			Free			Stop				Stop

Intersection Summary

Area Type:	Other
Control Type:	Unsignalized
Intersection Capacity Utilization	46.4%
ICU Level of Service	A
Analysis Period (min)	15

Intersection												
Int Delay, s/veh	8.2											
Movement	EBL	EBT	EBR	WBL	WBT	WBR	NBL	NBT	NBR	SBL	SBT	SBR
Lane Configurations												
Traffic Vol, veh/h	183	297	9	1	188	21	36	1	5	32	1	294
Future Vol, veh/h	183	297	9	1	188	21	36	1	5	32	1	294
Conflicting Peds, #/hr	0	0	0	0	0	0	0	0	0	0	0	0
Sign Control	Free	Free	Free	Free	Free	Free	Stop	Stop	Stop	Stop	Stop	Stop
RT Channelized	-	-	None	-	-	None	-	-	None	-	-	None
Storage Length	150	-	-	-	-	-	-	-	-	100	-	100
Veh in Median Storage, #	-	0	-	-	0	-	-	0	-	-	0	-
Grade, %	-	0	-	-	0	-	-	0	-	-	0	-
Peak Hour Factor	86	89	78	78	86	78	78	78	78	78	78	89
Heavy Vehicles, %	2	2	2	2	2	2	2	2	2	2	2	2
Mvmt Flow	213	334	12	1	219	27	46	1	6	41	1	330

Major/Minor	Major1			Major2			Minor1			Minor2		
Conflicting Flow All	246	0	0	345	0	0	987	1013	339	995	1005	232
Stage 1	-	-	-	-	-	-	765	765	-	235	235	-
Stage 2	-	-	-	-	-	-	222	248	-	760	771	-
Critical Hdwy	4.12	-	-	4.12	-	-	7.12	6.52	6.22	7.12	6.52	6.22
Critical Hdwy Stg 1	-	-	-	-	-	-	6.12	5.52	-	6.12	5.52	-
Critical Hdwy Stg 2	-	-	-	-	-	-	6.12	5.52	-	6.12	5.52	-
Follow-up Hdwy	2.218	-	-	2.218	-	-	3.518	4.018	3.318	3.518	4.018	3.318
Pot Cap-1 Maneuver	1321	-	-	1214	-	-	226	239	703	224	241	807
Stage 1	-	-	-	-	-	-	396	412	-	768	711	-
Stage 2	-	-	-	-	-	-	781	701	-	398	410	-
Platoon blocked, %		-	-		-	-						
Mov Cap-1 Maneuver	1321	-	-	1214	-	-	111	200	703	185	202	807
Mov Cap-2 Maneuver	-	-	-	-	-	-	111	200	-	185	202	-
Stage 1	-	-	-	-	-	-	332	346	-	768	710	-
Stage 2	-	-	-	-	-	-	460	700	-	330	344	-

Approach	EB			WB			NB			SB		
HCM Control Delay, s/v	3.15			0.04			53.76			14.47		
HCM LOS							F			B		

Minor Lane/Major Mvmt	NBLn1	EBL	EBT	EBR	WBL	WBT	WBR	SBLn1	SBLn2	SBLn3
Capacity (veh/h)	125	1321	-	-	9	-	-	185	202	807
HCM Lane V/C Ratio	0.429	0.161	-	-	0.001	-	-	0.222	0.006	0.409
HCM Control Delay (s/veh)	53.8	8.2	-	-	8	0	-	30	22.9	12.5
HCM Lane LOS	F	A	-	-	A	A	-	D	C	B
HCM 95th %tile Q(veh)	1.9	0.6	-	-	0	-	-	0.8	0	2

Lanes, Volumes, Timings  
1: US 24 & Judge Orr Road



Lane Group	EBL	EBT	EBR	WBL	WBT	WBR	NEL	NET	NER	SWL	SWT	SWR
Lane Configurations												
Traffic Volume (vph)	30	140	216	325	134	25	110	359	198	31	668	27
Future Volume (vph)	30	140	216	325	134	25	110	359	198	31	668	27
Ideal Flow (vphpl)	1900	1900	1900	1900	1900	1900	1900	1900	1900	1900	1900	1900
Storage Length (ft)	0		275	0		0	0		0	0		0
Storage Lanes	0		1	0		0	0		0	0		0
Taper Length (ft)	25			25			25			25		
Lane Util. Factor	1.00	1.00	1.00	1.00	1.00	1.00	0.95	0.95	0.95	0.95	0.95	0.95
Frt			0.850		0.992			0.955			0.993	
Flt Protected		0.991			0.968			0.991			0.998	
Satd. Flow (prot)	0	1846	1583	0	1789	0	0	3350	0	0	3507	0
Flt Permitted		0.991			0.968			0.991			0.998	
Satd. Flow (perm)	0	1846	1583	0	1789	0	0	3350	0	0	3507	0
Link Speed (mph)		45			45			55			55	
Link Distance (ft)		1085			2173			1190			1114	
Travel Time (s)		16.4			32.9			14.8			13.8	
Peak Hour Factor	0.78	0.85	0.87	0.89	0.84	0.78	0.83	0.90	0.87	0.78	0.92	0.78
Adj. Flow (vph)	38	165	248	365	160	32	133	399	228	40	726	35
Shared Lane Traffic (%)												
Lane Group Flow (vph)	0	203	248	0	557	0	0	760	0	0	801	0
Enter Blocked Intersection	No	No	No	No	No	No	No	No	No	No	No	No
Lane Alignment	Left	Left	Right	Left	Left	Right	Left	Left	Right	Left	Left	Right
Median Width(ft)		12			12			0			0	
Link Offset(ft)		0			0			0			0	
Crosswalk Width(ft)		16			16			16			16	
Two way Left Turn Lane												
Headway Factor	1.00	1.00	1.00	1.00	1.00	1.00	1.00	1.00	1.00	1.00	1.00	1.00
Turning Speed (mph)	15		9	15		9	15		9	15		9
Sign Control		Yield			Yield			Yield			Yield	

Intersection Summary

Area Type:	Other
Control Type:	Roundabout
Intersection Capacity Utilization	88.6%
ICU Level of Service	E
Analysis Period (min)	15

Intersection									
Intersection Delay, s/veh	9.5								
Intersection LOS	A								
Approach	EB		WB		NE		SW		
Entry Lanes	1		1		2		2		
Conflicting Circle Lanes	2		2		2		2		
Adj Approach Flow, veh/h	451		557		760		801		
Demand Flow Rate, veh/h	460		568		776		818		
Vehicles Circulating, veh/h	1154		582		248		671		
Vehicles Exiting, veh/h	335		209		1113		479		
Ped Vol Crossing Leg, #/h	0		0		0		0		
Ped Cap Adj	1.000		1.000		1.000		1.000		
Approach Delay, s/veh	5.9		15.2		3.9		12.8		
Approach LOS	A		C		A		B		
Lane	Left	Bypass	Left	Left	Right	Bypass	Left	Right	
Designated Moves	LT	R	LTR		LT	TR	R	LT	TR
Assumed Moves	LT		LTR		LT	TR		LT	TR
RT Channelized		Free				Free			
Lane Util	1.000		1.000		0.470	0.530		0.469	0.531
Follow-Up Headway, s	2.535		2.535		2.667	2.535		2.667	2.535
Critical Headway, s	4.328		4.328		4.645	4.328		4.645	4.328
A (Intercept)	1420		1420		1350	1420		1350	1420
B (Slope)	8.501e-4		8.501e-4		9.199e-4	8.501e-4		9.199e-4	8.501e-4
Entry Flow, veh/h	207	253	568		255	288	233	384	434
Cap Entry Lane, veh/h	532	1938	866		1074	1150	1938	728	803
Entry HV Adj Factor	0.979	0.980	0.980		0.981	0.979	0.980	0.981	0.979
Flow Entry, veh/h	203	248	557		250	282	228	377	425
Cap Entry, veh/h	521	1900	849		1054	1126	1900	714	786
V/C Ratio	0.389	0.131	0.656		0.237	0.250	0.120	0.527	0.541
Control Delay, s/veh	13.2	0.0	15.2		5.7	5.5	0.0	13.2	12.5
LOS	B	A	C		A	A	A	B	B
95th %tile Queue, veh	2	0	5		1	1	0	3	3

Lanes, Volumes, Timings  
2: Cessna Drive & Judge Orr Road

Lane Group	EBL	EBT	EBR	WBL	WBT	WBR	NBL	NBT	NBR	SBL	SBT	SBR
Lane Configurations												
Traffic Volume (vph)	1	336	31	4	439	1	19	1	1	2	1	19
Future Volume (vph)	1	336	31	4	439	1	19	1	1	2	1	19
Ideal Flow (vphpl)	1900	1900	1900	1900	1900	1900	1900	1900	1900	1900	1900	1900
Storage Length (ft)	150		0	150		0	100		0	100		100
Storage Lanes	1		0	0		0	0		0	1		1
Taper Length (ft)	25			25			25			25		
Lane Util. Factor	1.00	1.00	1.00	1.00	1.00	1.00	1.00	1.00	1.00	1.00	1.00	1.00
Frt		0.986						0.995				0.850
Flt Protected	0.950				0.999			0.956		0.950		
Satd. Flow (prot)	1770	1837	0	0	1861	0	0	1772	0	1770	1863	1583
Flt Permitted	0.950				0.999			0.956		0.950		
Satd. Flow (perm)	1770	1837	0	0	1861	0	0	1772	0	1770	1863	1583
Link Speed (mph)		45			45			30		30		
Link Distance (ft)		2173			1039			672		678		
Travel Time (s)		32.9			15.7			15.3		15.4		
Peak Hour Factor	0.78	0.89	0.78	0.78	0.91	0.78	0.78	0.78	0.78	0.78	0.78	0.78
Adj. Flow (vph)	1	378	40	5	482	1	24	1	1	3	1	24
Shared Lane Traffic (%)												
Lane Group Flow (vph)	1	418	0	0	488	0	0	26	0	3	1	24
Enter Blocked Intersection	No	No	No	No	No	No	No	No	No	No	No	No
Lane Alignment	Left	Left	Right	Left	Left	Right	Left	Left	Right	Left	Left	Right
Median Width(ft)		12			12			12		12		12
Link Offset(ft)		0			0			0		0		0
Crosswalk Width(ft)		16			16			16		16		16
Two way Left Turn Lane												
Headway Factor	1.00	1.00	1.00	1.00	1.00	1.00	1.00	1.00	1.00	1.00	1.00	1.00
Turning Speed (mph)	15		9	15		9	15		9	15		9
Sign Control		Free			Free			Stop				Stop

Intersection Summary

Area Type:	Other
Control Type:	Unsignalized
Intersection Capacity Utilization	40.9%
ICU Level of Service	A
Analysis Period (min)	15

Intersection												
Int Delay, s/veh	1											
Movement	EBL	EBT	EBR	WBL	WBT	WBR	NBL	NBT	NBR	SBL	SBT	SBR
Lane Configurations	↖	↗			↕			↕		↖	↗	↗
Traffic Vol, veh/h	1	336	31	4	439	1	19	1	1	2	1	19
Future Vol, veh/h	1	336	31	4	439	1	19	1	1	2	1	19
Conflicting Peds, #/hr	0	0	0	0	0	0	0	0	0	0	0	0
Sign Control	Free	Free	Free	Free	Free	Free	Stop	Stop	Stop	Stop	Stop	Stop
RT Channelized	-	-	None	-	-	None	-	-	None	-	-	None
Storage Length	150	-	-	-	-	-	-	-	-	100	-	100
Veh in Median Storage, #	-	0	-	-	0	-	-	0	-	-	0	-
Grade, %	-	0	-	-	0	-	-	0	-	-	0	-
Peak Hour Factor	78	89	78	78	91	78	78	78	78	78	78	78
Heavy Vehicles, %	2	2	2	2	2	2	2	2	2	2	2	2
Mvmt Flow	1	378	40	5	482	1	24	1	1	3	1	24

Major/Minor	Major1			Major2			Minor1			Minor2		
Conflicting Flow All	484	0	0	417	0	0	893	894	397	874	913	483
Stage 1	-	-	-	-	-	-	400	400	-	493	493	-
Stage 2	-	-	-	-	-	-	493	494	-	381	420	-
Critical Hdwy	4.12	-	-	4.12	-	-	7.12	6.52	6.22	7.12	6.52	6.22
Critical Hdwy Stg 1	-	-	-	-	-	-	6.12	5.52	-	6.12	5.52	-
Critical Hdwy Stg 2	-	-	-	-	-	-	6.12	5.52	-	6.12	5.52	-
Follow-up Hdwy	2.218	-	-	2.218	-	-	3.518	4.018	3.318	3.518	4.018	3.318
Pot Cap-1 Maneuver	1079	-	-	1142	-	-	262	281	652	270	273	584
Stage 1	-	-	-	-	-	-	626	602	-	558	547	-
Stage 2	-	-	-	-	-	-	558	546	-	642	590	-
Platoon blocked, %	-	-	-	-	-	-	-	-	-	-	-	-
Mov Cap-1 Maneuver	1079	-	-	1142	-	-	248	278	652	266	271	584
Mov Cap-2 Maneuver	-	-	-	-	-	-	248	278	-	266	271	-
Stage 1	-	-	-	-	-	-	626	601	-	554	543	-
Stage 2	-	-	-	-	-	-	530	543	-	638	589	-

Approach	EB			WB			NB			SB		
HCM Control Delay, s/v	0.03			0.09			20.63			12.41		
HCM LOS							C			B		

Minor Lane/Major Mvmt	NBLn1	EBL	EBT	EBR	WBL	WBT	WBR	SBLn1	SBLn2	SBLn3
Capacity (veh/h)	257	1079	-	-	19	-	-	266	271	584
HCM Lane V/C Ratio	0.105	0.001	-	-	0.004	-	-	0.01	0.005	0.042
HCM Control Delay (s/veh)	20.6	8.3	-	-	8.2	0	-	18.6	18.3	11.4
HCM Lane LOS	C	A	-	-	A	A	-	C	C	B
HCM 95th %tile Q(veh)	0.3	0	-	-	0	-	-	0	0	0.1

Lanes, Volumes, Timings  
1: US 24 & Judge Orr Road



Lane Group	EBL	EBT	EBR	WBL	WBT	WBR	NEL	NET	NER	SWL	SWT	SWR
Lane Configurations												
Traffic Volume (vph)	53	105	99	218	117	15	227	685	339	17	553	25
Future Volume (vph)	53	105	99	218	117	15	227	685	339	17	553	25
Ideal Flow (vphpl)	1900	1900	1900	1900	1900	1900	1900	1900	1900	1900	1900	1900
Storage Length (ft)	0		275	0		0	0		0	0		0
Storage Lanes	0		1	0		0	0		0	0		0
Taper Length (ft)	25			25			25			25		
Lane Util. Factor	1.00	1.00	1.00	1.00	1.00	1.00	0.95	0.95	0.95	0.95	0.95	0.95
Frt			0.850		0.994			0.959			0.993	
Flt Protected		0.983			0.970			0.991			0.998	
Satd. Flow (prot)	0	1831	1583	0	1796	0	0	3364	0	0	3507	0
Flt Permitted		0.983			0.970			0.991			0.998	
Satd. Flow (perm)	0	1831	1583	0	1796	0	0	3364	0	0	3507	0
Link Speed (mph)		45			45			55			55	
Link Distance (ft)		1085			2173			1190			1114	
Travel Time (s)		16.4			32.9			14.8			13.8	
Peak Hour Factor	0.78	0.83	0.83	0.87	0.84	0.78	0.87	0.92	0.89	0.78	0.92	0.78
Adj. Flow (vph)	68	127	119	251	139	19	261	745	381	22	601	32
Shared Lane Traffic (%)												
Lane Group Flow (vph)	0	195	119	0	409	0	0	1387	0	0	655	0
Enter Blocked Intersection	No	No	No	No	No	No	No	No	No	No	No	No
Lane Alignment	Left	Left	Right	Left	Left	Right	Left	Left	Right	Left	Left	Right
Median Width(ft)		12			12			0			0	
Link Offset(ft)		0			0			0			0	
Crosswalk Width(ft)		16			16			16			16	
Two way Left Turn Lane												
Headway Factor	1.00	1.00	1.00	1.00	1.00	1.00	1.00	1.00	1.00	1.00	1.00	1.00
Turning Speed (mph)	15		9	15		9	15		9	15		9
Sign Control		Yield			Yield			Yield			Yield	

Intersection Summary

Area Type:	Other
Control Type:	Roundabout
Intersection Capacity Utilization	88.8%
ICU Level of Service	E
Analysis Period (min)	15

Intersection									
Intersection Delay, s/veh	10.1								
Intersection LOS	B								
Approach	EB		WB		NE		SW		
Entry Lanes	1		1		2		2		
Conflicting Circle Lanes	2		2		2		2		
Adj Approach Flow, veh/h	314		409		1387		655		
Demand Flow Rate, veh/h	320		417		1415		668		
Vehicles Circulating, veh/h	891		1095		221		664		
Vehicles Exiting, veh/h	441		152		869		848		
Ped Vol Crossing Leg, #/h	0		0		0		0		
Ped Cap Adj	1.000		1.000		1.000		1.000		
Approach Delay, s/veh	5.8		27.0		5.9		10.5		
Approach LOS	A		D		A		B		
Lane	Left	Bypass	Left	Left	Right	Bypass	Left	Right	
Designated Moves	LT	R	LTR		LT	TR	R	LT	TR
Assumed Moves	LT		LTR		LT	TR		LT	TR
RT Channelized		Free				Free			
Lane Util	1.000		1.000		0.470	0.530		0.470	0.530
Follow-Up Headway, s	2.535		2.535		2.667	2.535		2.667	2.535
Critical Headway, s	4.328		4.328		4.645	4.328		4.645	4.328
A (Intercept)	1420		1420		1350	1420		1350	1420
B (Slope)	8.501e-4		8.501e-4		9.199e-4	8.501e-4		9.199e-4	8.501e-4
Entry Flow, veh/h	199	121	417		482	544	389	314	354
Cap Entry Lane, veh/h	666	1938	560		1102	1177	1938	733	808
Entry HV Adj Factor	0.982	0.980	0.981		0.981	0.980	0.980	0.980	0.981
Flow Entry, veh/h	195	119	409		473	533	381	308	347
Cap Entry, veh/h	654	1900	549		1081	1154	1900	718	792
V/C Ratio	0.299	0.063	0.745		0.438	0.462	0.201	0.428	0.438
Control Delay, s/veh	9.3	0.0	27.0		8.1	8.1	0.0	10.9	10.2
LOS	A	A	D		A	A	A	B	B
95th %tile Queue, veh	1	0	6		2	2	1	2	2

Lanes, Volumes, Timings  
2: Cessna Drive & Judge Orr Road

JR Engineering  
05/21/2025

Lane Group	EBL	EBT	EBR	WBL	WBT	WBR	NBL	NBT	NBR	SBL	SBT	SBR
Lane Configurations												
Traffic Volume (vph)	16	434	11	1	302	2	43	1	6	1	1	9
Future Volume (vph)	16	434	11	1	302	2	43	1	6	1	1	9
Ideal Flow (vphpl)	1900	1900	1900	1900	1900	1900	1900	1900	1900	1900	1900	1900
Storage Length (ft)	150		0	150		0	100		0	100		100
Storage Lanes	1		0	0		0	0		0	1		1
Taper Length (ft)	25			25			25			25		
Lane Util. Factor	1.00	1.00	1.00	1.00	1.00	1.00	1.00	1.00	1.00	1.00	1.00	1.00
Frt		0.996			0.999			0.983				0.850
Flt Protected	0.950							0.959		0.950		
Satd. Flow (prot)	1770	1855	0	0	1861	0	0	1756	0	1770	1863	1583
Flt Permitted	0.950							0.959		0.950		
Satd. Flow (perm)	1770	1855	0	0	1861	0	0	1756	0	1770	1863	1583
Link Speed (mph)		45			45			30				30
Link Distance (ft)		2173			1039			672				678
Travel Time (s)		32.9			15.7			15.3				15.4
Peak Hour Factor	0.78	0.91	0.78	0.78	0.89	0.78	0.78	0.78	0.78	0.78	0.78	0.78
Adj. Flow (vph)	21	477	14	1	339	3	55	1	8	1	1	12
Shared Lane Traffic (%)												
Lane Group Flow (vph)	21	491	0	0	343	0	0	64	0	1	1	12
Enter Blocked Intersection	No	No	No	No	No	No	No	No	No	No	No	No
Lane Alignment	Left	Left	Right	Left	Left	Right	Left	Left	Right	Left	Left	Right
Median Width(ft)		12			12			12				12
Link Offset(ft)		0			0			0				0
Crosswalk Width(ft)		16			16			16				16
Two way Left Turn Lane												
Headway Factor	1.00	1.00	1.00	1.00	1.00	1.00	1.00	1.00	1.00	1.00	1.00	1.00
Turning Speed (mph)	15		9	15		9	15		9	15		9
Sign Control		Free			Free			Stop				Stop

Intersection Summary

Area Type:	Other
Control Type:	Unsignalized
Intersection Capacity Utilization	39.6%
ICU Level of Service	A
Analysis Period (min)	15

Intersection												
Int Delay, s/veh	1.8											
Movement	EBL	EBT	EBR	WBL	WBT	WBR	NBL	NBT	NBR	SBL	SBT	SBR
Lane Configurations												
Traffic Vol, veh/h	16	434	11	1	302	2	43	1	6	1	1	9
Future Vol, veh/h	16	434	11	1	302	2	43	1	6	1	1	9
Conflicting Peds, #/hr	0	0	0	0	0	0	0	0	0	0	0	0
Sign Control	Free	Free	Free	Free	Free	Free	Stop	Stop	Stop	Stop	Stop	Stop
RT Channelized	-	-	None	-	-	None	-	-	None	-	-	None
Storage Length	150	-	-	-	-	-	-	-	-	100	-	100
Veh in Median Storage, #	-	0	-	-	0	-	-	0	-	-	0	-
Grade, %	-	0	-	-	0	-	-	0	-	-	0	-
Peak Hour Factor	78	91	78	78	89	78	78	78	78	78	78	78
Heavy Vehicles, %	2	2	2	2	2	2	2	2	2	2	2	2
Mvmt Flow	21	477	14	1	339	3	55	1	8	1	1	12

Major/Minor	Major1			Major2			Minor1			Minor2		
Conflicting Flow All	342	0	0	491	0	0	868	869	484	862	875	341
Stage 1	-	-	-	-	-	-	525	525	-	343	343	-
Stage 2	-	-	-	-	-	-	343	344	-	519	532	-
Critical Hdwy	4.12	-	-	4.12	-	-	7.12	6.52	6.22	7.12	6.52	6.22
Critical Hdwy Stg 1	-	-	-	-	-	-	6.12	5.52	-	6.12	5.52	-
Critical Hdwy Stg 2	-	-	-	-	-	-	6.12	5.52	-	6.12	5.52	-
Follow-up Hdwy	2.218	-	-	2.218	-	-	3.518	4.018	3.318	3.518	4.018	3.318
Pot Cap-1 Maneuver	1217	-	-	1072	-	-	273	290	583	275	288	702
Stage 1	-	-	-	-	-	-	536	529	-	672	637	-
Stage 2	-	-	-	-	-	-	673	636	-	540	526	-
Platoon blocked, %		-	-		-	-						
Mov Cap-1 Maneuver	1217	-	-	1072	-	-	262	285	583	266	282	702
Mov Cap-2 Maneuver	-	-	-	-	-	-	262	285	-	266	282	-
Stage 1	-	-	-	-	-	-	527	520	-	671	636	-
Stage 2	-	-	-	-	-	-	659	635	-	523	517	-

Approach	EB			WB			NB			SB		
HCM Control Delay, s/v	0.32			0.03			21.53			11.67		
HCM LOS							C			B		

Minor Lane/Major Mvmt	NBLn1	EBL	EBT	EBR	WBL	WBT	WBR	SBLn1	SBLn2	SBLn3
Capacity (veh/h)	281	1217	-	-	7	-	-	266	282	702
HCM Lane V/C Ratio	0.228	0.017	-	-	0.001	-	-	0.005	0.005	0.016
HCM Control Delay (s/veh)	21.5	8	-	-	8.4	0	-	18.6	17.8	10.2
HCM Lane LOS	C	A	-	-	A	A	-	C	C	B
HCM 95th %tile Q(veh)	0.9	0.1	-	-	0	-	-	0	0	0.1

Lanes, Volumes, Timings  
1: US 24 & Judge Orr Road



Lane Group	EBL	EBT	EBR	WBL	WBT	WBR	NEL	NET	NER	SWL	SWT	SWR
Lane Configurations												
Traffic Volume (vph)	30	225	216	373	163	35	110	359	340	59	668	27
Future Volume (vph)	30	225	216	373	163	35	110	359	340	59	668	27
Ideal Flow (vphpl)	1900	1900	1900	1900	1900	1900	1900	1900	1900	1900	1900	1900
Storage Length (ft)	0		275	0		0	0		0	0		0
Storage Lanes	0		1	0		0	0		0	0		0
Taper Length (ft)	25			25			25			25		
Lane Util. Factor	1.00	1.00	1.00	1.00	1.00	1.00	0.95	0.95	0.95	0.95	0.95	0.95
Frt			0.850		0.991			0.937			0.994	
Flt Protected		0.994			0.969			0.993			0.996	
Satd. Flow (prot)	0	1852	1583	0	1789	0	0	3293	0	0	3504	0
Flt Permitted		0.994			0.969			0.993			0.996	
Satd. Flow (perm)	0	1852	1583	0	1789	0	0	3293	0	0	3504	0
Link Speed (mph)		45			45			55			55	
Link Distance (ft)		1085			2173			1190			1114	
Travel Time (s)		16.4			32.9			14.8			13.8	
Peak Hour Factor	0.78	0.87	0.87	0.90	0.86	0.78	0.83	0.90	0.89	0.79	0.92	0.78
Adj. Flow (vph)	38	259	248	414	190	45	133	399	382	75	726	35
Shared Lane Traffic (%)												
Lane Group Flow (vph)	0	297	248	0	649	0	0	914	0	0	836	0
Enter Blocked Intersection	No	No	No	No	No	No	No	No	No	No	No	No
Lane Alignment	Left	Left	Right	Left	Left	Right	Left	Left	Right	Left	Left	Right
Median Width(ft)		12			12			0			0	
Link Offset(ft)		0			0			0			0	
Crosswalk Width(ft)		16			16			16			16	
Two way Left Turn Lane												
Headway Factor	1.00	1.00	1.00	1.00	1.00	1.00	1.00	1.00	1.00	1.00	1.00	1.00
Turning Speed (mph)	15		9	15		9	15		9	15		9
Sign Control		Yield			Yield			Yield			Yield	

Intersection Summary

Area Type:	Other
Control Type:	Roundabout
Intersection Capacity Utilization	103.3%
ICU Level of Service	G
Analysis Period (min)	15

Intersection									
Intersection Delay, s/veh	12.2								
Intersection LOS	B								
Approach	EB		WB		NE		SW		
Entry Lanes	1		1		2		2		
Conflicting Circle Lanes	2		2		2		2		
Adj Approach Flow, veh/h	545		649		914		836		
Demand Flow Rate, veh/h	556		662		933		854		
Vehicles Circulating, veh/h	1239		582		379		752		
Vehicles Exiting, veh/h	366		341		1163		492		
Ped Vol Crossing Leg, #/h	0		0		0		0		
Ped Cap Adj	1.000		1.000		1.000		1.000		
Approach Delay, s/veh	11.7		20.4		3.8		15.6		
Approach LOS	B		C		A		C		
Lane	Left	Bypass	Left	Left	Right	Bypass	Left	Right	
Designated Moves	LT	R	LTR		LT	TR	R	LT	TR
Assumed Moves	LT		LTR		LT	TR		LT	TR
RT Channelized		Free				Free			
Lane Util	1.000		1.000		0.470	0.530		0.470	0.530
Follow-Up Headway, s	2.535		2.535		2.667	2.535		2.667	2.535
Critical Headway, s	4.328		4.328		4.645	4.328		4.645	4.328
A (Intercept)	1420		1420		1350	1420		1350	1420
B (Slope)	8.501e-4		8.501e-4		9.199e-4	8.501e-4		9.199e-4	8.501e-4
Entry Flow, veh/h	303	253	662		255	288	390	401	453
Cap Entry Lane, veh/h	495	1938	866		953	1029	1938	676	749
Entry HV Adj Factor	0.980	0.980	0.981		0.981	0.979	0.980	0.980	0.979
Flow Entry, veh/h	297	248	649		250	282	382	393	443
Cap Entry, veh/h	485	1900	849		934	1007	1900	663	733
V/C Ratio	0.612	0.131	0.765		0.268	0.280	0.201	0.593	0.605
Control Delay, s/veh	21.5	0.0	20.4		6.6	6.4	0.0	16.0	15.1
LOS	C	A	C		A	A	A	C	C
95th %tile Queue, veh	4	0	7		1	1	1	4	4

Lanes, Volumes, Timings  
2: Cessna Drive & Judge Orr Road



Lane Group	EBL	EBT	EBR	WBL	WBT	WBR	NBL	NBT	NBR	SBL	SBT	SBR
Lane Configurations												
Traffic Volume (vph)	256	336	31	4	439	28	19	1	1	12	1	105
Future Volume (vph)	256	336	31	4	439	28	19	1	1	12	1	105
Ideal Flow (vphpl)	1900	1900	1900	1900	1900	1900	1900	1900	1900	1900	1900	1900
Storage Length (ft)	150		0	150		0	100		0	100		100
Storage Lanes	1		0	0		0	0		0	1		1
Taper Length (ft)	25			25			25			25		
Lane Util. Factor	1.00	1.00	1.00	1.00	1.00	1.00	1.00	1.00	1.00	1.00	1.00	1.00
Frt		0.986			0.991			0.995				0.850
Flt Protected	0.950							0.956		0.950		
Satd. Flow (prot)	1770	1837	0	0	1846	0	0	1772	0	1770	1863	1583
Flt Permitted	0.950							0.956		0.950		
Satd. Flow (perm)	1770	1837	0	0	1846	0	0	1772	0	1770	1863	1583
Link Speed (mph)		45			45			30				30
Link Distance (ft)		2173			1039			672				678
Travel Time (s)		32.9			15.7			15.3				15.4
Peak Hour Factor	0.88	0.89	0.78	0.78	0.91	0.78	0.78	0.78	0.78	0.78	0.78	0.83
Adj. Flow (vph)	291	378	40	5	482	36	24	1	1	15	1	127
Shared Lane Traffic (%)												
Lane Group Flow (vph)	291	418	0	0	523	0	0	26	0	15	1	127
Enter Blocked Intersection	No	No	No	No	No	No	No	No	No	No	No	No
Lane Alignment	Left	Left	Right	Left	Left	Right	Left	Left	Right	Left	Left	Right
Median Width(ft)		12			12			12				12
Link Offset(ft)		0			0			0				0
Crosswalk Width(ft)		16			16			16				16
Two way Left Turn Lane												
Headway Factor	1.00	1.00	1.00	1.00	1.00	1.00	1.00	1.00	1.00	1.00	1.00	1.00
Turning Speed (mph)	15		9	15		9	15		9	15		9
Sign Control		Free			Free			Stop				Stop

Intersection Summary

Area Type:	Other
Control Type:	Unsignalized
Intersection Capacity Utilization	62.4%
ICU Level of Service	B
Analysis Period (min)	15

Intersection												
Int Delay, s/veh	6											
Movement	EBL	EBT	EBR	WBL	WBT	WBR	NBL	NBT	NBR	SBL	SBT	SBR
Lane Configurations												
Traffic Vol, veh/h	256	336	31	4	439	28	19	1	1	12	1	105
Future Vol, veh/h	256	336	31	4	439	28	19	1	1	12	1	105
Conflicting Peds, #/hr	0	0	0	0	0	0	0	0	0	0	0	0
Sign Control	Free	Free	Free	Free	Free	Free	Stop	Stop	Stop	Stop	Stop	Stop
RT Channelized	-	-	None	-	-	None	-	-	None	-	-	None
Storage Length	150	-	-	-	-	-	-	-	-	100	-	100
Veh in Median Storage, #	-	0	-	-	0	-	-	0	-	-	0	-
Grade, %	-	0	-	-	0	-	-	0	-	-	0	-
Peak Hour Factor	88	89	78	78	91	78	78	78	78	78	78	83
Heavy Vehicles, %	2	2	2	2	2	2	2	2	2	2	2	2
Mvmt Flow	291	378	40	5	482	36	24	1	1	15	1	127

Major/Minor	Major1			Major2			Minor1			Minor2		
Conflicting Flow All	518	0	0	417	0	0	1473	1508	397	1471	1510	500
Stage 1	-	-	-	-	-	-	979	979	-	511	511	-
Stage 2	-	-	-	-	-	-	493	529	-	960	999	-
Critical Hdwy	4.12	-	-	4.12	-	-	7.12	6.52	6.22	7.12	6.52	6.22
Critical Hdwy Stg 1	-	-	-	-	-	-	6.12	5.52	-	6.12	5.52	-
Critical Hdwy Stg 2	-	-	-	-	-	-	6.12	5.52	-	6.12	5.52	-
Follow-up Hdwy	2.218	-	-	2.218	-	-	3.518	4.018	3.318	3.518	4.018	3.318
Pot Cap-1 Maneuver	1048	-	-	1142	-	-	105	121	652	105	120	571
Stage 1	-	-	-	-	-	-	301	328	-	546	537	-
Stage 2	-	-	-	-	-	-	558	527	-	308	321	-
Platoon blocked, %	-	-	-	-	-	-	-	-	-	-	-	-
Mov Cap-1 Maneuver	1048	-	-	1142	-	-	58	87	652	75	86	571
Mov Cap-2 Maneuver	-	-	-	-	-	-	58	87	-	75	86	-
Stage 1	-	-	-	-	-	-	217	237	-	542	534	-
Stage 2	-	-	-	-	-	-	430	524	-	221	232	-

Approach	EB			WB			NB			SB		
HCM Control Delay, s/v	4.01			0.08			102.68			19.03		
HCM LOS							F			C		

Minor Lane/Major Mvmt	NBLn1	EBL	EBT	EBR	WBL	WBT	WBR	SBLn1	SBLn2	SBLn3
Capacity (veh/h)	62	1048	-	-	17	-	-	75	86	571
HCM Lane V/C Ratio	0.437	0.278	-	-	0.004	-	-	0.206	0.015	0.222
HCM Control Delay (s/veh)	102.7	9.8	-	-	8.2	0	-	65.4	47.3	13.1
HCM Lane LOS	F	A	-	-	A	A	-	F	E	B
HCM 95th %tile Q(veh)	1.7	1.1	-	-	0	-	-	0.7	0	0.8

Lanes, Volumes, Timings  
1: US 24 & Judge Orr Road



Lane Group	EBL	EBT	EBR	WBL	WBT	WBR	NEL	NET	NER	SWL	SWT	SWR
Lane Configurations		↕	↗		↕			↕			↕	
Traffic Volume (vph)	53	162	99	378	213	47	227	685	434	36	553	25
Future Volume (vph)	53	162	99	378	213	47	227	685	434	36	553	25
Ideal Flow (vphpl)	1900	1900	1900	1900	1900	1900	1900	1900	1900	1900	1900	1900
Storage Length (ft)	0		275	0		0	0		0	0		0
Storage Lanes	0		1	0		0	0		0	0		0
Taper Length (ft)	25			25			25			25		
Lane Util. Factor	1.00	1.00	1.00	1.00	1.00	1.00	0.95	0.95	0.95	0.95	0.95	0.95
Frt			0.850		0.989			0.952			0.993	
Flt Protected		0.987			0.972			0.991			0.997	
Satd. Flow (prot)	0	1839	1583	0	1791	0	0	3339	0	0	3504	0
Flt Permitted		0.987			0.972			0.991			0.997	
Satd. Flow (perm)	0	1839	1583	0	1791	0	0	3339	0	0	3504	0
Link Speed (mph)		45			45			55			55	
Link Distance (ft)		1085			2173			1190			1114	
Travel Time (s)		16.4			32.9			14.8			13.8	
Peak Hour Factor	0.78	0.85	0.83	0.90	0.87	0.78	0.87	0.92	0.91	0.78	0.92	0.78
Adj. Flow (vph)	68	191	119	420	245	60	261	745	477	46	601	32
Shared Lane Traffic (%)												
Lane Group Flow (vph)	0	259	119	0	725	0	0	1483	0	0	679	0
Enter Blocked Intersection	No	No	No	No	No	No	No	No	No	No	No	No
Lane Alignment	Left	Left	Right	Left	Left	Right	Left	Left	Right	Left	Left	Right
Median Width(ft)		12			12			0			0	
Link Offset(ft)		0			0			0			0	
Crosswalk Width(ft)		16			16			16			16	
Two way Left Turn Lane												
Headway Factor	1.00	1.00	1.00	1.00	1.00	1.00	1.00	1.00	1.00	1.00	1.00	1.00
Turning Speed (mph)	15		9	15		9	15		9	15		9
Sign Control		Yield			Yield			Yield			Yield	



















Intersection Summary

Area Type:	Other
Control Type:	Roundabout
Intersection Capacity Utilization	116.3%
ICU Level of Service	H
Analysis Period (min)	15

Intersection									
Intersection Delay, s/veh	47.2								
Intersection LOS	E								
Approach	EB		WB		NE		SW		
Entry Lanes	1		1		2		2		
Conflicting Circle Lanes	2		2		2		2		
Adj Approach Flow, veh/h	378		725		1483		679		
Demand Flow Rate, veh/h	385		739		1513		693		
Vehicles Circulating, veh/h	1088		1095		311		944		
Vehicles Exiting, veh/h	549		242		1041		890		
Ped Vol Crossing Leg, #/h	0		0		0		0		
Ped Cap Adj	1.000		1.000		1.000		1.000		
Approach Delay, s/veh	9.9		178.9		6.2		17.0		
Approach LOS	A		F		A		C		
Lane	Left	Bypass	Left	Left	Right	Bypass	Left	Right	
Designated Moves	LT	R	LTR		LT	TR	R	LT	TR
Assumed Moves	LT		LTR		LT	TR		LT	TR
RT Channelized		Free				Free			
Lane Util	1.000		1.000		0.470	0.530		0.470	0.530
Follow-Up Headway, s	2.535		2.535		2.667	2.535		2.667	2.535
Critical Headway, s	4.328		4.328		4.645	4.328		4.645	4.328
A (Intercept)	1420		1420		1350	1420		1350	1420
B (Slope)	8.501e-4		8.501e-4		9.199e-4	8.501e-4		9.199e-4	8.501e-4
Entry Flow, veh/h	264	121	739		482	544	487	326	367
Cap Entry Lane, veh/h	563	1938	560		1014	1090	1938	566	636
Entry HV Adj Factor	0.982	0.980	0.981		0.981	0.980	0.980	0.979	0.981
Flow Entry, veh/h	259	119	725		473	533	477	319	360
Cap Entry, veh/h	553	1900	549		995	1069	1900	554	624
V/C Ratio	0.469	0.063	1.320		0.475	0.499	0.251	0.576	0.577
Control Delay, s/veh	14.5	0.0	178.9		9.2	9.2	0.0	17.8	16.2
LOS	B	A	F		A	A	A	C	C
95th %tile Queue, veh	2	0	31		3	3	1	4	4

Lanes, Volumes, Timings  
2: Cessna Drive & Judge Orr Road

JR Engineering  
05/21/2025

												
Lane Group	EBL	EBT	EBR	WBL	WBT	WBR	NBL	NBT	NBR	SBL	SBT	SBR
Lane Configurations												
Traffic Volume (vph)	186	434	11	1	302	21	43	1	6	32	1	296
Future Volume (vph)	186	434	11	1	302	21	43	1	6	32	1	296
Ideal Flow (vphpl)	1900	1900	1900	1900	1900	1900	1900	1900	1900	1900	1900	1900
Storage Length (ft)	150		0	150		0	100		0	100		100
Storage Lanes	1		0	0		0	0		0	1		1
Taper Length (ft)	25			25			25			25		
Lane Util. Factor	1.00	1.00	1.00	1.00	1.00	1.00	1.00	1.00	1.00	1.00	1.00	1.00
Frt		0.996			0.990			0.983				0.850
Flt Protected	0.950							0.959		0.950		
Satd. Flow (prot)	1770	1855	0	0	1844	0	0	1756	0	1770	1863	1583
Flt Permitted	0.950							0.959		0.950		
Satd. Flow (perm)	1770	1855	0	0	1844	0	0	1756	0	1770	1863	1583
Link Speed (mph)		45			45			30				30
Link Distance (ft)		2173			1039			672				678
Travel Time (s)		32.9			15.7			15.3				15.4
Peak Hour Factor	0.86	0.91	0.78	0.78	0.89	0.78	0.78	0.78	0.78	0.78	0.78	0.89
Adj. Flow (vph)	216	477	14	1	339	27	55	1	8	41	1	333
Shared Lane Traffic (%)												
Lane Group Flow (vph)	216	491	0	0	367	0	0	64	0	41	1	333
Enter Blocked Intersection	No	No	No	No	No	No	No	No	No	No	No	No
Lane Alignment	Left	Left	Right	Left	Left	Right	Left	Left	Right	Left	Left	Right
Median Width(ft)		12			12			12				12
Link Offset(ft)		0			0			0				0
Crosswalk Width(ft)		16			16			16				16
Two way Left Turn Lane												
Headway Factor	1.00	1.00	1.00	1.00	1.00	1.00	1.00	1.00	1.00	1.00	1.00	1.00
Turning Speed (mph)	15		9	15		9	15		9	15		9
Sign Control		Free			Free			Stop				Stop

Intersection Summary

Area Type:	Other
Control Type:	Unsignalized
Intersection Capacity Utilization	60.2%
ICU Level of Service	B
Analysis Period (min)	15

Intersection												
Int Delay, s/veh	13.7											
Movement	EBL	EBT	EBR	WBL	WBT	WBR	NBL	NBT	NBR	SBL	SBT	SBR
Lane Configurations												
Traffic Vol, veh/h	186	434	11	1	302	21	43	1	6	32	1	296
Future Vol, veh/h	186	434	11	1	302	21	43	1	6	32	1	296
Conflicting Peds, #/hr	0	0	0	0	0	0	0	0	0	0	0	0
Sign Control	Free	Free	Free	Free	Free	Free	Stop	Stop	Stop	Stop	Stop	Stop
RT Channelized	-	-	None	-	-	None	-	-	None	-	-	None
Storage Length	150	-	-	-	-	-	-	-	-	100	-	100
Veh in Median Storage, #	-	0	-	-	0	-	-	0	-	-	0	-
Grade, %	-	0	-	-	0	-	-	0	-	-	0	-
Peak Hour Factor	86	91	78	78	89	78	78	78	78	78	78	89
Heavy Vehicles, %	2	2	2	2	2	2	2	2	2	2	2	2
Mvmt Flow	216	477	14	1	339	27	55	1	8	41	1	333

Major/Minor	Major1			Major2			Minor1			Minor2		
Conflicting Flow All	366	0	0	491	0	0	1259	1285	484	1265	1279	353
Stage 1	-	-	-	-	-	-	917	917	-	355	355	-
Stage 2	-	-	-	-	-	-	343	369	-	910	924	-
Critical Hdwy	4.12	-	-	4.12	-	-	7.12	6.52	6.22	7.12	6.52	6.22
Critical Hdwy Stg 1	-	-	-	-	-	-	6.12	5.52	-	6.12	5.52	-
Critical Hdwy Stg 2	-	-	-	-	-	-	6.12	5.52	-	6.12	5.52	-
Follow-up Hdwy	2.218	-	-	2.218	-	-	3.518	4.018	3.318	3.518	4.018	3.318
Pot Cap-1 Maneuver	1192	-	-	1072	-	-	147	165	583	146	166	691
Stage 1	-	-	-	-	-	-	326	351	-	662	629	-
Stage 2	-	-	-	-	-	-	673	621	-	329	348	-
Platoon blocked, %	-	-	-	-	-	-	-	-	-	-	-	-
Mov Cap-1 Maneuver	1192	-	-	1072	-	-	62	134	583	117	136	691
Mov Cap-2 Maneuver	-	-	-	-	-	-	62	134	-	117	136	-
Stage 1	-	-	-	-	-	-	267	287	-	661	628	-
Stage 2	-	-	-	-	-	-	348	620	-	264	285	-

Approach	EB			WB			NB			SB		
HCM Control Delay, s/v	2.66			0.03			182.57			19.02		
HCM LOS							F			C		

Minor Lane/Major Mvmt	NBLn1	EBL	EBT	EBR	WBL	WBT	WBR	SBLn1	SBLn2	SBLn3
Capacity (veh/h)	70	1192	-	-	6	-	-	117	136	691
HCM Lane V/C Ratio	0.912	0.181	-	-	0.001	-	-	0.351	0.009	0.481
HCM Control Delay (s/veh)	182.6	8.7	-	-	8.4	0	-	51.6	31.8	15
HCM Lane LOS	F	A	-	-	A	A	-	F	D	B
HCM 95th %tile Q(veh)	4.5	0.7	-	-	0	-	-	1.4	0	2.6