



Preliminary Drainage Report

Waterview East Commercial El Paso County, Colorado

Prepared for:

Heath Herber
Waterview Commercial Investors, LLC
2727 Glen Arbor Drive
Colorado Springs, CO 80920

Prepared by:

Jessica McCallum, P.E
Kimley-Horn and Associates, Inc.
2 North Nevada Avenue, Suite 900
Colorado Springs, CO 80903
(719) 284-7275

Project #: 196195000

PCD Filing No.: SP-22-009

Prepared: September 6, 2023

Kimley»»Horn



CERTIFICATION

DESIGN ENGINEER'S STATEMENT

The attached drainage plan and report were prepared under my direction and supervision and are correct to the best of my knowledge and belief. Said drainage report has been prepared according to the criteria established by the County for drainage reports and said report is in conformity with the master plan of the drainage basin. I accept responsibility for any liability caused by any negligent acts, errors, or omissions on my part in preparation of this report.



SIGNATURE (Affix Seal): _____ 9/6/2023
Jessica McCallum, PE
Colorado P.E. No. 59054
Date

OWNER/DEVELOPER'S STATEMENT

I, the developer, have read and will comply with all the requirements specified in this Drainage Report and Plan.

Waterview Commercial Investors, LLC
Name of Developer

Heath A Herber 8/14/2023
Authorized Signature Date

Heath A Herber
Printed Name

Manager
Title

2727 Glen Arbor Drive, C.S.C. 80920
Address:

EL PASO COUNTY

Filed in accordance with the requirements of the Drainage Criteria Manual, Volumes 1 and 2, El Paso County Engineering Criteria Manual and Land Development Code as amended.

Josh Palmer, P.E.
County Engineer/ ECM Administrator

APPROVED
Engineering Department
03/27/2024 8:32:20 AM
dotmijkamp
EPC Department of Public Works

Conditions:

CERTIFICATION 1
DESIGN ENGINEER’S STATEMENT 1
OWNER/DEVELOPER’S STATEMENT 1
EL PASO COUNTY..... 1

INTRODUCTION 3
PURPOSE AND SCOPE OF STUDY 3
LOCATION 3
DESCRIPTION OF PROPERTY 3

DRAINAGE BASINS 4
MAJOR BASIN DESCRIPTIONS 4
MASTER DRAINAGE REPORT STUDY 4
EXISTING SUB-BASIN DESCRIPTIONS..... 4
PROPOSED SUB-BASIN DESCRIPTIONS 5

DRAINAGE DESIGN CRITERIA..... 11
DEVELOPMENT CRITERIA REFERENCE 11
HYDROLOGIC SOIL GROUP 12
HYDROLOGIC CRITERIA 12
HYDRAULIC CRITERIA..... 12
VARIANCES FROM CRITERIA 12
DETENTION REQUIRMENTS..... 12

DRAINAGE FACILITY DESIGN 13
GENERAL CONCEPT 13
Downstream Infrastructure Capacity..... 13
EROSION CONTROL PLAN 14
FLOODPLAIN STATEMENT 14
DRAINAGE FEE..... 14
GROUNDWATER CONSIDERATIONS 14

THE FOUR STEP PROCESS 14

SUMMARY 15
COMPLIANCE WITH STANDARDS..... 15

REFERENCES 15

APPENDIX 16

APPENDIX A – VICINITY MAP 17

APPENDIX B – FEMA FIRM PANEL AND SOILS MAP 18

APPENDIX C – HYDROLOGIC CALCULATIONS 19

APPENDIX D – HYDRAULIC CALCULATIONS 20

APPENDIX E – SUPPORTING DOCUMENTS 21

APPENDIX F – DRAINAGE EXHIBITS 22

INTRODUCTION

PURPOSE AND SCOPE OF STUDY

The purpose of this report is to outline the required storm sewer and drainage improvements necessary to support the Waterview East Subdivision project, (the “Property”), in El Paso County, Colorado (the “County”). This Final Drainage Report identifies on-site and off-site drainage patterns, storm sewer and inlet locations, areas tributary to the Site and proposes to safely route developed storm water to adequate outfalls. The Property is 22.1 acres.

The Property is located within the Big Johnson and West Fork of the Jimmy Camp Creek drainage basins and is part of the subject area of the *Master Development Drainage Plan Amendment for Waterview East and Preliminary Drainage Plan for Trails at Aspen Ridge* prepared by Matrix Design Group dated September 2019. Reference the **Appendix E** for applicable excerpts from the Drainage Letter

LOCATION

The Project is located within part of the West ½ of Section 9, Township 15 South, Range 65 West of the 6th Principal Meridian, County of El Paso, State of Colorado (“the Site”). The Site is bounded by Powers Boulevard (Highway 21) on the west, The Trails at Aspen Ridge Filing No. 1 to the east and to the south, and Bradley Road to the north. A vicinity map has been provided in the **Appendix A** of this report.

The Site is currently owned by Waterview East Development, LLC. The site is currently unplatted.

DESCRIPTION OF PROPERTY

The Site is approximately 22.1 acres consisting of undeveloped land with native vegetation and is classified as Vegetation within the site is characterized primarily by prairie grasses along with some area of scrub brush and a limited occurrence of small oaks. The Site does not currently provide water quality or detention for the Project area. The existing land use is undeveloped vacant land. There are no existing irrigation ditches on the Site.

The existing topography consists of slopes ranging from 1% to 33%.

According to NRCS soil mapping data, USCS Type A and B soils are the primary soil type within the site. Soils present at the Site consist mainly of “Blakeland loamy sand” which represent a moderate hazard for erosion. **Appendix B** contains detailed NRCS soil data.

The development of this site will include commercial developments, including convenience store, restaurants, storage units and retail stores. Roadway improvements to the site will include mowing, clearing, and grubbing, weed control, paved access road construction, roadway grading, three onsite extended detention basins, native seeding, and water quality features.

A Topographic field survey was completed and updated for the Project by Ridgeline Land Surveying dated February 7th, 2023 and is the basis for design for the drainage improvements.

DRAINAGE BASINS

MAJOR BASIN DESCRIPTIONS

The western half of the Property lies within the Big Johnson drainage basin, and the eastern half of the Property lies within the West Fork of Jimmy Camp Creek drainage basin. The watershed is generally located in the central portion of El Paso County. Refer to **Appendix A** for the Flood Insurance Rate Map (FIRM) number 08041C0768G effective date, December 7, 2018. Previous reports used in reference to the Site include the following: Master Development Drainage Plan Amendment for Waterview East and Preliminary Drainage Plan for Trails at Aspen Ridge prepared by Matrix Design Group dated September 2019. Please reference **Appendix E** for excerpts of the Master Development Drainage Plan. Additional reports previously conducted for the Site include: Waterview East Preliminary Drainage Report prepared by Stantec Consulting, Inc and dated June 2018. There was a Drainage Basin Planning Study conducted for the Big Johnson basin in February 1992.

MASTER DRAINAGE REPORT STUDY

The Waterview East commercial development project is part of the “Master Development Drainage Plan Amendment for Waterview East & Preliminary Drainage Plan for Trails at Aspen Ridge” Prepared by: Matrix Design Group September 2019. As outlined in the Master Drainage Plan, the “East Pond” was sized to include flows from the future “Commercial Lot south of Bradley Road and West of Legacy Drive”. In these watershed calculations a conservative weighted imperviousness value of 95% was used. This value is substantially higher than the calculated impervious value of 55% in proposed conditions.

As noted in the Master Drainage Plan, the eastern portion of the Site which is part of the West Fork Jimmy Camp Creek drainage basin will require on site detention. As noted in the Master Drainage Plan, the western portion of the Site which is part of the Big Johnson Reservoir drainage basin for future development of this lot “...On-site detention will be required and must discharge to the Powers Boulevard ditch.” Based on the pond sizing calculations and required on site detention, the proposed development is in compliance with the above-mentioned Master Drainage Plan. Offsite flows are addressed in the existing sub-basin descriptions below.

EXISTING SUB-BASIN DESCRIPTIONS

Historically, runoff from the Site is split almost directly down the center. With the eastern portion of the Site heading east and the western portion of the site heading west. The site has been divided into three (3) existing onsite subbasins, EX-1 to EX-3 and one (1) tributary off-site basin, OS-1.

Sub-Basin EX-1

The on-site sub-basin EX-1 is undeveloped consisting of native grasses and shrubs with an area of 10.45 acres comprising the eastern half of the property. Drainage flows overland from west to the east at slopes ranging from 1-33%. Flows are collected in the existing curb and gutter along Legacy Drive and are conveyed to an existing 10' CDOT Type R inlet at the intersection of Legacy Drive and Frontside Drive. Flows are then carried through existing storm infrastructure into East Pond as outlined in the “Master Development Drainage Plan Amendment for Waterview East & Preliminary Drainage Plan for Trails at Aspen Ridge”

Prepared by: Matrix Design Group September 2019. Runoff during the 5-year and 100-year events are 3.53 cfs and 24.72 cfs respectively.

Sub-Basin EX-2

The on-site sub-basin EX-2 is undeveloped consisting of native grasses and shrubs with an area of 11.41 acres comprising the western half of the property. Drainage flows overland from northeast to southwest at slopes ranging from 1-33%. Flows are collected in the existing roadside ditch along Powers Blvd and travel south where they are conveyed west through an existing 60" CMP under Powers Blvd and into Big Johnson Reservoir. Runoff during the 5-year and 100-year events are 2.62 cfs and 22.34 cfs respectively.

Sub-Basin EX-3

The on-site sub-basin EX-3 is undeveloped, consisting of native grasses and shrubs, with a curb cut access. It has an area of 0.24 acres comprising a portion of the eastern site boundary. Drainage flows overland from west to east at slopes ranging from 1-25%. Flows are collected in the existing Frontside Drive curb and gutter and travels south where they are conveyed to existing storm infrastructure into the East Pond as outlined in the "Master Development Drainage Plan Amendment for Waterview East & Preliminary Drainage Plan for Trails at Aspen Ridge" Prepared by: Matrix Design Group September 2019. Runoff during the 5-year and 100-year events are 0.22 cfs and 0.93 cfs respectively.

Sub-Basin OS-1

The off-site sub-basin OS-1 is undeveloped consisting of native grasses and shrubs with an area of 0.59 acres comprising the northern boundary of the Site. Drainage flows overland from north to south at slopes ranging from 5-33%. Flows convey through Basin EX-1 and are ultimately collected via existing curb and gutter along Legacy Drive, which are conveyed to an existing 10' CDOT Type R inlet at the intersection of Legacy Drive and Frontside Drive. Flows are then carried through existing storm infrastructure into East Pond as outlined in the "Master Development Drainage Plan Amendment for Waterview East & Preliminary Drainage Plan for Trails at Aspen Ridge" Prepared by: Matrix Design Group September 2019. Runoff during the 5-year and 100-year events are 0.19 cfs and 1.61 cfs respectively.

Refer to **Appendix F** for the Existing Drainage Conditions Map.

PROPOSED SUB-BASIN DESCRIPTIONS

For the proposed condition, stormwater will generally maintain historic flow patterns for the east and west portions of the site. Proposed roadways internal to the site will alter some of the existing flow paths. Proposed curb and gutter, and proposed storm inlets will convey flows to one of four proposed Private Full Spectrum Extended Detention Basins. From there flows will outfall to existing historic drainage paths, which will ultimately outfall to existing natural drainage channels, sub regional pond, or water quality features. The proposed project has been divided into twenty-nine (29) on-site sub-basins and one (1) off-site basin.

Sub-Basin A1

The on-site sub-basin A1 consists of proposed parking, landscaping, roofing, and sidewalk. The sub-basin has an area of 0.90 acres and a weighted imperviousness of 57%. Runoff in this basin will travel overland and into a crossspan to a proposed private in sump CDOT Type D area inlet with HS-20 rated grate, design point 1. Flows will then be conveyed to proposed Private Full Spectrum Extended Detention Basin (Design Point 23). Runoff during the 5-year and 100-

year events are 1.91 cfs and 5.28 cfs respectively.

Sub-Basin A2

The on-site sub-basin A2 consists of proposed drive aisle, landscaping, roofing, and sidewalk. The sub-basin has an area of 0.37 acres and a weighted imperviousness of 58%. Runoff in this basin will travel overland into a proposed private in sump CDOT Type D area inlet with HS-20 rated grate, design point 2. Flows will then be conveyed via proposed stormwater infrastructure to proposed Private Full Spectrum Extended Detention Basin (Design Point 23). Runoff during the 5-year and 100-year events are 0.85 cfs and 2.32 cfs respectively.

Sub-Basin A3

The on-site sub-basin A3 consists of proposed drive aisle, landscaping, roofing, and sidewalk. The sub-basin has an area of 0.38 acres and a weighted imperviousness of 80%. Runoff in this basin will travel overland into a proposed private in sump CDOT Type D area inlet with HS-20 rated grate, design point 3. Flows will then be conveyed via proposed stormwater infrastructure to proposed Private Full Spectrum Extended Detention Basin (Design Point 23). Runoff during the 5-year and 100-year events are 1.15 cfs and 2.82 cfs respectively.

Sub-Basin A4

The on-site sub-basin A4 consists of proposed drive aisle, landscaping, roofing, and sidewalk. The sub-basin has an area of 0.31 acres and a weighted imperviousness of 95%. Runoff in this basin will travel overland and into a proposed crossspan to a proposed private in sump CDOT Type D area inlet with HS-20 rated grate, design point 4. Flows will then be conveyed via proposed stormwater infrastructure to proposed Private Full Spectrum Extended Detention Basin (Design Point 23). Runoff during the 5-year and 100-year events are 1.04 cfs and 2.40 cfs respectively.

Sub-Basin A5

The on-site sub-basin A5 consists of proposed drive aisle, landscaping, roofing, and sidewalk. The sub-basin has an area of 0.29 acres and a weighted imperviousness of 92%. Runoff in this basin will travel overland into a proposed private in sump 5' CDOT Type R inlet, design point 5. Flows will then be conveyed via proposed stormwater infrastructure to proposed Private Full Spectrum Extended Detention Basin (Design Point 23). Runoff during the 5-year and 100-year events are 1.02 cfs and 2.39 cfs respectively.

Sub-Basin A6

The on-site sub-basin A6 consists of proposed drive aisle, landscaping, roofing, and sidewalk. The sub-basin has an area of 0.30 acres and a weighted imperviousness of 89%. Runoff in this basin will travel overland and into a proposed crossspan to a proposed private in sump CDOT Type D area inlet with HS-20 rated grate, design point 6. Flows will then be conveyed via proposed stormwater infrastructure to proposed Private Full Spectrum Extended Detention Basin (Design Point 23). Runoff during the 5-year and 100-year events are 0.97 cfs and 2.29 cfs respectively.

Sub-Basin A7

The on-site sub-basin A7 consists of proposed drive aisle, landscaping, and sidewalk. The sub-

basin has an area of 0.40 acres and a weighted imperviousness of 92%. Runoff in this basin will travel overland and into a proposed crossspan to a proposed private sump CDOT Type C area inlet with HS-20 rated grate, design point 7. Flows will then be conveyed via proposed stormwater infrastructure to proposed Private Full Spectrum Extended Detention Basin (Design Point 23). Runoff during the 5-year and 100-year events are 1.48 cfs and 3.44 cfs respectively.

Sub-Basin A8

The on-site sub-basin A8 consists of proposed drive aisle, landscaping, and sidewalk. The sub-basin has an area of 0.46 acres and a weighted imperviousness of 94%. Runoff in this basin will travel overland and into a proposed crossspan to a proposed private in sump CDOT Type C area inlet with HS-20 rated grate, design point 8. Flows will then be conveyed via proposed stormwater infrastructure to proposed Private Full Spectrum Extended Detention Basin (Design Point 23). Runoff during the 5-year and 100-year events are 1.72 cfs and 3.98 cfs respectively.

Sub-Basin A9

The on-site sub-basin A9 consists of proposed drive aisle, landscaping, and sidewalk. The sub-basin has an area of 0.45 acres and a weighted imperviousness of 94%. Runoff in this basin will travel overland and into a proposed crossspan to a proposed private in sump CDOT Type C area inlet with HS-20 rated grate, design point 9. Flows will then be conveyed via proposed stormwater infrastructure to proposed Private Full Spectrum Extended Detention Basin (Design Point 23). Runoff during the 5-year and 100-year events are 1.68 cfs and 3.88 cfs respectively.

Sub-Basin A10

The on-site sub-basin A10 consists of proposed drive aisle, landscaping, and sidewalk. The sub-basin has an area of 0.61 acres and a weighted imperviousness of 88%. Runoff in this basin will travel overland and into a proposed crossspan to a proposed private in sump 10' Type R inlet, design point 10. Flows will then be conveyed via proposed stormwater infrastructure to proposed Private Full Spectrum Extended Detention Basin (Design Point 23). Runoff during the 5-year and 100-year events are 2.09 cfs and 4.95 cfs respectively.

Sub-Basin A11

The on-site sub-basin A11 consists of proposed drive aisle, landscaping, roofing, and sidewalk. The sub-basin has an area of 0.26 acres and a weighted imperviousness of 75%. Runoff in this basin will travel overland and into a proposed private in sump CDOT Type D area inlet with HS-20 rated grate, design point 11. Flows will then be conveyed via proposed stormwater infrastructure to proposed Private Full Spectrum Extended Detention Basin (Design Point 23). Runoff during the 5-year and 100-year events are 0.62 cfs and 1.56 cfs respectively.

Sub-Basin A12

The on-site sub-basin A12 consists of proposed drive aisle, landscaping, roofing, and sidewalk. The sub-basin has an area of 1.05 acres and a weighted imperviousness of 79%. Runoff in this basin will travel overland into a proposed private in sump 10' CDOT Type R inlet, design point 12. Flows will then be conveyed via proposed stormwater infrastructure to proposed Private Full Spectrum Extended Detention Basin (Design Point 23). Runoff during the 5-year and 100-year events are 2.59 cfs and 6.32 cfs respectively.

Sub-Basin A13

The on-site sub-basin A13 consists of proposed drive aisle, landscaping, and sidewalk. The sub-basin has an area of 0.33 acres and a weighted imperviousness of 78%. Runoff in this basin will travel overland into a proposed private in sump CDOT Type C area inlet with HS-20 rated grate, design point 13. Flows will then be conveyed via proposed stormwater infrastructure to proposed Private Full Spectrum Extended Detention Basin (Design Point 23). Runoff during the 5-year and 100-year events are 0.94 cfs and 2.32 cfs respectively.

Sub-Basin A14

The on-site sub-basin A14 consists of proposed drive aisle, landscaping, roofing, and sidewalk. The sub-basin has an area of 0.34 acres and a weighted imperviousness of 93%. Runoff in this basin will travel overland into a proposed private in sump CDOT Type C area inlet with HS-20 rated grate, design point 14. Flows will then be conveyed via proposed stormwater infrastructure to proposed Private Full Spectrum Extended Detention Basin (Design Point 23). Runoff during the 5-year and 100-year events are 1.12 cfs and 2.60 cfs respectively.

Sub-Basin A15

The on-site sub-basin A15 consists of proposed drive aisle, landscaping, roofing, and sidewalk. The sub-basin has an area of 0.44 acres and a weighted imperviousness of 90%. Runoff in this basin will travel overland and into a proposed crossspan to a proposed private in sump CDOT Type C area inlet with HS-20 rated grate, design point 15. Flows will then be conveyed via proposed stormwater infrastructure to proposed Private Full Spectrum Extended Detention Basin (Design Point 23). Runoff during the 5-year and 100-year events are 1.48 cfs and 3.48 cfs respectively.

Sub-Basin A16

The on-site sub-basin A16 consists of proposed drive aisle, landscaping, roofing, and sidewalk. The sub-basin has an area of 0.31 acres and a weighted imperviousness of 85%. Runoff in this basin will travel overland and into a proposed crossspan to a proposed private in sump CDOT Type C area inlet with HS-20 rated grate, design point 16. Flows will then be conveyed via proposed stormwater infrastructure to proposed Private Full Spectrum Extended Detention Basin (Design Point 23). Runoff during the 5-year and 100-year events are 0.95 cfs and 2.27 cfs respectively.

Sub-Basin A17

The on-site sub-basin A17 consists of proposed drive aisle, landscaping, and roofing. The sub-basin has an area of 0.82 acres and a weighted imperviousness of 95%. Runoff in this basin will travel overland into a proposed private in sump CDOT Type C area inlet with HS-20 rated grate, design point 17. Flows will then be conveyed via proposed stormwater infrastructure to proposed Private Full Spectrum Extended Detention Basin (Design Point 22). Runoff during the 5-year and 100-year events are 1.44 cfs and 3.88 cfs respectively.

Sub-Basin A18

The on-site sub-basin A18 consists of proposed drive aisle, and roofing. The sub-basin has an area of 1.34 acres and a weighted imperviousness of 95%. Runoff in this basin will travel overland and into a proposed crossspan to a proposed private in sump CDOT Type C area inlet with HS-20 rated grate, design point 18. Flows will then be conveyed via proposed stormwater

infrastructure to proposed Private Full Spectrum Extended Detention Basin (Design Point 22). Runoff during the 5-year and 100-year events are 4.57 cfs and 10.60 cfs respectively.

Sub-Basin A19

The on-site sub-basin A19 consists of proposed drive aisle, and roofing. The sub-basin has an area of 0.60 acres and a weighted imperviousness of 95%. Runoff in this basin will travel overland into a proposed private in sump CDOT Type C area inlet with HS-20 rated grate, design point 19. Flows will then be conveyed via proposed stormwater infrastructure to proposed Private Full Spectrum Extended Detention Basin (Design Point 22). Runoff during the 5-year and 100-year events are 2.14 cfs and 4.96 cfs respectively.

Sub-Basin A20 – NOT USED

Sub-Basin A21

The on-site sub-basin A21 consists of proposed drive aisle, and roofing. The sub-basin has an area of 0.85 acres and a weighted imperviousness of 83%. Runoff in this basin will travel overland and into a proposed crossspan through a proposed curb cut at design point 21. Flows will then be conveyed down a proposed riprap channel directly into the proposed Private Full Spectrum Extended Detention Basin (Design Point 22). Runoff during the 5-year and 100-year events are 2.17 cfs and 5.28 cfs respectively.

Sub-Basin A22

The on-site sub-basin A22 consists of landscaping and proposed Private Full Spectrum Extended Detention Basin. The sub-basin has an area of 0.34 acres and a weighted imperviousness of 2%. Runoff in this basin will flow directly into the extended detention pond. The controlled release rates from the pond will outfall into the existing roadside ditch along Powers Blvd at or less than historic rates. Runoff during the 5-year and 100-year events are 0.10 cfs and 0.85 cfs respectively.

Sub-Basin A23

The on-site sub-basin A23 consists of landscaping, roofing, and proposed Private Full Spectrum Extended Detention Basin. The sub-basin has an area of 0.84 acres and a weighted imperviousness of 18%. Runoff in this basin will flow directly into the extended detention pond. Flows from A23 will outfall into the proposed storm infrastructure and flow into existing stormwater infrastructure located in Frontside Drive at DP 26. Runoff during the 5-year and 100-year events are 0.57 cfs and 2.59 cfs respectively.

Sub-Basin A24

The on-site sub-basin A24 consists of landscaping and proposed Private Full Spectrum Extended Detention Basin. The sub-basin has an area of 0.48 acres and a weighted imperviousness of 3%. Runoff in this basin will travel overland directly into the extended detention basin. Flows from A24 will outfall into the proposed storm infrastructure and flow into existing stormwater infrastructure located in Frontside Drive at DP 26. Runoff during the 5-year and 100-year events are 0.16 cfs and 1.25 cfs respectively.

Sub-Basin A25

The on-site sub-basin A25 consists of landscaping, parking, sidewalk, and drive aisle. The sub-basin has an area of 1.78 acres and a weighted imperviousness of 70%. Runoff in this basin will travel overland into a proposed private in sump 10' CDOT Type R inlet, design point 25. Flows from this sub-basin will follow existing flow patterns. Flows will then be conveyed via proposed stormwater infrastructure to proposed Private Full Spectrum Extended Detention Basin (Design Point 24). Runoff during the 5-year and 100-year events are 4.95 cfs and 12.61 cfs respectively.

Sub-Basin A26

The on-site sub-basin A26 consists of landscaping, and drive aisle along the eastern property line. The sub-basin has an area of 2.66 acres and a weighted imperviousness of 29%. Runoff in this basin will sheet flow directly into Legacy Hill Dr where it will be carried by curb and gutter into the existing storm water infrastructure. Flows from this sub-basin will follow existing flow patterns. Runoff during the 5-year and 100-year events are 2.28 cfs and 8.15 cfs respectively.

The portions of the drive aisle from this basin that flow offsite will sheet flow into the existing offsite in sump CDOT Type R inlet within Frontside Drive. The total flow from sub-basin 26 and sub-basin OS1 entering the existing 10' type R curb inlet is 9.5 cfs in the 100-year event. The existing 10' Type R inlet has a capacity of 10.3 cfs. Therefore, the inlet can capture the 100-year storm event from sub-basins A16 and OS-1.

The East Pond (Design Point M, PUDSP-19-001 and EA18228) has adequate capacity and can treat this additional flow. Please reference **Appendix E** for the UD-Detention spreadsheet for this pond with relevant acreages highlighted, as well as the Proposed Drainage Map showing tributary basins. Per the Master Development Drainage Report the Site was allowed to discharge 7.0 cfs in the 5-year event and 28 cfs in the 100-year event to the East Pond at Design Point M (PUDSP-19-001 and EA18228). Ponds A23, A24, and A27 release to the storm sewer infrastructure that routes flows to the East Pond and Sub-Basin A26 and OS-1 releases to the roadways where the flow is captured by existing inlets. The total 5-year and 100-year runoff from the Project is 3.22 cfs and 25.39 cfs, respectively. Therefore, the release to the East Pond is in compliance with the Master Development Drainage Plan.

Sub-Basin A27

The on-site sub-basin A27 consists primarily of landscaping along the north side of the site and a portion of the drive aisle that branches from Legacy Hill Drive into the site. The sub-basin has an area of 2.60 acres and a weighted imperviousness of 15%. Runoff in this basin will flow directly into a proposed swale that discharges into Pond A27 (Design Point 27) or enter a proposed swale at the north property line that discharges to a Type C inlet with a 12" storm sewer line that discharges into Pond A27 (Design Point 27). Runoff during the 5-year and 100-year events are 3.17 cfs and 11.55 cfs respectively.

Sub-Basin A28

The on-site sub-basin A28 consists primarily of landscaping along the west side of the site. The sub-basin has an area of 2.02 acres and a weighted imperviousness of 2%. Runoff in this basin will flow into the existing swale bordering Powers Blvd, curb and gutter in the private drive aisle. Runoff during the 5-year and 100-year events are 0.65 cfs and 5.51 cfs respectively.

Sub-basin A28 is currently vacant land and is not proposed to be developed. Therefore, the runoff reduction method per the CRITERIA was implemented. Sub-Basin A28 is a separate pervious area that does not require water quality capture volume per the CRITERIA's Version

3.07 UD-BMP spreadsheet. The spreadsheet is provided in **Appendix C**.

Sub-Basin A29

The on-site sub-basin A29 consists of landscaping, and drive aisle along the eastern property line. The sub-basin has an area of 0.57 acres and a weighted imperviousness of 82%. Runoff in this basin will sheet flow directly into Frontside Drive where it will be carried by curb and gutter into the existing storm water infrastructure. Flows from this sub-basin will follow existing flow patterns. Runoff during the 5-year and 100-year events are 1.47 cfs and 3.56 cfs respectively.

Due to the proximity of this basin to the southwest access point and the basin sitting approximately 5' above Frontside Drive, it is not practical to capture and treat this runoff. Sub-basin A29 is less than 1 acre. Therefore, per the El Paso County Engineering Criteria Manual Appendix I.7.1.C.1.a, the basin is excluded from needing water quality capture volume treatment and detention.

Sub-Basin OS1

The off-site sub-basin OS1 consists of ROW landscaping and a roadway improvement of existing Legacy Hill Drive to provide a dedicated right turn lane into the property. The sub-basin has an area of 0.22 acres and a weighted imperviousness of 64%. Runoff in this basin will sheet flow directly into Legacy Hill Dr where it will be carried by curb and gutter into the existing storm water infrastructure. Flows from this sub-basin will follow existing flow patterns. Runoff during the 5-year and 100-year events are 0.57 cfs and 1.34 cfs respectively.

The portions of the drive aisle from this basin that flow offsite will sheet flow into the existing offsite in sump CDOT Type R inlet within Frontside Drive. The total flow from sub-basin 26 and sub-basin OS1 entering the existing 10' type R curb inlet is 9.5 cfs in the 100-year event. The existing 10' Type R inlet has a capacity of 10.3 cfs. Therefore, the inlet can capture the 100-year storm event from sub-basins A16 and OS-1.

The East Pond (Design Point M, PUDSP-19-001 and EA18228) has adequate capacity and can treat this additional flow. Please reference **Appendix E** for the UD-Detention spreadsheet for this pond with relevant acreages highlighted, as well as the Proposed Drainage Map showing tributary basins. Per the Master Development Drainage Report the Site was allowed to discharge 7.0 cfs in the 5-year event and 28 cfs in the 100-year event to the East Pond at Design Point M (PUDSP-19-001 and EA18228). Ponds A23, A24, and A27 release to the storm sewer infrastructure that routes flows to the East Pond and Sub-Basin A26 and OS-1 releases to the roadways where the flow is captured by existing inlets. The total 5-year and 100-year runoff from the Project is 3.22 cfs and 25.39 cfs, respectively. Therefore, the release to the East Pond is in compliance with the Master Development Drainage Plan.

Refer to **Appendix F** for the Proposed Drainage Conditions Map.

DRAINAGE DESIGN CRITERIA

DEVELOPMENT CRITERIA REFERENCE

The proposed storm facilities are designed to be in compliance with the El Paso County Drainage Criteria Manual, Volumes 1 and 2 (The "CRITERIA") and the Urban Storm Drainage Criteria Manual (the "MANUAL"). Site drainage is not significantly impacted by such constraints

as utilities or existing development.

HYDROLOGIC SOIL GROUP

According to NRCS soil mapping data, USCS Type A and B soils are the primary soil type within the site. Soils present at the Site consist mainly of “Blakeland loamy sand” which represent a moderate hazard for erosion. **Appendix B** contains detailed NRCS soil data.

HYDROLOGIC CRITERIA

The 5-year and 100-year design storm events were used in determining rainfall and runoff for the proposed drainage analysis per chapter 5 of the CRITERIA. Design runoff was calculated using the Rational Method for developed conditions as established in the CRITERIA and MANUAL. Runoff coefficients for the proposed development were determined using Table 5-1 of the CRITERIA by calculating weighted impervious values for each specific site basin. Based upon this approach, the drainage design provided for the Site is conservative and in keeping with the zoning and historic drainage concept for the area.

HYDRAULIC CRITERIA

The proposed drainage facilities are designed in accordance with the Criteria and Manual. Floodplain identification was determined using FIRM panels by FEMA and information provided in the Criteria. Detailed sizing will be completed with the Final Drainage Report. The proposed inlet and street capacity and existing inlet were designed using the MHFD-Inlet, Version 5.02 (August 2022) Excel worksheet. Cross pan calculations will be completed with the Final Drainage Report. See **Appendix D** for inlet capacity calculations.

VARIANCES FROM CRITERIA

There are no proposed variances from the EPC Drainage Criteria Manual for the proposed development.

DETENTION REQUIRMENTS

Preliminary detention pond and water quality calculations have been completed. A total of four proposed private full spectrum extended detention basins have been designed for WQCV, EURV and 100-year flows. The four EDBs have been summarized below.

Pond	Approximate 100-yr Detention Volume Required (ac-ft)	Approximate WQCV Required (ac-ft)	Proposed 100-yr Volume (ac-ft)	Proposed Pond Volume (ac-ft)	5-Year Pond Release Rate (cfs)	100-Year Pond Release Rate (cfs)
A22	0.611	0.103	0.517	0.902	0.2	3.6
A23	1.174	0.200	0.989	1.618	0.3	9.6
A24	0.250	0.042	0.204	0.397	0.1	3.1
A27	0.108	0.020	0.069	0.144	0.0	3.2

Pond A22 captures and treats flows from sub-basins A17-A22 for water quality treatment and

detention. The proposed outlet structure has been designed to release at a rate of 0.2 cfs and 3.6 cfs for the minor and major storm, respectively.

Pond A23 captures and treats flows from sub-basins A1-A16 and A23 for water quality treatment and detention. The proposed outlet structure has been designed to release at a rate of 0.3 cfs and 9.6 cfs for the minor and major storm, respectively.

Pond A24 captures and treats flows from sub-basins A24-A25 for water quality treatment and detention. The proposed outlet structure has been designed to release at a rate of 0.1 cfs and 3.1 cfs for the minor and major storm, respectively.

Pond A27 captures and treats flows from sub-basin A27 for water quality treatment and detention. The proposed outlet structure has been designed to release at a rate of 0.0 cfs and 3.2 cfs for the minor and major storm, respectively.

The East Pond, as designed in the Master Development Drainage Report, captures and treats flows from sub-basin A26 and OS-1 for water quality treatment and detention. Per the Master Development Drainage Report the Site was allowed to discharge 7.0 cfs in the 5-year event and 28 cfs in the 100-year event to the East Pond at Design Point M. Ponds A23, A24, and A27 release to the storm sewer infrastructure that routes flows to the East Pond and Sub-Basin A26 releases to the roadways where the flow is captured by existing inlets. The total 5-year and 100-year runoff from the Project is 2.65 cfs and 24.05 cfs, respectively. Therefore, the release to the East Pond is in compliance with the Master Development Drainage Plan.

UD-detention Pond calculations are provided in **Appendix D**.

Ponds will be maintained by the metro district for the overall development. A maintenance access road will be provided with each pond, built per County standards.

DRAINAGE FACILITY DESIGN

GENERAL CONCEPT

The proposed development includes commercial buildings, landscape, and drive aisles. The proposed development will decrease permeability on the site. This decrease has been accounted for in the Master Drainage Plan. The proposed drainage patterns will match historic patterns as much as possible and not significantly increase developed flows. The runoff within the site will be captured and treated via proposed private Full Spectrum Extended Detention Basins before being released into historic discharge points. There will be four (4) proposed Full Spectrum Detention Basins, also referred to as Pond A22, Pond A23, Pond A24 and Pond A27, throughout this report.

Provided in **Appendix C** are the hydrologic calculations used in pond sizing. Provided in **Appendix D** are preliminary pond sizing calculations. Existing and proposed Drainage Maps can be found in **Appendix F**.

Downstream Infrastructure Capacity

The capacity of the existing Powers Boulevard ditch and proposed flows to this ditch were provided in **Appendix D**. The existing ditch capacity is approximately 80.11 cfs. Sub-basin A28 and Pond A22 release to the ditch with a combined 100-year release rate of 9.12 cfs.

EROSION CONTROL PLAN

Grading and Erosion Control Plans will be submitted separately as a standalone construction document.

FLOODPLAIN STATEMENT

According to Flood Insurance Rate Map Number 08041C0768G, dated December 7, 2018, the entire subject Property lies within Zone X, "Areas determined to be outside the 0.2% annual chance Floodplain. The FIRM Map is included in **Appendix B**.

DRAINAGE FEE

The project is within the Big Johnson drainage basin, and the West Fork of Jimmy Camp Creek drainage basin which is a part of the El Paso County Drainage Basin Fee Program. Total fees will be finalized with the Final Drainage report. Drainage fees shall be paid at the time of final plat recordation.

GROUNDWATER CONSIDERATIONS

Per the Geotechnical Engineering Study prepared by Entech, on May 25, 2022, groundwater was not encountered in any of the test borings which were drilled to 20 feet. This indicates that groundwater will have little effect on shallow foundations proposed for the Site based on final grades and depth of excavation. The proposed improvements are not anticipated to be negatively affected by groundwater. Reference **Appendix E** for the Geotechnical Report prepared by Entech.

THE FOUR STEP PROCESS

The Project was designed in accordance with the four-step process to minimize adverse impacts of urbanization, as outlined in the El Paso County Engineering Manual for BMP selection as noted below:

Step 1. Employ Runoff Reduction Practices – Currently the Site is undeveloped with no existing stormwater infrastructure on-site. The re-development of the Site will decrease current runoff totals. The existing Site has an overall imperviousness of 4%. The proposed improvements will increase imperviousness to 54%. See **Appendix C** for supplemental information showing the calculations for the net imperviousness.

Each individual lot will be required to implement their own runoff reduction techniques to meet EPC Criteria. These calculations will be provided in the individual lots Final Drainage Reports.

Step 2. Implement BMPs That Provide a Water Quality Capture Volume with Slow Release – Water quality treatment will be provided through the use of a proposed private extended detention basins. Water quality will be provided through extended detention basins for flows from sub-basins A1-A25 and A27. The sub-basins treated for water quality and detention via extended detention basins account for 16.86 acres or 76.3% of the total disturbed area.

Sub-basin A26 is captured by existing inlets and routed to the Master Development Drainage Report East Pond (Design Point M) for water quality treatment and detention.

Sub-basin OS-1 is captured by existing inlets and routed to the Master Development Drainage Report East Pond (Design Point M) for water quality treatment and detention.

Sub-basin A28 does not require water quality capture volume treatment per the runoff reduction method and CRITERIA Version 3.07 UD-BMP spreadsheet.

Sub-basin A29 is exempt per El Paso County Engineering Criteria Manual Appendix I.7.1.C.1.a.

Step 3 Stabilize Drainageways– Stabilizing proposed roadside ditches, swales, and channels by designing them with slopes that control the flow rates. Placement of riprap upstream and downstream of culverts to help reduce erosion of the roadside ditches. Check dams will be used in areas with steeper grades to slow the runoff. We anticipate this will minimize erosion. Existing drainage ways will be graded to reduce the velocity of the water to minimize erosion.

Step 4. Implement Site Specific and Other Source Control BMPs – The Site does not require “Covering of Storage/Handling Areas” or “Spill Containment and Control” (specialized BMPs) in the final constructed condition. There is no proposed material storage or other Site operations that would introduce contaminants to the City’s MS4 that would require Site specific control or source control BMP for the proposed project.

All flows leaving the Site will be released at or below historic rates and will cause no impact to downstream facilities and additional off-site improvements are not required by this Project. Reference the Downstream Infrastructure Capacity section of this report for details.

SUMMARY

COMPLIANCE WITH STANDARDS

The drainage design presented within this report the Waterview East Commercial project, conforms to the El Paso County Stormwater Criteria Manual, and the Urban Drainage and Flood Control District Manual. Additionally, the Site runoff and storm drain facilities will not adversely affect the water quality or peak flows downstream in Big Johnson Reservoir or West Fork of Jimmy Camp Creek Drainage basin , or surrounding developments.

REFERENCES

1. El Paso County “Engineering Criteria Manual” Volumes 1 & 2, December 2004, revised October 2018
2. Soil Survey of El Paso County Area, Colorado, Natural Resources Conservation Service (NRCS), April 2022.
3. Flood Insurance Rate Map, El Paso County, Colorado and Incorporated Areas, Map Number 08041C0768G, Federal Emergency Management Agency (FEMA), December 7, 2018
4. Master Development Drainage Plan Amendment for Waterview East & Preliminary Drainage Plan for Trails at Aspen Ridge, Matrix Design Group, June 2019, Revised: September 2019.
5. Waterview East Preliminary Drainage Report, Stantec Consulting Incorporated, June 2018.
6. Preliminary Subsurface Soils Investigation Waterview Commercial Site, Entech Engineering, Inc, May 2022.

APPENDIX

APPENDIX A – VICINITY MAP

Waterview East Commercial Vicinity Map (Not to Scale)

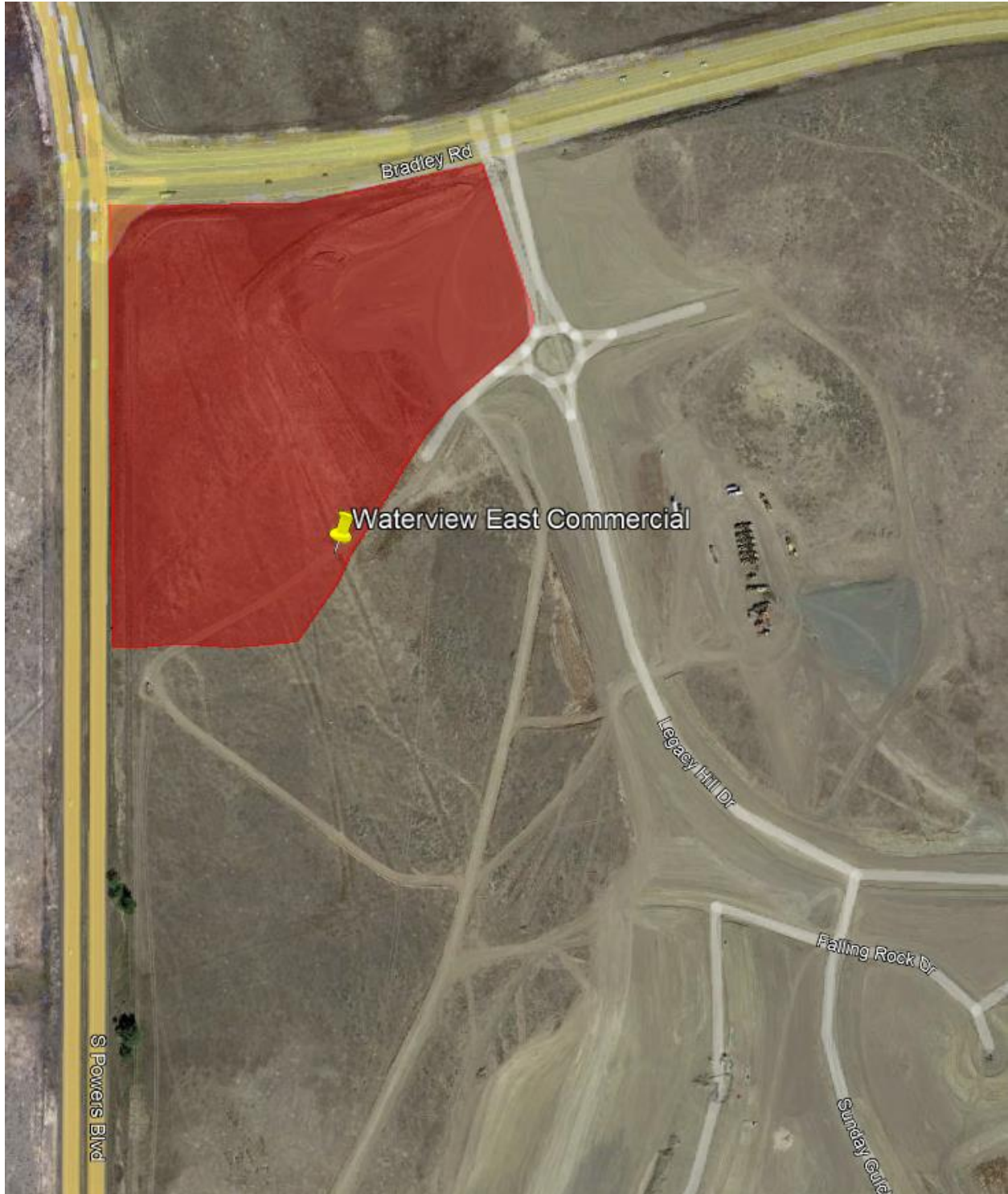

APPENDIX B – FEMA FIRM PANEL AND SOILS MAP

National Flood Hazard Layer FIRMMette



104°41'3"W 38°45'44"N

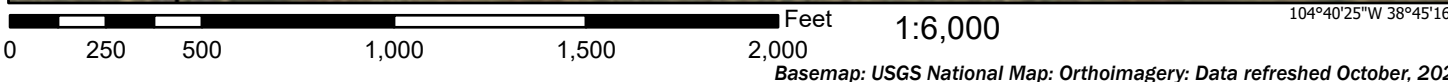

Legend

SEE FIS REPORT FOR DETAILED LEGEND AND INDEX MAP FOR FIRM PANEL LAYOUT

SPECIAL FLOOD HAZARD AREAS		Without Base Flood Elevation (BFE) <i>Zone A, V, A99</i>
		With BFE or Depth <i>Zone AE, AO, AH, VE, AR</i>
		Regulatory Floodway
OTHER AREAS OF FLOOD HAZARD		0.2% Annual Chance Flood Hazard, Areas of 1% annual chance flood with average depth less than one foot or with drainage areas of less than one square mile <i>Zone X</i>
		Future Conditions 1% Annual Chance Flood Hazard <i>Zone X</i>
		Area with Reduced Flood Risk due to Levee. See Notes. <i>Zone X</i>
		Area with Flood Risk due to Levee <i>Zone D</i>
OTHER AREAS		NO SCREEN Area of Minimal Flood Hazard <i>Zone X</i>
		Effective LOMRs
GENERAL STRUCTURES		Area of Undetermined Flood Hazard <i>Zone D</i>
		Channel, Culvert, or Storm Sewer
		Levee, Dike, or Floodwall
OTHER FEATURES		20.2 Cross Sections with 1% Annual Chance Water Surface Elevation
		17.5 Water Surface Elevation
		Coastal Transect
		Base Flood Elevation Line (BFE)
		Limit of Study
MAP PANELS		Digital Data Available
		No Digital Data Available
		Unmapped
		The pin displayed on the map is an approximate point selected by the user and does not represent an authoritative property location.

This map complies with FEMA's standards for the use of digital flood maps if it is not void as described below. The basemap shown complies with FEMA's basemap accuracy standards

The flood hazard information is derived directly from the authoritative NFHL web services provided by FEMA. This map was exported on **4/29/2022 at 2:29 PM** and does not reflect changes or amendments subsequent to this date and time. The NFHL and effective information may change or become superseded by new data over time.

This map image is void if the one or more of the following map elements do not appear: basemap imagery, flood zone labels, legend, scale bar, map creation date, community identifiers, FIRM panel number, and FIRM effective date. Map images for unmapped and unmodernized areas cannot be used for regulatory purposes.

Custom Soil Resource Report for El Paso County Area, Colorado



Preface

Soil surveys contain information that affects land use planning in survey areas. They highlight soil limitations that affect various land uses and provide information about the properties of the soils in the survey areas. Soil surveys are designed for many different users, including farmers, ranchers, foresters, agronomists, urban planners, community officials, engineers, developers, builders, and home buyers. Also, conservationists, teachers, students, and specialists in recreation, waste disposal, and pollution control can use the surveys to help them understand, protect, or enhance the environment.

Various land use regulations of Federal, State, and local governments may impose special restrictions on land use or land treatment. Soil surveys identify soil properties that are used in making various land use or land treatment decisions. The information is intended to help the land users identify and reduce the effects of soil limitations on various land uses. The landowner or user is responsible for identifying and complying with existing laws and regulations.

Although soil survey information can be used for general farm, local, and wider area planning, onsite investigation is needed to supplement this information in some cases. Examples include soil quality assessments (<http://www.nrcs.usda.gov/wps/portal/nrcs/main/soils/health/>) and certain conservation and engineering applications. For more detailed information, contact your local USDA Service Center (<https://offices.sc.egov.usda.gov/locator/app?agency=nrcs>) or your NRCS State Soil Scientist (http://www.nrcs.usda.gov/wps/portal/nrcs/detail/soils/contactus/?cid=nrcs142p2_053951).

Great differences in soil properties can occur within short distances. Some soils are seasonally wet or subject to flooding. Some are too unstable to be used as a foundation for buildings or roads. Clayey or wet soils are poorly suited to use as septic tank absorption fields. A high water table makes a soil poorly suited to basements or underground installations.

The National Cooperative Soil Survey is a joint effort of the United States Department of Agriculture and other Federal agencies, State agencies including the Agricultural Experiment Stations, and local agencies. The Natural Resources Conservation Service (NRCS) has leadership for the Federal part of the National Cooperative Soil Survey.

Information about soils is updated periodically. Updated information is available through the NRCS Web Soil Survey, the site for official soil survey information.

The U.S. Department of Agriculture (USDA) prohibits discrimination in all its programs and activities on the basis of race, color, national origin, age, disability, and where applicable, sex, marital status, familial status, parental status, religion, sexual orientation, genetic information, political beliefs, reprisal, or because all or a part of an individual's income is derived from any public assistance program. (Not all prohibited bases apply to all programs.) Persons with disabilities who require

alternative means for communication of program information (Braille, large print, audiotape, etc.) should contact USDA's TARGET Center at (202) 720-2600 (voice and TDD). To file a complaint of discrimination, write to USDA, Director, Office of Civil Rights, 1400 Independence Avenue, S.W., Washington, D.C. 20250-9410 or call (800) 795-3272 (voice) or (202) 720-6382 (TDD). USDA is an equal opportunity provider and employer.

Contents

Preface	2
Soil Map	5
Soil Map.....	6
Legend.....	7
Map Unit Legend.....	8
Map Unit Descriptions.....	8
El Paso County Area, Colorado.....	10
8—Blakeland loamy sand, 1 to 9 percent slopes.....	10
56—Nelson-Tassel fine sandy loams, 3 to 18 percent slopes.....	11
86—Stoneham sandy loam, 3 to 8 percent slopes.....	13
108—Wiley silt loam, 3 to 9 percent slopes.....	14
Soil Information for All Uses	16
Suitabilities and Limitations for Use.....	16
Land Management.....	16
Erosion Hazard (Road, Trail).....	16
References	21

Soil Map

The soil map section includes the soil map for the defined area of interest, a list of soil map units on the map and extent of each map unit, and cartographic symbols displayed on the map. Also presented are various metadata about data used to produce the map, and a description of each soil map unit.

Custom Soil Resource Report Soil Map

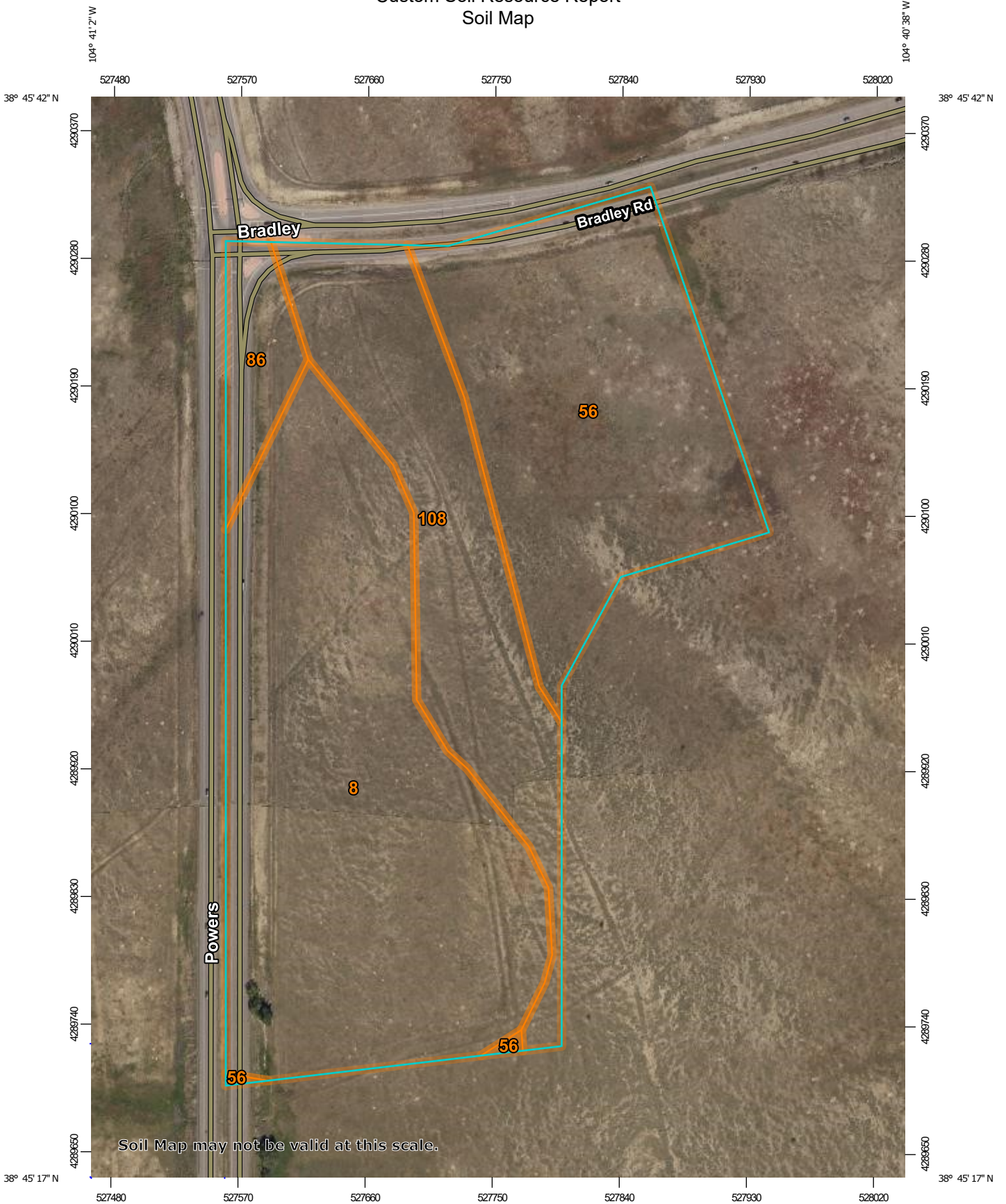

Map Scale: 1:3,720 if printed on A portrait (8.5" x 11") sheet.

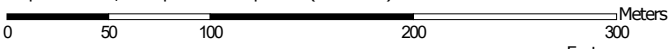

Map projection: Web Mercator Corner coordinates: WGS84 Edge tics: UTM Zone 13N WGS84



MAP LEGEND

Area of Interest (AOI)

 Area of Interest (AOI)

Soils

 Soil Map Unit Polygons

 Soil Map Unit Lines

 Soil Map Unit Points

Special Point Features





-  Blowout
-  Borrow Pit
-  Clay Spot
-  Closed Depression
-  Gravel Pit
-  Gravelly Spot
-  Landfill
-  Lava Flow
-  Marsh or swamp
-  Mine or Quarry
-  Miscellaneous Water
-  Perennial Water
-  Rock Outcrop
-  Saline Spot
-  Sandy Spot
-  Severely Eroded Spot
-  Sinkhole
-  Slide or Slip
-  Sodic Spot

-  Spoil Area
-  Stony Spot
-  Very Stony Spot
-  Wet Spot
-  Other
-  Special Line Features

Water Features

 Streams and Canals

Transportation

-  Rails
-  Interstate Highways
-  US Routes
-  Major Roads
-  Local Roads

Background

 Aerial Photography

MAP INFORMATION

The soil surveys that comprise your AOI were mapped at 1:24,000.

Warning: Soil Map may not be valid at this scale.

Enlargement of maps beyond the scale of mapping can cause misunderstanding of the detail of mapping and accuracy of soil line placement. The maps do not show the small areas of contrasting soils that could have been shown at a more detailed scale.

Please rely on the bar scale on each map sheet for map measurements.

Source of Map: Natural Resources Conservation Service
 Web Soil Survey URL:
 Coordinate System: Web Mercator (EPSG:3857)

Maps from the Web Soil Survey are based on the Web Mercator projection, which preserves direction and shape but distorts distance and area. A projection that preserves area, such as the Albers equal-area conic projection, should be used if more accurate calculations of distance or area are required.

This product is generated from the USDA-NRCS certified data as of the version date(s) listed below.

Soil Survey Area: El Paso County Area, Colorado
 Survey Area Data: Version 19, Aug 31, 2021

Soil map units are labeled (as space allows) for map scales 1:50,000 or larger.

Date(s) aerial images were photographed: Aug 14, 2018—Sep 23, 2018

The orthophoto or other base map on which the soil lines were compiled and digitized probably differs from the background imagery displayed on these maps. As a result, some minor shifting of map unit boundaries may be evident.

Map Unit Legend

Map Unit Symbol	Map Unit Name	Acres in AOI	Percent of AOI
8	Blakeland loamy sand, 1 to 9 percent slopes	19.2	45.9%
56	Nelson-Tassel fine sandy loams, 3 to 18 percent slopes	12.2	29.3%
86	Stoneham sandy loam, 3 to 8 percent slopes	1.8	4.3%
108	Wiley silt loam, 3 to 9 percent slopes	8.6	20.5%
Totals for Area of Interest		41.8	100.0%

Map Unit Descriptions

The map units delineated on the detailed soil maps in a soil survey represent the soils or miscellaneous areas in the survey area. The map unit descriptions, along with the maps, can be used to determine the composition and properties of a unit.

A map unit delineation on a soil map represents an area dominated by one or more major kinds of soil or miscellaneous areas. A map unit is identified and named according to the taxonomic classification of the dominant soils. Within a taxonomic class there are precisely defined limits for the properties of the soils. On the landscape, however, the soils are natural phenomena, and they have the characteristic variability of all natural phenomena. Thus, the range of some observed properties may extend beyond the limits defined for a taxonomic class. Areas of soils of a single taxonomic class rarely, if ever, can be mapped without including areas of other taxonomic classes. Consequently, every map unit is made up of the soils or miscellaneous areas for which it is named and some minor components that belong to taxonomic classes other than those of the major soils.

Most minor soils have properties similar to those of the dominant soil or soils in the map unit, and thus they do not affect use and management. These are called noncontrasting, or similar, components. They may or may not be mentioned in a particular map unit description. Other minor components, however, have properties and behavioral characteristics divergent enough to affect use or to require different management. These are called contrasting, or dissimilar, components. They generally are in small areas and could not be mapped separately because of the scale used. Some small areas of strongly contrasting soils or miscellaneous areas are identified by a special symbol on the maps. If included in the database for a given area, the contrasting minor components are identified in the map unit descriptions along with some characteristics of each. A few areas of minor components may not have been observed, and consequently they are not mentioned in the descriptions, especially where the pattern was so complex that it was impractical to make enough observations to identify all the soils and miscellaneous areas on the landscape.

Custom Soil Resource Report

The presence of minor components in a map unit in no way diminishes the usefulness or accuracy of the data. The objective of mapping is not to delineate pure taxonomic classes but rather to separate the landscape into landforms or landform segments that have similar use and management requirements. The delineation of such segments on the map provides sufficient information for the development of resource plans. If intensive use of small areas is planned, however, onsite investigation is needed to define and locate the soils and miscellaneous areas.

An identifying symbol precedes the map unit name in the map unit descriptions. Each description includes general facts about the unit and gives important soil properties and qualities.

Soils that have profiles that are almost alike make up a *soil series*. Except for differences in texture of the surface layer, all the soils of a series have major horizons that are similar in composition, thickness, and arrangement.

Soils of one series can differ in texture of the surface layer, slope, stoniness, salinity, degree of erosion, and other characteristics that affect their use. On the basis of such differences, a soil series is divided into *soil phases*. Most of the areas shown on the detailed soil maps are phases of soil series. The name of a soil phase commonly indicates a feature that affects use or management. For example, Alpha silt loam, 0 to 2 percent slopes, is a phase of the Alpha series.

Some map units are made up of two or more major soils or miscellaneous areas. These map units are complexes, associations, or undifferentiated groups.

A *complex* consists of two or more soils or miscellaneous areas in such an intricate pattern or in such small areas that they cannot be shown separately on the maps. The pattern and proportion of the soils or miscellaneous areas are somewhat similar in all areas. Alpha-Beta complex, 0 to 6 percent slopes, is an example.

An *association* is made up of two or more geographically associated soils or miscellaneous areas that are shown as one unit on the maps. Because of present or anticipated uses of the map units in the survey area, it was not considered practical or necessary to map the soils or miscellaneous areas separately. The pattern and relative proportion of the soils or miscellaneous areas are somewhat similar. Alpha-Beta association, 0 to 2 percent slopes, is an example.

An *undifferentiated group* is made up of two or more soils or miscellaneous areas that could be mapped individually but are mapped as one unit because similar interpretations can be made for use and management. The pattern and proportion of the soils or miscellaneous areas in a mapped area are not uniform. An area can be made up of only one of the major soils or miscellaneous areas, or it can be made up of all of them. Alpha and Beta soils, 0 to 2 percent slopes, is an example.

Some surveys include *miscellaneous areas*. Such areas have little or no soil material and support little or no vegetation. Rock outcrop is an example.

El Paso County Area, Colorado

8—Blakeland loamy sand, 1 to 9 percent slopes

Map Unit Setting

National map unit symbol: 369v
Elevation: 4,600 to 5,800 feet
Mean annual precipitation: 14 to 16 inches
Mean annual air temperature: 46 to 48 degrees F
Frost-free period: 125 to 145 days
Farmland classification: Not prime farmland

Map Unit Composition

Blakeland and similar soils: 98 percent
Minor components: 2 percent
Estimates are based on observations, descriptions, and transects of the mapunit.

Description of Blakeland

Setting

Landform: Hills, flats
Landform position (three-dimensional): Side slope, talf
Down-slope shape: Linear
Across-slope shape: Linear
Parent material: Alluvium derived from sedimentary rock and/or eolian deposits derived from sedimentary rock

Typical profile

A - 0 to 11 inches: loamy sand
AC - 11 to 27 inches: loamy sand
C - 27 to 60 inches: sand

Properties and qualities

Slope: 1 to 9 percent
Depth to restrictive feature: More than 80 inches
Drainage class: Somewhat excessively drained
Runoff class: Low
Capacity of the most limiting layer to transmit water (Ksat): High to very high (5.95 to 19.98 in/hr)
Depth to water table: More than 80 inches
Frequency of flooding: None
Frequency of ponding: None
Calcium carbonate, maximum content: 5 percent
Available water supply, 0 to 60 inches: Low (about 4.5 inches)

Interpretive groups

Land capability classification (irrigated): 3e
Land capability classification (nonirrigated): 6e
Hydrologic Soil Group: A
Ecological site: R049XB210CO - Sandy Foothill
Hydric soil rating: No

Minor Components

Other soils

Percent of map unit: 1 percent

Custom Soil Resource Report

Hydric soil rating: No

Pleasant

Percent of map unit: 1 percent

Landform: Depressions

Hydric soil rating: Yes

56—Nelson-Tassel fine sandy loams, 3 to 18 percent slopes

Map Unit Setting

National map unit symbol: 3690

Elevation: 5,600 to 6,400 feet

Mean annual precipitation: 12 to 14 inches

Mean annual air temperature: 48 to 52 degrees F

Frost-free period: 135 to 155 days

Farmland classification: Not prime farmland

Map Unit Composition

Nelson and similar soils: 55 percent

Tassel and similar soils: 40 percent

Minor components: 5 percent

Estimates are based on observations, descriptions, and transects of the mapunit.

Description of Nelson

Setting

Landform: Hills

Landform position (three-dimensional): Side slope, crest

Down-slope shape: Linear

Across-slope shape: Linear

Parent material: Calcareous residuum weathered from interbedded sedimentary rock

Typical profile

A - 0 to 5 inches: fine sandy loam

Ck - 5 to 23 inches: fine sandy loam

Cr - 23 to 27 inches: weathered bedrock

Properties and qualities

Slope: 3 to 12 percent

Depth to restrictive feature: 20 to 40 inches to paralithic bedrock

Drainage class: Well drained

Runoff class: Medium

Capacity of the most limiting layer to transmit water (Ksat): Moderately low to high
(0.06 to 2.00 in/hr)

Depth to water table: More than 80 inches

Frequency of flooding: None

Frequency of ponding: None

Calcium carbonate, maximum content: 10 percent

Maximum salinity: Nonsaline to very slightly saline (0.0 to 2.0 mmhos/cm)

Available water supply, 0 to 60 inches: Very low (about 2.8 inches)

Interpretive groups

Land capability classification (irrigated): 4e
Land capability classification (nonirrigated): 6e
Hydrologic Soil Group: B
Ecological site: R067BY045CO - Shaly Plains
Other vegetative classification: SHALY PLAINS (069AY046CO)
Hydric soil rating: No

Description of Tassel

Setting

Landform: Hills
Landform position (three-dimensional): Side slope, crest
Down-slope shape: Linear
Across-slope shape: Linear
Parent material: Calcareous slope alluvium over residuum weathered from sandstone

Typical profile

A - 0 to 4 inches: fine sandy loam
C - 4 to 10 inches: fine sandy loam
Cr - 10 to 14 inches: weathered bedrock

Properties and qualities

Slope: 3 to 18 percent
Depth to restrictive feature: 6 to 20 inches to paralithic bedrock
Drainage class: Well drained
Runoff class: Medium
Capacity of the most limiting layer to transmit water (Ksat): Moderately high (0.20 to 0.60 in/hr)
Depth to water table: More than 80 inches
Frequency of flooding: None
Frequency of ponding: None
Calcium carbonate, maximum content: 10 percent
Available water supply, 0 to 60 inches: Very low (about 1.2 inches)

Interpretive groups

Land capability classification (irrigated): None specified
Land capability classification (nonirrigated): 6s
Hydrologic Soil Group: D
Ecological site: R067BY045CO - Shaly Plains
Other vegetative classification: SHALY PLAINS (069AY046CO)
Hydric soil rating: No

Minor Components

Other soils

Percent of map unit: 4 percent
Hydric soil rating: No

Pleasant

Percent of map unit: 1 percent
Landform: Depressions
Hydric soil rating: Yes

86—Stoneham sandy loam, 3 to 8 percent slopes

Map Unit Setting

National map unit symbol: 36b2
Elevation: 5,100 to 6,500 feet
Mean annual precipitation: 13 to 15 inches
Mean annual air temperature: 48 to 52 degrees F
Frost-free period: 135 to 155 days
Farmland classification: Not prime farmland

Map Unit Composition

Stoneham and similar soils: 95 percent
Minor components: 5 percent
Estimates are based on observations, descriptions, and transects of the mapunit.

Description of Stoneham

Setting

Landform: Hills
Landform position (three-dimensional): Side slope
Down-slope shape: Linear
Across-slope shape: Linear
Parent material: Calcareous loamy alluvium

Typical profile

A - 0 to 4 inches: sandy loam
Bt - 4 to 8 inches: sandy clay loam
Btk - 8 to 11 inches: sandy clay loam
Ck - 11 to 60 inches: loam

Properties and qualities

Slope: 3 to 8 percent
Depth to restrictive feature: More than 80 inches
Drainage class: Well drained
Runoff class: Medium
Capacity of the most limiting layer to transmit water (Ksat): Moderately high to high
(0.60 to 2.00 in/hr)
Depth to water table: More than 80 inches
Frequency of flooding: None
Frequency of ponding: None
Calcium carbonate, maximum content: 15 percent
Maximum salinity: Nonsaline to very slightly saline (0.0 to 2.0 mmhos/cm)
Available water supply, 0 to 60 inches: High (about 9.5 inches)

Interpretive groups

Land capability classification (irrigated): 3e
Land capability classification (nonirrigated): 4e
Hydrologic Soil Group: B
Ecological site: R067BY024CO - Sandy Plains

Custom Soil Resource Report

Other vegetative classification: SANDY PLAINS (069AY026CO)
Hydric soil rating: No

Minor Components

Other soils

Percent of map unit: 4 percent
Hydric soil rating: No

Pleasant

Percent of map unit: 1 percent
Landform: Depressions
Hydric soil rating: Yes

108—Wiley silt loam, 3 to 9 percent slopes

Map Unit Setting

National map unit symbol: 367b
Elevation: 5,200 to 6,200 feet
Mean annual precipitation: 12 to 14 inches
Mean annual air temperature: 48 to 52 degrees F
Frost-free period: 135 to 155 days
Farmland classification: Not prime farmland

Map Unit Composition

Wiley and similar soils: 95 percent
Minor components: 5 percent
Estimates are based on observations, descriptions, and transects of the mapunit.

Description of Wiley

Setting

Landform: Hills
Landform position (three-dimensional): Side slope
Down-slope shape: Linear
Across-slope shape: Linear
Parent material: Calcareous silty eolian deposits

Typical profile

A - 0 to 4 inches: silt loam
Bt - 4 to 16 inches: silt loam
Bk - 16 to 60 inches: silt loam

Properties and qualities

Slope: 3 to 9 percent
Depth to restrictive feature: More than 80 inches
Drainage class: Well drained
Runoff class: Medium
Capacity of the most limiting layer to transmit water (Ksat): Moderately high to high
(0.60 to 2.00 in/hr)
Depth to water table: More than 80 inches

Custom Soil Resource Report

Frequency of flooding: None

Frequency of ponding: None

Calcium carbonate, maximum content: 15 percent

Maximum salinity: Nonsaline to very slightly saline (0.0 to 2.0 mmhos/cm)

Available water supply, 0 to 60 inches: High (about 11.5 inches)

Interpretive groups

Land capability classification (irrigated): 4e

Land capability classification (nonirrigated): 6e

Hydrologic Soil Group: B

Ecological site: R067BY002CO - Loamy Plains

Other vegetative classification: LOAMY PLAINS (069AY006CO)

Hydric soil rating: No

Minor Components

Other soils

Percent of map unit: 4 percent

Hydric soil rating: No

Pleasant

Percent of map unit: 1 percent

Landform: Depressions

Hydric soil rating: Yes

Soil Information for All Uses

Suitabilities and Limitations for Use

The Suitabilities and Limitations for Use section includes various soil interpretations displayed as thematic maps with a summary table for the soil map units in the selected area of interest. A single value or rating for each map unit is generated by aggregating the interpretive ratings of individual map unit components. This aggregation process is defined for each interpretation.

Land Management

Land management interpretations are tools designed to guide the user in evaluating existing conditions in planning and predicting the soil response to various land management practices, for a variety of land uses, including cropland, forestland, hayland, pastureland, horticulture, and rangeland. Example interpretations include suitability for a variety of irrigation practices, log landings, haul roads and major skid trails, equipment operability, site preparation, suitability for hand and mechanical planting, potential erosion hazard associated with various practices, and ratings for fencing and waterline installation.

Erosion Hazard (Road, Trail)

The ratings in this interpretation indicate the hazard of soil loss from unsurfaced roads and trails. The ratings are based on soil erosion factor K, slope, and content of rock fragments.

The ratings are both verbal and numerical. The hazard is described as "slight," "moderate," or "severe." A rating of "slight" indicates that little or no erosion is likely; "moderate" indicates that some erosion is likely, that the roads or trails may require occasional maintenance, and that simple erosion-control measures are needed; and "severe" indicates that significant erosion is expected, that the roads or trails require frequent maintenance, and that costly erosion-control measures are needed.

Numerical ratings indicate the severity of individual limitations. The ratings are shown as decimal fractions ranging from 0.01 to 1.00. They indicate gradations between the point at which a soil feature has the greatest negative impact on the specified aspect of forestland management (1.00) and the point at which the soil feature is not a limitation (0.00).

Custom Soil Resource Report

The map unit components listed for each map unit in the accompanying Summary by Map Unit table in Web Soil Survey or the Aggregation Report in Soil Data Viewer are determined by the aggregation method chosen. An aggregated rating class is shown for each map unit. The components listed for each map unit are only those that have the same rating class as listed for the map unit. The percent composition of each component in a particular map unit is presented to help the user better understand the percentage of each map unit that has the rating presented.

Other components with different ratings may be present in each map unit. The ratings for all components, regardless of the map unit aggregated rating, can be viewed by generating the equivalent report from the Soil Reports tab in Web Soil Survey or from the Soil Data Mart site. Onsite investigation may be needed to validate these interpretations and to confirm the identity of the soil on a given site.







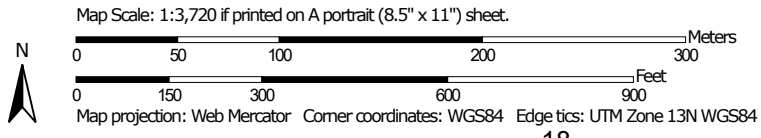















Custom Soil Resource Report
Map—Erosion Hazard (Road, Trail)



Soil Map may not be valid at this scale.



MAP LEGEND

- Area of Interest (AOI)**
 -  Area of Interest (AOI)
- Soils**
 - Soil Rating Polygons**
 -  Very severe
 -  Severe
 -  Moderate
 -  Slight
 -  Not rated or not available
 - Soil Rating Lines**
 -  Very severe
 -  Severe
 -  Moderate
 -  Slight
 -  Not rated or not available
 - Soil Rating Points**
 -  Very severe
 -  Severe
 -  Moderate
 -  Slight
 -  Not rated or not available
- Water Features**
 -  Streams and Canals
- Transportation**
 -  Rails
 -  Interstate Highways
-  US Routes
-  Major Roads
-  Local Roads
- Background**
 -  Aerial Photography

MAP INFORMATION

The soil surveys that comprise your AOI were mapped at 1:24,000.

Warning: Soil Map may not be valid at this scale.

Enlargement of maps beyond the scale of mapping can cause misunderstanding of the detail of mapping and accuracy of soil line placement. The maps do not show the small areas of contrasting soils that could have been shown at a more detailed scale.

Please rely on the bar scale on each map sheet for map measurements.

Source of Map: Natural Resources Conservation Service
 Web Soil Survey URL:
 Coordinate System: Web Mercator (EPSG:3857)

Maps from the Web Soil Survey are based on the Web Mercator projection, which preserves direction and shape but distorts distance and area. A projection that preserves area, such as the Albers equal-area conic projection, should be used if more accurate calculations of distance or area are required.

This product is generated from the USDA-NRCS certified data as of the version date(s) listed below.

Soil Survey Area: El Paso County Area, Colorado
 Survey Area Data: Version 19, Aug 31, 2021

Soil map units are labeled (as space allows) for map scales 1:50,000 or larger.

Date(s) aerial images were photographed: Aug 14, 2018—Sep 23, 2018

The orthophoto or other base map on which the soil lines were compiled and digitized probably differs from the background imagery displayed on these maps. As a result, some minor shifting of map unit boundaries may be evident.

Tables—Erosion Hazard (Road, Trail)

Map unit symbol	Map unit name	Rating	Component name (percent)	Rating reasons (numeric values)	Acres in AOI	Percent of AOI
8	Blakeland loamy sand, 1 to 9 percent slopes	Moderate	Blakeland (98%)	Slope/erodibility (0.50)	19.2	45.9%
56	Nelson-Tassel fine sandy loams, 3 to 18 percent slopes	Moderate	Nelson (55%)	Slope/erodibility (0.50)	12.2	29.3%
86	Stoneham sandy loam, 3 to 8 percent slopes	Moderate	Stoneham (95%)	Slope/erodibility (0.50)	1.8	4.3%
108	Wiley silt loam, 3 to 9 percent slopes	Moderate	Wiley (95%)	Slope/erodibility (0.50)	8.6	20.5%
Totals for Area of Interest					41.8	100.0%

Rating	Acres in AOI	Percent of AOI
Moderate	41.8	100.0%
Totals for Area of Interest	41.8	100.0%

Rating Options—Erosion Hazard (Road, Trail)

Aggregation Method: Dominant Condition

Component Percent Cutoff: None Specified

Tie-break Rule: Higher

References

- American Association of State Highway and Transportation Officials (AASHTO). 2004. Standard specifications for transportation materials and methods of sampling and testing. 24th edition.
- American Society for Testing and Materials (ASTM). 2005. Standard classification of soils for engineering purposes. ASTM Standard D2487-00.
- Cowardin, L.M., V. Carter, F.C. Golet, and E.T. LaRoe. 1979. Classification of wetlands and deep-water habitats of the United States. U.S. Fish and Wildlife Service FWS/OBS-79/31.
- Federal Register. July 13, 1994. Changes in hydric soils of the United States.
- Federal Register. September 18, 2002. Hydric soils of the United States.
- Hurt, G.W., and L.M. Vasilas, editors. Version 6.0, 2006. Field indicators of hydric soils in the United States.
- National Research Council. 1995. Wetlands: Characteristics and boundaries.
- Soil Survey Division Staff. 1993. Soil survey manual. Soil Conservation Service. U.S. Department of Agriculture Handbook 18. http://www.nrcs.usda.gov/wps/portal/nrcs/detail/national/soils/?cid=nrcs142p2_054262
- Soil Survey Staff. 1999. Soil taxonomy: A basic system of soil classification for making and interpreting soil surveys. 2nd edition. Natural Resources Conservation Service, U.S. Department of Agriculture Handbook 436. http://www.nrcs.usda.gov/wps/portal/nrcs/detail/national/soils/?cid=nrcs142p2_053577
- Soil Survey Staff. 2010. Keys to soil taxonomy. 11th edition. U.S. Department of Agriculture, Natural Resources Conservation Service. http://www.nrcs.usda.gov/wps/portal/nrcs/detail/national/soils/?cid=nrcs142p2_053580
- Tiner, R.W., Jr. 1985. Wetlands of Delaware. U.S. Fish and Wildlife Service and Delaware Department of Natural Resources and Environmental Control, Wetlands Section.
- United States Army Corps of Engineers, Environmental Laboratory. 1987. Corps of Engineers wetlands delineation manual. Waterways Experiment Station Technical Report Y-87-1.
- United States Department of Agriculture, Natural Resources Conservation Service. National forestry manual. http://www.nrcs.usda.gov/wps/portal/nrcs/detail/soils/home/?cid=nrcs142p2_053374
- United States Department of Agriculture, Natural Resources Conservation Service. National range and pasture handbook. <http://www.nrcs.usda.gov/wps/portal/nrcs/detail/national/landuse/rangepasture/?cid=stelprdb1043084>

Custom Soil Resource Report

United States Department of Agriculture, Natural Resources Conservation Service. National soil survey handbook, title 430-VI. http://www.nrcs.usda.gov/wps/portal/nrcs/detail/soils/scientists/?cid=nrcs142p2_054242

United States Department of Agriculture, Natural Resources Conservation Service. 2006. Land resource regions and major land resource areas of the United States, the Caribbean, and the Pacific Basin. U.S. Department of Agriculture Handbook 296. http://www.nrcs.usda.gov/wps/portal/nrcs/detail/national/soils/?cid=nrcs142p2_053624

United States Department of Agriculture, Soil Conservation Service. 1961. Land capability classification. U.S. Department of Agriculture Handbook 210. http://www.nrcs.usda.gov/Internet/FSE_DOCUMENTS/nrcs142p2_052290.pdf

APPENDIX C – HYDROLOGIC CALCULATIONS

$$I = \frac{28.5 P_1}{(10 + T_D)^{0.786}}$$

Where:

I = rainfall intensity (inches per hour)

P₁ = one-hour rainfall depth (inches) from NOAA Atlas 14

Point Precipitation Frequency Estimates, Colorado Springs, CO

T_c = storm duration (minutes)

	<u>2-yr</u>	<u>5-yr</u>	<u>10-yr</u>	<u>100-yr</u>
P ₁ =	1.01	1.29	1.56	2.75

Time Intensity Frequency Tabulation

TIME	2 YR	5 YR	10 YR	100 YR
5	3.43	4.38	5.29	9.33
10	2.73	3.49	4.22	7.44
15	2.29	2.93	3.54	6.24
30	1.58	2.02	2.45	4.31
60	1.02	1.30	1.58	2.78
120	0.63	0.80	0.97	1.71

Weighted Imperviousness Calculations - Existing Conditions

SUB-BASIN	AREA (SF)	AREA (Acres)	ROOF AREA	ROOF IMPERVIOUSNESS	ROOF				LANDSCAPE AREA	LANDSCAPE IMPERVIOUSNESS	LANDSCAPE				PAVEMENT AREA	PAVEMENT IMPERVIOUSNESS	PAVEMENT				WEIGHTED IMPERVIOUSNESS	WEIGHTED COEFFICIENTS			
					C2	C5	C10	C100			C2	C5	C10	C100			C2	C5	C10	C100		C2	C5	C10	C100
EX-1	451188	10.45	0	90%	0.71	0.73	0.75	0.81	10.12	2%	0.03	0.09	0.17	0.36	0.33	100%	0.89	0.90	0.92	0.96	5%	0.06	0.12	0.19	0.38
EX-2	501101	11.41	0	90%	0.71	0.73	0.75	0.81	11.41	2%	0.03	0.09	0.17	0.36	0.00	100%	0.89	0.90	0.92	0.96	2%	0.03	0.09	0.17	0.36
EX-3	11114	0.24	0	90%	0.71	0.73	0.75	0.81	0.20	2%	0.03	0.09	0.17	0.36	0.04	100%	0.89	0.90	0.92	0.96	19%	0.18	0.23	0.30	0.46
OS-1	28574	0.59	0	90%	0.71	0.73	0.75	0.81	0.59	2%	0.03	0.09	0.17	0.36	0.00	100%	0.89	0.90	0.92	0.96	2%	0.03	0.09	0.17	0.36
TOTAL	963,403	22.69	0.00	90%	0.71	0.73	0.75	0.81	22.32	2%	0.03	0.09	0.17	0.36	0.37	100%	0.89	0.90	0.92	0.96	4%	0.04	0.10	0.18	0.37

Waterview East Commercial
 Drainage Report
 El Paso County, CO

Waterview East Commercial Existing Runoff Calculations Time of Concentration																
Watercourse Coefficient Forest & Meadow 2.50 Short Grass Pasture & Lawns 7.00 Grassed Waterway 15.00 Fallow or Cultivation 5.00 Nearly Bare Ground 10.00 Paved Area & Shallow Gutter 20.00																
DESIGN POINT	SUB-BASIN DATA				INITIAL / OVERLAND TIME			TRAVEL TIME T(t)					T(c) CHECK (URBANIZED BASINS)			FINAL T(c) min.
	DRAIN BASIN	AREA sq. ft.	AREA ac.	C(5)	Length ft.	Slope %	T(i) min	Length ft.	Slope %	Coeff.	Velocity fps	T(t) min.	COMP. T(c)	TOTAL LENGTH	L/180+10	
1	EX-1	451,188	10.36	0.12	100	3.4%	12.1	742	9.7%	7.00	2.2	5.7	17.8	842	14.7	14.7
2	EX-2	501,101	11.50	0.09	100	2.8%	13.1	1710	5.6%	7.00	1.7	17.2	30.3	1810	20.1	20.1
3	EX-3	11,114	0.26	0.23	100	9.6%	7.5	40	0.6%	7.00	0.5	1.2	8.7	140	10.8	8.7
4	OS-1	28,574	0.66	0.09	34	33.0%	3.4	625	2.8%	7.00	1.2	8.9	12.3	659	13.7	12.3

Waterview East Commercial Existing Runoff Calculations (Rational Method Procedure)												
BASIN INFORMATION				DIRECT RUNOFF				CUMULATIVE RUNOFF				NOTES
DESIGN POINT	DRAIN BASIN	AREA ac.	RUNOFF COEFF	T(c) min	C x A	I in/hr	Q cfs	T(c) min	C x A	I in/hr	Q cfs	
1	EX-1	10.36	0.12	14.7	1.19	2.96	3.53				3.53	
2	EX-2	11.50	0.09	20.1	1.04	2.53	2.62				2.62	
3	EX-3	0.26	0.23	8.7	0.06	3.67	0.22				0.22	
4	OS-1	0.66	0.09	12.3	0.06	3.20	0.19				0.19	

Waterview East Commercial Existing Runoff Calculations (Rational Method Procedure)												
BASIN INFORMATION				DIRECT RUNOFF				CUMULATIVE RUNOFF				NOTES
DESIGN POINT	DRAIN BASIN	AREA ac.	RUNOFF COEFF	T(c) min	C x A	I in/hr	Q cfs	T(c) min	C x A	I in/hr	Q cfs	
1	EX-1	10.36	0.38	14.7	3.92	6.30	24.72				24.72	
2	EX-2	11.50	0.36	20.1	4.14	5.40	22.34				22.34	
3	EX-3	0.26	0.46	8.7	0.12	7.83	0.93				0.93	
4	OS-1	0.66	0.36	12.3	0.24	6.83	1.61				1.61	

Waterview East Commercial Existing Runoff Calculations (Rational Method Procedure)												
BASIN INFORMATION				DIRECT RUNOFF				CUMMULATIVE RUNOFF				NOTES
DESIGN POINT	DRAIN BASIN	AREA ac.	RUNOFF COEFF	T(c) min	C x A	I in/hr	Q cfs	T(c) min	C x A	I in/hr	Q cfs	
1	EX-1	10.36	0.19	14.7	2.00	3.58	7.16					
2	EX-2	11.5	0.17	20.1	1.96	3.06	5.99					
3	EX-3	0.255	0.30	8.7	0.08	4.44	0.34					

2 yr, 6 hr rainfall (in)	1.51
2 yr, 24 hr rainfall (in)	1.91
100 yr, 6 hr rainfall (in)	4.27
100 yr, 24 hr rainfall (in)	5.16
Elevation (hundreds of feet)]	59.4
2 yr, 1 hr rainfall (in)	1.01
100 yr, 1 hr rainfall (in)	2.75

2	1.01	
100	2.75	
5	1.0999	Cant use slope of line since the x-axis is log base 10

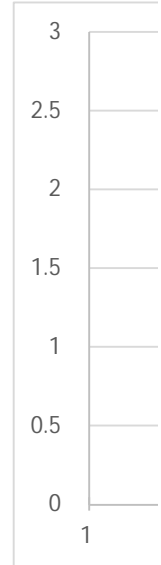

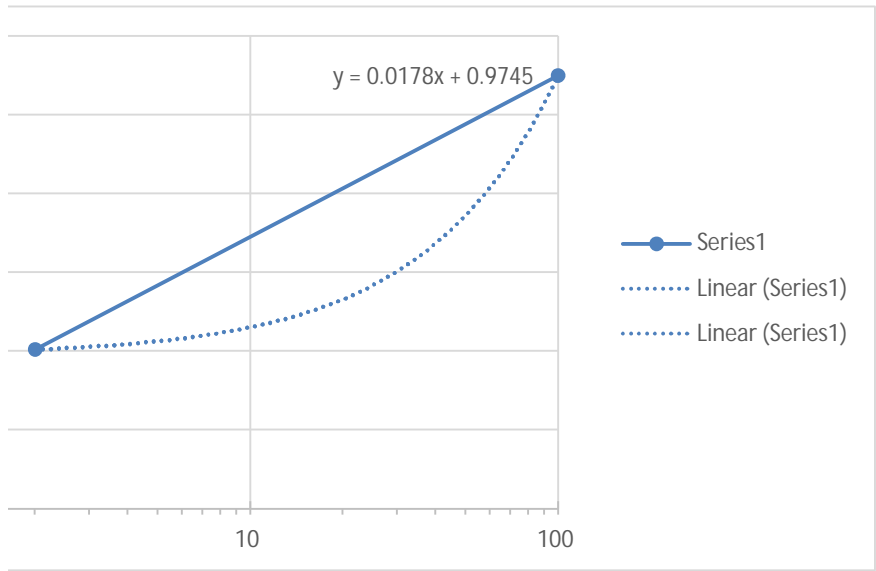

$$I = \frac{28.5 P_1}{(10 + T_D)^{0.786}}$$

Where:

I = rainfall intensity (inches per hour)

P₁ = one-hour rainfall depth (inches) from NOAA Atlas 14

Point Precipitation Frequency Estimates, Colorado Springs, CO

T_c = storm duration (minutes)

	<u>2-yr</u>	<u>5-yr</u>	<u>10-yr</u>	<u>100-yr</u>
P ₁ =	1.01	1.29	1.56	2.75

Time Intensity Frequency Tabulation

TIME	2 YR	5 YR	10 YR	100 YR
5	3.43	4.38	5.29	9.33
10	2.73	3.49	4.22	7.44
15	2.29	2.93	3.54	6.24
30	1.58	2.02	2.45	4.31
60	1.02	1.30	1.58	2.78
120	0.63	0.80	0.97	1.71

Weighted Imperviousness Calculations

SUB-BASIN	AREA (SF)	AREA (Acres)	ROOF AREA	ROOF IMPERVIOUSNESS	ROOF				LANDSCAPE AREA	LANDSCAPE IMPERVIOUSNESS	LANDSCAPE				PAVEMENT AREA	PAVEMENT IMPERVIOUSNESS	PAVEMENT				WEIGHTED IMPERVIOUSNESS	WEIGHTED COEFFICIENTS			
					C2	C5	C10	C100			C2	C5	C10	C100			C2	C5	C10	C100		C2	C5	C10	C100
A1	39274	0.90	0.25	90%	0.71	0.73	0.75	0.81	0.37	2%	0.03	0.09	0.17	0.36	0.28	100%	0.89	0.90	0.92	0.96	57%	0.48	0.52	0.56	0.67
A2	16059	0.37	0.13	90%	0.71	0.73	0.75	0.81	0.14	2%	0.03	0.09	0.17	0.36	0.10	100%	0.89	0.90	0.92	0.96	58%	0.49	0.52	0.57	0.67
A3	16515	0.38	0.16	90%	0.71	0.73	0.75	0.81	0.06	2%	0.03	0.09	0.17	0.36	0.16	100%	0.89	0.90	0.92	0.96	80%	0.67	0.70	0.73	0.80
A4	13339	0.31	0.16	90%	0.71	0.73	0.75	0.81	-	2%	0.03	0.09	0.17	0.36	0.15	100%	0.89	0.90	0.92	0.96	95%	0.80	0.81	0.83	0.88
A5	12691	0.29	0.10	90%	0.71	0.73	0.75	0.81	0.01	2%	0.03	0.09	0.17	0.36	0.17	100%	0.89	0.90	0.92	0.96	92%	0.79	0.80	0.82	0.88
A6	13229	0.30	0.12	90%	0.71	0.73	0.75	0.81	0.02	2%	0.03	0.09	0.17	0.36	0.16	100%	0.89	0.90	0.92	0.96	89%	0.76	0.78	0.80	0.86
A7	17626	0.40	-	90%	0.71	0.73	0.75	0.81	0.03	2%	0.03	0.09	0.17	0.36	0.37	100%	0.89	0.90	0.92	0.96	92%	0.82	0.83	0.86	0.91
A8	20134	0.46	-	90%	0.71	0.73	0.75	0.81	0.03	2%	0.03	0.09	0.17	0.36	0.43	100%	0.89	0.90	0.92	0.96	94%	0.84	0.85	0.87	0.92
A9	19638	0.45	-	90%	0.71	0.73	0.75	0.81	0.03	2%	0.03	0.09	0.17	0.36	0.42	100%	0.89	0.90	0.92	0.96	94%	0.84	0.85	0.87	0.92
A10	26556	0.61	0.10	90%	0.71	0.73	0.75	0.81	0.07	2%	0.03	0.09	0.17	0.36	0.44	100%	0.89	0.90	0.92	0.96	88%	0.77	0.78	0.81	0.87
A11	11290	0.26	0.07	90%	0.71	0.73	0.75	0.81	0.06	2%	0.03	0.09	0.17	0.36	0.13	100%	0.89	0.90	0.92	0.96	75%	0.64	0.67	0.70	0.78
A12	45715	1.05	-	90%	0.71	0.73	0.75	0.81	0.23	2%	0.03	0.09	0.17	0.36	0.82	100%	0.89	0.90	0.92	0.96	79%	0.70	0.72	0.76	0.83
A13	14227	0.33	0.07	90%	0.71	0.73	0.75	0.81	0.07	2%	0.03	0.09	0.17	0.36	0.19	100%	0.89	0.90	0.92	0.96	78%	0.68	0.70	0.73	0.81
A14	14821	0.34	0.01	90%	0.71	0.73	0.75	0.81	0.02	2%	0.03	0.09	0.17	0.36	0.30	100%	0.89	0.90	0.92	0.96	93%	0.82	0.84	0.86	0.91
A15	19172	0.44	0.25	90%	0.71	0.73	0.75	0.81	0.02	2%	0.03	0.09	0.17	0.36	0.17	100%	0.89	0.90	0.92	0.96	90%	0.75	0.77	0.79	0.85
A16	13705	0.31	0.04	90%	0.71	0.73	0.75	0.81	0.04	2%	0.03	0.09	0.17	0.36	0.23	100%	0.89	0.90	0.92	0.96	85%	0.74	0.76	0.79	0.86
A17	35681	0.82	0.29	90%	0.71	0.73	0.75	0.81	0.30	2%	0.03	0.09	0.17	0.36	0.24	100%	0.89	0.90	0.92	0.96	61%	0.52	0.55	0.59	0.69
A18	58375	1.34	0.72	90%	0.71	0.73	0.75	0.81	-	2%	0.03	0.09	0.17	0.36	0.62	100%	0.89	0.90	0.92	0.96	95%	0.79	0.81	0.83	0.88
A19	26189	0.60	0.30	90%	0.71	0.73	0.75	0.81	-	2%	0.03	0.09	0.17	0.36	0.30	100%	0.89	0.90	0.92	0.96	95%	0.80	0.82	0.84	0.89
A20	-	-	-	90%	0.71	0.73	0.75	0.81	-	2%	0.03	0.09	0.17	0.36	-	100%	0.89	0.90	0.92	0.96	-	-	-	-	
A21	36850	0.85	0.77	90%	0.71	0.73	0.75	0.81	0.07	2%	0.03	0.09	0.17	0.36	0.01	100%	0.89	0.90	0.92	0.96	83%	0.66	0.68	0.70	0.77
A22	14829	0.34	-	90%	0.71	0.73	0.75	0.81	0.34	2%	0.03	0.09	0.17	0.36	0.00	100%	0.89	0.90	0.92	0.96	2%	0.03	0.09	0.17	0.36
A23	36700	0.84	0.15	90%	0.71	0.73	0.75	0.81	0.69	2%	0.03	0.09	0.17	0.36	-	100%	0.89	0.90	0.92	0.96	18%	0.15	0.20	0.27	0.44
A24	21078	0.48	-	90%	0.71	0.73	0.75	0.81	0.48	2%	0.03	0.09	0.17	0.36	0.00	100%	0.89	0.90	0.92	0.96	3%	0.04	0.10	0.18	0.36
A25	77446	1.78	0.29	90%	0.71	0.73	0.75	0.81	0.52	2%	0.03	0.09	0.17	0.36	0.97	100%	0.89	0.90	0.92	0.96	70%	0.61	0.64	0.67	0.76
A26	116046	2.66	-	90%	0.71	0.73	0.75	0.81	1.93	2%	0.03	0.09	0.17	0.36	0.73	100%	0.89	0.90	0.92	0.96	29%	0.27	0.31	0.38	0.53
A27	113318	2.60	-	90%	0.71	0.73	0.75	0.81	2.25	2%	0.03	0.09	0.17	0.36	0.35	100%	0.89	0.90	0.92	0.96	15%	0.15	0.20	0.27	0.44
A28	87847	2.02	-	90%	0.71	0.73	0.75	0.81	2.02	2%	0.03	0.09	0.17	0.36	-	100%	0.89	0.90	0.92	0.96	2%	0.03	0.09	0.17	0.36
A29	25004	0.57	-	90%	0.71	0.73	0.75	0.81	0.11	2%	0.03	0.09	0.17	0.36	0.47	100%	0.89	0.90	0.92	0.96	82%	0.73	0.75	0.78	0.85
TOTAL	963,354	22.1	3.99	90%	0.71	0.73	0.75	0.81	9.92	2%	0.03	0.09	0.17	0.36	8.21	100%	0.89	0.90	0.92	0.96	54%	0.47	0.51	0.55	0.66

SUB-BASIN	AREA (SF)	AREA (Acres)	ROOF AREA	ROOF IMPERVIOUSNESS	ROOF				LANDSCAPE AREA	LANDSCAPE IMPERVIOUSNESS	LANDSCAPE				PAVEMENT AREA	PAVEMENT IMPERVIOUSNESS	PAVEMENT				WEIGHTED IMPERVIOUSNESS	WEIGHTED COEFFICIENTS			
					C2	C5	C10	C100			C2	C5	C10	C100			C2	C5	C10	C100		C2	C5	C10	C100
OS1	9455	0.22	-	90%	0.71	0.73	0.75	0.81	0.08	2%	0.03	0.09	0.17	0.36	0.14	100%	0.89	0.90	0.92	0.96	64%	0.57	0.60	0.64	0.74

Waterview East Commercial
 Drainage Report
 El Paso County, CO

Waterview East Commercial - Drainage Report																				
Proposed Runoff Calculations																				
Time of Concentration																				
Watercourse Coefficient																				
					Forest & Meadow	2.50						Short Grass Pasture & Lawns	7.00						Grassed Waterway	15.00
					Fallow or Cultivation	5.00						Nearly Bare Ground	10.00						Paved Area & Shallow Gutter	20.00
DESIGN POINT	SUB-BASIN DATA				INITIAL / OVERLAND TIME			TRAVEL TIME					T(c) CHECK (URBANIZED BASINS)			FINAL T(c) min.				
	DRAIN BASIN	AREA sq. ft.	AREA ac.	C(5)	Length ft.	Slope %	T(i) min	Length ft.	Slope %	Coef.	Velocity fps	T(t) min.	COMP. T(c)	TOTAL LENGTH	L/180+10					
1	A1	39,274	0.90	0.52	100	7.6%	5.4	110	1.0%	20.00	2.0	0.9	6.3	210	11.2	6.3				
2	A2	16,059	0.37	0.52	60	15.6%	3.3	20	3.1%	20.00	3.5	0.1	5.0	80	10.4	5.0				
3	A3	16,515	0.38	0.70	70	7.5%	3.2	70	1.6%	20.00	2.5	0.5	5.0	140	10.8	5.0				
4	A4	13,339	0.31	0.81	100	0.8%	5.7	23	0.8%	20.00	1.8	0.2	5.9	123	10.7	5.9				
5	A5	12,691	0.29	0.80	60	3.0%	2.9	65	2.8%	20.00	3.3	0.3	5.0	125	10.7	5.0				
6	A6	13,229	0.30	0.78	100	1.0%	5.9	38	1.0%	20.00	2.0	0.3	6.2	138	10.8	6.2				
7	A7	17,626	0.40	0.83	50	2.6%	2.5	216	1.4%	20.00	2.4	1.5	5.0	266	11.5	5.0				
8	A8	20,134	0.46	0.85	50	3.2%	2.2	218	2.1%	20.00	2.9	1.3	5.0	268	11.5	5.0				
9	A9	19,638	0.45	0.85	50	3.6%	2.1	216	2.9%	20.00	3.4	1.1	5.0	266	11.5	5.0				
10	A10	26,556	0.61	0.78	80	3.1%	3.5	220	3.4%	20.00	3.7	1.0	5.0	300	11.7	5.0				
11	A11	11,290	0.26	0.67	100	0.8%	8.6	63	1.1%	20.00	2.1	0.5	9.1	163	10.9	9.1				
12	A12	45,715	1.05	0.72	100	0.5%	8.7	388	2.8%	20.00	3.3	1.9	10.6	488	12.7	10.6				
13	A13	14,227	0.33	0.70	20	0.2%	5.6	92	2.0%	20.00	2.8	0.5	6.1	112	10.6	6.1				
14	A14	14,821	0.34	0.84	100	0.5%	6.0	134	0.8%	20.00	1.8	1.2	7.2	234	11.3	7.2				
15	A15	19,172	0.44	0.77	60	1.0%	4.7	30	3.0%	20.00	3.5	0.1	5.0	90	10.5	5.0				
16	A16	13,705	0.31	0.76	100	2.0%	4.9	329	1.7%	20.00	2.6	2.1	7.0	429	12.4	7.0				
17	A17	35,681	0.82	0.55	100	0.5%	12.7	300	0.9%	20.00	1.9	2.6	15.3	400	12.2	12.2				
18	A18	58,375	1.34	0.81	100	2.7%	3.8	269	1.4%	20.00	2.4	1.9	5.7	369	12.1	5.7				
19	A19	26,189	0.60	0.82	50	3.1%	2.5	240	2.3%	20.00	3.0	1.3	5.0	290	11.6	5.0				
20	A20	-	-	-	-	-	-	-	-	-	-	-	-	-	-	-				
21	A21	36,850	0.85	0.68	100	1.6%	6.6	156	0.8%	20.00	1.8	1.5	8.1	256	11.4	8.1				
22	A22	14,829	0.34	0.09	100	1.4%	16.5	247	1.5%	20.00	2.4	1.7	18.2	347	11.9	11.9				
23	A23	36,700	0.84	0.20	100	2.0%	13.0	201	4.8%	7.00	1.5	2.2	15.2	301	11.7	11.7				
24	A24	21,078	0.48	0.10	100	1.9%	14.8	116	7.0%	7.00	1.9	1.0	15.8	216	11.2	11.2				
25	A25	77,446	1.78	0.64	60	15.0%	2.7	60	2.0%	7.00	1.0	1.0	5.0	120	10.7	5.0				
26	A26	116,046	2.66	0.31	100	6.1%	7.9	1220	3.0%	7.00	1.2	16.8	24.7	1320	17.3	17.3				
27	A27	113,318	2.60	0.20	35	6.8%	5.2	475	3.0%	7.00	1.2	6.5	11.7	510	12.8	11.7				
28	A28	87,847	2.02	0.09	50	4.9%	7.7	148	3.9%	7.00	1.4	1.8	9.5	198	11.1	9.5				
29	A29	25,004	0.57	0.75	36	3.0%	2.7	625	2.8%	8.00	1.3	7.8	10.5	661	13.7	10.5				
30	OS1	9,455	0.22	0.60	18	15.4%	1.6	193	2.4%	14.00	2.2	1.5	5.0	211	11.2	5.0				

Waterview East Commercial
 Drainage Report
 El Paso County, CO

Waterview East Commercial - Drainage Report Proposed Runoff Calculations (Rational Method Procedure)												
BASIN INFORMATION				DIRECT RUNOFF				CUMULATIVE RUNOFF				NOTES
DESIGN POINT	DRAIN BASIN	AREA ac.	RUNOFF COEFF	T(c) min	C x A	I in/hr	Q cfs	T(c) min	C x A	I in/hr	Q cfs	
1	A1	0.90	0.52	6.3	0.47	4.10	1.91				1.91	
2	A2	0.37	0.52	5.0	0.19	4.38	0.85				0.85	
3	A3	0.38	0.70	5.0	0.26	4.38	1.15				1.15	
4	A4	0.31	0.81	5.9	0.25	4.18	1.04				1.04	
5	A5	0.29	0.80	5.0	0.23	4.38	1.02				1.02	
6	A6	0.30	0.78	6.2	0.24	4.12	0.97				0.97	
7	A7	0.40	0.83	5.0	0.34	4.38	1.48				1.48	
8	A8	0.46	0.85	5.0	0.39	4.38	1.72				1.72	
9	A9	0.45	0.85	5.0	0.38	4.38	1.68				1.68	
10	A10	0.61	0.78	5.0	0.48	4.38	2.09				2.09	
11	A11	0.26	0.67	9.1	0.17	3.62	0.62				0.62	
12	A12	1.05	0.72	10.6	0.76	3.41	2.59				2.59	
13	A13	0.33	0.70	6.1	0.23	4.13	0.94				0.94	
14	A14	0.34	0.84	7.2	0.29	3.92	1.12				1.12	
15	A15	0.44	0.77	5.0	0.34	4.38	1.48				1.48	
16	A16	0.31	0.76	7.0	0.24	3.97	0.95				0.95	
17	A17	0.82	0.55	12.2	0.45	3.22	1.44				1.44	
18	A18	1.34	0.81	5.7	1.08	4.22	4.57				4.57	
19	A19	0.60	0.82	5.0	0.49	4.38	2.14				2.14	
20	A20	-	-	-	-	-	-				-	
21	A21	0.85	0.68	8.1	0.57	3.78	2.17				2.17	
22	A22	0.34	0.09	11.9	0.03	3.25	0.10				0.10	
23	A23	0.84	0.20	11.7	0.17	3.27	0.57				0.57	
24	A24	0.48	0.10	11.2	0.05	3.33	0.16				0.16	
25	A25	1.78	0.64	5.0	1.13	4.38	4.95				4.95	
26	A26	2.66	0.31	17.3	0.83	2.73	2.28				2.28	
27	A27	2.60	0.20	11.7	0.52	3.27	1.69				1.69	
28	A28	2.02	0.09	9.5	0.18	3.56	0.65				0.65	
29	A29	0.57	0.75	10.5	0.43	3.43	1.47				1.47	
30	OS1	0.22	0.60	5.0	0.13	4.38	0.57				0.57	

Waterview East Commercial - Drainage Report Proposed Runoff Calculations (Rational Method Procedure)												
BASIN INFORMATION				DIRECT RUNOFF				CUMULATIVE RUNOFF				NOTES
DESIGN POINT	DRAIN BASIN	AREA ac.	RUNOFF COEFF	T(c) min	C x A	I in/hr	Q cfs	T(c) min	C x A	I in/hr	Q cfs	
1	A1	0.90	0.67	6.3	0.60	8.73	5.28				5.28	
2	A2	0.37	0.67	5.0	0.25	9.33	2.32				2.32	
3	A3	0.38	0.80	5.0	0.30	9.33	2.82				2.82	
4	A4	0.31	0.88	5.9	0.27	8.90	2.40				2.40	
5	A5	0.29	0.88	5.0	0.26	9.33	2.39				2.39	
6	A6	0.30	0.86	6.2	0.26	8.77	2.29				2.29	
7	A7	0.40	0.91	5.0	0.37	9.33	3.44				3.44	
8	A8	0.46	0.92	5.0	0.43	9.33	3.98				3.98	
9	A9	0.45	0.92	5.0	0.42	9.33	3.88				3.88	
10	A10	0.61	0.87	5.0	0.53	9.33	4.95				4.95	
11	A11	0.26	0.78	9.1	0.20	7.71	1.56				1.56	
12	A12	1.05	0.83	10.6	0.87	7.26	6.32				6.32	
13	A13	0.33	0.81	6.1	0.26	8.80	2.32				2.32	
14	A14	0.34	0.91	7.2	0.31	8.36	2.60				2.60	
15	A15	0.44	0.85	5.0	0.37	9.33	3.48				3.48	
16	A16	0.31	0.86	7.0	0.27	8.45	2.27				2.27	
17	A17	0.82	0.69	12.2	0.57	6.85	3.89				3.89	
18	A18	1.34	0.88	5.7	1.18	9.00	10.60				10.60	
19	A19	0.60	0.89	5.0	0.53	9.33	4.96				4.96	
20	A20	-	-	-	-	-	-				-	
21	A21	0.85	0.77	8.1	0.65	8.06	5.28				5.28	
22	A22	0.34	0.36	11.9	0.12	6.93	0.85				0.85	
23	A23	0.84	0.44	11.7	0.37	6.98	2.59				2.59	
24	A24	0.48	0.36	11.2	0.18	7.11	1.25				1.25	
25	A25	1.78	0.76	5.0	1.35	9.33	12.61				12.61	
26	A26	2.66	0.53	17.3	1.40	5.83	8.15				8.15	
27	A27	2.60	0.44	11.7	1.15	6.97	7.99				11.55	
28	A28	2.02	0.36	9.5	0.73	7.59	5.52				5.52	
29	A29	0.57	0.85	10.5	0.49	7.30	3.56				3.56	
30	OS1	0.22	0.66	5.0	0.14	9.33	1.34				1.34	

SUMMARY - PROPOSED RUNOFF TABLE						
DESIGN POINT	BASIN DESIGNATION	BASIN AREA (ACRES)	DIRECT 5-YR RUNOFF (CFS)	DIRECT 100-YR RUNOFF (CFS)	CUMULATIVE 5-YR RUNOFF (CFS)	CUMULATIVE 100-YR RUNOFF (CFS)
1	A1	0.90	1.91	5.28	1.91	5.28
2	A2	0.37	0.85	2.32	0.85	2.32
3	A3	0.38	1.15	2.82	1.15	2.82
4	A4	0.31	1.04	2.40	1.04	2.40
5	A5	0.29	1.02	2.39	1.02	2.39
6	A6	0.30	0.97	2.29	0.97	2.29
7	A7	0.40	1.48	3.44	1.48	3.44
8	A8	0.46	1.72	3.98	1.72	3.98
9	A9	0.45	1.68	3.88	1.68	3.88
10	A10	0.61	2.09	4.95	2.09	4.95
11	A11	0.26	0.62	1.56	0.62	1.56
12	A12	1.05	2.59	6.32	2.59	6.32
13	A13	0.33	0.94	2.32	0.94	2.32
14	A14	0.34	1.12	2.60	1.12	2.60
15	A15	0.44	1.48	3.48	1.48	3.48
16	A16	0.31	0.95	2.27	0.95	2.27
17	A17	0.82	1.44	3.89	1.44	3.89
18	A18	1.34	4.57	10.60	4.57	10.60
19	A19	0.60	2.14	4.96	2.14	4.96
20	A20	-	-	-	-	-
21	A21	0.85	2.17	5.28	2.17	5.28
22	A22	0.34	0.10	0.85	0.10	0.85
23	A23	0.84	0.57	2.59	0.57	2.59
24	A24	0.48	0.16	1.25	0.16	1.25
25	A25	1.78	4.95	12.61	4.95	12.61
26	A26	2.66	2.28	8.15	2.28	8.15
27	A27	2.60	1.69	7.99	3.17	11.55
28	A28	2.02	0.65	5.52	0.65	5.52
29	A29	0.57	1.47	3.56	1.47	3.56
30	OS1	0.22	0.57	1.34	0.57	1.34

Waterview East - Tributary Drainage Basins

Pond ID	Tributary Basins	Impervious Area (Acres)	Total Area (Acres)	% Imperviousness
Pond A22	A17-A22	3.24	3.95	77.20%
Pond A23	A1-A16, A23	6.15	8.05	74.80%
Pond A24	A24-A25	1.26	2.26	55.40%
Pond A27	A27	0.35	2.6	15.00%

DETENTION BASIN STAGE-STORAGE TABLE BUILDER

MHFD-Detention, Version 4.06 (July 2022)

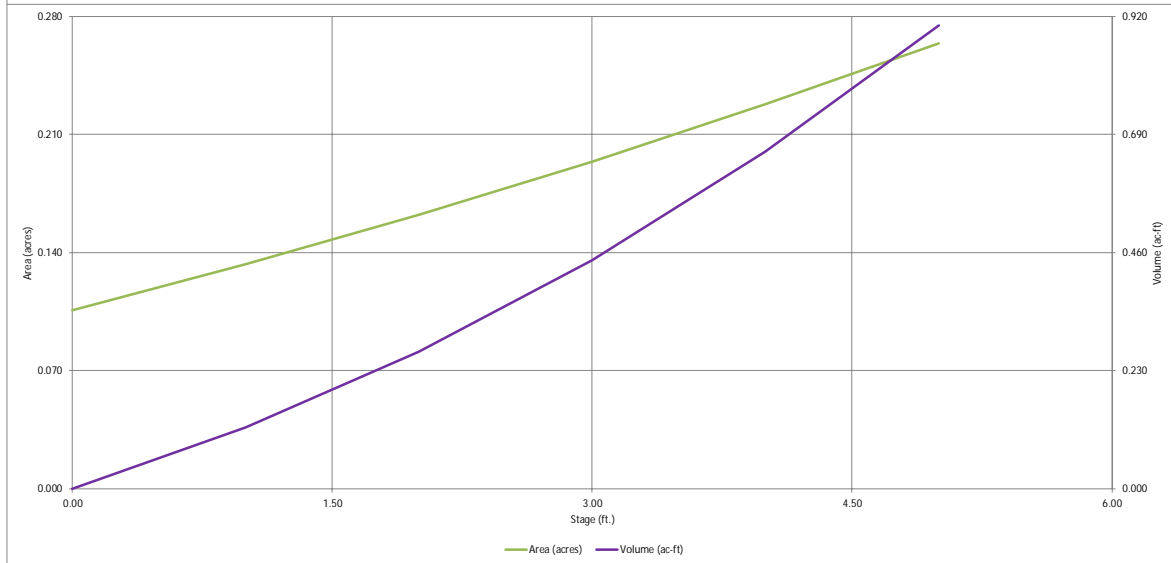
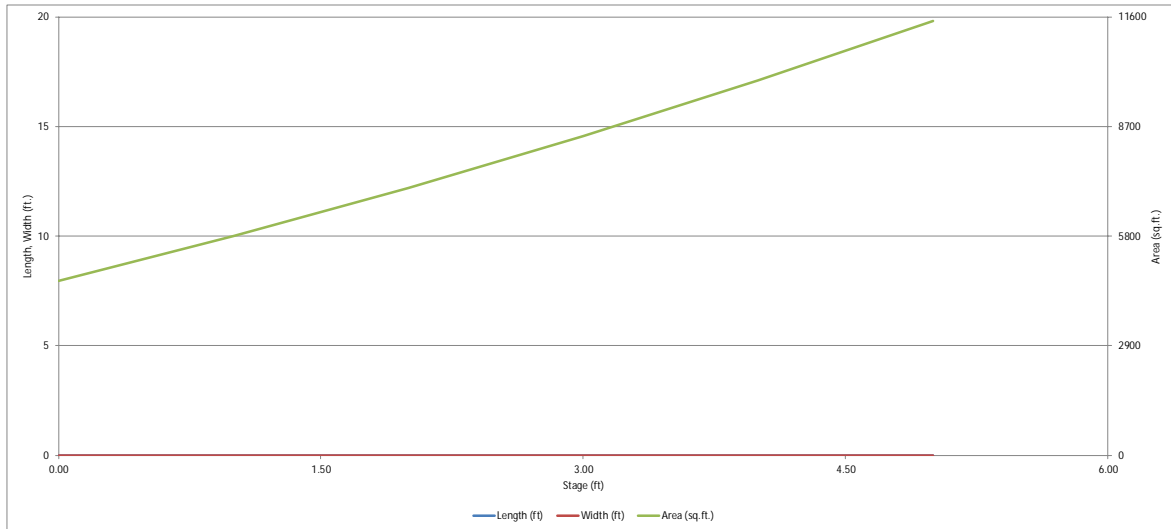

DETENTION BASIN OUTLET STRUCTURE DESIGN

MHFD-Detention, Version 4.06 (July 2022)

Project: Waterview East Commercial
 Basin ID: EDB A22 (Sub-basins A17, A18, A19, A20, A21 and A22)

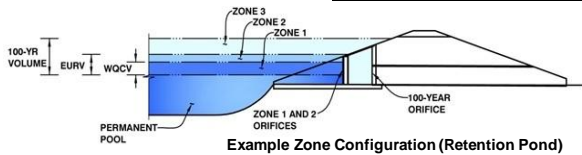

	Estimated Stage (ft)	Estimated Volume (ac-ft)	Outlet Type
Zone 1 (WOCV)	0.88	0.103	Orifice Plate
Zone 2 (EURV)	2.69	0.283	Orifice Plate
Zone 3 (100-year)	3.80	0.226	Weir&Pipe (Restrict)
Total (all zones)		0.611	

User Input: Orifice at Underdrain Outlet (typically used to drain WOCV in a Filtration BMP)

Underdrain Orifice Invert Depth =	N/A	ft (distance below the filtration media surface)
Underdrain Orifice Diameter =	N/A	inches

Calculated Parameters for Underdrain

Underdrain Orifice Area =	N/A	ft ²
Underdrain Orifice Centroid =	N/A	feet

User Input: Orifice Plate with one or more orifices or Elliptical Slot Weir (typically used to drain WOCV and/or EURV in a sedimentation BMP)

Centroid of Lowest Orifice =	0.00	ft (relative to basin bottom at Stage = 0 ft)
Depth at top of Zone using Orifice Plate =	2.69	ft (relative to basin bottom at Stage = 0 ft)
Orifice Plate: Orifice Vertical Spacing =	N/A	inches
Orifice Plate: Orifice Area per Row =	N/A	sq. inches

Calculated Parameters for Plate

WO Orifice Area per Row =	N/A	ft ²
Elliptical Half-Width =	N/A	feet
Elliptical Slot Centroid =	N/A	feet
Elliptical Slot Area =	N/A	ft ²

User Input: Stage and Total Area of Each Orifice Row (numbered from lowest to highest)

	Row 1 (required)	Row 2 (optional)	Row 3 (optional)	Row 4 (optional)	Row 5 (optional)	Row 6 (optional)	Row 7 (optional)	Row 8 (optional)
Stage of Orifice Centroid (ft)	0.00	1.20	1.79					
Orifice Area (sq. inches)	1.60	1.60	1.60					

	Row 9 (optional)	Row 10 (optional)	Row 11 (optional)	Row 12 (optional)	Row 13 (optional)	Row 14 (optional)	Row 15 (optional)	Row 16 (optional)
Stage of Orifice Centroid (ft)								
Orifice Area (sq. inches)								

User Input: Vertical Orifice (Circular or Rectangular)

	Not Selected	Not Selected	
Invert of Vertical Orifice =	N/A	N/A	ft (relative to basin bottom at Stage = 0 ft)
Depth at top of Zone using Vertical Orifice =	N/A	N/A	ft (relative to basin bottom at Stage = 0 ft)
Vertical Orifice Diameter =	N/A	N/A	inches

Calculated Parameters for Vertical Orifice

	Not Selected	Not Selected	
Vertical Orifice Area =	N/A	N/A	ft ²
Vertical Orifice Centroid =	N/A	N/A	feet

User Input: Overflow Weir (Dropbox with Flat or Sloped Gate and Outlet Pipe OR Rectangular/Trapezoidal Weir and No Outlet Pipe)

	Zone 3 Weir	Not Selected	
Overflow Weir Front Edge Height, Ho =	2.73	N/A	ft (relative to basin bottom at Stage = 0 ft)
Overflow Weir Front Edge Length =	4.00	N/A	feet
Overflow Weir Gate Slope =	0.00	N/A	H:V
Horiz. Length of Weir Sides =	4.00	N/A	feet
Overflow Gate Type =	Type C Gate	N/A	
Debris Clogging % =	50%	N/A	%

Calculated Parameters for Overflow Weir

	Zone 3 Weir	Not Selected	
Height of Gate Upper Edge, Hi =	2.73	N/A	feet
Overflow Weir Slope Length =	4.00	N/A	feet
Grate Open Area / 100-yr Orifice Area =	26.32	N/A	
Overflow Gate Open Area w/o Debris =	11.14	N/A	ft ²
Overflow Gate Open Area w/ Debris =	5.57	N/A	ft ²

User Input: Outlet Pipe w/ Flow Restriction Plate (Circular Orifice, Restrictor Plate, or Rectangular Orifice)

	Zone 3 Restrictor	Not Selected	
Depth to Invert of Outlet Pipe =	0.00	N/A	ft (distance below basin bottom at Stage = 0 ft)
Outlet Pipe Diameter =	18.00	N/A	inches
Restrictor Plate Height Above Pipe Invert =	5.20		inches

Calculated Parameters for Outlet Pipe w/ Flow Restriction Plate

	Zone 3 Restrictor	Not Selected	
Outlet Orifice Area =	0.42	N/A	ft ²
Outlet Orifice Centroid =	0.25	N/A	feet
Half-Central Angle of Restrictor Plate on Pipe =	1.13	N/A	radians

User Input: Emergency Spillway (Rectangular or Trapezoidal)

Spillway Invert Stage =	3.40	ft (relative to basin bottom at Stage = 0 ft)
Spillway Crest Length =	10.00	feet
Spillway End Slopes =	4.00	H:V
Freeboard above Max Water Surface =	1.00	feet

Calculated Parameters for Spillway

Spillway Design Flow Depth =	0.54	feet
Stage at Top of Freeboard =	4.94	feet
Basin Area at Top of Freeboard =	0.26	acres
Basin Volume at Top of Freeboard =	0.88	acre-ft

Routed Hydrograph Results

The user can override the default CUHP hydrographs and runoff volumes by entering new values in the Inflow Hydrographs table (Columns W through AF).

	WOCV	EURV	2 Year	5 Year	10 Year	25 Year	50 Year	100 Year	500 Year
Design Storm Return Period	N/A	N/A	1.01	1.29	1.56	2.00	2.25	2.75	3.14
One-Hour Rainfall Depth (in)									
CUHP Runoff Volume (acre-ft)	0.103	0.385	0.227	0.300	0.371	0.509	0.586	0.752	0.879
Inflow Hydrograph Volume (acre-ft)	N/A	N/A	0.227	0.300	0.371	0.509	0.586	0.752	0.879
CUHP Predevelopment Peak Q (cfs)	N/A	N/A	0.0	0.1	0.1	1.6	2.5	4.4	5.8
OPTIONAL Override Predevelopment Peak Q (cfs)	N/A	N/A							
Predevelopment Unit Peak Flow, q (cfs/acre)	N/A	N/A	0.01	0.01	0.02	0.42	0.62	1.10	1.47
Peak Inflow Q (cfs)	N/A	N/A	4.3	5.6	6.9	9.8	11.4	14.8	17.2
Peak Outflow Q (cfs)	0.0	0.2	0.1	0.2	0.2	1.3	2.7	3.6	6.0
Ratio Peak Outflow to Predevelopment Q	N/A	N/A	N/A	2.8	2.2	0.8	1.1	0.8	1.0
Structure Controlling Flow	Plate	Plate	Plate	Plate	Plate	Overflow Weir 1	Overflow Weir 1	Outlet Plate 1	Spillway
Max Velocity through Gate 1 (fps)	N/A	N/A	N/A	N/A	N/A	0.1	0.2	0.3	0.3
Max Velocity through Gate 2 (fps)	N/A	N/A	N/A	N/A	N/A	N/A	N/A	N/A	N/A
Time to Drain 97% of Inflow Volume (hours)	40	65	57	62	65	66	64	62	60
Time to Drain 99% of Inflow Volume (hours)	44	71	62	68	72	73	73	71	70
Maximum Ponding Depth (ft)	0.88	2.69	1.65	2.08	2.47	2.85	2.94	3.36	3.57
Area at Maximum Ponding Depth (acres)	0.13	0.18	0.15	0.16	0.18	0.19	0.19	0.21	0.21
Maximum Volume Stored (acre-ft)	0.104	0.387	0.212	0.280	0.345	0.417	0.432	0.517	0.561

DETENTION BASIN OUTLET STRUCTURE DESIGN

MHFD-Detention, Version 4.06 (July 2022)

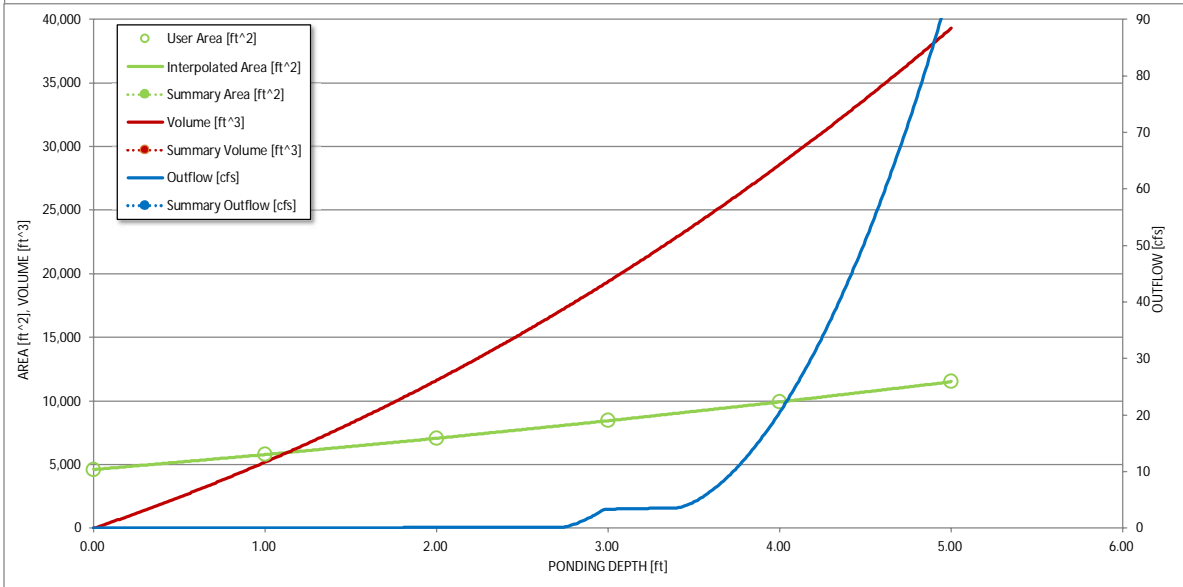
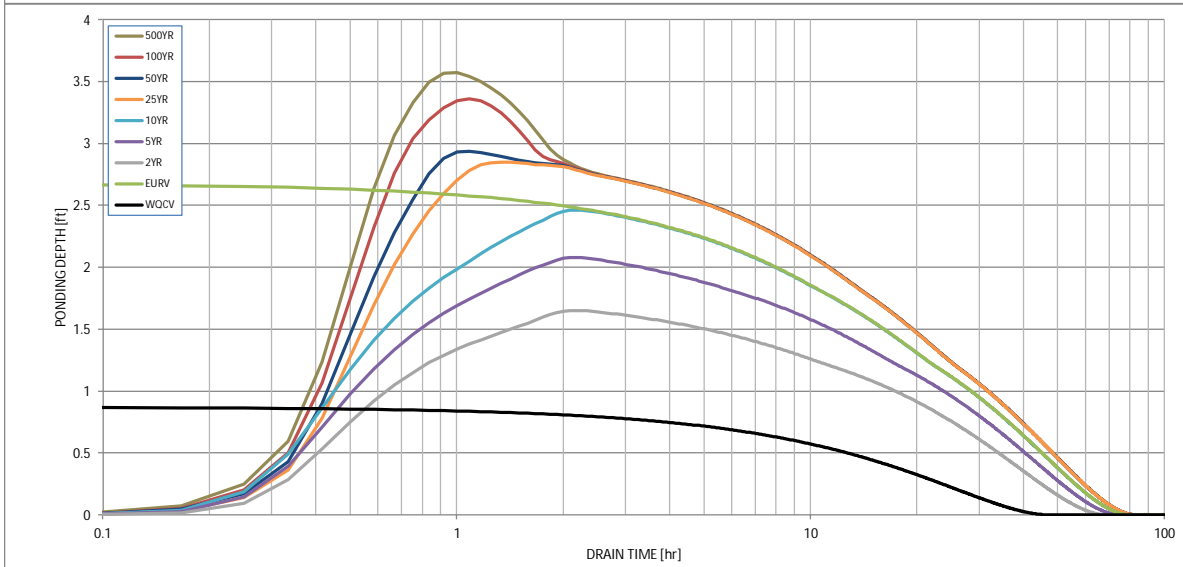
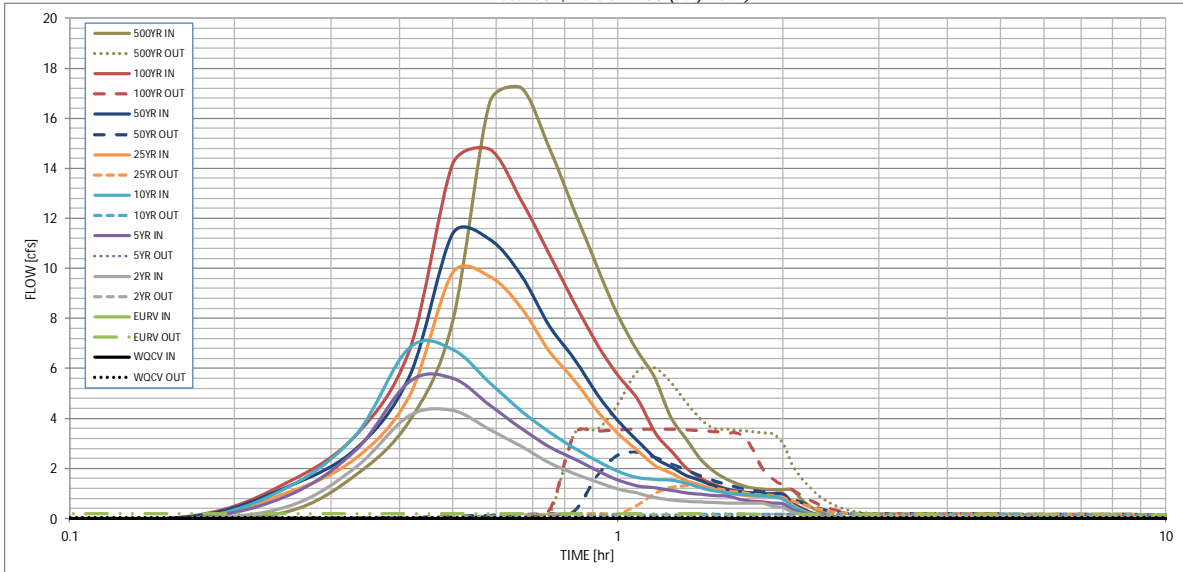

S-A-V-D Chart Axis Override	X-axis	Left Y-Axis	Right Y-Axis
minimum bound			
maximum bound			

DETENTION BASIN OUTLET STRUCTURE DESIGN

Outflow Hydrograph Workbook Filename: _____

Inflow Hydrographs

The user can override the calculated inflow hydrographs from this workbook with inflow hydrographs developed in a separate program.

Time Interval	SOURCE	CUHP	CUHP	CUHP	CUHP	CUHP	CUHP	CUHP	CUHP	CUHP
	TIME	WQCV [cfs]	EURV [cfs]	2 Year [cfs]	5 Year [cfs]	10 Year [cfs]	25 Year [cfs]	50 Year [cfs]	100 Year [cfs]	500 Year [cfs]
5.00_min	0:00:00	0.00	0.00	0.00	0.00	0.00	0.00	0.00	0.00	0.00
	0:05:00	0.00	0.00	0.00	0.00	0.00	0.00	0.00	0.00	0.00
	0:10:00	0.00	0.00	0.00	0.00	0.00	0.00	0.09	0.11	0.28
	0:15:00	0.00	0.00	0.49	0.93	1.27	1.05	1.29	1.46	1.77
	0:20:00	0.00	0.00	2.08	2.76	3.39	2.44	2.82	3.37	3.92
	0:25:00	0.00	0.00	4.13	5.49	6.85	4.93	5.71	6.77	7.89
	0:30:00	0.00	0.00	4.32	5.61	6.76	9.83	11.39	14.18	16.64
	0:35:00	0.00	0.00	3.56	4.54	5.45	9.68	11.17	14.77	17.23
	0:40:00	0.00	0.00	2.89	3.61	4.32	8.44	9.73	12.72	14.83
	0:45:00	0.00	0.00	2.23	2.87	3.48	6.70	7.72	10.58	12.32
	0:50:00	0.00	0.00	1.80	2.39	2.82	5.53	6.38	8.63	10.06
	0:55:00	0.00	0.00	1.46	1.92	2.30	4.32	4.97	6.97	8.14
	1:00:00	0.00	0.00	1.19	1.55	1.89	3.42	3.93	5.75	6.73
	1:05:00	0.00	0.00	1.02	1.33	1.65	2.74	3.14	4.81	5.63
	1:10:00	0.00	0.00	0.85	1.24	1.57	2.13	2.43	3.46	4.05
	1:15:00	0.00	0.00	0.75	1.14	1.54	1.82	2.08	2.72	3.19
	1:20:00	0.00	0.00	0.70	1.04	1.41	1.52	1.73	2.04	2.37
	1:25:00	0.00	0.00	0.67	0.97	1.23	1.35	1.52	1.62	1.87
	1:30:00	0.00	0.00	0.65	0.93	1.11	1.15	1.30	1.36	1.57
	1:35:00	0.00	0.00	0.63	0.90	1.03	1.03	1.17	1.19	1.37
	1:40:00	0.00	0.00	0.62	0.79	0.98	0.96	1.08	1.09	1.25
	1:45:00	0.00	0.00	0.62	0.71	0.95	0.91	1.02	1.04	1.19
	1:50:00	0.00	0.00	0.62	0.66	0.92	0.88	0.99	1.02	1.16
	1:55:00	0.00	0.00	0.51	0.63	0.88	0.87	0.98	1.01	1.15
	2:00:00	0.00	0.00	0.44	0.59	0.78	0.86	0.97	1.01	1.15
	2:05:00	0.00	0.00	0.28	0.37	0.50	0.55	0.62	0.65	0.74
	2:10:00	0.00	0.00	0.17	0.23	0.32	0.35	0.39	0.41	0.47
	2:15:00	0.00	0.00	0.10	0.14	0.19	0.22	0.24	0.25	0.29
	2:20:00	0.00	0.00	0.06	0.08	0.11	0.13	0.14	0.15	0.17
	2:25:00	0.00	0.00	0.03	0.05	0.06	0.07	0.08	0.08	0.10
	2:30:00	0.00	0.00	0.01	0.02	0.03	0.03	0.04	0.04	0.04
	2:35:00	0.00	0.00	0.00	0.01	0.01	0.01	0.01	0.01	0.01
	2:40:00	0.00	0.00	0.00	0.00	0.00	0.00	0.00	0.00	0.00
	2:45:00	0.00	0.00	0.00	0.00	0.00	0.00	0.00	0.00	0.00
	2:50:00	0.00	0.00	0.00	0.00	0.00	0.00	0.00	0.00	0.00
	2:55:00	0.00	0.00	0.00	0.00	0.00	0.00	0.00	0.00	0.00
	3:00:00	0.00	0.00	0.00	0.00	0.00	0.00	0.00	0.00	0.00
	3:05:00	0.00	0.00	0.00	0.00	0.00	0.00	0.00	0.00	0.00
	3:10:00	0.00	0.00	0.00	0.00	0.00	0.00	0.00	0.00	0.00
	3:15:00	0.00	0.00	0.00	0.00	0.00	0.00	0.00	0.00	0.00
	3:20:00	0.00	0.00	0.00	0.00	0.00	0.00	0.00	0.00	0.00
	3:25:00	0.00	0.00	0.00	0.00	0.00	0.00	0.00	0.00	0.00
	3:30:00	0.00	0.00	0.00	0.00	0.00	0.00	0.00	0.00	0.00
	3:35:00	0.00	0.00	0.00	0.00	0.00	0.00	0.00	0.00	0.00
	3:40:00	0.00	0.00	0.00	0.00	0.00	0.00	0.00	0.00	0.00
	3:45:00	0.00	0.00	0.00	0.00	0.00	0.00	0.00	0.00	0.00
	3:50:00	0.00	0.00	0.00	0.00	0.00	0.00	0.00	0.00	0.00
	3:55:00	0.00	0.00	0.00	0.00	0.00	0.00	0.00	0.00	0.00
	4:00:00	0.00	0.00	0.00	0.00	0.00	0.00	0.00	0.00	0.00
	4:05:00	0.00	0.00	0.00	0.00	0.00	0.00	0.00	0.00	0.00
	4:10:00	0.00	0.00	0.00	0.00	0.00	0.00	0.00	0.00	0.00
	4:15:00	0.00	0.00	0.00	0.00	0.00	0.00	0.00	0.00	0.00
	4:20:00	0.00	0.00	0.00	0.00	0.00	0.00	0.00	0.00	0.00
	4:25:00	0.00	0.00	0.00	0.00	0.00	0.00	0.00	0.00	0.00
	4:30:00	0.00	0.00	0.00	0.00	0.00	0.00	0.00	0.00	0.00
	4:35:00	0.00	0.00	0.00	0.00	0.00	0.00	0.00	0.00	0.00
	4:40:00	0.00	0.00	0.00	0.00	0.00	0.00	0.00	0.00	0.00
	4:45:00	0.00	0.00	0.00	0.00	0.00	0.00	0.00	0.00	0.00
	4:50:00	0.00	0.00	0.00	0.00	0.00	0.00	0.00	0.00	0.00
	4:55:00	0.00	0.00	0.00	0.00	0.00	0.00	0.00	0.00	0.00
	5:00:00	0.00	0.00	0.00	0.00	0.00	0.00	0.00	0.00	0.00
	5:05:00	0.00	0.00	0.00	0.00	0.00	0.00	0.00	0.00	0.00
	5:10:00	0.00	0.00	0.00	0.00	0.00	0.00	0.00	0.00	0.00
	5:15:00	0.00	0.00	0.00	0.00	0.00	0.00	0.00	0.00	0.00
	5:20:00	0.00	0.00	0.00	0.00	0.00	0.00	0.00	0.00	0.00
	5:25:00	0.00	0.00	0.00	0.00	0.00	0.00	0.00	0.00	0.00
	5:30:00	0.00	0.00	0.00	0.00	0.00	0.00	0.00	0.00	0.00
	5:35:00	0.00	0.00	0.00	0.00	0.00	0.00	0.00	0.00	0.00
	5:40:00	0.00	0.00	0.00	0.00	0.00	0.00	0.00	0.00	0.00
	5:45:00	0.00	0.00	0.00	0.00	0.00	0.00	0.00	0.00	0.00
	5:50:00	0.00	0.00	0.00	0.00	0.00	0.00	0.00	0.00	0.00
	5:55:00	0.00	0.00	0.00	0.00	0.00	0.00	0.00	0.00	0.00
	6:00:00	0.00	0.00	0.00	0.00	0.00	0.00	0.00	0.00	0.00

DETENTION BASIN STAGE-STORAGE TABLE BUILDER

MHFD-Detention, Version 4.04 (February 2021)

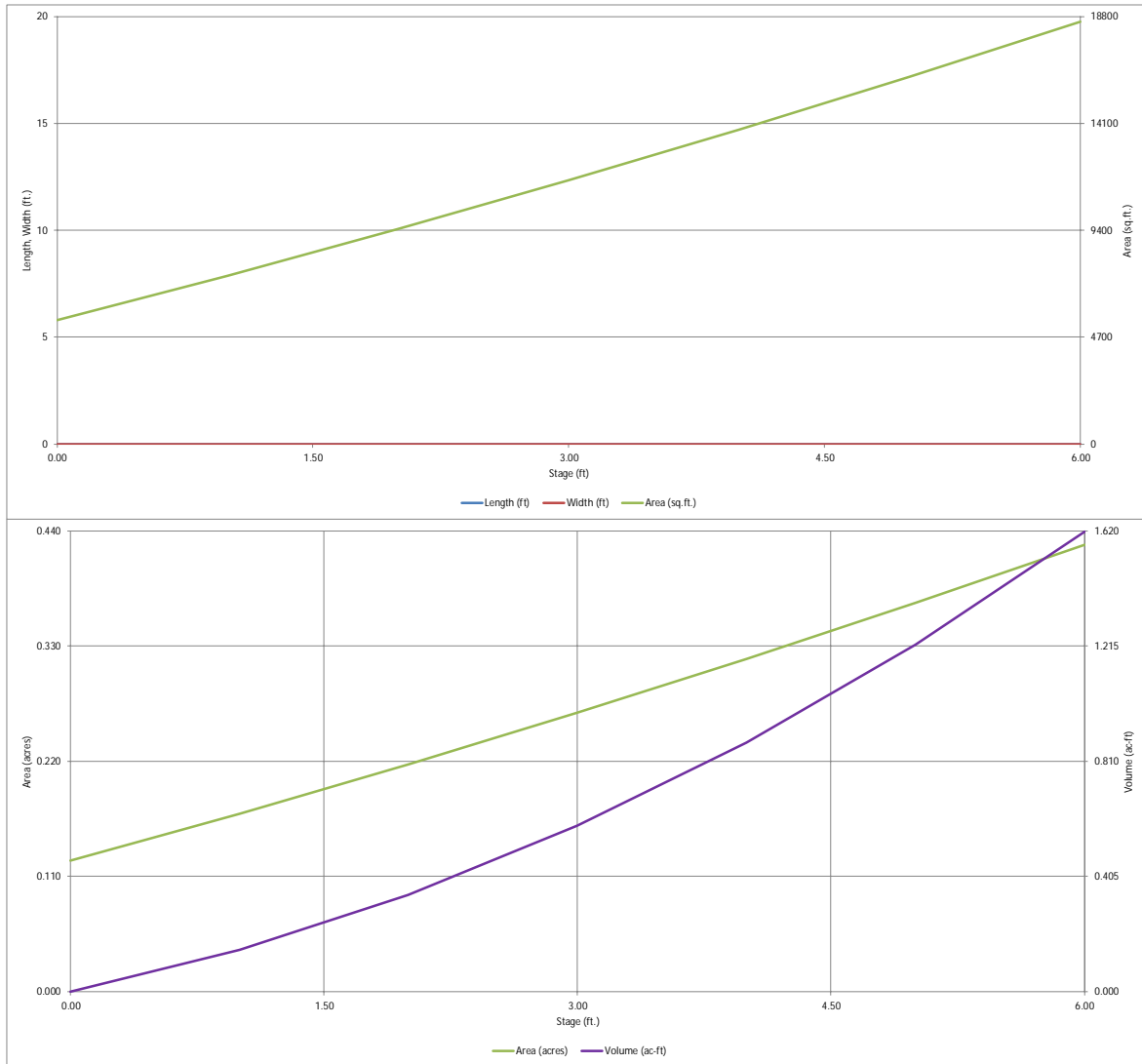

DETENTION BASIN OUTLET STRUCTURE DESIGN

MHFD-Detention, Version 4.04 (February 2021)

Project: Waterview East Commercial
 Basin ID: EDB A23 (Sub-basins A1-A16 and A23)

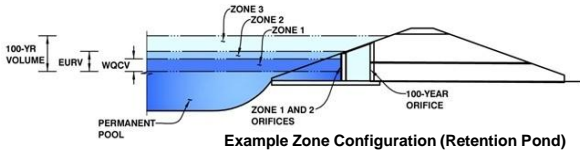

Example Zone Configuration (Retention Pond)

	Estimated Stage (ft)	Estimated Volume (ac-ft)	Outlet Type
Zone 1 (WOCV)	1.30	0.200	Orifice Plate
Zone 2 (EURV)	3.50	0.521	Orifice Plate
Zone 3 (100-year)	4.88	0.453	Weir&Pipe (Restrict)
Total (all zones)		1.174	

User Input: Orifice at Underdrain Outlet (typically used to drain WOCV in a Filtration BMP)

Underdrain Orifice Invert Depth = ft (distance below the filtration media surface)
 Underdrain Orifice Diameter = inches

Calculated Parameters for Underdrain

Underdrain Orifice Area = ft²
 Underdrain Orifice Centroid = feet

User Input: Orifice Plate with one or more orifices or Elliptical Slot Weir (typically used to drain WOCV and/or EURV in a sedimentation BMP)

Invert of Lowest Orifice = 0.00 ft (relative to basin bottom at Stage = 0 ft)
 Depth at top of Zone using Orifice Plate = 3.04 ft (relative to basin bottom at Stage = 0 ft)
 Orifice Plate: Orifice Vertical Spacing = N/A inches
 Orifice Plate: Orifice Area per Row = N/A inches

Calculated Parameters for Plate

WO Orifice Area per Row = N/A ft²
 Elliptical Half-Width = N/A feet
 Elliptical Slot Centroid = N/A feet
 Elliptical Slot Area = N/A ft²

User Input: Stage and Total Area of Each Orifice Row (numbered from lowest to highest)

	Row 1 (required)	Row 2 (optional)	Row 3 (optional)	Row 4 (optional)	Row 5 (optional)	Row 6 (optional)	Row 7 (optional)	Row 8 (optional)
Stage of Orifice Centroid (ft)	0.00	1.50	2.03					
Orifice Area (sq. inches)	2.40	2.40	2.40					

	Row 9 (optional)	Row 10 (optional)	Row 11 (optional)	Row 12 (optional)	Row 13 (optional)	Row 14 (optional)	Row 15 (optional)	Row 16 (optional)
Stage of Orifice Centroid (ft)								
Orifice Area (sq. inches)								

User Input: Vertical Orifice (Circular or Rectangular)

	Not Selected	Not Selected	
Invert of Vertical Orifice =	N/A	N/A	ft (relative to basin bottom at Stage = 0 ft)
Depth at top of Zone using Vertical Orifice =	N/A	N/A	ft (relative to basin bottom at Stage = 0 ft)
Vertical Orifice Diameter =	N/A	N/A	inches

Calculated Parameters for Vertical Orifice

	Not Selected	Not Selected	
Vertical Orifice Area =	N/A	N/A	ft ²
Vertical Orifice Centroid =	N/A	N/A	feet

User Input: Overflow Weir (Dropbox with Flat or Sloped Gate and Outlet Pipe OR Rectangular/Trapezoidal Weir (and No Outlet Pipe))

	Zone 3 Weir	Not Selected	
Overflow Weir Front Edge Height, Ho =	3.50	N/A	ft (relative to basin bottom at Stage = 0 ft)
Overflow Weir Front Edge Length =	4.00	N/A	feet
Overflow Weir Gate Slope =	0.00	N/A	H:V
Horiz. Length of Weir Sides =	4.00	N/A	feet
Overflow Gate Type =	Type C Gate	N/A	
Debris Clogging % =	50%	N/A	%

Calculated Parameters for Overflow Weir

	Zone 3 Weir	Not Selected	
Height of Gate Upper Edge, H ₁ =	3.50	N/A	feet
Overflow Weir Slope Length =	4.00	N/A	feet
Gate Open Area / 100-yr Orifice Area =	11.04	N/A	
Overflow Gate Open Area w/o Debris =	11.14	N/A	ft ²
Overflow Gate Open Area w/ Debris =	5.57	N/A	ft ²

User Input: Outlet Pipe w/ Flow Restriction Plate (Circular Orifice, Restrictor Plate, or Rectangular Orifice)

	Zone 3 Restrictor	Not Selected	
Depth to Invert of Outlet Pipe =	0.00	N/A	ft (distance below basin bottom at Stage = 0 ft)
Outlet Pipe Diameter =	18.00	N/A	inches
Restrictor Plate Height Above Pipe Invert =	10.00		inches

Calculated Parameters for Outlet Pipe w/ Flow Restriction Plate

	Zone 3 Restrictor	Not Selected	
Outlet Orifice Area =	1.01	N/A	ft ²
Outlet Orifice Centroid =	0.48	N/A	feet
Half-Central Angle of Restrictor Plate on Pipe =	1.68	N/A	radians

User Input: Emergency Spillway (Rectangular or Trapezoidal)

Spillway Invert Stage = 4.40 ft (relative to basin bottom at Stage = 0 ft)
 Spillway Crest Length = 20.00 feet
 Spillway End Slopes = 4.00 H:V
 Freeboard above Max Water Surface = 1.00 feet

Calculated Parameters for Spillway

Spillway Design Flow Depth = 0.58 feet
 Stage at Top of Freeboard = 5.98 feet
 Basin Area at Top of Freeboard = 0.43 acres
 Basin Volume at Top of Freeboard = 1.61 acre-ft

Routed Hydrograph Results

The user can override the default CUHP hydrographs and runoff volumes by entering new values in the Inflow Hydrographs table (Columns W through AF).

	WOCV	EURV	2 Year	5 Year	10 Year	25 Year	50 Year	100 Year	500 Year
Design Storm Return Period	N/A	N/A	1.01	1.29	1.56	2.00	2.25	2.75	3.14
One-Hour Rainfall Depth (in)	0.200	0.721	0.456	0.604	0.758	1.058	1.220	1.571	1.831
CUHP Runoff Volume (acre-ft)	N/A	N/A	0.456	0.604	0.758	1.058	1.220	1.571	1.831
Inflow Hydrograph Volume (acre-ft)	N/A	N/A	0.1	0.1	0.9	4.8	6.6	10.5	13.3
CUHP Predevelopment Peak Q (cfs)	N/A	N/A							
OPTIONAL Override Predevelopment Peak Q (cfs)	N/A	N/A							
Predevelopment Unit Peak Flow, q (cfs/acre)	N/A	N/A	0.01	0.02	0.11	0.60	0.82	1.31	1.65
Peak Inflow Q (cfs)	N/A	N/A	8.5	11.0	13.5	19.5	22.5	29.7	34.5
Peak Outflow Q (cfs)	0.1	0.4	0.2	0.3	0.4	4.2	7.0	9.6	15.1
Ratio Peak Outflow to Predevelopment Q	N/A	N/A	N/A	2.2	0.4	0.9	1.1	0.9	1.1
Structure Controlling Flow	Plate	Overflow Weir 1	Plate	Plate	Plate	Overflow Weir 1	Overflow Weir 1	Outlet Plate 1	Spillway
Max Velocity through Gate 1 (fps)	N/A	N/A	N/A	N/A	N/A	0.3	0.6	0.8	0.8
Max Velocity through Gate 2 (fps)	N/A	N/A	N/A	N/A	N/A	N/A	N/A	N/A	N/A
Time to Drain 97% of Inflow Volume (hours)	41	64	58	62	66	64	62	59	58
Time to Drain 99% of Inflow Volume (hours)	45	71	63	68	72	72	71	69	68
Maximum Ponding Depth (ft)	1.30	3.50	2.37	2.92	3.45	3.78	3.90	4.35	4.59
Area at Maximum Ponding Depth (acres)	0.18	0.29	0.24	0.26	0.29	0.31	0.31	0.34	0.35
Maximum Volume Stored (acre-ft)	0.201	0.722	0.425	0.561	0.708	0.803	0.843	0.989	1.071

DETENTION BASIN OUTLET STRUCTURE DESIGN

MHFD-Detention, Version 4.04 (February 2021)

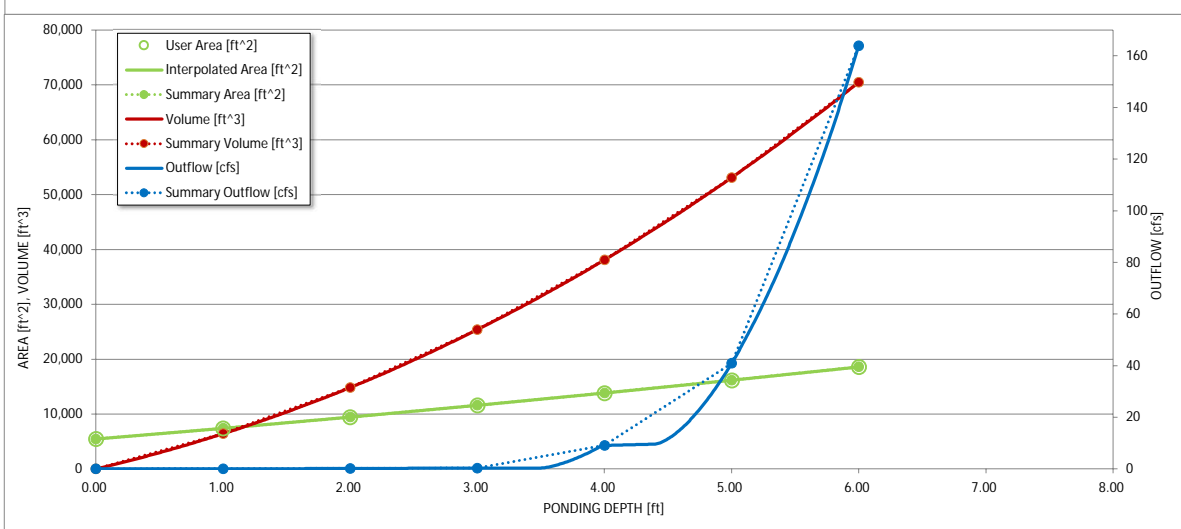
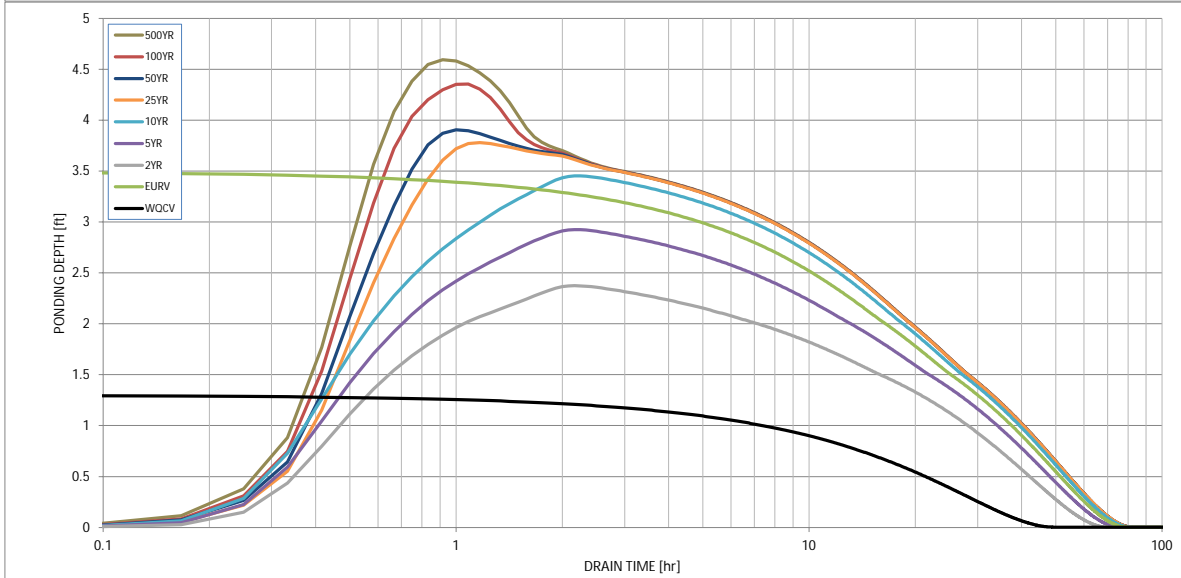
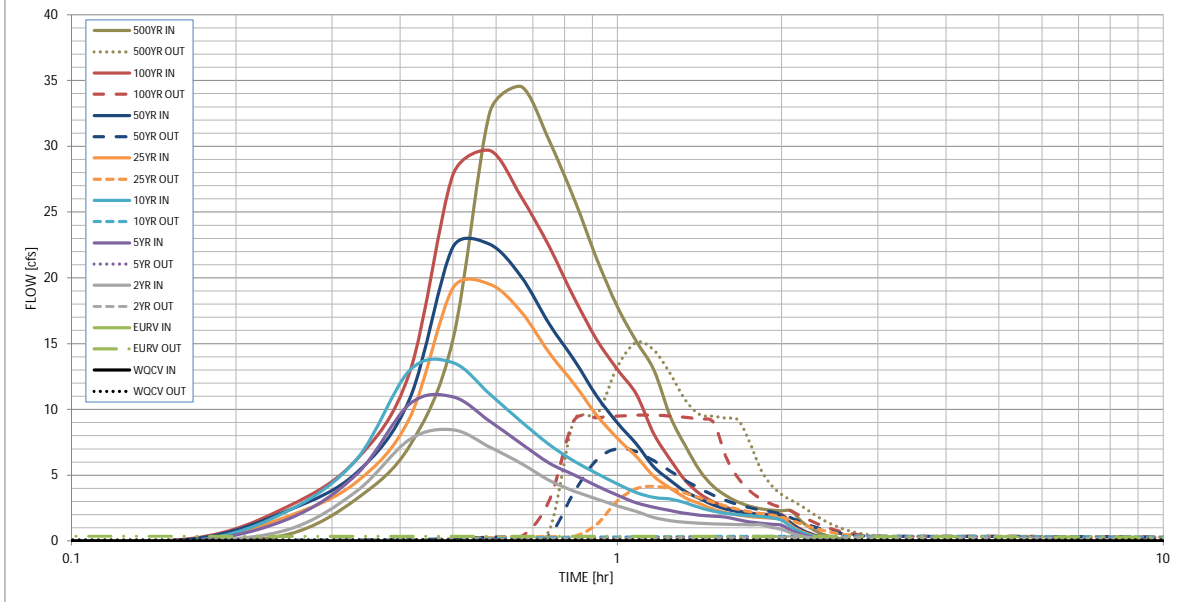

S-A-V-D Chart Axis Override	X-axis	Left Y-Axis	Right Y-Axis
minimum bound			
maximum bound			

DETENTION BASIN OUTLET STRUCTURE DESIGN

Outflow Hydrograph Workbook Filename: _____

Inflow Hydrographs

The user can override the calculated inflow hydrographs from this workbook with inflow hydrographs developed in a separate program.

Time Interval	SOURCE	CUHP	CUHP	CUHP	CUHP	CUHP	CUHP	CUHP	CUHP	CUHP
	TIME	WOCV [cfs]	EURV [cfs]	2 Year [cfs]	5 Year [cfs]	10 Year [cfs]	25 Year [cfs]	50 Year [cfs]	100 Year [cfs]	500 Year [cfs]
5.00 min	0:00:00	0.00	0.00	0.00	0.00	0.00	0.00	0.00	0.00	0.00
	0:05:00	0.00	0.00	0.00	0.00	0.00	0.00	0.00	0.00	0.00
	0:10:00	0.00	0.00	0.00	0.00	0.00	0.00	0.16	0.20	0.51
	0:15:00	0.00	0.00	0.89	1.69	2.31	1.90	2.34	2.65	3.23
	0:20:00	0.00	0.00	3.81	5.08	6.24	4.50	5.21	6.22	7.24
	0:25:00	0.00	0.00	7.72	10.41	12.97	9.35	10.81	12.82	15.32
	0:30:00	0.00	0.00	8.45	10.95	13.55	19.22	22.34	27.83	32.55
	0:35:00	0.00	0.00	7.13	9.10	11.17	19.51	22.54	29.68	34.53
	0:40:00	0.00	0.00	5.90	7.40	9.08	17.43	20.10	26.18	30.43
	0:45:00	0.00	0.00	4.61	5.93	7.34	14.30	16.50	22.38	25.99
	0:50:00	0.00	0.00	3.79	5.02	6.07	11.93	13.76	18.47	21.46
	0:55:00	0.00	0.00	3.20	4.19	5.15	9.57	11.02	15.31	17.82
	1:00:00	0.00	0.00	2.67	3.47	4.33	7.80	8.97	13.04	15.18
	1:05:00	0.00	0.00	2.25	2.90	3.67	6.42	7.38	11.17	13.01
	1:10:00	0.00	0.00	1.79	2.56	3.31	4.91	5.63	8.13	9.46
	1:15:00	0.00	0.00	1.55	2.31	3.18	4.01	4.60	6.19	7.20
	1:20:00	0.00	0.00	1.42	2.10	2.90	3.28	3.74	4.59	5.33
	1:25:00	0.00	0.00	1.34	1.96	2.53	2.83	3.22	3.57	4.14
	1:30:00	0.00	0.00	1.30	1.87	2.28	2.41	2.73	2.97	3.43
	1:35:00	0.00	0.00	1.27	1.81	2.11	2.14	2.42	2.56	2.95
	1:40:00	0.00	0.00	1.25	1.60	1.99	1.97	2.22	2.30	2.64
	1:45:00	0.00	0.00	1.23	1.45	1.92	1.85	2.08	2.13	2.43
	1:50:00	0.00	0.00	1.23	1.35	1.86	1.78	2.00	2.05	2.34
	1:55:00	0.00	0.00	1.03	1.28	1.76	1.74	1.96	2.02	2.30
	2:00:00	0.00	0.00	0.89	1.19	1.58	1.72	1.93	2.01	2.29
	2:05:00	0.00	0.00	0.60	0.80	1.06	1.15	1.29	1.35	1.54
	2:10:00	0.00	0.00	0.39	0.52	0.70	0.76	0.86	0.89	1.02
	2:15:00	0.00	0.00	0.25	0.33	0.45	0.50	0.56	0.58	0.66
	2:20:00	0.00	0.00	0.15	0.20	0.28	0.31	0.34	0.36	0.41
	2:25:00	0.00	0.00	0.09	0.13	0.17	0.19	0.22	0.23	0.26
	2:30:00	0.00	0.00	0.04	0.07	0.09	0.11	0.12	0.12	0.14
	2:35:00	0.00	0.00	0.02	0.03	0.04	0.05	0.05	0.05	0.06
	2:40:00	0.00	0.00	0.00	0.01	0.01	0.01	0.01	0.01	0.01
	2:45:00	0.00	0.00	0.00	0.00	0.00	0.00	0.00	0.00	0.00
	2:50:00	0.00	0.00	0.00	0.00	0.00	0.00	0.00	0.00	0.00
	2:55:00	0.00	0.00	0.00	0.00	0.00	0.00	0.00	0.00	0.00
	3:00:00	0.00	0.00	0.00	0.00	0.00	0.00	0.00	0.00	0.00
	3:05:00	0.00	0.00	0.00	0.00	0.00	0.00	0.00	0.00	0.00
	3:10:00	0.00	0.00	0.00	0.00	0.00	0.00	0.00	0.00	0.00
	3:15:00	0.00	0.00	0.00	0.00	0.00	0.00	0.00	0.00	0.00
	3:20:00	0.00	0.00	0.00	0.00	0.00	0.00	0.00	0.00	0.00
	3:25:00	0.00	0.00	0.00	0.00	0.00	0.00	0.00	0.00	0.00
	3:30:00	0.00	0.00	0.00	0.00	0.00	0.00	0.00	0.00	0.00
	3:35:00	0.00	0.00	0.00	0.00	0.00	0.00	0.00	0.00	0.00
	3:40:00	0.00	0.00	0.00	0.00	0.00	0.00	0.00	0.00	0.00
	3:45:00	0.00	0.00	0.00	0.00	0.00	0.00	0.00	0.00	0.00
	3:50:00	0.00	0.00	0.00	0.00	0.00	0.00	0.00	0.00	0.00
	3:55:00	0.00	0.00	0.00	0.00	0.00	0.00	0.00	0.00	0.00
	4:00:00	0.00	0.00	0.00	0.00	0.00	0.00	0.00	0.00	0.00
	4:05:00	0.00	0.00	0.00	0.00	0.00	0.00	0.00	0.00	0.00
	4:10:00	0.00	0.00	0.00	0.00	0.00	0.00	0.00	0.00	0.00
	4:15:00	0.00	0.00	0.00	0.00	0.00	0.00	0.00	0.00	0.00
	4:20:00	0.00	0.00	0.00	0.00	0.00	0.00	0.00	0.00	0.00
	4:25:00	0.00	0.00	0.00	0.00	0.00	0.00	0.00	0.00	0.00
	4:30:00	0.00	0.00	0.00	0.00	0.00	0.00	0.00	0.00	0.00
	4:35:00	0.00	0.00	0.00	0.00	0.00	0.00	0.00	0.00	0.00
	4:40:00	0.00	0.00	0.00	0.00	0.00	0.00	0.00	0.00	0.00
	4:45:00	0.00	0.00	0.00	0.00	0.00	0.00	0.00	0.00	0.00
	4:50:00	0.00	0.00	0.00	0.00	0.00	0.00	0.00	0.00	0.00
	4:55:00	0.00	0.00	0.00	0.00	0.00	0.00	0.00	0.00	0.00
	5:00:00	0.00	0.00	0.00	0.00	0.00	0.00	0.00	0.00	0.00
	5:05:00	0.00	0.00	0.00	0.00	0.00	0.00	0.00	0.00	0.00
	5:10:00	0.00	0.00	0.00	0.00	0.00	0.00	0.00	0.00	0.00
	5:15:00	0.00	0.00	0.00	0.00	0.00	0.00	0.00	0.00	0.00
	5:20:00	0.00	0.00	0.00	0.00	0.00	0.00	0.00	0.00	0.00
	5:25:00	0.00	0.00	0.00	0.00	0.00	0.00	0.00	0.00	0.00
	5:30:00	0.00	0.00	0.00	0.00	0.00	0.00	0.00	0.00	0.00
	5:35:00	0.00	0.00	0.00	0.00	0.00	0.00	0.00	0.00	0.00
	5:40:00	0.00	0.00	0.00	0.00	0.00	0.00	0.00	0.00	0.00
	5:45:00	0.00	0.00	0.00	0.00	0.00	0.00	0.00	0.00	0.00
	5:50:00	0.00	0.00	0.00	0.00	0.00	0.00	0.00	0.00	0.00
	5:55:00	0.00	0.00	0.00	0.00	0.00	0.00	0.00	0.00	0.00
	6:00:00	0.00	0.00	0.00	0.00	0.00	0.00	0.00	0.00	0.00

DETENTION BASIN STAGE-STORAGE TABLE BUILDER

MHFD-Detention, Version 4.04 (February 2021)

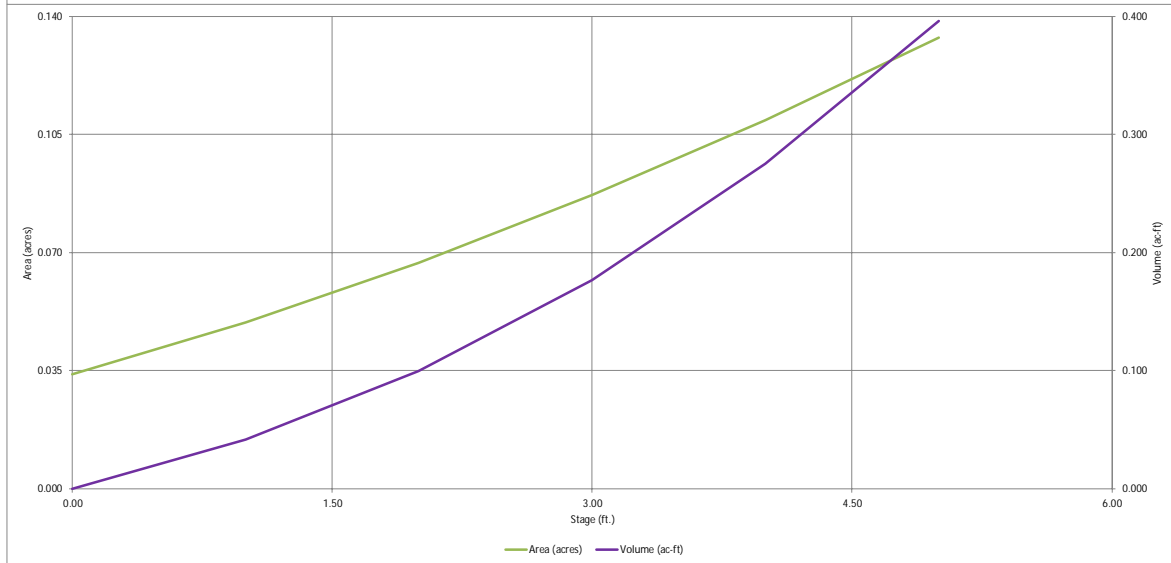
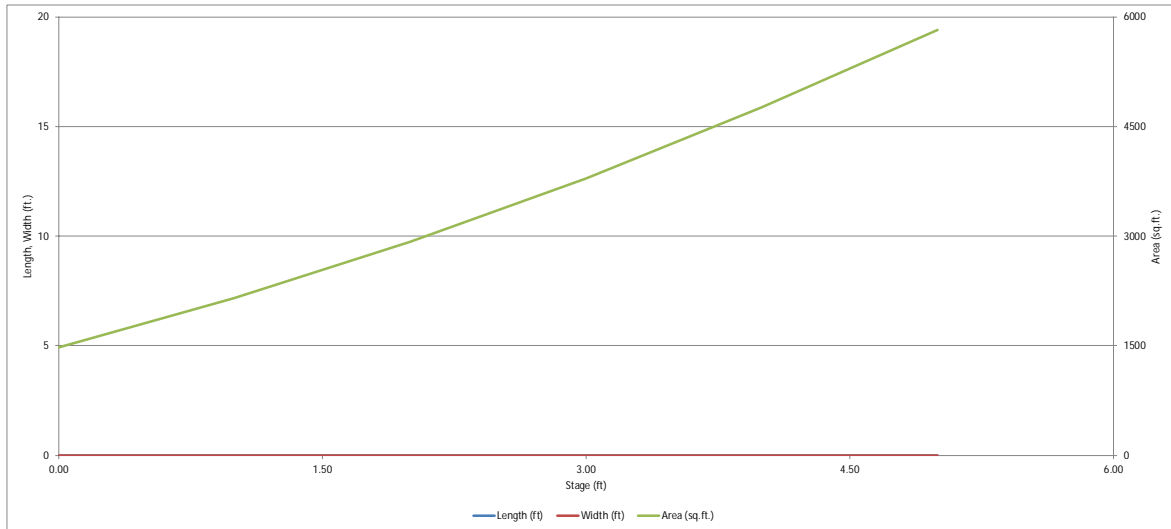

DETENTION BASIN OUTLET STRUCTURE DESIGN

MHFD-Detention, Version 4.04 (February 2021)

Project: Waterview East Commercial
Basin ID: EDB A24 (Sub-basins A24 and A25)

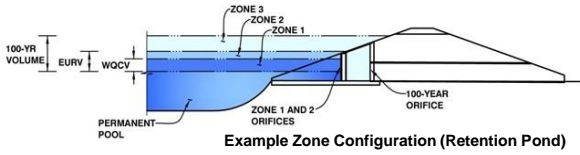

Example Zone Configuration (Retention Pond)

	Estimated Stage (ft)	Estimated Volume (ac-ft)	Outlet Type
Zone 1 (WOCV)	1.01	0.042	Orifice Plate
Zone 2 (EURV)	2.58	0.100	Orifice Plate
Zone 3 (100-year)	3.77	0.108	Weir&Pipe (Restrict)
Total (all zones)		0.250	

User Input: Orifice at Underdrain Outlet (typically used to drain WOCV in a Filtration BMP)

Underdrain Orifice Invert Depth = ft (distance below the filtration media surface)
Underdrain Orifice Diameter = inches

Calculated Parameters for Underdrain

Underdrain Orifice Area = ft²
Underdrain Orifice Centroid = feet

User Input: Orifice Plate with one or more orifices or Elliptical Slot Weir (typically used to drain WOCV and/or EURV in a sedimentation BMP)

Calculated Parameters for Plate

Invert of Lowest Orifice = 0.00 ft (relative to basin bottom at Stage = 0 ft)
Depth at top of Zone using Orifice Plate = 2.58 ft (relative to basin bottom at Stage = 0 ft)
Orifice Plate: Orifice Vertical Spacing = N/A inches
Orifice Plate: Orifice Area per Row = 0.60 sq. inches (diameter = 7/8 inch)

WO Orifice Area per Row = 4.167E-03 ft²
Elliptical Half-Width = N/A feet
Elliptical Slot Centroid = N/A feet
Elliptical Slot Area = N/A ft²

User Input: Stage and Total Area of Each Orifice Row (numbered from lowest to highest)

	Row 1 (required)	Row 2 (optional)	Row 3 (optional)	Row 4 (optional)	Row 5 (optional)	Row 6 (optional)	Row 7 (optional)	Row 8 (optional)
Stage of Orifice Centroid (ft)	0.00	1.20	1.75					
Orifice Area (sq. inches)	0.60	0.60	0.60					

	Row 9 (optional)	Row 10 (optional)	Row 11 (optional)	Row 12 (optional)	Row 13 (optional)	Row 14 (optional)	Row 15 (optional)	Row 16 (optional)
Stage of Orifice Centroid (ft)								
Orifice Area (sq. inches)								

User Input: Vertical Orifice (Circular or Rectangular)

Calculated Parameters for Vertical Orifice

	Not Selected	Not Selected	
Invert of Vertical Orifice =	N/A	N/A	ft (relative to basin bottom at Stage = 0 ft)
Depth at top of Zone using Vertical Orifice =	N/A	N/A	ft (relative to basin bottom at Stage = 0 ft)
Vertical Orifice Diameter =	N/A	N/A	inches

	Not Selected	Not Selected	
Vertical Orifice Area =	N/A	N/A	ft ²
Vertical Orifice Centroid =	N/A	N/A	feet

User Input: Overflow Weir (Dropbox with Flat or Sloped Gate and Outlet Pipe OR Rectangular/Trapezoidal Weir (and No Outlet Pipe))

Calculated Parameters for Overflow Weir

	Zone 3 Weir	Not Selected	
Overflow Weir Front Edge Height, Ho =	2.58	N/A	ft (relative to basin bottom at Stage = 0 ft)
Overflow Weir Front Edge Length =	4.00	N/A	feet
Overflow Weir Gate Slope =	0.00	N/A	H:V
Horiz. Length of Weir Sides =	4.00	N/A	feet
Overflow Gate Type =	Type C Gate	N/A	
Debris Clogging % =	50%	N/A	%

	Zone 3 Weir	Not Selected	
Height of Gate Upper Edge, H ₁ =	2.58	N/A	feet
Overflow Weir Slope Length =	4.00	N/A	feet
Gate Open Area / 100-yr Orifice Area =	30.32	N/A	
Overflow Gate Open Area w/o Debris =	11.14	N/A	ft ²
Overflow Gate Open Area w/ Debris =	5.57	N/A	ft ²

User Input: Outlet Pipe w/ Flow Restriction Plate (Circular Orifice, Restrictor Plate, or Rectangular Orifice)

Calculated Parameters for Outlet Pipe w/ Flow Restriction Plate

	Zone 3 Restrictor	Not Selected	
Depth to Invert of Outlet Pipe =	0.00	N/A	ft (distance below basin bottom at Stage = 0 ft)
Outlet Pipe Diameter =	18.00	N/A	inches
Restrictor Plate Height Above Pipe Invert =	4.70		inches

	Zone 3 Restrictor	Not Selected	
Outlet Orifice Area =	0.37	N/A	ft ²
Outlet Orifice Centroid =	0.23	N/A	feet
Half-Central Angle of Restrictor Plate on Pipe =	1.07	N/A	radians

User Input: Emergency Spillway (Rectangular or Trapezoidal)

Calculated Parameters for Spillway

Spillway Invert Stage =	3.50	ft (relative to basin bottom at Stage = 0 ft)
Spillway Crest Length =	10.00	feet
Spillway End Slopes =	4.00	H:V
Freeboard above Max Water Surface =	1.00	feet

Spillway Design Flow Depth =	0.36	feet
Stage at Top of Freeboard =	4.86	feet
Basin Area at Top of Freeboard =	0.13	acres
Basin Volume at Top of Freeboard =	0.38	acre-ft

Routed Hydrograph Results

The user can override the default CUHP hydrographs and runoff volumes by entering new values in the Inflow Hydrographs table (Columns W through AF).

	WOCV	EURV	2 Year	5 Year	10 Year	25 Year	50 Year	100 Year	500 Year
Design Storm Return Period	N/A	N/A	1.01	1.29	1.56	2.00	2.25	2.75	3.14
One-Hour Rainfall Depth (in)	0.042	0.142	0.089	0.120	0.154	0.236	0.278	0.375	0.444
CUHP Runoff Volume (acre-ft)	N/A	N/A	0.089	0.120	0.154	0.236	0.278	0.375	0.444
Inflow Hydrograph Volume (acre-ft)	N/A	N/A	0.0	0.0	0.3	1.5	2.1	3.4	4.2
CUHP Predevelopment Peak Q (cfs)	N/A	N/A	N/A	N/A	N/A	N/A	N/A	N/A	N/A
OPTIONAL Override Predevelopment Peak Q (cfs)	N/A	N/A	N/A	N/A	N/A	N/A	N/A	N/A	N/A
Predevelopment Unit Peak Flow, q (cfs/acre)	N/A	N/A	0.01	0.02	0.14	0.69	0.94	1.49	1.87
Peak Inflow Q (cfs)	N/A	N/A	1.7	2.2	2.9	4.6	5.5	7.5	8.9
Peak Outflow Q (cfs)	0.0	0.1	0.0	0.1	0.1	1.9	2.8	3.1	4.1
Ratio Peak Outflow to Predevelopment Q	N/A	N/A	N/A	1.4	0.4	1.2	1.3	0.9	1.0
Structure Controlling Flow	Plate	Overflow Weir 1	Plate	Plate	Overflow Weir 1	Overflow Weir 1	Outlet Plate 1	Outlet Plate 1	Spillway
Max Velocity through Gate 1 (fps)	N/A	N/A	N/A	N/A	0.0	0.2	0.2	0.3	0.3
Max Velocity through Gate 2 (fps)	N/A	N/A	N/A	N/A	N/A	N/A	N/A	N/A	N/A
Time to Drain 97% of Inflow Volume (hours)	40	62	55	60	63	60	58	55	53
Time to Drain 99% of Inflow Volume (hours)	43	68	60	65	70	68	67	65	64
Maximum Ponding Depth (ft)	1.01	2.58	1.74	2.17	2.60	2.75	2.81	3.30	3.59
Area at Maximum Ponding Depth (acres)	0.05	0.08	0.06	0.07	0.08	0.08	0.08	0.09	0.10
Maximum Volume Stored (acre-ft)	0.042	0.142	0.083	0.111	0.143	0.156	0.161	0.204	0.231

DETENTION BASIN OUTLET STRUCTURE DESIGN

MHFD-Detention, Version 4.04 (February 2021)

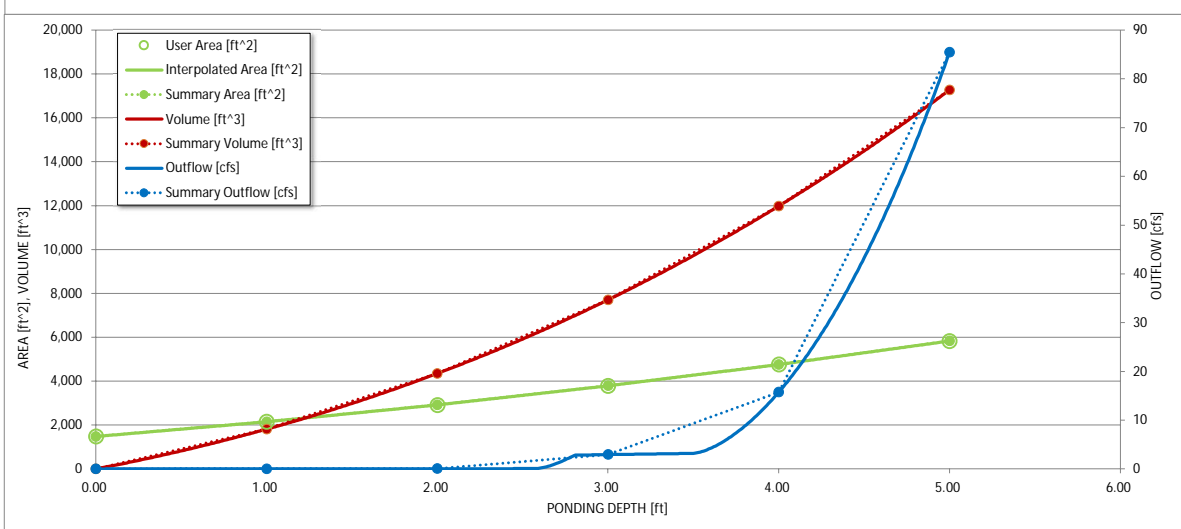
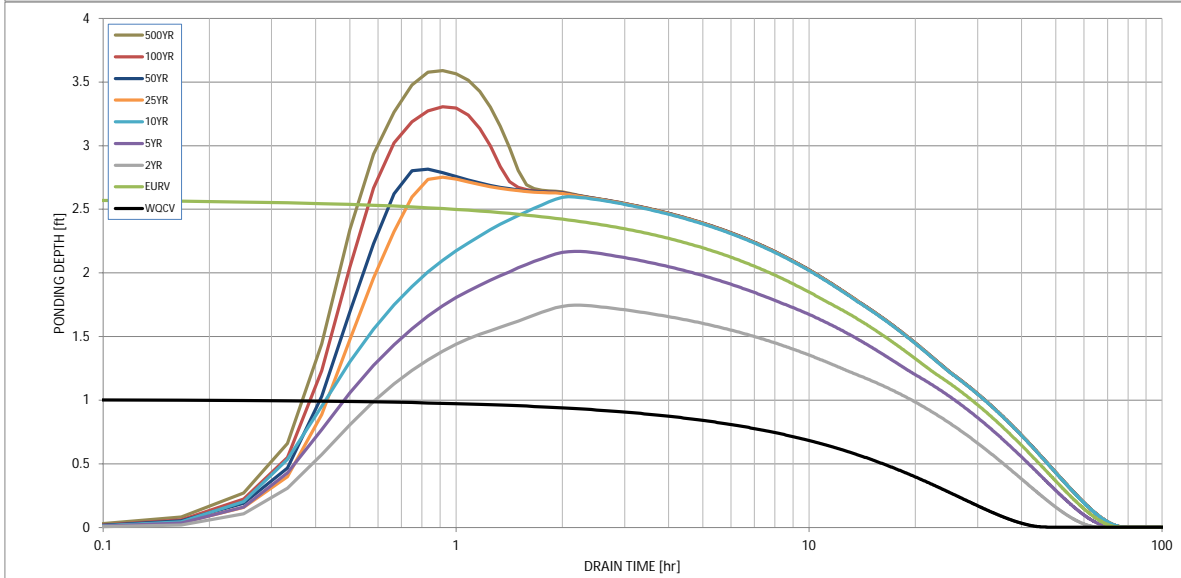
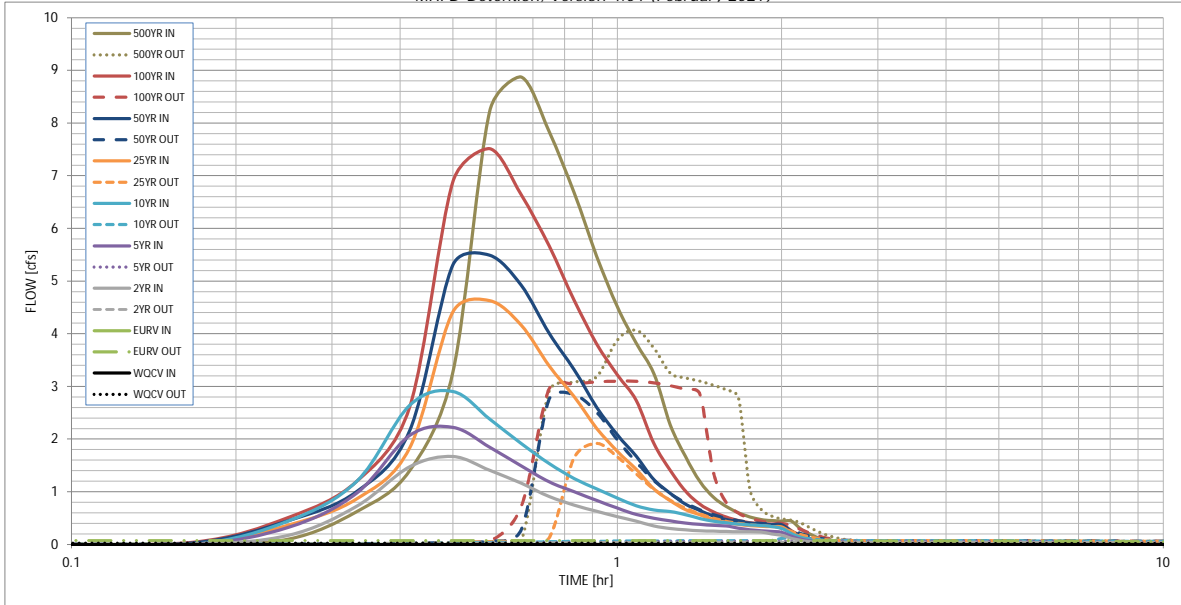

S-A-V-D Chart Axis Override	X-axis	Left Y-Axis	Right Y-Axis
minimum bound			
maximum bound			

DETENTION BASIN OUTLET STRUCTURE DESIGN

Outflow Hydrograph Workbook Filename: _____

Inflow Hydrographs

The user can override the calculated inflow hydrographs from this workbook with inflow hydrographs developed in a separate program.

Time Interval	SOURCE	CUHP	CUHP	CUHP	CUHP	CUHP	CUHP	CUHP	CUHP	CUHP
	TIME	WOCV [cfs]	EURV [cfs]	2 Year [cfs]	5 Year [cfs]	10 Year [cfs]	25 Year [cfs]	50 Year [cfs]	100 Year [cfs]	500 Year [cfs]
5.00 min	0:00:00	0.00	0.00	0.00	0.00	0.00	0.00	0.00	0.00	0.00
	0:05:00	0.00	0.00	0.00	0.00	0.00	0.00	0.00	0.00	0.00
	0:10:00	0.00	0.00	0.00	0.00	0.00	0.00	0.03	0.04	0.10
	0:15:00	0.00	0.00	0.17	0.33	0.45	0.37	0.45	0.51	0.63
	0:20:00	0.00	0.00	0.73	0.97	1.20	0.87	1.00	1.20	1.40
	0:25:00	0.00	0.00	1.47	2.07	2.64	1.83	2.16	2.61	3.27
	0:30:00	0.00	0.00	1.67	2.22	2.90	4.42	5.31	6.89	8.23
	0:35:00	0.00	0.00	1.40	1.84	2.38	4.63	5.49	7.51	8.88
	0:40:00	0.00	0.00	1.16	1.49	1.92	4.17	4.92	6.64	7.84
	0:45:00	0.00	0.00	0.91	1.19	1.53	3.39	4.01	5.66	6.68
	0:50:00	0.00	0.00	0.74	1.00	1.25	2.80	3.32	4.64	5.47
	0:55:00	0.00	0.00	0.63	0.83	1.05	2.20	2.60	3.81	4.51
	1:00:00	0.00	0.00	0.53	0.69	0.88	1.77	2.08	3.22	3.82
	1:05:00	0.00	0.00	0.44	0.57	0.74	1.42	1.67	2.73	3.24
	1:10:00	0.00	0.00	0.35	0.50	0.65	1.05	1.23	1.92	2.27
	1:15:00	0.00	0.00	0.30	0.45	0.62	0.83	0.97	1.40	1.67
	1:20:00	0.00	0.00	0.27	0.40	0.57	0.66	0.77	1.01	1.19
	1:25:00	0.00	0.00	0.26	0.38	0.49	0.56	0.64	0.76	0.90
	1:30:00	0.00	0.00	0.25	0.36	0.44	0.47	0.54	0.62	0.72
	1:35:00	0.00	0.00	0.25	0.35	0.41	0.42	0.47	0.52	0.60
	1:40:00	0.00	0.00	0.24	0.31	0.39	0.38	0.43	0.45	0.52
	1:45:00	0.00	0.00	0.24	0.28	0.37	0.36	0.40	0.41	0.47
	1:50:00	0.00	0.00	0.24	0.26	0.36	0.34	0.39	0.39	0.45
	1:55:00	0.00	0.00	0.20	0.25	0.34	0.34	0.38	0.39	0.44
	2:00:00	0.00	0.00	0.17	0.23	0.30	0.33	0.37	0.39	0.44
	2:05:00	0.00	0.00	0.12	0.15	0.20	0.22	0.25	0.26	0.30
	2:10:00	0.00	0.00	0.08	0.10	0.14	0.15	0.17	0.17	0.20
	2:15:00	0.00	0.00	0.05	0.06	0.09	0.10	0.11	0.11	0.13
	2:20:00	0.00	0.00	0.03	0.04	0.05	0.06	0.07	0.07	0.08
	2:25:00	0.00	0.00	0.02	0.03	0.03	0.04	0.04	0.04	0.05
	2:30:00	0.00	0.00	0.01	0.01	0.02	0.02	0.02	0.02	0.03
	2:35:00	0.00	0.00	0.00	0.01	0.01	0.01	0.01	0.01	0.01
	2:40:00	0.00	0.00	0.00	0.00	0.00	0.00	0.00	0.00	0.00
	2:45:00	0.00	0.00	0.00	0.00	0.00	0.00	0.00	0.00	0.00
	2:50:00	0.00	0.00	0.00	0.00	0.00	0.00	0.00	0.00	0.00
	2:55:00	0.00	0.00	0.00	0.00	0.00	0.00	0.00	0.00	0.00
	3:00:00	0.00	0.00	0.00	0.00	0.00	0.00	0.00	0.00	0.00
	3:05:00	0.00	0.00	0.00	0.00	0.00	0.00	0.00	0.00	0.00
	3:10:00	0.00	0.00	0.00	0.00	0.00	0.00	0.00	0.00	0.00
	3:15:00	0.00	0.00	0.00	0.00	0.00	0.00	0.00	0.00	0.00
	3:20:00	0.00	0.00	0.00	0.00	0.00	0.00	0.00	0.00	0.00
	3:25:00	0.00	0.00	0.00	0.00	0.00	0.00	0.00	0.00	0.00
	3:30:00	0.00	0.00	0.00	0.00	0.00	0.00	0.00	0.00	0.00
	3:35:00	0.00	0.00	0.00	0.00	0.00	0.00	0.00	0.00	0.00
	3:40:00	0.00	0.00	0.00	0.00	0.00	0.00	0.00	0.00	0.00
	3:45:00	0.00	0.00	0.00	0.00	0.00	0.00	0.00	0.00	0.00
	3:50:00	0.00	0.00	0.00	0.00	0.00	0.00	0.00	0.00	0.00
	3:55:00	0.00	0.00	0.00	0.00	0.00	0.00	0.00	0.00	0.00
	4:00:00	0.00	0.00	0.00	0.00	0.00	0.00	0.00	0.00	0.00
	4:05:00	0.00	0.00	0.00	0.00	0.00	0.00	0.00	0.00	0.00
	4:10:00	0.00	0.00	0.00	0.00	0.00	0.00	0.00	0.00	0.00
	4:15:00	0.00	0.00	0.00	0.00	0.00	0.00	0.00	0.00	0.00
	4:20:00	0.00	0.00	0.00	0.00	0.00	0.00	0.00	0.00	0.00
	4:25:00	0.00	0.00	0.00	0.00	0.00	0.00	0.00	0.00	0.00
	4:30:00	0.00	0.00	0.00	0.00	0.00	0.00	0.00	0.00	0.00
	4:35:00	0.00	0.00	0.00	0.00	0.00	0.00	0.00	0.00	0.00
	4:40:00	0.00	0.00	0.00	0.00	0.00	0.00	0.00	0.00	0.00
	4:45:00	0.00	0.00	0.00	0.00	0.00	0.00	0.00	0.00	0.00
	4:50:00	0.00	0.00	0.00	0.00	0.00	0.00	0.00	0.00	0.00
	4:55:00	0.00	0.00	0.00	0.00	0.00	0.00	0.00	0.00	0.00
	5:00:00	0.00	0.00	0.00	0.00	0.00	0.00	0.00	0.00	0.00
	5:05:00	0.00	0.00	0.00	0.00	0.00	0.00	0.00	0.00	0.00
	5:10:00	0.00	0.00	0.00	0.00	0.00	0.00	0.00	0.00	0.00
	5:15:00	0.00	0.00	0.00	0.00	0.00	0.00	0.00	0.00	0.00
	5:20:00	0.00	0.00	0.00	0.00	0.00	0.00	0.00	0.00	0.00
	5:25:00	0.00	0.00	0.00	0.00	0.00	0.00	0.00	0.00	0.00
	5:30:00	0.00	0.00	0.00	0.00	0.00	0.00	0.00	0.00	0.00
	5:35:00	0.00	0.00	0.00	0.00	0.00	0.00	0.00	0.00	0.00
	5:40:00	0.00	0.00	0.00	0.00	0.00	0.00	0.00	0.00	0.00
	5:45:00	0.00	0.00	0.00	0.00	0.00	0.00	0.00	0.00	0.00
	5:50:00	0.00	0.00	0.00	0.00	0.00	0.00	0.00	0.00	0.00
	5:55:00	0.00	0.00	0.00	0.00	0.00	0.00	0.00	0.00	0.00
	6:00:00	0.00	0.00	0.00	0.00	0.00	0.00	0.00	0.00	0.00

DETENTION BASIN STAGE-STORAGE TABLE BUILDER

MHFD-Detention, Version 4.06 (July 2022)

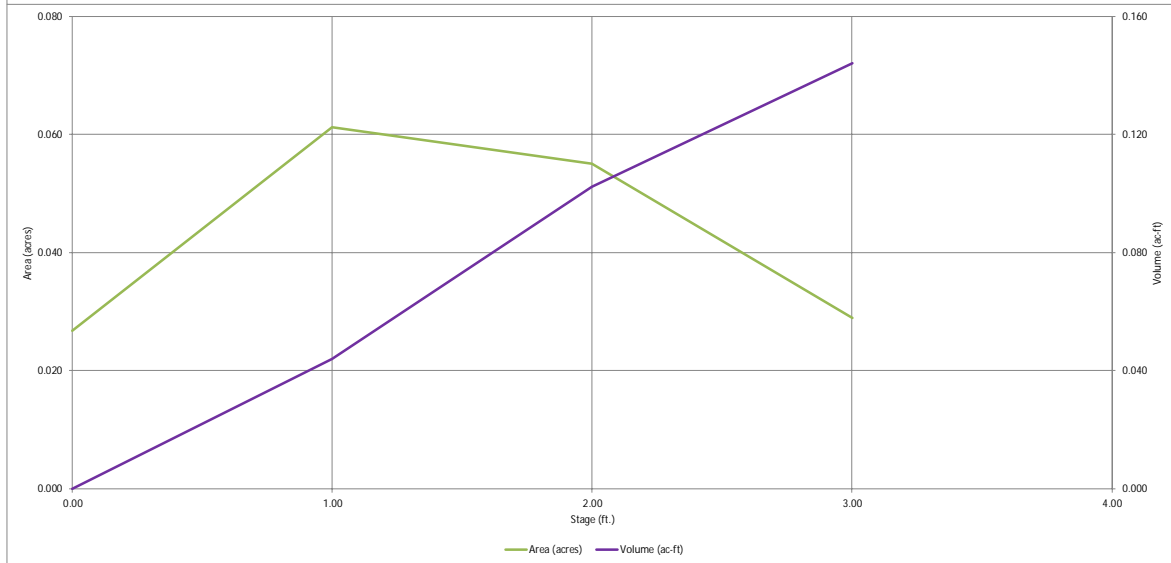
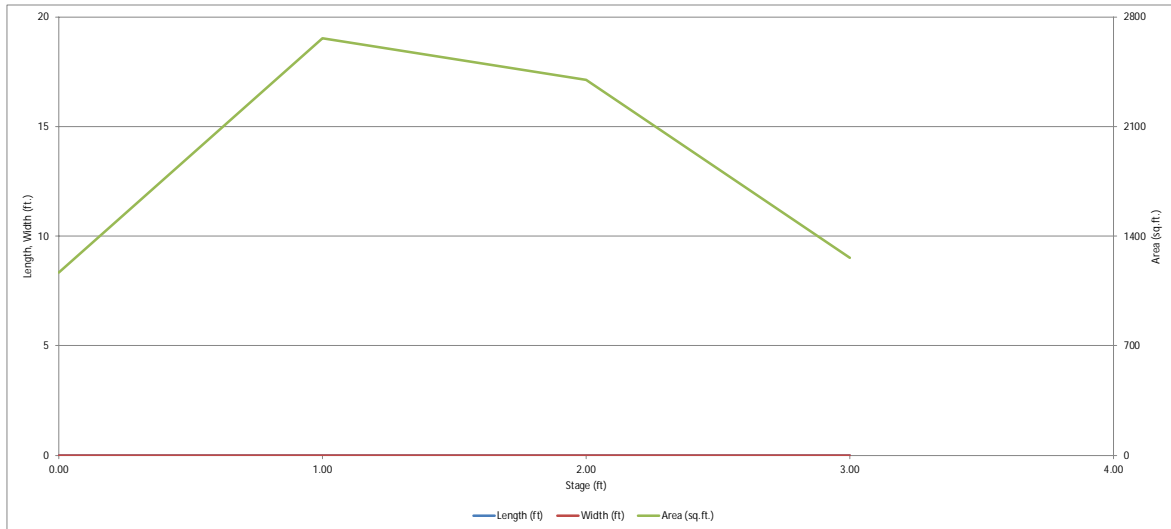

DETENTION BASIN OUTLET STRUCTURE DESIGN

MHFD-Detention, Version 4.06 (July 2022)

Project: Waterview East Commercial
Basin ID: EDB A27 (Sub-basins A27)

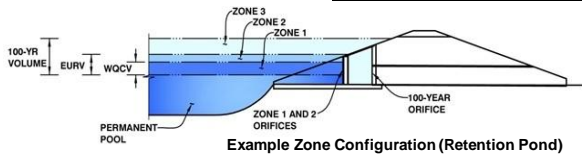

	Estimated Stage (ft)	Estimated Volume (ac-ft)	Outlet Type
Zone 1 (WOCV)	0.56	0.020	Orifice Plate
Zone 2 (EURV)	0.85	0.015	Orifice Plate
Zone 3 (100-year)	2.12	0.073	Weir&Pipe (Restrict)
Total (all zones)		0.108	

User Input: Orifice at Underdrain Outlet (typically used to drain WOCV in a Filtration BMP)

Underdrain Orifice Invert Depth =	N/A	ft (distance below the filtration media surface)
Underdrain Orifice Diameter =	N/A	inches

Calculated Parameters for Underdrain

Underdrain Orifice Area =	N/A	ft ²
Underdrain Orifice Centroid =	N/A	feet

User Input: Orifice Plate with one or more orifices or Elliptical Slot Weir (typically used to drain WOCV and/or EURV in a sedimentation BMP)

Centroid of Lowest Orifice =	0.00	ft (relative to basin bottom at Stage = 0 ft)
Depth at top of Zone using Orifice Plate =	0.85	ft (relative to basin bottom at Stage = 0 ft)
Orifice Plate: Orifice Vertical Spacing =	N/A	inches
Orifice Plate: Orifice Area per Row =	N/A	sq. inches

Calculated Parameters for Plate

WQ Orifice Area per Row =	N/A	ft ²
Elliptical Half-Width =	N/A	feet
Elliptical Slot Centroid =	N/A	feet
Elliptical Slot Area =	N/A	ft ²

User Input: Stage and Total Area of Each Orifice Row (numbered from lowest to highest)

	Row 1 (required)	Row 2 (optional)	Row 3 (optional)	Row 4 (optional)	Row 5 (optional)	Row 6 (optional)	Row 7 (optional)	Row 8 (optional)
Stage of Orifice Centroid (ft)	0.00	0.70						
Orifice Area (sq. inches)	0.30	0.25						

	Row 9 (optional)	Row 10 (optional)	Row 11 (optional)	Row 12 (optional)	Row 13 (optional)	Row 14 (optional)	Row 15 (optional)	Row 16 (optional)
Stage of Orifice Centroid (ft)								
Orifice Area (sq. inches)								

User Input: Vertical Orifice (Circular or Rectangular)

	Not Selected	Not Selected	
Invert of Vertical Orifice =	N/A	N/A	ft (relative to basin bottom at Stage = 0 ft)
Depth at top of Zone using Vertical Orifice =	N/A	N/A	ft (relative to basin bottom at Stage = 0 ft)
Vertical Orifice Diameter =	N/A	N/A	inches

Calculated Parameters for Vertical Orifice

	Not Selected	Not Selected	
Vertical Orifice Area =	N/A	N/A	ft ²
Vertical Orifice Centroid =	N/A	N/A	feet

User Input: Overflow Weir (Dropbox with Flat or Sloped Gate and Outlet Pipe OR Rectangular/Trapezoidal Weir and No Outlet Pipe)

	Zone 3 Weir	Not Selected	
Overflow Weir Front Edge Height, Ho =	0.85	N/A	ft (relative to basin bottom at Stage = 0 ft)
Overflow Weir Front Edge Length =	4.00	N/A	feet
Overflow Weir Gate Slope =	0.00	N/A	H:V
Horiz. Length of Weir Sides =	4.00	N/A	feet
Overflow Gate Type =	Type C Gate	N/A	
Debris Clogging % =	50%	N/A	%

Calculated Parameters for Overflow Weir

	Zone 3 Weir	Not Selected	
Height of Gate Upper Edge, Hi =	0.85	N/A	feet
Overflow Weir Slope Length =	4.00	N/A	feet
Grate Open Area / 100-yr Orifice Area =	17.52	N/A	
Overflow Gate Open Area w/o Debris =	11.14	N/A	ft ²
Overflow Gate Open Area w/ Debris =	5.57	N/A	ft ²

User Input: Outlet Pipe w/ Flow Restriction Plate (Circular Orifice, Restrictor Plate, or Rectangular Orifice)

	Zone 3 Restrictor	Not Selected	
Depth to Invert of Outlet Pipe =	0.00	N/A	ft (distance below basin bottom at Stage = 0 ft)
Outlet Pipe Diameter =	18.00	N/A	inches
Restrictor Plate Height Above Pipe Invert =	7.00		inches

Calculated Parameters for Outlet Pipe w/ Flow Restriction Plate

	Zone 3 Restrictor	Not Selected	
Outlet Orifice Area =	0.64	N/A	ft ²
Outlet Orifice Centroid =	0.34	N/A	feet
Half-Central Angle of Restrictor Plate on Pipe =	1.35	N/A	radians

User Input: Emergency Spillway (Rectangular or Trapezoidal)

Spillway Invert Stage =	2.12	ft (relative to basin bottom at Stage = 0 ft)
Spillway Crest Length =	5.00	feet
Spillway End Slopes =	4.00	H:V
Freeboard above Max Water Surface =	1.00	feet

Calculated Parameters for Spillway

Spillway Design Flow Depth =	0.36	feet
Stage at Top of Freeboard =	3.48	feet
Basin Area at Top of Freeboard =	0.03	acres
Basin Volume at Top of Freeboard =	0.14	acre-ft

Routed Hydrograph Results

The user can override the default CUHP hydrographs and runoff volumes by entering new values in the Inflow Hydrographs table (Columns W through AF).

	WOCV	EURV	2 Year	5 Year	10 Year	25 Year	50 Year	100 Year	500 Year
Design Storm Return Period	N/A	N/A	1.01	1.29	1.56	2.00	2.25	2.75	3.14
One-Hour Rainfall Depth (in)									
CUHP Runoff Volume (acre-ft)	0.020	0.035	0.018	0.029	0.053	0.143	0.188	0.306	0.386
Inflow Hydrograph Volume (acre-ft)	N/A	N/A	0.018	0.029	0.053	0.143	0.188	0.306	0.386
CUHP Predevelopment Peak Q (cfs)	N/A	N/A	0.0	0.0	0.3	1.6	2.2	3.6	4.5
OPTIONAL Override Predevelopment Peak Q (cfs)	N/A	N/A							
Predevelopment Unit Peak Flow, q (cfs/acre)	N/A	N/A	0.01	0.02	0.12	0.63	0.86	1.37	1.73
Peak Inflow Q (cfs)	N/A	N/A	0.2	0.4	0.7	2.1	2.7	4.0	5.0
Peak Outflow Q (cfs)	0.0	0.0	0.0	0.0	0.3	1.8	2.4	3.2	3.7
Ratio Peak Outflow to Predevelopment Q	N/A	N/A	N/A	0.2	0.8	1.1	1.1	0.9	0.8
Structure Controlling Flow	Plate	Overflow Weir 1	Plate	Plate	Overflow Weir 1	Overflow Weir 1	Outlet Plate 1	Outlet Plate 1	Outlet Plate 1
Max Velocity through Gate 1 (fps)	N/A	N/A	N/A	N/A	0.0	0.2	0.2	0.3	0.3
Max Velocity through Gate 2 (fps)	N/A	N/A	N/A	N/A	N/A	N/A	N/A	N/A	N/A
Time to Drain 97% of Inflow Volume (hours)	50	66	48	62	67	56	52	43	38
Time to Drain 99% of Inflow Volume (hours)	54	72	52	67	73	67	65	60	58
Maximum Ponding Depth (ft)	0.56	0.85	0.49	0.70	0.90	1.02	1.06	1.43	1.82
Area at Maximum Ponding Depth (acres)	0.05	0.06	0.04	0.05	0.06	0.06	0.06	0.06	0.06
Maximum Volume Stored (acre-ft)	0.020	0.035	0.017	0.027	0.038	0.045	0.047	0.069	0.092

DETENTION BASIN OUTLET STRUCTURE DESIGN

MHFD-Detention, Version 4.06 (July 2022)

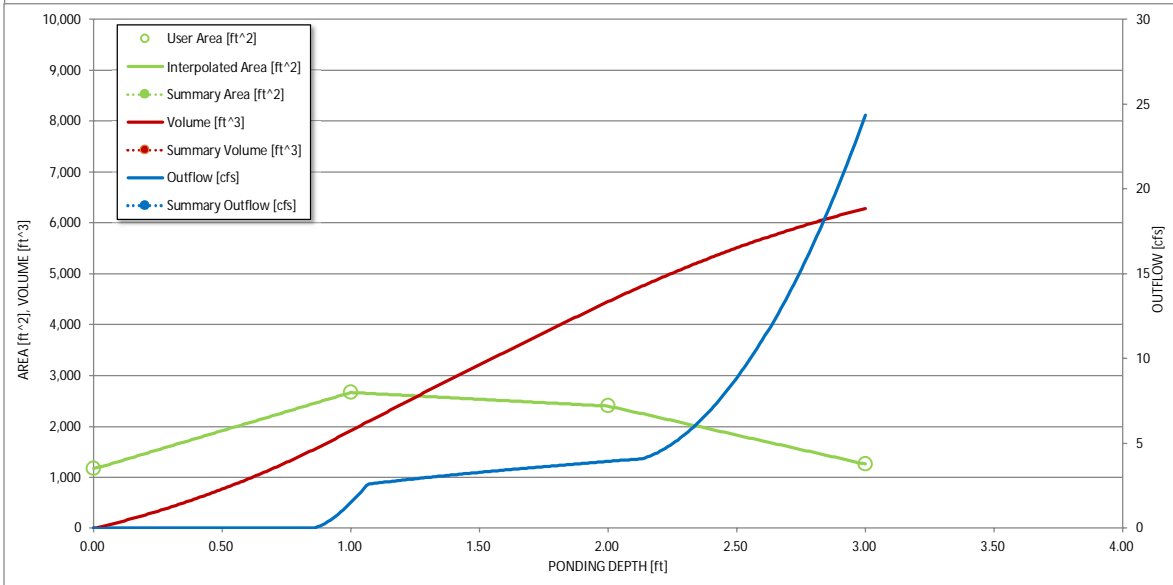
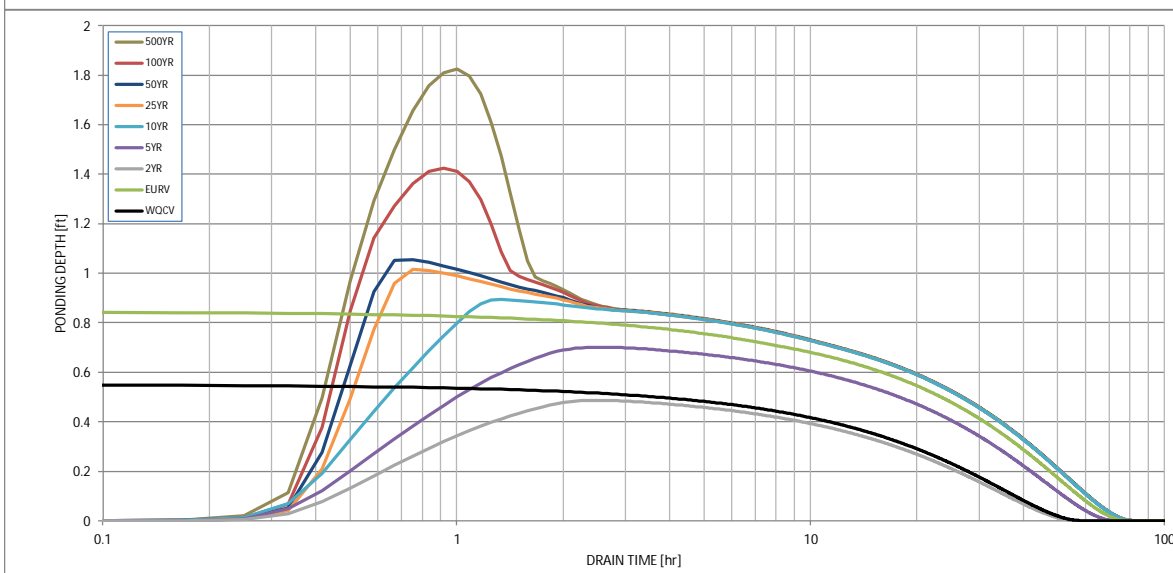
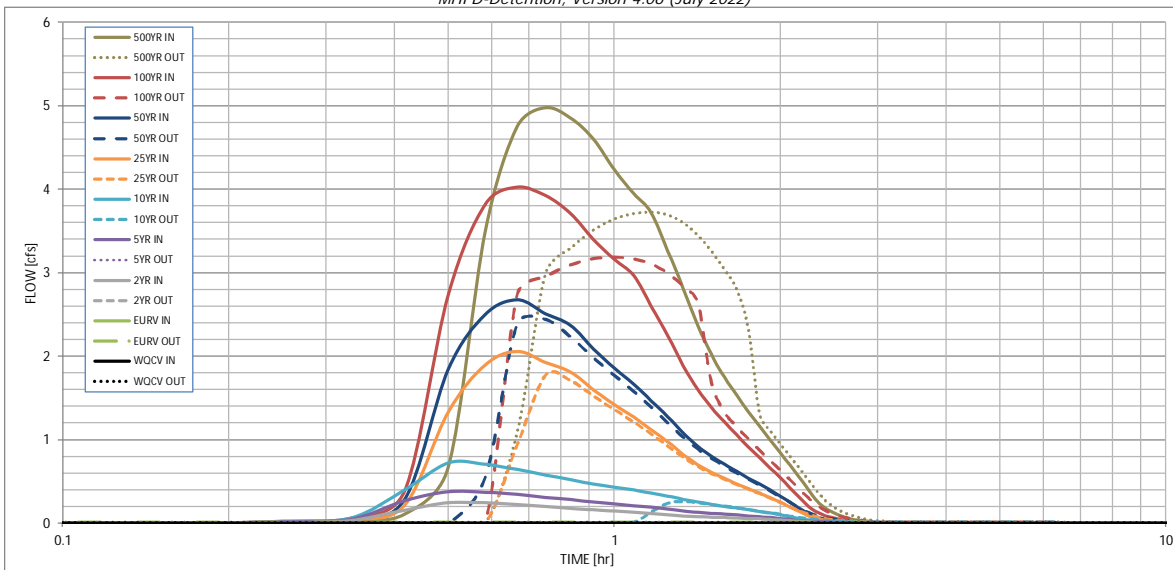

S-A-V-D Chart Axis Override	X-axis	Left Y-Axis	Right Y-Axis
minimum bound			
maximum bound			

DETENTION BASIN OUTLET STRUCTURE DESIGN

Outflow Hydrograph Workbook Filename: _____

Inflow Hydrographs

The user can override the calculated inflow hydrographs from this workbook with inflow hydrographs developed in a separate program.

Time Interval	SOURCE	CUHP	CUHP	CUHP	CUHP	CUHP	CUHP	CUHP	CUHP	CUHP
	TIME	WQCV [cfs]	EURV [cfs]	2 Year [cfs]	5 Year [cfs]	10 Year [cfs]	25 Year [cfs]	50 Year [cfs]	100 Year [cfs]	500 Year [cfs]
5.00_min	0:00:00	0.00	0.00	0.00	0.00	0.00	0.00	0.00	0.00	0.00
	0:05:00	0.00	0.00	0.00	0.00	0.00	0.00	0.00	0.00	0.00
	0:10:00	0.00	0.00	0.00	0.00	0.00	0.00	0.00	0.00	0.00
	0:15:00	0.00	0.00	0.01	0.02	0.02	0.02	0.02	0.02	0.03
	0:20:00	0.00	0.00	0.04	0.05	0.07	0.04	0.05	0.06	0.11
	0:25:00	0.00	0.00	0.16	0.27	0.40	0.21	0.29	0.39	0.67
	0:30:00	0.00	0.00	0.24	0.38	0.72	1.33	1.84	2.73	3.50
	0:35:00	0.00	0.00	0.25	0.37	0.71	1.90	2.50	3.82	4.75
	0:40:00	0.00	0.00	0.23	0.35	0.64	2.06	2.68	4.03	4.98
	0:45:00	0.00	0.00	0.20	0.31	0.58	1.93	2.51	3.93	4.86
	0:50:00	0.00	0.00	0.18	0.28	0.52	1.81	2.37	3.71	4.60
	0:55:00	0.00	0.00	0.16	0.26	0.47	1.60	2.09	3.40	4.23
	1:00:00	0.00	0.00	0.15	0.23	0.43	1.42	1.86	3.16	3.95
	1:05:00	0.00	0.00	0.13	0.21	0.40	1.27	1.67	2.97	3.72
	1:10:00	0.00	0.00	0.12	0.19	0.36	1.12	1.47	2.60	3.27
	1:15:00	0.00	0.00	0.10	0.17	0.33	0.98	1.28	2.25	2.82
	1:20:00	0.00	0.00	0.09	0.15	0.29	0.83	1.08	1.89	2.37
	1:25:00	0.00	0.00	0.08	0.13	0.25	0.70	0.93	1.60	2.02
	1:30:00	0.00	0.00	0.07	0.12	0.23	0.61	0.80	1.39	1.75
	1:35:00	0.00	0.00	0.07	0.11	0.21	0.54	0.71	1.21	1.53
	1:40:00	0.00	0.00	0.06	0.10	0.18	0.47	0.62	1.06	1.34
	1:45:00	0.00	0.00	0.06	0.09	0.16	0.42	0.54	0.92	1.16
	1:50:00	0.00	0.00	0.05	0.08	0.14	0.36	0.47	0.79	1.00
	1:55:00	0.00	0.00	0.05	0.07	0.12	0.31	0.40	0.66	0.84
	2:00:00	0.00	0.00	0.04	0.06	0.10	0.25	0.33	0.55	0.70
	2:05:00	0.00	0.00	0.03	0.05	0.08	0.20	0.25	0.43	0.55
	2:10:00	0.00	0.00	0.02	0.03	0.06	0.14	0.18	0.31	0.40
	2:15:00	0.00	0.00	0.02	0.02	0.04	0.09	0.11	0.20	0.26
	2:20:00	0.00	0.00	0.01	0.02	0.03	0.06	0.07	0.13	0.18
	2:25:00	0.00	0.00	0.01	0.02	0.03	0.04	0.05	0.09	0.12
	2:30:00	0.00	0.00	0.01	0.01	0.02	0.03	0.03	0.06	0.09
	2:35:00	0.00	0.00	0.01	0.01	0.02	0.02	0.02	0.04	0.06
	2:40:00	0.00	0.00	0.01	0.01	0.01	0.01	0.02	0.03	0.04
	2:45:00	0.00	0.00	0.00	0.01	0.01	0.01	0.01	0.02	0.02
	2:50:00	0.00	0.00	0.00	0.01	0.01	0.01	0.01	0.01	0.02
	2:55:00	0.00	0.00	0.00	0.00	0.01	0.01	0.01	0.01	0.01
	3:00:00	0.00	0.00	0.00	0.00	0.00	0.00	0.01	0.01	0.01
	3:05:00	0.00	0.00	0.00	0.00	0.00	0.00	0.00	0.00	0.01
	3:10:00	0.00	0.00	0.00	0.00	0.00	0.00	0.00	0.00	0.01
	3:15:00	0.00	0.00	0.00	0.00	0.00	0.00	0.00	0.00	0.00
	3:20:00	0.00	0.00	0.00	0.00	0.00	0.00	0.00	0.00	0.00
	3:25:00	0.00	0.00	0.00	0.00	0.00	0.00	0.00	0.00	0.00
	3:30:00	0.00	0.00	0.00	0.00	0.00	0.00	0.00	0.00	0.00
	3:35:00	0.00	0.00	0.00	0.00	0.00	0.00	0.00	0.00	0.00
	3:40:00	0.00	0.00	0.00	0.00	0.00	0.00	0.00	0.00	0.00
	3:45:00	0.00	0.00	0.00	0.00	0.00	0.00	0.00	0.00	0.00
	3:50:00	0.00	0.00	0.00	0.00	0.00	0.00	0.00	0.00	0.00
	3:55:00	0.00	0.00	0.00	0.00	0.00	0.00	0.00	0.00	0.00
	4:00:00	0.00	0.00	0.00	0.00	0.00	0.00	0.00	0.00	0.00
	4:05:00	0.00	0.00	0.00	0.00	0.00	0.00	0.00	0.00	0.00
	4:10:00	0.00	0.00	0.00	0.00	0.00	0.00	0.00	0.00	0.00
	4:15:00	0.00	0.00	0.00	0.00	0.00	0.00	0.00	0.00	0.00
	4:20:00	0.00	0.00	0.00	0.00	0.00	0.00	0.00	0.00	0.00
	4:25:00	0.00	0.00	0.00	0.00	0.00	0.00	0.00	0.00	0.00
	4:30:00	0.00	0.00	0.00	0.00	0.00	0.00	0.00	0.00	0.00
	4:35:00	0.00	0.00	0.00	0.00	0.00	0.00	0.00	0.00	0.00
	4:40:00	0.00	0.00	0.00	0.00	0.00	0.00	0.00	0.00	0.00
	4:45:00	0.00	0.00	0.00	0.00	0.00	0.00	0.00	0.00	0.00
	4:50:00	0.00	0.00	0.00	0.00	0.00	0.00	0.00	0.00	0.00
	4:55:00	0.00	0.00	0.00	0.00	0.00	0.00	0.00	0.00	0.00
	5:00:00	0.00	0.00	0.00	0.00	0.00	0.00	0.00	0.00	0.00
	5:05:00	0.00	0.00	0.00	0.00	0.00	0.00	0.00	0.00	0.00
	5:10:00	0.00	0.00	0.00	0.00	0.00	0.00	0.00	0.00	0.00
	5:15:00	0.00	0.00	0.00	0.00	0.00	0.00	0.00	0.00	0.00
	5:20:00	0.00	0.00	0.00	0.00	0.00	0.00	0.00	0.00	0.00
	5:25:00	0.00	0.00	0.00	0.00	0.00	0.00	0.00	0.00	0.00
	5:30:00	0.00	0.00	0.00	0.00	0.00	0.00	0.00	0.00	0.00
	5:35:00	0.00	0.00	0.00	0.00	0.00	0.00	0.00	0.00	0.00
	5:40:00	0.00	0.00	0.00	0.00	0.00	0.00	0.00	0.00	0.00
	5:45:00	0.00	0.00	0.00	0.00	0.00	0.00	0.00	0.00	0.00
	5:50:00	0.00	0.00	0.00	0.00	0.00	0.00	0.00	0.00	0.00
	5:55:00	0.00	0.00	0.00	0.00	0.00	0.00	0.00	0.00	0.00
	6:00:00	0.00	0.00	0.00	0.00	0.00	0.00	0.00	0.00	0.00

Design Procedure Form: Runoff Reduction

UD-BMP (Version 3.07, March 2018)

Sheet 1 of 1

Designer: Jessica McCallum, P.E.
Company: Kimley-Horn
Date: September 6, 2023
Project: Waterview East Commercial - Sub-Basin A28
Location: El Paso County

SITE INFORMATION (User Input in Blue Cells)

WQCV Rainfall Depth = 0.60 inches
 Depth of Average Runoff Producing Storm, d_6 = 0.43 inches (for Watersheds Outside of the Denver Region, Figure 3-1 in USDCM Vol. 3)

Area Type	SPA																			
Area ID	A28																			
Downstream Design Point ID	A28																			
Downstream BMP Type	RP																			
DCIA (ft ²)	--																			
UIA (ft ²)	--																			
RPA (ft ²)	--																			
SPA (ft ²)	87,847																			
HSG A (%)	100%																			
HSG B (%)	0%																			
HSG C/D (%)	0%																			
Average Slope of RPA (ft/ft)	--																			
UIA:RPA Interface Width (ft)	--																			

CALCULATED RUNOFF RESULTS

Area ID	A28																			
UIA:RPA Area (ft ²)	--																			
L / W Ratio	--																			
UIA / Area	--																			
Runoff (in)	0.00																			
Runoff (ft ³)	0																			
Runoff Reduction (ft ³)	4392																			

CALCULATED WQCV RESULTS

Area ID	A28																			
WQCV (ft ³)	0																			
WQCV Reduction (ft ³)	0																			
WQCV Reduction (%)	0%																			
Untreated WQCV (ft ³)	0																			

CALCULATED DESIGN POINT RESULTS (sums results from all columns with the same Downstream Design Point ID)

Downstream Design Point ID	A28																			
DCIA (ft ²)	0																			
UIA (ft ²)	0																			
RPA (ft ²)	0																			
SPA (ft ²)	87,847																			
Total Area (ft ²)	87,847																			
Total Impervious Area (ft ²)	0																			
WQCV (ft ³)	0																			
WQCV Reduction (ft ³)	0																			
WQCV Reduction (%)	0%																			
Untreated WQCV (ft ³)	0																			

CALCULATED SITE RESULTS (sums results from all columns in worksheet)

Total Area (ft ²)	87,847
Total Impervious Area (ft ²)	0
WQCV (ft ³)	0
WQCV Reduction (ft ³)	0
WQCV Reduction (%)	0%
Untreated WQCV (ft ³)	0

APPENDIX D – HYDRAULIC CALCULATIONS

AREA INLET IN A SWALE

Waterview East Commercial
Inlet A1

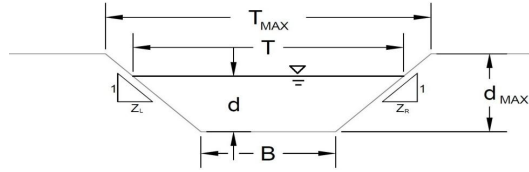

This worksheet uses the NRCS vegetative retardance method to determine Manning's n.
For more information see Section 7.2.3 of the USDCM.

Analysis of Trapezoidal Grass-Lined Channel Using SCS Method

NRCS Vegetal Retardance (A, B, C, D, or E) A, B, C, D, or E =

Manning's n (Leave cell D16 blank to manually enter an n value) n = 0.013

Channel Invert Slope S₀ = 0.0050 ft/ft

Bottom Width B = 0.00 ft

Left Side Slope Z₁ = 12.00 ft/ft

Right Side Slope Z₂ = 12.00 ft/ft

Check one of the following soil types:

Soil Type:	Max. Velocity (V _{MAX})	Max Froude No. (F _{MAX})
Non-Cohesive	5.0 fps	0.60
Cohesive	7.0 fps	0.80
Paved	N/A	N/A

Choose One:

Non-Cohesive

Cohesive

Paved

	Minor Storm	Major Storm	
Maximum Allowable Top Width of Channel for Minor & Major Storm	T _{MAX} = 10.00	10.00	ft
Maximum Allowable Water Depth in Channel for Minor & Major Storm	d _{MAX} = 0.67	0.67	ft

Allowable Channel Capacity Based On Channel Geometry

MINOR STORM Allowable Capacity is based on Top Width Criterion Minor Storm

MAJOR STORM Allowable Capacity is based on Top Width Criterion Major Storm

	Minor Storm	Major Storm	
Q _{allow}	5.9	5.9	cfs
d _{allow}	0.42	0.42	ft

Water Depth in Channel Based On Design Peak Flow

Design Peak Flow Q_o = 1.9

Water Depth d = 0.27

	Minor Storm	Major Storm	
Q _o	1.9	5.8	cfs
d	0.27	0.41	ft

Minor storm max. allowable capacity GOOD - greater than the design flow given on sheet 'Inlet Management'

Major storm max. allowable capacity GOOD - greater than the design flow given on sheet 'Inlet Management'

AREA INLET IN A SWALE

Waterview East Commercial
Inlet A1

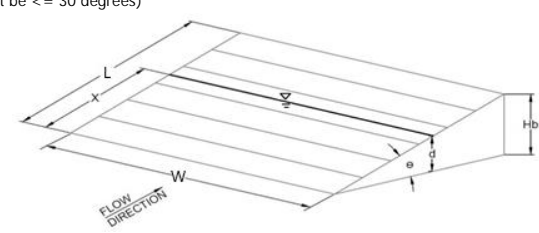
Inlet Design Information (Input)																												
Type of Inlet CDOT Type D (In Series)	Inlet Type = CDOT Type D (In Series)																											
Angle of Inclined Grate (must be ≤ 30 degrees) Width of Grate Length of Grate Open Area Ratio Height of Inclined Grate Clogging Factor Grate Discharge Coefficient Orifice Coefficient Weir Coefficient	<table style="width: 100%; border-collapse: collapse;"> <tr><td style="width: 50%;">θ =</td><td style="width: 20%; text-align: center;">0.00</td><td style="width: 30%;">degrees</td></tr> <tr><td>W =</td><td style="text-align: center;">3.00</td><td>ft</td></tr> <tr><td>L =</td><td style="text-align: center;">6.00</td><td>ft</td></tr> <tr><td>A_{RATIO} =</td><td style="text-align: center;">0.70</td><td></td></tr> <tr><td>H_B =</td><td style="text-align: center;">0.00</td><td>ft</td></tr> <tr><td>C_r =</td><td style="text-align: center;">0.38</td><td></td></tr> <tr><td>C_d =</td><td style="text-align: center;">0.78</td><td></td></tr> <tr><td>C_o =</td><td style="text-align: center;">0.52</td><td></td></tr> <tr><td>C_w =</td><td style="text-align: center;">1.67</td><td></td></tr> </table>	θ =	0.00	degrees	W =	3.00	ft	L =	6.00	ft	A_{RATIO} =	0.70		H_B =	0.00	ft	C_r =	0.38		C_d =	0.78		C_o =	0.52		C_w =	1.67	
θ =	0.00	degrees																										
W =	3.00	ft																										
L =	6.00	ft																										
A_{RATIO} =	0.70																											
H_B =	0.00	ft																										
C_r =	0.38																											
C_d =	0.78																											
C_o =	0.52																											
C_w =	1.67																											
	<table style="width: 100%; border-collapse: collapse;"> <thead> <tr> <th></th> <th style="text-align: center;">MINOR</th> <th style="text-align: center;">MAJOR</th> <th></th> </tr> </thead> <tbody> <tr> <td>d =</td> <td style="text-align: center;">0.27</td> <td style="text-align: center;">0.41</td> <td></td> </tr> <tr> <td>Q_a =</td> <td style="text-align: center;">4.2</td> <td style="text-align: center;">7.9</td> <td>cfs</td> </tr> <tr> <td>Q_b =</td> <td style="text-align: center;">0.0</td> <td style="text-align: center;">0.0</td> <td>cfs</td> </tr> <tr> <td>$C\%$ =</td> <td style="text-align: center;">100</td> <td style="text-align: center;">100</td> <td>%</td> </tr> </tbody> </table>		MINOR	MAJOR		d =	0.27	0.41		Q_a =	4.2	7.9	cfs	Q_b =	0.0	0.0	cfs	$C\%$ =	100	100	%							
	MINOR	MAJOR																										
d =	0.27	0.41																										
Q_a =	4.2	7.9	cfs																									
Q_b =	0.0	0.0	cfs																									
$C\%$ =	100	100	%																									
Water Depth at Inlet (for depressed inlets, 1 foot is added for depression) Total Inlet Interception Capacity (assumes clogged condition) Bypassed Flow Capture Percentage = Q_a/Q_o																												

AREA INLET IN A SWALE

Waterview East Commercial
Inlet A2

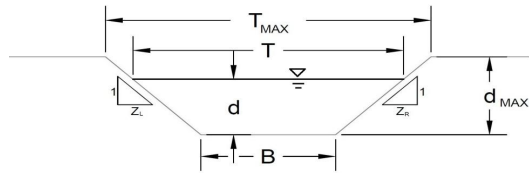

This worksheet uses the NRCS vegetative retardance method to determine Manning's n.
For more information see Section 7.2.3 of the USDCM.

Analysis of Trapezoidal Grass-Lined Channel Using SCS Method

NRCS Vegetal Retardance (A, B, C, D, or E) A, B, C, D, or E =

Manning's n (Leave cell D16 blank to manually enter an n value) n = 0.013

Channel Invert Slope S₀ = 0.0100 ft/ft

Bottom Width B = 0.00 ft

Left Side Slope Z1 = 45.00 ft/ft

Right Side Slope Z2 = 45.00 ft/ft

Check one of the following soil types:

Soil Type:	Max. Velocity (V _{MAX})	Max Froude No. (F _{MAX})
Non-Cohesive	5.0 fps	0.60
Cohesive	7.0 fps	0.80
Paved	N/A	N/A

Choose One:

Non-Cohesive

Cohesive

Paved

	Minor Storm	Major Storm	
Maximum Allowable Top Width of Channel for Minor & Major Storm	16.00	16.00	ft
Maximum Allowable Water Depth in Channel for Minor & Major Storm	0.50	0.50	ft

Allowable Channel Capacity Based On Channel Geometry

MINOR STORM Allowable Capacity is based on Top Width Criterion Minor Storm

MAJOR STORM Allowable Capacity is based on Top Width Criterion Major Storm

	Minor Storm	Major Storm	
Q _{allow}	3.2	3.2	cfs
d _{allow}	0.18	0.18	ft

Water Depth in Channel Based On Design Peak Flow

Design Peak Flow Q_o = 0.9 cfs

Water Depth d = 0.11 ft

Minor storm max. allowable capacity GOOD - greater than the design flow given on sheet 'Inlet Management'

Major storm max. allowable capacity GOOD - greater than the design flow given on sheet 'Inlet Management'

AREA INLET IN A SWALE

Waterview East Commercial
Inlet A2

Inlet Design Information (Input)	
Type of Inlet	<div style="display: flex; justify-content: space-between;"> CDOT Type D (In Series) Inlet Type = CDOT Type D (In Series) </div>
Angle of Inclined Grate (must be <= 30 degrees)	$\theta = 0.00$ degrees
Width of Grate	$W = 3.00$ ft
Length of Grate	$L = 6.00$ ft
Open Area Ratio	$A_{RATIO} = 0.70$
Height of Inclined Grate	$H_B = 0.00$ ft
Clogging Factor	$C_f = 0.38$
Grate Discharge Coefficient	$C_d = 0.78$
Orifice Coefficient	$C_o = 0.52$
Weir Coefficient	$C_w = 1.67$

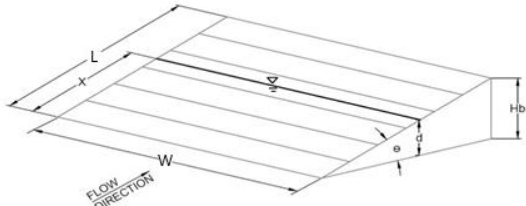

	MINOR	MAJOR	
$d =$	0.11	0.16	
$Q_a =$	1.0	1.8	cfs
$Q_b =$	0.0	0.5	cfs
$C\% =$	100	80	%

Water Depth at Inlet (for depressed inlets, 1 foot is added for depression)	$d = 0.11$	$d = 0.16$	
Total Inlet Interception Capacity (assumes clogged condition)	$Q_a = 1.0$	$Q_a = 1.8$	cfs
Bypassed Flow	$Q_b = 0.0$	$Q_b = 0.5$	cfs
Capture Percentage = Q_a/Q_o	$C\% = 100$	$C\% = 80$	%

AREA INLET IN A SWALE

Waterview East Commercial
Inlet A3

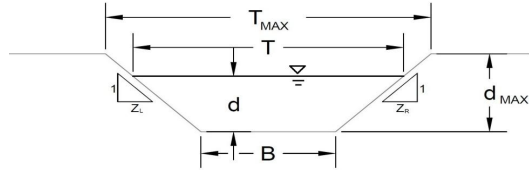

This worksheet uses the NRCS vegetative retardance method to determine Manning's n.
For more information see Section 7.2.3 of the USDCM.

Analysis of Trapezoidal Grass-Lined Channel Using SCS Method

NRCS Vegetal Retardance (A, B, C, D, or E) A, B, C, D, or E =

Manning's n (Leave cell D16 blank to manually enter an n value) n = 0.013

Channel Invert Slope S₀ = 0.0145 ft/ft

Bottom Width B = 0.00 ft

Left Side Slope Z₁ = 10.00 ft/ft

Right Side Slope Z₂ = 10.00 ft/ft

Check one of the following soil types:

Soil Type:	Max. Velocity (V _{MAX})	Max Froude No. (F _{MAX})
Non-Cohesive	5.0 fps	0.60
Cohesive	7.0 fps	0.80
Paved	N/A	N/A

Choose One:

Non-Cohesive

Cohesive

Paved

	Minor Storm	Major Storm	
Maximum Allowable Top Width of Channel for Minor & Major Storm	16.00	16.00	ft
Maximum Allowable Water Depth in Channel for Minor & Major Storm	0.50	0.50	ft

Allowable Channel Capacity Based On Channel Geometry

MINOR STORM Allowable Capacity is based on Depth Criterion

MAJOR STORM Allowable Capacity is based on Depth Criterion

	Minor Storm	Major Storm	
Q _{allow}	13.6	13.6	cfs
d _{allow}	0.50	0.50	ft

Water Depth in Channel Based On Design Peak Flow

Design Peak Flow Q_o = 1.2 cfs

Water Depth d = 0.20 ft

Minor storm max. allowable capacity GOOD - greater than the design flow given on sheet 'Inlet Management'

Major storm max. allowable capacity GOOD - greater than the design flow given on sheet 'Inlet Management'

AREA INLET IN A SWALE

Waterview East Commercial
Inlet A3

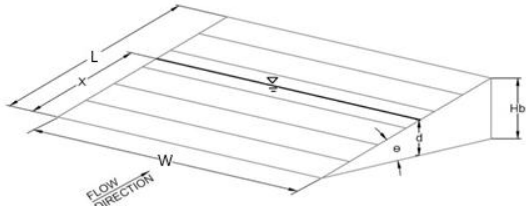
Inlet Design Information (Input)																												
Type of Inlet CDOT Type D (In Series)	Inlet Type = CDOT Type D (In Series)																											
Angle of Inclined Grate (must be ≤ 30 degrees) Width of Grate Length of Grate Open Area Ratio Height of Inclined Grate Clogging Factor Grate Discharge Coefficient Orifice Coefficient Weir Coefficient	<table border="1" style="width: 100%; border-collapse: collapse;"> <tr><td>$\theta =$</td><td style="text-align: center;">0.00</td><td>degrees</td></tr> <tr><td>$W =$</td><td style="text-align: center;">3.00</td><td>ft</td></tr> <tr><td>$L =$</td><td style="text-align: center;">6.00</td><td>ft</td></tr> <tr><td>$A_{RATIO} =$</td><td style="text-align: center;">0.70</td><td></td></tr> <tr><td>$H_B =$</td><td style="text-align: center;">0.00</td><td>ft</td></tr> <tr><td>$C_r =$</td><td style="text-align: center;">0.38</td><td></td></tr> <tr><td>$C_d =$</td><td style="text-align: center;">0.78</td><td></td></tr> <tr><td>$C_o =$</td><td style="text-align: center;">0.52</td><td></td></tr> <tr><td>$C_w =$</td><td style="text-align: center;">1.67</td><td></td></tr> </table>	$\theta =$	0.00	degrees	$W =$	3.00	ft	$L =$	6.00	ft	$A_{RATIO} =$	0.70		$H_B =$	0.00	ft	$C_r =$	0.38		$C_d =$	0.78		$C_o =$	0.52		$C_w =$	1.67	
$\theta =$	0.00	degrees																										
$W =$	3.00	ft																										
$L =$	6.00	ft																										
$A_{RATIO} =$	0.70																											
$H_B =$	0.00	ft																										
$C_r =$	0.38																											
$C_d =$	0.78																											
$C_o =$	0.52																											
$C_w =$	1.67																											
	<table border="1" style="width: 100%; border-collapse: collapse;"> <thead> <tr> <th></th> <th style="text-align: center;">MINOR</th> <th style="text-align: center;">MAJOR</th> <th></th> </tr> </thead> <tbody> <tr> <td>$d =$</td> <td style="text-align: center;">0.20</td> <td style="text-align: center;">0.28</td> <td></td> </tr> <tr> <td>$Q_a =$</td> <td style="text-align: center;">2.6</td> <td style="text-align: center;">4.3</td> <td>cfs</td> </tr> <tr> <td>$Q_b =$</td> <td style="text-align: center;">0.0</td> <td style="text-align: center;">0.0</td> <td>cfs</td> </tr> <tr> <td>$C\% =$</td> <td style="text-align: center;">100</td> <td style="text-align: center;">100</td> <td>%</td> </tr> </tbody> </table>		MINOR	MAJOR		$d =$	0.20	0.28		$Q_a =$	2.6	4.3	cfs	$Q_b =$	0.0	0.0	cfs	$C\% =$	100	100	%							
	MINOR	MAJOR																										
$d =$	0.20	0.28																										
$Q_a =$	2.6	4.3	cfs																									
$Q_b =$	0.0	0.0	cfs																									
$C\% =$	100	100	%																									
Water Depth at Inlet (for depressed inlets, 1 foot is added for depression) Total Inlet Interception Capacity (assumes clogged condition) Bypassed Flow Capture Percentage = Q_a/Q_o																												

AREA INLET IN A SWALE

Waterview East Commercial
Inlet A4

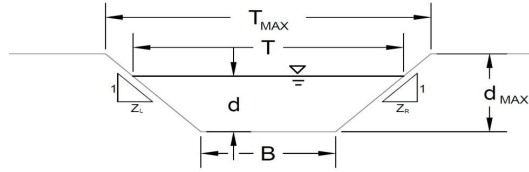

This worksheet uses the NRCS vegetative retardance method to determine Manning's n.
For more information see Section 7.2.3 of the USDCM.

Analysis of Trapezoidal Grass-Lined Channel Using SCS Method

NRCS Vegetal Retardance (A, B, C, D, or E) A, B, C, D, or E =

Manning's n (Leave cell D16 blank to manually enter an n value) n = 0.013

Channel Invert Slope S₀ = 0.0050 ft/ft

Bottom Width B = 0.00 ft

Left Side Slope Z₁ = 12.00 ft/ft

Right Side Slope Z₂ = 12.00 ft/ft

Check one of the following soil types:

Soil Type:	Max. Velocity (V _{MAX})	Max Froude No. (F _{MAX})
Non-Cohesive	5.0 fps	0.60
Cohesive	7.0 fps	0.80
Paved	N/A	N/A

Choose One:

Non-Cohesive

Cohesive

Paved

	Minor Storm	Major Storm	
Maximum Allowable Top Width of Channel for Minor & Major Storm	8.00	8.00	ft
Maximum Allowable Water Depth in Channel for Minor & Major Storm	0.50	0.50	ft

Allowable Channel Capacity Based On Channel Geometry

MINOR STORM Allowable Capacity is based on Top Width Criterion

MAJOR STORM Allowable Capacity is based on Top Width Criterion

	Minor Storm	Major Storm	
Q _{allow}	3.3	3.3	cfs
d _{allow}	0.33	0.33	ft

Water Depth in Channel Based On Design Peak Flow

Design Peak Flow Q_o = 1.0 cfs

Water Depth d = 0.22 ft

Minor storm max. allowable capacity GOOD - greater than the design flow given on sheet 'Inlet Management'

Major storm max. allowable capacity GOOD - greater than the design flow given on sheet 'Inlet Management'

AREA INLET IN A SWALE

Waterview East Commercial
Inlet A4

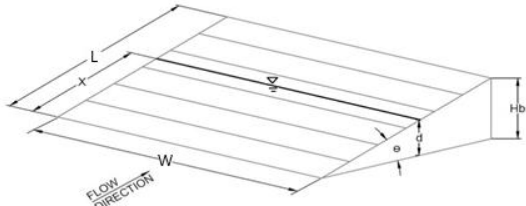
Inlet Design Information (Input)																					
Type of Inlet	<div style="border: 1px solid black; padding: 2px; display: inline-block;">CDOT Type D (In Series) ▾</div>																				
Inlet Type =	<div style="border: 1px solid black; padding: 2px; display: inline-block;">CDOT Type D (In Series)</div>																				
Angle of Inclined Grate (must be ≤ 30 degrees)	<table style="width: 100%; border-collapse: collapse;"> <tr> <td style="width: 60%;">$\theta =$</td> <td style="width: 20%; text-align: center;">0.00</td> <td style="width: 20%; text-align: right;">degrees</td> </tr> </table>	$\theta =$	0.00	degrees																	
$\theta =$	0.00	degrees																			
Width of Grate	<table style="width: 100%; border-collapse: collapse;"> <tr> <td style="width: 60%;">$W =$</td> <td style="width: 20%; text-align: center;">3.00</td> <td style="width: 20%; text-align: right;">ft</td> </tr> </table>	$W =$	3.00	ft																	
$W =$	3.00	ft																			
Length of Grate	<table style="width: 100%; border-collapse: collapse;"> <tr> <td style="width: 60%;">$L =$</td> <td style="width: 20%; text-align: center;">6.00</td> <td style="width: 20%; text-align: right;">ft</td> </tr> </table>	$L =$	6.00	ft																	
$L =$	6.00	ft																			
Open Area Ratio	<table style="width: 100%; border-collapse: collapse;"> <tr> <td style="width: 60%;">$A_{RATIO} =$</td> <td style="width: 20%; text-align: center;">0.70</td> <td style="width: 20%;"></td> </tr> </table>	$A_{RATIO} =$	0.70																		
$A_{RATIO} =$	0.70																				
Height of Inclined Grate	<table style="width: 100%; border-collapse: collapse;"> <tr> <td style="width: 60%;">$H_B =$</td> <td style="width: 20%; text-align: center;">0.00</td> <td style="width: 20%; text-align: right;">ft</td> </tr> </table>	$H_B =$	0.00	ft																	
$H_B =$	0.00	ft																			
Clogging Factor	<table style="width: 100%; border-collapse: collapse;"> <tr> <td style="width: 60%;">$C_f =$</td> <td style="width: 20%; text-align: center;">0.38</td> <td style="width: 20%;"></td> </tr> </table>	$C_f =$	0.38																		
$C_f =$	0.38																				
Grate Discharge Coefficient	<table style="width: 100%; border-collapse: collapse;"> <tr> <td style="width: 60%;">$C_d =$</td> <td style="width: 20%; text-align: center;">0.78</td> <td style="width: 20%;"></td> </tr> </table>	$C_d =$	0.78																		
$C_d =$	0.78																				
Orifice Coefficient	<table style="width: 100%; border-collapse: collapse;"> <tr> <td style="width: 60%;">$C_o =$</td> <td style="width: 20%; text-align: center;">0.52</td> <td style="width: 20%;"></td> </tr> </table>	$C_o =$	0.52																		
$C_o =$	0.52																				
Weir Coefficient	<table style="width: 100%; border-collapse: collapse;"> <tr> <td style="width: 60%;">$C_w =$</td> <td style="width: 20%; text-align: center;">1.67</td> <td style="width: 20%;"></td> </tr> </table>	$C_w =$	1.67																		
$C_w =$	1.67																				
	<table style="width: 100%; border-collapse: collapse;"> <thead> <tr> <th></th> <th style="text-align: center;">MINOR</th> <th style="text-align: center;">MAJOR</th> <th></th> </tr> </thead> <tbody> <tr> <td style="padding: 2px;">$d =$</td> <td style="text-align: center; padding: 2px;">0.22</td> <td style="text-align: center; padding: 2px;">0.30</td> <td></td> </tr> <tr> <td style="padding: 2px;">$Q_a =$</td> <td style="text-align: center; padding: 2px;">3.0</td> <td style="text-align: center; padding: 2px;">4.8</td> <td style="text-align: right; padding: 2px;">cfs</td> </tr> <tr> <td style="padding: 2px;">$Q_b =$</td> <td style="text-align: center; padding: 2px;">0.0</td> <td style="text-align: center; padding: 2px;">0.0</td> <td style="text-align: right; padding: 2px;">cfs</td> </tr> <tr> <td style="padding: 2px;">$C\% =$</td> <td style="text-align: center; padding: 2px;">100</td> <td style="text-align: center; padding: 2px;">100</td> <td style="text-align: right; padding: 2px;">%</td> </tr> </tbody> </table>		MINOR	MAJOR		$d =$	0.22	0.30		$Q_a =$	3.0	4.8	cfs	$Q_b =$	0.0	0.0	cfs	$C\% =$	100	100	%
	MINOR	MAJOR																			
$d =$	0.22	0.30																			
$Q_a =$	3.0	4.8	cfs																		
$Q_b =$	0.0	0.0	cfs																		
$C\% =$	100	100	%																		
Water Depth at Inlet (for depressed inlets, 1 foot is added for depression)																					
Total Inlet Interception Capacity (assumes clogged condition)																					
Bypassed Flow																					
Capture Percentage = Q_a/Q_o																					

ALLOWABLE CAPACITY FOR ONE-HALF OF STREET (Minor & Major Storm)

(Based on Regulated Criteria for Maximum Allowable Flow Depth and Spread)

Project: Waterview East Commercial
 Inlet ID: Inlet A5

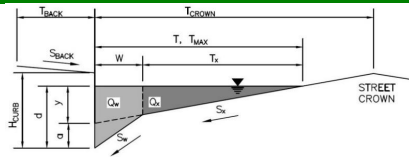

Gutter Geometry:

Maximum Allowable Width for Spread Behind Curb
 Side Slope Behind Curb (leave blank for no conveyance credit behind curb)
 Manning's Roughness Behind Curb (typically between 0.012 and 0.020)
 Height of Curb at Gutter Flow Line
 Distance from Curb Face to Street Crown
 Gutter Width
 Street Transverse Slope
 Gutter Cross Slope (typically 2 inches over 24 inches or 0.083 ft/ft)
 Street Longitudinal Slope - Enter 0 for sump condition
 Manning's Roughness for Street Section (typically between 0.012 and 0.020)

$T_{BACK} = 12.0$ ft
 $S_{BACK} =$ ft/ft
 $n_{BACK} = 0.020$

$H_{CURB} = 6.00$ inches
 $T_{CROWN} = 12.0$ ft
 $W = 3.00$ ft
 $S_X = 0.020$ ft/ft
 $S_W = 0.083$ ft/ft
 $S_0 = 0.000$ ft/ft
 $n_{STREET} = 0.016$

Max. Allowable Spread for Minor & Major Storm
 Max. Allowable Depth at Gutter Flowline for Minor & Major Storm
 Check boxes are not applicable in SUMP conditions

	Minor Storm	Major Storm	
$T_{MAX} =$	12.0	12.0	ft
$d_{MAX} =$	6.0	6.0	inches
	<input type="checkbox"/>	<input type="checkbox"/>	

[MINOR STORM Allowable Capacity is not applicable to Sump Condition](#)
[MAJOR STORM Allowable Capacity is not applicable to Sump Condition](#)

$Q_{allow} =$

Minor Storm	Major Storm
SUMP	SUMP

 cfs

INLET IN A SUMP OR SAG LOCATION

MHFD-Inlet, Version 5.02 (August 2022)

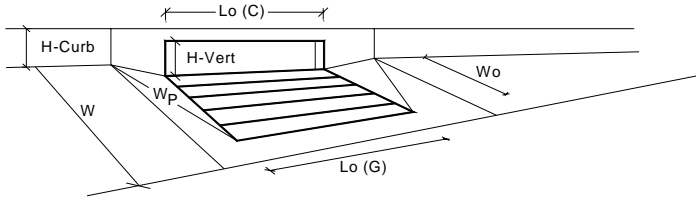

Design Information (Input)	MINOR		MAJOR		
Type of Inlet	CDOT Type R Curb Opening		CDOT Type R Curb Opening		
Local Depression (additional to continuous gutter depression 'a' from above)	3.00		3.00		inches
Number of Unit Inlets (Grate or Curb Opening)	1		1		
Water Depth at Flowline (outside of local depression)	5.1		5.1		inches
Grate Information	MINOR		MAJOR		<input type="checkbox"/> Override Depths
Length of a Unit Grate	N/A		N/A		feet
Width of a Unit Grate	N/A		N/A		feet
Open Area Ratio for a Grate (typical values 0.15-0.90)	N/A		N/A		
Clogging Factor for a Single Grate (typical value 0.50 - 0.70)	N/A		N/A		
Grate Weir Coefficient (typical value 2.15 - 3.60)	N/A		N/A		
Grate Orifice Coefficient (typical value 0.60 - 0.80)	N/A		N/A		
Curb Opening Information	MINOR		MAJOR		
Length of a Unit Curb Opening	5.00		5.00		feet
Height of Vertical Curb Opening in Inches	6.00		6.00		inches
Height of Curb Orifice Throat in Inches	6.00		6.00		inches
Angle of Throat (see USDCM Figure ST-5)	63.40		63.40		degrees
Side Width for Depression Pan (typically the gutter width of 2 feet)	3.00		3.00		feet
Clogging Factor for a Single Curb Opening (typical value 0.10)	0.10		0.10		
Curb Opening Weir Coefficient (typical value 2.3-3.7)	3.60		3.60		
Curb Opening Orifice Coefficient (typical value 0.60 - 0.70)	0.67		0.67		
Low Head Performance Reduction (Calculated)	MINOR		MAJOR		
Depth for Grate Midwidth	N/A		N/A		ft
Depth for Curb Opening Weir Equation	0.18		0.18		ft
Grated Inlet Performance Reduction Factor for Long Inlets	N/A		N/A		
Curb Opening Performance Reduction Factor for Long Inlets	1.00		1.00		
Combination Inlet Performance Reduction Factor for Long Inlets	N/A		N/A		
Total Inlet Interception Capacity (assumes clogged condition)	MINOR		MAJOR		
Inlet Capacity IS GOOD for Minor and Major Storms (>Q Peak)	2.6		2.6		cfs
	1.0		2.4		cfs

AREA INLET IN A SWALE

Waterview East Commercial
Inlet A6

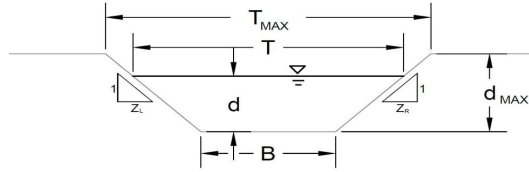

This worksheet uses the NRCS vegetative retardance method to determine Manning's n.
For more information see Section 7.2.3 of the USDCM.

Analysis of Trapezoidal Grass-Lined Channel Using SCS Method

NRCS Vegetal Retardance (A, B, C, D, or E) A, B, C, D, or E =

Manning's n (Leave cell D16 blank to manually enter an n value) n = 0.013

Channel Invert Slope S₀ = 0.0066 ft/ft

Bottom Width B = 0.00 ft

Left Side Slope Z₁ = 12.00 ft/ft

Right Side Slope Z₂ = 12.00 ft/ft

Check one of the following soil types:

Soil Type:	Max. Velocity (V _{MAX})	Max Froude No. (F _{MAX})
Non-Cohesive	5.0 fps	0.60
Cohesive	7.0 fps	0.80
Paved	N/A	N/A

Choose One:

Non-Cohesive

Cohesive

Paved

	Minor Storm	Major Storm	
Maximum Allowable Top Width of Channel for Minor & Major Storm	10.00	10.00	ft
Maximum Allowable Water Depth in Channel for Minor & Major Storm	0.67	0.67	ft

Allowable Channel Capacity Based On Channel Geometry

MINOR STORM Allowable Capacity is based on Top Width Criterion Q_{allow} = 6.8 cfs

MAJOR STORM Allowable Capacity is based on Top Width Criterion d_{allow} = 0.42 ft

Water Depth in Channel Based On Design Peak Flow

Design Peak Flow Q_o = 1.0 cfs

Water Depth d = 0.20 ft

Minor storm max. allowable capacity GOOD - greater than the design flow given on sheet 'Inlet Management'

Major storm max. allowable capacity GOOD - greater than the design flow given on sheet 'Inlet Management'

AREA INLET IN A SWALE

Waterview East Commercial
Inlet A6

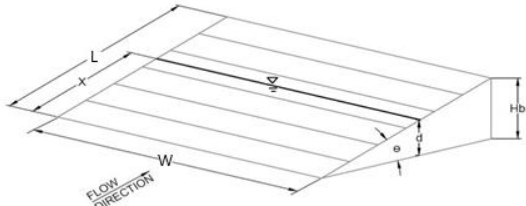
Inlet Design Information (Input)																												
Type of Inlet CDOT Type D (In Series)	Inlet Type = CDOT Type D (In Series)																											
Angle of Inclined Grate (must be ≤ 30 degrees) Width of Grate Length of Grate Open Area Ratio Height of Inclined Grate Clogging Factor Grate Discharge Coefficient Orifice Coefficient Weir Coefficient	<table border="1" style="width: 100%; border-collapse: collapse;"> <tr><td>$\theta =$</td><td style="text-align: center;">0.00</td><td>degrees</td></tr> <tr><td>$W =$</td><td style="text-align: center;">3.00</td><td>ft</td></tr> <tr><td>$L =$</td><td style="text-align: center;">6.00</td><td>ft</td></tr> <tr><td>$A_{RATIO} =$</td><td style="text-align: center;">0.70</td><td></td></tr> <tr><td>$H_B =$</td><td style="text-align: center;">0.00</td><td>ft</td></tr> <tr><td>$C_r =$</td><td style="text-align: center;">0.38</td><td></td></tr> <tr><td>$C_d =$</td><td style="text-align: center;">0.78</td><td></td></tr> <tr><td>$C_o =$</td><td style="text-align: center;">0.52</td><td></td></tr> <tr><td>$C_w =$</td><td style="text-align: center;">1.67</td><td></td></tr> </table>	$\theta =$	0.00	degrees	$W =$	3.00	ft	$L =$	6.00	ft	$A_{RATIO} =$	0.70		$H_B =$	0.00	ft	$C_r =$	0.38		$C_d =$	0.78		$C_o =$	0.52		$C_w =$	1.67	
$\theta =$	0.00	degrees																										
$W =$	3.00	ft																										
$L =$	6.00	ft																										
$A_{RATIO} =$	0.70																											
$H_B =$	0.00	ft																										
$C_r =$	0.38																											
$C_d =$	0.78																											
$C_o =$	0.52																											
$C_w =$	1.67																											
	<table border="1" style="width: 100%; border-collapse: collapse;"> <thead> <tr> <th></th> <th style="text-align: center;">MINOR</th> <th style="text-align: center;">MAJOR</th> <th></th> </tr> </thead> <tbody> <tr> <td>$d =$</td> <td style="text-align: center;">0.20</td> <td style="text-align: center;">0.28</td> <td></td> </tr> <tr> <td>$Q_a =$</td> <td style="text-align: center;">2.7</td> <td style="text-align: center;">4.3</td> <td>cfs</td> </tr> <tr> <td>$Q_b =$</td> <td style="text-align: center;">0.0</td> <td style="text-align: center;">0.0</td> <td>cfs</td> </tr> <tr> <td>$C\% =$</td> <td style="text-align: center;">100</td> <td style="text-align: center;">100</td> <td>%</td> </tr> </tbody> </table>		MINOR	MAJOR		$d =$	0.20	0.28		$Q_a =$	2.7	4.3	cfs	$Q_b =$	0.0	0.0	cfs	$C\% =$	100	100	%							
	MINOR	MAJOR																										
$d =$	0.20	0.28																										
$Q_a =$	2.7	4.3	cfs																									
$Q_b =$	0.0	0.0	cfs																									
$C\% =$	100	100	%																									
Water Depth at Inlet (for depressed inlets, 1 foot is added for depression) Total Inlet Interception Capacity (assumes clogged condition) Bypassed Flow Capture Percentage = Q_a/Q_o																												

AREA INLET IN A SWALE

Waterview East Commercial
Inlet A7

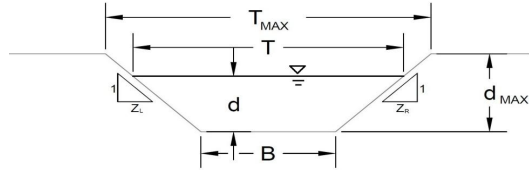

This worksheet uses the NRCS vegetative retardance method to determine Manning's n.
For more information see Section 7.2.3 of the USDCM.

Analysis of Trapezoidal Grass-Lined Channel Using SCS Method

NRCS Vegetal Retardance (A, B, C, D, or E) A, B, C, D, or E =

Manning's n (Leave cell D16 blank to manually enter an n value) n = 0.013

Channel Invert Slope S₀ = 0.0050 ft/ft

Bottom Width B = 0.00 ft

Left Side Slope Z₁ = 12.00 ft/ft

Right Side Slope Z₂ = 12.00 ft/ft

Check one of the following soil types:

Soil Type:	Max. Velocity (V _{MAX})	Max Froude No. (F _{MAX})
Non-Cohesive	5.0 fps	0.60
Cohesive	7.0 fps	0.80
Paved	N/A	N/A

Choose One:

Non-Cohesive

Cohesive

Paved

	Minor Storm	Major Storm	
Maximum Allowable Top Width of Channel for Minor & Major Storm	4.00	4.00	ft
Maximum Allowable Water Depth in Channel for Minor & Major Storm	0.33	0.33	ft

Allowable Channel Capacity Based On Channel Geometry

MINOR STORM Allowable Capacity is based on Top Width Criterion Minor Storm

MAJOR STORM Allowable Capacity is based on Top Width Criterion Major Storm

	Minor Storm	Major Storm	
Q _{allow}	0.5	0.5	cfs
d _{allow}	0.17	0.17	ft

Water Depth in Channel Based On Design Peak Flow

Design Peak Flow Q_o = 1.5 cfs

Water Depth d = 0.25 ft

WARNING: MINOR STORM max. allowable capacity is less than the design flow given on sheet 'Inlet Management'

WARNING: MAJOR STORM max. allowable capacity is less than the design flow given on sheet 'Inlet Management'

Warning 05

AREA INLET IN A SWALE

Waterview East Commercial
Inlet A7

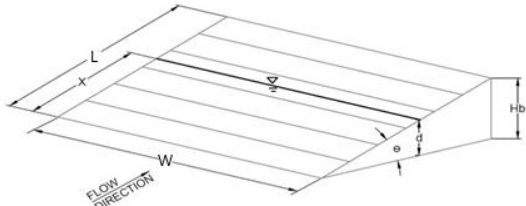
Inlet Design Information (Input)																												
Type of Inlet CDOT Type C	Inlet Type = CDOT Type C																											
Angle of Inclined Grate (must be ≤ 30 degrees) Width of Grate Length of Grate Open Area Ratio Height of Inclined Grate Clogging Factor Grate Discharge Coefficient Orifice Coefficient Weir Coefficient	<table style="width: 100%; border-collapse: collapse;"> <tr><td>$\theta =$</td><td style="text-align: center;">0.00</td><td>degrees</td></tr> <tr><td>$W =$</td><td style="text-align: center;">3.00</td><td>ft</td></tr> <tr><td>$L =$</td><td style="text-align: center;">3.00</td><td>ft</td></tr> <tr><td>$A_{RATIO} =$</td><td style="text-align: center;">0.70</td><td></td></tr> <tr><td>$H_B =$</td><td style="text-align: center;">0.00</td><td>ft</td></tr> <tr><td>$C_r =$</td><td style="text-align: center;">0.50</td><td></td></tr> <tr><td>$C_d =$</td><td style="text-align: center;">0.96</td><td></td></tr> <tr><td>$C_o =$</td><td style="text-align: center;">0.64</td><td></td></tr> <tr><td>$C_w =$</td><td style="text-align: center;">2.05</td><td></td></tr> </table>	$\theta =$	0.00	degrees	$W =$	3.00	ft	$L =$	3.00	ft	$A_{RATIO} =$	0.70		$H_B =$	0.00	ft	$C_r =$	0.50		$C_d =$	0.96		$C_o =$	0.64		$C_w =$	2.05	
$\theta =$	0.00	degrees																										
$W =$	3.00	ft																										
$L =$	3.00	ft																										
$A_{RATIO} =$	0.70																											
$H_B =$	0.00	ft																										
$C_r =$	0.50																											
$C_d =$	0.96																											
$C_o =$	0.64																											
$C_w =$	2.05																											
	<table style="width: 100%; border-collapse: collapse;"> <thead> <tr> <th></th> <th style="text-align: center;">MINOR</th> <th style="text-align: center;">MAJOR</th> <th></th> </tr> </thead> <tbody> <tr> <td>$d =$</td> <td style="text-align: center;">0.25</td> <td style="text-align: center;">0.34</td> <td></td> </tr> <tr> <td>$Q_a =$</td> <td style="text-align: center;">2.3</td> <td style="text-align: center;">3.7</td> <td>cfs</td> </tr> <tr> <td>$Q_b =$</td> <td style="text-align: center;">0.0</td> <td style="text-align: center;">0.0</td> <td>cfs</td> </tr> <tr> <td>$C\% =$</td> <td style="text-align: center;">100</td> <td style="text-align: center;">100</td> <td>%</td> </tr> </tbody> </table>		MINOR	MAJOR		$d =$	0.25	0.34		$Q_a =$	2.3	3.7	cfs	$Q_b =$	0.0	0.0	cfs	$C\% =$	100	100	%							
	MINOR	MAJOR																										
$d =$	0.25	0.34																										
$Q_a =$	2.3	3.7	cfs																									
$Q_b =$	0.0	0.0	cfs																									
$C\% =$	100	100	%																									
Water Depth at Inlet (for depressed inlets, 1 foot is added for depression) Total Inlet Interception Capacity (assumes clogged condition) Bypassed Flow Capture Percentage = Q_a/Q_o																												

Warning 05: Depth (d) exceeds max allowable depth (dmax).
Warning 06: Top Width (T) exceeds max allowable top width (Tmax).

AREA INLET IN A SWALE

Waterview East Commercial
Inlet A8

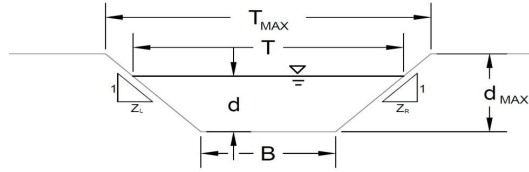

This worksheet uses the NRCS vegetative retardance method to determine Manning's n.
For more information see Section 7.2.3 of the USDCM.

Analysis of Trapezoidal Grass-Lined Channel Using SCS Method

NRCS Vegetal Retardance (A, B, C, D, or E) A, B, C, D, or E =

Manning's n (Leave cell D16 blank to manually enter an n value) n = 0.013

Channel Invert Slope S₀ = 0.0070 ft/ft

Bottom Width B = 0.00 ft

Left Side Slope Z₁ = 12.00 ft/ft

Right Side Slope Z₂ = 12.00 ft/ft

Check one of the following soil types:

Soil Type:	Max. Velocity (V _{MAX})	Max Froude No. (F _{MAX})
Non-Cohesive	5.0 fps	0.60
Cohesive	7.0 fps	0.80
Paved	N/A	N/A

Choose One:

Non-Cohesive

Cohesive

Paved

	Minor Storm	Major Storm	
Maximum Allowable Top Width of Channel for Minor & Major Storm	4.00	4.00	ft
Maximum Allowable Water Depth in Channel for Minor & Major Storm	0.33	0.33	ft

Allowable Channel Capacity Based On Channel Geometry

MINOR STORM Allowable Capacity is based on Top Width Criterion

MAJOR STORM Allowable Capacity is based on Top Width Criterion

	Minor Storm	Major Storm	
Q _{allow}	0.6	0.6	cfs
d _{allow}	0.17	0.17	ft

Water Depth in Channel Based On Design Peak Flow

Design Peak Flow

Water Depth

	Minor Storm	Major Storm	
Q _o	1.7	4.0	cfs
d	0.25	0.34	ft

WARNING: MINOR STORM max. allowable capacity is less than the design flow given on sheet 'Inlet Management'

WARNING: MAJOR STORM max. allowable capacity is less than the design flow given on sheet 'Inlet Management'

Warning 05

AREA INLET IN A SWALE

Waterview East Commercial
Inlet A8

Inlet Design Information (Input)

Type of Inlet: CDOT Type C (Depresser) Inlet Type = CDOT Type C (Depressed)

Angle of Inclined Gate (must be ≤ 30 degrees) $\theta = 0.00$ degrees

Width of Gate $W = 3.00$ ft

Length of Gate $L = 3.00$ ft

Open Area Ratio $A_{RATIO} = 0.70$

Height of Inclined Gate $H_B = 0.00$ ft

Clogging Factor $C_r = 0.50$

Grate Discharge Coefficient $C_d = 0.84$

Orifice Coefficient $C_o = 0.56$

Weir Coefficient $C_w = 1.81$

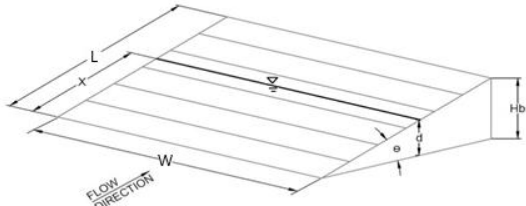

Water Depth at Inlet (for depressed inlets, 1 foot is added for depression)

	MINOR	MAJOR	
$d =$	1.25	1.34	
$Q_a =$	15.9	16.4	cfs
$Q_b =$	0.0	0.0	cfs
$C\% =$	100	100	%

Total Inlet Interception Capacity (assumes clogged condition)

Bypassed Flow

Capture Percentage = Q_a/Q_o

Warning 05: Depth (d) exceeds max allowable depth (dmax).
Warning 06: Top Width (T) exceeds max allowable top width (Tmax).

AREA INLET IN A SWALE

Waterview East Commercial
Inlet A9

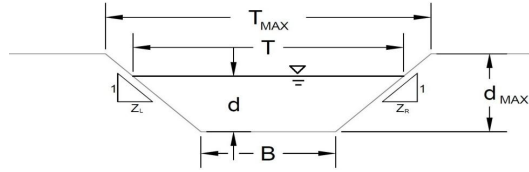

This worksheet uses the NRCS vegetative retardance method to determine Manning's n.
For more information see Section 7.2.3 of the USDCM.

Analysis of Trapezoidal Grass-Lined Channel Using SCS Method

NRCS Vegetal Retardance (A, B, C, D, or E) A, B, C, D, or E =

Manning's n (Leave cell D16 blank to manually enter an n value) n = 0.013

Channel Invert Slope S₀ = 0.0260 ft/ft

Bottom Width B = 0.00 ft

Left Side Slope Z₁ = 12.00 ft/ft

Right Side Slope Z₂ = 12.00 ft/ft

Check one of the following soil types:

Soil Type:	Max. Velocity (V _{max})	Max Froude No. (F _{max})
Non-Cohesive	5.0 fps	0.60
Cohesive	7.0 fps	0.80
Paved	N/A	N/A

Choose One:

Non-Cohesive

Cohesive

Paved

	Minor Storm	Major Storm	
Maximum Allowable Top Width of Channel for Minor & Major Storm	4.00	4.00	ft
Maximum Allowable Water Depth in Channel for Minor & Major Storm	0.33	0.33	ft

Allowable Channel Capacity Based On Channel Geometry

MINOR STORM Allowable Capacity is based on Top Width Criterion Minor Storm

MAJOR STORM Allowable Capacity is based on Top Width Criterion Major Storm

	Minor Storm	Major Storm	
Q _{allow}	1.2	1.2	cfs
d _{allow}	0.17	0.17	ft

Water Depth in Channel Based On Design Peak Flow

Design Peak Flow Q_o = 1.7 cfs

Water Depth d = 0.19 ft

WARNING: MINOR STORM max. allowable capacity is less than the design flow given on sheet 'Inlet Management'

WARNING: MAJOR STORM max. allowable capacity is less than the design flow given on sheet 'Inlet Management'

AREA INLET IN A SWALE

Waterview East Commercial
Inlet A9

Inlet Design Information (Input)

Type of Inlet: CDOT Type C (Depressed) Inlet Type = CDOT Type C (Depressed)

Angle of Inclined Grate (must be ≤ 30 degrees) $\theta = 0.00$ degrees

Width of Grate $W = 3.00$ ft

Length of Grate $L = 3.00$ ft

Open Area Ratio $A_{RATIO} = 0.70$

Height of Inclined Grate $H_B = 0.00$ ft

Clogging Factor $C_r = 0.50$

Grate Discharge Coefficient $C_d = 0.84$

Orifice Coefficient $C_o = 0.56$

Weir Coefficient $C_w = 1.81$

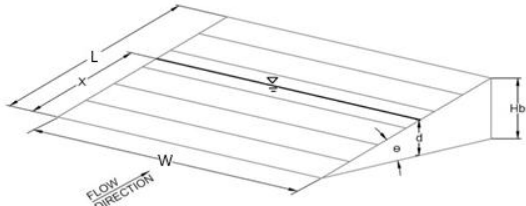

Water Depth at Inlet (for depressed inlets, 1 foot is added for depression)

	MINOR	MAJOR	
$d =$	1.19	1.26	
$Q_a =$	15.5	16.0	cfs
$Q_b =$	0.0	0.0	cfs
$C\% =$	100	100	%

Total Inlet Interception Capacity (assumes clogged condition)

Bypassed Flow

Capture Percentage = Q_a/Q_o

Warning 06: Top Width (T) exceeds max allowable top width (Tmax).

ALLOWABLE CAPACITY FOR ONE-HALF OF STREET (Minor & Major Storm)

(Based on Regulated Criteria for Maximum Allowable Flow Depth and Spread)

Project: Waterview East Commercial
 Inlet ID: Inlet A10

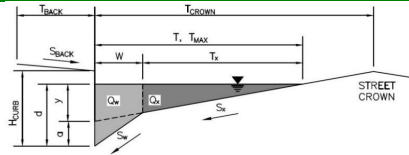

Gutter Geometry:

Maximum Allowable Width for Spread Behind Curb
 Side Slope Behind Curb (leave blank for no conveyance credit behind curb)
 Manning's Roughness Behind Curb (typically between 0.012 and 0.020)

$T_{BACK} = 12.0$ ft
 $S_{BACK} =$ ft/ft
 $n_{BACK} = 0.020$

Height of Curb at Gutter Flow Line
 Distance from Curb Face to Street Crown
 Gutter Width
 Street Transverse Slope
 Gutter Cross Slope (typically 2 inches over 24 inches or 0.083 ft/ft)
 Street Longitudinal Slope - Enter 0 for sump condition
 Manning's Roughness for Street Section (typically between 0.012 and 0.020)

$H_{CURB} = 6.00$ inches
 $T_{CROWN} = 12.0$ ft
 $W = 3.00$ ft
 $S_X = 0.020$ ft/ft
 $S_W = 0.083$ ft/ft
 $S_0 = 0.000$ ft/ft
 $n_{STREET} = 0.016$

Max. Allowable Spread for Minor & Major Storm
 Max. Allowable Depth at Gutter Flowline for Minor & Major Storm
 Check boxes are not applicable in SUMP conditions

	Minor Storm	Major Storm	
$T_{MAX} =$	12.0	12.0	ft
$d_{MAX} =$	6.0	6.0	inches
	<input type="checkbox"/>	<input type="checkbox"/>	

[MINOR STORM Allowable Capacity is not applicable to Sump Condition](#)
[MAJOR STORM Allowable Capacity is not applicable to Sump Condition](#)

$Q_{allow} =$

Minor Storm	Major Storm
SUMP	SUMP

 cfs

INLET IN A SUMP OR SAG LOCATION

MHFD-Inlet, Version 5.02 (August 2022)

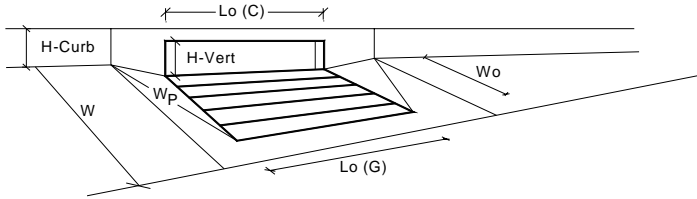

Design Information (Input)	MINOR	MAJOR	
Type of Inlet	CDOT Type R Curb Opening		
Local Depression (additional to continuous gutter depression 'a' from above)	3.00	3.00	inches
Number of Unit Inlets (Grate or Curb Opening)	1	1	
Water Depth at Flowline (outside of local depression)	6.0	6.0	inches
Grate Information	MINOR	MAJOR	<input checked="" type="checkbox"/> Override Depths
Length of a Unit Grate	N/A	N/A	feet
Width of a Unit Grate	N/A	N/A	feet
Open Area Ratio for a Grate (typical values 0.15-0.90)	N/A	N/A	
Clogging Factor for a Single Grate (typical value 0.50 - 0.70)	N/A	N/A	
Grate Weir Coefficient (typical value 2.15 - 3.60)	N/A	N/A	
Grate Orifice Coefficient (typical value 0.60 - 0.80)	N/A	N/A	
Curb Opening Information	MINOR	MAJOR	
Length of a Unit Curb Opening	10.00	10.00	feet
Height of Vertical Curb Opening in Inches	6.00	6.00	inches
Height of Curb Orifice Throat in Inches	6.00	6.00	inches
Angle of Throat (see USDCM Figure ST-5)	63.40	63.40	degrees
Side Width for Depression Pan (typically the gutter width of 2 feet)	3.00	3.00	feet
Clogging Factor for a Single Curb Opening (typical value 0.10)	0.10	0.10	
Curb Opening Weir Coefficient (typical value 2.3-3.7)	3.60	3.60	
Curb Opening Orifice Coefficient (typical value 0.60 - 0.70)	0.67	0.67	
Low Head Performance Reduction (Calculated)	MINOR	MAJOR	
Depth for Grate Midwidth	N/A	N/A	ft
Depth for Curb Opening Weir Equation	0.25	0.25	ft
Grated Inlet Performance Reduction Factor for Long Inlets	N/A	N/A	
Curb Opening Performance Reduction Factor for Long Inlets	0.93	0.93	
Combination Inlet Performance Reduction Factor for Long Inlets	N/A	N/A	
Total Inlet Interception Capacity (assumes clogged condition)	MINOR	MAJOR	
Inlet Capacity IS GOOD for Minor and Major Storms (>Q Peak)	6.1	6.1	cfs
Q PEAK REQUIRED =	2.1	5.0	cfs

AREA INLET IN A SWALE

Waterview East Commercial
Inlet A11

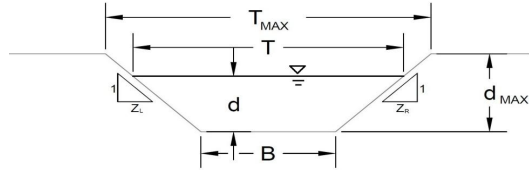

This worksheet uses the NRCS vegetative retardance method to determine Manning's n.
For more information see Section 7.2.3 of the USDCM.

Analysis of Trapezoidal Grass-Lined Channel Using SCS Method

NRCS Vegetal Retardance (A, B, C, D, or E) A, B, C, D, or E =

Manning's n (Leave cell D16 blank to manually enter an n value) n = 0.013

Channel Invert Slope S₀ = 0.0050 ft/ft

Bottom Width B = 0.00 ft

Left Side Slope Z₁ = 12.00 ft/ft

Right Side Slope Z₂ = 12.00 ft/ft

Check one of the following soil types:

Soil Type:	Max. Velocity (V _{max})	Max Froude No. (F _{max})
Non-Cohesive	5.0 fps	0.60
Cohesive	7.0 fps	0.80
Paved	N/A	N/A

Choose One:

Non-Cohesive

Cohesive

Paved

	Minor Storm	Major Storm	
Maximum Allowable Top Width of Channel for Minor & Major Storm	8.00	8.00	ft
Maximum Allowable Water Depth in Channel for Minor & Major Storm	0.67	0.67	ft

Allowable Channel Capacity Based On Channel Geometry

MINOR STORM Allowable Capacity is based on Top Width Criterion Minor Storm

MAJOR STORM Allowable Capacity is based on Top Width Criterion Major Storm

	Minor Storm	Major Storm	
Q _{allow}	3.3	3.3	cfs
d _{allow}	0.33	0.33	ft

Water Depth in Channel Based On Design Peak Flow

Design Peak Flow Q_o = 0.6 cfs

Water Depth d = 0.18 ft

Minor storm max. allowable capacity GOOD - greater than the design flow given on sheet 'Inlet Management'

Major storm max. allowable capacity GOOD - greater than the design flow given on sheet 'Inlet Management'

AREA INLET IN A SWALE

Waterview East Commercial
Inlet A11

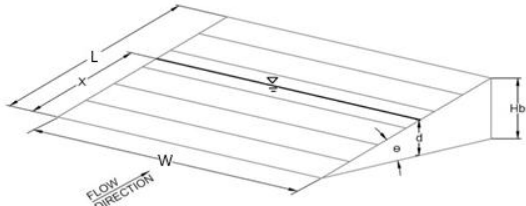
Inlet Design Information (Input)																												
Type of Inlet CDOT Type D (In Series)	Inlet Type = CDOT Type D (In Series)																											
Angle of Inclined Grate (must be ≤ 30 degrees) Width of Grate Length of Grate Open Area Ratio Height of Inclined Grate Clogging Factor Grate Discharge Coefficient Orifice Coefficient Weir Coefficient	<table style="width: 100%; border-collapse: collapse;"> <tr><td>θ =</td><td style="text-align: center;">0.00</td><td>degrees</td></tr> <tr><td>W =</td><td style="text-align: center;">3.00</td><td>ft</td></tr> <tr><td>L =</td><td style="text-align: center;">6.00</td><td>ft</td></tr> <tr><td>A_{RATIO} =</td><td style="text-align: center;">0.70</td><td></td></tr> <tr><td>H_B =</td><td style="text-align: center;">0.00</td><td>ft</td></tr> <tr><td>C_r =</td><td style="text-align: center;">0.38</td><td></td></tr> <tr><td>C_d =</td><td style="text-align: center;">0.78</td><td></td></tr> <tr><td>C_o =</td><td style="text-align: center;">0.52</td><td></td></tr> <tr><td>C_w =</td><td style="text-align: center;">1.67</td><td></td></tr> </table>	θ =	0.00	degrees	W =	3.00	ft	L =	6.00	ft	A _{RATIO} =	0.70		H _B =	0.00	ft	C _r =	0.38		C _d =	0.78		C _o =	0.52		C _w =	1.67	
θ =	0.00	degrees																										
W =	3.00	ft																										
L =	6.00	ft																										
A _{RATIO} =	0.70																											
H _B =	0.00	ft																										
C _r =	0.38																											
C _d =	0.78																											
C _o =	0.52																											
C _w =	1.67																											
	<table style="width: 100%; border-collapse: collapse;"> <thead> <tr> <th></th> <th style="text-align: center;">MINOR</th> <th style="text-align: center;">MAJOR</th> <th></th> </tr> </thead> <tbody> <tr> <td>d =</td> <td style="text-align: center;">0.18</td> <td style="text-align: center;">0.25</td> <td></td> </tr> <tr> <td>Q_a =</td> <td style="text-align: center;">2.2</td> <td style="text-align: center;">3.8</td> <td>cfs</td> </tr> <tr> <td>Q_b =</td> <td style="text-align: center;">0.0</td> <td style="text-align: center;">0.0</td> <td>cfs</td> </tr> <tr> <td>C% =</td> <td style="text-align: center;">100</td> <td style="text-align: center;">100</td> <td>%</td> </tr> </tbody> </table>		MINOR	MAJOR		d =	0.18	0.25		Q _a =	2.2	3.8	cfs	Q _b =	0.0	0.0	cfs	C% =	100	100	%							
	MINOR	MAJOR																										
d =	0.18	0.25																										
Q _a =	2.2	3.8	cfs																									
Q _b =	0.0	0.0	cfs																									
C% =	100	100	%																									
Water Depth at Inlet (for depressed inlets, 1 foot is added for depression) Total Inlet Interception Capacity (assumes clogged condition) Bypassed Flow Capture Percentage = Q _a /Q _o																												

ALLOWABLE CAPACITY FOR ONE-HALF OF STREET (Minor & Major Storm)

(Based on Regulated Criteria for Maximum Allowable Flow Depth and Spread)

Project: Waterview East Commercial
 Inlet ID: Inlet A12

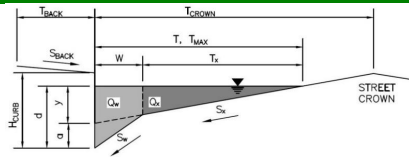

Gutter Geometry:

Maximum Allowable Width for Spread Behind Curb
 Side Slope Behind Curb (leave blank for no conveyance credit behind curb)
 Manning's Roughness Behind Curb (typically between 0.012 and 0.020)

$T_{BACK} = 12.0$ ft
 $S_{BACK} =$ ft/ft
 $n_{BACK} = 0.020$

Height of Curb at Gutter Flow Line
 Distance from Curb Face to Street Crown
 Gutter Width
 Street Transverse Slope
 Gutter Cross Slope (typically 2 inches over 24 inches or 0.083 ft/ft)
 Street Longitudinal Slope - Enter 0 for sump condition
 Manning's Roughness for Street Section (typically between 0.012 and 0.020)

$H_{CURB} = 6.00$ inches
 $T_{CROWN} = 12.0$ ft
 $W = 3.00$ ft
 $S_X = 0.020$ ft/ft
 $S_W = 0.083$ ft/ft
 $S_0 = 0.000$ ft/ft
 $n_{STREET} = 0.016$

Max. Allowable Spread for Minor & Major Storm
 Max. Allowable Depth at Gutter Flowline for Minor & Major Storm
 Check boxes are not applicable in SUMP conditions

	Minor Storm	Major Storm	
$T_{MAX} =$	12.0	12.0	ft
$d_{MAX} =$	6.0	6.0	inches
	<input type="checkbox"/>	<input type="checkbox"/>	

[MINOR STORM Allowable Capacity is not applicable to Sump Condition](#)
[MAJOR STORM Allowable Capacity is not applicable to Sump Condition](#)

$Q_{allow} =$

Minor Storm	Major Storm
SUMP	SUMP

 cfs

INLET IN A SUMP OR SAG LOCATION

MHFD-Inlet, Version 5.02 (August 2022)

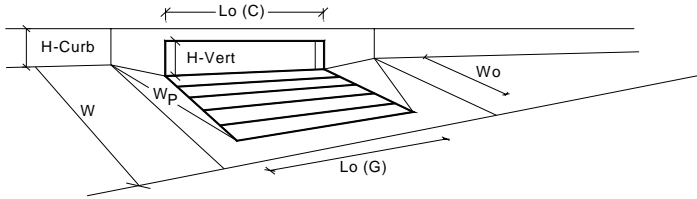

Design Information (Input)	MINOR		MAJOR	
Type of Inlet	CDOT Type R Curb Opening			
Local Depression (additional to continuous gutter depression 'a' from above)	3.00	3.00	inches	
Number of Unit Inlets (Grate or Curb Opening)	1			
Water Depth at Flowline (outside of local depression)	6.0	6.0	inches	
<u>Grate Information</u>	MINOR		MAJOR	
Length of a Unit Grate	N/A	N/A	<input checked="" type="checkbox"/> Override Depths	
Width of a Unit Grate	N/A	N/A	feet	
Open Area Ratio for a Grate (typical values 0.15-0.90)	N/A	N/A		
Clogging Factor for a Single Grate (typical value 0.50 - 0.70)	N/A	N/A		
Grate Weir Coefficient (typical value 2.15 - 3.60)	N/A	N/A		
Grate Orifice Coefficient (typical value 0.60 - 0.80)	N/A	N/A		
<u>Curb Opening Information</u>	MINOR		MAJOR	
Length of a Unit Curb Opening	10.00	10.00	feet	
Height of Vertical Curb Opening in Inches	6.00	6.00	inches	
Height of Curb Orifice Throat in Inches	6.00	6.00	inches	
Angle of Throat (see USDCM Figure ST-5)	63.40	63.40	degrees	
Side Width for Depression Pan (typically the gutter width of 2 feet)	3.00	3.00	feet	
Clogging Factor for a Single Curb Opening (typical value 0.10)	0.10	0.10		
Curb Opening Weir Coefficient (typical value 2.3-3.7)	3.60	3.60		
Curb Opening Orifice Coefficient (typical value 0.60 - 0.70)	0.67	0.67		
<u>Low Head Performance Reduction (Calculated)</u>	MINOR		MAJOR	
Depth for Grate Midwidth	N/A	N/A	ft	
Depth for Curb Opening Weir Equation	0.25	0.25	ft	
Grated Inlet Performance Reduction Factor for Long Inlets	N/A	N/A		
Curb Opening Performance Reduction Factor for Long Inlets	0.93	0.93		
Combination Inlet Performance Reduction Factor for Long Inlets	N/A	N/A		
Total Inlet Interception Capacity (assumes clogged condition)	MINOR		MAJOR	
WARNING: Inlet Capacity < Q Peak for Major Storm	6.1	6.1	cfs	
$Q_{PEAK\ REQUIRED}$	2.6	6.3	cfs	

AREA INLET IN A SWALE

Waterview East Commercial
Inlet A13

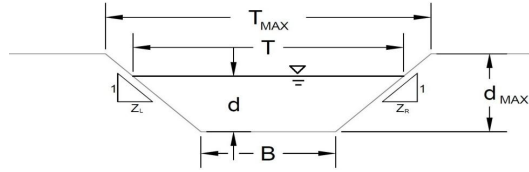

This worksheet uses the NRCS vegetative retardance method to determine Manning's n.
For more information see Section 7.2.3 of the USDCM.

Analysis of Trapezoidal Grass-Lined Channel Using SCS Method

NRCS Vegetal Retardance (A, B, C, D, or E) A, B, C, D, or E =

Manning's n (Leave cell D16 blank to manually enter an n value) n = 0.130

Channel Invert Slope S₀ = 0.0050 ft/ft

Bottom Width B = 0.00 ft

Left Side Slope Z₁ = 12.00 ft/ft

Right Side Slope Z₂ = 12.00 ft/ft

Check one of the following soil types:

Soil Type:	Max. Velocity (V _{MAX})	Max Froude No. (F _{MAX})
Non-Cohesive	5.0 fps	0.60
Cohesive	7.0 fps	0.80
Paved	N/A	N/A

Choose One:

Non-Cohesive

Cohesive

Paved

	Minor Storm	Major Storm	
Maximum Allowable Top Width of Channel for Minor & Major Storm	15.00	15.00	ft
Maximum Allowable Water Depth in Channel for Minor & Major Storm	0.69	0.69	ft

Allowable Channel Capacity Based On Channel Geometry

MINOR STORM Allowable Capacity is based on Top Width Criterion Q_{allow} = 1.7 cfs

MAJOR STORM Allowable Capacity is based on Top Width Criterion d_{allow} = 0.63 ft

Water Depth in Channel Based On Design Peak Flow

Design Peak Flow Q_o = 0.9 cfs

Water Depth d = 0.50 ft

Warning 05

Minor storm max. allowable capacity GOOD - greater than the design flow given on sheet 'Inlet Management'

WARNING: MAJOR STORM max. allowable capacity is less than the design flow given on sheet 'Inlet Management'

AREA INLET IN A SWALE

Waterview East Commercial
Inlet A13

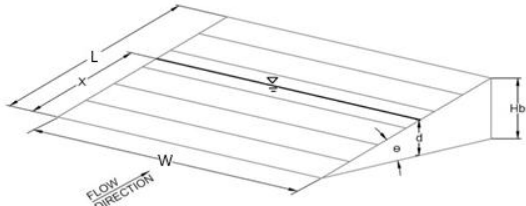
Inlet Design Information (Input)																												
Type of Inlet CDOT Type C	Inlet Type = CDOT Type C																											
Angle of Inclined Grate (must be ≤ 30 degrees) Width of Grate Length of Grate Open Area Ratio Height of Inclined Grate Clogging Factor Grate Discharge Coefficient Orifice Coefficient Weir Coefficient	<table style="width: 100%; border-collapse: collapse;"> <tr><td>$\theta =$</td><td style="text-align: center;">0.00</td><td>degrees</td></tr> <tr><td>$W =$</td><td style="text-align: center;">3.00</td><td>ft</td></tr> <tr><td>$L =$</td><td style="text-align: center;">3.00</td><td>ft</td></tr> <tr><td>$A_{RATIO} =$</td><td style="text-align: center;">0.70</td><td></td></tr> <tr><td>$H_B =$</td><td style="text-align: center;">0.00</td><td>ft</td></tr> <tr><td>$C_r =$</td><td style="text-align: center;">0.50</td><td></td></tr> <tr><td>$C_d =$</td><td style="text-align: center;">0.96</td><td></td></tr> <tr><td>$C_o =$</td><td style="text-align: center;">0.64</td><td></td></tr> <tr><td>$C_w =$</td><td style="text-align: center;">2.05</td><td></td></tr> </table>	$\theta =$	0.00	degrees	$W =$	3.00	ft	$L =$	3.00	ft	$A_{RATIO} =$	0.70		$H_B =$	0.00	ft	$C_r =$	0.50		$C_d =$	0.96		$C_o =$	0.64		$C_w =$	2.05	
$\theta =$	0.00	degrees																										
$W =$	3.00	ft																										
$L =$	3.00	ft																										
$A_{RATIO} =$	0.70																											
$H_B =$	0.00	ft																										
$C_r =$	0.50																											
$C_d =$	0.96																											
$C_o =$	0.64																											
$C_w =$	2.05																											
	<table style="width: 100%; border-collapse: collapse;"> <thead> <tr> <th></th> <th style="text-align: center;">MINOR</th> <th style="text-align: center;">MAJOR</th> <th></th> </tr> </thead> <tbody> <tr> <td>$d =$</td> <td style="text-align: center;">0.50</td> <td style="text-align: center;">0.70</td> <td></td> </tr> <tr> <td>$Q_a =$</td> <td style="text-align: center;">6.4</td> <td style="text-align: center;">10.7</td> <td>cfs</td> </tr> <tr> <td>$Q_b =$</td> <td style="text-align: center;">0.0</td> <td style="text-align: center;">0.0</td> <td>cfs</td> </tr> <tr> <td>$C\% =$</td> <td style="text-align: center;">100</td> <td style="text-align: center;">100</td> <td>%</td> </tr> </tbody> </table>		MINOR	MAJOR		$d =$	0.50	0.70		$Q_a =$	6.4	10.7	cfs	$Q_b =$	0.0	0.0	cfs	$C\% =$	100	100	%							
	MINOR	MAJOR																										
$d =$	0.50	0.70																										
$Q_a =$	6.4	10.7	cfs																									
$Q_b =$	0.0	0.0	cfs																									
$C\% =$	100	100	%																									
Water Depth at Inlet (for depressed inlets, 1 foot is added for depression) Total Inlet Interception Capacity (assumes clogged condition) Bypassed Flow Capture Percentage = Q_a/Q_o																												

Warning 05: Depth (d) exceeds max allowable depth (dmax).
Warning 06: Top Width (T) exceeds max allowable top width (Tmax).

AREA INLET IN A SWALE

Waterview East Commercial
Inlet A14

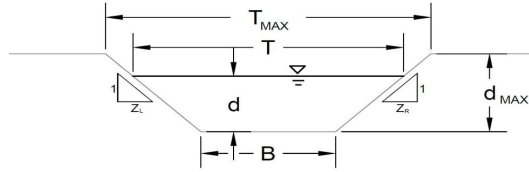

This worksheet uses the NRCS vegetative retardance method to determine Manning's n.
For more information see Section 7.2.3 of the USDCM.

Analysis of Trapezoidal Grass-Lined Channel Using SCS Method

NRCS Vegetal Retardance (A, B, C, D, or E) A, B, C, D, or E =

Manning's n (Leave cell D16 blank to manually enter an n value) n = 0.013

Channel Invert Slope S₀ = 0.0050 ft/ft

Bottom Width B = 0.00 ft

Left Side Slope Z₁ = 12.00 ft/ft

Right Side Slope Z₂ = 12.00 ft/ft

Check one of the following soil types:

Soil Type:	Max. Velocity (V _{MAX})	Max Froude No. (F _{MAX})
Non-Cohesive	5.0 fps	0.60
Cohesive	7.0 fps	0.80
Paved	N/A	N/A

Choose One:

Non-Cohesive

Cohesive

Paved

	Minor Storm	Major Storm	
Maximum Allowable Top Width of Channel for Minor & Major Storm	20.00	20.00	ft
Maximum Allowable Water Depth in Channel for Minor & Major Storm	0.50	0.50	ft

Allowable Channel Capacity Based On Channel Geometry

MINOR STORM Allowable Capacity is based on Depth Criterion

MAJOR STORM Allowable Capacity is based on Depth Criterion

	Minor Storm	Major Storm	
Q _{allow}	9.6	9.6	cfs
d _{allow}	0.50	0.50	ft

Water Depth in Channel Based On Design Peak Flow

Design Peak Flow

Water Depth

	Minor Storm	Major Storm	
Q _o	1.1	2.6	cfs
d	0.22	0.31	ft

Minor storm max. allowable capacity GOOD - greater than the design flow given on sheet 'Inlet Management'

Major storm max. allowable capacity GOOD - greater than the design flow given on sheet 'Inlet Management'

AREA INLET IN A SWALE

Waterview East Commercial
Inlet A14

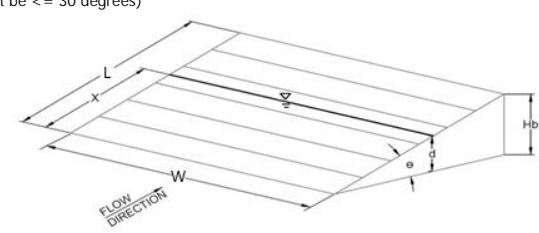
Inlet Design Information (Input)																												
Type of Inlet CDOT Type C	Inlet Type = CDOT Type C																											
Angle of Inclined Grate (must be ≤ 30 degrees) Width of Grate Length of Grate Open Area Ratio Height of Inclined Grate Clogging Factor Grate Discharge Coefficient Orifice Coefficient Weir Coefficient	<table style="width: 100%; border-collapse: collapse;"> <tr><td>θ =</td><td style="text-align: center;">0.00</td><td>degrees</td></tr> <tr><td>W =</td><td style="text-align: center;">3.00</td><td>ft</td></tr> <tr><td>L =</td><td style="text-align: center;">3.00</td><td>ft</td></tr> <tr><td>A_{RATIO} =</td><td style="text-align: center;">0.70</td><td></td></tr> <tr><td>H_B =</td><td style="text-align: center;">0.00</td><td>ft</td></tr> <tr><td>C_r =</td><td style="text-align: center;">0.50</td><td></td></tr> <tr><td>C_d =</td><td style="text-align: center;">0.96</td><td></td></tr> <tr><td>C_o =</td><td style="text-align: center;">0.64</td><td></td></tr> <tr><td>C_w =</td><td style="text-align: center;">2.05</td><td></td></tr> </table>	θ =	0.00	degrees	W =	3.00	ft	L =	3.00	ft	A _{RATIO} =	0.70		H _B =	0.00	ft	C _r =	0.50		C _d =	0.96		C _o =	0.64		C _w =	2.05	
θ =	0.00	degrees																										
W =	3.00	ft																										
L =	3.00	ft																										
A _{RATIO} =	0.70																											
H _B =	0.00	ft																										
C _r =	0.50																											
C _d =	0.96																											
C _o =	0.64																											
C _w =	2.05																											
	<table style="width: 100%; border-collapse: collapse;"> <thead> <tr> <th></th> <th style="text-align: center;">MINOR</th> <th style="text-align: center;">MAJOR</th> <th></th> </tr> </thead> <tbody> <tr> <td>d =</td> <td style="text-align: center;">0.22</td> <td style="text-align: center;">0.31</td> <td></td> </tr> <tr> <td>Q_a =</td> <td style="text-align: center;">1.9</td> <td style="text-align: center;">3.1</td> <td>cfs</td> </tr> <tr> <td>Q_b =</td> <td style="text-align: center;">0.0</td> <td style="text-align: center;">0.0</td> <td>cfs</td> </tr> <tr> <td>C% =</td> <td style="text-align: center;">100</td> <td style="text-align: center;">100</td> <td>%</td> </tr> </tbody> </table>		MINOR	MAJOR		d =	0.22	0.31		Q _a =	1.9	3.1	cfs	Q _b =	0.0	0.0	cfs	C% =	100	100	%							
	MINOR	MAJOR																										
d =	0.22	0.31																										
Q _a =	1.9	3.1	cfs																									
Q _b =	0.0	0.0	cfs																									
C% =	100	100	%																									
Water Depth at Inlet (for depressed inlets, 1 foot is added for depression) Total Inlet Interception Capacity (assumes clogged condition) Bypassed Flow Capture Percentage = Q _a /Q _o																												

AREA INLET IN A SWALE

Waterview East Commercial
Inlet A15

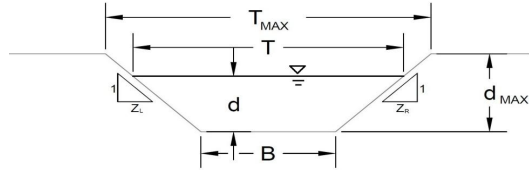

This worksheet uses the NRCS vegetative retardance method to determine Manning's n.
For more information see Section 7.2.3 of the USDCM.

Analysis of Trapezoidal Grass-Lined Channel Using SCS Method			A, B, C, D, or E =													
NRCS Vegetal Retardance (A, B, C, D, or E)			n = 0.013													
Manning's n (Leave cell D16 blank to manually enter an n value)			S ₀ = 0.0050 ft/ft													
Channel Invert Slope			B = 0.00 ft													
Bottom Width			Z1 = 12.00 ft/ft													
Left Side Slope			Z2 = 12.00 ft/ft													
Right Side Slope			Choose One: <input type="radio"/> Non-Cohesive <input type="radio"/> Cohesive <input type="radio"/> Paved													
Check one of the following soil types:			Minor Storm Major Storm T _{MAX} = 11.00 11.00 ft d _{MAX} = 0.16 0.16 ft													
<table border="1" style="width: 100%; border-collapse: collapse; text-align: center;"> <thead> <tr> <th style="text-align: left;">Soil Type:</th> <th style="text-align: left;">Max. Velocity (V_{MAX})</th> <th style="text-align: left;">Max Froude No. (F_{MAX})</th> </tr> </thead> <tbody> <tr> <td>Non-Cohesive</td> <td>5.0 fps</td> <td>0.60</td> </tr> <tr> <td>Cohesive</td> <td>7.0 fps</td> <td>0.80</td> </tr> <tr> <td>Paved</td> <td>N/A</td> <td>N/A</td> </tr> </tbody> </table>	Soil Type:	Max. Velocity (V _{MAX})	Max Froude No. (F _{MAX})	Non-Cohesive	5.0 fps	0.60	Cohesive	7.0 fps	0.80	Paved	N/A	N/A	Maximum Allowable Top Width of Channel for Minor & Major Storm Maximum Allowable Water Depth in Channel for Minor & Major Storm			
Soil Type:	Max. Velocity (V _{MAX})	Max Froude No. (F _{MAX})														
Non-Cohesive	5.0 fps	0.60														
Cohesive	7.0 fps	0.80														
Paved	N/A	N/A														
Allowable Channel Capacity Based On Channel Geometry			Minor Storm Major Storm Q _{allow} = 0.5 0.5 cfs d _{allow} = 0.16 0.16 ft													
MINOR STORM Allowable Capacity is based on Depth Criterion MAJOR STORM Allowable Capacity is based on Depth Criterion																
Water Depth in Channel Based On Design Peak Flow			O _d = 1.5 3.9 cfs d = 0.25 0.36 ft													
Design Peak Flow Water Depth																
WARNING: MINOR STORM max. allowable capacity is less than the design flow given on sheet 'Inlet Management' WARNING: MAJOR STORM max. allowable capacity is less than the design flow given on sheet 'Inlet Management'																

Warning 05

AREA INLET IN A SWALE

Waterview East Commercial
Inlet A15

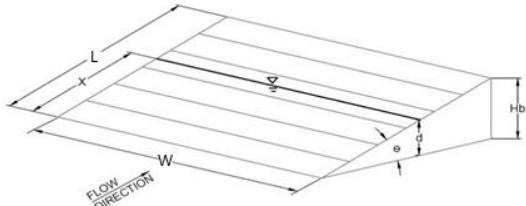
Inlet Design Information (Input)																												
Type of Inlet CDOT Type C	Inlet Type = CDOT Type C																											
Angle of Inclined Grate (must be ≤ 30 degrees) Width of Grate Length of Grate Open Area Ratio Height of Inclined Grate Clogging Factor Grate Discharge Coefficient Orifice Coefficient Weir Coefficient	<table style="width: 100%; border-collapse: collapse;"> <tr><td>θ =</td><td style="text-align: center;">0.00</td><td>degrees</td></tr> <tr><td>W =</td><td style="text-align: center;">3.00</td><td>ft</td></tr> <tr><td>L =</td><td style="text-align: center;">3.00</td><td>ft</td></tr> <tr><td>A_{RATIO} =</td><td style="text-align: center;">0.70</td><td></td></tr> <tr><td>H_B =</td><td style="text-align: center;">0.00</td><td>ft</td></tr> <tr><td>C_r =</td><td style="text-align: center;">0.50</td><td></td></tr> <tr><td>C_d =</td><td style="text-align: center;">0.96</td><td></td></tr> <tr><td>C_o =</td><td style="text-align: center;">0.64</td><td></td></tr> <tr><td>C_w =</td><td style="text-align: center;">2.05</td><td></td></tr> </table>	θ =	0.00	degrees	W =	3.00	ft	L =	3.00	ft	A _{RATIO} =	0.70		H _B =	0.00	ft	C _r =	0.50		C _d =	0.96		C _o =	0.64		C _w =	2.05	
θ =	0.00	degrees																										
W =	3.00	ft																										
L =	3.00	ft																										
A _{RATIO} =	0.70																											
H _B =	0.00	ft																										
C _r =	0.50																											
C _d =	0.96																											
C _o =	0.64																											
C _w =	2.05																											
	<table style="width: 100%; border-collapse: collapse; text-align: center;"> <thead> <tr> <th></th> <th>MINOR</th> <th>MAJOR</th> <th></th> </tr> </thead> <tbody> <tr> <td>d =</td> <td>0.25</td> <td>0.36</td> <td></td> </tr> <tr> <td>Q_a =</td> <td>2.3</td> <td>3.9</td> <td>cfs</td> </tr> <tr> <td>Q_b =</td> <td>0.0</td> <td>0.0</td> <td>cfs</td> </tr> <tr> <td>C% =</td> <td>100</td> <td>100</td> <td>%</td> </tr> </tbody> </table>		MINOR	MAJOR		d =	0.25	0.36		Q _a =	2.3	3.9	cfs	Q _b =	0.0	0.0	cfs	C% =	100	100	%							
	MINOR	MAJOR																										
d =	0.25	0.36																										
Q _a =	2.3	3.9	cfs																									
Q _b =	0.0	0.0	cfs																									
C% =	100	100	%																									
Water Depth at Inlet (for depressed inlets, 1 foot is added for depression) Total Inlet Interception Capacity (assumes clogged condition) Bypassed Flow Capture Percentage = Q_a/Q_o																												

Warning 05: Depth (d) exceeds max allowable depth (dmax).

AREA INLET IN A SWALE

Waterview East Commercial
Inlet A16

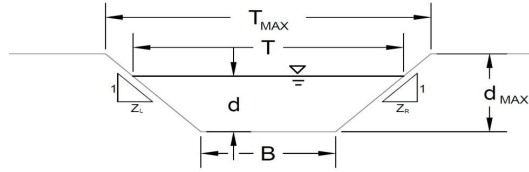

This worksheet uses the NRCS vegetative retardance method to determine Manning's n.
For more information see Section 7.2.3 of the USDCM.

Analysis of Trapezoidal Grass-Lined Channel Using SCS Method

NRCS Vegetal Retardance (A, B, C, D, or E) A, B, C, D, or E =

Manning's n (Leave cell D16 blank to manually enter an n value) n = 0.013

Channel Invert Slope S₀ = 0.0050 ft/ft

Bottom Width B = 0.00 ft

Left Side Slope Z₁ = 12.00 ft/ft

Right Side Slope Z₂ = 12.00 ft/ft

Check one of the following soil types:

Soil Type:	Max. Velocity (V _{MAX})	Max Froude No. (F _{MAX})
Non-Cohesive	5.0 fps	0.60
Cohesive	7.0 fps	0.80
Paved	N/A	N/A

Choose One:

Non-Cohesive

Cohesive

Paved

	Minor Storm	Major Storm	
Maximum Allowable Top Width of Channel for Minor & Major Storm	18.00	18.00	ft
Maximum Allowable Water Depth in Channel for Minor & Major Storm	0.50	0.50	ft

Allowable Channel Capacity Based On Channel Geometry

MINOR STORM Allowable Capacity is based on Depth Criterion

MAJOR STORM Allowable Capacity is based on Depth Criterion

	Minor Storm	Major Storm	
Q _{allow}	9.6	9.6	cfs
d _{allow}	0.50	0.50	ft

Water Depth in Channel Based On Design Peak Flow

Design Peak Flow Q_o = 1.0 cfs

Water Depth d = 0.21 ft

Minor storm max. allowable capacity GOOD - greater than the design flow given on sheet 'Inlet Management'

Major storm max. allowable capacity GOOD - greater than the design flow given on sheet 'Inlet Management'

AREA INLET IN A SWALE

Waterview East Commercial
Inlet A16

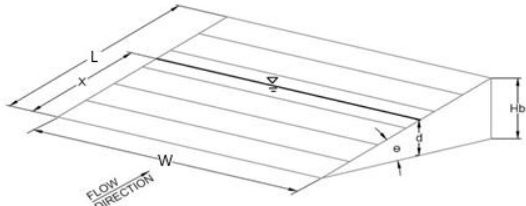
Inlet Design Information (Input)																												
Type of Inlet CDOT Type C	Inlet Type = CDOT Type C																											
Angle of Inclined Grate (must be ≤ 30 degrees) Width of Grate Length of Grate Open Area Ratio Height of Inclined Grate Clogging Factor Grate Discharge Coefficient Orifice Coefficient Weir Coefficient	<table style="width: 100%; border-collapse: collapse;"> <tr><td style="width: 50%;">θ =</td><td style="width: 20%; text-align: center;">0.00</td><td style="width: 30%;">degrees</td></tr> <tr><td>W =</td><td style="text-align: center;">3.00</td><td>ft</td></tr> <tr><td>L =</td><td style="text-align: center;">3.00</td><td>ft</td></tr> <tr><td>A_{RATIO} =</td><td style="text-align: center;">0.70</td><td></td></tr> <tr><td>H_B =</td><td style="text-align: center;">0.00</td><td>ft</td></tr> <tr><td>C_r =</td><td style="text-align: center;">0.50</td><td></td></tr> <tr><td>C_d =</td><td style="text-align: center;">0.96</td><td></td></tr> <tr><td>C_o =</td><td style="text-align: center;">0.64</td><td></td></tr> <tr><td>C_w =</td><td style="text-align: center;">2.05</td><td></td></tr> </table>	θ =	0.00	degrees	W =	3.00	ft	L =	3.00	ft	A_{RATIO} =	0.70		H_B =	0.00	ft	C_r =	0.50		C_d =	0.96		C_o =	0.64		C_w =	2.05	
θ =	0.00	degrees																										
W =	3.00	ft																										
L =	3.00	ft																										
A_{RATIO} =	0.70																											
H_B =	0.00	ft																										
C_r =	0.50																											
C_d =	0.96																											
C_o =	0.64																											
C_w =	2.05																											
	<table style="width: 100%; border-collapse: collapse;"> <thead> <tr> <th></th> <th style="text-align: center;">MINOR</th> <th style="text-align: center;">MAJOR</th> <th></th> </tr> </thead> <tbody> <tr> <td>d =</td> <td style="text-align: center;">0.21</td> <td style="text-align: center;">0.29</td> <td></td> </tr> <tr> <td>Q_a =</td> <td style="text-align: center;">1.8</td> <td style="text-align: center;">2.9</td> <td>cfs</td> </tr> <tr> <td>Q_b =</td> <td style="text-align: center;">0.0</td> <td style="text-align: center;">0.0</td> <td>cfs</td> </tr> <tr> <td>$C\%$ =</td> <td style="text-align: center;">100</td> <td style="text-align: center;">100</td> <td>%</td> </tr> </tbody> </table>		MINOR	MAJOR		d =	0.21	0.29		Q_a =	1.8	2.9	cfs	Q_b =	0.0	0.0	cfs	$C\%$ =	100	100	%							
	MINOR	MAJOR																										
d =	0.21	0.29																										
Q_a =	1.8	2.9	cfs																									
Q_b =	0.0	0.0	cfs																									
$C\%$ =	100	100	%																									
Water Depth at Inlet (for depressed inlets, 1 foot is added for depression) Total Inlet Interception Capacity (assumes clogged condition) Bypassed Flow Capture Percentage = Q_a/Q_o																												

AREA INLET IN A SWALE

Waterview East Commercial
Inlet A17

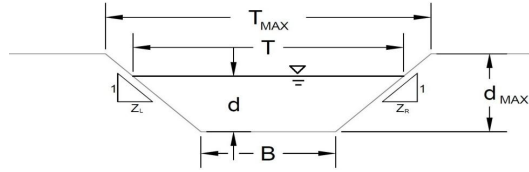

This worksheet uses the NRCS vegetat retardance method to determine Manning's n.
For more information see Section 7.2.3 of the USDCM.

Analysis of Trapezoidal Grass-Lined Channel Using SCS Method

NRCS Vegetal Retardance (A, B, C, D, or E) A, B, C, D, or E =

Manning's n (Leave cell D16 blank to manually enter an n value) n = 0.013

Channel Invert Slope S₀ = 0.0050 ft/ft

Bottom Width B = 0.00 ft

Left Side Slope Z₁ = 12.00 ft/ft

Right Side Sloe Z₂ = 12.00 ft/ft

Check one of the following soil types:

Soil Type:	Max. Velocity (V _{MAX})	Max Froude No. (F _{MAX})
Non-Cohesive	5.0 fps	0.60
Cohesive	7.0 fps	0.80
Paved	N/A	N/A

Choose One:

Non-Cohesive

Cohesive

Paved

	Minor Storm	Major Storm	
Maximum Allowable Top Width of Channel for Minor & Major Storm	26.00	26.00	ft
Maximum Allowable Water Depth in Channel for Minor & Major Storm	1.25	1.25	ft

Allowable Channel Capacity Based On Channel Geometry

MINOR STORM Allowable Capacity is based on Top Width Criterion Minor Storm

MAJOR STORM Allowable Capacity is based on Top Width Criterion Major Storm

	Minor Storm	Major Storm	
Q _{allow}	75.7	75.7	cfs
d _{allow}	1.08	1.08	ft

Water Depth in Channel Based On Design Peak Flow

Design Peak Flow Q_o = 1.4 cfs

Water Depth d = 0.25 ft

Minor storm max. allowable capacity GOOD - greater than the design flow given on sheet 'Inlet Management'

Major storm max. allowable capacity GOOD - greater than the design flow given on sheet 'Inlet Management'

AREA INLET IN A SWALE

Waterview East Commercial
Inlet A17

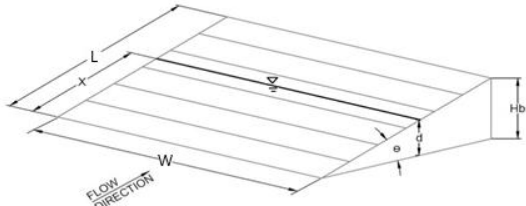
Inlet Design Information (Input)																												
Type of Inlet CDOT Type C	Inlet Type = CDOT Type C																											
Angle of Inclined Grate (must be ≤ 30 degrees) Width of Grate Length of Grate Open Area Ratio Height of Inclined Grate Clogging Factor Grate Discharge Coefficient Orifice Coefficient Weir Coefficient	<table style="width: 100%; border-collapse: collapse;"> <tr><td>$\theta =$</td><td style="text-align: center;">0.00</td><td>degrees</td></tr> <tr><td>$W =$</td><td style="text-align: center;">3.00</td><td>ft</td></tr> <tr><td>$L =$</td><td style="text-align: center;">3.00</td><td>ft</td></tr> <tr><td>$A_{RATIO} =$</td><td style="text-align: center;">0.70</td><td></td></tr> <tr><td>$H_B =$</td><td style="text-align: center;">0.00</td><td>ft</td></tr> <tr><td>$C_r =$</td><td style="text-align: center;">0.50</td><td></td></tr> <tr><td>$C_d =$</td><td style="text-align: center;">0.96</td><td></td></tr> <tr><td>$C_o =$</td><td style="text-align: center;">0.64</td><td></td></tr> <tr><td>$C_w =$</td><td style="text-align: center;">2.05</td><td></td></tr> </table>	$\theta =$	0.00	degrees	$W =$	3.00	ft	$L =$	3.00	ft	$A_{RATIO} =$	0.70		$H_B =$	0.00	ft	$C_r =$	0.50		$C_d =$	0.96		$C_o =$	0.64		$C_w =$	2.05	
$\theta =$	0.00	degrees																										
$W =$	3.00	ft																										
$L =$	3.00	ft																										
$A_{RATIO} =$	0.70																											
$H_B =$	0.00	ft																										
$C_r =$	0.50																											
$C_d =$	0.96																											
$C_o =$	0.64																											
$C_w =$	2.05																											
	<table style="width: 100%; border-collapse: collapse;"> <thead> <tr> <th></th> <th style="text-align: center;">MINOR</th> <th style="text-align: center;">MAJOR</th> <th></th> </tr> </thead> <tbody> <tr> <td>$d =$</td> <td style="text-align: center;">0.25</td> <td style="text-align: center;">0.36</td> <td></td> </tr> <tr> <td>$Q_a =$</td> <td style="text-align: center;">2.2</td> <td style="text-align: center;">3.9</td> <td>cfs</td> </tr> <tr> <td>$Q_b =$</td> <td style="text-align: center;">0.0</td> <td style="text-align: center;">0.0</td> <td>cfs</td> </tr> <tr> <td>$C\% =$</td> <td style="text-align: center;">100</td> <td style="text-align: center;">100</td> <td>%</td> </tr> </tbody> </table>		MINOR	MAJOR		$d =$	0.25	0.36		$Q_a =$	2.2	3.9	cfs	$Q_b =$	0.0	0.0	cfs	$C\% =$	100	100	%							
	MINOR	MAJOR																										
$d =$	0.25	0.36																										
$Q_a =$	2.2	3.9	cfs																									
$Q_b =$	0.0	0.0	cfs																									
$C\% =$	100	100	%																									
Water Depth at Inlet (for depressed inlets, 1 foot is added for depression) Total Inlet Interception Capacity (assumes clogged condition) Bypassed Flow Capture Percentage = Q_a/Q_o																												

ALLOWABLE CAPACITY FOR ONE-HALF OF STREET (Minor & Major Storm)

(Based on Regulated Criteria for Maximum Allowable Flow Depth and Spread)

Project: Waterview East Commercial
 Inlet ID: Inlet A18

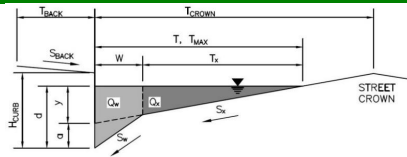

Gutter Geometry:

Maximum Allowable Width for Spread Behind Curb
 Side Slope Behind Curb (leave blank for no conveyance credit behind curb)
 Manning's Roughness Behind Curb (typically between 0.012 and 0.020)

$T_{BACK} = 10.0$ ft
 $S_{BACK} = 0.000$ ft/ft
 $n_{BACK} = 0.020$

Height of Curb at Gutter Flow Line
 Distance from Curb Face to Street Crown
 Gutter Width
 Street Transverse Slope
 Gutter Cross Slope (typically 2 inches over 24 inches or 0.083 ft/ft)
 Street Longitudinal Slope - Enter 0 for sump condition
 Manning's Roughness for Street Section (typically between 0.012 and 0.020)

$H_{CURB} = 6.00$ inches
 $T_{CROWN} = 40.0$ ft
 $W = 2.00$ ft
 $S_X = 0.037$ ft/ft
 $S_W = 0.083$ ft/ft
 $S_0 = 0.000$ ft/ft
 $n_{STREET} = 0.016$

Max. Allowable Spread for Minor & Major Storm
 Max. Allowable Depth at Gutter Flowline for Minor & Major Storm
 Check boxes are not applicable in SUMP conditions

	Minor Storm	Major Storm	
$T_{MAX} =$	40.0	40.0	ft
$d_{MAX} =$	6.0	6.0	inches
	<input type="checkbox"/>	<input type="checkbox"/>	

[MINOR STORM Allowable Capacity is not applicable to Sump Condition](#)
[MAJOR STORM Allowable Capacity is not applicable to Sump Condition](#)

$Q_{allow} =$

Minor Storm
SUMP

Major Storm
SUMP

 cfs

INLET IN A SUMP OR SAG LOCATION

MHFD-Inlet, Version 5.02 (August 2022)

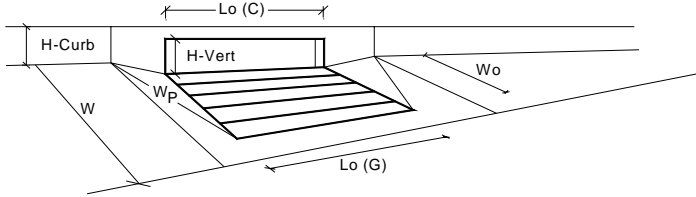

Design Information (Input)	MINOR	MAJOR	
Type of Inlet	CDOT Type R Curb Opening		
Local Depression (additional to continuous gutter depression 'a' from above)	3.00	3.00	inches
Number of Unit Inlets (Grate or Curb Opening)	3	3	
Water Depth at Flowline (outside of local depression)	6.0	6.0	inches
Grate Information	MINOR	MAJOR	<input type="checkbox"/> Override Depths
Length of a Unit Grate	N/A	N/A	feet
Width of a Unit Grate	N/A	N/A	feet
Open Area Ratio for a Grate (typical values 0.15-0.90)	N/A	N/A	
Clogging Factor for a Single Grate (typical value 0.50 - 0.70)	N/A	N/A	
Grate Weir Coefficient (typical value 2.15 - 3.60)	N/A	N/A	
Grate Orifice Coefficient (typical value 0.60 - 0.80)	N/A	N/A	
Curb Opening Information	MINOR	MAJOR	
Length of a Unit Curb Opening	5.00	5.00	feet
Height of Vertical Curb Opening in Inches	6.00	6.00	inches
Height of Curb Orifice Throat in Inches	6.00	6.00	inches
Angle of Throat (see USDCM Figure ST-5)	63.40	63.40	degrees
Side Width for Depression Pan (typically the gutter width of 2 feet)	2.00	2.00	feet
Clogging Factor for a Single Curb Opening (typical value 0.10)	0.10	0.10	
Curb Opening Weir Coefficient (typical value 2.3-3.7)	3.60	3.60	
Curb Opening Orifice Coefficient (typical value 0.60 - 0.70)	0.67	0.67	
Low Head Performance Reduction (Calculated)	MINOR	MAJOR	
Depth for Grate Midwidth	N/A	N/A	ft
Depth for Curb Opening Weir Equation	0.33	0.33	ft
Grated Inlet Performance Reduction Factor for Long Inlets	N/A	N/A	
Curb Opening Performance Reduction Factor for Long Inlets	0.79	0.79	
Combination Inlet Performance Reduction Factor for Long Inlets	N/A	N/A	
Total Inlet Interception Capacity (assumes clogged condition)	7.8	7.8	cfs
WARNING: Inlet Capacity < Q Peak for Major Storm	4.6	10.6	cfs

AREA INLET IN A SWALE

Waterview East Commercial
Inlet A19

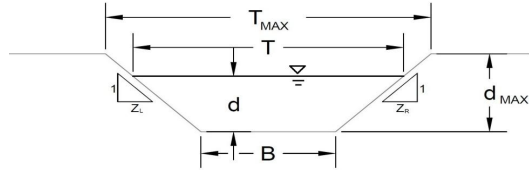

This worksheet uses the NRCS vegetat retardance method to determine Manning's n.
For more information see Section 7.2.3 of the USDCM.

Analysis of Trapezoidal Grass-Lined Channel Using SCS Method

NRCS Vegetal Retardance (A, B, C, D, or E) A, B, C, D, or E =

Manning's n (Leave cell D16 blank to manually enter an n value) n =

Channel Invert Slope S₀ = ft/ft

Bottom Width B = ft

Left Side Slope Z₁ = ft/ft

Right Side Slope Z₂ = ft/ft

Check one of the following soil types:

Soil Type:	Max. Velocity (V _{MAX})	Max Froude No. (F _{MAX})
Non-Cohesive	5.0 fps	0.60
Cohesive	7.0 fps	0.80
Paved	N/A	N/A

Choose One:

Non-Cohesive

Cohesive

Paved

	Minor Storm	Major Storm	
Maximum Allowable Top Width of Channel for Minor & Major Storm	T _{MAX} =		ft
Maximum Allowable Water Depth in Channel for Minor & Major Storm	d _{MAX} =		ft

Allowable Channel Capacity Based On Channel Geometry

MINOR STORM Allowable Capacity is based on Depth Criterion

MAJOR STORM Allowable Capacity is based on Depth Criterion

	Minor Storm	Major Storm	
Allowable Capacity	Q _{allow} =		cfs
Allowable Water Depth	d _{allow} =		ft

Water Depth in Channel Based On Design Peak Flow

Design Peak Flow Q_o = cfs

Water Depth d = ft

AREA INLET IN A SWALE

Waterview East Commercial
Inlet A19

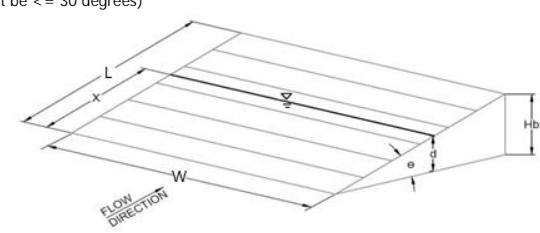
Inlet Design Information (Input)																												
Type of Inlet <input style="width: 90%;" type="text"/>	Inlet Type = <input style="width: 90%;" type="text"/>																											
Angle of Inclined Gate (must be ≤ 30 degrees) Width of Gate Length of Gate Open Area Ratio Height of Inclined Gate Clogging Factor Gate Discharge Coefficient Orifice Coefficient Weir Coefficient	<table style="width: 100%; border-collapse: collapse;"> <tr><td>θ =</td><td><input style="width: 80%;" type="text"/></td><td>degrees</td></tr> <tr><td>W =</td><td><input style="width: 80%;" type="text"/></td><td>ft</td></tr> <tr><td>L =</td><td><input style="width: 80%;" type="text"/></td><td>ft</td></tr> <tr><td>A_{RATIO} =</td><td><input style="width: 80%;" type="text"/></td><td></td></tr> <tr><td>H_B =</td><td><input style="width: 80%;" type="text"/></td><td>ft</td></tr> <tr><td>C_r =</td><td><input style="width: 80%;" type="text"/></td><td></td></tr> <tr><td>C_d =</td><td><input style="width: 80%;" type="text"/></td><td></td></tr> <tr><td>C_o =</td><td><input style="width: 80%;" type="text"/></td><td></td></tr> <tr><td>C_w =</td><td><input style="width: 80%;" type="text"/></td><td></td></tr> </table>	θ =	<input style="width: 80%;" type="text"/>	degrees	W =	<input style="width: 80%;" type="text"/>	ft	L =	<input style="width: 80%;" type="text"/>	ft	A_{RATIO} =	<input style="width: 80%;" type="text"/>		H_B =	<input style="width: 80%;" type="text"/>	ft	C_r =	<input style="width: 80%;" type="text"/>		C_d =	<input style="width: 80%;" type="text"/>		C_o =	<input style="width: 80%;" type="text"/>		C_w =	<input style="width: 80%;" type="text"/>	
θ =	<input style="width: 80%;" type="text"/>	degrees																										
W =	<input style="width: 80%;" type="text"/>	ft																										
L =	<input style="width: 80%;" type="text"/>	ft																										
A_{RATIO} =	<input style="width: 80%;" type="text"/>																											
H_B =	<input style="width: 80%;" type="text"/>	ft																										
C_r =	<input style="width: 80%;" type="text"/>																											
C_d =	<input style="width: 80%;" type="text"/>																											
C_o =	<input style="width: 80%;" type="text"/>																											
C_w =	<input style="width: 80%;" type="text"/>																											
	<table style="width: 100%; border-collapse: collapse;"> <tr> <td></td> <td style="text-align: center;">MINOR</td> <td style="text-align: center;">MAJOR</td> <td></td> </tr> <tr> <td>d =</td> <td><input style="width: 80%;" type="text"/></td> <td><input style="width: 80%;" type="text"/></td> <td></td> </tr> <tr> <td>Q_a =</td> <td><input style="width: 80%;" type="text"/></td> <td><input style="width: 80%;" type="text"/></td> <td>cfs</td> </tr> <tr> <td>Q_b =</td> <td><input style="width: 80%;" type="text"/></td> <td><input style="width: 80%;" type="text"/></td> <td>cfs</td> </tr> <tr> <td>$C\%$ =</td> <td><input style="width: 80%;" type="text"/></td> <td><input style="width: 80%;" type="text"/></td> <td>%</td> </tr> </table>		MINOR	MAJOR		d =	<input style="width: 80%;" type="text"/>	<input style="width: 80%;" type="text"/>		Q_a =	<input style="width: 80%;" type="text"/>	<input style="width: 80%;" type="text"/>	cfs	Q_b =	<input style="width: 80%;" type="text"/>	<input style="width: 80%;" type="text"/>	cfs	$C\%$ =	<input style="width: 80%;" type="text"/>	<input style="width: 80%;" type="text"/>	%							
	MINOR	MAJOR																										
d =	<input style="width: 80%;" type="text"/>	<input style="width: 80%;" type="text"/>																										
Q_a =	<input style="width: 80%;" type="text"/>	<input style="width: 80%;" type="text"/>	cfs																									
Q_b =	<input style="width: 80%;" type="text"/>	<input style="width: 80%;" type="text"/>	cfs																									
$C\%$ =	<input style="width: 80%;" type="text"/>	<input style="width: 80%;" type="text"/>	%																									
Water Depth at Inlet (for depressed inlets, 1 foot is added for depression) Total Inlet Interception Capacity (assumes clogged condition) Bypassed Flow Capture Percentage = Q_a/Q_o																												

ALLOWABLE CAPACITY FOR ONE-HALF OF STREET (Minor & Major Storm)

(Based on Regulated Criteria for Maximum Allowable Flow Depth and Spread)

Project: Waterview East Commercial
 Inlet ID: Inlet A25

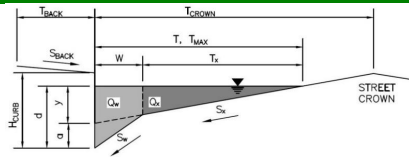

Gutter Geometry:

Maximum Allowable Width for Spread Behind Curb
 Side Slope Behind Curb (leave blank for no conveyance credit behind curb)
 Manning's Roughness Behind Curb (typically between 0.012 and 0.020)

$T_{BACK} = 12.0$ ft
 $S_{BACK} =$ ft/ft
 $n_{BACK} = 0.020$

Height of Curb at Gutter Flow Line
 Distance from Curb Face to Street Crown
 Gutter Width
 Street Transverse Slope
 Gutter Cross Slope (typically 2 inches over 24 inches or 0.083 ft/ft)
 Street Longitudinal Slope - Enter 0 for sump condition
 Manning's Roughness for Street Section (typically between 0.012 and 0.020)

$H_{CURB} = 6.00$ inches
 $T_{CROWN} = 12.0$ ft
 $W = 3.00$ ft
 $S_X = 0.020$ ft/ft
 $S_W = 0.083$ ft/ft
 $S_0 = 0.000$ ft/ft
 $n_{STREET} = 0.016$

Max. Allowable Spread for Minor & Major Storm
 Max. Allowable Depth at Gutter Flowline for Minor & Major Storm
 Check boxes are not applicable in SUMP conditions

	Minor Storm	Major Storm	
$T_{MAX} =$	12.0	12.0	ft
$d_{MAX} =$	6.0	6.0	inches
	<input type="checkbox"/>	<input type="checkbox"/>	

[MINOR STORM Allowable Capacity is not applicable to Sump Condition](#)
[MAJOR STORM Allowable Capacity is not applicable to Sump Condition](#)

$Q_{allow} =$

Minor Storm	Major Storm
SUMP	SUMP

 cfs

INLET IN A SUMP OR SAG LOCATION

MHFD-Inlet, Version 5.02 (August 2022)

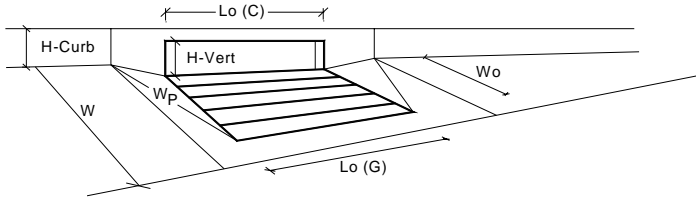

Design Information (Input)	MINOR MAJOR		
Type of Inlet	CDOT Type R Curb Opening		
Local Depression (additional to continuous gutter depression 'a' from above)	3.00	3.00	inches
Number of Unit Inlets (Grate or Curb Opening)	4	4	
Water Depth at Flowline (outside of local depression)	6.0	6.0	inches
Grate Information	MINOR	MAJOR	<input checked="" type="checkbox"/> Override Depths
Length of a Unit Grate	N/A	N/A	feet
Width of a Unit Grate	N/A	N/A	feet
Open Area Ratio for a Grate (typical values 0.15-0.90)	N/A	N/A	
Clogging Factor for a Single Grate (typical value 0.50 - 0.70)	N/A	N/A	
Grate Weir Coefficient (typical value 2.15 - 3.60)	N/A	N/A	
Grate Orifice Coefficient (typical value 0.60 - 0.80)	N/A	N/A	
Curb Opening Information	MINOR	MAJOR	
Length of a Unit Curb Opening	10.00	10.00	feet
Height of Vertical Curb Opening in Inches	6.00	6.00	inches
Height of Curb Orifice Throat in Inches	6.00	6.00	inches
Angle of Throat (see USDCM Figure ST-5)	63.40	63.40	degrees
Side Width for Depression Pan (typically the gutter width of 2 feet)	3.00	3.00	feet
Clogging Factor for a Single Curb Opening (typical value 0.10)	0.10	0.10	
Curb Opening Weir Coefficient (typical value 2.3-3.7)	3.60	3.60	
Curb Opening Orifice Coefficient (typical value 0.60 - 0.70)	0.67	0.67	
Low Head Performance Reduction (Calculated)	MINOR	MAJOR	
Depth for Grate Midwidth	N/A	N/A	ft
Depth for Curb Opening Weir Equation	0.25	0.25	ft
Grated Inlet Performance Reduction Factor for Long Inlets	N/A	N/A	
Curb Opening Performance Reduction Factor for Long Inlets	0.79	0.79	
Combination Inlet Performance Reduction Factor for Long Inlets	N/A	N/A	
Total Inlet Interception Capacity (assumes clogged condition)	14.0	14.0	cfs
Inlet Capacity IS GOOD for Minor and Major Storms (>Q Peak)	5.0	12.6	cfs

ALLOWABLE CAPACITY FOR ONE-HALF OF STREET (Minor & Major Storm)

(Based on Regulated Criteria for Maximum Allowable Flow Depth and Spread)

Project: Waterview East Commercial
 Inlet ID: Frontside Drive Inlet

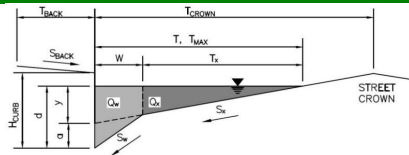

Gutter Geometry:							
Maximum Allowable Width for Spread Behind Curb	$T_{BACK} = $ <input style="width: 50px; text-align: center;" type="text" value="13.0"/> ft						
Side Slope Behind Curb (leave blank for no conveyance credit behind curb)	$S_{BACK} = $ <input style="width: 50px; text-align: center;" type="text" value="0.005"/> ft/ft						
Manning's Roughness Behind Curb (typically between 0.012 and 0.020)	$n_{BACK} = $ <input style="width: 50px; text-align: center;" type="text" value="0.013"/>						
Height of Curb at Gutter Flow Line	$H_{CURB} = $ <input style="width: 50px; text-align: center;" type="text" value="6.80"/> inches						
Distance from Curb Face to Street Crown	$T_{CROWN} = $ <input style="width: 50px; text-align: center;" type="text" value="26.0"/> ft						
Gutter Width	$W = $ <input style="width: 50px; text-align: center;" type="text" value="2.00"/> ft						
Street Transverse Slope	$S_X = $ <input style="width: 50px; text-align: center;" type="text" value="0.016"/> ft/ft						
Gutter Cross Slope (typically 2 inches over 24 inches or 0.083 ft/ft)	$S_W = $ <input style="width: 50px; text-align: center;" type="text" value="0.083"/> ft/ft						
Street Longitudinal Slope - Enter 0 for sump condition	$S_D = $ <input style="width: 50px; text-align: center;" type="text" value="0.000"/> ft/ft						
Manning's Roughness for Street Section (typically between 0.012 and 0.020)	$n_{STREET} = $ <input style="width: 50px; text-align: center;" type="text" value="0.013"/>						
Max. Allowable Spread for Minor & Major Storm	<table style="width: 100%; border-collapse: collapse;"> <tr> <td style="text-align: center; padding: 2px;">Minor Storm</td> <td style="text-align: center; padding: 2px;">Major Storm</td> <td style="padding: 2px;">ft</td> </tr> <tr> <td style="text-align: center; border: 1px solid black;"><input style="width: 50px; text-align: center;" type="text" value="26.0"/></td> <td style="text-align: center; border: 1px solid black;"><input style="width: 50px; text-align: center;" type="text" value="26.0"/></td> <td style="padding: 2px;"></td> </tr> </table>	Minor Storm	Major Storm	ft	<input style="width: 50px; text-align: center;" type="text" value="26.0"/>	<input style="width: 50px; text-align: center;" type="text" value="26.0"/>	
Minor Storm	Major Storm	ft					
<input style="width: 50px; text-align: center;" type="text" value="26.0"/>	<input style="width: 50px; text-align: center;" type="text" value="26.0"/>						
Max. Allowable Depth at Gutter Flowline for Minor & Major Storm	<table style="width: 100%; border-collapse: collapse;"> <tr> <td style="text-align: center; padding: 2px;">Minor Storm</td> <td style="text-align: center; padding: 2px;">Major Storm</td> <td style="padding: 2px;">inches</td> </tr> <tr> <td style="text-align: center; border: 1px solid black;"><input style="width: 50px; text-align: center;" type="text" value="6.8"/></td> <td style="text-align: center; border: 1px solid black;"><input style="width: 50px; text-align: center;" type="text" value="6.8"/></td> <td style="padding: 2px;"></td> </tr> </table>	Minor Storm	Major Storm	inches	<input style="width: 50px; text-align: center;" type="text" value="6.8"/>	<input style="width: 50px; text-align: center;" type="text" value="6.8"/>	
Minor Storm	Major Storm	inches					
<input style="width: 50px; text-align: center;" type="text" value="6.8"/>	<input style="width: 50px; text-align: center;" type="text" value="6.8"/>						
Check boxes are not applicable in SUMP conditions	<input type="checkbox"/> <input type="checkbox"/>						
MINOR STORM Allowable Capacity is not applicable to Sump Condition							
MAJOR STORM Allowable Capacity is not applicable to Sump Condition							
$Q_{allow} = $	<table style="width: 100%; border-collapse: collapse;"> <tr> <td style="text-align: center; padding: 2px;">Minor Storm</td> <td style="text-align: center; padding: 2px;">Major Storm</td> <td style="padding: 2px;">cfs</td> </tr> <tr> <td style="text-align: center; border: 1px solid black;"><input style="width: 50px; text-align: center;" type="text" value="SUMP"/></td> <td style="text-align: center; border: 1px solid black;"><input style="width: 50px; text-align: center;" type="text" value="SUMP"/></td> <td style="padding: 2px;"></td> </tr> </table>	Minor Storm	Major Storm	cfs	<input style="width: 50px; text-align: center;" type="text" value="SUMP"/>	<input style="width: 50px; text-align: center;" type="text" value="SUMP"/>	
Minor Storm	Major Storm	cfs					
<input style="width: 50px; text-align: center;" type="text" value="SUMP"/>	<input style="width: 50px; text-align: center;" type="text" value="SUMP"/>						

INLET IN A SUMP OR SAG LOCATION

MHFD-Inlet, Version 5.02 (August 2022)

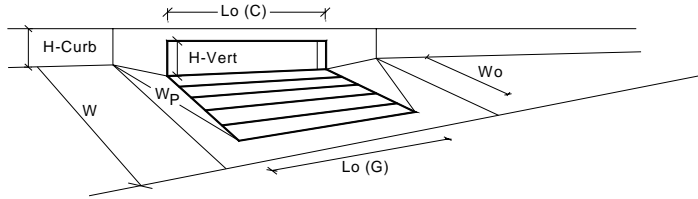

Design Information (Input)	MINOR		MAJOR		
Type of Inlet	CDOT Type R Curb Opening		CDOT Type R Curb Opening		
Local Depression (additional to continuous gutter depression 'a' from above)	2.00	2.00			inches
Number of Unit Inlets (Grate or Curb Opening)	1	1			
Water Depth at Flowline (outside of local depression)	6.5	6.5			inches
Grate Information	MINOR		MAJOR		<input type="checkbox"/> Override Depths
Length of a Unit Grate	N/A	N/A			feet
Width of a Unit Grate	N/A	N/A			feet
Open Area Ratio for a Grate (typical values 0.15-0.90)	N/A	N/A			
Clogging Factor for a Single Grate (typical value 0.50 - 0.70)	N/A	N/A			
Grate Weir Coefficient (typical value 2.15 - 3.60)	N/A	N/A			
Grate Orifice Coefficient (typical value 0.60 - 0.80)	N/A	N/A			
Curb Opening Information	MINOR		MAJOR		
Length of a Unit Curb Opening	10.00	10.00			feet
Height of Vertical Curb Opening in Inches	6.00	6.00			inches
Height of Curb Orifice Throat in Inches	6.00	6.00			inches
Angle of Throat (see USDCM Figure ST-5)	63.40	63.40			degrees
Side Width for Depression Pan (typically the gutter width of 2 feet)	2.00	2.00			feet
Clogging Factor for a Single Curb Opening (typical value 0.10)	0.10	0.10			
Curb Opening Weir Coefficient (typical value 2.3-3.7)	3.60	3.60			
Curb Opening Orifice Coefficient (typical value 0.60 - 0.70)	0.67	0.67			
Low Head Performance Reduction (Calculated)	MINOR		MAJOR		
Depth for Grate Midwidth	N/A	N/A			ft
Depth for Curb Opening Weir Equation	0.38	0.38			ft
Grated Inlet Performance Reduction Factor for Long Inlets	N/A	N/A			
Curb Opening Performance Reduction Factor for Long Inlets	0.96	0.96			
Combination Inlet Performance Reduction Factor for Long Inlets	N/A	N/A			
Total Inlet Interception Capacity (assumes clogged condition)	10.3	10.3			cfs
Inlet Capacity IS GOOD for Minor and Major Storms (>Q Peak)	2.9	9.5			cfs

Worksheet for A21 CURB CUT

Project Description	
Solve For	Crest Length

Input Data	
Discharge	5.28 cfs
Headwater Elevation	0.50 ft
Crest Elevation	0.00 ft
Tailwater Elevation	0.00 ft
Weir Coefficient	3.33 ft ^(1/2) /s
Number Of Contractions	0

Results	
Crest Length	4.5 ft
Headwater Height Above Crest	0.50 ft
Tailwater Height Above Crest	0.00 ft
Flow Area	2.2 ft ²
Velocity	2.35 ft/s
Wetted Perimeter	5.5 ft
Top Width	4.48 ft

Worksheet for A27 CURB CUT

Project Description	
Solve For	Crest Length

Input Data	
Discharge	11.55 cfs
Headwater Elevation	0.50 ft
Crest Elevation	0.00 ft
Tailwater Elevation	0.00 ft
Weir Coefficient	3.33 ft ^(1/2) /s
Number Of Contractions	0

Results	
Crest Length	9.8 ft
Headwater Height Above Crest	0.50 ft
Tailwater Height Above Crest	0.00 ft
Flow Area	4.9 ft ²
Velocity	2.35 ft/s
Wetted Perimeter	10.8 ft
Top Width	9.81 ft

Worksheet for Ex. Powers Ditch

Project Description	
Friction Method	Manning Formula
Solve For	Discharge

Input Data	
Channel Slope	0.029 ft/ft
Normal Depth	12.0 in

Section Definitions

	Station (ft)	Elevation (ft)	
	0+00		5,926.00
	0+17		5,925.00
	0+21		5,925.00
	0+23		5,926.00
	0+25		5,927.00

Roughness Segment Definitions

Start Station	Ending Station	Roughness Coefficient
(0+00, 5,926.00)	(0+25, 5,927.00)	0.030

Options	
Current Roughness Weighted Method	Pavlovskii's Method
Open Channel Weighting Method	Pavlovskii's Method
Closed Channel Weighting Method	Pavlovskii's Method

Results		
Discharge	80.11 cfs	FLOW FROM SUB-BASIN A28 AND POND A22 COMBINE TO 9.12 CFS
Roughness Coefficient	0.030	
Elevation Range	5,925.0 to 5,927.0 ft	
Flow Area	13.5 ft ²	
Wetted Perimeter	23.1 ft	
Hydraulic Radius	7.0 in	
Top Width	22.80 ft	
Normal Depth	12.0 in	
Critical Depth	13.6 in	
Critical Slope	0.015 ft/ft	
Velocity	5.93 ft/s	
Velocity Head	0.55 ft	
Specific Energy	1.55 ft	
Froude Number	1.359	
Flow Type	Supercritical	

Worksheet for Ex. Powers Ditch

GVF Input Data

Downstream Depth	0.0 in
Length	0.0 ft
Number Of Steps	0

GVF Output Data

Upstream Depth	0.0 in
Profile Description	N/A
Profile Headloss	0.00 ft
Downstream Velocity	Infinity ft/s
Upstream Velocity	Infinity ft/s
Normal Depth	12.0 in
Critical Depth	13.6 in
Channel Slope	0.029 ft/ft
Critical Slope	0.015 ft/ft

APPENDIX E – SUPPORTING DOCUMENTS



ENTECH
ENGINEERING, INC.

505 ELKTON DRIVE
COLORADO SPRINGS, CO 80907
PHONE (719) 531-5599
FAX (719) 531-5238

May 25, 2022

Waterview Commercial Investors, LLC
2727 Glen Arbor Drive
Colorado Springs, CO 80920

Attn: Heath Herber

Re: Preliminary Subsurface Soils Investigation
Waterview Commercial Site
Powers Boulevard and Bradley Road
El Paso County, Colorado

Dear Mr. Herber:

As requested, personnel of Entech Engineering, Inc. performed a Preliminary Subsurface Soil Investigation at the above referenced site. The site is a vacant parcel to be developed located on the southeast corner of Powers Boulevard and Bradley Road in south central El Paso County, Colorado. The site is indicated on the Vicinity Map, Figure 1. This letter presents the results of our soils investigation, laboratory tests, and preliminary recommendations for construction.

SITE CONDITIONS:

The site is currently undeveloped and the slope is gradual and generally trending to the east/southeast, with the north and west edges of the property sloping moderately towards the streets. Portions of the site have been used as dump sites and vegetation is absent in the northeast corner of the site due to recent grading. The rest consists of field grasses and weeds, and yucca. Previous site uses consist of agricultural grazing.

PROJECT DESCRIPTION:

The project is to consist of developing a 22-acre parcel into a multi-use commercial development.

FIELD INVESTIGATION AND LABORATORY TESTING PROGRAM:

The subsurface conditions on this site were investigated by drilling seven (7) exploratory test borings across the site in the approximate building locations. The approximate locations of the test borings are indicated on the Test Boring Location Map, Figure 2.

The test borings were advanced with a power-driven continuous flight auger drilling rig to depths of 20 feet below the existing ground surface. Samples were obtained during drilling using the Standard Penetration Test, ASTM D-1586, utilizing a California sampler. Results of the Standard Penetration Tests are shown on the Test Boring Logs. The Test Boring Logs are presented in Appendix A.

Water Content, ASTM D-2216, was obtained in the laboratory for the recovered samples. Grain-Size Analysis, ASTM D-422, and determination of Atterberg Limits, ASTM D-4318, were performed on samples for the purposes of classification. Volume change testing was performed on selected samples using the Swell/Consolidation Test (ASTM D-4546) in order to evaluate potential expansion/compression characteristics of the soil and bedrock. Sulfate testing was

performed to determine the corrosive potential of the soils. Laboratory test results are summarized in Table 1 and presented in Appendix B.

SOIL AND GROUNDWATER CONDITIONS:

Two soil types and one bedrock type were encountered in the test borings drilled for the preliminary subsurface investigation: Type 1: native silty to very silty sand (SM), Type 2: sandy clay (CL), and Type 3: native sandy claystone bedrock (CL). The soils were classified in accordance with the Unified Soil Classification System (USCS) using the laboratory testing results and the observations made during drilling.

Soil Type 1 classified as silty to very silty sand (SM). The sand was encountered in six of the seven test borings at the ground surface or 3 feet bgs and extending to depths ranging from 9 to 17 feet bgs or to the termination of borings (20 feet). Standard Penetration Testing on the sand resulted in N-values ranging from 10 to 43 bpf, indicating medium dense to dense states. Water content and grain size testing resulted in water contents of 2 to 8 percent, with 20 to 47 percent of the soil size particles passing the No. 200 sieve. Atterberg Limits testing on the sand resulted in no values. The sand is anticipated to exhibit low to negligible expansion potential. Sulfate testing resulted in less than 0.01 percent soluble sulfate by weight, indicating negligible potential for below grade concrete degradation due to sulfate attack.

Soil Type 2 classified as native sandy clay (CL). The native clay was encountered in five of the test borings at depths ranging from the ground surface to 17 feet bgs and extending to 3 feet or to the termination of the borings (20 feet). Standard Penetration Testing on the clay resulted in N-values of 12 to 36 blows per foot, indicating firm to very stiff consistencies. Water content and grain size testing resulted in water contents of 7 to 18 percent, with 81 to 85.5 percent of the soil size particles passing the No. 200 sieve. Atterberg Limits Testing resulted a liquid limit of 33 percent and a plastic index of 14 percent. Swell/Consolidation Testing on two samples of the sandy clay resulted in volume changes of -0.4 to 1.4 percent indicating a low consolidation potential and a low to moderate expansion potential. Sulfate testing resulted in less than 0.01 percent soluble sulfate by weight, indicating negligible potential for below grade concrete degradation due to sulfate attack.

Soil Type 3 classified as native sandy claystone bedrock (CL). The claystone was encountered in Test Boring Nos. 1, 2, and 3 at 14 to 18 feet bgs and extending to the termination of the boring (20 feet bgs). Standard Penetration Testing on the claystone resulted in N-values of 50 to greater than 50 blows per foot, indicating hard consistencies. Water content and grain size testing resulted in water contents of 10 to 14 percent moisture content, with 84 percent of the soil size particles passing the No. 200 sieve. Atterberg Limits Testing resulted in a liquid limit of 43 and a plastic index of 24 percent. Swell/Consolidation Testing resulted in a volume change of 2.1 percent indicating a moderate potential for expansion. Sulfate testing resulted in less than 0.01 percent soluble sulfate by weight, which indicates a negligible potential for below grade concrete degradation due to sulfate attack. The claystone in this area typically has high sulfate levels.

Additional soil descriptions are presented on the enclosed drill logs. (Appendix A). A Summary of Laboratory Test Results is presented in Table 1. Laboratory test results are included in Appendix B. The soils were classified using the results of the laboratory testing, the Unified Soil

Classification System (USCS), and visual classification. The soil types are expected to vary across the site. Also, stratification lines shown on the logs represent the approximate boundary between soil types and the actual transition are expected to be gradual and vary with location.

Groundwater was not encountered in any of the test borings which were drilled to 20 feet. This indicates that groundwater will have little effect on shallow foundations proposed for the site depending on final grades and depth of excavations. Groundwater conditions may vary due to variations in rainfall, drainage and other factors not readily apparent at this time. Development of the property, adjacent properties and associated changes in runoff can affect the groundwater surface elevations.

PRELIMINARY DEVELOPMENT CONSIDERATIONS AND RECOMMENDATIONS:

Grading plans were not available at the time of this investigation. The soils in the test borings generally consisted of silty sand and sandy clay overlying claystone bedrock. Bedrock was encountered in three of the test borings at depths of 14 to 18 feet. The clay soils (Test Boring No. 2) will likely require overexcavation. The sandy site soils are suitable to support shallow foundations in their in-situ condition. The foundations should rest entirely on similar bearing soils, medium dense silty sand or on reworked and recompacted on-site granular sands, or structural fill.

Expansive clays encountered will require mitigation, which may include overexcavation and replacement with non-expansive soils or drilled pier foundations. Additionally, loose or soft soils, if encountered beneath foundations, will require overexcavation and recompaction or replacement and potential stabilization. The estimated extent of removal/recompaction or overexcavation should be evaluated after additional drilling is completed, when grading plans are available. The final extent of removal/recompaction or overexcavation should be determined at the time of excavation observations.

Shallow foundations bearing on reworked on-site granular soils, native medium dense sand soils, or structural fill are anticipated for this site. Exterior footings should extend a minimum of 30 inches below the adjacent exterior site grade for frost protection. Drilled piers are a suitable alternative to overexcavation.

Groundwater is not expected to be encountered in shallow foundation excavations depending on final grades and depths of excavations. However, groundwater conditions may vary. Excavation of clay and sand soils will be moderate with rubber-tired equipment, the hard claystone bedrock where encountered will likely require track-mounted equipment.

ON-GRADE FLOOR SLABS:

If standard spread footing foundations are used, any grade supported floor slabs should be separated from other structural components and utility penetrations to allow for possible future vertical movement unless designed as part of the foundation. Uncontrolled fills, and expansive clays at or near slabs grade will require overexcavation. Control joints in grade-supported slabs are recommended at 10 to 15-foot perpendicular spacings to control cracking. We anticipate perimeter drains are not necessary for slab-on-grade construction provided the slabs are positioned above finished exterior site grade, irrigation is minimized and foundation wall backfill is properly placed.

Waterview Commercial Investors, LLC
Preliminary Subsurface Soils Investigation
Powers Boulevard and Bradley Road
El Paso County, Colorado

On-grade floor slabs should not be considered unless slab movement can be tolerated. If slab movement cannot be tolerated, then structural floors should be considered.

PRELIMINARY CONCRETE RECOMMENDATIONS:

Sulfate solubility testing was conducted on select samples recovered from the test borings to evaluate the potential for sulfate attack on concrete placed below surface grade. The test results indicated less than 0.01 percent soluble sulfate (by weight). These test results indicate that the sulfate component of the in-place soils present a negligible exposure threat to concrete placed below the site grade. Type II cement is recommended for the soils which pose a negligible to moderate threat, which will include imported structural fill materials. We recommend additional sulfate testing as the site is developed as high sulfate levels are common in this area.

To further avoid concrete degradation during construction it is recommended that concrete not be placed on frozen or wet ground. Care should be taken to prevent the accumulation or ponding of water in the foundation excavation prior to the placement of concrete. If standing water is present in the foundation excavation, it should be removed by ditching to sumps and pumping the water away from the foundation area prior to concrete placement. If concrete is placed during periods of cold temperatures, the concrete must be kept from freezing. This may require covering the concrete with insulated blankets and adding heat to prohibit freezing.

SITE GRADING:

Any areas to receive fill should have all topsoil, organic material or debris removed. Fill must be properly benched and compacted to minimize potentially unstable conditions in slope areas. Completed slopes should be 3:1 or flatter if constructed without reinforcing. Flatter slopes may be required depending upon specific conditions. The ground surface should be scarified, and moisture conditioned to within ± 2 percent of optimum moisture content and compacted to a minimum of 95 percent of its maximum Standard Proctor Dry Density, ASTM D-698, prior to placing new fill.

New fill should be placed in thin lifts not to exceed 6 inches after compaction while maintaining at least 95 percent of its maximum Modified Proctor Dry Density, ASTM D-1557 for granular soils and 95 percent of its maximum Standard Proctor Dry Density, ASTM D-698 for cohesive soils. These materials should be placed at a moisture content conducive to compaction, usually ± 2 percent of Proctor optimum moisture content. The placement and compaction of fill should be observed and tested by Entech during construction. Entech should approve any import materials prior to hauling them to the site.

ADDITIONAL SUBSURFACE SOIL INVESTIGATIONS:

Additional subsurface soil investigations are recommended when building locations and grading plans are determined. The individual open foundation excavations should also be observed prior to construction of the foundation in order to verify that no anomalies are present, that materials at the proper design bearing capacity have been encountered, no unsuitable fill soils are present, and that no soft or loose spots or debris are present in the foundation area. Final

Waterview Commercial Investors, LLC
Preliminary Subsurface Soils Investigation
Powers Boulevard and Bradley Road
El Paso County, Colorado

drainage recommendations should also be determined at the time of the excavation observations.

CLOSURE:

The Preliminary Subsurface Investigation, geotechnical evaluation and recommendations presented in this report are intended for use by Waterview Commercial Investors, LLC for the subject site. The borings were located to provide preliminary recommendations, variations in site subsurface conditions not indicated on the borings should be anticipated. Preliminary grading plans with respect to the soils encountered can be evaluated once plans become available. Additional subsurface investigation and testing is recommended to further evaluate the site after development plans are prepared.

In conducting the preliminary subsurface investigation, laboratory testing, engineering evaluation and reporting, Entech Engineering, Inc. endeavored to work in accordance with generally accepted professional geotechnical and geologic practices and principles consistent with the level of care and skill ordinarily exercised by members of the geotechnical profession currently practicing in same locality and under similar conditions. No other warranty, expressed or implied is made.

If there are any questions regarding the information provided herein or if Entech Engineering, Inc. can be of further assistance, please do not hesitate to contact us.

Respectfully Submitted,

ENTECH ENGINEERING, INC.

Stuart Wood
Geologist



Reviewed by:

Joseph C. Goode, Jr., P.E.
President

LLL/am

Entech Job No. 220689
AAPProjects/2022/220689 pssi



TABLE

TABLE 1
SUMMARY OF LABORATORY TEST RESULTS

CLIENT WATERVIEW COMMERCIAL
PROJECT WATERVIEW EAST DEV.
JOB NO. 220689

SOIL TYPE	TEST BORING NO.	DEPTH (FT)	WATER (%)	DRY DENSITY (PCF)	PASSING NO. 200 SIEVE (%)	LIQUID LIMIT (%)	PLASTIC INDEX (%)	SULFATE (WT %)	FHA SWELL (PSF)	SWELL/ CONSOL (%)	UNIFIED CLASSIFICATION	SOIL DESCRIPTION
1	3	2-3			21.7	NV	NP	<0.01			SM	SAND,S ILTY
1	4	5			47.1						SM	SAND, VERY SILTY
1	5	10			20.2						SM	SAND, SILTY
2	2	5	9.7	89.9	81.7	33	14	<0.01		-0.4	CL	CLAY, SANDY
2	6	20	21.9	100.5	81.4					1.4	CL	CLAY, SANDY
2	7	2-3			85.5						CL	CLAY, SANDY
3	1	15	13.9	109.6	84.4	43	24	<0.01		2.1	CL	CLAYSTONE, SANDY

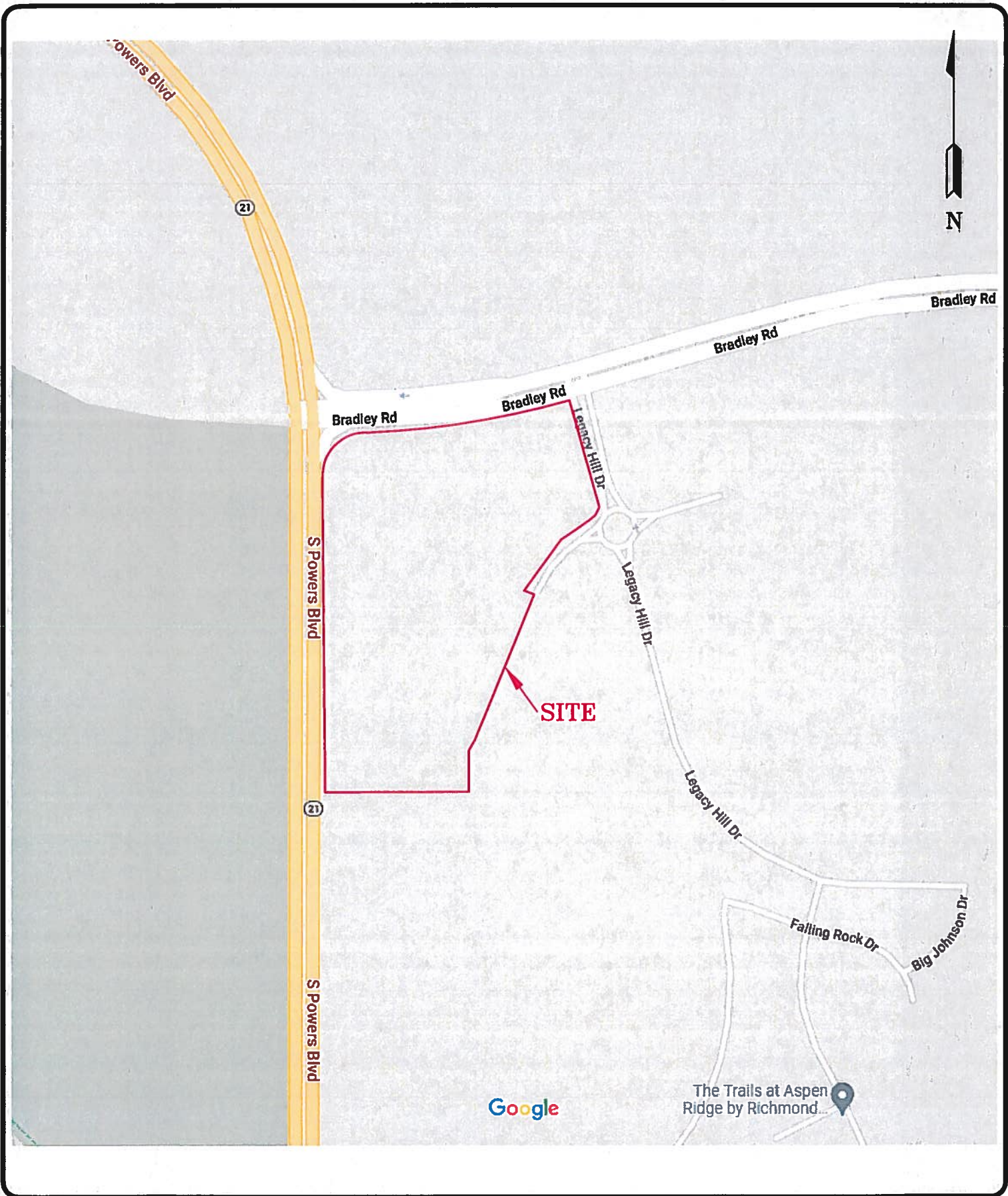
FIGURES

ENTECH
ENGINEERING, INC.
585 ELKTON DRIVE
COLORADO SPRINGS, CO. 80907 (719) 531-5599

VICINITY MAP
WATERVIEW EAST DEVELOPMENT
COLORADO SPRINGS, CO.
FOR: WATERVIEW COMMERCIAL INVESTORS, LLC

DRAWN: JAC	DATE: 4/29/22	CHECKED: DPS	DATE:
---------------	------------------	-----------------	-------

JOB NO.:
220689

FIG NO.:
1

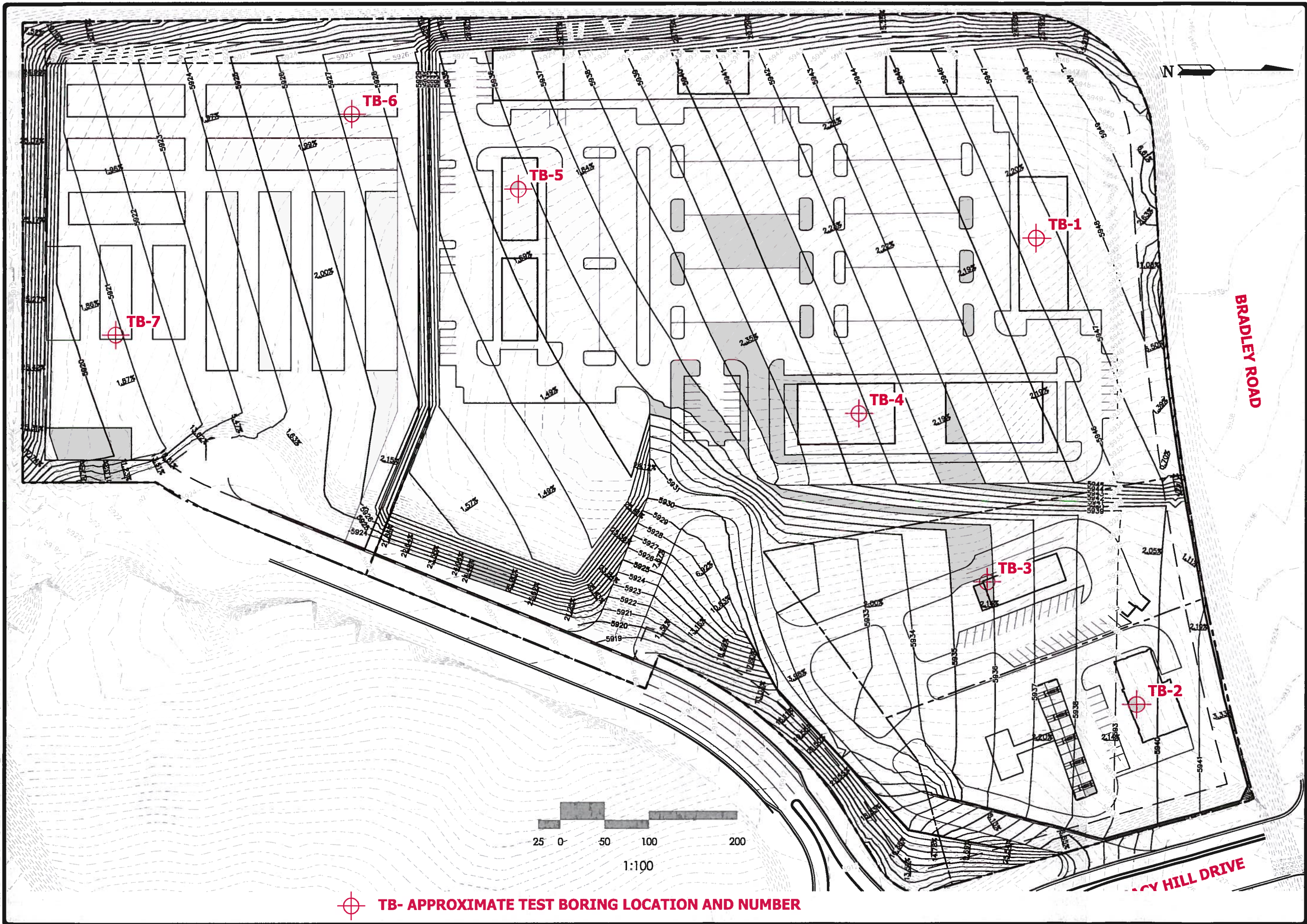

 TB- APPROXIMATE TEST BORING LOCATION AND NUMBER

REVISION	BY

ENTTECH
ENGINEERING, INC.
505 ELKTON DRIVE
COLORADO SPRINGS, CO. 80907 (719) 531-5599



TEST BORING LOCATION MAP
WATERVIEW EAST DEVELOPMENT
COLORADO SPRINGS, CO.
FOR: WATERVIEW COMMERCIAL INVESTORS, LLC

DRWN	JAC
CHKD	DPS
DATE	4/29/22
SCALE	1:100
JOB NO.	220489
FIGURE NO.	2

APPENDIX A: Test Boring Logs

TEST BORING NO. 1
 DATE DRILLED 4/11/2022
 Job # 220689

TEST BORING NO. 2
 DATE DRILLED 4/11/2022
 CLIENT WATERVIEW COMMERCIAL
 LOCATION WATERVIEW EAST DEV.

REMARKS	Depth (ft)	Symbol	Samples	Blows per foot	Watercontent %	Soil Type	REMARKS	Depth (ft)	Symbol	Samples	Blows per foot	Watercontent %	Soil Type
DRY TO 18', 4/14/22							DRY TO 17', 4/14/22						
SAND, SILTY, FINE TO MEDIUM GRAINED, TAN, DENSE, DRY TO MOIST	5			35	2.1	1	CLAY, SANDY, DARK BROWN, STIFF TO FIRM, MOIST	5			15	6.9	2
	5			31	4.9	1		5			22	7.1	2
CLAY, SANDY, BROWN, VERY STIFF, MOIST	10			34	8.4	2		10			13	11.5	2
CLAYSTONE, SANDY, BROWN, HARD, MOIST	15			50	11.1	3		15			17	13.8	2
				11"			CLAYSTONE, SANDY, BROWN, HARD, MOIST	20			50	10.3	3
	20			50	12.3	3		20			2"		



ENTECH
ENGINEERING, INC.

505 ELKTON DRIVE
 COLORADO SPRINGS, COLORADO 80907

TEST BORING LOG

DRAWN:

DATE:

CHECKED: *SW*

DATE: *4-26-22*

JOB NO.:
 220689

FIG NO.:
 A-1

TEST BORING NO. 3
 DATE DRILLED 4/11/2022
 Job # 220689

TEST BORING NO. 4
 DATE DRILLED 4/11/2022
 CLIENT WATERVIEW COMMERCIAL
 LOCATION WATERVIEW EAST DEV.

REMARKS

DRY TO 18', 4/14/22
 SAND, SILTY, FINE TO MEDIUM
 GRAINED, TAN, MEDIUM DENSE,
 DRY TO MOIST

CLAY, SANDY, GRAY BROWN,
 VERY STIFF, MOIST

CLAYSTONE, SANDY, GRAY
 BROWN, HARD, MOIST

Depth (ft)	Symbol	Samples	Blows per foot	Watercontent %	Soil Type
5			10	2.8	1
5			14	4.2	1
10			36	12.3	2
15			50 9"	13.4	3
20			50	13.7	3

REMARKS

DRY TO 18', 4/14/22
 SAND, VERY SILTY TO SILTY,
 FINE TO MEDIUM GRAINED, TAN,
 MEDIUM DENSE, MOIST

Depth (ft)	Symbol	Samples	Blows per foot	Watercontent %	Soil Type
5			21	5.3	1
5			12	5.1	1
10			28	3.0	1
15			16	3.4	1
20			19	3.5	1



ENTECH
ENGINEERING, INC.

505 ELKTON DRIVE
 COLORADO SPRINGS, COLORADO 80907

TEST BORING LOG

DRAWN:

DATE:

CHECKED: SW

DATE: 4-26-22

JOB NO:
 220689

FIG NO:
 A- 2

TEST BORING NO. 5
 DATE DRILLED 4/11/2022
 Job # 220689

TEST BORING NO. 6
 DATE DRILLED 4/11/2022
 CLIENT WATERVIEW COMMERCIAL
 LOCATION WATERVIEW EAST DEV.

REMARKS						REMARKS					
Depth (ft)	Symbol	Samples	Blows per foot	Watercontent %	Soil Type	Depth (ft)	Symbol	Samples	Blows per foot	Watercontent %	Soil Type
DRY TO 19', 4/14/22						DRY TO 19', 4/14/22					
SAND, SILTY, FINE TO MEDIUM GRAINED, TAN, MEDIUM DENSE, DRY TO MOIST						SAND, SILTY, FINE TO MEDIUM GRAINED, TAN, MEDIUM DENSE, MOIST					
5			29	2.4	1	5			17	4.2	1
			25	2.0	1				17	3.7	1
10			21	2.6	1	10			25	3.6	1
15			16	3.5	1	15			43	4.3	1
20			17	5.5	1	20			26	17.3	2
						CLAY, SANDY, BROWN, STIFF, MOIST					



ENTECH
ENGINEERING, INC.

505 ELKTON DRIVE
 COLORADO SPRINGS, COLORADO 80907

TEST BORING LOG

DRAWN: DATE: CHECKED: *SW* DATE: *4-26-22*

JOB NO:
 220689

FIG NO:
 A- 3

TEST BORING NO. 7
 DATE DRILLED 4/11/2022
 Job # 220689

TEST BORING NO.
 DATE DRILLED
 CLIENT WATERVIEW COMMERCIAL
 LOCATION WATERVIEW EAST DEV.

REMARKS

DRY TO 18.5', 4/14/22
 CLAY, SANDY, TAN, FIRM,
 MOIST

SAND, SILTY, FINE TO MEDIUM
 GRAINED, TAN, MEDIUM DENSE
 TO DENSE, MOIST

Depth (ft)	Symbol	Samples	Blows per foot	Watercontent %	Soil Type
0 - 12			12	18.5	2
12 - 22			22	6.0	1
22 - 23			23	3.0	1
23 - 40			40	3.9	1
40 - 20			32	8.6	1

REMARKS

Depth (ft)	Symbol	Samples	Blows per foot	Watercontent %	Soil Type
0 - 5					
5 - 10					
10 - 15					
15 - 20					



ENTECH
ENGINEERING, INC.

505 ELKTON DRIVE
 COLORADO SPRINGS, COLORADO 80907

TEST BORING LOG

DRAWN:

DATE:

CHECKED: SW

DATE: 4-26-22

JOB NO.:
 220689

FIG NO.:
 A-4

APPENDIX B: Laboratory Test Results

<u>UNIFIED CLASSIFICATION</u>	SM	<u>CLIENT</u>	WATERVIEW COMMERCIAL
<u>SOIL TYPE #</u>	1	<u>PROJECT</u>	WATERVIEW EAST DEV.
<u>TEST BORING #</u>	3	<u>JOB NO.</u>	220689
<u>DEPTH (FT)</u>	2-3	<u>TEST BY</u>	BL

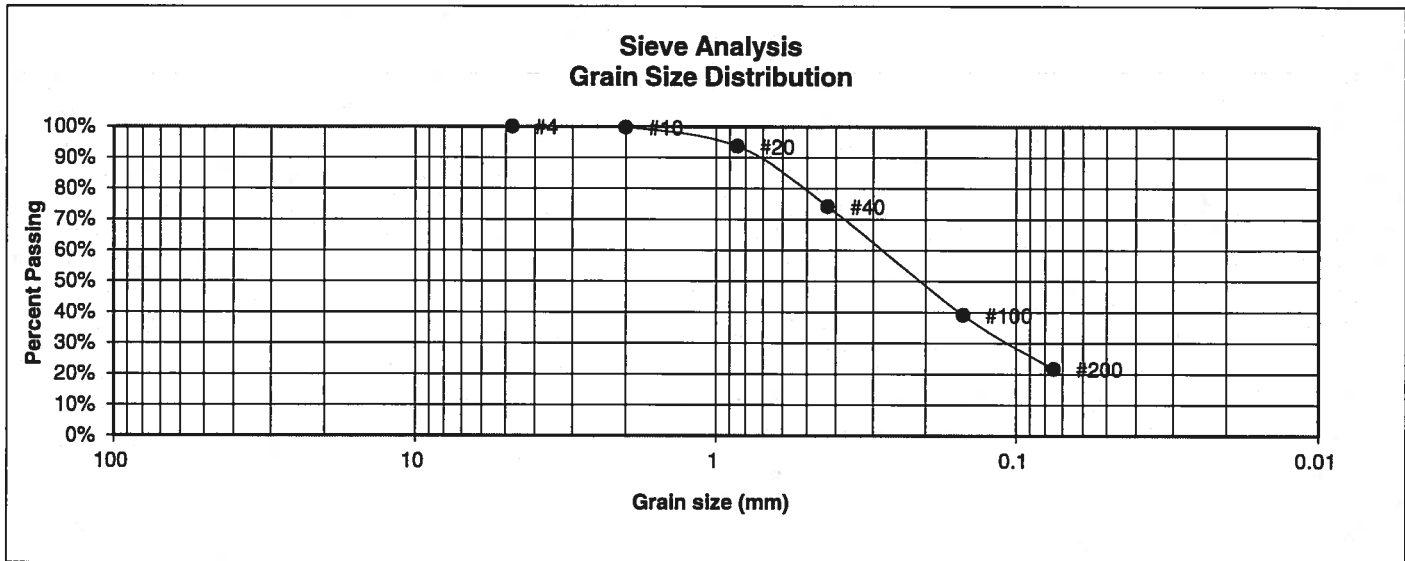

U.S. Sieve #	Percent Finer
3"	
1 1/2"	
3/4"	
1/2"	
3/8"	
4	100.0%
10	99.7%
20	93.6%
40	74.1%
100	39.1%
200	21.7%

<u>Atterberg Limits</u>	
Plastic Limit	NP
Liquid Limit	NV
Plastic Index	NP

<u>Swell</u>	
Moisture at start	
Moisture at finish	
Moisture increase	
Initial dry density (pcf)	
Swell (psf)	



**ENTECH
ENGINEERING, INC.**
505 ELKTON DRIVE
COLORADO SPRINGS, COLORADO 80907

**LABORATORY TEST
RESULTS**

DRAWN:	DATE:	CHECKED: <i>SW</i>	DATE: <i>4-26-22</i>
--------	-------	--------------------	----------------------

JOB NO.:
220689

FIG NO.:

B-1

<u>UNIFIED CLASSIFICATION</u>	SM	<u>CLIENT</u>	WATERVIEW COMMERCIAL
<u>SOIL TYPE #</u>	1	<u>PROJECT</u>	WATERVIEW EAST DEV.
<u>TEST BORING #</u>	4	<u>JOB NO.</u>	220689
<u>DEPTH (FT)</u>	5	<u>TEST BY</u>	BL

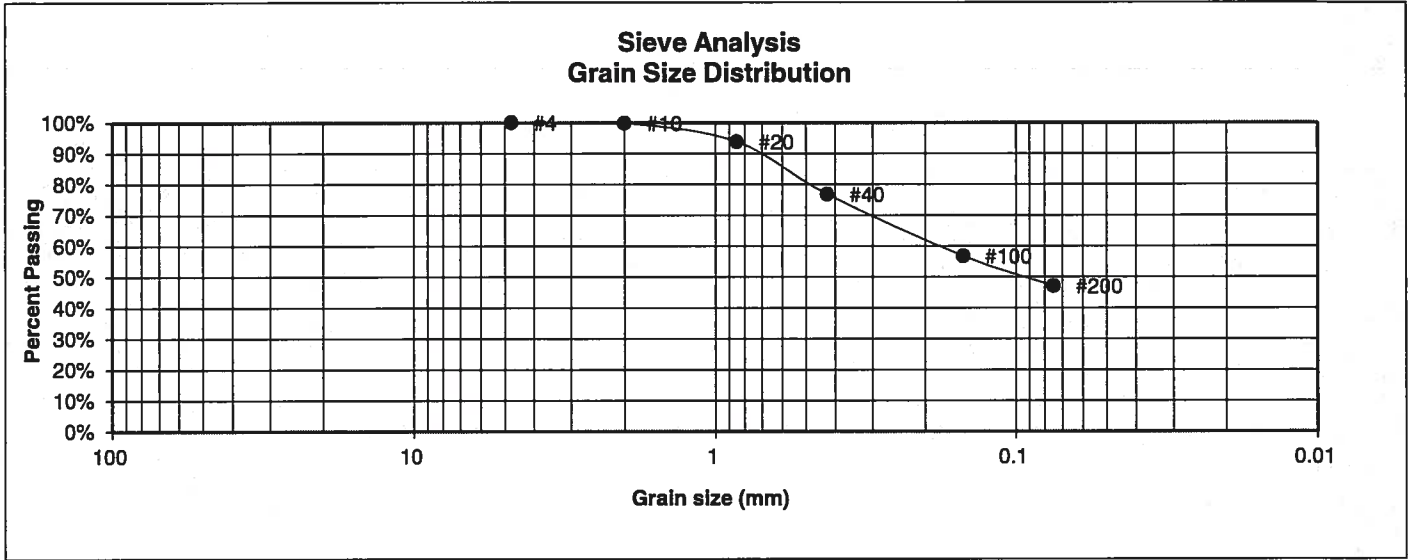

<u>U.S. Sieve #</u>	<u>Percent Finer</u>
3"	
1 1/2"	
3/4"	
1/2"	
3/8"	
4	100.0%
10	99.9%
20	93.8%
40	76.8%
100	56.8%
200	47.1%

Atterberg Limits
 Plastic Limit
 Liquid Limit
 Plastic Index

Swell
 Moisture at start
 Moisture at finish
 Moisture increase
 Initial dry density (pcf)
 Swell (psf)



**ENTECH
ENGINEERING, INC.**

505 ELKTON DRIVE
COLORADO SPRINGS, COLORADO 80907

**LABORATORY TEST
RESULTS**

DRAWN:	DATE:	CHECKED: <i>SW</i>	DATE: <i>4-26-22</i>
--------	-------	--------------------	----------------------

JOB NO.:
220689

FIG NO.:
B-2

<u>UNIFIED CLASSIFICATION</u>	SM	<u>CLIENT</u>	WATERVIEW COMMERCIAL
<u>SOIL TYPE #</u>	1	<u>PROJECT</u>	WATERVIEW EAST DEV.
<u>TEST BORING #</u>	5	<u>JOB NO.</u>	220689
<u>DEPTH (FT)</u>	10	<u>TEST BY</u>	BL

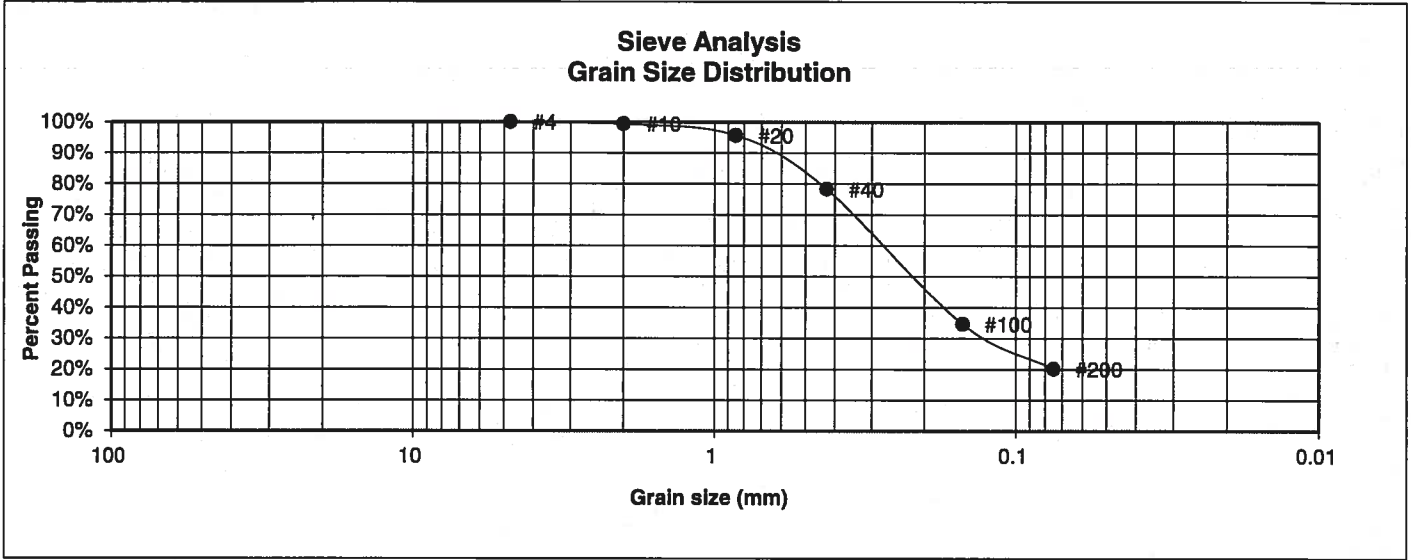

U.S. Sieve #	Percent Finer
3"	
1 1/2"	
3/4"	
1/2"	
3/8"	
4	100.0%
10	99.4%
20	95.7%
40	78.3%
100	34.7%
200	20.2%

- Atterberg Limits
 Plastic Limit
 Liquid Limit
 Plastic Index
- Swell
 Moisture at start
 Moisture at finish
 Moisture increase
 Initial dry density (pcf)
 Swell (psf)



ENTECH ENGINEERING, INC.
 505 ELKTON DRIVE
 COLORADO SPRINGS, COLORADO 80907

LABORATORY TEST RESULTS

DRAWN:	DATE:	CHECKED: SW	DATE: 4-26-22
--------	-------	-------------	---------------

JOB NO.: 220689
 FIG NO.: B-3

<u>UNIFIED CLASSIFICATION</u>	CL	<u>CLIENT</u>	WATERVIEW COMMERCIAL
<u>SOIL TYPE #</u>	2	<u>PROJECT</u>	WATERVIEW EAST DEV.
<u>TEST BORING #</u>	2	<u>JOB NO.</u>	220689
<u>DEPTH (FT)</u>	5	<u>TEST BY</u>	BL

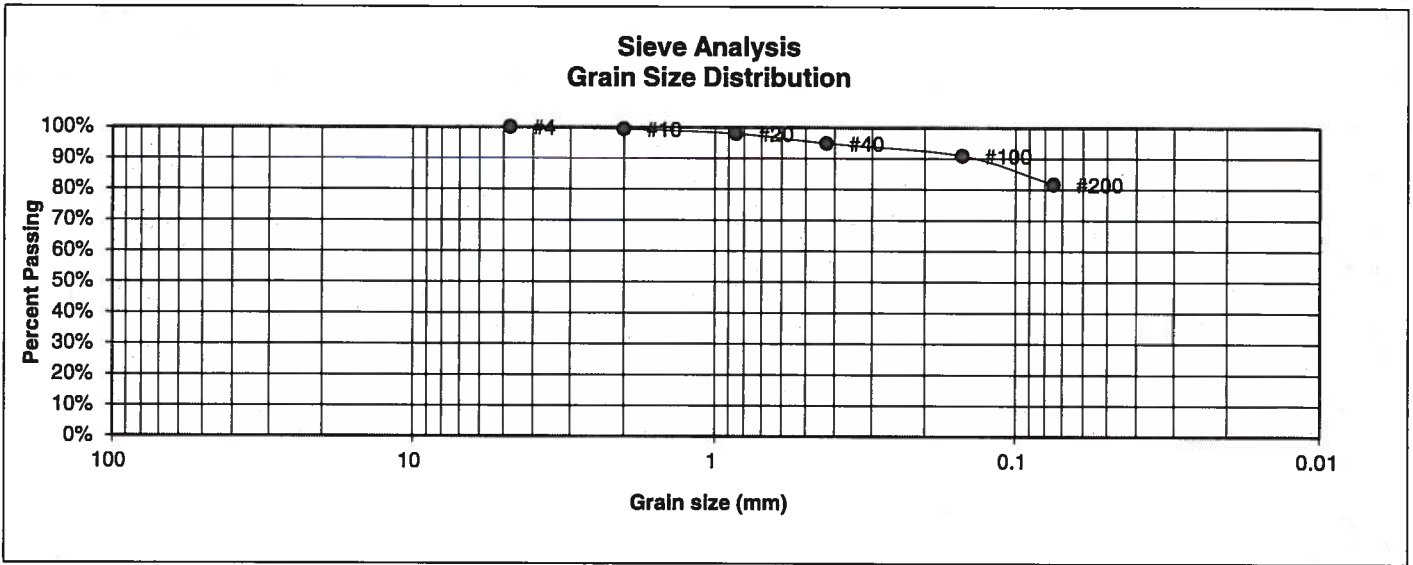

U.S. Sieve #	Percent Finer
3"	
1 1/2"	
3/4"	
1/2"	
3/8"	
4	100.0%
10	99.4%
20	98.0%
40	94.8%
100	90.9%
200	81.7%

<u>Atterberg Limits</u>	
Plastic Limit	19
Liquid Limit	33
Plastic Index	14

<u>Swell</u>	
Moisture at start	
Moisture at finish	
Moisture increase	
Initial dry density (pcf)	
Swell (psf)	



**ENTECH
ENGINEERING, INC.**
505 ELKTON DRIVE
COLORADO SPRINGS, COLORADO 80907

**LABORATORY TEST
RESULTS**

DRAWN:	DATE:	CHECKED: SW	DATE: 4-26-22
--------	-------	-------------	---------------

JOB NO.:
220689

FIG NO.:
B-4

<u>UNIFIED CLASSIFICATION</u>	CL	<u>CLIENT</u>	WATERVIEW COMMERCIAL
<u>SOIL TYPE #</u>	2	<u>PROJECT</u>	WATERVIEW EAST DEV.
<u>TEST BORING #</u>	6	<u>JOB NO.</u>	220689
<u>DEPTH (FT)</u>	20	<u>TEST BY</u>	BL

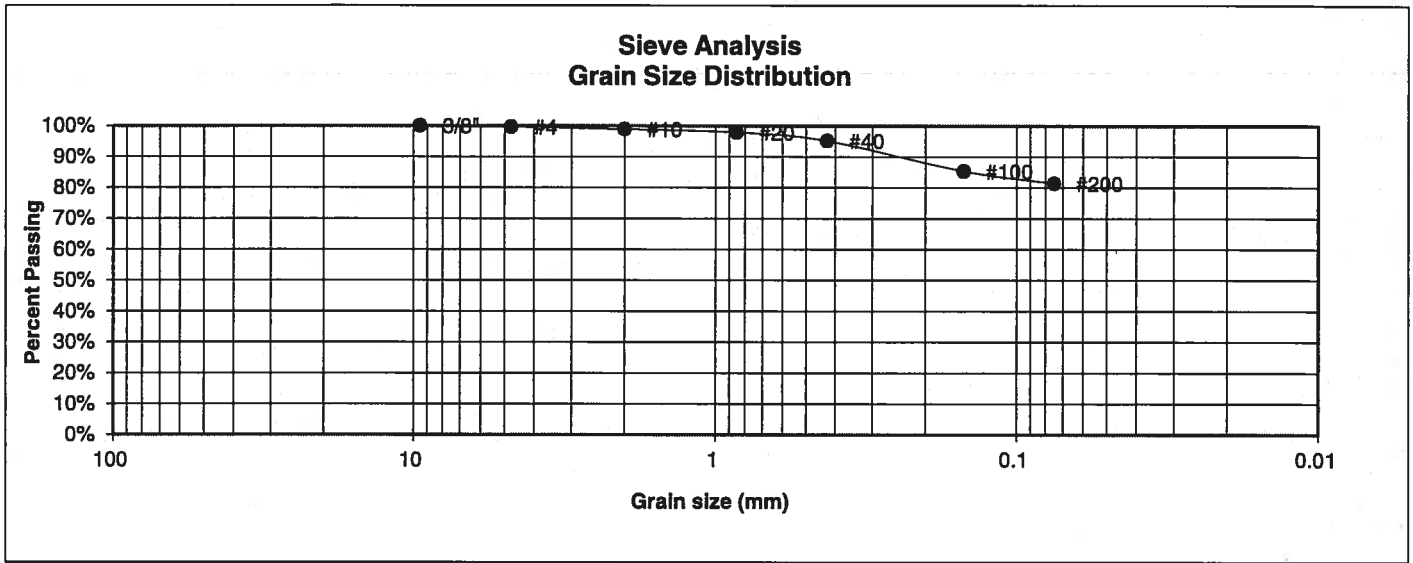

<u>U.S. Sieve #</u>	<u>Percent Finer</u>
3"	
1 1/2"	
3/4"	
1/2"	
3/8"	100.0%
4	99.6%
10	98.9%
20	97.9%
40	95.2%
100	85.3%
200	81.4%

Atterberg
Limits
Plastic Limit
Liquid Limit
Plastic Index

Swell
Moisture at start
Moisture at finish
Moisture increase
Initial dry density (pcf)
Swell (psf)



**ENTECH
ENGINEERING, INC.**
505 ELKTON DRIVE
COLORADO SPRINGS, COLORADO 80907

**LABORATORY TEST
RESULTS**

<u>DRAWN:</u>	<u>DATE:</u>	<u>CHECKED:</u> SW	<u>DATE:</u> 4-26-22
---------------	--------------	-----------------------	-------------------------

JOB NO.:
220689

FIG NO.:
B-5

<u>UNIFIED CLASSIFICATION</u>	CL	<u>CLIENT</u>	WATERVIEW COMMERCIAL
<u>SOIL TYPE #</u>	2	<u>PROJECT</u>	WATERVIEW EAST DEV.
<u>TEST BORING #</u>	7	<u>JOB NO.</u>	220689
<u>DEPTH (FT)</u>	2-3	<u>TEST BY</u>	BL

**Sieve Analysis
Grain Size Distribution**

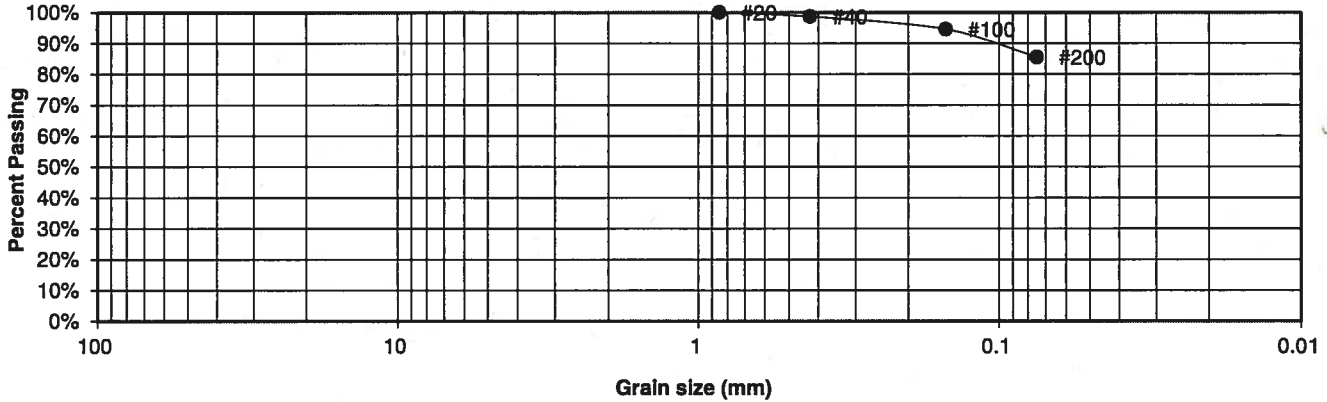

<u>U.S. Sieve #</u>	<u>Percent Finer</u>
3"	
1 1/2"	
3/4"	
1/2"	
3/8"	
4	
10	
20	100.0%
40	98.7%
100	94.5%
200	85.5%

- Atterberg Limits
 Plastic Limit
 Liquid Limit
 Plastic Index
- Swell
 Moisture at start
 Moisture at finish
 Moisture increase
 Initial dry density (pcf)
 Swell (psf)



**ENTECH
ENGINEERING, INC.**
 505 ELKTON DRIVE
 COLORADO SPRINGS, COLORADO 80907

**LABORATORY TEST
RESULTS**

DRAWN:	DATE:	CHECKED: <i>SW</i>	DATE: <i>4-26-22</i>
--------	-------	--------------------	----------------------

JOB NO.:
220689

FIG NO.:
B-6

<u>UNIFIED CLASSIFICATION</u>	CL	<u>CLIENT</u>	WATERVIEW COMMERCIAL
<u>SOIL TYPE #</u>	3	<u>PROJECT</u>	WATERVIEW EAST DEV.
<u>TEST BORING #</u>	1	<u>JOB NO.</u>	220689
<u>DEPTH (FT)</u>	15	<u>TEST BY</u>	BL

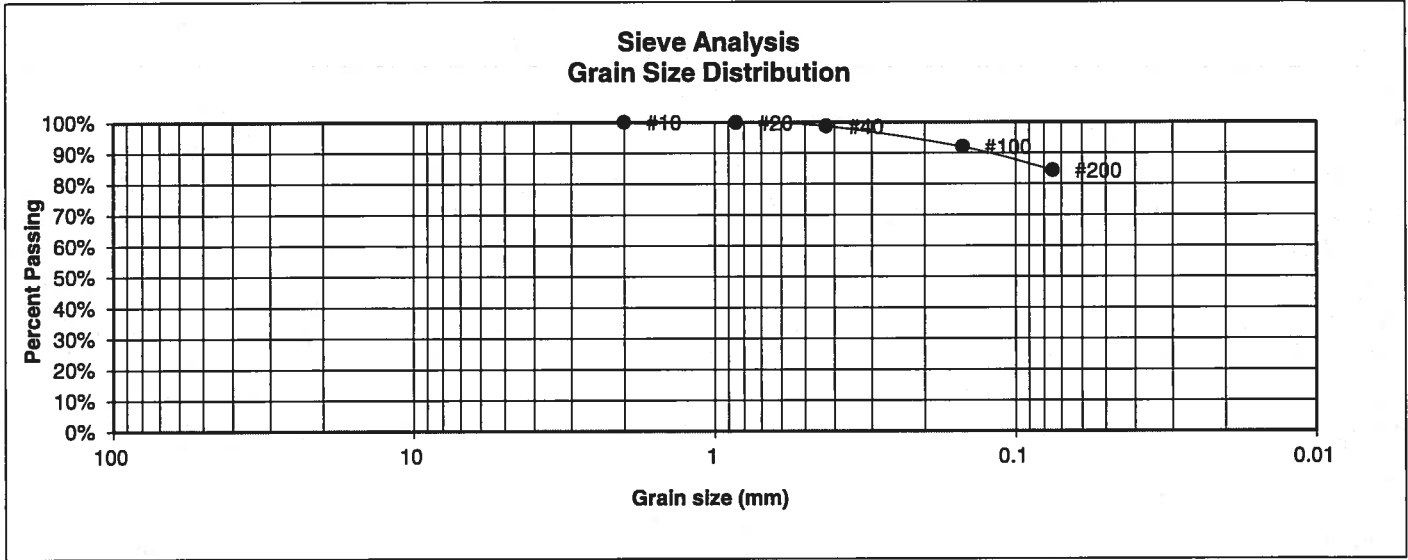

<u>U.S. Sieve #</u>	<u>Percent Finer</u>
3"	
1 1/2"	
3/4"	
1/2"	
3/8"	
4	
10	100.0%
20	99.9%
40	98.7%
100	92.0%
200	84.4%

<u>Atterberg Limits</u>	
Plastic Limit	19
Liquid Limit	43
Plastic Index	24

<u>Swell</u>	
Moisture at start	
Moisture at finish	
Moisture increase	
Initial dry density (pcf)	
Swell (psf)	



**ENTECH
ENGINEERING, INC.**
505 ELKTON DRIVE
COLORADO SPRINGS, COLORADO 80907

**LABORATORY TEST
RESULTS**

DRAWN:	DATE:	CHECKED: SW	DATE: 4-26-22
--------	-------	-------------	---------------

JOB NO.:
220689

FIG NO.:
B-7

CONSOLIDATION TEST RESULTS

TEST BORING #	2	DEPTH(ft)	5
DESCRIPTION	CL	SOIL TYPE	2
NATURAL UNIT DRY WEIGHT (PCF)			90
NATURAL MOISTURE CONTENT			9.7%
SWELL/CONSOLIDATION (%)			-0.4%

JOB NO. 220689
 CLIENT WATERVIEW COMMERCIAL
 PROJECT WATERVIEW EAST DEV.

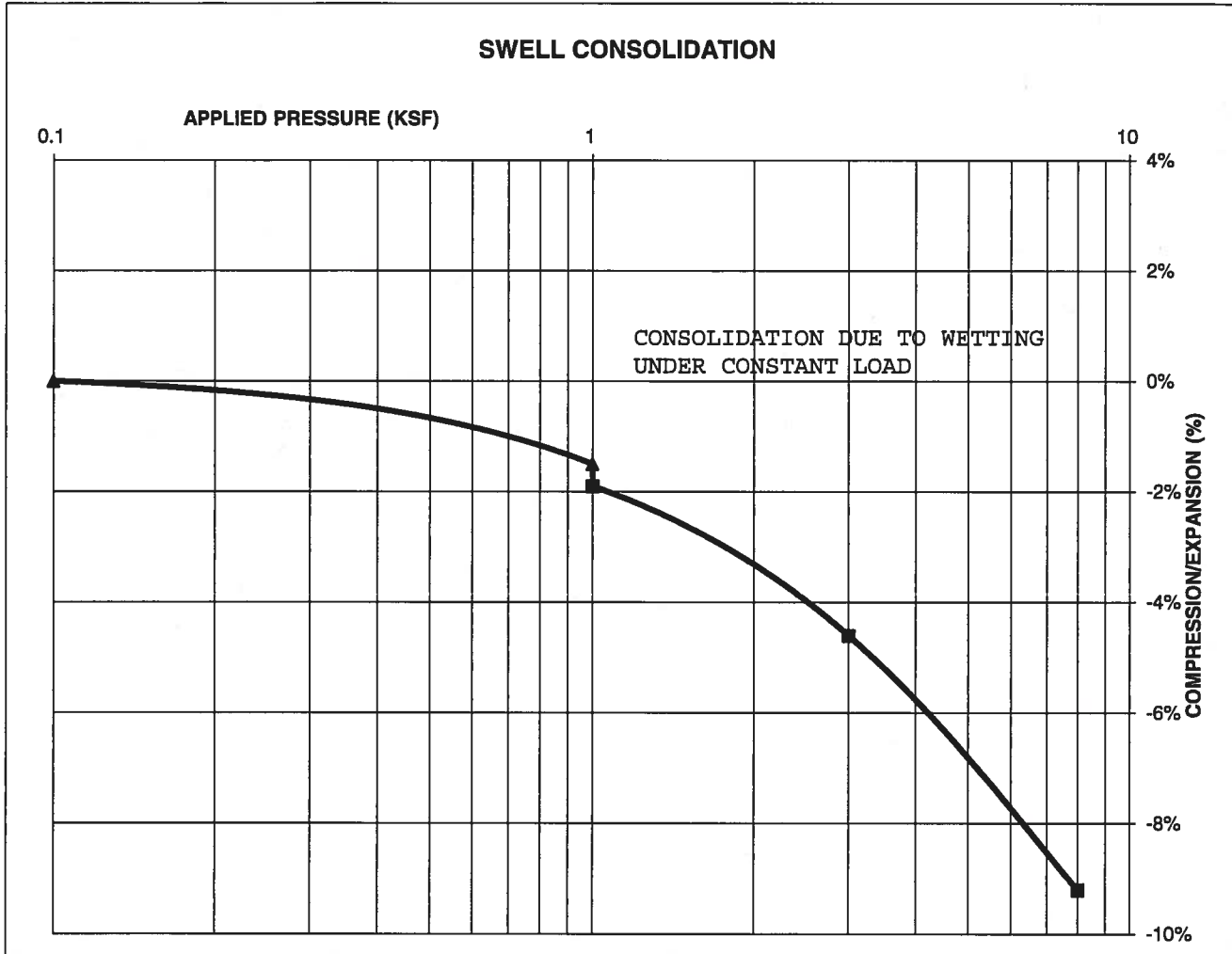

**ENTECH
ENGINEERING, INC.**

505 ELKTON DRIVE
 COLORADO SPRINGS, COLORADO 80907

**SWELL CONSOLIDATION
TEST RESULTS**

DRAWN:

DATE:

CHECKED: *SW*

DATE: *4-26-22*

JOB NO:
220689

FIG NO:
B-8

CONSOLIDATION TEST RESULTS

TEST BORING #	6	DEPTH(ft)	20
DESCRIPTION	CL	SOIL TYPE	2
NATURAL UNIT DRY WEIGHT (PCF)			100
NATURAL MOISTURE CONTENT			21.9%
SWELL/CONSOLIDATION (%)			1.4%

JOB NO. 220689
 CLIENT WATERVIEW COMMERCIAL
 PROJECT WATERVIEW EAST DEV.

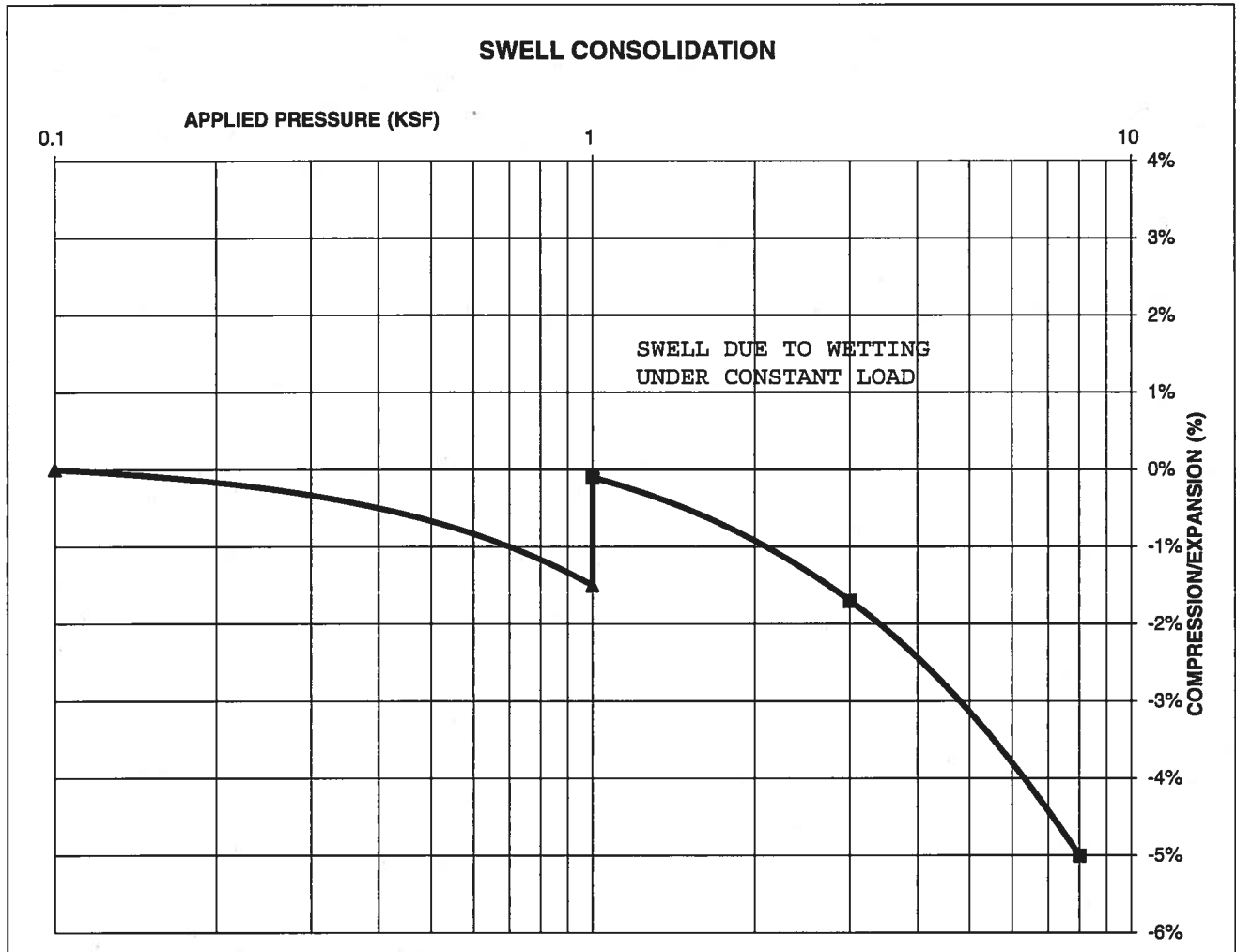

**ENTECH
ENGINEERING, INC.**

505 ELKTON DRIVE
 COLORADO SPRINGS, COLORADO 80907

**SWELL CONSOLIDATION
TEST RESULTS**

DRAWN:

DATE:

CHECKED: *SW*

DATE: *4-26-22*

JOB NO.:
220689

FIG NO.:
B-9

CONSOLIDATION TEST RESULTS

TEST BORING #	1	DEPTH(ft)	15
DESCRIPTION	CL	SOIL TYPE	3
NATURAL UNIT DRY WEIGHT (PCF)			110
NATURAL MOISTURE CONTENT			13.9%
SWELL/CONSOLIDATION (%)			2.1%

JOB NO. 220689
 CLIENT WATERVIEW COMMERCIAL
 PROJECT WATERVIEW EAST DEV.

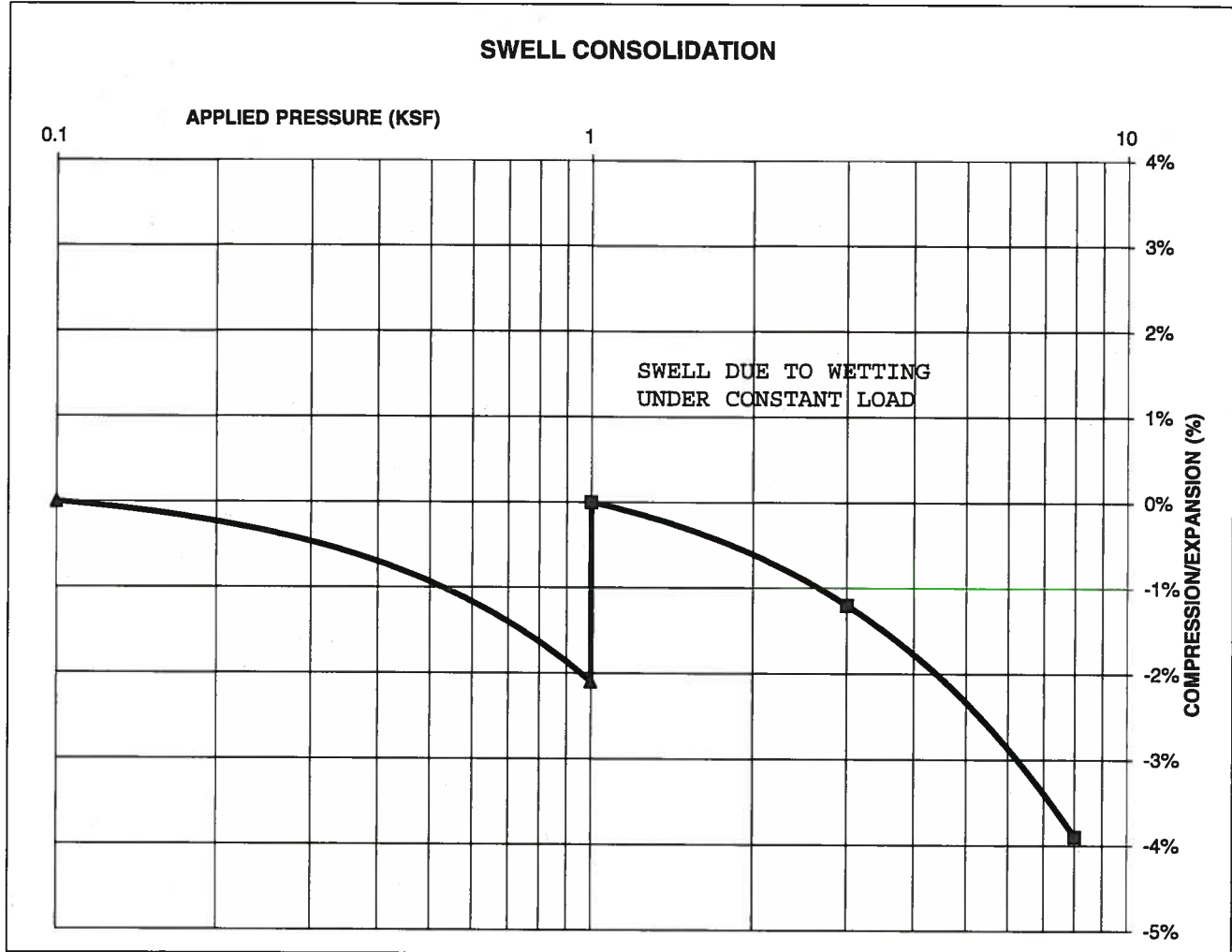

**ENTECH
 ENGINEERING, INC.**

505 ELKTON DRIVE
 COLORADO SPRINGS, COLORADO 80907

**SWELL CONSOLIDATION
 TEST RESULTS**

DRAWN:

DATE:

CHECKED: *SW*

DATE: *4-26-22*

JOB NO.:
 220689

FIG NO.:
B-10

El Paso County Drainage Basin Fees

Resolution No. 21-468

Basin Number	Receiving Waters	Year Studied	Drainage Basin Name	2022 Drainage Fee (per Impervious Acre)	2022 Bridge Fee (per Impervious Acre)
<u>Drainage Basins with DBPS's:</u>					
CHMS0200	Chico Creek	2013	Haegler Ranch	\$11,891	\$1,755
CHWS1200	Chico Creek	2001	Bennett Ranch	\$13,312	\$5,106
CHWS1400	Chico Creek	2013	Falcon	\$34,117	\$4,687
FOFO2000	Fountain Creek	2001	West Fork Jimmy Camp Creek	\$14,470	\$4,281
FOFO2600	Fountain Creek	1991*	Big Johnson / Crews Gulch	\$21,134	\$2,729
FOFO2800	Fountain Creek	1988*	Widefield	\$21,134	\$0
FOFO2900	Fountain Creek	1988*	Security	\$21,134	\$0
FOFO3000	Fountain Creek	1991*	Windmill Gulch	\$21,134	\$317
FOFO3100 / FOFO3200	Fountain Creek	1988*	Carson Street / Little Johnson	\$12,891	\$0
FOFO3400	Fountain Creek	1984*	Peterson Field	\$15,243	\$1,156
FOFO3600	Fountain Creek	1991*	Fisher's Canyon	\$21,134	\$0
FOFO4000	Fountain Creek	1996	Sand Creek	\$21,814	\$8,923
FOFO4200	Fountain Creek	1977	Spring Creek	\$10,961	\$0
FOFO4600	Fountain Creek	1984*	Southwest Area	\$21,134	\$0
FOFO4800	Fountain Creek	1991	Bear Creek	\$21,134	\$1,156
FOFO5800	Fountain Creek	1964	Camp Creek	\$2,342	\$0
FOMO1000	Monument Creek	1981	Douglas Creek	\$13,291	\$294
FOMO1200	Monument Creek	1977	Templeton Gap	\$13,644	\$317
FOMO2000	Monument Creek	1971	Pulpit Rock	\$7,008	\$0
FOMO2200	Monument Creek	1994	Cottonwood Creek / S. Pine	\$21,134	\$1,156
FOMO2400	Monument Creek	1966	Dry Creek	\$16,684	\$604
FOMO3600	Monument Creek	1989*	Black Squirrel Creek	\$9,595	\$604
FOMO3700	Monument Creek	1987*	Middle Tributary	\$17,636	\$0
FOMO3800	Monument Creek	1987*	Monument Branch	\$21,134	\$0
FOMO4000	Monument Creek	1996	Smith Creek	\$8,616	\$1,156
FOMO4200	Monument Creek	1989*	Black Forest	\$21,134	\$575
FOMO5200	Monument Creek	1993*	Dirty Woman Creek	\$21,134	\$1,156
FOMO5300	Fountain Creek	1993*	Crystal Creek	\$21,134	\$1,156
<u>Miscellaneous Drainage Basins: ¹</u>					
CHBS0800	Chico Creek		Book Ranch	\$19,830	\$2,871
CHEC0400	Chico Creek		Upper East Chico	\$10,803	\$313
CHWS0200	Chico Creek		Telephone Exchange	\$11,870	\$278
CHWS0400	Chico Creek		Livestock Company	\$19,552	\$233
CHWS0600	Chico Creek		West Squirrel	\$10,192	\$4,229
CHWS0800	Chico Creek		Solberg Ranch	\$21,134	\$0
FOFO1200	Fountain Creek		Crooked Canyon	\$6,381	\$0
FOFO1400	Fountain Creek		Calhan Reservoir	\$5,327	\$310
FOFO1600	Fountain Creek		Sand Canyon	\$3,849	\$0
FOFO2000	Fountain Creek		Jimmy Camp Creek ³	\$21,134	\$989
FOFO2200	Fountain Creek		Fort Carson	\$16,684	\$604
FOFO2700	Fountain Creek		West Little Johnson	\$1,392	\$0
FOFO3800	Fountain Creek		Stratton	\$10,137	\$453
FOFO5000	Fountain Creek		Midland	\$16,684	\$604
FOFO6000	Fountain Creek		Palmer Trail	\$16,684	\$604
FOFO6800	Fountain Creek		Black Canyon	\$16,684	\$604
FOMO4600	Monument Creek		Beaver Creek	\$12,635	\$0
FOMO3000	Monument Creek		Kettle Creek	\$11,413	\$0
FOMO3400	Monument Creek		Elkhorn	\$1,917	\$0
FOMO5000	Monument Creek		Monument Rock	\$9,160	\$0
FOMO5400	Monument Creek		Palmer Lake	\$14,647	\$0
FOMO5600	Monument Creek		Raspberry Mountain	\$4,927	\$0
PLPL0200	Monument Creek		Bald Mountain	\$10,500	\$0
<u>Interim Drainage Basins: ²</u>					
FOFO1800	Fountain Creek		Little Fountain Creek	\$2,702	\$0
FOMO4400	Monument Creek		Jackson Creek	\$8,365	\$0
FOMO4800	Monument Creek		Teachout Creek	\$5,809	\$873

1. The miscellaneous drainage fee previous to September 1999 resolution was the average of all drainage fees for basins with Basin Planning Studies performed within the last 14 years.

2. Interim Drainage Fees are based upon draft Drainage Basin Planning Studies or the Drainage Basin Identification and Fee Estimation Report. (Best available information suitable for setting a fee.)

3. This is an interim fee and will be adjusted when a DBPS is completed. In addition to the Drainage Fee a surety in the amount of \$7,285 per impervious acre shall be provided to secure payment of additional fees in the event that the DBPS results in a fee greater than the current fee. Fees paid in excess of the future revised fee will be reimbursed. See Resolution 06-326 (9/14/06) and Resolution 16-320 (9/07/16).

El Paso County Drainage Basin Fee Summary	
---	--

Total Impervious Acreage	12.83
--------------------------	-------

	2022 Drainage Fee (per Impervious Acre)	2022 Bridge Fee (per Impervious Acre)
West Fork Jimmy Camp Creek	\$ 14,470.00	\$ 4,281.00
Big Johnson/Crews Gulch	\$ 21,134.00	\$ 2,729.00
Total	\$ 456,799.32	\$ 89,938.30

Total Fees	\$ 546,737.62
------------	---------------

b. The **fully developed conditions** for the site are as follows:

1. **Big Johnson Reservoir:**

Under proposed conditions, developed flows for the westernmost drainage basin (Big Johnson Reservoir) will be directed into a proposed full spectrum detention pond on the west side of the site approximately 2,030 feet south of the intersection of Bradley Road and Powers Boulevard. Sub-basins and Design Points within this major basin are summarized in Tables 3.3, 3.4, and 3.5 below:

Table 3.3 Trails at Aspen Ridge Big Johnson Reservoir Proposed Conditions - Sub-basin Summary			
Basin	Area	Q5	Q100
	acres	cfs	cfs
Big Johnson Reservoir N	14.1	21.2	46.8
O	11.7	17.4	38.4
P	8.52	22.0	43.9
Q	2.4	4.2	8.8
OS-2	11.4	1.7	11.7

Table 3.4 Trails at Aspen Ridge Big Johnson Reservoir Proposed Design Point Summary					
Design Point	Sub-Basins	Downstream Design Point	Total Area (ac.)	Q(5) (cfs)	Q(100) (cfs)
N	N	P	14.1	21.2	46.8
O	O	P	11.7	17.4	38.4
P (Into West Pond)	N, O, P	West Pond Discharge	34.7	47.6	101.5
West Pond Discharge (UD-Detention)	N, O, P	Powers Ditch		1.0	28.3
Q	Q	Powers Ditch	2.4	4.9	10.3
OS-2 (This sub-basin is just southeast of the Powers and Bradley intersection. Flows which might have flowed across TAR to the Powers ditch will be diverted to the ditch prior to entering the TAR property.)	OS-2	Powers Ditch	11.4	1.7	11.7

Table 3.8 Trails at Aspen Ridge West Fork - Jimmy Camp Creek Proposed Design Point Flow Description	
Design Point	Description
OS-1	<ul style="list-style-type: none"> - This design point is at the downstream end of the offsite sub-basin north of Bradley Road. Flows in this sub-basin will sheet flow to the road ditch running along Bradley and Powers Boulevard. Once channelized in the ditch flows will be directed to a proposed 24-inch RCP storm pipe sleeved into one of the existing 42-inch CMP cross road pipes and conveyed on to design point A. - Please note that approximately 7.3 acres of the area tributary to this design point have been diverted from the Big Johnson Reservoir by CDOT construction of Powers Boulevard. Future development of that portion of the tributary sub-basin must redirect these flows to the Big Johnson Reservoir to maintain compliance with the two relevant DBPS reports. - Development of the OS-1 Sub-basin will require onsite detention and an FDR.
A	<ul style="list-style-type: none"> - This design point is at the manhole (MH-3) receiving flows from DP OS-1 to the north and flows from Sub-basin A captured in the two pairs of inlets on Frontside Drive to the east and west of its intersection with Legacy Drive. These flows will be conveyed on via 30-inch storm pipe to design point B. - Flows from the required onsite detention from the two commercial lots on either side of Legacy Drive will be picked up in the back of the inlets. A 24-inch storm pipe will be stubbed out for the west commercial lot (Inlet 1-A) and an 18-inch will be stubbed out for the east commercial lot (Inlet 3-A).
B	<ul style="list-style-type: none"> - This design point is at a manhole (MH-108) just downstream of an on-grade inlet (1-B) capturing gutter flows from the west half of Legacy Drive reflected in Sub-basin B. These flows are carried downstream via 30-inch storm pipe to design point C.
C	<ul style="list-style-type: none"> - This design point is a manhole (MH-6) which combines storm sewer flows from design point B with storm sewer flows from Sub-basin C. Flows in Sub-basin C will sheet flow off the residential lots and into the street curb and gutter. The road gutters will convey these flows on to be captured in four pairs of sump inlets (1-C through 8-C) and conveyed to the design point. The combined flows will be conveyed downstream via 42-inch storm pipe to design point D.
D	<ul style="list-style-type: none"> - This design point is at a manhole (MH-117) just downstream of an at-grade inlet (1-D) capturing flows from Sub-basin D. Flows in Sub-basin D will sheet flow to the Legacy Road curb and gutter. These gutter flows are captured in the at-grade inlet and combined with storm sewer flows from design point C and carried on via 42-inch storm pipe to design point E.
E	<ul style="list-style-type: none"> - This design point is located at a manhole (MH-15) just downstream of a pair of sump inlets capturing flows from Sub-basin E. Flows in Sub-basin E will sheet flow across the park area until being captured in the curb and gutter along Falling Rock Drive. Concentrated gutter flows will then be captured by the sump inlets and conveyed on via storm sewer to the design point. These flows will be combined with flows from design point D and carried on via 48-inch storm pipe to design point G.

Project Name: Trails at Aspen Ridge (Waterview II)
 Project Location: El Paso County, CO
 Designer: JTS
 Notes: Proposed Condition

Heavy Meadow	2
Tillage/Field	3
Short Pasture and Lawns	4
Nearly Bare Ground	5
Grassed Waterway	6
Paved Areas	7

Average Channel Velocity: 4 ft/s (If specific channel vel is used, this will be ignored)
 Average Slope for Initial Flow: 0.04 ft/ft (If Elevations are used, this will be ignored)

Sub-basin	Comments	Area		Rational 'C' Values													Flow Lengths				Average (decimal) Slope	Initial Tc (min)	Average (%) Slope	Channel Flow Type (See Key above) Ground Type	Velocity (ft/s)	Channel Tc (min)	Tc (min)	Rainfall Intensity & Rational Flow Rate				SWMM Values			
		sf	acres	Surface Type 1 Residential 1/8 or less (65% Imp.)		Surface Type 2 Pavement (100% Imp.)		Surface Type 3 Park (7% Imp.)		Surface Type 4 Undeveloped (2% Imp.)		Composite		Percent Impervious	Initial	True Initial	Channel	True Channel	i5	Q5								i100	Q100	Q5	Q100				
				C5	C100	Area (SF)	C5	C100	Area (SF)	C5	C100	Area	C5		C100	Area	C5	C100		ft	Length ft	ft	Length ft	Slope	Tc (min)	Slope		(ft/s)	Tc (min)	(min)	in/hr	cfs	in/hr	cfs	cfs
West Fork-Jimmy Camp Creek OS-1	- The most northwestern portion of this basin (7.268 Acres) outside of the proposed Trails at Aspen Ridge development was rerouted out of the Big Johnson Reservoir basin by CDOT construction of Powers Boulevard and Bradley Road. Future development of the rerouted area will require routing the flows back to the Big Johnson Reservoir to return the area to compliance with the relevant DBPS studies.	853,954	19.60	0.45	0.59		0.90	0.96		0.65	0.80		0.09	0.36	853954	0.09	0.36	2.00	780.00	300.00	300.00	780.00	0.10	23.57	1.40	5	1.2	11.0	34.6	2.23	4.0	3.75	26.7	1.1	16.2
A	-Drainage area is upstream of two pairs of inlets near roundabout at intersection of Frontside Dr. and Legacy Dr. -Development of adjacent commercial lots will require FDR and onsite detention. -Note: The Commercial development will have 95% impervious (per DCM), but since it is required to detain prior to discharging to storm sewer the C values reflect undeveloped commercial areas.	804,622	18.47	0.45	0.59	22315	0.90	0.96	78609	0.65	0.80		0.09	0.36	703698	0.18	0.42	13.32	861.00	300.00	869.00	1430.00	0.06	26.77	1.10	7	2.1	11.4	38.1	2.10	7.0	3.54	28.0	5.0	34.6
B	- At grade inlet approximately 400 feet downstream of roundabout.	46,101	1.06	0.45	0.59	46101	0.90	0.96		0.65	0.80		0.09	0.36		0.45	0.59	65.00	185.00	185.00	400.00	400.00	0.04	9.86	3.40	7	3.7	1.8	11.7	3.86	1.9	6.48	4.1	2.5	7.0
C	- Includes the area north of Moose Meadow Street and between Beartrack Point and Sidewinder Drive and four pairs of sump inlets	648,154	14.88	0.45	0.59	627120	0.90	0.96	21034	0.65	0.80		0.09	0.36		0.46	0.60	66.14	162.00	162.00	822.00	822.00	0.05	8.51	3.29	7	3.6	3.8	12.3	3.77	26.3	6.34	57.2	19.5	58.9
D	-drainage area upstream of at grade inlet approximately 575 feet south of Moose Meadow Street.	96,065	2.21	0.45	0.59		0.90	0.96	14,978	0.65	0.80	81087	0.09	0.36		0.69	0.82	21.50	473.00	300.00	555.00	728.00	0.06	8.85	4.00	7	4.0	3.0	11.9	3.83	5.9	6.44	11.8	4.1	14.2
E	- Located at a pair of sump inlets at the intersection of Sunday Gulch and Falling Rock Drive.	373,189	8.57	0.45	0.59	49513	0.90	0.96	40601	0.65	0.80	283075	0.09	0.36		0.65	0.79	24.81	859.00	300.00	1450.00	2009.00	0.07	12.39	4.00	7	4.0	8.4	20.8	2.96	16.6	4.97	33.9	12.8	39.1
F	-Represents area captured by at grade inlets on Lazy Ridge Drive and Wagon Hammer Drive, as well as sump inlets west of the intersection of Lookout Court and Sunday Gulch.	569,234	13.07	0.45	0.59	569234	0.90	0.96		0.65	0.80		0.09	0.36		0.45	0.59	65.00	332.00	300.00	868.00	900.00	0.07	11.14	2.00	7	2.8	5.3	16.4	3.32	19.7	5.57	43.3	15.4	46.2
G	-At grade inlet on the east side of Sunday Gulch near intersection with Lookout Court.	48,227	1.11	0.45	0.59	48227	0.90	0.96		0.65	0.80		0.09	0.36		0.45	0.59	65.00	80.00	80.00	667.00	667.00	0.05	6.12	2.45	7	3.1	3.6	9.7	4.15	2.1	6.97	4.6	2.1	6.1
H	-This represents the area draining to Buffalo Horn Drive with the exception any flow by from the at grade inlets in Sub-basin F.	1,022,296	23.47	0.45	0.59	921233	0.90	0.96	39,492	0.65	0.80	61571	0.09	0.36		0.48	0.62	62.86	250.00	250.00	1074.00	1074.00	0.04	11.13	2.00	7	2.8	6.3	17.5	3.22	36.6	5.42	79.1	26.8	80.4

Sub-basin	Comments	Area		Rational 'C' Values														Flow Lengths								Rainfall Intensity & Rational Flow Rate						SWMM Values			
		sf	acres	Surface Type 1 Residential 1/8 or less (65% Imp.)			Surface Type 2 Pavement (100% Imp.)			Surface Type 3 Park (7% Imp.)			Surface Type 4 Undeveloped (2% Imp.)			Composite		Percent Impervious	Initial	True	Channel	True Channel	Average (decimal) Slope	Initial Tc (min)	Average (%) Slope	Channel Flow Type (See Key above) Ground Type	Velocity (ft/s)	Channel Tc (min)	Total (min)	i5 in/hr	Q5 cfs	i100 in/hr	Q100 cfs	Q5 cfs	Q100 cfs
				C5	C100	Area (SF)	C5	C100	Area (SF)	C5	C100	Area	C5	C100	Area	C5	C100		ft	Length ft	ft	Length ft													
I	-Represents area draining to the proposed sump inlet at the end of the cul-de-sac on Falling Rock Drive.	344,236	7.90	0.45	0.59	305401	0.90	0.96	31104	0.65	0.80	7731	0.09	0.36		0.50	0.63	66.86	153.00	153.00	1104.00	1104.00	0.05	7.88	2.61	7	3.2	5.7	13.6	3.62	14.3	6.08	30.4	10.5	31.8
J	-Represents drainage area tributary to sump inlets near intersection of Redshirt Point and Big Johnson Drive.	229,049	5.26	0.45	0.59	70187	0.90	0.96	158,862	0.65	0.80		0.09	0.36		0.76	0.85	89.28	266.00	266.00	909.00	909.00	0.09	4.77	3.20	7	3.6	4.2	9.0	4.27	17.2	7.17	32.2	11.1	32.7
K	-This sub-basin is tributary to the future sump inlets near the intersection of Big Johnson Drive and Roundhouse Drive.	1,414,842	32.48	0.45	0.59	1414842	0.90	0.96		0.65	0.80		0.09	0.36		0.45	0.59	65.00	400.00	300.00	1400.00	1500.00	0.06	13.26	3.50	7	3.7	6.7	19.9	3.02	44.5	5.07	98.0	33.3	101.7
L	Marksheffel Tributary to Jimmy Camp Creek	330,836	7.59	0.45	0.59	259741	0.90	0.96		0.65	0.80	71095	0.09	0.36		0.49	0.64	52.54	290.00	290.00	490.00	490.00	0.05	10.88	5.40	7	4.6	1.8	12.6	3.73	14.1	6.27	30.5		
M	West Fork-Jimmy Camp Creek	447,971	10.29	0.45	0.59		0.90	0.96		0.65	0.80	447971	0.09	0.36		0.65	0.80	7.00	437.00	300.00	10.00	147.00	0.06	9.32	1.00	7	2.0	1.2	10.5	4.02	27.1	6.75	56.0	14.2	61.8
N	Big Johnson Reservoir	614,283	14.10	0.45	0.59	614283	0.90	0.96		0.65	0.80		0.09	0.36		0.45	0.59	65.00	150.00	150.00	1229.00	1229.00	0.03	9.94	2.50	7	3.2	6.5	16.4	3.32	21.2	5.58	46.8		
O	-Represents area upstream of sump inlet at intersection of Rainy Creek Trail and Triple Tree Loop	510,492	11.72	0.45	0.59	510,492	0.90	0.96	0	0.65	0.80	0	0.09	0.36	0	0.45	0.59	65.00	104.00	104.00	1230.00	1230.00	0.02	9.47	1.40	7	2.4	8.7	18.1	3.17	16.8	5.32	37.1		
P	-Drainage area in and around the West Pond.	370,936	8.52	0.45	0.59		0.90	0.96	70,884	0.65	0.80	300052	0.09	0.36		0.70	0.83	24.77	560.00	300.00	378.00	638.00	0.06	9.43	2.00	7	2.8	3.8	13.2	3.67	22.0	6.16	43.9		
Q	-This area is infeasible to detain and discharges to the Powers Boulevard Ditch -Less than one acre (0.31 Acres) of developed area is within the Big Johnson Reservoir Basin, therefore, compliance with the county's MS4 permit is maintained.	106,017	2.43	0.45	0.59	38,063	0.90	0.96	0	0.65	0.80	67,954	0.09	0.36	0	0.58	0.72	27.82	143.00	143.00	687.00	687.00	0.06	6.08	3.35	4	1.3	9.0	15.1	3.45	4.9	5.80	10.3		
R	-This area is infeasible to detain and discharges to the swale at the southeast corner of the property. -Less than one acre (0.67 Acres) of developed area is within the West Fork Jimmy Camp Creek Basin, therefore, compliance with the county's MS4 permit is maintained.	81,300	1.87	0.45	0.59		0.90	0.96		0.65	0.80	81300	0.09	0.36		0.65	0.80	7.00	21.00	21.00	220.00	220.00	0.33	1.16	10.00	5	3.2	1.2	5.0	5.10	6.2	8.58	12.9	1.7	7.8
OS-2	- Commercially zoned lot just southeast of the intersection of Bradley and Powers. This area will be required to provide its own detention which must discharge to the Powers Boulevard Ditch.	498,467	11.44	0.45	0.59		0.90	0.96		0.65	0.80		0.09	0.36	498467	0.09	0.36	2.00	971.00	300.00	1411.00	2082.00	0.04	34.50	2.83	5	1.7	20.7	55.2	1.67	1.7	2.81	11.7		

APPENDIX F – DRAINAGE EXHIBITS

K:\COS_LA\196195000 - Waterview East Commercial\CADD\PlanSheets\CD_DR_EX.dwg McCallum, Jessica 8/11/2023 8:43 AM

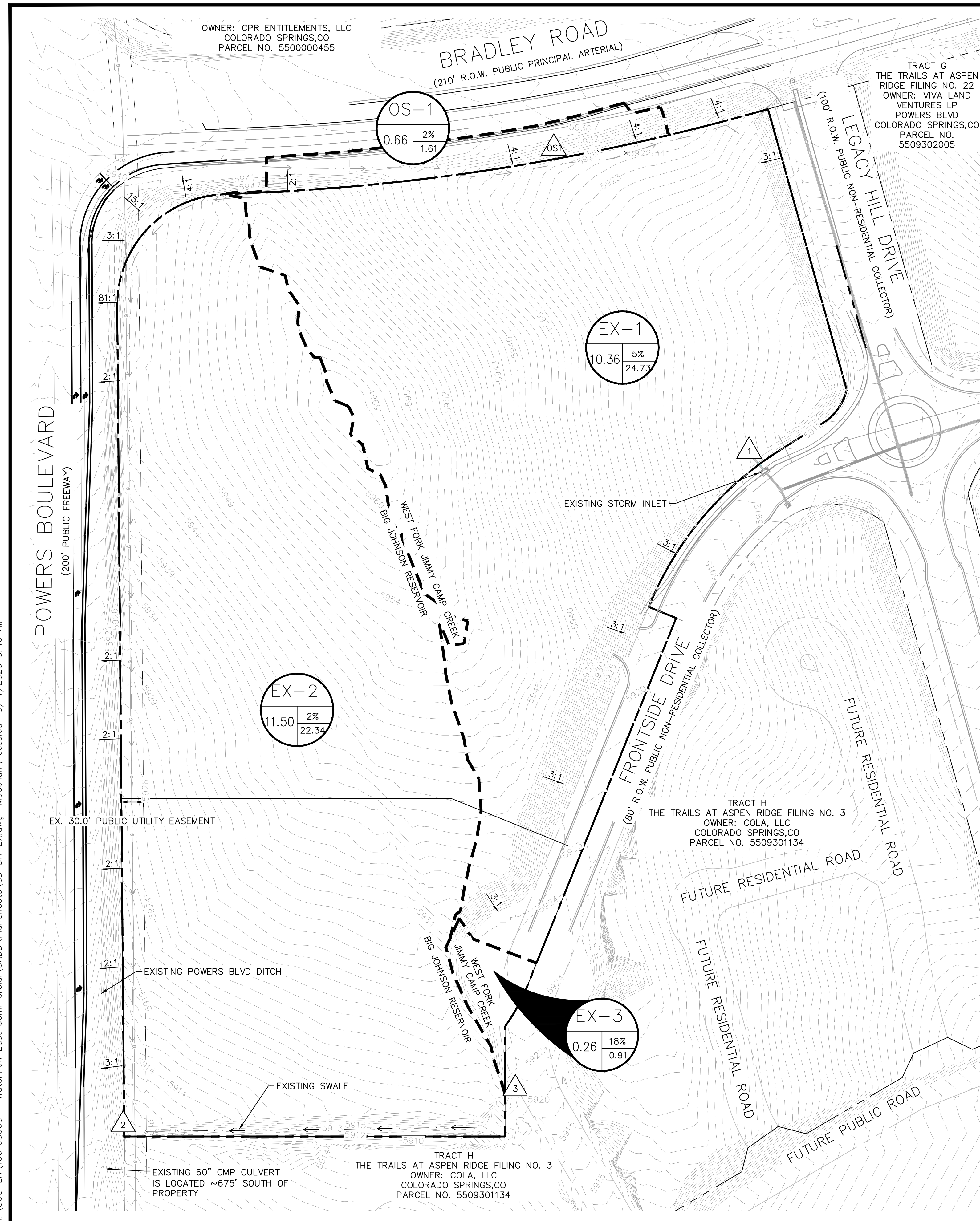

LEGEND

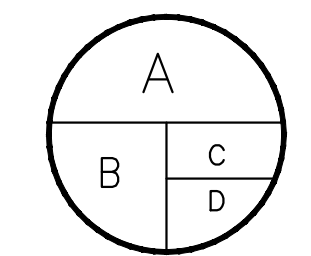

- A = BASIN DESIGNATION
- B = AREA (ACRES)
- C = BASIN IMPERVIOUSNESS
- D = 100-YR DESIGN STORM RUNOFF (CFS)

- # DESIGN POINT
- EXISTING FLOW DIRECTION
- - - DRAINAGE BASIN BOUNDARY
- - - PROPERTY LINE
- - - PROPOSED MAJOR CONTOUR
- - - PROPOSED MINOR CONTOUR
- - - EXISTING MAJOR CONTOUR
- - - EXISTING MINOR CONTOUR
- - - SWALE FLOW DIRECTION

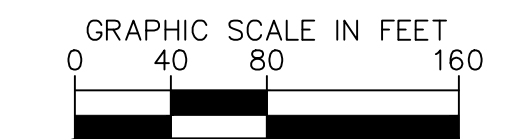
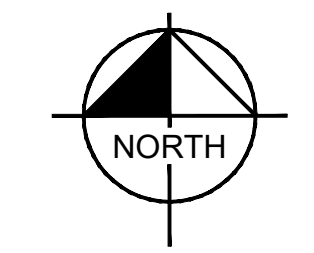

SUMMARY - EXISTING RUNOFF TABLE

DESIGN POINT	BASIN DESIGNATION	BASIN AREA (ACRES)	DIRECT 5-YR RUNOFF (CFS)	DIRECT 100-YR RUNOFF (CFS)	CUMULATIVE 5-YR RUNOFF (CFS)	CUMULATIVE 100-YR RUNOFF (CFS)
1	EX-1	10.36	3.54	24.73	3.73	26.35
2	EX-2	11.50	2.62	22.34	2.62	22.34
3	EX-3	0.26	0.21	0.91	0.21	0.91
4	OS-1	0.66	0.19	1.61	0.19	1.61



WATERVIEW EAST COMMERCIAL
CONSTRUCTION DOCUMENTS
EXISTING DRAINAGE MAP

DESIGNED BY: JAR
DRAWN BY: JAR
CHECKED BY: EUG
DATE: 05/06/2022

PRELIMINARY
FOR REVIEW ONLY
NOT FOR CONSTRUCTION
Kimley-Horn
Kimley-Horn and Associates, Inc.

PROJECT NO.
196195000

SHEET
DR-EX

NO. REVISION BY DATE APPR

Kimley-Horn
2022 KIMLEY-HORN AND ASSOCIATES, INC.
2 North Nevada Avenue, Suite 300
Colorado Springs, Colorado 80903 (719) 453-0180

MATCHLINE DR-1

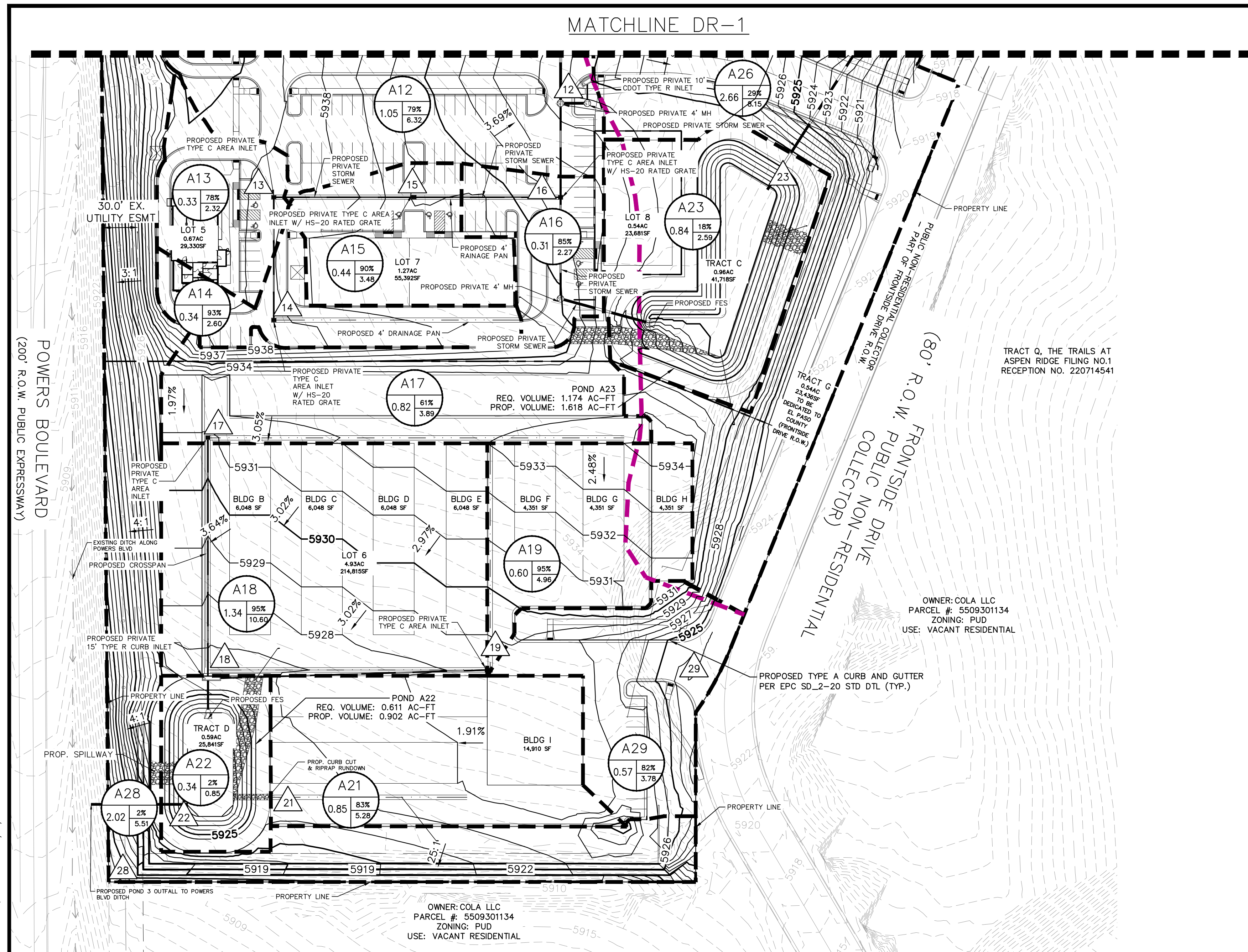

LEGEND

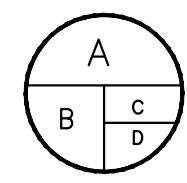

A = BASIN DESIGNATION
 B = AREA (ACRES)
 C = BASIN IMPERVIOUSNESS
 D = 100-YR DESIGN STORM RUNOFF (CFS)

- DESIGN POINT
- FLOW DIRECTION
- MAJOR DRAINAGE BASIN BOUNDARY
- DRAINAGE BASIN BOUNDARY
- PROPERTY LINE
- PROPOSED MAJOR CONTOUR
- PROPOSED MINOR CONTOUR
- EXISTING MAJOR CONTOUR
- EXISTING MAJOR CONTOUR
- EXISTING DITCH/SWALE
- PROPOSED SWALE
- PROPOSED STORM SEWER
- PROPOSED STORM MANHOLE
- PROPOSED STORM INLET
- EXISTING STORM SEWER
- EXISTING STORM MANHOLE
- EXISTING STORM INLET

SUMMARY - PROPOSED RUNOFF TABLE						
DESIGN POINT	BASIN DESIGNATION	BASIN AREA (ACRES)	DIRECT 5-YR RUNOFF (CFS)	DIRECT 100-YR RUNOFF (CFS)	CUMULATIVE 5-YR RUNOFF (CFS)	CUMULATIVE 100-YR RUNOFF (CFS)
1	A1	0.90	1.91	5.28	1.91	5.28
2	A2	0.37	0.85	2.32	0.85	2.32
3	A3	0.38	1.15	2.82	1.15	2.82
4	A4	0.31	1.04	2.40	1.04	2.40
5	A5	0.29	1.02	2.39	1.02	2.39
6	A6	0.30	0.97	2.29	0.97	2.29
7	A7	0.40	1.48	3.44	1.48	3.44
8	A8	0.46	1.72	3.98	1.72	3.98
9	A9	0.45	1.68	3.88	1.68	3.88
10	A10	0.61	2.09	4.95	2.09	4.95
11	A11	0.26	0.62	1.56	0.62	1.56
12	A12	1.05	2.59	6.32	2.59	6.32
13	A13	0.33	0.94	2.32	0.94	2.32
14	A14	0.34	1.12	2.60	1.12	2.60
15	A15	0.44	1.48	3.48	1.48	3.48
16	A16	0.31	0.95	2.27	0.95	2.27
17	A17	0.82	1.44	3.89	1.44	3.89
18	A18	1.34	4.57	10.60	4.57	10.60
19	A19	0.60	2.14	4.96	2.14	4.96
20	A20	-	-	-	-	-
21	A21	0.85	2.17	5.28	2.17	5.28
22	A22	0.34	0.10	0.85	0.10	0.85
23	A23	0.84	0.57	2.59	0.57	2.59
24	A24	0.48	0.16	1.25	0.16	1.25
25	A25	1.78	4.95	12.61	4.95	12.61
26	A26	2.66	2.28	8.15	2.28	8.15
27	A27	2.60	1.69	7.99	3.17	11.55
28	A28	2.02	0.65	5.52	0.65	5.52
29	A29	0.57	1.47	3.56	1.47	3.56
30	OS1	0.22	0.57	1.34	0.57	1.34

PBMP SUMMARY TABLE		
BASINS	PBMP TRIBUTARY AREA (AC)	PBMP
A24, A25	2.2600	EDB - A24
A1-A16, A23	8.0500	EDB - A23
A17-A22	3.9500	EDB - A22
A27	2.6000	EDB - A27
A26, OS-1	2.8800	EAST POND

NOTES:
 1. SUB-BASIN A28 NOT TREATED PER MILE HIGH FLOOD CONTROL DISTRICT RUNOFF REDUCTION METHOD.
 2. SUB-BASIN A29 NOT TREATED BY A PBMP IS EXCLUDED BASED ON ECM APP 1.7.1.C.1.A.

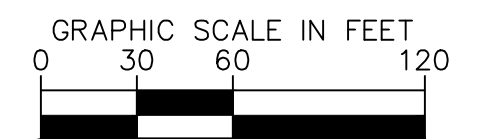
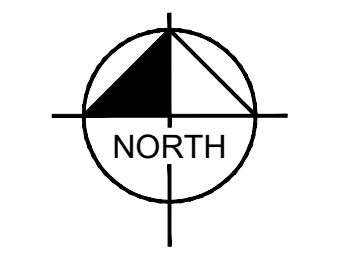

NO. _____ BY _____ DATE _____
 REVISION _____

Kimley»Horn
 2022 KIMLEY-HORN AND ASSOCIATES, INC.
 2 North Nevada Avenue, Suite 300
 Colorado Springs, Colorado 80903 (719) 453-0180

DESIGNED BY: JAR
 DRAWN BY: JAR
 CHECKED BY: EJJ
 DATE: 05/06/2022

WATERVIEW EAST COMMERCIAL
 CONSTRUCTION DOCUMENTS
 PROPOSED DRAINAGE MAP

PRELIMINARY
 FOR REVIEW ONLY
 NOT FOR
 CONSTRUCTION
 Kimley»Horn
 Kimley-Horn and Associates, Inc.

PROJECT NO.
 196195000

SHEET
 DR-2

K:\COS_LA\196195000 - Waterview East Commercial\CADD\PlanSheets\CD_DR.dwg McCallum, Jessica 9/6/2023 1:37 PM