



Security Fire Protection District
Fire Chief ~ David Girardin

Date: 03/14/2023

To: Whom it may concern

This letter is being written to confirm that the proposed fire access routes have been approved by the Security Fire Protection district for: Waterview East Commercial development site.

Address: 0 Bradley Road Colorado Springs, CO 80925
TSN: 5509200002

All fire access routes have been approved according to the provided/attached proposal.

If you have any questions please feel free to contact me.

Thank you,
David Girardin
Fire Chief
Security Fire Protection District

CC:

Alex Martin
Fire Marshal
Security Fire Protection District

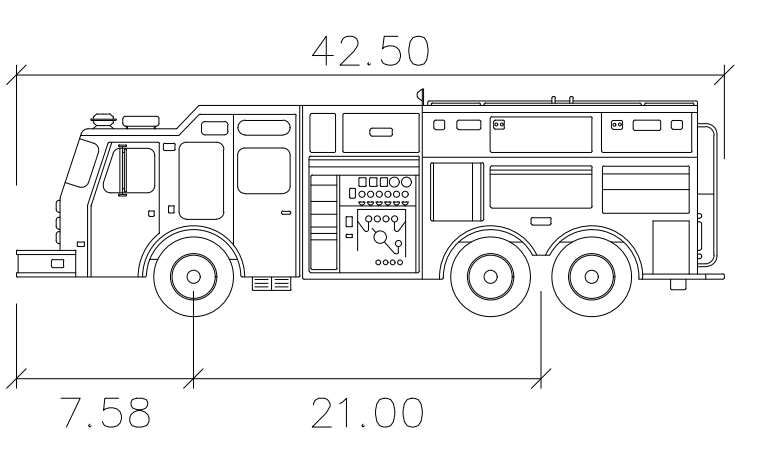
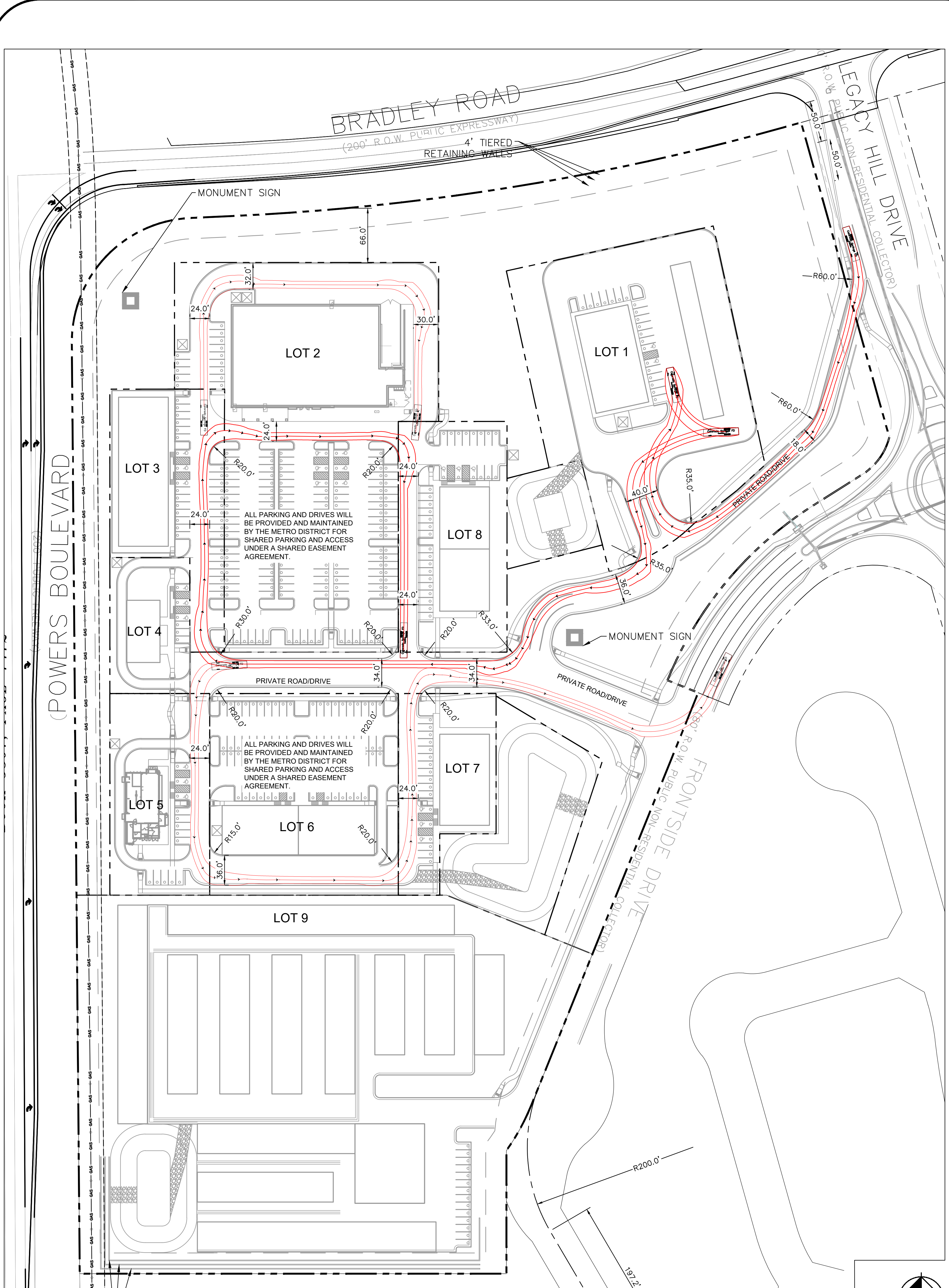

Colorado Springs FD

	feet
Width	: 8.42
Track	: 8.50
Lock to Lock Time	: 5.0
Steering Angle	: 44.0

