

FINAL DRAINAGE REPORT FOR CLAREMONT BUSINESS PARK 2 FILING NO. 2 EL PASO COUNTY, COLORADO

Prepared for:

Doubletree Ventures
106 S. Kyrene Road #2
Chandler, AZ 85226
(480) 313-2724

Prepared by:

M&S Civil Consultants
212 N. Wahsatch Avenue
Suite 305
Colorado Springs, CO 80903 (719) 955-5485

February 2023

Project #10-020
PCD Filing No.: VR233



**FINAL DRAINAGE REPORT FOR CLAREMONT
BUSINESS PARK 2 FILING NO. 2
EL PASO COUNTY COLORADO**

DRAINAGE PLAN STATEMENTS

ENGINEERS STATEMENT

The attached drainage plan and report was prepared under my direction and supervision and are correct to the best of my knowledge and belief. Said drainage report has been prepared according to the criteria established by the County for drainage reports and said report is in conformity with the master plan of the drainage basin. I accept responsibility for any liability caused by any negligent acts, errors or omissions on my part in preparing this report.

Virgil A. Sanchez, P.E. #37160
For and on Behalf of M&S Civil Consultants, Inc



DEVELOPER'S STATEMENT

I, the developer(s) have read and will comply with all the requirements specified in this drainage report and plan.

BY: _____

TITLE: Managing Partner DATE: 06/11/23

ADDRESS: Brian Zurek
106 S. Kryene Road
Chandler, AZ 85226

EL PASO COUNTY'S STATEMENT

Filed in accordance with the requirements of El Paso County Land Development Code, Drainage Criteria Manual Volumes 1 and 2, and the Engineering Manual, as amended.

BY: _____ DATE: _____
Joshua Palmer, P.E.
County Engineer / ECM Administrator

CONDITIONS:

**FINAL DRAINAGE REPORT FOR CLAREMONT
BUSINESS PARK 2 FILING NO. 2
EL PASO COUNTY COLORADO**

TABLE OF CONTENTS

Purpose	4
General Location and Description	4
Soils	5
Previous Reports	5
Drainage Criteria	5
Floodplain Statement	7
Existing Drainage Conditions	7
Four Step Process	9
Proposed Drainage Conditions	10
Water Quality Provisions and Maintenance	14
Erosion Control	15
Construction Cost Opinion	15
Drainage & Bridge Fees	16
Summary	16
References	17

APPENDIX

Vicinity Map
Soils Map
FEMA FIRM Panel
Hydrologic Calculations
Hydraulic Calculations / SFB WQCV Calculations
BOCC Resolution 16-426
Excerpt of "Final Drainage Report for Claremont Business Park Filing No.2",
Matrix Design dated November 2006 & Existing Drainage Map
Existing Drainage Map
Proposed Drainage Map

FINAL DRAINAGE REPORT FOR CLAREMONT BUSINESS PARK 2 FILING NO. 2 EL PASO COUNTY COLORADO

Purpose

This Final Drainage Report for Claremont Business Park 2 Filing No. 2 is in support of the Final Plat, Preliminary Plan, and Construction Drawings of the subject site. This report functions to identify the existing and proposed runoff patterns and recommend proposed drainage improvements which are intended to safely convey runoff through the proposed development, while minimizing impacts to downstream facilities and adjacent properties. The analysis has been prepared in accordance with the requirements set forth by El Paso County and remains in compliance with the Final Drainage Report for Claremont Business Park 2 Filing No. 1 by M&S Civil Consultants.

General Location and Description

The Claremont Business Park 2 Filing No.2 is a Replat of Lots 8, 9 & 10 and Tract B of Claremont Business Park 2 Filing No.1. The site is located in the Northeast $\frac{1}{4}$ of the Northeast $\frac{1}{4}$ of Section 8, and the Southeast $\frac{1}{4}$ of the Southeast $\frac{1}{4}$ of Section 5, Township 14 South, Range 65 West of the 6th P.M. in El Paso County, Colorado. The site is bordered to the southeast by U.S. Highway 24 and to the northeast by N. Marksheffel Road, to the north and west by Meadowbrook Parkway, and to the south by Claremont Business Park 2 Filing No. 1 (Lots 1-7). See Vicinity Map in Appendix for details.

The site consists of 4.988 acres which is currently vacant land. The replat will eliminate Tract B and redistribute the three (3) lots based around a newly aligned private roadway. The development project will construct a roadway and utilities through the site and into Filing 1. An existing access easement which is a portion of existing Lots 6 and 7 will allow for the proposed roadway to connect to the existing roadway (Gary Watson Point.) The Claremont Business Park 2 Filing 2 site is currently zoned "CS" and the proposed principal use for the site will be neighborhood commercial and light industrial.

In addition to the construction of the roadway and utilities, a storm sewer system will be constructed that will function to collect runoff from the future lots and a single (1) sand filter basin water quality pond will initially be provided to treat runoff from aforementioned improvements. The proposed storm sewer will tie into an existing system near Meadowbrook Parkway, which ultimately conveys runoff southwest into the East Fork of Sand Creek.

Per Resolution 16-426 of the BoCC, on-site WQCV is required but on-site stormwater detention is not required. (refer to appendix).

Individual drainage letters and/or reports shall be required with the development of each lot not otherwise clearly analyzed by this report for Claremont Business Park 2 Filing No. 2.

Soils

The Natural Resources Conservation Service, United States Department of Agriculture, Web Soil Survey, indicates that the soils for this project are: Blakeland Loamy Sand (8), Blendon Sandy Loam (10) and Ellicott Loamy Course Sand (28). These soils have been characterized as having Hydrologic Soil Types "A" & "B". The soils classification used for this study is "B". Refer to the Soils Map located in the Appendix of this report

Previous Studies

The proposed site and surrounding existing drainage facilities have been included in multiple drainage letters and reports. The following is a list of existing documents that were pertinent to analyzing this site.

- Falcon Drainage Basin Planning Study, by Matrix Design Group, dated September 2015.
- Final Drainage Report for Claremont Business Park Filing No.2, by Matrix Design Group, Inc. dated November 2006.
- Final Drainage Report for Claremont Business Park 2 Filing No. 1, by M&S Civil Consultants, approved 2/11/2021.
- Final Drainage Letter for Lot 1 of Claremont Business Park 2 Filing No.1, by M&S Civil Consultants, approved 4/01/2021.
- Final Drainage Letter for Lot 2 of Claremont Business Park 2 Filing No.1, by M&S Civil Consultants, approved 5/19/2021.
- Final Drainage Letter for Lot 3 of Claremont Business Park 2 Filing No.1, by M&S Civil Consultants, approved 05/19/2021.
- Final Drainage Letter for Lot 4 of Claremont Business Park 2 Filing No.1, by M&S Civil Consultants, approved 05/19/2021.
- Final Drainage Letter for Lot 5 of Claremont Business Park 2 Filing No.1, by M&S Civil Consultants, approved 03/03/2021.
- Final Drainage Letter for Lot 6 of Claremont Business Park 2 Filing No.1, by M&S Civil Consultants, approved 07/08/2021.
- Final Drainage Letter for Lot 7 of Claremont Business Park 2 Filing No.1, by M&S Civil Consultants, approved 3/31/2021.

Drainage Criteria

As required by El Paso County, Colorado, this report has been prepared in accordance to the criteria set forth in the El Paso County Drainage Criteria Manual Volume 1 & 2 (DCM), the El Paso County Engineering Criteria Manual (ECM), and El Paso County Resolutions 15-042 and 19-245.

Design Event Frequency

The 100-year storm event was used as the major storm for the project, and the 5-year storm event was used as the minor storm.

Method of Analysis

The rational method was used to calculate peak flows as the tributary areas are less than 100 acres.

Where: $Q=C*i*A$

Q = Maximum runoff rate in cubic feet per second (cfs)

C = Runoff coefficient

i = Average rainfall intensity (inches per hour)

A = Area of drainage sub-basin (acres)

Runoff Coefficient

Rational Method coefficients from Table 6-6 of the Drainage Criteria Manual for developed land were utilized in the Rational Method calculations. Composite percent impervious and C values were calculated using roofs, commercial areas, asphalt drives, landscaped areas and parks found within the aforementioned table.

Time of Concentration

The time of concentration consists of the initial time of overland flow and the travel time (street or channel, etc) to a downstream structure or point of interest. A minimum time of concentrations of 5 minutes is utilized for urban areas.

Rainfall Intensity

The hypothetical rainfall depths for the 1-hour storm duration were taken from Table 6-2 of the Drainage Criteria Manual.

Project 1-Hour Rainfall Depth Storm Recurrence Interval Rainfall Depth (inches)

5-year 1.50" 100-year 2.52"

The rainfall intensity equation for the Rational Method was taken from Drainage Criteria Manual Volume 1 Figure 6-5.

Hydraulic Grade Line Analysis

StormCAD was utilized to analyze the proposed storm sewer system and determine the Hydraulic Grade Line (HGL's) profiles for the major and minor storms. The standard method was used to calculate head loss in the system with K coefficients taken from Table 9-4 of the Colorado Springs DCM.

In addition to the DCM, The Mile High Flood District BMP Sizing (UD-BMPv.3.07) and Detention Design (MHFD Detention v4.06) worksheets were utilized for to check to verify the existing the water quality ponds still functions with the revised tributary areas and impervious values. These spreadsheets were also utilized for the design of the proposed and future on-site water quality ponds. The MFHD-Inlet v5.02 worksheet was utilized to calculate both the street capacities and evaluate inlet capacities.

Floodplain Statement

According to the Federal Emergency Management Agency (FEMA) Flood Insurance Rate Map (FIRM) Panel No. 08041C0756G, revised December 7, 2018. No portion of this site is located within the 100 year floodplain. See Appendix.

Existing Drainage Conditions

As the site has been graded previously with the development of Filing 1, the vegetation is sparse, consisting primarily of native grasses and weeds. Existing site terrain generally slopes from north to southwest at grade rates that vary between 1.2% and 2%. A soil retention wall runs along the eastside of the proposed site, next to U.S. Highway 24 and N. Marksheffel Road, and borders a large portion of the back of the proposed lots. A depression or sediment pond is located in the southwest corner of the site, which was to serve as a future singular water quality pond for the 3 future lots. An existing 24" ADS private storm drain has been constructed along the east side of Meadowbrook Parkway that extends to this existing sediment pond. This pipe will serve as the outfall for the proposed site development.

As the proposed project will construct street improvements within Lots 6 and 7 of Claremont Business Park Filing No. 1, the existing and proposed drainage analysis will be expanded to evaluate changes in drainage patterns to ensure no negative affects to downstream facilities. An existing conditions drainage map is included in the appendix of this report to accompany the following discussion.

Existing Conditions Detailed Drainage Discussion

Design Point 1 (Q5 = 1.8 cfs, Q100 = 11.8 cfs) consists of runoff from undeveloped **Basins A, B, and C**. **Basins A and B** are 0.19 and 0.30 acres of existing roadway embankment located generally between the subject site and existing US. Hwy 24 and Marksheffel Road. **Basin C** consists of 4.90 acres of that generally consist of the remaining undeveloped portions of the subject site. Runoff from the three basins is conveyed to an existing sediment pond located in the southwest corner of the site at DP1. An existing 24" ADS (Pipe 11) is located at the southwest corner of the pond which collects runoff.

Design Point 2 was omitted.

Design Point 3 (Q5 = 2.2 cfs, Q100 = 4.4 cfs) consists of runoff from **Basin H1** and **Basin I1**. **Basin H1** is 0.18 acres of undeveloped roadway embankment and **Basin I1** consists 0.57 acres of roof top, asphalt paving and landscaped areas. Runoff from the two basins flow into an existing 3.0 foot wide x 6 inch high concrete chase with 6 inch curb heights which discharges into the cul-de-sac of Gary Watson Point.

Design Point 4 (Q5 = 1.8 cfs, Q100 = 4.1 cfs) consists of runoff from **Basin H2** and **Basin I2**. **Basin H2** is 0.40 acres of undeveloped roadway embankment and **Basin I2** consists 0.48 acres of asphalt paving and landscaped areas. Runoff from basins is collected in curb and gutter which discharges into the cul-de-sac of Gary Watson Point.

Design Point 5 (Q5 = 0.8 cfs, Q100 = 1.6 cfs) consists of runoff from **Basin H3** and **Basin 17**. **Basin H3** is 0.04 acres of undeveloped roadway embankment and **Basin 17** consists 0.23 acres of asphalt paving and landscaped areas. Runoff from basins is collected in curb and gutter which discharges into the cul-de-sac of Gary Watson Point.

Design Point 6 (Q5 = 8.2 cfs, Q100 = 16.5 cfs) consists of runoff from **Basin 13, 14, 15, 16** and **DP3-5**. **Basins 13, 14, 15,** and **16** are of 0.58, 0.43, 0.23, and 0.19 acres in size respectively and consist of roof top, asphalt paving and landscaped areas within the development. The runoff from the four basins combines with flows from **DP3-5** within the private street section of Gary Watson. Runoff is collected by a pair of existing 15' Type R at grade inlets located at **DP6**. Collected runoff is conveyed to the west underground via private 24" storm sewer to an existing WQ pond 2 (**PR13-14**). **Inlet 3** collects Q5=4.1 and Q100=7.9cfs, with Q5=0.0 cfs and Q100=0.4 cfs of flow-by in the respective storm events. **Inlet 4** collects Q5=4.1 and Q100=8.0cfs, with Q5=0.0 cfs and Q100=0.3 cfs of flow-by in the respective storm events. Runoff bypassing the existing inlets continues westward to **Design Point 7** and **8**.

Design Point 7 (Q5 = 2.4 cfs, Q100 = 7.5 cfs) consists of flow-by runoff from **Inlet 3** and flows within **Basin J1**. **Basin J1** consists 0.76 acres of rooftop, asphalt paving and landscaped areas. Runoff from **Basin J1** and flow-by from the inlet is conveyed within the curb and gutter to an existing 15' Type R at grade inlets located at **DP7**. **Inlet 5** collects Q5=2.4 and Q100=7.3cfs, with Q5=0.0 cfs and Q100=0.2 cfs of flow-by in the respective storm events. An existing 18" storm sewer (**PR15**) conveys the intercepted runoff underneath Gary Watson.

Design Point 8 (Q5 = 0.9 cfs, Q100 = 4.1 cfs) consists of flow-by runoff from **Inlet 4** and flows within **Basin J2 and J3**. **Basins J2** and **J3** are of 0.25 and 0.01 acres in size respectively and consist of roof top, asphalt paving and landscaped areas within the development. Runoff from **Basins J2** and **J3** and flow-by from the inlet is conveyed within the curb and gutter to an existing 15' Type R at grade inlets located at **DP8**. **Inlet 6** collects Q5=0.9 and Q100=4.1cfs, with no flow-by in either of the storm events. An existing 18" storm sewer (**PR16**) conveys the intercepted runoff from the pair of inlets southward underground.

Design Point 9 (Q5 = 3.8 cfs, Q100 = 9.7 cfs) consists of runoff from **Basin H4, L** and **M4**. **Basin H4** and **L** are 0.10 and 1.32 acres of undeveloped roadway embankment and **Basin M4** consists of 0.98 acres of roof top, asphalt paving and landscaped areas. Runoff from the three basins flow into an existing a 2' foot trapezoidal channel located at the south end of the property.

Design Point 10 (Q5 = 5.3 cfs, Q100 = 12.3 cfs) consists of runoff from **Basin M2, M3** and **DP9**. **Basins M2** and **M3** are of 0.24 and 0.37 acres in size respectively and consist of roof top, asphalt paving and landscaped areas within the development. Runoff from the two basins combine with **DP9** flows in an existing a 2' foot trapezoidal channel located at the south end of the property. Runoff at **DP10** will enter the existing Filing 1 **WQ Pond 2** via an existing trapezoidal grouted riprap rundown.

Design Point 11 (Q5 = 1.4 cfs, Q100 = 2.5 cfs) consists of runoff from **Basin M1** and **K4**. **Basins M1** and **K4** are of 0.28 and 0.05 acres in size respectively and consist of roof top, asphalt paving and

landscaped areas within the development. The runoff from the two basins is directed into the existing **WQ Pond 2** via an existing concrete rundown at **DP11**.

Design Point 12 (Q5 = 1.1 cfs, Q100 = 2.0 cfs) consists of runoff from **Basin K2, K3** and **N1**. **Basins K2, K3** and **N1** are of 0.05, 0.15 and 0.06 acres in size respectively and consist of roof top, asphalt paving and landscaped areas within the development. The runoff from the three basins is directed into the existing **WQ Pond 2** via an existing concrete rundown at **DP12**.

Design Point 13 (Q5 = 0.7 cfs, Q100 = 1.3 cfs) consists of runoff from **Basin K1**. **Basins K1** is 0.17 acres in size and consists of roof top, asphalt paving and landscaped areas within the development. The runoff from the basins is directed to an existing beehive grated manhole (Inlet 7) located in the southwest corner of the lot. Runoff collect by the inlet combines with flows from **PR12** and is conveyed in **PR13** a private 24" storm sewer that outfalls into **WQ Pond 2**.

Design Point 14 (Q5 = 19.3 cfs, Q100 = 43.9 cfs) consists of runoff from **Basin N2** and **DP10-13**. **Basins N2** is 0.41 acres in size and consists of a sand filter water quality pond (**WQ Pond 2**).

Basin D, O1, O2,

Basins D, O1, and **O2** are 0.23, 0.12 and 0.06 acres in size and consist of asphalt, concrete, and landscaped areas along the western periphery of the development. The runoff from the three basins is directed to Existing Meadowbrook Parkway. The 5 year event and 100 year event peak runoff rates from **Basin D, O1,** and **O2** are Q5 = 0.1 cfs, Q100 = 0.7 cfs, Q5 = 0.1 cfs, Q100 = 0.4 cfs and Q5 = 0.1 cfs, Q100 = 0.3 cfs respectively.

Basin P

Basins P (Q5 = 0.0 cfs, Q100 = 0.3 cfs) is 0.11 acres in size and consists of landscaped and undeveloped areas along the southern periphery of the development. The runoff from the basins is directed to the adjacent development.

Four Step Process

The development will follow the "Four Step Process" as outlined below:

Step 1 - Employ Runoff Reduction Practices

The proposed development uses Low Impact Development (LID) practices to reduce runoff. When possible runoff is to be directed to pervious areas to promote infiltration and limit directly connected impervious areas.

Step 2 - Stabilize Drainageways

There are no drainageways on-site to stabilize. The site is upstream of an existing 42"/48" RCP storm sewer system that discharges directly into the Sand Creek Channel via an outlet structure with wingwalls (privately owned and maintained by the Central Marksheffel Metropolitan District). The Claremont Commercial Filing No. 2 site proposes Sand Filter Water Quality Facilities that will treat

runoff prior to discharging to the existing storm sewer system. There will be no adverse affects on downstream developments as a result of the development of this subdivision.

Step 3 - Provide Water Quality Capture Volume

One (1) Sand Filter Basin water quality facility is proposed to provide WQCV at the time of the writing of this report. Up to four (4) future Sand Filter water quality facilities maybe required with the full build out of the parcel.

Step 4 - Consider Need for Industrial and Commercial BMP's

This submittal provides a Preliminary Grading and Erosion Control plan. A Final GEC plan with BMP's in place shall be required with a Final Plat and Site Development applications. The proposed project will use silt fence, a vehicle tracking control pad, a concrete washout area, mulching and reseeding to mitigate the potential for erosion across the site.

Proposed Drainage Characteristics

General Concept Drainage Discussion

The "Final Drainage Report for Claremont Business Park Filing No. 2", dated November 2006, by Matrix Design Group, Inc. indicated that flows discharged from the subject site were to be collected and conveyed to the East Fork of Sand Creek Channel via a storm system that was to parallel Meadowbrook Parkway. As a portion of the construction of Claremont Business Park 2 Filing No.1 the existing storm sewer system was extended along the eastern side of Meadowbrook Parkway to collect runoff from the Lots 8, 9 & 10 and Tract B of Claremont Business Park 2 Filing No.1 and thus remain in compliance with the previous drainage plans and studies.

The Claremont Business Park 2 Filing No.2 project will Replat of Lots 8, 9 & 10 and Tract B of Claremont Business Park 2 Filing No.1, eliminate Tract B and redistribute the three (3) lots based around a newly aligned private roadway. The subject site is anticipated to continue to consist of neighborhood commercial and light industrial use and thus the properties will consist of asphalt, curb and gutter, parking areas, buildings, and landscaping.

A private storm sewer will be extended via drainage easements to collect runoff from each lot and the roadway. In lieu of a singular water quality pond (as previously anticipated by the CBP2, Filing 1 FDR) to treat the runoff from the subject site, each lot will be required to provide and maintain its own water quality facilities.

The initial construction of the project will include the construction of storm main to each lot, the construction of El Jefe Heights roadway and subsurface utilities such as water and wastewater to support future development. Temporary sediment basins will be constructed at the terminus of the storm sewers stubs to collect runoff from the undeveloped lots. A permanent water quality pond will be constructed at the southwest corner of Lot 2 to provide treatment for the proposed roadway and

Lot 2. With the exception of the current permanent WQ Pond 3, no routing was considered when evaluating the discharge from the proposed lots to size the proposed storms sewer.

Per the approved "Final Drainage Report for Claremont Business Park 2 Filing No.1 the percent impervious for the site is 80.4%. The percent impervious per the proposed report is 86.7%. The reason for the discrepancy is due to the approved report did not account for 0.48 acres of El Jefe Heights roadway at 100% imperviousness and it included 0.36 acres of pond at 7% imperviousness. Given these two parameters we calculate the percent impervious would be equivalent.

Individual drainage letters and/or reports shall be required with the development of each future lot not otherwise clearly analyzed by this report. A proposed conditions drainage map is included in the Appendix of this report to accompany the following discussion.

Proposed Conditions Detailed Drainage Discussion

Design Point 1 (Q5 = 5.9 cfs, Q100 = 11.2 cfs) consists of runoff from **Basin A** and **Basin B**. **Basin A** is 0.21 acres of undeveloped roadway embankment and **Basin B** consists 1.50 acres of future roof top, asphalt paving and landscaped areas associated with commercial or industrial development. Runoff from the two basins will be directed to the southwest and collected by a private 18" ADS storm (**PR1**) at the southwest corner of the lot. A temporary sediment basin in the interim shall be installed until the development of Lot 1 at which time a WQ facility or CDS unit will be provided.

Design Point 2 was omitted.

Design Point 3 (Q5 = 1.2 cfs, Q100 = 2.3 cfs) consists of runoff from **Basin F**. **Basin F** consists 0.30 acres of future roof top, asphalt paving and landscaped areas associated with commercial or industrial development within the northeastern portion of Lot 3. Runoff from the basin will be directed to the southeast and collected by a private 18" ADS storm at the middle of the eastern boundary of the lot. A temporary sediment basin in the interim shall be installed until the development of Lot 3 at which time a WQ facility or CDS unit will be provided.

Design Point 4 (Q5 = 1.0 cfs, Q100 = 1.7 cfs) consists of runoff from **Basin E2**. **Basin E2** consists 0.21 acres of asphalt paving, sidewalks, and landscaped areas associated with a portion of EL Jefe Heights. Runoff from the basin will be directed to the south and collected at low point by a private 5' Type R sump inlet (Inlet 1). A proposed private 18" ADS Storm Drain will convey the collected runoff east under the roadway.

Design Point 5 (Q5 = 1.2 cfs, Q100 = 2.2 cfs) consists of runoff from **Basin E1**. **Basin E1** consists 0.27 acres of asphalt paving, sidewalks, and landscaped areas associated with a portion of EL Jefe Heights. Runoff from the basin will be directed to the south and collected at low point by a private 5' Type R sump inlet (Inlet 2). Runoff collect by the inlet combines with flows conveyed by **PR5**, in **PR6** a private 18" storm sewer that outfalls into **WQ Pond 3**. In the event that the inlets at **DP4** and **DP5** were to

become clogged runoff would overtop the localized high point of the road and continue south within El Jefe Heights.

Design Point 6 (Q5 = 7.8 cfs, Q100 = 14.8 cfs) consists of runoff from **Basin C, C1, D, D1** and **Pipe Run 6 (PR6)**. **Basin C & C1** is 0.12 and 0.17 acres respectively, of undeveloped roadway embankment and **Basin D & D1** consists 0.77 and 0.78 acres respectively, of future roof top, asphalt paving and landscaped areas associated with commercial or industrial development within Lot 2. Runoff from the basin will be directed to the southwest to a permanent WQ facility and combine with flows conveyed within **PR6**. In the interim flows from Lot 2 will be directed to a temporary 30" diameter dome grate with inline drain. The flow will then be routed via a 18" RCP storm sewer (**PR6A**) Q5 = 6.0 cfs, Q100 = 11.6 to the permanent sand filter water quality facility. Upon vertical construction the dome grate will be replaced with a sump inlet. In the event that the dome grate inlet was to become clogged runoff would overtop the berm and outfall into the proposed sand filter WQ facility. A permanent sand filter water quality facility will discharge runoff to the south via a private 18" RCP/ADS storm sewer (**PR7**) Q5 = 3.3 cfs, Q100 = 4.0 cfs where it will combine with flows conveyed within **PR4**, a private 24" ADS storm sewer (**PR8**) at peak flow rates of Q5 = 6.1 cfs, Q100 = 10.7 cfs.

Design Point 7 (Q5 = 4.7 cfs, Q100 = 8.7 cfs) consists of runoff from **Basin G2**. **Basin G2** consists 1.15 acres of future roof top, asphalt paving and landscaped areas associated with commercial or industrial development within the northeastern portion of Lot 3. Runoff from the basin will be directed to the southwest and collected by a private 18" ADS storm at the middle of the eastern boundary of the lot. A existing temporary sediment basin has been installed and shall remain until the development of Lot 3 at which time a WQ facility or CDS unit will be provided Remove the existing 24" PP and existing riprap as necessary to install the proposed 18" PP with inline storm sewer and reinstall riprap as needed.

The subject site fully developed peak flow being discharge to an existing 24" ADS (**PR11**) which is located at the southwest corner of the site is estimated at Q5 = 7.4 cfs, Q100 = 13.8 cfs.

Design Point 8 (Q5 = 2.2 cfs, Q100 = 4.3 cfs) consists of runoff from **Basin H1** and **Basin I1**. **Basin H1** is 0.16 acres of undeveloped roadway embankment and **Basin I1** consists 0.55 acres of roof top, asphalt paving and landscaped areas. Runoff from the two basins flow into an existing 3.0 foot wide x 6 inch high concrete chase with 6 inch curb heights which discharges into the cul-de-sac of Gary Watson Point.

Design Point 9 (Q5 = 1.8 cfs, Q100 = 4.1 cfs) consists of runoff from **Basin H2** and **Basin I2**. **Basin H2** is 0.40 acres of undeveloped roadway embankment and **Basin I2** consists 0.48 acres of asphalt paving and landscaped areas. Runoff from basins is collected in curb and gutter which discharges into the cul-de-sac of Gary Watson Point.

Design Point 10 (Q5 = 0.8 cfs, Q100 = 1.6 cfs) consists of runoff from **Basin H3** and **Basin I7**. **Basin H3** is 0.04 acres of undeveloped roadway embankment and **Basin I7** consists 0.23 acres of asphalt paving and landscaped areas. Runoff from basins is collected in curb and gutter which discharges into the cul-de-sac of Gary Watson Point.

Design Point 11 (Q5 = 8.4 cfs, Q100 = 16.7 cfs) consists of runoff from **Basin I3, I4, I5, I6** and **DP3-5**. **Basins I3, I4, I5,** and **I6** are of 0.45, 0.55, 0.23, and 0.19 acres in size respectively and consist of roof top, asphalt paving and landscaped areas within the development. The runoff from the four basins combines with flows from **DP3-5** within the private street section of Gary Watson. Runoff is collected by a pair of existing 15' Type R at-grade inlets located at **DP11**. Collected runoff is conveyed to the west underground via private 24" storm sewer to an existing WQ pond (Fil1Pond) (**PR13-14**). **Inlet 3** collects Q5=4.1 cfs and Q100=7.9 cfs, with Q5=0.0 cfs and Q100=0.4 cfs of flow-by in the respective storm events. **Inlet 4** collects Q5=4.2 cfs and Q100=8.0cfs, with Q5=0.0 cfs and Q100=0.3 cfs of flow-by in the respective storm events. Runoff bypassing the existing inlets continues westward to **Design Point 12** and **13**.

Design Point 12 (Q5 = 2.8 cfs, Q100 = 8.1 cfs) consists of flow-by runoff from **Inlet 3** and flows within **Basin J1**. **Basin J1** consists 0.69 acres of rooftop, asphalt paving and landscaped areas. Runoff from **Basin J1** and flow-by from the inlet is conveyed within the curb and gutter to an existing 15' Type R at-grade inlets located at **DP12**. **Inlet 5** collects Q5=2.4 cfs and Q100=7.3 cfs, with Q5=0.0 cfs and Q5=0.2 cfs of flow-by in the respective storm events. An existing 18" storm sewer (**PR15**) conveys the intercepted runoff underneath Gary Watson.

Design Point 13 (Q5 = 1.0 cfs, Q100 = 5.0 cfs) consists of flow-by runoff from **Inlet 4** and flows within **Basin J2 and J3**. **Basins J2** and **J3** are of 0.25 and 0.01 acres in size respectively and consist of roof top, asphalt paving and landscaped areas within the development. Runoff from **Basins J2** and **J3** and flow-by from the inlet is conveyed within the curb and gutter to an existing 15' Type R at-grade inlets located at **DP13**. **Inlet 6** collects Q5=1.0 cfs and Q100=5.0 cfs, with no flow-by in the respective storm events. An existing 18" storm sewer (**PR16**) conveys the intercepted runoff from the pair of inlets southward underground.

Design Point 14 (Q5 = 3.8 cfs, Q100 = 9.7 cfs) consists of runoff from **Basin H4, L** and **M4**. **Basin H4** and **L** are 0.10 and 1.32 acres of undeveloped roadway embankment and **Basin M4** consists of 0.98 acres of roof top, asphalt paving and landscaped areas. Runoff from the three basins flow into an existing a 2' foot trapezoidal channel located at the south end of the property.

Design Point 15 (Q5 = 5.3 cfs, Q100 = 12.3 cfs) consists of runoff from **Basin M2, M3** and **DP14**. **Basins M2** and **M3** are of 0.24 and 0.37 acres in size respectively and consist of roof top, asphalt paving and landscaped areas within the development. Runoff from the two basins combine with **DP14** flows in an existing a 2' foot trapezoidal channel located at the south end of the property. Runoff at **DP15** will enter the existing Filing 1 **WQ Pond 2** via an existing trapezoidal grouted riprap rundown.

Design Point 16 (Q5 = 1.4 cfs, Q100 = 2.5 cfs) consists of runoff from **Basin M1** and **K4**. **Basins M1** and **K4** are of 0.28 and 0.05 acres in size respectively and consist of roof top, asphalt paving and landscaped areas within the development. The runoff from the two basins is directed into the existing Filing 1 **WQ Pond 2** via an existing triangular riprap rundown.

Design Point 17 (Q5 = 1.1 cfs, Q100 = 2.0 cfs) consists of runoff from **Basin K2, K3** and **N1**. **Basins K2, K3** and **N1** are of 0.05, 0.15 and 0.06 acres in size respectively and consist of roof top, asphalt paving and landscaped areas within the development. The runoff from the three basins is directed into the existing Filing 1 **WQ Pond 2** via an existing triangular riprap rundown.

Design Point 18 (Q5 = 0.7 cfs, Q100 = 1.3 cfs) consists of runoff from **Basin K1**. **Basins K1** is 0.17 acres in size and consists of roof top, asphalt paving and landscaped areas within the development. The runoff from the basins is directed to an existing beehive grated manhole located in the southwest corner of the lot.

Design Point 19 (Q5 = 19.3 cfs, Q100 = 43.7 cfs) consists of runoff from **Basin N2** and **DP15-17**. **Basins N2** is 0.41 acres in size and consists of an existing sand filter water quality pond (**WQ Pond 2**). In the Appendix is a comparison of weighted percent imperviousness of the existing WQ Pond 2 for the Claremont Business Park 2 Filing No. 2, illustrating that the acreage is lower but the imperviousness is slightly higher. This is due to the extension of El Jefe Heights. Accompanying the impervious sheets are the MHFD-Detention sheets. These sheets illustrate the capacity of the existing pond 2 prior to and after the extension of El Jefe Heights. In both cases the existing pond 2 has the required storage volume. There will be no negative impact on the downstream storm system.

Basin G1, O1, O2,

Basins G1, O1, and **O2** are 0.27, 0.12 and 0.06 acres in size and consist of asphalt, concrete, and landscaped areas along the western periphery of the development. The runoff from the three basins is directed to Existing Meadowbrook Parkway. The 5 year event and 100 year event peak runoff rates from Basin **G1, O1,** and **O2** are Q5 = 0.4 cfs, Q100 = 1.2 cfs, Q5 = 0.1 cfs, Q100 = 0.4 cfs and Q5 = 0.1 cfs, Q100 = 0.3 cfs respectively.

Basin P

Basins P (Q5 = 0.0 cfs, Q100 = 0.3 cfs) is 0.11 acres in size and consists of landscaped and undeveloped areas along the southern periphery of the development. The runoff from the basins is directed to the adjacent development.

The Matrix "Final Drainage Report for Claremont Business Park Filing No. 2" calculated that DP 1 combining Sub Basins B1 and B2 generated of (Q5=31.5 cfs and Q100=63.6). The proposed developments (CBPF2 Filings 1 and 2) will release Q5=19.3 cfs and Q100=43.7 cfs which is less than what was anticipated by the Matrix report. Therefore the proposed development shall not have a negative impact on the downstream storm system and is adequately sized to convey the proposed generated flows.

Water Quality Provision and Maintenance

The subject site was previously analyzed within the Final Drainage Report for Claremont Business Park Filing No. 2 prepared by Matrix Design Group approved April 24, 2006. Per Resolution 16-426 of the

BoCC, on-site WQCV is required but on-site stormwater full spectrum detention (refer FDR for Claremont Business Park Fil. 2). The water quality volume required for the site has been determined using the MHFD UD-Detention workbook per the guidelines set forth in the City of Colorado Springs/El Paso County Drainage Criteria Manual - Volume II.

As previously discussed water quality for the site (CBP2F2) will be provided by proposed Sand Filter Basins (SFB). Pond 3 is to be constructed initially and will function to treat runoff from the newly constructed improvements (roadway, sidewalks) and Lot 2 or approx 2.32 acres at 80.3% imperviousness.

Pond 3 will provide 0.051 acre-feet of water quality storage. Per ECM section 1.7.1.C.1, 20% of the project site (not to exceed 1.0 acre) may be excluded from the 100% WQ treatment requirement per El Paso County criteria. This report identifies that **Basins G1, O1, O2** and **P** is unable to reach one of the proposed WQ ponds. Combined total acreage of the Basins is 0.56 AC, and doesn't exceed the 1.0 acre maximum allowance of acreage runoff allowed per EPC criteria.

Flows tributary to the SFB (Pond 3) are released through outlet structure into a proposed/existing storm sewer system located along Meadowbrook Parkway. Water quality pond 1 will be private and shall be maintained by the property owners (equal shares determined by size of lot 1). Water quality pond 4 will be private and shall be maintained by the property owners (equal shares determined by size of lot 3). Water quality pond 5 will be private and shall be maintained by the property owners (equal shares determined by size of lot 3). Access shall be granted to the owner and El Paso County for access and maintenance of the private WQCV facility. A private maintenance agreement document shall accompany the final drainage report(s) submittal(s) which construct the WQ pond (Pond 3).

Erosion Control

It is the policy of the El Paso County that a grading and erosion control plan (GEC) with the drainage report. The GEC incorporates silt fence, vehicle traffic control, inlet and outlet controls, sediment basin and other best management practices (BMP's) as identified in the DCM Volume 2.

Construction Cost Opinion

Private Drainage Facilities (**NON-Reimbursable**) Including Sand Filter WQ Pond 3:

Item	Description	Quantity	Unit Cost	Cost
1.	18" PP	339 LF	\$48 /LF	\$16,272.00
2.	18" RCP	42 LF	\$60 /LF	\$2,520.00
3.	18" RCP FES	2 LF	\$650 /LF	\$1,300.00
4.	24" PP	415 LF	\$75 /EA	\$31,125.00
5.	Type L Riprap	8 CY	\$75 /CY	\$600.00
6.	ADS Inline Drain and Dome GrateInlet	1 EA	\$3,500 /EA	\$3,500.00
7.	CDOT Type R 5' Sump Inlet	2 EA	\$6,500 /EA	\$13,000.00

8.	CDOT Type C Grated Inlet	1	EA	\$4,500	/EA	\$4,500.00
9.	Type II Manhole	7	EA	\$5,000	/EA	\$35,000.00
11.	Retaining Wall	1	LS	\$24,800	/LS	\$24,800.00
10.	WQCV Sand Filter Pond	1	EA	\$25,000	/EA	\$25,000.00
						<hr/> \$157,617.00
	Engineering Costs (10%)					\$15,761.70
	Total					<hr/> \$173,378.70

Note: The required infrastructure (private) and future ponds (private) for Claremont Business Park 2 Filing 2, Lots 1-3 will be provided in subsequent drainage report and/or letters.

M & S Civil Consultants, Inc. (M & S) cannot and does not guarantee the construction cost will not vary from these opinions of probable costs. These opinions represent our best judgment as design professionals familiar with the construction industry and this development in particular. The above is only an estimate of the facility cost in 2023.

Drainage and Bridge Fees

This site is in the Sand Creek Drainage Basin. The site was previously subdivided into ten commercial lots as a portion of Claremont Business Park 2, Filing No.1. The proposed project will replat the existing Lot and create Claremont Business Park 2, Filing No.2

Drainage fees were paid at the time of the previous platting as Tract C of Claremont Business Park Filing No. 2 (Reception No. 207712506), therefore no additional Drainage Bridge and/or Pond fees are required.

Summary

The proposed design meets the design assumptions utilized in the “Final Drainage Report for Claremont Business Park Filing No. 2”, by Matrix Design Group, Inc that is included in Appendix. The Matrix "Final Drainage Report for Claremont Business Park Filing No. 2" calculated that DP 1 combining Sub Basins B1 and B2 generated of (Q5=31.5 cfs and Q100=63.6). The proposed developments (Filing 1 and Filing 2) will release Q5=20.3 cfs and Q100=36.5 which is less than what was anticipated by the Matrix report. Therefore the proposed development shall not have a negative impact on the downstream storm system and is adequately sized to convey the proposed generated flows. Thus the development of Claremont Business Park 2 Filing No.2 shall not adversely affect the surrounding development. The proposed drainage facilities will adequately convey, detain and route runoff from the onsite & offsite flows to existing facilities. All drainage facilities described herein and shown on the included Proposed Drainage Map (See Appendix) are subject to change being dependent upon individual lot development but owners/developer of the lots shall comply with this final drainage report that will be submitted with the final plat application. Care will be taken to accommodate overland emergency flow routes on site and temporary drainage conditions.

References

1. "El Paso County and City of Colorado Springs Drainage Criteria Manual".
2. "Urban Storm Drainage Criteria Manual"
3. Soil Survey Staff, Natural Resources Conservation Service, United States Department of Agriculture. Web Soil Survey. Available online at the following link: <http://websoilsurvey.sc.egov.usda.gov/>. Accessed: February 02 , 2023.
4. Flood Insurance Rate Map (FIRM), Federal Emergency Management Agency, Effective dated December 7, 2018.
5. "Final Drainage Report for Claremont Business Park Filing No. 2", by Matrix Design Group, Inc dated November 2006.
6. "Falcon Drainage Basin Planning Study", by Matrix Design Group, dated September 2015.
7. "Final Drainage Report for Claremont Business Park Filing No.2", by Matrix Design Group, Inc. dated November 2006.
8. "Final Drainage Report for Claremont Business Park 2 Filing No. 1", by M&S Civil Consultants, approved 2/11/2021.
9. "Final Drainage Letter for Lot 1 of Claremont Business Park 2 Filing No.1", by M&S Civil Consultants, approved 04/01/2021.
10. "Final Drainage Letter for Lot 2 of Claremont Business Park 2 Filing No.1", by M&S Civil Consultants, approved 05/19/2021.
11. "Final Drainage Letter for Lot 3 of Claremont Business Park 2 Filing No.1", by M&S Civil Consultants, approved 05/19/2021.
12. "Final Drainage Letter for Lot 4 of Claremont Business Park 2 Filing No.1", by M&S Civil Consultants, approved 05/19/2021.
13. "Final Drainage Letter for Lot 5 of Claremont Business Park 2 Filing No.1", by M&S Civil Consultants, approved 03/03/2021.
14. "Final Drainage Letter for Lot 6 of Claremont Business Park 2 Filing No.1", by M&S Civil Consultants, approved 07/08/2021.
15. "Final Drainage Letter for Lot 7 of Claremont Business Park 2 Filing No.1", by M&S Civil Consultants, approved 03/31/2021.

Appendix

Vicinity Map

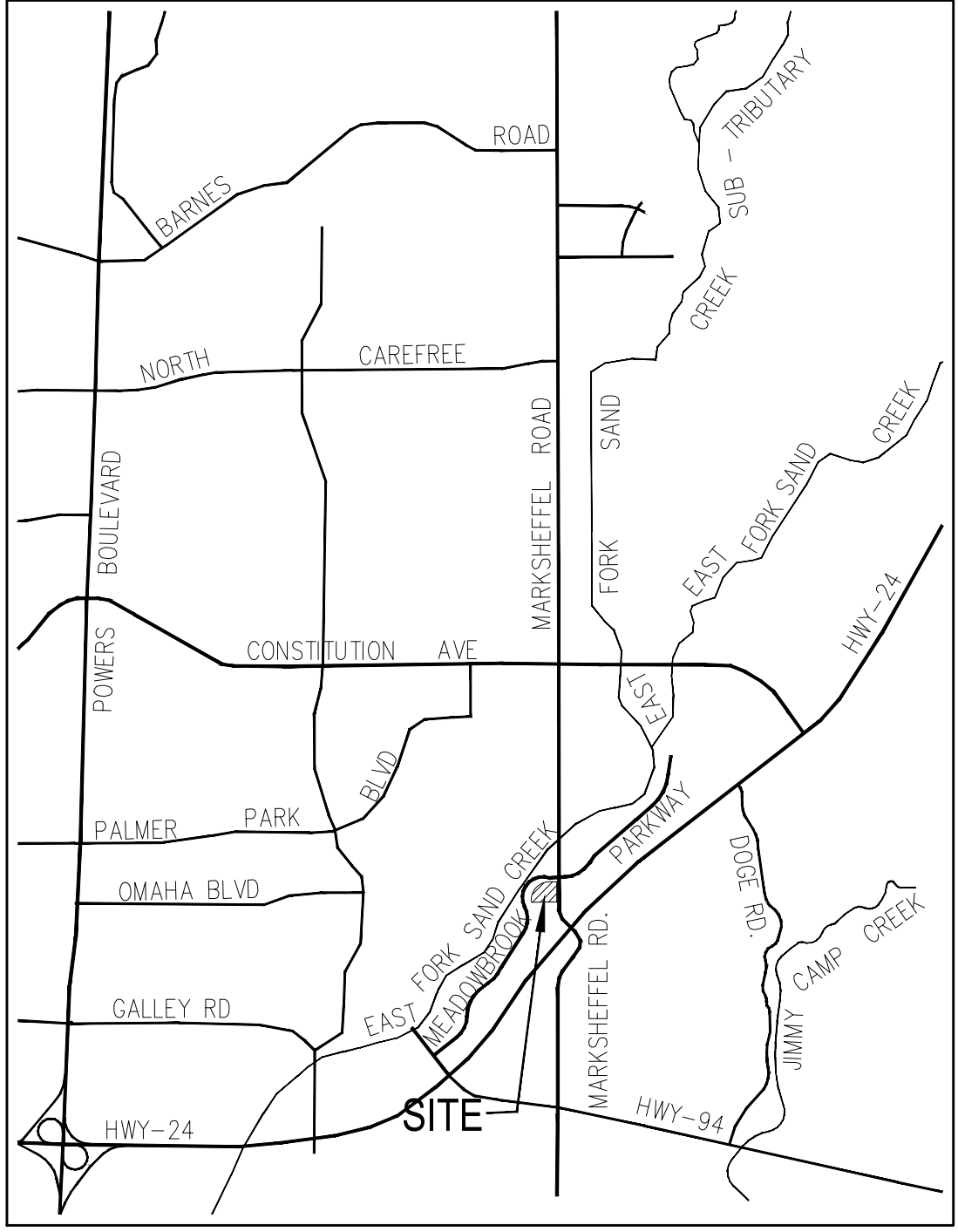

VICINITY MAP

N.T.S.

Soils Map

CLAREMONT BUSINESS PARK 2 FILING NO. 2

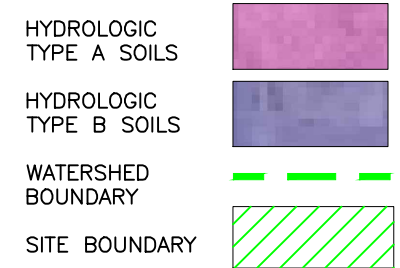
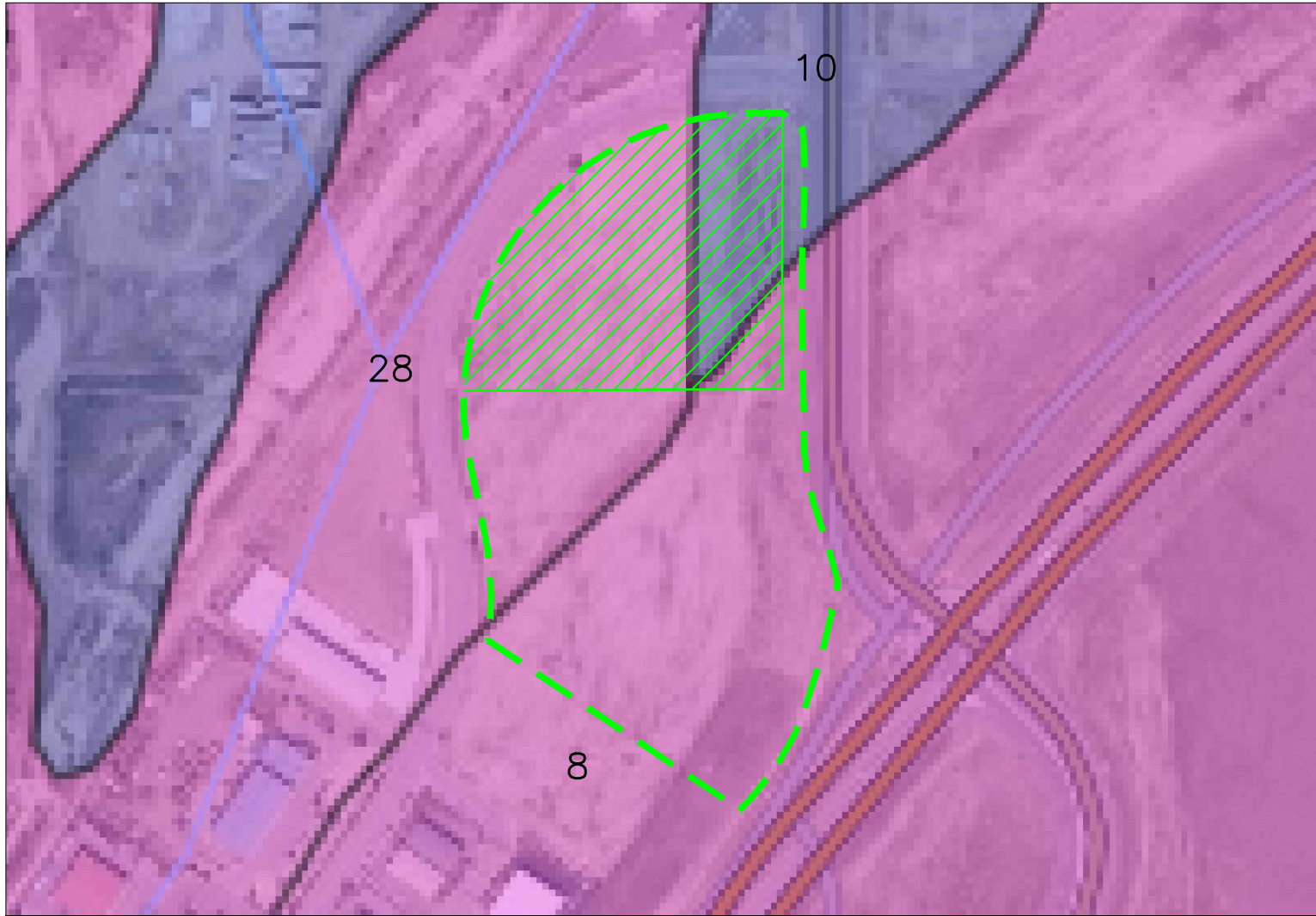

1" = 300'

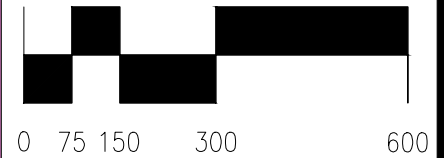

Scale in Feet

Map unit symbol	Map unit name	Rating
8	Blakeland loamy sand, 1 to 9 percent slopes	A
10	Blendon sandy loam, 0 to 3 percent slopes	B
28	Ellicott loamy coarse sand, 0 to 5 percent slopes	A

SOILS MAP

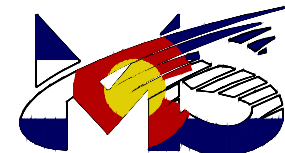

CIVIL CONSULTANTS, INC.

212 N. WAHSATCH AVE., STE 305
 COLORADO SPRINGS, CO 80903
 PHONE: 719.955.5485

FEMA FIRM Panel

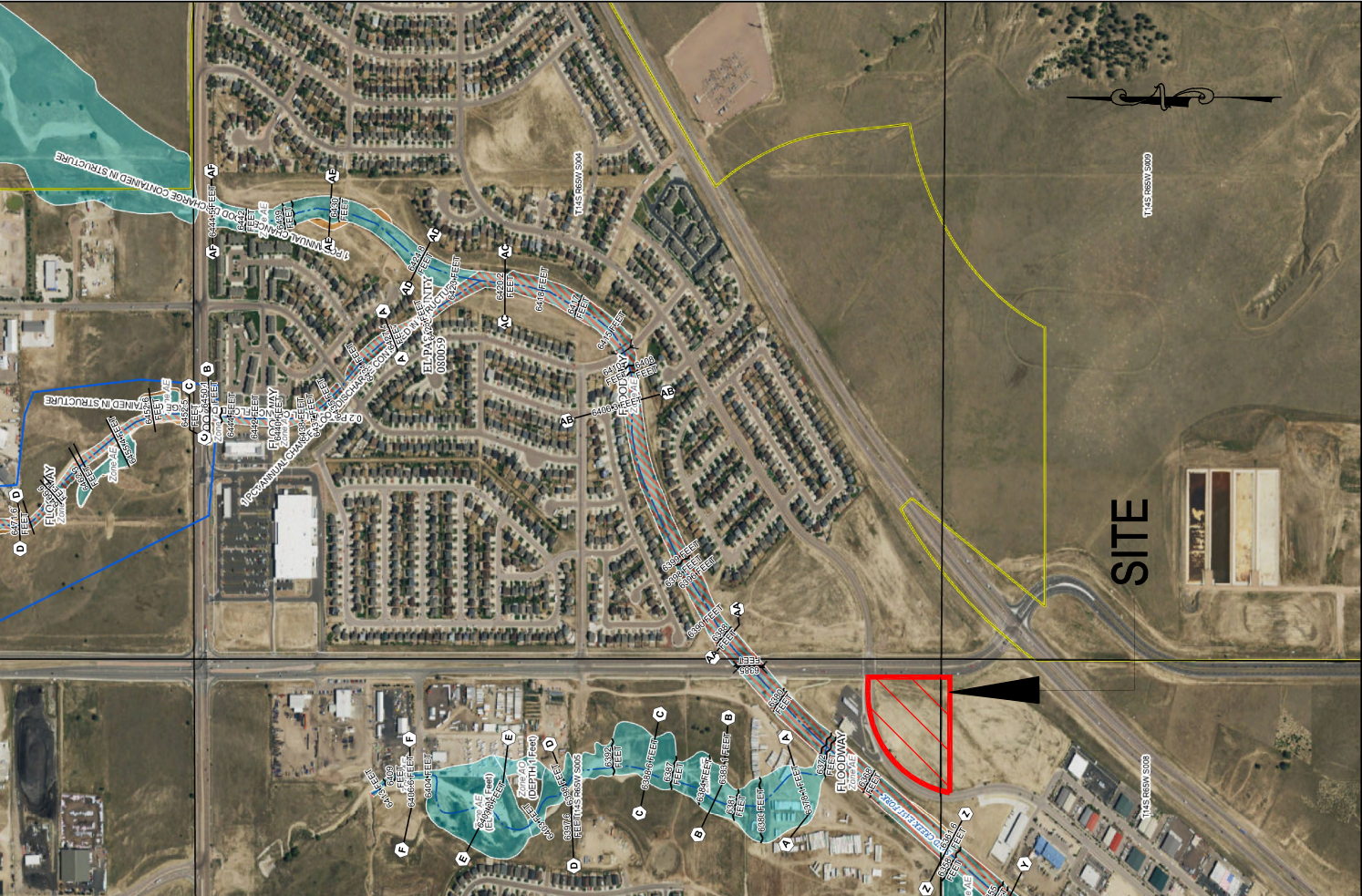

FLOOD HAZARD INFORMATION

SEE FIS REPORT FOR DETAILED LEGEND AND INDEX MAP FOR DRAFT FIRM PANEL LAYOUT

LEGEND

SITE BOUNDARY

	Without Base Flood Elevation (BFE) Zone A, V, A59
	With BFE or Depth Zone AE, AH, VE, AR
	Regulatory Floodway
	0.2% Annual Chance Flood Hazard, Areas of 1% Annual Chance flood with average depth less than one foot or with drainage areas of less than one square mile Zone X
	Future Conditions 1% Annual Flood Zone X
	Area with Reduced Flood Risk due to levee Sea Notes Zone X
	Area with Flood Risk due to Levee Zone D
	Area of Minimal Flood Hazard Zone X
	Effective LOMs
	Area of Undetermined Flood Hazard Zone D
	Channel, Culvert, or Storm Sewer
	Levee, Dike, or Floodwall
	20.2 Cross Sections with 1% Annual Chance
	17.5 Water Surface Elevation
	Coastal Transsect
	Profile Baseline
	Hydrographic Feature
	Base Flood Elevation Line (BFE)
	Limit of Study
	Jurisdiction Boundary

NOTES TO USERS

For information and questions about this Flood Insurance Rate Map (FIRM), available products associated with this map, or to request a copy of this map, please contact the FEMA Map Information Center at 1-877-FEMA-MAP (1-877-352-2527) or visit the FEMA Flood Map Service Center website at <https://msc.fema.gov>. Additional information about this map, including the date of the map, can be obtained directly from the website, and/or original versions of this map. Many of these products can be obtained directly from the website. Communities already listed on adjacent FIRM panels must obtain a current copy of the adjacent panel as well as the current FIRM index. These may be obtained directly from the Flood Map Service Center at the number listed above.

For community and countywide map dates, refer to the Flood Insurance Study Report for this jurisdiction. To determine if flood insurance is available in this community, contact your insurance agent or call the National Flood Insurance Program at 1-800-456-6620.

The base map shown is the USGS National Map, Contouring, Laid (revised October, 2020).

Base map information shown on this FIRM was provided in digital format by the United States Geological Survey (USGS).

This map was prepared from FEMA's National Flood Hazard Layer (NFHL) with 12/27/2022 3:40 PM and does not include any changes or updates to the NFHL. For the most current information, please see the Flood Hazard Update Information Sheet at <https://www.fema.gov/media-library/assets/documents/115418>.

This map complies with FEMA's standards for the use of digital flood maps if it is not void as described below. The map is not void if the map is used for purposes other than determining flood insurance rates, or if any of the following map elements do not appear: basemap imagery, flood zone labels, legend, scale bar, map creation date, community identifiers, FIRM panel number, and FIRM effective date.

SCALE

Map Projection:
GCS, Geoidetic Reference System 1980;
Vertical Datum: NAVD83

For the specific vertical datum for elevation features, datum conversions, or vertical monuments used to create this map, please see the Flood Insurance Study (FIS) Report for your community at <https://msc.fema.gov>.

1 inch = 500 feet

1:6,000

0 250 500 1,000 1,500 2,000 Feet

0 50 100 200 300 400 Meters

Scale in Feet

FIRM MAP

NATIONAL FLOOD INSURANCE PROGRAM
FLOOD INSURANCE RATE MAP

PANEL 756 of 1275

Panel Contains:
COMMUNITY EL PASO COUNTY
CITY OF COLORADO SPRINGS
NUMBER 080059
080060
PANEL 0756
0756

MAD NUMBER 080410756G
EFFECTIVE DATE December 07, 2018



HYDROLOGIC CALCULATIONS

FINAL DRAINAGE REPORT FOR CLAREMONT BUSINESS PARK 2 FILING NO.2
EXISTING DRAINAGE CALCULATIONS
(Area Runoff Coefficient Summary)

BASIN	TOTAL AREA (SF)	TOTAL AREA (Acres)	ROOFS 0.73-0.81 COMMERCIAL AREAS 0.81-0.88 ASPHALT DRIVES 0.90-0.96			LANDSCAPED AREAS 0.16-0.41 GRAVEL STORAGE YARD 0.30-0.50 LIGHT INDUST AREAS 0.59-0.70			PARKS 0.12-0.39 GREENBELTS/AGRI. 0.09-0.36			WEIGHTED	
			AREA (Acres)	C ₅	C ₁₀₀	AREA (Acres)	C ₅	C ₁₀₀	AREA (Acres)	C ₅	C ₁₀₀	C ₅	C ₁₀₀
A	8359.8	0.19	0.00	0.90	0.96	0.00	0.16	0.41	0.19	0.09	0.36	0.09	0.36
B	13279.6	0.30	0.00	0.81	0.88	0.00	0.30	0.50	0.30	0.09	0.36	0.09	0.36
C	213471.0	4.90	0.00	0.90	0.96	0.00	0.16	0.41	4.90	0.09	0.36	0.09	0.36
D	9961.3	0.23	0.00	0.90	0.96	0.00	0.16	0.41	0.23	0.09	0.36	0.09	0.36
H1	7641.7	0.18	0.00	0.90	0.96	0.00	0.73	0.81	0.18	0.09	0.36	0.09	0.36
H2	17510.6	0.40	0.00	0.90	0.96	0.00	0.73	0.81	0.40	0.09	0.36	0.09	0.36
H3	1583.1	0.04	0.00	0.90	0.96	0.00	0.73	0.81	0.04	0.09	0.36	0.09	0.36
H4	4363.6	0.10	0.00	0.81	0.88	0.00	0.30	0.50	0.10	0.09	0.36	0.09	0.36
I1	24996.2	0.57	0.33	0.90	0.96	0.21	0.73	0.81	0.03	0.16	0.41	0.80	0.88
I2	21018.4	0.48	0.32	0.90	0.96	0.12	0.73	0.81	0.05	0.16	0.41	0.79	0.87
I3	25471.7	0.58	0.32	0.90	0.96	0.08	0.73	0.81	0.18	0.16	0.41	0.65	0.77
I4	18732.1	0.43	0.28	0.90	0.96	0.11	0.73	0.81	0.03	0.16	0.41	0.80	0.88
I5	10207.0	0.23	0.12	0.90	0.96	0.08	0.73	0.81	0.04	0.16	0.41	0.73	0.83
I6	8155.2	0.19	0.12	0.90	0.96	0.00	0.73	0.81	0.07	0.16	0.41	0.62	0.75
I7	10159.6	0.23	0.19	0.90	0.96	0.00	0.73	0.81	0.04	0.16	0.41	0.77	0.87
J1	33120.0	0.76	0.45	0.90	0.96	0.12	0.73	0.81	0.19	0.16	0.41	0.69	0.80
J2	10980.0	0.25	0.14	0.90	0.96	0.08	0.73	0.81	0.04	0.16	0.41	0.73	0.83
J3	626.0	0.01	0.00	0.90	0.96	0.00	0.73	0.81	0.01	0.16	0.41	0.16	0.41
K1	7398.7	0.17	0.12	0.90	0.96	0.04	0.73	0.81	0.01	0.16	0.41	0.83	0.90
K2	2320.2	0.05	0.01	0.90	0.96	0.04	0.73	0.81	0.00	0.16	0.41	0.72	0.81
K3	6474.8	0.15	0.09	0.90	0.96	0.05	0.73	0.81	0.01	0.16	0.41	0.78	0.87
K4	2266.5	0.05	0.00	0.90	0.96	0.05	0.73	0.81	0.00	0.16	0.41	0.69	0.78
L	57315.2	1.32	0.00	0.90	0.96	0.00	0.73	0.81	1.32	0.09	0.36	0.09	0.36
M1	12396.2	0.28	0.19	0.90	0.96	0.08	0.73	0.81	0.02	0.16	0.41	0.81	0.88
M2	10573.8	0.24	0.00	0.90	0.96	0.20	0.73	0.81	0.05	0.16	0.41	0.62	0.73
M3	15906.8	0.37	0.33	0.90	0.96	0.00	0.73	0.81	0.04	0.16	0.41	0.83	0.91
M4	42578.8	0.98	0.77	0.90	0.96	0.11	0.73	0.81	0.10	0.12	0.39	0.80	0.89
N1	2827.1	0.06	0.06	0.90	0.96	0.00	0.73	0.81	0.00	0.16	0.41	0.90	0.96
N2	18017.7	0.41	0.00	0.90	0.96	0.00	0.30	0.50	0.41	0.12	0.39	0.12	0.39
O1	5318.2	0.12	0.01	0.90	0.96	0.00	0.30	0.50	0.12	0.12	0.41	0.16	0.44
O2	2824.6	0.06	0.01	0.90	0.96	0.00	0.30	0.50	0.06	0.12	0.41	0.22	0.48
P	4961.4	0.11	0.00	0.90	0.96	0.00	0.30	0.50	0.11	0.09	0.36	0.09	0.36

Calculated by: DLM
Date: 2/20/2023
Checked by: VAS

FINAL DRAINAGE REPORT FOR CLAREMONT BUSINESS PARK 2 FILING NO.2
EXISTING DRAINAGE CALCULATIONS
(Area Drainage Summary)

From Area Runoff Coefficient Summary				OVERLAND				STREET / CHANNEL FLOW				Time of Travel (T _t)		INTENSITY *		TOTAL FLOWS	
BASIN	AREA TOTAL (Acres)	C ₅	C ₁₀₀	C ₅	Length (ft)	Height (ft)	T _c (min)	Length (ft)	Slope (%)	Velocity (fps)	T _t (min)	*TOTAL (min)	CHECK (min)	I ₅ (in/hr)	I ₁₀₀ (in/hr)	Q ₅ (c.f.s.)	Q ₁₀₀ (c.f.s.)
		From DCM Table 5-1															
A	0.19	0.09	0.36	0.09	40	5.0	5.0	0	0.0%	0.0	0.0	5.0	10.2	5.2	8.7	0.1	0.6
B	0.30	0.09	0.36	0.09	40	8.0	4.3	0	0.0%	0.0	0.0	4.3	10.2	5.2	8.7	0.1	1.0
C	4.90	0.09	0.36	0.09	100	2.0	14.5	637	1.7%	1.3	8.3	22.8	14.1	3.6	6.1	1.6	10.7
D	0.23	0.09	0.36	0.09	20	0.5	6.0	0	0.0%	0.0	0.0	6.0	10.1	4.9	8.2	0.1	0.7
H1	0.18	0.09	0.36	0.09	76	20.0	5.4	0	0.0%	0.0	0.0	5.4	10.4	5.1	8.5	0.1	0.5
H2	0.40	0.09	0.36	0.09	100	17.0	7.2	0	0.0%	0.0	0.0	7.2	10.6	4.6	7.8	0.2	1.1
H3	0.04	0.09	0.36	0.09	100	17.0	7.2	0	2.0%	1.4	0.0	7.2	10.6	4.6	7.8	0.0	0.1
H4	0.10	0.09	0.36	0.09	100	17.0	7.2	0	0.0%	0.0	0.0	7.2	10.6	4.6	7.8	0.0	0.3
I1	0.57	0.80	0.88	0.80	100	3.0	3.8	216	2.5%	3.2	1.1	5.0	11.8	5.2	8.7	2.4	4.4
I2	0.48	0.79	0.87	0.79	50	2.0	2.5	261	1.0%	2.0	2.2	5.0	11.7	5.2	8.7	2.0	3.6
I3	0.58	0.65	0.77	0.65	67	2.6	4.3	246	0.9%	1.8	2.2	6.5	11.7	4.8	8.0	1.8	3.6
I4	0.43	0.80	0.88	0.80	67	2.6	2.8	246	0.9%	1.8	2.2	5.0	11.7	5.2	8.7	1.8	3.3
I5	0.23	0.73	0.83	0.73	25	0.5	2.6	146	1.4%	2.4	1.0	5.0	11.0	5.2	8.7	0.9	1.7
I6	0.19	0.62	0.75	0.62	31	0.3	4.8	120	1.3%	2.3	0.9	5.7	10.8	5.0	8.3	0.6	1.2
I7	0.23	0.77	0.87	0.77	50	0.3	5.2	133	1.1%	2.1	1.1	6.2	11.0	4.8	8.1	0.9	1.6
J1	0.76	0.69	0.80	0.69	85	3.0	4.5	327	0.9%	1.9	2.8	7.4	12.3	4.6	7.7	2.4	4.7
J2	0.25	0.73	0.83	0.73	25	0.5	2.6	185	1.4%	2.3	1.3	5.0	11.2	5.2	8.7	1.0	1.8
J3	0.01	0.16	0.41	0.16	10	1.0	2.6	0	0.0%	0.0	0.0	5.0	10.1	5.2	8.7	0.0	0.1
K1	0.17	0.83	0.90	0.83	25	0.5	2.0	115	3.0%	3.5	0.5	5.0	10.8	5.2	8.7	0.7	1.3
K2	0.05	0.72	0.81	0.72	25	0.5	2.7	55	1.8%	2.7	0.3	5.0	10.4	5.2	8.7	0.2	0.4
K3	0.15	0.78	0.87	0.78	25	0.5	2.3	120	1.4%	2.4	0.8	5.0	10.8	5.2	8.7	0.6	1.1
K4	0.05	0.69	0.78	0.69	25	0.5	3.0	91	1.0%	2.0	0.8	5.0	10.6	5.2	8.7	0.2	0.4
L	1.32	0.09	0.36	0.09	100	17.0	7.2	0	0.0%	0.0	0.0	7.2	10.6	4.6	7.8	0.5	3.7
M1	0.28	0.81	0.88	0.81	25	0.5	2.1	203	1.0%	2.0	1.7	5.0	11.3	5.2	8.7	1.2	2.2
M2	0.24	0.62	0.73	0.62	25	0.5	3.5	148	1.0%	1.5	1.6	5.1	11.0	5.1	8.6	0.8	1.5
M3	0.37	0.83	0.91	0.83	50	2.0	2.2	112	2.5%	3.2	0.6	5.0	10.9	5.2	8.7	1.6	2.9
M4	0.98	0.80	0.89	0.80	100	1.0	5.3	326	1.2%	2.2	2.4	7.8	12.4	4.5	7.6	3.5	6.6
N1	0.06	0.90	0.96	0.90	50	1.0	2.0	0	0.0%	0.0	0.0	5.0	10.3	5.2	8.7	0.3	0.5
N2	0.41	0.12	0.39	0.12	60	1.2	10.9	30	33.0%	11.5	0.0	10.9	10.5	4.1	6.8	0.2	1.1
O1	0.12	0.16	0.44	0.16	32	0.5	8.3	0	0.0%	0.0	0.0	8.3	10.2	4.4	7.4	0.1	0.4
O2	0.06	0.22	0.48	0.22	25	0.5	6.3	0	0.0%	0.0	0.0	6.3	10.1	4.8	8.1	0.1	0.3
P	0.11	0.09	0.36	0.09	25	0.5	7.1	0	0.0%	0.0	0.0	7.1	10.1	4.6	7.8	0.0	0.3

* Intensity equations assume a minimum travel time of 5 minutes.

Calculated by: DLM
Date: 2/20/2023
Checked by: VAS

FINAL DRAINAGE REPORT FOR CLAREMONT BUSINESS PARK 2 FILING NO.2
EXISTING DRAINAGE CALCULATIONS
(Basin Routing Summary)

From Area Runoff Coefficient Summary				OVERLAND			PIPE / CHANNEL FLOW				Time of Travel (T _t)	INTENSITY *		TOTAL FLOWS		COMMENTS		
DESIGN POINT	CONTRIBUTING BASINS DPS AND/OR PIPES	CA ₅	CA ₁₀₀	C _s	Length (ft)	Height (ft)	T _c (min)	Length (ft)	Slope (%)	Velocity (fps)	T _t (min)	*TOTAL (min)	I ₅ (in/hr)	I ₁₀₀ (in/hr)	Q ₅ (c.f.s.)		Q ₁₀₀ (c.f.s.)	
1	A, B, C	0.49	1.94		Basin C Tc used								14.1	3.6	6.1	1.8	11.8	Exist PVT 24" Storm Sewer
2				NOT USED														
3	H1, I1	0.47	0.57		Basin H1 Tc used + Basin I1 routing								7.1	4.6	7.8	2.2	4.4	Existing Curb and Gutter
							5.4	316	2.1%	2.9	1.7							
4	H2, I2	0.42	0.56		Basin H2 Tc used + Basin I2 routing								8.9	4.3	7.2	1.8	4.1	Existing Curb and Gutter
							7.2	235	2.8%	3.3	1.7							
5	H3, I7	0.18	0.22		Basin H1 Tc used + Basin I1 routing								8.6	4.4	7.3	0.8	1.6	Existing Curb and Gutter
							7.2	183	1.1%	2.1	1.5							
6	DP3, DP4, DP5 I3, I4, I5, I6	2.09	2.51		Basin H3 Tc used + Basin I7 Routing								11.5	3.9	6.6	8.2	16.5	2-Exist 15' CDOT Type R Inlet
		1.04	1.25				7.2	520	1.0%	2.0	4.3					4.1	8.3	(assumed split flows 100-yr)
7	FB INLET 3, J1	0.52	0.97		Basin J1 Tc Used								7.4	4.6	7.7	2.4	7.5	Exist 15' CDOT Type R Inlet
8	FB INLET 4, J2, J3	0.18	0.47		Basin J2 Tc Used								5.0	5.2	8.7	0.9	4.1	Exist 15' CDOT Type R Inlet
9	H4, L, M4	0.91	1.38		Basin L Tc used + Basin M4 Routing								9.6	4.2	7.0	3.8	9.7	Existing Pvt Swale
							7.2	326	1.2%	2.2	2.4							
10	DP9, M2, M3	1.37	1.88		Basin DP9 Tc used + Basin M3 Routing								11.7	3.9	6.5	5.3	12.3	Existing Pvt Swale/Concrete Riprap Rundown
							9.6	125	1.0%	1.0	2.1							
11	M1, K4	0.27	0.29		Basin M1 Tc Used								5.0	5.2	8.7	1.4	2.5	Existing Conc. Rock Rundown
12	K2, K3, N1	0.21	0.23		Basin K3 Tc Used								5.0	5.2	8.7	1.1	2.0	Existing Conc. Rock Rundown
13	K1	0.14	0.15		Basin K1 Tc Used								5.0	5.2	8.7	0.7	1.3	Existing Inlet
14	DP10, DP11, DP12 DP13, N2, PR14, PR17	4.96	6.72		DP10 Tc Used								11.7	3.9	6.5	19.3	43.9	Existing Sand Filter FSD Pond 2

* Intensity equations assume a minimum travel time of 5 minutes.

Calculated by: DLM
Date: 2/20/2023
Checked by: VAS

FINAL DRAINAGE REPORT FOR CLAREMONT BUSINESS PARK 2 FILING NO.2
EXISTING DRAINAGE CALCULATIONS
(Storm Sewer Routing Summary)

PIPE RUN	Contributing Pipes/Design Points	Equivalent CA_5	Equivalent CA_{100}	Maximum T_C	Intensity*		Flow		Pipe Size
					I_5	I_{100}	Q_5	Q_{100}	
11	DP1	0.49	1.94	14.1	3.6	6.1	1.8	11.8	EX 24" PP
12	PR11	0.49	1.94	14.1	3.6	6.1	1.8	11.8	EX 24" PP
13	INLET 3	1.05	1.20	11.5	3.9	6.6	4.1	7.9	EX 15" PP
14	PR13, INLET 4	2.09	2.42	11.5	3.9	6.6	8.2	15.9	EX 24" PP
15	INLET 5	0.52	0.95	7.4	4.6	7.7	2.4	7.3	EX 18" PP
16	PR15, INLET 6	0.70	1.42	7.4	4.6	7.7	3.2	11.0	EX 24" PP
17	PR16, DP13	0.84	1.57	7.4	4.6	7.7	3.9	12.1	EX 24" PP
18	POND 2 OUTFALL	5.52	5.75	30.0	2.5	4.2	13.7	23.9	EX 30" PP
19	PR12, PR18	6.01	7.69	22.0	2.9	4.9	17.7	38.0	EX 24" PP

* Intensity equations assume a minimum travel time of 5 minutes.

DP - Design Point
 PR - Pipe Run

FB- Flow By from Design Point
 INT- Intercepted Flow from Design Point

Calculated by: DLM
 Date: 2/20/2023
 Checked by: VAS

FINAL DRAINAGE REPORT FOR CLAREMONT BUSINESS PARK 2 FILING NO.2
PROPOSED DRAINAGE CALCULATIONS
(Area Runoff Coefficient Summary)

			ROOFS 0.73-0.81 COMMERCIAL AREAS 0.81-0.88 ASPHALT DRIVES 0.90-0.96				LANDSCAPED AREAS 0.16-0.41 GRAVEL STORAGE YARD 0.30-0.50 LIGHT INDUST AREAS 0.59-0.70				PARKS 0.12-0.39 GREENBELTS/AGRI. 0.09-0.36				WEIGHTED		
BASIN	TOTAL AREA (SF)	TOTAL AREA (Acres)	AREA (Acres)	C ₂	C ₅	C ₁₀₀	AREA (Acres)	C ₂	C ₅	C ₁₀₀	AREA (Acres)	C ₂	C ₅	C ₁₀₀	C ₂	C ₅	C ₁₀₀
A	9300.8	0.21	0.00	0.89	0.90	0.96	0.00	0.07	0.16	0.41	0.21	0.03	0.09	0.36	0.03	0.09	0.36
B	65284.4	1.50	1.50	0.79	0.81	0.88	0.00	0.23	0.30	0.50	0.00	0.05	0.12	0.39	0.79	0.81	0.88
C	5372.3	0.12	0.00	0.89	0.90	0.96	0.00	0.07	0.16	0.41	0.12	0.03	0.09	0.36	0.03	0.09	0.36
CI	7457.3	0.17	0.00	0.89	0.90	0.96	0.00	0.07	0.16	0.41	0.17	0.03	0.09	0.36	0.03	0.09	0.36
D	33587.9	0.77	0.77	0.79	0.81	0.88	0.00	0.23	0.30	0.50	0.00	0.05	0.12	0.39	0.79	0.81	0.88
D1	34028.4	0.78	0.78	0.79	0.81	0.88	0.00	0.23	0.30	0.50	0.00	0.05	0.12	0.39	0.79	0.81	0.88
E1	11683.7	0.27	0.22	0.89	0.90	0.96	0.05	0.79	0.81	0.88	0.00	0.05	0.12	0.39	0.87	0.88	0.95
E2	9082.0	0.21	0.17	0.89	0.90	0.96	0.04	0.79	0.81	0.88	0.00	0.05	0.12	0.39	0.87	0.88	0.95
F	12955.1	0.30	0.30	0.79	0.81	0.88	0.00	0.07	0.16	0.41	0.00	0.05	0.12	0.39	0.79	0.81	0.88
G1	11586.1	0.27	0.06	0.89	0.90	0.96	0.00	0.57	0.59	0.70	0.21	0.05	0.12	0.39	0.25	0.30	0.52
G2	50180.3	1.15	0.00	0.89	0.90	0.96	1.15	0.79	0.81	0.88	0.00	0.03	0.09	0.36	0.79	0.81	0.88
H1	7154.6	0.16	0.00	0.89	0.90	0.96	0.00	0.71	0.73	0.81	0.16	0.03	0.09	0.36	0.03	0.09	0.36
H2	17510.6	0.40	0.00	0.89	0.90	0.96	0.00	0.71	0.73	0.81	0.40	0.03	0.09	0.36	0.03	0.09	0.36
H3	1583.1	0.04	0.00	0.89	0.90	0.96	0.00	0.71	0.73	0.81	0.04	0.03	0.09	0.36	0.03	0.09	0.36
H4	4363.6	0.10	0.00	0.79	0.81	0.88	0.00	0.23	0.30	0.50	0.10	0.03	0.09	0.36	0.03	0.09	0.36
I1	23800.3	0.55	0.33	0.89	0.90	0.96	0.21	0.71	0.73	0.81	0.00	0.07	0.16	0.41	0.82	0.83	0.90
I2	21018.4	0.48	0.32	0.89	0.90	0.96	0.12	0.71	0.73	0.81	0.05	0.07	0.16	0.41	0.77	0.79	0.87
I3	19407.4	0.45	0.31	0.89	0.90	0.96	0.08	0.71	0.73	0.81	0.05	0.07	0.16	0.41	0.76	0.78	0.87
I4	23928.1	0.55	0.40	0.89	0.90	0.96	0.11	0.71	0.73	0.81	0.04	0.07	0.16	0.41	0.80	0.81	0.89
I5	10207.0	0.23	0.12	0.89	0.90	0.96	0.08	0.71	0.73	0.81	0.04	0.07	0.16	0.41	0.71	0.73	0.83
I6	8155.2	0.19	0.12	0.89	0.90	0.96	0.00	0.71	0.73	0.81	0.07	0.07	0.16	0.41	0.58	0.62	0.75
I7	10159.6	0.23	0.19	0.89	0.90	0.96	0.00	0.71	0.73	0.81	0.04	0.07	0.16	0.41	0.75	0.77	0.87
J1	30237.3	0.69	0.52	0.89	0.90	0.96	0.12	0.71	0.73	0.81	0.06	0.07	0.16	0.41	0.79	0.81	0.89
J2	10980.0	0.25	0.14	0.89	0.90	0.96	0.08	0.71	0.73	0.81	0.04	0.07	0.16	0.41	0.71	0.73	0.83
J3	626.0	0.01	0.00	0.89	0.90	0.96	0.00	0.71	0.73	0.81	0.01	0.07	0.16	0.41	0.07	0.16	0.41
K1	7398.7	0.17	0.12	0.89	0.90	0.96	0.04	0.71	0.73	0.81	0.01	0.07	0.16	0.41	0.81	0.83	0.90
K2	2320.2	0.05	0.01	0.89	0.90	0.96	0.04	0.71	0.73	0.81	0.00	0.07	0.16	0.41	0.70	0.72	0.81
K3	6474.8	0.15	0.09	0.89	0.90	0.96	0.05	0.71	0.73	0.81	0.01	0.07	0.16	0.41	0.76	0.78	0.87
K4	2266.5	0.05	0.00	0.89	0.90	0.96	0.05	0.71	0.73	0.81	0.00	0.07	0.16	0.41	0.66	0.69	0.78
L	57315.2	1.32	0.00	0.89	0.90	0.96	0.00	0.71	0.73	0.81	1.32	0.03	0.09	0.36	0.03	0.09	0.36
M1	12396.2	0.28	0.19	0.89	0.90	0.96	0.08	0.71	0.73	0.81	0.02	0.07	0.16	0.41	0.79	0.81	0.88
M2	10573.8	0.24	0.00	0.89	0.90	0.96	0.20	0.71	0.73	0.81	0.05	0.07	0.16	0.41	0.58	0.62	0.73
M3	15906.8	0.37	0.33	0.89	0.90	0.96	0.00	0.71	0.73	0.81	0.04	0.07	0.16	0.41	0.81	0.83	0.91
M4	42578.8	0.98	0.77	0.89	0.90	0.96	0.11	0.71	0.73	0.81	0.10	0.05	0.12	0.39	0.79	0.80	0.89
N1	2827.1	0.06	0.06	0.89	0.90	0.96	0.00	0.71	0.73	0.81	0.00	0.07	0.16	0.41	0.89	0.90	0.96
N2	18017.7	0.41	0.00	0.89	0.90	0.96	0.00	0.23	0.30	0.50	0.41	0.05	0.12	0.39	0.05	0.12	0.39
O1	5318.2	0.12	0.01	0.89	0.90	0.96	0.00	0.23	0.30	0.50	0.12	0.05	0.12	0.41	0.10	0.16	0.44
O2	2824.6	0.06	0.01	0.89	0.90	0.96	0.00	0.23	0.30	0.50	0.06	0.05	0.12	0.41	0.16	0.22	0.48
P	4961.4	0.11	0.00	0.89	0.90	0.96	0.00	0.23	0.30	0.50	0.11	0.03	0.09	0.36	0.03	0.09	0.36

Calculated by: GT
Date: 5/17/2023
Checked by: VAS

FINAL DRAINAGE REPORT FOR CLAREMONT BUSINESS PARK 2 FILING NO.2
PROPOSED DRAINAGE CALCULATIONS
(Area Drainage Summary)

From Area Runoff Coefficient Summary					OVERLAND				STREET / CHANNEL FLOW				Time of Travel (T _t)		INTENSITY *			TOTAL FLOWS		
BASIN	AREA TOTAL (Acres)	C ₂	C ₅	C ₁₀₀	C _s	Length (ft)	Height (ft)	T _c (min)	Length (ft)	Slope (%)	Velocity (fps)	T _t (min)	*TOTAL (min)	CHECK (min)	I ₂ (in/hr)	I ₅ (in/hr)	I ₁₀₀ (in/hr)	Q ₂ (c.f.s.)	Q ₅ (c.f.s.)	Q ₁₀₀ (c.f.s.)
		From DCM Table 3-1																		
A	0.21	0.03	0.09	0.36	0.09	40	5.0	5.0	0	0.0%	0.0	0.0	5.0	10.2	4.1	5.2	8.7	0.0	0.1	0.7
B	1.50	0.79	0.81	0.88	0.81	80	1.0	4.4	240	1.7%	2.6	1.5	5.9	11.8	3.9	4.9	8.3	4.6	6.0	10.9
C	0.12	0.03	0.09	0.36	0.09	40	16.0	3.4	0	0.0%	0.0	0.0	5.0	10.2	4.1	5.2	8.7	0.0	0.1	0.4
CI	0.17	0.03	0.09	0.36	0.09	60	22.0	4.3	0	0.0%	0.0	0.0	5.0	10.3	4.1	5.2	8.7	0.0	0.1	0.5
D	0.77	0.79	0.81	0.88	0.81	60	1.2	3.2	250	1.6%	2.5	1.6	5.0	11.7	4.1	5.2	8.7	2.5	3.2	5.9
D1	0.78	0.79	0.81	0.88	0.81	60	1.2	3.2	250	1.6%	2.5	1.6	5.0	11.7	4.1	5.2	8.7	2.5	3.3	6.0
E1	0.27	0.87	0.88	0.95	0.88	30	0.6	1.7	280	2.0%	2.8	1.7	5.0	11.7	4.1	5.2	8.7	1.0	1.2	2.2
E2	0.21	0.87	0.88	0.95	0.88	30	0.6	1.7	280	2.0%	2.8	1.7	5.0	11.7	4.1	5.2	8.7	0.7	1.0	1.7
F	0.30	0.79	0.81	0.88	0.81	60	1.2	3.2	150	1.3%	2.3	1.1	5.0	11.2	4.1	5.2	8.7	1.0	1.2	2.3
G1	0.27	0.25	0.30	0.52	0.30	30	1.0	5.3	0	0.0%	0.0	0.0	5.3	10.2	4.1	5.1	8.5	0.3	0.4	1.2
G2	1.15	0.79	0.81	0.88	0.81	60	0.6	4.1	400	1.0%	2.0	3.3	7.4	12.6	3.7	4.6	7.7	3.3	4.3	7.8
H1	0.16	0.03	0.09	0.36	0.09	76	20.0	5.4	0	0.0%	0.0	0.0	5.4	10.4	4.0	5.1	8.5	0.0	0.1	0.5
H2	0.40	0.03	0.09	0.36	0.09	100	17.0	7.2	0	0.0%	0.0	0.0	7.2	10.6	3.7	4.6	7.8	0.0	0.2	1.1
H3	0.04	0.03	0.09	0.36	0.09	100	17.0	7.2	0	2.0%	1.4	0.0	7.2	10.6	3.7	4.6	7.8	0.0	0.0	0.1
H4	0.10	0.03	0.09	0.36	0.09	100	17.0	7.2	0	0.0%	0.0	0.0	7.2	10.6	3.7	4.6	7.8	0.0	0.0	0.3
I1	0.55	0.82	0.83	0.90	0.83	100	3.0	3.4	216	2.5%	3.2	1.1	5.0	11.8	4.1	5.2	8.7	1.8	2.3	4.3
I2	0.48	0.77	0.79	0.87	0.79	50	2.0	2.5	261	1.0%	2.0	2.2	5.0	11.7	4.1	5.2	8.7	1.5	2.0	3.6
I3	0.45	0.76	0.78	0.87	0.78	67	2.6	3.0	246	0.9%	1.8	2.2	5.2	11.7	4.1	5.1	8.6	1.4	1.8	3.3
I4	0.55	0.80	0.81	0.89	0.81	67	2.6	2.7	246	0.9%	1.8	2.2	5.0	11.7	4.1	5.2	8.7	1.8	2.3	4.2
I5	0.23	0.71	0.73	0.83	0.73	25	0.5	2.6	146	1.4%	2.4	1.0	5.0	11.0	4.1	5.2	8.7	0.7	0.9	1.7
I6	0.19	0.58	0.62	0.75	0.62	31	0.3	4.8	120	1.3%	2.3	0.9	5.7	10.8	4.0	5.0	8.3	0.4	0.6	1.2
I7	0.23	0.75	0.77	0.87	0.77	50	0.3	5.2	133	1.1%	2.1	1.1	6.2	11.0	3.9	4.8	8.1	0.7	0.9	1.6
J1	0.69	0.79	0.81	0.89	0.81	85	3.0	3.2	327	0.9%	1.9	2.8	6.1	12.3	3.9	4.9	8.2	2.1	2.7	5.1
J2	0.25	0.71	0.73	0.83	0.73	25	0.5	2.6	185	1.4%	2.3	1.3	5.0	11.2	4.1	5.2	8.7	0.7	1.0	1.8
J3	0.01	0.07	0.16	0.41	0.16	10	1.0	2.6	0	0.0%	0.0	0.0	5.0	10.1	4.1	5.2	8.7	0.0	0.0	0.1
K1	0.17	0.81	0.83	0.90	0.83	25	0.5	2.0	115	3.0%	3.5	0.5	5.0	10.8	4.1	5.2	8.7	0.6	0.7	1.3
K2	0.05	0.70	0.72	0.81	0.72	25	0.5	2.7	55	1.8%	2.7	0.3	5.0	10.4	4.1	5.2	8.7	0.2	0.2	0.4
K3	0.15	0.76	0.78	0.87	0.78	25	0.5	2.3	120	1.4%	2.4	0.8	5.0	10.8	4.1	5.2	8.7	0.5	0.6	1.1
K4	0.05	0.66	0.69	0.78	0.69	25	0.5	3.0	91	1.0%	2.0	0.8	5.0	10.6	4.1	5.2	8.7	0.1	0.2	0.4
L	1.32	0.03	0.09	0.36	0.09	100	17.0	7.2	0	0.0%	0.0	0.0	7.2	10.6	3.7	4.6	7.8	0.1	0.5	3.7
M1	0.28	0.79	0.81	0.88	0.81	25	0.5	2.1	203	1.0%	2.0	1.7	5.0	11.3	4.1	5.2	8.7	0.9	1.2	2.2
M2	0.24	0.58	0.62	0.73	0.62	25	0.5	3.5	148	1.0%	1.5	1.6	5.1	11.0	4.1	5.1	8.6	0.6	0.8	1.5
M3	0.37	0.81	0.83	0.91	0.83	50	2.0	2.2	112	2.5%	3.2	0.6	5.0	10.9	4.1	5.2	8.7	1.2	1.6	2.9
M4	0.98	0.79	0.80	0.89	0.80	100	1.0	5.3	326	1.2%	2.2	2.4	7.8	12.4	3.6	4.5	7.6	2.8	3.5	6.6
N1	0.06	0.89	0.90	0.96	0.90	50	1.0	2.0	0	0.0%	0.0	0.0	5.0	10.3	4.1	5.2	8.7	0.2	0.3	0.5
N2	0.41	0.05	0.12	0.39	0.12	60	1.2	10.9	30	33.0%	11.5	0.0	10.9	10.5	3.2	4.1	6.8	0.1	0.2	1.1
O1	0.12	0.10	0.16	0.44	0.16	32	0.5	8.3	0	0.0%	0.0	0.0	8.3	10.2	3.5	4.4	7.4	0.0	0.1	0.4
O2	0.06	0.16	0.22	0.48	0.22	25	0.5	6.3	0	0.0%	0.0	0.0	6.3	10.1	3.8	4.8	8.1	0.0	0.1	0.3
P	0.11	0.03	0.09	0.36	0.09	25	0.5	7.1	0	0.0%	0.0	0.0	7.1	10.1	3.7	4.6	7.8	0.0	0.0	0.3

* Intensity equations assume a minimum travel time of 5 minutes.

Calculated by: GT
Date: 5/17/2023
Checked by: VAS

FINAL DRAINAGE REPORT FOR CLAREMONT BUSINESS PARK 2 FILING NO.2
PROPOSED DRAINAGE CALCULATIONS
(Basin Routing Summary)

From Area Runoff Coefficient Summary					OVERLAND			PIPE / CHANNEL FLOW				Time of Travel (T _t)	INTENSITY*			TOTAL FLOWS			COMMENTS	
DESIGN POINT	CONTRIBUTING BASINS DPS AND/OR PIPES	CA ₂	CA ₄	CA ₁₀₀	C _s	Length (ft)	Height (ft)	T _c (min)	Length (ft)	Slope (%)	Velocity (fps)	T _t (min)	*TOTAL (min)	I ₂ (in/hr)	I ₅ (in/hr)	I ₁₀₀ (in/hr)	Q ₂ (c.f.s.)	Q ₅ (c.f.s.)		Q ₁₀₀ (c.f.s.)
1	A, B	1.19	1.23	1.40				5.0	240	1.7%	2.6	1.5	6.6	3.8	4.8	8.0	4.5	5.9	11.2	Proposed PVT 18" Storm Sewer
	NOT USED																			
3	F	0.23	0.24	0.26									5.0	4.1	5.2	8.7	1.0	1.2	2.3	Proposed PVT 15" Storm Sewer
4	E2	0.18	0.18	0.20									5.0	4.1	5.2	8.7	0.7	1.0	1.7	Proposed 5" Type R Sump Inlet
5	E1	0.23	0.24	0.25									5.0	4.1	5.2	8.7	1.0	1.2	2.2	Proposed 5" Type R Sump Inlet
6	C, D, C1, D1, PR6	1.65	1.71	1.92				5.0	370	1.6%	2.5	2.4	7.4	3.7	4.6	7.7	6.0	7.8	14.8	Proposed WQ Pond 3
7	G2	0.91	0.93	1.01									5.3	4.1	5.1	8.5	3.7	4.7	8.7	Existing Curb and Gutter
8	H1, I1	0.45	0.47	0.55				5.4	316	2.1%	2.9	1.7	7.1	3.7	4.6	7.8	1.7	2.2	4.3	Existing Curb and Gutter
9	H2, I2	0.38	0.42	0.56				7.2	235	2.8%	3.3	1.7	8.9	3.4	4.3	7.2	1.3	1.8	4.1	Existing Curb and Gutter
10	H3, I7	0.18	0.18	0.22				7.2	183	1.1%	2.1	1.5	8.6	3.5	4.4	7.3	0.6	0.8	1.6	Existing Curb and Gutter
11	DP3, DP4, DP5 I3, I4, I5, I6	2.06	2.15	2.54				7.2	520	1.0%	2.0	4.3	11.5	3.1	3.9	6.6	6.5	8.4	16.7	2-Exist 15" CDOT Type R Inlet
12	FB INLET 3, J1	1.03	1.08	1.27									6.1	3.9	4.9	8.2	3.2	4.2	8.4	(assumed split flows 100-yr)
13	FB INLET 4, J2, J3	0.55	0.58	0.98									6.1	3.9	4.9	8.2	2.1	2.8	8.1	Exist 15" CDOT Type R Inlet
14	H4, L, M4	0.18	0.19	0.58									5.0	4.1	5.2	8.7	0.7	1.0	5.0	Exist 15" CDOT Type R Inlet
15	H4, L, M4	0.81	0.91	1.38				7.2	326	1.2%	2.2	2.4	9.6	3.3	4.2	7.0	2.7	3.8	9.7	Existing Pnt Swale
16	DP14, M2, M3	1.25	1.37	1.88				9.6	125	1.0%	1.0	2.1	11.7	3.1	3.9	6.5	3.9	5.3	12.3	Existing Pnt Swale/Concrete Riprap Rounddown
17	M1, K4	0.26	0.27	0.29									5.0	4.1	5.2	8.7	1.1	1.4	2.5	Existing Conc. Rock Rounddown
18	K2, K3, N1	0.21	0.21	0.23									5.0	4.1	5.2	8.7	0.9	1.1	2.0	Existing Conc. Rock Rounddown
19	K1	0.14	0.14	0.15									5.0	4.1	5.2	8.7	0.6	0.7	1.3	Existing Inlet
19	DP15, DP16, DP17 N2, PR14, PR17	4.66	4.95	6.69									11.7	3.1	3.9	6.5	14.5	19.3	43.7	Existing Sand Filter FSD Pond 2

* Intensity equations assume a minimum travel time of 5 minutes.

Calculated by: GT
Date: 5/17/2023
Checked by: VAS

FINAL DRAINAGE REPORT FOR CLAREMONT BUSINESS PARK 2 FILING NO.2
PROPOSED DRAINAGE CALCULATIONS
(Storm Sewer Routing Summary)

PIPE RUN	Contributing Pipes/Design Points	Equivalent CA ₅	Equivalent CA ₁₀₀	Maximum T _C	Intensity*		Flow		Pipe Size
					I ₅	I ₁₀₀	Q ₅	Q ₁₀₀	
1	FUTURE POND 1 OUTFALL	0.98	1.37	30.0	2.5	4.2	2.4	5.7	PROP 18" PP
2	NOT USED								
3	FUTURE POND 4 OUTFALL	0.18	0.24	30.0	2.5	4.2	0.4	1.0	PROP 18" PP
4	PR1, PR3	1.16	1.61	30.0	2.5	4.2	2.9	6.7	PROP 24" PP
5	DP4	0.18	0.20	5.0	5.2	8.7	1.0	1.7	PROP 18" PP
6	PR5, DP5	0.42	0.45	5.0	5.2	8.7	2.2	3.9	PROP 18" RCP
6A	C, C1 90%D, D1	1.16	1.34	5.0	5.2	8.7	6.0	11.6	PROP 18" RCP
7	POND 3 OUTFALL	1.31	0.97	30.0	2.5	4.2	3.3	4.0	PROP 18" RCP/PP
8	PR4, PR7	2.47	2.58	30.0	2.5	4.2	6.1	10.7	PROP 24" PP
9	FUTURE POND 5 OUTFALL	0.52	0.73	30.0	2.5	4.2	1.3	3.0	PROP 18" PP
10	PR8, PR9	2.99	3.31	30.0	2.5	4.2	7.4	13.8	PROP 24" PP
11	PR10	2.99	3.31	30.0	2.5	4.2	7.4	13.8	EX 24" PP
12	PR11	2.99	3.31	30.0	2.5	4.2	7.4	13.8	EX 24" PP
13	INLET 3	1.07	1.22	11.5	3.9	6.6	4.2	8.0	PROP 15" PP
14	PR13, INLET 4	2.15	2.43	11.5	3.9	6.6	8.4	16.0	PROP 24" PP
15	INLET 5	0.58	0.95	6.1	4.9	8.2	2.8	7.8	PROP 24" PP
16	PR15, INLET 6	0.77	1.53	6.1	4.9	8.2	3.7	12.6	PROP 18" PP
17	PR16, DP18	0.91	1.69	6.1	4.9	8.2	4.4	13.8	EXIST 24" PP
18	POND 2 OUTFALL	5.52	5.72	30.0	2.5	4.2	13.7	23.8	EXIST 24" PP
19	PR18, PR12	8.51	9.03	30.0	2.5	4.2	21.1	37.6	EXIST 42" RCP

* Intensity equations assume a minimum travel time of 5 minutes.

DP - Design Point
PR - Pipe Run

FB- Flow By from Design Point
INT- Intercepted Flow from Design Point

Calculated by: GT

Date: 5/17/2023

Checked by: VAS

**Existing undeveloped

***Ultimate build out, developed. Used to size future pond 1 and storm sewer.

HYDRAULIC CALCULATIONS / SFB WQCV CALCULATIONS

ALLOWABLE CAPACITY FOR ONE-HALF OF STREET (Minor & Major Storm)

(Based on Regulated Criteria for Maximum Allowable Flow Depth and Spread)

Project: **Claremont Business Park 2 Filing No. 2 (Existing Conditions)**

Inlet ID: **Inlet 3 DP 6 (North)**

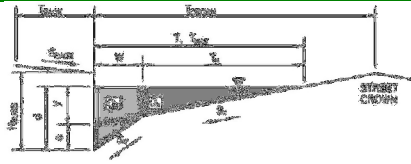

Gutter Geometry:										
Maximum Allowable Width for Spread Behind Curb	$T_{BACK} = 7.5$ ft									
Side Slope Behind Curb (leave blank for no conveyance credit behind curb)	$S_{BACK} = 0.020$ ft/ft									
Manning's Roughness Behind Curb (typically between 0.012 and 0.020)	$n_{BACK} = 0.020$									
Height of Curb at Gutter Flow Line	$H_{CURB} = 6.00$ inches									
Distance from Curb Face to Street Crown	$T_{CROWN} = 17.0$ ft									
Gutter Width	$W = 2.00$ ft									
Street Transverse Slope	$S_x = 0.020$ ft/ft									
Gutter Cross Slope (typically 2 inches over 24 inches or 0.083 ft/ft)	$S_w = 0.083$ ft/ft									
Street Longitudinal Slope - Enter 0 for sump condition	$S_o = 0.012$ ft/ft									
Manning's Roughness for Street Section (typically between 0.012 and 0.020)	$n_{STREET} = 0.015$									
Max. Allowable Spread for Minor & Major Storm	<table border="1"> <tr> <th></th> <th>Minor Storm</th> <th>Major Storm</th> </tr> <tr> <td>T_{MAX}</td> <td>15.8</td> <td>17.0</td> </tr> <tr> <td>d_{MAX}</td> <td>4.6</td> <td>7.8</td> </tr> </table>		Minor Storm	Major Storm	T_{MAX}	15.8	17.0	d_{MAX}	4.6	7.8
	Minor Storm	Major Storm								
T_{MAX}	15.8	17.0								
d_{MAX}	4.6	7.8								
Max. Allowable Depth at Gutter Flowline for Minor & Major Storm										
Allow Flow Depth at Street Crown (check box for yes, leave blank for no)	<table border="1"> <tr> <th></th> <th>Minor Storm</th> <th>Major Storm</th> </tr> <tr> <td>Q_{allow}</td> <td>6.5</td> <td>12.7</td> </tr> </table>		Minor Storm	Major Storm	Q_{allow}	6.5	12.7			
	Minor Storm	Major Storm								
Q_{allow}	6.5	12.7								
MINOR STORM Allowable Capacity is based on Depth Criterion										
MAJOR STORM Allowable Capacity is based on Spread Criterion										
<p>Minor storm max. allowable capacity GOOD - greater than the design peak flow of 4.10 cfs on sheet 'Inlet Management'</p> <p>Major storm max. allowable capacity GOOD - greater than the design peak flow of 8.30 cfs on sheet 'Inlet Management'</p>										

INLET ON A CONTINUOUS GRADE

MHFD-Inlet, Version 5.02 (August 2022)

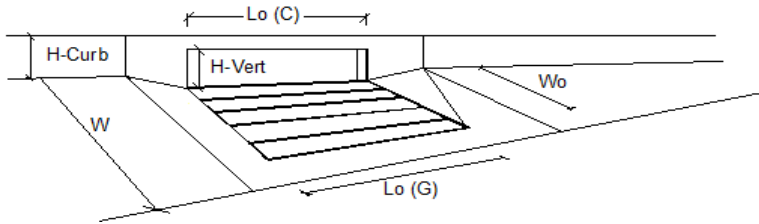

Design Information (Input)	MINOR	MAJOR	
Type of Inlet	CDOT Type R Curb Opening		
Local Depression (additional to continuous gutter depression 'a')	3.0	3.0	inches
Total Number of Units in the Inlet (Grate or Curb Opening)	3	3	
Length of a Single Unit Inlet (Grate or Curb Opening)	5.00	5.00	ft
Width of a Unit Grate (cannot be greater than W, Gutter Width)	N/A	N/A	ft
Clogging Factor for a Single Unit Grate (typical min. value = 0.5)	N/A	N/A	
Clogging Factor for a Single Unit Curb Opening (typical min. value = 0.1)	0.10	0.10	
Street Hydraulics: OK - $Q < \text{Allowable Street Capacity}$			
Total Inlet Interception Capacity	4.1	7.9	cfs
Total Inlet Carry-Over Flow (flow bypassing inlet)	0.0	0.4	cfs
Capture Percentage = Q_i/Q_o	100	96	%

ALLOWABLE CAPACITY FOR ONE-HALF OF STREET (Minor & Major Storm)

(Based on Regulated Criteria for Maximum Allowable Flow Depth and Spread)

Project: **Claremont Business Park 2 Filing No. 2 (Existing Conditions)**

Inlet ID: **Inlet 4 DP6 (South)**

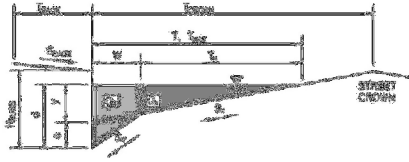

Gutter Geometry:									
Maximum Allowable Width for Spread Behind Curb	$T_{BACK} = 7.5$ ft								
Side Slope Behind Curb (leave blank for no conveyance credit behind curb)	$S_{BACK} = 0.020$ ft/ft								
Manning's Roughness Behind Curb (typically between 0.012 and 0.020)	$n_{BACK} = 0.020$								
Height of Curb at Gutter Flow Line	$H_{CURB} = 6.00$ inches								
Distance from Curb Face to Street Crown	$T_{CROWN} = 17.0$ ft								
Gutter Width	$W = 2.00$ ft								
Street Transverse Slope	$S_x = 0.020$ ft/ft								
Gutter Cross Slope (typically 2 inches over 24 inches or 0.083 ft/ft)	$S_w = 0.083$ ft/ft								
Street Longitudinal Slope - Enter 0 for sump condition	$S_o = 0.011$ ft/ft								
Manning's Roughness for Street Section (typically between 0.012 and 0.020)	$n_{STREET} = 0.016$								
Max. Allowable Spread for Minor & Major Storm	<table border="1"> <tr> <td></td> <td>Minor Storm</td> <td>Major Storm</td> <td></td> </tr> <tr> <td>$T_{MAX} =$</td> <td>15.8</td> <td>17.0</td> <td>ft</td> </tr> </table>		Minor Storm	Major Storm		$T_{MAX} =$	15.8	17.0	ft
	Minor Storm	Major Storm							
$T_{MAX} =$	15.8	17.0	ft						
Max. Allowable Depth at Gutter Flowline for Minor & Major Storm	<table border="1"> <tr> <td></td> <td>Minor Storm</td> <td>Major Storm</td> <td></td> </tr> <tr> <td>$d_{MAX} =$</td> <td>4.6</td> <td>7.8</td> <td>inches</td> </tr> </table>		Minor Storm	Major Storm		$d_{MAX} =$	4.6	7.8	inches
	Minor Storm	Major Storm							
$d_{MAX} =$	4.6	7.8	inches						
Allow Flow Depth at Street Crown (check box for yes, leave blank for no)	<table border="1"> <tr> <td></td> <td>Minor Storm</td> <td>Major Storm</td> <td></td> </tr> <tr> <td></td> <td><input type="checkbox"/></td> <td><input type="checkbox"/></td> <td></td> </tr> </table>		Minor Storm	Major Storm			<input type="checkbox"/>	<input type="checkbox"/>	
	Minor Storm	Major Storm							
	<input type="checkbox"/>	<input type="checkbox"/>							
MINOR STORM Allowable Capacity is based on Depth Criterion									
MAJOR STORM Allowable Capacity is based on Spread Criterion									
Minor storm max. allowable capacity GOOD - greater than the design peak flow of 4.10 cfs on sheet 'Inlet Management'	<table border="1"> <tr> <td></td> <td>Minor Storm</td> <td>Major Storm</td> <td></td> </tr> <tr> <td>$Q_{allow} =$</td> <td>5.8</td> <td>11.4</td> <td>cfs</td> </tr> </table>		Minor Storm	Major Storm		$Q_{allow} =$	5.8	11.4	cfs
	Minor Storm	Major Storm							
$Q_{allow} =$	5.8	11.4	cfs						
Major storm max. allowable capacity GOOD - greater than the design peak flow of 8.30 cfs on sheet 'Inlet Management'									

INLET ON A CONTINUOUS GRADE

MHFD-Inlet, Version 5.02 (August 2022)

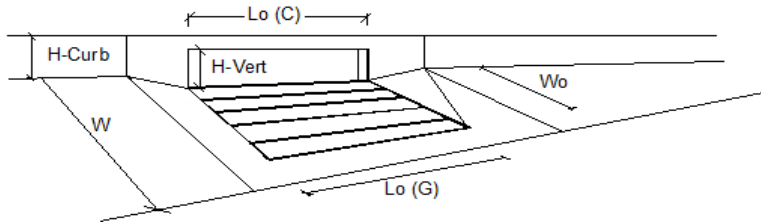

Design Information (Input)	MINOR	MAJOR	
Type of Inlet	CDOT Type R Curb Opening		
Local Depression (additional to continuous gutter depression 'a')	3.0	3.0	inches
Total Number of Units in the Inlet (Grate or Curb Opening)	3	3	
Length of a Single Unit Inlet (Grate or Curb Opening)	5.00	5.00	ft
Width of a Unit Grate (cannot be greater than W, Gutter Width)	N/A	N/A	ft
Clogging Factor for a Single Unit Grate (typical min. value = 0.5)	N/A	N/A	
Clogging Factor for a Single Unit Curb Opening (typical min. value = 0.1)	0.10	0.10	
Street Hydraulics: OK - $Q < \text{Allowable Street Capacity}$			
Total Inlet Interception Capacity	4.1	8.0	cfs
Total Inlet Carry-Over Flow (flow bypassing inlet)	0.0	0.3	cfs
Capture Percentage = Q_i/Q_n	100	96	%

ALLOWABLE CAPACITY FOR ONE-HALF OF STREET (Minor & Major Storm)

(Based on Regulated Criteria for Maximum Allowable Flow Depth and Spread)

Project: **Claremont Business Park 2 Filing No. 2 (Existing Conditions)**

Inlet ID: **Inlet 5 DP7 (North)**

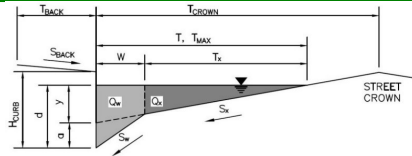

Gutter Geometry:									
Maximum Allowable Width for Spread Behind Curb	$T_{BACK} = 7.5$ ft								
Side Slope Behind Curb (leave blank for no conveyance credit behind curb)	$S_{BACK} = 0.020$ ft/ft								
Manning's Roughness Behind Curb (typically between 0.012 and 0.020)	$n_{BACK} = 0.020$								
Height of Curb at Gutter Flow Line	$H_{CURB} = 6.00$ inches								
Distance from Curb Face to Street Crown	$T_{CROWN} = 17.0$ ft								
Gutter Width	$W = 2.00$ ft								
Street Transverse Slope	$S_x = 0.020$ ft/ft								
Gutter Cross Slope (typically 2 inches over 24 inches or 0.083 ft/ft)	$S_w = 0.083$ ft/ft								
Street Longitudinal Slope - Enter 0 for sump condition	$S_o = 0.010$ ft/ft								
Manning's Roughness for Street Section (typically between 0.012 and 0.020)	$n_{STREET} = 0.015$								
Max. Allowable Spread for Minor & Major Storm	<table border="1"> <tr> <th></th> <th>Minor Storm</th> <th>Major Storm</th> <th>ft</th> </tr> <tr> <td>T_{MAX}</td> <td>15.8</td> <td>17.0</td> <td></td> </tr> </table>		Minor Storm	Major Storm	ft	T_{MAX}	15.8	17.0	
	Minor Storm	Major Storm	ft						
T_{MAX}	15.8	17.0							
Max. Allowable Depth at Gutter Flowline for Minor & Major Storm	<table border="1"> <tr> <th></th> <th>Minor Storm</th> <th>Major Storm</th> <th>inches</th> </tr> <tr> <td>d_{MAX}</td> <td>4.6</td> <td>7.8</td> <td></td> </tr> </table>		Minor Storm	Major Storm	inches	d_{MAX}	4.6	7.8	
	Minor Storm	Major Storm	inches						
d_{MAX}	4.6	7.8							
Allow Flow Depth at Street Crown (check box for yes, leave blank for no)	<table border="1"> <tr> <th></th> <th>Minor Storm</th> <th>Major Storm</th> </tr> <tr> <td><input type="checkbox"/></td> <td><input type="checkbox"/></td> <td><input type="checkbox"/></td> </tr> </table>		Minor Storm	Major Storm	<input type="checkbox"/>	<input type="checkbox"/>	<input type="checkbox"/>		
	Minor Storm	Major Storm							
<input type="checkbox"/>	<input type="checkbox"/>	<input type="checkbox"/>							
MINOR STORM Allowable Capacity is based on Depth Criterion									
MAJOR STORM Allowable Capacity is based on Spread Criterion									
Minor storm max. allowable capacity GOOD - greater than the design peak flow of 2.40 cfs on sheet 'Inlet Management'									
Major storm max. allowable capacity GOOD - greater than the design peak flow of 7.50 cfs on sheet 'Inlet Management'									
Q_{allow}	<table border="1"> <tr> <th></th> <th>Minor Storm</th> <th>Major Storm</th> <th>cfs</th> </tr> <tr> <td></td> <td>5.9</td> <td>11.6</td> <td></td> </tr> </table>		Minor Storm	Major Storm	cfs		5.9	11.6	
	Minor Storm	Major Storm	cfs						
	5.9	11.6							

INLET ON A CONTINUOUS GRADE

MHFD-Inlet, Version 5.02 (August 2022)

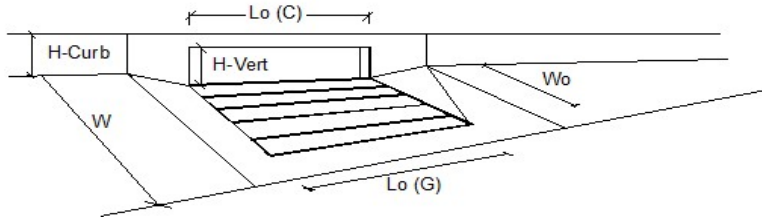

Design Information (Input)	MINOR	MAJOR	
Type of Inlet	CDOT Type R Curb Opening		
Local Depression (additional to continuous gutter depression 'a')	3.0	3.0	inches
Total Number of Units in the Inlet (Grate or Curb Opening)	3	3	
Length of a Single Unit Inlet (Grate or Curb Opening)	5.00	5.00	ft
Width of a Unit Grate (cannot be greater than W, Gutter Width)	N/A	N/A	ft
Clogging Factor for a Single Unit Grate (typical min. value = 0.5)	N/A	N/A	
Clogging Factor for a Single Unit Curb Opening (typical min. value = 0.1)	0.10	0.10	
Street Hydraulics: OK - Q < Allowable Street Capacity			
Total Inlet Interception Capacity	Q = 2.4	7.3	cfs
Total Inlet Carry-Over Flow (flow bypassing inlet)	Q_b = 0.0	0.2	cfs
Capture Percentage = Q _i /Q _s	C% = 100	98	%

ALLOWABLE CAPACITY FOR ONE-HALF OF STREET (Minor & Major Storm)

(Based on Regulated Criteria for Maximum Allowable Flow Depth and Spread)

Project: **Claremont Business Park 2 Filing No. 2 (Existing Conditions)**

Inlet ID: **Inlet 6 DP7 (South)**

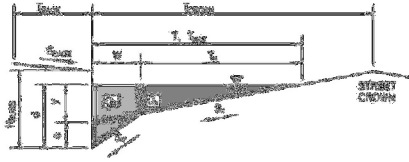

Gutter Geometry:					
Maximum Allowable Width for Spread Behind Curb	T _{BACK} = 7.5 ft				
Side Slope Behind Curb (leave blank for no conveyance credit behind curb)	S _{BACK} = 0.020 ft/ft				
Manning's Roughness Behind Curb (typically between 0.012 and 0.020)	n _{BACK} = 0.020				
Height of Curb at Gutter Flow Line	H _{CURB} = 6.00 inches				
Distance from Curb Face to Street Crown	T _{CROWN} = 17.0 ft				
Gutter Width	W = 2.00 ft				
Street Transverse Slope	S _x = 0.020 ft/ft				
Gutter Cross Slope (typically 2 inches over 24 inches or 0.083 ft/ft)	S _w = 0.083 ft/ft				
Street Longitudinal Slope - Enter 0 for sump condition	S _o = 0.010 ft/ft				
Manning's Roughness for Street Section (typically between 0.012 and 0.020)	n _{STREET} = 0.016				
Max. Allowable Spread for Minor & Major Storm	T _{MAX} = <table border="1"><tr><th>Minor Storm</th><th>Major Storm</th></tr><tr><td>15.8</td><td>17.0</td></tr></table> ft	Minor Storm	Major Storm	15.8	17.0
Minor Storm	Major Storm				
15.8	17.0				
Max. Allowable Depth at Gutter Flowline for Minor & Major Storm	d _{MAX} = <table border="1"><tr><th>Minor Storm</th><th>Major Storm</th></tr><tr><td>4.6</td><td>7.8</td></tr></table> inches	Minor Storm	Major Storm	4.6	7.8
Minor Storm	Major Storm				
4.6	7.8				
Allow Flow Depth at Street Crown (check box for yes, leave blank for no)	<input type="checkbox"/> <input type="checkbox"/>				
MINOR STORM Allowable Capacity is based on Depth Criterion	Q _{allow} = <table border="1"><tr><th>Minor Storm</th><th>Major Storm</th></tr><tr><td>5.5</td><td>10.9</td></tr></table> cfs	Minor Storm	Major Storm	5.5	10.9
Minor Storm		Major Storm			
5.5	10.9				
MAJOR STORM Allowable Capacity is based on Spread Criterion					
Minor storm max. allowable capacity GOOD - greater than the design peak flow of 0.90 cfs on sheet 'Inlet Management'					
Major storm max. allowable capacity GOOD - greater than the design peak flow of 4.10 cfs on sheet 'Inlet Management'					

INLET ON A CONTINUOUS GRADE

MHFD-Inlet, Version 5.02 (August 2022)

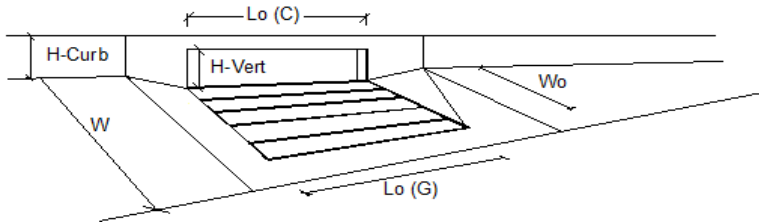

Design Information (Input)	MINOR	MAJOR	
Type of Inlet	CDOT Type R Curb Opening		
Local Depression (additional to continuous gutter depression 'a')	3.0	3.0	inches
Total Number of Units in the Inlet (Grate or Curb Opening)	3	3	
Length of a Single Unit Inlet (Grate or Curb Opening)	5.00	5.00	ft
Width of a Unit Grate (cannot be greater than W, Gutter Width)	N/A	N/A	ft
Clogging Factor for a Single Unit Grate (typical min. value = 0.5)	N/A	N/A	
Clogging Factor for a Single Unit Curb Opening (typical min. value = 0.1)	0.10	0.10	
Street Hydraulics: OK - $Q < \text{Allowable Street Capacity}$			
Total Inlet Interception Capacity	0.9	4.1	cfs
Total Inlet Carry-Over Flow (flow bypassing inlet)	0.0	0.0	cfs
Capture Percentage = Q_i/Q_n	100	100	%

AREA INLET IN A SWALE

Claremont Business Park 2 Filing No. 2 (Existing Conditions)
Inlet 7 (DP13)

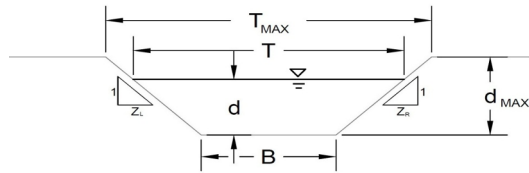

This worksheet uses the NRCS vegetative retardance method to determine Manning's n.
 For more information see Section 7.2.3 of the USDCM.

Analysis of Trapezoidal Grass-Lined Channel Using SCS Method

NRCS Vegetal Retardance (A, B, C, D, or E) A, B, C, D, or E =

Manning's n (Leave cell D16 blank to manually enter an n value) n = 0.025

Channel Invert Slope S₀ = 0.1200 ft/ft

Bottom Width B = 0.00 ft

Left Side Slope Z1 = 3.00 ft/ft

Right Side Slope Z2 = 3.00 ft/ft

Check one of the following soil types:

Soil Type:	Max. Velocity (V _{MAX})	Max Froude No. (F _{MAX})
Non-Cohesive	5.0 fps	0.60
Cohesive	7.0 fps	0.80
Paved	N/A	N/A

Choose One:

Non-Cohesive

Cohesive

Paved

	Minor Storm	Major Storm	
Maximum Allowable Top Width of Channel for Minor & Major Storm	T_{MAX} = 1.92	2.40	ft
Maximum Allowable Water Depth in Channel for Minor & Major Storm	d_{MAX} = 0.32	0.40	ft

Allowable Channel Capacity Based On Channel Geometry

MINOR STORM Allowable Capacity is based on Depth Criterion

MAJOR STORM Allowable Capacity is based on Depth Criterion

	Minor Storm	Major Storm	
Allowable Capacity	Q_{allow} = 1.8	3.3	cfs
Water Depth	d_{allow} = 0.32	0.40	ft

Water Depth in Channel Based On Design Peak Flow

Design Peak Flow Q_o = 0.7 cfs

Water Depth d = 0.22 ft

Minor storm max. allowable capacity GOOD - greater than the design flow given on sheet 'Inlet Management'

Major storm max. allowable capacity GOOD - greater than the design flow given on sheet 'Inlet Management'

AREA INLET IN A SWALE

Claremont Business Park 2 Filing No. 2 (Existing Conditions)
Inlet 7 (DP13)

Inlet Design Information (Input)	
Type of Inlet	CDOT Type C (Depressed) Inlet Type = CDOT Type C (Depressed)
Angle of Inclined Gate (must be <= 30 degrees)	$\theta = 0.00$ degrees
Width of Gate	$W = 3.00$ ft
Length of Gate	$L = 3.00$ ft
Open Area Ratio	$A_{RATIO} = 0.70$
Height of Inclined Gate	$H_B = 0.00$ ft
Clogging Factor	$C_f = 0.50$
Grate Discharge Coefficient	$C_d = 0.84$
Orifice Coefficient	$C_o = 0.56$
Weir Coefficient	$C_w = 1.81$

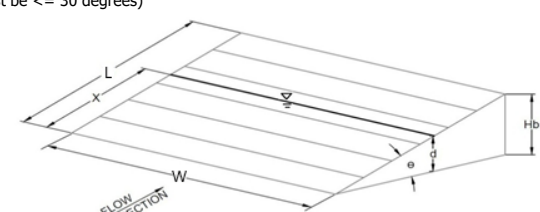

	MINOR	MAJOR	
$d =$	1.22	1.28	
$Q_a =$	15.7	16.1	cfs
$Q_b =$	0.0	0.0	cfs
$C\% =$	100	100	%

Water Depth at Inlet (for depressed inlets, 1 foot is added for depression)

Total Inlet Interception Capacity (assumes clogged condition)

Bypassed Flow

Capture Percentage = Q_a/Q_o

Warning 04: Froude No. exceeds USDCM Volume I recommendation.

The open channel flow calculator

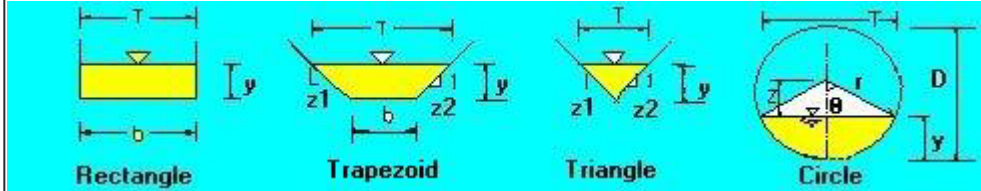
Select Channel Type: Trapezoid ▾			
Velocity(V)&Discharge(Q) ▾	Select unit system: Feet(ft) ▾		
Channel slope: <input type="text" value=".014"/> <small>ft/ft</small>	Water depth(y): <input type="text" value="0.66"/> <small>ft</small>	Bottom width(b) <input type="text" value="2"/> <small>ft</small>	
Flow velocity <input type="text" value="3.8908"/> <small>ft/s</small>	LeftSlope (Z1): <input type="text" value="4"/> to 1 (H:V)	RightSlope (Z2): <input type="text" value="4"/> to 1 (H:V)	
Flow discharge <input type="text" value="11.9152"/> <small>ft^3/s</small>	Input n value <input type="text" value="0.025"/> or select n		
<input type="button" value="Calculate!"/>	Status: <input type="text" value="Calculation finished"/>	<input type="button" value="Reset"/>	
Wetted perimeter <input type="text" value="7.44"/> <small>ft</small>	Flow area <input type="text" value="3.06"/> <small>ft^2</small>	Top width(T) <input type="text" value="7.28"/> <small>ft</small>	
Specific energy <input type="text" value="0.9"/> <small>ft</small>	Froude number <input type="text" value="1.06"/>	Flow status <input type="text" value="Supercritical flow"/>	
Critical depth <input type="text" value="0.68"/> <small>ft</small>	Critical slope <input type="text" value="0.0124"/> <small>ft/ft</small>	Velocity head <input type="text" value="0.24"/> <small>ft</small>	

Copyright 2000 Dr. Xing Fang, Department of Civil Engineering, Lamar University.

TRAPIZODIAL CHANNEL ROUTING
 FLOWS TO PIPE RUN 6A $Q_{100} = 11.6$ cfs

Nyloplast Dome Grate Inlet Capacity Chart

This chart is based on equations from the FAA Airport Drainage AC 150/5320-5B, 1970, Page 35. Certain assumptions have been made and no two installations will necessarily perform the same way. Safety factors should change with site conditions such that a safety factor 1.25 should be used for an inlet in pavement, and a safety factor of 2.0 should be used in turf areas.

Basin Outlet Pipe Size	Flow Rate CFS*
4"	0.229
6"	0.662
8"	1.441
10"	2.612
12"	4.152
15"	7.126
18"	12.163
24"	25.821
30"	52.173

Nyloplast Dome Grates 8" - 30"

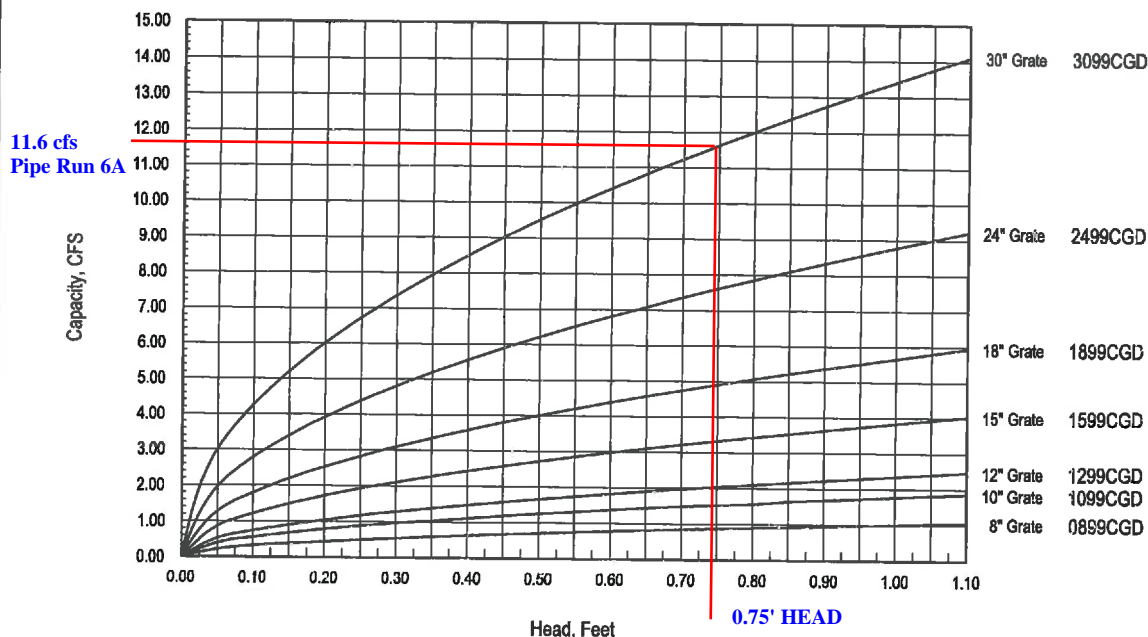

*Maximum flow capacity before drain basin begins to backfill. Calculation based on an average pipe slope of 1%.

Dome Grates	
Grate Size	Approx. Drain Area (SQ IN)
8"	30.00
10"	54.00
12"	70.37
15"	115.49
18"	170.74
24"	285.19
30"	405.75

DOME GRATE AT PIPE RUN 6A

THIS PRINT DISCLOSES SUBJECT MATTER IN WHICH NYLOPLAST HAS PROPRIETARY RIGHTS. THE RECEIPT OR POSSESSION OF THIS PRINT DOES NOT CONFER, TRANSFER, OR LICENSE THE USE OF THE DESIGN OR TECHNICAL INFORMATION SHOWN HEREIN REPRODUCTION OF THIS PRINT OR ANY INFORMATION CONTAINED HEREIN, OR MANUFACTURE OF ANY ARTICLE HEREFROM, FOR THE DISCLOSURE TO OTHERS IS FORBIDDEN, EXCEPT BY SPECIFIC WRITTEN PERMISSION FROM NYLOPLAST.

©2007 NYLOPLAST

DRAWN BY	AWA	MATERIAL	 3130 VERONA AVE BUFORD, GA 30818 PHN (770) 932-2443 FAX (770) 932-2490 www.nyloplast-us.com
DATE	3-7-00		
APPD BY	CJA	PROJECT NO./NAME	TITLE
DATE	3-7-00		8 IN - 30 IN DOME GRATE INLET CAPACITY
DWG SIZE	A	SCALE 1:2 SHEET 1 OF 1	DWG NO. 7001-110-000 REV D

CLAREMONT BUSINESS PARK 2 FILING NO.2 (EXISTING CONDITIONS)

Weighted Percent Imperviousness of Ex Fil 2 WQ Sand Filter Pond 2				
Contributing Basins	Area (Acres)	C_s	Impervious % (I)	(Acres)*(I)
<i>H1</i>	0.18	0.09	2	0.35
<i>H2</i>	0.40	0.09	2	0.80
<i>H3</i>	0.04	0.09	2	0.07
<i>H4</i>	0.10	0.09	2	0.20
<i>I1</i>	0.57	0.80	94.4	54.17
<i>I2</i>	0.48	0.79	93.8	45.26
<i>I3</i>	0.58	0.65	84.3	49.29
<i>I4</i>	0.43	0.80	94.4	40.59
<i>I5</i>	0.23	0.73	90	21.09
<i>I6</i>	0.19	0.62	82.1	15.37
<i>I7</i>	0.23	0.77	92.5	21.57
<i>J1</i>	0.76	0.69	87.1	66.22
<i>J2</i>	0.25	0.73	90	22.69
<i>J3</i>	0.01	0.16	13	0.19
<i>K1</i>	0.17	0.83	96.1	16.32
<i>K2</i>	0.05	0.72	89.3	4.76
<i>K3</i>	0.15	0.78	93.1	13.84
<i>K4</i>	0.05	0.69	87.1	4.53
<i>L</i>	1.32	0.09	2	2.63
<i>M1</i>	0.28	0.81	95	27.03
<i>M2</i>	0.24	0.62	82.1	19.93
<i>M3</i>	0.37	0.83	96.1	35.09
<i>M4</i>	0.98	0.80	94.4	92.27
<i>N1</i>	0.06	0.90	100	6.49
<i>N2</i>	0.41	0.12	7	2.90
Totals	8.55			563.68
Imperviousness of WQ Pond 2	65.9			

8.55 B soils
8.55 total area

DETENTION BASIN STAGE-STORAGE TABLE BUILDER

MHFD-Detention, Version 4.02 (February 2020)

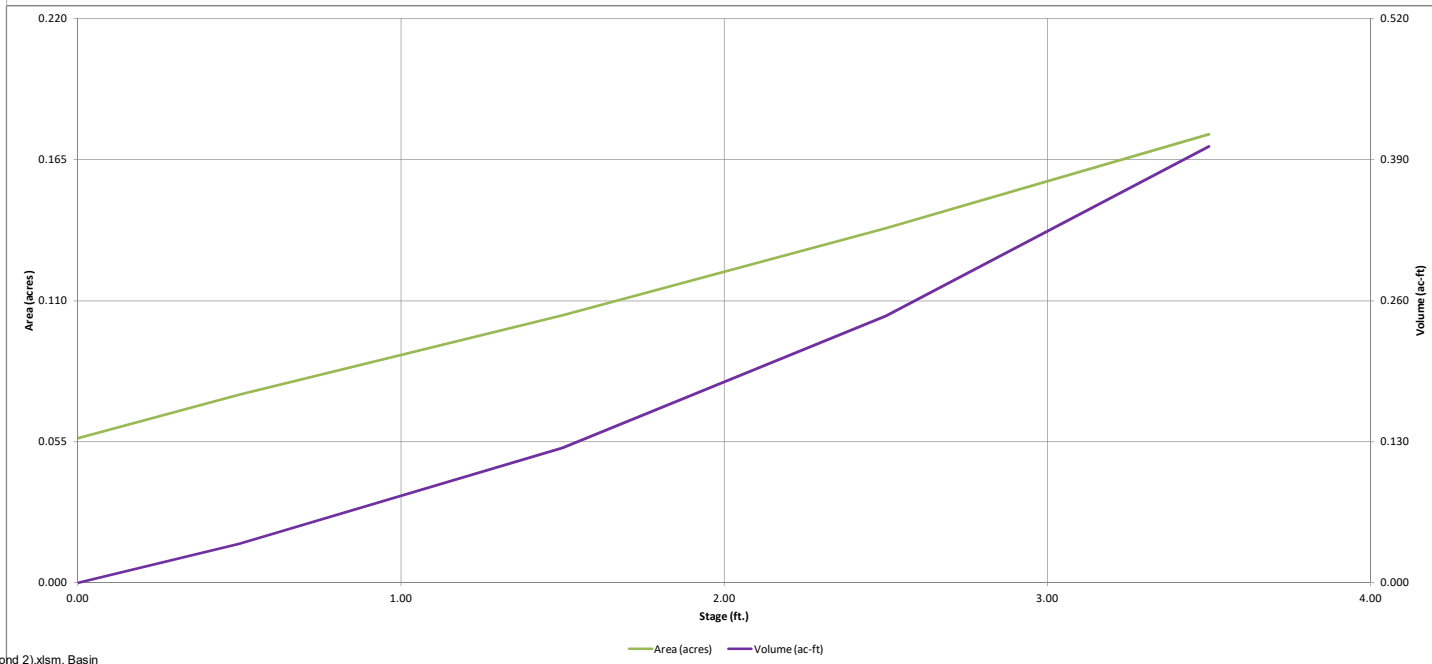
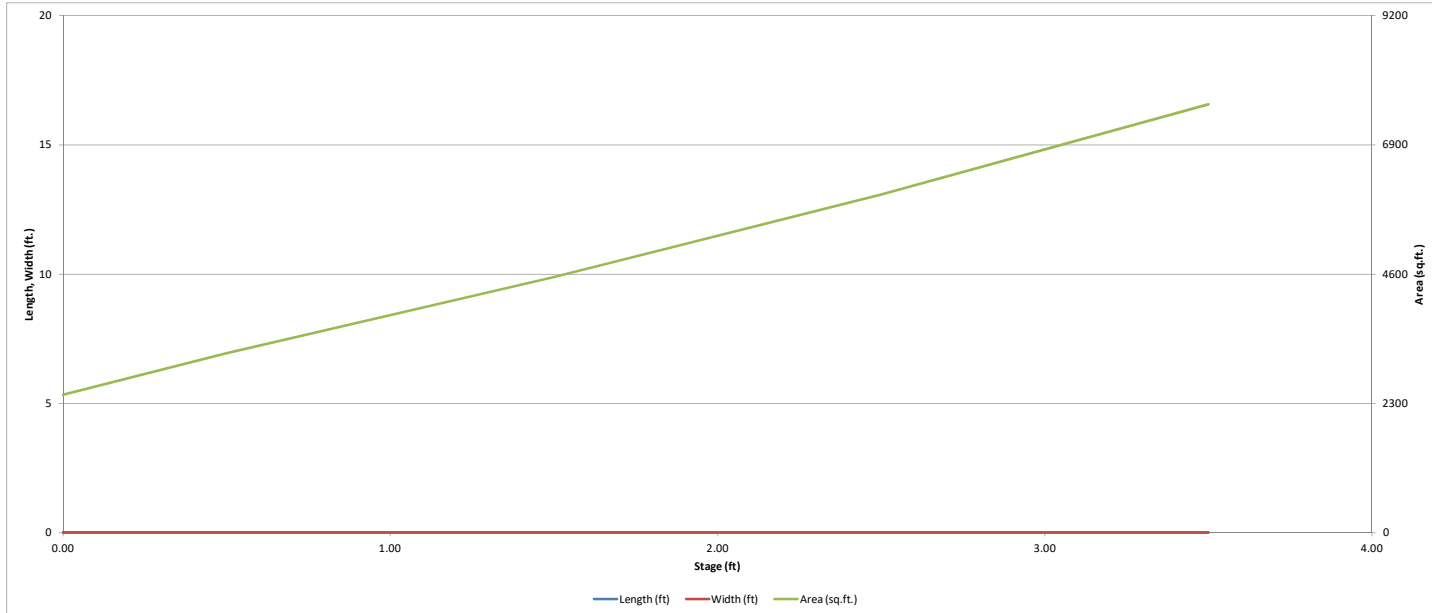

DETENTION BASIN OUTLET STRUCTURE DESIGN

MHFD-Detention, Version 4.02 (February 2020)

Project: CLAREMONT BUSINESS PARK 2 FILING NO.1
Basin ID: EX WQCV POND 2 (EXISTING CONDITIONS NOT TO BE MODIFIED)

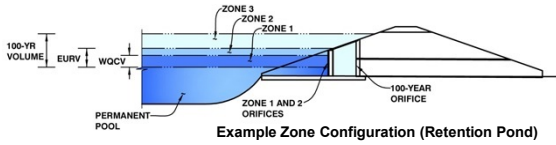

	Estimated Stage (ft)	Estimated Volume (ac-ft)	Outlet Type
Zone 1 (WQCV)	1.76	0.147	Filtration Media
Zone 2 (100-year)	#VALUE!	0.839	Weir&Pipe (Restrict)
Zone 3			
Total (all zones)		0.986	

User Input: Orifice at Underdrain Outlet (typically used to drain WQCV in a Filtration BMP)

Underdrain Orifice Invert Depth = ft (distance below the filtration media surface)
 Underdrain Orifice Diameter = inches

Calculated Parameters for Underdrain
 Underdrain Orifice Area = ft²
 Underdrain Orifice Centroid = feet

User Input: Orifice Plate with one or more orifices or Elliptical Slot Weir (typically used to drain WQCV and/or EURV in a sedimentation BMP)

Invert of Lowest Orifice = ft (relative to basin bottom at Stage = 0 ft)
 Depth at top of Zone using Orifice Plate = ft (relative to basin bottom at Stage = 0 ft)
 Orifice Plate: Orifice Vertical Spacing = inches
 Orifice Plate: Orifice Area per Row = inches

Calculated Parameters for Plate
 WQ Orifice Area per Row = ft²
 Elliptical Half-Width = feet
 Elliptical Slot Centroid = feet
 Elliptical Slot Area = ft²

User Input: Stage and Total Area of Each Orifice Row (numbered from lowest to highest)

	Row 1 (optional)	Row 2 (optional)	Row 3 (optional)	Row 4 (optional)	Row 5 (optional)	Row 6 (optional)	Row 7 (optional)	Row 8 (optional)
Stage of Orifice Centroid (ft)	N/A	N/A	N/A	N/A	N/A	N/A	N/A	N/A
Orifice Area (sq. inches)	N/A	N/A	N/A	N/A	N/A	N/A	N/A	N/A

	Row 9 (optional)	Row 10 (optional)	Row 11 (optional)	Row 12 (optional)	Row 13 (optional)	Row 14 (optional)	Row 15 (optional)	Row 16 (optional)
Stage of Orifice Centroid (ft)	N/A	N/A	N/A	N/A	N/A	N/A	N/A	N/A
Orifice Area (sq. inches)	N/A	N/A	N/A	N/A	N/A	N/A	N/A	N/A

User Input: Vertical Orifice (Circular or Rectangular)

Invert of Vertical Orifice = ft (relative to basin bottom at Stage = 0 ft)
 Depth at top of Zone using Vertical Orifice = ft (relative to basin bottom at Stage = 0 ft)
 Vertical Orifice Diameter = inches

Calculated Parameters for Vertical Orifice
 Vertical Orifice Area = ft²
 Vertical Orifice Centroid = feet

User Input: Overflow Weir (Dropbox with Flat or Sloped Grate and Outlet Pipe OR Rectangular/Trapezoidal Weir (and No Outlet Pipe))

	Zone 2 Weir	Not Selected
Overflow Weir Front Edge Height, H _o	1.75	
Overflow Weir Front Edge Length	7.00	
Overflow Weir Grate Slope	0.00	
Horiz. Length of Weir Sides	2.91	
Overflow Grate Open Area %	70%	% , grate open area/total area
Debris Clogging %	50%	%

Calculated Parameters for Overflow Weir
 Height of Grate Upper Edge, H_u = feet
 Overflow Weir Slope Length = feet
 Grate Open Area / 100-yr Orifice Area = ft²
 Overflow Grate Open Area w/o Debris = ft²
 Overflow Grate Open Area w/ Debris = ft²

User Input: Outlet Pipe w/ Flow Restriction Plate (Circular Orifice, Restrictor Plate, or Rectangular Orifice)

	Zone 2 Restrictor	Not Selected
Depth to Invert of Outlet Pipe	2.75	
Outlet Pipe Diameter	30.00	
Restrictor Plate Height Above Pipe Invert	13.80	

Calculated Parameters for Outlet Pipe w/ Flow Restriction Plate
 Outlet Orifice Area = ft²
 Outlet Orifice Centroid = feet
 Half-Central Angle of Restrictor Plate on Pipe = radians

User Input: Emergency Spillway (Rectangular or Trapezoidal)

Spillway Invert Stage = ft (relative to basin bottom at Stage = 0 ft)
 Spillway Crest Length = feet
 Spillway End Slopes = H:V
 Freeboard above Max Water Surface = feet

Calculated Parameters for Spillway
 Spillway Design Flow Depth = feet
 Stage at Top of Freeboard = feet
 Basin Area at Top of Freeboard = acres
 Basin Volume at Top of Freeboard = acre-ft

Routed Hydrograph Results

The user can override the default CUHP hydrographs and runoff volumes by entering new values in the Inflow Hydrographs table (Columns W through AF).

	WQCV	EURV	2 Year	5 Year	10 Year	25 Year	50 Year	100 Year	500 Year
Design Storm Return Period	N/A	N/A	1.19	1.50	1.75	2.00	2.25	2.52	2.53
One-Hour Rainfall Depth (in)	N/A	N/A	0.539	0.733	0.899	1.100	1.274	1.485	1.492
CUHP Runoff Volume (acre-ft)	N/A	N/A	0.539	0.733	0.899	1.100	1.274	1.485	1.492
Inflow Hydrograph Volume (acre-ft)	N/A	N/A	1.2	3.2	4.8	8.5	10.6	13.3	13.4
CUHP Predevelopment Peak Q (cfs)	N/A	N/A							
OPTIONAL Override Predevelopment Peak Q (cfs)	N/A	N/A							
Predevelopment Unit Peak Flow, q (cfs/acre)	N/A	N/A	0.14	0.38	0.56	0.99	1.24	1.55	1.56
Peak Inflow Q (cfs)	N/A	N/A	10.9	14.8	17.5	21.8	25.4	30.0	30.1
Peak Outflow Q (cfs)	0.2	42.6	8.2	13.7	16.1	22.5	23.0	23.9	23.9
Ratio Peak Outflow to Predevelopment Q	N/A	N/A	N/A	4.3	3.4	2.7	2.2	1.8	1.8
Structure Controlling Flow	Overflow Weir 1	Outlet Plate 1	Overflow Weir 1	Overflow Weir 1	Overflow Weir 1	Outlet Plate 1	Outlet Plate 1	Outlet Plate 1	Outlet Plate 1
Max Velocity through Gate 1 (fps)	0.00	1.59	0.57	1.0	1.1	1.6	1.6	1.7	1.7
Max Velocity through Gate 2 (fps)	N/A	N/A	N/A	N/A	N/A	N/A	N/A	N/A	N/A
Time to Drain 97% of Inflow Volume (hours)	13	12	14	14	13	13	12	12	11
Time to Drain 99% of Inflow Volume (hours)	13	13	15	15	15	15	15	14	14
Maximum Ponding Depth (ft)	1.76	2.54	2.08	2.22	2.27	2.42	2.62	2.97	2.98
Area at Maximum Ponding Depth (acres)	0.11	0.14	0.12	0.13	0.13	0.13	0.14	0.15	0.15
Maximum Volume Stored (acre-ft)	0.147	0.243	0.183	0.201	0.207	0.227	0.256	0.306	0.307

DETENTION BASIN OUTLET STRUCTURE DESIGN

MHFD-Detention, Version 4.00 (December 2019)

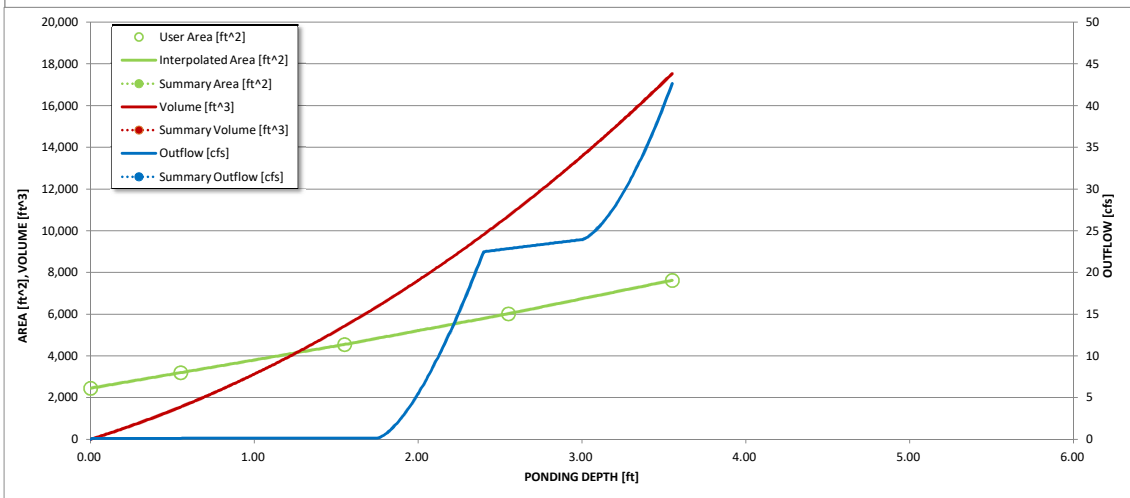
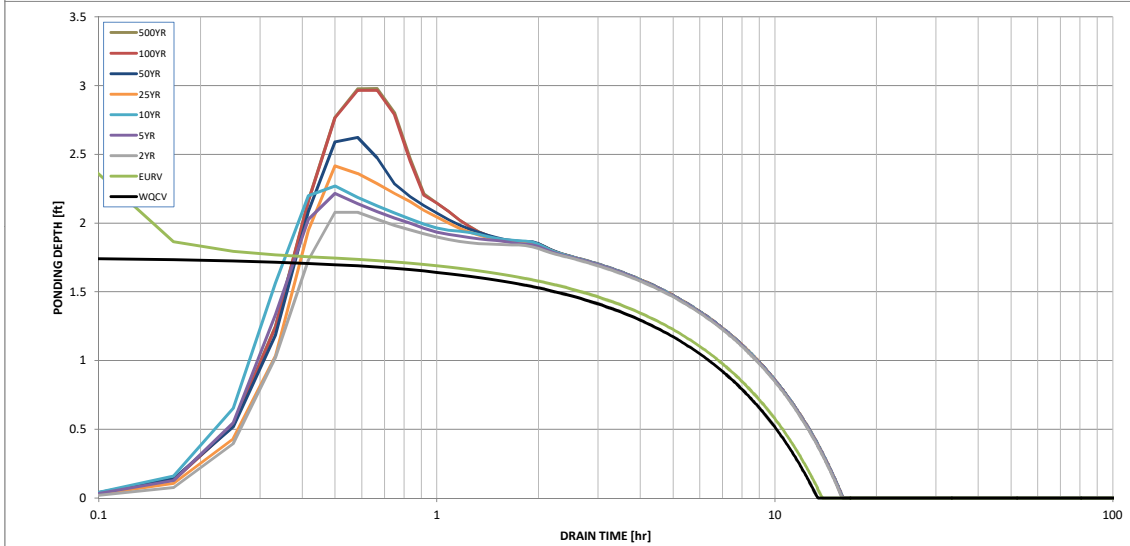
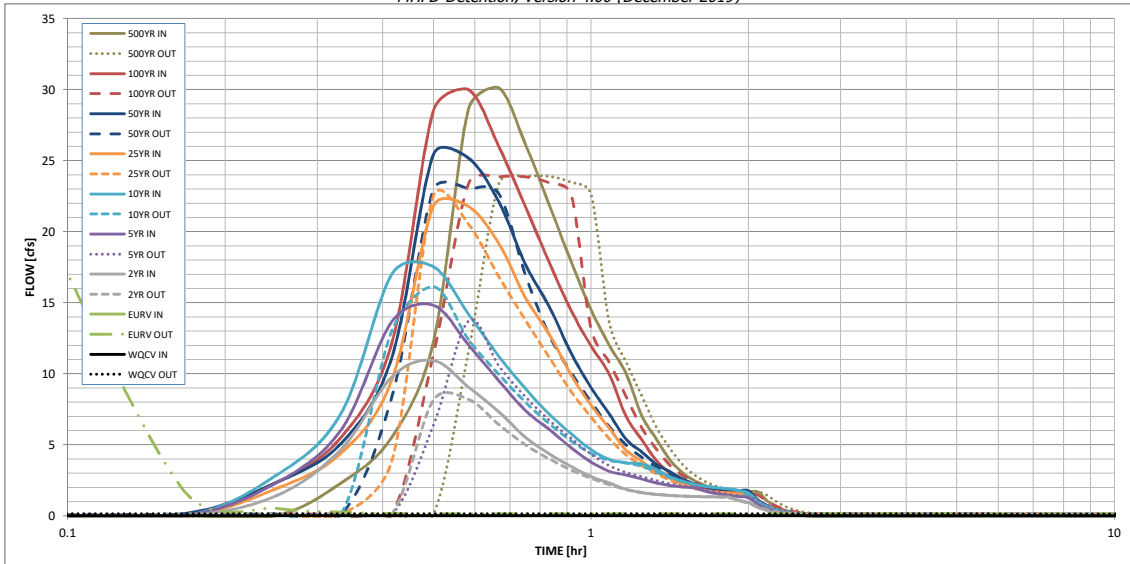

S-A-V-D Chart Axis Override	X-axis	Left Y-Axis	Right Y-Axis
minimum bound			
maximum bound			

CLAREMONT BUSINESS PARK 2 FILING NO.2 (EXISTING CONDITIONS)

Weighted Percent Imperviousness of Ex Fil 2 WQ Sand Filter Pond 2				
Contributing Basins	Area (Acres)	C₅	Impervious % (I)	(Acres)*(I)
<i>H1</i>	0.16	0.09	2	0.33
<i>H2</i>	0.40	0.09	2	0.80
<i>H3</i>	0.04	0.09	2	0.07
<i>H4</i>	0.10	0.09	2	0.20
<i>I1</i>	0.55	0.83	96.1	52.51
<i>I2</i>	0.48	0.79	93.8	45.26
<i>I3</i>	0.45	0.78	93.1	41.48
<i>I4</i>	0.55	0.81	95	52.18
<i>I5</i>	0.23	0.73	90	21.09
<i>I6</i>	0.19	0.62	82.1	15.37
<i>I7</i>	0.23	0.77	92.5	21.57
<i>J1</i>	0.69	0.81	95	65.94
<i>J2</i>	0.25	0.73	90	22.69
<i>J3</i>	0.01	0.16	13	0.19
<i>K1</i>	0.17	0.83	96.1	16.32
<i>K2</i>	0.05	0.72	89.3	4.76
<i>K3</i>	0.15	0.78	93.1	13.84
<i>K4</i>	0.05	0.69	87.1	4.53
<i>L</i>	1.32	0.09	2	2.63
<i>M1</i>	0.28	0.81	95	27.03
<i>M2</i>	0.24	0.62	82.1	19.93
<i>M3</i>	0.37	0.83	96.1	35.09
<i>M4</i>	0.98	0.80	94.4	92.27
<i>N1</i>	0.06	0.90	100	6.49
<i>N2</i>	0.41	0.12	7	2.90
Totals	8.43			565.48
Imperviousness of WQ Pond 2	67.1			

A soils 100%
 B soils 0%

DETENTION BASIN STAGE-STORAGE TABLE BUILDER

MHFD-Detention, Version 4.02 (February 2020)

Project: CLAREMONT BUSINESS PARK 2 FILING NO.1

Basin ID: EX WQCV POND 2 (PROPOSED CONDITIONS EXTENSION OF EL JEFE HEIGHTS, NOT TO BE MODIFIED)

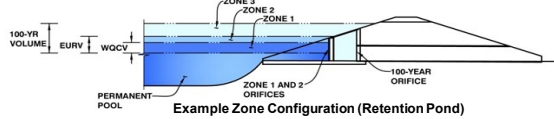

Watershed Information

Selected BMP Type =	SF	
Watershed Area =	8.43	acres
Watershed Length =	665	ft
Watershed Length to Centroid =	325	ft
Watershed Slope =	0.018	ft/ft
Watershed Imperviousness =	67.10%	percent
Percentage Hydrologic Soil Group A =	0.0%	percent
Percentage Hydrologic Soil Group B =	100.0%	percent
Percentage Hydrologic Soil Groups C/D =	0.0%	percent
Target WQCV Drain Time =	12.0	hours
Location for 1-hr Rainfall Depths =	User Input	

After providing required inputs above including 1-hour rainfall depths, click 'Run CUHP' to generate runoff hydrographs using the embedded Colorado Urban Hydrograph Procedure.

Water Quality Capture Volume (WQCV) =	0.148	acre-feet
Excess Urban Runoff Volume (EURV) =	0.619	acre-feet
2-yr Runoff Volume (P1 = 1.19 in.) =	0.541	acre-feet
5-yr Runoff Volume (P1 = 1.5 in.) =	0.734	acre-feet
10-yr Runoff Volume (P1 = 1.75 in.) =	0.897	acre-feet
25-yr Runoff Volume (P1 = 2 in.) =	1.095	acre-feet
50-yr Runoff Volume (P1 = 2.25 in.) =	1.267	acre-feet
100-yr Runoff Volume (P1 = 2.52 in.) =	1.474	acre-feet
500-yr Runoff Volume (P1 = 2.53 in.) =	1.481	acre-feet
Approximate 2-yr Detention Volume =	0.482	acre-feet
Approximate 5-yr Detention Volume =	0.644	acre-feet
Approximate 10-yr Detention Volume =	0.818	acre-feet
Approximate 25-yr Detention Volume =	0.880	acre-feet
Approximate 50-yr Detention Volume =	0.916	acre-feet
Approximate 100-yr Detention Volume =	0.986	acre-feet

Optional User Overrides

		acre-feet
		acre-feet
	1.19	inches
	1.50	inches
	1.75	inches
	2.00	inches
	2.25	inches
	2.52	inches
	2.53	inches

Define Zones and Basin Geometry

Zone 1 Volume (WQCV) =	0.148	acre-feet
Zone 2 Volume (100-year - Zone 1) =	0.838	acre-feet
Select Zone 3 Storage Volume (Optional) =		acre-feet
Total Detention Basin Volume =	0.986	acre-feet
Initial Surcharge Volume (ISV) =	N/A	ft ³
Initial Surcharge Depth (ISD) =	N/A	ft
Total Available Detention Depth (H _{total}) =	user	ft
Depth of Trickle Channel (H _{TC}) =	N/A	ft
Slope of Trickle Channel (S _{TC}) =	N/A	ft/ft
Slopes of Main Basin Sides (S _{main}) =	user	H:V
Basin Length-to-Width Ratio (R _{L/W}) =	user	
Initial Surcharge Area (A _{ISV}) =	user	ft ²
Surcharge Volume Length (L _{ISV}) =	user	ft
Surcharge Volume Width (W _{ISV}) =	user	ft
Depth of Basin Floor (H _{FLOOR}) =	user	ft
Length of Basin Floor (L _{FLOOR}) =	user	ft
Width of Basin Floor (W _{FLOOR}) =	user	ft
Area of Basin Floor (A _{FLOOR}) =	user	ft ²
Volume of Basin Floor (V _{FLOOR}) =	user	ft ³
Depth of Main Basin (H _{MAIN}) =	user	ft
Length of Main Basin (L _{MAIN}) =	user	ft
Width of Main Basin (W _{MAIN}) =	user	ft
Area of Main Basin (A _{MAIN}) =	user	ft ²
Volume of Main Basin (V _{MAIN}) =	user	ft ³
Calculated Total Basin Volume (V _{total}) =	user	acre-feet

Depth Increment =		ft									
Stage - Storage Description	Stage (ft)	Optional Override Stage (ft)	Length (ft)	Width (ft)	Area (ft ²)	Optional Override Area (ft ²)	Area (acre)	Volume (ft ³)	Volume (ac-ft)		
Media Surface	--	0.00	--	--	--	2,450	0.056				
6365	--	0.55	--	--	--	3,196	0.073	1,553	0.036		
6366	--	1.55	--	--	--	4,546	0.104	5,424	0.125		
6367	--	2.55	--	--	--	6,018	0.138	10,706	0.246		
6368	--	3.55	--	--	--	7,623	0.175	17,526	0.402		

DETENTION BASIN STAGE-STORAGE TABLE BUILDER

MHFD-Detention, Version 4.02 (February 2020)

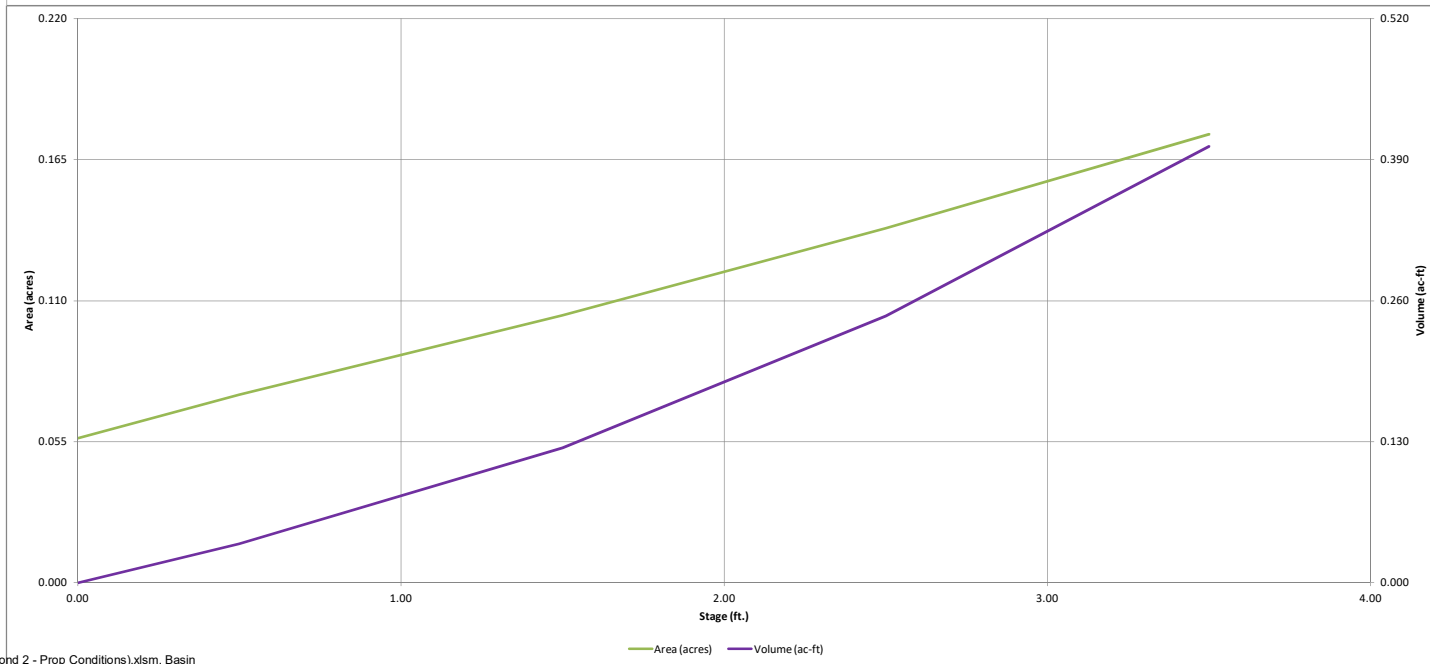
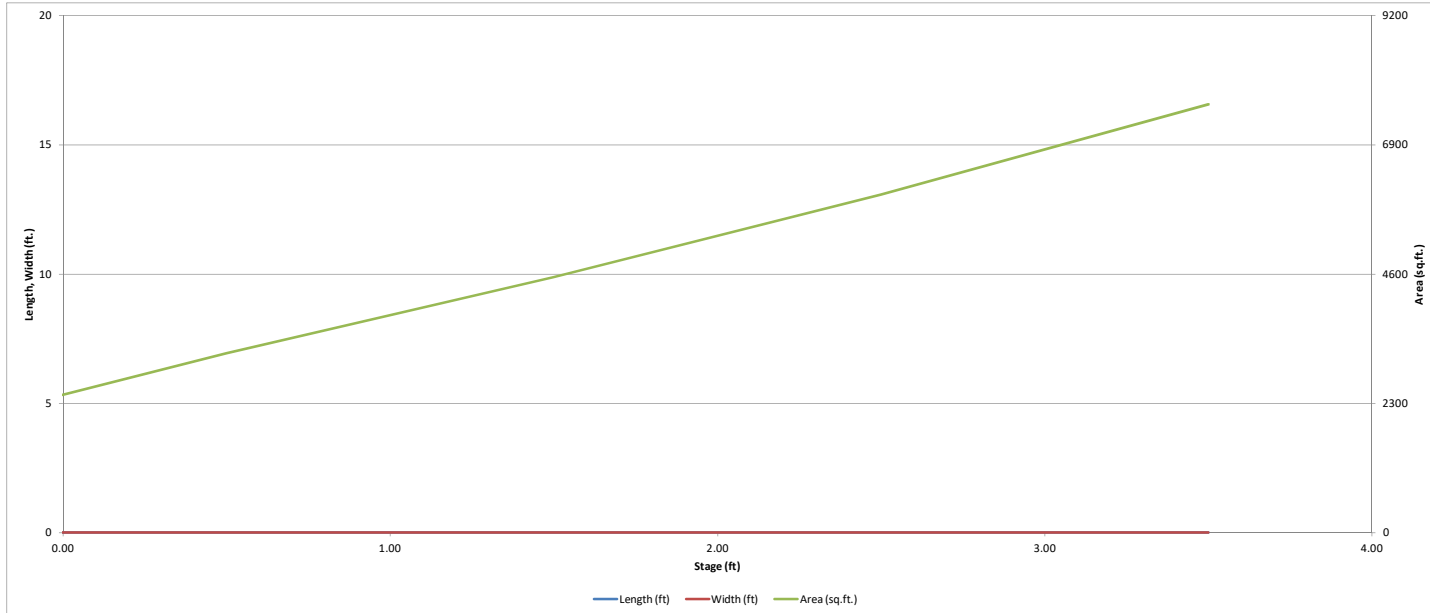

DETENTION BASIN OUTLET STRUCTURE DESIGN

MHFD-*Detention*, Version 4.02 (February 2020)

Project: CLAREMONT BUSINESS PARK 2 FILING NO.1

Basin ID: EX WQCV POND 2 (PROPOSED CONDITIONS EXTENTION OF EL JEFE HEIGHTS, NOT TO BE MODIFIED)

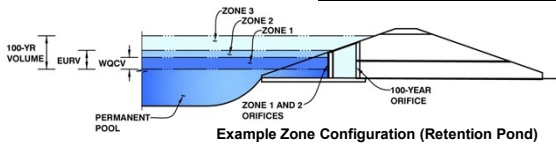

	Estimated Stage (ft)	Estimated Volume (ac-ft)	Outlet Type
Zone 1 (WQCV)	1.77	0.148	Filtration Media
Zone 2 (100-year)	#VALUE!	0.838	Weir&Pipe (Restrict)
Zone 3			
Total (all zones)		0.986	

User Input: Orifice at Underdrain Outlet (typically used to drain WQCV in a Filtration BMP)

Underdrain Orifice Invert Depth =	2.50	ft (distance below the filtration media surface)
Underdrain Orifice Diameter =	1.66	inches

Underdrain Orifice Area =	0.0	ft ²
Underdrain Orifice Centroid =	0.07	feet

User Input: Orifice Plate with one or more orifices or Elliptical Slot Weir (typically used to drain WQCV and/or EURV in a sedimentation BMP)

Invert of Lowest Orifice =	N/A	ft (relative to basin bottom at Stage = 0 ft)
Depth at top of Zone using Orifice Plate =	N/A	ft (relative to basin bottom at Stage = 0 ft)
Orifice Plate: Orifice Vertical Spacing =	N/A	inches
Orifice Plate: Orifice Area per Row =	N/A	inches

WQ Orifice Area per Row =	N/A	ft ²
Elliptical Half-Width =	N/A	feet
Elliptical Slot Centroid =	N/A	feet
Elliptical Slot Area =	N/A	ft ²

User Input: Stage and Total Area of Each Orifice Row (numbered from lowest to highest)

	Row 1 (optional)	Row 2 (optional)	Row 3 (optional)	Row 4 (optional)	Row 5 (optional)	Row 6 (optional)	Row 7 (optional)	Row 8 (optional)
Stage of Orifice Centroid (ft)	N/A	N/A	N/A	N/A	N/A	N/A	N/A	N/A
Orifice Area (sq. inches)	N/A	N/A	N/A	N/A	N/A	N/A	N/A	N/A
	Row 9 (optional)	Row 10 (optional)	Row 11 (optional)	Row 12 (optional)	Row 13 (optional)	Row 14 (optional)	Row 15 (optional)	Row 16 (optional)
Stage of Orifice Centroid (ft)	N/A	N/A	N/A	N/A	N/A	N/A	N/A	N/A
Orifice Area (sq. inches)	N/A	N/A	N/A	N/A	N/A	N/A	N/A	N/A

User Input: Vertical Orifice (Circular or Rectangular)

Invert of Vertical Orifice =	Not Selected	ft (relative to basin bottom at Stage = 0 ft)
Depth at top of Zone using Vertical Orifice =	Not Selected	ft (relative to basin bottom at Stage = 0 ft)
Vertical Orifice Diameter =	Not Selected	inches

Vertical Orifice Area =	Not Selected	ft ²
Vertical Orifice Centroid =	Not Selected	feet

User Input: Overflow Weir (Dropbox with Flat or Sloped Grate and Outlet Pipe OR Rectangular/Trapezoidal Weir (and No Outlet Pipe))

Overflow Weir Front Edge Height, H _o =	1.75	ft (relative to basin bottom at Stage = 0 ft)
Overflow Weir Front Edge Length =	7.00	feet
Overflow Weir Grate Slope =	0.00	H:V
Horiz. Length of Weir Sides =	2.91	feet
Overflow Grate Open Area % =	70%	%, grate open area/total area
Debris Clogging % =	50%	%

Height of Grate Upper Edge, H _u =	1.75	feet
Overflow Weir Slope Length =	2.91	feet
Grate Open Area / 100-yr Orifice Area =	6.47	
Overflow Grate Open Area w/o Debris =	14.26	ft ²
Overflow Grate Open Area w/ Debris =	7.13	ft ²

User Input: Outlet Pipe w/ Flow Restriction Plate (Circular Orifice, Restrictor Plate, or Rectangular Orifice)

Depth to Invert of Outlet Pipe =	Zone 2 Restrictor	ft (distance below basin bottom at Stage = 0 ft)
Outlet Pipe Diameter =	30.00	inches
Restrictor Plate Height Above Pipe Invert =	13.80	inches

Outlet Orifice Area =	Zone 2 Restrictor	ft ²
Outlet Orifice Centroid =	0.67	feet
Half-Central Angle of Restrictor Plate on Pipe =	1.49	N/A radians

User Input: Emergency Spillway (Rectangular or Trapezoidal)

Spillway Invert Stage =	3.00	ft (relative to basin bottom at Stage = 0 ft)
Spillway Crest Length =	12.50	feet
Spillway End Slopes =	4.00	H:V
Freeboard above Max Water Surface =	1.00	feet

Spillway Design Flow Depth =	0.75	feet
Stage at Top of Freeboard =	4.75	feet
Basin Area at Top of Freeboard =	0.18	acres
Basin Volume at Top of Freeboard =	0.40	acre-ft

Routed Hydrograph Results

The user can override the default CUHP hydrographs and runoff volumes by entering new values in the Inflow Hydrographs table (Columns W through AF).

	WQCV	EURV	2 Year	5 Year	10 Year	25 Year	50 Year	100 Year	500 Year
Design Storm Return Period	N/A	N/A	1.19	1.50	1.75	2.00	2.25	2.52	2.53
One-Hour Rainfall Depth (in)	N/A	N/A	0.541	0.734	0.897	1.095	1.267	1.474	1.481
CUHP Runoff Volume (acre-ft)	N/A	N/A	0.541	0.734	0.897	1.095	1.267	1.474	1.481
Inflow Hydrograph Volume (acre-ft)	N/A	N/A	1.1	3.2	4.7	8.3	10.4	13.0	13.1
CUHP Predevelopment Peak Q (cfs)	N/A	N/A	N/A	N/A	N/A	N/A	N/A	N/A	N/A
OPTIONAL Override Predevelopment Peak Q (cfs)	N/A	N/A	N/A	N/A	N/A	N/A	N/A	N/A	N/A
Predevelopment Unit Peak Flow, q (cfs/acre)	N/A	N/A	0.14	0.37	0.56	0.99	1.24	1.55	1.56
Peak Inflow Q (cfs)	N/A	N/A	11.0	14.8	17.5	21.7	25.3	29.7	29.9
Peak Outflow Q (cfs)	0.2	42.6	8.3	13.7	16.0	22.5	23.0	23.8	23.8
Ratio Peak Outflow to Predevelopment Q	N/A	N/A	N/A	4.3	3.4	2.7	2.2	1.8	1.8
Structure Controlling Flow	Overflow Weir 1	Outlet Plate 1	Overflow Weir 1	Overflow Weir 1	Overflow Weir 1	Outlet Plate 1	Outlet Plate 1	Outlet Plate 1	Outlet Plate 1
Max Velocity through Gate 1 (fps)	0.01	1.59	0.57	0.9	1.1	1.6	1.6	1.7	1.7
Max Velocity through Gate 2 (fps)	N/A	N/A	N/A	N/A	N/A	N/A	N/A	N/A	N/A
Time to Drain 97% of Inflow Volume (hours)	13	12	14	14	13	13	12	12	12
Time to Drain 99% of Inflow Volume (hours)	13	13	15	15	15	15	15	14	14
Maximum Ponding Depth (ft)	1.77	2.56	2.08	2.21	2.27	2.41	2.61	2.95	2.96
Area at Maximum Ponding Depth (acres)	0.11	0.14	0.12	0.13	0.13	0.13	0.14	0.15	0.15
Maximum Volume Stored (acre-ft)	0.148	0.246	0.185	0.201	0.207	0.227	0.253	0.302	0.304

DETENTION BASIN OUTLET STRUCTURE DESIGN

MHFD-Detention, Version 4.00 (December 2019)

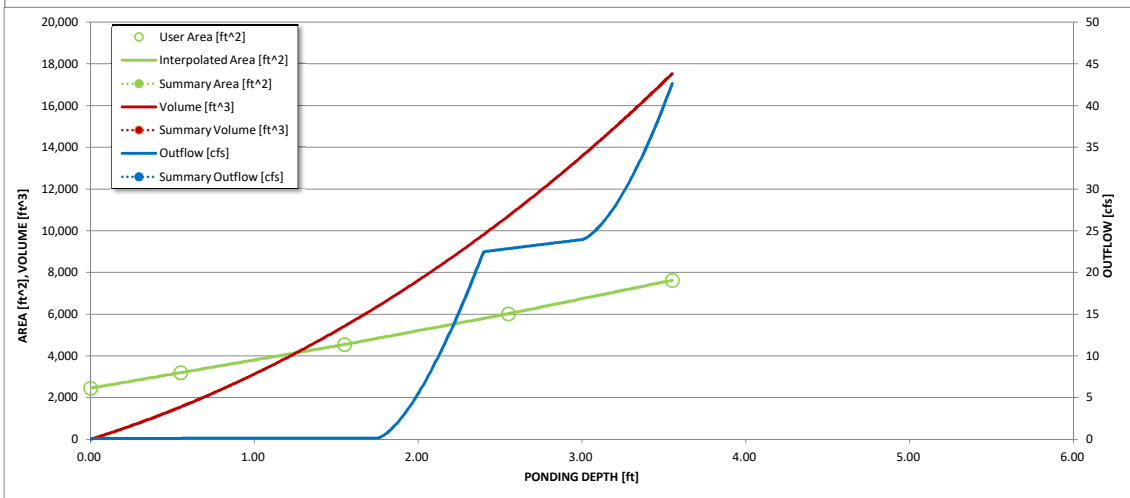
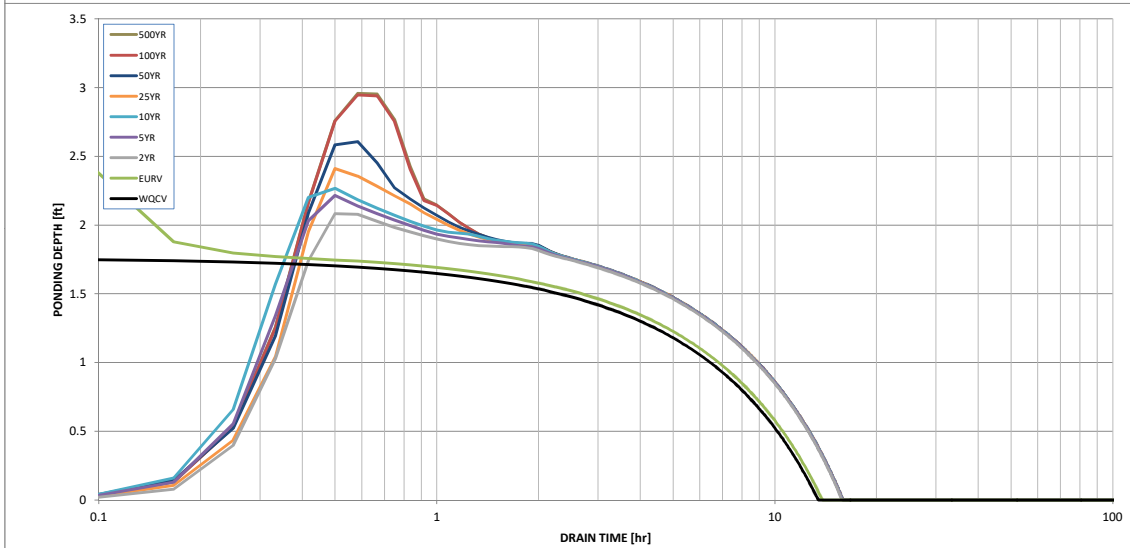
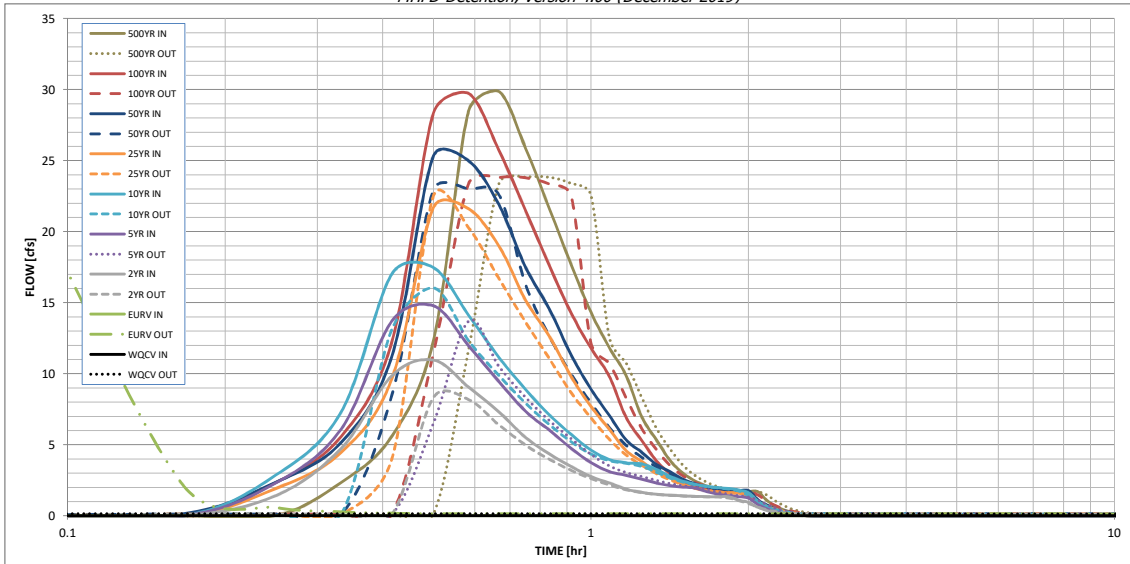

S-A-V-D Chart Axis Override	X-axis	Left Y-Axis	Right Y-Axis
minimum bound			
maximum bound			

Design Procedure Form: Sand Filter (SF)

UD-BMP (Version 3.07, March 2018)

Sheet 1 of 2

Designer: Darin Moffett
Company: M&S Civil Consultants
Date: February 23, 2023
Project: Lot 1 Pond 1 (Future) (CALCS PROVIDED FOR INFORMATION ONLY, POND 1 TO BE DESIGNED AND CONSTRUCTED WITH FUTURE DEVELOPMENT)
Location: Lot 1 - Claremont Buiness Park 2 - Filing No. 2

<p>1. Basin Storage Volume</p> <p>A) Effective Imperviousness of Tributary Area, I_p (100% if all paved and roofed areas upstream of sand filter)</p> <p>B) Tributary Area's Imperviousness Ratio ($i = I_p/100$)</p> <p>C) Water Quality Capture Volume (WQCV) Based on 12-hour Drain Time $WQCV = 0.8 * (0.91 * i^3 - 1.19 * i^2 + 0.78 * i)$</p> <p>D) Contributing Watershed Area (including sand filter area)</p> <p>E) Water Quality Capture Volume (WQCV) Design Volume $V_{WQCV} = WQCV / 12 * Area$</p> <p>F) For Watersheds Outside of the Denver Region, Depth of Average Runoff Producing Storm</p> <p>G) For Watersheds Outside of the Denver Region, Water Quality Capture Volume (WQCV) Design Volume</p> <p>H) User Input of Water Quality Capture Volume (WQCV) Design Volume (Only if a different WQCV Design Volume is desired)</p>	<p>$I_p =$ <input type="text" value="83.4"/> %</p> <p>$i =$ <input type="text" value="0.834"/></p> <p>WQCV = <input type="text" value="0.28"/> watershed inches</p> <p>Area = <input type="text" value="74,372"/> sq ft</p> <p>$V_{WQCV} =$ <input type="text" value=""/></p> <p>$d_e =$ <input type="text" value="0.60"/> in</p> <p>$V_{WQCV \text{ OTHER}} =$ <input type="text" value="2,426"/> cu ft</p> <p>$V_{WQCV \text{ USER}} =$ <input type="text" value=""/></p>
<p>2. Basin Geometry</p> <p>A) WQCV Depth</p> <p>B) Sand Filter Side Slopes (Horizontal distance per unit vertical, 4:1 or flatter preferred). Use "0" if sand filter has vertical walls.</p> <p>C) Minimum Filter Area (Flat Surface Area)</p> <p>D) Actual Filter Area</p> <p>E) Volume Provided</p>	<p>$D_{WQCV} =$ <input type="text" value="1.2"/> ft</p> <p>$Z =$ <input type="text" value="4.00"/> ft / ft</p> <p>$A_{Min} =$ <input type="text" value="775"/> sq ft</p> <p>$A_{Actual} =$ <input type="text" value="873"/> sq ft</p> <p>$V_T =$ <input type="text" value=""/></p>
<p>3. Filter Material</p>	<p>Choose One _____</p> <p><input checked="" type="radio"/> 18" CDOT Class B or C Filter Material</p> <p><input type="radio"/> Other (Explain): _____</p> <p>_____</p> <p>_____</p>
<p>4. Underdrain System</p> <p>A) Are underdrains provided?</p> <p>B) Underdrain system orifice diameter for 12 hour drain time</p> <p style="margin-left: 20px;">i) Distance From Lowest Elevation of the Storage Volume to the Center of the Orifice</p> <p style="margin-left: 20px;">ii) Volume to Drain in 12 Hours</p> <p style="margin-left: 20px;">iii) Orifice Diameter, 3/8" Minimum</p>	<p>Choose One _____</p> <p><input checked="" type="radio"/> YES</p> <p><input type="radio"/> NO</p> <p>$y =$ <input type="text" value="2.5"/> ft</p> <p>$Vol_{12} =$ <input type="text" value="2,426"/> cu ft</p> <p>$D_o =$ <input type="text" value="1 1/16"/> in</p>

Design Procedure Form: Sand Filter (SF)

Sheet 2 of 2

Designer: Darin Moffett
Company: M&S Civil Consultants
Date: February 23, 2023
Project: Lot 1 Pond 1 (Future) (CALCS PROVIDED FOR INFORMATION ONLY, POND 1 TO BE DESIGNED AND CONSTRUCTED WITH FUTURE DEVELOPMENT)
Location: Lot 1 - Claremont Buisness Park 2 - Filing No. 2

5. Impermeable Geomembrane Liner and Geotextile Separator Fabric

A) Is an impermeable liner provided due to proximity of structures or groundwater contamination?

Choose One

YES NO

6. Inlet / Outlet Works

A) Describe the type of energy dissipation at inlet points and means of conveying flows in excess of the WQCV through the outlet

TBD
Concrete Outlet Box with Unrestricted 18" RCP

Notes: _____

CLAREMONT BUSINESS PARK 2 FILING NO. 2 (PROPOSED CONDITIONS)

Weighted Percent Imperviousness of Proposed WQ Sand Filter Pond 1				
Contributing Basins	Area (Acres)	C₅	Impervious % (I)	(Acres)*(I)
A	0.21	0.09	2	0.43
B	1.50	0.81	90	134.89
Totals	1.71			135.31
Imperviousness % to FSD	79.0			

A soils 35%
 B soils 65%

DETENTION BASIN STAGE-STORAGE TABLE BUILDER

MHFD-Detention, Version 4.06 (July 2022)

Project: Claremont Business Park 2 Filing No. 2

Basin ID: Lot 1 - Future Pond 1 (CALCS PROVIDED FOR INFORMATION ONLY, POND 1 TO BE DESIGNED AND CONSTRUCTED WITH FUTURE DEVELOPMENT)

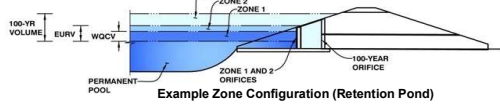

Watershed Information

Selected BMP Type =	SF
Watershed Area =	1.71 acres
Watershed Length =	300 ft
Watershed Length to Centroid =	150 ft
Watershed Slope =	0.017 ft/ft
Watershed Imperviousness =	79.00% percent
Percentage Hydrologic Soil Group A =	35.0% percent
Percentage Hydrologic Soil Group B =	65.0% percent
Percentage Hydrologic Soil Groups C/D =	0.0% percent
Target WQCV Drain Time =	12.0 hours
Location for 1-hr Rainfall Depths =	User Input

After providing required inputs above including 1-hour rainfall depths, click 'Run CUHP' to generate runoff hydrographs using the embedded Colorado Urban Hydrograph Procedure.

Water Quality Capture Volume (WQCV) =	0.037	acre-feet
Excess Urban Runoff Volume (EURV) =	0.159	acre-feet
2-yr Runoff Volume (P1 = 1.19 in.) =	0.121	acre-feet
5-yr Runoff Volume (P1 = 1.5 in.) =	0.159	acre-feet
10-yr Runoff Volume (P1 = 1.75 in.) =	0.192	acre-feet
25-yr Runoff Volume (P1 = 2 in.) =	0.229	acre-feet
50-yr Runoff Volume (P1 = 2.25 in.) =	0.263	acre-feet
100-yr Runoff Volume (P1 = 2.52 in.) =	0.303	acre-feet
500-yr Runoff Volume (P1 = 3.14 in.) =	0.388	acre-feet
Approximate 2-yr Detention Volume =	0.118	acre-feet
Approximate 5-yr Detention Volume =	0.155	acre-feet
Approximate 10-yr Detention Volume =	0.190	acre-feet
Approximate 25-yr Detention Volume =	0.211	acre-feet
Approximate 50-yr Detention Volume =	0.223	acre-feet
Approximate 100-yr Detention Volume =	0.237	acre-feet

Optional User Overrides

	acre-feet
	acre-feet
1.19	inches
1.50	inches
1.75	inches
2.00	inches
2.25	inches
2.52	inches
	inches

Define Zones and Basin Geometry

Zone 1 Volume (WQCV) =	0.037	acre-feet
Zone 2 Volume (100-year - Zone 1) =	0.200	acre-feet
Select Zone 3 Storage Volume (Optional) =		acre-feet
Total Detention Basin Volume =	0.237	acre-feet
Initial Surcharge Volume (ISV) =	N/A	ft ³
Initial Surcharge Depth (ISD) =	N/A	ft
Total Available Detention Depth (H _{total}) =	user	ft
Depth of Trickle Channel (H _{TC}) =	N/A	ft
Slope of Trickle Channel (S _{TC}) =	N/A	ft/ft
Slopes of Main Basin Sides (S _{main}) =	user	H:V
Basin Length-to-Width Ratio (R _{LW}) =	user	
Initial Surcharge Area (A _{ISV}) =	user	ft ²
Surcharge Volume Length (L _{ISV}) =	user	ft
Surcharge Volume Width (W _{ISV}) =	user	ft
Depth of Basin Floor (H _{FLOOR}) =	user	ft
Length of Basin Floor (L _{FLOOR}) =	user	ft
Width of Basin Floor (W _{FLOOR}) =	user	ft
Area of Basin Floor (A _{FLOOR}) =	user	ft ²
Volume of Basin Floor (V _{FLOOR}) =	user	ft ³
Depth of Main Basin (H _{MAIN}) =	user	ft
Length of Main Basin (L _{MAIN}) =	user	ft
Width of Main Basin (W _{MAIN}) =	user	ft
Area of Main Basin (A _{MAIN}) =	user	ft ²
Volume of Main Basin (V _{MAIN}) =	user	ft ³
Calculated Total Basin Volume (V _{total}) =	user	acre-feet

Stage - Storage Description	Stage (ft)	Optional Override Stage (ft)	Length (ft)	Width (ft)	Area (ft ²)	Optional Override Area (ft ²)	Area (acre)	Volume (ft ³)	Volume (ac-ft)
Media Surface	--	0.00	--	--	873	873	0.020		
	--	0.50	--	--	1,265	1,265	0.029	534	0.012
	--	1.50	--	--	2,124	2,124	0.049	2,229	0.051
	--	2.50	--	--	3,084	3,084	0.071	4,833	0.111
	--	3.50	--	--	4,144	4,144	0.095	8,447	0.194
	--	4.00	--	--	4,712	4,712	0.108	10,661	0.245

DETENTION BASIN STAGE-STORAGE TABLE BUILDER

MHFD-Detention, Version 4.06 (July 2022)

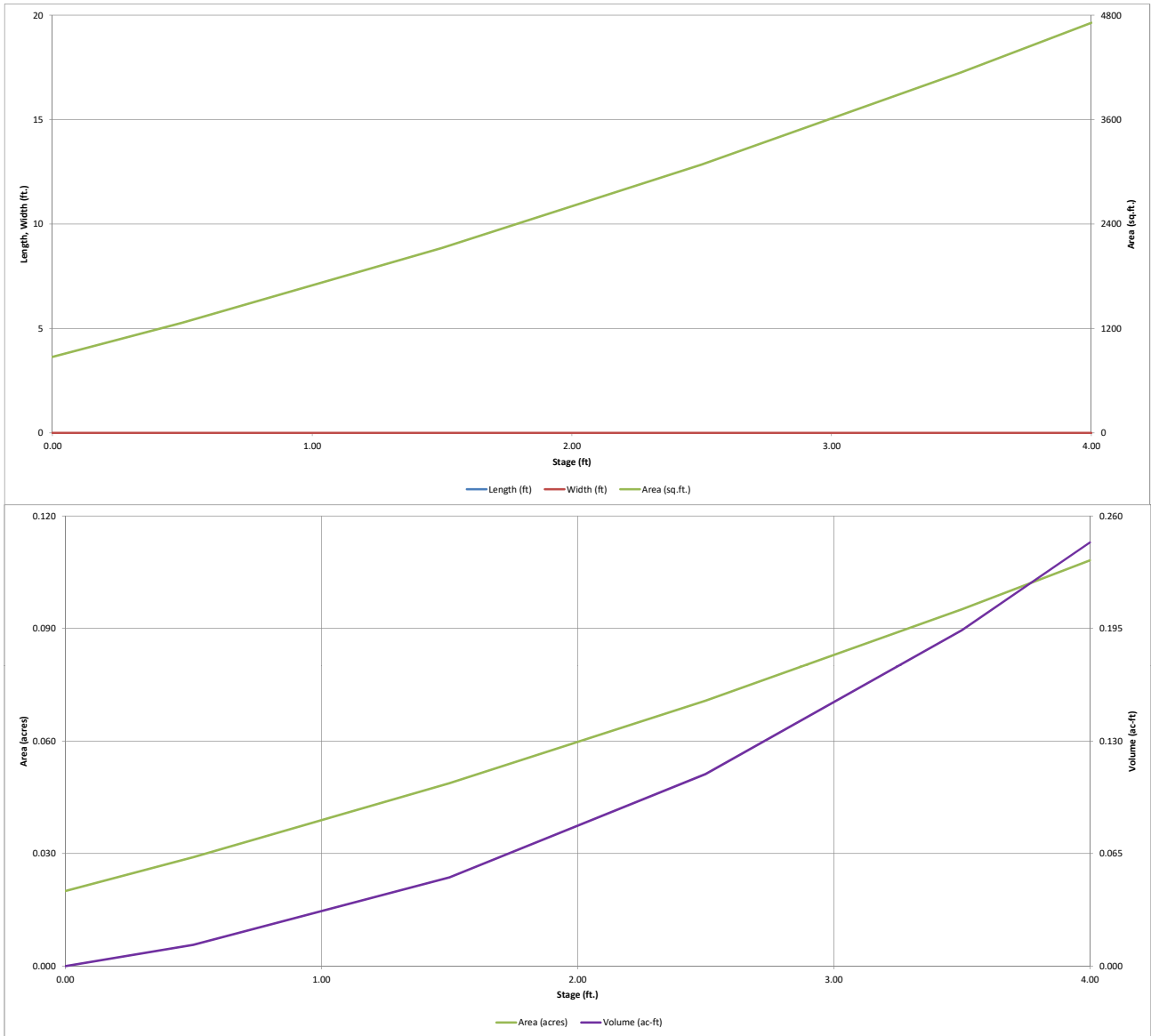

DETENTION BASIN OUTLET STRUCTURE DESIGN

MHFD- Detention, Version 4.06 (July 2022)

Project: Claremont Business Park 2 Filing No. 2

Basin ID: Lot 1 - Future Pond 1 (CALCS PROVIDED FOR INFORMATION ONLY, POND 1 TO BE DESIGNED AND CONSTRUCTED WITH FUTURE DEVELOPMENT)

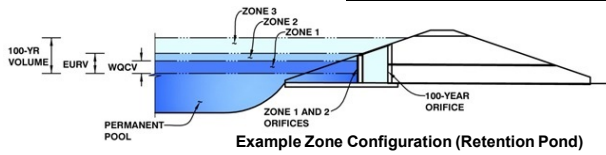

	Estimated Stage (ft)	Estimated Volume (ac-ft)	Outlet Type
Zone 1 (WQCV)	1.19	0.037	Filtration Media
Zone 2 (100-year)	3.93	0.200	Weir&Pipe (Restrict)
Zone 3			
Total (all zones)		0.237	

User Input: Orifice at Underdrain Outlet (typically used to drain WQCV in a Filtration BMP)

Underdrain Orifice Invert Depth = ft (distance below the filtration media surface)
 Underdrain Orifice Diameter = inches

Calculated Parameters for Underdrain
 Underdrain Orifice Area = ft²
 Underdrain Orifice Centroid = feet

User Input: Orifice Plate with one or more orifices or Elliptical Slot Weir (typically used to drain WQCV and/or EURV in a sedimentation BMP)

Centroid of Lowest Orifice = ft (relative to basin bottom at Stage = 0 ft)
 Depth at top of Zone using Orifice Plate = ft (relative to basin bottom at Stage = 0 ft)
 Orifice Plate: Orifice Vertical Spacing = inches
 Orifice Plate: Orifice Area per Row = sq. inches

Calculated Parameters for Plate
 WQ Orifice Area per Row = ft²
 Elliptical Half-Width = feet
 Elliptical Slot Centroid = feet
 Elliptical Slot Area = ft²

User Input: Stage and Total Area of Each Orifice Row (numbered from lowest to highest)

	Row 1 (optional)	Row 2 (optional)	Row 3 (optional)	Row 4 (optional)	Row 5 (optional)	Row 6 (optional)	Row 7 (optional)	Row 8 (optional)
Stage of Orifice Centroid (ft)	N/A	N/A	N/A	N/A	N/A	N/A	N/A	N/A
Orifice Area (sq. inches)	N/A	N/A	N/A	N/A	N/A	N/A	N/A	N/A

	Row 9 (optional)	Row 10 (optional)	Row 11 (optional)	Row 12 (optional)	Row 13 (optional)	Row 14 (optional)	Row 15 (optional)	Row 16 (optional)
Stage of Orifice Centroid (ft)	N/A	N/A	N/A	N/A	N/A	N/A	N/A	N/A
Orifice Area (sq. inches)	N/A	N/A	N/A	N/A	N/A	N/A	N/A	N/A

User Input: Vertical Orifice (Circular or Rectangular)

	Not Selected	Not Selected	
Invert of Vertical Orifice =	<input type="text"/>	<input type="text"/>	ft (relative to basin bottom at Stage = 0 ft)
Depth at top of Zone using Vertical Orifice =	<input type="text"/>	<input type="text"/>	ft (relative to basin bottom at Stage = 0 ft)
Vertical Orifice Diameter =	<input type="text"/>	<input type="text"/>	inches

Calculated Parameters for Vertical Orif
 Vertical Orifice Area = ft²
 Vertical Orifice Centroid = feet

User Input: Overflow Weir (Dropbox with Flat or Sloped Gate and Outlet Pipe OR Rectangular/Trapezoidal Weir and No Outlet Pipe)

	Zone 2 Weir	Not Selected	
Overflow Weir Front Edge Height, Ho =	<input type="text" value="1.19"/>	<input type="text"/>	ft (relative to basin bottom at Stage = 0 ft)
Overflow Weir Front Edge Length =	<input type="text" value="2.91"/>	<input type="text"/>	feet
Overflow Weir Gate Slope =	<input type="text" value="0.00"/>	<input type="text"/>	H:V
Horiz. Length of Weir Sides =	<input type="text" value="2.91"/>	<input type="text"/>	feet
Overflow Gate Type =	<input type="text" value="Type C Gate"/>	<input type="text"/>	
Debris Clogging % =	<input type="text" value="50%"/>	<input type="text"/>	%

Calculated Parameters for Overflow Weir
 Height of Gate Upper Edge, H_t = feet
 Overflow Weir Slope Length = feet
 Gate Open Area / 100-yr Orifice Area =
 Overflow Gate Open Area w/o Debris =
 Overflow Gate Open Area w/ Debris =

User Input: Outlet Pipe w/ Flow Restriction Plate (Circular Orifice, Restrictor Plate, or Rectangular Orifice)

	Zone 2 Restrictor	Not Selected	
Depth to Invert of Outlet Pipe =	<input type="text" value="2.75"/>	<input type="text"/>	ft (distance below basin bottom at Stage = 0 ft)
Outlet Pipe Diameter =	<input type="text" value="18.00"/>	<input type="text"/>	inches
Restrictor Plate Height Above Pipe Invert =	<input type="text" value="18.00"/>	<input type="text"/>	inches

Calculated Parameters for Outlet Pipe w/ Flow Restriction Plate
 Outlet Orifice Area = ft²
 Outlet Orifice Centroid = feet
 Half-Central Angle of Restrictor Plate on Pipe = degrees

User Input: Emergency Spillway (Rectangular or Trapezoidal)

Spillway Invert Stage =	<input type="text" value="2.00"/>	ft (relative to basin bottom at Stage = 0 ft)
Spillway Crest Length =	<input type="text" value="20.00"/>	feet
Spillway End Slopes =	<input type="text" value="4.00"/>	H:V
Freeboard above Max Water Surface =	<input type="text" value="1.00"/>	feet

Calculated Parameters for Spillway
 Spillway Design Flow Depth = feet
 Stage at Top of Freeboard = feet
 Basin Area at Top of Freeboard = acres
 Basin Volume at Top of Freeboard = acre-ft

Routed Hydrograph Results

The user can override the default CUHP hydrographs and runoff volumes by entering new values in the Inflow Hydrographs table (Columns W through AI)

	WQCV	EURV	2 Year	5 Year	10 Year	25 Year	50 Year	100 Year
Design Storm Return Period =	N/A	N/A	1.19	1.50	1.75	2.00	2.25	2.52
One-Hour Rainfall Depth (in) =	N/A	N/A	1.19	1.50	1.75	2.00	2.25	2.52
CUHP Runoff Volume (acre-ft) =	0.037	0.159	0.121	0.159	0.192	0.229	0.263	0.303
Inflow Hydrograph Volume (acre-ft) =	N/A	N/A	0.121	0.159	0.192	0.229	0.263	0.303
CUHP Predevelopment Peak Q (cfs) =	N/A	N/A	0.0	0.3	0.7	1.3	1.8	2.3
OPTIONAL Override Predevelopment Peak Q (cfs) =	N/A	N/A						
Predevelopment Unit Peak Flow, q (cfs/acre) =	N/A	N/A	0.02	0.20	0.38	0.78	1.03	1.34
Peak Inflow Q (cfs) =	N/A	N/A	2.5	3.2	3.9	4.8	5.5	6.2
Peak Outflow Q (cfs) =	0.0	20.3	1.7	2.8	3.4	4.7	5.6	6.5
Ratio Peak Outflow to Predevelopment Q =	N/A	N/A	N/A	8.1	5.1	3.5	3.2	2.8
Structure Controlling Flow =	Overflow Weir 1	Spillway	Overflow Weir 1	Overflow Weir 1	Overflow Weir 1	Overflow Weir 1	Overflow Weir 1	Overflow Weir 1
Max Velocity through Gate 1 (fps) =	N/A	3.26	0.28	0.5	0.6	0.8	0.9	1.1
Max Velocity through Gate 2 (fps) =	N/A	N/A	N/A	N/A	N/A	N/A	N/A	N/A
Time to Drain 97% of Inflow Volume (hours) =	12	6	13	13	13	12	12	12
Time to Drain 99% of Inflow Volume (hours) =	12	7	14	14	14	14	14	14
Maximum Ponding Depth (ft) =	1.19	3.12	1.39	1.47	1.51	1.58	1.63	1.68
Area at Maximum Ponding Depth (acres) =	0.04	0.09	0.05	0.05	0.05	0.05	0.05	0.05
Maximum Volume Stored (acre-ft) =	0.037	0.160	0.046	0.050	0.051	0.055	0.058	0.060

DETENTION BASIN OUTLET STRUCTURE DESIGN

MHFD-Detention, Version 4.06 (July 2022)

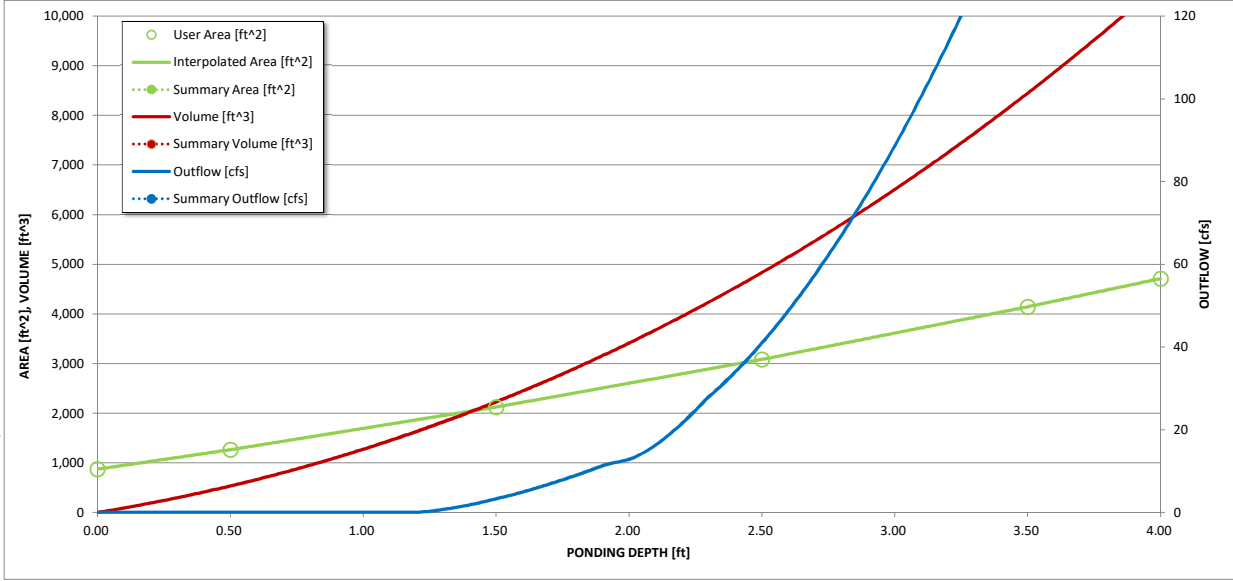
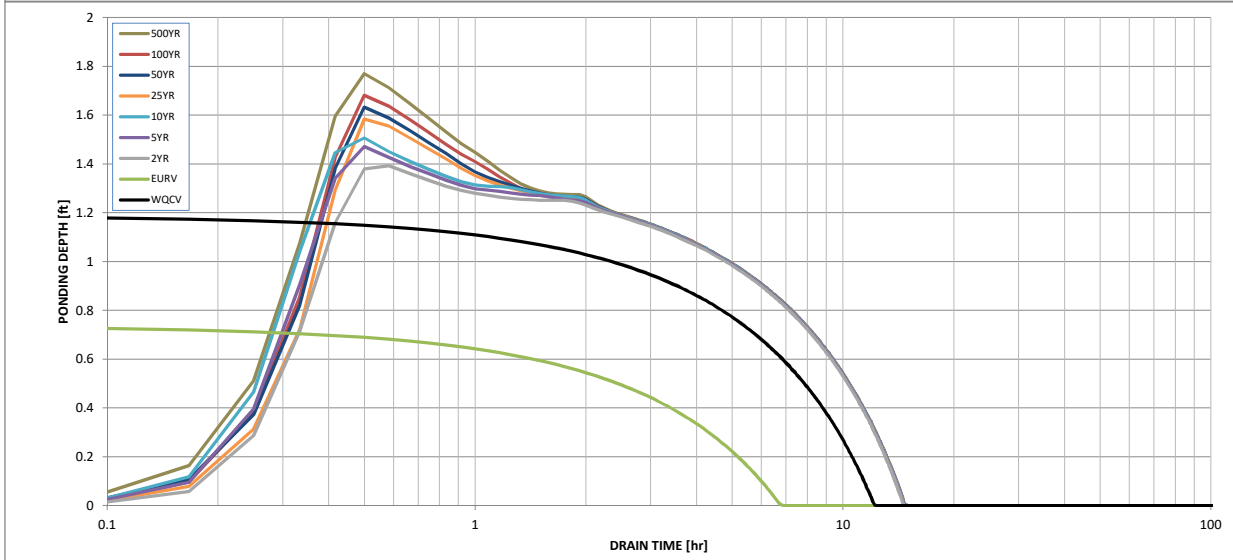
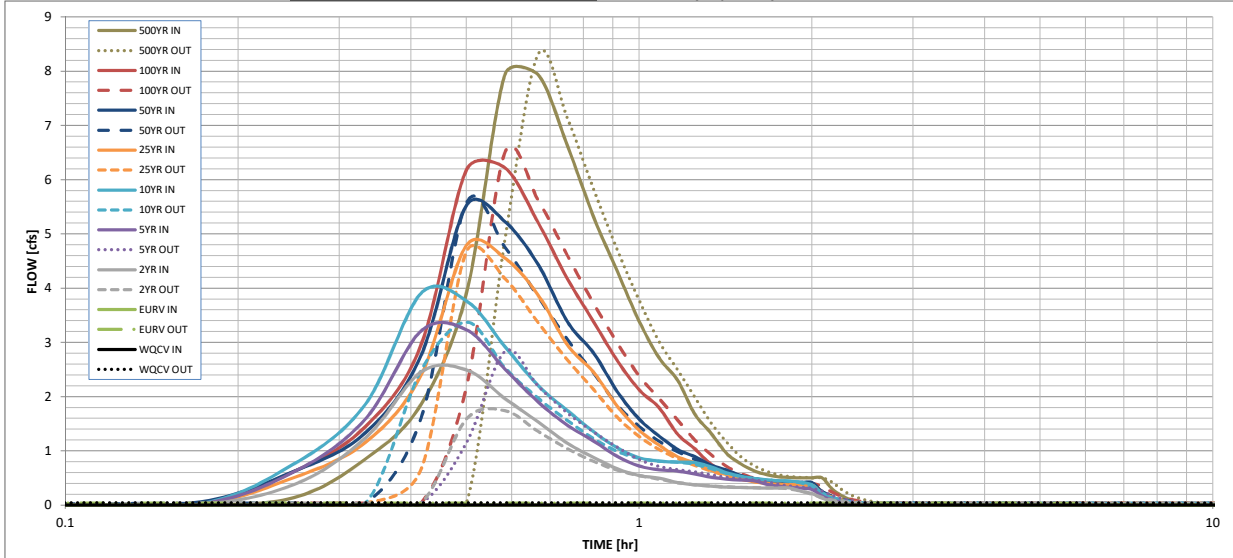

S-A-V-D Chart Axis Override	X-axis	Left Y-Axis	Right Y-Axis
minimum bound			
maximum bound			

DETENTION BASIN OUTLET STRUCTURE DESIGN

Outflow Hydrograph Workbook Filename: _____

Inflow Hydrographs

The user can override the calculated inflow hydrographs from this workbook with inflow hydrographs developed in a separate program.

Time Interval	SOURCE	CUHP	CUHP	CUHP	CUHP	CUHP	CUHP	CUHP	CUHP	CUHP
	TIME	WQCV [cfs]	EURV [cfs]	2 Year [cfs]	5 Year [cfs]	10 Year [cfs]	25 Year [cfs]	50 Year [cfs]	100 Year [cfs]	500 Year [cfs]
5.00 min	0:00:00	0.00	0.00	0.00	0.00	0.00	0.00	0.00	0.00	0.00
	0:05:00	0.00	0.00	0.00	0.00	0.00	0.00	0.00	0.00	0.00
	0:10:00	0.00	0.00	0.00	0.00	0.00	0.00	0.04	0.00	0.14
	0:15:00	0.00	0.00	0.38	0.61	0.76	0.51	0.62	0.62	0.85
	0:20:00	0.00	0.00	1.24	1.59	1.86	1.16	1.34	1.45	1.86
	0:25:00	0.00	0.00	2.45	3.21	3.90	2.40	2.76	2.95	3.90
	0:30:00	0.00	0.00	2.49	3.23	3.76	4.79	5.53	6.17	7.93
	0:35:00	0.00	0.00	1.96	2.51	2.92	4.56	5.23	6.22	7.93
	0:40:00	0.00	0.00	1.53	1.90	2.20	3.87	4.43	5.21	6.62
	0:45:00	0.00	0.00	1.14	1.47	1.74	2.95	3.38	4.17	5.30
	0:50:00	0.00	0.00	0.87	1.18	1.35	2.45	2.80	3.38	4.30
	0:55:00	0.00	0.00	0.67	0.90	1.05	1.82	2.09	2.66	3.39
	1:00:00	0.00	0.00	0.55	0.72	0.87	1.38	1.59	2.13	2.71
	1:05:00	0.00	0.00	0.50	0.65	0.81	1.11	1.27	1.80	2.30
	1:10:00	0.00	0.00	0.42	0.63	0.79	0.89	1.03	1.31	1.68
	1:15:00	0.00	0.00	0.37	0.57	0.79	0.78	0.90	1.04	1.33
	1:20:00	0.00	0.00	0.35	0.52	0.71	0.65	0.74	0.76	0.97
	1:25:00	0.00	0.00	0.33	0.48	0.60	0.57	0.65	0.61	0.77
	1:30:00	0.00	0.00	0.32	0.46	0.53	0.48	0.55	0.50	0.64
	1:35:00	0.00	0.00	0.32	0.45	0.49	0.43	0.49	0.45	0.56
	1:40:00	0.00	0.00	0.32	0.39	0.47	0.40	0.45	0.42	0.52
	1:45:00	0.00	0.00	0.32	0.35	0.45	0.39	0.44	0.41	0.51
	1:50:00	0.00	0.00	0.32	0.33	0.44	0.38	0.42	0.40	0.50
	1:55:00	0.00	0.00	0.25	0.31	0.42	0.37	0.42	0.40	0.50
	2:00:00	0.00	0.00	0.21	0.29	0.37	0.37	0.42	0.40	0.50
	2:05:00	0.00	0.00	0.13	0.17	0.22	0.22	0.25	0.24	0.30
	2:10:00	0.00	0.00	0.07	0.10	0.13	0.13	0.15	0.14	0.18
	2:15:00	0.00	0.00	0.04	0.06	0.07	0.07	0.08	0.08	0.10
	2:20:00	0.00	0.00	0.02	0.03	0.04	0.04	0.05	0.05	0.06
	2:25:00	0.00	0.00	0.01	0.01	0.02	0.02	0.02	0.02	0.03
	2:30:00	0.00	0.00	0.00	0.00	0.00	0.01	0.01	0.01	0.01
	2:35:00	0.00	0.00	0.00	0.00	0.00	0.00	0.00	0.00	0.00
	2:40:00	0.00	0.00	0.00	0.00	0.00	0.00	0.00	0.00	0.00
	2:45:00	0.00	0.00	0.00	0.00	0.00	0.00	0.00	0.00	0.00
	2:50:00	0.00	0.00	0.00	0.00	0.00	0.00	0.00	0.00	0.00
	2:55:00	0.00	0.00	0.00	0.00	0.00	0.00	0.00	0.00	0.00
	3:00:00	0.00	0.00	0.00	0.00	0.00	0.00	0.00	0.00	0.00
	3:05:00	0.00	0.00	0.00	0.00	0.00	0.00	0.00	0.00	0.00
	3:10:00	0.00	0.00	0.00	0.00	0.00	0.00	0.00	0.00	0.00
	3:15:00	0.00	0.00	0.00	0.00	0.00	0.00	0.00	0.00	0.00
	3:20:00	0.00	0.00	0.00	0.00	0.00	0.00	0.00	0.00	0.00
	3:25:00	0.00	0.00	0.00	0.00	0.00	0.00	0.00	0.00	0.00
	3:30:00	0.00	0.00	0.00	0.00	0.00	0.00	0.00	0.00	0.00
	3:35:00	0.00	0.00	0.00	0.00	0.00	0.00	0.00	0.00	0.00
	3:40:00	0.00	0.00	0.00	0.00	0.00	0.00	0.00	0.00	0.00
	3:45:00	0.00	0.00	0.00	0.00	0.00	0.00	0.00	0.00	0.00
	3:50:00	0.00	0.00	0.00	0.00	0.00	0.00	0.00	0.00	0.00
	3:55:00	0.00	0.00	0.00	0.00	0.00	0.00	0.00	0.00	0.00
	4:00:00	0.00	0.00	0.00	0.00	0.00	0.00	0.00	0.00	0.00
	4:05:00	0.00	0.00	0.00	0.00	0.00	0.00	0.00	0.00	0.00
	4:10:00	0.00	0.00	0.00	0.00	0.00	0.00	0.00	0.00	0.00
	4:15:00	0.00	0.00	0.00	0.00	0.00	0.00	0.00	0.00	0.00
	4:20:00	0.00	0.00	0.00	0.00	0.00	0.00	0.00	0.00	0.00
	4:25:00	0.00	0.00	0.00	0.00	0.00	0.00	0.00	0.00	0.00
	4:30:00	0.00	0.00	0.00	0.00	0.00	0.00	0.00	0.00	0.00
	4:35:00	0.00	0.00	0.00	0.00	0.00	0.00	0.00	0.00	0.00
	4:40:00	0.00	0.00	0.00	0.00	0.00	0.00	0.00	0.00	0.00
	4:45:00	0.00	0.00	0.00	0.00	0.00	0.00	0.00	0.00	0.00
	4:50:00	0.00	0.00	0.00	0.00	0.00	0.00	0.00	0.00	0.00
	4:55:00	0.00	0.00	0.00	0.00	0.00	0.00	0.00	0.00	0.00
	5:00:00	0.00	0.00	0.00	0.00	0.00	0.00	0.00	0.00	0.00
	5:05:00	0.00	0.00	0.00	0.00	0.00	0.00	0.00	0.00	0.00
	5:10:00	0.00	0.00	0.00	0.00	0.00	0.00	0.00	0.00	0.00
	5:15:00	0.00	0.00	0.00	0.00	0.00	0.00	0.00	0.00	0.00
	5:20:00	0.00	0.00	0.00	0.00	0.00	0.00	0.00	0.00	0.00
	5:25:00	0.00	0.00	0.00	0.00	0.00	0.00	0.00	0.00	0.00
	5:30:00	0.00	0.00	0.00	0.00	0.00	0.00	0.00	0.00	0.00
	5:35:00	0.00	0.00	0.00	0.00	0.00	0.00	0.00	0.00	0.00
	5:40:00	0.00	0.00	0.00	0.00	0.00	0.00	0.00	0.00	0.00
	5:45:00	0.00	0.00	0.00	0.00	0.00	0.00	0.00	0.00	0.00
	5:50:00	0.00	0.00	0.00	0.00	0.00	0.00	0.00	0.00	0.00
	5:55:00	0.00	0.00	0.00	0.00	0.00	0.00	0.00	0.00	0.00
6:00:00	0.00	0.00	0.00	0.00	0.00	0.00	0.00	0.00	0.00	

Design Procedure Form: Sand Filter (SF)

UD-BMP (Version 3.07, March 2018)

Sheet 1 of 2

Designer: EUGENE TELLEZ
Company: M&S Civil Consultants
Date: May 8, 2023
Project: Lot 2 Pond 3 (POND 3 TO BE DESIGNED AND CONSTRUCTED WITH THIS REPORT)
Location: Lot 2 - Claremont Buiness Park 2 - Filing No. 2

<p>1. Basin Storage Volume</p> <p>A) Effective Imperviousness of Tributary Area, I_p (100% if all paved and roofed areas upstream of sand filter)</p> <p>B) Tributary Area's Imperviousness Ratio ($i = I_p/100$)</p> <p>C) Water Quality Capture Volume (WQCV) Based on 12-hour Drain Time $WQCV = 0.8 * (0.91 * i^3 - 1.19 * i^2 + 0.78 * i)$</p> <p>D) Contributing Watershed Area (including sand filter area)</p> <p>E) Water Quality Capture Volume (WQCV) Design Volume $V_{WQCV} = WQCV / 12 * Area$</p> <p>F) For Watersheds Outside of the Denver Region, Depth of Average Runoff Producing Storm</p> <p>G) For Watersheds Outside of the Denver Region, Water Quality Capture Volume (WQCV) Design Volume</p> <p>H) User Input of Water Quality Capture Volume (WQCV) Design Volume (Only if a different WQCV Design Volume is desired)</p>	<p>$I_p =$ <input type="text" value="80.3"/> %</p> <p>$i =$ <input type="text" value="0.803"/></p> <p>WQCV = <input type="text" value="0.26"/> watershed inches</p> <p>Area = <input type="text" value="101,060"/> sq ft</p> <p>$V_{WQCV} =$ <input type="text" value=""/> cu ft</p> <p>$d_e =$ <input type="text" value="0.60"/> in</p> <p>$V_{WQCV \text{ OTHER}} =$ <input type="text" value="3,104"/> cu ft</p> <p>$V_{WQCV \text{ USER}} =$ <input type="text" value=""/> cu ft</p>
<p>2. Basin Geometry</p> <p>A) WQCV Depth</p> <p>B) Sand Filter Side Slopes (Horizontal distance per unit vertical, 4:1 or flatter preferred). Use "0" if sand filter has vertical walls.</p> <p>C) Minimum Filter Area (Flat Surface Area)</p> <p>D) Actual Filter Area</p> <p>E) Volume Provided</p>	<p>$D_{WQCV} =$ <input type="text" value="1.6"/> ft</p> <p>$Z =$ <input type="text" value="4.00"/> ft / ft</p> <p>$A_{Min} =$ <input type="text" value="1014"/> sq ft</p> <p>$A_{Actual} =$ <input type="text" value="1045"/> sq ft</p> <p>$V_T =$ <input type="text" value=""/> cu ft</p>
<p>3. Filter Material</p>	<p>Choose One _____</p> <p><input checked="" type="radio"/> 18" CDOT Class B or C Filter Material</p> <p><input type="radio"/> Other (Explain): _____</p>
<p>4. Underdrain System</p> <p>A) Are underdrains provided?</p> <p>B) Underdrain system orifice diameter for 12 hour drain time</p> <p style="margin-left: 20px;">i) Distance From Lowest Elevation of the Storage Volume to the Center of the Orifice</p> <p style="margin-left: 20px;">ii) Volume to Drain in 12 Hours</p> <p style="margin-left: 20px;">iii) Orifice Diameter, 3/8" Minimum</p>	<p>Choose One _____</p> <p><input checked="" type="radio"/> YES</p> <p><input type="radio"/> NO</p> <p>$y =$ <input type="text" value="2.5"/> ft</p> <p>$Vol_{12} =$ <input type="text" value="3,104"/> cu ft</p> <p>$D_o =$ <input type="text" value="1 1/4"/> in</p>

Design Procedure Form: Sand Filter (SF)

Sheet 2 of 2

Designer: EUGENE TELLEZ
Company: M&S Civil Consultants
Date: May 8, 2023
Project: Lot 2 Pond 3 (POND 3 TO BE DESIGNED AND CONSTRUCTED WITH THIS REPORT)
Location: Lot 2 - Claremont Buisness Park 2 - Filing No. 2

5. Impermeable Geomembrane Liner and Geotextile Separator Fabric

A) Is an impermeable liner provided due to proximity of structures or groundwater contamination?

Choose One

YES NO

6. Inlet / Outlet Works

A) Describe the type of energy dissipation at inlet points and means of conveying flows in excess of the WQCV through the outlet

TBD
Concrete Outlet Box with Restricted 18" RCP

Notes: _____

CLAREMONT BUSINESS PARK 2 FILING NO. 2 (PROPOSED CONDITIONS)

Weighted Percent Imperviousness of Proposed WQ Sand Filter Pond 3				
Contributing Basins	Area (Acres)	C₅	Impervious % (I)	(Acres)*(I)
<i>C1</i>	0.17	0.09	2	0.34
<i>D1</i>	0.78	0.81	90	70.31
<i>E1</i>	0.27	0.88	97	26.02
<i>E2</i>	0.21	0.88	97	20.22
<i>C</i>	0.12	0.09	2	0.25
<i>D</i>	0.77	0.81	90	69.40
Totals	2.32			186.53
Imperviousness of WQ Pond 2	80.3			

A soils 70%
 B soils 30%

DETENTION BASIN STAGE-STORAGE TABLE BUILDER

MHFD-*Detention, Version 4.06 (July 2022)*

Project: Claremont Business Park 2 Filing No. 2

Basin ID: Lot 2 - Pond 3 (POND 3 TO BE DESIGNED AND CONSTRUCTED WITH THIS REPORT)

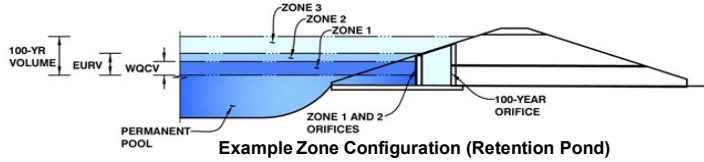

Watershed Information

Selected BMP Type =	SF
Watershed Area =	2.32 acres
Watershed Length =	383 ft
Watershed Length to Centroid =	150 ft
Watershed Slope =	0.036 ft/ft
Watershed Imperviousness =	80.30% percent
Percentage Hydrologic Soil Group A =	70.0% percent
Percentage Hydrologic Soil Group B =	30.0% percent
Percentage Hydrologic Soil Groups C/D =	0.0% percent
Target WQCV Drain Time =	12.0 hours
Location for 1-hr Rainfall Depths =	User Input

After providing required inputs above including 1-hour rainfall depths, click 'Run CUHP' to generate runoff hydrographs using the embedded Colorado Urban Hydrograph Procedure.

Water Quality Capture Volume (WQCV) =	0.051	acre-feet
Excess Urban Runoff Volume (EURV) =	0.234	acre-feet
2-yr Runoff Volume (P1 = 1.19 in.) =	0.161	acre-feet
5-yr Runoff Volume (P1 = 1.5 in.) =	0.208	acre-feet
10-yr Runoff Volume (P1 = 1.75 in.) =	0.249	acre-feet
25-yr Runoff Volume (P1 = 2 in.) =	0.297	acre-feet
50-yr Runoff Volume (P1 = 2.25 in.) =	0.341	acre-feet
100-yr Runoff Volume (P1 = 2.52 in.) =	0.393	acre-feet
500-yr Runoff Volume (P1 = 3.14 in.) =	0.506	acre-feet
Approximate 2-yr Detention Volume =	0.162	acre-feet
Approximate 5-yr Detention Volume =	0.211	acre-feet
Approximate 10-yr Detention Volume =	0.255	acre-feet
Approximate 25-yr Detention Volume =	0.294	acre-feet
Approximate 50-yr Detention Volume =	0.316	acre-feet
Approximate 100-yr Detention Volume =	0.339	acre-feet

Optional User Overrides

	acre-feet
	acre-feet
1.19	inches
1.50	inches
1.75	inches
2.00	inches
2.25	inches
2.52	inches
	inches

Define Zones and Basin Geometry

Zone 1 Volume (WQCV) =	0.051	acre-feet
Zone 2 Volume (100-year - Zone 1) =	0.288	acre-feet
Select Zone 3 Storage Volume (Optional) =		acre-feet
Total Detention Basin Volume =	0.339	acre-feet
Initial Surcharge Volume (ISV) =	N/A	ft ³
Initial Surcharge Depth (ISD) =	N/A	ft
Total Available Detention Depth (H _{total}) =	user	ft
Depth of Trickle Channel (H _{TC}) =	N/A	ft
Slope of Trickle Channel (S _{TC}) =	N/A	ft/ft
Slopes of Main Basin Sides (S _{main}) =	user	H:V
Basin Length-to-Width Ratio (R _{L/W}) =	user	

Depth Increment =		ft								
Stage - Storage Description	Stage (ft)	Optional Override Stage (ft)	Length (ft)	Width (ft)	Area (ft ²)	Optional Override Area (ft ²)	Area (acre)	Volume (ft ³)	Volume (ac-ft)	
Media Surface	--	0.00	--	--	--	1,045	0.024			
	--	0.65	--	--	--	1,487	0.034	823	0.019	
	--	1.65	--	--	--	2,280	0.052	2,706	0.062	
	--	2.65	--	--	--	3,273	0.075	5,483	0.126	
	--	3.65	--	--	--	3,616	0.083	8,927	0.205	
	--	4.65	--	--	--	3,890	0.089	12,680	0.291	
	--	5.65	--	--	--	4,175	0.096	16,713	0.384	
	--	6.20	--	--	--	4,780	0.110	19,176	0.440	
	--		--	--	--					
	--		--	--	--					
	--		--	--	--					
	--		--	--	--					
	--		--	--	--					
	--		--	--	--					
	--		--	--	--					
	--		--	--	--					
	--		--	--	--					
	--		--	--	--					
	--		--	--	--					
	--		--	--	--					
	--		--	--	--					
	--		--	--	--					
	--		--	--	--					
	--		--	--	--					
	--		--	--	--					
	--		--	--	--					
	--		--	--	--					
	--		--	--	--					
	--		--	--	--					
	--		--	--	--					
	--		--	--	--					

DETENTION BASIN STAGE-STORAGE TABLE BUILDER

MHFD-Detention, Version 4.06 (July 2022)

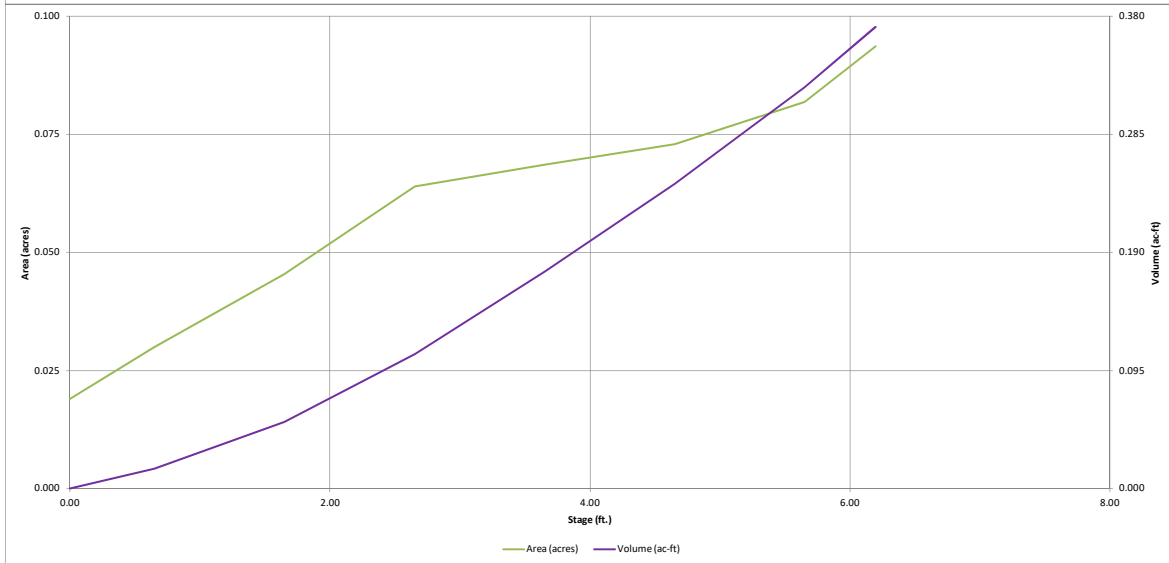
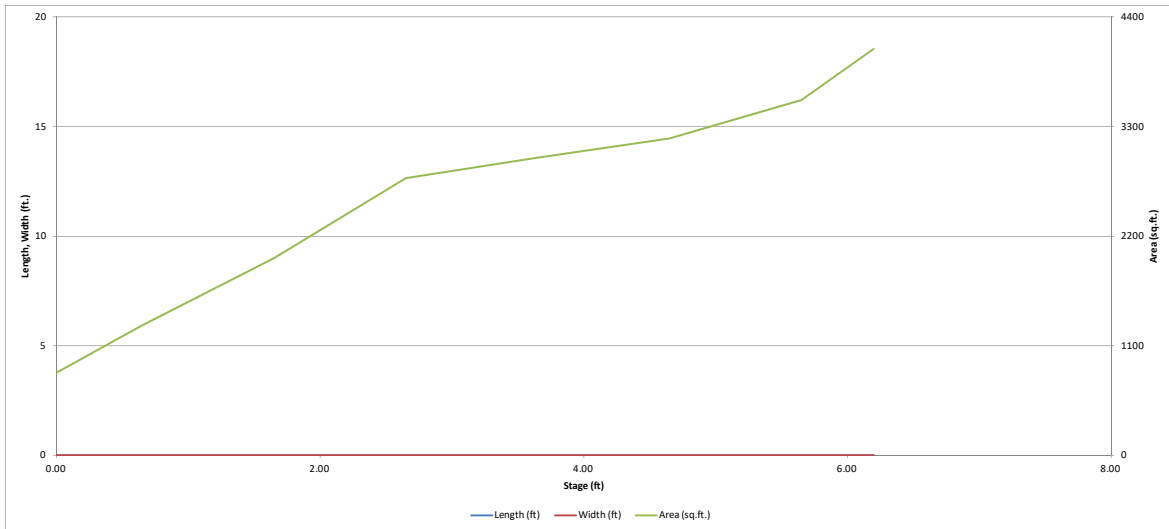

DETENTION BASIN OUTLET STRUCTURE DESIGN

MHFD- Detention, Version 4.06 (July 2022)

Project: Claremont Business Park 2 Filing No. 2

Basin ID: Lot 2 - Pond 3 (POND 3 TO BE DESIGNED AND CONSTRUCTED WITH THIS REPORT)

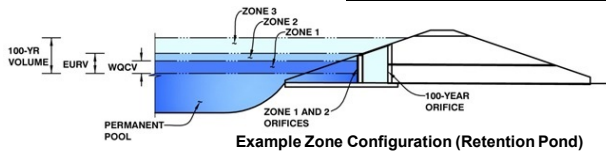

	Estimated Stage (ft)	Estimated Volume (ac-ft)	Outlet Type
Zone 1 (WQCV)	1.44	0.051	Filtration Media
Zone 2 (100-year)	5.18	0.288	Weir&Pipe (Restrict)
Zone 3			
Total (all zones)		0.339	

User Input: Orifice at Underdrain Outlet (typically used to drain WQCV in a Filtration BMP)

Underdrain Orifice Invert Depth = 2.50 ft (distance below the filtration media surface)
 Underdrain Orifice Diameter = 0.84 inches

Calculated Parameters for Underdrain
 Underdrain Orifice Area = 0.0 ft²
 Underdrain Orifice Centroid = 0.04 feet

User Input: Orifice Plate with one or more orifices or Elliptical Slot Weir (typically used to drain WQCV and/or EURV in a sedimentation BMP)

Centroid of Lowest Orifice = N/A ft (relative to basin bottom at Stage = 0 ft)
 Depth at top of Zone using Orifice Plate = N/A ft (relative to basin bottom at Stage = 0 ft)
 Orifice Plate: Orifice Vertical Spacing = N/A inches
 Orifice Plate: Orifice Area per Row = N/A sq. inches

Calculated Parameters for Plate
 WQ Orifice Area per Row = N/A ft²
 Elliptical Half-Width = N/A feet
 Elliptical Slot Centroid = N/A feet
 Elliptical Slot Area = N/A ft²

User Input: Stage and Total Area of Each Orifice Row (numbered from lowest to highest)

	Row 1 (optional)	Row 2 (optional)	Row 3 (optional)	Row 4 (optional)	Row 5 (optional)	Row 6 (optional)	Row 7 (optional)	Row 8 (optional)
Stage of Orifice Centroid (ft)	N/A	N/A	N/A	N/A	N/A	N/A	N/A	N/A
Orifice Area (sq. inches)	N/A	N/A	N/A	N/A	N/A	N/A	N/A	N/A

	Row 9 (optional)	Row 10 (optional)	Row 11 (optional)	Row 12 (optional)	Row 13 (optional)	Row 14 (optional)	Row 15 (optional)	Row 16 (optional)
Stage of Orifice Centroid (ft)	N/A	N/A	N/A	N/A	N/A	N/A	N/A	N/A
Orifice Area (sq. inches)	N/A	N/A	N/A	N/A	N/A	N/A	N/A	N/A

User Input: Vertical Orifice (Circular or Rectangular)

	Not Selected	Not Selected	
Invert of Vertical Orifice =			ft (relative to basin bottom at Stage = 0 ft)
Depth at top of Zone using Vertical Orifice =			ft (relative to basin bottom at Stage = 0 ft)
Vertical Orifice Diameter =			inches

Calculated Parameters for Vertical Orif
 Vertical Orifice Area = Not Selected
 Vertical Orifice Centroid = Not Selected

User Input: Overflow Weir (Dropbox with Flat or Sloped Gate and Outlet Pipe OR Rectangular/Trapezoidal Weir and No Outlet Pipe)

	Zone 2 Weir	Not Selected	
Overflow Weir Front Edge Height, Ho =	1.45		ft (relative to basin bottom at Stage = 0 ft)
Overflow Weir Front Edge Length =	3.00		feet
Overflow Weir Gate Slope =	0.00		H:V
Horiz. Length of Weir Sides =	3.00		feet
Overflow Gate Type =	Type C Gate		
Debris Clogging % =	70%		%

Calculated Parameters for Overflow W
 Height of Gate Upper Edge, H_t = 1.45
 Overflow Weir Slope Length = 3.00
 Gate Open Area / 100-yr Orifice Area = 17.58
 Overflow Gate Open Area w/o Debris = 6.26
 Overflow Gate Open Area w/ Debris = 1.88

User Input: Outlet Pipe w/ Flow Restriction Plate (Circular Orifice, Restrictor Plate, or Rectangular Orifice)

	Zone 2 Restrictor	Not Selected	
Depth to Invert of Outlet Pipe =	2.75		ft (distance below basin bottom at Stage = 0 ft)
Outlet Pipe Diameter =	18.00		inches
Restrictor Plate Height Above Pipe Invert =	4.60		inches

Calculated Parameters for Outlet Pipe w/ Flow Restriction Pl
 Outlet Orifice Area = 0.36
 Outlet Orifice Centroid = 0.23
 Half-Central Angle of Restrictor Plate on Pipe = 1.06 N/A

User Input: Emergency Spillway (Rectangular or Trapezoidal)

Spillway Invert Stage =	4.90	ft (relative to basin bottom at Stage = 0 ft)
Spillway Crest Length =	18.00	feet
Spillway End Slopes =	4.00	H:V
Freeboard above Max Water Surface =	1.00	feet

Calculated Parameters for Spillway
 Spillway Design Flow Depth = 0.19 feet
 Stage at Top of Freeboard = 6.09 feet
 Basin Area at Top of Freeboard = 0.11 acres
 Basin Volume at Top of Freeboard = 0.43 acre-ft

Routed Hydrograph Results

The user can override the default CUHP hydrographs and runoff volumes by entering new values in the Inflow Hydrographs table (Columns W through AI)

	WQCV	EURV	2 Year	5 Year	10 Year	25 Year	50 Year	100 Year
Design Storm Return Period =								
One-Hour Rainfall Depth (in) =	N/A	N/A	1.19	1.50	1.75	2.00	2.25	2.52
CUHP Runoff Volume (acre-ft) =	0.051	0.234	0.161	0.208	0.249	0.297	0.341	0.393
Inflow Hydrograph Volume (acre-ft) =	N/A	N/A	0.161	0.208	0.249	0.297	0.341	0.393
CUHP Predevelopment Peak Q (cfs) =	N/A	N/A	0.0	0.1	0.5	1.4	2.0	2.8
OPTIONAL Override Predevelopment Peak Q (cfs) =	N/A	N/A						
Predevelopment Unit Peak Flow, q (cfs/acre) =	N/A	N/A	0.02	0.03	0.20	0.61	0.86	1.20
Peak Inflow Q (cfs) =	N/A	N/A	3.7	4.8	5.7	7.0	8.1	9.0
Peak Outflow Q (cfs) =	0.0	4.3	2.2	3.3	3.6	3.8	3.9	4.0
Ratio Peak Outflow to Predevelopment Q =	N/A	N/A	N/A	49.0	7.8	2.7	2.0	1.4
Structure Controlling Flow =	Filtration Media	Outlet Plate 1	Overflow Weir 1	Overflow Weir 1	Outlet Plate 1	Outlet Plate 1	Outlet Plate 1	Outlet Plate 1
Max Velocity through Gate 1 (fps) =	N/A	0.69	0.34	0.5	0.6	0.6	0.6	0.6
Max Velocity through Gate 2 (fps) =	N/A	N/A	N/A	N/A	N/A	N/A	N/A	N/A
Time to Drain 97% of Inflow Volume (hours) =	18	17	19	19	18	18	17	17
Time to Drain 99% of Inflow Volume (hours) =	18	19	21	21	20	20	20	20
Maximum Ponding Depth (ft) =	1.43	4.00	1.77	1.88	1.98	2.39	2.65	3.01
Area at Maximum Ponding Depth (acres) =	0.05	0.09	0.06	0.06	0.06	0.07	0.07	0.08
Maximum Volume Stored (acre-ft) =	0.051	0.234	0.069	0.074	0.081	0.107	0.125	0.153

DETENTION BASIN OUTLET STRUCTURE DESIGN

MHFD-Detention, Version 4.06 (July 2022)

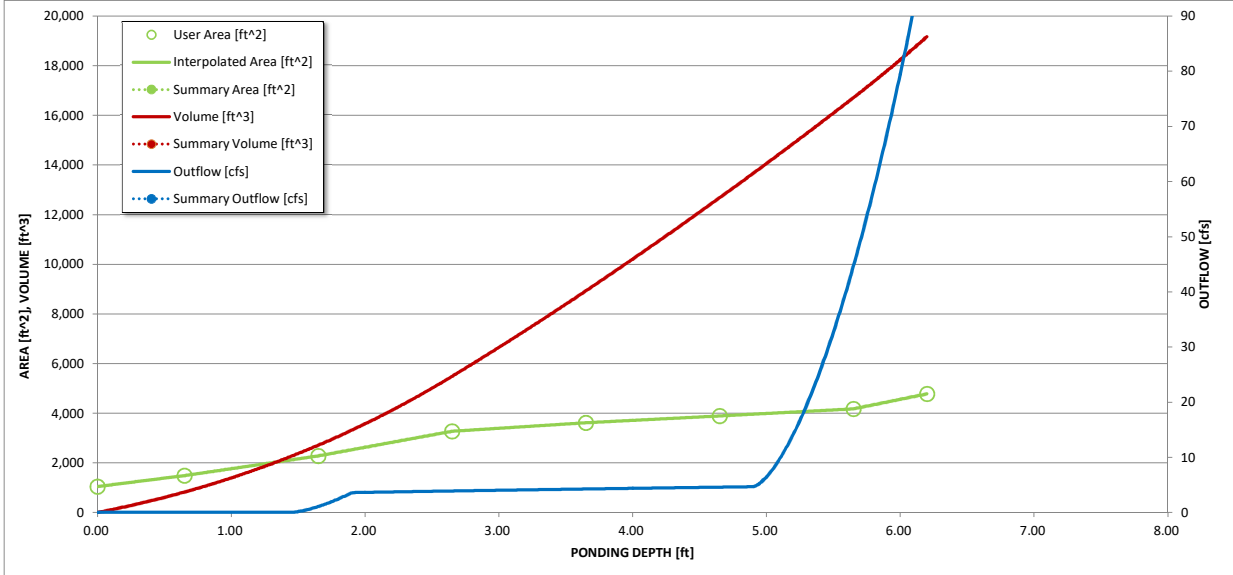
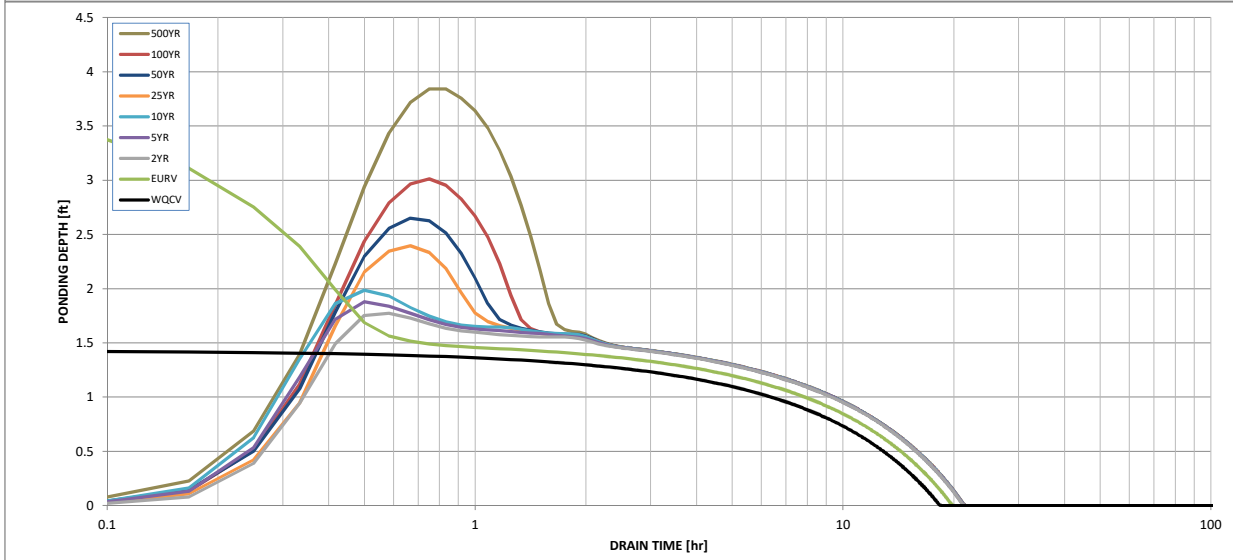
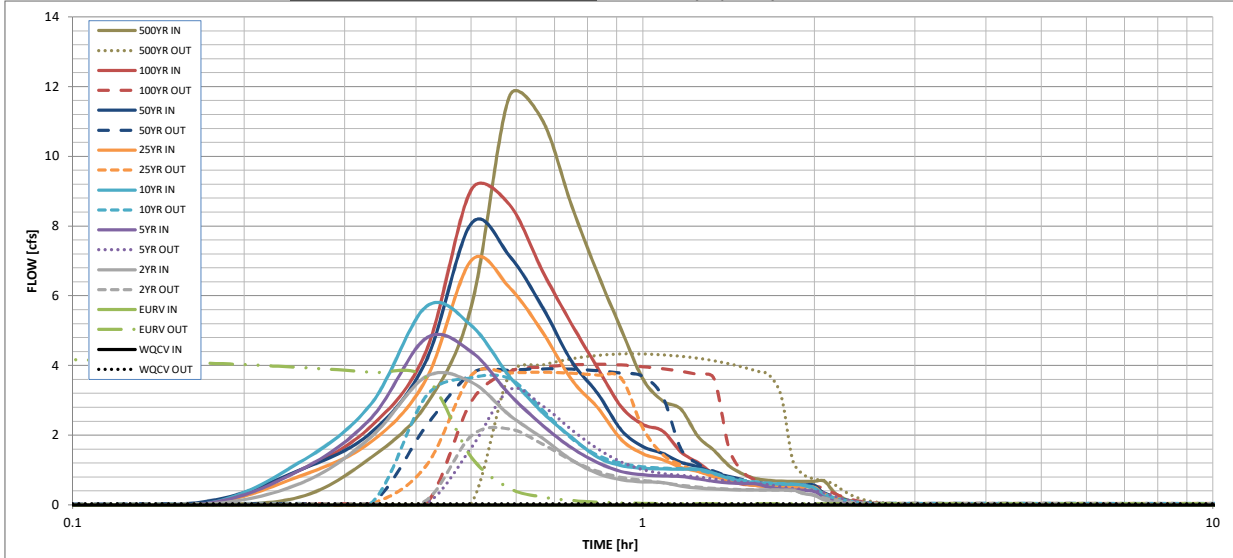

S-A-V-D Chart Axis Override	X-axis	Left Y-Axis	Right Y-Axis
minimum bound			
maximum bound			

DETENTION BASIN OUTLET STRUCTURE DESIGN

Outflow Hydrograph Workbook Filename: _____

Inflow Hydrographs

The user can override the calculated inflow hydrographs from this workbook with inflow hydrographs developed in a separate program.

Time Interval	SOURCE	CUHP	CUHP	CUHP	CUHP	CUHP	CUHP	CUHP	CUHP	CUHP
	TIME	WQCV [cfs]	EURV [cfs]	2 Year [cfs]	5 Year [cfs]	10 Year [cfs]	25 Year [cfs]	50 Year [cfs]	100 Year [cfs]	500 Year [cfs]
5.00 min	0:00:00	0.00	0.00	0.00	0.00	0.00	0.00	0.00	0.00	0.00
	0:05:00	0.00	0.00	0.00	0.00	0.00	0.00	0.00	0.00	0.00
	0:10:00	0.00	0.00	0.00	0.00	0.00	0.00	0.07	0.01	0.22
	0:15:00	0.00	0.00	0.61	0.99	1.22	0.82	1.00	0.99	1.35
	0:20:00	0.00	0.00	1.94	2.48	2.89	1.80	2.07	2.25	2.87
	0:25:00	0.00	0.00	3.68	4.78	5.69	3.59	4.13	4.41	5.68
	0:30:00	0.00	0.00	3.52	4.40	5.15	7.01	8.07	9.04	11.71
	0:35:00	0.00	0.00	2.58	3.17	3.69	6.24	7.15	8.62	11.03
	0:40:00	0.00	0.00	1.91	2.29	2.66	4.96	5.68	6.71	8.58
	0:45:00	0.00	0.00	1.29	1.64	1.94	3.59	4.12	5.18	6.63
	0:50:00	0.00	0.00	0.90	1.21	1.37	2.78	3.20	3.92	5.03
	0:55:00	0.00	0.00	0.72	0.95	1.13	1.87	2.14	2.81	3.61
	1:00:00	0.00	0.00	0.66	0.86	1.05	1.46	1.67	2.31	2.98
	1:05:00	0.00	0.00	0.64	0.83	1.03	1.29	1.47	2.12	2.74
	1:10:00	0.00	0.00	0.54	0.81	1.03	1.07	1.22	1.52	1.95
	1:15:00	0.00	0.00	0.48	0.74	1.03	0.96	1.09	1.21	1.56
	1:20:00	0.00	0.00	0.45	0.67	0.91	0.80	0.91	0.88	1.12
	1:25:00	0.00	0.00	0.44	0.63	0.76	0.72	0.81	0.69	0.88
	1:30:00	0.00	0.00	0.43	0.61	0.68	0.61	0.68	0.59	0.74
	1:35:00	0.00	0.00	0.43	0.60	0.63	0.55	0.62	0.56	0.70
	1:40:00	0.00	0.00	0.43	0.50	0.61	0.52	0.59	0.54	0.68
	1:45:00	0.00	0.00	0.43	0.45	0.60	0.51	0.57	0.54	0.67
	1:50:00	0.00	0.00	0.43	0.43	0.60	0.50	0.56	0.54	0.67
	1:55:00	0.00	0.00	0.33	0.41	0.57	0.50	0.56	0.54	0.67
	2:00:00	0.00	0.00	0.27	0.38	0.49	0.50	0.56	0.54	0.67
	2:05:00	0.00	0.00	0.14	0.20	0.26	0.26	0.29	0.28	0.35
	2:10:00	0.00	0.00	0.07	0.10	0.13	0.14	0.15	0.15	0.18
	2:15:00	0.00	0.00	0.03	0.05	0.06	0.06	0.07	0.07	0.09
	2:20:00	0.00	0.00	0.01	0.02	0.02	0.02	0.03	0.03	0.03
	2:25:00	0.00	0.00	0.00	0.00	0.00	0.00	0.00	0.00	0.00
	2:30:00	0.00	0.00	0.00	0.00	0.00	0.00	0.00	0.00	0.00
	2:35:00	0.00	0.00	0.00	0.00	0.00	0.00	0.00	0.00	0.00
	2:40:00	0.00	0.00	0.00	0.00	0.00	0.00	0.00	0.00	0.00
	2:45:00	0.00	0.00	0.00	0.00	0.00	0.00	0.00	0.00	0.00
	2:50:00	0.00	0.00	0.00	0.00	0.00	0.00	0.00	0.00	0.00
	2:55:00	0.00	0.00	0.00	0.00	0.00	0.00	0.00	0.00	0.00
	3:00:00	0.00	0.00	0.00	0.00	0.00	0.00	0.00	0.00	0.00
	3:05:00	0.00	0.00	0.00	0.00	0.00	0.00	0.00	0.00	0.00
	3:10:00	0.00	0.00	0.00	0.00	0.00	0.00	0.00	0.00	0.00
	3:15:00	0.00	0.00	0.00	0.00	0.00	0.00	0.00	0.00	0.00
	3:20:00	0.00	0.00	0.00	0.00	0.00	0.00	0.00	0.00	0.00
	3:25:00	0.00	0.00	0.00	0.00	0.00	0.00	0.00	0.00	0.00
	3:30:00	0.00	0.00	0.00	0.00	0.00	0.00	0.00	0.00	0.00
	3:35:00	0.00	0.00	0.00	0.00	0.00	0.00	0.00	0.00	0.00
	3:40:00	0.00	0.00	0.00	0.00	0.00	0.00	0.00	0.00	0.00
	3:45:00	0.00	0.00	0.00	0.00	0.00	0.00	0.00	0.00	0.00
	3:50:00	0.00	0.00	0.00	0.00	0.00	0.00	0.00	0.00	0.00
	3:55:00	0.00	0.00	0.00	0.00	0.00	0.00	0.00	0.00	0.00
	4:00:00	0.00	0.00	0.00	0.00	0.00	0.00	0.00	0.00	0.00
	4:05:00	0.00	0.00	0.00	0.00	0.00	0.00	0.00	0.00	0.00
	4:10:00	0.00	0.00	0.00	0.00	0.00	0.00	0.00	0.00	0.00
	4:15:00	0.00	0.00	0.00	0.00	0.00	0.00	0.00	0.00	0.00
	4:20:00	0.00	0.00	0.00	0.00	0.00	0.00	0.00	0.00	0.00
	4:25:00	0.00	0.00	0.00	0.00	0.00	0.00	0.00	0.00	0.00
	4:30:00	0.00	0.00	0.00	0.00	0.00	0.00	0.00	0.00	0.00
	4:35:00	0.00	0.00	0.00	0.00	0.00	0.00	0.00	0.00	0.00
	4:40:00	0.00	0.00	0.00	0.00	0.00	0.00	0.00	0.00	0.00
	4:45:00	0.00	0.00	0.00	0.00	0.00	0.00	0.00	0.00	0.00
	4:50:00	0.00	0.00	0.00	0.00	0.00	0.00	0.00	0.00	0.00
	4:55:00	0.00	0.00	0.00	0.00	0.00	0.00	0.00	0.00	0.00
	5:00:00	0.00	0.00	0.00	0.00	0.00	0.00	0.00	0.00	0.00
	5:05:00	0.00	0.00	0.00	0.00	0.00	0.00	0.00	0.00	0.00
	5:10:00	0.00	0.00	0.00	0.00	0.00	0.00	0.00	0.00	0.00
	5:15:00	0.00	0.00	0.00	0.00	0.00	0.00	0.00	0.00	0.00
	5:20:00	0.00	0.00	0.00	0.00	0.00	0.00	0.00	0.00	0.00
	5:25:00	0.00	0.00	0.00	0.00	0.00	0.00	0.00	0.00	0.00
	5:30:00	0.00	0.00	0.00	0.00	0.00	0.00	0.00	0.00	0.00
	5:35:00	0.00	0.00	0.00	0.00	0.00	0.00	0.00	0.00	0.00
	5:40:00	0.00	0.00	0.00	0.00	0.00	0.00	0.00	0.00	0.00
	5:45:00	0.00	0.00	0.00	0.00	0.00	0.00	0.00	0.00	0.00
	5:50:00	0.00	0.00	0.00	0.00	0.00	0.00	0.00	0.00	0.00
	5:55:00	0.00	0.00	0.00	0.00	0.00	0.00	0.00	0.00	0.00
6:00:00	0.00	0.00	0.00	0.00	0.00	0.00	0.00	0.00	0.00	

Design Procedure Form: Sand Filter (SF)

UD-BMP (Version 3.07, March 2018)

Sheet 1 of 2

Designer: Darin Moffett
Company: M&S Civil Consultants
Date: February 23, 2023
Project: Lot 3 Pond 4 (CALCS PROVIDED FOR INFORMATION ONLY, POND 4 TO BE DESIGNED AND CONSTRUCTED WITH FUTURE DEVELOPMENT)
Location: Lot 2 - Claremont Buiness Park 2 - Filing No. 2

<p>1. Basin Storage Volume</p> <p>A) Effective Imperviousness of Tributary Area, I_p (100% if all paved and roofed areas upstream of sand filter)</p> <p>B) Tributary Area's Imperviousness Ratio ($i = I_p/100$)</p> <p>C) Water Quality Capture Volume (WQCV) Based on 12-hour Drain Time $WQCV = 0.8 * (0.91 * i^3 - 1.19 * i^2 + 0.78 * i)$</p> <p>D) Contributing Watershed Area (including sand filter area)</p> <p>E) Water Quality Capture Volume (WQCV) Design Volume $V_{WQCV} = WQCV / 12 * Area$</p> <p>F) For Watersheds Outside of the Denver Region, Depth of Average Runoff Producing Storm</p> <p>G) For Watersheds Outside of the Denver Region, Water Quality Capture Volume (WQCV) Design Volume</p> <p>H) User Input of Water Quality Capture Volume (WQCV) Design Volume (Only if a different WQCV Design Volume is desired)</p>	<p>$I_p =$ <input type="text" value="90.0"/> %</p> <p>$i =$ <input type="text" value="0.900"/></p> <p>WQCV = <input type="text" value="0.32"/> watershed inches</p> <p>Area = <input type="text" value="12,955"/> sq ft</p> <p>$V_{WQCV} =$ <input type="text" value=""/> cu ft</p> <p>$d_e =$ <input type="text" value="0.60"/> in</p> <p>$V_{WQCV \text{ OTHER}} =$ <input type="text" value=""/> cu ft</p> <p>$V_{WQCV \text{ USER}} =$ <input type="text" value="349"/> cu ft</p>
<p>2. Basin Geometry</p> <p>A) WQCV Depth</p> <p>B) Sand Filter Side Slopes (Horizontal distance per unit vertical, 4:1 or flatter preferred). Use "0" if sand filter has vertical walls.</p> <p>C) Minimum Filter Area (Flat Surface Area)</p> <p>D) Actual Filter Area</p> <p>E) Volume Provided</p>	<p>$D_{WQCV} =$ <input type="text" value="0.8"/> ft</p> <p>$Z =$ <input type="text" value="4.00"/> ft / ft</p> <p>$A_{Min} =$ <input type="text" value="146"/> sq ft</p> <p>$A_{Actual} =$ <input type="text" value="288"/> sq ft</p> <p>$V_T =$ <input type="text" value="350"/> cu ft</p>
<p>3. Filter Material</p>	<p>Choose One _____</p> <p><input checked="" type="radio"/> 18" CDOT Class B or C Filter Material</p> <p><input type="radio"/> Other (Explain): _____</p> <p>_____</p> <p>_____</p>
<p>4. Underdrain System</p> <p>A) Are underdrains provided?</p> <p>B) Underdrain system orifice diameter for 12 hour drain time</p> <p style="margin-left: 20px;">i) Distance From Lowest Elevation of the Storage Volume to the Center of the Orifice</p> <p style="margin-left: 20px;">ii) Volume to Drain in 12 Hours</p> <p style="margin-left: 20px;">iii) Orifice Diameter, 3/8" Minimum</p>	<p>Choose One _____</p> <p><input checked="" type="radio"/> YES</p> <p><input type="radio"/> NO</p> <p>$y =$ <input type="text" value="2.5"/> ft</p> <p>$Vol_{12} =$ <input type="text" value="349"/> cu ft</p> <p>$D_o =$ <input type="text" value="7/16"/> in</p>

Design Procedure Form: Sand Filter (SF)

Sheet 2 of 2

Designer: Darin Moffett
Company: M&S Civil Consultants
Date: February 23, 2023
Project: Lot 3 Pond 4 (CALCS PROVIDED FOR INFORMATION ONLY. POND 4 TO BE DESIGNED AND CONSTRUCTED WITH FUTURE DEVELOPMENT)
Location: Lot 2 - Claremont Buisness Park 2 - Filing No. 2

5. Impermeable Geomembrane Liner and Geotextile Separator Fabric

A) Is an impermeable liner provided due to proximity of structures or groundwater contamination?

Choose One

YES NO

6. Inlet / Outlet Works

A) Describe the type of energy dissipation at inlet points and means of conveying flows in excess of the WQCV through the outlet

TBD
Concrete Outlet Box with Unrestricted 18" RCP

Notes: _____

CLAREMONT BUSINESS PARK 2 FILING NO. 2 (PROPOSED CONDITIONS)

Weighted Percent Imperviousness of Proposed WQ Sand Filter Pond 4				
<i>Contributing Basins</i>	<i>Area (Acres)</i>	<i>C₅</i>	<i>Impervious % (I)</i>	<i>(Acres)*(I)</i>
<i>F</i>	0.30	0.81	90	26.77
Totals	0.30			26.77
Imperviousness of WQ Pond 2	90.0			

A soils 100%
B soils 0%

DETENTION BASIN STAGE-STORAGE TABLE BUILDER

MHFD-Detention, Version 4.06 (July 2022)

Project: Claremont Business Park 2 Filing No. 2

Basin ID: Lot 3 - Pond 4 (CALCS PROVIDED FOR INFORMATION ONLY, POND 4 TO BE DESIGNED AND CONSTRUCTED WITH FUTURE DEVELOPMENT)

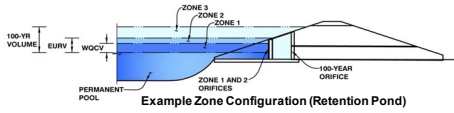

Watershed Information

Selected BMP Type =	SF	
Watershed Area =	0.30	acres
Watershed Length =	200	ft
Watershed Length to Centroid =	100	ft
Watershed Slope =	0.013	ft/ft
Watershed Imperviousness =	90.00%	percent
Percentage Hydrologic Soil Group A =	100.0%	percent
Percentage Hydrologic Soil Group B =	0.0%	percent
Percentage Hydrologic Soil Groups C/D =	0.0%	percent
Target WQCV Drain Time =	12.0	hours
Location for 1-hr Rainfall Depths =	User Input	

After providing required inputs above including 1-hour rainfall depths, click "Run CUHP" to generate runoff hydrographs using the embedded Colorado Urban Hydrograph Procedure.

Water Quality Capture Volume (WQCV) =	0.008	acre-feet
Excess Urban Runoff Volume (EURV) =	0.037	acre-feet
2-yr Runoff Volume (P1 = 1.19 in.) =	0.025	acre-feet
5-yr Runoff Volume (P1 = 1.5 in.) =	0.032	acre-feet
10-yr Runoff Volume (P1 = 1.75 in.) =	0.037	acre-feet
25-yr Runoff Volume (P1 = 2 in.) =	0.044	acre-feet
50-yr Runoff Volume (P1 = 2.25 in.) =	0.050	acre-feet
100-yr Runoff Volume (P1 = 2.52 in.) =	0.057	acre-feet
500-yr Runoff Volume (P1 = 3.14 in.) =	0.072	acre-feet
Approximate 2-yr Detention Volume =	0.024	acre-feet
Approximate 5-yr Detention Volume =	0.031	acre-feet
Approximate 10-yr Detention Volume =	0.037	acre-feet
Approximate 25-yr Detention Volume =	0.044	acre-feet
Approximate 50-yr Detention Volume =	0.048	acre-feet
Approximate 100-yr Detention Volume =	0.051	acre-feet

Optional User Overrides

		acre-feet
		acre-feet
	1.19	inches
	1.50	inches
	1.75	inches
	2.00	inches
	2.25	inches
	2.52	inches
		inches

Define Zones and Basin Geometry

Zone 1 Volume (WQCV) =	0.008	acre-feet
Zone 2 Volume (100-year - Zone 1) =	0.043	acre-feet
Select Zone 3 Storage Volume (Optional) =		acre-feet
Total Detention Basin Volume =	0.051	acre-feet
Initial Surcharge Volume (ISV) =	N/A	ft ³
Initial Surcharge Depth (ISD) =	N/A	ft
Total Available Detention Depth (H _{total}) =	user	ft
Depth of Trickle Channel (H _{tc}) =	N/A	ft
Slope of Trickle Channel (S _{tc}) =	N/A	ft/ft
Slopes of Main Basin Sides (S _{main}) =	user	H:V
Basin Length-to-Width Ratio (R _{LW}) =	user	
Initial Surcharge Area (A _{ISV}) =	user	ft ²
Surcharge Volume Length (L _{ISV}) =	user	ft
Surcharge Volume Width (W _{ISV}) =	user	ft
Depth of Basin Floor (H _{FLOOR}) =	user	ft
Length of Basin Floor (L _{FLOOR}) =	user	ft
Width of Basin Floor (W _{FLOOR}) =	user	ft
Area of Basin Floor (A _{FLOOR}) =	user	ft ²
Volume of Basin Floor (V _{FLOOR}) =	user	ft ³
Depth of Main Basin (H _{MAIN}) =	user	ft
Length of Main Basin (L _{MAIN}) =	user	ft
Width of Main Basin (W _{MAIN}) =	user	ft
Area of Main Basin (A _{MAIN}) =	user	ft ²
Volume of Main Basin (V _{MAIN}) =	user	ft ³
Calculated Total Basin Volume (V _{total}) =	user	acre-feet

Depth Increment =	ft	Optional Override Stage (ft)	Length (ft)	Width (ft)	Area (ft ²)	Optional Override Area (ft ²)	Area (acre)	Volume (ft ³)	Volume (ac-ft)
6273.5		Media Surface	--	--	--	288	0.007		
			--	--	--	453	0.010	185	0.004
			--	--	--	861	0.020	842	0.019
			--	--	--	1,369	0.031	1,957	0.045
			--	--	--	1,661	0.038	2,715	0.062

DETENTION BASIN STAGE-STORAGE TABLE BUILDER

MHFD-Detention, Version 4.06 (July 2022)

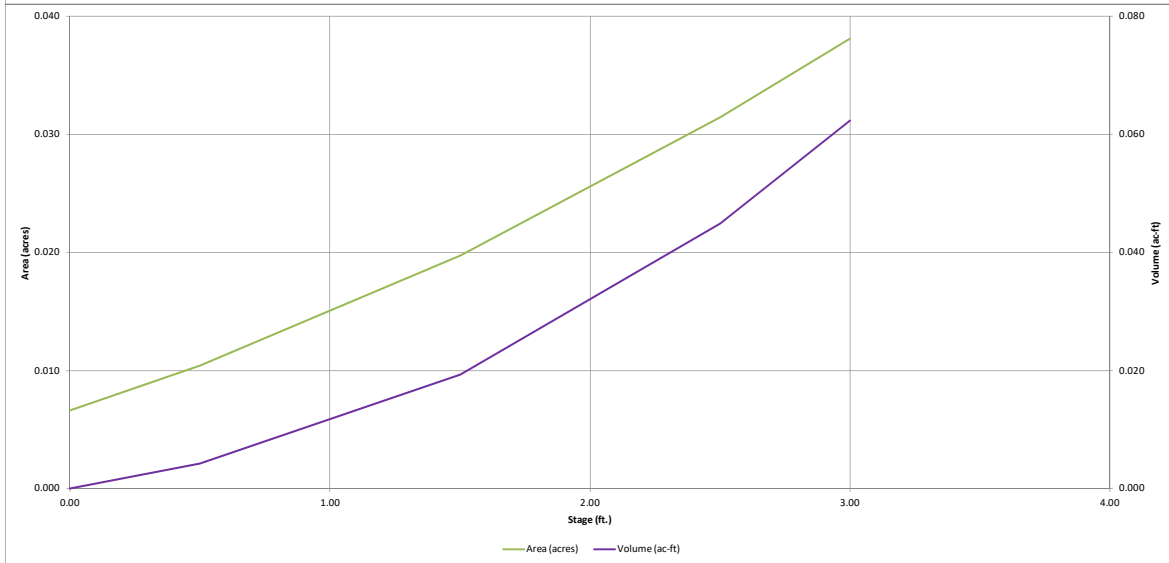
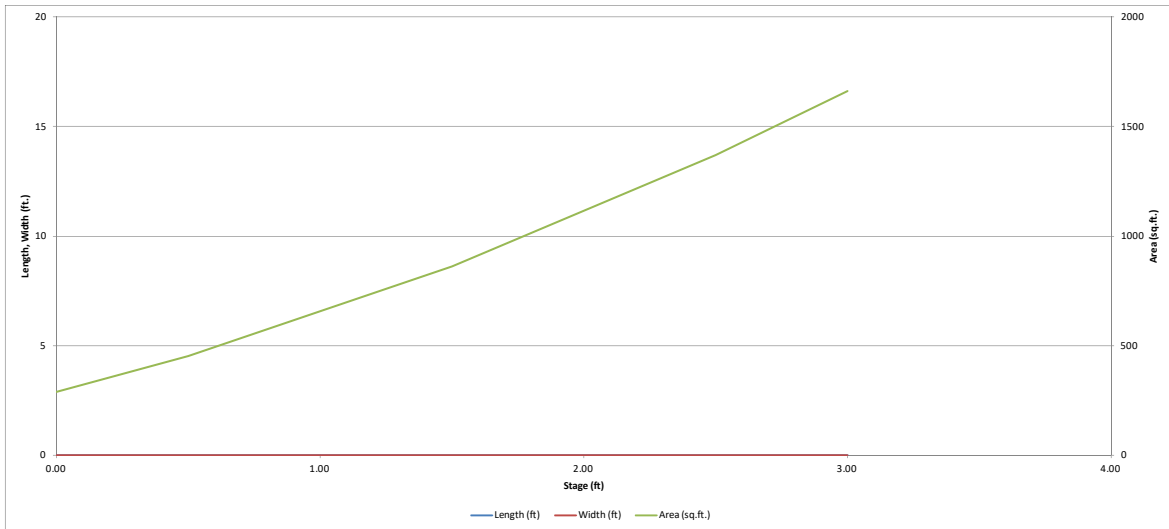

DETENTION BASIN OUTLET STRUCTURE DESIGN

MHFD- Detention, Version 4.06 (July 2022)

Project: Claremont Business Park 2 Filing No. 2

Basin ID: Lot 3 - Pond 4 (CALCS PROVIDED FOR INFORMATION ONLY. POND 4 TO BE DESIGNED AND CONSTRUCTED WITH FUTURE DEVELOPMENT)

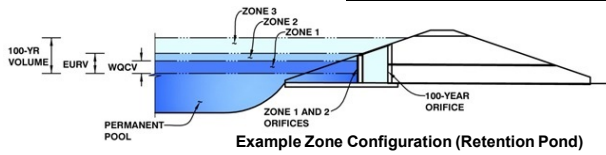

	Estimated Stage (ft)	Estimated Volume (ac-ft)	Outlet Type
Zone 1 (WQCV)	0.82	0.008	Filtration Media
Zone 2 (100-year)	2.70	0.043	Weir&Pipe (Restrict)
Zone 3			
Total (all zones)		0.051	

User Input: Orifice at Underdrain Outlet (typically used to drain WQCV in a Filtration BMP)

Underdrain Orifice Invert Depth = 2.50 ft (distance below the filtration media surface)
 Underdrain Orifice Diameter = 0.42 inches

Calculated Parameters for Underdrain
 Underdrain Orifice Area = 0.0 ft²
 Underdrain Orifice Centroid = 0.02 feet

User Input: Orifice Plate with one or more orifices or Elliptical Slot Weir (typically used to drain WQCV and/or EURV in a sedimentation BMP)

Centroid of Lowest Orifice = N/A ft (relative to basin bottom at Stage = 0 ft)
 Depth at top of Zone using Orifice Plate = N/A ft (relative to basin bottom at Stage = 0 ft)
 Orifice Plate: Orifice Vertical Spacing = N/A inches
 Orifice Plate: Orifice Area per Row = N/A sq. inches

Calculated Parameters for Plate
 WQ Orifice Area per Row = N/A ft²
 Elliptical Half-Width = N/A feet
 Elliptical Slot Centroid = N/A feet
 Elliptical Slot Area = N/A ft²

User Input: Stage and Total Area of Each Orifice Row (numbered from lowest to highest)

	Row 1 (optional)	Row 2 (optional)	Row 3 (optional)	Row 4 (optional)	Row 5 (optional)	Row 6 (optional)	Row 7 (optional)	Row 8 (optional)
Stage of Orifice Centroid (ft)	N/A	N/A	N/A	N/A	N/A	N/A	N/A	N/A
Orifice Area (sq. inches)	N/A	N/A	N/A	N/A	N/A	N/A	N/A	N/A

	Row 9 (optional)	Row 10 (optional)	Row 11 (optional)	Row 12 (optional)	Row 13 (optional)	Row 14 (optional)	Row 15 (optional)	Row 16 (optional)
Stage of Orifice Centroid (ft)	N/A	N/A	N/A	N/A	N/A	N/A	N/A	N/A
Orifice Area (sq. inches)	N/A	N/A	N/A	N/A	N/A	N/A	N/A	N/A

User Input: Vertical Orifice (Circular or Rectangular)

Invert of Vertical Orifice = Not Selected ft (relative to basin bottom at Stage = 0 ft)
 Depth at top of Zone using Vertical Orifice = Not Selected ft (relative to basin bottom at Stage = 0 ft)
 Vertical Orifice Diameter = Not Selected inches

Calculated Parameters for Vertical Orif
 Vertical Orifice Area = Not Selected ft²
 Vertical Orifice Centroid = Not Selected feet

User Input: Overflow Weir (Dropbox with Flat or Sloped Gate and Outlet Pipe OR Rectangular/Trapezoidal Weir and No Outlet Pipe)

Overflow Weir Front Edge Height, Ho = 0.82 ft (relative to basin bottom at Stage = 0 ft)
 Overflow Weir Front Edge Length = 3.00 feet
 Overflow Weir Gate Slope = 0.00 H:V
 Horiz. Length of Weir Sides = 3.00 feet
 Overflow Gate Type = Type C Grate
 Debris Clogging % = 70%

Calculated Parameters for Overflow Weir
 Height of Gate Upper Edge, H_t = 0.82 feet
 Overflow Weir Slope Length = 3.00 feet
 Grate Open Area / 100-yr Orifice Area = 5.10
 Overflow Gate Open Area w/o Debris = 6.26
 Overflow Gate Open Area w/ Debris = 1.88

User Input: Outlet Pipe w/ Flow Restriction Plate (Circular Orifice, Restrictor Plate, or Rectangular Orifice)

Depth to Invert of Outlet Pipe = 2.75 ft (distance below basin bottom at Stage = 0 ft)
 Outlet Pipe Diameter = 15.00 inches
 Restrictor Plate Height Above Pipe Invert = 15.00 inches

Calculated Parameters for Outlet Pipe w/ Flow Restriction Plate
 Outlet Orifice Area = 1.23 ft²
 Outlet Orifice Centroid = 0.63 feet
 Half-Central Angle of Restrictor Plate on Pipe = 3.14

User Input: Emergency Spillway (Rectangular or Trapezoidal)

Spillway Invert Stage = 1.50 ft (relative to basin bottom at Stage = 0 ft)
 Spillway Crest Length = 6.00 feet
 Spillway End Slopes = 4.00 H:V
 Freeboard above Max Water Surface = 1.00 feet

Calculated Parameters for Spillway
 Spillway Design Flow Depth = 0.13 feet
 Stage at Top of Freeboard = 2.63 feet
 Basin Area at Top of Freeboard = 0.03 acres
 Basin Volume at Top of Freeboard = 0.05 acre-ft

Routed Hydrograph Results

The user can override the default CUHP hydrographs and runoff volumes by entering new values in the Inflow Hydrographs table (Columns W through AI)

	WQCV	EURV	2 Year	5 Year	10 Year	25 Year	50 Year	100 Year
Design Storm Return Period =	N/A	N/A	1.19	1.50	1.75	2.00	2.25	2.52
One-Hour Rainfall Depth (in) =	N/A	N/A	0.025	0.032	0.037	0.044	0.050	0.057
CUHP Runoff Volume (acre-ft) =	0.008	0.037	0.025	0.032	0.037	0.044	0.050	0.057
Inflow Hydrograph Volume (acre-ft) =	N/A	N/A	0.0	0.0	0.0	0.0	0.1	0.1
CUHP Predevelopment Peak Q (cfs) =	N/A	N/A	0.0	0.0	0.0	0.0	0.1	0.1
OPTIONAL Override Predevelopment Peak Q (cfs) =	N/A	N/A	0.0	0.0	0.0	0.0	0.1	0.1
Predevelopment Unit Peak Flow, q (cfs/acre) =	N/A	N/A	0.00	0.00	0.00	0.13	0.28	0.47
Peak Inflow Q (cfs) =	N/A	N/A	0.4	0.5	0.6	0.7	0.8	0.9
Peak Outflow Q (cfs) =	0.0	5.5	0.3	0.4	0.6	0.7	0.8	1.0
Ratio Peak Outflow to Predevelopment Q =	N/A	N/A	N/A	#DIV/0!	#DIV/0!	18.9	9.3	6.8
Structure Controlling Flow =	Overflow Weir 1	Spillway	Overflow Weir 1	Overflow Weir 1	Overflow Weir 1	Overflow Weir 1	Overflow Weir 1	Overflow Weir 1
Max Velocity through Gate 1 (fps) =	N/A	1.97	0.04	0.1	0.1	0.1	0.1	0.2
Max Velocity through Gate 2 (fps) =	N/A	N/A	N/A	N/A	N/A	N/A	N/A	N/A
Time to Drain 97% of Inflow Volume (hours) =	12	0	14	13	13	13	13	12
Time to Drain 99% of Inflow Volume (hours) =	12	0	15	14	14	14	14	14
Maximum Ponding Depth (ft) =	0.82	2.24	0.90	0.93	0.95	0.98	0.98	1.01
Area at Maximum Ponding Depth (acres) =	0.01	0.03	0.01	0.01	0.01	0.01	0.01	0.02
Maximum Volume Stored (acre-ft) =	0.008	0.037	0.009	0.009	0.010	0.010	0.010	0.011

DETENTION BASIN OUTLET STRUCTURE DESIGN

MHFD-Detention, Version 4.06 (July 2022)

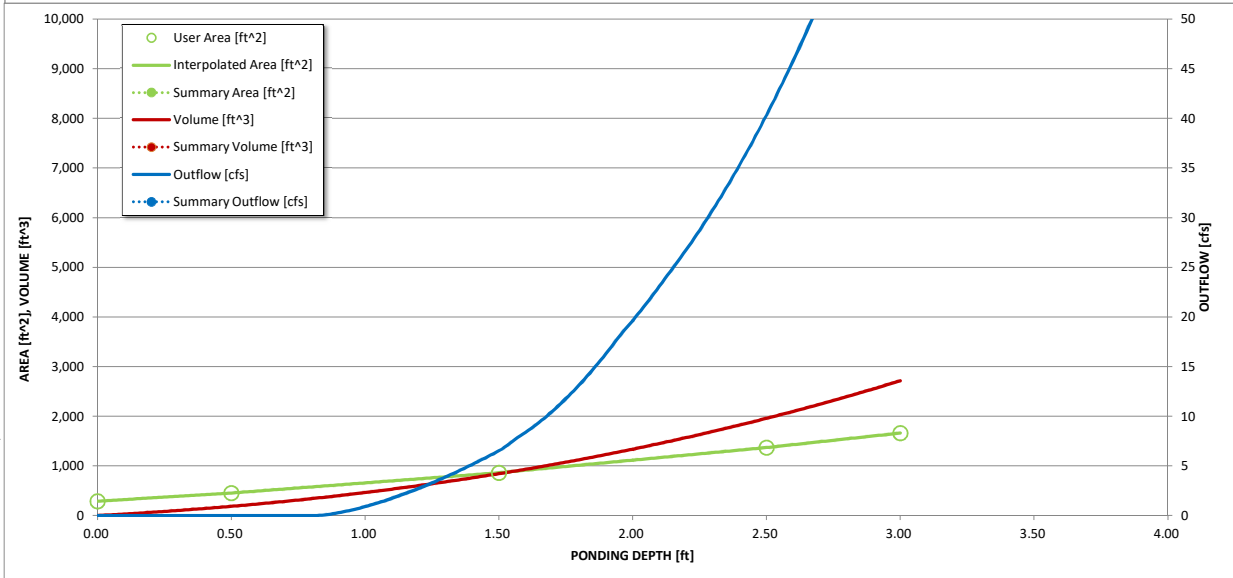
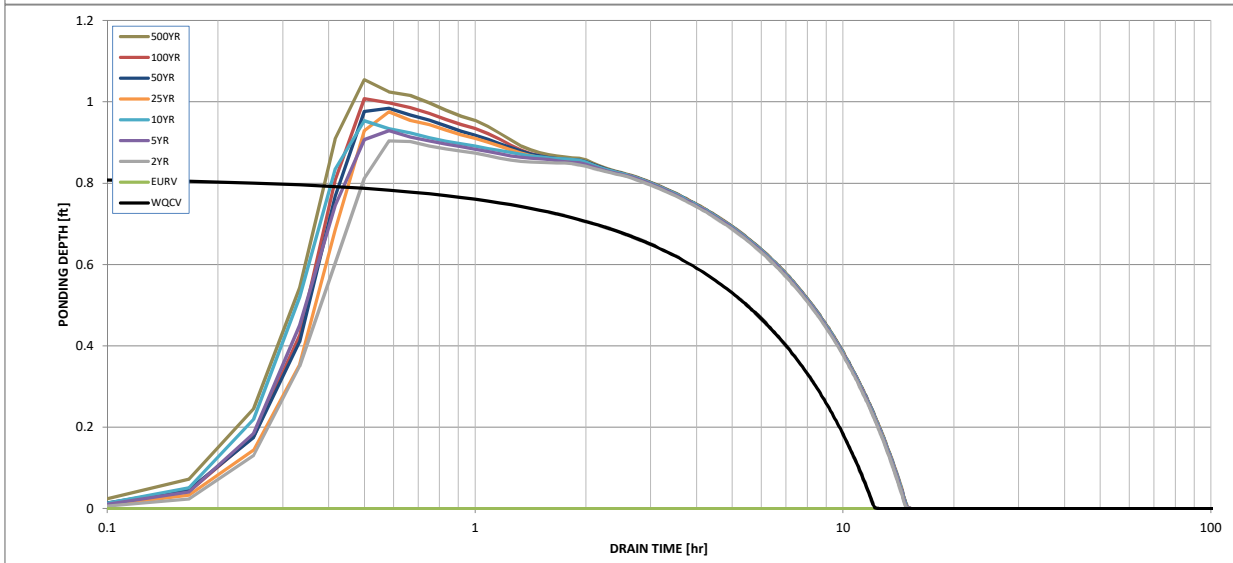
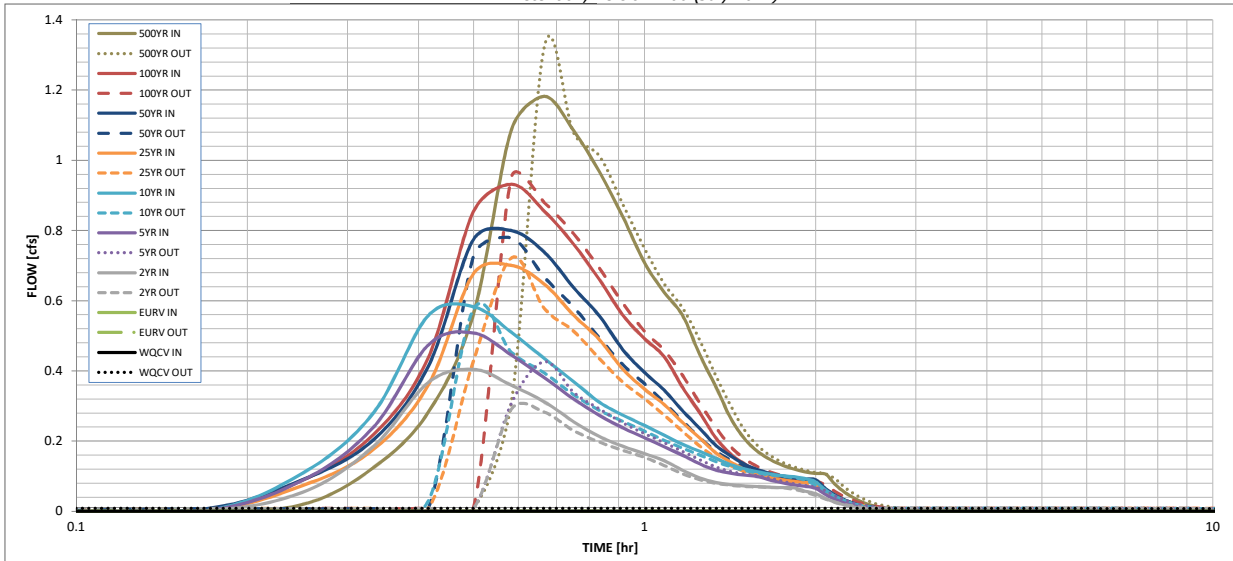

S-A-V-D Chart Axis Override	X-axis	Left Y-Axis	Right Y-Axis
minimum bound			
maximum bound			

DETENTION BASIN OUTLET STRUCTURE DESIGN

Outflow Hydrograph Workbook Filename: _____

Inflow Hydrographs

The user can override the calculated inflow hydrographs from this workbook with inflow hydrographs developed in a separate program.

Time Interval	SOURCE	CUHP	CUHP	CUHP	CUHP	CUHP	CUHP	CUHP	CUHP	CUHP
	TIME	WQCV [cfs]	EURV [cfs]	2 Year [cfs]	5 Year [cfs]	10 Year [cfs]	25 Year [cfs]	50 Year [cfs]	100 Year [cfs]	500 Year [cfs]
5.00 min	0:00:00	0.00	0.00	0.00	0.00	0.00	0.00	0.00	0.00	0.00
	0:05:00	0.00	0.00	0.00	0.00	0.00	0.00	0.00	0.00	0.00
	0:10:00	0.00	0.00	0.00	0.00	0.00	0.00	0.01	0.00	0.02
	0:15:00	0.00	0.00	0.05	0.09	0.11	0.07	0.09	0.09	0.12
	0:20:00	0.00	0.00	0.18	0.24	0.28	0.18	0.20	0.22	0.28
	0:25:00	0.00	0.00	0.37	0.47	0.56	0.36	0.41	0.44	0.56
	0:30:00	0.00	0.00	0.40	0.51	0.58	0.68	0.77	0.85	1.09
	0:35:00	0.00	0.00	0.36	0.44	0.51	0.70	0.80	0.93	1.18
	0:40:00	0.00	0.00	0.31	0.38	0.44	0.65	0.74	0.86	1.09
	0:45:00	0.00	0.00	0.26	0.32	0.37	0.56	0.64	0.76	0.97
	0:50:00	0.00	0.00	0.21	0.27	0.31	0.49	0.56	0.66	0.84
	0:55:00	0.00	0.00	0.19	0.24	0.27	0.40	0.46	0.56	0.71
	1:00:00	0.00	0.00	0.16	0.21	0.24	0.35	0.40	0.49	0.62
	1:05:00	0.00	0.00	0.14	0.18	0.22	0.30	0.34	0.44	0.56
	1:10:00	0.00	0.00	0.12	0.16	0.19	0.25	0.29	0.35	0.45
	1:15:00	0.00	0.00	0.10	0.14	0.17	0.21	0.24	0.28	0.36
	1:20:00	0.00	0.00	0.08	0.12	0.15	0.17	0.19	0.21	0.27
	1:25:00	0.00	0.00	0.08	0.11	0.13	0.14	0.16	0.16	0.21
	1:30:00	0.00	0.00	0.07	0.10	0.12	0.12	0.13	0.14	0.17
	1:35:00	0.00	0.00	0.07	0.10	0.11	0.10	0.12	0.12	0.15
	1:40:00	0.00	0.00	0.07	0.09	0.11	0.10	0.11	0.10	0.13
	1:45:00	0.00	0.00	0.07	0.08	0.10	0.09	0.10	0.10	0.12
	1:50:00	0.00	0.00	0.07	0.08	0.10	0.08	0.10	0.09	0.11
	1:55:00	0.00	0.00	0.06	0.07	0.09	0.08	0.09	0.09	0.11
	2:00:00	0.00	0.00	0.05	0.07	0.08	0.08	0.09	0.08	0.11
	2:05:00	0.00	0.00	0.04	0.05	0.06	0.06	0.06	0.06	0.08
	2:10:00	0.00	0.00	0.03	0.03	0.04	0.04	0.05	0.04	0.05
	2:15:00	0.00	0.00	0.02	0.02	0.03	0.03	0.03	0.03	0.04
	2:20:00	0.00	0.00	0.01	0.02	0.02	0.02	0.02	0.02	0.03
	2:25:00	0.00	0.00	0.01	0.01	0.01	0.01	0.02	0.01	0.02
	2:30:00	0.00	0.00	0.01	0.01	0.01	0.01	0.01	0.01	0.01
	2:35:00	0.00	0.00	0.00	0.00	0.01	0.01	0.01	0.01	0.01
	2:40:00	0.00	0.00	0.00	0.00	0.00	0.00	0.00	0.00	0.00
	2:45:00	0.00	0.00	0.00	0.00	0.00	0.00	0.00	0.00	0.00
	2:50:00	0.00	0.00	0.00	0.00	0.00	0.00	0.00	0.00	0.00
	2:55:00	0.00	0.00	0.00	0.00	0.00	0.00	0.00	0.00	0.00
	3:00:00	0.00	0.00	0.00	0.00	0.00	0.00	0.00	0.00	0.00
	3:05:00	0.00	0.00	0.00	0.00	0.00	0.00	0.00	0.00	0.00
	3:10:00	0.00	0.00	0.00	0.00	0.00	0.00	0.00	0.00	0.00
	3:15:00	0.00	0.00	0.00	0.00	0.00	0.00	0.00	0.00	0.00
	3:20:00	0.00	0.00	0.00	0.00	0.00	0.00	0.00	0.00	0.00
	3:25:00	0.00	0.00	0.00	0.00	0.00	0.00	0.00	0.00	0.00
	3:30:00	0.00	0.00	0.00	0.00	0.00	0.00	0.00	0.00	0.00
	3:35:00	0.00	0.00	0.00	0.00	0.00	0.00	0.00	0.00	0.00
	3:40:00	0.00	0.00	0.00	0.00	0.00	0.00	0.00	0.00	0.00
	3:45:00	0.00	0.00	0.00	0.00	0.00	0.00	0.00	0.00	0.00
	3:50:00	0.00	0.00	0.00	0.00	0.00	0.00	0.00	0.00	0.00
	3:55:00	0.00	0.00	0.00	0.00	0.00	0.00	0.00	0.00	0.00
	4:00:00	0.00	0.00	0.00	0.00	0.00	0.00	0.00	0.00	0.00
	4:05:00	0.00	0.00	0.00	0.00	0.00	0.00	0.00	0.00	0.00
	4:10:00	0.00	0.00	0.00	0.00	0.00	0.00	0.00	0.00	0.00
	4:15:00	0.00	0.00	0.00	0.00	0.00	0.00	0.00	0.00	0.00
	4:20:00	0.00	0.00	0.00	0.00	0.00	0.00	0.00	0.00	0.00
	4:25:00	0.00	0.00	0.00	0.00	0.00	0.00	0.00	0.00	0.00
	4:30:00	0.00	0.00	0.00	0.00	0.00	0.00	0.00	0.00	0.00
	4:35:00	0.00	0.00	0.00	0.00	0.00	0.00	0.00	0.00	0.00
	4:40:00	0.00	0.00	0.00	0.00	0.00	0.00	0.00	0.00	0.00
	4:45:00	0.00	0.00	0.00	0.00	0.00	0.00	0.00	0.00	0.00
	4:50:00	0.00	0.00	0.00	0.00	0.00	0.00	0.00	0.00	0.00
	4:55:00	0.00	0.00	0.00	0.00	0.00	0.00	0.00	0.00	0.00
	5:00:00	0.00	0.00	0.00	0.00	0.00	0.00	0.00	0.00	0.00
	5:05:00	0.00	0.00	0.00	0.00	0.00	0.00	0.00	0.00	0.00
	5:10:00	0.00	0.00	0.00	0.00	0.00	0.00	0.00	0.00	0.00
	5:15:00	0.00	0.00	0.00	0.00	0.00	0.00	0.00	0.00	0.00
	5:20:00	0.00	0.00	0.00	0.00	0.00	0.00	0.00	0.00	0.00
	5:25:00	0.00	0.00	0.00	0.00	0.00	0.00	0.00	0.00	0.00
	5:30:00	0.00	0.00	0.00	0.00	0.00	0.00	0.00	0.00	0.00
	5:35:00	0.00	0.00	0.00	0.00	0.00	0.00	0.00	0.00	0.00
	5:40:00	0.00	0.00	0.00	0.00	0.00	0.00	0.00	0.00	0.00
	5:45:00	0.00	0.00	0.00	0.00	0.00	0.00	0.00	0.00	0.00
	5:50:00	0.00	0.00	0.00	0.00	0.00	0.00	0.00	0.00	0.00
	5:55:00	0.00	0.00	0.00	0.00	0.00	0.00	0.00	0.00	0.00
6:00:00	0.00	0.00	0.00	0.00	0.00	0.00	0.00	0.00	0.00	

Design Procedure Form: Sand Filter (SF)

UD-BMP (Version 3.07, March 2018)

Sheet 1 of 2

Designer: Darin Moffett
Company: M&S Civil Consultants
Date: February 23, 2023
Project: Lot 3 Pond 5 (CALCS PROVIDED FOR INFORMATION ONLY, POND 5 TO BE DESIGNED AND CONSTRUCTED WITH FUTURE DEVELOPMENT)
Location: Lot 2 - Claremont Buiness Park 2 - Filing No. 2

<p>1. Basin Storage Volume</p> <p>A) Effective Imperviousness of Tributary Area, I_p (100% if all paved and roofed areas upstream of sand filter)</p> <p>B) Tributary Area's Imperviousness Ratio ($i = I_p/100$)</p> <p>C) Water Quality Capture Volume (WQCV) Based on 12-hour Drain Time $WQCV = 0.8 * (0.91 * i^3 - 1.19 * i^2 + 0.78 * i)$</p> <p>D) Contributing Watershed Area (including sand filter area)</p> <p>E) Water Quality Capture Volume (WQCV) Design Volume $V_{WQCV} = WQCV / 12 * Area$</p> <p>F) For Watersheds Outside of the Denver Region, Depth of Average Runoff Producing Storm</p> <p>G) For Watersheds Outside of the Denver Region, Water Quality Capture Volume (WQCV) Design Volume</p> <p>H) User Input of Water Quality Capture Volume (WQCV) Design Volume (Only if a different WQCV Design Volume is desired)</p>	<p>$I_p =$ <input type="text" value="90.0"/> %</p> <p>$i =$ <input type="text" value="0.900"/></p> <p>WQCV = <input type="text" value="0.32"/> watershed inches</p> <p>Area = <input type="text" value="50,180"/> sq ft</p> <p>$V_{WQCV} =$ <input type="text" value=""/> cu ft</p> <p>$d_e =$ <input type="text" value="0.60"/> in</p> <p>$V_{WQCV \text{ OTHER}} =$ <input type="text" value="1,874"/> cu ft</p> <p>$V_{WQCV \text{ USER}} =$ <input type="text" value=""/> cu ft</p>
<p>2. Basin Geometry</p> <p>A) WQCV Depth</p> <p>B) Sand Filter Side Slopes (Horizontal distance per unit vertical, 4:1 or flatter preferred). Use "0" if sand filter has vertical walls.</p> <p>C) Minimum Filter Area (Flat Surface Area)</p> <p>D) Actual Filter Area</p> <p>E) Volume Provided</p>	<p>$D_{WQCV} =$ <input type="text" value="0.8"/> ft</p> <p>$Z =$ <input type="text" value="4.00"/> ft / ft</p> <p>$A_{Min} =$ <input type="text" value="565"/> sq ft</p> <p>$A_{Actual} =$ <input type="text" value="887"/> sq ft</p> <p>$V_T =$ <input type="text" value=""/> cu ft</p>
<p>3. Filter Material</p>	<p>Choose One _____</p> <p><input checked="" type="radio"/> 18" CDOT Class B or C Filter Material</p> <p><input type="radio"/> Other (Explain): _____</p> <p>_____</p> <p>_____</p>
<p>4. Underdrain System</p> <p>A) Are underdrains provided?</p> <p>B) Underdrain system orifice diameter for 12 hour drain time</p> <p style="margin-left: 20px;">i) Distance From Lowest Elevation of the Storage Volume to the Center of the Orifice</p> <p style="margin-left: 20px;">ii) Volume to Drain in 12 Hours</p> <p style="margin-left: 20px;">iii) Orifice Diameter, 3/8" Minimum</p>	<p>Choose One _____</p> <p><input checked="" type="radio"/> YES</p> <p><input type="radio"/> NO</p> <p>$y =$ <input type="text" value="2.5"/> ft</p> <p>$Vol_{12} =$ <input type="text" value="1,874"/> cu ft</p> <p>$D_o =$ <input type="text" value="15/16"/> in</p>

Design Procedure Form: Sand Filter (SF)

Sheet 2 of 2

Designer: Darin Moffett
Company: M&S Civil Consultants
Date: February 23, 2023
Project: Lot 3 Pond 5 (CALCS PROVIDED FOR INFORMATION ONLY, POND 5 TO BE DESIGNED AND CONSTRUCTED WITH FUTURE DEVELOPMENT)
Location: Lot 2 - Claremont Buisness Park 2 - Filing No. 2

5. Impermeable Geomembrane Liner and Geotextile Separator Fabric

A) Is an impermeable liner provided due to proximity of structures or groundwater contamination?

Choose One

<input type="radio"/> YES	<input checked="" type="radio"/> NO
---------------------------	-------------------------------------

6. Inlet / Outlet Works

A) Describe the type of energy dissipation at inlet points and means of conveying flows in excess of the WQCV through the outlet

TBD
Concrete Outlet Box with Unrestricted 18" RCP

Notes: _____

CLAREMONT BUSINESS PARK 2 FILING NO. 2 (PROPOSED CONDITIONS)

Weighted Percent Imperviousness of Proposed WQ Sand Filter Pond 5				
Contributing Basins	Area (Acres)	C₅	Impervious % (I)	(Acres)*(I)
G2	1.15	0.81	90	103.68
Totals	1.15			103.68
Imperviousness of WQ Pond 2	90.0			

A soils 100%
 B soils 0%

DETENTION BASIN STAGE-STORAGE TABLE BUILDER

MHFD-Detention, Version 4.06 (July 2022)

Project: Claremont Business Park 2 Filing No. 2

Basin ID: Lot 3 - Pond 5 (CALCS PROVIDED FOR INFORMATION ONLY, POND 5 TO BE DESIGNED AND CONSTRUCTED WITH FUTURE DEVELOPMENT)

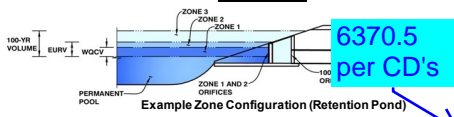

Watershed Information

Selected BMP Type =	SF
Watershed Area =	1.15 acres
Watershed Length =	460 ft
Watershed Length to Centroid =	225 ft
Watershed Slope =	0.010 ft/ft
Watershed Imperviousness =	90.00% percent
Percentage Hydrologic Soil Group A =	100.0% percent
Percentage Hydrologic Soil Group B =	0.0% percent
Percentage Hydrologic Soil Groups C/D =	0.0% percent
Target WQCV Drain Time =	12.0 hours
Location for 1-hr Rainfall Depths =	User Input

After providing required inputs above including 1-hour rainfall depths, click "Run CUHP" to generate runoff hydrographs using the embedded Colorado Urban Hydrograph Procedure.

Water Quality Capture Volume (WQCV) =	0.031 acre-feet
Excess Urban Runoff Volume (EURV) =	0.141 acre-feet
2-yr Runoff Volume (P1 = 1.19 in.) =	0.097 acre-feet
5-yr Runoff Volume (P1 = 1.5 in.) =	0.125 acre-feet
10-yr Runoff Volume (P1 = 1.75 in.) =	0.148 acre-feet
25-yr Runoff Volume (P1 = 2 in.) =	0.172 acre-feet
50-yr Runoff Volume (P1 = 2.25 in.) =	0.196 acre-feet
100-yr Runoff Volume (P1 = 2.52 in.) =	0.223 acre-feet
500-yr Runoff Volume (P1 = 3.14 in.) =	0.284 acre-feet
Approximate 2-yr Detention Volume =	0.093 acre-feet
Approximate 5-yr Detention Volume =	0.120 acre-feet
Approximate 10-yr Detention Volume =	0.143 acre-feet
Approximate 25-yr Detention Volume =	0.168 acre-feet
Approximate 50-yr Detention Volume =	0.183 acre-feet
Approximate 100-yr Detention Volume =	0.196 acre-feet

Optional User Overrides

	acre-feet
	acre-feet
	1.19 inches
	1.50 inches
	1.75 inches
	2.00 inches
	2.25 inches
	2.52 inches
	inches

Define Zones and Basin Geometry

Zone 1 Volume (WQCV) =	0.031 acre-feet
Zone 2 Volume (100-year - Zone 1) =	0.165 acre-feet
Select Zone 3 Storage Volume (Optional) =	acre-feet
Total Detention Basin Volume =	0.196 acre-feet
Initial Surge Volume (ISV) =	N/A ft ³
Initial Surge Depth (ISD) =	N/A ft
Total Available Detention Depth (H _{total}) =	user ft
Depth of Trickle Channel (H _{tc}) =	N/A ft
Slope of Trickle Channel (S _{tc}) =	N/A ft/ft
Slopes of Main Basin Sides (S _{main}) =	user H:V
Basin Length-to-Width Ratio (R _{LW}) =	user
Initial Surge Area (A _{ISV}) =	user ft ²
Surge Volume Length (L _{ISV}) =	user ft
Surge Volume Width (W _{ISV}) =	user ft
Depth of Basin Floor (H _{FLOOR}) =	user ft
Length of Basin Floor (L _{FLOOR}) =	user ft
Width of Basin Floor (W _{FLOOR}) =	user ft
Area of Basin Floor (A _{FLOOR}) =	user ft ²
Volume of Basin Floor (V _{FLOOR}) =	user ft ³
Depth of Main Basin (H _{MAIN}) =	user ft
Length of Main Basin (L _{MAIN}) =	user ft
Width of Main Basin (W _{MAIN}) =	user ft
Area of Main Basin (A _{MAIN}) =	user ft ²
Volume of Main Basin (V _{MAIN}) =	user ft ³
Calculated Total Basin Volume (V _{total}) =	user acre-feet

Stage - Storage Description	Stage (ft)	Optional Override Stage (ft)	Length (ft)	Width (ft)	Area (ft ²)	Optional Override Area (ft ²)	Area (acre)	Volume (ft ³)	Volume (ac-ft)
Media Surface	--	0.00	--	--	--	887	0.020		
		0.50	--	--	--	1,138	0.026	506	0.012
		1.50	--	--	--	1,715	0.039	1,933	0.044
		2.50	--	--	--	2,392	0.055	3,986	0.092
		3.50	--	--	--	3,172	0.073	6,768	0.155
		4.50	--	--	--	4,000	0.092	10,354	0.238

DETENTION BASIN STAGE-STORAGE TABLE BUILDER

MHFD-Detention, Version 4.06 (July 2022)

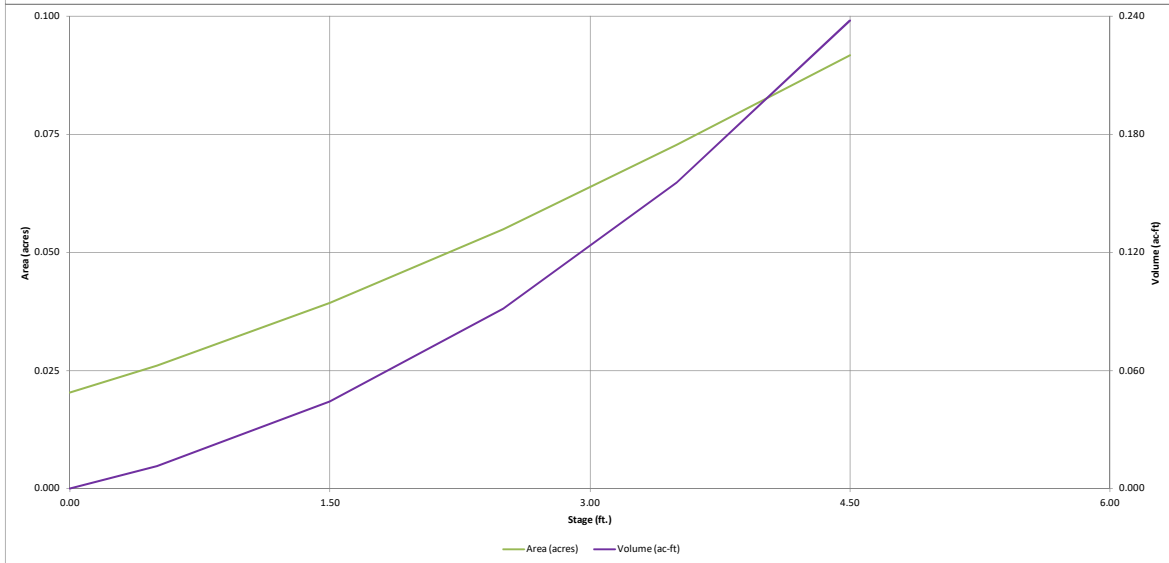
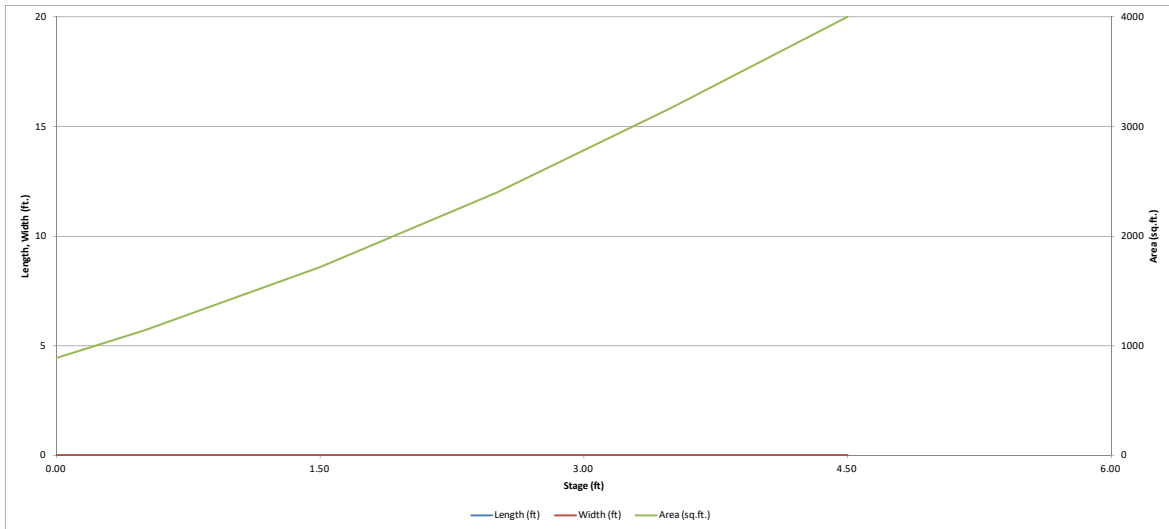

DETENTION BASIN OUTLET STRUCTURE DESIGN

MHFD- Detention, Version 4.06 (July 2022)

Project: Claremont Business Park 2 Filing No. 2

Basin ID: Lot 3 - Pond 5 (CALCS PROVIDED FOR INFORMATION ONLY, POND 5 TO BE DESIGNED AND CONSTRUCTED WITH FUTURE DEVELOPMENT)

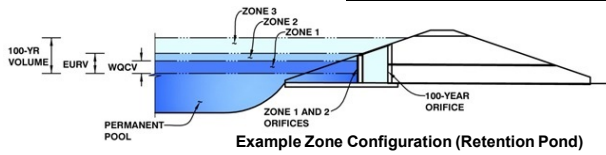

	Estimated Stage (ft)	Estimated Volume (ac-ft)	Outlet Type
Zone 1 (WQCV)	1.14	0.031	Filtration Media
Zone 2 (100-year)	4.03	0.165	Weir&Pipe (Restrict)
Zone 3			
Total (all zones)		0.196	

User Input: Orifice at Underdrain Outlet (typically used to drain WQCV in a Filtration BMP)

Underdrain Orifice Invert Depth = ft (distance below the filtration media surface)
 Underdrain Orifice Diameter = inches

Calculated Parameters for Underdrain
 Underdrain Orifice Area = ft²
 Underdrain Orifice Centroid = feet

User Input: Orifice Plate with one or more orifices or Elliptical Slot Weir (typically used to drain WQCV and/or EURV in a sedimentation BMP)

Centroid of Lowest Orifice = ft (relative to basin bottom at Stage = 0 ft)
 Depth at top of Zone using Orifice Plate = ft (relative to basin bottom at Stage = 0 ft)
 Orifice Plate: Orifice Vertical Spacing = inches
 Orifice Plate: Orifice Area per Row = sq. inches

Calculated Parameters for Plate
 WQ Orifice Area per Row = ft²
 Elliptical Half-Width = feet
 Elliptical Slot Centroid = feet
 Elliptical Slot Area = ft²

User Input: Stage and Total Area of Each Orifice Row (numbered from lowest to highest)

	Row 1 (optional)	Row 2 (optional)	Row 3 (optional)	Row 4 (optional)	Row 5 (optional)	Row 6 (optional)	Row 7 (optional)	Row 8 (optional)
Stage of Orifice Centroid (ft)	<input type="text" value="N/A"/>	<input type="text" value="N/A"/>	<input type="text" value="N/A"/>	<input type="text" value="N/A"/>	<input type="text" value="N/A"/>	<input type="text" value="N/A"/>	<input type="text" value="N/A"/>	<input type="text" value="N/A"/>
Orifice Area (sq. inches)	<input type="text" value="N/A"/>	<input type="text" value="N/A"/>	<input type="text" value="N/A"/>	<input type="text" value="N/A"/>	<input type="text" value="N/A"/>	<input type="text" value="N/A"/>	<input type="text" value="N/A"/>	<input type="text" value="N/A"/>

	Row 9 (optional)	Row 10 (optional)	Row 11 (optional)	Row 12 (optional)	Row 13 (optional)	Row 14 (optional)	Row 15 (optional)	Row 16 (optional)
Stage of Orifice Centroid (ft)	<input type="text" value="N/A"/>	<input type="text" value="N/A"/>	<input type="text" value="N/A"/>	<input type="text" value="N/A"/>	<input type="text" value="N/A"/>	<input type="text" value="N/A"/>	<input type="text" value="N/A"/>	<input type="text" value="N/A"/>
Orifice Area (sq. inches)	<input type="text" value="N/A"/>	<input type="text" value="N/A"/>	<input type="text" value="N/A"/>	<input type="text" value="N/A"/>	<input type="text" value="N/A"/>	<input type="text" value="N/A"/>	<input type="text" value="N/A"/>	<input type="text" value="N/A"/>

User Input: Vertical Orifice (Circular or Rectangular)

Invert of Vertical Orifice = ft (relative to basin bottom at Stage = 0 ft)
 Depth at top of Zone using Vertical Orifice = ft (relative to basin bottom at Stage = 0 ft)
 Vertical Orifice Diameter = inches

Calculated Parameters for Vertical Orif
 Vertical Orifice Area = ft²
 Vertical Orifice Centroid = feet

User Input: Overflow Weir (Dropbox with Flat or Sloped Gate and Outlet Pipe OR Rectangular/Trapezoidal Weir and No Outlet Pipe)

Overflow Weir Front Edge Height, Ho = ft (relative to basin bottom at Stage = 0 ft)
 Overflow Weir Front Edge Length = feet
 Overflow Weir Gate Slope = H:V
 Horiz. Length of Weir Sides = feet
 Overflow Gate Type =
 Debris Clogging % = %

Calculated Parameters for Overflow Weir
 Height of Gate Upper Edge, H_t = feet
 Overflow Weir Slope Length = feet
 Gate Open Area / 100-yr Orifice Area =
 Overflow Gate Open Area w/o Debris =
 Overflow Gate Open Area w/ Debris =

User Input: Outlet Pipe w/ Flow Restriction Plate (Circular Orifice, Restrictor Plate, or Rectangular Orifice)

Depth to Invert of Outlet Pipe = ft (distance below basin bottom at Stage = 0 ft)
 Outlet Pipe Diameter = inches
 Restrictor Plate Height Above Pipe Invert = inches

Calculated Parameters for Outlet Pipe w/ Flow Restriction Plate
 Outlet Orifice Area = ft²
 Outlet Orifice Centroid = feet
 Half-Central Angle of Restrictor Plate on Pipe =

User Input: Emergency Spillway (Rectangular or Trapezoidal)

Spillway Invert Stage = ft (relative to basin bottom at Stage = 0 ft)
 Spillway Crest Length = feet
 Spillway End Slopes = H:V
 Freeboard above Max Water Surface = feet

Calculated Parameters for Spillway
 Spillway Design Flow Depth = feet
 Stage at Top of Freeboard = feet
 Basin Area at Top of Freeboard = acres
 Basin Volume at Top of Freeboard = acre-ft

Routed Hydrograph Results

The user can override the default CUHP hydrographs and runoff volumes by entering new values in the Inflow Hydrographs table (Columns W through AI)

	WQCV	EURV	2 Year	5 Year	10 Year	25 Year	50 Year	100 Year
Design Storm Return Period =								
One-Hour Rainfall Depth (in) =	<input type="text" value="N/A"/>	<input type="text" value="N/A"/>	<input type="text" value="1.19"/>	<input type="text" value="1.50"/>	<input type="text" value="1.75"/>	<input type="text" value="2.00"/>	<input type="text" value="2.25"/>	<input type="text" value="2.52"/>
CUHP Runoff Volume (acre-ft) =	<input type="text" value="0.031"/>	<input type="text" value="0.141"/>	<input type="text" value="0.097"/>	<input type="text" value="0.125"/>	<input type="text" value="0.148"/>	<input type="text" value="0.172"/>	<input type="text" value="0.196"/>	<input type="text" value="0.223"/>
Inflow Hydrograph Volume (acre-ft) =	<input type="text" value="N/A"/>	<input type="text" value="N/A"/>	<input type="text" value="0.097"/>	<input type="text" value="0.125"/>	<input type="text" value="0.148"/>	<input type="text" value="0.172"/>	<input type="text" value="0.196"/>	<input type="text" value="0.223"/>
CUHP Predevelopment Peak Q (cfs) =	<input type="text" value="N/A"/>	<input type="text" value="N/A"/>	<input type="text" value="0.0"/>	<input type="text" value="0.0"/>	<input type="text" value="0.0"/>	<input type="text" value="0.1"/>	<input type="text" value="0.3"/>	<input type="text" value="0.5"/>
OPTIONAL Override Predevelopment Peak Q (cfs) =	<input type="text" value="N/A"/>	<input type="text" value="N/A"/>						
Predevelopment Unit Peak Flow, q (cfs/acre) =	<input type="text" value="N/A"/>	<input type="text" value="N/A"/>	<input type="text" value="0.00"/>	<input type="text" value="0.01"/>	<input type="text" value="0.01"/>	<input type="text" value="0.12"/>	<input type="text" value="0.25"/>	<input type="text" value="0.40"/>
Peak Inflow Q (cfs) =	<input type="text" value="N/A"/>	<input type="text" value="N/A"/>	<input type="text" value="1.4"/>	<input type="text" value="1.7"/>	<input type="text" value="2.0"/>	<input type="text" value="2.4"/>	<input type="text" value="2.8"/>	<input type="text" value="3.2"/>
Peak Outflow Q (cfs) =	<input type="text" value="0.0"/>	<input type="text" value="17.3"/>	<input type="text" value="0.9"/>	<input type="text" value="1.3"/>	<input type="text" value="1.6"/>	<input type="text" value="2.2"/>	<input type="text" value="2.5"/>	<input type="text" value="3.0"/>
Ratio Peak Outflow to Predevelopment Q =	<input type="text" value="N/A"/>	<input type="text" value="N/A"/>	<input type="text" value="N/A"/>	<input type="text" value="120.0"/>	<input type="text" value="104.1"/>	<input type="text" value="15.6"/>	<input type="text" value="8.9"/>	<input type="text" value="6.5"/>
Structure Controlling Flow =	<input type="text" value="Filtration Media"/>	<input type="text" value="Spillway"/>	<input type="text" value="Overflow Weir 1"/>	<input type="text" value="Overflow Weir 1"/>	<input type="text" value="Overflow Weir 1"/>	<input type="text" value="Overflow Weir 1"/>	<input type="text" value="Overflow Weir 1"/>	<input type="text" value="Overflow Weir 1"/>
Max Velocity through Gate 1 (fps) =	<input type="text" value="N/A"/>	<input type="text" value="2.19"/>	<input type="text" value="0.14"/>	<input type="text" value="0.2"/>	<input type="text" value="0.2"/>	<input type="text" value="0.4"/>	<input type="text" value="0.4"/>	<input type="text" value="0.5"/>
Max Velocity through Gate 2 (fps) =	<input type="text" value="N/A"/>	<input type="text" value="N/A"/>	<input type="text" value="N/A"/>	<input type="text" value="N/A"/>	<input type="text" value="N/A"/>	<input type="text" value="N/A"/>	<input type="text" value="N/A"/>	<input type="text" value="N/A"/>
Time to Drain 97% of Inflow Volume (hours) =	<input type="text" value="12"/>	<input type="text" value="8"/>	<input type="text" value="14"/>	<input type="text" value="14"/>	<input type="text" value="13"/>	<input type="text" value="13"/>	<input type="text" value="13"/>	<input type="text" value="12"/>
Time to Drain 99% of Inflow Volume (hours) =	<input type="text" value="12"/>	<input type="text" value="9"/>	<input type="text" value="15"/>	<input type="text" value="15"/>	<input type="text" value="15"/>	<input type="text" value="15"/>	<input type="text" value="14"/>	<input type="text" value="14"/>
Maximum Ponding Depth (ft) =	<input type="text" value="1.14"/>	<input type="text" value="3.30"/>	<input type="text" value="1.33"/>	<input type="text" value="1.38"/>	<input type="text" value="1.41"/>	<input type="text" value="1.48"/>	<input type="text" value="1.51"/>	<input type="text" value="1.55"/>
Area at Maximum Ponding Depth (acres) =	<input type="text" value="0.03"/>	<input type="text" value="0.07"/>	<input type="text" value="0.04"/>	<input type="text" value="0.04"/>	<input type="text" value="0.04"/>	<input type="text" value="0.04"/>	<input type="text" value="0.04"/>	<input type="text" value="0.04"/>
Maximum Volume Stored (acre-ft) =	<input type="text" value="0.031"/>	<input type="text" value="0.141"/>	<input type="text" value="0.038"/>	<input type="text" value="0.039"/>	<input type="text" value="0.041"/>	<input type="text" value="0.043"/>	<input type="text" value="0.044"/>	<input type="text" value="0.046"/>

DETENTION BASIN OUTLET STRUCTURE DESIGN

MHFD-Detention, Version 4.06 (July 2022)

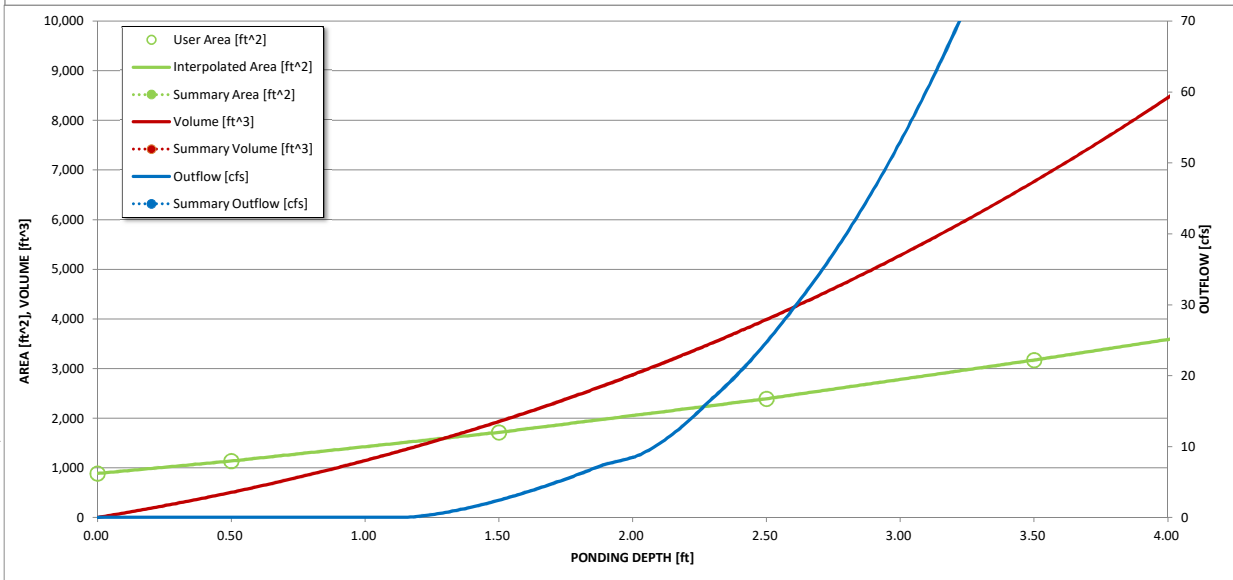
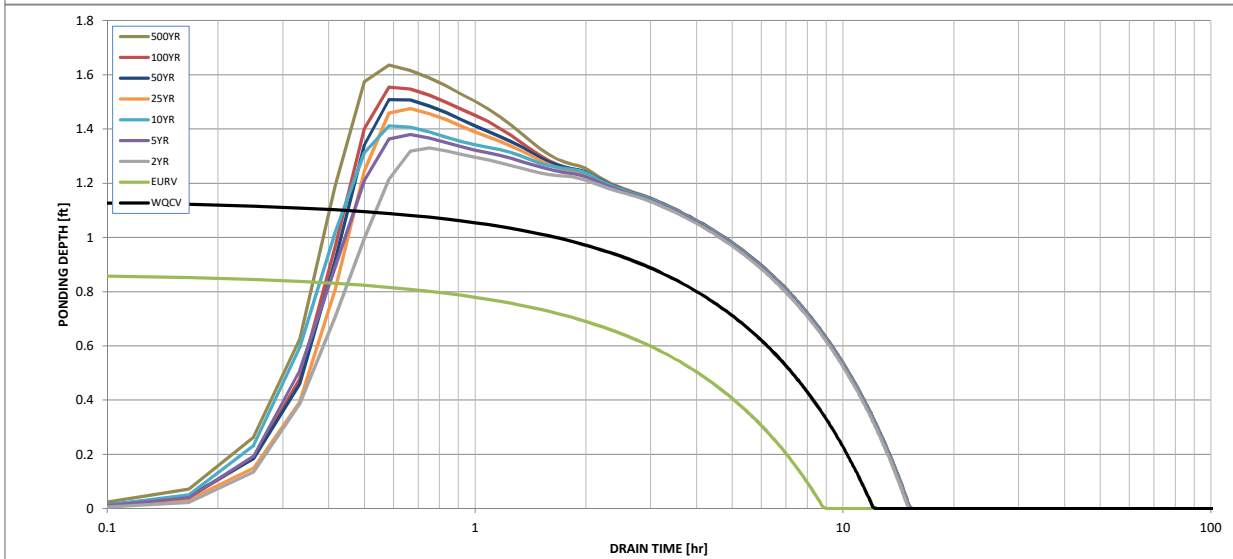
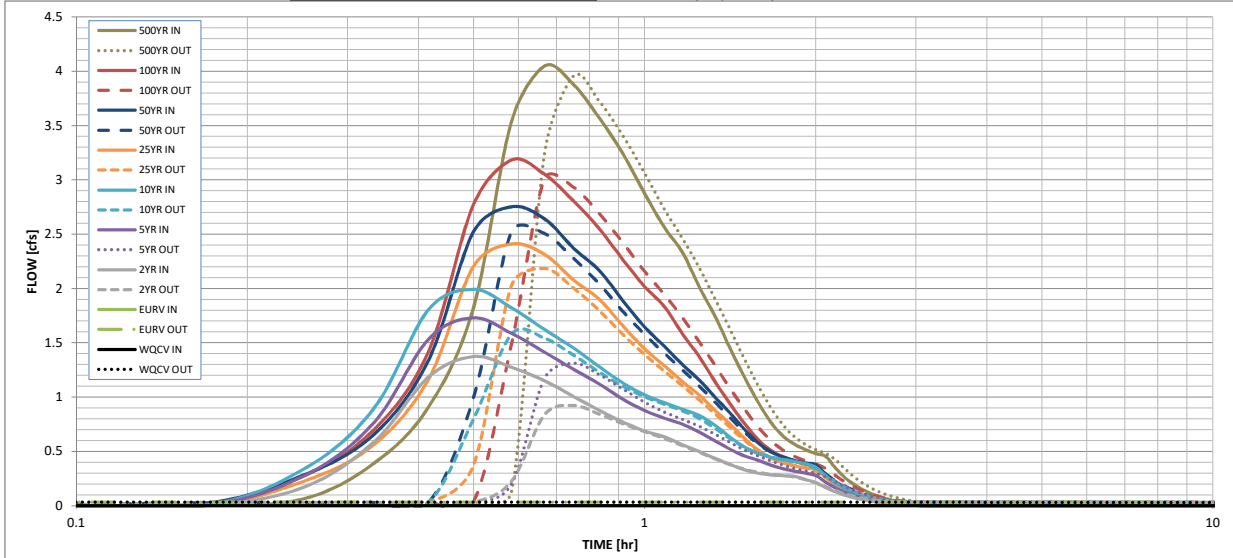

S-A-V-D Chart Axis Override	X-axis	Left Y-Axis	Right Y-Axis
minimum bound			
maximum bound			

DETENTION BASIN OUTLET STRUCTURE DESIGN

Outflow Hydrograph Workbook Filename: _____

Inflow Hydrographs

The user can override the calculated inflow hydrographs from this workbook with inflow hydrographs developed in a separate program.

Time Interval	SOURCE	CUHP	CUHP	CUHP	CUHP	CUHP	CUHP	CUHP	CUHP	CUHP
	TIME	WQCV [cfs]	EURV [cfs]	2 Year [cfs]	5 Year [cfs]	10 Year [cfs]	25 Year [cfs]	50 Year [cfs]	100 Year [cfs]	500 Year [cfs]
5.00 min	0:00:00	0.00	0.00	0.00	0.00	0.00	0.00	0.00	0.00	0.00
	0:05:00	0.00	0.00	0.00	0.00	0.00	0.00	0.00	0.00	0.00
	0:10:00	0.00	0.00	0.00	0.00	0.00	0.00	0.02	0.00	0.06
	0:15:00	0.00	0.00	0.16	0.27	0.33	0.22	0.28	0.27	0.38
	0:20:00	0.00	0.00	0.58	0.76	0.89	0.56	0.65	0.70	0.91
	0:25:00	0.00	0.00	1.18	1.53	1.80	1.16	1.34	1.42	1.82
	0:30:00	0.00	0.00	1.37	1.73	1.99	2.20	2.52	2.77	3.53
	0:35:00	0.00	0.00	1.27	1.59	1.82	2.41	2.75	3.18	4.05
	0:40:00	0.00	0.00	1.15	1.41	1.62	2.31	2.64	3.05	3.88
	0:45:00	0.00	0.00	1.00	1.26	1.45	2.08	2.37	2.81	3.57
	0:50:00	0.00	0.00	0.88	1.12	1.28	1.90	2.16	2.55	3.24
	0:55:00	0.00	0.00	0.77	0.98	1.13	1.66	1.88	2.27	2.88
	1:00:00	0.00	0.00	0.69	0.88	1.02	1.45	1.65	2.02	2.56
	1:05:00	0.00	0.00	0.63	0.81	0.95	1.29	1.47	1.84	2.33
	1:10:00	0.00	0.00	0.56	0.75	0.89	1.14	1.30	1.58	2.01
	1:15:00	0.00	0.00	0.50	0.68	0.83	1.02	1.15	1.37	1.73
	1:20:00	0.00	0.00	0.43	0.59	0.74	0.88	0.99	1.14	1.44
	1:25:00	0.00	0.00	0.38	0.52	0.63	0.75	0.85	0.93	1.18
	1:30:00	0.00	0.00	0.33	0.46	0.54	0.62	0.70	0.76	0.96
	1:35:00	0.00	0.00	0.30	0.42	0.48	0.51	0.58	0.61	0.77
	1:40:00	0.00	0.00	0.28	0.37	0.45	0.44	0.50	0.51	0.64
	1:45:00	0.00	0.00	0.28	0.34	0.42	0.40	0.45	0.45	0.57
	1:50:00	0.00	0.00	0.27	0.32	0.41	0.37	0.41	0.41	0.52
	1:55:00	0.00	0.00	0.24	0.30	0.39	0.35	0.39	0.38	0.48
	2:00:00	0.00	0.00	0.21	0.28	0.36	0.33	0.38	0.36	0.45
	2:05:00	0.00	0.00	0.17	0.22	0.28	0.26	0.29	0.28	0.35
	2:10:00	0.00	0.00	0.13	0.16	0.21	0.20	0.22	0.21	0.26
	2:15:00	0.00	0.00	0.10	0.13	0.16	0.15	0.17	0.16	0.20
	2:20:00	0.00	0.00	0.07	0.09	0.12	0.11	0.13	0.12	0.15
	2:25:00	0.00	0.00	0.05	0.07	0.09	0.08	0.09	0.09	0.11
	2:30:00	0.00	0.00	0.04	0.05	0.07	0.06	0.07	0.07	0.08
	2:35:00	0.00	0.00	0.03	0.04	0.05	0.05	0.05	0.05	0.06
	2:40:00	0.00	0.00	0.02	0.03	0.03	0.03	0.04	0.04	0.04
	2:45:00	0.00	0.00	0.01	0.02	0.02	0.02	0.03	0.02	0.03
	2:50:00	0.00	0.00	0.01	0.01	0.01	0.01	0.02	0.02	0.02
	2:55:00	0.00	0.00	0.00	0.01	0.01	0.01	0.01	0.01	0.01
	3:00:00	0.00	0.00	0.00	0.00	0.00	0.00	0.00	0.00	0.00
	3:05:00	0.00	0.00	0.00	0.00	0.00	0.00	0.00	0.00	0.00
	3:10:00	0.00	0.00	0.00	0.00	0.00	0.00	0.00	0.00	0.00
	3:15:00	0.00	0.00	0.00	0.00	0.00	0.00	0.00	0.00	0.00
	3:20:00	0.00	0.00	0.00	0.00	0.00	0.00	0.00	0.00	0.00
	3:25:00	0.00	0.00	0.00	0.00	0.00	0.00	0.00	0.00	0.00
	3:30:00	0.00	0.00	0.00	0.00	0.00	0.00	0.00	0.00	0.00
	3:35:00	0.00	0.00	0.00	0.00	0.00	0.00	0.00	0.00	0.00
	3:40:00	0.00	0.00	0.00	0.00	0.00	0.00	0.00	0.00	0.00
	3:45:00	0.00	0.00	0.00	0.00	0.00	0.00	0.00	0.00	0.00
	3:50:00	0.00	0.00	0.00	0.00	0.00	0.00	0.00	0.00	0.00
	3:55:00	0.00	0.00	0.00	0.00	0.00	0.00	0.00	0.00	0.00
	4:00:00	0.00	0.00	0.00	0.00	0.00	0.00	0.00	0.00	0.00
	4:05:00	0.00	0.00	0.00	0.00	0.00	0.00	0.00	0.00	0.00
	4:10:00	0.00	0.00	0.00	0.00	0.00	0.00	0.00	0.00	0.00
	4:15:00	0.00	0.00	0.00	0.00	0.00	0.00	0.00	0.00	0.00
	4:20:00	0.00	0.00	0.00	0.00	0.00	0.00	0.00	0.00	0.00
	4:25:00	0.00	0.00	0.00	0.00	0.00	0.00	0.00	0.00	0.00
	4:30:00	0.00	0.00	0.00	0.00	0.00	0.00	0.00	0.00	0.00
	4:35:00	0.00	0.00	0.00	0.00	0.00	0.00	0.00	0.00	0.00
	4:40:00	0.00	0.00	0.00	0.00	0.00	0.00	0.00	0.00	0.00
	4:45:00	0.00	0.00	0.00	0.00	0.00	0.00	0.00	0.00	0.00
	4:50:00	0.00	0.00	0.00	0.00	0.00	0.00	0.00	0.00	0.00
	4:55:00	0.00	0.00	0.00	0.00	0.00	0.00	0.00	0.00	0.00
	5:00:00	0.00	0.00	0.00	0.00	0.00	0.00	0.00	0.00	0.00
	5:05:00	0.00	0.00	0.00	0.00	0.00	0.00	0.00	0.00	0.00
	5:10:00	0.00	0.00	0.00	0.00	0.00	0.00	0.00	0.00	0.00
	5:15:00	0.00	0.00	0.00	0.00	0.00	0.00	0.00	0.00	0.00
	5:20:00	0.00	0.00	0.00	0.00	0.00	0.00	0.00	0.00	0.00
	5:25:00	0.00	0.00	0.00	0.00	0.00	0.00	0.00	0.00	0.00
	5:30:00	0.00	0.00	0.00	0.00	0.00	0.00	0.00	0.00	0.00
	5:35:00	0.00	0.00	0.00	0.00	0.00	0.00	0.00	0.00	0.00
	5:40:00	0.00	0.00	0.00	0.00	0.00	0.00	0.00	0.00	0.00
	5:45:00	0.00	0.00	0.00	0.00	0.00	0.00	0.00	0.00	0.00
	5:50:00	0.00	0.00	0.00	0.00	0.00	0.00	0.00	0.00	0.00
	5:55:00	0.00	0.00	0.00	0.00	0.00	0.00	0.00	0.00	0.00
6:00:00	0.00	0.00	0.00	0.00	0.00	0.00	0.00	0.00	0.00	

ALLOWABLE CAPACITY FOR ONE-HALF OF STREET (Minor & Major Storm)

(Based on Regulated Criteria for Maximum Allowable Flow Depth and Spread)

Project: Claremont Business Park 2 Filing 2 (Proposed Conditions)

Inlet ID: Inlet 1 (DP5)

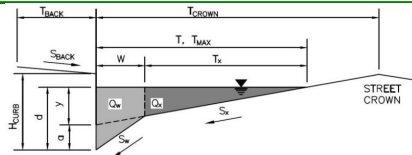

Gutter Geometry:						
Maximum Allowable Width for Spread Behind Curb	$T_{BACK} = 7.5$ ft					
Side Slope Behind Curb (leave blank for no conveyance credit behind curb)	$S_{BACK} = 0.020$ ft/ft					
Manning's Roughness Behind Curb (typically between 0.012 and 0.020)	$n_{BACK} = 0.020$					
Height of Curb at Gutter Flow Line	$H_{CURB} = 6.00$ inches					
Distance from Curb Face to Street Crown	$T_{CROWN} = 18.0$ ft					
Gutter Width	$W = 2.00$ ft					
Street Transverse Slope	$S_x = 0.020$ ft/ft					
Gutter Cross Slope (typically 2 inches over 24 inches or 0.083 ft/ft)	$S_w = 0.083$ ft/ft					
Street Longitudinal Slope - Enter 0 for sump condition	$S_o = 0.000$ ft/ft					
Manning's Roughness for Street Section (typically between 0.012 and 0.020)	$n_{STREET} = 0.015$					
Max. Allowable Spread for Minor & Major Storm	<table border="1" style="display: inline-table; border-collapse: collapse;"> <tr> <td style="text-align: center;">Minor Storm</td> <td style="text-align: center;">Major Storm</td> <td rowspan="2" style="text-align: center;">ft</td> </tr> <tr> <td style="text-align: center;">$T_{MAX} = 15.8$</td> <td style="text-align: center;">18.0</td> </tr> </table>	Minor Storm	Major Storm	ft	$T_{MAX} = 15.8$	18.0
Minor Storm	Major Storm	ft				
$T_{MAX} = 15.8$	18.0					
Max. Allowable Depth at Gutter Flowline for Minor & Major Storm	<table border="1" style="display: inline-table; border-collapse: collapse;"> <tr> <td style="text-align: center;">Minor Storm</td> <td style="text-align: center;">Major Storm</td> <td rowspan="2" style="text-align: center;">inches</td> </tr> <tr> <td style="text-align: center;">$d_{MAX} = 4.6$</td> <td style="text-align: center;">7.8</td> </tr> </table>	Minor Storm	Major Storm	inches	$d_{MAX} = 4.6$	7.8
Minor Storm	Major Storm	inches				
$d_{MAX} = 4.6$	7.8					
Check boxes are not applicable in SUMP conditions	<input type="checkbox"/> <input type="checkbox"/>					
MINOR STORM Allowable Capacity is not applicable to Sump Condition						
MAJOR STORM Allowable Capacity is not applicable to Sump Condition						
Q_{allow}	<table border="1" style="display: inline-table; border-collapse: collapse;"> <tr> <td style="text-align: center;">Minor Storm</td> <td style="text-align: center;">Major Storm</td> <td rowspan="2" style="text-align: center;">cfs</td> </tr> <tr> <td style="text-align: center;">SUMP</td> <td style="text-align: center;">SUMP</td> </tr> </table>	Minor Storm	Major Storm	cfs	SUMP	SUMP
Minor Storm	Major Storm	cfs				
SUMP	SUMP					

INLET IN A SUMP OR SAG LOCATION

MHFD-Inlet, Version 5.02 (August 2022)

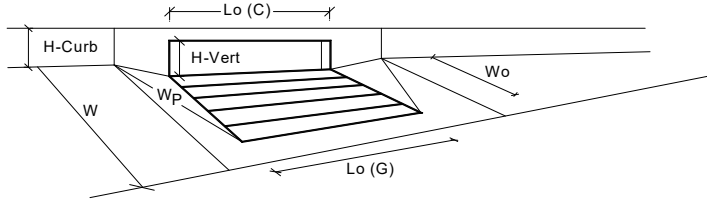

Design Information (Input)	MINOR MAJOR	
Type of Inlet CDOT Type R Curb Opening ▾	CDOT Type R Curb Opening	
Local Depression (additional to continuous gutter depression 'a' from above)	3.00	3.00
Number of Unit Inlets (Grate or Curb Opening)	1	1
Water Depth at Flowline (outside of local depression)	4.6	5.8
Grate Information	MINOR	MAJOR
Length of a Unit Grate	N/A	N/A
Width of a Unit Grate	N/A	N/A
Open Area Ratio for a Grate (typical values 0.15-0.90)	N/A	N/A
Clogging Factor for a Single Grate (typical value 0.50 - 0.70)	N/A	N/A
Grate Weir Coefficient (typical value 2.15 - 3.60)	N/A	N/A
Grate Orifice Coefficient (typical value 0.60 - 0.80)	N/A	N/A
Curb Opening Information	MINOR	MAJOR
Length of a Unit Curb Opening	5.00	5.00
Height of Vertical Curb Opening in Inches	6.00	6.00
Height of Curb Orifice Throat in Inches	6.00	6.00
Angle of Throat (see USDCM Figure ST-5)	63.40	63.40
Side Width for Depression Pan (typically the gutter width of 2 feet)	2.00	2.00
Clogging Factor for a Single Curb Opening (typical value 0.10)	0.10	0.10
Curb Opening Weir Coefficient (typical value 2.3-3.7)	3.60	3.60
Curb Opening Orifice Coefficient (typical value 0.60 - 0.70)	0.67	0.67
Low Head Performance Reduction (Calculated)	MINOR	MAJOR
Depth for Grate Midwidth	N/A	N/A
Depth for Curb Opening Weir Equation	0.22	0.32
Grated Inlet Performance Reduction Factor for Long Inlets	N/A	N/A
Curb Opening Performance Reduction Factor for Long Inlets	1.00	1.00
Combination Inlet Performance Reduction Factor for Long Inlets	N/A	N/A
Total Inlet Interception Capacity (assumes clogged condition)	MINOR	MAJOR
Inlet Capacity IS GOOD for Minor and Major Storms (>Q Peak)	2.8	5.0
Q PEAK REQUIRED =	1.2	2.2

ALLOWABLE CAPACITY FOR ONE-HALF OF STREET (Minor & Major Storm)

(Based on Regulated Criteria for Maximum Allowable Flow Depth and Spread)

Project: Claremont Business Park 2 Filing 2 (Proposed Conditions)

Inlet ID: Inlet 2 (DP5)

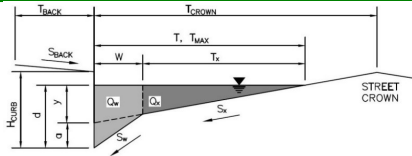

Gutter Geometry:						
Maximum Allowable Width for Spread Behind Curb	$T_{BACK} = 7.5$ ft					
Side Slope Behind Curb (leave blank for no conveyance credit behind curb)	$S_{BACK} = 0.020$ ft/ft					
Manning's Roughness Behind Curb (typically between 0.012 and 0.020)	$n_{BACK} = 0.020$					
Height of Curb at Gutter Flow Line	$H_{CURB} = 6.00$ inches					
Distance from Curb Face to Street Crown	$T_{CROWN} = 18.0$ ft					
Gutter Width	$W = 2.00$ ft					
Street Transverse Slope	$S_x = 0.020$ ft/ft					
Gutter Cross Slope (typically 2 inches over 24 inches or 0.083 ft/ft)	$S_w = 0.083$ ft/ft					
Street Longitudinal Slope - Enter 0 for sump condition	$S_o = 0.000$ ft/ft					
Manning's Roughness for Street Section (typically between 0.012 and 0.020)	$n_{STREET} = 0.015$					
Max. Allowable Spread for Minor & Major Storm	<table border="1" style="display: inline-table; border-collapse: collapse;"> <tr> <td style="text-align: center;">Minor Storm</td> <td style="text-align: center;">Major Storm</td> <td rowspan="2" style="text-align: center;">ft</td> </tr> <tr> <td style="text-align: center;">$T_{MAX} = 15.8$</td> <td style="text-align: center;">18.0</td> </tr> </table>	Minor Storm	Major Storm	ft	$T_{MAX} = 15.8$	18.0
Minor Storm	Major Storm	ft				
$T_{MAX} = 15.8$	18.0					
Max. Allowable Depth at Gutter Flowline for Minor & Major Storm	<table border="1" style="display: inline-table; border-collapse: collapse;"> <tr> <td style="text-align: center;">Minor Storm</td> <td style="text-align: center;">Major Storm</td> <td rowspan="2" style="text-align: center;">inches</td> </tr> <tr> <td style="text-align: center;">$d_{MAX} = 4.6$</td> <td style="text-align: center;">7.8</td> </tr> </table>	Minor Storm	Major Storm	inches	$d_{MAX} = 4.6$	7.8
Minor Storm	Major Storm	inches				
$d_{MAX} = 4.6$	7.8					
Check boxes are not applicable in SUMP conditions	<input type="checkbox"/> <input type="checkbox"/>					
MINOR STORM Allowable Capacity is not applicable to Sump Condition						
MAJOR STORM Allowable Capacity is not applicable to Sump Condition						
	<table border="1" style="display: inline-table; border-collapse: collapse;"> <tr> <td style="text-align: center;">Minor Storm</td> <td style="text-align: center;">Major Storm</td> <td rowspan="2" style="text-align: center;">cfs</td> </tr> <tr> <td style="text-align: center;">$Q_{allow} = \text{SUMP}$</td> <td style="text-align: center;">SUMP</td> </tr> </table>	Minor Storm	Major Storm	cfs	$Q_{allow} = \text{SUMP}$	SUMP
Minor Storm	Major Storm	cfs				
$Q_{allow} = \text{SUMP}$	SUMP					

INLET IN A SUMP OR SAG LOCATION

MHFD-Inlet, Version 5.02 (August 2022)

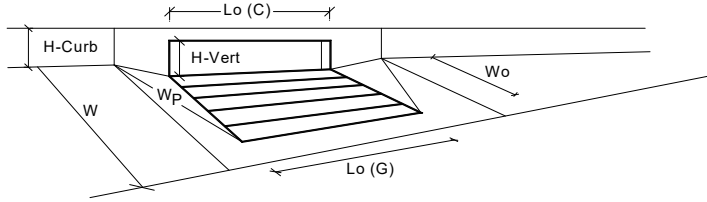

Design Information (Input)	MINOR MAJOR	
Type of Inlet	CDOT Type R Curb Opening	
Local Depression (additional to continuous gutter depression 'a' from above)	3.00	3.00
Number of Unit Inlets (Grate or Curb Opening)	1	1
Water Depth at Flowline (outside of local depression)	4.6	5.8
Grate Information	MINOR	MAJOR
Length of a Unit Grate	N/A	N/A
Width of a Unit Grate	N/A	N/A
Open Area Ratio for a Grate (typical values 0.15-0.90)	N/A	N/A
Clogging Factor for a Single Grate (typical value 0.50 - 0.70)	N/A	N/A
Grate Weir Coefficient (typical value 2.15 - 3.60)	N/A	N/A
Grate Orifice Coefficient (typical value 0.60 - 0.80)	N/A	N/A
Curb Opening Information	MINOR	MAJOR
Length of a Unit Curb Opening	5.00	5.00
Height of Vertical Curb Opening in Inches	6.00	6.00
Height of Curb Orifice Throat in Inches	6.00	6.00
Angle of Throat (see USDCM Figure ST-5)	63.40	63.40
Side Width for Depression Pan (typically the gutter width of 2 feet)	2.00	2.00
Clogging Factor for a Single Curb Opening (typical value 0.10)	0.10	0.10
Curb Opening Weir Coefficient (typical value 2.3-3.7)	3.60	3.60
Curb Opening Orifice Coefficient (typical value 0.60 - 0.70)	0.67	0.67
Low Head Performance Reduction (Calculated)	MINOR	MAJOR
Depth for Grate Midwidth	N/A	N/A
Depth for Curb Opening Weir Equation	0.22	0.32
Grated Inlet Performance Reduction Factor for Long Inlets	N/A	N/A
Curb Opening Performance Reduction Factor for Long Inlets	1.00	1.00
Combination Inlet Performance Reduction Factor for Long Inlets	N/A	N/A
Total Inlet Interception Capacity (assumes clogged condition)	MINOR	MAJOR
Inlet Capacity IS GOOD for Minor and Major Storms (>Q Peak)	2.8	5.0
Q PEAK REQUIRED =	1.0	1.7

ALLOWABLE CAPACITY FOR ONE-HALF OF STREET (Minor & Major Storm)

(Based on Regulated Criteria for Maximum Allowable Flow Depth and Spread)

Project: **Claremont Business Park 2 Filing 2 (Proposed Conditions)**

Inlet ID: **Inlet 3 (DP11 North)**

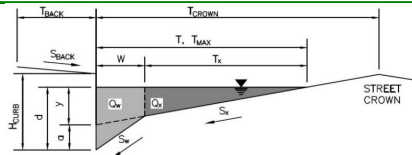

Gutter Geometry:									
Maximum Allowable Width for Spread Behind Curb	$T_{BACK} = 7.5$ ft								
Side Slope Behind Curb (leave blank for no conveyance credit behind curb)	$S_{BACK} = 0.020$ ft/ft								
Manning's Roughness Behind Curb (typically between 0.012 and 0.020)	$n_{BACK} = 0.020$								
Height of Curb at Gutter Flow Line	$H_{CURB} = 6.00$ inches								
Distance from Curb Face to Street Crown	$T_{CROWN} = 17.0$ ft								
Gutter Width	$W = 2.00$ ft								
Street Transverse Slope	$S_x = 0.020$ ft/ft								
Gutter Cross Slope (typically 2 inches over 24 inches or 0.083 ft/ft)	$S_w = 0.083$ ft/ft								
Street Longitudinal Slope - Enter 0 for sump condition	$S_o = 0.012$ ft/ft								
Manning's Roughness for Street Section (typically between 0.012 and 0.020)	$n_{STREET} = 0.015$								
Max. Allowable Spread for Minor & Major Storm	<table border="1"> <tr> <td></td> <td>Minor Storm</td> <td>Major Storm</td> <td>ft</td> </tr> <tr> <td>$T_{MAX} =$</td> <td>15.8</td> <td>17.0</td> <td></td> </tr> </table>		Minor Storm	Major Storm	ft	$T_{MAX} =$	15.8	17.0	
	Minor Storm	Major Storm	ft						
$T_{MAX} =$	15.8	17.0							
Max. Allowable Depth at Gutter Flowline for Minor & Major Storm	<table border="1"> <tr> <td></td> <td>Minor Storm</td> <td>Major Storm</td> <td>inches</td> </tr> <tr> <td>$d_{MAX} =$</td> <td>4.6</td> <td>7.8</td> <td></td> </tr> </table>		Minor Storm	Major Storm	inches	$d_{MAX} =$	4.6	7.8	
	Minor Storm	Major Storm	inches						
$d_{MAX} =$	4.6	7.8							
Allow Flow Depth at Street Crown (check box for yes, leave blank for no)	<table border="1"> <tr> <td></td> <td>Minor Storm</td> <td>Major Storm</td> </tr> <tr> <td></td> <td><input type="checkbox"/></td> <td><input type="checkbox"/></td> </tr> </table>		Minor Storm	Major Storm		<input type="checkbox"/>	<input type="checkbox"/>		
	Minor Storm	Major Storm							
	<input type="checkbox"/>	<input type="checkbox"/>							
MINOR STORM Allowable Capacity is based on Depth Criterion									
MAJOR STORM Allowable Capacity is based on Spread Criterion									
Minor storm max. allowable capacity GOOD - greater than the design peak flow of 4.20 cfs on sheet 'Inlet Management'									
Major storm max. allowable capacity GOOD - greater than the design peak flow of 8.40 cfs on sheet 'Inlet Management'									
$Q_{allow} =$	<table border="1"> <tr> <td></td> <td>Minor Storm</td> <td>Major Storm</td> <td>cfs</td> </tr> <tr> <td></td> <td>6.5</td> <td>12.7</td> <td></td> </tr> </table>		Minor Storm	Major Storm	cfs		6.5	12.7	
	Minor Storm	Major Storm	cfs						
	6.5	12.7							

INLET ON A CONTINUOUS GRADE

MHFD-Inlet, Version 5.02 (August 2022)

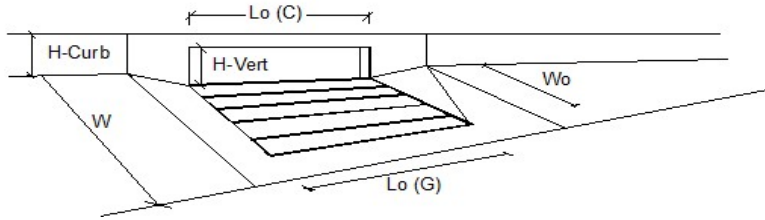

Design Information (Input)	MINOR	MAJOR	
Type of Inlet	CDOT Type R Curb Opening		
Local Depression (additional to continuous gutter depression 'a')	3.0	3.0	inches
Total Number of Units in the Inlet (Grate or Curb Opening)	3	3	
Length of a Single Unit Inlet (Grate or Curb Opening)	5.00	5.00	ft
Width of a Unit Grate (cannot be greater than W, Gutter Width)	N/A	N/A	ft
Clogging Factor for a Single Unit Grate (typical min. value = 0.5)	N/A	N/A	
Clogging Factor for a Single Unit Curb Opening (typical min. value = 0.1)	0.10	0.10	
Street Hydraulics: OK - Q < Allowable Street Capacity			
Total Inlet Interception Capacity	Q = 4.2	8.0	cfs
Total Inlet Carry-Over Flow (flow bypassing inlet)	Q_b = 0.0	0.4	cfs
Capture Percentage = Q _i /Q _s	C% = 100	95	%

ALLOWABLE CAPACITY FOR ONE-HALF OF STREET (Minor & Major Storm)

(Based on Regulated Criteria for Maximum Allowable Flow Depth and Spread)

Project: **Claremont Business Park 2 Filing 2 (Proposed Conditions)**

Inlet ID: **Inlet 4 (DP11 South)**

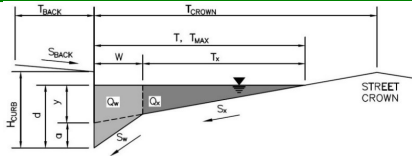

Gutter Geometry:

Maximum Allowable Width for Spread Behind Curb
 Side Slope Behind Curb (leave blank for no conveyance credit behind curb)
 Manning's Roughness Behind Curb (typically between 0.012 and 0.020)

T_{BACK} =	7.5	ft
S_{BACK} =	0.020	ft/ft
n_{BACK} =	0.020	

Height of Curb at Gutter Flow Line
 Distance from Curb Face to Street Crown
 Gutter Width
 Street Transverse Slope
 Gutter Cross Slope (typically 2 inches over 24 inches or 0.083 ft/ft)
 Street Longitudinal Slope - Enter 0 for sump condition
 Manning's Roughness for Street Section (typically between 0.012 and 0.020)

H_{CURB} =	6.00	inches
T_{CROWN} =	17.0	ft
W =	2.00	ft
S_x =	0.020	ft/ft
S_w =	0.083	ft/ft
S_o =	0.011	ft/ft
n_{STREET} =	0.015	

Max. Allowable Spread for Minor & Major Storm
 Max. Allowable Depth at Gutter Flowline for Minor & Major Storm
 Allow Flow Depth at Street Crown (check box for yes, leave blank for no)

	Minor Storm	Major Storm	
T_{MAX} =	15.8	17.0	ft
d_{MAX} =	4.6	7.8	inches
	<input type="checkbox"/>	<input type="checkbox"/>	

MINOR STORM Allowable Capacity is based on Depth Criterion
 MAJOR STORM Allowable Capacity is based on Spread Criterion

	Minor Storm	Major Storm	
Q_{allow} =	6.2	12.2	cfs

Minor storm max. allowable capacity GOOD - greater than the design peak flow of 4.20 cfs on sheet 'Inlet Management'
Major storm max. allowable capacity GOOD - greater than the design peak flow of 8.40 cfs on sheet 'Inlet Management'

INLET ON A CONTINUOUS GRADE

MHFD-Inlet, Version 5.02 (August 2022)

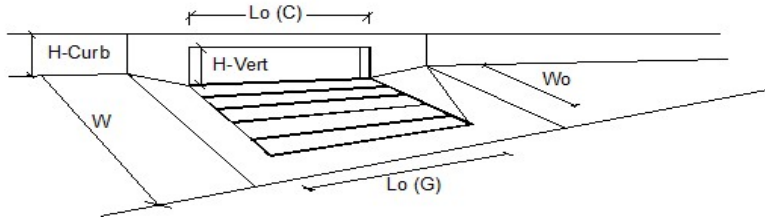

Design Information (Input)	MINOR	MAJOR	
Type of Inlet	CDOT Type R Curb Opening		
Local Depression (additional to continuous gutter depression 'a')	3.0	3.0	inches
Total Number of Units in the Inlet (Grate or Curb Opening)	3	3	
Length of a Single Unit Inlet (Grate or Curb Opening)	5.00	5.00	ft
Width of a Unit Grate (cannot be greater than W, Gutter Width)	N/A	N/A	ft
Clogging Factor for a Single Unit Grate (typical min. value = 0.5)	N/A	N/A	
Clogging Factor for a Single Unit Curb Opening (typical min. value = 0.1)	0.10	0.10	
Street Hydraulics: OK - Q < Allowable Street Capacity			
Total Inlet Interception Capacity	Q =	4.2	8.0 cfs
Total Inlet Carry-Over Flow (flow bypassing inlet)	Q_b =	0.0	0.4 cfs
Capture Percentage = Q _i /Q _s	C% =	100	95 %

ALLOWABLE CAPACITY FOR ONE-HALF OF STREET (Minor & Major Storm)

(Based on Regulated Criteria for Maximum Allowable Flow Depth and Spread)

Project: **Claremont Business Park 2 Filing 2 (Proposed Conditions)**
 Inlet ID: **Inlet 5 (DP12)**

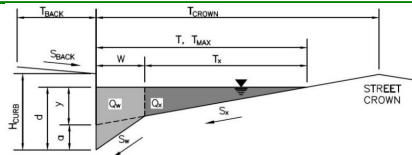

Gutter Geometry:									
Maximum Allowable Width for Spread Behind Curb	$T_{BACK} = 7.5$ ft								
Side Slope Behind Curb (leave blank for no conveyance credit behind curb)	$S_{BACK} = 0.020$ ft/ft								
Manning's Roughness Behind Curb (typically between 0.012 and 0.020)	$n_{BACK} = 0.020$								
Height of Curb at Gutter Flow Line	$H_{CURB} = 6.00$ inches								
Distance from Curb Face to Street Crown	$T_{CROWN} = 17.0$ ft								
Gutter Width	$W = 2.00$ ft								
Street Transverse Slope	$S_x = 0.020$ ft/ft								
Gutter Cross Slope (typically 2 inches over 24 inches or 0.083 ft/ft)	$S_w = 0.083$ ft/ft								
Street Longitudinal Slope - Enter 0 for sump condition	$S_o = 0.010$ ft/ft								
Manning's Roughness for Street Section (typically between 0.012 and 0.020)	$n_{STREET} = 0.015$								
Max. Allowable Spread for Minor & Major Storm	<table border="1"> <tr> <td></td> <td>Minor Storm</td> <td>Major Storm</td> <td>ft</td> </tr> <tr> <td>$T_{MAX} =$</td> <td>15.8</td> <td>17.0</td> <td></td> </tr> </table>		Minor Storm	Major Storm	ft	$T_{MAX} =$	15.8	17.0	
	Minor Storm	Major Storm	ft						
$T_{MAX} =$	15.8	17.0							
Max. Allowable Depth at Gutter Flowline for Minor & Major Storm	<table border="1"> <tr> <td></td> <td>Minor Storm</td> <td>Major Storm</td> <td>inches</td> </tr> <tr> <td>$d_{MAX} =$</td> <td>4.6</td> <td>7.8</td> <td></td> </tr> </table>		Minor Storm	Major Storm	inches	$d_{MAX} =$	4.6	7.8	
	Minor Storm	Major Storm	inches						
$d_{MAX} =$	4.6	7.8							
Allow Flow Depth at Street Crown (check box for yes, leave blank for no)	<table border="1"> <tr> <td></td> <td>Minor Storm</td> <td>Major Storm</td> </tr> <tr> <td></td> <td><input type="checkbox"/></td> <td><input type="checkbox"/></td> </tr> </table>		Minor Storm	Major Storm		<input type="checkbox"/>	<input type="checkbox"/>		
	Minor Storm	Major Storm							
	<input type="checkbox"/>	<input type="checkbox"/>							
MINOR STORM Allowable Capacity is based on Depth Criterion									
MAJOR STORM Allowable Capacity is based on Spread Criterion									
Minor storm max. allowable capacity GOOD - greater than the design peak flow of 2.80 cfs on sheet 'Inlet Management'									
Major storm max. allowable capacity GOOD - greater than the design peak flow of 8.10 cfs on sheet 'Inlet Management'									
$Q_{allow} =$	<table border="1"> <tr> <td></td> <td>Minor Storm</td> <td>Major Storm</td> <td>cfs</td> </tr> <tr> <td></td> <td>5.9</td> <td>11.6</td> <td></td> </tr> </table>		Minor Storm	Major Storm	cfs		5.9	11.6	
	Minor Storm	Major Storm	cfs						
	5.9	11.6							

INLET ON A CONTINUOUS GRADE

MHFD-Inlet, Version 5.02 (August 2022)

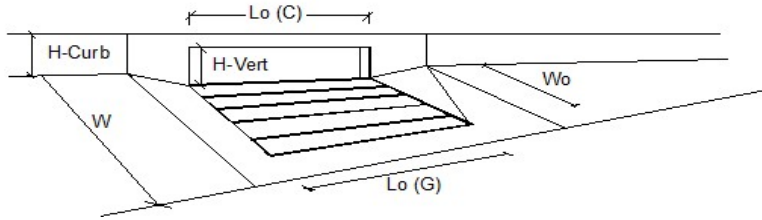

Design Information (Input)	MINOR	MAJOR	
Type of Inlet	CDOT Type R Curb Opening		
Local Depression (additional to continuous gutter depression 'a')	3.0	3.0	inches
Total Number of Units in the Inlet (Grate or Curb Opening)	3	3	
Length of a Single Unit Inlet (Grate or Curb Opening)	5.00	5.00	ft
Width of a Unit Grate (cannot be greater than W, Gutter Width)	N/A	N/A	ft
Clogging Factor for a Single Unit Grate (typical min. value = 0.5)	N/A	N/A	
Clogging Factor for a Single Unit Curb Opening (typical min. value = 0.1)	0.10	0.10	
Street Hydraulics: OK - Q < Allowable Street Capacity			
Total Inlet Interception Capacity	Q = 2.8	7.8	cfs
Total Inlet Carry-Over Flow (flow bypassing inlet)	Q_b = 0.0	0.3	cfs
Capture Percentage = Q _i /Q _s	C% = 100	96	%

ALLOWABLE CAPACITY FOR ONE-HALF OF STREET (Minor & Major Storm)

(Based on Regulated Criteria for Maximum Allowable Flow Depth and Spread)

Project: **Claremont Business Park 2 Filing 2 (Proposed Conditions)**

Inlet ID: **Inlet 6 (DP13)**

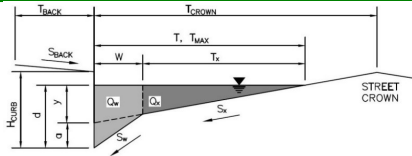

Gutter Geometry:									
Maximum Allowable Width for Spread Behind Curb	$T_{BACK} = 7.5$ ft								
Side Slope Behind Curb (leave blank for no conveyance credit behind curb)	$S_{BACK} = 0.020$ ft/ft								
Manning's Roughness Behind Curb (typically between 0.012 and 0.020)	$n_{BACK} = 0.020$								
Height of Curb at Gutter Flow Line	$H_{CURB} = 6.00$ inches								
Distance from Curb Face to Street Crown	$T_{CROWN} = 17.0$ ft								
Gutter Width	$W = 2.00$ ft								
Street Transverse Slope	$S_x = 0.020$ ft/ft								
Gutter Cross Slope (typically 2 inches over 24 inches or 0.083 ft/ft)	$S_y = 0.083$ ft/ft								
Street Longitudinal Slope - Enter 0 for sump condition	$S_o = 0.010$ ft/ft								
Manning's Roughness for Street Section (typically between 0.012 and 0.020)	$n_{STREET} = 0.015$								
Max. Allowable Spread for Minor & Major Storm	<table border="1"> <tr> <th></th> <th>Minor Storm</th> <th>Major Storm</th> <th></th> </tr> <tr> <td>T_{MAX}</td> <td>15.8</td> <td>17.0</td> <td>ft</td> </tr> </table>		Minor Storm	Major Storm		T_{MAX}	15.8	17.0	ft
	Minor Storm	Major Storm							
T_{MAX}	15.8	17.0	ft						
Max. Allowable Depth at Gutter Flowline for Minor & Major Storm	<table border="1"> <tr> <th></th> <th>Minor Storm</th> <th>Major Storm</th> <th></th> </tr> <tr> <td>d_{MAX}</td> <td>4.6</td> <td>7.8</td> <td>inches</td> </tr> </table>		Minor Storm	Major Storm		d_{MAX}	4.6	7.8	inches
	Minor Storm	Major Storm							
d_{MAX}	4.6	7.8	inches						
Allow Flow Depth at Street Crown (check box for yes, leave blank for no)	<table border="1"> <tr> <th></th> <th>Minor Storm</th> <th>Major Storm</th> </tr> <tr> <td></td> <td><input type="checkbox"/></td> <td><input type="checkbox"/></td> </tr> </table>		Minor Storm	Major Storm		<input type="checkbox"/>	<input type="checkbox"/>		
	Minor Storm	Major Storm							
	<input type="checkbox"/>	<input type="checkbox"/>							
MINOR STORM Allowable Capacity is based on Depth Criterion									
MAJOR STORM Allowable Capacity is based on Spread Criterion									
Minor storm max. allowable capacity GOOD - greater than the design peak flow of 1.00 cfs on sheet 'Inlet Management'									
Major storm max. allowable capacity GOOD - greater than the design peak flow of 5.00 cfs on sheet 'Inlet Management'									
Q_{allow}	<table border="1"> <tr> <th></th> <th>Minor Storm</th> <th>Major Storm</th> <th></th> </tr> <tr> <td></td> <td>5.9</td> <td>11.6</td> <td>cfs</td> </tr> </table>		Minor Storm	Major Storm			5.9	11.6	cfs
	Minor Storm	Major Storm							
	5.9	11.6	cfs						

INLET ON A CONTINUOUS GRADE

MHFD-Inlet, Version 5.02 (August 2022)

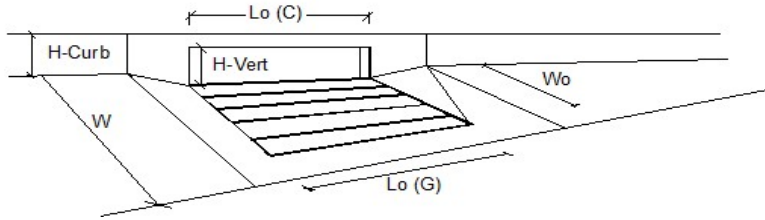

Design Information (Input)	MINOR	MAJOR	
Type of Inlet	CDOT Type R Curb Opening		
Local Depression (additional to continuous gutter depression 'a')	3.0	3.0	inches
Total Number of Units in the Inlet (Grate or Curb Opening)	3	3	
Length of a Single Unit Inlet (Grate or Curb Opening)	5.00	5.00	ft
Width of a Unit Grate (cannot be greater than W, Gutter Width)	N/A	N/A	ft
Clogging Factor for a Single Unit Grate (typical min. value = 0.5)	N/A	N/A	
Clogging Factor for a Single Unit Curb Opening (typical min. value = 0.1)	0.10	0.10	
Street Hydraulics: OK - Q < Allowable Street Capacity			
Total Inlet Interception Capacity	Q = 1.0	Q = 5.0	cfs
Total Inlet Carry-Over Flow (flow bypassing inlet)	Q _b = 0.0	Q _b = 0.0	cfs
Capture Percentage = Q _i /Q _s	C% = 100	C% = 100	%

AREA INLET IN A SWALE

Claremont Business Park 2 Filing 2 (Proposed Conditions)
Inlet 7 (DP18)

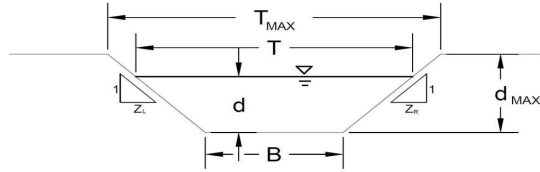

This worksheet uses the NRCS vegetal retardance method to determine Manning's n.

For more information see Section 7.2.3 of the USDCM.

Analysis of Trapezoidal Grass-Lined Channel Using SCS Method																
NRCS Vegetal Retardance (A, B, C, D, or E)			A, B, C, D, or E =													
Manning's n (Leave cell D16 blank to manually enter an n value)			n = 0.025													
Channel Invert Slope			S ₀ = 0.1200 ft/ft													
Bottom Width			B = 0.00 ft													
Left Side Slope			Z ₁ = 3.00 ft/ft													
Right Side Slope			Z ₂ = 3.00 ft/ft													
Check one of the following soil types:																
Soil Type:	Max. Velocity (V _{MAX})	Max Froude No. (F _{MAX})														
Non-Cohesive	5.0 fps	0.60	Choose One: <input type="radio"/> Non-Cohesive <input checked="" type="radio"/> Cohesive <input type="radio"/> Paved													
Cohesive	7.0 fps	0.80														
Paved	N/A	N/A														
Maximum Allowable Top Width of Channel for Minor & Major Storm			<table border="1" style="width: 100%; text-align: center;"> <tr> <td></td> <td>Minor Storm</td> <td>Major Storm</td> <td></td> </tr> <tr> <td>T_{MAX} =</td> <td>1.92</td> <td>2.40</td> <td>ft</td> </tr> </table>			Minor Storm	Major Storm		T _{MAX} =	1.92	2.40	ft				
	Minor Storm	Major Storm														
T _{MAX} =	1.92	2.40	ft													
Maximum Allowable Water Depth in Channel for Minor & Major Storm			<table border="1" style="width: 100%; text-align: center;"> <tr> <td></td> <td>Minor Storm</td> <td>Major Storm</td> <td></td> </tr> <tr> <td>d_{MAX} =</td> <td>0.32</td> <td>0.40</td> <td>ft</td> </tr> </table>			Minor Storm	Major Storm		d _{MAX} =	0.32	0.40	ft				
	Minor Storm	Major Storm														
d _{MAX} =	0.32	0.40	ft													
Allowable Channel Capacity Based On Channel Geometry MINOR STORM Allowable Capacity is based on Depth Criterion MAJOR STORM Allowable Capacity is based on Depth Criterion			<table border="1" style="width: 100%; text-align: center;"> <tr> <td></td> <td>Minor Storm</td> <td>Major Storm</td> <td></td> </tr> <tr> <td>Q_{allow} =</td> <td>1.8</td> <td>3.3</td> <td>cfs</td> </tr> <tr> <td>d_{allow} =</td> <td>0.32</td> <td>0.40</td> <td>ft</td> </tr> </table>			Minor Storm	Major Storm		Q _{allow} =	1.8	3.3	cfs	d _{allow} =	0.32	0.40	ft
	Minor Storm	Major Storm														
Q _{allow} =	1.8	3.3	cfs													
d _{allow} =	0.32	0.40	ft													
Water Depth in Channel Based On Design Peak Flow Design Peak Flow Water Depth			<table border="1" style="width: 100%; text-align: center;"> <tr> <td></td> <td>0.7</td> <td>1.3</td> <td>cfs</td> </tr> <tr> <td>Q_o =</td> <td></td> <td></td> <td></td> </tr> <tr> <td>d =</td> <td>0.22</td> <td>0.28</td> <td>ft</td> </tr> </table>			0.7	1.3	cfs	Q _o =				d =	0.22	0.28	ft
	0.7	1.3	cfs													
Q _o =																
d =	0.22	0.28	ft													
Minor storm max. allowable capacity GOOD - greater than the design flow given on sheet 'Inlet Management' Major storm max. allowable capacity GOOD - greater than the design flow given on sheet 'Inlet Management'																

MHFD-Inlet, Version 5.02 (August 2022)
AREA INLET IN A SWALE

Claremont Business Park 2 Filing 2 (Proposed Conditions)
Inlet 7 (DP18)

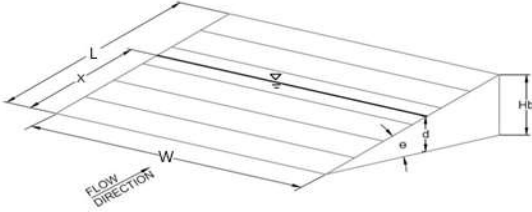
Inlet Design Information (Input)																					
Type of Inlet	CDOT Type C (Depressed)																				
Inlet Type =	CDOT Type C (Depressed)																				
Angle of Inclined Grate (must be <= 30 degrees)	$\theta = 0.00$ degrees																				
Width of Grate	$W = 3.00$ ft																				
Length of Grate	$L = 3.00$ ft																				
Open Area Ratio	$A_{RATIO} = 0.70$																				
Height of Inclined Grate	$H_B = 0.00$ ft																				
Clogging Factor	$C_f = 0.50$																				
Grate Discharge Coefficient	$C_d = 0.84$																				
Orifice Coefficient	$C_o = 0.56$																				
Weir Coefficient	$C_w = 1.81$																				
																					
Water Depth at Inlet (for depressed inlets, 1 foot is added for depression)																					
Total Inlet Interception Capacity (assumes clogged condition)																					
Bypassed Flow																					
Capture Percentage = Q_a/Q_o																					
	<table border="1"> <thead> <tr> <th></th> <th>MINOR</th> <th>MAJOR</th> <th></th> </tr> </thead> <tbody> <tr> <td>$d =$</td> <td>1.22</td> <td>1.28</td> <td></td> </tr> <tr> <td>$Q_a =$</td> <td>15.7</td> <td>16.1</td> <td>cfs</td> </tr> <tr> <td>$Q_b =$</td> <td>0.0</td> <td>0.0</td> <td>cfs</td> </tr> <tr> <td>$C\% =$</td> <td>100</td> <td>100</td> <td>%</td> </tr> </tbody> </table>		MINOR	MAJOR		$d =$	1.22	1.28		$Q_a =$	15.7	16.1	cfs	$Q_b =$	0.0	0.0	cfs	$C\% =$	100	100	%
	MINOR	MAJOR																			
$d =$	1.22	1.28																			
$Q_a =$	15.7	16.1	cfs																		
$Q_b =$	0.0	0.0	cfs																		
$C\% =$	100	100	%																		

Warning 04: Froude No. exceeds USDCM Volume I recommendation.



CIVIL CONSULTANTS, INC.

212 N. Wahsatch Ave., Ste. 305
Colorado Springs, CO
719.955.5485

Project: CUREMONT BUSINESS PARK 2 FILING 2
Date: RIPRAP APPROX CUR.

2-12-22

Prop 18" RCP (Pipe Run 6)

$$n = 0.013 \quad D = 1.5'$$

$$S = 0.005 \quad Q_{100} = 3.9 \text{ cfs}$$

$$TW = \text{min} = 0.4 D = 0.4 (1.5) = 0.6$$

Flow is supercritical $\frac{y_0}{D_0} = \frac{9.3''}{4.25} = 0.775$

$$D' = \frac{(D + y_0)}{2}$$

$$D' = (1.5 + .78) / 2 = 1.14'$$

$$D_{50} = 0.2 (1.14) \left(\frac{3.9}{1.482 \cdot (1.14)^{2.5}} \right)^{4/3} \left(\frac{1.14}{0.6} \right) = 0.003 < 1''$$

Use $D_{50} = 9''$ Depth = $2.0 \times D_{50} = 1.5'$

$$L = 4.0 \times D = 6.0'$$

$$\begin{aligned} \text{END WIDTH} &= 3.0 + D + 2/3 L \\ &= 8.5' \end{aligned}$$



CIVIL CONSULTANTS, INC.

05-22-23

212 N. Wahsatch Ave., Ste. 305
Colorado Springs, CO
719.955.5485

Project: CLAREMONT BUSINESS PARK 2 FILLING 2

Date: RIPRAP AREA CALC.

PROPOSED 18" RCP (PER RUN GA)

$$n = 0.013$$

$$D = 1.5'$$

$$S = 0.01$$

$$Q_{100} = 11.6 \text{ cfs} \quad \text{BASINS C, C}_1, D, D_1$$

$$T_w = \text{min} = 0.4 \times 1.5 = 0.6$$

FLOW IS SUPERCRITICAL (FLOWMASTER) $y_0 = 1.4$

$$V_0 = 7.26 \text{ ft/s}$$

$$D' = \frac{D + y_0}{2} = \frac{1.5 + 1.4}{2} = 1.45$$

$$D_{50} = 0.2 (1.45) \left(\frac{11.6}{\sqrt{32.2} \times (1.45)^{2.5}} \right)^{4/3} \left(\frac{1.45}{0.6} \right) = 0.53 < 1''$$

$$\text{USE } D_{50} = 9'' \quad \text{DEPTH} = 2.0 \times D_{50} = 18''$$

$$L = 4.0 \times 1.5 = 6.0$$

$$\begin{aligned} \text{END WIDTH} &= 3.0 \times D + \frac{2}{3} L \\ &= 3.0 \times 1.5 + \frac{2}{3} (6) = 8.5' \end{aligned}$$

CLAREMONT BUSINESS PARK INDEX MAP

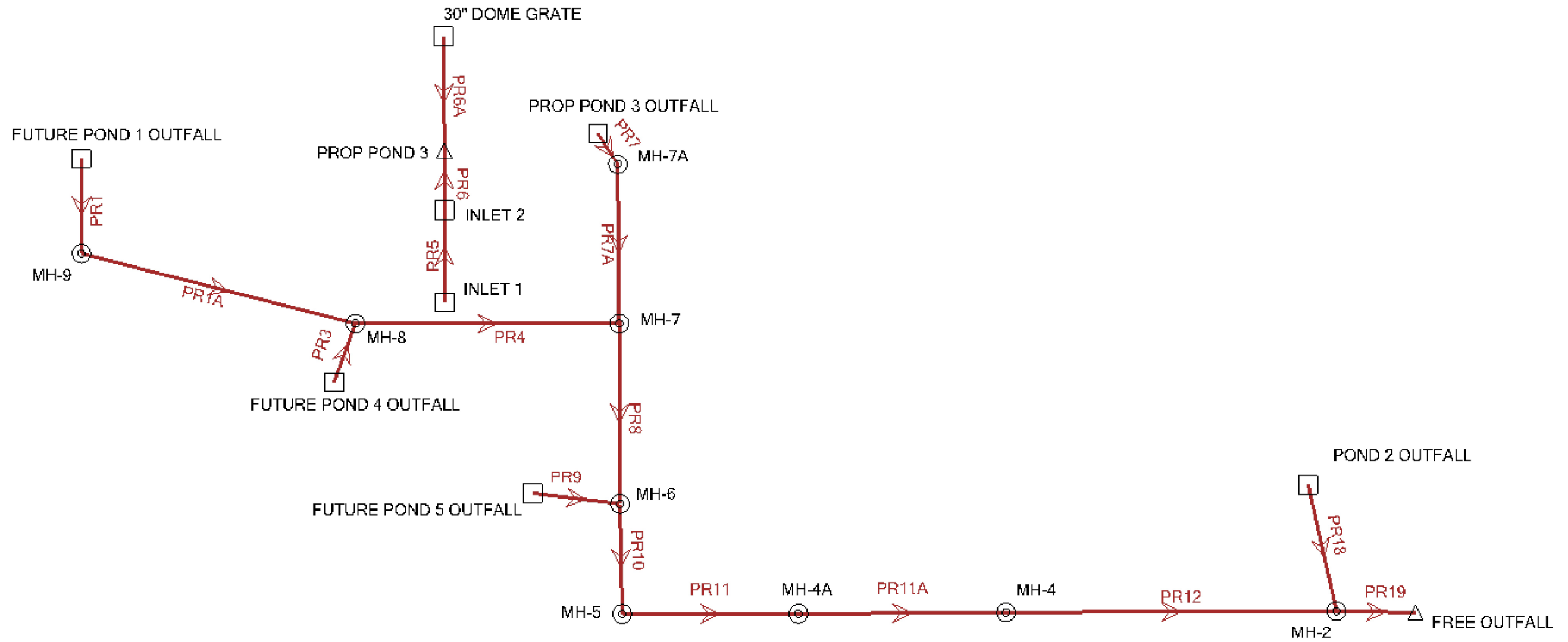

Conduit FlexTable: CBP 2 STRM 100 YR

Label	Upstream Structure	Flow (cfs)	Length (Unified) (ft)	Velocity (ft/s)	Depth (Normal) (ft)	Depth (Critical) (ft)	Hydraulic Grade Line (In) (ft)	Hydraulic Grade Line (Out) (ft)	Headloss (ft)	Upstream Structure Hydraulic Grade Line (In) (ft)	Upstream Structure Velocity (In-Governing) (ft/s)	Upstream Structure Headloss Coefficient	Upstream Structure Headloss (ft)	Elevation Ground (Start) (ft)	Elevation Ground (Stop) (ft)
PR10	MH-6	13.80	30.0	5.73	1.43	1.34	6,366.96	6,366.88	0.08	6,367.27	3.67	0.900	0.32	6,373.76	6,374.49
PR19	MH-2	37.60	23.2	10.39	1.41	1.90	6,358.90	6,358.31	0.59	6,359.69	6.75	1.020	0.78	6,367.70	6,367.74
PR12	MH-4	13.80	239.6	6.40	1.30	1.34	6,361.41	6,359.80	1.61	6,361.44	11.85	0.050	0.03	6,367.74	6,370.58
PR18	POND 2 OUTFALL	23.80	39.7	17.12	0.82	1.66	6,362.19	6,359.69	2.50	6,363.29	6.87	1.500	1.10	6,366.20	6,367.74
PR9	FUTURE POND 5 OUTFALL	3.00	20.6	5.07	0.55	0.66	6,368.44	6,368.14	0.30	6,368.81	4.02	1.500	0.38	6,369.78	6,374.49
PR8	MH-7	10.70	181.1	5.44	1.20	1.17	6,367.62	6,367.27	0.35	6,368.32	2.33	1.520	0.70	6,375.45	6,374.49
PR4	MH-8	6.70	119.5	4.87	0.90	0.92	6,371.26	6,370.64	0.62	6,371.88	0.76	1.770	0.62	6,376.02	6,375.45
PR1A	MH-9	5.70	137.3	7.66	0.66	0.92	6,374.33	6,371.88	2.45	6,374.85	3.97	1.320	0.51	6,379.87	6,376.02
PR7A	MH-7A	4.00	60.6	4.32	0.78	0.77	6,368.37	6,368.32	0.05	6,368.58	3.02	1.770	0.21	6,376.55	6,375.45
PR1	FUTURE POND 1 OUTFALL	5.70	70.4	4.78	0.96	0.92	6,375.05	6,374.85	0.21	6,375.58	4.76	1.500	0.53	6,378.00	6,379.87
PR5	INLET 1	1.70	37.3	0.96	0.49	0.49	6,373.48	6,373.47	0.01	6,373.50	0.96	1.500	0.02	6,375.11	6,375.11
PR7	PROP POND 3 OUTFALL	4.00	14.9	4.18	0.80	0.77	6,368.60	6,368.58	0.02	6,368.84	3.21	1.500	0.24	6,371.80	6,376.55
PR6	INLET 2	3.90	21.5	2.21	0.66	0.76	6,373.39	6,373.36	0.03	6,373.47	0.96	1.100	0.08	6,375.11	6,370.35
PR3	FUTURE POND 4 OUTFALL	1.00	11.4	2.98	0.37	0.37	6,371.88	6,371.88	0.00	6,371.90	0.82	1.500	0.02	6,376.02	6,374.00
PR11A	MH-4A	13.80	115.8	11.86	0.80	1.34	6,365.52	6,361.10	4.42	6,365.55	6.18	0.050	0.03	6,370.58	6,372.41
PR11	MH-5	13.80	84.3	5.72	1.44	1.34	6,366.21	6,365.69	0.52	6,366.88	4.62	1.320	0.67	6,372.41	6,373.76
PR6A	30" DOME GRATE	11.60	27.3	6.56	(N/A)	1.30	6,373.69	6,373.36	0.33	6,374.70	6.56	1.500	1.00	6,370.35	6,375.00

Invert (Start) (ft)	Invert (Stop) (ft)	Conduit Description	Manning's n	Slope (Calculated) (ft/ft)
PR10 6,365.07	6,365.22	Circle - 24.0 in	0.013	-0.005
PR19 6,356.72	6,357.00	Circle - 42.0 in	0.013	-0.012
PR12 6,358.50	6,360.07	Circle - 24.0 in	0.013	-0.007
PR18 6,360.53	6,358.00	Circle - 30.0 in	0.013	0.064
PR9 6,367.78	6,367.58	Circle - 18.0 in	0.013	0.010
PR8 6,366.42	6,365.52	Circle - 24.0 in	0.013	0.005
PR4 6,370.34	6,369.74	Circle - 24.0 in	0.013	0.005
PR1A 6,373.41	6,370.84	Circle - 18.0 in	0.013	0.019
PR7A 6,367.23	6,366.92	Circle - 18.0 in	0.013	0.005
PR1 6,374.09	6,373.71	Circle - 18.0 in	0.013	0.005
PR5 6,371.03	6,370.84	Circle - 18.0 in	0.013	0.005
PR7 6,367.60	6,367.53	Circle - 18.0 in	0.013	0.005
PR6 6,370.54	6,370.35	Circle - 18.0 in	0.013	0.009
PR3 6,370.84	6,370.90	Circle - 18.0 in	0.013	-0.005
PR11A 6,360.30	6,364.18	Circle - 24.0 in	0.013	-0.034
PR11 6,364.35	6,364.77	Circle - 24.0 in	0.013	-0.005
PR6A 6,370.35	6,370.62	Circle - 18.0 in	0.013	-0.010

Storm 1 - 100 yr

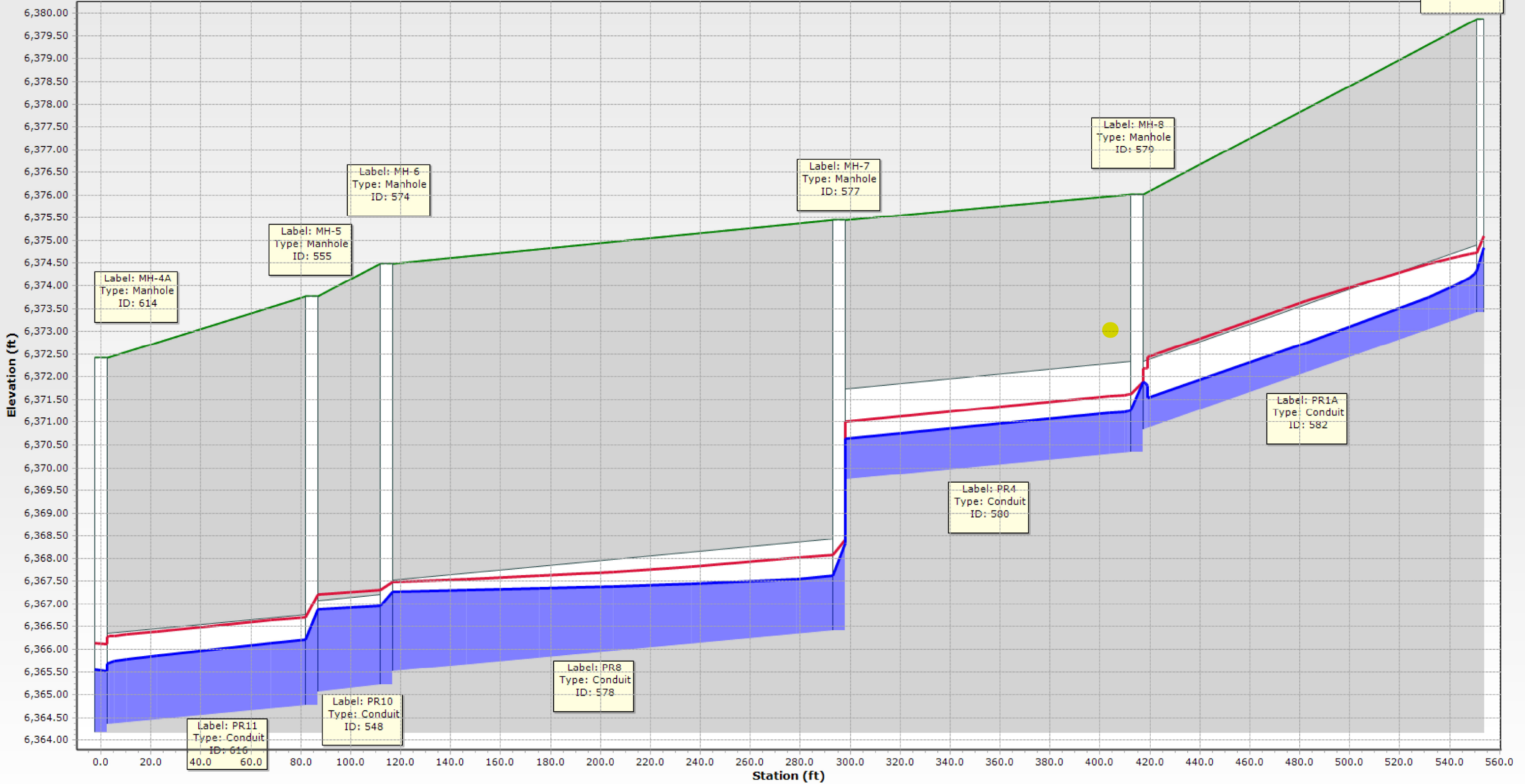

Storm 1 - Lat 1 - 100 yr

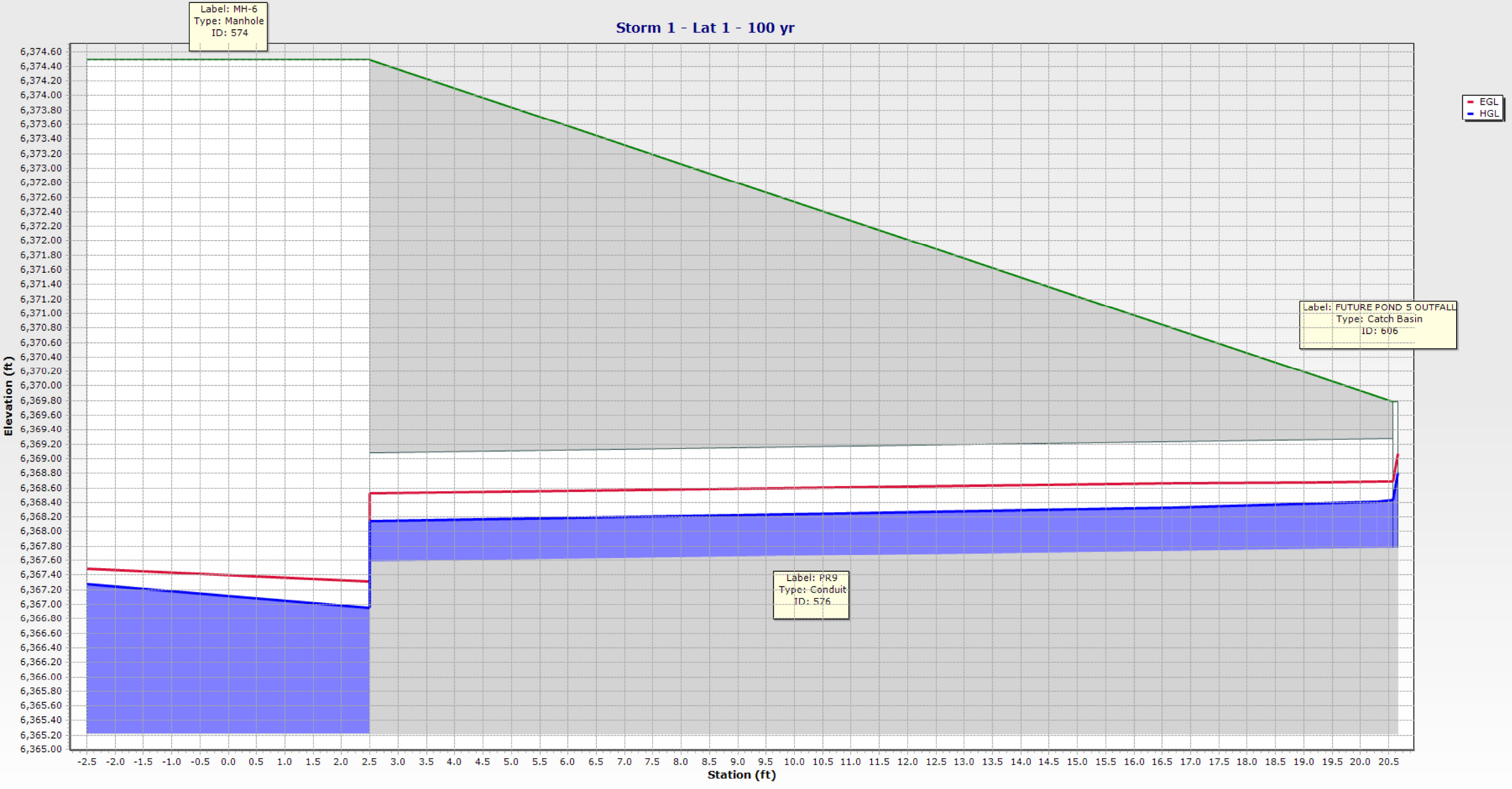

Label: MH-6
Type: Manhole
ID: 574

Label: FUTURE POND 5 OUTFALL
Type: Catch Basin
ID: 606

Label: PR9
Type: Conduit
ID: 576

EGL
HGL

Storm 1 - Lat 2 - 100 yr

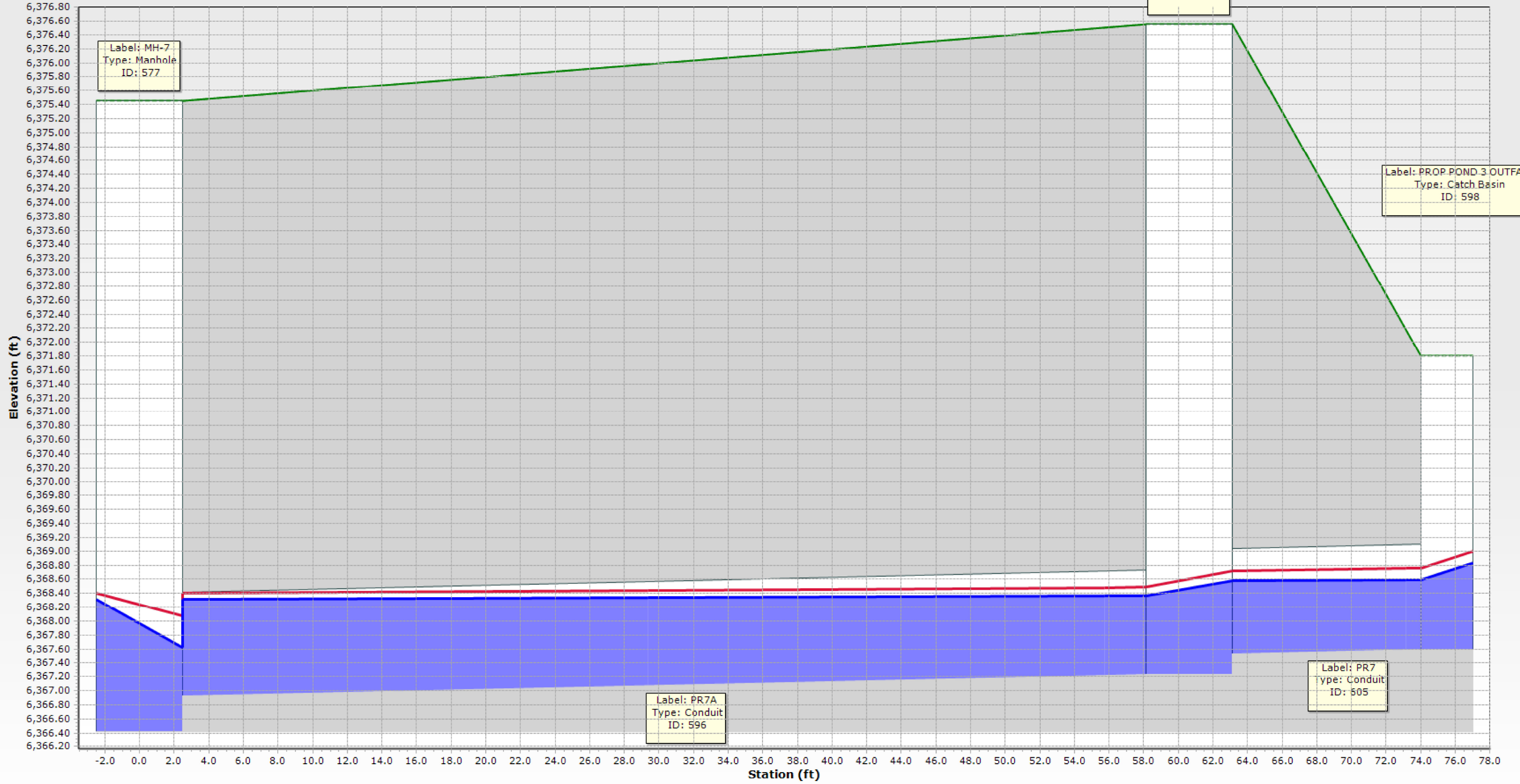

Storm 1 - Lat 3 - 100 yr

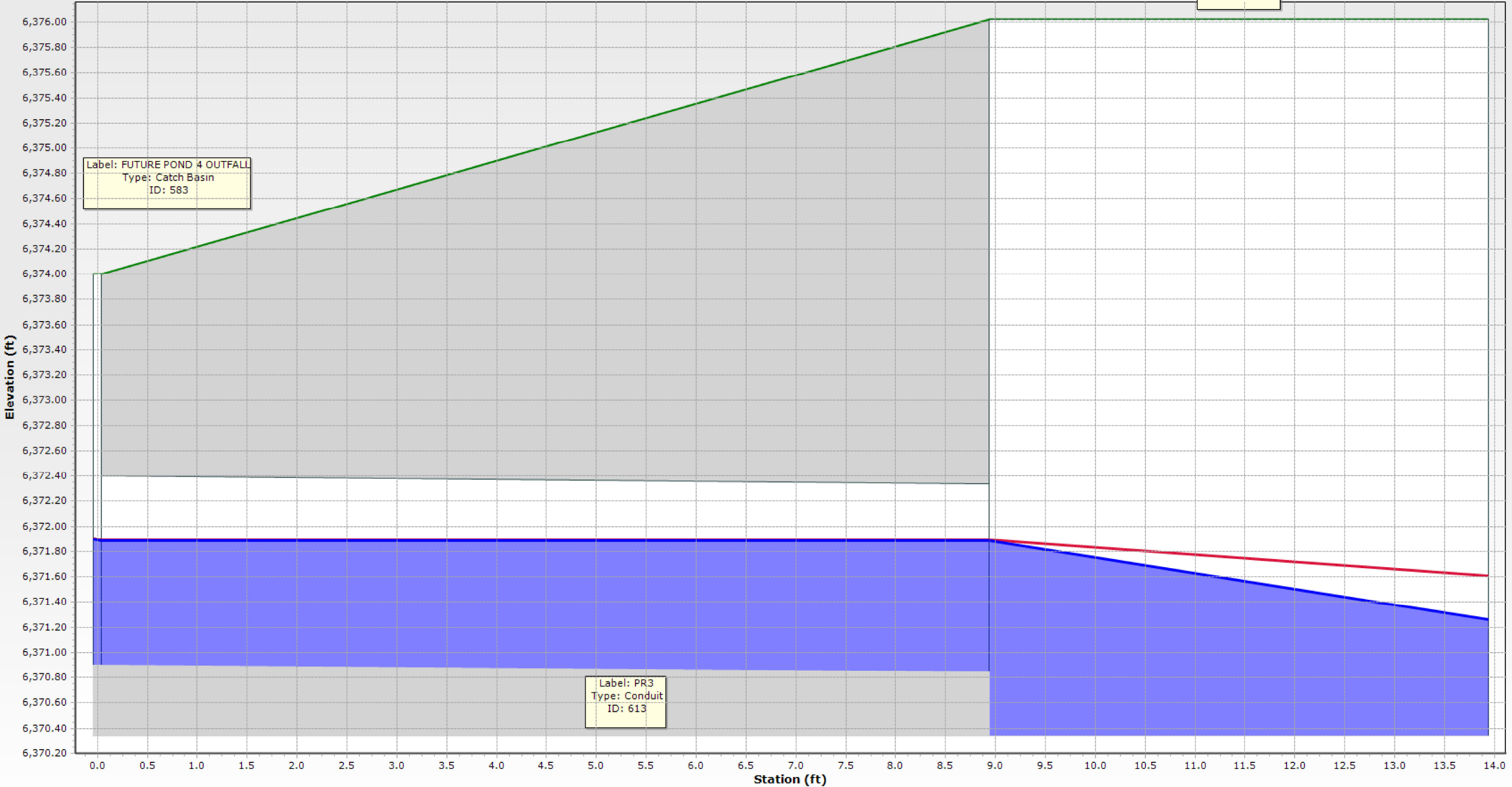

Label: FUTURE POND 4 OUTFALL
Type: Catch Basin
ID: 583

Label: PR3
Type: Conduit
ID: 613

Label: MH-8
Type: Manhole
ID: 579

EGL
HGL

Storm 1 - Lat 4 - 100 yr

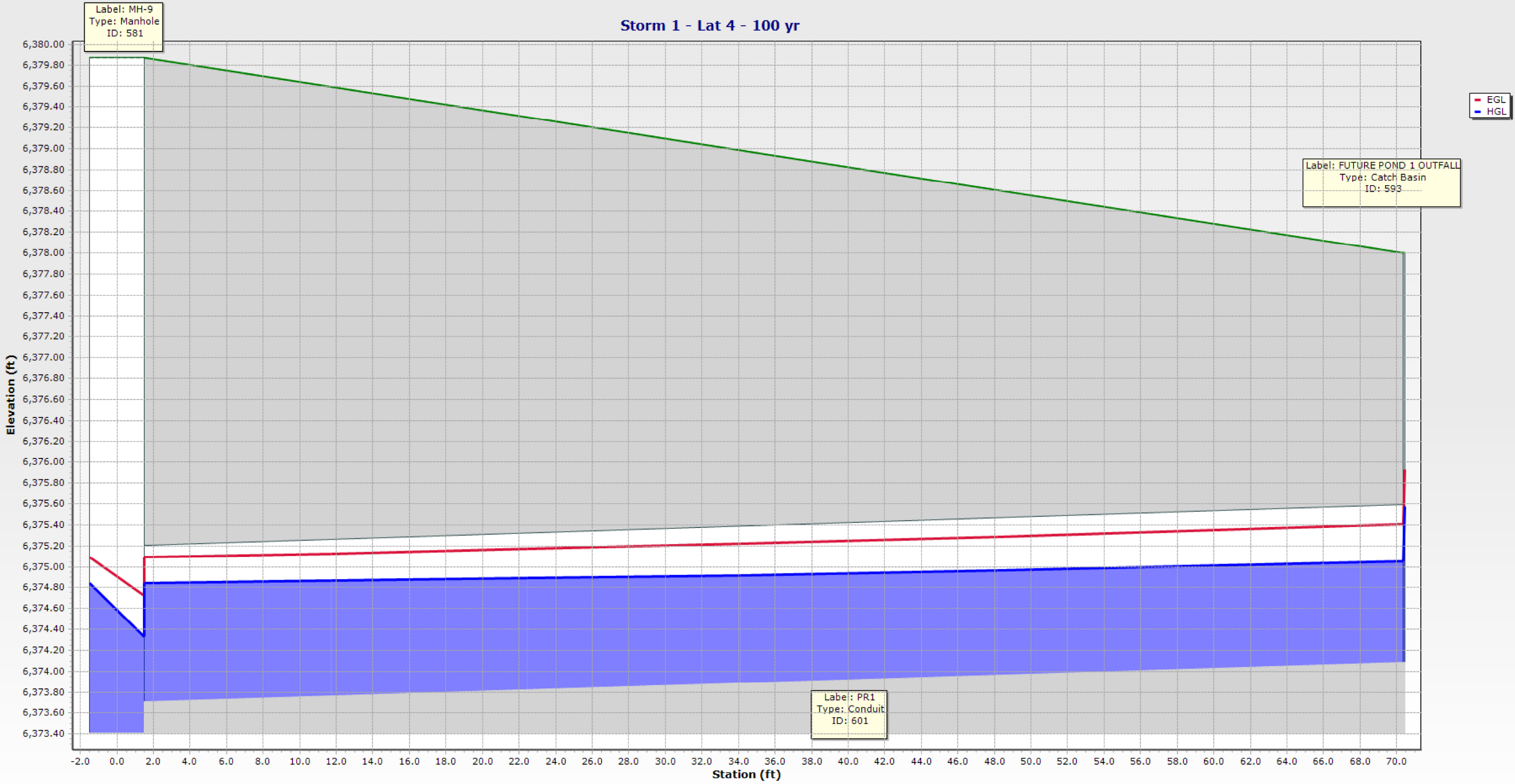

Storm 2 - 100 yr

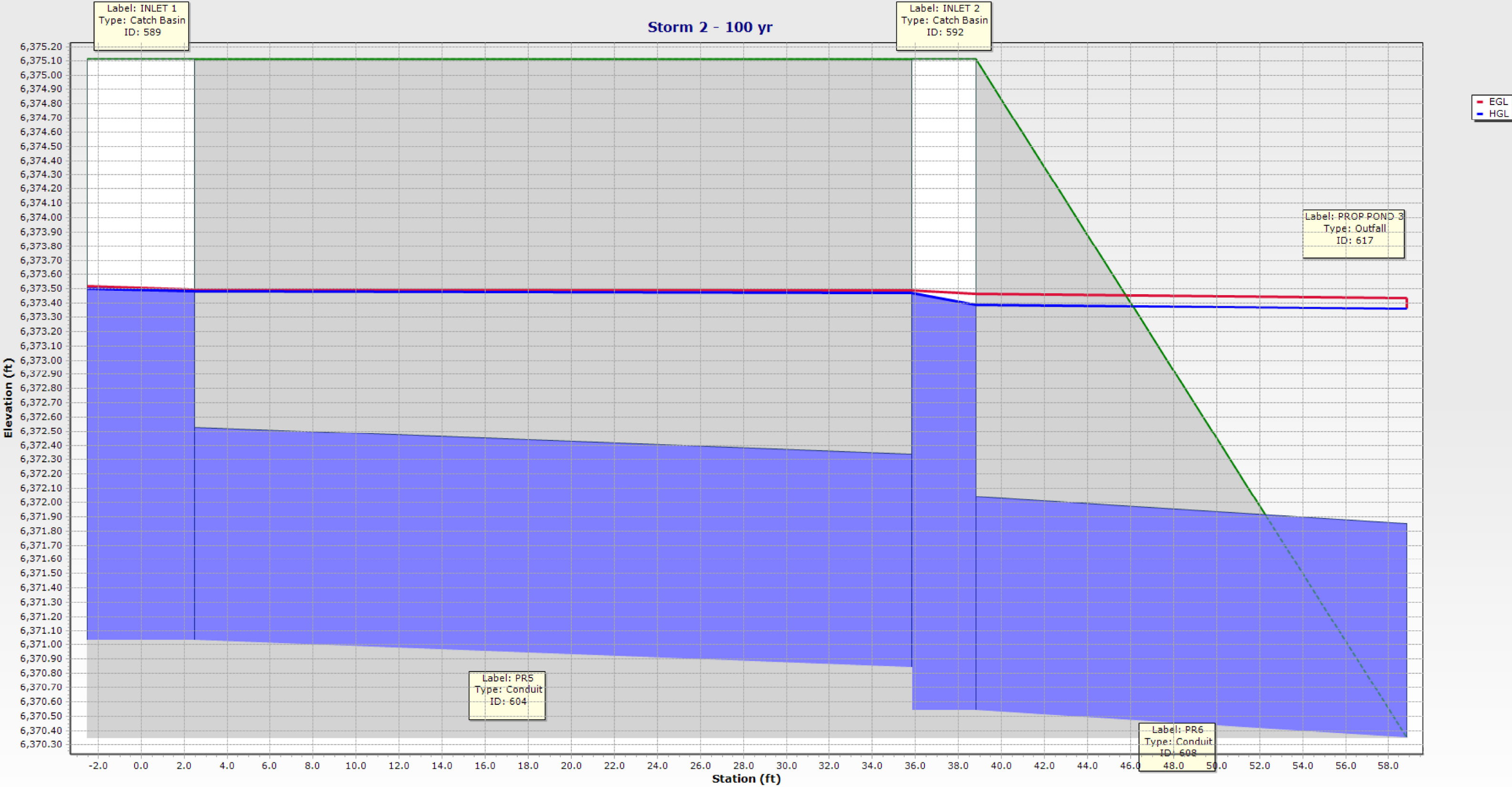

Storm 3 - 100 yr

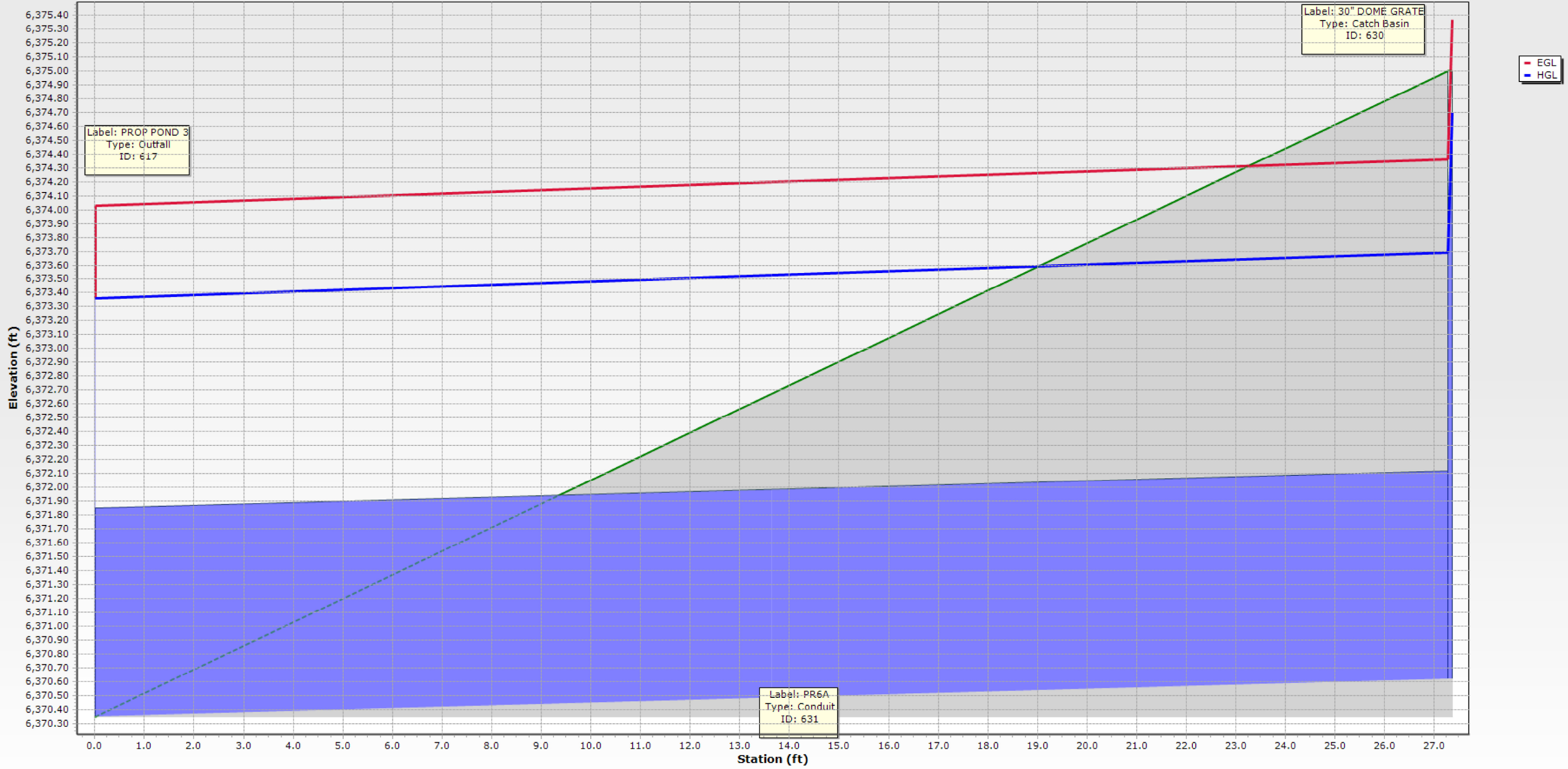

**EXCERPT OF "FINAL DRAINAGE REPORT FOR CLAREMONT
BUSINESS PARK FIL NO. 2 ", BY MATRIX DESIGN DATED
NOVEMBER 2006
&
EXISTING DRAINAGE MAP**



FINAL DRAINAGE REPORT
For
“Claremont Business Park Filing No. 2”

Prepared for:
El Paso County
Department of Public Works
Engineering Division

On Behalf of:
Claremont Development, Inc.

Prepared by:

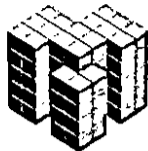

Matrix Design Group, Inc.
Integrated Design Solutions *Infrastructure Engineering*
Community Development
Program Management

2435 Research Parkway, Suite 300
Colorado Springs, CO 80920
(719) 575-0100
fax (719) 572-0208

Revised November 2006

Engineer's Statement:

The *revisions* (changes made to the base Final Drainage Report since July, 2006) to the attached drainage plan and report were prepared under my direction and supervision and are correct to the best of my knowledge and belief. The revisions encompassed adding additional right of way to the study area at the County's request, the handling of offsite drainage due to the additional right of way, a breakdown of private drainage within lot numbers 10 through 25 of Filing No. 2 due to cross-lot drainage (contrary to note # 25 on the recorded plat), profiling additional inlets along the channel edge, and rip-rap sizing for outlet structures along the channel. The Final Drainage Report dated July, 2006 was prepared under the direct supervision of Richard G. Gallegos, Jr. in July, 2006 and stamped (see next sheet).

The Final Drainage Report was prepared according to the criteria established by the County for drainage reports and said report is in conformity with the master plan of the drainage basin. I accept responsibility for any liability caused by any negligent acts, errors or omissions on my part in preparing the *revisions* to this report.

Brady A. Shyrock
Registered Professional Engineer
State of Colorado
No. 38164

SEAL



Engineer's Statement:

The attached drainage plan and report were prepared under my direction and supervision and are correct to the best of my knowledge and belief. Said drainage report has been prepared according to the criteria established by the County for drainage reports and said report is in conformity with the master plan of the drainage basin. I accept responsibility for any liability caused by any negligent acts, errors or omissions on my part in preparing this report.

SEAL

Richard G. Gallegos, Jr.
Registered Professional Engineer
State of Colorado
No. 36247

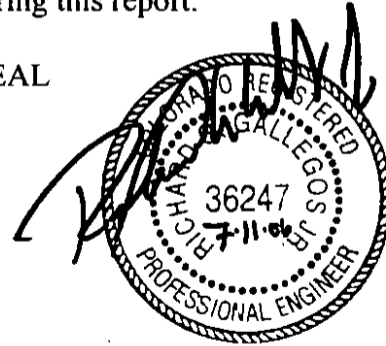

Developer's Statement:

I, the developer have read and will comply with all of the requirements specified in this drainage report and plan.

Claremont Development, Inc.
Business Name

By: _____

Title: _____

Address: 3460 Capital Drive
Colorado Springs, CO 80915

El Paso County:

Filed in accordance with Section 51.1 of the El Paso Land Development Code, as amended.

John Hamacher
Mr. John McCarty, County Engineer/Director

4/23/07
Date

Conditions:

D. Drainage and Bridge Fees

Claremont Business Park Filing No. 2 has not been previously platted. The drainage basin and bridge fees have been determined per the El Paso County Drainage Basin Fees Sheet, dated February 3, 2006, Resolution No. 06-31. The site is located entirely within the Sand Creek Drainage Basin. The fees are based upon the percent impervious of the development, which have been included within the appendix of this report. The fees due have been calculated as follows.

Claremont Business Park Filing No. 2
Final Drainage Report
Drainage and Bridge Fees

	Area (ac.)	Fee/Imp. Acre	% Imp.	Fee Due	Reimbursable Const. Costs	Fee Credit	Fee Due at Platting	Fee Credit Remaining
Drainage Fee	62.967	\$15,000.00	80%	\$755,604.00	\$0.00	\$1,225,355.45	\$0.00	\$469,751.45
Bridge Fee	62.967	\$1,503.00	80%	\$75,711.52	\$75,711.52	\$0.00	\$0.00	\$0.00
Total Fee Due at Platting							\$0.00	

The developer of Claremont Business Park is completing the construction of the channel improvements on behalf of the Central Marksheffel Metropolitan District. The construction costs for both Filing 1 and Filing 2 combined exceed the drainage fees due for the site. No drainage fees will be required at the time of platting.

It should be noted that the Central Marksheffel Business District is reimbursing the developer of Claremont Business Park Filing 2 for the construction costs of the channel minus the drainage fees due for the site. The District has \$1,225,355.45 of drainage credits available within the Sand Creek Basin. This credit amount is based upon the construction cost estimate for the channel minus the drainage fees assessed for Claremont Business Park Filing No. 1. The District will use an additional \$755,604.00 of the drainage credits for the platting of Claremont Business Park Filing No. 2. The District will have \$469,751.45 of drainage credits left within the Sand Creek Fee basin.

The Central Marksheffel Business District has also constructed the Marksheffel Road Bridge over East Fork Sand Creek. This structure has been identified as a needed public improvement within the Drainage Basin Planning Study for Sand Creek and is eligible for reimbursement. Since the construction of the Marksheffel Bridge is in excess of the \$75,711.52 in bridge fees due for this site, no bridge fees are required at the time of platting. The fee will be deducted from the eligible reimbursable construction costs of the bridge and the remaining credits will be utilized or reimbursement applied for by the Central Marksheffel Business District.

BOCC RESOLUTION 16-426

502
Chuck Broerman
11/28/2016 11:50:04 AM
Doc \$0.00 2
Rec \$0.00 Pages

EL PASO COUNTY, W

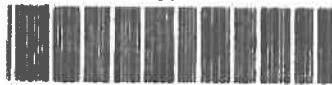

216137149

RESOLUTION NO. 16- 426

**BOARD OF COUNTY COMMISSIONERS
COUNTY OF EL PASO, STATE OF COLORADO**

Resolution Denying an Appeal by Hammers Construction LLC (APP-16-002) of the Administrative Determination made by the Planning and Community Development Department Executive Director regarding the requirement for permanent/post construction Water Quality (permanent stormwater quality best management practices or BMP's).

WHEREAS, pursuant to §§30-11-101(1)(e) and 30-11-107(1)(e), C.R.S., the Board of County Commissioners of El Paso County, Colorado (hereinafter "Board") has the legislative authority to manage the concerns of El Paso County when deemed by the Board to be in the best interests of the County and its inhabitants; and

WHEREAS, after consultation with the County Attorney's Office, the Executive Director of Planning and Community Development on August 4, 2016 issued an administrative determination finding made an administrative determination that all undeveloped lots within the Claremont Business Park are subject to installation of permanent stormwater management best management practices (BMP's) associated with development, and that the terms of a 2008 approved deviation relieving the developer of the requirements have not been met.; and

WHEREAS, an appeal of the administrative determination was filed by Hammers Construction on August 10, 2016, and a hearing date was set for September 27, 2016 to hear the appeal; and

WHEREAS, the hearing was continued to a date certain of November 22, 2016; and

WHEREAS, at the Applicant's appeal hearing on November 22, 2016, testimony from the Applicant and the Applicant's representatives was heard by the Board in favor of the appeal, testimony from representatives of Planning and Community Development Department and was presented, and such testimony and associated evidence was weighed by the Board; and

WHEREAS, the Board, having reviewed the testimony and evidence, hereby finds and determines that the requested appeal of the administrative determination by the Planning and Community Development Executive Director by the Applicant did not satisfy the criteria of approval to overturn the administrative determination.

NOW, THEREFORE, BE IT RESOLVED that the Board of County Commissioners of El Paso County, Colorado, hereby denies the appeal of the administrative determination by Hammers Construction and determines that permanent stormwater management best management practices (BMP's) are required with new development within the Claremont Business Park: and

BE IT FURTHER RESOLVED that Sallie Clark, duly elected, qualified member and Chair of the Board of County Commissioners, or Darryl Glenn, duly elected, qualified member and Vice Chair of the Board of County Commissioners, be and is hereby authorized on behalf of the Board to execute any and all documents necessary to carry out the intent of the Board as described herein.

DONE THIS 22nd day of November, 2016, at Colorado Springs Colorado.

**BOARD OF COUNTY COMMISSIONERS
EL PASO COUNTY, COLORADO**

ATTEST:  *Richard D. Broerman*
County Clerk & Recorder

By: *Sallie Clark*
Chair of the Board

EXISTING DRAINAGE MAP

FINAL DRAINAGE REPORT FOR CLAREMONT BUSINESS PARK 2 FILING NO.2

COUNTY OF EL PASO, STATE OF COLORADO

EXISTING CONDITIONS DRAINAGE MAP

MAY 2023

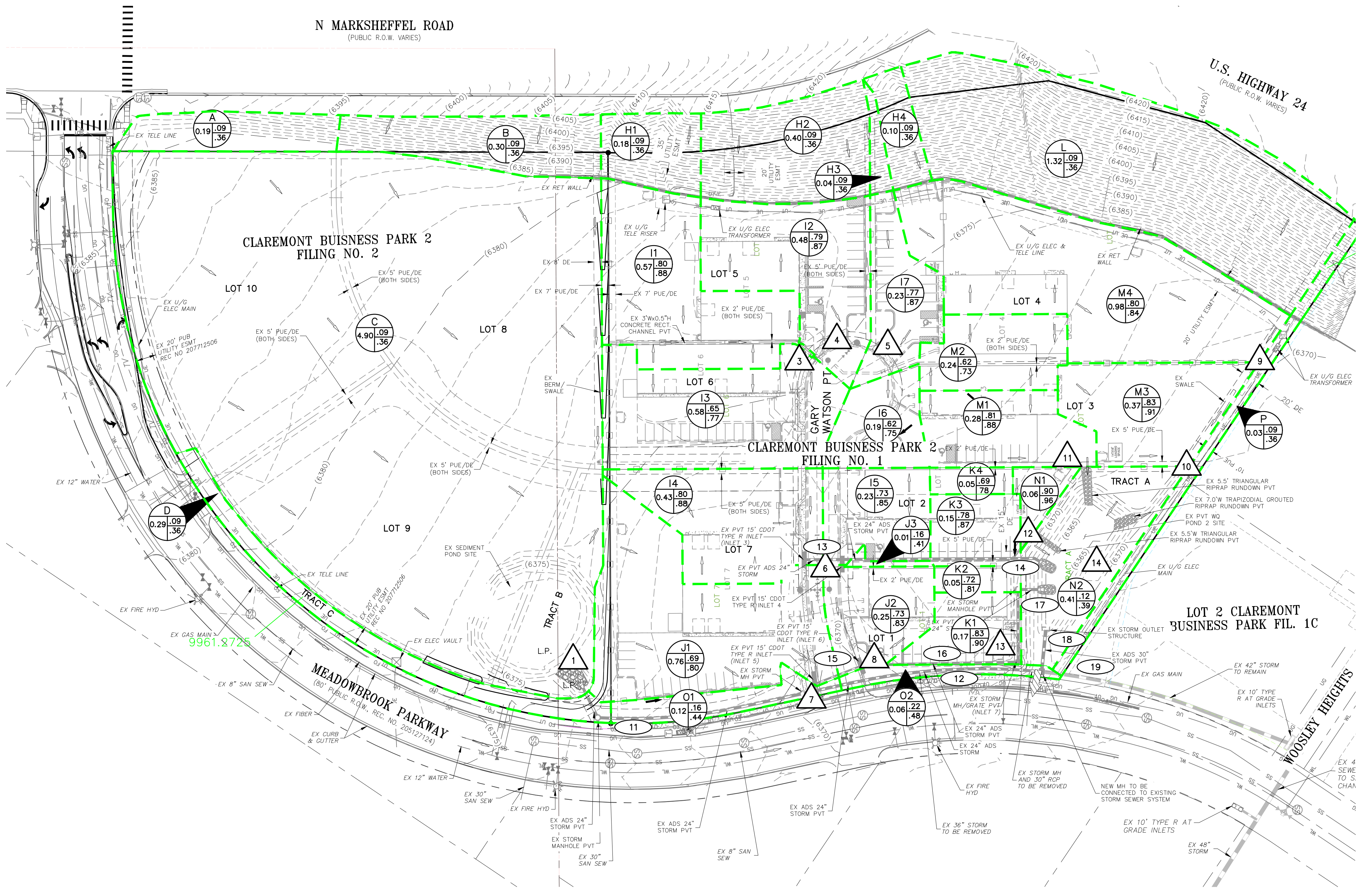

LEGEND

- BASIN DESIGNATION
- PIPE RUN REFERENCE LABEL
- SURFACE DESIGN POINT
- BASIN BOUNDARY
- EXISTING CONTOUR
- PROP CONTOUR
- UNDERGROUND ELECTRICAL
- EXISTING GAS LINE
- STORM SEWER PIPE
- EXISTING STORM SEWER PIPE
- CROSSSPAN
- INLET
- EXISTING FLOW DIRECTION ARROW
- EMERGENCY OVERTFLOW DIRECTION
- FLOW DIRECTION
- FLARED END SECTION
- HIGH POINT
- LOW POINT

BASIN SUMMARY

BASIN	AREA (ACRES)	Q ₅	Q ₁₀₀
A	0.19	0.1	0.6
B	0.30	0.1	1.0
C	4.90	1.6	10.7
D	0.23	0.1	0.7
H1	0.18	0.1	0.5
H2	0.40	0.2	1.1
H3	0.04	0.0	0.1
H4	0.10	0.0	0.3
I1	0.57	2.4	4.4
I2	0.48	2.0	3.6
I3	0.58	1.8	3.6
I4	0.43	1.8	3.3
I5	0.23	0.9	1.7
I6	0.19	0.6	1.2
I7	0.23	0.9	1.6
J1	0.76	2.4	4.7
J2	0.25	1.0	1.8
J3	0.01	0.0	0.1
K1	0.17	0.7	1.3
K2	0.05	0.2	0.4
K3	0.15	0.6	1.1
K4	0.06	0.2	0.4
L	1.32	0.5	3.7
M1	0.28	1.2	2.2
M2	0.24	0.8	1.5
M3	0.37	1.6	2.9
M4	0.98	3.5	6.6
N1	0.06	0.3	0.5
N2	0.41	0.2	1.1
O1	0.12	0.1	0.4
O2	0.06	0.1	0.3
P	0.11	0.0	0.3

DESIGN POINT SUMMARY

DESIGN POINT	Q ₅	Q ₁₀₀	BASIN	STRUCTURE
1	1.8	11.8	A, B, C	24" PP
2			USED	
3	2.2	4.4	H1, I1	EX STREET
4	1.8	4.1	H2, I2	EX STREET
5	0.8	1.6	H3, I7	EX STREET
6	8.2	16.5	DP3-5, I3-16	EX 15" INLETS
7	2.4	7.5	FB INLETS, J1	EX 15" INLET
8	0.9	4.1	FB INLET4, J2, J3	EX 15" INLET
9	3.8	9.7	H4, L, M4	EX SWALE
10	5.3	12.3	DP9, M2, M3	EX SWALE/RD
11	1.4	2.5	M1, K4	EX CONC. RD
12	1.1	2.0	K2, K3, N1	EX CONC. RD
13	0.7	1.3	K1	EX AREA INLET
14	19.3	43.9	DPT0-13, N2, PR14, PR17	EX FSD POND 2

STORM SEWER SUMMARY

PIPE RUN	Q ₅	Q ₁₀₀	PIPE SIZE	CONTRIBUTING DP/BASIN/PIPES
11	1.8	11.8	EX 24"	DP1
12	1.8	11.8	EX 24"	PR11
13	4.1	7.9	EX 15"	INLET 3
14	8.2	15.9	EX 24"	PR13, INLET 4
15	2.4	7.3	EX 18"	INLET 5
16	3.2	11.0	EX 24"	PR15, INLET 6
17	3.9	12.1	EX 24"	PR16, DP13
18	13.7	23.9	EX 30"	POND 2 OUTFALL
19	17.7	38.0	EX 42"	PR12, PR18

File: C:\10020-EDM-CB-Dunkin\Drawings\Drainage\Drainage\0020-EDM.dwg Plotstamp: 5/18/2023 11:49 AM

FOR LOCATING & MARKING GAS, ELECTRIC, WATER & TELEPHONE LINES
FOR BURIED UTILITY INFORMATION 48 HRS BEFORE YOU DIG CALL 1-800-922-1987

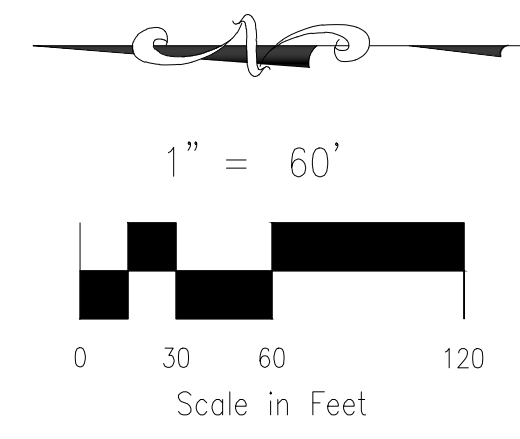

102 E. PIKES PEAK AVE., 5TH FLOOR
COLORADO SPRINGS, CO 80903
PHONE: 719.955.5485

CLAREMONT BUSINESS PARK 2 FIL. NO.2
EXISTING CONDITIONS DRAINAGE MAP

PROJECT NO. 10-022A FILE: \dwg\Eng Exhibits\10020 EDM.dwg

DESIGNED BY: DLM	SCALE: HORIZ: 1"=60'	DATE: 05-15-2023
DRAWN BY: DLM	VERT: N/A	
CHECKED BY: VAS		SHEET 1 OF 1

EDM01

PROPOSED DRAINAGE MAP

FINAL DRAINAGE REPORT FOR CLAREMONT BUSINESS PARK 2 FILING NO.1 COUNTY OF EL PASO, STATE OF COLORADO PROPOSED CONDITIONS DRAINAGE MAP

MAY 2023

LEGEND

- BASIN DESIGNATION
- PIPE RUN REFERENCE LABEL
- SURFACE DESIGN POINT
- BASIN BOUNDARY
- EXISTING CONTOUR
- PROP CONTOUR
- UG-E UNDERGROUND ELECTRICAL
- EXISTING GAS LINE
- STORM SEWER PIPE
- EXISTING STORM SEWER PIPE
- CROSSSPAN
- INLET
- EXISTING FLOW DIRECTION ARROW
- EMERGENCY OVERFLOW DIRECTION
- FLOW DIRECTION
- FLARED END SECTION
- HIGH POINT
- LOW POINT

BASIN SUMMARY			
BASIN	AREA (ACRES)	Q ₅	Q ₁₀₀
A	0.21	0.1	0.7
B	1.50	6.0	10.9
C	0.12	0.1	0.4
C1	0.17	0.1	0.5
D	0.77	3.2	5.9
D1	0.78	3.3	6.0
E1	0.27	1.2	2.2
E2	0.21	1.0	1.7
F	0.30	1.2	2.3
G1	0.27	0.4	1.2
G2	1.15	4.3	7.8
H1	0.16	0.1	0.5
H2	0.40	0.2	1.1
H3	0.04	0.0	0.1
H4	0.10	0.0	0.3
I1	0.55	2.3	4.3
I2	0.48	2.0	3.6
I3	0.45	1.8	3.3
I4	0.55	2.3	4.2
I5	0.23	0.9	1.7
I6	0.19	0.6	1.2
I7	0.23	0.9	1.6
J1	0.69	2.7	5.1
J2	0.25	1.0	1.8
J3	0.01	0.0	0.1
K1	0.17	0.7	1.3
K2	0.05	0.2	0.4
K3	0.15	0.6	1.1
K4	0.05	0.2	0.4
L	1.32	5.3	9.7
M1	0.28	1.2	2.2
M2	0.24	0.8	1.5
M3	0.37	1.6	2.9
M4	0.98	3.5	6.6
N1	0.06	0.3	0.5
N2	0.41	0.2	1.1
O1	0.12	0.1	0.4
O2	0.06	0.1	0.3
P	0.11	0.0	0.3

DESIGN POINT SUMMARY				
DESIGN POINT	Q ₅	Q ₁₀₀	BASIN	STRUCTURE
1	5.9	11.2	A, B	18" PP
2				OMITTED
3	1.2	2.3	F	18" PP
4	1.0	1.7	E2	PROP 5" INLET
5	1.2	2.2	E1	PROP 5" INLET
6	7.8	14.6	C, D, C1, D1, PR6	WO POND 3
7	4.7	8.7	G2	EX STREET
8	2.2	4.3	H1, I1	EX STREET
9	1.8	4.1	H2, I2	EX STREET
10	0.8	1.6	H3, I7	EX STREET
11	8.4	16.7	DP3-5, I3-16	EX 15" INLETS
12	2.8	8.1	FB INLETS, J1	EX 15" INLET
13	1.0	5.0	FB INLETS, J2, J3	EX 15" INLET
14	3.8	9.7	H4, L, M4	EX SWALE
15	5.3	12.3	DP9, M2, M3	EX SWALE/RD
16	1.4	2.5	M1, K4	EX CONC. RD
17	1.1	2.0	K2, K3, N1	EX CONC. RD
18	0.7	1.3	K1	EX AREA INLET
19	19.3	43.7	DP15-17, N2, PR14, PR17	EX FSD POND 2

STORM SEWER SUMMARY				
PIPE RUN	Q ₅	Q ₁₀₀	PIPE SIZE	CONTRIBUTING DP/BASIN/PIPES
1	2.4	5.7	18"	FUT POND 1 OUTFALL
2			NOT USED	
3	0.4	1.0	18"	FUT POND 4 OUTFALL
4	3.9	6.7	24"	PR1-PR3
5	1.0	1.7	18"	DP4
6	2.2	3.9	18"	PR5, DP5
6A	6.0	11.6	18"	C, C1, 90% D, D1
7	3.3	4.0	18"	POND 3 OUTFALL
8	6.1	10.7	24"	PR4, PR7
9	1.3	3.0	18"	FUT POND 5 OUTFALL
10	7.4	13.8	24"	PR8, PR9
11	7.4	13.8	24"/EX24"	PR10
12	7.4	13.8	EX 24"	PR11
13	4.2	8.0	EX 15"	INLET 3
14	8.4	16.0	EX 24"	PR13, INLET 4
15	2.8	7.8	EX 18"	INLET 5
16	3.7	12.6	EX 24"	PR15, INLET 6
17	4.4	13.8	EX 24"	PR16, DP18
18	13.7	23.8	EX 30"	EX POND 2 OUTFALL
19	21.1	37.6	EX 42"	DP18, PR12

SF WQCV FUTURE PONDS SUMMARY	
EPC/URBAN DRAINAGE SAND FILTER BASIN-SEE STD. DET.	
POND 1 AREA REQUIRED	773 SF
POND 4 AREA PROVIDED	288 SF
POND 5 AREA PROVIDED	565 SF

SF WQCV POND 3 SUMMARY	
EPC/URBAN DRAINAGE SAND FILTER BASIN-SEE STD. DET.	
AREA REQUIRED	1,014 SF
AREA PROVIDED	1,045 SF

SF ELEV = 6370.35

POND 3 SAND FILTER DETENTION BASIN DATA	
WO WATER SURFACE EL =	6371.78
WO VOLUME=	0.051 AC-FT
100-YR WATER SURFACE EL=	6373.36
100-YR VOLUME=	0.153 AC-FT
SPILLWAY CREST EL=	6375.30
TOP OF EMBANKMENT EL=	6376.55
RATIONAL 100-YR INFLOW=	14.8 CFS
MHFD 100-YR INFLOW=	9.0 CFS
MHFD 100-YR RELEASE=	4.0 CFS

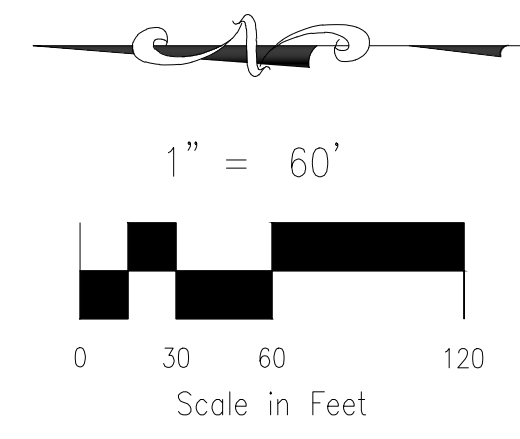

102 E. PIKES PEAK AVE., 5TH FLOOR
COLORADO SPRINGS, CO 80903
PHONE: 719.955.5485

**CLAREMONT BUSINESS PARK 2 FIL. NO.2
PROP. CONDITIONS DRAINAGE MAP**

PROJECT NO. 10-022A FILE: \dwg\Eng Exhibits\10020 PDM.dwg

DESIGNED BY: DLM	SCALE:	DATE: 05-17-2023
DRAWN BY: DLM	HORIZ: 1"=60'	
CHECKED BY: VAS	VERT: N/A	

SHEET 1 OF 1 PDM01

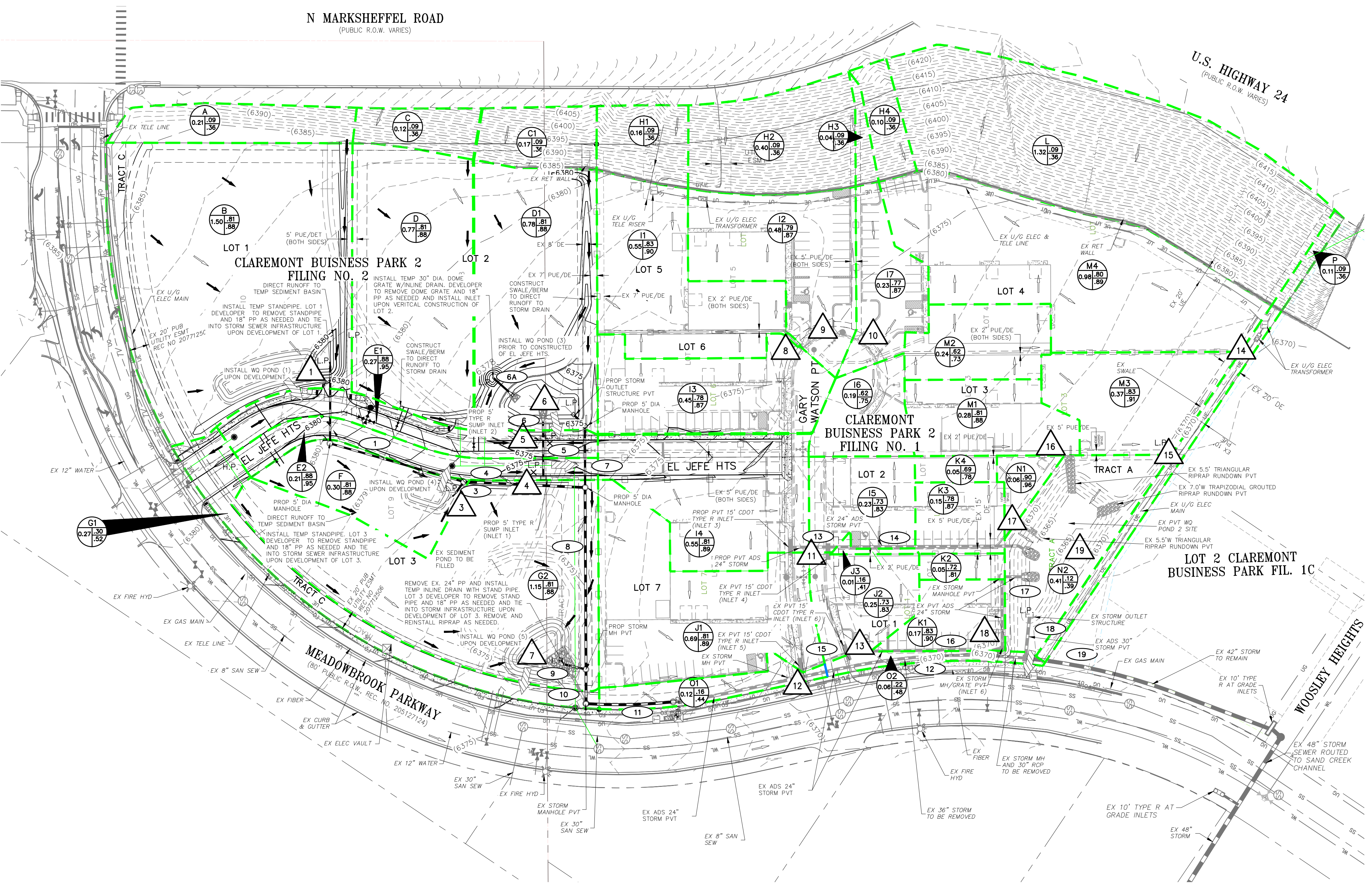

File: C:\10020-2-CBP-Dunkin\Drawings\Drainage\Map\10020-PDM.dwg Plotstamp: 5/24/2023 10:39 AM

FOR LOCATING & MARKING GAS, ELECTRIC, WATER & TELEPHONE LINES
FOR BURIED UTILITY INFORMATION 48 HRS BEFORE YOU DIG CALL 1-800-922-1987

V2_Final Drainage Report.pdf Markup Summary

Callout (1)

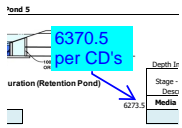

Subject: Callout
Page Label: 83
Author: CDurham
Date: 7/12/2023 7:35:00 AM
Status:
Color: ■
Layer:
Space:

6370.5 per CD's