

PROPOSED DESIGN WILL USE A MTD FOR "PRE-TREATMENT. SEE XK BAYSAVER DETAIL FOR SEDIMENTATION, TRASH, DEBRIS, OIL/GREASE SEPERATION

Doesn't the "Bayseparator Removal Analysis" doc show that this should be "Yes." Please explain this apparent discrepancy.

**T-11 Manufactured Treatment Devices 3-28-2022**

**General Description**

Manufactured Treatment Devices (MTDs) include many different types of proprietary devices that use various treatment processes and designs to remove targeted pollutants. For example, some MTDs are suitable for pretreatment and gross solids removal, whereas others incorporate advanced designs targeting specific metals, nutrients and other pollutants in stormwater runoff. Standardized testing protocols and third-party performance verification can be used to support selection of MTDs that meet treatment objectives for a site.

This fact sheet discusses two general categories of MTDs: sedimentation MTDs and filtration MTDs. Sedimentation MTDs use sedimentation processes to remove pollutants. The most common sedimentation MTDs are hydrodynamic separators (HDSs). Filtration MTDs utilize various filtration processes to remove pollutants and are subcategorized in this fact sheet as high-rate media filtration (HRMF) and high-rate biofiltration (HRBF) devices. Other types of MTDs are also available on the market but are not discussed in this fact sheet.

<b>MS4 Permit Applicability (Design-Dependent)</b>	<b>HDS</b>	<b>HRMF</b>	<b>HRBF</b>
Meets Runoff Reduction Standard	No	No	No <sup>3</sup>
Meets WQCV Capture Standard	No	No	No
Meets Pollutant Removal Standard	No	Yes	Yes
<b>Typical Effectiveness for Targeted Pollutants<sup>1,2</sup></b>			
Sediment/Solids	Medium	High	High
Total Phosphorus	Low	High <sup>4</sup>	High
Total Nitrogen	Low	Low-Medium	Low
Total Metals	Low	High	High
Bacteria	Low	Low-Medium	Low-Medium
<b>Common Applications</b>			
Step 1: Runoff Reduction	No	No	No <sup>3</sup>
Pretreatment (in Treatment Train)	Yes	No	No
Primary Treatment	No	Yes	Yes
WQCV + Flood Control	No	No	No
<b>Cost</b>			
Life-Cycle Costs	Medium	Medium-High	Low

<sup>1</sup> Typical effectiveness for HDSs is based on New Jersey Department of Environmental Protection Technical Acceptance and Reciprocity Partnership (TARP) protocol for performance in a laboratory setting, with testing requirements for specific composition and gradation, average particle size, influent concentration, required inflow rates, and other parameters.

<sup>2</sup> Filtration MTD performance varies based on proprietary media/filter designs and targeted pollutants. "Typical" effectiveness descriptions are based on a combination of Washington Ecology's approved treatment technologies based on the Technology Assessment Protocol–Ecology (TAPE) use designation and the International Stormwater BMP Database 2020 Summary Statistics.

<sup>3</sup> The Runoff Reduction Standard is not met with HRBF devices sold as-is. HRBFs can be designed/retrofitted with additional appurtenances, such as extra underdrain pipe(s) or a chamber on the downstream side of the device, which will detain and regulate the release of treated stormwater and allow for infiltration.

<sup>4</sup> Total phosphorus removal is typically high when it is specifically targeted for removal with proprietary media.

## Sedimentation MTD Description

Sedimentation MTDs include hydrodynamic separators (HDSs) and other MTDs utilizing sedimentation processes. These devices typically use gravity and/or centripetal force coupled with strategically placed components to separate, settle, trap, and retain coarse particulates. The primary target pollutant of sedimentation MTDs is suspended sediment.<sup>1</sup> Some systems target sediment exclusively, while others also provide trash and debris removal and/or oil and grease separation. Collected pollutants are typically directed to and stored in a collection chamber within the device, and treated stormwater is discharged back into the storm drain system.

Most sedimentation MTDs are constructed as concrete vaults with maintenance access.

Concrete vaults typically use swirl concentration, a series of baffles or weir plates, or a combination of these sediment removal methods. Sedimentation MTDs are manufactured from various materials, such as corrugated metal pipe (CMP) and polyvinyl chloride (PVC) pipe, but precast concrete is most common and generally more durable. These materials serve as housing for the internal components of the MTD. The inner components and their configurations differ among products and manufacturers.

HDSs are the most commonly installed sedimentation MTD in the Front Range of Colorado. Unlike SCMs that detain and release, filter, or infiltrate the WQCV (with some capable of providing full-spectrum detention), HDSs treat stormwater over a short residence time, typically providing a lower level of treatment than storage, filtration, or infiltration-based SCMs.

As stand-alone practices, sedimentation MTDs do not meet the Runoff Reduction, WQCV, or Pollutant Removal Standards<sup>2</sup> in Colorado MS4 Permits. Therefore, these MTDs are most appropriate for a stormwater treatment train system as a pretreatment component. For example, many HDSs can remove coarse particulates and buoyant materials like trash and debris; therefore, they can play an important role in providing pretreatment to reduce maintenance requirements and costs for downgradient SCMs in a treatment train.

## Sedimentation MTD Terminology

There are several commonly used terms that are used to define how a sedimentation MTD functions, such as swirl concentration, cyclonic separation, vortex separation, and screening. These terms are synonymous, each referencing the process of using centripetal force and/or gravity, coupled with a target velocity, to provide the required centripetal force and hydraulic residence time to remove sediment from stormwater. This process has become most widely referred to as hydrodynamic separation, and the MTDs that perform this process are called HDSs.

Some sedimentation MTDs incorporate additional storage to increase residence time and promote gravitational settling in a quiescent environment. However, to meaningfully increase residence time, significant additional storage is usually needed, increasing costs, which is a reason that flow-through HDSs are the most common types of sedimentation MTDs.

---

<sup>1</sup> Suspended solids are often measured as suspended sediment concentration (SSC), which is similar to total suspended solids (TSS), but typically is a slightly higher concentration due to the inclusion of larger particles as a result of the SSC sampling method. See Gray (2000) for additional information.

<sup>2</sup> As of 2022, HDSs have not met the 30 mg/L effluent Pollutant Reduction Standard when following standard TAPE or TARP laboratory testing protocols.

When evaluating sedimentation MTDs, it is important to identify the pollutants targeted for treatment and the MTD's treatment efficiency for those pollutants, along with the maintenance frequency needed to maintain performance. The volume of collected pollutants serves as a primary indicator for the maintenance of most MTDs. Frequency of maintenance is ultimately a function of available storage capacity and pollutant loading rates characteristic of the tributary basin. Lack of storage capacity can measurably reduce treatment efficiency. Since storage capacities vary widely among the many available sedimentation MTDs on the market today, available storage is an important component to consider when specifying MTDs.

### Sedimentation MTD Components

Sedimentation MTDs include a variety of designs to promote sedimentation. For HDSs, the primary components typically include: 1) an inflow pipe that conveys runoff into the device, 2) a "swirl" and/or treatment chamber that removes pollutants, 3) a storage chamber for removed pollutants, 4) various internal plates and/or weirs that promote sedimentation, 5) an outlet pipe that conveys treated runoff to the downstream storm drain system, and 6) a maintenance hole that provides access to the chambers. These components often are housed in a precast concrete vault or maintenance hole. The internal components of the MTD create unique hydraulics that remove and retain sediment and other pollutants while allowing runoff that is treated to pass quickly through the MTD.

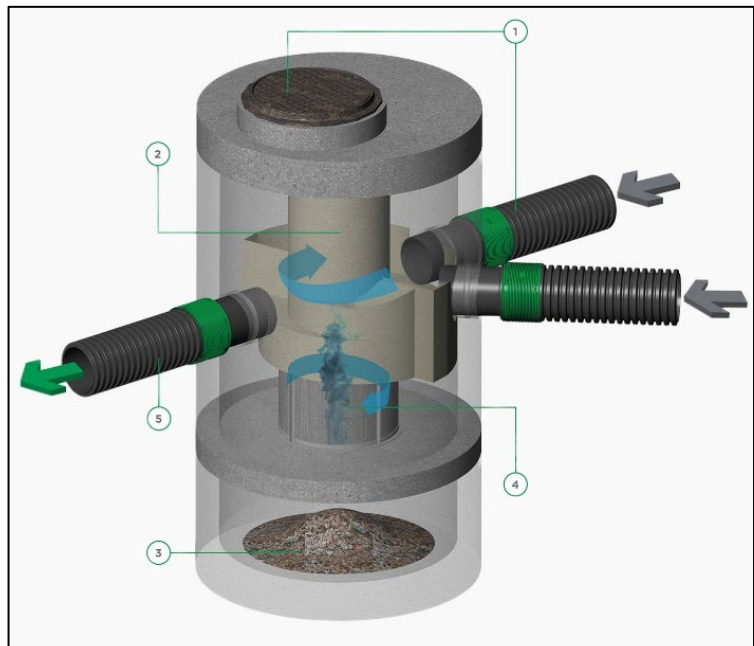

Figure 1. Typical components of HDSs. **Note: this placeholder figure will be replaced with a new figure consistent with other fact sheets.**

HDS Component	Intent
Inlet Pipe(s)	Convey runoff into the MTD.
Internal Flow Components	Create hydraulic conditions to remove sediment, trash, debris, and other pollutants (components vary by device).
Treatment Chamber	Provides an environment where hydrodynamic separation and/or gravitational settling occurs. The treatment chamber often has a cylindrical shape to create a vortex as runoff flows through the device. Sediment is removed by gravitational settling, centripetal forces, and/or screens and weirs.
Storage Chamber	Stores pollutants removed from the treatment chamber.
Internal Bypass	Provides integrated internal bypass mechanism to convey flows that exceed the peak design flow of the system.
Outlet Pipe	Conveys runoff from the BMP into the storm drain.
Access Chambers	Allow access for inspection and maintenance of chambers via a maintenance hole or access hatch at grade.

### Filtration MTD Description

Filtration MTDs, including high-rate media filters (HRMFs) and high-rate biofilters (HRBFs), treat stormwater by filtering it through engineered media at high velocities. As a result, HRMFs and HRBFs require a smaller footprint than traditional bioretention and sand filter SCMs to treat a given runoff volume.

HRMFs use one or more media types to remove pollutants from stormwater. Commonly used materials include sand, peat, crushed rock, volcanic rock, granular activated carbon, compost, minerals, granular organic materials, and fabrics. Containment of the filter media, the configuration of internal parts, and the hydraulics of HRMFs are proprietary and differ among HRMFs.

HRBFs treat stormwater with bioengineered media that support vegetation. Physical, biological, and chemical processes occur between the media and the vegetation of an HRBF. Treatment processes include filtration, transpiration, evaporation, settling, biological uptake, microbiological uptake, and pollutant transformation.

Both HRMFs and HRBFs are well suited to provide permanent treatment in densely developed urban settings, new developments with limited available space, urban retrofits, and large-scale

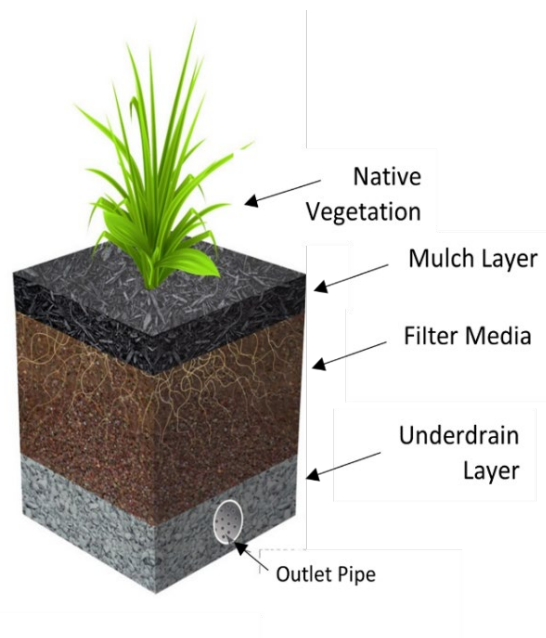

Figure 2. HRBF components. **Note: this placeholder figure will be replaced with a new figure consistent with other fact sheets.**

projects where traditional bioretention is cost-prohibitive due to the surface area required to meet large-volume treatment goals.

### Filtration MTD Components

The primary components of HRMFs and HRBFs include: 1) an inflow pipe that conveys runoff into the MTD, 2) a chamber that contains the various layers of biological filter media (HRBF) or non-biological filter media (HRMF) to remove pollutants, 3) one or more storage chambers for removed pollutants (HRMFs only), 4) an outlet pipe to convey treated runoff to the downstream storm system or other outfalls, and 5) maintenance access points to the filter media and storage chambers. For HRBFs, the filter media layers include shredded hardwood mulch as the top layer, a proprietary biological media mixture, and a granular, well-draining, compactible rock subbase layer to support the overlying media and facilitate drainage to the outlet pipe.

HRMF and HRBF Components		Intent
Inlet Pipe		Conveys stormwater into the MTD.
Housing Chamber		Houses internal components in concrete vaults, maintenance holes, steel containers, plastic containers, or steel mesh baskets.
Filter Media <u>for HRMFs</u>		Removes targeted pollutants via filtration through proprietary media and a specific type of filtration process. Media filter and hydraulic configurations vary substantially among devices (e.g., cartridges or other filter units, upflow or downflow).
Biological Filter Media <u>for HRBFs</u>	Shredded Hardwood Mulch	Removes coarse particulates and other buoyant materials from runoff, helps media retain water for later vegetative use, provides pretreatment for other filter media layers.
	Bio-filtration Media	Filters and treats stormwater through physical, biological, and chemical processes and biological interaction with vegetation. Decomposes organics, reduces heavy metals through adsorption and removes fine particulates and hydrocarbons. Enables biological growth.
	Granular Rock Subbase	Provides subsurface structural support for components and drainage to the outlet pipe.
Pollutant Storage Chamber(s) (HRMFs)		Provides internal storage for collected pollutants.
Outlet Pipe		Conveys stormwater out of the filtration MTD.
Maintenance Access		Provides access to pollutant storage chambers and media chambers to facilitate inspection and maintenance activities. Enables repairs and part replacements (e.g., replace filter cartridges, wash filters).

HRMFs and HRBFs are considered “high-rate” when stormwater can infiltrate through the media at a faster rate than the infiltration rate of typical saturated Type A and B soils. Some products have been third-party verified as having infiltration rates up to 175 inches per hour while also meeting target treatment performance standards (Washington Ecology 2020). Although HRBFs do not meet the Runoff Reduction Permit Standard, they can be configured as a treatment train with a pipe or downstream storage chamber that enables infiltration of treated stormwater.

Typical Benefits and Limitations of Selected MTD Types			
Characteristic	HDS	HRMF	HRBF
Removes trash, debris, and other buoyant materials and stores material below ground (out of sight).	Yes	Yes	No
Depending on the product, it may include processes to remove oil and grease.	Yes	Yes	Yes
Effective pretreatment for primary treatment SCMs and detention facilities.	Yes	No <sup>1</sup>	No <sup>1</sup>
Effective treatment at high surface loading rates with a small footprint. Suitable for constrained sites in highly urbanized areas (space-efficient).	Yes	Yes	Yes
Delivered as one package for assembly and/or installation.	Yes	Yes	Yes
Provides vegetated features in urban areas.	No	No	Yes
Allows other uses of surface area due to underground installations and/or small surface footprint.	Yes	Yes	Yes
Meets one or more MS4 Permit design standards. (Effective for stand-alone treatment of stormwater.)	No	Yes	Yes
Depending on the product and its media design, it may remove fine particles, targeted metals, or phosphorus.	No	Yes	Yes
Potential for resuspension of captured pollutants.	Yes	No	No
Maintenance needs are visible at surface.	No	No	Yes

<sup>1</sup>Considered primary treatment SCMs.

### Site Considerations for MTDs

MTDs are most applicable in highly developed, space-limited urban areas because they require a nominal area of land at grade. Underground MTDs generally are located beneath parking lots, sidewalks, and low-traffic streets. HRBFs are often situated along sidewalks and curbs.

Consider the following factors when determining if an MTD is suitable for a site:

- Tributary Area:** As the first step in MTD selection and sizing, characterize the tributary drainage area of the site, land use and imperviousness, pollutant types and sources, and soil erosion characteristics. Use this information to evaluate whether various MTDs can effectively control pollutants at the site. For example, a sedimentation MTD is unlikely to provide meaningful treatment for areas where targeted pollutants are fine sediment, nutrients, or dissolved pollutants. Conversely, if a site has coarse sediment, trash, and



debris, an appropriately sized and maintained sedimentation MTD can serve as an effective pretreatment practice.

- **Third-Party Verification for Treatment Objectives:** Review information provided in third-party verification programs to verify whether performance expectations for the MTD meet the treatment needs at the site and/or MS4 permit design standards. For example, treatment objectives could include pretreatment for a stormwater facility, treatment for targeted pollutants, or specific pollutant removal objectives in critical areas. Treatment capabilities among MTDs vary; therefore, review of third-party performance verification is an essential step in MTD selection.
- **Geotechnical Considerations:** Consult with a geotechnical engineer to determine if soils on a site will provide the necessary bearing capacity for the MTD without settlement over time and to identify any soil preparation or backfill requirements needed for a stable foundation and appropriate backfill around the device. If soils are contaminated and the MTD does not require imported fill to be used as backfill, consider specifying a soil-tight MTD.
- **High Water Table:** Avoid use of underground MTDs in areas with a shallow water table due to issues with the exfiltration of stormwater to groundwater or infiltration of groundwater into the device. Surface-based MTDs are more appropriate in areas with high water tables because they require less depth to install than underground MTDs. MTDs should also be used with caution in areas with contaminated soils. Additional waterproofing may be necessary to prevent the exfiltration of stormwater from the MTD into the contaminated soils or infiltration of contaminated water into the MTD system. In some cases, high groundwater is not anticipated or evaluated during design and prior to construction. In such cases, waterproofing methods similar to those used for sanitary maintenance access holes are recommended. Buoyancy must always be evaluated. Anchoring systems are often required to resist buoyant forces acting on the MTD.
- **Location and Access:** Evaluate land uses that will occur above the MTD to ensure clear and unobstructed access for routine and emergency inspection and maintenance activities. Areas directly above the MTD should be clear of structures, vehicles, and other items that could obstruct access or visual inspection at any time. When feasible, avoid locating maintenance access holes or vaults beneath traffic lanes, so traffic control is not required for routine maintenance activities. When possible, provide signage related to the facility to ensure others do not block maintenance access or use the location as a staging area (for materials or snow storage). Additionally, if the device is located under a street or parking lot, the MTD will need to be rated for traffic loads.
- **Parking Structures and Other Structures Built Above MTDs:** Avoid installing MTDs beneath parking structures or other types of buildings. In cases where no alternatives are feasible, local governments should consider additional requirements to ensure adequate maintenance access and operation throughout the MTD's life cycle. Coordination with geotechnical and structural engineers is required to ensure that the device will not interfere with the building foundation, structural support, dewatering systems, or other utility lines. MTDs installed beneath parking garages or other structures must be accessible at all times (e.g., access maintenance holes cannot be located beneath parking spots, frequent access routes, or storage areas). Parking garages often limit height clearances and do not provide

enough vertical clearance for maintenance vehicles to enter and access subsurface MTDs during maintenance operations.

- **Elevation Constraints:** Evaluate elevation constraints. The depth of the MTD and the invert elevations of the inlet and outlet pipes are often dependent on the elevation of the local storm drain outfall when a site discharges treated stormwater into a public storm drain system. When discharging to a stream or river, consider the normal high water elevation. Verify that the MTD will work with pipes installed at elevations that give enough fall to the public storm drain system or receiving water and that the depth of the device is adequate to provide the necessary treatment and storage volumes. Assess the potential effects of tailwater from the downstream conveyance system. Tailwater effects can impede MTD performance by affecting the hydraulics of the device.
- **Existing Underground Utilities:** For retrofits or projects proposed in developed areas, identify existing underground utilities that may constrain the footprint and depth at which the MTD can be placed.

#### Organizations with Testing Protocols for MTDs

**TAPE** – Technology Assessment Protocol–Ecology is the stormwater quality treatment certification program implemented by the Washington State Department of Ecology for evaluating the performance of emerging technologies to treat polluted stormwater.

**TARP** – Technology Acceptance Reciprocity Partnership is the stormwater treatment certification protocol required by New Jersey Department of Environmental Protection (NJDEP) to certify the level of treatment performance of manufactured stormwater treatment products.

**NJCAT** – New Jersey Corporation for Advanced Technology has a Technology Verification Program that specifically encourages collaboration between vendors and users of technology. This program evaluates vendor-specific performance claims.

**STEPP** –The National Municipal Stormwater Alliance (NMSA) established the National Center for Stormwater Testing and Evaluation for Products and Practices (STEPP) to promote development of a national testing and verification program for manufactured products as well as public domain practices in the stormwater sector. STEPP will provide a program for third-party testing and verification of pretreatment MTDs, primary treatment MTDs, and traditional surface-based SCMs that will be a useful reference for designers and reviewers once the program is launched.

**ASTM** – American Society for Testing and Materials is currently developing a national standard for the performance of MTDs. The standard is consistent with the NJDEP TARP protocol and, once published, can be used to evaluate the performance of MTDs.

#### Community Values

The primary benefit of underground MTDs to the surrounding community is maximizing the amount of surface space dedicated to other uses that may be needed in dense urban environments, including plazas, parking areas, and other services that benefit the community.



To avoid creating a nuisance from mosquitos or odors, perform regular maintenance and treat standing water in sedimentation MTDs using larvicides to control mosquitos in the summer months.

In the case of HRBFs, which include a limited vegetated surface area, native plants and/or trees are a component of many HRBFs, which can serve as an aesthetic amenity in urban areas, while still having a relatively small surface footprint.

## **Maintenance**

Maintenance requirements are a fundamental consideration when specifying an MTD. Proper routine maintenance is critical for the adequate function of the MTD. Before MTD selection, obtain and review manufacturer's maintenance guidance, including inspection methods, maintenance frequency, equipment, maintenance methods, and cost. Also, consider confined space entry requirements, availability of maintenance contractors, materials replacement cost/frequency, and sediment disposal requirements. Maintenance requirements can vary significantly depending on the specific MTD. Additionally, actual maintenance frequencies may be more (or less) frequent, depending on site conditions. Therefore, an operations and maintenance plan is needed for each installation. As part of the MTD selection process, request estimates of life-cycle costs from the manufacturer for MTDs under consideration.

Most sedimentation MTDs require a vacuum truck with a hose that will extend to the storage chamber. This can be used to remove most trash and debris in addition to sediment. In some MTDs, trash, litter and debris are stored in a separate compartment from accumulated sediment, and access may be through a different maintenance hole or hatch. Confined space entry access may be necessary.

For sedimentation MTDs that act as traps for trash, debris, and sediment, the need for maintenance is indicated by sediment accumulation, with triggers for maintenance typically specified by the manufacturer. Frequency of maintenance is ultimately a function of available storage capacity, pollutant loading rates for the tributary watershed, and the removal efficiency of the treatment devices.

HRMF maintenance focuses on its filter media and filter configuration; therefore, each HRMF has a unique set of maintenance requirements based on media type and the unit's hydraulics. Typical maintenance involves either cleaning the filter media or replacing it with new media. The former usually involves thoroughly rinsing the filter media with clean water and removing any collected pollutants. When maintenance requires the replacement of filters or a component of the filter, the manufacturer's instructions should provide clear information on methods, costs, and expected frequencies.

Maintaining HRBFs typically requires routine replacement of the shredded mulch on the top layer of the MTD and removal of trash and debris that has accumulated on top of the mulch or against the inlet trash rack or grate. Over time, sediment will clog the mulch layer and inhibit stormwater from flowing through the underlying media layer as intended. The shredded hardwood mulch specified by the manufacturer should be used exclusively when replacing the mulch layer. The biofilter media below the mulch layer and the plants or trees are typically self-preserving with a low media replacement frequency (e.g., possibly 10 years). Proper irrigation

of HRBFs is necessary; therefore, water availability for irrigation is an essential consideration for HRBF selection.

### **Maintenance Considerations During MTD Selection**

To avoid selection for MTDs with onerous maintenance requirements, consider the following maintenance practices:

- Review manufacturer's maintenance guide to determine the frequency and types of maintenance activities required. The guidance should clearly describe how to inspect and maintain the device, triggers for maintenance, and methods for measuring accumulated pollutants to determine when maintenance is needed.
- MTD collection chambers must be accessible by maintenance equipment, and unimpeded by internal weirs and baffles. MTDs that allow visual observation of collected pollutants are easier to inspect and maintain than devices that do not provide visual indicators.
- Assess how much time it will take to inspect and maintain the MTD and whether the time requirement is a reasonable expectation for the entity responsible for maintenance.
- Avoid MTDs that require confined space entry for routine maintenance activities. Be aware of confined space entry requirements for clearing out clogged orifices, pipes, and weirs that will likely be required under certain conditions for underground MTDs.
- Identify and review documents, forms, and tools needed for inspection and maintenance. These may include an inspection and maintenance plan, inspection forms, required personal protective equipment, and equipment necessary for maintaining the MTD.
- For HDSs, identify how a vacuum truck will access the different chambers of the MTD and ensure that standard suction hose lengths can reach the bottom of the vault of the maintenance hole. MTD designs should allow easy access with the suction hose to maneuver the vacuum suction hose to extend to the bottom and the full extent of each device's chamber.
- Salts from deicing contribute to the deterioration of concrete and other materials in sedimentation MTDs. Therefore, for installations where deicing activities regularly occur during the winter, plan on a few additional inspection and maintenance visits during winter to rinse accumulated salts out of the device with a hose. Salt may also affect plant growth in HRBFs.

### **Design Procedure and Criteria**

Design procedures and criteria are specific to the type of MTD selected and must follow the manufacturer's design and specification procedure. Most sedimentation- and filtration-MTDs are sized based on flow rate; however, some can be sized based on volume and/or flow rate. The general steps for sizing and specification based on flow rate are described below as general guidance, recognizing that some variation in the procedure may be required for various MTDs.

1. **Calculate the water quality event peak flow rate,  $Q_{WQ}$ :** Sedimentation and filtration MTDs are typically sized based on a design peak flow rate. The water quality event peak flow rate ( $Q_{WQ}$ ) is the peak discharge associated with the 80<sup>th</sup> percentile runoff event, corresponding to a storm depth of 0.6 inches.<sup>3</sup> Because sedimentation and filtration MTDs typically serve small, highly impervious drainage areas (time of concentration is typically 15 minutes or less), apply the Rational Method to calculate the water quality event peak flow rate:

$$Q_{WQ} = C \cdot I \cdot A$$

Where:

$Q_{WQ}$  = water quality event peak flow rate (cubic feet per second [cfs])

$C$  = runoff coefficient for tributary drainage area, see Runoff chapter

$I$  = rainfall intensity for water quality event (inches/hour)

$A$  = tributary area draining to MTD (acres)

2. **Determine the maximum treatment flow rate,  $Q_{MAX}$ :** The maximum treatment flow rate is the greatest flow rate than can be discharged through an MTD while still achieving specific treatment efficiency goals such as percent TSS removal and/or maximum effluent concentrations of TSS. Third-party verification of maximum treatment flow rates is important to ensure that the MTD does not surcharge or experience excessive scouring of accumulated sediment at the maximum treatment flow rate.

For HDSs, the manufacturer specifies the maximum treatment flow rate for a given HDS type and size. To ensure that the selected HDS provides adequate performance at the maximum treatment flow rate, verify that that the HDS is included on the “Laboratory Verified and NJDEP Certified” list.<sup>4</sup>

3. **Identify potentially appropriate MTDs:** To select an appropriately sized MTD, compare the calculated water quality event peak flow ( $Q_{WQ}$ ) with the maximum treatment flow rate ( $Q_{MAX}$ ). The MTD is acceptable for further consideration if  $Q_{MAX}$  is greater than or equal to  $Q_{WQ}$ .

Because various MTDs will meet the water quality event peak flow rate requirements for a given site, the designer should then consider which devices are best suited to site characteristics, the pollutants targeted at the site, and the ability to meet MS4 permit design standards. Ideally, performance claims should be verified through established testing protocols, including established third-party verification programs (see text box).

---

<sup>3</sup> See the Runoff chapter in Volume 1 for guidance on calculating the discharge associated with the water quality event.

<sup>4</sup> The NJCAT performance standard for TSS removal efficiency is 50% for a particle size distribution with a d50 of 75 microns based on a weighted, cumulative average of the percent of pollutants removed at flow rates through the device at 25%, 50%, 75%, 100% and 125% of a device’s  $Q_{MAX}$  (NJCAT 2013).

### Verifying Performance When Selecting an MTD

MHFD does not have a technology verification program or maintain a list of “approved” MTDs. Instead, designers should utilize information available through other state and national verification programs to support MTD selection. National verification programs such as STEPP, supported by new ASTM standards, are under development as of publication of this fact sheet and may be appropriate for use in the future. Two existing well-established programs that can be used to support MTD selection are described below. Ultimately, it is the responsibility of the design engineer, not the manufacturer, to ensure that the specified MTD will meet the water quality requirements for a given project.

#### **NJDEP for Sedimentation MTDs**

Sedimentation MTDs on the “Stormwater Technologies: Laboratory Verified and NJDEP Certified” list on the NJDEP’s website (<http://www.njcat.org/verification-process/technology-verification-database.html>) are verified to provide levels of treatment that are suitable for pretreatment of runoff. If a product claims to be “NJCAT-verified” but is not on the list referenced above, it is not an acceptable pretreatment device. This is because NJCAT “verification” is not synonymous with TARP “certification” through NJDEP. A product can receive verification from NJCAT for any performance criterion it can demonstrate it meets; however, the performance criterion for which it receives verification may not meet the performance standards in the TARP protocol required by NJDEP (and likely does not meet them).

More than a dozen sedimentation MTDs on the NJDEP list are verified to meet the performance standards outlined in the TARP program; however, not all offer internal bypass capability. Most devices target TSS, but not trash, and many, but not all, can remove oil and grease using absorbent pads. Storage capacities vary widely between the different devices, as do maximum treatment flow rates necessary to meet the pollutant removal standard for a given device size.

#### **TAPE for Filtration MTDs and Other MTDs**

The Technology Assessment Protocol – Ecology (TAPE) is the program implemented by Washington State Ecology for reviewing and certifying proprietary MTDs. The agency’s website (<https://ecology.wa.gov/Regulations-Permits/Guidance-technical-assistance/Stormwater-permittee-guidance-resources/Emerging-stormwater-treatment-technologies#tape>) categorizes proprietary products approved for use in Washington State based the level of use each product has been approved for, and the type of treatment each product provides, in accordance with the TAPE program.

Filtration MTDs expected to meet Colorado’s MS4 performance standard for 30 mg/L TSS include those with a General Use Level Designation (GULD) for Basic, Enhanced, or Phosphorus treatment categories.

Sedimentation MTDs suitable for pretreatment, but not expected to meet Colorado’s MS4 performance standard for 30 mg/L TSS, include those with a GULD for Pretreatment on TAPE’s website.

4. **Evaluate inflow and outflow pipes configurations:** Allowable pipe configurations vary widely between products, and designers must understand vertical and horizontal pipe placement constraints. The angle between the inlet and outlet pipe, often dictated by the proposed storm drain system layout, is crucial for sedimentation MTDs to function as intended. The design engineer must understand the manufacturer's allowable pipe layouts and entrance/exit locations, any pipe orientation or angle constraints, and horizontal and vertical placement requirements for the MTD. Some sedimentation MTDs accommodate multiple inlet pipes, while others only allow one inlet and one outlet pipe. Some devices require a 180-degree angle between the inlet and outlet pipes, while others allow for variable angles and multiple inlet pipes. During design, check that inflow and outflow elevations are appropriate for the MTD being specified and within the design flow recommendations from the manufacturer. Some types of sedimentation MTDs are very sensitive to inlet and outlet elevations, and a difference of even an inch can influence whether the MTD functions as intended.
5. **Evaluate internal flow components:** Internal flow components in a sedimentation MTD facilitate sedimentation and retain captured pollutants despite the short hydraulic residence times of runoff in these types of devices. Internal flow components may include baffles, weirs, deflection plates, screens, and other features and are typically standard features designed by the manufacturer rather than the design engineer. Therefore, the designer should evaluate the ability of internal flow components to control targeted pollutants, ease of maintenance, and durability when comparing MTD alternatives.
6. **Assess storage chamber size and access:** Most sedimentation MTDs have a separate chamber or sump area that stores collected pollutants. The storage chamber is designed to retain sediment, litter, and debris removed in the treatment chamber and minimize the potential for resuspension. Consider the sediment, trash, and debris loads from the contributing drainage area, and select a device with sufficient storage to limit routine maintenance to once or twice per year. An undersized storage chamber leads to nuisance conditions and frequent maintenance. Provide direct access from the street level to the storage chamber for inspection and maintenance.
7. **Specify selected MTD.** Once the MTD has been selected based on the process and considerations above, the remaining design steps for the specified MTD can be completed.
8. **Size the internal bypass:** An internal bypass is built into some sedimentation MTDs to divert flows that exceed the water quality event peak flow rate and convey flows around the treatment and storage chambers to prevent resuspension of pollutants. This is called an "internal bypass" because the pipe or weir that bypasses the larger flows is typically incorporated as a component of the MTD. Internal bypasses generally tend to be less expensive than an external bypass, which requires additional maintenance holes and more pipe. Internal bypass configurations vary widely between devices, and the layout of the bypass must be compatible with the storm drain system's upstream and downstream elevations and hydraulics. Size the internal bypass peak flow rate for the maximum design flows expected in the upstream and downstream storm drains. If a sedimentation MTD does not have an internal bypass, an external bypass is required.

9. **Compute the Hydraulic Grade Line (HGL) and Energy Grade Line (EGL):** Compute the HGL and EGL for the MTD and the upstream and downstream storm drain system. Refer to the procedures and criteria in the Streets, Inlets, and Storm Drains chapter of Volume 1. The bypass should be designed to avoid pressurized flow and prevent resuspension of accumulated pollutants. When backwater conditions are present, account for high tailwater when evaluating the hydraulics of the MTD and bypass, and verify that the device will operate as intended (some MTDs require a specific range of velocities within the treatment chamber to create unique hydraulic effects to remove sediment).
10. **Plan access to all chambers:** Access chamber configurations vary between products. Direct, unobstructed access to all chambers of a sedimentation MTD is required for maintenance operations and repair.

## References

- Allen, V., Berg, D., Fairbaugh, C. 2020. Improving Post-construction Stormwater Management Program *Results* Through Incorporation of Performance Verification Standards for Stormwater Control Measures. WEFTEC 2020.
- Gray, J. R. 2000. Comparability of suspended-sediment concentration and total suspended solids data (No. 4191). US Department of the interior, US Geological Survey.
- International Stormwater BMP Database, accessible at [www.bmpdatabase.org](http://www.bmpdatabase.org).
- New Jersey Department of Environmental Protection (NJDEP). 2013. NJDEP Laboratory Protocol to Assess Total Suspended Solids Removal by a Hydrodynamic Sedimentation Manufactured Treatment Devices. New Jersey Department of Environmental Protection Laboratory Protocol for HDS MTDs. January 25.
- Sprague, C. J. and Cashatt, C. (2020). New ASTM Standards for Evaluating Stormwater Control Measures. In *World Environmental and Water Resources Congress 2020: Nevada and California Water History* (pp. 137-148). Reston, VA: American Society of Civil Engineers. May.
- Washington Ecology. 2020. TAPE List of Approved Technologies. June 2020. General Use Designation for Basic (TSS), Enhanced, Phosphorus and Oil Treatment for Contech Engineered Solutions Filterra. June.