



LSC TRANSPORTATION CONSULTANTS, INC.
2504 East Pikes Peak Avenue, Suite 304
Colorado Springs, CO 80909
(719) 633-2868
FAX (719) 633-5430
E-mail: lsc@lsctrans.com
Website: <http://www.lsctrans.com>

Homestead North Phase 1 Updated Traffic Impact Study SP-20-008 (LSC #204380) August 4, 2021

Traffic Engineer's Statement

This traffic report and supporting information were prepared under my responsible charge and they comport with the standard of care. So far as is consistent with the standard of care, said report was prepared in general conformance with the criteria established by the County for traffic reports.



Developer's Statement

I, the Developer, have read and will comply with all commitments made on my behalf within this report.

← provide signature

Date

Homestead North Phase 1

Updated Traffic Impact Study

Mr. Jim Morley
Morley-Bentley Investments, LLC
20 Boulder Crescent, 1st Floor
Colorado Springs, CO 80903

AUGUST 4, 2021

LSC Transportation Consultants
Prepared by: Kirstin D. Ferrin, P.E.
Reviewed by: Jeffrey C. Hodsdon, P.E.

LSC #204380
SP-20-008



CONTENTS	
REPORT CONTENTS	4
RECENT TRAFFIC REPORTS	5
STUDY AREA	5
Study Area Land Use	5
Sketch Plan	5
Study Area Access Plan	6
CURRENTLY-PROPOSED LAND USE AND ACCESS.....	6
Land Use and Vehicle Access.....	6
Sight-Distance Analysis	7
Pedestrian and Bicycle Access.....	7
EXISTING ROAD AND TRAFFIC CONDITIONS.....	7
Existing Traffic Volumes	8
BACKGROUND (BASELINE) CONDITIONS	8
TRIP GENERATION.....	9
TRIP DISTRIBUTION AND ASSIGNMENT.....	9
TOTAL TRAFFIC.....	10
Short-Term Total Traffic Volumes	10
2040 Total Traffic Volumes	10
LEVEL OF SERVICE ANALYSIS	10
Briargate Parkway/Vollmer Road	11
Briargate Parkway/Wheatland Drive.....	11
Vollmer Road/Sam Bass Drive	11
Vollmer Road/Jane Kirkham Drive.....	11
SUBDIVISION STREET CLASSIFICATIONS	12
AREA MTCP 2040 ROADWAY IMPROVEMENT PROJECTS.....	12
AUXILIARY TURN LANES	13
DEVIATION REQUESTS.....	13
TRANSPORTATION IMPROVEMENT FEE PROGRAM	14
CONCLUSIONS AND RECOMMENDATIONS	14
Trip Generation	14
Level of Service	14
Recommended Improvements.....	14

Enclosures: 15

Tables 1 and 3

Figures 1-13

TAZ Map

MTCP Maps

Traffic Count Reports

Level of Service Reports



LSC TRANSPORTATION CONSULTANTS, INC.
2504 East Pikes Peak Avenue, Suite 304
Colorado Springs, CO 80909
(719) 633-2868
FAX (719) 633-5430
E-mail: lsc@lsctrans.com
Website: <http://www.lsctrans.com>

August 4, 2021

Mr. Jim Morley
Morley-Bentley Investments, LLC
20 Boulder Crescent, 1st Floor
Colorado Springs, CO 80903

RE: Homestead North Phase 1
Updated Traffic Impact Study
El Paso County, Colorado
LSC #204380
SP-20-008

Dear Mr. Morley:

LSC Transportation Consultants, Inc. has prepared this updated Traffic Impact Study for Homestead North Phase 1. As shown in Figure 1, Homestead North is located east of Vollmer Road and north of the future extension of Briargate Parkway in El Paso County, Colorado. Homestead North Phase 1 is part of the Sterling Ranch Master Plan area. This report is intended as a site-specific, final plat traffic report for the currently proposed filing.

REPORT CONTENTS

The preparation of this report included the following:

- A list of previous Sterling Ranch traffic reports and traffic reports completed by LSC Transportation Consultants, Inc. for other area developments;
- A summary of the proposed land use and access plan;
- The existing roadway and traffic conditions in the site's vicinity, including the roadway widths, surface conditions, lane geometries, traffic controls, and posted speed limits;
- Existing (2020) traffic-volume data;
- Estimates of projected short-term and long-term traffic volumes;
- The projected average weekday and peak-hour vehicle trips to be generated by the proposed development;
- The assignment of the projected site-generated traffic volumes to the area roadways;
- The projected short-term and long-term total traffic volumes on the area roadways;
- The projected levels of service at the key intersections in the vicinity of the site;
- The recommended street classifications for the internal streets within the proposed development;

- The project's obligation to the County roadway improvement fee program; and
- Recommended roadway improvements

RECENT TRAFFIC REPORTS

LSC prepared a traffic impact study (TIS) for the entire Sterling Ranch development dated June 5, 2008. LSC also prepared a traffic impact analysis for the first phase of the Sterling Ranch development, dated March 16, 2015; a memorandum for Phases 1-3, dated October 2, 2017; and a traffic impact analysis for the Sterling Ranch Phase 2 Preliminary Plan, dated December 20, 2018. The following site-specific, final plat traffic reports have also been prepared:

- Branding Iron at Sterling Ranch Filing No. 1 and Homestead at Sterling Ranch Filing No. 1, dated December 19, 2017
- Sterling Ranch Filing No. 2, dated April 3, 2018
- *Sterling Ranch Phase 2*, dated December 20, 2018
- Copper Chase at Sterling Ranch, dated December 20, 2018
- Homestead at Sterling Ranch Filing No. 2, dated March 3, 2020
- *Branding Iron at Sterling Ranch Filing No. 2*, dated March 31, 2020 (revised May 6, 2020)
Sterling Ranch Filing No. 2 and Sterling Ranch Phase 2, dated May 19, 2021

LSC prepared a TIS for the Retreat at TimberRidge, located just north of the Homestead North development, dated January 25, 2018. LSC also prepared transportation memoranda for the Retreat at TimberRidge Preliminary Plan dated June 29th, 2018 and the Retreat at TimberRidge Filing No. 1 dated April 3, 2020.

STUDY AREA

Study Area Land Use

Sketch Plan

Figure 2 shows the location of currently-proposed Homestead North Phase 1 development. These parcels were included as part of traffic analysis zone (TAZ) 21 in the 2008 master traffic impact report. Table 1 shows the land uses assumed for TAZ 21 in the 2008 report and the land uses assumed in this report. A copy of the TAZ map from the 2008 report has been attached. As shown in Table 1, the 2008 report assumed the study area would be developed with 327 single-family homes. This same area is now planned to be developed with about 224 single-family homes. This includes 147 single-family homes currently proposed in Phase 1 and 77 single-family homes assumed in future Homestead North phases.

Study Area Access Plan

The access plan for the current study area is generally consistent with the access plan shown in the master traffic report. The following summarizes the changes:

- The Sterling Ranch access to Briargate Parkway just east of Vollmer Road (Wheatland Drive) was previously shown as a right-in/right-out-only intersection in the Sketch Plan. The south leg is now proposed as a three-quarter-movement (left-in/right-in/right-out-only) access. A deviation request for this access point has been submitted and approved. The north leg that will serve Homestead North Phase 1 is still proposed to be restricted to right-in/right-out only.
- An additional right-in-only access (Jane Kirkham Drive) is proposed from northbound Vollmer Road between Briargate Parkway and the first full-movement site access. The applicant is requesting this access to reduce the out-of-direction travel to the southern portion of the development for motorists arriving from the south, west, or southwest. As there is not sufficient intersection spacing for an eastbound left turn from Briargate Parkway (Stapleton) at Wheatland Drive, this access would be a good alternative to improve to accessibility to the southern portion of the site. Future residents in the southern portion of the site would not need to travel about one-quarter mile up Vollmer, turn right at Sam Bass Drive, and backtrack through the north portion of the subdivision to reach the homes in the southern portion. The right-in-only connection would have a northbound right-turn deceleration lane on Vollmer and very minimal impact to Vollmer operations as only the right-in turning movement would be allowed.

These changes to the plan will result in some localized shifts in intersection turning movements shown in the master traffic study long-term traffic projections, but nothing significant requiring an update to the master study.

CURRENTLY PROPOSED LAND USE AND ACCESS

Land Use and Vehicle Access

Homestead North Phase 1 is planned to include 147 lots for single-family homes. A full-movement site access (Sam Bass Drive) is proposed to Vollmer Road about 1,410 feet north of Briargate Parkway and 1,370 feet south of Poco Road. An additional right-in-only access (Jane Kirkham Drive) is proposed to Vollmer Road 704 feet north of Briargate Parkway and about 704 feet south of Sam Bass Drive. An access is also proposed to Briargate Parkway 750 feet east of Vollmer Road aligning with Wheatland Drive. In the short term, full-movement access will be allowed at this intersection, as only a half section of Briargate Parkway is planned to be constructed between Vollmer Road and Wheatland Drive. Once Briargate Parkway is widened to the full Principal Arterial cross-section **and** the roadway is extended east of Wheatland, the north leg serving Homestead North will be restricted to right-in/right-out only and the south leg will be restricted to three-quarter movements (left-in/right-in/right-out only). In the future, Homestead North Phase 1 will also have access through future Homestead North phases and the Retreat at TimberRidge to Poco Road.

Sight Distance Analysis

Figure 3 shows a sight distance analysis at the future intersection of Vollmer Road/Sam Bass Drive. Based on a design speed of 40 miles per hour (mph) and the criteria contained in Table 2-21 of the *El Paso County Engineering Criteria Manual (ECM)*, the required intersection sight distance at the future intersections is 445 feet. Based on the criteria contained in Table 2-17 of the ECM, the required stopping sight distance approaching this intersection is 305 feet. As shown in Figure 4, the future intersection analyzed will meet the criteria.

Pedestrian and Bicycle Access

There are no existing schools within two miles of the site. However, there are planned future school sites within the Sterling Ranch Master Plan area south of Briargate Parkway. There are planned sidewalks on Vollmer Road and Briargate Parkway adjacent to the site. School crossings will be needed at the intersection of Briargate Parkway/Vollmer Road. School crossings should not be allowed at the intersection of Briargate Parkway/Wheatland Drive.

EXISTING ROAD AND TRAFFIC CONDITIONS

The adjacent streets are shown in Figure 1 and are described below. Copies of the *2016 El Paso County Major Transportation Corridors Plan (MTCP)*, *2040 Roadway Plan*, and *2016 MTCP 2060 Corridor Preservation Plan* with the site location identified on each of them have been attached to this report.

Vollmer Road is currently a five-lane urban street within the City of Colorado Springs limits between Black Forest Road and Cowpoke Road; and a two-lane, rural, paved roadway north of Cowpoke Road extending to north of Hodgen Road. In the southbound direction, Vollmer Road has a posted speed limit of 45 miles per hour (mph). South of Cowpoke Road, Vollmer Road has a 40-mph posted speed limit. The *2040 El Paso County Major Transportation Corridors Plan (MTCP)* and the Sterling Ranch master traffic study show Vollmer Road as a four-lane Urban Minor Arterial adjacent to the site. Vollmer Road is planned to transition to a 2-lane Rural Minor Arterial north of Poco Road. In the interim, auxiliary turn lanes will be completed on Vollmer Road at Briargate Parkway as part of the Homestead at Sterling Ranch Filing No. 2 development.

Marksheffel Road is a Principal Arterial extending north from the City of Fountain to Woodmen Road. Marksheffel Road is planned to ultimately be widened to six lanes and extended north and west from Woodmen Road to connect to Research Parkway at Black Forest Road. Marksheffel Road is shown as a six-lane Principal Arterial through the Sterling Ranch Master Plan area on the El Paso County MTCP.

Briargate Parkway is a six-lane, Principal Arterial that extends east from I-25 to Grand Lawn Circle (about one-half mile east of Powers Boulevard). Briargate Parkway/Stapleton Road is planned ultimately to extend to Towner Drive. The section of Briargate Parkway between Vollmer Road

and the first Sterling Ranch access (Wheatland Drive) is planned to be constructed in the short term as a partial cross-section with the Homestead at Sterling Ranch Filing No. 2 development.

Poco Road is an existing gravel road which extends east for about three-quarters of a mile from Lochwinnoch Lane to Vollmer Road. Poco Road is planned to be extended east of Vollmer Road as an Urban Local Road to serve the Retreat at Timber Ridge Filing No. 1 (PCD-SF-19-009).

Existing Traffic Volumes

Figure 4 shows the existing (2020) peak-hour traffic volumes at the intersections of Dines/Vollmer. The traffic volumes shown for the intersection of Dines/Vollmer were based on traffic counts conducted by LSC in May 2020. These traffic counts were conducted at a time when COVID-19 pandemic-related restrictions were in place. However, traffic counts conducted at the intersection of Black Forest Road/Vollmer Road in December 2019 (pre-pandemic) and repeated during the same week that the Dines/Vollmer counts were conducted indicate only minor impacts to traffic volumes on Vollmer Road due to these restrictions. The traffic count sheets are attached.

Figure 4 also shows the daily traffic volumes on Vollmer Road in the vicinity of the site. These volumes are estimates by LSC, based on the 2020 peak-hour counts and the ratio of peak-hour to daily traffic volumes from 24-hour traffic counts conducted on Vollmer Road just south of Poco Road by LSC in 2017.

BACKGROUND (BASELINE) CONDITIONS

Background traffic is the traffic estimated to be on the adjacent roadways and at adjacent intersections without the proposed development's trip generation of site-generated traffic volumes. Background traffic includes the through traffic and the traffic generated by nearby developments, but assumes zero traffic generated by Homestead North Phase 1.

Figure 5 shows the projected short-term background traffic volumes at the key area intersections. The short-term background volumes assume a half section of Briargate Parkway has been constructed between Vollmer Road and Wheatland Drive and that full-movement access is permitted at the intersection of Briargate/Wheatland. The short-term background traffic includes the existing traffic volumes (from Figure 3) plus increases in through traffic due to regional growth, plus traffic estimated to be generated by buildout of the Homestead at Sterling Ranch Filings 1 and 2, Branding Iron at Sterling Ranch Filings 1 and 2, Sterling Ranch Filing No. 2, Sterling Ranch Phase 2, and the Retreat at TimberRidge Filing No. 1 to be located generally northeast of the intersection of Vollmer Road and Poco Road.

Figure 6 shows the projected 2040 background traffic volumes at the key area intersections. 2040 background traffic volume estimates were based on 2040 volume projections in the *El Paso County Major Transportation Corridors Plan* (MTCP) and previous work completed in the area by LSC,

including the *Sterling Ranch Updated Traffic Impact Analysis* by LSC (dated June 5, 2008) and the *Retreat at TimberRidge Updated Traffic Impact Analysis* by LSC (dated January 25, 2018). The 2040 background traffic volumes assume buildout of the Sterling Ranch development, including future phases of Homestead North, and buildout of the Retreat at TimberRidge. The 2040 background traffic assumes Briargate Parkway/Stapleton Road has been constructed between Black Forest Road and Towner Avenue and that the intersection of Briargate/Wheatland is restricted to a three-quarter movement (left-in/right-in/right-out only) for the south leg and right-in/right-out only for the north leg. The 2040 background traffic also assumes a connection between the intersection of Wheatland/Briargate and Poco Road through the Homestead North area.

TRIP GENERATION

The site-generated vehicle trips were estimated using the nationally published trip-generation rates from *Trip Generation, 10th Edition, 2017* by the Institute of Transportation Engineers (ITE). Table 1 shows the trip-generation estimates.

Homestead North Phase 1 is projected to generate about 1,388 new external vehicle-trips on the average weekday, with about half entering and half exiting the site during a 24-hour period. During the morning peak hour, which generally occurs for one hour between 6:30 and 8:30 a.m., about 27 vehicles would enter and 82 vehicles would exit the site. During the afternoon peak hour, which generally occurs for one hour between 4:15 and 6:15 p.m., about 92 vehicles would enter and 54 vehicles would exit the site.

TRIP DISTRIBUTION AND ASSIGNMENT

The directional distribution of the site-generated traffic volumes on the street and roadway system serving the site is one of the most important factors in determining the site's traffic impacts. The specific short-term and long-term distribution estimates are shown in Figure 7. The directional distribution estimates are based on the following factors: the location of the site with respect to the Colorado Springs metropolitan area, the planned access system for the site, the street and roadway system serving the site, the land uses proposed for the site, and the distribution of existing traffic volumes at the intersection of Dines Boulevard/Vollmer. The short-term distribution estimate assumes only the short section of Briargate Parkway between Vollmer Road and Wheatland Drive has been constructed in the vicinity of the site and the long-term distribution estimate assumes full buildout of the future roadway network in the vicinity of the site.

When the distribution percentages (from Figure 7) are applied to the trip-generation estimates (from Table 1), the resulting site-generated traffic volumes can be determined. Figures 8 and 9 show the short-term and 2040 site-generated traffic volume estimate for Homestead North Phase 1. The short-term site-generated traffic volumes assume the intersection of Briargate/Wheatland as an interim full-movement intersection. The long-term site-generated traffic volumes assume the north leg of this intersection has been restricted to right-in/right-out only.

TOTAL TRAFFIC

Short-Term Total Traffic Volumes

Figure 10 shows the projected short-term total traffic volumes at the intersection of Briargate/Vollmer and the site access points. The short-term total traffic volumes are the sum of the short-term background traffic volumes (from Figure 5) and the short-term site-generated traffic volumes (from Figure 8).

2040 Total Traffic Volumes

Figure 11 shows the projected 2040 total traffic volumes at the intersection of Briargate/Vollmer and the site access points. The 2040 total traffic volumes are the sum of the 2040 background traffic volumes (from Figure 6) and the long-term site-generated traffic volumes (from Figure 9).

LEVEL OF SERVICE ANALYSIS

Level of service (LOS) is a quantitative measure of the level of congestion or delay at an intersection. Level of service is indicated on a scale from “A” to “F.” LOS A represents control delay of less than 10 seconds for unsignalized intersections. LOS F represents control delay of more than 50 seconds for unsignalized intersections. Table 2 shows the level of service delay ranges.

Table 2: Intersection Levels of Service Delay Ranges

Level of Service	Signalized Intersections	Unsignalized Intersections
	Average Control Delay (seconds per vehicle)	Average Control Delay (seconds per vehicle) ⁽¹⁾
A	10.0 sec or less	10.0 sec or less
B	10.1-20.0 sec	10.1-15.0 sec
C	20.1-35.0 sec	15.1-25.0 sec
D	35.1-55.0 sec	25.1-35.0 sec
E	55.1-80.0 sec	35.1-50.0 sec
F	80.1 sec or more	50.1 sec or more

(1) For unsignalized intersections, if V/C ratio is greater than 1.0 the level of service is LOS F, regardless of the projected average control delay per vehicle.

The intersection of Briargate/Vollmer and the site access points have been analyzed to determine the projected intersection levels of service for short-term and 2040 background and total traffic scenarios for the morning and afternoon peak-hour periods. The short-term analysis of the intersection of Briargate/Vollmer and the short-term and 2040 analysis of the site access points were based on the unsignalized intersection analysis procedures from the *Highway Capacity Manual, 6th Edition*. The intersection of Briargate/Vollmer was analyzed as a signalized

intersection using Synchro for the 2040 analysis. Figures 5, 6, 10, and 11 show the level of service analysis results. The level of service reports are attached.

Briargate Parkway/Vollmer Road

The intersection of Briargate/Vollmer is projected to operate at a satisfactory level of service (LOS C or better) as a stop sign-controlled intersection, based on the short-term total traffic. This analysis assumes Briargate Parkway has only been extended east of Vollmer Road to Wheatland Drive. By 2040, it was assumed that Briargate Road would be extended east to Black Forest Road and west to connect to its current terminus. It was also assumed that the intersection of Briargate/Vollmer would be signal-controlled by 2040. This intersection is projected to operate at an overall satisfactory level of service (LOS D or better) as a signalized intersection.

Briargate Parkway/Wheatland Drive

The intersection of Briargate/Wheatland is projected to operate at a LOS B or better for all movements as a full-movement stop sign-controlled intersection, based on the short-term total traffic. The half section of Briargate Parkway has been constructed between Vollmer Road to Wheatland Drive. The other half section adjacent to Homestead North will be completed with this adjacent development, bringing the segment between Vollmer and Wheatland to the full Principal Arterial cross-section. In the interim, following the development of Homestead North but prior to the extension of Briargate Parkway east of Wheatland, the use of all-way, stop-sign traffic control (AWSC) may be the best solution, given the width of the full arterial cross section. This can potentially be addressed with the signing & striping plan.

By 2040, it was assumed that the south leg of the intersection of Briargate/Wheatland would be restricted to three-quarter movement (left-in/right-in/right-out only) and the north leg would be restricted to right-in/right-out only. These restrictions are likely to occur prior to 2040, as Briargate Parkway is extended to the east of Wheatland. Based on the 2040 total traffic volumes and lane geometry shown in Figure 11, all movements at this intersection are projected to operate at LOS D or better during the peak hours.

Vollmer Road/Sam Bass Drive

The intersection of Vollmer Road/Sam Bass Drive is projected to operate at LOS C or better for all movements during the peak hours as a stop sign-controlled intersection, based on the projected short-term and 2040 total traffic volumes.

Vollmer Road/Jane Kirkham Drive

As indicated above (restated here): *An additional right-in-only access (Jane Kirkham Drive) is proposed from northbound Vollmer Road between Briargate Parkway and the first full-movement site access. The applicant is requesting this access to reduce the out-of-direction travel to the*

southern portion of the development for motorists arriving from the south, west, or southwest. As there is not sufficient intersection spacing for an eastbound left turn from Briargate Parkway (Stapleton) at Wheatland Drive, this access would be a good alternative to improve to accessibility to the southern portion of the site. Future residents in the southern portion of the site would not need to travel about one-quarter mile up Vollmer, turn right at Sam Bass Drive, and backtrack through the north portion of the subdivision to reach the homes in the southern portion. The right-in only connection would have a northbound right-turn deceleration lane on Vollmer and very minimal impact to Vollmer operations, as only the right-in turning movement would be allowed.

The right-in only “access” would need to be designed with channelization, signing, and striping to prevent left-in turning movements from the north.

The internal intersection of Jane Kirkham Drive and Texas Jack Drive would need to be designed, signed, and marked for one-way traffic eastbound west of Texas Jack Drive.

Potentially, the traffic control at the intersection of Jane Kirkham Drive and Texas Jack Drive may need to be all-way stop-sign control or possibly stop-sign control northbound and southbound and “free” for eastbound traffic arriving from Vollmer.

The stopping sight distance for traffic turning from northbound Vollmer onto Jane Kirkham Drive will be a consideration in the design.

← Will this be a continuous accel-decel lane on Vollmer?

SUBDIVISION STREET CLASSIFICATIONS

Figure 12 shows the recommended street classifications for the streets in the vicinity of the site.

AREA MTCP 2040 ROADWAY IMPROVEMENT PROJECTS

The *El Paso County 2016 Major Transportation Corridors Plan Update* identified the following 2040 roadway improvement projects within the study area:

- C13: Vollmer Road, from Marksheffel Road to Stapleton Drive [Briargate Parkway], as a Rural 4-Lane Minor Arterial. The *Retreat at TimberRidge Preliminary Plan Transportation Memorandum* by LSC Transportation Consultants, Inc. dated June 29th, 2018 recommends Vollmer Road be upgraded to a 4-lane **Urban** Minor Arterial from Marksheffel Road to Poco Road. LSC recommends a transition section between the 4-Lane Minor Arterial section south of Poco Road and the 2-lane **Rural** Arterial section north of Poco Road be constructed between Sam Bass Drive and Poco Road. This could be accomplished by having the second northbound through lane transition to a “trap” right-turn lane at Poco Road. The second southbound through lane could be added either by providing a southbound acceleration lane at Poco Road or having Vollmer Road flare out just south of Poco Road.

- N5 Stapleton Drive [Briargate Parkway], from Towner Road to Black Forest Road, as a 4-Lane Urban Principal Arterial.
- N12: Marksheffel Road, from Woodman Road to Research Parkway, as a 4-Lane Urban Principal Arterial.
- M11: Vollmer Road Bicycle & Primary Regional Trail, from Marksheffel Road to Shoup Road.

AUXILIARY TURN LANES

Doesn't this interfere with the acceleration lane as designed?

- Based on the projected short-term total traffic volumes and the criteria contained in the *El Paso County Engineering Criteria Manual (ECM)*, northbound right-turn deceleration lanes are projected to be warranted on Vollmer Road approaching the proposed right right-in-only access and Sam Bass Drive. These lanes should be 155' feet long plus a 160-foot taper.
- Based on the projected short-term and 2040 total traffic volumes and the criteria contained in the *El Paso County Engineering Criteria Manual (ECM)*, a southbound left-turn lane is **not** projected to be warranted on Vollmer Road approaching Sam Bass Drive. However, left-turn lanes are included in the standard cross section for a Minor Arterial and LSC recommends this turn lane be included in the design for the Vollmer Road improvements adjacent to the site. ●
- Based on the projected 2040 total traffic volumes and the criteria contained in the *El Paso County Engineering Criteria Manual (ECM)*, a westbound right-turn deceleration lane is projected to be warranted on Briargate Parkway approaching Wheatland Drive. This lane should be 235' feet long plus a 200-foot taper. ●

The *Retreat at TimberRidge Preliminary Plan Transportation Memorandum* dated June 29, 2019 identified the need for a northbound right-turn deceleration lane on Vollmer Road approaching Poco Road. The design and installation of that lane should be completed with final plat(s) for the Retreat at TimberRidge and/or future Homestead North filings.

DEVIATION REQUESTS

The following deviation requests to the criteria contained in the *El Paso County Engineering Criteria Manual (ECM)* will be included with this submittal:

- The proposed spacing of internal local roads within Homestead North Phase 1
- The proposed spacing for a right-in only access. This "access" would be a public street connection-one-way eastbound with an "intersection" with Vollmer, but would only include the "departure lane" from the connection at Vollmer Road (Urban Minor Arterial).

Provide the deviation request and address the cross-section. Will noise walls be provided for the adjacent lots?

TRANSPORTATION IMPROVEMENT FEE PROGRAM

The applicant will be required to participate in the Countywide Transportation Improvement Fee Program. These projects will annex into the 10 mil PID, which has a per-lot upfront building permit fee of \$1,221 per dwelling unit. The total building permit fee amount for the 147 lots within Homestead North Phase 1 would be \$179,487.

CONCLUSIONS AND RECOMMENDATIONS

Trip Generation

Homestead North Phase 1 is projected to generate about 1,388 new external vehicle trips on the average weekday, with about half entering and half exiting the site during a 24-hour period. During the morning peak hour, which generally occurs for one hour between 6:30 and 8:30 a.m., about 27 vehicles would enter and 82 vehicles would exit the site. During the afternoon peak hour, which generally occurs for one hour between 4:15 and 6:15 p.m., about 92 vehicles would enter and 54 vehicles would exit the site.

Level of Service

- In the short term, the intersection of Briargate/Vollmer is projected to operate at a satisfactory level of service as a stop sign-controlled "T" intersection. By 2040, it was assumed that Briargate Road/Stapleton Road would be extended west to Black Forest Road and east to connect to its current terminus. It was also assumed that the intersection of Briargate/Vollmer would be signal controlled by 2040. This intersection is projected to operate at an overall satisfactory level of service (LOS D or better) as a signalized intersection.
- The proposed site access points to Vollmer Road and Briargate Parkway are projected to operate at a satisfactory level of service as stop sign-controlled intersections, based on the short-term and 2040 total traffic volumes and lane geometry shown in Figures 10 and 11.

Recommended Improvements

- A list of all roadway segment improvements in the vicinity of the site is presented in Table 3. The location of each roadway segment is identified in Figure 13.
- Please refer to the Auxiliary Turn Lanes section above for auxiliary turn-lane recommendations. Figures 10 and 11 also show turn lanes as part of the intersection laneage graphics.

Please contact me if you have any questions regarding this report.

Sincerely,

LSC TRANSPORTATION CONSULTANTS, INC.

By Jeffrey C. Hodsdon, P.E.
Principal

KDF:jas

Enclosures: Tables 1 and 3
Figures 1-13
TAZ Map
MTCP Maps
Traffic Count Reports
Level of Service Reports

Tables



**Table 1
Trip Generation Estimate
Homestead North Phase 1**

Land Use Code	Land Use Description	Trip Generation Units	Trip Generation Rates ⁽¹⁾				Total External Trips Generated					
			Average Weekday Traffic	Morning Peak Hour		Evening Peak Hour		Average Weekday Traffic	Morning Peak Hour		Evening Peak Hour	
				In	Out	In	Out		In	Out		
Trip Generation Estimate for the Currently Proposed Homestead North Phase 1												
210	Single-Family Detached Housing	147 DU ⁽²⁾	9.44	0.19	0.56	0.62	0.37	1,388	27	82	92	54
Trip Generation Estimate for Future Homestead North Phases												
210	Single-Family Detached Housing	77 DU	9.44	0.19	0.56	0.62	0.37	727	14	43	48	28
		224 DU						2,115	41	125	140	82
Trip Generation Estimate for TAZ 21 From the Sterling Ranch Updated Traffic Impact Analysis June 5, 2008												
210	Single-Family Detached Housing	327 DU	9.57	0.19	0.56	0.64	0.37	3,129	61	184	208	122
	Change in trip generation estimate	-103 DU						-1,014	-20	-59	-68	-40

Notes:

(1) Source: "Trip Generation, 10th Edition, 2017" by the Institute of Transportation Engineers (ITE)

(2) DU = dwelling unit

Table 3
(page 1 of 3)

Homestead North

Roadway Segment Improvements

Segment ID⁽¹⁾	Improvement Description	Timing	Design ADT (vpd)	Projected Short-Term ADT (vph)	Projected 2040 ADT (vpd)	Responsibility
Adjacent Roadway Improvements						
V4	Improve Vollmer Road from Sterling Ranch boundary south of Dines Boulevard to Briargate Parkway to a standard 4-Lane Urban Minor Arterial Cross Section ⁽²⁾	Short-Term Future (With Homestead North)	20,000	8,110	17,480	Sterling Ranch (With Homestead North)
V5	Improve Vollmer Road from Briargate Parkway to Sam Bass Drive to a standard 4-Lane Urban Minor Arterial Cross Section ⁽²⁾	Short-Term Future (With Homestead North)	20,000	7,145	11,805	Sterling Ranch (With Homestead North)
V6	Widen the east side of Vollmer Road in the vicinity of Poco Road to the rural standard (32' wide interim total including 8' of pavement and 2' gravel shoulder)	Short-Term Future (With Retreat at TimberRidge Fils 1 & 2)	10,000	7,010	10,580	Retreat at TimberRidge Fil 1
	Improve Vollmer Road between Sam Bass Drive and Poco Road to a 4-lane Urban Minor Arterial but with necessary lane transitions, redirect tapers, etc. south of Poco to adequately transition between the 4-Lane Urban Minor Arterial Cross Section and the 2-Lane Rural Arterial Cross Section north of Poco Road	Short-Term Future (With Homestead North)	20,000			Sterling Ranch (With Homestead North)
B1	Construct the south half section of Briargate Pkwy (4-Lane Principal Arterial) between Vollmer Road and Wheatland Dr	Short-Term Future (With Homestead at Sterling Ranch Fil 2)	20,000	1,190	36,150	Sterling Ranch
	Construct the north half section of Briargate Pkwy (4-Lane Principal Arterial) between Vollmer Road and Wheatland Dr	Long-Term Future	40,000			Sterling Ranch

Notes:

(1) See Figure 13

(2) Adequate transition/redirect tapers would be needed between the various cross sections on Vollmer Road. Based on the criteria contained in Table 2-29 of the *El Paso Engineering Criteria Manual* an appropriate taper ratio for a roadway with a design speed of 40 mile per hour is 20:1

(3) Source: Table 20 *Road Impact Fee Study Updated* November 16, 2016

(4) Source: *The Ranch Sketch Plan Master Traffic Impact Study* by LSC Transportation Consultants, Inc. July 9, 2019 PCD File No. SKP-18-006

Source: LSC Transportation Consultants, Inc. (August 2021)

Table 3

(page 2 of 3)

Homestead North

Roadway Segment Improvements

Segment ID⁽¹⁾	Improvement Description	Timing	Design ADT (vpd)	Projected Short-Term ADT (vph)	Projected 2040 ADT (vpd)	Responsibility
Other Area Roadway Improvements						
V1 northbound	Consideration of restriping the 38' of pavement for two 11' southbound lanes (remove the bike lane but add sharro markings), a 12' northbound lane and a 4' outside paved shoulder along the east edge ⁽²⁾ (Note this segment is located within the City of Colorado Springs)	To be evaluated with the first development within Sterling Ranch Phase 2	5,500 (Directional northbound)	4,670 (Directional northbound)	7,840 (Directional northbound)	Sterling Ranch ---
V1 southbound			10,000 (Directional southbound)	4,670 (Directional southbound)	7,840 (Directional southbound)	
V1	Improve Vollmer Road from Dry Needle Place to Marksheffel Road to a standard 4-Lane Urban Minor Arterial Cross Section (Add a second northbound through lane and painted center median) ⁽²⁾	Intermediate-Term Future	20,000	9,335	15,680	Sterling Ranch if necessary prior to construction by Others
V2	Improve Vollmer Road from south of Marksheffel Road to Lochwinnoch Lane to a standard 4-Lane Urban Minor Arterial Cross Section ⁽²⁾	Short-Term Future (With Sterling Ranch Fil No. 2 Or Sterling Ranch Phase 2)	20,000 (Note: Existing Capacity 8,000 ⁽³⁾)	9,490	18,800	Sterling Ranch
V3	Improve Vollmer Road from Lochwinnoch Lane to Sterling Ranch boundary to provide 36' of pavement (existing pavement approx. 23.38') and stripe for one through lane and plus a 6' paved, striped outside shoulder in each direction ⁽²⁾	Short-Term Future (With Homestead North)	11,000 (Note: Existing Capacity 8,000)	8,855	18,735	Sterling Ranch
	Improve Vollmer Road from Lochwinnoch Lane to Sterling Ranch boundary south of Dines Boulevard to a standard 4-Lane Urban Minor Arterial Cross Section ⁽²⁾	Long-Term Future	20,000	8,040	17,735	Sterling Ranch if necessary prior to construction by Others
V7	Improve Vollmer Road from Poco Road to Shoup Road to a Rural 2-Lane Arterial Cross Section ⁽²⁾	Long-Term Future	10,000	7,010	9,430	El Paso County Project ID U-12

Notes:

(1) See Figure 13

(2) Adequate transition/redirect tapers would be needed between the various cross sections on Vollmer Road. Based on the criteria contained in Table 2-29 of the *El Paso Engineering Criteria Manual* an appropriate taper ratio for a roadway with a design speed of 40 mile per hour is 20:1

(3) Source: Table 20 *Road Impact Fee Study Updated* November 16, 2016

(4) Source: *The Ranch Sketch Plan Master Traffic Impact Study* by LSC Transportation Consultants, Inc. July 9, 2019 PCD File No. SKP-18-006

Source: LSC Transportation Consultants, Inc. (August 2021)

Table 3
(page 3 of 3)

Homestead North

Roadway Segment Improvements

Segment ID ⁽¹⁾	Improvement Description	Timing	Design ADT (vpd)	Projected Short-Term ADT (vph)	Projected 2040 ADT (vpd)	Responsibility
SR1	Construct Sterling Ranch Road as an Urban Non-Residential Collector from Marksheffel Road to Dines Boulevard	With Sterling Ranch Fil No. 2	20,000	5,410	12,785	Sterling Ranch
SR2	Construct Sterling Ranch Road as an Urban Non-Residential Collector from Dines Boulevard to Briargate Parkway	Long-Term Future	20,000	0	10,175	Sterling Ranch
M1	Construct Marksheffel Road as an Urban Principal Arterial to City of Colorado Springs standards in 107' of right-of-way between Vollmer Road and Sterling Ranch Road	With Sterling Ranch Fil No. 2 Or Sterling Ranch Phase 2	40,000	4,035	24,185	Sterling Ranch
M2	Construct Marksheffel Road as an Urban Principal Arterial to City of Colorado Springs standards in 107' of right-of-way between Sterling Ranch Road and the south boundary of the Sterling Ranch Master Plan Area	Intermediate Term (With Sterling Ranch Phase 2)	40,000	5,085	26,710	Sterling Ranch
M3	Construct Marksheffel Road between the south boundary of the Sterling Ranch Master Plan Area and Woodmen Road (Note this segment is located within the City of Colorado Springs)	Intermediate Term	40,000	5,085	26,710	Others
M4	Construct Marksheffel Road between Black Forest Road and Vollmer Road	Long-Term Future	40,000	0	25,515	Others
B2-B3	Construct Briargate Pkwy as a 4-Lane Principal Arterial between Wheatland Dr and Banning Lewis Parkway	Long-Term Future	40,000	0	37,840	Sterling Ranch
B4	Construct Stapleton Road as a 4-Lane Principal Arterial between Banning Lewis Parkway and Meridian Road	Long-Term Future	40,000	0	34,375 ⁽⁴⁾	Others
B5	Construct Briargate Pkwy as a 4-Lane Principal Arterial between its current terminus and Black Forest Road and between Black Forest Road and Vollmer Road	Long-Term Future	40,000	0	33,160	Others
---	Construct Banning Lewis Parkway as a 4-Lane Principal Arterial between the south Sterling Ranch boundary and Briargate Pkwy	Long-Term Future	40,000	0	---	Sterling Ranch w/ cost recovery
---	Construct Banning Lewis Parkway as a 4-Lane Principal Arterial between Woodmen Road and the south Sterling Ranch boundary (Note this segment is located within the City of Colorado Springs)	Long-Term Future	40,000	0	---	Others
---	Widen Woodmen Road from 4-lane to 6-lane section from Powers Boulevard to US 24	Long-Term Future	---	---	---	Woodmen Road Metro District/ Others
---	Widen Black Forest Road from 2-lane to 6-lane section from Woodmen Road to Baker Road (Note this segment is located within the City of Colorado Springs)	Long-Term Future	---	---	---	Woodmen Heights District/ Wolf Ranch/ Other Adjacent Properties

Notes:

(1) See Figure 13

(2) Adequate transition/redirect tapers would be needed between the various cross sections on Vollmer Road. Based on the criteria contained in Table 2-29 of the *El Paso Engineering Criteria Manual* an appropriate taper ratio for a roadway with a design speed of 40 mile per hour is 20:1

(3) Source: Table 20 *Road Impact Fee Study Updated* November 16, 2016

(4) Source: *The Ranch Sketch Plan Master Traffic Impact Study* by LSC Transportation Consultants, Inc. July 9, 2019 PCD File No. SKP-18-006

Source: LSC Transportation Consultants, Inc. (August 2021)

delete the highlighted text

Figures





Approximate Scale
Scale: 1" = 3,000'

Figure 1
Vicinity
Map

Homestead North Phase 1 (LSC #204380)

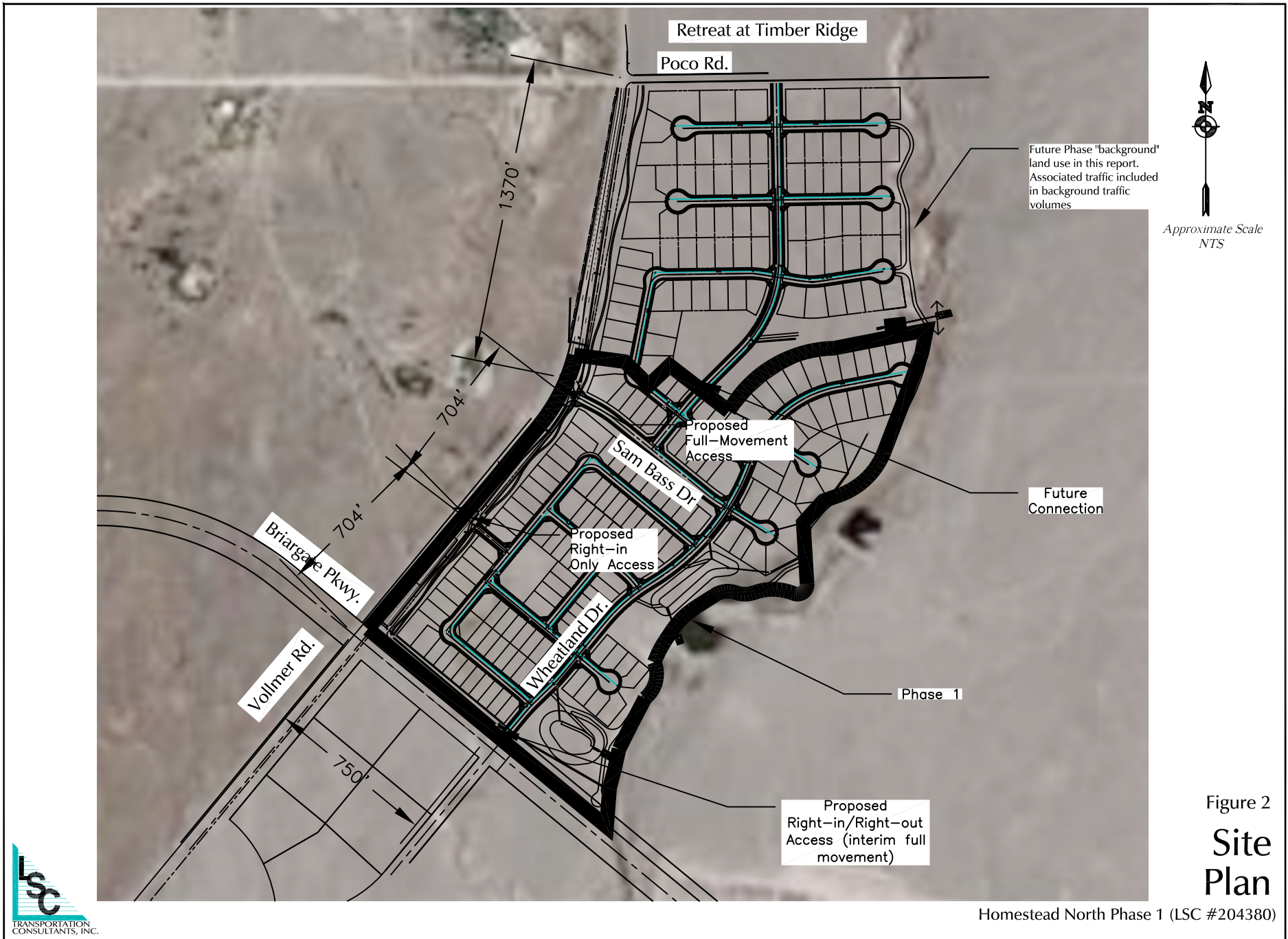





Figure 2
Site Plan

Homestead North Phase 1 (LSC #204380)

LEGEND:

-  = ECM Required Intersection Sight Distance (445' based on a design speed of 40mph from Table 2-21)
-  = ECM Required Stopping Sight Distance (travel path) (305' based on a design speed of 40mph from Table 2-17)
-  = Stopping Sight Distance Sight Line

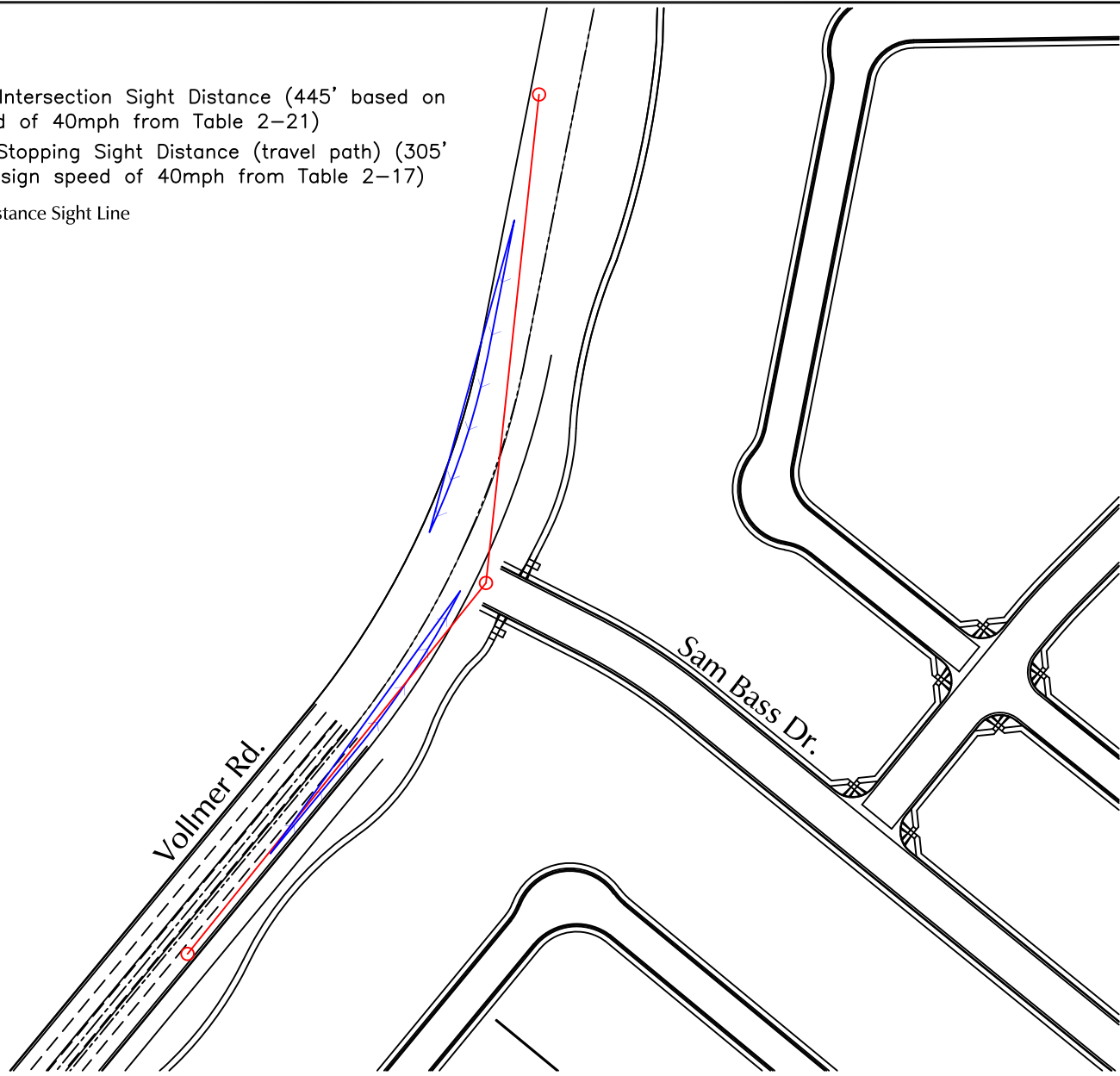
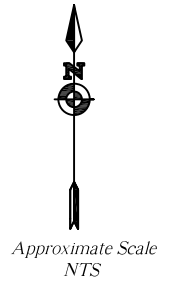
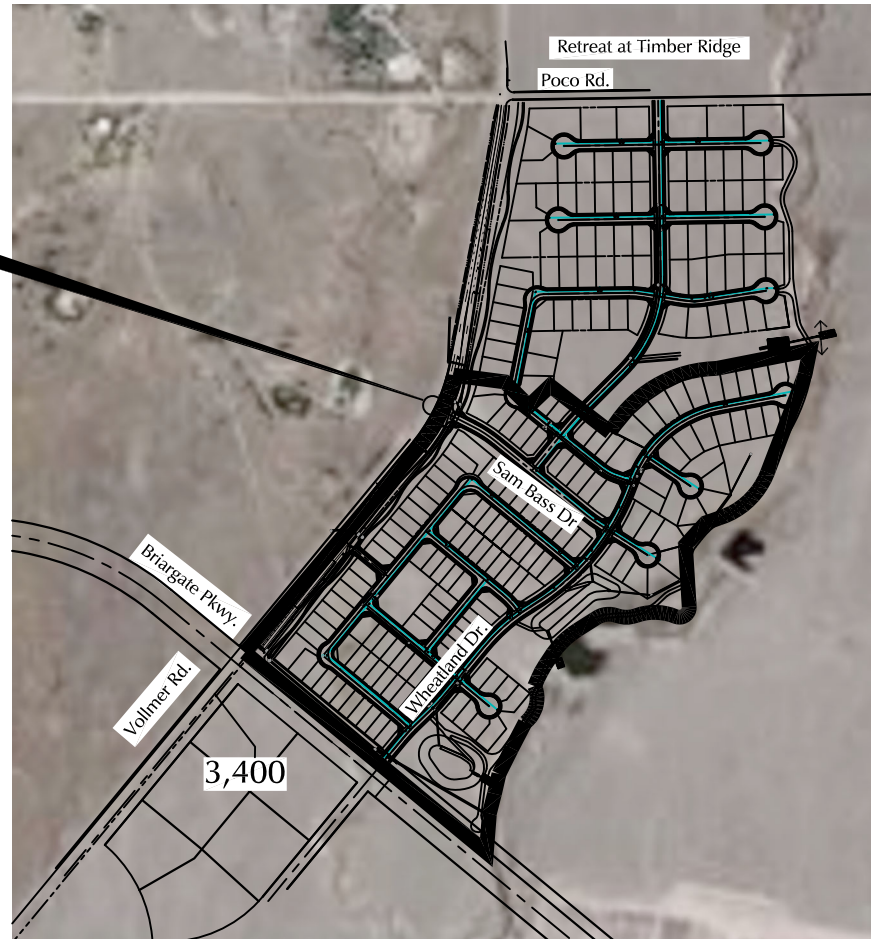
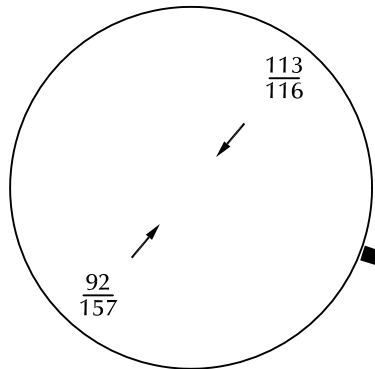


Figure 3
Sight Distance Analysis
Homestead North Phase 1 (LSC #204380)





LEGEND:

$\frac{XX}{XX}$ = AM Weekday Peak-Hour Traffic (vehicles per hour) / PM Weekday Peak-Hour Traffic (vehicles per hour) Based on counts by LSC May 2020

XXX = Average Weekday Traffic (vehicles per day) Estimate by LSC

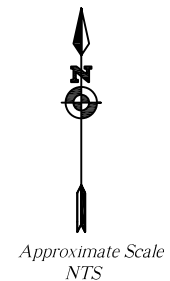
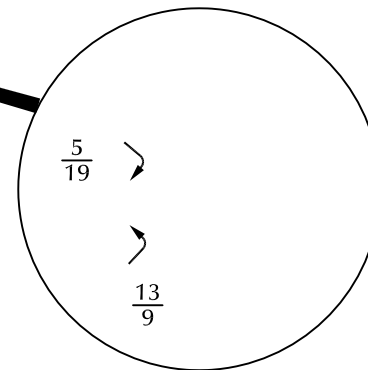
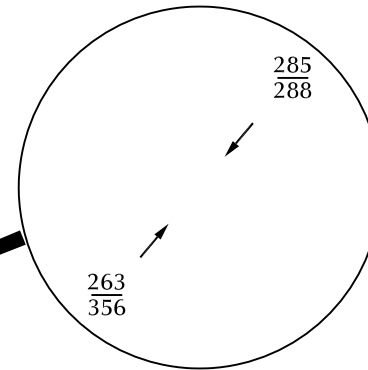
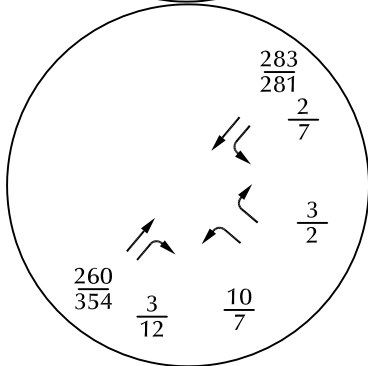
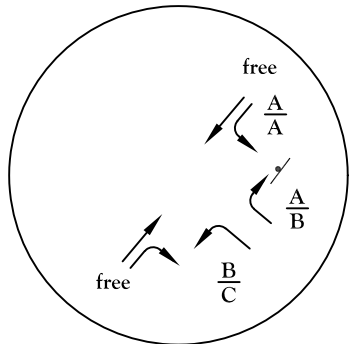
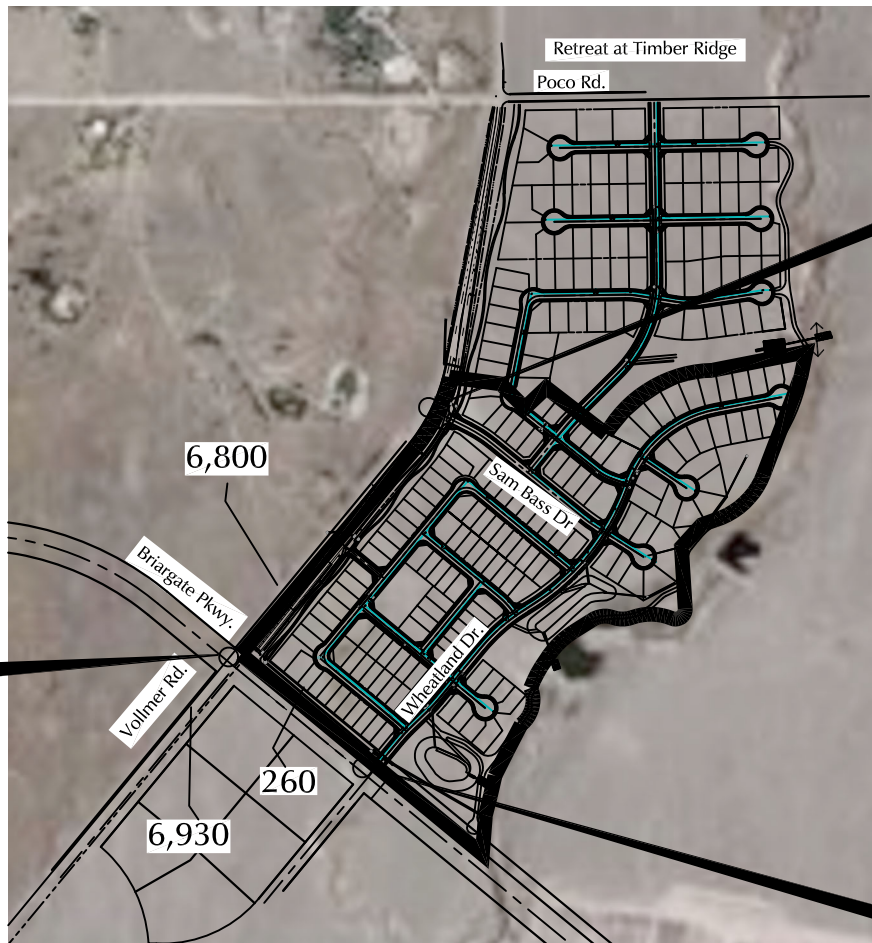
Note: Counts may be impacted by restrictions due to the COVID-19 pandemic.



Figure 4

Existing Traffic

Homestead North Phase 1 (LSC #204380)



LEGEND:

┆ = Stop Sign = Traffic Signal

$\frac{XX}{XX}$ = AM Weekday Peak-Hour Traffic (vehicles per hour)
 PM Weekday Peak-Hour Traffic (vehicles per hour)

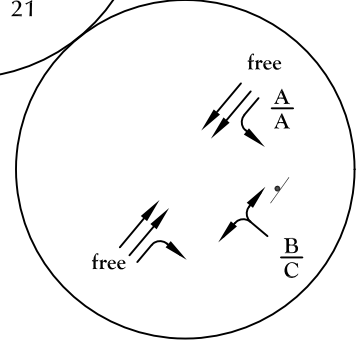
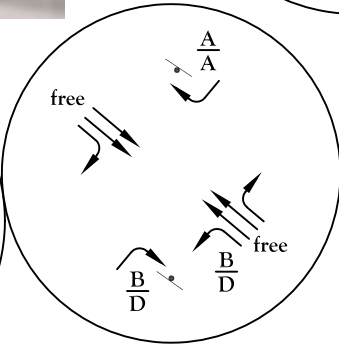
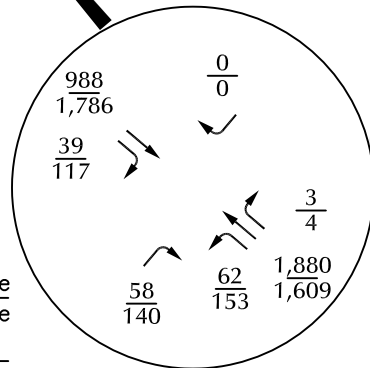
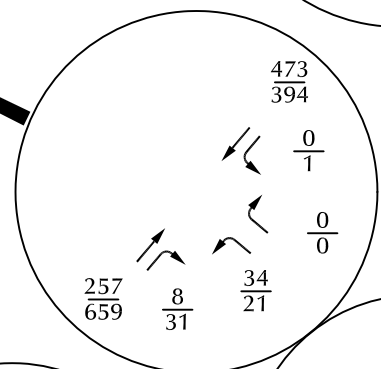
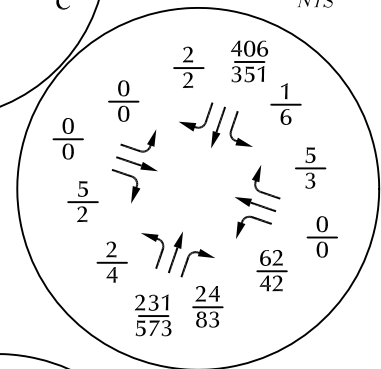
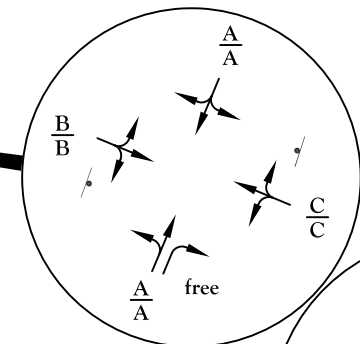
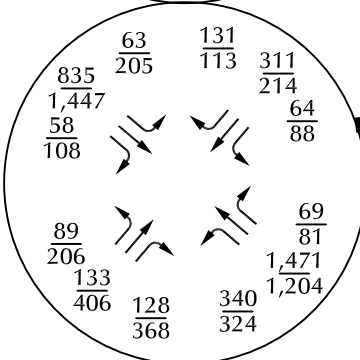
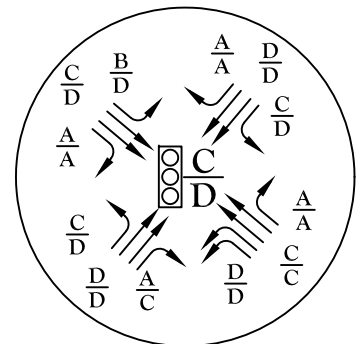
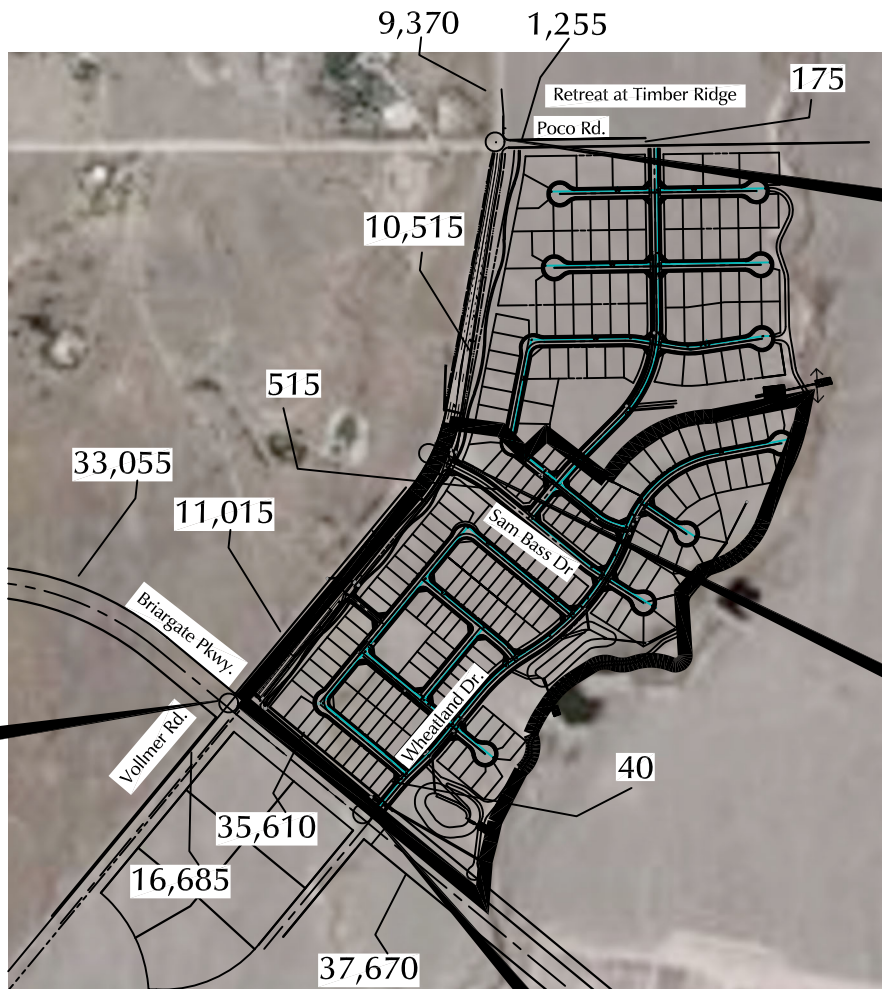
XXX = Average Weekday Traffic (vehicles per day)

$\frac{A}{B}$ = AM Individual Movement Peak-Hour Level of Service
 PM Individual Movement Peak-Hour Level of Service

$\frac{C}{D}$ = AM Entire Intersection Peak-Hour Level of Service
 PM Entire Intersection Peak-Hour Level of Service



Figure 5
Short-term Background Traffic
 Homestead North Phase 1 (LSC #204380)

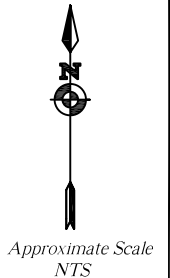


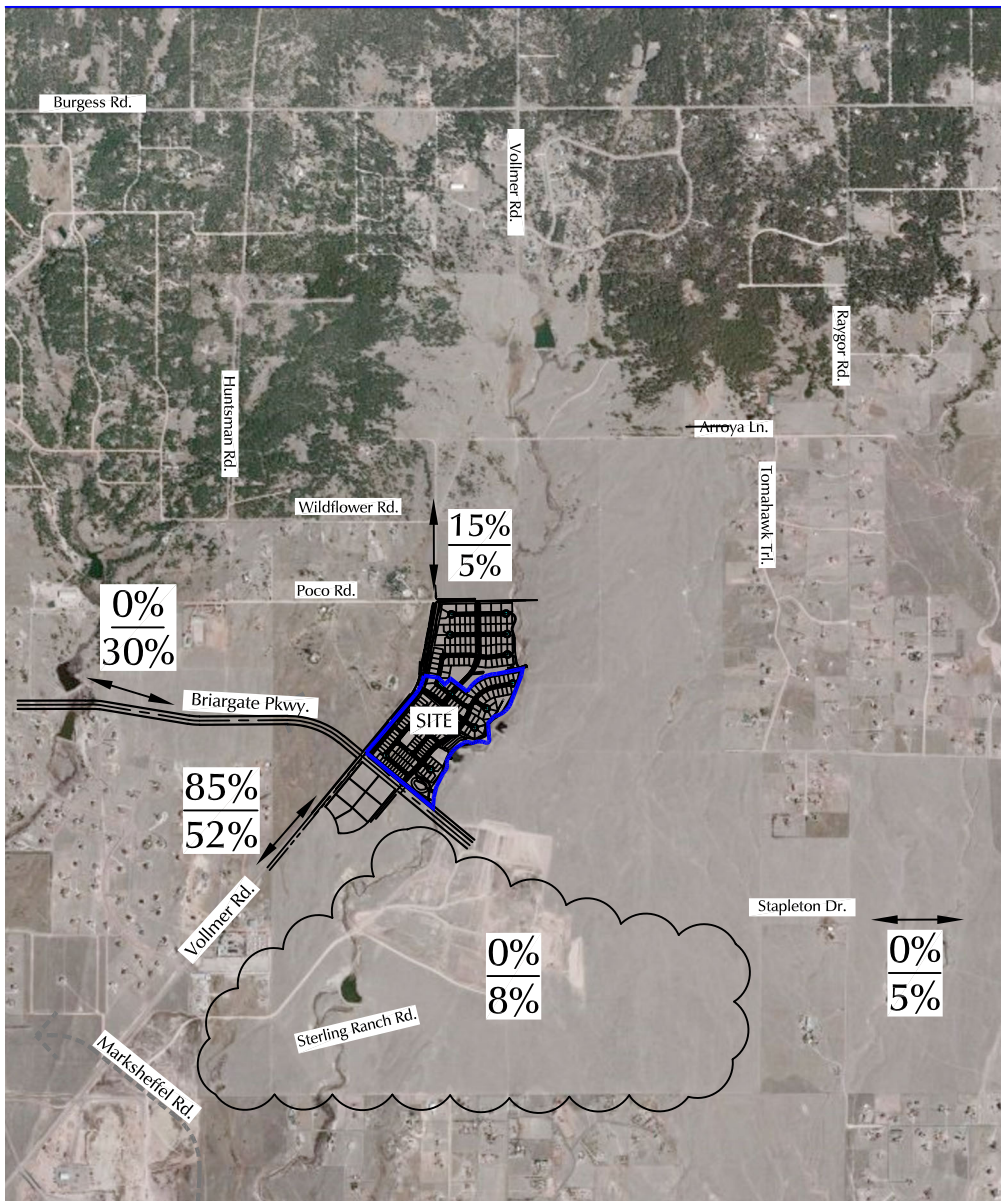
LEGEND:


\uparrow = Stop Sign \square = Traffic Signal
 $\frac{XX}{XX}$ = AM Weekday Peak-Hour Traffic (vehicles per hour)
 $\frac{XX}{XX}$ = PM Weekday Peak-Hour Traffic (vehicles per hour)
 XXX = Average Weekday Traffic (vehicles per day)
 $\frac{A}{B}$ = AM Individual Movement Peak-Hour Level of Service
 $\frac{C}{D}$ = PM Individual Movement Peak-Hour Level of Service
 $\frac{C}{D}$ = AM Entire Intersection Peak-Hour Level of Service
 $\frac{C}{D}$ = PM Entire Intersection Peak-Hour Level of Service



Figure 6
2040 Background Traffic
 Homestead North Phase 1 (LSC #204380)






 Approximate Scale
 Scale: 1" = 3,000'

LEGEND:

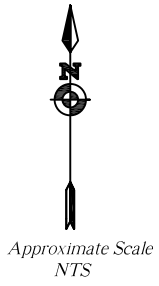
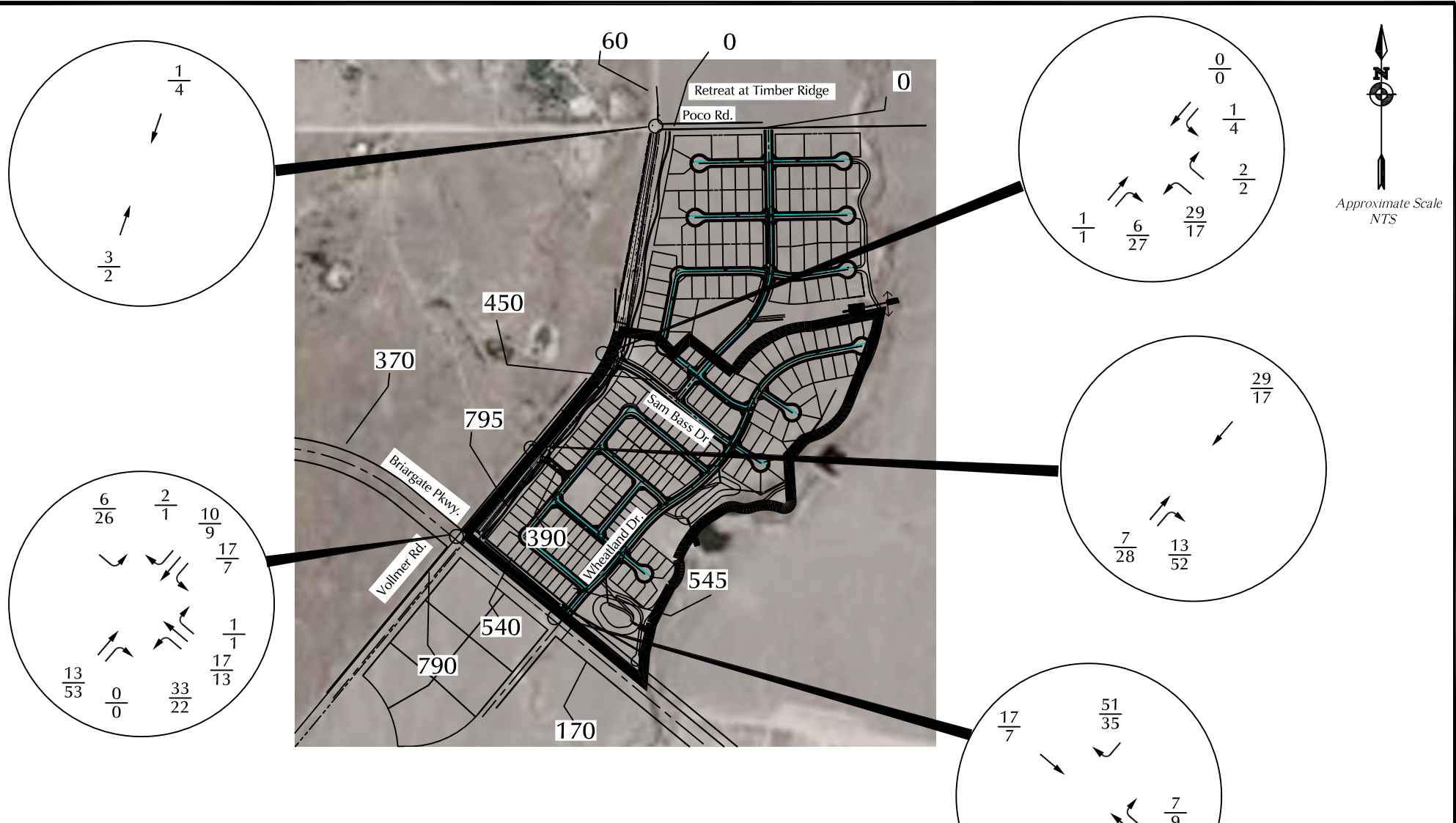
$$\frac{XX\%}{XX\%} = \frac{\text{Short-Term Percent Directional Distribution}}{\text{Long-Term Percent Directional Distribution}}$$

Figure 7

Directional Distribution of Site-Generated Traffic

Homestead North Phase 1 (LSC #204380)



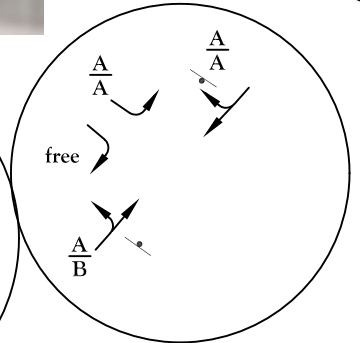
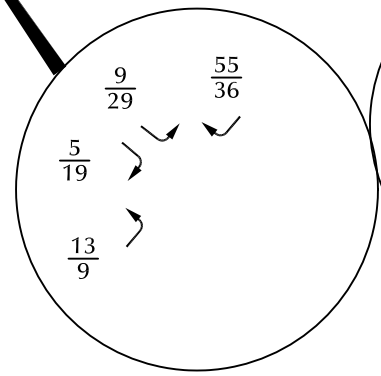
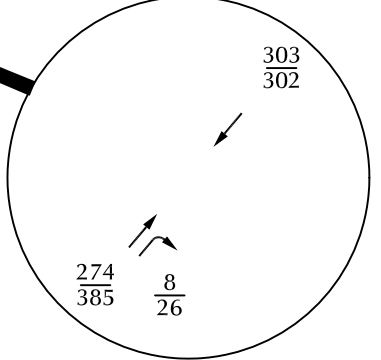
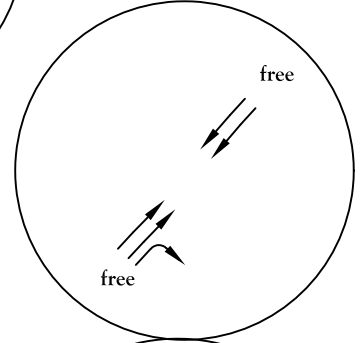
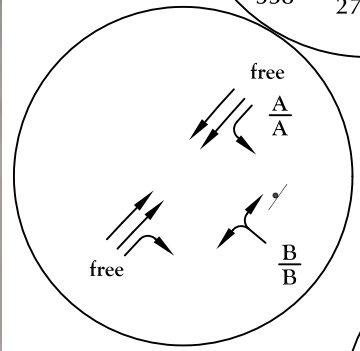
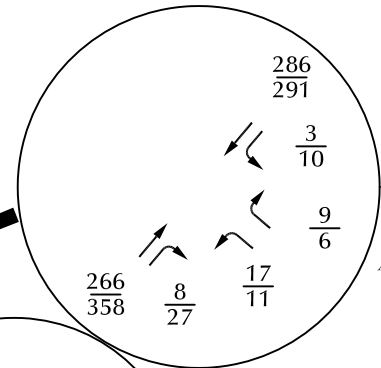
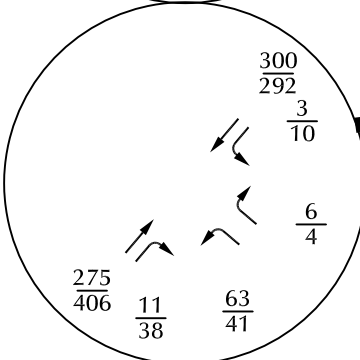
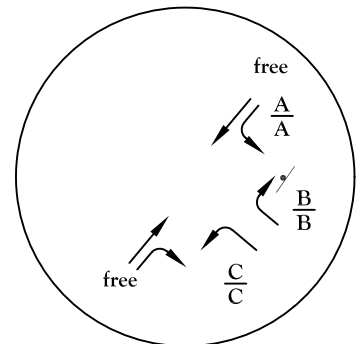
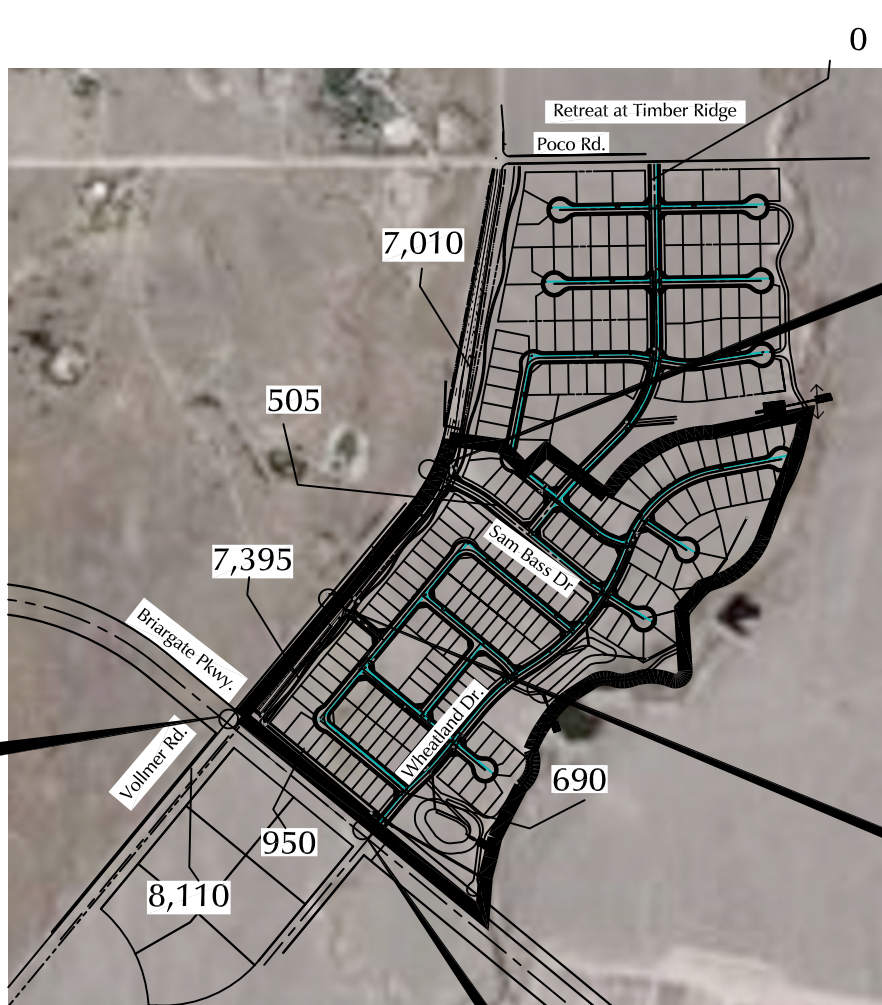


LEGEND:

- $\frac{XX}{XX}$ = AM Weekday Peak-Hour Traffic (vehicles per hour)
- $\frac{XX}{XX}$ = PM Weekday Peak-Hour Traffic (vehicles per hour)
- XXX = Average Weekday Traffic (vehicles per day)

Figure 9
Long-Term Site-Generated Traffic
 Homestead North Phase 1 (LSC #204380)





Approximate Scale
NTS

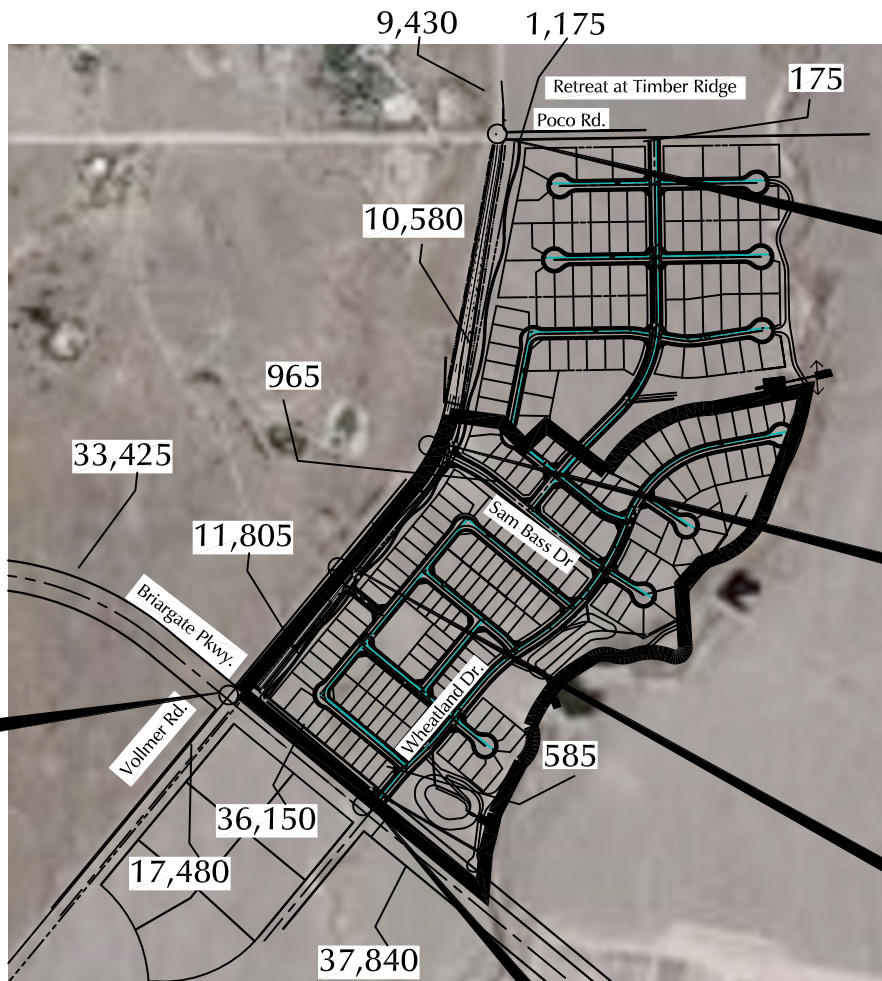
LEGEND:

- = Stop Sign
- = Traffic Signal
- $\frac{XX}{XX}$ = AM Weekday Peak-Hour Traffic (vehicles per hour)
PM Weekday Peak-Hour Traffic (vehicles per hour)
- XXX = Average Weekday Traffic (vehicles per day)
- $\frac{A}{B}$ = AM Individual Movement Peak-Hour Level of Service
PM Individual Movement Peak-Hour Level of Service
- $\frac{C}{D}$ = AM Entire Intersection Peak-Hour Level of Service
PM Entire Intersection Peak-Hour Level of Service

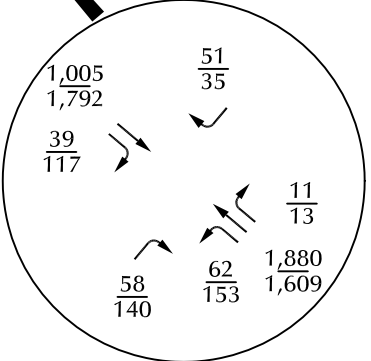
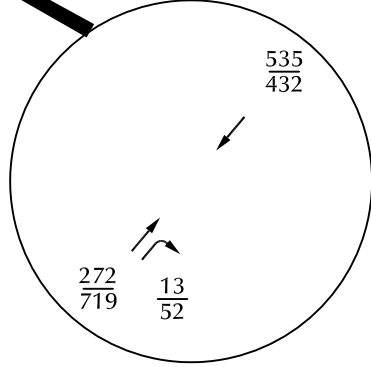
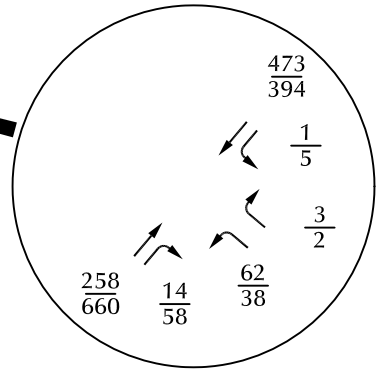
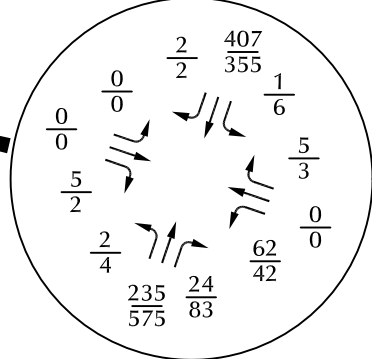
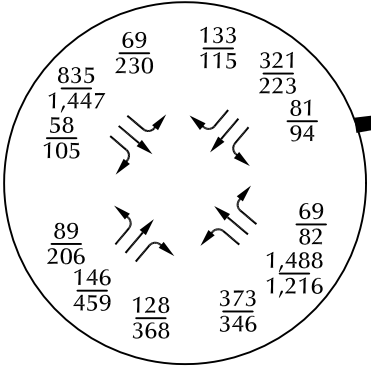


Figure 10
Short-Term Total Traffic

Homestead North Phase 1 (LSC #204380)



Approximate Scale
NTS

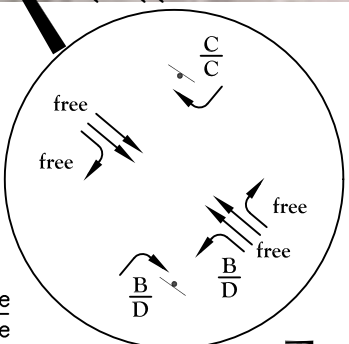
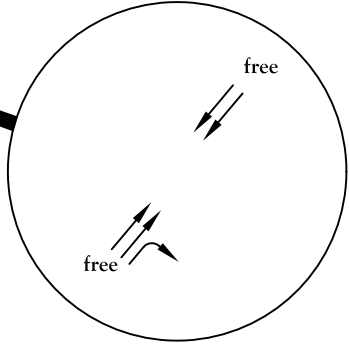
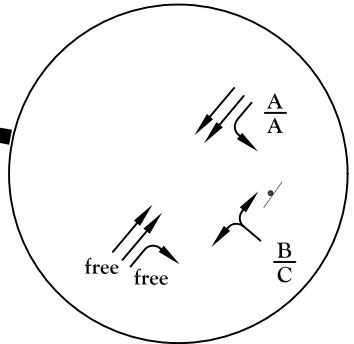
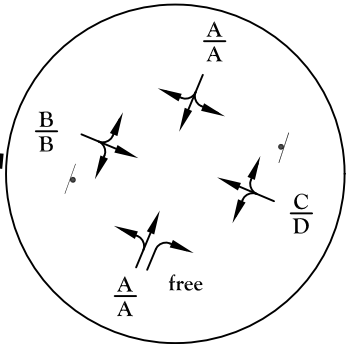
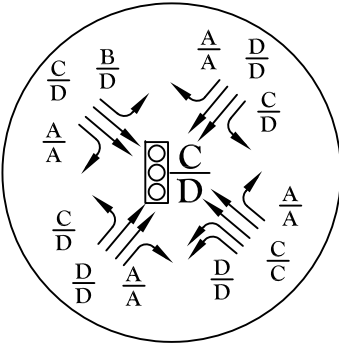
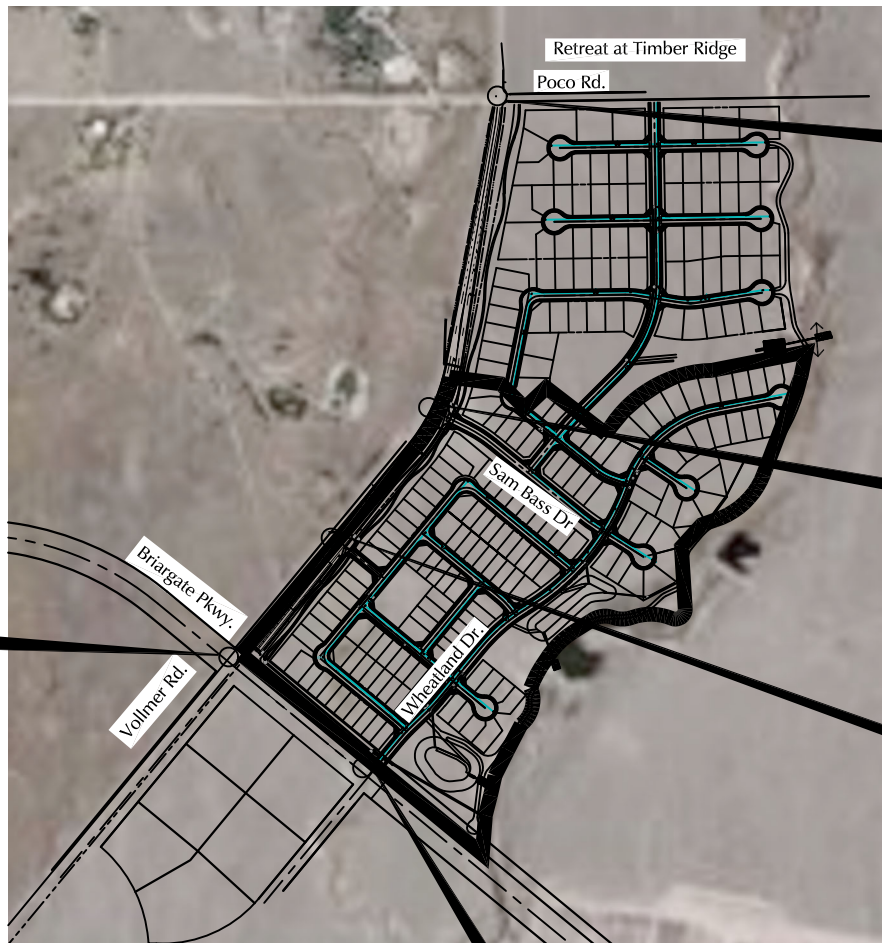


LEGEND:

- $\frac{XX}{XX}$ = AM Weekday Peak-Hour Traffic (vehicles per hour)
- $\frac{XX}{XX}$ = PM Weekday Peak-Hour Traffic (vehicles per hour)
- XXX = Average Weekday Traffic (vehicles per day)




Figure 11a
2040 Total Traffic
Homestead North Phase 1 (LSC #204380)



Approximate Scale
NTS

LEGEND:

┤ = Stop Sign  = Traffic Signal






- $\frac{A}{B}$ = AM Individual Movement Peak-Hour Level of Service
PM Individual Movement Peak-Hour Level of Service
- $\frac{C}{D}$ = AM Entire Intersection Peak-Hour Level of Service
PM Entire Intersection Peak-Hour Level of Service

Figure 11b
2040 Total Lane Geometry,
Traffic Control, and Level of Service

Homestead North Phase 1 (LSC #204380)



LEGEND:

-  = Urban Principal Arterial
-  = Urban Minor Arterial (4 lanes)
-  = Rural Minor Arterial (2 lanes)
-  = Urban Local
-  = Urban Local (low volume)

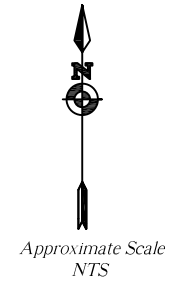
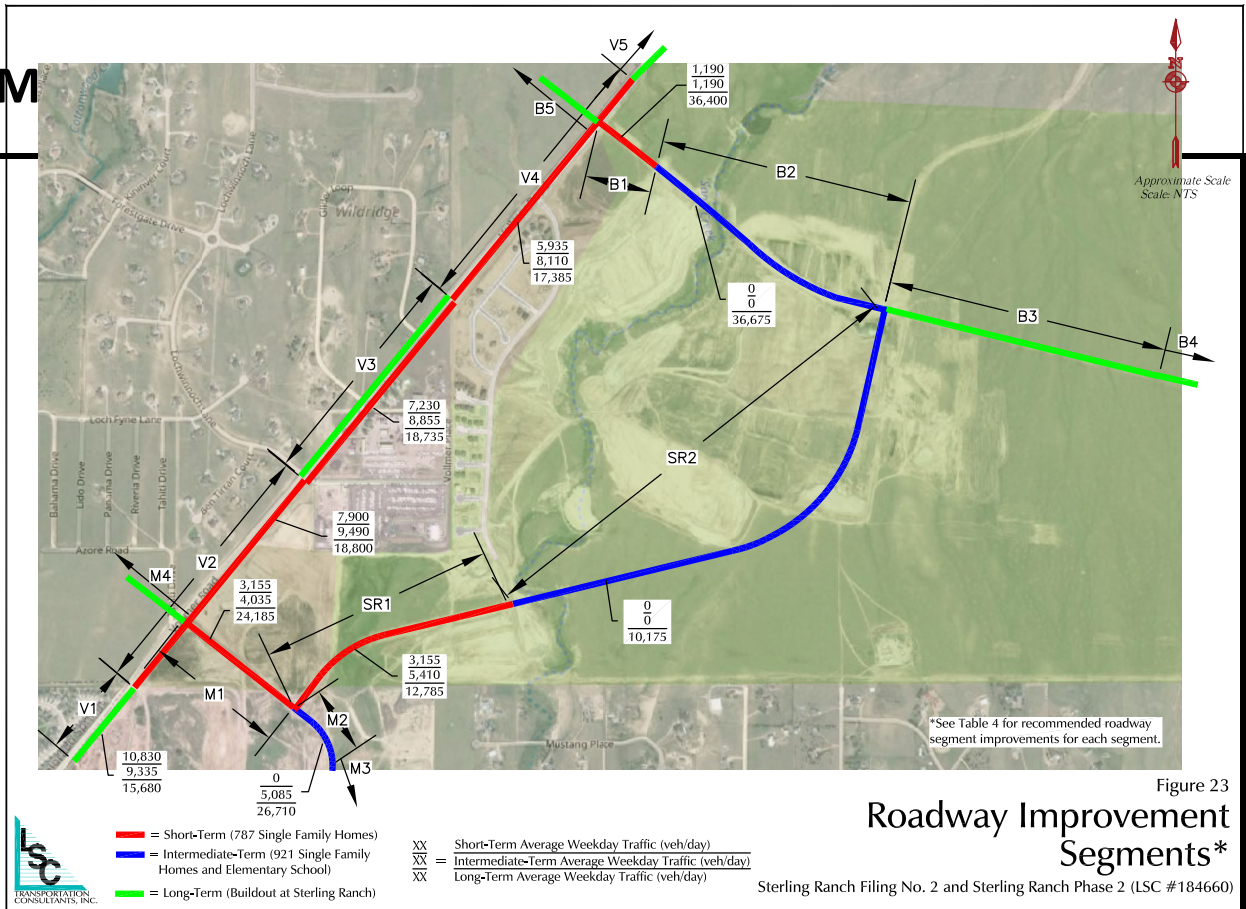


Figure 12
Recommended Classification
Homestead North Phase 1 (LSC #204380)

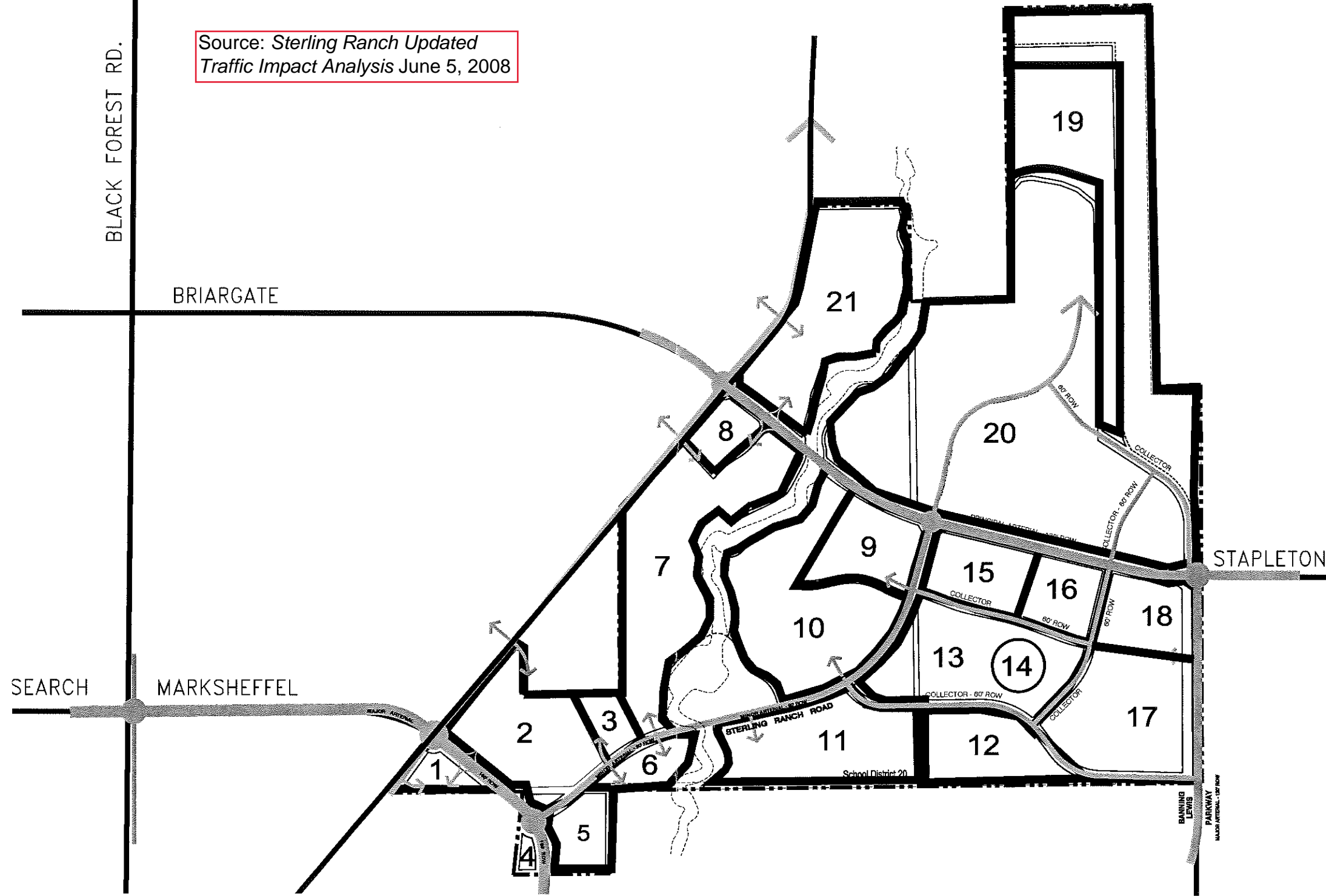
TAZ M



(Insert Sterling Ranch Filing 2 Fig. 23, show V6 and V7.)



Source: Sterling Ranch Updated
Traffic Impact Analysis June 5, 2008



Traffic Analysis Zones
Sterling Ranch



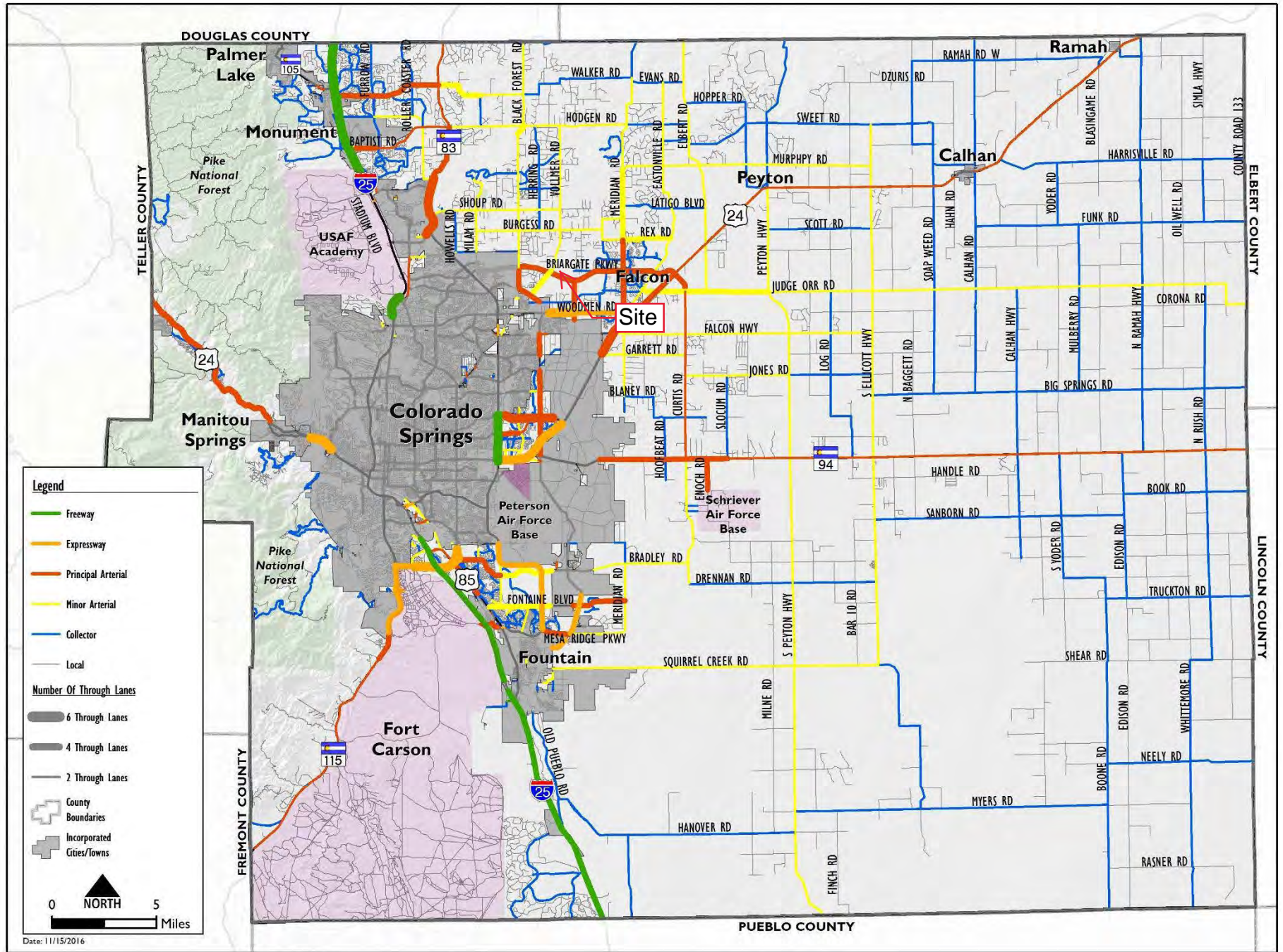
Not to Scale

Figure 3
LSC # 074230



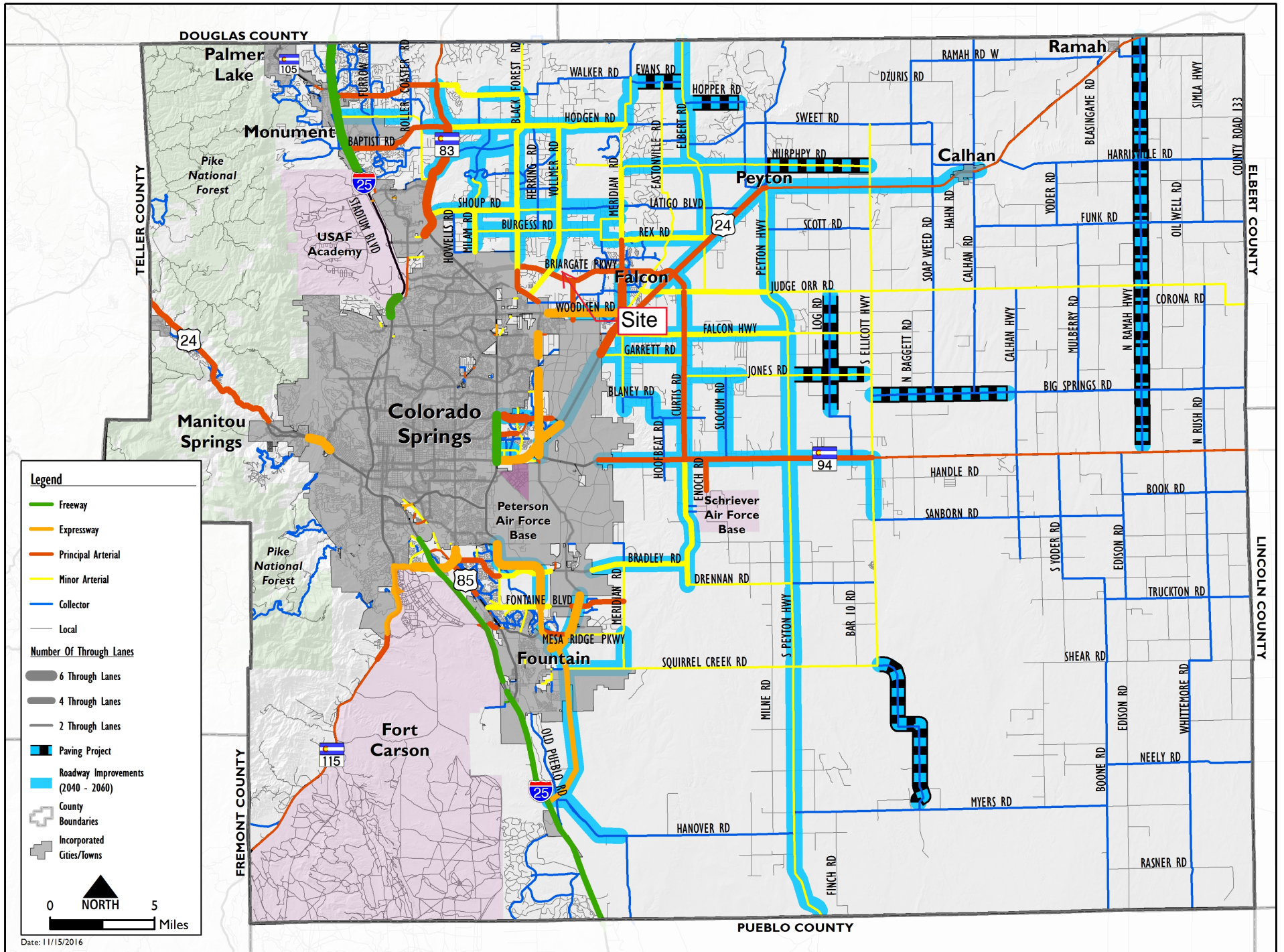
MTCP Maps





Map 14: 2040 Roadway Plan (Classification and Lanes)

Map 17: 2060 Corridor Preservation



Legend

- Freeway
- Expressway
- Principal Arterial
- Minor Arterial
- Collector
- Local

Number Of Through Lanes

- 6 Through Lanes
- 4 Through Lanes
- 2 Through Lanes

- Paving Project
- Roadway Improvements (2040 - 2060)
- County Boundaries
- Incorporated Cities/Towns

0 5
NORTH
Miles

Traffic Counts



LSC Transportation Consultants, Inc.
 545 E Pikes Peak Ave, Suite 210
 Colorado Springs, CO 80905
 719-633-2868

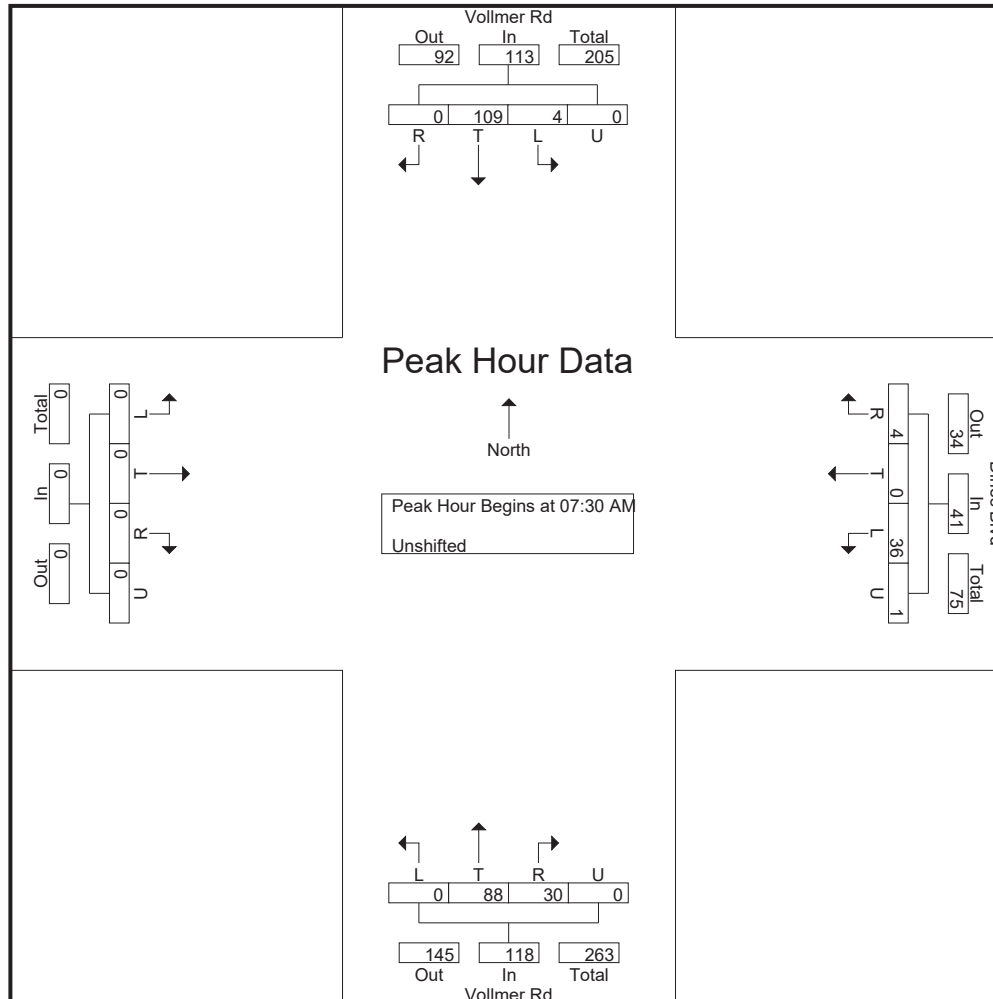
File Name : Vollmer Rd - Dines Blvd AM
 Site Code : 00204380
 Start Date : 5/27/2020
 Page No : 1

Groups Printed- Unshifted

Start Time	Vollmer Rd Southbound					Dines Blvd Westbound					Vollmer Rd Northbound					Eastbound					Int. Total
	L	T	R	U	App. Total	L	T	R	U	App. Total	L	T	R	U	App. Total	L	T	R	U	App. Total	
06:30 AM	1	30	0	0	31	2	0	1	0	3	0	4	3	0	7	0	0	0	0	0	41
06:45 AM	1	28	0	0	29	3	0	2	0	5	0	11	2	0	13	0	0	0	0	0	47
Total	2	58	0	0	60	5	0	3	0	8	0	15	5	0	20	0	0	0	0	0	88
07:00 AM	1	24	0	0	25	8	0	3	0	11	0	19	3	0	22	0	0	0	0	0	58
07:15 AM	1	29	0	0	30	4	0	0	0	4	0	26	5	0	31	0	0	0	0	0	65
07:30 AM	0	27	0	0	27	9	0	1	0	10	0	21	8	0	29	0	0	0	0	0	66
07:45 AM	0	33	0	0	33	8	0	3	1	12	0	21	6	0	27	0	0	0	0	0	72
Total	2	113	0	0	115	29	0	7	1	37	0	87	22	0	109	0	0	0	0	0	261
08:00 AM	1	25	0	0	26	7	0	0	0	7	0	23	6	0	29	0	0	0	0	0	62
08:15 AM	3	24	0	0	27	12	0	0	0	12	0	23	10	0	33	0	0	0	0	0	72
Grand Total	8	220	0	0	228	53	0	10	1	64	0	148	43	0	191	0	0	0	0	0	483
Apprch %	3.5	96.5	0	0		82.8	0	15.6	1.6		0	77.5	22.5	0		0	0	0	0		
Total %	1.7	45.5	0	0	47.2	11	0	2.1	0.2	13.3	0	30.6	8.9	0	39.5	0	0	0	0	0	

LSC Transportation Consultants, Inc.
 545 E Pikes Peak Ave, Suite 210
 Colorado Springs, CO 80905
 719-633-2868

File Name : Vollmer Rd - Dines Blvd AM
 Site Code : 00204380
 Start Date : 5/27/2020
 Page No : 3



LSC Transportation Consultants, Inc.

545 E Pikes Peak Ave, Suite 210
 Colorado Springs, CO 80905
 719-633-2868

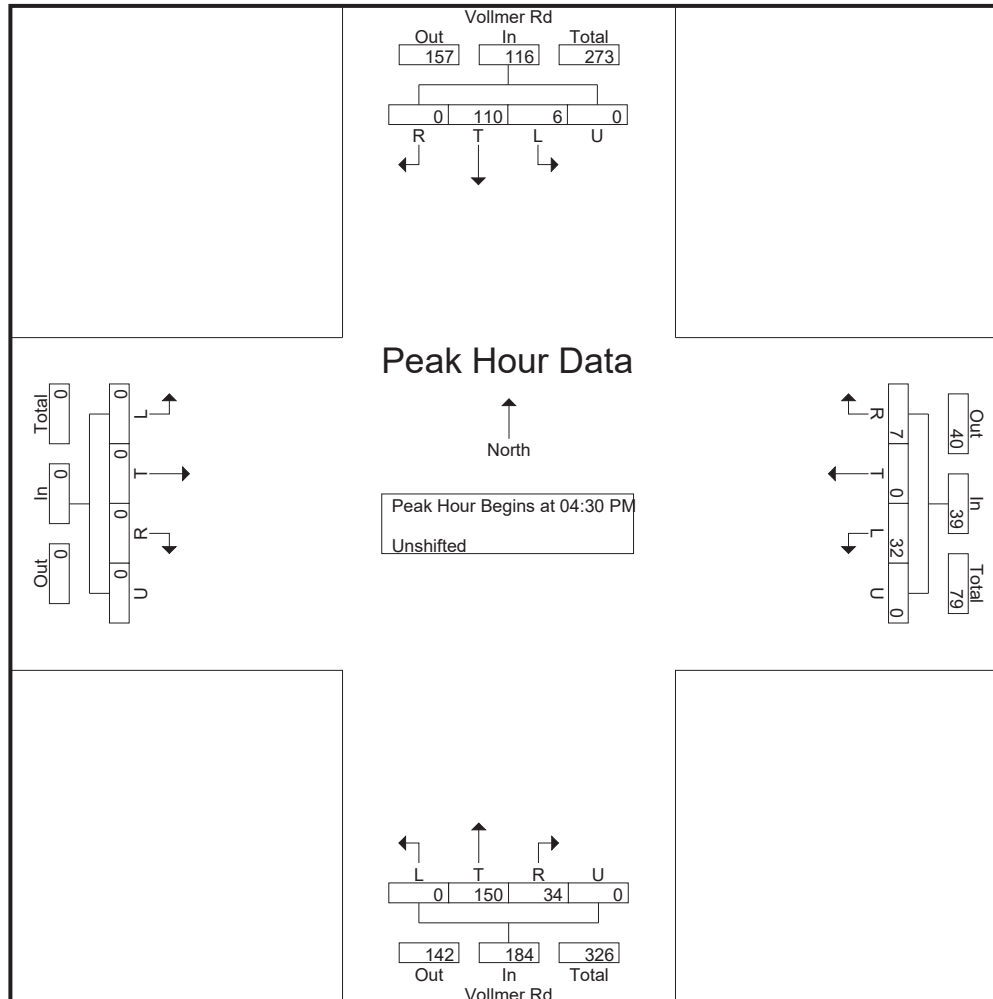
File Name : Vollmer Rd - Dines Blvd PM
 Site Code : 00204380
 Start Date : 5/27/2020
 Page No : 1

Groups Printed- Unshifted

Start Time	Vollmer Rd Southbound					Westbound					Vollmer Rd Northbound					Eastbound					Int. Total
	L	T	R	U	App. Total	L	T	R	U	App. Total	L	T	R	U	App. Total	L	T	R	U	App. Total	
04:00 PM	0	21	0	0	21	6	0	0	0	6	0	39	8	0	47	0	0	0	0	0	74
04:15 PM	1	29	0	0	30	9	0	1	1	11	0	30	9	0	39	0	0	0	0	0	80
04:30 PM	3	28	0	0	31	8	0	3	0	11	0	50	11	0	61	0	0	0	0	0	103
04:45 PM	0	23	0	0	23	4	0	0	0	4	0	35	12	0	47	0	0	0	0	0	74
Total	4	101	0	0	105	27	0	4	1	32	0	154	40	0	194	0	0	0	0	0	331
05:00 PM	2	26	0	0	28	13	0	0	0	13	0	31	4	0	35	0	0	0	0	0	76
05:15 PM	1	33	0	0	34	7	0	4	0	11	0	34	7	0	41	0	0	0	0	0	86
05:30 PM	1	20	0	0	21	7	0	2	0	9	0	43	13	0	56	0	0	0	0	0	86
05:45 PM	0	13	0	0	13	2	0	2	0	4	0	33	8	0	41	0	0	0	0	0	58
Total	4	92	0	0	96	29	0	8	0	37	0	141	32	0	173	0	0	0	0	0	306
Grand Total	8	193	0	0	201	56	0	12	1	69	0	295	72	0	367	0	0	0	0	0	637
Apprch %	4	96	0	0		81.2	0	17.4	1.4		0	80.4	19.6	0		0	0	0	0	0	
Total %	1.3	30.3	0	0	31.6	8.8	0	1.9	0.2	10.8	0	46.3	11.3	0	57.6	0	0	0	0	0	

LSC Transportation Consultants, Inc.
 545 E Pikes Peak Ave, Suite 210
 Colorado Springs, CO 80905
 719-633-2868

File Name : Vollmer Rd - Dines Blvd PM
 Site Code : 00204380
 Start Date : 5/27/2020
 Page No : 3



Levels of Service



Intersection						
Int Delay, s/veh	0.3					
Movement	WBL	WBR	NBT	NBR	SBL	SBT
Lane Configurations	↘	↗	↑	↗	↘	↑
Traffic Vol, veh/h	10	3	260	3	2	283
Future Vol, veh/h	10	3	260	3	2	283
Conflicting Peds, #/hr	0	0	0	0	0	0
Sign Control	Stop	Stop	Free	Free	Free	Free
RT Channelized	-	None	-	None	-	None
Storage Length	-	235	-	235	385	-
Veh in Median Storage, #	0	-	0	-	-	0
Grade, %	0	-	0	-	-	0
Peak Hour Factor	85	85	85	85	85	85
Heavy Vehicles, %	2	2	2	2	2	2
Mvmt Flow	12	4	306	4	2	333

Major/Minor	Minor1	Major1	Major2		
Conflicting Flow All	643	306	0	0	310
Stage 1	306	-	-	-	-
Stage 2	337	-	-	-	-
Critical Hdwy	6.42	6.22	-	-	4.12
Critical Hdwy Stg 1	5.42	-	-	-	-
Critical Hdwy Stg 2	5.42	-	-	-	-
Follow-up Hdwy	3.518	3.318	-	-	2.218
Pot Cap-1 Maneuver	438	734	-	-	1250
Stage 1	747	-	-	-	-
Stage 2	723	-	-	-	-
Platoon blocked, %			-	-	-
Mov Cap-1 Maneuver	437	734	-	-	1250
Mov Cap-2 Maneuver	437	-	-	-	-
Stage 1	747	-	-	-	-
Stage 2	722	-	-	-	-

Approach	WB	NB	SB
HCM Control Delay, s	12.7	0	0.1
HCM LOS	B		

Minor Lane/Major Mvmt	NBT	NBR	WBLn1	WBLn2	SBL	SBT
Capacity (veh/h)	-	-	437	734	1250	-
HCM Lane V/C Ratio	-	-	0.027	0.005	0.002	-
HCM Control Delay (s)	-	-	13.5	9.9	7.9	-
HCM Lane LOS	-	-	B	A	A	-
HCM 95th %tile Q(veh)	-	-	0.1	0	0	-

Intersection						
Int Delay, s/veh	0.3					
Movement	WBL	WBR	NBT	NBR	SBL	SBT
Lane Configurations	↘	↗	↑	↗	↘	↑
Traffic Vol, veh/h	7	2	354	12	7	281
Future Vol, veh/h	7	2	354	12	7	281
Conflicting Peds, #/hr	0	0	0	0	0	0
Sign Control	Stop	Stop	Free	Free	Free	Free
RT Channelized	-	None	-	None	-	None
Storage Length	-	235	-	235	385	-
Veh in Median Storage, #	0	-	0	-	-	0
Grade, %	0	-	0	-	-	0
Peak Hour Factor	85	85	85	85	85	85
Heavy Vehicles, %	2	2	2	2	2	2
Mvmt Flow	8	2	416	14	8	331

Major/Minor	Minor1	Major1	Major2		
Conflicting Flow All	763	416	0	0	430
Stage 1	416	-	-	-	-
Stage 2	347	-	-	-	-
Critical Hdwy	6.42	6.22	-	-	4.12
Critical Hdwy Stg 1	5.42	-	-	-	-
Critical Hdwy Stg 2	5.42	-	-	-	-
Follow-up Hdwy	3.518	3.318	-	-	2.218
Pot Cap-1 Maneuver	372	637	-	-	1129
Stage 1	666	-	-	-	-
Stage 2	716	-	-	-	-
Platoon blocked, %			-	-	-
Mov Cap-1 Maneuver	369	637	-	-	1129
Mov Cap-2 Maneuver	369	-	-	-	-
Stage 1	666	-	-	-	-
Stage 2	711	-	-	-	-

Approach	WB	NB	SB
HCM Control Delay, s	14	0	0.2
HCM LOS	B		

Minor Lane/Major Mvmt	NBT	NBRWBLn1	WBLn2	SBL	SBT
Capacity (veh/h)	-	-	369	637	1129
HCM Lane V/C Ratio	-	-	0.022	0.004	0.007
HCM Control Delay (s)	-	-	15	10.7	8.2
HCM Lane LOS	-	-	C	B	A
HCM 95th %tile Q(veh)	-	-	0.1	0	0

Timings
1: Vollmer Rd & Briargate Pkwy

2040 Background Traffic
AM Peak Hour

Lane Group	EBL	EBT	EBR	WBL	WBT	WBR	NBL	NBT	NBR	SBL	SBT	SBR
Lane Configurations												
Traffic Volume (vph)	63	835	58	340	1471	69	89	133	128	64	311	131
Future Volume (vph)	63	835	58	340	1471	69	89	133	128	64	311	131
Turn Type	pm+pt	NA	Perm	Prot	NA	Perm	pm+pt	NA	Perm	pm+pt	NA	Perm
Protected Phases	5	2		1	6		3	8		7	4	
Permitted Phases	2		2			6	8		8	4		4
Detector Phase	5	2	2	1	6	6	3	8	8	7	4	4
Switch Phase												
Minimum Initial (s)	5.0	5.0	5.0	5.0	5.0	5.0	5.0	5.0	5.0	5.0	5.0	5.0
Minimum Split (s)	10.0	10.0	10.0	10.0	10.0	10.0	10.0	10.0	10.0	10.0	10.0	10.0
Total Split (s)	10.0	53.0	53.0	22.0	65.0	65.0	15.0	30.0	30.0	15.0	30.0	30.0
Total Split (%)	8.3%	44.2%	44.2%	18.3%	54.2%	54.2%	12.5%	25.0%	25.0%	12.5%	25.0%	25.0%
Yellow Time (s)	3.0	3.0	3.0	3.0	3.0	3.0	3.0	3.0	3.0	3.0	3.0	3.0
All-Red Time (s)	2.0	2.0	2.0	2.0	2.0	2.0	2.0	2.0	2.0	2.0	2.0	2.0
Lost Time Adjust (s)	0.0	0.0	0.0	0.0	0.0	0.0	0.0	0.0	0.0	0.0	0.0	0.0
Total Lost Time (s)	5.0	5.0	5.0	5.0	5.0	5.0	5.0	5.0	5.0	5.0	5.0	5.0
Lead/Lag	Lead	Lag	Lag	Lead	Lag	Lag	Lead	Lag	Lag	Lead	Lag	Lag
Lead-Lag Optimize?	Yes	Yes	Yes	Yes	Yes	Yes	Yes	Yes	Yes	Yes	Yes	Yes
Recall Mode	None	None	None	None	None	None	None	None	None	None	None	None
Act Effct Green (s)	44.3	38.9	38.9	15.4	52.4	52.4	22.7	15.9	15.9	22.0	15.5	15.5
Actuated g/C Ratio	0.46	0.40	0.40	0.16	0.54	0.54	0.24	0.16	0.16	0.23	0.16	0.16
v/c Ratio	0.38	0.62	0.08	0.65	0.80	0.08	0.35	0.24	0.35	0.20	0.57	0.36
Control Delay	17.7	25.7	0.2	48.0	24.2	1.1	32.9	40.6	7.4	30.4	45.0	7.9
Queue Delay	0.0	0.0	0.0	0.0	0.0	0.0	0.0	0.0	0.0	0.0	0.0	0.0
Total Delay	17.7	25.7	0.2	48.0	24.2	1.1	32.9	40.6	7.4	30.4	45.0	7.9
LOS	B	C	A	D	C	A	C	D	A	C	D	A
Approach Delay		23.6			27.6			26.5			33.5	
Approach LOS		C			C			C			C	

Intersection Summary

Cycle Length: 120	
Actuated Cycle Length: 96.5	
Natural Cycle: 70	
Control Type: Actuated-Uncoordinated	
Maximum v/c Ratio: 0.80	
Intersection Signal Delay: 27.3	Intersection LOS: C
Intersection Capacity Utilization 75.0%	ICU Level of Service D
Analysis Period (min) 15	

Splits and Phases: 1: Vollmer Rd & Briargate Pkwy



Intersection												
Int Delay, s/veh	1.6											
Movement	EBL	EBT	EBR	WBL	WBT	WBR	NBL	NBT	NBR	SBL	SBT	SBR
Lane Configurations		↕			↕			↕	↕		↕	
Traffic Vol, veh/h	0	0	5	62	0	5	2	231	24	1	406	2
Future Vol, veh/h	0	0	5	62	0	5	2	231	24	1	406	2
Conflicting Peds, #/hr	0	0	0	0	0	0	0	0	0	0	0	0
Sign Control	Stop	Stop	Stop	Stop	Stop	Stop	Free	Free	Free	Free	Free	Free
RT Channelized	-	-	None	-	-	None	-	-	None	-	-	None
Storage Length	-	-	-	-	-	-	-	-	-	-	-	-
Veh in Median Storage, #	-	0	-	-	0	-	-	0	-	-	0	-
Grade, %	-	0	-	-	0	-	-	0	-	-	0	-
Peak Hour Factor	95	95	95	95	95	95	95	95	95	95	95	95
Heavy Vehicles, %	2	2	2	2	2	2	2	2	2	2	2	2
Mvmt Flow	0	0	5	65	0	5	2	243	25	1	427	2

Major/Minor	Minor2		Minor1		Major1		Major2					
Conflicting Flow All	692	702	428	680	678	243	429	0	0	268	0	0
Stage 1	430	430	-	247	247	-	-	-	-	-	-	-
Stage 2	262	272	-	433	431	-	-	-	-	-	-	-
Critical Hdwy	7.12	6.52	6.22	7.12	6.52	6.22	4.12	-	-	4.12	-	-
Critical Hdwy Stg 1	6.12	5.52	-	6.12	5.52	-	-	-	-	-	-	-
Critical Hdwy Stg 2	6.12	5.52	-	6.12	5.52	-	-	-	-	-	-	-
Follow-up Hdwy	3.518	4.018	3.318	3.518	4.018	3.318	2.218	-	-	2.218	-	-
Pot Cap-1 Maneuver	358	362	627	365	374	796	1130	-	-	1296	-	-
Stage 1	603	583	-	757	702	-	-	-	-	-	-	-
Stage 2	743	685	-	601	583	-	-	-	-	-	-	-
Platoon blocked, %								-	-	-	-	-
Mov Cap-1 Maneuver	355	361	627	361	373	796	1130	-	-	1296	-	-
Mov Cap-2 Maneuver	355	361	-	361	373	-	-	-	-	-	-	-
Stage 1	602	582	-	755	701	-	-	-	-	-	-	-
Stage 2	737	684	-	595	582	-	-	-	-	-	-	-

Approach	EB	WB	NB	SB
HCM Control Delay, s	10.8	16.8	0.1	0
HCM LOS	B	C		

Minor Lane/Major Mvmt	NBL	NBT	NBR	EBLn1	WBLn1	SBL	SBT	SBR
Capacity (veh/h)	1130	-	-	627	376	1296	-	-
HCM Lane V/C Ratio	0.002	-	-	0.008	0.188	0.001	-	-
HCM Control Delay (s)	8.2	0	-	10.8	16.8	7.8	0	-
HCM Lane LOS	A	A	-	B	C	A	A	-
HCM 95th %tile Q(veh)	0	-	-	0	0.7	0	-	-

Intersection						
Int Delay, s/veh	0.6					
Movement	WBL	WBR	NBT	NBR	SBL	SBT
Lane Configurations	↘↗		↑↑	↗	↘	↑↑
Traffic Vol, veh/h	34	0	257	8	0	473
Future Vol, veh/h	34	0	257	8	0	473
Conflicting Peds, #/hr	0	0	0	0	0	0
Sign Control	Stop	Stop	Free	Free	Free	Free
RT Channelized	-	None	-	None	-	None
Storage Length	0	-	-	155	205	-
Veh in Median Storage, #	0	-	0	-	-	0
Grade, %	0	-	0	-	-	0
Peak Hour Factor	95	95	95	95	95	95
Heavy Vehicles, %	2	2	2	2	2	2
Mvmt Flow	36	0	271	8	0	498

Major/Minor	Minor1	Major1	Major2		
Conflicting Flow All	520	136	0	0	279
Stage 1	271	-	-	-	-
Stage 2	249	-	-	-	-
Critical Hdwy	6.84	6.94	-	-	4.14
Critical Hdwy Stg 1	5.84	-	-	-	-
Critical Hdwy Stg 2	5.84	-	-	-	-
Follow-up Hdwy	3.52	3.32	-	-	2.22
Pot Cap-1 Maneuver	486	888	-	-	1281
Stage 1	750	-	-	-	-
Stage 2	769	-	-	-	-
Platoon blocked, %			-	-	-
Mov Cap-1 Maneuver	486	888	-	-	1281
Mov Cap-2 Maneuver	486	-	-	-	-
Stage 1	750	-	-	-	-
Stage 2	769	-	-	-	-

Approach	WB	NB	SB
HCM Control Delay, s	13	0	0
HCM LOS	B		

Minor Lane/Major Mvmt	NBT	NBRWBLn1	SBL	SBT
Capacity (veh/h)	-	-	486	1281
HCM Lane V/C Ratio	-	-	0.074	-
HCM Control Delay (s)	-	-	13	0
HCM Lane LOS	-	-	B	A
HCM 95th %tile Q(veh)	-	-	0.2	0

Intersection												
Int Delay, s/veh	0.5											
Movement	EBL	EBT	EBR	WBL	WBT	WBR	NBL	NBT	NBR	SBL	SBT	SBR
Lane Configurations		↑↑	↑	↑	↑↑	↑			↑			↑
Traffic Vol, veh/h	0	988	39	62	1880	3	0	0	58	0	0	0
Future Vol, veh/h	0	988	39	62	1880	3	0	0	58	0	0	0
Conflicting Peds, #/hr	0	0	0	0	0	0	0	0	0	0	0	0
Sign Control	Free	Free	Free	Free	Free	Free	Stop	Stop	Stop	Stop	Stop	Stop
RT Channelized	-	-	None	-	-	None	-	-	None	-	-	None
Storage Length	-	-	155	100	-	155	-	-	0	-	-	0
Veh in Median Storage, #	-	0	-	-	0	-	-	0	-	-	0	-
Grade, %	-	0	-	-	0	-	-	0	-	-	0	-
Peak Hour Factor	95	95	95	95	95	95	95	95	95	95	95	95
Heavy Vehicles, %	2	2	2	2	2	2	2	2	2	2	2	2
Mvmt Flow	0	1040	41	65	1979	3	0	0	61	0	0	0

Major/Minor	Major1			Major2			Minor1			Minor2		
Conflicting Flow All	-	0	0	1081	0	0	-	-	520	-	-	990
Stage 1	-	-	-	-	-	-	-	-	-	-	-	-
Stage 2	-	-	-	-	-	-	-	-	-	-	-	-
Critical Hdwy	-	-	-	4.14	-	-	-	-	6.94	-	-	6.94
Critical Hdwy Stg 1	-	-	-	-	-	-	-	-	-	-	-	-
Critical Hdwy Stg 2	-	-	-	-	-	-	-	-	-	-	-	-
Follow-up Hdwy	-	-	-	2.22	-	-	-	-	3.32	-	-	3.32
Pot Cap-1 Maneuver	0	-	-	641	-	-	0	0	501	0	0	245
Stage 1	0	-	-	-	-	-	0	0	-	0	0	-
Stage 2	0	-	-	-	-	-	0	0	-	0	0	-
Platoon blocked, %	-	-	-	-	-	-	-	-	-	-	-	-
Mov Cap-1 Maneuver	-	-	-	641	-	-	-	-	501	-	-	245
Mov Cap-2 Maneuver	-	-	-	-	-	-	-	-	-	-	-	-
Stage 1	-	-	-	-	-	-	-	-	-	-	-	-
Stage 2	-	-	-	-	-	-	-	-	-	-	-	-

Approach	EB			WB			NB			SB		
HCM Control Delay, s	0			0.4			13.2			0		
HCM LOS							B			A		

Minor Lane/Major Mvmt	NBLn1	EBT	EBR	WBL	WBT	WBR	SBLn1
Capacity (veh/h)	501	-	-	641	-	-	-
HCM Lane V/C Ratio	0.122	-	-	0.102	-	-	-
HCM Control Delay (s)	13.2	-	-	11.3	-	-	0
HCM Lane LOS	B	-	-	B	-	-	A
HCM 95th %tile Q(veh)	0.4	-	-	0.3	-	-	-

Timings
1: Vollmer Rd & Briargate Pkwy

2040 Background Traffic
PM Peak Hour

Lane Group	EBL	EBT	EBR	WBL	WBT	WBR	NBL	NBT	NBR	SBL	SBT	SBR
Lane Configurations												
Traffic Volume (vph)	205	1447	108	324	1204	81	206	406	368	88	214	113
Future Volume (vph)	205	1447	108	324	1204	81	206	406	368	88	214	113
Turn Type	pm+pt	NA	Perm	Prot	NA	Perm	pm+pt	NA	Perm	pm+pt	NA	Perm
Protected Phases	5	2		1	6		3	8		7	4	
Permitted Phases	2		2			6	8		8	4		4
Detector Phase	5	2	2	1	6	6	3	8	8	7	4	4
Switch Phase												
Minimum Initial (s)	5.0	5.0	5.0	5.0	5.0	5.0	5.0	5.0	5.0	5.0	5.0	5.0
Minimum Split (s)	10.0	10.0	10.0	10.0	10.0	10.0	10.0	10.0	10.0	10.0	10.0	10.0
Total Split (s)	20.0	44.0	44.0	35.0	59.0	59.0	20.0	28.0	28.0	13.0	21.0	21.0
Total Split (%)	16.7%	36.7%	36.7%	29.2%	49.2%	49.2%	16.7%	23.3%	23.3%	10.8%	17.5%	17.5%
Yellow Time (s)	3.0	3.0	3.0	3.0	3.0	3.0	3.0	3.0	3.0	3.0	3.0	3.0
All-Red Time (s)	2.0	2.0	2.0	2.0	2.0	2.0	2.0	2.0	2.0	2.0	2.0	2.0
Lost Time Adjust (s)	0.0	0.0	0.0	0.0	0.0	0.0	0.0	0.0	0.0	0.0	0.0	0.0
Total Lost Time (s)	5.0	5.0	5.0	5.0	5.0	5.0	5.0	5.0	5.0	5.0	5.0	5.0
Lead/Lag	Lead	Lag	Lag	Lead	Lag	Lag	Lead	Lag	Lag	Lead	Lag	Lag
Lead-Lag Optimize?	Yes	Yes	Yes	Yes	Yes	Yes	Yes	Yes	Yes	Yes	Yes	Yes
Recall Mode	None	Max	Max	None	Max	Max	None	None	None	None	None	None
Act Effct Green (s)	63.9	50.7	50.7	16.7	54.2	54.2	32.0	21.8	21.8	20.7	13.0	13.0
Actuated g/C Ratio	0.56	0.44	0.44	0.15	0.47	0.47	0.28	0.19	0.19	0.18	0.11	0.11
v/c Ratio	0.76	0.94	0.14	0.68	0.76	0.10	0.66	0.61	0.63	0.41	0.56	0.33
Control Delay	40.9	44.6	0.4	53.9	29.3	0.2	44.5	47.9	9.2	37.9	54.0	2.5
Queue Delay	0.0	0.0	0.0	0.0	0.0	0.0	0.0	0.0	0.0	0.0	0.0	0.0
Total Delay	40.9	44.6	0.4	53.9	29.3	0.2	44.5	47.9	9.2	37.9	54.0	2.5
LOS	D	D	A	D	C	A	D	D	A	D	D	A
Approach Delay		41.4			32.8			32.5			36.6	
Approach LOS		D			C			C			D	

Intersection Summary

Cycle Length: 120
 Actuated Cycle Length: 114.4
 Natural Cycle: 90
 Control Type: Actuated-Uncoordinated
 Maximum v/c Ratio: 0.94
 Intersection Signal Delay: 36.2
 Intersection LOS: D
 Intersection Capacity Utilization 83.2%
 ICU Level of Service E
 Analysis Period (min) 15

Splits and Phases: 1: Vollmer Rd & Briargate Pkwy



Intersection												
Int Delay, s/veh	1.1											
Movement	EBL	EBT	EBR	WBL	WBT	WBR	NBL	NBT	NBR	SBL	SBT	SBR
Lane Configurations		↕			↕			↕	↕		↕	
Traffic Vol, veh/h	0	0	2	42	0	3	4	573	83	6	351	2
Future Vol, veh/h	0	0	2	42	0	3	4	573	83	6	351	2
Conflicting Peds, #/hr	0	0	0	0	0	0	0	0	0	0	0	0
Sign Control	Stop	Stop	Stop	Stop	Stop	Stop	Free	Free	Free	Free	Free	Free
RT Channelized	-	-	None	-	-	None	-	-	None	-	-	None
Storage Length	-	-	-	-	-	-	-	-	-	-	-	-
Veh in Median Storage, #	-	0	-	-	0	-	-	0	-	-	0	-
Grade, %	-	0	-	-	0	-	-	0	-	-	0	-
Peak Hour Factor	95	95	95	95	95	95	95	95	95	95	95	95
Heavy Vehicles, %	2	2	2	2	2	2	2	2	2	2	2	2
Mvmt Flow	0	0	2	44	0	3	4	603	87	6	369	2

Major/Minor	Minor2		Minor1		Major1		Major2					
Conflicting Flow All	1038	1080	370	994	994	603	371	0	0	690	0	0
Stage 1	382	382	-	611	611	-	-	-	-	-	-	-
Stage 2	656	698	-	383	383	-	-	-	-	-	-	-
Critical Hdwy	7.12	6.52	6.22	7.12	6.52	6.22	4.12	-	-	4.12	-	-
Critical Hdwy Stg 1	6.12	5.52	-	6.12	5.52	-	-	-	-	-	-	-
Critical Hdwy Stg 2	6.12	5.52	-	6.12	5.52	-	-	-	-	-	-	-
Follow-up Hdwy	3.518	4.018	3.318	3.518	4.018	3.318	2.218	-	-	2.218	-	-
Pot Cap-1 Maneuver	209	218	676	224	245	499	1188	-	-	905	-	-
Stage 1	640	613	-	481	484	-	-	-	-	-	-	-
Stage 2	454	442	-	640	612	-	-	-	-	-	-	-
Platoon blocked, %								-	-	-	-	-
Mov Cap-1 Maneuver	205	215	676	221	242	499	1188	-	-	905	-	-
Mov Cap-2 Maneuver	205	215	-	221	242	-	-	-	-	-	-	-
Stage 1	636	608	-	478	481	-	-	-	-	-	-	-
Stage 2	448	439	-	633	607	-	-	-	-	-	-	-

Approach	EB		WB		NB		SB	
HCM Control Delay, s	10.3		24.7		0		0.2	
HCM LOS	B		C					

Minor Lane/Major Mvmt	NBL	NBT	NBR	EBLn1	WBLn1	SBL	SBT	SBR
Capacity (veh/h)	1188	-	-	676	230	905	-	-
HCM Lane V/C Ratio	0.004	-	-	0.003	0.206	0.007	-	-
HCM Control Delay (s)	8	0	-	10.3	24.7	9	0	-
HCM Lane LOS	A	A	-	B	C	A	A	-
HCM 95th %tile Q(veh)	0	-	-	0	0.8	0	-	-

Intersection						
Int Delay, s/veh	0.4					
Movement	WBL	WBR	NBT	NBR	SBL	SBT
Lane Configurations	Y		↑↑	↑	↑	↑↑
Traffic Vol, veh/h	21	0	660	31	1	394
Future Vol, veh/h	21	0	660	31	1	394
Conflicting Peds, #/hr	0	0	0	0	0	0
Sign Control	Stop	Stop	Free	Free	Free	Free
RT Channelized	-	None	-	None	-	None
Storage Length	0	-	-	155	205	-
Veh in Median Storage, #	0	-	0	-	-	0
Grade, %	0	-	0	-	-	0
Peak Hour Factor	95	95	95	95	95	95
Heavy Vehicles, %	2	2	2	2	2	2
Mvmt Flow	22	0	695	33	1	415

Major/Minor	Minor1	Major1	Major2		
Conflicting Flow All	905	348	0	0	728
Stage 1	695	-	-	-	-
Stage 2	210	-	-	-	-
Critical Hdwy	6.84	6.94	-	-	4.14
Critical Hdwy Stg 1	5.84	-	-	-	-
Critical Hdwy Stg 2	5.84	-	-	-	-
Follow-up Hdwy	3.52	3.32	-	-	2.22
Pot Cap-1 Maneuver	276	648	-	-	871
Stage 1	456	-	-	-	-
Stage 2	805	-	-	-	-
Platoon blocked, %			-	-	-
Mov Cap-1 Maneuver	276	648	-	-	871
Mov Cap-2 Maneuver	276	-	-	-	-
Stage 1	456	-	-	-	-
Stage 2	804	-	-	-	-

Approach	WB	NB	SB
HCM Control Delay, s	19.2	0	0
HCM LOS	C		

Minor Lane/Major Mvmt	NBT	NBRWBLn1	SBL	SBT
Capacity (veh/h)	-	-	276	871
HCM Lane V/C Ratio	-	-	0.08	0.001
HCM Control Delay (s)	-	-	19.2	9.1
HCM Lane LOS	-	-	C	A
HCM 95th %tile Q(veh)	-	-	0.3	0

Intersection												
Int Delay, s/veh	2.6											
Movement	EBL	EBT	EBR	WBL	WBT	WBR	NBL	NBT	NBR	SBL	SBT	SBR
Lane Configurations		↑↑	↑	↑	↑↑	↑			↑			↑
Traffic Vol, veh/h	0	1786	117	153	1609	4	0	0	140	0	0	0
Future Vol, veh/h	0	1786	117	153	1609	4	0	0	140	0	0	0
Conflicting Peds, #/hr	0	0	0	0	0	0	0	0	0	0	0	0
Sign Control	Free	Free	Free	Free	Free	Free	Stop	Stop	Stop	Stop	Stop	Stop
RT Channelized	-	-	None	-	-	None	-	-	None	-	-	None
Storage Length	-	-	155	100	-	155	-	-	0	-	-	0
Veh in Median Storage, #	-	0	-	-	0	-	-	0	-	-	0	-
Grade, %	-	0	-	-	0	-	-	0	-	-	0	-
Peak Hour Factor	95	95	95	95	95	95	95	95	95	95	95	95
Heavy Vehicles, %	2	2	2	2	2	2	2	2	2	2	2	2
Mvmt Flow	0	1880	123	161	1694	4	0	0	147	0	0	0

Major/Minor	Major1			Major2			Minor1			Minor2		
Conflicting Flow All	-	0	0	2003	0	0	-	-	940	-	-	847
Stage 1	-	-	-	-	-	-	-	-	-	-	-	-
Stage 2	-	-	-	-	-	-	-	-	-	-	-	-
Critical Hdwy	-	-	-	4.14	-	-	-	-	6.94	-	-	6.94
Critical Hdwy Stg 1	-	-	-	-	-	-	-	-	-	-	-	-
Critical Hdwy Stg 2	-	-	-	-	-	-	-	-	-	-	-	-
Follow-up Hdwy	-	-	-	2.22	-	-	-	-	3.32	-	-	3.32
Pot Cap-1 Maneuver	0	-	-	282	-	-	0	0	265	0	0	305
Stage 1	0	-	-	-	-	-	0	0	-	0	0	-
Stage 2	0	-	-	-	-	-	0	0	-	0	0	-
Platoon blocked, %	-	-	-	-	-	-	-	-	-	-	-	-
Mov Cap-1 Maneuver	-	-	-	282	-	-	-	-	265	-	-	305
Mov Cap-2 Maneuver	-	-	-	-	-	-	-	-	-	-	-	-
Stage 1	-	-	-	-	-	-	-	-	-	-	-	-
Stage 2	-	-	-	-	-	-	-	-	-	-	-	-

Approach	EB			WB			NB			SB		
HCM Control Delay, s	0			2.9			34.4			0		
HCM LOS							D			A		

Minor Lane/Major Mvmt	NBLn1	EBT	EBR	WBL	WBT	WBR	SBLn1
Capacity (veh/h)	265	-	-	282	-	-	-
HCM Lane V/C Ratio	0.556	-	-	0.571	-	-	-
HCM Control Delay (s)	34.4	-	-	33.5	-	-	0
HCM Lane LOS	D	-	-	D	-	-	A
HCM 95th %tile Q(veh)	3.1	-	-	3.3	-	-	-

Intersection												
Int Delay, s/veh	7.9											
Movement	EBL	EBT	EBR	WBL	WBT	WBR	NBL	NBT	NBR	SBL	SBT	SBR
Lane Configurations	↖	↗			↖			↔			↔	
Traffic Vol, veh/h	9	0	5	0	0	0	13	0	0	0	0	55
Future Vol, veh/h	9	0	5	0	0	0	13	0	0	0	0	55
Conflicting Peds, #/hr	0	0	0	0	0	0	0	0	0	0	0	0
Sign Control	Free	Free	Free	Free	Free	Free	Stop	Stop	Stop	Stop	Stop	Stop
RT Channelized	-	-	None	-	-	None	-	-	None	-	-	None
Storage Length	100	-	-	-	-	-	-	-	-	-	-	-
Veh in Median Storage, #	-	0	-	-	0	-	-	0	-	-	0	-
Grade, %	-	0	-	-	0	-	-	0	-	-	0	-
Peak Hour Factor	85	85	85	85	85	85	85	85	85	85	85	85
Heavy Vehicles, %	2	2	2	2	2	2	2	2	2	2	2	2
Mvmt Flow	11	0	6	0	0	0	15	0	0	0	0	65

Major/Minor	Major1			Major2			Minor1			Minor2		
Conflicting Flow All	1	0	0	6	0	0	59	26	3	26	29	1
Stage 1	-	-	-	-	-	-	25	25	-	1	1	-
Stage 2	-	-	-	-	-	-	34	1	-	25	28	-
Critical Hdwy	4.12	-	-	4.12	-	-	7.12	6.52	6.22	7.12	6.52	6.22
Critical Hdwy Stg 1	-	-	-	-	-	-	6.12	5.52	-	6.12	5.52	-
Critical Hdwy Stg 2	-	-	-	-	-	-	6.12	5.52	-	6.12	5.52	-
Follow-up Hdwy	2.218	-	-	2.218	-	-	3.518	4.018	3.318	3.518	4.018	3.318
Pot Cap-1 Maneuver	1622	-	-	1615	-	0	937	867	1081	984	864	1084
Stage 1	-	-	-	-	-	0	993	874	-	1022	895	-
Stage 2	-	-	-	-	-	0	982	895	-	993	872	-
Platoon blocked, %	-	-	-	-	-	-	-	-	-	-	-	-
Mov Cap-1 Maneuver	1622	-	-	1615	-	-	876	861	1081	979	858	1084
Mov Cap-2 Maneuver	-	-	-	-	-	-	876	861	-	979	858	-
Stage 1	-	-	-	-	-	-	986	868	-	1015	895	-
Stage 2	-	-	-	-	-	-	923	895	-	986	866	-

Approach	EB	WB	NB	SB
HCM Control Delay, s	4.7	0	9.2	8.5
HCM LOS			A	A

Minor Lane/Major Mvmt	NBLn1	EBL	EBT	EBR	WBL	WBT	SBLn1
Capacity (veh/h)	876	1622	-	-	1615	-	1084
HCM Lane V/C Ratio	0.017	0.007	-	-	-	-	0.06
HCM Control Delay (s)	9.2	7.2	-	-	0	-	8.5
HCM Lane LOS	A	A	-	-	A	-	A
HCM 95th %tile Q(veh)	0.1	0	-	-	0	-	0.2

Intersection						
Int Delay, s/veh	1.6					
Movement	WBL	WBR	NBT	NBR	SBL	SBT
Lane Configurations	↘	↗	↑	↗	↘	↑
Traffic Vol, veh/h	63	6	275	11	3	300
Future Vol, veh/h	63	6	275	11	3	300
Conflicting Peds, #/hr	0	0	0	0	0	0
Sign Control	Stop	Stop	Free	Free	Free	Free
RT Channelized	-	None	-	None	-	None
Storage Length	-	235	-	235	385	-
Veh in Median Storage, #	0	-	0	-	-	0
Grade, %	0	-	0	-	-	0
Peak Hour Factor	85	85	85	85	85	85
Heavy Vehicles, %	2	2	2	2	2	2
Mvmt Flow	74	7	324	13	4	353

Major/Minor	Minor1	Major1	Major2		
Conflicting Flow All	685	324	0	0	337
Stage 1	324	-	-	-	-
Stage 2	361	-	-	-	-
Critical Hdwy	6.42	6.22	-	-	4.12
Critical Hdwy Stg 1	5.42	-	-	-	-
Critical Hdwy Stg 2	5.42	-	-	-	-
Follow-up Hdwy	3.518	3.318	-	-	2.218
Pot Cap-1 Maneuver	414	717	-	-	1222
Stage 1	733	-	-	-	-
Stage 2	705	-	-	-	-
Platoon blocked, %			-	-	-
Mov Cap-1 Maneuver	413	717	-	-	1222
Mov Cap-2 Maneuver	413	-	-	-	-
Stage 1	733	-	-	-	-
Stage 2	703	-	-	-	-

Approach	WB	NB	SB
HCM Control Delay, s	15.1	0	0.1
HCM LOS	C		

Minor Lane/Major Mvmt	NBT	NBR	WBLn1	WBLn2	SBL	SBT
Capacity (veh/h)	-	-	413	717	1222	-
HCM Lane V/C Ratio	-	-	0.179	0.01	0.003	-
HCM Control Delay (s)	-	-	15.6	10.1	8	-
HCM Lane LOS	-	-	C	B	A	-
HCM 95th %tile Q(veh)	-	-	0.6	0	0	-

Intersection						
Int Delay, s/veh	0.6					
Movement	WBL	WBR	NBT	NBR	SBL	SBT
Lane Configurations	↘↗		↑↑	↗	↘	↑↑
Traffic Vol, veh/h	17	9	266	8	3	286
Future Vol, veh/h	17	9	266	8	3	286
Conflicting Peds, #/hr	0	0	0	0	0	0
Sign Control	Stop	Stop	Free	Free	Free	Free
RT Channelized	-	None	-	None	-	None
Storage Length	0	-	-	155	205	-
Veh in Median Storage, #	0	-	0	-	-	0
Grade, %	0	-	0	-	-	0
Peak Hour Factor	85	85	85	85	85	85
Heavy Vehicles, %	2	2	2	2	2	2
Mvmt Flow	20	11	313	9	4	336

Major/Minor	Minor1	Major1	Major2			
Conflicting Flow All	489	157	0	0	322	0
Stage 1	313	-	-	-	-	-
Stage 2	176	-	-	-	-	-
Critical Hdwy	6.84	6.94	-	-	4.14	-
Critical Hdwy Stg 1	5.84	-	-	-	-	-
Critical Hdwy Stg 2	5.84	-	-	-	-	-
Follow-up Hdwy	3.52	3.32	-	-	2.22	-
Pot Cap-1 Maneuver	508	861	-	-	1235	-
Stage 1	715	-	-	-	-	-
Stage 2	837	-	-	-	-	-
Platoon blocked, %			-	-	-	-
Mov Cap-1 Maneuver	506	861	-	-	1235	-
Mov Cap-2 Maneuver	506	-	-	-	-	-
Stage 1	715	-	-	-	-	-
Stage 2	834	-	-	-	-	-

Approach	WB	NB	SB
HCM Control Delay, s	11.4	0	0.1
HCM LOS	B		

Minor Lane/Major Mvmt	NBT	NBRWBLn1	SBL	SBT
Capacity (veh/h)	-	-	590	1235
HCM Lane V/C Ratio	-	-	0.052	0.003
HCM Control Delay (s)	-	-	11.4	7.9
HCM Lane LOS	-	-	B	A
HCM 95th %tile Q(veh)	-	-	0.2	0

Intersection												
Int Delay, s/veh	6.7											
Movement	EBL	EBT	EBR	WBL	WBT	WBR	NBL	NBT	NBR	SBL	SBT	SBR
Lane Configurations	↖	↗			↖			↔			↔	
Traffic Vol, veh/h	62	0	19	0	0	0	9	0	0	0	0	36
Future Vol, veh/h	62	0	19	0	0	0	9	0	0	0	0	36
Conflicting Peds, #/hr	0	0	0	0	0	0	0	0	0	0	0	0
Sign Control	Free	Free	Free	Free	Free	Free	Stop	Stop	Stop	Stop	Stop	Stop
RT Channelized	-	-	None	-	-	None	-	-	None	-	-	None
Storage Length	100	-	-	-	-	-	-	-	-	-	-	-
Veh in Median Storage, #	-	0	-	-	0	-	-	0	-	-	0	-
Grade, %	-	0	-	-	0	-	-	0	-	-	0	-
Peak Hour Factor	85	85	85	85	85	85	85	85	85	85	85	85
Heavy Vehicles, %	2	2	2	2	2	2	2	2	2	2	2	2
Mvmt Flow	73	0	22	0	0	0	11	0	0	0	0	42

Major/Minor	Major1		Major2			Minor1		Minor2				
Conflicting Flow All	1	0	0	22	0	0	179	158	11	158	169	1
Stage 1	-	-	-	-	-	-	157	157	-	1	1	-
Stage 2	-	-	-	-	-	-	22	1	-	157	168	-
Critical Hdwy	4.12	-	-	4.12	-	-	7.12	6.52	6.22	7.12	6.52	6.22
Critical Hdwy Stg 1	-	-	-	-	-	-	6.12	5.52	-	6.12	5.52	-
Critical Hdwy Stg 2	-	-	-	-	-	-	6.12	5.52	-	6.12	5.52	-
Follow-up Hdwy	2.218	-	-	2.218	-	-	3.518	4.018	3.318	3.518	4.018	3.318
Pot Cap-1 Maneuver	1622	-	-	1593	-	0	783	734	1070	808	724	1084
Stage 1	-	-	-	-	-	0	845	768	-	1022	895	-
Stage 2	-	-	-	-	-	0	996	895	-	845	759	-
Platoon blocked, %	-	-	-	-	-	-	-	-	-	-	-	-
Mov Cap-1 Maneuver	1622	-	-	1593	-	-	727	701	1070	781	691	1084
Mov Cap-2 Maneuver	-	-	-	-	-	-	727	701	-	781	691	-
Stage 1	-	-	-	-	-	-	807	733	-	976	895	-
Stage 2	-	-	-	-	-	-	957	895	-	807	725	-

Approach	EB	WB	NB	SB
HCM Control Delay, s	5.6	0	10	8.5
HCM LOS			B	A

Minor Lane/Major Mvmt	NBLn1	EBL	EBT	EBR	WBL	WBT	SBLn1
Capacity (veh/h)	727	1622	-	-	1593	-	1084
HCM Lane V/C Ratio	0.015	0.045	-	-	-	-	0.039
HCM Control Delay (s)	10	7.3	-	-	0	-	8.5
HCM Lane LOS	B	A	-	-	A	-	A
HCM 95th %tile Q(veh)	0	0.1	-	-	0	-	0.1

Intersection						
Int Delay, s/veh	1.1					
Movement	WBL	WBR	NBT	NBR	SBL	SBT
Lane Configurations	↘	↗	↑	↗	↘	↑
Traffic Vol, veh/h	41	4	406	38	10	292
Future Vol, veh/h	41	4	406	38	10	292
Conflicting Peds, #/hr	0	0	0	0	0	0
Sign Control	Stop	Stop	Free	Free	Free	Free
RT Channelized	-	None	-	None	-	None
Storage Length	-	235	-	235	385	-
Veh in Median Storage, #	0	-	0	-	-	0
Grade, %	0	-	0	-	-	0
Peak Hour Factor	85	85	85	85	85	85
Heavy Vehicles, %	2	2	2	2	2	2
Mvmt Flow	48	5	478	45	12	344

Major/Minor	Minor1	Major1	Major2		
Conflicting Flow All	846	478	0	0	523
Stage 1	478	-	-	-	-
Stage 2	368	-	-	-	-
Critical Hdwy	6.42	6.22	-	-	4.12
Critical Hdwy Stg 1	5.42	-	-	-	-
Critical Hdwy Stg 2	5.42	-	-	-	-
Follow-up Hdwy	3.518	3.318	-	-	2.218
Pot Cap-1 Maneuver	333	587	-	-	1043
Stage 1	624	-	-	-	-
Stage 2	700	-	-	-	-
Platoon blocked, %			-	-	-
Mov Cap-1 Maneuver	329	587	-	-	1043
Mov Cap-2 Maneuver	329	-	-	-	-
Stage 1	624	-	-	-	-
Stage 2	692	-	-	-	-

Approach	WB	NB	SB
HCM Control Delay, s	17.2	0	0.3
HCM LOS	C		

Minor Lane/Major Mvmt	NBT	NBR	WBLn1	WBLn2	SBL	SBT
Capacity (veh/h)	-	-	329	587	1043	-
HCM Lane V/C Ratio	-	-	0.147	0.008	0.011	-
HCM Control Delay (s)	-	-	17.8	11.2	8.5	-
HCM Lane LOS	-	-	C	B	A	-
HCM 95th %tile Q(veh)	-	-	0.5	0	0	-

Intersection						
Int Delay, s/veh	0.4					
Movement	WBL	WBR	NBT	NBR	SBL	SBT
Lane Configurations	Y		↑↑	↑	↑	↑↑
Traffic Vol, veh/h	11	6	358	27	10	291
Future Vol, veh/h	11	6	358	27	10	291
Conflicting Peds, #/hr	0	0	0	0	0	0
Sign Control	Stop	Stop	Free	Free	Free	Free
RT Channelized	-	None	-	None	-	None
Storage Length	0	-	-	155	205	-
Veh in Median Storage, #	0	-	0	-	-	0
Grade, %	0	-	0	-	-	0
Peak Hour Factor	85	85	85	85	85	85
Heavy Vehicles, %	2	2	2	2	2	2
Mvmt Flow	13	7	421	32	12	342

Major/Minor	Minor1	Major1	Major2		
Conflicting Flow All	616	211	0	0	453
Stage 1	421	-	-	-	-
Stage 2	195	-	-	-	-
Critical Hdwy	6.84	6.94	-	-	4.14
Critical Hdwy Stg 1	5.84	-	-	-	-
Critical Hdwy Stg 2	5.84	-	-	-	-
Follow-up Hdwy	3.52	3.32	-	-	2.22
Pot Cap-1 Maneuver	422	794	-	-	1104
Stage 1	630	-	-	-	-
Stage 2	819	-	-	-	-
Platoon blocked, %			-	-	-
Mov Cap-1 Maneuver	417	794	-	-	1104
Mov Cap-2 Maneuver	417	-	-	-	-
Stage 1	630	-	-	-	-
Stage 2	810	-	-	-	-

Approach	WB	NB	SB
HCM Control Delay, s	12.5	0	0.3
HCM LOS	B		

Minor Lane/Major Mvmt	NBT	NBRWBLn1	SBL	SBT
Capacity (veh/h)	-	-	501	1104
HCM Lane V/C Ratio	-	-	0.04	0.011
HCM Control Delay (s)	-	-	12.5	8.3
HCM Lane LOS	-	-	B	A
HCM 95th %tile Q(veh)	-	-	0.1	0

Timings
1: Vollmer Rd & Briargate Pkwy

2040 Total Traffic
AM Peak Hour

Lane Group	EBL	EBT	EBR	WBL	WBT	WBR	NBL	NBT	NBR	SBL	SBT	SBR
Lane Configurations												
Traffic Volume (vph)	69	835	58	373	1488	69	89	146	128	81	321	133
Future Volume (vph)	69	835	58	373	1488	69	89	146	128	81	321	133
Turn Type	pm+pt	NA	Perm	Prot	NA	Perm	pm+pt	NA	Perm	pm+pt	NA	Perm
Protected Phases	5	2		1	6		3	8		7	4	
Permitted Phases	2		2			6	8		8	4		4
Detector Phase	5	2	2	1	6	6	3	8	8	7	4	4
Switch Phase												
Minimum Initial (s)	5.0	5.0	5.0	5.0	5.0	5.0	5.0	5.0	5.0	5.0	5.0	5.0
Minimum Split (s)	10.0	10.0	10.0	10.0	10.0	10.0	10.0	10.0	10.0	10.0	10.0	10.0
Total Split (s)	10.0	53.0	53.0	22.0	65.0	65.0	15.0	30.0	30.0	15.0	30.0	30.0
Total Split (%)	8.3%	44.2%	44.2%	18.3%	54.2%	54.2%	12.5%	25.0%	25.0%	12.5%	25.0%	25.0%
Yellow Time (s)	3.0	3.0	3.0	3.0	3.0	3.0	3.0	3.0	3.0	3.0	3.0	3.0
All-Red Time (s)	2.0	2.0	2.0	2.0	2.0	2.0	2.0	2.0	2.0	2.0	2.0	2.0
Lost Time Adjust (s)	0.0	0.0	0.0	0.0	0.0	0.0	0.0	0.0	0.0	0.0	0.0	0.0
Total Lost Time (s)	5.0	5.0	5.0	5.0	5.0	5.0	5.0	5.0	5.0	5.0	5.0	5.0
Lead/Lag	Lead	Lag	Lag	Lead	Lag	Lag	Lead	Lag	Lag	Lead	Lag	Lag
Lead-Lag Optimize?	Yes	Yes	Yes	Yes	Yes	Yes	Yes	Yes	Yes	Yes	Yes	Yes
Recall Mode	None	None	None	None	None	None	None	None	None	None	None	None
Act Effct Green (s)	44.8	39.4	39.4	16.1	53.7	53.7	22.9	16.0	16.0	22.7	16.0	16.0
Actuated g/C Ratio	0.46	0.40	0.40	0.16	0.55	0.55	0.23	0.16	0.16	0.23	0.16	0.16
v/c Ratio	0.43	0.62	0.08	0.70	0.81	0.08	0.35	0.27	0.35	0.26	0.59	0.36
Control Delay	20.0	26.1	0.2	49.9	24.6	1.2	33.3	41.2	7.4	31.4	45.6	8.1
Queue Delay	0.0	0.0	0.0	0.0	0.0	0.0	0.0	0.0	0.0	0.0	0.0	0.0
Total Delay	20.0	26.1	0.2	49.9	24.6	1.2	33.3	41.2	7.4	31.4	45.6	8.1
LOS	B	C	A	D	C	A	C	D	A	C	D	A
Approach Delay		24.1			28.6			27.3			34.1	
Approach LOS		C			C			C			C	

Intersection Summary

Cycle Length: 120
 Actuated Cycle Length: 98.2
 Natural Cycle: 70
 Control Type: Actuated-Uncoordinated
 Maximum v/c Ratio: 0.81
 Intersection Signal Delay: 28.1
 Intersection LOS: C
 Intersection Capacity Utilization 75.8%
 ICU Level of Service D
 Analysis Period (min) 15

Splits and Phases: 1: Vollmer Rd & Briargate Pkwy



Intersection												
Int Delay, s/veh	1.6											
Movement	EBL	EBT	EBR	WBL	WBT	WBR	NBL	NBT	NBR	SBL	SBT	SBR
Lane Configurations		↕			↕			↕	↕		↕	
Traffic Vol, veh/h	0	0	5	62	0	5	2	235	24	1	407	2
Future Vol, veh/h	0	0	5	62	0	5	2	235	24	1	407	2
Conflicting Peds, #/hr	0	0	0	0	0	0	0	0	0	0	0	0
Sign Control	Stop	Stop	Stop	Stop	Stop	Stop	Free	Free	Free	Free	Free	Free
RT Channelized	-	-	None	-	-	None	-	-	None	-	-	None
Storage Length	-	-	-	-	-	-	-	-	-	-	-	-
Veh in Median Storage, #	-	0	-	-	0	-	-	0	-	-	0	-
Grade, %	-	0	-	-	0	-	-	0	-	-	0	-
Peak Hour Factor	95	95	95	95	95	95	95	95	95	95	95	95
Heavy Vehicles, %	2	2	2	2	2	2	2	2	2	2	2	2
Mvmt Flow	0	0	5	65	0	5	2	247	25	1	428	2

Major/Minor	Minor2		Minor1		Major1		Major2					
Conflicting Flow All	697	707	429	685	683	247	430	0	0	272	0	0
Stage 1	431	431	-	251	251	-	-	-	-	-	-	-
Stage 2	266	276	-	434	432	-	-	-	-	-	-	-
Critical Hdwy	7.12	6.52	6.22	7.12	6.52	6.22	4.12	-	-	4.12	-	-
Critical Hdwy Stg 1	6.12	5.52	-	6.12	5.52	-	-	-	-	-	-	-
Critical Hdwy Stg 2	6.12	5.52	-	6.12	5.52	-	-	-	-	-	-	-
Follow-up Hdwy	3.518	4.018	3.318	3.518	4.018	3.318	2.218	-	-	2.218	-	-
Pot Cap-1 Maneuver	356	360	626	362	372	792	1129	-	-	1291	-	-
Stage 1	603	583	-	753	699	-	-	-	-	-	-	-
Stage 2	739	682	-	600	582	-	-	-	-	-	-	-
Platoon blocked, %								-	-	-	-	-
Mov Cap-1 Maneuver	353	359	626	358	371	792	1129	-	-	1291	-	-
Mov Cap-2 Maneuver	353	359	-	358	371	-	-	-	-	-	-	-
Stage 1	602	582	-	751	698	-	-	-	-	-	-	-
Stage 2	733	681	-	594	581	-	-	-	-	-	-	-

Approach	EB	WB	NB	SB
HCM Control Delay, s	10.8	16.9	0.1	0
HCM LOS	B	C		

Minor Lane/Major Mvmt	NBL	NBT	NBR	EBLn1	WBLn1	SBL	SBT	SBR
Capacity (veh/h)	1129	-	-	626	373	1291	-	-
HCM Lane V/C Ratio	0.002	-	-	0.008	0.189	0.001	-	-
HCM Control Delay (s)	8.2	0	-	10.8	16.9	7.8	0	-
HCM Lane LOS	A	A	-	B	C	A	A	-
HCM 95th %tile Q(veh)	0	-	-	0	0.7	0	-	-

Intersection						
Int Delay, s/veh	1.1					
Movement	WBL	WBR	NBT	NBR	SBL	SBT
Lane Configurations	↘↗		↑↑	↗	↘	↑↑
Traffic Vol, veh/h	62	3	258	14	1	473
Future Vol, veh/h	62	3	258	14	1	473
Conflicting Peds, #/hr	0	0	0	0	0	0
Sign Control	Stop	Stop	Free	Free	Free	Free
RT Channelized	-	None	-	None	-	None
Storage Length	0	-	-	155	205	-
Veh in Median Storage, #	0	-	0	-	-	0
Grade, %	0	-	0	-	-	0
Peak Hour Factor	95	95	95	95	95	95
Heavy Vehicles, %	2	2	2	2	2	2
Mvmt Flow	65	3	272	15	1	498

Major/Minor	Minor1	Major1	Major2		
Conflicting Flow All	523	136	0	0	287
Stage 1	272	-	-	-	-
Stage 2	251	-	-	-	-
Critical Hdwy	6.84	6.94	-	-	4.14
Critical Hdwy Stg 1	5.84	-	-	-	-
Critical Hdwy Stg 2	5.84	-	-	-	-
Follow-up Hdwy	3.52	3.32	-	-	2.22
Pot Cap-1 Maneuver	484	888	-	-	1272
Stage 1	749	-	-	-	-
Stage 2	768	-	-	-	-
Platoon blocked, %			-	-	-
Mov Cap-1 Maneuver	484	888	-	-	1272
Mov Cap-2 Maneuver	484	-	-	-	-
Stage 1	749	-	-	-	-
Stage 2	767	-	-	-	-

Approach	WB	NB	SB
HCM Control Delay, s	13.5	0	0
HCM LOS	B		

Minor Lane/Major Mvmt	NBT	NBRWBLn1	SBL	SBT
Capacity (veh/h)	-	-	494	1272
HCM Lane V/C Ratio	-	-	0.139	0.001
HCM Control Delay (s)	-	-	13.5	7.8
HCM Lane LOS	-	-	B	A
HCM 95th %tile Q(veh)	-	-	0.5	0

Intersection												
Int Delay, s/veh	0.9											
Movement	EBL	EBT	EBR	WBL	WBT	WBR	NBL	NBT	NBR	SBL	SBT	SBR
Lane Configurations		↑↑	↑	↑	↑↑	↑			↑			↑
Traffic Vol, veh/h	0	1005	39	62	1880	11	0	0	58	0	0	51
Future Vol, veh/h	0	1005	39	62	1880	11	0	0	58	0	0	51
Conflicting Peds, #/hr	0	0	0	0	0	0	0	0	0	0	0	0
Sign Control	Free	Free	Free	Free	Free	Free	Stop	Stop	Stop	Stop	Stop	Stop
RT Channelized	-	-	None	-	-	None	-	-	None	-	-	None
Storage Length	-	-	155	100	-	155	-	-	0	-	-	0
Veh in Median Storage, #	-	0	-	-	0	-	-	0	-	-	0	-
Grade, %	-	0	-	-	0	-	-	0	-	-	0	-
Peak Hour Factor	95	95	95	95	95	95	95	95	95	95	95	95
Heavy Vehicles, %	2	2	2	2	2	2	2	2	2	2	2	2
Mvmt Flow	0	1058	41	65	1979	12	0	0	61	0	0	54

Major/Minor	Major1			Major2			Minor1			Minor2		
Conflicting Flow All	-	0	0	1099	0	0	-	-	529	-	-	990
Stage 1	-	-	-	-	-	-	-	-	-	-	-	-
Stage 2	-	-	-	-	-	-	-	-	-	-	-	-
Critical Hdwy	-	-	-	4.14	-	-	-	-	6.94	-	-	6.94
Critical Hdwy Stg 1	-	-	-	-	-	-	-	-	-	-	-	-
Critical Hdwy Stg 2	-	-	-	-	-	-	-	-	-	-	-	-
Follow-up Hdwy	-	-	-	2.22	-	-	-	-	3.32	-	-	3.32
Pot Cap-1 Maneuver	0	-	-	631	-	-	0	0	494	0	0	245
Stage 1	0	-	-	-	-	-	0	0	-	0	0	-
Stage 2	0	-	-	-	-	-	0	0	-	0	0	-
Platoon blocked, %	-	-	-	-	-	-	-	-	-	-	-	-
Mov Cap-1 Maneuver	-	-	-	631	-	-	-	-	494	-	-	245
Mov Cap-2 Maneuver	-	-	-	-	-	-	-	-	-	-	-	-
Stage 1	-	-	-	-	-	-	-	-	-	-	-	-
Stage 2	-	-	-	-	-	-	-	-	-	-	-	-

Approach	EB			WB			NB			SB		
HCM Control Delay, s	0			0.4			13.3			23.8		
HCM LOS							B			C		

Minor Lane/Major Mvmt	NBLn1	EBT	EBR	WBL	WBT	WBR	SBLn1
Capacity (veh/h)	494	-	-	631	-	-	245
HCM Lane V/C Ratio	0.124	-	-	0.103	-	-	0.219
HCM Control Delay (s)	13.3	-	-	11.4	-	-	23.8
HCM Lane LOS	B	-	-	B	-	-	C
HCM 95th %tile Q(veh)	0.4	-	-	0.3	-	-	0.8

Timings
1: Vollmer Rd & Briargate Pkwy

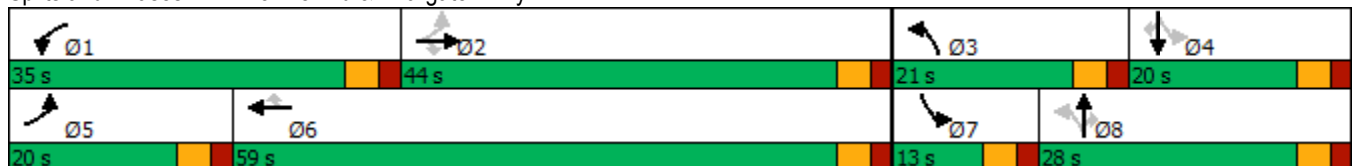
2040 Total Traffic
PM Peak Hour

Lane Group	EBL	EBT	EBR	WBL	WBT	WBR	NBL	NBT	NBR	SBL	SBT	SBR
Lane Configurations												
Traffic Volume (vph)	230	1447	108	346	1216	82	206	459	368	94	223	115
Future Volume (vph)	230	1447	108	346	1216	82	206	459	368	94	223	115
Turn Type	pm+pt	NA	Perm	Prot	NA	Perm	pm+pt	NA	Perm	pm+pt	NA	Perm
Protected Phases	5	2		1	6		3	8		7	4	
Permitted Phases	2		2			6	8		8	4		4
Detector Phase	5	2	2	1	6	6	3	8	8	7	4	4
Switch Phase												
Minimum Initial (s)	5.0	5.0	5.0	5.0	5.0	5.0	5.0	5.0	5.0	5.0	5.0	5.0
Minimum Split (s)	10.0	10.0	10.0	10.0	10.0	10.0	10.0	10.0	10.0	10.0	10.0	10.0
Total Split (s)	20.0	44.0	44.0	35.0	59.0	59.0	21.0	28.0	28.0	13.0	20.0	20.0
Total Split (%)	16.7%	36.7%	36.7%	29.2%	49.2%	49.2%	17.5%	23.3%	23.3%	10.8%	16.7%	16.7%
Yellow Time (s)	3.0	3.0	3.0	3.0	3.0	3.0	3.0	3.0	3.0	3.0	3.0	3.0
All-Red Time (s)	2.0	2.0	2.0	2.0	2.0	2.0	2.0	2.0	2.0	2.0	2.0	2.0
Lost Time Adjust (s)	0.0	0.0	0.0	0.0	0.0	0.0	0.0	0.0	0.0	0.0	0.0	0.0
Total Lost Time (s)	5.0	5.0	5.0	5.0	5.0	5.0	5.0	5.0	5.0	5.0	5.0	5.0
Lead/Lag	Lead	Lag	Lag	Lead	Lag	Lag	Lead	Lag	Lag	Lead	Lag	Lag
Lead-Lag Optimize?	Yes	Yes	Yes	Yes	Yes	Yes	Yes	Yes	Yes	Yes	Yes	Yes
Recall Mode	None	Max	Max	None	Max	Max	None	None	None	None	None	None
Act Effct Green (s)	64.8	50.6	50.6	17.7	54.1	54.1	33.4	20.8	20.8	21.7	13.9	13.9
Actuated g/C Ratio	0.55	0.43	0.43	0.15	0.46	0.46	0.29	0.18	0.18	0.19	0.12	0.12
v/c Ratio	0.84	0.96	0.14	0.70	0.78	0.11	0.66	0.74	0.65	0.50	0.56	0.33
Control Delay	53.2	49.5	0.4	54.8	31.3	0.3	44.2	53.5	9.7	41.7	54.5	2.4
Queue Delay	0.0	0.0	0.0	0.0	0.0	0.0	0.0	0.0	0.0	0.0	0.0	0.0
Total Delay	53.2	49.5	0.4	54.8	31.3	0.3	44.2	53.5	9.7	41.7	54.5	2.4
LOS	D	D	A	D	C	A	D	D	A	D	D	A
Approach Delay		47.0			34.7			35.8			37.9	
Approach LOS		D			C			D			D	

Intersection Summary

Cycle Length: 120
 Actuated Cycle Length: 116.9
 Natural Cycle: 90
 Control Type: Actuated-Uncoordinated
 Maximum v/c Ratio: 0.96
 Intersection Signal Delay: 39.6
 Intersection Capacity Utilization 84.4%
 Analysis Period (min) 15
 Intersection LOS: D
 ICU Level of Service E

Splits and Phases: 1: Vollmer Rd & Briargate Pkwy



Intersection												
Int Delay, s/veh	1.1											
Movement	EBL	EBT	EBR	WBL	WBT	WBR	NBL	NBT	NBR	SBL	SBT	SBR
Lane Configurations		↕			↕			↕	↕		↕	
Traffic Vol, veh/h	0	0	2	42	0	3	4	575	83	6	355	2
Future Vol, veh/h	0	0	2	42	0	3	4	575	83	6	355	2
Conflicting Peds, #/hr	0	0	0	0	0	0	0	0	0	0	0	0
Sign Control	Stop	Stop	Stop	Stop	Stop	Stop	Free	Free	Free	Free	Free	Free
RT Channelized	-	-	None	-	-	None	-	-	None	-	-	None
Storage Length	-	-	-	-	-	-	-	-	-	-	-	-
Veh in Median Storage, #	-	0	-	-	0	-	-	0	-	-	0	-
Grade, %	-	0	-	-	0	-	-	0	-	-	0	-
Peak Hour Factor	95	95	95	95	95	95	95	95	95	95	95	95
Heavy Vehicles, %	2	2	2	2	2	2	2	2	2	2	2	2
Mvmt Flow	0	0	2	44	0	3	4	605	87	6	374	2

Major/Minor	Minor2		Minor1		Major1		Major2					
Conflicting Flow All	1045	1087	375	1001	1001	605	376	0	0	692	0	0
Stage 1	387	387	-	613	613	-	-	-	-	-	-	-
Stage 2	658	700	-	388	388	-	-	-	-	-	-	-
Critical Hdwy	7.12	6.52	6.22	7.12	6.52	6.22	4.12	-	-	4.12	-	-
Critical Hdwy Stg 1	6.12	5.52	-	6.12	5.52	-	-	-	-	-	-	-
Critical Hdwy Stg 2	6.12	5.52	-	6.12	5.52	-	-	-	-	-	-	-
Follow-up Hdwy	3.518	4.018	3.318	3.518	4.018	3.318	2.218	-	-	2.218	-	-
Pot Cap-1 Maneuver	207	216	671	222	243	498	1182	-	-	903	-	-
Stage 1	637	610	-	480	483	-	-	-	-	-	-	-
Stage 2	453	441	-	636	609	-	-	-	-	-	-	-
Platoon blocked, %								-	-	-	-	-
Mov Cap-1 Maneuver	203	213	671	219	240	498	1182	-	-	903	-	-
Mov Cap-2 Maneuver	203	213	-	219	240	-	-	-	-	-	-	-
Stage 1	633	605	-	477	480	-	-	-	-	-	-	-
Stage 2	447	438	-	629	604	-	-	-	-	-	-	-

Approach	EB		WB		NB		SB	
HCM Control Delay, s	10.4		25		0		0.1	
HCM LOS	B		D					

Minor Lane/Major Mvmt	NBL	NBT	NBR	EBLn1	WBLn1	SBL	SBT	SBR
Capacity (veh/h)	1182	-	-	671	227	903	-	-
HCM Lane V/C Ratio	0.004	-	-	0.003	0.209	0.007	-	-
HCM Control Delay (s)	8.1	0	-	10.4	25	9	0	-
HCM Lane LOS	A	A	-	B	D	A	A	-
HCM 95th %tile Q(veh)	0	-	-	0	0.8	0	-	-

Intersection						
Int Delay, s/veh	0.7					
Movement	WBL	WBR	NBT	NBR	SBL	SBT
Lane Configurations	↘↗		↑↑	↗	↘	↑↑
Traffic Vol, veh/h	38	2	660	58	5	394
Future Vol, veh/h	38	2	660	58	5	394
Conflicting Peds, #/hr	0	0	0	0	0	0
Sign Control	Stop	Stop	Free	Free	Free	Free
RT Channelized	-	None	-	None	-	None
Storage Length	0	-	-	155	205	-
Veh in Median Storage, #	0	-	0	-	-	0
Grade, %	0	-	0	-	-	0
Peak Hour Factor	95	95	95	95	95	95
Heavy Vehicles, %	2	2	2	2	2	2
Mvmt Flow	40	2	695	61	5	415

Major/Minor	Minor1	Major1	Major2		
Conflicting Flow All	913	348	0	0	756
Stage 1	695	-	-	-	-
Stage 2	218	-	-	-	-
Critical Hdwy	6.84	6.94	-	-	4.14
Critical Hdwy Stg 1	5.84	-	-	-	-
Critical Hdwy Stg 2	5.84	-	-	-	-
Follow-up Hdwy	3.52	3.32	-	-	2.22
Pot Cap-1 Maneuver	273	648	-	-	851
Stage 1	456	-	-	-	-
Stage 2	797	-	-	-	-
Platoon blocked, %			-	-	-
Mov Cap-1 Maneuver	271	648	-	-	851
Mov Cap-2 Maneuver	271	-	-	-	-
Stage 1	456	-	-	-	-
Stage 2	792	-	-	-	-

Approach	WB	NB	SB
HCM Control Delay, s	20.2	0	0.1
HCM LOS	C		

Minor Lane/Major Mvmt	NBT	NBRWBLn1	SBL	SBT
Capacity (veh/h)	-	-	279	851
HCM Lane V/C Ratio	-	-	0.151	0.006
HCM Control Delay (s)	-	-	20.2	9.3
HCM Lane LOS	-	-	C	A
HCM 95th %tile Q(veh)	-	-	0.5	0

Intersection												
Int Delay, s/veh	2.8											
Movement	EBL	EBT	EBR	WBL	WBT	WBR	NBL	NBT	NBR	SBL	SBT	SBR
Lane Configurations		↑↑	↑	↑	↑↑	↑			↑			↑
Traffic Vol, veh/h	0	1792	117	153	1609	13	0	0	140	0	0	35
Future Vol, veh/h	0	1792	117	153	1609	13	0	0	140	0	0	35
Conflicting Peds, #/hr	0	0	0	0	0	0	0	0	0	0	0	0
Sign Control	Free	Free	Free	Free	Free	Free	Stop	Stop	Stop	Stop	Stop	Stop
RT Channelized	-	-	None	-	-	None	-	-	None	-	-	None
Storage Length	-	-	155	100	-	155	-	-	0	-	-	0
Veh in Median Storage, #	-	0	-	-	0	-	-	0	-	-	0	-
Grade, %	-	0	-	-	0	-	-	0	-	-	0	-
Peak Hour Factor	95	95	95	95	95	95	95	95	95	95	95	95
Heavy Vehicles, %	2	2	2	2	2	2	2	2	2	2	2	2
Mvmt Flow	0	1886	123	161	1694	14	0	0	147	0	0	37

Major/Minor	Major1			Major2			Minor1			Minor2		
Conflicting Flow All	-	0	0	2009	0	0	-	-	943	-	-	847
Stage 1	-	-	-	-	-	-	-	-	-	-	-	-
Stage 2	-	-	-	-	-	-	-	-	-	-	-	-
Critical Hdwy	-	-	-	4.14	-	-	-	-	6.94	-	-	6.94
Critical Hdwy Stg 1	-	-	-	-	-	-	-	-	-	-	-	-
Critical Hdwy Stg 2	-	-	-	-	-	-	-	-	-	-	-	-
Follow-up Hdwy	-	-	-	2.22	-	-	-	-	3.32	-	-	3.32
Pot Cap-1 Maneuver	0	-	-	281	-	-	0	0	264	0	0	305
Stage 1	0	-	-	-	-	-	0	0	-	0	0	-
Stage 2	0	-	-	-	-	-	0	0	-	0	0	-
Platoon blocked, %	-	-	-	-	-	-	-	-	-	-	-	-
Mov Cap-1 Maneuver	-	-	-	281	-	-	-	-	264	-	-	305
Mov Cap-2 Maneuver	-	-	-	-	-	-	-	-	-	-	-	-
Stage 1	-	-	-	-	-	-	-	-	-	-	-	-
Stage 2	-	-	-	-	-	-	-	-	-	-	-	-

Approach	EB			WB			NB			SB		
HCM Control Delay, s	0			2.9			34.6			18.4		
HCM LOS							D			C		

Minor Lane/Major Mvmt	NBLn1	EBT	EBR	WBL	WBT	WBR	SBLn1
Capacity (veh/h)	264	-	-	281	-	-	305
HCM Lane V/C Ratio	0.558	-	-	0.573	-	-	0.121
HCM Control Delay (s)	34.6	-	-	33.7	-	-	18.4
HCM Lane LOS	D	-	-	D	-	-	C
HCM 95th %tile Q(veh)	3.1	-	-	3.3	-	-	0.4