



MVE, INC.
ENGINEERS SURVEYORS

1903 kelaray street, suite 200
colorado springs, co 80909
719.635.5736

Final Drainage Report

Security Fire Station No. 4

Project No. 61134

February, 2021

PCD File No. PPR 20-029

Final Drainage Report

for

Security Fire Station No. 4

Project No. 61134

February, 2021

prepared for

Security Fire Department

400 Security Boulevard

Security, CO 80911

719.392.3271

prepared by

MVE, Inc.

1903 Lelaray Street, Suite 200

Colorado Springs, CO 80909

719.635.5736

Copyright © MVE, Inc., 2021

61134-Security Fire Station 4-FDR.odt

TABLE OF CONTENTS

Cover Sheet	1
Table of Contents	2
Certifications and Approvals.....	3
I. Report Purpose.....	4
II. General Description	4
III. Design Criteria and Methodology	5
IV. Existing Reports, Mapping, and Information.....	6
V. FEMA Floodplain.....	7
VI. Hydrologic Soils Information.....	7
VII. Existing Drainage Conditions	8
VIII. Developed <i>Onsite</i> Drainage Conditions and Improvements	10
IX. Full Spectrum Detention Pond	20
X. Erosion Control.....	21
XI. Stormwater Management Plan (SWMP)	21
XII. Drainage/ Bridge Fees.....	21
XIII. Opinion Of Probable Cost	22
XIV. Four Step Process	22
XV. Conclusion	23

APPENDIX

Exhibit 1:	Location Map
Exhibit 2:	FEMA FIRM Map
Exhibit 3:	SCS Soils Map and Data
Exhibit 4:	Existing Drainage Report Exhibits
Exhibit 5:	Charts and Tables
Exhibit 6:	West Fork Jimmy Camp Creek DBPS Exhibits
Exhibit 7:	Detention Pond Charts and Tables
Exhibit 8:	Hydrologic Calculations for Existing and Developed Conditions
Exhibit 9:	Hydraulic Calculations for Existing and Developed Conditions
Exhibit 10:	Calculation Sheets (CS) for Inlets and Pipe Hydraulics
Exhibit 11:	Historic Drainage Conditions (map pocket)
Exhibit 12:	Developed Drainage Conditions (map pocket)

Certifications and Approvals

Design Engineer's Statement:

The attached drainage plan and report were prepared under my direction and supervision and are correct to the best of my knowledge and belief. Said drainage report has been prepared according to the criteria established by the County for drainage reports and said report is in conformity with the applicable master plan of the drainage basin. I accept responsibility for any liability caused by any negligent acts, errors or omissions on my part in preparing this report.



Kenneth C. Harris, P.E. Colorado No. 23635

4-9-2021
Date

Owner/Developer's Statement:

I, the owner/developer have read and will comply with all of the requirements specified in this drainage report and plan.



David Girardin, Fire Chief
Security Fire Department
400 Security Blvd
Security, CO 80911

4-9-2021
Date

El Paso County:

Filed in accordance with the requirements of the Drainage Criteria Manual, Volumes 1 and 2, El Paso County Engineering Criteria Manual and Land Development Code as amended.

Jennifer Irvine, P.E.
County Engineer / ECM Administrator

Date

Conditions:

Flood Plain Statement

See Section V of this report.

I. **Report Purpose**

- The purpose of this report is to evaluate the existing and developed drainage characteristics for the Security Fire Station #4 project site. This will include:
 - The evaluation of offsite conditions both upstream and downstream of the project site.
 - A description of the existing offsite and onsite drainage improvements.
 - Recommendations regarding onsite drainage improvements.
 - Evaluation of the capacity of offsite drainage improvements.
 - Recommendations regarding detention and storm water quality.
 - General recommendations regarding erosion control.

II. **General Description**

The project site is a portion of an unplatted parcel located in the northeasterly corner of the Wayfarer Drive/ Mesa Ridge Parkway intersection. The site is located in the Northwest Quarter of Section 28, Township 15 South, Range 65 West of the 6th Principal Meridian, El Paso County, Colorado

The site is located in the southerly portion of the West Jimmy Camp Creek Master Drainage basin (*Appendix, Exhibit 6*). There are several swales that are located along the south side of the site. One swale only collects runoff from Mesa Ridge Parkway and routes it in a westerly direction to an existing riprap rundown and CDoT Type C grated inlet and 30" RCP that flows south under Mesa Ridge Parkway. The other swale is located north of the northerly right-of-way for Mesa Ridge Parkway. This swale collects runoff from the unplatted area located to the north of Mesa Ridge Parkway. The purpose of this swale was to prevent storm water runoff from the unplatted property north of Mesa Ridge Parkway from entering Mesa Ridge Parkway right of way.

The project site is a 1.21-acre tract located approximately in the center of the unplatted parcel (*Appendix, Exhibit 1*). The northeasterly corner of the site is located approximately 650 feet west of the Wayfarer Drive/ Mesa Ridge Parkway intersection. The site extends north and south across the unplatted parcel. Access to the site will be from Wayfarer Drive. The subdivisions that are located near the project site include: The Glen at Widefield Subdivision #2, The Glen at Widefield Subdivision Filing No. 4 and The Glen at Widefield Subdivision Filing No. 2 (*Appendix, Exhibit 4*). Runoff from these subdivisions will not impact the site.

The site slopes from north to south at an average grade of 3.5%. The vegetation consists of native grasses along with bushes sporadically located.

There are no irrigation facilities and/ or existing utilities that encumber the site.

III. Design Criteria and Methodology

- **Design Manuals**

Pertinent portions of the Drainage Plans that were submitted and approved by El Paso County for the subdivisions in the vicinity of the site are included in Exhibit 4.

The following publications and/ or criteria manuals were used in the preparation of this Drainage Study. Copies of applicable tables, graphs, and nomographs are included in the Appendix of this report (*Exhibit 4, Appendix*)

- El Paso County Drainage Criteria Manual (EPCDCM), dated September 30, 1990, Revised July, 2019
- Colorado Springs Drainage Criteria Manuals, Volume 1 and 2, dated May, 2014
- Urban Drainage and Flood Control Manual, Volumes 2 and 3, dated August 2018
- CDOT Erosion Control Field Handbook, dated April 20, 2017

- **Specific Criteria**

- Design storms

The majority of the facilities are designed to accommodate runoff from the 100-year storm event. This was necessary in order to capture all of the runoff in the proposed detention pond.

The design storms used in this report are as follows:

- Minor storm: 5 year
- Major storm: 100 year

- Drainage Areas

Areas of offsite and onsite sub basins were determined using survey field data, Final Drainage Reports for surrounding subdivisions, and from the USGS mapping.

- Runoff Estimation

Rational Method: This method was used to estimate runoff quantities for sites and sub basins less than 130 acres (per criteria).

Intensity-Duration-Frequency (IDF) curves were obtained from the CSDCM , (*Exhibit 5, Appendix*)

- Onsite Storm Sewer and Inlets

There are no existing storm sewer facilities located on the project site. All proposed onsite storm sewer facilities will be privately owned and maintained. They will include pipes, inlets, cleanouts, flared end sections, concrete chases, etc.

- **Drainage swale and borrow ditch sizing**
Offsite swales are evaluated with runoff from the major 100-year storm events. All of the swales are located offsite south of the project site. These swales were previously constructed with the construction of Mesa Ridge Parkway and Powers Boulevard. Since runoff from the project does not have any impact on the existing swales, the swales were only evaluated for information purposes only. No improvements are proposed to these swales.
- **Detention/ Water Quality Pond**
 - Design Criteria: Urban Drainage Flood Control Manual (UDFCM)
 - Type: Sand Filter Basin
- **Emergency Overflow**
The emergency overflow is designed to safely route the runoff from the 100-year storm event downstream to acceptable facilities. The runoff was determined by isolating the sub basins that contributed flow to the pond and then determine the composite runoff coefficient. The rainfall intensity was determined based on the minimum allowable time of concentration, 5 minutes. The Rational Method was used to determine the design flow. The structure that carries the flow consists of riprap swale, concrete cutoff walls, and a maintenance road.
- **Erosion control**
The following facilities are anticipated to be required:
 - Erosion Control Blankets
 - Riprap aprons
 - Silt fences
 - Staked hay bales
 - Erosion control fabric
 - Erosion control logs

The locations of the above facilities will be shown on a Grading and Erosion Control Plan which is to be prepared for the Storm Water Management Permit Application and submitted under separate cover.

IV. EXISTING REPORTS, MAPPING AND INFORMATION

- **Mesa Ridge Phase 1 and 2 (*excerpts included in Exhibit4, Appendix*)**
A portion of the Mesa Ridge Parkway Phases 1 and 2 is located along the south side of the project site.

Runoff from the Parkway sheet flows into the borrow ditch located along the north side of the highway. This borrow ditch only accommodates runoff from the north half of the Mesa Ridge Parkway right-of-way. A high point in the borrow ditch is located approximately 1,000 feet east of the project site. At this point the flow is routed either east or west in the borrow ditch. The water flows in a

westerly direction to a concrete channel and then eventually to a concrete box culvert located under Powers Boulevard. The location of these facilities is not shown on the Drainage Maps.

- **The Glen at Widefield Subdivision No. 4**

The Glen at Widefield Subdivision No. 4 is located along the northerly side of Wayfarer Drive. The drainage plan shows all of the runoff from the minor storm event remains in the street and flows to the east to outfall into Mesa Ridge Parkway (*Exhibit 4, Appendix*). The stormwater does not outfall onto either the site or the unplatted parcel located along the east and the west sides of the project site. Analysis of the 100-year event in Wayfarer Drive is beyond the scope of this report.

- **The Glen at Widefield Subdivision No. 2** The Glen at Widefield Subdivision No. 2 is located on the north and east side of the unplatted tract. The drainage map for “The Glen at Widefield Subdivision No. 2” indicates that no storm water runoff enters the project site but is directed to a detention pond located on the unplatted parcel immediately south of The Glen at Widefield Subdivision No. 2. The outfall for this pond directs the water away from the project site.

V. FEMA FLOODPLAIN

The project site is located in FEMA map # 08041CO956G, 12/07/2018 (*Appendix, Exhibit 2*). The entire site is located outside the 100-year floodplain in Zone X which is an “Area of Minimal Disturbance” for which there are no special requirements or restrictions for the construction of commercial or industrial structures.

VI. HYDROLOGIC SOILS INFORMATION

The hydrologic soils groups were obtained from the USDA National Resource Conservation Service website for soils types in El Paso County, Colorado (*Appendix, Exhibit 3*). The soils are identified as follows:

- **Nelson-Tassel sandy loams** which have the following characteristics:
 - Well drained
 - Frequency of flooding: none
 - Frequency of ponding: none
 - Hydrologic Soil Group: B

- **Stoneham Sandy Loams** which have the following characteristics:
 - Well drained
 - Frequency of flooding: none
 - Frequency of ponding: none
 - Hydrologic Soil Group: B
 - A detailed description of each of the type soil is included in Appendix Exhibit 3.

VII. EXISTING DRAINAGE CONDITIONS

○ General Description

All historic runoff from Sub basins OS1, OS3, and Sub basin A is collected by two (2) swales that route water in a westerly direction. Only runoff from OS1 effects the project site (Sub basin A) Both swales are located along the northerly right-of-way for Mesa Ridge Parkway. Swale 1 is located south and inside the right-of-way. The swale is located south of the project site. Swale 2 is located north and outside the right-of-way. Swale 2 enters and leaves the project site at Design Point 1 and Design Point 3 respectively. The most northerly swale collects runoff from the Sub basins OS1, A, and OS3. The most southerly swale collects runoff from only the northerly ½ of the right of way of Mesa Ridge Parkway and routes it in a westerly direction. Both swales intersect west of the site and drain into an existing riprap rundown and CDoT Type C grated inlet at DP5. Flows will then be conveyed in an existing 30" RCP that flows south under Mesa Ridge Parkway. Per the Final Drainage Report for Lot 1 and Tract A, Widefield Commercial Center Subdivision Filing No. 1 by Kiowa Engineering Corporation, Project No, 09011, Revised June 21, 2010, the flows in the existing 30" RCP have the capacity to carry the ultimate design flows. This location is indicated by reference on the Existing Conditions Drainage Map.

Hydraulic analysis of swale 2 is included in this report and demonstrates the off-site swale west of the site to be a suitable outfall for the proposed onsite full spectrum sand filter basin as well as the existing offsite flows that are carried in the swale. The off-site Swale 2 to the west possesses the necessary capacity to carry the flows from this site to the afore mentioned Type C inlet at DP5.

○ Design Point 1, Runoff from OS1

Runoff from OS1 (2.08 acres) sheet flows in a southerly direction to Swale 2 located north of the northerly right-of-way line for Mesa Ridge Parkway. The swale routes the water in a westerly direction to a point where it intersects with Swale1 located to the south of the northerly right-of-way line for Mesa Ridge Parkway. From here the water is routed in a westerly direction and drains into an existing riprap rundown and CDoT Type C grated inlet at DP5. Flows will then be conveyed in an existing 30" RCP that flows south under Mesa Ridge Parkway. The hydraulic characteristics of the swales will be maintained upon site development since the developed runoff from the fire station site will be held to the historical rated by a Full Spectrum Detention Pond (FSDP).

Only the runoff from Sub basins OS1 and A will have an impact the site. The values for Sub basin OS1 are the same for the developed conditions. The hydrologic characteristics for the runoff from OS1 at DP1 for the existing conditions are as follows.

- Drainage Area = 2.06 acres
 - Runoff Coefficients: 5 year = 0.09, 100 year = 0.36
 - Time of Concentration: 17.0 minutes
 - Runoff: 5 year = 0.6 cfs, 100 year = 4.2 cfs
- **Design Point 3, Runoff from Sub basin A**
 Sub basin A represents the project site. Runoff from Sub basin A (1.21 acres) is collected by swale 2 located in the southerly portion of the site. Swale 2 routes the water in a westerly direction along the south side of Sub basin OS3. The following is a summary of the hydrologic characteristics for the runoff from Sub basin A:
 - Drainage Area = 1.21 acres
 - Runoff Coefficients: 5 year = 0.09, 100 year = 0.36
 - Time of Concentration: 17.0 minutes (Tc since OS1 controls)
 - Runoff: 5 year = 0.4 cfs, 100 year = 2.4 cfs
- **Design Point 4, Runoff from OS2**
 Sub basin OS2 encompasses the southerly half of Wayfarer Drive. Storm water runoff from this Sub basin routed in an easterly direction in the southerly curb and gutter section along Wayfarer Drive. The water enters the Mesa Ridge Parkway intersection located approximately 650 feet east of the project site. The water from Wayfarer Drive will be prevented from entering the project site by two EPC Standard Driveways that enter the project site.
- **Design Point 5, Runoff from OS3**
 Sub basin OS3 is located west of the fire station site. The Sub basin is shown on the drainage maps for information purposes only since the runoff has no impact on the project site. Runoff from the unplatted area (OS3) sheet flows in a southerly direction to swale 1 and swale 2 which are located north and south, respectively, of the northerly right-of-way line for Mesa Ridge Parkway. The runoff combines with runoff from Sub basin OS1 and Sub basin A and is routed in a westerly direction to a concrete from the easterly unplatted parcel (OS1) in Swale 2 and the Sub basin A. The water is routed west in Swale #2.

VIII. DEVELOPED ONSITE DRAINAGE CONDITIONS AND IMPROVEMENTS

○ **Criteria Summary**

The hydrologic and hydraulic characteristics of the project site and the proposed drainage improvements were evaluated in the following manner:

1. Runoff from the fire station site and the surrounding offsite areas was not discussed in any of the FDR's of the surrounding subdivisions.
2. The hydraulic characteristics for the proposed storm sewer pipe were determined using approximate slopes of the pipe. The hydraulic characteristics will need to be verified once the actual slopes of the storm sewers have been determined.
3. The FSDP to be constructed for the project site is designed as a stand-alone facility sized to accommodate all of the runoff from the project site.
4. Runoff coefficients and times of concentration were selected based on proposed land use. A minimum time of concentration of 5 minutes was selected in conformance with the El Paso County Drainage Criteria.
5. Estimation of the amounts of water at each Design Point was determined using the Rational Method.
6. The routing of the runoff from the 100-year storm event is discussed for each sub basin. The FSDP facilities are designed to handle 100% of the runoff from the 100-year storm.
7. The proposed inlets are manufactured by Nyoplast. Examples of these units are included in *Exhibit 5, Appendix*.
8. 100% of the developed runoff will be routed through the FSDP located in the southern portion of the site. The type pond will be a Sand Filter. This facility is to be sized according to the ECM 1 criteria as well as the Urban Drainage and Flood Control criteria. The specific parameters of the pond are discussed in Section IX of this report.
9. Included in this report are copies of pertinent portions of the Final Drainage Studies (*Appendix, Exhibit 4*) for the subdivisions adjacent to the project site.

○ **Design Point 1**

○ Contributing Sub basin Description

Runoff from Sub basin OS2 is directed to DP 1. This runoff is from water from ½ the street right-of-way of Wayfarer Drive. All of the water will be prevented from entering the project site with the installation of EPC Standard Driveways to the project site. The high points for both the driveways are to be installed just south of the intersection with Wayfarer Drive. Additional discussions of the hydrologic and hydraulic characteristics of the contributing subdivisions can be found in the Final Drainage Report prepared for The Glen at Widefield #2. Excerpts from this report are included in *Exhibit 4, Appendix*.

- Sub basin Characteristics
 - The hydrologic and hydraulic characteristics for the Sub basin OS2 were not evaluated since the runoff has no impact on the developed conditions of the project site.
- Stormwater Routing for Developed Conditions
 - The runoff from OS2 is collected by the southerly curb of Wayfarer Drive. The water is then routed to DP 2 via the existing concrete curb and gutter section along the southerly side of Wayfarer Drive. Evaluation of the hydrologic and hydraulic characteristics at this location is beyond the scope of this report since this runoff has no impact on the fire station site.
- Proposed Drainage Facilities
 - Concrete EPC Standard Driveways are to be constructed in the southerly curb line of Wayfarer Drive. The water will be prevented from entering the fire station site by the afore mentioned Driveways.
- **Design Point 2**
 - Contributing Sub basin Description
 - Runoff from Sub basins OS2, and A (0.04 acres, Q5 = 0.2 cfs, Q100 = 0.3 cfs), B (0.1 acres, 5 year = 0.2 cfs, 100 year 0.3), and C (0.02 acres, Q5 = 0.1 cfs, Q100 = 0.2 cfs) is collected at DP 2. Sub-basin OS2 is discussed in previous sections of this report. Sub-basins A, B and C are located south of the southerly right of way line for Wayfarer Drive. The areas in Sub basins A, B, and C are to be graded to Wayfarer Drive. These Sub basins are to consist of landscaping and concrete sidewalks.
 - Stormwater Routing for Developed Conditions
 - The runoff from Sub basins OS2, A, B, C is to be routed to DP2 by proposed public concrete standard driveways. Stormwater from Wayfarer Drive will be prevented from entering the project site with the construction of high points in the driveways. The water is then routed along the southerly curb and gutter section in an easterly direction to the Mesa Ridge Parkway intersection. Additional evaluation of the hydrologic and hydraulic characteristics for these sub basins is beyond the scope of this report since the runoff has no impact on the project site.
- **Design Point 3**
 - Contributing Sub basin Description
 - Runoff from Sub basin D (0.08 acres) is collected at DP3 by a sump inlet (STR1). The Sub basin consists of a landscaped area. The discharges for the design flows were determined to be Q5 = negligible and Q100 = 0.3 cfs.
 - Stormwater Routing for Developed Conditions

The runoff sheet flows to a private sump inlet (STR1) located in the middle of a landscaped area. The total runoff at DP3 is $Q_5 = \text{negligible}$ and $Q_{100} = 0.3 \text{ cfs}$. The water collected by the proposed sump inlet is routed in an easterly direction via a proposed private 12" storm sewer pipe (STR 11).

- Proposed Drainage Facilities

A private sump inlet is proposed (Exhibit 8, Appendix, and Calculation Sheet CS 1) at DP 3. The inlet is sized to intercept 100% of the runoff from Sub Basin D. The water is then routed to another private inlet at DP 4 via a private 12" HDPE (STR 11). The pipe segment was sized for the runoff from 100-year storm since the driveway embankment prevents runoff from proceeding "downstream". The hydrologic and hydraulic properties of the inlet (STR1) and the storm sewer (STR 11) are as follows:

- STR 3 Sump Inlet (CS1)

- Type: 12" Standard Grate Inlet by Nyoplast

- Surface Flow: 0.3 cfs

- Interception Rate: 0.3 cfs

- Bypass: 0 cfs

- Downstream ID: 12" HDPE (STR 11)

- ID: STR11 (CS 5)

- Size of pipe segment = 12 inches

- Design flows: 100 year = 0.3 cfs.

- Approximate slope: 1.0 %

- Depth of flow: 100 year = 0.2 feet

- Velocity: 100 year = 2.7 fps

- 100-year routing

The runoff from the 100-year storm is contained within STR 11 and routed to DP 4 via a private 12" HDPE pipe (STR 11).

- **Design Point 4**

- Contributing Sub basin Description

- Runoff from Sub basin F (0.03 acres) ($Q_5 = \text{negligible}$ and $Q_{100} = 0.3 \text{ cfs}$) is collected at a sump inlet at DP 4. The Sub basin consists of a paved driveway.

- Stormwater Routing for Developed Conditions

- Water collected at DP3 and DP4 is routed in a southerly direction in a proposed private 12" HDPE (STR3) to an underground fitting (STR4) at DP7. From here the water is routed to DP13 via a 12" HDPE (STR12 and 13).

The hydraulic data for the proposed downstream pipe (STR3) is as follows:

ID: STR3 (CS 6)
Diameter of pipe segment = 12 inches
Design flows: 100 year = 0.5 cfs.
Approximate slope: 1.0 %
Depth of flow: 100 year = 0.2 feet
Velocity: 100 year = 2.7 fps

ID: STR12 and STR13 (CS 11)
Design flows: 100 year = 1.2 cfs.
Size of pipe segment = 12 inches
Approximate slope: 1.0 %
Depth of flow: 100 year = 0.3 feet
Velocity: 100 year = 4.1 fps

- 100-year routing
All water from the 100-year storm event is contained within the pipe segment (STR3).
- **Design Point 5**
 - Contributing Sub basin Description
Runoff from Sub basin I (0.09 acres) (Q5 = 0.4 and Q100 = 0.7 cfs) is collected by a downspout from the fire station roof. The entire Sub basin is composed of the westerly ½ section of the fire station roof.
 - Stormwater Routing for Developed Conditions
The water collected at DP5 discharges into a private 12" HDPE via an underground tee fitting (STR7). From here the water is routed in a southwest direction by two sections of 12" HDPE storm sewers (STR17 and STR8) to DP16.
 - Proposed Drainage Facilities
The hydraulic characteristics for both of the 12" HDPE pipes are summarized below:

ID: STR8 and STR17 (CS 10)
Design flows: 100 year = 0.8 cfs.
Size of pipe segment = 12 inches
Approximate slope: 0.5 %
Depth of flow: 100 year = 0.3 feet
Velocity: 100 year = 2.7 fps
- 100-year routing
All water from the 100-year storm event is contained within the pipe segments (STR 17 and STR3).

- **Design Point 6**

- Contributing Sub basin Description

- Runoff from Sub basin E (0.24 acres) ($Q_5 = 1.0$ and $Q_{100} = 1.8$ cfs) is collected at a private curb and gutter inlet (STR19) at DP6. The majority of Sub basin E is composed of paved parking and driveway surfaces.

- Stormwater Routing for Developed Conditions

- The water collected by the inlet (STR19) is routed by a private 12" HDPE (STR9) downstream to an underground wye fitting at DP16

- Proposed Drainage Facilities

- The following are summaries of the hydraulic characteristics for the inlet (STR19) and the downstream pipe segment (STR9).

- STR19 curb and gutter grated inlet (CS3)

- Type: Double 24" square grated inlet by Nyoplast (CS3)

- Surface Flow: 1.8 cfs

- Interception: 1.2 cfs

- Bypass: 0.60 cfs

- Downstream ID: 12" HDPE (9)

- ID: Pipe segment STR9 (CS 7)

- Design flows: 100 year = 1.2 cfs.

- Size of pipe segment = 12 inches

- Approximate slope: 0.5 %

- Depth of flow: 100 year = 0.4 feet

- Velocity: 100 year = 3.2 fps

- 100-year routing

- All of the runoff generated by the 100-year storm event is routed to the full spectrum detention (FSD) by the private underground storm sewer system.

- **Design Point 8**

- Contributing Sub basin Description

- Runoff from Sub basin M (0.02 acres) ($Q_5 = 0.1$ and $Q_{100} = 10.2$ cfs) is collected at the top of a riprap chute (STR21) that discharges into the proposed FSD at DP17. Bypass from the inlet (STR19)(0.6 cfs) is also collected at DP8. The majority of Sub basin M is composed of paved parking and driveway surfaces.

- Stormwater Routing for Developed Conditions

- The water is collected by a proposed riprap chute (STR21) that discharges into the proposed FSDP at DP17.

- Proposed Drainage Facilities (CS15)

- STR 21 (Riprap Chute) is sized for 100% of the 100-year storm.

The hydraulic properties of private STR 21 are as follows. The hydraulic parameters for STR21 are for 100% interception of the runoff from 100-year storm.

STR ID: Riprap chute 21 (CS15)
Design flows: 100 year = 0.9 cfs.
Bottom width of chute: 2 ft.
Approximate slope: 10%
Side Slope: 3 to 1
Depth of flow: 100 year = 0.1 feet
Velocity: 100 year = 3.6 fps

- 100-year routing
All of the runoff generated by the 100-year storm event is routed downstream in the STR 11 with only a minimal amount of bypass on the surface.
- **Design Point 9**
 - Contributing Sub basin Description
DP9 is located at the FSDP outlet. Refer to Section 9 of this report for hydraulics and structure sizing.
- **Design Point 10**
 - Contributing Sub basin Description
Stormwater runoff from OS1 (2.1 acres) is collected at DP 10. OS1 is comprised of natural grassland with a few small bushes. The hydrologic and hydraulic characteristics are based on existing conditions. It is assumed that a FSDP will be required when OS1 is developed. The discharges at DP10 were determined to be $Q_5 = 0.6$ cfs and $Q_{100} = 4.2$ cfs.
 - Stormwater Routing for Developed Conditions
The water in the existing swale is routed from DP10 to the proposed FSDP outfall.
 - Proposed Drainage Facilities (CS 16)
STR ID: Rip Rap swale from DP10 to the outfall of the FSDP (DP14)
Design flows: 100 year = 4.2 cfs.
Bottom width: 2 ft.
Approximate slope: 2%
Side Slope: 3 to 1
Depth of flow: 100 year = 0.5 feet
Velocity: 100 year = 2.7 fps
- 100-year routing

All of the runoff generated by the 100-year storm event is routed downstream to the existing swale at DP11. From here the water is routed to the existing downstream facilities as described in previous sections of this report.

- **Design Point 11**

- Contributing Sub basin Description

- DP 11 is located where Swale 1 exits the project site. Swale 1 is located north of the Mesa Ridge Parkway northern right of way line. The swale is sized for the combination of the emergency flow (6.7 cfs) from the FSDP and the flow from OS1 at DP10 (4.2 cfs) for a total of 10.9 cfs

- Stormwater Routing for Developed Conditions

- The water in the proposed swale is routed from DP14 to DP11 where the swale exits the project site.

- Proposed Drainage Facilities (CS17)

- STR ID: Riprap lined swale from DP14 to DP11.

- 100-year routing

- All of the runoff generated by the 100-year storm event is routed downstream to the existing swale at DP11. From here the water is routed to the existing downstream facilities as described in previous sections of this report.

- **Design Point 12**

- Contributing Sub basin Description

- DP12 is located at the pipe outfall (STR22) of the FSDP.

- Stormwater Routing for Developed Conditions

- The water discharges into a proposed riprap lined swale and is carried downstream to DP11 where it exits the project site.

- Proposed Drainage Facilities (Exhibit 8, Appendix, CS 22)

- The following are summaries of the hydraulic characteristics for the outfall pipe from the FSDP.

- ID: Pipe segment STR22 (CS 22)

- Design flows: 100 year = 1.2 cfs.

- Size of pipe segment = 12 inches

- Approximate slope: 3.0 % (Approximate only. This will need to be verified after the design of the pond structures has been complete.

- Depth of flow: 100 year = 0.2 feet

- Velocity: 100 year = 6.0 fps

- 100-year routing

All of the discharge from the 12" pipe (STR22) outfalls into the proposed riprap swale at DP12 and is carried in a westerly direction to DP11 where it exits the project site.

- **Design Point 13**

- Contributing Sub basin Description

- Runoff from Sub basin J (0.18 acres) (Q100 = 1.3 cfs) is collected by a private curb and gutter inlet (STR6) at DP13 and is route to FSDP by a 12" HDPE pipe (STR20) The majority of Sub basin J is composed of paved parking and driveway surfaces.

- Stormwater Routing for Developed Conditions

- Proposed Drainage Facilities(Appendix, CS3)

- Inlet STR6 has the following hydraulic characteristics:

- STR6 curb and gutter grated inlet (CS3)
 - Type: 24" square grated Inlet by Nyoplast (CS4)
 - Surface Flow: 1.9 cfs
 - Interception: 1.2 cfs
 - Bypass: 0.70 cfs
 - Downstream ID: 12" HDPE (9)

- Pipe STR20 has the following hydraulic characteristics:

- ID: Pipe segment STR20 (CS12)
 - Design flows: 100 year = 2.4 cfs.
 - Size of pipe segment = 12 inches
 - Approximate slope: 1.0 %
 - Depth of flow: 100 year = 0.4 feet
 - Velocity: 100 year = 5.0 fps

- 100-year routing

- The water in pipe segment STR20 is routed to the FSDP via pipe segment STR20.

- **Design Point 14**

- A riprap lined swale from DP14 to DP11 (located on westerly property line where swale 1 exits the property) (CS19)

- Proposed Drainage Facilities (CS19)

- STR ID: Riprap lined swale from DP14 to DP11.
 - Design flows: 100 year = 10.9 cfs.
 - Bottom width: 2 ft.
 - Approximate slope: 2%
 - Side Slope: 3 to 1
 - Depth of flow: 100 year = 0.7 feet

Velocity: 100 year = 3.5 fps
Froude Number: 0.91 (sub critical)
Riprap Size: 12"
Depth: 2'

○ **Design Point 15**

- Contributing Sub basin Description
DP15 is located at the downstream end of the 12" HDPE pipe (STR14) where it outfalls into the FSDP.
- Stormwater Routing for Developed Conditions (CS13)
The water in DP14 (Q100 = 4.3 cfs) combines with the water in STR10 (Q100 = 1.9) for a total flow in a 12' pipe (STR14) at a wye installed at the upstream junction with pipe segment STR10 and STR 20.
- Proposed Drainage Facilities (Appendix, CS3)
The hydraulic properties for STR14 (CS13) are as follows:
 - Design flows: 100 year = 4.3 cfs.
 - Size of pipe segment = 12 inches
 - Approximate slope: 10% (This slope will need to be verified upon completion of the construction plans)
 - Depth of flow: 100 year = 0.4 feet
 - Velocity: 100 year = 10.4 fps

A Rip Rap Pad is proposed at the pipe outlet in order to dissipate energy before entering the pond.

○ **Design Point 16**

- Contributing Sub basin Description
DP16 is located at a proposed underground wye fitting. Flow from pipe (STR8 Q100 year = 0.8 cfs) combines with flow from pipe STR9 (Q100 year = 1.2 cfs). The total flow in pipe segment 10 is Q100 = 2.0 cfs.
- Stormwater Routing for Developed Conditions (CS12)
The hydraulic properties for STR20 (CS12) are as follows:
 - Design flows: 100 year = 2.4 cfs.
 - Size of pipe segment = 12 inches
 - Approximate slope: 1.0% (This slope will need to be verified upon completion of the construction plans)
 - Depth of flow: 100 year = 0.4 feet
 - Velocity: 100 year = 5.0 fps
- 100-year routing
All of the water is routed into the FSDP via pipe segment STR 14.

- **Design Point 17**
DP 17 is located at the downstream end of the riprap chase. The hydraulic properties of the chase are discussed in previous section DP8.
- **Drainage Sub basin G (no concentrated flow at a design point, sheet flow)**
Runoff from Sub basin G (0.19 acres, Q5 = 0.1 cfs, Q100 = 0.6 cfs) sheet flows to the easterly property line. This area is to remain in a natural state. The runoff is to sheet flow onto undeveloped unplatted tract (OS 1). Stormwater runoff from this area will not have to be routed into the proposed FSD pond since no development is to occur in this sub basin.
- **Drainage Sub basin L (no concentrated flow at a design point. sheet flow)**
Sub basin L consists (0.12 acres) of the area along the south side of the project site. The runoff (Q5 year = negligible, Q100 = 0.4 cfs) sheet flows in a southerly direction to a swale located to the north of the right of way boundary line.
- **Drainage Sub Basin N (no concentrated flow at a design point. sheet flow)**
Runoff from Sub basin N (0.05 acres, Q5 = negligible, Q100 = 0.2 cfs) sheet flows to the Swale 1 located north of the north right-of-way line for Mesa Ridge Parkway. Stormwater runoff from this area will not have to be routed into the proposed FSD pond since no development is to occur in this sub basin.
- **Drainage Sub Basin O (no concentrated flow at a design point, sheet flow)**
Runoff from Sub basin O (0.1 acres, Q5 = negligible, Q100 = negligible) sheet flows to the westerly property line of the project site. Sub basin O is located along the west side of the FSDP. Runoff from this subbasin will not have to be routed into the proposed FSD pond since no development is to occur in this sub basin.
- **Drainage Sub basin P (no concentrated flow at a design point, sheet flow)**
Runoff from Sub basin P (0.04 acres, Q5 = negligible, Q100 = 0.1 cfs) sheet flows to the westerly property line. This area is a thin strip along the westerly property line of the project site. It is to remain in a natural state. Stormwater runoff from this area will not have to be routed into the proposed FSD pond since no development is to occur in this sub basin.

IX. FULL SPECTRUM DETENTION POND (EXHIBIT 7, APPENDIX)

100% of the runoff from the developed portion of the site is to be collected by a Full Spectrum Detention Pond (FSDP). The pond is designed to only release less than the historic flow with the exception of the emergency overflow. No change to

the routing of the water as it leaves the pond. The water is routed in a westerly direction in the existing grass-lined swale located north of the northerly right of way line where it eventually passes under Powers Boulevard via a concrete box culvert. Hydraulic analysis of this box culvert is beyond the scope of this report. However, it is assumed that the developed runoff will be minimal, if any, since the FSDP will be detaining 100% of the 100-year developed runoff.

The following elevations for the FSDP are based on an elevation of "0" located at the bottom of the pond.

○ **Design Flows**

- Sub basins discharging into the FSDP: D (0.08 acres), E (0.24 acres), F (0.03 acres), H (0.09 acres), I (0.09 acres), J (0.18 acres), K (0.13 acres), M (0.03 acres) for a total area of 0.87 acres. The remaining portion of the project site is to remain in a natural state where no development is to occur.
- Peak Inflow: $Q_{100} = 2.8$ cfs
- Peak Outflow: $Q_{100} = 1.2$ cfs.
- Emergency Overflow = 6.7 cfs (based on using the Rational Method for the area that contribute flows to the FSDP (Exhibit 7, Appendix)

○ **Pond Characteristics**

- Type: Sand Filter
- Water Quality Capture Volume (WQCV) = 0.015 acre-ft., elevation = 0.81 ft.
- Excess Urban Runoff Volume (EURV) = 0.044 acre-ft. elevation = 2.19 ft.
- 100-year runoff volume = 0.041 acre- ft., elevation = 3.05 ft.
- Media Surface elevations = 0.00 ft.
- Spillway elevation = 3.5 ft.
- Top of berm elevation = 5.0 ft.

○ **Outlet Structure**

- Rows for Orifice: 3
- Orifice size = 1 inch
- Number of rows = 3
- Overflow Weir Elevation for outfall structure = 2.5 ft.
- Overflow Grate Size = approximately a 3' by 3'
- Debris Clogging = 50%

- **Emergency Spillway (CS20 and CS21)**

- Hydraulics
 - Riprap Emergency Overflow Chute
 - Design Flow: 6.7 cfs
 - Depth of flow: 0.3 ft
 - Velocity: 9.5 fps
- Physical Properties
 - Spillway Invert Elevation = 3.5 ft.
 - Spillway Side Slopes = 3 to 1
 - Spillway slope: 33% (Side slope of detention pond)
 - Freeboard= 1.0 ft.
 - Riprap size: 12"
 - Riprap depth: 24"

- **Outfall Pipe (sized for 100-year event) (Exhibit 8, Appendix, CS 25)**

The following are summaries of the hydraulic characteristics for the outfall pipe from the FSDP.

- ID: Pipe segment STR22 (CS 22)
 - Design flows: 100 year = 1.2 cfs.
 - Size of pipe segment = 12 inches
 - Approximate slope: 3.0 % (Approximate only. This will need to be verified after the design of the pond structures has been complete.
 - Depth of flow: 100 year = 0.2 feet
 - Velocity: 100 year = 6.0 fps

X. EROSION CONTROL

Recommended erosion control measures are summarized in the Storm Water Management Permit Application that is being submitted under separate cover.

XI. STORMWATER MANAGEMENT PLAN (SWMP)

A **SWMP** has been completed and is being submitted under separate cover.

XII. DRAINAGE/ BRIDGE FEES

Pending approval of the Subdivision Exemption, it is understood, that there will no Drainage/ Bridge Fees that are to be collected for this development.

XIII. OPINION OF PROBABLE COSTS

		Unit Cost	Total
6" HDPE	106 LF	18	\$1,908
12" HDPE	475 LF	24	11,400
12" Sq. Nyloplast Grated Inlet	2 EA	4,200	8,400
24" Sq. Nyloplast Grated Inlet	3 EA	4,600	13,800
12" Riprap Swale (DP10 to DP11)	62 CY	116	7,192
	Subtotal		42,700
Pond Excavation	386 CY	21	8,106
Sand Filter Media	41 CY	50	2,050
Slotted Underdrain	30 LF	21	630
Pond Rip Rap	27 CY	116	3,132
Outlet Structure	1 EA	3,500	3,500
Concrete Cutoff Wall (Spillway)	2.3 CY	175	403
12" Gravel Maintenance Road	40 CY	52	2,080
	Subtotal		19,901
	Total		\$62,601

XIV. FOUR STEP PROCESS

As stated in the City of Colorado Springs DCM Volume 2, the Four Step Process is applicable to all new and re-developed projects with construction activities that disturb 1 acre or greater or that disturb less than 1 acre but are part of a larger common plan development. Included is the Four Step Process for Security Fire Station Filing 4.

Step 1: Employ Runoff Reduction Practices

All roof drains and downspouts are located at the corners of the proposed building. All of the water collected discharges directly into the storm sewer that eventually discharges into the proposed FSDP. With the combination of the building footprint and the required parking and driveway facilities, there is only a minimal amount of pervious area that can be used for infiltration prior to entering a storm sewer system.

Step 2: Implement BMPs that provide a water quality capture volume with slow release

A Full Spectrum Detention pond is to be constructed for this project. 100% of the 100-year flow from sub basins that will have pavement and buildings will enter the pond via inlets, storm sewers and a riprap chase. These areas are summarized in the Basin Discharge Summary on the Proposed Drainage Map. These areas are included in Table 6 – Emergency Overflow Discharge Calcs.

All the sub basins having no improvements (Basins A, G, L, N, O & P) will maintain their historical patterns and will not flow into the pond. These basins are 100% pervious open space or landscaped areas that produce no water quality requirements and do not increase the developed flow rates. These basins are not

considered to be contaminant producing basins. Practically, they serve as vegetated runoff reduction areas.

The two concrete driveways entering/exiting the site (Basins B & C) cannot practically drain into the pond because, by necessity, they slope from the driveway, down towards Wayfarer Drive and they are located within the Wayfarer Drive right-of-way. The amount of paved area within these basins is very small (1,216 sf or less than 0.03 acres). This area is negligible for the purposes of water quality. ECM I.7.C.1.a provides that these basins may be excluded from the 100% capture requirement because they comprise less than 20% of the site and are less than one acre, because it is not practical to capture these areas in the on-site control measure, and because the implementation of a separate control measure is not practicable since they are driveway accesses that drain directly into the street.

The water quality / detention pond is to be a full spectrum sand filter type. The outlet structure is designed with orifices at different heights on the outlet structure in order to discharge the historical rates for the various storms. A riprap lined emergency overflow is to be constructed in case of an outlet box failure. The design parameters are summarized in Section IX of this report and Exhibit 7 in the Appendix.

Step 3: Stabilize streams.

None of the water generated by this project will be entering any streams in the immediate vicinity of the project. The water leaving the detention pond discharges into an existing ditch that was constructed by previous developers. This swale is grass lined with a positive slope to the west. Since there is a possibility of an emergency overflow of the pond occurring the swale from the pond outfall to the project's westerly property line will be stabilized with soil riprap. The water from the project does not enter a stream until it crosses under Mesa Ridge Parkway. Since the water leaving the project site is to be held at historic levels, it is safely assumed that it will not have any significant effect on the existing downstream streams or structures.

Step 4: Consider Need for Industrial and Commercial BMPs

Adequate provisions will be made by the Fire Department to protect the surrounding areas from any chemical spills. All chemicals will be stored inside the building.

XV. CONCLUSION

This Final Drainage Report presents existing and proposed drainage conditions for the proposed Security Fire Station No 4 project. The majority of the site is composed of either the building, paved surfaces, of small sections of native grass and landscaping. A full spectrum Detention pond will be constructed. The pond will be designed to capture 100% of the runoff from the sub basins that are to be occupied by the building and/or pavement. The majority of the runoff from the remaining areas will maintain the existing runoff pattern since runoff from these areas will have no negative impact. The development will have negligible and

inconsequential effects on the existing downstream site drainage and drainage improvements Full Spectrum Detention and Water Quality treatment will be provided. A permanent BMP Maintenance Agreement and Easement will be required for the FSDP. Also, an Operations and Maintenance Manual (O&M) Manual is to be provided. The proposed project will not, with respect to stormwater runoff, negatively impact the adjacent properties and downstream properties.

References

El Paso County Engineering Criteria Manual (EPC ECM), Revised October 14, 2020

El Paso County Drainage Criteria Manual Volumes 1 & 2 (EPC DCM), Revised October 31, 2020

Colorado Springs Drainage Criteria Manual, Volume 1, dated May 2014

Colorado Springs Drainage Criteria Manual, Volume 2, dated May 2014

Urban Drainage and Flood Control Manual, Volumes 2 and 3, dated August 2018

CDOT Erosion Control Field Handbook, dated April 20, 2017

Final Drainage Report for Lot 1 and Tract A, Widefield Commercial Center Subdivision Filing No. 1 by Kiowa Engineering Corporation, Project No, 09011, Revised June 21, 2010

APPENDIX

EXHIBIT 1
LOCATION MAP

Mesa Ridge Pkwy, Colorado Springs, CO 80925



Mesa Ridge Pkwy, Colorado Springs, CO 80925

38.721245, -104.678850

Security Fire Station #4



EXHIBIT 2

FEMA FIRM MAP

National Flood Hazard Layer FIRMette



38°43'32.54"N

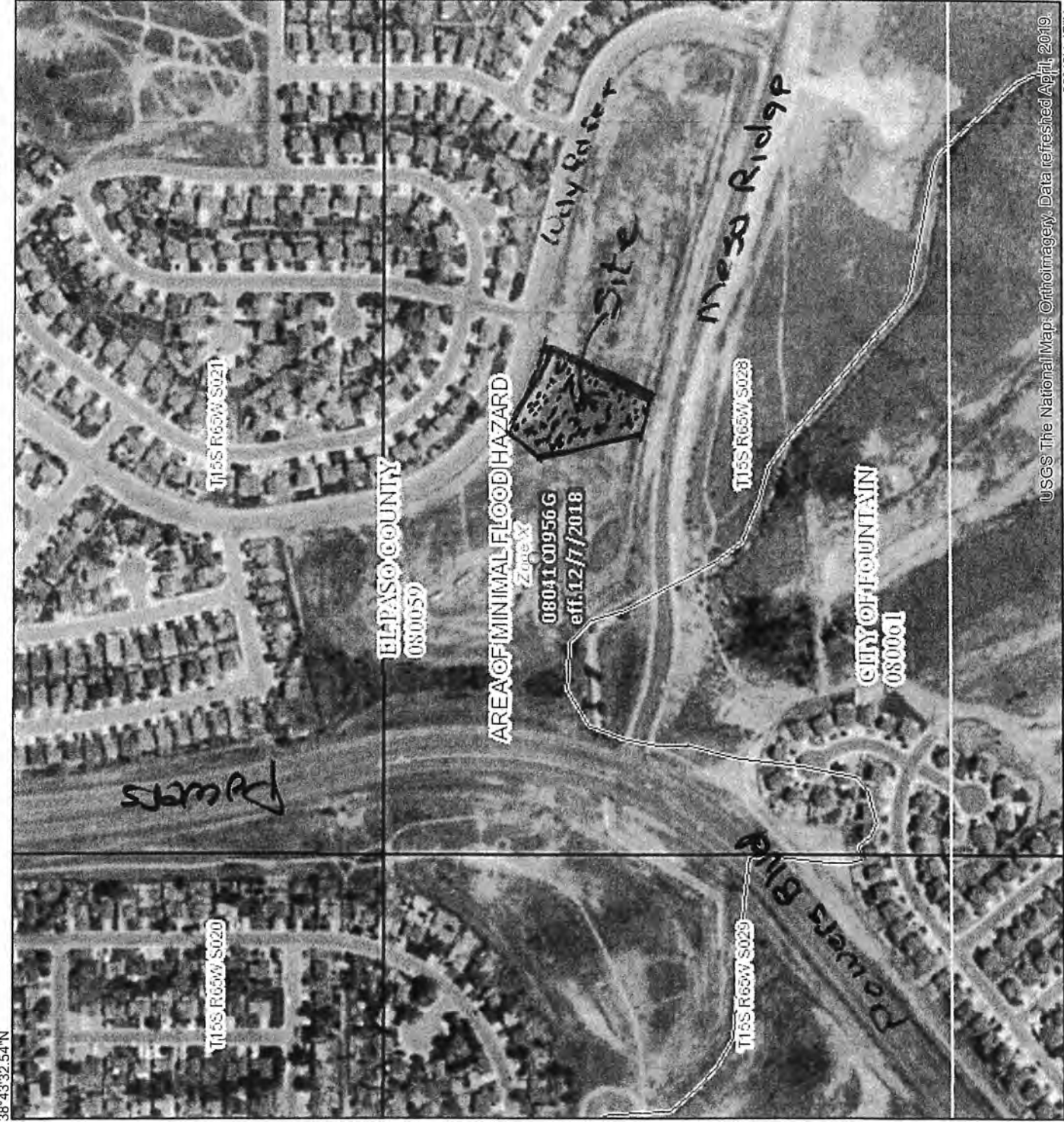

USGS The NationalMap: Orthoimagery. Data refreshed April 2019

38°43'4.47"N



Legend

SEE FIS REPORT FOR DETAILED LEGEND AND INDEX MAP FOR FIRM PANEL LAYOUT

SPECIAL FLOOD HAZARD AREAS

- Without Base Flood Elevation (BFE) Zone A, V, ABG
- With BFE or Depth Zone AE, AO, AH, VE, AR
- Regulatory Floodway

OTHER AREAS OF FLOOD HAZARD

- 0.2% Annual Chance Flood Hazard. Areas of 1% annual chance flood with average depth less than one foot or with drainage areas of less than one square mile Zone X
- Future Conditions 1% Annual Chance Flood Hazard Zone X
- Area with Reduced Flood Risk due to Levee. See Notes. Zone X
- Area with Flood Risk due to Levee Zone D

OTHER AREAS

- Area of Minimal Flood Hazard Zone X
- Effective LOMRS
- Area of Undetermined Flood Hazard Zone I

GENERAL STRUCTURES

- Channel, Culvert, or Storm Sewer
- Levee, Dike, or Floodwall

OTHER FEATURES

- Cross Sections with 1% Annual Chance Water Surface Elevation
- Coastal Transect
- Base Flood Elevation Line (BFE)
- Limit of Study
- Jurisdiction Boundary
- Coastal Transect Baseline
- Profile Baseline
- Hydrographic Feature

MAP PANELS

- Digital Data Available
- No Digital Data Available
- Unmapped

The pin displayed on the map is an approximate point selected by the user and does not represent an authoritative property location.

This map complies with FEMA's standards for the use of digital flood maps if it is not void as described below. The basemap shown complies with FEMA's basemap accuracy standards

The flood hazard information is derived directly from the authoritative NFHL web services provided by FEMA. This map was exported on 9/11/2019 at 5:50:19 PM and does not reflect changes or amendments subsequent to this date and time. The NFHL and effective information may change or become superseded by new data over time.

This map image is void if the one or more of the following map elements do not appear: basemap imagery, flood zone labels, legend, scale bar, map creation date, community identifiers, FIRM panel number, and FIRM effective date. Map images for unmapped and unmodernized areas cannot be used for regulatory purposes.

EXHIBIT 3

SCS SOILS MAP AND DATA



United States
Department of
Agriculture

NRCS

Natural
Resources
Conservation
Service

A product of the National
Cooperative Soil Survey,
a joint effort of the United
States Department of
Agriculture and other
Federal agencies, State
agencies including the
Agricultural Experiment
Stations, and local
participants

Custom Soil Resource Report for El Paso County Area, Colorado



Scale: 1" = 500'

Soil Map

The soil map section includes the soil map for the defined area of interest, a list of soil map units on the map and extent of each map unit, and cartographic symbols displayed on the map. Also presented are various metadata about data used to produce the map, and a description of each soil map unit.

Custom Soil Resource Report
Soil Map

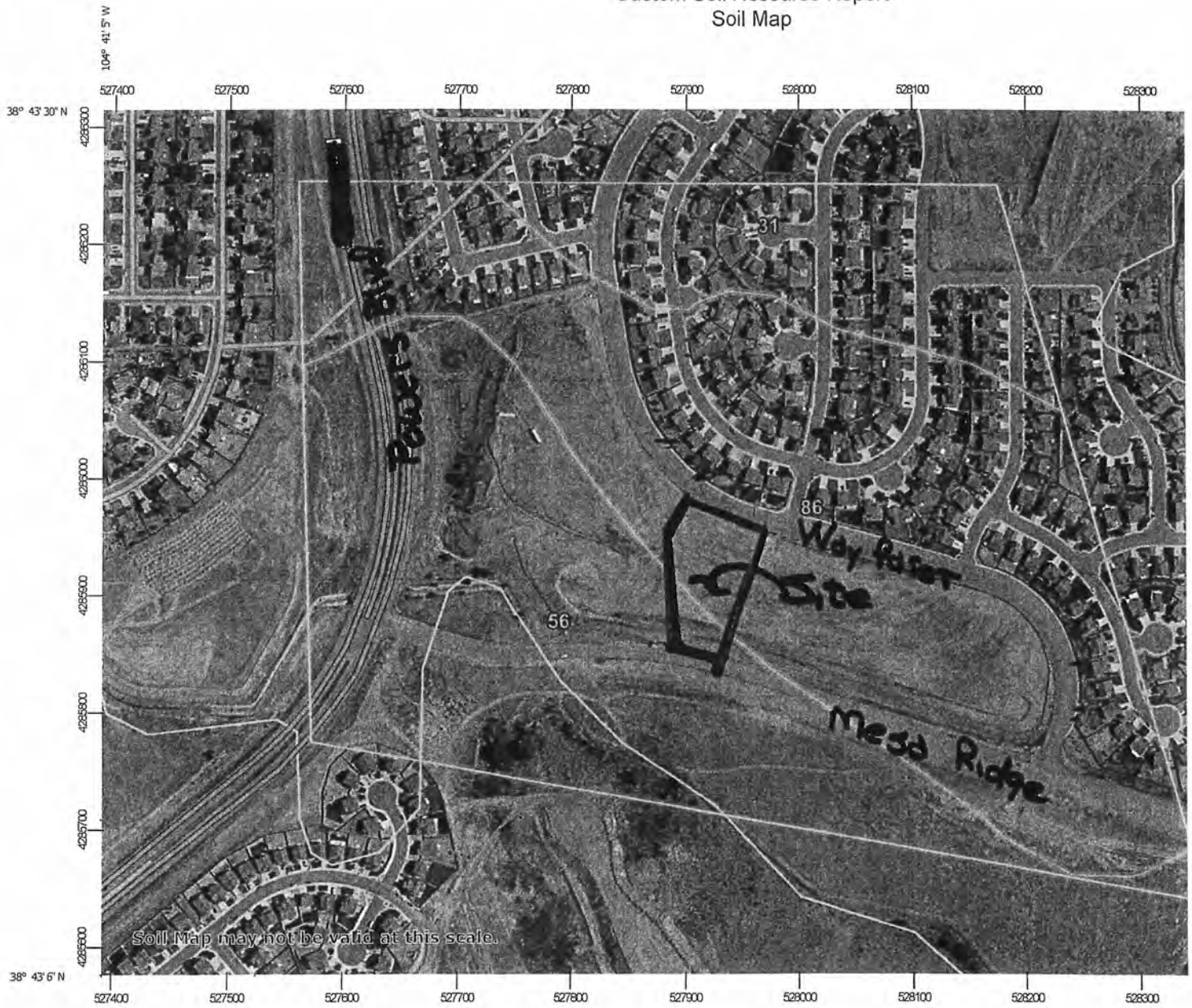

Map Scale: 1:5,210 if printed on A landscape (11" x 8.5") sheet.

0 50 100 200 300 Meters

0 250 500 1000 1500 Feet

Map projection: Web Mercator Corner coordinates: WGS84 Edge tics: UTM Zone 13N WGS84

Scale = NTS

MAP LEGEND

- Area of Interest (AOI)
- Soils**
- Soil Map Unit Polygons
- Soil Map Unit Lines
- Soil Map Unit Points
- Special Point Features**
- Blowout
- Borrow Pit
- Clay Spot
- Closed Depression
- Gravel Pit
- Gravelly Spot
- Landfill
- Lava Flow
- Marsh or swamp
- Mine or Quarry
- Miscellaneous Water
- Perennial Water
- Rock Outcrop
- Saline Spot
- Sandy Spot
- Severely Eroded Spot
- Sinkhole
- Slide or Slip
- Sodic Spot
- Spoil Area
- Stony Spot
- Very Stony Spot
- Wet Spot
- Other
- Special Line Features
- Water Features**
- Streams and Canals
- Transportation**
- Rails
- Interstate Highways
- US Routes
- Major Roads
- Local Roads
- Background**
- Aerial Photography

MAP INFORM

The soil surveys that comprise your AOI are at a scale of 1:24,000.

Warning: Soil Map may not be valid at scales greater than 1:24,000. Enlargement of maps beyond the scale may result in a misunderstanding of the detail of map line placement. The maps do not show contrasting soils that could have been present at the scale.

Please rely on the bar scale on each map for distance measurements.

Source of Map: Natural Resources Canada
 Web Soil Survey URL: [http://www.nrc.ca/soil](#)
 Coordinate System: Web Mercator (EPSG:3857)

Maps from the Web Soil Survey are based on the Web Mercator projection, which preserves direction and area. A projection that uses the Albers equal-area conic projection, should be used for accurate calculations of distance or area.

This product is generated from the US National Wetlands Inventory of the version date(s) listed below.

Soil Survey Area: El Paso County Agricultural Survey Area Data: Version 16, Sep 1998

Soil map units are labeled (as space available) at a scale of 1:50,000 or larger.

Date(s) aerial images were photographed: 17, 2014

The orthophoto or other base map on which these maps are compiled and digitized probably differs from the imagery displayed on these maps. As a result, shifting of map unit boundaries may be observed.

Map Unit Legend

Map Unit Symbol	Map Unit Name	Acres in AOI	Percent of AOI
31	Fort Collins loam, 3 to 8 percent slopes	12.5	13.5%
56	Nelson-Tassel fine sandy loams, 3 to 18 percent slopes	33.8	36.4%
86	Stoneham sandy loam, 3 to 8 percent slopes	46.5	50.1%
Totals for Area of Interest		92.9	100.0%

Map Unit Descriptions

The map units delineated on the detailed soil maps in a soil survey represent the soils or miscellaneous areas in the survey area. The map unit descriptions, along with the maps, can be used to determine the composition and properties of a unit.

A map unit delineation on a soil map represents an area dominated by one or more major kinds of soil or miscellaneous areas. A map unit is identified and named according to the taxonomic classification of the dominant soils. Within a taxonomic class there are precisely defined limits for the properties of the soils. On the landscape, however, the soils are natural phenomena, and they have the characteristic variability of all natural phenomena. Thus, the range of some observed properties may extend beyond the limits defined for a taxonomic class. Areas of soils of a single taxonomic class rarely, if ever, can be mapped without including areas of other taxonomic classes. Consequently, every map unit is made up of the soils or miscellaneous areas for which it is named and some minor components that belong to taxonomic classes other than those of the major soils.

Most minor soils have properties similar to those of the dominant soil or soils in the map unit, and thus they do not affect use and management. These are called noncontrasting, or similar, components. They may or may not be mentioned in a particular map unit description. Other minor components, however, have properties and behavioral characteristics divergent enough to affect use or to require different management. These are called contrasting, or dissimilar, components. They generally are in small areas and could not be mapped separately because of the scale used. Some small areas of strongly contrasting soils or miscellaneous areas are identified by a special symbol on the maps. If included in the database for a given area, the contrasting minor components are identified in the map unit descriptions along with some characteristics of each. A few areas of minor components may not have been observed, and consequently they are not mentioned in the descriptions, especially where the pattern was so complex that it was impractical to make enough observations to identify all the soils and miscellaneous areas on the landscape.

The presence of minor components in a map unit in no way diminishes the usefulness or accuracy of the data. The objective of mapping is not to delineate pure taxonomic classes but rather to separate the landscape into landforms or

Custom Soil Resource Report

landform segments that have similar use and management requirements. The delineation of such segments on the map provides sufficient information for the development of resource plans. If intensive use of small areas is planned, however, onsite investigation is needed to define and locate the soils and miscellaneous areas.

An identifying symbol precedes the map unit name in the map unit descriptions. Each description includes general facts about the unit and gives important soil properties and qualities.

Soils that have profiles that are almost alike make up a *soil series*. Except for differences in texture of the surface layer, all the soils of a series have major horizons that are similar in composition, thickness, and arrangement.

Soils of one series can differ in texture of the surface layer, slope, stoniness, salinity, degree of erosion, and other characteristics that affect their use. On the basis of such differences, a soil series is divided into *soil phases*. Most of the areas shown on the detailed soil maps are phases of soil series. The name of a soil phase commonly indicates a feature that affects use or management. For example, Alpha silt loam, 0 to 2 percent slopes, is a phase of the Alpha series.

Some map units are made up of two or more major soils or miscellaneous areas. These map units are complexes, associations, or undifferentiated groups.

A *complex* consists of two or more soils or miscellaneous areas in such an intricate pattern or in such small areas that they cannot be shown separately on the maps. The pattern and proportion of the soils or miscellaneous areas are somewhat similar in all areas. Alpha-Beta complex, 0 to 6 percent slopes, is an example.

An *association* is made up of two or more geographically associated soils or miscellaneous areas that are shown as one unit on the maps. Because of present or anticipated uses of the map units in the survey area, it was not considered practical or necessary to map the soils or miscellaneous areas separately. The pattern and relative proportion of the soils or miscellaneous areas are somewhat similar. Alpha-Beta association, 0 to 2 percent slopes, is an example.

An *undifferentiated group* is made up of two or more soils or miscellaneous areas that could be mapped individually but are mapped as one unit because similar interpretations can be made for use and management. The pattern and proportion of the soils or miscellaneous areas in a mapped area are not uniform. An area can be made up of only one of the major soils or miscellaneous areas, or it can be made up of all of them. Alpha and Beta soils, 0 to 2 percent slopes, is an example.

Some surveys include *miscellaneous areas*. Such areas have little or no soil material and support little or no vegetation. Rock outcrop is an example.

El Paso County Area, Colorado

31—Fort Collins loam, 3 to 8 percent slopes

Map Unit Setting

National map unit symbol: 3684
Elevation: 5,200 to 6,500 feet
Mean annual precipitation: 14 to 16 inches
Mean annual air temperature: 48 to 52 degrees F
Farmland classification: Not prime farmland

Map Unit Composition

Fort collins and similar soils: 85 percent
Estimates are based on observations, descriptions, and transects of the mapunit.

Description of Fort Collins

Setting

Landform: Hills
Landform position (three-dimensional): Side slope
Down-slope shape: Linear
Across-slope shape: Linear
Parent material: Loamy alluvium

Typical profile

A - 0 to 9 inches: loam
Bt - 9 to 16 inches: clay loam
Bk - 16 to 21 inches: clay loam
Ck - 21 to 60 inches: loam

Properties and qualities

Slope: 3 to 8 percent
Depth to restrictive feature: More than 80 inches
Natural drainage class: Well drained
Runoff class: Medium
Capacity of the most limiting layer to transmit water (Ksat): Moderately high to high (0.57 to 2.00 in/hr)
Depth to water table: More than 80 inches
Frequency of flooding: None
Frequency of ponding: None
Calcium carbonate, maximum in profile: 15 percent
Salinity, maximum in profile: Nonsaline to very slightly saline (0.0 to 2.0 mmhos/cm)
Available water storage in profile: High (about 10.1 inches)

Interpretive groups

Land capability classification (irrigated): None specified
Land capability classification (nonirrigated): 6e
Hydrologic Soil Group: B
Ecological site: Loamy Plains (R067BY002CO)
Other vegetative classification: LOAMY PLAINS (069AY006CO)
Hydric soil rating: No

Minor Components

Other soils

Percent of map unit:
Hydric soil rating: No

Pleasant

Percent of map unit:
Landform: Depressions
Hydric soil rating: Yes

56—Nelson-Tassel fine sandy loams, 3 to 18 percent slopes

Map Unit Setting

National map unit symbol: 3690
Elevation: 5,600 to 6,400 feet
Mean annual precipitation: 12 to 14 inches
Mean annual air temperature: 48 to 52 degrees F
Frost-free period: 135 to 155 days
Farmland classification: Not prime farmland

Map Unit Composition

Nelson and similar soils: 45 percent
Tassel and similar soils: 30 percent
Estimates are based on observations, descriptions, and transects of the mapunit.

Description of Nelson

Setting

Landform: Hills
Landform position (three-dimensional): Crest, side slope
Down-slope shape: Linear
Across-slope shape: Linear
Parent material: Calcareous residuum weathered from interbedded sedimentary rock

Typical profile

A - 0 to 5 inches: fine sandy loam
Ck - 5 to 23 inches: fine sandy loam
Cr - 23 to 27 inches: weathered bedrock

Properties and qualities

Slope: 3 to 12 percent
Depth to restrictive feature: 20 to 40 inches to paralithic bedrock
Natural drainage class: Well drained
Runoff class: Medium
Capacity of the most limiting layer to transmit water (Ksat): Moderately low to high
(0.06 to 2.00 in/hr)
Depth to water table: More than 80 inches
Frequency of flooding: None

Custom Soil Resource Report

Frequency of ponding: None
Calcium carbonate, maximum in profile: 10 percent
Salinity, maximum in profile: Nonsaline to very slightly saline (0.0 to 2.0 mmhos/cm)
Available water storage in profile: Very low (about 2.8 inches)

Interpretive groups

Land capability classification (irrigated): 4e
Land capability classification (nonirrigated): 6e
Hydrologic Soil Group: B
Ecological site: Shaly Plains (R067BY045CO)
Other vegetative classification: SHALY PLAINS (069AY046CO)
Hydric soil rating: No

Description of Tassel

Setting

Landform: Hills
Landform position (three-dimensional): Crest, side slope
Down-slope shape: Linear
Across-slope shape: Linear
Parent material: Calcareous slope alluvium over residuum weathered from sandstone

Typical profile

A - 0 to 4 inches: fine sandy loam
C - 4 to 10 inches: fine sandy loam
Cr - 10 to 14 inches: weathered bedrock

Properties and qualities

Slope: 3 to 18 percent
Depth to restrictive feature: 6 to 20 inches to paralithic bedrock
Natural drainage class: Well drained
Runoff class: Medium
Capacity of the most limiting layer to transmit water (Ksat): Moderately high (0.20 to 0.60 in/hr)
Depth to water table: More than 80 inches
Frequency of flooding: None
Frequency of ponding: None
Calcium carbonate, maximum in profile: 10 percent
Available water storage in profile: Very low (about 1.2 inches)

Interpretive groups

Land capability classification (irrigated): None specified
Land capability classification (nonirrigated): 6s
Hydrologic Soil Group: D
Ecological site: Shaly Plains (R067BY045CO)
Other vegetative classification: SHALY PLAINS (069AY046CO)
Hydric soil rating: No

Minor Components

Other soils

Percent of map unit:
Hydric soil rating: No

Pleasant

Percent of map unit:

Custom Soil Resource Report

Landform: Depressions

Hydric soil rating: Yes

86—Stoneham sandy loam, 3 to 8 percent slopes

Map Unit Setting

National map unit symbol: 36b2

Elevation: 5,100 to 6,500 feet

Mean annual precipitation: 13 to 15 inches

Mean annual air temperature: 48 to 52 degrees F

Frost-free period: 135 to 155 days

Farmland classification: Not prime farmland

Map Unit Composition

Stoneham and similar soils: 85 percent

Estimates are based on observations, descriptions, and transects of the mapunit.

Description of Stoneham

Setting

Landform: Hills

Landform position (three-dimensional): Side slope

Down-slope shape: Linear

Across-slope shape: Linear

Parent material: Calcareous loamy alluvium

Typical profile

A - 0 to 4 inches: sandy loam

Bt - 4 to 8 inches: sandy clay loam

Btk - 8 to 11 inches: sandy clay loam

Ck - 11 to 60 inches: loam

Properties and qualities

Slope: 3 to 8 percent

Depth to restrictive feature: More than 80 inches

Natural drainage class: Well drained

Runoff class: Medium

Capacity of the most limiting layer to transmit water (Ksat): Moderately high to high (0.60 to 2.00 in/hr)

Depth to water table: More than 80 inches

Frequency of flooding: None

Frequency of ponding: None

Calcium carbonate, maximum in profile: 15 percent

Salinity, maximum in profile: Nonsaline to very slightly saline (0.0 to 2.0 mmhos/cm)

Available water storage in profile: High (about 9.5 inches)

Interpretive groups

Land capability classification (irrigated): 3e

Land capability classification (nonirrigated): 4e

Custom Soil Resource Report

Hydrologic Soil Group: B

Ecological site: Sandy Plains (R067BY024CO)

Other vegetative classification: SANDY PLAINS (069AY026CO)

Hydric soil rating: No

Minor Components

Other soils

Percent of map unit:

Hydric soil rating: No

Pleasant

Percent of map unit:

Landform: Depressions

Hydric soil rating: Yes

EXHIBIT 4

EXISTING DRAINAGE REPORT EXHIBITS

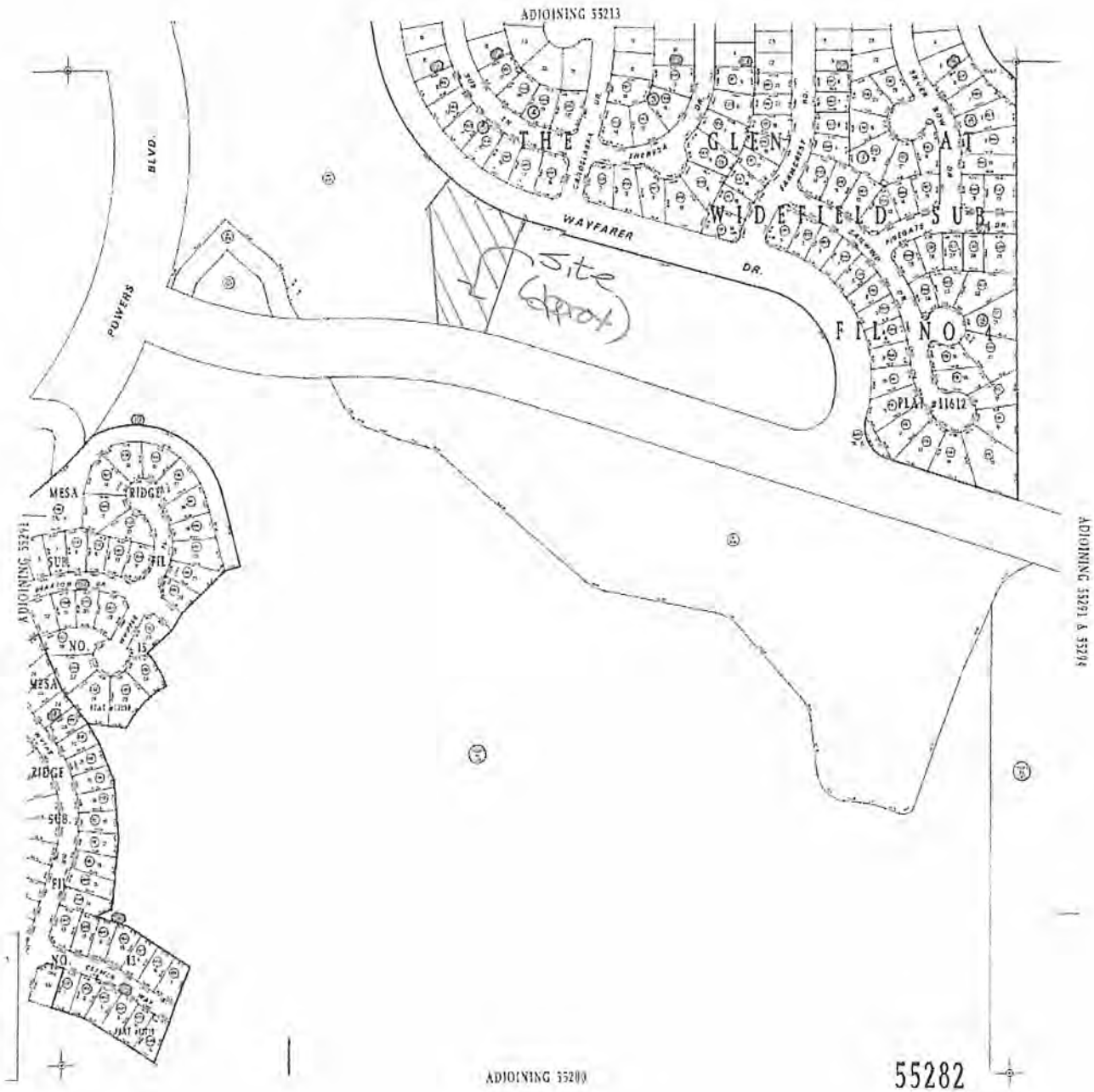

Adjacent S/D Drainage (M) for
The Glen @ Wildfield S/D (NTS)

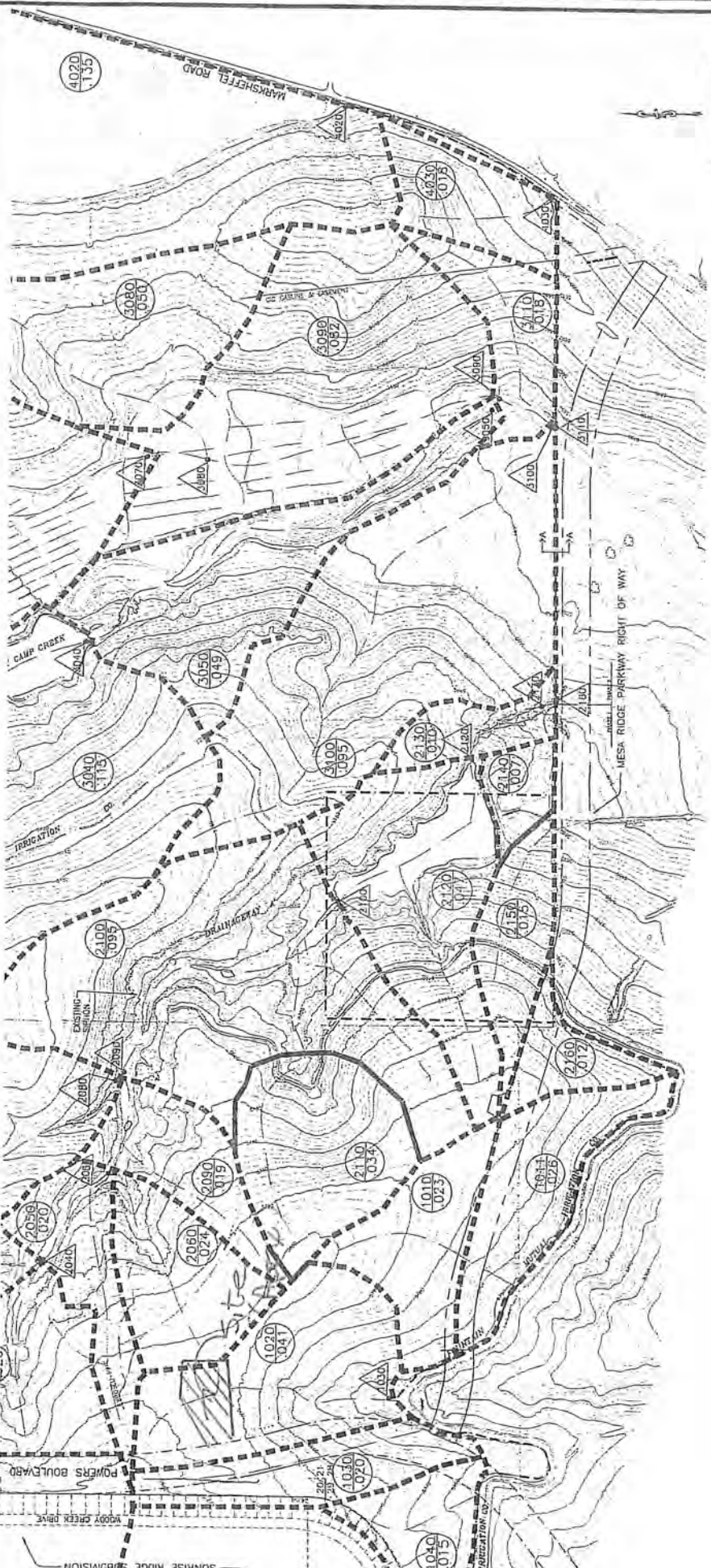

*FDR Drainage Map (Historical)
 for Mesa Ridge Parkway Phase I
 (NTS)*

NOTE:
 IS THE MASTER DEVELOPMENT PLAN FOR THE GLEN AT WISFIELD
 AND THE ADJACENT PORTION OF FLOPS TO THE MESA RIDGE
 PARKWAY RIGHT OF WAY.



LEGEND

	SUB-BASIN NUMBER
	SUB-BASIN SQUARE MILEAGE
	DESIGN POINT
	FLOWPATH
	SUB-BASIN BOUNDARY

DESIGN POINT FLOWS
 (PROPOSED CONDITION WITH DETENTION)

DESIGN PT	5-YEAR	100-YEAR
1030	38 cfs	95 cfs
2130	197 cfs	415 cfs
2180	168 cfs	340 cfs
3110	758 cfs	3095 cfs
4030	28 cfs	44 cfs
CUMULATIVE AT SECTION A/A	500 cfs	500 cfs

EXHIBIT 5

CHARTS AND TABLES

Table 6-6. Runoff Coefficients for Rational Method
(Source: UDFCD 2001)

Land Use or Surface Characteristics	Percent Impervious	Runoff Coefficients											
		2-year		5-year		10-year		25-year		50-year		100-year	
		HSG A&B	HSG C&D	HSG A&B	HSG C&D	HSG A&B	HSG C&D	HSG A&B	HSG C&D	HSG A&B	HSG C&D	HSG A&B	HSG C&D
Business													
Commercial Areas	95	0.79	0.80	0.81	0.82	0.83	0.84	0.85	0.87	0.87	0.88	0.88	0.89
Neighborhood Areas	70	0.45	0.49	0.49	0.53	0.53	0.57	0.58	0.62	0.60	0.65	0.62	0.68
Residential													
1/8 Acre or less	65	0.41	0.45	0.45	0.49	0.49	0.54	0.54	0.59	0.57	0.62	0.59	0.65
1/4 Acre	40	0.23	0.28	0.30	0.35	0.36	0.42	0.42	0.50	0.46	0.54	0.50	0.58
1/3 Acre	30	0.18	0.22	0.25	0.30	0.32	0.38	0.39	0.47	0.43	0.52	0.47	0.57
1/2 Acre	25	0.15	0.20	0.22	0.28	0.30	0.36	0.37	0.46	0.41	0.51	0.46	0.56
1 Acre	20	0.12	0.17	0.20	0.26	0.27	0.34	0.35	0.44	0.40	0.50	0.44	0.55
Industrial													
Light Areas	80	0.57	0.60	0.59	0.63	0.63	0.66	0.66	0.70	0.68	0.72	0.70	0.74
Heavy Areas	90	0.71	0.73	0.73	0.75	0.75	0.77	0.78	0.80	0.80	0.82	0.81	0.83
Parks and Cemeteries													
Playgrounds	13	0.07	0.13	0.16	0.23	0.24	0.31	0.32	0.42	0.37	0.48	0.41	0.54
Railroad Yard Areas	40	0.23	0.28	0.30	0.35	0.36	0.42	0.42	0.50	0.46	0.54	0.50	0.58
Undeveloped Areas													
Historic Flow Analysis-- Greenbelts, Agriculture	2	0.03	0.05	0.09	0.16	0.17	0.26	0.26	0.38	0.31	0.45	0.36	0.51
Pasture/Meadow	0	0.02	0.04	0.08	0.15	0.15	0.25	0.25	0.37	0.30	0.44	0.35	0.50
Forest	0	0.02	0.04	0.08	0.15	0.15	0.25	0.25	0.37	0.30	0.44	0.35	0.50
Exposed Rock	100	0.89	0.89	0.90	0.90	0.92	0.92	0.94	0.94	0.95	0.95	0.96	0.96
Offsite Flow Analysis (when landuse is undefined)	45	0.26	0.31	0.32	0.37	0.38	0.44	0.44	0.51	0.48	0.55	0.51	0.59
Streets													
Paved	100	0.89	0.89	0.90	0.90	0.92	0.92	0.94	0.94	0.95	0.95	0.96	0.96
Gravel	80	0.57	0.60	0.59	0.63	0.63	0.66	0.66	0.70	0.68	0.72	0.70	0.74
Drive and Walks													
Roofs	90	0.89	0.89	0.90	0.90	0.92	0.92	0.94	0.94	0.95	0.95	0.96	0.96
Lawns	0	0.02	0.04	0.08	0.15	0.15	0.25	0.25	0.37	0.30	0.44	0.35	0.50

3.2 Time of Concentration

One of the basic assumptions underlying the Rational Method is that runoff is a function of the average rainfall rate during the time required for water to flow from the hydraulically most remote part of the drainage area under consideration to the design point. However, in practice, the time of concentration can be an empirical value that results in reasonable and acceptable peak flow calculations.

For urban areas, the time of concentration (t_c) consists of an initial time or overland flow time (t_i) plus the travel time (t_r) in the storm sewer, paved gutter, roadside drainage ditch, or drainage channel. For non-urban areas, the time of concentration consists of an overland flow time (t_i) plus the time of travel in a concentrated form, such as a swale or drainageway. The travel portion (t_r) of the time of concentration can be estimated from the hydraulic properties of the storm sewer, gutter, swale, ditch, or drainageway. Initial time, on the other hand, will vary with surface slope, depression storage, surface cover, antecedent rainfall, and infiltration capacity of the soil, as well as distance of surface flow. The time of concentration is represented by Equation 6-7 for both urban and non-urban areas.

Figure 6-5. Colorado Springs Rainfall Intensity Duration Frequency

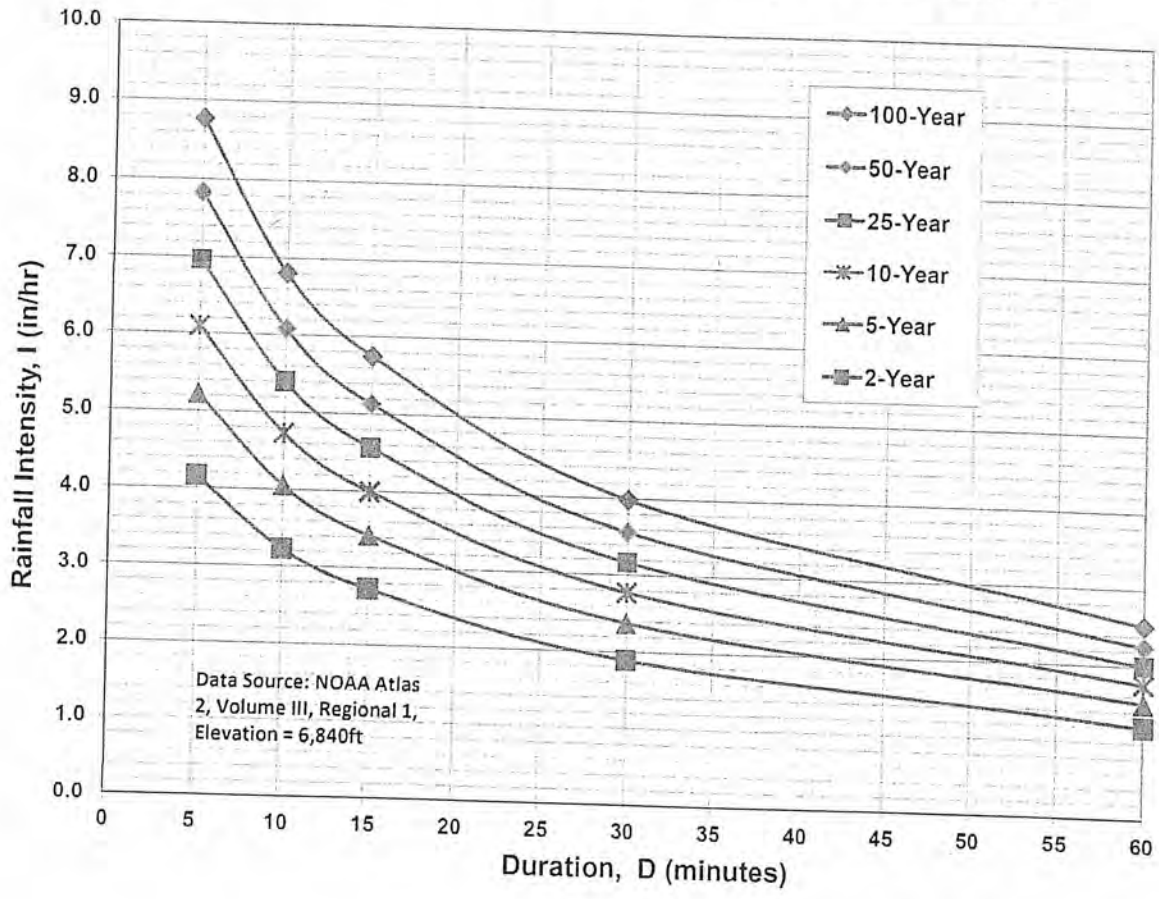

IDF Equations

$$I_{100} = -2.52 \ln(D) + 12.735$$

$$I_{50} = -2.25 \ln(D) + 11.375$$

$$I_{25} = -2.00 \ln(D) + 10.111$$

$$I_{10} = -1.75 \ln(D) + 8.847$$

$$I_5 = -1.50 \ln(D) + 7.583$$

$$I_2 = -1.19 \ln(D) + 6.035$$

Note: Values calculated by equations may not precisely duplicate values read from figure.

$$t_c = t_j + t_i \quad (\text{Eq. 6-7})$$

Where:

t_c = time of concentration (min)

t_i = overland (initial) flow time (min)

t_j = travel time in the ditch, channel, gutter, storm sewer, etc. (min)

3.2.1 Overland (Initial) Flow Time

The overland flow time, t_i , may be calculated using Equation 6-8.

$$t_i = \frac{0.395(1.1 - C_5)\sqrt{L}}{S^{0.33}} \quad (\text{Eq. 6-8})$$

Where:

t_i = overland (initial) flow time (min)

C_5 = runoff coefficient for 5-year frequency (see Table 6-6)

L = length of overland flow (300 ft maximum for non-urban land uses, 100 ft maximum for urban land uses)

S = average basin slope (ft/ft)

Note that in some urban watersheds, the overland flow time may be very small because flows quickly concentrate and channelize.

3.2.2 Travel Time

For catchments with overland and channelized flow, the time of concentration needs to be considered in combination with the travel time, t_j , which is calculated using the hydraulic properties of the swale, ditch, or channel. For preliminary work, the overland travel time, t_i , can be estimated with the help of Figure 6-25 or Equation 6-9 (Guo 1999).

$$V = C_v S_w^{0.5} \quad (\text{Eq. 6-9})$$

Where:

V = velocity (ft/s)

C_v = conveyance coefficient (from Table 6-7)

S_w = watercourse slope (ft/ft)

Table 6-7. Conveyance Coefficient, C_v

Type of Land Surface	C_v
Heavy meadow	2.5
Tillage/field	5
Riprap (not buried)*	6.5
Short pasture and lawns	7
Nearly bare ground	10
Grassed waterway	15
Paved areas and shallow paved swales	20

* For buried riprap, select C_v value based on type of vegetative cover.

The travel time is calculated by dividing the flow distance (in feet) by the velocity calculated using Equation 6-9 and converting units to minutes.

The time of concentration (t_c) is then the sum of the overland flow time (t_o) and the travel time (t_t) per Equation 6-7.

3.2.3 First Design Point Time of Concentration in Urban Catchments

Using this procedure, the time of concentration at the first design point (typically the first inlet in the system) in an urbanized catchment should not exceed the time of concentration calculated using Equation 6-10. The first design point is defined as the point where runoff first enters the storm sewer system.

$$t_c = \frac{L}{180} + 10 \quad (\text{Eq. 6-10})$$

Where:

t_c = maximum time of concentration at the first design point in an urban watershed (min)

L = waterway length (ft)

Equation 6-10 was developed using the rainfall-runoff data collected in the Denver region and, in essence, represents regional "calibration" of the Rational Method. Normally, Equation 6-10 will result in a lesser time of concentration at the first design point and will govern in an urbanized watershed. For subsequent design points, the time of concentration is calculated by accumulating the travel times in downstream drainageway reaches.

3.2.4 Minimum Time of Concentration

If the calculations result in a t_c of less than 10 minutes for undeveloped conditions, it is recommended that a minimum value of 10 minutes be used. The minimum t_c for urbanized areas is 5 minutes.

3.2.5 Post-Development Time of Concentration

As Equation 6-8 indicates, the time of concentration is a function of the 5-year runoff coefficient for a drainage basin. Typically, higher levels of imperviousness (higher 5-year runoff coefficients) correspond to shorter times of concentration, and lower levels of imperviousness correspond to longer times of

For Colorado Springs and much of the Fountain Creek watershed, the 1-hour depths are fairly uniform and are summarized in Table 6-2. Depending on the location of the project, rainfall depths may be calculated using the described method and the NOAA Atlas maps shown in Figures 6-6 through 6-17.

Table 6-2. Rainfall Depths for Colorado Springs

Return Period	1-Hour Depth	6-Hour Depth	24-Hour Depth
2	1.19	1.70	2.10
5	1.50	2.10	2.70
10	1.75	2.40	3.20
25	2.00	2.90	3.60
50	2.25	3.20	4.20
100	2.52	3.50	4.60

Where $Z = 6,840 \text{ ft}/100$

These depths can be applied to the design storms or converted to intensities (inches/hour) for the Rational Method as described below. However, as the basin area increases, it is unlikely that the reported point rainfalls will occur uniformly over the entire basin. To account for this characteristic of rain storms an adjustment factor, the Depth Area Reduction Factor (DARF) is applied. This adjustment to rainfall depth and its effect on design storms is also described below. The UDFCD UD-Rain spreadsheet, available on UDFCD's website, also provides tools to calculate point rainfall depths and Intensity-Duration-Frequency curves² and should produce similar depth calculation results.

2.2 Design Storms

Design storms are used as input into rainfall/runoff models and provide a representation of the typical temporal distribution of rainfall events when the creation or routing of runoff hydrographs is required. It has long been observed that rainstorms in the Front Range of Colorado tend to occur as either short-duration, high-intensity, localized, convective thunderstorms (cloud bursts) or longer-duration, lower-intensity, broader, frontal (general) storms. The significance of these two types of events is primarily determined by the size of the drainage basin being studied. Thunderstorms can create high rates of runoff within a relatively small area, quickly, but their influence may not be significant very far downstream. Frontal storms may not create high rates of runoff within smaller drainage basins due to their lower intensity, but tend to produce larger flood flows that can be hazardous over a broader area and extend further downstream.

- **Thunderstorms:** Based on the extensive evaluation of rain storms completed in the Carlton study (Carlton 2011), it was determined that typical thunderstorms have a duration of about 2 hours. The study evaluated over 300,000 storm cells using gage-adjusted NEXRAD data, collected over a 14-year period (1994 to 2008). Storms lasting longer than 3 hours were rarely found. Therefore, the results of the Carlton study have been used to define the shorter duration design storms.

To determine the temporal distribution of thunderstorms, 22 gage-adjusted NEXRAD storm cells were studied in detail. Through a process described in a technical memorandum prepared by the City of Colorado Springs (City of Colorado Springs 2012), the results of this analysis were interpreted and normalized to the 1-hour rainfall depth to create the distribution shown in Table 6-3 with a 5 minute time interval for drainage basins up to 1 square mile in size. This distribution represents the rainfall

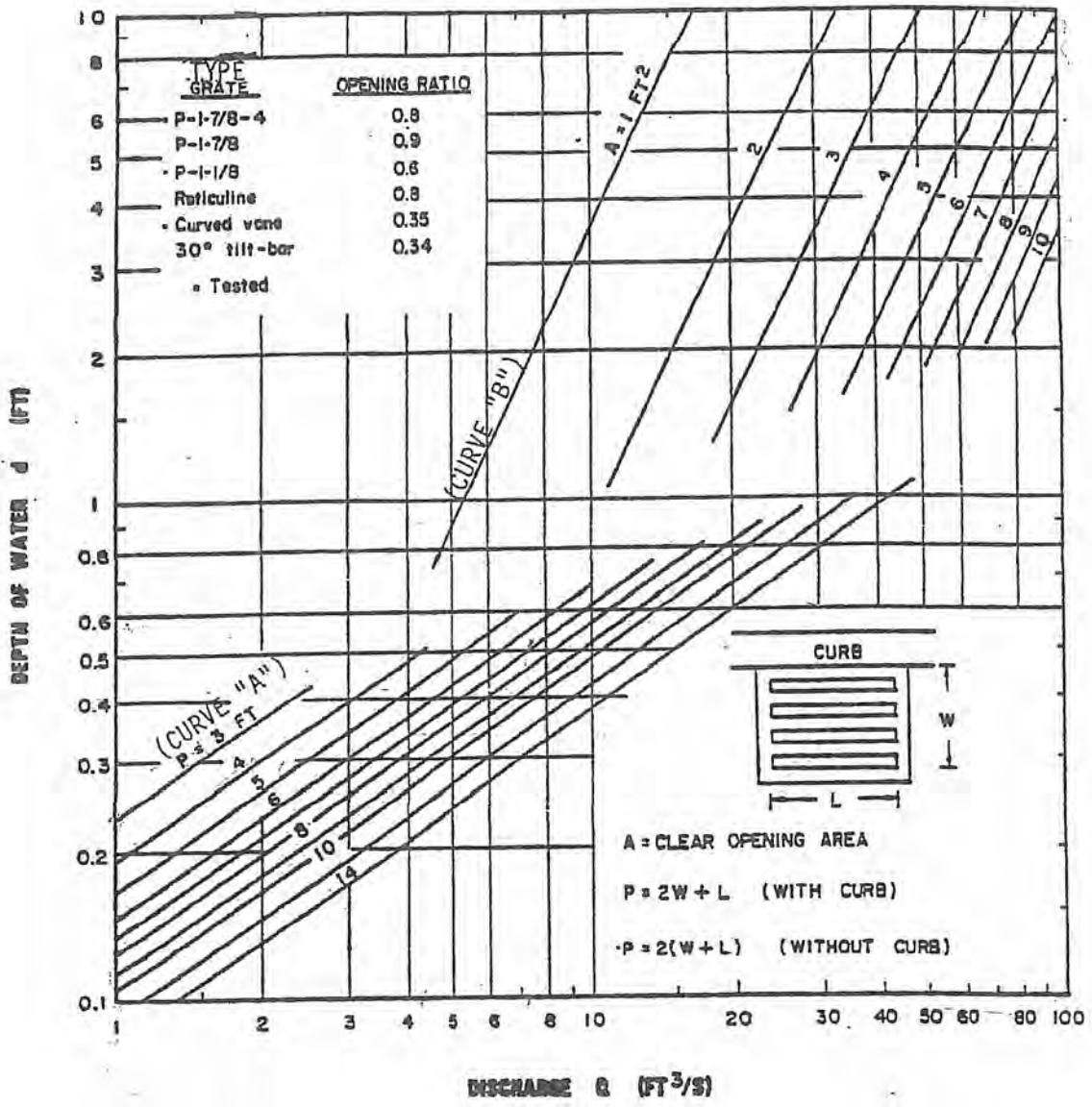

Reference: USDOT, March 1984
HEC NO. 12

NOTE: Use with effective P or A



The City of Colorado Springs / El Paso County
Drainage Criteria Manual

Hydraulic Capacity of Grate Inlet in Sump

Date
OCT. 1987
Figure
7 - 6

Heavy Duty



Nyloplast® Heavy Duty Drain Basins are used as a collection point typically where two or more drain lines converge. Basins can provide a transition between different sizes and types of pipe, and can also change the elevation or direction of the pipe. Drain Basins are also beneficial when faced with shallow pipe burial applications.

Watertight connection

Structures are shipped with rubber gaskets to insure a watertight connection. This prevents the soil infiltration that plagues precast structures and prevents long-term settlement around the basin.

Flexible resilient connection

The real world can be tough on underground structures. Soils consolidate unevenly and external loads can further complicate matters. Flexible connections allow minor movement to take place without compromising the structural or watertight integrity of the basin. Additionally, the need to wait for grout to set-up is totally eliminated. With Nyloplast, you can connect and backfill immediately.

Quick, easy and inexpensive installation

The product is lightweight and easily handled which translates into faster installation with less equipment and personnel, which results in a lower total cost.

Field Adjustments

Basins are easily adjustable in the field to meet final grade. Last minute trimming or extensions are easily made to insure proper positive drainage is achieved.

Not sure about final elevations or wondering how to connect unexpected laterals? Our **Inserta Tee®** (<http://www.insertatee.com/>) option (pictured right) allows field connections while still preserving the Nyloplast benefits of a resilient connection and watertight performance.



Nyloplast Grate Inlet Capacity Charts

EXHIBIT 6

WEST FORK JIMMY CAMP CREEK DBPS EXHIBITS

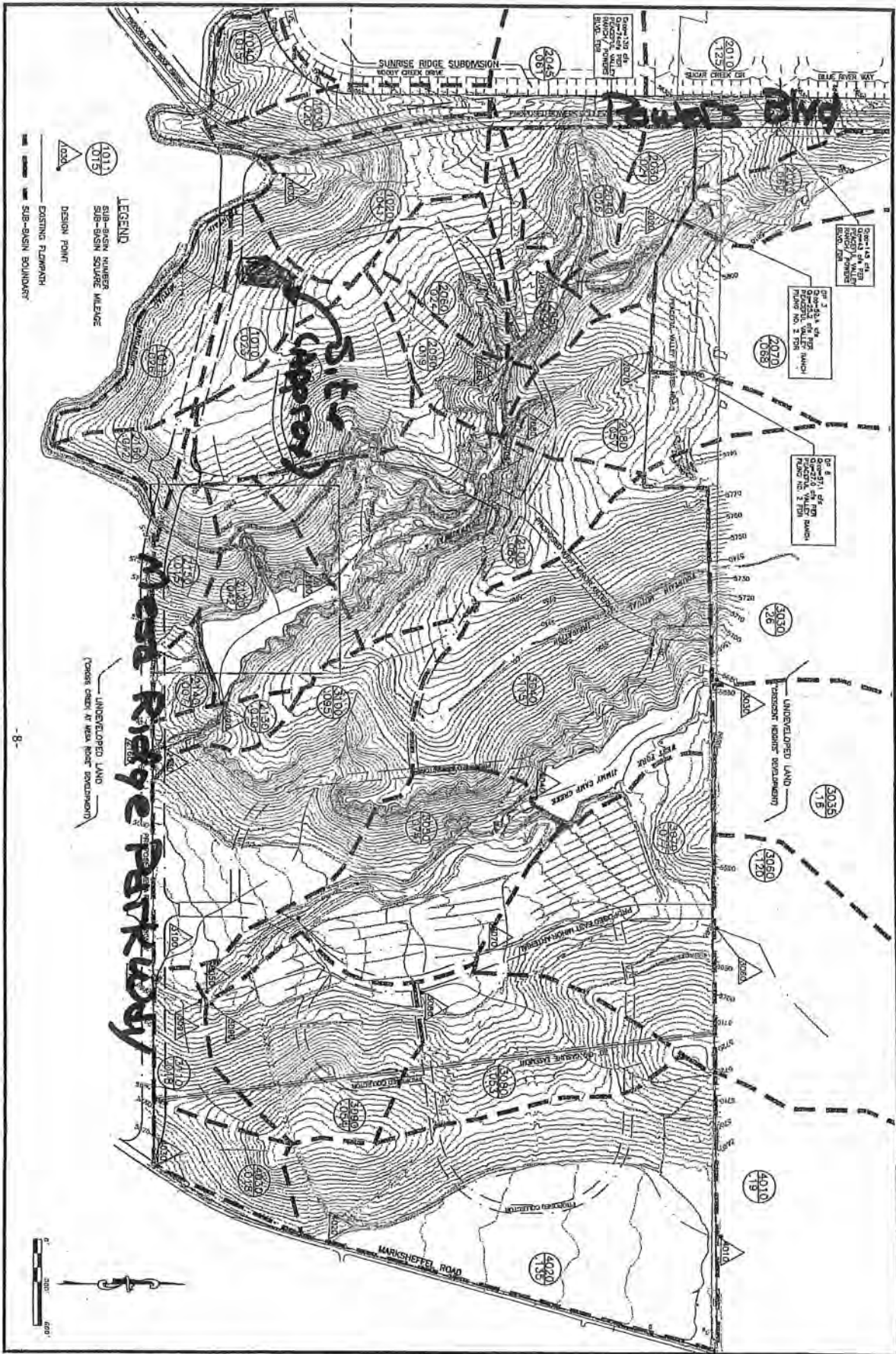

-8-

FIG. 3A

**West Fork Jimmy Camp Creek
Drainage Basin Planning Study
HYDROLOGIC SUB-BASIN MAP
EL PASO COUNTY, COLORADO**

Kiowa Engineering Corporation
1804 S. 21st Street
Colorado Springs, Colorado
80904
(719) 830-7342

El Paso County Drainage Basin Fees

Resolution No. 17-348

Basin Number	Receiving Waters	Year Studied	Drainage Basin Name	2018 Drainage Fee (per Impervious Acre)	2018 Bridge Fee (per Impervious Acre)
<u>Drainage Basins with DBPS's:</u>					
CHMS0200	Chico Creek	2013	Haegler Ranch	\$9,676	\$1,428
CHWS1200	Chico Creek	2001	Bennett Ranch	\$10,832	\$4,155
CHWS1400	Chico Creek	2013	Falcon	\$27,762	\$3,814
FOFO2000	Fountain Creek	2001	West Fork Jimmy Camp Creek	\$11,775	\$3,484
FOFO2600	Fountain Creek	1991*	Big Johnson / Crews Gulch	\$17,197	\$2,221
FOFO2800	Fountain Creek	1988*	Widefield	\$17,197	\$0
FOFO2900	Fountain Creek	1988*	Security	\$17,197	\$0
FOFO3000	Fountain Creek	1991*	Windmill Gulch	\$17,197	\$258
FOFO3100 / FOF03200	Fountain Creek	1988*	Carson Street / Little Johnson	\$10,490	\$0
FOFO3400	Fountain Creek	1984*	Peterson Field	\$12,404	\$941
FOFO3600	Fountain Creek	1991*	Fisher's Canyon	\$17,197	\$0
FOFO4000	Fountain Creek	1996	Sand Creek	\$17,197	\$5,210
FOFO4200	Fountain Creek	1977	Spring Creek	\$8,919	\$0
FOFO4600	Fountain Creek	1984*	Southwest Area	\$17,197	\$0
FOFO4800	Fountain Creek	1991	Bear Creek	\$17,197	\$941
FOFO5400	Fountain Creek	1977	21st Street	\$5,174	\$0
FOFO5600	Fountain Creek	1964	19th Street	\$3,385	\$0
FOFO5800	Fountain Creek	1964	Camp Creek	\$1,906	\$0
FOMO0400	Monument Creek	1986*	Mesa	\$8,995	\$0
FOMO1000	Monument Creek	1981	Douglas Creek	\$10,815	\$239
FOMO1200	Monument Creek	1977	Templeton Gap	\$11,103	\$258
FOMO1400	Monument Creek	1976	Pope's Bluff	\$3,445	\$588
FOMO1600	Monument Creek	1976	South Rockrimmon	\$4,043	\$0
FOMO1800	Monument Creek	1973	North Rockrimmon	\$5,174	\$0
FOMO2000	Monument Creek	1971	Pulpit Rock	\$5,703	\$0
FOMO2200	Monument Creek	1994	Cottonwood Creek / S. Pine	\$17,197	\$941
FOMO2400	Monument Creek	1966	Dry Creek	\$13,576	\$492
FOMO3600	Monument Creek	1989*	Black Squirrel Creek	\$7,808	\$492
FOMO3700	Monument Creek	1987*	Middle Tributary	\$14,351	\$0
FOMO3800	Monument Creek	1987*	Monument Branch	\$17,197	\$0
FOMO4000	Monument Creek	1996	Smith Creek	\$7,011	\$941
FOMO4200	Monument Creek	1989*	Black Forest	\$17,197	\$468
FOMO5200	Monument Creek	1993*	Dirty Woman Creek	\$17,197	\$941
FOMO5300	Fountain Creek	1993*	Crystal Creek	\$17,197	\$941
<u>Miscellaneous Drainage Basins: ¹</u>					
CHBS0800	Chico Creek		Book Ranch	\$16,136	\$2,336
CHEC0400	Chico Creek		Upper East Chico	\$8,791	\$255
CHWS0200	Chico Creek		Telephone Exchange	\$9,659	\$226
CHWS0400	Chico Creek		Livestock Company	\$15,910	\$189
CHWS0600	Chico Creek		West Squirrel	\$8,293	\$3,442
CHWS0800	Chico Creek		Solberg Ranch	\$17,197	\$0
FOFO1200	Fountain Creek		Crooked Canyon	\$5,192	\$0
FOFO1400	Fountain Creek		Calhan Reservoir	\$4,335	\$253
FOFO1600	Fountain Creek		Sand Canyon	\$3,132	\$0
FOFO2000	Fountain Creek		Jimmy Camp Creek ²	\$17,197	\$804
FOFO2200	Fountain Creek		Fort Carson	\$13,576	\$492
FOFO2700	Fountain Creek		West Little Johnson	\$1,133	\$0
FOFO3800	Fountain Creek		Stratton	\$8,249	\$369
FOFO5000	Fountain Creek		Midland	\$13,576	\$492
FOFO6000	Fountain Creek		Palmer Trail	\$13,576	\$492
FOFO6800	Fountain Creek		Black Canyon	\$13,576	\$492
FOMO4600	Monument Creek		Beaver Creek	\$10,281	\$0
FOMO3000	Monument Creek		Kettle Creek	\$9,287	\$0
FOMO3400	Monument Creek		Elkhorn	\$1,560	\$0
FOMO5000	Monument Creek		Monument Rock	\$7,454	\$0
FOMO5400	Monument Creek		Palmer Lake	\$11,919	\$0
FOMO5600	Monument Creek		Raspberry Mountain	\$4,009	\$0
PLPL0200	Monument Creek		Bald Mountain	\$8,544	\$0
<u>Interim Drainage Basins: ²</u>					
FOFO1800	Fountain Creek		Little Fountain Creek	\$2,199	\$0
FOMO4400	Monument Creek		Jackson Creek	\$6,807	\$0
FOMO4800	Monument Creek		Teachout Creek	\$4,727	\$710

1. The miscellaneous drainage fee previous to September 1999 resolution was the average of all drainage fees for basins with Basin Planning Studies performed within the last 14 years.

2. Interim Drainage Fees are based upon draft Drainage Basin Planning Studies or the Drainage Basin Identification and Fee Estimation Report. (Best available information suitable for setting a fee.)

3. This is an interim fee and will be adjusted when a DBPS is completed. In addition to the Drainage Fee a surety in the amount of \$7,285 per impervious acre shall be provided to secure payment of additional fees in the event that the DBPS results in a fee greater than the current fee. Fees paid in excess of the future revised fee will be reimbursed. See Resolution 06-326 (9/14/06) and Resolution 16-320 (9/07/16).

EXHIBIT 7

DETENTION POND CHARTS AND TABLES

Detention Basin Outlet Structure Design

UD-Detention, Version 3.07 (February 2017)

Project: Security Fire Station No. 4

Basin ID: Full Spectrum Sand Filter Basin

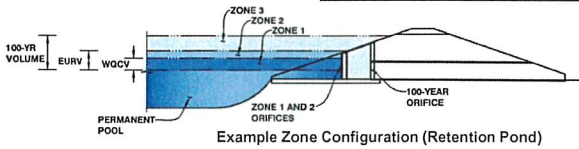

Example Zone Configuration (Retention Pond)

	Stage (ft)	Zone Volume (ac-ft)	Outlet Type
Zone 1 (WQCV)	0.83	0.015	Filtration Media
Zone 2 (EURV)	2.24	0.044	Orifice Plate
Zone 3 (100-year)	3.08	0.041	Weir&Pipe (Restrict)
		0.100	Total

User Input: Orifice at Underdrain Outlet (typically used to drain WQCV in a Filtration BMP)

Underdrain Orifice Invert Depth =	2.00	ft (distance below the filtration media surface)
Underdrain Orifice Diameter =	0.59	inches

Calculated Parameters for Underdrain

Underdrain Orifice Area =	0.0	ft ²
Underdrain Orifice Centroid =	0.02	feet

User Input: Orifice Plate with one or more orifices or Elliptical Slot Weir (typically used to drain WQCV and/or EURV in a sedimentation BMP)

Invert of Lowest Orifice =	0.83	ft (relative to basin bottom at Stage = 0 ft)
Depth at top of Zone using Orifice Plate =	2.24	ft (relative to basin bottom at Stage = 0 ft)
Orifice Plate: Orifice Vertical Spacing =	5.60	inches
Orifice Plate: Orifice Area per Row =	0.78	sq. inches (diameter = 1 inch)

Calculated Parameters for Plate

WQ Orifice Area per Row =	5.417E-03	ft ²
Elliptical Half-Width =	N/A	feet
Elliptical Slot Centroid =	N/A	feet
Elliptical Slot Area =	N/A	ft ²

User Input: Stage and Total Area of Each Orifice Row (numbered from lowest to highest)

	Row 1 (required)	Row 2 (optional)	Row 3 (optional)	Row 4 (optional)	Row 5 (optional)	Row 6 (optional)	Row 7 (optional)	Row 8 (optional)
Stage of Orifice Centroid (ft)	0.83	1.30	1.77					
Orifice Area (sq. inches)	0.78	0.78	0.78					

	Row 9 (optional)	Row 10 (optional)	Row 11 (optional)	Row 12 (optional)	Row 13 (optional)	Row 14 (optional)	Row 15 (optional)	Row 16 (optional)
Stage of Orifice Centroid (ft)								
Orifice Area (sq. inches)								

User Input: Vertical Orifice (Circular or Rectangular)

	Not Selected	Not Selected	
Invert of Vertical Orifice =	N/A	N/A	ft (relative to basin bottom at Stage = 0 ft)
Depth at top of Zone using Vertical Orifice =	N/A	N/A	ft (relative to basin bottom at Stage = 0 ft)
Vertical Orifice Diameter =	N/A	N/A	inches

Calculated Parameters for Vertical Orifice

	Not Selected	Not Selected	
Vertical Orifice Area =	N/A	N/A	ft ²
Vertical Orifice Centroid =	N/A	N/A	feet

User Input: Overflow Weir (Dropbox) and Grate (Flat or Sloped)

	Zone 3 Weir	Not Selected	
Overflow Weir Front Edge Height, H _o =	3.00	N/A	ft (relative to basin bottom at Stage = 0 ft)
Overflow Weir Front Edge Length =	2.92	N/A	feet
Overflow Weir Slope =	0.00	N/A	H:V (enter zero for flat grate)
Horiz. Length of Weir Sides =	2.92	N/A	feet
Overflow Grate Open Area % =	81%	N/A	% grate open area/total area
Debris Clogging % =	50%	N/A	%

Calculated Parameters for Overflow Weir

	Zone 3 Weir	Not Selected	
Height of Grate Upper Edge, H _g =	3.00	N/A	feet
Over Flow Weir Slope Length =	2.92	N/A	feet
Grate Open Area / 100-yr Orifice Area =	61.76	N/A	should be ≥ 4
Overflow Grate Open Area w/o Debris =	6.91	N/A	ft ²
Overflow Grate Open Area w/ Debris =	3.45	N/A	ft ²

User Input: Outlet Pipe w/ Flow Restriction Plate (Circular Orifice, Restrictor Plate, or Rectangular Orifice)

	Zone 3 Restrictor	Not Selected	
Depth to Invert of Outlet Pipe =	2.00	N/A	ft (distance below basin bottom at Stage = 0 ft)
Outlet Pipe Diameter =	12.00	N/A	inches
Restrictor Plate Height Above Pipe Invert =	2.40	N/A	inches

Calculated Parameters for Outlet Pipe w/ Flow Restriction Plate

	Zone 3 Restrictor	Not Selected	
Outlet Orifice Area =	0.11	N/A	ft ²
Outlet Orifice Centroid =	0.12	N/A	feet
Half-Central Angle of Restrictor Plate on Pipe =	0.93	N/A	radians

User Input: Emergency Spillway (Rectangular or Trapezoidal)

Spillway Invert Stage =	3.50	ft (relative to basin bottom at Stage = 0 ft)
Spillway Crest Length =	8.00	feet
Spillway End Slopes =	3.00	H:V
Freeboard above Max Water Surface =	1.00	feet

Calculated Parameters for Spillway

Spillway Design Flow Depth =	0.23	feet
Stage at Top of Freeboard =	4.73	feet
Basin Area at Top of Freeboard =	0.09	acres

Routed Hydrograph Results

	WQCV	EURV	2 Year	5 Year	10 Year	25 Year	50 Year	100 Year	500 Year
Design Storm Return Period =									
One-Hour Rainfall Depth (in) =	0.53	1.07	1.19	1.50	1.75	2.00	2.25	2.52	3.00
Calculated Runoff Volume (acre-ft) =	0.015	0.059	0.048	0.065	0.086	0.117	0.138	0.167	0.215
OPTIONAL Override Runoff Volume (acre-ft) =									
Inflow Hydrograph Volume (acre-ft) =	0.014	0.058	0.048	0.064	0.085	0.117	0.137	0.166	0.215
Predevelopment Unit Peak Flow, q (cfs/acre) =	0.00	0.00	0.01	0.02	0.20	0.67	0.93	1.25	1.77
Predevelopment Peak Q (cfs) =	0.0	0.0	0.0	0.0	0.2	0.7	0.9	1.3	1.8
Peak Inflow Q (cfs) =	0.2	1.0	0.8	1.1	1.5	2.0	2.4	2.8	3.7
Peak Outflow Q (cfs) =	0.0	0.1	0.1	0.1	0.1	0.3	1.0	1.2	1.6
Ratio Peak Outflow to Predevelopment Q =	N/A	N/A	N/A	4.2	0.5	0.5	1.0	1.0	0.9
Structure Controlling Flow =	Filtration Media	Plate	Plate	Plate	Plate	Overflow Grate 1	Overflow Grate 1	Outlet Plate 1	Spillway
Max Velocity through Grate 1 (fps) =	N/A	N/A	N/A	N/A	N/A	0.0	0.1	0.2	0.2
Max Velocity through Grate 2 (fps) =	N/A	N/A	N/A	N/A	N/A	N/A	N/A	N/A	N/A
Time to Drain 97% of Inflow Volume (hours) =	12	23	22	24	25	27	26	26	25
Time to Drain 99% of Inflow Volume (hours) =	12	24	23	25	27	29	29	29	28
Maximum Ponding Depth (ft) =	0.69	2.00	1.76	2.14	2.55	3.04	3.09	3.21	3.56
Area at Maximum Ponding Depth (acres) =	0.02	0.04	0.03	0.04	0.05	0.05	0.06	0.06	0.06
Maximum Volume Stored (acre-ft) =	0.012	0.049	0.041	0.054	0.073	0.097	0.100	0.107	0.128

Note: UDCF worksheet indicates 5 year pre-developed flow is 0.0 cfs. Installing a pond will insure there is a 5 yr pond outflow that is greater than 0.0 cfs. In this case the 5-yr outflow is 0.1 cfs, a very negligible and inconsequential amount.

Detention Basin Outlet Structure Design

UD-Detention, Version 3.07 (February 2017)

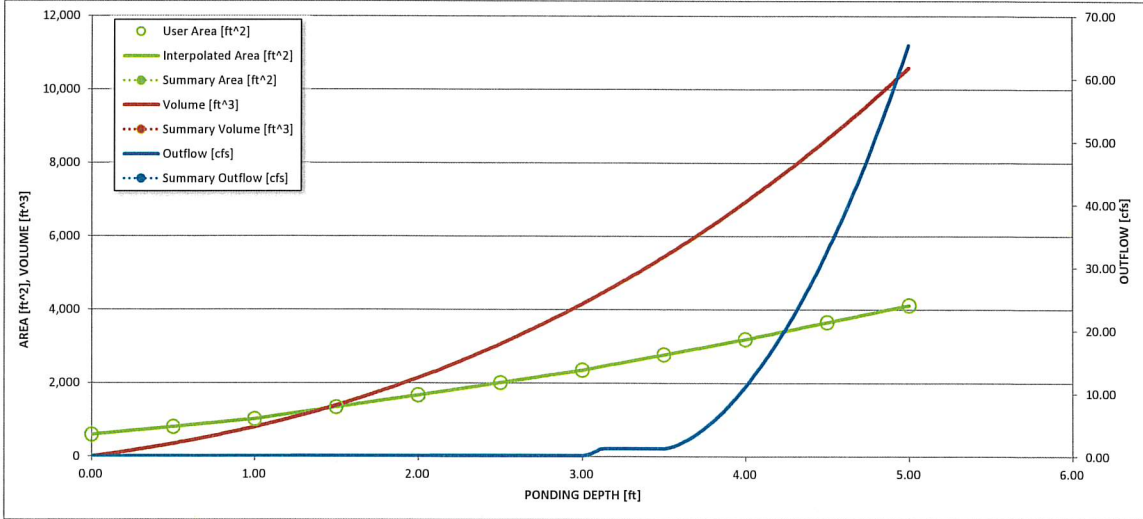
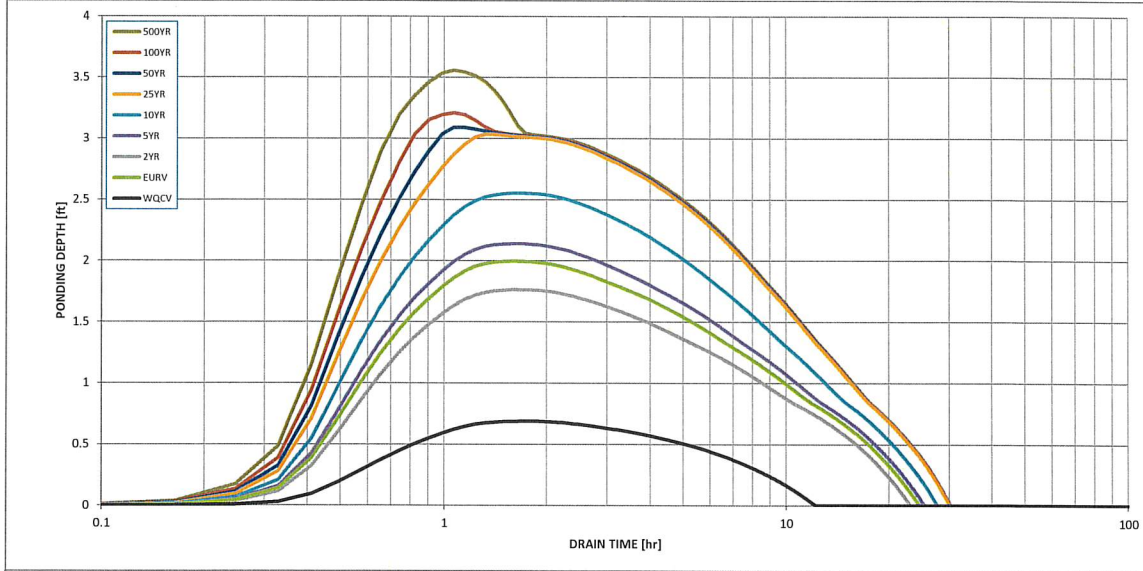
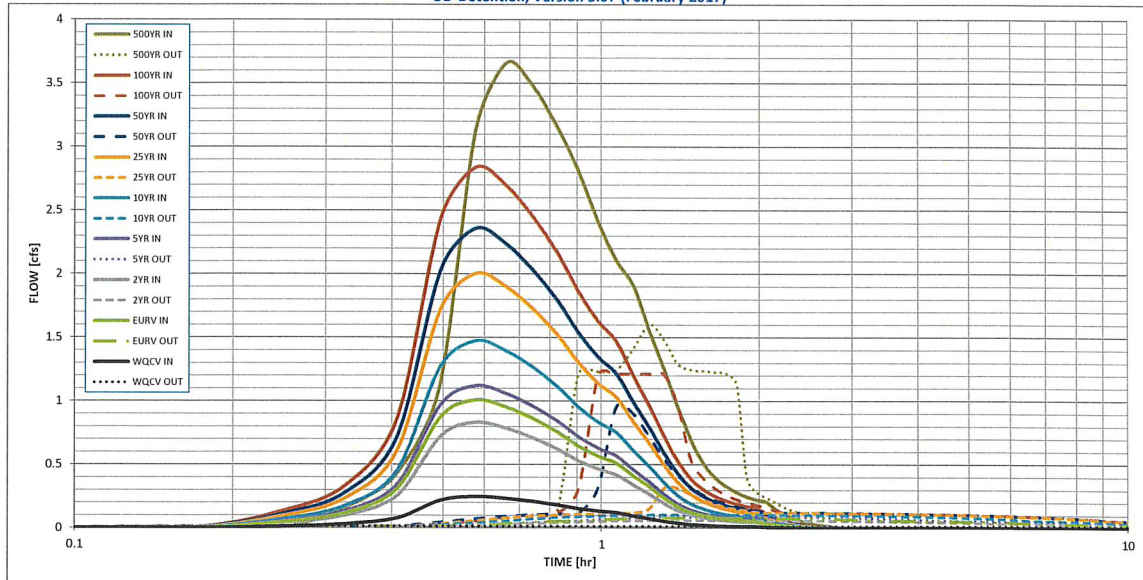

S-A-V-D Chart Axis Override	X-axis	Left Y-Axis	Right Y-Axis
minimum bound			
maximum bound			

Table 7
Emergency Overflow Discharge Calcs

Developed Conditions

Security Fire Station

February 15, 2021

Sub basin ID Contributing to Pond	Area (acres)	"C"		C*A	
		5 year	100 year	5 year	100 year
D	0.08	0.12	0.39	0.00	0.03
E	0.24	0.80	0.87	0.19	0.21
F	0.03	0.90	0.96	0.03	0.03
H	0.09	0.90	0.96	0.08	0.09
I	0.09	0.90	0.96	0.08	0.09
J	0.18	0.73	0.83	0.13	0.15
K	0.13	0.08	0.35	0.01	0.05
M	0.03	0.90	0.96	0.03	0.03
subtotals	0.87			0.55	0.67
Composite "C"				0.63	0.76

Time of Concentration

5 minutes

Rainfall Intensity (inches per hour)

5.20

8.70

Design Runoff for Emergency Swale Design (cfs)

3.3

6.7

EXHIBIT 8

HYDROLOGIC CALCULATIONS

Table 1

Basin Summary

Existing/ Historic Conditions

Sub basin ID	Area	Time of Conc	Runoff Coefficient		Design Discharges	
	(Acres)	min.	5 year	100 year	5 year (cfs)	100 year (cfs)
OS1	2.06	17	0.09	0.36	0.60	4.20
OS4	0.44	17	0.09	0.36	0.10	0.90
A	1.21	17	0.09	0.36	0.40	2.40

Table 2
 Design Point Summary
 Existing/ Historic Conditions

Design Point ID	Description	Contributing Sub Basins	Q5 (cfs)	Q100 (cfs)
1	SE corner of the site at Swale 1	OS1	0.6	4.2
2	SE corner of the site at Swale 2	OS4	0.1	0.9
3	Swale 1 project site outlet point on west PL	A, OS1	1	4.2
4	NW corner of site on Wayfayer Drive	OS2	NA	NA
5	Downstream facility locations	ID shown for info purposes only	NA	NA

Table 8
Sub Basin Summary
Developed Conditions

Security Fire Station

02/15/21

Storm Sewer Structure #	Sub basin ID	Area (acres)	"C"		Runoff (cfs)	
			5 year	100 year	5 year	100 year
	A	0.04	0.90	0.96	0.2	0.3
	B	0.01	0.90	0.96	0.0	0.1
	C	0.02	0.90	0.96	0.1	0.2
	D	0.08	0.12	0.39	0.0	0.3
	E	0.24	0.80	0.87	1.0	1.8
	F	0.03	0.90	0.96	0.1	0.2
	G	0.19	0.08	0.35	0.1	0.6
	H	0.09	0.90	0.96	0.4	0.7
	I	0.09	0.90	0.96	0.4	0.7
	J	0.18	0.73	0.83	0.7	1.3
	K	0.13	0.08	0.35	0.1	0.4
	L	0.12	0.08	0.35	0.0	0.4
	M	0.02	0.90	0.96	0.1	0.2
	N	0.05	0.08	0.35	0.0	0.2
	O	0.01	0.08	0.35	0.0	0.0
	P	0.04	0.08	0.35	0.0	0.1
	OS1	2.08	0.09	0.36	0.6	4.2

11	D	0.08	0.12	0.39	0.0	0.3
	Subtotl STR 11	0.08			0.0	0.3
3	D	0.08	0.12	0.39	0.0	0.3
	F	0.03	0.90	0.96	0.1	0.2
	Subtotal STR3	0.27			0.1	0.5
13	D	0.08	0.12	0.39	0.0	0.3
	F	0.03	0.90	0.96	0.1	0.2
	H	0.09	0.90	0.96	0.4	0.7
	Subtotal STR13	0.2			0.5	1.2
20	D	0.08	0.12	0.39	0.0	0.3
	F	0.03	0.90	0.96	0.1	0.2
	H	0.09	0.90	0.96	0.4	0.7
	J	0.18	0.73	0.83	0.7	1.3
	Subtotal STR20	0.38			1.2	2.5
17	I	0.09	0.90	0.96	0.4	0.7
	Subtotal STR23	0.09			0.4	0.7
8	I	0.09	0.90	0.96	0.4	0.7

Storm Sewer Structure #	Sub basin ID	Area (acres)	"C"		Runoff (cfs)	
			5 year	100 year	5 year	100 year
Subtotal STR8		0.09			0.4	0.7
9	E	0.24	0.80	0.87	1.0	1.8
Subtotal STR9		0.24			1.0	1.8
10	I	0.09	0.90	0.96	0.4	0.7
	E	0.24	0.80	0.87	1.0	1.8
Subtotal STR10		0.33			1.4	2.5
20	D	0.08	0.12	0.39	0.0	0.3
	F	0.03	0.90	0.96	0.1	0.2
	H	0.09	0.90	0.96	0.4	0.7
	J	0.18	0.73	0.83	0.7	1.3
Subtotal STR20		0.38			1.2	2.5
14	D	0.08	0.12	0.39	0.0	0.3
	F	0.03	0.90	0.96	0.1	0.2
	H	0.09	0.90	0.96	0.4	0.7
	J	0.18	0.73	0.83	0.7	1.3
	I	0.09	0.90	0.96	0.4	0.7
	E	0.24	0.80	0.87	1.0	1.8
Subtotal STR14		0.51			2.1	3.8
21	M	0.02	0.90	0.96	0.1	0.2
	6 bypass					
Subtotal STR21		0.02			0.1	0.2
Swale 2 west of site	emergency overflow	See Calc Sheets ___ to ___			2.5	5.8
	OS1	1.21	0.09	0.36	0.4	2.4
	G	0.19	0.08	0.35	0.1	0.6
	L	0.12	0.08	0.35	0.0	0.4
Subtotal Swale 2 west of site		NA	NA	NA	3.0	9.2

**Security Fire Station
Runoff Coefficients Summary
(Existing Conditions)
February 15, 2021**

BASIN	STREETS / DEVELOPED		LANDSCAPED AREA		NATURAL			RUNOFF COEFFICIENT	
	TOTAL AREA (Acres)	AREA (Acres)	C ₅	C ₁₀₀	AREA (Acres)	C ₅	C ₁₀₀	C ₅	C ₁₀₀
A	1.21		0.90	0.96		0.12	0.39	0.09	0.36
OS1	2.08		0.90	0.96		0.12	0.39	0.09	0.36
OS4	NA		0.90	0.96		0.12	0.39	#VALUE!	#VALUE!
OS2	NA		0.90	0.96		0.12	0.39	#VALUE!	#VALUE!
OS3	NA		0.90	0.96		0.12	0.39	#VALUE!	#VALUE!

**Security Fire Station
Area Drainage Summary
(Existing Conditions)
February 15, 2021**

BASIN	From Area Runoff Coefficient Summary		OVERLAND				STREET / CHANNEL FLOW				Time of Travel (T _t)			INTENSITY *			TOTAL FLOWS	
	AREA TOTAL (Acres)	C _s <small>From DGM Table 5-1</small>	C _s	C ₁₀₀	Length (ft)	Height (ft)	T _c (min)	Length (ft)	Slope (%)	Velocity (fps)	T _v (min)	TOTAL (min)	CHECK (min)	I ₅ (in/hr)	I ₁₀₀ (in/hr)	Q ₅ (cfs)	Q ₁₀₀ (cfs)	
A	1.21	0.09	0.09	0.36	150	4.9	15.1	400	3.3%	3.6	1.8	17.0	13.1	3.3	5.6	0.4	2.4	
OS1	2.08	0.09	0.09	0.36	150	4.9	15.1	400	3.3%	3.6	1.8	17.0	13.1	3.3	5.6	0.6	4.2	
OS4	NA	#VALUE!	#VALUE!	#VALUE!			#VALUE!					#VALUE!	10.0	#VALUE!	#VALUE!	#VALUE!	#VALUE!	
OS2	NA	#VALUE!	#VALUE!	#VALUE!			#VALUE!			0.0	#DIV/0!	#VALUE!	10.0	#VALUE!	#VALUE!	#VALUE!	#VALUE!	
OS3	NA	#VALUE!	#VALUE!	#VALUE!			#VALUE!			0.0	#DIV/0!	#VALUE!	10.0	#VALUE!	#VALUE!	#VALUE!	#VALUE!	

Note: Runoff from OS2, OS3, and OS4 was not determined since it has not impact on the Fire Station site

* Intensity equations assume a minimum travel time of 5 minutes.

Calculated by: Ken H

Date: 2/15/2021

Checked by: _____

Security Fire Station
DRAINAGE CALCULATIONS
(Area Runoff Coefficient Summary)
Developed Onsite Conditions

February 15, 2021

BASIN	PAVEMENT/ ROOF			LANDSCAPED			NATURAL			RUNOFF COEFFICIENT		
	TOTAL AREA (Acres)	AREA (Acres)	C ₅	C ₁₀₀	AREA (Acres)	C ₅	C ₁₀₀	AREA (Acres)	C ₅	C ₁₀₀	C ₅	C ₁₀₀
A	0.04	0.04	0.90	0.96	0.00	0.12	0.39	0.00	0.08	0.35	0.90	0.96
B	0.01	0.01	0.90	0.96	0.00	0.12	0.39	0.00	0.08	0.35	0.90	0.96
C	0.02	0.02	0.90	0.96	0.00	0.12	0.39	0.00	0.08	0.35	0.90	0.96
D	0.08	0.00	0.90	0.96	0.08	0.12	0.39	0.00	0.08	0.35	0.12	0.39
E	0.24	0.21	0.90	0.96	0.02	0.12	0.39	0.00	0.08	0.35	0.80	0.87
F	0.03	0.03	0.90	0.96	0.00	0.12	0.39	0.00	0.08	0.35	0.90	0.96
G	0.19	0.00	0.90	0.96	0.00	0.12	0.39	0.19	0.08	0.35	0.08	0.35
H	0.09	0.09	0.90	0.96	0.00	0.12	0.39	0.00	0.08	0.35	0.90	0.96
I	0.09	0.09	0.90	0.96	0.00	0.12	0.39	0.00	0.08	0.35	0.90	0.96
J	0.18	0.14	0.90	0.96	0.04	0.12	0.39	0.00	0.08	0.35	0.73	0.83
K	0.13	0.00	0.90	0.96	0.00	0.12	0.39	0.13	0.08	0.35	0.08	0.35
L	0.12	0.00	0.90	0.96	0.00	0.12	0.39	0.12	0.08	0.35	0.08	0.35
M	0.02	0.02	0.90	0.96	0.00	0.12	0.39	0.00	0.08	0.35	0.90	0.96
N	0.05	0.00	0.90	0.96	0.00	0.12	0.39	0.05	0.08	0.35	0.08	0.35
O	0.01	0.00	0.90	0.96	0.00	0.12	0.39	0.01	0.08	0.35	0.08	0.35
P	0.04	0.00	0.90	0.96	0.00	0.12	0.39	0.04	0.08	0.35	0.08	0.35

Security Fire Station FINAL DRAINAGE REPORT Developed Onsite Conditions

February 15, 2021

BASIN	From Area Runoff Coefficient Summary		Time of Travel (T _i)			INTENSITY *			TOTAL FLOWS	
	AREA TOTAL (Acres)	C _s	C ₁₀₀	TOTAL (min)	CHECK (min)	I ₅ (in/hr)	I ₁₀₀ (in/hr)	Q ₅ (c.f.s.)	Q ₁₀₀ (c.f.s.)	
A	0.04	0.90	0.96	5.0	10.0	5.2	8.7	0.2	0.3	
B	0.01	0.90	0.96	5.0	10.0	5.2	8.7	0.0	0.1	
C	0.02	0.90	0.96	5.0	10.0	5.2	8.7	0.1	0.2	
D	0.08	0.12	0.39	5.0	10.0	5.2	8.7	0.0	0.3	
E	0.24	0.80	0.87	5.0	10.0	5.2	8.7	1.0	1.8	
F	0.03	0.90	0.96	5.0	10.0	5.2	8.7	0.1	0.2	
G	0.19	0.08	0.35	5.0	10.0	5.2	8.7	0.1	0.6	
H	0.09	0.90	0.96	5.0	10.0	5.2	8.7	0.4	0.7	
I	0.09	0.90	0.96	5.0	10.0	5.2	8.7	0.4	0.7	
J	0.18	0.73	0.83	5.0	10.0	5.2	8.7	0.7	1.3	
K	0.13	0.08	0.35	5.0	10.0	5.2	8.7	0.1	0.4	
L	0.12	0.08	0.35	5.0	10.0	5.2	8.7	0.0	0.4	
M	0.02	0.90	0.96	5.0	10.0	5.2	8.7	0.1	0.2	
N	0.05	0.08	0.35	5.0	10.0	5.2	8.7	0.0	0.2	
O	0.01	0.08	0.35	5.0	10.0	5.2	8.7	0.0	0.0	
P	0.04	0.08	0.35	5.0	10.0	5.2	8.7	0.0	0.1	

Inlet Summary

Structure/ Inlet #	Design Point	Contributing Sub Basins	Surface flow from Sub basins	Upstream Inlet Str Number	Bypass from upstream inlets	Total Surface flow at inlet	Inlet Description	Condition	Inlet interception	Inlet Bypass	Inlet Interception %	Spread	Depth of flow over inlet	Calculations sheet	Comments
		cfs	cfs		cfs	cfs			cfs	cfs	%	ft	inches		
1	3	D	0.3	NA	0	0.3	12" standard	sump	0.3	0	100%	NA	2.4	1	Used the smallest C&G inlet due to the negligible desing flow
2	4	F	0.2	1	0	0.2	12" drop in	sump	0.2	0	100%	NA	1.2	2	
4	7	H	0.7	NA	0	NA	no inlet at this location, roof drain connects directly into the storm sewer	NA	0.7	0	100%	NA	NA	NA	no inlet at this location, roof drain connects directly into the storm sewer
19	6	E	1.8	NA	0	1.8	Double 24" square drop in grate	on grade	1.2	0.6	67%	8.5	2.0	3	
6	13	J	1.3	19	0.6	1.9	Double 24" square drop in grate	on grade	1.2	0.7	63%	8.0	2.0	4	
21	17	M	0.2	6	0.7	0.9	Riprap chase to floor of detention Basin	NA	0.9	0	100%	NA	NA	NA	

Notes

- 1 Cross slopes at each inlet is assumed to be 1.5%
- 2 Maximum Depth at Curb face is 6"
- 3 Inlets were sized to intercept approximately 100% of the 100 year flow
- 4 Maximum spread from face of curbis 15'

EXHIBIT 9

HYDRAULIC CALCULATIONS

Table 4
 Basin Discharge Summary
 Developed Conditions

Security Fire Station

February 15, 2021

Sub basin ID	Area	Time of Conc	Runoff Coefficient		Design Discharges	
	(Acres)	min.	5 year	100 year	5 year (cfs)	100 year (cfs)
A	0.04	5	0.90	0.96	0.20	0.30
B	0.01	5	0.90	0.96	Negligible	0.10
C	0.02	5	0.90	0.96	0.10	0.20
D	0.08	5	0.12	0.39	Negligible	0.30
E	0.24	5	0.80	0.87	1.00	1.80
F	0.03	5	0.90	0.96	0.10	0.20
G	0.19	5	0.08	0.35	0.10	0.60
H	0.09	5	0.90	0.96	0.40	0.70
I	0.09	5	0.90	0.96	0.40	0.70
J	0.18	5	0.73	0.83	0.70	1.30
K	0.13	5	0.08	0.35	0.10	0.40
L	0.12	5	0.08	0.35	Negligible	0.40
M	0.02	5	0.90	0.96	0.10	0.20
N	0.05	5	0.08	0.35	Negligible	0.20
O	0.01	5	0.08	0.35	Negligible	Negligible
P	0.04	5	0.08	0.35	Negligible	0.10

Table 5
Design Point Summary
Surface Flow Developed Conditions

Security Fire Station

February 15, 2021

Design Point ID	Contributing sub Basin for surface flow	Discharge from Sub basin (100 yr) (cfs)	Upstream Design Point	Upstream Bypass (100 yr) (cfs)	Total Q100 (surface flow) (cfs)
1	OS2	NA	NA	NA	NA
2	OS2, A	NA	NA	NA	NA
3	D	0.30	NA	0.0	0.3
4	F	0.10	NA	0.0	0.1
5	Underground fitting in the storm sewer pipe system	NA	4	0.0	0.0
6	E	1.80	NA	0.0	1.8
7	H	0.70	NA	0.0	0.7
8	M, bypass DP13	0.20	13	0.7	0.9
9	Pond Outflow Structure	See pond report narrative			
10	OS1	4.20	NA	0.0	4.2
11	OS1, pond overflow	6.70	Pond	NA	6.7
12	Outfall end of pipe from pond	See pond report narrative			
13	J, bypass DP9	1.30	6	0.7	2.0
14	Pond emergency overflow	See pond report narrative			
15	D,F,H,J,I,E	See pond report narrative			
16	Underground fitting in the storm sewer pipe system				
17	M, bypass DP13	0.20	6	0.7	6.9

Notes

- 1 The storm sewer system is sized for the 100 year storm foow in order to route it to the FSDP
- 2 See report narrative for charateristics of the pond outlet structure, inflow, emergency overflow.

Table 6
Storm Sewer Summary
Developed Conditions

Security Fire Station

February 15, 2021

Storm Sewer Reach			Design Flow (cfs)							Pipe Hydraulic Characteristics				
Pipe Segment	Tributary Upstream Pipe Segments	Down stream Design Point	Upstream Pipe Segment #1 ID	Discharge from segment 1	Upstream Pipe Segment #2 ID	Discharge from segment 2	Contributing upstream Inlet ID	Inlet Interception rate	Total Design flow for pipe segment	size (HDPE)	Approx. slope	Depth	Velocity	Calc Sht #
				cfs		cfs	\	cfs	cfs	inches	%	(feet)	fps	
11	1	DP4	NA	NA	NA	NA	1	0.3	0.3	12	1.0	0.2	2.7	5
3	27	DP13	11	0.3	NA	NA	2	0.2	0.5	12	1.0	0.2	2.7	6
16	27	DP5	NA	NA	16	0.1	NA	0.1	0.1	12	0.5	0.4	3.6	9
8	16	DP5	16	0.1	NA	NA	7	0.7	0.8	12	0.5	0.3	2.7	
9	NA	DP16	NA	NA	NA	NA	19	1.2	1.2	12	0.5	0.4	3.2	7
10	9,8	DP16	8	0.7	9	1.2	NA	NA	1.9	12	1.0	0.5	3.6	8
12	3,4	7	3	0.5	NA	NA	Roof Drain at DP7	0.7	1.2	12	1.0	0.3	4.1	11
13	5	NA	12	1.2	NA	NA	NA	NA	1.2	12	1.0	0.3	4.1	11
20	13	45 deg wye	13	1.2	NA	NA	6	1.2	2.4	12	1.0	0.4	5.0	12
14	45 deg wye	15	10	1.9	20	2.4	NA	NA	4.3	12	10.0	0.4	10.4	13
22	pond	12	NA	NA	NA	NA	NA	1.8	1.8	12	2.5	0.3	6.3	14

- 1 Refer to Inleet spreadsheet for interception and bypass rates
- 2 Refer to CS sheets in the report for hydraulic characteristics of the pipe segments.

EXHIBIT 10

CALCULATION SHEETS (CS)

051
 Jump Inlet
 STR # 1
 DP # 3
 2/15/21



Nyloplast Inlet Capacity Table

DISCLAIMER: SAFETY FACTORS ARE NOT INCLUDED IN THESE CALCULATIONS. ACTUAL CALCULATIONS SHOULD BE CARRIED OUT AND VERIFIED BY THE DESIGN ENGINEER TAKING INTO ACCOUNT ALL LOCAL CONDITIONS. NYLOPLAST RECOMMENDS USING A MINIMUM SAFETY FACTOR OF 1.25 FOR PAVED AREAS AND 2.0 FOR TURF AREAS. ADS/NYLOPLAST IS NOT RESPONSIBLE FOR MISUSE OF THIS TOOL.

Input	
Type of Grate	12" Standard
Head (ft)	0.2
Properties	
Orifice Flow Area (in)	60.62
Orifice Flow Area (ft)	0.42
Weir Flow Perimeter (in)	43.75
Weir Flow Perimeter (ft)	3.65
Solution	
Capacity (cfs)	0.90
Capacity (gpm)	404.07

$$Q_{weir} = CLH^{3/2}$$
C = 3.33 Weir Discharge Coefficient
L = Perimeter of Grate Opening (ft)
H = Flow Height of Water Surface Above Weir (ft)

$$Q_{orifice} = CA\sqrt{2gh}$$
C = 0.60 Orifice Discharge Coefficient
A = Area of the Orifice (ft²)
g = Gravitational Constant (32.2 $\frac{ft}{s^2}$)
H = Depth of Water Above Center of Orifice (ft)



Nyloplast Inlet Capacity Table

DISCLAIMER: SAFETY FACTORS ARE NOT INCLUDED IN THESE CALCULATIONS. ACTUAL CALCULATIONS SHOULD BE CARRIED OUT AND VERIFIED BY THE DESIGN ENGINEER TAKING INTO ACCOUNT ALL LOCAL CONDITIONS. NYLOPLAST RECOMMENDS USING A MINIMUM SAFETY FACTOR OF 1.25 FOR PAVED AREAS AND 2.0 FOR TURF AREAS. ADS/NYLOPLAST IS NOT RESPONSIBLE FOR MISUSE OF THIS TOOL.

CS 2
 C#G 50mp
 ST# 2
 DP# 4
 2/15/9

Input

Type of Grate	12" Drop In
Head (ft)	0.1

Properties

Orifice Flow Area (in)	39.75
Orifice Flow Area (ft)	0.27
Weir Flow Perimeter (in)	33.31
Weir Flow Perimeter (ft)	2.78

Solution

Capacity (cfs)	0.29
Capacity (gpm)	131.19

$$Q_{weir} = CLH^{3/2}$$

$C = 3.33$ Weir Discharge Coefficient

$L =$ Perimeter of Grate Opening (ft)

$H =$ Flow Height of Water Surface Above Weir (ft)

$$Q_{orifice} = CA\sqrt{2gh}$$

$C = 0.60$ Orifice Discharge Coefficient

$A =$ Area of the Orifice (ft²)

$g =$ Gravitational Constant $\left(32.2 \frac{ft}{s^2}\right)$

$H =$ Depth of Water Above Center of Orifice (ft)

CS 3
INLET # 19
DP 6



Nyloplast Inlet Capacity Table

DISCLAIMER: SAFETY FACTORS ARE NOT INCLUDED IN THESE CALCULATIONS. ACTUAL CALCULATIONS SHOULD BE CARRIED OUT AND VERIFIED BY THE DESIGN ENGINEER TAKING INTO ACCOUNT ALL LOCAL CONDITIONS. NYLOPLAST RECOMMENDS USING A MINIMUM SAFETY FACTOR OF 1.25 FOR PAVED AREAS AND 2.0 FOR TURF AREAS. ADS/NYLOPLAST IS NOT RESPONSIBLE FOR MISUSE OF THIS TOOL.

Input	
Type of Grate	24" Drop In
Head (ft)	0.14

(DOUBLE)

Properties	
Orifice Flow Area (in)	164.94
Orifice Flow Area (ft)	1.14
Weir Flow Perimeter (in)	66.28
Weir Flow Perimeter (ft)	5.52

Solution	
Capacity (cfs)	0.96
Capacity (gpm)	432.40

* 2 = 1.9 cfs

$$Q_{weir} = CLH^{3/2}$$

$C = 3.33$ Weir Discharge Coefficient

$L =$ Perimeter of Grate Opening (ft)

$H =$ Flow Height of Water Surface Above Weir (ft)

$$Q_{orifice} = CA\sqrt{2gh}$$

$C = 0.60$ Orifice Discharge Coefficient

$A =$ Area of the Orifice (ft²)

$g =$ Gravitational Constant (32.2 $\frac{ft}{s^2}$)

$H =$ Depth of Water Above Center of Orifice (ft)

CS4
INLET #6
DP 13



Nyloplast Inlet Capacity Table

DISCLAIMER: SAFETY FACTORS ARE NOT INCLUDED IN THESE CALCULATIONS. ACTUAL CALCULATIONS SHOULD BE CARRIED OUT AND VERIFIED BY THE DESIGN ENGINEER TAKING INTO ACCOUNT ALL LOCAL CONDITIONS. NYLOPLAST RECOMMENDS USING A MINIMUM SAFETY FACTOR OF 1.25 FOR PAVED AREAS AND 2.0 FOR TURF AREAS. ADS/NYLOPLAST IS NOT RESPONSIBLE FOR MISUSE OF THIS TOOL.

Input	
Type of Grate	24" Drop In
Head (ft)	0.16
Properties	
Orifice Flow Area (in)	164.94
Orifice Flow Area (ft)	1.14
Weir Flow Perimeter (in)	66.28
Weir Flow Perimeter (ft)	5.52
Solution	
Capacity (cfs)	1.18
Capacity (gpm)	528.29

$$Q_{weir} = CLH^{3/2}$$

$C = 3.33$ Weir Discharge Coefficient

$L =$ Perimeter of Grate Opening (ft)

$H =$ Flow Height of Water Surface Above Weir (ft)

$$Q_{orifice} = CA\sqrt{2gh}$$

$C = 0.60$ Orifice Discharge Coefficient

$A =$ Area of the Orifice (ft²)

$g =$ Gravitational Constant $\left(32.2 \frac{ft}{s^2}\right)$

$H =$ Depth of Water Above Center of Orifice (ft)

REV 2.1.21

CS # 5

The open channel flow calculator

2/15/21

STR #11
KOYT

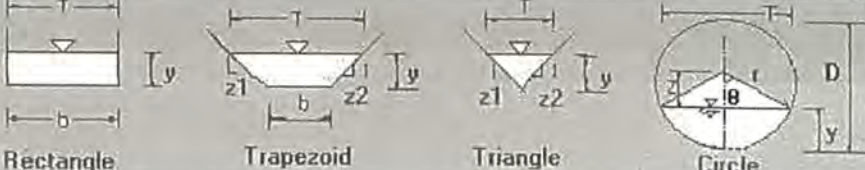
Select Channel Type: Circle <input type="checkbox"/>			
Depth from Q <input type="checkbox"/>	Select unit system: Feet(ft) <input type="checkbox"/>		
Channel slope: <input type="text" value=".01"/> ft/ft	Water depth(y): <input type="text" value="0.16"/> ft	Radius (r) <input type="text" value="1"/> ft	
Flow velocity <input type="text" value="2.6689"/> ft/s	LeftSlope (Z1): <input type="text" value="to 1 (H:V)"/>	RightSlope (Z2): <input type="text" value="to 1 (H:V)"/>	
Flow discharge <input type="text" value=".3"/> ft^3/s	Input n value <input type="text" value=".012"/> or select n		
Calculate!	Status: <input type="text" value="Calculation finished"/>	Reset	
Wetted perimeter <input type="text" value="1.13"/> ft	Flow area <input type="text" value="0.11"/> ft^2	Top width(T) <input type="text" value="1.07"/> ft	
Specific energy <input type="text" value="0.27"/> ft	Froude number <input type="text" value="1.45"/>	Flow status <input type="text" value="Supercritical flow"/>	
Critical depth <input type="text" value="0.19"/> ft	Critical slope <input type="text" value="0.0042"/> ft/ft	Velocity head <input type="text" value="0.11"/> ft	

Copyright 2000 Dr. Xing Fang, Department of Civil Engineering, Lamar University.

CS 6

Pipe segment 3
100y

The open channel flow calculator		
Select Channel Type: Circle ▼		
Depth from Q ▼	Select unit system: Feet(ft) ▼	
Channel slope: <input type="text" value="0.01"/> <small>ft/ft</small>	Water depth(y): <input type="text" value="0.2"/> <small>ft</small>	Radius (r) <input type="text" value="1"/> <small>ft</small>
Flow velocity <input type="text" value="3.1284"/> <small>ft/s</small>	LeftSlope (Z1): <input type="text" value="to 1 (H:V)"/>	RightSlope (Z2): <input type="text" value="to 1 (H:V)"/>
Flow discharge <input type="text" value="0.5"/> <small>ft^3/s</small>	Input n value <input type="text" value="0.012"/> or select n	
<input type="button" value="Calculate!"/>	Status: <input type="text" value="Calculation finished"/>	<input type="button" value="Reset"/>
Wetted perimeter <input type="text" value="1.29"/> <small>ft</small>	Flow area <input type="text" value="0.16"/> <small>ft^2</small>	Top width(T) <input type="text" value="1.2"/> <small>ft</small>
Specific energy <input type="text" value="0.35"/> <small>ft</small>	Froude number <input type="text" value="1.49"/>	Flow status <input type="text" value="Supercritical flow"/>
Critical depth <input type="text" value="0.24"/> <small>ft</small>	Critical slope <input type="text" value="0.0041"/> <small>ft/ft</small>	Velocity head <input type="text" value="0.15"/> <small>ft</small>

C37
Pipe Segment 89

The open channel flow calculator

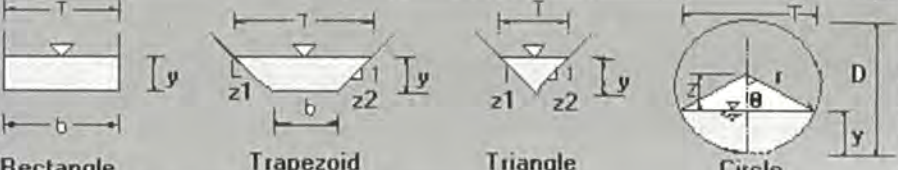
Select Channel Type: Circle <input type="checkbox"/>			
Depth from Q <input type="checkbox"/>	Select unit system: Feet(ft) <input type="checkbox"/>		
Channel slope: <input type="text" value="0.005"/> <input type="text" value="ft/ft"/>	Water depth(y): <input type="text" value="0.36"/> <input type="text" value="ft"/>	Radius (r) <input type="text" value="1"/> <input type="text" value="ft"/>	
Flow velocity <input type="text" value="3.1677"/> <input type="text" value="ft/s"/>	LeftSlope (Z1): <input type="text"/> to 1 (H:V)	RightSlope (Z2): <input type="text"/> to 1 (H:V)	
Flow discharge <input type="text" value="1.2"/> <input type="text" value="ft^3/s"/>	Input n value <input type="text" value="0.012"/> or select r		
<input type="button" value="Calculate!"/>	Status: <input type="text" value="Calculation finished"/>	<input type="button" value="Reset"/>	
Wetted perimeter <input type="text" value="1.74"/> <input type="text" value="ft"/>	Flow area <input type="text" value="0.38"/> <input type="text" value="ft^2"/>	Top width(T) <input type="text" value="1.53"/> <input type="text" value="ft"/>	
Specific energy <input type="text" value="0.51"/> <input type="text" value="ft"/>	Froude number <input type="text" value="1.12"/>	Flow status <input type="text" value="Supercritical flow"/>	
Critical depth <input type="text" value="0.38"/> <input type="text" value="ft"/>	Critical slope <input type="text" value="0.0038"/> <input type="text" value="ft/ft"/>	Velocity head <input type="text" value="0.16"/> <input type="text" value="ft"/>	

C38
Pipe Segment 10
100 ft

The open channel flow calculator

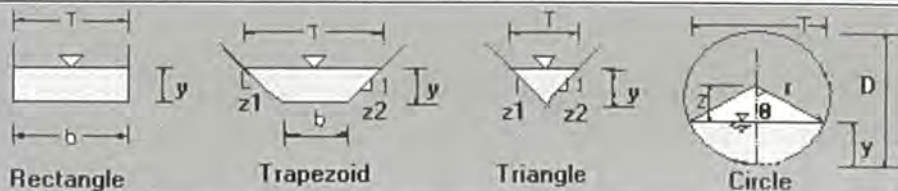
Select Channel Type: Circle ▼			
Depth from Q ▼	Select unit system: Feet(ft) ▼		
Channel slope: <input type="text" value="0.005"/> <small>ft/ft</small>	Water depth(y): <input type="text" value="0.45"/> <small>ft</small>	Radius (r) <input type="text" value="1"/> <small>ft</small>	
Flow velocity <input type="text" value="3.6356"/> <small>ft/s</small>	LeftSlope (Z1): <input type="text"/> to 1 (H:V)	RightSlope (Z2): <input type="text"/> <small>to 1 (H:V)</small>	
Flow discharge <input type="text" value="1.9"/> <small>ft^3/s</small>	Input n value <input type="text" value="0.012"/> or select n		
<input type="button" value="Calculate!"/>	Status: <input type="text" value="Calculation finished"/>	<input type="button" value="Reset"/>	
Wetted perimeter <input type="text" value="1.98"/> <small>ft</small>	Flow area <input type="text" value="0.53"/> <small>ft^2</small>	Top width(T) <input type="text" value="1.67"/> <small>ft</small>	
Specific energy <input type="text" value="0.66"/> <small>ft</small>	Froude number <input type="text" value="1.14"/>		Flow status <input type="text" value="Supercritical flow"/>
Critical depth <input type="text" value="0.48"/> <small>ft</small>	Critical slope <input type="text" value="0.0038"/> <small>ft/ft</small>		Velocity head <input type="text" value="0.21"/> <small>ft</small>

CS 9
Pipe Segment 16
100 years

The open channel flow calculator

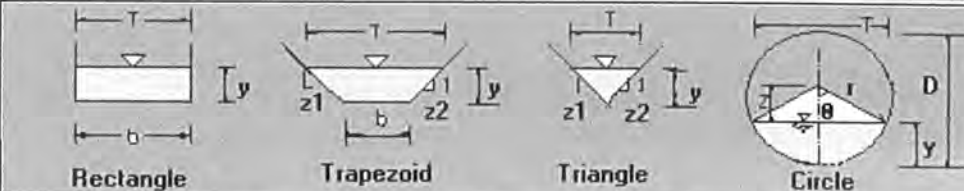
Select Channel Type: Circle ▼			
Depth from Q ▼	Select unit system: Feet(ft) ▼		
Channel slope: <input type="text" value="0.005"/> <small>ft/ft</small>	Water depth(y): <input type="text" value="0.44"/> <small>ft</small>	Radius (r) <input type="text" value="1"/> <small>ft</small>	
Flow velocity <input type="text" value="3.5891"/> <small>ft/s</small>	LeftSlope (Z1): <input type="text" value="to 1 (H:V)"/>	RightSlope (Z2): <input type="text" value="to 1 (H:V)"/>	
Flow discharge <input type="text" value="0.1"/> <small>ft^3/s</small>	Input n value <input type="text" value="0.012"/> or select n		
<input type="button" value="Calculate!"/>	Status: <input type="text" value="Calculation finished"/>		<input type="button" value="Reset"/>
Wetted perimeter <input type="text" value="1.95"/> <small>ft</small>	Flow area <input type="text" value="0.51"/> <small>ft^2</small>	Top width(T) <input type="text" value="1.66"/> <small>ft</small>	
Specific energy <input type="text" value="0.64"/> <small>ft</small>	Froude number <input type="text" value="1.14"/>		Flow status <input type="text" value="Supercritical flow"/>
Critical depth <input type="text" value="0.47"/> <small>ft</small>	Critical slope <input type="text" value="0.0038"/> <small>ft/ft</small>		Velocity head <input type="text" value="0.2"/> <small>ft</small>

C510
Pipe Segment
100 yr

The open channel flow calculator

Select Channel Type: Circle ▼			
Depth from Q ▼	Select unit system: Feet(ft) ▼		
Channel slope: <input type="text" value="0.005"/> <small>ft/ft</small>	Water depth(y): <input type="text" value="0.28"/> <small>ft</small>	Radius (r) <input type="text" value="1"/> <small>ft</small>	
Flow velocity <input type="text" value="2.7217"/> <small>ft/s</small>	LeftSlope (Z1): <input type="text" value=""/> to 1 (H:V)	RightSlope (Z2): <input type="text" value=""/> to 1 (H:V)	
Flow discharge <input type="text" value="0.7"/> <small>ft^3/s</small>	Input n value <input type="text" value="0.012"/> or select n		
<input type="button" value="Calculate!"/>	Status: <input type="text" value="Calculation finished"/>	<input type="button" value="Reset"/>	
Wetted perimeter <input type="text" value="1.53"/> <small>ft</small>	Flow area <input type="text" value="0.26"/> <small>ft^2</small>	Top width(T) <input type="text" value="1.38"/> <small>ft</small>	
Specific energy <input type="text" value="0.39"/> <small>ft</small>	Froude number <input type="text" value="1.1"/>	Flow status <input type="text" value="Supercritical flow"/>	
Critical depth <input type="text" value="0.29"/> <small>ft</small>	Critical slope <input type="text" value="0.004"/> <small>ft/ft</small>	Velocity head <input type="text" value="0.12"/> <small>ft</small>	

C511
Pipe Segment 12
100yr

The open channel flow calculator

Select Channel Type:

Circle



Rectangle

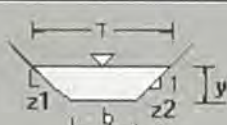

Trapezoid

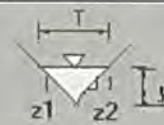

Triangle

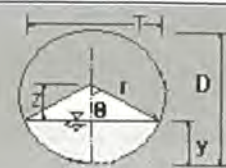

Circle

Depth from Q

Select unit system: Feet(ft)

Channel slope: 0.01

ft/ft

Water depth(y): 0.3

ft

Radius (r)

1

ft

Flow velocity: 4.0546

ft/s

LeftSlope (Z1):

to 1 (H:V)

RightSlope (Z2):

to 1 (H:V)

Flow discharge: 1.2

ft³/s

Input n value: 0.012

or select n

Calculate!

Status: Calculation finished

Reset

Wetted perimeter: 1.6

ft

Flow area: 0.3

ft²

Top width(T): 1.43

ft

Specific energy: 0.56

ft

Froude number: 1.56

Flow status

Supercritical flow

Critical depth: 0.38

ft

Critical slope: 0.0038

ft/ft

Velocity head: 0.26

ft

C512
Pipe Segment 20
100 year

The open channel flow calculator

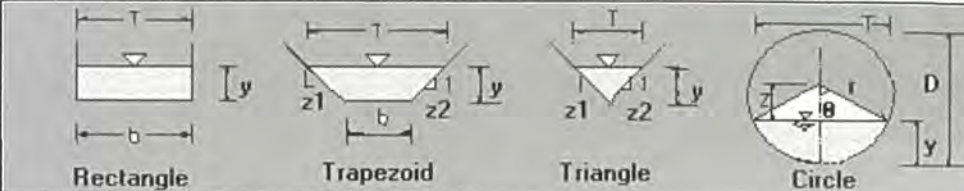
Select Channel Type: Circle <input type="checkbox"/>			
Depth from Q <input type="checkbox"/>	Select unit system: Feet(ft) <input type="checkbox"/>		
Channel slope: <input type="text" value="0.01"/> <small>ft/ft</small>	Water depth(y): <input type="text" value="0.43"/> <small>ft</small>	Radius (r) <input type="text" value="1"/> <small>ft</small>	
Flow velocity <input type="text" value="4.9754"/> <small>ft/s</small>	LeftSlope (Z1): <input type="text"/> to 1 (H:V)	RightSlope (Z2): <input type="text"/> to 1 (H:V)	
Flow discharge <input type="text" value="2.4"/> <small>ft^3/s</small>	Input n value <input type="text" value="0.012"/> or select n		
<input type="button" value="Calculate!"/>	Status: <input type="text" value="Calculation finished"/>	<input type="button" value="Reset"/>	
Wetted perimeter <input type="text" value="1.92"/> <small>ft</small>	Flow area <input type="text" value="0.49"/> <small>ft^2</small>	Top width(T) <input type="text" value="1.64"/> <small>ft</small>	
Specific energy <input type="text" value="0.81"/> <small>ft</small>	Froude number <input type="text" value="1.61"/>	Flow status <input type="text" value="Supercritical flow"/>	
Critical depth <input type="text" value="0.54"/> <small>ft</small>	Critical slope <input type="text" value="0.0038"/> <small>ft/ft</small>	Velocity head <input type="text" value="0.38"/> <small>ft</small>	

5

C5 13
Pipe Segment 14
100 year

The open channel flow calculator

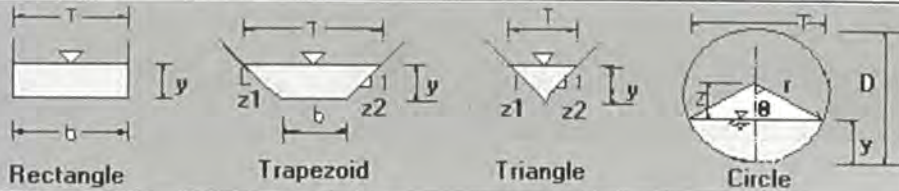
Select Channel Type: Circle <input type="checkbox"/>			
Depth from Q <input type="checkbox"/>	Select unit system: Feet(ft) <input type="checkbox"/>		
Channel slope: <input type="text" value=".05"/> ft/ft	Water depth(y): <input type="text" value="0.38"/> ft	Radius (r) <input type="text" value="1"/> ft	
Flow velocity <input type="text" value="10.4252"/> ft/s	LeftSlope (Z1): <input type="text"/> to 1 (H:V)	RightSlope (Z2): <input type="text"/> to 1 (H:V)	
Flow discharge <input type="text" value="4.3"/> ft^3/s	Input n value <input type="text" value="0.012"/> or select n		
<input type="button" value="Calculate!"/>	Status: <input type="text" value="Calculation finished"/>	<input type="button" value="Reset"/>	
Wetted perimeter <input type="text" value="1.81"/> ft	Flow area <input type="text" value="0.42"/> ft^2	Top width(T) <input type="text" value="1.57"/> ft	
Specific energy <input type="text" value="2.07"/> ft	Froude number <input type="text" value="3.56"/>	Flow status <input type="text" value="Supercritical flow"/>	
Critical depth <input type="text" value="0.73"/> ft	Critical slope <input type="text" value="0.0038"/> ft/ft	Velocity head <input type="text" value="1.69"/> ft	

CS 14
Pipe Segment 20
100 year

The open channel flow calculator

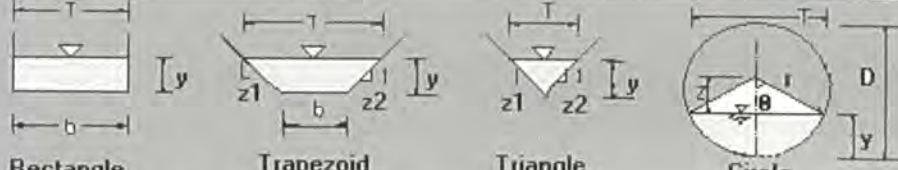
Select Channel Type: Circle <input type="checkbox"/>			
Depth from Q <input type="checkbox"/>	Select unit system: Feet(ft) <input type="checkbox"/>		
Channel slope: <input type="text" value=".025"/> ft/ft	Water depth(y): <input type="text" value="0.3"/> ft	Radius (r) <input type="text" value="1"/> ft	
Flow velocity <input type="text" value="6.3469"/> ft/s	LeftSlope (Z1): <input type="text"/> to 1 (H:V)	RightSlope (Z2): <input type="text"/> to 1 (H:V)	
Flow discharge <input type="text" value="1.8"/> ft^3/s	Input n value <input type="text" value="0.012"/> or select n		
<input type="button" value="Calculate!"/>	Status: <input type="text" value="Calculation finished"/>	<input type="button" value="Reset"/>	
Wetted perimeter <input type="text" value="1.58"/> ft	Flow area <input type="text" value="0.29"/> ft^2	Top width(T) <input type="text" value="1.42"/> ft	
Specific energy <input type="text" value="0.92"/> ft	Froude number <input type="text" value="2.47"/>	Flow status <input type="text" value="Supercritical flow"/>	
Critical depth <input type="text" value="0.47"/> ft	Critical slope <input type="text" value="0.0038"/> ft/ft	Velocity head <input type="text" value="0.63"/> ft	

The open channel flow calculator

C315
STR 21
DP: 8 to 17, 100 ft

Select Channel Type: Trapezoid ▾			
Depth from Q ▾	Select unit system: Feet(ft) ▾		
Channel slope: .10 ft/ft	Water depth(y): 0.11 ft	Bottom width(b) 2 ft	
Flow velocity: 3.593352 ft/s	LeftSlope (Z1): 3 to 1 (H:V)	RightSlope (Z2): 3 to 1 (H:V)	
Flow discharge: 0.9 ft^3/s	Input n value: .025 or select n clean, uncoated castiron: 0.014 ▾		
Calculate!	Status: Calculation finished	Reset	
Wetted perimeter: 2.68 ft	Flow area: 0.25 ft^2	Top width(T): 2.65 ft	
Specific energy: 0.31 ft	Froude number: 2.06	Flow status: Supercritical flow	
Critical depth: 0.17 ft	Critical slope: 0.017 ft/ft	Velocity head: 0.2 ft	

C316
 National Swale from
 DP 10 to Pond out fall
 100 year

The open channel flow calculator

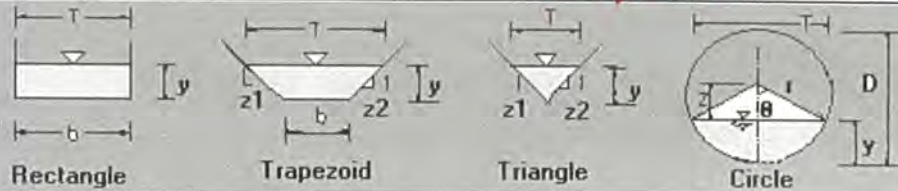
Select Channel Type: Trapezoid ▾			
Depth from Q ▾	Select unit system: Feet(ft) ▾		
Channel slope: <input type="text" value=".02"/> <small>ft/ft</small>	Water depth(y): <input type="text" value="0.46"/> <small>ft</small>	Bottom width(b) <input type="text" value="2"/> <small>ft</small>	
Flow velocity <input type="text" value="2.737249"/> <small>ft/s</small>	LeftSlope (Z1): <input type="text" value="3"/> to 1 (H:V)	RightSlope (Z2): <input type="text" value="3"/> to 1 (H:V)	
Flow discharge <input type="text" value="4.2"/> <small>ft^3/s</small>	Input n value <input type="text" value="0.035"/> or select n		
<input type="button" value="Calculate!"/>	Status: <input type="text" value="Calculation finished"/>	<input type="button" value="Reset"/>	
Wetted perimeter <input type="text" value="4.88"/> <small>ft</small>	Flow area <input type="text" value="1.53"/> <small>ft^2</small>	Top width(T) <input type="text" value="4.73"/> <small>ft</small>	
Specific energy <input type="text" value="0.57"/> <small>ft</small>	Froude number <input type="text" value="0.85"/>	Flow status <input type="text" value="Subcritical flow"/>	
Critical depth <input type="text" value="0.42"/> <small>ft</small>	Critical slope <input type="text" value="0.0276"/> <small>ft/ft</small>	Velocity head <input type="text" value="0.12"/> <small>ft</small>	

CS 17

Riprap Jumble
From DP 14 to DP 11

The open channel flow calculator

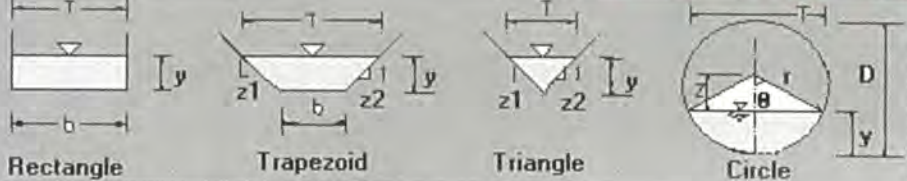
Select Channel Type: Trapezoid ▾			
Depth from Q ▾	Select unit system: Feet(ft) ▾		
Channel slope: .02 ft/ft	Water depth(y): 0.73 ft	Bottom width(b) 2 ft	
Flow velocity 3.563 ft/s	LeftSlope (Z1): 3 to 1 (H:V)	RightSlope (Z2): 3 to 1 (H:V)	
Flow discharge 10.9 ft^3/s	Input n value 0.035 or select n clean,uncoated castiron:0.014 ▾		
Calculate!	Status: Calculation finished		Reset
Wetted perimeter 6.62 ft	Flow area 3.06 ft^2	Top width(T) 6.38 ft	
Specific energy 0.93 ft	Froude number 0.91	Flow status Subcritical flow	
Critical depth 0.7 ft	Critical slope 0.024 ft/ft	Velocity head 0.2 ft	

C517
Pipe Outfall from Pond
STD 22

The open channel flow calculator

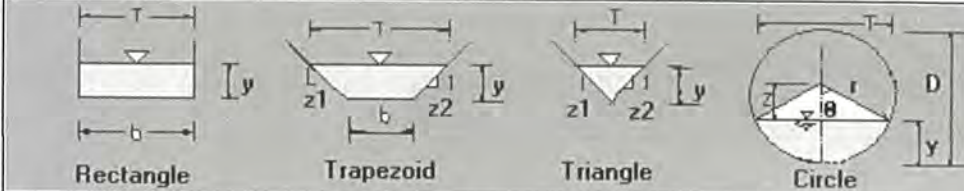
Select Channel Type: Circle ▼			
Depth from Q ▼	Select unit system: Feet(ft) ▼		
Channel slope: <input type="text" value=".03"/> <small>ft/ft</small>	Water depth(y): <input type="text" value="0.23"/> <small>ft</small>	Radius (r) <input type="text" value="1"/> <small>ft</small>	
Flow velocity <input type="text" value="5.9873"/> <small>ft/s</small>	LeftSlope (Z1): <input type="text"/> to 1 (H:V)	RightSlope (Z2): <input type="text"/> <small>to 1 (H:V)</small>	
Flow discharge <input type="text" value="1.2"/> <small>ft^3/s</small>	Input n value <input type="text" value="0.012"/> or select n <small>clean,uncoated castiron:0.014</small> ▼		
<input type="button" value="Calculate!"/>	Status: <input type="text" value="Calculation finished"/>	<input type="button" value="Reset"/>	
Wetted perimeter <input type="text" value="1.4"/> <small>ft</small>	Flow area <input type="text" value="0.21"/> <small>ft^2</small>	Top width(T) <input type="text" value="1.29"/> <small>ft</small>	
Specific energy <input type="text" value="0.79"/> <small>ft</small>	Froude number <input type="text" value="2.64"/>	Flow status <input type="text" value="Supercritical flow"/>	
Critical depth <input type="text" value="0.38"/> <small>ft</small>	Critical slope <input type="text" value="0.0038"/> <small>ft/ft</small>	Velocity head <input type="text" value="0.56"/> <small>ft</small>	

CS18
 Riprap Swale JTR 23
 Emergency Overflow

The open channel flow calculator

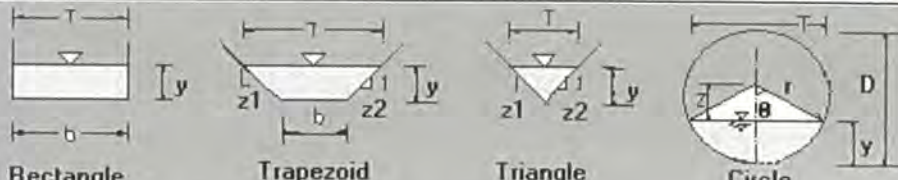
Select Channel Type: Trapezoid ▾			
Depth from Q ▾	Select unit system: Feet(ft) ▾		
Channel slope: <input type="text" value=".05"/> <input type="text" value="ft/ft"/>	Water depth(y): <input type="text" value="0.46"/> <input type="text" value="ft"/>	Bottom W(b) <input type="text" value="2"/> <input type="text" value="ft"/>	
Flow velocity <input type="text" value="4.366563"/> <input type="text" value="ft/s"/>	LeftSlope (Z1): <input type="text" value="3"/> to 1 (H:V)	RightSlope (Z2): <input type="text" value="3"/> to 1 (H:V)	
Flow discharge <input type="text" value="6.7"/> <input type="text" value="ft^3/s"/>	Input n value <input type="text" value=".035"/> or select n		
<input type="button" value="Calculate!"/>	Status: <input type="text" value="Calculation finished"/>	<input type="button" value="Reset"/>	
Wetted perimeter <input type="text" value="4.88"/> <input type="text" value="ft"/>	Flow area <input type="text" value="1.53"/> <input type="text" value="ft^2"/>	Top width(T) <input type="text" value="4.73"/> <input type="text" value="ft"/>	
Specific energy <input type="text" value="0.75"/> <input type="text" value="ft"/>	Froude number <input type="text" value="1.35"/>	Flow status <input type="text" value="Supercritical flow"/>	
Critical depth <input type="text" value="0.54"/> <input type="text" value="ft"/>	Critical slope <input type="text" value="0.0255"/> <input type="text" value="ft/ft"/>	Velocity head <input type="text" value="0.3"/> <input type="text" value="ft"/>	

	A	B	C	D	E	F	G	H	I	
1	Trapezoidal Riprap-Lined Waterway Design.xlsm									
2	Landowner	Security fire station		County	El Paso			V 11.2019		
3	Computed By	ken Harrison		Date	2/21/2021			11/15/2019		
4	Checked by			Date						
5	<i>Note: Macros must be enabled in this spreadsheet in order for the "Solve" button to work.</i>									
6	Design flow, Q=	10.2	cfs			WW horiz. Length=	40.0	ft		
7	Slope, S=	0.02	ft/ft =	50.00	:1	U/S WW F.L. elev=	100.0	ft		
8	Bottom Width, W=	2	ft			D/S WW F.L. elev=	99.2	ft		
9	Side slope, Z=	3	:1			Waterway drop=	0.8	ft		
10	Safety factor=	1.2		Typically 1.2		WW length along slope=	40.0	ft		
11	Rock shape =	Angular								
12	Min. req'd D50=	2.16	in			Spreadsheet formatting key:				
13	D50 used=	12.00	in			XXX	=Input cells			
14	n=	0.038				X.XX	=Output from "Solve" button			
15	Freeboard=	1.00	ft			X.XX	=Other computed output			
16						Red text	=Instructions, warnings, info			
17	Flow depth, d=	0.73	ft	Calculated						
18	Critical depth, d _c =	0.67	ft							
19	Critical slope, S _c =	0.029	ft/ft	0.7S _c =	0.0202	ft/ft				
20				1.3S _c =	0.0376	ft/ft				
21	Design slope, S=	0.0200	ft/ft	Design slope OK. Flow is Subcritical.						
22	Velocity=	3.31	fps			Est. riprap unit wt=	1.4	Tons/CY		
23				Rock shape =	Angular	Rock Gs =	2.65			
24	Riprap thickness:			Required riprap gradation for D50 selected						
25	Minimum=	2.00	ft	%	Rock dia., inches		Rock weight, lb			
26	Provided=	2.00	ft	Smaller	min.	max.	min.	max.		
27				100	18.0	24.0	425	1007		
28	Sideslope height:			85	15.6	21.6	277	734		
29	Minimum=	1.73	ft	50	12.0	18.0	126	425		
30	Provided=	3.00	ft	10	9.6	15.6	64	277		
31										
32										
33										
34										
35										
36	Quantities:									
37	Riprap volume=	81.9	CY							
38	Approx. weight=	114.6	Tons							
39	Geotextile area=	229.4	SY*							
40										
41										
42	*Geotextile area									
43	includes actual covered									
44	surfaces only (no extra									
45	for laps or anchorage)									
46										

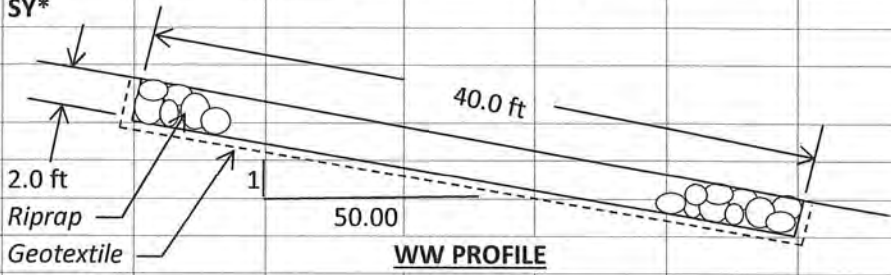

Trapezoidal Riprap-Lined Waterway Design.xlsm

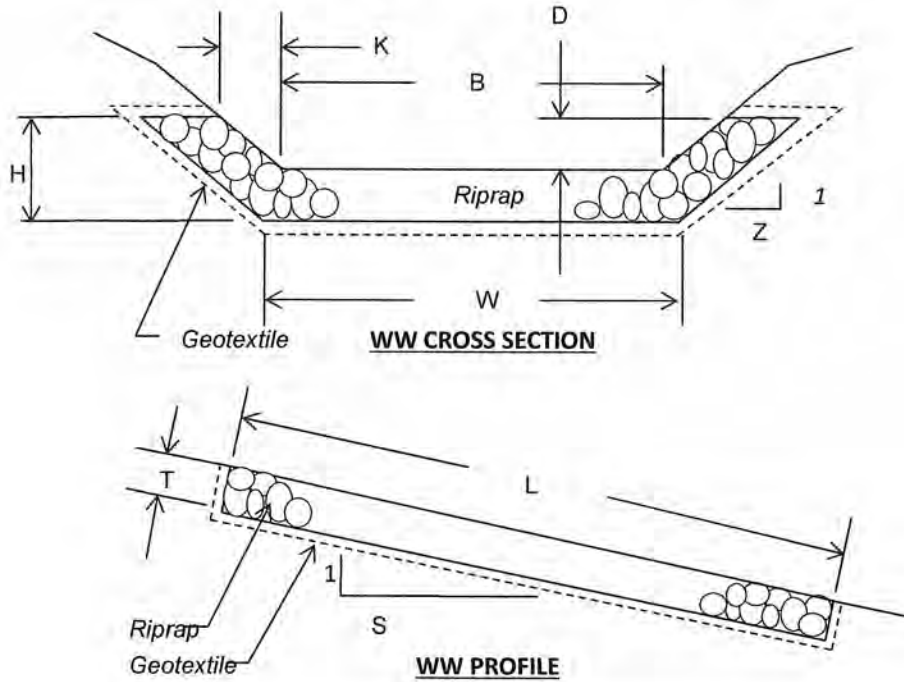

CONSTRUCTION DETAILS

WATERWAY NUMBER	REACH		(W)	(B)	(H)	(D)	(Z)	(K)	(L)	(T)	(S)	slope %		
	FROM	TO												
1	1+00	1+40	2.65	2.00	3.0	3.00	3	12	40.0	2.0	50.0	2.0		
								-						
								-						
								-						

NOTES AND SPECIFICATIONS:

1. PLACE SPOIL WHERE IT WILL NOT INTERFERE WITH SURFACE WATER FLOW INTO THE WATERWAY
- 2.
- 3.
- 4.
- 5.
- 6.



TRAPEZOIDAL LINED WATERWAY

CLIENT: Security fire station
 COUNTY: El Paso

Date

Designed: ken Hz 2/21/21
 Drawn: _____
 Checked: 0 1/0/00
 Approved: _____

Rock Riprap Lined Waterway Design - Cut/Paste Plan

(Version WI-July-2010, Based on Design of Rock Chutes by Robinson, Rice, Kadavy, ASAE, 1998)

Client Security fire station
 Designer: Ken Harrison
 Date: 2/21/2021

County: El Paso
 Checked by: _____
 Date: _____

Design Values

D₅₀ dia. = 12.0 in.
 Rock_{ww} thickness = 2.0 Feet.

Rock Gradation Envelope

% Passing	Diameter, in. (weight, lbs.)
D ₁₀₀ -----	18 - 24 (413 - 978)
D ₈₅ -----	16 - 22 (269 - 713)
D ₅₀ -----	12 - 18 (122 - 413)
D ₁₀ -----	10 - 16 (63 - 269)

Coefficient of Uniformity, (D₆₀)/(D₁₀) < 1.7

Quantities

Rock = 82 yd³
 Geotextile (WCS-13)^a = 229 yd²

Notes: ^a Geotextile Class I (Non-woven) shall be overlapped and anchored (18-in. minimum along sides and 24-in. minimum on the ends) --- quantity not included.

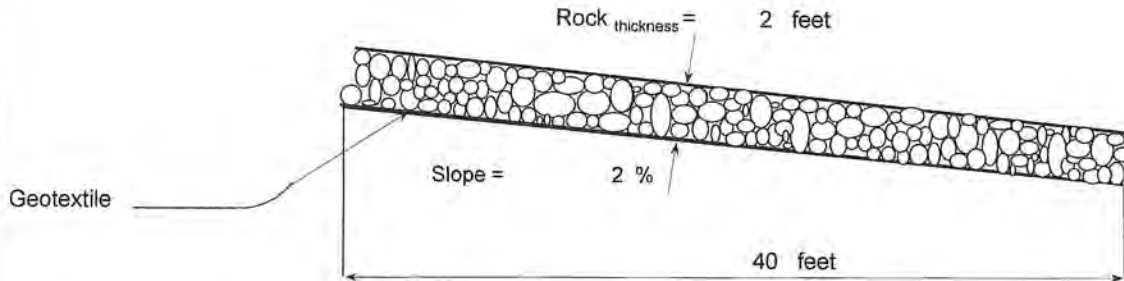

Profile Along Centerline of Rock Lined Waterway

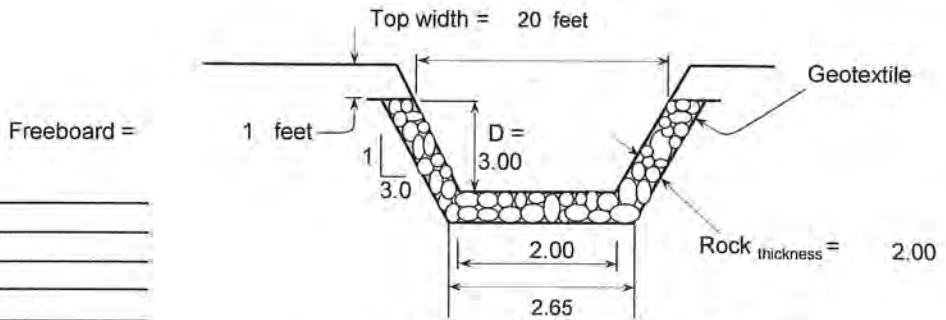

Rock Lined WW Cross Section

Profile, Cross Sections, and Quantities



Date	File Name
Ken Harrison 2/21/21	
Drawn _____	
Checked 0 1/0/00	
Approved _____	Sheet ___ of ___

Notes:

Detention Pond spillway
CS 20

The open channel flow calculator

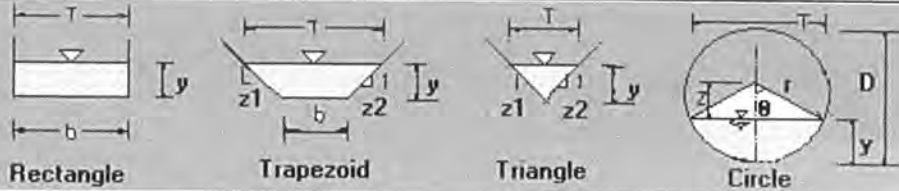
Select Channel Type: Trapezoid ▾			
Depth from Q ▾	Select unit system: Feet(ft) ▾		
Channel slope: <input type="text" value=".33"/> <input type="text" value="ft/ft"/>	Water depth(y): <input type="text" value="0.25"/> <input type="text" value="ft"/>	Bottom width(b) <input type="text" value="2"/> <input type="text" value="ft"/>	
Flow velocity <input type="text" value="9.512058"/> <input type="text" value="ft/s"/>	LeftSlope (Z1): <input type="text" value="3"/> to 1 (H:V)	RightSlope (Z2): <input type="text" value="3"/> <input type="text" value="to 1 (H:V)"/>	
Flow discharge <input type="text" value="6.7"/> <input type="text" value="ft^3/s"/>	Input n value <input type="text" value=".03"/> or select n		
<input type="button" value="Calculate!"/>	Status: <input type="text" value="Calculation finished"/>	<input type="button" value="Reset"/>	
Wetted perimeter <input type="text" value="3.61"/> <input type="text" value="ft"/>	Flow area <input type="text" value="0.7"/> <input type="text" value="ft^2"/>	Top width(T) <input type="text" value="3.53"/> <input type="text" value="ft"/>	
Specific energy <input type="text" value="1.66"/> <input type="text" value="ft"/>	Froude number <input type="text" value="3.75"/>	Flow status <input type="text" value="Supercritical flow"/>	
Critical depth <input type="text" value="0.54"/> <input type="text" value="ft"/>	Critical slope <input type="text" value="0.0188"/> <input type="text" value="ft/ft"/>	Velocity head <input type="text" value="1.4"/> <input type="text" value="ft"/>	

Rock Chute Design Data *for STR 21 §23*

(Version WI-July-2010, Based on Design of Rock Chutes by Robinson, Rice, Kadavy, ASAE, 1998)

Project: Security fire station
Designer: Ken Harrison
Date: February 21, 2021

County: El Paso
Checked by: _____
Date: _____

Input Geometry:

Upstream Channel	Chute	Downstream Channel
Bw = 2.0 ft.	Bw = 2.0 ft.	Bw = 2.0 ft.
Side slopes = 3.0 (m:1)	Factor of safety = 1.20 (F_s) 1.2 Min	Side slopes = 3.0 (m:1)
Velocity n-value = 0.027	Side slopes = 3.0 (m:1) → 2.0:1 max.	Velocity n-value = 0.027
Bed slope = 0.0200 ft./ft.	Bed slope (3:1) = 0.330 ft./ft → 3.0:1 max.	Bed slope = 0.0200 ft./ft.
Freeboard = 0.5 ft. →		Base flow = 6.7 cfs
Outlet apron depth, d = 1.0 ft.		

Note: n value = a) velocity n from waterway program or b) computed manning's n for channel

Design Storm Data (Table 2, FOTG, WI-NRCS Grade Stabilization Structure No. 410):

Apron elev. --- Inlet = 100.0 ft. ----- Outlet 91.0 ft. --- ($H_{drop} = 8$ ft.)

Q_{high} = Runoff from design storm capacity from Table 2, FOTG Standard 410
 Q_5 = Runoff from a 5-year, 24-hour storm.

Note: The total required capacity is routed through the chute (principal spillway) or in combination with an auxiliary spillway.

Input tailwater (T_w): 0.33 1.20

$Q_{high} = 6.2$ cfs	High flow storm through chute	→ T_w (ft.) = Program
$Q_5 = 1.2$ cfs	Low flow storm through chute	→ T_w (ft.) = Program

Profile and Cross Section (Output):

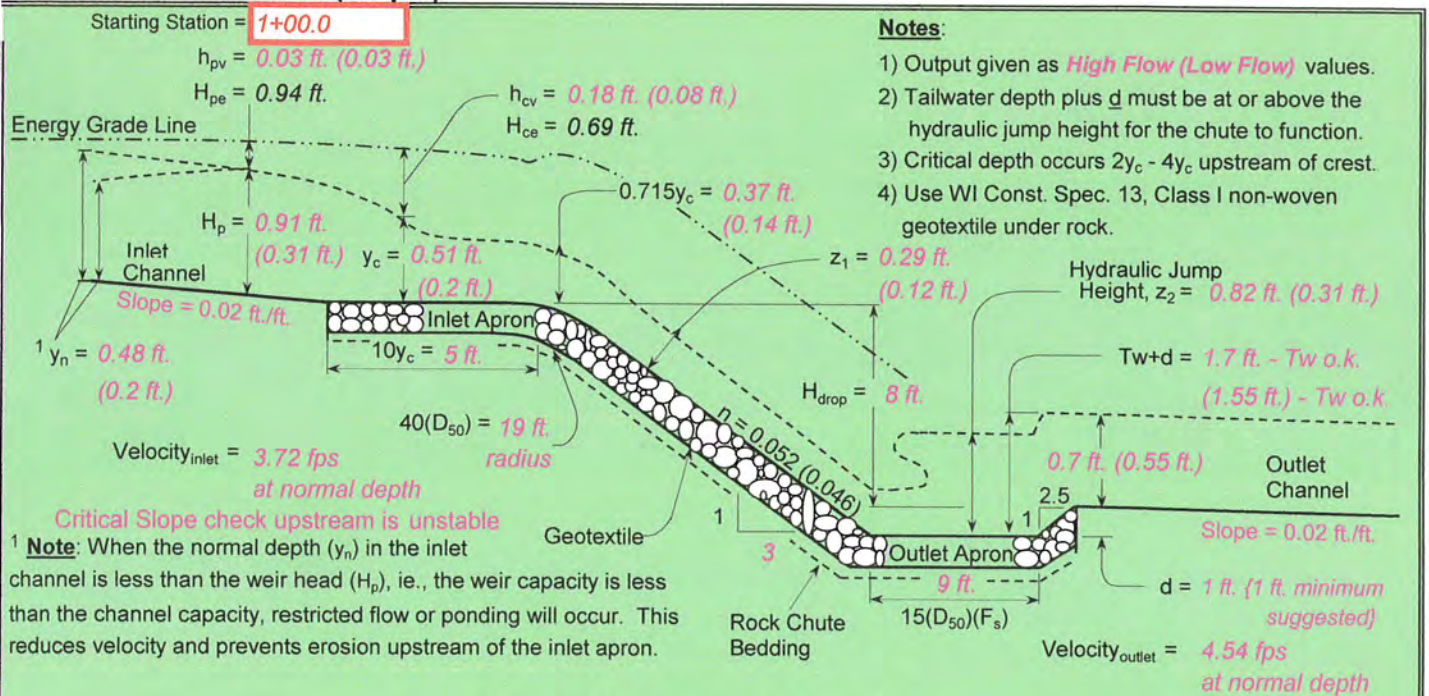

Profile Along Centerline of Chute

Typical Cross Section

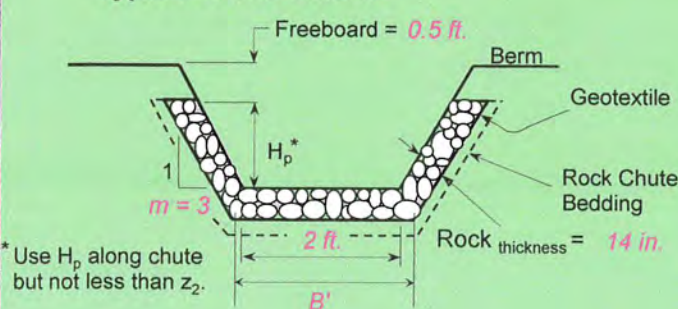

$F_s = 1.20$	Factor of safety (multiplier)
$z_1 = 0.29$ ft.	Normal depth in chute
n-value = 0.052	Manning's roughness coefficient
$D_{50}(F_s) = 7$ in.	Minimum Design D50*
$2(D_{50})(F_s) = 14$ in.	Rock chute thickness
$T_w + d = 1.7$ ft.	Tailwater above outlet apron
$z_2 = 0.82$ ft.	Hydraulic jump height
*** The outlet will function adequately	

High Flow Storm Information

C521

Rock Chute Design - Plan Sheet

(Version WI-July-2010, Based on Design of Rock Chutes by Robinson, Rice, Kadavy, ASAE, 1998)

Project: Security fire station
 Designer: Ken Harrison
 Date: 2/21/2021

County: El Paso
 Checked by: _____
 Date: _____

Minimum	Enter	Rock Gradation Envelope		Quantities ^a
Design Values	Plan Values	% Passing	Diameter, in. (weight, lbs.)	
7.0 in. D ₅₀ dia. =	12.00 in.			Rock = 55 yd ³
14.0 in. Rock _{chute} thickness =	24.00 in.	D ₁₀₀ -----	18 - 24 (413 - 978)	Geotextile (WCS-13) ^b = 121 yd ²
5 ft. Inlet apron length =	10.00 ft.	D ₈₅ -----	16 - 22 (269 - 713)	Bedding 12 in. = 47 yd ³
9 ft. Outlet apron length =	10.00 ft.	D ₅₀ -----	12 - 18 (122 - 413)	Excavation = 0 yd ³
19 ft. Radius =	33 ft.	D ₁₀ -----	10 - 16 (63 - 269)	Earthfill = 0 yd ³
Will bedding be used? Yes -----		Depth (in.) = 12.0		Seeding = 0.0 acres

Notes: ^a Rock, bedding, and geotextile quantities are determined from the x-section below (neglect radius).
^b Geotextile Class I (non-woven) shall be overlapped and anchored (18-in. min. along sides and 24-in. min. on the ends).

Degree of angularity =

1	50% angular, 50% rounded
2	100% rounded

Stakeout Notes

Sta.	Elev. (Pnt)
1+00.0	100 ft. (1)
1+04.6	100 ft. (2)
1+10.0	99.6 ft. (3)
1+15.1	98.3 ft. (4)
1+37.3	91 ft. (5)
1+47.3	91 ft. (6)
1+49.8	92 ft. (7)

Profile Along Centerline of Rock Chute **** Note: The outlet will function adequately**

Rock Chute Cross Section

Profile, Cross Sections, and Quantities

Class I non-woven

Rock gradation envelope can be met with DOT Extra Heavy riprap Gradation

Rock Chute Cost Estimate

Unit	Unit Cost	Cost
Rock	\$10.00 /yd ³	\$550.00
Geotextile	\$12.00 /yd ²	\$1,452.00
Bedding	\$12.00 /yd ³	\$564.00
Excavation	\$12.00 /yd ³	\$0.00
Earthfill	\$1.00 /yd ³	\$0.00
Seeding	\$2.00 /ac.	\$0.00
Total		\$2,566.00



Security fire station
 El Paso County

Date		File Name
Designed	Ken Harrison	
Drawn		Drawing Name
Checked		Sheet ___ of ___
Approved		

CS21

Rock Chute Design - Cut/Paste Plan

(Version WI-July-2010, Based on Design of Rock Chutes by Robinson, Rice, Kadavy, ASAE, 1998)

Project: Security fire station
 Designer: Ken Harrison
 Date: 2/21/2021

County: El Paso
 Checked by: _____
 Date: _____

Design Values	Rock Gradation Envelope	Quantities ^a
D ₅₀ dia. = 12.0 in.	% Passing Diameter, in. (weight, lbs.)	Rock = 55 yd ³
Rock _{chute} thickness = 24.0 in.	D ₁₀₀ ----- 18 - 24 (413 - 978)	Geotextile (WCS-13) ^b = 121 yd ²
Inlet apron length = 10 ft.	D ₈₅ ----- 16 - 22 (269 - 713)	Bedding 12 in. = 47 yd ³
Outlet apron length = 10 ft.	D ₅₀ ----- 12 - 18 (122 - 413)	Excavation = 0 yd ³
Radius = 33 ft.	D ₁₀ ----- 10 - 16 (63 - 269)	Earthfill = 0 yd ³
Will bedding be used? Yes	Coefficient of Uniformity, (D ₆₀)/(D ₁₀) < 1.7	Seeding = 0.0 acres

Notes: ^a Rock, bedding, and geotextile quantities are determined from x-section below (neglect radius).
^b Geotextile Class I (Non-woven) shall be overlapped and anchored (18-in. minimum along sides and 24-in. minimum on the ends) — quantity not included.

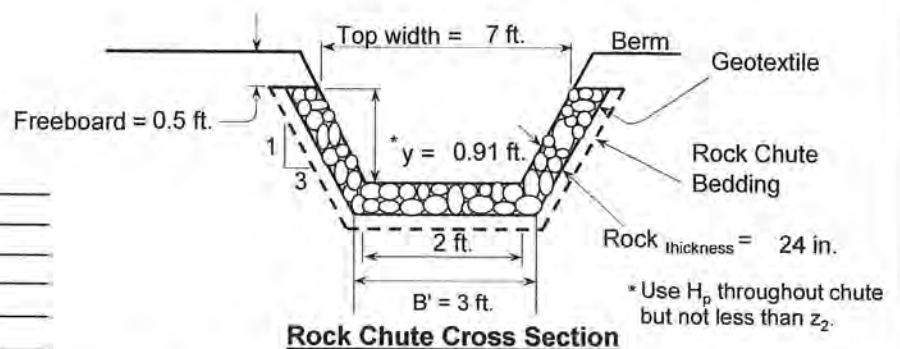
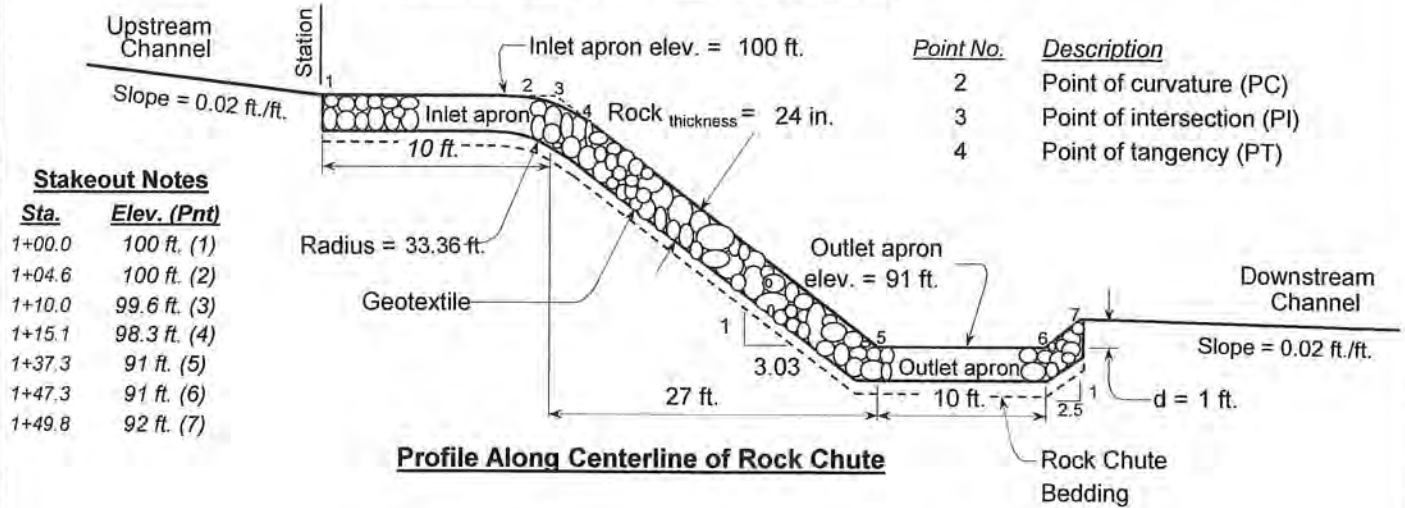

Profile, Cross Sections, and Quantities

<p>Natural Resources Conservation Service United States Department of Agriculture</p>	Security fire station	Date _____ Designed <u>Ken Harrison</u> _____ Drawn _____ Checked _____ Approved _____	File Name _____ Drawing Name _____ Sheet ___ of ___	
	El Paso County			

Rock Chute Design Calculations

(Version WI-July-2010, Based on Design of Rock Chutes by Robinson, Rice, Kadavy, ASAE, 1998)

Project: Security fire station
Designer: Ken Harrison
Date: 2/21/2021

County: El Paso
Checked by: _____
Date: _____

V. Calculate the rock chute parameters (w/o a factor of safety applied)

<u>High Flow</u>	<u>Low Flow</u>	
$q_i = 0.19$ cms/m	$q_i = 0.05$ cms/m	(Equivalent unit discharge)
$D_{50} \text{ (mm)} = 148.27 \rightarrow (5.84 \text{ in.})$	$D_{50} = 70.32$ mm	(Median <u>angular</u> rock size)
$n = 0.052$	$n = 0.046$	(Manning's roughness coefficient)
$z_1 = 0.29$ ft.	$z_1 = 0.12$ ft.	(Normal depth in the chute)
$A_1 = 0.8$ ft ²	$A_1 = 0.3$ ft ²	(Area associated with normal depth)
Velocity = 7.45 fps	Velocity = 4.38 fps	(Velocity in chute slope)
$z_{\text{mean}} = 0.22$ ft.	$z_{\text{mean}} = 0.10$ ft.	(Mean depth)
$F_1 = 2.78$	$F_1 = 2.43$	(Froude number)
$L_{\text{rock apron}} = 7.30$ ft.	----	(Length of rock outlet apron = $15 \cdot D_{50}$)

VI. Calculate the height of hydraulic jump height (conjugate depth)

<u>High Flow</u>	<u>Low Flow</u>	
$z_2 = 0.82$ ft.	$z_2 = 0.31$ ft.	(Hydraulic jump height)
$Q_{\text{high}} = 6.2$ cfs	$Q_{\text{high}} = 1.2$ cfs	(Capacity in channel)
$A_2 = 3.6$ ft ²	$A_2 = 0.9$ ft ²	(Flow area in channel)

VII. Calculate the energy lost through the jump (absorbed by the rock)

<u>High Flow</u>	<u>Low Flow</u>	
$E_1 = 1.15$ ft.	$E_1 = 0.41$ ft.	(Total energy <u>before</u> the jump)
$E_2 = 0.86$ ft.	$E_2 = 0.34$ ft.	(Total energy <u>after</u> the jump)
$R_E = 25.11$ %	$R_E = 17.86$ %	(Relative loss of energy)

Calculate Quantities for Rock Chute

<u>-----Rock Riprap Volume-----</u>	
<u>Area Calculations</u>	<u>Length @ Rock CL</u>
$h = 0.91$	Inlet = 9.84
$x_1 = 6.32$	Outlet = 10.35
$L = 2.88$	Slope = 28.72
$A_s = 5.76$	2.5:1 Lip = 2.49
$x_2 = 6.00$	Total = 51.40 ft.
$A_b = 17.30$	Rock Volume
$A_b + 2 \cdot A_s = 28.81$ ft²	54.84 yd³

<u>-----Bedding Volume-----</u>	
<u>Area Calculations</u>	<u>Bedding Thickness</u>
$h = 2.91$	$t_1, t_2 = 12.00$ in.
$x_1 = 3.16$	
$L = 9.20$	
$A_s = 9.20$	Length @ Bed CL
$x_2 = 3.00$	Total = 51.37 ft.
$A_b = 5.97$	Bedding Volume
$A_b + 2 \cdot A_s = 24.38$ ft²	46.39 yd³

<u>-----Geotextile Quantity-----</u>	
<u>Width</u>	<u>Length @ Bot. Rock</u>
2*Slope = 18.40	Total = 51.38 ft.
Bottom = 2.65	Geotextile Area
Total = 21.05 ft.	120.20 yd²

Note: 1) The radius is not considered when calculating quantities of riprap, bedding, or geotextile.
 2) The geotextile quantity does not include overlapping (18-in. min.) or anchoring material (18-in. min. along sides, 24-in. min. on ends).

Rock Chute Design Calculations

(Version WI-July-2010, Based on Design of Rock Chutes by Robinson, Rice, Kadavy, ASAE, 1998)

Project: Security fire station
Designer: Ken Harrison
Date: 2/21/2021

County: El Paso
Checked by: _____
Date: _____

I. Calculate the normal depth in the inlet channel

<u>High Flow</u>		<u>Low Flow</u>	
$y_n =$	0.48 ft.	$y_n =$	0.20 ft. (Normal depth)
Area =	1.7 ft ²	Area =	0.5 ft ² (Flow area in channel)
$Q_{high} =$	6.2 cfs	$Q_{low} =$	1.2 cfs (Capacity in channel)
Scupstreamchannel =	0.016 ft/ft		

II. Calculate the critical depth in the chute

<u>High Flow</u>		<u>Low Flow</u>	
$y_c =$	0.51 ft.	$y_c =$	0.20 ft. (Critical depth in chute)
Area =	1.8 ft ²	Area =	0.5 ft ² (Flow area in channel)
$Q_{high} =$	6.2 cfs	$Q_{low} =$	1.2 cfs (Capacity in channel)
$H_{ce} =$	0.69 ft.	$H_{ce} =$	0.28 ft. (Total minimum specific energy head)
$h_{cv} =$	0.18 ft.	$h_{cv} =$	0.08 ft. (Velocity head corresponding to y_c)
$10y_c =$	5.15 ft.	---	---
$0.715y_c =$	0.37 ft.	$0.715y_c =$	0.14 ft. (Depth of flow over the weir crest or brink)

III. Calculate the tailwater depth in the outlet channel

<u>High Flow</u>		<u>Low Flow</u>	
$T_w =$	0.70 ft.	$T_w =$	0.55 ft. (Tailwater depth)
Area =	2.8 ft ²	Area =	2.0 ft ² (Flow area in channel)
$Q_{high} =$	12.9 cfs	$Q_{low} =$	7.9 cfs (Capacity in channel)
$H_2 =$	0.00 ft.	$H_2 =$	0.00 ft. (Downstream head above weir crest, $H_2 = 0$, if $H_2 < 0.715y_c$)

IV. Calculate the head for a trapezoidal shaped broadcrested weir

$C_d =$ **1.00** (Coefficient of discharge for broadcrested weirs)

<u>High Flow</u>		<u>Low Flow</u>	
$H_p =$	0.93 ft.	0.91 ft.	(Weir head)
Area =	4.4 ft ²	4.3 ft ²	(Flow area in channel)
$V_o =$	0.00 fps	1.45 fps	(Approach velocity)
$h_{pv} =$	0.00 ft.	0.03 ft.	(Velocity head corresponding to H_p)
$Q_{high} =$	6.2 cfs	6.2 cfs	(Capacity in channel)

Trial and error procedure solving simultaneously for velocity and head

<u>Low Flow</u>		<u>High Flow</u>	
$H_p =$	0.33 ft.	0.31 ft.	(Weir head)
Area =	1.0 ft ²	0.9 ft ²	(Flow area in channel)
$V_o =$	0.00 fps	1.35 fps	(Approach velocity)
$h_{pv} =$	0.00 ft.	0.03 ft.	(Velocity head corresponding to H_p)
$Q_{low} =$	1.2 cfs	1.2 cfs	(Capacity in channel)

Trial and error procedure solving simultaneously for velocity and head

KCH Engineering Solutions

5228 Cracker Barrel Circle
Colorado Springs, CO 80917
(719) 246-4471

JOB Security Fire Station

SHEET NO. _____ OF _____

CALCULATED BY _____ DATE 2-21-21

CHECKED BY _____ DATE _____

SCALE _____

1. 12" HDPE 475'

2 Gravel maintenance Road

Length = 100'

Width 10'

Depth 0.5'

Volume 190 y

3 Concrete Cut Wall @ top of emergency overflow

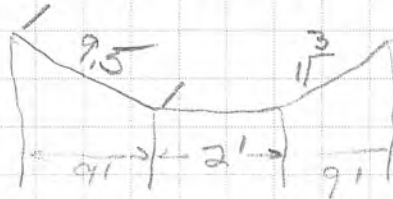

Total length = 21'

Depth 3'

Width 1'

Volume 2.3 c.y

4. Pond Excavation

Pond: Height \approx 4'

Bottom side \approx 20'

Top width 60'

Volume 256 c.y

CONSTRUCTIONWORKZONE

The online toolbox for the construction professional

Powered By **BNi** Building News

[Estimating Tools Start](#) [Back](#)

Description:	Concrete catch basin,CIP,3'8"x 3'8",6" wall,4'deep
Unit:	EA.
Material:	550.00
Inst:	817.40
Total:	<u>1,367.40</u>

Local Cost:

State: ▼
Metro area: ▼
Local cost:

CONSTRUCTIONWORKZONE

The online toolbox for the construction professional

Powered By **BNI Building News**

[Estimating Tools Start](#) [Back](#)

Description:	Place concrete,footing,3500# or 4000#,by pump
Unit:	C.Y.
Material:	117.19
Inst:	55.79
Total:	<u>172.98</u>

Local Cost:

State: Select state ▼
Metro area: Select metro area ▼
Local cost:

CONSTRUCTIONWORKZONE

The online toolbox for the construction professional

Powered By **BNI** Building News

[Estimating Tools Start](#) [Back](#)

Description:	PVC,class 150 pipe,12" dia
Unit:	L.F.
Material:	31.92
Inst:	8.17
Total:	<u>40.10</u>

Local Cost:

State: ▼

Metro area: ▼

Local cost:

EXHIBIT 11

HISTORIC DRAINAGE CONDITIONS (MAP POCKET)

EXHIBIT 12

DEVELOPED DRAINAGE CONDITIONS (MAP POCKET)



Inlet Summary

Structure/ Inlet #	Design Point	Contributing Sub Basins	Surface flow from Sub basins	Upstream Inlet S/R Number	Bypass from upstream inlets	Total Surface flow at inlet	Inlet Description	Condition	Inlet Interception	Inlet Bypass	Inlet Interception %	Spread	Depth of flow over inlet	Calculations sheet	Comments
			cfs		cfs	cfs			cfs	cfs	%	ft	inches		
1	3	D	0.3	NA	0	0.3	12" standard	sump	0.3	0	100%	NA	2.4	1	Used the smallest C&G inlet due to the negligible desing flow
2	4	F	0.2	1	0	0.2	12" drop in	sump	0.2	0	100%	NA	1.2	2	no inlet at this location, roof drain connects directly into the storm sewer
4	7	H	0.7	NA	0	NA	Double 24" square drop in grate	on grade	0.7	0	100%	NA	NA	NA	no inlet at this location, roof drain connects directly into the storm sewer
19	6	E	1.8	NA	0	1.8	Double 24" square drop in grate	on grade	1.2	0.6	67%	8.5	2.0	3	
6	13	J	1.3	19	0.6	1.9	Double 24" square drop in grate	on grade	1.2	0.7	63%	8.0	2.0	4	
21	17	M	0.2	6	0.7	0.9	Riprap chase to floor of detention Basin	NA	0.9	0	100%	NA	NA	NA	

- Notes
- 1 Cross slopes at each inlet is assumed to be 1.5%
 - 2 Maximum Depth at Curb face is 6"
 - 3 Inlets were sized to intercept approximately 100% of the 100 year flow
 - 4 Maximum spread from face of curbs is 15'

Storm Sewer Summary

Pipe Segment	Tributary/ Upstream Pipe Segments	Down stream Design Point	Design Flow (cfs)				Pipe Hydraulic Characteristics							
			Upstream Pipe Segment #1 ID	Discharge from segment 1	Upstream Pipe Segment #2 ID	Discharge from segment 2	Contributing upstream inlet ID	Inlet Interception rate	Total Design flow for pipe segment	size (HPE)	Approx. slope	Depth	Velocity	Calc Sht #
			cfs	cfs	cfs	cfs	cfs	cfs	inches	%	(feet)	fps		
11	1	DP4	NA	NA	NA	NA	1	0.3	0.3	12	1.0	0.2	2.7	5
3	27	DP13	11	0.3	NA	NA	2	0.2	0.5	12	1.0	0.2	2.7	6
16	27	DP5	NA	NA	16	0.1	NA	0.1	0.1	12	0.5	0.4	3.6	9
8	16	DP5	16	0.1	NA	NA	7	0.7	0.8	12	0.5	0.3	2.7	
9	NA	DP16	NA	NA	NA	NA	19	1.2	1.2	12	0.5	0.4	3.2	7
10	9,8	DP16	8	0.7	9	1.2	NA	NA	1.9	12	1.0	0.5	3.6	8
12	3,4	7	3	0.5	NA	NA	Root Drain at DP7	0.7	1.2	12	1.0	0.3	4.1	11
13	5	NA	12	1.2	NA	NA	NA	NA	1.2	12	1.0	0.3	4.1	11
20	13	45 deg wye	13	1.2	NA	NA	6	1.2	2.4	12	1.0	0.4	5.0	12
14	45 deg wye	15	10	1.9	20	2.4	NA	NA	4.3	12	10.0	0.4	10.4	13
22	pond	12	NA	NA	NA	NA	NA	1.8	1.8	12	2.5	0.3	6.3	14

- 1 Refer to Inlet spreadsheet for interception and bypass rates
- 2 Refer to CS sheets in the report for hydraulic characteristics of the pipe segments.

Design Point Summary

Surface Flow Developed Conditions

Design Point ID	Contributing sub Basin for surface flow	Discharge from Sub basin (100 yr) (cfs)	Upstream Design Point	Upstream Bypass (100 yr) (cfs)	Total Q100 (surface flow) (cfs)
1	OS2	NA	NA	NA	NA
2	OS2, A	NA	NA	NA	NA
3	D	0.30	NA	0.0	0.3
4	F	0.10	NA	0.0	0.1
5	Underground fitting in the storm sewer pipe system	NA	4	0.0	0.0
6	E	1.80	NA	0.0	1.8
7	H	0.70	NA	0.0	0.7
8	M, bypass DP13	0.20	13	0.7	0.9
9	Pond Outflow Structure	See pond report narrative			
10	OS1	4.20	NA	0.0	4.2
11	OS1, pond overflow	6.70	Pond	NA	6.7
12	Outfall end of pipe from pond	See pond report narrative			
13	J, bypass DP9	1.30	6	0.7	2.0
14	Pond emergency overflow	See pond report narrative			
15	D,F,H,J,I,E	See pond report narrative			
16	Underground fitting in the storm sewer pipe system				
17	M, bypass DP13	0.20	6	0.7	6.9

- 1 The storm sewer system is sized for the 100 year storm foww in order to route it to the FSDP
- 2 See report narrative for characteristics of the pond outlet structure, inflow, emergency overflow.

Basin Discharge Summary

Sub basin ID	Area (Acres)	Time of Conc min.	Runoff Coefficient		Design Discharges	
			5 year	100 year	5 year (cfs)	100 year (cfs)
A	0.04	5	0.90	0.96	0.20	0.30
B	0.01	5	0.90	0.96	Negligible	0.10
C	0.02	5	0.90	0.96	0.10	0.20
D	0.08	5	0.12	0.39	Negligible	0.30
E	0.24	5	0.80	0.87	1.00	1.80
F	0.03	5	0.90	0.96	0.10	0.20
G	0.19	5	0.08	0.35	0.10	0.60
H	0.09	5	0.90	0.96	0.40	0.70
I	0.09	5	0.90	0.96	0.40	0.70
J	0.18	5	0.73	0.83	0.70	1.30
K	0.13	5	0.08	0.35	0.10	0.40
L	0.12	5	0.08	0.35	Negligible	0.40
M	0.02	5	0.90	0.96	0.10	0.20
N	0.05	5	0.08	0.35	Negligible	0.20
O	0.01	5	0.08	0.35	Negligible	Negligible
P	0.04	5	0.08	0.35	Negligible	0.10

Full Spectrum Detention Pond

Design Flows	
Peak Inflow: Q100 = 2.8 cfs	
Peak Outflow: Q100 = 1.2 cfs	
Emergency Overflow = 6.7 cfs	
Pond Characteristics	
Type: Sand Filter	
WQCV = 0.015 acre-ft., elev = 0.83 ft. (5780.83)	
EURV = 0.044 acre-ft. elev = 2.24 ft. (5782.24)	
100-year = 0.041 acre-ft., elev = 3.08 ft. (5783.08)	
Media Surface elev = 0.00 ft. (5780.0)	
Spillway elevation = 3.5 ft. (5783.5)	
Top of berm elevation = 5.0 ft. (5785.0)	
Outlet Structure	
Overflow Weir Elevation = 3.0 ft. (5783.0)	
Overflow Grate Size = approximately a 3' by 3'	
Emergency Spillway	
Spillway Invert Elevation = 3.5 ft. (5783.5)	
Top of Bank= 5.0 ft. (5785.0)	

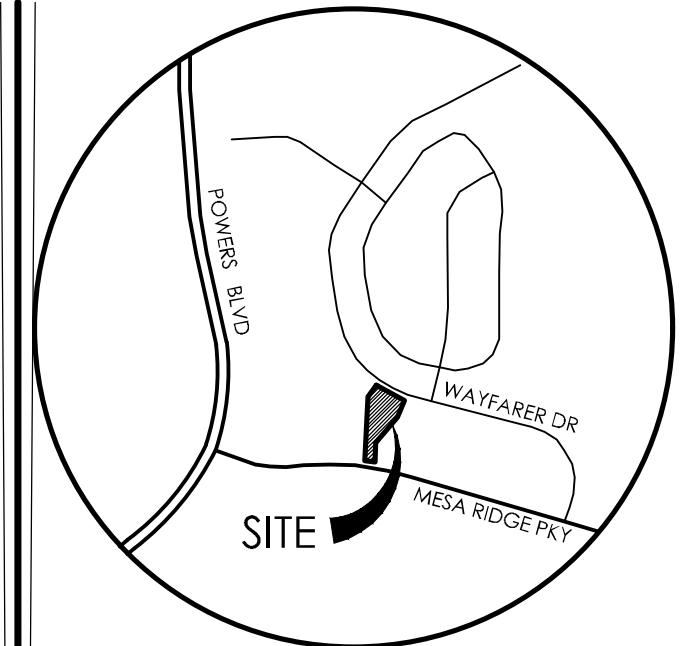

VICINITY MAP
NOT TO SCALE

BENCHMARK

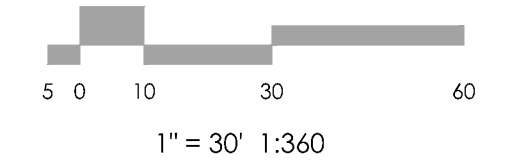
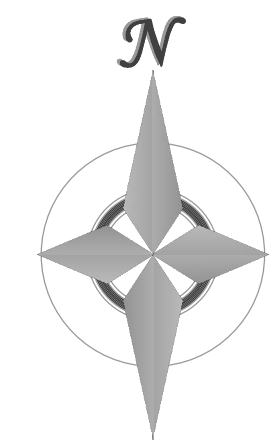

MVE, INC.
ENGINEERS / SURVEYORS

1903 Library Street, Suite 200 Colorado Springs, CO 80909 719.635.5736

REVISIONS

DESIGNED BY _____
DRAWN BY _____
CHECKED BY _____
AS-BUILTS BY _____
CHECKED BY _____

SECURITY FIRE STATION NO. 4

DRAINAGE MAP
PROPOSED

MVE PROJECT 61134
MVE DRAWING DRAIN-PP

APRIL 7, 2021
SHEET 1 OF 1

LEGEND

PROPOSED

- INDEX CONTOUR
- INTERMEDIATE CONTOUR
- BASIN BOUNDARY
- GENERAL FLOW/DIRECTION
- SLOPE DIRECTION
- BASIN LABEL
- BASIN ID
- BASIN AREA (AC.)
- POINT OF INTEREST
- DRAINAGE ITEM (SEE TABLE)

EXISTING

- PROPERTY LINE
- EASEMENT LINE
- ADJACENT PROPERTY LINE
- INDEX CONTOUR
- INTERMEDIATE CONTOUR