

WOODMOOR WATER AND SANITATION DISTRICT NO. 1

WELL NO. 22

EL PASO COUNTY, COLORADO

SWMP, GRADING AND EROSION CONTROL PLAN

CONTACTS

OWNER (APPLICANT):	WOODMOOR WATER AND SANITATION DISTRICT NO. 1 1845 WOODMOOR DRIVE MONUMENT, CO 80132	JESSE SHAFTER, P.E. (719) 488-2525 JESSE@WOODMOORWATER.COM
ENVIRONMENTAL ENGINEER:	JVA, INC 1675 LARIMER STREET, SUITE 550 DENVER, CO 80202	RICHARD HOOD, P.E. (303) 444-1951 RHOO@JVAJVA.COM
CIVIL ENGINEER (SWMP PREPARER):	JVA, INC 1319 SPRUCE STREET BOULDER, CO 80302	KENNETH J. CLIFFORD, P.E. (303) 565-4973 KCLIFFORD@JVAJVA.COM



DRAWING INDEX

SHEET NO.	TITLE
GO.0	COVER SHEET
GO.1	LEGEND NOTES AND ABBREVIATIONS
CE1.0	EROSION CONTROL PLAN
CE1.1	SWMP AND GEC NOTES
CE1.2	EROSION CONTROL DETAILS
CE1.3	EROSION CONTROL DETAILS
CI.0	GRADING AND DRAINAGE PLAN
CD1.0	CIVIL DETAILS

AUGUST 2023

PREPARED UNDER THE SUPERVISION OF

JVA, Inc.

AT LEAST (10) DAYS PRIOR TO THE ANTICIPATED START OF CONSTRUCTION, FOR PROJECTS THAT WILL DISTURB ONE (1) ACRE OR MORE, THE OWNER, OR OPERATOR OF CONSTRUCTION ACTIVITY SHALL SUBMIT A PERMIT APPLICATION FOR STORMWATER DISCHARGE TO THE COLORADO DEPARTMENT OF PUBLIC HEALTH AND ENVIRONMENT, WATER QUALITY DIVISION. THE APPLICATION CONTAINS CERTIFICATION OF COMPLETION OF A STORMWATER MANAGEMENT PLAN (SWMP), OF WHICH THIS GRADING AND EROSION CONTROL PLAN MAY BE A PART. FOR INFORMATION OF APPLICATION MATERIALS CONTACT:

COLORADO DEPARTMENT OF PUBLIC HEALTH AND ENVIRONMENT
WATER QUALITY CONTROL DIVISION
WOOD - PERMITS
4300 CHERRY CREEK DRIVE SOUTH
DENVER, CO 80246-1530
ATTN: PERMITS UNIT

ENGINEER'S STATEMENT:

THIS GRADING AND EROSION CONTROL PLAN WAS PREPARED UNDER MY DIRECTION AND SUPERVISION AND IS CORRECT TO THE BEST OF MY KNOWLEDGE AND BELIEF. SAID PLAN HAS BEEN PREPARED ACCORDING TO THE CRITERIA ESTABLISHED BY THE COUNTY FOR GRADING AND EROSION CONTROL PLANS. I ACCEPT RESPONSIBILITY FOR ANY LIABILITY CAUSED BY ANY NEGLIGENT ACTS, ERRORS OR OMISSIONS ON MY PART IN PREPARING THIS PLAN.

ENGINEER OF RECORD: DATE: _____

OWNER'S STATEMENT:

I, THE OWNER/DEVELOPER HAVE READ AND WILL COMPLY WITH THE REQUIREMENTS OF THE GRADING AND EROSION CONTROL PLAN.

8-30-23
OWNER SIGNATURE DATE

EL PASO COUNTY:

COUNTY PLAN REVIEW IS PROVIDED ONLY FOR GENERAL CONFORMANCE WITH THE COUNTY DESIGN CRITERIA. THE COUNTY IS NOT RESPONSIBLE FOR THE ACCURACY AND ADEQUACY OF THE DESIGN, DIMENSIONS, AND/OR ELEVATIONS WHICH SHALL BE CONFIRMED AT THE JOB SITE. THE COUNTY THROUGH THE APPROVAL OF THIS DOCUMENT ASSUMES NO RESPONSIBILITY FOR COMPLETENESS AND/OR ACCURACY OF THIS DOCUMENT.

FILED IN ACCORDANCE WITH THE REQUIREMENTS OF THE EL PASO COUNTY LAND DEVELOPMENT CODE, DRAINAGE CRITERIA MANUAL VOLUMES 1 AND 2, AND ENGINEERING CRITERIA MANUAL, AS AMENDED.

IN ACCORDANCE WITH EGM SECTION 1.12, THESE CONSTRUCTION DOCUMENTS WILL BE VALID FOR CONSTRUCTION FOR A PERIOD OF 2 YEARS FROM THE DATE SIGNED BY THE EL PASO COUNTY ENGINEER. IF CONSTRUCTION HAS NOT STARTED WITHIN THOSE 2 YEARS, THE PLANS WILL NEED TO BE RESUBMITTED FOR APPROVAL, INCLUDING PAYMENT OF REVIEW FEES AT THE PLANNING AND COMMUNITY DEVELOPMENT DIRECTOR'S DISCRETION.

Joshua Palmer, P.E. DATE: _____
County Engineer/ECM Administrator

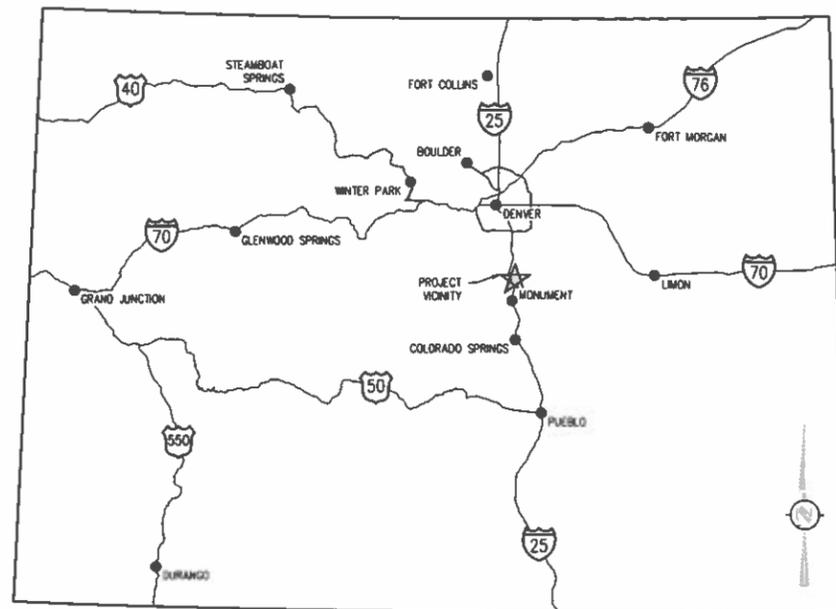

VICINITY MAP
NTS



PROJECT LOCATION MAP
NTS

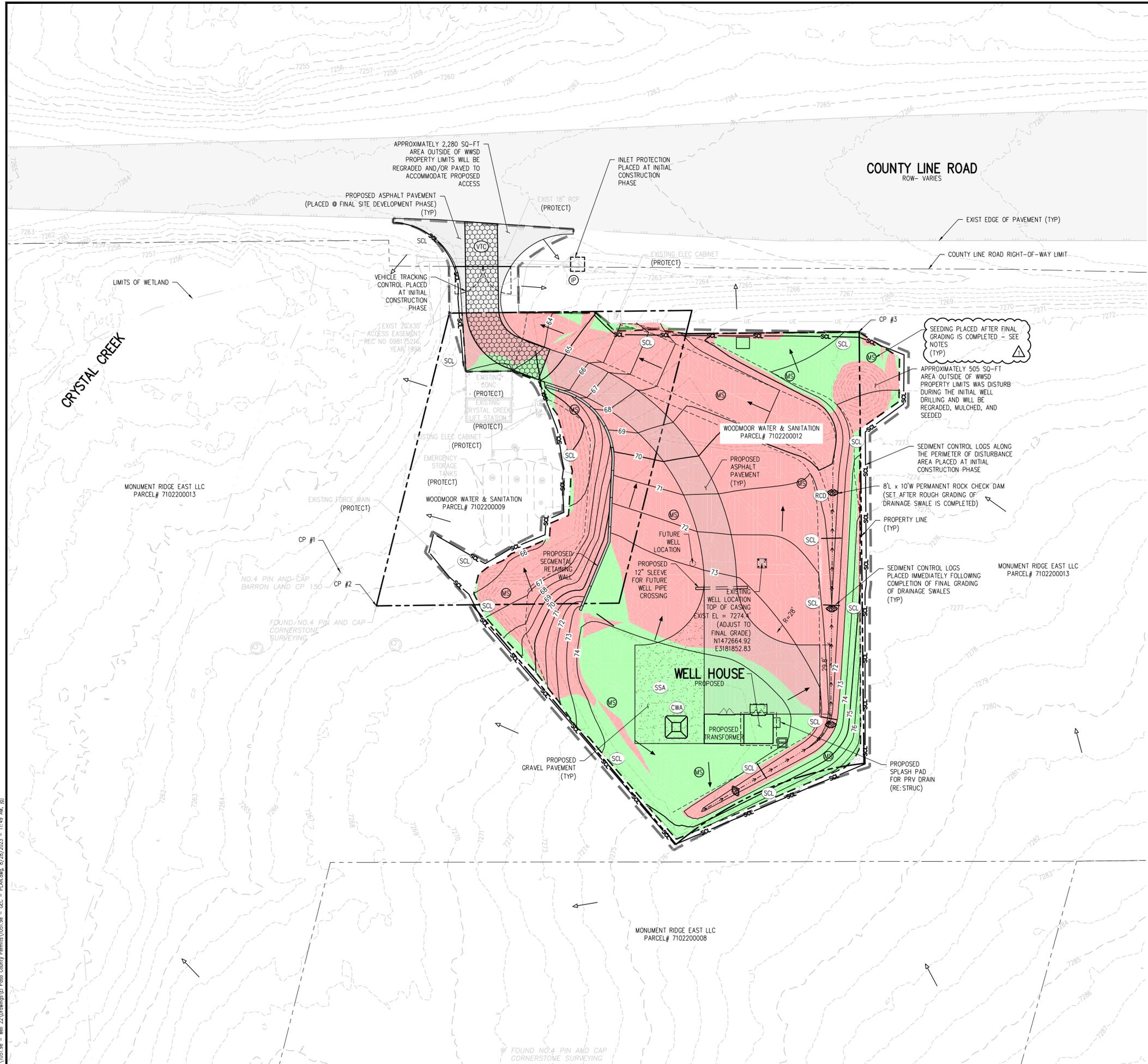

EROSION CONTROL LEGEND

	EXISTING INDEX CONTOUR
	EXISTING INTERMEDIATE CONTOUR
	PROPOSED INDEX CONTOUR
	PROPOSED INTERMEDIATE CONTOUR
	RIGHT-OF-WAY
	PROPERTY LINE
	LIMITS OF CONSTRUCTION/DISTURBANCE BOUNDARY
	LIMITS OF EARTHWORK CUT/FILL
	VEHICLE TRACKING CONTROL
	STABILIZED STAGING AREA
	INLET PROTECTION
	CONCRETE WASHOUT AREA
	SEDIMENT CONTROL LOG
	ROCK CHECK DAM
	MULCHING AND SEEDING
	HISTORIC DRAINAGE
	DEVELOPED DRAINAGE
	EARTHWORK CUT AREA
	EARTHWORK FILL AREA

- EROSION AND SEDIMENTATION NOTES:**
- CONTRACTOR IS RESPONSIBLE FOR INSTALLING AND MAINTAINING ALL CONTROLS DURING INITIAL, INTERIM, AND FINAL CONDITIONS.
 - CONTRACTOR IS RESPONSIBLE FOR TAKING THE NECESSARY PRECAUTIONS TO PROTECT EXISTING FEATURES OUTSIDE OF LIMITS OF CONSTRUCTION.
 - AT THE COMPLETION OF THE DRILLING THE CONTRACTOR WILL REDISTRIBUTE THE SOIL STOCK PILES WITHIN THE DISTURBANCE AREA. SOME OF THE SOIL MAY BE HAULED OFF-SITE.
 - ALL CONTROLS SHALL BE INSTALLED WITHIN THE PROPERTY LINES UNLESS OTHERWISE SPECIFIED. WHEN CONSTRUCTION ACTIVITIES DISTURB ADJACENT AND/OR RIGHT-OF-WAY PROPERTIES, COORDINATION WITH PROPERTY OWNERS IS REQUIRED PRIOR TO CONSTRUCTION.
 - GRADING/DISTURBANCE WITHIN THE RIGHT-OF-WAY MAY REQUIRE CONTRACTOR TO OBTAIN A WORK WITHIN RIGHT-OF-WAY PERMIT. CONTRACTOR TO VERIFY WITH EL PASO COUNTY PRIOR TO CONSTRUCTION.
 - ON-SITE AND OFF-SITE SEEDING WILL OCCUR OVER ALL DISTURBED NON-PAVED AREAS (GRAVEL OR ASPHALT PAVING) AND THE WELL HOUSE AND TRANSFORMER SITES, AS SHOWN ON THIS PLAN. COMPACTION OF SOIL MUST BE PREVENTED IN AREAS DESIGNATED FOR MULCHING AND SEEDING. IF COMPACTION PREVENTION IS NOT FEASIBLE PRIOR FINAL MULCHING AND SEEDING, THEN THE CONTRACTOR MUST FIRST LOOSEN SOIL.

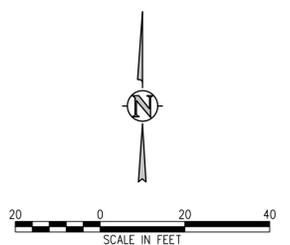

N:\1051.9e - Well 22\Drawings\El Paso County Permits\1051.9e - DEC - PLAN.dwg, 8/28/2023 - 11:49 AM, JGJ

NO. DATE DESIGNED BY



DESIGNED BY: JGJ
DRAWN BY: JGJ
CHECKED BY: KJC
JOB #: 1051.9e
DATE: AUGUST 2023
© JVA, INC.

WOODMOOR WSD NO. 1
WELL NO. 22
EL PASO COUNTY, COLORADO
EROSION CONTROL PLAN

SHEET NO.
CE1.0

STORMWATER MANAGEMENT PLAN (SWMP)

THIS STORMWATER MANAGEMENT PLAN IS TO BE RETAINED AND MAINTAINED ONSITE INCLUDING FINAL LANDSCAPING PLANS AND ANY OTHER EROSION CONTROL DOCUMENTATION. A SWMP ADMINISTRATOR WILL BE DESIGNATED BY THE CONTRACTOR AND IS RESPONSIBLE FOR DEVELOPING, IMPLEMENTING, MAINTAINING, AND REVISING THIS SWMP.

NAME: _____
CONTACT INFO: _____

THE SITE IS LOCATED AT 1755 COUNTY LINE ROAD IN MONUMENT, COLORADO. THE WOODMOOR WATER & SANITATION DISTRICT NO. 1 (WWSO) PROPOSES TO BUILD A NEW GROUNDWATER WELL (REFERRED TO AS WELL NO. 22) ON THEIR PROPERTY.

Table with 3 columns: PHASE, ESTIMATED, ACTUAL. Rows include MOBILIZE TO SITE, INSTALL TEMPORARY EROSION CONTROL, INITIAL SITE GRADING, BUILD WELL HOUSE/ TRANSFORMER, FINE GRADING, etc.

THE EXISTING SITE CONSISTS OF DEVELOPED LAND AND NATIVE GRASSLAND, AND IS APPROXIMATELY 95% COVERED WITH VEGETATIVE GROUND COVER. THE ESTIMATED HISTORIC AND DEVELOPED RUNOFF COEFFICIENTS ARE 0.25 AND 0.25, RESPECTIVELY.

OFFSITE RUNOFF FLOWS ONTO THE PROPERTY ARE GENERALLY FROM THE SOUTHWEST. ONSITE FLOWS ALSO TYPICALLY FLOW FROM THE SOUTHWEST. THE MAJOR POTENTIAL POLLUTANT SOURCE FROM THE SITE IS EXPECTED TO BE FROM THE EXPOSURE OF SOIL DURING THE EXTENT OF THE DRILLING OPERATIONS.

THE CONTRACTOR SHALL BE RESPONSIBLE FOR THE REMOVAL OF ALL WASTES FROM CONSTRUCTION SITES FOR DISPOSAL IN ACCORDANCE WITH LOCAL AND STATE REGULATORY REQUIREMENTS. NO CONSTRUCTION DEBRIS, TREE SLASH, BUILDING MATERIAL WASTES, OR UNUSED BUILDING MATERIALS SHALL BE BURIED, DUMPED, OR DISCHARGED AT THE SITE.

OTHER POTENTIAL TEMPORARY POLLUTION SOURCES WOULD BE FROM THE NORMAL DRILLING ACTIVITY SUCH AS VEHICLE TRAFFIC ACCESSING AND LEAVING THE SITE, VEHICLE FUELING, STORAGE OF MATERIALS, AND LOADING/ UNLOADING AREAS.

THERE WILL BE NO OTHER NON-STORMWATER DISCHARGED FROM THE SITE.

BEST MANAGEMENT PRACTICES FOR STORMWATER MANAGEMENT

NON STRUCTURAL BMPs WILL BE IMPLEMENTED TO THE MAXIMUM EXTENT POSSIBLE. THE UTILIZATION OF NON STRUCTURAL BMPs WILL BE AN ONGOING PROCESS DIRECTED AT PREVENTING EROSION.

PLANNED STRUCTURAL BMPs FOR EROSION AND SEDIMENT CONTROL ARE SHOWN ON THE EROSION AND SEDIMENTATION CONTROL PLAN. IMPLEMENTING THESE MEASURES SHOULD MINIMIZE NUISANCE SILT AND SEDIMENTATION EXITING THE SITE AND PREVENT CLOGGING EXISTING STORM SEWERS.

APPLICATION OF THESE BMPs FOR STORMWATER MANAGEMENT ARE FOR CONSTRUCTION PERIODS AND ARE CONSIDERED TEMPORARY. POST-DEVELOPMENT STORMWATER MANAGEMENT IS PROVIDED THROUGH GRADING AND SEEDING STABILIZATION.

CONCRETE WASHOUT AREA (CWA):

A TEMPORARY CONCRETE WASHOUT AREA WILL BE NECESSARY DURING THE POURING OF THE WELL HOUSE FOUNDATION. IT CAN THEN BE REMOVED ONCE ALL ON-SITE CONCRETE FORMING HAS BEEN COMPLETED.

VEHICLE TRACKING CONTROL (VTC):

A STABILIZED CONSTRUCTION ENTRANCE WILL BE PROVIDED AT COUNTY LINE ROAD (ALSO REFERRED TO COUNTY ROAD 404 OR PALMER DIVIDE AVE). THE CONSTRUCTION ACCESS AND PARKING WILL BE GRADED AND COVERED WITH A CRUSHED STONE BASE COURSE DURING CONSTRUCTION.

SEDIMENT CONTROL LOGS (SCL):

SEDIMENT CONTROL LOGS SHALL BE INSTALLED WITH RESPECT TO PROPOSED DRAINAGE PATTERNS. SEDIMENT CONTROL LOGS SHALL BE CONSTRUCTED ALONG THE PORTIONS OF THE PERIMETER THE PROPOSED LIMITS OF WORK AND AROUND TEMPORARY SOIL STOCKPILES.

INLET PROTECTION (IP):

THE INLET PROTECTION WILL BE INSTALLED AT THE EXISTING 18" REINFORCED CONCRETE PIPE LOCATED AT THE EXISTING ENTRANCE TO THE CRYSTAL CREEK LIFT STATION. A TEMPORARY INLET SEDIMENT TRAP WILL BE CONSTRUCTED AROUND THE EXISTING FLARED END SECTION LOCATED ON THE EAST SIDE OF THE SAID ENTRANCE.

DUST CONTROL MEASURES:

DISTURBED AREAS NOT YET READY TO BE SEEDED OR OTHERWISE STABILIZED SHALL BE WATERED, OR RIPPED AS NECESSARY TO PRECLUDE VISIBLE DUST EMISSIONS.

ITEMS ARE SCHEDULED TO BE IMPLEMENTED ACCORDING TO THE CONSTRUCTION SCHEDULE. AS WORK PROCEEDS, IMPLEMENTATION OF INDIVIDUAL BMPs IS TO COINCIDE WITH THE CONSTRUCTION THEREBY MINIMIZING THE EXPOSURE OF UNPROTECTED AREAS.

THE EROSION AND SEDIMENT CONTROL PLAN MAY BE MODIFIED BY THE OWNER'S ENGINEER, COUNTY ENGINEERING INSPECTORS, OR MUNICIPALITY, OR ITS AUTHORIZED REPRESENTATIVE AS FIELD CONDITIONS WARRANT.

PERMANENT STABILIZATION MEASURES:

NATIVE PERENNIAL SEEDING WILL BE ESTABLISHED AFTER FINAL GRADING OF THE SITE IS COMPLETED.

MATERIALS AND SPILL PREVENTION:

THE CONTRACTOR WILL STORE CONSTRUCTION MATERIALS AND EQUIPMENT IN CONFINED AREAS ON SITE FROM WHICH RUNOFF WILL BE CONTAINED AND FILTERED. MATERIALS WILL BE STORED OFF THE GROUND AND PROTECTED FROM THE WEATHER BY A COVER OR STORED IN A CONTAINER SUCH AS A VAN OR TRAILER.

INSPECTION AND MAINTENANCE:

THE EROSION CONTROL MEASURES WILL BE INSPECTED DAILY DURING DRILLING OPERATIONS BY THE CONTRACTOR AND AFTER EACH RAIN EVENT. ALL INSPECTIONS SHALL BE DOCUMENTED AND SHALL INCLUDE THE DATE OF INSPECTION, ANY INCIDENCE OF NON-COMPLIANCE, SIGNED CERTIFICATION THAT THE SITE IS IN COMPLIANCE, AND ANY NOTES, DRAWINGS, MAPS, ETC. PERTAINING TO REPAIRS.

FINAL STABILIZATION AND LONG-TERM STORMWATER QUALITY:

FINAL STABILIZATION IS REACHED WHEN ALL SOIL DISTURBING ACTIVITIES AT THE SITE HAVE BEEN COMPLETED, AND UNIFORM VEGETATIVE COVER HAS BEEN ESTABLISHED WITH A DENSITY OF AT LEAST 70% OR PRE-DISTURBANCE LEVELS OR EQUIVALENT PERMANENT, PHYSICAL EROSION REDUCTION METHODS HAVE BEEN EMPLOYED.

STANDARD NOTES FOR EL PASO COUNTY GRADING AND EROSION CONTROL PLANS

- 1. STORMWATER DISCHARGES FROM CONSTRUCTION SITES SHALL NOT CAUSE OR THREATEN TO CAUSE POLLUTION, CONTAMINATION, OR DEGRADATION OF STATE WATERS. ALL WORK AND EARTH DISTURBANCE SHALL BE DONE IN A MANNER THAT MINIMIZES POLLUTION OF ANY ON-SITE OR OFF-SITE WATERS, INCLUDING WETLANDS.
2. NOTWITHSTANDING ANYTHING DEPICTED IN THESE PLANS IN WORDS OR GRAPHIC REPRESENTATION, ALL DESIGN AND CONSTRUCTION RELATED TO ROADS, STORM DRAINAGE AND EROSION CONTROL SHALL CONFORM TO THE STANDARDS AND REQUIREMENTS OF THE MOST RECENT VERSION OF THE RELEVANT ADOPTED EL PASO COUNTY STANDARDS, INCLUDING THE LAND DEVELOPMENT CODE, THE ENGINEERING CRITERIA MANUAL, THE DRAINAGE CRITERIA MANUAL, AND THE DRAINAGE CRITERIA MANUAL VOLUME 2.
3. A SEPARATE STORMWATER MANAGEMENT PLAN (SWMP) FOR THIS PROJECT SHALL BE COMPLETED AND AN EROSION AND STORMWATER QUALITY CONTROL PERMIT (ESQCP) ISSUED PRIOR TO COMMENCING CONSTRUCTION.
4. ONCE THE ESQCP IS APPROVED AND A NOTICE TO PROCEED HAS BEEN ISSUED, THE CONTRACTOR MAY INSTALL THE INITIAL STAGE EROSION AND SEDIMENT CONTROL MEASURES AS INDICATED ON THE APPROVED G.C.
5. CONTROL MEASURES MUST BE INSTALLED PRIOR TO COMMENCEMENT OF ACTIVITIES THAT MAY CONTRIBUTE POLLUTANTS TO STORMWATER.
6. ALL TEMPORARY SEDIMENT AND EROSION CONTROL MEASURES SHALL BE MAINTAINED AND REMAIN IN EFFECTIVE OPERATING CONDITION UNTIL PERMANENT SOIL EROSION CONTROL MEASURES ARE IMPLEMENTED AND FINAL STABILIZATION IS ESTABLISHED.
7. TEMPORARY STABILIZATION SHALL BE IMPLEMENTED ON DISTURBED AREAS AND STOCKPILES WHERE GROUND DISTURBING CONSTRUCTION ACTIVITY HAS PERMANENTLY CEASED OR TEMPORARILY CEASED FOR LONGER THAN 14 DAYS.
8. FINAL STABILIZATION MUST BE IMPLEMENTED AT ALL APPLICABLE CONSTRUCTION SITES. FINAL STABILIZATION IS ACHIEVED WHEN ALL GROUND DISTURBING ACTIVITIES ARE COMPLETE AND ALL DISTURBED AREAS EITHER HAVE A UNIFORM VEGETATIVE COVER WITH INDIVIDUAL PLANT DENSITY OF 70 PERCENT OF PRE-DISTURBANCE LEVELS ESTABLISHED OR EQUIVALENT PERMANENT ALTERNATIVE STABILIZATION METHOD IS IMPLEMENTED.
9. ALL PERMANENT STORMWATER MANAGEMENT FACILITIES SHALL BE INSTALLED AS DESIGNED IN THE APPROVED PLANS. ANY PROPOSED CHANGES THAT EFFECT THE DESIGN OR FUNCTION OF PERMANENT STORMWATER MANAGEMENT STRUCTURES MUST BE APPROVED BY THE EGM ADMINISTRATOR PRIOR TO IMPLEMENTATION.
10. EARTH DISTURBANCES SHALL BE CONDUCTED IN SUCH A MANNER SO AS TO EFFECTIVELY MINIMIZE ACCELERATED SOIL EROSION AND RESULTING SEDIMENTATION.
11. COMPACTION OF SOIL MUST BE PREVENTED IN AREAS DESIGNATED FOR INFILTRATION CONTROL MEASURES OR WHERE FINAL STABILIZATION WILL BE ACHIEVED BY VEGETATIVE COVER.
12. ANY TEMPORARY OR PERMANENT FACILITY DESIGNED AND CONSTRUCTED FOR THE CONVEYANCE OF STORMWATER AROUND, THROUGH, OR FROM THE EARTH DISTURBANCE AREA SHALL BE A STABILIZED CONVEYANCE DESIGNED TO MINIMIZE EROSION AND THE DISCHARGE OF SEDIMENT OFF SITE.
13. CONCRETE WASH WATER SHALL BE CONTAINED AND DISPOSED OF IN ACCORDANCE WITH THE SWMP. NO WASH WATER SHALL BE DISCHARGED TO OR ALLOWED TO ENTER STATE WATERS, INCLUDING ANY SURFACE OR SUBSURFACE STORM DRAINAGE SYSTEM OR FACILITIES.
14. DURING DEWATERING OPERATIONS, UNCONTAMINATED GROUNDWATER MAY BE DISCHARGED ON-SITE, BUT SHALL NOT LEAVE THE SITE IN THE FORM OF SURFACE RUNOFF UNLESS AN APPROVED STATE DEWATERING PERMIT IS IN PLACE.
15. EROSION CONTROL BLANKETING OR OTHER PROTECTIVE COVERING SHALL BE USED ON SLOPES STEEPER THAN 3:1.
16. CONTRACTOR SHALL BE RESPONSIBLE FOR THE REMOVAL OF ALL WASTES FROM CONSTRUCTION SITES FOR DISPOSAL IN ACCORDANCE WITH LOCAL AND STATE REGULATORY REQUIREMENTS.
17. WASTE MATERIALS SHALL NOT BE TEMPORARILY PLACED OR STORED IN THE STREET, ALLEY, OR OTHER PUBLIC WAY, UNLESS IN ACCORDANCE WITH AN APPROVED TRAFFIC CONTROL PLAN.
18. TRACKING OF SOILS AND CONSTRUCTION DEBRIS OFF-SITE SHALL BE MINIMIZED. MATERIALS TRACKED OFF-SITE SHALL BE CLEANED UP AND PROPERLY DISPOSED OF IMMEDIATELY.
19. THE OWNER/DEVELOPER SHALL BE RESPONSIBLE FOR THE REMOVAL OF ALL CONSTRUCTION DEBRIS, DIRT, TRASH, ROCK, SEDIMENT, SOIL, AND SAND THAT MAY ACCUMULATE IN ROADS, STORM DRAINS AND OTHER DRAINAGE CONVEYANCE SYSTEMS AND STORMWATER APPURTENANCES AS A RESULT OF SITE DEVELOPMENT.
20. THE QUANTITY OF MATERIALS STORED ON THE PROJECT SITE SHALL BE LIMITED, AS MUCH AS PRACTICAL, TO THAT QUANTITY REQUIRED TO PERFORM THE WORK IN AN ORDERLY SEQUENCE.
21. NO CHEMICAL(S) HAVING THE POTENTIAL TO BE RELEASED IN STORMWATER ARE TO BE STORED OR USED ON-SITE UNLESS PERMISSION FOR THE USE OF SUCH CHEMICAL(S) IS GRANTED IN WRITING BY THE EGM ADMINISTRATOR.
22. BULK STORAGE OF ALLOWED PETROLEUM PRODUCTS OR OTHER ALLOWED LIQUID CHEMICALS IN EXCESS OF 55 GALLONS SHALL REQUIRE ADEQUATE SECONDARY CONTAINMENT PROTECTION TO CONTAIN ALL SPILLS ON-SITE AND TO PREVENT ANY SPILLED MATERIALS FROM ENTERING STATE WATERS, ANY SURFACE OR SUBSURFACE STORM DRAINAGE SYSTEM OR OTHER FACILITIES.
23. NO PERSON SHALL CAUSE THE IMPEDIMENT OF STORMWATER FLOW IN THE CURB AND GUTTER OR DITCH EXCEPT WITH APPROVED SEDIMENT CONTROL MEASURES.
24. OWNER/DEVELOPER AND THEIR AGENTS SHALL COMPLY WITH THE "COLORADO WATER QUALITY CONTROL ACT" (TITLE 25, ARTICLE 8, CRS), AND THE "CLEAN WATER ACT" (33 USC 1344), IN ADDITION TO THE REQUIREMENTS OF THE LAND DEVELOPMENT CODE, DCM VOLUME II, AND THE EGM APPENDIX I. ALL APPROPRIATE PERMITS MUST BE OBTAINED BY THE CONTRACTOR PRIOR TO CONSTRUCTION (1041, NPDES, FLOODPLAIN, 404, FUGITIVE DUST, ETC.).
25. ALL CONSTRUCTION TRAFFIC MUST ENTER/EXIT THE SITE AT APPROVED CONSTRUCTION ACCESS POINTS.
26. PRIOR TO CONSTRUCTION THE PERMITEE SHALL VERIFY THE LOCATION OF EXISTING UTILITIES.
27. A WATER SOURCE SHALL BE AVAILABLE ON-SITE DURING EARTHWORK OPERATIONS AND SHALL BE UTILIZED AS REQUIRED TO MINIMIZE DUST FROM EARTHWORK EQUIPMENT AND WIND.
28. THE SOILS REPORT FOR THIS SITE HAS BEEN PREPARED BY KUMAR & ASSOCIATES INC., DATED AUGUST 2022, AND SHALL BE CONSIDERED A PART OF THESE PLANS.
29. AT LEAST TEN (10) DAYS PRIOR TO THE ANTICIPATED START OF CONSTRUCTION, FOR PROJECTS THAT WILL DISTURB ONE (1) ACRE OR MORE, THE OWNER OR OPERATOR OF CONSTRUCTION ACTIVITY SHALL SUBMIT A PERMIT APPLICATION FOR STORMWATER DISCHARGE TO THE COLORADO DEPARTMENT OF PUBLIC HEALTH AND ENVIRONMENT, WATER QUALITY DIVISION. THE APPLICATION CONTAINS CERTIFICATION OF COMPLETION OF A STORMWATER MANAGEMENT PLAN (SWMP), OF WHICH THIS GRADING AND EROSION CONTROL PLAN MAY BE A PART. FOR INFORMATION OR APPLICATION MATERIALS CONTACT:
COLORADO DEPARTMENT OF PUBLIC HEALTH AND ENVIRONMENT
WATER QUALITY CONTROL DIVISION
WOOD -PERMITS
4300 CHERRY CREEK DRIVE SOUTH
DENVER, CO 80246-1530
ATTN: PERMITS UNIT

EL PASO COUNTY SELF-MONITORING INSPECTIONS

THE PERMIT HOLDER OR AUTHORIZED AGENT SHALL CONDUCT SELF-MONITORING INSPECTIONS. THE PURPOSE OF SELF-MONITORING INSPECTIONS IS FOR THE PERMIT HOLDER TO ENSURE THAT ALL BMPs ARE INSTALLED ACCORDING TO APPROVED PLANS, THE BMPs ARE ADEQUATE AND ARE BEING PROPERLY MAINTAINED, THE SWMP IS UPDATED TO REFLECT CURRENT CONDITIONS, AND ONLY ALLOWABLE DISCHARGES ARE OCCURRING OFF THE SITE.

• ALL CONSTRUCTION ACTIVITY IS COMPLETED EXCEPT FINAL STABILIZATION BECAUSE PLANTED VEGETATIVE COVER HAS NOT YET BECOME ESTABLISHED;

• ALL ACTIVITIES FOR FINAL STABILIZATION HAVE BEEN COMPLETED WITH THE EXCEPTION OF SEED APPLICATION WHICH MAY NOT HAVE OCCURRED DUE TO SEASONAL CONDITIONS OR THE NECESSITY TO REAPPLY ADDITIONAL SEED TO AUGMENT PREVIOUS EFFORTS; AND

• THE SWMP HAS BEEN UPDATED TO LOCATE THOSE AREAS SUBJECT TO THE REDUCED INSPECTION FREQUENCY. ROUTINE SELF-MONITORING INSPECTIONS AFTER PRECIPITATION EVENTS ARE NOT REQUIRED DURING AN APPROVED 30 DAY INSPECTION CYCLE.

1. ROUTINE SELF-MONITORING INSPECTIONS. THE ROUTINE SELF-MONITORING INSPECTIONS ARE TO BE PERFORMED AND DOCUMENTED AT LEAST ONCE EVERY 7 CALENDAR DAYS; OR AT LEAST ONCE EVERY 14 CALENDARS, IF POST-STORM EVENT INSPECTIONS ARE CONDUCTED WITHIN 24 HOURS AFTER THE END OF A PRECIPITATION OR SNOW MELT EVENT. POST-STORM INSPECTIONS MAY BE USED TO FULFILL THE 14 DAY INSPECTION REQUIREMENT. IN ADDITION TO THE BI-WEEKLY INSPECTIONS THE OWNER OR REPRESENTATIVE SHALL PERFORM POST-STORM INSPECTIONS OF ALL BMPs AFTER ANY PRECIPITATION OR SNOWMELT EVENT THAT CAUSES SURFACE EROSION TO ENSURE THAT THE BMPs HAVE OPERATED AS DESIGNED, TO DETERMINE IF MAINTENANCE IS NEEDED, AND TO LOCATE AND CLEAN UP ANY AREAS WHERE MATERIALS MAY HAVE RUN OFF SITE.

THE OWNER OR HIS REPRESENTATIVE WILL RECORD THE RESULTS OF ALL INSPECTIONS BY COMPLETING AN INSPECTION REPORT OR SIMILAR INSPECTION CHECKLIST INCLUDED IN THE SWMP. COMPLETED INSPECTION REPORTS SHALL BE KEPT ON SITE AND AVAILABLE TO COUNTY INSPECTORS. THE COUNTY MAY REQUIRE THE SUBMISSION OF THESE INSPECTION REPORTS ON A SITE-SPECIFIC BASIS.

2. OPERATOR COMPLIANCE INSPECTION. WHEN A COMPLIANCE INSPECTION CONDUCTED BY A COUNTY STORMWATER INSPECTOR DOCUMENTS THE FAILURE TO IMPLEMENT CONTROL MEASURES OR IMPLEMENTATION OF INADEQUATE CONTROL MEASURES, THE COUNTY STORMWATER INSPECTOR MAY REQUIRE THE ESQCP OWNER OR THEIR REPRESENTATIVE TO INSPECT AND PROVIDE A REPORT TO THE COUNTY THAT THE CONTROL MEASURES HAVE BEEN IMPLEMENTED OR CORRECTED.

MULCHING AND SEEDING NOTES FOR EL PASO COUNTY

- 1. ALL DISTURBED AREAS MUST BE MULCHED WITHIN 21 DAY AFTER FINAL GRADE AND SEEDED AREAS ARE TO BE MULCHED WITH 24 HOURS AFTER SEEDING.
2. MATERIAL USED FOR MULCH CAN BE CERTIFIED CLEAN, WEED- AND SEED-FREE LONG STEMMED FIELD OR MARSH HAY, OR STRAW OF OATS, BARLEY, WHEAT, RYE OR TRITICALE CERTIFIED BY THE COLORADO DEPARTMENT OF AGRICULTURE WEED FEE FORAGE CERTIFICATION PROGRAM.
3. HYDRAULIC MULCHING MATERIAL SHALL CONSIST OF VIRGIN WOOD FIBER MANUFACTURED FORM CLEAN WHOLE WOOD CHIPS. WOOD CHIPS CANNOT CONTAIN ANY GROWTH OR GERMINATION INHIBITORS OR BE PRODUCED FROM RECYCLED WASTE. GRAVEL CAN ALSO BE USED.
4. MULCH IS TO BE APPLIED EVENLY AT THE RATE OF 2 TONS PER ACRE.
5. MULCH IS TO BE ANCHORED EITHER BY CRIMPING (TUCKING MULCH FIBERS 4 INCHES INTO THE SOIL), USING NETTING (USED IN SMALL AREAS WITH STEEP SLOPES), OR WITH TACKIFIER.
6. HYDRAULIC MULCHING AND TACKIFIERS ARE NOT TO BE USED IN THE PRESENCE OF FREE SURFACE WATER.

EL PASO COUNTY CONSERVATION DISTRICT SHOTGUN MIX

Table with 4 columns: COMMON NAME, RECOMMENDED VARIETY, % OF SEED MIX, PLS/ACRE. Rows include BLUESTEM, BIC, LITTLE BLUESTEM, GREEN NEEDLEGRASS, WHEATGRASS, WESTERN, GRAMA, SIDEOTS, SWITCHGRASS, PRAIRIE SANDREED, YELLOW INDIANGRASS.

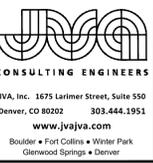

JVA, Inc. 1675 Larimer Street, Suite 550
Denver, CO 80202 303.444.1951
www.jvajva.com
Bozler & Fort Collins & Winter Park
Glenwood Springs & Denver

Table with 2 columns: NO, REVISION DESCRIPTION. Row 1: 1, 08/25/23 SWW SWMP REVISIONS PER COUNTY COMMENTS.



DESIGNED BY: MHT/JGJ
DRAWN BY: MHT/JGJ
CHECKED BY: KJC
JOB #: 1051.9e
DATE: AUGUST 2023
© JVA, INC.

WOODMOOR WSD NO. 1
WELL NO. 22
EL PASO COUNTY, COLORADO
SWMP AND GEC NOTES
SHEET NO. CE1.1

Stabilized Staging Area (SSA)

SM-6

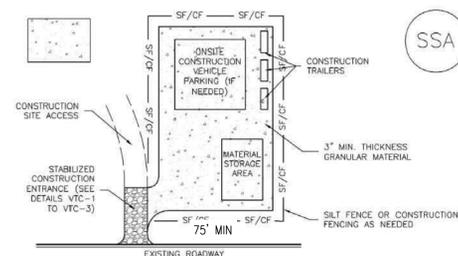

SSA-1. STABILIZED STAGING AREA

- STABILIZED STAGING AREA INSTALLATION NOTES**
- SEE PLAN VIEW FOR
-LOCATION OF STAGING AREA(S)
-CONTRACTOR MAY ADJUST LOCATION AND SIZE OF STAGING AREA WITH APPROVAL FROM THE LOCAL JURISDICTION.
 - STABILIZED STAGING AREA SHOULD BE APPROPRIATE FOR THE NEEDS OF THE SITE. OVERSIZING RESULTS IN A LARGER AREA TO STABILIZE FOLLOWING CONSTRUCTION.
 - STAGING AREA SHALL BE STABILIZED PRIOR TO OTHER OPERATIONS ON THE SITE.
 - THE STABILIZED STAGING AREA SHALL CONSIST OF A MINIMUM 3" THICK GRANULAR MATERIAL.
 - UNLESS OTHERWISE SPECIFIED BY LOCAL JURISDICTION, ROCK SHALL CONSIST OF DOT SECT. #703, AASHTO #3 COARSE AGGREGATE OR 6" (MINUS) ROCK.
 - ADDITIONAL PERIMETER BMPs MAY BE REQUIRED INCLUDING BUT NOT LIMITED TO SILT FENCE AND CONSTRUCTION FENCING.
- STABILIZED STAGING AREA MAINTENANCE NOTES**
- INSPECT BMPs EACH WORKDAY, AND MAINTAIN THEM IN EFFECTIVE OPERATING CONDITION. MAINTENANCE OF BMPs SHOULD BE PROACTIVE, NOT REACTIVE. INSPECT BMPs AS SOON AS POSSIBLE (AND ALWAYS WITHIN 24 HOURS) FOLLOWING A STORM THAT CAUSES SURFACE EROSION, AND PERFORM NECESSARY MAINTENANCE.
 - FREQUENT OBSERVATIONS AND MAINTENANCE ARE NECESSARY TO MAINTAIN BMPs IN EFFECTIVE OPERATING CONDITION. INSPECTIONS AND CORRECTIVE MEASURES SHOULD BE DOCUMENTED THOROUGHLY.
 - WHERE BMPs HAVE FAILED, REPAIR OR REPLACEMENT SHOULD BE INITIATED UPON DISCOVERY OF THE FAILURE.
 - ROCK SHALL BE REAPPLIED OR REGRADED AS NECESSARY IF RUTTING OCCURS OR UNDERLYING SUBGRADE BECOMES EXPOSED.

November 2010 Urban Drainage and Flood Control District SSA-3
Urban Storm Drainage Criteria Manual Volume 3

Vehicle Tracking Control (VTC)

SM-4

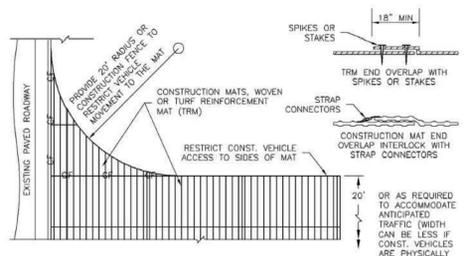
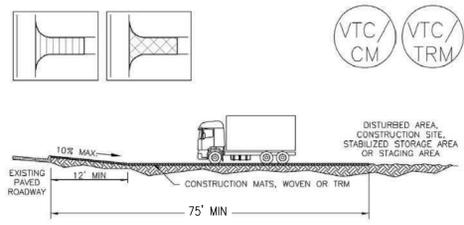

VTC-3. VEHICLE TRACKING CONTROL W/ CONSTRUCTION MAT OR TURF REINFORCEMENT MAT (TRM)

November 2010 Urban Drainage and Flood Control District VTC-5
Urban Storm Drainage Criteria Manual Volume 3

SM-4 Vehicle Tracking Control (VTC)

- STABILIZED CONSTRUCTION ENTRANCE/EXIT INSTALLATION NOTES**
- SEE PLAN VIEW FOR
-LOCATION OF CONSTRUCTION ENTRANCE(S)/EXIT(S).
-TYPE OF CONSTRUCTION ENTRANCE(S)/EXIT(S) (WITH/WITHOUT WHEEL WASH, CONSTRUCTION MAT OR TRM).
 - CONSTRUCTION MAT OR TRM STABILIZED CONSTRUCTION ENTRANCES ARE ONLY TO BE USED ON SHORT DURATION PROJECTS (TYPICALLY RANGING FROM A WEEK TO A MONTH) WHERE THERE WILL BE LIMITED VEHICULAR ACCESS.
 - A STABILIZED CONSTRUCTION ENTRANCE/EXIT SHALL BE LOCATED AT ALL ACCESS POINTS WHERE VEHICLES ACCESS THE CONSTRUCTION SITE FROM PAVED RIGHT-OF-WAYS.
 - STABILIZED CONSTRUCTION ENTRANCE/EXIT SHALL BE INSTALLED PRIOR TO ANY LAND DISTURBING ACTIVITIES.
 - A NON-WOVEN GEOTEXTILE FABRIC SHALL BE PLACED UNDER THE STABILIZED CONSTRUCTION ENTRANCE/EXIT PRIOR TO THE PLACEMENT OF ROCK.
 - UNLESS OTHERWISE SPECIFIED BY LOCAL JURISDICTION, ROCK SHALL CONSIST OF DOT SECT. #703, AASHTO #3 COARSE AGGREGATE OR 6" (MINUS) ROCK.
- STABILIZED CONSTRUCTION ENTRANCE/EXIT MAINTENANCE NOTES**
- INSPECT BMPs EACH WORKDAY, AND MAINTAIN THEM IN EFFECTIVE OPERATING CONDITION. MAINTENANCE OF BMPs SHOULD BE PROACTIVE, NOT REACTIVE. INSPECT BMPs AS SOON AS POSSIBLE (AND ALWAYS WITHIN 24 HOURS) FOLLOWING A STORM THAT CAUSES SURFACE EROSION, AND PERFORM NECESSARY MAINTENANCE.
 - FREQUENT OBSERVATIONS AND MAINTENANCE ARE NECESSARY TO MAINTAIN BMPs IN EFFECTIVE OPERATING CONDITION. INSPECTIONS AND CORRECTIVE MEASURES SHOULD BE DOCUMENTED THOROUGHLY.
 - WHERE BMPs HAVE FAILED, REPAIR OR REPLACEMENT SHOULD BE INITIATED UPON DISCOVERY OF THE FAILURE.
 - ROCK SHALL BE REAPPLIED OR REGRADED AS NECESSARY TO THE STABILIZED ENTRANCE/EXIT TO MAINTAIN A CONSISTENT DEPTH.
 - SEDIMENT TRACKED ONTO PAVED ROADS IS TO BE REMOVED THROUGHOUT THE DAY AND AT THE END OF THE DAY BY SHOVELING OR SWEEPING. SEDIMENT MAY NOT BE WASHED DOWN STORM SEWER DRAINS.
- NOTE: MANY JURISDICTIONS HAVE BMP DETAILS THAT VARY FROM UDFCD STANDARD DETAILS. CONSULT WITH LOCAL JURISDICTIONS AS TO WHICH DETAIL SHOULD BE USED WHEN DIFFERENCES ARE NOTED.
- (DETAILS ADAPTED FROM CITY OF BROOMFIELD, COLORADO, NOT AVAILABLE IN AUTOCAD)

VTC-6 Urban Drainage and Flood Control District November 2010
Urban Storm Drainage Criteria Manual Volume 3

SC-2

Sediment Control Log (SCL)

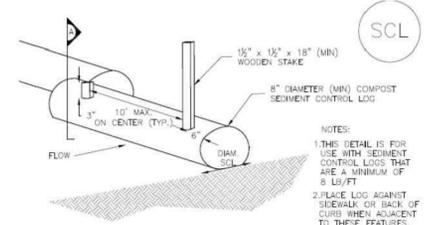

COMPOST SEDIMENT CONTROL LOG (WEIGHTED)

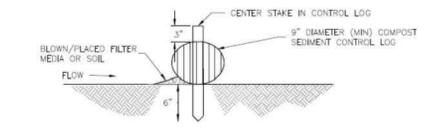

COMPOST SEDIMENT CONTROL LOG (A)

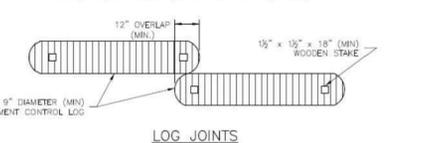

SCL-2. COMPOST SEDIMENT CONTROL LOG (WEIGHTED)

SC-4 Urban Drainage and Flood Control District November 2015
Urban Storm Drainage Criteria Manual Volume 3

SC-2 Sediment Control Log (SCL)

- SEDIMENT CONTROL LOG INSTALLATION NOTES**
- SEE PLAN VIEW FOR LOCATION AND LENGTH OF SEDIMENT CONTROL LOGS.
 - SEDIMENT CONTROL LOGS THAT ACT AS A PERIMETER CONTROL SHALL BE INSTALLED PRIOR TO ANY UPGRADIENT LAND-DISTURBING ACTIVITIES.
 - SEDIMENT CONTROL LOGS SHALL CONSIST OF STRAW, COMPOST, EXCELSIOR OR COCONUT FIBER, AND SHALL BE FREE OF ANY NOXIOUS WEED SEEDS OR DEFECTS INCLUDING RIPS, HOLES AND OBVIOUS WEAR.
 - SEDIMENT CONTROL LOGS MAY BE USED AS SMALL CHECK DAMS IN DITCHES AND SWALES. HOWEVER, THEY SHOULD NOT BE USED IN PERENNIAL STREAMS.
 - IT IS RECOMMENDED THAT SEDIMENT CONTROL LOGS BE TRENCHED INTO THE GROUND TO A DEPTH OF APPROXIMATELY 1/3 OF THE DIAMETER OF THE LOG. IF TRENCHING TO THIS DEPTH IS NOT FEASIBLE AND/OR DESIRABLE (SHORT TERM INSTALLATION WITH DESIRE NOT TO DAMAGE LANDSCAPE) A LESSER TRENCHING DEPTH MAY BE ACCEPTABLE WITH MORE ROBUST STAKING. COMPOST LOGS THAT ARE 8 LB/FT DO NOT NEED TO BE TRENCHED.
 - THE UPHILL SIDE OF THE SEDIMENT CONTROL LOG SHALL BE BACKFILLED WITH SOIL OR FILTER MATERIAL THAT IS FREE OF ROCKS AND DEBRIS. THE SOIL SHALL BE TIGHTLY COMPACTED INTO THE SHAPE OF A RIGHT TRIANGLE USING A SHOVEL OR WEIGHTED LAWN ROLLER OR BLOWN IN PLACE.
 - FOLLOW MANUFACTURERS' GUIDANCE FOR STAKING. IF MANUFACTURERS' INSTRUCTIONS DO NOT SPECIFY SPACING, STAKES SHALL BE PLACED ON 4' CENTERS AND EMBEDDED A MINIMUM OF 6" INTO THE GROUND. 3" OF THE STAKE SHALL PROTRUDE FROM THE TOP OF THE LOG. STAKES THAT ARE BROKEN PRIOR TO INSTALLATION SHALL BE REPLACED. COMPOST LOGS SHOULD BE STAKED 10' ON CENTER.
- SEDIMENT CONTROL LOG MAINTENANCE NOTES**
- INSPECT BMPs EACH WORKDAY, AND MAINTAIN THEM IN EFFECTIVE OPERATING CONDITION. MAINTENANCE OF BMPs SHOULD BE PROACTIVE, NOT REACTIVE. INSPECT BMPs AS SOON AS POSSIBLE (AND ALWAYS WITHIN 24 HOURS) FOLLOWING A STORM THAT CAUSES SURFACE EROSION, AND PERFORM NECESSARY MAINTENANCE.
 - FREQUENT OBSERVATIONS AND MAINTENANCE ARE NECESSARY TO MAINTAIN BMPs IN EFFECTIVE OPERATING CONDITION. INSPECTIONS AND CORRECTIVE MEASURES SHOULD BE DOCUMENTED THOROUGHLY.
 - WHERE BMPs HAVE FAILED, REPAIR OR REPLACEMENT SHOULD BE INITIATED UPON DISCOVERY OF THE FAILURE.
 - SEDIMENT ACCUMULATED UPSTREAM OF SEDIMENT CONTROL LOG SHALL BE REMOVED AS NEEDED TO MAINTAIN FUNCTIONALITY OF THE BMP. TYPICALLY WHEN DEPTH OF ACCUMULATED SEDIMENTS IS APPROXIMATELY 1/2 OF THE HEIGHT OF THE SEDIMENT CONTROL LOG.
 - SEDIMENT CONTROL LOG SHALL BE REMOVED AT THE END OF CONSTRUCTION/COMPOST FROM COMPOST LOGS MAY BE LEFT IN PLACE AS LONG AS BAGS ARE REMOVED AND THE AREA SEEDED. IF DISTURBED AREAS EXIST AFTER REMOVAL, THEY SHALL BE COVERED WITH TOP SOIL, SEEDS AND MULCHED OR OTHERWISE STABILIZED IN A MANNER APPROVED BY THE LOCAL JURISDICTION.
- (DETAILS ADAPTED FROM TOWN OF PARKER, COLORADO, SERRANO COUNTY, COLORADO, DOUGLAS COUNTY, COLORADO, AND CITY OF ALBUQUA, COLORADO, NOT AVAILABLE IN AUTOCAD)
- NOTE: MANY JURISDICTIONS HAVE BMP DETAILS THAT VARY FROM UDFCD STANDARD DETAILS. CONSULT WITH LOCAL JURISDICTIONS AS TO WHICH DETAIL SHOULD BE USED WHEN DIFFERENCES ARE NOTED.

SC-6 Urban Drainage and Flood Control District November 2015
Urban Storm Drainage Criteria Manual Volume 3

NO.	DATE	REVISIONS PER COUNTY COMMENTS	DESIGN	DRAWN
1	08/25/23	SWW	DES	DWN



DESIGNED BY: MHT/JGJ
DRAWN BY: MHT/JGJ
CHECKED BY: KJC
JOB #: 1051.9e
DATE: AUGUST 2023
© JVA, INC.

WOODMOOR WSD NO. 1
WELL NO. 22
EL PASO COUNTY, COLORADO
EROSION CONTROL DETAILS

SHEET NO.
CE1.2

Inlet Protection (IP) SC-6

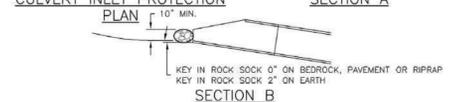
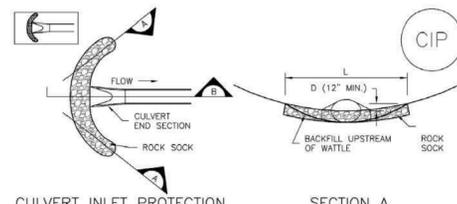

CIP-1. CULVERT INLET PROTECTION

CULVERT INLET PROTECTION INSTALLATION NOTES

- SEE PLAN VIEW FOR:
 - LOCATION OF CULVERT INLET PROTECTION.
- SEE ROCK SOCK DESIGN DETAIL FOR ROCK GRADATION REQUIREMENTS AND JOINTING DETAIL.

CULVERT INLET PROTECTION MAINTENANCE NOTES

- INSPECT BMPs EACH WORKDAY, AND MAINTAIN THEM IN EFFECTIVE OPERATING CONDITION. MAINTENANCE OF BMPs SHOULD BE PROACTIVE, NOT REACTIVE. INSPECT BMPs AS SOON AS POSSIBLE (AND ALWAYS WITHIN 24 HOURS) FOLLOWING A STORM THAT CAUSES SURFACE EROSION, AND PERFORM NECESSARY MAINTENANCE.
- FREQUENT OBSERVATIONS AND MAINTENANCE ARE NECESSARY TO MAINTAIN BMPs IN EFFECTIVE OPERATING CONDITION. INSPECTIONS AND CORRECTIVE MEASURES SHOULD BE DOCUMENTED THOROUGHLY.
- WHERE BMPs HAVE FAILED, REPAIR OR REPLACEMENT SHOULD BE INITIATED UPON DISCOVERY OF THE FAILURE.
- SEDIMENT ACCUMULATED UPSTREAM OF THE CULVERT SHALL BE REMOVED WHEN THE SEDIMENT DEPTH IS 1/2 THE HEIGHT OF THE ROCK SOCK.
- CULVERT INLET PROTECTION SHALL REMAIN IN PLACE UNTIL THE UPSTREAM DISTURBED AREA IS PERMANENTLY STABILIZED AND APPROVED BY THE LOCAL JURISDICTION.

(DETAILS ADAPTED FROM AURORA, COLORADO, NOT AVAILABLE IN AUTOCAD)

NOTE: MANY JURISDICTIONS HAVE BMP DETAILS THAT VARY FROM UDFCD STANDARD DETAILS. CONSULT WITH LOCAL JURISDICTIONS AS TO WHICH DETAIL SHOULD BE USED WHEN DIFFERENCES ARE NOTED.

August 2013 Urban Drainage and Flood Control District Urban Storm Drainage Criteria Manual Volume 3 IP-7

Inlet Protection (IP) SC-6

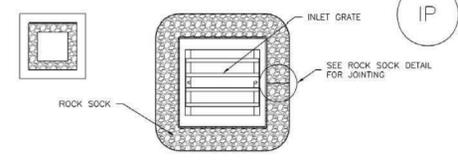

IP-3. ROCK SOCK SUMP/AREA INLET PROTECTION

ROCK SOCK SUMP/AREA INLET PROTECTION INSTALLATION NOTES

- SEE ROCK SOCK DESIGN DETAIL FOR INSTALLATION REQUIREMENTS.
- STRAW WATTLES/SEDIMENT CONTROL LOGS MAY BE USED IN PLACE OF ROCK SOCKS FOR INLETS IN PEROUS AREAS. INSTALL PER SEDIMENT CONTROL LOG DETAIL.

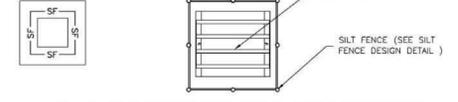

IP-4. SILT FENCE FOR SUMP INLET PROTECTION

SILT FENCE INLET PROTECTION INSTALLATION NOTES

- SEE SILT FENCE DESIGN DETAIL FOR INSTALLATION REQUIREMENTS.
- POSTS SHALL BE PLACED AT EACH CORNER OF THE INLET AND AROUND THE EDGES AT A MAXIMUM SPACING OF 3 FEET.
- STRAW WATTLES/SEDIMENT CONTROL LOGS MAY BE USED IN PLACE OF SILT FENCE FOR INLETS IN PEROUS AREAS. INSTALL PER SEDIMENT CONTROL LOG DETAIL.

August 2013 Urban Drainage and Flood Control District Urban Storm Drainage Criteria Manual Volume 3 IP-5

SC-6 Inlet Protection (IP)

GENERAL INLET PROTECTION INSTALLATION NOTES

- SEE PLAN VIEW FOR:
 - LOCATION OF INLET PROTECTION.
 - TYPE OF INLET PROTECTION (IP-1, IP-2, IP-3, IP-4, IP-5, IP-6)
- INLET PROTECTION SHALL BE INSTALLED PROMPTLY AFTER INLET CONSTRUCTION OR PAVING IS COMPLETE (TYPICALLY WITHIN 48 HOURS). IF A RAINFALL/RUNOFF EVENT IS FORECAST, INSTALL INLET PROTECTION PRIOR TO ONSET OF EVENT.
- MANY JURISDICTIONS HAVE BMP DETAILS THAT VARY FROM UDFCD STANDARD DETAILS. CONSULT WITH LOCAL JURISDICTIONS AS TO WHICH DETAIL SHOULD BE USED WHEN DIFFERENCES ARE NOTED.

INLET PROTECTION MAINTENANCE NOTES

- INSPECT BMPs EACH WORKDAY, AND MAINTAIN THEM IN EFFECTIVE OPERATING CONDITION. MAINTENANCE OF BMPs SHOULD BE PROACTIVE, NOT REACTIVE. INSPECT BMPs AS SOON AS POSSIBLE (AND ALWAYS WITHIN 24 HOURS) FOLLOWING A STORM THAT CAUSES SURFACE EROSION, AND PERFORM NECESSARY MAINTENANCE.
- FREQUENT OBSERVATIONS AND MAINTENANCE ARE NECESSARY TO MAINTAIN BMPs IN EFFECTIVE OPERATING CONDITION. INSPECTIONS AND CORRECTIVE MEASURES SHOULD BE DOCUMENTED THOROUGHLY.
- WHERE BMPs HAVE FAILED, REPAIR OR REPLACEMENT SHOULD BE INITIATED UPON DISCOVERY OF THE FAILURE.
- SEDIMENT ACCUMULATED UPSTREAM OF INLET PROTECTION SHALL BE REMOVED AS NECESSARY TO MAINTAIN BMP EFFECTIVENESS, TYPICALLY WHEN STORAGE VOLUME REACHES 50% OF CAPACITY, A DEPTH OF 6" WHEN SILT FENCE IS USED, OR 1/2 OF THE HEIGHT FOR STRAW BALES.
- INLET PROTECTION IS TO REMAIN IN PLACE UNTIL THE UPSTREAM DISTURBED AREA IS PERMANENTLY STABILIZED, UNLESS THE LOCAL JURISDICTION APPROVES EARLIER REMOVAL OF INLET PROTECTION IN STREETS.
- WHEN INLET PROTECTION AT AREA INLETS IS REMOVED, THE DISTURBED AREA SHALL BE COVERED WITH TOP SOIL, SEEDED AND MULCHED, OR OTHERWISE STABILIZED IN A MANNER APPROVED BY THE LOCAL JURISDICTION.

(DETAIL ADAPTED FROM TOWN OF PARKER, COLORADO AND CITY OF AURORA, COLORADO, NOT AVAILABLE IN AUTOCAD)

NOTE: MANY JURISDICTIONS HAVE BMP DETAILS THAT VARY FROM UDFCD STANDARD DETAILS. CONSULT WITH LOCAL JURISDICTIONS AS TO WHICH DETAIL SHOULD BE USED WHEN DIFFERENCES ARE NOTED.

NOTE: THE DETAILS INCLUDED WITH THIS FACT SHEET SHOW COMMONLY USED, CONVENTIONAL METHODS OF INLET PROTECTION IN THE DENVER METROPOLITAN AREA. THERE ARE MANY PROPRIETARY INLET PROTECTION METHODS ON THE MARKET. UDFCD NEITHER ENDORSES NOR DISCOURAGES USE OF PROPRIETARY INLET PROTECTION. HOWEVER, IN THE EVENT PROPRIETARY METHODS ARE USED, THE APPROPRIATE DETAIL FROM THE MANUFACTURER MUST BE INCLUDED IN THE SWMP AND THE BMP MUST BE INSTALLED AND MAINTAINED AS SHOWN IN THE MANUFACTURER'S DETAILS.

NOTE: SOME MUNICIPALITIES DISCOURAGE OR PROHIBIT THE USE OF STRAW BALES FOR INLET PROTECTION. CHECK WITH LOCAL JURISDICTION TO DETERMINE IF STRAW BALE INLET PROTECTION IS ACCEPTABLE.

IP-8 Urban Drainage and Flood Control District Urban Storm Drainage Criteria Manual Volume 3 August 2013

Concrete Washout Area (CWA) MM-1

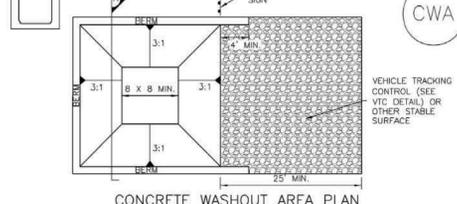

CWA-1. CONCRETE WASHOUT AREA

CWA INSTALLATION NOTES

- SEE PLAN VIEW FOR:
 - CWA INSTALLATION LOCATION.
- DO NOT LOCATE AN UNLINED CWA WITHIN 400' OF ANY NATURAL DRAINAGE PATHWAY OR WATERBODY. DO NOT LOCATE WITHIN 1000' OF ANY WELLS OR DRINKING WATER SOURCES. IF SITE CONSTRAINTS MAKE THIS INFEASIBLE, OR IF HIGHLY PERMEABLE SOILS EXIST ON SITE, THE CWA MUST BE INSTALLED WITH AN IMPERMEABLE LINER (16 MIL MIN. THICKNESS) OR SURFACE STORAGE ALTERNATIVES USING PREFABRICATED CONCRETE WASHOUT DEVICES OR A LINED ABOVE GROUND STORAGE ARE SHOULD BE USED.
- THE CWA SHALL BE INSTALLED PRIOR TO CONCRETE PLACEMENT ON SITE.
- CWA SHALL INCLUDE A FLAT SUBSURFACE PIT THAT IS AT LEAST 8' BY 8' SLOPES LEADING OUT OF THE SUBSURFACE PIT SHALL BE 3:1 OR FLATTER. THE PIT SHALL BE AT LEAST 3' DEEP.
- BERM SURROUNDING SIDES AND BACK OF THE CWA SHALL HAVE MINIMUM HEIGHT OF 1'.
- VEHICLE TRACKING PAD SHALL BE SLOPED 2% TOWARDS THE CWA.
- SIGNS SHALL BE PLACED AT THE CONSTRUCTION ENTRANCE, AT THE CWA, AND ELSEWHERE AS NECESSARY TO CLEARLY INDICATE THE LOCATION OF THE CWA TO OPERATORS OF CONCRETE TRUCKS AND PUMP TRUCKS.
- USE EXCAVATED MATERIAL FOR PERIMETER BERM CONSTRUCTION.

November 2010 Urban Drainage and Flood Control District Urban Storm Drainage Criteria Manual Volume 3 CWA-3

MM-1 Concrete Washout Area (CWA)

CWA MAINTENANCE NOTES

- INSPECT BMPs EACH WORKDAY, AND MAINTAIN THEM IN EFFECTIVE OPERATING CONDITION. MAINTENANCE OF BMPs SHOULD BE PROACTIVE, NOT REACTIVE. INSPECT BMPs AS SOON AS POSSIBLE (AND ALWAYS WITHIN 24 HOURS) FOLLOWING A STORM THAT CAUSES SURFACE EROSION, AND PERFORM NECESSARY MAINTENANCE.
- FREQUENT OBSERVATIONS AND MAINTENANCE ARE NECESSARY TO MAINTAIN BMPs IN EFFECTIVE OPERATING CONDITION. INSPECTIONS AND CORRECTIVE MEASURES SHOULD BE DOCUMENTED THOROUGHLY.
- WHERE BMPs HAVE FAILED, REPAIR OR REPLACEMENT SHOULD BE INITIATED UPON DISCOVERY OF THE FAILURE.
- THE CWA SHALL BE REPAIRED, CLEANED, OR ENLARGED AS NECESSARY TO MAINTAIN CAPACITY FOR CONCRETE WASTE, CONCRETE MATERIALS, ACCUMULATED IN PIT, SHALL BE REMOVED ONCE THE MATERIALS HAVE REACHED A DEPTH OF 2'.
- CONCRETE WASHOUT WATER, WASTED PIECES OF CONCRETE AND ALL OTHER DEBRIS IN THE SUBSURFACE PIT SHALL BE TRANSPORTED FROM THE JOB SITE IN A WATER-TIGHT CONTAINER AND DISPOSED OF PROPERLY.
- THE CWA SHALL REMAIN IN PLACE UNTIL ALL CONCRETE FOR THE PROJECT IS PLACED.
- WHEN THE CWA IS REMOVED, COVER THE DISTURBED AREA WITH TOP SOIL, SEED AND MULCH OR OTHERWISE STABILIZED IN A MANNER APPROVED BY THE LOCAL JURISDICTION.

(DETAIL ADAPTED FROM DOUGLAS COUNTY, COLORADO AND THE CITY OF PARKER, COLORADO, NOT AVAILABLE IN AUTOCAD)

NOTE: MANY JURISDICTIONS HAVE BMP DETAILS THAT VARY FROM UDFCD STANDARD DETAILS. CONSULT WITH LOCAL JURISDICTIONS AS TO WHICH DETAIL SHOULD BE USED WHEN DIFFERENCES ARE NOTED.

CWA-4 Urban Drainage and Flood Control District Urban Storm Drainage Criteria Manual Volume 3 November 2010

Check Dams (CD) EC-12

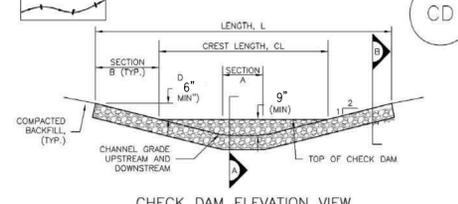

CD-1. CHECK DAM

CHECK DAM INSTALLATION NOTES

- SEE PLAN VIEW FOR:
 - LOCATION OF CHECK DAMS.
 - CHECK DAM TYPE (CHECK DAM OR REINFORCED CHECK DAM).
 - LENGTH (L), CREST LENGTH (CL), AND DEPTH (D)
- CHECK DAMS INDICATED ON INITIAL SWMP SHALL BE INSTALLED AFTER CONSTRUCTION FENCE, BUT PRIOR TO ANY UPSTREAM LAND DISTURBING ACTIVITIES.
- RIPRAP UTILIZED FOR CHECK DAMS SHOULD BE OF APPROPRIATE SIZE FOR THE APPLICATION. TYPICAL TYPES OF RIPRAP USED FOR CHECK DAMS ARE TYPE M (D50 12") OR TYPE L (D50 9").
- RIPRAP PAD SHALL BE TRENCHED INTO THE GROUND A MINIMUM OF 1'.
- THE ENDS OF THE CHECK DAM SHALL BE A MINIMUM OF 6" HIGHER THAN THE CENTER OF THE CHECK DAM.

CHECK DAM MAINTENANCE NOTES

- INSPECT BMPs EACH WORKDAY, AND MAINTAIN THEM IN EFFECTIVE OPERATING CONDITION. MAINTENANCE OF BMPs SHOULD BE PROACTIVE, NOT REACTIVE. INSPECT BMPs AS SOON AS POSSIBLE (AND ALWAYS WITHIN 24 HOURS) FOLLOWING A STORM THAT CAUSES SURFACE EROSION, AND PERFORM NECESSARY MAINTENANCE.
- FREQUENT OBSERVATIONS AND MAINTENANCE ARE NECESSARY TO MAINTAIN BMPs IN EFFECTIVE OPERATING CONDITION. INSPECTIONS AND CORRECTIVE MEASURES SHOULD BE DOCUMENTED THOROUGHLY.
- WHERE BMPs HAVE FAILED, REPAIR OR REPLACEMENT SHOULD BE INITIATED UPON DISCOVERY OF THE FAILURE.
- SEDIMENT ACCUMULATED UPSTREAM OF THE CHECK DAMS SHALL BE REMOVED WHEN THE SEDIMENT DEPTH IS WITHIN 1/2 OF THE HEIGHT OF THE CREST.
- CHECK DAMS ARE TO REMAIN IN PLACE UNTIL THE UPSTREAM DISTURBED AREA IS STABILIZED AND APPROVED BY THE LOCAL JURISDICTION.
- WHEN CHECK DAMS ARE REMOVED, EXCAVATIONS SHALL BE FILLED WITH SUITABLE COMPACTED BACKFILL. DISTURBED AREA SHALL BE SEEDED AND MULCHED AND COVERED WITH GEOTEXTILE OR OTHERWISE STABILIZED IN A MANNER APPROVED BY THE LOCAL JURISDICTION.

(DETAILS ADAPTED FROM DOUGLAS COUNTY, COLORADO, NOT AVAILABLE IN AUTOCAD)

NOTE: MANY JURISDICTIONS HAVE BMP DETAILS THAT VARY FROM UDFCD STANDARD DETAILS. CONSULT WITH LOCAL JURISDICTIONS AS TO WHICH DETAIL SHOULD BE USED WHEN DIFFERENCES ARE NOTED.

November 2010 Urban Drainage and Flood Control District Urban Storm Drainage Criteria Manual Volume 3 CD-3

EC-12 Check Dams (CD)

CHECK DAM MAINTENANCE NOTES

- INSPECT BMPs EACH WORKDAY, AND MAINTAIN THEM IN EFFECTIVE OPERATING CONDITION. MAINTENANCE OF BMPs SHOULD BE PROACTIVE, NOT REACTIVE. INSPECT BMPs AS SOON AS POSSIBLE (AND ALWAYS WITHIN 24 HOURS) FOLLOWING A STORM THAT CAUSES SURFACE EROSION, AND PERFORM NECESSARY MAINTENANCE.
- FREQUENT OBSERVATIONS AND MAINTENANCE ARE NECESSARY TO MAINTAIN BMPs IN EFFECTIVE OPERATING CONDITION. INSPECTIONS AND CORRECTIVE MEASURES SHOULD BE DOCUMENTED THOROUGHLY.
- WHERE BMPs HAVE FAILED, REPAIR OR REPLACEMENT SHOULD BE INITIATED UPON DISCOVERY OF THE FAILURE.
- SEDIMENT ACCUMULATED UPSTREAM OF THE CHECK DAMS SHALL BE REMOVED WHEN THE SEDIMENT DEPTH IS WITHIN 1/2 OF THE HEIGHT OF THE CREST.
- CHECK DAMS ARE TO REMAIN IN PLACE UNTIL THE UPSTREAM DISTURBED AREA IS STABILIZED AND APPROVED BY THE LOCAL JURISDICTION.
- WHEN CHECK DAMS ARE REMOVED, EXCAVATIONS SHALL BE FILLED WITH SUITABLE COMPACTED BACKFILL. DISTURBED AREA SHALL BE SEEDED AND MULCHED AND COVERED WITH GEOTEXTILE OR OTHERWISE STABILIZED IN A MANNER APPROVED BY THE LOCAL JURISDICTION.

(DETAILS ADAPTED FROM DOUGLAS COUNTY, COLORADO, NOT AVAILABLE IN AUTOCAD)

NOTE: MANY JURISDICTIONS HAVE BMP DETAILS THAT VARY FROM UDFCD STANDARD DETAILS. CONSULT WITH LOCAL JURISDICTIONS AS TO WHICH DETAIL SHOULD BE USED WHEN DIFFERENCES ARE NOTED.

CD-4 Urban Drainage and Flood Control District Urban Storm Drainage Criteria Manual Volume 3 November 2010

REVISIONS PER COUNTY COMMENTS

NO.	DATE	DESCRIPTION
1	08/25/23	SWW DESIGNED



DESIGNED BY: MHT/JGJ
DRAWN BY: MHT/JGJ
CHECKED BY: KJC
JOB #: 1051.9e
DATE: AUGUST 2023
© JVA, INC.

WOODMOOR WSD NO. 1
WELL NO. 22
EL PASO COUNTY, COLORADO
EROSION CONTROL DETAILS

SHEET NO.
CE1.3

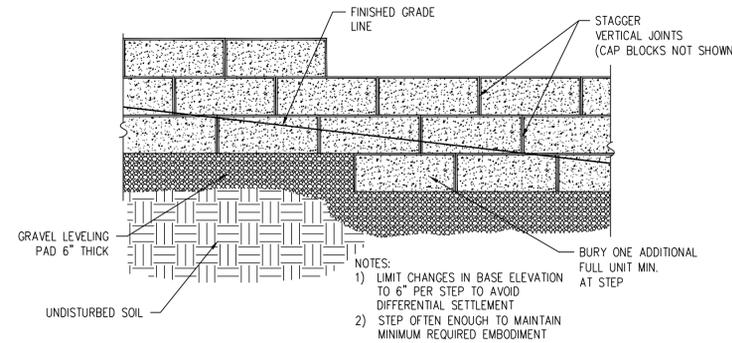

STEPPING BASE DETAIL

- NOTES:
- LIMIT CHANGES IN BASE ELEVATION TO 6" PER STEP TO AVOID DIFFERENTIAL SETTLEMENT
 - STEP OFTEN ENOUGH TO MAINTAIN MINIMUM REQUIRED EMBODIMENT

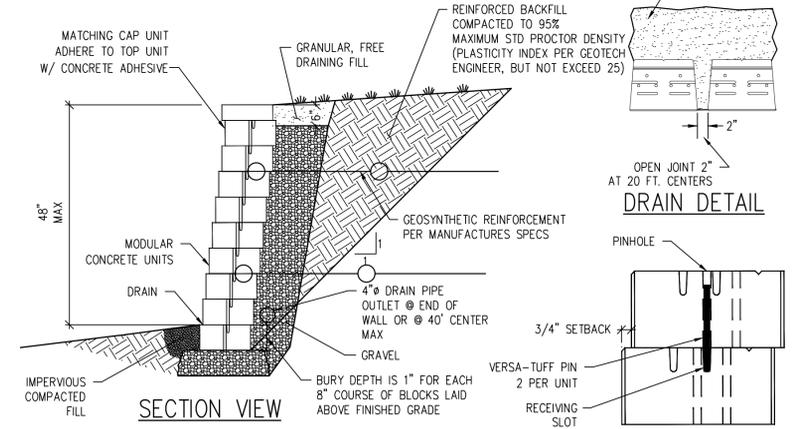

SECTION VIEW

NOTES:

- THE ABOVE DETAILS ARE GENERAL WALL LAYOUT & QUALITY INFORMATION. CONTRACTOR TO REVIEW AND FOLLOW ALL OF BLOCK MANUFACTURER'S DESIGN, SUBMITTAL AND INSTALLATION REQUIREMENTS.
- BLOCKS TO BE VERSA-LOCK "STANDARD" SPLIT FACE OR ACCEPTED. BLOCK COLORS TO BE SUBMITTED FOR APPROVAL.
- SUBMIT FINAL BLOCK COLOR AND TEXTURE SAMPLE TO OWNER FOR APPROVAL PRIOR TO CONSTRUCTION.
- BACKFILL TO HAVE MAX PLASTICITY INDEX OF 25.
- ALL RETAINING WALLS (OR ADDITION OF MULTIPLE TIERED WALLS) THAT EXCEED A FOUR FOOT HEIGHT OR INCLUDE A SURCHARGE LOAD WILL REQUIRE A BUILDING PERMIT PRIOR TO OBTAINING A PUBLIC WORKS PERMIT.

SEGMENTAL RETAINING WALL

1
C1.0

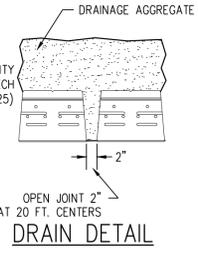

DRAIN DETAIL

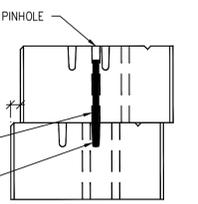

PINNING DETAIL

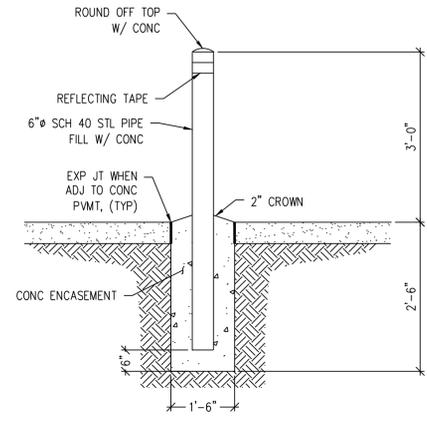

BOLLARD DETAIL

2
C1.0

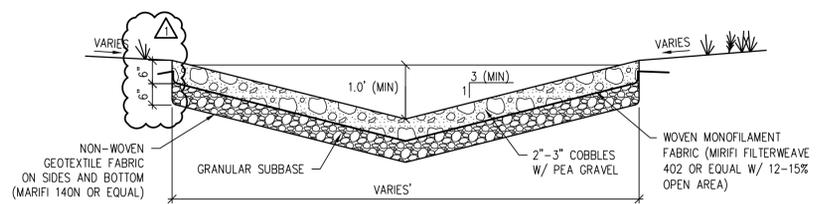

NOTES:

- GRANULAR SUBBASE SHALL MEET AASHTO No. 4 COARSE AGGREGATE (WASHED 3/4" - 1-1/2" GRAVEL). COBBLES SHALL BE 2"-3" AVERAGE DIAMETER. PEA GRAVEL SHALL MEET CDOT CLASS B FILTER MATERIAL.
- MAINTENANCE REQUIREMENTS:
 - NONIRRIGATED NATIVE GRASS AT 6 TO 8 INCHES TALL. COLLECT CUTTINGS AND DISPOSE OF THEM OFFSITE OR USE A MULCHING MOWER.
 - AS NEEDED BY INSPECTION, REMOVE ALL COLLECTED DEBRIS AND LITTER. KEEP THE AREA CLEAN FOR AESTHETIC REASONS, WHICH ALSO REDUCES FLOATABLES BEING FLUSHED DOWNSTREAM. REPAIR SWALE IF DAMAGED AFTER STORM EVENTS
 - ANNUALLY CHECK THE SWALE FOR RIPRAP PLACEMENT, COBBLE LAYER COVERAGE, AND SEDIMENT ACCUMULATED IN SWALE AND NEAR INLETS AND FLARED END SECTIONS.
 - ROUTINELY REMOVE ACCUMULATED SEDIMENT NEAR CULVERTS AND WITHIN THE CHANNEL TO MAINTAIN FLOW CAPACITY. REPLACE THE GRASS AREAS DAMAGED IN THE PROCESS. PERIODICALLY REPAIR AND REVEGETATE ERODED AREAS IN THE CHANNELS DUE TO HIGH FLOWS.
 - WHEN THE WATER IN THE SWALE FAILS TO INFILTRATE DUE TO HIGH SEDIMENT DEPOSITS IN THE COBBLE/PEA GRAVEL LAYER, REMOVE CLEAN AND STOCKPILE THE COBBLE/PEA GRAVEL LAYER.
- REMOVE AND REPLACE THE WORN GEO FABRIC LAYER IF NECESSARY, REPLACE THE CLEANED COBBLE/PEA GRAVEL LAYER.

LOW GRADIENT WATER QUALITY INFILTRATION SWALE

6
C1.0

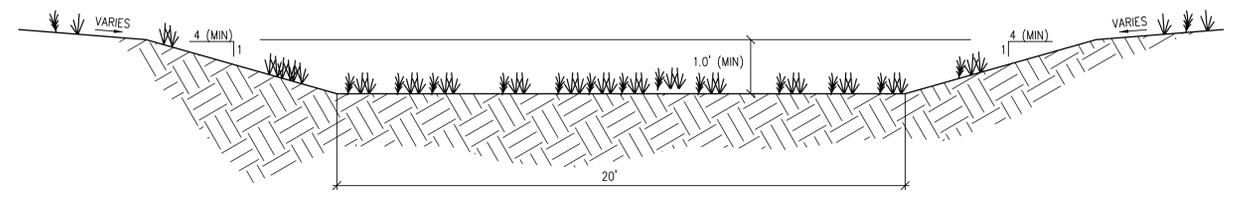

LOW GRADIENT WIDE NATIVE GRASS SWALE

7
C1.0

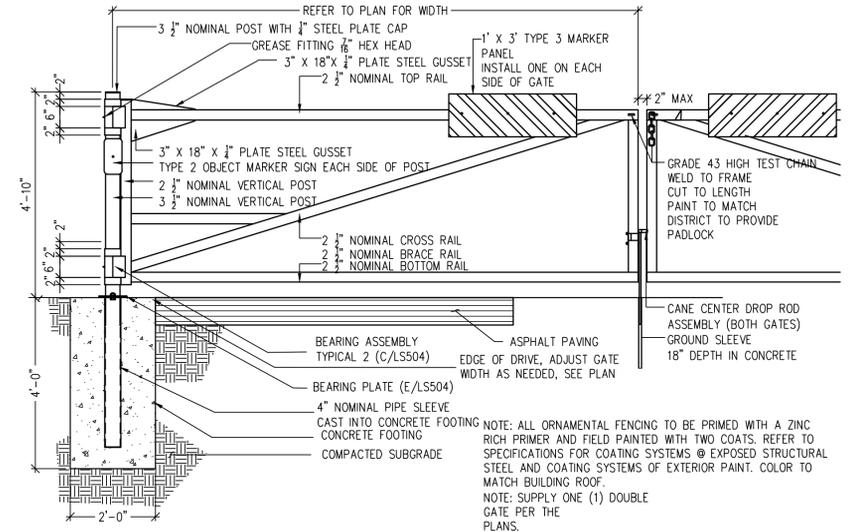

GENERAL NOTES

1. NOMINAL SIZE	ACTUAL O.D.	ACTUAL I.D.	WALL THICKNESS	WEIGHT PER LIN. FT.	COMPONENT
2 1/2"	2.875"	2.469"	.203"	5.79 LB	TOP AND BOTTOM RAILS, BRACE, GATE POST
3 1/2"	4.00"	3.548"	.226"	9.11 LB	GATE POST
4"	4.50"	4.026"	.237"	10.79 LB	BEARING COLLARS AND SLEEVES, CAST IN PLACE PIPE SLEEVE

2. ALL PIPE TO BE SEAMLESS STANDARD WEIGHT STRUCTURAL STEEL.
 3. ALL SIZES NOTED REFER TO NOMINAL SIZE UNLESS NOTED OTHERWISE.

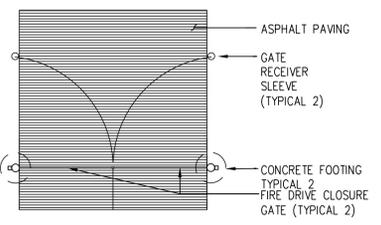

CLOSURE PLAN

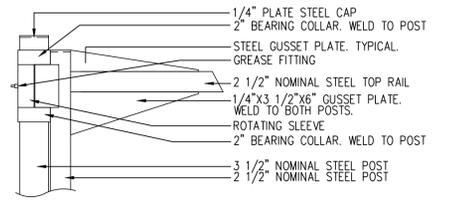

BEARING ASSEMBLY (TYPICAL 2 PER SIDE)

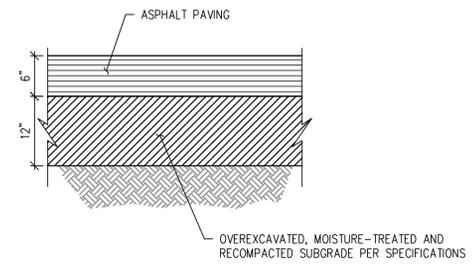

FULL DEPTH ASPHALT PAVEMENT SECTION DETAIL

4
C1.0

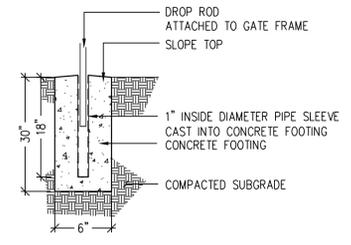

GATE RECEIVER SLEEVE

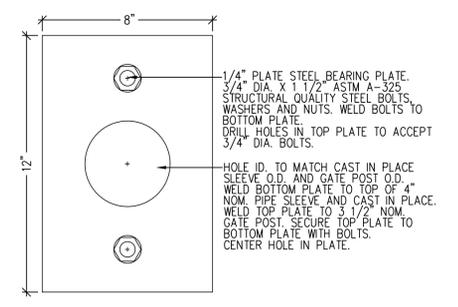

BEARING PLATE

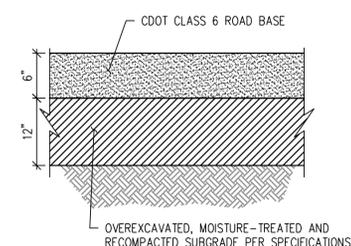

GRAVEL SECTION DETAIL

5
C1.0

NO.	DATE	DESIGN	BY	REVISIONS PER COUNTY COMMENTS
1	08/25/23	SWW	SWW	REVISIONS PER COUNTY COMMENTS
2		DESIGN	DWIN	



DESIGNED BY: JGJ
 DRAWN BY: JGJ
 CHECKED BY: KJC
 JOB #: 1051.9e
 DATE: AUGUST 2023
 © JVA, INC.

WOODMOOR WSD NO. 1
 WELL NO. 22
 EL PASO COUNTY, COLORADO