



LSC TRANSPORTATION CONSULTANTS, INC.
2504 East Pikes Peak Avenue, Suite 304
Colorado Springs, CO 80909
(719) 633-2868
FAX (719) 633-5430
E-mail: lsc@lsctrans.com
Website: <http://www.lsctrans.com>

Windermere 2022 Zone Change Traffic Impact Study (LSC #S224090) April 27, 2022

Traffic Engineer's Statement

This traffic report and supporting information were prepared under my responsible charge and they comport with the standard of care. So far as is consistent with the standard of care, said report was prepared in general conformance with the criteria established by the County for traffic reports.

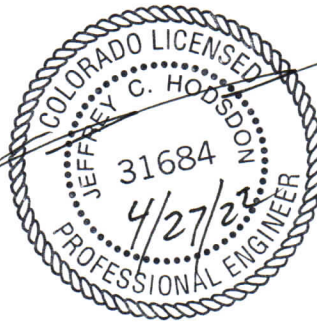

Developer's Statement

I, the Developer, have read and will comply with all commitments made on my behalf within this report.

Date

Windermere Zone Change Traffic Impact Study

Prepared for:
Todd Stephens
Windsor Ridge Homes
4164 Austin Bluffs Parkway, Suite 361
Colorado Springs, CO 80918

APRIL 27, 2022

LSC Transportation Consultants
Prepared by: Kirstin D. Ferrin, P.E.
Reviewed by: Jeffrey C. Hodsdon, P.E.

LSC #S224090



CONTENTS

REPORT CONTENTS 1

 Previous Traffic Reports Completed in the Area 2

LAND USE AND ACCESS 2

PEDESTRIAN AND BICYCLE ACCESS 2

ROADWAY AND TRAFFIC CONDITIONS..... 2

 Intersection Sight Distance 3

 North Carefree Circle/Antelope Ridge Drive 3

 Site Access Points..... 3

 Crash History..... 3

 Existing Traffic Volumes 4

 Existing Levels of Service..... 4

2040 BACKGROUND TRAFFIC 5

TRIP GENERATION..... 5

DIRECTIONAL DISTRIBUTION AND ASSIGNMENT 5

SHORT-TERM TOTAL TRAFFIC 6

2040 TOTAL TRAFFIC..... 6

PROJECTED INTERSECTION LEVELS OF SERVICE 6

 North Carefree/Marksheffel 7

 North Carefree/Antelope Ridge 7

 Antelope Ridge Full-Movement Access Points 7

QUEUING ANALYSIS 8

TRAFFIC SIGNAL WARRANT ANALYSIS..... 8

DEVIATION REQUESTS..... 9

CONCLUSIONS AND RECOMMENDATIONS 9

 Trip Generation..... 9

 Projected Levels of Service..... 9

 Intersection Sight Distance 10

 Traffic Signal Warrant 10

 Roadway Improvements 11

 Marksheffel/North Carefree Intersection 12

Enclosures: 12

Table 2-4

Figures 1-10

Traffic Count Reports

Level of Service Reports

Queuing Reports

Crash Data

MTCP Maps

Rocky Mountain Classical Academy Carpool Plan and key pages from the Parent-
Student Handbook



LSC TRANSPORTATION CONSULTANTS, INC.
2504 East Pikes Peak Avenue, Suite 304
Colorado Springs, CO 80909
(719) 633-2868
FAX (719) 633-5430
E-mail: lsc@lsctrans.com
Website: <http://www.lsctrans.com>

April 27, 2022

Todd Stephens
Windsor Ridge Homes
4164 Austin Bluffs Parkway, Suite 361
Colorado Springs, CO 80918

RE: Windermere
Zone Change
El Paso County, CO
Traffic Impact Study
LSC #S224090

Dear Mr. Stephens:

In response to your request, LSC Transportation Consultants, Inc. has prepared this traffic impact analysis for a proposed zone change for a portion of the Windermere residential development. As shown in Figure 1, the site is located north of North Carefree Circle between Marksheffel Road and Antelope Ridge Drive in El Paso County, Colorado. The southern 9-acres of the Windermere development is planned to be rezoned to RM-30. Site access is proposed to Antelope Ridge Drive.

REPORT CONTENTS

This report presents:

- The existing roadway and traffic conditions in the site's vicinity including the roadway widths, surface conditions, lane geometries, traffic controls, and posted speed limits;
- Current traffic-volume data;
- Estimates of projected 2040 background traffic volumes;
- The projected average weekday and peak-hour vehicle trips to be generated by the proposed development;
- The assignment of the projected site-generated traffic volumes to the area roadways;
- The projected short-term total traffic volumes on the area roadways;
- The projected levels of service at the key intersections in the vicinity of the site;
- The recommendations for roadway improvements to mitigate the traffic impacts;
- The recommended street classifications for the internal streets within the proposed development; and
- The project's obligation to the County roadway improvement fee program.

Previous Traffic Reports Completed in the Area

LSC completed a traffic impact study (TIS) for the entire Windermere Preliminary Plan (SP-193) dated August 31, 2020. Since completion of that report, a final plat was submitted for 163 lots for single-family homes on the northern 44 acres of the preliminary plan area. The land use and access proposed for Filing 1 are consistent with the preliminary plan TIS. The preliminary plan TIS also assumed an additional 40 lots for single-family homes on the southern 9-acre parcel.

LSC also completed a traffic study for the Gardens at North Carefree located west of the site. The latest update was dated October 16, 2018. This study accounts for the land use, trip generation, and roadway network included in that study.

LAND USE AND ACCESS

As shown in Figure 1, the site is located north of North Carefree Circle between Marksheffel Road and Antelope Ridge Drive. The Chateau at Antelope Ridge residential development is located just north of the site. There are also existing single-family homes west of the site.

Figure 2 shows the site land use and access plan. The southern 9 acres of the Windermere Preliminary Plan area is proposed to be rezoned to RM-30. Under this zoning, the site could be developed with 277 multi-family dwelling units. Access to the site is planned at two full-movement access points to Antelope Ridge Drive. The south access point would align with the existing south intersection of Pronghorn Meadows Circle. The north access is located about 755 feet north of the south intersection of Pronghorn Meadows/Antelope Ridge and about 675 feet south of the north intersection of Pronghorn Meadows/Antelope Ridge. This access is consistent with what was assumed in the Preliminary Plan TIS.

PEDESTRIAN AND BICYCLE ACCESS

Sidewalks are planned on all of the streets interior to the Windermere development. Sidewalks are also planned adjacent to the site along Antelope Ridge Drive and North Carefree Circle, but not along Marksheffel Road.

ROADWAY AND TRAFFIC CONDITIONS

The roadways in the site's vicinity are shown in Figure 1 and are described below. Copies of the *2016 El Paso County Major Transportation Corridors Plan (MTCP) 2040 Roadway Plan* and *2016 MTCP 2060 Corridor Preservation Plan* with the site location identified on them have been attached to this report.

North Carefree Circle is a six-lane Principal Arterial. In the vicinity of Antelope Ridge Drive, North Carefree Circle has a posted limit of 35 miles per hour (mph).

Marksheffel Road is a Principal Arterial extending north from the City of Fountain to Woodmen Road. Marksheffel has two through lanes in each direction, plus a raised median south of North Carefree Circle and one through lane in each direction north of North Carefree Circle. The posted speed limit adjacent to the site is 50 mph. Marksheffel Road is ultimately planned to be widened to six lanes and extended north and west from Woodmen Road to connect to Research Parkway at Black Forest Road. Marksheffel Road is shown as a six-lane Principal Arterial adjacent to the site on the *2016 El Paso County Major Transportation Corridors Plan (MTCP) 2040 Roadway Plan* and as an Expressway on the *2016 MTCP 2060 Corridor Preservation Plan*. Marksheffel Road is planned to be constructed north from Woodmen Road to Vollmer Road in the short-term future.

Antelope Ridge Drive is an Urban Residential Collector that extends north from North Carefree Circle to about one-half mile north of Stetson Hills Boulevard. In the vicinity of the site, Antelope Ridge Drive has one through lane in each direction and a striped center median. The posted speed limit on Antelope Ridge Drive is 35 mph. The intersection of Antelope Ridge Drive/North Carefree Circle is currently stop-sign controlled.

Intersection Sight Distance

North Carefree Circle/Antelope Ridge Drive

The intersection sight distance from the southbound approach to the west along North Carefree at the intersection of North Carefree and Antelope Ridge Drive does not meet the sight distance criteria contained in *A Policy on Geometric Design of Highways and Streets* pp. 657-663 (published by AASHTO) for design speeds of 40 mph or 45 mph. The field-measured sight distance is about 425 to 475 feet and the AASHTO standard is about 568 feet for passenger vehicles, given the geometric conditions and an assumed 40-mph design speed (the posted speed is 35 mph). The raised center median is about 17 feet wide including the eastbound left-turn lane. The raised center median to the west contains landscaping rock, which contributes to some extent to the limited sight distance.

Site Access Points

The access point locations on Antelope Ridge Drive meet *Engineering Criteria Manual (ECM)* criteria for stopping sight distance and intersection sight distance.

Crash History

Two crashes were reported to the Colorado State Patrol (CSP) at the intersection of North Carefree Circle/Antelope Ridge Drive between 2019 and March 2022. Both crashes occurred in 2019. The first crash was a rear-end crash involving two southbound vehicles. The second crash involved a southbound left-turning vehicle and a westbound through vehicle. A copy of these data is attached for reference.

Existing Traffic Volumes

Figure 3 shows the existing morning and afternoon peak-hour traffic volumes at the intersections of North Carefree Circle/Marksheffel Road, North Carefree Circle/Antelope Ridge Drive and the south Antelope Ridge Drive/Pronghorn Meadows Circle intersection. The average weekday traffic volumes shown are estimates by LSC, based on traffic counts conducted by LSC in August 2018 and March 2022. The traffic count reports are attached.

Existing Levels of Service

Level of service (LOS) is a quantitative measure of the level of delay at an intersection. Level of service is indicated on a scale from “A” to “F.” LOS A represents control delay of less than 10 seconds for unsignalized and signalized intersections. LOS F represents control delay of more than 50 seconds for unsignalized intersections and more than 80 seconds for signalized intersections. Table 1 shows the level of service delay ranges.

Table 1: Intersection Levels of Service Delay Ranges

Level of Service	Signalized Intersections	Unsignalized Intersections
	Average Control Delay (seconds per vehicle)	Average Control Delay (seconds per vehicle) ⁽¹⁾
A	10.0 sec or less	10.0 sec or less
B	10.1-20.0 sec	10.1-15.0 sec
C	20.1-35.0 sec	15.1-25.0 sec
D	35.1-55.0 sec	25.1-35.0 sec
E	55.1-80.0 sec	35.1-50.0 sec
F	80.1 sec or more	50.1 sec or more

For unsignalized intersections, if V/C ratio is greater than 1.0, the level of service is LOS F, regardless of the projected average control delay per vehicle.

The intersections of North Carefree Circle/Marksheffel Road and North Carefree Circle/Antelope Ridge Drive and the south Antelope Ridge Drive/Pronghorn Meadows Circle intersection have been analyzed to determine the existing levels of service based on the unsignalized method of analysis procedures outlined in the *Highway Capacity Manual, 6th Edition* by the Transportation Research Board. The results of the level of service analysis are shown in Figure 3. The level of service reports are attached.

The eastbound left-turn movement at the intersection of North Carefree Circle/Marksheffel Road is currently operating at LOS F during both the morning and afternoon peak hours.

The southbound left-turn movement at intersection of North Carefree Circle/Antelope Ridge Drive is currently operating at LOS F during the morning peak hour and LOS C during the

afternoon peak hours. These are based on *Highway Capacity Manual* procedures analysis and not actual delay measured in the field. The limited sight distance at this intersection may have an effect on delay. The limited sight distance also likely has an effect on motorists' decisions to not use this left-turn movement. If the sight distance were better and/or if the intersection were signalized, the volume of left turns would likely be higher.

All movements at the two-way, stop-sign-controlled Pronghorn Meadows Circle/Antelope Ridge Drive south intersection are currently operating at a level of service C or better during the peak hours.

2040 BACKGROUND TRAFFIC

Figure 4 shows the projected 2040 background traffic volumes. Background traffic is the traffic estimated to be on the roadways without the Windermere traffic. The estimates assume the extension of North Carefree Circle east of Marksheffel Road. Background through traffic estimates for North Carefree Circle may be conservative, as traffic increases and the extension of North Carefree Circle into Banning Lewis Ranch will depend largely on the level of growth within Banning Lewis Ranch in this area. Note: The 2040 background traffic volumes account for additional latent southbound left-turn demand at North Carefree/Antelope Ridge Drive, assuming a signal or alternative improvement will be in place, improving the level of service for this turning movement.

TRIP GENERATION

The site-generated vehicle-trips were estimated using the nationally-published trip-generation rates from *Trip Generation, 11th Edition, 2022* by the Institute of Transportation Engineers (ITE). Table 2 shows the current trip-generation estimate. Table 2 also shows the trip-generation estimate for Windermere Filing No. 1 that is currently under review.

As shown in Table 2, the 9-acre portion of the Windermere proposed to be rezoned to RM-30 is projected to generate about 1,867 new vehicle trips on the average weekday, with about one-half of the vehicles entering and one-half of the vehicles exiting in a 24-hour period. During the morning peak hour, which generally occurs for one hour between 6:30 and 8:30 a.m., about 27 vehicles would enter and 84 vehicles would exit the site. During the afternoon peak hour, which generally occurs for one hour between 4:30 and 6:30 p.m., about 89 vehicles would enter and 52 vehicles would exit the site.

DIRECTIONAL DISTRIBUTION AND ASSIGNMENT

The estimated directional distribution of the site-generated traffic volumes on the adjacent roadways is an important factor in determining the traffic impacts of the site. Figure 5 shows the specific distribution estimates for the short-term and long-term site-generated traffic volumes, respectively. The estimates are based on the following factors: the location of the site with

respect to the regional residential, employment, commercial, and activity centers and the balance of the Colorado Springs area; the land use proposed for the site; the proposed access system for the site; and the roadway system serving the site. The short-term distribution estimate is based on the existing street network and the long-term distribution estimates assume the extension of Barnes Road and North Carefree Circle east of Marksheffel Road into Banning Lewis Ranch.

When the distribution percentages (from Figure 5) are applied to the trip-generation estimates (from Table 2), the site-generated traffic volumes on the adjacent roadways can be determined. Figures 6a and 6b show the short-term site-generated traffic volumes for Windermere Filing No. 1 (currently under review) and the 9-acre parcel currently proposed to be rezoned to RM-30, respectively. Figures 7a and 7b show the long-term site-generated traffic volumes for Windermere Filing No. 1 (currently under review) and the 9-acre parcel currently proposed to be rezoned to RM-30, respectively.

SHORT-TERM TOTAL TRAFFIC

Figure 8 shows the projected short-term total traffic volumes. The short-term total traffic volumes are the sum of the existing traffic volumes (from Figure 3) plus the short-term traffic volumes estimated to be generated by development of Windermere Filing No. 1 (from Figure 6a) plus the short-term traffic volumes estimated to be generated by development of the 9-acre parcel currently proposed to be rezoned to RM-30 (from Figure 6b). The short-term total traffic volumes identify the short-term impacts of the development.

2040 TOTAL TRAFFIC

Figure 9 shows the projected 2040 total traffic volumes. The 2040 total traffic volumes are the sum of the 2040 background traffic volumes (from Figure 4) plus the long-term traffic volumes estimated to be generated by the development of Windermere Filing No. 1 (from Figure 7a) plus the long-term traffic volumes estimated to be generated by development of the 9-acre parcel currently proposed to be rezoned to RM-30 (from Figure 7b).

PROJECTED INTERSECTION LEVELS OF SERVICE

The intersections of North Carefree/Marksheffel, North Carefree/Antelope Ridge, Antelope Ridge/Pronghorn Meadows (south), and the proposed north site-access point to Antelope Ridge were analyzed to determine the projected levels of service for the short-term total and 2040 background and total traffic volumes, based on the unsignalized intersection analysis procedures from the *Highway Capacity Manual 6th Edition* and/or the Synchro signalized intersection procedures. Figures 4, 8, and 9 show the level of service analysis results. The level of service reports are attached.

North Carefree/Marksheffel

The eastbound left-turn movement at the intersection of North Carefree Circle/Marksheffel Road is currently operating at LOS F during the morning and afternoon peak hours. The City of Colorado Springs has recently completed a traffic-signal warrant analysis for this intersection and has indicated it will be converted to traffic-signal control, once funding is available. The intersection of North Carefree/Marksheffel is projected to operate at an overall LOS D or better during the peak hours, based on the projected short-term and 2040 total traffic volumes. By 2040, the northbound and eastbound left-turn movements are projected to operate at LOS E during the morning peak hour. These movements have projected delays in the LOS E range simply because they arrive at the traffic signal at the beginning of the red phase at an intersection with many phases and a long cycle length. These movements would not be considered “failing” since their volume-to-capacity ratios are less than one. The justification is that to progress through traffic along an arterial corridor, the traffic signal offsets and left-turn phase times have been adjusted to favor the through band, which can result in higher delay for the left-turn movements even though there is sufficient capacity for them.

North Carefree/Antelope Ridge

The southbound left turn from the stop-sign-controlled North Carefree Circle/Antelope Ridge Drive intersection is currently operating at a LOS F during the morning peak hour. With the addition of traffic projected to be generated by development of Windermere Filing No. 1 and the 9-acre parcel currently proposed to be rezoned to RM-30, this movement is projected to operate at LOS E during the afternoon peak hour. By 2040, the southbound left-turn and right-turn movements and eastbound left-turn movement are projected to operate at LOS F during peak hours, based on both background and total traffic volumes (with or without this project). If signalized, this intersection is projected to operate at a satisfactory level of service. There may also be viable alternatives to signalization of this intersection to improve the level of service.

Antelope Ridge Full-Movement Access Points

The proposed north full-movement site-access point to Antelope Ridge Drive is projected to operate at LOS D or better for all movements during the peak hours as a stop-sign-controlled intersection, based on the short-term and 2040 total traffic volumes.

The proposed south full-movement site-access point to Antelope Ridge Drive is projected to operate at LOS E during the morning peak hour and LOS C during the during the afternoon peak hour as a stop-sign-controlled intersection, based on the 2040 total traffic volumes.

The morning peak-hour traffic patterns on Antelope Ridge Drive adjacent to the site are highly impacted by the Rocky Mountain Classical Academy located north of the site. A copy of the school carpool plan is attached (may not be the official version). The school Parent-Student Handbook posted online notes that the “City of Colorado Springs, El Paso County Sheriff’s Department, and

District Security Resource Officers have approved our traffic plan.” Only right turns are permitted out of the school access during pick-up and drop-off times. To facilitate better traffic flow, school staff meters the exiting vehicles into platoons of up to ten cars per line. LSC staff observed the afternoon pick-up time in September 2021 and based on this recent field observation, operations appear to be generally in accordance with the established plan. The HCM analysis of the site-access points to Antelope Ridge Drive did not account for the “metering” of exiting vehicles from the Rocky Mountain Classical Academy, which helps to create additional gaps in the southbound through traffic. These gaps generally reduce the side-street delay.

QUEUING ANALYSIS

A queuing analysis was performed using Synchro/SimTraffic to determine if the existing turn lanes at the intersection of North Carefree Circle/Antelope Ridge Drive will be sufficient to accommodate the projected queues, based on the short-term and 2040 total traffic volumes. The 2040 total morning peak-hour traffic volumes were entered into the Synchro model. The simulation was run five times. The queuing reports are attached.

Based on the projected 2040 total traffic morning peak-hour volumes, the projected maximum southbound queue on Antelope Ridge Drive approaching North Carefree Circle is about 273 feet, assuming the intersection is traffic-signal controlled. If the intersection remains stop-sign controlled the southbound left-turn lane is projected to be blocked during 94 percent of the morning peak hour

Based on the projected 2040 total traffic morning peak-hour volumes, the projected maximum eastbound left-turn queue on North Carefree Circle approaching Antelope Ridge Drive is about 2,483 feet, if the intersection remains two-way stop sign-controlled and 222 feet if the intersection is signalized. The existing eastbound left-turn lane is about 350 feet long.

TRAFFIC SIGNAL WARRANT ANALYSIS

The intersection of North Carefree Circle/Antelope Ridge Drive has been analyzed to determine if either an Eight-Hour or a Four-Hour Vehicular-Volume Traffic-Signal Warrant would be met, based on the short-term or 2040 total traffic volumes. Tables 3 and 4 show a detailed analysis for the short-term and 2040 total traffic volumes, respectively.

The traffic-signal warrant analysis was performed, based on eight hours of manual traffic counts conducted at the intersection of North Carefree/Antelope Ridge in March 2022. Future off-peak traffic volumes were based on hourly variation of traffic data recently released by the Institute of Transportation Engineers. The minor approach volume for the short-term traffic-signal warrant analysis includes all the southbound left-turning vehicles plus about 25 percent of the southbound right-turning vehicles. This is based on the assumption that, if this intersection were signalized, these vehicles would reroute their trips and make a left turn toward Marksheffel Road. The 2040 background and total traffic volumes shown in Figures 4 and 9 already assume this shift

in the existing traffic pattern, so the minor approach volumes shown in Table 4 include only the southbound left-turn movements.

As shown in Table 3, only three of hours analyzed are projected to meet the threshold for the Eight-Hour Vehicular-Volume Traffic-Signal Warrant and only one of the hours analyzed is projected to meet the threshold for the Four-Hour Vehicular Volume Traffic Signal Warrant, based on the short-term total traffic volumes. As shown in Table 4, by 2040, the signal would likely meet a Four-Hour Vehicular-Volume Traffic-Signal Warrant. This intersection may also meet an Eight-Hour Vehicular-Volume Traffic-Signal Warrant by 2040. Seven of the nine hours analyzed are projected to meet the thresholds. The minor-street volume from 12:00 noon to 1:00 p.m. is projected to be 74 and the minor-street volume from 2:00 to 3:00 p.m. is 70 vehicles per hour. These volumes are just below the threshold of 75 vehicles per hour.

Another of the MUTCD traffic-signal warrants is Crash Experience. However, only two crashes were reported at the intersection between 2019 and March 2022 and the minimum number of crashes for this warrant to be met is five.

Note: Once a signal warrant (or warrants) is satisfied, this does not mean that a signal will necessarily be installed. The decision to install a traffic signal rests with El Paso County.

DEVIATION REQUESTS

There are no deviations proposed to the criteria contained in the *El Paso County Engineering Criteria Manual* for the streets within the Windermere development.

CONCLUSIONS AND RECOMMENDATIONS

Trip Generation

- The 9-acre portion of the Windermere proposed to be rezoned to RM-30 is projected to generate about 1,867 new vehicle trips on the average weekday, with about one-half of the vehicles entering and one-half of the vehicles exiting in a 24-hour period. During the morning peak hour, which generally occurs for one hour between 6:30 and 8:30 a.m., about 27 vehicles would enter and 84 vehicles would exit the site. During the afternoon peak hour, which generally occurs for one hour between 4:30 and 6:30 p.m., about 89 vehicles would enter and 52 vehicles would exit the site.

Projected Levels of Service

- The eastbound left-turn movement at the intersection of North Carefree Circle/Marksheffel Road is currently operating at LOS F during the morning and afternoon peak hours. The City of Colorado Springs has recently completed a traffic-signal warrant analysis for this intersection and has indicated it will be converted to traffic-signal control, once funding is

available. The intersection of North Carefree/Marksheffel is projected to operate at an overall LOS D or better during the peak hours, based on the projected short-term and 2040 total traffic volumes. By 2040, the northbound and eastbound left-turn movements are projected to operate at LOS E during the morning peak hour. These movements have projected delays in the LOS E range simply because they arrive at the traffic signal at the beginning of the red phase at an intersection with many phases and a long cycle length. These movements would not be considered “failing” since their volume-to-capacity ratios are less than one. The justification is that to progress through traffic along an arterial corridor, the traffic-signal offsets and left-turn phase times have been adjusted to favor the through band, which can result in higher delay for the left-turn movements, even though there is sufficient capacity for them.

- The southbound left turn from the stop-sign-controlled North Carefree Circle/Antelope Ridge Drive intersection is currently operating at a LOS F during the morning peak hours. With the addition of traffic projected to be generated by development of Windermere Filing No. 1 and the 9-acre parcel currently proposed to be rezoned to RM-30, this movement is projected to operate at LOS E during the afternoon peak hour. By 2040, the southbound left-turn and right-turn movements and eastbound left-turn movement are projected to operate at LOS F during peak hours, based on both background and total traffic volumes (with or without this project). If signalized, this intersection is projected to operate at a satisfactory level of service. There may also be viable alternatives to the conventional, four-leg signalized intersection to improve the level of service.
- The proposed north full-movement site-access point to Antelope Ridge Drive is projected to operate at LOS D or better for all movements during the peak hours as a stop-sign-controlled intersection, based on the short-term and 2040 total traffic volumes.
- The proposed south full-movement site-access point to Antelope Ridge Drive is projected to operate at LOS E during the morning peak hour and LOS C during the afternoon peak hour as a stop-sign-controlled intersection, based on the 2040 total traffic volumes. The HCM analysis did not account for the “metering” of exiting vehicles from the Rocky Mountain Classical Academy, which helps to create additional gaps in the southbound through traffic. These gaps generally reduce the side-street delay.

Intersection Sight Distance

- The access-point locations on Antelope Ridge Drive meet *ECM* criteria for stopping sight distance and intersection sight distance.

Traffic Signal Warrant

- The intersection of North Carefree Circle/Antelope Ridge Drive is not projected to meet an Eight-Hour or Four-Hour Vehicular-Volume Traffic-Signal Warrant, based on the projected short-term total traffic volumes. By 2040, but not prior, a Four-Hour Vehicular-Volume warrant is projected to be met and an Eight-Hour Vehicular-Volume warrant is

projected to be close to being met, based on assumed linear growth rates in through traffic. The timing of a warrant being met will depend, in part, on the growth in through traffic on North Carefree Circle. Refer to the Traffic Signal Warrant Analysis section of this report for additional detail.

Roadway Improvements

- Based on the short-term total traffic volumes and the criteria contained in the *ECM*, southbound left-turn lanes are not projected to be warranted on Antelope Ridge Drive approaching the site-access points. However, in the vicinity of the site, Antelope Ridge Drive has an existing painted median. Antelope Ridge should be restriped to provide southbound left-turn lanes approaching both site-access points. Restriping for exclusive left-turn bays is shown on striping and signing plan sheets submitted with the Filing 1 CD drawing set. Based on a design speed of 40 mph, the *ECM* prescribes 180-foot-long left-turn lanes with 160-foot tapers.
- Based on the short-term and 2040 total traffic volumes and the criteria contained in the *ECM*, a northbound right-turn deceleration lane is projected to be warranted on Antelope Ridge Drive approaching both site-access points. Based on a design speed of 40 mph, these right-turn lanes should be 155 feet long plus a 160-foot taper.
- In order to mitigate the intersection sight-distance deficiency at North Carefree/Antelope Ridge Drive until through volumes are sufficiently high for a traffic-signal warrant to be met, and/or as potential alternatives to signalization, the County could consider the following:
 - Reducing eastbound North Carefree to two-through lanes and utilizing the width of the inside lane to create a wider median area. This wider median could be used for a two-stage left-turning movement for southbound left turns. A variation of this concept that might be considered is the use of a “channelized-T” configuration (the access on the south side of the intersection would become a right-in/right-out). The relatively short distance to the Marksheffel intersection may eliminate this option from consideration or require a variation to the traditional channelized T (which uses a left-turn acceleration lane).
 - Another option could be to convert the intersection to a “three-quarter movement” by prohibiting the southbound left turn and enhancing the U-turn capability at the intersection to the west. The left-turn lane queuing would need to be evaluated, and treatments could be investigated to deal with the competing northbound right turns, but there are three through lanes and an acceleration lane just east of the Akers intersection, which easily accommodates U-turns of most vehicles. Installation of a raised northbound right-turn island would separate westbound U-turning traffic from northbound right-turning traffic, eliminating this conflict. This concept could be considered a variation of the “Michigan Left” where motorists are forced to turn right and are provided a downstream opportunity to complete a U-turn as opposed to being offered a left-turn opportunity at an intersection.

Marksheffel/North Carefree Intersection

- The City of Colorado Springs has recently completed a traffic signal-warrant analysis for this intersection and has indicated it will be converted to traffic-signal control, once funding is available.

* * * * *

Please contact me if you have any questions regarding this report.

Respectfully Submitted,

LSC TRANSPORTATION CONSULTANTS, INC.

By: Jeffrey C. Hodsdon, P.E.
Principal

JCH/KDF:jas

Enclosures: Table 2-4
Figures 1-10
Traffic Count Reports
Level of Service Reports
Queuing Reports
Crash Data
MTCP Maps
Rocky Mountain Classical Academy Carpool Plan and key pages from the Parent-
Student Handbook

Tables



**Table 2
Trip Generation Estimate
Windermere**

Land Use Code	Land Use Description	Trip Generation Units	Trip Generation Rates ⁽¹⁾				Total Trips Generated					
			Average Weekday Traffic	Morning Peak Hour		Afternoon Peak Hour		Average Weekday Traffic	Morning Peak Hour		Afternoon Peak Hour	
				In	Out	In	Out		In	Out		
Trip Generation Estimate Based on the Currently Proposed Zone Change												
220	Multifamily Housing (Low-Rise)	277 DU ⁽²⁾	6.74	0.10	0.30	0.32	0.19	1,867	27	84	89	52
Trip Generation Estimate For Windermere Filing No. 1 (Currently Under Review)												
210	Single-Family Detached Housing	163 DU	9.43	0.18	0.52	0.59	0.35	1,537	30	84	97	57
Total Trip Generation for the Approved PUD and currently proposed zone change								3,404	57	168	186	109
Trip Generation Estimate From the <i>Windermere Traffic Impact Study</i>, August 31, 2020												
210	Single-Family Detached Housing	203 DU	9.44	0.19	0.56	0.62	0.37	1,916	38	113	127	74
Change in trip generation estimate								1,488	19	55	59	35

Notes:

(1) Source: "*Trip Generation, 11th Edition, 2021*" by the Institute of Transportation Engineers (ITE)

(2) DU = dwelling unit

Source: LSC Transportation Consultants, Inc.

Apr-22

Table 3
Windermere
Traffic Signal Warrant Analysis of North Carefree Circle/Antelope Ridge Drive
MUTCD Warrants 1 and 2
Short-Term Total Traffic

Hour	Traffic Volumes							Warrant 1, Eight Hour Vehicular Volume Evaluation ⁽⁵⁾								Warrant 2, Four Hour Vehicular Volume Evaluation ⁽⁵⁾				
	Existing ⁽¹⁾		Windermere Fil 1 and Proposed Multi-Family Generated Traffic ⁽⁴⁾			Estimated Short-Term Total Volume		Warrant Thresholds		Warrant Threshold Met?		Existing		Short-Term						
	Major ⁽²⁾	Minor ⁽³⁾	EB LT	WB RT	SB LT	Major ⁽²⁾	Minor ⁽³⁾	Condition A		Condition B		Existing		Short-Term		Warrant Threshold Minor Street Minimum	Warrant Theshold Met?	Warrant Threshold Minor Street Minimum	Warrant Theshold Met?	
								Major	Minor	Major	Minor	A	B	A	B					
6:30-7:30 AM	655	111	14	14	45	683	156	600	150	900	75	No	No	Yes	No	268	No	257	No	
7:30-8:30 AM	812	197	23	23	54	858	251	600	150	900	75	Yes	No	Yes	No	197	Yes	186	Yes	
11:00 - 12:00 AM	446	53	32	32	22	510	75	600	150	900	75	No	No	No	No	367	No	335	No	
12:00-1:00 PM	475	33	35	35	23	545	56	600	150	900	75	No	No	No	No	353	No	318	No	
2:00 - 3:00 PM	756	26	44	43	25	843	51	600	150	900	75	No	No	No	No	222	No	189	No	
3:00-4:00 PM	871	90	54	52	27	977	117	600	150	900	75	No	No	No	Yes	182	No	156	No	
4:00 - 5:00 PM	808	56	71	69	30	948	86	600	150	900	75	No	No	No	Yes	198	No	163	No	
5:00 - 6:00 PM	839	45	73	71	35	983	80	600	150	900	75	No	No	No	Yes	190	No	154	No	
Number of Hours The Thresholds Are Met												1	0	2	3			1		
Warrant Met?												No						No		

Notes:

- (1) Based on counts by LSC in August 2018 and March 2022.
- (2) North Carefree Circle eastbound and westbound left-turn, through, and right-turn volumes.
- (3) Antelope Ridge Drive southbound left-turn volume plus 25% of the southbound right-turn volume.
 (25% of the southbound right-turn vehicles were assumed to reroute their trips and make a left turn towards Marksheffel Road if this intersection were to be signalized.)
- (4) Off-peak site-generated traffic volumes are based on 2021 ITE data on the hourly distribution of vehicle trips for Land Uses 210 and 220.
- (5) Thresholds are based on 2 or more lanes on major approach and 1 lane on minor approach.

Table 4
Windermere
Traffic Signal Warrant Analysis of North Carefree Circle/Antelope Ridge Drive
MUTCD Warrants 1 and 2
2040 Total Traffic

Hour	Traffic Volumes								Warrant 1, Eight Hour Vehicular Volume Evaluation ⁽⁵⁾								Warrant 2, Four Hour Vehicular Volume Evaluation ⁽⁵⁾				
	2040 Background Traffic		Windermere Fil 1 and Proposed Multi-Family Generated Traffic ⁽⁴⁾				Estimated 2040 Total Volume		Warrant Thresholds		Warrant Threshold Met?		2040 Background		2040 Total						
	Major ⁽²⁾	Minor ⁽³⁾	EB LT	WB TH	WB RT	SB LT	SB RT	Major ⁽²⁾	Minor ⁽³⁾	Condition A	Condition B	2040 Background		2040 Total		Warrant Threshold Minor Street Minimum	Warrant Theshold Met?	Warrant Threshold Minor Street Minimum	Warrant Theshold Met?		
										Major	Minor	Major	Minor	A	B	A	B				
6:30-7:30 AM	2045	114	23	31	48	40	0	2147	154	600	150	900	75	No	Yes	Yes	Yes	80	Yes	80	Yes
7:30-8:30 AM	1955	204	28	38	55	44	0	2038	248	600	150	900	75	Yes	Yes	Yes	Yes	80	Yes	80	Yes
8:30-9:30 AM	1319	70	9	12	25	18	0	1353	88	600	150	900	75	No	No	No	Yes	80	No	80	Yes
11:00 AM - Noon	1261	64	10	15	16	11	0	1287	75	600	150	900	75	No	No	No	Yes	94	No	91	No
Noon - 1:00 PM	1401	47	35	47	29	27	0	1465	74	600	150	900	75	No	No	No	No	80	No	80	No
2:00 - 3:00 PM	2117	41	43	59	31	29	0	2191	70	600	150	900	75	No	No	No	No	80	No	80	No
3:00-4:00 PM	2020	213	53	72	36	33	0	2109	246	600	150	900	75	Yes	Yes	Yes	Yes	80	Yes	80	Yes
4:00 - 5:00 PM	2234	71	60	82	37	33	0	2331	104	600	150	900	75	No	No	No	Yes	80	No	80	Yes
5:00 - 6:00 PM	3118	69	31	44	25	18	0	3174	87	600	150	900	75	No	No	No	Yes	80	No	80	Yes
Number of Hours The Thresholds Are Met														2	3	3	7		3		6
Warrant Met?														Approaching				No		Yes	

Notes:

- (1) Based on counts by LSC in August 2018 and March 2022.
- (2) North Carefree Circle eastbound and westbound left-turn, through, and right-turn volumes.
- (3) Antelope Ridge Drive southbound left-turn volume only.
- (4) Off-peak site-generated traffic volumes are based on 2018 ITE data on the hourly distribution of vehicle trips for Land Use 210.
- (5) Thresholds are based on 2 or more lanes on major approach and 1 lane on minor approach.

Figures





Approximate Scale
Scale: 1" = 1,000'

Figure 1
**Vicinity
Map**

Windermere 2022 Amendment (LSC #S224090)

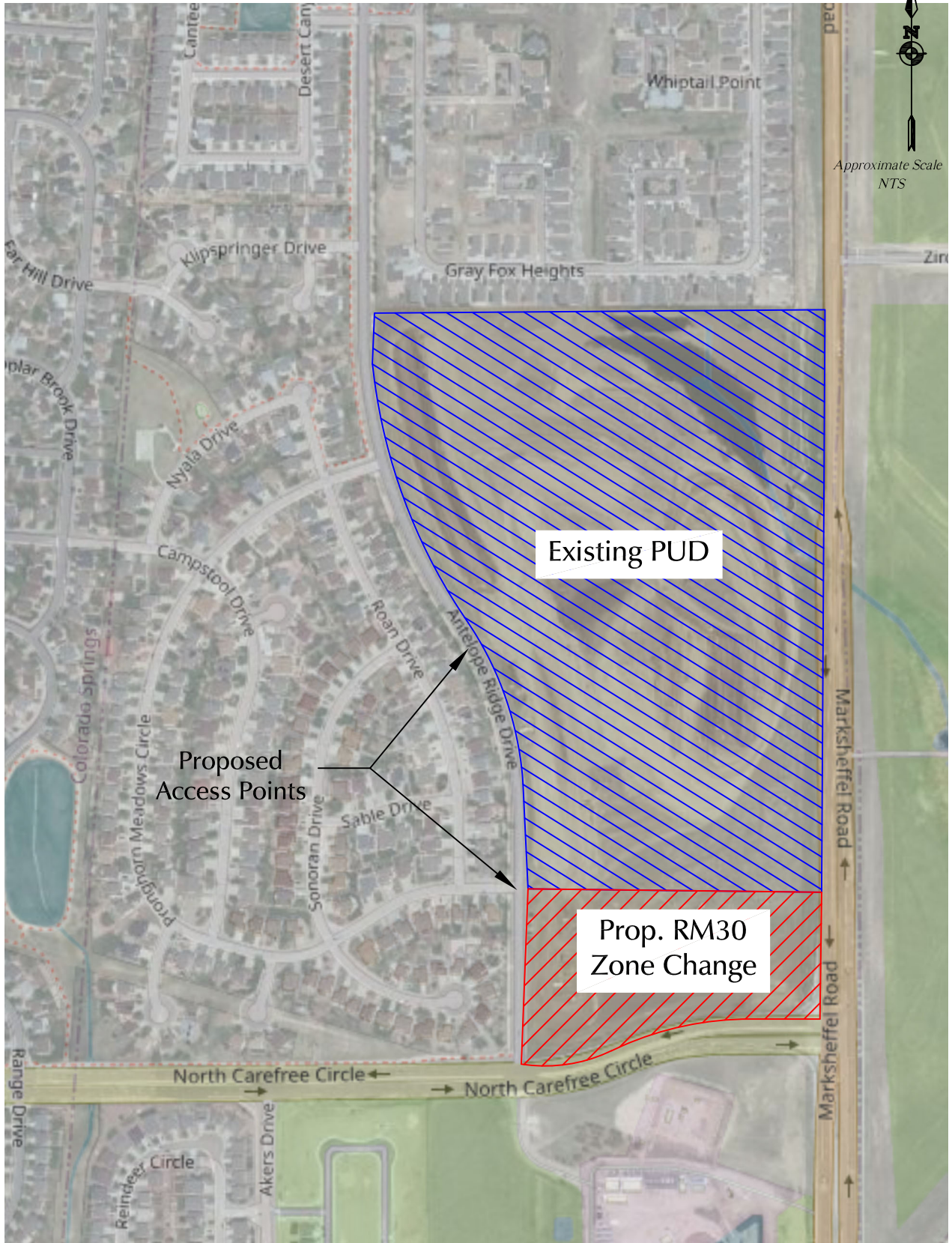

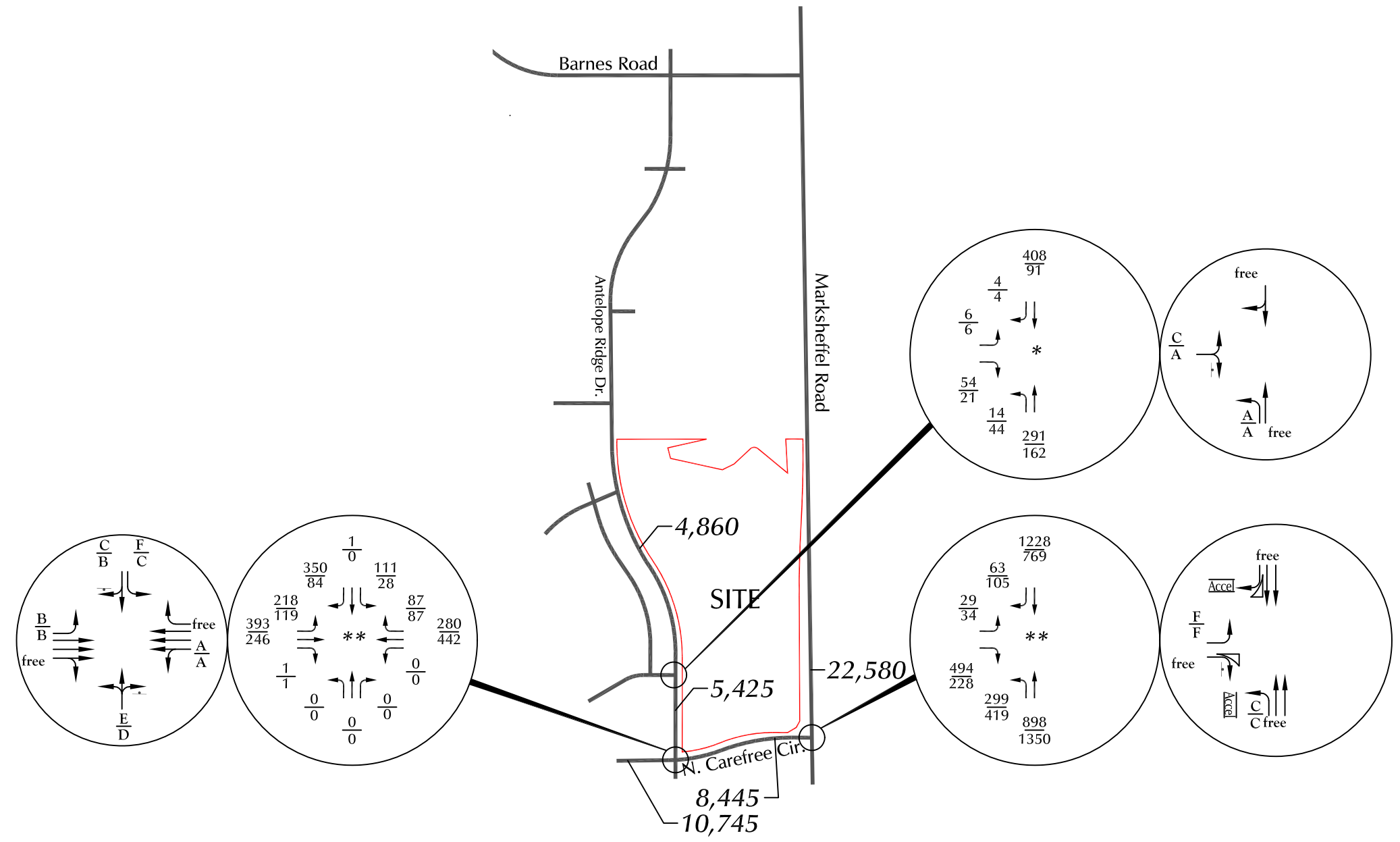
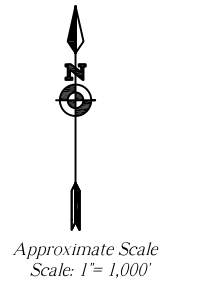

LEGEND:

- = Stop Sign
- = Traffic Signal
- $\frac{XX}{XX}$ = AM Weekday Peak-Hour Traffic (vehicles per hour)
PM Weekday Peak-Hour Traffic (vehicles per hour)
- $\frac{A}{C}$ = AM Individual Movement Peak-Hour Level of Service
PM Individual Movement Peak-Hour Level of Service
- $\frac{A}{D}$ = AM Entire Intersection Peak-Hour Level of Service
PM Entire Intersection Peak-Hour Level of Service
- 16,330 = Average Weekday Traffic (vehicles per day)

* Based on counts August 2018
** Based on counts March 2022

Figure 3
Existing Traffic,
Lane Geometry, Traffic Control
and Levels of Service
Windermere 2022 Amendment (LSC #S224090)



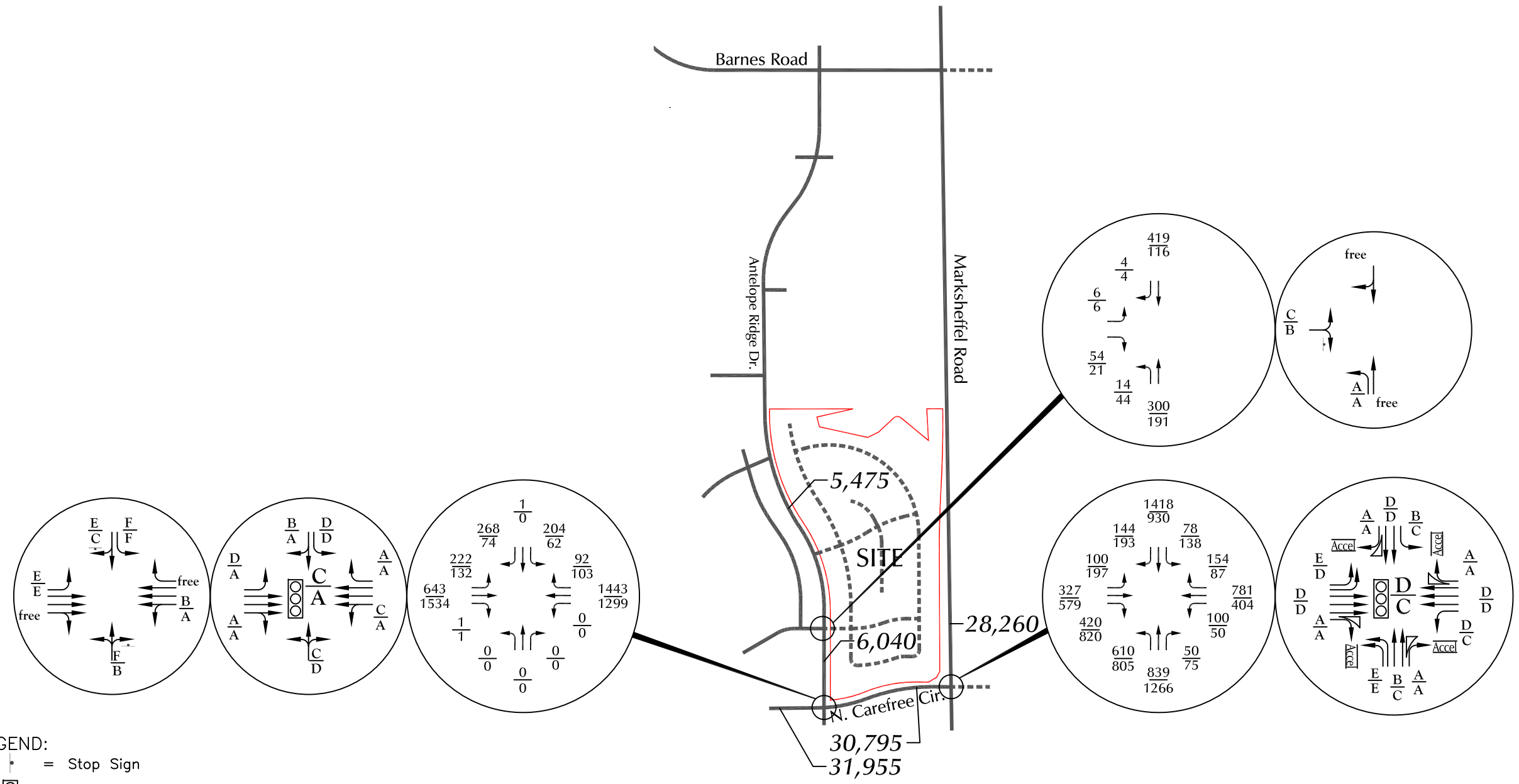

LEGEND:

- = Stop Sign
- ⓪⓪⓪ = Traffic Signal
- $\frac{XX}{XX}$ = AM Weekday Peak-Hour Traffic (vehicles per hour)
PM Weekday Peak-Hour Traffic (vehicles per hour)
- $\frac{A}{C}$ = AM Individual Movement Peak-Hour Level of Service
PM Individual Movement Peak-Hour Level of Service
- $\frac{A}{D}$ = AM Entire Intersection Peak-Hour Level of Service
PM Entire Intersection Peak-Hour Level of Service

16,330 = Average Weekday Traffic (vehicles per day)

Figure 4
Year 2040 Background Traffic,
Lane Geometry, Traffic Control
and Levels of Service



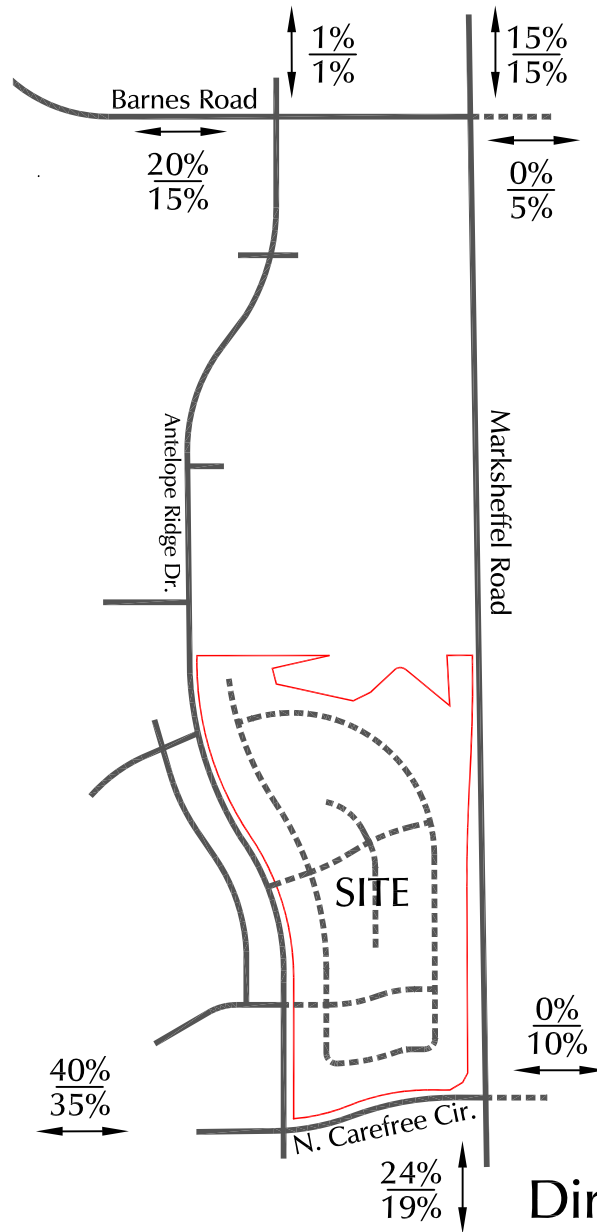

Approximate Scale
Scale: 1" = 1,000'

LEGEND:



35%
50%

= $\frac{\text{Short-Term Percent Directional Distribution}}{\text{Long-Term Percent Directional Distribution}}$

Directional Distribution of Site-Generated Traffic

Windermere 2022 Amendment (LSC #S224090)

Figure 5

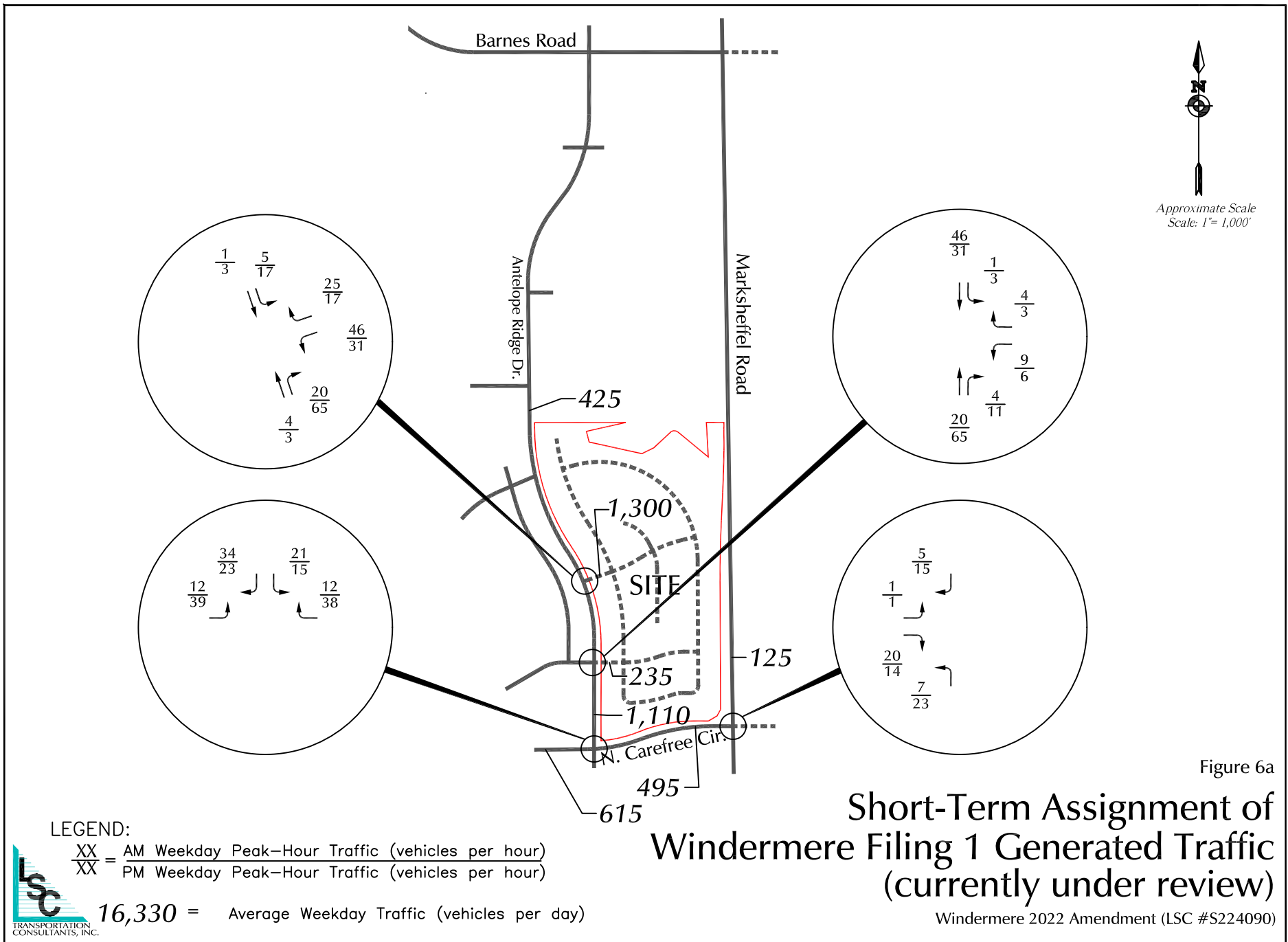

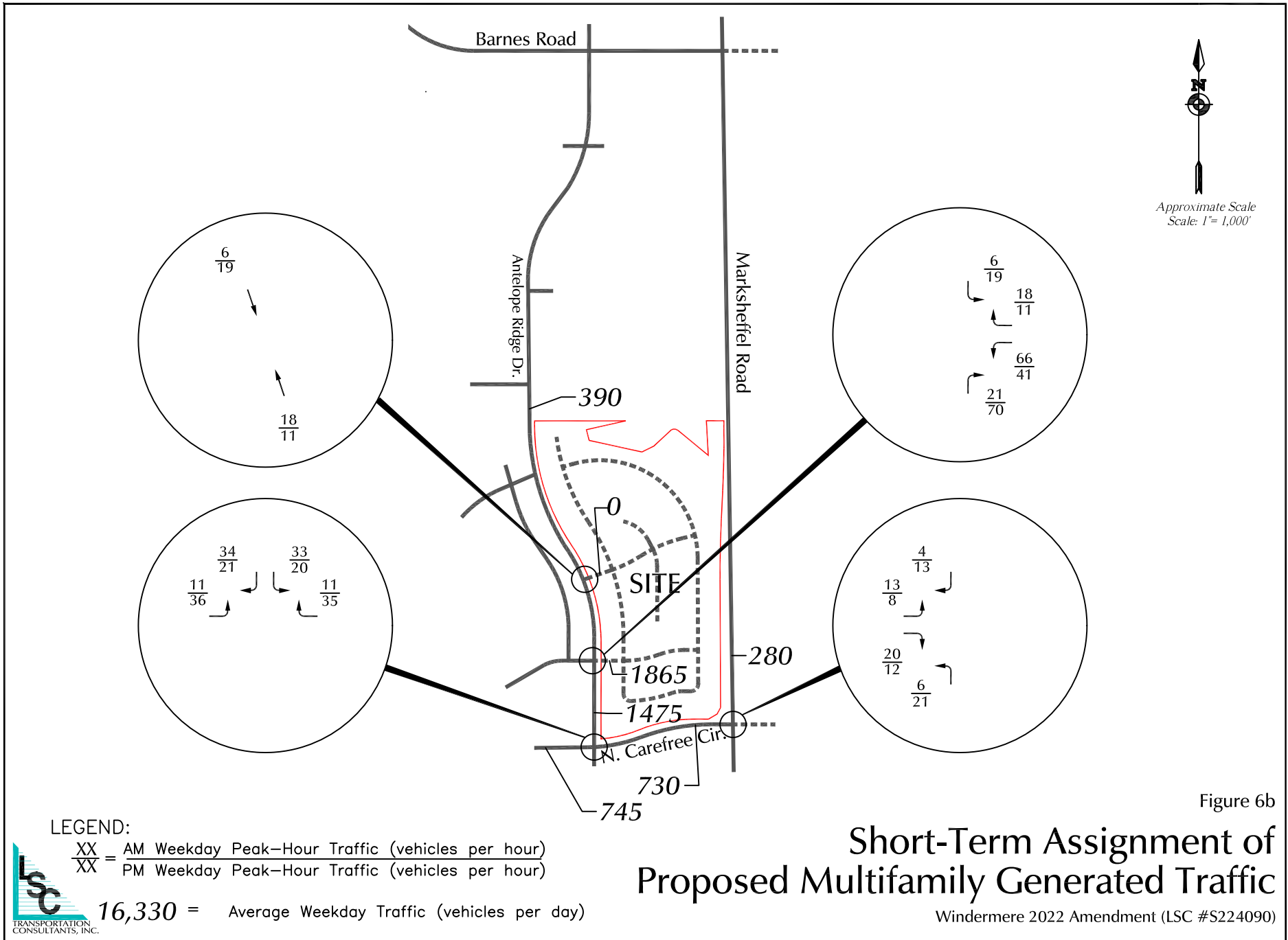

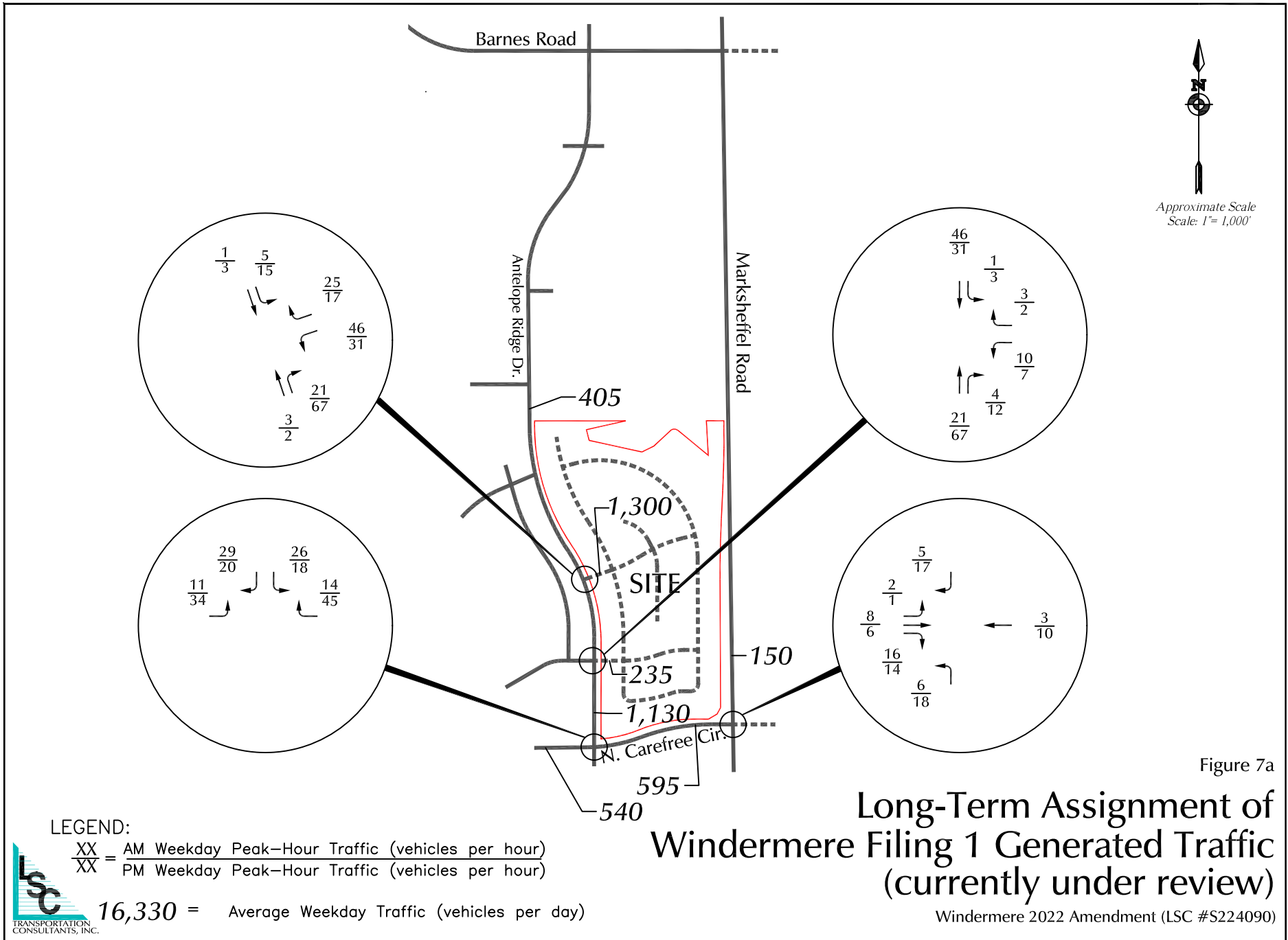

Approximate Scale
 Scale: 1" = 1,000'

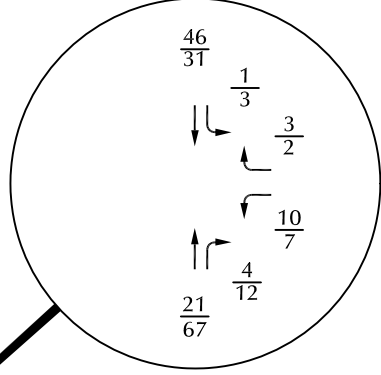
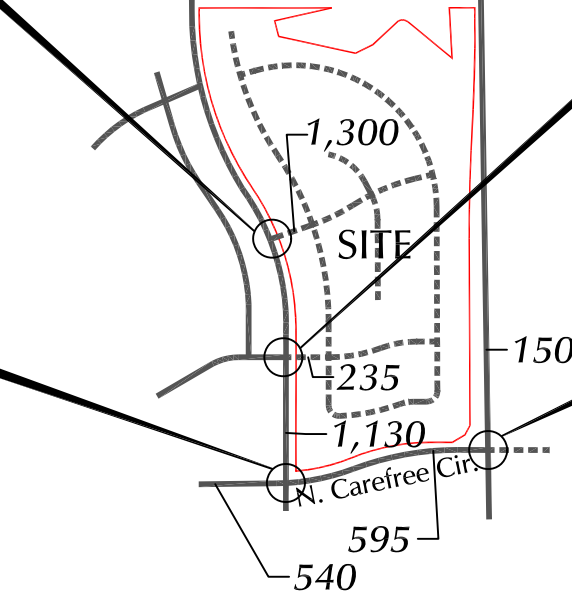
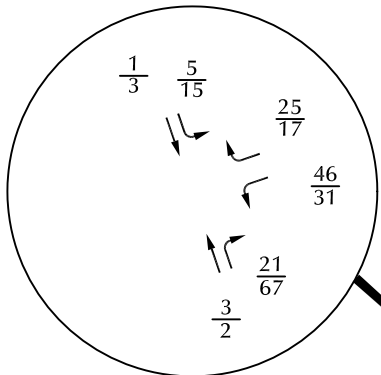

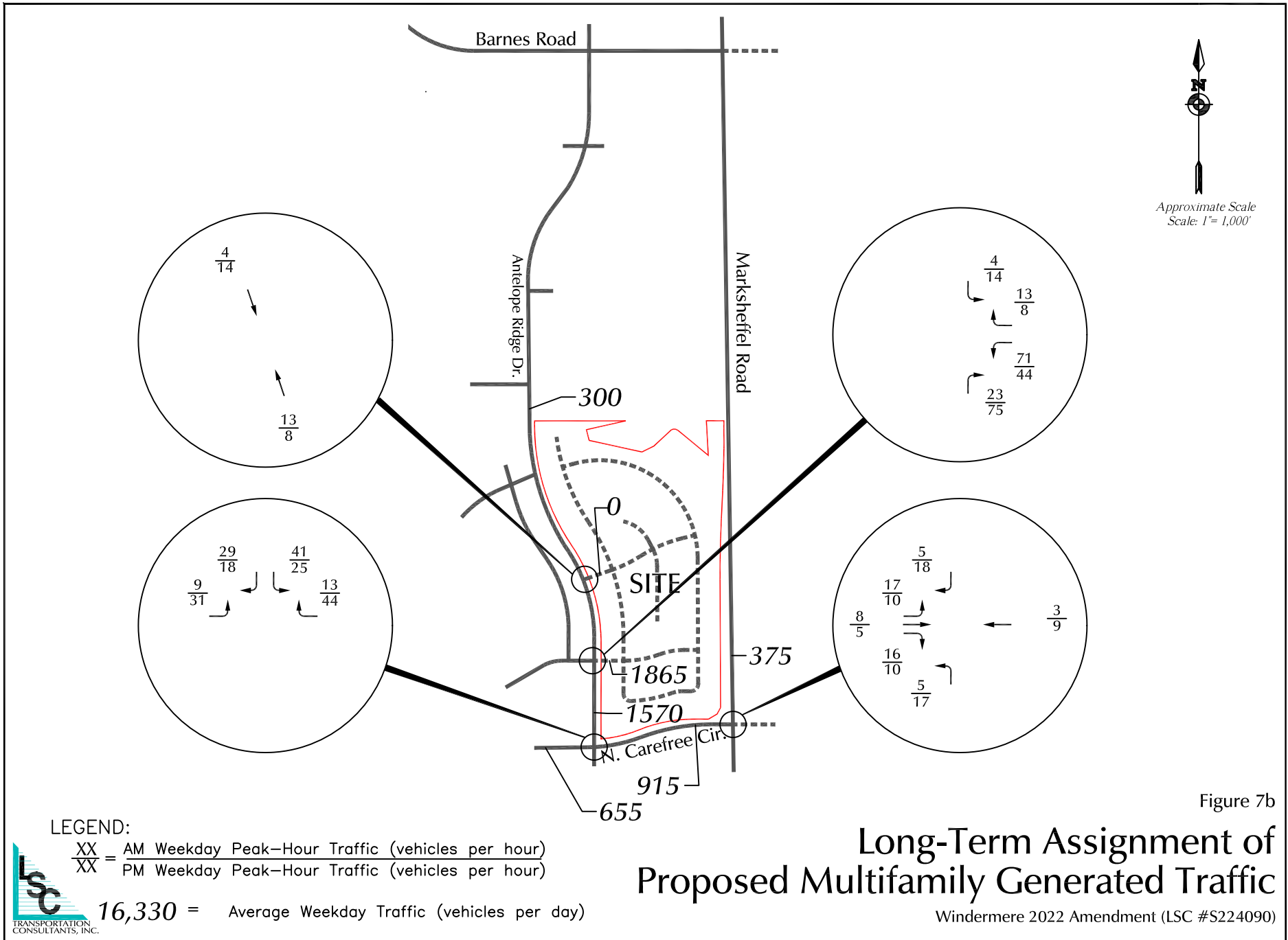

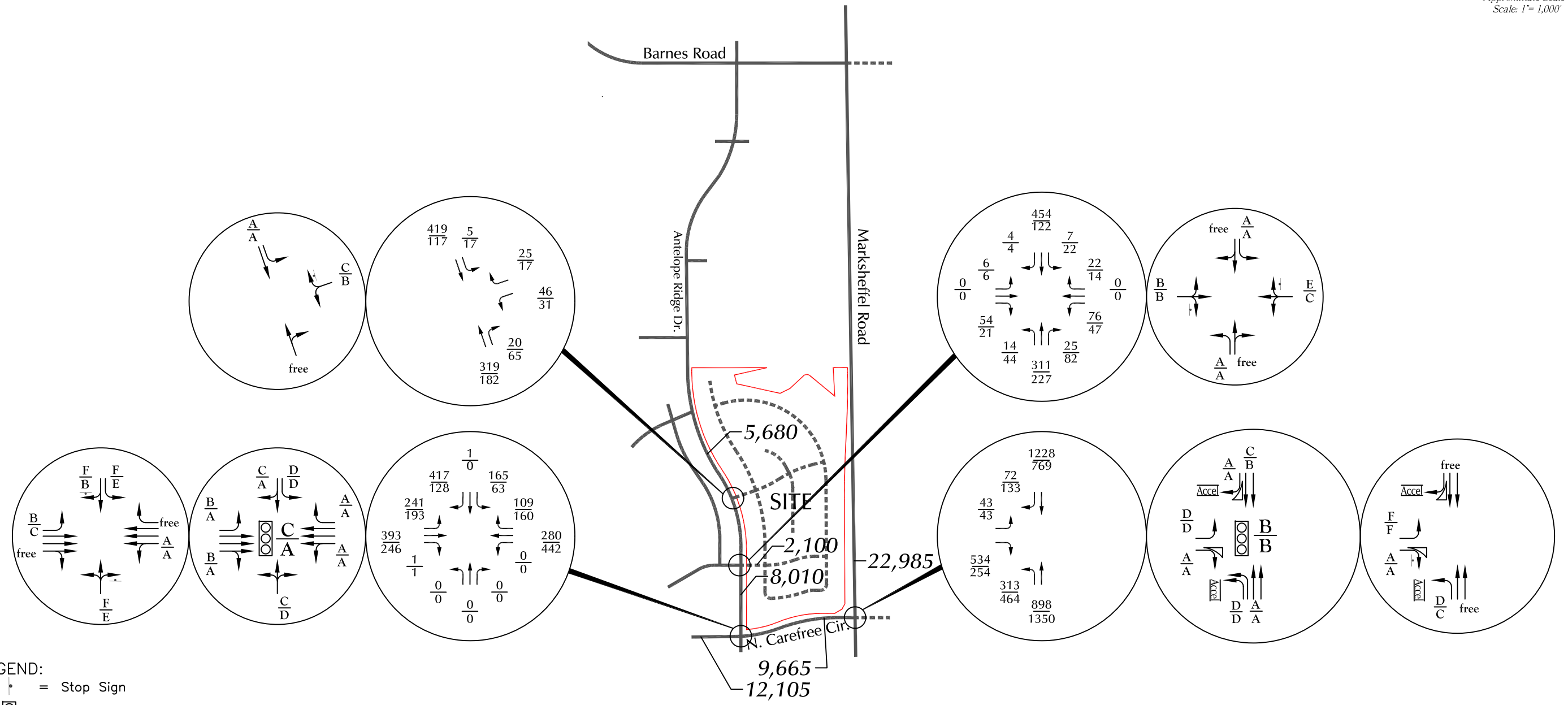

LEGEND:

- = Stop Sign
- = Traffic Signal
- $\frac{XX}{XX}$ = AM Weekday Peak-Hour Traffic (vehicles per hour) / PM Weekday Peak-Hour Traffic (vehicles per hour)
- $\frac{A}{C}$ = AM Individual Movement Peak-Hour Level of Service / PM Individual Movement Peak-Hour Level of Service
- $\frac{A}{D}$ = AM Entire Intersection Peak-Hour Level of Service / PM Entire Intersection Peak-Hour Level of Service
- 16,330 = Average Weekday Traffic (vehicles per day)

Figure 8
**Short-Term Total Traffic,
 Lane Geometry, Traffic Control
 and Levels of Service**
 Windermere 2022 Amendment (LSC #S224090)



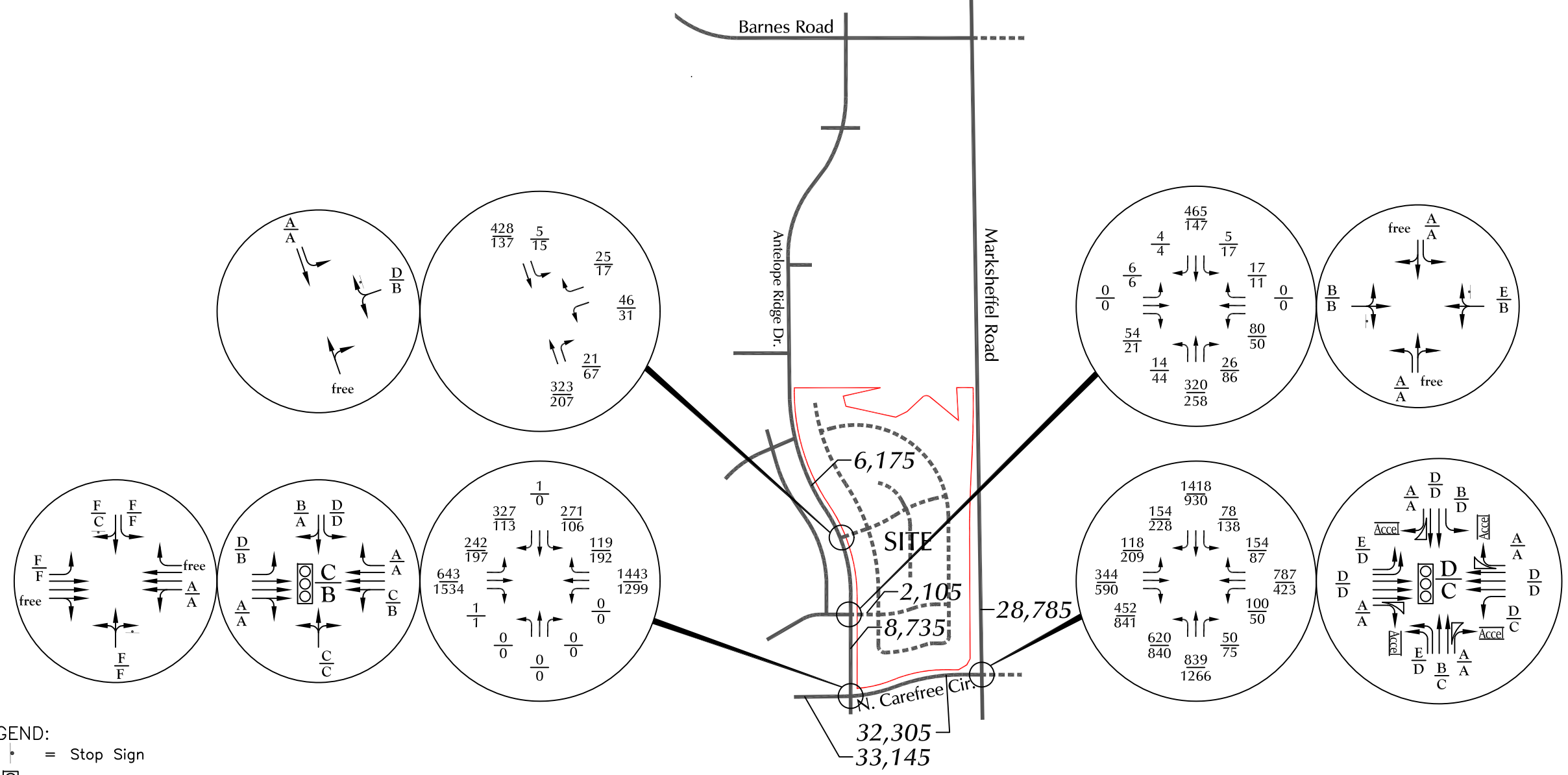

LEGEND:

- = Stop Sign
- ⓪⓪ = Traffic Signal
- $\frac{XX}{XX}$ = AM Weekday Peak-Hour Traffic (vehicles per hour)
PM Weekday Peak-Hour Traffic (vehicles per hour)
- $\frac{A}{C}$ = AM Individual Movement Peak-Hour Level of Service
PM Individual Movement Peak-Hour Level of Service
- $\frac{A}{D}$ = AM Entire Intersection Peak-Hour Level of Service
PM Entire Intersection Peak-Hour Level of Service
- 16,330 = Average Weekday Traffic (vehicles per day)

Figure 9
Year 2040 Total Traffic,
Lane Geometry, Traffic Control
and Levels of Service
Windermere 2022 Amendment (LSC #S224090)



Traffic Counts



LSC Transportation Consultants, Inc.

2504 E Pikes Peak Ave, Suite 304
 Colorado Springs, CO 80909
 719-633-2868

File Name : Antelope Ridge Dr - N Carefree Cir AM
 Site Code : S224090
 Start Date : 3/9/2022
 Page No : 1

Groups Printed- Unshifted

Start Time	Antelope Ridge Dr Southbound					N Carefree Cir Westbound					Northbound					N Carefree Cir Eastbound					Int. Total
	R	T	L	U	App. Total	R	T	L	U	App. Total	R	T	L	U	App. Total	R	T	L	U	App. Total	
06:30 AM	10	0	14	0	24	9	23	0	0	32	0	0	0	0	0	0	47	4	0	51	107
06:45 AM	19	0	22	0	41	5	36	0	0	41	0	0	0	0	0	0	82	9	0	91	173
Total	29	0	36	0	65	14	59	0	0	73	0	0	0	0	0	0	129	13	0	142	280
07:00 AM	34	0	21	0	55	11	49	0	0	60	0	0	0	0	0	0	104	23	0	127	242
07:15 AM	47	0	26	0	73	20	89	0	0	109	0	0	0	0	0	0	103	41	0	144	326
07:30 AM	100	1	27	0	128	22	70	0	0	92	0	0	0	0	0	0	98	68	0	166	386
07:45 AM	169	0	37	0	206	34	72	0	0	106	0	0	0	0	0	1	88	86	0	175	487
Total	350	1	111	0	462	87	280	0	0	367	0	0	0	0	0	1	393	218	0	612	1441
Grand Total	379	1	147	0	527	101	339	0	0	440	0	0	0	0	0	1	522	231	0	754	1721
Apprch %	71.9	0.2	27.9	0		23	77	0	0		0	0	0	0		0.1	69.2	30.6	0		
Total %	22	0.1	8.5	0	30.6	5.9	19.7	0	0	25.6	0	0	0	0	0	0.1	30.3	13.4	0	43.8	

LSC Transportation Consultants, Inc.

2504 E Pikes Peak Ave, Suite 304
 Colorado Springs, CO 80909
 719-633-2868

File Name : Antelope Ridge Dr - N Carefree Cir AM
 Site Code : S224090
 Start Date : 3/9/2022
 Page No : 3

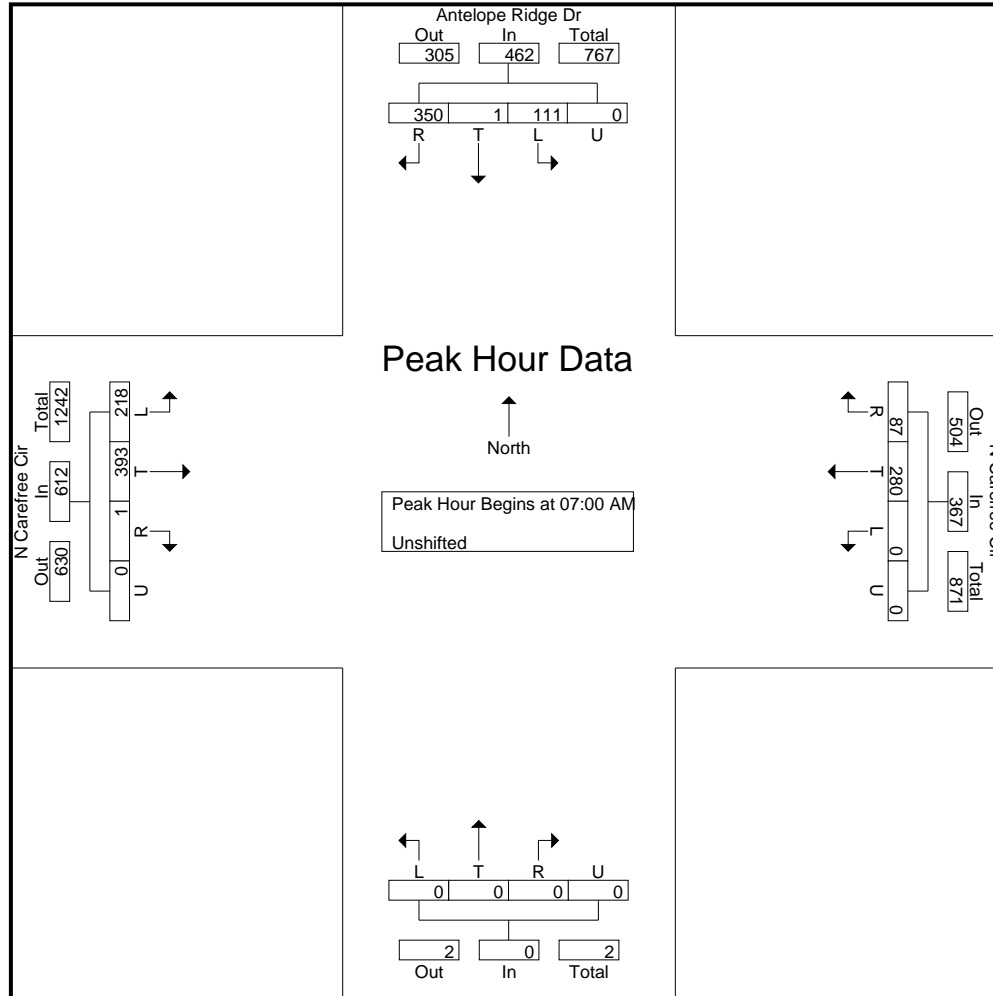

LSC Transportation Consultants, Inc.

2504 E. Pikes Peak Ave, Suite 304
 Colorado Springs, CO 80909
 719-633-2868

Default Comments

Change These in The Preferences Window

Select File/Preference in the Main Scree

Then Click the Comments Tab

Groups Printed- Unshifted

Start Time	Antelope Ridge Dr Southbound					N Carefree Cir Westbound					Northbound					N Carefree Cir Eastbound					Int. Total
	Right	T	L	U	App. Total	Right	T	L	U	App. Total	Right	T	L	U	App. Total	Right	T	L	U	App. Total	
07:30 AM	24	0	8	0	32	5	25	0	1	31	0	0	0	0	0	0	39	29	0	68	131
07:35 AM	33	0	16	0	49	5	19	0	0	24	0	0	0	0	0	0	18	14	0	32	105
07:40 AM	49	0	9	0	58	11	26	0	0	37	0	0	0	0	0	0	27	26	0	53	148
07:45 AM	50	0	9	0	59	14	20	0	0	34	0	0	0	0	0	0	28	28	0	56	149
07:50 AM	60	0	10	0	70	16	24	0	1	41	0	0	0	0	0	0	32	25	1	58	169
07:55 AM	58	0	12	0	70	10	21	0	0	31	0	0	0	0	0	1	26	18	0	45	146
Total	274	0	64	0	338	61	135	0	2	198	0	0	0	0	0	1	170	140	1	312	848
08:00 AM	49	0	12	0	61	4	18	0	0	22	0	0	0	0	0	1	24	10	0	35	118
08:05 AM	26	0	9	0	35	4	19	0	0	23	0	0	0	0	0	0	15	9	0	24	82
08:10 AM	6	0	3	0	9	3	20	0	0	23	0	0	0	0	0	0	17	3	0	20	52
08:15 AM	10	0	7	0	17	3	20	0	0	23	0	0	0	0	0	0	21	10	0	31	71
08:20 AM	4	0	6	0	10	4	13	0	0	17	0	0	0	0	0	0	15	5	0	20	47
08:25 AM	5	0	4	0	9	1	15	1	0	17	0	0	0	0	0	0	15	3	0	18	44
08:30 AM	5	0	4	0	9	1	17	0	0	18	1	0	0	0	1	0	15	8	0	23	51
08:35 AM	2	0	6	0	8	2	14	0	0	16	0	0	0	0	0	1	19	5	0	25	49
08:40 AM	9	0	7	0	16	1	15	0	0	16	0	0	0	0	0	0	14	1	0	15	47
08:45 AM	8	0	3	0	11	2	24	0	0	26	0	0	0	0	0	0	11	2	2	15	52
08:50 AM	7	0	2	0	9	2	21	0	0	23	1	0	0	0	1	0	13	3	0	16	49
08:55 AM	2	0	1	0	3	2	27	1	0	30	0	0	0	0	0	0	18	2	0	20	53
Total	133	0	64	0	197	29	223	2	0	254	2	0	0	0	2	2	197	61	2	262	715
09:00 AM	6	0	5	0	11	1	10	0	0	11	0	0	0	0	0	0	24	6	0	30	52
09:05 AM	2	0	2	0	4	2	12	0	0	14	0	0	0	0	0	0	13	7	0	20	38
09:10 AM	6	0	5	0	11	3	18	0	0	21	0	0	0	0	0	0	10	2	0	12	44
09:15 AM	2	0	2	0	4	1	18	0	1	20	0	0	0	0	0	0	10	3	0	13	37
09:20 AM	7	0	3	0	10	6	11	0	0	17	0	0	0	0	0	0	13	4	0	17	44
09:25 AM	6	0	7	0	13	3	10	1	1	15	0	0	0	0	0	0	6	5	0	11	39

LSC Transportation Consultants, Inc.

2504 E. Pikes Peak Ave, Suite 304

Colorado Springs, CO 80909

719-633-2868

Default Comments

Change These in The Preferences Window

Select File/Preference in the Main Scree

Then Click the Comments Tab

Groups Printed- Unshifted

Start Time	Antelope Ridge Dr Southbound					N Carefree Cir Westbound					Northbound					N Carefree Cir Eastbound					Int. Total
	Right	T	L	U	App. Total	Right	T	L	U	App. Total	Right	T	L	U	App. Total	Right	T	L	U	App. Total	
11:00 AM	4	0	5	0	9	2	9	0	0	11	0	0	0	0	0	1	7	5	0	13	33
11:05 AM	2	0	3	0	5	1	19	0	0	20	0	0	0	0	0	0	11	6	0	17	42
11:10 AM	4	0	3	0	7	1	14	0	0	15	1	0	0	0	1	0	14	5	0	19	42
11:15 AM	3	0	1	0	4	0	18	0	0	18	0	0	0	0	0	1	11	5	0	17	39
11:20 AM	4	0	5	0	9	4	15	1	1	21	1	0	0	0	1	0	12	8	0	20	51
11:25 AM	6	0	3	0	9	4	17	0	1	22	1	0	0	0	1	0	11	10	0	21	53
11:30 AM	6	0	0	0	6	2	17	0	0	19	0	0	0	0	0	0	13	5	0	18	43
11:35 AM	11	0	3	0	14	3	17	2	0	22	0	0	0	0	0	0	7	9	0	16	52
11:40 AM	10	0	3	0	13	2	14	0	0	16	2	0	0	0	2	1	10	7	0	18	49
11:45 AM	5	0	3	0	8	4	18	0	0	22	0	0	0	0	0	0	24	4	1	29	59
11:50 AM	4	0	5	0	9	2	14	0	0	16	1	0	0	0	1	0	20	1	0	21	47
11:55 AM	9	0	2	0	11	2	13	0	0	15	0	0	0	0	0	1	16	6	0	23	49
Total	68	0	36	0	104	27	185	3	2	217	6	0	0	0	6	4	156	71	1	232	559
12:00 PM	1	0	0	0	1	2	20	0	0	22	0	1	0	0	1	0	13	4	0	17	41
12:05 PM	7	0	1	0	8	3	20	0	0	23	0	0	0	0	0	0	15	4	0	19	50
12:10 PM	3	0	4	0	7	7	17	0	0	24	0	0	0	0	0	0	21	4	0	25	56
12:15 PM	2	0	0	0	2	2	15	0	0	17	0	0	0	0	0	0	19	4	0	23	42
12:20 PM	4	0	2	0	6	5	14	0	0	19	0	0	0	0	0	0	9	3	0	12	37
12:25 PM	3	0	2	0	5	1	14	0	0	15	0	0	0	0	0	1	15	8	0	24	44
12:30 PM	7	0	1	0	8	2	13	0	1	16	0	0	0	0	0	0	19	7	1	27	51
12:35 PM	5	0	3	0	8	2	17	0	0	19	0	0	0	0	0	0	14	5	0	19	46
12:40 PM	5	0	3	0	8	1	28	0	1	30	0	0	0	0	0	0	10	4	0	14	52
12:45 PM	6	0	1	0	7	2	11	0	0	13	0	0	0	0	0	0	12	6	1	19	39
12:50 PM	5	0	1	0	6	2	22	0	0	24	0	0	0	0	0	0	14	3	0	17	47
12:55 PM	4	0	2	0	6	4	12	0	1	17	0	0	1	0	1	0	17	8	0	25	49
Total	52	0	20	0	72	33	203	0	3	239	0	1	1	0	2	1	178	60	2	241	554

LSC Transportation Consultants, Inc.

2504 E. Pikes Peak Ave, Suite 304
 Colorado Springs, CO 80909
 719-633-2868

File Name : Antelope Ridge Dr - N Carefree Cir 2-4 SW
 Site Code : S224090
 Start Date : 4/5/2022
 Page No : 1

Groups Printed- Unshifted

Start Time	Antelope Ridge Dr Southbound					N Carefree Cir Westbound					Northbound					N Carefree Cir Eastbound					Int. Total
	Right	T	L	U	App. Total	Right	T	L	U	App. Total	Right	T	L	U	App. Total	Right	T	L	U	App. Total	
02:00 PM	7	0	0	0	7	5	18	0	0	23	0	0	0	0	0	0	12	8	0	20	50
02:05 PM	3	0	4	0	7	3	21	0	0	24	0	0	0	0	0	0	22	4	0	26	57
02:10 PM	5	0	4	0	9	1	15	0	0	16	1	0	0	0	1	0	15	4	0	19	45
02:15 PM	7	0	0	0	7	1	24	0	0	25	0	0	0	0	0	0	18	11	0	29	61
02:20 PM	8	0	3	0	11	3	16	0	0	19	0	0	0	0	0	0	21	6	0	27	57
02:25 PM	2	0	3	0	5	3	25	1	0	29	0	0	0	0	0	0	22	8	0	30	64
02:30 PM	2	0	3	0	5	3	30	0	0	33	0	0	0	0	0	0	22	8	0	30	68
02:35 PM	11	0	2	0	13	6	43	0	0	49	0	0	0	0	0	0	17	9	0	26	88
02:40 PM	13	0	2	0	15	6	42	0	0	48	0	0	0	0	0	0	24	13	2	39	102
02:45 PM	7	0	2	0	9	6	29	1	0	36	1	0	0	0	1	0	33	17	0	50	96
02:50 PM	11	0	0	0	11	5	25	0	0	30	0	0	0	0	0	0	40	18	0	58	99
02:55 PM	8	0	3	0	11	7	24	0	0	31	0	0	0	0	0	0	22	19	0	41	83
Total	84	0	26	0	110	49	312	2	0	363	2	0	0	0	2	0	268	125	2	395	870
03:00 PM	8	0	1	0	9	12	29	0	0	41	0	0	0	0	0	0	13	17	0	30	80
03:05 PM	26	0	5	0	31	2	25	0	0	27	0	0	0	0	0	0	27	20	0	47	105
03:10 PM	43	0	8	0	51	6	17	0	0	23	0	0	0	0	0	0	31	26	0	57	131
03:15 PM	31	0	10	0	41	8	18	0	0	26	0	0	0	0	0	0	27	35	0	62	129
03:20 PM	24	0	5	0	29	15	24	0	0	39	0	0	0	0	0	0	20	21	0	41	109
03:25 PM	8	0	2	0	10	13	33	0	0	46	0	0	0	0	0	0	19	13	0	32	88
03:30 PM	24	0	4	0	28	8	27	0	0	35	0	0	0	0	0	0	28	13	0	41	104
03:35 PM	54	0	18	0	72	7	27	0	0	34	0	0	0	0	0	0	13	13	0	26	132
03:40 PM	52	0	15	0	67	5	35	0	0	40	0	0	0	0	0	0	19	17	0	36	143
03:45 PM	27	0	16	0	43	5	31	0	0	36	0	0	0	0	0	0	18	6	0	24	103
03:50 PM	7	0	3	0	10	4	27	0	0	31	0	0	0	0	0	0	22	8	0	30	71
03:55 PM	10	0	3	0	13	5	38	0	0	43	0	0	0	0	0	0	14	10	0	24	80
Total	314	0	90	0	404	90	331	0	0	421	0	0	0	0	0	0	251	199	0	450	1275
Grand Total	398	0	116	0	514	139	643	2	0	784	2	0	0	0	2	0	519	324	2	845	2145
Apprch %	77.4	0	22.6	0		17.7	82	0.3	0		100	0	0	0		0	61.4	38.3	0.2		
Total %	18.6	0	5.4	0	24	6.5	30	0.1	0	36.6	0.1	0	0	0	0.1	0	24.2	15.1	0.1	39.4	

LSC Transportation Consultants, Inc.

2504 E Pikes Peak Ave, Suite 304
 Colorado Springs, CO 80909
 719-633-2868

File Name : Antelope Ridge Dr - N Carefree Cir PM
 Site Code : S224090
 Start Date : 3/16/2022
 Page No : 1

Groups Printed- Unshifted

Start Time	Antelope Ridge Dr Southbound					N Carefree Cir Westbound					Northbound					N Carefree Cir Eastbound					Int. Total
	R	T	L	U	App. Total	R	T	L	U	App. Total	R	T	L	U	App. Total	R	T	L	U	App. Total	
04:00 PM	7	0	9	0	16	18	87	0	0	105	0	0	0	0	0	0	43	23	0	66	187
04:15 PM	26	0	13	0	39	21	94	0	0	115	0	0	0	0	0	0	53	28	0	81	235
04:30 PM	24	0	6	0	30	29	100	0	0	129	0	0	0	0	0	0	59	32	0	91	250
04:45 PM	22	0	8	0	30	15	118	0	0	133	0	0	0	0	0	0	58	30	0	88	251
Total	79	0	36	0	115	83	399	0	0	482	0	0	0	0	0	0	213	113	0	326	923
05:00 PM	19	0	9	0	28	21	116	0	0	137	0	0	0	0	0	0	51	31	0	82	247
05:15 PM	19	0	5	0	24	22	108	0	0	130	0	0	0	0	0	0	78	26	0	104	258
05:30 PM	14	0	8	0	22	19	96	0	0	115	0	0	0	0	0	0	75	23	0	98	235
05:45 PM	19	0	5	0	24	12	66	0	0	78	0	0	0	0	0	0	69	26	0	95	197
Total	71	0	27	0	98	74	386	0	0	460	0	0	0	0	0	0	273	106	0	379	937
Grand Total	150	0	63	0	213	157	785	0	0	942	0	0	0	0	0	0	486	219	0	705	1860
Apprch %	70.4	0	29.6	0		16.7	83.3	0	0		0	0	0	0	0	0	68.9	31.1	0		
Total %	8.1	0	3.4	0	11.5	8.4	42.2	0	0	50.6	0	0	0	0	0	0	26.1	11.8	0	37.9	

LSC Transportation Consultants, Inc.

2504 E Pikes Peak Ave, Suite 304
 Colorado Springs, CO 80909
 719-633-2868

File Name : Antelope Ridge Dr - N Carefree Cir PM
 Site Code : S224090
 Start Date : 3/16/2022
 Page No : 3

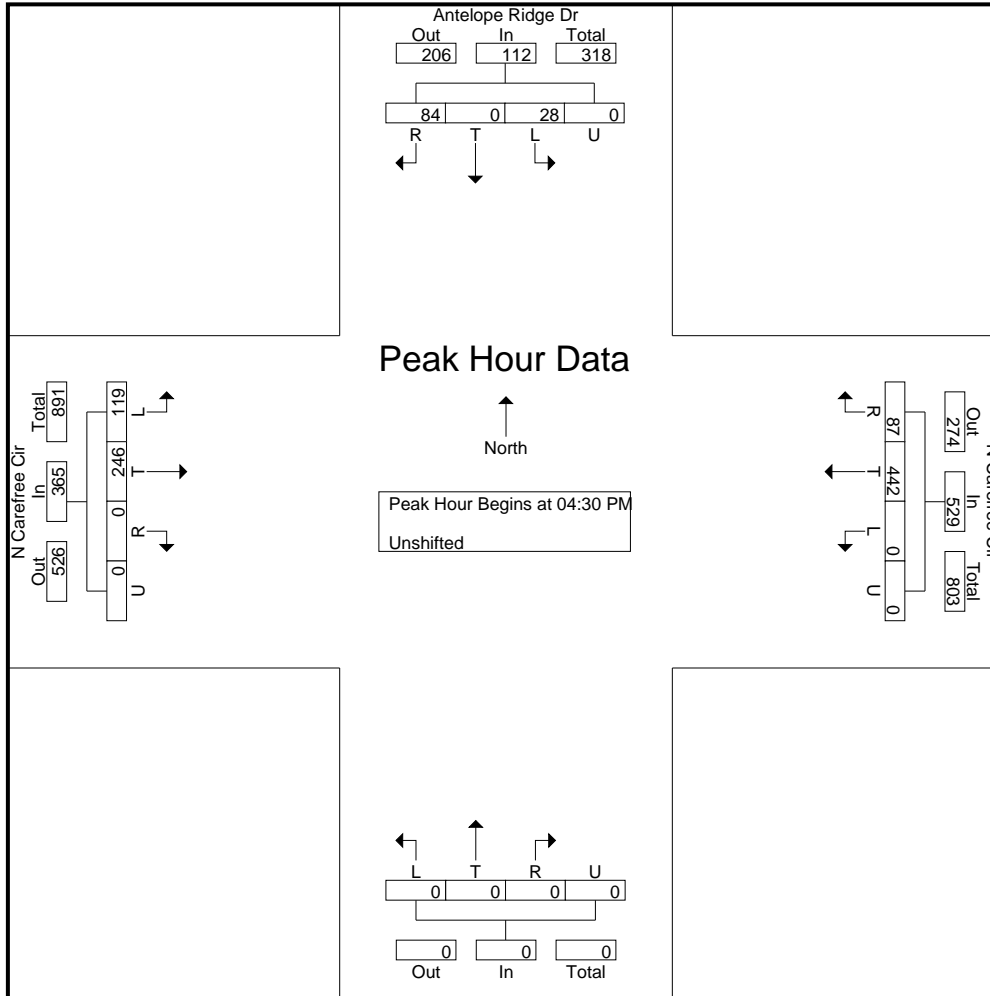

LSC Transportation Consultants, Inc.

2504 E Pikes Peak Ave, Suite 304
 Colorado Springs, CO 80909
 719-633-2868

File Name : Marksheffel Rd - N Carefree Cir AM 3-22
 Site Code : S224090
 Start Date : 3/9/2022
 Page No : 1

Groups Printed- Unshifted

Start Time	Marksheffel Rd Southbound					Westbound					Marksheffel Rd Northbound					N Carefree Cir Eastbound					Int. Total
	L	T	R	U	App. Total	L	T	R	U	App. Total	L	T	R	U	App. Total	L	T	R	U	App. Total	
06:30 AM	0	226	10	0	236	0	0	0	0	0	27	146	0	0	173	8	0	95	0	103	512
06:45 AM	0	351	20	0	371	0	0	0	0	0	35	148	0	0	183	5	0	97	0	102	656
Total	0	577	30	0	607	0	0	0	0	0	62	294	0	0	356	13	0	192	0	205	1168
07:00 AM	0	346	19	0	365	0	0	0	0	0	59	189	0	0	248	3	0	119	6	128	741
07:15 AM	0	339	6	0	345	0	0	0	0	0	94	249	0	0	343	2	0	129	4	135	823
07:30 AM	0	291	25	0	316	0	0	0	0	0	76	227	0	1	304	5	0	117	2	124	744
07:45 AM	0	252	13	0	265	0	0	0	0	0	70	233	0	0	303	5	0	129	2	136	704
Total	0	1228	63	0	1291	0	0	0	0	0	299	898	0	1	1198	15	0	494	14	523	3012
08:00 AM	0	254	19	0	273	0	0	0	0	0	57	184	0	0	241	12	0	83	1	96	610
08:15 AM	0	245	28	0	273	0	0	0	0	0	43	161	0	0	204	3	0	45	0	48	525
Grand Total	0	2304	140	0	2444	0	0	0	0	0	461	1537	0	1	1999	43	0	814	15	872	5315
Apprch %	0	94.3	5.7	0		0	0	0	0	0	23.1	76.9	0	0.1		4.9	0	93.3	1.7		
Total %	0	43.3	2.6	0	46	0	0	0	0	0	8.7	28.9	0	0	37.6	0.8	0	15.3	0.3	16.4	

LSC Transportation Consultants, Inc.

2504 E Pikes Peak Ave, Suite 304
 Colorado Springs, CO 80909
 719-633-2868

File Name : Marksheffel Rd - N Carefree Cir AM 3-22

Site Code : S224090

Start Date : 3/9/2022

Page No : 3

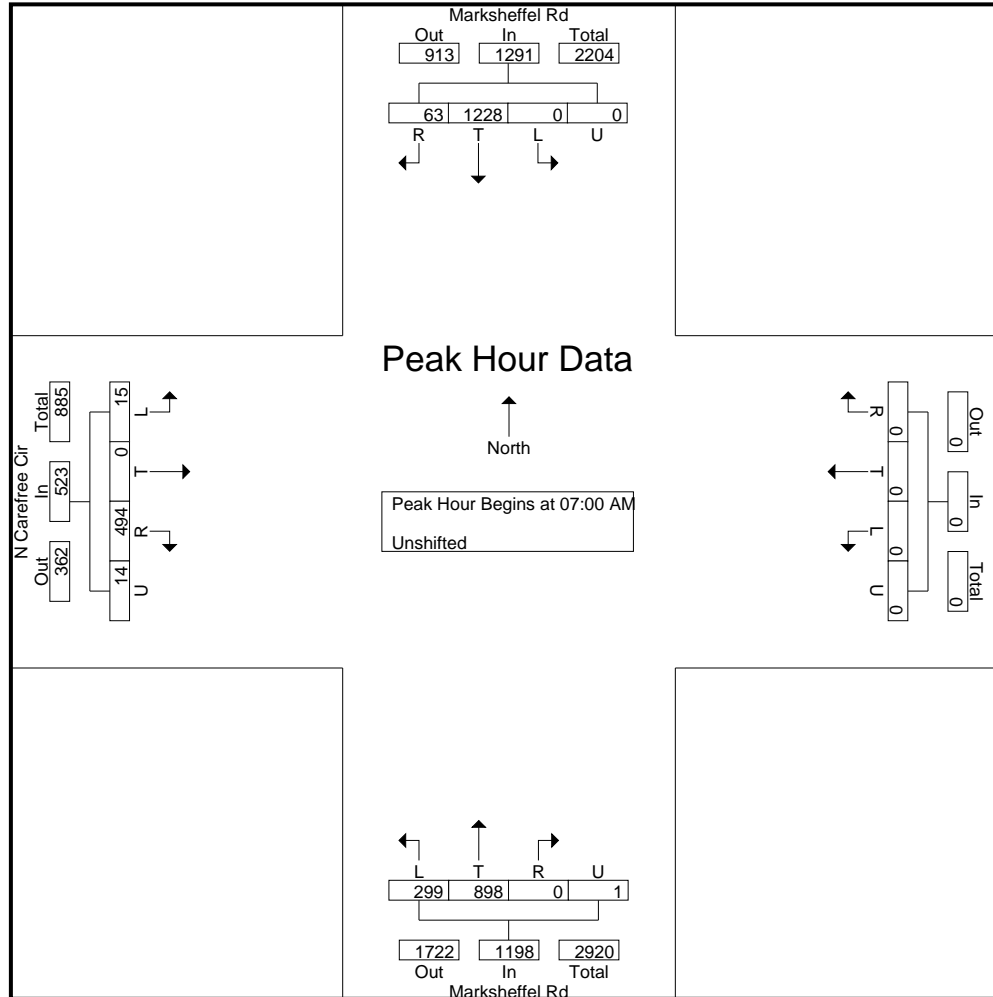

LSC Transportation Consultants, Inc.

2504 E Pikes Peak Ave, Suite 304
 Colorado Springs, CO 80909
 719-633-2868

File Name : Marksheffel Rd - N Carefree Cir PM 3-22
 Site Code : S224090
 Start Date : 3/16/2022
 Page No : 1

Groups Printed- Unshifted

Start Time	Marksheffel Rd Southbound					Westbound					Marksheffel Rd Northbound					N Carefree Cir Eastbound					Int. Total
	R	T	L	U	App. Total	R	T	L	U	App. Total	R	T	L	U	App. Total	R	T	L	U	App. Total	
04:00 PM	17	197	0	0	214	0	0	0	0	0	0	328	96	0	424	49	0	5	0	54	692
04:15 PM	26	185	0	0	211	0	0	0	0	0	0	333	86	0	419	61	0	13	1	75	705
04:30 PM	21	211	0	1	233	0	0	0	0	0	0	341	113	0	454	57	0	5	0	62	749
04:45 PM	32	156	0	0	188	0	0	0	0	0	0	362	99	0	461	60	0	9	0	69	718
Total	96	749	0	1	846	0	0	0	0	0	0	1364	394	0	1758	227	0	32	1	260	2864
05:00 PM	28	192	0	0	220	0	0	0	0	0	0	342	111	0	453	49	0	5	0	54	727
05:15 PM	24	210	0	0	234	0	0	0	0	0	0	305	96	0	401	62	0	15	0	77	712
05:30 PM	26	216	0	0	242	0	0	0	0	0	0	282	86	0	368	57	0	17	0	74	684
05:45 PM	16	158	0	0	174	0	0	0	0	0	0	273	64	0	337	62	0	16	0	78	589
Total	94	776	0	0	870	0	0	0	0	0	0	1202	357	0	1559	230	0	53	0	283	2712
Grand Total	190	1525	0	1	1716	0	0	0	0	0	0	2566	751	0	3317	457	0	85	1	543	5576
Apprch %	11.1	88.9	0	0.1		0	0	0	0	0	0	77.4	22.6	0		84.2	0	15.7	0.2		
Total %	3.4	27.3	0	0	30.8	0	0	0	0	0	0	46	13.5	0	59.5	8.2	0	1.5	0	9.7	

LSC Transportation Consultants, Inc.

2504 E Pikes Peak Ave, Suite 304
 Colorado Springs, CO 80909
 719-633-2868

File Name : Marksheffel Rd - N Carefree Cir PM 3-22

Site Code : S224090

Start Date : 3/16/2022

Page No : 3

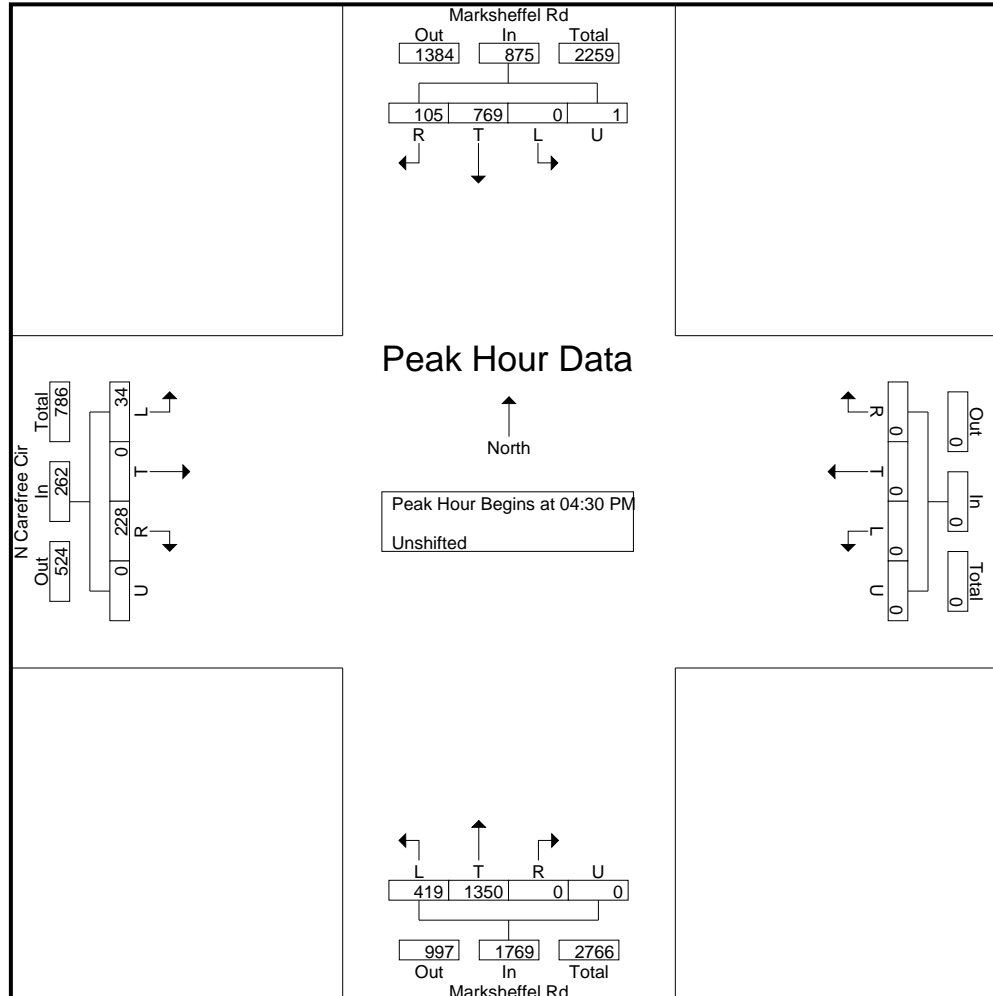

LSC Transportation Consultants, Inc.

2504 E Pikes Peak Ave, Suite 304

Colorado Springs, CO 80909

719-633-2868

File Name : Antelope Ridge Dr - S Pronghorn Meadows Dr AM

Site Code : 00184640

Start Date : 8/15/2018

Page No : 1

Groups Printed- Unshifted

Start Time	Antelope Ridge Dr Southbound				Westbound				Antelope Ridge Dr Northbound				S Pronghorn Meadows Dr Eastbound				Int. Total
	Left	Thru	Right	Peds	Left	Thru	Right	Peds	Left	Thru	Right	Peds	Left	Thru	Right	Peds	
06:30	0	17	1	0	0	0	0	0	3	10	0	0	1	0	8	0	40
06:45	0	37	0	0	0	0	0	0	1	25	0	0	1	0	16	0	80
Total	0	54	1	0	0	0	0	0	4	35	0	0	2	0	24	0	120
07:00	0	39	0	0	0	0	0	0	2	47	0	0	0	0	12	0	100
07:15	0	72	0	0	0	0	0	0	6	86	0	0	2	0	16	0	182
07:30	0	184	1	0	0	0	0	0	3	157	0	0	0	0	17	0	362
07:45	0	198	3	0	0	0	0	0	3	61	0	0	4	0	9	0	278
Total	0	493	4	0	0	0	0	0	14	351	0	0	6	0	54	0	922
08:00	0	61	1	0	0	0	0	0	4	8	0	0	1	0	4	0	79
08:15	0	21	0	0	0	0	0	0	1	18	0	0	1	0	7	0	48
Grand Total	0	629	6	0	0	0	0	0	23	412	0	0	10	0	89	0	1169
Apprch %	0	99.1	0.9	0	0	0	0	0	5.3	94.7	0	0	10.1	0	89.9	0	
Total %	0	53.8	0.5	0	0	0	0	0	2	35.2	0	0	0.9	0	7.6	0	

LSC Transportation Consultants, Inc.

2504 E Pikes Peak Ave, Suite 304

Colorado Springs, CO 80909

719-633-2868

File Name : Antelope Ridge Dr - S Pronghorn Meadows Dr AM

Site Code : 00184640

Start Date : 8/15/2018

Page No : 2

Start Time	Antelope Ridge Dr Southbound					Westbound					Antelope Ridge Dr Northbound					S Pronghorn Meadows Dr Eastbound					Int. Total
	Left	Thru	Right	Peds	App. Total	Left	Thru	Right	Peds	App. Total	Left	Thru	Right	Peds	App. Total	Left	Thru	Right	Peds	App. Total	
Peak Hour Analysis From 6:30:00 AM to 8:15:00 AM - Peak 1 of 1																					
Peak Hour for Entire Intersection Begins at 7:00:00 AM																					
7:00:00 AM	0	39	0	0	39	0	0	0	0	0	2	47	0	0	49	0	0	12	0	12	100
7:15:00 AM	0	72	0	0	72	0	0	0	0	0	6	86	0	0	92	2	0	16	0	18	182
7:30:00 AM	0	184	1	0	185	0	0	0	0	0	3	157	0	0	160	0	0	17	0	17	362
7:45:00 AM	0	198	3	0	201	0	0	0	0	0	3	61	0	0	64	4	0	9	0	13	278
Total Volume	0	493	4	0	497	0	0	0	0	0	14	351	0	0	365	6	0	54	0	60	922
% App. Total	0	99.2	0.8	0		0	0	0	0		3.8	96.2	0	0		10	0	90	0		
PHF	.000	.622	.333	.000	.618	.000	.000	.000	.000	.000	.583	.559	.000	.000	.570	.375	.000	.794	.000	.833	.637

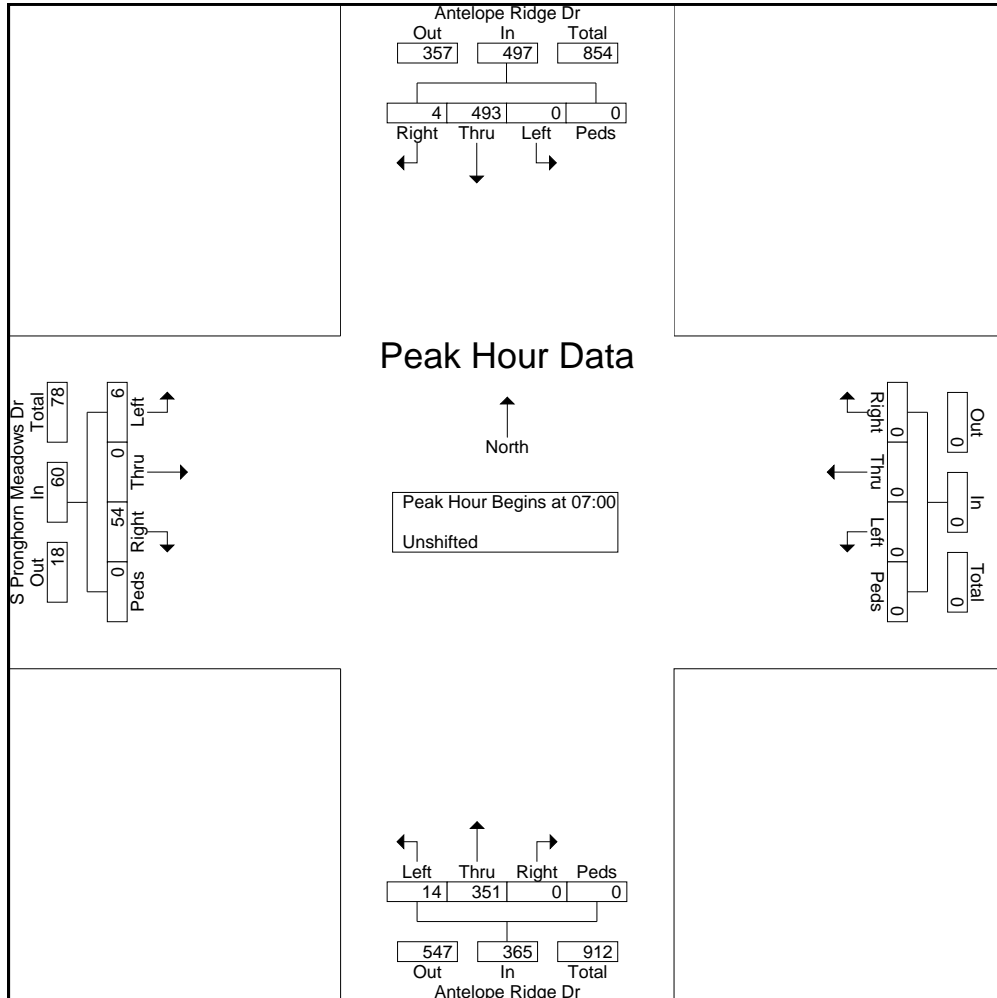

LSC Transportation Consultants, Inc.

2504 E Pikes Peak Ave, Suite 304

Colorado Springs, CO 80909

719-633-2868

File Name : Antelope Ridge Dr - S Pronghorn Meadows Dr PM

Site Code : 00184640

Start Date : 8/15/2018

Page No : 1

Groups Printed- Unshifted

Start Time	Antelope Ridge Dr Southbound				Westbound				Antelope Ridge Dr Northbound				S Pronghorn Meadows Dr Eastbound				Int. Total
	Left	Thru	Right	Peds	Left	Thru	Right	Peds	Left	Thru	Right	Peds	Left	Thru	Right	Peds	
16:00	0	27	2	0	0	0	0	0	12	37	0	0	1	0	7	0	86
16:15	0	19	4	0	0	0	0	0	13	42	0	0	0	0	5	0	83
16:30	0	24	0	0	0	0	0	0	8	30	0	0	2	0	7	0	71
16:45	0	12	5	0	0	0	0	0	9	51	0	0	0	0	8	0	85
Total	0	82	11	0	0	0	0	0	42	160	0	0	3	0	27	0	325
17:00	0	21	0	0	0	0	0	0	8	63	0	0	2	0	6	0	100
17:15	0	26	3	0	0	0	0	0	14	67	0	0	1	0	4	0	115
17:30	0	24	0	0	0	0	0	0	6	43	0	0	1	0	7	0	81
17:45	0	36	1	0	0	0	0	0	16	42	0	0	2	0	4	0	101
Total	0	107	4	0	0	0	0	0	44	215	0	0	6	0	21	0	397
Grand Total	0	189	15	0	0	0	0	0	86	375	0	0	9	0	48	0	722
Apprch %	0	92.6	7.4	0	0	0	0	0	18.7	81.3	0	0	15.8	0	84.2	0	
Total %	0	26.2	2.1	0	0	0	0	0	11.9	51.9	0	0	1.2	0	6.6	0	

LSC Transportation Consultants, Inc.

2504 E Pikes Peak Ave, Suite 304

Colorado Springs, CO 80909

719-633-2868

File Name : Antelope Ridge Dr - S Pronghorn Meadows Dr PM

Site Code : 00184640

Start Date : 8/15/2018

Page No : 2

Start Time	Antelope Ridge Dr Southbound					Westbound					Antelope Ridge Dr Northbound					S Pronghorn Meadows Dr Eastbound					Int. Total
	Left	Thru	Right	Peds	App. Total	Left	Thru	Right	Peds	App. Total	Left	Thru	Right	Peds	App. Total	Left	Thru	Right	Peds	App. Total	
Peak Hour Analysis From 16:00 to 17:45 - Peak 1 of 1																					
Peak Hour for Entire Intersection Begins at 17:00																					
17:00	0	21	0	0	21	0	0	0	0	0	8	63	0	0	71	2	0	6	0	8	100
17:15	0	26	3	0	29	0	0	0	0	0	14	67	0	0	81	1	0	4	0	5	115
17:30	0	24	0	0	24	0	0	0	0	0	6	43	0	0	49	1	0	7	0	8	81
17:45	0	36	1	0	37	0	0	0	0	0	16	42	0	0	58	2	0	4	0	6	101
Total Volume	0	107	4	0	111	0	0	0	0	0	44	215	0	0	259	6	0	21	0	27	397
% App. Total	0	96.4	3.6	0		0	0	0	0		17	83	0	0		22.2	0	77.8	0		
PHF	.000	.743	.333	.000	.750	.000	.000	.000	.000	.000	.688	.802	.000	.000	.799	.750	.000	.750	.000	.844	.863

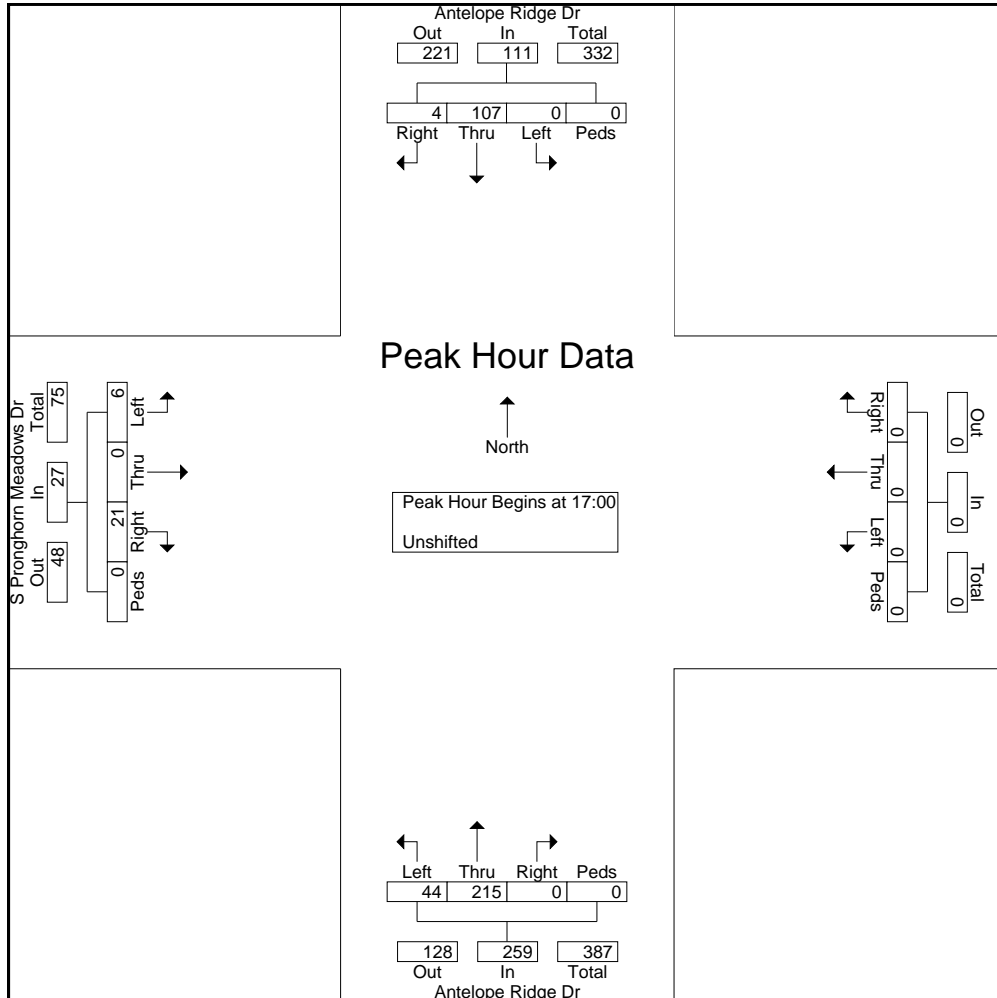

Levels of Service



HCM 6th TWSC
4: Antelope Ridge Dr. & North Carefree

Existing Traffic
AM Peak Hour

Intersection												
Int Delay, s/veh	13.2											
Movement	EBL	EBT	EBR	WBL	WBT	WBR	NBL	NBT	NBR	SBL	SBT	SBR
Lane Configurations	↵ ↑↑↑			↵↑↑		↵		↵		↵	↵	
Traffic Vol, veh/h	218	393	1	0	280	87	0	1	0	111	1	350
Future Vol, veh/h	218	393	1	0	280	87	0	1	0	111	1	350
Conflicting Peds, #/hr	0	0	0	0	0	0	0	0	0	0	0	0
Sign Control	Free	Free	Free	Free	Free	Free	Stop	Stop	Stop	Stop	Stop	Stop
RT Channelized	-	-	None	-	-	None	-	-	None	-	-	None
Storage Length	345	-	-	-	-	155	-	-	-	150	-	-
Veh in Median Storage, #	-	0	-	-	0	-	-	0	-	-	0	-
Grade, %	-	0	-	-	0	-	-	0	-	-	0	-
Peak Hour Factor	87	87	87	87	87	87	50	50	50	75	75	75
Heavy Vehicles, %	1	2	2	2	2	1	2	2	2	1	2	1
Mvmt Flow	251	452	1	0	322	100	0	2	0	148	1	467

Major/Minor	Major1		Major2		Minor1		Minor2					
Conflicting Flow All	422	0	0	453	0	0	1084	1377	227	1006	1277	161
Stage 1	-	-	-	-	-	-	955	955	-	322	322	-
Stage 2	-	-	-	-	-	-	129	422	-	684	955	-
Critical Hdwy	5.32	-	-	5.34	-	-	6.44	6.54	7.14	6.42	6.54	7.12
Critical Hdwy Stg 1	-	-	-	-	-	-	7.34	5.54	-	7.32	5.54	-
Critical Hdwy Stg 2	-	-	-	-	-	-	6.74	5.54	-	6.72	5.54	-
Follow-up Hdwy	3.11	-	-	3.12	-	-	3.82	4.02	3.92	3.81	4.02	3.91
Pot Cap-1 Maneuver	740	-	-	713	-	-	228	144	661	255	165	730
Stage 1	-	-	-	-	-	-	214	335	-	579	650	-
Stage 2	-	-	-	-	-	-	792	587	-	370	335	-
Platoon blocked, %	-	-	-	-	-	-	-	-	-	-	-	-
Mov Cap-1 Maneuver	740	-	-	713	-	-	60	95	661	185	109	730
Mov Cap-2 Maneuver	-	-	-	-	-	-	60	95	-	185	109	-
Stage 1	-	-	-	-	-	-	141	221	-	383	650	-
Stage 2	-	-	-	-	-	-	285	587	-	242	221	-

Approach	EB	WB	NB	SB
HCM Control Delay, s	4.4	0	43.7	32.3
HCM LOS			E	D

Minor Lane/Major Mvmt	NBLn1	EBL	EBT	EBR	WBL	WBT	WBR	SBLn1	SBLn2
Capacity (veh/h)	95	740	-	-	713	-	-	185	718
HCM Lane V/C Ratio	0.021	0.339	-	-	-	-	-	0.8	0.652
HCM Control Delay (s)	43.7	12.3	-	-	0	-	-	74.5	18.9
HCM Lane LOS	E	B	-	-	A	-	-	F	C
HCM 95th %tile Q(veh)	0.1	1.5	-	-	0	-	-	5.5	4.9

Intersection						
Int Delay, s/veh	4.6					
Movement	EBL	EBR	NBL	NBT	SBT	SBR
Lane Configurations	↘	↗	↘	↑↑	↑↑	↗
Traffic Vol, veh/h	29	494	299	898	1228	63
Future Vol, veh/h	29	494	299	898	1228	63
Conflicting Peds, #/hr	0	0	0	0	0	0
Sign Control	Stop	Stop	Free	Free	Free	Free
RT Channelized	-	Free	-	None	-	Yield
Storage Length	0	0	350	-	-	350
Veh in Median Storage, #	1	-	-	0	0	-
Grade, %	0	-	-	0	0	-
Peak Hour Factor	92	92	87	87	93	93
Heavy Vehicles, %	2	2	2	2	2	2
Mvmt Flow	32	537	344	1032	1320	68

Major/Minor	Minor2	Major1	Major2			
Conflicting Flow All	2524	-	1320	0	-	0
Stage 1	1320	-	-	-	-	-
Stage 2	1204	-	-	-	-	-
Critical Hdwy	6.84	-	4.14	-	-	-
Critical Hdwy Stg 1	5.84	-	-	-	-	-
Critical Hdwy Stg 2	5.84	-	-	-	-	-
Follow-up Hdwy	3.52	-	2.22	-	-	-
Pot Cap-1 Maneuver	~ 23	0	519	-	-	-
Stage 1	214	0	-	-	-	-
Stage 2	247	0	-	-	-	-
Platoon blocked, %				-	-	-
Mov Cap-1 Maneuver	~ 8	-	519	-	-	-
Mov Cap-2 Maneuver	53	-	-	-	-	-
Stage 1	72	-	-	-	-	-
Stage 2	247	-	-	-	-	-

Approach	EB	NB	SB
HCM Control Delay, s	144.5	6.1	0
HCM LOS	F		

Minor Lane/Major Mvmt	NBL	NBT	EBLn1	EBLn2	SBT	SBR
Capacity (veh/h)	519	-	53	-	-	-
HCM Lane V/C Ratio	0.662	-	0.595	-	-	-
HCM Control Delay (s)	24.5	-	144.5	0	-	-
HCM Lane LOS	C	-	F	A	-	-
HCM 95th %tile Q(veh)	4.8	-	2.3	-	-	-

Notes
 ~: Volume exceeds capacity \$: Delay exceeds 300s +: Computation Not Defined *: All major volume in platoon

HCM 6th TWSC
4: Antelope Ridge Dr. & North Carefree

Existing Traffic
PM Peak Hour

Intersection												
Int Delay, s/veh	3.2											
Movement	EBL	EBT	EBR	WBL	WBT	WBR	NBL	NBT	NBR	SBL	SBT	SBR
Lane Configurations	↵ ↑↑↑			↵↑↑		↵		↵		↵	↵	
Traffic Vol, veh/h	119	246	1	0	442	87	0	1	0	28	0	84
Future Vol, veh/h	119	246	1	0	442	87	0	1	0	28	0	84
Conflicting Peds, #/hr	0	0	0	0	0	0	0	0	0	0	0	0
Sign Control	Free	Free	Free	Free	Free	Free	Stop	Stop	Stop	Stop	Stop	Stop
RT Channelized	-	-	None	-	-	None	-	-	None	-	-	None
Storage Length	345	-	-	-	-	155	-	-	-	150	-	-
Veh in Median Storage, #	-	0	-	-	0	-	-	0	-	-	0	-
Grade, %	-	0	-	-	0	-	-	0	-	-	0	-
Peak Hour Factor	88	88	88	92	92	92	50	50	50	83	83	83
Heavy Vehicles, %	1	2	2	2	2	1	2	2	2	1	2	1
Mvmt Flow	135	280	1	0	480	95	0	2	0	34	0	101

Major/Minor	Major1			Major2			Minor1			Minor2		
Conflicting Flow All	575	0	0	281	0	0	743	1126	141	863	1031	240
Stage 1	-	-	-	-	-	-	551	551	-	480	480	-
Stage 2	-	-	-	-	-	-	192	575	-	383	551	-
Critical Hdwy	5.32	-	-	5.34	-	-	6.44	6.54	7.14	6.42	6.54	7.12
Critical Hdwy Stg 1	-	-	-	-	-	-	7.34	5.54	-	7.32	5.54	-
Critical Hdwy Stg 2	-	-	-	-	-	-	6.74	5.54	-	6.72	5.54	-
Follow-up Hdwy	3.11	-	-	3.12	-	-	3.82	4.02	3.92	3.81	4.02	3.91
Pot Cap-1 Maneuver	628	-	-	857	-	-	361	203	749	309	232	651
Stage 1	-	-	-	-	-	-	405	514	-	454	553	-
Stage 2	-	-	-	-	-	-	727	501	-	562	514	-
Platoon blocked, %	-	-	-	-	-	-	-	-	-	-	-	-
Mov Cap-1 Maneuver	628	-	-	857	-	-	255	159	749	256	182	651
Mov Cap-2 Maneuver	-	-	-	-	-	-	255	159	-	256	182	-
Stage 1	-	-	-	-	-	-	318	403	-	356	553	-
Stage 2	-	-	-	-	-	-	614	501	-	439	403	-

Approach	EB			WB			NB			SB		
HCM Control Delay, s	4			0			27.9			13.9		
HCM LOS							D			B		

Minor Lane/Major Mvmt	NBLn1	EBL	EBT	EBR	WBL	WBT	WBR	SBLn1	SBLn2
Capacity (veh/h)	159	628	-	-	857	-	-	256	651
HCM Lane V/C Ratio	0.013	0.215	-	-	-	-	-	0.132	0.155
HCM Control Delay (s)	27.9	12.3	-	-	0	-	-	21.2	11.5
HCM Lane LOS		D	B	-	-	A	-	C	B
HCM 95th %tile Q(veh)		0	0.8	-	-	0	-	0.4	0.5

Intersection						
Int Delay, s/veh	3.6					
Movement	EBL	EBR	NBL	NBT	SBT	SBR
Lane Configurations	↘	↗	↘	↑↑	↑↑	↗
Traffic Vol, veh/h	34	228	419	1350	769	105
Future Vol, veh/h	34	228	419	1350	769	105
Conflicting Peds, #/hr	0	0	0	0	0	0
Sign Control	Stop	Stop	Free	Free	Free	Free
RT Channelized	-	Free	-	None	-	Yield
Storage Length	0	0	350	-	-	350
Veh in Median Storage, #	1	-	-	0	0	-
Grade, %	0	-	-	0	0	-
Peak Hour Factor	87	87	93	93	92	92
Heavy Vehicles, %	2	2	2	2	2	2
Mvmt Flow	39	262	451	1452	836	114

Major/Minor	Minor2	Major1	Major2			
Conflicting Flow All	2464	-	836	0	-	0
Stage 1	836	-	-	-	-	-
Stage 2	1628	-	-	-	-	-
Critical Hdwy	6.84	-	4.14	-	-	-
Critical Hdwy Stg 1	5.84	-	-	-	-	-
Critical Hdwy Stg 2	5.84	-	-	-	-	-
Follow-up Hdwy	3.52	-	2.22	-	-	-
Pot Cap-1 Maneuver	~ 25	0	794	-	-	-
Stage 1	386	0	-	-	-	-
Stage 2	146	0	-	-	-	-
Platoon blocked, %				-	-	-
Mov Cap-1 Maneuver	~ 11	-	794	-	-	-
Mov Cap-2 Maneuver	76	-	-	-	-	-
Stage 1	167	-	-	-	-	-
Stage 2	146	-	-	-	-	-

Approach	EB	NB	SB
HCM Control Delay, s	94.4	3.6	0
HCM LOS	F		

Minor Lane/Major Mvmt	NBL	NBT	EBLn1	EBLn2	SBT	SBR
Capacity (veh/h)	794	-	76	-	-	-
HCM Lane V/C Ratio	0.567	-	0.514	-	-	-
HCM Control Delay (s)	15.3	-	94.4	0	-	-
HCM Lane LOS	C	-	F	A	-	-
HCM 95th %tile Q(veh)	3.6	-	2.2	-	-	-

Notes
 ~: Volume exceeds capacity \$: Delay exceeds 300s +: Computation Not Defined *: All major volume in platoon

Intersection												
Int Delay, s/veh	81.4											
Movement	EBL	EBT	EBR	WBL	WBT	WBR	NBL	NBT	NBR	SBL	SBT	SBR
Lane Configurations	↖ ↑↑↑ ↗			↖ ↑↑↑ ↗		↖		↖ ↗		↖	↗	
Traffic Vol, veh/h	241	393	1	0	280	109	0	1	0	165	1	417
Future Vol, veh/h	241	393	1	0	280	109	0	1	0	165	1	417
Conflicting Peds, #/hr	0	0	0	0	0	0	0	0	0	0	0	0
Sign Control	Free	Free	Free	Free	Free	Free	Stop	Stop	Stop	Stop	Stop	Stop
RT Channelized	-	-	None	-	-	None	-	-	None	-	-	None
Storage Length	345	-	-	-	-	155	-	-	-	150	-	-
Veh in Median Storage, #	-	0	-	-	0	-	-	0	-	-	0	-
Grade, %	-	0	-	-	0	-	-	0	-	-	0	-
Peak Hour Factor	87	87	87	87	87	87	50	50	50	56	56	56
Heavy Vehicles, %	1	2	2	2	2	1	2	2	2	1	2	1
Mvmt Flow	277	452	1	0	322	125	0	2	0	295	2	745

Major/Minor	Major1		Major2		Minor1		Minor2					
Conflicting Flow All	447	0	0	453	0	0	1137	1454	227	1058	1329	161
Stage 1	-	-	-	-	-	-	1007	1007	-	322	322	-
Stage 2	-	-	-	-	-	-	130	447	-	736	1007	-
Critical Hdwy	5.32	-	-	5.34	-	-	6.44	6.54	7.14	6.42	6.54	7.12
Critical Hdwy Stg 1	-	-	-	-	-	-	7.34	5.54	-	7.32	5.54	-
Critical Hdwy Stg 2	-	-	-	-	-	-	6.74	5.54	-	6.72	5.54	-
Follow-up Hdwy	3.11	-	-	3.12	-	-	3.82	4.02	3.92	3.81	4.02	3.91
Pot Cap-1 Maneuver	721	-	-	713	-	-	212	129	661	~ 238	154	~ 730
Stage 1	-	-	-	-	-	-	197	317	-	579	650	-
Stage 2	-	-	-	-	-	-	791	572	-	344	317	-
Platoon blocked, %		-	-	-	-	-						
Mov Cap-1 Maneuver	721	-	-	713	-	-	79	661	~ 164	95	~ 730	
Mov Cap-2 Maneuver	-	-	-	-	-	-	79	-	~ 164	95	-	
Stage 1	-	-	-	-	-	-	121	195	-	357	650	-
Stage 2	-	-	-	-	-	-	-	572	-	~ 210	195	-

Approach	EB	WB	NB	SB
HCM Control Delay, s	5	0		170.1
HCM LOS			-	F

Minor Lane/Major Mvmt	NBLn1	EBL	EBT	EBR	WBL	WBT	WBR	SBLn1	SBLn2
Capacity (veh/h)	-	721	-	-	713	-	-	164	719
HCM Lane V/C Ratio	-	0.384	-	-	-	-	-	1.797	1.038
HCM Control Delay (s)	-	13.1	-	-	0	-	-	\$ 429.5	67.7
HCM Lane LOS	-	B	-	-	A	-	-	F	F
HCM 95th %tile Q(veh)	-	1.8	-	-	0	-	-	21.5	18.5

Notes
 ~: Volume exceeds capacity \$: Delay exceeds 300s +: Computation Not Defined *: All major volume in platoon

Timings
4: Antelope Ridge Dr. & North Carefree

Short-Term Total Traffic
AM Peak Hour



Lane Group	EBL	EBT	WBT	WBR	NBT	SBL	SBT
Lane Configurations	↶	↶↶↶	↶↶↶	↶	↷	↶	↷
Traffic Volume (vph)	241	393	280	109	1	165	1
Future Volume (vph)	241	393	280	109	1	165	1
Turn Type	Perm	NA	NA	Perm	NA	Perm	NA
Protected Phases		2	6		8		4
Permitted Phases	2			6		4	
Detector Phase	2	2	6	6	8	4	4
Switch Phase							
Minimum Initial (s)	4.0	4.0	4.0	4.0	4.0	20.0	20.0
Minimum Split (s)	23.0	23.0	23.0	23.0	23.0	27.0	27.0
Total Split (s)	75.0	75.0	75.0	75.0	45.0	45.0	45.0
Total Split (%)	62.5%	62.5%	62.5%	62.5%	37.5%	37.5%	37.5%
Yellow Time (s)	5.0	5.0	5.0	5.0	5.0	5.0	5.0
All-Red Time (s)	2.0	2.0	2.0	2.0	2.0	2.0	2.0
Lost Time Adjust (s)	0.0	0.0	0.0	0.0	0.0	0.0	0.0
Total Lost Time (s)	7.0	7.0	7.0	7.0	7.0	7.0	7.0
Lead/Lag							
Lead-Lag Optimize?							
Recall Mode	C-Max	C-Max	C-Max	C-Max	None	None	None
Act Effct Green (s)	73.4	73.4	73.4	73.4	32.6	32.6	32.6
Actuated g/C Ratio	0.61	0.61	0.61	0.61	0.27	0.27	0.27
v/c Ratio	0.44	0.15	0.10	0.12	0.00	0.76	0.91
Control Delay	16.5	10.8	7.4	4.9	28.0	53.0	28.6
Queue Delay	0.0	0.0	0.0	0.0	0.0	0.0	0.0
Total Delay	16.5	10.8	7.4	4.9	28.0	53.0	28.6
LOS	B	B	A	A	C	D	C
Approach Delay		13.0	6.7		28.0		35.5
Approach LOS		B	A		C		D

Intersection Summary

Cycle Length: 120
 Actuated Cycle Length: 120
 Offset: 0 (0%), Referenced to phase 2:EBTL and 6:WBTL, Start of Green
 Natural Cycle: 55
 Control Type: Actuated-Coordinated
 Maximum v/c Ratio: 0.91
 Intersection Signal Delay: 22.3
 Intersection LOS: C
 Intersection Capacity Utilization 62.1%
 ICU Level of Service B
 Analysis Period (min) 15

Splits and Phases: 4: Antelope Ridge Dr. & North Carefree

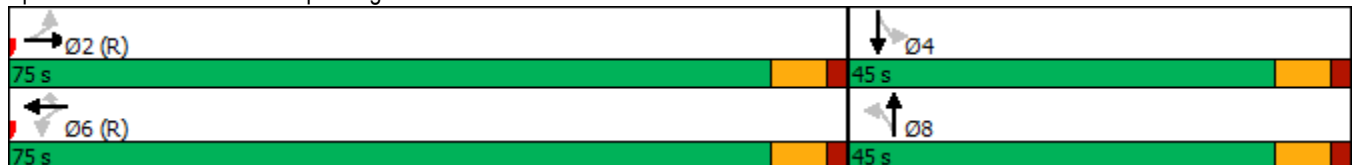

Intersection						
Int Delay, s/veh	7.4					
Movement	EBL	EBR	NBL	NBT	SBT	SBR
Lane Configurations	↖	↗	↖	↕↕	↕↕	↗
Traffic Vol, veh/h	43	534	313	898	1228	72
Future Vol, veh/h	43	534	313	898	1228	72
Conflicting Peds, #/hr	0	0	0	0	0	0
Sign Control	Stop	Stop	Free	Free	Free	Free
RT Channelized	-	Free	-	None	-	Yield
Storage Length	0	0	350	-	-	350
Veh in Median Storage, #	1	-	-	0	0	-
Grade, %	0	-	-	0	0	-
Peak Hour Factor	92	92	87	87	93	93
Heavy Vehicles, %	2	2	2	2	2	2
Mvmt Flow	47	580	360	1032	1320	77

Major/Minor	Minor2	Major1	Major2		
Conflicting Flow All	2556	-	1320	0	-
Stage 1	1320	-	-	-	-
Stage 2	1236	-	-	-	-
Critical Hdwy	6.84	-	4.14	-	-
Critical Hdwy Stg 1	5.84	-	-	-	-
Critical Hdwy Stg 2	5.84	-	-	-	-
Follow-up Hdwy	3.52	-	2.22	-	-
Pot Cap-1 Maneuver	~ 22	0	519	-	-
Stage 1	214	0	-	-	-
Stage 2	237	0	-	-	-
Platoon blocked, %				-	-
Mov Cap-1 Maneuver	~ 7	-	519	-	-
Mov Cap-2 Maneuver	49	-	-	-	-
Stage 1	65	-	-	-	-
Stage 2	237	-	-	-	-

Approach	EB	NB	SB
HCM Control Delay, s	246	6.8	0
HCM LOS	F		

Minor Lane/Major Mvmt	NBL	NBT	EBLn1	EBLn2	SBT	SBR
Capacity (veh/h)	519	-	49	-	-	-
HCM Lane V/C Ratio	0.693	-	0.954	-	-	-
HCM Control Delay (s)	26.1	-	246	0	-	-
HCM Lane LOS	D	-	F	A	-	-
HCM 95th %tile Q(veh)	5.3	-	4	-	-	-

Notes
 ~: Volume exceeds capacity \$: Delay exceeds 300s +: Computation Not Defined *: All major volume in platoon

Timings
5: Marksheffel & North Carefree

Short-Term Total Traffic
AM Peak Hour

Lane Group	EBL	EBR	NBL	NBT	SBT	SBR
Lane Configurations						
Traffic Volume (vph)	43	534	313	898	1228	72
Future Volume (vph)	43	534	313	898	1228	72
Turn Type	Prot	Free	Prot	NA	NA	Free
Protected Phases	7		5	2	6	
Permitted Phases		Free				Free
Detector Phase	7		5	2	6	
Switch Phase						
Minimum Initial (s)	20.0		20.0	4.0	4.0	
Minimum Split (s)	25.0		25.0	11.0	11.0	
Total Split (s)	25.0		30.0	95.0	65.0	
Total Split (%)	20.8%		25.0%	79.2%	54.2%	
Yellow Time (s)	3.0		3.0	3.0	3.0	
All-Red Time (s)	2.0		2.0	2.0	2.0	
Lost Time Adjust (s)	0.0		0.0	0.0	0.0	
Total Lost Time (s)	5.0		5.0	5.0	5.0	
Lead/Lag			Lead		Lag	
Lead-Lag Optimize?			Yes		Yes	
Recall Mode	None		None	C-Max	C-Max	
Act Effct Green (s)	20.0	120.0	20.5	96.0	69.5	120.0
Actuated g/C Ratio	0.17	1.00	0.17	0.80	0.58	1.00
v/c Ratio	0.16	0.37	0.62	0.36	0.64	0.05
Control Delay	51.1	1.8	51.1	5.0	20.4	0.1
Queue Delay	0.0	0.0	0.0	0.0	0.0	0.0
Total Delay	51.1	1.8	51.1	5.0	20.4	0.1
LOS	D	A	D	A	C	A
Approach Delay	5.5			16.9	19.3	
Approach LOS	A			B	B	

Intersection Summary

Cycle Length: 120
 Actuated Cycle Length: 120
 Offset: 0 (0%), Referenced to phase 2:NBT and 6:SBT, Start of Green
 Natural Cycle: 90
 Control Type: Actuated-Coordinated
 Maximum v/c Ratio: 0.64
 Intersection Signal Delay: 15.8
 Intersection LOS: B
 Intersection Capacity Utilization 79.8%
 ICU Level of Service D
 Analysis Period (min) 15

Splits and Phases: 5: Marksheffel & North Carefree



Intersection												
Int Delay, s/veh	4.5											
Movement	EBL	EBT	EBR	WBL	WBT	WBR	NBL	NBT	NBR	SBL	SBT	SBR
Lane Configurations		↕			↕		↕	↕		↕	↕	
Traffic Vol, veh/h	6	0	54	76	0	22	14	311	25	7	454	4
Future Vol, veh/h	6	0	54	76	0	22	14	311	25	7	454	4
Conflicting Peds, #/hr	0	0	0	0	0	0	0	0	0	0	0	0
Sign Control	Stop	Stop	Stop	Stop	Stop	Stop	Free	Free	Free	Free	Free	Free
RT Channelized	-	-	None	-	-	None	-	-	None	-	-	None
Storage Length	-	-	-	-	-	-	80	-	-	80	-	-
Veh in Median Storage, #	-	0	-	-	0	-	-	0	-	-	0	-
Grade, %	-	0	-	-	0	-	-	0	-	-	0	-
Peak Hour Factor	88	100	88	92	92	92	75	80	92	92	80	75
Heavy Vehicles, %	2	2	2	2	2	2	2	2	2	2	2	2
Mvmt Flow	7	0	61	83	0	24	19	389	27	8	568	5

Major/Minor	Minor2		Minor1		Major1		Major2					
Conflicting Flow All	1040	1041	571	1058	1030	403	573	0	0	416	0	0
Stage 1	587	587	-	441	441	-	-	-	-	-	-	-
Stage 2	453	454	-	617	589	-	-	-	-	-	-	-
Critical Hdwy	7.12	6.52	6.22	7.12	6.52	6.22	4.12	-	-	4.12	-	-
Critical Hdwy Stg 1	6.12	5.52	-	6.12	5.52	-	-	-	-	-	-	-
Critical Hdwy Stg 2	6.12	5.52	-	6.12	5.52	-	-	-	-	-	-	-
Follow-up Hdwy	3.518	4.018	3.318	3.518	4.018	3.318	2.218	-	-	2.218	-	-
Pot Cap-1 Maneuver	208	230	520	203	233	647	1000	-	-	1143	-	-
Stage 1	496	497	-	595	577	-	-	-	-	-	-	-
Stage 2	586	569	-	477	495	-	-	-	-	-	-	-
Platoon blocked, %								-	-	-	-	-
Mov Cap-1 Maneuver	196	224	520	176	227	647	1000	-	-	1143	-	-
Mov Cap-2 Maneuver	196	224	-	176	227	-	-	-	-	-	-	-
Stage 1	487	494	-	584	566	-	-	-	-	-	-	-
Stage 2	554	558	-	418	492	-	-	-	-	-	-	-

Approach	EB		WB		NB		SB	
HCM Control Delay, s	14.5		38.6		0.4		0.1	
HCM LOS	B		E					

Minor Lane/Major Mvmt	NBL	NBT	NBR	EBLn1	WBLn1	SBL	SBT	SBR
Capacity (veh/h)	1000	-	-	446	210	1143	-	-
HCM Lane V/C Ratio	0.019	-	-	0.153	0.507	0.007	-	-
HCM Control Delay (s)	8.7	-	-	14.5	38.6	8.2	-	-
HCM Lane LOS	A	-	-	B	E	A	-	-
HCM 95th %tile Q(veh)	0.1	-	-	0.5	2.6	0	-	-

Intersection						
Int Delay, s/veh	1.4					
Movement	WBL	WBR	NBT	NBR	SBL	SBT
Lane Configurations						
Traffic Vol, veh/h	46	25	319	20	5	419
Future Vol, veh/h	46	25	319	20	5	419
Conflicting Peds, #/hr	0	0	0	0	0	0
Sign Control	Stop	Stop	Free	Free	Free	Free
RT Channelized	-	None	-	None	-	None
Storage Length	0	-	-	-	80	-
Veh in Median Storage, #	0	-	0	-	-	0
Grade, %	0	-	0	-	-	0
Peak Hour Factor	92	92	75	92	92	75
Heavy Vehicles, %	2	2	2	2	2	2
Mvmt Flow	50	27	425	22	5	559

Major/Minor	Minor1	Major1	Major2		
Conflicting Flow All	1005	436	0	0	447
Stage 1	436	-	-	-	-
Stage 2	569	-	-	-	-
Critical Hdwy	6.42	6.22	-	-	4.12
Critical Hdwy Stg 1	5.42	-	-	-	-
Critical Hdwy Stg 2	5.42	-	-	-	-
Follow-up Hdwy	3.518	3.318	-	-	2.218
Pot Cap-1 Maneuver	268	620	-	-	1113
Stage 1	652	-	-	-	-
Stage 2	566	-	-	-	-
Platoon blocked, %			-	-	-
Mov Cap-1 Maneuver	267	620	-	-	1113
Mov Cap-2 Maneuver	267	-	-	-	-
Stage 1	652	-	-	-	-
Stage 2	564	-	-	-	-

Approach	WB	NB	SB
HCM Control Delay, s	19	0	0.1
HCM LOS	C		

Minor Lane/Major Mvmt	NBT	NBRWBLn1	SBL	SBT
Capacity (veh/h)	-	-	334	1113
HCM Lane V/C Ratio	-	-	0.231	0.005
HCM Control Delay (s)	-	-	19	8.2
HCM Lane LOS	-	-	C	A
HCM 95th %tile Q(veh)	-	-	0.9	0

Intersection												
Int Delay, s/veh	6.1											
Movement	EBL	EBT	EBR	WBL	WBT	WBR	NBL	NBT	NBR	SBL	SBT	SBR
Lane Configurations	↵ ↑↑↑			↵ ↑↑↑		↵		↵		↵	↵	
Traffic Vol, veh/h	193	246	1	0	442	160	0	1	0	63	0	128
Future Vol, veh/h	193	246	1	0	442	160	0	1	0	63	0	128
Conflicting Peds, #/hr	0	0	0	0	0	0	0	0	0	0	0	0
Sign Control	Free	Free	Free	Free	Free	Free	Stop	Stop	Stop	Stop	Stop	Stop
RT Channelized	-	-	None	-	-	None	-	-	None	-	-	None
Storage Length	345	-	-	-	-	155	-	-	-	150	-	-
Veh in Median Storage, #	-	0	-	-	0	-	-	0	-	-	0	-
Grade, %	-	0	-	-	0	-	-	0	-	-	0	-
Peak Hour Factor	88	88	88	92	92	92	50	50	50	83	83	83
Heavy Vehicles, %	1	2	2	2	2	1	2	2	2	1	2	1
Mvmt Flow	219	280	1	0	480	174	0	2	0	76	0	154

Major/Minor	Major1			Major2			Minor1			Minor2		
Conflicting Flow All	654	0	0	281	0	0	911	1373	141	1031	1199	240
Stage 1	-	-	-	-	-	-	719	719	-	480	480	-
Stage 2	-	-	-	-	-	-	192	654	-	551	719	-
Critical Hdwy	5.32	-	-	5.34	-	-	6.44	6.54	7.14	6.42	6.54	7.12
Critical Hdwy Stg 1	-	-	-	-	-	-	7.34	5.54	-	7.32	5.54	-
Critical Hdwy Stg 2	-	-	-	-	-	-	6.74	5.54	-	6.72	5.54	-
Follow-up Hdwy	3.11	-	-	3.12	-	-	3.82	4.02	3.92	3.81	4.02	3.91
Pot Cap-1 Maneuver	576	-	-	857	-	-	288	145	749	247	184	651
Stage 1	-	-	-	-	-	-	311	431	-	454	553	-
Stage 2	-	-	-	-	-	-	727	461	-	446	431	-
Platoon blocked, %	-	-	-	-	-	-	-	-	-	-	-	-
Mov Cap-1 Maneuver	576	-	-	857	-	-	155	90	749	171	114	651
Mov Cap-2 Maneuver	-	-	-	-	-	-	155	90	-	171	114	-
Stage 1	-	-	-	-	-	-	193	267	-	281	553	-
Stage 2	-	-	-	-	-	-	555	461	-	274	267	-

Approach	EB	WB	NB	SB
HCM Control Delay, s	6.6	0	45.9	22
HCM LOS			E	C

Minor Lane/Major Mvmt	NBLn1	EBL	EBT	EBR	WBL	WBT	WBR	SBLn1	SBLn2
Capacity (veh/h)	90	576	-	-	857	-	-	171	651
HCM Lane V/C Ratio	0.022	0.381	-	-	-	-	-	0.444	0.237
HCM Control Delay (s)	45.9	15	-	-	0	-	-	41.9	12.2
HCM Lane LOS	E	C	-	-	A	-	-	E	B
HCM 95th %tile Q(veh)	0.1	1.8	-	-	0	-	-	2	0.9

Timings
4: Antelope Ridge Dr. & North Carefree

Short-Term Total Traffic
PM Peak Hour



Lane Group	EBL	EBT	WBT	WBR	NBT	SBL	SBT
Lane Configurations	↔	↕↕↕	↔↔↔	↔	↕↕	↔	↕
Traffic Volume (vph)	193	246	442	160	1	63	0
Future Volume (vph)	193	246	442	160	1	63	0
Turn Type	Perm	NA	NA	Perm	NA	Perm	NA
Protected Phases		2	6		8		4
Permitted Phases	2			6		4	
Detector Phase	2	2	6	6	8	4	4
Switch Phase							
Minimum Initial (s)	4.0	4.0	4.0	4.0	4.0	20.0	20.0
Minimum Split (s)	23.0	23.0	23.0	23.0	23.0	27.0	27.0
Total Split (s)	78.0	78.0	78.0	78.0	42.0	42.0	42.0
Total Split (%)	65.0%	65.0%	65.0%	65.0%	35.0%	35.0%	35.0%
Yellow Time (s)	5.0	5.0	5.0	5.0	5.0	5.0	5.0
All-Red Time (s)	2.0	2.0	2.0	2.0	2.0	2.0	2.0
Lost Time Adjust (s)	0.0	0.0	0.0	0.0	0.0	0.0	0.0
Total Lost Time (s)	7.0	7.0	7.0	7.0	7.0	7.0	7.0
Lead/Lag							
Lead-Lag Optimize?							
Recall Mode	C-Max	C-Max	C-Max	C-Max	None	None	None
Act Effct Green (s)	86.0	86.0	86.0	86.0	20.0	20.0	20.0
Actuated g/C Ratio	0.72	0.72	0.72	0.72	0.17	0.17	0.17
v/c Ratio	0.35	0.08	0.13	0.15	0.01	0.32	0.26
Control Delay	8.2	5.1	3.5	1.1	42.0	48.3	1.1
Queue Delay	0.0	0.0	0.0	0.0	0.0	0.0	0.0
Total Delay	8.2	5.1	3.5	1.1	42.0	48.3	1.1
LOS	A	A	A	A	D	D	A
Approach Delay		6.5	2.9		42.0		16.7
Approach LOS		A	A		D		B

Intersection Summary

Cycle Length: 120
 Actuated Cycle Length: 120
 Offset: 0 (0%), Referenced to phase 2:EBTL and 6:WBTL, Start of Green
 Natural Cycle: 60
 Control Type: Actuated-Coordinated
 Maximum v/c Ratio: 0.35
 Intersection Signal Delay: 6.5
 Intersection LOS: A
 Intersection Capacity Utilization 53.4%
 ICU Level of Service A
 Analysis Period (min) 15

Splits and Phases: 4: Antelope Ridge Dr. & North Carefree



Intersection						
Int Delay, s/veh	5.3					
Movement	EBL	EBR	NBL	NBT	SBT	SBR
Lane Configurations						
Traffic Vol, veh/h	43	254	464	1350	769	133
Future Vol, veh/h	43	254	464	1350	769	133
Conflicting Peds, #/hr	0	0	0	0	0	0
Sign Control	Stop	Stop	Free	Free	Free	Free
RT Channelized	-	Free	-	None	-	Yield
Storage Length	0	0	350	-	-	350
Veh in Median Storage, #	1	-	-	0	0	-
Grade, %	0	-	-	0	0	-
Peak Hour Factor	87	87	93	93	92	92
Heavy Vehicles, %	2	2	2	2	2	2
Mvmt Flow	49	292	499	1452	836	145

Major/Minor	Minor2	Major1	Major2			
Conflicting Flow All	2560	-	836	0	-	0
Stage 1	836	-	-	-	-	-
Stage 2	1724	-	-	-	-	-
Critical Hdwy	6.84	-	4.14	-	-	-
Critical Hdwy Stg 1	5.84	-	-	-	-	-
Critical Hdwy Stg 2	5.84	-	-	-	-	-
Follow-up Hdwy	3.52	-	2.22	-	-	-
Pot Cap-1 Maneuver	~ 22	0	794	-	-	-
Stage 1	386	0	-	-	-	-
Stage 2	129	0	-	-	-	-
Platoon blocked, %				-	-	-
Mov Cap-1 Maneuver	~ 8	-	794	-	-	-
Mov Cap-2 Maneuver	66	-	-	-	-	-
Stage 1	144	-	-	-	-	-
Stage 2	129	-	-	-	-	-

Approach	EB	NB	SB
HCM Control Delay, s	149.9	4.3	0
HCM LOS	F		

Minor Lane/Major Mvmt	NBL	NBT	EBLn1	EBLn2	SBT	SBR
Capacity (veh/h)	794	-	66	-	-	-
HCM Lane V/C Ratio	0.628	-	0.749	-	-	-
HCM Control Delay (s)	16.9	-	149.9	0	-	-
HCM Lane LOS	C	-	F	A	-	-
HCM 95th %tile Q(veh)	4.5	-	3.4	-	-	-

Notes
 ~: Volume exceeds capacity \$: Delay exceeds 300s +: Computation Not Defined *: All major volume in platoon

Timings
5: Marksheffel & North Carefree

Short-Term Total Traffic
PM Peak Hour

Lane Group	EBL	EBR	NBL	NBT	SBT	SBR
Lane Configurations						
Traffic Volume (vph)	43	254	464	1350	769	133
Future Volume (vph)	43	254	464	1350	769	133
Turn Type	Prot	Free	Prot	NA	NA	Free
Protected Phases	7		5	2	6	
Permitted Phases		Free				Free
Detector Phase	7		5	2	6	
Switch Phase						
Minimum Initial (s)	20.0		15.0	4.0	4.0	
Minimum Split (s)	25.0		20.0	11.0	11.0	
Total Split (s)	27.0		32.0	93.0	61.0	
Total Split (%)	22.5%		26.7%	77.5%	50.8%	
Yellow Time (s)	3.0		3.0	3.0	3.0	
All-Red Time (s)	2.0		2.0	2.0	2.0	
Lost Time Adjust (s)	0.0		0.0	0.0	0.0	
Total Lost Time (s)	5.0		5.0	5.0	5.0	
Lead/Lag			Lead		Lag	
Lead-Lag Optimize?			Yes		Yes	
Recall Mode	None		None	C-Max	C-Max	
Act Effct Green (s)	20.0	120.0	22.5	96.0	67.5	120.0
Actuated g/C Ratio	0.17	1.00	0.19	0.80	0.56	1.00
v/c Ratio	0.17	0.18	0.77	0.51	0.42	0.09
Control Delay	48.6	0.7	54.7	6.2	17.9	0.1
Queue Delay	0.0	0.0	0.0	0.0	0.0	0.0
Total Delay	48.6	0.7	54.7	6.2	17.9	0.1
LOS	D	A	D	A	B	A
Approach Delay	7.6			18.6	15.3	
Approach LOS	A			B	B	

Intersection Summary

Cycle Length: 120
 Actuated Cycle Length: 120
 Offset: 0 (0%), Referenced to phase 2:NBT and 6:SBT, Start of Green
 Natural Cycle: 65
 Control Type: Actuated-Coordinated
 Maximum v/c Ratio: 0.77
 Intersection Signal Delay: 16.5
 Intersection LOS: B
 Intersection Capacity Utilization 63.7%
 ICU Level of Service B
 Analysis Period (min) 15

Splits and Phases: 5: Marksheffel & North Carefree



Intersection												
Int Delay, s/veh	2.8											
Movement	EBL	EBT	EBR	WBL	WBT	WBR	NBL	NBT	NBR	SBL	SBT	SBR
Lane Configurations		↕			↕		↕	↕		↕	↕	
Traffic Vol, veh/h	6	0	21	47	0	14	44	227	82	22	122	4
Future Vol, veh/h	6	0	21	47	0	14	44	227	82	22	122	4
Conflicting Peds, #/hr	0	0	0	0	0	0	0	0	0	0	0	0
Sign Control	Stop	Stop	Stop	Stop	Stop	Stop	Free	Free	Free	Free	Free	Free
RT Channelized	-	-	None	-	-	None	-	-	None	-	-	None
Storage Length	-	-	-	-	-	-	80	-	-	80	-	-
Veh in Median Storage, #	-	0	-	-	0	-	-	0	-	-	0	-
Grade, %	-	0	-	-	0	-	-	0	-	-	0	-
Peak Hour Factor	84	84	84	92	92	92	84	84	92	92	78	78
Heavy Vehicles, %	2	2	2	2	2	2	2	2	2	2	2	2
Mvmt Flow	7	0	25	51	0	15	52	270	89	24	156	5

Major/Minor	Minor2		Minor1		Major1		Major2					
Conflicting Flow All	633	670	159	638	628	315	161	0	0	359	0	0
Stage 1	207	207	-	419	419	-	-	-	-	-	-	-
Stage 2	426	463	-	219	209	-	-	-	-	-	-	-
Critical Hdwy	7.12	6.52	6.22	7.12	6.52	6.22	4.12	-	-	4.12	-	-
Critical Hdwy Stg 1	6.12	5.52	-	6.12	5.52	-	-	-	-	-	-	-
Critical Hdwy Stg 2	6.12	5.52	-	6.12	5.52	-	-	-	-	-	-	-
Follow-up Hdwy	3.518	4.018	3.318	3.518	4.018	3.318	2.218	-	-	2.218	-	-
Pot Cap-1 Maneuver	392	378	886	389	400	725	1418	-	-	1200	-	-
Stage 1	795	731	-	612	590	-	-	-	-	-	-	-
Stage 2	606	564	-	783	729	-	-	-	-	-	-	-
Platoon blocked, %								-	-	-	-	-
Mov Cap-1 Maneuver	367	357	886	362	378	725	1418	-	-	1200	-	-
Mov Cap-2 Maneuver	367	357	-	362	378	-	-	-	-	-	-	-
Stage 1	766	716	-	589	568	-	-	-	-	-	-	-
Stage 2	572	543	-	746	714	-	-	-	-	-	-	-

Approach	EB		WB		NB		SB	
HCM Control Delay, s	10.6		15.5		1		1	
HCM LOS	B		C					

Minor Lane/Major Mvmt	NBL	NBT	NBR	EBLn1	WBLn1	SBL	SBT	SBR
Capacity (veh/h)	1418	-	-	674	409	1200	-	-
HCM Lane V/C Ratio	0.037	-	-	0.048	0.162	0.02	-	-
HCM Control Delay (s)	7.6	-	-	10.6	15.5	8.1	-	-
HCM Lane LOS	A	-	-	B	C	A	-	-
HCM 95th %tile Q(veh)	0.1	-	-	0.1	0.6	0.1	-	-

Intersection						
Int Delay, s/veh	1.4					
Movement	WBL	WBR	NBT	NBR	SBL	SBT
Lane Configurations	Y		T		T	T
Traffic Vol, veh/h	31	17	182	65	17	117
Future Vol, veh/h	31	17	182	65	17	117
Conflicting Peds, #/hr	0	0	0	0	0	0
Sign Control	Stop	Stop	Free	Free	Free	Free
RT Channelized	-	None	-	None	-	None
Storage Length	0	-	-	-	80	-
Veh in Median Storage, #	0	-	0	-	-	0
Grade, %	0	-	0	-	-	0
Peak Hour Factor	92	92	84	92	92	78
Heavy Vehicles, %	2	2	2	2	2	2
Mvmt Flow	34	18	217	71	18	150

Major/Minor	Minor1	Major1	Major2		
Conflicting Flow All	439	253	0	0	288
Stage 1	253	-	-	-	-
Stage 2	186	-	-	-	-
Critical Hdwy	6.42	6.22	-	-	4.12
Critical Hdwy Stg 1	5.42	-	-	-	-
Critical Hdwy Stg 2	5.42	-	-	-	-
Follow-up Hdwy	3.518	3.318	-	-	2.218
Pot Cap-1 Maneuver	575	786	-	-	1274
Stage 1	789	-	-	-	-
Stage 2	846	-	-	-	-
Platoon blocked, %			-	-	-
Mov Cap-1 Maneuver	567	786	-	-	1274
Mov Cap-2 Maneuver	567	-	-	-	-
Stage 1	789	-	-	-	-
Stage 2	834	-	-	-	-

Approach	WB	NB	SB
HCM Control Delay, s	11.2	0	0.9
HCM LOS	B		

Minor Lane/Major Mvmt	NBT	NBRWBLn1	SBL	SBT
Capacity (veh/h)	-	-	629	1274
HCM Lane V/C Ratio	-	-	0.083	0.015
HCM Control Delay (s)	-	-	11.2	7.9
HCM Lane LOS	-	-	B	A
HCM 95th %tile Q(veh)	-	-	0.3	0

Intersection												
Int Delay, s/veh	23.5											
Movement	EBL	EBT	EBR	WBL	WBT	WBR	NBL	NBT	NBR	SBL	SBT	SBR
Lane Configurations	↖ ↑↑↑			↖↑↑		↖		↖		↖	↖	
Traffic Vol, veh/h	222	643	1	0	1443	92	0	1	0	204	1	268
Future Vol, veh/h	222	643	1	0	1443	92	0	1	0	204	1	268
Conflicting Peds, #/hr	0	0	0	0	0	0	0	0	0	0	0	0
Sign Control	Free	Free	Free	Free	Free	Free	Stop	Stop	Stop	Stop	Stop	Stop
RT Channelized	-	-	None	-	-	None	-	-	None	-	-	None
Storage Length	350	-	-	-	-	-	-	-	-	330	-	-
Veh in Median Storage, #	-	0	-	-	0	-	-	0	-	-	0	-
Grade, %	-	0	-	-	0	-	-	0	-	-	0	-
Peak Hour Factor	80	95	80	80	95	80	50	50	50	80	80	80
Heavy Vehicles, %	1	2	2	2	2	1	2	2	2	1	2	1
Mvmt Flow	278	677	1	0	1519	115	0	2	0	255	1	335

Major/Minor	Major1		Major2		Minor1			Minor2				
Conflicting Flow All	1634	0	0	678	0	0	1842	2868	339	2347	2753	760
Stage 1	-	-	-	-	-	-	1234	1234	-	1519	1519	-
Stage 2	-	-	-	-	-	-	608	1634	-	828	1234	-
Critical Hdwy	5.32	-	-	5.34	-	-	6.44	6.54	7.14	6.42	6.54	7.12
Critical Hdwy Stg 1	-	-	-	-	-	-	7.34	5.54	-	7.32	5.54	-
Critical Hdwy Stg 2	-	-	-	-	-	-	6.74	5.54	-	6.72	5.54	-
Follow-up Hdwy	3.11	-	-	3.12	-	-	3.82	4.02	3.92	3.81	4.02	3.91
Pot Cap-1 Maneuver	~ 193	-	-	558	-	-	80	16	561	~ 39	19	~ 301
Stage 1	-	-	-	-	-	-	137	247	-	~ 87	180	-
Stage 2	-	-	-	-	-	-	410	158	-	302	247	-
Platoon blocked, %	-	-	-	-	-	-	-	-	-	-	-	-
Mov Cap-1 Maneuver	~ 193	-	-	558	-	-	-	0	561	-	0	~ 301
Mov Cap-2 Maneuver	-	-	-	-	-	-	-	0	-	-	0	-
Stage 1	-	-	-	-	-	-	137	0	-	~ 87	180	-
Stage 2	-	-	-	-	-	-	-	158	-	-	0	-

Approach	EB	WB	NB	SB
HCM Control Delay, s	78.3	0		
HCM LOS			-	-

Minor Lane/Major Mvmt	NBLn1	EBL	EBT	EBR	WBL	WBT	WBR	SBLn1	SBLn2
Capacity (veh/h)	-	~ 193	-	-	558	-	-	-	301
HCM Lane V/C Ratio	-	1.438	-	-	-	-	-	-	1.117
HCM Control Delay (s)	-	269.7	-	-	0	-	-	-	125.2
HCM Lane LOS	-	F	-	-	A	-	-	-	F
HCM 95th %tile Q(veh)	-	16.8	-	-	0	-	-	-	13.6

Notes
 ~: Volume exceeds capacity \$: Delay exceeds 300s +: Computation Not Defined *: All major volume in platoon

Timings
4: Antelope Ridge Dr. & North Carefree

2040 Background Traffic
AM Peak Hour



Lane Group	EBL	EBT	WBT	WBR	NBT	SBL	SBT
Lane Configurations	↗	↗↗↗	↖↖↖	↖	↔	↗	↖
Traffic Volume (vph)	222	643	1443	92	1	204	1
Future Volume (vph)	222	643	1443	92	1	204	1
Turn Type	pm+pt	NA	NA	Perm	NA	Perm	NA
Protected Phases	5	2	6		8		4
Permitted Phases	2			6		4	
Detector Phase	5	2	6	6	8	4	4
Switch Phase							
Minimum Initial (s)	4.0	10.0	10.0	10.0	5.0	5.0	5.0
Minimum Split (s)	11.0	15.0	15.0	15.0	10.0	10.0	10.0
Total Split (s)	20.0	68.0	48.0	48.0	32.0	32.0	32.0
Total Split (%)	20.0%	68.0%	48.0%	48.0%	32.0%	32.0%	32.0%
Yellow Time (s)	3.0	3.0	3.0	3.0	3.0	3.0	3.0
All-Red Time (s)	2.0	2.0	2.0	2.0	2.0	2.0	2.0
Lost Time Adjust (s)	0.0	0.0	0.0	0.0	0.0	0.0	0.0
Total Lost Time (s)	5.0	5.0	5.0	5.0	5.0	5.0	5.0
Lead/Lag	Lead		Lag	Lag			
Lead-Lag Optimize?	Yes		Yes	Yes			
Recall Mode	None	C-Max	C-Max	C-Max	None	None	None
Act Effct Green (s)	67.4	67.4	48.5	48.5	22.6	22.6	22.6
Actuated g/C Ratio	0.67	0.67	0.48	0.48	0.23	0.23	0.23
v/c Ratio	0.82	0.20	0.62	0.14	0.00	0.79	0.58
Control Delay	41.5	6.8	21.4	3.8	27.0	54.2	10.3
Queue Delay	0.0	0.0	0.0	0.0	0.0	0.0	0.0
Total Delay	41.5	6.8	21.4	3.8	27.0	54.2	10.3
LOS	D	A	C	A	C	D	B
Approach Delay		16.9	20.2		27.0		29.2
Approach LOS		B	C		C		C

Intersection Summary

Cycle Length: 100
 Actuated Cycle Length: 100
 Offset: 86 (86%), Referenced to phase 2:EBTL and 6:WBTL, Start of Green
 Natural Cycle: 60
 Control Type: Actuated-Coordinated
 Maximum v/c Ratio: 0.82
 Intersection Signal Delay: 20.9
 Intersection LOS: C
 Intersection Capacity Utilization 70.8%
 ICU Level of Service C
 Analysis Period (min) 15

Splits and Phases: 4: Antelope Ridge Dr. & North Carefree



Timings
5: Marksheffel & North Carefree

2040 Background Traffic
AM Peak Hour

Lane Group	EBL	EBT	EBR	WBL	WBT	WBR	NBL	NBT	NBR	SBL	SBT	SBR
Lane Configurations												
Traffic Volume (vph)	100	327	420	100	781	154	610	839	50	78	1418	144
Future Volume (vph)	100	327	420	100	781	154	610	839	50	78	1418	144
Turn Type	pm+pt	NA	Free	pm+pt	NA	Free	Prot	NA	Free	pm+pt	NA	Free
Protected Phases	7	4		3	8		5	2		1	6	
Permitted Phases	4		Free	8		Free			Free	6		Free
Detector Phase	7	4		3	8		5	2		1	6	
Switch Phase												
Minimum Initial (s)	4.0	4.0		4.0	4.0		4.0	4.0		4.0	4.0	
Minimum Split (s)	9.0	11.0		11.0	11.0		11.0	11.0		11.0	11.0	
Total Split (s)	10.0	20.0		17.0	27.0		28.0	71.0		12.0	55.0	
Total Split (%)	8.3%	16.7%		14.2%	22.5%		23.3%	59.2%		10.0%	45.8%	
Yellow Time (s)	3.0	3.0		3.0	3.0		3.0	3.0		3.0	3.0	
All-Red Time (s)	2.0	2.0		2.0	2.0		2.0	2.0		2.0	2.0	
Lost Time Adjust (s)	0.0	-2.0		0.0	-2.0		0.0	-2.0		0.0	-2.0	
Total Lost Time (s)	5.0	3.0		5.0	3.0		5.0	3.0		5.0	3.0	
Lead/Lag	Lead	Lag		Lead	Lag		Lead	Lag		Lead	Lag	
Lead-Lag Optimize?	Yes	Yes		Yes	Yes		Yes	Yes		Yes	Yes	
Recall Mode	None	None		None	None		None	C-Max		None	C-Max	
Act Effct Green (s)	21.4	18.4	120.0	31.1	23.7	120.0	23.3	70.7	120.0	56.7	52.0	120.0
Actuated g/C Ratio	0.18	0.15	1.00	0.26	0.20	1.00	0.19	0.59	1.00	0.47	0.43	1.00
v/c Ratio	0.78	0.44	0.28	0.43	0.82	0.10	0.97	0.42	0.03	0.23	0.97	0.10
Control Delay	74.2	48.5	0.4	40.1	53.6	0.1	75.8	14.8	0.0	11.6	51.3	0.1
Queue Delay	0.0	0.0	0.0	0.0	0.0	0.0	0.0	0.0	0.0	0.0	0.0	0.0
Total Delay	74.2	48.5	0.4	40.1	53.6	0.1	75.8	14.8	0.0	11.6	51.3	0.1
LOS	E	D	A	D	D	A	E	B	A	B	D	A
Approach Delay		27.7			44.4			39.2			44.9	
Approach LOS		C			D			D			D	

Intersection Summary

Cycle Length: 120
 Actuated Cycle Length: 120
 Offset: 0 (0%), Referenced to phase 2:NBT and 6:SBTL, Start of Green
 Natural Cycle: 90
 Control Type: Actuated-Coordinated
 Maximum v/c Ratio: 0.97
 Intersection Signal Delay: 40.2
 Intersection LOS: D
 Intersection Capacity Utilization 92.2%
 ICU Level of Service F
 Analysis Period (min) 15

Splits and Phases: 5: Marksheffel & North Carefree



Intersection												
Int Delay, s/veh	1.1											
Movement	EBL	EBT	EBR	WBL	WBT	WBR	NBL	NBT	NBR	SBL	SBT	SBR
Lane Configurations		↕			↕		↗	↑	↗	↗	↗	
Traffic Vol, veh/h	6	0	54	0	0	0	14	300	0	0	419	4
Future Vol, veh/h	6	0	54	0	0	0	14	300	0	0	419	4
Conflicting Peds, #/hr	0	0	0	0	0	0	0	0	0	0	0	0
Sign Control	Stop	Stop	Stop	Stop	Stop	Stop	Free	Free	Free	Free	Free	Free
RT Channelized	-	-	None	-	-	None	-	-	None	-	-	None
Storage Length	-	-	-	-	-	-	80	-	100	80	-	-
Veh in Median Storage, #	-	0	-	-	0	-	-	0	-	-	0	-
Grade, %	-	0	-	-	0	-	-	0	-	-	0	-
Peak Hour Factor	88	88	88	92	92	92	92	80	92	92	80	92
Heavy Vehicles, %	2	2	2	2	2	2	2	2	2	2	2	2
Mvmt Flow	7	0	61	0	0	0	15	375	0	0	524	4

Major/Minor	Minor2		Minor1		Major1		Major2					
Conflicting Flow All	931	931	526	962	933	375	528	0	0	375	0	0
Stage 1	526	526	-	405	405	-	-	-	-	-	-	-
Stage 2	405	405	-	557	528	-	-	-	-	-	-	-
Critical Hdwy	7.12	6.52	6.22	7.12	6.52	6.22	4.12	-	-	4.12	-	-
Critical Hdwy Stg 1	6.12	5.52	-	6.12	5.52	-	-	-	-	-	-	-
Critical Hdwy Stg 2	6.12	5.52	-	6.12	5.52	-	-	-	-	-	-	-
Follow-up Hdwy	3.518	4.018	3.318	3.518	4.018	3.318	2.218	-	-	2.218	-	-
Pot Cap-1 Maneuver	247	267	552	235	266	671	1039	-	-	1183	-	-
Stage 1	535	529	-	622	598	-	-	-	-	-	-	-
Stage 2	622	598	-	515	528	-	-	-	-	-	-	-
Platoon blocked, %								-	-	-	-	-
Mov Cap-1 Maneuver	244	263	552	207	262	671	1039	-	-	1183	-	-
Mov Cap-2 Maneuver	244	263	-	207	262	-	-	-	-	-	-	-
Stage 1	528	529	-	613	590	-	-	-	-	-	-	-
Stage 2	613	590	-	458	528	-	-	-	-	-	-	-

Approach	EB	WB	NB	SB
HCM Control Delay, s	13.5	0	0.3	0
HCM LOS	B	A		

Minor Lane/Major Mvmt	NBL	NBT	NBR	EBLn1	WBLn1	SBL	SBT	SBR
Capacity (veh/h)	1039	-	-	490	-	1183	-	-
HCM Lane V/C Ratio	0.015	-	-	0.139	-	-	-	-
HCM Control Delay (s)	8.5	-	-	13.5	0	0	-	-
HCM Lane LOS	A	-	-	B	A	A	-	-
HCM 95th %tile Q(veh)	0	-	-	0.5	-	0	-	-

Intersection

Int Delay, s/veh 3.7

Movement	EBL	EBT	EBR	WBL	WBT	WBR	NBL	NBT	NBR	SBL	SBT	SBR
Lane Configurations	↘ ↑↑↑			↑↑↑		↗		↔		↘	↗	
Traffic Vol, veh/h	132	1534	1	0	1299	103	0	1	0	62	0	74
Future Vol, veh/h	132	1534	1	0	1299	103	0	1	0	62	0	74
Conflicting Peds, #/hr	0	0	0	0	0	0	0	0	0	0	0	0
Sign Control	Free	Free	Free	Free	Free	Free	Stop	Stop	Stop	Stop	Stop	Stop
RT Channelized	-	-	None	-	-	None	-	-	None	-	-	None
Storage Length	350	-	-	-	-	-	-	-	-	330	-	-
Veh in Median Storage, #	-	0	-	-	0	-	-	0	-	-	0	-
Grade, %	-	0	-	-	0	-	-	0	-	-	0	-
Peak Hour Factor	87	95	87	92	95	92	50	50	50	83	83	83
Heavy Vehicles, %	1	2	2	2	2	1	2	2	2	1	2	1
Mvmt Flow	152	1615	1	0	1367	112	0	2	0	75	0	89

Major/Minor	Major1			Major2			Minor1			Minor2		
Conflicting Flow All	1479	0	0	1616	0	0	2467	3399	808	2318	3287	684
Stage 1	-	-	-	-	-	-	1920	1920	-	1367	1367	-
Stage 2	-	-	-	-	-	-	547	1479	-	951	1920	-
Critical Hdwy	5.32	-	-	5.34	-	-	6.44	6.54	7.14	6.42	6.54	7.12
Critical Hdwy Stg 1	-	-	-	-	-	-	7.34	5.54	-	7.32	5.54	-
Critical Hdwy Stg 2	-	-	-	-	-	-	6.74	5.54	-	6.72	5.54	-
Follow-up Hdwy	3.11	-	-	3.12	-	-	3.82	4.02	3.92	3.81	4.02	3.91
Pot Cap-1 Maneuver	230	-	-	195	-	-	32	7	278	~41	9	337
Stage 1	-	-	-	-	-	-	44	113	-	111	213	-
Stage 2	-	-	-	-	-	-	446	188	-	254	113	-
Platoon blocked, %	-	-	-	-	-	-	-	-	-	-	-	-
Mov Cap-1 Maneuver	230	-	-	195	-	-	11	2	278	-	3	337
Mov Cap-2 Maneuver	-	-	-	-	-	-	11	2	-	-	3	-
Stage 1	-	-	-	-	-	-	15	38	-	~38	213	-
Stage 2	-	-	-	-	-	-	328	188	-	82	38	-

Approach	EB	WB	NB	SB
HCM Control Delay, s	4	0	\$ 2705	
HCM LOS			F	-

Minor Lane/Major Mvmt	NBLn1	EBL	EBT	EBR	WBL	WBT	WBR	SBLn1	SBLn2
Capacity (veh/h)	2	230	-	-	195	-	-	-	337
HCM Lane V/C Ratio	1	0.66	-	-	-	-	-	-	0.265
HCM Control Delay (s)	\$ 2705	46.6	-	-	0	-	-	-	19.5
HCM Lane LOS	F	E	-	-	A	-	-	-	C
HCM 95th %tile Q(veh)	0.9	4.1	-	-	0	-	-	-	1

Notes
 ~: Volume exceeds capacity \$: Delay exceeds 300s +: Computation Not Defined *: All major volume in platoon

Timings
4: Antelope Ridge Dr. & North Carefree

2040 Background Traffic
PM Peak Hour



Lane Group	EBL	EBT	WBT	WBR	NBT	SBL	SBT
Lane Configurations	↗	↗↗↗	↖↖↖	↖	↔	↗	↖
Traffic Volume (vph)	132	1534	1299	103	1	62	0
Future Volume (vph)	132	1534	1299	103	1	62	0
Turn Type	pm+pt	NA	NA	Perm	NA	Perm	NA
Protected Phases	5	2	6		8		4
Permitted Phases	2			6		4	
Detector Phase	5	2	6	6	8	4	4
Switch Phase							
Minimum Initial (s)	4.0	10.0	10.0	10.0	5.0	5.0	5.0
Minimum Split (s)	11.0	15.0	15.0	15.0	10.0	10.0	10.0
Total Split (s)	12.0	65.0	53.0	53.0	35.0	35.0	35.0
Total Split (%)	12.0%	65.0%	53.0%	53.0%	35.0%	35.0%	35.0%
Yellow Time (s)	3.0	3.0	3.0	3.0	3.0	3.0	3.0
All-Red Time (s)	2.0	2.0	2.0	2.0	2.0	2.0	2.0
Lost Time Adjust (s)	0.0	0.0	0.0	0.0	0.0	0.0	0.0
Total Lost Time (s)	5.0	5.0	5.0	5.0	5.0	5.0	5.0
Lead/Lag	Lead		Lag	Lag			
Lead-Lag Optimize?	Yes		Yes	Yes			
Recall Mode	None	C-Max	C-Max	C-Max	None	None	None
Act Effct Green (s)	81.6	82.6	68.8	68.8	10.5	10.6	10.6
Actuated g/C Ratio	0.82	0.83	0.69	0.69	0.10	0.11	0.11
v/c Ratio	0.43	0.38	0.39	0.10	0.01	0.50	0.29
Control Delay	6.4	3.4	8.2	1.8	37.0	52.5	2.5
Queue Delay	0.0	0.0	0.0	0.0	0.0	0.0	0.0
Total Delay	6.4	3.4	8.2	1.8	37.0	52.5	2.5
LOS	A	A	A	A	D	D	A
Approach Delay		3.7	7.7		37.0		25.4
Approach LOS		A	A		D		C

Intersection Summary

Cycle Length: 100
 Actuated Cycle Length: 100
 Offset: 86 (86%), Referenced to phase 2:EBTL and 6:WBTL, Start of Green
 Natural Cycle: 40
 Control Type: Actuated-Coordinated
 Maximum v/c Ratio: 0.50
 Intersection Signal Delay: 6.5
 Intersection LOS: A
 Intersection Capacity Utilization 77.4%
 ICU Level of Service D
 Analysis Period (min) 15

Splits and Phases: 4: Antelope Ridge Dr. & North Carefree



Timings
5: Marksheffel & North Carefree

2040 Background Traffic
PM Peak Hour

Lane Group	EBL	EBT	EBR	WBL	WBT	WBR	NBL	NBT	NBR	SBL	SBT	SBR
Lane Configurations												
Traffic Volume (vph)	197	579	820	50	404	87	805	1266	75	138	930	193
Future Volume (vph)	197	579	820	50	404	87	805	1266	75	138	930	193
Turn Type	pm+pt	NA	Free	pm+pt	NA	Free	Prot	NA	Free	pm+pt	NA	Free
Protected Phases	7	4		3	8		5	2		1	6	
Permitted Phases	4		Free	8		Free			Free	6		Free
Detector Phase	7	4		3	8		5	2		1	6	
Switch Phase												
Minimum Initial (s)	4.0	4.0		4.0	4.0		4.0	4.0		4.0	4.0	
Minimum Split (s)	11.0	11.0		11.0	11.0		11.0	11.0		11.0	11.0	
Total Split (s)	18.0	25.0		18.0	25.0		37.0	65.0		12.0	40.0	
Total Split (%)	15.0%	20.8%		15.0%	20.8%		30.8%	54.2%		10.0%	33.3%	
Yellow Time (s)	3.0	3.0		3.0	3.0		3.0	3.0		3.0	3.0	
All-Red Time (s)	2.0	2.0		2.0	2.0		2.0	2.0		2.0	2.0	
Lost Time Adjust (s)	0.0	0.0		0.0	0.0		0.0	-2.0		0.0	-2.0	
Total Lost Time (s)	5.0	5.0		5.0	5.0		5.0	3.0		5.0	3.0	
Lead/Lag	Lead	Lag		Lead	Lag		Lead	Lag		Lead	Lag	
Lead-Lag Optimize?	Yes	Yes		Yes	Yes		Yes	Yes		Yes	Yes	
Recall Mode	None	None		None	None		None	C-Max		None	C-Max	
Act Effct Green (s)	32.9	22.7	120.0	23.9	15.8	120.0	33.1	64.7	120.0	46.8	40.2	120.0
Actuated g/C Ratio	0.27	0.19	1.00	0.20	0.13	1.00	0.28	0.54	1.00	0.39	0.34	1.00
v/c Ratio	0.76	0.63	0.55	0.26	0.63	0.06	0.89	0.70	0.05	0.66	0.83	0.13
Control Delay	53.2	48.6	1.4	34.4	53.4	0.1	54.6	23.5	0.1	36.0	44.6	0.2
Queue Delay	0.0	0.0	0.0	0.0	0.0	0.0	0.0	0.0	0.0	0.0	0.0	0.0
Total Delay	53.2	48.6	1.4	34.4	53.4	0.1	54.6	23.5	0.1	36.0	44.6	0.2
LOS	D	D	A	C	D	A	D	C	A	D	D	A
Approach Delay		24.9			43.1			34.3			36.9	
Approach LOS		C			D			C			D	

Intersection Summary

Cycle Length: 120
 Actuated Cycle Length: 120
 Offset: 0 (0%), Referenced to phase 2:NBT and 6:SBTL, Start of Green
 Natural Cycle: 80
 Control Type: Actuated-Coordinated
 Maximum v/c Ratio: 0.89
 Intersection Signal Delay: 33.0
 Intersection LOS: C
 Intersection Capacity Utilization 83.2%
 ICU Level of Service E
 Analysis Period (min) 15

Splits and Phases: 5: Marksheffel & North Carefree



Intersection												
Int Delay, s/veh	1.5											
Movement	EBL	EBT	EBR	WBL	WBT	WBR	NBL	NBT	NBR	SBL	SBT	SBR
Lane Configurations		↕			↕		↗	↑	↖	↗	↖	↖
Traffic Vol, veh/h	6	0	21	0	0	0	44	191	0	0	116	4
Future Vol, veh/h	6	0	21	0	0	0	44	191	0	0	116	4
Conflicting Peds, #/hr	0	0	0	0	0	0	0	0	0	0	0	0
Sign Control	Stop	Stop	Stop	Stop	Stop	Stop	Free	Free	Free	Free	Free	Free
RT Channelized	-	-	None	-	-	None	-	-	None	-	-	None
Storage Length	-	-	-	-	-	-	80	-	100	80	-	-
Veh in Median Storage, #	-	0	-	-	0	-	-	0	-	-	0	-
Grade, %	-	0	-	-	0	-	-	0	-	-	0	-
Peak Hour Factor	88	88	88	92	92	92	92	84	92	92	84	92
Heavy Vehicles, %	2	2	2	2	2	2	2	2	2	2	2	2
Mvmt Flow	7	0	24	0	0	0	48	227	0	0	138	4

Major/Minor	Minor2		Minor1		Major1		Major2					
Conflicting Flow All	463	463	140	475	465	227	142	0	0	227	0	0
Stage 1	140	140	-	323	323	-	-	-	-	-	-	-
Stage 2	323	323	-	152	142	-	-	-	-	-	-	-
Critical Hdwy	7.12	6.52	6.22	7.12	6.52	6.22	4.12	-	-	4.12	-	-
Critical Hdwy Stg 1	6.12	5.52	-	6.12	5.52	-	-	-	-	-	-	-
Critical Hdwy Stg 2	6.12	5.52	-	6.12	5.52	-	-	-	-	-	-	-
Follow-up Hdwy	3.518	4.018	3.318	3.518	4.018	3.318	2.218	-	-	2.218	-	-
Pot Cap-1 Maneuver	509	496	908	500	495	812	1441	-	-	1341	-	-
Stage 1	863	781	-	689	650	-	-	-	-	-	-	-
Stage 2	689	650	-	850	779	-	-	-	-	-	-	-
Platoon blocked, %								-	-	-	-	-
Mov Cap-1 Maneuver	496	480	908	475	479	812	1441	-	-	1341	-	-
Mov Cap-2 Maneuver	496	480	-	475	479	-	-	-	-	-	-	-
Stage 1	835	781	-	666	629	-	-	-	-	-	-	-
Stage 2	666	629	-	828	779	-	-	-	-	-	-	-

Approach	EB	WB	NB	SB
HCM Control Delay, s	9.9	0	1.3	0
HCM LOS	A	A		

Minor Lane/Major Mvmt	NBL	NBT	NBR	EBLn1	WBLn1	SBL	SBT	SBR
Capacity (veh/h)	1441	-	-	767	-	1341	-	-
HCM Lane V/C Ratio	0.033	-	-	0.04	-	-	-	-
HCM Control Delay (s)	7.6	-	-	9.9	0	0	-	-
HCM Lane LOS	A	-	-	A	A	A	-	-
HCM 95th %tile Q(veh)	0.1	-	-	0.1	-	0	-	-

Intersection

Int Delay, s/veh 31.1

Movement	EBL	EBT	EBR	WBL	WBT	WBR	NBL	NBT	NBR	SBL	SBT	SBR
Lane Configurations	↘ ↑↑↑			↘↑↑↑		↗		↔		↘	↗	
Traffic Vol, veh/h	242	643	1	0	1443	119	0	1	0	271	1	327
Future Vol, veh/h	242	643	1	0	1443	119	0	1	0	271	1	327
Conflicting Peds, #/hr	0	0	0	0	0	0	0	0	0	0	0	0
Sign Control	Free	Free	Free	Free	Free	Free	Stop	Stop	Stop	Stop	Stop	Stop
RT Channelized	-	-	None	-	-	None	-	-	None	-	-	None
Storage Length	350	-	-	-	-	-	-	-	-	330	-	-
Veh in Median Storage, #	-	0	-	-	0	-	-	0	-	-	0	-
Grade, %	-	0	-	-	0	-	-	0	-	-	0	-
Peak Hour Factor	80	95	80	80	95	80	50	50	50	80	80	80
Heavy Vehicles, %	1	2	2	2	2	1	2	2	2	1	2	1
Mvmt Flow	303	677	1	0	1519	149	0	2	0	339	1	409

Major/Minor	Major1	Major2	Minor1	Minor2
Conflicting Flow All	1668	0	0	678
Stage 1	-	-	-	-
Stage 2	-	-	-	-
Critical Hdwy	5.32	-	-	5.34
Critical Hdwy Stg 1	-	-	-	-
Critical Hdwy Stg 2	-	-	-	-
Follow-up Hdwy	3.11	-	-	3.12
Pot Cap-1 Maneuver	~ 186	-	-	558
Stage 1	-	-	-	-
Stage 2	-	-	-	-
Platoon blocked, %	-	-	-	-
Mov Cap-1 Maneuver	~ 186	-	-	558
Mov Cap-2 Maneuver	-	-	-	-
Stage 1	-	-	-	-
Stage 2	-	-	-	-

Approach	EB	WB	NB	SB
HCM Control Delay, s	107.9	0		
HCM LOS			-	-

Minor Lane/Major Mvmt	NBLn1	EBL	EBT	EBR	WBL	WBT	WBR	SBLn1	SBLn2
Capacity (veh/h)	-	~ 186	-	-	558	-	-	-	301
HCM Lane V/C Ratio	-	1.626	-	-	-	-	-	-	1.362
HCM Control Delay (s)	-	\$ 349.7	-	-	0	-	-	-	216.6
HCM Lane LOS	-	F	-	-	A	-	-	-	F
HCM 95th %tile Q(veh)	-	20.2	-	-	0	-	-	-	21

Notes
 ~: Volume exceeds capacity \$: Delay exceeds 300s +: Computation Not Defined *: All major volume in platoon

Timings
4: Antelope Ridge Dr. & North Carefree

2040 Total Traffic
AM Peak Hour



Lane Group	EBL	EBT	WBT	WBR	NBT	SBL	SBT
Lane Configurations	↖	↕↕↕	↖↕↕	↗	↕↕	↖	↗
Traffic Volume (vph)	242	643	1443	119	1	271	1
Future Volume (vph)	242	643	1443	119	1	271	1
Turn Type	pm+pt	NA	NA	Perm	NA	Perm	NA
Protected Phases	5	2	6		8		4
Permitted Phases	2			6		4	
Detector Phase	5	2	6	6	8	4	4
Switch Phase							
Minimum Initial (s)	4.0	10.0	10.0	10.0	5.0	5.0	5.0
Minimum Split (s)	11.0	15.0	15.0	15.0	10.0	10.0	10.0
Total Split (s)	21.0	64.0	43.0	43.0	36.0	36.0	36.0
Total Split (%)	21.0%	64.0%	43.0%	43.0%	36.0%	36.0%	36.0%
Yellow Time (s)	3.0	3.0	3.0	3.0	3.0	3.0	3.0
All-Red Time (s)	2.0	2.0	2.0	2.0	2.0	2.0	2.0
Lost Time Adjust (s)	0.0	0.0	0.0	0.0	0.0	0.0	0.0
Total Lost Time (s)	5.0	5.0	5.0	5.0	5.0	5.0	5.0
Lead/Lag	Lead		Lag	Lag			
Lead-Lag Optimize?	Yes		Yes	Yes			
Recall Mode	None	C-Max	C-Max	C-Max	None	None	None
Act Effct Green (s)	62.2	62.2	42.5	42.5	27.8	27.8	27.8
Actuated g/C Ratio	0.62	0.62	0.42	0.42	0.28	0.28	0.28
v/c Ratio	0.90	0.21	0.70	0.20	0.00	0.86	0.60
Control Delay	54.6	8.9	26.9	4.2	24.0	54.9	10.6
Queue Delay	0.0	0.0	0.0	0.0	0.0	0.0	0.0
Total Delay	54.6	8.9	26.9	4.2	24.0	54.9	10.6
LOS	D	A	C	A	C	D	B
Approach Delay		23.0	24.9		24.0		30.7
Approach LOS		C	C		C		C

Intersection Summary

Cycle Length: 100
 Actuated Cycle Length: 100
 Offset: 86 (86%), Referenced to phase 2:EBTL and 6:WBTL, Start of Green
 Natural Cycle: 65
 Control Type: Actuated-Coordinated
 Maximum v/c Ratio: 0.90
 Intersection Signal Delay: 25.6
 Intersection LOS: C
 Intersection Capacity Utilization 75.5%
 ICU Level of Service D
 Analysis Period (min) 15

Splits and Phases: 4: Antelope Ridge Dr. & North Carefree

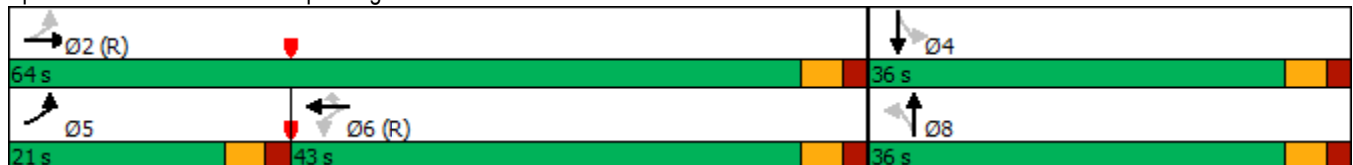

Timings
5: Marksheffel & North Carefree

2040 Total Traffic
AM Peak Hour

Lane Group	EBL	EBT	EBR	WBL	WBT	WBR	NBL	NBT	NBR	SBL	SBT	SBR
Lane Configurations												
Traffic Volume (vph)	118	344	452	100	787	154	620	839	50	78	1418	154
Future Volume (vph)	118	344	452	100	787	154	620	839	50	78	1418	154
Turn Type	pm+pt	NA	Free	pm+pt	NA	Free	Prot	NA	Free	pm+pt	NA	Free
Protected Phases	7	4		3	8		5	2		1	6	
Permitted Phases	4		Free	8		Free			Free	6		Free
Detector Phase	7	4		3	8		5	2		1	6	
Switch Phase												
Minimum Initial (s)	5.0	4.0		4.0	4.0		4.0	4.0		4.0	4.0	
Minimum Split (s)	10.0	11.0		9.0	11.0		11.0	11.0		11.0	11.0	
Total Split (s)	11.0	27.0		11.0	27.0		26.0	70.0		12.0	56.0	
Total Split (%)	9.2%	22.5%		9.2%	22.5%		21.7%	58.3%		10.0%	46.7%	
Yellow Time (s)	3.0	3.0		3.0	3.0		3.0	3.0		3.0	3.0	
All-Red Time (s)	2.0	2.0		2.0	2.0		2.0	2.0		2.0	2.0	
Lost Time Adjust (s)	0.0	-2.0		0.0	-2.0		-2.0	-2.0		0.0	-2.0	
Total Lost Time (s)	5.0	3.0		5.0	3.0		3.0	3.0		5.0	3.0	
Lead/Lag	Lead	Lag		Lead	Lag		Lead	Lag		Lead	Lag	
Lead-Lag Optimize?	Yes	Yes		Yes	Yes		Yes	Yes		Yes	Yes	
Recall Mode	None	None		None	None		None	C-Max		None	C-Max	
Act Effct Green (s)	27.7	23.7	120.0	27.7	23.7	120.0	23.3	69.8	120.0	57.8	53.0	120.0
Actuated g/C Ratio	0.23	0.20	1.00	0.23	0.20	1.00	0.19	0.58	1.00	0.48	0.44	1.00
v/c Ratio	0.83	0.36	0.30	0.46	0.80	0.10	0.95	0.43	0.03	0.23	0.96	0.10
Control Delay	76.6	42.7	0.5	42.0	52.8	0.1	72.5	15.4	0.0	11.5	47.1	0.1
Queue Delay	0.0	0.0	0.0	0.0	0.0	0.0	0.0	0.0	0.0	0.0	0.0	0.0
Total Delay	76.6	42.7	0.5	42.0	52.8	0.1	72.5	15.4	0.0	11.5	47.1	0.1
LOS	E	D	A	D	D	A	E	B	A	B	D	A
Approach Delay		26.2			43.8			37.9			41.1	
Approach LOS		C			D			D			D	

Intersection Summary

Cycle Length: 120
 Actuated Cycle Length: 120
 Offset: 0 (0%), Referenced to phase 2:NBT and 6:SBTL, Start of Green
 Natural Cycle: 90
 Control Type: Actuated-Coordinated
 Maximum v/c Ratio: 0.96
 Intersection Signal Delay: 38.0
 Intersection LOS: D
 Intersection Capacity Utilization 92.1%
 ICU Level of Service F
 Analysis Period (min) 15

Splits and Phases: 5: Marksheffel & North Carefree

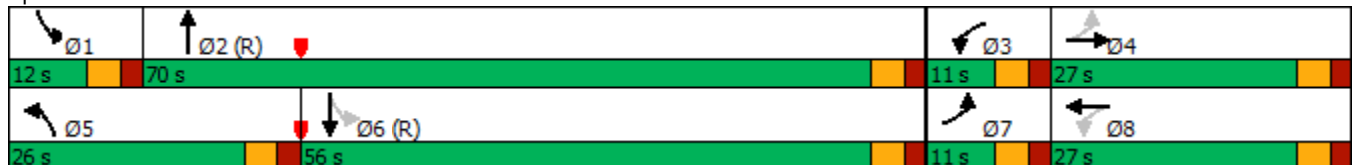

Intersection												
Int Delay, s/veh	4.5											
Movement	EBL	EBT	EBR	WBL	WBT	WBR	NBL	NBT	NBR	SBL	SBT	SBR
Lane Configurations		↕			↕		↗	↑	↗	↗	↗	↗
Traffic Vol, veh/h	6	0	54	80	0	17	14	320	26	5	465	4
Future Vol, veh/h	6	0	54	80	0	17	14	320	26	5	465	4
Conflicting Peds, #/hr	0	0	0	0	0	0	0	0	0	0	0	0
Sign Control	Stop	Stop	Stop	Stop	Stop	Stop	Free	Free	Free	Free	Free	Free
RT Channelized	-	-	None	-	-	None	-	-	None	-	-	None
Storage Length	-	-	-	-	-	-	80	-	100	80	-	-
Veh in Median Storage, #	-	0	-	-	0	-	-	0	-	-	0	-
Grade, %	-	0	-	-	0	-	-	0	-	-	0	-
Peak Hour Factor	88	88	88	94	94	94	94	81	94	94	81	94
Heavy Vehicles, %	2	2	2	2	2	2	2	2	2	2	2	2
Mvmt Flow	7	0	61	85	0	18	15	395	28	5	574	4

Major/Minor	Minor2		Minor1		Major1		Major2					
Conflicting Flow All	1034	1039	576	1042	1013	395	578	0	0	423	0	0
Stage 1	586	586	-	425	425	-	-	-	-	-	-	-
Stage 2	448	453	-	617	588	-	-	-	-	-	-	-
Critical Hdwy	7.12	6.52	6.22	7.12	6.52	6.22	4.12	-	-	4.12	-	-
Critical Hdwy Stg 1	6.12	5.52	-	6.12	5.52	-	-	-	-	-	-	-
Critical Hdwy Stg 2	6.12	5.52	-	6.12	5.52	-	-	-	-	-	-	-
Follow-up Hdwy	3.518	4.018	3.318	3.518	4.018	3.318	2.218	-	-	2.218	-	-
Pot Cap-1 Maneuver	202	213	517	198	224	777	996	-	-	1150	-	-
Stage 1	496	497	-	701	626	-	-	-	-	-	-	-
Stage 2	675	604	-	477	496	-	-	-	-	-	-	-
Platoon blocked, %	1	1		1	1	1		-	-	1	-	-
Mov Cap-1 Maneuver	194	209	517	172	219	777	996	-	-	1150	-	-
Mov Cap-2 Maneuver	194	209	-	172	219	-	-	-	-	-	-	-
Stage 1	489	495	-	690	617	-	-	-	-	-	-	-
Stage 2	649	595	-	419	494	-	-	-	-	-	-	-

Approach	EB	WB	NB	SB
HCM Control Delay, s	14.6	41.1	0.3	0.1
HCM LOS	B	E		

Minor Lane/Major Mvmt	NBL	NBT	NBR	EBLn1	WBLn1	SBL	SBT	SBR
Capacity (veh/h)	996	-	-	443	199	1150	-	-
HCM Lane V/C Ratio	0.015	-	-	0.154	0.519	0.005	-	-
HCM Control Delay (s)	8.7	-	-	14.6	41.1	8.1	-	-
HCM Lane LOS	A	-	-	B	E	A	-	-
HCM 95th %tile Q(veh)	0	-	-	0.5	2.6	0	-	-

Intersection						
Int Delay, s/veh	1.6					
Movement	WBL	WBR	NBT	NBR	SBL	SBT
Lane Configurations	↔		↔		↔	↔
Traffic Vol, veh/h	46	25	323	21	5	428
Future Vol, veh/h	46	25	323	21	5	428
Conflicting Peds, #/hr	0	0	0	0	0	0
Sign Control	Stop	Stop	Free	Free	Free	Free
RT Channelized	-	None	-	None	-	None
Storage Length	0	-	-	-	80	-
Veh in Median Storage, #	0	-	0	-	-	0
Grade, %	0	-	0	-	-	0
Peak Hour Factor	94	94	64	94	94	52
Heavy Vehicles, %	2	2	2	2	2	2
Mvmt Flow	49	27	505	22	5	823

Major/Minor	Minor1	Major1	Major2		
Conflicting Flow All	1349	516	0	0	527
Stage 1	516	-	-	-	-
Stage 2	833	-	-	-	-
Critical Hdwy	6.42	6.22	-	-	4.12
Critical Hdwy Stg 1	5.42	-	-	-	-
Critical Hdwy Stg 2	5.42	-	-	-	-
Follow-up Hdwy	3.518	3.318	-	-	2.218
Pot Cap-1 Maneuver	166	559	-	-	1040
Stage 1	599	-	-	-	-
Stage 2	427	-	-	-	-
Platoon blocked, %			-	-	-
Mov Cap-1 Maneuver	165	559	-	-	1040
Mov Cap-2 Maneuver	165	-	-	-	-
Stage 1	599	-	-	-	-
Stage 2	425	-	-	-	-

Approach	WB	NB	SB
HCM Control Delay, s	29.9	0	0.1
HCM LOS	D		

Minor Lane/Major Mvmt	NBT	NBRWBLn1	SBL	SBT
Capacity (veh/h)	-	-	219	1040
HCM Lane V/C Ratio	-	-	0.345	0.005
HCM Control Delay (s)	-	-	29.9	8.5
HCM Lane LOS	-	-	D	A
HCM 95th %tile Q(veh)	-	-	1.5	0

HCM 6th TWSC
 4: Antelope Ridge Dr. & North Carefree

2040 Total Traffic
 PM Peak Hour

Intersection

Int Delay, s/veh 8.7

Movement	EBL	EBT	EBR	WBL	WBT	WBR	NBL	NBT	NBR	SBL	SBT	SBR
Lane Configurations	↘ ↑↑↑			↑↑↑		↑		↔		↘	↑	
Traffic Vol, veh/h	197	1534	1	0	1299	192	0	1	0	106	0	113
Future Vol, veh/h	197	1534	1	0	1299	192	0	1	0	106	0	113
Conflicting Peds, #/hr	0	0	0	0	0	0	0	0	0	0	0	0
Sign Control	Free	Free	Free	Free	Free	Free	Stop	Stop	Stop	Stop	Stop	Stop
RT Channelized	-	-	None	-	-	None	-	-	None	-	-	None
Storage Length	350	-	-	-	-	-	-	-	-	330	-	-
Veh in Median Storage, #	-	0	-	-	0	-	-	0	-	-	0	-
Grade, %	-	0	-	-	0	-	-	0	-	-	0	-
Peak Hour Factor	87	95	87	92	95	92	50	50	50	83	83	83
Heavy Vehicles, %	1	2	2	2	2	1	2	2	2	1	2	1
Mvmt Flow	226	1615	1	0	1367	209	0	2	0	128	0	136

Major/Minor	Major1	Major2	Minor1	Minor2
Conflicting Flow All	1576	0	0	1616
Stage 1	-	-	-	-
Stage 2	-	-	-	-
Critical Hdwy	5.32	-	-	5.34
Critical Hdwy Stg 1	-	-	-	-
Critical Hdwy Stg 2	-	-	-	-
Follow-up Hdwy	3.11	-	-	3.12
Pot Cap-1 Maneuver	~ 206	-	-	195
Stage 1	-	-	-	-
Stage 2	-	-	-	-
Platoon blocked, %	-	-	-	-
Mov Cap-1 Maneuver	~ 206	-	-	195
Mov Cap-2 Maneuver	-	-	-	-
Stage 1	-	-	-	-
Stage 2	-	-	-	-

Approach	EB	WB	NB	SB
HCM Control Delay, s	17.3	0		
HCM LOS			-	-

Minor Lane/Major Mvmt	NBLn1	EBL	EBT	EBR	WBL	WBT	WBR	SBLn1	SBLn2
Capacity (veh/h)	-	~ 206	-	-	195	-	-	-	337
HCM Lane V/C Ratio	-	1.099	-	-	-	-	-	-	0.404
HCM Control Delay (s)	-	140.4	-	-	0	-	-	-	22.7
HCM Lane LOS	-	F	-	-	A	-	-	-	C
HCM 95th %tile Q(veh)	-	10.6	-	-	0	-	-	-	1.9

Notes
 ~: Volume exceeds capacity \$: Delay exceeds 300s +: Computation Not Defined *: All major volume in platoon

Timings
4: Antelope Ridge Dr. & North Carefree

2040 Total Traffic
PM Peak Hour



Lane Group	EBL	EBT	WBT	WBR	NBT	SBL	SBT
Lane Configurations	↖	↕↕↕	↖↕↕	↗	↕↕	↖	↗
Traffic Volume (vph)	197	1534	1299	192	1	106	0
Future Volume (vph)	197	1534	1299	192	1	106	0
Turn Type	pm+pt	NA	NA	Perm	NA	Perm	NA
Protected Phases	5	2	6		8		4
Permitted Phases	2			6		4	
Detector Phase	5	2	6	6	8	4	4
Switch Phase							
Minimum Initial (s)	4.0	10.0	10.0	10.0	5.0	5.0	5.0
Minimum Split (s)	11.0	15.0	15.0	15.0	10.0	10.0	10.0
Total Split (s)	12.0	65.0	53.0	53.0	35.0	35.0	35.0
Total Split (%)	12.0%	65.0%	53.0%	53.0%	35.0%	35.0%	35.0%
Yellow Time (s)	3.0	3.0	3.0	3.0	3.0	3.0	3.0
All-Red Time (s)	2.0	2.0	2.0	2.0	2.0	2.0	2.0
Lost Time Adjust (s)	0.0	0.0	0.0	0.0	0.0	0.0	0.0
Total Lost Time (s)	5.0	5.0	5.0	5.0	5.0	5.0	5.0
Lead/Lag	Lead		Lag	Lag			
Lead-Lag Optimize?	Yes		Yes	Yes			
Recall Mode	None	C-Max	C-Max	C-Max	None	None	None
Act Effct Green (s)	75.7	75.7	57.7	57.7	14.3	14.3	14.3
Actuated g/C Ratio	0.76	0.76	0.58	0.58	0.14	0.14	0.14
v/c Ratio	0.57	0.42	0.47	0.21	0.01	0.63	0.37
Control Delay	12.9	5.1	13.9	2.5	33.0	53.1	6.9
Queue Delay	0.0	0.0	0.0	0.0	0.0	0.0	0.0
Total Delay	12.9	5.1	13.9	2.5	33.0	53.1	6.9
LOS	B	A	B	A	C	D	A
Approach Delay		6.1	12.4		33.0		29.3
Approach LOS		A	B		C		C

Intersection Summary

Cycle Length: 100
 Actuated Cycle Length: 100
 Offset: 86 (86%), Referenced to phase 2:EBTL and 6:WBTL, Start of Green
 Natural Cycle: 40
 Control Type: Actuated-Coordinated
 Maximum v/c Ratio: 0.63
 Intersection Signal Delay: 10.5
 Intersection LOS: B
 Intersection Capacity Utilization 79.8%
 ICU Level of Service D
 Analysis Period (min) 15

Splits and Phases: 4: Antelope Ridge Dr. & North Carefree

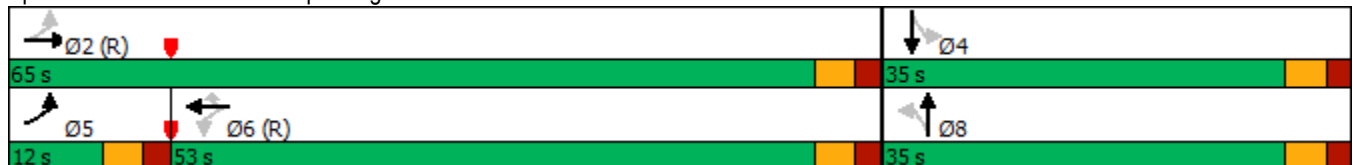

Timings
5: Marksheffel & North Carefree

2040 Total Traffic
PM Peak Hour

Lane Group	EBL	EBT	EBR	WBL	WBT	WBR	NBL	NBT	NBR	SBL	SBT	SBR
Lane Configurations												
Traffic Volume (vph)	209	590	841	50	423	87	840	1266	75	138	930	228
Future Volume (vph)	209	590	841	50	423	87	840	1266	75	138	930	228
Turn Type	pm+pt	NA	Free	pm+pt	NA	Free	Prot	NA	Free	pm+pt	NA	Free
Protected Phases	7	4		3	8		5	2		1	6	
Permitted Phases	4		Free	8		Free			Free	6		Free
Detector Phase	7	4		3	8		5	2		1	6	
Switch Phase												
Minimum Initial (s)	4.0	4.0		4.0	4.0		4.0	4.0		4.0	4.0	
Minimum Split (s)	11.0	11.0		11.0	11.0		11.0	11.0		11.0	11.0	
Total Split (s)	19.0	31.0		12.0	24.0		39.0	65.0		12.0	38.0	
Total Split (%)	15.8%	25.8%		10.0%	20.0%		32.5%	54.2%		10.0%	31.7%	
Yellow Time (s)	3.0	3.0		3.0	3.0		3.0	3.0		3.0	3.0	
All-Red Time (s)	2.0	2.0		2.0	2.0		2.0	2.0		2.0	2.0	
Lost Time Adjust (s)	0.0	0.0		0.0	0.0		0.0	-2.0		0.0	-2.0	
Total Lost Time (s)	5.0	5.0		5.0	5.0		5.0	3.0		5.0	3.0	
Lead/Lag	Lead	Lag		Lead	Lag		Lead	Lag		Lead	Lag	
Lead-Lag Optimize?	Yes	Yes		Yes	Yes		Yes	Yes		Yes	Yes	
Recall Mode	None	None		None	None		None	C-Max		None	C-Max	
Act Effct Green (s)	34.7	25.1	120.0	22.6	15.9	120.0	34.4	63.8	120.0	44.4	37.9	120.0
Actuated g/C Ratio	0.29	0.21	1.00	0.19	0.13	1.00	0.29	0.53	1.00	0.37	0.32	1.00
v/c Ratio	0.77	0.58	0.56	0.27	0.66	0.06	0.90	0.71	0.05	0.68	0.87	0.15
Control Delay	52.9	45.5	1.4	34.4	54.3	0.1	54.1	24.1	0.1	39.2	49.5	0.2
Queue Delay	0.0	0.0	0.0	0.0	0.0	0.0	0.0	0.0	0.0	0.0	0.0	0.0
Total Delay	52.9	45.5	1.4	34.4	54.3	0.1	54.1	24.1	0.1	39.2	49.5	0.2
LOS	D	D	A	C	D	A	D	C	A	D	D	A
Approach Delay		23.9			44.1			34.8			39.8	
Approach LOS		C			D			C			D	

Intersection Summary

Cycle Length: 120
 Actuated Cycle Length: 120
 Offset: 0 (0%), Referenced to phase 2:NBT and 6:SBTL, Start of Green
 Natural Cycle: 90
 Control Type: Actuated-Coordinated
 Maximum v/c Ratio: 0.90
 Intersection Signal Delay: 33.7
 Intersection LOS: C
 Intersection Capacity Utilization 85.3%
 ICU Level of Service E
 Analysis Period (min) 15

Splits and Phases: 5: Marksheffel & North Carefree

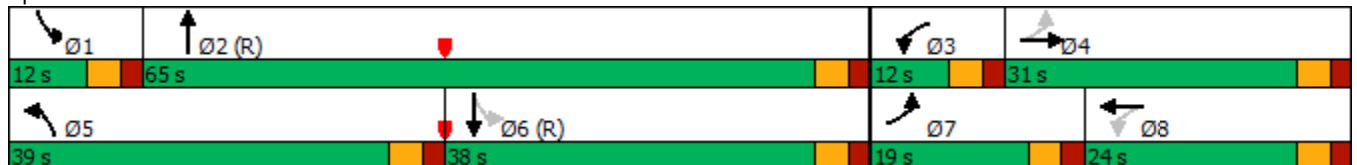

Intersection												
Int Delay, s/veh	2.4											
Movement	EBL	EBT	EBR	WBL	WBT	WBR	NBL	NBT	NBR	SBL	SBT	SBR
Lane Configurations		↕			↕		↗	↑	↖	↗	↖	↖
Traffic Vol, veh/h	6	0	21	50	0	11	44	258	86	17	147	4
Future Vol, veh/h	6	0	21	50	0	11	44	258	86	17	147	4
Conflicting Peds, #/hr	0	0	0	0	0	0	0	0	0	0	0	0
Sign Control	Stop	Stop	Stop	Stop	Stop	Stop	Free	Free	Free	Free	Free	Free
RT Channelized	-	-	None	-	-	None	-	-	None	-	-	None
Storage Length	-	-	-	-	-	-	80	-	100	80	-	-
Veh in Median Storage, #	-	0	-	-	0	-	-	0	-	-	0	-
Grade, %	-	0	-	-	0	-	-	0	-	-	0	-
Peak Hour Factor	88	88	88	92	92	92	92	84	92	92	84	92
Heavy Vehicles, %	2	2	2	2	2	2	2	2	2	2	2	2
Mvmt Flow	7	0	24	54	0	12	48	307	93	18	175	4

Major/Minor	Minor2		Minor1		Major1		Major2					
Conflicting Flow All	669	709	177	628	618	307	179	0	0	400	0	0
Stage 1	213	213	-	403	403	-	-	-	-	-	-	-
Stage 2	456	496	-	225	215	-	-	-	-	-	-	-
Critical Hdwy	7.12	6.52	6.22	7.12	6.52	6.22	4.12	-	-	4.12	-	-
Critical Hdwy Stg 1	6.12	5.52	-	6.12	5.52	-	-	-	-	-	-	-
Critical Hdwy Stg 2	6.12	5.52	-	6.12	5.52	-	-	-	-	-	-	-
Follow-up Hdwy	3.518	4.018	3.318	3.518	4.018	3.318	2.218	-	-	2.218	-	-
Pot Cap-1 Maneuver	404	370	866	435	428	841	1397	-	-	1165	-	-
Stage 1	789	726	-	689	627	-	-	-	-	-	-	-
Stage 2	637	560	-	778	725	-	-	-	-	-	-	-
Platoon blocked, %	1	1		1	1	1		-	-	1	-	-
Mov Cap-1 Maneuver	383	352	866	408	408	841	1397	-	-	1165	-	-
Mov Cap-2 Maneuver	383	352	-	408	408	-	-	-	-	-	-	-
Stage 1	762	715	-	666	606	-	-	-	-	-	-	-
Stage 2	606	541	-	745	714	-	-	-	-	-	-	-

Approach	EB		WB		NB		SB	
HCM Control Delay, s	10.6		14.4		0.8		0.8	
HCM LOS	B		B					

Minor Lane/Major Mvmt	NBL	NBT	NBR	EBLn1	WBLn1	SBL	SBT	SBR
Capacity (veh/h)	1397	-	-	676	450	1165	-	-
HCM Lane V/C Ratio	0.034	-	-	0.045	0.147	0.016	-	-
HCM Control Delay (s)	7.7	-	-	10.6	14.4	8.1	-	-
HCM Lane LOS	A	-	-	B	B	A	-	-
HCM 95th %tile Q(veh)	0.1	-	-	0.1	0.5	0	-	-

Intersection						
Int Delay, s/veh	1.3					
Movement	WBL	WBR	NBT	NBR	SBL	SBT
Lane Configurations	Y		P		Y	↑
Traffic Vol, veh/h	31	17	207	67	15	137
Future Vol, veh/h	31	17	207	67	15	137
Conflicting Peds, #/hr	0	0	0	0	0	0
Sign Control	Stop	Stop	Free	Free	Free	Free
RT Channelized	-	None	-	None	-	None
Storage Length	0	-	-	-	80	-
Veh in Median Storage, #	0	-	0	-	-	0
Grade, %	0	-	0	-	-	0
Peak Hour Factor	92	92	84	92	92	84
Heavy Vehicles, %	2	2	2	2	2	2
Mvmt Flow	34	18	246	73	16	163

Major/Minor	Minor1	Major1	Major2		
Conflicting Flow All	478	283	0	0	319
Stage 1	283	-	-	-	-
Stage 2	195	-	-	-	-
Critical Hdwy	6.42	6.22	-	-	4.12
Critical Hdwy Stg 1	5.42	-	-	-	-
Critical Hdwy Stg 2	5.42	-	-	-	-
Follow-up Hdwy	3.518	3.318	-	-	2.218
Pot Cap-1 Maneuver	546	756	-	-	1241
Stage 1	765	-	-	-	-
Stage 2	838	-	-	-	-
Platoon blocked, %			-	-	-
Mov Cap-1 Maneuver	539	756	-	-	1241
Mov Cap-2 Maneuver	539	-	-	-	-
Stage 1	765	-	-	-	-
Stage 2	827	-	-	-	-

Approach	WB	NB	SB
HCM Control Delay, s	11.6	0	0.7
HCM LOS	B		

Minor Lane/Major Mvmt	NBT	NBRWBLn1	SBL	SBT
Capacity (veh/h)	-	-	600	1241
HCM Lane V/C Ratio	-	-	0.087	0.013
HCM Control Delay (s)	-	-	11.6	7.9
HCM Lane LOS	-	-	B	A
HCM 95th %tile Q(veh)	-	-	0.3	0

Queuing Reports



Intersection: 4: Antelope Ridge Dr. & North Carefree

Movement	EB	WB	NB	SB	SB
Directions Served	L	R	LTR	L	TR
Maximum Queue (ft)	248	10	24	355	516
Average Queue (ft)	106	1	1	346	486
95th Queue (ft)	197	7	10	388	643
Link Distance (ft)		930	140		503
Upstream Blk Time (%)					81
Queuing Penalty (veh)					487
Storage Bay Dist (ft)	350			330	
Storage Blk Time (%)	0			94	2
Queuing Penalty (veh)	0			310	4

Provide queuing report for south access WB movements - 170' available

Queuing and Blocking Report
 North Carefree/Antelope Ridge Signal Control

2040 Total Traffic
 AM Peak Hour

Intersection: 4: Antelope Ridge Dr. & North Carefree

Movement	EB	EB	EB	EB	WB	WB	WB	WB	NB	SB	SB
Directions Served	L	T	T	TR	LT	T	T	R	LTR	L	TR
Maximum Queue (ft)	222	134	92	194	336	352	368	82	12	273	134
Average Queue (ft)	104	54	24	67	143	166	174	31	1	157	60
95th Queue (ft)	177	109	65	133	318	347	354	68	11	242	102
Link Distance (ft)		355	355	355	930	930	930	930	140		503
Upstream Blk Time (%)											
Queuing Penalty (veh)											
Storage Bay Dist (ft)	350									330	
Storage Blk Time (%)											
Queuing Penalty (veh)											

Queuing and Blocking Report
 North Carefree/Antelope Ridge Signal Control

2040 Total Traffic With TWSC
 PM Peak Hour

Intersection: 4: Antelope Ridge Dr. & North Carefree

Movement	EB	WB	NB	SB	SB
Directions Served	L	R	LTR	L	TR
Maximum Queue (ft)	186	22	12	354	508
Average Queue (ft)	88	3	2	317	420
95th Queue (ft)	159	15	12	429	711
Link Distance (ft)		930	140		503
Upstream Blk Time (%)					77
Queuing Penalty (veh)					170
Storage Bay Dist (ft)	350			330	
Storage Blk Time (%)				84	0
Queuing Penalty (veh)				95	0

Queuing and Blocking Report
 North Carefree/Antelope Ridge Signal Control

2040 Total Traffic
 PM Peak Hour

Intersection: 4: Antelope Ridge Dr. & North Carefree

Movement	EB	EB	EB	EB	WB	WB	WB	WB	NB	SB	SB
Directions Served	L	T	T	TR	LT	T	T	R	LTR	L	TR
Maximum Queue (ft)	186	172	153	259	259	285	294	121	24	156	63
Average Queue (ft)	82	62	36	109	79	95	102	35	2	83	35
95th Queue (ft)	147	131	108	220	202	229	230	80	12	140	57
Link Distance (ft)		355	355	355	930	930	930	930	140		503
Upstream Blk Time (%)											
Queuing Penalty (veh)											
Storage Bay Dist (ft)	350									330	
Storage Blk Time (%)											
Queuing Penalty (veh)											

Crash History



Accident Date	Reference Point Name	Reference Point At Name	Accident Narrative
4/15/2019	ANTELOPE RIDGE RD	N CAREFREE CIR	Vehicle 2 was stopped on Antelope Ridge Road facing south at the stop sign with North Carefree. Vehicle 1 was traveling south on Antelope Ridge Road directly behind vehicle 2. Vehicle 1 did not stop and collided with the rear of vehicle 2. Both vehicles came to rest at place of impact.
5/3/2019	ANTELOPE RIDGE DR	N CAREFREE CIR	Vehicle #1 was facing southbound on Antelope Ridge Dr stopped at a stop sign at the intersection on the north side of North Carefree Cir. Vehicle #2 was traveling westbound on North Carefree Cir in the #2 lane approaching the intersection of Antelope Ridge Dr. Vehicle #1 preceeded from the stop and entered the intersection to make a left turn onto eastbound North Carefree Cir. Vehicle #1 struck Vehicle #2 with the front of the vehicle into the passenger side of Vehicle #2. Both vehicles were moved prior to my

MTCP Maps



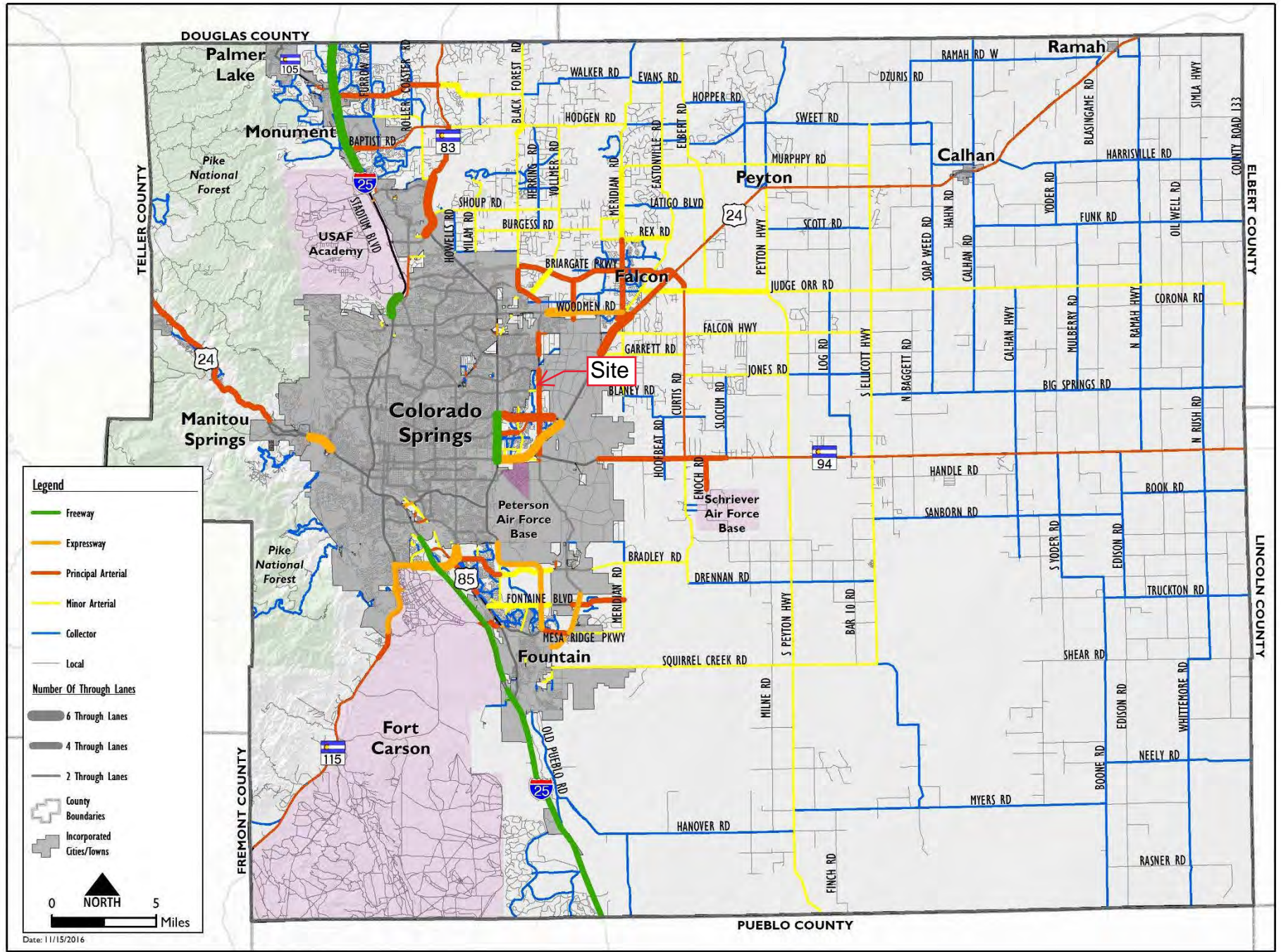

Map 14: 2040 Roadway Plan (Classification and Lanes)

Map 17: 2060 Corridor Preservation

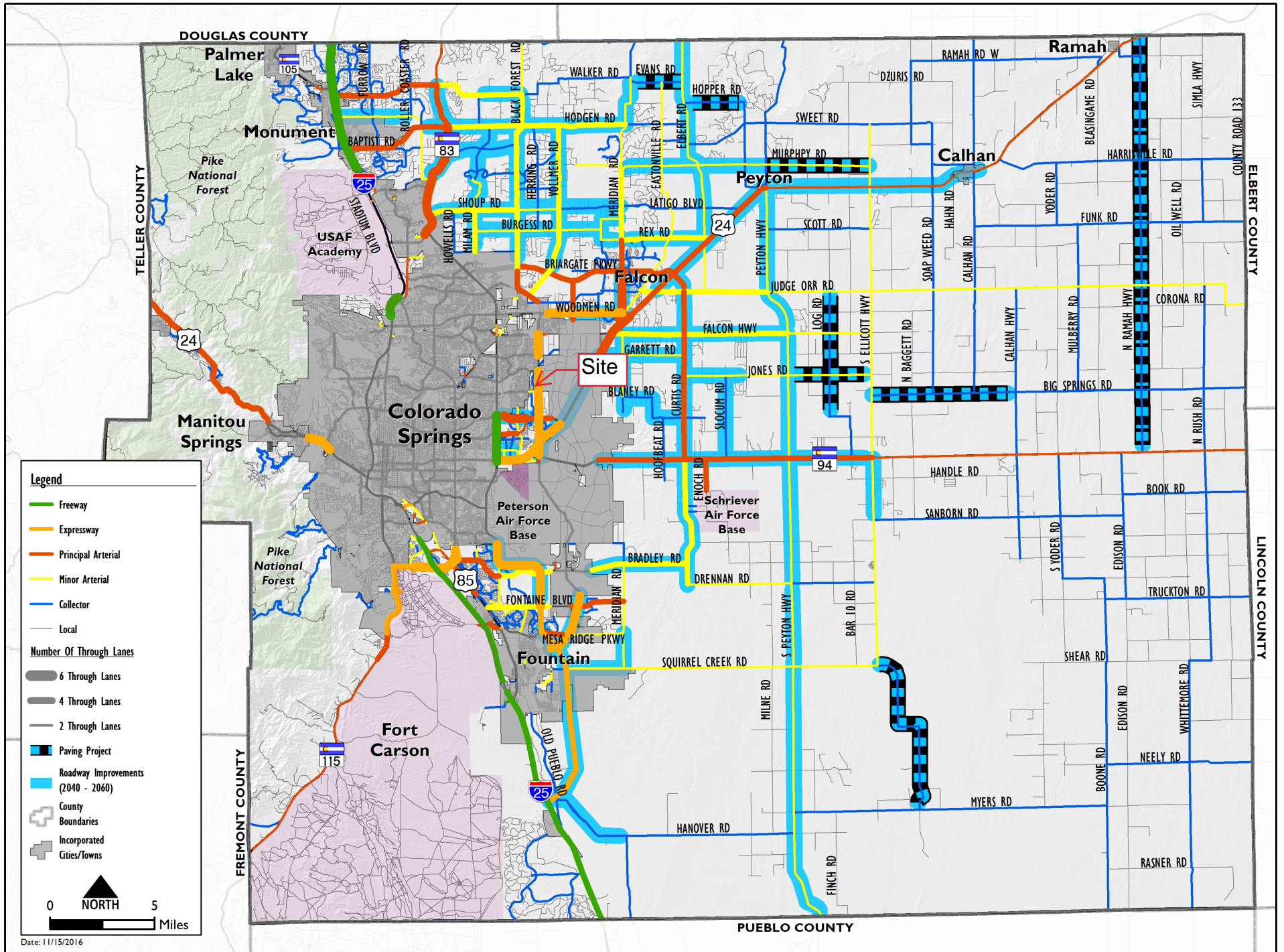

Additional Attachments

Rocky Mountain Classical Academy Carpool Plan and
Key Pages from the Parent-Student Handbook



Morning Carpool Drop—Doors open at 7:30am Classes start at 8:00am

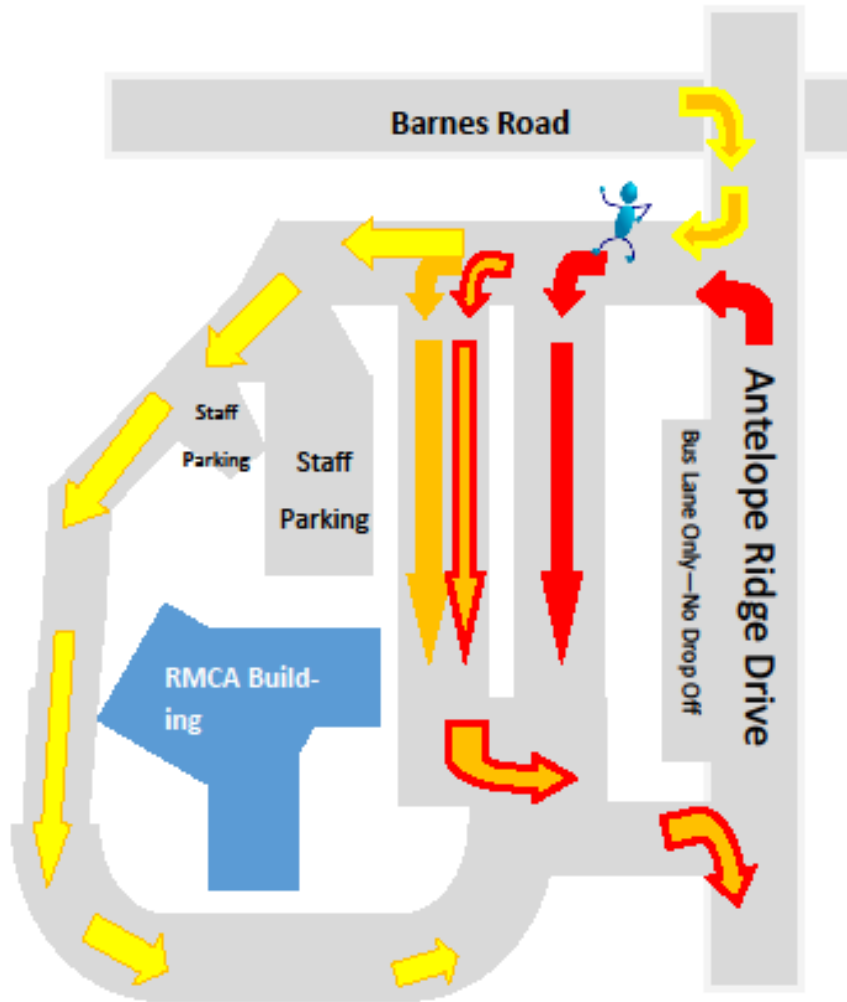

- PRE-SCHOOL**
- If Preschooler has a K-8 sibling drop off between 7:45 and 8am (K-8 students come in with pre-school and continue to appropriate locations)
 - Preschool without K-8 sibling drop off between 8 and 8:15 am
 - Must come in from the north Barnes entrance

*Starting at 7:30, staff will open access to the parking lot for student drop-off.

*Staff will direct you to the lane for entry. Stay in the lane to which you are you directed.

***NEVER CROSS OR CHANGE LANES WHEN ENTERING AND/OR EXITING CAR POOL.**

***NEVER DROP STUDENTS OFF IN BUS LANE**

No cell phone use during carpool

***RIGHT TURN ONLY TO EXIT after drop-off.**

*Never park in a drop off lane and exit your car *Do not threaten RMCA staff , other drivers or students.

*The City of Colorado Springs & El Paso County Sherriff's Department have approved this traffic plan. Keep our students, faculty, and yourself safe by following all procedures.

Violating any of the carpool rules creates serious safety hazards and drivers who do not comply may have their carpool privileges revoked by administration. These drivers would need to make other arrangements for drop-off.

Be Good to Our Neighbors!

Please note that Antelope Ridge to our east, and Falcon Ridge to our west are PRIVATE PROPERTIES! Do not drive though, park in, or walk through these properties. You will be ticketed or towed.

Our neighbors to the south in Whispering Pines need access to their driveways and streets. We ask that you do not park in front of their homes, block driveways or roadways

if you do not live in the neighborhood and walk to school, please use carpool

Afterschool Carpool Pick-Up

K-4 dismisses at 3:00 pm

Pre-K 3:15 pm,

5th-8th dismiss at 3:30 pm

Parents of 5th-8th & Pre-K grade: Wait until 3:30pm to enter the line. If you arrive before elementary carpool is complete, you will be asked to leave the parking lot and return to the end of the line



Pre-K/Kindle/5th grade

1st/8th Grades

2nd/7th Grades

3rd/4th/6th Grades

All cars EXIT

* If you have a K-4 grade student with a Pre-K sibling, the K-4 student will wait in the Pre-K waiters room from 3 to 3:30, then when called will go out through the gate from Kindie gate. This will mean parents 2 stops in close proximity in the fire lane.

- Display your carpool numbers on the front dashboard of your car.
- K-4 dismiss at 3:00 pm. Older siblings go the youngest sibling's carpool line.
- If you have children in both K-4 and 5-8, the K-4 younger siblings will to their waiters room until the 5th-8th grade sibling picks them up after the 5th-8th grade dismissal at 3:30 pm.
- All siblings go to the youngest 5th-8th grade student's carpool line.

Enter the parking lot from the designated direction as display on the map. In 30 minutes, we safely move and average of 765 cars every day, providing pickup for 1,200 students. Traffic safety is a serious matter, we need YOUR help to ensure the safety of our children's lives.

- Once your children load into your car, wait for Staff to direct you to pull forward. Do not pull around any cars. RMCA reserves the legal right to deny violators the privilege of carpool.
- Only RIGHT TURNS are permitted to exit the parking lot during carpool and only RIGHT TURNS are accepted by the City of Colorado and El Paso Sheriff Department's approved traffic plan.

ONLY STAFF may access the building through the staff doors before and during school. All others must enter through the front entrance near the flagpole for safety purposes.



Parent-Student Handbook

2020 - 2021

Last Update 08-02-19
RMCA Board of Directors

SCHOOL CONTACT INFORMATION

Pre-K-8 CAMPUS
4620 Antelope Ridge
Colorado Springs, CO 80922

PHONE: 719-622-8000
FAX: 719-622-8004

OFFICE HOURS:
Monday – Friday 7:30am – 4:00pm

SCHOOL HOURS:
Full-day kindergarten, first thru fourth grade:
Monday-Friday from 8:00am – 3:00pm

Fifth thru eighth grade:
Monday-Friday from 8:00am – 3:30pm

Homeschool Program Kindergarten – High School

“HOMESCHOOL CAMPUS”
RMCA Home School Program
3525 Akers Drive, Suite 100
Colorado Springs, CO 80922

PHONE: 719-591-5666
FAX: 719-591-5777

SCHOOL HOURS:
Monday-Friday from 8:00am – 3:00pm

OFFICE HOURS:
Monday-Friday from 8:00am – 4:00pm

Website: www.rmcaacs.org

Email: info@rmcaacs.org

following link to D49's website: <http://www.d49.org/sf/feeforservicebus/Pages/default.aspx>.

Carpool and Traffic Safety

Elementary (K-5)

Upon enrollment, you will be given a carpool number. Please display in a visible location on your dashboard during carpool pickup. If you lose your carpool display number, you may obtain another from the front office at your child's campus.

Carpool Procedures (See Appendix C for carpool maps)

RMCA operates two carpools each day, one for morning drop off, and one for afternoon pickup. Our City of Colorado Springs, El Paso County Sheriff's Department, and District Security Resource Officers have approved our traffic plan. Please follow all procedures, because doing so ensures the safest possible movement of over 2,200 people and 860 cars in both daily carpools. **Our traffic flows best when we release blocks of up to ten cars per line.** This sometimes causes short personal delays, but it makes overall carpool time shrink.

Many of the streets off of Antelope Ridge Drive are not public or city streets. Do not park in our bordering neighborhoods and wait for students. Doing so violates privately owned communities, prevents our neighbors from safely navigating to and from home, and potentially disrupts emergency services. Please support RMCA in this process as we strive to be good neighbors.

Violating any of the carpool rules creates serious safety hazards and drivers who do not comply may have their carpool privileges revoked. These drivers will need to make other arrangements for the drop off and pick up of their child.

RMCA operates a staff parking lot. Staff cars have been designated staff parking stickers. Cars not displaying a staff parking sticker and parked in the staff lot may be towed at the vehicle owners expense. Except for AM/PM Kindergarten pick up, please do not park in the carpool lane closest to the school during the school day. This creates a safety hazard for the school. Please utilize the visitor parking at all times.

Morning Carpool Procedures

Starting at 7:30am, staff will open access to the parking lot for student drop-off. Staff will direct you into a lane for entry. Stay in the lane you are directed into.

- Never cross over or change lanes when entering and/or exiting carpool.

- Never drop off students in the bus lane.
- Right turns onto Antelope Ridge only to exit after drop-off.
- No cell phone use.
- Never park in a drop off lane and exit your car.
- Do not engage in conflict with staff or fellow drivers.
- If there is a carpool violation, please refer that to the school administration

Afternoon Carpool Procedures

Only PreK-5th grade students have carpool numbers. Display these on the front dashboard of your car. Kindergarten through 4th grades dismiss at 3:00pm. Older siblings go to youngest sibling’s carpool line. If you have children in both K-4th and 5th-8th, the K-4th younger siblings will wait inside for the 5th-8th grade sibling to pick them up after the 5th-8th sibling dismisses at 3:30 pm. All siblings then go to the youngest 5th-8th grade student’s line.

Enter the parking lot from the designated direction as displayed on the map you receive during the enrollment process.

Kindergarten and 5th use the “yellow” lane that goes behind the school.

1st and 8th graders use the “purple” lane closest to the building.

2nd and 7th graders use the “green” middle lane in front of the building.

3rd, 4th and 6th graders use the “blue” lane closest to the street. Once your children load into your car, wait for Staff to direct you to pull forward. Do not pull around any cars.

RMCA reserves the legal right to deny violators the privilege of carpool.

Only RIGHT TURNS are permitted to exit the parking lot during carpool and right turns only are accepted by the City of Colorado Springs and El Paso Sheriff Department’s approved traffic plan.

Parents of 5th-8th graders: Wait until at least 3:15pm to enter the line. If you arrive before elementary carpool is complete, you will be directed to leave the parking lot and return to the end of the line. This allows elementary parents arriving at the end of elementary carpool to pick up their children without disrupting middle school traffic.

Walkers

K-8 Campus

Your student may not walk home without prior, written notification from a parent or guardian on the family dismissal plan.

Someone Else Picking Up Your

Student(s)