

STORMWATER MANAGEMENT PLAN

For the

a recreational
lifestyle community

WOODMEN HILLS

THERIOT WATER TANK REPLACEMENT

Contractor

Name: TBD
Company: TBD
Address: TBD

Qualified Stormwater Manager

Name: TBD
Company: TBD
Address: TBD

August 2024

Prepared By:



Colorado Springs, CO

5540 Tech Center Dr., Suite 100
Colorado Springs, CO 80919
Phone: 719.227.0072
www.respec.com

Item 1. Add owner & contact
information to cover page.

STORMWATER MANAGEMENT PLAN
Woodmen Hills Metropolitan District
Theriot Water Tank Replacement

TABLE OF CONTENTS

SECTION 1.0 SITE DESCRIPTION

- 1.1 Site Location
- 1.2 Description of Construction
- 1.3 Sequence of Construction Activities
- 1.4 Estimates of Excavation
- 1.5 Drainage Characteristics
- 1.6 Soils Description
- 1.7 Vegetation
- 1.8 Discharge
- 1.9 Receiving Waters

SECTION 2.0 EROSION AND SEDIMENT CONTROLS

- 2.1 Site Location

SECTION 3.0 STORMWATER MANAGEMENT

- 3.1 Qualified Stormwater Manager
- 3.2 Potential Pollutants
- 3.3 Pollutant Prevention Control Measures
- 3.4 Control Measure Selection
- 3.5 Material Handling and Spill Prevention
- 3.6 Final Stabilization and Long-Term Storm Water Management
- 3.7 Inspection and Maintenance
- 3.8 SWMP Availability and Revisions
- 3.9 Non-Stormwater Discharges

APPENDIX A – General Permit Application (to be added to this document)

APPENDIX B – Operation & Maintenance Inspection Records

APPENDIX C – Standard Control Measures/BMP Details

APPENDIX D – Grading & Erosion Control Plan

APPENDIX E – Erosion & Stormwater Quality Control Permit

CONTACT INFORMATION

Owner/Operator Information

Name: Woodmen Hills Metropolitan District
Address: 8046 Eastonville Rd, Peyton, CO 80831
Contact: JD Shivers, Operator in Responsible Charge
Telephone: 719-495-2500

Prepared by

Name: RESPEC, LLC
Address: 5540 Tech Center Dr., Suite 100, Colorado Springs, CO 80919
Contact: Ryan Mangino, P.E.
Telephone: 719-402-0021
Email: ryan.mangino@respec.com

Contractor

Name: TBD
Address: TBD
Contact: TBD
Telephone: TBD

Qualified Stormwater Manager

Name: TBD
Address: TBD
Contact: TBD
Telephone: TBD

1.0 SITE DESCRIPTION

1.1 Site Location

The subject facility is a proposed water storage tank to replace an existing water storage tank and pump station. The facility will serve (and be owned and operated by) the Woodmen Hills Metropolitan District (WHMD, the District). The site is located in the District's boundary, specifically in the northwest quarter of the southeast quarter of Section 36, Township 12 South, Range 65 West of the 6th Principal Meridian, El Paso County, Colorado (El Paso County Parcel #: 5236001016). The one-acre site is located on the northern boundary of the District, with residential lots to the south and west, undeveloped land to the north, and Theriot Road to the east. The vicinity map below shows the site's overall location:



VICINITY MAP

N.T.S.

1.2 Description of Construction

The proposed project includes a 5,630 square-foot concrete water storage tank. Underground utility appurtenances are also included in the excavation for the tank. The tank will have an average height above grade of 28.6 feet, but not exceeding 30.0 feet. Construction will also include some site grading, landscape installation, and revegetation.

1.3 Sequence of Construction Activities

Sequence of activities will be based upon site contractor timing and scheduling. Upon site contractor selection, contractor is to include sequence of activities schedule in the section provided in Appendix B of this report. A standard sequence of events typically includes the following:

Item 6. Update anticipated start/completion dates specific to this project.

Description	Timeframe
• Erosion Control BMP's	November 2024 – May 2025
• Mobilization	November 2024
• Construction Staking	November 2024
• Clearing and Grubbing	November 2024
• Excavation	November 2024 – March 2025
• Buried pipelines/tank installation	December 2024 – April 2025
• Backfill and grading	January – March 2025
• Final grading	April 2025
• Revegetation	April 2025

The anticipated time period for site excavation and grading operations is to start in November 2024 with final site stabilization by late spring 2025. This time schedule could vary depending on construction schedules.

1.4 Estimates of Excavation

The total acreage of disturbed land for the construction of the facilities is approximately 0.8 acres. All disturbance and grading will take place on the site. The total volume of earthwork cut/fill operations is roughly 2,700 cubic yards of export to be replaced with the same amount of structural import, as well as a net cut of the site around 912 cubic yards.

Item 7. Include total site area in addition to estimated disturbance.

1.5 Drainage Characteristics

Existing

Existing drainage sheet-flows to the south and west into existing drainage infrastructure (side-lot ditches and culverts along roadways). There are no existing drainage facilities (storm pipes, inlets, culverts, etc.) on the site.

Proposed

Proposed drainage will generally remain the same as the existing drainage. The additional impermeable area for this project will be offset with permeable pavement, with a greater area of permeable pavement to forgo a detention pond. Currently, no pond exists, and drainage characteristics will be improved by offsetting the proposed impermeable area with an additional area of ~4,500 SF of permeable pavement. A drainage exhibit and calculations are enclosed with this letter.

The same landscaping plan that was approved with the treatment facility constructed in 2023 is proposed for this project as the site and frontage are not changing. As mentioned above, the existing tank and pump station are being replaced with a new tank.

The permeable material will consist of roughly 9,027 square feet of 5-inch-thick gravel and a 1-inch “permeable paver” with 3/8-inch gravel at finished grade. This system will allow storm water to be detained instead of flowing immediately offsite.

Based on information from Volume 3, Chapters 3 and 4 of the *Urban Drainage and Flood Control District (UDFCD) Urban Storm Drainage Criteria Manual (USDCM)*, the following Water Quality Control and Storage Volumes were calculated for this project:

- Required Water Quality Capture Volume (WQCV): **199.4 Cubic Feet**

112.126

This information should be provided in a Drainage Report or Drainage Letter, not the SWMP.

4

This information should be provided in a Drainage Report or Drainage Letter, not the SWMP.

- WQCV Provided: **1,805 Cubic Feet**

(per enclosed calculations – higher of calculations attained from Volume 3 and UDFCD Permeable Pavement System Workbook)

1.6 **Soils Description**

Item 8. Discuss erosion potential of the soils

A field exploration performed by Vivid Engineering Group on May 24, 2023, included drilling five exploratory borings at locations within the proposed tank footprint.

Prior to drilling, the site geology was evaluated by reviewing geologic maps including the Colorado Geological Survey Falcon Quadrangle Geologic Map, El Paso County, Colorado (Morgan & White, 2012). Mapping in the area indicates sandstone of the Dawson Formation at shallow depths in the general area of the proposed water tank. The mapping is generally consistent with our explorations. However, existing fill material or native clayey sand materials were encountered at each of our borings overlying the bedrock.

According to the geotechnical evaluation report dated August 29, 2023, the subsurface conditions consisted of existing fill or native soil material at the ground surface overlying the shallow sandstone bedrock of the Dawson Formation.

Existing Fill

Silty to clayey sand with sandy clay fill was present at the ground surface in three of the five borings and extended to approximately 4.5 to 8 feet below the existing ground surface. The sand fill was brown, dark brown, yellowish-brown and grayish-brown in color, slightly moist to wet, and loose to medium dense in relative density based on field penetration resistance testing.

Sand and Clay

Native clayey sand with sandy lean clay was encountered at the ground surface in boring B-3 and below the existing fill in boring B-5 and extended to depths of approximately 5 and 4.5 feet below the existing ground surface, respectively. The sand was light brown to olive-brown or brown in color, moist, and medium dense to dense in relative density based on field penetration resistance testing. One-dimensional swell/settlement testing performed on a sample of clayey sand resulted in no movement when saturated under a 500 pound per square foot (PSF) surcharge pressure.

Bedrock

Weathered sandstone and formational sandstone and claystone bedrock of the Dawson Formation were encountered in each boring underlying the soils described above and extended to the maximum depth explored. Claystone was encountered in one boring only between the approximate depths of 8 and 12 feet and was observed to be olive-brown to gray in color, moist, and hard based on field penetration resistance testing. The sandstone was uncemented to moderately cemented, olive, light brown, bluish- gray to olive-brown in color, moist to wet, and moderately hard to very hard based on field penetration resistance testing. One-dimensional swell/settlement testing performed on five samples of the bedrock resulted in low compression to low expansion potential of (-1.3 to 0.3%), based on measured test results when saturated under a 1,000 pounds per square foot (PSF) surcharge pressure.

1.7 **Vegetation**

The developed portion of the site was cleared during construction of the existing water tank and pump station, with current vegetation consisting of native grasses, weeds, and some trees. The calculated percent

impervious are for this site is approximately 50%. Prior to disturbance of nearby areas, vegetation of those areas included native grasses and weeds with about 50% vegetation coverage verified by visual inspection.

The extent of disturbed areas shall be re-seeded with El Paso County-approved groundcover/seed mix as specified.

1.8 Discharge

Construction dewatering is not anticipated within the limits of construction. Should it be required, BMPs shall be implemented immediately. In addition, the contractor shall obtain a Construction Dewatering Permit from CDPHE and shall comply with all conditions of that permit.

1.9 Receiving Waters

This area of development (including the subject site) drain into the Black Squirrel Creek basin which ultimately outfalls into the Arkansas River.

There are no streams that cross the project area.

2.0 EROSION AND SEDIMENT CONTROLS

All erosion and sediment control measures will be implemented in a manner that will protect properties and public facilities from the adverse effects of erosion and sedimentation as a result of construction activities. Control measures include any best management practice or other method used to prevent or reduce the discharge of pollutants to state waters. Control measures include, but are not limited to, best management practices. Control measures can include other methods such as the installation, operation, and maintenance of structural controls and treatment devices. In order to prevent an increase in sediment load downstream of the site, control measures will be implemented during the construction life of this project. Silt fencing will be placed in areas shown on the approved grading and erosion control plan. Roadways shall be inspected to ensure that sediment from on-site construction activity is not being discharged with stormwater. A vehicle tracking control pad will be required to aid in minimizing soil tracking onto roadways. All disturbed areas will be reseeded with the specified, County-approved seed mix and watered until a mature stand is established. All disturbed areas will be protected by silt fence, diversion swales, and temporary sediment traps until such time as the site has been re-vegetated. Additional methods will include brooms and shovels to relocate small amounts of soil erosion. There will be no asphalt or concrete batch plants located on the site.

2.1 Site Location

A Grading & Erosion Control (GEC) Plan was prepared and submitted for the proposed construction and should be used in conjunction with the design drawings. Location of erosion control facilities are shown on the plans. The GEC Plan will serve as the SWMP site map. It includes limits of disturbance, flow arrows that depict stormwater flow directions on-site and runoff direction, areas of cut/fill, proposed stockpile areas, proposed material storage areas, proposed waste accumulation areas, concrete washout areas, locations of all structural control measures, locations of all non-structural control measures, locations of streams or drainageways. The GEC Plan will be amended as needed to implement additional control measures over and above those included. All construction control measures/BMP details are included in Appendix E. Further information can be found in the El Paso County DCM, Volume 2 and ECM.

3.0 STORMWATER MANAGEMENT

3.1 Qualified Stormwater Manager

The Qualified Stormwater Manager is an individual knowledgeable in the principles and practices of erosion and sediment control and pollution prevention, and with the skills to assess conditions at construction sites that could impact stormwater quality and to assess the effectiveness of stormwater controls implemented to meet the requirements of the stormwater discharges associated with construction activity permit. A copy of the signed SWMP permit application is included in Appendix A.

3.2 Potential Pollutants

Pollutant sources which shall be evaluated for potential to contribute pollutants to stormwater discharge from the subject site may include the following:

- Disturbed and stored soils
- Vehicle tracking of sediments
- Management of contaminated soils
- Loading and unloading operations
- Outdoor storage activities (building materials, utility piping and appurtenances, chemicals, fertilizer, etc.)
- Vehicle and equipment maintenance and fueling
- Significant dust or particulate generating processes
- Onsite waste management practices (waste piles, liquid wastes, and dumpsters)
- Concrete truck/equipment washing, including the concrete truck chute associated fixtures and equipment
- Non-industrial waste sources such as worker trash and portable toilets
- Other areas or procedures where potential spills can occur

3.3 Pollutant Prevention Control Measures

The following are common practices to mitigate potential pollutants from entering stormwater runoff:

- Wind erosion shall be controlled by spraying site roadways and/or temporary stabilization of material stockpiles. Each dump truck hauling material from the site will be required to be covered with a tarpaulin.
- Snow removal and/or stockpiling will be considered prior to placement at the site. Snow stockpiles must be kept away from any stormwater conveyance system (i.e., inlets, ponds, outfall locations, roadway surfaces, etc.)
- Tracking control must be implemented by the contractor to prevent unnecessary soil from entering paved surfaces. The measures to be used will be preventing equipment in the construction area from moving off-site. A vehicle tracking pad will be required according to El Paso County specifications. Brooms and shovels may be required for tracking control. Note that Arroya Ln. is a gravel road until the intersection with Vollmer Rd.
- Equipment fueling and maintenance shall be performed in a designated fueling area which will be established to contain any spill resulting from fueling, maintenance, or repair of equipment. Contractors will be responsible for containment, cleanup, and disposal of any leak or spill and any costs associated with the cleanup and disposal in accordance with applicable local, county, and state regulations.

This information is not relevant to this project.

- Storage containers, drums, and bags shall be stored away from direct traffic routes to prevent accidental spills. Ensure packages and containers are intact.
- Bulk storage, 55 gallons or greater, for petroleum products and other liquid chemicals must have secondary containment, or equivalent protection, in order to contain spills and prevent spilled material from entering state waters.
- Empty drums shall be covered to prevent collection of precipitation.
- Containers shall be stored on pallets to prevent corrosion of containers, which can result when containers come in contact with moisture on the ground.
- All construction trash and debris will be deposited in an onsite dumpster. All refuse dumpsters and receptacles shall be equipped with functional lids to prevent rain and snow from entering. Lids must be closed when dumpsters and receptacles are not actively in use.
- Regularly scheduled removal of construction trash and debris. Visual inspection of waste bins and leaks will be done multiple times per week by construction staff and District operations staff. Waste disposal bins will be emptied prior to reaching their full capacity.
- Portable restroom facilities will be used by the construction crew during the construction phase. These facilities will be located a minimum of 10 feet from stormwater inlets and 50 feet from State waters and secured at all four corners to prevent overturning. Restroom facilities shall be inspected daily for spills and cleaned on a weekly basis.

The contractor is certainly not limited to these measures which may require adjusting the control measures as the project progresses and implement further controls as prudence and good judgment deem necessary.

3.4 Control Measure Selection

Item 18. A VTC will be required.

All structural and non-structural control measures will be implemented in a manner that will protect properties and public facilities from the adverse effects of erosion, sedimentation, and release of other pollutants as a result of construction activities. Control measures will be implemented in areas shown on the approved grading and erosion control plan. Roadways shall be inspected to ensure that sediment from on-site construction activity is not being discharged with stormwater. Vehicle tracking control pads may be required to aid in minimizing soil tracking onto roadways. All disturbed areas will be reseeded with a native seed mix and watered until a mature stand is established. Soil compaction shall be minimized where final stabilization will be achieved through vegetative cover. All disturbed areas will be protected by silt fence, diversion swales, sediment control logs, inlet protection, and temporary sediment traps until such time as the site has been re-vegetated.

The implemented control measures will need to be modified and maintained regularly to adapt to changing site conditions and to ensure that all potential stormwater pollutants are properly managed. The BMPs and pollutant sources must be reviewed on an ongoing basis.

Item 18. Update discussion to provide narrative description of structural control measures relevant to this project (i.e., CMs shown on GEC plan)

3.5 Material Handling and Spill Prevention

The most probable sources of non-storm water pollution are daily maintenance operations. If mobile fuel trucks are used to service equipment, absorbent materials and containers for the storage of used absorbent material will be nearby. Place debris, overburden, soil stockpiles and waste materials away from areas of runoff.

Practices to reduce the potential for pollution in stormwater runoff from the site must be included in a spill prevention plan to be provided by the contractor. Included in the spill prevention plan shall be:

- Notification procedures to be used in the event of an accident
- Instructions for clean-up procedures and identification of a spill kit location

Item 11. If Spill Prevention & Response Plan is to be provided by the contractor, provide an appendix placeholder for it to be inserted.

Item 22. Temporary stabilization measures must be implemented for earth disturbing activities on any portion of the site where ground disturbing construction activity has permanently ceased, or temporarily ceased for more than 14 calendar days.

- Provisions for adsorbents to be made available for use in fuel areas and for containers to be available for used adsorbents
- Procedures for properly washing out concrete truck chutes and other equipment in a manner and location so that the materials and wash water can not discharge from the site.

3.6 Final Stabilization and Long-Term Storm Water Management

Soil erosion control measures for all slopes, channels, ditches, or any disturbed land area shall be completed within twenty-one (21) calendar days after final grading, or final earth disturbance, has been completed. Disturbed areas and stockpiles which are not at final grade, but will remain dormant for longer than 30 days, shall also be mulched within 21 days after interim grading. An area that is going to remain in an interim state for more than 60 days shall also be seeded. All temporary soil erosion control measures and BMPs shall be maintained until permanent soil erosion control measures are implemented.

Vegetative cover density shall be a minimum of seventy percent (70%) of pre-disturbed levels to be considered stabilized.

This project does not rely on control measures owned or operated by another entity.

It 22. Long-term stormwater quality (i.e., the proposed permeable pavers) should be discussed here

Item 22. Revise to "until final stabilization has been achieved"

3.7 Inspection and Maintenance

A thorough inspection of the storm water management system shall be performed every 14 days as well as within 24-hrs after any precipitation or snowmelt event that causes surface erosion. If any system deficiencies are noted, corrective actions must begin immediately. Documentation of inspection must be available if requested. Areas to be inspected for evidence of, or the potential for, pollutants leaving the construction site boundaries, entering the stormwater drainage system, or discharging to state waters include:

- Construction site perimeter
- All disturbed areas
- Designated haul routes
- Material and waste storage areas exposed to precipitation
- Locations where stormwater has the potential to discharge offsite
- Locations where vehicles exit the site

In addition, implemented control measures shall be inspected to confirm they are in effective operational condition and are adequate to minimize pollutant discharges. These repairs may include, but are not limited to, the following:

- Repairing erosion of side slopes
- Cleaning silt fences whenever sediment has reached a depth of six (6) inches at the fence
- Repairing or replacing broken wooden parts or torn fabric on silt fences
- Removing any accumulated trash or debris

An Operation and Maintenance Inspection Record form is included in Appendix C. The following items must be documented by contractor as part of the site inspections and kept within this report. Completed inspected records shall be kept in Appendix D of this SWMP and kept onsite.

- Inspection date
- Name(s), title(s), and signature(s) of personnel making inspection

- Weather conditions at the time of inspection
- Phase of construction at the time of inspection
- Estimated acreage of disturbance at the time of inspection
- Location(s) of discharges of sediment or other pollutants from site
- Location(s) of control measures that need to be maintained
- Location(s) of control measures that fail to operate as designed or proved inadequate
- Location(s) where additional control measures are needed that were not in place at time of inspection
- Description of the minimum inspection frequency utilized when conducting each inspection
- Deviations from the minimum inspection schedule
- Signed statement of compliance added to the report after corrective action has been implemented

30-day inspections must take place on this site where construction activity is complete, but vegetative cover is still being established.

3.8 SWMP Availability and Revisions

A copy (electronic or hardcopy) of this SWMP is to be retained onsite or be onsite when construction activities are occurring at the site unless another location is approved by the Division. Records of the SWMP changes made that includes the date and identification of the changes must be kept at the site within this report. The SWMP should be viewed as a “living document” throughout the lifetime of the project. This SWMP shall be revised by informing Engineer of deviations to original plan. Engineer will then update this report and all applicable drawings, forms, tables, etc. as deemed necessary.

Revisions to the SWMP are required when the following occurs:

- A change in design, construction, operation, or maintenance of the site requiring implementation of new or revised control measures
- The SWMP proves ineffective in controlling pollutants in stormwater runoff in compliance with the permit conditions
- Control measures identified in the SWMP are no longer necessary and are removed
- Corrective actions are taken onsite that result in a change to the SWMP

The provisions of the SWMP as written and updated must be implemented from commencement of construction activity until final stabilization is complete.

3.9 Non-Stormwater Discharges

This permit covers stormwater discharges from construction activity and does not include the following: uncontaminated springs, concrete washout water, or landscape irrigation return flow. Discharges resulting from emergency firefighting activities are authorized by this permit.

Item 14. Discharge of concrete wash water to ground (e.g. a concrete washout area) is an allowable non-stormwater discharge per the COR400000 Permit if properly identified in the SWMP and if the appropriate control measures are implemented. Revise discussion. Reference COR400000 Part I.A.1.b.ii for more information if needed.

***APPENDIX A – General Permit Application
(to be added to this document)***

APPENDIX B – Operation & Maintenance Inspection Records

CONSTRUCTION STORMWATER SITE INSPECTION REPORT

Facility Name		Permittee					
Date of Inspection		Weather Conditions					
Permit Certification #		Disturbed Acreage					
Phase of Construction		Inspector Title					
Inspector Name							
Is the above inspector a qualified stormwater manager? (permittee is responsible for ensuring that the inspector is a qualified stormwater manager)			<table border="1" style="width: 100%; border-collapse: collapse;"> <tr> <td style="width: 50%; text-align: center;">YES</td> <td style="width: 50%; text-align: center;">NO</td> </tr> <tr> <td style="text-align: center;"><input type="checkbox"/></td> <td style="text-align: center;"><input type="checkbox"/></td> </tr> </table>	YES	NO	<input type="checkbox"/>	<input type="checkbox"/>
YES	NO						
<input type="checkbox"/>	<input type="checkbox"/>						

INSPECTION FREQUENCY					
Check the box that describes the minimum inspection frequency utilized when conducting each inspection					
At least one inspection every 7 calendar days	<input type="checkbox"/>				
At least one inspection every 14 calendar days, with post-storm event inspections conducted within 24 hours after the end of any precipitation or snowmelt event that causes surface erosions	<input type="checkbox"/>				
<ul style="list-style-type: none"> • This is this a post-storm event inspection. Event Date: _____ 	<input type="checkbox"/>				
Reduced inspection frequency - Include site conditions that warrant reduced inspection frequency	<input type="checkbox"/>				
<ul style="list-style-type: none"> • Post-storm inspections at temporarily idle sites 	<input type="checkbox"/>				
<ul style="list-style-type: none"> • Inspections at completed sites/area 	<input type="checkbox"/>				
<ul style="list-style-type: none"> • Winter conditions exclusion 	<input type="checkbox"/>				
Have there been any deviations from the minimum inspection schedule? If yes, describe below.	<table border="1" style="width: 100%; border-collapse: collapse;"> <tr> <td style="width: 50%; text-align: center;">YES</td> <td style="width: 50%; text-align: center;">NO</td> </tr> <tr> <td style="text-align: center;"><input type="checkbox"/></td> <td style="text-align: center;"><input type="checkbox"/></td> </tr> </table>	YES	NO	<input type="checkbox"/>	<input type="checkbox"/>
YES	NO				
<input type="checkbox"/>	<input type="checkbox"/>				

INSPECTION REQUIREMENTS*
i. Visually verify all implemented control measures are in effective operational condition and are working as designed in the specifications
ii. Determine if there are new potential sources of pollutants
iii. Assess the adequacy of control measures at the site to identify areas requiring new or modified control measures to minimize pollutant discharges
iv. Identify all areas of non-compliance with the permit requirements, and if necessary, implement corrective action
*Use the attached Control Measures Requiring Routine Maintenance and Inadequate Control Measures Requiring Corrective Action forms to document results of this assessment that trigger either maintenance or corrective actions

AREAS TO BE INSPECTED			
Is there evidence of, or the potential for, pollutants leaving the construction site boundaries, entering the stormwater drainage system or discharging to state waters at the following locations?			
	NO	YES	If "YES" describe discharge or potential for discharge below. Document related maintenance, inadequate control measures and corrective actions Inadequate Control Measures Requiring Corrective Action form
Construction site perimeter	<input type="checkbox"/>	<input type="checkbox"/>	
All disturbed areas	<input type="checkbox"/>	<input type="checkbox"/>	
Designated haul routes	<input type="checkbox"/>	<input type="checkbox"/>	
Material and waste storage areas exposed to precipitation	<input type="checkbox"/>	<input type="checkbox"/>	
Locations where stormwater has the potential to discharge offsite	<input type="checkbox"/>	<input type="checkbox"/>	
Locations where vehicles exit the site	<input type="checkbox"/>	<input type="checkbox"/>	
Other: _____	<input type="checkbox"/>	<input type="checkbox"/>	

REPORTING REQUIREMENTS

The permittee shall report the following circumstances orally within twenty-four (24) hours from the time the permittee becomes aware of the circumstances, and shall mail to the division a written report containing the information requested within five (5) working days after becoming aware of the following circumstances. The division may waive the written report required if the oral report has been received within 24 hours.

All Noncompliance Requiring 24-Hour Notification per Part II.L.6 of the Permit		
a. Endangerment to Health or the Environment Circumstances leading to any noncompliance which may endanger health or the environment regardless of the cause of the incident (See Part II.L.6.a of the Permit) <i>This category would primarily result from the discharge of pollutants in violation of the permit</i>		
b. Numeric Effluent Limit Violations <ul style="list-style-type: none"> o Circumstances leading to any unanticipated bypass which exceeds any effluent limitations (See Part II.L.6.b of the Permit) o Circumstances leading to any upset which causes an exceedance of any effluent limitation (See Part II.L.6.c of the Permit) o Daily maximum violations (See Part II.L.6.d of the Permit) <i>Numeric effluent limits are very uncommon in certifications under the COR400000 general permit. This category of noncompliance only applies if numeric effluent limits are included in a permit certification.</i>		

Has there been an incident of noncompliance requiring 24-hour notification?	NO	YES	
	<input type="checkbox"/>	<input type="checkbox"/>	If "YES" document below

Date and Time of Incident	Location	Description of Noncompliance	Description of Corrective Action	Date and Time of 24 Hour Oral Notification	Date of 5 Day Written Notification *

*Attach copy of 5 day written notification to report. Indicate if written notification was waived, including the name of the division personnel who granted waiver.

After adequate corrective action(s) and maintenance have been taken, or where a report does not identify any incidents requiring corrective action or maintenance, the individual(s) designated as the Qualified Stormwater Manager, shall sign and certify the below statement:

"I verify that, to the best of my knowledge and belief, all corrective action and maintenance items identified during the inspection are complete, and the site is currently in compliance with the permit."

Name of Qualified Stormwater Manager

Title of Qualified Stormwater Manager

Signature of Qualified Stormwater Manager

Date

Notes/Comments

APPENDIX C – Standard Control Measures/BMP Details

Erosion Control Blankets

What it is

Erosion control blankets are geotextiles or filter fabrics that are used to stabilize soils, steep slopes and drainage channels.

TYPES OF EROSION CONTROL BLANKETS

- WOVEN OR BONDED SYNTHETIC MATERIALS SUCH AS POLYPROPYLENE, POLYESTER, POLYETHYLENE, NYLON, POLYVINYL CHLORIDE, GLASS AND VARIOUS MIXTURES OF THESE.
- MULCH MATTING MADE FROM JUTE OR OTHER WOOD FIBER THAT HAS BEEN FORMED INTO SHEETS.
- NETTING MADE FROM JUTE OR OTHER WOOD FIBER, PLASTIC, PAPER, OR COTTON USED TO HOLD MULCH AND MATTING TO THE GROUND.
- BLANKETS OF WOVEN STRAW MULCH WITH A SYNTHETIC LAYER OR NET.



When and Where to use it

- In temporary and permanent swales.
- To protect recently seeded slopes.
- In drainageway channels.

When and Where NOT to use it

- In swales with slopes greater than 5 percent or with stormwater velocities > 8 feet per second.

Installation and Maintenance Requirements

Installation requirements are provided in Figures ECB-1 and ECB-2.

Maintenance requirements include regular inspections to determine if fabric is damaged or has come loose, and appropriate repairs or replacement of damaged materials.

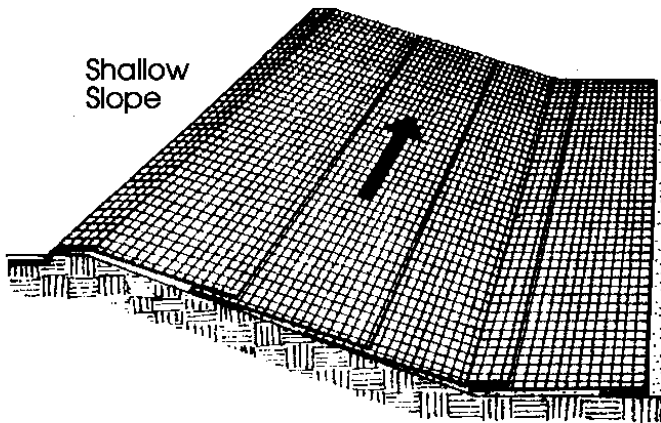

Shallow Slope

On shallow slopes, strips of netting may be applied across the slope.

Where there is a berm at the top of the slope, bring the netting over the berm and anchor it behind the berm.

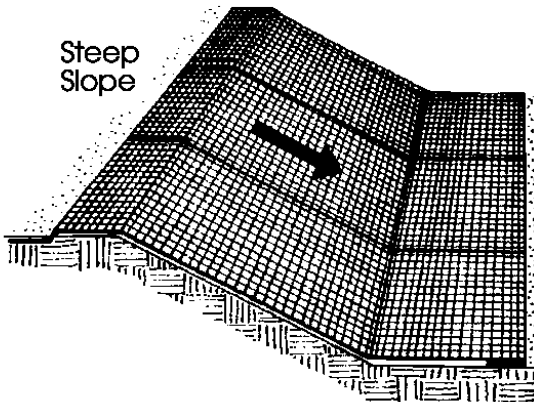

Steep Slope

On steep slopes, apply strips of netting parallel to the direction of flow and anchor securely.

Bring netting down to a level area before terminating the installation. Turn the end under 6" and staple at 12" intervals.

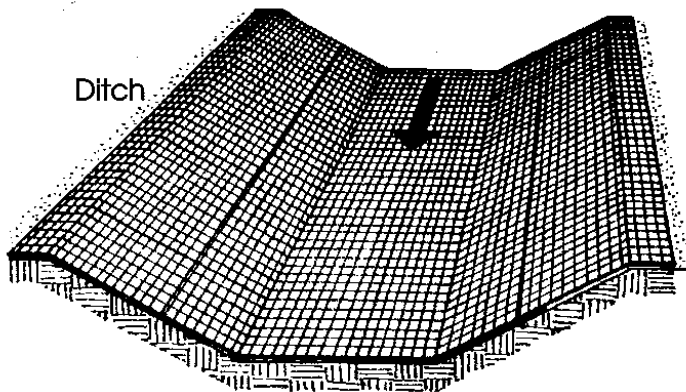
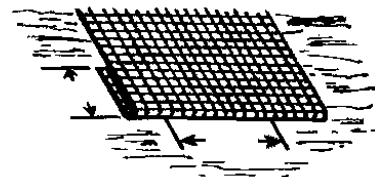

Ditch

In ditches, apply netting parallel to the direction of flow. Use check slots every 15 feet. Do not join strips in the center of the ditch.

From: Virginia Soil and Water Conservation Commission, 1985

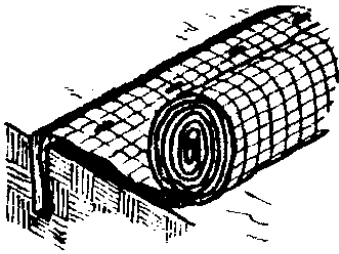

Anchor Slot: Bury the up-channel end of the net in a 6" deep trench. Tamp the soil firmly. Staple at 12" intervals across the net.

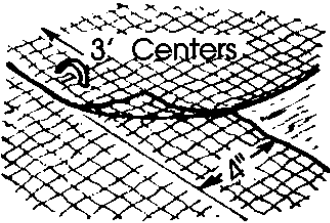

Overlap: Overlap edges of the strips at least 4". Staple every 3 feet down the center of the strip.

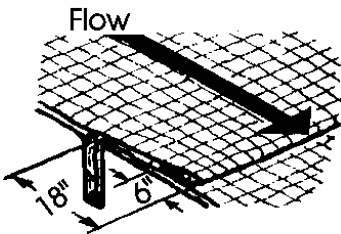
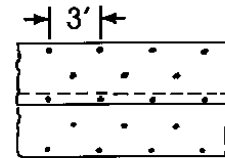

Joining Strips: Insert the new roll of net in a trench, as with the Anchor Slot. Overlap the up-channel end of the previous roll 18" and turn the end under 6". Staple the end of the previous roll just below the anchor slot and at the end at 12" intervals.

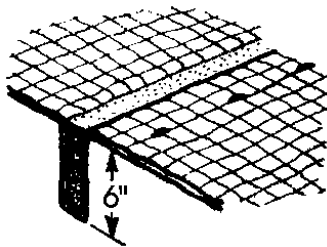

Check Slots: On erodible soils or steep slopes, check slots should be made every 15 feet. Insert a fold of the net into a 6" trench and tamp firmly. Staple at 12" intervals across the net. Lay the net smoothly on the surface of the soil - do not stretch the net, and do not allow wrinkles.

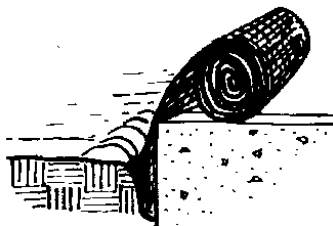

Anchoring Ends At Structures: Place the end of the net in a 6" slot on the up-channel side of the structure. Fill the trench and tamp firmly. Roll the net up the channel. Place staples at 12" intervals along the anchor end of the net.

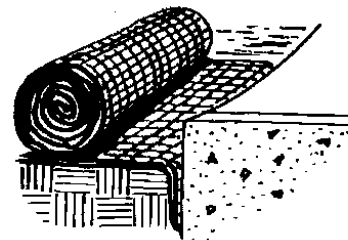

From: Virginia Soil and Water Conservation Commission, 1985

City of Colorado Springs
Storm Water Quality

Figure ECB-2
Erosion Control Blanket
Installation Requirements

Silt Fence

What it is

A silt fence is a temporary sediment barrier constructed of filter fabric stretched across supporting posts. The bottom edge of the fabric is entrenched and covered with backfill.



When and Where to use it

- On the down gradient perimeters of a construction site.
- On a contour to control overland sheet flow.
- At the top or toe of a steep slope.
- As a form of inlet protection (see inlet protection factsheet).

Figure SF-1 depicts five cases where the use of silt fence is appropriate.

When and Where NOT to use it

- In areas of concentrated flows such as in ditches, swales or channels that drain areas greater than 1.0 acre.
- At the top of a slope or at high points which do not receive any drainage flows.



This photo reveals a silt fence that has become unentrenched because it was not securely installed.



This photo illustrates what will happen to a silt fence if it is installed in an area of concentrated flow.

Construction Detail and Maintenance Requirements

Figure SF-2 provides a construction detail and maintenance requirements for a silt fence.

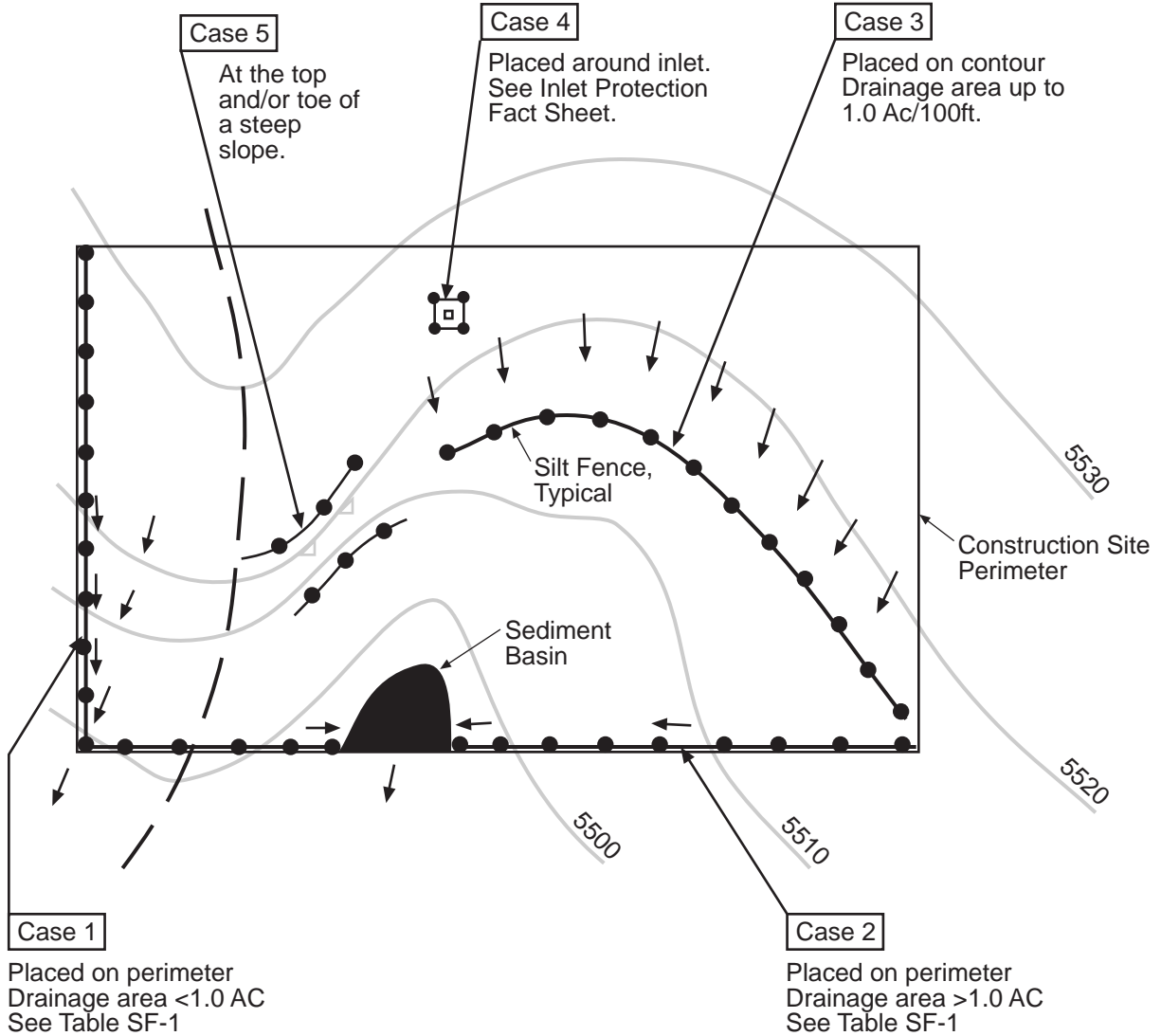

Table SF-1

Silt Fence Used as Perimeter Control	Case 1		Case 2 DA > 1.0 AC
	DA < 0.25 AC	0.25 < DA < 1 AC	
Continuous Grade	OK ⁽¹⁾	OK ⁽¹⁾	OK ⁽¹⁾
Area of Concentrated Flow	OK	NO ⁽²⁾	NO ⁽³⁾

(1) Temporary Swale or Straw Bale Barrier may be used as alternative to a Silt Fence.

(2) Check Dam may also be used as alternative to Silt Fence at low point.

(3) Sediment Basin is required for concentrated flow from drainage areas > 1.0 AC.

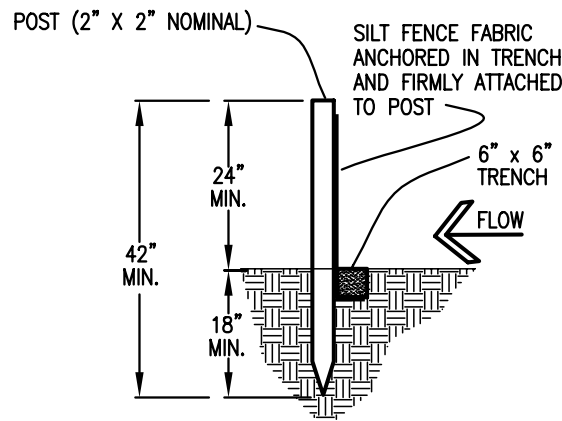
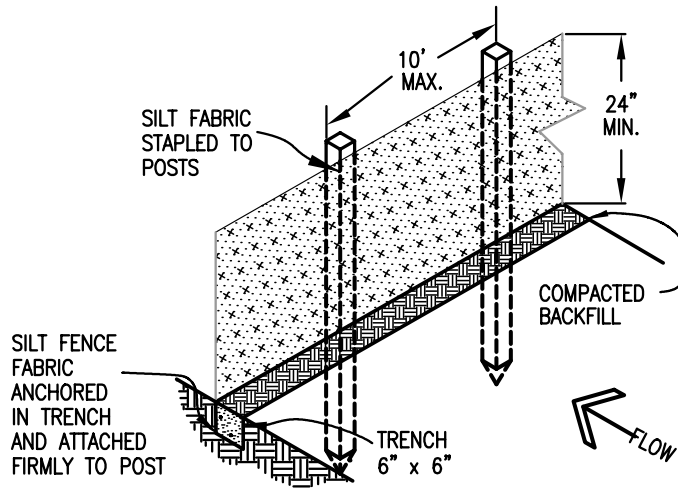

SILT FENCE

SILT FENCE NOTES

INSTALLATION REQUIREMENTS

1. SILT FENCES SHALL BE INSTALLED PRIOR TO ANY LAND DISTURBING ACTIVITIES.
2. WHEN JOINTS ARE NECESSARY, SILT FENCE GEOTEXTILE SHALL BE SPLICED TOGETHER ONLY AT SUPPORT POST AND SECURELY SEALED.
3. METAL POSTS SHALL BE "STUDDED TEE" OR "U" TYPE WITH MINIMUM WEIGHT OF 1.33 POUNDS PER LINEAR FOOT. WOOD POSTS SHALL HAVE A MINIMUM DIAMETER OR CROSS SECTION DIMENSION OF 2 INCHES.
4. THE FILTER MATERIAL SHALL BE FASTENED SECURELY TO METAL OR WOOD POSTS USING WIRE TIES, OR TO WOOD POSTS WITH 3/4" LONG #9 HEAVY-DUTY STAPLES. THE SILT FENCE GEOTEXTILE SHALL NOT BE STAPLED TO EXISTING TREES.
5. WHILE NOT REQUIRED, WIRE MESH FENCE MAY BE USED TO SUPPORT THE GEOTEXTILE. WIRE FENCE SHALL BE FASTENED SECURELY TO THE UPSLOPE SIDE OF THE POSTS USING HEAVY-DUTY WIRE STAPLES AT LEAST 3/4" LONG, TIE WIRES OR HOG RINGS. THE WIRE SHALL EXTEND INTO THE TRENCH A MINIMUM OF 6" AND SHALL NOT EXTEND MORE THAN 3' ABOVE THE ORIGINAL GROUND SURFACE.

6. ALONG THE TOE OF FILLS, INSTALL THE SILT FENCE ALONG A LEVEL CONTOUR AND PROVIDE AN AREA BEHIND THE FENCE FOR RUNOFF TO POND AND SEDIMENT TO SETTLE. A MINIMUM DISTANCE OF 5 FEET FROM THE TOE OF THE FILL IS RECOMMENDED.
7. THE HEIGHT OF THE SILT FENCE FROM THE GROUND SURFACE SHALL BE MINIMUM OF 24 INCHES AND SHALL NOT EXCEED 36 INCHES; HIGHER FENCES MAY INPOUND VOLUMES OF WATER SUFFICIENT TO CAUSE FAILURE OF THE STRUCTURE.

MAINTENANCE REQUIREMENTS

1. CONTRACTOR SHALL INSPECT SILT FENCES IMMEDIATELY AFTER EACH RAINFALL, AT LEAST DAILY DURING PROLONGED RAINFALL, AND WEEKLY DURING PERIODS OF NO RAINFALL. DAMAGED, COLLAPSED, UNENTRENCHED OR INEFFECTIVE SILT FENCES SHALL BE PROMPTLY REPAIRED OR REPLACED.
2. SEDIMENT SHALL BE REMOVED FROM BEHIND SILT FENCE WHEN IT ACCUMULATES TO HALF THE EXPOSED GEOTEXTILE HEIGHT.
3. SILT FENCES SHALL BE REMOVED WHEN ADEQUATE VEGETATIVE COVER IS ATTAINED AS APPROVED BY THE CITY.

Top View of Silt Fence Posts Detail

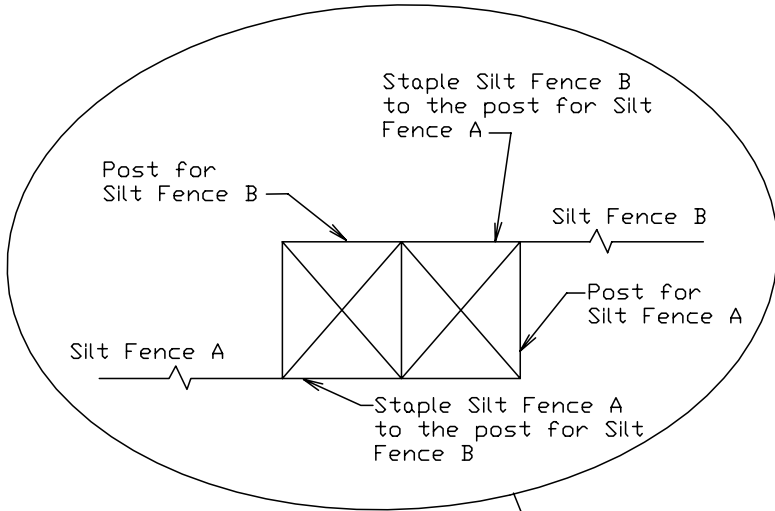

Refer to "Top View of Silt Fence Posts Detail"

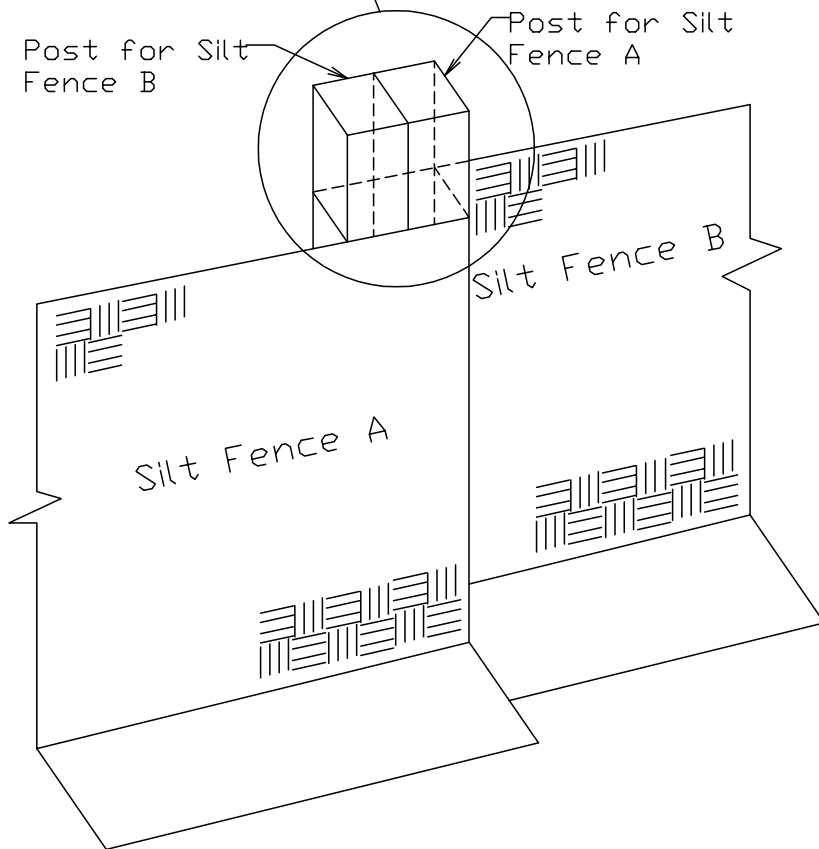

Vehicle Tracking

What it is

Vehicle tracking refers to the stabilization of construction entrances, roads, parking areas, and staging areas to prevent the tracking of sediment from the construction site.



When and Where to use it

- All points where vehicles exit the construction site onto a public road.
- Construction entrance/exit should be located at permanent access locations if at all possible.
- Construction roads and parking areas.
- Loading and unloading areas.
- Storage and staging areas.
- Where trailers are parked.
- Any construction area that receives high vehicular traffic.

When and Where NOT to use it

- The vehicle tracking area should not be located in areas that are wet or where soils erode easily.



This picture shows an unstabilized entrance where dirt is being tracked onto a public road.

Construction Details and Maintenance Requirements

Figure VT-1 and VT-2 provide construction details and maintenance requirements for vehicle tracking.

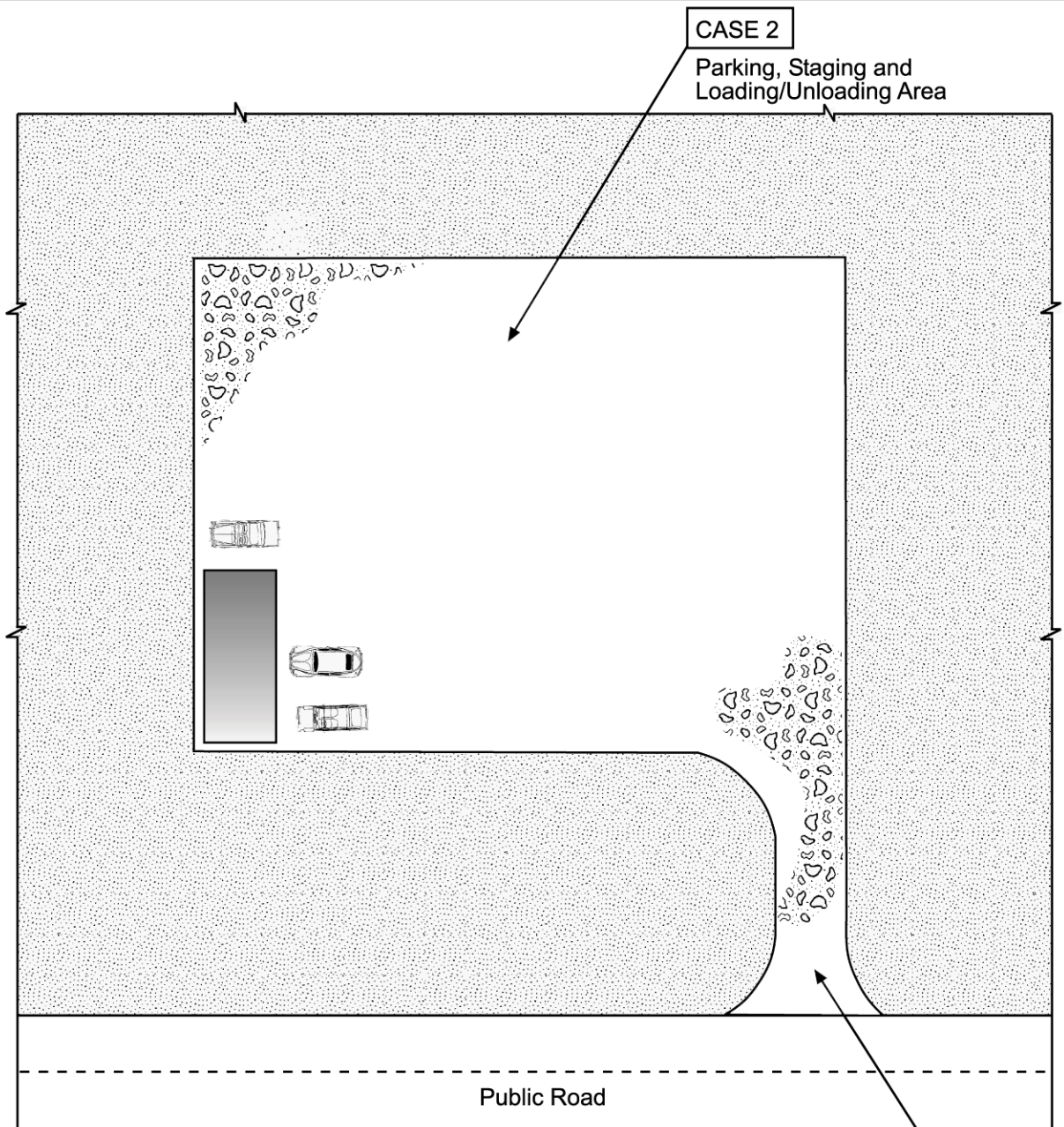
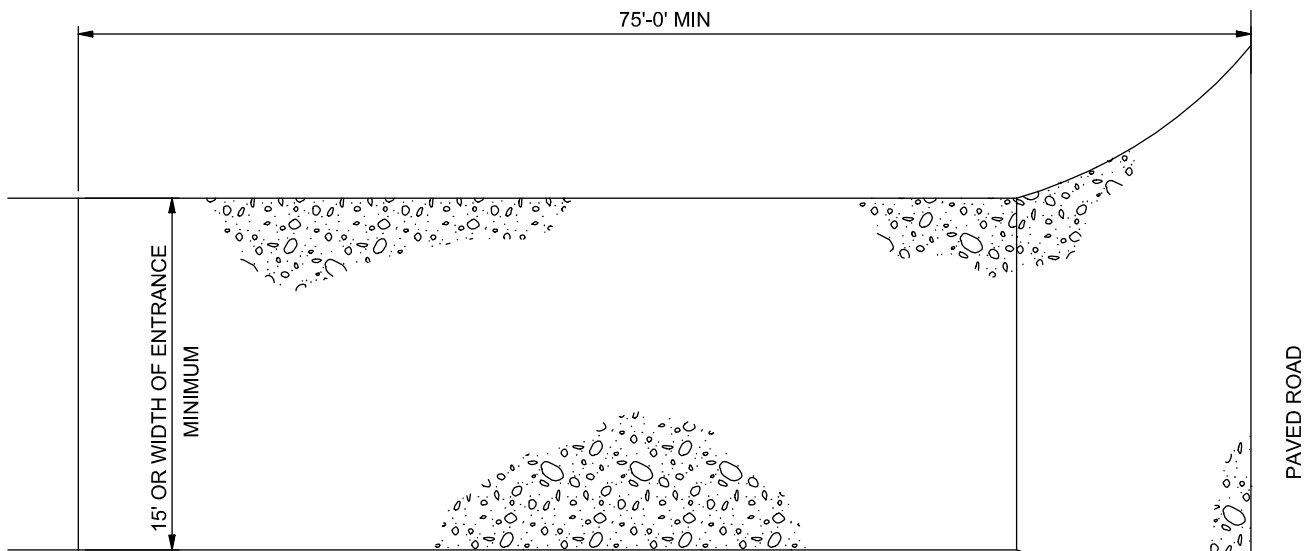
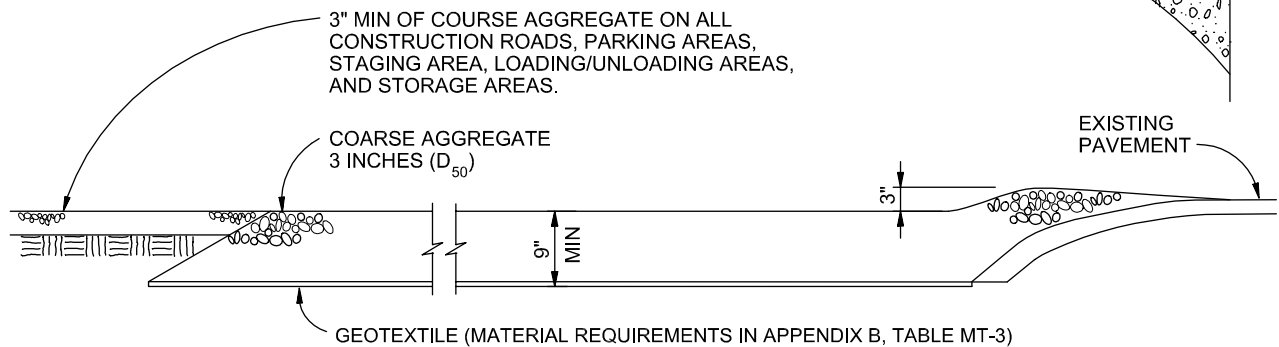

Table VT-1

	Case 1	Case 2
Gravel Thickness	9"	3"
Filter Fabric	YES	NO



PLAN



SECTION

VEHICLE TRACKING

NTS

VEHICLE TRACKING NOTES

INSTALLATION REQUIREMENTS

1. ALL ENTRANCES TO THE CONSTRUCTION SITE ARE TO BE STABILIZED PRIOR TO CONSTRUCTION BEGINNING.
2. CONSTRUCTION ENTRANCES ARE TO BE BUILT WITH AN APRON TO ALLOW FOR TURNING TRAFFIC, BUT SHOULD NOT BE BUILT OVER EXISTING PAVEMENT EXCEPT FOR A SLIGHT OVERLAP.
3. AREAS TO BE STABILIZED ARE TO BE PROPERLY GRADED AND COMPACTED PRIOR TO LAYING DOWN GEOTEXTILE AND STONE.
4. CONSTRUCTION ROADS, PARKING AREAS, LOADING/UNLOADING ZONES, STORAGE AREAS, AND STAGING AREAS ARE TO BE STABILIZED.
5. CONSTRUCTION ROADS ARE TO BE BUILT TO CONFORM TO SITE GRADES, BUT SHOULD NOT HAVE SIDE SLOPES OR ROAD GRADES THAT ARE EXCESSIVELY STEEP.

MAINTENANCE REQUIREMENTS

1. REGULAR INSPECTIONS ARE TO BE MADE OF ALL STABILIZED AREAS, ESPECIALLY AFTER STORM EVENTS.
2. STONES ARE TO BE REAPPLIED PERIODICALLY AND WHEN REPAIR IS NECESSARY.
3. SEDIMENT TRACKED ONTO PAVED ROADS IS TO BE REMOVED DAILY BY SHOVELING OR SWEEPING. SEDIMENT IS NOT TO BE WASHED DOWN STORM SEWER DRAINS.
4. STORM SEWER INLET PROTECTION IS TO BE IN PLACE, INSPECTED, AND CLEANED IF NECESSARY.
5. OTHER ASSOCIATED SEDIMENT CONTROL MEASURES ARE TO BE INSPECTED TO ENSURE GOOD WORKING CONDITION.

City of Colorado Springs
Stormwater Quality

Figure VT-2
Vehicle Tracking

Application Examples

Description

Concrete waste management involves designating and properly managing a specific area of the construction site as a concrete washout area. A concrete washout area can be created using one of several approaches designed to receive wash water from washing of tools and concrete mixer chutes, liquid concrete waste from dump trucks, mobile batch mixers, or pump trucks. Three basic approaches are available: excavation of a pit in the ground, use of an above ground storage area, or use of prefabricated haul-away concrete washout containers. Surface discharges of concrete washout water from construction sites are prohibited.



Photograph CWA-1. Example of concrete washout area. Note gravel tracking pad for access and sign.

Appropriate Uses

Concrete washout areas must be designated on all sites that will generate concrete wash water or liquid concrete waste from onsite concrete mixing or concrete delivery.

Because pH is a pollutant of concern for washout activities, when unlined pits are used for concrete washout, the soil must have adequate buffering capacity to result in protection of state groundwater standards; otherwise, a liner/containment must be used. The following management practices are recommended to prevent an impact from unlined pits to groundwater:

- The use of the washout site should be temporary (less than 1 year), and
- The washout site should be not be located in an area where shallow groundwater may be present, such as near natural drainages, springs, or wetlands.

Design and Installation

Concrete washout activities must be conducted in a manner that does not contribute pollutants to surface waters or stormwater runoff. Concrete washout areas may be lined or unlined excavated pits in the ground, commercially manufactured prefabricated washout containers, or aboveground holding areas constructed of berms, sandbags or straw bales with a plastic liner.

Although unlined washout areas may be used, lined pits may be required to protect groundwater under certain conditions.

Do not locate an unlined washout area within 400 feet of any natural drainage pathway or waterbody or within 1,000 feet of any wells or drinking water sources. Even for lined concrete washouts, it is advisable to locate the facility away from waterbodies and drainage paths. If site constraints make these

Concrete Washout Area	
Functions	
Erosion Control	No
Sediment Control	No
Site/Material Management	Yes

setbacks infeasible or if highly permeable soils exist in the area, then the pit must be installed with an impermeable liner (16 mil minimum thickness) or surface storage alternatives using prefabricated concrete washout devices or a lined aboveground storage area should be used.

Design details with notes are provided in Detail CWA-1 for pits and CWA-2 for aboveground storage areas. Pre-fabricated concrete washout container information can be obtained from vendors.

Maintenance and Removal

A key consideration for concrete washout areas is to ensure that adequate signage is in place identifying the location of the washout area. Part of inspecting and maintaining washout areas is ensuring that adequate signage is provided and in good repair and that the washout area is being used, as opposed to washout in non-designated areas of the site.

Remove concrete waste in the washout area, as needed to maintain BMP function (typically when filled to about two-thirds of its capacity). Collect concrete waste and deliver offsite to a designated disposal location.

Upon termination of use of the washout site, accumulated solid waste, including concrete waste and any contaminated soils, must be removed from the site to prevent on-site disposal of solid waste. If the wash water is allowed to evaporate and the concrete hardens, it may be recycled.



Photograph CWA-2. Prefabricated concrete washout. Photo courtesy of CDOT.



Photograph CWA-3. Earthen concrete washout. Photo courtesy of CDOT.

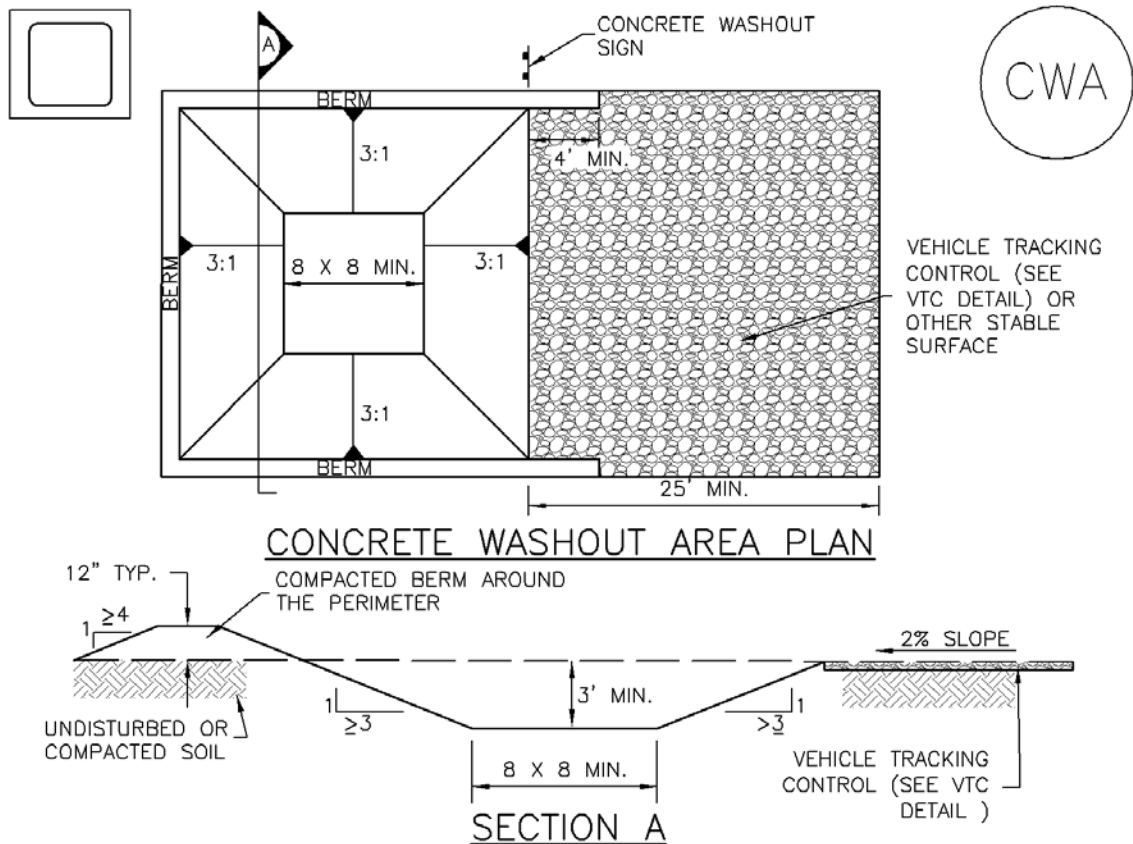

CWA-1. CONCRETE WASHOUT AREA

CWA INSTALLATION NOTES

1. SEE PLAN VIEW FOR:
-CWA INSTALLATION LOCATION.
2. DO NOT LOCATE AN UNLINED CWA WITHIN 400' OF ANY NATURAL DRAINAGE PATHWAY OR WATERBODY. DO NOT LOCATE WITHIN 1,000' OF ANY WELLS OR DRINKING WATER SOURCES. IF SITE CONSTRAINTS MAKE THIS INFEASIBLE, OR IF HIGHLY PERMEABLE SOILS EXIST ON SITE, THE CWA MUST BE INSTALLED WITH AN IMPERMEABLE LINER (16 MIL MIN. THICKNESS) OR SURFACE STORAGE ALTERNATIVES USING PREFABRICATED CONCRETE WASHOUT DEVICES OR A LINED ABOVE GROUND STORAGE ARE SHOULD BE USED.
3. THE CWA SHALL BE INSTALLED PRIOR TO CONCRETE PLACEMENT ON SITE.
4. CWA SHALL INCLUDE A FLAT SUBSURFACE PIT THAT IS AT LEAST 8' BY 8' SLOPES LEADING OUT OF THE SUBSURFACE PIT SHALL BE 3:1 OR FLATTER. THE PIT SHALL BE AT LEAST 3' DEEP.
5. BERM SURROUNDING SIDES AND BACK OF THE CWA SHALL HAVE MINIMUM HEIGHT OF 1'.
6. VEHICLE TRACKING PAD SHALL BE SLOPED 2% TOWARDS THE CWA.
7. SIGNS SHALL BE PLACED AT THE CONSTRUCTION ENTRANCE, AT THE CWA, AND ELSEWHERE AS NECESSARY TO CLEARLY INDICATE THE LOCATION OF THE CWA TO OPERATORS OF CONCRETE TRUCKS AND PUMP RIGS.
8. USE EXCAVATED MATERIAL FOR PERIMETER BERM CONSTRUCTION.

CWA MAINTENANCE NOTES

1. INSPECT BMPs EACH WORKDAY, AND MAINTAIN THEM IN EFFECTIVE OPERATING CONDITION. MAINTENANCE OF BMPs SHOULD BE PROACTIVE, NOT REACTIVE. INSPECT BMPs AS SOON AS POSSIBLE (AND ALWAYS WITHIN 24 HOURS) FOLLOWING A STORM THAT CAUSES SURFACE EROSION, AND PERFORM NECESSARY MAINTENANCE.

2. FREQUENT OBSERVATIONS AND MAINTENANCE ARE NECESSARY TO MAINTAIN BMPs IN EFFECTIVE OPERATING CONDITION. INSPECTIONS AND CORRECTIVE MEASURES SHOULD BE DOCUMENTED THOROUGHLY.

3. WHERE BMPs HAVE FAILED, REPAIR OR REPLACEMENT SHOULD BE INITIATED UPON DISCOVERY OF THE FAILURE.

4. THE CWA SHALL BE REPAIRED, CLEANED, OR ENLARGED AS NECESSARY TO MAINTAIN CAPACITY FOR CONCRETE WASTE. CONCRETE MATERIALS, ACCUMULATED IN PIT, SHALL BE REMOVED ONCE THE MATERIALS HAVE REACHED A DEPTH OF 2'.

5. CONCRETE WASHOUT WATER, WASTED PIECES OF CONCRETE AND ALL OTHER DEBRIS IN THE SUBSURFACE PIT SHALL BE TRANSPORTED FROM THE JOB SITE IN A WATER-TIGHT CONTAINER AND DISPOSED OF PROPERLY.

6. THE CWA SHALL REMAIN IN PLACE UNTIL ALL CONCRETE FOR THE PROJECT IS PLACED.

7. WHEN THE CWA IS REMOVED, COVER THE DISTURBED AREA WITH TOP SOIL, SEED AND MULCH OR OTHERWISE STABILIZED IN A MANNER APPROVED BY THE LOCAL JURISDICTION.

(DETAIL ADAPTED FROM DOUGLAS COUNTY, COLORADO AND THE CITY OF PARKER, COLORADO, NOT AVAILABLE IN AUTOCAD).

NOTE: MANY JURISDICTIONS HAVE BMP DETAILS THAT VARY FROM UDFCD STANDARD DETAILS. CONSULT WITH LOCAL JURISDICTIONS AS TO WHICH DETAIL SHOULD BE USED WHEN DIFFERENCES ARE NOTED.

APPENDIX D – Grading & Erosion Control Plan

2024/08/21 2:38 PM By: Ryan Mangino N:\Projects\112.126. Theriot Concrete Tank Drawings\Design\112.126_1_Civil_RMM.dwg IF BAR DOES NOT MEASURE ONE INCH, SCALE OF THIS DRAWING HAS BEEN ALTERED 1'

EROSION CONTROL NOTES:

- 1. STORMWATER DISCHARGES FROM CONSTRUCTION SITES SHALL NOT CAUSE OR THREATEN TO CAUSE POLLUTION, CONTAMINATION, OR DEGRADATION OF STATE WATERS. ALL WORK AND EARTH DISTURBANCE SHALL BE DONE IN A MANNER THAT MINIMIZES POLLUTION OF ANY ON-SITE OR OFF-SITE WATERS, INCLUDING WETLANDS.
2. NOTWITHSTANDING ANYTHING DEPICTED IN THESE PLANS IN WORDS OR GRAPHIC REPRESENTATION, ALL DESIGN AND CONSTRUCTION RELATED TO ROADS, STORM DRAINAGE, AND EROSION CONTROL SHALL CONFORM TO THE STANDARDS AND REQUIREMENTS OF THE MOST RECENT VERSION OF THE RELEVANT ADOPTED EL PASO COUNTY STANDARDS, INCLUDING THE LAND DEVELOPMENT CODE, THE ENGINEERING CRITERIA MANUAL, THE DRAINAGE CRITERIA MANUAL, AND THE DRAINAGE CRITERIA MANUAL VOLUME 2. ANY DEVIATIONS FROM REGULATIONS AND STANDARDS MUST BE REQUESTED, AND APPROVED, IN WRITING.
3. A SEPARATE STORMWATER MANAGEMENT PLAN (SWMP) FOR THIS PROJECT SHALL BE COMPLETED AND AN EROSION AND STORMWATER QUALITY CONTROL PERMIT (ESQCP) ISSUED PRIOR TO COMMENCING CONSTRUCTION. MANAGEMENT OF THE SWMP DURING CONSTRUCTION IS THE RESPONSIBILITY OF THE DESIGNATED QUALIFIED STORMWATER MANAGER OR CERTIFIED EROSION CONTROL INSPECTOR. THE SWMP SHALL BE LOCATED ON SITE AT ALL TIMES DURING CONSTRUCTION AND SHALL BE KEPT UP TO DATE WITH WORK PROGRESS AND CHANGES IN THE FIELD.
4. ONCE THE ESQCP IS APPROVED AND A "NOTICE TO PROCEED" HAS BEEN ISSUED, THE CONTRACTOR MAY INSTALL THE INITIAL STAGE EROSION AND SEDIMENT CONTROL MEASURES AS INDICATED ON THE APPROVED GEC. A PRECONSTRUCTION MEETING BETWEEN THE CONTRACTOR, ENGINEER, AND EL PASO COUNTY WILL BE HELD PRIOR TO ANY CONSTRUCTION. IT IS THE RESPONSIBILITY OF THE APPLICANT TO COORDINATE THE MEETING TIME AND PLACE WITH COUNTY STAFF.
5. CONTROL MEASURES MUST BE INSTALLED PRIOR TO COMMENCEMENT OF ACTIVITIES THAT COULD CONTRIBUTE POLLUTANTS TO STORMWATER. CONTROL MEASURES FOR ALL SLOPES, CHANNELS, DITCHES, AND DISTURBED LAND AREAS SHALL BE INSTALLED IMMEDIATELY UPON COMPLETION OF THE DISTURBANCE.
6. ALL TEMPORARY SEDIMENT AND EROSION CONTROL MEASURES SHALL BE MAINTAINED AND REMAIN IN EFFECTIVE OPERATING CONDITION UNTIL PERMANENT SOIL EROSION CONTROL MEASURES ARE IMPLEMENTED AND FINAL STABILIZATION IS ESTABLISHED. ALL PERSONS ENGAGED IN LAND DISTURBANCE ACTIVITIES SHALL ASSESS THE ADEQUACY OF CONTROL MEASURES AT THE SITE AND IDENTIFY IF CHANGES TO THOSE CONTROL MEASURES ARE NEEDED TO ENSURE THE CONTINUED EFFECTIVE PERFORMANCE OF THE CONTROL MEASURES. ALL CHANGES TO TEMPORARY SEDIMENT AND EROSION CONTROL MEASURES MUST BE INCORPORATED INTO THE STORMWATER MANAGEMENT PLAN.
7. TEMPORARY STABILIZATION SHALL BE IMPLEMENTED ON DISTURBED AREAS AND STOCKPILES WHERE GROUND-DISTURBING CONSTRUCTION ACTIVITY HAS PERMANENTLY CEASED OR TEMPORARILY CEASED FOR LONGER THAN 14 DAYS.
8. FINAL STABILIZATION MUST BE IMPLEMENTED AT ALL APPLICABLE CONSTRUCTION SITES. FINAL STABILIZATION IS ACHIEVED WHEN ALL GROUND-DISTURBING ACTIVITIES ARE COMPLETE AND ALL DISTURBED AREAS EITHER HAVE A UNIFORM VEGETATIVE COVER WITH INDIVIDUAL PLANT DENSITY OF 70 PERCENT OF PRE-DISTURBANCE LEVELS ESTABLISHED OR EQUIVALENT PERMANENT ALTERNATIVE STABILIZATION METHOD IS IMPLEMENTED. ALL TEMPORARY SEDIMENT AND EROSION CONTROL MEASURES SHALL BE REMOVED UPON FINAL STABILIZATION AND BEFORE PERMIT CLOSURE.
9. ALL PERMANENT STORMWATER MANAGEMENT FACILITIES SHALL BE INSTALLED AS DESIGNED IN THE APPROVED PLANS. ANY PROPOSED CHANGES THAT EFFECT THE DESIGN OR FUNCTION OF PERMANENT STORMWATER MANAGEMENT STRUCTURES MUST BE APPROVED BY THE ECM ADMINISTRATOR PRIOR TO IMPLEMENTATION.
10. EARTH DISTURBANCES SHALL BE CONDUCTED IN SUCH A MANNER SO AS TO EFFECTIVELY MINIMIZE ACCELERATED SOIL EROSION AND RESULTING SEDIMENTATION. ALL DISTURBANCES SHALL BE DESIGNED, CONSTRUCTED, AND COMPLETED SO THAT THE EXPOSED AREA OF ANY DISTURBED LAND SHALL BE LIMITED TO THE SHORTEST PRACTICAL PERIOD OF TIME. PRE-EXISTING VEGETATION SHALL BE PROTECTED AND MAINTAINED WITHIN 50 HORIZONTAL FEET OF A WATERS OF THE STATE UNLESS SHOWN TO BE INFEASIBLE AND SPECIFICALLY REQUESTED AND APPROVED.
11. COMPACTION OF SOIL MUST BE PREVENTED IN AREAS DESIGNATED FOR INFILTRATION CONTROL MEASURES OR WHERE FINAL STABILIZATION WILL BE ACHIEVED BY VEGETATIVE COVER. AREAS DESIGNATED FOR INFILTRATION CONTROL MEASURES SHALL ALSO BE PROTECTED FROM SEDIMENTATION DURING CONSTRUCTION UNTIL FINAL STABILIZATION IS ACHIEVED. IF COMPACTION PREVENTION IS NOT FEASIBLE DUE TO SITE CONSTRAINTS, ALL AREAS DESIGNATED FOR INFILTRATION AND VEGETATION CONTROL MEASURES MUST BE LOOSENEED PRIOR TO INSTALLATION OF THE CONTROL MEASURE(S).
12. ANY TEMPORARY OR PERMANENT FACILITY DESIGNED AND CONSTRUCTED FOR THE CONVEYANCE OF STORMWATER AROUND, THROUGH, OR FROM THE EARTH DISTURBANCE AREA SHALL BE A STABILIZED CONVEYANCE DESIGNED TO MINIMIZE EROSION AND THE DISCHARGE OF SEDIMENT OFF SITE.
13. CONCRETE WASH WATER SHALL BE CONTAINED AND DISPOSED OF IN ACCORDANCE WITH THE SWMP. NO WASH WATER SHALL BE DISCHARGE TO OR ALLOWED TO ENTER STATE WATERS, INCLUDING ANY SURFACE OR SUBSURFACE STORM DRAINAGE SYSTEM OR FACILITIES. CONCRETE WASHOUTS SHALL NOT BE LOCATED IN AN AREA WHERE SHALLOW GROUNDWATER MAY BE PRESENT, OR WITHIN 50 FEET OF A SURFACE WATER BODY, CREEK, OR STREAM.
14. DURING DEWATERING OPERATIONS OF UNCONTAMINATED GROUND WATER MAY BE DISCHARGED ON SITE, BUT SHALL NOT LEAVE THE SITE IN THE FORM OF SURFACE RUNOFF UNLESS AN APPROVED STATE DEWATERING PERMIT IS IN PLACE.
15. EROSION CONTROL BLANKETING OR OTHER PROTECTIVE COVERING SHALL BE USED ON SLOPES STEEPER THAN 3:1.
16. CONTRACTOR SHALL BE RESPONSIBLE FOR THE REMOVAL OF ALL WASTES FROM THE CONSTRUCTION SITE FOR DISPOSAL IN ACCORDANCE WITH LOCAL AND STATE REGULATORY REQUIREMENTS. NO CONSTRUCTION DEBRIS, TREE SLASH, BUILDING MATERIAL WASTES, OR UNUSED BUILDING MATERIALS SHALL BE BURIED, DUMPED, OR DISCHARGED AT THE SITE.
17. WASTE MATERIALS SHALL NOT BE TEMPORARILY PLACED OR STORED IN THE STREET, ALLEY, OR OTHER PUBLIC WAY, UNLESS IN ACCORDANCE WITH AN APPROVED TRAFFIC CONTROL PLAN. CONTROL MEASURES MAY BE REQUIRED BY EL PASO COUNTY ENGINEERING IF DEEMED NECESSARY, BASED ON SPECIFIC CONDITIONS AND CIRCUMSTANCES.
18. TRACKING OF SOILS AND CONSTRUCTION DEBRIS OFF SITE SHALL BE MINIMIZED. MATERIALS TRACKED OFF SITE SHALL BE CLEANED UP AND PROPERLY DISPOSED OF IMMEDIATELY.
19. THE OWNER/DEVELOPER SHALL BE RESPONSIBLE FOR THE REMOVAL OF ALL CONSTRUCTION DEBRIS, DIRT, TRASH, ROCK, SEDIMENT, SOIL, AND SAND THAT MAY ACCUMULATE IN ROADS, STORM DRAINS, AND OTHER DRAINAGE CONVEYANCE SYSTEMS AND STORMWATER APPURTENANCES AS A RESULT OF SITE DEVELOPMENT.
20. THE QUANTITY OF MATERIALS STORED ON THE PROJECT SITE SHALL BE LIMITED, AS MUCH AS PRACTICAL, TO THAT QUANTITY REQUIRED TO PERFORM THE WORK IN AN ORDERLY SEQUENCE. ALL MATERIALS STORED ON SITE SHALL BE STORED IN A NEAT, ORDERLY MANNER, IN THEIR ORIGINAL CONTAINERS, AND WITH ORIGINAL MANUFACTURER'S LABELS.
21. NO CHEMICAL(S) HAVING THE POTENTIAL TO BE RELEASED IN STORMWATER ARE TO BE STORED OR USED ON SITE UNLESS PERMISSION FOR THE USE OF SUCH CHEMICAL(S) IS GRANTED IN WRITING BY THE ECM ADMINISTRATOR. IN GRANTING APPROVAL FOR THE USE OF SUCH CHEMICAL(S), SPECIAL CONDITIONS AND MONITORING MAY BE REQUIRED.
22. BULK STORAGE OF ALLOWED PETROLEUM PRODUCTS OR OTHER ALLOWED LIQUID CHEMICALS IN EXCESS OF 55 GALLONS SHALL REQUIRE ADEQUATE SECONDARY CONTAINMENT PROTECTION TO CONTAIN ALL SPILLS ON SITE AND TO PREVENT ANY SPILLED MATERIALS FROM ENTERING STATE WATERS, ANY SURFACE OR SUBSURFACE STORM DRAINAGE SYSTEM, OR OTHER FACILITIES.
23. NO PERSON SHALL CAUSE THE IMPEDIMENT OF STORMWATER FLOW IN THE CURB AND GUTTER OR DITCH EXCEPT WITH APPROVED SEDIMENT CONTROL MEASURES.
24. OWNER/DEVELOPER AND THEIR AGENTS SHALL COMPLY WITH THE "COLORADO WATER QUALITY CONTROL ACT" (TITLE 25, ARTICLE 8, CRS) AND THE "CLEAN WATER ACT" (33 USC 1344), IN ADDITION TO THE REQUIREMENTS OF THE LAND DEVELOPMENT CODE, DCM VOLUME II AND THE ECM APPENDIX I. ALL APPROPRIATE PERMITS MUST BE OBTAINED BY THE CONTRACTOR PRIOR TO CONSTRUCTION (1041, NPDES, FLOODPLAIN, 404, FUGITIVE DUST, ETC.). IN THE EVENT OF CONFLICTS BETWEEN THESE REQUIREMENTS AND OTHER LAWS, RULES, OR REGULATIONS OF OTHER FEDERAL, STATE, LOCAL, OR COUNTY AGENCIES, THE MOST RESTRICTIVE LAWS, RULES, OR REGULATIONS SHALL APPLY.
25. ALL CONSTRUCTION TRAFFIC MUST ENTER/EXIT THE SITE ONLY AT APPROVED CONSTRUCTION ACCESS POINTS.
26. PRIOR TO CONSTRUCTION, THE PERMITTEE SHALL VERIFY THE LOCATION OF EXISTING UTILITIES.
27. A WATER SOURCE SHALL BE AVAILABLE ON SITE DURING EARTHWORK OPERATIONS AND SHALL BE UTILIZED AS REQUIRED TO MINIMIZE DUST FROM EARTHWORK EQUIPMENT AND WIND.
28. THE SOILS REPORT FOR THIS SITE WAS PREPARED BY VIVID ENGINEERING (DATED 09/17/2021) AND SHALL BE CONSIDERED A PART OF THESE PLANS.
29. CONTRACTOR SHALL BE RESPONSIBLE FOR ANY RE-EXCAVATION OF SEDIMENT AND DEBRIS THAT COLLECTS IN THE DOWNSTREAM SEDIMENT BASIN DEPRESSION REQUIRED TO ENSURE THAT THE BASIN MEETS THE DESIGN GRADES FOLLOWING CONSTRUCTION. THE ROADSIDE DITCHES CONVEYING SITE RUNOFF TO THE BASIN SHALL ALSO BE CLEANED AND FREE OF SEDIMENT ONCE THE SITE BECOMES STABILIZED.
30. AT LEAST TEN (10) DAYS PRIOR TO THE ANTICIPATED START OF CONSTRUCTION, FOR PROJECTS THAT WILL DISTURB ONE (1) ACRE OR MORE, THE OWNER OR OPERATOR OF CONSTRUCTION ACTIVITY SHALL SUBMIT A PERMIT APPLICATION FOR STORMWATER DISCHARGE TO THE COLORADO DEPARTMENT OF PUBLIC HEALTH AND ENVIRONMENT, WATER QUALITY DIVISION. THE APPLICATION CONTAINS CERTIFICATION OF COMPLETION OF A STORMWATER MANAGEMENT PLAN (SWMP), OF WHICH THIS GRADING AND EROSION CONTROL PLAN MAY BE A PART. FOR INFORMATION OR APPLICATIONS MATERIALS, CONTACT:

COLORADO DEPARTMENT OF PUBLIC HEALTH AND ENVIRONMENT
WATER QUALITY CONTROL DIVISION
WOOD - PERMITS
4300 CHERRY CREEK DRIVE SOUTH
DENVER, CO 80246-1530
ATTN: PERMITS UNIT

TIMING, CONSTRUCTION STAGING, AND SEQUENCING:

EXPECTED START DATE: SPRING 2024
INSTALL TEMPORARY EROSION CONTROL - 2 DAYS
- PERIMETER SILT FENCING
- VEHICLE TRACKING CONTROL PAD

EARTHWORK/ROUGH GRADING - 3 MONTHS
INSTALL FINAL SITE IMPROVEMENTS - 6 MONTHS
REMOVE TEMPORARY EROSION CONTROL - 5 DAYS

MINIMUM BEST MANAGEMENT PRACTICES ELEMENTS:

- STEP 1- EROSION AND SEDIMENT CONTROL
INSTALL SEDIMENT TRAPPING DEVICES (PERIMETER CONTROLS) PRIOR TO THE START OF CONSTRUCTION.
STEP 2- SPILL PREVENTION AND RESPONSE
STEP 3- MATERIAL MANAGEMENT
MATERIAL AND EQUIPMENT STORAGE AREAS SHALL BE SECURE AND CONTAINED TO PREVENT DISCHARGE OF ANY MATERIAL IN RUNOFF. WASTE SHALL BE CONTAINED AND DISPOSED OF PROPERLY. MAINTAIN BMP'S DURING BUILDING AND UTILITY CONSTRUCTION.
STEP 4- INSPECTION AND MAINTENANCE (SEE EROSION CONTROL NOTES)
STEP 5- INSTALL FINAL STABILIZATION - BASE COURSE, LANDSCAPING, EROSION CONTROL BLANKETS, AND SEEDING.
STEP 6- REMOVE TEMPORARY CONTROLS - SILT FENCING AFTER PERMANENT FEATURES ARE INSTALLED.

FINAL STABILIZATION AND LONG-TERM STORMWATER MANAGEMENT:

FINAL STABILIZATION MEASURES INCLUDE BASE COURSE, PARTIAL LANDSCAPE, AND REVEGETATION

EARTHWORK SUMMARY:

PROPOSED SITE:
CUT - 1,017 CY
FILL - 91 (*1.15) = 105 CY
NET - 912 CY CUT

STRUCTURAL EXPORT/IMPORT = 2,737 CY (EA)

DISTURBED AREA - 35,806 SF, 0.82 AC
SEED MIX AREA - 18,187 SF, 0.42 AC

EROSION CONTROL FACILITIES:

SILT FENCE (SF) - 280 LF
VEHICLE TRACKING PAD (VT) - 1

FINAL AREAS DISTURBED BY EARTHWORK SHALL BE PERMANENTLY REVEGETATED WITH GRASS MIX. SEED MIX FOR THIS PROJECT SHALL BE AS FOLLOWS (SEE BELOW):

Table with 3 columns: COMMON NAME (TYPE & VARIETY), PURE (%), ORIGIN. Rows include ANNUAL RYEGRASS, SLENDER WHEATGRASS, OATS, PERENNIAL RYEGRASS, CRESTED WHEATGRASS, MOUNTAIN BROME, HARD FESCUE, CANADA BLUEGRASS, SIDEOTS GRAMA, SWITCHGRASS, BIG BLUESTEM, BLUE GRAMA, SAND DROPSEED, and TOTAL.

Colorado Springs, CO
5540 Tech Center Dr., Suite 100
Colorado Springs, CO 80919
Phone: 719.227.0072
www.respec.com
RESPEC logo

WOODMEN HILLS METROPOLITAN DISTRICT
THERIOT CONCRETE WATER TANK
GRADING & EROSION CONTROL NOTES

REVISIONS table with columns: NO., DESCRIPTION, BY, APP., DATE. Rows 1-7.

100% DESIGN



Proj.#: 112.126
Date: 07/08/24
Design: RMM
Drawn: RMM
Check: JPM

PCD File No. PPR-

2024/07/01 8:57 AM By: Ryan Mangino N:\Projects\112 Woodmen Hills\112.126 Theriot Concrete Tank Drawings\Design\112.126_1_Civil_RMM.dwg IF BAR DOES NOT MEASURE ONE INCH, SCALE OF THIS DRAWING HAS BEEN ALTERED 1"

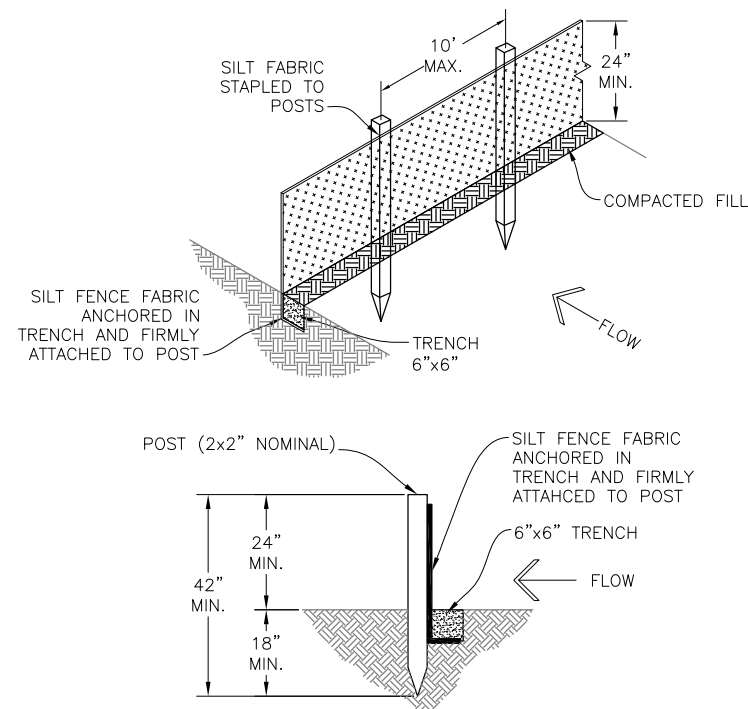

SILT FENCE DETAIL

INSTALLATION REQUIREMENTS:

1. SILT FENCES SHALL BE INSTALLED PRIOR TO ANY LAND DISTURBING ACTIVITIES.
2. WHEN JOINTS ARE NECESSARY, SILT FENCE GEOTEXTILE SHALL BE SPliced TOGETHER ONLY AT SUPPORT POST AND SECURELY SEALED.
3. METAL POSTS SHALL BE "STUDDED TEE" OR "U" TYPE WITH MINIMUM WEIGHT OF 1.33 POUNDS PER LINEAR FOOT. WOOD POSTS SHALL HAVE A MINIMUM DIAMETER OR CROSS SECTION DIMENSION OF 2 INCHES.
4. THE FILTER MATERIAL SHALL BE FASTENED SECURELY TO METAL POSTS USING WIRE TIES, OR TO WOOD POSTS WITH 3/4" LONG #9 HEAVY-DUTY STAPLES. THE SILT FENCE GEOTEXTILE SHALL NOT BE STAPLED TO EXISTING TREES.
5. WHILE NOT REQUIRED, WIRE MESH FENCE MAY BE USED TO SUPPORT THE GEOTEXTILE. WIRE FENCE SHALL BE FASTENED SECURELY TO THE UPSLOPE SIDE OF THE POSTS USING HEAVY-DUTY WIRE STAPLES AT LEAST 3/4" LONG, TIE WIRES OR HOG RINGS. THE WIRE SHALL EXTEND INTO THE TRENCH A MINIMUM OF 6 INCHES AND SHALL NOT EXTEND MORE THAN 3 FEET ABOVE THE ORIGINAL GROUND SURFACE.

6. ALONG THE TOE OF FILLS, INSTALL THE SILT FENCE ALONG A LEVEL CONTOUR AND PROVIDE AN AREA BEHIND THE FENCE FOR RUNOFF TO POND AND SEDIMENT TO SETTLE. A MINIMUM DISTANCE OF 5 FEET FROM THE TOE OF THE FILL IS RECOMMENDED.
7. THE HEIGHT OF THE SILT FENCE FROM THE GROUND SURFACE SHALL BE MINIMUM OF 24 INCHES AND SHALL NOT EXCEED 36 INCHES. HIGHER FENCES MAY IMPOUND VOLUMES OF WATER SUFFICIENT TO CAUSE FAILURE OF THE STRUCTURE.

MAINTENANCE REQUIREMENTS:

1. CONTRACTOR SHALL INSPECT SILT FENCES IMMEDIATELY AFTER EACH RAINFALL, AT LEAST DAILY DURING PROLONGED RAINFALL, AND WEEKLY DURING PERIODS OF NO RAINFALL. DAMAGED, COLLAPSED, UNENTRENCHED OR INEFFECTIVE SILT FENCES SHALL BE PROMPTLY REPAIRED OR REPLACED.
2. SEDIMENT SHALL BE REMOVED FROM BEHIND SILT FENCE WHEN IT ACCUMULATES TO HALF THE EXPOSED GEOTEXTILE HEIGHT.
3. SILT FENCES SHALL BE REMOVED WHEN ADEQUATE VEGETATIVE COVER IS ATTAINED.

A **SILT FENCE DETAIL**
C7 SCALE: N.T.S.

TOP VIEW

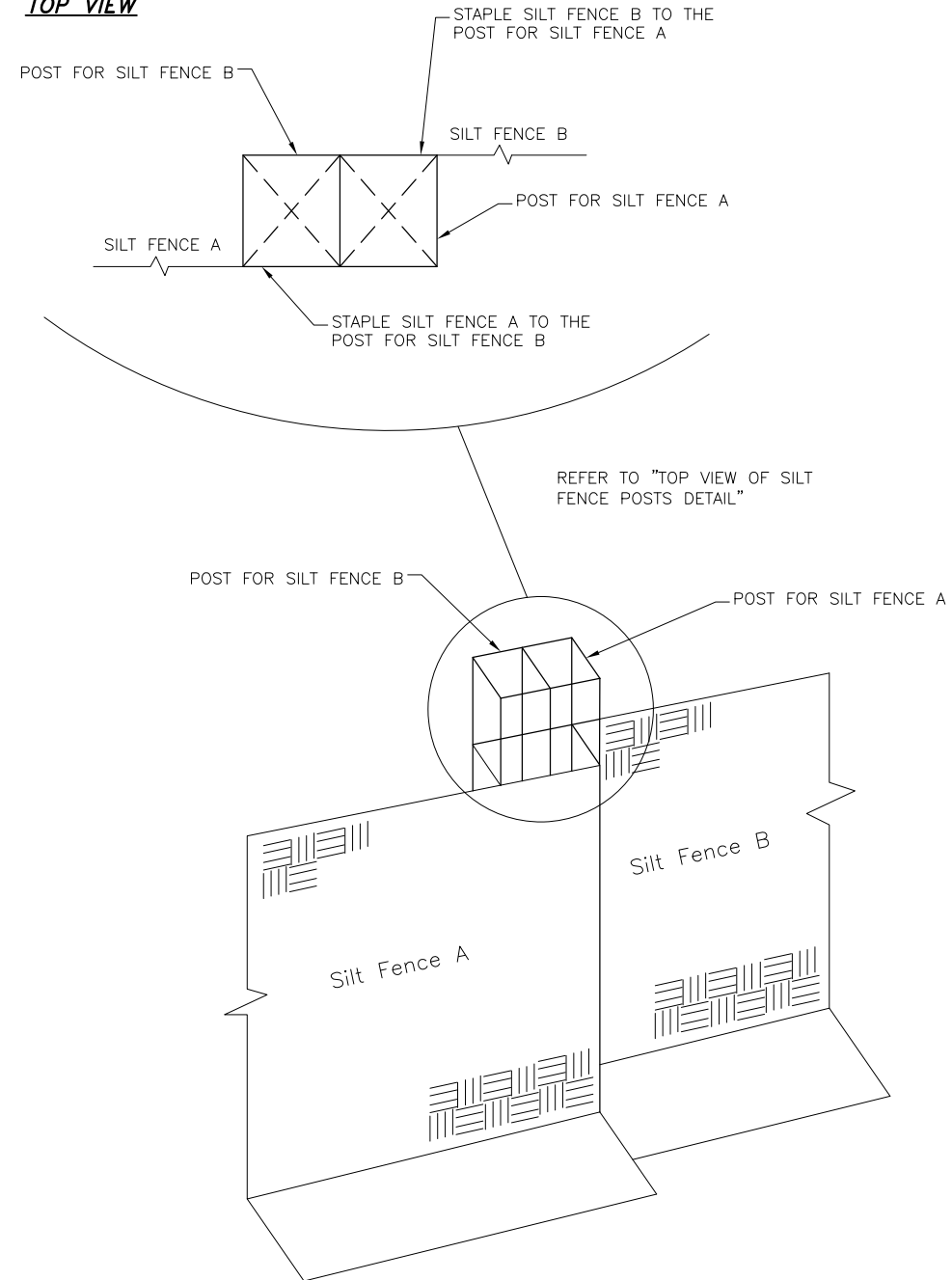

B **SILT FENCE POSTS DETAIL**
C7 SCALE: N.T.S.

Colorado Springs, CO
5540 Tech Center Dr., Suite 100
Colorado Springs, CO 80919
Phone: 719.227.0072
www.respec.com

RESPEC

WOODMEN HILLS METROPOLITAN DISTRICT
THERIOT CONCRETE WATER TANK
GRADING & EROSION CONTROL DETAILS 1

NO.	DESCRIPTION	BY	APP.	DATE
1				
2				
3				
4				
5				
6				
7				

100% DESIGN

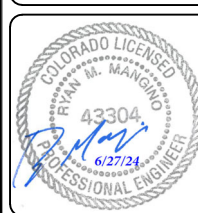

Proj.#: 112.126
Date: 07/08/24
Design: RMM
Drawn: RMM
Check: JPM

C7
SHEET 7 OF 19

PCD File No. PPR-

2024/07/01 8:58 AM By: Ryan Mangino N:\Projects\112 Woodmen Hills\112.126 Theriot Concrete Tank Drawings\Design\112126_1_Civil_RMM.dwg

IF BAR DOES NOT MEASURE ONE INCH, SCALE OF THIS DRAWING HAS BEEN ALTERED

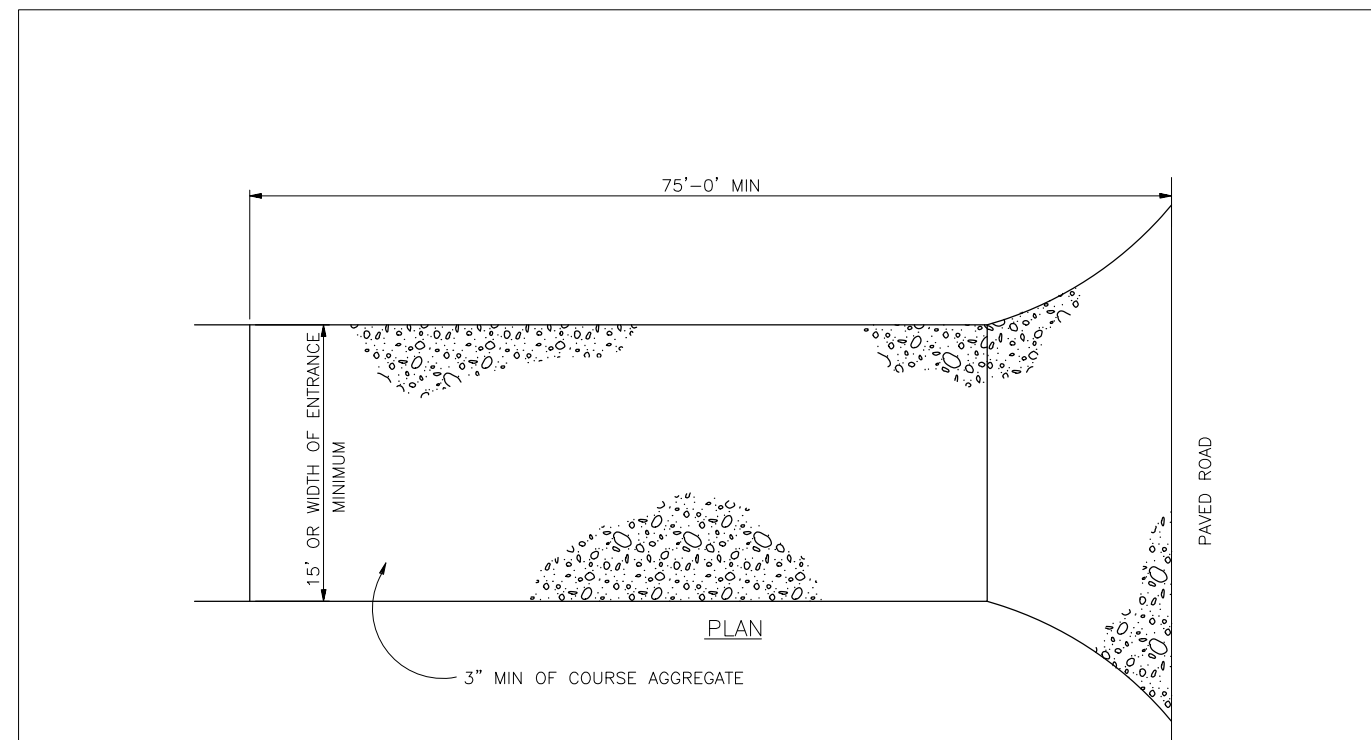

VEHICLE TRACKING PAD DETAIL

INSTALLATION REQUIREMENTS:

1. ALL ENTRANCES TO THE CONSTRUCTION SITE ARE TO BE STABILIZED PRIOR TO COMMENCEMENT OF CONSTRUCTION.
2. CONSTRUCTION ENTRANCES ARE TO BE BUILT WITH AN APRON TO ALLOW FOR TURNING TRAFFIC, BUT SHOULD NOT BE BUILT OVER EXISTING PAVEMENT EXCEPT FOR A SLIGHT OVERLAP.
3. AREAS TO BE STABILIZED ARE TO BE PROPERLY GRADED AND COMPACTED.
4. CONSTRUCTION ROADS, PARKING AREAS, LOADING/UNLOADING ZONES, STORAGE AREAS, AND STAGING AREAS ARE TO BE STABILIZED.
5. CONSTRUCTION ROADS ARE TO BE BUILT TO CONFORM TO SITE GRADES, BUT SHOULD NOT HAVE SIDE SLOPES OR ROAD GRADES THAT ARE EXCESSIVELY STEEP.

MAINTENANCE REQUIREMENTS

1. REGULAR INSPECTIONS ARE TO BE MADE OF ALL STABILIZED AREAS, ESPECIALLY AFTER STORM EVENTS.
2. STONES ARE TO BE REAPPLIED PERIODICALLY AND WHEN REPAIR IS NECESSARY.
3. SEDIMENT TRACKED ONTO PAVED ROADS IS TO BE REMOVED DAILY BY SHOVELING OR SWEEPING. SEDIMENT IS NOT TO BE WASHED DOWN STORM SEWER DRAINS.
4. OTHER ASSOCIATED SEDIMENT CONTROL MEASURES ARE TO BE INSPECTED TO ENSURE GOOD WORKING CONDITION.
5. TO BE REMOVED JUST PRIOR TO FINAL SURFACING AND STABILIZATION.

A
C8 VEHICLE TRACKING PAD DETAIL
SCALE: N.T.S.

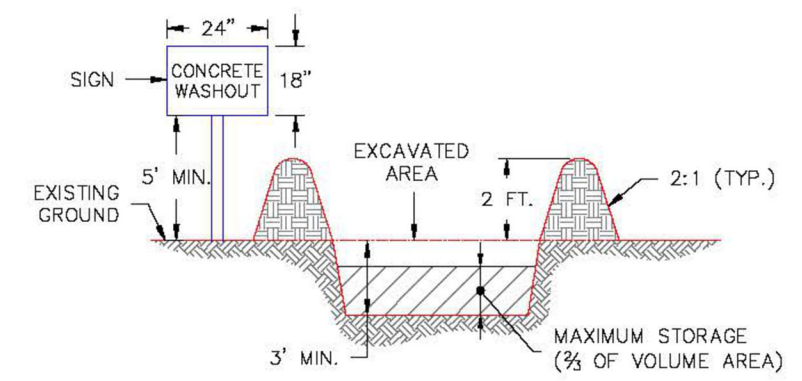
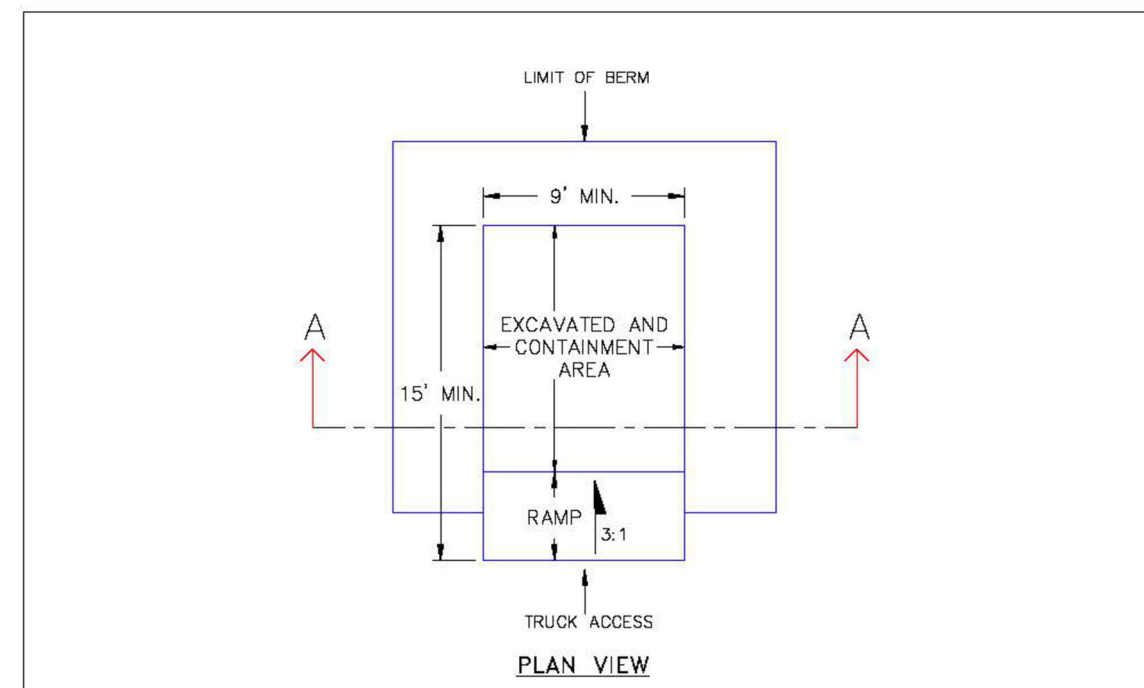

SECTION A-A

NOTES:

1. SIGN MATERIAL, EXCAVATION, AND RESTORATION ARE INCLUDED IN THE COST OF THE CONCRETE WASHOUT STRUCTURE.
2. EROSION BALES MAY BE USED AS AN ALTERNATIVE FOR THE BERM.

DATE APPROVED: 1/1/08 John A. McCarty DEPARTMENT OF TRANSPORTATION	Concrete Washout Structure Standard Drawing REVISION DATE: 7/17/07 FILE NAME: SD_3-84	
---	--	--

B
C8 CONCRETE WASHOUT STRUCTURE DETAIL
SCALE: N.T.S.

Colorado Springs, CO
5540 Tech Center Dr., Suite 100
Colorado Springs, CO 80919
Phone: 719.227.0072
www.respec.com

WOODMEN HILLS METROPOLITAN DISTRICT
THERIOT CONCRETE WATER TANK
GRADING & EROSION CONTROL DETAILS 2

NO.	DESCRIPTION	BY	APP.	DATE
1				
2				
3				
4				
5				
6				
7				

100% DESIGN

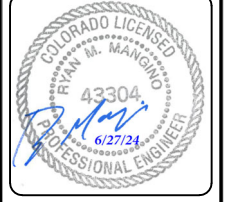

Proj.#: 112.126
Date: 07/08/24
Design: RMM
Drawn: RMM
Check: JPM

2024/07/01 8:59 AM By: Ryan Mangino N:\Projects\112 Woodmen Hills\112.126 Theriot Concrete Tank Drawings\Design\112.126_1_Civil_RMM.dwg IF BAR DOES NOT MEASURE ONE INCH, SCALE OF THIS DRAWING HAS BEEN ALTERED 1"

Temporary and Permanent Seeding (TS/PS) EC-2

Description

Temporary seeding can be used to stabilize disturbed areas that will be inactive for an extended period. Permanent seeding should be used to stabilize areas at final grade that will not be otherwise stabilized. Effective seeding includes preparation of a seedbed, selection of an appropriate seed mixture, proper planting techniques, and protection of the seeded area with mulch, geotextiles, or other appropriate measures.



Photograph TS/PS-1. Equipment used to drill seed. Photo courtesy of Douglas County.

Appropriate Uses

When the soil surface is disturbed and will remain inactive for an extended period (typically 30 days or longer), proactive stabilization measures should be implemented. If the inactive period is short-lived (on the order of two weeks), techniques such as surface roughening may be appropriate. For longer periods of inactivity, temporary seeding and mulching can provide effective erosion control. Permanent seeding should be used on finished areas that have not been otherwise stabilized.

Typically, local governments have their own seed mixes and timelines for seeding. Check jurisdictional requirements for seeding and temporary stabilization.

Design and Installation

Effective seeding requires proper seedbed preparation, selection of an appropriate seed mixture, use of appropriate seeding equipment to ensure proper coverage and density, and protection with mulch or fabric until plants are established.

The USDCM Volume 2 *Revegetation* Chapter contains detailed seed mix, soil preparations, and seeding and mulching recommendations that may be referenced to supplement this Fact Sheet.

Drill seeding is the preferred seeding method. Hydroseeding is not recommended except in areas where steep slopes prevent use of drill seeding equipment, and even in these instances it is preferable to hand seed and mulch. Some jurisdictions do not allow hydroseeding or hydromulching.

Seedbed Preparation

Prior to seeding, ensure that areas to be revegetated have soil conditions capable of supporting vegetation. Overlot grading can result in loss of topsoil, resulting in poor quality subsoils at the ground surface that have low nutrient value, little organic matter content, few soil microorganisms, rooting restrictions, and conditions less conducive to infiltration of precipitation. As a result, it is typically necessary to provide stockpiled topsoil, compost, or other

Temporary and Permanent Seeding	
Functions	
Erosion Control	Yes
Sediment Control	No
Site/Material Management	No

June 2012 Urban Drainage and Flood Control District
Urban Storm Drainage Criteria Manual Volume 3 TS/PS-1

EC-2 Temporary and Permanent Seeding (TS/PS)

soil amendments and rototill them into the soil to a depth of 6 inches or more.

Topsoil should be salvaged during grading operations for use and spread on areas to be revegetated later. Topsoil should be viewed as an important resource to be utilized for vegetation establishment, due to its water-holding capacity, structure, texture, organic matter content, biological activity, and nutrient content. The rooting depth of most native grasses in the semi-arid Denver metropolitan area is 6 to 18 inches. At a minimum, the upper 6 inches of topsoil should be stripped, stockpiled, and ultimately respread across areas that will be revegetated.

Where topsoil is not available, subsoils should be amended to provide an appropriate plant-growth medium. Organic matter, such as well digested compost, can be added to improve soil characteristics conducive to plant growth. Other treatments can be used to adjust soil pH conditions when needed. Soil testing, which is typically inexpensive, should be completed to determine and optimize the types and amounts of amendments that are required.

If the disturbed ground surface is compacted, rip or rototill the surface prior to placing topsoil. If adding compost to the existing soil surface, rototilling is necessary. Surface roughening will assist in placement of a stable topsoil layer on steeper slopes, and allow infiltration and root penetration to greater depth.

Prior to seeding, the soil surface should be rough and the seedbed should be firm, but neither too loose nor compacted. The upper layer of soil should be in a condition suitable for seeding at the proper depth and conducive to plant growth. Seed-to-soil contact is the key to good germination.

Seed Mix for Temporary Vegetation

To provide temporary vegetative cover on disturbed areas which will not be paved, built upon, or fully landscaped or worked for an extended period (typically 30 days or more), plant an annual grass appropriate for the time of planting and mulch the planted areas. Annual grasses suitable for the Denver metropolitan area are listed in Table TS/PS-1. These are to be considered only as general recommendations when specific design guidance for a particular site is not available. Local governments typically specify seed mixes appropriate for their jurisdiction.

Seed Mix for Permanent Revegetation

To provide vegetative cover on disturbed areas that have reached final grade, a perennial grass mix should be established. Permanent seeding should be performed promptly (typically within 14 days) after reaching final grade. Each site will have different characteristics and a landscape professional or the local jurisdiction should be contacted to determine the most suitable seed mix for a specific site. In lieu of a specific recommendation, one of the perennial grass mixes appropriate for site conditions and growth season listed in Table TS/PS-2 can be used. The pure live seed (PLS) rates of application recommended in these tables are considered to be absolute minimum rates for seed applied using proper drill-seeding equipment.

If desired for wildlife habitat or landscape diversity, shrubs such as rubber rabbitbrush (*Chrysothamnus nauseosus*), fourwing saltbush (*Atriplex canescens*) and skunkbrush sumac (*Rhus trilobata*) could be added to the upland seedmixes at 0.25, 0.5 and 1 pound PLS/acre, respectively. In riparian zones, planting root stock of such species as American plum (*Prunus americana*), woods rose (*Rosa woodsii*), plains cottonwood (*Populus sargentii*), and willow (*Populus spp.*) may be considered. On non-topsoiled upland sites, a legume such as Ladak alfalfa at 1 pound PLS/acre can be included as a source of nitrogen for perennial grasses.

TS/PS-2 Urban Drainage and Flood Control District
Urban Storm Drainage Criteria Manual Volume 3 June 2012

Temporary and Permanent Seeding (TS/PS) EC-2

Seeding dates for the highest success probability of perennial species along the Front Range are generally in the spring from April through early May and in the fall after the first of September until the ground freezes. If the area is irrigated, seeding may occur in summer months, as well. See Table TS/PS-3 for appropriate seeding dates.

Table TS/PS-1. Minimum Drill Seeding Rates for Various Temporary Annual Grasses

Species ^a (Common name)	Growth Season ^b	Pounds of Pure Live Seed (PLS)/acre ^c	Planting Depth (inches)
1. Oats	Cool	35 - 50	1 - 2
2. Spring wheat	Cool	25 - 35	1 - 2
3. Spring barley	Cool	25 - 35	1 - 2
4. Annual ryegrass	Cool	10 - 15	½
5. Millet	Warm	3 - 15	½ - ¾
6. Sudangrass	Warm	5-10	½ - ¾
7. Sorghum	Warm	5-10	½ - ¾
8. Winter wheat	Cool	20-35	1 - 2
9. Winter barley	Cool	20-35	1 - 2
10. Winter rye	Cool	20-35	1 - 2
11. Triticale	Cool	25-40	1 - 2

^a Successful seeding of annual grass resulting in adequate plant growth will usually produce enough dead-plant residue to provide protection from wind and water erosion for an additional year. This assumes that the cover is not disturbed or mowed closer than 8 inches.

Hydraulic seeding may be substituted for drilling only where slopes are steeper than 3:1 or where access limitations exist. When hydraulic seeding is used, hydraulic mulching should be applied as a separate operation, when practical, to prevent the seeds from being encapsulated in the mulch.

^b See Table TS/PS-3 for seeding dates. Irrigation, if consistently applied, may extend the use of cool season species during the summer months.

^c Seeding rates should be doubled if seed is broadcast, or increased by 50 percent if done using a Brillion Drill or by hydraulic seeding.

June 2012 Urban Drainage and Flood Control District
Urban Storm Drainage Criteria Manual Volume 3 TS/PS-3

Colorado Springs, CO
5540 Tech Center Dr., Suite 100
Colorado Springs, CO 80919
Phone: 719.227.0072
www.respec.com



WOODMEN HILLS METROPOLITAN DISTRICT
THERIOT CONCRETE WATER TANK
GRADING & EROSION CONTROL DETAILS 3

NO.	DESCRIPTION	BY	APP.	DATE
1				
2				
3				
4				
5				
6				
7				

100% DESIGN



Proj.#: 112.126
Date: 07/08/24
Design: RMM
Drawn: RMM
Check: JPM

2024/07/01 9:00 AM By: Ryan Mangino N:\Projects\112 Woodmen Hills\112.126 Theriot Concrete Tank Drawings\Design\112.126_1_Civil_RMM.dwg IF BAR DOES NOT MEASURE ONE INCH, SCALE OF THIS DRAWING HAS BEEN ALTERED 1"

EC-2 Temporary and Permanent Seeding (TS/PS)

Table TS/PS-2. Minimum Drill Seeding Rates for Perennial Grasses

Common ² Name	Botanical Name	Growth Season ^b	Growth Form	Seeds/ Pound	Pounds of PLS/acre
Alkali Soil Seed Mix					
Alkali sacaton	<i>Sporobolus airoides</i>	Cool	Bunch	1,750,000	0.25
Basin wildrye	<i>Elymus cinereus</i>	Cool	Bunch	165,000	2.5
Sodar streambank wheatgrass	<i>Agropyron riparium 'Sodar'</i>	Cool	Sod	170,000	2.5
Jose tall wheatgrass	<i>Agropyron elongatum 'Jose'</i>	Cool	Bunch	79,000	7.0
Arriba western wheatgrass	<i>Agropyron smithii 'Arriba'</i>	Cool	Sod	110,000	5.5
Total					17.75
Fertile Loamy Soil Seed Mix					
Ephriam crested wheatgrass	<i>Agropyron cristatum 'Ephriam'</i>	Cool	Sod	175,000	2.0
Dural hard fescue	<i>Festuca ovina 'durtiscula'</i>	Cool	Bunch	565,000	1.0
Lincoln smooth brome	<i>Bromus inermis leysii 'Lincoln'</i>	Cool	Sod	130,000	3.0
Sodar streambank wheatgrass	<i>Agropyron riparium 'Sodar'</i>	Cool	Sod	170,000	2.5
Arriba western wheatgrass	<i>Agropyron smithii 'Arriba'</i>	Cool	Sod	110,000	7.0
Total					15.5
High Water Table Soil Seed Mix					
Meadow foxtail	<i>Alopecurus pratensis</i>	Cool	Sod	900,000	0.5
Redtop	<i>Agrostis alba</i>	Warm	Open sod	5,000,000	0.25
Reed canarygrass	<i>Phalaris arundinacea</i>	Cool	Sod	68,000	0.5
Lincoln smooth brome	<i>Bromus inermis leysii 'Lincoln'</i>	Cool	Sod	130,000	3.0
Pathfinder switchgrass	<i>Panicum virgatum 'Pathfinder'</i>	Warm	Sod	389,000	1.0
Alkar tall wheatgrass	<i>Agropyron elongatum 'Alkar'</i>	Cool	Bunch	79,000	5.5
Total					10.75
Transition Turf Seed Mix^c					
Ruebens Canadian bluegrass	<i>Poa compressa 'Ruebens'</i>	Cool	Sod	2,500,000	0.5
Dural hard fescue	<i>Festuca ovina 'durtiscula'</i>	Cool	Bunch	565,000	1.0
Citation perennial ryegrass	<i>Lolium perenne 'Citation'</i>	Cool	Sod	247,000	3.0
Lincoln smooth brome	<i>Bromus inermis leysii 'Lincoln'</i>	Cool	Sod	130,000	3.0
Total					7.5

TS/PS-4 Urban Drainage and Flood Control District Urban Storm Drainage Criteria Manual Volume 3 June 2012

EC-2 Temporary and Permanent Seeding (TS/PS)

Table TS/PS-2. Minimum Drill Seeding Rates for Perennial Grasses (cont.)

Common Name	Botanical Name	Growth Season ^b	Growth Form	Seeds/ Pound	Pounds of PLS/acre
Sandy Soil Seed Mix					
Blue grama	<i>Bouteloua gracilis</i>	Warm	Sod-forming bunchgrass	825,000	0.5
Camper little bluestem	<i>Schizachyrium scoparium 'Camper'</i>	Warm	Bunch	240,000	1.0
Prairie sandreed	<i>Calamovilfa longifolia</i>	Warm	Open sod	274,000	1.0
Sand dropseed	<i>Sporobolus cryptandrus</i>	Cool	Bunch	5,298,000	0.25
Vaughn sideoats grama	<i>Bouteloua curtipendula 'Vaughn'</i>	Warm	Sod	191,000	2.0
Arriba western wheatgrass	<i>Agropyron smithii 'Arriba'</i>	Cool	Sod	110,000	5.5
Total					10.25
Heavy Clay, Rocky Foothill Seed Mix					
Ephriam crested wheatgrass ^d	<i>Agropyron cristatum 'Ephriam'</i>	Cool	Sod	175,000	1.5
Oahe Intermediate wheatgrass	<i>Agropyron intermedium 'Oahe'</i>	Cool	Sod	115,000	5.5
Vaughn sideoats grama ^e	<i>Bouteloua curtipendula 'Vaughn'</i>	Warm	Sod	191,000	2.0
Lincoln smooth brome	<i>Bromus inermis leysii 'Lincoln'</i>	Cool	Sod	130,000	3.0
Arriba western wheatgrass	<i>Agropyron smithii 'Arriba'</i>	Cool	Sod	110,000	5.5
Total					17.5

^a All of the above seeding mixes and rates are based on drill seeding followed by crimped straw mulch. These rates should be doubled if seed is broadcast and should be increased by 50 percent if the seeding is done using a Brillion Drill or is applied through hydraulic seeding. Hydraulic seeding may be substituted for drilling only where slopes are steeper than 3:1. If hydraulic seeding is used, hydraulic mulching should be done as a separate operation.
^b See Table TS/PS-3 for seeding dates.
^c If site is to be irrigated, the transition turf seed rates should be doubled.
^d Crested wheatgrass should not be used on slopes steeper than 6H to 1V.
^e Can substitute 0.5 lbs PLS of blue grama for the 2.0 lbs PLS of Vaughn sideoats grama.

June 2012 Urban Drainage and Flood Control District Urban Storm Drainage Criteria Manual Volume 3 TS/PS-5

EC-2 Temporary and Permanent Seeding (TS/PS)

Table TS/PS-3. Seeding Dates for Annual and Perennial Grasses

Seeding Dates	Annual Grasses (Numbers in table reference species in Table TS/PS-1)		Perennial Grasses	
	Warm	Cool	Warm	Cool
January 1–March 15			✓	✓
March 16–April 30	4	1,2,3	✓	✓
May 1–May 15	4		✓	
May 16–June 30	4,5,6,7			
July 1–July 15	5,6,7			
July 16–August 31				
September 1–September 30		8,9,10,11		
October 1–December 31			✓	✓

Mulch

Cover seeded areas with mulch or an appropriate rolled erosion control product to promote establishment of vegetation. Anchor mulch by crimping, netting or use of a non-toxic tackifier. See the Mulching BMP Fact Sheet for additional guidance.

Maintenance and Removal

Monitor and observe seeded areas to identify areas of poor growth or areas that fail to germinate. Reseed and mulch these areas, as needed.

An area that has been permanently seeded should have a good stand of vegetation within one growing season if irrigated and within three growing seasons without irrigation in Colorado. Reseed portions of the site that fail to germinate or remain bare after the first growing season.

Seeded areas may require irrigation, particularly during extended dry periods. Targeted weed control may also be necessary.

Protect seeded areas from construction equipment and vehicle access.

TS/PS-6 Urban Drainage and Flood Control District Urban Storm Drainage Criteria Manual Volume 3 June 2012

Colorado Springs, CO
 5540 Tech Center Dr., Suite 100
 Colorado Springs, CO 80919
 Phone: 719.227.0072
 www.respac.com



WOODMEN HILLS METROPOLITAN DISTRICT
 THERIOT CONCRETE WATER TANK
 GRADING & EROSION CONTROL DETAILS 4

NO.	DESCRIPTION	BY	APP.	DATE
1				
2				
3				
4				
5				
6				
7				

100% DESIGN



Proj.#: 112.126
 Date: 07/08/24
 Design: RMM
 Drawn: RMM
 Check: JPM

2024/07/01 9:02 AM By: Ryan Mangino N:\Projects\112 Woodmen Hills\112.126 Theriot Concrete Tank Drawings\Design\112.126_1_Civil_RMM.dwg IF BAR DOES NOT MEASURE ONE INCH, SCALE OF THIS DRAWING HAS BEEN ALTERED 1"

Mulching (MU)

EC-4

Description

Mulching consists of evenly applying straw, hay, shredded wood mulch, rock, bark or compost to disturbed soils and securing the mulch by crimping, tackifiers, netting or other measures. Mulching helps reduce erosion by protecting bare soil from rainfall impact, increasing infiltration, and reducing runoff. Although often applied in conjunction with temporary or permanent seeding, it can also be used for temporary stabilization of areas that cannot be reseeded due to seasonal constraints.



Photograph MU-1. An area that was recently seeded, mulched, and crimped.

Mulch can be applied either using standard mechanical dry application methods or using hydromulching equipment that hydraulically applies a slurry of water, wood fiber mulch, and often a tackifier.

Appropriate Uses

Use mulch in conjunction with seeding to help protect the seedbed and stabilize the soil. Mulch can also be used as a temporary cover on low to mild slopes to help temporarily stabilize disturbed areas where growing season constraints prevent effective reseeding. Disturbed areas should be properly mulched and tacked, or seeded, mulched and tacked promptly after final grade is reached (typically within no longer than 14 days) on portions of the site not otherwise permanently stabilized.

Standard dry mulching is encouraged in most jurisdictions; however, hydromulching may not be allowed in certain jurisdictions or may not be allowed near waterways.

Do not apply mulch during windy conditions.

Design and Installation

Prior to mulching, surface-roughen areas by rolling with a crimping or punching type roller or by track walking. Track walking should only be used where other methods are impractical because track walking with heavy equipment typically compacts the soil.

A variety of mulches can be used effectively at construction sites. Consider the following:

Mulch	
Functions	
Erosion Control	Yes
Sediment Control	Moderate
Site/Material Management	No

June 2012 Urban Drainage and Flood Control District MU-1
Urban Storm Drainage Criteria Manual Volume 3

EC-4

Mulching (MU)

- Clean, weed-free and seed-free cereal grain straw should be applied evenly at a rate of 2 tons per acre and must be tacked or fastened by a method suitable for the condition of the site. Straw mulch must be anchored (and not merely placed) on the surface. This can be accomplished mechanically by crimping or with the aid of tackifiers or nets. Anchoring with a crimping implement is preferred, and is the recommended method for areas flatter than 3:1. Mechanical crimpers must be capable of tucking the long mulch fibers into the soil to a depth of 3 inches without cutting them. An agricultural disk, while not an ideal substitute, may work if the disk blades are dull or blunted and set vertically; however, the frame may have to be weighted to afford proper soil penetration.
- Grass hay may be used in place of straw; however, because hay is comprised of the entire plant including seed, mulching with hay may seed the site with non-native grass species which might in turn out-compete the native seed. Alternatively, native species of grass hay may be purchased, but can be difficult to find and are more expensive than straw. Purchasing and utilizing a certified weed-free straw is an easier and less costly mulching method. When using grass hay, follow the same guidelines as for straw (provided above).
- On small areas sheltered from the wind and heavy runoff, spraying a tackifier on the mulch is satisfactory for holding it in place. For steep slopes and special situations where greater control is needed, erosion control blankets anchored with stakes should be used instead of mulch.
- Hydraulic mulching consists of wood cellulose fibers mixed with water and a tackifying agent and should be applied at a rate of no less than 1,500 pounds per acre (1,425 lbs of fibers mixed with at least 75 lbs of tackifier) with a hydraulic mulcher. For steeper slopes, up to 2000 pounds per acre may be required for effective hydroseeding. Hydromulch typically requires up to 24 hours to dry; therefore, it should not be applied immediately prior to inclement weather. Application to roads, waterways and existing vegetation should be avoided.
- Erosion control mats, blankets, or nets are recommended to help stabilize steep slopes (generally 3:1 and steeper) and waterways. Depending on the product, these may be used alone or in conjunction with grass or straw mulch. Normally, use of these products will be restricted to relatively small areas. Biodegradable mats made of straw and jute, straw-coconut, coconut fiber, or excelsior can be used instead of mulch. (See the ECM/TRM BMP for more information.)
- Some tackifiers or binders may be used to anchor mulch. Check with the local jurisdiction for allowed tackifiers. Manufacturer's recommendations should be followed at all times. (See the Soil Binder BMP for more information on general types of tackifiers.)
- Rock can also be used as mulch. It provides protection of exposed soils to wind and water erosion and allows infiltration of precipitation. An aggregate base course can be spread on disturbed areas for temporary or permanent stabilization. The rock mulch layer should be thick enough to provide full coverage of exposed soil on the area it is applied.

Maintenance and Removal

After mulching, the bare ground surface should not be more than 10 percent exposed. Reapply mulch, as needed, to cover bare areas.

MU-2 Urban Drainage and Flood Control District June 2012
Urban Storm Drainage Criteria Manual Volume 3

Colorado Springs, CO
5540 Tech Center Dr., Suite 100
Colorado Springs, CO 80919
Phone: 719.227.0072
www.respec.com



WOODMEN HILLS METROPOLITAN DISTRICT
THERIOT CONCRETE WATER TANK
GRADING & EROSION CONTROL DETAILS 5

NO.	DESCRIPTION	BY	APP.	DATE
1				
2				
3				
4				
5				
6				
7				

100% DESIGN



Proj.#: 112.126
Date: 07/08/24
Design: RMM
Drawn: RMM
Check: JPM

PCD File No. PPR-

C11
SHEET 11 OF 19

APPENDIX E – ESQCP

EROSION AND STORMWATER QUALITY CONTROL PERMIT (ESQCP) EL PASO COUNTY APPLICATION AND PERMIT

APPLICANT INFORMATION

PERMIT NUMBER

Owner Information	
Owner	Woodmen Hills Metropolitan District
Name (person of responsibility)	JD Shivvers
Company/Agency	Woodmen Hills Metropolitan District
Position of Applicant	Water Enterprise Director
Address (physical address, not PO Box)	8046 Eastonville Road
City	Peyton
State	CO
Zip Code	80831
Mailing address, if different from above	
Telephone	719-495-2500
FAX number	
Email Address	Jd.shivvers@whmd.org
Cellular Phone number	
Contractor/Operator Information	
Name (person of responsibility)	TBD
Company	
Address (physical address, not PO Box)	
City	
State	
Zip Code	
Mailing address, if different from above	
Telephone	
FAX number	
Email Address	
Cellular Phone number	
Erosion Control Supervisor (ECS)*	TBD
ECS Phone number*	
ECS Cellular Phone number*	

*Required for all applicants. May be provided at later date pending securing a contract when applicable.

PROJECT INFORMATION

Project Information	
Project Name	Woodmen Hills Metropolitan District – Theriot Water Tank Replacement
Legal Description	Lot A, Woodmen Hills Filing No. 2, County of El Paso, State of Colorado
Address (or nearest major cross streets)	8990 Theriot Road, Peyton, CO 80831
Acreage (total and disturbed)	Total: 1.0 acre (43,560 sf) Disturbed: 0.82 acres (35,806 sf)
Schedule	Start of Construction: November 2024 Completion of Construction: May 2025 Final Stabilization: Summer 2025
Project Purpose	The purpose of the project is to construct a water storage tank to replace an existing water storage tank and pump station on the same site. The new facility will bolster water storage capacity for the District.
Description of Project	The proposed project includes construction of a 5,630 square-foot concrete water storage tank and underground site piping associated with the tank.
Tax Schedule Number	5236001016

FOR OFFICE USE ONLY

The following signature from the ECM Administrator signifies the approval of this ESQCP. All work shall be performed in accordance with the permit, the El Paso County Engineering Criteria Manual (ECM) Standards, City of Colorado Springs Drainage Criteria Manual, Volume 2 (DCM2) as adopted by El Paso County Addendum, approved plans, and any attached conditions. The approved plans are an enforceable part of the ESQCP. Construction activity, except for the installation of initial construction BMPs, is not permitted until issuance of a Construction permit and Notice to Proceed.

Signature of ECM Administrator: _____

Date _____

1.1 REQUIRED SUBMISSIONS

In addition to this completed and signed application, the following items must be submitted to obtain an ESQCP:

- Permit fees
- Stormwater Management Plan (SWMP) meeting the requirements of DCM2 and ECM either as part of the plan set or as a separate document.
- Cost estimates of construction and maintenance of construction and permanent stormwater control measures (Cost estimates shall be provided on a unit cost basis for all stormwater BMPs);
- Financial surety in an amount agreeable to the ECM Administrator based on the cost estimates of the stormwater quality protection measures provided. The financial surety shall be provided in the form of a Letter of Credit, Surety with a Bonding Company, or other forms acceptable to El Paso County;
- Operation and Maintenance Plan for any proposed permanent stormwater control measures; and
- Signed Private Detention Basin/Stormwater Quality Best Management Practice Maintenance Agreement and Easement, if any permanent stormwater control measures are to be located on site.

1.2 RESPONSIBILITY FOR DAMAGE

The County and its officers and employees, including but not limited to the ECM Administrator, shall not be answerable or accountable in any manner, for injury to or death of any person, including but not limited to a permit holder, persons employed by the permit holder, persons acting in behalf of the permit holder, or for damage to property resulting from any activities undertaken by a permit holder or under the direction of a permit holder. The permit holder shall be responsible for any liability imposed by law and for injuries to or death of any person, including but not limited to the permit holder, persons employed by the permit holder, persons acting in behalf of the permit holder, or damage to property arising out of work or other activity permitted and done by the permit holder under a permit, or arising out of the failure on the permit holder's part to perform the obligations under any permit in respect to maintenance or any other obligations, or resulting from defects or obstructions, or from any cause whatsoever during the progress of the work, or other activity, or at any subsequent time work or other activity is being performed under the obligations provided by and contemplated by the permit.

To the extent allowed by law, the permit holder shall indemnify, save, and hold harmless the County and its officers and employees, including but not limited to the BOCC and ECM Administrator, from all claims, suits or actions of every name, kind and description brought for or on account of injuries to or death of any person, including but not limited to the permit holder, persons employed by the permit holder, persons acting in behalf of the permit holder and the public, or damage to property resulting from the performance of work or other activity under the permit, or arising out of the failure on the permit holder's part to perform his obligations under any permit in respect to maintenance or any other obligations, or resulting from defects or obstructions, or from any cause whatsoever during the progress of the work, or other activity or at any subsequent time work or other activity is being performed under the obligations provided by and contemplated by the permit, except as otherwise provided by state law. The permit holder waives any and all rights to any type of expressed or implied indemnity against the County, its officers or employees.

1.3 APPLICATION CERTIFICATION

We, as the Applicants or the representative of the Applicants, hereby certify that this application is correct and complete as per the requirements presented in this application and the El Paso County Engineering Criteria Manual and Drainage Criteria Manual, Volume 2 and El Paso County Addendum.

We, as the Applicants or the representatives of the Applicants, have read and will comply with all of the requirements of the specified Stormwater Management Plan and any other documents specifying stormwater best management practices to be used on the site including permit conditions that may be required by the ECM Administrator. We understand that the stormwater control measures are to be maintained on the site and revised as necessary to protect stormwater quality as the project progresses. We further understand that a Construction Permit must be obtained and all necessary stormwater quality control measures are to be installed in accordance with the SWMP, the El Paso County Engineering Criteria Manual, Drainage Criteria Manual, Volume 2 and El Paso County Addendum before land disturbance begins and that failure to comply will result in a Stop Work Order and may result in other penalties as allowed by law. We further understand and agree to indemnify, save, and hold harmless the County and its officers and employees, including but not limited to the BOCC and ECM Administrator, from all claims, suits or actions of every name, kind and description as outlined in Section 1.2 Responsibility for Damage.

JD Shivers
Signature of Owner or Representative

Date: 8/21/2024

JD Shivers
Print Name of Owner or Representative

Signature of Operator or Representative

Date: _____

Print Name of Operator or Representative

Permit Fee \$ _____

Surcharge \$ _____

Financial Surety \$ _____

Type of Surety _____

Total \$ _____