

Department of Public Works

Engineering Division
719-520-6460
Chuck Brown Transportation Complex
3275 Akers Drive
Colorado Springs, CO 80922
www.ElPasoCo.com

Board of County Commissioners
Holly Williams, District 1
Carrie Geitner, District 2
Stan VanderWerf, District 3
Longinos Gonzalez, Jr., District 4
Cami Bremer, District 5

SUMMARY MEMORANDUM

TO: El Paso County Board of County Commissioners
FROM: El Paso County Department of Public Works
DATE: July 18, 2023
RE: ECM-23-001, Proposed Amendments to the El Paso County Engineering Criteria Manual

Summary

A request by the El Paso County Department of Public Works (DPW) for approval of various amendments to the El Paso County Engineering Criteria Manual (ECM). The request also includes the ability to administratively approve revisions necessary to carry out the intent of the proposed amendments. The ECM was completed in 2004 and revisions were made in 2006, 2007, 2009, 2011, 2015, 2016, 2019, and 2020.

Notation

Please see the Planning Commission Minutes for a complete discussion of the topic and the Planning Commission staff report for staff analysis.

Discussion

Planning Commission had a general discussion on the proposed amendments to the ECM. The Planning Commission had no objections to the proposed amendments but did recommend further revising proposed revisions to sections 2.2.5 and Section 4.4.1 to reflect active voice approach as well as an administrative correction to the Planning Commission Staff Report to clarify that Chapter 4 was included in the revisions. These recommendations did not substantively change the intent of the proposed amendments and are included in the proposed draft that have been prepared for consideration by the Board of County Commissioners.

The below is a detailed summary of the proposed ECM Amendments:

Page No. and Sect. or Table No.)	Change
3 (Sect. 1.5.)	Added a bridge design reference text
6 (Sect. 1.12.)	Add clarification for required construction plan sheet size

18	(Sect. 1.22.)	Amended name of County Department
19	(Sect. 1.22.)	Added MTCP acronym and definition
21	(Table 2-1)	Corrected ECM section reference number (within table)
22	(Sect. 2.1.3.)	Deleted reference to Standard Drawings being contained within Appendix F of the ECM
23	(Table 2-2)	Amended text and date for Standard Drawings
23	(Sect. 2.1.4.)	Amended Resolution reference number and added impact fee requirement clarification
25-36	(multiple figures)	Figures updated to reflect new safety edge requirement
36	(Sect. 2.2.5.)	Deleted text and added text to clarify CDOT access permit requirement clarification
39	(Sect. 2.2.7.B.)	Deleted word “Policy” from subsection title
39-40	(Sect. 2.2.7.D.)	Added new subsection D. (re: Safety Edge)
41	(Table 2-4)	Added text and amended text
42	(Table 2-5)	Added text, added a footnote, and amended text
42-3	(Table 2-6)	Amended text and deleted text
43-4	(Table 2-7)	Added text and amended text
49	(Table 2-12)	Amended numeral (measurement) in footnote 1
49	(Table 2-13)	Amended numeral (measurement) in footnote 1
52	(Sect. 2.3.6.A.)	Amended numeral (measurement)
56	(Sect. 2.3.6.G.)	Deleted text and added reference to AASHTO Green Book
57	(Figure 2-23)	Deleted current figure (to be replaced with AASHTO figure)
57	(Table 2-21)	Footnote 2 - Deleted text and added reference to AASHTO
58	(Sect. 2.3.7.)	Deleted text (wording error / typo)
59	(Sect. 2.3.7.C.)	Deleted paragraph (conflicted with Table 2-7, fn. 1)
69-70	(Sect. 2.3.7.I.)	Deleted text and added text (re: Roundabout design requirements)
71	(Figure 2-31)	corrected pavement width on cul-de-sac figure
72	(Sect. 2.3.8.B.)	Deleted text and added text (re: eyebrows and knuckles)
73-4	(Figure 2-32)	Amended title of Figure 2-32, deleted figure, and added figures related to eyebrows and knuckles
77	(Sect. 2.4.1.C.2.)	Added clarification text to access design to include multi-family
78	(Table 2-34)	Table deleted from ECM and replaced with correct AASHTO sight distance table



79	(Sect. 2.4.1.E.3.)	Added text (“and Local”) to recognize that commercial and industrial access can be obtained from local roads
80	(Sect. 2.4.1.F.2.)	Deleted maximum numeral (measurement) for access design
80	(Sect. 2.4.1.G.)	Added text to clarify apron design requirements
84	(Sect. 2.5.2.C.5.)	Amended title of subsection, deleted text, and added text related to eyebrow and knuckle requirements
135	(Sect. 4.4.1.)	Amended first sentence to clarify USPS design approval requirement
136	(Sect. 4.4.2.)	Added text (re: cluster boxes and kiosks)
136	(Sect. 4.4.4.)	Added text, deleted text, and corrected numeral type
136-7	(Sect. 4.4.5.)	Changed numeral, deleted text, and added text (re: mailbox location and installation)
137-38	(two figures)	Amended title for Figures 4-1 and 4-2; both figures deleted and replaced with new figures for mail box-pullouts
138	(Sect. 4.4.6.)	Deleted entire subsection (duplicative criteria)
138	(Sect. 4.4.7.)	Deleted entire subsection related to responsibility for mailbox damage (inconsistent with adopted snow and ice-control policy)
268	(Appx. F)	Amended title for Appendix F, amended text, and added text
268-70	(Table)	Amended a drawing title and several dates to be amended
270	(Appx. F)	Added title text “EPC Standard Specifications” before drawings
270-	(Appx. F)	Amended standard drawings to add safety edge, clarify sidewalk and curb and gutter pour is not monolithic, add knuckle and eyebrow standard drawings, update cul-de-sac standard drawings

Planning Commission Recommendation and Vote

Mr. Trowbridge moved / Mr. Moraes seconded for approval, various amendments to Chapters 1, 2, 4 and Appendix F of the El Paso County Engineering Criteria Manual, that this item be forwarded to the Board of County Commissioners for their consideration. The motion was approved (7-0). The item was heard as a regular agenda item.

Attachments

1. Proposed Changes to the El Paso County Engineering Criteria Manual (redline version)
2. Proposed Changes to the El Paso County Engineering Criteria Manual (clean version)
3. Proposed Changes to the El Paso County Engineering Criteria Manual Standard Drawings (clean version)
4. HBA Letter of Support
5. Planning Commission Staff Report
6. Planning Commission Minutes from June 1, 2023.
7. Signed Planning Commission Resolution
8. Draft BOCC Resolution



**ENGINEERING CRITERIA MANUAL
COUNTY OF
EL PASO, COLORADO**

Adopted: December 23, 2004

Revised: December 13, 2016

Published in 2018



SUPPLEMENT HISTORY TABLE

The table below allows users of this Manual to quickly and accurately determine what resolutions have been considered for codification in each supplement. Resolutions that are of a general and permanent nature are codified in the Code and are considered "Includes." Resolutions that are not of a general and permanent nature are not codified in the Code and are considered "Omits."

In addition, by adding to this table with each supplement, users of this Manual will be able to gain a more complete picture of the Manual's historical evolution.

Res. No.	Date Adopted	Included/ Omitted	Supp. No.
19-245	7- 2-19	Included	1
Res. No. 20-222	6-23-20	Included	2

Chapter 1 GENERAL PROVISIONS

1.1. TITLE

This document is called the "Engineering Criteria Manual" and shall be referred to throughout the text as the "ECM."

1.2. AUTHORITY

The El Paso Board of County Commissioners (BOCC) has adopted the ECM by resolution pursuant to the authority given by the Colorado Constitution and the following sections of the Colorado Revised Statutes, as amended:

- Article 1 of Title 32 (Special District Act/Provisions),
- Article 1 of Title 34 (Preservation of Commercial Mineral Deposits),
- Article 2 of Title 43 (State, County and Municipal Highways),
- Article 4 of Title 41 (Airports),
- Article 6 of Title 28 (Division of Aviation),
- Article 11 of Title 30 (County Powers and Functions),
- Article 15 of Title 30 (County Regulations under Police Power),
- Article 20 of Title 29 (Local Government Land Use Control Act),
- Article 28 of Title 30 (County Planning and Building Code),
- Article 30.5 of Title 38 (Conservation Easements),
- Article 32 of Title 22 (Zoning, Planning and Building Code Duties of School District Boards),
- Article 65.1 of Title 24 (Areas and Activities of State Interest), and
- Article 68 of Title 24 (Vested Property Rights).

1.3. PURPOSE

The purpose of this ECM is to set standards for designing, constructing, locating, maintaining, choosing materials for, repairing, reconstructing and using public improvements and guiding design and construction of common development improvements in El Paso County (County). The ECM was developed to be consistent with the El Paso County Land Development Code (LDC). The standards are necessary to protect and promote public health, safety, and the general welfare of the public; ensure that public infrastructure meets commonly accepted engineering standards; and maintain consistency and fairness in development review.

The ECM governs the quality of workmanship must be adhered when constructing public and development-related improvements. The ECM also provides standards for County staff to adhere to in reviewing plans and inspecting construction.

1.4. APPLICABILITY

1.4.1. Activities

The provisions of ECM shall apply to the planning, design, construction, enlargement, alteration, relocation, removal, conversion, demolition, repair, excavation and use of any public improvements. The ECM shall also apply as guidance or as specific regulatory standards when required by the LDC to common development improvements. The ECM applies to public and private projects including:

-
- new construction and modification of transportation facilities, storm drainage facilities, utilities, and any facility located in County rights-of-way or easements, whether occurring under permit or franchise, and other transportation facilities, storm drainage facilities, utilities and any facilities mandated by the LDC.
 - facilities outside County rights-of-way (such as private roads or drainage systems), which are regulated through the LDC and County's police power authority to ensure public health, safety, and welfare, and Title 30, Article 15, Colorado Revised Statutes.
 - every new placement and every planned, non-emergency replacement of existing utility poles and other utility structures within the County's rights-of-way.
 - reconstruction, resurfacing, restoration, and rehabilitation of existing transportation facilities, storm drainage facilities, utilities and any other facilities located in County rights-of-way or easements, as well as other transportation facilities, storm drainage facilities, utilities, and facilities mandated by the LDC, as far as practicable and feasible.

1.4.2. Jurisdiction

The ECM applies to all subdividers, developers, landowners, owners of facilities located in the County's rights-of-way or easements and their employees, agents or contractors that design, construct, and maintain facilities or conduct activities subject to review and approval under the provisions of the ECM or where required by the LDC in El Paso County. The ECM further applies to the County and their employees, agents or contractors.

1.5. STANDARDS ADOPTED BY REFERENCE

The BOCC hereby adopts the following documents and standards by reference:

- Colorado Department of Transportation (CDOT) Standard Specifications for Road and Bridge Construction;
- Colorado Department of Transportation (CDOT) State Highway Access Code;
- Colorado Department of Transportation (CDOT) Field Materials Manual;
- [Colorado Department of Transportation \(CDOT\) LRFD Bridge Design Manual](#);
- American Association of State Highway & Transportation Officials (AASHTO) including Roadway Design Guide and Bicycle Design;
- Institute of Transportation Engineers (ITE) Trip Generation Manual;
- American Society for Testing Materials (ASTM);
- Manual on Uniform Traffic Control Devices (MUTCD);
- Colorado Springs and El Paso County Drainage Criteria Manual Volume 1 (DCM1);
- City of Colorado Springs' Drainage Criteria Manual Volume 2 (DCM2): Stormwater Quality Policies, Procedures and Best Management Practices;
- The State of Colorado, Department of Transportation M&S Standards;
- El Paso County's Road Impact Fee Program;
- ASCE Code of Ethics;
- City of Colorado Springs Drainage Criteria Manual Volume 1, 2014 Update: Chapter 6 and Section 3.2.1 of Chapter 13;

-
- The Urban Drainage and Flood Control District's Urban Storm Drainage Criteria Manual: Volume 3, Chapter 7, Construction BMPs (version applicable at time of project design);
 - United States Access Board, Proposed Guidelines for Pedestrian Facilities in the Public Right-of-Way (PROWAG), 2011;
 - United States Access Board, Proposed Guidelines for Pedestrian Facilities in the Public Right-of-Way; Shared Use Paths Supplement, 2013;
 - United States Department of Justice, 2010 ADA Standards for Accessible Design (ADA Standards), 2010; and
 - United States Department of Justice, Americans with Disabilities Act Title II Regulations (ADA Regulations), 2010.

The referenced documents and standards are enforceable parts of the ECM and may be amended and revised at the discretion of the BOCC in accordance with requirements and processes prescribed by the Colorado Constitution and applicable provisions of the Colorado Revised Statute.

(Res. No. 19-245 , 7-2-19; Res. No. 20-222 , 6-23-20)

1.6. MINIMUM STANDARDS

The standards presented in this ECM are considered the minimum requirements and design values necessary to accomplish the purpose of the ECM. Where minimum values are stated, greater values should be used whenever practical and consistent with State law; where maximum values are stated, lesser values should be used where practical.

Situations might arise where the application of individual standards from the ECM will not ensure the protection of public health, safety, and welfare. Accordingly, the ECM Administrator may impose additional or more stringent standards than those contained in the ECM, or require the modification of plans, specifications or operations to achieve the necessary public health, safety, and welfare. Modifications may include, but are not limited to, scheduling, phasing or timing restrictions. The standards contained herein are not a substitute for sound professional engineering judgment.

1.7. NO STANDARDS SPECIFIC PROVIDED IN ECM

In the case of those improvements that are required by the County, but are not specifically addressed by the ECM, the County will require the owner, permit holder, developer, contractor, and their agents to follow applicable local, state, and federal guidelines or standards promulgated by professional organizations. The ECM Administrator shall be consulted for guidance on proper references.

1.8. MUNICIPAL STANDARDS MAY APPLY IN 3-MILE PLAN AREA

In areas subject to the requirements of C.R.S. § 31-12-105 (3-Mile Plan Areas), the design standards of the municipality may be applied if approved by the ECM Administrator. In cases where ECM standards are more restrictive, the ECM Administrator may require compliance with the ECM.

1.9. DEVIATIONS FROM STANDARDS

The ECM standards represent appropriate practice under most conditions, based on past experience in the County and in other jurisdictions. The Standards are intended to ensure that facilities are safe and appropriate for use in the County.

Engineering design is an endeavor that examines alternative solutions to real world situations. These standards are not intended to limit the introduction of new ideas. Situations will arise where alternatives to these standards may

Created: 2021-06-08 11:35:47 [EST]

(Supp. No. 2)

better accommodate existing conditions, overcome adverse topography or allow for more cost-effective solutions without adversely affecting safety, operations, maintenance or aesthetics.

Accordingly, requests for deviations from these standards will be considered by the ECM Administrator. The request for a deviation may be considered if the request is not based exclusively on financial considerations. The deviation must not be detrimental to public safety or surrounding property. Requests must be submitted and reviewed in accordance with the process outlined in Chapter 5 and include supporting information demonstrating compliance with all of the following criteria:

- The deviation will achieve the intended result with a comparable or superior design and quality of improvement.
- The deviation will not adversely affect safety or operations.
- The deviation will not adversely affect maintenance and its associated cost.
- The deviation will not adversely affect aesthetic appearance.
- The deviation meets the design intent and purpose of these Standards.
- The deviation meets the control measure requirements of Part I.E.3 and Part I.E.4 of the County's MS4 permit, as applicable.

It is recognized that the need for and timing of a deviation request may not be predictable. Requests should be submitted as soon as the need becomes known. No request will be considered until an application for a permit or other approval has been submitted. Known deviation requests that affect lot yield or scope of development must be decided before holding any public hearing or making an official decision on the application. This is important for public notice and participation in the decision process.

Deviations that affect engineering design, to the extent they are known, must be decided before submitting construction plans. This will minimize additional effort in the preparation of plans with non-standard features that cannot be approved.

The ECM Administrator is the final authority on all deviation requests. The ECM Administrator reserves the right to deny a deviation from these Standards, at any time, in the interest of public health, safety, and welfare.

1.9.1. PUD Zoning Districts

The ECM Administrator may establish, on a case-by-case basis, special standards (i.e., deviations) that apply to a project with a Planned Unit Development (PUD) zoning classification. The ECM Administrator, in establishing such standards, shall first find that there are mitigating elements in the design of the project that allow for such special standards and that the special standards are in conformance with the intent and purpose of these Standards.

1.9.2. Alternate Materials and Methods of Construction

The provisions of these Standards are not intended to prevent the use of any material or method of construction not specifically prescribed by these Standards, provided any alternate is approved in writing by the ECM Administrator as a deviation.

The ECM Administrator, as indicated above, shall require that sufficient evidence or proof be submitted to substantiate any request that may be made regarding the alternate method or material.

(Res. No. 19-245 , 7-2-19)

1.10. CONFLICTING PROVISIONS

The following standards shall apply in considering conflicts between provisions of the ECM:

- Whenever any provision of the ECM conflicts with a provision in any federal, state or local law, ordinance, resolution, rule, or regulation, the more restrictive or higher standard shall be used.
- Whenever any provision of the ECM conflicts with another provision of the ECM, the more restrictive or higher standard shall be used.
- Whenever any provision of the ECM conflicts with any provision of the documents and standards adopted by referenced, the provision of the ECM shall be used.

1.11. PERMITS REQUIRED

No owner, permit holder, developer, contractor, and their agents shall do or cause to be done any work governed by the ECM without first having obtained a permit to do the work in accordance with the provisions of Chapter 5. All work shall be done in accordance with the ECM, approved plans, and the conditions of the required permits. In many cases, a Notice to Proceed is also required before beginning work in accordance with the terms and conditions of a permit issued under the provisions of Chapter 5.

Other permits, approvals or agreements may be required by the County or others having jurisdiction before initiating any activities subject to the ECM. It is the responsibility of the owner, permit holder, developer, contractor and their agents to identify and secure all required permits, approvals, or agreements required to do the work.

1.12. PLAN REVIEW PROCEDURES, GENERAL

For County-constructed roads and drainage projects, plan review requirements are governed by the ECM and the policies and procedures of the ECM Administrator. For owner, permit holder, and developer-constructed public improvements and development or subdivision related improvements, all plans, reports, drawings, and specifications that support permit or land use applications are governed by the LDC, ECM and the policies and procedures of the ECM Administrator.

Construction plans are required (sheets shall be 11" x 17" - half size) for all proposed road and drainage-related improvements. Chapter 5 of the ECM outlines the submittal requirements. In some cases, additional engineering data may be required to be submitted. Construction documents will be valid for a period of 2 years from the date signed by the El Paso County Engineer. If construction has not started within 2 years of being signed by the El Paso County Engineer, the plans will need to be resubmitted for approval. Fees for the re-approval will be in accordance with the fee schedule current at the time of plan re-approval.

Engineering Record Drawings (also known as "as-built" plans) for roads and drainage facilities must be submitted before final acceptance of any public facility and release of the required surety.

1.13. PROFESSIONAL QUALIFICATIONS

Professionals in the fields of engineering, architecture, geology or surveying who prepare or are responsible for preparing plans, drawings, specifications, calculations, technical reports, etc., for the purpose of obtaining County permits or approvals, shall be registered or authorized to practice in the state of Colorado. Registration or authorization to practice shall be in the specific technical area pertinent to the documents being prepared. In some cases, specific additional or special professional qualifications are required for preparing specific studies or plans. Any specific additional or special professional qualifications are identified in those sections of the ECM specifically governing preparation of the study or plan.

1.14. ERRORS AND OMISSIONS

At the discretion of the ECM Administrator, any significant errors or omissions in the approved plans or information used as a basis for such approvals may constitute grounds for withdrawal of the approvals and stoppage of any or all permitted work. It is the responsibility of the owner, permit holder, developer, contractor or their agents to demonstrate why work should continue and to make changes in plans that may be required by the ECM Administrator before the plans are re-approved.

1.15. OWNER, PERMIT HOLDER, DEVELOPER, CONTRACTOR AND AGENT RESPONSIBILITIES

1.15.1. Permit and Construction

It is the responsibility of the owner, permit holder, developer, contractor, and their agents to:

- Have an approved set of plans, required permits and Notice to Proceed before commencement of any work governed by the ECM.
- Notify the ECM Administrator in advance of the commencement of any authorized work, in accordance with permit requirements. A pre-construction meeting and field review may be required by the ECM Administrator before the commencement of any work on significant projects.
- Perform all work in accordance with the terms and conditions of the permit, ECM, and all applicable local, state, and federal laws.
- Have an approved set of plans, permits, and a copy of the ECM on the job site wherever work is being accomplished.
- Provide tests to substantiate the adequacy and placement of construction materials if requested by the ECM Administrator.

1.15.2. General Right-of-Way and Site Maintenance

The owner, permit holder, developer, contractor, and their agents shall:

- Schedule and control work so as to comply with all applicable provisions of El Paso County codes and applicable state and federal laws and to prevent any hazards to public safety, health, and welfare.
- Maintain two-way traffic on existing roads for vehicles, bicycles, and pedestrians at all times unless detour plans or lane closures have been approved in advance by the ECM Administrator.
- Keep roads, bridges, bikeways, and pedestrian facilities free of dirt, debris or any obstructions. Paved temporary detour(s) shall be provided when necessary and not detrimental to the abutting properties. See Chapter 6 for providing accessible pedestrian facilities in work zones.
- Maintain pedestrian and vehicular access to occupied buildings, except where written approval from the building owner has been obtained.
- Complete on-site grading in a manner that minimizes off-site erosion and siltation in conformance with all statutory requirements, permits, and approved plans.

1.15.3. Work Conditions

- A. **Action by ECM Administrator to Protect Public or Private Interests.** When the owner, permit holder, developer, contractor, or their agents have not taken sufficient precautions for the safety of the public or the protection of the work, adjacent structures or property, and when, as a result, the ECM Administrator determines a loss-of-life or damage could result, the ECM Administrator, with or without

notice to the owner, permit holder, developer, contractor or their agents, may provide suitable protection by causing work to be done and materials to be furnished and placed as the ECM Administrator may consider necessary to protect the public or any private interest. The cost and expense of the ECM Administrator's action including the cost of labor, equipment and material is the responsibility of the owner, permit holder, developer, contractor, or their agents. All costs shall be paid by the owner, permit holder, developer, contractor, or their agents within 30 calendar days upon receipt of the invoice from the ECM Administrator.

The action performed under the direction of the ECM Administrator shall in no way relieve the owner, permit holder, developer, contractor, or their agents of responsibility for damages that may occur during or after such precaution has been taken.

- B. **Action by Owner to Protect Public or Private Interests.** When an emergency threatening loss of life or damage to the work or an adjoining structure or property is identified by the owner, permit holder, developer, contractor or their agents and the person who identified the emergency is unable to obtain special instructions or authorization from the ECM Administrator, the owner, permit holder, developer, contractor, or their agents are hereby permitted to act to prevent loss of life or damage. The ECM Administrator shall be notified of such emergency work within four hours of the action.
- C. **Final Cleanup.** The owner, permit holder, developer, contractor or their agents shall be responsible for daily clean-up on the project area and shall remove and properly dispose of all surplus and discarded materials, rubbish, and temporary structures from the project area and adjacent areas. They shall, where appropriate, leave the project area swept and in a neat and clean condition. The owner, permit holder, developer, contractor or their agents shall restore all work areas that have been damaged by the operations to general conformity with the specifications for the item or items involved and to the original condition.

The owner, permit holder, developer, contractor or their agents will be responsible for keeping roads free of dirt, mud, and any debris during construction. The work shall conform to the requirements for erosion control, as described in the statutes, ordinances or regulations. The owner, permit holder, developer, contractor or their agents shall be responsible, at their own expense, for keeping on-site roads used as construction routes and rights-of-way clean of mud, rocks, and debris at all times during said construction.

The owner, permit holder, developer, contractor or their agents shall inspect and clean the interior of all manholes and catch basins within the construction limits or impacted by the construction.

The owner, permit holder, developer, contractor or their agents shall, within 24 hours of the ECM Administrator's notification of noncompliance with this section, commence clean-up operations and shall diligently pursue completion of said clean up to the satisfaction of the ECM Administrator. The County may revoke any and all permit approvals until the owner, permit holder, developer, contractor or their agents remedy the problem if:

- the owner, permit holder, developer, contractor or their agents fail to respond within 24 hours, or
- the ECM Administrator is unable to contact the owner, permit holder, developer, contractor or their agents after reasonable effort, or
- the owner, permit holder, developer, contractor or their agents fail to diligently pursue clean-up operations to the satisfaction of the ECM Administrator.

The ECM Administrator may also choose to have the streets and rights-of-way cleaned by County crews or an outside contracted firm and invoice the owner, permit holder, developer, contractor or their agents for all costs. All cost shall be paid by the owner, permit holder, developer, contractor or their agents within thirty days of being invoiced.

-
- D. **Suspension of Work.** In case of suspension of work for any cause whatsoever, the owner, permit holder, developer, contractor or their agents, before leaving the job site, shall take such precautions as may be necessary to prevent damage to the work; provide for proper drainage; and erect any necessary barricades, signs, or other facilities. The owner, permit holder, developer, contractor or their agents will take the above precautions at their own expense, as required by applicable standards.

1.15.4. Protection of Existing Facilities

The owner, permit holder, developer, contractor or their agents shall notify the electric and gas utility, telephone company, cable television, and all other interested parties before beginning work. They shall have their facilities staked and located in the field in order to ensure that there are no interruptions of these services during progress of the work.

Existing power lines, telephone lines, trees, shrubbery, fences, water mains and services, gas mains and services, sewer mains and services, cables, conduits, drainage and irrigation ditches and pipes, embankments, and other structures in the vicinity of the work not authorized to be removed, shall be supported and protected from damage by the owner, permit holder, developer, contractor or their agents during the construction and until completion of work.

The owner, permit holder, developer, contractor or their agents shall preserve intact any underground pipes or other utilities encountered during construction. The owner, permit holder, developer, contractor or their agents shall be liable for all damages done to such existing facilities and structures and shall hold the County harmless from any liability or expense for injuries, damages or repairs to such facilities. The type, size, approximate location and number of all known underground utilities shall be shown on all drawings. It shall be the responsibility of the owner, permit holder, developer, contractor or their agents to verify the existence and location of all underground utilities along the route of the work.

1.15.5. Traffic Control

The flow of traffic on public streets and roadways shall be maintained at all times during construction in accordance with the rules, regulations, and conditions as set forth in the Work in the Right-of-Way Permit issued by the ECM Administrator. Existing pedestrian access routes and circulation paths should be maintained through construction, alterations, and maintenance operations whenever feasible. When the pedestrian access routes and circulation paths must be closed during these operations, an alternate pedestrian access route should be provided. See Section 6.3.11 for more information.

The owner, permit holder, developer, contractor or their agents shall be responsible for the provision of a safe travel-way on all roadways on and adjacent to the job site. The owner, permit holder, developer, contractor or their agents shall erect or cause erection of proper traffic control warning devices around all excavations, embankments, and obstructions. The owner, permit holder, developer, contractor or their agents shall be responsible for the proper maintenance of said erected devices, in accordance with their approved Work in the Right-of-Way permit.

The owner, permit holder, developer, contractor or their agents shall cause suitable warning lights or flares to be provided and kept lighted at night or other times when visibility is limited.

The owner, permit holder, developer, contractor or their agents shall provide flaggers or off-duty police protection, as may be determined by the ECM Administrator, for the protection of the public and workers on the job site.

The owner, permit holder, developer, contractor or their agents shall coordinate with the ECM Administrator so that arrangements may be made by the owner, permit holder, developer, contractor or their agents for detours, parking, and access to property adjacent to work, etc., 48 hours before they are needed.

The owner, permit holder, developer, contractor or their agents shall not work within any portion of a road right-of-way without receiving a Work in the Right-of-Way Permit from the ECM Administrator at least 48 hours before they begin work. Full roadway closures will be reviewed on a case-by-case basis; time of review will vary based on the extent of the closure.

The County reserves the right to refuse to allow full road closures. Requirements for such closures will be determined at the time of issuance of the permit. The owner, permit holder, developer, contractor or their agents will be responsible for all public notices, public meetings, and requirements as outlined in the Work in the Right-of-Way Permit. The owner, permit holder, developer, contractor or their agents shall notify the police and fire departments at least 48 hours before closure and immediately after opening of any street, alley, or fire lane.

The ECM Administrator shall close down work that is not controlled in accordance with approved barricading procedures or on projects that require a Work in the Right-of-Way Permit, but on which one has not been obtained by the owner, permit holder, developer, contractor or their agents.

No work shall be allowed at signalized intersections or on arterial roadways that impedes normal traffic flow from 6:00 a.m. to 8:30 a.m. and 3:30 p.m. to 7:00 p.m., except during emergencies or with prior approval of the ECM Administrator.

1.15.6. Safety

Machinery, equipment, materials, and all hazards shall be guarded or eliminated in accordance with the MAPC and all applicable federal regulations including Office of Safety and Health Administration (OSHA), state, County, and municipal laws and regulations. No blasting shall be done without the prior approval of the County. Safety equipment, devices, and clothing shall be utilized by personnel where required by federal, state, and local laws. The owner, permit holder, developer, contractor or their agents shall strictly comply with MUTCD for temporary and permanent traffic control.

1.15.7. Removal of Unacceptable Work

Work shall be considered unacceptable if it does not conform to the approved plans and specifications or if it results in an inferior or unsatisfactory product. Unacceptable work found to exist prior to the final acceptance of the work shall be immediately removed and replaced or corrected by, and at the expense of, the owner, permit holder, developer, contractor or their agents, whether the unacceptable work is the result of poor workmanship, poor design, use of defective materials, damage through carelessness or any other cause. This expense includes total and complete restoration of any disturbed surface to original or to better than the original condition that existed before the repairs or replacement, regardless of improvements on lands where the repairs or replacement are required.

1.15.8. Control of Materials

- A. **Samples and Tests.** To ascertain whether materials comply with contract requirements, samples shall be taken at the source or at the job destination as often as the ECM Administrator deems necessary. Samples shall be collected in accordance with standard practices, except where methods and procedures for sampling materials are otherwise set forth in this ECM.

The owner, permit holder, developer, contractor or their agents shall furnish, when requested by the ECM Administrator, a written statement of the origin, composition, and sample manufacture process of a material.

Any samples shall be collected and any tests performed shall be done so at the expense of the owner, permit holder, developer, contractor or their agents.

-
- B. **Storage of Material.** Material shall be stored to ensure the preservation of its quality and suitability for the work. Stored material, even though inspected prior to storage, shall be subject to inspection prior to its use in the work and shall meet all requirements of these Standards at the time it is used. Stored material shall be located to facilitate inspection. With the ECM Administrator's approval, the owner, permit holder, developer, contractor or their agents may use portions of the right-of-way for storage purposes. Any additional storage required shall be secured by, and at the expense of, the owner, permit holder, developer, contractor or their agents.
 - C. **Defective Materials.** Materials not in conformance with the requirements of these Standards shall be considered defective and shall be rejected. Rejected materials shall be removed from the job site at the expense of the owner, permit holder, developer, contractor or their agents.

1.15.9. Protection of Public and Utility Interests

- A. **Public Convenience and Safety.** Fire hydrants shall be visible and accessible to the fire district from the road at all times. No permanent or temporary obstructions (including, but not limited to, fencing, street lighting, landscaping, and mailboxes) shall be placed within 6 feet of a fire hydrant.

Unless otherwise specified, the owner, permit holder, developer, contractor or their agents shall give written notice to the proper authorities in charge of streets, gas and water pipes, sanitary and storm sewer facilities, electric service, cable television and other conduits, railroads, poles, manholes, catch basins and all other property that may be affected by the operations, at least 48 hours before breaking ground. The owner, permit holder, developer, contractor or their agents shall not hinder or interfere with any person in the protection of such property or with the operation of utilities at any time. The owner, permit holder, developer, contractor or their agents must obtain all necessary information regarding existing utilities, protect such utilities from damage, and avoid unnecessary exposure so that they shall not cause harm to the public.

The owner, permit holder, developer, contractor or their agents shall obtain all necessary information regarding the planned installation of new utilities and cables, conduits and transformers; make proper provision; and give proper notification so that new utilities and electrical equipment can be installed at the proper time without delay or unnecessary inconvenience. All underground utilities and electrical equipment shall be installed prior to the placement of the final lift of pavement.

When the work involves excavation adjacent to any properties or structures along the work site, the owner, permit holder, developer, contractor or their agents shall give such property owners sufficient written notice thereof, and shall furnish a copy to the ECM Administrator.

- B. **Protection and Restoration of Property and Monuments.** The owner, permit holder, developer, contractor or their agents shall use every precaution to prevent the damage or destruction of public or private property adjacent to or interfering with the work (such as poles; trees; shrubbery; crops; fences; monuments; and all overhead structures, such as wires and cables) within or outside of the right-of-way.

The owner, permit holder, developer, contractor or their agents shall protect and support all water, gas, sanitary sewer, storm sewer, electrical pipes and conduits, railroad tracks, buildings, walls, fences, landscaping, significant wetlands, or other properties that might be damaged during the execution of work. All reasonable and proper precautions shall be taken to protect property, persons, animals, and vehicles from injury. Wherever necessary, fencing or railing shall be placed around any excavation and a sufficient number of amber lights shall be on from twilight until sunrise. One or more guards shall be employed as additional security wherever they are needed or required by the ECM Administrator.

The owner, permit holder, developer, contractor or their agents shall not prevent the flow of water in the gutters of the street and shall use proper means to permit the flow of surface water along the gutters while the work is in progress.

The owner, permit holder, developer, contractor or their agents shall protect and carefully preserve all land boundary and all survey control monuments until the surveyor for the owner, permit holder, developer, contractor or their agents have referenced their location for relocation. All monuments disturbed or removed by the owner, permit holder, developer, contractor or their agents shall be replaced by a licensed surveyor at the expense of the owner, permit holder, developer, contractor or their agents.

The owner, permit holder, developer, contractor or their agents shall be responsible for the damage or destruction of property resulting from neglect, misconduct, or omission in the manner or method of execution or nonexecution of the work, or caused by defective work or the use of unsatisfactory materials. They shall restore such property to a condition similar to or better than existed before such damage or injury was done by repairing, rebuilding, or replacing it as might be directed.

The owner, permit holder, developer, contractor or their agents shall bear the cost of repairing underground pipes, wires, or conduits damaged by the work. The owner, permit holder, developer, contractor or their agents shall be liable for all damage caused by storms and fire. They shall, under no circumstances, start fires without first securing the necessary permits and approval of the authority having jurisdiction, even though they may be ordered or required to do such burning. While burning brush, stumps, or rubbish, care shall be taken not to damage any standing trees, shrubs or other property.

The owner, permit holder, developer, contractor or their agents shall ensure the continued availability of public services including, but not limited to, postal, solid waste collection, emergency services, and public utilities.

- C. **Protection of Streams, Lakes, and Reservoirs.** The owner, permit holder, developer, contractor or their agents shall take all necessary precautions to prevent pollution of streams, lakes, reservoirs, and irrigation ditches with fuels, oils, bitumen, sodium chloride, calcium chloride or other harmful materials. The operations shall be conducted and scheduled to avoid or minimize siltation of streams, lakes, and reservoirs. A plan for erosion protection shall be submitted to the ECM Administrator for approval before starting work and must conform to all local, state, and federal laws and regulations.
- D. **Barricades, Warning Signs, and Flagmen.** Work shall be barricaded as necessary at all times. Between the hours of sunset and sunrise barricades shall be properly lighted to warn all persons. Signs, barricades, lights, and warning devices shall be constructed and used in accordance with the most current version of the MUTCD. These guidelines shall be strictly enforced by the ECM Administrator during the progress of the work.

The owner, permit holder, developer, contractor or their agents shall be responsible for obtaining a Work in the Right-of-Way Permit before beginning work. The owner, permit holder, developer, contractor or their agents shall apply for the permit and submit a traffic control plan for review and approval by the ECM Administrator.

The owner, permit holder, developer, contractor or their agents shall be responsible for all damages to the work due to failure to place barricades, signs, lights, and flaggers and other workers to protect it. Whenever evidence of such damage is found prior to acceptance, the ECM Administrator may order the damaged portion immediately removed and replaced by the owner, permit holder, developer, contractor or their agents.

1.15.10. Warranty

The permit holder is required to warrant Improvements for 2 years, as described in Chapter 5 and the standard Development Agreement and Subdivision Improvement Agreement. The preliminary and final acceptance processes are also described in Chapter 5.

(Res. No. 20-222 , 6-23-20)

1.16. ADMINISTRATION

1.16.1. Discretionary Authority

The ECM Administrator may utilize discretionary authority as it relates to the provisions of the ECM. Judgments will take into consideration the individual situation, but in no instance will safety features or structural integrity prescribed by these Standards be sacrificed. Where the design standards, standard specifications or standard drawings do not cover improvements, the ECM Administrator shall establish appropriate standards.

1.16.2. Delegation and Review of Differences of Opinion

The ECM Administrator may appoint personnel as appropriate to administer these standards. The personnel appointed may only exercise the specific authority delegated to them by the ECM Administrator.

When a difference of opinion occurs between personnel appointed to exercise the authority of the ECM Administrator and an owner, permit holder, developer, contractor or their agents, the owner, permit holder, developer, contractor or their agents are required to obtain a review and decision from the ECM Administrator before appealing an issue to the BOCC. To obtain a review and decision, the owner, permit holder, developer, contractor or their agents shall submit a written request to the ECM Administrator identifying the conflict and describing the unresolved issue. After reviewing all pertinent information, the ECM Administrator will advise those interested parties of the decision relative to the conflict.

1.16.3. Interpretation

Interpretations of this ECM are made by the ECM Administrator. The ECM Administrator's interpretations of provisions may be appealed to the BOCC. The meanings and construction of words and phrases established in this section apply throughout the ECM.

- Words and phrases must be read in context and construed according to the rules of grammar and common usage. Words and phrases that have acquired a technical or particular meaning, whether by definition under the definitions section of the ECM, by legislative declaration or otherwise, must be construed accordingly.
- The particular controls the general.
- Mandatory requirements use the words "shall," "must" or "will" and are sometimes labeled "Standards." Recommendations use the words "may" or "should" and are sometimes labeled "Guidelines" or "Criteria".
- Words used in the present tense include the future, unless the context clearly indicates otherwise.
- Words or provisions apply. The word "or" indicates connected words or that provisions may apply singly or in any combination.
- Words indicating a specific gender apply to all persons and things unless the context clearly indicates otherwise.

(Supp. No. 2)

Created: 2021-06-08 11:35:47 [EST]

-
- A reference to days is to calendar days unless otherwise specified in this code or state statute. If a deadline falls on a weekend or County holiday, the deadline extends to the next working day.
 - When computing a period of days, the first day is excluded and the last day is included. If the last day falls on a weekend or County holiday, the last day is the next working day.

Section and subsection headings are for convenience only. They do not govern, limit or modify the scope, meaning or intent of the ECM.

1.16.4. Revisions to Approved Plans

Work performed within or outside the public right-of-way as mandated by the LDC, ECM or other County codes shall comply with the approved plans, the approved specifications, and these standards. The ECM Administrator must approve any revision to construction plans before the change is implemented.

1.16.5. Enforcement

The ECM Administrator has the authority to enforce the ECM as well as other referenced or pertinent standards and specifications. The ECM Administrator shall appoint personnel as appropriate to inspect work completed pursuant to the ECM standards. Personnel appointed may only exercise the specific authority delegated to them by the ECM Administrator.

Whenever any work is being done contrary to the provisions of these Standards, the ECM Administrator may order the work stopped by a written notice served on any persons engaged in doing the work or causing of the work to be done. Persons shall stop work until authorized by the ECM Administrator to proceed.

1.16.6. Inspection

The ECM Administrator is authorized to inspect all work completed and all material furnished. Inspections may extend to all or any part of the work and to the preparation, fabrication or manufacture of the materials to be used. The ECM Administrator shall notify the owner, permit holder, developer, contractor or their agents of any failure of the work or material conformity with these Standards. The ECM Administrator shall have the authority to reject materials until any questions at issue can be resolved by the ECM Administrator.

The ECM Administrator shall, in no case, act as foreman or perform other duties for, or interfere with the management of work done by, the owner, permit holder, developer, contractor or their agents. Any "advice" that the ECM Administrator might give the owner, permit holder, developer, contractor or their agents shall not be construed as binding upon the County in any way or release the owner, permit holder, developer, contractor or their agents from fulfilling all of the terms of these Standards.

The presence or absence of the ECM Administrator shall not relieve, in any degree, the responsibility or the obligation of the owner, permit holder, developer, contractor or their agents. The ECM Administrator, or an authorized designee, shall, at all times, be provided reasonable and safe access to inspect the work whenever it is in preparation or progress.

1.16.7. Right to Require Additional Tests

Whenever there is insufficient evidence of compliance with any of the provisions of these Standards or evidence that any material or construction does not conform to the requirements herein, the ECM Administrator may require that the owner, permit holder, developer, contractor or their agents, at their expense, provide test results to establish compliance. Such tests shall be as specified by these Standards or by other recognized test standards approved by the ECM Administrator. If there are no recognized and accepted test methods, the ECM Administrator shall determine test procedures. Before testing begins, all tests shall be made by an agency approved by the ECM Administrator. Reports of such test results shall be retained by the County.

1.17. SURETY

Where authorized by the ECM, surety may be required by the ECM Administrator to guarantee the performance of, maintenance of or to correct permitted work. The type and amount of surety shall be per the applicable ECM Standard or, if not specified, at the discretion of the ECM Administrator.

Types of surety include, but are not limited to, cash deposits, assigned savings, and bonds. The ECM Administrator shall release surety upon satisfactory completion of the required work or any previously specified stipulations related to the required work in accordance with the surety release provisions of the ECM.

1.18. PENALTIES

Failure to comply with the ECM will be cause for withholding or withdrawing approval of plans or drawings; withholding of surety, final inspection approval or occupancy certificates; and other penalties as provided by County regulations or state law.

1.19. NO WAIVER OF LEGAL RIGHTS

The County shall not be precluded or stopped by any measurement, estimate, or certificate made either before or after the completion and acceptance of the work from showing:

- The true amount and character of the work performed and materials furnished by the owner, permit holder, developer, contractor or their agents, or
- That any such measurement, estimate or certificate is untrue or incorrectly made, or
- That the work or materials do not conform in fact to these Standards.

1.20. AMENDMENT AND REVISIONS

The ECM may be amended or revised at the sole discretion of the BOCC in accordance with requirements and process prescribed by the Colorado Constitution and applicable provisions of Colorado Revised Statute.

Upon consultation with the County Attorney, the ECM Administrator may make the following changes or corrections to the provisions of the ECM when the changes or corrections do not alter the sense or meaning of its provisions:

- Misspellings. Misspelled words may be corrected.
- Histories. Erroneous legislative histories may be corrected.
- Cross-references. Cross-references may be changed to agree with new, amended, reenacted, renumbered, re-lettered, reallocated or corrected ordinances or resolutions.
- Capitalization. Improper capitalization may be corrected.
- Headings. Descriptive headings of titles, chapters, sections or subsections may be edited or added to briefly and clearly indicate the subject matter of the title, chapter, section or subsection.
- Renumbering; re-lettering. The numbering or lettering of sections, including duplicative numbering or lettering created by conflicting enactments, may be corrected or properly arranged.
- Changed job titles; agency names. References in design standards to specific job titles or agency names that are changed without substantial effect on job or agency responsibilities may be changed to refer to the new job title or agency name.

-
- Punctuation. Punctuation, including hyphenization, may be corrected.
 - Clerical Errors. Typographical or grammatical errors may be corrected.
 - Gender. Gender-specific terms that occur may be changed to gender-neutral terms and necessary grammatical changes to properly use the gender neutral terms may be made.
 - Mandated Changes. Additions, deletions, or revisions to design standards may be made when required for compliance with mandatory regional, state or federal regulations.

Any change or correction made under the authority of this section may not affect the substantive meaning of any enactment of the County. Any erroneous or inadvertent substantive change must be construed as a clerical error and given no effect. If the ECM Administrator or County Attorney is in doubt whether a specific change or correction is authorized by this section, the ECM Administrator may not make the change or correction under authority of this section.

1.21. SEVERABILITY

Except as otherwise provided, a determination by a court that a provision of the ECM is unconstitutional or invalid does not make the remainder of the ECM unconstitutional or invalid. A determination by a court that the application of the ECM to a particular project or parcel of land is unconstitutional or invalid does not apply to any other project or parcel of land.

1.22. TERMS AND DEFINITIONS

Whenever, in these Standards, the words "as ordered", "as directed", "as required", "as permitted", "as allowed", or words or phrases of like meaning are used, it shall be understood that the order, direction, requirement, permission, or allowance of the ECM Administrator is intended. Unless otherwise specified herein, the words "approved", "reasonable", "suitable", "acceptable", "properly", "satisfactory", or words of like meaning shall mean approved, reasonable, suitable, acceptable, proper or satisfactory in the judgment of the ECM Administrator. The following terms, definitions, and acronyms used in the ECM shall be defined as follows (See the LDC for additional definitions of terms not defined in this section):

AASHTO — American Association of State Highway and Transportation Officials.

Acceleration Lane — A speed change lane, including tapered areas, to enable a vehicle entering a roadway to increase its speed to a rate at which it can safely merge with through traffic.

Access — The place, means or way by which vehicles shall have a safe, adequate and usable ingress and egress to a property, use or parking space from a road.

ADA — Americans with Disabilities Act of 1990.

ADT Average daily traffic — The total two-directional volume of traffic during a given time period (in whole days), greater than one day and less than one year, divided by the number of days in that time period.

Alteration— A change to a facility within or adjacent to public roadways that affects or could affect pedestrian access, circulation, or use. Alterations include, but are not limited to, resurfacing, rehabilitation, reconstruction, historic restoration, or changes or rearrangement of structural parts or elements of a facility. Many modifications to traffic signals are also considered alterations.

Applicable Construction Activities — Construction activities that result in a land disturbance of greater than or equal to one acre or that is less than one acre, but is part of a larger common plan of development or sale that would disturb, or has disturbed since March 2, 2001, one acre or more, unless excluded consistent with Chapter 5 or the disturbed areas have been finally stabilized.

Applicant — The individual, firm, business entity, trust, association, syndicate, partnership, or corporation of record or any person designated by the property owner who has applied for or is requesting a permit.

ASTM — American Society for Testing and Materials.

Best Management Practices — Schedules of activities, prohibitions of practices, maintenance procedures, and other management practices to prevent or reduce the pollution of "state surface waters." BMPs also include treatment requirements for and operating procedures and practices to control plant site runoff, spillage or leaks, sludge or waste disposal, or drainage from raw material storage. The term BMP is used interchangeably with the term control measure, and can include other methods such as the installation, operation, and maintenance of structural controls and treatment devices.

Board of County Commissioners or BOCC — The El Paso County legislative board.

CDOT — Colorado Department of Transportation.

Clear Zone — The total roadside border area, starting at the edge of the travel lane, available for safe use by errant vehicles. This area may consist of a shoulder, a recoverable slope, a nonrecoverable slope or a clear runout area.

Common Development Improvement — Improvements under the ownership or control and maintained by a private or public entity other than El Paso County, including greenways, drainage systems and permanent stormwater management facilities.

Common Plan of Development or Sale — A contiguous area where multiple separate and distinct construction activities may be taking place at different times on different schedules, but remain related. "Contiguous" means construction activities located in close proximity to each other (i.e., within ¼ mile). Construction activities are considered to be "related" if they share the same development plan, builder or contractor, equipment, storage areas, etc.

Construction activity — Refers to ground surface disturbing and associated activities (land disturbance), which include, but are not limited to, clearing, grading, excavation, demolition, installation of new or improved haul roads and access roads, staging areas, stockpiling of fill materials, and borrow areas. Construction does not include routine maintenance to maintain the original line and grade, hydraulic capacity, or original purpose of the facility. Activities to conduct repairs that are not part of regular maintenance or for replacement are construction activities and are not routine maintenance. Repaving activities where underlying and/or surrounding soil is cleared, graded, or excavated as part of the repaving operation are considered construction activities unless they are an excluded site described in section 1.7.2.E of this ECM. Construction activity is from initial ground breaking to final stabilization regardless of ownership of the construction activities.

Control Measure — Any best management practice or other method used to prevent or reduce the discharge of pollutants to waters of the state. Control measures include but are not limited to best management practices. Control measures can include other methods such as the installation, operation, and maintenance of structure controls and treatment devices.

Construction Plans — Project drawings subject to County review and approval prior to construction that show the location, character, and dimensions of the proposed work, such as layouts, profiles, cross sections, details, methods, and general notes.

Construction Representative — The person who directly inspects or who directly supervises the inspection of the construction of a project, on behalf of the permit holder, to ensure compliance with the plans and standard specifications. The Construction Representative maintains the Engineering Record Drawings. The Construction Representative is not required to be a registered Professional Engineer, but shall have adequate construction and design experience to perform the work required by these standards.

Contractor — A person, partnership, corporation, subcontractor or other legal entity that undertakes to construct, install, alter, move, demolish, repair, replace, excavate or add to any public improvements covered by these Standards.

County — El Paso County, Colorado.

County Attorney — El Paso County Attorney.

County Engineer — The County Road Engineer for El Paso County with authority and duties as designated in Colorado Revised Statutes or his/her authorized designee.

Deceleration Lane — A speed change lane including tapered areas, to enable a turning vehicle to slow to a safe turning speed after it has left the mainstream of faster moving traffic.

Defect Warranty Period — Shall be the time frame during which the permit holder is held liable for all work performed and materials utilized prior to final acceptance by El Paso County.

Design Engineer — The engineer who directly prepared plans and calculations or who directly supervises the preparation of project plans and calculations. The Design Engineer seals, signs, and dates the plans and calculations certifying that they meet the required standards.

Design Speed — A selected speed used to determine the various geometric design features of the roadway.

Developer — A property owner, or his/her agents or contractors, who are responsible for applying for or receiving a permit or approval for development.

Development Agreement — An agreement with the County which clearly establishes the terms and conditions of the approval, including the applicant's responsibility regarding project phasing, the provision of public and private facilities and improvements, and any other mutually agreed to terms and requirements. The agreement may also serve to implement the site specific development plan which establishes vested rights under Article 68 of Title 24, C.R.S.

Deviation — A technical adjustment from these Standards approved by the ECM Administrator due to unusual circumstances.

Driveway — A physical access that connects a private property or properties to the County road system. These accesses are typically privately owned and privately maintained. El Paso County permits where driveways connect to the public road system and how they connect to the road. All driveway maintenance is the responsibility of the property owner(s).

Easement — A right granted by a property owner to specifically named parties or to the public for the use of certain land for specified purposes. Where appropriate to the context, easement may also refer to the land covered by the grant.

ECM — The El Paso County Engineering Criteria Manual.

ECM Administrator — The County Engineer or his/her authorized designee.

Encroachment — Occupancy of a County right-of-way by non-roadway structures or other objects.

Emergency Work — Construction work that responds to an unforeseen combination of circumstances or the resulting conditions that call for immediate action to restore utility service, pedestrian and traffic flow, or mitigate a safety hazard.

Encroachment — Occupancy of the County right-of-way by non-County-owned non-roadway structures or other objects.

Engineer — A Professional Engineer licensed by the State of Colorado.

EPC PSD-DPW — El Paso County ~~Public Services Department~~Department of Public Works.

FEMA — Federal Emergency Management Agency.

FHWA — Federal Highway Administration.

Created: 2021-06-08 11:35:47 [EST]

(Supp. No. 2)

Final Acceptance — The acknowledgement by the County that the defect warranty period has expired and there are no outstanding items to be corrected under the provisions of the defect warranty.

Franchise — A document granted by the County authorizing the use of County right-of-ways by public or private entities, subject to specified conditions in accordance with State law.

Full Movement Intersection or Access — An intersection or access that allows a full range of turn movements between the two intersecting roads or access.

Inspector — The authorized representative of the County Engineer assigned to make detailed inspection of construction work to assure compliance with these Standards and the plans as approved by the County.

ITE — Institute of Transportation Engineers.

Intersection — The area embraced within the prolongation or connection of the lateral curb lines, or if none, the lateral boundary lines of the roadways of two roads that join one another at, or approximately at, right angles, or the area within which vehicles traveling on different roads that join at any other angle may come into conflict. The junction of an alley or driveway access with a roadway or highway shall not constitute an intersection.

Land Development Code or LDC — The zoning, subdivision, and other land development regulations adopted by the Board of County Commissioners.

Land Disturbing Activity — Any activity that results in a change in the existing land surface (both vegetative and non-vegetative). Land disturbing activities include, but are not limited to clearing, grading, excavation, demolition, installation of new or improved haul roads and access roads, staging areas, stockpiling of fill materials, and borrow areas. Compaction that is associated with stabilization of structures and road construction shall also be considered a land disturbing activity.

Level of Service or LOS — A qualitative measure of traffic flow. Six levels are defined as A through F with A being the best operating conditions and F being the worst (See Highway Capacity Manual).

Manual — El Paso County Engineering Criteria Manual.

Maximum Extent Feasible— Where existing physical constraints make it impracticable for altered elements, spaces, or facilities to fully comply with the ADA and PROWAG requirements for new construction, compliance is required to the extent practicable within the scope of the project. Also referred to as "Maximum Extent Practicable".

MPH — Miles per hour.

MTCP — [The El Paso County Major Transportation Corridors Plan-Update.](#)

MUTCD — The Manual on Uniform Traffic Control Devices, published by the U.S. Department of Transportation.

Municipal Separate Storm Sewer System (MS4) — The system of conveyances owned or operated by El Paso County designed or used for collecting or conveying stormwater, including but not limited to roads with drainage systems, inlets, catch basins, curbs, gutters, pipes, man-made channels, ditches, detention and water quality basins, or storm drains.

Neighborhood Path — A local pathway system that may or may not connect to a larger regional trail network.

Notice to Proceed — A document issued by the ECM Administrator authorizing a permit holder to begin construction of common development, subdivision or public improvements in accordance with an approved set of plans.

NPDES — National Pollutant Discharge Elimination System.

Owner — Any individual, corporation, partnership or other legal entity holding controlling title on property that is the subject a permit or improvements covered by these Standards.

PCD — El Paso Planning and Community Development Department.

Pedestrian Access Route— A continuous and unobstructed path of travel provided for pedestrians with disabilities within or coinciding with a Pedestrian Circulation Path. The Pedestrian Access Route shall comply with PROWAG.

Pedestrian Circulation Path— A prepared exterior or interior surface provided for pedestrian travel within or adjacent to public roadways. The Pedestrian Circulation Path does not have to be accessible; however, the Pedestrian Access Route contained within the Pedestrian Circulation Path shall be accessible to those with disabilities.

Permit Holder — Any individual, corporation, partnership or other legal entity holding a valid permit authorized pursuant to the ECM.

Posted Speed — Maximum vehicle speed signed along a roadway.

Preliminary Acceptance — An acknowledgement by the County that, to the best of the County's knowledge, all work has been completed in accordance with the plans and specifications and the defect warranty period should begin.

Public Improvements — Improvements under the ownership or control of the County and maintained by the County including, but not limited to, the components of the street system and storm drainage system covered by these Standards.

Public Utility — Public utility as defined by Section 401103, C.R.S., 1973.

Record Drawings — An approved final revision of a design drawing or plan updated to include information from field inspections showing the true condition or configuration of what has been built. The drawing or plan is designated Record Drawing by stamp or lettering on the drawing.

Regional Trail — A bike or pedestrian facility designated by the County as a regional trail.

Right-of-Way or ROW — All property in which the County has any form of ownership or title and which is held for public purposes, regardless of whether or not any public improvement exists thereon or whether or not it is used, improved, or maintained for public use.

Roads, Private — A road that is owned and maintained by a private individual, organization, or company, other than a government. All roads within private gated communities are considered private roads and shall be maintained by the residents of that gated community. In order to accept a road for maintenance in El Paso County, any road, existing or proposed, must first meet the standards found within the ECM for a public road.

Roads, Public — Any street, highway, or road under the jurisdiction of and maintained by a public authority and opened to public travel.

Standards — The requirements contained in the El Paso County Engineering Criteria Manual.

Subdivision Improvements Agreement — An enforceable agreement between an applicant and El Paso County that serves as the security arrangement to secure the cost of public improvements required by the ECM and LDC.

Surety — A financial guarantee, by the applicant or permit holder and naming El Paso County as beneficiary, that public infrastructure and other common development or subdivision improvements required by the ECM, LDC, or other County rules and regulations will be completed.

Surveyor — A Professional Land Surveyor licensed by the State of Colorado.

Technically Infeasible— With respect to the accessibility of ADA and PROWAG requirements.

Transportation Impact Study or TIS — A report that documents a study of traffic conditions before and after construction of a proposed development. It addresses any deficiencies in the transportation system, either current or after development, and proposes recommended mitigation.

Warrant — A threshold condition that, if found to be satisfied as part of an engineering study, shall result in analysis of other traffic conditions or factors to determine whether a traffic control signal or other transportation system improvement is justified.

(Res. No. 19-245 , 7-2-19; Res. No. 20-222 , 6-23-20)

Chapter 2 TRANSPORTATION FACILITIES

2.1. OVERVIEW

This chapter addresses the standards and technical criteria to be used to plan, design, construct, choose materials, locate, repair, maintain, reconstruct, and use roadways and other transportation facilities and the associated extrinsic structures.

2.1.1. Purpose

The purpose of this chapter is to provide detailed design guidelines and criteria for the preparation of plans for all County-owned and maintained transportation facilities and access to those facilities. These facilities include roadways and their structures, as well as extrinsic structures that support the use of the transportation facility.

2.1.2. Chapter Content and References

Table 2-1 outlines the chapter content and references used as a basis for the standards established in Chapter 2.

Table 2-1. Contents and Basis of Transportation Facility Standards

Intent Use	ECM Content	ECM Section(s)	Reference Document(s)
Planning			
	Roadway	2.2.1 - 2.2.4 and Appendix B	1, 2, 3
	Access	2.2.5	2
	Soils Investigations	2.2.6 and Appendix C and D	
	Pavement Design	2.2.7	8
Design			
	Roadway	2.3.1 - 2.3.9	3, 7, 9, 11, 12, 13
	Access	2.4.1 - 2.4.2	2, 12
	Extrinsic Structures	2.5.1 - 2.5.7	7, 11
	Structures	2.6.1 - 2.6.10	4, 5, 6, 9, 10
Construction			
	Permitting	5.3 and 5.4	1
	Inspections	5-115.10 and Appendix J	1
	Acceptance	5.3	1

References

1. El Paso County Land Development Code

2. El Paso County Major Transportation Corridor Plan
3. AASHTO, A Policy on Geometric Design of Highways and Roadways
4. AASHTO, Standard Specifications for Highway Bridges
5. AASHTO, LRFD Bridge Design Specifications
6. AASHTO, LRFD Bridge Construction Specifications
7. AASHTO, Roadside Design Guide
8. AASHTO, Standard Specifications Material, Sampling and Testing
9. CDOT, Standard Specifications for Road and Bridge Construction
10. CDOT, Bridge Manual
11. CDOT, M&S Standards
12. US Department of Transportation, Manual on Uniform Traffic Control Devices
13. FHWA, Roundabouts: An Informational Guide

2.1.3. Standard Drawings

Table 2-2 identifies the standard drawings that are included in Appendix F as an enforceable part of these Standards. The Standard Drawing shall be used when designing improvements for County-owned and maintained facilities. Any change to a Standard Drawing shall be approved by the ECM Administrator and noted in the construction plans.

Table 2-2. Standard Drawings

File Name	Detail/Description	Approval Date
SD_2-1	Urban Local Roadway (low volume)	6/23/2020
SD_2-2	Urban Local Roadway	6/23/2020
SD_2-3	Urban NonResidential Collector Roadway	6/23/2020
SD_2-4	Urban Residential Collector Roadway	6/23/2020
SD_2-5	Urban Minor Arterial Roadway	6/23/2020
SD_2-6	Urban Principal 4-Lane Arterial Roadway	6/23/2020
SD_2-7	Urban Principal 6-Lane Arterial Roadway	6/23/2020
SD_2-8	Urban Expressway 4-Lane Roadway	6/23/2020
SD_2-9	Urban Expressway 6-Lane Roadway	6/23/2020
SD-2-10	Rural Gravel Local Roadway	12/31/2005
SD_2-11	Rural Local Roadway	12/31/2005
SD-2-12	Rural Minor Collector Roadway	12/31/2005
SD_2-13	Rural Major Collector Roadway	12/31/2005
SD_2-14	Rural Minor Arterial Roadway	12/31/2005
SD_2-15	Rural Principal 4-Lane Arterial Roadway	12/31/2005
SD_2-16	Rural Principal 6-Lane Arterial Roadway	12/31/2005
SD_2-17	Rural Expressway 4-Lane Roadway	12/31/2005
SD_2-18	Rural Expressway 6-Lane Roadway	12/31/2005
SD_2-20	Typical Curb and Gutter Details	6/23/2020
SD_2-21	Patterned Concrete Median Paving	01/18/2011
SD_2-22	Plowable Median Nose Detail	1/12/2016
SD-2-23	Driveway Cut Detail	08/11/2011

Created: 2021-06-08 11:35:48 [EST]

(Supp. No. 2)

SD-2-24	Driveway Detail w/ Attached Sidewalk	6/23/2020
SD_2-25	Driveway Detail w/ Detached Sidewalk	6/23/2020
SD_2-26	Typical Cross Pan Layout Detail	8/11/2011
SD_2-40	Pedestrian Curb Ramp Detail	6/23/2020
SD_2-41	Pedestrian Curb Ramp Detail	6/23/2020
SD_2-42	Detectable Warning Surface Details	6/23/2020
SD_2-50	Parallel Pedestrian Curb Ramp Detail	6/23/2020
SD_2-70	Type C Aluminum Bridge Railing	08/11/2011
SD_2-71	Oklahoma TR-1 Bridge Railing	08/11/2011
SD_2-72	Nevada Concrete Safety Bridge Railing	08/11/2011
SD_2-73	Safety Shaped Concrete Bridge Railing	08/11/2011
SD_2-74	Texas Type TT Bridge Railing	08/11/2011
SD_2-75	Urban Cul-de-Sac Details	01/01/2008
SD_2-76	Rural Cul-de-Sac Details	01/01/2008
SD_2-77	Urban Knuckle	07/09/2009- <u>approved BoCC date</u>
SD_2-78	Urban Local Low-Volume Knuckle-Eyebrow	07/09/2009 <u>approved BoCC date</u>

2.1.4. Relationship Between ECM and El Paso County Road Impact Fee Program

El Paso County approved a Road Impact Fee Program in 2012 pursuant to Resolution ~~12-38219-471~~, as amended. The Fee Program establishes an impact fee applicable to subdivision and certain zoning actions, and it provides a method of establishing credit for the construction of certain transportation improvements identified in the EPC Major Transportation Corridors Plan. Construction of roads that do not meet these criteria may not be eligible for credit under the Road Impact Fee Program.

(Res. No. 20-222 , 6-23-20)

2.2. PLANNING

2.2.1. Basis for Planning

Proper planning of traffic systems helps to provide a safe and effective transportation network to meet existing and future demands within the County. All transportation system components shall be designed to promote:

- Safety - for vehicular and other modes of travel
- Accessibility - to all users, including those with disabilities
- Performance - efficiency of service for all users
- Livability - impacts mitigated by circulation system improvements and coordinates with adjoining land uses
- Economy - of construction and use of land

The goal of planning transportation facilities is to create a network of roadways that connect, enhance circulation, and provide a balanced relationship between all that uses the roadways through coordination with developed land use plans (strategic and small area).

Transportation system planning requires consideration of the following when planning, designing and laying out facilities:

- Adjoining land uses;
- Natural features (topography, creeks, and wooded areas);
- Circulation;
- Impact to traffic;
- Roadway functional classification standards;
- Road way access criteria;
- Soils investigations; and
- Pavement design.

2.2.2. Circulation

Circulation is important in transportation system design for the following reasons:

- Operation of the arterial road system is improved by dispersing local traffic onto multiple roads and access points;
- Local roads are to be used only for accessing developed lots;
- Response time for emergency services is reduced;
- Time and mileage traveled by individuals and service providers, including school bus transportation, mail delivery, utilities, etc., are reduced; and
- Use of transit systems, and pedestrian and bicycle facilities, is promoted.

2.2.3. Transportation Impact Study (TIS)

- General.** The goal of the TIS is to identify the traffic-related issues that result from development and to determine mitigation techniques required to maintain acceptable levels of service, meet the transportation planning goals, and implement the El Paso County Major Transportation Corridors Plan (MTCP).
- TIS Preparation Guidelines.** A TIS shall be prepared in accordance with the general guidelines in Appendix B. A number of specific parameters shall be evaluated in the TIS based on the level of complexity of the development and location within the transportation network. Three levels of analysis are permitted. Prior to assuming a specific level of required analysis, the design engineer should consult with the ECM Administrator to determine what level of analysis is appropriate and desired in support of a specific project proposal.
- Qualifications to Prepare a TIS.** A TIS shall be prepared under the supervision of, and sealed by, a licensed Professional Engineer in the State of Colorado with experience in traffic engineering and transportation planning.

2.2.4. Roadway Functional Classifications and Urban/Rural Designations

Roadway functional classification is one parameter used to determine appropriate road design. The function of a road is determined by the volume of traffic, length of vehicle trips, and whether the road provides service primarily for vehicular movement or access to abutting land uses. For example, arterial roadways

generally carry significantly greater traffic volumes and variety of traffic types at higher speeds than collector roads. Similarly, collector roads will carry greater traffic volumes at higher speeds than local roads.

Roadway functional classifications for regional based facilities are established by the most recently adopted MTCP. Other roadways are classified by the BOCC based on whether the adjoining land uses are rural or urban in nature (i.e. developments with lots greater than or equal to 2.5 acres), along with the existing and projected objectives of the roadway.

The County recognizes six roadway functional classifications within the rural designation: expressways, principal arterials, minor arterials, major collectors, minor collectors, and locals. The County recognizes seven roadway functional classifications within the urban roadway designation: expressways, principal arterials, minor arterials, nonresidential collectors, residential major collectors, residential minor collectors, and locals.

These Standards have been developed in support of the County roadway functional classification system.

A. Rural Roadways.

1. **Expressway.** Expressways serve high-speed and high-volume traffic over long distances. Access is highly controlled and may have both grade-separated interchanges and full movement signalized intersections. Adjacent, existing and future, land uses shall be served by other network roadways, no direct parcel access is permitted (See Figure 2-1 and Figure 2-2).

Figure 2-1. Typical Rural Expressway Partial Cross Section (6 Lane)

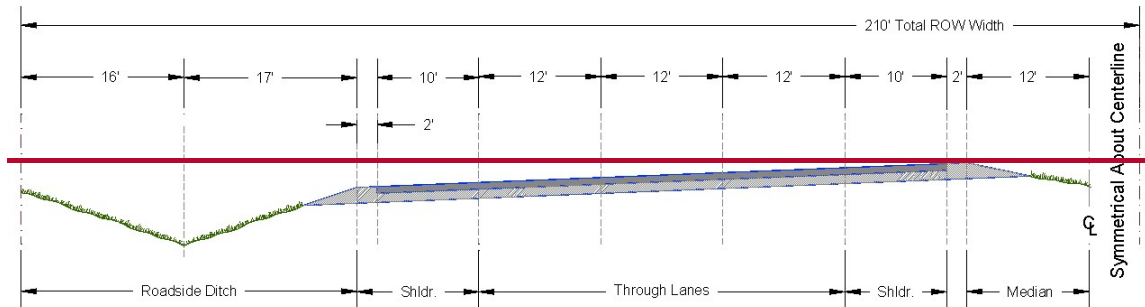
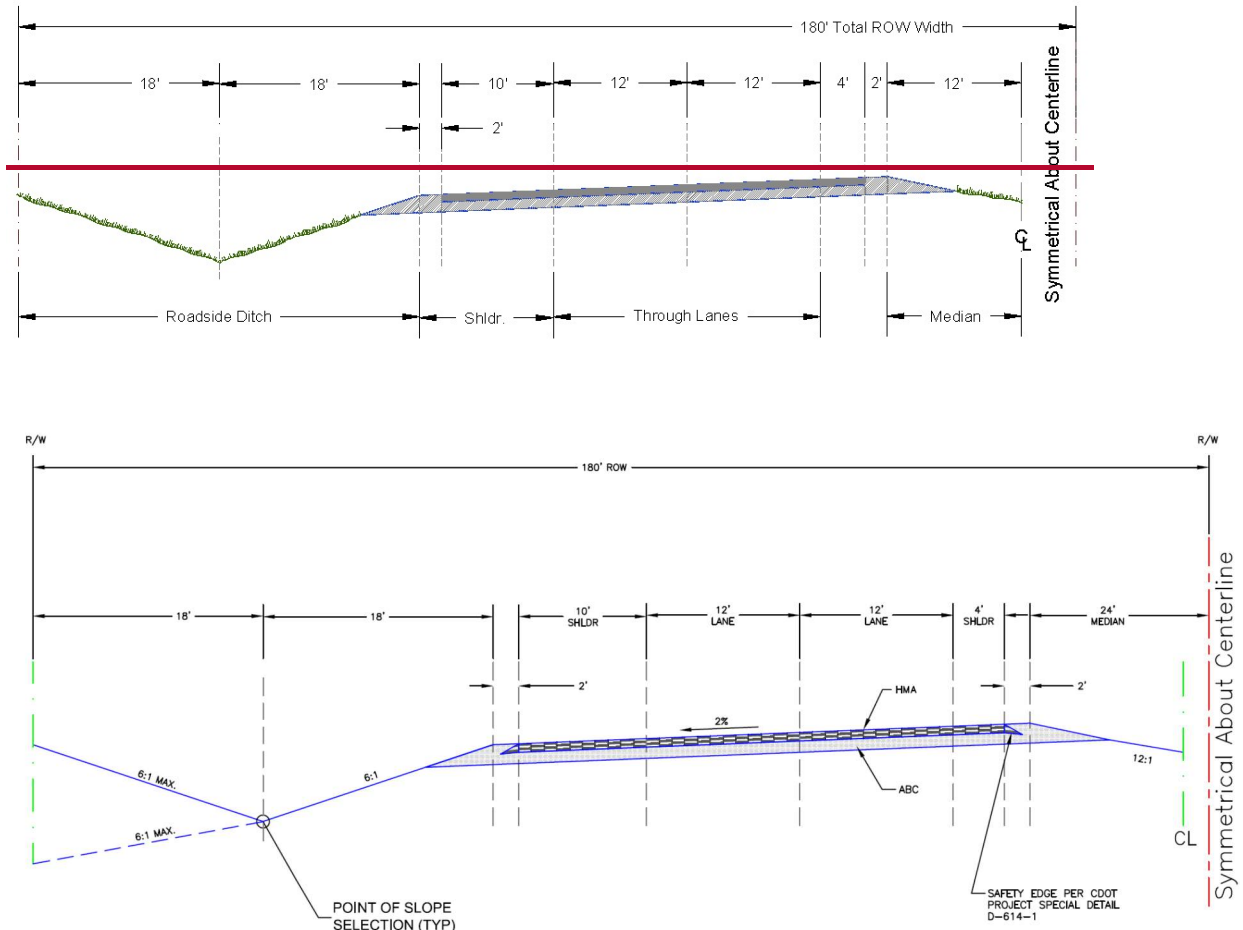

Figure 2-2. Typical Rural Expressway Partial Cross Section (4 Lane)



2. **Principal Arterial.** Principal arterials serve high-speed and high-volume traffic over long distances. Access is highly controlled with a limited number of full movement intersections and medians with infrequent openings, and no direct parcel access. Adjacent, existing and future, land uses shall be served by other network roadways, service roads, and inter parcel connections (See Figure 2-3 and Figure 2-4).

Figure 2-3. Typical Rural Principal Arterial Partial Cross Section (6 Lane)

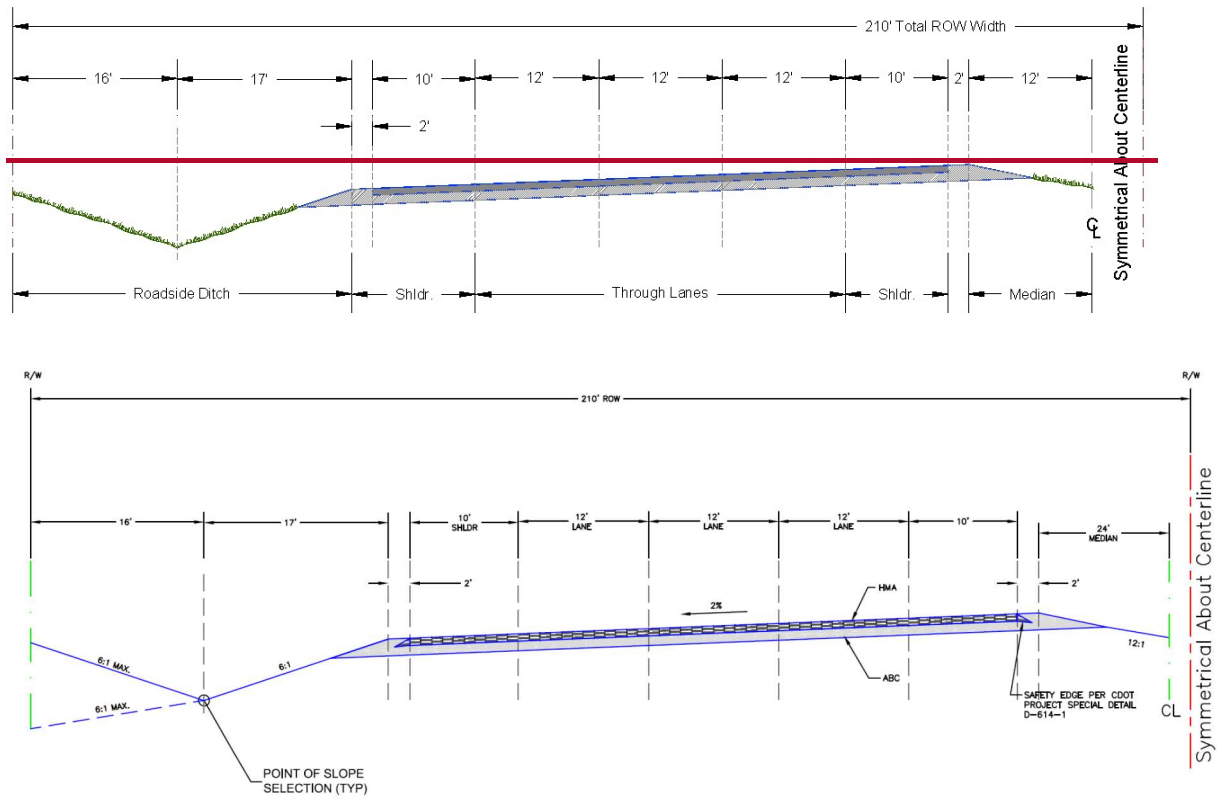
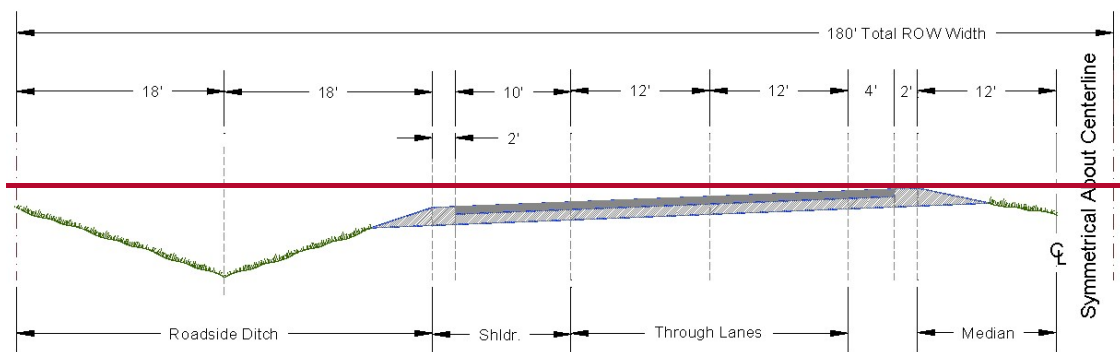
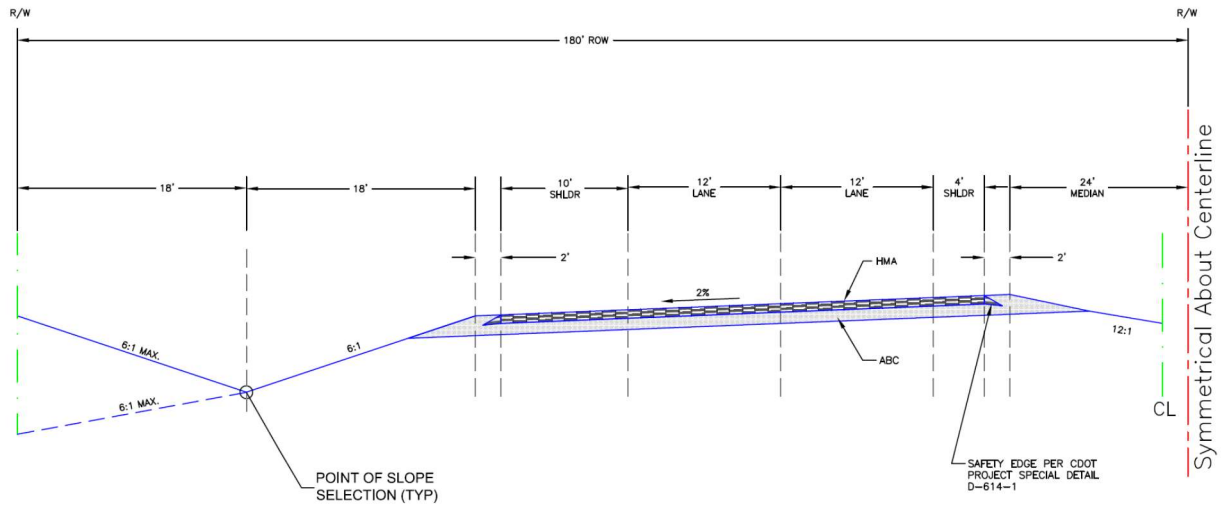

Figure 2-4. Typical Rural Principal Arterial Partial Cross-Section (4 Lane)





- Minor Arterial.** Minor arterials serve high-speed and high-volume traffic over medium distances, or are anticipated to serve this kind of traffic within a twenty-year period. Access is restricted through prescribed distances between intersections, use of medians, and no full movement parcel access (See Figure 2-5). Minor arterial status is assigned to rural roadways where the probability of significant travel demand in the future is high. Rights-of-way, easements, setbacks, and access limitations shall be pursued through the land development process on properties adjacent to minor arterials.

Figure 2-5. Typical Rural Minor Arterial Partial Cross Section

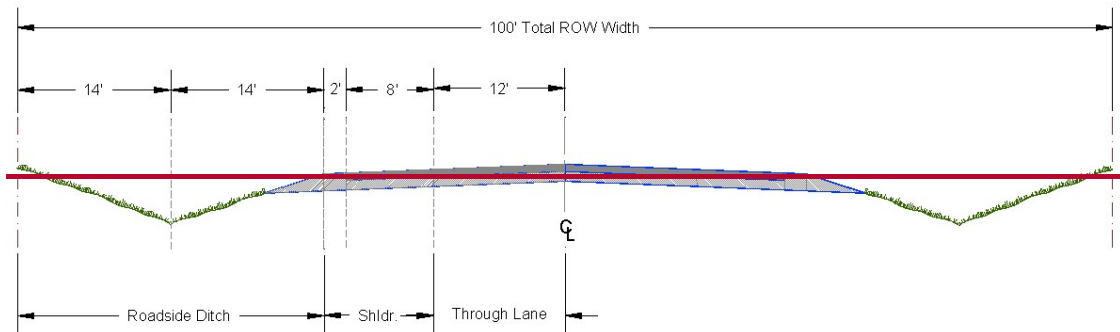

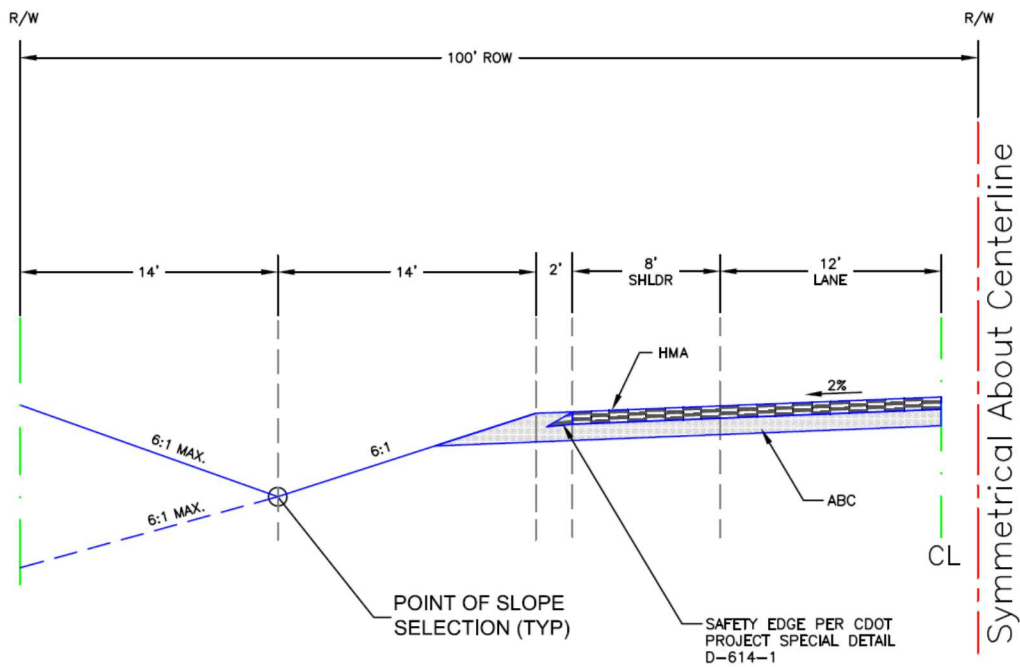

- Major Collector.** Major collectors serve as links between local access and arterial facilities over medium-to-long distances. Major collectors are managed to maximize the safe operation of through-movements at speed. No full movement access is permitted where the local roadways can be expected to provide access (See Figure 2-6). Where no local public roadway can provide access, temporary direct parcel or partial turn movement access may be permitted, provided the design meets requirements presented in these Standards.

Figure 2-6. Typical Rural Major Collector Cross Section

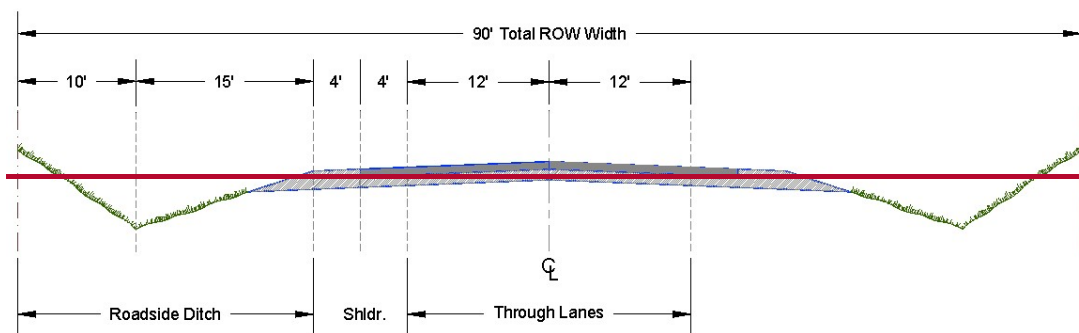

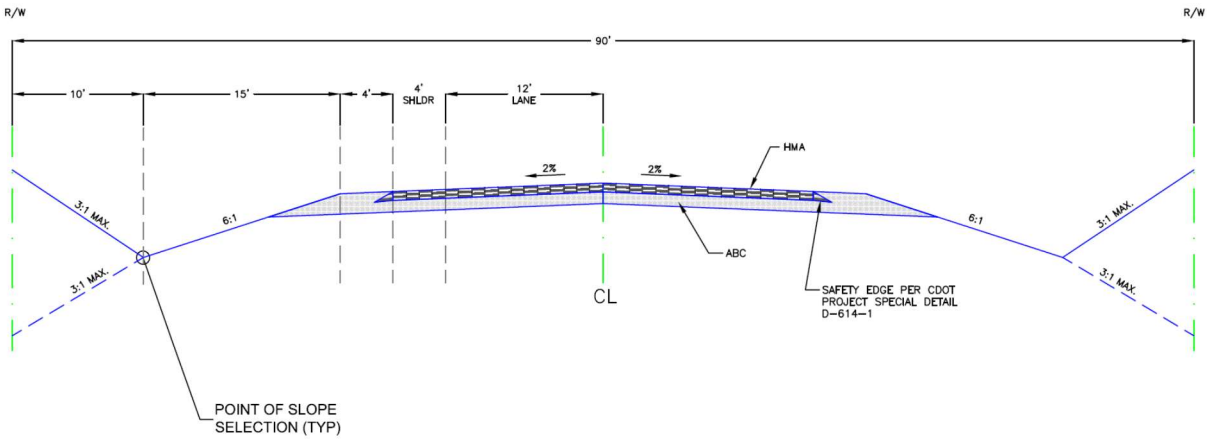

5. **Minor Collector.** Minor collectors link local roadways to major collectors or arterial roadways. No full movement access is permitted where local roadways can be expected to provide access (See Figure 2-7). Where no local public or private roadway can provide access or where lot size is five acres or more, temporary direct parcel or partial turn movement access may be permitted. Access location and design are to be reviewed by the ECM Administrator to ensure roadway objectives are being met.

Figure 2-7. Typical Rural Minor Collector Cross Section

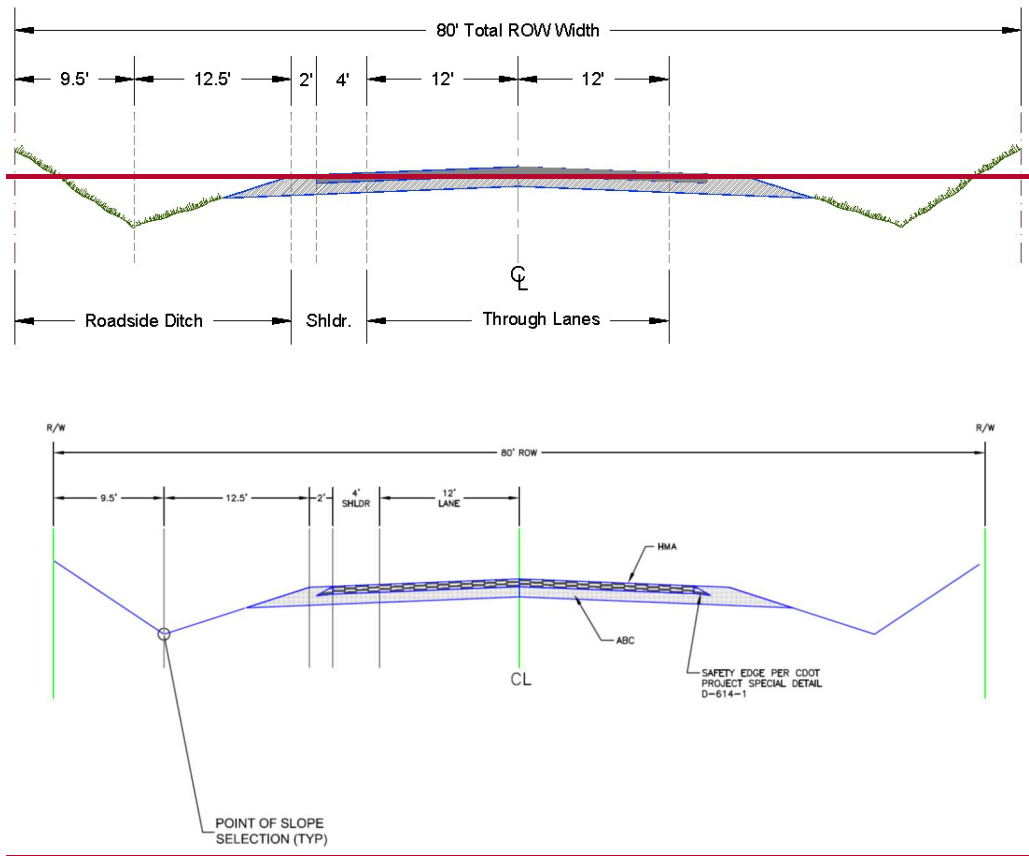

6. **Local.** Local roadways provide direct lot access and deliver lot-generated trips to collector roadways. Although access needs are high, accesses shall not be allowed to compromise the safety, health or welfare of roadway users (See Figure 2-8).

Figure 2-8. Typical Rural Local Cross Section

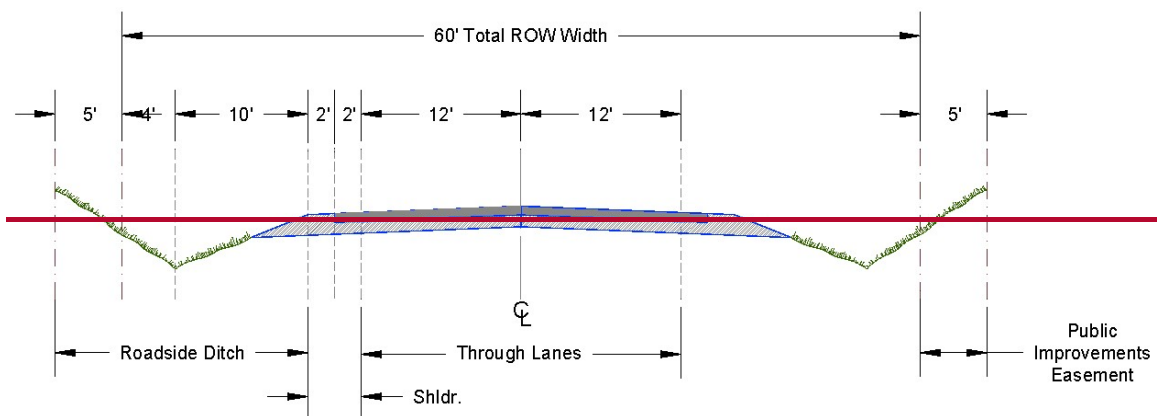

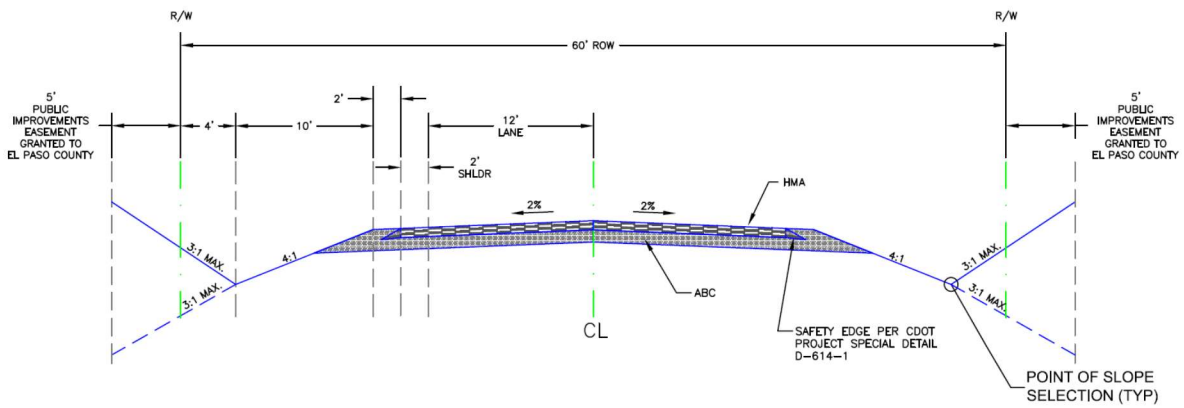

B. Urban Roadways.

1. **Expressway.** Expressways serve high-speed and high-volume traffic over long distances. Access is highly controlled and may have both grade-separated interchanges and full movement signaled intersections. Adjacent, existing and future, land uses shall be served by other network roadways, no direct parcel access is permitted (See Figure 2-9 and Figure 2-10).

Figure 2-9. Typical Urban Expressway Cross Section (6 Lane)

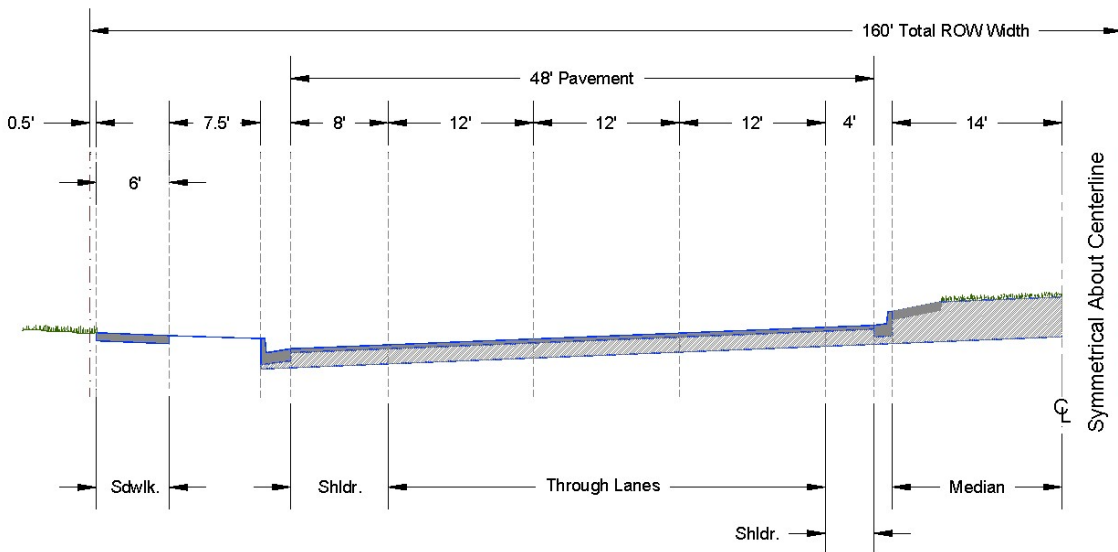
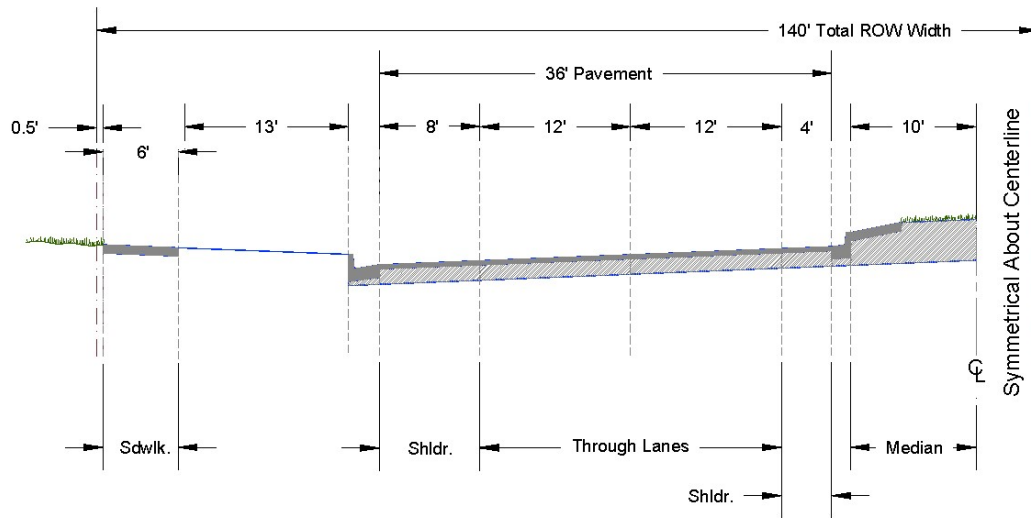

Figure 2-10. Typical Urban Expressway Cross Section (4 Lane)



- Principal Arterial.** Principal arterials serve high-speed and high-volume traffic over long distances. Access is highly controlled with a limited number of full movement intersections and medians with infrequent openings, and no direct parcel access. Adjacent, existing and future, land uses shall be served by other network roadways, service roads, and inter parcel connections (See Figure 2-11 and 2-12).

Figure 2-11. Typical Urban Principal Arterial Cross Section (6 Lane)

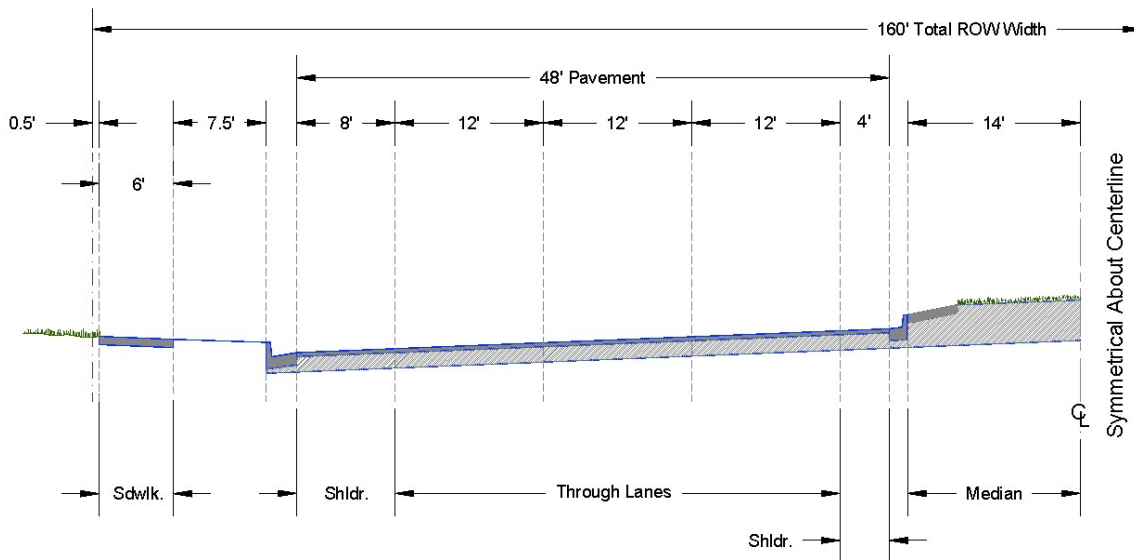
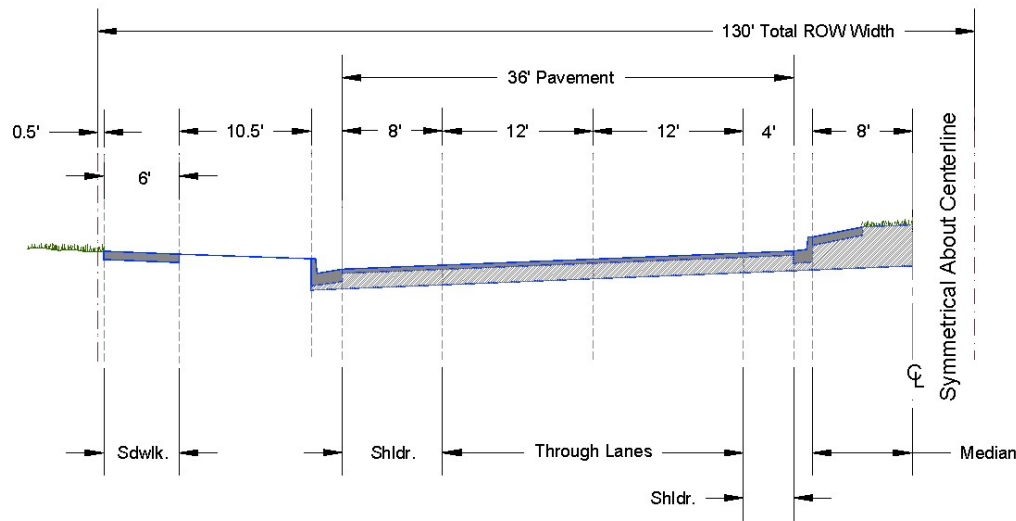
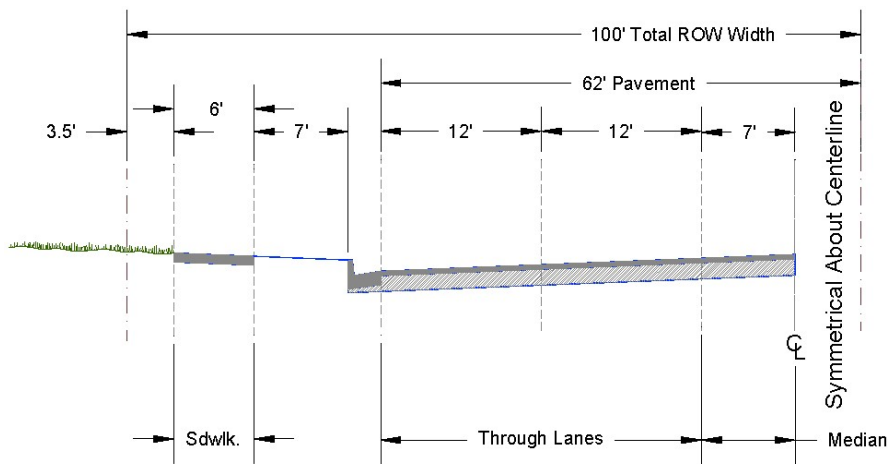

Figure 2-12. Typical Urban Principal Arterial Cross Section (4 Lane)



- Minor Arterial.** Minor arterials serve high-volume traffic over medium distances in developed or developing urban areas. Access is restricted and based on prescribed distances between intersections, use of medians, and no full movement parcel access is permitted where the local roadways can be expected to provide access (See Figure 2-13). Where no local public or private roadway can provide access, temporary lot or partial turn movement access may be permitted, provided the design meets these Standards.

Figure 2-13. Typical Urban Minor Arterial Cross Section



- Nonresidential Collector.** Nonresidential collectors link local roadways and arterial roadways in locations characterized by nonresidential land uses or uncommitted future land uses. Urban nonresidential collectors are intended to accommodate multiple modes of transportation, high-volume turning movements or significant changes in roadway use over time (See Figure 2-14). Urban nonresidential collectors are managed to maximize the safe operation of through-

movements. Intersection and parcel access locations and design are reviewed by the ECM Administrator to ensure roadway objectives are being met.

Figure 2-14. Typical Urban Nonresidential Collector Cross Section

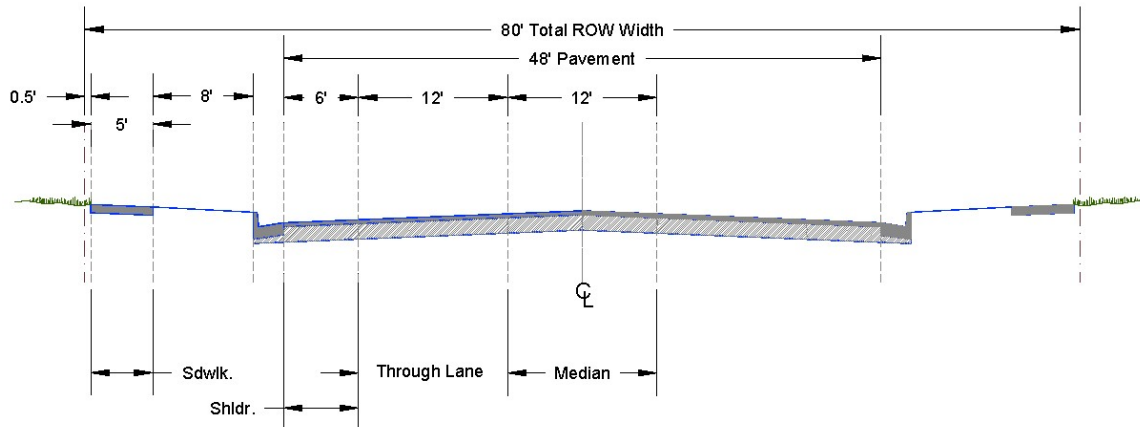

- 5. Residential Collector.** Residential collectors link local and arterial roadways in exclusively residential areas where build-out conditions for land development and roadway use can be reasonably forecasted (See Figure 2-15). Residential major collectors are managed to maximize the safe operation of through-movements. No full movement parcel access is permitted where the local roadways can be expected to provide access. Where no local public or private roadways can provide access, partial turn movement access may be permitted. Intersection and access location and design are reviewed by the ECM Administrator to ensure roadway objectives are being met.

Figure 2-15. Typical Urban Residential Collector Cross Section

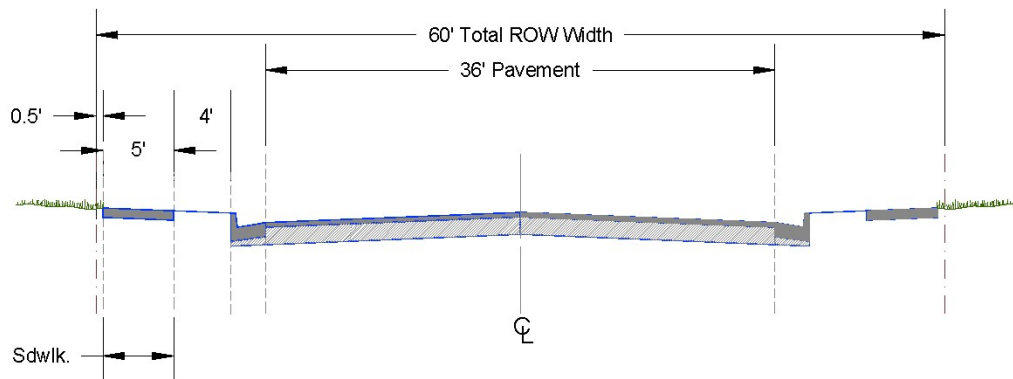

- 6. Local.** Local roadways link to collector or arterial roadways. Direct parcel access is permitted provided they meet sight distance and other design requirements presented in these Standards (See Figure 2-16). Intersection and parcel access location and design are reviewed by the ECM Administrator to ensure safe operations.

Figure 2-16. Typical Urban Local Cross Section

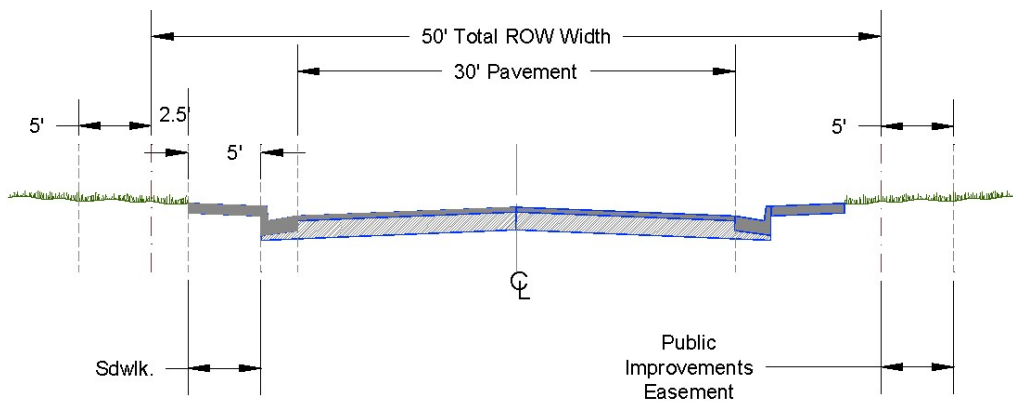

7. **Local (low volume).** Local (low volume) roadways provide direct lot access and deliver lot-generated trips to collector roadways. Although access needs are high, accesses shall not be allowed to compromise the safety, health or welfare of roadway users (See Figure 2-17).

Figure 2-17. Typical Urban Local (low volume) Cross Section

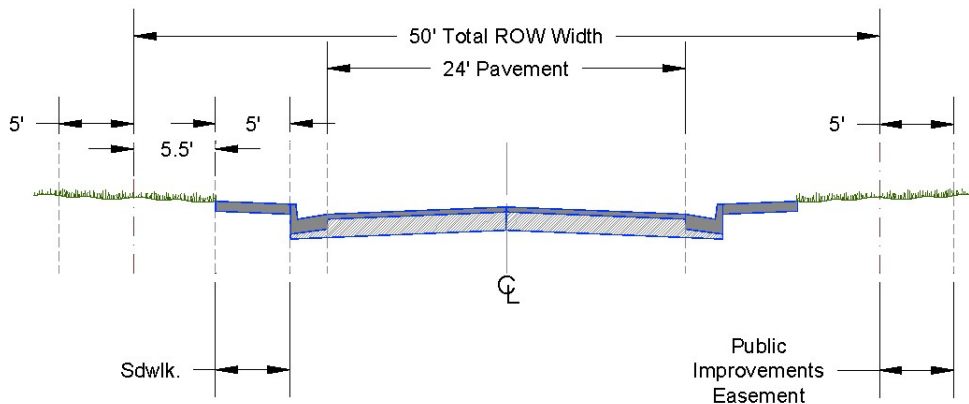

2.2.5. Roadway Access Criteria

All new or modified accesses to the County roadways shall meet the requirements of the ECM. Standards and technical criteria not specifically addressed in the ECM shall follow the provisions of the AASHTO, A Policy on Geometric Design of Highways and Roadways ("Green Book") and the Colorado State Highway Access Code. ~~In addition, should any access request fall within the preview of the Major Thoroughfare Task Force (MTTF), per their adopted bylaws, then the request shall be brought before the MTTF for a recommendation.~~ When CDOT State Highway Access Permit is required, or access is located within the influence zone of an intersection, interchange or as determined by the ECM Administrator, CDOT concurrence shall be provided by the applicant.

A. Rural and Urban Expressway Access Criteria.

-
1. **Intersection Spacing and General Access Standards.** Full movement intersections and major access spacing shall meet the requirements of this section. Right-in/right-out and three quarter movement accesses may be permitted as a deviation only if they meet the criteria presented in this section for sight distances, turn lane requirements, grades and do not negatively impact traffic operations or safety.
 2. **No Alternative Access to Road System.** Where reasonable access can be obtained from the local roadway system, a temporary direct lot or partial turn movement access may be permitted provided the access meets these Standards or as otherwise required by the ECM Administrator.
 3. **Access and Lot Division.** No additional access right shall accrue and no additional access shall be provided when splitting or dividing of existing lots of land. When an alternative is reasonably available in the opinion of the ECM Administrator, all access to the newly created properties shall be provided internally from the existing access or new access to a roadway of lower functional classification.
 4. **Relocation of Access when Alternative is Available.** All access to an expressway not meeting the minimum one-mile spacing requirement shall be closed in favor of an alternative access when an alternative is reasonably available in the opinion of the ECM Administrator.
- B. Rural and Urban Principal Arterial and Rural Minor Arterial Access Criteria.**
1. **Spacing.** Spacing of roads accessing a principal arterial or rural minor arterial that will result in a full movement intersection shall be planned at one-half mile (one-quarter mile for rural minor arterials). Should the one-half mile spacing not be "viable or practical" for providing access to the adjacent land, a deviation may be considered and approved by the ECM Administrator. If a deviation is granted, only one additional full movement intersection will be permitted by the ECM Administrator. The Applicant shall have the burden of proof that no other "viable or practical" access is available. A deviation request should be supported by a traffic study or memorandum that provides information to assist the ECM Administrator in determining the proposed deviation minimizes negative safety and other operational impacts. If the development is at the intersection of two major corridors, the full movement access should be located on the lower functional classification roadway. The intersection shall only be approved if the intersection and roadway are shown to operate safely and efficiently with buildout design hour/peak hour projected traffic volumes. The intersection must also show a public benefit. An arterial progression through bandwidth percentage of 35 percent or greater must be achieved or the inclusion of a signal at the access must not degrade the existing signal progression. The intersection must not create any queuing or blocking of lane entries or access points. The intersection must be in a location such that any necessary turn, acceleration and deceleration lanes can be accommodated to maintain safe operations and capacity. The analysis should consider all potential future additional requirements for left turn or other exclusive phasing at a signal for which the need is created by traffic generated by land uses on both sides of the roadway.
 2. **Topographic and Other Limitations.** Where topography or other existing conditions make the required spacing inappropriate or unfeasible, location of the access shall be determined with consideration given to topography, established property ownerships, unique physical limitations, pre-existing historical land use patterns, and physical design constraints, with every attempt to achieve an access spacing of one-half mile. The final location shall serve as many properties as possible to reduce the need for additional direct access to the principal arterial or rural minor arterial. In selecting locations for full movement intersections, preference shall be given to roads that meet, or may be reasonably expected to meet, signal warrants in the future.

-
3. **Access and Lot Division.** No additional access right shall accrue and no additional access shall be provided when splitting or dividing existing lots of land. When an alternative is reasonably available in the opinion of the ECM Administrator, all access to the newly created properties shall be provided internally from the existing access or new access to a roadway of lower functional classification.
 - C. **Urban Minor Arterial Access Criteria.** Spacing of roads accessing an urban minor arterial that will result in a full movement intersection shall be planned at one-quarter mile. However, one parcel access shall be granted to each existing lot, if it does not create safety or operational problems. The parcel access will provide for right turns only. The access may allow for left turns in (three-quarters movement) if the addition of left turns will improve the operation at an adjacent full movement intersection and meet appropriate design standards.
 - D. **Collector Access Standards.** Collector roadways shall intersect another roadway (centerline to centerline) in accordance with the standards in Section 2.3.7. On minor collector roadways, the closest local roadway intersection to an arterial roadway shall be 330 feet (right-of-way line of arterial to centerline of local roadway). On major collector roadways, the closest local roadway intersection to an arterial roadway shall be 660 feet (right-of-way line of arterial to centerline of local roadway). Single-family residence access to major collector roadways is not permitted (even though existing conditions show otherwise).
 - E. **Rural and Urban Local Roadways.** Roads shall not intersect urban local roadways closer than 175 feet from each other (centerline to centerline) and shall not intersect a rural local roadway closer than 330 feet from each other. On an urban local roadway, the closest intersection to a collector roadway shall be at least 200 feet (centerline to centerline). To an arterial roadway, the closest intersection shall be 330 feet (arterial right-of-way line to local roadway centerline).

2.2.6. Soils Investigations

- A. **General.** Soil investigations are conducted to help in preparing designs of roadways and other public facilities. The soil investigation report provides detailed information for use in designing facilities to maximize their performance and enhance the lifecycle costs of the asset.
- B. **Reporting Requirements.** As appropriate for the project, the following soil investigation reports shall be developed: (1) Geological Hazards Report, (2) Geotechnical Report, (3) Pavement Design Report, and (4) Inspection and Testing Report. A Professional Geologist or Professional Engineer licensed in the State of Colorado must prepare all soil investigations, as defined by Colorado State Statutes.
- C. **Purpose of Reports.**
 1. **Geologic Hazards Report.** This report identifies geologic conditions that may pose hazards to a proposed project.
 2. **Geotechnical Report.** This report evaluates the characteristics of the soils and the general issues of groundwater, soil stability, dipping bedrock, and swell/collapse potential that may pose hazards to, or affect the design of, roadway and related improvements within the right-of-way, public easements or slope easements. If groundwater is found within certain parameters, a subsurface water investigation shall be conducted to determine potential impacts to a proposed project.
 3. **Pavement Design Report.** This report investigates and details the characteristics of the soil and subsurface conditions affecting the roadway pavement design. The soil investigation associated with this report occurs after the roadways are graded and utilities are installed. The soil investigation associated with this report occurs after the roadways are graded and the deepest utility is installed.

-
4. **Inspection and Testing Report.** The inspection and testing report is prepared following construction. It is based on the construction inspections and tests performed under the direct supervision of a Professional Engineer licensed in the State of Colorado, who must sign the report as defined by Colorado State Statutes. Analysis results of all fill material shall be included in the report.
- D. **Report Preparation Guidelines.** All reports shall be prepared in conformance with the guidelines in Appendix C.

2.2.7. Pavement Design

- A. **General.** Pavement design is a critical component of roadway design. Proper pavement design helps to ensure roadway performance and reduce the lifecycle costs associated with maintaining the roadway system.
- B. **Road Paving Policy.** Paved roads meet the paving requirements established by Roadway Functional Classifications in Section 2.2.4.
 1. **New Roads.** New roadways shall be paved if it connects to an existing roadway that is paved at the time of final approval of the development or it connects to a roadway internal to the development that is required to be paved. New roadways are not required to be paved where:
 - The new roadway has a projected ADT of less the 200 ADT within the proposed 20-year design life and the new road connects to an existing gravel road or
 - The new road is located in an area of gravel roads and, to reduce the cost of maintenance, the ECM Administrator has determined that a gravel road is the most appropriate application.
 2. **Existing Roads.** Existing roadways shall be paved where:
 - Any development causes an existing gravel road to exceed a projected ADT of 200 (Note: the extent of paving will be determined by the ECM Administrator based on the Transportation Impact Study [Section 2.2.3]).
 - In accordance with the terms and conditions of BoCC Resolution 07-495 regarding the Resident Participation Program.
 3. **New Gravel Roads.** New gravel roads may be permitted in accordance with the allowances in Section 2.2.7B.1 except where:
 - The road is projected to have an ADT of 200 or more. All roads with a projected ADT of 200 or more shall be paved to facilitate compliance with Colorado Air Quality Control Commission Regulation No. 1, Emission Control Regulations for Particulates, Smokes, and Sulfur Oxides for the State of Colorado.
 - The new gravel road would be an extension of an existing paved road.
- C. **Pavement Design Report.** A Pavement Design Report is required to be submitted and approved before paving any County road. The final pavement design may be submitted after the ECM Administrator approval of the associated roadway, profile, drainage, and final construction plans. The Pavement Design Report shall conform to the requirements of Appendix D. The soil investigation associated with this report occurs after the roadways are graded and the deepest utility is installed.

D. **Safety Edge.** Shoulders should be paved equivalent depth in accordance with the functional or physical characteristic of the roadway. The use of a safety edge (Project Special Detail D-614-1 of the CDOT Standard Plans - M & S Standards) is required in all projects having roadway pavement including but not limited to new construction and modification of transportation facilities, repair, reconstruction, resurfacing, restoration, and

rehabilitation of existing transportation facilities. Instead of a vertical drop-off, the safety edge shapes the edge of the pavement to 30 to 35 degrees.

(Res. No. 20-222-, 6-23-20)

2.3. ROADWAY DESIGN

2.3.1. Roadway Design Criteria

Table 2-3 outlines the general roadway design criteria that shall guide roadway design and layout. All proposed roadway designs and layouts shall conform to the general roadway design criteria; the MTC; and all other applicable criteria, standards, and regulations.

Table 2-3. Roadway Design Criteria

Criteria	Concern	Guideline
Ensure Vehicular and Pedestrian Access	The primary function of local roads is to serve abutting properties.	Road widths, placement of sidewalks, patterns of roads, and number of intersections are related to safe and efficient access to abutting lands.
Minimize Through Trips	Through traffic on local and collector roads potentially increases the average speed and volume. Therefore increasing the potential for accidents and reducing residential amenities.	Through traffic can be discouraged between neighborhoods and higher volume roads by creating a circuitous route, channeling or controlling median crossings along peripheral routes.
Control Access to Arterials	Local circulation systems and land development patterns should not detract from the efficiency of peripheral arterial facilities. The local roads that intersect arterial systems will tend to have higher volumes since they tend to be primarily exit points.	The number of access points between local circulation systems and adjacent arterial roads should be minimized. Intersections along arterial routes should be properly spaced for efficient signalization and traffic flow.
Discourage Speeding	Residential roads should be designed to discourage fast movement.	Use of curvilinear alignments, traffic calming devices, and circuitous routes in the road system.
Minimize Modal Conflicts (bike, pedestrian, transit, low speed vehicles)	Pedestrian travel from within the area to points outside should require a minimal number of road crossings.	Typical methods include use of cul-de-sacs and looped roads, special pedestrian routes or walkways, and the proper placement of high pedestrian traffic generators. In general, vehicular flow must be outward oriented to the peripheral arterials and pedestrian travel should be inward-oriented to avoid these heavier vehicular flows.
Minimize Space Devoted to Road Use	It is desirable to minimize local road mileage, thereby reducing construction and maintenance costs, as well as permitting the most efficient use of land. Roads should also have an appearance commensurate with their function.	Roads should be designed to complement local character.

Created: 2021-06-08 11:35:48 [EST]

(Supp. No. 2)

Relate Road to Topography	Local roads are more attractive and economical if constructed to closely adhere to topography (minimize cut and fill).	The important role that roads play in the overall storm drainage system can be enhanced by closely following existing topography.
Layout Road to Achieve Optimum Subdivision of Land	The arrangement of roads should allow for economical and practical patterns, shapes, and sizes of adjacent lots. Roads as a function of land use must not unduly hinder the development of land.	Distances between roads, number of roads, and related elements all have a bearing on efficient subdivision of an area. Access to adjoining properties should also be encouraged.

2.3.2. Design Standards by Functional Classification

Section 2.2.4 of these standards identifies the Roadway Functional Classifications recognized and used by the County. Table 2-4 through Table 2-7 summarize many of the minimum roadway design standards by category and functional classification. Detailed road Standard Drawings are provided in Appendix F.

Table 2-4. Roadway Design Standards for Rural Expressways and Arterials

Criteria	Expressways		Arterials		
	6 Lane	4 Lane	6 Lane Principal	4 Lane Principal	Minor
Design Speed/Posted Speed (MPH)	70/65	70/65	70/65	70/65	60/55
Clear Zone	See Table 2-1634'	See Table 2-1634'	See Table 2-1634'	See Table 2-1634'	See Table 2-1630'
Minimum Centerline Curve Radius	2,050 ¹	2,050 ¹	2,050 ¹	2,050 ¹	1,505 ¹
Number of Through Lanes	6	4	6	4	2
Lane Width	12'	12'	12'	12'	12'
Right-of-Way	210'	180'	210'	180'	100'
Paved Width (excluding safety edge)	56' ²	38' ²	56' ²	38' ²	40'
Median Width	24'	24'	24'	24'	n/a
Outside Shoulder Width (paved/gravel)	12'(10'/2')	12'(10'/2')	12'(10'/2')	12'(10'/2')	10'(8'/2')
Inside Shoulder Width (paved/gravel)	12'(10'/2')	6'(4'/2')	12'(10'/2')	6'(4'/2')	n/a
Design ADT		48,000		40,000	10,000
Design Vehicle	WB-67	WB-67	WB-67	WB-67	WB-67
Access Permitted	No	No	No	No	No
Access Spacing	n/a	n/a	n/a	n/a	n/a
Intersection Spacing	1 mile	1 mile	½ mile	½ mile	¼ mile
Parking Permitted	No	No	No	No	No
Minimum Flowline Grade	1%	1%	1%	1%	1%
Centerline Grade (Min.—Max.)	1—5%	1—5%	1—5%	1—5%	1—6%
Intersection Grades (Min.—Max.)	1—2%	1—2%	1—3% ³	1—3% ³	1—4% ³

¹ Assumes 4% superelevation, 6% for 70 MPH design speeds

² Pavement width in each direction for divided roadways

³ Where pedestrian crosswalks are anticipated at intersections, maximum grade at crosswalks with stop/yield control is 2%

Table 2-5. Roadway Design Standards for Rural Collectors and Locals

Criteria	Collectors		Local	
	Major	Minor	Local	Gravel
Design Speed/Posted Speed (MPH)	50/45	40/35	30/30	50/30/45-30 ⁵
Clear Zone	See Table 2-1620 ¹	See Table 2-1614 ¹	See Table 2-167 ¹	See Table 2-1612 ¹
Minimum Centerline Curve Radius	930 ²	565'	300'	As Approved
Number of Through Lanes	2	2	2	2
Lane Width	12'	12'	12'	12'
Right of Way	90'	80'	70' ³	70' ³
Paved Width (excluding safety edge)	32'	32'	28'	n/a
Median Width	n/a	n/a	n/a	n/a
Outside Shoulder Width (paved/gravel)	8'(4'/4')	6'(4'/2')	4'(2'/2')	4'(0'/4')
Inside Shoulder Width (paved/gravel)	n/a	n/a	n/a	n/a
Design ADT	3,000	1,500	750	200
Design Vehicle	WB-67	WB-67	WB-50	WB-50
Access Permitted	No	Yes	Yes	Yes
Access Spacing	n/a	Frontage	Frontage	Frontage
Intersection Spacing	¼ mile	660'	330'	330'
Parking Permitted	No	Yes	Yes	No
Minimum Flowline Grade	1%	1%	1%	1%
Centerline Grade (Min.-Max.)	1—8% ¹	1—8% ¹	1—8% ¹	1—8%
Intersection Grades (Min.-Max.)	1—4% ⁴	1—4% ⁴	1—4% ⁴	1—4% ⁴
¹ 10% maximum grade permitted at the discretion of the ECM Administrator				
² Assumes 4% superelevation, 6% for 70 MPH design speeds				
³ 60-foot right-of-way plus two 5-foot Public Improvements Easements granted to El Paso County				
⁴ Where pedestrian crosswalks are anticipated at intersections, maximum grade at crosswalks with stop/yield control is 2%				
⁵ For existing gravel roads, design and posted speeds may exceed this criterion at the ECM Administrator's discretion.				

Table 2-6. Roadway Design Standards for Urban Expressways and Arterials

Criteria	Expressways		Arterials		
	6 Lane	4 Lane	6 Lane Principal	4 Lane Principal	Minor
Design Speed/Posted Speed (MPH)	60/55	60/55	50/45	50/45	40/35

Clear Zone	See Table 2-1630¹	See Table 2-1630¹	See Table 2-1620¹	See Table 2-1620¹	See Table 2-1614¹
Minimum Centerline Curve Radius	1,505 ¹¹	1,505 ¹¹	930 ¹¹	930 ¹¹	565'
Number of Through Lanes	6	4	6	4	4
Lane Width	12'	12'	12'	12'	12'
Right-of-Way	160'	140'	160'	130'	100'
Paved Width (Excluding Gutter Pan)	48' ²	36' ²	48' ²	36' ²	62'
Median Width (Including Curb & Gutter)	31'	23'	31'	19'	14'
Shoulder Width (Ext., Excluding Gutter)	8'	8'	8'	8'	n/a
Shoulder Width (Int., Excluding Gutter)	4'	4'	4'	4'	n/a
Required Curb/ Gutter Type	6" ramp	6" ramp	6" vertical	6" vertical	6" vertical
Sidewalk Width (@-FL)	6' detached	6' detached	6' detached	6' detached	6' detached
Design ADT		48,000		40,000	20,000
Design Vehicle	WB-67	WB-67	WB-67	WB-67	WB-67
Bike Lanes Permitted	No	No	Yes	Yes	No
Access Permitted	No	No	No	No	No ³
Access Spacing	n/a	n/a	n/a	n/a	See Table 2-35
Intersection Spacing	1 mile	1 mile	½ mile	½ mile	¼ mile
Parking	No	No	No	No	No
Minimum Flowline Grade of Curb	.50%	.50%	.50%	.50%	.50%
Centerline Grade (Min.-Max.)	0.5—5%	0.5—5%	0.5—6%	0.5—6%	0.5—6%
Intersection Grades (Min.-Max.)	0.5—2%	0.5—2%	0.5—3% ⁴	0.5—3% ⁴	0.5—4% ⁴
¹ Assumes 4% superelevation, 6% for 70 MPH design speeds					
² Pavement width in each direction for divided roadways					
³ Where no local public or private roadway can provide access, temporary or partial turn movement parcel access may be permitted					
⁴ Maximum grade at crosswalks with stop/yield control is 2%					

Table 2-7. Roadway Design Standards for Urban Collectors and Locals

Criteria	Collectors		Local	
	Non-Residential	Residential	Local	Local ⁴ (low volume)
Design Speed/Posted Speed (MPH)	40/35	40/35	25/25	20/20
Clear Zone	See Table 2-1614¹	See Table 2-1614¹	See Table 2-1612¹	See Table 2-167¹
Minimum Centerline Curve Radius	565'	565'	200'	100'
Number of Through Lanes	2	2	2	2
Lane Width	12'	12'	12'	12'

Right-of-Way	80'	60'	60' ³	60' ³
Paved Width (Excluding Gutter Pan)	48'	36'	30'	24'
Median Width (Including Curb & Gutter)	12'	n/a	n/a	n/a
Shoulder Width (Ext., Excluding Gutter)	6'	6'	n/a	n/a
Shoulder Width (Int., Excluding Gutter)	n/a	n/a	n/a	n/a
Required Curb/ Gutter Type (Vertical)	6"	6"	6" (or ramp)	6" (or ramp)
Sidewalk Width (@ FL from top back of curb when attached)	5' detached	5' detached	5' attached	5' attached
Design ADT	20,000	10,000	3,000	300
Design Vehicle	WB-50	WB-50	WB-50	SU-30
Bike Lanes Permitted	No	Yes	No	No
Access Permitted	No ⁵	No ⁵	Yes	Yes
Access Spacing	See Table 2-35	See Table 2-35	Frontage	Frontage
Intersection Spacing	660' ²	660' ²	175'	150'
Parking Permitted	No	No	Yes	Yes
Minimum Flowline Grade of Curb	.50%	.50%	.50%	.50%
Centerline Grade (Min.-Max.)	0.5—6% ¹	0.5—8% ¹	0.5—8% ¹	0.5—8% ¹
Intersection Grades (Min.-Max.)	0.5—4% ⁶	0.5—4% ⁶	0.5—4% ⁶	0.5—4% ⁶
¹ 10% maximum <u>centerline</u> grade permitted (<u>ADA accessibility requirements shall still be met</u>) at the discretion of the ECM Administrator				
² 330 feet when intersecting local roadways				
³ 50-foot right-of-way plus two 5-foot Public Improvements Easements granted to El Paso County				
⁴ Section can be used for cul-de-sacs, or roads with two ways out having a maximum of 300 ADT and a maximum length of 1,200 feet				
⁵ Where no local public or private roadway can provide access, temporary or partial turn movement parcel access may be permitted				
⁶ Maximum grade at crosswalks with stop/yield control is 2%				

2.3.3. Horizontal Alignment

- A. **General Criteria.** Proper roadway alignment provides for safe and continuous operation at a uniform design speed. Proposed road layouts shall have a logical relationship to existing or platted roads and fit within the overall transportation plan.
- B. **Intersections.** All new roadways must intersect at or nearly at right angles. Modified roadways shall intersect at or nearly at right angles or otherwise allow for safe operation as determined by the ECM Administrator.
- C. **Design Speed.** Design speed is a speed selected to determine the various geometric design features of a roadway. Design speed shall be used to determine stopping sight distance and intersection sight distance requirements for new road facilities. The design speeds by functional classification are provided in Table 2-4 through Table 2-7.
- D. **Superelevation.**

- General.** The maximum rate of superelevation is controlled by factors including climate conditions, terrain conditions, land use characteristics (rural or urban), and frequency of slow-moving vehicles. For a given design speed, the superelevation rate applied shall have a logical relationship to the side friction factor.
- Establishing the Rate.** Superelevation shall be consistent with Table 2-8, the AASHTO Green Book, and CDOT M & S Standards. However, the maximum rate used for expressways shall be 0.060 and arterial roadways shall be 0.040. Superelevation is not permitted on roadways with design speeds less than 50 MPH.
- Adjustments to the Rate.** Standard rates of superelevation must be maintained throughout the curve when possible. In general, roadway intersections, established roadway grades, curb, and adverse drainage conditions may require a reduction in the rate of superelevation or the application of different rates for each half of the roadway to create a safe condition in an urban environment. In areas where pavement warping is required for adverse drainage, superelevations should be avoided.

Table 2-8. Design Values for Rate of Superelevation (e) and Minimum Length of Runoff

R (feet)	V _d =50 MPH			V _d =60 MPH			V _d =70 MPH ¹		
	L (feet)			L (feet)			L (feet)		
	e (%)	2 Ls	4 Ls	e (%)	2 Ls	4 Ls	e (%)	2 Ls	4 Ls
23,000	NC	0	0	NC	0	0	NC	0	0
20,000	NC	0	0	NC	0	0	NC	0	0
17,000	NC	0	0	NC	0	0	NC	0	0
14,000	NC	0	0	NC	0	0	NC	0	0
12,000	NC	0	0	NC	0	0	RC	60	90
10,000	NC	0	0	NC	0	0	2.1	63	95
8,000	NC	0	0	RC	53	80	2.5	75	113
6,000	RC	48	72	2.3	61	92	3.2	96	144
5,000	RC	48	72	2.5	67	100	3.7	111	167
4,000	2.3	55	83	2.8	75	112	4.4	132	198
3,500	2.5	60	90	3.0	80	120	4.9	147	221
3,000	2.7	65	97	3.3	88	132	5.3	159	238
2,500	2.9	70	104	3.5	93	140	5.8	174	251
2,000	3.2	77	115	3.8	101	152	R_{min}=2050		
1,800	3.3	79	119	3.9	104	156			
1,600	3.5	84	126	4.0	107	160			
1,400	3.7	89	133	R_{min}=1505					
1,200	3.9	94	140						
1,000	4.0	96	144						
	R_{min}=930								

where:

e_{max} = 4% (Recommended by the ECM Administrator, must obtain approval for differences)

R = radius of curve, feet

V_d = design speed

e = rate of superelevation

L = minimum length of runoff (does not include tangent runout)

NC = normal crown section

RC = remove adverse crown, superelevate at normal slope

¹ e_{max} = 6% for V=70MPH

- E. **Horizontal Curve Radii.** Horizontal alignment design speed must be consistent with the requirement for vertical alignment design speed. The minimum acceptable design radii are shown in Tables 2-4 through 2-7. Reverse and compound curves should be used only when a single radius curve will not work. For driver safety, compound curves shall have a ratio no greater than 1.5 where the value of the larger radius is divided by the smaller radius.
- F. **Minimum Tangent Length.**
 - 1. **Intersection.** Whenever a roadway intersects a roadway of higher classification, a tangent length (measured from the nearest gutter flowline of the intersected roadway to the point of curvature in the intersecting roadway) shall be provided for a safe sight distance and traffic operation. The minimum required tangent lengths indicated in Table 2-9 only apply to the roadways with lower functional classifications. The angle of departure shall not exceed 10 degrees for the length of tangent.

Table 2-9. Minimum Tangent Lengths at Intersection

Higher Classification Roadway (below)	Lower Classification Intersecting Roadway			
	Local	Collector	Arterial	Expressway
Expressway	n/a	n/a	250	Special Design ^{1,2}
Arterial	n/a	200	250 ¹	n/a
Collector	n/a	200 ¹	n/a	n/a
¹ In the case of where each intersecting roadway is of the same classification, the ECM Administrator will designate which roadway takes precedence				
² Use AASHTO, A Policy on Geometric Design of Highways and Roadways for design requirements				

- 2. **Reverse Curves.** The tangent between reverse curves shall be no less than the length shown in Table 2-10.
- 3. **Broken Back Curves.** Two curves in the same direction (broken back curves) shall be separated by a tangent with a length of at least two times the minimum length shown in Table 2-10. For local roadways, a minimum tangent of 200 feet shall be used to separate all broken back curves.

Table 2-10. Minimum Tangent Lengths between Curves

Roadway Classification	Minimum Tangent Length (Feet)
Expressway	250
Arterial	200
Collector	150

- G. **Consistent Radii.** All curves along a roadway shall be designed with radii that are approximately equal to provide consistency and minimize unexpected maneuvers for the driver.
- H. **Curves with Small Deflection Angles (10° or less).** High volume roadways using minimum length curves shall be designed with the minimum centerline arc lengths shown in Table 2-11. All other roadways shall be designed for safe travel and to create a smooth appearance.

Table 2-11. Centerline Arc Lengths

Functional Classification	Minimum Centerline Arc Length (feet)
Expressway	500
Arterial	400

- I. **Horizontal Curves on Vertical Curves.** Horizontal curves shall not begin near the crest of a vertical curve nor near the bottom of a sag vertical curve.
- J. **Lane Shifts or Drops.** Transitions for roadways are useful in maintaining the safety, traffic flow, and operations of the roadway and access. When the County requires a lane shift or drop based on information obtained in a TIS, the design, installation, and purchase of the right-of-way to accommodate the required lanes is the responsibility of the owner, applicant or developer.
- K. **Joining Existing Improvements.** Connection with existing roadways shall be made to match the alignment grade of the existing improvements, in accordance with the horizontal alignment criteria.
- L. **Effect of Grade.** Grade affects the operating speeds of vehicles and should be recognized as a critical issue in the design of roadways. Where practical, the roadway should be designed for a higher design speed on the downgrade portions and a lower design speed on the upgrade. This variation in design speed will depend on the rate and length of grade and the degrees of curvature, as compared with other curves on the roadway section.
- M. **Sight Distance on Horizontal Curves.** The proposed horizontal alignment must provide for the minimum stopping distance for the design speed at all points along the roadway. In addition, the design must take into account the visibility at intersections, around curves, and roadside encroachments.
- N. **Future Extension Confirmation.** When a roadway is designated within the MTCP for future extension, additional survey and preliminary design beyond the current project boundaries may be requested by the ECM Administrator to confirm coordination.

2.3.4. Vertical Alignment

- A. **Vertical Curves.** Vertical curves may either be a crest or sag-type curve (See Figure 2-18).
 - 1. **Crest Vertical Curves.** Figure 2-19 and Table 2-12 show the required lengths of vertical curves for different algebraic differences in grade to provide required stopping sight distances for each design speed.

Design values of crest vertical curves for passing sight distance differ from those for stopping sight distance because of the different height criterion (4.25 feet instead of 0.5 feet). K-values for crest vertical curves based on passing sight distance are shown in Table 2-13.

Figure 2-18. Types of Vertical Curves

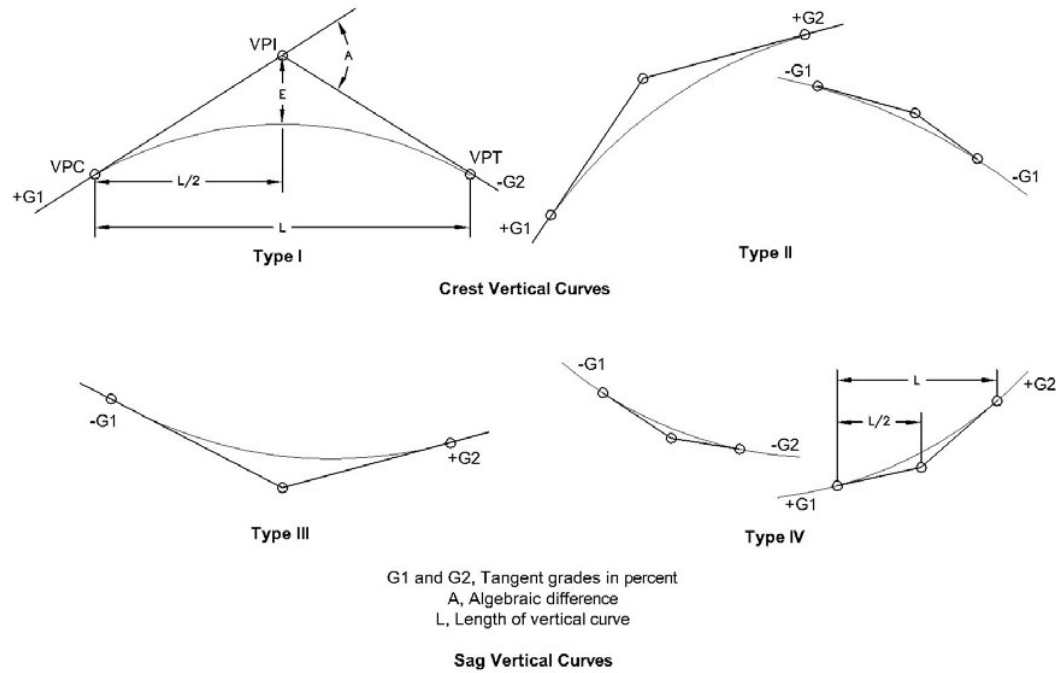

Figure 2-19. Design Controls for Stopping Sight Distances on Crest Vertical Curves

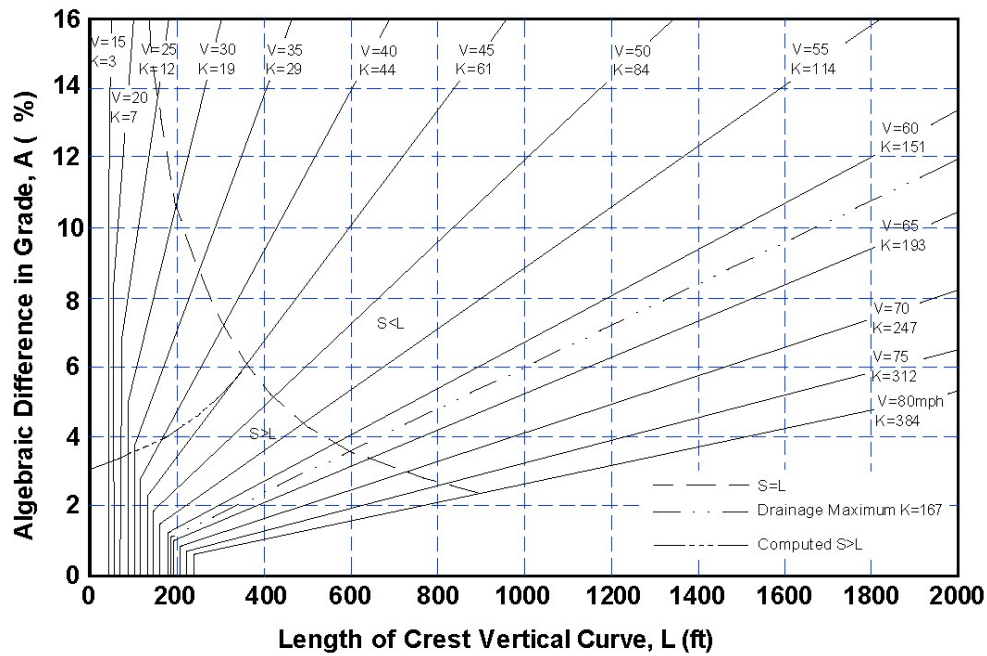

Table 2-12. Design Controls for Stopping Sight Distances on Crest Vertical Curves

Design Speed (MPH)	Stopping Sight Distance (feet)	Rate of Vertical Curvature, K ¹	
		Calculated	Design
25	155	11.1	12
30	200	18.5	19
40	305	43.1	44
50	425	83.7	84
60	570	150.6	151
70	730	246.9	247

¹ Assumes an eye height of 3.5 feet and an object height of 0.52 feet under open road conditions.

Where:

K = rate of vertical curvature $K = L/A$, the length of curve per percent algebraic difference in intersecting grades)

L = length of vertical curve, feet

A = algebraic differences in intersecting grades

S = estimated sight distance, feet

Table 2-13. Design Controls for Passing Sight Distance on Crest Vertical Curves

Design Speed (MPH)	Minimum Passing Sight Distance (feet)	Rate of Vertical Curvature, K ¹
25	900	289
30	1090	424
40	1470	772
50	1835	1203
60	2135	1628
70	2480	2197

¹ Assumes an eye height of 3.5 feet and an object height of 0.53.5 feet under open road conditions.

Where:

K = rate of vertical curvature ($K = L/A$, the length of curve per percent algebraic difference in intersecting grades)

L = length of vertical curve, feet

A = algebraic differences in intersecting grades

S = estimated sight distance, feet

2. **Sag Vertical Curves.** Table 2-14 and Figure 2-20 show the required lengths of sag vertical curves for different algebraic differences in grade to provide required stopping sight distances for each design speed.

Figure 2-20. Design Controls for Stopping Distances on Sag Vertical Curves

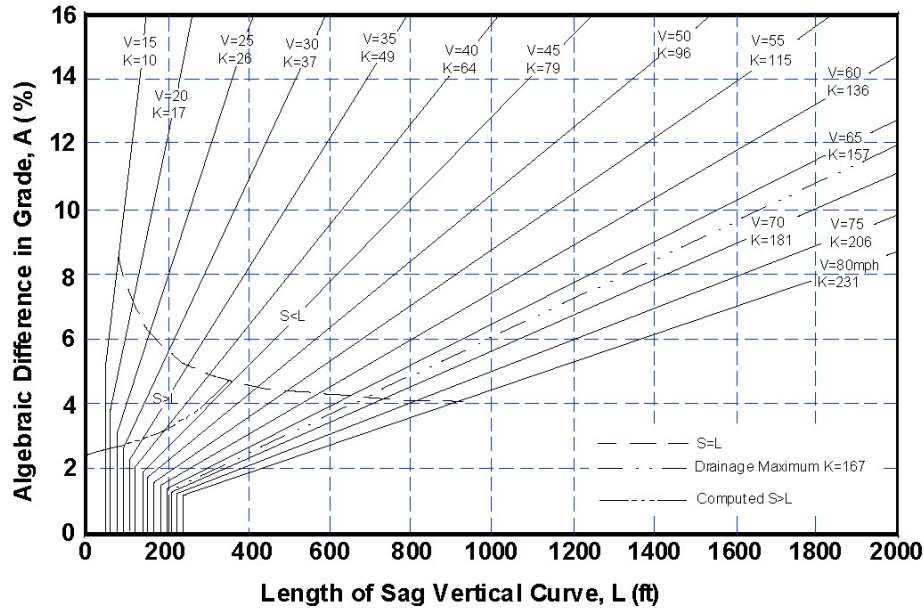

Table 2-14. Design Controls for Stopping Distance on Sag Vertical Curves

Design Speed (MPH)	Stopping Sight Distance (feet)	Rate of Vertical Curvature, K ¹	
		Calculated	Design
25	155	25.5	26
30	200	36.4	37
40	305	63.4	64
50	425	95.7	96
60	570	135.7	136
70	730	180.3	181

¹ Assumes an eye height of 3.5 feet and an object height of 0.5 feet under open road conditions.

Where:

K = rate of vertical curvature ($K = L/A$, the length of curve per percent algebraic difference in intersecting grades)

L = length of vertical curve, feet

A = algebraic differences in intersecting grades

S = estimated sight distance, feet

- B. **Maximum and Minimum Grades for Roadways.** The maximum and minimum grades for specific roadway classifications are shown in Table 2-15. The centerline grade in the bulb of a cul-de-sac shall not exceed 3 percent.

Table 2-15. Minimum and Maximum Roadway Grades

Functional Classification or Facility Type	Maximum Centerline Grade (%)	Minimum Centerline Grade (%)	Minimum Gutter Flowline Grade (%)	Minimum Roadside Ditch Flowline Grade (%)
Expressway (Urban/Rural)	5/5	0.5/1	0.5	1

Arterial (Urban/Rural)	6/5 or 6 (for minor)	0.5/1	0.5	1
Collector (Urban/Rural)	8 ^{1,2} /8 ¹	0.5/1	0.5	1
Local (Urban/Rural)	8 ¹ /8 ¹	0.5/1	0.5	1
Cul-De-Sac	3		1	0.5
¹ 10% maximum grade permitted at the discretion of the ECM Administrator				
² 6% maximum grade permitted for Non-residential Collector				

- C. **Joining Existing Improvements.** Connection with existing roadways shall be made to match the grade of the existing improvements, in accordance with vertical alignment criteria.
- D. **Intersection Approach Grades.** Intersection approach grades can be found in Section 2.3.7C.4.
- E. **Grade Breaks and Vertical Curves.** Vertical curves are required when the algebraic difference in grades is equal to or greater than 1.0%. In addition, the maximum grade break allowed at the point of tangency at a curb return for local and collector roads shall be 2%. Grade breaks of less than 1.0% are permitted.
- F. **Cross Fall.** Except at intersections or where a superelevation is required, roadways must be designed to maintain a level cross slope from top of curb to top of curb (or flowline to flowline). The distance from an intersection where cross-fall will be permitted shall be determined by the ECM Administrator.
- G. **Spiral Curves.** Major and minor arterial roadways may be designed with spiral curves with approval of the ECM Administrator.
- H. **Future Extension Confirmation.** When a roadway is designated within the MTCP for future extension, additional survey and preliminary design beyond the current project boundaries may be requested by the ECM Administrator to confirm coordination.

2.3.5. Clear Zones

Clear zones and recovery areas shall conform to CDOT Highway Access Code, AASHTO Green Book, and AASHTO Roadside Design Guide, as modified by Table 2-16. Where a site-specific investigation indicates a high probability of continuing crashes, or such occurrence are indicated by crash history, the greater clear-zone distances may be required by the ECM Administrator. Clear zones may be limited to 30 feet, when approved by the ECM Administrator, to provide a consistent roadway template if previous experience with similar projects or designs indicates satisfactory performance. In addition, in no case shall a permanent structure, including light poles, fire hydrants or trees be placed within these clear zones or in any other location that would obstruct sight distances without prior approval from the ECM Administrator.

Table 2-16. Clear Zone Distances¹

Design Speed	Design ADT	1V:6H or flatter	Foreslopes 1V:5H to 1V:4H	1V:3H	1V:3H	Backslopes 1V:5H to 1V:4H	1V:6H or flatter
40 mph or less	Under 750	7—10	7—10	²	7—10	7—10	7—10
	750—1,500	10—12	12—14	²	10—12	10—12	10—12
	1,500—6,000	12—14	14—16	²	12—14	12—14	12—14
	Over 6,000	14—16	16—18	²	14—16	14—16	14—16
50 mph	Under 750	10—12	12—14	²	8—10	8—10	10—12
	750—1,500	12—14	16—20	²	10—12	12—14	14—16

Created: 2021-06-08 11:35:48 [EST]

(Supp. No. 2)

	1,500— 6,000	16—18	20—26	²	12—14	14—16	16—18
	Over 6,000	18—20	24—28	²	14—16	18—22	20—22
60 mph	Under 750	16—18	20—24	²	10—12	12—14	14—16
	750—1,500	20—24	26—32*	²	12—14	16—18	20—22
	1,500— 6,000	26—30	32—40*	²	14—18	18—22	24—26
	Over 6,000	30—32*	36—44*	²	20—22	24—26	26—28
70 mph	Under 750	18—20	20—26	²	10—12	14—16	14—16
	750—1,500	24—26	28—36*	²	12—16	18—20	20—22
	1,500— 6,000	28—32*	34—42*	²	16—20	22—24	26—28
	Over 6,000	30—34*	38—46*	²	22—24	26—30	28—30

¹ Distances are provided in feet from the edge of the through lane.

² Since recovery is less likely on the unshielded, traversable 1V:3H slopes, fixed objects should not be present in the vicinity of the toe of these slopes. Recovery of high-speed vehicles that encroach beyond the edge of the shoulder may be expected to occur beyond the toe of the slope. Determination of the width of the recovery area at the toe of slope should take into consideration right-of-way availability, environmental concerns, economic factors, safety needs, and crash histories. Also, the distance between the edge of the through-traveled lane and the beginning of the 1V:3H slope should influence the recovery area provided at the toe of slope.

2.3.6. Sight Distance

Sight distance is the length of roadway that is clearly visible to the driver and is dependent upon the height of the driver's eye above the road surface, the specified object height above the road surface, and the height of sight obstructions within the line of sight. The minimum sight distance available on a roadway should be sufficient to enable a vehicle traveling at or near the design speed to stop before reaching a stationary object. In evaluating the overall performance of a roadway, both the horizontal and vertical sight distances should be considered.

- A. **Sight Distance Calculations.** For general sight distance calculations, the height of the driver's eye is considered to be 3.5 feet above the road surface and the object is considered to be 0.52-feet above the road surface. However, for passing sight distance calculations, the height of the object is considered to be 4.25 feet above the road surface.

The sight distance design shall assume that a 6-foot-high fence (as measured from actual finish grade) exists at all property lines except where a sight distance easement has been established.

- B. **Stopping Sight Distance on Straight Roadways.** The minimum stopping sight distance is the distance required by the driver of a vehicle traveling at the design speed to bring the vehicle to a stop after an object on the road becomes visible. Stopping sight distance is the sum of the braking distance and the brake reaction time (the interval between the instant that the driver recognizes the existence of an object on the roadway and the instant the driver applies the brakes). The braking distance is related to the initial speed and the coefficient of friction between the tires and the roadway. The wet condition governs the stopping distances for purposes of design. Table 2-17 provides the required minimum stopping sight distances on straight roadways with grades of less than 3%. In no case shall the stopping sight distance be less than as specified in Table 2-17. For grades in excess of 3%, refer to Table 2-18.

Table 2-17. Stopping Sight Distances

Design Speed (MPH)	Brake Reaction Distance (feet) ¹	Braking Distance on Level (feet)	Stopping Sight Distance	
			Calculated (feet)	Design (feet)
25	91.9	60.0	151.9	155
30	110.3	86.4	196.7	200
40	147.0	153.6	300.6	305
50	183.8	240.0	423.8	425
60	220.5	345.5	566.0	570
70	257.3	470.3	727.6	730

¹ Brake reaction distance predicted on a time of 2.5 seconds; deceleration rate of 11.2 feet/second used to determine calculated sight distance.

- C. **Stopping Sight Distance on Horizontal Curve.** Stopping sight distance on horizontal curves is based upon lateral clearance from the inner edge of pavement to sight obstruction, for various radii of inner edge of pavement and design speeds. The position of the driver's eye and the object sighted shall be assumed to be 6 feet from the inner edge of pavement, with the sight distance being measured along this arc. Figure 2-21 is a design chart showing the required middle ordinates for clear sight areas to satisfy stopping sight distances required for curves of various degrees. Figure 2-21 utilizes the stopping sight distance values in Table 2-17. A value at or approaching the upper limit should be used as a minimum wherever conditions permit.

Figure 2-21. Design Controls for Stopping Distance on Horizontal Curve

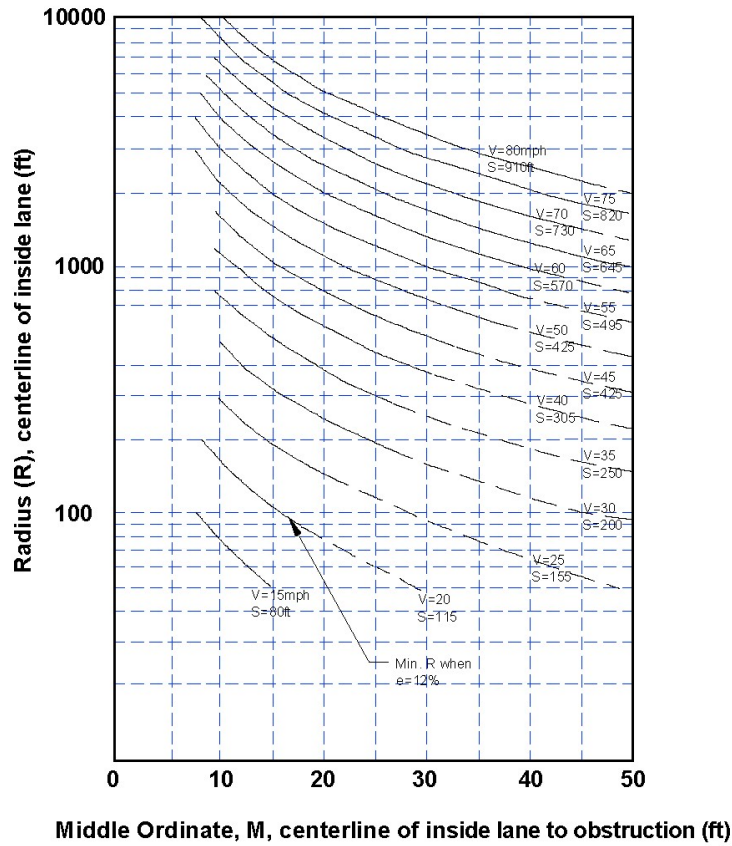

Where:

V=design speed, MPH

M=middle ordinate, centerline of inside lane to obstruction, feet

R=radius of inside lane, feet

S=estimated sight distance, fee (See Table 2-17)

- D. **Stopping Sight Distances at Grade.** When a roadway is constructed on a grade steeper than 3 percent, the braking distance should not only include to the initial speed and coefficient of friction, but also the percent grade (both up and down). Table 2-18 provides the required stopping sight distances at grade in wet conditions.

Table 2-18. Stopping Distance at Grade

Design Speed (MPH)	Downgrades			Design Speed (MPH)	Upgrades		
	Stopping Distance (feet)				Stopping Distance (feet)		
	3%	6%	9%		3%	6%	9%
25	158	165	173	25	147	143	140
30	205	215	227	30	200	184	179
40	315	333	354	40	289	278	269

50	446	474	507	50	405	288	375
60	598	638	686	60	538	515	495
70	771	825	891	70	690	658	631

- E. **Decision Sight Distance in Areas of Visual Noise.** Decision sight distance is defined as the distance it takes for a driver to detect an unexpected or difficult-to-perceive hazard along the roadway that may be visually cluttered, recognize this hazard, select an appropriate speed and path, and complete the required safety maneuver. Based on this definition, these values tend to be greater than stopping sight distances. Interchanges and intersections, locations where unusual or unexpected maneuvers are required, changes in cross section, and areas of "visual noise" are examples of locations where decision sight distances may be needed. Table 2-19 provides the required decision sight distances.

Table 2-19. Decision Sight Distance

Design Speed (MPH)	Decision Sight Distance for Avoidance Maneuver (feet)				
	A	B	C	D	E
30 or less	220	490	450	535	620
40	330	690	600	715	825
50	465	910	750	890	1,030
60	610	1,150	990	1,125	1,280
70	780	1,410	1,105	1,275	1,445
Where:					
Avoidance Maneuver A = stop on rural road (t = 3.0 seconds)					
Avoidance Maneuver B = stop on urban road (t = 9.1 seconds)					
Avoidance Maneuver C = speed/path/direction change on rural road (t = 10.2 - 11.2 seconds)					
Avoidance Maneuver D = speed/path/direction change on suburban road (t = 12.1 - 12.9 seconds)					
Avoidance Maneuver E = speed/path/direction change on urban road (t = 14.0 - 14.5 seconds)					

- F. **Passing Sight Distance for Two-Lane Roads.** Passing sight distance is the minimum distance (traveling at the design speed) that must be available to enable the driver of one vehicle to pass another safely and comfortably without interfering with oncoming traffic. Required passing sight distances are provided in Table 2-20.

Table 2-20. Minimum Passing Sight Distance for Two-Lane Roads

Design Speed (MPH)	Assumed Speeds		Passing Sight Distance (feet)	
	Passed Vehicle (MPH)	Passing Vehicle (MPH)	Figure 2-22	Design
25	22	32	897	900
30	26	36	1,088	1,090
40	34	44	1,470	1,470
50	41	51	1,832	1,835
60	47	57	2,133	2,135
70	54	64	2,479	2,480

Figure 2-22. Total Passing Sight Distance for Two-Lane Roads

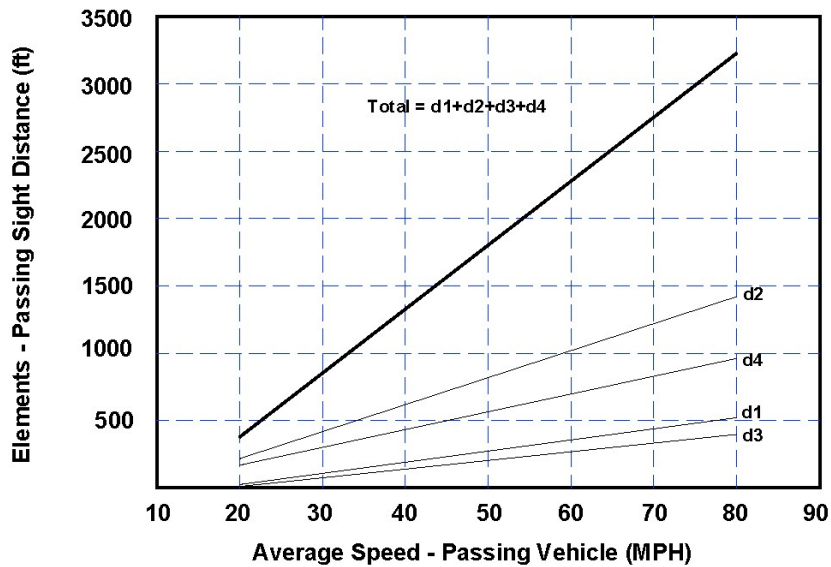

- d1 - distance traversed during perception and reaction time and during initial acceleration to the point of encroachment on the left lane
- d2 - distance traveled while the passing vehicle occupies the left lane
- d3 - distance between the passing vehicle at the end of its maneuver and the opposing vehicle
- d4 - distance traversed by an opposing vehicle for two-thirds of the time the passing vehicle occupies the left lane, or 2/3 of d2

G. **Intersection sight distance.** This section applies to intersections where one public road meets a second public road. The intersection sight distance provides for vehicles to enter traffic and accelerate to the average running speed. Intersection sight distances shall be measured as shown on Figure 2-23. The intersection sight distance shall be [Intersection sight distance shall be per AASHTO Green Book, as shown in Table 2-21.](#)

Figure 2-23. Sign Distance Triangle (Stop Controlled) Replace this figure with AASHTO figure

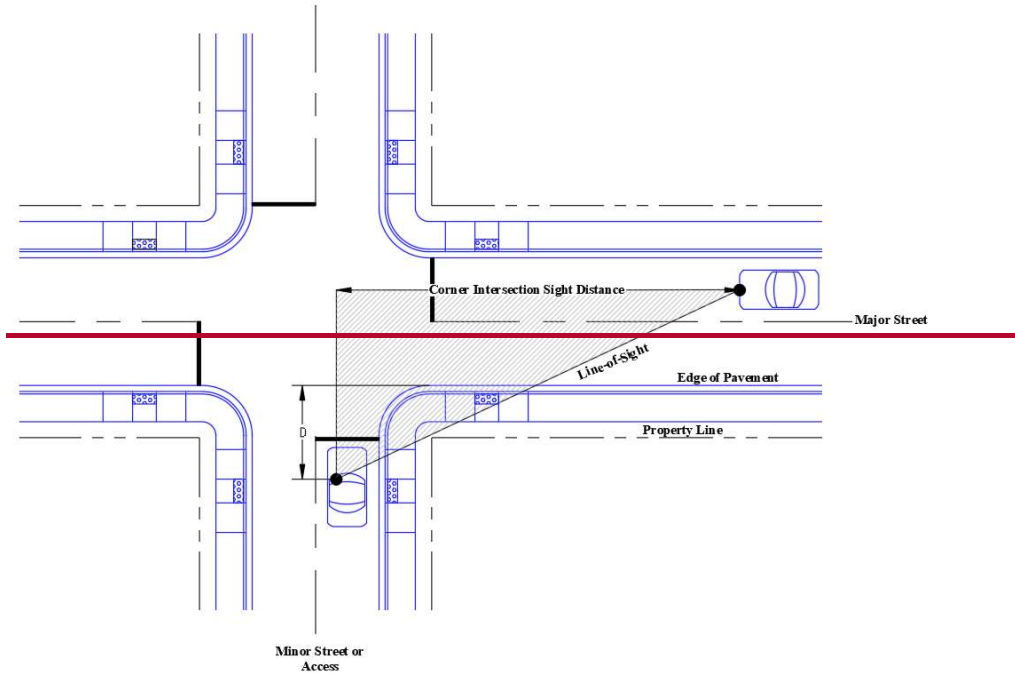

Table 2-21. Intersection Sight Distance

Higher Functional Classification Roadway Design Speed (MPH)	Intersection sight distance (feet) ^{1, 3}
50	555
40	445
30	335 ²
25	280 ²
¹ Intersection sight distance measured from a point on the minor road at 13 feet back from the edge of the major road pavement ("D") and measured from a height of eye at 3.5 feet on the minor road to a height of object at 3.5 feet on the major road.	
² At local/local road intersections only, "D" shall be 10 feet and the sight distance shall be measured to the centerline of the road per AASHTO 9.5.3.	
³ These values only apply to two-lane roads with stop control, all other situations require special design considerations.	

1. **Sight Distance Triangles within Easements.** There shall be an unobstructed sight distance along both approaches and both sides at an intersection (within the right-of-way) for distances sufficient to allow the operators of vehicles, approaching simultaneously, to see each other in time to prevent collisions at the intersection.

All sight distance triangles must be within the public right-of-way or a sight distance easement (See Figure 2-23). If the line of sight crosses onto private property, a "Sight Distance Easement" shall be dedicated to provide the required sight distance. The easement or right-of-way shall be dedicated to the County. Maintenance of a sight distance easement shall be the responsibility of the property owner or the homeowners' association unless otherwise approved by the County.

-
2. **Encroachment into Sight Distance Triangles or Easements.** Any object within the sight distance triangle or easement more than 30 inches above the flowline elevation of the adjacent roadway shall constitute a sight obstruction, and shall be removed or lowered. The objects may include but are not limited to berms, buildings, parked vehicles on private property, cut slopes, hedges, trees, bushes, utility cabinets or tall crops. Trees may be permitted at the discretion of the ECM Administrator if pruned to at least 8 feet above the flowline elevation of the adjacent roadway.
 3. **On-Roadway Parking within Sight Distance Triangles.** The ECM Administrator may limit on-street parking to protect visibility and enhance roadway capacity.

2.3.7. Intersections

- A. **Intersection Design Guidelines.** Intersections shall be designed to provide safe movement for all those using roadways within the County (motorists, pedestrians, and bicyclists). By their nature, intersections are conflict locations. Vehicles, pedestrians, and bicycles all cross paths. Each crossing is a conflict point. The basic design of intersections includes the following objectives:
 - Minimize points of conflict
 - Simplify areas of conflict
 - Limit conflict frequency
 - Limit conflict severity
- B. **Intersection Spacing and General Access Standards.** Full movement intersections and major accesses spacing shall meet the requirements in Section 2.2.5. While access to a major roadway should be avoided, right-in/right-out and three quarter movement accesses may be permitted as a deviation if they meet the criteria for sight distances, turn lane requirements, grades and do not negatively impact traffic operations or safety. The applicant shall have the burden of proof that no other "viable or practical" property access is available. A deviation request should be supported by a traffic study or memorandum that provides information to assist the ECM Administrator in determining the proposed deviation minimizes negative safety and other operational impacts along upstream and downstream roadway segments. The addition of such an access shall minimize impacts to queuing or blocking of lane entries or access points and minimize impacts to progression. The access must be in a location such that any necessary turn lanes and acceleration/deceleration lanes can be accommodated to maintain safe operations and capacity. The analysis should consider all potential future additional requirements ~~for~~ to accommodate traffic generated by adjacent land uses. Buildout design hour/peak hour projected traffic volumes should be used.
- C. **Intersection Alignment.**
 1. **Offset.** All lanes traversing an intersection shall be in alignment. A maximum 2-foot lane offset may be approved by the ECM Administrator if no other alternative exists.
 2. **Angle.** Crossing roadways shall intersect at 90 degrees whenever possible. In no case shall roadways be permitted to intersect at less than 80 degrees or more than 100 degrees.
 3. **Horizontal Alignment.** The horizontal alignment of roadways through an intersection shall be designed in conformance with this chapter depending on the classification of the roadways intersecting. Intersections may be placed on horizontal curves, provided the minimum tangent lengths shown in Table 2-11 are provided on the lower functional classification roadway and the required sight distance is met.
 4. **Vertical Alignment.** The roadway profile grade shall not exceed the value presented in Table 2-22 on the approach to the intersection, as measured along the centerline of the roadway for a

minimum distance equal to the grade lengths presented in Table 2-23 for each of the roadway functional classifications.

The grade of the roadway with the higher functional classification shall prevail at intersections. Grading of lower functional classifications, adjacent property, private access shall adapt to the higher functional classification roadway grade.

~~In cases where the natural grade for which a roadway is to be constructed is steeper than 4 percent (hillside areas). A deviation from the presented standards may be requested for to accommodate these conditions up to a maximum of 8 percent.~~

Where crosswalks are provided at intersections, roadway grades shall be set to provide compliant crosswalk cross slopes. On approaches with stop or yield control, roadway grades shall be 2% maximum. On uncontrolled approaches or at traffic signals designed to permit arrival during the green phase, roadway grades shall be the maximum permitted for that functional classification, but in no case greater than 5%. See Section 6.3.2.

5. **Intersection Sight Distance.** The sight distance at intersections shall be shown geographically on the construction plans. A note shall be added to each leg of the intersection stating that intersection sight distance exceeds the minimum sight distance for ___ mph design speed.

Table 2-22. Intersection Grades by Roadway Functional Classification

Functional Classification	Maximum Intersection Grade (%)	Minimum Intersection Grade (%)
Expressway (Urban/Rural)	2/2	0.5/1
Arterial (Urban/Rural)	3/3 (4 for minor) ¹	0.5/1
Collector (Urban/Rural)	4/4 ¹	0.5/1
Local (Urban/Rural)	4/4 ¹	0.5/1

¹ Maximum grade at crosswalks with stop/yield control is 2%

Table 2-23. Intersection Profile Grade Lengths¹

Higher Classification Roadway (below)	Lower Classification Roadway			
	Local	Collector	Arterial	Expressway
Expressway	n/a	n/a	200	250 ¹
Arterial	n/a	120	200 ¹	n/a
Collector	100	120 ¹	n/a	n/a
Local	100 ¹	n/a	n/a	n/a

¹ In the case of where each intersecting roadway is of the same classification, the ECM Administrator will designate which roadway takes precedence and the distance required.

D. Turn Lanes Required.

1. **Exclusive Left Turn Lane Required.** Exclusive left turn lanes shall be provided wherever left turn lanes are specified as being needed by an approved TIS, identified in the MTCP, required by the ECM, or determined to be warranted by the ECM Administrator. Information in the TIS shall be used to determine whether an exclusive left turn lane is warranted. Warrant determinations shall also be based on this chapter, which include:
 - Expressways Left Turn Lane (State Highway Access Code Designation - EX): A left turn lane is required for any access that allows left turn ingress movement, except for field approaches.

A left turn acceleration lane may be required if the design would be a benefit to safety and operation of the roadway.

- Principal Arterials Left Turn Lane (State Highway Access Code Designation - RA for Rural and NR-A for Urban): A left turn lane is required for an access with a projected peak hour left ingress turning volume of 10 VPH or greater. A left turn acceleration lane may be required if it would be a benefit to the safety and operation of the roadway.
 - Minor Arterials (State Highway Access Code Designation - RB for Rural and NR-B for Urban) and Lower Classifications Left Turn Lane: A left turn lane is required for any access with a projected peak hour ingress turning volume of 25 VPH or greater.
2. **Exclusive Right Turn Lanes Required.** Exclusive right turn lanes shall be provided wherever right turn lanes are specified as being needed by an approved TIS, identified in the MTCP, required by the ECM or determined to be warranted by the ECM Administrator. Information in the TIS shall be used to determine whether an exclusive right turn lane is warranted. Warrant determinations shall also be based on this chapter, which include:
- Expressway Right Turn Lane (State Highway Access Code Designation - EX): A right turn lane is required for any access with a projected peak hour right turn ingress turning volume of 10 VPH or greater. A right turn acceleration lane is required for any access with a projected peak hour right turn egress turning volume of 10 VPH or greater.
 - Principal Arterials Right Turn Lane (State Highway Access Code Designation - RA for Rural and NR-A for Urban): A right turn lane is required for any access with a projected peak hour right ingress turning volume of 25 VPH or greater. A right turn acceleration lane is required for any access with a projected peak hour right turning volume of 50 VPH or greater when the posted speed on the roadway is greater than 40 MPH. A right turn acceleration lane may also be required at a signalized intersection if a free right-turn is needed to maintain an appropriate level of service in the intersection.
 - Minor Arterials (State Highway Access Code Designation - RB for Rural and NR-B for Urban) and Lower Classifications Right Turn Lane: A right turn lane is required for any access with a projected peak hour right turning volume of 50 VPH or greater. An acceleration lane is generally not required.
3. **Acceleration Lanes Required.** Where acceleration lanes are required, deviations may be considered at stop controlled intersections under certain circumstances. As stated in the AASHTO "Green Book" (PGDHS), acceleration lanes are not always desirable. Please refer to the "Green Book" for additional information concerning instances where acceleration lanes may not be desirable. Deviations may also be considered at intersections with traffic signals.
4. **Lane Shifts or Drops Required.** Lane shifts or drops shall be provided wherever redirection of traffic are specified as being needed by an approved traffic control plan, required by the ECM or determined to be warranted by the ECM Administrator.
5. **Conflicts between Exclusive Turn Lanes.** Where two intersections have exclusive turn lanes that overlap, or the ending points of the exclusive turn lanes have less than 300 feet or one-half their length of separation (whichever is shorter) and a significant structure or topographical feature does not preclude widening, a continuous exclusive turn lane shall be established between the intersections to improve roadway consistency, safety, and to maintain edge of pavement continuity.

If restrictive topography allows only one exclusive turn lane, normally a left turn deceleration lane is given first priority. Where a left turn is installed and the travel lanes must be redirected, an overlay of pavement is required.

-
- E. **Turn Lane Design.** Turn lanes typically consist of a combination of several components (i.e. tapers, lane length, and storage). The use and design of these components varies based on the type of access, roadway classification, and site-specific conditions. Figure 2-24 presents a graphical guide to basic exclusive turn lane elements.

Figure 2-24. Guide to Basic Exclusive Turn Lane Elements

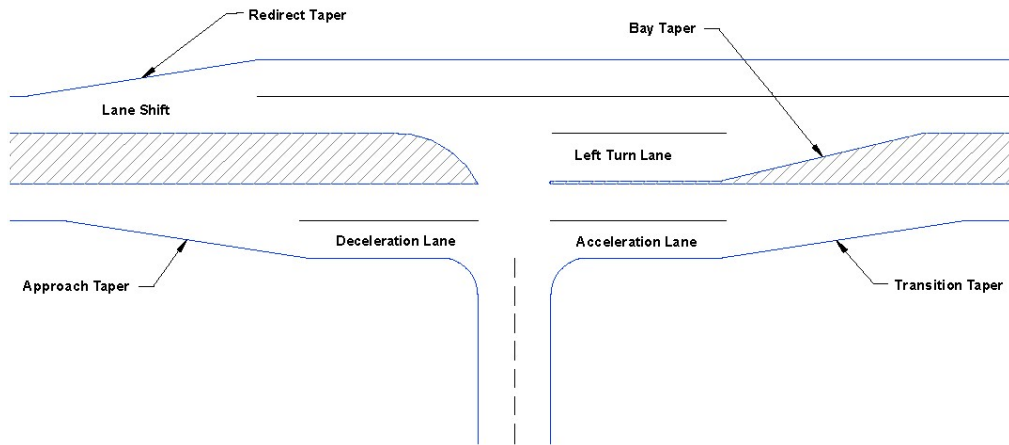

1. **Turn Lane Design Elements.**

- **Left Turn Lane.** The design elements for a left turn lane are the bay taper, lane length, storage length, which in combination makes up the left turn lane. The elements are shown in Figure 2-25. The specific designs for these lanes shall be in accordance with this chapter. For each high volume access and major intersection, both acceleration and deceleration lanes shall be considered in designing an exclusive left turn lane.

Figure 2-25. Design Elements for Left Turn Lanes

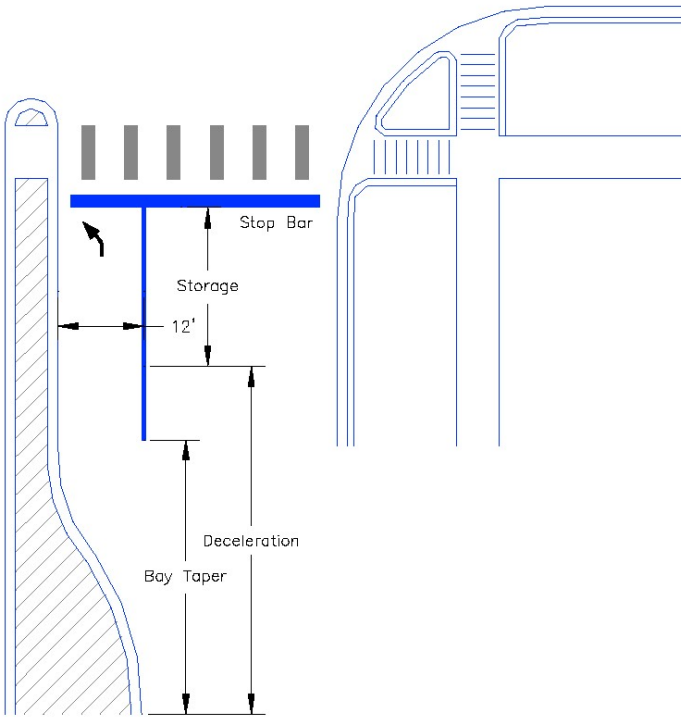

- Right Turn Lane. The design elements for a right turn and deceleration lanes are the approach taper, lane length, storage length, which in combination makes up the right turn lane. The elements are as shown in Figure 2-26. For each high volume access and major intersection, both acceleration and deceleration lanes shall be considered in designing an exclusive right turn lane. The specific designs for these lanes shall be in accordance with this chapter. Specific lane shift and lane drop design criteria can be found in Section 2.3.8J.3.
- Acceleration Lane. The design elements for an acceleration lane are the transition taper and acceleration length. For each high volume access and major intersection, both acceleration and deceleration lanes shall be considered in designing an exclusive right or left turn lane. The specific designs for these lanes shall be in accordance with this chapter.
- Shift or Drop Lane. The design elements for a transition or drop lane are the redirect taper, full width auxiliary lane, and storage length. The use and design of these elements varies based on the roadway classification and site-specific conditions.

Figure 2-26. Design Elements for Right Turn Lanes

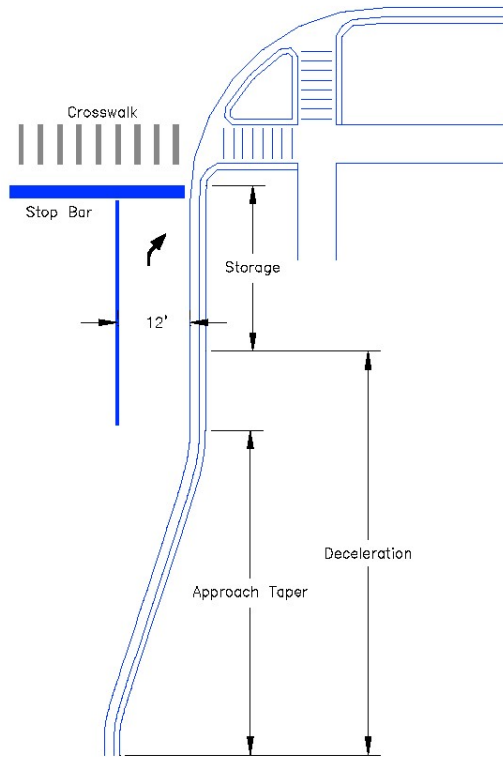

2. Tapers.

- Approach Tapers. The basis for designing a deceleration lane and taper is to provide sufficient length for a vehicle to decelerate and brake primarily outside the through traffic lanes. Table 2-24 provides the required deceleration lane and taper design lengths by design speed. Deceleration lane lengths shall be adjusted for a grade of 3% or more using the factors in Table 2-25. The required length allows a motorist to decelerate in gear for at least 3 seconds followed by safe braking to a complete stop.

Table 2-24. Required Deceleration Lane and Taper Lengths

Design Speed (MPH)	Lane Length (feet)	Approach Taper (feet)	Total Length (feet)
25	115	120	235
30	115	120	235
40	155	160	315
50	235	200	435
60	290	240	530
70	Special Design	Special Design	Special Design

Table 2-25. Deceleration Lane Grade Adjustment Factors

Roadway Grade	Factors
Upgrade	
3% to 4.9%	0.90

5% to 7%	0.80
Downgrade	
3% to 4.9%	1.20
5% to 7%	1.35

- Bay Tapers. Table 2-26 provides the required bay taper length by lane width. A bay taper is designed to direct left-turning vehicles into the turn lane. A minimum taper ratio of 8:1 may be used for tangent bay tapers in constrained locations. Bay tapers should be used (asymmetrical reverse curves) for deceleration transition tapers. Straight transition tapers should be avoided at design speeds above 40, and where a vertical crest or horizontal curve is present. Under these conditions, an immediate bay taper and lane striping should be substituted for a straight transition taper to reduce drifting of the through vehicles into the deceleration lane. Where horizontal or crest vertical curves exist, the ECM Administrator may require the deceleration transition taper to begin with an immediate asymmetrical reverse curve bay taper of 1/3L then 2/3L with the remaining required transition taper length at full lane width. Partial tangent transition tapers, symmetrical reverse curve tapers or asymmetrical reverse curve tapers may be used for transition taper design provided a radius of at least 150 feet is used in curve calculations.

Table 2-26. Required Bay Taper Lengths for 12-foot Lanes (for use with design of left turn deceleration lanes)

Design Speed (MPH)	Lane Length (feet)	Bay Taper (feet)	Total Length (feet)
25	115	80	195
30	115	120	235
40	155	160	315
50	235	200	435
60	290	Special Design	Special Design
70	Special Design	Special Design	Special Design
Taper = $WV/3$			
where: W = lane width, feet, V = design speed, MPH			

- Transition Tapers. The basis for designing an acceleration lane and transition taper is to provide sufficient length for a vehicle to accelerate to the appropriate speed and merge into the through traffic lanes without disrupting traffic flow. Table 2-27 provides the required acceleration lane and transition taper design lengths by design speed. Acceleration lane lengths in Table 2-27 shall be adjusted for a grade of 3% or more using the factors in Table 2-28. The total length of the acceleration lane includes the values of both the lane and transition taper. The length of a transition taper is calculated by multiplying the width of the lane by a standard ratio. The beginning and ending point of all tapers shall be rounded.

Table 2-27. Design Criteria for Acceleration Lanes

Posted Speed Limit (MPH)	25	30	35	40	45	50	55	60	65	70
Acceleration Length (feet)	N/A	190	270	380	550	760	960	1170	1380	1590
Transition Taper Ratio	7.5:1	8:1	10:1	12:1	13.5:1	15:1	18.5:1	25:1	25:1	25:1

Created: 2021-06-08 11:35:48 [EST]

(Supp. No. 2)

Table 2-28. Grade Adjustment Factors for Acceleration Lanes

	Design Speed (MPH)		
	40 to 50	60	70
Upgrade			
3 to 4.9%	1.3	1.5	1.7
5 to 7.5%	1.5	2.0	2.5
Downgrade			
3 to 4.9%	0.7	0.65	0.6
5 to 7.5%	0.6	0.55	0.5

- **Redirect Tapers.** Redirect tapers shall be used where an exclusive turn lane, median or other redirection of vehicles is necessary and where redirection of the flow of traffic is necessary to accommodate the exclusive turn lane or median due to constraints. Redirect tapers required for redirecting through travel lanes shall be installed in conformance with Table 2-29. If the redirect taper would result in a horizontal curve design deficiency for the through movement, the horizontal curve shall be corrected. Redirect taper should be designed as straight tapers with the beginning and ending points rounded.

Table 2-29. Redirect Tapers for Through Lanes

	Design Speed (MPH)				
	30 or less	40	50	60	70
Straight Taper Ratio	15:1	20:1	45:1	55:1	65:1

3. **Storage Lengths.** The basis for designing the length of required storage is to provide sufficient length for vehicles to queue within the lane without affecting other movements. Table 2-30 provides the required storage lengths for stop-controlled intersections. Figure 2-27 provides the required calculated storage lengths for signal-controlled intersections. Where the ECM Administrator determines that meeting the required storage length is impractical or results in an unsafe condition, the minimum storage length shall be based on the mean arrival rate, but in no case shall the minimum storage length be less than 50 feet.

Table 2-30. Required Storage Lengths for Stop-Controlled Intersections

DHV (VPH)	<60	61—120	121—180	181—250	>250
Storage Length (feet)	50—75	100	150	200	250 or more

Figure 2-27. Required Storage Lengths for Signal-Controlled Intersections

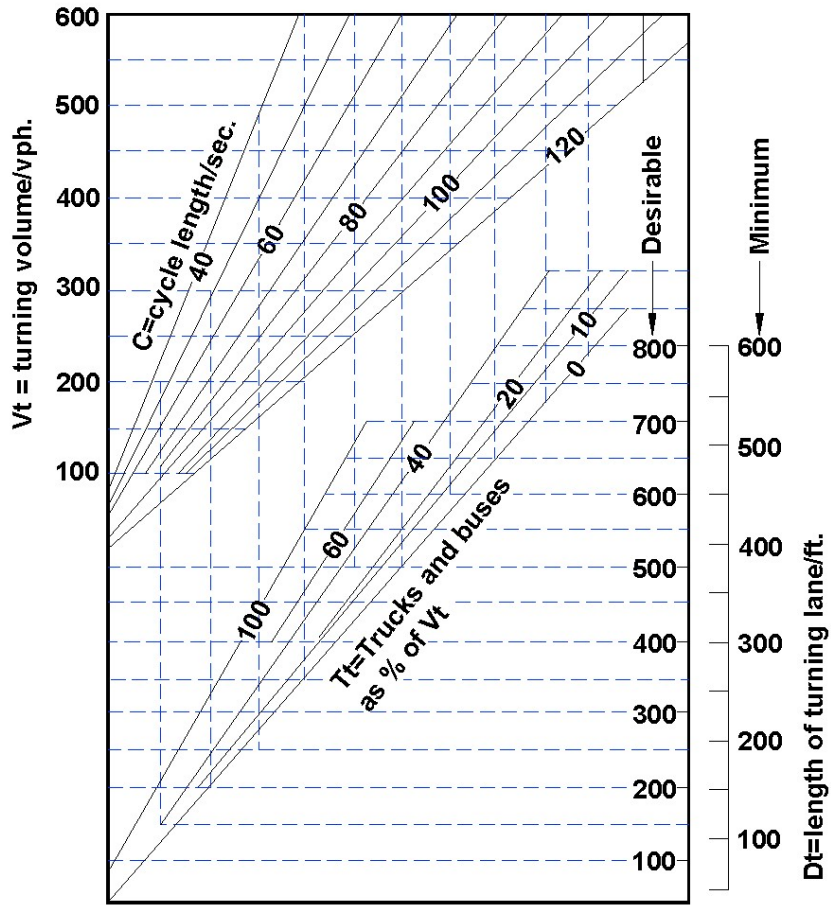

F. Curb Returns.

1. **Radii.** Table 2-31 and Table 2-32 present minimum curb return radii at intersections for each roadway type, rural and urban. A paved shoulder adjacent to an exclusive turn or acceleration lane is required where no curb and gutter exist or are proposed. Shoulders adjacent to an exclusive turn or acceleration lane shall be at least 4 feet wide and paved.

Table 2-31. Minimum Curb Return Radius at Intersection (Urban Roads)

	Local	Collector	Minor Arterial	Principal Arterial	Expressway
Local	20'	25'	30'	30'	Special Design
Collector	25'	25'	30'	40'	Special Design
Minor Arterial	30'	30'	50'	Special Design	Special Design
Principal Arterial	30'	40'	Special Design	Special Design	Special Design
Expressway	Special Design	Special Design	Special Design	Special Design	Special Design

Table 2-32. Minimum Curb Return Radius at Intersections (Rural Roads)

	Local	Collector	Minor Arterial	Principal Arterial	Expressway
Local	20'	30'	40'	40'	Special Design
Collector	30'	30'	40'	40'	Special Design
Minor Arterial	40'	40'	50'	Special Design	Special Design
Principal Arterial	40'	40'	Special Design	Special Design	Special Design
Expressway	Special Design	Special Design	Special Design	Special Design	Special Design

2. **Grades.** The minimum grade for flowlines around the curb return shall be 1%. In some instances, the minimum grade for flowlines around curb returns may be reduced to 0.5% with approval from the ECM Administrator.
- G. **Design Vehicles.** Intersections shall be designed to accommodate the AASHTO design vehicles. The following minimum allowable design vehicle criteria shall apply. For special circumstances, other design vehicles and criteria may be required by the ECM Administrator or proposed by the design engineer where trucking volumes and typical truck sizes suggest an alternative design vehicle would be more appropriate.
1. **SU-30 (Single Unit Truck).** At all intersections, SU-30 vehicles shall be able to turn easily from one roadway to the next and remain in the correct lane for each roadway.
 2. **B-40 (Bus).** At all intersections, B-40 vehicles may use one or more traffic lanes to complete a turn when turning from the correct lane without crossing into opposing traffic lanes and without tracking onto the curb at corners.
 3. **WB-50 (Large Semi Trailer).** WB-50 vehicles may use one or more traffic lanes to complete a turn without tracking onto the curb at corners. In addition, the vehicle must make the turn in one forward maneuver encroaching into opposing traffic lanes. These requirements shall apply to all arterial/arterial, arterial/collector, arterial/local, and collector/collector intersections. For all other intersections, the vehicles may use the entire paved surface of the road to negotiate the turn.
 4. **WB-67 (Large Semi Trailer).** WB-67 vehicles may use one or more traffic lanes to complete a turn without tracking onto the curb at corners. In addition, the vehicle must make the turn in one forward maneuver encroaching into opposing traffic lanes. These requirements shall apply to all arterial/arterial, and arterial/collector intersections. For all other intersections, the vehicles may use the entire paved surface of the road to negotiate the turn.
- H. **Intersection Channelization.** Channelization is intended to separate or regulate conflicting traffic movements into definite paths of travel by the use of pavement markings, raised islands or other suitable means to facilitate the safe and orderly movement of all modes of travel using a particular corridor. See Figure 2-28 for a channelization example associated with a portion of an intersection exclusive right turn lane.

Figure 2-28. Channelization Example

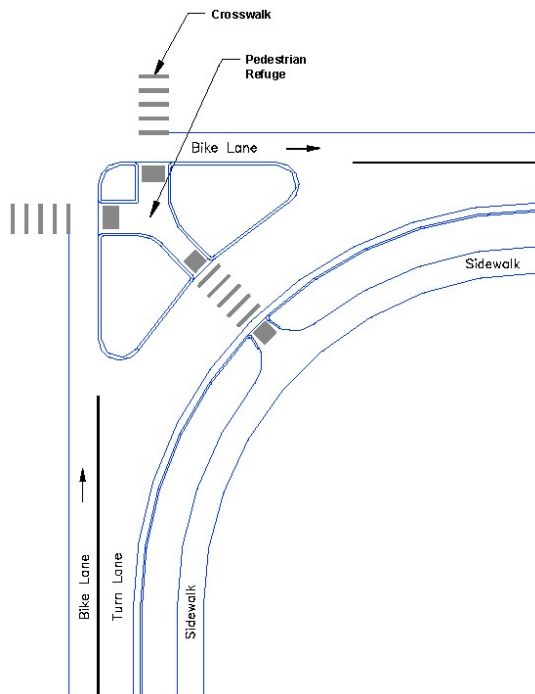

- I. **Roundabouts.** Roundabouts are considered a form of traffic control. Roundabouts shall be considered as two types: (1) modern roundabouts and (2) mini roundabouts.
 1. **Modern Roundabouts Design Guidelines.** Modern roundabouts shall be designed based on site-specific needs for high volume roadways. The use of modern roundabouts may be considered for many reasons; some may include, but not be limited to:
 - Traffic volumes on both roadways are approximately equal (i.e. within 10% of each other), or
 - Where significant percentages (20% or greater) of traffic on the major roadway is conducting left turns, or
 - Where the intersection is expected to warrant signalization within twenty years.Specific guidelines for designing the main elements of a modern roundabout shown in Figure 2-29 include:
 - Modern roundabouts shall be designed to accommodate the largest design vehicle of the intersecting streets.

Figure 2-29. Typical Design Elements of a Modern Roundabout

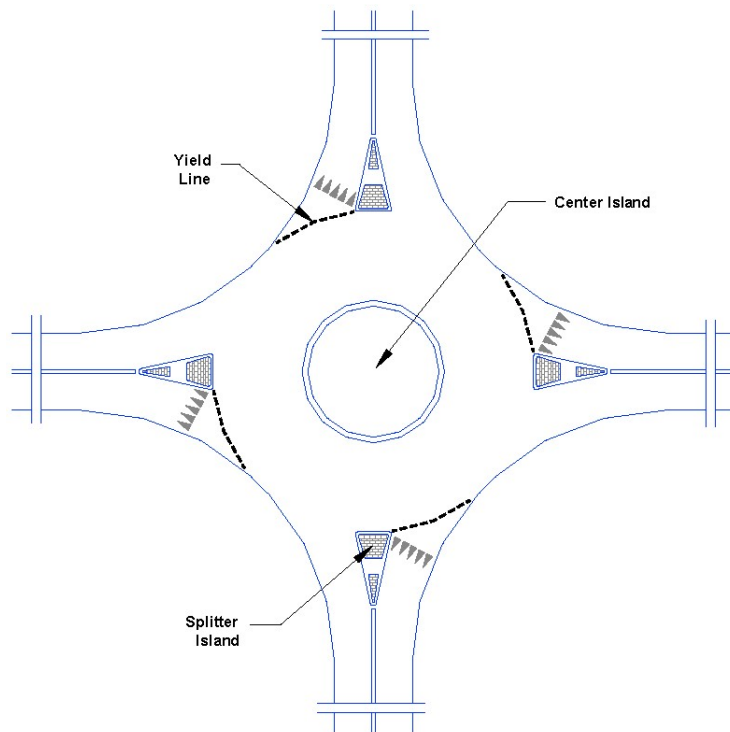

- The design of the center island will be in accordance with the Roundabout Design Guide and approved by the ECM Administrator. Should a truck apron be warranted based on site-specific design parameters, the width shall be selected based on what is appropriate to accommodate the free circulation of the design vehicle.
- ~~The circulatory roadway width shall be a minimum of 1.2 times the width of the widest entering roadway or 20 feet, whichever is greater. The width may include the apron when approved by the ECM Administrator.~~
- The roundabout design shall be completed with the aid of computer software. The ECM Administrator is authorized to require the use of a specific software package when warranted by the needs of a specific intersection.
- ~~Roundabout designs shall conform with NCHRP Report 672 – Roundabouts: An Informational Guide, Second Edition (2010), the Wisconsin DOT Facilities Development Manual (FDM) (as amended), found at <https://wisconsin.gov/pages/doing-business/eng-consultants/cns/lt-rsrcs/rdwy/fdm.aspx>. Any other criteria proposed for use shall be confirmed by the ECM Administrator prior to design. The design process shall be iterative with submittals generally conforming with the Wisconsin DOT design procedures as directed by the ECM Administrator. The Wisconsin DOT details, signing and striping recommendations, and lines of sight, should be utilized to the extent practicable. (The design shall conform with the FHWA Roundabout Design Guide or other design criteria approved by the ECM Administrator).~~
- Raised splitter islands are required on all approaches.

- Roundabout signage and markings Signage shall conform with the requirements of the MUTCD.
 - Roundabout lighting shall be provided and conform with the 2019 CDOT Lighting Design Guidelines, as amended.
2. **Mini Roundabouts Design Guidelines.** Mini roundabouts may be allowed in a neighborhood setting for traffic calming. Mini roundabouts may be used on urban local roadways. Mini roundabouts are prohibited in areas without curb and gutter. Specific guidelines for designing the main elements of a mini roundabout shown in Figure 2-30 include:
- The design shall conform with the Roundabout Design Guide, FHWA Standards or other design criteria approved by the ECM Administrator.
 - The circular roadway shall be a minimum of 20 feet wide flowline to flowline, and the approach legs shall be a minimum of 16 feet wide.
 - Mini roundabouts shall be designed to accommodate WB-50 vehicles.
 - To enhance truck movement through smaller-diameter roundabouts, a concrete truck apron may be used to assist with tracking.

Figure 2-30. Typical Mini Roundabout Cross Section

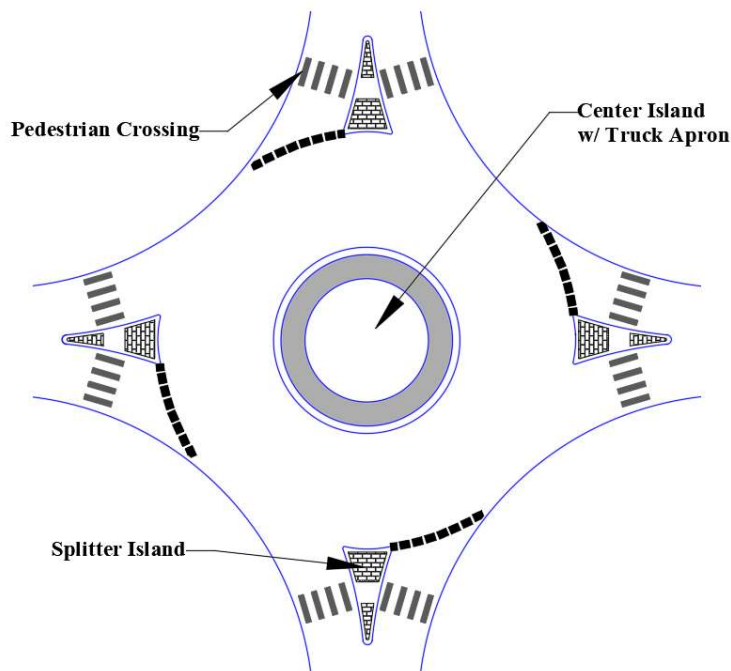

2.3.8. Roadway Terminations

- A. **Cul-de-Sacs.** Cul-de-sacs shall be used only where absolutely necessary. Cul-de-sacs shall have a minimum radius of 45 feet and a maximum length of 750 feet for urban conditions and a minimum radius of 50 feet and a maximum length of 1,600 feet for rural conditions, be designed in conformance with Figure 2-31. The maximum length of cul-de-sac shall be measured from the right-of-way of the intersecting street to the center of the cul-de-sac bulb. Hammerhead turnarounds are not permitted as

permanent roadway terminations. The cul-de-sac right-of-way width shall be consistent with the right-of-way associated with the roadway functional classification and provide for the turnaround, sidewalks, utilities, and necessary drainage facilities. A request for a deviation from the maximum length criteria will not be considered without an express written endorsement from the Fire District in which the proposed cul-de-sac is located.

In special cases where a divided 4 lane roadway that terminates adjacent to a subdivision or development, the length of the collector or local roads that intersect the divide 4 lane roadway shall be measured from the point of intersection with the divided 4 lane roadway regardless of the length of the terminated divided 4 lane roadway. In all other cases, the length of the cul-de-sac or terminated road shall be measured from the point at which the road providing access to a site begins.

Figure 2-31. Typical Cul-de-Sac Requirements (Urban and Rural)

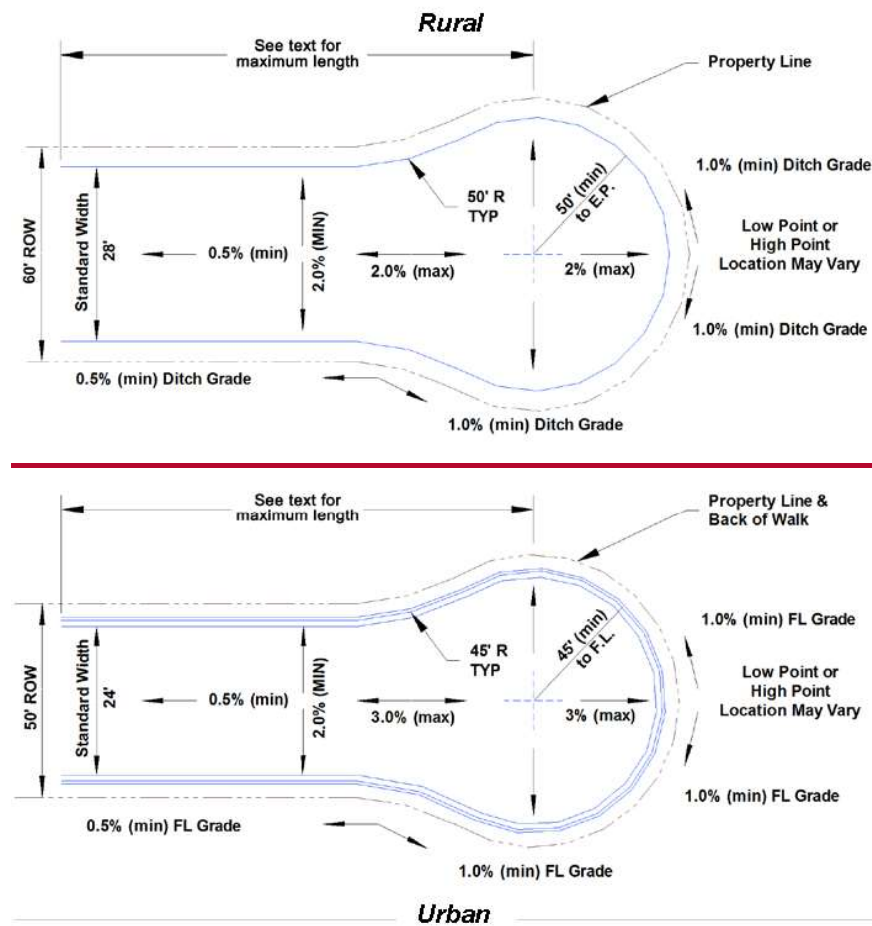

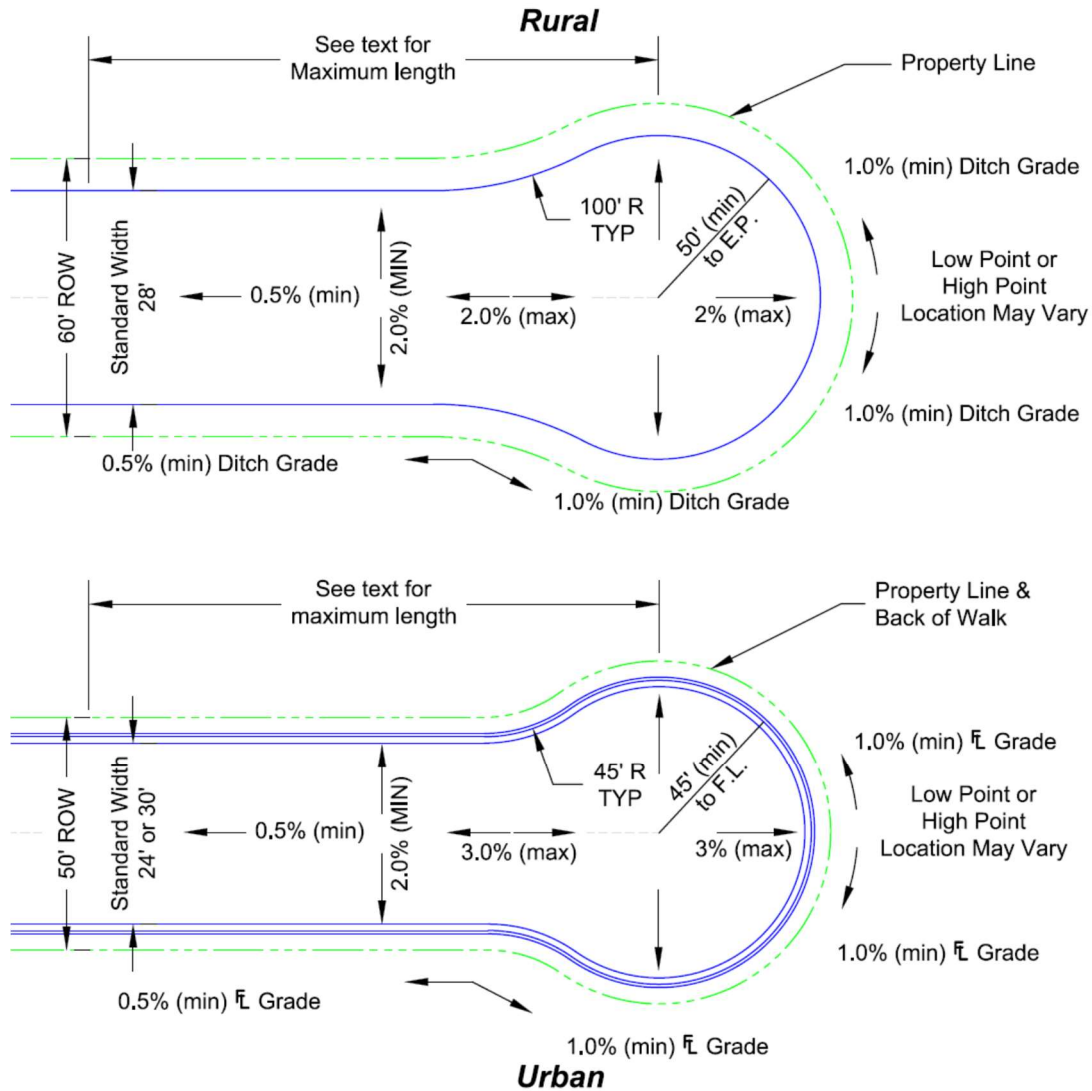

- B. **Eyebrows and Knuckles.** Eyebrows and knuckles shall be permitted only on urban local roadways in conformance with Figure 2-32 and detailed standard drawings SD 2-77 and SD 2-78. Eyebrows are permitted if they are. The location of the eyebrow shall be in conformance with intersection spacing requirements presented in Table 2-4 through Table 2-26. If the maximum length of the eyebrow is exceeded, the roadway design shall conform to minimum cul-de-sac requirements. Knuckles are permitted at intersections where the intersection angle is between 70-110 degrees and where each street extends in only one direction from the intersection; otherwise the roadway shall be designed in accordance with minimum centerline curve radius.

Figure 2-32. Typical Eyebrow ~~and Knuckle~~ Requirements

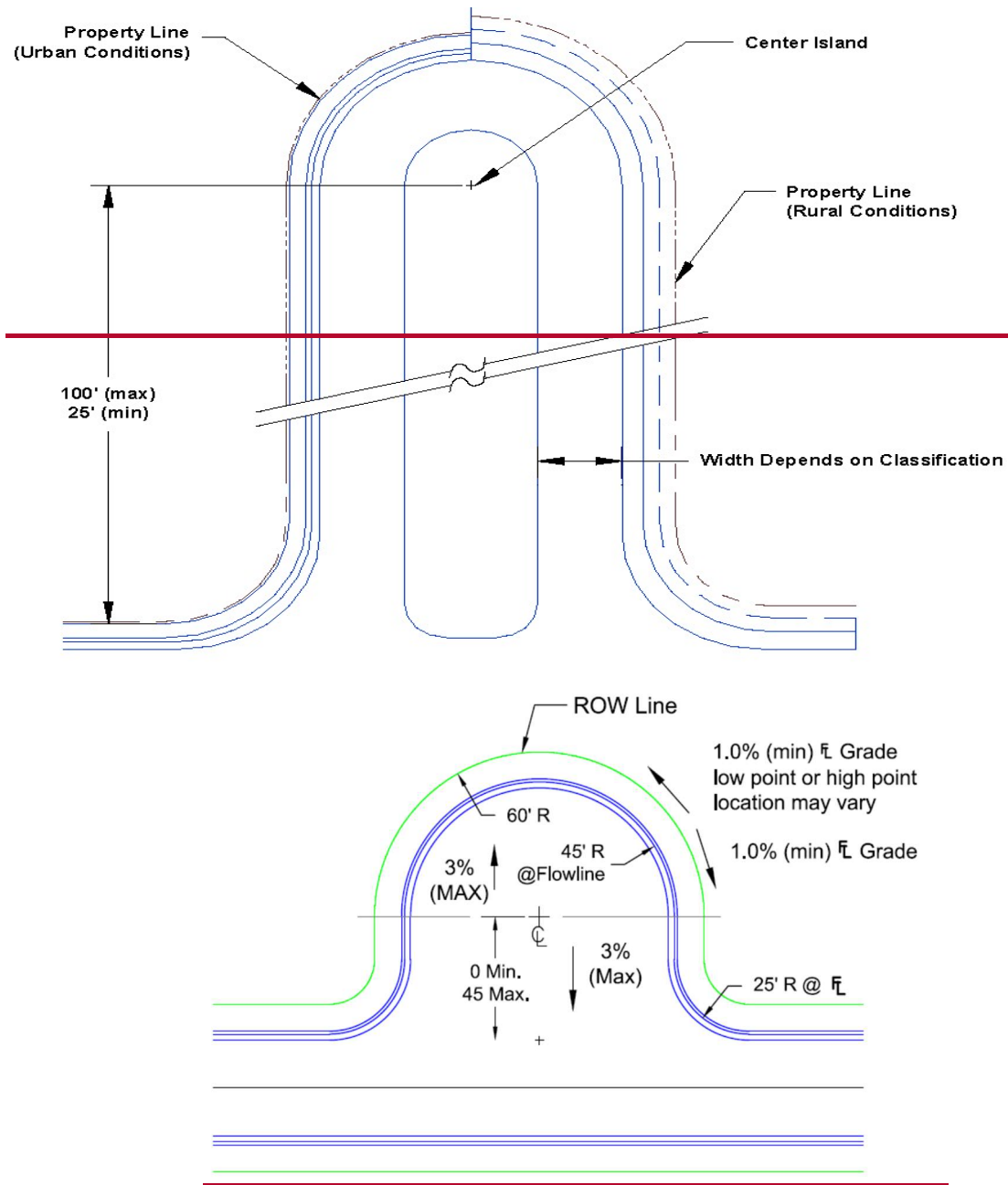

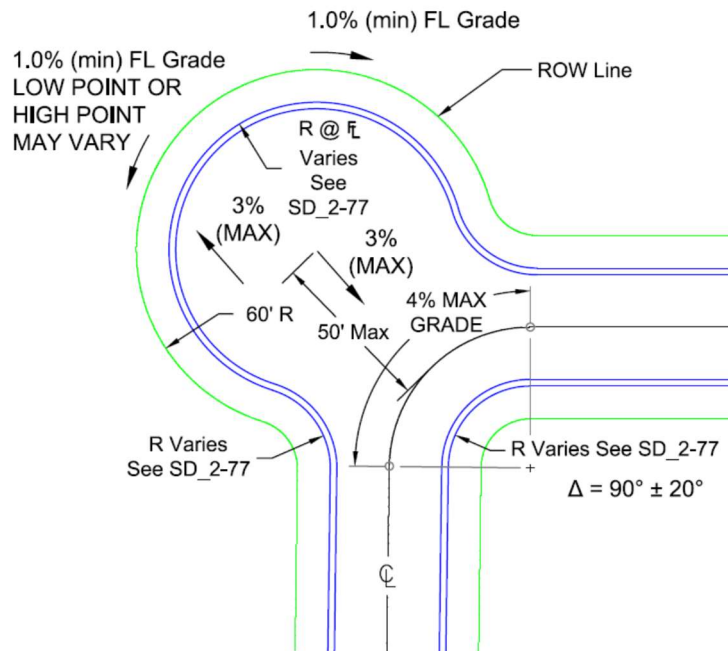

- C. **Temporary Cul-de-Sacs (or Hammerheads).** Where a roadway will be temporarily terminated, a temporary cul-de-sac or hammerhead turnaround shall be constructed in accordance with Figure 2-33 or Figure 2-34. No curb and gutter is required on temporary cul-de-sac or hammerhead turnaround. Temporary turnarounds shall not exceed 600 feet in length except as otherwise approved by the BOCC in association with a phased development plan. The minimum dimensions for the temporary cul-de-sacs shall follow those of Figure 2-31 in all other respects.

The following criteria language will be required for all easements.

The non-revocable public improvement easement shown at the end of ____ Street cul-de-sac is intended for turn around and emergency response purposes. At such a time that ____ Street is extended by the adjacent property owner/developer and accepted by the County, the non-revocable public improvement easement for the cul-de-sac will be vacated, leaving a standard street ROW and the cul-de-sac improvements will be removed and replaced with a standard street section. The easement vacation, cul-de-sac removal and standard street section construction and site restoration is the responsibility of the owner/developer extending ____ Street.

1. **Cul-de-Sac Terminates Within the Plat.** If the cul-de-sac terminates within the proposed plat, the cul-de-sac shall be dedicated as public right-of-way or non-exclusive public improvement easement. If the road right-of-way is stubbed to an adjacent property for future extension, the right-of-way width at the boundary shall match the proposed street right-of-way width. The cul-de-sac at the end of street is intended as a turn around and also is for emergency response purposes until the road is extended. The cul-de-sac shall meet all current standards. If the street is extended by the adjacent property owner/developer, the cul-de-sac right-of-way or public improvement easement may be vacated, leaving a standard street right-of-way. The cul-de-sac improvements within the right-of-way or public improvement easement will be for public use and publicly maintained.

The lot(s) adjacent to cul-de-sacs may be granted an administrative variance (minor variation during platting) and platted at less than the required minimum acreage. However, the lots will be

sized such that if and when the street is extended and the cul-de-sac right-of-way is vacated and the standard street right-of-way is defined, the lots adjacent to the vacated cul-de-sac will meet the minimum zoned acreage requirements that were in place when the plat was approved. No direct access shall be allowed off the anticipated cul-de-sac unless the cul-de-sac is designed to be permanent. The administrative variance would be according to the Land Development Code and is permissive, not mandatory.

When the road is extended at some future time, the responsibility for conversion of the cul-de-sac to the typical road cross section and site restoration shall be the owner/developer requiring the street extension. The same owner/developer will at that time also be responsible for vacation and replat of the lots.

2. **Cul-de-Sac Terminates Outside the Plat of a Phased Development.** If the owner is platting in phases and the cul-de-sac will terminate within the phased development but outside the current subdivision plat, the entire cul-de-sac shall be dedicated as a non-revocable public improvement easement. Where the cul-de-sac will terminate outside the proposed plat, the applicant must provide a copy of the recorded easement for the entire public improvement cul-de-sac easement. The cul-de-sac design shall meet all current standards. Until further land use actions, the non-revocable public improvement easement shall remain in public use and publicly maintained until further resolution or disposition of extension.

When the road is extended at some future time, the developer of the extension at that time shall be responsible for conversion of the cul-de-sac to the typical road cross section and site restoration shall be the responsibility of the owner/developer extending the street. The developer at that time shall also be responsible for vacation of the easements.

3. **Cul-de-Sac Terminates on Property not Owned by the Current Developer.** If the cul-de-sac will terminate on property not owned by the current developer, the developer shall acquire a public improvement easement from the adjacent property owner for the cul-de-sac. The entire cul-de-sac shall be dedicated as a non-revocable public improvement easement by separate instrument. No direct lot access to the proposed development will be provided off the cul-de-sac turnaround. Where the cul-de-sac will terminate outside the proposed plat, the applicant must provide proof of ownership for the entire cul-de-sac turnaround. The cul-de-sac shall meet all current standards. Until further land use actions, the non-revocable public improvement easement shall remain in public use and publicly maintained until further resolution or disposition of extension.

When the road is extended at some future time, the developer at that time shall be responsible for conversion of the cul-de-sac to the typical road cross section and site restoration shall be the responsibility of the owner/developer extending the street. The developer at that time shall also be responsible for vacation of any public right-of-way.

Figure 2-33. Typical Temporary Cul-de-Sac Requirements

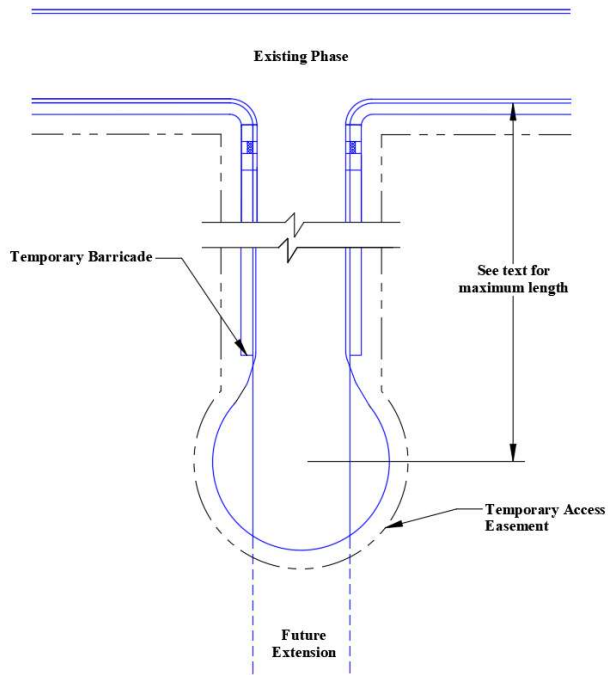
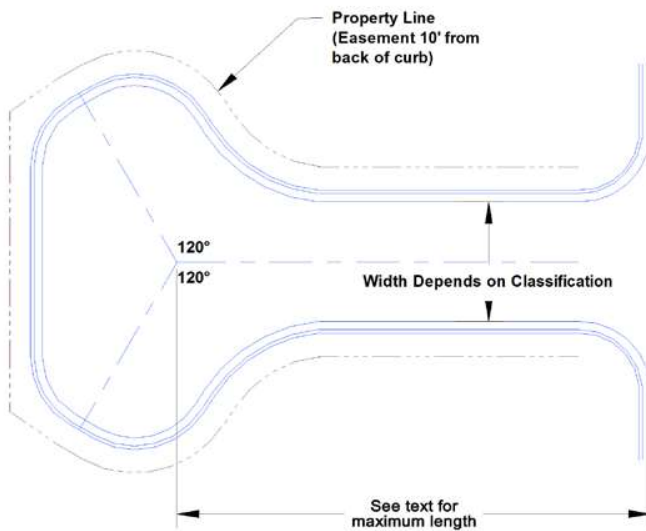

Figure 2-34. Typical Temporary Hammerhead Turnaround Requirements



(Res. No. 20-222 , 6-23-20)

2.4. ROADWAY ACCESS DESIGN

2.4.1. Access Design Criteria

- A. **Access Design Guidelines.** Access points shall be designed to provide safe movement for both those entering and traveling on roadways within the County. Like intersections, access points are conflict locations. The basic design of access points includes the following objectives:
- Adequate spacing
 - Proper alignments
 - Clear sight distances
 - Coordinated widths with its intended use
 - Clearances from intersections
- B. **Access Spacing.** Accesses shall be separated by a distance equal to the entering sight distance values in Table 2-35. When turn lanes are present or will be needed in the future, the accesses shall be separated by a sufficient distance so that exclusive turn lanes including tapers will not overlap. Access shall not be permitted within a turn lane. Warrant criteria, design, and construction of turn lanes shall be governed by the requirements contained in Section 2.3.7D.
- C. **Access Alignment.**
1. **Horizontal Alignment.** Access points shall be aligned at 90 degrees to the adjacent road centerline or along a radial line in a cul-de-sac.
 2. **Vertical Alignment.** Maximum access grades are 4% for commercial and industrial properties with a required 30-foot landing length and a 4% for rural residential **and multi-family** properties with a required 15-foot landing length. Access point approach grades and configuration shall be designed and constructed to accommodate the ultimate road standard of the intersecting roadway to prevent major access point reconstruction. Where an access approach will cross an existing sidewalk, the access shall be designed and constructed to match the elevation of the sidewalk where the two intersect. Reverse slope private accesses may be allowed as long as sight distance requirements are met.
- D. **Access Sight Distances.** Accesses and specific turn movements shall not be permitted where the sight distance is not adequate to allow the safe movement of a motorist using or passing the access. Any potentially obstructing objects, such as but not limited to advertising signs, structures, trees, and bushes, shall be designed, placed, and maintained at a height not to interfere with the sight distance needed by any vehicle using the access. Reconstruction of the horizontal and vertical curvature along the roadway or side slopes adjacent to the roadway may be necessary to increase sight distances.
1. **Sight Distance Along Roadways.** Horizontal and vertical sight distances shall conform to Table 2-33 for the vehicle traveling on the roadway toward the access. The lengths shown in Table 2-33 shall be adjusted for any grade of 3% or greater using the figures set forth in Table 2-34.

Table 2-33. Minimum Sight Distance Along Roadway (Horizontal and Vertical)

Posted Speed (MPH)	25	30	35	40	45	50	55	60	65	70
Design Sight distance (feet)	150	200	250	325	400	475	550	650	725	850

Minimum Sight distance (feet) ^{1, 2}	150	200	225	275	325	400	450	525	550	625
---	-----	-----	-----	-----	-----	-----	-----	-----	-----	-----

¹To calculate sight distance at the proposed access location, a height of 3.5 feet shall be used for the driver's eyes of a vehicle on the highway approaching the access location. The driver's eyes shall be assumed to be at the centerline of the inside lane (inside with respect to the curve) for measurement purposes. A height of 3.5 feet shall be used for a vehicle assumed to be on the centerline of the access 5 feet back from the edge of the roadway.

²If an auxiliary lane is present, the entering posted speed for the deceleration lane and the posted speed at the end of the acceleration lane shall be used.

Table 2-34. Sight Distance Adjustment Factors for Roadway Grade

Roadway Grade	Factors
Upgrade	
3% to 4.9%	0.90
5% to 7.5%	0.80
Downgrade	
3% to 4.9%	1.20
5% to 7.5%	1.35

Approach Grade (%)	Design Speed (mph)													
	15	20	25	30	35	40	45	50	55	60	65	70	75	80
-6	1.1	1.1	1.1	1.1	1.1	1.1	1.1	1.2	1.2	1.2	1.2	1.2	1.2	1.2
-5	1.0	1.0	1.1	1.1	1.1	1.1	1.1	1.1	1.1	1.1	1.2	1.2	1.2	1.2
-4	1.0	1.0	1.0	1.1	1.1	1.1	1.1	1.1	1.1	1.1	1.1	1.1	1.1	1.1
-3 to +3	1.0	1.0	1.0	1.0	1.0	1.0	1.0	1.0	1.0	1.0	1.0	1.0	1.0	1.0
+4	1.0	1.0	1.0	1.0	0.9	0.9	0.9	0.9	0.9	0.9	0.9	0.9	0.9	0.9
+5	1.0	1.0	1.0	0.9	0.9	0.9	0.9	0.9	0.9	0.9	0.9	0.9	0.9	0.9
+6	1.0	1.0	0.9	0.9	0.9	0.9	0.9	0.9	0.9	0.9	0.9	0.9	0.9	0.9

Note: Based on ratio of stopping sight distance on specified approach grade to stopping sight distance on level terrain.

- Entering Sight Distance.** This section applies to entering sight distance where a non-public road or driveway meets a public road. The entering sight distance necessary for the entering vehicle shall conform to Table 2-35. These lengths shall be adjusted for any grade of 3% or greater using Table 2-34. The design vehicle used to determine the entering sight distance shall be selected from Table 2-36.

If the median provides at least 20 feet of storage for a crossing or turning vehicle and can safely store the design vehicle, then the sight distance may be calculated assuming a two-stop condition.

Table 2-35. Entering Sight Distance for Driveways (Access Design)

Design Vehicle ³	Posted Speed of Roadway (MPH)				
	25	35	45	55	65

Two Lane Roadway^{1,2}					
Passenger Cars, Pickup Trucks	250	350	450	550	n/a
Single Unit Trucks	325	455	585	715	n/a
Multi-Unit Trucks	425	595	765	935	n/a
Four Lane Roadway^{1,2}					
Passenger Cars, Pickup Trucks	n/a	420	540	660	780
Single Unit Trucks	n/a	525	675	825	975
Multi-Unit Trucks	n/a	700	900	1,100	1,300
Six Lane Roadway^{1,2}					
Passenger Cars, Pickup Trucks	n/a	n/a	585	715	845
Single Unit Trucks	n/a	n/a	765	935	1,105
Multi-Unit Trucks	n/a	n/a	945	1,155	1,365
¹ For calculating sight distance, a height of 3.5 feet shall be used for the driver's eyes at the access location and a height of 3.5 feet for the oncoming vehicle. The entering driver's eyes shall be 10 feet behind the edge of the roadway.					
² If an auxiliary lane is present, the entering posted speed for the deceleration lane and the posted speed at the end of the acceleration lane shall be used.					
³ From Table 2-36.					
⁴ This table is for use for determining entering sight distance for driveways.					

Table 2-36. Design Vehicle Selection

Land Use(s) Served by Access	Design Vehicle
Residential, Non-School Bus Route	Passenger Cars, Pickup Trucks
Residential, School Bus Route	Single Unit Trucks
Office	Single Unit Trucks
Recreational	Single Unit Trucks
Commercial/Retail	Multi-Unit Trucks ¹
Industrial	Multi-Unit Trucks ¹
Agricultural Field Approaches (<1 VPD)	Single Unit Trucks
¹ If less than 2 multi-unit truck trips per day (average), use single-unit truck	

E. Access Width.

1. **Residential Access Points.** Two-way residential access points shall have a 10-foot minimum and a 24-foot maximum width.
2. **One-Way Commercial or Industrial Access Points.** One-way commercial or industrial access points shall have a minimum 15-foot and a maximum 30-foot inbound access, and a minimum 20-foot and maximum 35-foot outbound access width.
3. **Two-Way Commercial or Industrial Access Points.** Two-way commercial or industrial parcel access points shall have:
 - For Nonresidential Collector **and Local** Roadways: A minimum 25-foot and maximum 40-foot access width.
 - For Minor Arterial Roadways (when approved by the ECM Administrator): A minimum 35-foot and maximum 40-foot access width.

-
4. **Deviations to Commercial or Industrial Access Point Widths.** Wider commercial or industrial access point widths, where necessary to accommodate buses, trucks or other oversized vehicles, may be approved through deviation. Such parcel access points shall be designed to meet the additional loading and turning radius requirements.
- F. **Access Clearance from Intersections.**
1. **Residential.** Access to residential corner lots shall be located a minimum of 10 feet from the point of curvature or point of tangency of the curb line at the intersection. If no curb exists, access points shall be located not less than 35 feet from where the projected right of way lines intersect. No portion of an access will be permitted within curb returns or curb ramps.
 2. **Commercial.** Access to commercial or industrial properties fronting collector or local roads shall be located a minimum of 50 feet from the point of curvature or point of tangency of the curb line at the intersection. Access to commercial or industrial parcels fronting Nonresidential Collector roadways shall be located a minimum of 115 ~~–480~~ feet from the point of curvature or point of tangency of the curb line at the intersection depending on the sight distance and location with respect to the intersection, intersection control, and posted speed.

In all cases, a minimum corner clearance of 50 feet shall be provided. If the minimum corner clearance cannot be attained, the ECM Administrator may require investigation to determine if left turns should be prohibited into or out of the access point. For proposed access points near stop or signalized intersections, the ECM Administrator will require studies to determine if stopping queues will block the access point and if left turns should be prohibited into or out of the access point.
- G. **Construction of Access Points.** Prior to constructing, reconstructing, paving, altering, enlarging, or changing the use of any access point entering a County roadway, an approved Driveway Permit must be obtained. In the case of more complex access projects (i.e. commercial, industrial, or multi-family residential complexes), a Construction Permit may also be required if determined as being warranted through an Engineering Site Plan review. At a minimum, commercial, industrial, or multifamily development shall provide an asphalt or concrete apron for the first fifty (50) feet of the new access when connecting to a paved roadway.

2.5. EXTRINSIC STRUCTURES

2.5.1. Curbs and Gutters

- A. **Curbs and Gutters.** Curbs and gutters shall be designed and installed where required by the functional classification (See Table 2-6 and Table 2-7), the County rules and regulations including the LDC or when required by the ECM Administrator. The curb and gutter will be part of an overall surface water conveyance system. The intent of the system will be to adequately and efficiently control surface water flows during typical storm events (less than 5-year events) while still allowing proper traffic circulation. Gutter slope should be modified to provide compliant counter slope at curb ramps. See Section 6.3.3.
- B. **Curb Cuts and Accesses.** Curb cuts and accesses shall be constructed in accordance with the Standard Drawings. Radius returns are required when the number of parking spaces served by the access exceeds 10.

2.5.2. Pedestrian Facilities

- A. **General.** All pedestrian facilities shall be designed in accordance with Americans with Disabilities Act (ADA) and PROWAG requirements, AASHTO Green Book, and the requirements of these Standards. The

standard that results in the greatest overall safety of pedestrians shall prevail when designing and constructing pedestrian facilities. See Chapter 6 for requirements and guidance.

B. **Sidewalks.** All sidewalks within a development will be designed and constructed by the developer. The design of such sidewalks shall continue to be included within the construction drawings associated with the respective final plat or site development plan, as applicable, and shall comply with the following standards:

1. **Sidewalk Widths.** Minimum-required sidewalk widths by roadway classifications are specified in Table 2-4 through Table 2-7 and Appendix F. The ECM Administrator may require additional width in activity areas and routes leading to and from these areas. This additional width shall be determined through additional study in higher pedestrian traffic areas.
2. **Sidewalk Crossings of Accesses.** Access crossings shall be designed in accordance with Standard Drawings SD_2-24 and SD_2-25 in Appendix F. Sidewalk across accesses should be accessible per the requirements of Chapter 6.
3. **Sidewalks on Both Sides of the Roadway.** Sidewalks shall be installed on both sides of the roadway.
4. **In-Fill Sidewalk, Curb, and Gutter.** In developed areas, sidewalks, curbs, and gutters may be required to be upgraded to current standards at the ECM Administrator's discretion.
5. **Sidewalk Widening.** Existing sidewalks shall only be permitted to be widened if the increase in width is 4 feet or more. If an existing sidewalk is required to be widened by less than 4 feet to meet the requirements of the ECM, the existing walk shall be entirely replaced with a sidewalk meeting the minimum width requirements.
6. **Concrete Thickness.** All developments within the RS-5000 (Residential Suburban) or RS-6000 (Residential Suburban) zoning districts shall be required to construct sidewalks at a thickness of five inches (5") for all sidewalks along the entire length of any roadway from which temporary or permanent access will be provided. All other sidewalks within either the RS-5000 or RS-6000 zoning districts (e.g., sidewalks in common areas, sidewalks along identified school parcels, sidewalks in open space, etc.) may be designed and constructed to a thickness of five inches (5") but may, at the developer's discretion, be reduced to a thickness no less than four inches (4").

Developments within a Planned Unit Development (PUD) zoning district shall be required to design and construct sidewalks to a thickness of five inches (5") for all sidewalks along the entire length of any roadway from which temporary or permanent access will be provided unless an alternative thickness is approved by the Board of County Commissioners as an element of the associated PUD development standards. Under no circumstances shall any sidewalk be designed and constructed to a thickness of less than four inches (4"). All other sidewalks within a PUD zoning district (e.g., sidewalks in common areas, sidewalks along identified school parcels, sidewalks in open space, etc.) may be designed and constructed to a thickness of five inches (5") but may, at the developer's discretion, be reduced to a thickness no less than four inches (4").

Sidewalks within all other developments not located within the RS-5000 or RS-6000 zoning districts or within a PUD may be designed and constructed to a thickness of five inches (5") but may, at the developer's discretion, be reduced to a thickness no less than four inches (4").

At high volume access or alley crossings, the thickness shall be a minimum of six inches (6"). Sidewalks located at an access for commercial or industrial traffic will be terminated at the edges of the access allowing the access design to set precedence for thickness of pavement.

7. **Sidewalk Slope.**

-
- **Cross Slope:** Maximum cross slope for sidewalks shall be 2%. 1.5% typical cross slope is suggested to allow for construction tolerances. See Chapter 6.
 - **Longitudinal Slope of Attached Sidewalks:** Longitudinal slope of attached sidewalks shall be consistent with roadway slopes. Attached sidewalk slopes greater than 5% are only permitted where adjacent roadway slopes are steeper than 5%. See Chapter 6.
 - **Detached Sidewalks and ADA Requirements:** Longitudinal slope of detached sidewalks shall be flatter than 5% wherever feasible. Sidewalk slopes greater than 5% require ramp runs. See Chapter 6.
8. **Sidewalk Clearances.** Horizontal and vertical sidewalk clearances shall meet the requirements of Figure 2-35. See Section 6.3.1 for clearance requirements related to accessibility.
 9. **Driveway Option.** Where five inch (5") sidewalks with mountable curb have been installed, the thickness at driveways can remain five inches (5"). As an alternative, the mountable curb and sidewalk at driveways can be poured at six inches (6"). The desired thickness must be identified on the approved construction drawings for the project. Where five inch (5") sidewalks are installed, the Cut Back Swale Standard Drawing (SD_3-88) can be used as an acceptable stormwater BMP along the constructed five inch (5") sidewalk. The proposed stormwater BMPs will need to be provided in detail in the approved erosion control plan for the project.

Where four inch (4") sidewalks are installed, the sidewalks shall be a minimum of 4-inches thick except at driveways, high volume access, or alley crossings where the thickness shall increase to a minimum of six inches (6"). Sidewalks located at an access for commercial or industrial traffic will be terminated at the edges of the access allowing the access design to set precedence for thickness of pavement. The Cut Back Swale Standard Drawing (SD_3-88) is not an acceptable stormwater BMP for any sidewalk that is less than five inches (5") thick.

C. **Accessible Curb Ramps.**

1. **Ramp Requirements.** Accessible curb ramps shall be installed at all intersections where pedestrian routes cross streets and at certain mid-block locations for all new construction and alteration projects to the adjacent roadway. See Chapter 6.
2. **4-Way Intersections.** Curb ramps shall be installed at all intersection corners. Access ramps shall be constructed in accordance with Standard Drawings in Appendix F.
3. **"T" Intersections.** All "T" intersections shall have a minimum of four curb ramps as shown in Figure 2-36. A private access may be used as a curb ramp provided it is designed to meet ramp requirements and it is within the intersection and directly across from other ramps.

Figure 2-35. Sidewalk Clearances

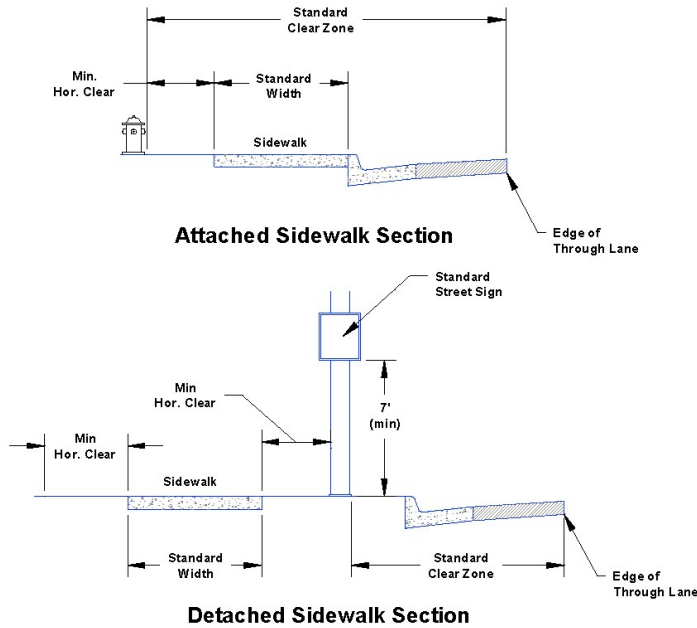
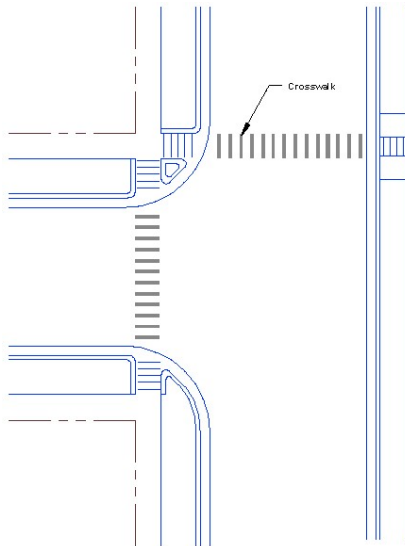

Figure 2-36. Access Ramp Locations at "T" Intersections



4. **Mid-Block Ramps on Local Roadways.** Curb ramps on local roadways shall be spaced no greater than 600 feet apart. Where spacing is greater than 600 feet, mid-block curb ramps shall be provided at spacings that minimize travel distances between curb ramps. Private accesses may be used for these access points where the access is designed to meet curb ramp requirements. The pavement markings and signing required by the ECM and MUTCD shall be provided for mid-block curb ramps.

-
5. **Access, Cul-de-Sacs, Knuckles, and Eyebrows.** A curb ramp shall be provided at all accesses. Either a curb ramp or a private access that meets curb ramp requirements shall be provided in all cul-de-sacs and knuckles. Curb ramps are not required for eyebrows unless there are amenities within the eyebrow, however, if they are provided they shall be in accordance with the requirements of ECM 2-6.
 6. **Underwalk Drains (Chases).** Underwalk drains shall not interfere with the pedestrian use. The chase plate shall be flush with the sidewalk surface and be securely fastened, as specified in the Standard Drawing in Appendix F. Underwalk drains shall not be located within a curb ramp, curb cut, or private access.
 7. **Inlets.** Inlets located in a sidewalk shall be integrated with sidewalks. The inlet access shall be flush with the sidewalk surface. No manholes, inlets, or other storm sewer facilities are allowed within curb ramps. Inlets shall be located at or behind the tangent points of a curb return.
- D. **Grade-Separated Roadway Crossings.** The construction of a grade-separated pedestrian crossing may be requested by the ECM Administrator when a regional trail intersects with either an Expressway or Principal Arterial. If available, existing structures should be used to accommodate the proposed grade separation. See Section 6.3.9.
 - E. **Rural Roads and Pedestrians.** Rural road sections shall provide sufficient shoulder width for pedestrian travel. Table 2-4 and Table 2-5 outline the requirements for rural roadways.
 - F. **Pedestrian Street Crossings (Crosswalks).** All crosswalks shall be properly marked to ensure safe pedestrian movement. Crosswalks will be required at all signalized intersections, school areas, and high pedestrian areas, as determined by the ECM Administrator. See Section 6.3.2.
 1. **Crosspans.** Crosswalks shall not be located in crosspans.
 2. **Maximum Crosswalk Length and Pedestrian Refuge Areas.** The maximum length for any crosswalk shall be 48 feet. Any roadway crossing longer than 48 feet shall be provided with pedestrian refuge areas. Pedestrian refuge areas shall be created in medians or splitter islands to increase pedestrian safety. Vehicle turning radii shall be considered in the design of pedestrian refuge areas.
 3. **Traffic Signals.** All pedestrian traffic signals shall be designed and installed in accordance with MUTCD and an approved TIS. See Section 6.3.6.
 - G. **Multi-Use (Shared-Use) Path Width.** Where a multi-use path is proposed, the minimum path width shall be 10 feet wide. See Section 6.3.7.
 - H. **Clear Path Pedestrian Minimum.** The minimum horizontal clearance around utility structures, furniture, and other encroachments shall be greater or equal to 4 feet (see Figure 2-35). A Work in the Right-of-Way Permit is required for any private improvements within the right-of-way.

2.5.3. Noise Analysis and Mitigation

A noise study shall be prepared where a new expressway or principal arterial is planned or where roadway construction is planned which will result in changing an existing road classification from a lower classification road to an expressway or principal arterial. Noise mitigation may be required where noise levels exceed or are predicted to exceed 67 dBA Leq or exceed the current Federal Standards.

2.5.4. Bus Shelters

- A. **Location.** The location of a bus shelter shall be determined by the transit provider with the concurrence of the ECM Administrator.

-
- B. **Visibility.** Bus shelters shall have maximum transparency, and be highly visible from the surrounding area to assure the users' safety. The shelter may not be located within required sight distance triangles.
 - C. **Minimum Size and Capacity.**
 - 1. **Opening Size.** Openings shall be at least 48 inches wide and shall meet PROWAG requirements. See Section 6.3.8.
 - 2. **Capacity and Size.** Capacity shall be based on maximum passenger accumulation at the stop. The shelter size shall be based on approximately 5 square feet per person.
 - 3. **Placement.** Shelters shall not obstruct pedestrian flow or motorist's sight distance. Minimum pedestrian clear path widths shall be maintained.
 - 4. **Pad Requirements.** A 6-inch thick concrete pad is required under all bus shelters. The pad shall extend at least 6 inches beyond each edge of the shelter.
 - 5. **Passenger Loading Area Width and Detached Sidewalks.** Shelters located adjacent to detached sidewalks shall include a fifteen foot wide concrete area between the sidewalk and the curb for passenger loading and unloading.
 - 6. **Relocation of Shelters.** The ECM Administrator may require a shelter to be relocated or removed in the future to accommodate other needs within the roadway right-of-way at the sole expense of the transit provider.
 - 7. **Bicycle Racks and Trash Containers.** All shelters are required to provide one trash container and one bicycle rack.
 - 8. **Sidewalk Connections.** A sidewalk connection shall be provided between the bus shelter and the existing sidewalk or nearby pedestrian destinations. The minimum width shall be as required in Sections 2.5.2.B.1 and 6.3.8.

2.5.5. Crosspans

- A. **Basic Requirements.** Crosspans for passing storm drainage flow across roadways shall be constructed in accordance with the Standard Drawing in Appendix F.
- B. **Dimensions and Depth.** Crosspans adjacent to local roadways shall be a minimum of 6 feet wide with a typical depth of $\frac{7}{8}$ -inch. Crosspans adjacent to collector roadways shall be a minimum of 8 feet wide with a typical depth of $1\frac{1}{8}$ inches. Crosspans adjacent to arterial roadways shall be 10 feet wide with a typical depth of $1\frac{1}{2}$ inches.
- C. **Prohibited on Arterial and Collector Roadways.** No crosspans shall cross roadways classified as urban residential collectors and higher.
- D. **Minimum Grade.** The flowline of the crosspan shall have a minimum grade of 0.5%.
- E. **Crosspan Transitions.**
 - 1. **Design Speeds.** Pavement transition from standard crown to crosspan shall be designed using the appropriate design speeds for urban roadways in Table 2-6 and Table 2-7.
 - 2. **Intersections.** Transitions from standard crown to crosspan at intersections shall be designed in accordance with Figure 2-37.

Figure 2-37. Standard Intersection Crowns

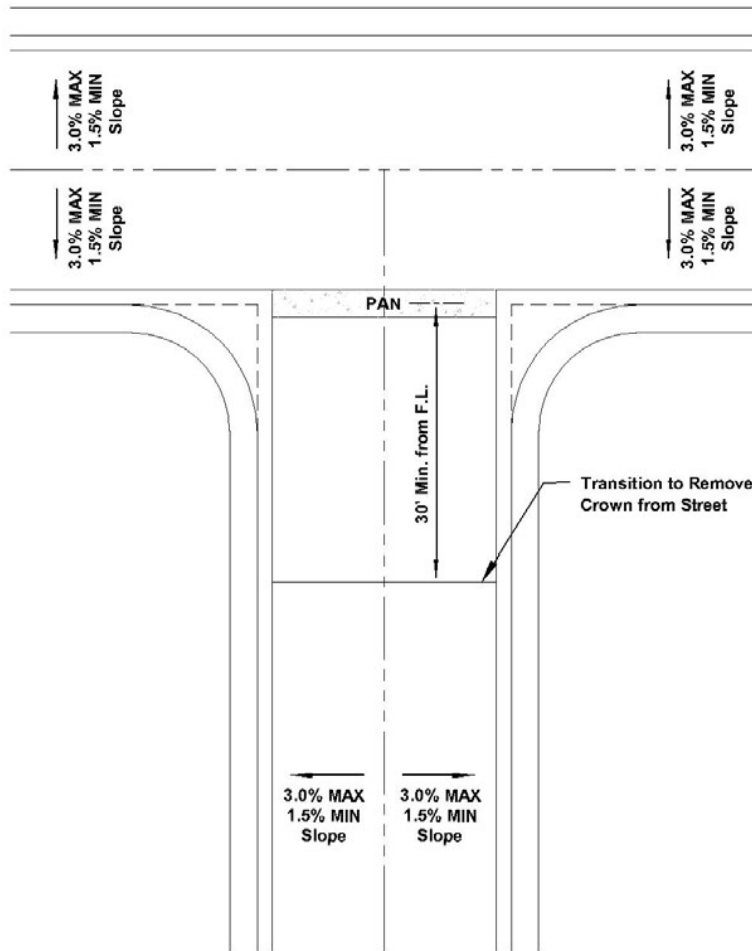

- F. **Pavement Material.** Approaches to crossspans shall be constructed with full depth asphalt wedges on asphalt roadways per the Standard Drawing in Appendix F. If pavement is concrete, crossspans may be poured monolithically with the main line paving process.

2.5.6. Medians and Traffic Islands

- A. **General Requirements.** The design and construction details for medians shall be in accordance with roadway cross sections presented in Appendix F. The minimum width of any raised median shall be 4 feet. See Section 6.3.5 for accessibility requirements.
- B. **Drainage.** Landscaped medians shall be provided with drainage facilities to handle sprinkler runoff and nuisance flows. Sprinklers shall be designed to prevent spray onto the pavement surface. A properly designed drain system shall be required. When low maintenance landscaping is used in conjunction with trickle irrigation, drainage requirements may be waived.
- C. **Curb and Gutter.** If gutters are not needed to handle drainage referenced above, medians may be constructed with outfall curb and gutter. Due to its fragility, glue-down curbs are prohibited.
- D. **Nose.** The position of the median nose shall be placed so that vehicles do not track onto the median. The minimum radius for nose curbs shall be 2 feet to flowline.

-
- E. **Paving.** All non-landscaped areas of medians shall be paved with stamped concrete, colored concrete or exposed aggregate concrete, as determined by the ECM Administrator.
 - F. **Transitions.** The ends of medians shall transition into turn lanes with a minimum radius of 100 feet. A change of direction must be accomplished with the use of radii. Angle points shall not be allowed.
 - G. **Corner Islands Separating Right Turns.** Standard corner islands shall be used in all high capacity intersections to channelize traffic, provide pedestrian refuge or where required by the ECM Administrator.
 - H. **Median Design for Left Turn Lanes.** Where a single left turn lane is necessary, a median area of 16 feet shall be provided. The median area shall consist of a 12-foot turn lane and a 4-foot painted separator. If a barrier median is necessary, the median area should consist of a 12-foot lane exclusive of gutter, and a minimum 6-foot raised median divider.
 - I. **Median Islands Separating Opposing Traffic.** Median islands are required at all high capacity intersections. If raised medians are not required by these standards, the median islands may be raised or painted. The design shall be in accordance with these Standards and as follows:
 - 1. **No Obstruction.** Medians must not obstruct the minimum left turn radius for the design vehicle(s).
 - 2. **Drainage.** Landscaped medians shall include drainage facilities to handle sprinkler run-off and nuisance flows. When low maintenance landscaping is used in conjunction with trickle irrigation, drainage requirements may be waived and outfall curb and gutter should be used.
 - J. **Median Islands on Minor Arterials, Collectors or Local Roadways.** Raised medians may be placed in minor arterial, collector, and all local roadways. If medians are included, they shall be placed in the public right-of-way, and they must meet the following standards for design:
 - 1. **No Obstruction.** The medians may not obstruct the design vehicle turns.
 - 2. **Visibility.** The medians must be placed such that the required visibility in the intersection is not obstructed.
 - 3. **Undiminished Use.** Medians must be placed so they do not diminish the intersection use.
 - 4. **Alignment.** Lanes on one side of the intersection must align with the correct lanes on the opposite side of the intersection.
 - 5. **Median Maintenance.** Maintenance of median landscape will be limited at the discretion of the ECM Administrator.
 - 6. **Public Use.** The ECM Administrator may use these islands for roadway signing and may choose to remove the median if it is deemed necessary by the ECM Administrator.
 - 7. **Additional Right-of-Way.** Any additional right-of-way necessary to accommodate the medians shall be provided.
 - K. **Splitter Islands.** Raised splitter islands for roundabouts shall be designed in accordance with the Roundabout Design Guide, FHWA Standards, or other design criteria approved by the ECM Administrator.

2.5.7. Bicycle Facilities

- A. **General.**

-
1. **Permitted Bicycle Travel Areas.** Bicyclists may share vehicular travel lanes in cases where no designated bike lanes are provided, except in certain cases where bicycle travel may be prohibited or is unsafe.
 2. **Accessibility Requirements.** All design for off-roadway bicycle paths are considered multi-use (shared-use) paths and shall conform to the requirements of Chapter 6.
 3. **Use of Drainage System and Open Space.** The bike path and pathway system may use the drainage and open space system.
 4. **Access Easements.** Where bike paths cross private land or coincide with private access facilities, a public access easement shall be provided.
 5. **Maintenance Responsibility.** Maintenance and operation responsibility for new bike paths will be determined by the ECM Administrator.
- B. On-Roadway Bike Lanes Design Requirements.**
1. **On-Roadway Bike Routes.** Specific roadways may be designated as on-roadway bicycle routes. These routes are on roadways with lower traffic volumes and speeds, wide outside lanes, and minimal stop signs, stop lights, curb cuts, private access, and interference with turning traffic. Roadways designated as on-roadway bicycle routes shall be designed with additional width for bike lanes. Some roadways within new developments or re-developments must also contain additional roadway width for bike lanes.
 2. **One-Way Road Cross Sections.** Bicycle lanes on one-way roadways shall be on the right side of the roadway.
 3. **Signage and Striping.** All designated bike lanes shall be signed and striped in accordance with MUTCD.
 4. **Actuation Loop.** Separate actuation loops are required in bike lanes at signalized intersections.
 5. **Bike Lanes at Intersections.** Where a separate right turn lane exists, the bicycle lane shall transition and be placed between the through lane and the right turn lane. The bike lane width shall remain the same as the approaching bike lane.
- C. Off-Roadway Bicycle Paths Design Requirements.**
1. **General Design Requirements.** The general design of bicycle paths in the County shall meet these Standards. The bicycle path shall be designed to ensure safe, secure, and connected travel for bicyclists and other users of the off-roadway system/facilities.
 2. **Bike Path Location and Easements.** Bike path locations shall be based on safety, circulation, and access considerations. Where needed, a 20-foot minimum easement shall be procured for a 10-foot-wide bike path in accordance with Figure 2-38.
 3. **Preserving Trees.** Where possible, bike paths shall be routed to minimize the loss of trees and disruption of natural environmental conditions.
 4. **Distance from Obstacles.** A minimum of 2 feet is required between the bike path edge and any vertical obstructions such as trees, utility poles, signs, fences, or other obstacles. The ECM Administrator may require greater separation where grades exceed 4%.
 5. **Clearing of Vegetation.** During construction, minimal vegetation will be removed to assist with path installation.
 6. **Overhead Clearance.** All bike paths shall have a minimum of 10 feet clear vertical clearance above the path.

7. **Cross Section.** The typical cross section shown in Figure 2-38 shall be maintained along the entire length of the bike path.
8. **Grade.** Minimum bicycle path grade shall be 0.60% except in sag curves where proper drainage shall be provided by the cross slope. The minimum grade shall be waived if cross slope is 2% and good drainage is provided and unobstructed. A maximum grade of 8% is permitted.
9. **Design Speed.** For paved surfaces, a minimum design speed of 20 MPH shall be used. Where grades exceed 4%, a design speed of 30 MPH shall be used. For unpaved surfaces, a minimum design speed of 10 MPH shall be used. Where grades exceed 4%, a design speed of 20 MPH shall be used.

Figure 2-38. Typical Bicycle Path Cross Section

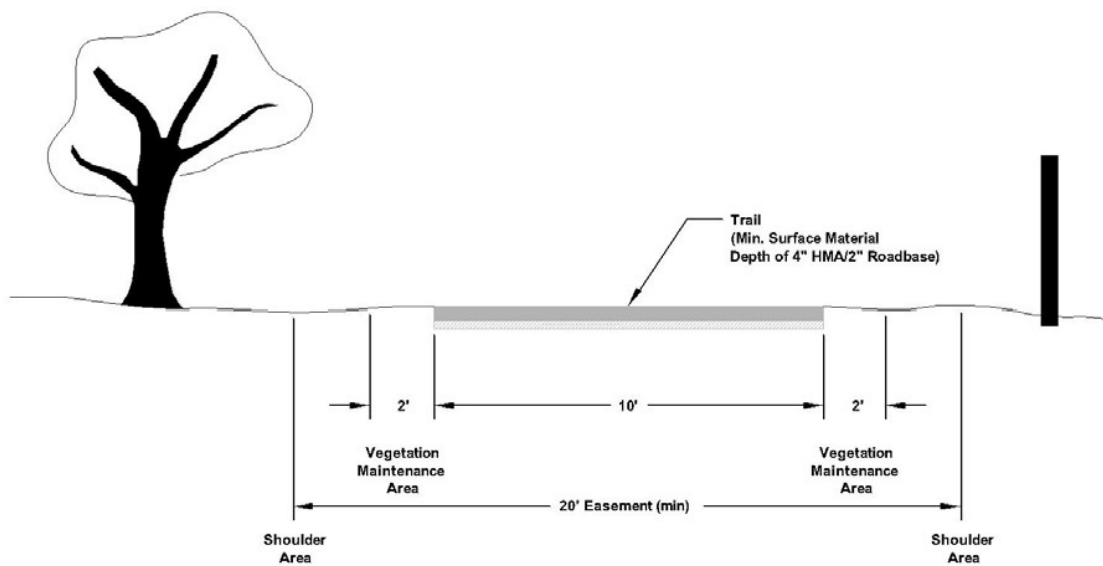

10. **Radius of Curvature.** Based upon a superelevation rate (e) of 2%, the minimum radius of curvature to be used is 95 feet at 20 MPH.

The minimum radius is a limiting value of curvature for a given design speed. At a proposed design speed both the superelevation rate and the assumed value for side friction factor determine the minimum safe radius. The minimum radius of curvature is determined from the following equation:

$$R = V^2 / [5(0.01e + f)]$$

Where:

R = radius of curve, feet

V = vehicle design speed, MPH

e = rate of superelevation, percent (The bicycle path superelevation rate shall be a minimum of 2% and a maximum of 3%.)

f = side friction factor (Friction factors used for design should be selected based upon the point at which centrifugal force causes the bicyclist to recognize a feeling of discomfort and instinctively

act to avoid higher speed. Extrapolating values used in highway design, design friction factors for paved bicycle paths can be assumed to vary from 0.27 at 20 MPH to 0.22 at 30 MPH. Unpaved surface friction factors are to be reduced by 50% to allow a sufficient margin of safety.)

11. **Substandard Radius Curves.** When substandard radius curves must be used on bicycle paths because of right-of-way, topographical or other considerations, standard curve warning signs and supplemental pavement markings shall be installed in accordance with the MUTCD. The negative effects of substandard curves can also be partially offset by widening the pavement through curves.
12. **Sight Distance.** Sight distance requirements shall be in conformance with AASHTO requirements. Figure 2-39, Figure 2-40, Figure 2-41, and Section 2.3.7 provide the required sight distance requirements. Obstructions to the visibility of motorists or bike path users shall be removed or the bike path aligned around the obstruction to maximize visibility. Lateral clearances on horizontal curves should be calculated based on the sum of the stopping sight distance for bicyclists traveling in opposite directions around the curve.

Figure 2-39. Minimum Stopping Sight Distance (Bicycle Paths)

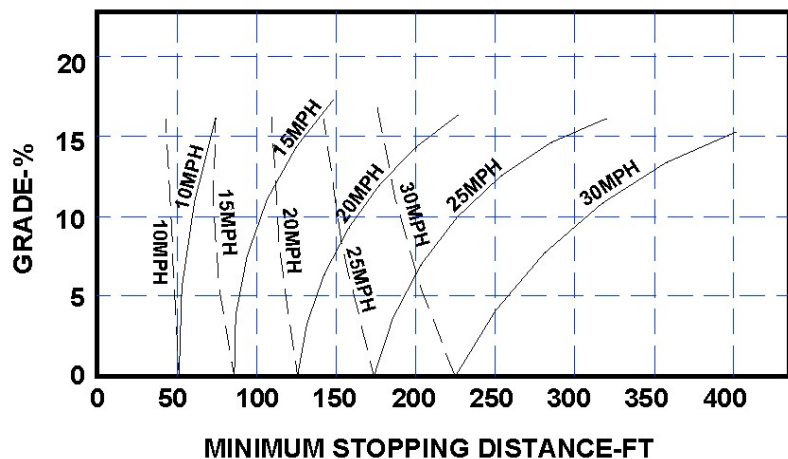

13. **Cross Slope.** The cross slope of multi-use (shared-use) paths shall not exceed 2%. 1.5% Typical cross slope is recommended to allow for variability during construction.
14. **Drainage.** All bicycle paths shall drain freely. Where a bike path is cut into a hillside, a ditch shall be placed along the high side of the bike path to prevent sheet flow across it.
15. **Safety Considerations.** The safety of pedestrians, and others who may use or travel on a bike path, shall be a prime consideration in the bike path design.

Figure 2-40. Minimum Length of Vertical Curves (Bicycle Paths)

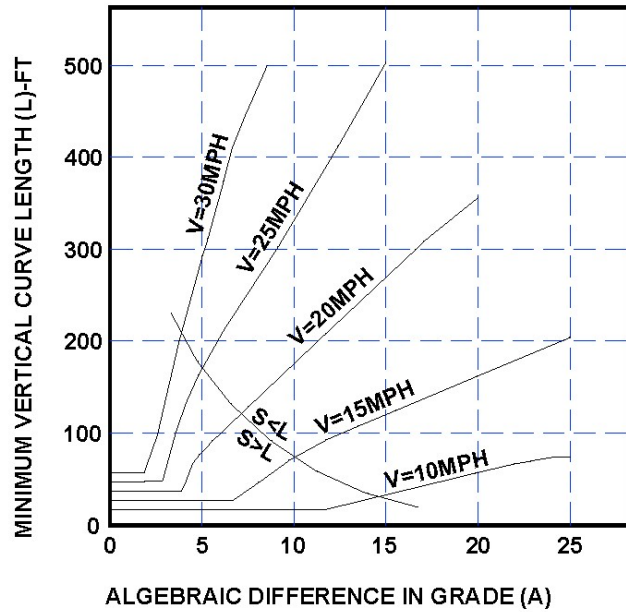
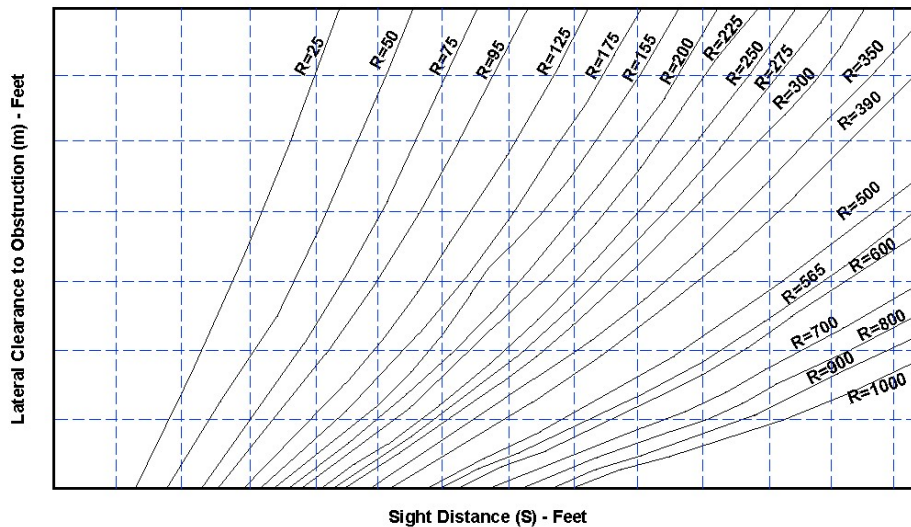

Figure 2-41. Minimum Lateral Clearances on Horizontal Curves (Bicycle Paths)



16. **Barriers and Other Safety Devices.** For bike paths adjacent to roadways with speed limits over 25 MPH, and with slopes greater than 6%, the ECM Administrator may require special safety measures. Examples include barriers or other safety devices between the roadway and bike path, or an increase in the distance between the bike path and highway.
17. **Signs for Hazards and Regulatory Messages.** Standard signage and pavement markings in the MUTCD are required to alert bike path users to hazards and to convey regulatory messages.

-
18. **Intersection Grade.** Maximum grade of the bike path at intersections is 3% extending for 30 feet in each direction from the centerline of the intersection.
 19. **Curb Ramps.** Standard sidewalk curb ramps will be provided at all bike path curb crossings to allow continuity of bike path use by bicyclists and pedestrians. Curb depressions equaling the bike path width shall be used, with the bike path surface sloping to the pavement at 8.3% maximum slope. See Section 6.3.7.
 20. **Water Crossings.** All bike paths require either a bridge or a fair weather crossing. All bridges shall be designed in accordance with the requirements of Section 2.6.
 21. **Grade-Separated Roadway Crossings.** Grade-separated bicycle crossings shall be provided for regional/neighborhood paths and trails that intersect with major roadways as determined by the ECM Administrator.
 22. **Railings, Fences, or Barriers.** Railings, fences, or barriers on both sides of a bicycle path structure shall be a minimum of 4.5 feet high. Smooth, snag-free rub rails should be attached to the barriers at handlebar height of 3.5 feet. Barriers should not impede storm water runoff from the path.
 23. **Bicycle Path Underpasses.** A minimum of 10 feet of vertical clearance from trail surface to underside of bridge shall be provided. Twelve feet of clearance shall be provided if equestrian accommodations are required.
 24. **Trail Surface Elevation and Flooding.** The trail surface elevation shall be at or above the high water mark for the 10-year storm.
 25. **Signage and Pavement Marking.** All signs, except locally adopted bike route signs, shall conform to MUTCD. All curves with restricted sight distances are required to be painted with a centerline to separate traffic. The centerline shall be 4 inches wide and painted yellow.
 26. **Turning Radius at Bike Path Intersections.** The minimum turning radius at bike path intersections shall be 20 feet.

2.5.8. Other Features in the Right-of-Way

- A. **Landscaping.** Landscaping within the County's right-of-way shall provide adequate erosion control for roadside areas; a natural streetscape environment; and safe conditions for motorists, pedestrians, and bicyclists. The landscaping must be appropriate for the conditions and easily maintained by the use of power-mowing equipment.

If plantings are proposed within the County's right-of-way, written approval from the ECM Administrator must be obtained prior to placement and proper maintenance must be performed to ensure that a safety hazard is not created.

- B. **Side Slopes and Grading in Right-of-Way.**
 1. **Cut and Fill Slopes.** Cut and fill slopes should be flattened and rounded to fit with the topography.
 2. **Slope Benches (outside EPC Right-of-Way, inside Easement).** Benches shall be on a slope of no more than 20:1 towards the roadway to prevent ponding of moisture behind the bench, thus creating additional slope blend with geological stratum rather than conforming to any set grade. For ease of maintenance, a 20-foot wide bench is considered satisfactory.

-
3. **Slopes.** The maximum slopes for all areas within or outside of the right-of-way that can affect public improvements shall be a maximum of 3:1. In general, retaining walls are discouraged and not allowed within the right-of-way. Maximum slopes maybe further restricted by clear zones.
 4. **Off-Site Fill Material.** Any material from an off-site location to be used in right-of-way or areas within the influence area of the right-of-way must be tested to ensure these Standards are being met.
- C. **Roadside Ditches.** Roadside ditches shall be designed to the following criteria.
- Ditches shall have a minimum depth of 24 inches to accommodate driveway culverts.
 - If 100-year flows require ditches to be greater than 24 inches deep, additional rights-of-way must be provided to accommodate the ditch.
 - Ditches shall be stabilized with vegetation, stone or concrete paving where velocities will erode natural soils. Asphalt paving of ditches is prohibited.
 - Ditches with steep flow lines shall be interrupted with dikes (ditch checks) at such intervals to maintain a velocity not to exceed what is appropriate for the ditch material.
 - Type C Grate Inlets are not permitted in roadside ditch applications.
 - Ditches shall have a minimum grade of 1.0% or as dictated by the roadway grade and surrounding slopes.
 - Side slopes of ditches shall be designed to minimize drifting snow onto the roadway.
- D. **Design Features to Prevent Snow Drifting.** Many areas of El Paso County have problems with drifting snow. Snow drifting on El Paso County roads is a dangerous problem for the traveling public and snow removal crews. Snow drifting has left motorists stranded, has created the need for rescue efforts for stuck motorists, impedes emergency vehicles, and has even caused deaths in El Paso County. Snow drifting increases the snow removal costs to allow motorists and emergency vehicles access to subdivisions. Therefore, subdivision applicants shall address the issue of drifting snow on El Paso County roads early in the subdivision planning and design process.

A map has been developed by snow removal crews for roads that have recurring snow drifting problems. The map is shown in Figure 2-42. Snow drifting along applicable arterial roads must be addressed when the subdivision:

- Is in a rural area.
- Consist of lot sizes 2.5 acres or larger, and
- Occurs along a road with snow drifting problems according to Figure 2-42

When all previous conditions are met, the subdivision applicant shall:

- Provide written documentation of measures taken to minimize snow drifting on identified El Paso County roads adjacent to the subdivision.
- Provide a 150 foot building setback to accommodate snow fencing/storage along the applicable arterial road.
- Provide plat notes that discuss setbacks, necessary easements, and maintenance responsibilities. El Paso County will maintain the snow fence if there is an easement and the plat notes identify that El Paso County is responsible for maintenance.

- Identify the type of snow fence to be used. The preferred snow fence is an earthen berm. Other acceptable snow fence types include a living snow fence, vertical slat fence, Wyoming snow fence (with horizontal slats) and other approved snow fence types.
- Identify the primary direction of wind and snow drifting. Typically, a snow fence will be required on the windward side of the arterial and a snow storage area will be required on the leeward side of the arterial.

Figure 2-42. Roads with Snow Drifting Problems

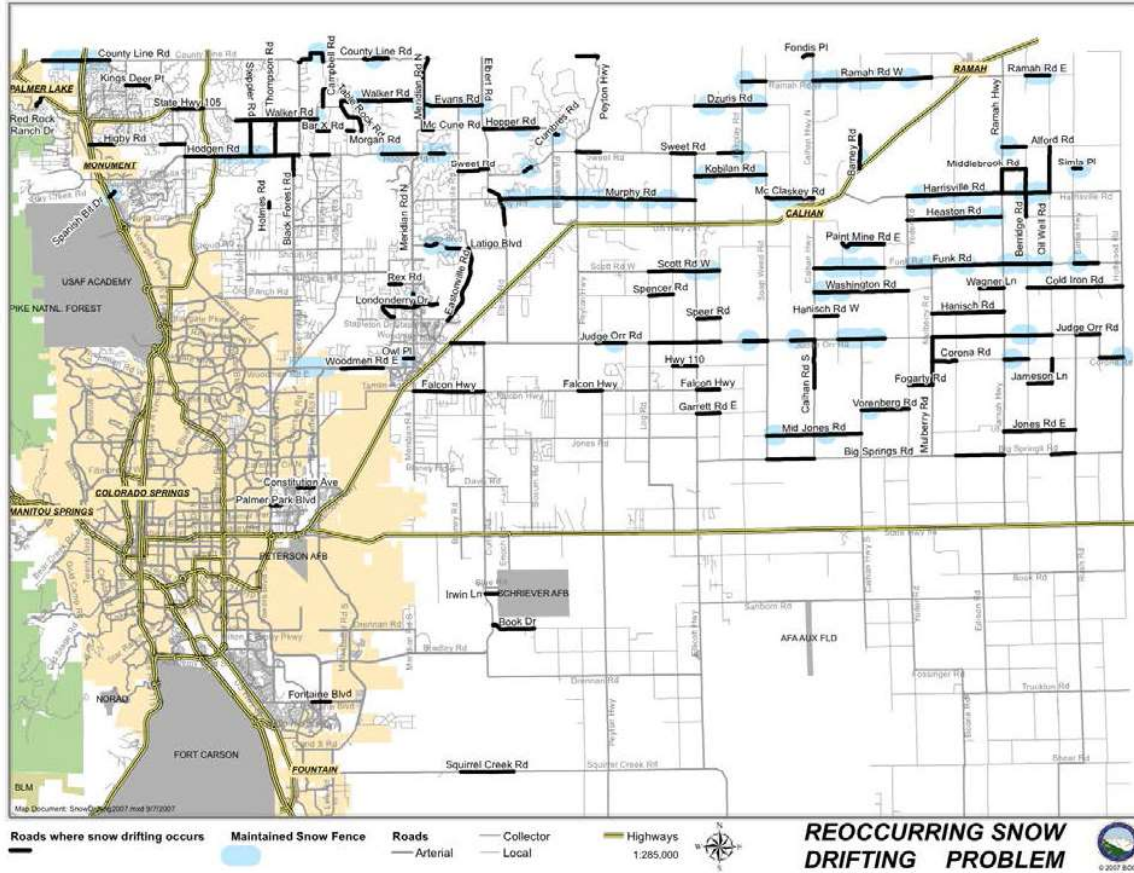

(Res. No. 20-222 , 6-23-20)

2.6. STRUCTURE DESIGN

2.6.1. Structures That Must Conform to the Standards

All culvert pipe, box culverts, guardrails, and bridges that will be owned and maintained by the County shall conform to these standards.

(Supp. No. 2)

Created: 2021-06-08 11:35:49 [EST]

2.6.2. Drainage Capacity and Erosion Control

Bridges and major drainage structures shall be designed to conform to the hydraulic requirements presented in Chapter 3. The design of all structures shall include measures to control bank erosion and bridge scour.

2.6.3. Design Criteria

Designs of structures shall conform to these Standards and the criteria contained in the following documents.

Structural Standards:

- AASHTO, Standard Specifications for Highway Bridges
- AASHTO, LRFD Bridge Design Specifications
- AASHTO, LRFD Bridge Construction Specifications
- AASHTO, A Policy on Geometric Design of Highways and Roadways
- AASHTO, Roadside Design Guide
- CDOT, Bridge Manual, Volumes I and II
- CDOT, Standard Specifications for Road and Bridge Construction
- CDOT, M&S Standards

Borings and Soils Tests:

- Borings and soils tests shall conform to the requirements for Soils Investigations in Appendix C

2.6.4. Design Approach

Load and Resistance Factor Design (LRFD) is the recognized design approach for structures.

2.6.5. Deflection Control

Designs of three-sided concrete drainage structures shall include deflection control.

2.6.6. Bridges (Major Structures)

- Design Life.** All bridges shall have a minimum design life of 50 years.
- Sufficiency Rating.** All major structures shall be rated for structural sufficiency prior to approval of the plans by the County. The design shall conform to Federal Bridge Rating Guidelines for new bridges.
- Basic Construction Parameters.** Bridges shall be constructed of reinforced concrete or steel. Bridges constructed of timber are prohibited.
- Span Construction Types.** Typical span types and approximate acceptable span limitations are shown in Table 2-37.

Table 2-37. Bridge Span Types

Span Type	Approximate Limitations
Reinforced Concrete Slab	<40 feet
Prestressed Concrete Slab	<50 feet
Prestressed Concrete Double Tee Girders	<120 feet
Prestressed Concrete Box Girders	<140 feet

Created: 2021-06-08 11:35:50 [EST]

(Supp. No. 2)

Prestressed Concrete B-T Girders (Bulb Tee)	<160 feet
Rolled Beams	<100 feet; with cover plate up to 120 feet
Plate Girders	<70 feet
Trusses	>140 feet

E. **Vehicular Bridges.** Vehicular bridges shall be designed to carry vehicles, pedestrians, and bicycles.

1. **Design Loads.** All vehicular bridges shall be designed for vehicle loadings of HS-15 or higher. A pedestrian load of 85 psf shall be applied to all sidewalks wider than 2 feet, in combination with vehicular design live load. Sidewalks in this case include wide curbs or other structures that may be used by pedestrians.

2. **Deflection.** Maximum deflection on a vehicular bridge shall be:

$$D_{max} = S/1000$$

Where:

D_{max} = deflection, feet

S = span, feet

3. **Clear Width.** The clear width for bridges on roadways with curbed approaches shall meet or exceed the curb-to-curb width of the roadway approaches. For roadways with shoulders and no curbs, the clear width should be the same as the approach roadway width.

4. **Sidewalks.** Sidewalks conforming to the roadway cross sections shall be provided on both sides of a bridge. Sidewalk and bike path widths will match those of the approaching roadway segments. If no sidewalks or bike paths currently exist, sidewalks conforming to the roadway functional classification shall be provided (See Table 2-4 through Table 2-7).

F. **Pedestrian, Equestrian, and Bicycle Bridges (PEB bridges).**

1. **Design Approach.** PEB bridges shall be designed with the LFD method, as provided by AASHTO Standard Specifications for Highway Bridges. PEB bridges shall be designed to comply with the accessibility requirements of Chapter 6.

2. **Vehicle Design Loads.** The minimum design vehicle loading for a PEB bridge follows the H-truck configuration loading. Table 2-38 presents specific H-truck loading based upon clear deck width for PEB bridges.

Table 2-38. H-Truck Loading for PEB Bridges

PEB Bridge Width (feet)	H- Truck Loading
6—10	H-5 Truck Configuration (10,000 lb)
>10	H-10 truck configuration (20,000 lb)
>6	Not wide enough for any vehicles

3. **Pedestrians and Bicycle Design Loads.** The pedestrian live load for the main member shall be 85 psf. When the deck influence area, A_1 , is greater than 400 square feet, a reduction may be made per the following equation:

$$\text{Pedestrian live load} = 85 / [0.25 + (15/A_1^{1/2})]$$

At no time shall the pedestrian live load of the main member be less than 65 psf.

The design live load for the secondary member shall be 85 psf.

4. **Equestrian Design Loads.** A concentrated load of $P = 1,000$ lb shall be used when horse traffic is present.
5. **Wind.** Wind load is a horizontal load. There is no required combination of wind on live loads (pedestrian or vehicular). For wind overturning force, see AASHTO Standard Specifications for Highway Bridges. Table 2-39 presents a listing of design wind loads applicable to the vertical area of PEB bridge members.

Table 2-39. Design Wind Load for PEB Bridges

Member Type	Design Wind Load (psf)
Truss and Arches	75
Girders and Beams	50
Open Truss	35

6. **Deflection.** Maximum deflection on a PEB bridge shall be as follows:

$$D_{\max} = S/1000$$

where:

D_{\max} = deflection, feet

S = span, feet

7. **Vibrations for PEB Bridge without Live Load.** When the PEB bridge has no vehicular or pedestrian traffic, the frequency shall be greater than 3 Hz to avoid the first harmonic.
8. **Vibrations for PEB Bridge with Live Load.** When the PEB bridge has a live load (e.g., running and jumping), the frequency shall be greater than 5 Hz to avoid the second harmonic.
9. **Allowable Fatigue Stress.** Fatigue provisions are not required for pedestrian live load stresses where heavy pedestrian loads are infrequent. Fatigue provisions shall be included for wind loads.
10. **Half-through Truss Spans.** Half-through truss spans shall be designed per AASHTO Guide Specifications for Design of Pedestrian Bridges.

2.6.7. Railings

- A. **Using Rigid Railings.** Railing systems can be rigid or they can allow deflection to reduce penetration. Highway structures normally warrant the use of a rigid railing.
- B. **Criteria.** Railings used on any bridge structure in the County shall comply with AASHTO and CDOT Criteria.
- C. **Traffic Railing.**
 1. **Accepted Bridge Railing Types.** Bridge railings must handle vehicles on the bridge under impact conditions. Vehicles and impact conditions are specified in the design. Table 2-40 presents the acceptable bridge railings for bridges in the County.

Table 2-40. Acceptable Bridge Railing Types

Type of Railing	Reference(s)
CDOT Railing Types 3, 7, 8 and 10	CDOT Standards
Oklahoma Modified TR-1	AASHTO and Appendix F
BR1 Type C Aluminum Bridge Railing	AASHTO and Appendix F

Safety-Shaped Concrete Bridge Railing	AASHTO and Appendix F
Nevada Concrete Safety Shape (w/ Steel Rails)	AASHTO and Appendix F
Texas Type HT (Heavy Truck)	AASHTO and Appendix F
Texas Type TT (Tank Truck)	AASHTO and Appendix F

2. **Using Other Types of Railing.** Other railings may be proposed for review and approval by the ECM Administrator. Structural calculations or crash test results shall be submitted with such proposals.
 3. **Transitions.** Transitions shall be provided when a semi-rigid roadside guardrail meets a rigid bridge railing.
 4. **Gradual Stiffening.** The transition shall provide a gradual stiffening of the approach by adjusting the post spacing or rail strength or by transitioning to a different, stiffer barrier.
 5. **Flexible Bridge Railings.** Transitions may not be necessary when bridge railings have some flexibility. Any design without a transition shall satisfy AASHTO criteria.
 6. **Alternatives in Congested Areas.** In urban areas or where roadways and sidewalks prevent installation of approach guardrail transitions, one or more of the following alternatives shall be followed:
 - Extend the guardrail or bridge rail in a manner that prevents encroachment of vehicle onto any roadway system below the bridge. A tapered end section parallel to the roadway may be an option.
 - Provide a barrier curb.
 - Restrict speed. The ECM Administrator approval is required for this option.
 - Provide a recovery area.
 7. **Placement and Lateral Clearance.** The rail system shall be placed 2 feet beyond the useable shoulder.
- D. **Roadside Barrier Railing.**
1. **Required Barriers.** Barriers are required only when the warrants in the AASHTO Roadside Design Guide are met.
 2. **Acceptable Roadside Barriers.** Roadside barriers are flexible, semi-rigid or rigid. Table 2-41 presents the acceptable roadside barriers in the County.

Table 2-41. Acceptable Roadside Barriers

Category	Type of Barrier	Reference
Semi-Rigid Systems	Blocked-Out W-Beam (Strong Post)	Refer to M & S Standards
	Blocked-Out Three-Beam (Strong Post0)	Refer to M & S Standards
	Modified Three-Beam	Refer to M & S Standards
Rigid Systems	Concrete Safety Shape	Refer to M & S Standards
	Stone Masonry Wall	Refer to M & S Standards

3. **Transitions.** In the case of roadside barriers, the gradual stiffening shall decrease from structure to roadway.

4. **Lateral Offset from the Edge-of-Traveled Way.** Roadside barriers shall be placed as far from the through lane as conditions allow. A roadside barrier shall not be placed beyond the shy line offset given in Table 2-42.

Table 2-42. Shy Line Offset Values

Design Speed (MPH)	Shy Line Offset Ls (feet)
70	9.2
60	7.9
50	6.6
40	4.6
30	3.6
25	3.0

5. **Deflection Distance.** If a rail is installed along the face of an exposed pier, abutment or wall, sufficient clearance shall be provided to allow dynamic lateral deflection. This will enable the rail to cushion and deflect an errant vehicle. Figure 2-43 provides the barrier-to-obstruction distance.

Figure 2-43. Deflection Distance

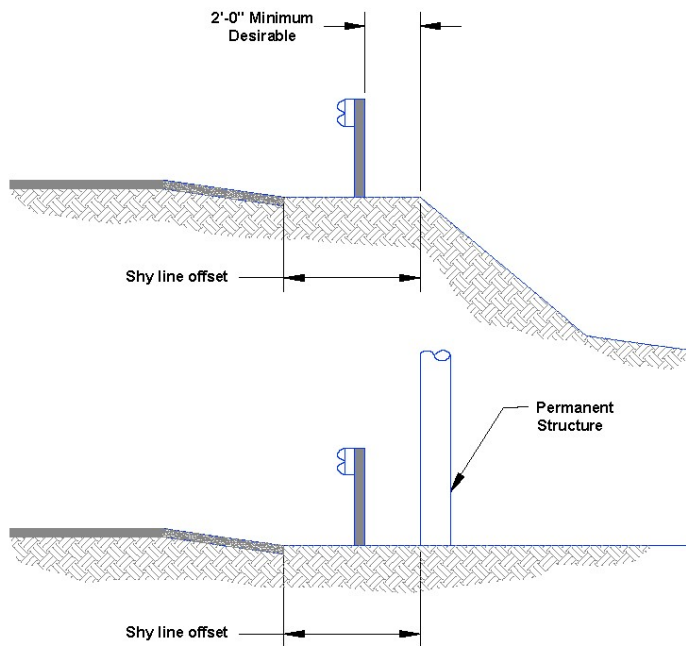

6. **Terrain Effect.** Most roadside barriers are designed and tested on level terrain. Caution must be taken when slopes are 1:6 or more. Figure 2-44 shows recommended barrier location on a 1:6 slope.

Figure 2-44. Terrain Effects Barrier Location on a 1:6 Slope

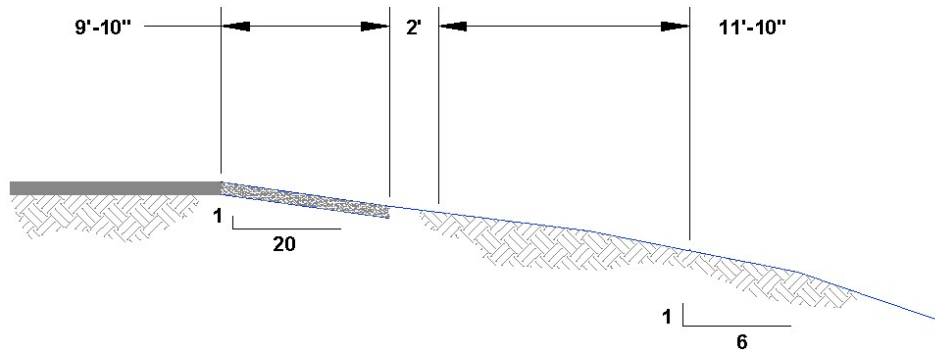

7. **Length of Need.** AASHTO Roadside Design Guide shall be used to determine the length of need requirements.
- E. **Pedestrian Railing.**
1. **Pedestrian Railing Required.** A pedestrian railing shall be used at all locations where pedestrians are adjacent to a 2:1 or steeper drop-off equal to or greater than 30 inches high.
 2. **Placement.** The railing shall be placed on the outer edge of the sidewalk when pedestrian traffic is separated from vehicular traffic by a traffic railing.
 3. **Height and Openings.** Pedestrian railing height shall be a minimum of 42 inches, measured from the walkway surface (See Figure 2-45). Railings shall not have openings large enough to pass a 4-inch sphere.

Figure 2-45. Typical Pedestrian Railing

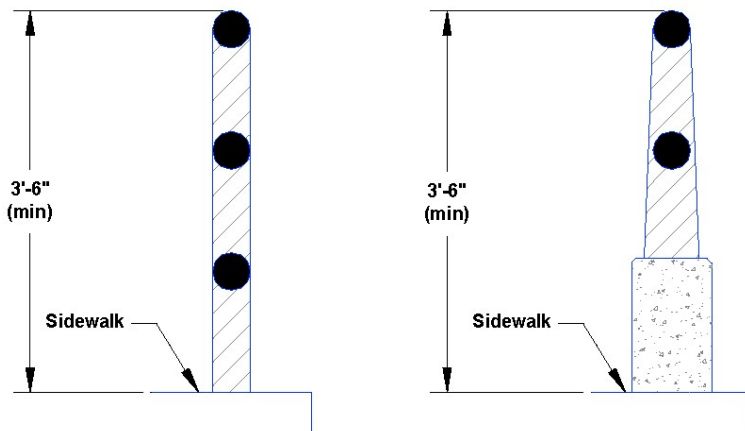

4. **Construction Material.** A pedestrian railing shall be constructed of metal fabric, chain link (vinyl clad only), metal rails only or metal rails placed above a concrete parapet.
5. **Metal Rail Design Loads.** The design live loading shall be 0.050 kips per Linear Foot, both transversely and vertically, acting simultaneously on each longitudinal element. A concentrated load of 0.20 kips, acting on the top rail and simultaneous with the design live loading can be considered at any point and in any direction.

6. **Chain Link/Metal Fabric Design Loads.** The design live load shall be 0.015 Kips per Square Foot acting normal to the entire surface.

F. **Bicycle Railing.**

1. **Bicycle Railing Required.** A bicycle railing shall be used wherever bicycle lanes are adjacent to the edge of a bridge or hazard. The railing shall be warranted when the roadway has designated bike lanes.
2. **Placement.** The bicycle railing shall be placed on the outer edge of the bike lane.
3. **Height and Rub Rail.** Bicycle railing height shall be a minimum of 54 inches, measured from the riding surface. Smooth, snag-free rub rail shall be attached to the railings at the handlebar height of 3.5 feet (See Figure 2-46).

Figure 2-46. Typical Bicycle Railing

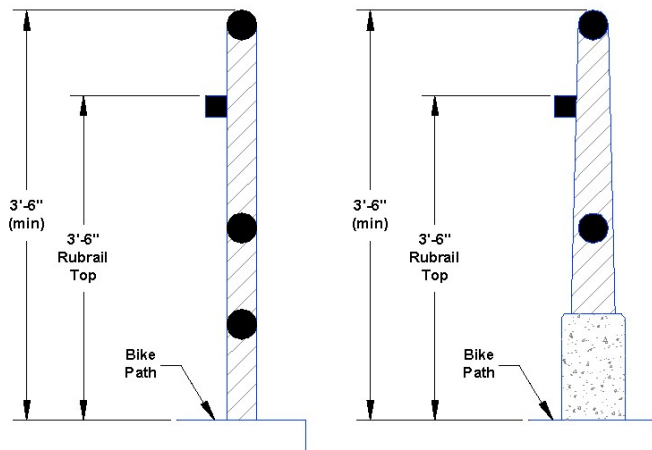

4. **Construction Materials.** A bicycle railing shall be constructed of metal rails only, metal rails above a concrete parapet, chain link or metal fabric.
5. **Design loads.** Design loads shall conform to pedestrian railing design loads in Section 2.6.7E.

G. **Combination Pedestrian, Vehicle or Bicycle Traffic Barrier.**

1. **Conditions for Use.** The combination barrier shall be provided for structures whenever a raised curb and an attached sidewalk exist.
2. **Placement.** The combination barrier shall be installed adjacent to the roadway with either a pedestrian or bicycle railing, as appropriate. The combination barrier shall be placed on the outboard side as shown in Figure 2-47.

Figure 2-47. Typical Combination Barrier

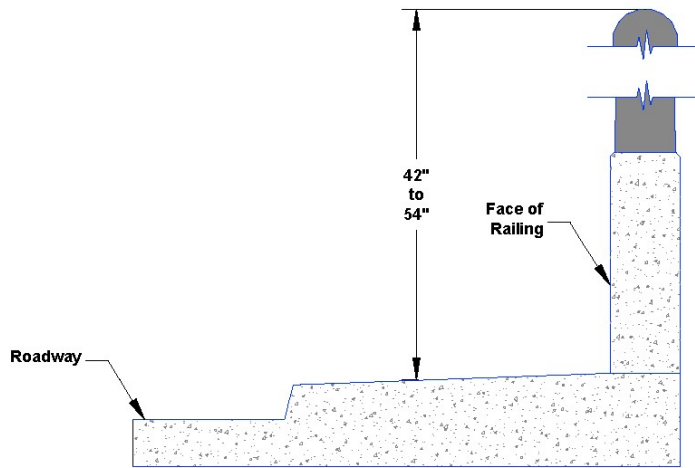

3. **Height.** If the sidewalk width is 6 feet or greater, the railing height shall be between 42 and 54 inches, measured from the sidewalk surface.

2.6.8. Retaining Walls and Abutments

A. General requirements.

1. **Accepted Retaining Walls.** Four types of retaining wall systems are accepted by the County: conventional retaining walls and abutments, anchored walls, mechanically stabilized earth walls, and prefabricated modular walls.
2. **Backfill Materials.** The backfill materials used shall be granular and free-draining.
3. **Drainage.** Drainage shall be provided to reduce hydrostatic pressure behind the wall.
4. **Design Life.** All retaining walls shall have a minimum design life of 50 years.

B. Conventional Retaining Walls and Abutments.

1. **Design Basis.** Conventional retaining walls and abutments are proportioned to provide stability against bearing capacity failure, overturning, and sliding.
2. **Avoid Placement in Right-of-Way.** Retaining walls are discouraged within the public right-of-way. They will be allowed only when necessary to support public improvements and when approved by the ECM Administrator.
3. **Requirements When Beyond Right-of-Way.** Retaining walls needed to support private improvements shall not be located in the public right-of-way. However, if the failure of a related retaining wall could threaten any improvements or safety within the right-of-way, the retaining wall shall be designed to ECM standards.
4. **Loading.** Design of conventional retaining walls and abutments shall satisfy the following loading factors:
 - Lateral earth and water pressures including any live and dead load surcharges,
 - The weight of the wall,
 - Temperature and shrinkage effects, and

-
- Seismic loads.

C. **Anchored Walls.**

1. **Design Basis.** Anchored walls provide additional lateral resistance with the use of anchors. Their design is based on the suitability of the subsurface soil and rock conditions.
2. **Loading.** Design of conventional retaining walls and abutments shall satisfy the following loading factors:
 - Lateral earth and water pressures including any live and dead load surcharges,
 - The weight of the wall, and
 - Seismic loads.

D. **Mechanically Stabilized Earth Walls.**

1. **Design Basis.** Mechanically Stabilized Earth Walls (MSEW) are flexible composites of granular soil and tensile inclusions that behave as earth embankments with vertical or nearly vertical faces. MSEW are proportioned to provide stability against overturning and sliding. Bearing pressure generally governs design.
2. **Loading.** Design of conventional retaining walls and abutments shall satisfy the following loading factors:
 - Lateral earth and water pressures including any live and dead load surcharges,
 - The weight of the wall, and
 - Seismic loads.
3. **Application for MSEW.** An MSEW should be used where substantial total and differential settlement is expected. This type of wall may also be used where conventional gravity, cantilever or counterforted concrete retaining walls are considered.
4. **Unacceptable Uses of MSEW.** An MSEW shall not be used in any of the following conditions:
 - Where utilities other than highway drainage are to be constructed within the reinforced zone,
 - Where floodplain erosion or scour may undermine the reinforced fill zone or any supporting footing, and
 - Where surface or groundwater contaminated by acid mine drainage or other industrial pollutants is present.

E. **Prefabricated Modular Walls.**

1. **Design Basis.** Prefabricated modular walls employ soil-filled interlocking modules to resist earth pressures. Stability of modular walls depends upon the weight and strength of the fill soil. Each module level shall be investigated for sliding and overturning.
2. **Loading.** Design of conventional retaining walls and abutments shall satisfy the following loading factors:
 - Lateral earth and water pressures including any live and dead load surcharges,
 - The weight of the wall, and
 - Seismic loads.

-
3. **Earth Pressure and Lateral Thrust Calculations.** Earth pressure shall be computed on a plane surface where modules form an irregular, stepped surface. K_a , used to compute lateral thrust, shall be computed based on the friction angle of the backfill behind the modules.
 4. **Application for Prefabricated Modular Wall.** A prefabricated modular wall may be used where conventional gravity, cantilever or counterforted concrete retaining walls are considered.
 5. **Unacceptable Uses of Prefabricated Modular Wall.** A prefabricated modular wall shall not be used in any of the following conditions:
 - On curves with radii less than 800 feet, unless the chord can be substituted with a series of chords and
 - Where groundwater or surface runoff is contaminated with acid.

F. **Placement of Walls.**

1. **Clear Zone Placement.** Walls shall not be placed within the clear zone. Walls located in the clear zone shall be snag-proof and crash resistant or include an AASHTO barrier.
2. **Relationship to Shoulder.** Full or partial height walls shall not be located closer than the outer edge of the shoulder.
3. **Retaining Wall at Roadway Level.** When the top of the retaining wall is at the level of a roadway, the face of the parapet wall or rail shall be at least 4 feet from the edge of the traveled way.

2.6.9. Buried Structures

- A. **Materials.** Buried structures may be constructed of precast or cast-in-place concrete, aluminum, or steel materials.
- B. **Design Life.** The design life for buried structures shall be a minimum of 100 years.
- C. **Non-Vehicular Loads.**
 1. **Load Factors.** Buried structures shall be designed for force effects resulting from horizontal and vertical earth pressure, pavement load, live load, and vehicular dynamic load.
 2. **Other Load Factors.** When relevant for site or construction conditions, earth and live load surcharges and downdrag loads shall also be evaluated.
 3. **Water Buoyancy Loads.** Water buoyancy loads shall be analyzed for buried structures with inverts below the water table.
- D. **Vehicular Loads.**
 1. **Wheel Loads.** Where depth of fill is greater than 2 feet, wheel loads may be considered uniformly distributed over a rectangular area equal to the dimensions of the tire contact area.
For depth of fill 2 feet or less, wheel loads shall be increased by 1.15 times the depth of fill in select granular backfill.
 2. **Recreational Trails.** The minimum design vehicular loading for buried structures supporting recreational trails shall accommodate maintenance traffic. The minimum design loading shall be H-15.
 3. **All Other Traffic.** Buried structures below traffic other than recreational traffic shall be designed for vehicular loadings of HS-20 or higher.

4. **Sidewalks.** A pedestrian load of 85 psf shall be applied to all sidewalks, where warranted for location above buried structures, wider than 2 feet, and considered simultaneously with vehicular design live load.
- E. **Embankment Installation.** The soil envelope shall be wide enough to ensure lateral restraint for the buried structure. In no cases shall the width of the soil envelope on each side of the buried structure be less than the values specified in Table 2-43.

Table 2-43. Minimum Width of Soil Envelope around Buried Structures

Diameter, S (inches)	Minimum Envelope Width (feet)
<24	S/12
24–144	2.0
>144	5.0

- F. **Minimum Soil Cover.** The depth of cover of a well compacted granular sub-base, taken from the top of rigid pavement or the bottom of flexible pavement, shall be no less than the values specified in Table 2-44 and Table 2-45.

Table 2-44. Minimum Soil Cover for Buried Structures

Type	Condition	Minimum Cover
Structural Plate Pipe Structures		$S/8 \geq 12.0$ inches
Long Span Structural Plate Pipe Structures		Table 2-45
Structural Plate Box Structures		1.4 to 5.0 feet
Reinforced Concrete Pipe	Unpaved areas and under flexible pavement	$B/8$ or $B'/8 \geq 12.0$ inches (whichever is greater)
	Compacted granular fill under rigid pavement	9.0 inches
Where:		
S = diameter of pipe, inches		
B = outside diameter or width of the structure, feet		
B' = out-to-out vertical rise to pipe, feet		
ID = inside diameter, inches		

Table 2-45. Minimum Soil Cover for Buried Long Span Plate Pipe Structures

Steel Thickness Without Ribs (inches)	Top Radius (feet)				
	≥ 15.0	15–17	17–20	20–23	23–25
0.111	2.5	-	-	-	-
0.140	2.5	3.0	-	-	-
0.170	2.5	3.0	3.0	-	-
0.188	2.5	3.0	3.0	-	-
0.218	2.0	2.5	2.5	3.0	-
0.249	2.0	2.0	2.5	3.0	4.0
0.280	2.0	2.0	2.5	3.0	4.0

- G. **Multiple pipe crossings.** Due to maintenance issues, parallel culverts (a.k.a. culvert batteries) are not permitted except in areas where low headwater is unavoidable, areas where approach velocity is supercritical, or in the vicinity of a bend immediately upstream. Refer to Chapter 9 of the CDOT Drainage Design Manual for additional information.
- H. **Structural Plate Box Structures.**
1. **Design.** The shallow covers and extreme shapes of box culverts require special design procedures. Flexural requirements of metal box culverts govern the choice of section in all cases.
 2. **Geometric Requirements.** Table 2-46 and Figure 2-48 provide the geometric requirements for structural plate box structures.

Table 2-46. Geometric Requirements for Structural Plate Boxes

Parameter	Required Range
Span, S	8'9" to 25'5"
Rise, R	2'6" to 10'6"
Radius of crown, r^c	<24'9½"
Radius of haunch, r^h	>2'6"
Haunch radius included angle, Δ	50 to 70 degrees
Length of leg, D	4¾" to 71"
Minimum length of rib of leg, L	19"; D - 3"; or within 3" of top of footing (whichever is lowest)

Figure 2-48. Typical Structural Plate Box

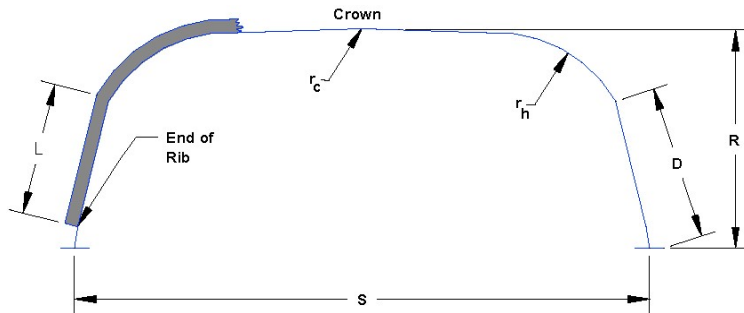

3. **Embankment Installation.** The combined width of the soil envelope and embankment beyond shall be adequate to support all the loads on the culvert.
 4. **Live Loads.** Live load distribution for culvert tops may be based on provisions for deck slabs spanning parallel to traffic.
 5. **Maximum Soil Cover.** Maximum soil cover for structural plate box structures shall be limited to a depth of cover of 5 feet.
 6. **Concrete Relieving Slabs.** Concrete relieving slabs may be used to reduce flexural moments in box culverts. The length of the concrete relieving slab shall project at least 1 foot beyond the haunch on each side of the culvert.
- I. **Reinforced Concrete Pipe.**

1. **Design.** Buried reinforced concrete pipes shall be designed to resist structural failure due to flexure, thrust, shear, and radial tension. The dimensions of the pipe sections shall be determined with either the direct or indirect design method as outlined in the AASHTO standards referenced.
2. **Trench and Embankment Installations.** Both trench and embankment installations shall be designed for embankment loads and pressure distribution. The earth pressure distribution shall be the Hedger pressure distribution as shown in Figure 2-49 and Table 2-47.

Table 2-47. Coefficients for Use with Figure 2-48

Coefficient	Installation Type			
	1	2	3	4
VAF	1.35	1.4	1.4	1.45
HAF	0.45	0.4	0.37	0.3
A1	0.62	.85	1.05	1.45
A2	0.73	0.55	0.35	0.0
A3	1.35	1.4	1.4	1.45
A4	0.19	0.15	0.1	0.0
A5	0.08	0.08	0.1	0.11
A6	0.18	0.17	0.17	0.19
A	1.4	1.45	1.45	1.45
B	0.4	0.4	0.36	0.3
C	0.18	0.19	0.2	0.25
E	0.08	0.1	0.12	0.0
F	0.05	0.05	0.05	-
U	0.8	0.82	0.85	0.9
V	0.8	0.7	0.6	-

Figure 2-49. Hedger Pressure Distribution

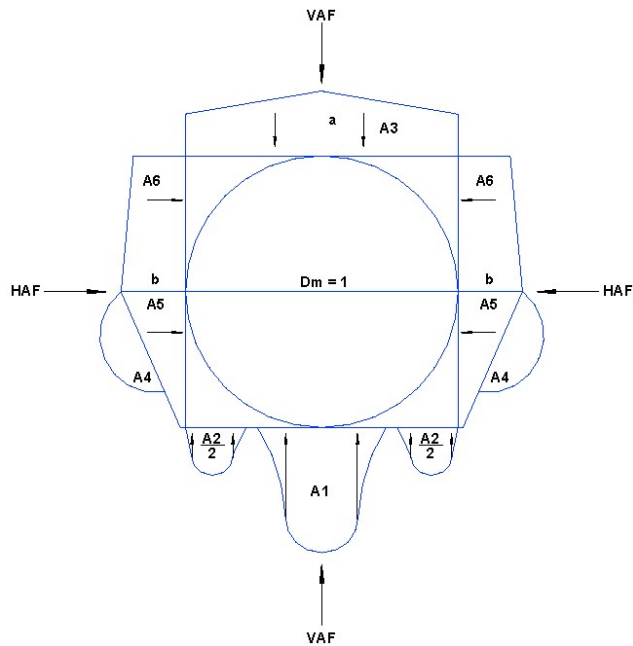

3. **Live Loads.** For standard installations, the live load on the pipe shall be assumed to have a uniform vertical distribution across the top of the pipe and the same distribution across the bottom of the pipe.
- J. **Reinforced Concrete Cast-in-Place and Precast Arches and Box Culverts.**
1. **Trench and Embankment Installations.** Trenches or embankments shall be constructed according to these Standards.
 2. **Other Installations.** Other installation methods (such as partial positive projection, 0.0 projection, negative projection, induced trench, and jacked installations) may be used to reduce the loads on a culvert.
 3. **Vehicular Live Loads.** All vehicular box culverts shall be designed for vehicular loadings of HS-20 or higher. For single-span culverts, the effects of live load may be neglected where the depth of fill is more than 8 feet and exceeds the span length. For multiple span culverts, the effects of live load may be neglected when depth of fill exceeds the distance between faces of end walls.
 4. **Less Than Two Feet of Soil Cover.** Distribution of wheel loads and concentrated loads for culverts with less than 2 feet of cover shall be as specified for slab-type superstructures.
 5. **No Soil Cover.** If soil cover is not provided, the top of reinforced concrete box structures shall be designed for direct application of vehicular and pedestrian loads.
 6. **Crack Width Control.** Steel reinforcement shall be well distributed over the zone of maximum concrete tension to control flexural cracking.
- K. **Thermoplastic Pipe.** Thermoplastic pipe shall not be used in El Paso County right-of-way or in any publicly maintained easements.
- L. **Precast Reinforced Concrete Three-Sided Structures.**

-
1. **Design.** Design of three-sided structures shall be based on a pinned connection at the footing and shall take into account anticipated footing movement. Each precast, three-sided structure shall be analyzed independently with no shear or stress transfer assumed between sections.
 2. **Geometric Requirements.** Wall thickness shall be a minimum of 8.0 inches for spans under 24 feet and 10 inches for spaces 24 feet and longer.
 3. **Shear Key.** Flat top structures with shallow cover shall be provided with shear keys in the top surface.
 4. **Minimum Reinforcement.** The flexural reinforcement in the direction of span shall provide a ratio of reinforcement/gross concrete area ≥ 0.002 . This minimum reinforcement shall be provided at all cross sections subject to flexural tension, at the inside face of walls, and in each direction at the top of slabs of three-sided sections with less than 2.0 feet of fill.
 5. **Deflection Control.** Deflection criteria shall be addressed in the design of all precast reinforced concrete, three-sided structures.

2.6.10. Subdrains

- A. **Controlling Groundwater.** Subdrains used for the purpose of controlling groundwater on private property may be constructed within the County's right-of-way if certain criteria are met. The system shall be private and must be maintained by viable private parties and approved with a Work in the Right-of-Way Permit.
- B. **Protecting Right-of-Way Improvements.** Subdrains constructed for the purpose of protecting public improvements may be installed only if other means are not possible. Subdrains installed for the protection of public improvements shall be maintained by the County.
- C. **Design Criteria.**
 1. **Positive Outfall.** A subdrain shall have a positive outfall for gravity drainage.
 2. **Adequate Engineering.** The subdrain shall be designed in consideration of site-specific groundwater conditions, soil properties, topography, and layout of proposed development.
 3. **Sanitary Sewer Kept Dry.** The subdrain system shall maintain adequate flow capacity under peak hydraulic loading rates to keep groundwater below the invert of the sanitary sewer.
 4. **No Offsite Transport.** The subdrain shall neither receive groundwater inflow from additional upstream developments, nor transfer collected groundwater to downstream developments without first recording legally binding documents of the agreements established between multiple owners.
 5. **Water Rights.** The subdrain shall not injure existing water rights.
 6. **Monitoring after Construction.** The subdrain shall incorporate provisions to allow monitoring of groundwater levels to confirm that it is functioning as designed.
 7. **Design for Seasonal High Water.** The subdrain shall be designed in consideration of seasonal high groundwater levels.
 8. **Groundwater Barriers.** The subdrain shall be designed with clay cutoff walls to preclude hydraulic communication with offsite utility trenches either upstream or downstream.
 9. **Filter Fabric.** The subdrain trench shall be lined with a filter fabric specifically selected to minimize the invasion of fine soil particles into the bedding gravel.

10. **Pipe Diameter.** The minimum subdrain pipe diameter is 4 inches for mains and 3 inches for laterals or as determined by a completed geotechnical analysis.
11. **Subdrain Placement and Cleanouts.** The Standard Drawings in Appendix F show general requirements for subdrain placement, location of cleanouts, and service.

(Res. No. 20-222 , 6-23-20)

Chapter 3 STORMWATER MANAGEMENT

3.1. OVERVIEW

This chapter provides policies and procedures to attain reasonable standardization of drainage design throughout the County.

3.1.1. Purpose

The purpose of this chapter is to discuss specific drainage and grading related criteria for projects that disturb surface soils within the unincorporated areas of the County. In addition, with the issuance of a County-wide National Pollutant Discharge Elimination System (NPDES) permit, this chapter and adopted Addendum presented in Appendix I provide specific criteria and standards for the management and protection of surface water quality.

The most current version of the Drainage Criteria Manual Volume 1 (DCM1) can be found here:

<https://publicworks.elpasoco.com/policies-manuals/>

The most current version of the drainage fees and bridge fees can be found at the following website under Fees:

<https://publicworks.elpasoco.com/road-bridge-planning/>

3.1.2. Chapter Content and References

Table 3-1 outlines the chapter content and references used as a basis for the standards established in Chapter 3.

Table 3-1. Contents and Basis of Drainage Facility Standards

Intent Use	ECM Content	ECM Section(s)	Reference Document(s)
Planning			
	Plan Basis	3.2.1 - 3.2.3	2
	Plan Objectives and Policies	3.2.4 - 3.2.8 and Appendix I	2, 3
Design			
	Storm Sewers	3.3.2	2, 3
	Culverts	3.3.3	2, 3
	Open Channels	3.3.4	2, 3
	Drainage Ditches	3.3.5	2, 3
	Roadways	3.3.6	2, 3
	Permanent Stormwater Management Facilities	3.3.7	n/a
Construction			

Created: 2021-06-08 11:35:50 [EST]

(Supp. No. 2)

	Permitting	5.3, 5.6 and Appendix I	1, 3
	Inspections	5.11 and Appendix I	1, 3
	Acceptance	5.3 and Appendix I	1, 3
	Site Grading	3.3.4	2.3

References

1. El Paso County Land Development Code.
2. City of Colorado Springs Drainage Criteria Manual Volume 1 (DCM 1).
3. City of Colorado Springs Drainage Criteria Manual Volume 2 (DCM 2).
4. City of Colorado Springs Drainage Criteria Manual 2014 Update: Chapter 6 and Section 3.2.1 of Chapter 13.
5. Urban Drainage and Flood Control District Criteria Manual Volume 3, Chapter 7.

3.1.3. Standard Drawings

Table 3-2 identifies the standard drawings that are included in Appendix F as an enforceable part of these Standards. The standard drawings shall be used in all applications for which a public improvement is to be designed. Any change to a standard drawing shall be approved by the ECM Administrator and noted on the construction plans.

Table 3-2. Standard Drawings

File Name	Detail/Description	Approval Date
SD_3-1	Storm Sewer Manhole Detail Type I	07/09/2009
SD-3-2	Storm Sewer Manhole Detail Type II	11/10/2004
SD_3-3	Storm Sewer Manhole Detail Type III	08/11/2011
SD_3-5	Storm Sewer Manhole Lid Detail	09/16/2010
SD_3-7	Storm Sewer Manhole Riser and Cover Detail	08/11/2011
SD-3-8	Grate Inlet for Common Areas (guidance)	08/11/2011
SD_3-14	Driveway Access on Rural Local Roadway	08/11/2011
SD_3-24	Sidewalk Underdrain w/ Curb Outlet Detail	08/11/2011
SD_3-25	Curb Opening w/ Drainage Chase Detail 1 of 2	08/11/2011
SD_3-25A	Curb Opening w/ Drainage Chase Detail 2 of 2	08/11/2011
SD_3-30	Desilting Basin Outlet	08/11/2011
SD_3-31	Temporary Desilting Basin at Inlet	08/11/2011
SD_3-32	Temporary Desilting Basin at Sump	08/11/2011
SD_3-33	On Street Temporary Desilting Basin Detail	
SD_3-34	Temporary Desilting Basin Detail (guidance)	08/11/2011
SD_3-35	Debris Cage for Desilting Basin Riser	08/11/2011
SD_3-36	Desilting Basin Riser Detail	08/11/2011
SD_3-41	Lined Ditch Splashwall Detail (plan and section)	08/11/2011
SD_3-44	Lined Ditch Behind Retaining Wall Detail	08/11/2011
SD_3-48	Beehive Grate Detail (guidance)	08/11/2011
SD_3-60	Temporary Street Sandbag Detail and Section	08/11/2011
SD_3-62	Typical Check Dam Detail	08/11/2011
SD_3-71	Canyon Subdrain Detail	08/11/2011

Created: 2021-06-08 11:35:50 [EST]

(Supp. No. 2)

SD_3-81	Lug Connection Detail (cast in place concrete pipe)	08/11/2011
SD_3-82	Plan and Section of an Extended Detention Basin Sedimentation Facility	01/01/08
SD_3-83	Typical WQCV Outlet Structure Profiles Including 100-Year Detention	01/01/08
SD_3-84	Concrete Washout Structure	01/01/08
SD_3-85	Erosion Log Check Dams	01/01/08
SD_3-86	Culvert Inlet and Outlet Protection Erosion Logs Above Inlets and Outlets for Slope 3:1 or Steeper	01/01/08
SD_3-87	Erosion Log Barrier	01/01/08
SD_3-88	Cut Back Swale	12/13/2016

(Res. No. 19-245 , 7-2-19)

3.2. PLANNING

3.2.1. Developing a Plan for Drainage

All drainage systems being designed in the County shall take into account both minor intensity and major intensity storms. The objective of drainage system planning for minor intensity storms reoccurrence interval is to allow for the proper design of minor drainage systems (i.e., curb and gutters, storm sewers, culverts, open channels, and detention ponds) while minimizing minor damage and maintenance costs. The objective of drainage planning for major intensity storms (100-year reoccurrence interval) is to allow for proper design of major drainage systems (i.e., bridges, storm sewers, open channels, and detention ponds) while minimizing the possibility of major damage and/or loss of life.

It is the design engineer's responsibility to develop, justify, and submit values and calculations used in the preparation of drainage for county review and approval.

3.2.2. Natural and Artificial Systems

Conveyance systems include drainage facilities, both natural and artificial, that collect, contain, and convey stormwater runoff. Natural conveyance systems include, but are not limited to, swales, wetlands, drainage courses, streams, and rivers. Artificial conveyance systems include, but are not limited to, gutters, ditches, pipes, catch basins, manholes, constructed wetlands, open channels, and swales. Requirements for artificial conveyance systems, where natural systems already exist, shall not be interpreted to supersede County requirements for protection of natural systems.

3.2.3. Requirements of Adequate Drainage Systems Required

Adequate drainage designs shall provide for removal of runoff from the roadway or the upstream end of any development, and for carrying runoff water from the upstream side to the downstream side. These functions shall be accomplished without causing objectionable backwater, causing excessive or increased velocities, creating damages to downstream ownerships, unduly affecting the safe operation of traffic on the roadway, damaging the roadway or damaging water quality.

3.2.4. Suitable Outfall Location Definition

A suitable outfall location refers to a stream which is a hydraulically adequate historic natural stream or channel segment which developed conveyance systems (i.e. storm drain systems, channels, and detention

Created: 2021-06-08 11:35:50 [EST]

(Supp. No. 2)

basin outlets) shall utilize for ultimate discharge of stormwater runoff from development. A suitable outfall stream may be a perennial or ephemeral stream in its previously undeveloped, natural condition. The other choice for a new stormwater outfall is a connection to an existing hydrologically and hydraulically adequate man-made system.

Any and all proposed man-made systems for stormwater conveyance shall outfall to a location as identified above, which is capable of receiving developed flows without negative impacts to streambed stability and/or natural sediment transport functions. Man-made conveyance systems are not limited to storm drain systems, detention basin outlets, and lined channels, but also include any change in the land configuration by grading which results in a new runoff pattern in terms of flow direction and quantity of runoff.

All suitable outfall streams as defined above shall be defined on a map of the basin and included in the applicable drainage basin planning study. In the event an older planning study does not define a suitable discharge point for a new stormwater discharge in the basin, the above criteria shall still apply.

3.2.5. Basic Objectives

The purpose of the drainage system is to collect, transmit, and discharge drainage consistent with the following objectives:

- A. **Space Planning.** Adequate space shall be provided and properly allocated for drainage facilities to ensure that downstream water quality impacts are minimized. When topography of a site dictates the need for addressing water quality near State Waters, adequate space must be provided for the location of permanent water quality structures prior to the discharge to State Waters. At no time shall concentrated flows be allowed from developed lots to discharge directly to State Waters.

Up to 20 percent, not to exceed one (1) acre, of an applicable development site may be excluded from Water Quality Capture Volume (WQCV) calculations when it has been determined that it is not practicable to capture runoff from portions of the site that will not drain towards a permanent control measure. The Owner must determine that implementation of a separate control measure for that portion of the site is not practicable and such determination shall be reviewed and approved by the ECM Administrator. See Appendix I for additional information.
- B. **Multi-Use Resource.** Stormwater runoff shall be treated as a multi-use resource and the design of storm drainage management facilities shall be planned to ensure that the multi-use aspects of drainage facilities are maintained.
- C. **Jurisdictional Boundaries and Master Planning.** Drainage boundaries are non-jurisdictional and regional cooperation is required to receive approval of facilities that have potential multi-jurisdictional and regional impacts through the preparation of a new or use of an existing Drainage Basin Planning Study.
- D. **Floodplain Management.** The design of drainage facilities shall consider the general purpose of the County's Floodplain Regulations and reduce the hazard of floods to life and property, protect and preserve hydraulic characteristics of water courses used for conveyance of floodwaters, protect the public from the extraordinary financial expenditures for flood control and relief, and promote the multi-use resource concept with the intent to provide and preserve quality open space, trails, and tree lines.
- E. **Stormwater Quantity and Quality.** Land disturbance activities shall properly manage and mitigate both stormwater quantity and quality related impacts. Quantity related impacts shall be mitigated in a manner that controls possible damage caused by the amount of surface water being transported to any one design point. Quality related impacts shall be mitigated using the design standards and permanent BMP selection process discussed in Appendix I.

All applicable development sites must have operational permanent stormwater quality control measures at the completion of the site. In the case where permanent water quality control measures are part of future phasing, the permittee must have a mechanism to ensure that all control measures will be implemented, regardless of completion of future phases or site ownership. In such cases, temporary water quality control measures must be implemented as feasible and maintained until removed or modified. All temporary water quality control measure must meet one of the design standards discussed in Appendix I.

- F. **Water Rights.** When proposed drainage systems interfere with existing water rights, the value and use of the water are affected; therefore, the design of any proposed stormwater drainage system incorporating retention shall identify the impact to water rights, and shall be approved by the State Engineer as appropriate.

Colorado Revised Statute (CRS) § 37-92-602(8) provides legal protection for any regional or individual site stormwater detention and infiltration facility in Colorado, except those in the Fountain Creek watershed, that are not required by or operated in compliance with a Municipal Separate Storm Sewer System (MS4) permit, provided it meets the following criteria:

1. It is owned or operated by a governmental entity or is subject to oversight by a governmental entity (e.g., required under an MS4 permit).
2. It continuously releases or infiltrates at least 97% of all of the runoff from a rainfall event that is less than or equal to a 5-year storm within 72 hours after the end of the event.
3. It continuously releases or infiltrates as quickly as practicable, but in all cases releases or infiltrates at least 99% of the runoff within 120 hours after the end of events greater than a 5-year storm.
4. It operates passively and does not subject the stormwater runoff to any active treatment process (e.g., coagulation, flocculation, disinfection, etc.).
5. The runoff treated in stormwater detention and infiltration facilities shall not be used for any other purpose by the owner/operator/overseer (or that entity's assignees).
6. The run off shall not be released for subsequent diversion or storage by the owner/operator/overseer (or that entity's assignees).
7. It shall not be the basis for a water right or credit.

Most stormwater detention and infiltration facilities constructed in unincorporated El Paso County are subject to the oversight of El Paso County and are required by an MS4 permit. Thus, El Paso County developed a registration process to meet the requirements of CRS § 37-92-602(8). Please refer to Section 3.3.7 for required information to be submitted during plan review to allow for facilities to be protected under the provisions of the statute.

3.2.6. County Policy on Drainage Diversion

Colorado drainage law recognizes the inequity in transferring the burden of managing storm drainage from one location or property to another. Liability questions may also arise when the historic drainage continuum is altered. Therefore, diversion of stormwater runoff from one basin to another is discouraged unless specific and prudent reasons justify such a transfer without impacting the historical drainage paths within the basin and the appropriate legal agreements have been recorded.

3.2.7. County Roadside Ditches

Consistent with Section 3.2.5, the County's existing roadside ditch and ditch systems shall not be used as an outfall conveyance for developed runoff. The main purpose of these ditch systems is to collect and properly convey stormwater from adjacent public roadways. Roadside ditches should not be considered as a suitable outfall for conveyance of developed runoff. Should a roadside ditch be the only true option, downstream capture and storage of sediment shall be planned for and provided for in the construction plans.

3.2.8. Hydrology

- A. **Design Storm Criteria.** Design storm flows shall be calculated based on appropriate criteria and guidelines presented in the DCM 1 to assure minimum design standards and that a regional drainage solution is developed. Information presented in these Standards do not replace information presented in the other referenced standards, but instead should be considered as additional criteria and shall be used in determining design storm runoff for both on-site and off-site flows.
- B. **Peak Volumes and Times of Concentration.** Peak volumes and times of concentrations shall consider fully developed land use scenarios to determine runoff coefficients and changes in flow patterns (from the undeveloped site conditions). Estimated times of concentration shall be based on proposed grading. The proposed project or developed land use shall not change historical runoff values, cause downstream damage or adversely impact adjacent properties.
- C. **Entire Project Area.** Phased or partial development analysis will not be accepted. The entire project area shall be analyzed based on full build-out to properly site and size storage areas and conveyance systems.
- D. **Off-Site Runoff.** The analysis of off-site runoff is dependent on regional drainage characteristics, the existing/proposed land use, and topographic features. If an existing storm drainage master plan is available for the area, the storm drainage master plan shall be used as a baseline document and updated with proposed information. Should no off-site information be available for fully developed flows, the design engineer must perform a regional analysis to ensure that the project does not change historic runoff values, cause downstream damage or adversely impact adjacent properties.
- E. **Design Runoff.** Design runoff shall be based on the following information:
 - The 5-year minor design storm may be used in accordance with City of Colorado Springs adopted revisions to DCM 1.
 - Within floodplain and floodplain fringe areas, as defined by the FEMA, the runoff criteria shall be based on a 100-year frequency storm.
 - For all drainage channels and storm drain systems, which will convey drainage from a tributary area equal to and greater than one square mile, the runoff criteria shall be based on a 100-year frequency storm.
 - For tributary areas under one square mile, (1) the storm drain system shall be designed so that the combination of storm drain system capacity and overflow will be able to carry the 100-year frequency storm without damage to or flooding of adjacent existing buildings or potential building sites, and (2) the runoff criteria for the minor storm and underground storm drain systems shall be based upon a frequency storm consistent with DCM 1 and 2.
- F. **Design Runoff Methods.** Storm discharge flows shall be based on the adopted storm drainage master plan. If no established storm discharge flows are available, the storm drainage flows shall be based on the following:

-
- Design flows for watersheds less than 100 acres shall be developed using the Rational Method. Methods other than Rational Method shall not be accepted for watersheds less than 100 acres in size.
 - Design flows for watersheds greater than 100 acres shall be developed using Soil Conservation Service (SCS) Methods, tabular or computer modeling or U.S. Army Corps of Engineers HEC I or HEC HMS computational methods.
 - When determining design flows for floodplain management and flood proofing, design runoff shall be based upon existing conditions in accordance with the Regional Building Development's Floodplain Management Requirements and FEMA Regulations.

G. **Design Points.** Basin delineation within a development or specific design area is problematic with relation to the design of proper drainage systems and the long-range management of discharge quantities. Therefore, specific design points shall be analyzed in the design process. Discharge volumes for minor and major storm events shall be calculated at all design points. Examples of typical design points include:

- Curb inlets/catch basin;
- Area drains;
- Discharge points: pipes, swales, channels, detention basins, and sedimentation basins to a suitable outfall (existing or natural system);
- Transition points: pipe to channel or swale, crosspans, at any location where developed runoff exits the project boundary and at any point where off-site runoff enters the project boundary;
- Ditchout locations;
- Intersections; and
- Inflow and outflow from sedimentation basins and detention basins.

3.2.9. Site Grading

A. **Basic Objectives.** The goal of site grading is to develop features that direct and store surface water in a manner consistent with the following objectives:

- Assist in directing surface away from existing and proposed structures and towards well-developed conveyance/storage systems to minimize property damage;
- Minimize the amount of surface erosion and sediment transport by limiting steep grades in excess of 4:1 through terracing and using applicable permanent BMPs;
- Site grading shall be designed in a manner that minimizes the use of retaining walls and limits severe transitions at property boundaries;
- Storing surface runoff on site to minimize downstream impacts and control discharge flows; and
- Enhance surface water quality through the use of BMPs designed to remove constituents of concern collected during smaller storm events.

Site grading should imitate natural landforms and work effectively with the developed drainage plan to minimize erosion. The overall area being graded should be kept to a minimum per provisions presented in an approved ESQCP. Once construction is complete, all disturbed areas must be revegetated or other permanent BMPs must be installed.

B. **County Policy on Site Grading.** Site grading shall be designed to the level of detail necessary to ensure that the developed drainage plan is followed for each parcel or lot. In most cases, this will require lot

templates to be developed showing the direction of overall lot drainage, key drainage features/structures, slopes exceeding 10 percent, and approved discharge points. Lot templates are recommended for all commercial development and proposed residential development densities of one unit per acre or more. Where drainage conditions across individual lots are critical to the function of the overall drainage systems or where otherwise required by the ECM Administrator, lot templates shall be developed.

3.2.10. Major Drainageways/Floodplain Management

- A. **Permitting and Regulations.** All construction within the 100-year floodplain must comply with applicable local, state, and federal regulations. The Floodplain Administrator and ECM Administrator shall be consulted prior to submitting any formal proposal that requires or will potentially cause a change in base flood elevations in designated floodplains. Proposed modifications to the 100-year floodplain must be approved through the FEMA map revision process.

The preservation and enhancement of natural floodplains is encouraged whenever feasible. Filling floodplain fringes is generally discouraged because discharge and flood storage capacity will be impacted, affecting water surface elevations, velocity of flow, and downstream peak flows. All construction in the floodplain should be undertaken with caution and in accordance with applicable regulations.

Wetland regulations and permitting issues are also relevant to the major drainage system. A permit under Section 404 of the federal Clean Water Act (CWA) is required for any activities impacting waters of the U.S. and jurisdictional wetlands.

- B. **Embankments and Levees.** Permanent earth embankments, roadway embankments, walls or other structures along a water course for the purpose of flood control are not allowed as provisions for new development or redevelopment. Any existing or proposed roadway embankment that could be considered a levee or "non-levee embankment" providing flood control shall meet County, State, and FEMA requirements prior to development or redevelopment of an area potentially impacted by the subject floodplain.

(Res. No. 19-245 , 7-2-19)

3.3. DESIGN¹

3.3.1. Storm Sewers

- A. **Design Basis.** The installation of storm sewer systems is required when the other parts of the minor system (i.e., curb, gutter, and roadside ditches) no longer have capacity for additional runoff and required spread widths are exceeded.

The design of storm sewers shall be done in accordance with these Standards, the DCM1 and 2, and other references cited for additional discussion and basic design concepts. Hydraulics, debris and detritus, maintenance, inlet conditions, outlet conditions, safety, the effects on traffic, property, economics, and aesthetics shall be considered in the design of all underground storm drainage conduits.

¹Editor's note(s)—Res. No. 19-245 , adopted July 2, 2019, changed the title of § 3.3 to read as herein set out. Formerly, such section pertained to Stormwater Design.

B. **Service Life.**

1. **Minimum Service Life.** The minimum design service life for storm sewer systems shall be 50 years.
2. **Extended Service Life Required.** The service life for storm sewer systems shall be increased to 100 years when:
 - The depth of cover exceeds 15 feet,
 - A portion of the system is or may be located under a structure or the overhang of a structure,
 - The system is located within the traveled way of 4-lane or major and minor arterial roadways (rural and urban),
 - The centerline of a storm sewer pipe is located 15 feet or less horizontally from a structure, or
 - A storm sewer pipe is under a pressure head (typically caused by an installation on a steep slope).

- C. **Minimum Pipe Size.** Storm sewers shall be designed and sized to convey the minor storm runoff peaks without surcharging the sewer. To ensure that this objective is achieved, the hydraulic and energy grade lines shall be estimated by calculating both the major and minor losses (i.e., friction, expansion, contraction, bend, and junction losses). The final energy grade line shall be at or below the proposed ground surface.

The minimum allowable pipe size for storm sewers is dependent upon the estimated flows and a practical diameter from a maintenance standpoint. The minimum pipe size shall have a cross sectional area equivalent to an 18" circular pipe.

- D. **Minimum Gradient.** The minimum gradient shall be 0.5% or a minimum velocity of 4 feet per second (fps) with the pipe flowing one quarter full. Storm sewer pipes shall be designed to flow full and free of pressure heads except for short runs where the grade changes and a small pressure head cannot be avoided. Where it is necessary to design for a pressure head, it shall be approved by the ECM Administrator and shall use pressure pipe with watertight joints with a 100-year service life.

- E. **Vertical Alignment.** The storm sewer grade shall withstand AASHTO HS-20 or higher loading on the pipe. The minimum cover depends upon the pipe size, type and class, and soil bedding condition.

The minimum clearances between the proposed storm sewer, water main, and sanitary sewer (either above or below) shall be in accordance with the applicable district standards and Chapter 4.

- F. **Horizontal Alignment.** In most cases, the curvilinear storm sewer shall be avoided. Where a demonstrated need exists and where the pipe will have a diameter of 48-inches or less, a curvilinear alignment may be approved. The limitations on the radius for pulled-joint pipe are dependent on the pipe length and diameter, and the amount of opening permitted in the joint per the pipe manufacturer's recommendations.

- G. **Manholes.** Maximum spacing and locations of manholes and cleanouts are to be installed per requirements described in DCM 1, except as modified by Section 3.3.1.J.2. Manholes shall be installed 1/8" below the surface of the pavement on the lowest side of the manhole.

- H. **Inlets.** The capacities of standard inlets under various flow conditions shall be calculated or obtained from the DCM Volumes I and II.

- I. **Angle of Confluence.** In no case shall a component of lateral velocity oppose the mainline velocity by an angle of confluence. The angle of confluence shall be 90° or less, except where lateral measures 36 inches in diameter or more, in which case the angle of confluence shall be 60° or less. The change in energy gradient in the cleanout or junction shall not exceed 3 feet. In no case shall the energy gradient

exceed the elevation of 6 inches below the gutter grade on inlets, grate for grated inlets, or 6 inches below the bottom of the roof slab on cleanouts.

J. **Design Criteria Summary.**

1. **Minimum Class of Pipe.** All storm sewers within the County's right-of-way (right-of-way) are required to be RCP (minimum Class 3, Wall B). Other materials for storm pipe may be allowed, assuming a comparable service life can be achieved and the design criteria presented in this section are met. Pipe must maintain its original manufactured dimensions after installation.
2. **Changes in Conduit Size.** Where the conduit size increases, the inside top slopes of the conduits shall be continuous in elevation. Change in conduit sizes shall be accomplished in a reinforced concrete manhole or cleanout structure only.
3. **Consistent with Plans.** All pipes in the storm sewer system shall have size and slope indicated in the profiles on the plans.
4. **Stationing.** Storm sewer stationing shall run upgrade from the lower end of the drain. When a storm sewer runs longitudinally in a roadway, the stationing may be the roadway stationing.
5. **Minimum and Maximum Cover.** Minimum and maximum cover for storm pipes shall be determined based on loading, type and class of pipe, manufacturer's recommendations, and soil bedding conditions. Should a design warrant a cover depth of greater than 15 feet, an extended service life shall be accommodated (see Section 3.3.1 B2).
6. **Alignment Priority.** Drainage alignment priority shall be given to the larger of any two connecting storm drain systems. Pipes larger than 36 inches shall not run into and out of storm drain inlets in lieu of manholes without a specially designed inlet structure.
7. **Changes in Flow from Supercritical to Subcritical.** Hydraulic calculations shall be provided when the flow changes from supercritical to subcritical flow.
8. **Maximum Velocity.** The maximum storm sewer velocity shall be 18 fps.
9. **No Diversions of Drainage.** Diversion of drainage to other than an approved storm system is not permitted.
10. **Concrete Cutoff Walls and Anchoring.** Reinforced cast-in-place concrete cutoff walls shall be installed at intervals of no greater than 30 feet (horizontally) for all pipes placed in slopes where there is the possibility of erosion of the pipe trench on the slope. In addition, anchoring shall be installed at intervals of no greater than 30 feet for all culvert pipe placed on or within slopes 3:1 or steeper.
11. **Special Bedding Requirements.** When other pipe materials are proposed, the bedding of the pipe will be performed in a manner that is consistent with the material manufacturer's recommendations to achieve the required service life and meet the design criteria presented within these Standards.

K. **Storm Sewer Easements.**

1. **Minimum Widths.** Table 3-3 is a general guide for establishing minimum easement widths, although special conditions, such as deep locations, may require additional widths. The minimum easement width should be as shown in the table or twice the pipe depth plus the pipe diameter (rounded to the nearest 5 feet), whichever is larger. In general, storm sewer pipes should be centered in the easement.

Table 3-3. Easement Width Minimums

Pipe Diameter or Equivalent (inches)	Minimum Width (feet)
18—35	15
36—60	15
Over 61	30

2. **Location.** Storm sewers and easements are to be placed on one side of the lot ownership lines in a new development and in existing developments where conditions will permit.
3. **Joint Easements Permitted and Separations.** In general, storm sewer easements are to be established exclusively for drainage facilities. Joint use easements will be permitted, such as sewer, water, non-motorized public access, where necessary. Each underground line shall be separated by a minimum of 10 feet horizontally.
4. **Access to Storm Sewer.** Physical access shall be provided to all storm sewer easements. Should special access to storm sewer easements be required because of grade differential, a minimum access easement of 15 feet shall be established. A 15-foot wide access road shall be provided within the access easement. The access road shall have a maximum grade of 15 percent. Maintenance vehicle access is required every 1,500 feet or more often if site conditions demand. Joint use for non-motorized public use access may be permitted.
5. **Surface Use.** In areas to be improved over a storm sewer easement, only at-grade parking lots or fences may be constructed. Permanent structures are not permitted over or within storm sewer easements.

3.3.2. Culverts

- A. **Selection of Culvert.** The selection of a culvert for installation shall be based on information outlined in the DCM1. The required pipe strength shall be determined from the actual depth of cover, true load, and proposed field conditions. See also Section 2.6.9.G for restrictions on the number of culverts.
- B. **Service Life.** The minimum design service life for all culverts shall follow the design service life for storm sewer systems outlined in Section 3.3.1B.
- C. **Minimum Pipe Size.** The minimum allowable culvert size shall follow the minimum size criteria for storm sewer systems in Section 3.3.1C. The minimum culvert size shall have a cross-sectional area equivalent to an 18-inch circular pipe.
- D. **Minimum Gradient.** In designing culverts, both the minimum and maximum velocities must be considered. A flow velocity greater than approximately 3 fps during the initial storm is required to ensure that self-cleaning conditions exist. A velocity less than approximately 7 to 12 fps (subcritical flow regime) minimizes possible culvert damage due to scouring and downstream channel erosion.
- E. **Culvert Entrances.**
 1. **Entrances.** Entrances shall be rounded, beveled or expanded, whichever is appropriate, to increase the capacity of the culvert, whether the outlet is free or submerged and whether the slope is above or below critical.
 2. **Flared End Sections Required.** Flared end sections are required for outlets and inlets of culverts that do not have headwalls (except for private driveway culverts).
 3. **Inlet Aprons.** Inlet aprons shall be used as transitions between the culvert and an improved approach channel, and may be used between the culvert and a natural approach channel. These shall be designed to prevent grade cutting of natural channels and to provide for a more efficient entrance condition.

-
- F. **Outlet Dissipater.** A suitable energy dissipater shall be installed to reduce discharge velocities to non-erodible levels at each culvert outlet.
- G. **Slope Drains.**
1. **Defined.** A slope drain is a culvert placed on a grade of 5:1 (20%) or greater that does not fall within a road right-of-way. Slope drains may be permanent installations or temporary drains for a future extension of a permanent installation, above or below ground.
 2. **Concealed.** Any slope drain that would be conspicuous or placed in landscaped areas shall be concealed.
 3. **Concrete Encasement.** For installations on steep slopes or difficult topography, 6-inch concrete shall completely encase the pipe.
 4. **Watertight Joints.** All slope drains shall have positive watertight joint connections in conformance with manufacturer's recommendations.
- H. **Debris and Silt Control Facilities.**
1. **Flows Transporting Debris.** When determined or observed by the ECM Administrator that flows are likely to carry floating debris, sediment or other abrasive materials in sufficient size to block or obstruct the conduit, a trash fence, rack or deflector is required. Vehicular access shall be provided to accommodate maintenance activities. These facilities shall be constructed upstream of the inlet so they will not obstruct the entrance.
 2. **Flows Transporting Silt.** Where temporary drainage flows will be transporting silt, a temporary desilting basin shall be required to prevent silting of the culvert.
- I. **Design Criteria Summary.**
1. **Minimum Class of Pipe.** All culverts within the County's right-of-way are required to be RCP (minimum Class 3). Other materials for storm pipe may be allowed, assuming a comparable service life can be achieved and the design criteria presented in this section are met. Pipe must maintain its manufactured dimensions after installation.
 2. **Consistent with Plans.** Culverts in the storm drain system shall have classification indicated in the profiles on the plans.
 3. **Stationing.** Culvert stationing shall run upgrade from the lower end of the drain. When a culvert runs longitudinally in a roadway, the stationing may be the roadway stationing.
 4. **Discharge Areas.** Culvert outfalls shall extend to the nearest well-defined natural drainage channel that can adequately convey the discharge. Downstream conditions shall be investigated to verify the appropriateness of the point of discharge. This may require off-site storm drains or channel stabilization measures.
 5. **Abrasive Load.** When the culvert is expected to carry a large amount of abrasive material, such as rocks and boulders, a special design to protect the full length of invert area (the lower 90°) and walls within curves to the spring line is required.
 6. **Superelevation Sections.** Drainage must be picked up prior to reversing superelevation sections to prevent cross flows from one side of the roadway to the other side or median.
 7. **Minimum and Maximum Cover.** Minimum and maximum cover for culverts shall be determined based on loading, type and class of pipe, manufacturer's recommendation, and soil bedding conditions. Should a design warrant a cover depth of greater than 15 feet, an extended service life shall be accommodated (see Section 3.3.1.B.2).

-
8. **Changes in Flow from Supercritical to Subcritical.** Hydraulic calculations shall be provided when the flow changes from supercritical to subcritical.
 9. **Special Bedding Requirements.** When other culvert materials are proposed, the bedding of the culvert will be performed in a manner that is consistent with the material manufacturer's recommendations to achieve the required service life and meet the design criteria presented within these Standards.

3.3.3. Open Channels

- A. **Design Options.** Due to the complexities of open channels, there are a wide range of design options available. Therefore, this section only covers those issues that are particularly useful in the design of a channel and have the greatest effect on the performance and costs. The exact method of analysis and design shall be clearly documented.
- B. **Conformance with Standards.** All open channels shall conform to these Standards and the DCM1 and 2.
- C. **Channel Types.**
 1. **Soft-Lined Channels.** Soft-lined channels may be used where the following conditions exist:
 - A fully improved channel section is determined to be economically unfeasible.
 - Adequate bank protection, where necessary, is to be installed for alignment control and for safeguarding adjacent property.
 - Channel work will not significantly alter the watercourse or cause detrimental effects on adjacent property.
 - Planted wetlands are not allowed within the lowest portion of a newly constructed channel.
 - The channel conforms to the permissible velocities contained in the DCM1 and 2.
 - A low-flow channel is required because the main channel grade has been determined to result in ponding during low flows.
 - Drop structures will be used to accommodate changes in channel grades.
 2. **Hard-Lined Channels.** Hard-lined channels shall be used where the conditions required for soft-lined channels do not exist. Concrete or other lining materials used in hard-lined channels shall be designed to withstand all loads including hydrostatic uplift, lateral earth pressures, velocities and debris loads, truck subcharge, and possible wheel loads.
- D. **Minimum Channel Gradient.** The minimum gradient shall be dictated by the calculated hydraulics for the estimated channel low flows (2 to 5 year storm events). In addition, soft-lined channels will be designed to accommodate low flow events by armoring the lowest portion of the channel. This armoring will allow these low flow events to be accommodated within the channel without causing excessive erosion or sediment transport.
- E. **Channel Alignment.**
 1. **Bends.** A bend in channel alignment should be located where the velocity is lowest. The degree of bend shall be as minimal as practicable.
 2. **Radius of Curvature.** The minimum radius of curvature of the centerline of a channel shall be at least 3 times the width of a rectangular channel or 2 times the top width of a trapezoidal channel to minimize development of spiral flow.
- F. **Channel Transitions.**

-
1. **Change in Channel Shape.** Transitions between two different shaped channels shall be designed to produce a smooth, low-head-loss transfer of flow. The water surface level of the downstream channel must be set below the water surface level of the upstream channel by at least the sum of the increase in velocity head, plus transition and friction losses.
 2. **Downstream of a Conduit.** The channel downstream of a conduit shall have a water surface far enough below the conduit to prevent a submerged outlet for a design storm.
 3. **Maximum Angle of Deviation.** The maximum angle of deviation in any transition shall be 12.5°.
- G. **Angle of Confluence.**
1. **Determined by Downstream Flow.** The angle of confluence shall be determined by the downstream flow characteristics. The angle shall be designed to produce a smooth, low-head-loss transfer of flow and shall consider flow-rate changes, roughness, shape, and slope.
 2. **Lateral and Main Velocity.** In no case shall a component of lateral velocity oppose the mainline velocity by an angle of confluence.
 3. **Conduit Connection to Channel.** A conduit connection to a channel shall be made at an elevation at the top of the channel water surface and the angle of confluence shall produce a smooth low-head-loss transfer of flow.
- H. **Cutoff Walls.**
1. **Lined Channels.** Lined channels shall have a cutoff wall constructed at each end of the lining along the full width of section. Intermediate cutoff walls shall be provided at 250-foot intervals.
 2. **Unlined Channels.** Graded, unlined channels, or channels with rock slope protection, shall have a rock or other type of suitable cutoff wall at each end along the full width or section.
- I. **Debris and Silt Control Facilities.**
1. **Flows Transporting Debris.** When determined or observed by the ECM Administrator that flows into a channel are likely to carry floating debris or rocks in any quantity, a trash fence, rack or deflector is required upstream of the channel. This facility shall be designed and located to prevent an obstruction or blockage of the channel entrance. Maintenance access to debris/rock racks is required. The channel entrance and upstream area shall be designed to provide for overtopping of the rack without overtopping the channel or damaging adjacent property.
 2. **Flows Transporting Silt.** Where flows will be transporting significant quantities of silt, a temporary or permanent desilting basin shall be required to prevent silting in the channel or downstream from the channel.
- J. **Outlet Dissipater.** A suitable energy dissipater for all open channel flow shall be installed to reduce velocities to pre-improved conditions where:
- Channels discharge into an unimproved or natural channel and the velocities exceed those permissible for the material involved; and
 - Roadway gutters discharge onto natural ground with velocities exceeding those permissible for the material involved.
- K. **Open Channel Easements and Access.**
1. **Minimum Width and Access Road.** All easements shall be wide enough to provide for the channel structure and adequate maintenance access.
 - For channels 30 feet or more in top width, a minimum access road width of 15 feet shall be provided on each side of the channel.

-
- For channels with a top width of less than 30 feet, a minimum access road width of 15 feet shall be provided on one side of the channel and 4 feet on the opposite side.
 - The minimum width of any channel easement shall be the top width of channel plus 4 feet on each side of the channel.
 - For channels with a depth greater than 10 feet and a length longer than 1,000 feet, access to the bottom of the channel in the form of a vehicular ramp shall be provided at an interval of 500 feet.
 - Easement and maintenance access provisions shall be made for public road discharge (i.e., ditch outs) and for cross-lot drainage in subdivisions.
2. **Exclusion of Access Road.** When the lack of an access road is not considered detrimental to the maintenance and integrity of the channel, the access road can be omitted under the following conditions:
- Where suitable exit-entry ramps are provided to intermediate channels with a minimum bottom width of 8 feet at roadway crossings and at other approved, needed locations to facilitate travel or maintenance of emergency vehicles in the channel bottom. At a minimum, one access ramp must be provided at each end of a channel.
 - Where vehicular access to the channel on a maximum spacing of 1,000 feet and at other approved, needed locations is provided to small channels with a bottom width of less than 8 feet.
3. **Easement Location.**
- Easements shall be placed on one side of a lot or parcel lines in new developments and where conditions permit in existing developments.
 - Easements for public road discharge and capture of created sediment shall be located where appropriate based on topography and available property.
4. **Fencing.** Fencing is required for all channels abutting residential developments, schools, parks, and pedestrian walkways based on the following criteria:
- All concrete-lined or rip-rapped channels where the design frequency storm provides a velocity that exceeds 5 feet per second and 2 feet in depth, or a combination thereof, for a factor of ten. Fencing is not required for right-of-way ditches.
 - All constructed channels steeper than 4:1 where the design frequency storm provides a velocity that exceeds 5 feet per second and 2 feet in depth, or a combination thereof.
 - Fencing shall be installed on both sides of the channel easement, with gate openings at all access points.
 - Fencing shall be located at a minimum of 6 inches inside the easement boundary lines.
 - All new fences shall be chain link, a minimum of 6 feet in height with a top rail and vinyl-coated for natural color compatibility (green or brown).

3.3.4. Drainage Ditches

- A. **Application of Standards.** A ditch located within a development, not including roadside ditches, that conveys less than 15 cubic feet per second of public drainage is considered a drainage ditch. The requirements for open channels shall apply to drainage ditches.

In rural subdivisions where no overlot site grading will be performed, and "natural" drainageways will be conveying developed runoff, the easement width for increased capacity of these drainage channels will be determined by the engineer. Typical lot line easements designated as drainage and utility easements are generally not adequate for the purpose of runoff control. The size of the drainage channel easement shall be large enough to accommodate the developed design runoff without impact to adjacent lots or public improvements. The engineer must determine the easement width for these drainage channels early in the subdivision planning and design process. The easement size must also meet the requirements in the Land Development Code.

- B. **Right-of-way and Terrace Ditches.** A right-of-way or terrace ditch is one that is located along the top of a slope and is designed to convey surface water towards designated down drain locations. The following standards shall apply to right-of-way and terrace ditches.
1. **Minimum Grade.** Minimum grade shall be 2 percent or a grade that will produce a minimum velocity of 6 fps when flowing full and 4 fps when a quarter full.
 2. **Minimum Freeboard.** Minimum freeboard shall be 0.5 foot. Where energy gradients necessitate, more freeboard is required.
 3. **Angle of Confluence.** The maximum angle of confluence on any ditch connection shall be 60°. Connections at any angle of confluence may require some means to contain the drainage flow within the ditches (splash aprons, splash walls, etc.).
 4. **Downdrains.** Downdrains may be either ditch or pipe. All drainage flow in an open ditch down drain shall be totally contained within the ditch.
 5. **Outfall.** Right-of-way ditch drainage must outfall either into a constructed channel within the development or a well-defined natural channel. An energy dissipater will be required upstream of the outfall in a natural channel.
 6. **Single Lot Right-of-way Ditches.** Single lot right-of-way ditches may terminate at the toe of the slope within the lot, with an adequate energy dissipater.
- C. **Toe Ditches.** Toe ditches shall be required at the toe of fill slopes where any drainage is directed toward or along the slope. Right-of-way or terrace ditch sections may be used as toe ditches if they have adequate capacity for the drainage flow.

3.3.5. Roadways

When the drainage in the roadway exceeds allowable limits, a storm sewer or an open channel system is required to convey the excess flows. The primary function of roadways is for traffic movement. Therefore, the drainage function is subservient to the traffic objective. Design criteria for the collection, conveyance, and protection of surface water runoff on public roadways shall meet the requirements of these Standards and the DCM1 and 2 CDOT M&S Standards.

3.3.6. Subsurface Drainage

When localized groundwater impacts the design of public improvements, a subsurface drainage system may be constructed, provided an acceptable subsurface drain system from the drainage system to the point of connection within the County's right-of-way is provided.

- A. **Subsurface Drainage Required.** Subsurface drainage systems shall be provided in the following situations:
- Where necessary for stability and protection of adjacent properties from the influence of groundwater on cut and fill slopes.

-
- Where natural or artificially introduced groundwater (i.e., derived from meteoric or landscape irrigation and similar sources, respectively) affects or is likely to affect the project in a potentially unstable, hazardous or otherwise deleterious manner.

B. Design Requirements.

1. **Minimum Pipe Size.** The minimum size of a collector line within the County's right-of-way shall be 6 inches.
2. **Materials.** Polyvinyl chloride (PVC) pipe shall be allowable conduit for seepage collector lines within the County's right-of-way.
3. **Cleanout.** A suitable cleanout or manhole shall be located in the seepage collector line on 350-foot spacing for straight runs of pipe, and at each break in alignment or grade.
4. **Outlets.** All discharge outlets for new construction on existing lots or newly developed lots shall be taken to the nearest existing underground public storm drain system. Discharge from a sump pump shall not be directly onto a County road. Prior to connecting to the County's system, an approved Encroachment Permit must be obtained from the ECM Administrator.
5. **Minimum Grade.** The minimum allowable grade of seepage collector pipes shall be 0.5%.
6. **Depth and Spacing.** Depth and spacing of the collection system will depend upon the permeability of the soil, the elevation of the water table, and the quantity of water encountered.

C. Permitting Requirement.

1. **Construction Dewatering Permit.** Dewatering associated with construction activity is allowed when performed consistent with the Colorado Department of Public Health and Environment Low Risk Discharge Policy for Discharges of Uncontaminated Groundwater to Land. The discharge of groundwater that will leave the permitted site in the form of surface runoff requires additional permit coverage by an appropriate CDPS Construction Dewatering Permit. The discharge of construction dewatering into the MS4 shall not occur without prior notification to and approval from El Paso County Department of Public Works and shall only be approved when done consistent with the Low Risk Discharge Policy or approved CDPS Construction Dewatering Permit.
2. **NPDES Permit.** In the event no other option exists but to "day light" a subsurface discharge, thereby transforming ground water flow into surface water flow, an NPDES permit may be required by the Colorado Department of Public Health and Environment. It shall be the responsibility of the applicant and/or owner to apply for and maintain any required NPDES permit.
3. **Well Permit.** The Colorado Division of Water Resources may require a Well Permit for any subsurface discharge that meets the definition of "well," found in CRS § 37-91-102(4.5).

(Res. No. 19-245 , 7-2-19)

3.3.7. Permanent Stormwater Management Facilities

Post construction stormwater management often relies on facilities designed for detention or infiltration of stormwater from developed areas with a goal to release accumulated runoff at levels that mimic historic levels. There are specific notification requirements that apply to all new stormwater detention and infiltration facilities, including individual site facilities built by private parties as a development requirement. For any stormwater detention and infiltration facility constructed after August 5, 2015 and seeking protection under the new statute, the "entity that owns, operates, or has oversight for" shall, prior to operation of the facility, provide notice to all parties on the substitute water supply plan notification email list maintained by the State Engineer.

Created: 2021-06-08 11:35:50 [EST]

(Supp. No. 2)

El Paso County developed a Post Construction Stormwater Detention Facility Documentation Form and procedure to assist applicants in the process of registering stormwater detention and infiltration facilities pursuant to the provisions of CRS § 37-92-602(8). This documentation form can be found in Appendix E, Checklists and Permits.

With submission of a Final Drainage Report for a project, the design engineer must include for each detention and infiltration facility proposed for the project:

1. A completed Post Construction Stormwater Detention Facility Documentation Form.
2. A completed Stormwater Detention and Infiltration Facility Design Data Sheet for each facility included in the project.
3. An Operations and Maintenance Manual.
4. A Private Detention Basin/Stormwater Quality Best Management Practice Maintenance Agreement and Easement.

The Stormwater Detention and Infiltration Facility Design Data Sheet can be downloaded from the statewide notification and compliance portal at: <https://maperture.digitaldataservices.com/gvh/?viewer=cswdif>, or by contacting the El Paso County Project Engineer assigned to the project.

El Paso County Planning and Community Development Project Engineers will review the submitted documentation forms for completeness and accuracy. Upon verification of completed and accurate documentation and data sheets, El Paso County staff will upload each facility into the statewide reporting portal once the facility become operational.

(Res. No. 19-245 , 7-2-19)

3.4. GRADING AND EROSION CONTROL PLANS

The intent of the Grading and Erosion Control (GEC) Plan is to provide for overall subdivision or development grading design as part of the engineering required for review and approval by the County. This plan is done at the time subdivision or development construction drawings are prepared by the Professional Engineer working for the developer. This is complex work whereby cuts and fills are analyzed for balance and slopes and contours are proposed as an integral part of the engineering design. A second important purpose of the GEC Plan is to estimate the cost of the overall grading and erosion control measures known as Best Management Practices (BMPs) or control measures, and of ultimate site stabilization. The County subdivision regulations require that collateral for these activities be posted prior to any land disturbing activity. It is therefore important that the GEC Plan be completed and approved at the time of subdivision construction drawing approval so that these costs can be accurately estimated and included with the required subdivision collateral.

The Board of Commissioners of El Paso County passed Resolution No. 07-279 on June 28, 2007 "Authorizing a Joint Policy Statement on Clarifications to Previously Approved Regulations Concerning Grading, Erosion Control, and Dust." The clarifications include definitions and checklists of required components of GEC Plans and Stormwater Management Plans (SWMP) and Standard Notes for the GEC Plans, SWMP and construction plans. The checklists and standard notes can be found in Appendix E of this manual. These checklists and standard notes replace the requirements in City of Colorado Springs/El Paso County Drainage Criteria Manual for GEC Plans and the City of Colorado Springs Drainage Criteria Manual, Volume 2: Stormwater Quality Policies, Procedures, and Best Management Practices (BMPs) (DCM2) for SWMP.

A checklist was developed to assist in the development and review of GEC Plans submitted for review and approval. The checklist shall be used by applicants (i.e. Engineer of Record) to ensure the submitted GEC Plan contains all the required elements. The same checklist is used by El Paso County Project Engineers to guide the review of submitted plans. A copy of a completed review checklist is signed and dated by the Project Engineer

Created: 2021-06-08 11:35:50 [EST]

(Supp. No. 2)

upon completion of a submittal review. The signed and dated checklist is kept with all other project documents in an electronic database.

At the time of GEC Plan approval, the exact timing and phasing of the work is not always known because the start date may be delayed or the earthwork contractor, who has expertise in planning and phasing the land disturbing activity, may not yet be under contract. Detailed phasing of the work and the proposed construction schedule shall be deferred to the required SWMP.

El Paso County also developed a checklist to guide the development and review of the SWMP to ensure all the required elements are. Given that SWMPs are intended to be dynamic documents to reflect onsite conditions at all times, El Paso County does not approve the submitted SWMP. Rather it performs a completeness review to ensure the applicant has at the time of project commencement a SWMP on site that addresses all the required elements of Part I.E.3.a.iv.B of the MS4 permit. The SWMP Checklist is used by El Paso County Project Engineers to perform the completeness review of a submitted SWMP. The completed SWMP Checklist is signed and dated by the Project Engineer and is included with other project records in an electronic database to document the review process.

Per Section 1.12 of this ECM, GEC Plans shall expire if site construction or land disturbance has not commenced within 24 months of plan approval, and the plans must be resubmitted for re-approval. Previously approved plans shall also be resubmitted for re-approval when any of the following occur:

- Change in ownership of the property to be disturbed;
- Development design changes that alter hydrology or hydraulics of permanent drainage systems; or
- Grading design changes that affect 1 or more acres of land.

(Res. No. 19-245 , 7-2-19)

Chapter 4 UTILITIES AND OTHER RIGHT-OF-WAY USES

4.1. OVERVIEW

All activities using the County's rights-of-way for other than transportation are subject to the Standards in this chapter, which regulates these activities through the Work in the Right-of-Way Permit processes. Detailed permit requirements are contained in Chapter 5 Permits and Inspections.

4.1.1. Purpose

The purpose of this chapter is to provide guidelines for those proposing to perform work or place a privately owned structure within the County's right-of-way. The main focus of the criteria within this chapter is on utilities, however, it also discusses the importance of coordination and the expectation of those performing any and all work within the County's right-of-way.

4.1.2. Chapter Content and References

Table 4-1 outlines the chapter content and references used as a basis for the standards established in Chapter 4.

Table 4-1. Contents and Basis of Utility and Other Right-of-Way Uses

Intent Use	ECM Content	ECM Section(s)	Reference Document(s)
Planning			
	Rights	4.2.1	1
	Uses	4.2.2	1

Created: 2021-06-08 11:35:50 [EST]

(Supp. No. 2)

Design			
	Requirements and Standards	4.3.1 - 4.3.4	1
	Utility Locations	4.3.5	2
	Installation Standards	4.3.6 - 4.3.8	2, 3
	Mailboxes	4.4	1
Construction			
	Permitting	5.3, 5.5 and 5.7	1
	Inspections	5.11 and Appendix K	1
	Acceptance	5.3 and 5.5	1

References

1. El Paso County Land Development Code
2. Utility District (location dependent) Installation Standards/Specifications
3. US Department of Transportation, Manual on Uniform Traffic Control Devices

4.1.3. Standard Drawings

Table 4-2 identifies the standard drawings that are included in Appendix F as an enforceable part of these Standards. The Standard Drawing shall be used in all applications for which a public improvement is to be designed. Any deviations from a Standard Drawing shall be approved by the ECM Administrator and noted in the construction plans.

Table 4-2. Standard Drawings

Figure Name	Detail/Description	Approval Date
SD_4-1	Urban Local Roadway - Utility Placement	08/11/2011
SD_4-2	Urban Residential Minor Collector Roadway - Utility Placement	08/11/2011
SD_4-3	Urban NonResidential Collector Roadway - Utility Placement	08/11/2011
SD_4-4	Urban Residential Major Collector Roadway - Utility Placement	08/11/2011
SD_4-5 & 4-5A	Urban Minor Arterial Roadway - Utility Placement	08/11/2011
SD_4-6 & 4-6A	Urban Principal 4-Lane Arterial Roadway - Utility Placement	08/11/2011
SD_4-7 & 4-7A	Urban Principal 6-Lane Arterial Roadway - Utility Placement	08/11/2011
SD_4-8 & 4-8A	Urban Expressway 4-Lane Roadway - Utility Placement	08/11/2011
SD_4-9 & 4-9A	Urban Expressway 6-Lane Roadway - Utility Placement	08/11/2011
SD-4-10	Rural Gravel Local Roadway- Utility Placement	08/11/2011
SD_4-11	Rural Local Roadway - Utility Placement	08/11/2011
SD-4-12	Rural Minor Collector Roadway - Utility Placement	08/11/2011
SD_4-13	Rural Major Collector Roadway - Utility Placement	08/11/2011
SD_4-14 & 4-14A	Rural Minor Arterial Roadway - Utility Placement	08/11/2011
SD_4-15 & 4-15A	Rural Principal 4-Lane Arterial Roadway - Utility Placement	08/11/2011
SD_4-16 & 4-16A	Rural Principal 6-Lane Arterial Roadway - Utility Placement	08/11/2011
SD_4-17 & 4-17A	Rural Expressway 4-Lane Roadway - Utility Placement	08/11/2011
SD_4-18 & 4-18A	Rural Expressway 6-Lane Roadway - Utility Placement	08/11/2011
SD_4-20	Utility Trench Repair Detail (asphalt pavement)	08/11/2011
SD_4-21	Utility Trench Repair Detail (newly overlaid pavement)	08/11/2011
SD_4-22	Utility Trench Repair Detail (concrete pavement)	08/11/2011

Created: 2021-06-08 11:35:50 [EST]

(Supp. No. 2)

SD_4-23	Utility Trench Repair Detail (flowable fill)	08/11/2011
---------	--	------------

4.2. PLANNING

4.2.1. Rights of Utilities

Section 38-5-101, Colorado Revised Statutes, authorizes the placement of utilities within the County's right-of-way. While the County is obligated to allow the public right-of-way to be used to provide development with sanitary and storm sewers, water mains and service lines, gas mains and service lines, electrical main lines and service lines, telephone cable lines and service lines, etc., the County must establish and enforce these Standards for design, installation, and maintenance of utilities and other facilities within the right-of-way. The County must enforce these Standards to protect the value and use of the right-of-way and roadways for transportation.

4.2.2. Use of Right-of-Way Policy

- A. **Coordination with Roadway Improvements.** Every attempt shall be made to coordinate proposed utility and facility installations with existing conditions and other proposed construction activities, such as utility main lines and service lines to all lots, tracts or parcels of land shall be placed prior to completion of roadways.
- B. **No Disturbance of Roadway Surface.** When roadway construction is completed, utility and facility placement shall not disturb the roadway surfaces, except for an emergency repair. Jacking or boring under the surface will be required for new utility placement in hard surfaced roadways. The size of disturbed area necessary to install a utility or facility shall be kept to a minimum.
- C. **Coordination with Other Utilities.** Each utility company or district must coordinate with the other utility companies in the location of its utility; that is, the companies shall mutually ascertain the most satisfactory location of their utility.
- D. **Impact Traffic Operations and Safety.** Accommodation of utilities and other facilities within the County's right-of-way shall not materially degrade or adversely affect traffic operations, safety, maintenance or the structural integrity of the roadway.
- E. **Impact on Accessibility.** Accommodation of utilities and other facilities within the County's right-of-way shall not materially degrade or affect accessibility of pedestrian facilities. See Chapter 6.

(Res. No. 20-222 , 6-23-20)

4.3. UTILITY DESIGN

4.3.1. Permit Required

A Work in the Right-of-Way Permit shall be obtained from the ECM Administrator for the placement of utilities within the County's right-of-way. The installation of utilities in dedicated right-of-way in new subdivisions will be exempt from requiring a Work in the Right-of-Way Permit, but such installations shall obtain approval of a layout plan showing proposed utility locations prior to beginning construction. The approved layout plan(s) shall be submitted as part of the Construction Permit.

A Work in the Right-of-Way Permit shall be obtained from the ECM Administrator for the maintenance of utilities within the County's right-of-way.

Created: 2021-06-08 11:35:50 [EST]

(Supp. No. 2)

4.3.2. Damages Caused by Utility Installations

Any damage to existing installations caused by the installation of utilities shall be repaired or replaced at the expense of the permit holder, contractor or utility company making the installation. Examples of existing installations include culverts damaged or cut, sidewalks cut or undermined, curbs or gutters cut or undermined, fencing cut or damaged, vegetation destroyed, hard surface cut or undermined.

4.3.3. Adjustment or Relocation Cost Obligations

Utilities are deemed acceptable to the ECM Administrator if they are installed per plans showing horizontal and elevation control, within the County's right-of-way, and approved by the ECM Administrator. In the case where utilities are installed prior to or without plan approval, the utility company will cover expenses for relocation and adjustments due to road improvements or reconstruction.

4.3.4. General Standards

- A. **Existing Utility Districts.** Where a utility district exists and has adopted installation standards, the utility district's requirements shall be followed and used in preparing the utility design.
- B. **Area Not Currently in a Utility District.** In areas not covered by a utility district, the standards contained in this section shall be used in preparing the utility design. These standards generally follow industry codes that are used by the utility companies for design and installation of their facilities.

4.3.5. Utility Location

- A. **Minimize Relocation and Disruption of Traffic.** Utility facilities shall be located to minimize the need for future relocation, to accommodate roadway improvements, and to provide service access to such facilities with minimum disruption to roadway traffic.
- B. **Minimize Disruption of Other Utilities.** Utility equipment or facilities to be installed in the County's right-of-way shall not disrupt the operation of existing utilities. Other utilities, including but not limited to electrical, telephone, cable TV, and fiber optic lines, are preferred for underground installation at locations compatible with other utilities, storm drains, and future roadway construction.
- C. **Precedence of Gravity Systems.** Gravity systems, whether sanitary sewer or storm drainage, shall have precedence over other systems in design and construction.
- D. **Aboveground Utilities.**
 - 1. **Compatibility.** The location of poles, vaults, boxes or other aboveground utility objects shall be compatible with driveways, intersections, and other roadway features. They shall not interfere with sight distance, signage, traffic signals, drainage facilities, etc. Where possible, utilities shall share facilities to minimize the number of obstructions in the County's right-of-way.
 - 2. **Clear Zone.** The placement of aboveground utility facilities or equipment within the County's right-of-way shall conform to the "clear zone" guidelines in Chapter 2. Utility poles and other aboveground utility equipment shall be placed outside of clear zone areas unless a deviation is approved by the ECM Administrator and provisions for vehicular safety are installed.
 - 3. **Roadway Vertical Clearances.** A 19-foot minimum vertical clearance for overhead lines shall be maintained over all County roadways. The minimum vertical clearance for overhead power and communication lines above the roadway and the minimum lateral and vertical clearance from bridges shall comply with state and federal standards.
 - 4. **Pedestrian and Bike Path Clearances.** Utility poles and equipment shall not be placed in pedestrian or bicycle facilities, or protrude into the vertical space over sidewalks, walkways or

bikeways. As specified in Chapter 2, there shall be an unobstructed vertical clearance of at least 7 feet above the surface of any sidewalk and 10 feet above any bike path. A 2-foot horizontal clearance shall be maintained between the edge of any bike path and any vertical utility obstruction. See Chapter 6.

E. Underground Utilities.

1. **Scoping Meeting.** A Scoping Meeting is required with the ECM Administrator for all proposals to install underground utilities in the right-of-way of any arterial or expressway roadway or in more than 2,000 feet of right-of-way of non-arterial roadway. Final approval of all utility installations within the road right-of-way rests with the ECM Administrator even if the utility ownership falls within an existing utility district.
2. **Longitudinal Placement.** Longitudinal placement of underground utilities in the County's right-of-way shall comply with the typical utility locations shown in the utility Standard Drawing in Appendix F. When determining the planned longitudinal placements of utilities, the design engineer shall consider the roadway functional classification in the Major Transportation Corridors Plan to try to anticipate future roadway alterations and limit the need for relocation of utilities in the future.
3. **Lateral Placement.** Lateral placement of underground utilities across a County right-of-way shall be as near a right angle to the road centerline as practicable. Utility crossings should avoid deep cuts, bridge footings and retaining walls, or locations where roadway drainage would be affected. Utility crossings may be designated by the ECM Administrator.

4.3.6. Underground Utilities Standards

A. Cover and Separation. Cover over underground utilities and the separation between underground utilities shall conform to applicable federal and state regulations, these Standards, and the Standard Drawings in Appendix F.

1. Water Lines.

- **Water Mains:** At no time shall a water main be placed less than 5 feet in depth measured perpendicularly to the ground line at any point of the road cross section.
- **Water Service Lines:** At no time shall water service lines be placed less than 5 feet in depth measured perpendicularly to the ground line, at any point of the road cross section, to the right-of-way line.
- **Meter and Stop Boxes:** Meter and stop boxes shall be set at the inside edge of the right-of-way line, but not within curb ramps. Where a utility easement exists adjacent and parallel to the right-of-way, meter and stop boxes shall be placed in the utility easement.
- **Fire Hydrants:** Fire Districts must be contacted to determine location, spacing, and equipment standards.

2. Sanitary Sewer Lines.

- **Sewer Mains:** At no time shall a sewer main be placed less than 5 feet in depth measured perpendicularly to the ground line at any point of the road cross section.
- **Sanitary Sewer Service Lines:** At no time shall sewer service lines be placed at a depth of less than 5 feet measured perpendicularly to the ground line at any point of the road cross section, to the right-of-way line.

3. Storm Sewer Lines.

-
- Storm Sewer Lines: At no time shall storm sewer lines be placed less than 2 feet in depth measured perpendicularly to the finished road surface. When placed outside the road, at no time shall the storm sewer lines be placed less than 1 foot in depth from the ground surface.
 - Storm Sewer Lines: Include pipe culverts, box culverts, and manholes, excluding the risers.
4. **Gas.**
 - Gas Mains: At no time shall the depth of gas mains be less than 3 feet as measured perpendicularly to the ground line at any point of the road cross section.
 - Gas Service Lines: At no time shall the depth of gas service lines be less than 2.5 feet, as measured perpendicularly to the ground line at any point of the road cross section, to the right-of-way line.
 5. **Electrical Lines.**
 - Main Lines: At no time shall the depth of electrical main lines be less than 4 feet as measured perpendicularly to the ground line at any point of the road cross section.
 - Service Lines: At no time shall the depth of electrical service lines be less than 2.5 feet, as measured perpendicularly to the ground line at any point of the road cross section, to the right-of-way line.
 6. **Telephone and Cable TV.**
 - Telephone Cable TV Main Lines: At no time shall the depth of telephone main cables be less than 2.5 feet, as measured perpendicularly to the ground line at any point of the road cross section.
 - Telephone and Cable TV Service Lines: At no time shall the depth of telephone service lines be less than 2.5 feet, as measured perpendicularly to the ground line at any point of the road cross section, to the right-of-way line.

B. Casings.

1. **When Required.** Casings shall be installed for roadway crossings when required by appropriate industry codes or by the ECM Administrator. Casings may be required in the following situations:
 - To facilitate the insertion, removal, replacement or maintenance of a carrier line crossing or other circumstances where it is necessary to avoid open trench construction.
 - To protect carrier lines from external loads or shock during or after construction of a road.
 - To protect jacked or bored installation of coated carrier lines unless assurance is provided that no damage will result.
 2. **Type and Sizing.** The type of casing used shall meet industry and applicable state and federal standards and shall be designed to withstand road loading. The casing shall be sized to accommodate other compatible utilities and future needs.
 3. **Extension.** Within the County's right-of-way, casing pipes shall extend to the outside of curbs or ditches or beyond the toe of fill slopes.
 4. **Ends Sealed.** Casing pipes shall be sealed at both ends, except for necessary vents or drains.
- C. **Carrier Pipes.** Carrier pipes, i.e., pipes that directly enclose a transmitted fluid or gas, shall conform to the material and design requirements of the appropriate utility industry and state and federal codes and specifications.

Carrier pipes shall be designed to withstand road loading plus all loads imposed under all ranges of operating pressure from zero to maximum internal pressure.

- D. **Marking.** Location markers and emergency information shall be provided by the utility when required by applicable state and federal standards.
- E. **Appurtenances.** To avoid damage to appurtenances by snowplows and other maintenance activities, all appurtenances shall be installed below the roadway surface. Damage to appurtenances that occurs during maintenance activities will be the responsibility of the utility owner.

The depth of the appurtenance will depend on the surface type. Appurtenances installed within a paved roadway shall be installed a minimum of 1/8" below the pavement surface.

Appurtenances installed within a gravel roadway shall be installed a minimum of 8" below the gravel surface and shall be covered with gravel. A concrete collar shall be installed around the appurtenance for protection. A strip of tape shall be placed above the appurtenance to help identify the location of the appurtenance.

1. **Vents.** Vents may be required for casings, tunnels, and galleries enclosing carriers of fluids or gases in accordance with state and federal standards. Vent standpipes shall be located as close to the right-of-way line as possible to minimize interference with road operation and maintenance, and shall not be concealed by vegetation.
2. **Drains.** Drains may be required for casings, tunnels or galleries enclosing carriers of fluids or gases in accordance with state and federal standards. Drains for carriers of hazardous materials shall be directed to artificial holding areas to prevent possible surface or groundwater contamination. Drains for which only water or other non-hazardous liquids may discharge may be directed into roadway drainage systems at locations approved by the ECM Administrator. The drainage outfall shall not be used as a waste way for routine purging of the carrier pipe unless specifically authorized by the ECM Administrator.
3. **Manholes.** Manholes shall be designed and located in a manner that will cause the least interference to other utilities or future road expansion.

4.3.7. Underground Utility Installation Standards

- A. **General.** All utility installation, maintenance, and repair shall conform to these Standards and Appendices F and K.
- B. **Logistical Planning.** Logistical planning shall be coordinated with and approved by the ECM Administrator as part of an approved Work in the Right-of-Way Permit. Logistics plans shall include requirements for advance warning signs, directional signs, flagmen, lighting, and all such standard traffic control devices deemed necessary. Upon approval of the logistics and construction plans, implementation of logistics plans shall be complied with by the utility company performing the work to best guarantee the safety of the motorist, pedestrian, workers, and equipment.
- C. **Maintenance during Peak Traffic Periods.** Utility construction maintenance activities on heavily traveled roadways are prohibited during the peak traffic volume periods. The ECM Administrator shall establish appropriate work hours for all projects. The closing of any lane to traffic shall have written approval from the ECM Administrator.
- D. **Alternative Installation Methods.**
 1. **Plowing.** Plowing of communication and electrical lines on or adjacent to existing roads by means of a vibratory plow may be allowed by the ECM Administrator provided the structural integrity of

the roadway will not be impaired. Plowing may be no closer than 4 feet from the pavement. Use of a "static" type plow is not allowed.

2. **Boring.** Boring may be required for pipelines or conduits to cross roads, instead of trenching, as directed by the ECM Administrator. If sufficient right-of-way exists, the length of the bore shall extend a minimum of 4 feet from the edge of the pavement. Unused holes or abandoned casings shall be backfilled. Water boring under roadways shall not be permitted. Existing carriers and conduit installed under a roadway shall be physically located prior to boring.

4.3.8. Utility Installation on Roadway Structures

- A. **General.** Attachment of utility lines to a roadway structure, including bridges, may be allowed where such attachment conforms to sound engineering practice for preserving the roadway structure and ensuring its safe operation, maintenance, and appearance. Attachment of any utility to any bridge within the County's right-of-way requires the approval of the ECM Administrator.

Attachment of a utility shall not be considered unless the structure is designed to support the additional load and can accommodate the utility facility without limiting features such as ease of maintenance.
- B. **Placement of Utility Features.** Utility features, such as manholes or access panels, shall not be placed within the roadway portion of the structure.
- C. **Hazardous Substance.** A pipeline carrying a hazardous substance shall not be attached to a roadway structure unless specifically approved by the ECM Administrator.
- D. **Clearance Requirements.** The utility attachment shall not reduce any clearance requirement of the structure. Attachment to the outside of a structure shall be avoided unless there are no reasonable alternatives.
- E. **Vibration and Noise.** Utility mountings shall be of a type that does not create noise from vibration.
- F. **Sleeves Required.** Any hole created in a structure abutment shall be sleeved, be of a minimum size necessary to accommodate the utility line, and be sealed to prevent any leakage of water or backfill material.
- G. **Alignment.** A utility line behind an abutment shall curve or angle out to align outside the roadbed area in as short a distance as is operationally practicable.
- H. **Communication and Electric Lines.** Communication and electrical power line attachments shall be suitably insulated, grounded, and preferably carried in protective conduit or pipe from point of exit from the ground to re-entry. Carrier pipe and casing pipe shall be properly isolated from electric power line attachments.

(Res. No. 20-222 , 6-23-10)

4.4. MAILBOXES

4.4.1. United States Postal Service (USPS) Coordination

The applicant shall provide USPS approval of mailbox type and location prior to approval of the construction plans. ~~Mailbox type and location require approval of the USPS.~~ Discussions with the local postmaster early in the project design process are important to ensure proper coordination.

Created: 2021-06-08 11:35:50 [EST]

(Supp. No. 2)

4.4.2. Mail Box Types

To assist in clarifying the differences between the types of mailboxes typically installed within the County's right-of-ways, the following three descriptions were developed:

- Type 1 is a typical post mounted individual mail box
- Type 2 is an individual mail box that has been modified by the owner through the addition of a larger/permanent supportive structure
- Type 3 relates to cluster boxes (CBUs) or mailbox kiosks (multiple CBUs at one location).

These descriptions are only applicable to this section and were primarily developed to assist in determining the different levels of actions required for locating and installing these types of mailboxes within the County's right-of-way.

4.4.3. Work in the Right-of-Way Permit Required

A Work in the Right-of-Way Permit shall be obtained from the ECM Administrator to locate either Type 2 or 3 mailboxes within the County's right-of-way.

4.4.4. Mailbox Construction Plans

Construction plans shall clearly show the proposed location or relocation of either Type 2 or 3 mailboxes. The applicant shall provide a statement that the postmaster has approved the proposed mailbox type(s) and location(s). The statement shall be signed and dated by the local postmaster or authorized representative prior to obtaining approval of construction drawings or a Work in the Right-of-Way Permit. ~~Construction plans shall include a statement that the postmaster has approved the proposed mailbox type(s) and location(s). The statement shall be signed and dated by the local postmaster or authorized representative prior to obtaining approval of a Work in the Right-of-Way Permit.~~

The relocation of Type ~~1~~ mail boxes will be done so through direct coordination between the owner and local postal carrier.

4.4.5. Location and Installation

Pullouts for mail delivery vehicles shall be installed to serve cluster mailbox units located along arterial or collector roads, or any road with a posted speed of 35 MPH or above.

- Lower Functional Classification Roadway.** Where a choice of roadway locations exists, mailboxes shall be located on the lower functional classification roadway.
- Not Impede Access or Sight Distance.** Mailboxes shall be located so as not to impede access or sight distance visibility.
- Clear Zone Placement.** Type ~~1~~ ~~or 3~~ mailboxes located within a roadway clear zone shall have breakaway features. Type 2 and Type 3 mailboxes shall not be located in the clear zone.
- Temporary Relocation.** If it becomes necessary to remove or otherwise disturb existing mailboxes, the mailboxes shall be temporarily placed so their function will not be impaired. The boxes shall be reinstalled in accordance with the local postal carrier's requirements.
- Type 3 Mailbox Placement.** Type 3 mailboxes and the pullout for the mailbox shall be located within the public right-of-way or in a public improvement easement dedication but outside the roadway clear zone. If in an easement, the easement must allow for access by the United States Postal Service. A license agreement with provisions for the structure to remain within the right-of-way is required. The Type 3 mailbox and associated structures shall be maintained by a private entity in accordance with the

license agreement. Figures 4-1 and 4-2 show the required right-of-way and clear zone. The following conditions also apply:

- The Type 3 mailbox must be within the right-of-way so additional right-of-way dedication is required
- Provisions shall include the ability to park vehicles temporarily outside the clear zone and a minimum of thirty-six (36) feet shall be provided for parking queue.
- Pullout tapers shall be designed and constructed in accordance with Table 2-27.
- The pavement section of the pullout shall match the pavement section for the roadway and the pavement grade shall slope away from the centerline of the road.
- Signage (R7-6) shall be provided for the pullout area to limit extended parking in accordance with the MUTCD.
- Attached sidewalk is allowed in the pullout area to includes the pullout tapers.
- Discussions with Growth Management or the local Postmaster are required for mailbox location, concrete specifications, and mailbox type. ~~If contact with Growth Management or the local Postmaster is bypassed, you may be required to relocate the concrete pad at your own expense and mail delivery may be delayed.~~
- Mailboxes shall be located along accessible pedestrian route in compliance with the requirements of Chapter 6. See Section 6.3.10.

Figure 4-1. Mailbox Pad Pull-Off-out Area Detail, Urban Application

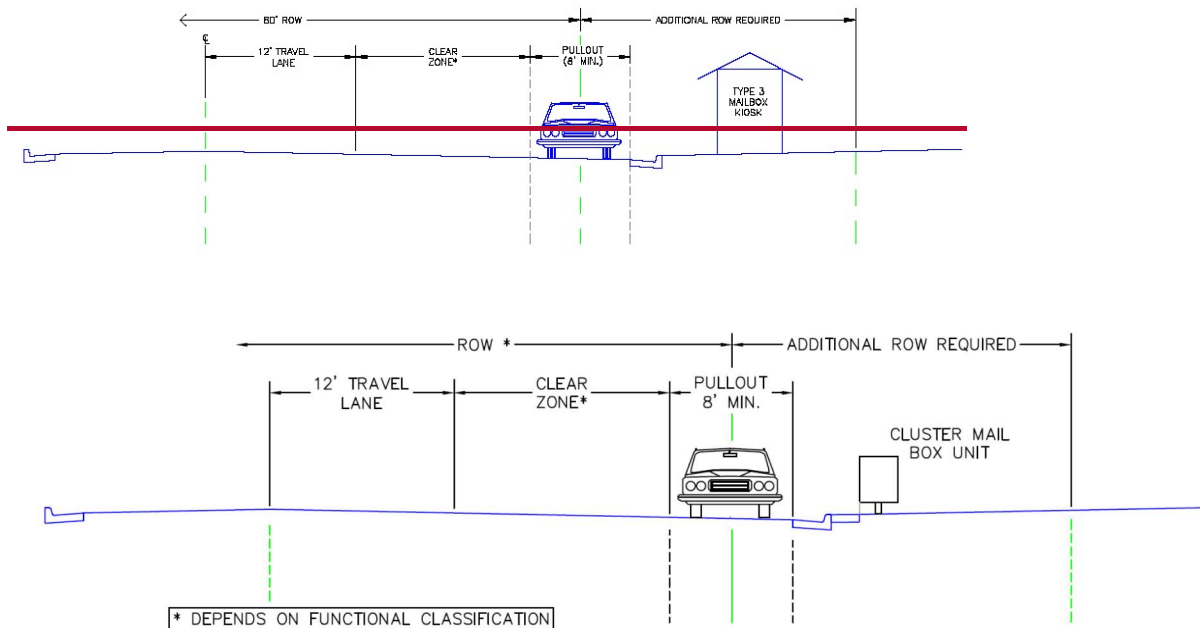
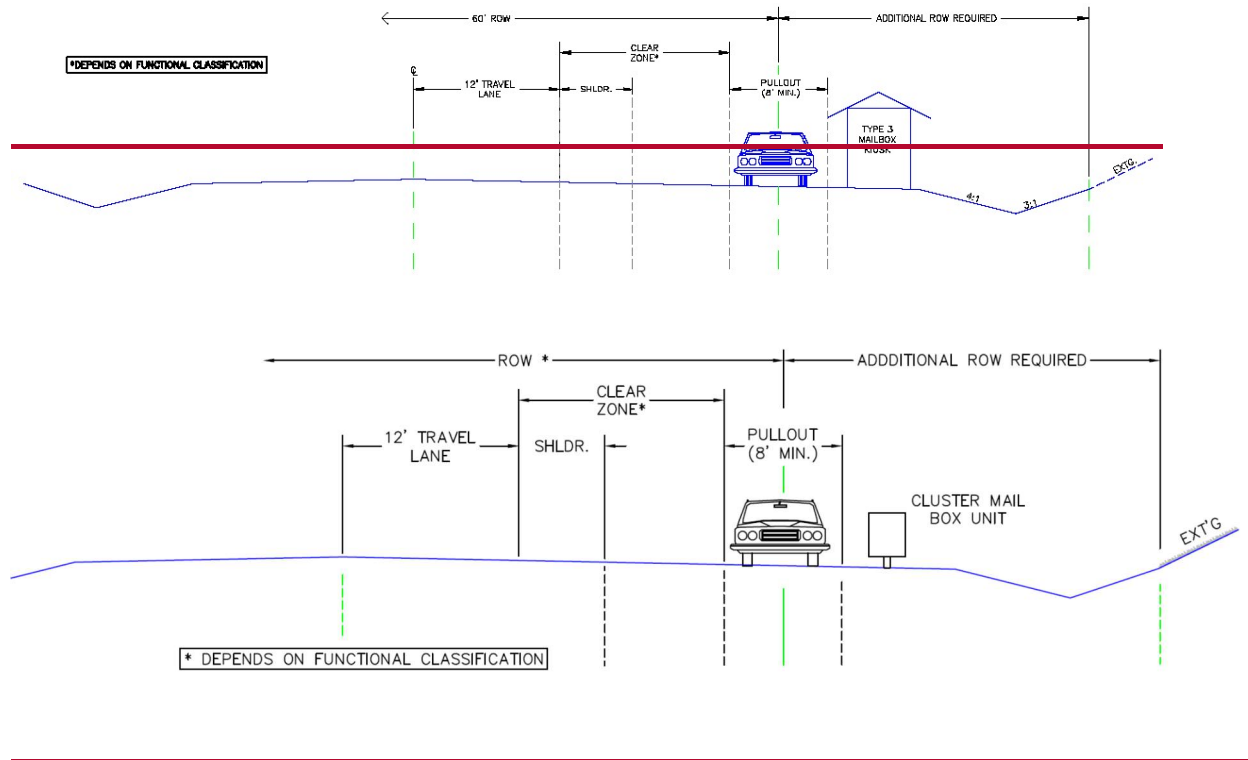

Figure 4-2. Mailbox Pad Pull-Off-out Area Detail, Rural Application



4.4.6. Road Improvements

Turnouts for mail delivery vehicles shall be installed to serve cluster mailbox units located along arterial or collector roads, or any road with a posted speed of 35 MPH or above.

4.4.7. Snowplow Activities

If a mailbox of any type is destroyed during snowplow activities, a standard wooden post and standard mailbox will be provided to the property owner, if the budget allows.

(Res. No. 20-222 , 6-23-20)

Chapter 5 PERMITS AND INSPECTIONS

5.1. OVERVIEW

This chapter addresses the review, permitting and inspection process for projects involving the use, construction, enlargement, alteration, relocation, removal, conversion, demolition, repair, maintenance and excavation of any public improvements; work within a County right-of-way (right-of-way) or easement, transport of over dimensional loads on County roads; removal of trees or plants from the County's right-of-way or easements; the discharge of stormwater from a construction site or land development activity to , deviations from ECM standards, and the construction, enlargement, alteration, relocation, removal, conversion, demolition, repair and maintenance of common development improvements governed by the ECM or LDC.

5.1.1. Purpose

The purpose of this chapter is to identify permit and inspection requirements and standards for activities associated with the construction, enlargement, alteration, relocation, removal, conversion, demolition, repair, maintenance and excavation of public infrastructure or common development improvements, the use of or work within a County right-of-way or easement, the discharge of stormwater to County drainage facilities or water bodies located within El Paso County, and requests for deviations from these standards. The chapter also establishes the acceptance process for public infrastructure and common development improvements.

5.1.2. Chapter Content and References

Table 5-1 outlines the chapter content and references used as a basis for the standards established in Chapter 5.

Table 5-1. Contents and Basis of Permits and Inspections

Intent Use	ECM Content	ECM Section(s)	Reference Document(s)
Permits			
	Construction	5.3	
	Driveway	5.4 and Appendix B	
	Work in right-of-way	5.5 and Appendix K	
	Erosion and Sediment Quality Control	5.6 and Appendix I	
	Special Transport	5.7	
Deviation from Standards			
	Process to gain approval	5.8	1
Site Development Plan Review			
	Process to gain approval	5.9	1
Construction Control and Inspections			
	Inspections	5.10.2 - 5.10.4	
	Monumenting Roadways	5.10.5	
	Record Drawings	5.10.6	

References

1. El Paso County Land Development Code.
(Res. No. 19-245 , 7-2-19)

5.2. PERMITS

5.2.1. Permit Required

It shall be unlawful for any person, owner, firm or corporation or other legal entity to construct, enlarge, alter, repair, move, improve, remove, excavate, convert or demolish any public improvements, work or locate any facility in a County right-of-way or easement, transport over dimensional loads on a County road, remove or place trees or vegetation in a County right-of-way or easement, or to construct, enlarge, alter, repair, move, improve, remove, excavate, convert or demolish any common development improvements regulated by the ECM or the LDC without first obtaining the required permits for the activity.

5.2.2. Permit Administration

The ECM Administrator is hereby authorized to administer, approve, and enforce the permit requirements of these Standards; develop procedures for the administration, approval and enforcement of the permit requirements of these Standards; and delegate the authority for the administration, approval and enforcement of the permit requirements of these Standards.

The ECM Administrator shall administer, approve and enforce all permits in a manner consistent with the general purpose and intent of the ECM.

The ECM Administrator shall have the authority to review and approve the following permit types:

- Construction Permits.
- Driveway Permits (Access Permits).
- Work in Right-of-Way Permits including (1) Excavation Permits, (2) Temporary Obstruction Permits, and (3) Encroachment Permits.
- Erosion and Stormwater Quality Control Permits including (1) Erosion and Stormwater Quality Control Permits (ESQCP), and (2) Building Erosion and Stormwater Quality Control Permits (BESQCP).
- Special Transport Permits.
- Annual Maintenance Permits.

5.2.3. Conditions of Approval

The ECM Administrator is authorized to impose any reasonable conditions upon a permit necessary to carry out the general purpose and intent of the ECM. Conditions shall be directly related to the impacts of the proposed action and shall be roughly proportional in both extent and amount to the anticipated impacts of the action.

5.2.4. Simultaneous Processing of Applications

Where possible and without creating an undue administrative burden on the County's decision-making bodies and staff, the ECM intends to accommodate the simultaneous processing of applications for different County permits and approvals that may be required for the same project or activity in order to expedite the overall review process. Review and decision-making bodies and staff considering applications submitted simultaneously shall render separate reports, recommendations, and decisions on each application based on the specific standards applicable to each permit or approval.

Some permits depend on the applicant having previously received another permit or approval, or require the applicant to take particular action within some time period following the issuance of a permit or approval in order to avoid having the permit or approval lapse. Therefore, even though this ECM intends to

accommodate simultaneous processing of County required permits or approvals, applicants should note that each of the permits or approvals set forth in the ECM, LDC and other County regulations has its own timing and review process.

5.2.5. Pre-Application Conferences

The purpose of a pre-application conference is to familiarize the applicant and the staff with the applicable provisions of the ECM that are required to permit the proposed project or activity. This conference is not required, but is recommended particularly for complex projects. The conference should be held prior to developing a detailed plan for the project or activity to ensure that the plan will address all applicable requirements of the ECM.

Any potential applicant may request a pre-application conference. Prior to the pre-application conference, the applicant shall provide to the ECM Administrator a description of the character, location, and magnitude of the proposed project or activity and any other supporting documents such as maps, drawings, models, and a description of the project or activity for which a permit or approval is sought.

The ECM Administrator shall schedule a pre-application conference after receipt of a request. At the conference, the applicant, the ECM Administrator, and any other persons the ECM Administrator deems appropriate to attend shall discuss the proposed activity. As a result of the pre-application conference, the ECM Administrator may eliminate or expand the list of required application submittals by providing the applicant with an amended application checklist.

5.2.6. Responsibility for Damage

The County and its officers and employees, including but not limited to the ECM Administrator, shall not be answerable or accountable in any manner, for injury to or death of any person, including but not limited to a permit holder, persons employed by the permit holder, persons acting in behalf of the permit holder, or for damage to property resulting from any activities undertaken by a permit holder or under the direction of a permit holder. The permit holder shall be responsible for any liability imposed by law and for injuries to or death of any person, including but not limited to the permit holder, persons employed by the permit holder, persons acting in behalf of the permit holder, or damage to property arising out of work or other activity permitted and done by the permit holder under a permit, or arising out of the failure on the permit holder's part to perform the obligations under any permit in respect to maintenance or any other obligations, or resulting from defects or obstructions, or from any cause whatsoever during the progress of the work, or other activity, or at any subsequent time work or other activity is being performed under the obligations provided by and contemplated by the permit.

To the extent allowed by law, the permit holder shall indemnify, save, and hold harmless the County and its officers and employees, including but not limited to the BOCC and ECM Administrator, from all claims, suits or actions of every name, kind and description brought for or on account of injuries to or death of any person, including but not limited to the permit holder, persons employed by the permit holder, persons acting in behalf of the permit holder and the public, or damage to property resulting from the performance of work or other activity under the permit, or arising out of the failure on the permit holder's part to perform his obligations under any permit in respect to maintenance or any other obligations, or resulting from defects or obstructions, or from any cause whatsoever during the progress of the work, or other activity or at any subsequent time work or other activity is being performed under the obligations provided by and contemplated by the permit, except as otherwise provided by state law. The permit holder waives any and all rights to any type of expressed or implied indemnity against the County, its officers or employees.

5.2.7. Contractor Certification

- A. **General Requirements.** Any contractor performing work in a County right-of-way or easement must be certified by the County to be knowledgeable of the specifications, testing, inspection, and other procedures required by the ECM. To become certified, a person must take, and pass, a written test given by the ECM Administrator.
- B. **Testing.** A written test will be conducted by the ECM Administrator to ensure that every contractor responsible for work performed within a County right-of-way or easement is knowledgeable of the requirements of the County for that work. The person being certified may pick one or all of the 3 following areas of testing: (1) earthwork, (2) concrete work, and (3) asphalt work. The ECM Administrator shall develop a standardized written test and shall determine the minimum grade that will be required before a contractor is certified to perform work.
- C. **Work Performed Under a Contractor Certification.** Each contractor who is issued a contractor certification may designate other persons who are authorized to perform work on behalf of the certified contractor. The certified contractor holder is still responsible for the work even though the work is performed by an authorized representative. The certified contractor or authorized representative must be on the site of the work at all times during construction. If a certified contractor or an authorized representative is not present at the construction site during construction activity, a stop work order for all work on the site may be issued until a certified contractor or an authorized representative arrives on site.
- D. **Expiration.** Contractor Certification is good for a period of 2 years. At the end of 2 years, the certified contractor must pay a renewal fee to renew the certification. The ECM Administrator may require the contractor to retest before issuing the renewal when significant changes in the specifications, testing, inspection, and other procedures required by the ECM have occurred during the certification period or where the certified contractor has had a history of substandard performance or violations during the certification period.
- E. **Revocation of Certification.** If it is found that work performed by a certified contractor is repeatedly substandard according to the requirements and specifications of the ECM, the ECM Administrator may revoke the contractor's certification. A contractor's certification cannot be revoked unless the ECM Administrator determines that allowing the certified contractor to continue to perform work on public property would be detrimental to the health, safety and welfare of the general public. If revoked, the contractor shall not be granted a new certification for one-year. Prior to revoking the certification, the ECM Administrator shall provide 7 days written notice to the certified contractor and allow the certified contractor to provide materials documenting the certified contractor's performance and the reasons that certification should not be revoked. The ECM Administrator shall consider the materials presented by the certified contractor prior to rendering a decision concerning revocation of the contractor's certification. The certified contractor may appeal the decision of the ECM Administrator to the BOCC.
- F. **Obligation of Contractors Performing Work in the County Right-of-Way.** Before any certified contractor shall perform work within a County right-of-way or easement that requires a permit under the ECM, the certified contractor shall have on file with the ECM Administrator general permit bond in the minimum amount of \$20,000.00. Such bond shall be for the benefit of the BOCC of El Paso County by and through the ECM Administrator and shall assure recovery by the County of any expense incurred by the County in completing work begun, but not finished, by the certified contractor in accordance with these Standards. Such bond shall remain in place for at least 2 years after completion of the work.

Before any certified contractor shall perform work within a County right-of-way or easement, the certified contractor shall show evidence of a valid and enforceable bodily injury and property damage

liability insurance policy, with minimum limits of \$1,000,000.00 combined single limit coverage. Such policy shall be for the protection of the County from all suits, actions or claims of any type for injuries or damages allegedly sustained by any person or property as a result of the operations or completed operations of the work. Such policy shall specifically cover the acts and operations of any subcontractors or independent contractors of the certified contractor.

- G. **Special Districts, Utilities and Municipalities.** Special districts, utilities governed by the State Public Utilities Commission, and municipalities are not be required to be certified contractors, but when using a contractor to perform work within a County right-of-way or easement shall be required to use only certified contractors. Special districts, utilities governed by the State Public Utilities Commission, and municipalities, by obtaining a permit, do agree to accept liabilities for their work in within a County right-of-way or easement.

5.2.8. Surety from Public Agency, Public Utilities and Quasi-Governmental Agencies

Appropriate surety or collateral is required for all new construction associated with development.

When obtaining a work in the right-of-way permit, municipalities, quasigovernmental agencies, special districts, mutual companies, electric, gas and communication utilities, may provide a Letter of Responsibility in lieu of posting the required surety in a form acceptable to the ECM Administrator. This Letter of Responsibility in lieu of posting the required surety does not apply to any new development. The Letter of Responsibility used in obtaining a work in the right-of-way permit does not relieve the Public Agency, Public Utility, or Quasi-Governmental Agency from their responsibility to complete the project as planned. Every entity is required to assure that they have the financial ability to fund the entire project. Acceptable documentation verifying assets adequate to assure construction should be included in District documentation and may be verified. They must also show that they have the ability to obtain required surety for the project, even if a Letter of Responsibility is used in lieu of the surety. Special districts, metro districts, or other districts specifically created for construction or financing of improvements cannot provide a Letter of Responsibility in lieu of posting the required financial assurance.

5.2.9. Nonexclusive Remedy

The remedies provided in the ECM are not exclusive or in lieu of other rights and remedies that the County may have at law or in equity. The County is hereby authorized to seek legal and equitable relief for actual or threatened injury to the public rights-of-way or County-owned infrastructure, including, but not limited to, damages to the right-of-way, roads, sidewalks, bridges, or drainageways whether or not caused by a violation of any of the provisions of the ECM.

5.3. CONSTRUCTION PERMIT

5.3.1. General

Construction Permits are a tool to:

- provide for the administration of the orderly construction, alteration or reconstruction of public improvements within a County right-of-way or easement; and
- protect the public interest and safety in the development of private property by providing general review and oversight of the construction, alteration and reconstruction of common development and subdivision improvements regulated by the ECM and LDC.

5.3.2. Construction Permit Required

Construction Permits are required for:

- construction, alteration or reconstruction of public improvements within any County right-of-way or easement; and
- construction, alteration or reconstruction of common development improvements covered by the ECM, LDC, development agreement, or subdivision improvement agreement.
- site preparation activities including grading, stripping of soil or vegetation, depositing fill material, and trenching or excavating.

5.3.3. Notice to Proceed Required

No work shall begin under an approved Construction Permit until the ECM Administrator has also issued a Notice to Proceed.

5.3.4. Construction Permit Not Required

Construction Permits are not required for the following activities:

- Grading in an area of one acre or less which is isolated and self-contained. When a negative impact is identified by the ECM Administrator, a permit shall be required.
- An excavation below finished grade for basements and footing of a building, retaining wall or other structure authorized by a valid building permit including any fill using material from such excavation.
- Routine agricultural uses of agricultural land.
- Exploratory excavations of less than 500 square feet (excluding mining activity) being performed at the direction of a professional soils engineer or engineering geologist or utility locates.
- A fill less than one foot in depth and placed on natural terrain with a slope flatter than 5 horizontal feet to 1 vertical foot, or less than 3 feet in depth, not intended to support structures, which does not exceed 50 cubic yards on any one lot and does not obstruct a drainage course.

Even if a Construction Permit is not required, any clearing, grading, or land disturbance activities shall be in accordance with these Standards and may require an ESQCP, BESQCP or other County permits.

5.3.5. Relationship to Other ECM Permits

In most cases, construction of public facilities within any County right-of-way or easement or the construction of common development improvements covered by a development agreement or subdivision improvement agreement will often require that the applicant obtain other County permits or approvals including an ESQCP or BESQCP. A Construction Permit will not be issued by the ECM Administrator until all other required County permits and approvals have been obtained.

5.3.6. Relationship to LDC Approvals

A Construction Permit is generally required in connection with subdivision approvals and complex development approvals including some site development plan approvals, planned unit development approvals, and commercial and multifamily residential development approvals governed by the LDC. In most cases, construction plans are required as part of the development review process which are reviewed and approved by the ECM Administrator. Therefore, the necessary construction plans to obtain a Construction Permit have often already been prepared by the applicant, and reviewed and approved by the ECM Administrator. If a complete set of construction drawings have been approved by the ECM Administrator in

connection with a subdivision or development review application reviewed and approved by the BOCC, no additional plan review is necessary to obtain a construction permit.

5.3.7. Application for Permit

A. Complete Application Required

1. **General.** Applicants shall file a complete application for a Construction Permit. Each application shall:
 - Identify and describe the work to be covered by the permit for which the application is made.
 - Describe the land on which the proposed work is to be done, by legal description, street address, or similar description that readily identifies and definitively locates the proposed work location.
 - Be accompanied by plans, diagrams, computations and specifications, and other data as required in these Standards.
 - State the valuation of the work to be performed.
 - Identify all other required County permits or approvals including permit or approval type, permit number (if permit has been approved by the ECM Administrator) or case number, date of approval (or date of application if approval has not been received), and description of work for which the permit or approval was sought.
 - Include all other materials requested by the ECM Administrator including those identified in the ECM Administrator approved checklist.
2. **Traffic Control.** Construction activities shall not interfere with traffic on the adjacent roadways. If interference with traffic is required, a traffic control plan shall be submitted and approved by the ECM Administrator as part of the Construction Permit application. All traffic control shall conform to MUTCD standards.
3. **Signed by Applicant.** All applications for Construction Permit shall be signed by the applicant, or an authorized agent, who may be required to submit evidence to indicate their authority.
4. **Determination of Application Completeness.** An application will be considered complete if it is submitted in the required form, including all mandatory information and supporting materials specified by the ECM Administrator, and is accompanied by the applicable fee. If an application is determined to be incomplete, the ECM Administrator shall provide notice to the applicant along with an explanation of the application's deficiencies. No further processing of the application shall occur until the deficiencies are corrected in the resubmittal. An application which is determined to be incomplete may or may not retain its same processing cycle.

B. Construction Plan Submittal Requirements.

1. **General.** Submittal requirements consist of application, design plans, grading plans (where required), erosion control plans (where required), drainage calculations, and other information as required by the ECM Administrator. An application for Construction Permit and checklist provided by the ECM Administrator shall accompany all submittals. The application form and checklist are subject to change at the discretion of the ECM Administrator. Therefore, the applicant is advised to contact the ECM Administrator to ensure that the most current form and checklist are used.
2. **Signed and Sealed by PE.** The seal of the design engineer shall appear on each plan sheet. The design engineer shall be a registered Colorado Registered Professional Engineer.

5.3.8. Construction Permit Review and Issuance

- A. **Review Process.** The application, checklist, plans, specifications, and other data filed by an applicant for a Construction Permit shall be reviewed by the ECM Administrator. The plans may also be reviewed by other departments or agencies to verify compliance with any applicable laws.

As discussed in 5.3.6, construction plan review is often conducted as part of the subdivision and development approvals. Upon completion of the detailed review by the ECM Administrator and any other departments or agencies, the ECM Administrator will return written comments and may provide one set of plans with "Red Line" comments. More than one review and "Red Line" comments may be required. All applicable "Red Line" plans shall be returned to the ECM Administrator with the revised plan set. After the design engineer has completed all revisions, final revised plans shall be submitted to the ECM Administrator for signoff and the latest set of "Red Line" plans shall be returned to the ECM Administrator. Current review procedures are provided in the Land Development Code Procedures Manual.

- B. **Criteria for Approval.** If the ECM Administrator finds that the work described in an application for a Construction Permit and the plans and other data conform to the requirements of these Standards and other pertinent laws regulations or ordinances and that all required fees have been paid, a Construction Permit may be issued to the applicant.

A Construction Permit may only be approved if it meets the criteria set forth below:

- The construction plan complies with all applicable requirements of the ECM;
- The applicant has obtained an ESQCP and all other required County permits and approvals for the project;
- All approvals required by the LDC have been obtained, the construction plans are consistent with the approvals obtained, and all conditions associated with any LDC approvals have been met;
- All required review and permit fees have been paid; and
- The required surety has been provided in a form acceptable to the ECM Administrator.

Any Construction Permit application that in the opinion of the ECM Administrator fails to meet the criteria for approval listed above may be denied a Construction Permit by the ECM Administrator. In denying a Construction Permit, the ECM Administrator shall provide a statement outlining the reasons for denial of the permit.

- C. **Authority to Deny Permit to Applicant in Violation of ECM.** The ECM Administrator may deny a Construction Permit to any applicant where the applicant, or any parent or subsidiary corporation (if the applicant is a corporation) has:

- Failed to substantially comply with local regulations adopted in support of the El Paso County's Colorado Discharge Permit System General Permit (See Appendix I);
- Conducted or is conducting land-disturbing activity without an approved Construction Permit, ESQCP, or any other permit required by the ECM;
- Failed to pay a civil penalty assessed pursuant to the ECM for failure to comply with the applicable sedimentation and erosion control requirements, where the payment is due and no appeal regarding the penalty is pending.

- D. **Approved Plans.** When issuing a Construction Permit, the ECM Administrator shall approve the plans by signing the appropriate approval block. The approved plans shall be attached to and become an enforceable part of the Construction Permit.

-
- E. **Valid Permit and Notice to Proceed.** A Construction Permit is valid once issued, but work may not proceed until a Notice to Proceed is issued by the ECM Administrator. Generally, a Notice to Proceed will be provided to the permit holder following the preconstruction meeting. A Notice to Proceed may be issued concurrently with the Construction Permit where the ECM Administrator has determined that a preconstruction meeting is not required.
 - F. **Preconstruction Meeting.** The ECM Administrator may require a preconstruction meeting prior to issuing a Notice to Proceed. The ECM Administrator shall specify in the approved permit whether or not a preconstruction meeting is required and who is required to attend. The applicant is responsible for scheduling the meeting with the ECM Administrator.
 - G. **Onsite Quality Control.** The permit holder shall provide onsite quality control by an experienced construction representative during all phases of construction. All quality control and inspections shall meet the requirements presented in Section 5.11. Field changes made during the construction process that modifies the overall design intent as permitted or do not meet minimum County standards shall be considered a change to the permit and shall be approved by the design engineer and ECM Administrator. No adjustment to the surety is warranted unless extensive redesign is required.
 - H. **Change in Approved Plan.** The approved plans and specifications shall not be changed, modified, or altered without written authorization from the ECM Administrator. All work shall be done in conformance with the approved permit, plans, specifications, and these Standards.
 - I. **Approved Plans and Copy of ECM at Work Site.** One set of approved plans, a copy of the Construction Permit and any conditions of approval, and a copy of the ECM shall be maintained at the work site at all times during construction activities.
 - J. **No Violation of Standards.** The issuing and granting of a Construction Permit shall not be construed to be a permit for, or an approval of, any violation of any of the provisions of these Standards or of any regulations of the County. No permit presuming to give authority to violate or cancel the provisions of these Standards shall be valid unless a deviation has been expressly and specifically approved by the ECM Administrator.
 - K. **Limit of Plan Review and Permit Approval.** Construction Permit approval means that the plans have been reviewed for reasonableness and compliance with minimum ECM Standards. Construction Permit approval does not relieve the design engineer from responsibility for errors, omissions, or deficiencies in the plans
 - L. **Correction of Errors.** The issuance of a Construction Permit based on plans, specifications or other data shall not prevent the ECM Administrator from requiring the correction of errors in the plans, specifications and other data, or from stopping construction operations being conducted in violation of these Standards or any other regulations of the County.

5.3.9. Construction Permit Suspension or Revocation

The ECM Administrator may suspend or revoke any Construction Permit, in writing, issued under the provisions of these Standards whenever the Construction Permit is issued in error or on the basis of incorrect information supplied by the applicant or whenever the permit may have been issued in violation of any provision of these Standards. In the event a permit is suspended or revoked, no refund of permit fees shall be made unless the permit was issued by the ECM Administrator in error.

5.3.10. Violations

Construction Permits may be enforced by injunction, including both the enjoining of actions or inactions in violation of the ECM, and a mandatory injunction to require the action accomplished without, or in violation of the terms of, a Construction Permit. In any such injunctive action the County shall be entitled to an award

of its costs of suit and any costs incurred in the correcting any action undertaken in violation of the provisions of the information presented herein.

The County shall be entitled to recover its attorney's fees incurred in bringing action to compel compliance with the provisions of these regulations or to compel compliance with any plan approved hereunder.

5.3.11. Construction Permit Fees

Construction Permit fees shall be paid in full prior to any pre-construction conference or notice to proceed. The fee for Construction Permits shall be determined by resolution of the Board of County Commissioners.

5.3.12. County Inspections

- A. **General Requirements.** All work performed under a Construction Permit shall be subject to inspection by the ECM Administrator. The permit holder shall notify the ECM Administrator when work is ready for inspection. The ECM Administrator shall require that every request for inspection be filed at least 48 hours before the inspection is desired. The request may be in writing, email or by telephone. It is understood that in some cases it may not be possible to give 48 hours' notice. However, every attempt shall be made to provide the ECM Administrator with at least 48 hours' notice. Where the ECM Administrator determines that a permit holder consistently fails to provide adequate notice, the ECM Administrator may issue a stop work order or suspend the permit.

It shall be the responsibility of the permit holder to provide access to and means for proper inspection of all regulated construction activities.

5.3.13. Permit Holder Inspections

In accordance with the provisions of Section 5.11, the permit holder shall provide inspection services of all public improvements and common development improvements. All improvements shall be inspected by a construction representative or a qualified individual under the supervision of a construction representative. All inspection costs, including the services of the construction representative and required testing, shall be paid by the permit holder. Copies of all inspections and required testing shall be provided to the ECM Administrator.

5.3.14. Insurance

Before any permit holder shall perform work under a Construction Permit, the permit holder shall show evidence of a valid and enforceable bodily injury and property damage liability insurance policy, with minimum limits of \$1,000,000.00 combined single limit coverage. Such policy shall be for the protection of the County from all suits, actions or claims of any type for injuries or damages allegedly sustained by any person or property as a result of the operations or completed operations of the work. Such policy shall specifically cover the acts and operations of any subcontractors or independent contractors of the permit holder, in addition to the permit holder's employees or agents.

In addition to the insurance described above, the permit holder personally, by obtaining an approved Construction Permit, agrees to be liable to the County for any expenses incurred by the County because of the permit holder's acts of omissions relating to the work, and the permit holder shall hold the County harmless from any claims of anyone else arising from or relating to the work.

5.3.15. Construction Surety, Warranties, and Acceptance of Public and Common Development Improvements

- A. **General.** The purpose of this section is to set forth the policies and procedural guidelines for providing an acceptable guarantee of performance and compliance with County and State requirements for the acceptance of public and common development improvements.
- B. **Requirements of Applicant.** The applicant shall be required to submit construction surety in a form acceptable to the ECM Administrator prior to the issuance of a Construction Permit. The construction surety shall be released in accordance with the provisions of Section 5.3.16.E or as otherwise allowed by any approved development agreement or subdivision improvements agreement. Two-year defect warranty surety shall be posted by the permit holder for public and common development improvements prior to preliminary acceptance and release of any portion of the construction surety.
- C. **Construction Surety Default.** The ECM Administrator may demand payment on construction surety if the applicant fails to:
- Renew the construction surety at least 30 days in advance of the expiration; or
 - Comply with a written notice of violation or correction within the time specified in the notice.
- D. **Construction Surety Requirements.**
1. **Types of Surety.** The applicant is required to ensure the construction of all public and common development improvements and utilities are in accordance with the Construction Permit, approved plans and drawings, the standards of this ECM, and any development or subdivision improvements agreement. The construction surety must be posted prior to issuance of a Construction Permit for the proposed work or recording of the final plat in the case of a subdivision.
 2. **Surety Estimates.** All surety estimates will be prepared based on unit prices for new public or private sector construction in the County. The applicant shall complete and submit a Construction Surety Estimate to the ECM Administrator. The ECM Administrator will review the surety estimate for public and common development improvements and will coordinate with the appropriate utility providers to review the surety estimate for water, sewer, and other utilities.
 3. **Forms of Acceptable Construction Surety.** The acceptable forms of surety guarantee for construction surety are: Performance Bond from a bond or insurance company authorized to do business in the State of Colorado, Letter of Credit from a financial institution authorized to do business in the State of Colorado, cash, or Certified or Cashier's Check. Other forms or construction surety such as a plat restriction or deeds of trust may be approved by the Board of County Commissioners.
 4. **Posting Construction Surety.** The applicant shall provide all construction surety in a form acceptable to the ECM Administrator. Surety forms shall be completed, executed and then submitted, along with any other required supporting documentation, to the ECM Administrator for approval prior to the issuance of a Construction Permit or recording a final plat in the case of a subdivision.
 - Surety with a Bonding Company: The applicable "Performance Bond with Surety" form is completed by the applicant and the surety company. An original power of attorney for the individual signing for the surety company shall be attached to the bond. The bond shall be signed or countersigned by a Colorado Resident Agent of the surety. Once the bond is completed and executed, the original is submitted for approval.

- Collateral Assignment of Certificate of Deposit: The applicable "Performance Bond with Certificate of Deposit" form shall be completed and executed by the applicant. Both the applicant and the financial institution must complete the "collateral assignment" form. The original of the completed and executed bond and collateral assignment, along with the certificate of deposit or an original receipt for the certificate of deposit, are submitted for approval.
- Certified or Cashier's Check: The applicable "Performance Bond with Cash Escrow" form and the "Request for Taxpayer Identification Number (Form W-9)" shall be completed and executed by the applicant. The check shall be made payable to the El Paso County. The cashier's check and the original of the completed and executed bond and Form W-9 are submitted for approval. Checks are cashed and the funds placed in an interest bearing performance bond account maintained by the County.
- Letter of Credit from an Insured Lending Institution: The applicable "Irrevocable Letter of Credit" form shall be completed by the lending institution and be in favor of the BOCC, and shall guarantee construction of the improvements according to the approved plans and specifications. This Letter of Credit shall be automatically extended for additional periods of one year from the present or future expiration date, unless the bank notifies the ECM Administrator and the "Customer" via courier or certified mail at least 120 calendar days prior to the then expiration date that the bank has elected not to renew the Letter of Credit. 30 days after receipt of such notice, the County may draw on the Letter of Credit by presentation of the Letter of Credit, and a demand in writing signed by a person who has been duly authorized to sign on the County's behalf.

Under no circumstances shall the required performance bond, collateral assignment of certificate of deposit, certified or cashier's check or irrevocable letter of credit be tied to or be considered a portion of the developer's financing for the development.

5. **Construction Surety Term.** The construction surety shall have minimum term of one year.

E. **Preliminary Acceptance, Surety Reductions and Inspection.**

1. **General.** The permit holder seeking preliminary acceptance shall notify the ECM Administrator that the public and common development improvements are complete and ready to be accepted by the County. The permit holder shall schedule a preliminary acceptance walk-through. The ECM Administrator shall develop a punch list of items to be corrected prior to preliminary acceptance and noncritical items which must only be completed prior to final acceptance. The walk-through shall involve at a minimum the ECM Administrator and the construction representative.

Upon satisfactory completion of punch list items required for preliminary acceptance and a determination by the ECM Administrator that the installed improvements meet all applicable Standards, a preliminary acceptance recommendation shall be forwarded by the ECM Administrator to the BOCC for action. If the BOCC approve preliminary acceptance of an improvement, then construction surety shall be released in accordance with Sections 5.3.16E.3 and 5.3.16E.4 upon receipt of a defect warranty bond (See Section 5.3.16F).

Upon preliminary acceptance by the BOCC and release of the construction surety by the ECM Administrator, the facilities to be publicly maintained will be included in the County system for maintenance. A roads system maintenance acceptance form and drainage facility maintenance form shall be prepared by the BOCC identifying the systems to be added into the maintenance system.

A determination concerning final acceptance will not be made for 2 years from the date of preliminary acceptance.

-
2. **Preliminary Acceptance Limitation.** The preliminary acceptance of an improvement shall in no way constitute an assumption by the County of liability for defects in the improvement due to workmanship or materials. By accepting the improvement, the County does not warrant or guarantee that the improvement has been properly designed or constructed. Any errors or omission of the permit holder, design engineer, or construction engineer shall not be the responsibility of the County.

The permit holder shall be responsible for making any repair of facility failures that occur during the 2-year defect warranty period.

3. **Surety Reductions and Inspections.** Once the initial surety estimate is prepared, to request any reduction in surety the permit holder shall submit an approved "Surety Inspection Request Form" to the ECM Administrator.

Requests for construction surety reduction will be subject to the following conditions based upon the percentage of work completed and approved by the County, or other authority or agency having jurisdiction over the improvement. The following conditions apply to surety reductions and inspection fees.

- No more than 3 inspections for surety reductions will be scheduled during any twelve-month period. Additional inspections for surety reductions can be requested and will be scheduled and conducted based on staff availability but shall be scheduled only after regular inspections are completed.
- A surety reduction inspection fee must accompany each request for reduction.
- Inspections will be scheduled within 30 days of receipt of the surety reduction inspection request form and applicable fee.
- Reductions will not occur until completion and approval of at least 30% of the public and common development improvements.

Twenty percent of the original construction surety amount will be retained until final completion and preliminary acceptance of all public and common development improvements. Preliminary acceptance will not begin until the applicable defect warranty surety is posted.

4. **Release of Construction Surety.** Construction surety shall be released upon completion and preliminary acceptance of all public and common development improvements and posting of defect warranty surety. A county public improvement is deemed to be complete when it is preliminarily accepted and taken over for maintenance by the County. Other public improvements are deemed to be complete when approved by the public authority or state agency responsible for maintaining and operating the improvement. A common development improvement is deemed to be approved once the ECM Administrator determines that the improvements are complete and operates in accordance with the approved plans. For common development improvements that include permanent stormwater quality control measures, additional final inspection criteria are provided in Appendix I.

Engineering Record Drawings are required at the time of preliminary acceptance in accordance with Section 5.10.6. However, any field modifications made to the site contrary to the accepted drawings during the warranty period will be documented during inspections, and an addendum must be submitted to revise the Engineering Record Drawings prior to receiving Final Acceptance.

F. **Warranty Requirements.**

1. **General.** The permit holder is required to warranty all improvements against defects in materials or workmanship. This warranty must be posted prior to preliminary acceptance by the County or

the release of any portion of the construction surety except as otherwise provided. The amount of the defect warranty shall be equal to 20% of those items as identified in the approved surety estimate.

2. **Form of Defect Warranty Surety.** The permit holder shall provide a defect warranty in a form acceptable to the ECM Administrator. The approved Defect Warranty Form shall be completed, executed and then submitted, along with any required supporting documentation, to the ECM Administrator for approval prior to the preliminary acceptance.
 3. **Defect Warranty Period.** The permit holder is required to warrant improvements for 2 years.
 4. **Permit Holder Responsibilities During Defect Warranty Period.** The permit holder shall repair or correct any deficiencies or defects in workmanship or materials that may occur before final acceptance is granted. Any repairs or correction shall be noted and a copy of the repair description and action shall be provided to the ECM Administrator.
- G. **Final Acceptance, Inspection and Release of Defect Warranty.**

1. **General.** The permit holder seeking final acceptance shall notify the ECM Administrator to schedule a final walk-through inspection at least 30 days and no more than 90 days before the end of the defect warranty period. The final walk-through inspection shall include the permit holder (or representative), the construction representative (if different than the permit holder representative), and the ECM Administrator. The ECM Administrator may invite additional County or outside agency representatives. The ECM Administrator will generate a punch list of items for repair or correction.

Once all items identified on the punch list have been repaired or corrected to the satisfaction of the ECM Administrator and the ECM Administrator determines that the installed improvements meet all applicable Standards, the ECM Administrator shall prepare and schedule final acceptance documents for public improvements for Board of County Commissioner hearing and approval. The defect warranty may be released by the ECM Administrator upon action of the BOCC to accept the public improvements.

2. **Final Acceptance Certification.** Prior to scheduling final acceptance for BOCC approval, the final punch list certification shall be signed by the ECM Administrator, construction representative, and permit holder stating that all items identified in the punch list have been repaired, corrected or completed.
3. **Final Acceptance and Release of Defect Warranty.** Upon final acceptance of the improvements by the BOCC, the ECM Administrator shall release the defect warranty.
4. **Failure to Make Repairs or Corrections.** If the permit holder fails to make the required repairs or corrections identified during the final walk-through inspection within 6 months, the ECM Administrator may draw on the defect warranty in order to perform the required repairs or corrections.

(Res. No. 19-245 , 7-2-19)

5.4. DRIVEWAY PERMIT

5.4.1. General

For the safety of the general public, the County has determined the minimum requirements and technical standards for driveways, and associated culverts and drainage structures constructed within the County right-of-way. The Driveway Permit is a tool to help the County regulate the location and construction of

Created: 2021-06-08 11:35:50 [EST]

(Supp. No. 2)

driveways that will intersect any County road, determine compliance with general access standards, and determine whether or not an access will intersect a county road. This section provides an orderly procedure for obtaining a Driveway Permit.

5.4.2. Driveway Permit Required

Driveway Permits are required to construct, reconstruct, pave, alter, enlarge or change the use of any driveway intersecting a County road; install, re-install, replace, or move a culvert associated with a driveway intersecting a County road; or verify a driveway location is on a private road before issuing a building permit. Where a new driveway is to be constructed in conjunction with the construction of a new principal structure, the Driveway Permit shall be issued as a condition for obtaining a building permit. Where the use of a principal structure or property is proposed to change, a new Driveway Permit may be required prior to the use conversion.

No person shall commence work on any driveway or culvert within a County right-of-way before the Driveway Permit has been issued.

5.4.3. Restrictions on Locations

All driveways shall meet the criteria for access outlined in Chapter 2 of the ECM. In addition, accesses shall be subject to any subdivision plat restrictions.

5.4.4. Application

- A. **Complete Application Required.** Applicants shall file a complete application for a Driveway Permit on forms provided by the ECM Administrator. Based on the proposal, additional submissions may be required to provide the ECM Administrator with sufficient information to provide for review of the application.

The ECM Administrator may allow Driveway Permits to be processed in groups within a common development or subdivision to reduce the administrative burden on applicants requesting permits concurrently for multiple lots.

- B. **Additional Requirements for Commercial or Multifamily Driveways.** All commercial and multifamily driveways are subject to site development plan review. Due to the higher complexity and possible impacts, a transportation impact study may be required to support review and approval of a Driveway Permit application for a driveway serving commercial and multifamily development. Where the transportation impact study determines or these Standards require public improvements such as acceleration and deceleration lanes, exclusive left or right hand turn lanes, or a traffic signal, the applicant shall also be required to obtain a Construction Permit to construct, reconstruct, alter, or enlarge the necessary public improvements.
- C. **Signed by Applicant.** All applications for Driveway Permit shall be signed by the applicant, or an authorized agent, who may be required to submit evidence to indicate their authority.
- D. **Proposed Driveway Location to be Marked.** For access onto a County public road with open ditch drainage (not curb and gutter), the applicant may be required by the ECM Administrator to stake the proposed location of the driveway at the point of intersection with County road. If staking is required, the driveway location shall be staked with 2 stakes marked "driveway" placed along the edge of the County right-of-way, and shall be clearly visible from the road. In evaluating the Driveway Permit application, the ECM Administrator may conduct a field inspection of the location of the proposed driveway. If the location has not been staked in accordance with this section, the Driveway Permit may be denied by the ECM Administrator or a reinspection fee may be assessed prior to reinspecting the location and issuing the Driveway Permit.

-
- E. **Determination of Application Completeness.** An application will be considered complete if it is submitted in the required form, includes all mandatory information, including all supporting materials specified by the ECM Administrator, and is accompanied by the applicable fee. If an application is determined to be incomplete, the ECM Administrator shall provide notice to the applicant along with an explanation of the application's deficiencies. No further processing of the application shall occur until the deficiencies are corrected in a future resubmittal. An application which is determined to be incomplete may or may not retain its same processing cycle.
- F. **Application for Second Driveway Access.** In some situations, El Paso County will consider a second driveway access for a lot, if requested. If a second driveway access is requested, all driveway criteria must be met for both driveways.

5.4.5. Driveway Permit Review and Issuance

- A. **Review Process.** The application and other data filed by an applicant for a Driveway Permit shall be reviewed by the ECM Administrator. The application may also be reviewed by other departments or agencies to verify compliance with any applicable laws.

If the ECM Administrator finds that the work described in an application for a Driveway Permit conform to the requirements of these Standards and other pertinent laws regulations or ordinances and that all required fees have been paid, a Driveway Permit shall be issued to the applicant.

- B. **Criteria for Approval.** A Driveway Permit may only be approved if it meets the criteria set forth below:
- The submitted application complies with all applicable requirements of the ECM;
 - The ECM Administrator determines that the access will not create an unsafe condition for the traveling public;
 - All required review and permit fees have been paid and any required construction surety has been posted in a form acceptable to the ECM Administrator.

Any Driveway Permit application that in the opinion of the ECM Administrator fails to meet the criteria for approval listed above may be denied a Driveway Permit by the ECM Administrator. In denying a Driveway Permit, the ECM Administrator shall provide a statement outlining the reasons for denial of the permit.

- C. **Change in Approved Permit.** The approved permit shall not be changed, modified, or altered without written authorization from the ECM Administrator. All work shall be done in conformance with the approved permit and these Standards.
- D. **Violation of Standards.** The issuing and granting of a Driveway Permit shall not be construed to be a permit for, or an approval of, any violation of any of the provisions of these Standards or of any regulations of the County. No permit presuming to give authority to violate or cancel the provisions of these Standards shall be valid. unless expressly and specifically varied by the ECM Administrator.
- E. **Limit of Permit Approval.** Driveway Permit approval means that the permit has been reviewed for reasonableness and compliance with minimum ECM Standards. The Driveway Permit does guarantee that if the permit specifications are met and construction complies with the standards outlined in the ECM and on the Driveway Permit, the permit holder will not be liable for damages to the County road after construction is completed.
- F. **County Authority Preserved.** The County, notwithstanding the issuance of any permit or construction of any driveway, reserves the right to make any changes, additions, repairs or relocation of any part of a driveway within the dedicated right-of-way at any time, including but not limited to, in connection

with the relocation, reconstruction, widening and maintaining the road or right-of-way, without compensating the owner of the driveway for the damages to or destruction of the driveway.

5.4.6. Driveway Permit Holder Responsibilities

- A. **Maintenance Responsibility.** The property owner is responsible for maintaining the driveway approaches, culvert and ditch to permit free and unobstructed flow of water. The County does not assume any responsibility for repair or replacement of concrete or decorative pavement, decorative endwalls/headwalls, the removal or clearance of snow or ice, or the opening of windrows of such material, upon any portion of the driveway within the County right-of-way.
- B. **Utility Locates.** The permit holder shall be responsible for contacting the Utility Notification Center of Colorado for utility locates at least 48 hours in advance of the driveway construction if excavation is required.
- C. **Traffic Control.** Driveway construction activities shall not interfere with traffic on the adjacent roadway. If interference with traffic is required, a traffic control plan shall be submitted and approved by the ECM Administrator as part of the permit application. All traffic control shall conform to MUTCD standards.
- D. **Drainage Interference.** A permit holder shall not obstruct the natural free and clear passage of water along the gutters or other waterways. If surface drainage is to be affected, the permit holder is responsible for the proper disposition of the runoff.
- E. **Responsibility for Clean Up and Restoration.** The permit holder shall assume all responsibility for removing all debris and slash from the County's right-of-way associated with the driveway construction activities. If, upon inspection, the ECM Administrator determines that debris and slash have not been removed from the County right-of-way, the ECM Administrator shall notify the permit holder of the violation of the permit conditions. The permit holder, upon notification from the ECM Administrator shall correct all work to the extent necessary, using the method required by the ECM Administrator. The work shall be completed within the time period specified in the notice from the ECM Administrator.

If the permit holder fails to restore the right-of-way in the manner and to the condition required by the ECM Administrator, the ECM Administrator may have the County perform the restorations. In that event, the permit holder shall pay to the County, within 30 days of billing, the cost of restoring the right-of-way.

5.4.7. Driveway Permit Expiration

Every Driveway Permit issued by the ECM Administrator shall expire if a building permit is not obtained within 90-days, the work authorized by the permit is not substantially begun within one year from the date of the permit or if the construction of work authorized by the permit is suspended or abandoned for a period of one year at any time after the work is begun. Before work can begin or be resumed, the Driveway Permit shall be reissued by the ECM Administrator.

5.4.8. Driveway Permit Suspension or Revocation

The ECM Administrator may suspend or revoke any Driveway Permit, in writing, issued under the provisions of these Standards whenever the Driveway Permit is issued in error or on the basis of incorrect information supplied by the applicant or whenever the Driveway Permit may have been issued in violation of any provisions of these Standards. In the event a Driveway Permit is suspended or revoked, no refund of permit fees shall be made unless issued in error by the ECM Administrator.

5.4.9. Driveway Permit Fees

Driveway Permit fees shall be paid in full at the time of the driveway permit application. The fee for Driveway Permits shall be as determined by resolution of the BOCC.

5.4.10. Inspections

The ECM Administrator may conduct an inspection of the driveway to ensure full compliance with all provisions of the ECM and terms of the permit.

5.4.11. Driveway Construction Surety

When determined necessary by the ECM Administrator, the applicant shall be required to submit driveway construction surety in a form and amount acceptable to the ECM Administrator prior to the issuance of a Driveway Permit. Surety shall be released upon final completion and approval of the ECM Administrator.

5.5. WORK IN THE RIGHT-OF-WAY PERMIT

5.5.1. General

The County holds public right-of-way and easement as an asset in trust for its citizens and manages the use of the right-of-way and other uses for public purposes, including use by public utilities pursuant to Section 38-5-101 of the Colorado Revised Statutes. To provide for the health, safety and welfare of its citizens and to ensure the structural integrity of its roads and the appropriate use of right-of-way, the County strives to keep its right-of-way in a state of good repair and free from unnecessary encumbrances.

The Work in the Right-of-Way Permit is a tool to help regulate obstructions of, excavations in, and the use of the County's right-of-way and easements by, among other things, granting a permit holder authority to obstruct, excavate, or install facilities within the right-of-way or easement, and provide for the subsequent restoration of the County's right-of-way, easement, and public improvements located therein.

5.5.2. Work in the Right-of-Way Permit and Notice to Proceed Required

- A. **General Requirements.** A Work in the Right-of-Way Permit is required for obstructing or excavating within any public right-of-way or easement, and for encroaching upon any County right-of-way or easement.

No person may obstruct or excavate any right-of-way or easement, or encroach upon any County right-of-way or easement without first having obtained the appropriate Work in the Right-of-Way Permit from the ECM Administrator. In addition, no person may excavate or obstruct the right-of-way or easement beyond the date or dates specified in the permit unless: (1) the person requests a permit extension before the expiration of the initial permit, and (2) a new permit or permit extension is granted.

No work shall begin until a Work in the Right-of-Way Permit has been issued.

- B. **Work in the Right-of-Way Permit Types.**

1. **Excavation in the Right-of-Way.** A Work in the Right-of-Way Permit is required to excavate that part of the right-of-way described in the permit to the extent and for the duration specified in the permit including, but not limited to:
 - Grade, trench, cut, or change the elevation of the surface of a County right-of-way or easement including any road, drainageway, ditch, drainage facility, and reservoir/catch basin or drainage structure located within a County right-of-way or easement.

-
2. **Temporary Obstruction of the Right-of-Way.** A Work in the Right-of-Way Permit is required to hinder free and open passage over a specified portion of right-of-way by placing equipment or materials in the right-of-way or conducting an approved activity within the right-of-way for the duration specified therein including, but not limited to:
 - Place within a County right-of-way or easement any rubbish, brush, earth, or other material of any nature whatsoever;
 - Place any equipment, barrier, sign, detour, post or bollard so as to change the flow of vehicular or pedestrian traffic in a County right-of-way or easement.
 3. **Encroachment in the Right-of-Way.** A Work in the Right-of-Way Permit is required to locate, erect or maintain any structure, including but not limited to driveway monuments, flag, banner, post, sign, pole, fence, guardrail, wall, loading platform, gang mailbox, pipe, drainage ditch or facility, conduit, irrigation facility, utility, or wire on, over, or under a County right-of-way or easement.

All Work in the Right-of-Way Permits for encroachments shall require the owner of the encroachment to fulfill the registrant requirements of Section 5.5.8 and file an Encroachment Removal Agreement.
 4. **Annual Maintenance Permit.** This permit is approved by the El Paso County Board of County Commissioners. The following conditions apply:
 - The Annual Maintenance Permit is for maintenance of existing utilities requiring only access to vaults, cabinets, manholes, etc.
 - No excavation is permitted

C. **Working Without a Permit - Registrants.**

1. **Registrant Identified Emergencies.** When a condition arises where emergency work must be performed on a facility located within the County right-of-way (i.e., existing approved encroachment), the registrant shall immediately notify the ECM Administrator of the event regarding its facilities which it considers to be an emergency. The registrant may proceed to take whatever actions are necessary in order to respond to the emergency in accordance with approved Standards. Within 2 business days after the occurrence of the emergency, the registrant shall apply for the necessary permits, pay the associated fees and fulfill the rest of the requirements necessary to comply with the ECM for the actions the registrant took in response to the emergency.
2. **ECM Administrator Identified Emergencies.** In the event that the ECM Administrator becomes aware of an emergency regarding a registrant's equipment or facilities located in the County right-of-way or easement, the ECM Administrator shall attempt to contact the local representative of each registrant affected, or potentially affected, by the emergency. The ECM Administrator may take whatever action deemed necessary in order to respond to the emergency, the cost of which shall be borne by the registrant whose equipment or facilities occasioned the emergency.

D. **Working Without a Permit - Non-Registrants.**

1. **General.** Non-registrants shall not work in the County right-of-way without a valid Work in the Right-of-Way Permit except as otherwise permitted.
2. **Emergency Repair of Service Lines.** When a condition arises where emergency work must be performed on a service line located within the County right-of-way, the property owner shall immediately notify the ECM Administrator of the event regarding the emergency. The property

owner may proceed to take whatever actions are necessary in order to respond to the emergency provided a contractor certified and bonded with the ECM Administrator or registrant performs all work within the County right-of-way. Within 2 business days after the occurrence of the emergency, the property owner shall apply for the necessary permits, pay the associated fees and fulfill the rest of the requirements necessary to bring the action into compliance with the ECM.

3. **Mailboxes and Other Exceptions.** A property owner may erect a single mailbox in accordance with USPS standards, maintain and mow areas of vegetation within the County right-of-way, maintain roadside ditches, and maintain that portion of the driveway located within the County right-of-way without obtaining a Work in the Right-of-Way Permit. Caution should be used when working in the County right-of-way. Although a permit is not required, all activities shall conform to these Standards.

5.5.3. Application for Permit

A. Complete Application Required.

1. **General.** Applicants shall file a complete application for a Work in the Right-of-Way Permit. Each application shall:
 - Identify and describe the work to be covered by the permit for which the application is made.
 - Describe the land on which the proposed work is to be done, by legal description, street address, or similar description that shall readily identify and definitively locate the proposed work location.
 - Be accompanied by plans, diagrams, computations and specifications, and other data as required by these Standards and the approved application and permit checklists.
 - Be accompanied by a traffic management plan that clearly describes the traffic management to be implemented and maintained during excavation, obstruction or placement of the encroachment.
 - Identify in detail the activities including proposed dates and times of operation, schedule for start and completion.
 - Include all other materials requested by the ECM Administrator.
2. **Signed by Applicant.** All applications for Work in the Right-of-Way Permit shall be signed by the applicant, or an authorized agent, who may be required to submit evidence to indicate their authority.
3. **Joint Applications.** Applicants may jointly make application for permits to excavate, obstruct or encroach on the County right-of-way at the same place and time. The ECM Administrator may reduce the disruption and degradation portions of the permit fee for applicants who join in during a scheduled obstruction, excavation, or encroachment action whether or not it is a joint application by 2 or more applicants or a single application.
4. **Encroachment Removal Agreement.** An approved executed Encroachment Removal Agreement is required for any planned encroachment into the County right-of-way or easement. A metes and bounds easement for the encroachment shall be provided to the ECM Administrator with a statement of justification as to why the appurtenance must remain in the County right-of-way or easement.

In the event the County performs work in this area which requires removal of the encroachment, the registrant shall at their own cost remove and relocate the appurtenance, or the ECM

Administrator may have the encroachment removed at the County's expense and invoice the registrant.

5. **Supplemental Applications.** A Work in the Right-of-Way Permit is valid only for the area of the right-of-way or easement specified in the permit. No permit holder may perform any work outside the area specified in the permit, except as provided. Any permit holder that determines an area greater than that specified in the permit must be obstructed, excavated or encroached upon must, before working in that greater area: (1) make application for a permit modification and pay any additional fees, and (2) be granted a new permit or permit modification.

A Work in the Right-of-Way Permit is valid only for the dates specified in the permit. No permit holder may begin its work before the permit start date or, except as provided herein, continue working after the end date. If a permit holder does not finish the work by the permit end date, the permit holder must: (1) make application for a permit extension for the additional time needed before the permit expires, and (2) receive the extension before working after the end date of the previous permit.

6. **Determination of Application Completeness.** An application will be considered complete if it is submitted in the required form and includes all mandatory information, including all supporting materials specified by the ECM Administrator. If an application is determined to be incomplete, the ECM Administrator shall provide notice to the applicant along with an explanation of the application's deficiencies. No further processing of the application shall occur until the deficiencies are corrected in a resubmittal. An application which is determined to be incomplete may or may not retain its same processing cycle.

B. Plan Submittal Requirements.

1. **General.** Plans for any work or activity within the County right-of-way or easement shall be submitted to the ECM Administrator for approval. For minor installations such as service lines, drops, etc., simple sketch plans with pertinent information as to location and depth may suffice as the plans.

For complex applications and if requested on the application, the following shall be provided:

- Engineering scale drawings showing the location of all facilities and improvements proposed.
- Location and approximate depth of the subject and related facilities and any other facilities in the immediate vicinity.
- A description of the methods that will be used in the work.
- The County road and associated right-of-way affected by the work.
- Offset distances from the roadway centerline to the back of curb or edge of pavement surface and the associated right-of-way line.
- A legend explaining symbols, characters, abbreviations, scale, north arrow, and other data.
- The location of any public streets, trails, walks or alleys and private property accesses that will be temporarily closed to use during the work.
- Any facilities to be abandoned, if applicable.
- Any other information required by the ECM Administrator.

2. **Traffic Control.** Work within the County right-of-way shall not interfere with traffic. If interference with traffic is require, a traffic control plan shall be submitted and approved by the ECM Administrator as part of the permit application. All traffic control shall conform to MUTCD standards.

-
3. **Signed and Sealed by PE.** The seal of the design engineer shall appear on each sheet. The design engineer shall be a registered Colorado Registered Professional Engineer.

5.5.4. Work in the Right-of-Way Permit Review and Issuance

- A. **Review Process.** The application, plans, specifications, and other data filed by an applicant for a Work in the Right-of-Way Permit shall be reviewed by the ECM Administrator. The plans may also be reviewed by other departments or agencies to verify compliance with any applicable laws.

Upon completion of the detailed review by the ECM Administrator and any other departments or agencies, the ECM Administrator will return one set of plans with "Red Line" comments. More than one review may be required. All successive sets of "Red Line" plans shall be returned to the ECM Administrator with the corresponding revised set of plans. After the design engineer has completed all revisions, final revised plans shall be submitted to the ECM Administrator for signoff and the most recent set of "Red Line" plans shall be returned to the ECM Administrator. Plan review priority will be given to plans submitted for final review over plans submitted for initial or intermediate review.

If the ECM Administrator finds that the work described in an application for a Work in the Right-of-Way Permit and the plans and other data conform to the requirements of these Standards and other pertinent laws regulations or ordinances and that all required fees have been paid, a Work in the Right-of-Way Permit may be issued to the applicant at the discretion of the ECM Administrator.

A Work in the Right-of-Way Permit is valid once issued, but the ECM Administrator might require a preconstruction meeting.

- B. **Authority of ECM Administrator.** The ECM Administrator shall have the discretionary authority to issue or deny a permit. A Work in the Right-of-Way Permit is considered a privilege. The ECM Administrator will decide all questions that may arise as to the quality and acceptability of materials furnished and work performed. The ECM Administrator shall have the authority to suspend work, wholly or in part, because of the failure of the permit holder to properly execute the work in accordance with these Standards. The ECM Administrator may undertake the inspection of the material at the source and shall have full entry at all times to those areas where the manufacture or production of the materials is taking place. The ECM Administrator shall also have the authority to waive, wholly or in part, the requirements presented in these Standards, dealing with individual projects, for reasons deemed to be in the public's interest.
- C. **Permit Conditions.** The ECM Administrator may impose reasonable conditions upon the issuance of the permit and the performance of the permit holder in order to protect the public health, safety and welfare, to insure the structural integrity of the right-of-way, to protect the property and safety of other users of the right-of-way, and to minimize the disruption and inconvenience to the traveling public. In addition, the ECM Administrator may develop permit conditions that provide reasonable assurance that utilities and their contractors working in the right-of-way are competent and qualified. These permit conditions may include, but not be limited to, instruction in state and local laws, including one-call, construction zone traffic safety, and construction standards, including restoration standards.
- D. **Criteria for Approval.** A Work in the Right-of-Way Permit may only be approved if it meets the criteria set forth below:
- The proposal complies with all applicable requirements of the ECM or a deviation has been granted;
 - All required review and permit fees have been paid; and
 - The required insurance and surety has been provided in a form acceptable to the ECM Administrator.

Any Work in the Right-of-Way Permit application that in the opinion of the ECM Administrator fails to meet the criteria for approval listed above may be denied a Work in the Right-of-Way Permit by the ECM Administrator. In denying a Work in the Right-of-Way Permit, the ECM Administrator shall provide a statement outlining the reasons for denial of the permit.

E. Authority to Deny Permit.

1. **Mandatory Denial.** Except in the case of an emergency, the ECM Administrator shall deny a Work in the Right-of-Way Permit to any applicant, or any parent or subsidiary corporation (if the applicant is a corporation) where the applicant:

- has failed within the past 3 years to comply, or is presently not in full compliance, with the requirements of the ECM;
- where grounds exist for the revocation of an existing permit.
- has outstanding debt owed to the County that is in arrears, due, owing and unpaid.

2. **Permissive Denial.** The ECM Administrator may deny a permit in order to protect the public health, safety and welfare, to prevent interference with the safety and convenience of ordinary travel over the County right-of-way, would cause a conflict or interfere with an exhibition, celebration, festival, or any other event, or when necessary to protect the County right-of-way and its users. The ECM Administrator may consider one or more of the following factors: the extent to which right-of-way space where the permit is sought is available; the competing demands for the particular space in the County right-of-way; the availability of other locations in the County right-of-way or in other right-of-way for the facilities of the permit applicant; the applicability of standards or other regulations of the County right-of-way that affect location of facilities in the County right-of-way; the degree of compliance of the applicant with the terms and conditions of its franchise, if any; the degree of disruption to surrounding communities and businesses that will result from the use of that part of the County right-of-way; the condition and age of the right-of-way, and whether and when it is scheduled for total or partial reconstruction; and the balancing of the costs of disruption to the public and damage to the County right-of-way, against the benefits to that part of the public served by the expansion into additional parts of the County right-of-way.

To protect health, safety, and welfare or when necessary to protect the County right-of-way and its current use, the ECM Administrator shall have the power to prohibit or limit the placement and location of new or additional facilities within the County's right-of-way.

F. **Approved Plans.** When issuing a Work in the Right-of-Way Permit, the ECM Administrator shall endorse the plans in writing or by stamping the plans and specifications "Approved, El Paso County ECM Administrator". The approved plans shall be attached to and become an enforceable part of the Work in the Right-of-Way Permit.

G. **Preconstruction Meeting.** The ECM Administrator may require a preconstruction meeting prior to issuing a Notice to Proceed. The ECM Administrator shall specify in the approved permit whether or not a preconstruction meeting is required and who is required to attend. The applicant is responsible for scheduling the meeting with the ECM Administrator.

H. **Change in Approved Plan.** The approved plans and specifications shall not be changed, modified, or altered without written authorization from the ECM Administrator. All work shall be done in conformance with the approved permit, plans, specifications, and these Standards.

I. **Approved Plans at Work Site.** One set of approved plans, a copy of the Work in the Right-of-Way Permit and any conditions of approval shall be maintained at the work site at all times during the progress of the work or activity.

-
- J. **Maintenance of Drainage Within Right-of-Way.** A permit holder shall not obstruct the natural free and clear passage of water along the gutters or other waterways. If surface drainage is to be affected, the permit holder is responsible for the proper disposition of the runoff.
- K. **Utility Locates.** The permit holder shall be responsible for contacting the Utility Notification Center of Colorado for utility locates at least 48 hours in advance of the work that requires the ground to be disturbed.
- L. **Violation of Standards.** The issuing and granting of a Work in the Right-of-Way Permit shall not be construed to be a permit for, or an approval of, any violation of any of the provisions of these Standards or of any regulations of the County. No permit presuming to give authority to violate or cancel the provisions of these Standards shall be valid unless a deviation has been unless expressly and specifically approved by the ECM Administrator.
- M. **Limit of Plan Review and Permit Approval.** Work in the Right-of-Way Permit approval means that the plans have been reviewed for reasonableness and compliance with minimum ECM Standards. Work in the Right-of-Way Permit approval does not relieve the design engineer from responsibility for errors, omissions, or deficiencies in the plans.
- Permits issued by the ECM Administrator pertain only to work within the County-owned right-of-way and in no way allow a permit holder to enter onto private property adjacent to County-owned right-of-way nor to alter or disturb any facilities or installations that exist within the County-owned right-of-way that are owned by others unless expressly and specifically approved.
- N. **Correction of Errors.** The issuance of a Work in the Right-of-Way Permit based on plans, specifications or other data shall not prevent the ECM Administrator from requiring the correction of errors in the plans, specifications and other data, or from stopping construction operations being conducted in violation of these Standards or any other regulations of the County.
- O. **Right-of-Way Patching and Restoration.**
1. **General.** The work to be done under the Work in the Right-of-Way Permit, and the required patching and restoration of the County's right-of-way must be completed within the dates specified in the permit, increased by as many days as work could not be done because of circumstances constituting force majeure or when work was prohibited as unseasonal or unreasonable. In addition to patching their work, the permit holder must restore the general area of the work, and the surrounding areas, including the paving and its foundations, to the same condition that existed before the commencement of the work.
 2. **Patching and Restoration Methods.** The permit holder shall perform excavation, backfilling, patching and restoration according to the Standards and with the materials specified by the ECM Administrator. The ECM Administrator shall have the authority to prescribe the manner and extent of the restoration in written procedures of general application or on a case-by-case basis. Methods of restoration may include, but are not limited to, patching, replacement of the base, and milling and overlay of the affected area of the County roadway. The permit holder shall at the time of application of permit post construction surety when required by the ECM Administrator.
 3. **Defects and Repair.** The permit holder shall correct defects in patching, or restoration performed by the permit holder or its agents for up to 2 years following restoration. The permit holder, upon notification from the ECM Administrator shall correct all restoration work to the extent necessary, using the method required by the ECM Administrator. The work shall be completed within the timeframe specified by the ECM Administrator.
 4. **County Action to Restore or Correct.** If the permit holder fails to restore the County's right-of-way in the manner and to the condition required by the ECM Administrator, or fails to

satisfactorily and timely complete all restorations required by the ECM Administrator, the ECM Administrator may have the County perform the restorations. In that event, the permit holder shall pay to the County, within 30 days of billing, the cost of restoring the right-of-way plus an additional degradation fee established by the ECM Administrator

5.5.5. Work in the Right-of-Way Permit Expiration and Extension

- A. **Expiration.** Every Work in the Right-of-Way Permit issued by the ECM Administrator shall expire if the work authorized by the permit is not substantially begun within one year from the date of the permit or if the construction of work authorized by the permit is suspended or abandoned for a period of one year at any time after the work is begun. The permit will also expire if it is not picked up within 90 days of the permit being issued. Before such work can be resumed, the Work in the Right-of-Way Permit shall be reissued by the ECM Administrator. The fee for a reissued Work in the Right-of-Way Permit shall be one-fourth of the amount required for a new Work in the Right-of-Way Permit for the work, provided no changes have been made or are required by the ECM Administrator in the originally approved plans and specifications. A copy of the permit must be available at the site for review at all times.
- B. **Extension.** Any permit holder with an unexpired Work in the Right-of-Way Permit may apply for an extension of the time within which work may begin under that permit if the permit holder is unable to begin work within the time required for good cause, and that the cause is acceptable to the ECM Administrator. There shall be an extension fee assessed to cover administrative costs.

5.5.6. Work in the Right-of-Way Permit Suspension or Revocation

- A. **Permit Issued in Error or Violation of ECM.** The ECM Administrator may suspend or revoke any Work in the Right-of-Way Permit, in writing, whenever the Work in the Right-of-Way Permit is issued in error or on the basis of incorrect information supplied by the applicant or whenever the permit may have been issued in violation of any provisions of these Standards. In the event a permit is suspended or revoked, no refund of permit fees shall be made unless the permit was issued by the ECM Administrator in error.
- B. **Breach of Permit Terms and Conditions.** Permit holders hold Work in the Right-of-Way Permits as a privilege. The County reserves its right to revoke any Work in the Right-of-Way Permit, without fee refund, in the event of a substantial breach of the terms and conditions of any statute, ordinance, standard, rule or regulation, or any condition of the permit. A substantial breach by the permit holder shall include, but shall not be limited to, the following:
- The violation of any material provision of the Work in the Right-of-Way Permit;
 - An evasion or attempt to evade any material provision of the Work in the Right-of-Way Permit, or the perpetration or attempt to perpetrate any fraud or deceit upon the County or its citizens;
 - Any material misrepresentation of fact in the application for a Work in the Right-of-Way Permit;
 - The failure to maintain the required bonds or insurance;
 - The failure to complete the work in a timely manner;
 - The failure to correct a condition indicated on an order of the ECM Administrator;
 - Hiring illegal aliens;
 - Failing to report damage to other utilities; or
 - Failing to report injuries.

If the ECM Administrator determines that the permit holder has committed a substantial breach of a term or condition of any statute, ordinance, rule, regulation or any condition of the permit, the ECM Administrator shall make a written demand upon the permit holder to remedy the violation. The demand shall state that continued violations may be cause for revocation of the permit. Further, a substantial breach will allow the ECM Administrator to place additional or revised conditions on the permit.

Within 48 hours of receiving notification of the breach, the permit holder shall contact the ECM Administrator with a plan, acceptable to the ECM Administrator, for correction. The permit holder's failure to contact the ECM Administrator, or the failure to submit an acceptable plan, or failure to reasonably implement the approved plan, shall be cause for immediate revocation of the permit. Further, the permit holder's failure to contact the ECM Administrator, or failure to submit an acceptable plan, or failure to implement the approved plan, shall automatically place the permit holder on probation for one full year. Permit fees may increase while an applicant is on probation.

- C. **Violation of Permit Conditions.** From time to time, the ECM Administrator may establish a list of permit conditions which, if breached, will automatically place the permit holder on probation for one full year, such as, but not limited to, working out of the allotted time period, working on right-of-way grossly outside of the permit, failing to report utility hits, failing to report injuries or hiring illegal aliens.
- D. **Breach of Permit While on Probation.** If a permit holder, while on probation, commits a breach as outlined above, the permit holder's permit will automatically be revoked and permit holder will not be allowed further permits for one full year, except for emergency repairs.
- E. **Reimbursement of County Costs for Revoked Permit.** If a permit is revoked, the permit holder shall reimburse the County for the County's reasonable costs, including restoration costs and the costs of collection and reasonable attorneys' fees incurred in connection with revocation.

5.5.7. Fees

A. General.

- 1. **Excavation.** The excavation fee shall be in an amount sufficient to recover the following costs if applicable:
 - The County management and administrative cost;
 - The traffic management fee;
 - The degradation cost;
 - The trench fee for trenches over 1,320 linear feet; and
 - The incentive/disincentive.
- 2. **Temporary Obstruction Fee.** The obstruction fee shall be in an amount sufficient to recover the following costs if applicable:
 - The County management and administrative cost; and
 - The traffic management fee.
- 3. **Encroachment.** The encroachment fee shall be in an amount sufficient to recover the following costs if applicable:
 - The County management and administrative cost;
 - The traffic management fee;
 - The registration and monitoring costs;

- The degradation cost;
- The incentive/disincentive; and
- The trench fee for trenches over 1,320 linear feet.

4. **Annual Maintenance Permit (\$600.00 currently).**

- The County management and administration cost.

- B. **Work in the Right-of-Way Permit Review Fees.** The Work in the Right-of-Way Permit review fee shall be paid in full at the time the Work in the Right-of-Way Permit application is submitted for approval to the ECM Administrator. The permit review fees shall be determined by resolution of the BOCC. Applications for which no Work in the Right-of-Way Permit is issued within one year following the date of the original application shall expire; and plans and other data submitted for review may be returned to the applicant or destroyed by the ECM Administrator. The ECM Administrator may extend the time for action by the applicant for a period not exceeding one year upon request by the applicant showing that circumstances beyond the control of the applicant have prevented action from being taken. No application shall be extended more than once. In order to renew action on an application after expiration, the applicant shall resubmit plans and pay a new plan review fee.

All resubmittals or incomplete applications are subject to re-review fees. Re-review fees shall be established by resolution the BOCC. A re-review fee may be assessed at the discretion of the ECM Administrator for each plan review when the redlines are not corrected or when resubmittal materials are not complete. The purpose of the re-review fee shall not to be interpreted as requiring re-review fees the first time a submittal is rejected for failure to comply with the requirements of these Standards, but rather as controlling the practice of not making required plan corrections or submitting complete materials.

- C. **Work in the Right-of-Way Permit Fees.** The fee for Work in the Right-of-Way Permit shall be as determined by resolution of the BOCC plus any mapping, registration and monitoring, degradation or traffic management costs assessed by the ECM Administrator. Work in the Right-of-Way Permit fees shall be paid in full at the time the plans and specifications have been approved by the ECM Administrator and the Work in the Right-of-Way Permit is issued. The ECM Administrator may allow the registrants to pay permit fees within 30 days of billing.

1. **Computation of Traffic Management Fee.** The ECM Administrator shall determine the traffic management fee component of the fees for excavation, obstruction or encroachments, and in doing so shall have the purpose of providing a financial incentive to permit holders to minimize their obstruction and use of the right-of-way and to get in and get out of the right-of-way as quickly as possible. In aid of that purpose, the ECM Administrator shall use in the computation of the traffic management fee, to the extent practicable, economic and accounting principles relating to the quantification of the social costs resulting from road obstructions, including (1) losses to businesses and merchants which would not have occurred but for the obstructions, and (2) social costs to the users of the County's right-of-way resulting from traffic delays, diversions, disruption in services, missed or delayed appointments, and decline in quality of life. Fees may vary from one location to another based on the size of the area to be obstructed; the duration that the County right-of-way or parts of it will be unavailable for public use and travel; the proximity of businesses and enterprises which rely in whole or in part on access by members of the public or the delivery of supplies or raw materials; the importance of the particular right-of-way as to the traveling public; the use of the particular right-of-way for emergency vehicles and the availability of alternate routes; the traffic volumes carried by the particular right-of-way; and the amount of vehicular, bicycle, and pedestrian traffic that is reasonably likely to be disrupted. The methodology used to establish the fee shall be approved by the BOCC.

2. **Computation of Degradation Fees.** The ECM Administrator shall determine the degradation fee component of the fees for excavation, obstruction or encroachments. The degradation fee shall have the purpose of providing a financial incentive for permit holders to minimize their damage to public improvements and to coordinate their new construction, repair and replacement programs with County maintenance and capital improvement programs. The ECM Administrator shall use in the computation of the degradation fee, to the extent practicable, economic and accounting principles relating to the decrease in the useful life of the County's right-of-way and impact public improvements caused by excavation in or disturbance of the County right-of-way or those improvements, resulting in the need to reconstruct improvements earlier than would be required if the excavation or disturbance did not occur. The degradation fee shall consider:
- The number, size, depth and duration of the excavations, disruptions or damage to the County's right-of-way;
 - The traffic volume carried within the County's right-of-way and the character of the neighborhood surrounding the County right-of-way;
 - The pre-existing condition of the County's right-of-way and the remaining useful life of the County's right-of-way affected by the excavation;
 - Whether the relative cost of the method of restoration to the permit holder is in reasonable balance with the prevention of an accelerated depreciation of the County's right-of-way that would otherwise result from the work, disturbance or damage to the County's right-of-way; and
 - The likelihood that the particular method of restoration would be effective in slowing the depreciation of the County's right-of-way that would otherwise take place.

The methodology used to establish the fee shall be approved by the BOCC.

3. **Incentive/Disincentive.**

- Earn 1 point for each item successfully completed per permit
- Track running average* of points earned for each permit holder
- Post averages on Transportation website

Five Rating Categories

- 24-hours minimum notification of start and completion of project
- Proper setup and continual maintenance of work zone per approved traffic control plan
- Submit all required compaction test per ECM at time of project completion
- Perform all patch work and restoration per ECM
- Completed project within time period specified on the permit (weather allowance is considered)

Permit costs using the incentive/disincentive points earned:

POINTS EARNED	PERMIT COST
0	200%
1	150%
2	125%
3	100%
4	90%

5	75%
---	-----

* Running averages will be rounded up or down to the nearest whole number

4. **Computation of Registration and Monitoring Fees.** The ECM Administrator may assess a registration and monitoring fee to all encroachment and registration renewal applications to cover the cost of maintaining the registry and monitoring County right-of-way information. The methodology used to establish the fee shall be approved by the BOCC.

- D. **Investigation Fees (Working without a Permit/Notice to Proceed).** Whenever any work for which a Work in the Right-of-Way Permit is required by these Standards is begun without the required Work in the Right-of-Way Permit or Notice to Proceed, a special investigation shall be made before a Work in the Right-of-Way Permit or the Notice to Proceed may be issued for the work. All work shall cease immediately upon written notice by the ECM Administrator.

An investigation fee shall be collected whether or not a permit is then or subsequently issued. The investigation fee shall be as determined by resolution of the BOCC. The payment of investigation fees shall not exempt any person from compliance with all other provisions of these Standards nor from any penalty prescribed by law.

- E. **Delay Penalty.** The ECM Administrator may impose a delay penalty for unreasonable delays in right-of-way excavation, obstruction, patching, or restoration by the permit holder. The delay penalty shall be proposed by the ECM Administrator and established by resolution of the BOCC. The delay penalty may also include a traffic management fee at the discretion of the ECM Administrator calculated in accordance with Section 5.5.7C.1.

- F. **Fee Refunds.** The ECM Administrator may authorize the refunding of any fee which was erroneously paid or collected. In addition, upon written request from the permit holder, the ECM Administrator may authorize the refunding of not more than eighty percent of the Work in the Right-of-Way Permit fee when no work has been done under a Work in the Right-of-Way Permit issued in accordance with these procedures. The ECM Administrator shall not refund any fee except upon written request filed by the original permit holder. The written request must be filed not later than one year after the date of the fee payment.

5.5.8. Registration and Right-of-Way Occupancy

- A. **Registration.** Any person, agency, corporation, or other entity who occupies or seeks to occupy the right-of-way or place any equipment or facilities in or on the right-of-way, including those with installation and maintenance responsibilities by lease, sublease or assignment, must register with the ECM Administrator.

Registration is not intended to apply to or require the following persons to register with the ECM Administrator: (1) property owners maintaining service lines solely for the purpose of connecting to utility service facilities located in the County's right-of-way or those facilities not subject to an Work in the right-of-way Permit; and (2) agents, contractors or subcontractors of a right-of-way user who has registered with the ECM Administrator.

- B. **Registration Prior to Work.** No person, agency, corporation, or other entity may construct, install, repair, remove, relocate, or perform any other work on, or use any non-county-owned facilities installed in any County right-of-way without first being registered with the ECM Administrator.

- C. **Annual Registration Renewal.** Registration is required on an annual basis to maintain facilities within the County right-of-way. If a registrant fails to renew their registration, the ECM Administrator shall assume that the registrant's facilities are abandoned and any facilities of the registrant's found in a

County right-of-way shall be deemed to be a nuisance. The ECM Administrator may exercise any remedies or rights it has at law or in equity, to abate or correct the nuisance, including, but not limited to, abating the nuisance or taking possession of the facilities and restoring the County's right-of-way to a useable condition, and the registrant shall reimburse the County for all costs incurred.

D. **Failure to Register.** One year after the passage of this section, any facilities of a person, agency, corporation, or other entity found in a County right-of-way that have not been registered shall be deemed to be a nuisance. The ECM Administrator may exercise any remedies or rights it has at law or in equity, to abate or correct such nuisance, including, but not limited to, abating the nuisance or taking possession of the facilities and restoring the County's right-of-way to a useable condition, and the person, agency, corporation, or other entity who owns said facilities shall reimburse the County for all costs incurred.

E. **Registration Information.**

1. **Information Required.** The information provided to the ECM Administrator at the time of registration shall include, but not be limited to:

- Each registrant's name, Utility Notification Center of Colorado registration number, address and e-mail address if applicable, and telephone and facsimile numbers.
- The name, address and e-mail address, if applicable, and telephone and facsimile numbers of a local representative. The local representative or designee shall be available at all times. Current information regarding how to contact the local representative in an emergency shall be provided at the time of registration.
- A certificate of insurance or self-insurance: (1) Verifying that an insurance policy has been issued to the registrant by an insurance company licensed to do business in the State of Colorado, or a form of self-insurance acceptable to the ECM Administrator; (2) Verifying that the registrant is insured against claims for personal injury, including death, as well as claims for property damage arising out of the: (i) use and occupancy of the County's right-of-way by the registrant, its officers, agents, and employees, and (ii) placement and use of facilities and equipment in the County's right-of-way by the registrant, its officers, agents, and employees, including, but not limited to, protection against liability arising from completed operations, damage of underground facilities and collapse of property; Naming the County as an additional insured as to whom the coverages required herein are in force and applicable and for whom defense will be provided as to all such coverages; Requiring that the County be notified 30 days in advance of cancellation of the policy or material modification of a coverage term; Indicating comprehensive liability coverage, automobile liability coverage, workers compensation and umbrella coverage established by the County in amounts sufficient to protect the County and the public and to carry out the purposes and policies of this section. The ECM Administrator may require a copy of the actual insurance policies.
- An acknowledgment by the registrant of the indemnification of the County.
- A copy of the registrant's order granting a certificate of authority from the Colorado Public Utilities Commission or other applicable state or federal agency, where the person, agency, corporation, or other entity is lawfully required to have such certificate from the commission or other state or federal agency.

2. **Notice of Changes.** The registrant shall keep all of the information listed above current at all times by providing the ECM Administrator information as to changes within fifteen days following the date on which the registrant has knowledge of any change.

F. **Reporting Obligations.**

-
1. **Mapping Data for New and Replaced Facilities.** Registrants shall provide mapping information for all new or replaced facilities in a format approved by the ECM Administrator. Registrants shall provide the mapping information required by the ECM Administrator including:
 - Location and approximate depth of registrant's mains, cables, conduits, switches, and related equipment and facilities, with the location based on: (1) Offsets from property lines, distances from the centerline of the County's right-of-way, and curb lines as determined by the County; (2) Coordinates derived from the coordinate system being used by the County; or (3) Any other system agreed upon by the registrant and the ECM Administrator.
 - The type and size of the facility;
 - A description showing above ground appurtenances;
 - A legend explaining symbols, characters, abbreviations, scale, and other data shown on the map; and
 - Any facilities to be abandoned, if applicable.
 2. **Data on Existing Facilities.** At the request of the ECM Administrator, a registrant shall provide existing data on its existing facilities within the County's right-of-way in the form maintained by the registrant at the time the request is made, if available.
 3. **Construction and Maintenance Plans.** Each registrant shall, at the time of registration and by December 1 of each year, file a construction and major maintenance plan for underground facilities with the ECM Administrator (in this paragraph, a "plan"). The plan shall be submitted using a format designated by the ECM Administrator and shall contain the information determined by the ECM Administrator to be necessary to facilitate the coordination and reduction in the frequency of excavations and obstructions of the County right-of-way.

The plan shall include, but not be limited to, the following information:

 - The locations and the estimated beginning and ending dates of all projects for facilities to be constructed in the County's right-of-way to be commenced during the next calendar year (in this paragraph, a "next year project"); and
 - To the extent known, the tentative locations and estimated beginning and ending dates for all projects for facilities to be constructed in the County's right-of-way contemplated for the 5 years following the next calendar year (in this paragraph, a "5-year project"). The term "project" in this paragraph shall include both next year projects and 5-year projects.
 4. **Availability of Plans.** The ECM Administrator will have available for inspection in the ECM Administrator's office a list of all plans submitted by registrants. All registrants are responsible for keeping themselves informed of the current status of this list and the plans filed with the ECM Administrator.
 5. **Changes in Next Year Projects and Coordination.** Thereafter, by February 1, each registrant may change any project in its list of next year projects, and must notify the ECM Administrator and all other registrants of all changes. A registrant may at any time join in a next year project of another registrant listed by the other registrant, subject to the prior consent of such other registrant. Where registrants join in a next year project to reduce disruption and degradation of the County's right-of-ways and infrastructure, the ECM Administrator may reduce the disruption and degradation fees. In cases where registrants join in a County next year road construction, reconstruction or resurfacing project, disruption and degradation fees may be waived by the ECM Administrator.

-
6. **Additional Next Year Projects.** Failure by a registrant to include a project in a plan submitted to the ECM Administrator shall not, in and of itself, constitute grounds for denial of a permit if the registrant has used commercially reasonable efforts to anticipate and plan for the project.
 7. **Utility Coordination Committee.** The ECM Administrator may create an advisory utility coordination committee. Participation on the committee is voluntary. It will be composed of any registrants that wish to assist the County in obtaining information and by making recommendations regarding the use of the County's right-of-way, and to improve the process of performing construction work therein. The ECM Administrator may determine the size of such committee and shall appoint members from a list of registrants that have expressed a desire to assist the County.
- G. **Relocation of Facilities.**
1. **Responsibility of the Registrant.** The registrant must promptly and at its own expense, with due regard for seasonal working conditions, permanently remove and relocate its facilities in the right-of-way whenever it is necessary to prevent interference, and not merely for the convenience of the County, in connection with: (1) A present or future use of the County's right-of-way for a public project; (2) The public health or safety; or (3) The safety and convenience of ordinary travel over the County's right-of-way.
 2. **Relocation Notification Procedure.** The ECM Administrator shall notify the registrant at least six months in advance of the need to relocate existing facilities so the registrant can plan the relocation. The ECM Administrator shall provide a second notification to the registrant one month before the registrant needs to begin the relocation. The registrant shall begin relocation of the facilities within one week of the second notification. All facilities shall be relocated within one month. The ECM Administrator may allow a different schedule if it does not interfere with the County's project. The registrant shall diligently work to relocate the facilities within the above schedule.
 3. **Delay to County Project.** The ECM Administrator shall notify the registrant if the registrant's progress will not meet the relocation schedule.
- H. **Interference By Other Facilities.** When the County does work in the right-of-way as part of its governmental right-of-way management function and finds it necessary to maintain, support, or move a registrant's facilities to carry out the work without damaging the registrant's facilities, the ECM Administrator shall notify the registrant's local representative as early as is reasonably possible. The County costs associated will be billed to the registrant and must be paid within 30 days from the date of billing.
- Each registrant shall be responsible for the cost of repairing any facilities in the County right-of-way which it or its facilities damage.
- I. **Right-of-Way Vacation.** If the County vacates a right-of-way that contains the facilities of a registrant, the registrant's rights in the vacated County right-of-way are governed by state law.
 - J. **Abandoned Facilities.** A registrant shall notify the County when facilities are to be abandoned in County right-of-way. A registrant that has abandoned facilities in a County right-of-way shall remove them from that right-of-way if required in conjunction with other County right-of-way repair, excavation or construction, unless this requirement is waived by the ECM Administrator.
 - K. **Indemnification and Liability.** By registering with the County, a registrant agrees to defend and indemnify the County in accordance with Section 5.2.6.

5.5.9. Insurance, Bonding, Construction Surety and Warranty Requirements

- A. **Permit Holder Insurance.** Before any permit holder shall perform work within the County's right-of-way under a Work in the Right-of-Way Permit, the permit holder shall show evidence of a valid and enforceable bodily injury and property damage liability insurance policy, with minimum limits of \$1,000,000.00 combined single limit coverage. Such policy shall be for the protection of the County from all suits, actions or claims of any type for injuries or damages allegedly sustained by any person or property as a result of the encroachments. Such policy shall specifically cover the acts and operations of any subcontractors or independent contractors of the permit holder, in addition to the permit holder's employees or agents. Special districts, utilities governed by State Public Utilities Commission, and municipalities, by obtaining a permit, do agree to accept liabilities for their work in the County's right-of-way.

In addition to the insurance described above, the permit holder personally, by working under an approved Work in the Right-of-Way Permit, agrees to be liable to the County for any expenses incurred by the County because of the permit holder's acts of omissions relating to the work, and the permit holder shall hold the County harmless from any claims of anyone else arising from or relating to the work.

- B. **Indemnification and Liability.** By accepting a Work in the Right-of-Way Permit, a permit holder agrees to defend and indemnify the County in accordance with Section 5.2.6.
- C. **Defect Warranty.** The permit holder shall warrantee all restoration work and its maintenance for 2 years following its completion and approval by the ECM Administrator. The permit holder shall post a defect warranty prior to the release of any portion of the construction surety. The amount of the defect warranty shall be based on an estimate of the percentage cost of roads construction, drainage facilities construction, utilities, and erosion control and revegetation damaged by the action. During the 2 year warrantee period the permit holder shall, upon notification from the ECM Administrator, correct all defective restoration to the extent necessary within the time period specified in the notice, using the method required by the ECM Administrator. If the defective work is not corrected by the permit holder, and the County does the work and sends a bill to the permit holder, who fails to pay for such work, the County may exercise its rights under the defect warranty. The following are exempt from having to file a defect warranty: special districts, utilities governed by the State Public Utilities Commission, and municipalities.

5.5.10. Inspections, Corrections and Project Closeout

- A. **Progress Inspections and Orders.** Inspections during the construction period will be made by the ECM Administrator to ensure that work is progressing in compliance with the permit and ECM. The permit holder shall make the work-site available to the ECM Administrator and to all others as authorized by law for inspection at all reasonable times during the execution and upon completion of the work. At the time of inspection the ECM Administrator may order the immediate cessation of any work which poses a serious threat to the life, health, safety or well-being of the public.

The ECM Administrator may issue an order to the permit holder for any work which does not conform to the applicable standards, approved plans and specifications, or permit conditions. The order shall state that failure to correct the violation will be cause for revocation of the permit. Within 10 days after issuance of the order, the permit holder shall present proof to the ECM Administrator that the violation has been corrected. If such proof has not been presented within the required time, the ECM Administrator may revoke the permit.

- B. **Inspection Before Pavement Placement.** Before a pavement section is replaced (patched) the contractor shall notify the ECM Administrator as to the date such work is proposed. Failure to notify the ECM Administrator may result in a request to have work re-done in order to pass a final inspection.

-
- C. **Completion Certificate and Project Closeout.** When the work under a Work in the Right-of-Way Permit is completed, the permit holder shall submit a completion certificate to the ECM Administrator within 5 days following completion. The completion statement, signed by the permit holder, shall show the completion date for the work performed, identify the installer and design engineer, and certify that the work was completed according to the requirements of the ECM Administrator. If the work involved the placement of any permanent facilities, record drawings meeting the requirements of Section 5.11.6 shall be submitted.

5.6. EROSION AND STORMWATER QUALITY CONTROL

5.6.1. General

The Erosion and Stormwater Quality Control Permit (ESQCP) and Builder's Erosion and Stormwater Quality Control Permit (BESQCP) are established tools to: protect water quality in the County; provide for the enforcement of specific stormwater control measures (also known as Best Management Practices (BMPs)) during construction through final stabilization; and implement control measures required by the County's MS4 Permit. The permits and associated standards are intended to minimize soil erosion and sedimentation during and after construction and to control non-point source pollution by requiring the implementation of soil erosion, sedimentation, and runoff control measures for protection of water quality. Refer to Appendix I for specific application and permit holder responsibilities for ESQCPs and BESQCPs.

5.6.2. ESQCP Permit and Notice to Proceed Required

An ESQCP is required for construction activities that result in land disturbance of greater than or equal to 1 acre or that is less than one acre, but is part of a larger common plan of development or sale that would disturb 1 acre or more, unless the activity meets exclusion criteria in Section 5.6.3. Any project involving land disturbing activity of less than 1 acre but which disturbs more than 500 cubic yards of material (stockpiling, cut and/or fill) may be considered an applicable construction activity at the ECM Administrator's discretion when potential pollutants, site topography, hydraulics or proximity to a surface water body are of significant concern.

For builders of single residential homes that are not part of a larger common plan of development or sale, and that will disturb less than 1 acre of land, a BESQCP may be obtained following a simplified procedure. ;b1; No work shall begin under an approved ESQCP or BESQCP until the ECM Administrator has issued a Notice to Proceed under an approved Construction Permit or until issuance of a Building Permit.

5.6.3. [Activities not subject to ESQCP or BESQCP requirements]

The following construction activities are not subject to ESQCP or BESQCP requirements:

- A. Construction activities that qualify for the R-Factor waiver provided in Colorado Regulation No. 61, 5 CCR 1002-61, Section 61.3(2)(f)(ii)(B).
- B. Large lot single family home construction when land disturbance greater than 1 acre occurs on a single-family residential lot or agricultural zoned land with a parcel size greater than or equal to 2.5 acres and a total site impervious area less than or equal to 10 percent. Up to 20% impervious area may be allowed when a study specific to the watershed and/or parcel is conducted by the owner and approved by the ECM Administrator which demonstrates that expected soil and vegetation are suitable to infiltrate 100% of the Water Quality Capture Volume (WQCV). See Appendix I for information on WQCV.

-
- C. Facilities associated with oil and gas exploration, production, processing, or treatment operations, or transmission facilities, whether or not such field activities or operations may be considered construction activity.

5.6.4. Relationship to Other ECM Permits

In most cases, construction of public facilities within any County right-of-way or easement or the construction of common development improvements including grading will require that the applicant obtain an ESQCP. In cases where a submitted drainage report demonstrates the need for permanent stormwater quality management, a grading and erosion control plan may be required in cases where land disturbance is less than 1 acre.

5.6.5. Application, Review, Approval, Inspections and Enforcement

Application, review, approval, inspections, and enforcement for ESQCP or BESQCP shall conform to the requirements of Appendix I.

(Res. No. 19-245 , 7-2-19)

5.7. SPECIAL TRANSPORT PERMIT

5.7.1. General

The ECM Administrator is responsible for ensuring the long-term structural stability of roads and bridges in the County has established a Special Transport Permit as a tool to allow over dimensional loads and vehicles to be routed along County routes with adequate capacity to accommodate the proposed load or vehicle dimensions, ensure adequate safety provisions are provided to protect the traveling public, reduce damage to County facilities, track over dimensional loads, and obtain reasonable fees to provide for the administration of permits and impacts to County facilities. This section provides an orderly procedure for obtaining a Special Transport Permit.

There are two types of Special Transport Permits:

1. **Annual.**
 - For vehicles and fleets moving multiple oversize/overweight loads during the year.
 - Maximum width of 17', pilot cars required per Section 5.8.6.
 - Maximum length of 110', pilot cars requirements per Section 5.8.6.
 - Maximum height of 16', pilot cars requirements per Section 5.8.6.
 - Maximum weight of 200,000 lbs; pilot cars requirements per Section 5.8.6.
2. **Oversize/Overweight (Special).**
 - Single oversize/overweight loads exceeding Annual Permit maximum dimensions or weights.
 - Requires 1 or more pilot cars.

5.7.2. Special Transport Permit Required

Pursuant to the laws of the State of Colorado, the County requires that a Special Transport Permit be obtained from the ECM Administrator, when transporting a load or vehicle on a County road where overall dimensions or weight of the load or vehicle exceed 1 or more of the following limits:

(Supp. No. 2)

Created: 2021-06-08 11:35:50 [EST]

-
- Overall height (Total distance from ground to top part of load): 13 feet.
 - Overall width: 8.5 feet.
 - Overall length for single vehicles: 45 feet.
 - Overall length for combination vehicles: 75 feet.
 - Overhang: 4 feet front and 10 feet rear.
 - Overall weight for combination vehicles: 85,000 lbs.
 - Overall weight for single vehicles (3 or more axles): 54,000 lbs.
 - Overall weight for single vehicles (2 axles): 36,000 lbs.
 - Weight on Any Single Axle (with low-pressure tires): 20,000 lbs. per single axle, 36,000 lbs. for tandem axle and 54,000 lbs. for tridem axles.

5.7.3. Prohibited Loads or Vehicles

The following over dimensional loads and vehicles are prohibited on the County roads:

- Front overhangs exceeding 32 feet.
- Rear overhangs exceeding 35 feet.
- Five and Six-axle vehicles carry more than 74.5 tons.

5.7.4. Application

- Complete Application Required.** Applicants shall file a complete application for a Special Transport Permit on forms provided by the ECM Administrator. Application for permits shall be made not less than 5 days in advance of the time transport is to be done. The application shall fully describe the load dimensions and proposed route including when the transport will occur.
- Signed by Applicant.** All applications for Special Transport Permit shall be signed by the applicant, or an authorized agent, who may be required to submit evidence to indicate their authority.
- Determination of Application Completeness.** An application will be considered complete if it is submitted in the required form, includes all mandatory information, including all supporting materials specified by the ECM Administrator, and is accompanied by the applicable fee. If an application is determined to be incomplete, the ECM Administrator shall provide notice to the applicant along with an explanation of the application's deficiencies. No further processing of the application shall occur until the deficiencies are corrected in a future resubmittal. An application which is determined to be incomplete may or may not retain its same processing cycle.

5.7.5. Special Transport Permit Review and Issuance

- Review Process.** The application and other data filed by an applicant for a Special Transport Permit shall be reviewed by the ECM Administrator.

If the ECM Administrator finds that the transport described in an application for a Special Transport Permit and other data conform to the requirements of these Standards and other pertinent laws regulations or ordinances and that all required fees have been paid, a Special Transport Permit may be issued to the applicant. A Special Transport Permit is valid once issued and transport may proceed in accordance with the dates prescribed in the permit.

-
- B. **Criteria for Approval.** The ECM Administrator may issue a Special Transport Permit if the proposed transport meets these Standards, no alternative routes are available that would limit transport of the over dimensional load over County roads, and the proposed method is satisfactory.
- C. **Conditions of Approval.** The ECM Administrator shall have the authority to affix reasonable conditions to the granting of a Special Transport Permit.

5.7.6. Special Transport Permit Standards and Permit Holder Responsibilities

- A. **Pilot Car Required.** One pilot car is required when the overall dimensions/weight of load/vehicle fall within one or more of the following limits:

- Overall height equals or exceeds 16 feet.
- Overall width equals or exceeds 11 feet but less than 14 feet.
- Overall length exceeds 45 feet for single vehicles or exceeds 75 feet for combination vehicles, but less than 100 feet.
- Front overhang equals or exceeds 25 feet in length.
- Rear overhang equals or exceeds 20 feet in length.
- Overall weight equals or exceeds 75 tons.

2 pilot cars, fore and aft, are required when the overall dimensions/weight of load/vehicle fall within one or more of the following limits:

- Overall width equals or exceeds 14 feet.
- Overall length equals or exceeds 100 feet.

A pilot car shall be a single vehicle with a minimum width of 60 inches, and may operate with a nondestructive vertical clearance-measuring device suitable for measuring heights in excess of 14 feet.

A pilot car shall be equipped with one stop/slow paddle, one orange vest, one (18" x 18" minimum) red hand-flag, 2-way radio to communicate with transporting vehicle, top-mount flashing amber warning-light and the proper load signs.

A single pilot car shall precede the load/vehicle on 2 or 3-lane roads and follow on 4 or more lane highways and divided highways. When 2 pilot cars are required, one shall precede and one shall follow.

Pilot cars and transporting vehicle shall remain to the right of the roadway centerline, and along the most right lane, at all times, unless it is absolutely necessary to stay left.

- A pilot car shall not:
- Preempt opposing traffic.
- Tow another vehicle.
- Display the stop/slow sign paddle out of its window when moving.
- Stop opposing traffic, except in extreme emergencies.
- Convoy more than one load/vehicle at the same time.

Pilot cars shall accompany the extralegal load/vehicle at all times during the transportation operation. Pilot cars shall maintain proper intervals from the vehicle, to allow passing by other traffic.

- B. **Signs.** All signs shall:
- be neat, clean, legible and securely mounted.

-
- have black letters on a bright yellow background.
 - be illuminated for night moves, or be constructed of reflectorized material that is clearly visible to traffic.
 - read "oversize load" or "overweight load", as appropriate.
 - have lettering a minimum of 10 inches in height with a 2 inch minimum brushstroke and a minimum 1 inch margin all around.
 - be posted on the front and rear of the vehicle.
 - mounted at least 18 inches for vehicles and 48 inches for pilot cars, above road surface, and shall be visible from straight-ahead or behind and to 45 degrees either side thereof.
 - be posted on the front of the pilot car, when leading, and on rear, when following.
 - have a minimum sign area of 440 square inches for a pilot car.
- C. **Flagmen.** A flagman is required whenever 2 pilot cars are in use. Flagging shall be done in accordance with CDOT requirements.
- D. **Manufactured Housing.** Axle weight for manufactured housing unit shall not exceed 6,000 pounds per axle. Tractor units towing manufactured housing unit that exceeds legal width, up to 12 feet, shall be equipped with dual rear wheels and shall have an unladen weight of not less than 6,500 pounds. Tractor units towing manufactured housing unit exceeding 12 feet in width, shall be equipped with dual rear wheels and shall have an unladen weight, as of not less than 9,500 pounds.
- Manufactured housing units open on one side shall be covered with plywood or other approved rigid material. Approved flexible material billowing or flapping less than six inches, may be substituted for rigid material. Manufactured housing units, open on both sides, need not be covered if transported empty.
- E. **Transport During Inclement Weather Prohibited.** The permit holder shall ensure that the transportation of an over dimensional load/vehicle does not occur during inclement weather conditions, including snow, rain, fog and wind. The permit holder shall ensure that the transportation of an over dimensional load/vehicle does not occur when the pavement surface is hazardous due to inclement weather conditions. The permit holder shall ensure that no transportation of an over dimensional load/vehicle occurs when the visibility is less than 1000 feet. Any accident caused by the transportation of an over dimensional load/vehicle during inclement weather conditions, shall be considered a violation and shall constitute grounds for revoking the permit.
- F. **Vehicle Requirements.** The permit holder shall check the load/vehicle to ensure compliance with all applicable requirements and shall ensure that actual axle weights do not exceed those shown on the permit. The permit holder shall further ensure that permitted axle or axle group weights do not exceed the rated capacity of the vehicle tires. A permit holder shall use neither booster axles nor joe dog axles in transporting overweight loads.
- G. **Check Clearance.** The permit holder shall check all underpasses, bridges, mast arms of lighting and traffic signals, overhead wires and all other structures, for impaired vertical clearance. The permit holder shall arrange for either a bypass or a clearance at such locations.
- H. **Repair Damage.** The permit holder shall repair, at permit holder's sole cost, any damage to any public or private property, and pertinent improvements, resulting from transporting the permit holder's load/vehicle, to the satisfaction of the ECM Administrator. Any damage shall be reported to the ECM Administrator, in writing, within 72 hours. Failure to file a report will result in the cancellation of all future permit privileges, pending a satisfactory arrangement with the ECM Administrator to repair the damage.

I. **Hours for Transport.** The transportation of an over dimensional load/vehicle shall strictly occur between the hours 11:00 p.m. and 5:00 a.m. and shall not occur from 5:00 a.m. on Saturday until 11:00 p.m. on Sunday, when the overall dimensions of the load/vehicle fall within one or more of the following limits:

- Overall height equals or exceeds 18 feet.
- Overall width equals or exceeds 15 feet.
- Overall length equals or exceeds 110 feet.

Unless specifically authorized by the permit, no transportation of any over dimensional load/vehicle shall occur during the following times or holidays:

- 7:00 a.m. to 9:00 a.m. Monday through Friday.
- 4:00 p.m. to 6:00 p.m. Monday through Friday.
- Christmas Evening and Day.
- New Year's Evening and Day.
- Memorial Day.
- Independence Day.
- Labor Day.
- Thanksgiving Day.
- Any other national/state holiday.

J. **Permit Available for Surrender.** The Special Transport Permit is the property of the County, and must be surrendered upon demand, to any law enforcement officer or the County employee charged with the care and protection of the County's right-of-way.

K. **Insurance, Subrogation and Indemnity.** The permit holder shall maintain on file with the ECM Administrator, throughout the term of the permit, a County-approved general liability insurance policy and endorsement naming the County additional insured on primary basis. Insurers must be admitted to do business in the State of Colorado.

Signing the Special Transport Permit is prima facie evidence that the permit holder waives permit holder's right of subrogation against the County, its officers, elected and appointed officials, employees and volunteers for any loss, liability, damage, or cost sustained by any person or property, arising out of work or operations performed by or on behalf of the permit holder, including materials, parts, or equipment furnished in connection with such work or operations.

Signing the Special Transport Permit is prima facie evidence that the permit holder agrees to indemnify, defend and hold harmless the County, its officers, elected and appointed officials, employees and volunteers against any loss, liability, damage, or cost sustained by any person or property, arising out of work or operations performed by or on behalf of the permit holder, including materials, parts, or equipment furnished in connection with such work or operations.

5.7.7. Special Transport Permit Expiration and Extension

- A. **Expiration.** The date of expiration shall be identified in the Special Transport Permit. Transport shall be completed in the time allowed on the permit and in the manner as therein described.
- B. **Extension.** Any permit holder with an unexpired Special Transport Permit may apply for an extension of the time within which complete transport under that permit if the permit holder is unable to transport

the load within the time required for good cause, and that the cause is acceptable to the ECM Administrator.

5.7.8. Fees

- A. **Special Transport Permit.** Special Transport Permit fees shall be paid in full at the time of permit issuance. The fee for Special Transport Permit shall be as determined by resolution of the BOCC.
1. Annual permit (fleet) costs:
 - 5 times oversize/overweight permit plus 5% of Annual permit cost per vehicle to be permitted
 - No security deposit
 - If any of the maximum limits in Section 5.7.1 are exceeded, each vehicle exceeding the limit must have its own annual permit and cannot be included in the fleet annual permit.
 2. Oversize
 - Fee to be set by resolution of the BOCC
 - Security deposit based on load dimensions. The security deposit will be determined for both width and height. The security deposit required will be determined based on the greater deposit of width and height.

Width of Load	Height of Load	Deposit
≤14'	≤14'	\$0.00
>14' ≤20'	>14' ≤15'	\$100.00
>20' ≤28'	>15' ≤18'	\$250.00
>28' ≤36'	>18' ≤22'	\$1,000.00
>36'	>22'	\$2,500.00

- B. **Investigation Fees (Working without a Permit/Notice to Proceed).** Whenever any transport for which a Special Transport Permit is required by these Standards is begun without the required Special Transport Permit, a special investigation shall be made before a Special Transport Permit may be issued. Transport shall cease immediately upon notice by the ECM Administrator of failure to obtain a permit.

An investigation fee shall be collected whether or not a Special Transport Permit is then or subsequently issued. The investigation fees shall be determined by resolution of the BOCC. The payment of investigation fees shall not exempt any person from compliance with all other provisions of these Standards nor from any penalty prescribed by law.

5.7.9. Special Transport Permit Suspension or Revocation

The ECM Administrator may suspend or revoke any Special Transport Permit, in writing, issued under the provisions of these Standards whenever the Special Transport Permit is issued in error or on the basis of incorrect information supplied by the applicant or whenever the Special Transport Permit may have been issued in violation of any provisions of these Standards. In the event a Special Transport Permit is suspended or revoked, no refund of permit fees shall be made.

5.7.10. Voidance of Special Transport Permit

The Special Transport Permit is void if one of the following occurs:

- permit is not carried on the permitted vehicle.

-
- any part of the permit is not legible, or has been altered.
 - permit is not signed by an authorized representative of the County.
 - permit is presented without pertinent attachments.
 - permit is used on state or city highways.
 - route includes roads and bridges that have posted weight limits.
 - permitted dimensions/weight of an extralegal load/vehicle can be reduced to legal limits by repositioning and/or practical removal of a part, portion or unit.
 - permit is used to represent proper authority for transporting a load/vehicle that is not specifically described on the permit.
 - permit is used to represent proper authority for transporting a load/vehicle by an entity not specifically named on the permit, or organizationally related to the permit holder.
 - permit is used to represent proper authority for transporting a load/vehicle before or after the times and dates authorized by the permit.

5.8. DEVIATIONS FROM STANDARDS

5.8.1. General

The ECM establishes uniform standards for the design and construction of public improvements and common development improvements. These standards were established to promote consistent construction practices, and safeguard the interests of the County, its citizens, and the general public by ensuring that all improvements are designed and constructed in conformance with sound engineering principles and accepted standards. It is recognized that site conditions or a specific design or construction problem may require a design engineer to deviate from the adopted Standards. In cases where the design engineer can demonstrate, in writing, with engineering rationale and data that a provision of these Standards, if strictly adhered to, would cause unnecessary hardship or unsafe design because of topographical or other conditions particular to the site, and that a departure may be made without destroying the intent of such provision, the ECM Administrator may approve a deviation of the required Standard.

5.8.2. Deviation for Specific Projects

The ECM Administrator may make project-specific revisions to standard drawings and other BOCC promulgated technical engineering standards for use in any project, whether privately or publicly funded, in accordance with the procedures outlined in this section.

5.8.3. Submittal for Requested Deviation

A design engineer may request that the ECM Administrator deviate from a Standard relating to, and only for, a specific project by submitting a written request for such deviation to the ECM Administrator. The written request shall state the desired deviation, the reason for the requested deviation, the condition authorizing consideration of the request from Section 5.9.6 that apply to the desired deviation, a comparison between the County's existing standard and the proposed deviation; and a detailed statement addressing each of the Criteria for Approval in Section 5.9.7.

Any request for deviation of a Standard for a specific project shall be supported with reference to pertinent nationally accepted specifications or standards. Refer to the Deviation Form for more information.

5.8.4. Review of Requested Deviation

After completing a review of the information submitted, the ECM Administrator shall:

- Approve the request as proposed,
- Approve the request with conditions, or
- Deny the request.

The ECM Administrator's decision shall be documented in writing. A denial of a request shall be accompanied with a brief explanation of the reason for the denial.

The ECM Administrator may consult with others to assist in determination of whether to approve, approve with conditions, or deny a request to modify a Standard for a specific project.

5.8.5. Affect of Request on Development Review and Permits

A request for deviation constitutes permission to delay processing the all associated development applications for up to 21 calendar days to allow analysis and decision by the ECM Administrator. The ECM Administrator may advise the Development Services Department to add the time between receiving this request and the decision being made to the project timeline.

5.8.6. Limits of Consideration

The ECM Administrator may only consider a project-specific deviation to an existing Standard when one of the following conditions is met:

- The ECM standard is inapplicable to a particular situation.
- Topography, right-of-way, or other geographical conditions or impediments impose an undue economic hardship on the applicant, and an equivalent alternative that can accomplish the same design objective is available and does not compromise public safety or accessibility.
- A change to a standard is required to address a specific design or construction problem, and if not modified, the standard will impose an undue hardship on the applicant with little or no material benefit to the public.

5.8.7. Criteria for Approval

In approving a request for deviation, the deviation must not be detrimental to public safety or injurious to surrounding property. No deviation shall be approved unless it is demonstrated that:

- The request for a deviation is not based exclusively on financial considerations;
- The deviation will achieve the intended result with a comparable or superior design and quality of improvement;
- The deviation will not adversely affect safety or operations;
- The deviation will not adversely affect maintenance and its associated cost; and
- The deviation will not adversely affect aesthetic appearance.

5.8.8. Limits of Approval

Whether a request for deviation is approved as proposed or with conditions, the approval is for project-specific use and shall not constitute a precedent or general deviation from these Standards.

5.8.9. Review Fees

A Deviation Review Fee shall be paid in full at the time of submission of a request for deviation. The fee for Deviation Review shall be as determined by resolution of the BOCC.

5.8.10. Tracking Approved Deviations

The ECM Administrator shall track all approved deviations to review in coordination with the annual evaluation of potential amendments to the ECM.

5.9. SITE DEVELOPMENT PLAN REVIEW

5.9.1. Overview

Submission of a Site Development Plan (SDP) for review by the ECM Administrator is required for all multifamily, commercial and industrial development within unincorporated the County in accordance with the requirements of the ECM. Obtaining approval of the SDP is required as part of El Paso County's Site Development Plan Review process and must occur prior to issuance of a building permit from the Regional Building Department. The SDP is to be reviewed by the ECM Administrator for compliance with applicable ECM Standards and ensure coordination between proposed and existing improvements.

5.9.2. Review Process

In most cases where site development is occurring within El Paso County, an applicant must submit applicable information for review and acceptance by the ECM Administrator through the Site Development Plan review process outlined in the LDC. In many cases, the review process may require the submission of certain engineered plans and documents to allow complete review and approval of the proposed development. Submissions will vary with the level of complexity and impact of the project but may include:

- Grading and Erosion Control Plan.
- Drainage Report.
- Traffic Impact Study.
- Site Utility Plan.
- Specific Plans for Proposed Public Improvements.
- Traffic Control Devices Plans (i.e. signalization, signing and pavement marking, traffic control plans).
- Other submissions typically required by the ECM.

Guidance concerning submission requirements is provided by the LDC and will be clarified during the Early Assistance meeting outlined in the LDC.

5.9.3. Standards

Proposed public improvements shall meet the requirements of these Standards. The ECM standards will be used as guidance in the review of the SDP and accompanying reports and plans for private improvements should use the ECM to provide guidance.

5.9.4. Application Requirements

Engineering drawings submitted for approval with site development plans shall be prepared, stamped and signed by a Professional Engineer licensed to practice in the State of Colorado. Engineering drawings

submitted for the initial application submission and subsequent reviews shall be provided in .PDF file format and are not required to be stamped and signed by the engineer of record.

On or after July 1, 2019, all construction drawings and final plat base drawings submitted for final signature approval by the ECM Administrator shall be provided in .PDF and CAD file format (.DWG) 2016 or newer version. Included with the CAD file submitted for final approval shall be at least two survey reference points to allow the County to move, fit and rotate the project file to the survey coordinate system used by El Paso County.

(Res. No. 19-245 , 7-2-19)

5.10. CONSTRUCTION CONTROL AND INSPECTION

5.10.1. General

- A. **Work Done in Accordance with Approved Plans.** Work performed in the construction or improvement of County roads, storm drainage facilities or other public facilities shall be done to the satisfaction of the ECM Administrator in accordance with approved plans. No work may be started until required permits and a Notice to Proceed are obtained. Revisions to construction plans shall be approved by the ECM Administrator prior to implementation.
- B. **Construction Plans Onsite.** A copy of the approved construction plans and a copy of the El Paso County ECM are required to be on the construction site at all times.
- C. **Test Reports.** It is the responsibility of the permit holder to provide the ECM Administrator with test reports, certified by a Professional Engineer licensed in the State of Colorado, to verify compliance of materials used in the project. Sampling and testing shall be at a frequency and magnitude determined by the ECM Administrator. All costs incurred for sampling and testing shall be the responsibility of the permit holder.

5.10.2. Inspection

- A. **Permit Holder Inspection Services.** The permit holder is fully responsible for providing onsite inspection of all public improvements by a construction representative. The ECM Administrator will not authorize work to begin without designation of the permit holder's construction representative at the preconstruction meeting.
- B. **Construction Inspection Services and Conflict of Interest.** Individuals or firms serving as the construction representative for a project, and all employees of such firms, must be financially independent of the permit holder. It is the sole responsibility of the permit holder to ensure the requirements of this paragraph are met.
- C. **County Policies Concerning Inspection Services.** The County's policies on inspection services for privately-funded site improvements and privately-funded public infrastructure improvements are as follows:
 - **Permit holder Inspection Services:** Permit holder inspection services required by the County are the primary inspection services on a project, are more comprehensive and intensive than County inspection services, and are the responsibility of the permit holder and designated construction representative.
 - **County Inspection Services:** It is the policy of El Paso County to provide only "spot check" (oversight) inspection services. The County's inspection services are only secondary inspection services and do not relieve the permit holder or construction representative of responsibility for proper

Created: 2021-06-08 11:35:51 [EST]

(Supp. No. 2)

construction and compliance with the requirements of these Standards, nor do County inspection services constitute approval of any modification to the approved construction plans.

D. **County Inspection Activities.** Inspecting services provided by the County shall include:

- Acting as a liaison between the designated construction representative, and the County.
- Monitoring both work progress and performance testing results.
- The performance of administrative and coordination activities as required to support the processing and completion of the project.
- Maintaining a completion file containing the following: (1) The original of the project completion certification; (2) A copy of any portions of the log book determined to be important to the County initialed by the construction representative; (3) The results of material tests, compaction tests, and soil analysis as detailed in the log book.
- Inform the Development Services Department of all proposed plan changes, material changes, stop work orders, or errors or omissions in the approved plans or specifications as soon as practical.

E. **Construction Engineer's Activities.** The following represents the standard onsite construction representative's activities the County believes are necessary to provide quality onsite control. This list is not all inclusive and the permit holder will ensure the activities match the site conditions and the activities being performed:

- Maintain a project log book of daily inspection reports which contain the following information: (1) job number and name of design engineer and designees; (2) permit number; (3) date and time (arrival and departure) of site visits; (4) weather conditions, including temperature; (5) a description of construction activities; (6) statements of directions to change plans, specifications, stop work, reject materials, or other work quality actions; (7) public agency contacts which result in plan changes or other significant actions; (8) perceived problems and action taken; (9) final and staged inspections; (10) record all material and soil types and conditions; (11) test results; (12) record all pavement grade and depth measurements by stationing; (13) general remarks including citizen contact or complaints.
- All active site development projects will be required to make inspection reports available to the ECM Administrator during construction.
- Obtain and use a copy of County-approved construction plans, specifications, and a copy of this manual. The construction representative shall document any changes to the plans which may arise during construction in accordance with Section 5.11.6.
- Inspect and approve all materials such as pipe, aggregate, portland cement concrete, asphaltic concrete, and other products used onsite to ensure their compliance with the approved plans and specifications.
- Approve all plan or specification changes in writing and obtain ECM Administrator approval of changes for which a change in design intent is to be made prior to the commencement of work affected by the revision.
- Monitor construction activities to ensure end products meet approved plans and specifications.
- Perform (or have performed) material, composition, and other tests required to ensure compliance with approved specifications.
- For pavement construction, perform the following stage inspections and record date of each: (1) curbs are built to line and grade; (2) subgrade meets grade and compaction specifications; (3) base course meets depth/thickness, grade, and compaction specifications; (4) leveling course

meets depth/thickness, grade, and compaction specifications; and (5) wearing course meets depth/thickness, grade, and compaction specifications.

- Provide the ECM Administrator with 48-hour notice of impending stage inspections.

5.10.3. Haul Route Agreements

Haul route agreements may be required for new or expanded hauling within the right-of-way for activities such as development construction that are anticipated to cause extraordinary damage or accelerated deterioration to County roads.

If required by the ECM Administrator, the permit applicant shall submit a proposed haul route for review by the ECM Administrator prior to the start of hauling activities. Based on review of the proposed haul route, the ECM Administrator may require a haul route agreement.

5.10.4. Subdivision and Commercial Development Inspection

- A. **General.** The County shall inspect all public improvements relating to subdivision and commercial development. Construction events that require notification of the ECM Administrator by the permit holder include those general items listed below. Adequate notice is required to ensure the ECM Administrator as reasonable opportunity to inspect. For additional information on sites subject to Erosion and Stormwater Quality Control Permit (ESQCP) inspections please refer to Appendix I. Change: "as" to "has" in last sentence.
1. **Preconstruction Meeting.** A preconstruction meeting shall precede the start of construction and the issuance of a notice to proceed if required by the ECM Administrator. The meeting shall include the contractor, design or construction engineer, utilities, and other parties affected. Approved plans, including the traffic control plan, and all permits are required to be obtained prior to the meeting.
 2. **Temporary Erosion Control Inspection (Initial ESQCP Inspection).** Forty-eight hours' notice is required prior to land disturbance to allow inspection of initial site work involving drainage and initial BMPs required by the Stormwater Management Plan.
 3. **Grading, Subgrade and Stormwater Management Inspection.** Forty-eight hours' notice is required prior to trenching and placing of utilities or placement of road base to allow inspection of final grading and stormwater facilities.
 4. **Road Base Approval.** Forty-eight hours' notice is required prior to placement of asphalt or curb to allow for inspection of underground utilities and placement of road base. Inspection shall include review and approval of any density tests and certifications submitted in accordance with Appendix J.
 5. **Asphalt and Curb Placement.** Forty-eight hours' notice is required following placement of road surface treatment and curb to allow for inspection of road and curb.
- B. **Failure to Notify For Inspection.** Notification of the ECM Administrator by the permit holder of the construction events described above is essential for verification of compliance with these Standards. Failure to notify in a timely manner may require the County to arrange appropriate sampling and testing after-the-fact, with certification by a qualified private testing laboratory or by the ECM Administrator. The cost of such testing and certification shall be borne by the permit holder. The ECM Administrator may prohibit or limit further work on development construction until all required tests have been completed and corrections made to the satisfaction of the ECM Administrator. If necessary, the County may take further action as permitted by law.

5.10.5. Monumentation of Roadways

- A. **Not Offset.** Monuments within and adjacent to the County's right-of-way shall not be offset unless prior approval from the ECM Administrator is received in writing.
- B. **Centerline Monumentation.** Center line monumentation shall be installed. If the monument is located within a hard surfaced road, the monument shall be located in a valve box with cover at grade. If the monument is located within a gravel surfaced road, the monument shall be placed in a valve box 3 to 6 inches below road grade.
- C. **Monument Caps and Data.** All monuments shall be metallic caps stamped with the registered business name or the letters "L.S." followed by the registration number of the surveyor in charge. All monuments shall include state plane coordinate and elevation information meeting County GIS Standards along with any information required by State law.
- D. **Replacement of Disturbed Monuments.** The permit holder is responsible for replacement of any disturbed monumentation previously present. All disturbed monumentation including property corners shall be reset per state statute.

5.10.6. Engineering Record Drawings

- A. **Record Drawing Required.** Engineering Record Drawings are required for all projects that include public improvements or common development improvements, including but not limited to roadway improvements, public sidewalks and trails, storm drainage facilities, and utility infrastructure on public property or on private property within public easements or rights-of-way. Engineering Record Drawings are necessary for inclusion of public improvements into the El Paso County Asset Management System, to serve as a basis to plan and design future projects in the same area, to demonstrate ADA compliance, and to document compliance with permitting requirements such as the County's MS4 permit. Engineering Record Drawings shall be submitted in an electronic format acceptable to the ECM Administrator as described below in Section 5.10.6.D.
- B. **Reflect Changes to Construction Plans.** Engineering Record Drawings are a record of any substantial variations or changes to the original intended physical product of the approved construction plans, based upon visual field observations or field survey data. The revisions shall be shown on a copy of the original approved construction plans that are filed with the County. Engineering Record Drawings submitted for County review may be the same drawings as the original approved plan drawing if no substantial variation to the original approved design occurred. Engineering Record Drawings shall be accompanied by a certification letter from the Engineer of Record which shall state that the site and adjacent properties (as affected by work performed under the County permit) are stable with respect to settlement and subsidence, sloughing of cut and fill slopes, revegetation or other ground cover, and that the improvements (public improvements, common development improvements, site grading and paving) meet or exceed the minimum design requirements.

For sites including detention and/or water quality facilities, the certification letter shall include a statement that the facilities provide the required storage volume and will meet the required release rates, as documented by an attached UDFCD design form submitted with the original application, the stage areas, elevations and outlet dimensions. If the detention/WQCV facility cannot be modeled with UDFCD spreadsheets due to a large contributing area, other verified stage/storage/discharge tables for the applicable design storms shall be provided with the certification letter.

At the initiation of the Preliminary Acceptance process, Engineering Record Drawings shall be submitted for review and approval by the ECM Administrator.
- C. **Record Drawings Approval Process.** To facilitate the approval process of Engineering Record drawings, the following procedure shall be followed:

- The permit holder's engineer of record shall submit the Engineering Record Drawings for ECM Administrator review in the applicable formats specified below.
- The ECM Administrator will review the drawings and redline any necessary changes. The engineer of record shall update the drawings and resubmit the drawings for approval.
- Upon ECM Administrator approval of the final Engineering Record Drawings, the drawings will be uploaded to the El Paso County Planning and Community Development (PCD) Electronic Development Application Review Program (EDARP). If there are multiple hardcopy sets the County will retain one set.
- The Engineering Record Drawings shall clearly indicate the completed state of construction for the project. Each sheet of the record drawings shall be designated as "Engineering Record Drawings" and signed and dated by the engineer of record.
- Financial assurances for the Engineering Record Drawings line item in the project Financial Assurance Estimate will not be released until the Engineering Record Drawings are submitted, verified and approved, nor will partial releases of any line item be reduced to less than 20%. It is recommended that the required format of drawings and certification letter be submitted at least one month prior to the developer's request for Preliminary Acceptance to expedite the County acceptance process.

D. Required Engineering Record Drawings Format

1. A complete construction plan set, including the plat or parcel boundaries as applicable, conforming to the minimum requirements in this section is required. Hard copy drawings will only be accepted in special cases as approved by the ECM Administrator.
2. For projects submitted on or after July 1, 2019, Electronic CAD files shall be in AutoCAD format (.DWG) 2016 or newer or in .PDF file format.

Survey/GIS Reference Links:

State monument records:

https://www.colorado.gov/pacific/dora/AES_Monument_Records

<http://www.cp-db.com/kml/EIPasoCountyMonumentRecordsNetworkLink.kmz> (KMZ file)

Vertical benchmark data: <https://www.ngs.noaa.gov/NGSDataExplorer/>

CSU Survey control points

(GIS):

<https://maps.csu.org/ArcFMWebViewer27/index.html?viewer=GISPublic&runWorkflow=CSUDisclaimer&inTheme>

<http://desktop.arcgis.com/en/arcmap/10.3/map/working-with-arcmap/creating-a-map-package.htm>

<https://helpx.adobe.com/acrobat/using/geospatial-pdfs.html>

<https://thecadgeek.com/blog/2008/09/georeferenced-dwf-files/>

**BUILDERS EROSION AND STORMWATER QUALITY CONTROL PERMIT (BESQCP)
EL PASO COUNTY APPLICATION AND PERMIT**

PERMIT NUMBER: _____

Applicant Information	
Property Owner	
Applicant Name (Permit Holder)	
Company	
Position of Applicant	
Address (physical address, not PO Box)	
City	
State	
Zip Code	
Phone	

Contractor Information	
Name (person of responsibility)	
Company	
Position of Applicant	
Address	
City	
State	
Zip Code	
Phone	

Project Specifications	
Name and Legal Description	
Name of Subdivision Filing	
Address (or nearest major cross streets)	
Acreage (total and disturbed)	
Schedule (start and finish and date of final stabilization)	
Description of Project	
Tax Schedule Number	

FOR OFFICE USE ONLY

The following signature from the ECM Administrator signifies the approval of this BESQCP. All work shall be performed in accordance with the permit and the El Paso County ECM Standards.

Signature of ECM Administrator: _____ Date _____

Rev. 7/2019

1.1 REQUIRED SUBMISSIONS

In addition to this completed and signed application, all permit fees must be submitted to obtain a BESQCP. Submission and review of a Stormwater Management Plan and posting of financial sureties are not required for a BESQCP.

1.2 RESPONSIBILITY FOR DAMAGE

The County and its officers and employees, including but not limited to the ECM Administrator, shall not be answerable or accountable in any manner for damage to property or for injury to or death of any person, including but not limited to a permit holder, persons employed by the permit holder, or persons acting in behalf of the permit holder, from any cause. The permit holder shall be responsible for any liability imposed by law and for damage to property or injuries to or death of any person, including but not limited to the permit holder, persons employed by the permit holder, persons acting in behalf of the permit holder, arising out of work or other activity permitted and done under a permit, or arising out of the failure to perform the obligations under any permit with respect to maintenance or any other obligations, or resulting from defects or obstructions, or from any cause whatsoever during the progress of the work or other activity, or at any subsequent time work or other activity is being performed under the obligations provided by and contemplated by the permit.

The permit holder shall indemnify, save, and hold harmless the County and its officers and employees, including but not limited to the BOCC and ECM Administrator, from all claims, suits or actions of every name, kind and description brought for or on account of damage to property or injuries to or death of any person, including but not limited to the permit holder, persons employed by the permit holder, persons acting in behalf of the permit holder and the public, resulting from the performance of work or other activity under the permit, or arising out of a failure to perform obligations under any permit with respect to maintenance or any other obligations, or resulting from defects or obstructions, or from any cause whatsoever during the progress of the work or other activity, or at any subsequent time work or other activity is being performed under the obligations provided by and contemplated by the permit, except as otherwise provided by state law. The permit holder waives any and all rights to any type of expressed or implied indemnity against the County, its officers or employees. It is the intent of the parties that the permit holder will indemnify, save, and hold harmless the County, its officers and employees from any and all claims, suits or actions as set forth above regardless of the existence or degree of fault or negligence, whether active or passive, primary or secondary, on the part of the County, the permit holder, persons employed by the permit holder, or persons acting in behalf of the permit holder.

1.3 APPLICATION CERTIFICATION

I, as the Applicant or the representative of the Applicant, hereby certify that this application is correct and complete as per the requirements presented in this application, the El Paso County Engineering Criteria Manual, and the Drainage Criteria Manual, Volume 2 and El Paso County Addendum.

Rev.7/2019

Created: 2021-06-08 11:35:51 [EST]

I understand that stormwater control measures are to be implemented on the site and maintained as necessary to protect stormwater quality as the project progresses. The site and adjacent areas will be self-inspected to be sure that control measures are installed correctly and functioning for each stage of construction and following each rain event.

Installation and maintenance of control measures include, but are not limited to:

- Source control and physical barriers that prevent pollutants, including sediment, from leaving the site, especially into waterways or storm drain systems. Pollutants are also to be kept off of roadways, including roadside ditches, and adjacent properties.
- Protection of downstream storm drains, channels, ponds, or waterways.
- Immediate cleanup of sediment and other pollutants that are tracked or otherwise leave the permitted site.

Examples of pollutants that must be contained and cleaned up are:

- Sediment (mud or dirt)
- Excavated or imported soil, aggregate, or rock
- Landscaping materials, including topsoil
- Concrete washout water
- Stucco
- Paints
- Solvents
- Fuels and lubricants
- Pesticides and fertilizers
- Cleaning products
- Other chemicals
- Trash, litter, garbage
- Sanitary waste (e.g. portable toilets), other animal waste

Note: El Paso County does not require that a Stormwater Management Plan (SWMP) be reviewed for a BESQCP. It is recommended, however, that a SWMP be prepared and site personnel be trained in the procedures necessary to protect stormwater quality. The measures in the City of Colorado Springs' Drainage Criteria Manual, Volume 2, Chapter 3, and the El Paso County approved Addendum provide guidance on stormwater control measures for construction sites. **Sites covered by BESQCPs are still subject** to any other relevant regulations such as the Colorado Discharge Permit System regulations. The permit holder is responsible for subcontractors onsite complying with the terms of the permit holder's BESQCP.

_____ Date: _____
Signature of Applicant or Representative

Rev.7/2019

Chapter 6 ACCESSIBILITY

6.1. OVERVIEW

This chapter addresses the standards and technical criteria to be used to plan, design, construct, choose materials for, locate, repair, maintain, reconstruct, and use accessible pedestrian facilities within and adjacent to public roadways, whether such pedestrian facilities are located within the public right-of-way, easements, or tracts, and on Shared Use Paths.

Design criteria and requirements presented in this chapter shall apply to pedestrian facilities within and adjacent to public roadways, whether such pedestrian facilities are located within right-of-way, easements, or tracts, and whether such public roadways are dedicated to use by the public or in fact used by the general public, regardless of the entity responsible for operation and maintenance. Other pedestrian facilities outside of the public right-of-

way or easements or tracts adjacent thereto may be required, however, to comply with ADA Standards and requirements based on other codes and regulations.

All pedestrian facilities shall be designed and constructed in accordance with current Proposed Guidelines for Pedestrian Facilities in the Public Right-of-Way (PROWAG), including the Shared Use Paths Supplement.

This chapter provides key design criteria for ADA Compliance. All new construction and alterations shall adhere to all PROWAG criteria to the maximum extent feasible. All new construction and alterations shall meet the requirements of this chapter unless a deviation request detailing the specific existing site constraints and technical infeasibility is approved by the ECM Administrator. Traditional maintenance activities that do not affect the public's access to or usability of the roadway are not required to comply with requirements of this chapter.

6.1.1. Purpose

The purpose of this chapter is to provide detailed design guidelines and criteria relating to accessibility for the preparation of plans for and access to all roadways dedicated to use by the public or in fact used by the general public, regardless of the entity responsible for operation and maintenance. These facilities include sidewalks, curb ramps, street crossings, and other elements within and adjacent to public roadways.

6.1.2. Chapter Content and References

Table 6-1 outlines the chapter content and references used as a basis for the standards established in Chapter 6.

Table 6-1. Contents and Basis of Accessibility Standards

Intent Use	ECM Content	ECM Section(s)	Reference Document(s)
Design			
	Sidewalks	6.3.1	1, 8
	Pedestrian Street Crossings	6.3.2	1
	Curb Ramps/Blended Transitions	6.3.3	1, 9
	Detectable Warning Surfaces	6.3.4	1, 9
	Medians/Pedestrian Refuge Islands	6.3.5	1
	Pedestrian Signals/Pushbuttons	6.3.6	1, 3, 4, 9
	Shared Use Paths	6.3.7	1, 2, 3, 4, 7
	Transit Stops	6.3.8	1
	Pedestrian Over/Underpasses	6.3.9	1
	Ancillary Elements	6.3.10	1, 3, 4, 8
	Pedestrian Access in Work Zones	6.3.11	1, 3, 4, 9
Construction			
	Inspections	Ch. 5, 6.4, App. J	1, 3, 4
	Acceptance	Ch. 5, 6.4	1, 3, 4

References

1. United States Access Board, Proposed Guidelines for Pedestrian Facilities in the Public Right-of-Way (PROWAG), 2011
2. United States Access Board, Proposed Guidelines for Pedestrian Facilities in the Public Right-of-Way; Shared Use Paths Supplement, 2013
3. FHWA, Manual on Uniform Traffic Control Devices for Streets and Highways (MUTCD), 2009 with Revisions 1 and 2, 2012
4. CDOT, Supplement to the Federal Manual on Uniform Traffic Control Devices, 2009
5. United States Department of Justice, 2010 ADA Standards for Accessible Design (ADA Standards), 2010
6. United States Department of Justice, Americans With Disabilities Act Title II Regulations (ADA Regulations), 2010
7. AASHTO, AASHTO Guide for the Development of Bicycle Facilities, 2012
8. AASHTO, AASHTO Roadside Design Guide, 4th Edition, 2011
9. CDOT, M&S Standards
10. CDOT, Roadway Design Guide, 2018

6.1.3. Standard Drawings

Table 6-2 identifies the standard drawings that are included in Appendix F as an enforceable part of these Standards. The Standard Drawings shall be used when designing improvements for County-owned and maintained facilities. Any change to a Standard Drawing shall be approved by the ECM Administrator and noted in the construction plans. CDOT standard drawings adopted in the ECM are also applicable to the design of pedestrian facilities. Where noted in this chapter, El Paso County standard drawings supersede CDOT standard drawings.

Table 6-2. Standard Drawings

File Name	Detail/Description	Approval Date
SD_2-1	Urban Local Roadway (low volume)	6/23/2020
SD_2-2	Urban Local Roadway	6/23/2020
SD_2-3	Urban Nonresidential Collector Roadway	6/23/2020
SD_2-4	Urban Residential Collector Roadway	6/23/2020
SD_2-5	Urban Minor Arterial Roadway	6/23/2020
SD_2-6	Urban Principal 4-Lane Arterial Roadway	6/23/2020
SD_2-7	Urban Principal 6-Lane Arterial Roadway	6/23/2020
SD_2-8	Urban Expressway 4-Lane Roadway	6/23/2020
SD_2-9	Urban Expressway 6-Lane Roadway	6/23/2020
SD_2-20	Typical Curb and Gutter Details	6/23/2020
SD-2-24	Driveway Detail w/ Attached Sidewalk	6/23/2020
SD_2-25	Driveway Detail w/ Detached Sidewalk	6/23/2020
SD_2-40	Pedestrian Curb Ramp Detail	6/23/2020
SD_2-41	Pedestrian Curb Ramp Detail	6/23/2020
SD_2-42	Detectable Warning Surface Details	6/23/2020
SD_2-50	Parallel Pedestrian Curb Ramp Detail	6/23/2020

6.1.4. Relationship between ECM, ADA, and PROWAG

The Americans with Disabilities Act (ADA) of 1990 is the civil rights law that prohibits discrimination against individuals with disabilities and is the basis for creating accessibility in the private and state and local government sectors. It is often referred to as the ADA Regulations. The ADA Standards establish the design requirements for the construction and alteration of facilities, including sites and buildings. Although they are related and based on similar concepts, these standards are not directly applicable to the public rights-of-way. In order to address elements within and adjacent to public roadways, the United States Access Board created the Proposed Guidelines for Pedestrian Facilities in the Public Right-of-Way (PROWAG). These guidelines establish the design requirements for construction and alteration of elements within and adjacent to public roadways. The United States Access Board has also created a supplement to PROWAG to address specific design requirements for Shared Use Paths.

El Paso County requires that all pedestrian facilities within and adjacent to public roadways be designed and constructed in accordance with current PROWAG requirements, including the Shared Use Paths Supplement. The design criteria and requirements presented in this chapter are taken directly from PROWAG. Recommendations and best practices are provided to facilitate compliance during design and construction. Where additional guidance is required beyond what is presented in the ECM, refer to the ADA Regulations, 2010 ADA Standards, PROWAG (2011) with Shared Use Path Supplement (2013), MUTCD (2009 with revisions and Colorado Supplement), and other guidance and resources provided by the United States Access Board.

(Res. No. 20-222 , 6-23-20)

6.2. PLANNING AND APPLICABILITY

6.2.1. Definitions and Building Blocks of Accessible Design

A. Definitions.

Pedestrian Circulation Path: A prepared exterior or interior surface provided for pedestrian travel within or adjacent to public roadways. The Pedestrian Circulation Path does not have to be accessible; however, the Pedestrian Access Route contained within the Pedestrian Circulation Path shall be accessible to those with disabilities.

Pedestrian Access Route: A continuous and unobstructed path of travel provided for pedestrians with disabilities within or coinciding with a Pedestrian Circulation Path. The Pedestrian Access Route shall comply with PROWAG.

Alteration: A change to a facility within or adjacent to public roadways that affects or could affect pedestrian access, circulation, or use. Alterations include, but are not limited to, resurfacing, rehabilitation, reconstruction, historic restoration, or changes or rearrangement of structural parts or elements of a facility. Many modifications to traffic signals are also considered alterations. See Section 6.3.6.

Maximum Extent Feasible: Where existing physical constraints make it impracticable for altered elements, spaces, or facilities to fully comply with the requirements for new construction, compliance is required to the extent practicable within the scope of the project. Also referred to as "Maximum Extent Practicable".

Technically Infeasible: With respect to an alteration of a facility within or adjacent to public roadways, something that has little likelihood of being accomplished because existing physical or site constraints

prohibit modification or addition of elements, spaces, or features that are in full and strict compliance with minimum requirements.

- B. **Construction Tolerances.** The requirements and guidance provided in this chapter recognize the conventional tolerances associated with construction within or adjacent to public roadways. In accordance with PROWAG R103, "Dimensions are subject to conventional industry tolerances except where dimensions are stated as a range" and "Conventional industry tolerances include tolerances for field conditions and tolerances that may be a necessary consequence of a particular manufacturing process. Conventional industry tolerances do not apply to design work."

6.2.2. Accessibility for New Construction

All new construction projects, where pedestrian access is included, shall be accessible and compliant with the Engineering Criteria Manual.

6.2.3. Accessibility for Alteration Projects

Whenever existing facilities are altered, they shall meet accessibility requirements within the scope and limits of the project as determined by the ECM Administrator. Alterations include projects such as reconstruction, rehabilitation, resurfacing, widening, and projects of similar scope and scale. For example, if a project requires resurfacing of an intersection, then the curb ramps and sidewalks within the project limits shall be updated to comply with the requirements contained in the ECM.

- A. **Transitional Segments.** Transitional segments of Pedestrian Access Routes shall connect to existing unaltered segments of Pedestrian Circulation Paths and shall comply with Section 6.3.1 to the maximum extent practicable.
- B. **Reduction in Access Prohibited.** An alteration shall not decrease or have the effect of decreasing the accessibility of a facility or an accessible connection to an adjacent building or site below the requirements for new construction in effect at the time of the alteration.
- C. **Technical Infeasibility.** In alterations, it can be infeasible to make facilities fully compliant with the requirements of the ECM due to existing site constraints. Improvements at certain locations may be deemed "Technically Infeasible" when engineering judgement is used and the County concurs. If full compliance with the ECM is deemed technically infeasible, facilities being altered shall be made accessible to the maximum extent practicable. If full compliance cannot be achieved, a deviation request shall be made to the County in accordance with ECM Section 1.9 and Section 5.8. In the Deviation Request and Decision Form, the designer should fully and specifically document the existing site constraints that result in technical infeasibility and the efforts made to comply to the maximum extent practicable.

Examples of site constraints that may make it technically infeasible to make a facility fully compliant include:

- Underground structures or utilities that would need to be altered to make a facility compliant and would expand the project scope.
- Adjacent development or buildings that would need to be moved or altered to make a facility fully compliant.
- Required improvements that would alter the status of a Historic property.
- Drainage that could not be maintained if an area is made fully accessible.

-
- Underlying terrain that would require significant expansion of the project scope to achieve full compliance. An example would be altering an existing roadway profile to make the cross slope of a crosswalk fully compliant.

Project scope, not cost, shall determine when existing constraints make it technically infeasible to make a facility accessible. For example, if a roadway resurfacing project that does not include utility relocations would require relocating underground utilities to make a curb ramp accessible, then making the curb ramp fully accessible could be considered technically infeasible. If, however, a project requires relocation of utilities and widening of a roadway, then that same curb ramp should be made fully accessible.

- D. **Projects Solely to Improve Accessibility.** If the sole purpose of a project is to improve accessibility, the scope of the project is not required to be expanded to make other adjacent portions of the Pedestrian Access Route and/or Pedestrian Circulation Path accessible. For example, a project whose sole purpose is to repair and replace sidewalk in poor condition would not be required to be expanded to fix adjacent noncompliant curb ramps. In these cases, documentation of the sole purpose to improve accessibility shall be documented during project development and written approval obtained from the ECM Administrator.

6.2.4. Accessibility for Maintenance Projects

Traditional maintenance activities do not require that the adjacent pedestrian facilities be made accessible. These activities include crack sealing, graveling, chip sealing, cover coating, pavement patching, restriping, and similar activities meant to seal and protect the road surface and improve friction and that do not significantly affect the public's access to or usability of the road.

(Res. No. 20-222 , 6-23-20)

6.3. ACCESSIBLE DESIGN

6.3.1. Sidewalks (Pedestrian Access Routes/Pedestrian Circulation Paths)

- A. **General Requirements.** Accessible sidewalks provide a safe route and continuous path for users with disabilities. All new sidewalk and sidewalk that is being replaced as part of an alteration project shall comply with the requirements contained within this section. Pedestrian Access Routes shall be provided within Pedestrian Circulation Paths to connect with accessible elements, spaces, and facilities within and adjacent to public roadways.
- B. **Clear Width.** Minimum-required sidewalk widths by roadway classification are specified in Table 2-4 through Table 2-7 and Appendix F. The minimum clear width of accessible sidewalk is 4 feet in all cases, excluding the width of the curb. If the designer chooses to use a 4 ft. wide sidewalk, then 5 ft. x 5 ft. passing spaces are required to be included and spaced a maximum of every 200 feet, as shown in Figure 6-1. Utilizing a 5 ft. wide (or wider) sidewalk eliminates the need for passing spaces. When sidewalk wider than the minimum 4 ft. width is provided (for example in an urban commercial area), only part of the sidewalk area is classified as the Pedestrian Access Route and must comply with the requirements of Section 6.3.1. Providing at least the minimum width accessible Pedestrian Access Route ensures that persons with disabilities can access all accessible elements, spaces, and features along the roadway. If approved by the ECM Administrator, the remainder (classified as Pedestrian Circulation Path) may have street furniture, utility poles, etc. that would not be acceptable in the Pedestrian Access Route. Designers shall ensure that, where approved by the ECM Administrator, street furniture and other elements in the Pedestrian Circulation Path are detectable and will not present a hazard to pedestrians. All protruding objects within the Pedestrian Circulation Path shall

Created: 2021-06-08 11:35:51 [EST]

(Supp. No. 2)

meet the requirements of Section 6.3.1.F.6. Where feasible, designers are also encouraged to comply with slope and other requirements to improve the accessibility of the sidewalk area.

Figure 6-1. Passing Spaces

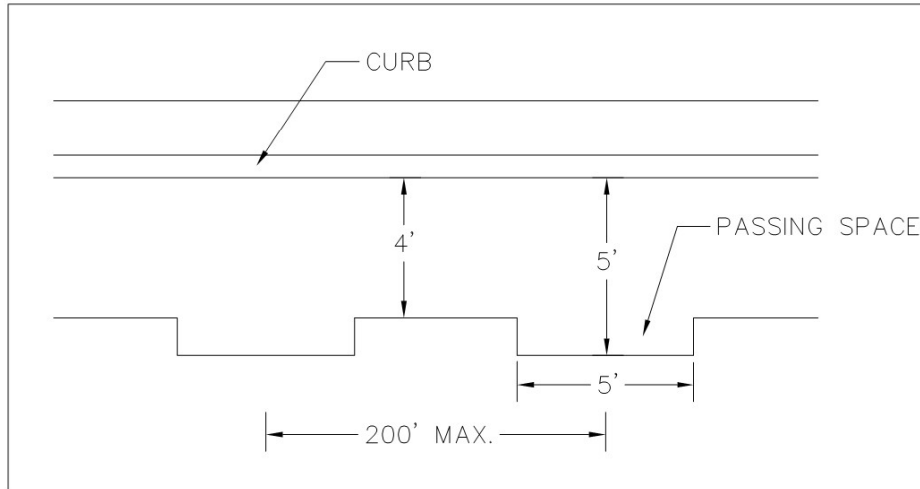

- C. **Vertical Alignment.** The vertical alignment of all elements within a Pedestrian Access Route (sidewalks, curb ramps, blended transitions, turning spaces, and gutter areas, etc.) shall be planar. Grade breaks shall be flush.
- D. **Grade.** The grade of Pedestrian Access Routes within and adjacent to public roadways shall not exceed 5%. When, however, the grade of the adjacent street is greater than 5%, the grade of adjacent Pedestrian Access Routes shall not exceed the general grade of the adjacent street or highway. In these cases, the Pedestrian Access Route is not considered a ramp even though its grade exceeds 5%. In all other areas, Pedestrian Access Routes with grades between 5% and 8.3% must comply with the requirements of Section 6.3.1.G.
- E. **Cross Slope.** The cross slope of all sidewalk contained within the Pedestrian Access Route shall not exceed 2%. Typical sidewalk cross slope of 1.5% is recommended for design to allow for construction tolerance.
- F. **Surface.**
 - 1. **General.** The surface of all elements contained within the Pedestrian Access Route shall be firm, stable, and slip resistant (e.g. concrete sidewalk with broom finish or slip-resistant plate over a drainage chase). Soft loose surfaces such as sand, gravel, or cobblestones can make it difficult for people using wheelchairs to move with ease.
 - 2. **Level Change.** The maximum level change for a non-beveled surface is 0.25 inches. The maximum level change for a beveled surface is 0.50 inches. The beveled surface shall have a slope not steeper than 50% (2:1 H:V). See Figure 6-2.

Figure 6-2. Vertical Surface Discontinuities

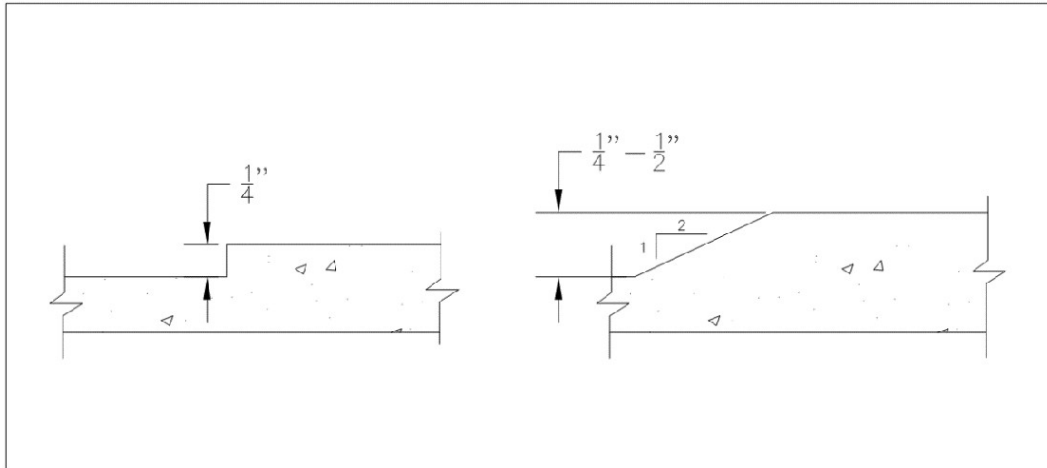

3. **Horizontal Opening (Grates and Joints).** The maximum horizontal openings in gratings and joints shall not permit passage of a 0.50-inch diameter sphere. Elongated openings in grating shall be oriented such that the long dimension is perpendicular to the main direction of travel. See Figure 6-3.

Figure 6-3. Horizontal Openings

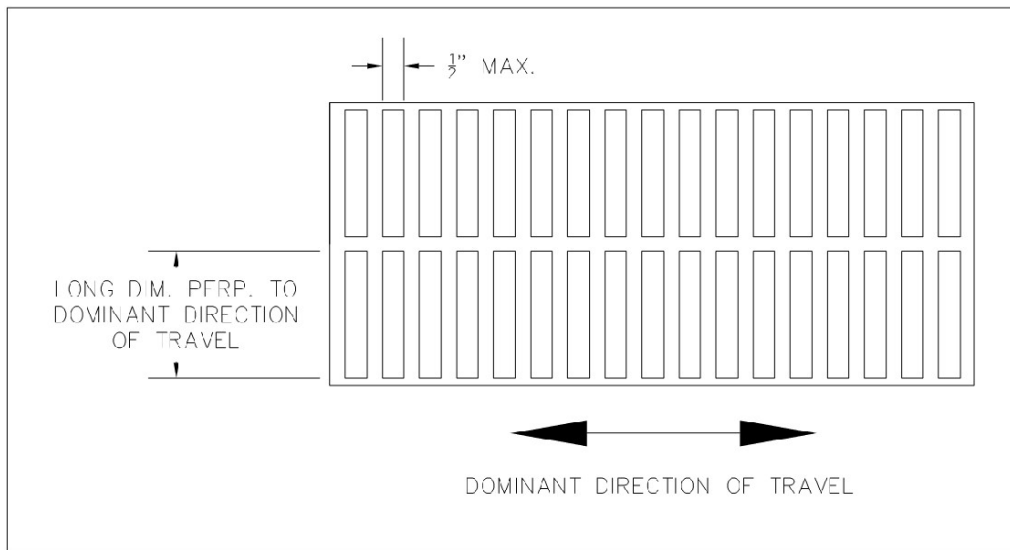

4. **Surface Obstructions.** Utility vaults, covers, frames, and other elements should be located outside of Pedestrian Access Routes, curb ramps, and turning spaces whenever possible. Over time, differential settlement at these interfaces can lead to vertical discontinuities.
5. **Railroad Crossings.** Railroad crossings shall be level with the top of rail.
 - The flangeway gap for a non-freight train rail shall not exceed 2.5 inches. See Figure 6-4.
 - The flangeway gap for a freight train rail shall not exceed 3 inches. See Figure 6-4.

Figure 6-4. Flangeway Gaps

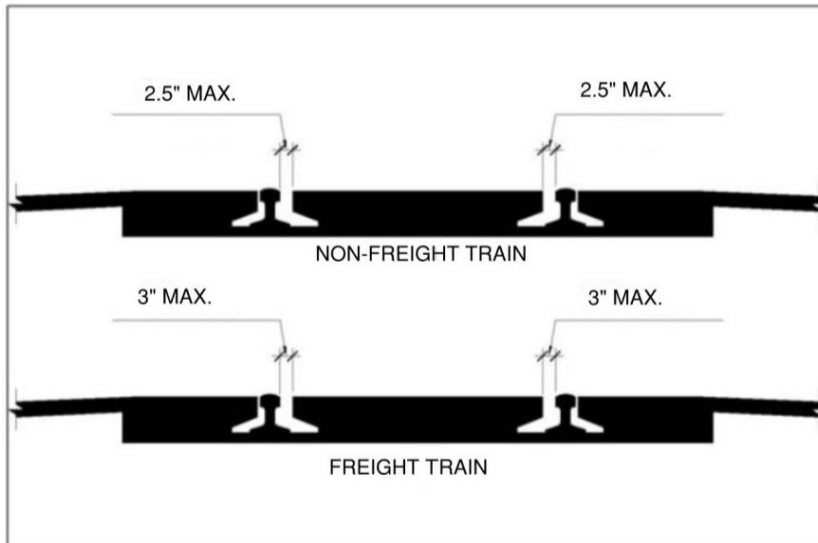

6. **Protruding Objects.** Roadside objects shall not be permitted to encroach upon or protrude into pedestrian routes including Pedestrian Access Routes and Pedestrian Circulation Paths. In cases where it is infeasible to locate objects outside of these pedestrian routes, a deviation must be approved by the ECM Administrator and these objects must be designed to be detectable and not present a hazard to pedestrians or vehicles. Objects include, but are not limited to, signs, street furniture, landscaping, and above ground utility poles and boxes. See Section 2.5.2.B.8 and Figure 2-35 for horizontal and vertical clearance requirements.
 - **General:** Requirements for protruding objects extend along the entire width of the Pedestrian Circulation Path. Protruding objects shall not decrease the minimum required clear width of the Pedestrian Access Route.
 - **Protrusion Limits:** Objects with leading edges more than 2.25 ft. and not more than 6.7 ft. above the finished surface shall not protrude more than 4 inches maximum into the Pedestrian Circulation Path. See Figure 6-5.

Figure 6-5. Protrusion Limits

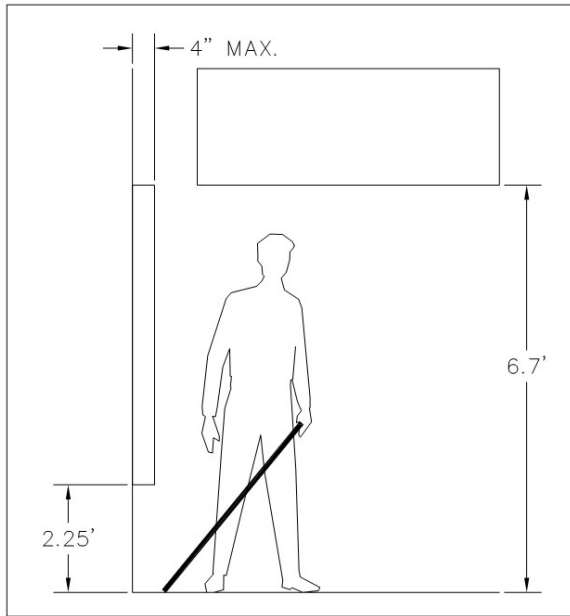

- Post-Mounted Objects:** When objects are mounted on free-standing posts or pylons and the object is between 2.25 ft. and 6.7 ft. above the finished surface, the maximum protrusion into the Pedestrian Circulation Path is 4 in., measured horizontally from the outside edge of the post or pylon.

Where objects are mounted between 2 or more posts or pylons and the clear distance between the posts is 1 ft. or greater, the lowest edge of the object shall be 2.25 ft. maximum or 6.7 ft. minimum above the finished grade. See Figure 6-6.

Figure 6-6. Protrusion Limits for Post-Mounted Objects

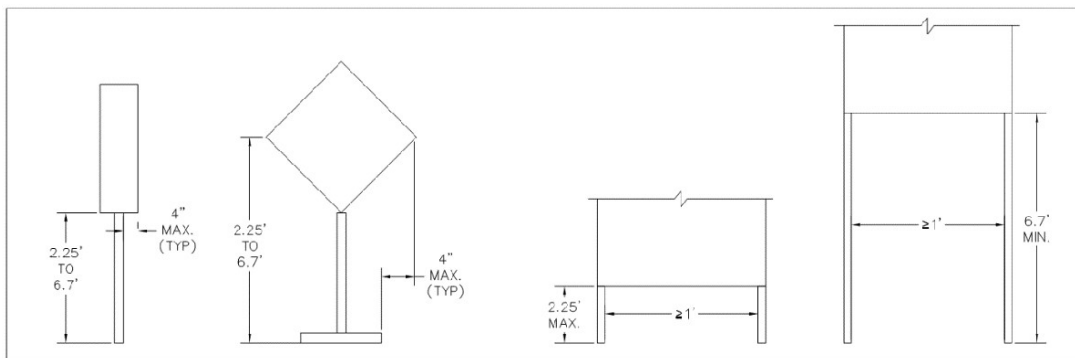

- Reduced Vertical Clearance:** Railing or other barriers to pedestrian travel shall be provided where the vertical clearance is less than 6.7 ft. high. The leading edge of the railing or barrier shall be located 2.25 ft. maximum above the finished surface. See Figure 6-7.

Figure 6-7. Reduced Vertical Clearance

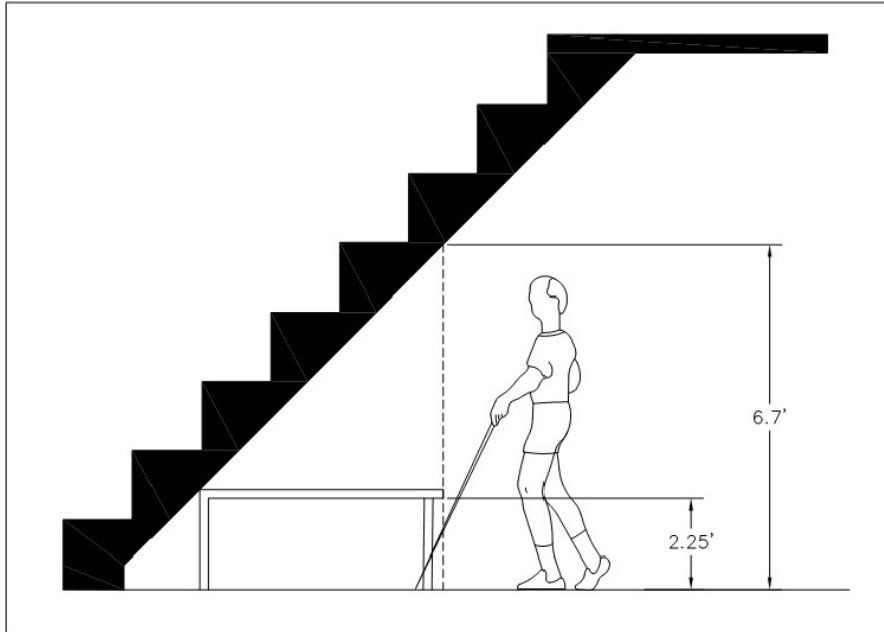

- G. **Ramps.** Ramps (not to be confused with curb ramps) include ramp runs and landings. See Figure 6-8. Ramps are required where the running slope of the sidewalk within a Pedestrian Access Route exceeds 5%.
1. **Running Slope.** The running slope of ramp runs is between 5% and 8.3%. Utilize the flattest slope feasible on ramp runs. A suggested maximum running slope of 7.5% is recommended for design to allow for variability during construction, since no construction tolerance is allowed.
 2. **Cross Slope.** The cross slope of ramps within the Pedestrian Access Route shall not exceed 2%. Typical ramp cross slope of 1.5% is recommended for design to allow for construction tolerance.
 3. **Clear Width.** The minimum clear width of ramps is 4 ft. if handrails are not provided. If handrails are provided, the minimum clear width of ramps between handrails is 3 ft.
 4. **Rise.** The maximum rise of a ramp run is limited to 2.5 ft. There is no limit to the number of consecutive ramp runs a Pedestrian Access Route may have, as long as intermediate landings are provided.
 5. **Landings.** Landings shall be provided at the top and bottom of every ramp run, and intermediate landings shall be provided for every 2.5 ft. of ramp rise. The slope of the landing in any direction shall not exceed 2%. It is recommended that the slopes of the landing be designed with a 1.5% slope to allow for construction tolerance. The clear width of the landing shall be at least as wide as the ramp run leading to the landing. The length of the landing shall be 5 ft. minimum. For ramps that change direction between runs, landings shall have minimum dimensions of 5 ft. x 5 ft. See Figure 6-8.

Figure 6-8. Landing Requirements in Ramps

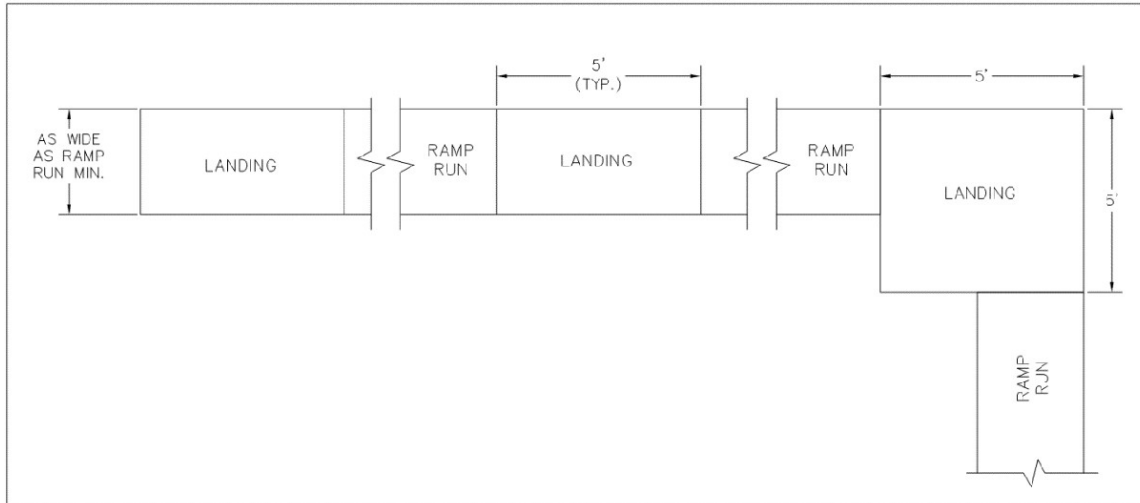

6. **Edge Protection.** Edge protection is required on all ramps and ramp landings. Edge protection can be provided by either extending the width of the ramp and landings 1 ft. minimum beyond the inside face of the handrails or providing a curb or barrier that prevents the passage of a 4 in. diameter sphere, where any portion of the sphere is within 4 in. of the finished surface.
 7. **Handrails.** PROWAG compliant handrails are required on all ramps that have a ramp rise of 6 in. or greater. Handrails should be continuous the full length of the ramp and shall be between 2.8 ft and 3.2 ft above the finished surface of the ramp. Handrails shall extend 1 ft. beyond the top and bottom of the ramp runs. See PROWAG Section R409 for additional physical requirements for handrails including, but not limited to, height, cross section, and extensions. Handrails should be designed and located in accordance with requirements of the AASHTO Roadside Design Guide. Where required, handrails should be located outside of the roadway clear zone whenever feasible. When they cannot be located outside of the clear zone, the designer should refer to the methodology of the AASHTO Roadside Design Guide to reduce the likelihood and severity of the obstacle being struck.
 8. **Stairs.** As a best practice, providing stairways along with ramps, where possible, benefits pedestrians with heart disease, limited stamina, and others for whom distance presents a greater barrier than steps. Stairs should be designed and located in accordance with requirements of the AASHTO Roadside Design Guide. Where required, stairs should be located outside of the roadway clear zone whenever feasible. When they cannot be located outside of the clear zone, the designer should refer to the methodology of the AASHTO Roadside Design Guide to reduce the likelihood and severity of the obstacle being struck.
- H. **Sidewalk at Driveways.**
1. **General.** Sidewalk across driveways shall comply with the general requirements for accessible sidewalk (running slope, cross slope, surface, clear width). Accessible sidewalk configurations at driveways are shown in Standard Drawings SD_2-24 and SD_2-25.

6.3.2. Pedestrian Street Crossings (Crosswalks)

- A. **General.** Pedestrian street crossings are roadway crossings that connect Pedestrian Access Routes on opposite sides of a roadway. A Pedestrian Access Route shall be provided where pedestrian access

across a roadway is permitted. Where pedestrian street crossings are deemed to be unsafe or unsuitable for all pedestrians, the designer should consider measures to prohibit pedestrian crossings, such as signage, landscaping, and pedestrian barriers.

- B. **Running Slope.** Where Pedestrian Access Routes are contained within the pedestrian street crossing, the running slope of the Pedestrian Access Route shall not exceed 5%. This is generally equal to the roadway cross slope in perpendicular crossings.
- C. **Cross Slope.** The cross slope of pedestrian street crossings is generally equal to the roadway profile in perpendicular crossings. Designers should consider this requirement for initial, interim, and ultimate configurations when setting roadway grades to allow for compliant pedestrian crossings. For example, if an intersection is initially constructed as a Two-Way-Stop-Controlled intersection but expected to ultimately be converted to an All-Way-Stop-Controlled intersection, all roadway grades must be set at 2% or flatter to accommodate compliant crosswalks in the ultimate condition.
 - 1. **Yield or stop controlled intersections:** The cross slope of a pedestrian street crossing at an intersection with yield or stop control that is within the Pedestrian Access Route shall not exceed 2%. A cross slope of 1.8% is recommended for design to allow for construction tolerance. This requirement may require the roadway profile to be "tabled" across the pedestrian street crossing. See Figure 6-9.
 - 2. **Intersections without yield or stop control:** The cross slope of a pedestrian street crossing at an intersection without yield or stop control or at a signalized intersection that is within the Pedestrian Access Route shall not exceed 5%. When traffic signals are designed to allow for arrival during the green phase on an approach, that approach is considered to be without stop or yield control because vehicles could traverse the intersection without slowing or stopping. See Figure 6-9.
 - 3. **Midblock crossings:** Where a midblock crosswalk is approved by the ECM Administrator, the cross slope of the midblock pedestrian street crossing within the Pedestrian Access Route shall not exceed the profile grade of the street or highway.

Figure 6-9. Example Street Intersection

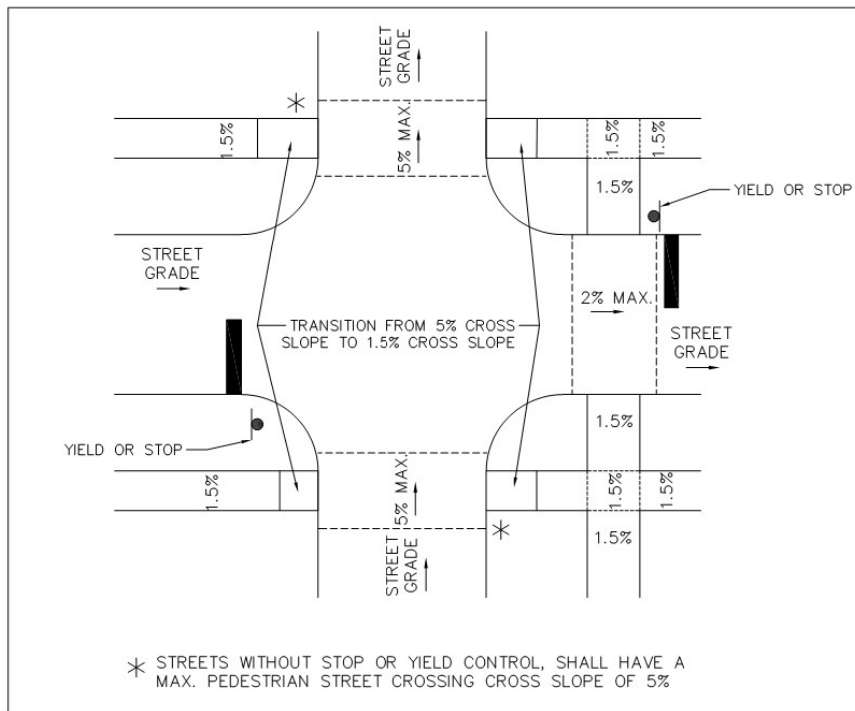

- D. **Roundabouts.** Design of accessible Pedestrian Access Routes at roundabouts requires careful design to provide guidance to pedestrians who are blind or have low vision because the crossings are located off to the side of the Pedestrian Circulation Path around the street or highway. Water fountains and other features that produce background noise should not be used in the middle of the roundabouts as pedestrians who are blind or have low vision rely on audible cues to help detect gaps in traffic.

Designers should refer to PROWAG R306.3 and other roundabout guidance when designing pedestrian facilities. Care should be taken to provide directional cues, separating the Pedestrian Access Route from the roadway with a landscape buffer, and locating the pedestrian street crossings set-back from the central island. Roundabouts with multi-lane approaches involve an increased risk of pedestrian exposure to accident when compared to those with single-lane approaches.

6.3.3. Curb Ramps/Blended Transitions

Curb ramps and blended transitions are used to transition the Pedestrian Access Route (sidewalk) to a pedestrian street crossing (crosswalk). Curb ramps and blended transitions shall comply with the requirements of this section. Selection of the type of curb ramp to be used at a given location should be based on:

- Intersection geometry
- Attached or detached sidewalk configuration
- Drainage
- Coordination with utilities and other roadside elements

Designers should design curb ramps individually, check critical slopes, ensure drainage does not pond in ramps, and consider directionality of the crossing. Designers are encouraged to use flatter slopes, where

possible, to allow for flexibility during construction. Designers should use ramps conforming with standard drawings SD_2-40, SD_2-41, SD_2-42, and SD_2-50 whenever feasible. When physical constraints prevent the application of these standard ramp designs, the designer should develop a design that fits project constraints and conforms with the requirements of this section to be approved by the ECM Administrator on a case-by-case basis. Designers are advised to see CDOT M-608-1 standard drawings for guidance in these cases.

A. Common Requirements for Curb Ramps and Blended Transitions.

1. **Clear Width.** The minimum clear width of curb ramps, blended transitions, and turning spaces is 4 ft. Widths should generally match the approaching sidewalk.
2. **Grade Breaks.** Grade breaks at the top and bottom of curb ramps shall be perpendicular to the direction of the ramp running slope. Grade breaks are not permitted within curb ramps and turning spaces. Surface slopes that meet at grade breaks shall be flush.
3. **Counter Slope.** The maximum counter slope of the gutter or street at the bottom of a curb ramp, blended transition, or turning space is 5%.
4. **Clear Space.** A minimum clear space of 4 ft. x 4 ft. shall be provided at the bottom of all curb ramps and blended transitions. The clear space shall be contained within the width of the pedestrian street crossing and be completely outside of the parallel vehicle travel lane. The cross slope of the clear space shall be equal to the street or highway grade. The maximum running slope of the clear space is 5% to comply with counter slope requirements.

B. Perpendicular Curb Ramps.

1. **General.** Perpendicular curb ramps have a running slope that cuts through or is built up to the gutter grade break at right angles.
2. **Running Slope.** Provide the flattest running slope possible on curb ramps, while maintaining adequate drainage. The running slope of a curb ramp is between 5% and 8.3%, but shall not require the ramp length to exceed 15 ft. A maximum running slope of 7.5% is recommended for design to allow for variability during construction, since construction tolerance is not allowed.
3. **Cross Slope.** The cross slope of curb ramps within the Pedestrian Access Route and at a stop or yield-controlled intersection shall not exceed 2%. A cross slope of 1.5% is recommended for design to allow for construction tolerance. The cross slope at intersections without stop or yield control shall not exceed 5%. The cross slope at midblock crossings can match the street or highway running slope. Where the ramp cross slope must exceed 2% in order to match a roadway grade greater than 2% at the end of the ramp, transition the ramp above the clear space to match the roadway grade. Spread the transition evenly over the length of the ramp. See Figure 6-10.

Figure 6-10. Transitioning Cross Slope Across Curb Ramp

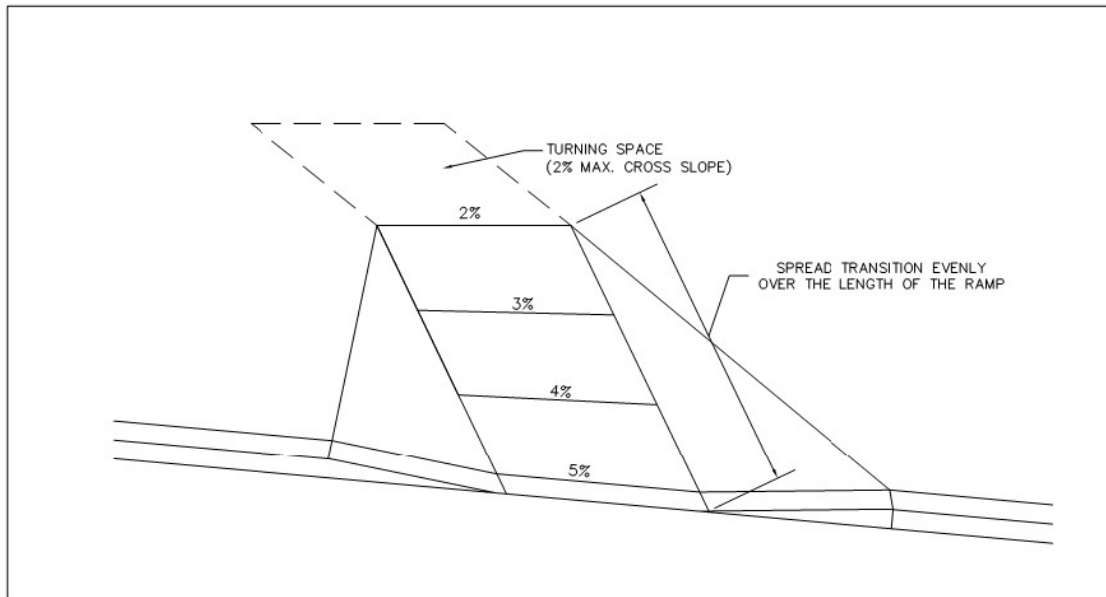

4. **Turning Space.** A 4 ft. x 4 ft. minimum turning space shall be provided at the top of the curb ramp and may overlap other turning and clear spaces. If the turning space is constrained at the back of the sidewalk, the turning space shall be 4 ft. x 5 ft. minimum. The 5 ft. dimension shall be provided in the direction of the ramp running slope. The maximum running slope of a turning space is 2%. Use 1.5% where practicable to allow for construction tolerance.
 5. **Flared Sides and Returned Curbs.** Where the Pedestrian Circulation Path crosses the curb ramp, the slope of the side flares shall not exceed 10%. A side flare slope of 9.5% is recommended to allow for construction tolerance. If the sides of a perpendicular ramp are not contained within the Pedestrian Circulation Path (e.g., detached sidewalk configurations) and are protected from cross travel by landscaping, street furniture, or other elements, 1'-6" flared sides should be used as shown in the standard drawings. Returned curbs in lieu of 1'-6" flared sides may be approved by the ECM Administrator on a case-by-case basis if the directional cues they provide to pedestrians who are blind or have low vision are important in the design.
- C. **Parallel Curb Ramps.**
1. **General.** Parallel curb ramps have a running slope that is aligned with the direction of sidewalk travel and lower the sidewalk to a level turning space where a turn is made to enter the pedestrian street crossing.
 2. **Running Slope.** Provide the flattest running slope possible on curb ramps, while maintaining adequate drainage. The running slope of a curb ramp is between 5% and 8.3%, but shall not require the ramp length to exceed 15 ft. A recommended maximum running slope of 7.5% is recommended for design to allow for variability during construction, since construction tolerance is not allowed.
 3. **Cross Slope.** The cross slope of parallel curb ramps within the Pedestrian Access Route shall not exceed 2%. A typical cross slope of 1.5% is recommended for design to allow for construction tolerance.
 4. **Turning Space.** A 4 ft. x 4 ft. minimum (5 ft. x width of sidewalk is preferred) turning space shall be provided between the parallel ramps to allow the pedestrian to turn and cross the

street. The maximum running slope of the turning space is 2%. A running slope of 1.5% is recommended for design to allow for construction tolerance. The maximum cross slope of the turning space at a stop or yield-controlled intersection is 2%. The cross slope at intersections without stop or yield control shall not exceed 5%. The cross slope of the turning space at midblock crossings can match the street or highway running slope. If the turning space is confined (by a building or other adjacent feature that would impact a pedestrian turning) on two or more sides, the turning space shall be 4 ft. x 5 ft. minimum. The 5 ft. dimensions shall be provided in the direction of the pedestrian street crossing.

D. Blended Transitions.

1. **General.** Blended transitions are raised pedestrian street crossings, depressed corners, or similar connections at the level of the sidewalk and the pedestrian street crossing that have a running slope of 5% or less.
2. **Running Slope.** Provide the flattest running slope possible on blended transitions, while maintaining adequate drainage. The maximum running slope of blended transitions is 5%.
3. **Cross Slope.** The cross slope of blended transitions within the Pedestrian Access Route and at a stop or yield-controlled intersection shall not exceed 2%. A cross slope of 1.5% is recommended for design to allow for construction tolerance. The cross slope at intersections without stop or yield control shall not exceed 5%. The cross slope at midblock crossings can match the street or highway running slope. When the blended transition cross slope must exceed 2% in order to match a roadway grade greater than 2% at the end of the blended transition, transition the blended transition to match the roadway grade. Spread the transition evenly over the length of the blended transition. See Figure 6-10.

- E. **Diagonal Curb Ramps.** A single diagonal curb ramp is not permitted to serve two pedestrian street crossings on a corner. Single diagonal curb ramps must be approved by the ECM Administrator and will only be considered as part of an alteration project where existing physical site constraints prevent two curb ramps from being installed. Diagonal curb ramps are not desirable because they can provide directional cues that lead pedestrians, especially those that are blind or have low vision, into the middle of an unsafe intersection.

6.3.4. Detectable Warning Surfaces (DWS)

Detectable warning surfaces shall consist of truncated domes aligned in a square or radial grid pattern. Detectable warning surfaces shall be provided where a curb ramp, landing, or Shared Use Path connects to a pedestrian street crossing, railroad crossing, traffic island or median. Detectable warning surfaces shall be made of cast iron with a patina natural finish and in accordance with the requirements of PROWAG Section R305. See SD_2-40, SD_2-41, SD_2-42, and SD_2-50 for details. See CDOT standard drawings M-608-1 for location and placement of DWS.

6.3.5. Medians/Pedestrian Refuge Islands

- A. **Clear Width.** The minimum clear width of Pedestrian Access Routes contained within a median or pedestrian refuge island is 5 feet.
- B. **Grade.** The grade of the Pedestrian Access Route through medians and pedestrian refuge islands shall comply with the running slope requirements for crosswalks. See Section 6.3.2.
- C. **Cross Slope.** The cross slope of the Pedestrian Access Route through medians and pedestrian refuge islands shall comply with the cross slope requirements for crosswalks. See Section 6.3.2.

-
- D. **Curb Ramps.** Curb ramps and blended transitions in medians and pedestrian refuge islands shall meet the requirements of Section 6.3.3.
 - E. **Detectable Warning Surfaces.** When a cut-through pedestrian refuge island is 6 feet wide or greater from the face of curb to face of curb, Detectable Warning Surfaces shall be installed. When installed, the Detectable Warning Surfaces must be separated by a surface without Detectable Warning Surface that is a minimum of 2 feet in length (parallel to pedestrian travel). If this 2-foot space cannot be provided, Detectable Warning Surfaces shall not be installed because the island is not wide enough to be considered a pedestrian refuge island.
 - F. **Pedestrian Signals.** Where pedestrian signals are provided and the pedestrian crossing phase is not designed to be long enough to permit crossing across the entire street, additional pushbuttons complying with Section 6.3.6 should be provided in the pedestrian refuge islands to actuate the pedestrian phase in order for pedestrians to complete the crossing.

6.3.6. Pedestrian Signals/Pushbuttons

- A. **General Requirements.** Requirements for application of pedestrian signals shall be in accordance with Section 4.03 of the MUTCD. Where installed, including at Shared Use Path crossings, all accessible pedestrian signals and pushbuttons shall be designed in accordance with Sections 4E.08 through 4E.13 of the latest version of the Manual on Uniform Traffic Control Devices for Streets and Highways (MUTCD). See CDOT standard drawings S-614-45 for guidance on location of pedestrian pushbuttons.
- B. **Applicability in Alterations.** Per PROWAG requirements, if the existing signal controller and software are altered, or if the existing signal head is replaced, the pedestrian pushbuttons and pedestrian signal heads shall be updated to meet the accessible pedestrian signal requirements contained in this section, unless a deviation is approved by the ECM Administrator.
- C. **Pedestrian Signal Phase Timing.** All pedestrian signal timing shall be based on a pedestrian clearance time that is calculated using a pedestrian walking speed of 3.5 ft/s or less and a crossing distance from the end of the curb ramp to the far side of the traveled way or the near side of a pedestrian refuge island with secondary pushbutton.
- D. **Pushbutton Separation.** Pedestrian pushbuttons shall be spaced a minimum of 10 feet apart to allow for pedestrians who are blind or have low vision to identify the correct crosswalk. If it is not feasible for the pedestrian pushbuttons to be spaced 10 feet apart, they may be placed closer than 10 ft apart or on the same pole. In these cases, the accessible pedestrian signals shall use speech messages. See Section 6.3.6.G.
- E. **Pushbutton Locations.** Pushbuttons should be located as close as possible to the curb ramp they are servicing and be adjacent to a clear and level (< 2% slope in all directions) platform. The pushbutton should be located within 5 ft. of the edge of the far crosswalk line and between 1.5 ft. to 6 ft. from the face of the curb or edge of pavement. Where there are physical constraints that make locating the pushbutton within 6 feet from the face of curb or edge of pavement infeasible, they should not be located farther than 10 feet from the face of curb or edge of pavement.
- F. **Pushbutton Mounting Heights and Reach Length.** Pushbuttons shall be mounted between 42 inches and 48 inches above the surface of the accessible route. The preferred mounting height is 42 inches. The pushbutton should not require a pedestrian to reach more than 10 inches to activate it. See Section 6.3.10.B.2.
- G. **Accessible Pedestrian Signals (APS).** Accessible Pedestrian Signals shall have audible and vibrotactile walk indications located on the pushbutton, locator tones, and tactile arrows.

-
1. Where pedestrian pushbuttons on one corner are separated by at least 10 feet, the audible walk indication shall be a percussive tone. Where two accessible pedestrian signals on one corner are on the same pole or separated by less than 10 feet, the audible walk indication shall be a speech message patterned after the model, "Broadway. Walk sign is on to cross Broadway."

6.3.7. Shared Use Paths

Shared Use Paths are facilities on separate right-of-way, easements, or tracts or otherwise physically separated from roadways that are designed for use by bicycles, pedestrians, and other non-automotive modes of recreation and transportation. Because these facilities are used by pedestrians, they shall be accessible and in compliance with the requirements of this chapter. Shared Use Paths are also called Multi-Use Paths in other ECM Chapters. The two terms are synonymous.

- A. **General.** Design of accessible Shared Use Paths should comply with the requirements in the ECM. Designers should also refer to the current version of the AASHTO Guide for the Development of Bicycle Facilities for additional design guidance.
- B. **Clear Width.** The requirements of a Pedestrian Access Route shall be met for the full width of the Shared Use Path, i.e. the entire width of the Shared Use Path must be fully accessible. The minimum clear width of a Shared Use Path is 10 ft. See Section 2.5.7.
- C. **Grade.** The grade of a Shared Use Path within or adjacent to public roadways shall be less than or equal to the adjacent street grade. Whenever feasible, the grade of the Shared Use Path shall be less than or equal to 5%.
- D. **Cross Slope.** The cross slope of Shared Use Paths shall not exceed 2%. A cross slope of 1.5% is recommended for design to allow for variability during construction.
- E. **Curb Ramps.** Curb ramps on Shared Use Paths shall meet the requirements of Section 6.3.3, except that the width of the curb ramp shall be equal to the full width of the Shared Use Path.

6.3.8. Transit Stops

Transit stops and facilities shall comply with requirements of Section 2.5.4 and those of the transit provider.

- A. **Boarding and Alighting Areas.**
 1. **Location.** Wherever feasible, transit stops should be located where the adjacent street grade is less than 2.5% to facilitate passenger boarding. Bollards and other potential obstructions shall be located so as not to protrude into the boarding and alighting area or Pedestrian Access Route or obstruct the boarding process.
 2. **Surface.** The surface of transit stops shall meet the requirements of Section 6.3.1.F.
 3. **Connectivity.** Transit platforms, shelters, and boarding/alighting areas shall be connected to streets, sidewalks, and Pedestrian Circulation Paths by accessible Pedestrian Access Routes.
 4. **Dimensions.** Boarding and alighting areas shall provide a minimum clear length of 8 ft. measured perpendicular to the curb and a minimum clear width of 5 ft. measured parallel to the roadway. See Figure 6-11.
 5. **Slope.** The slope of the boarding and alighting area parallel to the roadway should be the same as the roadway grade. The maximum running slope of the boarding and alighting area perpendicular to the roadway is 2%. A running slope of 1.5% is recommended for design to allow for construction tolerance. See Figure 6-11.

6. **Detectable Warning Surfaces.** Detectable warning surfaces are not required at boarding and alighting areas for bus-only transit stops. They are required for boarding and alighting areas for rail vehicles and buses AND rail vehicles.
- B. **Transit Shelters.** Transit shelters shall be connected to boarding and alighting areas by Pedestrian Access Routes. The boarding and alighting area may be located either within or outside of the shelter. Transit shelters shall provide a minimum 2.5 ft. x 4 ft. clear space entirely within the shelter. If seating is provided within the shelter, the clear space shall be located at one end of the seating or shall not overlap the area within 1.5 ft. of the front of the seating. The clear space shall have a running slope consistent with the grade of the adjacent Pedestrian Access Route and cross slope of 2% maximum. See Figure 6-11.

Figure 6-11. Boarding and Alighting Area Connection to Transit Shelter

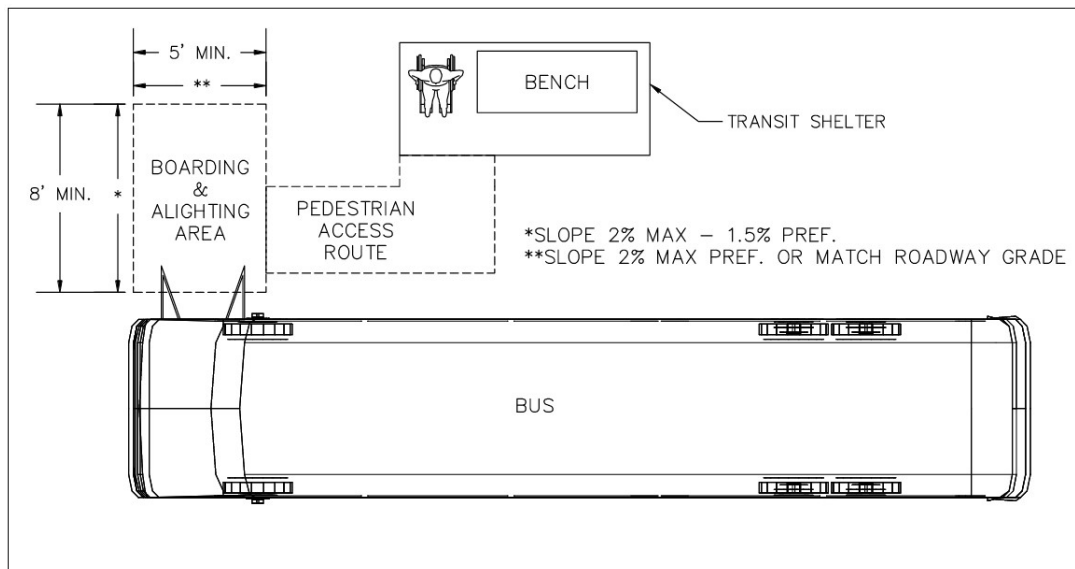

6.3.9. Pedestrian Over/Underpasses

- A. **General.** Provide Pedestrian Access Routes on overpasses and underpasses to connect with Pedestrian Access Routes on both sides of the structure. If pedestrian bridges over waterways are installed as part of Pedestrian Access Routes or Shared Use Paths, they shall comply with the requirements of a Pedestrian Access Route.
- B. **Ramps, Lifts, Elevators.** If the approach slopes of the overpass or underpass exceed 5%, then a ramp, lift, or elevator shall be provided to provide access.

6.3.10. Ancillary Elements

- A. **Signage (Pedestrians).** Signs providing directions, warnings, or other information for pedestrians only, excluding transit signs, shall comply with PROWAG R410 in addition to the MUTCD with revisions and supplements.
- B. **Operable Parts.** Operable parts consist of pedestrian signals, pushbuttons, and other similar elements that are to be operated by pedestrians.

1. **Clear Space.** Provide a 2.5 ft. x 4 ft. minimum clear space adjacent to the operable part. The cross slope of all sidewalk contained within the Pedestrian Access Route shall not exceed 2%. A cross slope of 1.5% is recommended for design to allow for construction tolerance. The running slope of the clear space shall match the grade of the adjacent Pedestrian Access Route.
2. **Height/Reach Ranges.**
 - **Forward Reach:** An operable part shall be located between 15 in. and 48 in. above the finished surface when a forward reach is required to activate the operable part. An obstruction is not allowed between the operable part and the clear space. See Figure 6-12.

Figure 6-12. Forward Reach Range

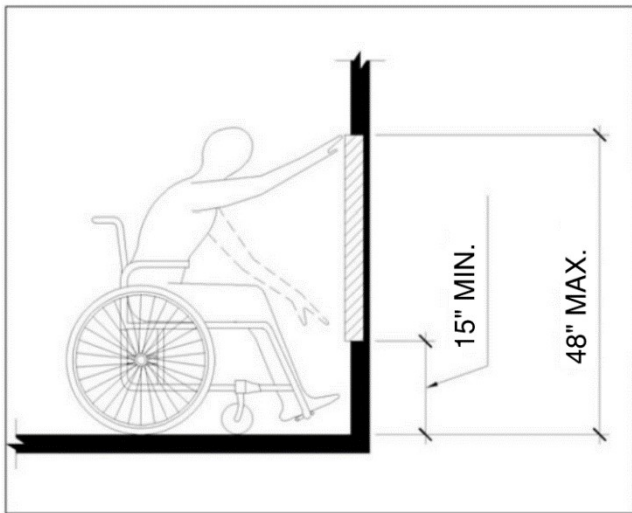

- **Side Reach:** An operable part shall be located between 15 in. and 48 in. above the finished surface when a side reach is required to activate the operable part. An obstruction is allowed between the operable part and the clear space if the obstruction protrudes less than 10 inches from the operable part. See Figure 6-13.

Figure 6-13. Side Reach Range

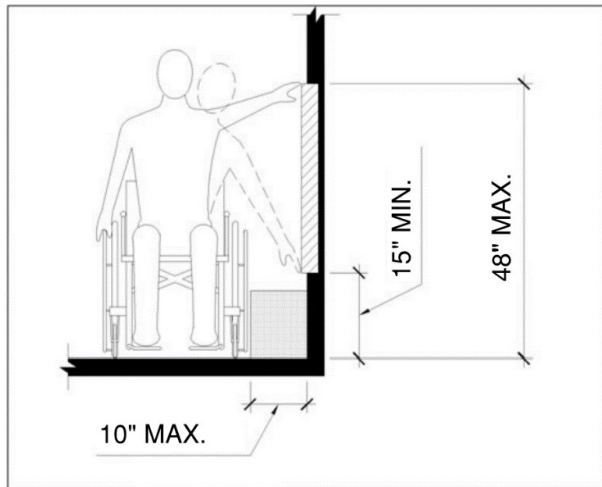

3. **Operation.** Operable parts shall be able to be operated with one hand and shall not require tight grasping, pinching, or twisting of the wrist. The maximum force required to operate the operable parts is 5 pounds.
4. **Mailboxes.** Both single and cluster mailboxes shall be located along an accessible Pedestrian Access Route within accessible reach ranges and with clear spaces in accordance with the requirements of this section. Mailbox locations must also comply with U.S. Postal Service and other requirements. See Section 4.4.
5. **Elements not Permitted in ECM.** The items listed below are not permitted by the ECM without a deviation approved by the ECM Administrator. If a deviation is approved, the designer shall refer to PROWAG for specific accessibility requirements.
 - Street furniture other than at transit stops
 - On-Street Parking (Marked or Metered)
 - Access Aisles (Marked or Metered On-Street Parking or Passenger Loading Zones)
 - Parking Meters and Pay Stations
 - Passenger Loading Zones
 - Stairs, Elevators, Escalators, and Lifts
 - Doors, Doorways, and Gates

6.3.11. Pedestrian Access Routes in Work Zones during Construction and Maintenance

Pedestrian access in Work Zones and Temporary Traffic Control (TTC) Zones shall be provided in accordance with MUTCD Section 6D.01.04, "If the TTC zone affects the movement of pedestrians, adequate pedestrian access and walkways shall be provided. If the TTC zone affects an accessible and detectable pedestrian facility, the accessibility and detectability shall be maintained along the alternate pedestrian route." Pedestrian accommodation in TTC zones shall not conflict with adopted CDOT Traffic Control Standards.

- A. **Planning for Pedestrians in Temporary Traffic Control (TTC) Zones.** Planning for pedestrians should be incorporated in the development of Traffic Control Plans for all projects within or adjacent to public roadways. In some cases, pedestrian demand will be low and accommodation measures will be

minimal. In other cases where pedestrian demand is high, dedicated temporary pedestrian facilities will be required. In accordance with MUTCD Section 6D.01.07, *"The following three items should be considered when planning for pedestrians in TTC zones:*

1. *Pedestrians should not be led into conflicts with vehicles, equipment, and operations.*
2. *Pedestrians should not be led into conflicts with vehicles moving through or around the worksite.*
3. *Pedestrians should be provided with a convenient and accessible path that replicates as nearly as practical the most desirable characteristics of the existing sidewalk(s) or footpath(s)."*

- B. **Approaches to accommodating pedestrians in work zones.** Technical requirements of Pedestrian Access Routes are also applicable in temporary work zones to the extent feasible. In order, the preferred methods for maintaining or providing Pedestrian Access Routes in TTC Zones are:
1. Maintain the existing pedestrian facilities (sidewalks, footpaths, etc.) whenever feasible.
 2. When the existing Pedestrian Access Route must be closed or blocked, develop an Alternate Pedestrian Route and Pedestrian Circulation Path parallel to the existing pedestrian facility on the same side of the street.
 3. When a parallel alternative Pedestrian Access Route cannot be developed on the same side of the street, an alternative pedestrian route (detour) may be provided on the other side of the street or outside of the TTC zone.

- C. **Traffic Control Devices.** All barricades, signs, and other temporary traffic control devices used to protect and direct pedestrians in TTC Zones shall be compliant with the MUTCD. The temporary facilities shall be detectable and include accessibility features consistent with the features of the existing pedestrian facilities. Pedestrian barriers and channelizing devices shall be detectable.

Pedestrian barricades should be placed between the Pedestrian Access Route and the work site in a location that protects pedestrians from hazards and provides guidance to the location of the alternate pedestrian route.

- D. **Short Duration Monitoring.** For short durations, such as those required for moving equipment or traffic control set-up and phase changes, the Pedestrian Access Route may be monitored by construction personnel who can provide guidance and direction to pedestrians until the Pedestrian Access Route through the work zone is restored or completed.

(Res. No. 20-222 , 6-23-20)

6.4. INSPECTION AND ACCEPTANCE

Inspection and acceptance of all accessible pedestrian facilities shall be based on the requirements in this chapter and in accordance with Chapter 5 and Appendix J. According to the ADA and PROWAG, all portions of the Pedestrian Access Route and associated elements must be accessible. Pedestrian facilities may be inspected at one or more locations, as determined by the project inspector, to verify that the facilities meet the requirements of this chapter. Standard Pedestrian Access Route and Curb Ramp Inspection Forms will be used for inspection and acceptance.

Table 6-3 summarizes the requirements for the most common accessible pedestrian elements. In no case shall the minimum, maximum, or ranges be deviated from in design without a deviation approved by the ECM Administrator. The construction tolerances shown are ONLY applicable during construction. Designers are encouraged to utilize design values greater than the minimums and less than the maximums to reduce noncompliant and unacceptable work during construction.

Table 6-3. - Common Design Values and Construction Tolerances

Created: 2021-06-08 11:35:51 [EST]

(Supp. No. 2)

Element	Design Values			Construction Tolerance
	Minimum	Maximum	Range	
P.A.R. Width	4 ft. ¹	—	—	- ¼"
P.A.R. Grade	N/A ²	5.0% ³	—	+0.5%
P.A.R. Cross Slope	N/A ²	2.0%	—	+0.5%
Ramp Run Slope	—	—	5.0—8.3%	None
Ramp Run Rise	N/A	2.5 ft. ⁴	—	+ ¼"
Ped. Street Crossing Cross Slope	N/A ²	2.0% ⁵ 5.0% ⁶ Adj. Str. Gr. ⁷	—	+0.5%
Ped. Street Crossing Running Slope	N/A ²	5.0%	—	+0.5%
Curb Ramp Width	4 ft. ^{8,13}	—	—	- ¼"
Curb Ramp Cross Slope	N/A ²	2.0% ⁹	—	+0.5%
Curb Ramp Running Slope	—	—	5.0—8.3%	None
Curb Ramp Counter Slope	N/A ²	5.0%	—	+0.5%
Curb Ramp Turning Space Slopes	N/A ²	2.0% ¹⁰	—	+0.5%
Curb Ramp Flare Slope	N/A	1'-6" Flare ¹¹ 10.0% ¹²	—	+0.5% ¹²
Shared Use Path Width	10 ft.	—	—	- ¼"
Shared Use Path Grade	N/A ²	5.0% ³	—	+0.5%
Shared Use Path Cross Slope	N/A ²	2.0%	—	+0.5%

NOTES:

1. Minimum width for Pedestrian Access Route. Design minimum should be per design criteria in Chapter 2.
2. No minimum slope or grade specified. But positive drainage without ponding should be ensured through combination of grade and cross slope.
3. Where adjacent street grade is greater than 5.0%, P.A.R. grade may equal adjacent street grade.
4. Consecutive Ramp Runs with 2.5 ft. maximum rise may be separated by landings.
5. At intersections/approaches with stop or yield control.
6. At intersections/approaches without stop or yield control, including traffic signals.
7. At mid-block crossings.
8. Minimum for accessibility. Should also be equal to approach sidewalk widths.
9. At top of curb ramp. Transition to match compliant crosswalk cross slope at bottom of ramp.
10. Slope in any direction. May match adjacent street grade at bottom of ramps.

Created: 2021-06-08 11:35:52 [EST]

(Supp. No. 2)

-
11. Where curb ramp flare is protected from cross travel (detached sidewalks).
 12. Where curb ramp flare is in Pedestrian Circulation Path (attached sidewalks).
 13. For Shared Use Paths, curb ramp width equals the full Shared Use Path width.

(Res. No. 20-222 , 6-23-20)

Appendix A REFERENCES

Adams County, Colorado: "Development Standards and Regulations", January 2004.

American Association of State Highway and Transportation Officials: "A Policy on Geometric Design of Rural Highways"

American Association of State Highway and Transportation Officials: "Guide Specifications for Design of Pedestrian Bridges"

American Association of State Highway and Transportation Officials: "Standard Specifications for Highway Bridges"

American Association of State Highway and Transportation Officials: "LRFD Bridge Design Specifications"

American Association of State Highway and Transportation Officials: "LRFD Bridge Construction Specifications"

American Association of State Highway and Transportation Officials: "Roadside Design Guide"

American Association of State Highway and Transportation Officials: "Standard Specifications for Transportation Material and Method of Sampling and Testing, Parts I and II"

City of Colorado Springs, Colorado: "Drainage Criteria Manual, Volumes 1 and 2"

City of Colorado Springs, Colorado: "Standard Specification Manual"

City of Colorado Springs, Colorado: "Subdivision Policy Manual"

City of Fort Collins, Colorado: "Storm Drainage Design Criteria and Construct Standards", May 1984

Colorado Department of Transportation: "Standard Specifications for Road and Bridge Construction"

Colorado Department of Transportation: "Bridge Manual, Volumes I and II"

Colorado Department of Transportation: "M&S Standards"

Douglas County, Colorado: "Roadway Design and Construction Standards", July 2003

El Paso County, Colorado: "Major Transportation Corridor Plan", August 3, 2004

Federal Highway Administration: "Roundabouts: An Informational Guide", 2010

Jefferson County, Colorado "Roadway Design and Construction Manual", February 2000

Larimer County, Colorado: "Road Manual", January 2000

U.S. Department of Transportation: "Manual on Uniform Traffic Control Devices (MUTCD)"

Soil Conservation Service (SCS): "Procedure for Determining Peak Flows in Colorado"

The American Society for Testing and Material (ASTM): "The Annual Book of ASTM Standards"

Appendix B TRANSPORTATION IMPACT STUDY GUIDELINES

(Supp. No. 2)

Created: 2021-06-08 11:35:52 [EST]

B.1. GENERAL

These Transportation Impact Study (TIS) guidelines are established to help ensure a standard process, set of assumptions, set of analytic techniques, and presentation format to be used in the preparation of the TIS. All TISs prepared for the County shall be prepared in conformance with these guidelines.

B.1.1. Types of Study

- A. **Master TIS.** Where large, complex projects (big box retail or residential developments over 100 acres) are planned or a project is phased over a multi-year build-out, it may be appropriate to prepare a Master TIS for the initial action followed by periodic updates for specific phases. The Master TIS must include overall phasing of improvements to coincide with project phasing.
- B. **Individual Site TIS.** An individual site TIS is prepared for a project that stands alone or is a phase of a master development. It can be for a new use in an existing or remodeled building, the construction of a new building (either single occupant or multi-user), construction of multiple buildings, or the construction of new residential development.

B.1.2. Levels of Analysis

For an Individual Site TIS, the following levels of analysis apply:

- A. **Full TIS.** A full TIS is required if one or more of the following conditions occur:
 - Vehicular Traffic: The site-generated traffic exceeds 1,000 trips/day or 100 peak-hour trips, or new high-volume access to an arterial roadway or State Highway is proposed.
 - Pedestrian Traffic: Paved pedestrian facilities exist or will be constructed on or adjacent to the site, or the proposed use will generate an increase in new pedestrian traffic.
 - Bicycle Traffic: Paved bicycle lanes or paths exist or will be constructed on or adjacent to the site, or the proposed use will generate an increase in new bicycle traffic.
 - When the site plan does not significantly comply with the Comprehensive Plan or the MTCP.
- B. **Intermediate TIS.** An Intermediate TIS may be considered instead of a Full TIS if all the following requirements are met:
 - Vehicular Traffic: Daily vehicle trip-end generation is between 501 and 1,000 inclusive, the peak hour trip generation is between 51 and 100, no high volume access to arterials or State Highways are proposed, and the Level of Service (LOS) of the adjacent facility when the development is completed equals or exceeds the minimum allowable LOS standard established for that facility.
 - Pedestrian Traffic: No paved pedestrian facilities exist or will be constructed on or adjacent to the site, or the proposed use will not generate any new pedestrian traffic.
 - Bicycle Traffic: No paved bicycle lanes or paths exist or will be constructed on or adjacent to the site, or the proposed use will not generate any new bicycle traffic.
- C. **Transportation Memorandum.** A Traffic Memorandum may be considered if all the following requirements are met:
 - Vehicular Traffic: Daily vehicle trip-end generation is less than or equal to 500, or the peak hour trip generation is between 21 and 50, and the proposed access is for local roadways or minor collector roadways only.

-
- Pedestrian Traffic: Paved pedestrian facilities exist or will be constructed on, or adjacent to, the site; or, the proposed use will not generate an increase in new pedestrian traffic.
 - Bicycle Traffic: Paved bicycle lanes or paths exist or will be constructed on, or adjacent to, the site; or, the proposed use will not generate an increase in new bicycle traffic.

D. **No TIS Required.** No TIS is required if all of the criteria below are satisfied:

- Vehicular Traffic: (1) Daily vehicle trip-end generation is less than 100 or the peak hour trip generation is less than 10; (2) there are no additional proposed minor or major roadway intersections on major collectors, arterials, or State Highways; (3) the increase in the number of vehicular trips does not exceed the existing trip generation by more than 10 peak hour trips or 100 daily trip ends; (4) the change in the type of traffic to be generated (i.e., the addition of truck traffic) does not adversely affect the traffic currently planned for and accommodated within, and adjacent to, the property; (5) acceptable LOS on the adjacent public roadways, accesses, and intersections will be maintained; (6) no roadway or intersection in the immediate vicinity has a history of safety or accident problems; and (7) there is no change of land use with access to a State Highway.
- Pedestrian Traffic: Paved pedestrian facilities exist or will be constructed on, or adjacent to, the site; or, the proposed use will not generate any new pedestrian traffic.
- Bicycle Traffic: Paved bicycle lanes or paths exist or will be constructed on, or adjacent to, the site; or, the proposed use will not generate any new bicycle traffic.

B.1.3. Revisions and Updates

An approved TIS that has been prepared in the last three years may be revised or updated where a proposed access is changed or a change in the proposed action may result in new trip generation that exceeds the original trip generation estimates. An amendment letter addressing the changes may be accepted provided the letter adequately addresses: (1) an estimate of site trip generation, (2) existing site trip generations, (3) the differences between anticipated estimates and existing trip generation, and (4) changes to the bicycle or pedestrian facilities. If the original TIS is older than three years, an entirely new TIS shall be prepared.

B.2. TIS PARAMETERS

A TIS shall include the following information.

B.2.1. Project Description

A description of the proposed project shall be prepared and include the type of land use and size of the proposed project (e.g., number of dwelling units of building square footage, etc.). Any proposed phasing shall be discussed and the anticipated completion date established. A figure depicting the proposed site plan shall also be included and the proposed vehicular access location shall be described. This section of the TIS shall also include a description of how pedestrians and bicycle travel will be accommodated within the proposed site plan. This shall include a discussion of types of sidewalks (attached/detached), pathways, and connections to local and perimeter destinations.

B.2.2. Analysis Horizons

Three study horizons are required for a Master TIS analysis: the existing (current), the short-range (short-range) and the long-range build-out (20-25 years). An Individual TIS analysis shall be based on build-out.

- A. **Existing Horizon.** The intent of completing an analysis of the existing (current) study horizon is to establish a baseline of traffic conditions.

-
- B. **Short-Range Horizon.** The intent of the short-range planning horizon is to investigate the immediate impacts of the completed, proposed project on the existing and committed roadway network. The short-range planning horizon year is defined as one year after the full occupancy of the project. If the project is proposed to occur over multiple phases, each phase shall be evaluated for impacts one year after the occupancy of the phase for the short-range analysis.
- C. **Long-Range Horizon.** The third planning horizon is the long-range planning horizon. It shall be based on the current MTCP planning horizon and related modeling. The model shall be updated based on existing counts where necessary. In such situations, the current counts shall be increased by application of a growth rate established by the ECM Administrator. The intent of the long-range planning horizon is to evaluate the implications of the fully developed project on the long-range traffic condition. This study horizon is for the ECM Administrator's use as an indicator of traffic for planning purposes and the determination of the necessary right-of-way.

B.2.3. Study Area

The limits of the transportation network to be studied shall be based on the size and extent of the proposed development, the existing and future land uses, and traffic conditions on and near the site.

The limits of the study area shall be agreed to by the ECM Administrator before preparing the TIS. The Master TIS shall generally establish the study area for all subsequent Individual TISs.

A. **Study Area Basis for Master TIS.**

- All adjacent and internal collector and arterial roadways;
- Offsite collector and arterial links within the study area that are impacted by 10 percent or more by the project;
- Continuity and adequacy of pedestrian and bicycle facilities to the nearest attraction (existing or planned);
- Access to the most direct public transportation services facility or public transportation services route where public transportation services are available; or
- Any pedestrian routes within 2 miles of a school.

B. **Study Area Basis for Individual Full TIS.**

- All adjacent roadways, intersections, and high-volume accesses;
- Nearest offsite major intersection(s);
- Offsite collector and arterial links within the study area that have impacted intersections as defined below or provide the primary connections between the project and urban services;
- Internal public roads, including establishing the road classification;
- Additional offsite major intersections where: the project contributes a 10 percent impact (during either the A.M. or P.M. peak hour) to any approach leg of the intersection where the intersection is operating at a LOS of C or better in the Short-Range Horizon, or the project contributes a 5 percent impact (during either the A.M. or P.M. peak hour) to any approach leg of the intersection where the intersection is operating at a LOS of D or worse in the Short-Range Horizon;
- Additional offsite minor intersection where the project contributes a 30 percent increase in volume (during either the A.M. or P.M. peak hour) to any approach leg of the intersection where any existing leg of the intersection is currently operating at a LOS of E or worse;
- Pedestrian and bicyclist destinations (existing or planned) to the nearest attraction;

-
- Access to the most direct public transportation services facility or public transportation services route (existing or planned) within 1,320 feet of the site where public transportation services are available; or
 - Any pedestrian routes within 2 miles of a school (residential land uses only).

C. Study Area Basis for Individual Intermediate TIS.

- All adjacent roadways, intersections, and high-volume accesses;
- The nearest offsite major intersection(s) only if: the project contributes a 10 percent impact (during either the A.M. or P.M. peak hour) to any approach leg of the intersection where the intersection is operating at a LOS of C or better in the Short-Range Horizon, or the project contributes a 5 percent impact (during either the A.M. or P.M. peak hour) to any approach leg of the intersection where the intersection is operating at a LOS of D or worse in the Short-Range Horizon,
- Offsite collector and arterial links within the study area that have impacted intersections;
- Internal public roads, including establishing the road classification;
- Pedestrian and bicyclist destinations (existing or planned) to the nearest attraction;
- Access to public transportation services where available; or
- Any pedestrian routes within 2 miles of a school (residential land uses only).

D. Traffic Memorandum.

- All adjacent roadways, intersections, and high-volume accesses;
- Internal public roads, including establishing the road classifications;
- Continuity and adequacy of pedestrian and bicycle facilities adjacent to the site; or
- Access to the most direct public transportation services facility or public transportation services route adjacent to the site.

B.2.4. Evaluation Elements

- A. **Evaluation Elements for a Master TIS.** The purpose of the Master TIS is to provide a general sense of the overall impacts to the transportation system and to identify the larger scale improvement needs necessitated by the proposed zoning (i.e., widening of arterials, connecting key gaps in the roadway system, etc.). For example, for a large development plan with a multi-phase build-out, the Master TIS would not only address the overall project, but also identify key measurable criteria that would trigger the construction of some incremental portion of the overall infrastructure improvement plan. Typically, with each phase of the project a new individual site TIS specific to that phase would be prepared. This new study would verify the accuracy of the original traffic projections, both on site and background, and check the criteria identified for infrastructure improvements and other pertinent information.

The key elements of the project impact assessment for a Master TIS shall include the following minimum evaluations:

- Conformity with the adopted MTCP and ECM;
- Peak hour link volume and LOS;
- Appropriateness of access locations;
- Multi-modal and Transportation Demand Management (TDM) opportunities;
- Pedestrian/bicycle requirements and improvements;

-
- Safety and accident analysis. Other items requested by the ECM Administrator in the Scoping Meeting; and
 - Neighborhood and public input issues.

In cases where a developer seeks vesting with a Site Specific Development Plan, the Master TIS is required to present all the detailed information required in an Individual Site Transportation Impact Study.

B. Evaluation Elements for a Full TIS. The key elements of the project impact assessment shall be specified by the ECM Administrator from the following list:

- Conformity with the adopted MTCP and ECM;
- Peak hour link volume and LOS;
- Peak hour intersection and access LOS;
- Appropriateness of access locations;
- Location and requirements for turn lanes or acceleration/deceleration lanes at accesses or intersections, including recommendations for taper lengths, storage length, acceleration/deceleration lengths, and other geometric design requirements;
- Sight distance evaluations and recommendations (intersection, stopping, passing);
- Multi-modal and TDM opportunities;
- Continuity and adequacy of pedestrian and bicycle facilities to the nearest attraction (existing or planned) within the study area;
- Recommended traffic control devices for intersections which may include two-way stop control, four-way stop control or yield signs, school flashes, school crossing guards, crosswalks, traffic signals, or roundabouts;
- Traffic Signal and stop sign warrants;
- Progression analysis for signalized intersections;
- Appropriateness of the existing roadway signing and striping;
- Safety and accident analysis;
- Other items as requested by the ECM Administrator in the Scoping Meeting; and
- Neighborhood and public input issues.

C. Evaluation Elements for an Intermediate TIS.

- The key elements of the project impact assessment shall be specified by The ECM Administrator from the following list:
- Conformity with the adopted MTCP and ECM;
- Peak hour link volume and LOS;
- Peak hour intersection and access LOS;
- Appropriateness of access locations;
- Location and requirements for turn lanes or acceleration/deceleration lanes at accesses or intersections, including recommendations for taper lengths, storage length, acceleration/deceleration lengths, and other geometric design requirements;

-
- Sight distance evaluations and recommendations (intersection, stopping, passing);
 - Continuity and adequacy of pedestrian and bicycle facilities to the nearest attraction (existing or planned) within the study area;
 - Recommended traffic control devices for intersections, which may include two-way stop control, four-way stop control or yield signs, school flashers, school crossing guards, crosswalks, traffic signals, or roundabouts;
 - Traffic signal and stop sign warrants;
 - Progression analysis for signalized intersections;
 - Appropriateness of the existing roadway signing and striping;
 - Safety and accident analysis;
 - Other items as requested by the ECM Administrator in the Scoping Meeting; and
 - Neighborhood and public input issues.
- D. **Traffic Memorandum.** The key elements of the project impact assessment shall be specified by the ECM Administrator from the following list:
- Peak hour link volume and LOS;
 - Peak hour access LOS;
 - Appropriateness of access locations;
 - Location and requirements for turn lanes or acceleration/deceleration lanes at the access, including recommendations for taper lengths, storage length, acceleration/deceleration lengths, and other geometric design requirements;
 - Sight distance evaluations and recommendations (intersection, stopping, passing);
 - Continuity and adequacy of pedestrian and bicycle facilities within the study area;
 - Appropriateness of the existing roadway signing and striping;
 - Other items as requested by the ECM Administrator in consultation with the applicant's traffic engineer; and
 - Neighborhood and public input issues.
- E. **Board of County Commissioners Rights Reserved.** The BOCC reserves the right and ability to review the cumulative impacts created by the proposed development and to require improvements to mitigate the impacts.

B.3. ASSESS TRAFFIC VOLUMES

B.3.1. Existing Traffic

- A. **Roadway Traffic Volumes/Traffic Counts.** Current A.M. and P.M. peak hour traffic counts as specified by the ECM Administrator shall be obtained for the roadways within the study area for one, non-holiday Tuesday, Wednesday, or Thursday. Each peak hour count shall be conducted over a two-hour period and shall include fifteen (15)-minute count data to clearly identify the peak hours.
- Weekend counts and average daily counts on local roadways may also be required where appropriate when requested by the ECM Administrator. The DOT or CDOT average weekday traffic (AWT) counts

may be used when available. Pedestrian counts and bicycle usage should be obtained. Vehicle classification counts may be required.

In any case, these volumes shall be no more than one year old (from the date of application submittal). The source(s) of each of the existing traffic volumes shall be explicitly stated. Summaries of current traffic counts shall be provided. The ECM Administrator may require the use of seasonal adjustment factors depending on when data was collected and if the project is considered to be in an area of higher risk for lower levels of services (i.e., Tourism).

- B. **Intersection LOS.** A.M. and P.M. peak hour intersection LOS shall be determined for the existing collector and arterial signalized and unsignalized intersections within the transportation network to be studied. The analysis shall use procedures described in the Highway Capacity Manual. Factors for intersections will be by approach and those used for roadways will be by facility unless otherwise directed by the ECM Administrator.
 - 1. **Existing and Short-Range Horizon.** Use calculated peak hour factors or 0.85, whichever is higher, and
 - 2. **Long-Range Horizon.** A peak hour factor of 0.95 may be used for the Long-Range Horizon. Greater values may be used if approved by the ECM Administrator.
- C. **Roadway Links.** Roadway links shall be analyzed. Acceptable maximum traffic volumes allowed for the specific class of roadway are shown in Table B-1.

Table B-1. Threshold Capacity

Facility Type	Lanes	ADT Threshold Capacity (Urban/Rural)
Local (low volume)/Local (rural)	2	300/750
Collector-Non-Residential	2	20,000
Local (urban)/Minor Collector (rural)	2	3,000/1,500
Major Collector	2	10,000/3,000
Minor Arterial	4	20,000/10,000
Principal Arterial (4-lane)	4	40,000/40,000
Principal Arterial (6-lane)	6	40,000/40,000
Expressway (4-lane)	4	48,000/48,000
Expressway (6-lane)	6	48,000/48,000

B.3.2. Background Traffic

- A. **Short-Range Volume Projections.** The traffic forecast for the short-range planning horizon shall be the sum of existing traffic volumes plus cumulative development traffic from approved land use actions (projects with reserved intersection capacity established through a certified Full TIS), plus background growth (as adjusted to avoid duplicative consideration of the identified development traffic from the approved land use already considered). The cumulative development traffic shall be based, in part, on the A.M. and P.M. peak hour and (ADT) data established and accepted from planned and approved land use actions within and near the study area. The assumed baseline surface transportation network shall reflect existing facilities (without the proposed project improvements) plus any committed improvements within the study area.

The short-range planning horizon background traffic growth rate shall be based:

-
- Straight line projection for the build-out year between the existing traffic volumes and the MTCP model forecast, CDOT rates;
 - Historical traffic counts projected to the build-out year (at least three years of traffic data should be used for this); or
 - Area-wide traffic count analysis that considers traffic volume trends in the study area's circulation system and uses proportion/extrapolation methods.

B. Long-Range Volume Projection.

- Straight line projection for the build-out year between the existing traffic volumes and the MTCP model forecast, CDOT rates;
- Historical traffic counts projected to the build-out year (at least three years of traffic data should be used for this);
- Area-wide traffic count analysis which considers traffic volume trends in the study area's circulation system and uses proportion/extrapolation methods; or
- Growth rate agreed upon with the ECM Administrator.

B.3.3. Project Traffic

- A. **Trip Generation Rate.** Trip generation shall be calculated from the latest data contained within the Institute of Transportation Engineers' Trip Generation Manual. Other industry publications (such as the ITE Journal or other sources) may be approved by the ECM Administrator. Data limitations, data age, choice of peak hours (for the land use or adjacent roadway traffic), choice of independent variables, and choice of average rate versus statistically significant modification shall be discussed in the study when appropriate. When data is not available for a proposed land use or a modification is proposed, the Applicant must conduct a local trip generation study following procedures prescribed in the ITE Trip Generation Manual and provide sufficient justification for the proposed generation rate. This rate must be approved by the ECM Administrator prior to its use in the written study.
- B. **Preliminary Land Use Assumptions.** The trip generation values contained in studies submitted prior to the establishment of a site-specific development plan shall be based on the maximum number of dwelling units permitted for the approved land uses or the maximum trip generation rates for the non-residential development proposed land use action. When a TIS is being developed for a project with an established site-specific development plan, trip generation shall be based on actual dwelling unit counts and square footage(s) proposed on the final plan.
- C. **Trip Generation Table.** A Trip Generation Table, listing each type of land use within the site at build-out, the size and unit of measure for each land use, trip generation rates (total daily traffic, A.M. and P.M. peaks), directional splits for each in/out access, and the resultant total trips generated shall be provided. The data source shall include ITE land use code. Build-out land uses and trip generations shall be used for both the short-range and long-range planning horizons.
- D. **Committed Trips/Capacity.** The trip generation stated in the TIS will establish the maximum number of trips permitted entering and exiting the development. If the number of committed trips is reached prior to full occupancy, the ECM Administrator reserves the right to require from the sponsor, at the sponsor's expense, supplemental traffic analyses prior to the issuance of additional building permits. This information shall demonstrate that uncommitted capacity is available on the transportation network to serve the excessive trips, or that additional transportation mitigation improvements can be reasonably installed to maintain compliant operation with the excessive trips. If no additional capacity is available, or no reasonable mitigation conforming to the requirements of these roadway standards can be implemented, the owner shall obtain an exception from the ECM Administrator for the non-

conformity or scale back the intensity of the proposed land uses as needed to achieve compliance. If the project is fully occupied and it is determined that the approved land use action's traffic exceeds that which was included in the approved TIS, the ECM Administrator is authorized to require the property to conduct additional traffic analysis and provide additional mitigation measures.

- E. **Adjustments to Trip Generation.** Trip-making reduction factors may be used after first generating trips at full ITE rates. These factors fall into two categories: those that reassign some portion of generated trips to the background stream of traffic, and those that remove or move generated trips. In all cases, the underlying assumptions of the ITE trip generation rates must be recognized and considered before any reductions are used in the TIS. Two specific situations will be closely reviewed. The first is when the traffic study assumes rates where the collection of mixed uses, such as at a shopping center, result in lower peak hour trips than when applying individual rates to each land use. The second is when reductions in the trip generation rates are assumed based on reductions due to travel demand management.
1. **Pass-by Trips.** This first category may be considered when trips to the proposed development currently exist as part of the background traffic stream, referred to as a pass-by trip. Pass-by percentages identified in the ITE Trip Generation Manual will be considered with appropriate explanation and documentation. Pass-by traffic must remain assigned to driveways and access points, but should not be added to the background traffic stream. A technical appendix, table, or map that illustrates the re-division of pass-by trips is required.
 2. **Internal Site Trips/ Transportation Demand Management (TDM).** Analytic support documentation of internal site trips, public transportation services use, and TDM actions shall be provided to show how trip adjustments are derived. Optimistic assumptions regarding public transportation use and TDM actions will not be accepted unless accompanied by specific implementation proposals that will become a condition of approval. Such implementation proposals must have a high expectation of realization within a 5-year period after projection initiation.
- F. **Trip Distribution.** Trip Distribution must be documented in the TIS. It may be based on the professional engineer's judgment applied to one or more of the following: MTCP traffic volume projections, gravity model, market analysis, existing traffic flows, or applied census data. Regardless of the basis of the estimates, the procedures and rationale used in determining the trip distributions must be fully explained, documented, and approved by the ECM Administrator.
- G. **Trip Assignment.** The project traffic will be assigned to the roadway system according to the trip distribution. The resulting project site-generated traffic and total site traffic will be depicted on figures for each analysis horizon. These figures will include peak hour traffic volume information, plus daily traffic volume information. Separate maps or values are required when the trip distribution differs by more than 10 percent between the short-and long-range analysis horizons.

B.3.4. Total Traffic

The total traffic projections will be determined for each of the analysis horizons identified in the base assumptions. The total traffic projections will include the existing traffic, plus the future background traffic, plus the project generated traffic. The future total traffic projections will be depicted on figures for each study year. Based upon the total traffic projections, roadway standards, and MTCP, the applicant shall provide roadway functional classification recommendations.

B.4. ASSESS PROJECT IMPACTS

B.4.1. Project Impact Assessment

The key elements of the project impact assessment include evaluations of issues outlined for a specific Analysis Level.

A. **Project Impacts.** The key elements of the project impact analysis include:

- Generalized Daily Traffic Volume Level of Service
- Using the daily traffic volumes forecast and general daily level of service thresholds, a general evaluation should be made of the arterial roadway system for the short term and long-term horizon years. Incremental differences attributable to the land use action should be identified. A map showing generalized levels of service should be presented for each design year.
- For unsignalized intersections of 2 lane (and rarely on 4-lane) roads, where traffic on the main road is not stop controlled, an evaluation for the need for auxiliary speed change lanes is to be provided (reference Section 2.3.7.D).
- Peak Hour Intersection Level of Service
- An a.m. and p.m. peak hour intersection level of service analysis shall be conducted for each intersection, based on procedures specified in the Highway Capacity Manual. All level of service analysis worksheets shall be included in the Appendix.
- The principal objective of the intersection level of service traffic impact analysis is to identify whether the traffic from the proposed project when added to the existing plus short and long term planning horizon traffic will result in a significant impact and an unacceptable LOS. For definitional purposes, the threshold for acceptable LOS is not less than LOS D for peak hours.
- Significance for signalized intersections is defined as when the added project traffic causes an intersection to fail the minimum acceptable LOS standard; or when the background traffic conditions (without project traffic) causes an intersection to fail the minimum acceptable LOS standards; and when the project traffic causes more than a 2 percent increase in the intersection delay. Significance for unsignalized intersections is defined when backstacking to adjacent intersections would create impeded traffic flows and/or excessive congestion; when added project traffic is determined to create potential safety problems.

B. **Traffic Signals and Access Locations.** Traffic signals warranted by the land use action a signal warrant analysis (based on the MUTCD) shall be identified. The acceptability of the signal locations must be demonstrated through a signal progression (time-space) analysis. The analysis shall consider any existing access or intersection or a possible future signal location along the arterial for a distance of at least one mile in each direction of the proposed signal. A cycle length of between 80 and 120 seconds should be selected and agreed to by the ECM Administrator. A travel speed of 45 mph on majors and 35 mph on minors, unless the existing posted speed limit is less, must be used. A major arterial bandwidth of 50 percent and a minor arterial bandwidth of 40 percent are considered desirable, and must be used where existing conditions allow. Where intersections or other accesses have no signals presently, but are expected to have signals, a 60 percent mainline, 40 percent cross roadway, and cycle split should be assumed. Where more detailed information is available from turning movement projections, other split assumptions may be made.

Any access where a signal would reduce the desirable bandwidth shall be identified. In general terms, that access should remain unsignalized and have turning movements limited by access design or median islands, unless the impacts to traffic operation and safety are made worse. The implications of

the land use action upon the adequacy of the signal locations for each design year shall be provided. Distances between signalized intersections (centerline) shall be indicated. Signal progression worksheets (time-space diagrams) shall be included in the TIS Appendix.

The following signalization and access parameters shall also be addressed:

- Turn lane storage needs shall be identified for the "necessary" situation, based on projected turning volumes and AASHTO analytic techniques. Appropriate documentation of the calculations must be provided;
- The identification of project sight distance at the project entrances and all internal roadways shall be conducted. Line of sight triangles for determining sight distances and landscape restrictions shall be prepared and submitted.
- Appropriateness of acceleration or deceleration lanes.
- All proposed project entrances on arterials shall be evaluated as to whether they require acceleration lanes or deceleration lanes per the requirements presented in these Standards.

C. **Pedestrian and Bicycle Impact Evaluations.** Pedestrian and bicycle facility demand shall be identified and related items for discussion shall include:

- School routing plans shall be developed per the MUTCD between the project and all schools within 2 miles of the project boundary.
- The demand for pedestrian and bicycle facilities to serve high pedestrian activity areas with the land use shall be evaluated and properly accommodated for the planning of the project.
- The need for links of bicycle or pedestrian facilities to neighboring land uses or attractions (trails, etc.) within 1,320 feet or greater if applicable to unique pedestrian-oriented destinations) of the project site.
- Existing and proposed sidewalk width, separation from traffic, and space available for trees, public transportation services stops (if any), or other related elements (if any).
- Geometric improvements and recommended traffic control devices to accommodate pedestrians and bicyclists.

D. **Pedestrian and Bicycle Level of Service.** Existing and proposed pedestrian and bicycle facilities shall be evaluated for compliance with the following elements:

1. **Directness.** Walking distance to destinations like public transportation services stops, schools, parks, and commercial or activity areas shall be direct. Measurement of directness is the ratio of the actual distance to a destination via a sidewalk or pathway divided by the minimum distance characterized by a grid roadway system,
2. **Continuity.** The sidewalk/walkway system shall be complete, without gaps. The pedestrian corridor shall be integrated with the activities along the corridor and shall provide continuous access to destinations,
3. **Roadway Crossings.** Safety and comfort is essential while crossing roadways, intersections, and mid-block crossings. Factors that affect safety include number of lanes to cross, crossing delay for pedestrians, signal indication, cross-walks, lighting, raised medians, visibility, curb ramps, pedestrian buttons, convenience, comfort, and security,
4. **Visual Interest and Amenity.** Pedestrians enjoy visually appealing environments that are compatible with local architecture and include roadway lighting, fountains, and benches.

-
5. **Security.** Pedestrians shall be visible to motorists, separated from motor vehicles and bicycles, and under adequate roadway lighting.
 6. **Surface Condition.** Pedestrian facilities shall be free from obstructions, cracks, and interruptions.
- E. **Special Studies.** This section provides the ECM Administrator with opportunities to require specific focused traffic analyses that may be unique to the proposed land use action. The ECM Administrator will determine if special studies are required in a Scoping Meeting. These may include, but are not limited to, the following:
1. **Access Management.**
 - If a development is proposing a new access location on an arterial and an Access Management Plan does not exist, the ECM Administrator may require an Access Management Plan. Proposals to access roads classified as arterials and above shall require review through the Major Thoroughfares Task Force Process;
 - Access spacing;
 - Accident/safety concerns (accident statistics);
 - Truck routing;
 - Emergency and snow routes; and
 - Hazardous materials routes.
 2. **Neighborhood Transportation Impact Evaluation.** The TIS may be required to include a focused analysis of the potential project-related impacts on adjacent residential neighborhood quality of life issues, such as potential cut-through traffic and speeding/volume concerns. If it is determined that a neighborhood transportation impact evaluation is required, the following procedure shall be followed:
 - Examine existing transportation conditions within the neighborhood following the procedure as set forth for the transportation impact analysis. Daily and peak hour traffic volumes shall be collected for the local roadways to be included in the analysis;
 - Determine project-generated traffic for all modes within the neighborhood and show on a figure;
 3. **Determine total traffic projections for the local roadways.** This shall follow the same procedures as described earlier, including other projects and area-wide growth, if applicable:
 - Determine if the proposed project would create significant impacts to the residential roadways;
 - If necessary, develop measures including, but not limited to, traffic calming techniques, to mitigate any significant impacts; and
 - The neighborhood TIS shall also discuss how pedestrians and bicyclists would access the proposed project from the adjacent neighborhood(s), and the need for special facilities to enhance direct pedestrian and bicycle connectivity.
 4. **Sight Distance.** Sight distance concerns that are anticipated or observed which may impact access, intersection, or roadway operation and safety need to be discussed in the TIS. Recommendations regarding stopping sight distance, intersection sight distance, and passing sight distance needs shall be provided for detailing on the final development, site plan, or final construction plans.

B.5. DEVELOP MITIGATION MEASURES

When a project's vehicular impacts do not meet the minimum acceptable LOS standard, the TIS shall include feasible measures, which would mitigate the project's impacts. The mitigation measures are intended to be in addition to the minimum required improvements necessary to meet these standards. One goal of the mitigation measure(s) should be to minimize the demand for trips by single occupant vehicles and to increase the use of the alternative modes.

The intersection LOS shall be recalculated to reflect the effectiveness of the proposed mitigation measures and show that the project-related impacts have been reduced to an acceptable LOS. The LOS findings shall be shown in tabular form. The following mitigation categories are not listed in order of priority.

B.5.1. Transportation Demand Management Measures

Transportation Demand Management measures are designed to facilitate the use of alternate transportation modes in an effort to decrease demand on the roadway system by single occupant vehicles. A detailed description of the proposed TDM measures and implementation plan must be included in the TIS for any project seeking TDM-related trip reductions. If the TDM program is acceptable to The ECM Administrator, the total project vehicle trips may be reduced by an amount commensurate with applicable trip reduction policies.

A. Examples of TDM Measures.

- Vehicle trip reduction incentives and services offered by employers to encourage employees to utilize alternative modes of travel, such as carpooling, vanpooling, riding public transportation services, bicycling, walking, telecommuting, etc.;
- Vehicle trip reduction incentives and services affecting visitors to the project, such as shoppers, clients, patrons, etc.;
- Financial support for the capital or operating costs of enhanced public transportation services or vanpool service to the project;
- Provision of a mix of land uses in close proximity, facilitating trip making by walking, bicycling, or local shuttles;
- Provision of on-site facilities that encourage the use of alternate forms of transportation, such as bicycle lanes and amenities, enhanced pedestrian connections, telecommuting facilities, etc.; and
- Site trip cap and/or parking cap including trip-monitoring agreements.

B.5.2. Public Transportation Service

Suggested elements of a public transportation services program include:

- Contributions of equipment or funds to increase the capacity of existing public transportation systems,
- Public transportation shuttles provided by Applicant (e.g., bus, taxicab, van, etc.), and
- Contributions toward park and ride lots, public transportation services stations or centers.

B.5.3. Traffic Control

There are many ways to control traffic and enhance safety and mobility for motorists, pedestrians and bicyclists. Each component of a traffic control system must be viewed as a single unit in an overall network.

-
- A. **Medians.** Medians are grouped into three general types (i.e., raised, depressed, and flush) and are designed for both through traffic and access control.
 - B. **Signals.** Design of all traffic signals shall be in accordance with the MUTCD and the CDOT Standards and Specifications. Traffic signal plans shall be submitted to and approved by the ECM Administrator prior to initiating installation.
 - C. **Signing and Striping.** Signing and Striping plans are required for signing/striping of new roadways and re-signing/striping of existing roadways. All plans shall be prepared in accordance with the MUTCD and included with the final construction plans for review and approval.
 - D. **Traffic Control Plans.** Traffic control during construction shall be planned and performed in accordance with the MUTCD and be included with the final construction plans for review and approval.

B.5.4. Roadway Widening and Other Physical Improvements

Mitigation measures, which include roadway widening, and other physical improvements must be demonstrated to be physically feasible and must meet minimum ECM standards.

B.5.5. Roadway Restriping and Parking Regulations

The ECM Administrator must approve proposed striping and parking regulation mitigation(s). Generally, roadway restriping is not a preferred mitigation due to resulting parking impact. Therefore, any parking impacts should be clearly identified and proposed for mitigation to the extent feasible.

B.5.6. Geometric Improvements

Turn lanes and other auxiliary lane needs shall be identified for each access.

B.5.7. Traffic Calming

This section presents acceptable methods of neighborhood traffic calming for urban collector or rural minor collectors and local roads. This section also provides for specific design criteria for a number of traffic calming methods.

- A. **Intended Use.** The necessity or desire for traffic safety and calming stems from the perception that local and minor collector roadways are not always functioning as intended. These roadways should be low traffic volume roadways used for direct access to property. They are also intended as a system that is shared by vehicular, bicycle, and pedestrian traffic, in a manner that minimally impacts residents in these areas.

Traffic calming measures are intended to minimize these issues and return the quality of life to the neighborhood. Care must be taken by the designer so that the installation of traffic calming devices does not create unintended hazards that delay emergency response or jeopardize the safety of bicyclists, pedestrians, or motorists.

- B. **Traffic Calming for New Roadway Design.** New local and minor collectors roadways are to be designed to minimize cut-through traffic, high volumes, and high-speed operation and to maximize the efficiency of the roadway to provide vehicular access and bicycle and pedestrian traffic.
- C. **Roundabouts and Mini Roundabouts.** Roundabouts and Mini roundabouts are considered traffic control measures. These traffic control measures may be used in new or existing roadway design if the appropriate criteria are met.
- D. **Traffic Calming Design Criteria.** Table B-2 presents a brief list of traffic calming solutions and their intended uses. Traffic calming devices may only be used on local and minor collector roadways.

Table B-2. Traffic Calming Solutions

Device	Intended Use	Reference
Signals, Signs, and Striping	Creates a system that calms traffic through warnings, progression control, and highlighting surrounding land uses	Chapter 2, Transportation Facilities
Mini Roundabouts	An intersection device that can slow traffic through the use of specialized roadway geometry	Chapter 2, Transportation Facilities
Neckdowns	An intersection device that slows traffic through the use of narrowed roadway geometry	Standard Detail
Drop Off Zone for Schools	Creates a traffic calming condition by highlighting school bus operations, the presence of pedestrians and changes in roadway section	Standard Detail
Realigned Intersections	Creates a disruption in travel patterns by offsetting the standard intersection geometry	Chapter 2, Transportation Facilities

B.6. RECOMMENDATIONS AND REPORT CONCLUSIONS

B.6.1. Recommended Improvements

The findings of the TIS shall be provided in summary format, including the identification of any areas of significant impacts and recommended improvements/mitigation measures to achieve LOS standards.

- A. **Geometric Improvements.** The TIS shall include recommendations for all geometric improvements, such as pavement markings, signs, adding through or turn lanes, adding project access and assorted turn lanes, acceleration lanes, and changes in medians. Sufficient dimensions/data shall be identified to facilitate review. Anticipated right-of-way needs shall be identified.
- B. **Responsibility.** The location, nature, and extent of all transportation improvements recommended to achieve the required LOS for each analysis horizon shall be identified. In addition, the sponsor responsible to complete the improvements shall be identified.
- C. **Proposed Transportation Demand Management.** If TDM measures are recommended to mitigate the traffic impact of the proposed land use action, a specific TDM Implementation Proposal shall be developed and presented to the ECM Administrator. If accepted, this Implementation Proposal will become a condition of approval of the land use action requested. Each TDM Implementation Proposal shall be developed in conformance with the ECM Administrator's and the PPACG's Transportation Demand Management Program.
- D. **Summary Presentation.** A Recommended Improvements Summary Table shall be prepared. The recommended improvements identified on the Recommended Improvement Table shall be categorized as Master Planned, Background Committed, or Project Committed. Each project shall include a description of its location, the type of project, right-of-way needs (for roadways), and signal or turn lane improvements (for intersections). Commitment to funding and constructing each of the improvements shall be identified.

B.7. SIGNATURE AND APPROVAL BLOCK

El Paso County: County report review is provided only for general conformance with County standards and design criteria. The County is not responsible for the accuracy and adequacy of the data, analysis, or conclusions. The County through the approval of this document assumes not responsibility for completeness and/or accuracy of this document.

B.8. TRAFFIC REPORT STANDARDS

Traffic reports shall include the following unless the review engineer specifically waives them:

- Proposed classifications of all proposed internal roadways (e.g. "rural local road", "rural local low volume road", "urban minor arterial", etc.)
- Classification of all adjacent or impacted roadways per the MTCP. (e.g. "rural local road", "rural local low volume road", "urban minor arterial", etc.)
- Trigger points for the construction of all required future improvements including but not limited to turn lanes, signals, widenings, and openings or closings of accesses. ("Trigger points" are the conditions that, when met, will call for the construction of said improvements.) Cost estimates and escrow amounts can be determined at the final plat stage.
- For final plats, state definitively what improvements the developer will be constructing with the project.
- Clearly state in text and in supporting documents what the ADT and peak hour traffic levels are at all accesses currently, at full development, and long term (twenty years out.) Include intermediate stages for phased development.
- State whether or not any improvements affected by the project are reimbursable under the current Major Transportation Corridors Plan (MTCP).
- State whether the MTCP or other approved corridor study calls for the construction of improvements in the immediate area.
- List ECM criteria for stacking, storage, and taper for every affected auxiliary lane and access and state whether this access can be met. If it cannot be met, state the required modifications so that it can be met.
- State what the sight distance is for every affected access and whether it can be met. If it cannot be met, state the required modifications so that it can be met.
- State what the current applicable Transportation Impact Fees are and what option the developer will be selecting for payment. If the site is in a special district, so state and summarize the applicable fees.
- List other traffic studies by the consultant in the area of study within the past five years, in addition to any reports identified by County staff or that the applicant is aware of. State whether the current study is consistent with those studies and explain any discrepancies.
- List all deviations from the County Engineering Criteria that the applicant will be making. Include supporting information, together with a signed and stamped deviation request form.
- Include LOS for all affected intersections.
- Show total traffic generated by the proposed development using ITE trip generation figures.
- If an intersection does not meet LOS D or better, discuss what steps can be taken to bring the intersection to a satisfactory level.

-
- Include an engineer's certification page with the engineer's stamp, signature, and date. The statement must read as follows:
 - "The attached traffic report and supporting information were prepared under my responsible charge and they comport with the standard of care. So far as is consistent with the standard of care, said report was prepared in general conformance with the criteria established by the County for traffic reports."
 - Include a developer's statement on the certification page. The statement must read as follows:
"I, the Developer, have read and will comply with all commitments made on my behalf within this report." Include a printed or typed developer name and address as well as a signature block.

Appendix C SOILS INVESTIGATION REPORTS AND MITIGATION

C.1. PURPOSE

This appendix provides the minimum requirements for soils investigations associated with new and improved County infrastructure. In addition, it provides guidelines for the documentation to be developed for summarizing the results of these investigations.

C.2. GEOLOGIC HAZARDS REPORT

C.2.1. General Requirements

These guidelines outline the minimum information that shall be presented and evaluated in a Geologic Hazard Report. These guidelines are not intended to be a rigid framework of requirements, nor a specific format for each report submitted for County review. The level of detail and emphasis may vary due to unique or particular geologic conditions or due to the type of project.

C.2.2. Report Guidelines

- A. **Overall Project Information.** A general project description shall be included with each report and in a clear manner present at a minimum the following list of items:
- Size and location of the project;
 - Existing site land uses;
 - Proposed site land uses; and,
 - Identification of the person who prepared the study and his/her qualifications for conducting the study.
- B. **Study Overview.** A general overview of the report objectives, contents, methods, level of investigation, and findings should be provided:
- State the objective(s) and level of investigation for the study;
 - Cite the previous publicly available geologic reports which were reviewed or referenced in the course of preparing the geologic hazard study and indicate the author(s), firm, and date of each report;
 - List the methods of investigation as well as professional firm(s) who participated;
 - If the level of investigation varies within the subject area, describe in the text and show on the maps areas of concentration or exclusion;

- Describe the general physiographic setting of the project and its relationship to local topographic features;
- Describe the general geologic setting of the project and indicate any lithologic, tectonic, geomorphic, or soils problems specific to the area; and,
- Describe the general surface and groundwater conditions.

C. **Site Evaluation Techniques.** The most appropriate site evaluation techniques shall be determined by the geologist/geotechnical engineer based on site conditions and the activities being proposed for the site. However, the list below presents typical methodologies and techniques used to evaluate the potential geological hazards of a site. Based on their applicability to the site being investigated, the information listed under each technique shall be included with the submitted report unless otherwise indicated to not be required. A detailed explanation is necessary for exclusion of minimum requirements listed.

1. **Extent.** State the extent and method of surface and subsurface geologic studies.
2. **Geologic Mapping.** The geologic mapping shall:
 - Show important details corresponding to the size, extent and degree of the investigation on the project topographic map;
 - Show the abundance of distributions of earth materials and structural elements exposed or inferred in the subject area. Observed and inferred features or relationships should be so designated on the geologic map;
 - Portray all geologic information at a scale that is appropriate for readability and interpretation. When different sources are used. "Tie-points" between the sources shall be presented, and,
 - Indicate the geologic base map use, date, and significant additions and modifications to previous work.
3. **Aerial Photographs and Remote-Sensing Imagery.** When aerial photographs or imagery are used, the report shall:
 - Present the source(s) of photographs or images, if available;
 - Indicate data and scale of photographs or imagery; and,
 - Highlight critical points and their relationship to the project.
4. **Geophysical Investigations.** Geophysical investigation information shall:
 - Indicate the type and objectives of the geophysical investigation(s) (if any), quality of the data, and limitations of geophysical techniques;
 - Describe the information used to correlate the geophysical data and geologic conditions; and,
 - Display the geophysical data on the topographic/geologic maps and cross section.
5. **Drill-Hole Data.** Drill-hole data information shall:
 - Describe the specific investigative methods, tests conducted, drilling, and date of investigation;
 - Show the location of all borings on the topographic or geologic map; and,
 - Show boring logs, geophysical logs, or profiles obtained in the investigation.
6. **Test Pits and Trenches.** The test pit and trench information shall:

-
- Describe the location and dimensions of all pits and trenches and date of investigation;
 - Indicate the location of all excavations on the topographic/geologic map and profiles;
 - Provide a large scale descriptive log with sufficient detail; and,
 - Show sample location if supplemental laboratory tests were conducted.
7. **Field and Laboratory Tests.** The field and laboratory tests information shall:
- Describe the type of any tests conducted in the field or laboratory;
 - Describe the sample method and test procedures; and,
 - Show the test results on the data work sheets or on summary tables.
8. **Monitoring Programs.** The monitoring program information shall:
- Describe the type, objectives, and location of all monitoring programs in the subject area; and,
 - State the monitoring period, the firm(s) or individuals responsible for the care and disposal of the installations.
- D. **Geologic Descriptions.** As appropriate for site conditions, the report should provide the following general geologic description information.
1. **Bedrock Units.**
 - Rock type and bedding attitude or foliation;
 - Age of and correlation with recognized formations;
 - Dimensional characteristics such as thickness and extent;
 - Distribution and extent of the weathered zone;
 - Physical characteristics; and,
 - Response of bedrock materials to natural processes.
 2. **Surficial Deposits.**
 - Distribution, occurrence, and age;
 - Identification of material types and sources;
 - Dimensional characteristics such as thickness and extent;
 - Surface expression and relationships with present topography;
 - Physical and chemical characteristics; and,
 - Distributions and extent of altered zones.
 3. **Geomorphic Features.** Geomorphic features resulting from landslides, earthflows, debris flows, mudflows, rockfalls, debris avalanches, fault scarps, soil creep, erosion scarps, avalanched paths, and subsidence phenomenon.
 - Locations and distribution;
 - Dimensional characteristics;
 - Age of feature and history of activity;
 - Recurrence interval for geomorphic process; and,

-
- Physical characteristics.
4. **Structural Features.** Structural features include joints, faults, shear zones, folds, schistosity, and foliation.
 - Occurrence, distribution, and proximity to site;
 - Dimensional and displacement characteristics of faults;
 - Orientation and changes in orientation;
 - Physical characteristics such as brecciation, slickensides, gouge zones, sand boils, sag ponds, springs alignment;
 - Disrupted drainages, or ground-water barriers;
 - Nature of offset(s) and timing of movement(s); and,
 - Absolute or relative age of latest movement.
 5. **Surface Drainage.**
 - Distributions;
 - Relation to topography (drainage patterns);
 - Relation to areas of vegetations;
 - Relation to geologic features;
 - Source permanence, and variation in amount of surface water;
 - Evidence of earlier occurrence of water localities now dry;
 - Estimated peak flows an physiographic flood plain of drainages;
 - Probable maximum or 100-year flood limits, including flash and debris floods; and,
 - Outfall.
 6. **Ground Water.**
 - Distributions and occurrence;
 - Hydraulic gradients;
 - Relation to topography;
 - Relations to geologic features; and,
 - Seasonal variations.
- E. **Geologic Interpretation.** The report shall include interpretations and detailed descriptions of the following:
1. **Geologic Hazards.** Geologic hazards include landslides, avalanche, rockfall, mudflows, debris flows, radioactivity, etc.
 - Geomorphic and structural features/processes present in the area;
 - Man-induced features/processes;
 - Age and activity of the features/processes;
 - Natural contentions affecting the features/processes;

-
- Susceptibility to man-induced changes;
 - Potential impact of hazard(s) and risk to project;
 - Amenability of adverse conditions for adequate mitigation;
 - Long-term lateral and vertical stability of earth materials; and,
 - Impact of project on materials stability.
2. **Geologic Constraints.** Geologic constraints include expansive soil or rock, potentially unstable slopes, high groundwater levels, soil creep, hydrocompaction, shallow bedrock, erosion, etc.
- Soil, surface and ground water, and geomorphic conditions;
 - Man-induced conditions;
 - Activity of conditions
 - Effect of natural or man-induced changes;
 - Potential impact of conditions and risk to project;
 - Amenability of adverse conditions for adequate mitigation; and,
 - Impact of project on long-term project stability.
- F. **Relationship of Geologic Factors on the Proposed Action.** This topic normally constitutes the principal contribution of the report. It involves both the affects of geologic features upon the proposed grading, construction, and land use; and the effects of these proposed modifications upon future geological processes in the area. The following checklist includes the topics that ordinarily should be considered as part of the findings, conclusions, and recommendations of the geologic reports:
1. **Compatibility.** General compatibility of natural features with proposed action that should be discussed includes:
 - Topography;
 - Lateral stability of earth materials;
 - Problems of flood inundation, erosion, and deposition;
 - Problems caused by features or conditions in adjacent properties; and,
 - Other general problems.
 2. **Proposed Cuts.** A description of proposed cuts and the relationship to the activities being proposed including:
 - Prediction of what materials and structural features will be encountered;
 - Prediction of stability based on geologic factors;
 - Problems of excavation (e.g. unusually hard or massive rock, excessive flow of groundwater); and,
 - Recommendations for reorientation or repositioning of cuts, reductions of cut slopes, development of compound cut slopes, special stripping above daylight lines, buttressing, protections against erosion, handling of seepage water, setbacks for structures above cuts, etc.
 3. **Proposed Fill.** A description of proposed fill and the relationship to the action including:
 - General evaluation of planning with respect of canyon-filling and sidehill masses of fill; and

-
- Comment on suitability of existing natural materials for fill.
4. **Recommendations for Fill.** Recommendations concerning the positioning of fill masses, provision for underdrainage, buttressing, special protection against erosion including:
 - Recommendations for subsurface testing and exploration; and
 - Cuts and test holed needed for additional geologic information.
 5. **Special Recommendations.** Details concerning any unique or unusual recommendations concerning the action including recommendations about:
 - Areas to be left as natural ground;
 - Removal or buttressing of existing slide masses;
 - Flood protection;
 - Problem of groundwater level fluctuation;
 - Position of structures, with respect to active faults;
 - Problems associated with radon gas and soil radioactivity; and,
 - Problems caused by natural gases, such as methane and hydrogen sulfide, radon, and,
 - Protection of existing and proposed utility facilities.
- G. **Conclusions.** The report shall provide detailed conclusions of the analysis including:
1. **Land Compatibility.** State generally whether the intended use of the land is compatible with the investigated site conditions; and if mitigation measures are necessary. In addition, depict those areas where "no building" is recommended.
 2. **Construction Planning.** Discuss critical construction planning aspects that may need further consideration by the contractor including the stability of earth materials, grading plans and the need for selective location of project facilities.
 3. **Geologic Basis.** The report shall clearly state the geologic basis for all conclusions.
- H. **Recommendations.** The report shall provide recommendations to be used in later stages of the project based on this preliminary analysis of the project site including:
1. **Mitigation Procedures.** Discuss the development of mitigation procedures or design changed necessary to minimize or abate any hazardous condition requires a recommendation.
 2. **Long-term Project Objectives.** Recommendations should focus upon the long-term stability and safety of the proposed project.

C.3. GEOTECHNICAL REPORT

C.3.1. General Requirements

These guidelines outline the minimum information that shall be presented and evaluated in a Geotechnical Report. These guidelines are not intended to be a rigid framework of requirements, nor a specific format for all reports. The level of detail and emphasis may vary due to unique or particular conditions or due to the type of project. The Geotechnical Report shall generally show results from the applicable testing. The report shall also include a description of site characteristics, e.g., topography, drainage features, etc.

C.3.2. Detailed Report Requirements

A. **Required Items.** The following items are required to be included in all Geotechnical Reports:

- Site location and description
- Boring location diagram
- Laboratory test reports with evaluations (classification tests) (See Table C-1)

Table C-1. Applicable Geotechnical Laboratory Tests

Applicable Laboratory Tests
Visual classification
Liquid limit - AASHTO T89 or ASTM D4318
Plastic limit - AASHTO T90 or ASTM D4318
Plasticity Index
In-situ moisture content
Percent passing No. 200 sieve - AASHTO T11 or ASTM C117-90
Gradation of granular (sand & gravel) materials - AASHTO T27, ASTM D422 or ASTM C136
AASHTO classification and group index - AASHTO M145
Standard Penetrations Test
Swell Potential Evaluation - ASTM D4546-96

- Boring logs, to include but not limited to the following: (1) Date, Strata Elevation, Depth of Boring; (2) Natural moisture content, blow count and dry density of each undisturbed sample; and (3) Water table elevation
 - Seasonal variations in soil and groundwater conditions to include the expected seasonal groundwater elevation variation shall be summarized.
 - Shallow bedrock depth and description including mitigation requirements if bedrock is within 3 feet of subgrade.
 - Percentage of soluble sulfates.
 - Backfill and fill evaluation including any additional tests required for trench backfill evaluation, fill evaluation, etc.
 - Groundwater evaluation including the elevation of groundwater encountered in each boring at time of drilling and at 24 to 48 hours after drilling. If deemed necessary, the boring may remain open for up to 7 days if required for further assessment.
- B. **Recommendations and Mitigation Plans.** The report shall include recommendations and mitigation concerning but not limited to the following:
- Allowable soil pressure
 - Foundation types
 - Groundwater
 - Maximum stable slopes (cut, fill, and natural)
 - Retaining wall information (if applicable)
 - Detention pond design and construction (if applicable)

-
- Cut and fill criteria (such as compaction, moisture content, benching)
- C. **Engineer Seal.** All Geotechnical Reports shall be signed and seal by a professional engineer registered or authorized to practice in the State of Colorado.

C.3.3. Boring Standards

The following represent the minimum boring standards and guidelines for conducting borings for Geotechnical Reports.

A. **Timing of Soil Borings.**

1. **Initial Borings.** The information from the initial soil borings shall be summarized in the Geotechnical Report. The entire site shall be sampled for initial testing. This is required to evaluate soil and groundwater conditions and for evaluating roadway locations that may not yet be determined or may change.
2. **Structures.** Soil borings for design of transportation structures shall be taken prior to the design of the structure.
3. **Fill for Right-of-Way Grading.** Testing shall be provided for all proposed fill material. All proposed fill material shall be approved by The ECM Administrator prior to placement. The material shall meet minimum requirements and be equal to or better than existing conditions. No fill material with a liquid limit greater than 40 and plasticity index greater than 20 shall be used in the upper 2-feet of the pavement subbase without implementing proper mitigation techniques.

B. **Frequency of Borings.** The following represent the minimum number of borings that are required based on a typical improvements project. The number of borings may be increased based on the geotechnical engineer's recommendations or at the request of the ECM Administrator.

- A minimum of 2 borings for each project with public improvements shall be performed.
- A minimum 1 boring for each SCS (NRCS) soil type within a development shall be performed.
- A minimum of 1 boring shall be performed for each 10 acres of development up to 100 acres. One additional boring shall be performed for every 25 acres of development above the 100 acres.

C. **Borings for Structures.** The boring frequency for transportation structures shall satisfy AASHTO Bridge Design requirements and CDOT Materials Testing requirements.

D. **Depth of Borings.** Borings shall be performed to a minimum depth of 20 feet. In areas where the cut depths are expected to exceed 8 feet, borings shall be extended to a minimum of 15 feet below proposed finished grade. Borings shall extend deeper if needed to determine if bedrock or high groundwater levels are design concerns. Samples for structures shall be taken to a minimum depth of 10 feet below the footing elevation. Additional depth may be required for piers or piles.

It should be noted that boring depths will ultimately be determined by the geotechnical engineer based on site conditions. However, when depths different than those presented is performed, documentation as to the difference must be presented in the submitted report.

C.3.4. Testing

The following represent a listing of the minimum testing requirements and procedures for Geotechnical Reports. The actual numbers and types of tests will be based on the site and the activities being proposed.

A. **Applicable Tests.**

- Visual Classification

-
- Liquid Limit
 - Plastic Limit
 - Plasticity Index
 - Moisture Content
 - Percent Passing 200
 - Gradation (Granular Soils)
 - AASHTO Classification
 - Swell Potential Evaluation
 - Percentage of Soluble Sulfates
 - Standard Penetration/California Test
 - Corrosion Potential Resistivity
- B. **Classification Testing.** Soils shall be classified visually and representative samples tested to determine the soil properties. Sands and gravel samples shall be analyzed for gradation where needed to comply with classification requirements.

C.3.5. Soil Mitigation

Mitigation measures for soil problems revealed by the soils investigation shall be included in the Geotechnical Report. The following specific factors shall be addressed:

- A. **Mitigation Measures and Approval.** All special problems found in soils investigation (e.g., expansion, frost, soluble sulfates, shallow bedrock, heave, groundwater, soil instability, utility backfill, etc.) shall be addressed in the mitigation plans. All proposed mitigation shall be approved by the ECM Administrator.
- B. **Swell Criteria.** If the average swell is 2.0 percent or greater, the pavement design report must provide mitigation measures. The mitigation measures shall reduce destructive swell potential under the public improvements, including landscaping, to an acceptable level of less than 2.0 percent. The swell test report shall specify sample conditions, surcharge pressures, and other key testing factors.
- C. **Swell Mitigation Measures.** Some commonly accepted mitigation measures for swell include: (1) over excavation; (2) chemical treatment; and (3) moisture treatments. Other procedures may be proposed for approval by the ECM Administrator. The selected method must work for the full life expectancy of the improvements.
- D. **Mitigation of Unstable Subgrade.** Some commonly accepted mitigation measures for unstable subgrade include: (1) over-excavation; and (2) chemical treatment. Other procedures may be proposed for approval by The ECM Administrator. The selected method of mitigation must work for the full life expectancy of the improvements.
- E. **Mitigation Recommendations.**
1. **Extent of Mitigation.** Soil treatment shall extend to the back of curb, or to the back of walk for attached or monolithic walk. For detached walk, separate mitigation procedures may be required. A combination of mitigation methods may be required to sufficiently mitigate a soil problem.

-
2. **Approval of Chemical Treatment.** Mitigation procedures that alter existing soil conditions (such as lime, fly ash, or cement treatment) shall follow an approved mix design process. Additional testing is required to verify that no swell is introduced in the chemical treatment.

C.4. PAVEMENT DESIGN REPORT

The Pavement Design Report must be submitted and approved prior to any nonstructural concrete or paving installation. See Appendix D for specific requirements for the Pavement Design Report information.

C.5. INSPECTION AND TESTING REPORTS

All tests and inspection results performed by the sponsor's testing firm shall be submitted directly from the testing agency to the ECM Administrator at the time of field tests, and within ten (10) working days after the testing or retesting date of laboratory test (See Chapter 5 and Appendix J, Roadway and Ancillary Facility Inspections and Testing, for more detailed information).

C.6. SUBSURFACE WATER INVESTIGATION REPORT

C.6.1. When Required

If groundwater is encountered within 5 feet of the original ground surface, a Subsurface Water Investigation Report shall be submitted for approval by the ECM Administrator. This report is required to ensure mitigation of high groundwater effects upon public improvements within the right-of-way. This information may be a separate report or may be included in the Geotechnical Report. This report is not required for temporary dewatering activity needed to facilitate construction of buried utilities. However, all applicable state and federal requirements shall be followed.

C.6.2. Report Requirements

The subsurface water investigation report shall include the following information.

- A. **Site Location.** Site location and description including locations of any irrigation ditches and wetlands.
- B. **Groundwater.** Elevation of water table and seasonal high water level shall be presented within the report and critical issues pertaining to groundwater highlighted.
- C. **Additional Subsurface Information.** Other relevant subsurface information such as water ownership (water rights), groundwater quality (contamination or other undesirable characteristics).
- D. **Subsurface Drainage.** Subsurface drainage recommendations, including its effects on all conditions, including sensitive habitat.
- E. **Control Measures and Designs.**
 1. **Subsurface Drains.** Should subsurface drains be recommended, the drains must have a gravity discharge without any possibility of back flow or blockage of the outlet. Any subsurface drain system shall be owned and maintained by the Applicant or the Applicant's assigned successor(s). These drains may discharge into the ECM Administrator's storm drainage system, including inlets or detention ponds, upon appropriate submitted design and approval by the ECM Administrator. Anticipated impacts to the groundwater table on adjacent properties must be quantified.
 2. **Drain Lines.** Drain lines may be installed in the sanitary sewer trench, at an elevation of one sewer diameter lower than the sanitary sewer line.

-
3. **Drain Line Separation from Sewer.** Drain line separation from sewer shall be marked to specifically distinguish the drain from the sanitary sewer line.
 4. **Pipe Materials.** Pipe Materials shall be an approved material pipe, for long-term 100 years minimum design life, with appropriate cleanouts.
 5. **Drain Outlet.** Drain Outlet into an inlet structure or detention pond shall be designed to prevent any possibility of backflow and blockage of the drain line.
- F. **Engineer Seal.** All Subsurface Water Investigation Reports shall be signed and seal by a professional engineer registered or authorized to practice in the State of Colorado.

Appendix D PAVEMENT DESIGN CRITERIA AND REPORT

D.1. PURPOSE

This appendix provides the basic criteria, design procedures, and report guidelines for roadway pavements. Asphalt and Portland Cement Concrete (PCC) methodologies generally follow the CDOT methodology.

D.2. SUBGRADE INVESTIGATION

D.2.1. Field Investigation

The field investigation shall consist of borings or other suitable methods of sampling subgrade soils for visual classification to a depth of at least 5 feet below proposed subgrade elevation, at spacings of not more than 500 feet. A minimum of one boring shall be obtained for any roadway segment. Every fifth hole shall be 10 feet deep. The ECM Administrator may require more frequent testing or additional borings that extend deeper should bedrock or high groundwater be a design concern. All borings shall be field logged and visually classified. Samples shall be obtained from each soil type in the upper 24 inches of subgrade for testing and evaluation. The soil investigation associated with this report occurs after the roadways are graded and the deepest utility is installed. Multiple samples shall be taken alternating among lanes and shall be evenly spaced.

D.2.2. Classification Testing

Each boring location shall be tested to determine Liquid Limit, Plastic Limit, Plasticity Index, and the percentage passing the U.S. Standard No. 200 sieve. Samples of sands and gravels will require gradation analysis for classification determination. These data shall be determined using the following methods:

- Liquid Limit - AASHTO T 89 (ASTM D 4318)
- Plastic Limit - AASHTO T 90 (ASTM D 4318)
- % Passing No. 200 - AASHTO T 11 (ASTM C 117)
- Gradation - AASHTO T 27 (ASTM D 422)

The results of these tests shall be used to calculate the AASHTO Classification and Group Index using AASHTO M 145.

Additional testing that shall be performed include:

- Moisture Content - AASHTO T 265
- Water Soluble Sulfates (for rigid pavements only) - AASHTO T 290

D.2.3. Soil Grouping

Soil samples collected in the field investigation can be combined to form soil groups. These groups determined by laboratory testing shall be based upon the AASHTO Classification, Group Index and location within the area investigated. Groupings shall not consist of samples with different AASHTO Classifications. Composite samples can be manufactured by combining small portions of each subgrade sample contained within the group and mixing to provide a uniform composite sample of the soil group. Soils are to be grouped based on the AASHTO classification of the bulk materials. When significant disparities in Group Index (greater than 7) are noted, the subgrade soil groups shall be subdivided into two or more groups.

D.2.4. Subgrade Support Testing

Individual subgrade or composite samples shall be tested to determine the subgrade support value using either California Bearing Ratio (CBR) or Hveem Stabilometer (R-value) testing. In addition, a swell potential evaluation shall be performed when the plasticity index (PI) is greater than 10 or as deemed appropriate. These values shall be used in the design of pavement sections. Tests shall be conducted in accordance with the procedures listed below.

- A. **CBR Tests.** California Bearing Ratio tests shall be conducted in accord with AASHTO T 193 with the following modifications:
- Note 4 of AASHTO T 193 shall not apply. A 3-point CBR evaluation is required.
 - Surcharge shall be calculated using a unit weight of 140 pcf for Mix Asphalt and 135 pcf for untreated aggregate base course.
 - The design CBR value shall be determined from the CBR - Dry Density Curve and shall be the CBR value at 95 percent compaction.
 - In addition to the values requested in AASHTO T 193, Stress - Penetration curves for each sample, a CBR - Dry Density curve and Proctor Compaction test results shall be reported.
- B. **R-Value Tests.** Hveem Stabilometer tests shall be conducted in accordance with AASHTO T190. The design R-value shall be at 300 psi exudation pressure. The reported data shall consist of:
- Dry density and moisture content for each sample.
 - Expansion pressure for each sample.
 - Exudation Pressure - corrected R-value curve showing the 300-psi design R-value.
- C. **Swell Test.** The results of a swell potential evaluation (ASTM D4546-96) shall be presented in the Pavement Design Reports where the PI of the existing material is greater than 10.

If the swell (at an overburden pressure of 100-150 psf, at specified compaction per CDOT and at optimum moisture content) is 2.0% or greater, the Pavement Design Report must provide mitigative measures to minimize the destructive swell potential. Since the pavement is not placed on the soils until after the soil has been scarified, moisture treated, and compacted to optimum, the "% swell" shall be measured from the point after the overburden pressure is applied, to the point after water is added.

D.3. PAVEMENT DESIGN CRITERIA

This section provides the input data used for the design of pavements for El Paso County roads.

D.3.1. ESAL

Equivalent Single Axle Loads (ESAL) are considered equivalent units based on 20-year design criteria and an 18-kip axle loading. All data and design nomographs use ESAL units for pavement loading repetitions. ESAL criteria shall conform to Table D-2.

D.3.2. Design Serviceability

Design values in Table D-1 shall be used for all County roadways.

Table D-1. Pavement Design Values

Roadway Functional Classification	Serviceability Index, SI	Lanes	Directional Distribution Factor, DD	Lane Distribution Factor, DL	Truck (%)	Reliability (%)
Rural						
Local	2.0	2.0	0.5	1.0	3.0	75
Minor Collector	2.5	2.0	0.5	1.0	4.0	80
Major Collector	2.5	2.0	0.5	1.0	5.0	80
Minor Arterial	2.5	4.0	0.5	0.9	7.0	80
Principal Arterial, 4-lane	2.5	4.0	0.5	0.9	8.0	85
Principal Arterial, 6-lane	2.5	6.0	0.5	0.7	9.0	85
Expressway, 4-lane	2.5	4.0	0.5	0.9	8.0	90
Expressway, 6-lane	2.5	6.0	0.5	0.7	10.0	90
Urban						
Local (low volume)	2.0	2.0	0.5	1.0	3.0	80
Local	2.0	2.0	0.5	1.0	4.0	80
Residential Collector	2.5	2.0	0.5	1.0	5.0	85
Nonresidential Collector	2.5	2.0	0.5	1.0	15.0	85
Minor Arterial	2.5	2.0	0.5	1.0	6.0	85
Principal Arterial, 4-lane	2.5	4.0	0.5	0.9	8.0	90
Principal Arterial, 6-lane	2.5	6.0	0.5	0.7	8.0	90
Expressway, 4-lane	2.5	4.0	0.5	0.9	8.0	95
Expressway, 6-lane	2.5	6.0	0.5	0.7	8.0	95

D.3.3. Minimum Pavement Section

Table D-2 provides the minimum acceptable pavement sections for County roadways. Final pavement designs must be based on actual subgrade support test results and the Transportation Impact Study (TIS).

Table D-2. Minimum Pavement Sections

Roadway Functional Classification	ESAL	Composite Sections ¹		Portland Cement Concrete (in)
		Asphalt (in)	Base (in)	
Rural				
Local	36,500	3.0	4.0	5.0
Minor Collector	109,500	3.0	6.0	5.0
Major Collector	273,750	3.0	8.0	6.0

Minor Arterial	689,850	4.0	8.0	6.0
Principal Arterial, 4-lane	2,628,000	5.0	8.0	6.0
Principal Arterial, 6-lane	9,198,000	6.5	8.0	6.0
Expressway, 4-lane	3,942,000	6.5	10.0	6.0
Expressway, 6-lane	12,264,000	6.5	10.0	7.0
Urban				
Local (low volume)	36,500	3.0	4.0	5.0
Local	292,000	3.0	8.0	5.0
Residential Collector	821,000	4.0	8.0	6.0
Nonresidential Collector	821,000	4.0	8.0	6.0
Minor Arterial	1,971,000	5.0	8.0	6.0
Principal Arterial, 4-lane	5,256,000	5.0	8.0	6.0
Principal Arterial, 6-lane	8,176,000	6.5	8.0	6.0
Expressway, 4-lane	7,884,000	6.5	8.0	6.0
Expressway, 6-lane	9,811,000	6.5	10.0	7.0

D.3.4. Flexible Pavement Strength Coefficients

The standard design coefficients for pavement materials are provided in Table D-3. Design values shall be verified by predesign mix test data and supported by daily construction tests.

D.3.5. Portland Cement Concrete Working Stress (f_t)

The working stress (f_t) shall be 75% of that provided by third-point beam loading which shall have minimum laboratory 28-day strength of 650 psi based on actual tests of materials to be used.

D.3.6. Gravel Roads

A minimum thickness of 6 inches shall be used on all newly constructed gravel roads meeting material specifications presented in Table D-7.

D.4. PAVEMENT DESIGN PROCEDURE

D.4.1. Flexible Pavements

The following procedure shall be used in determining the Structural Number (SN) and thickness of the pavement being designed.

- A. **Define ESAL.** Determine ESAL from Table D-2. The ESAL calculated from the traffic volumes in the Traffic Impact Study shall be used whenever they exceed the minimum ESAL values given in Table D-2.
- B. **Define Serviceability Index (SI).** Determine the SI of the roadway classification from Table D-1 and use it in Figure D-1 or use AASHTO pavement design software.
- C. **Resilient Modulus Usage (M_R) and CBR.** Using the resilient modulus and ESAL, determine the SN from the appropriate design nomograph. The appropriate reliability value from Table D-1 and an overall deviation of 0.45 shall be used for flexible pavements. Resilient modulus shall be calculated using the following equations:

$$S_1 = [(R - 5) / 11.29] + 3$$

$$M_R = 10^{[(S_1 + 18.72) / 6.24]}$$

$$M_R = 1,500 * CBR$$

Where:

M_R = resilient modulus (psi)

S_1 = the soil support value

R = R-value obtained from the Hveem stabilometer

CBR = California Bearing Ratio

- D. **Pavement Design Thickness.** The design thickness for the pavement structure can be determined by the general equation:

$$SN = a_1 D_1 + a_2 D_2 + a_3 D_3 + \dots$$

Where:

a_1 = Hot Mix Asphalt (HMA) strength coefficients

a_2, a_3, a_n = strength coefficients of additional pavement components

D_1 = thickness of Hot Mix Asphalt (HMA) (inches)

D_2, D_3, D_n = thickness of additional pavement component sections

The strength coefficients for various components of the pavement structures are given in Table D-3. The component thickness selected must meet two conditions.

Pavement layer thickness shall be rounded up to the nearest 1/4 inch.

Table D-3. Strength Coefficients

Pavement Structure Component	Strength Coefficients	Limiting Test Criteria
Conventional Materials		
Hot Mix Asphalt	0.44	See Section D.5.4
Existing Bituminous Pavement	0.20-0.40 ¹	N/A
Aggregate Base Course/Recycled Concrete ²	0.11	(CBR 80+ or R 78+)
Existing Aggregate Base Course/Existing Recycled Concrete ²	0.09	(CBR 50+ or R 69+)
Granular Subbase Course	0.07	(CBR 15 or R 50+)
Treated Materials		
Cement Treated Aggregate Base	0.23	(7 day, 640-1000 psi)
Fly Ash	0.10	(7 day, 150 psi @ 70°±)
Lime Treated Subgrade	0.14	(7 day, 160 psi, PI < 6)
Kiln Dust	0.10	(7 day, 150 psi, PI < 6)
Cement Stabilized Subgrade ³	0.11	(7 day, 125 psi)
Cement Stabilized Subgrade ³	0.12	(7 day, 200 psi)
¹ An average value of 0.30 can be used, unless analysis of existing pavement dictates a more representative coefficient.		
² Materials must meet the requirements in Section D.5.5.1.		
³ If testing during construction shows the Cement Stabilized Subgrade strength is greater than 275 psi, the subgrade shall be micro fractured prior to paving.		
⁴ Crushed concrete shall not be used as a driving surface, even as a temporary driving surface during construction.		

- E. **Total HMA Thickness.** Total HMA thickness selected cannot be less than the minimum specified in Table D-2 for the roadway classification.
- F. **Base Course Thickness.** The base course thickness selected cannot exceed 2.5 times the HMA thickness selected. A composite section of asphalt over aggregate base must be used.
- G. **Swelling Soils.** The design must reference any mitigation measures required when the subgrade contains swelling soils. Pavement Design Reports recommending permeable layers such as untreated aggregate base course in the pavement system, must present the measures to be used to ensure adequate drainage of such layers, and to maintain segregation of the layers from the swelling soils.

D.4.2. Rigid Pavement

The design of rigid pavements is a function of structural quality of the subgrade soil (R-value or CBR), traffic (ESAL), and the strength of the concrete (working stress). In comparison to the strength of the concrete slab, the structural contributions of underlying layers to the capacity of the pavement are relatively insignificant. Therefore, the use of thick bases or subbases under concrete pavement to achieve greater structural capacity is considered to be uneconomical and is not recommended. The following procedure should be used in determining the thickness of rigid pavement.

- A. **Define ESAL.** Determine roadway classification and corresponding ESAL from Table D-2. The ESAL calculated from the traffic volumes in the traffic impact study shall be used whenever they exceed the minimum ESAL values given in Table D-2.
- B. **Define Serviceability Index (SI) and Other Variables.** Determine design Serviceability Index (SI) of the roadway from Table D-1. For the purposes of design, the Concrete Elastic Modulus (E_c) shall be 3.4, the Mean Concrete Modulus of Rupture (S'_c) shall be 650 psi, the Load Transfer Coefficient (J) shall depend on the whether the shoulders are tied or non-tied and doweled or non-doweled (The J's shall be used. 2.8 for tied shoulders and doweled pavement, 4.2 for non-tied shoulders and non-doweled pavement. All other combinations shall be 3.6), and the Drainage Coefficient (C_d) shall be assumed to be 1.0 unless there is justification for a different number.
- C. **Effective Modulus of Subgrade Reaction (k) Determination.** The Effective Modulus of Subgrade Reaction (k) shall be calculated using AASHTO. In most cases where there is no subbase, k can be calculated using the following equations:

$$S_1 = [(R - 5) / 11.29] + 3$$

$$M_R = 10^{[(S_1 + 18.72) / 6.24]}$$

$$M_R = 1,500 * CBR$$

$$k = M_R / 19.4$$

Where:

M_R = resilient modulus (psi)

S_1 = the soil support value

R = R-value obtained from the Hveem stabilometer

CBR = California Bearing Ratio

- D. **Software or Nomograph Used.** Determine the structural numbers using AASHTO pavement design software. Nomographs of the AASHTO parameters may be used instead (Figures D-2 and D-3). If the nomographs are used, copies of the nomograph determinations must be included with the design

submittal. The appropriate reliability from Table D-1 and an overall deviation of 0.35 shall be used for rigid pavements.

- E. **Slab Thickness.** Use the slab thickness or the minimum thickness from Table D-2, whichever is greater.
- F. **Swelling Soils.** The design must reference any mitigation measures required when the subgrade contains swelling soils. Pavement Design Reports recommending permeable layers such as untreated aggregate base course in the pavement system must present the measures to be used to ensure adequate drainage of such layers, and to maintain segregation of the layers from the swelling soils.

Figure D-1. Flexible Pavement Nomograph

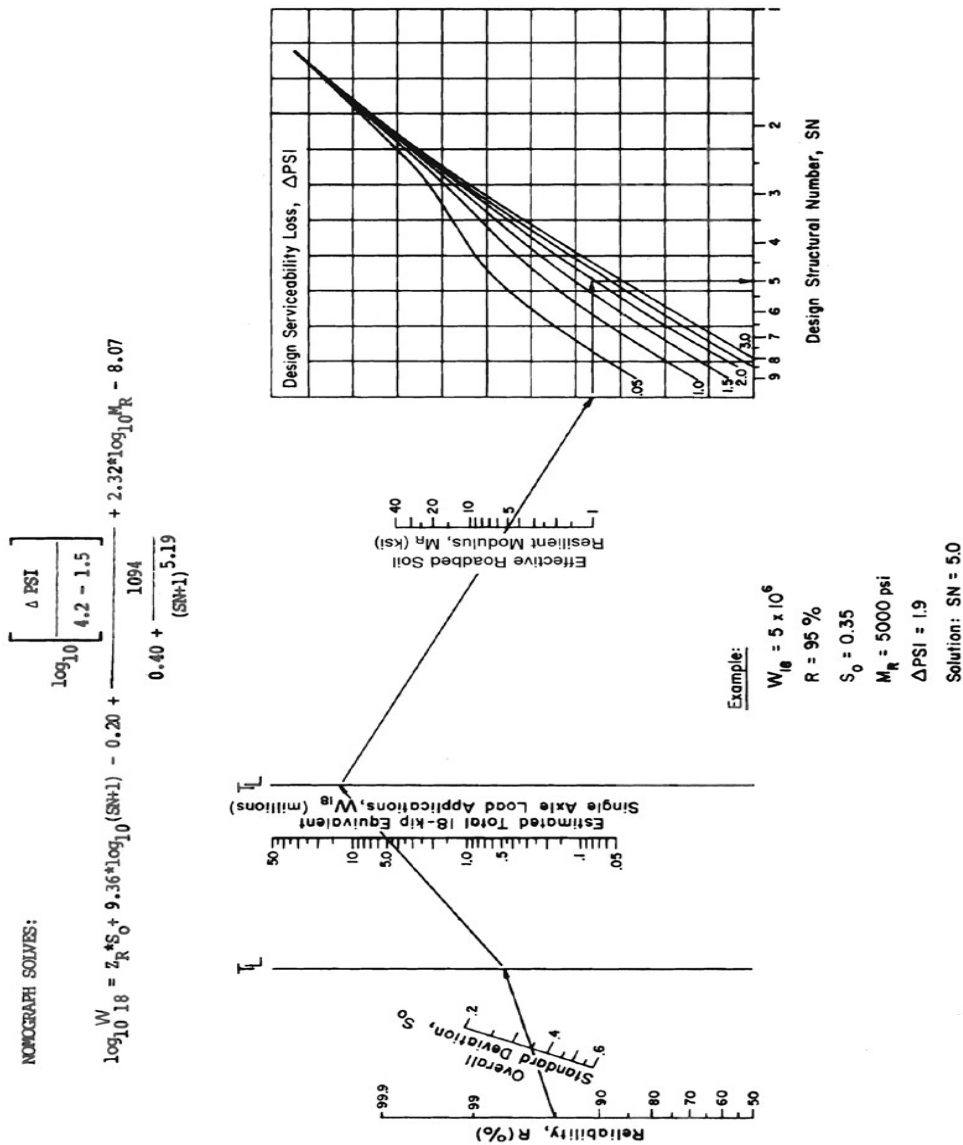

Figure D-2. Rigid Pavement Nomograph

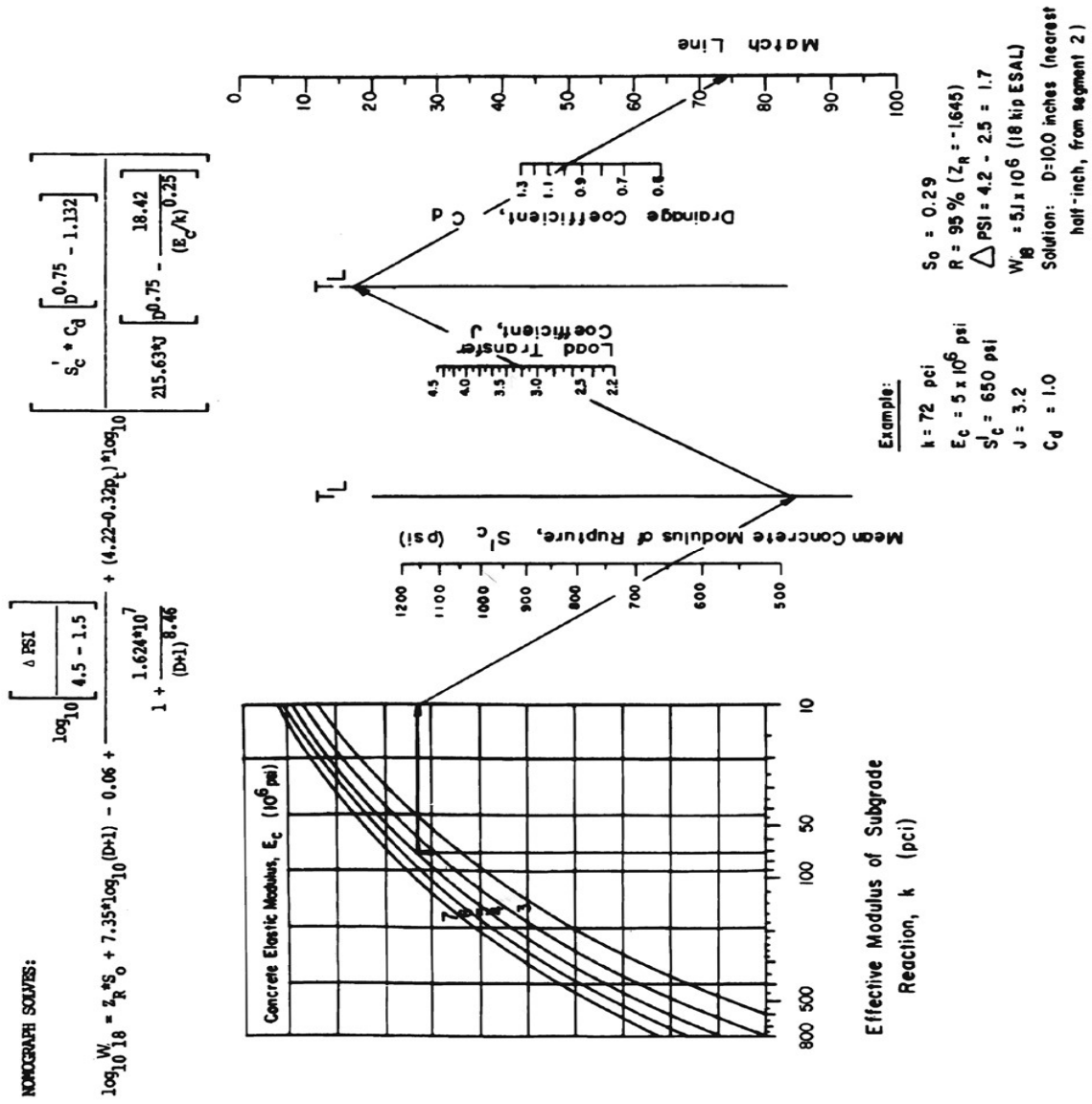
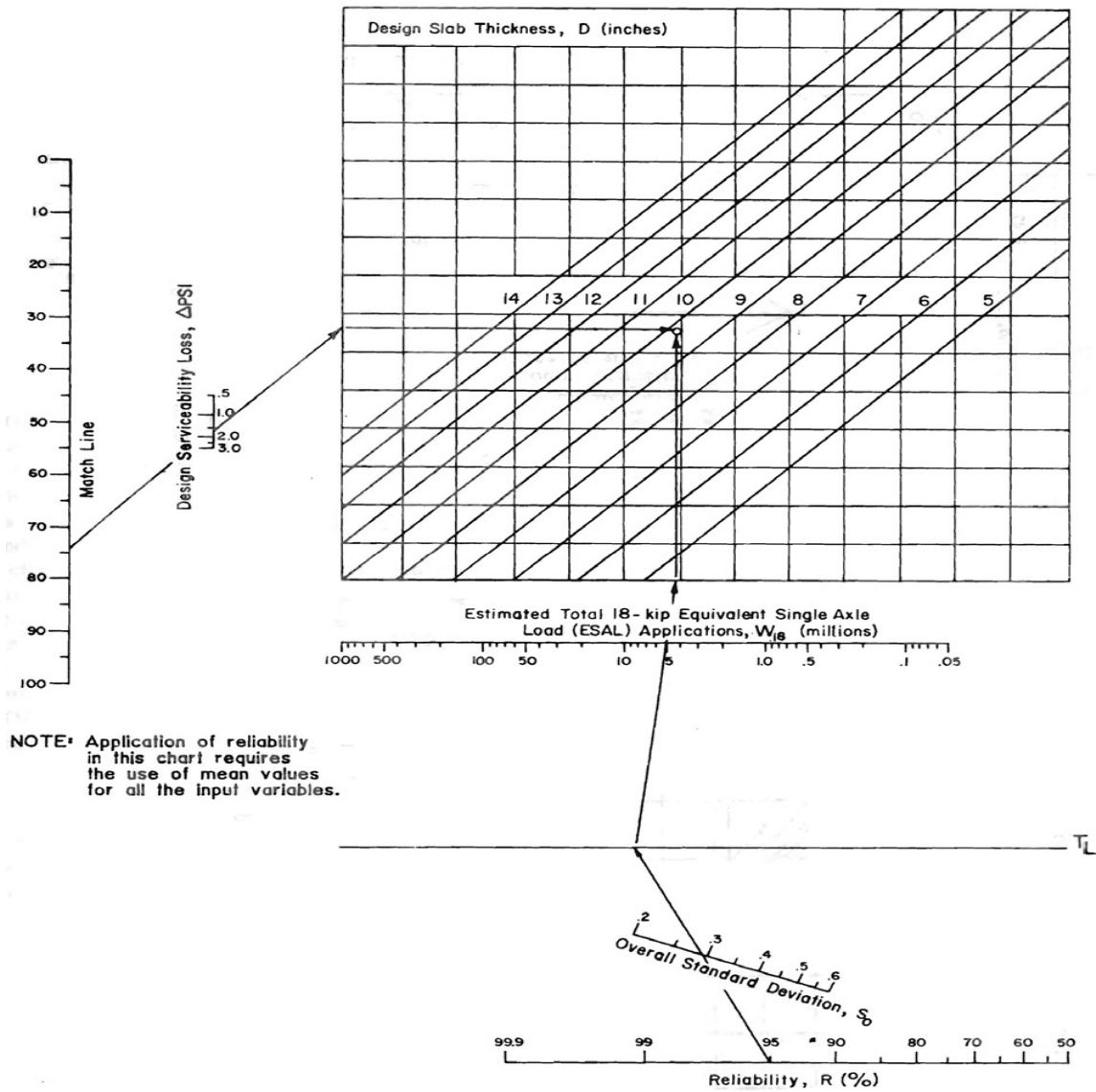

Figure D-3. Rigid Pavement Nomograph Cont.



D.5. MATERIAL SPECIFICATIONS

D.5.1. General

The material specifications presented are performance oriented. All sources of mined or manufactured materials used in public improvement construction must be annually approved by the ECM Administrator as having met the appropriate materials performance specifications.

D.5.2. Procedure for Material Source Approval

On or before April 1st of each year, or a minimum of 14 calendar days before construction, a material supplier for any public improvements may supply written documentation and material test results from a competent materials testing laboratory that describes:

- Material(s) being tested to meet the ECM Administrator specifications.
- The test procedures employed.
- The supplier's manufacturing, mining or treating process by which the tested materials were created.
- The material test results.

A signed statement shall be provided by the material supplier certifying the materials tested are representative of the materials to be provided for public improvements during the coming 365-day period.

D.5.3. Violations of Approval Conditions

Any and all material used to construct public improvements that is not from a certified source, or that is from a certified source and fails random material tests ordered by the ECM Administrator, may be subject to complete removal as a condition of the ECM Administrator acceptance of that public improvement. Additional tests will be required to confirm the existence and extent of the sub-standard material prior to the initiation of remedial action. The extent of the material to be removed will be at the discretion of the ECM Administrator.

D.5.4. Hot Mix Asphalt (HMA)

Hot mix asphalt (HMA) materials shall meet the requirements of and be placed according to the latest edition of the Pikes Peak Region Asphalt Specification. The Pikes Peak Region Asphalt Specification can be obtained online at: <http://adm.elpasoco.com/NR/rdonlyres/A8D006F3-BB2B-4FC1-AD65-32180CF4F2E6/0/PikesPeakRegionAsphaltPavingSpecs1106.pdf>.

D.5.5. Portland Cement Concrete Pavement

This material shall consist of a mixture of coarse and fine aggregates, Portland Cement, water and other materials or admixtures as required. Colorado Department of Transportation Class "P" mix may be used. The only alternatives to "P" shall be according to Section 412.03 of CDOT Standard Specifications. Other high-early strength concretes may be used where special conditions warrant, subject to written approval by the ECM Administrator.

- Cement Requirements.** Portland cement shall comply with the CDOT requirements and the type of cement shall be Type II, unless sulfate conditions dictate otherwise. Table 2.2.3 in Chapter 2.2 of ACI 201, indicates recommendations for sulfate resistance.
- Fine Aggregates.** Fine aggregates shall meet CDOT Section 703.01 requirements and gradation as shown in Table D-4.

Table D-4. Fine Aggregates for Portland Cement Concrete

Sieve Size Or Test Procedure	Percent Passing By Weight Or Test Requirement
3/8"	100
#4	95—100
#16	45—80
#50	10—30
#100	2—10

Created: 2021-06-08 11:35:53 [EST]

(Supp. No. 2)

#200	3, Maximum
Friable Particles, %	1.0, Maximum
Coal & Lignite, %	1.0, Maximum
Deleterious Material (AASHTO T-11), %	3.0, Maximum
Sand Equivalent (AASHTO T-176), %	80.0, Minimum
Fineness Modulus	2.50—3.50
Sodium Sulfate Soundness, %	20.0, Maximum

- C. **Coarse Aggregate.** Coarse aggregates shall meet CDOT Section 703.02 requirements and gradation as shown in Table D-5.

Table D-5. Coarse Aggregates for Portland Cement Concrete

Sieve Size Or Test Procedure	Percent Passing By Weight Or Test Requirement
2"	100
1½"	95—100
¾"	35—70
⅜"	10—30
#4	0—5
#200	1, Maximum (1.5% if crushed fines)
% Wear	45.0, Maximum
Clay Lumps & Friable Particles, %	2.0, Maximum
Coal & Lignite, %	0.5, Maximum
Sodium Sulfate Soundness, %	12.0, Maximum

- D. **Fly Ash.** Fly Ash shall comply with CDOT Section 701.02.
- E. **Water.** Water shall meet the requirements of CDOT Section 712.01.
- F. **Air Entraining and Chemical Admixtures.** Air entraining and chemical admixtures shall meet the requirements of CDOT Sections 711.02 and 711.03. No additive manufactured with the purposeful addition of chloride shall be permitted. Water-reducing admixtures are used when concrete temperatures are as follows: Type A is used with ambient temperature range of 50 to 90 degrees inclusive; Type D is used when ambient temperature is over 90 degrees.
- G. **Reinforcement.** Reinforcing steel shall meet the requirements of CDOT Section 709.01, grade 40 minimum.
- H. **Laboratory Design Strength.** Minimum compressive laboratory design strength shall be 3,750 psi; minimum modulus of rupture or flexural strength shall be 650 psi.
- I. **Aggregate Base Course Material.** This material shall consist of hard, durable particles or fragments of stone or gravel, crushed to required sizes, containing an appropriate quantity of sand or other finely-divided mineral matter which conform to the requirements of AASHTO M 147, and CDOT Section 703.03. In addition, the material must have an R-value of 72 or greater, or a CBR of 80+, and must be moisture stable.

The materials to be used in construction shall be tested and a mix design submitted to The ECM Administrator for approval. Only aggregate from approved sources shall be used. As a minimum, the mix design report shall contain documented gradation, Atterberg limits, and CBR/R-value testing.

Two types of crushed aggregate base course are acceptable. The gradation specifications for these two types of base course are listed in Table D-6.

D.5.6. Gravel for Gravel Roads

Gravel described in this section shall be used for gravel shoulders, repairing gravel surfaces, or in cases where gravel roads are allowed. The gradation specification for this material is listed in Table D-7.

Table D-6. Aggregate Base Course Materials

Sieve Designation	Percent Passing By Weight	
	Class 5	Class 6
1½"	100	
1"	95—100	
¾"		100
#4	30—70	30—65
#8		25—55
#200	3—15 ¹	3—12
Liquid Limit (LL)	30, Maximum	30, Maximum
¹ ASTM C-117		

Table D-7. Gravel for Gravel Roads

Sieve Designation	Percent Passing by Weight
¾"	100
#4	50—78
#8	37—67
#40	13—35
#200	4—15
Plastic Index (PI)	4—12

D.5.7. Cement Treated Aggregate Base Course

This material shall consist of a mixture of aggregate materials, Portland cement and water as outlined in CDOT Section 308. Acceptable aggregates include CDOT Classes 4, 5, and 6.

The materials to be used in construction shall be tested and a mix design submitted to the ECM Administrator for approval. As a minimum, the mix design report shall contain a description of material sources, gradations, and Atterberg limits of aggregates, cement type, Proctor compaction curves and unconfined compressive strength results for each mix, strength versus cement content curves, a design mix, and special construction procedures recommended. Testing shall be in accordance with appropriate AASHTO specifications.

The mix shall have a 7-day compressive strength of at least 650 psi, and no more than 1000 psi. The minimum acceptable cement content shall be 5 percent by weight. Only approved mix designs shall be used. Approvals are required on a project basis or an annual basis for suppliers. Mixes shall be approved, prior to issuance of a Construction Permit.

D.5.8. Class C Fly Ash Treated Subgrade

This material consists of a mixture of native or imported soils, Class C fly ash, and water, as outlined by ASTM C 618 or AASHTO M-295. Minimum in-place thickness for this material shall be eight (8) inches.

The materials to be used in construction shall be tested and a mix design submitted to the ECM Administrator for approval. As a minimum, the mix design report shall contain a description of material sources, gradations, and Atterberg limits of the native soils, fly ash type, Proctor compaction curves and unconfined compressive strength results for each mix, strength versus fly ash content curves, a design mix, and special construction procedures recommended. Testing shall be in accordance with appropriate AASHTO specifications.

To be approved, the mix shall have a minimum 7-day compressive strength of 150 psi. Only approved mix designs shall be used. Approvals are required on a project basis prior to issuance of a Construction Permit.

D.5.9. Lime Treated Subgrade

This material consists of a mixture of native or imported soils, hydrated or quick lime and water, as outlined by ASTM Specification C 977 or AASHTO M216. Minimum in-place thickness for this material shall be eight (8) inches.

The materials to be used in construction shall be tested and a mix design submitted to the ECM Administrator for approval. As a minimum, the mix design report shall contain a description of material sources, gradation and Atterberg limits of native soils, Atterberg limits and 7-day unconfined compressive test results for each mix, strength versus lime content curves, a design mix and special construction procedures recommended. Testing shall be in accordance with appropriate AASHTO methods.

The mix shall have a minimum 7-day compressive strength of 160 psi. In addition, the Plasticity Index of the treated soil shall not exceed 6. The minimum acceptable hydrated lime content shall be 4 percent by weight.

Only approved mix designs shall be used. Approvals are required on a project basis prior to issuance of a Construction Permit.

D.5.10. Kiln Dust Treated Subgrade

This material consists of a mixture of native or imported soils, kiln dust and water, as outlined by ASTM and AASHTO Specifications. Minimum in-place thickness for this material shall be eight (8) inches.

The materials to be used in construction shall be tested and a mix design submitted to the ECM Administrator for approval. As a minimum, the mix design report shall contain a description of material sources, gradation and Atterberg limits of native soils, Atterberg limits and 7-day unconfined compressive test results for each mix, strength versus kiln dust content curves, a design mix and special construction procedures recommended. Testing shall be in accordance with appropriate AASHTO methods.

The mix shall have a minimum 7-day compressive strength of 150 psi. In addition, the Plasticity Index of the treated soil shall not exceed 6.

Only approved mix designs shall be used. Approvals are required on a project basis prior to issuance of a Construction Permit.

D.6. PAVEMENT DESIGN REPORT

The Pavement Design Report shall be prepared by or under the supervision of and signed and seal by a professional engineer registered or authorized to practice in the State of Colorado. The Pavement Design Report shall include the following information:

- Vicinity map to locate the investigated area.
- Scaled drawings showing the location of borings.
- Scaled drawings showing the estimated extent of subgrade soil types and ESAL for each roadway.
- Pavement design alternatives for each roadway on a scaled drawing.
- Tabular listing of sample designation, sample depth, Group Number, Liquid Limit, Plasticity Index, percent passing the No. 200 sieve, AASHTO Classification, Group Index, soil description, and moisture content. Percent soluble sulfate will also be necessary for rigid pavements.
- Identification of any samples that were consolidated to create composite samples for testing purposes.
- CBR or R-value test results of each soil type used in the design.
- Pavement design nomographs properly drawn to show Soil Support - ESAL - SN and/or output from an approved AASHTO pavement design program.
- Design calculations including all design assumptions.
- A discussion regarding potential subgrade soil problems including, but not limited to: soils with swelling potential, frost susceptible soils, ground water, drainage considerations (surface and subsurface), cold weather construction (if appropriate), soluble sulfates in the subgrade, and other factors or properties that could affect the design or performance of the pavement system.
- Recommendations to alleviate or mitigate the impact of problems discussed in Item I.
- Pavement Mix Types to be used for the project.

Appendix E CHECKLISTS AND PERMITS

As described in Appendix I, an Erosion and Stormwater Quality Control Permit (ESQCP) is required for all applicable construction activity of this ECM. A Builder's Erosion and Stormwater Quality Control Permit (BESQCP) is used to protect stormwater quality on individual residential building lots that have less than one (<1) acre of total disturbed area and are not part of a larger plan of development or sale. BESQCPs are also required for large lot (>2.5 acres) single family home construction when more than one acre of disturbance occurs. Either an ESQCP or a BESQCP will be required for all applicable construction activity, unless excluded pursuant to Section 5.6.3 of this ECM.

Projects that go through any part of the development review process (land use applications including subdivision, site development plan, site plan, grading plan, grading and erosion control plan, location approval, etc.), shall obtain the ESQCP from the Planning and Community Development Department. Applicable construction activity that is not associated with a land use application shall obtain the ESQCP through the Department of Public Works Stormwater Program. As a general practice, applicable construction activity limited primarily to County Right-of-Way will make an ESQCP application to the Department of Public Works.

To assist in the preparation of Grading and Erosion Control Plans and Stormwater Management Plans, the County in conjunction with local stakeholders developed checklists to guide the completion and review of submitted plans. Standard Notes for Grading and Erosion Control Plans are also provided in this Appendix. The checklists provided in this Appendix are to be completed by the Engineer of Record and certified as to the completeness of the submitted plans required for ESQCP approval.

Permit Applications

Erosion and Stormwater Quality Control Permit

Builders Erosion and Stormwater Quality Control Permit

Checklists and Standard Notes

El Paso County Stormwater Management Plan Checklist

El Paso County Grading and Erosion Control Plan Submittal Checklist

Standard Notes for El Paso County Grading and Erosion Control Plans

(Res. No. 19-245 , 7-2-19)

**EROSION AND STORMWATER QUALITY CONTROL PERMIT (ESQCP)
EL PASO COUNTY APPLICATION AND PERMIT**

APPLICANT INFORMATION	PERMIT NUMBER
Owner Information	
Property Owner	
Applicant Name (Permit Holder)	
Company/Agency	
Position of Applicant	
Address (physical address, not PO Box)	
City	
State	
Zip Code	
Mailing address, if different from above	
Telephone	
FAX number	
Email Address	
Cellular Phone number	
Contractor/Operator Information	
Name (person of responsibility)	
Company	
Address (physical address, not PO Box)	
City	
State	
Zip Code	
Mailing address, if different from above	
Telephone	
FAX number	
Email Address	
Cellular Phone number	
Erosion Control Supervisor (ECS)*	
ECS Phone number*	
ECS Cellular Phone number*	

*Required for all applicants. May be provided at later date pending securing a contract when applicable.

- ENGINEERING CRITERIA MANUAL
Appendix E CHECKLISTS AND PERMITS

PROJECT INFORMATION

Project Information	
Project Name	
Legal Description	
Address (or nearest major cross streets)	
Acreage (total and disturbed)	Total: acres Disturbed: acres
Schedule	Start of Construction: Completion of Construction: Final Stabilization:
Project Purpose	
Description of Project	
Tax Schedule Number	

FOR OFFICE USE ONLY

The following signature from the ECM Administrator signifies the approval of this ESQCP. All work shall be performed in accordance with the permit, the El Paso County Engineering Criteria Manual (ECM) Standards, City of Colorado Springs Drainage Criteria Manual, Volume 2 (DCM2) as adopted by the El Paso County Addendum, approved plans, and any attached conditions. The approved plans are an enforceable part of the ESQCP. Construction activity, except for the installation of initial construction BMPs, is not permitted until issuance of a Construction Permit and Notice to Proceed.

Signature of ECM Administrator: _____ Date _____

1.1 REQUIRED SUBMISSIONS

In addition to this completed and signed application, the following items must be submitted to obtain an ESQCP:

- Permit fees;
- Stormwater Management Plan (SWMP) meeting the requirements of DCM2 and ECM either as part of the plan set or as a separate document;
- Operation and Maintenance Plan for any proposed permanent stormwater control measures; and
- Signed Private Detention Basin/Stormwater Quality Best Management Practice Maintenance Agreement and Easement, if any permanent stormwater control measures are to be constructed.

1.2 RESPONSIBILITY FOR DAMAGE

The County and its officers and employees, including but not limited to the ECM Administrator, shall not be answerable or accountable in any manner for damage to property or for injury to or death of any person, including but not limited to a permit holder, persons employed by the permit holder, or persons acting in behalf of the permit holder, from any cause. . The permit holder shall be responsible for any liability imposed by law and for damage to property or injuries to or death of any person, including but not limited to the permit holder, persons employed by the permit holder, persons acting in behalf of the permit holder, arising out of work or other activity permitted and done under a permit, or arising out of the failure to perform the obligations under any permit with respect to maintenance or any other obligations, or resulting from defects or obstructions, or from any cause whatsoever during the progress of the work or other activity, or at any subsequent time work or other activity is being performed under the obligations provided by and contemplated by the permit.

The permit holder shall indemnify, save, and hold harmless the County and its officers and employees, including but not limited to the BOCC and ECM Administrator, from all claims, suits or actions of every name, kind and description brought for or on account of damage to property or injuries to or death of any person, including but not limited to the permit holder, persons employed by the permit holder, persons acting in behalf of the permit holder and the public, resulting from the performance of work or other activity under the permit, or arising out of the failure to perform obligations under any permit with respect to maintenance or any other obligations, or resulting from defects or obstructions, or from any cause whatsoever during the progress of the work or other activity, or at any subsequent time work or other activity is being performed under the obligations provided by and contemplated by the permit, except as otherwise provided by state law. The permit holder waives any and all rights to any type of expressed or implied indemnity against the County, its officers or employees. It is the intent of the parties that the permit holder will indemnify, save, and hold harmless the County, its officers and employees from any and all claims, suits or actions as set forth above regardless of the existence or degree of fault or negligence, whether active or passive, primary or secondary, on the part of the County, the permit holder, persons employed by the permit holder, or persons acting in behalf of the permit holder.

- ENGINEERING CRITERIA MANUAL
Appendix E CHECKLISTS AND PERMITS

1.3 APPLICATION CERTIFICATION

We, as the Applicants or the representative of the Applicants, hereby certify that this application is correct and complete as per the requirements presented in this application, the El Paso County Engineering Criteria Manual, and Drainage Criteria Manual, Volume 2 and El Paso County Addendum.

We, as the Applicants or the representatives of the Applicants, have read and will comply with all of the requirements of the specified Stormwater Management Plan and any other documents specifying stormwater best management practices to be used on the site, including permit conditions that may be required by the ECM Administrator. We understand that the stormwater control measures are to be maintained on the site and revised as necessary to protect stormwater quality as the project progresses. We further understand that a Construction Permit must be obtained and all necessary stormwater quality control measures are to be installed in accordance with the SWMP, the El Paso County Engineering Criteria Manual, Drainage Criteria Manual, Volume 2 and El Paso County Addendum before land disturbance begins and that failure to comply will result in a Stop Work Order and may result in other penalties as allowed by law. We further understand and agree to indemnify, save, and hold harmless the County and its officers and employees, including but not limited to the BOCC and ECM Administrator, from all claims, suits or actions of every name, kind and description as outlined in Section 1.2 Responsibility for Damage.

Signature of Owner or Representative

Date: _____

Print Name of Owner or Representative

Signature of Operator or Representative

Date: _____

Print Name of Operator or Representative

Permit Fee	\$ _____	
Surcharge	\$ _____	
Financial Surety	\$ _____	Type of Surety _____
Total	\$ _____	

- ENGINEERING CRITERIA MANUAL
Appendix E CHECKLISTS AND PERMITS



2880 International Circle, Suite 110
Colorado Springs, CO 80910
Phone 719-520-6300
Fax 719-520-6695
www.elpasoco.com

**EL PASO COUNTY PLANNING AND
COMMUNITY DEVELOPMENT
DEPARTMENT**

STORMWATER MANAGEMENT PLAN CHECKLIST

Revised: July 2019		Applicant	PCD
1. STORMWATER MANAGEMENT PLAN (SWMP)			
1	Applicant (owner/designated operator), SWMP Preparer, Qualified Stormwater Manager, and Contractor Information. (On cover/title sheet)		
2	Table of Contents		
3	Site description and location to include: vicinity map with nearest street/crossroads description.		
4	Narrative description of construction activities proposed (e.g., may include clearing and grubbing, temporary stabilization, road grading, utility / storm installation, final grading, final stabilization, and removal of temporary control measures)		
5	Phasing plan – may require separate drawings indicating initial, interim, and final site phases for larger projects. Provide "living maps" that can be revised in the field as conditions dictate.		
6	Proposed sequence for major activities: Provide a construction schedule of anticipated starting and completion dates for each stage of land-disturbing activity depicting conservation measures anticipated, including the expected date on which the final stabilization will be completed.		
7	Estimates of the total site area and area to undergo disturbance; current area of disturbance must be updated on the SWMP as changes occur.		
8	Soil erosion potential and impacts on discharge that includes a summary of the data used to determine soil erosion potential		
9	A description of existing vegetation at the site and percent ground cover and method used to determine ground cover		
10	Location and description of all potential pollution sources including but not limited to: disturbed and stored soils; vehicle tracking; management of contaminated soils; loading and unloading operations; outdoor storage of materials; vehicle and equipment maintenance and fueling; significant dust generating process; routine maintenance activities involving fertilizers, pesticides, herbicides, detergents, fuels, solvents, oils, etc.; on-site waste management; concrete truck/equipment washing; dedicated asphalt, concrete batch plants and masonry mixing stations; non-industrial waste such as trash and portable toilets		
11	Material handling to include spill prevention and response plan and procedures.		
12	Spill prevention and pollution controls for dedicated batch plants		
13	Other SW pollutant control measures to include waste disposal and off site soil tracking		
14	Location and description of any anticipated allowable non-stormwater discharge (ground water, springs, irrigation, discharge covered by CDPHE Low Risk Guidance, etc.)		
15	Name(s) of ultimate receiving waters; size, type and location of stormwater outfall or storm sewer system discharge		
16	Description of all stream crossings located within the project area or statement that no streams cross the project area		
17	SWMP Map to include:		
17a	construction site boundaries		
17b	flow arrows to depict stormwater flow directions		
17c	all areas of disturbance		
17d	areas of cut and fill		
17e	areas used for storage of building materials, soils (stockpiles) or wastes		
17f	location of any dedicated asphalt / concrete batch plants		

- ENGINEERING CRITERIA MANUAL
Appendix E CHECKLISTS AND PERMITS



2880 International Circle, Suite 110
Colorado Springs, CO 80910
Phone 719-520-6300
Fax 719-520-6695
www.elpasoco.com

**EL PASO COUNTY PLANNING AND
COMMUNITY DEVELOPMENT
DEPARTMENT**

STORMWATER MANAGEMENT PLAN CHECKLIST

Revised: July 2019		Applicant	PCD
17g	location of all structural control measures		
17h	location of all non-structural control measures		
17i	springs, streams, wetlands and other surface waters, including areas that require maintenance of pre-existing vegetation within 50 feet of a receiving water		
18	Narrative description of all structural control measures to be used. Modifications to EPC standard control measures must meet or exceed County-approved details.		
19	Description of all non-structural control measures to be used including seeding, mulching, protection of existing vegetation, site watering, sod placement, etc.		
20	Technical drawing details for all control measure installation and maintenance; custom or other jurisdiction's details used must meet or exceed EPC standards		
21	Procedure describing how the SWMP is to be revised		
22	Description of Final Stabilization and Long-term Stormwater Quality (describe nonstructural and structural measures to control SW pollutants after construction operations have been completed, including detention, water quality control measure etc.)		
23	Specification that final vegetative cover density is to be 70% of pre-disturbed levels		
24	Outline of permit holder inspection procedures to install, maintain, and effectively operate control measures to manage erosion and sediment		
25	Record keeping procedures identified to include signature on inspection logs and location of SWMP records on-site		
26	If this project relies on control measures owned or operated by another entity, a documented agreement must be included in the SWMP that identifies location, installation and design specifications, and maintenance requirements and responsibility of the control measure(s). Please note: all items above must be addressed. If not applicable, explain why, simply identifying "not applicable" will not satisfy CDPHE requirement of explanation.		
2. ADDITIONAL REPORTS/PERMITS/DOCUMENTS			
a	Grading and Erosion Control Plan (signed)		
b	Erosion and Stormwater Quality Control Permit (ESQCP) (signed)		
3. Applicant Comments:			
a			
b			
c			
4. Checklist Review Certifications:			



2880 International Circle, Suite 110
Colorado Springs, CO 80910
Phone 719-520-6300
Fax 719-520-6695
www.elpasoco.com

**EL PASO COUNTY PLANNING AND
COMMUNITY DEVELOPMENT
DEPARTMENT**

STORMWATER MANAGEMENT PLAN CHECKLIST

Revised: July 2019

		Applicant	PCD
a	<p>Engineer of Record: The Stormwater Management Plan was prepared under my direction and supervision and is correct to the best of my knowledge and belief. Said Plan has been prepared according to the criteria established by the County and State for Stormwater Management Plans.</p>		
	<p>_____ Date _____ Engineer of Record Signature</p>		
b	<p>Review Engineer: The Stormwater Management Plan was reviewed and found to meet the checklist requirements except where otherwise noted or allowed by an approved deviation request.</p>		
	<p>_____ Date _____ Review Engineer</p>		

- ENGINEERING CRITERIA MANUAL
Appendix E CHECKLISTS AND PERMITS



2880 International Circle, Suite 110
Colorado Springs, CO 80910
Phone 719-520-6300
Fax 719-520-6695
www.elpasoco.com

**EL PASO COUNTY PLANNING AND
COMMUNITY DEVELOPMENT
DEPARTMENT**

GRADING AND EROSION CONTROL PLAN CHECKLIST

Revised: July 2019		Applicant	PCD
1. GRADING AND EROSION CONTROL PLAN			
a	Vicinity map.		
b	Adjacent city/town/jurisdictional boundaries, subdivision names, and property parcel numbers labeled.		
c	North arrow and acceptable scale (1"=20' to 1"=100').		
d	Legend for all symbols used in the plan.		
e	Existing and proposed property lines. Proposed subdivision boundary for subdivision projects.		
f	All existing structures.		
g	All existing utilities.		
h	Construction site boundaries.		
i	Existing vegetation (notes are acceptable in cases where there is no notable vegetation, only grasses/weeds, or site has already been stripped).		
j	FEMA 100-yr floodplain.		
k	Existing and proposed water courses including springs, streams, wetlands, detention ponds, stormwater quality structures, roadside ditches, irrigation ditches and other water surfaces. Show maintenance of pre-existing vegetation within 50 feet of a receiving water.		
l	Existing and proposed contours 2 feet or less (except for hillside).		
m	Limits of disturbance delineating all anticipated areas of soil disturbance.		
n	Identify and protect areas outside of the construction site boundary with existing fencing, construction fencing or other methods as appropriate.		
o	Offsite grading clearly shown and called out.		
p	Areas of cut and fill identified.		
q	Conclusions from soils/geotechnical report and geologic hazards report incorporated in grading design (slopes, embankments, materials, mitigation, etc.)		
r	Proposed slopes steeper than 3:1 with top and toe of slope delineated. Erosion control blanketing or other protective covering required.		
s	Stormwater flow direction arrows.		
t	Location of any dedicated asphalt / concrete batch plants.		
u	Areas used for staging, storage of building materials, soils (stockpiles) or wastes. The use of construction office trailers requires PCD permitting.		
v	All proposed temporary construction control measures, structural and non-structural. Temporary construction control measures shall be identified by phase of implementation to include "initial," "interim," and "final" or shown on separate phased maps identifying each phase.		
w	Vehicle tracking provided at all construction entrances/exits. Construction fencing, barricades, and/or signage provided at access points not to be used for construction.		
x	Temporary sediment ponds provided for disturbed drainage areas greater than 1 acre.		
y	Dewatering operations to include locations of diversion, pump and discharge(s) as anticipated at time of design.		
z	All proposed temporary construction control measure details. Custom or other jurisdiction's details used must meet or exceed EPC standards.		

- ENGINEERING CRITERIA MANUAL
Appendix E CHECKLISTS AND PERMITS



2880 International Circle, Suite 110
Colorado Springs, CO 80910
Phone 719-520-6300
Fax 719-520-6695
www.elpasoco.com

**EL PASO COUNTY PLANNING AND
COMMUNITY DEVELOPMENT
DEPARTMENT**

GRADING AND EROSION CONTROL PLAN CHECKLIST

Revised: July 2019		Applicant	PCD
aa	Any offsite stormwater control measure proposed for use by the project and not under the direct control or ownership of the Owner or Operator.		
bb	Existing and proposed permanent storm water management facilities, including areas proposed for stormwater infiltration or subsurface detention.		
cc	Existing and proposed easements (permanent and construction) including required off site easements.		
dd	Retaining walls (not to be located in County ROW unless approved via license agreement). Design by P.E. and building permit from Regional Building Department required for walls greater than or equal to 4 feet in height, series of walls, or walls supporting a surcharge.		
ee	Plan certified by a Colorado Registered P.E., with EPC standard signature blocks for Engineer, Owner and EPC.		
ff	<p>Engineer's Statement (for standalone GEC Plan): This Grading and Erosion Control Plan was prepared under my direction and supervision and is correct to the best of my knowledge and belief. Said Plan has been prepared according to the criteria established by the County for Grading and Erosion Control Plans. I accept responsibility for any liability caused by any negligent acts, errors or omissions on my part in preparing this plan.</p> <p>_____ Engineer of Record Signature Date</p>		
gg	<p>Engineer's Statement (for GEC Plan within Construction Drawing set): These detailed plans and specifications were prepared under my direction and supervision. Said plans and specifications have been prepared according to the criteria established by the County for detailed roadway, drainage, grading and erosion control plans and specifications, and said plans and specifications are in conformity with applicable master drainage plans and master transportation plans. Said plans and specifications meet the purposes for which the particular roadway and drainage facilities are designed and are correct to the best of my knowledge and belief. I accept responsibility for any liability caused by any negligent acts, errors or omissions on my part in preparation of these detailed plans and specifications.</p> <p>_____ Engineer of Record Signature Date</p>		
hh	<p>Owner's Statement (for standalone GEC Plan): I, the owner/developer have read and will comply with the requirements of the Grading and Erosion Control Plan.</p> <p>_____ Owner Signature Date</p>		
ii	<p>Owner's Statement (for GEC Plan within Construction Drawing set): I, the owner/developer have read and will comply with the requirements of the grading and erosion control plan and all of the requirements specified in these detailed plans and specifications.</p> <p>_____ Owner Signature Date</p>		

- ENGINEERING CRITERIA MANUAL
Appendix E CHECKLISTS AND PERMITS



2880 International Circle, Suite 110
Colorado Springs, CO 80910
Phone 719-520-6300
Fax 719-520-6695
www.elpasoco.com

**EL PASO COUNTY PLANNING AND
COMMUNITY DEVELOPMENT
DEPARTMENT**

GRADING AND EROSION CONTROL PLAN CHECKLIST

Revised: July 2019		Applicant	PCD
<p>El Paso County (standalone GEC Plan): County plan review is provided only for general conformance with County Design Criteria. The County is not responsible for the accuracy and adequacy of the design, dimensions, and/ or elevations which shall be confirmed at the job site. The County through the approval of this document assumes no responsibility for completeness and/ or accuracy of this document. Filed in accordance with the requirements of the El Paso County Land Development Code, Drainage Criteria Manual Volumes 1 and 2, and Engineering Criteria Manual, as amended.</p> <p>ij In accordance with ECM Section 1.12, these construction documents will be valid for construction for a period of 2 years from the date signed by the El Paso County Engineer. If construction has not started within those 2 years, the plans will need to be resubmitted for approval, including payment of review fees at the Planning and Community Development Director's discretion.</p> <p>_____ County Project Engineer Signature Date</p>			
2. ADDITIONAL REPORTS/PERMITS/DOCUMENTS			
a	Soils report / geotechnical investigation as appropriate for grading/utilities/drainage/road construction.		
b	Use Agreement/easement between the Owner or Operator and other third party for use of all offsite grading or stormwater control measures, used by the owner or operator but not under their direct control or ownership.		
c	Floodplain Development Permit		
d	USACE 404/wetlands permit/mitigation plan		
e	FEMA CLOMR		
f	State Engineer's permit/Notice Of Intent to Construct		
g	Stormwater Management Plan (SWMP)		
h	Financial Assurance Estimate (FAE) (signed)		
i	Erosion and Stormwater Quality Control Permit (ESQCP) (signed)		
j	Pre-Development Site Grading Acknowledgement and Right of Access Form (signed)		
k	Conditions of Approval met?		
3. STANDARD NOTES FOR EL PASO COUNTY GRADING AND EROSION CONTROL PLANS			
1	Stormwater discharges from construction sites shall not cause or threaten to cause pollution, contamination, or degradation of State Waters. All work and earth disturbance shall be done in a manner that minimizes pollution of any on-site or off-site waters, including wetlands.		
2	Notwithstanding anything depicted in these plans in words or graphic representation, all design and construction related to roads, storm drainage and erosion control shall conform to the standards and requirements of the most recent version of the relevant adopted El Paso County standards, including the Land Development Code, the Engineering Criteria Manual, the Drainage Criteria Manual, and the Drainage Criteria Manual Volume 2. Any deviations from regulations and standards must be requested, and approved, in writing.		

- ENGINEERING CRITERIA MANUAL
Appendix E CHECKLISTS AND PERMITS



2880 International Circle, Suite 110
Colorado Springs, CO 80910
Phone 719-520-6300
Fax 719-520-6695
www.elpasoco.com

**EL PASO COUNTY PLANNING AND
COMMUNITY DEVELOPMENT
DEPARTMENT**

GRADING AND EROSION CONTROL PLAN CHECKLIST

Revised: July 2019		Applicant	PCD
3	A separate Stormwater Management Plan (SMWP) for this project shall be completed and an Erosion and Stormwater Quality Control Permit (ESQCP) issued prior to commencing construction. Management of the SWMP during construction is the responsibility of the designated Qualified Stormwater Manager or Certified Erosion Control Inspector. The SWMP shall be located on site at all times during construction and shall be kept up to date with work progress and changes in the field.		
4	Once the ESQCP is approved and a "Notice to Proceed" has been issued, the contractor may install the initial stage erosion and sediment control measures as indicated on the approved GEC. A Preconstruction Meeting between the contractor, engineer, and El Paso County will be held prior to any construction. It is the responsibility of the applicant to coordinate the meeting time and place with County staff.		
5	Control measures must be installed prior to commencement of activities that could contribute pollutants to stormwater. Control measures for all slopes, channels, ditches, and disturbed land areas shall be installed immediately upon completion of the disturbance.		
6	All temporary sediment and erosion control measures shall be maintained and remain in effective operating condition until permanent soil erosion control measures are implemented and final stabilization is established. All persons engaged in land disturbance activities shall assess the adequacy of control measures at the site and identify if changes to those control measures are needed to ensure the continued effective performance of the control measures. All changes to temporary sediment and erosion control measures must be incorporated into the Stormwater Management Plan.		
7	Temporary stabilization shall be implemented on disturbed areas and stockpiles where ground disturbing construction activity has permanently ceased or temporarily ceased for longer than 14 days.		
8	Final stabilization must be implemented at all applicable construction sites. Final stabilization is achieved when all ground disturbing activities are complete and all disturbed areas either have a uniform vegetative cover with individual plant density of 70 percent of pre-disturbance levels established or equivalent permanent alternative stabilization method is implemented. All temporary sediment and erosion control measures shall be removed upon final stabilization and before permit closure.		
9	All permanent stormwater management facilities shall be installed as designed in the approved plans. Any proposed changes that effect the design or function of permanent stormwater management structures must be approved by the ECM Administrator prior to implementation.		
10	Earth disturbances shall be conducted in such a manner so as to effectively minimize accelerated soil erosion and resulting sedimentation. All disturbances shall be designed, constructed, and completed so that the exposed area of any disturbed land shall be limited to the shortest practical period of time. Pre-existing vegetation shall be protected and maintained within 50 horizontal feet of a waters of the state unless shown to be infeasible and specifically requested and approved.		
11	Compaction of soil must be prevented in areas designated for infiltration control measures or where final stabilization will be achieved by vegetative cover. Areas designated for infiltration control measures shall also be protected from sedimentation during construction until final stabilization is achieved. If compaction prevention is not feasible due to site constraints, all areas designated for infiltration and vegetation control measures must be loosened prior to installation of the control measure(s).		
12	Any temporary or permanent facility designed and constructed for the conveyance of stormwater around, through, or from the earth disturbance area shall be a stabilized conveyance designed to minimize erosion and the discharge of sediment off site.		

- ENGINEERING CRITERIA MANUAL
Appendix E CHECKLISTS AND PERMITS



2880 International Circle, Suite 110
Colorado Springs, CO 80910
Phone 719-520-6300
Fax 719-520-6695
www.elpasoco.com

**EL PASO COUNTY PLANNING AND
COMMUNITY DEVELOPMENT
DEPARTMENT**

GRADING AND EROSION CONTROL PLAN CHECKLIST

Revised: July 2019		Applicant	PCD
13	Concrete wash water shall be contained and disposed of in accordance with the SWMP. No wash water shall be discharged to or allowed to enter State Waters, including any surface or subsurface storm drainage system or facilities. Concrete washouts shall not be located in an area where shallow groundwater may be present, or within 50 feet of a surface water body, creek or stream.		
14	During dewatering operations of uncontaminated ground water may be discharged on site, but shall not leave the site in the form of surface runoff unless an approved State dewatering permit is in place.		
15	Erosion control blanketing or other protective covering shall be used on slopes steeper than 3:1.		
16	Contractor shall be responsible for the removal of all wastes from the construction site for disposal in accordance with local and State regulatory requirements. No construction debris, tree slash, building material wastes or unused building materials shall be buried, dumped, or discharged at the site.		
17	Waste materials shall not be temporarily placed or stored in the street, alley, or other public way, unless in accordance with an approved Traffic Control Plan. control measures may be required by El Paso County Engineering if deemed necessary, based on specific conditions and circumstances.		
18	Tracking of soils and construction debris off-site shall be minimized. Materials tracked off-site shall be cleaned up and properly disposed of immediately.		
19	The owner/developer shall be responsible for the removal of all construction debris, dirt, trash, rock, sediment, soil, and sand that may accumulate in roads, storm drains and other drainage conveyance systems and stormwater appurtenances as a result of site development.		
20	The quantity of materials stored on the project site shall be limited, as much as practical, to that quantity required to perform the work in an orderly sequence. All materials stored on-site shall be stored in a neat, orderly manner, in their original containers, with original manufacturer's labels.		
21	No chemical(s) having the potential to be released in stormwater are to be stored or used onsite unless permission for the use of such chemical(s) is granted in writing by the ECM Administrator. In granting approval for the use of such chemical(s), special conditions and monitoring may be required.		
22	Bulk storage of allowed petroleum products or other allowed liquid chemicals in excess of 55 gallons shall require adequate secondary containment protection to contain all spills onsite and to prevent any spilled materials from entering State Waters, any surface or subsurface storm drainage system or other facilities.		
23	No person shall cause the impediment of stormwater flow in the curb and gutter or ditch except with approved sediment control measures.		
24	Owner/developer and their agents shall comply with the "Colorado Water Quality Control Act" (Title 25, Article 8, CRS), and the "Clean Water Act" (33 USC 1344), in addition to the requirements of the Land Development Code, DCM Volume II and the ECM Appendix I. All appropriate permits must be obtained by the contractor prior to construction (1041, NPDES, Floodplain, 404, fugitive dust, etc.). In the event of conflicts between these requirements and other laws, rules, or regulations of other Federal, State, local, or County agencies, the most restrictive laws, rules, or regulations shall apply.		
25	All construction traffic must enter/exit the site only at approved construction access points.		
26	Prior to construction the permittee shall verify the location of existing utilities.		
27	A water source shall be available on site during earthwork operations and shall be utilized as required to minimize dust from earthwork equipment and wind.		

- ENGINEERING CRITERIA MANUAL
Appendix E CHECKLISTS AND PERMITS



2880 International Circle, Suite 110
Colorado Springs, CO 80910
Phone 719-520-6300
Fax 719-520-6695
www.elpasoco.com

**EL PASO COUNTY PLANNING AND
COMMUNITY DEVELOPMENT
DEPARTMENT**

GRADING AND EROSION CONTROL PLAN CHECKLIST

Revised: July 2019		Applicant	PCD
28	The soils report for this site has been prepared by _____ and shall be considered a part of these plans.		
29	<p>At least ten (10) days prior to the anticipated start of construction, for projects that will disturb one (1) acre or more, the owner or operator of construction activity shall submit a permit application for stormwater discharge to the Colorado Department of Public Health and Environment, Water Quality Division. The application contains certification of completion of a stormwater management plan (SWMP), of which this Grading and Erosion Control Plan may be a part. For information or application materials contact:</p> <p>Colorado Department of Public Health and Environment Water Quality Control Division WQCD – Permits 4300 Cherry Creek Drive South Denver, CO 80246-1530 Attn: Permits Unit</p>		
4. Applicant Comments:			
a			
b			
c			
5. Checklist Review Certifications:			
a	<p>Engineer of Record: The Grading and Erosion Control Plan was prepared under my direction and supervision and is complete and correct to the best of my knowledge and belief. Said Plan has been prepared according to the criteria established by the County for Grading and Erosion Control Plans.</p> <p>_____ Engineer of Record Signature</p> <p>_____ Date</p>		

- ENGINEERING CRITERIA MANUAL
Appendix E CHECKLISTS AND PERMITS



2880 International Circle, Suite 110
Colorado Springs, CO 80910
Phone 719-520-6300
Fax 719-520-6695
www.elpasoco.com

**EL PASO COUNTY PLANNING AND
COMMUNITY DEVELOPMENT
DEPARTMENT**

GRADING AND EROSION CONTROL PLAN CHECKLIST

Revised: July 2019		Applicant	PCD
b	Review Engineer: The Grading and Erosion Control Plan was reviewed and found to meet the checklist requirements except where otherwise noted or allowed by an approved deviation request.		
	_____ Review Engineer	_____ Date	

Appendix F STANDARD DRAWINGS & SPECIFICATIONS

Note: Drawings are listed by chapter and then sequential (intentional gaps in the numbering have been placed to allow for future additions). ~~EPC~~These Standard Drawings remain products in progress and will continue to be updated as necessary through an administrative process. Only those with listed Approval Dates shall be considered a standard and all others are presented for "reference" purposes only until such date that they are fully accepted by the ECM Administrator. EPC Standard Specifications remain products in progress and will continue to be updated as necessary through an administrative process. Only those with listed Approval Dates shall be considered a standard and all others are presented for "reference" purposes only until such date that they are fully accepted by the ECM Administrator.

EPC Standard Drawings

File Name	Detail/Description	Approval Date
SD_2-1	Urban Local Roadway (low volume)	06/23/2020
SD_2-2	Urban Local Roadway	06/23/2020
SD_2-3	Urban NonResidential Collector Roadway	06/23/2020
SD_2-4	Urban Residential Collector Roadway	06/23/2020
SD_2-5	Urban Minor Arterial Roadway	06/23/2020
SD_2-6	Urban Principal 4-Lane Arterial Roadway	06/23/2020
SD_2-7	Urban Principal 6-Lane Arterial Roadway	06/23/2020
SD_2-8	Urban Expressway 4-Lane Roadway	06/23/2020
SD_2-9	Urban Expressway 6-Lane Roadway	06/23/2020
SD-2-10	Rural Gravel Local Roadway	12/31/2005
SD_2-11	Rural Local Roadway	<u>BOCC Approval Date12/31/2005</u>
SD-2-12	Rural Minor Collector Roadway	<u>BOCC Approval Date12/31/2005</u>
SD_2-13	Rural Major Collector Roadway	<u>BOCC Approval Date12/31/2005</u>
SD_2-14	Rural Minor Arterial Roadway	<u>BOCC Approval Date12/31/2005</u>
SD_2-15	Rural Principal 4-Lane Arterial Roadway	<u>12/31/2005 BOCC Approval Date</u>
SD_2-16	Rural Principal 6-Lane Arterial Roadway	<u>BOCC Approval Date12/31/2005</u>
SD_2-17	Rural Expressway 4-Lane Roadway	<u>12/31/2005 BOCC Approval Date</u>
SD_2-18	Rural Expressway 6-Lane Roadway	<u>BOCC Approval Date12/31/2005</u>
SD_2-20	Typical Curb and Gutter Details	<u>BOCC Approval Date06/23/2020</u>
SD_2-21	Patterned Concrete Median Paving	01/18/2011

- ENGINEERING CRITERIA MANUAL
Appendix F STANDARD DRAWINGS & SPECIFICATIONS

SD_2-22	Plowable Median Nose Detail	1/12/2016
SD-2-23	Driveway Cut Detail	08/11/2011
SD-2-24	Driveway Detail w/Attached Sidewalk	06/23/2020
SD_2-25	Driveway Detail w/Detached Sidewalk	06/23/2020
SD_2-26	Typical Cross Pan Layout Detail	08/11/2011
SD_2-40	Pedestrian Curb Ramp Detail	06/23/2020
SD_2-41	Pedestrian Curb Ramp Detail	06/23/2020
SD_2-42	Detectable Warning Surface Details	06/23/2020
SD_2-50	Parallel Pedestrian Curb Ramp Detail	06/23/2020
SD_2-70	Type C Aluminum Bridge Railing	08/11/2011
SD_2-71	Oklahoma TR-1 Bridge Railing	08/11/2011
SD_2-72	Nevada Concrete Safety Bridge Railing	08/11/2011
SD_2-73	Safety Shaped Concrete Bridge Railing	08/11/2011
SD_2-74	Texas Type TT Bridge Railing	08/11/2011
SD_2-75	Urban Cul-de-Sac Details	01/01/2008
SD_2-76	Rural Cul-de-Sac Details	BOCC Approval Date01/01/2008
SD_2-77	Urban Knuckle	07/09/2009 BOCC Approval Date
SD_2-78	Urban Local Low-Volume Knuckle-Urban Eyebrow	07/09/2009 BoCC Approval Date
SD_3-1	Storm Sewer Manhole Detail Type I	07/09/2009
SD-3-2	Storm Sewer Manhole Detail Type II	11/10/2004
SD_3-3	Storm Sewer Manhole Detail Type III	08/11/2011
SD_3-5	Storm Sewer Manhole Lid Detail	09/16/2010
SD_3-7	Storm Sewer Manhole Riser and Cover Detail	08/11/2011
SD-3-8	Grate Inlet for Common Areas (guidance)	08/11/2011
SD_3-14	Driveway Access on Rural Local Roadway	08/11/2011
SD_3-24	Sidewalk Underdrain w/ Curb Outlet Detail	08/11/2011
SD_3-25	Curb Opening w/ Drainage Chase Detail 1 of 2	08/11/2011
SD_3-25A	Curb Opening w/ Drainage Chase Detail 2 of 2	08/11/2011
SD_3-30	Desilting Basin Outlet	08/11/2011
SD_3-31	Temporary Desilting Basin at Inlet	08/11/2011
SD_3-32	Temporary Desilting Basin at Sump	08/11/2011
SD_3-33	On Street Temporary Desilting Basin Detail	
SD_3-34	Temporary Desilting Basin Detail (guidance)	08/11/2011
SD_3-35	Debris Cage for Desilting Basin Riser	08/11/2011
SD_3-36	Desilting Basin Riser Detail	08/11/2011
SD_3-41	Lined Ditch Splashwall Detail (plan and section)	08/11/2011
SD_3-44	Lined Ditch Behind Retaining Wall Detail	08/11/2011
SD_3-48	Beehive Grate Detail (guidance)	08/11/2011
SD_3-60	Temporary Street Sandbag Detail and Section	08/11/2011
SD_3-62	Typical Check Dam Detail	08/11/2011

- ENGINEERING CRITERIA MANUAL
Appendix F STANDARD DRAWINGS & SPECIFICATIONS

SD_3-71	Canyon Subdrain Detail	08/11/2011
SD_3-81	Lug Connection Detail (cast in place concrete pipe)	08/11/2011
SD_3-82	Plan and Section of an Extended Detention Basin Sedimentation Facility	01/01/08
SD_3-83	Typical WQCV Outlet Structure Profiles Including 100-Year Detention	01/01/08
SD_3-84	Concrete Washout Structure	01/01/08
SD_3-85	Erosion Log Check Dams	01/01/08
SD_3-86	Culvert Inlet and Outlet Protection Erosion Logs Above Inlets and Outlets for Slope 3:1 or Steeper	01/01/08
SD_3-87	Erosion Log Barrier	01/01/08
SD_3-88	Cut Back Swale	12/13/2016
SD_4-1	Urban Local Roadway - Utility Placement	08/11/2011
SD_4-2	Urban Residential Minor Collector Roadway - Utility Placement	08/11/2011
SD_4-3	Urban NonResidential Collector Roadway - Utility Placement	08/11/2011
SD_4-4	Urban Residential Major Collector Roadway - Utility Placement	08/11/2011
SD_4-5 & 4-5A	Urban Minor Arterial Roadway - Utility Placement	08/11/2011
SD_4-6 & 4-6A	Urban Principal 4-Lane Arterial Roadway - Utility Placement	08/11/2011
SD_4-7 & 4-7A	Urban Principal 6-Lane Arterial Roadway - Utility Placement	08/11/2011
SD_4-8 & 4-8A	Urban Expressway 4-Lane Roadway - Utility Placement	08/11/2011
SD_4-9 & 4-9A	Urban Expressway 6-Lane Roadway - Utility Placement	08/11/2011
SD-4-10	Rural Gravel Local Roadway - Utility Placement	08/11/2011
SD_4-11	Rural Local Roadway - Utility Placement	08/11/2011
SD-4-12	Rural Minor Collector Roadway - Utility Placement	08/11/2011
SD_4-13	Rural Major Collector Roadway - Utility Placement	08/11/2011
SD_4-14 & 4-14A	Rural Minor Arterial Roadway - Utility Placement	08/11/2011
SD_4-15 & 4-15A	Rural Principal 4-Lane Arterial Roadway - Utility Placement	08/11/2011
SD_4-16 & 4-16A	Rural Principal 6-Lane Arterial Roadway - Utility Placement	08/11/2011
SD_4-17 & 4-17A	Rural Expressway 4-Lane Roadway - Utility Placement	08/11/2011
SD_4-18 & 4-18A	Rural Expressway 6-Lane Roadway - Utility Placement	08/11/2011
SD_4-20	Utility Trench Repair Detail (asphalt pavement)	08/11/2011
SD_4-21	Utility Trench Repair Detail (newly overlaid pavement)	08/11/2011
SD_4-22	Utility Trench Repair Detail (concrete pavement)	08/11/2011
SD_4-23	Utility Trench Repair Detail (flowable fill)	08/11/2011

(Res. No. 20-222 , 6-23-20)

EPC Standard Specifications

- ENGINEERING CRITERIA MANUAL
Appendix F STANDARD DRAWINGS

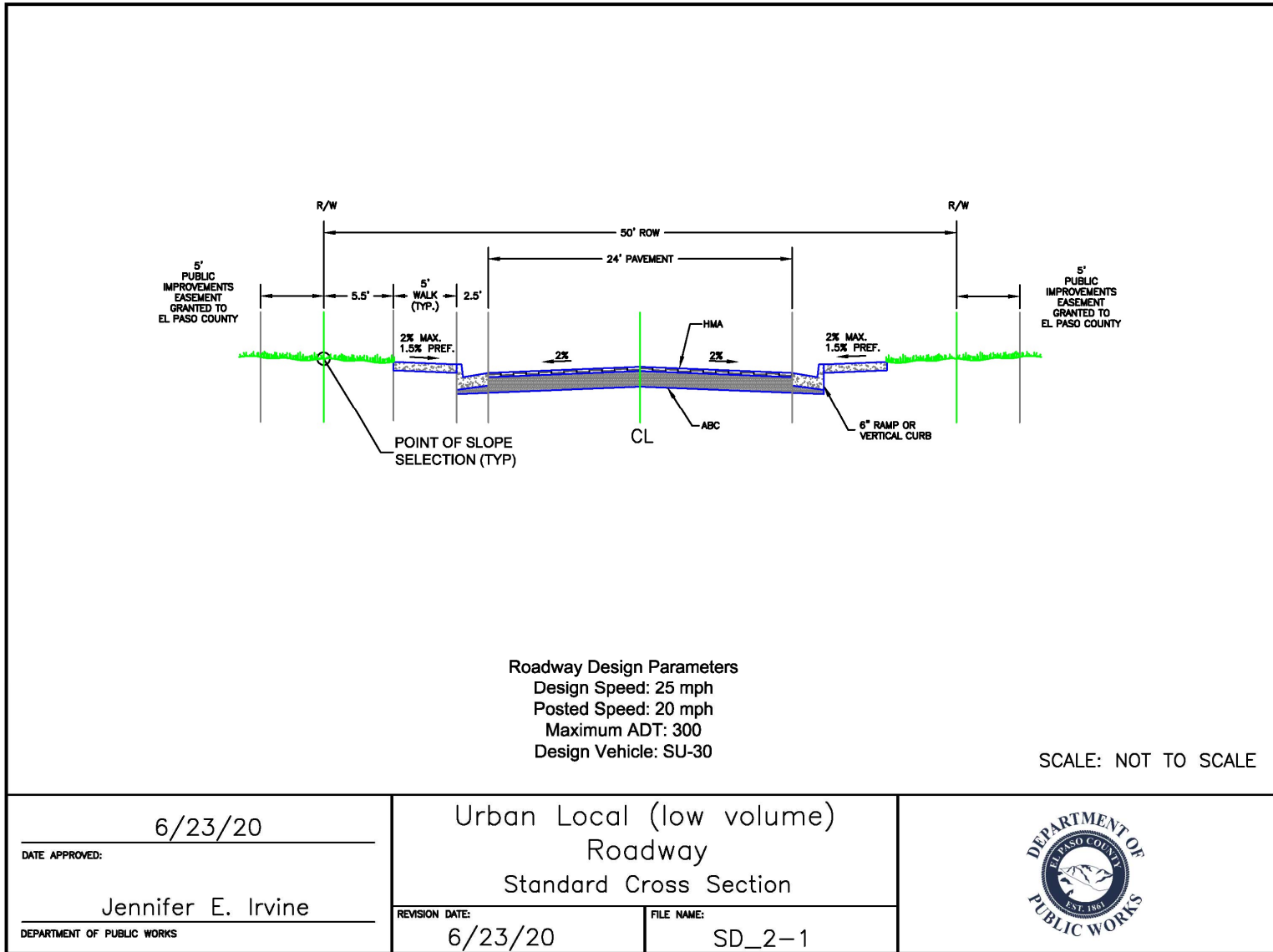

- ENGINEERING CRITERIA MANUAL
Appendix F STANDARD DRAWINGS

(Res. No. 20-222 , 6-23-20)

- ENGINEERING CRITERIA MANUAL
Appendix F STANDARD DRAWINGS

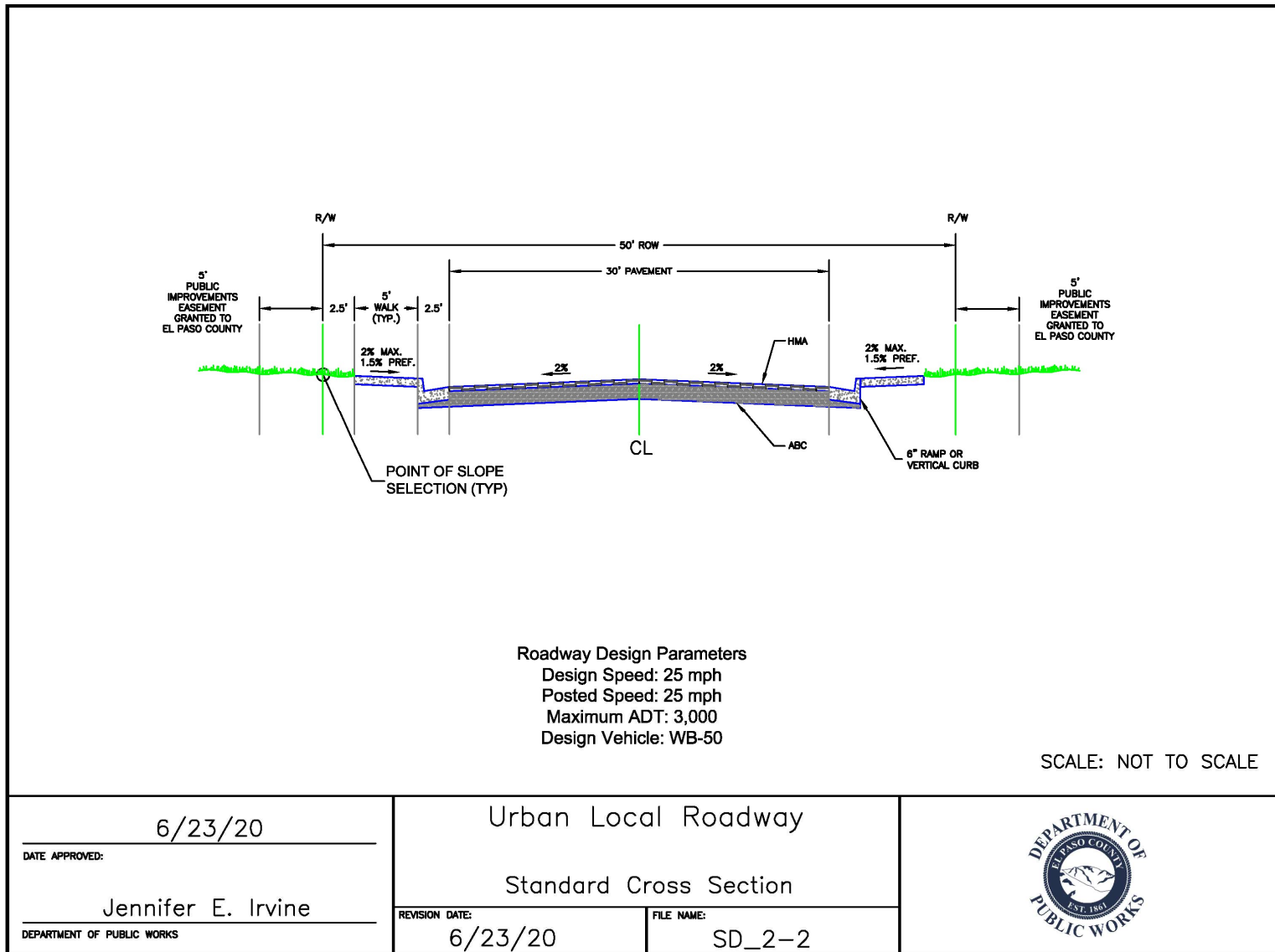

- ENGINEERING CRITERIA MANUAL
Appendix F STANDARD DRAWINGS

(Res. No. 20-222 , 6-23-20)

- ENGINEERING CRITERIA MANUAL
Appendix F STANDARD DRAWINGS

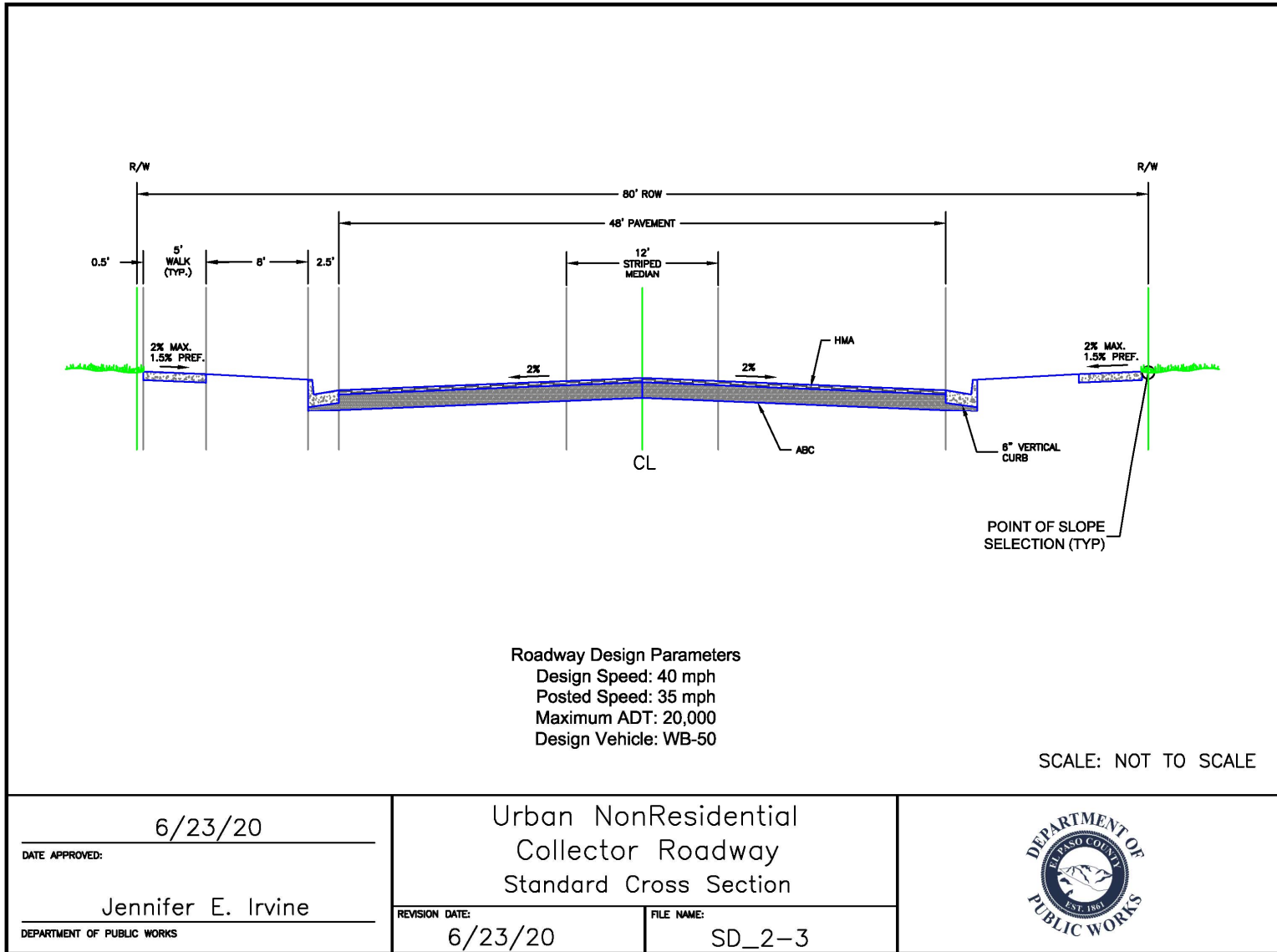

- ENGINEERING CRITERIA MANUAL
Appendix F STANDARD DRAWINGS

(Res. No. 20-222 , 6-23-20)

- ENGINEERING CRITERIA MANUAL
Appendix F STANDARD DRAWINGS

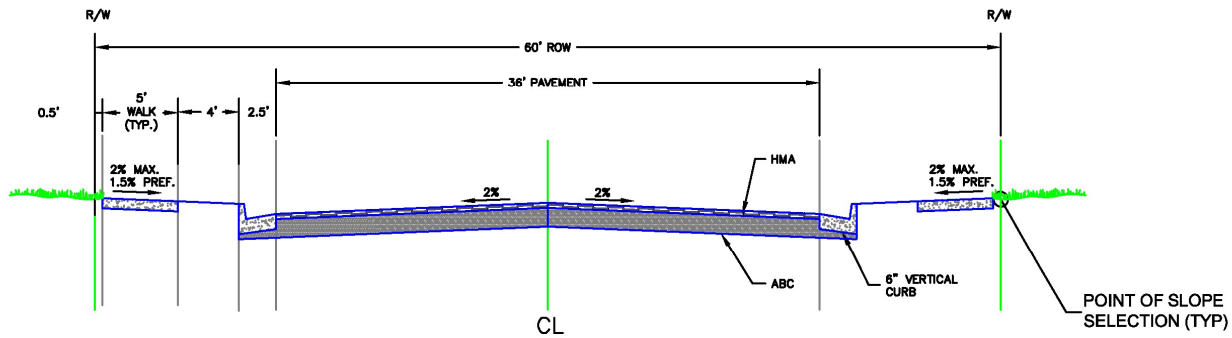

Roadway Design Parameters
 Design Speed: 40 mph
 Posted Speed: 35 mph
 Maximum ADT: 10,000
 Design Vehicle: WB-50

SCALE: NOT TO SCALE

6/23/20
 DATE APPROVED:
 Jennifer E. Irvine
 DEPARTMENT OF PUBLIC WORKS

Urban Residential
 Collector Roadway
 Standard Cross Section

REVISION DATE: 6/23/20 FILE NAME: SD_2-4



- ENGINEERING CRITERIA MANUAL
Appendix F STANDARD DRAWINGS

(Res. No. 20-222 , 6-23-20)

- ENGINEERING CRITERIA MANUAL
Appendix F STANDARD DRAWINGS

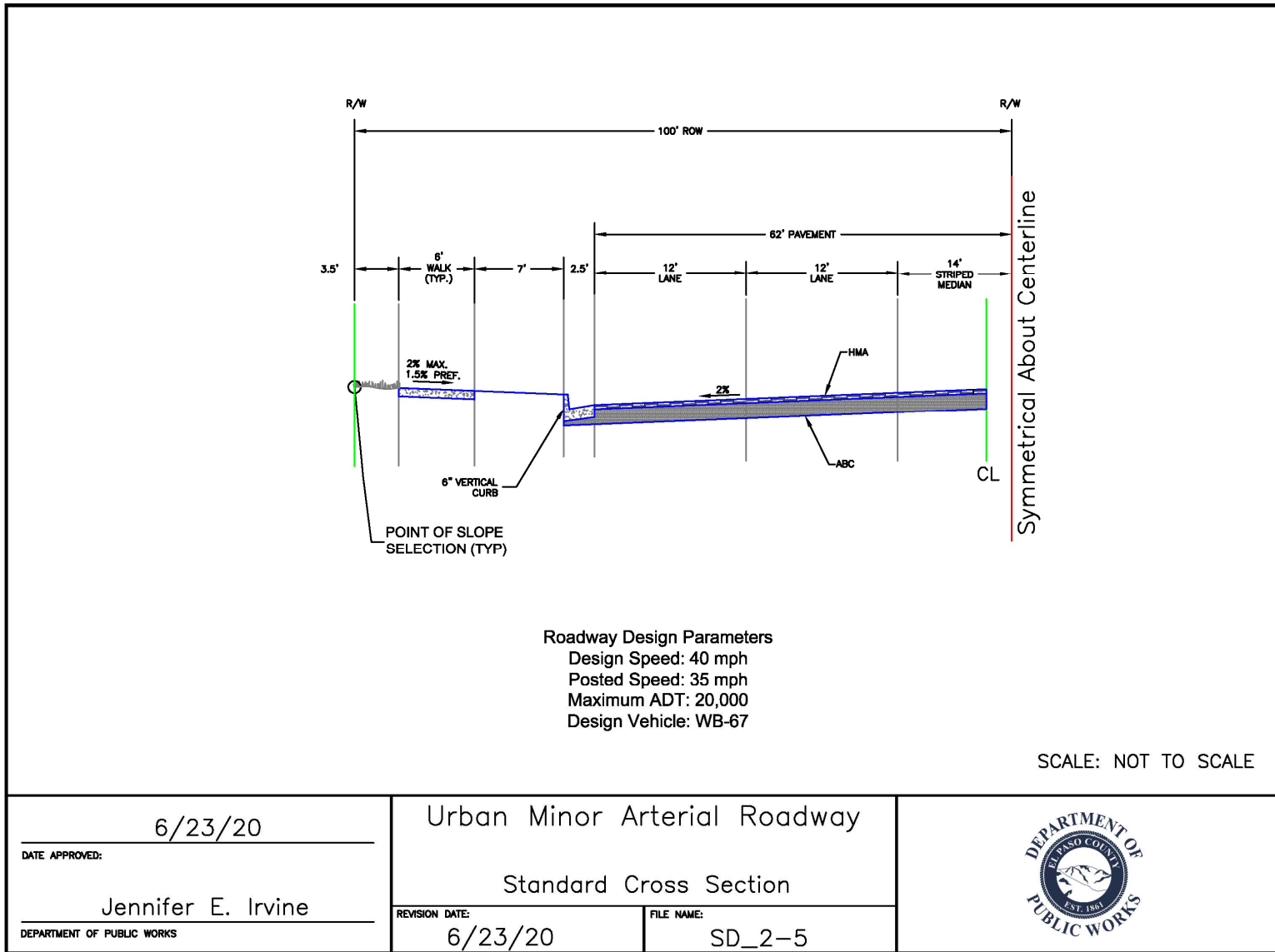

- ENGINEERING CRITERIA MANUAL
Appendix F STANDARD DRAWINGS

(Res. No. 20-222 , 6-23-20)

- ENGINEERING CRITERIA MANUAL
Appendix F STANDARD DRAWINGS

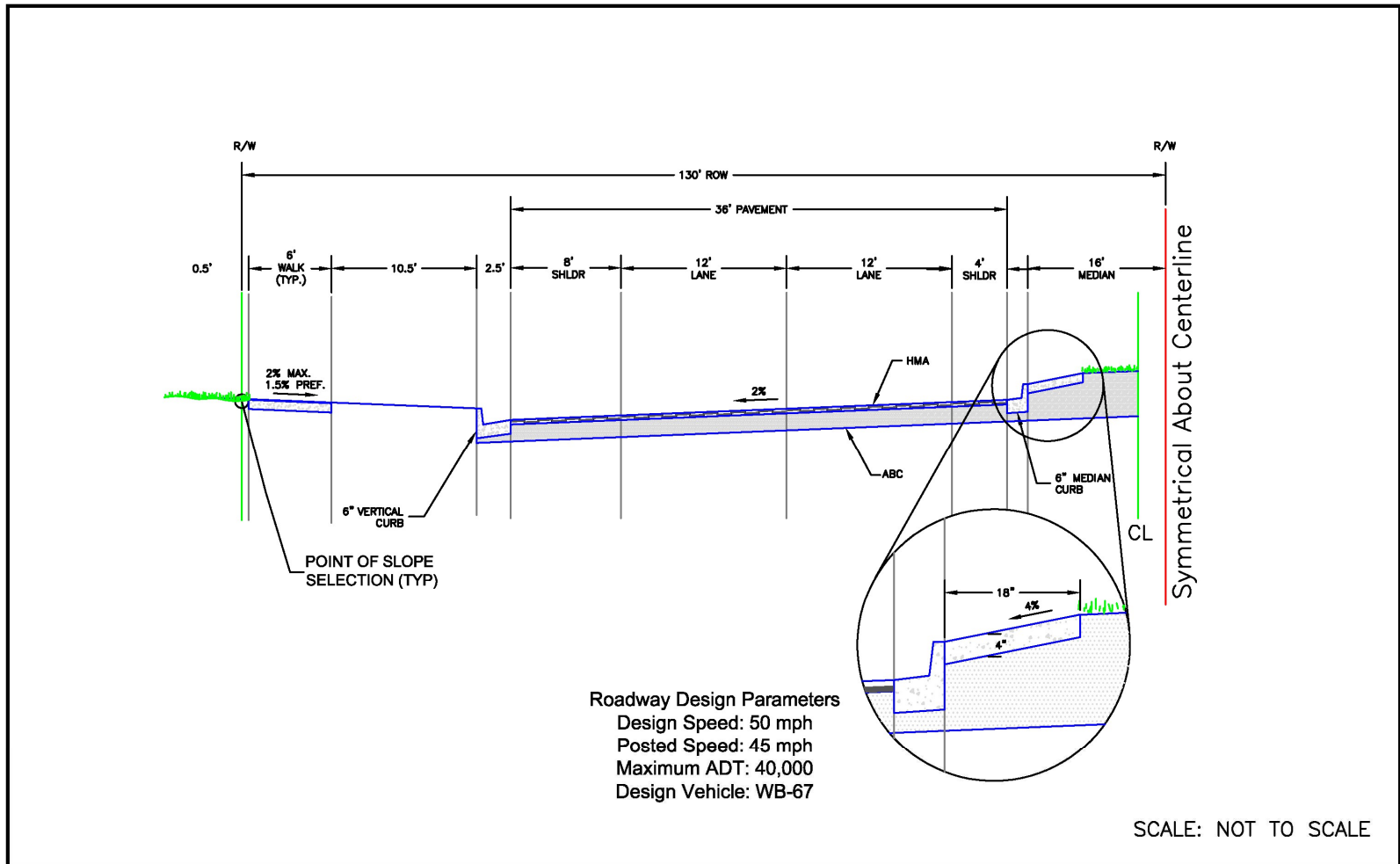

6/23/20
DATE APPROVED:
Jennifer E. Irvine
DEPARTMENT OF PUBLIC WORKS

Urban Principal 4-Lane
Arterial Roadway
Standard Cross Section

REVISION DATE: 6/23/20
FILE NAME: SD_2-6

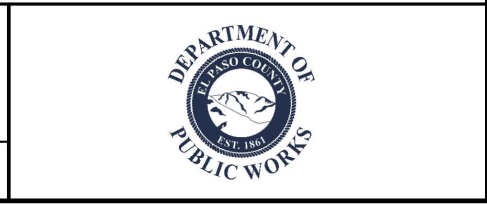

El Paso
(Supp. No. 2)

- ENGINEERING CRITERIA MANUAL
Appendix F STANDARD DRAWINGS

(Res. No. 20-222 , 6-23-20)

- ENGINEERING CRITERIA MANUAL
Appendix F STANDARD DRAWINGS

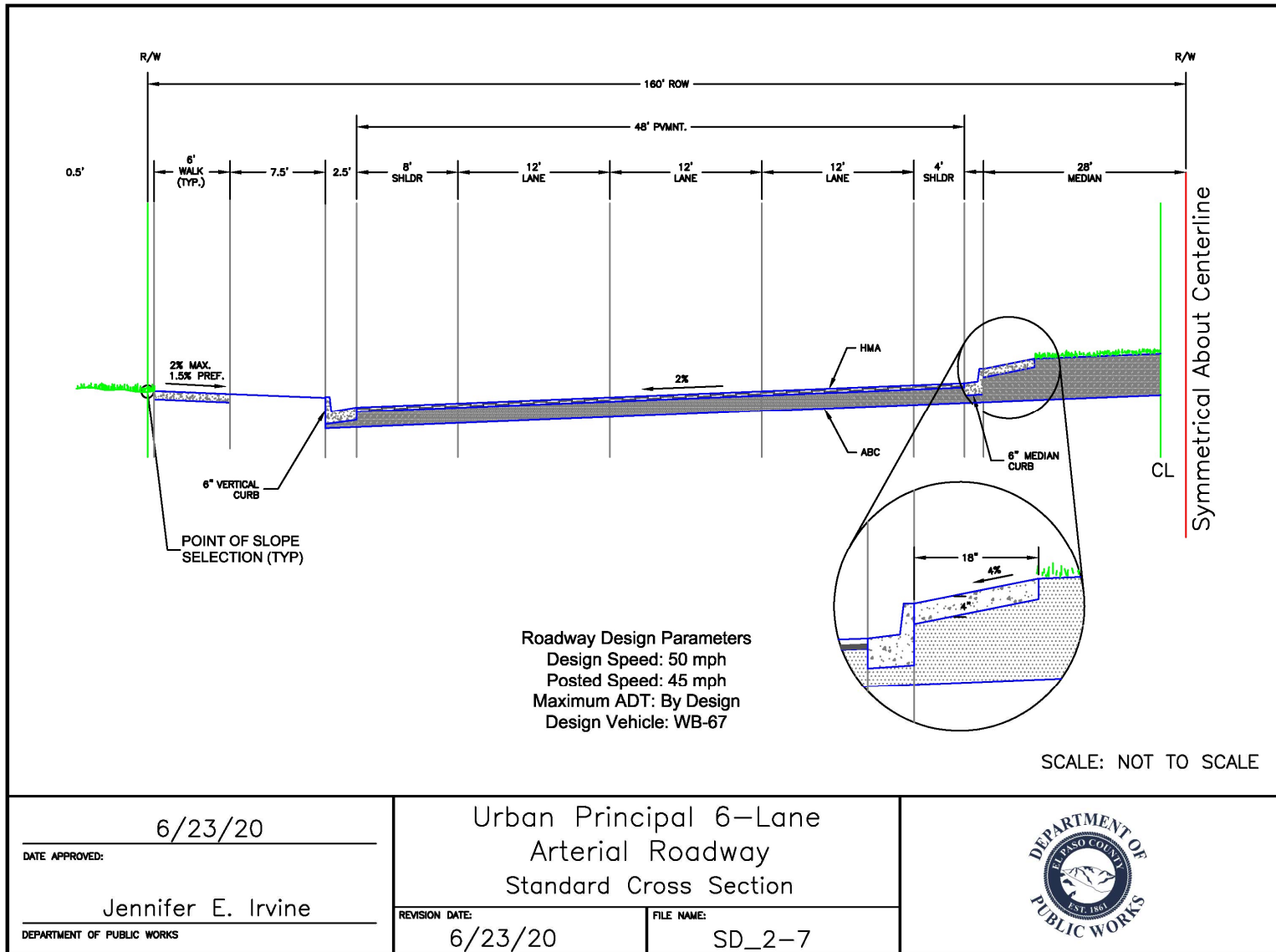

- ENGINEERING CRITERIA MANUAL
Appendix F STANDARD DRAWINGS

(Res. No. 20-222 , 6-23-20)

- ENGINEERING CRITERIA MANUAL
Appendix F STANDARD DRAWINGS

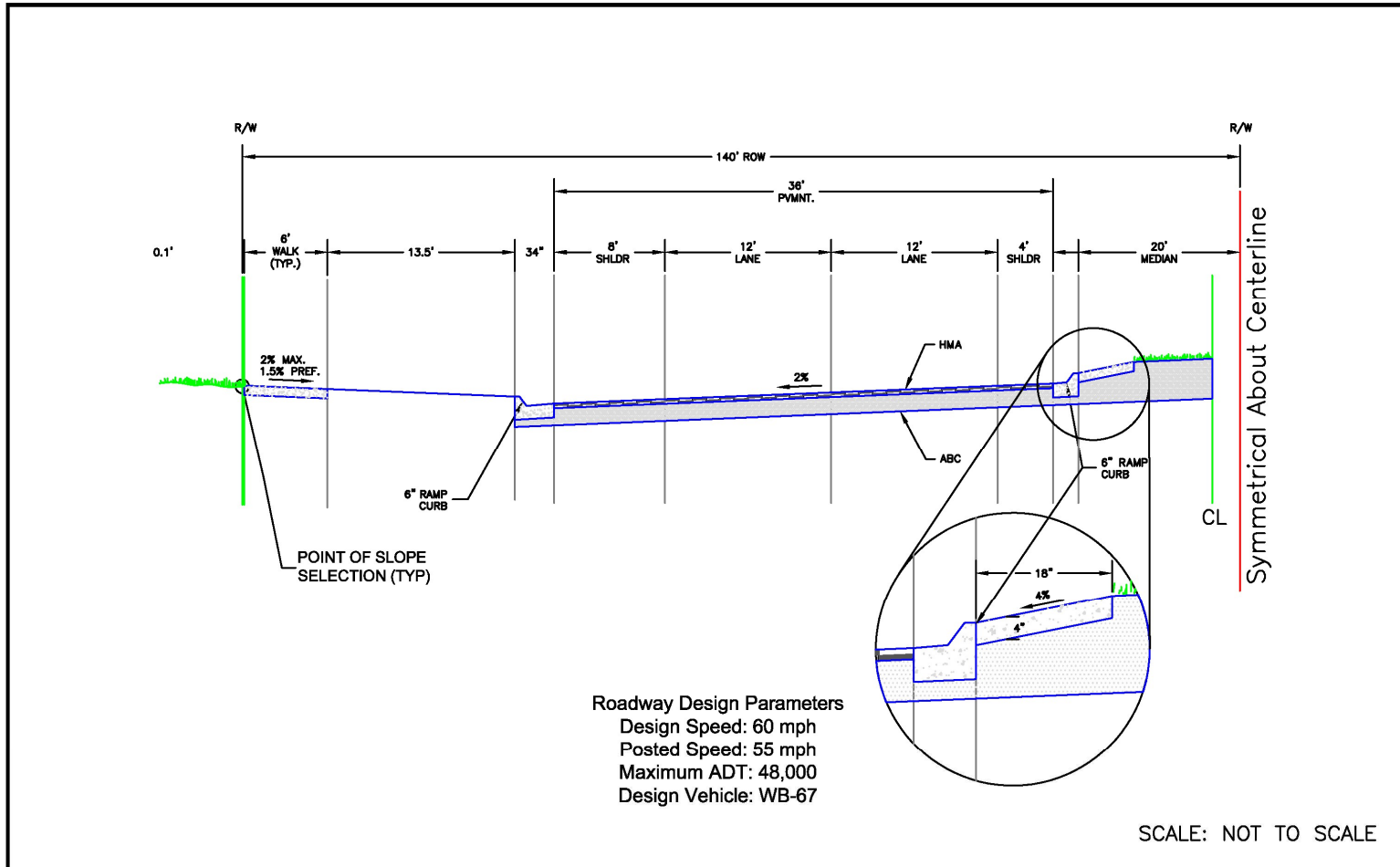

<p align="center">6/23/20</p> <p>DATE APPROVED:</p> <p align="center">Jennifer E. Irvine</p> <p>DEPARTMENT OF PUBLIC WORKS</p>	<p align="center">Urban Expressway 4-Lane Roadway Standard Cross Section</p>	
	<p>REVISION DATE: 6/23/20</p>	<p>FILE NAME: SD_2-8</p>

- ENGINEERING CRITERIA MANUAL
Appendix F STANDARD DRAWINGS

(Res. No. 20-222 , 6-23-20)

- ENGINEERING CRITERIA MANUAL
Appendix F STANDARD DRAWINGS

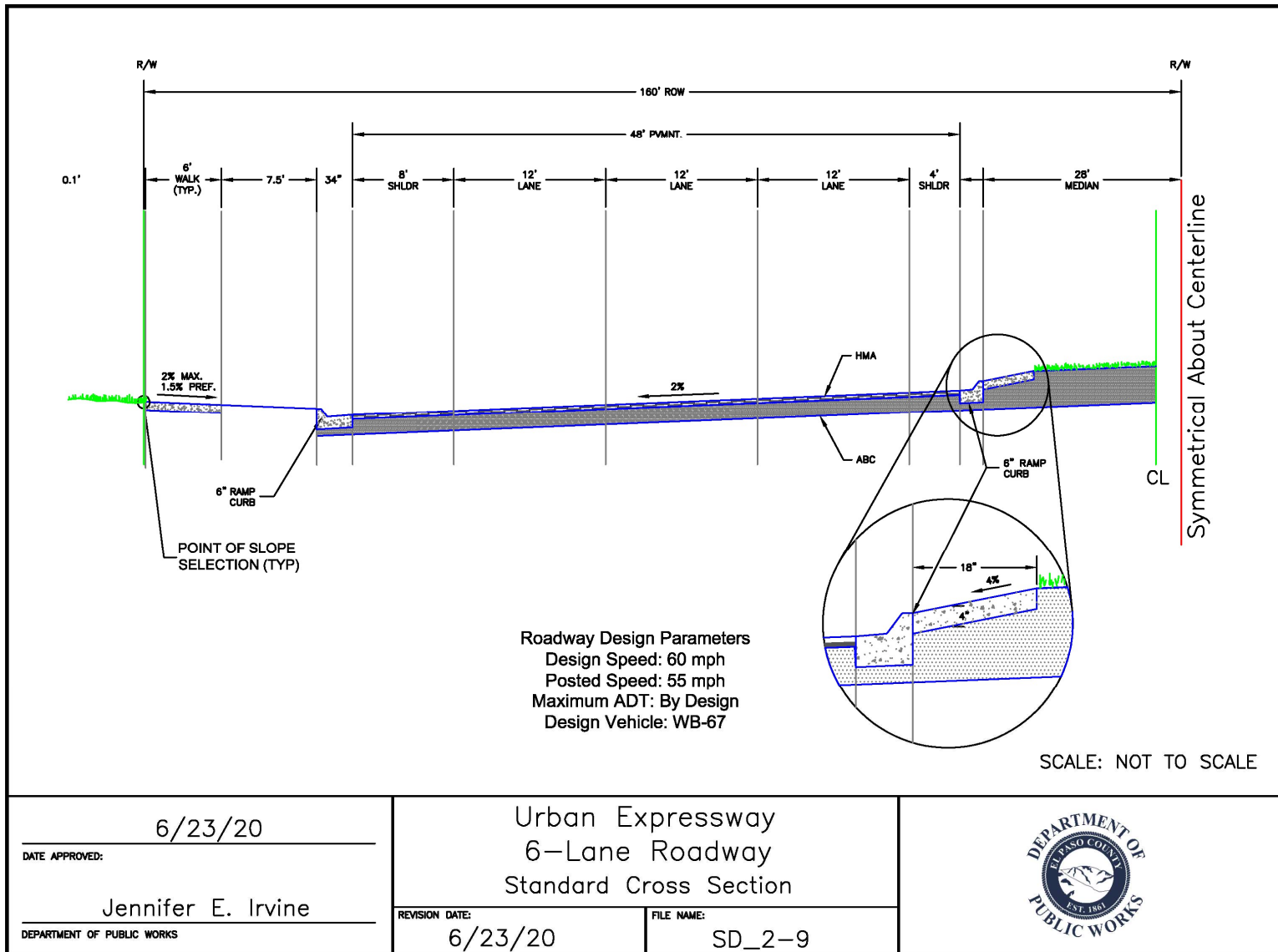

- ENGINEERING CRITERIA MANUAL
Appendix F STANDARD DRAWINGS

(Res. No. 20-222 , 6-23-20)

- ENGINEERING CRITERIA MANUAL
Appendix F STANDARD DRAWINGS

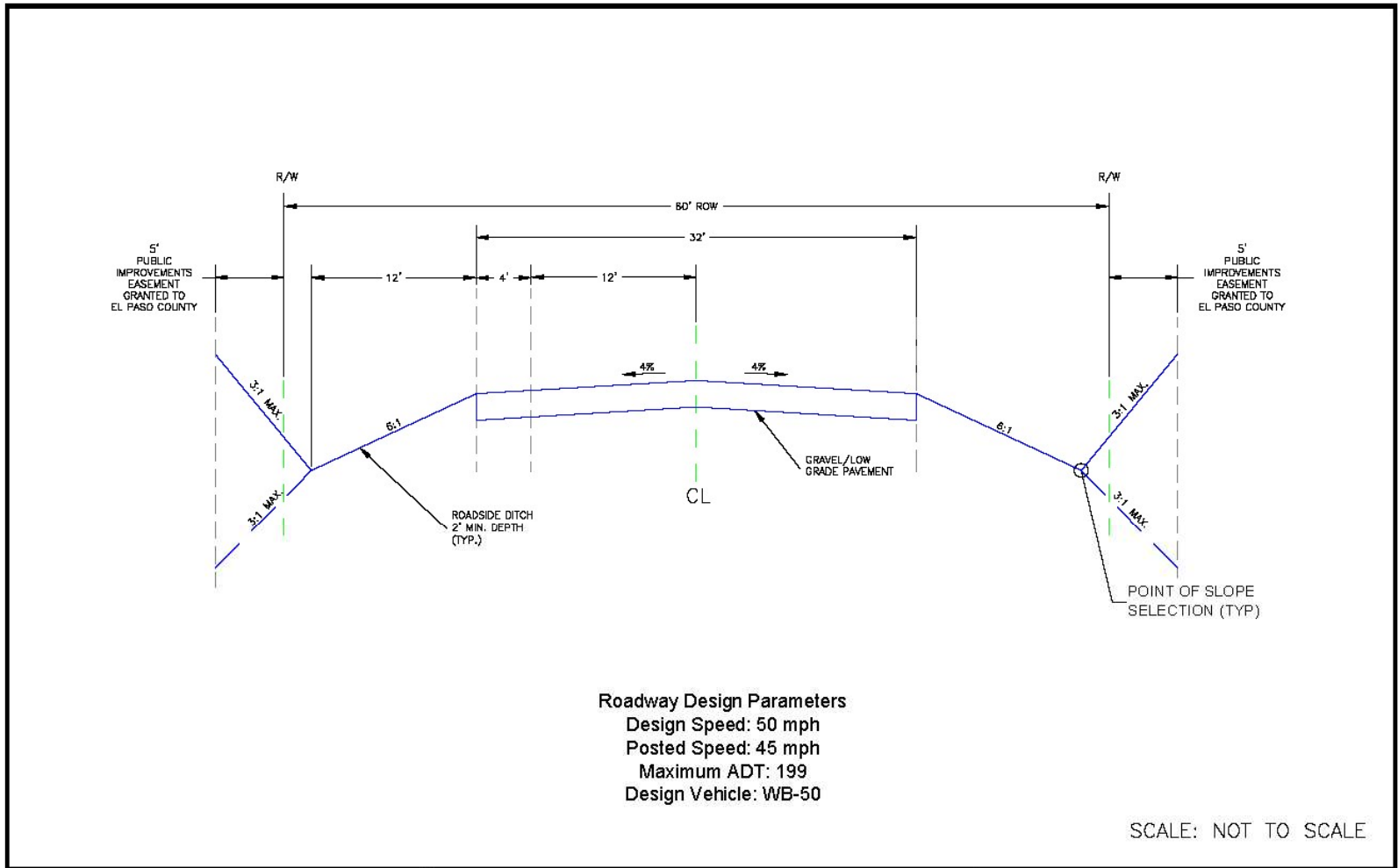

9/16/10
 DATE APPROVED:
 André P. Brackin
 DEPARTMENT OF TRANSPORTATION

Rural Gravel Local Roadway

Standard Cross Section

REVISION DATE: 12/8/15 FILE NAME: SD_2-10



El Pas
 (Supp. No. 2)

- ENGINEERING CRITERIA MANUAL
Appendix F STANDARD DRAWINGS

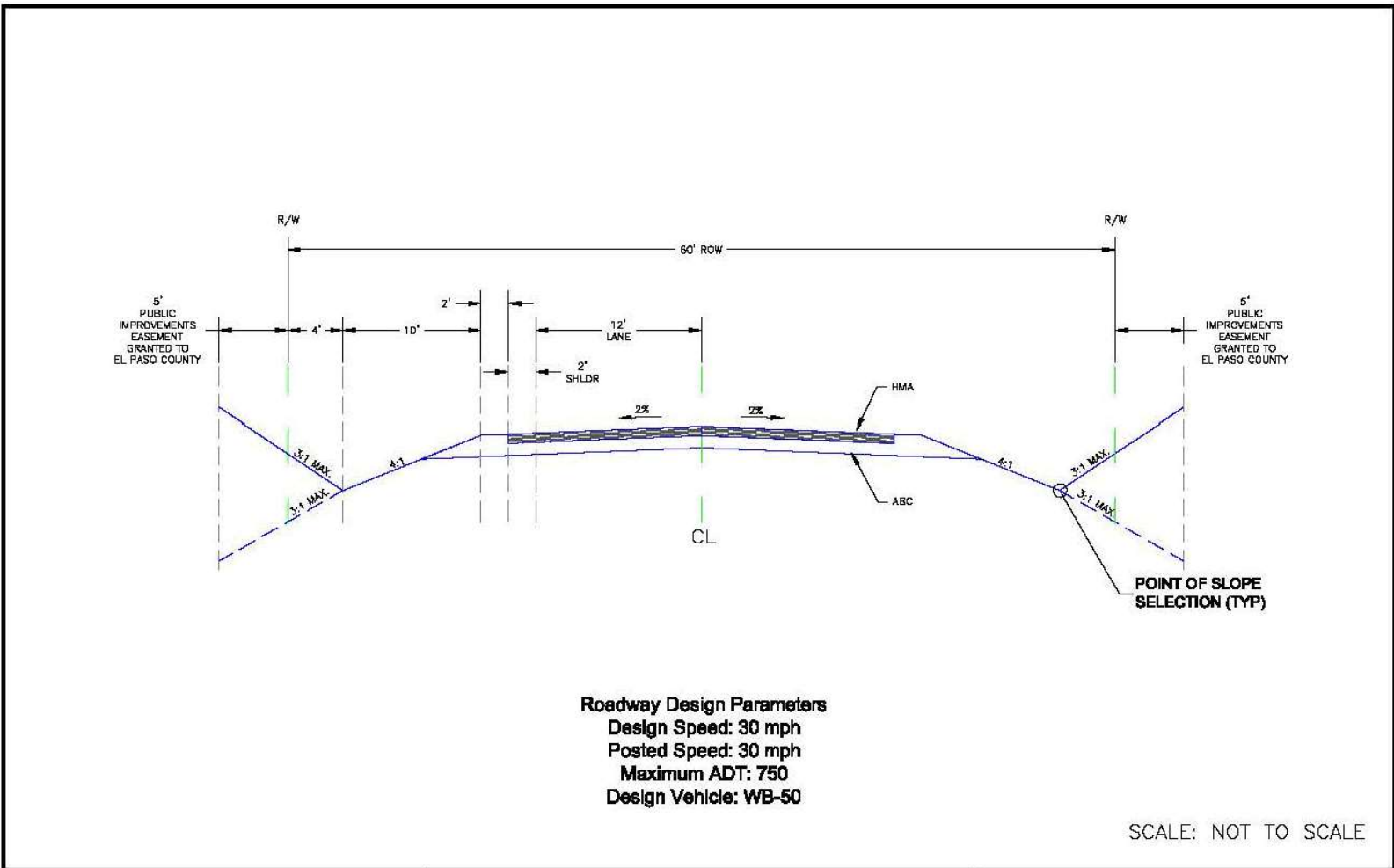

12/31/05
 DATE APPROVED:
 John A. McCarty
 DEPARTMENT OF TRANSPORTATION

Rural Local Roadway
 Standard Cross Section

REVISION DATE: 12/22/05 FILE NAME: SD_2-11



El Paso
 (Supp. No. 2)

- ENGINEERING CRITERIA MANUAL
Appendix F STANDARD DRAWINGS

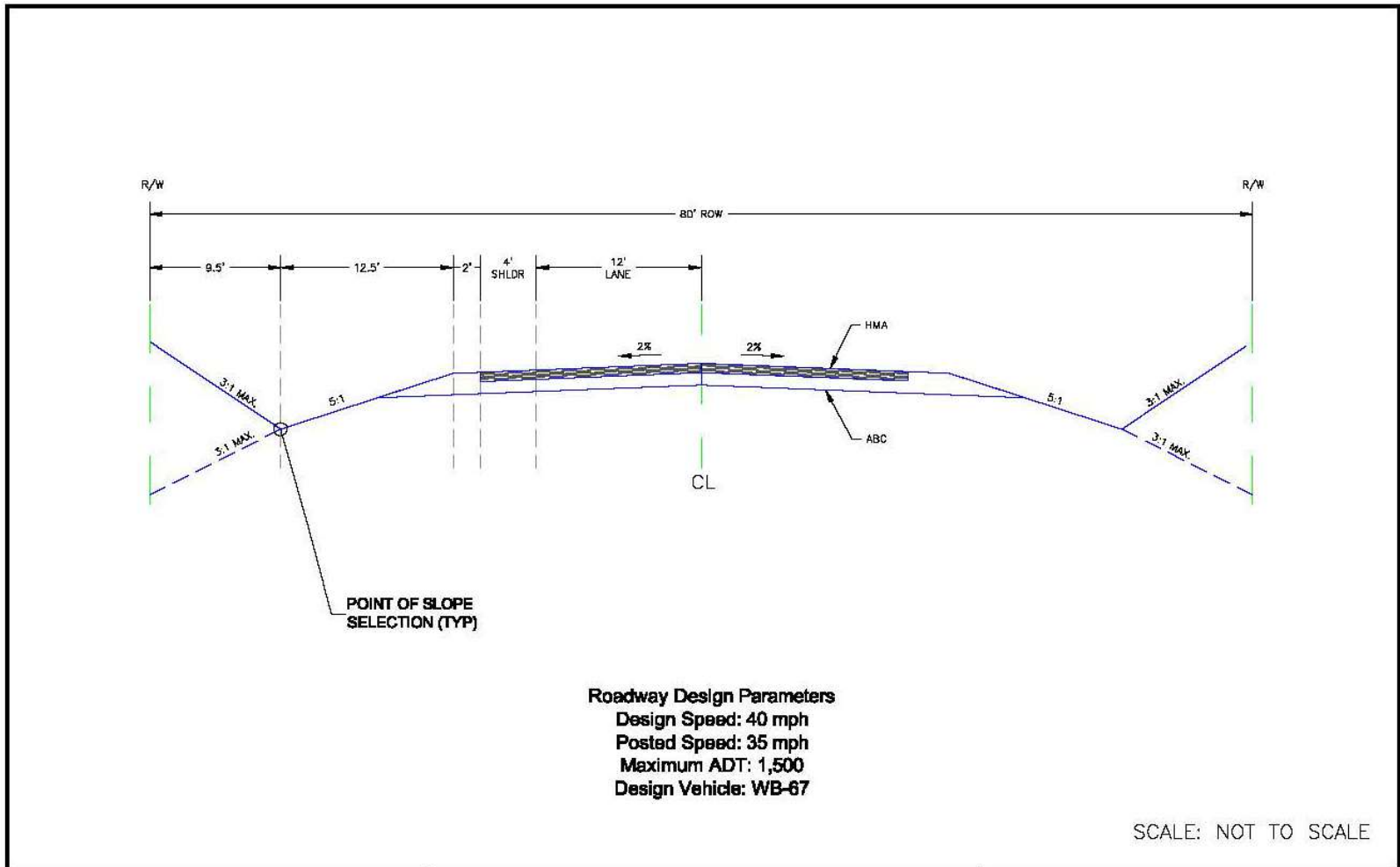

<p style="text-align: center;">12/31/05</p> <p>DATE APPROVED:</p> <p style="text-align: center;">John A. McCarty</p> <p>DEPARTMENT OF TRANSPORTATION</p>	<p>Rural Minor Collector Roadway</p> <p>Standard Cross Section</p> <p>REVISION DATE: 12/22/05</p> <p>FILE NAME: SD_2-12</p>	
--	---	---

El Paso
(Supp. No. 2)

- ENGINEERING CRITERIA MANUAL
Appendix F STANDARD DRAWINGS

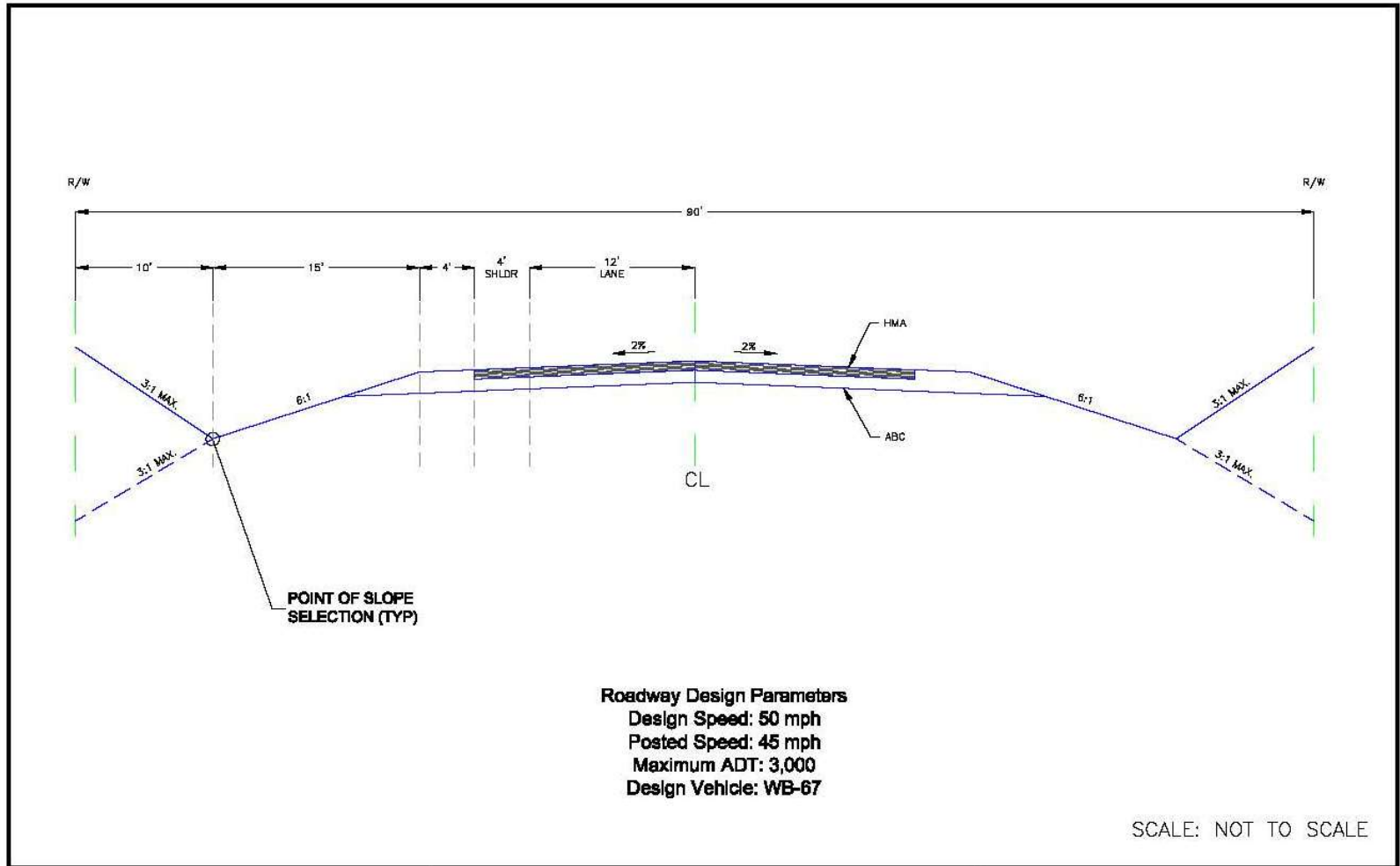

<p>12/31/05</p> <p>DATE APPROVED:</p> <p>John A. McCarty</p> <p>DEPARTMENT OF TRANSPORTATION</p>	<p>Rural Major Collector Roadway</p> <p>Standard Cross Section</p> <p>REVISION DATE: 12/22/05</p> <p>FILE NAME: SD_2-13</p>	
--	---	---

El Pasco
(Supp. No. 2)

- ENGINEERING CRITERIA MANUAL
Appendix F STANDARD DRAWINGS

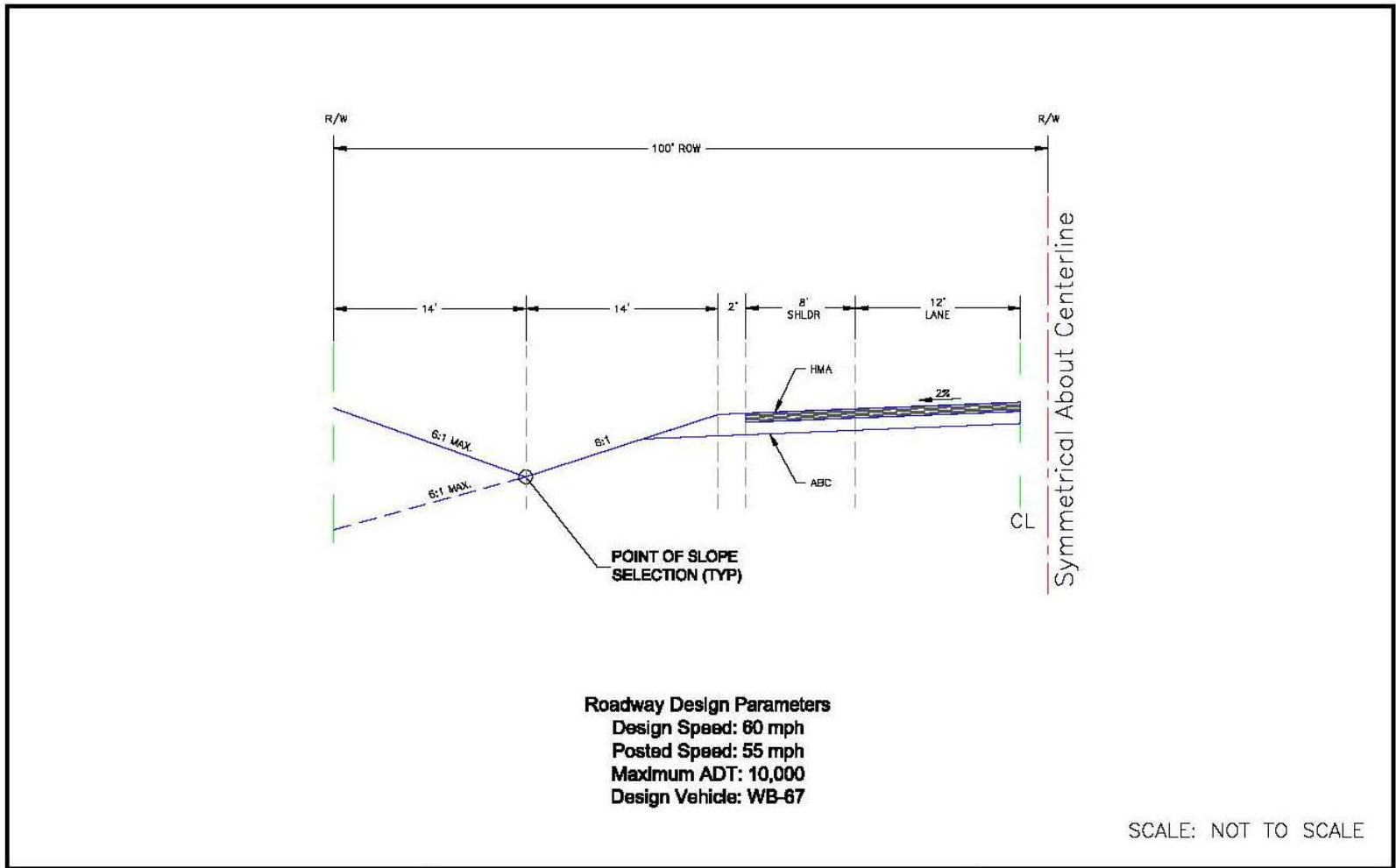

12/31/05 <small>DATE APPROVED:</small> John A. McCarty <small>DEPARTMENT OF TRANSPORTATION</small>	Rural Minor Arterial Roadway Standard Cross Section <small>REVISION DATE:</small> 12/22/05 <small>FILE NAME:</small> SD_2-14	
---	--	---

El Paso
(Supp. No. 2)

- ENGINEERING CRITERIA MANUAL
Appendix F STANDARD DRAWINGS

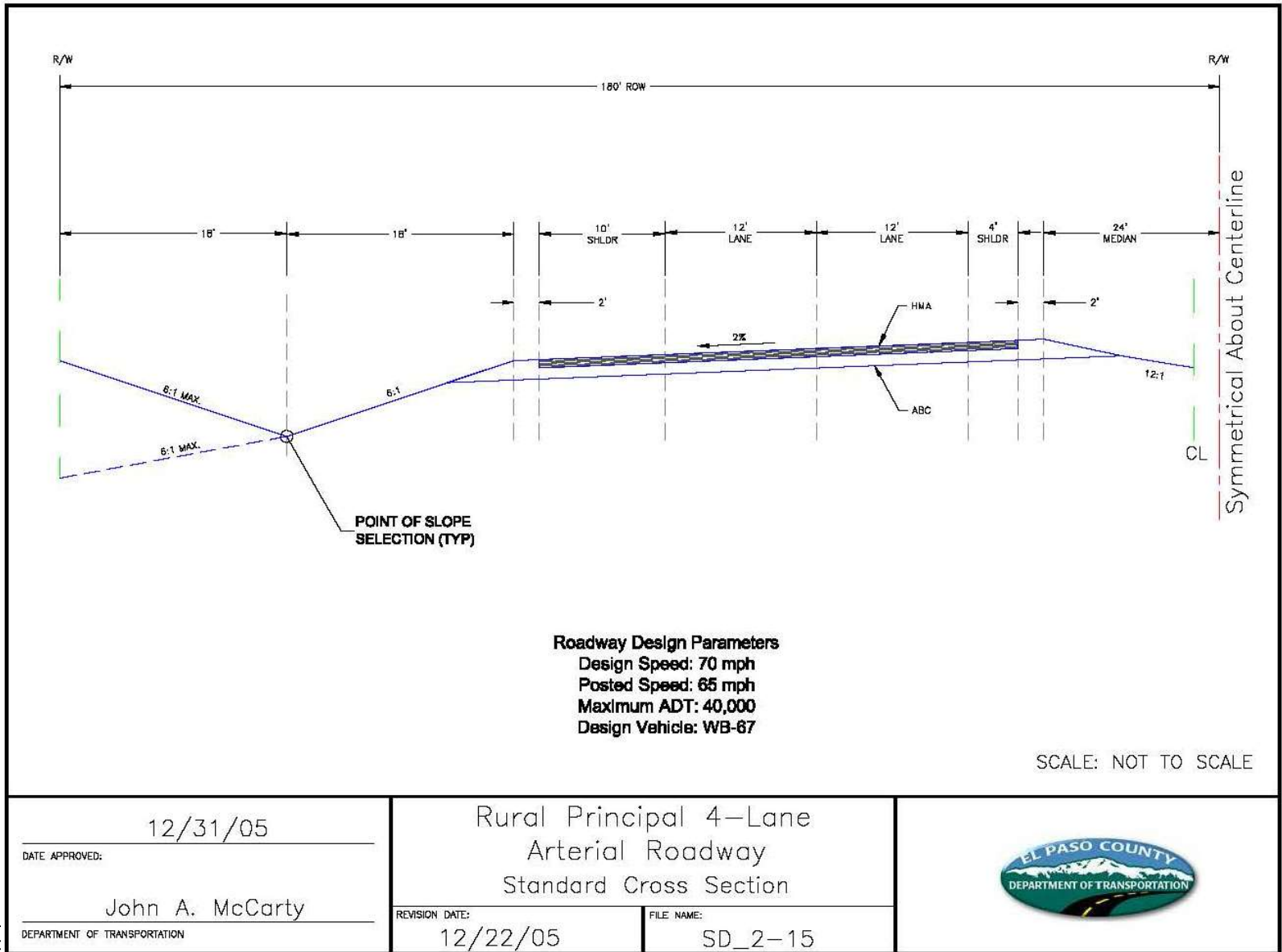

El Paso
(Supp. No. 2)

- ENGINEERING CRITERIA MANUAL
Appendix F STANDARD DRAWINGS

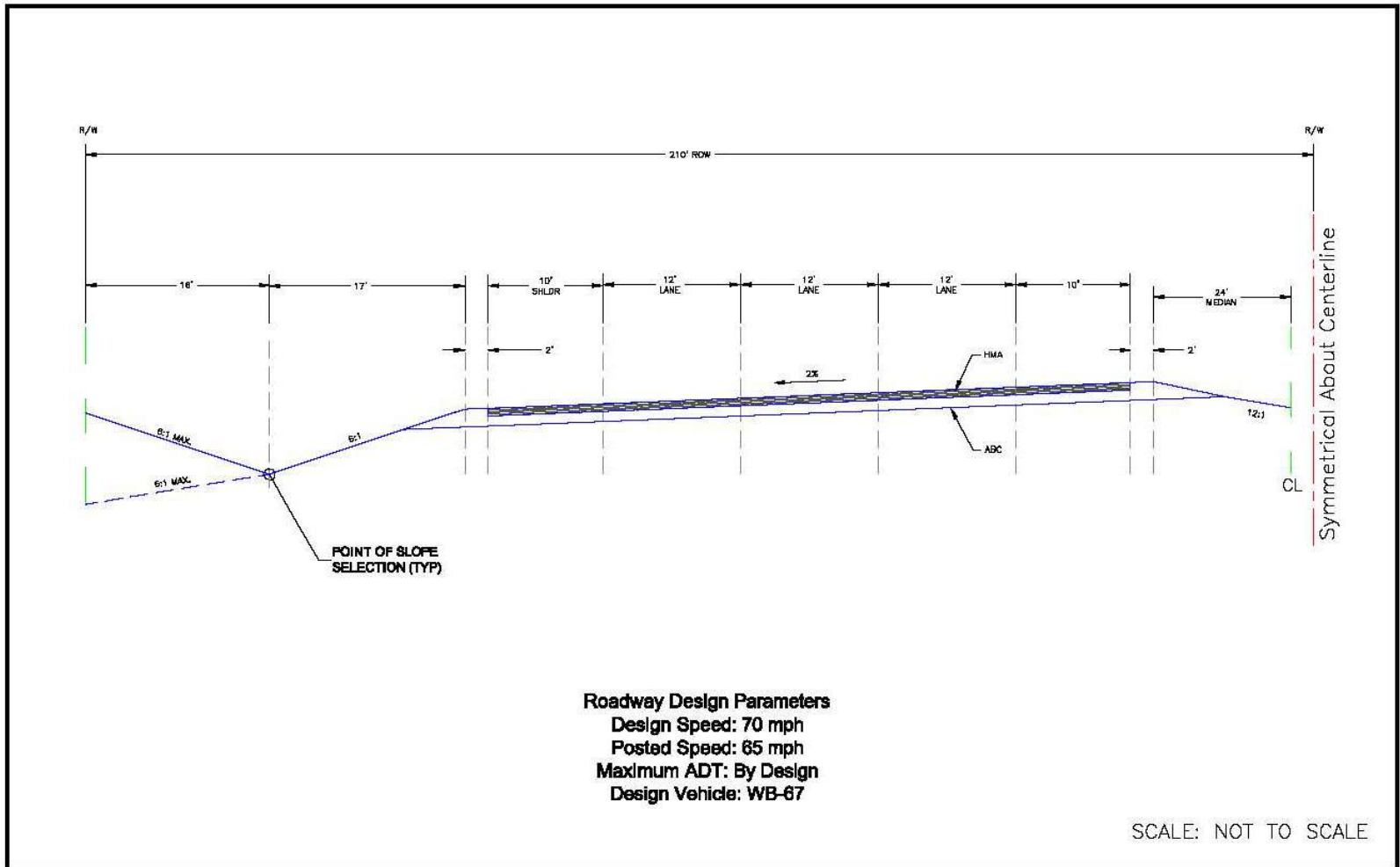

DATE APPROVED: 12/31/05 John A. McCarty DEPARTMENT OF TRANSPORTATION	Rural Principal 6-Lane Arterial Roadway Standard Cross Section REVISION DATE: 12/22/05 FILE NAME: SD_2-16	
--	---	---

El Paso
(Supp. No. 2)

- ENGINEERING CRITERIA MANUAL
Appendix F STANDARD DRAWINGS

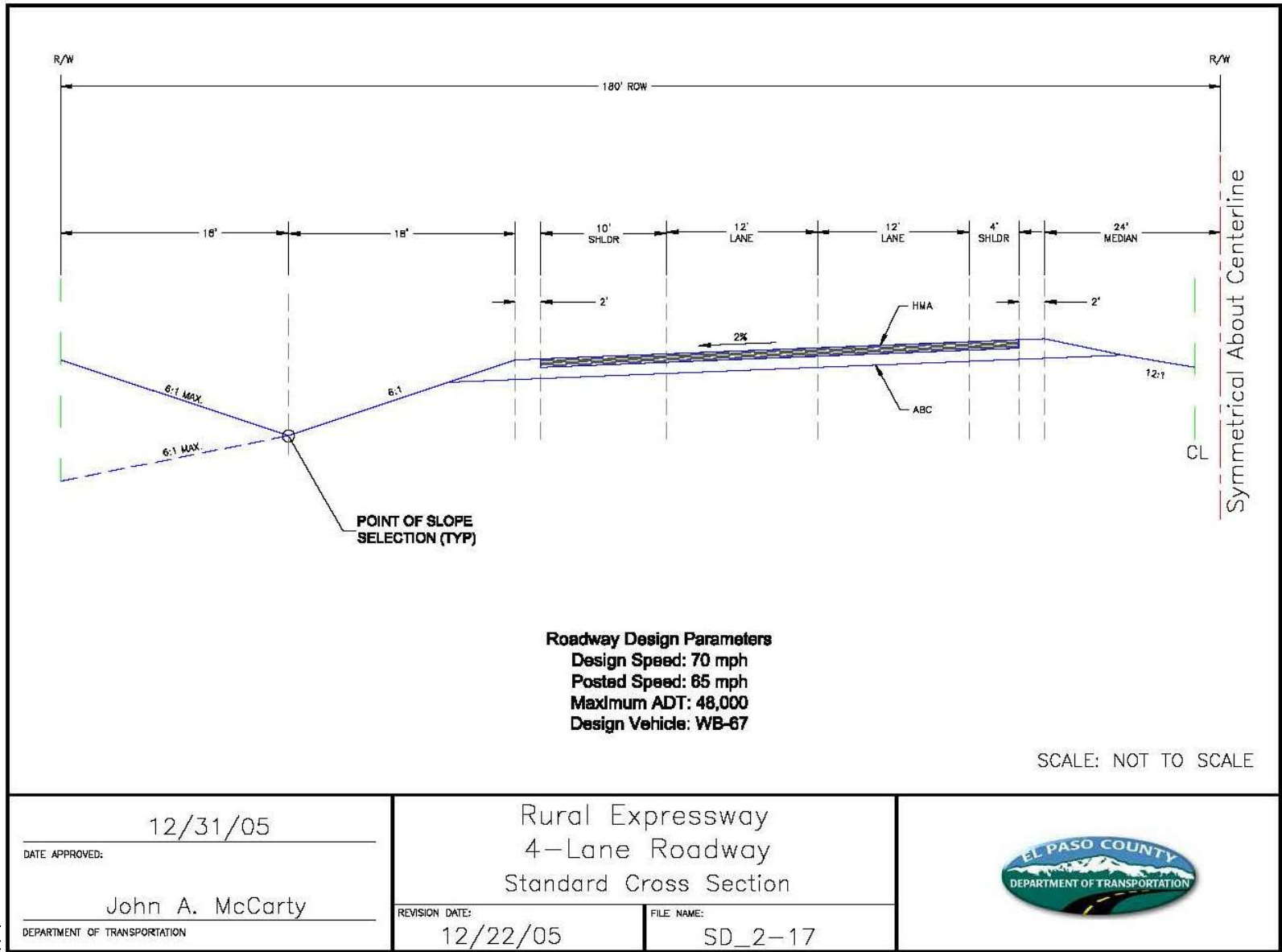

El Paso
(Supp. No. 2)

- ENGINEERING CRITERIA MANUAL
Appendix F STANDARD DRAWINGS

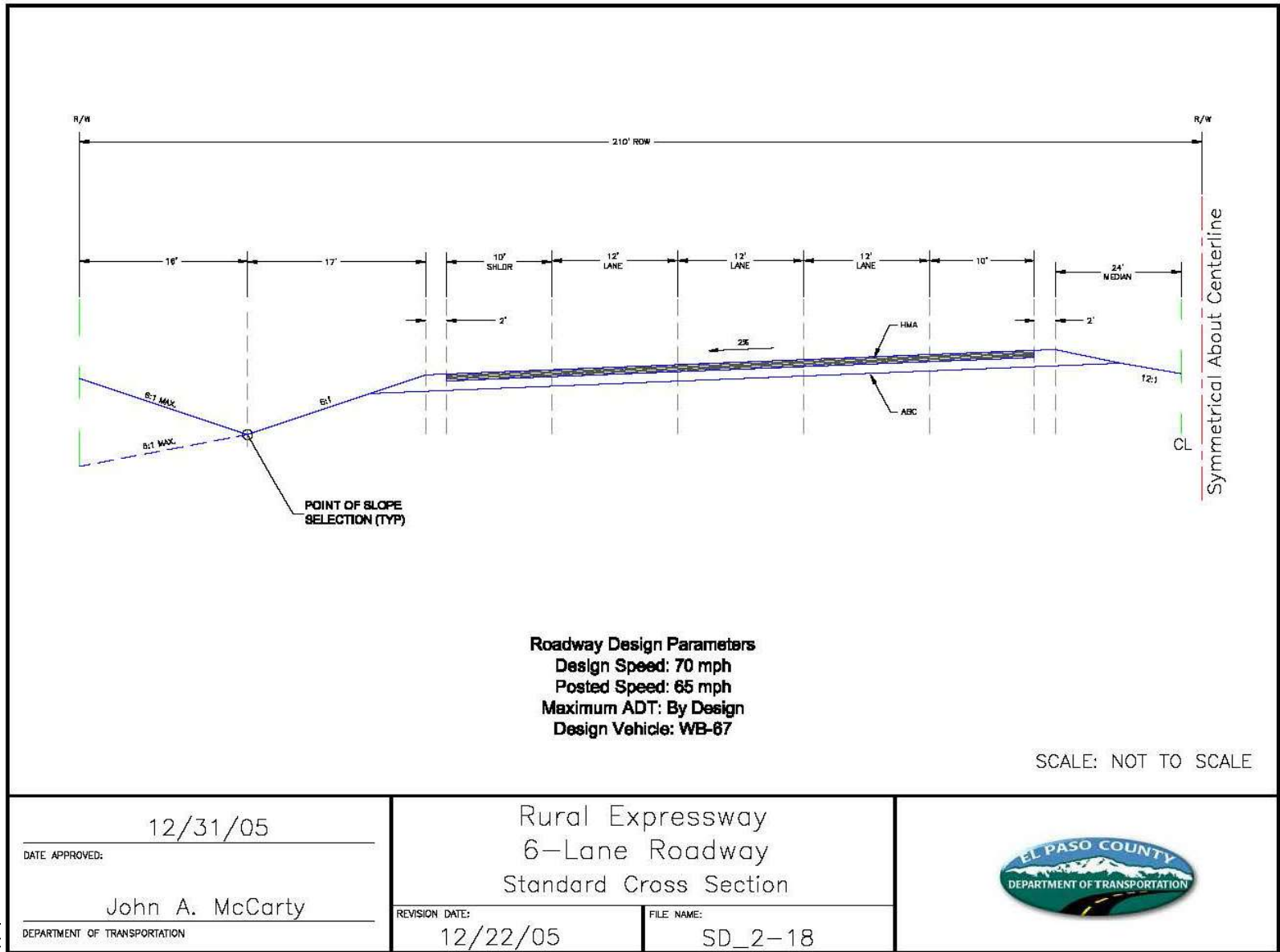

El Paso
(Supp. no. 2)

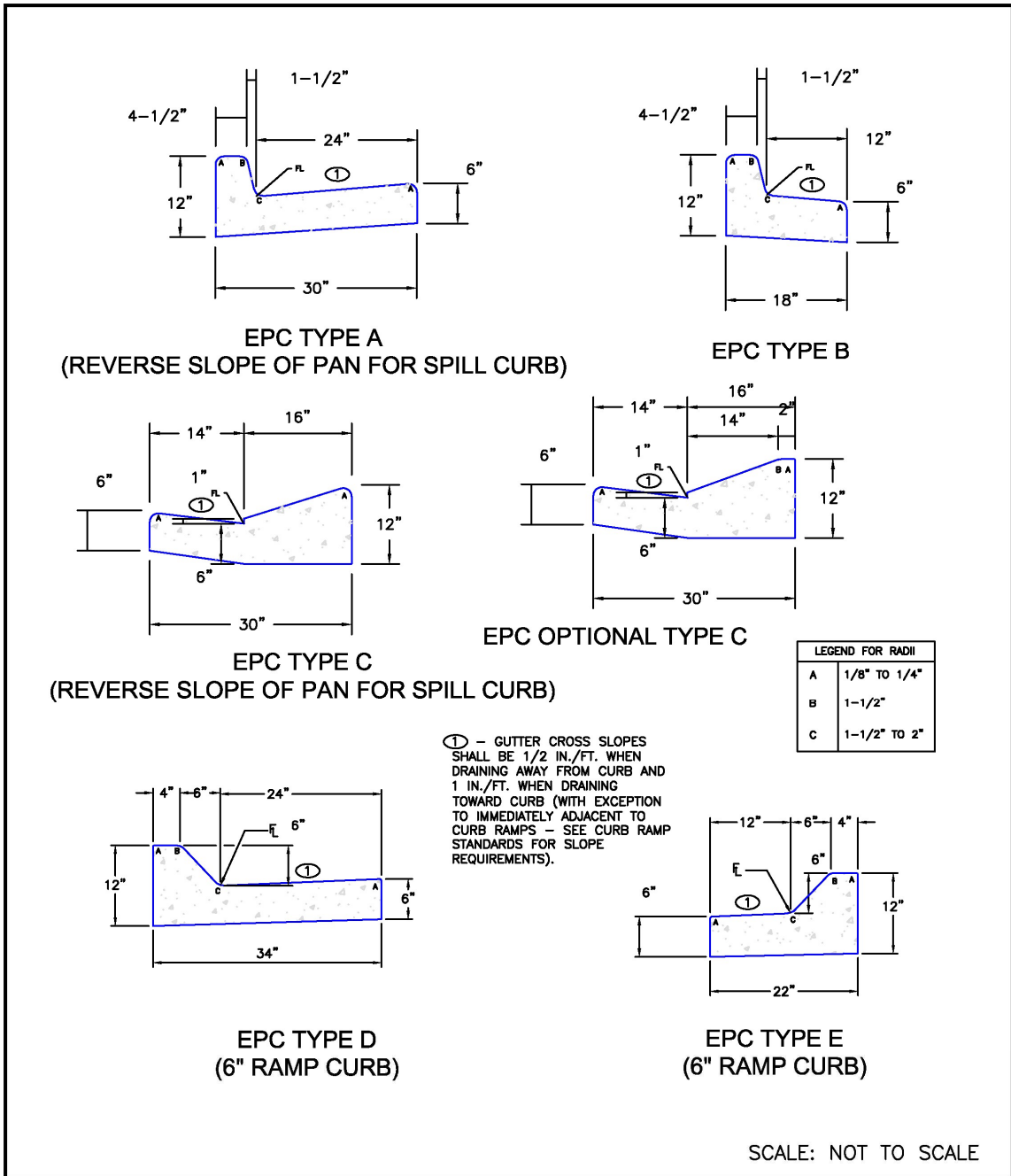

El Paso County, Colorado, Eng
(Supp. No. 2)

(Res. No. 20-222 , 6-23-20)

- ENGINEERING CRITERIA MANUAL
Appendix F STANDARD DRAWINGS

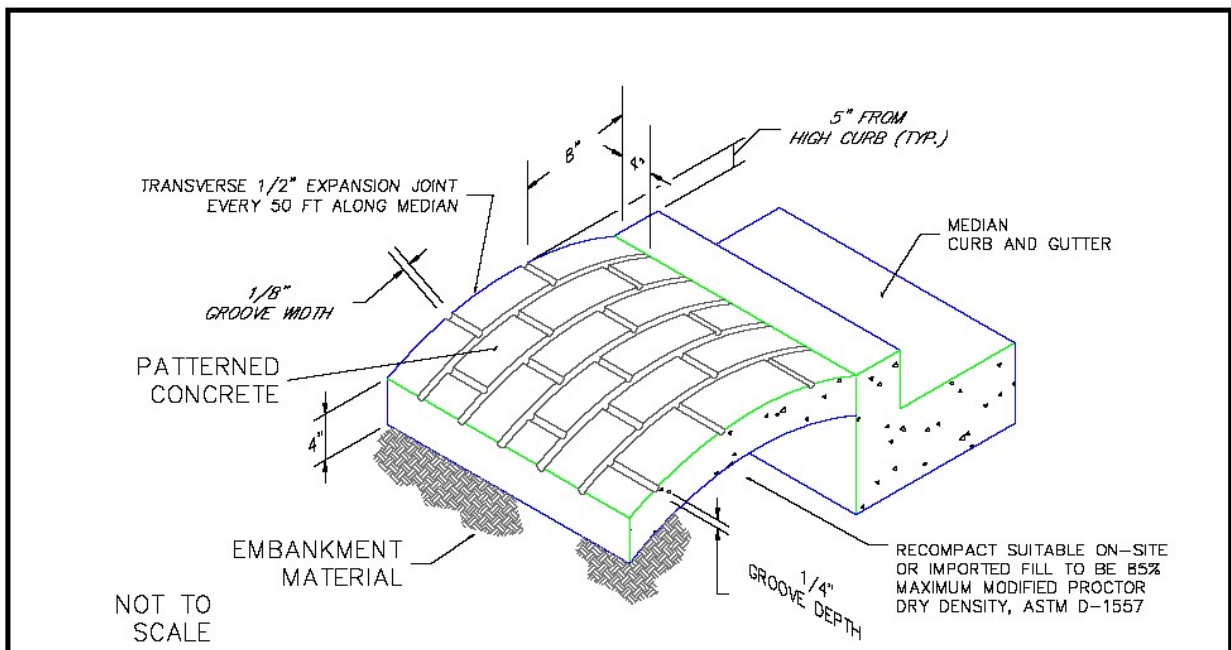

NOTES:

- A) The median paving shall be constructed with 4 inch thick, integrally colored concrete, embossed with a running bond 4" x 8" brick pattern as shown.
- B) Install 1/2" x 4" expansion material at median noses, fixed objects, and at transverse joints at 50 ft. intervals (maximum) along the median.
- C) The color additive shall be an approved commercially pure or synthetic mineral pigment, factory formulated and packaged in cubic yard dosage increments. The mixture shall be "Chromix" as manufactured by L.M. Scofield Company, "Davis Colors" as manufactured by Davis Color Company, Pigment No. 678, 5 lbs/sack, or an approved equal.
- D) Patterned concrete to be colored L.M. Scofield Company "Santa Barbara Brown, C-35", Davis Color Company, Pigment No. 678, 5 lbs/sack, or an approved equal.
- E) The Matching curing compound shall be a blend of waxes and pigments in a solvent emulsion base and conform to the requirements of ASTM C-309. The curing compound shall be "Lithochrome Colorwax" as manufactured by L.M. Scofield Company, Davis Color-Seal, as manufactured by Davis Color Company, or approved equal.
- F) The concrete mix design shall conform to the requirements of the color admixture manufacturer and shall meet CDOT Class B concrete requirements, unless otherwise approved.
- G) For weed control prior to median paving, apply a pre-emergent herbicide to median subgrade area per manufacturer's specifications for paving under Barrier 50 label (pbi Gordon). Trifluralin is labeled for use under asphalt under the Treflan 4EC label (Elanco).

SCALE: NOT TO SCALE

<p align="center">7/9/09</p> <p>DATE APPROVED:</p> <p align="center">André P. Brackin</p> <p>DEPARTMENT OF TRANSPORTATION</p>	<p align="center">Patterned Concrete Median Paving Standard Drawing</p>	
	<p>REVISION DATE:</p> <p align="center">1/18/11</p>	<p>FILE NAME:</p> <p align="center">SD_2-21</p>

(Supp. No. 2)

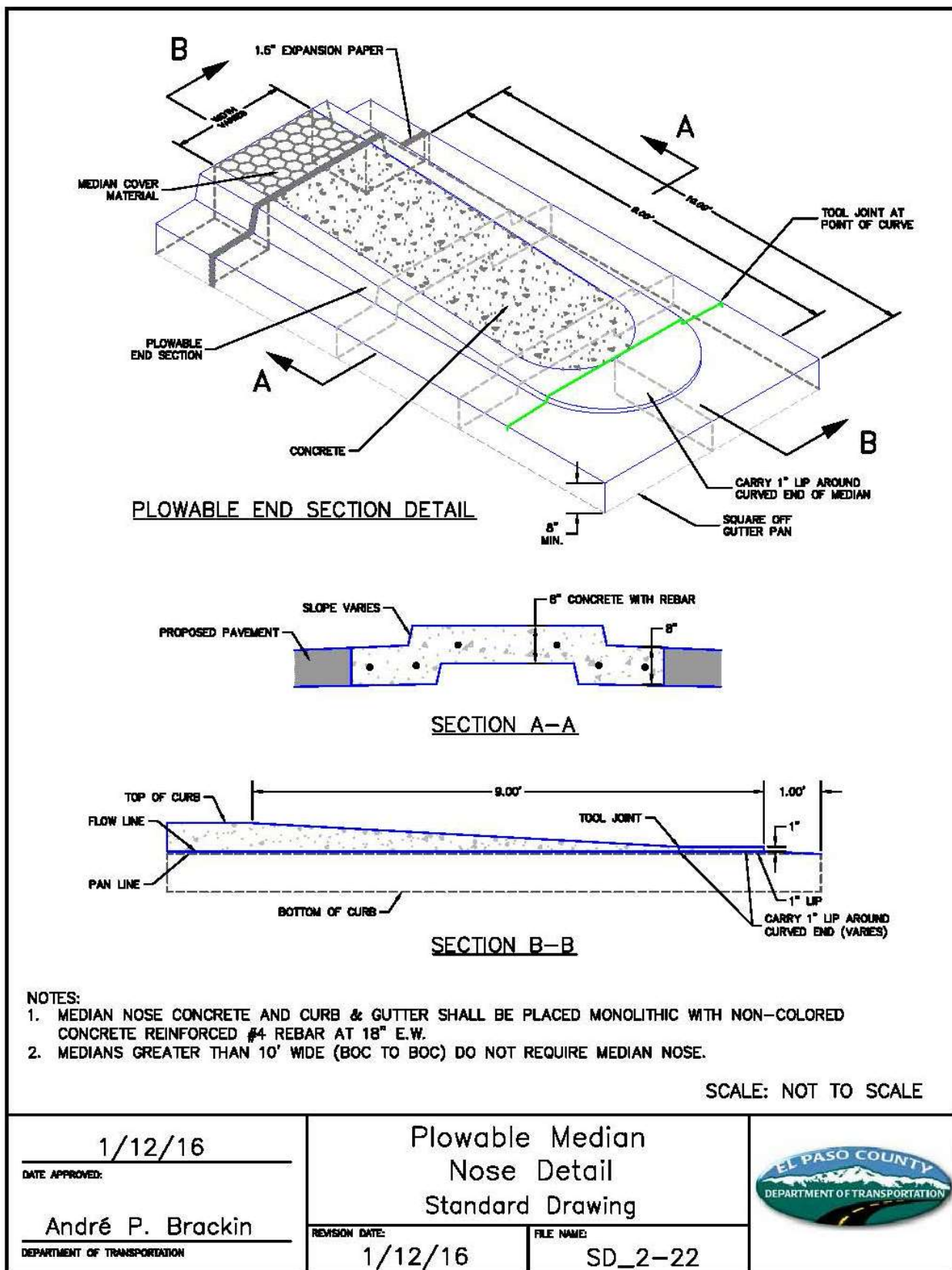

(Supp. No. 2)

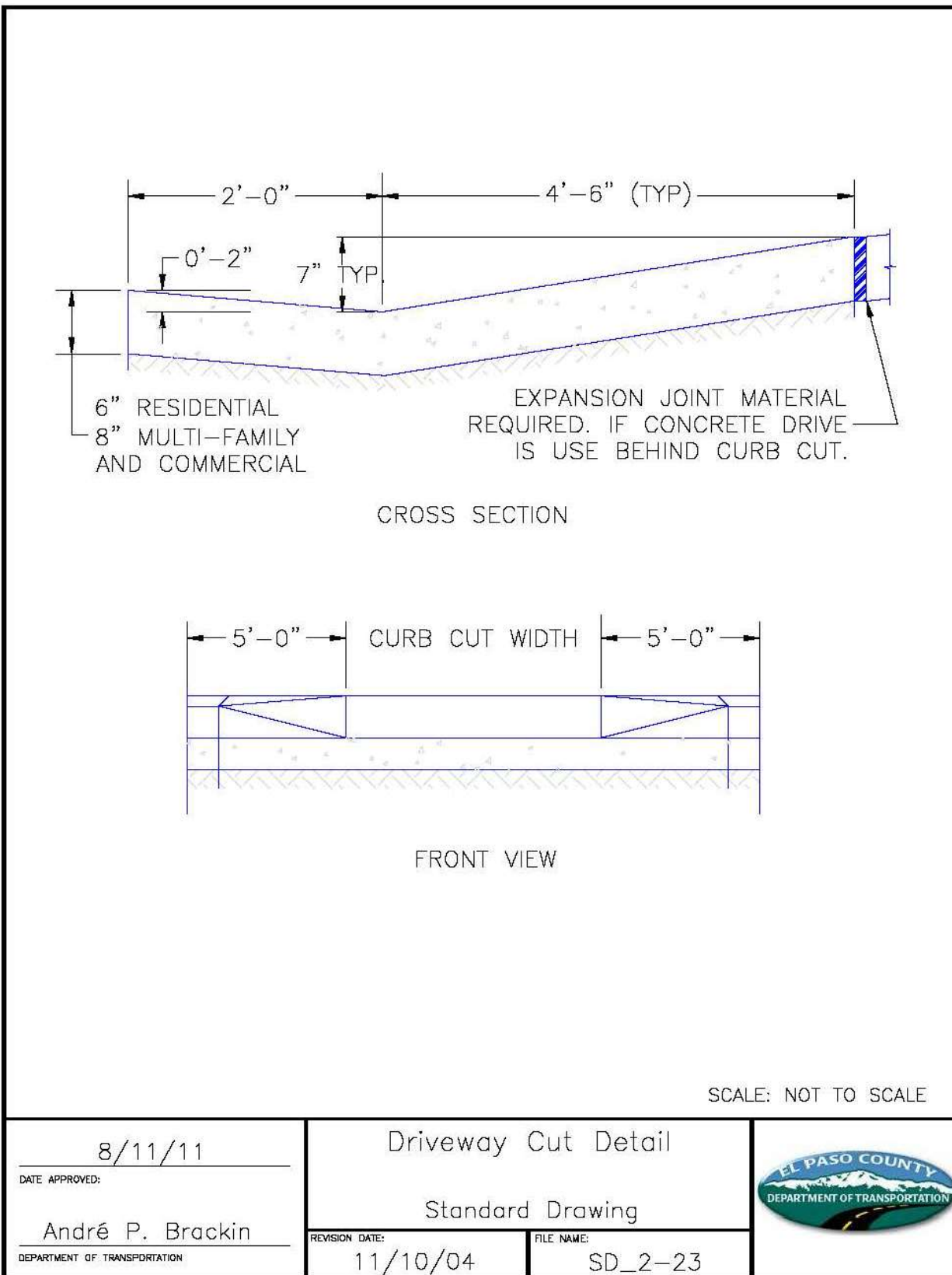

(Supp. No. 2)

- ENGINEERING CRITERIA MANUAL
Appendix F STANDARD DRAWINGS

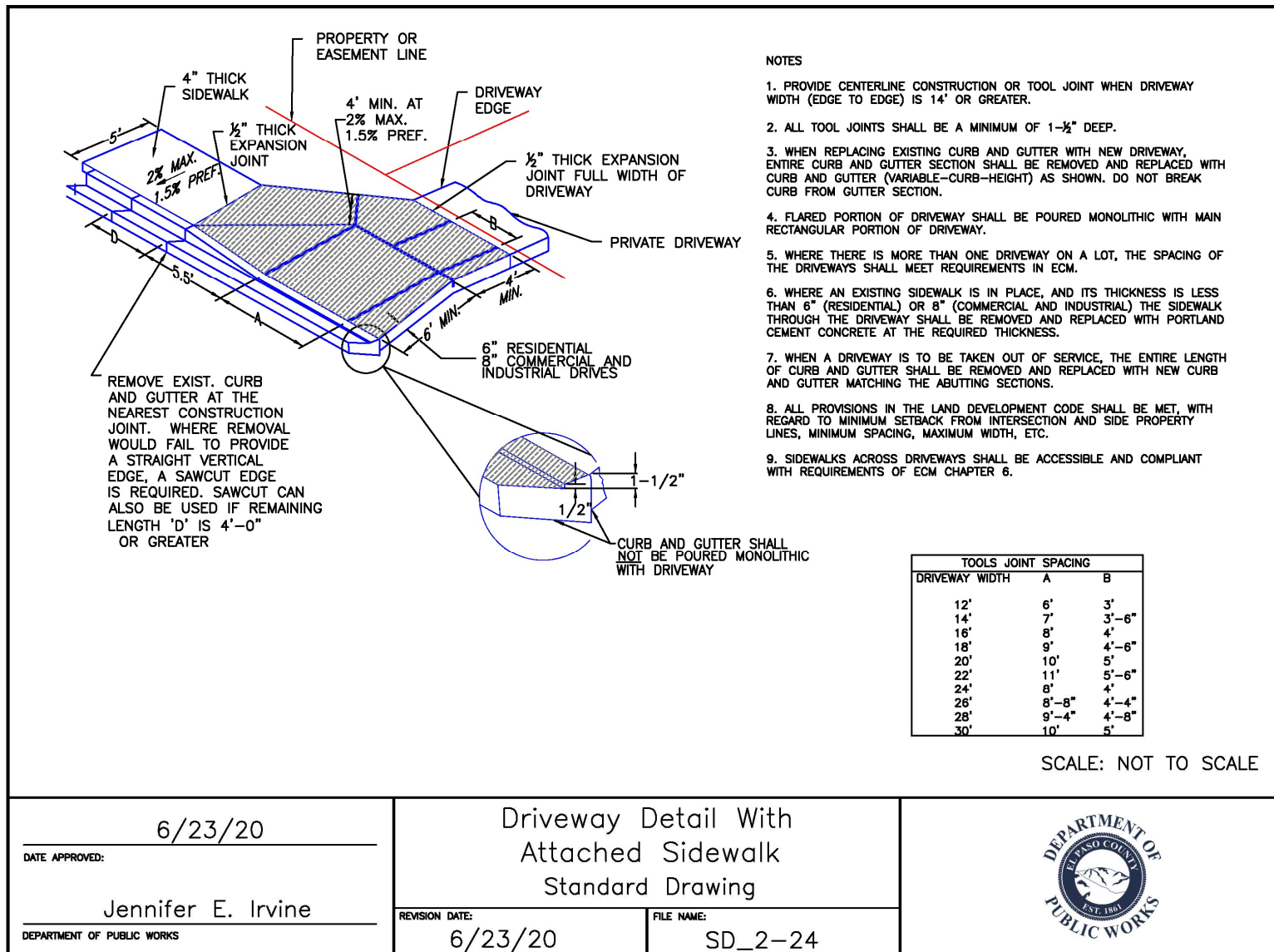

- ENGINEERING CRITERIA MANUAL
Appendix F STANDARD DRAWINGS

(Res. No. 20-222 , 6-23-20)

- ENGINEERING CRITERIA MANUAL
Appendix F STANDARD DRAWINGS

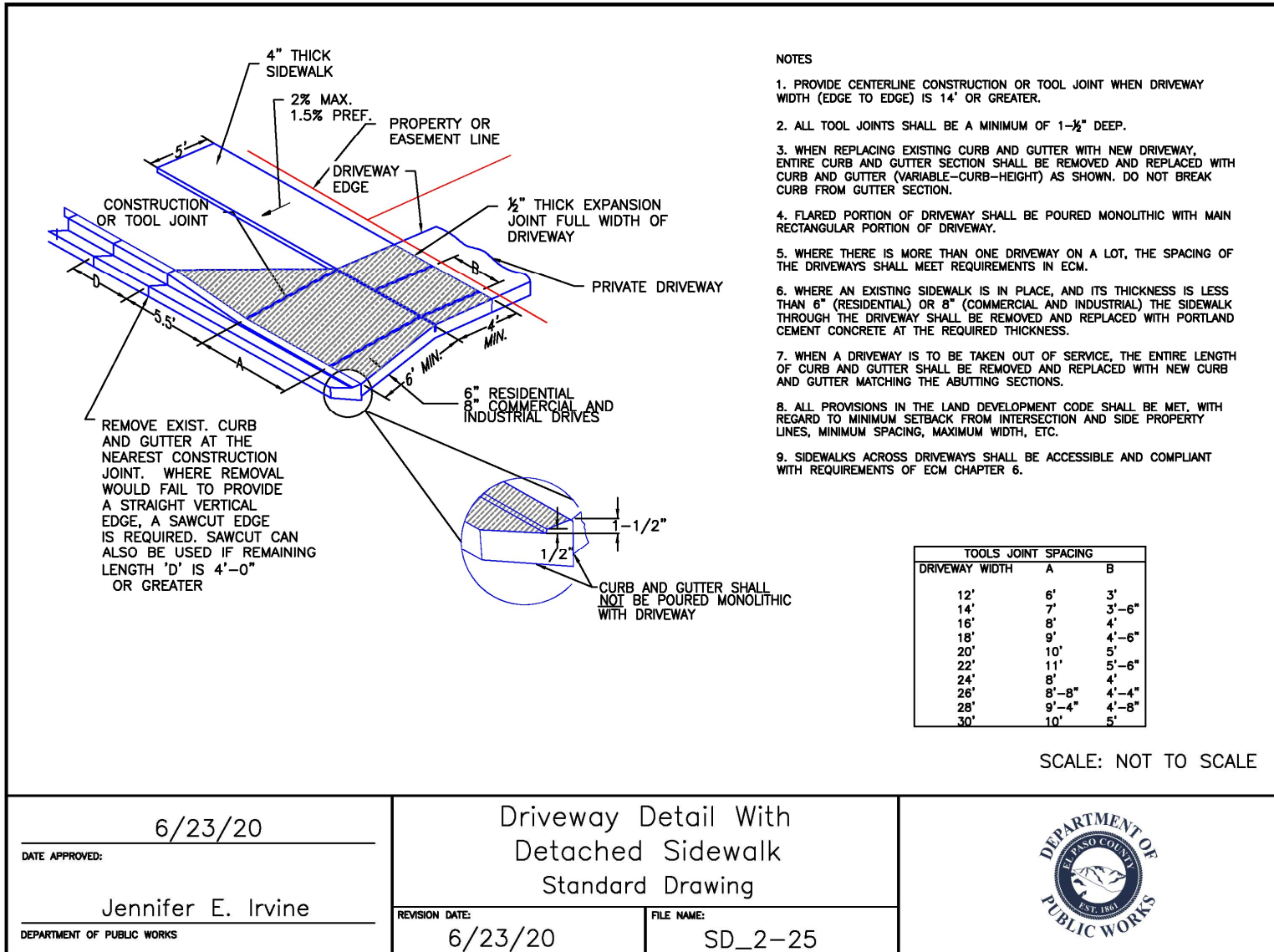

- ENGINEERING CRITERIA MANUAL
Appendix F STANDARD DRAWINGS

(Res. No. 20-222 , 6-23-20)

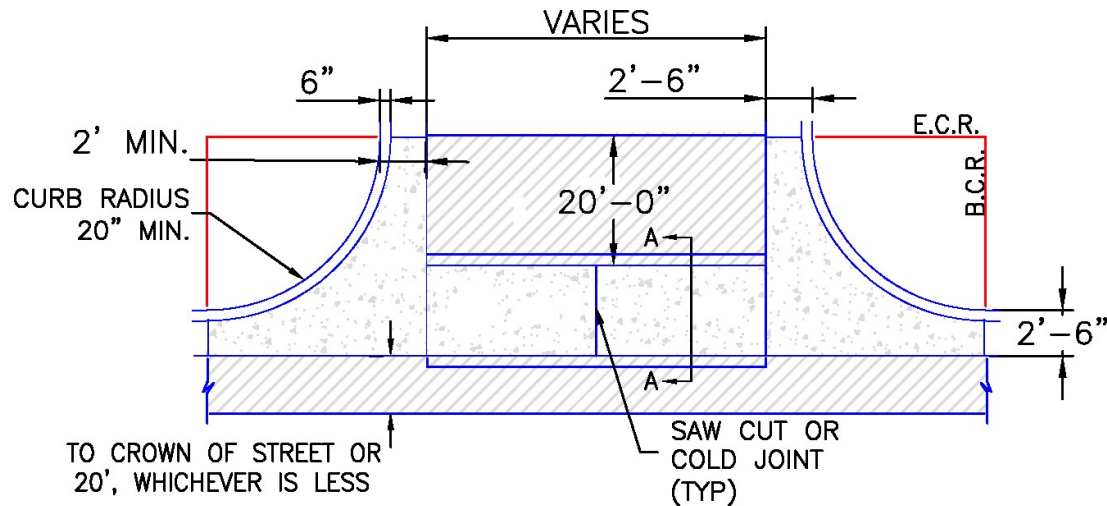

PLAN VIEW

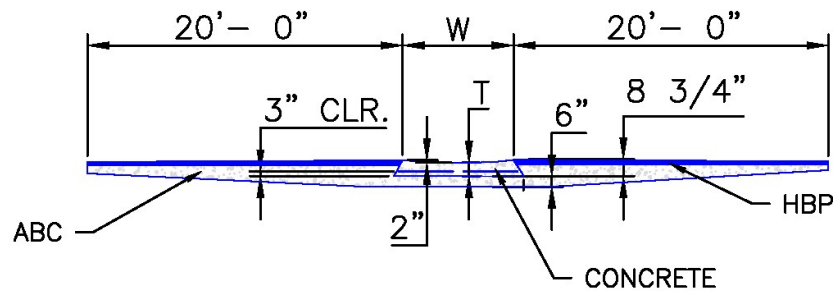

SECTION A-A

NOTES

1. W - WIDTH SHALL BE 6' FOR LOCAL, 8' FOR COLLECTORS, AND 10' FOR ARTERIAL ROADS.
2. T - SQUARED-OFF RETURN TO BE POURED MONOLITHICALLY, 8" PCC FOR LOCAL ROADS, 9" FOR COLLECTORS WITH 6x6 - 4.4 W.W.F. OR #4 REINFORCING BAR @ 18" EACH WAY.
3. = 3" MINIMUM ASPHALT DEPTH (2 LIFTS).
4. DESIGN TO SPECIFY ELEVATIONS AT PI AND PCR.

- ENGINEERING CRITERIA MANUAL
Appendix F STANDARD DRAWINGS

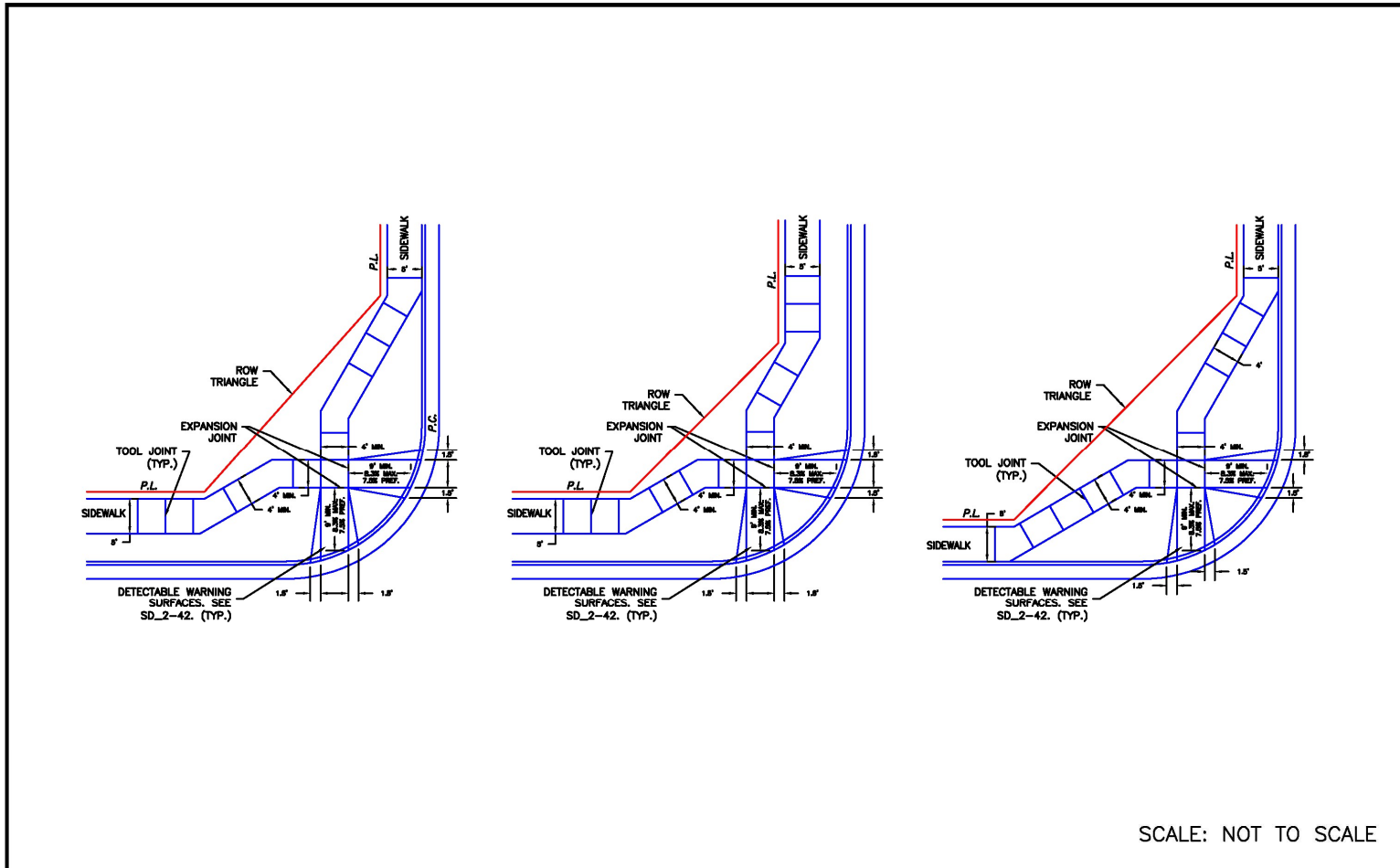

SCALE: NOT TO SCALE

<p align="center">6/23/20</p> <p>DATE APPROVED:</p> <p align="center">Jennifer E. Irvine</p> <p>DEPARTMENT OF PUBLIC WORKS</p>	<p>Pedestrian Curb Ramp Detail Standard Drawing</p>	
	<p>REVISION DATE: 6/23/20</p>	<p>FILE NAME: SD_2-40</p>

(Res. No. 20-222 , 6-23-20)

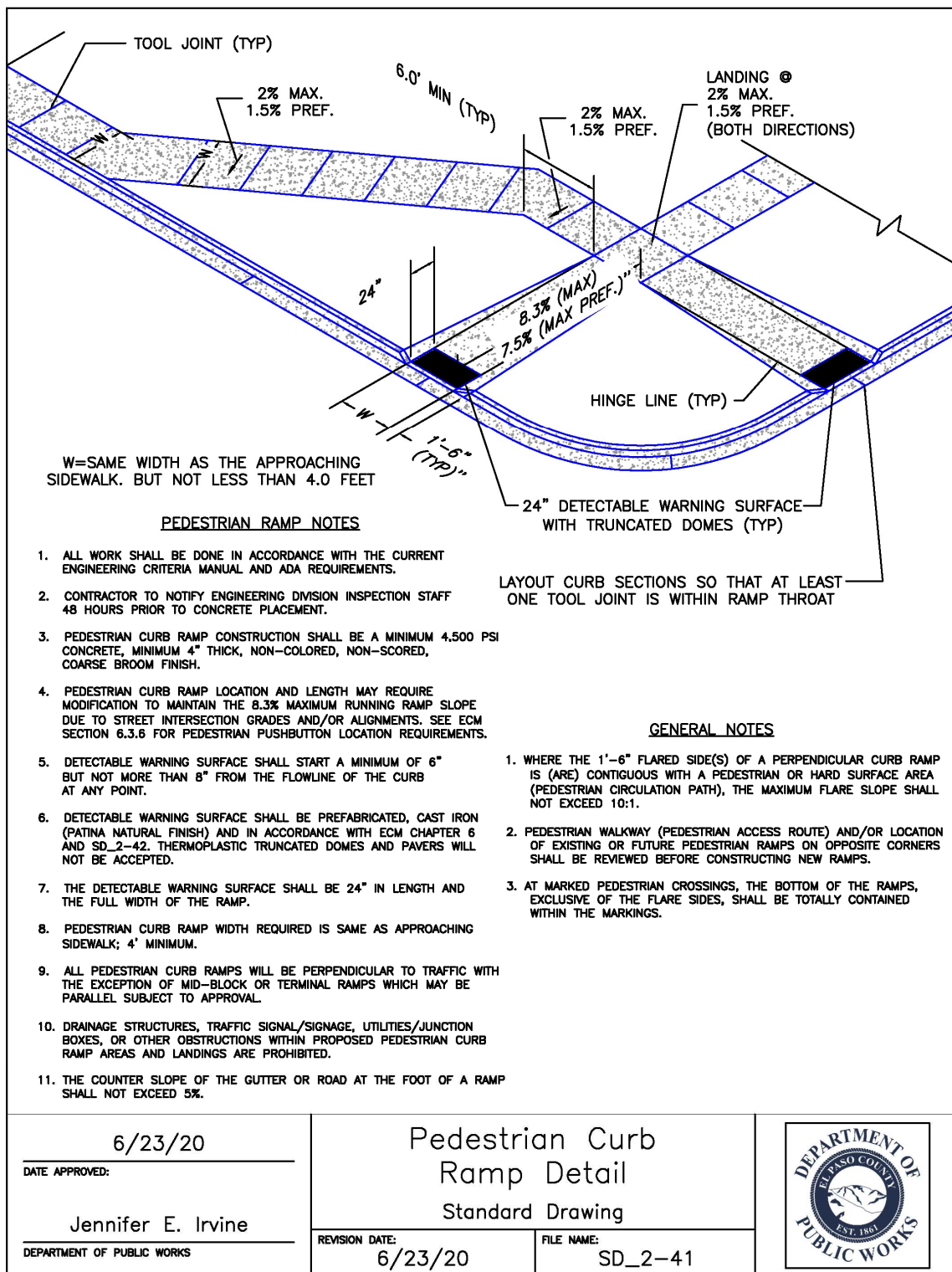

(Res. No. 20-222 , 6-23-20)

TRUNCATED DOME DETAILS

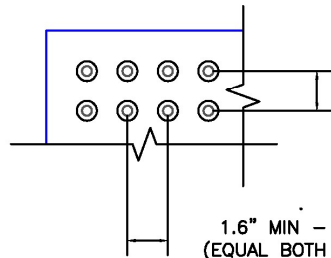

DOME SPACING

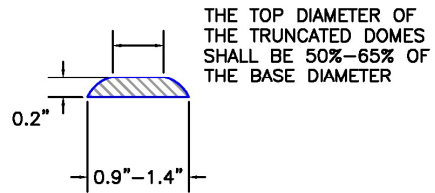

ELEVATION VIEW

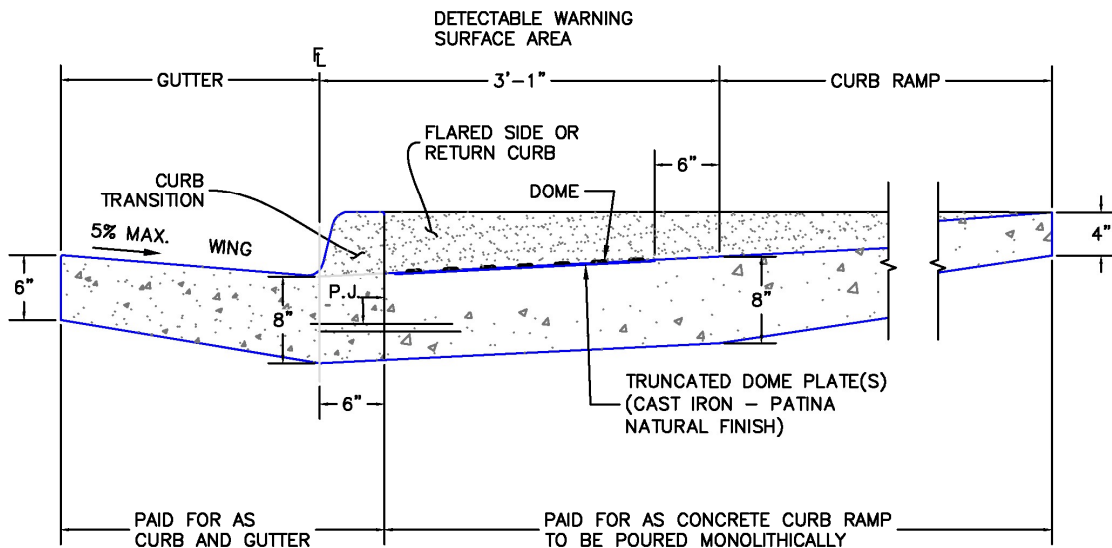

P.J.= PERMISSIBLE JOINT WITH EPOXY-COATED DEFORMED NO. 4 BARS
CONFORMING TO AASHTO M 284 AT 18 IN. SPACING

SIDE CROSS SECTION VIEW OF
DETECTABLE WARNING SURFACE, CURB AND GUTTER

<p style="text-align: center;">6/23/20</p> <p>DATE APPROVED:</p> <p style="text-align: center;">Jennifer E. Irvine</p> <p>DEPARTMENT OF PUBLIC WORKS</p>	<h3 style="margin: 0;">Detectable Warning Surface Details</h3> <p style="margin: 0;">Standard Drawing</p>	
	<p>REVISION DATE:</p> <p style="text-align: center;">6/23/20</p>	<p>FILE NAME:</p> <p style="text-align: center;">SD_2-42</p>

(Res. No. 20-222 , 6-23-20)

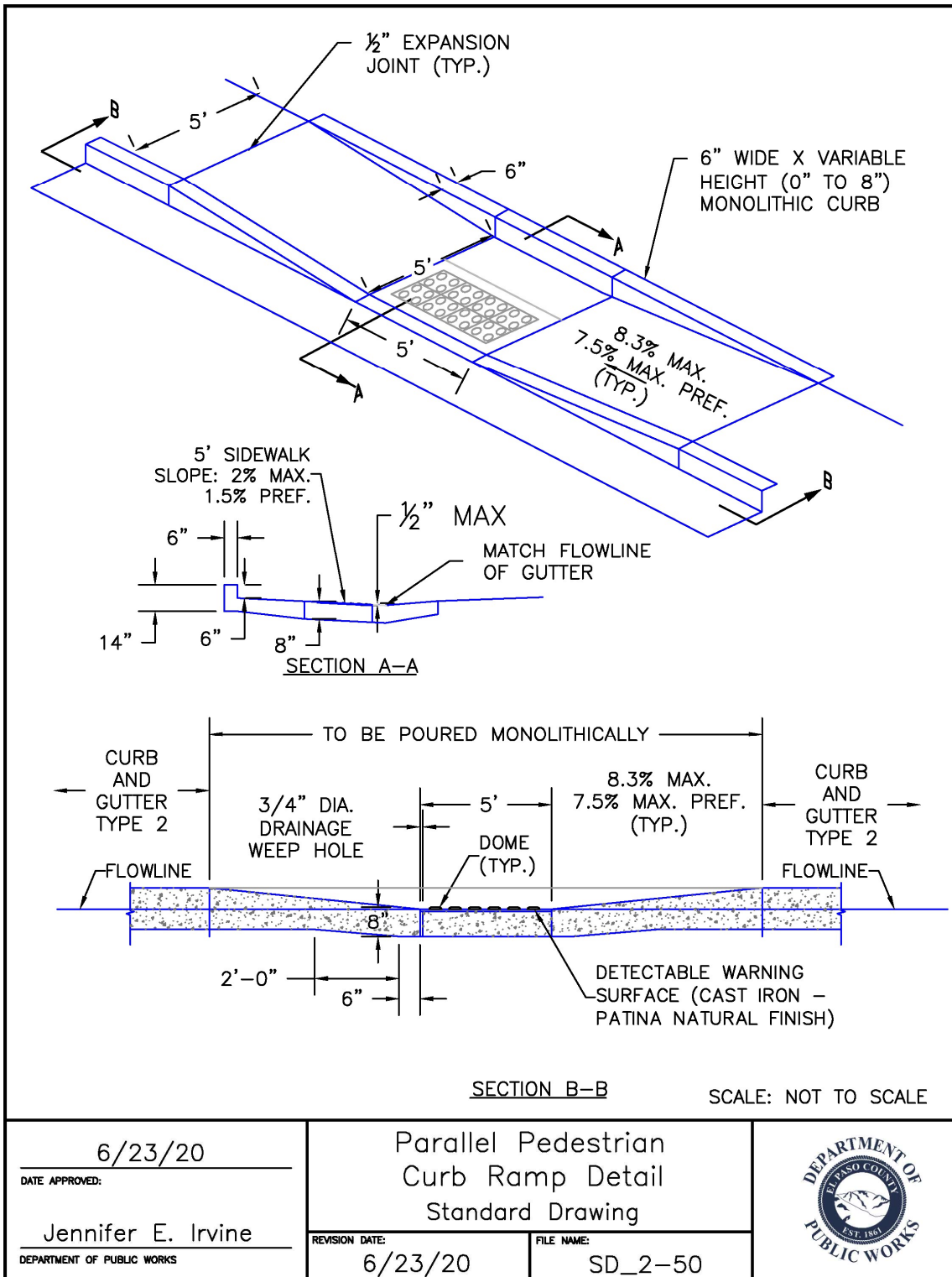

(Res. No. 20-222, 6-23-20)

- ENGINEERING CRITERIA MANUAL
Appendix F STANDARD DRAWINGS

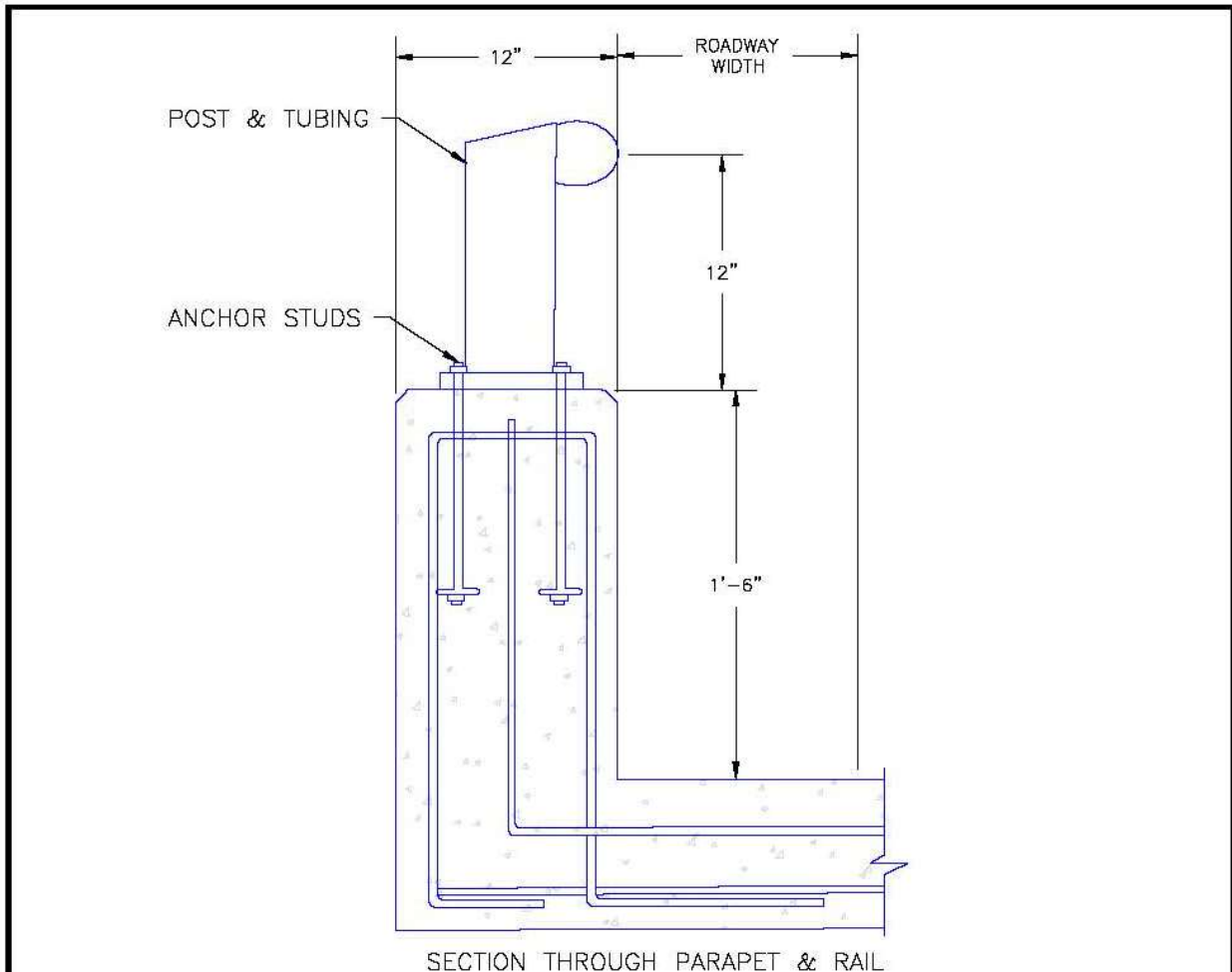

SECTION THROUGH PARAPET & RAIL

RAIL HEIGHT (IN.)	32"		
TEST VEHICLE (LB.)	1900-CAR	4660 - CAR	20,000-BUS
IMPACT SPEED (MPH)	60	60	57
IMPACT ANGLE (DEGREES)	18.8	25.0	14.8

FROM AASHTO ROADWAY GUIDELINE

SCALE: NOT TO SCALE

<p align="center">8/11/11</p> <p>DATE APPROVED:</p> <p align="center">André P. Brackin</p> <p>DEPARTMENT OF TRANSPORTATION</p>	<p align="center">Type C Aluminum Bridge Railing Standard Drawing</p> <p>REVISION DATE: 11/10/04</p> <p>FILE NAME: SD_2-70</p>	
--	--	---

(Supp. No. 2)

- ENGINEERING CRITERIA MANUAL
Appendix F STANDARD DRAWINGS

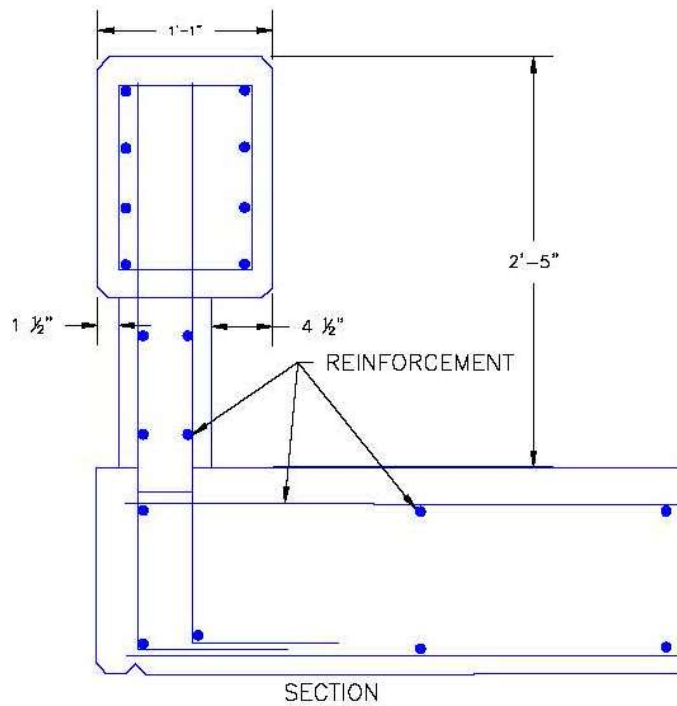
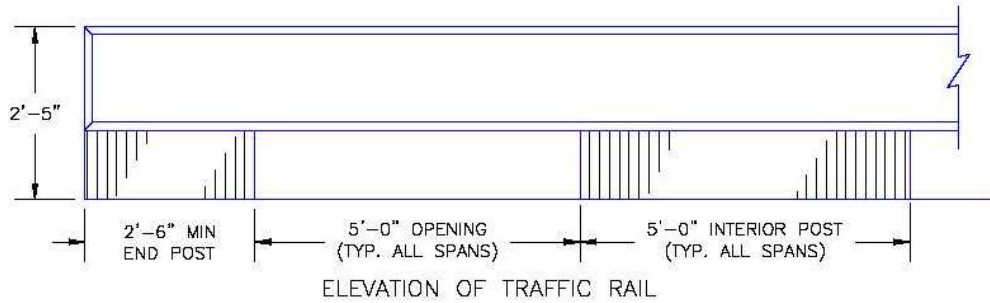

RAIL HEIGHT (IN.)	29	
TEST VEHICLE (LB.)	1980# - CAR	4660# - CAR
IMPACT SPEED (MPH)	59	59
IMPACT ANGLE (DEGREES)	18.9	25.4

FROM AASHTO ROADWAY GUIDELINE

SCALE: NOT TO SCALE

<p align="center">8/11/11</p> <p>DATE APPROVED:</p> <p align="center">André P. Brackin</p> <p>DEPARTMENT OF TRANSPORTATION</p>	<p align="center">Oklahoma TR-1 Bridge Railing Standard Drawing</p> <p>REVISION DATE: 11/10/04</p> <p>FILE NAME: SD_2-71</p>	
--	--	--

(Supp. No. 2)

- ENGINEERING CRITERIA MANUAL
Appendix F STANDARD DRAWINGS

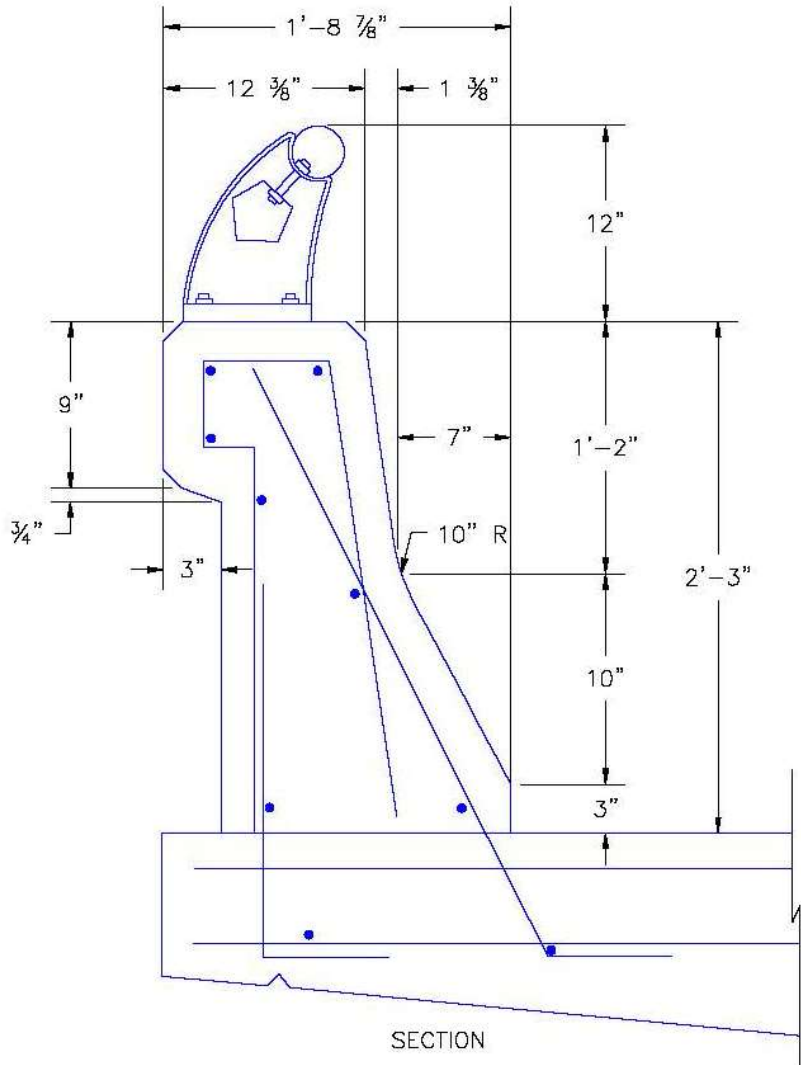

RAIL HEIGHT (IN.)	39		
TEST VEHICLE (LB.)	1900-CAR	4660 - CAR	40,000-BUS
IMPACT SPEED (MPH)	61	62	59
IMPACT ANGLE (DEGREES)	19.3	24.9	16.4

FROM AASHTO ROADWAY GUIDELINE

SCALE: NOT TO SCALE

<p align="center">8/11/11</p> <p>DATE APPROVED:</p> <p align="center">André P. Brackin</p> <p>DEPARTMENT OF TRANSPORTATION</p>	<p>Nevada Concrete Safety Shape Bridge Railing Standard Drawing</p>	
	<p>REVISION DATE:</p> <p align="center">11/10/04</p>	<p>FILE NAME:</p> <p align="center">SD_2-72</p>

(Supp. No. 2)

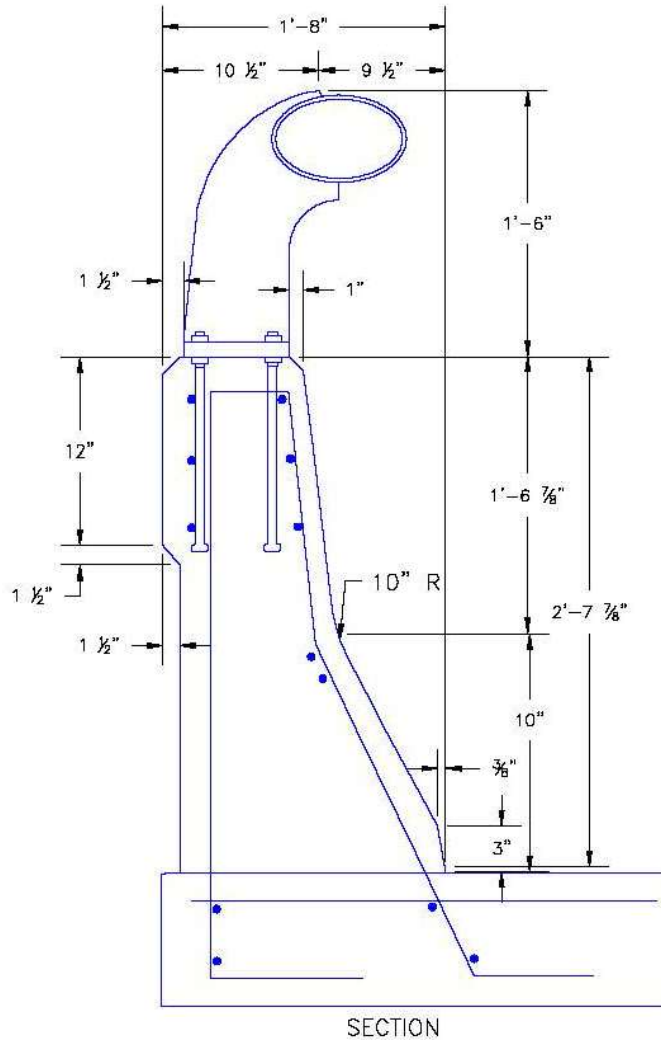

RAIL HEIGHT (IN.)	50
TEST VEHICLE (LB.)	80,150 – TRUCK
IMPACT SPEED (MPH)	48
IMPACT ANGLE (DEGREES)	14.5

FROM AASHTO ROADWAY GUIDELINE

SCALE: NOT TO SCALE

<p>8/11/11</p> <p>DATE APPROVED:</p> <p>André P. Brackin</p> <p>DEPARTMENT OF TRANSPORTATION</p>	<p>Safety Shaped Concrete Bridge Railing Standard Drawing</p> <p>REVISION DATE: 11/10/04</p> <p>FILE NAME: SD_2-73</p>	
--	--	---

(Supp. No. 2)

- ENGINEERING CRITERIA MANUAL
Appendix F STANDARD DRAWINGS

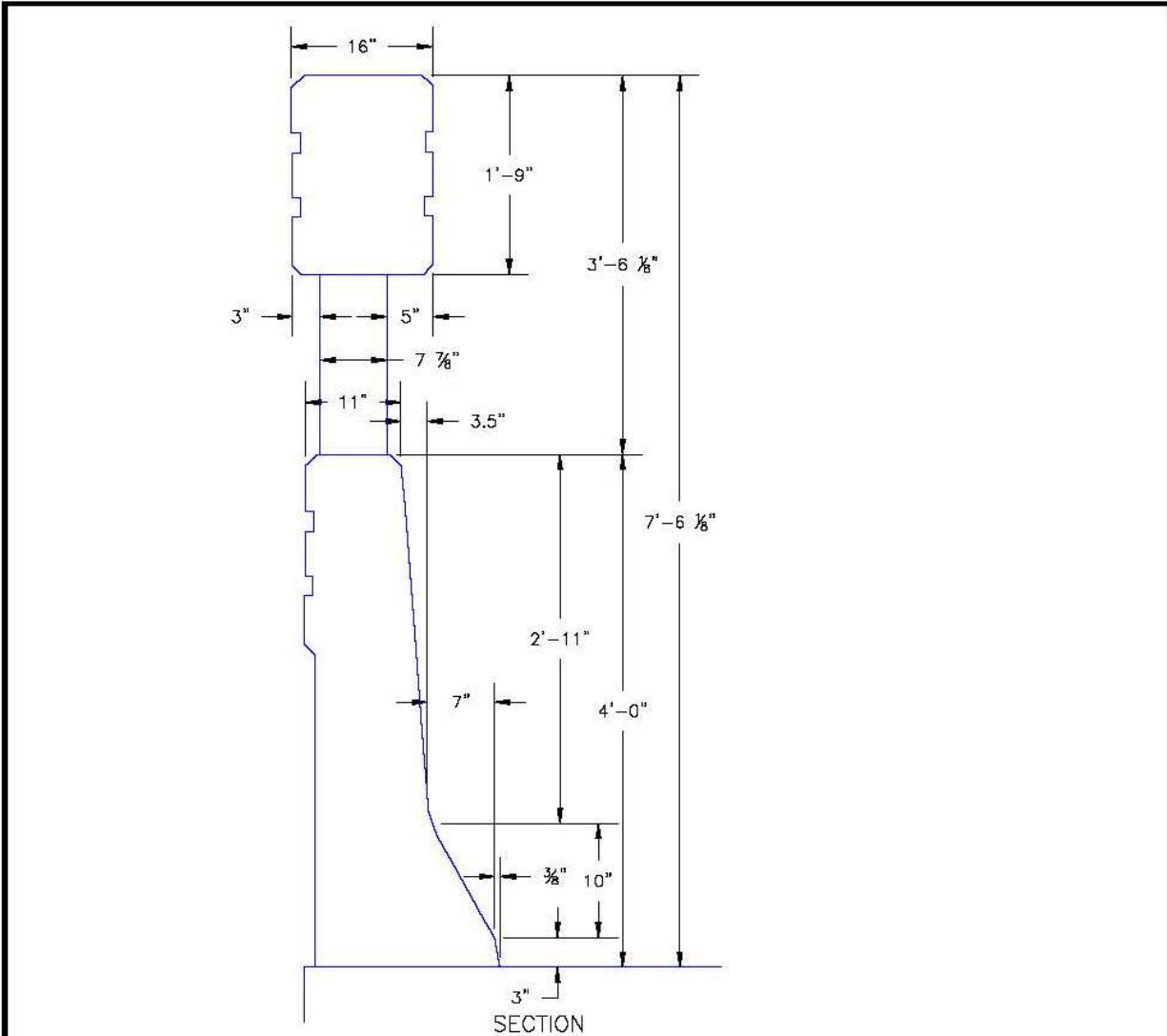

RAIL HEIGHT (IN.)	90
TEST VEHICLE (LB.)	80,190 – TANK TYPE TRACTOR–TRAILER
IMPACT SPEED (MPH)	52
IMPACT ANGLE (DEGREES)	15.0

FROM AASHTO ROADWAY GUIDELINE

SCALE: NOT TO SCALE

<p align="center">8/11/11</p> <p>DATE APPROVED:</p> <p align="center">André P. Brackin</p> <p>DEPARTMENT OF TRANSPORTATION</p>	<p align="center">Texas Type TT Bridge Railing Standard Drawing</p>	
<p>REVISION DATE:</p> <p align="center">11/10/04</p>	<p>FILE NAME:</p> <p align="center">SD_2-74</p>	

(Supp. No. 2)

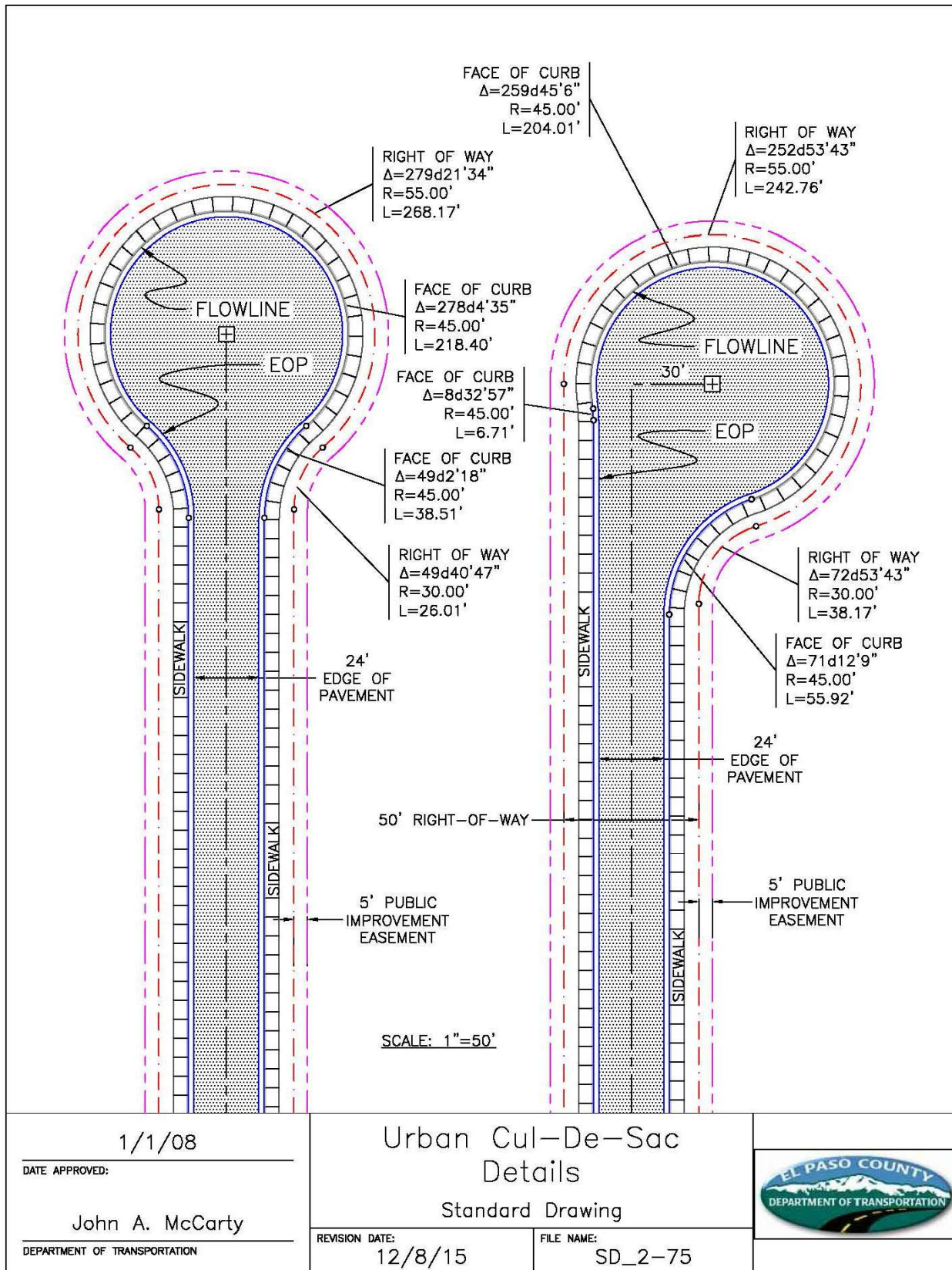

(Supp. No. 2)

- ENGINEERING CRITERIA MANUAL
Appendix F STANDARD DRAWINGS

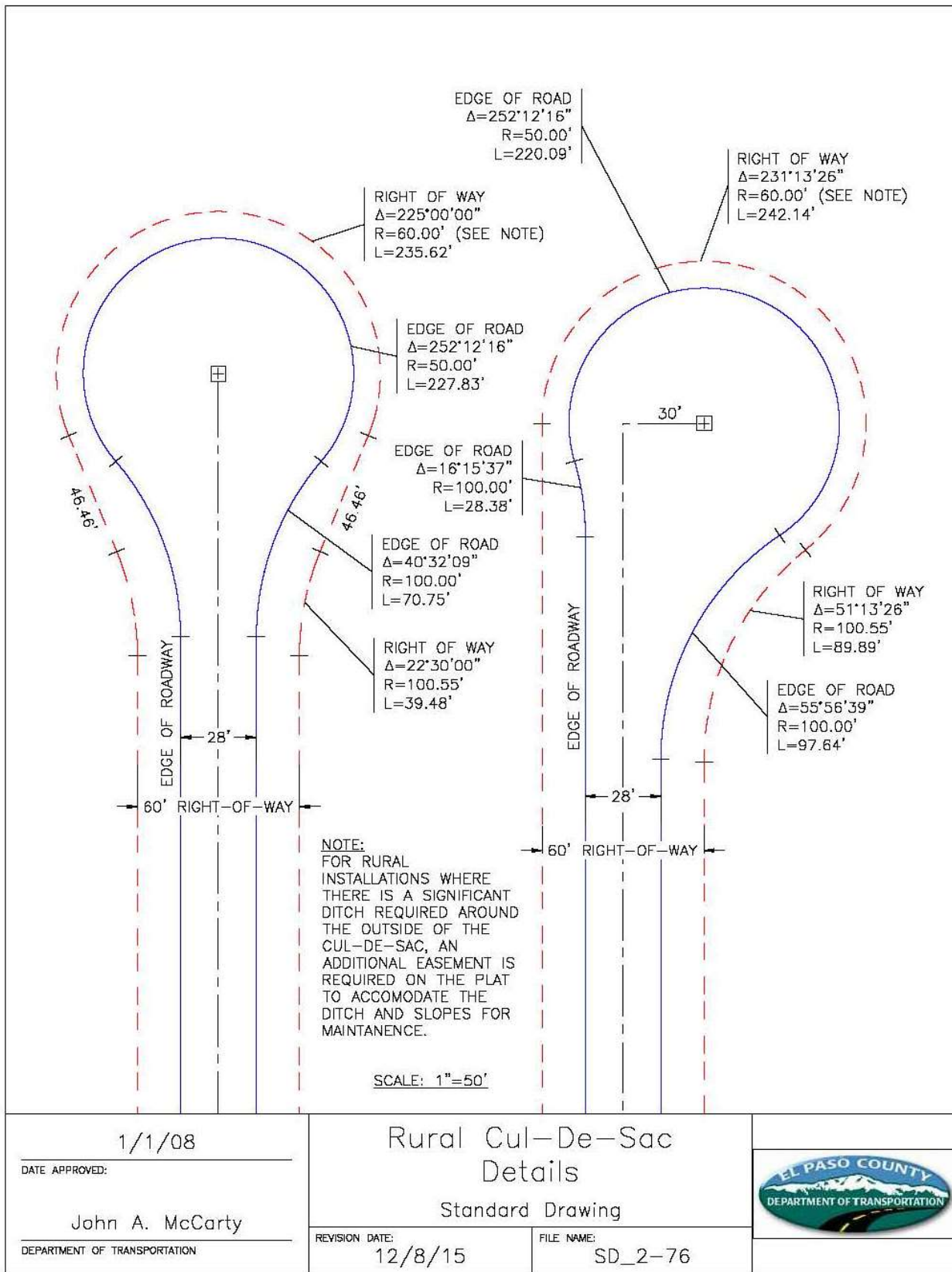

(Supp. No. 2)

URBAN LOCAL KNUCKLE DETAILS

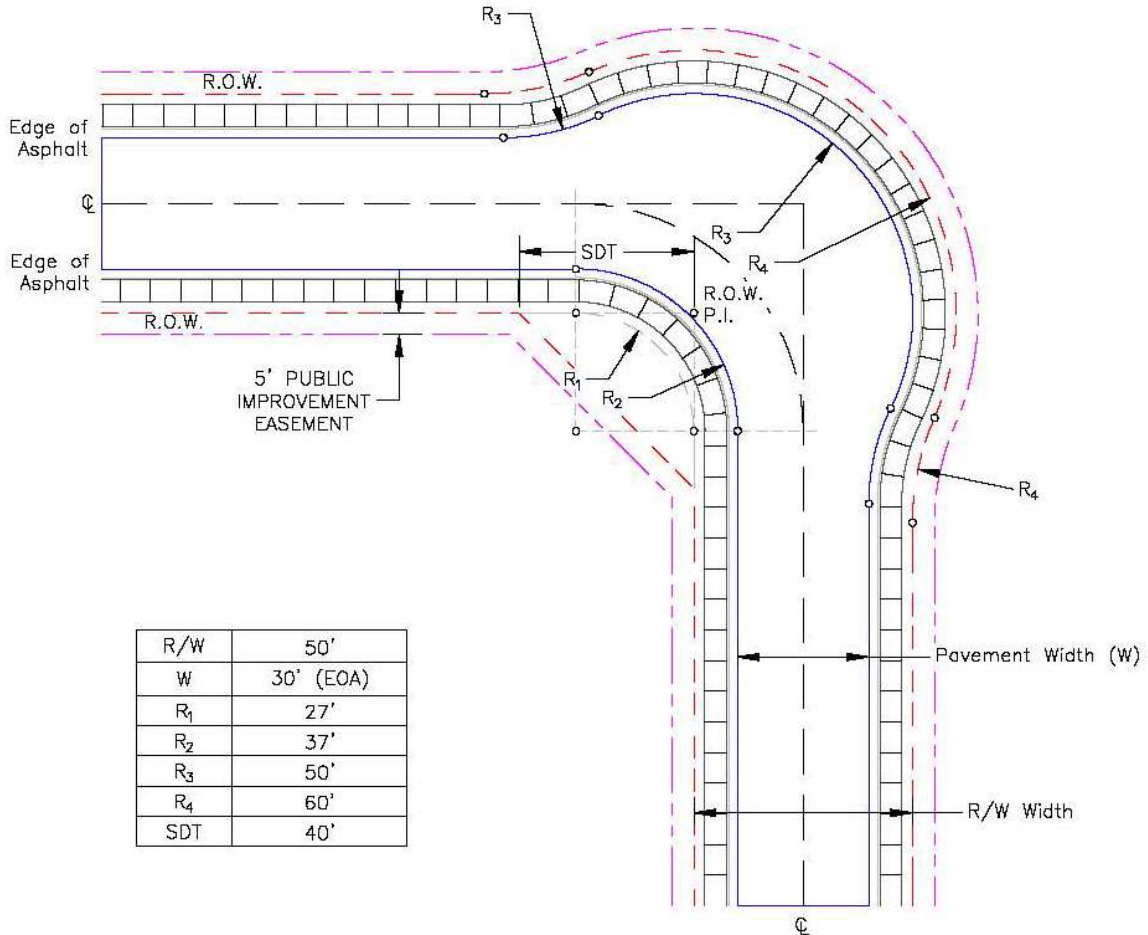

R/W	50'
W	30' (EOA)
R ₁	27'
R ₂	37'
R ₃	50'
R ₄	60'
SDT	40'

SDT = SIGHT DISTANCE TRIANGLE
DESIGN SPEED = 25 MPH

<p style="text-align: center;">7/9/09</p> <p>DATE APPROVED:</p> <p style="text-align: center;">André Brackin</p> <p style="text-align: center;">DEPARTMENT OF TRANSPORTATION</p>	<h3 style="margin: 0;">Urban Local Knuckle</h3> <p style="margin: 5px 0;">Standard Drawing</p>	
	<p>REVISION DATE:</p> <p style="font-size: 1.2em;">12/8/15</p>	<p>FILE NAME:</p> <p style="font-size: 1.2em;">SD_2-77</p>

(Supp. No. 2)

URBAN LOCAL LOW-VOLUME KNUCKLE DETAILS

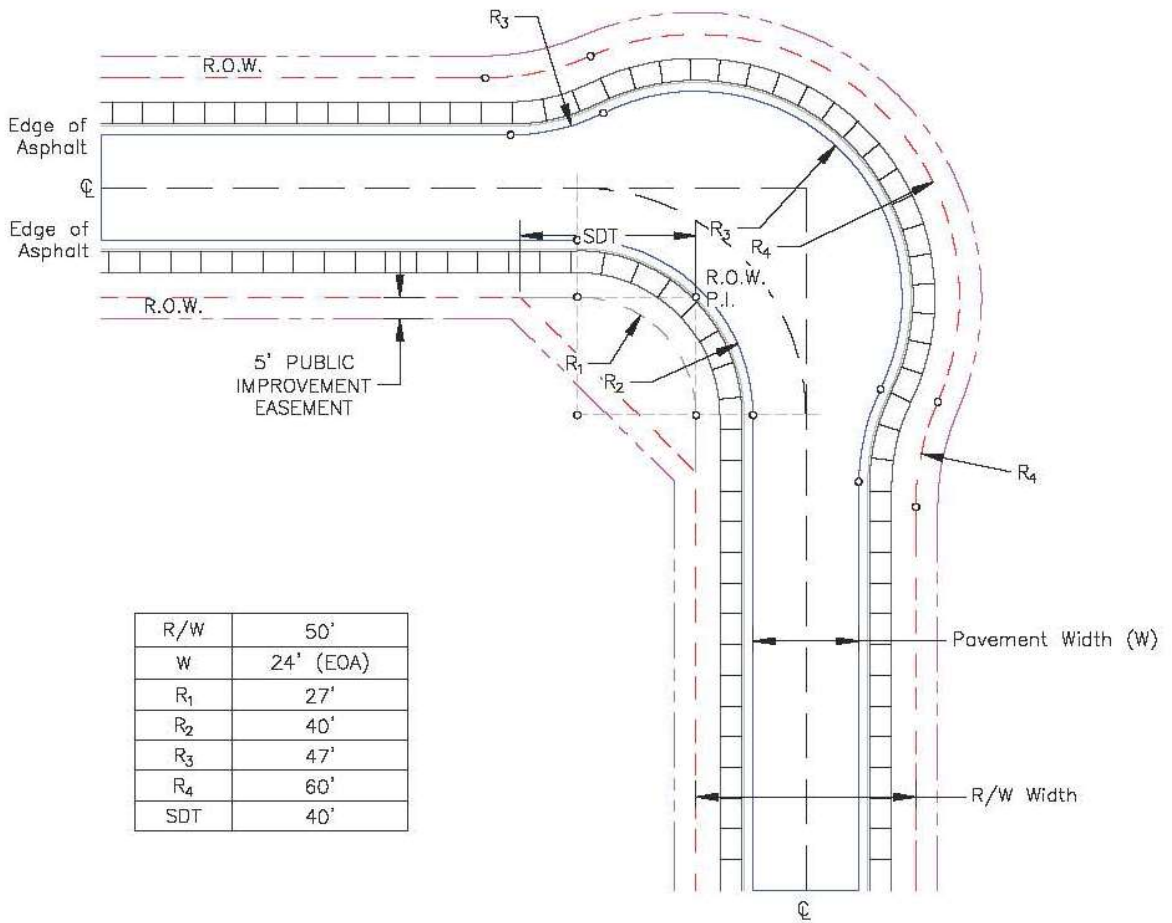

SDT = SIGHT DISTANCE TRIANGLE
DESIGN SPEED = 20 MPH

<p>7/9/09</p> <p>DATE APPROVED:</p> <p>André Brackin</p> <p>DEPARTMENT OF TRANSPORTATION</p>	<p>Urban Local Low-Volume Knuckle Standard Drawing</p> <p>REVISION DATE: 7/9/09</p> <p>FILE NAME: SD_2-78</p>	
--	---	---

(Supp. No. 2)

- ENGINEERING CRITERIA MANUAL
Appendix F STANDARD DRAWINGS

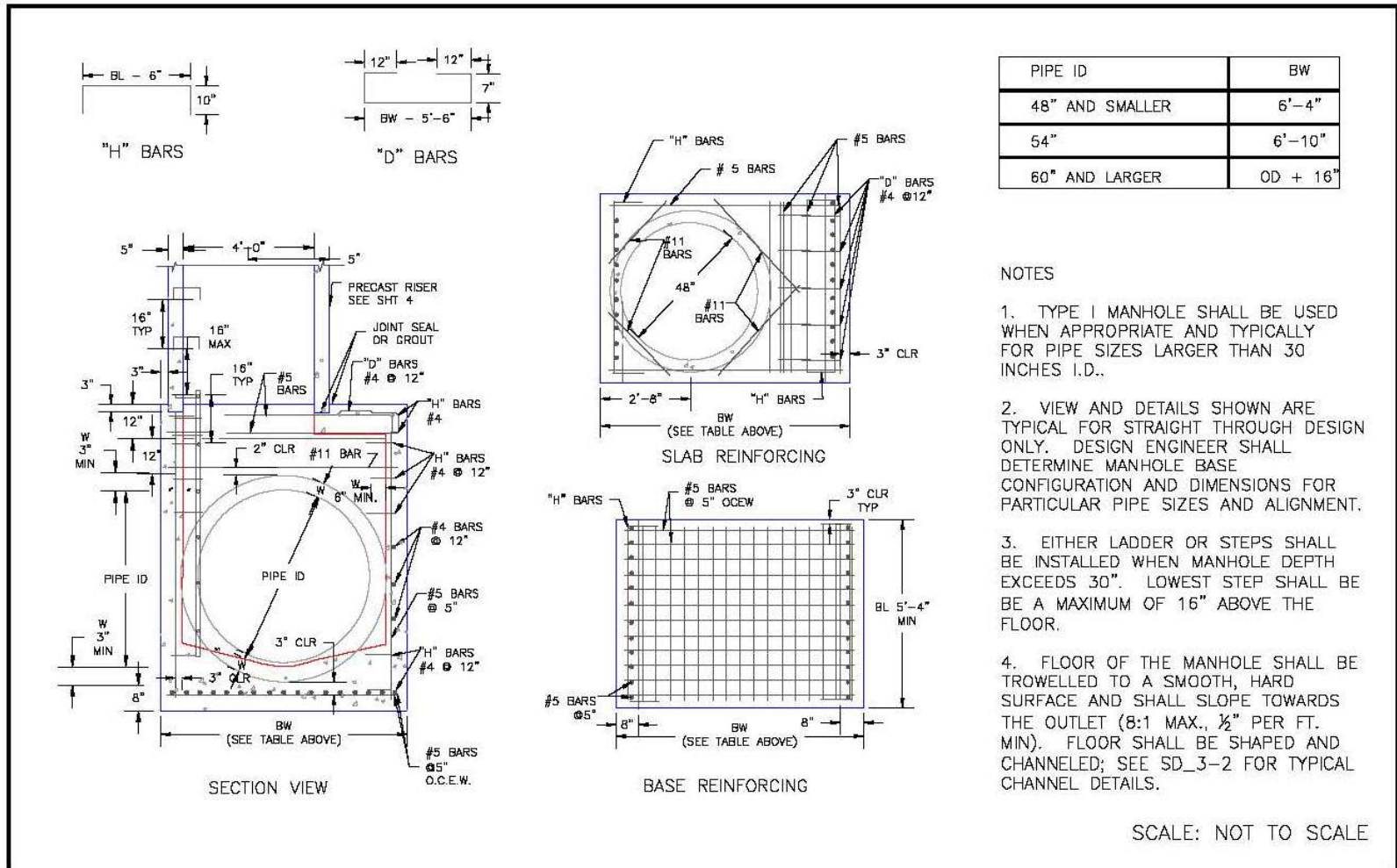

7/9/09
DATE APPROVED:
André Brackin
DEPARTMENT OF TRANSPORTATION

Storm Sewer Manhole Detail
Type I
Standard Drawing
REVISION DATE: 7/9/09
FILE NAME: SD_3-1



El Paso
(Supp. No. 2)

- ENGINEERING CRITERIA MANUAL
Appendix F STANDARD DRAWINGS

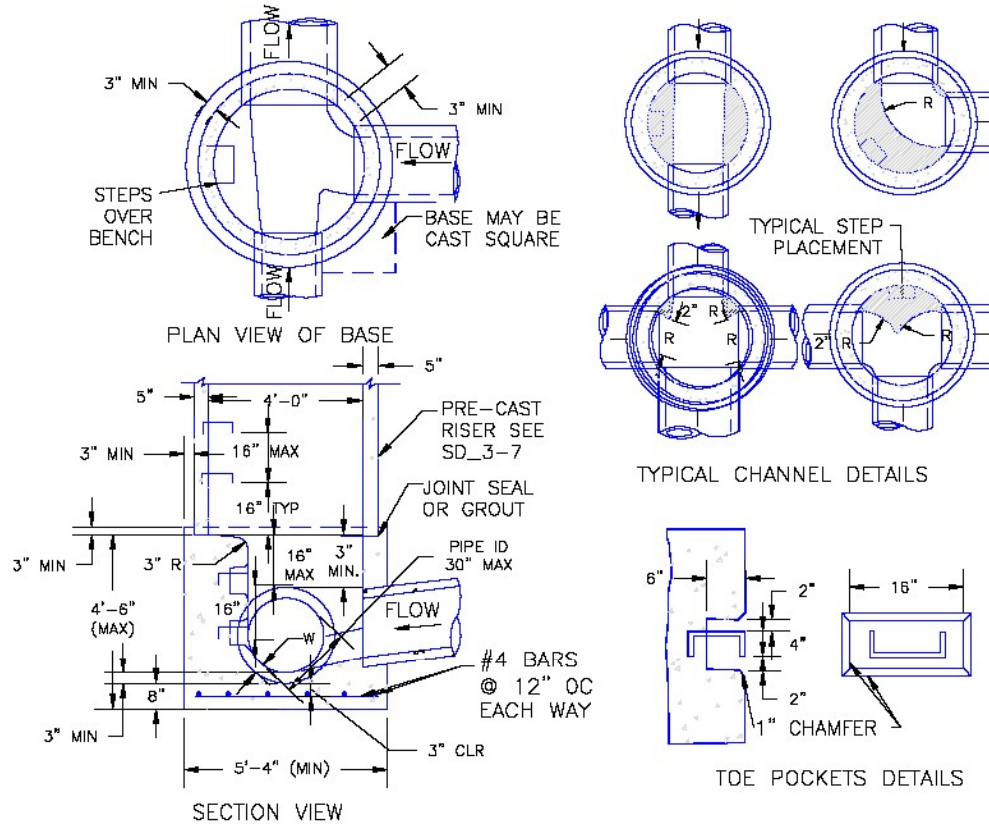

NOTES

1. TYPE II MANHOLES SHALL BE USED WHEN APPROPRIATE AND TYPICALLY WHEN THE PIPE SIZES ARE 30" OR LESS INSIDE DIAMETER.
2. VIEW AND DETAILS ARE TYPICAL. DESIGN ENGINEER SHALL DETERMINE MANHOLE BASE CONFIGURATION AND DIMENSIONS FOR PARTICULAR PIPE SIZES AND ALIGNMENT.
3. EITHER LADDER OF STEPS SHALL BE INSTALLED WHEN MANHOLE DEPTH EXCEEDS 30". STEPS IN BASE SHALL BE INSTALLED IN "TOE POCKETS" (SEE DETAIL THIS SHEET). LOWEST STEP SHALL BE A MAXIMUM OF 16" ABOVE THE FLOOR.
4. PIPES SHALL BE TRIMMED TO FINAL SHAPE AND SET BEFORE MANHOLE IS POURED.
5. BENCH SHALL BE SLOPED TOWARD CENTER OF MANHOLE BASE (4:1 MAX., 1/2" PER FOOT. MIN.).
6. FLOOR OF MANHOLE SHALL BE TROWELLED TO A SMOOTH, HARD SURFACE AND SHALL SLOPE TOWARDS THE OUTLET (8:1., 1/2" PER FT. MIN.) . FLOOR SHALL BE SHAPED AND CHANNELED; SEE DETAILS THIS SHEET.

- ENGINEERING CRITERIA MANUAL
Appendix F STANDARD DRAWINGS

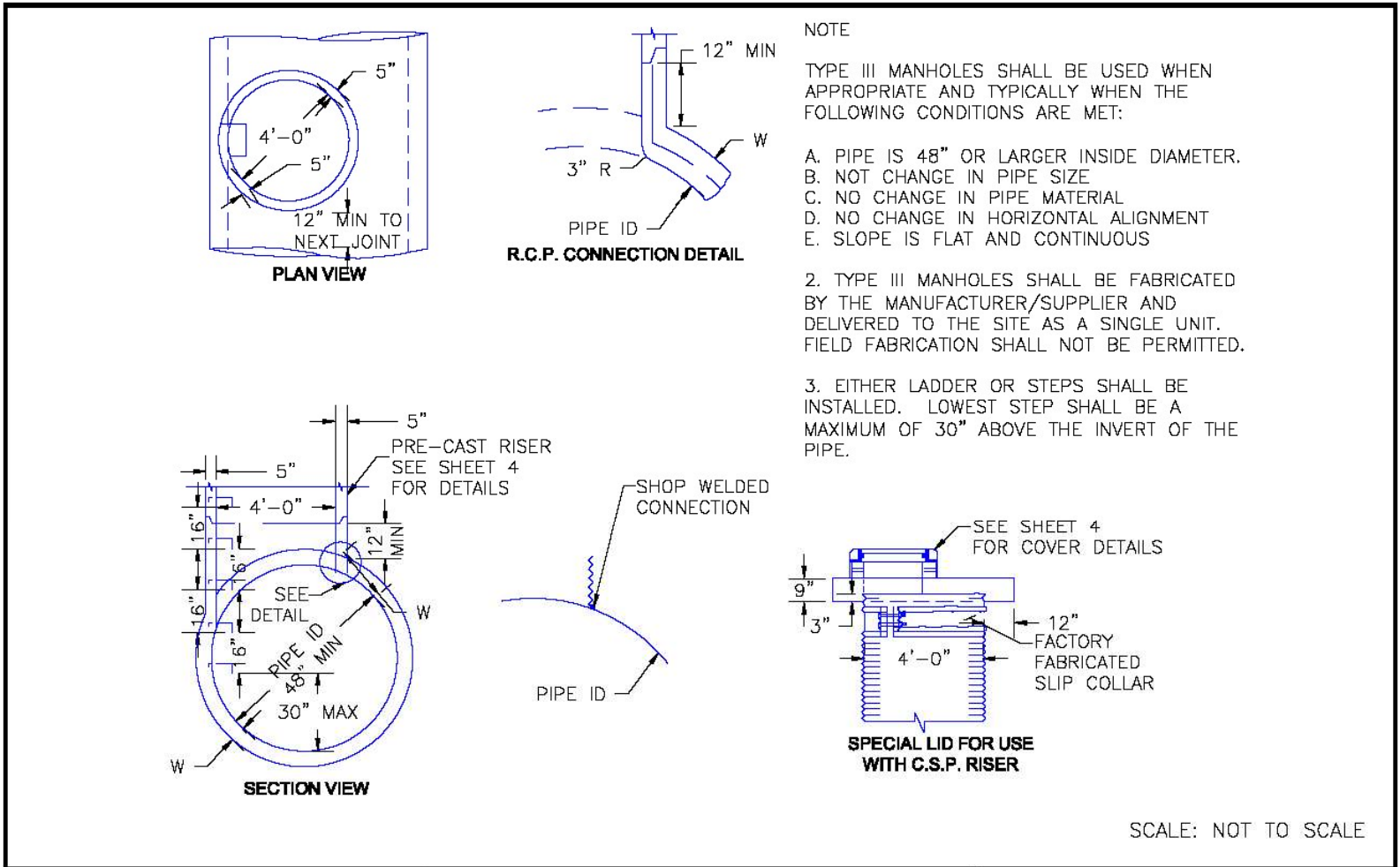

SCALE: NOT TO SCALE

<p>8/11/11</p> <p>DATE APPROVED:</p> <p>André P. Brackin</p> <p>DEPARTMENT OF TRANSPORTATION</p>	<p>Storm Sewer Manhole Detail Type III Standard Drawing</p> <p>REVISION DATE: 11/10/04</p> <p>FILE NAME: SD_3-3</p>	
--	---	---

El Paso
(Supp. No. 2)

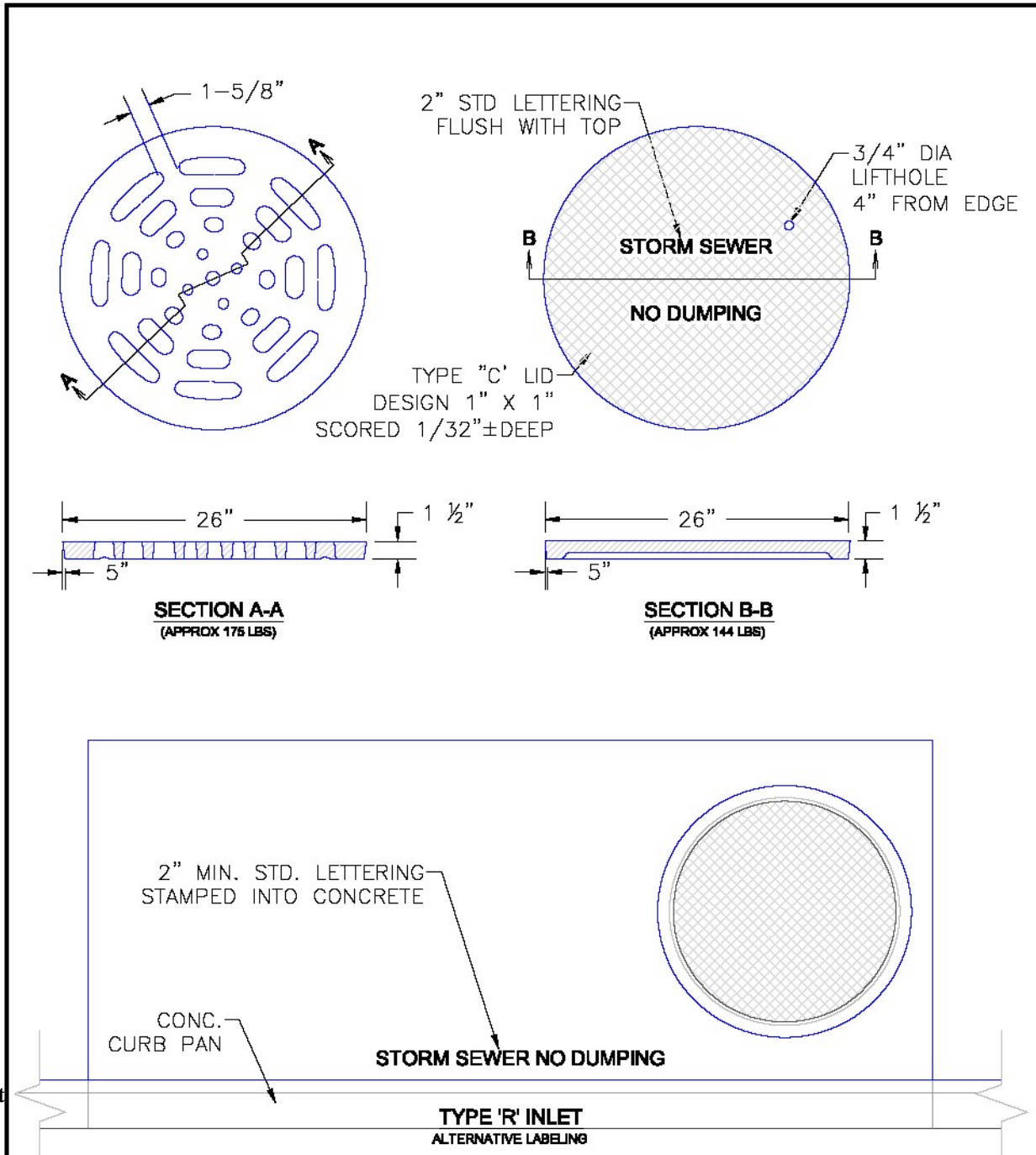

- ENGINEERING CRITERIA MANUAL
Appendix F STANDARD DRAWINGS

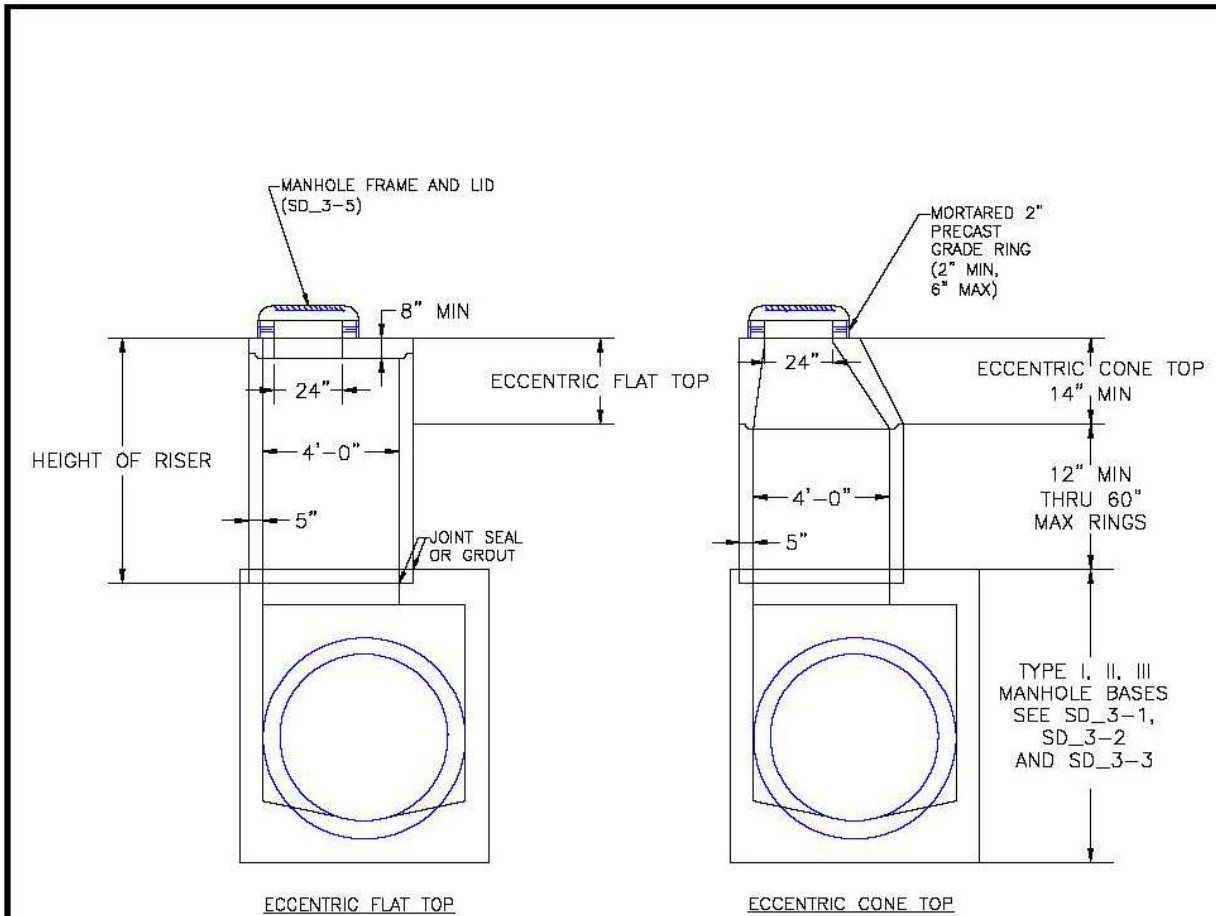

NOTES

1. ALL WORK SHALL BE DONE IN ACCORDANCE WITH THE STANDARD AND SUPPLEMENTAL SPECIFICATIONS APPLICABLE TO THE PROJECT.
2. PRECAST RISERS SHALL CONFORM TO ASTM C478.
3. STEPS SHALL BE INSTALLED WHEN MANHOLE DEPTH EXCEEDS 30". STEPS SHALL BE CAST IRON OR EXTRUDED ALUMINUM, 1000 LB CAPACITY, 12" WIDE WITH NON-SKID GROOVES AND DROP FRONT ON SAFETY NOSES, IN ACCORDANCE WITH APPROVED OSHA REQUIREMENTS.

- ENGINEERING CRITERIA MANUAL
Appendix F STANDARD DRAWINGS

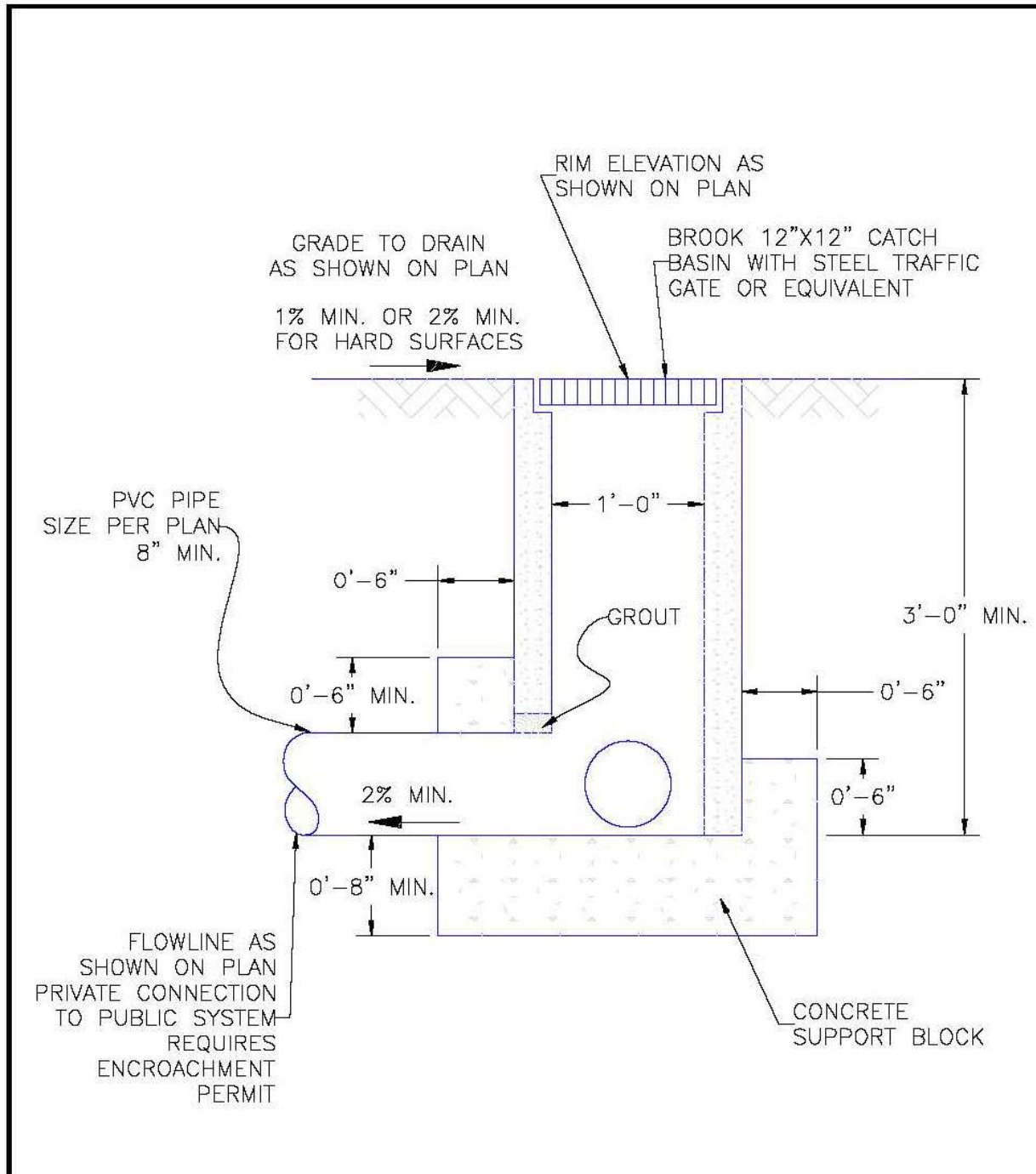

- ENGINEERING CRITERIA MANUAL
Appendix F STANDARD DRAWINGS

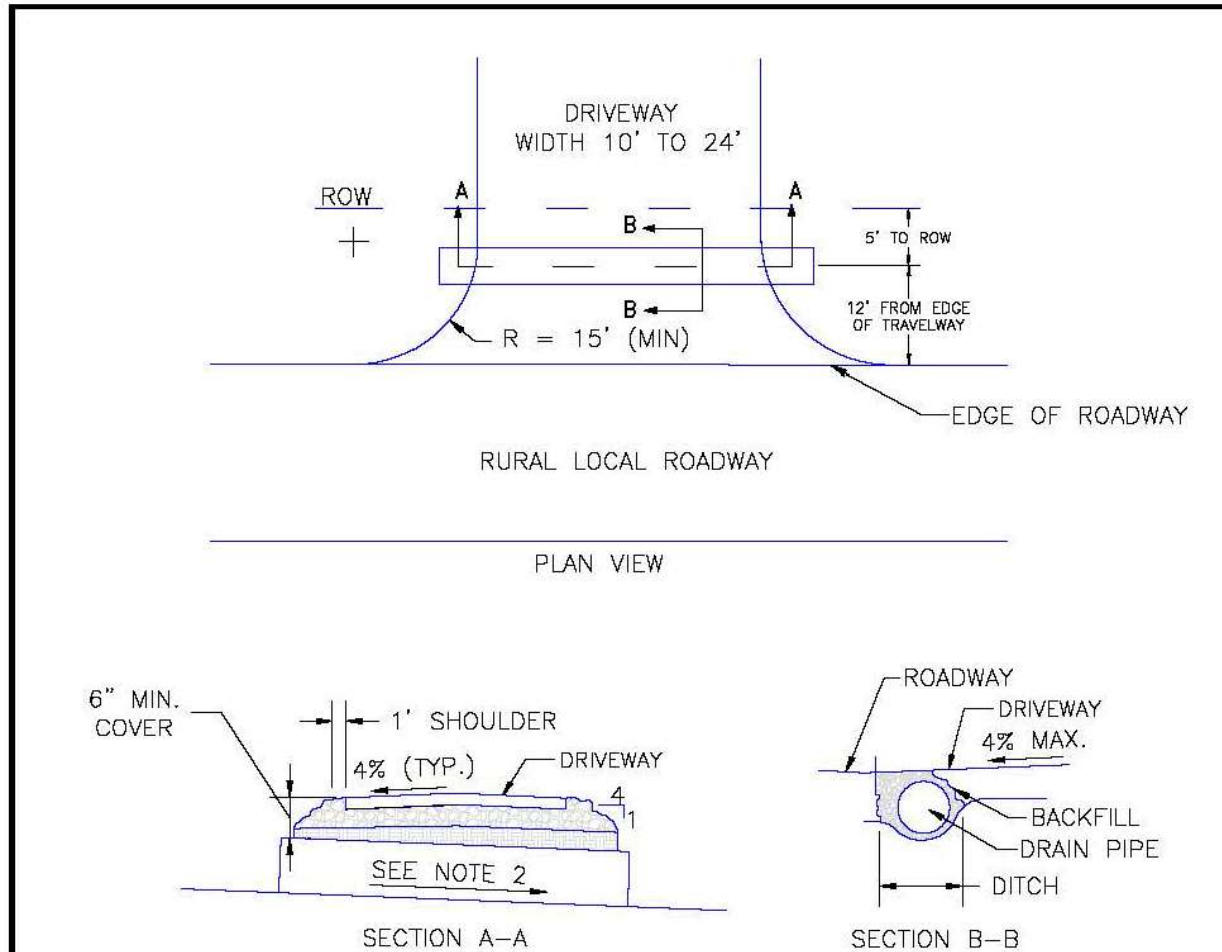

NOTES

1. SURFACE TREATMENT OF DRIVEWAY TO MATCH SURFACE TREATMENT OF ROAD WITHIN THE ROW.
2. DRAIN PIPE TO BE 18" DIAMETER CMP MINIMUM.
3. PIPE SLOPE TO BE CONSISTENT WITH FLOWLINE OF DITCH, MINIMUM OF 1% PREFERRED.
4. ALL DRIVEWAYS SHALL HAVE A 4 PERCENT CROWN.
5. WHEN SLOPING TOWARDS ROAD, DRIVEWAYS SHALL HAVE A MAXIMUM GRADE OF 4 PERCENT FOR A MINIMUM OF 20 FEET WHERE THE SITE ALLOWS.

- ENGINEERING CRITERIA MANUAL
Appendix F STANDARD DRAWINGS

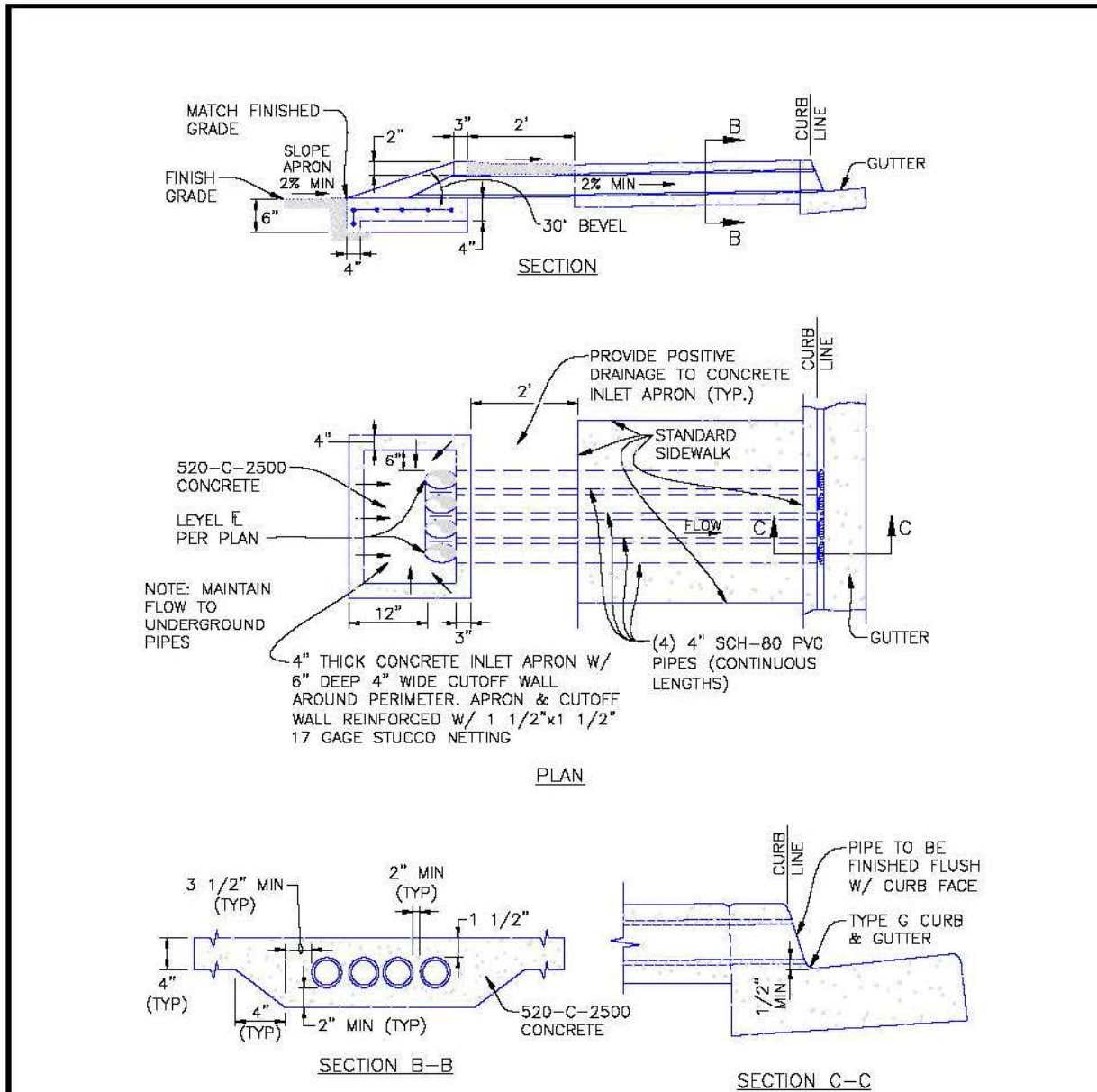

El Paso County, Colorado
(Supp. No. 2)

- ENGINEERING CRITERIA MANUAL
Appendix F STANDARD DRAWINGS

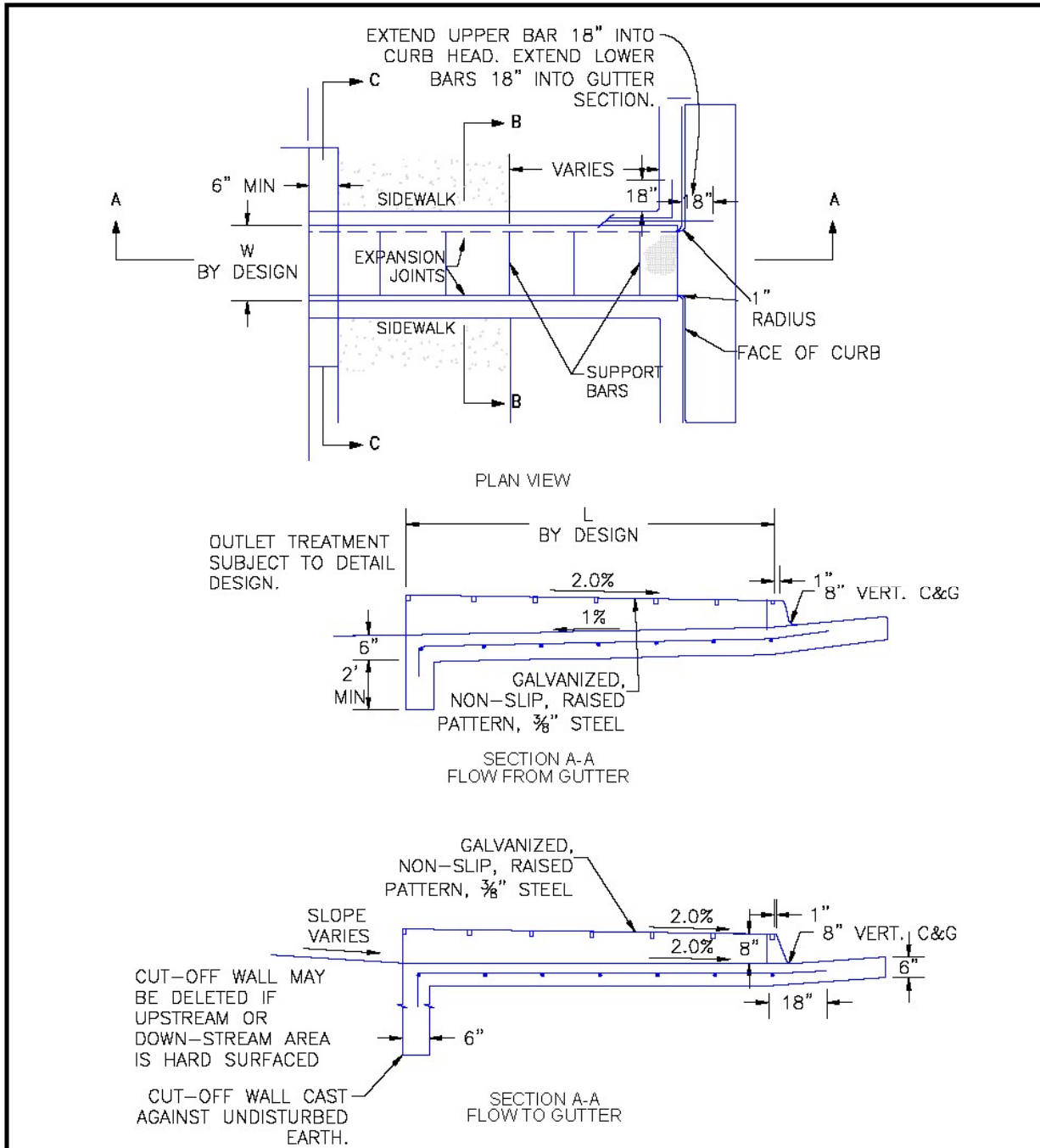

El Paso County, Colorado
(Supp. No. 2)

- ENGINEERING CRITERIA MANUAL
Appendix F STANDARD DRAWINGS

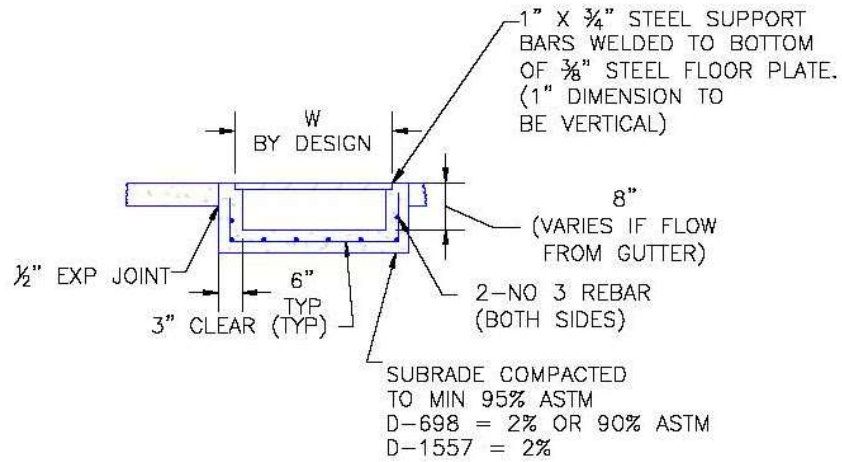

SECTION B-B

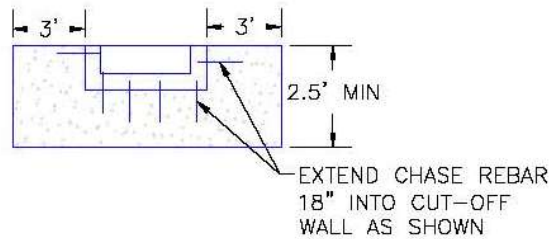

SECTION C-C

- ENGINEERING CRITERIA MANUAL
Appendix F STANDARD DRAWINGS

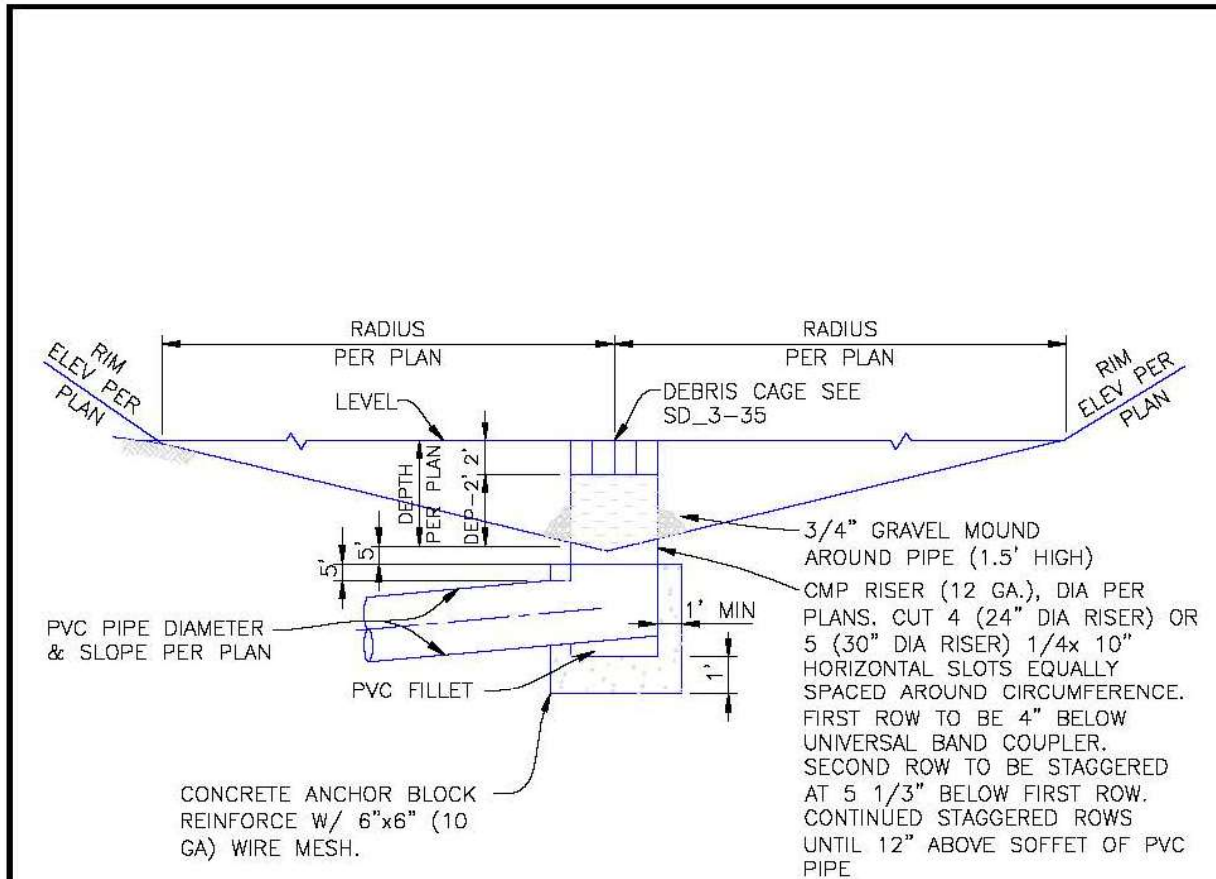

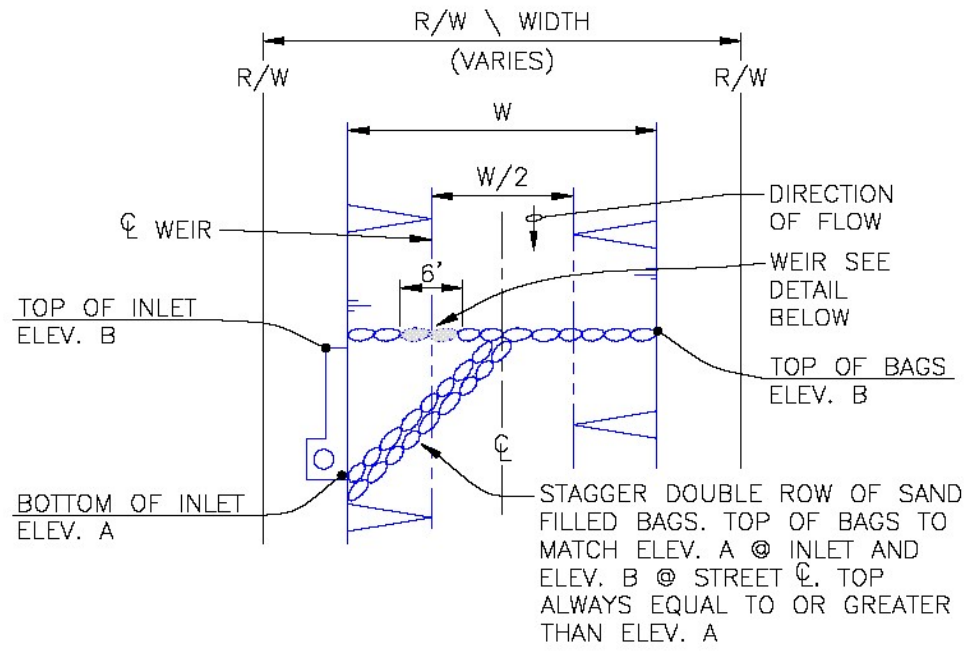

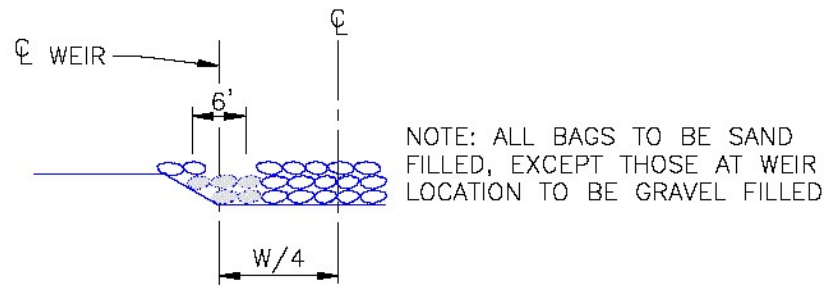

PLAN



WEIR ELEVATION

LEGEND:
GRAVEL FILLED BAG.. 
SAND FILLED BAG..... 

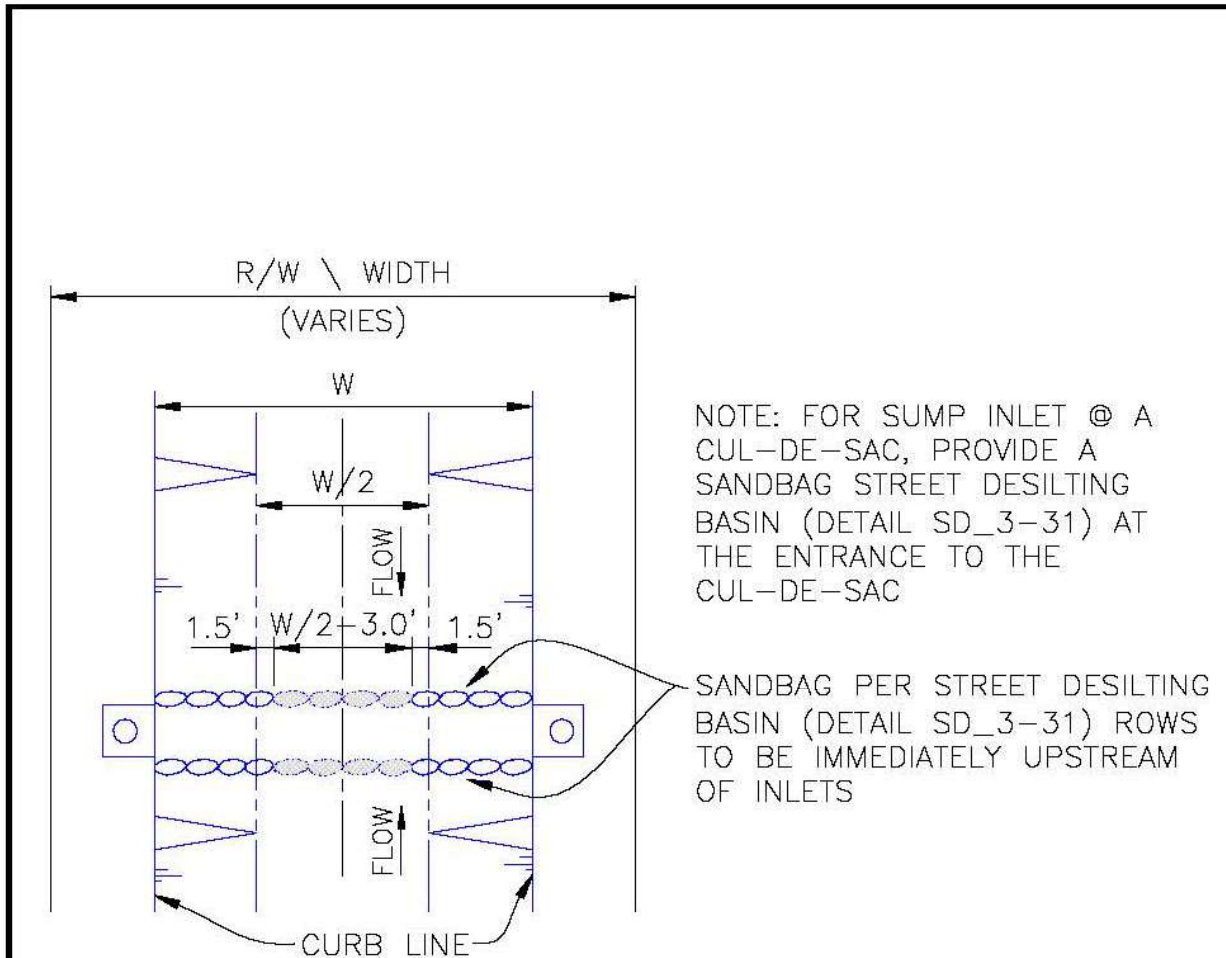

TEMP. DESILTING BASIN @ SUMP
NO SCALE

LEGEND:

GRAVEL FILLED BAG.. 

SAND FILLED BAG..... 

- ENGINEERING CRITERIA MANUAL
Appendix F STANDARD DRAWINGS

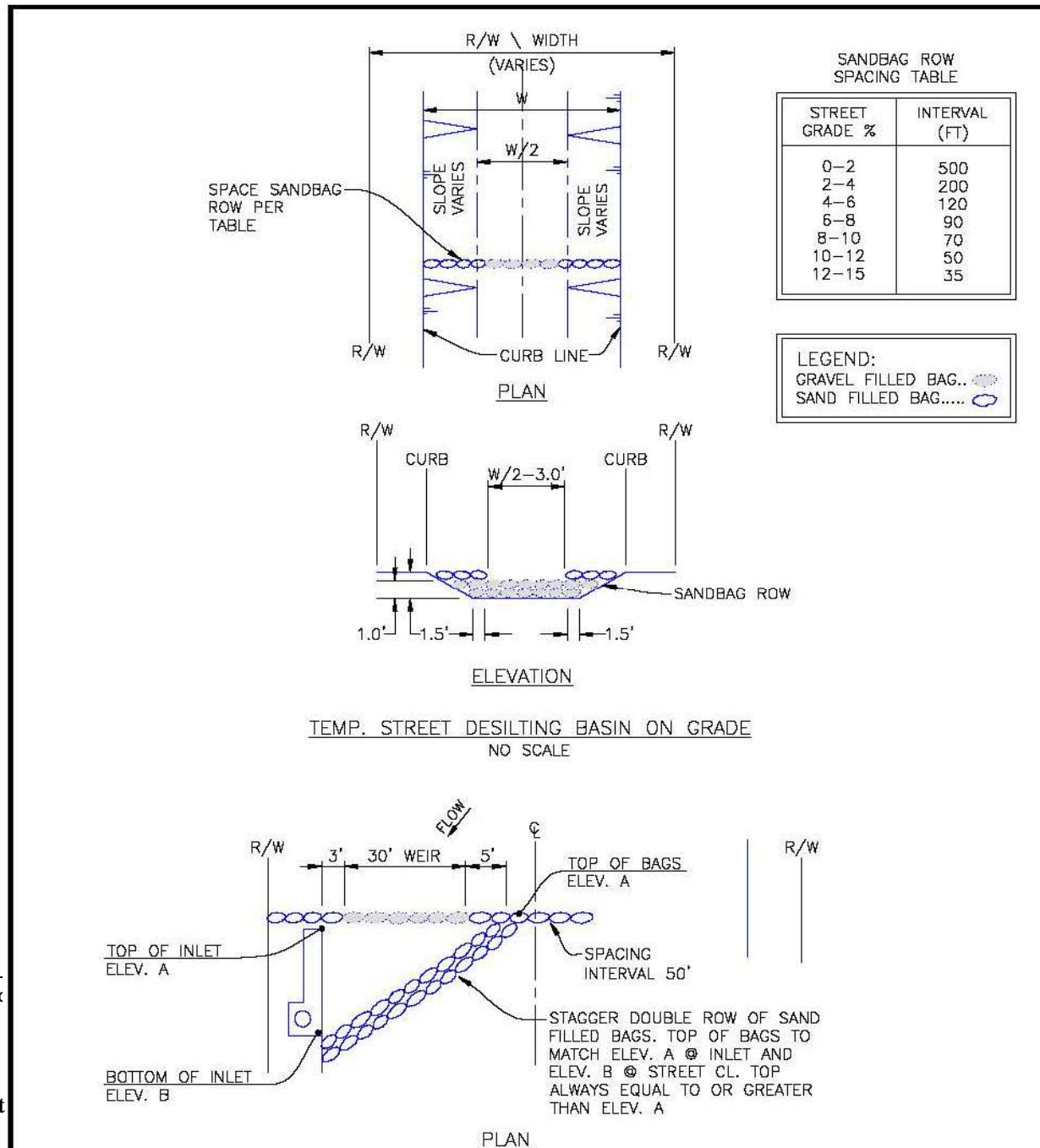

- ENGINEERING CRITERIA MANUAL
Appendix F STANDARD DRAWINGS

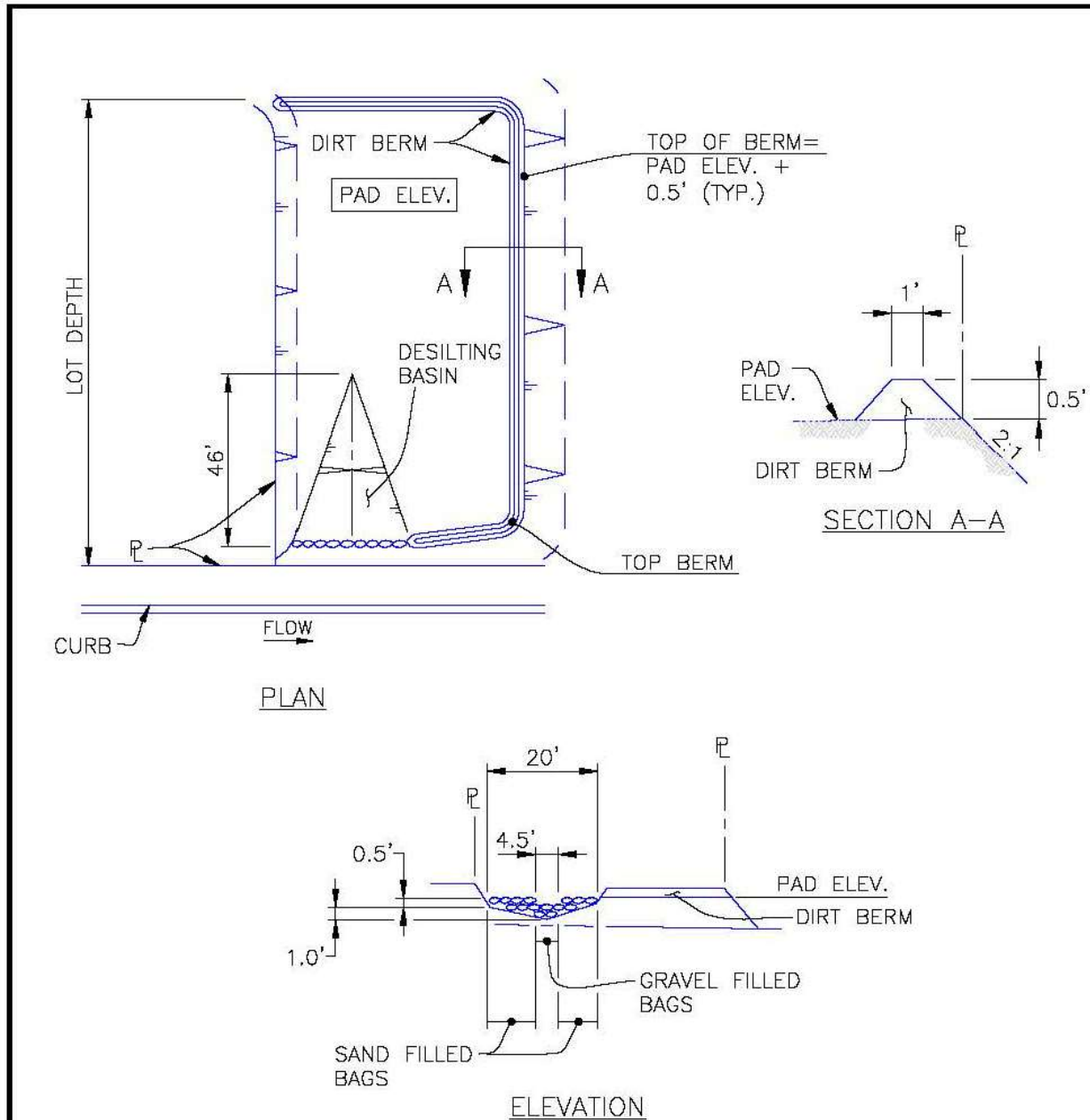

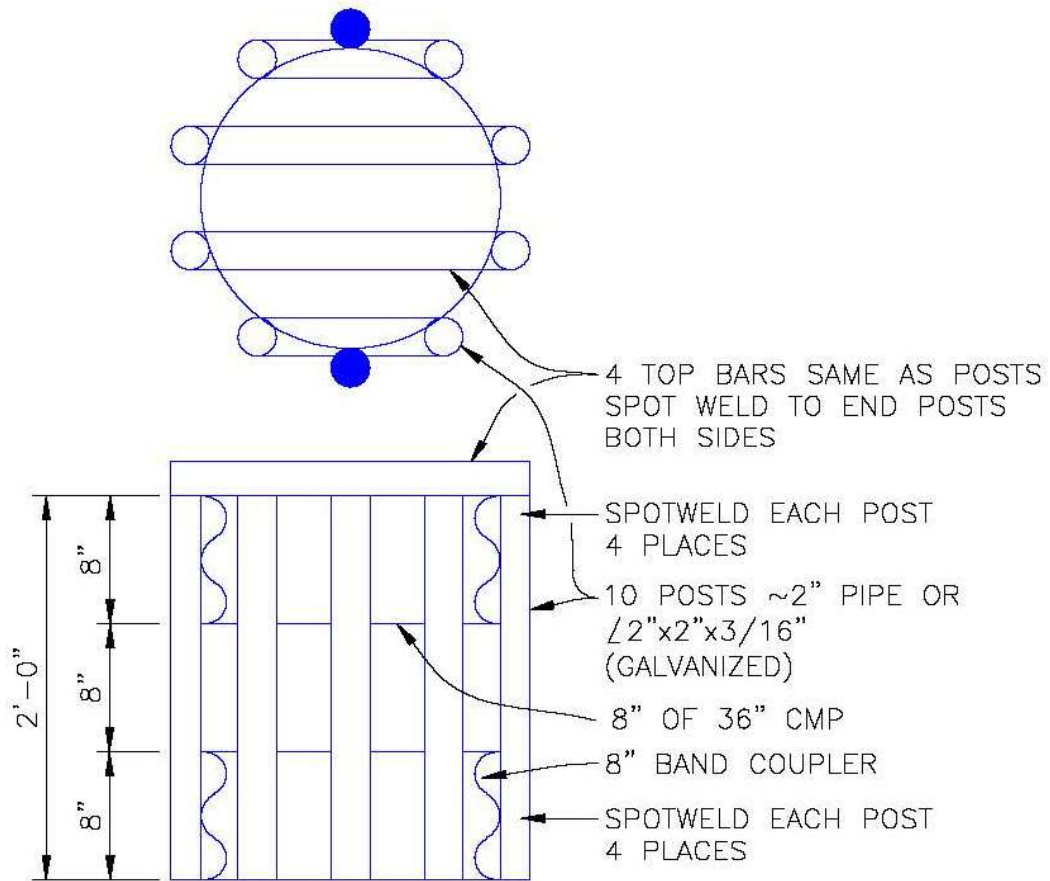

- ENGINEERING CRITERIA MANUAL
Appendix F STANDARD DRAWINGS

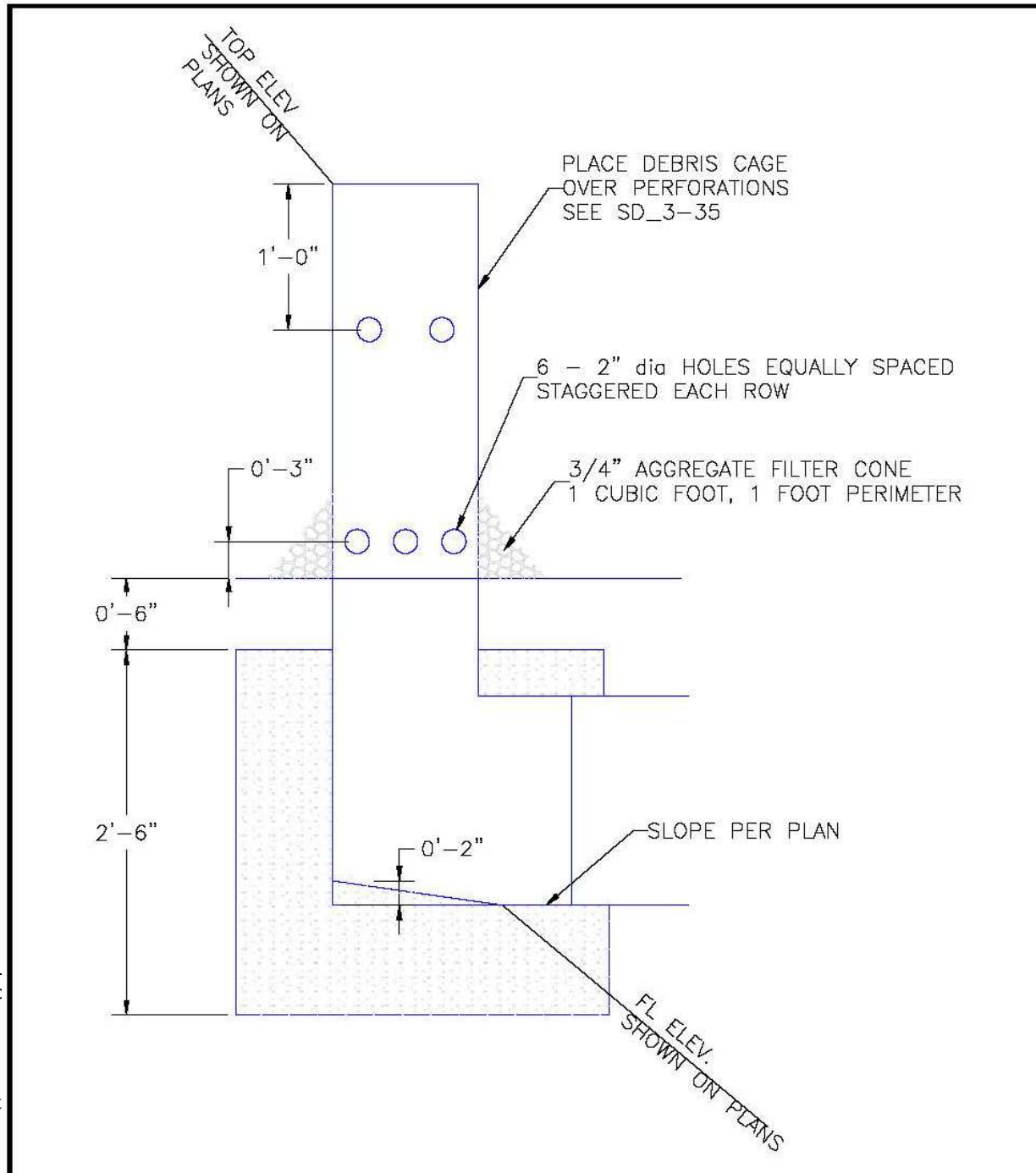

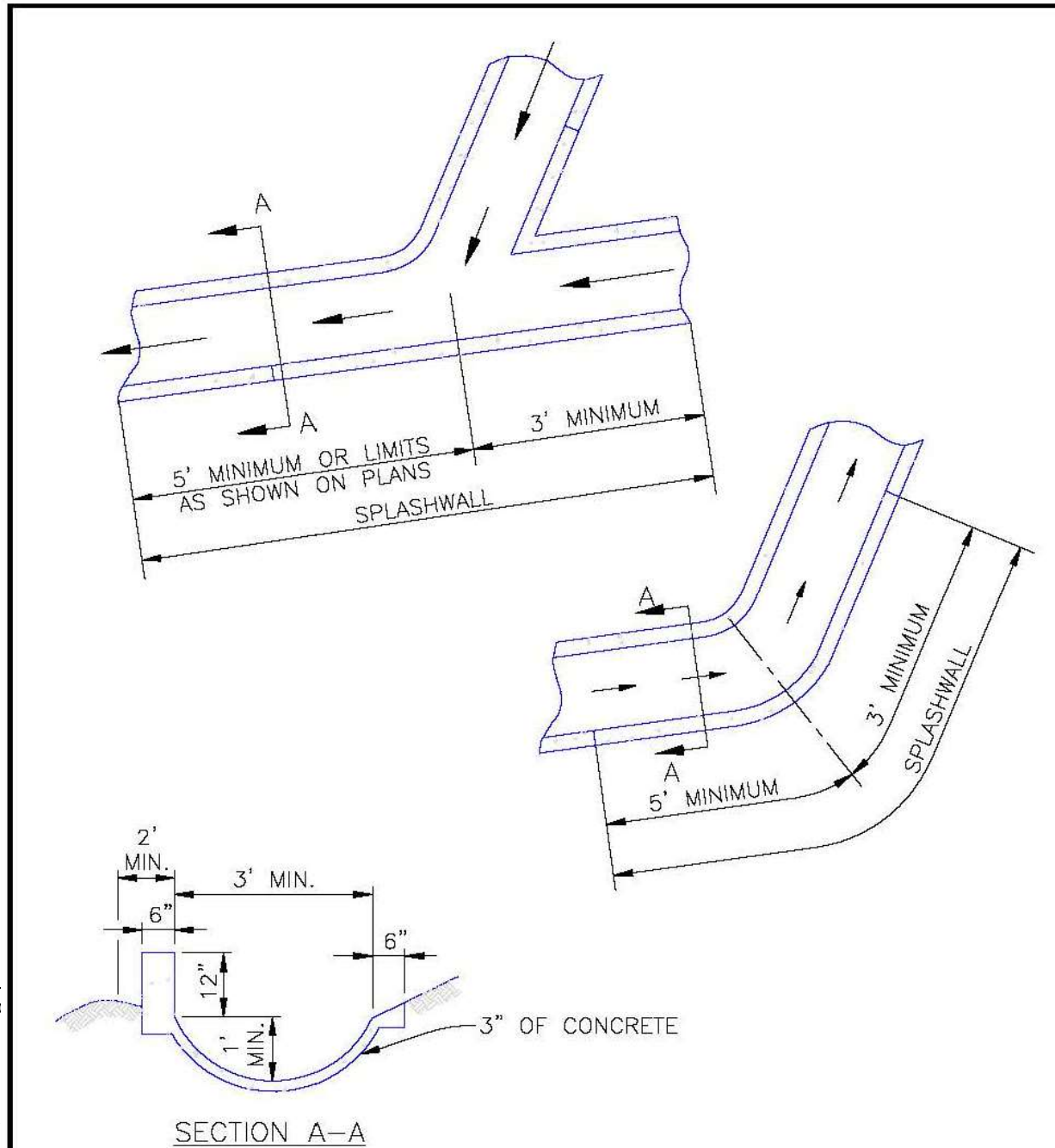

- ENGINEERING CRITERIA MANUAL
Appendix F STANDARD DRAWINGS

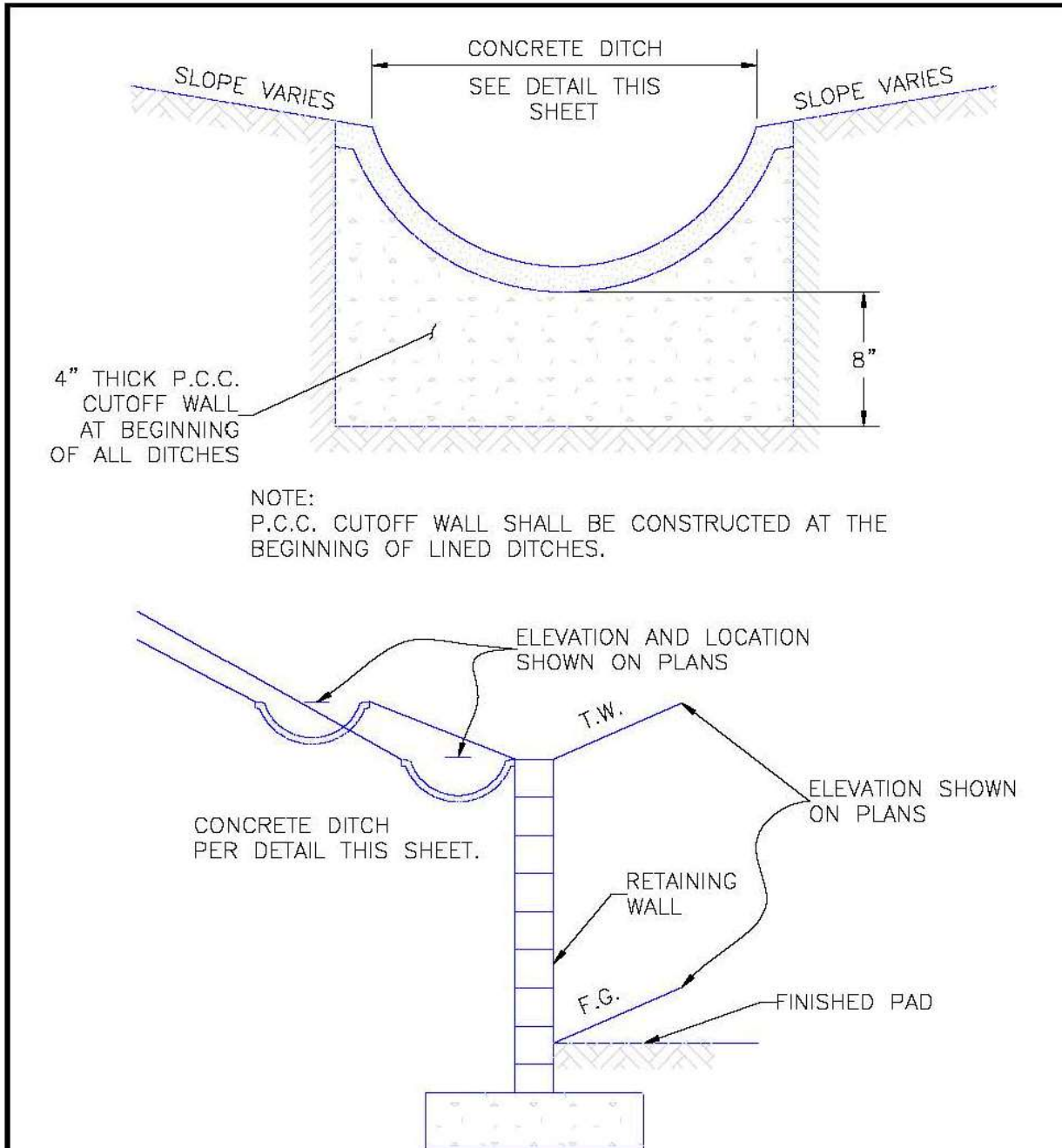

- ENGINEERING CRITERIA MANUAL
Appendix F STANDARD DRAWINGS

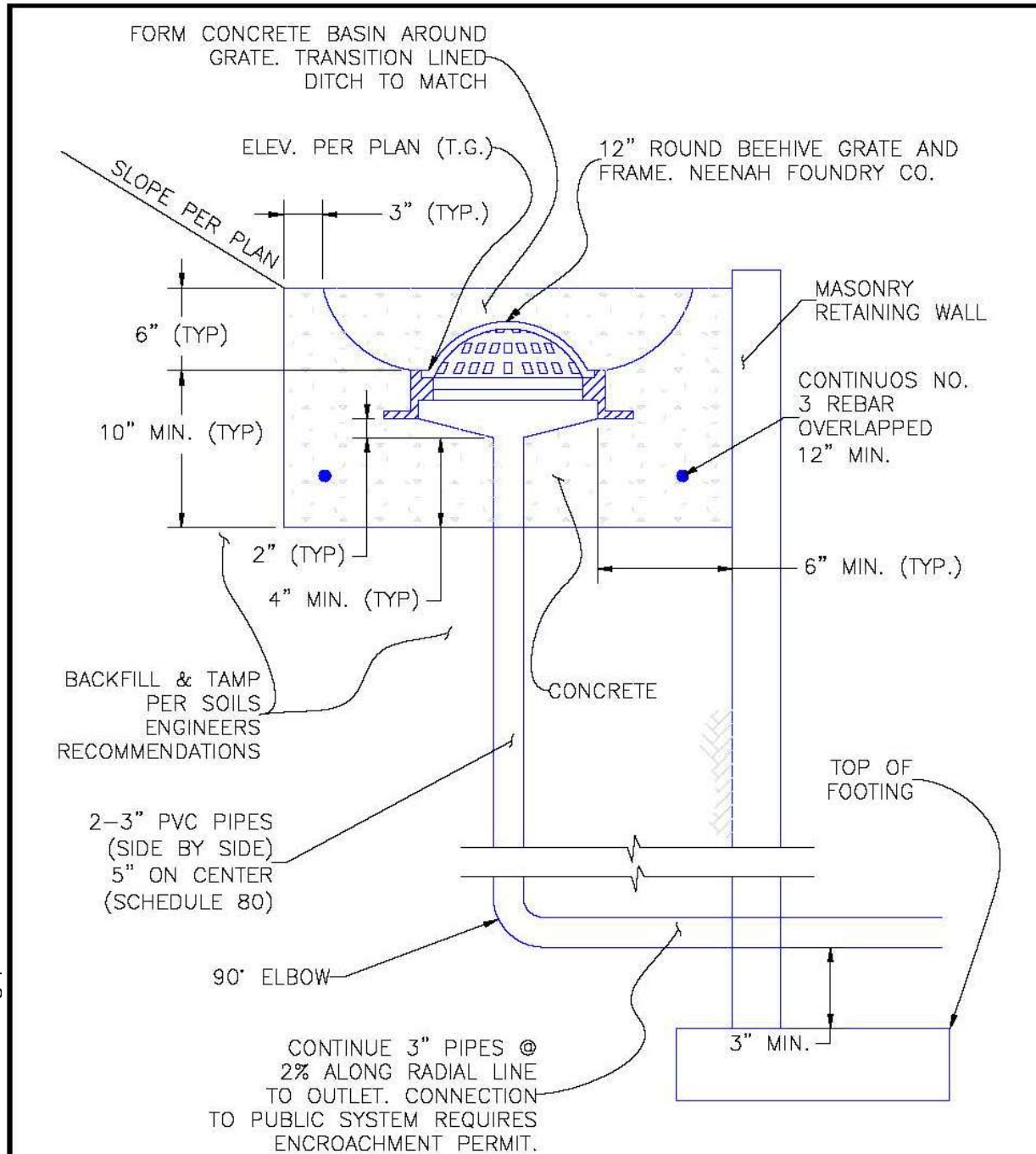

- ENGINEERING CRITERIA MANUAL
Appendix F STANDARD DRAWINGS

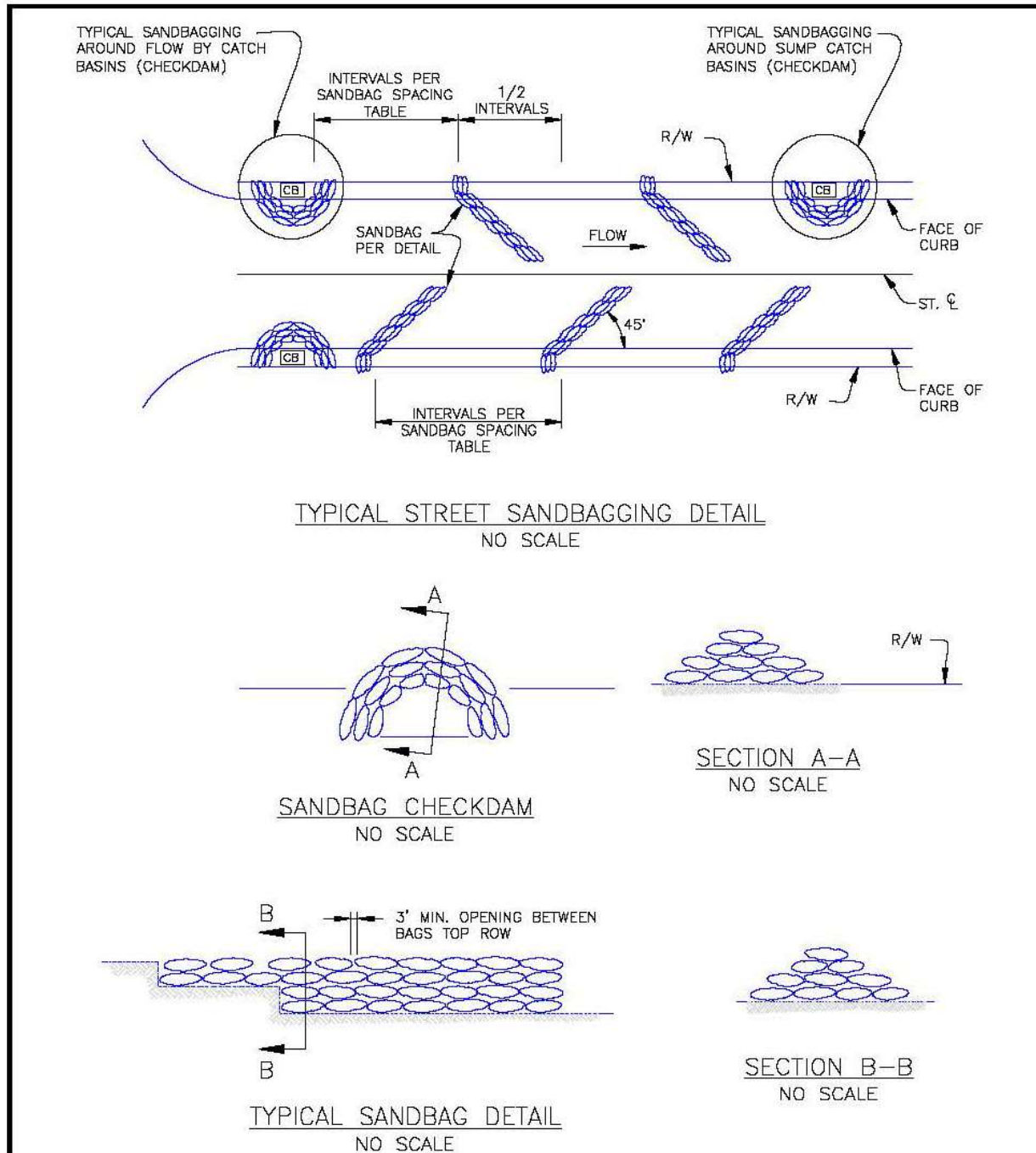

- ENGINEERING CRITERIA MANUAL
Appendix F STANDARD DRAWINGS

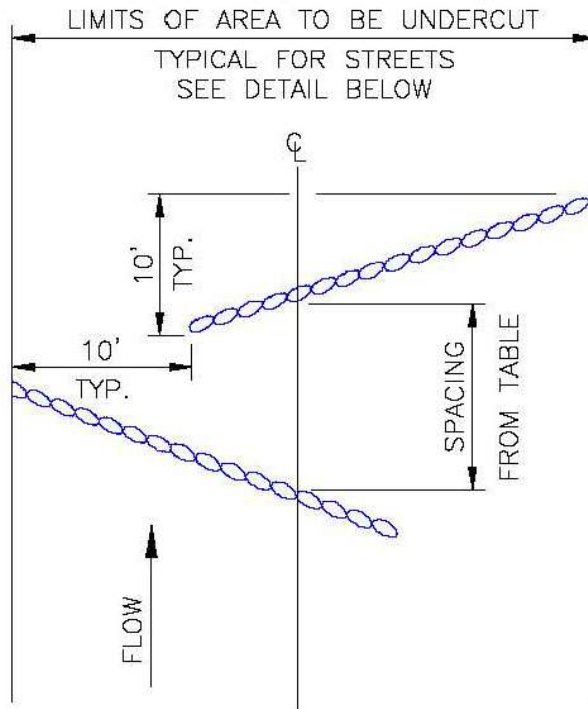

SANDBAG ROW
SPACING TABLE

STREET GRADE %	INTERVAL (FT)
0-2	500
2-4	200
4-6	120
6-8	90
8-10	70
10-12	50
12-15	35

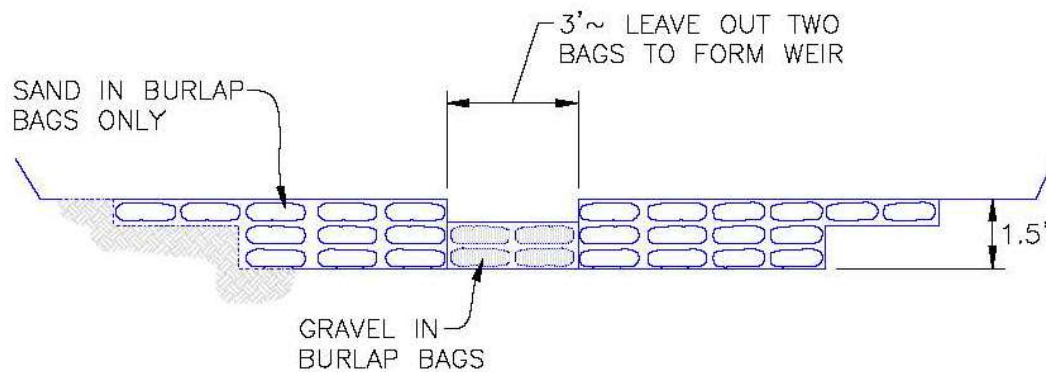

- ENGINEERING CRITERIA MANUAL
Appendix F STANDARD DRAWINGS

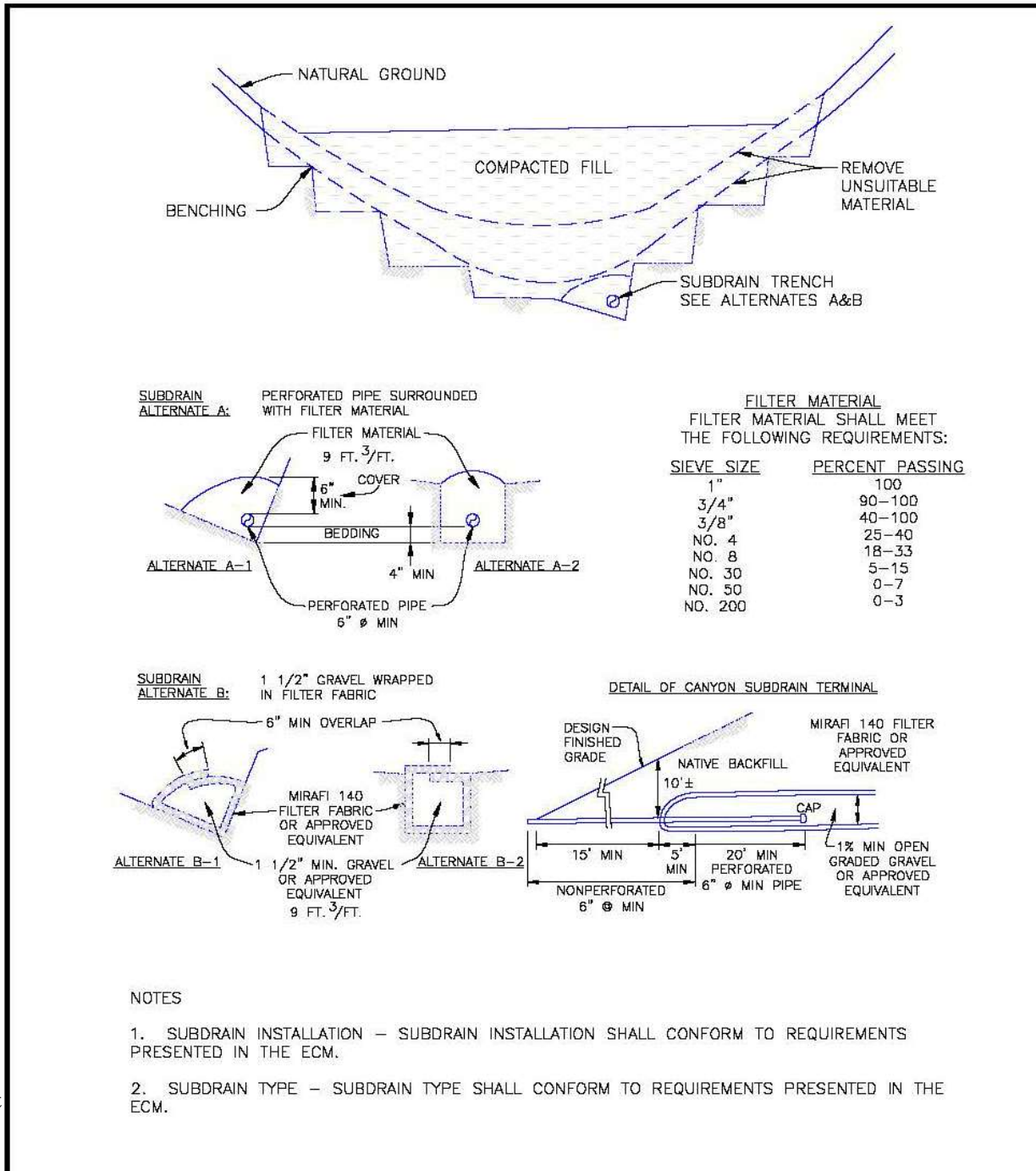

NOTES

1. SUBDRAIN INSTALLATION – SUBDRAIN INSTALLATION SHALL CONFORM TO REQUIREMENTS PRESENTED IN THE ECM.
2. SUBDRAIN TYPE – SUBDRAIN TYPE SHALL CONFORM TO REQUIREMENTS PRESENTED IN THE ECM.

- ENGINEERING CRITERIA MANUAL
Appendix F STANDARD DRAWINGS

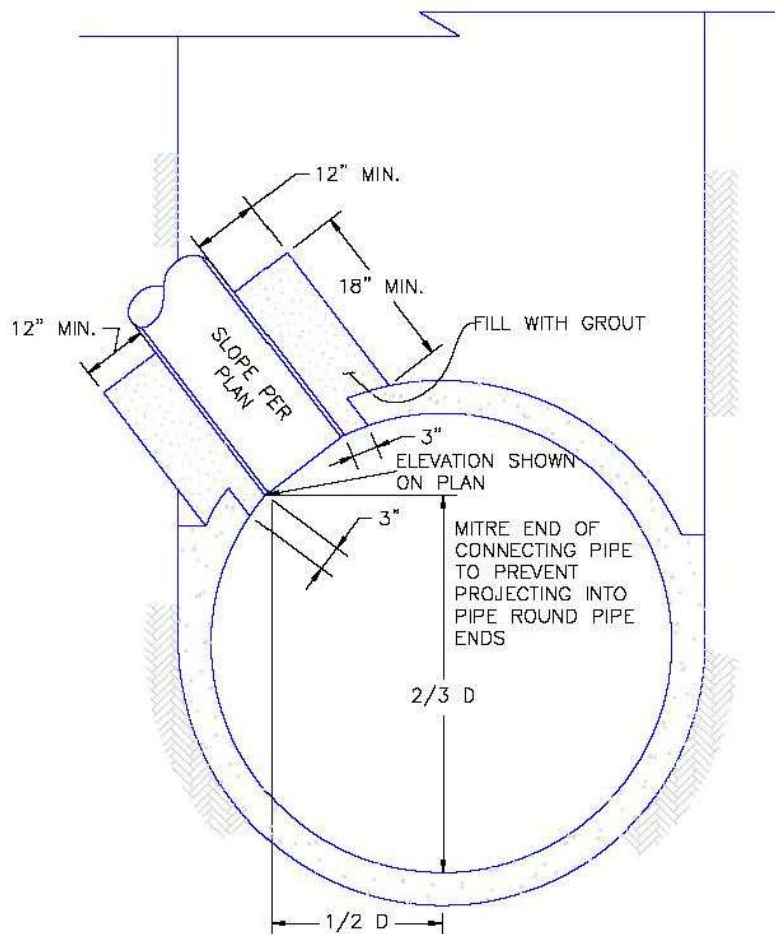

NOTE:

1. THE COMPRESSIVE STRENGTH OF CONCRETE MUST BE 4,000 PSI AT 28 DAYS OR BETTER.
2. MAXIMUM SLUMP SHALL BE 2".
3. TRENCH SIDES MUST STAND VERTICAL FROM THE BOTTOM OF THE TRENCH TO TWO FEET ABOVE THE TOP OF PIPE.
4. FULL TIME INSPECTION MUST BE PROVIDED TO ASSURE FULL COMPLIANCE.
5. 95% RELATIVE COMPACTION SHALL BE ACHIVED AND VERIFIED IN THE PIPE CONTACT SUPPORT AREA OF THE TRENCH.

- ENGINEERING CRITERIA MANUAL
Appendix F STANDARD DRAWINGS

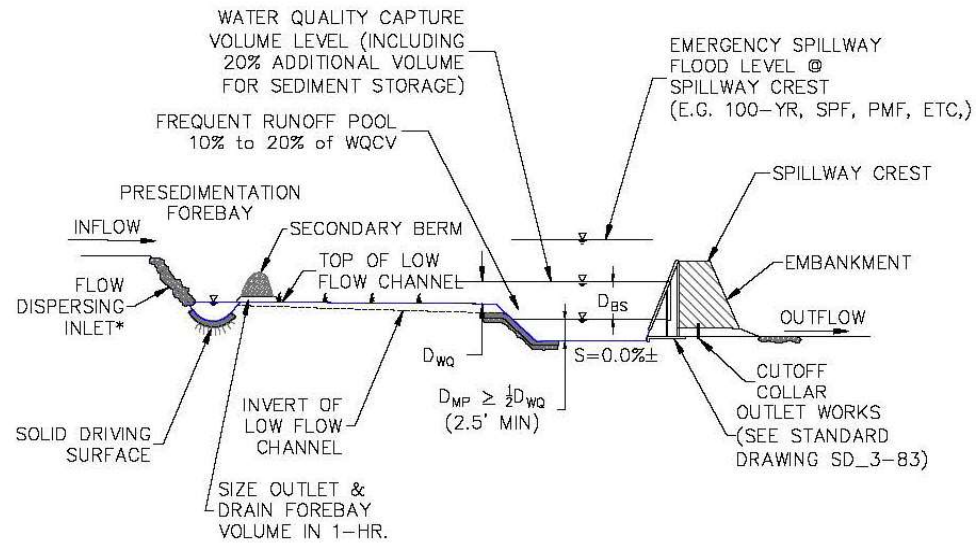
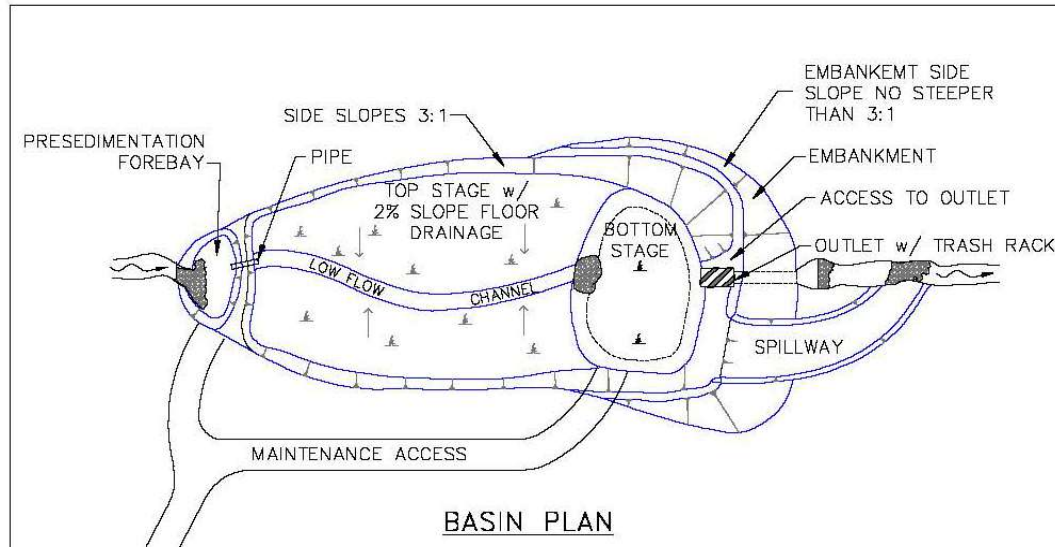

*COULD BE IMPACT BASIN, GSB DROP, CONCRETE RUNDOWN, OTHER HARDENED RUNDOWN

El Paso County, Colorado, Engine
(Supp. No. 2)

DATE APPROVED:
1/1/08
John A. McCarty

Plan & Section of an Extended
Detention Basin Sedimentation Facility
Standard Drawing



Maintenance access shall be designed and constructed to not contribute additional flow or sediment load directly to the forebay or outlet works.

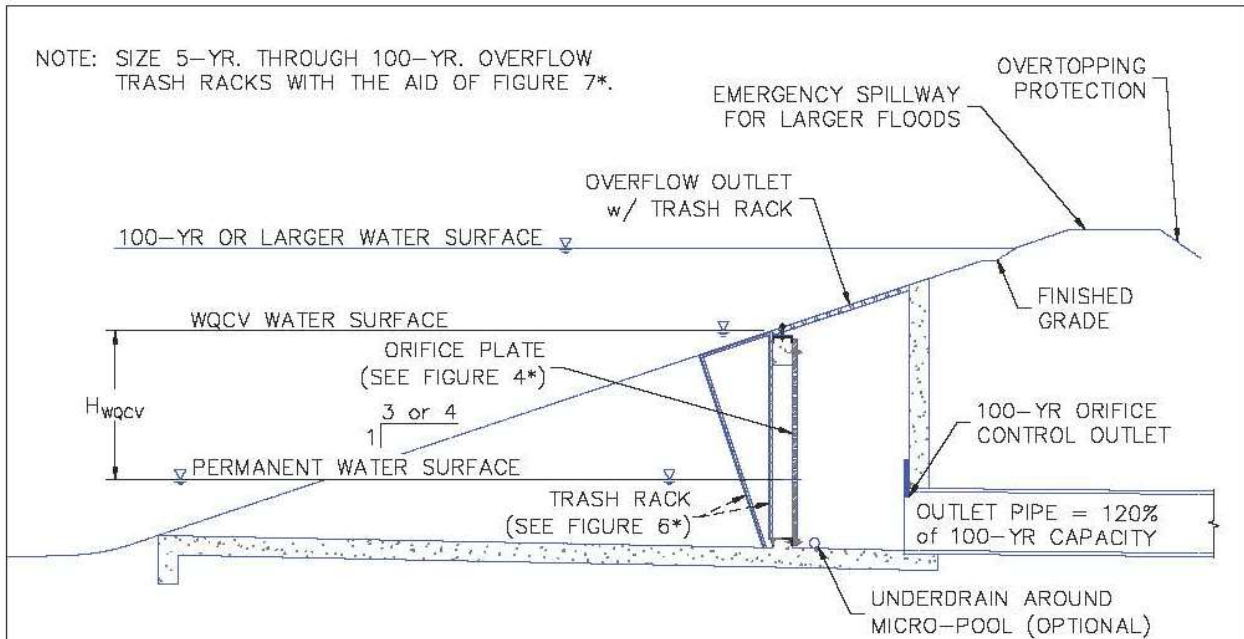

DROP BOX OUTLET OPTION

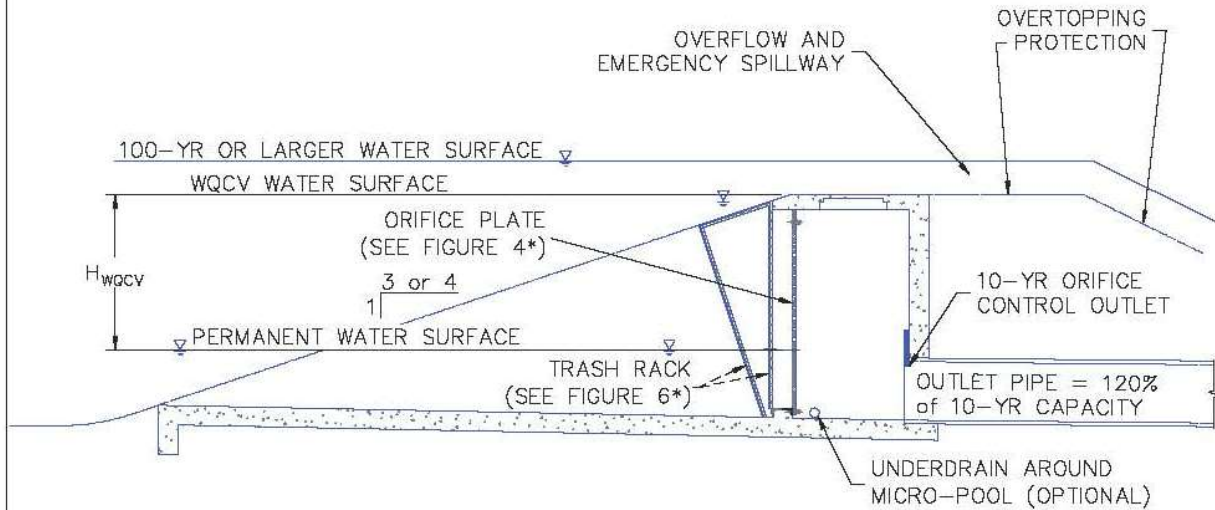

OVERTOPPING SPILLWAY OPTION

*FIGURES 4, 6 and 7 ARE IN THE CITY OF COLORADO SPRINGS ENGINEERING DIVISION'S DRAINAGE CRITERIA MANUAL, VOLUME 2.

<p align="center">1/1/08</p> <p>DATE APPROVED:</p> <p align="center">John A. McCarty</p> <p>DEPARTMENT OF TRANSPORTATION</p>	<p align="center">Typical WQCV Outlet Structure Profiles Including 100-Year Detention</p> <p align="center">Standard Drawing</p>	
	<p>REVISION DATE:</p> <p align="center">7/16/07</p>	

(Supp. No. 2)

- ENGINEERING CRITERIA MANUAL
Appendix F STANDARD DRAWINGS

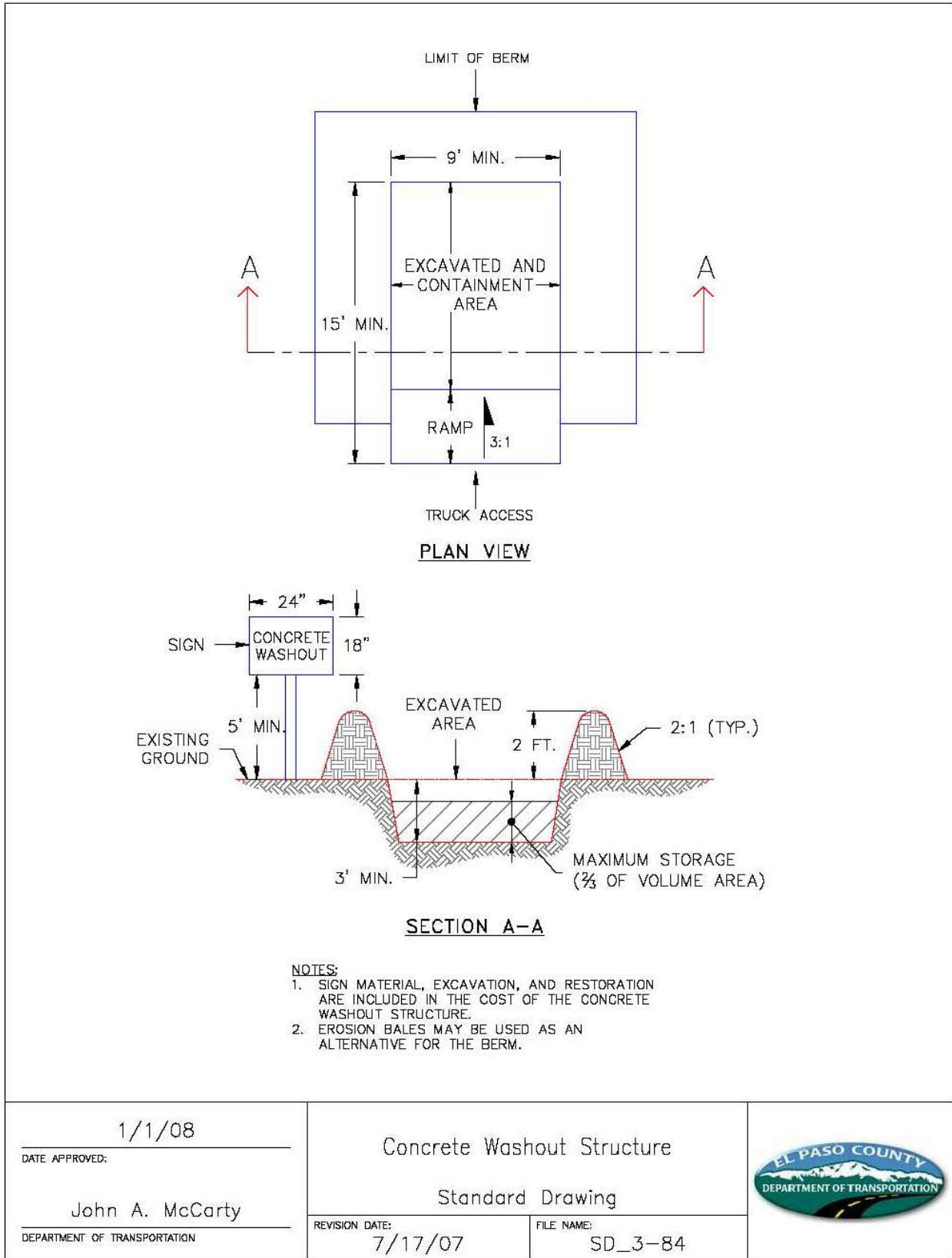

<p align="center">1/1/08</p> <p>DATE APPROVED:</p> <p align="center">John A. McCarty</p> <p>DEPARTMENT OF TRANSPORTATION</p>	<p align="center">Concrete Washout Structure</p> <p align="center">Standard Drawing</p>	
	<p>REVISION DATE:</p> <p align="center">7/17/07</p>	<p>FILE NAME:</p> <p align="center">SD_3-84</p>

(Supp. No. 2)

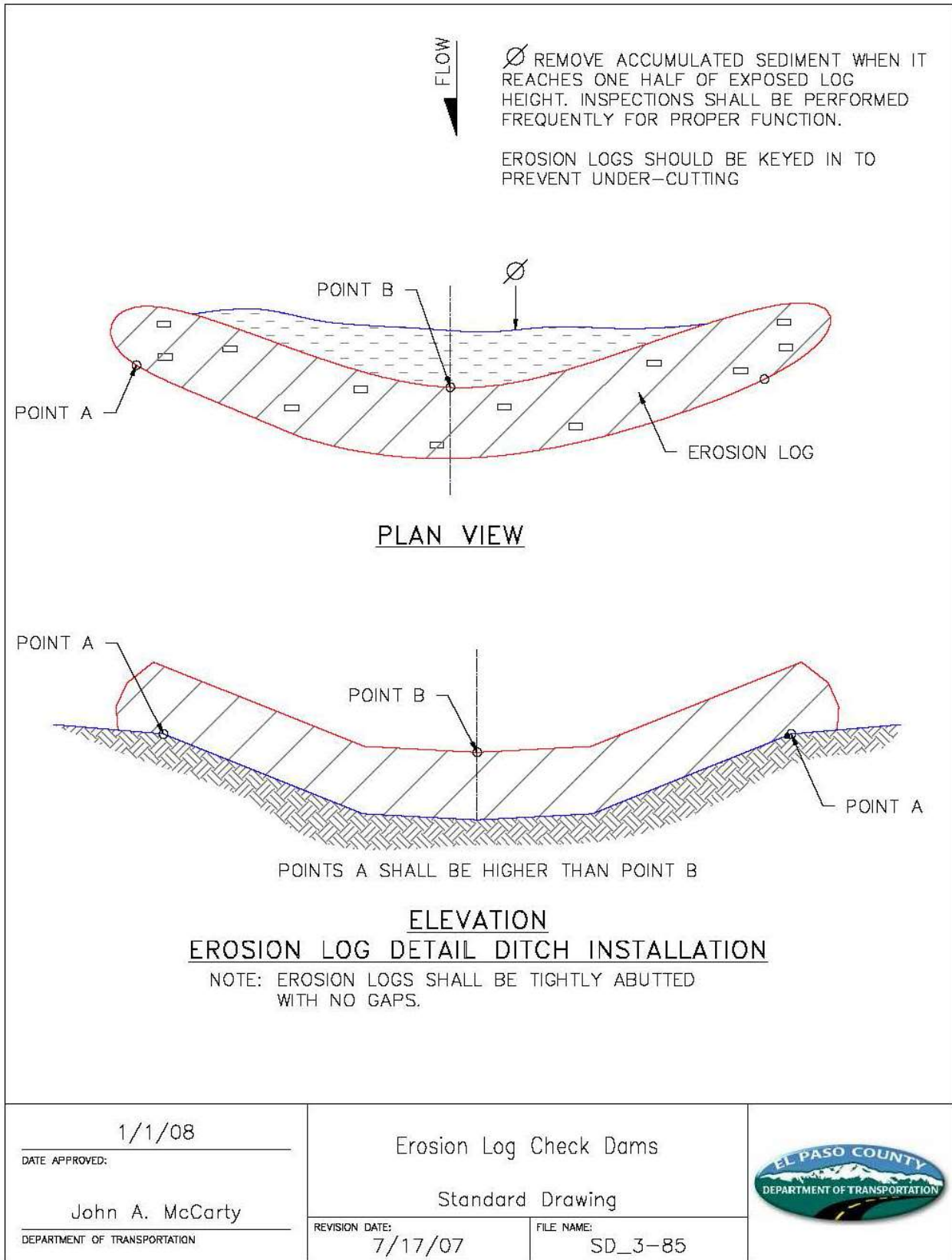

(Supp. No. 2)

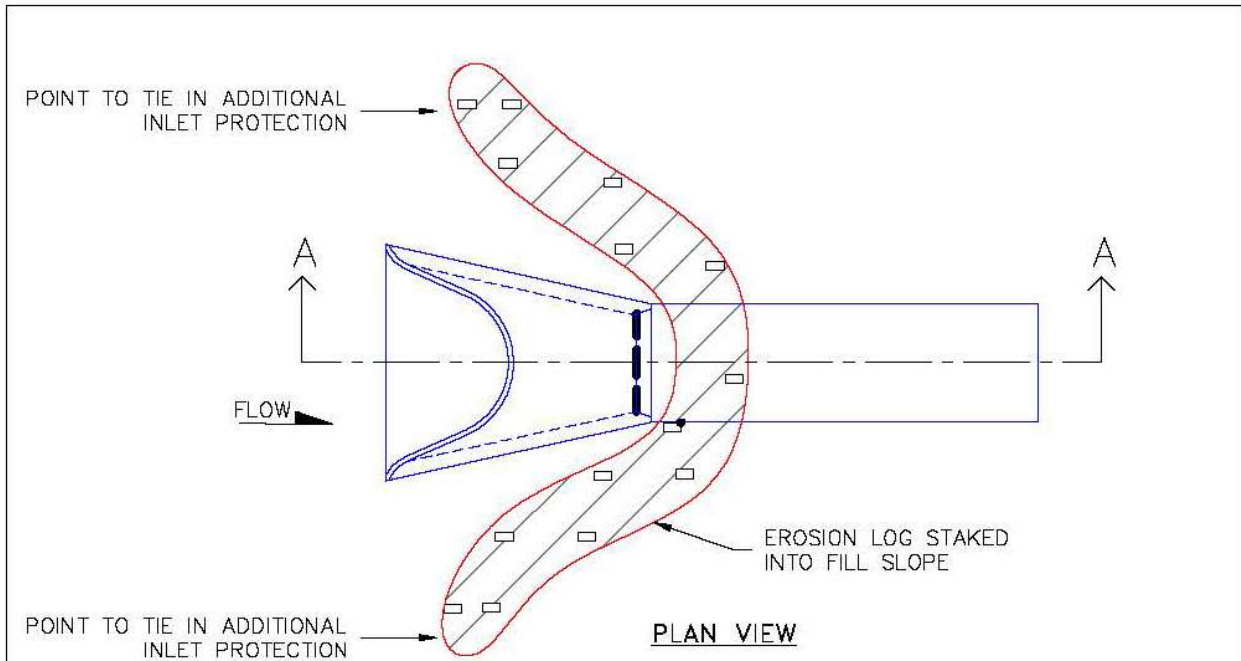

NOTE:

Ø REMOVE ACCUMULATED SEDIMENT WHEN IT REACHES ONE HALF OF EXPOSED LOG HEIGHT. INSPECTIONS SHALL BE PERFORMED FREQUENTLY FOR PROPER FUNCTION.

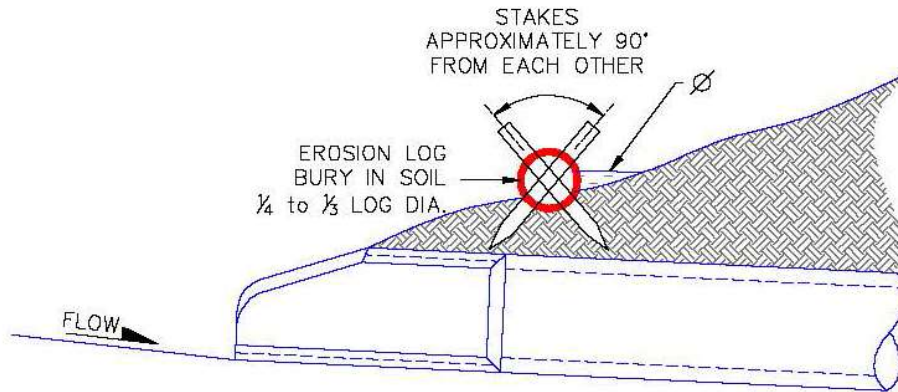

SECTION A-A

EROSION PROTECTION ABOVE CULVERT OUTLETS IS SIMILAR

EROSION LOGS SHOULD BE KEYED IN TO PREVENT UNDER-CUTTING

<p align="center">1/1/08</p> <p>DATE APPROVED:</p> <p align="center">John A. McCarty</p> <p>DEPARTMENT OF TRANSPORTATION</p>	<p align="center">Culvert Inlet and Outlet Protection Erosion Lags Above Inlets and Outlets For Slopes 3:1 or Steeper Standard Drawing</p> <p>REVISION DATE: 7/17/07</p> <p>FILE NAME: SD_3-86</p>	
--	--	---

(Supp. No. 2)

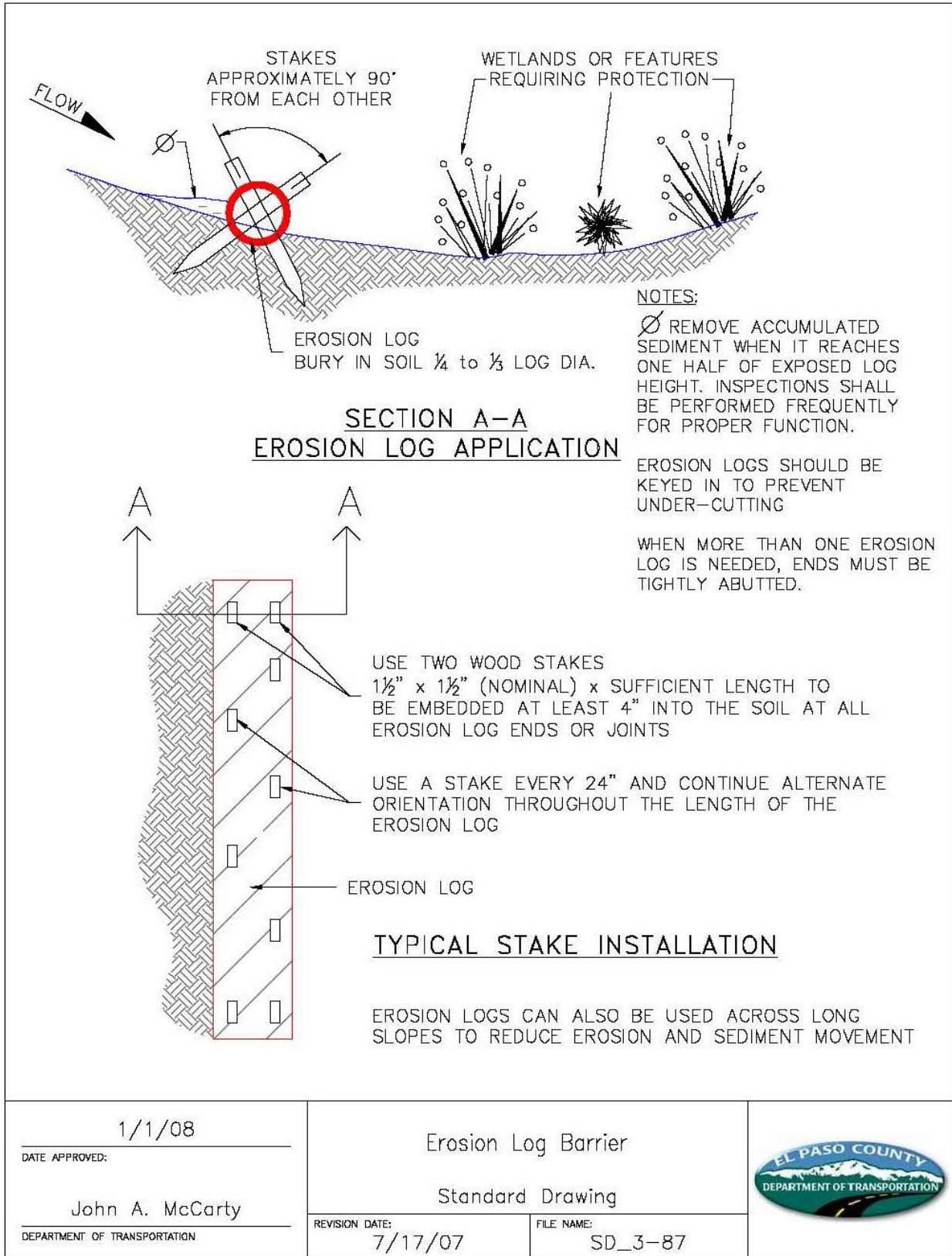

(Supp. No. 2)

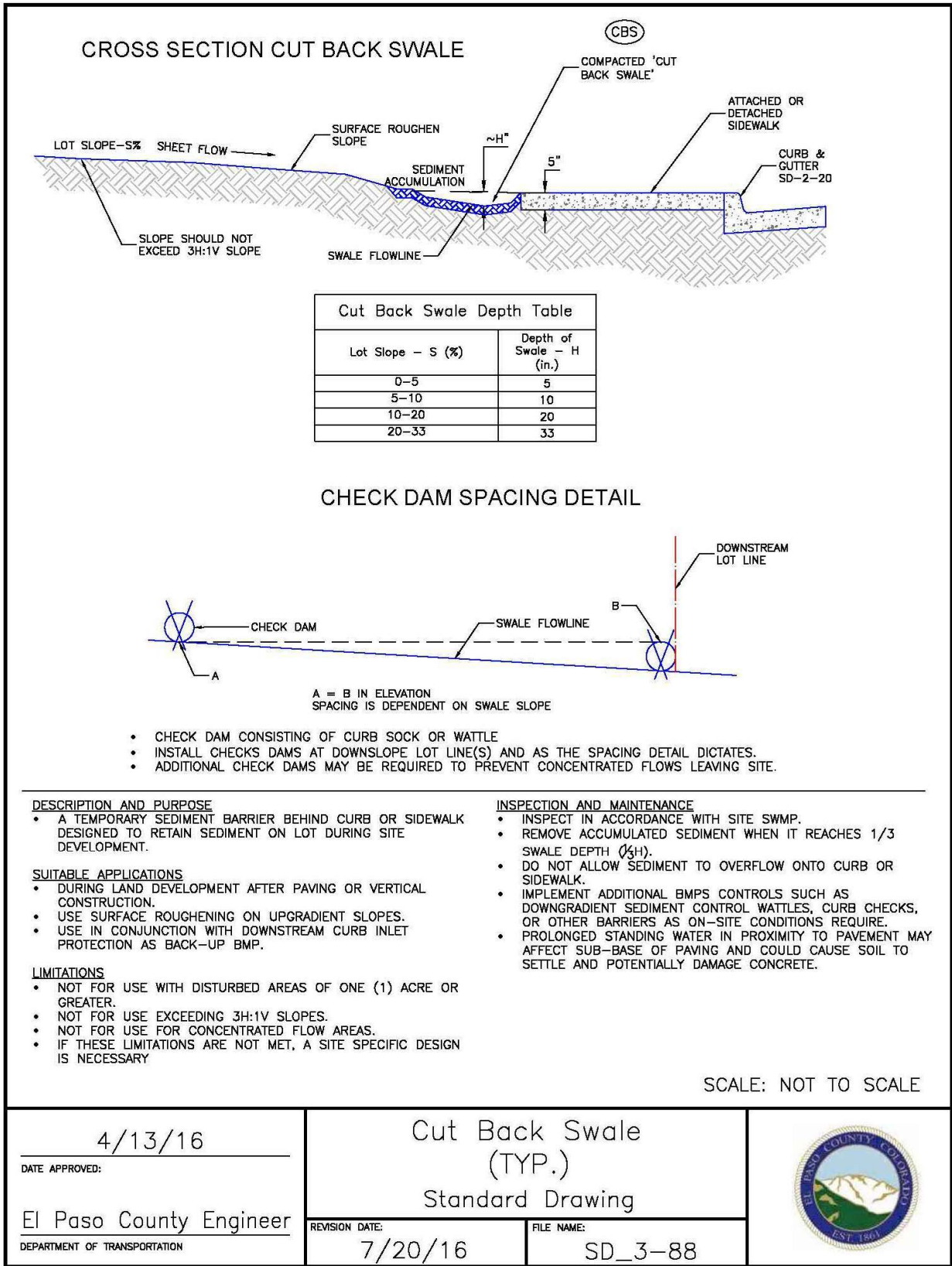

(Supp. No. 2)

- ENGINEERING CRITERIA MANUAL
Appendix F STANDARD DRAWINGS

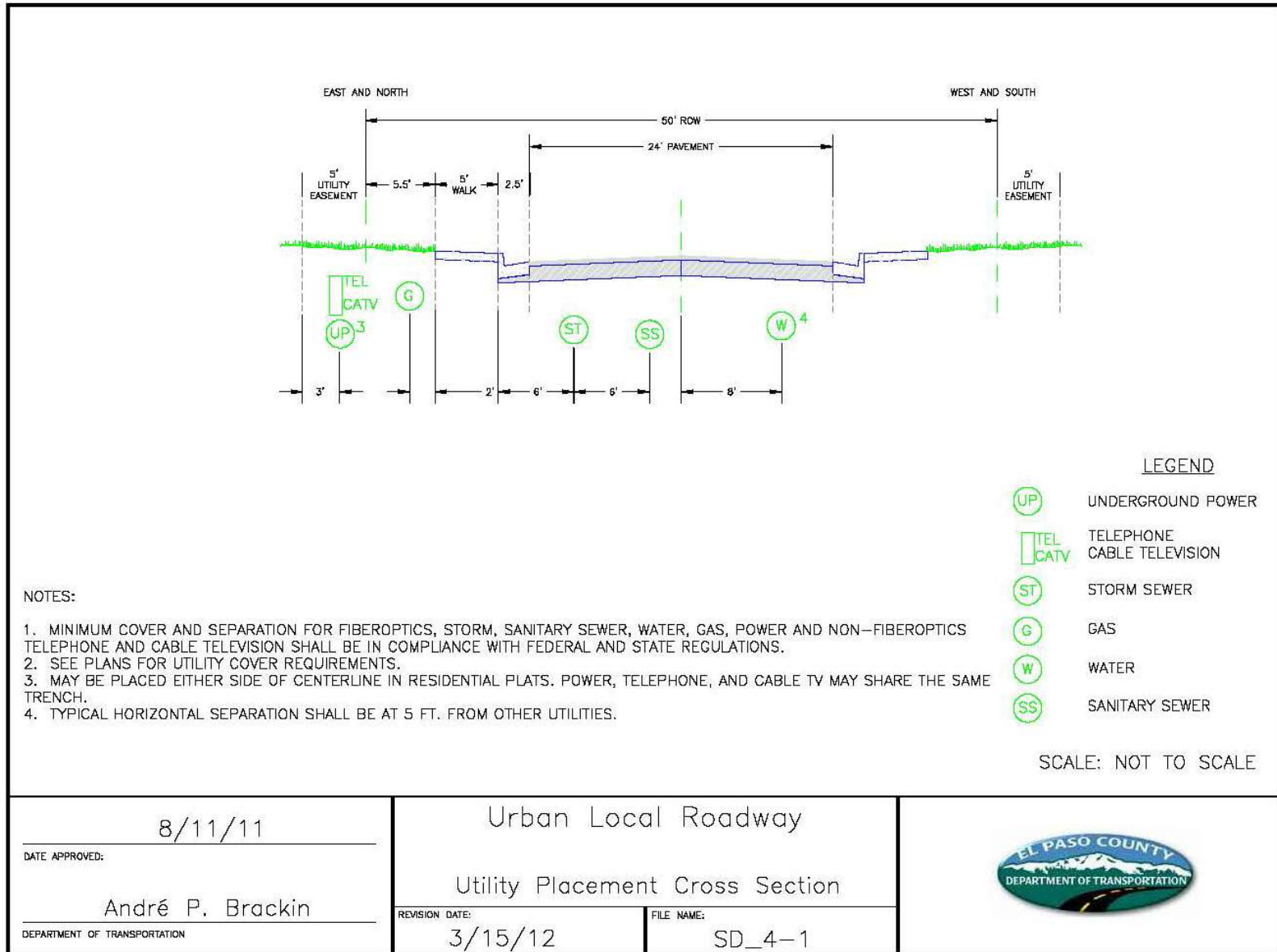

El Paso
(Supp. No. 2)

- ENGINEERING CRITERIA MANUAL
Appendix F STANDARD DRAWINGS

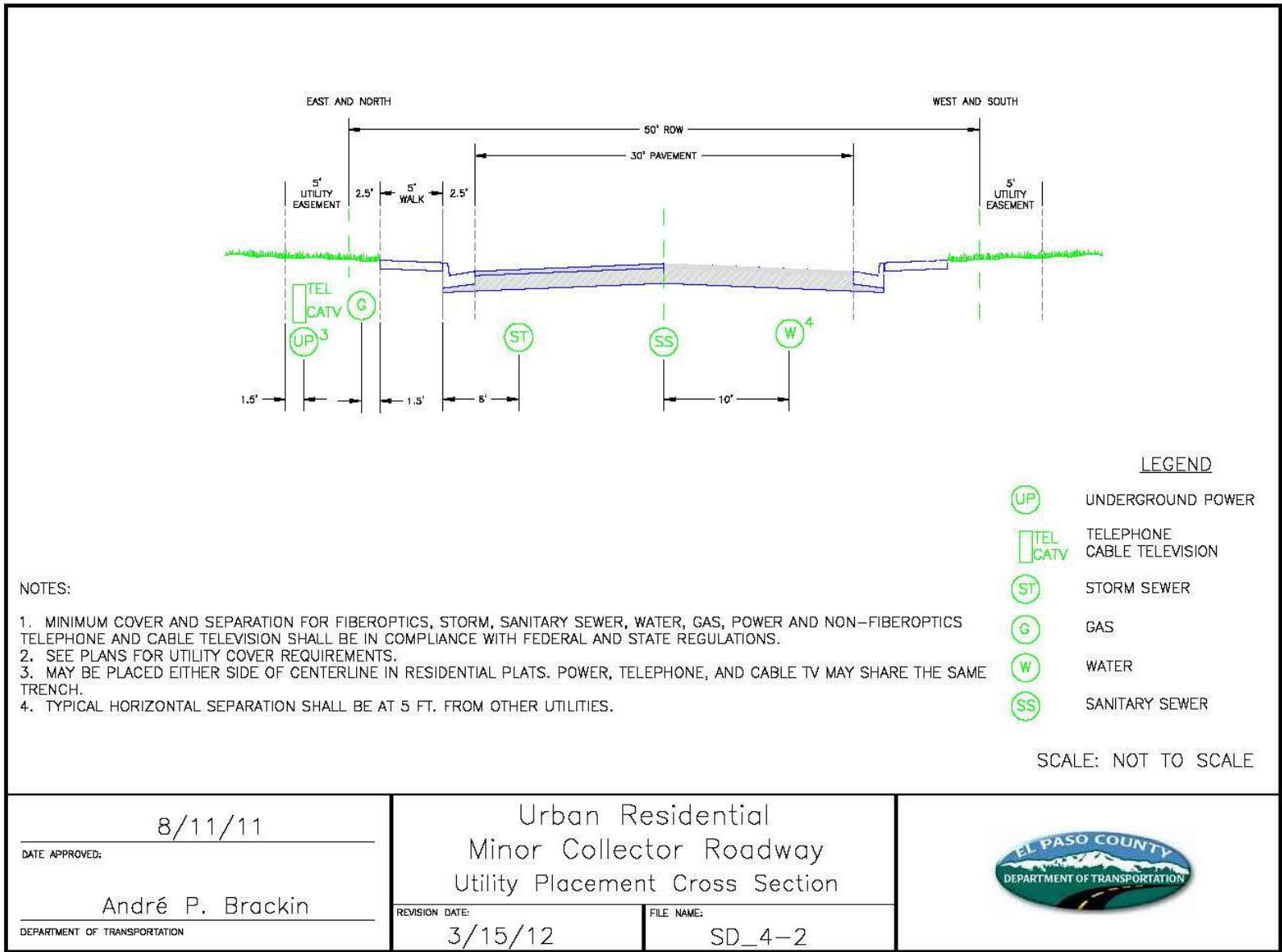

El Paso
(Supp. No. 2)

- ENGINEERING CRITERIA MANUAL
Appendix F STANDARD DRAWINGS

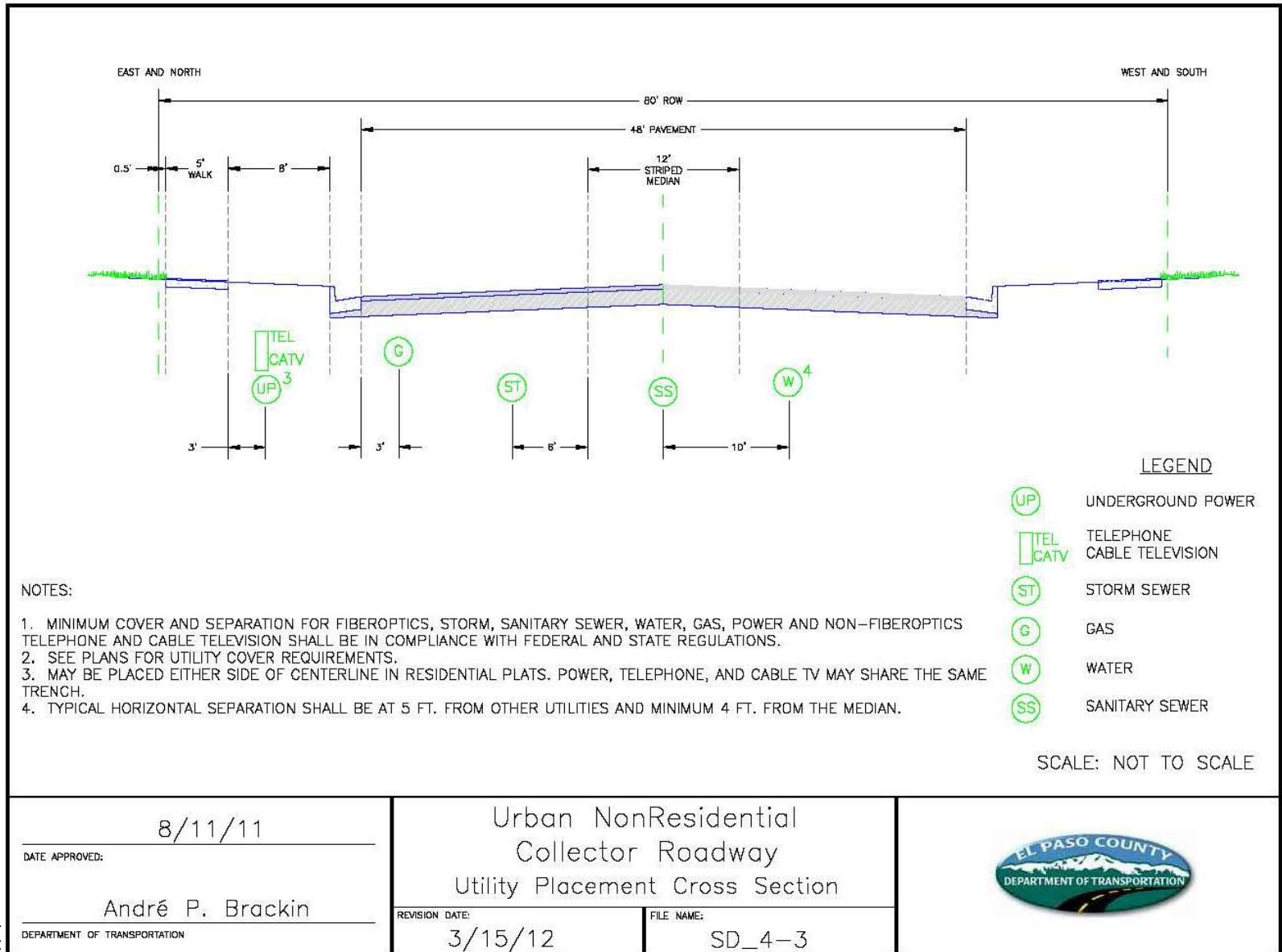

El Paso
(Supp. No. 2)

- ENGINEERING CRITERIA MANUAL
Appendix F STANDARD DRAWINGS

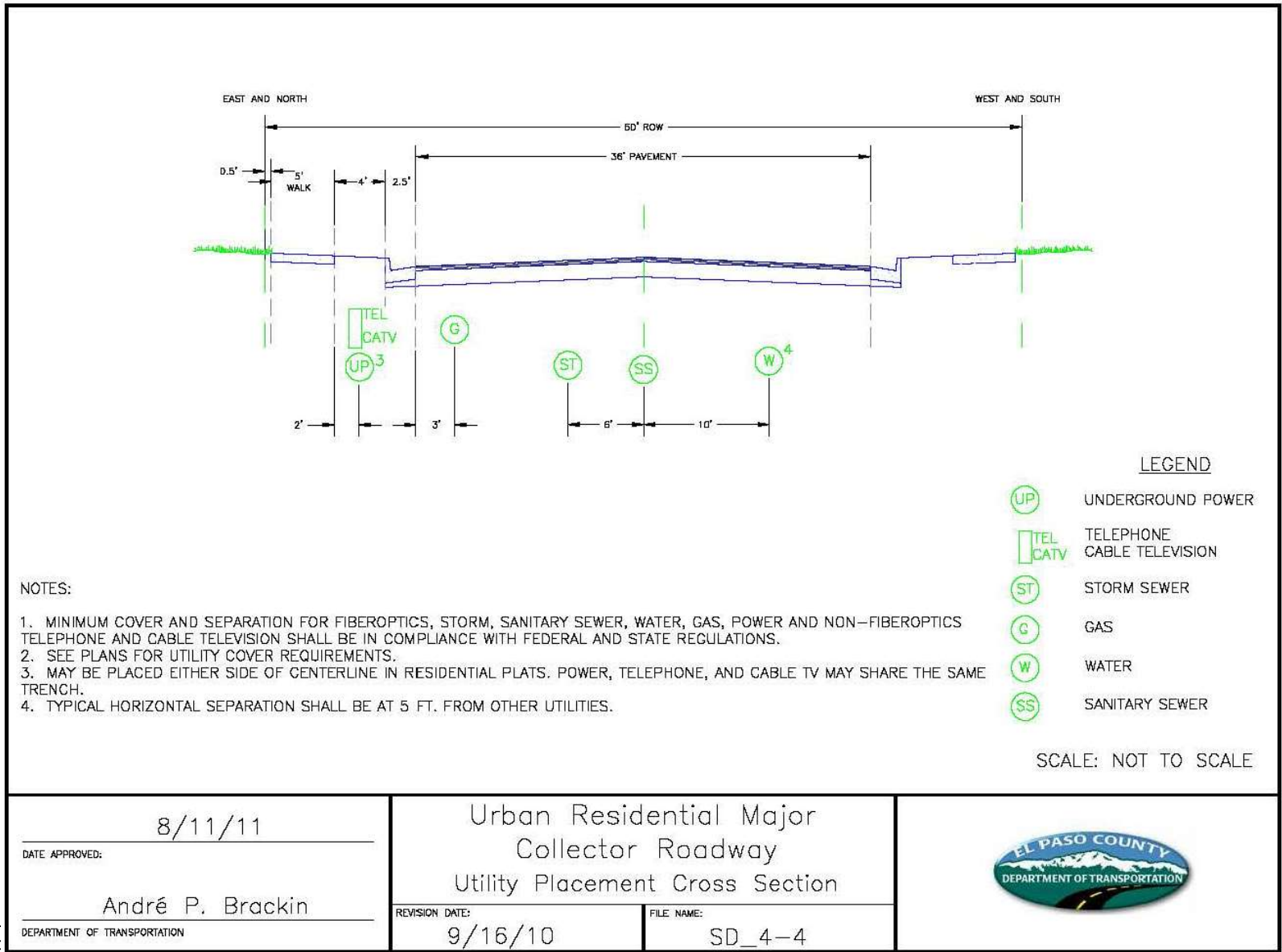

El Pas
(Supp. No. 2)

- ENGINEERING CRITERIA MANUAL
Appendix F STANDARD DRAWINGS

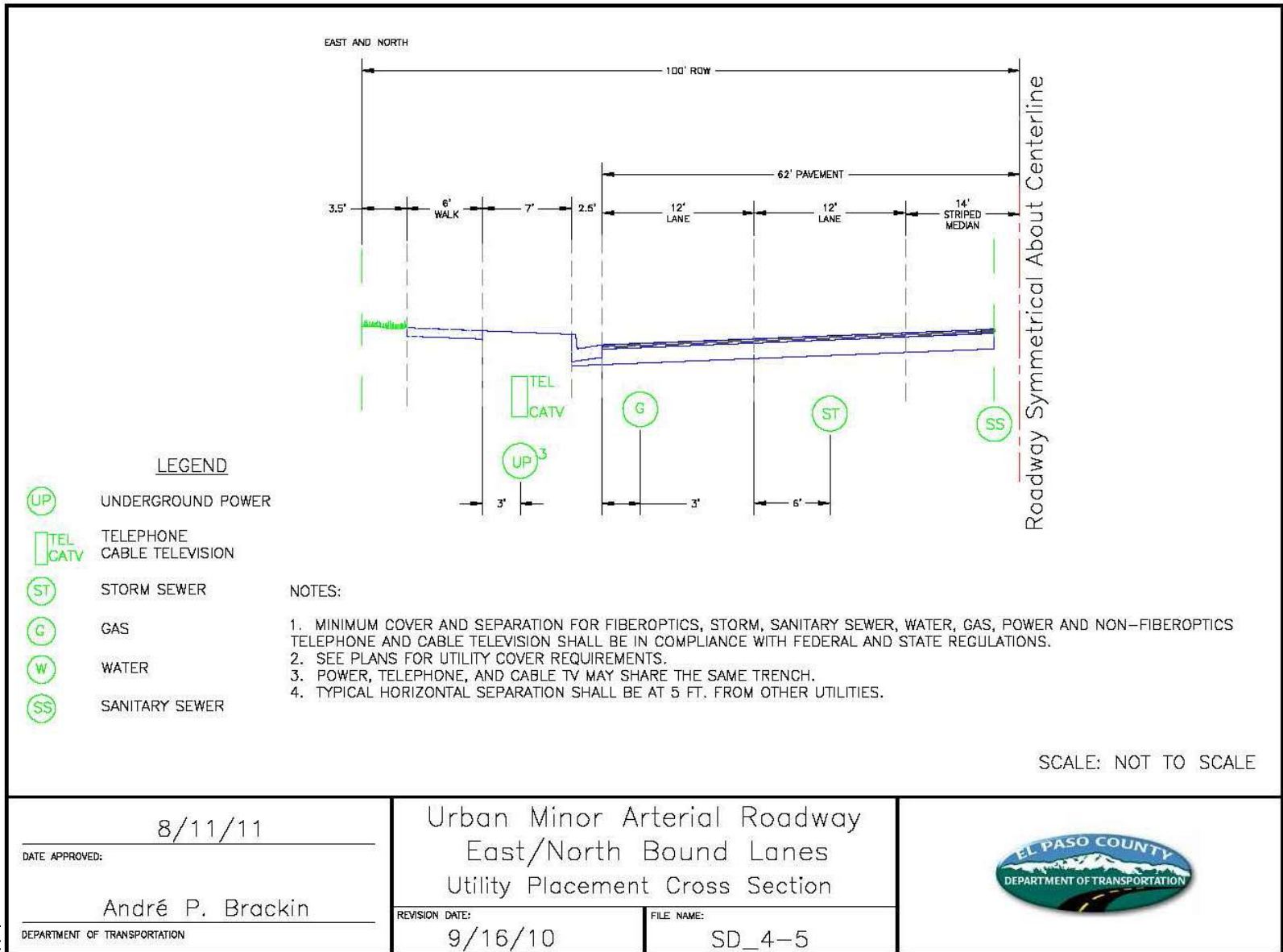

- ENGINEERING CRITERIA MANUAL
Appendix F STANDARD DRAWINGS

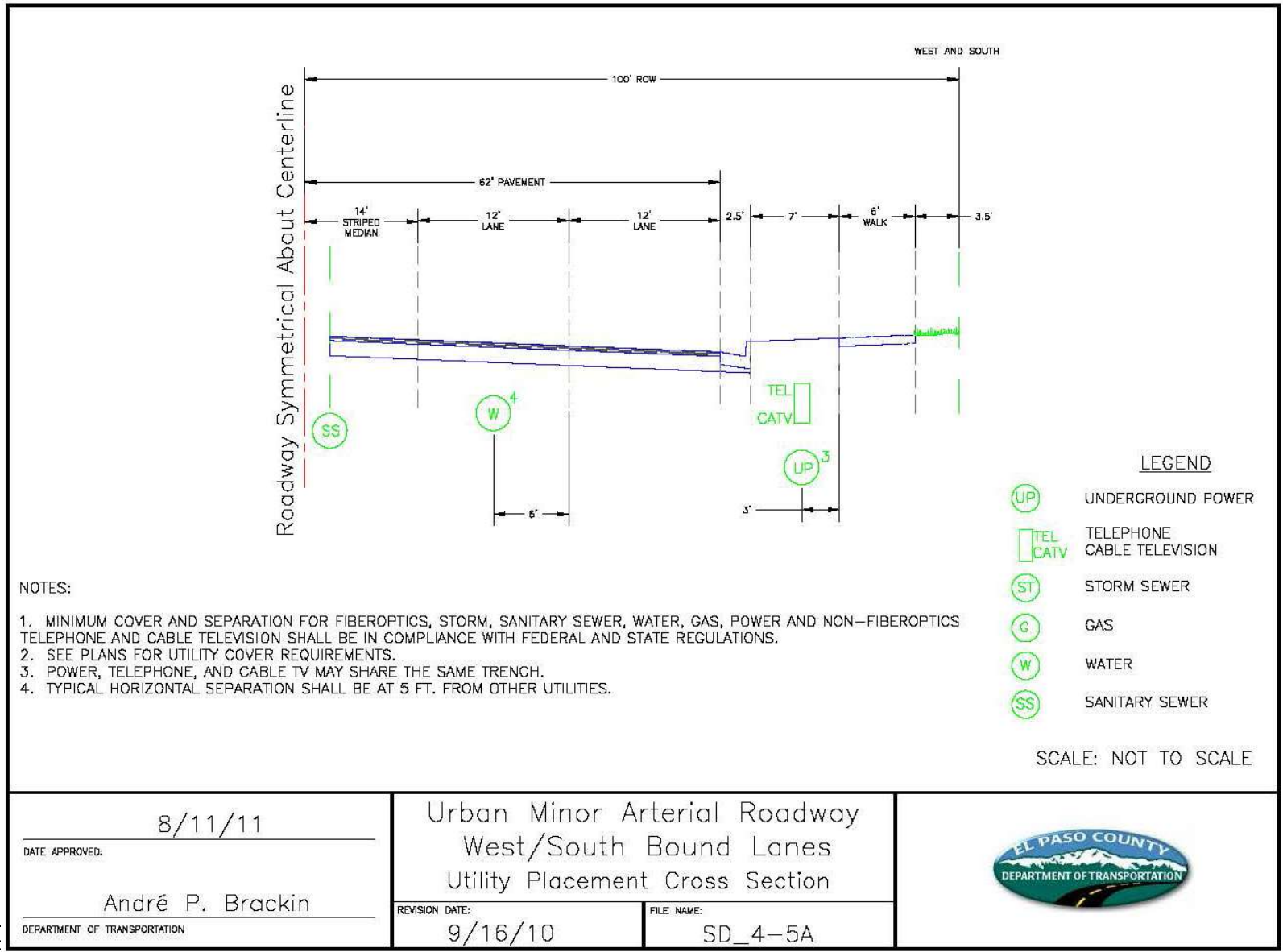

El Paso
(Supp. No. 2)

- ENGINEERING CRITERIA MANUAL
Appendix F STANDARD DRAWINGS

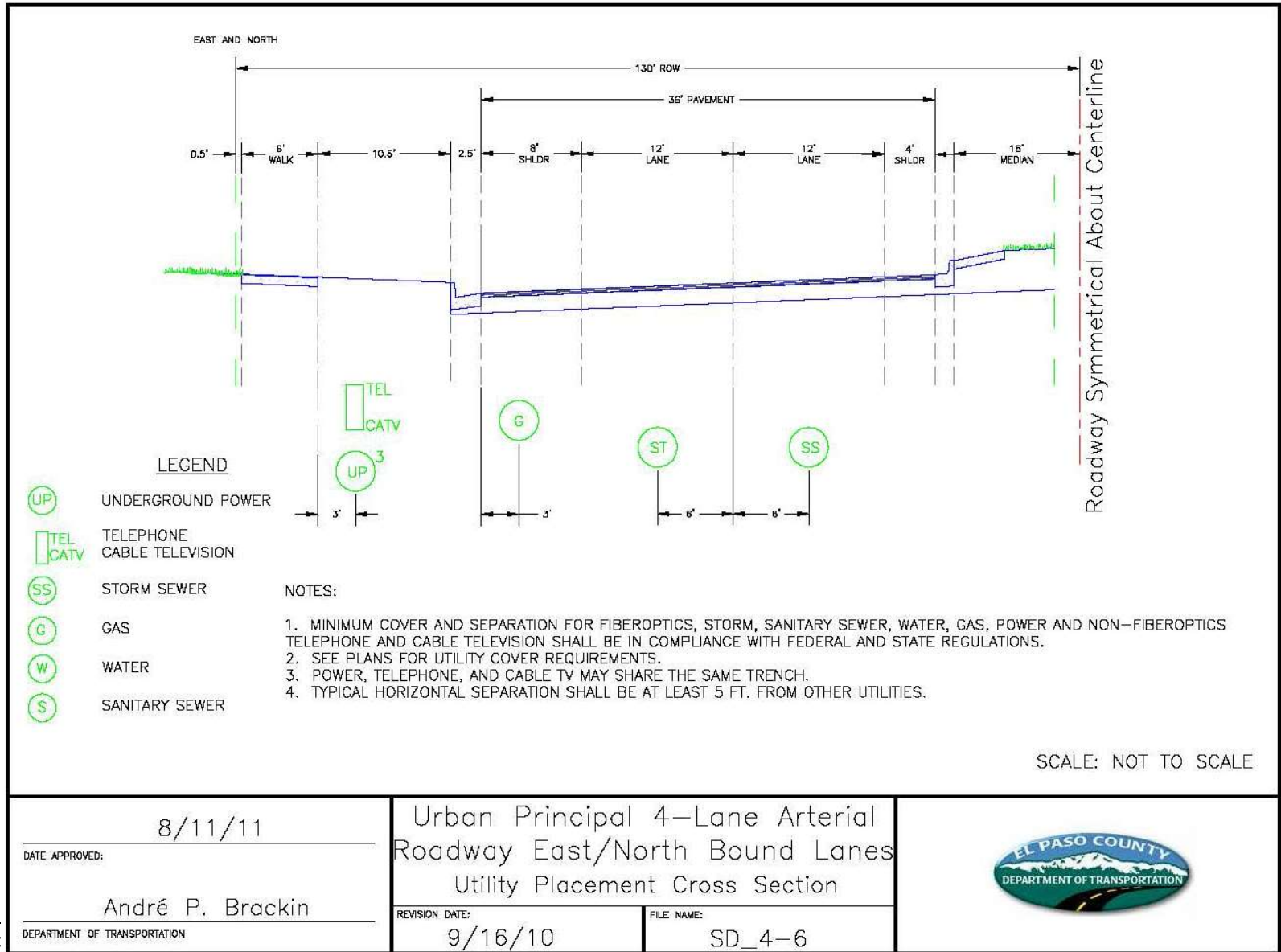

El Paso
(Supp. No. 2)

- ENGINEERING CRITERIA MANUAL
Appendix F STANDARD DRAWINGS

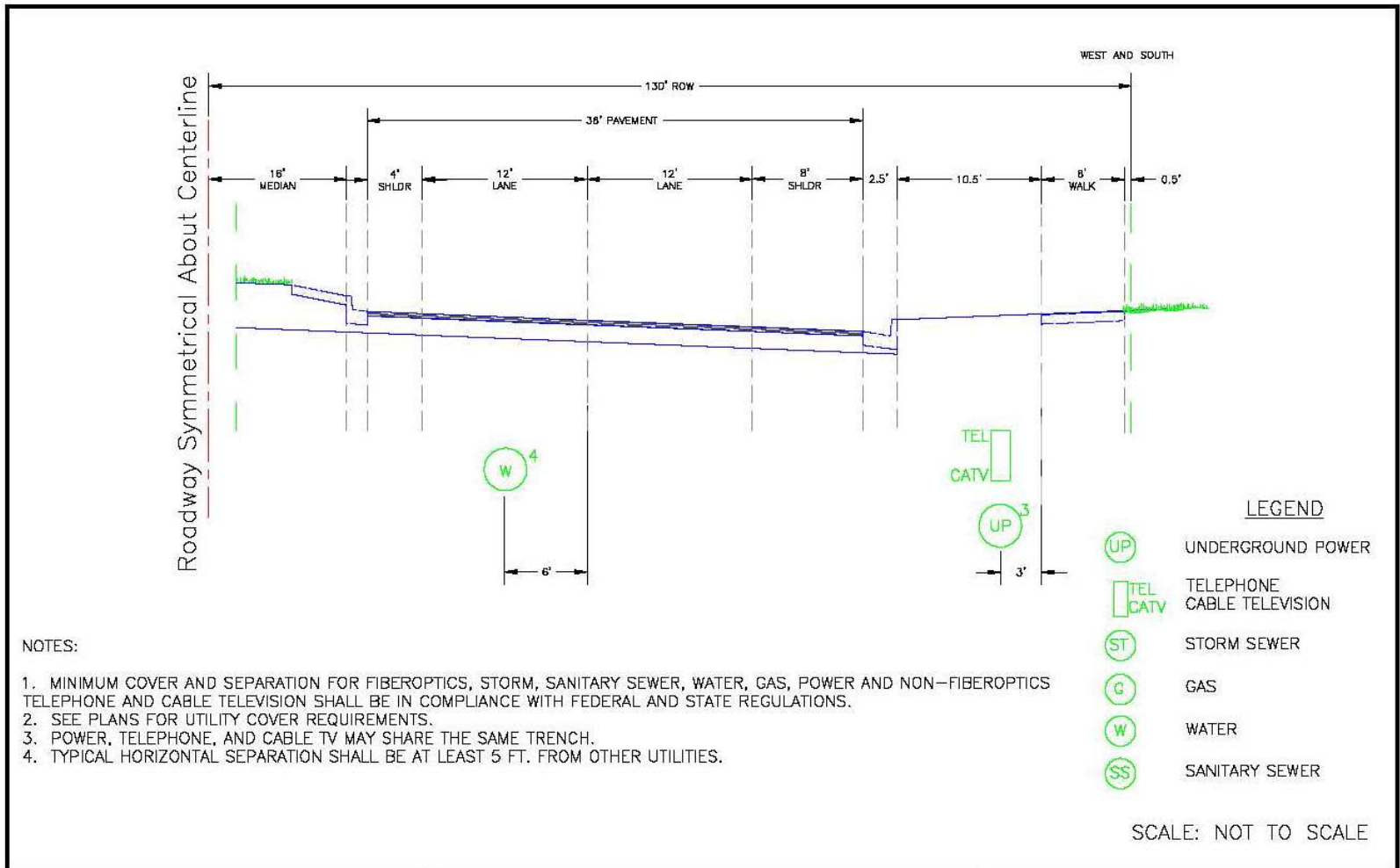

NOTES:

1. MINIMUM COVER AND SEPARATION FOR FIBEROPTICS, STORM, SANITARY SEWER, WATER, GAS, POWER AND NON-FIBEROPTICS TELEPHONE AND CABLE TELEVISION SHALL BE IN COMPLIANCE WITH FEDERAL AND STATE REGULATIONS.
2. SEE PLANS FOR UTILITY COVER REQUIREMENTS.
3. POWER, TELEPHONE, AND CABLE TV MAY SHARE THE SAME TRENCH.
4. TYPICAL HORIZONTAL SEPARATION SHALL BE AT LEAST 5 FT. FROM OTHER UTILITIES.

<p align="center">8/11/11</p> <p>DATE APPROVED:</p> <p align="center">André P. Brackin</p> <p>DEPARTMENT OF TRANSPORTATION</p>	<p align="center">Urban Principal 4-Lane Arterial Roadway West/South Bound Lanes Utility Placement Cross Section</p> <p>REVISION DATE: 9/16/10</p> <p>FILE NAME: SD_4-6A</p>	
--	--	---

El Paso
(Supp. No. 2)

- ENGINEERING CRITERIA MANUAL
Appendix F STANDARD DRAWINGS

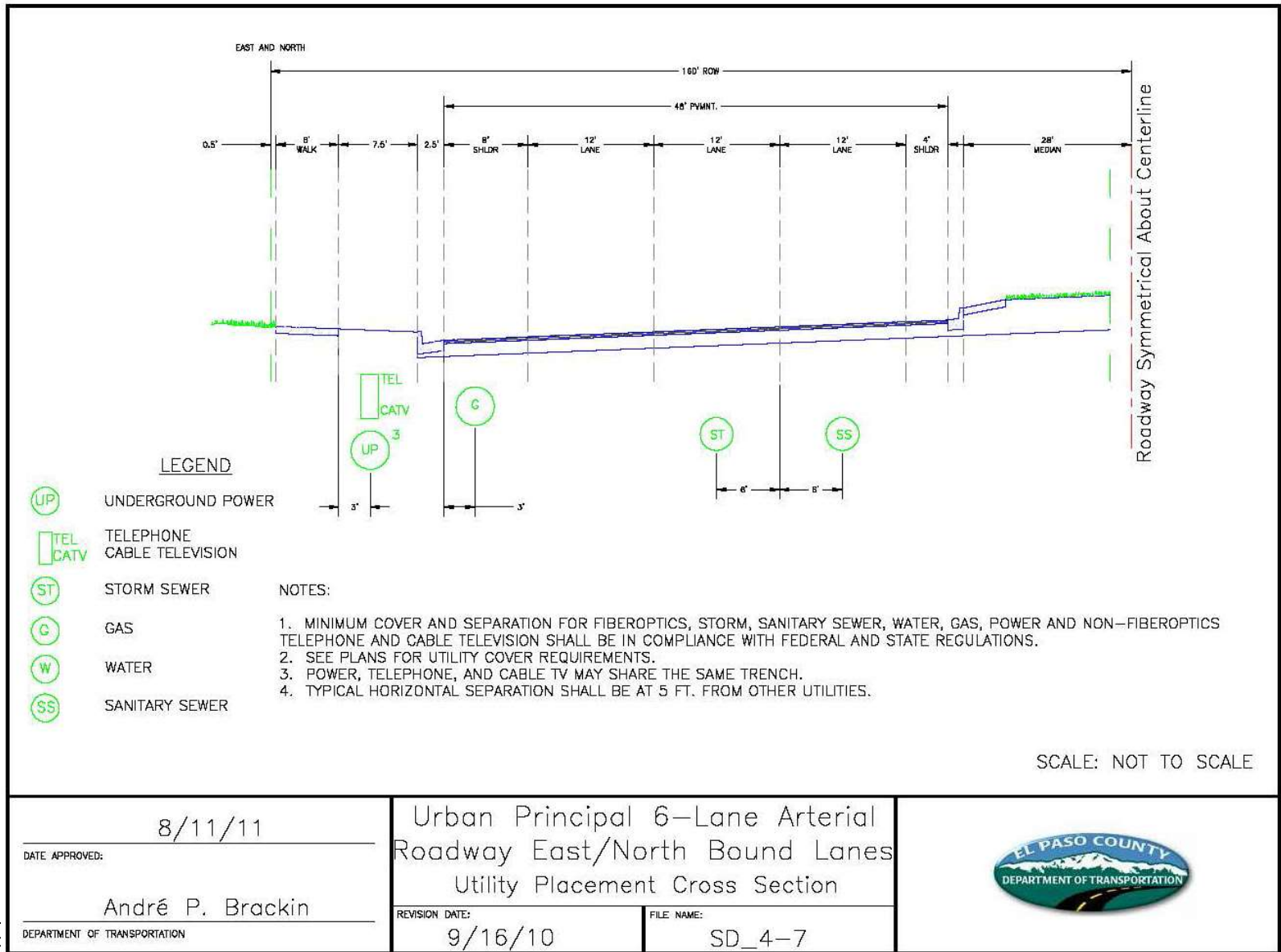

El Paso
(Supp. No. 2)

- ENGINEERING CRITERIA MANUAL
Appendix F STANDARD DRAWINGS

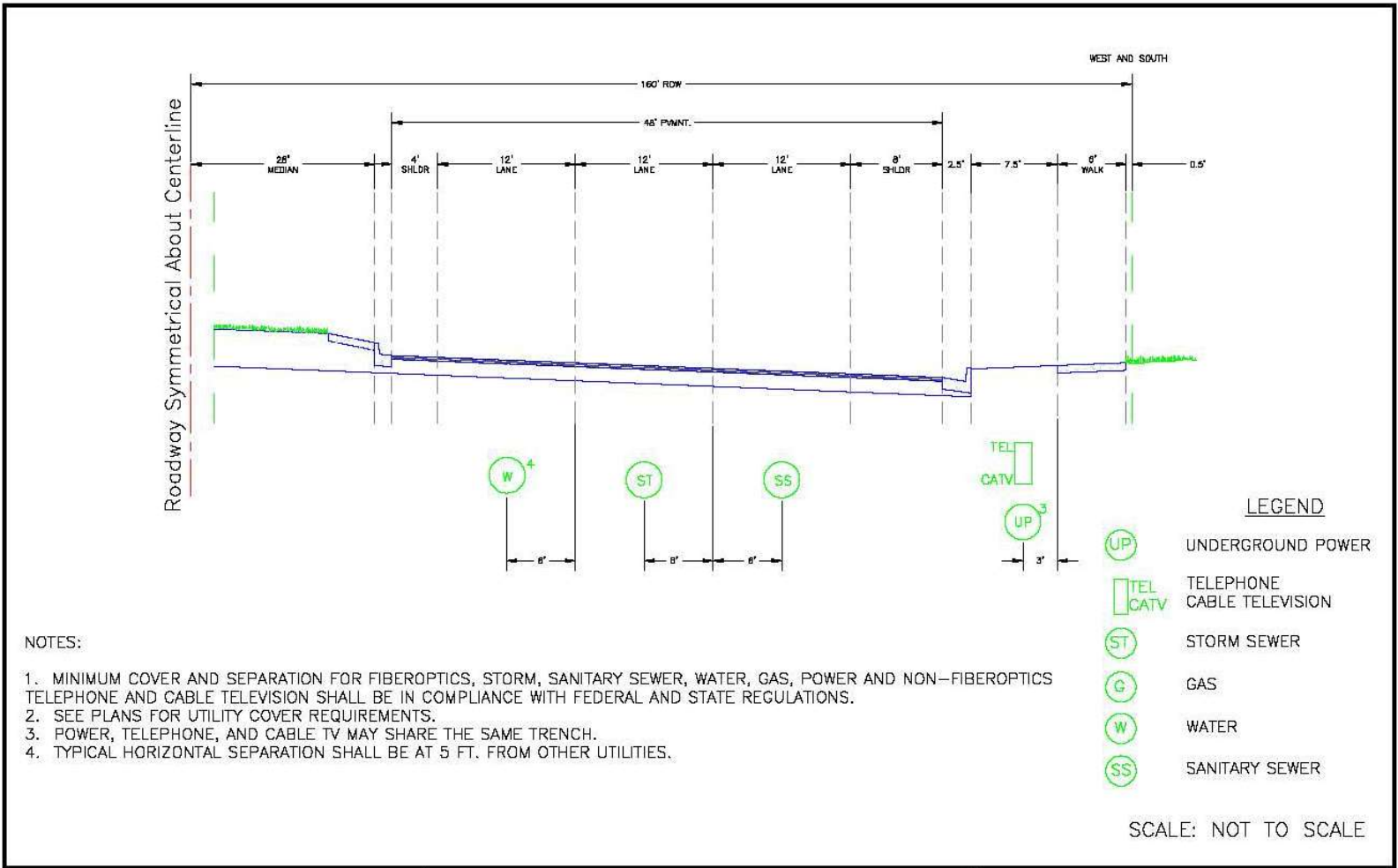

NOTES:

1. MINIMUM COVER AND SEPARATION FOR FIBEROPTICS, STORM, SANITARY SEWER, WATER, GAS, POWER AND NON-FIBEROPTICS TELEPHONE AND CABLE TELEVISION SHALL BE IN COMPLIANCE WITH FEDERAL AND STATE REGULATIONS.
2. SEE PLANS FOR UTILITY COVER REQUIREMENTS.
3. POWER, TELEPHONE, AND CABLE TV MAY SHARE THE SAME TRENCH.
4. TYPICAL HORIZONTAL SEPARATION SHALL BE AT 5 FT. FROM OTHER UTILITIES.

<p align="center">8/11/11</p> <p>DATE APPROVED:</p> <p align="center">André P. Brackin</p> <p>DEPARTMENT OF TRANSPORTATION</p>	<p align="center">Urban Principal 6-Lane Arterial Roadway West/South Bound Lanes Utility Placement Cross Section</p> <p>REVISION DATE: 9/16/10</p> <p>FILE NAME: SD_4-7A</p>	
--	--	---

El Paso
(Supp. No. 2)

- ENGINEERING CRITERIA MANUAL
Appendix F STANDARD DRAWINGS

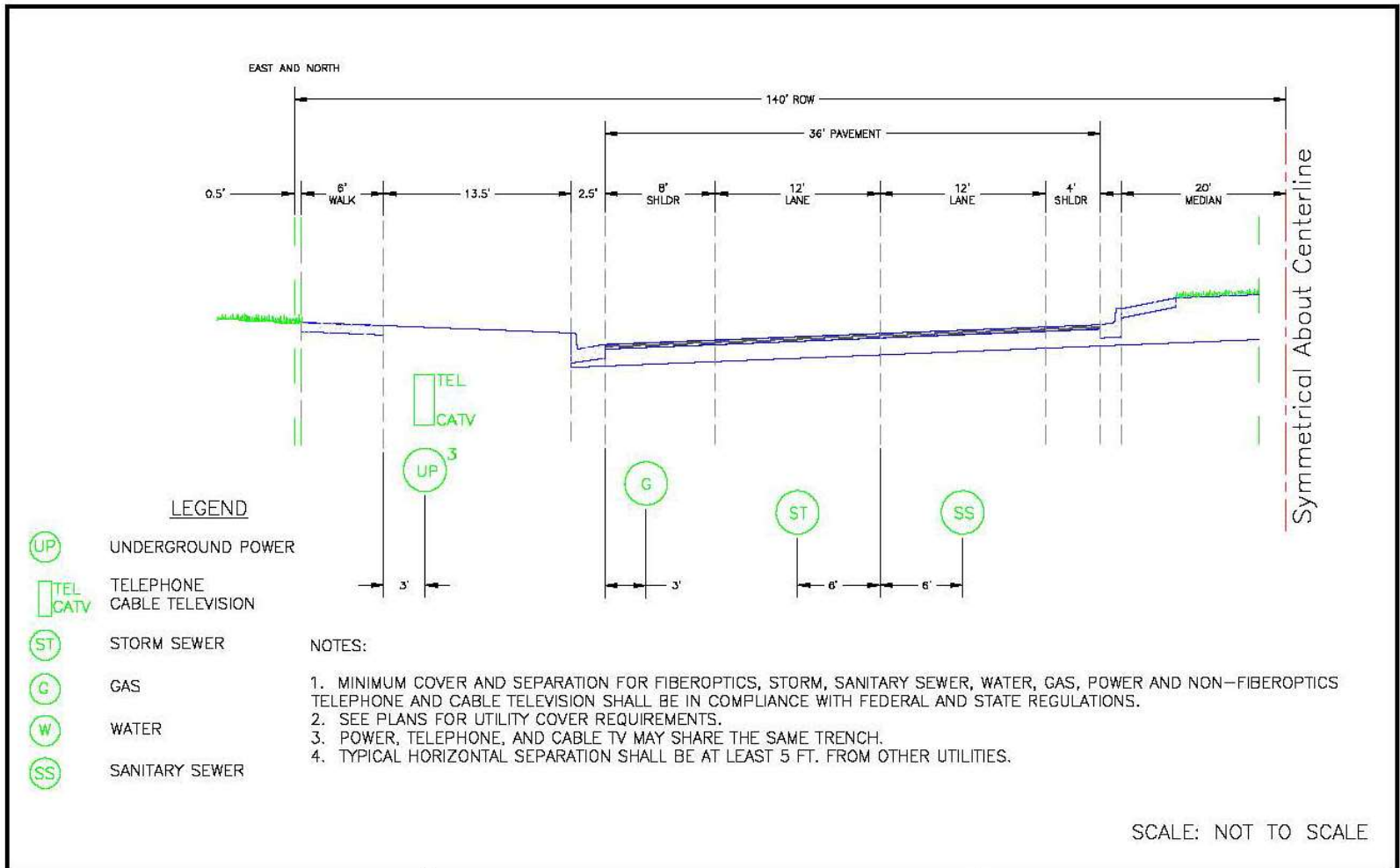

<p align="center">8/11/11</p> <p>DATE APPROVED:</p> <p align="center">André P. Brackin</p> <p>DEPARTMENT OF TRANSPORTATION</p>	<p align="center">Urban Expressway 4-Lane Roadway East/North Bound Lanes Utility Placement Cross Section</p> <p>REVISION DATE: 9/16/10</p> <p>FILE NAME: SD_4-8</p>	
--	---	---

El Paso
(Supp. No. 2)

- ENGINEERING CRITERIA MANUAL
Appendix F STANDARD DRAWINGS

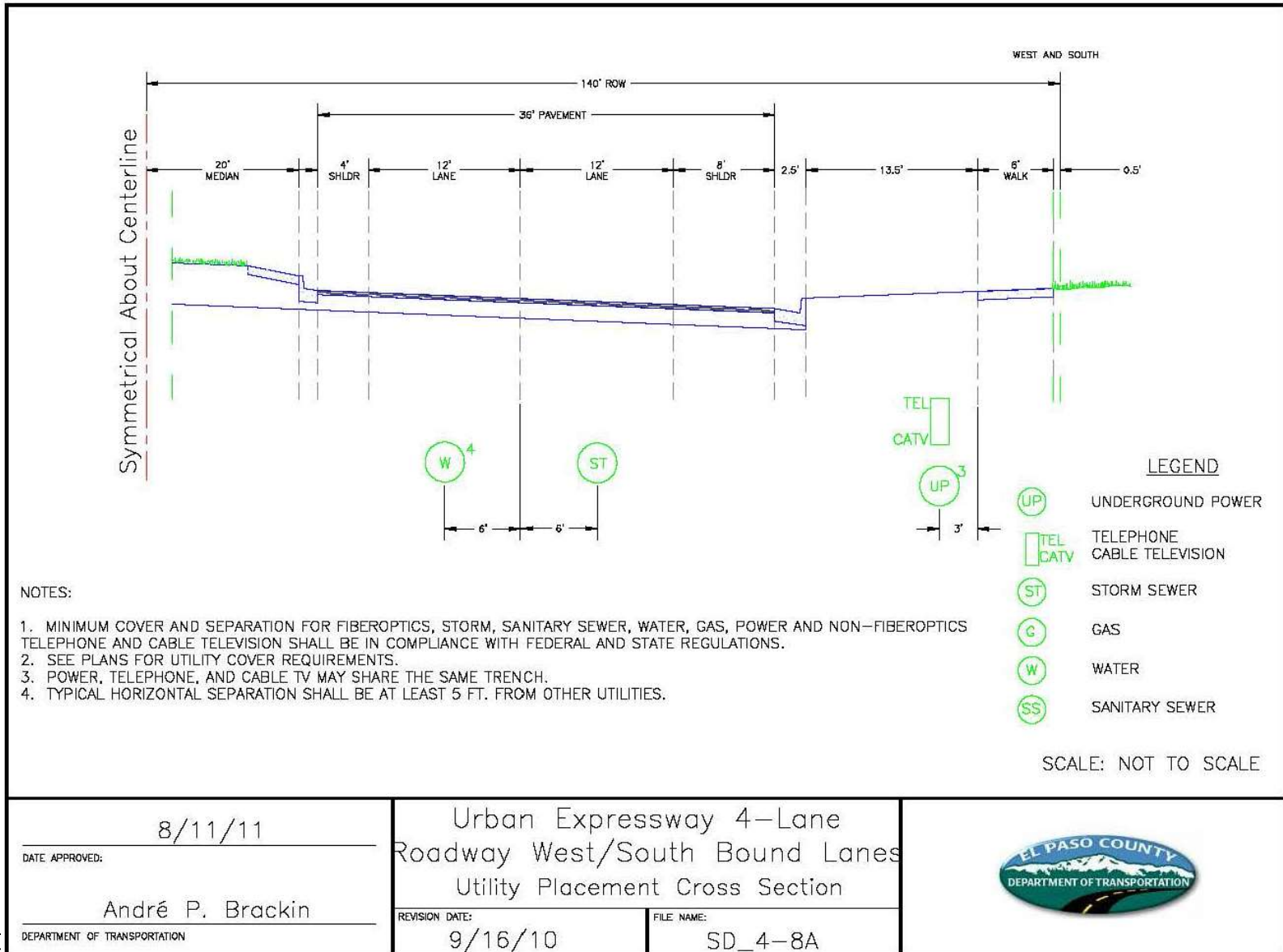

El Paso
(Supp. No. 2)

- ENGINEERING CRITERIA MANUAL
Appendix F STANDARD DRAWINGS

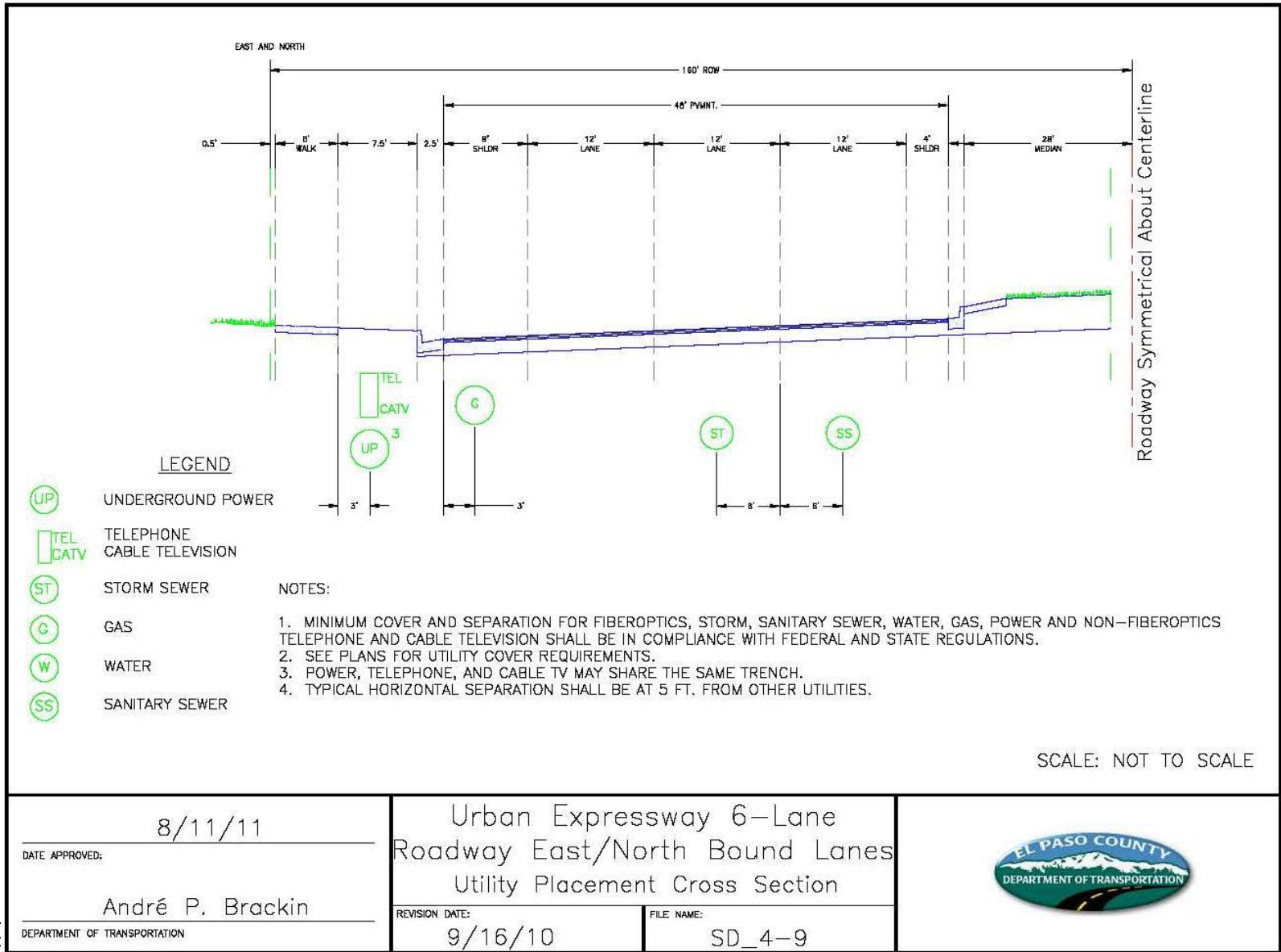

El Paso
(Supp. No. 2)

- ENGINEERING CRITERIA MANUAL
Appendix F STANDARD DRAWINGS

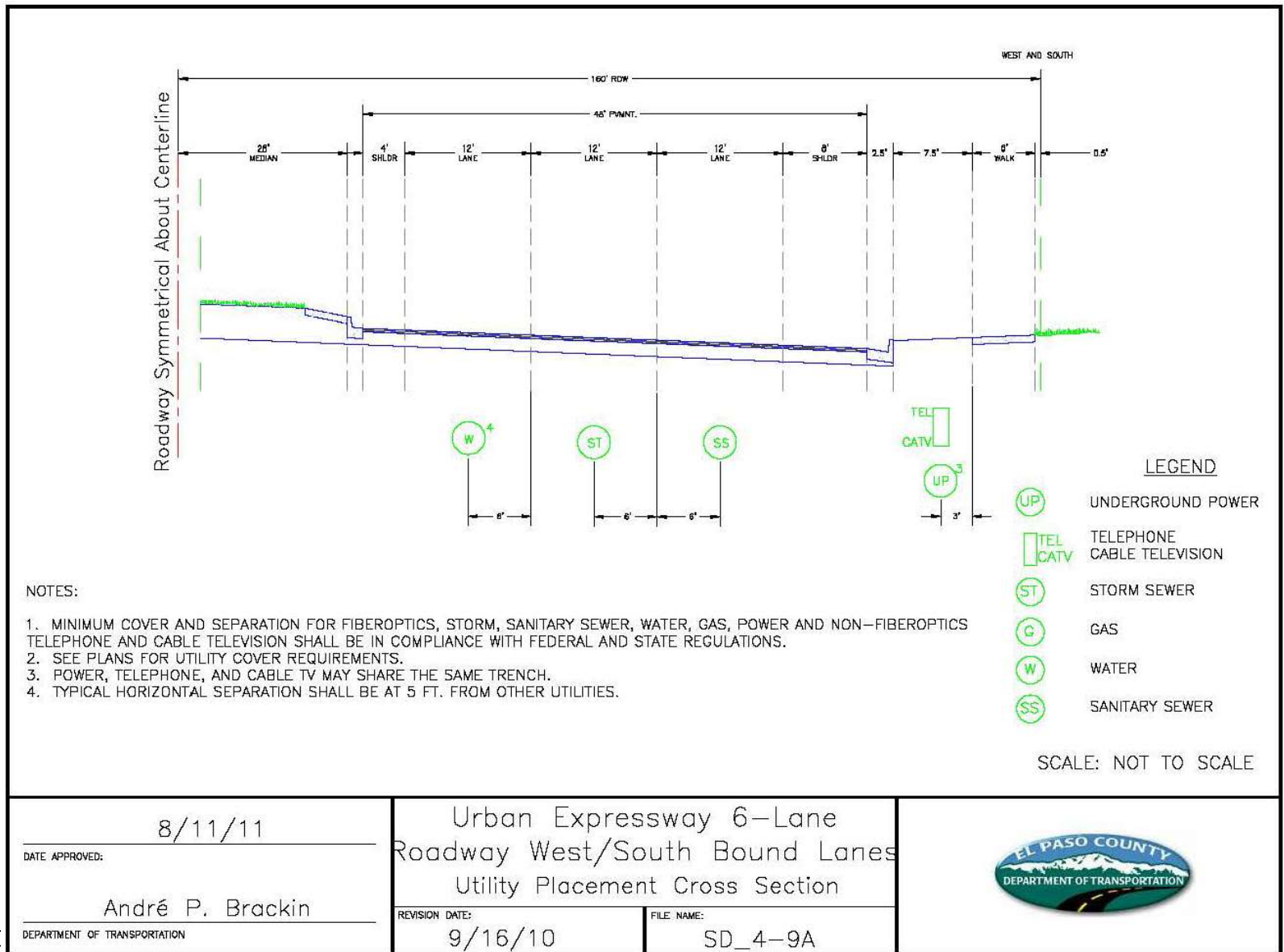

El Paso
(Supp. No. 2)

- ENGINEERING CRITERIA MANUAL
Appendix F STANDARD DRAWINGS

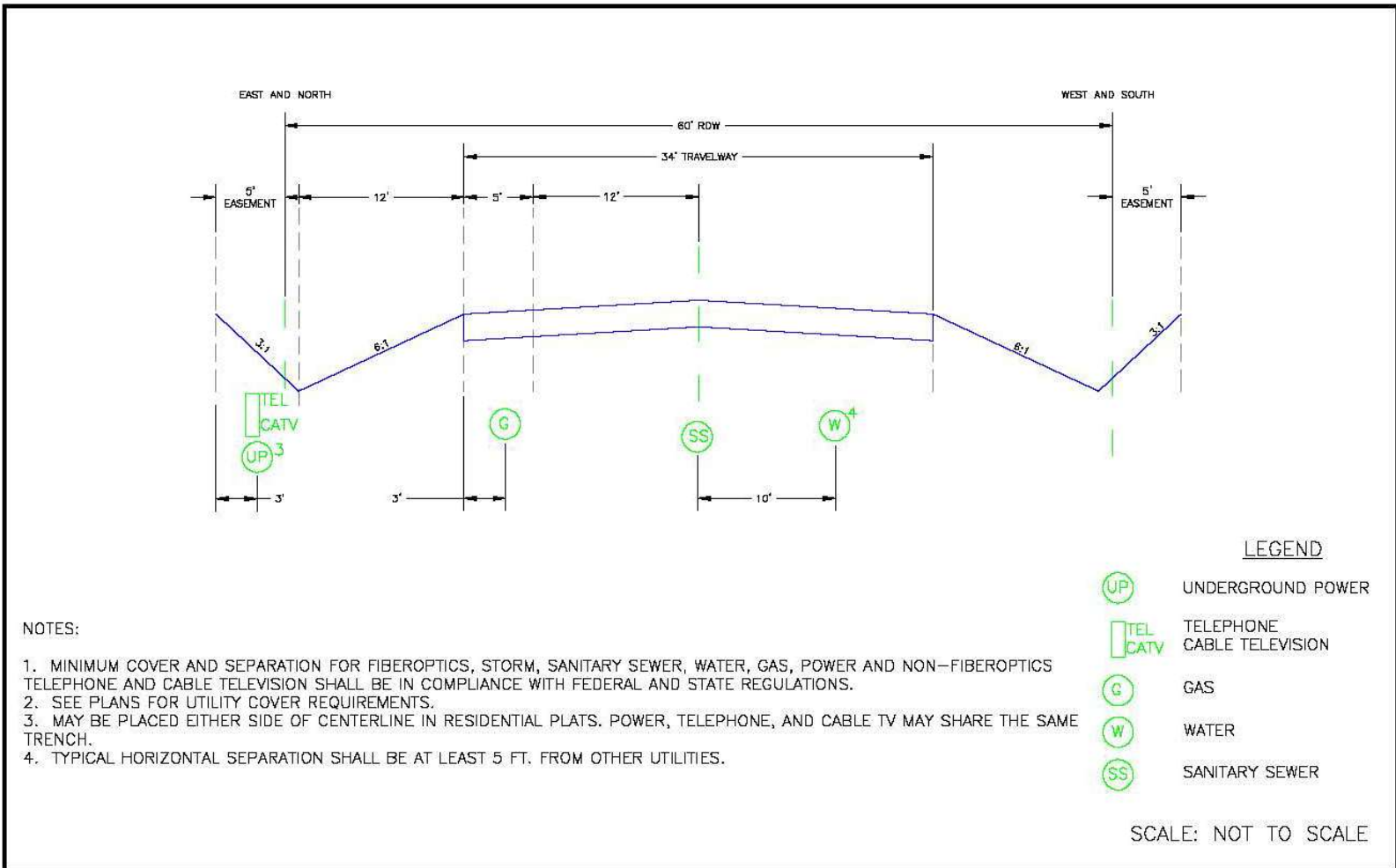

NOTES:

1. MINIMUM COVER AND SEPARATION FOR FIBEROPTICS, STORM, SANITARY SEWER, WATER, GAS, POWER AND NON-FIBEROPTICS TELEPHONE AND CABLE TELEVISION SHALL BE IN COMPLIANCE WITH FEDERAL AND STATE REGULATIONS.
2. SEE PLANS FOR UTILITY COVER REQUIREMENTS.
3. MAY BE PLACED EITHER SIDE OF CENTERLINE IN RESIDENTIAL PLATS. POWER, TELEPHONE, AND CABLE TV MAY SHARE THE SAME TRENCH.
4. TYPICAL HORIZONTAL SEPARATION SHALL BE AT LEAST 5 FT. FROM OTHER UTILITIES.

<p align="center">8/11/11</p> <p>DATE APPROVED:</p> <p align="center">André P. Brackin</p> <p>DEPARTMENT OF TRANSPORTATION</p>	<p align="center">Rural Gravel Local Roadway</p> <p align="center">Utility Placement Cross Section</p>	
	<p>REVISION DATE:</p> <p align="center">9/16/10</p>	<p>FILE NAME:</p> <p align="center">SD_4-10</p>

El Paso
(Supp. No. 2)

- ENGINEERING CRITERIA MANUAL
Appendix F STANDARD DRAWINGS

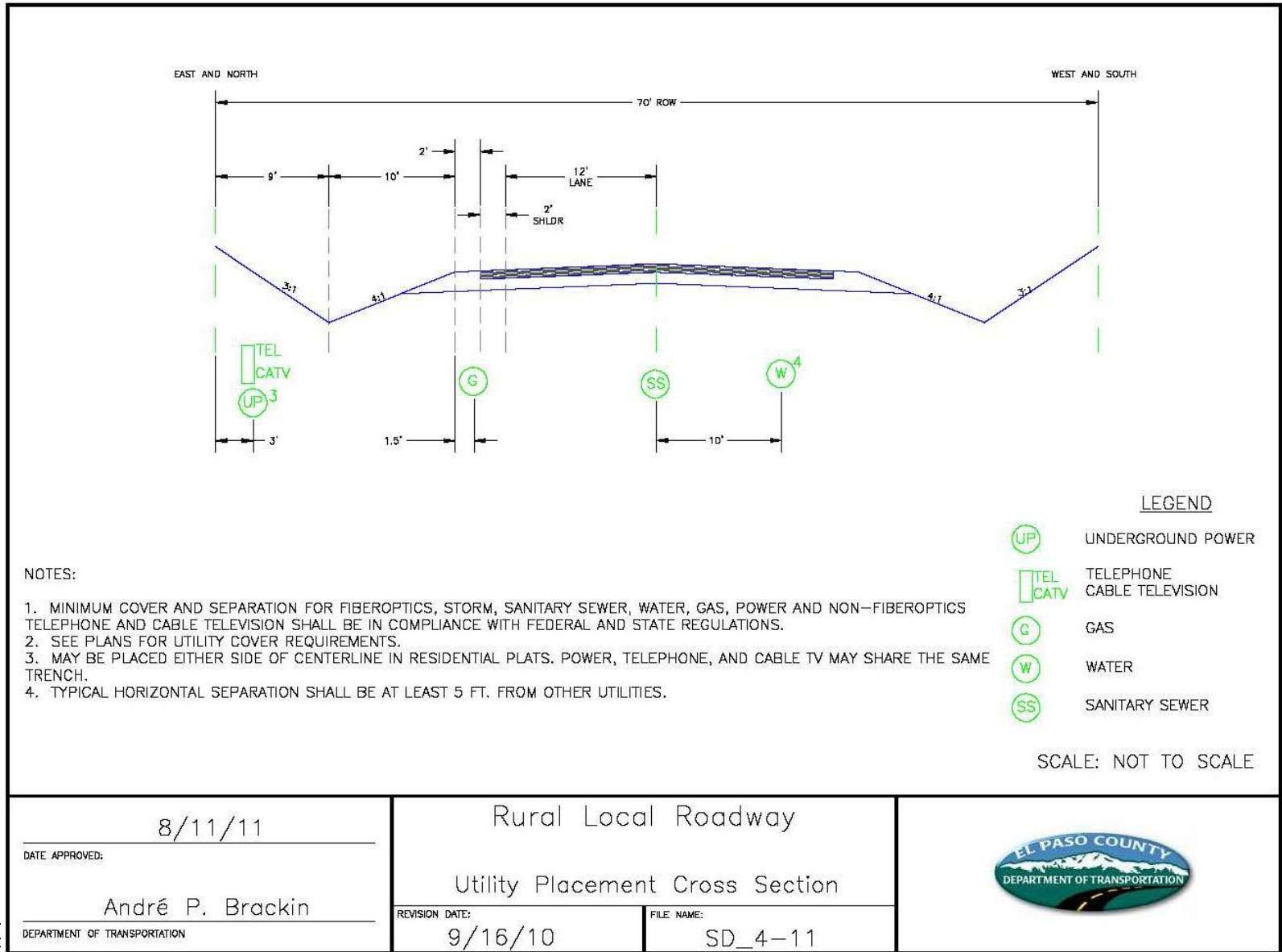

El Paso
(Supp. No. 2)

- ENGINEERING CRITERIA MANUAL
Appendix F STANDARD DRAWINGS

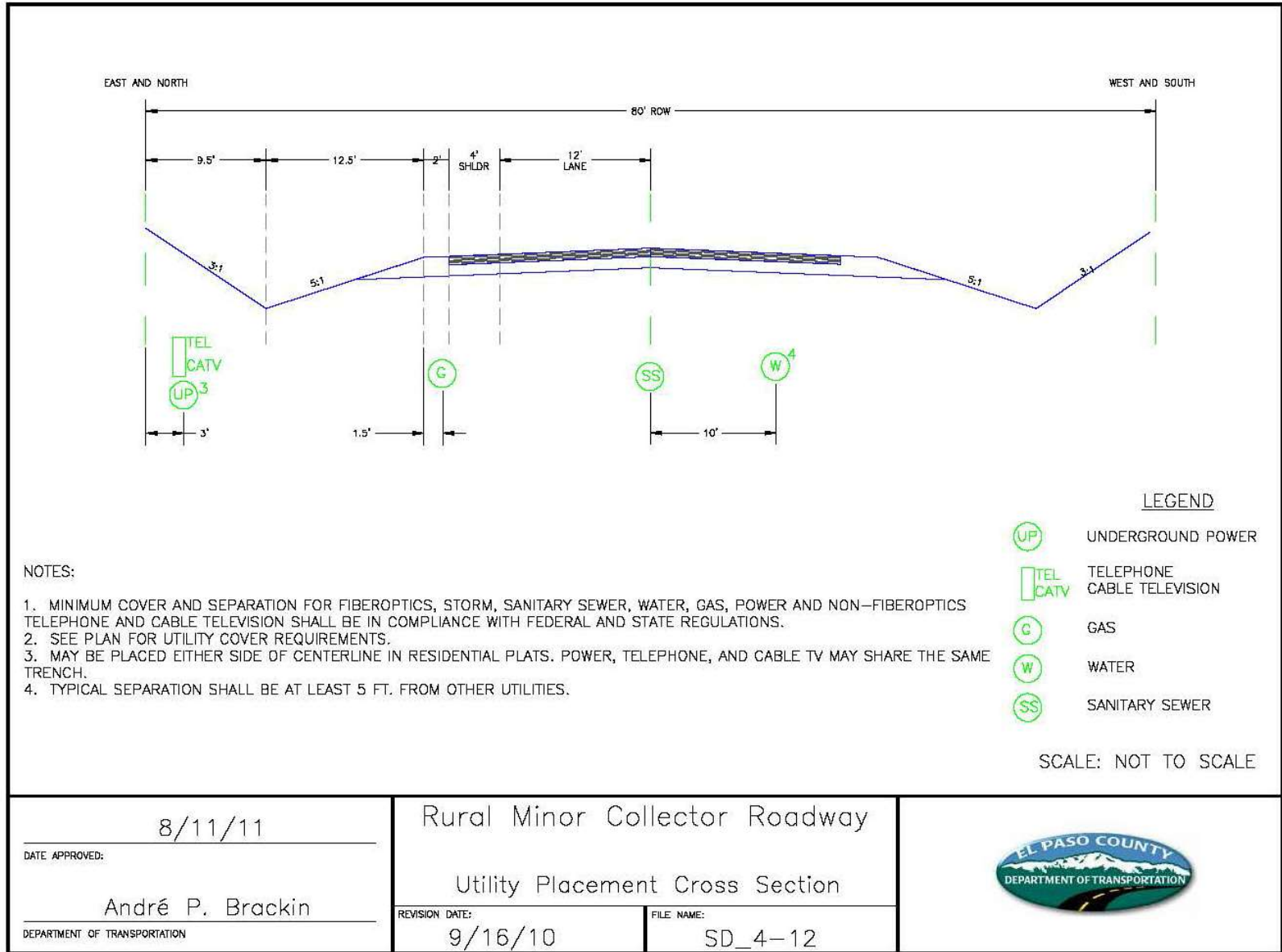

El Paso
(Supp. No. 2)

- ENGINEERING CRITERIA MANUAL
Appendix F STANDARD DRAWINGS

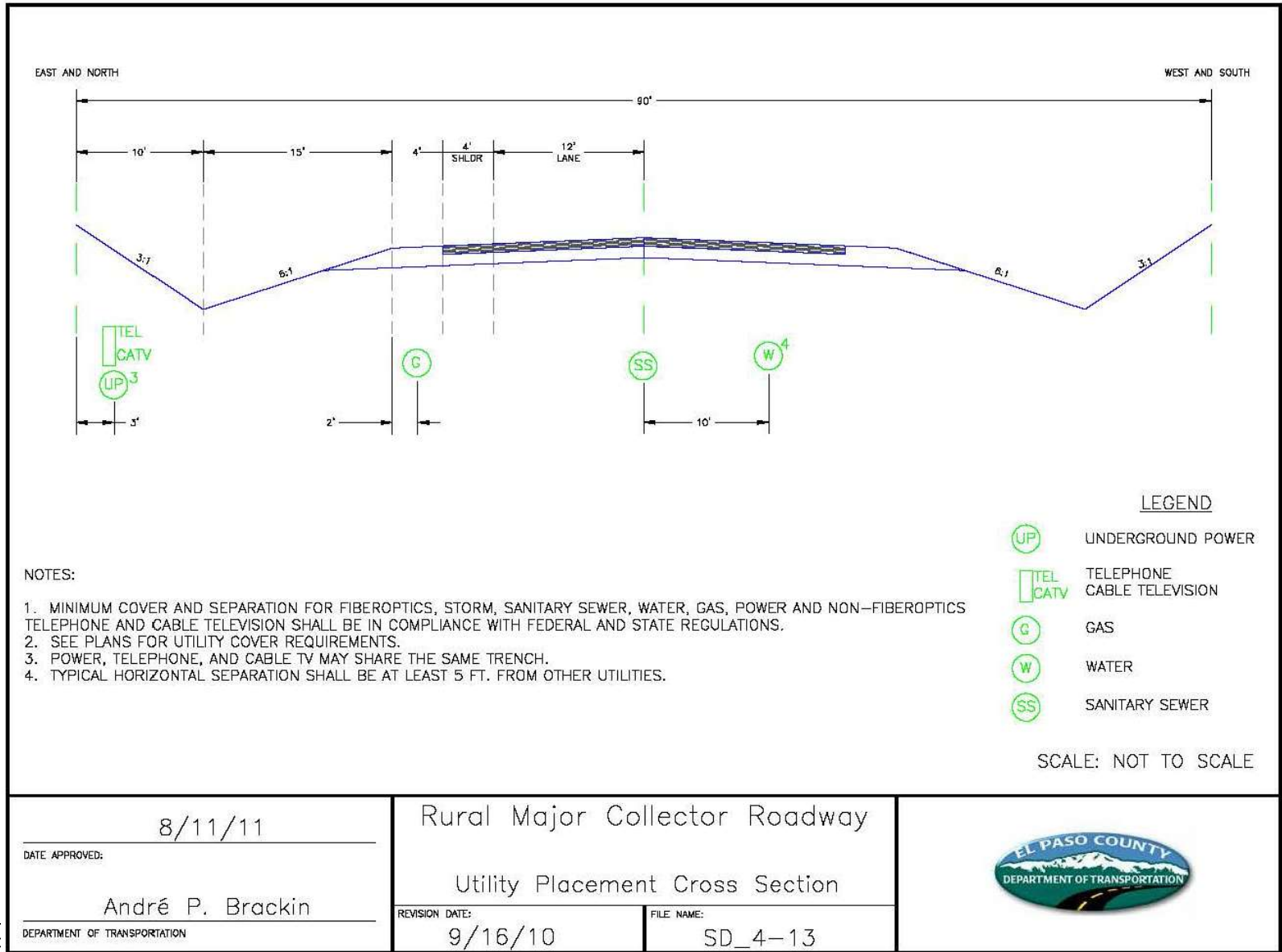

El Paso
(Supp. 100.2)

- ENGINEERING CRITERIA MANUAL
Appendix F STANDARD DRAWINGS

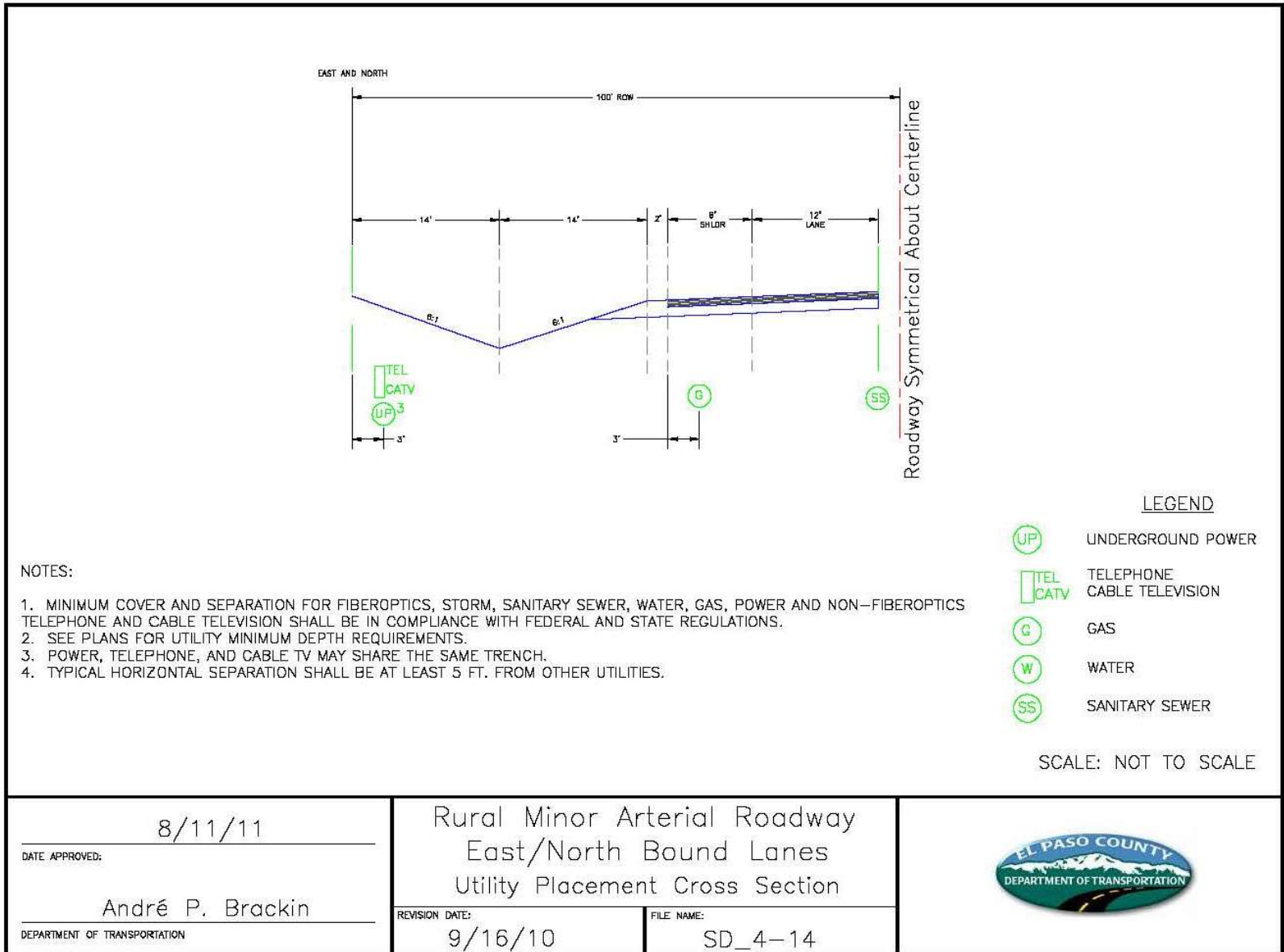

El Paso
(Supp. No. 2)

- ENGINEERING CRITERIA MANUAL
Appendix F STANDARD DRAWINGS

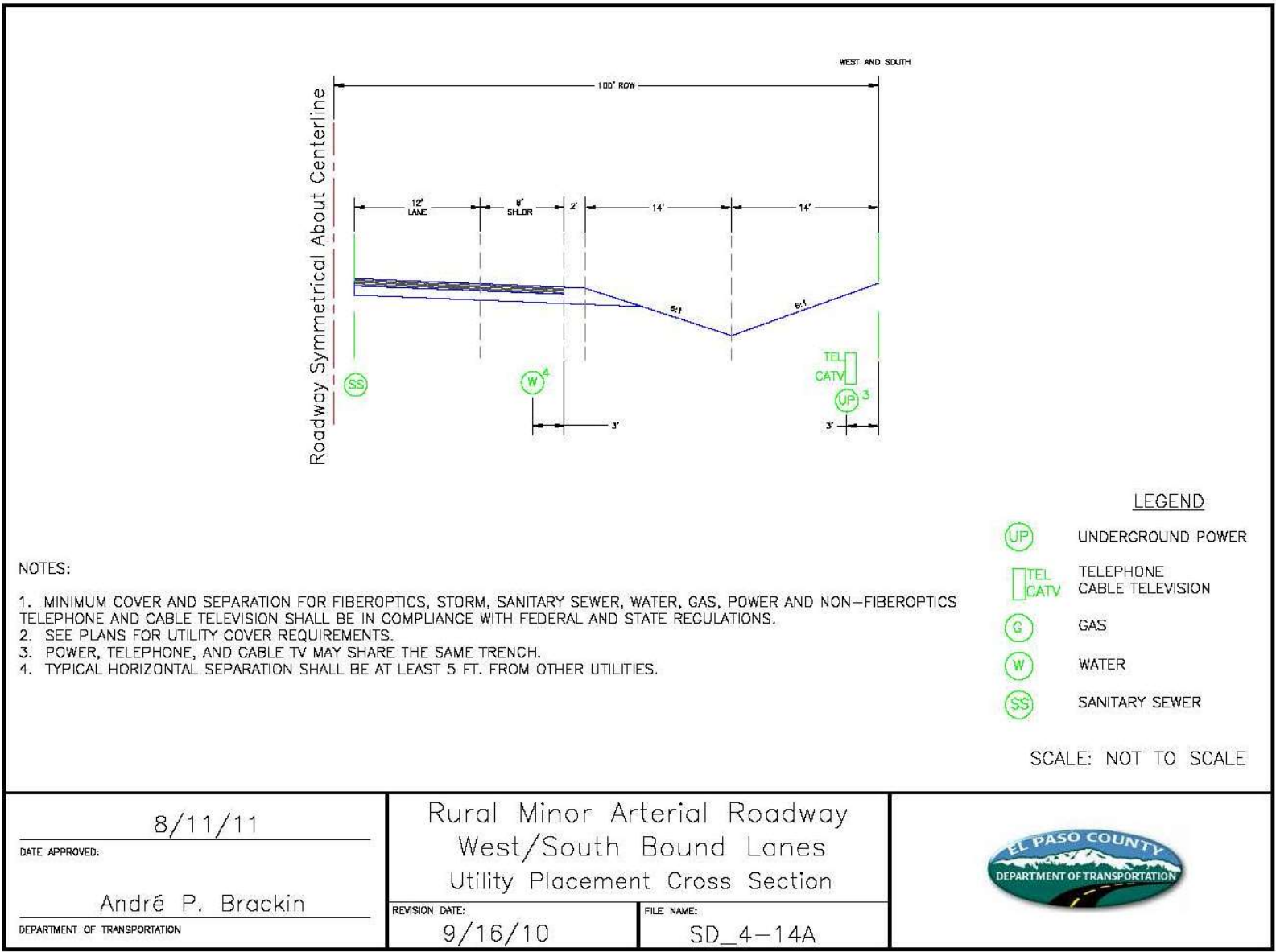

El Paso
(Supp. No. 2)

- ENGINEERING CRITERIA MANUAL
Appendix F STANDARD DRAWINGS

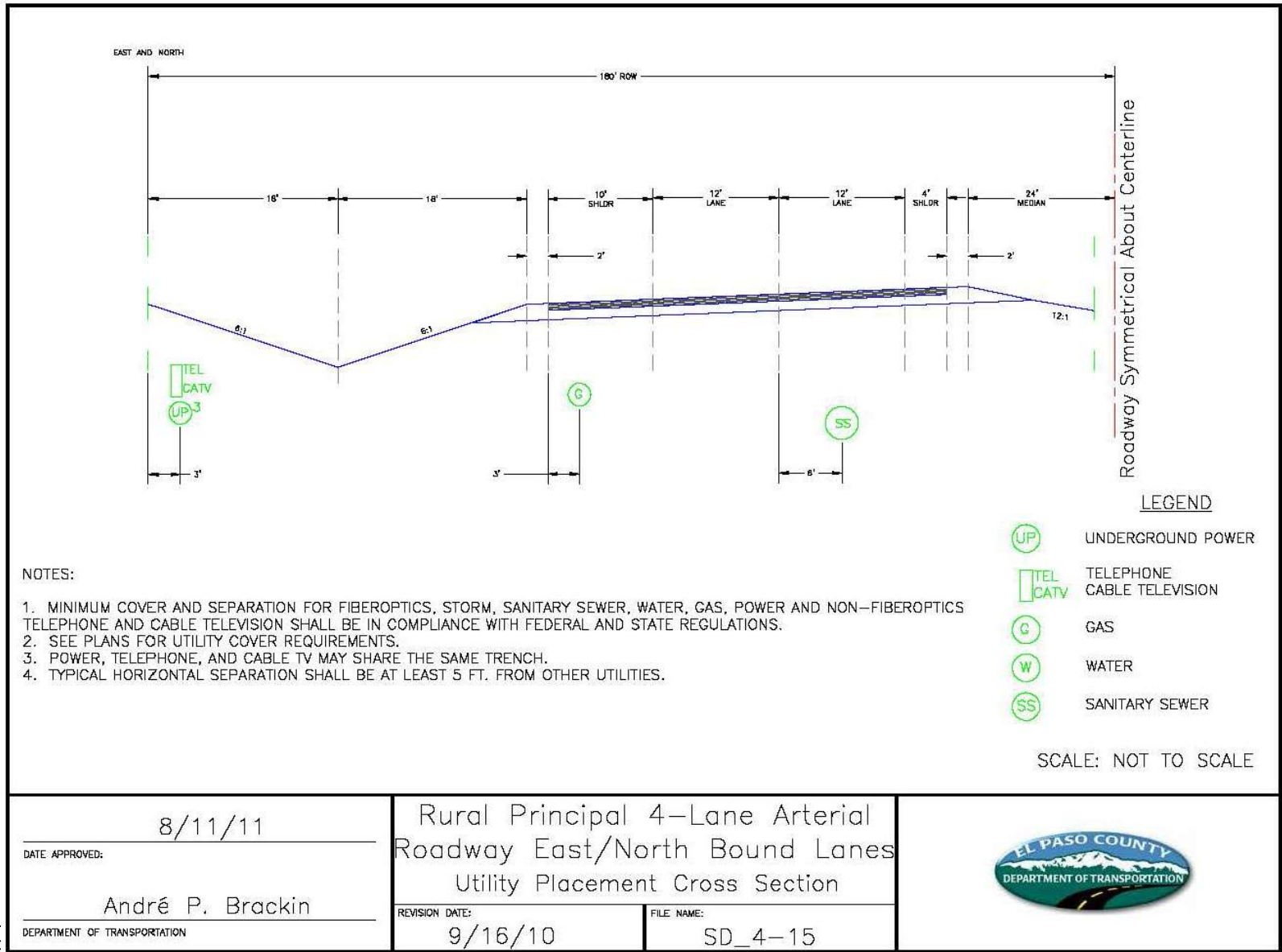

8/11/11
DATE APPROVED:
André P. Brackin
DEPARTMENT OF TRANSPORTATION

Rural Principal 4-Lane Arterial
Roadway East/North Bound Lanes
Utility Placement Cross Section

REVISION DATE: 9/16/10
FILE NAME: SD_4-15



El Paso
(Supp. No. 2)

- ENGINEERING CRITERIA MANUAL
Appendix F STANDARD DRAWINGS

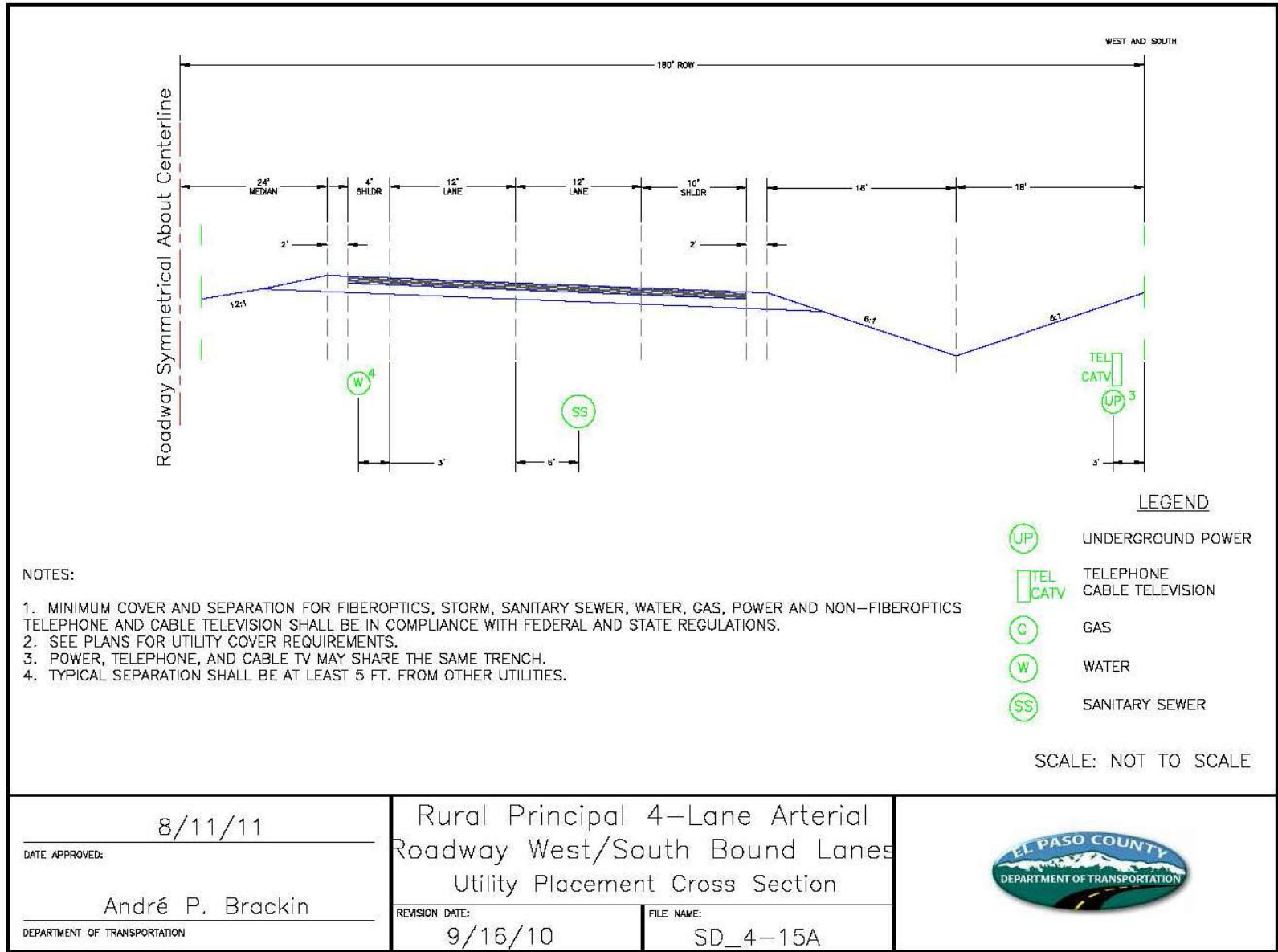

El Paso

(Supp. No. 2)

- ENGINEERING CRITERIA MANUAL
Appendix F STANDARD DRAWINGS

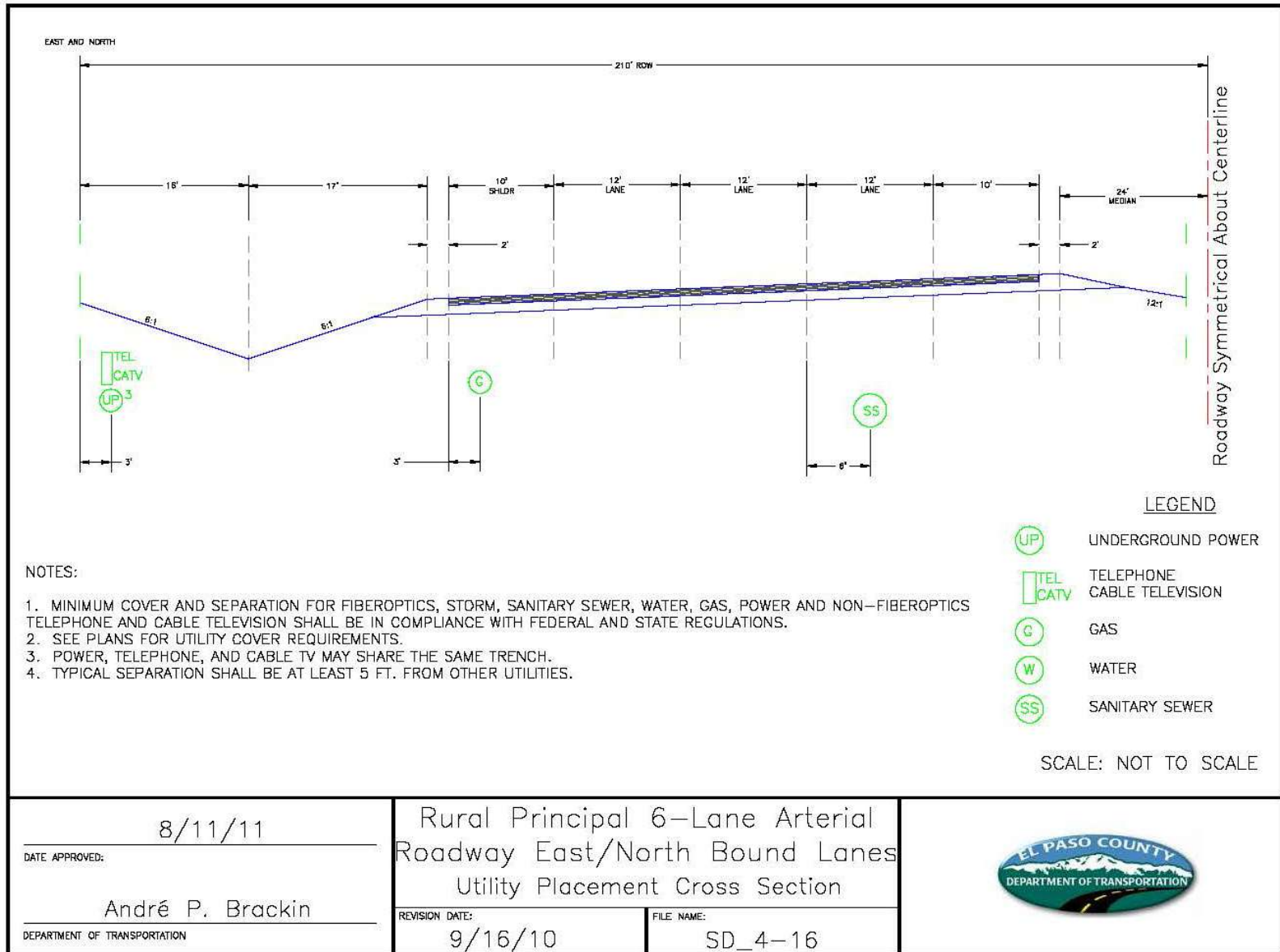

El Pas
(Supp. No. 2)

- ENGINEERING CRITERIA MANUAL
Appendix F STANDARD DRAWINGS

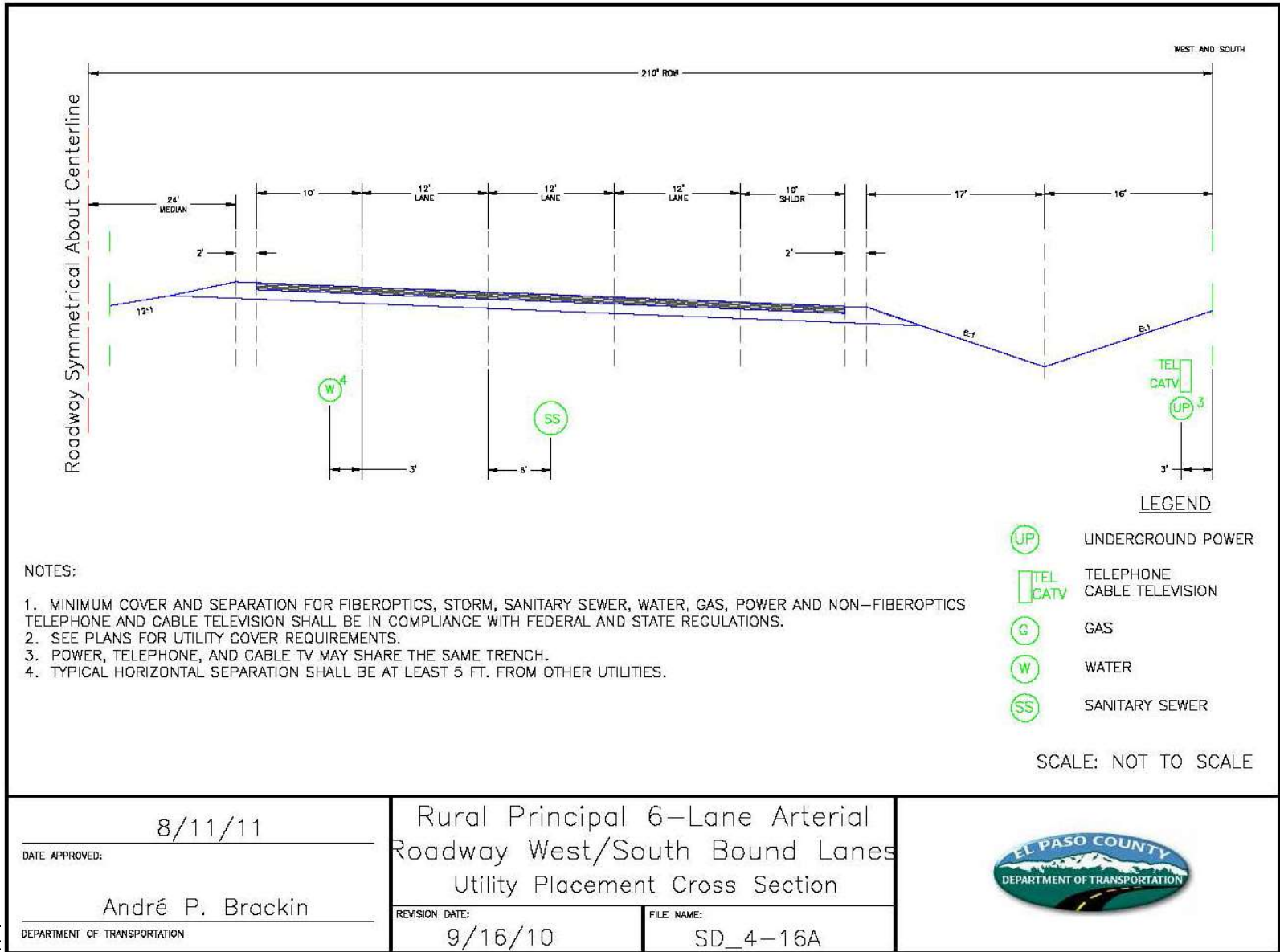

El Paso
(Supp. No. 2)

- ENGINEERING CRITERIA MANUAL
Appendix F STANDARD DRAWINGS

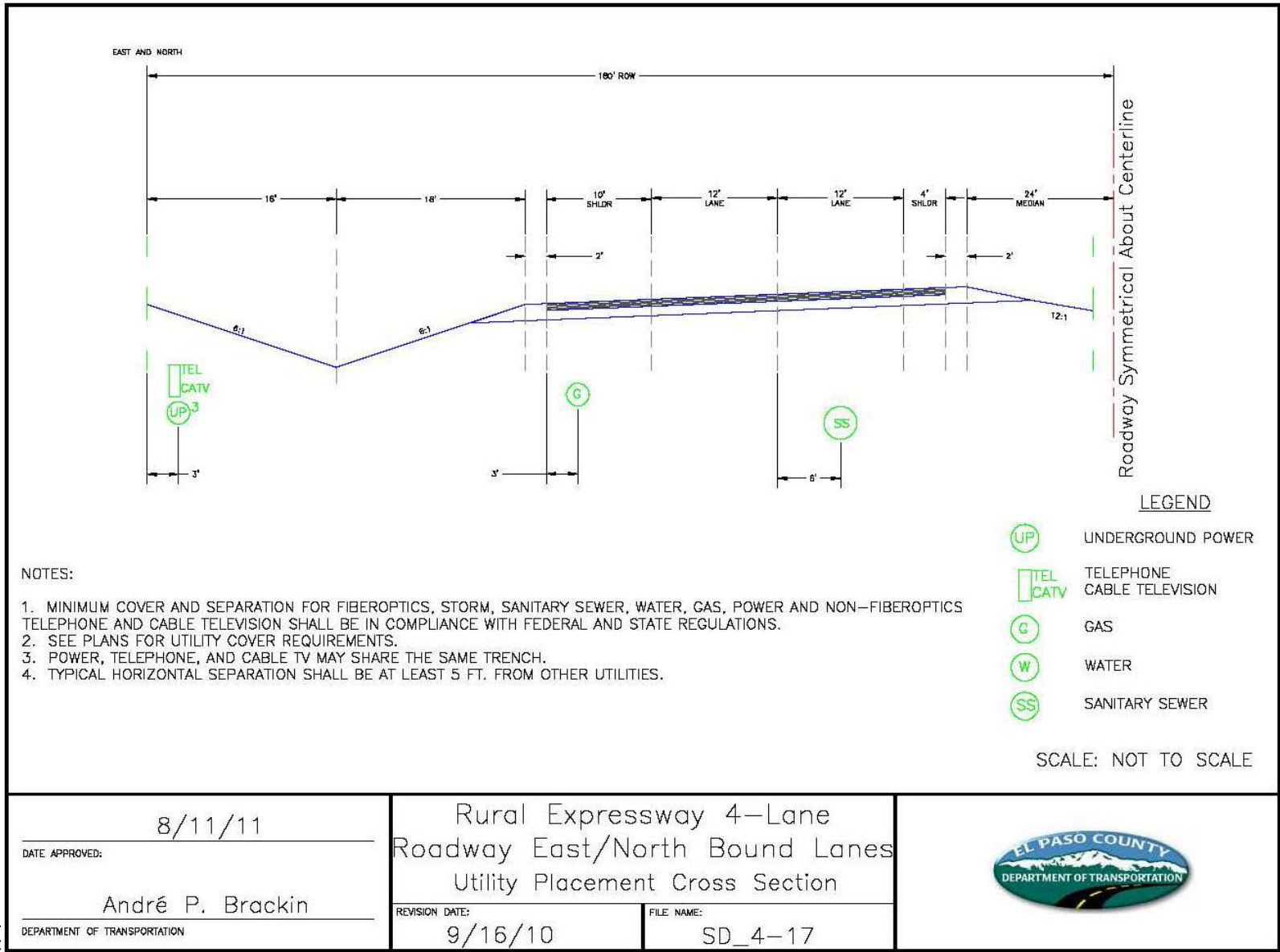

El Paso
(Supp. No. 2)

- ENGINEERING CRITERIA MANUAL
Appendix F STANDARD DRAWINGS

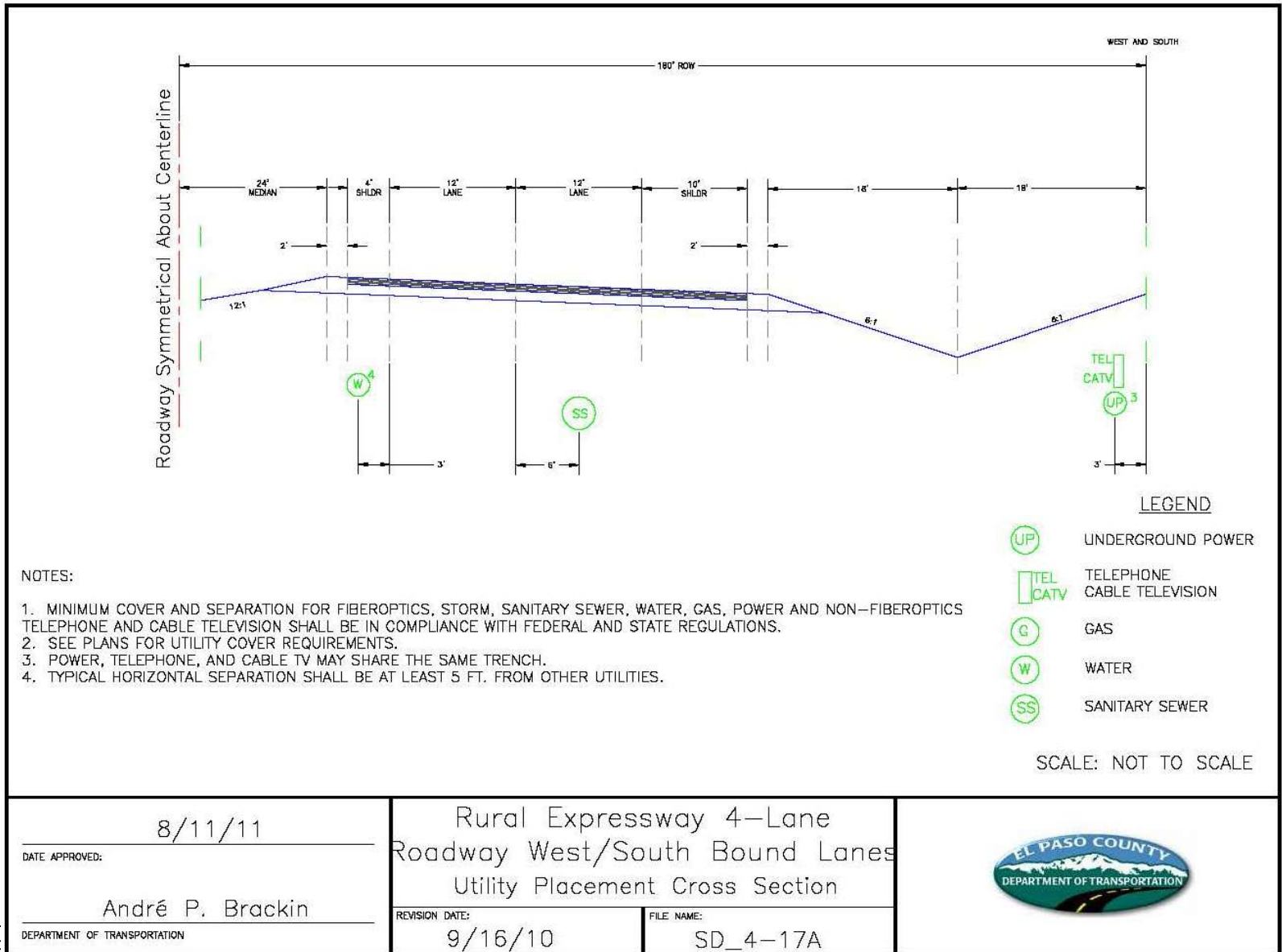

El Paso
(Supp. No. 2)

- ENGINEERING CRITERIA MANUAL
Appendix F STANDARD DRAWINGS

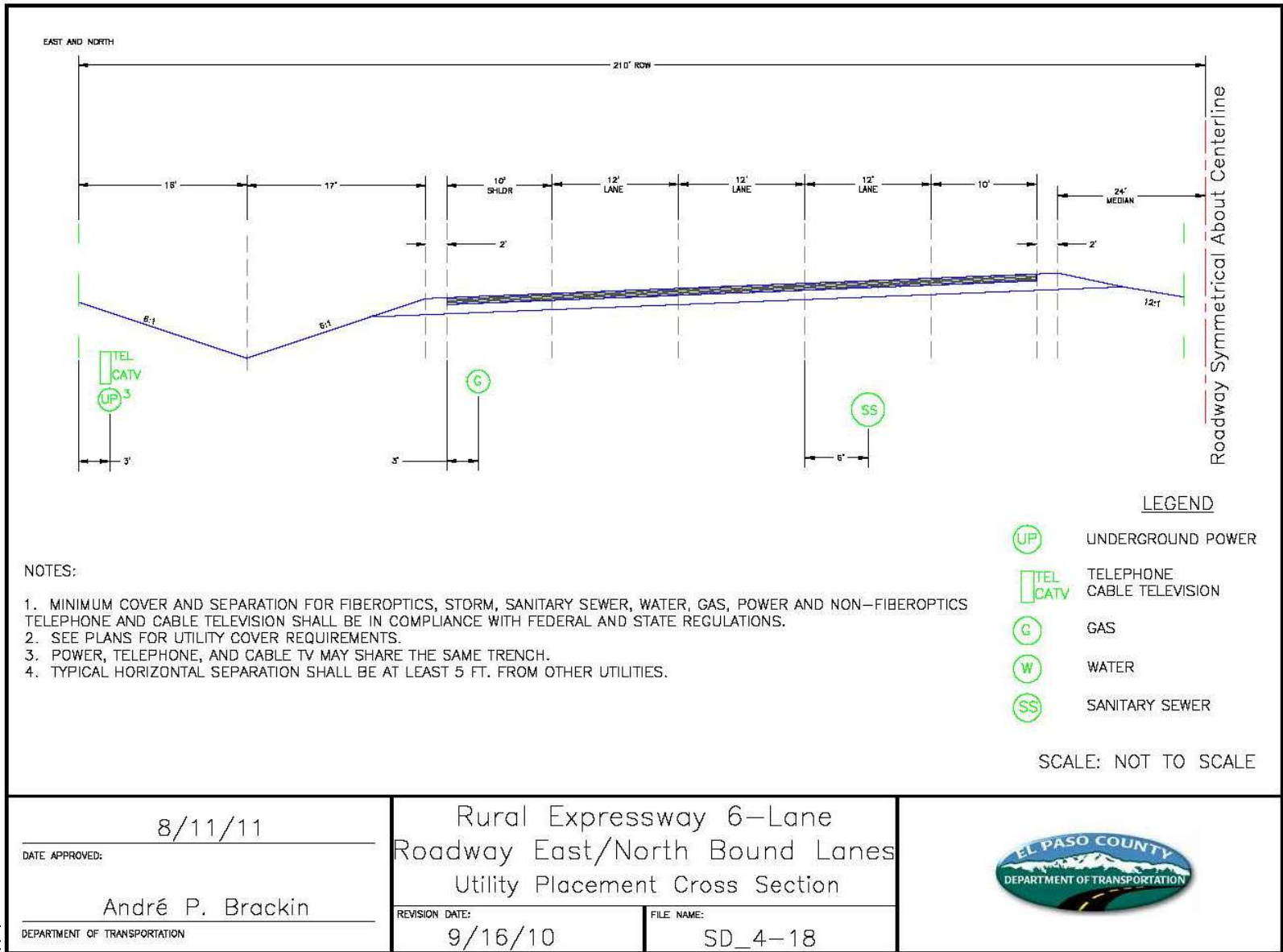

El Paso
(Supp. No. 2)

- ENGINEERING CRITERIA MANUAL
Appendix F STANDARD DRAWINGS

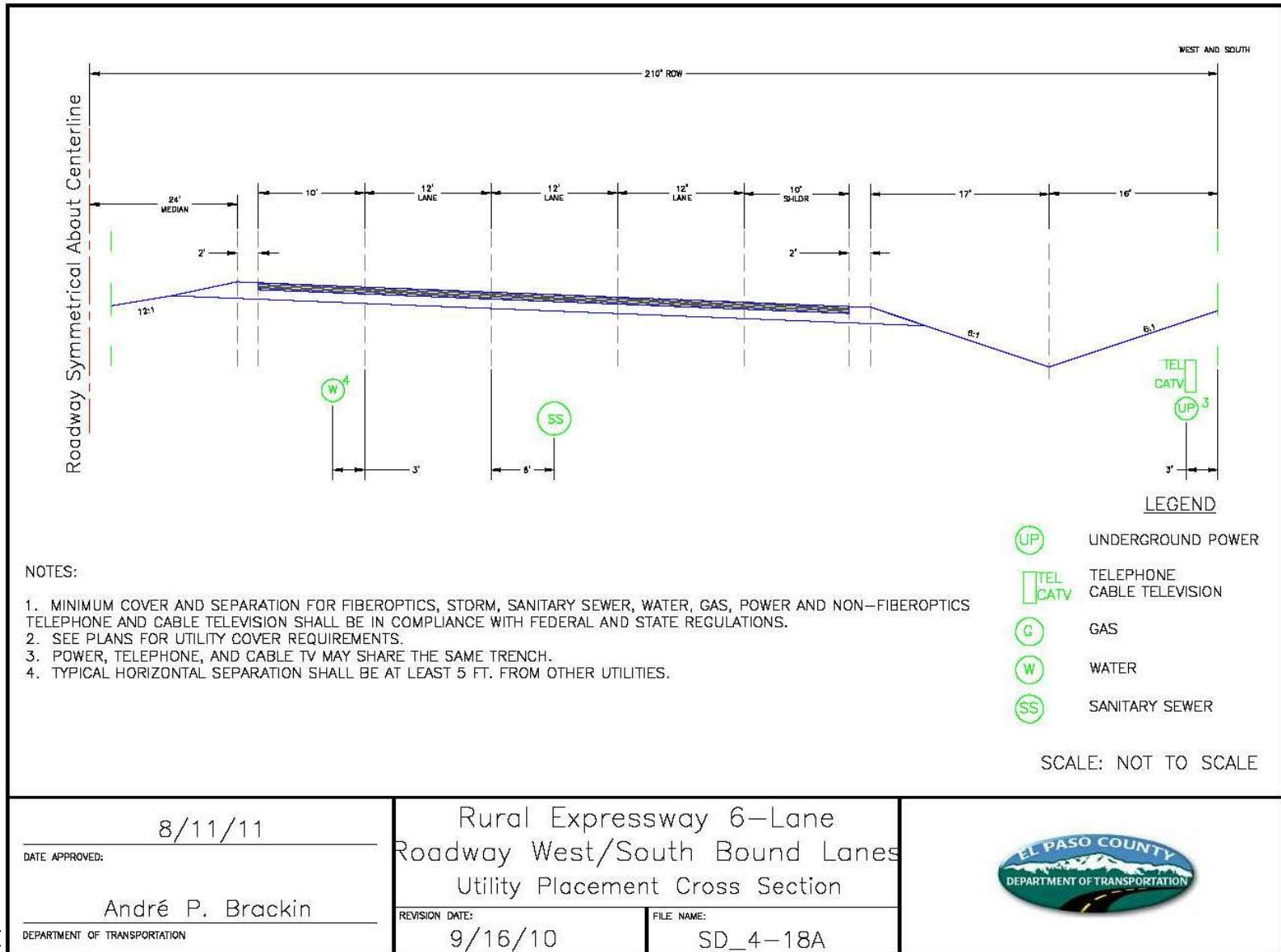

El Paso
(Supp. No. 2)

- ENGINEERING CRITERIA MANUAL
Appendix F STANDARD DRAWINGS

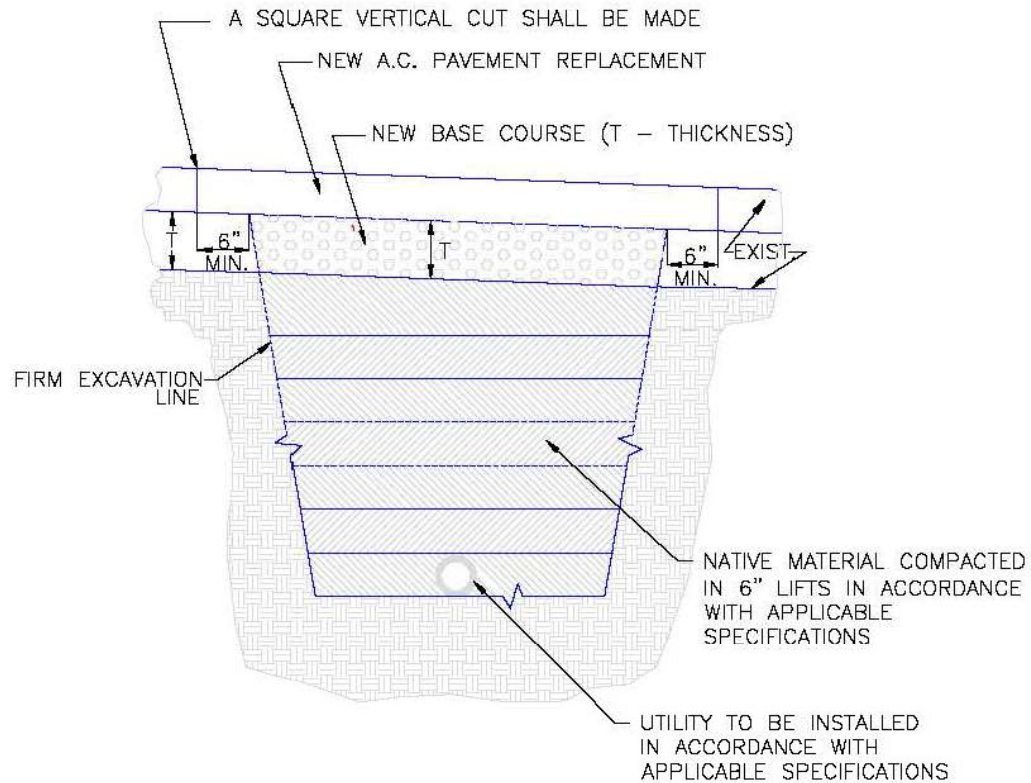

NOTES:

1. THIS DETAIL MAY BE USED FOR PAVEMENT CUTS LESS THAN 200 SQ. FT.
2. EXISTING PAVEMENT MAY BE ROUGH CUT INITIALLY IN CONJUNCTION WITH TRENCHING.
3. A SQUARE VERTICAL CUT SHALL BE MADE IN THE EXISTING A.C. PAVEMENT AFTER PLACEMENT OF BACKFILL PRIOR TO PAVEMENT REPLACEMENT.
4. THICKNESS OF NEW A.C. PAVEMENT REPLACEMENT SHALL MATCH EXISTING (4" MIN.)
5. THICKNESS OF NEW BASE COURSE SHALL BE MINIMUM OF 6" OR EQUAL TO EXISTING, WHICHEVER IS GREATER.

- ENGINEERING CRITERIA MANUAL
Appendix F STANDARD DRAWINGS

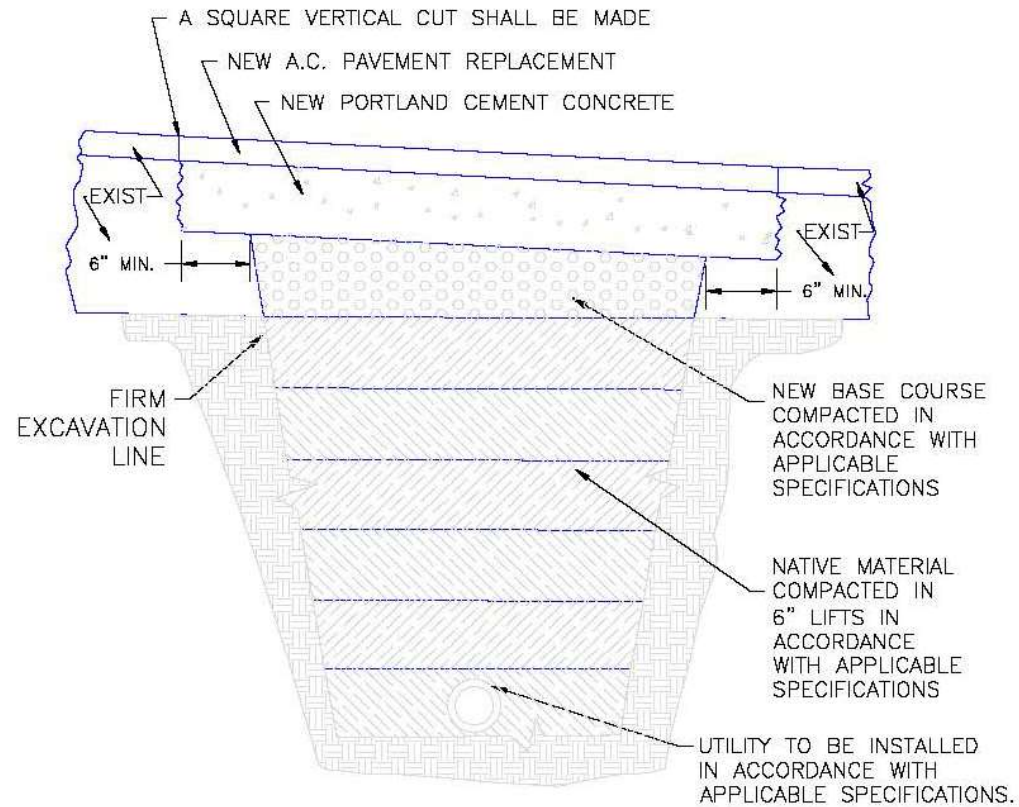

NOTES

1. THIS DETAIL MAY BE USED FOR PAVEMENT CUT LESS THAN 200 SQ. FT.
2. EXISTING PAVEMENT MAY BE ROUGH CUT INITIALLY IN CONJUNCTION WITH TRENCHING.
3. A SQUARE VERTICAL CUT SHALL BE MADE IN THE EXISTING A.C. PAVEMENT AFTER PLACEMENT OF BACKFILL AND PRIOR TO PAVEMENT REPLACEMENT.
4. THICKNESS OF NEW A.C. PAVEMENT REPLACEMENT SHALL MATCH EXISTING.
5. THICKNESS OF PORTLAND CEMENT CONCRETE SHALL BE A MINIMUM OF 6" WITH A 4000 PSI COMPRESSIVE STRENGTH AT 28 DAYS.
6. THICKNESS OF NEW BASE COURSE SHALL BE A MINIMUM OF 6" WHEN THE EXISTING BASE COURSE EXCEEDS 12" IN DEPTH. STREETS WITH LESS THAN 12" OF EXISTING BASE COURSE REQUIRE NO NEW BASE COURSE.

- ENGINEERING CRITERIA MANUAL
Appendix F STANDARD DRAWINGS

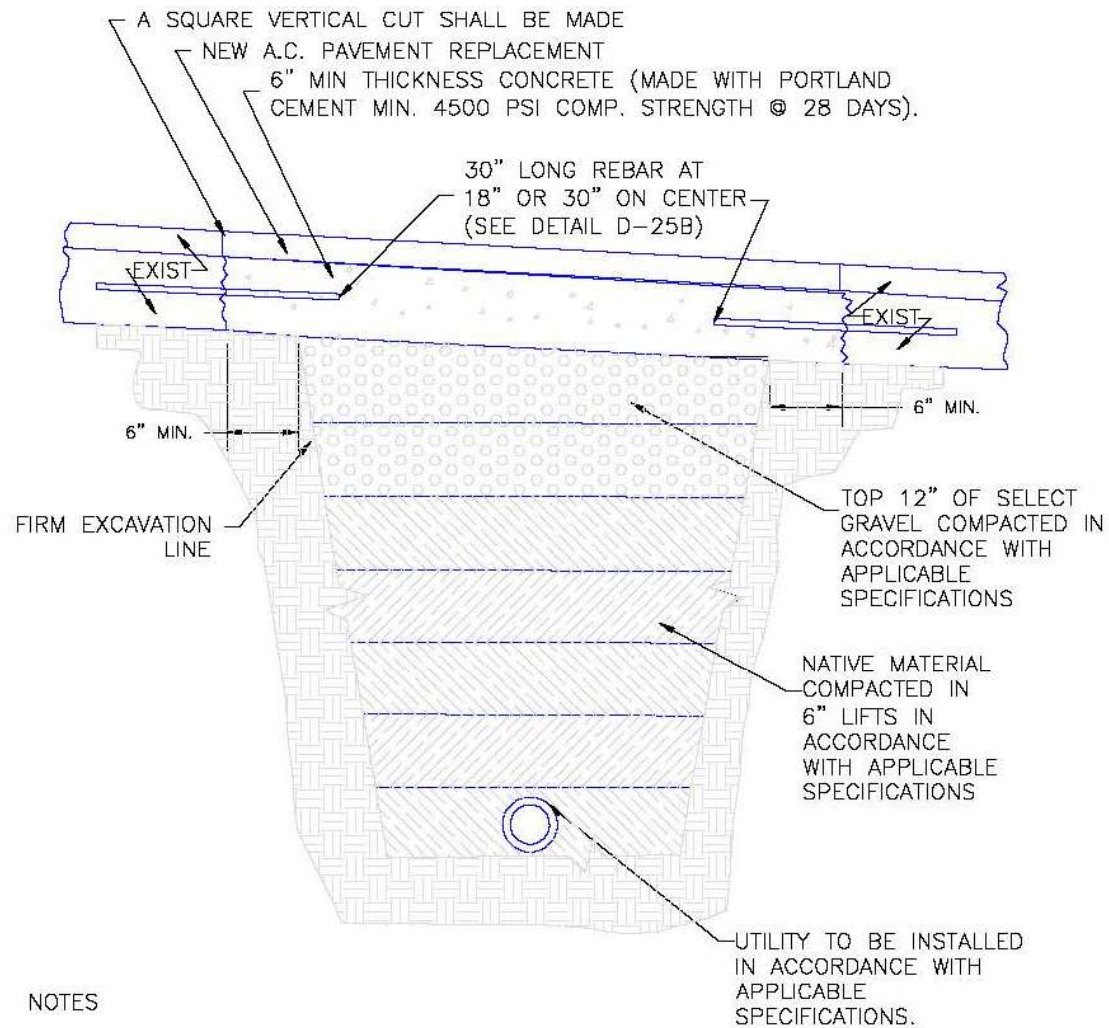

NOTES

1. EXISTING PAVEMENT MAY BE ROUGH CUT INITIALLY IN CONJUNCTION WITH TRENCHING.
2. A SQUARE, VERTICAL CUT SHALL BE MADE IN THE EXISTING A.C. PAVEMENT AFTER PLACEMENT OF BACKFILL AND PRIOR TO PAVEMENT REPLACEMENT.
3. THICKNESS OF CONCRETE AND A.C. SHALL BE EQUAL TO EXISTING CONCRETE AND A.C. THICKNESS WITH MINIMUM AS SHOWN.
4. DRILL AND EPOXY 30" LONG REBARS 15" DEEP INTO EXISTING CONCRETE PAVEMENT IN ACCORDANCE WITH DETAIL D-25B FOR TRANSVERSE AND LONGITUDINAL JOINTS.

- ENGINEERING CRITERIA MANUAL
Appendix F STANDARD DRAWINGS

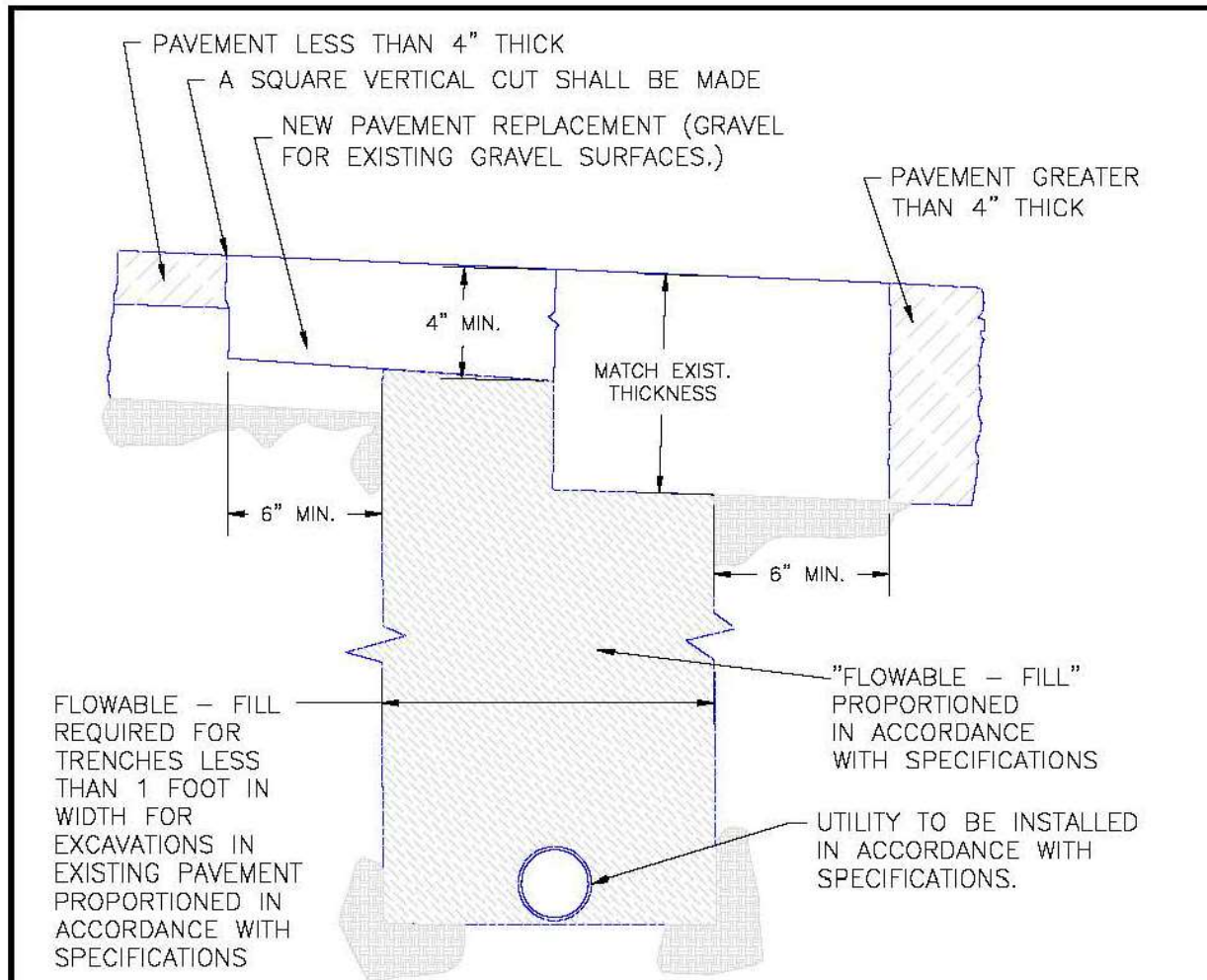

NOTES

1. EXISTING PAVEMENT MAY BE ROUGH CUT INITIALLY IN CONJUNCTION WITH TRENCHING.
2. A SQUARE, VERTICAL CUT SHALL BE MADE IN THE EXISTING A.C. PAVEMENT AFTER PLACEMENT OF BACKFILL AND PRIOR TO PAVEMENT REPLACEMENT.
3. THICKNESS OF NEW A.C. PAVEMENT REPLACEMENT SHALL MATCH EXISTING OR 4" MINIMUM, WHICHEVER IS GREATER.

Synthetic Sediment Control Log with Tailpiece

Description and Purpose

A synthetic sediment control log. Outer cover of silt filtration fabric surrounding an inner core of full rebound foam covered by a 6 mil plastic sleeve. Designed to be used where hard surfaces contact disturbed areas for pounding and on-site soil retention.

The Heavyweight Wattle

Suitable Applications — The Heavyweight Wattle may be suitable:

- Where hard surfaces contact soil.

Limitations

- The Heavyweight Wattle is not effective when the flap is not properly pinned and backfilled.
- The Heavyweight Wattle has a limited sediment capture zone and should only be used for lower volume sheet flows.
- The Heavyweight Wattle is not a substitute for adequate tracking pads and construction egress.

Installation



The Heavyweight™ Wattle

SIDEWALK Installation

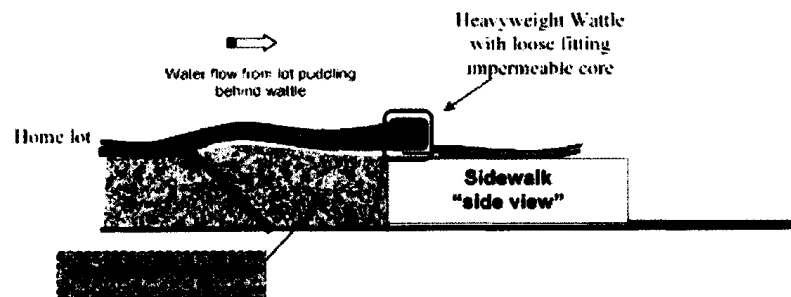

While crews remove concrete forms, install wattle immediately afterwards.

Wattle to be installed upon removal of concrete forms:

1. Lay the Heavyweight wattle directly on top of sidewalk, dropping tail of wattle behind sidewalk area.
2. Connect wattle together to form a continuous barrier.
3. Pin tail section into soil with fasteners behind sidewalk approximately every three feet.
4. Overlap the connection points and use two fasteners in this area.
5. Back-fill area behind sidewalk.
6. Site in compliance.

Fastener Recommendation: Use 60d nails or The Heavyweight wattle pins

Synthetic Stabilized Construction Entrance FODS TRACKOUT CONTROL SYSTEM INSTALLATION GUIDE

THE PURPOSE AND DESIGN OF THE FODS TRACKOUT CONTROL SYSTEM IS TO EFFECTIVELY REMOVE MOST SEDIMENT FROM VEHICLE TIRES AS THEY EXIT A DISTURBED LAND AREA ONTO A PAVED STREET. THIS MANUAL IS A PLATFORM FROM WHICH TO INSTALL A FODS TRACKOUT CONTROL SYSTEM (NOTE: THIS IS NOT A ONE SIZE FITS ALL GUIDE.) THE INSTALLATION MAY NEED TO BE MODIFIED TO MEET THE EXISTING CONDITIONS, EXPECTATIONS, OR DEMANDS OF A PARTICULAR SITE. THIS IS A GUIDELINE. ULTIMATELY THE FODS TRACKOUT CONTROL SYSTEM SHOULD BE INSTALLED SAFELY WITH PROPER ANCHORING AND SIGNS PLACED AROUND THE ENTRANCE AND EXIT TO CAUTION USERS AND OTHERS.

KEY NOTES:

- A. FODS TRACKOUT CONTROL SYSTEM MAT.
- B. FODS SAFETY SIGN.
- C. ANCHOR POINT.
- D. SILT OR ORANGE CONSTRUCTION FENCE.

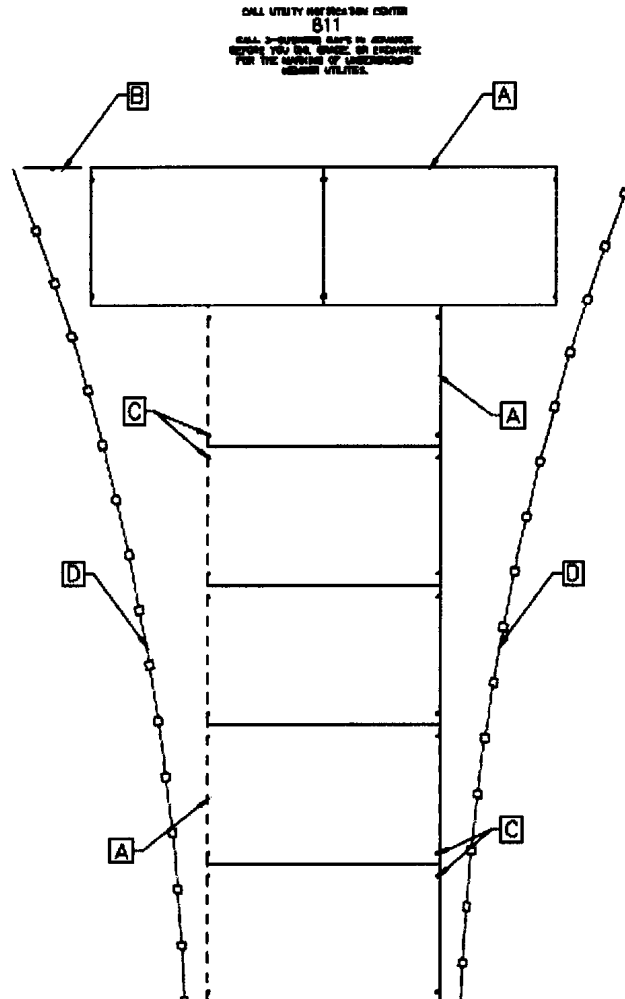

INSTALLATION:

1. THE SITE WHERE THE FODS TRACKOUT CONTROL SYSTEM IS TO BE PLACED SHOULD CORRESPOND TO BEST MANAGEMENT PRACTICES AS MUCH AS POSSIBLE. THE SITE WHERE FODS TRACKOUT CONTROL SYSTEM SHOULD ALSO MEET OR EXCEED THE LOCAL JURISDICTION OR STORM WATER POLLUTION PREVENTION PLAN (SWPPP) REQUIREMENTS.
2. CALL FOR UTILITY LOCATES 3 BUSINESS DAYS IN ADVANCE OF THE FODS TRACKOUT CONTROL SYSTEM INSTALLATION FOR THE MARKING OF UNDERGROUND MEMBER UTILITIES. CALL THE UTILITY NOTIFICATION CENTER AT 811.
3. ONCE THE SITE IS ESTABLISHED WHERE FODS TRACKOUT CONTROL SYSTEM IS TO BE PLACED, ANY EXCESSIVE UNEVEN TERRAIN SHOULD BE LEVELED OUT OR REMOVED SUCH AS LARGE ROCKS, LANDSCAPING MATERIALS, SUDDEN ABRUPT CHANGES IN ELEVATION, AND SIMILAR. FODS WILL SPAN AND SUPPORT OVER MOST OBSTACLES, BUT THE FLATTER AND SMOOTHER THE TERRAIN UNDER THE FODS TRACKOUT CONTROL SYSTEM WILL BE MORE EFFICIENT AND SAFER.
4. NEXT THE INDIVIDUAL MATS CAN START TO BE PLACED IN POSITION. THE FIRST MAT SHOULD BE PLACED NEXT TO THE PAVED SURFACE AND/OR CURB AT THE CLOSEST POINT OF EGRESS. THIS WILL ENSURE THAT THE VEHICLE WILL EXIT STRAIGHT FROM THE SITE TO THE PAVED SURFACE, FROM THE SITE TO THE PAVED SURFACE.
5. AFTER THE FIRST MAT IS PLACED DOWN IN ITS PROPER LOCATION, AN H BRACKET SHOULD BE PLACED AT THE END OF THE FIRST MAT, BEFORE ANOTHER MAT IS POSITIONED ADJACENT TO THE FIRST MAT.
6. ONCE THE SECOND MAT IS PLACED ADJACENT TO THE FIRST MAT, MAKE SURE THE H BRACKET IS CORRECTLY SITUATED BETWEEN THE TWO MATS.
7. NEXT, THE CONNECTOR STRAP SHOULD BE INSTALLED TO CONNECT THE TWO MATS TOGETHER.
8. AFTER THE FIRST MAT IS PLACED DOWN IN ITS PROPER LOCATION, IT SHOULD BE ANCHORED TO PREVENT THE POTENTIAL MOVEMENT WHILE THE ADJOINING MATS ARE INSTALLED NEXT. ANCHORS SHOULD BE PLACED AT EVERY ANCHOR POINT (IF FEASIBLE) TO HELP MAINTAIN THE MAT IN ITS CURRENT POSITION.
9. ONCE THE FIRST MAT IS ANCHORED DOWN, THE SUCCESSIVE MATS CAN THEN BE PLACED TO CREATE THE FODS TRACKOUT CONTROL SYSTEM.
10. UPON PLACEMENT OF EACH NEW MAT IN THE SYSTEM, THAT MAT SHOULD BE ANCHORED AT EVERY ANCHOR POINT TO HELP STABILIZE THE MAT AND ENSURE THE SYSTEM IS CONTINUOUS WITH NO GAPS IN BETWEEN THE MATS.
11. AFTER INSTALLATION OF THE FODS TRACKOUT CONTROL SYSTEM, FODS SAFETY SIGNS SHOULD BE PLACED AT THE ENTRANCE AND EXIT SIDES OF THE FODS TRACKOUT CONTROL SYSTEM.
12. A SILT FENCE OR ORANGE CONSTRUCTION FENCE SHOULD ALSO BE INSTALLED ON THE SIDES OF THE FODS TRACKOUT CONTROL SYSTEM TO DIRECT VEHICLES DOWN THE MATS AND BARRICADE PEDESTRIANS FROM CROSSING THE MATS. PEDESTRIANS SHOULD ALSO USE EXTREME CAUTION WHEN CROSSING THE MATS AS THE SURFACE IS UNEVEN AND MAY BE DIFFICULT TO WALK ON.

USE AND MAINTENANCE:

1. VEHICLES SHOULD TRAVEL DOWN THE LENGTH OF THE FODS TRACKOUT CONTROL SYSTEM AND NOT CUT ACROSS THE MATS.
2. DRIVERS SHOULD TURN THE WHEEL OF THEIR VEHICLES SUCH THAT THE VEHICLE WILL TAKE A SERPENTINE ROUTE DOWN THE LENGTH OF THE FODS TRACKOUT CONTROL SYSTEM.
3. MATS SHOULD BE CLEANED ONCE THE VOIDS BETWEEN THE PYRAMIDS BECOME FULL OF SEDIMENT. TYPICALLY THIS TASK WILL NEED TO BE PERFORMED WITHIN TWO WEEKS AFTER A STORM EVENT. BRUSHING IS THE PREFERRED METHOD OF CLEANING, EITHER MANUALLY OR MECHANICALLY.
4. THE USE OF ICE MELT, ROCK SALT, SNOW MELT, DEICER, ETC. SHOULD BE UTILIZED AS NECESSARY DURING THE WINTER MONTHS AND AFTER A SNOW EVENT.

Single Lot Access Vehicle Tracking Control Mats

Single Lot Access VTC (Mud Mats)

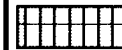

Description and Purpose

A stabilized construction access is defined by a point of entrance/exit to a construction site that is stabilized to reduce the tracking of mud and dirt onto public roads by construction vehicles.

Suitable Applications

Use at construction sites:

- Where dirt or mud can be tracked onto public roads.
- Where a single family lot needs a temporary access point.

Limitations

- Entrances and exits require periodic cleaning and maintenance.
- This BMP should be used in conjunction with street sweeping on adjacent public right of way
- Entrances and exits should be constructed on level ground only or sloping away from paved surfaces.

Implementation

- Construct on level ground or sloping down and away from paved surfaces where possible.
- For individual lots VTC perimeter may be reduced to minimum 8' x 15' due to space limitation. This is for access to single family lots only.)
- Limit the points of entrance/exit to the construction site.
- Properly grade each construction entrance/exit to prevent runoff from leaving the construction site.
- Route runoff from stabilized entrances/exits through a sediment trapping device before discharge.
- Require that all employees, subcontractors, and suppliers to utilize the stabilized construction access when lot access is necessary.
- Educate all employees, subcontractors, and suppliers on keeping vehicles off-site whenever possible.
- Limit access to only access that is absolutely necessary.

Inspection and Maintenance

- Inspect and verify that activity-based BMPs are in place prior to the commencement of associated activities. While activities associated with the BMPs are under way, inspect in accordance with the specified inspection schedule in the site SWMP.
- Visually inspect local roads adjacent to the site daily. Sweep or vacuum to remove visible accumulated sediment.
- Check for damage and repair as needed.
- Remove accumulated sediment as needed.
- Reset and restake as needed.
- Remove any sediment deposited on paved roadways immediately.

Lot Access-VTC (mud mats)

AGES Mud Mat Specifications

Each mat is made up of a double layer of high strength woven fabric that is stitched in such a way to encapsulate the reinforcing members that run perpendicular to the direction of traffic. These reinforcing ribs are secured individually within each pocket. There are approx. 24-26 pockets that each holds 1 bamboo post of approx. 2" diameter. This combination of reinforcing member and confining fabric result in a portable mat that can be rolled up for transport and ease of deployment. AGES Mud Mats can be used in construction site access, agriculture, golf & parks, other soft or sensitive ground condition areas where vehicle access is required.

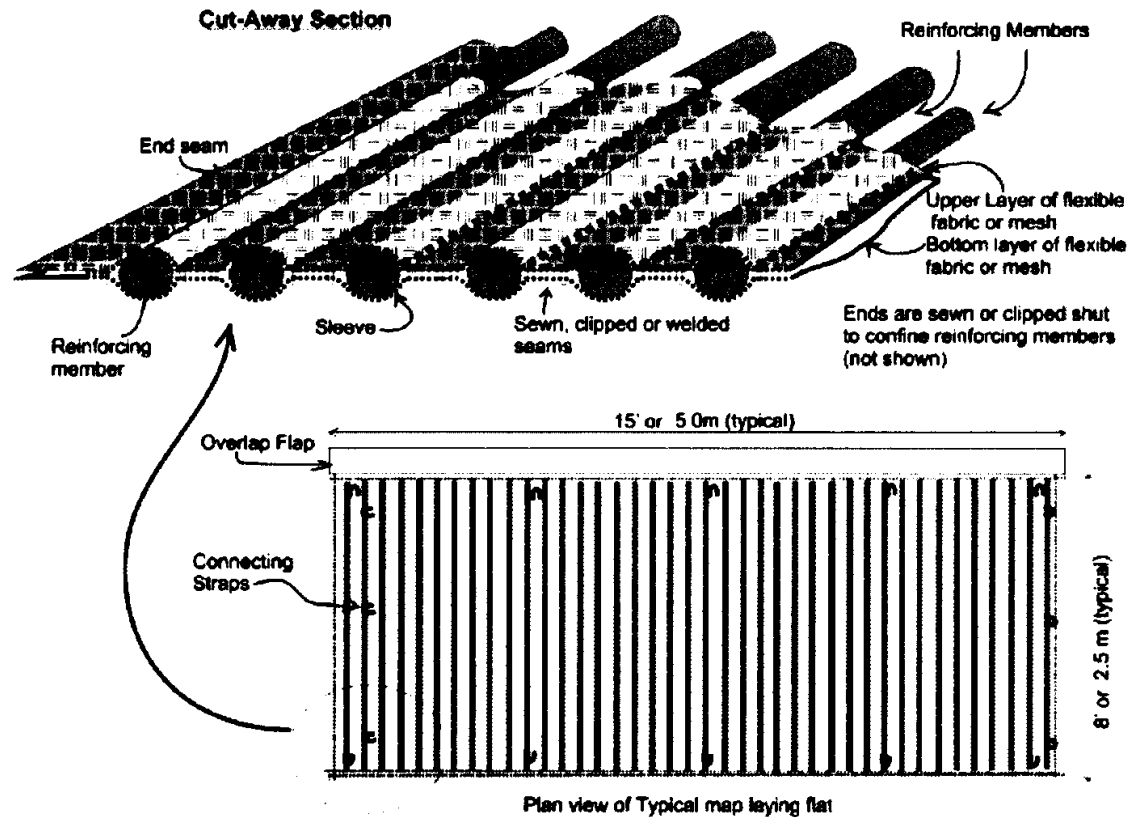

El Paso County, Colorado
(Supp. No. 2)

BOCC Memo Packet
Page 393 of 1032

PROPERTY	TEST PROCEDURE	VALUE
Grab Tensile Strength	ASTM D4632	802.6 lbs
Apparent Breaking Elongation	ASTM D4632	25% / 18%
Trapezoid Tearing Strength	ASTM D4633	807 lbs
Puncture Resistance	ASTM D4833	374.3 lbs
Mullen Burst	ASTM D3786	456.88 psi
Apparent Opening Size	ASTM D4751	70 US Sieve / 0.212mm
Constant Head Permittivity	ASTM D4491	20.16 gmm ²

APPROXIMATE DIMENSIONS PER MAT	
Size Deployed (approx.)	15' x 8'
Shipping Size (rolled)	1.5' dia x 8.5' long
Weight (approx.)	60 lbs

~5 carabineer clips for each mat (Side connection and end connection straps)~

Rubber Vehicle Tracking Control Pads

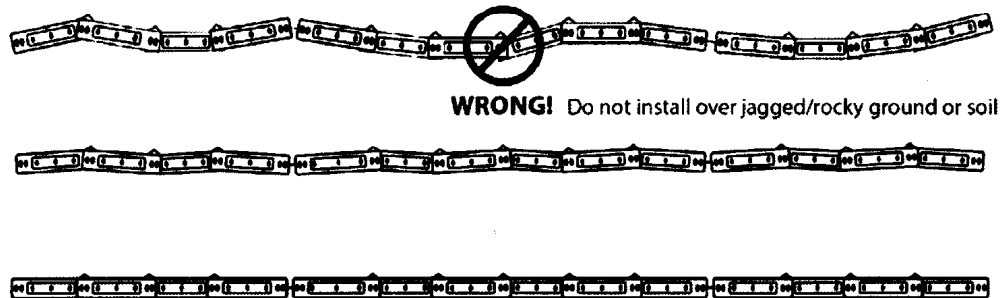
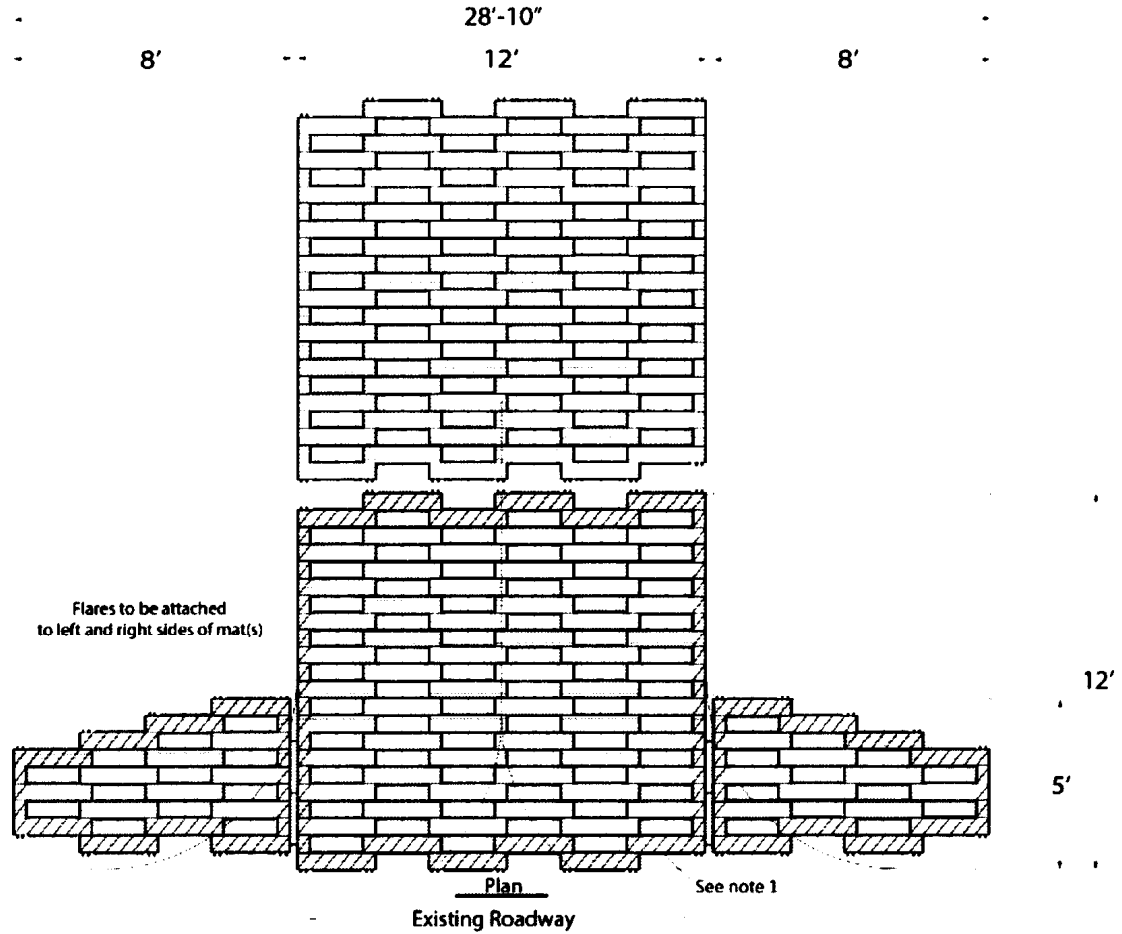

Outlet Structures

T-12

Description

This section provides guidance and details for outlet structures for the use primarily with BMPs utilizing sedimentation, (i.e., extended detention basins, retention ponds and constructed wetland ponds). The information provided in this section includes guidance for different size watersheds as well as for incorporating full spectrum detention as described in the *Storage* chapter of Volume 2.

The details contained in this Fact Sheet are intended to provide a starting point for design. UDFCD recommends that design details for outlet structures be specific for each site with structural details drawn to scale. The details provided in this Fact Sheet are not intended to be used without modification or additional detail.

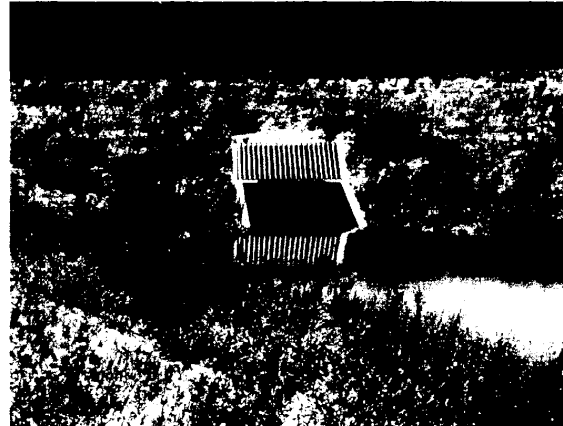

Photograph OS-1. Although each site is different, most sedimentation BMPs have similar outlet structures. Each structure should include a partially submerged orifice plate with a screen (or grate) protecting the orifice plate from clogging, and an overflow weir for flows exceeding the WQCV or excess urban runoff volume (EURV), when full spectrum detention is used.

Outlet Design

Large Watershed Considerations

UDFCD recommends that water quality treatment be provided close to the pollutant source. This is a fundamental concept of Low Impact Development (LID). Although flood control facilities, including full spectrum detention facilities, have been shown to be very effective for watersheds exceeding one square mile, this is not the case for water quality facilities. One reason for this is that the baseflow associated with a larger watershed will vary and can be difficult to estimate. The orifice plate should be designed to pass the baseflow while detaining the water quality capture volume (WQCV) for approximately 40 hours. When the baseflow is overestimated, the WQCV is not detained for the recommended time, passing through without treatment. When the baseflow is underestimated, the elevation of the permanent pool will be higher than designed, causing maintenance issues as well as reducing the volume available for detention of the WQCV, which also allows for a portion of this volume to pass through without treatment. For this reason, UDFCD recommends that facilities designed for both water quality and flood control be limited, where possible, to watersheds without a baseflow. The maximum recommended watershed for combined facilities is one square mile. Additional discussion on designing for baseflows is provided in the EDB BMP Fact Sheet (T-5).

El Paso County, Colorado, Engineeri
(Supp. No. 2)

Designing for Maintenance

Rather than using the minimum criteria, consider maximizing the width of the trash rack to the geometry of the outlet. This will reduce clogging and frequency of maintenance. Reduced clogging in EDB outlet structures will preserve the initial surcharge volume thus reducing frequency of inundation in the bottom of the basin. This will benefit the grasses and reduce long-term EDB maintenance requirements (including sediment removal in the grassed area) and may

T-12

Outlet Structures

Orifice Plates, Trash Racks, and Safety Grates

An orifice plate is used to release the WQCV slowly over 40 hours. For full spectrum detention, the orifice plate is extended to drain a larger volume, the EURV, over approximately 72 hours. The figures and tables in this section provide recommendations for orifice configurations and trash rack type and size. Guidance is provided for plates using both circular and rectangular orifices.

Orifice Sizing

Follow the design steps included in the BMP Fact Sheet for the appropriate BMP. The UD-Detention workbook, available at www.udfcd.org, can be used to route flows and calculate the required orifice sizes. UDFCD recommends a total of three orifices to maximize the orifice size and avoid clogging of the orifice plate. A detail showing the recommended orifice configuration is provided in Figure OS-4.

Trash Rack Sizing

Once the size of the orifice has been determined, this information, along with the total orifice area in the water quality plate, is used to determine the total open area of the grate. See Figure OS-1 and use the dashed line to size the trash rack. Include the portion of the trash rack that is inundated by the micropool in total open area of the grate.

Be aware, Figures OS-5, OS-6, OS-7, and OS-8 dimension the minimum width clear for the trash rack frame. It is also important to provide adequate width for attachment to the outlet structure (see Photos OS-2 and OS-3). Also, consider maximizing the width of the trash rack to the geometry of the outlet. This will reduce clogging and maintenance requirements associated with cleaning the trash rack. This Fact Sheet also



Photograph OS-2. This trash rack could not be properly

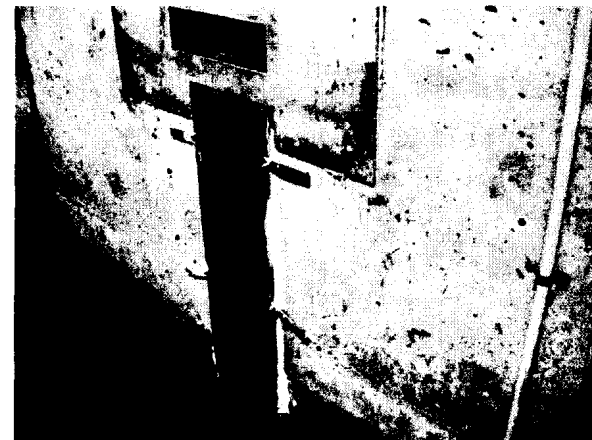

Outlet Structures

T-12

Safety Grates

Safety grates are intended to keep people and animals from inadvertently entering a storm drain. They are sometimes required even when debris entering a storm drain is not a concern. The grate on top of the outlet drop box is considered a safety grate and should be designed accordingly. The danger associated with outlet structures is the potential associated with pinning a person or animal to unexposed outlet pipe or grate. See the *Culverts and Bridges* chapter of Volume 2 of this manual for design criteria related to safety grates.

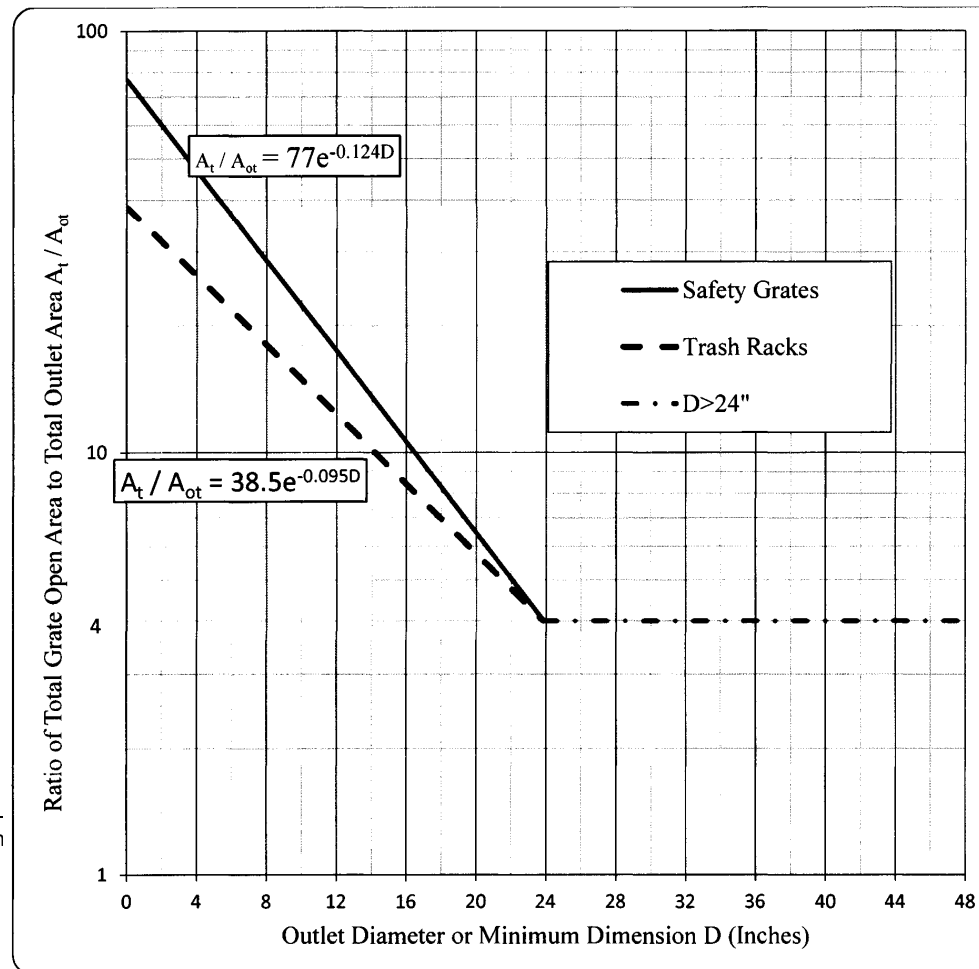

El Paso County, Colorado, Engineerin
(Supp. No. 2)

Figure OS-1. Trash Rack Sizing

T-12

Outlet Structures

Outlet Geometry

Outlets for small watersheds will typically be sized for maintenance operations while the geometry of outlets for larger watersheds may be determined based on the required size of the trash rack. For all watershed sizes, the outlet should be set back into the embankment of the pond to better allow access to the structure. This also provides a more attractive BMP. For larger watersheds, this will require wing walls. Wing walls are frequently cast-in-place concrete, although other materials, such as grouted boulders, may be used where appropriate. Consider safety, aesthetics, and maintenance when selecting materials and determining the geometry. A safety rail should be included for vertical drops of 3 feet or more. Depending on the location of the structure in relation to pedestrian trails, safety rails may also be required for lesser drops. Stepped grouted boulders can be used to reduce the height of vertical drops.

As shown in Figures EDB-1 and EDB-2 provided in BMP Fact Sheet T-5, wing walls can be flared or parallel. There are advantages to both configurations. Parallel wing walls may be more aesthetic; however, depending on the geometry of the pond, may limit accessibility to the trash rack. Flared wing walls can call attention to the structure but provide better accessibility and sometimes a vertical barrier from the micropool of an EDB, which can increase safety of the structure. Parallel walls can also be used with a second trash rack that is secured flush with the top of the wall as shown in Photo OS-4. This eliminates the need for a safety rail and may provide additional protection from clogging:

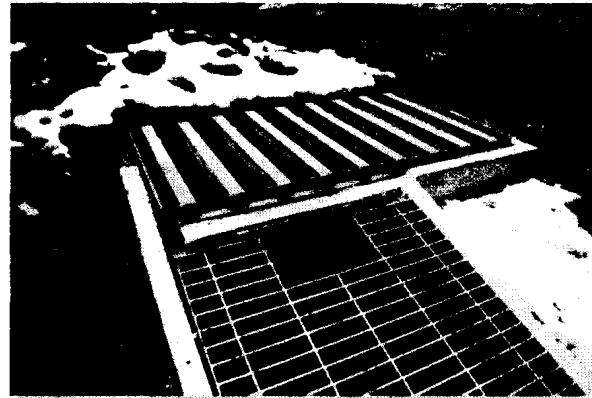

Photograph OS-4. Maintenance access to the water quality trash rack was compromised by the location of a secondary trash rack on this outlet. This may have been included as a safety rack or as additional protection from clogging. The owner modified the structure for better access. A safety rail would have been a better solution.

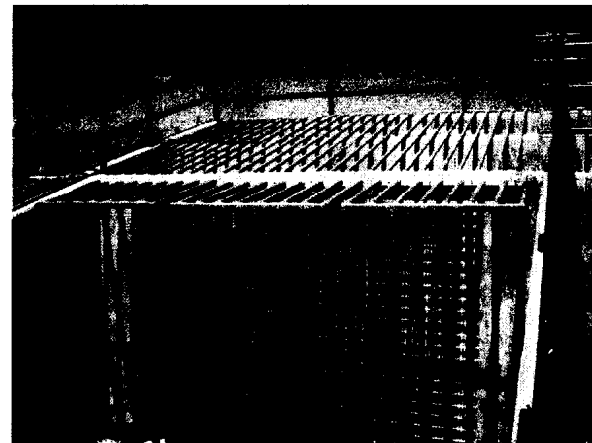

Photograph OS-5. Interruptions in the horizontal members of this trash rack and the spacing of the vertical members

Outlet Structures

T-12

Micropools within the Outlet Structure

The micropool of an EDB may be placed inside the structure when desired. This is becoming increasingly common for smaller watersheds and near airfields where large bird populations can be problematic. When designing this type of structure, consider maintenance of the water quality trash rack. The secondary trash rack should be designed to allow maintenance of the water quality trash rack similar to that shown in Photo OS-5. This concept can easily be incorporated into smaller outlet structures (see Figures OS-7 and OS-8 for details).

Outlet Structure Details

A number of details are presented in this section to assist designers with detailing outlet structures. Table OS-1 provides a list of details available at www.udfcd.org. These details are not intended to be used in construction plans without proper modifications as indicated in this table.

Table OS-1. Summary of Outlet Structure Details and Use

Figure	Detail	Use of Detail
OS-2	Typical outlet structure for full spectrum detention	Conceptual.
OS-3	Typical outlet structure for WQCV treatment and attenuation	Conceptual.
OS-4	Orifice plate and trash rack detail and notes	Outlet section. Modify per true structure geometry and concrete reinforcement. Modify notes per actual design.
OS-5	Typical outlet structure with well screen trash rack	Outlet sections. Modify per true structure geometry and concrete reinforcement. Add additional sections and detailing as necessary. Modify notes per actual design.
OS-6	Typical outlet structure with bar grate trash rack	Outlet sections. Modify per true structure geometry and concrete reinforcement. Add additional sections and detailing as necessary. Modify notes per actual design.
OS-7	Full spectrum detention outlet structure for 5-acre impervious area or less	Outlet profile and section. Modify per true EURV elevation and concrete reinforcement. Add additional sections and detailing as necessary.
OS-8	WQCV outlet structure for 5-acre impervious area or less	Outlet sections. Modify per true WQCV elevation and concrete reinforcement. Add additional sections and detailing as necessary.

T-12

Outlet Structures

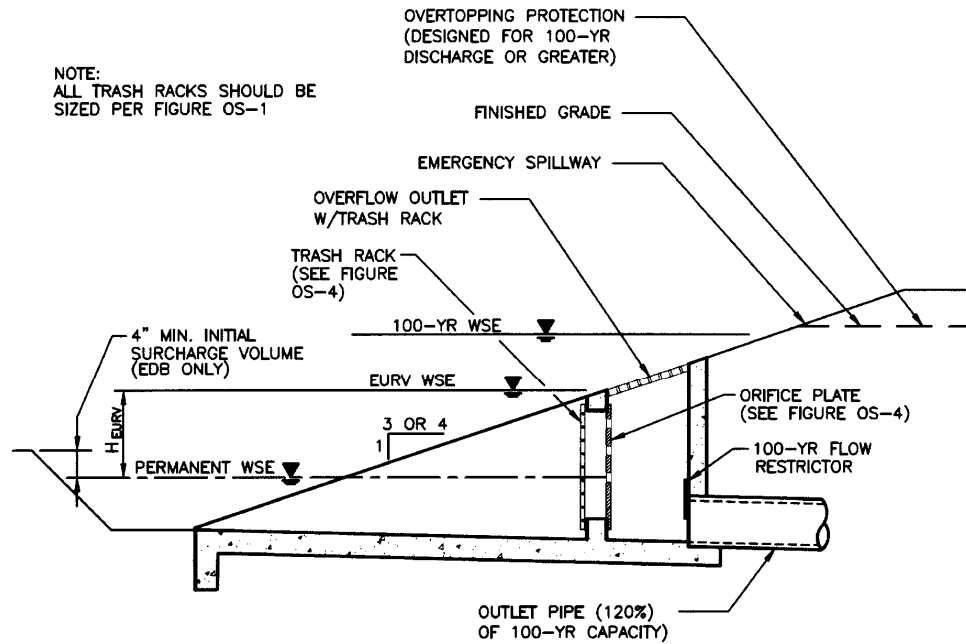

Figure OS-2. Typical outlet structure for full spectrum detention

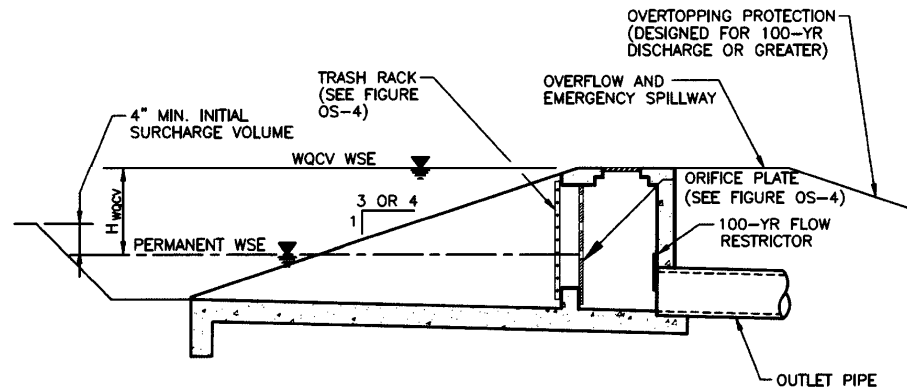
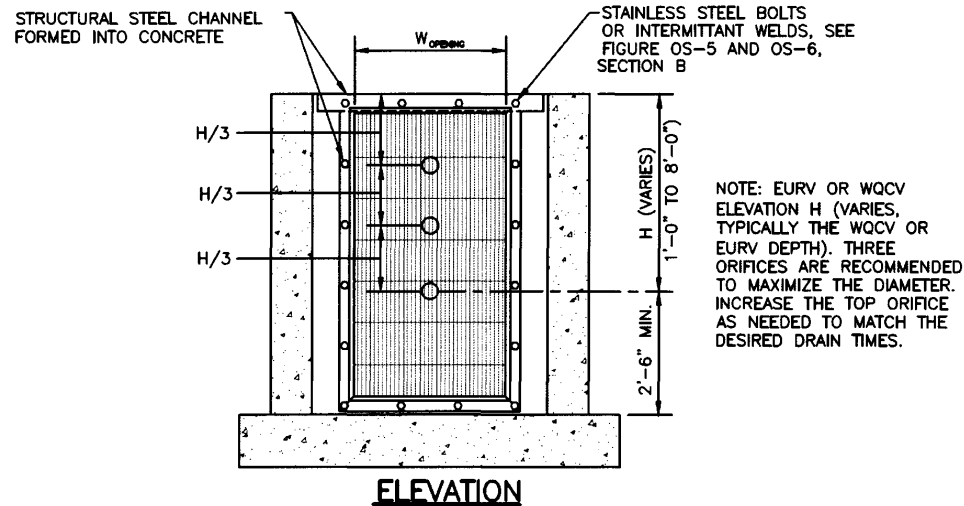

Figure OS-3. Typical outlet structure for WQCV treatment and attenuation

Outlet Structures

T-12



ORIFICE PLATE NOTES:

1. PROVIDE CONTINUOUS NEOPRENE GASKET MATERIAL BETWEEN THE ORIFICE PLATE AND CONCRETE.
2. BOLT PLATE TO CONCRETE 12" MAX. ON CENTER. SEE TABLE OS-2 FOR PLATE THICKNESS.

EURV AND WQCV TRASH RACKS:

1. WELL-SCREEN TRASH RACKS SHALL BE STAINLESS STEEL AND SHALL BE ATTACHED BY INTERMITTENT WELDS ALONG THE EDGE OF THE MOUNTING FRAME.
2. BAR GATE TRASH RACKS SHALL BE ALUMINUM AND SHALL BE BOLTED USING STAINLESS STEEL HARDWARE.
3. TRASH RACK OPEN AREAS ARE FOR SPECIFIED TRASH RACK MATERIALS. TOTAL TRASH RACK SIZE MAY NEED TO BE ADJUSTED FOR MATERIALS HAVING DIFFERENT OPEN AREA/GROSS AREA RATIO (R VALUE).
4. STRUCTURAL DESIGN OF TRASH RACKS SHALL BE BASED ON FULL HYDROSTATIC HEAD WITH ZERO HEAD DOWNSTREAM OF THE RACK.

OVERFLOW SAFETY GRATES:

1. ALL SAFETY GRATES SHALL BE MOUNTED USING STAINLESS STEEL HARDWARE AND PROVIDED WITH HINGED AND LOCKABLE OR BOLTABLE ACCESS PANELS.
2. SAFETY GRATES SHALL BE STAINLESS STEEL, ALUMINUM, OR STEEL. STEEL GRATES SHALL BE HOT DIP GALVANIZED AND MAY BE HOT POWDER COATED AFTER GALVANIZING.
3. SAFETY GRATES SHALL BE DESIGNED SUCH THAT THE DIAGONAL DIMENSION OF EACH OPENING IS SMALLER THAN THE DIAMETER OF THE OUTLET PIPE.
4. STRUCTURAL DESIGN OF SAFETY GRATES SHALL BE BASED ON FULL HYDROSTATIC HEAD WITH ZERO HEAD DOWNSTREAM OF THE RACK.

T-12

Outlet Structures

Table OS-2. Thickness of steel water quality plate

Steel plate thickness (in inches) based on design depth and span of plate											
		Head (feet)									
		3	4	5	6	7	8	9	10	11	12
Span (feet)	1	0.1875	0.1875	0.1875	0.1875	0.1875	0.1875	0.1875	0.1875	0.1875	0.1875
	2	0.1875	0.2500	0.2500	0.2500	0.2500	0.2500	0.2500	0.2500	0.2500	0.2500
	3	0.2500	0.2500	0.3750	0.3750	0.3750	0.3750	0.3750	0.3750	0.3750	0.5000
	4	0.2500	0.3750	0.3750	0.3750	0.3750	0.5000	0.5000	0.5000	0.5000	0.5000

Outlet Structures

T-12

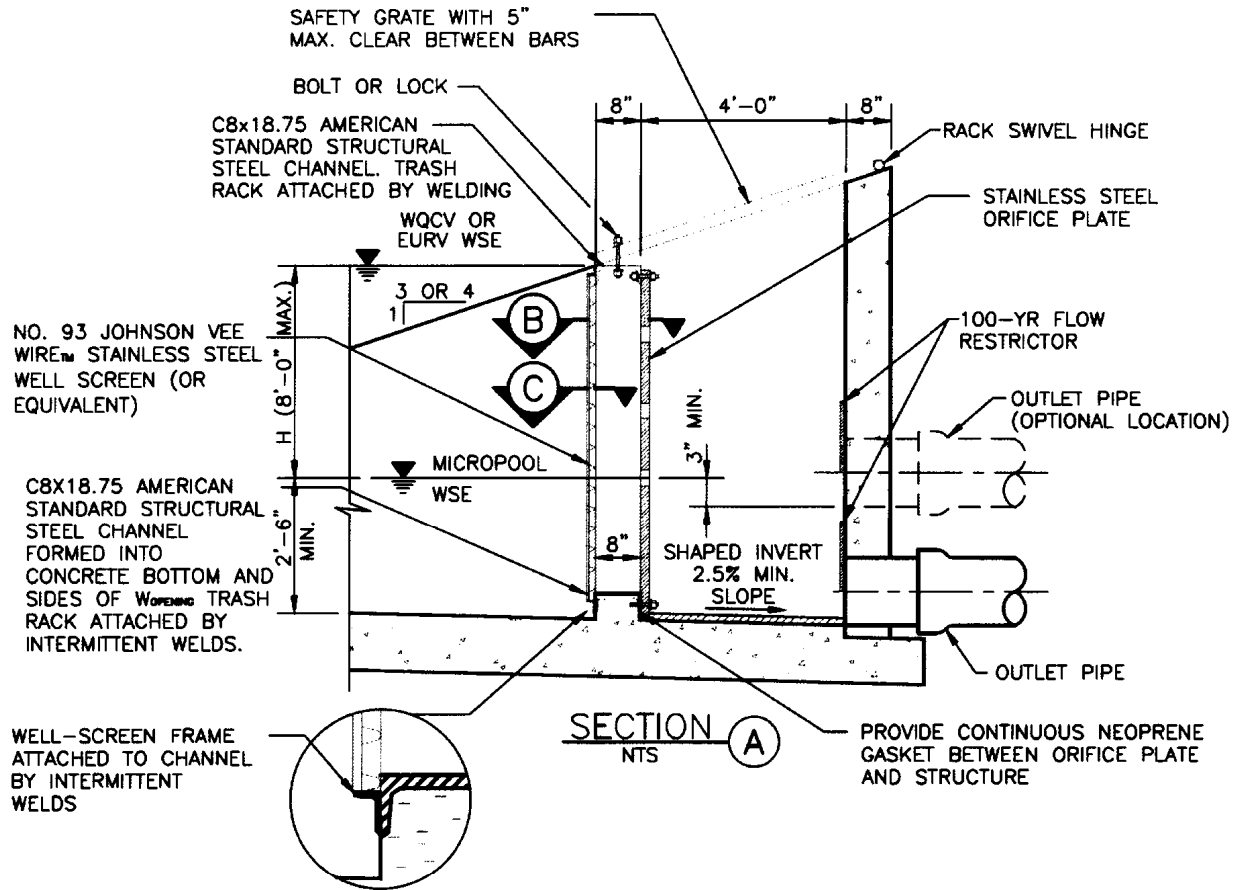

El Paso County, Colorado
(Supp. No. 2)

BOCC Memo Packet
Page 403 of 1032

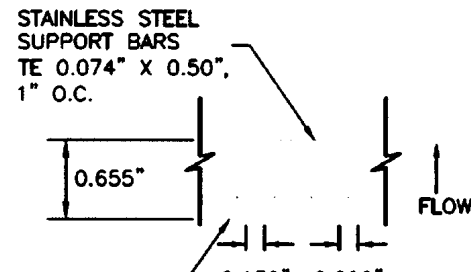
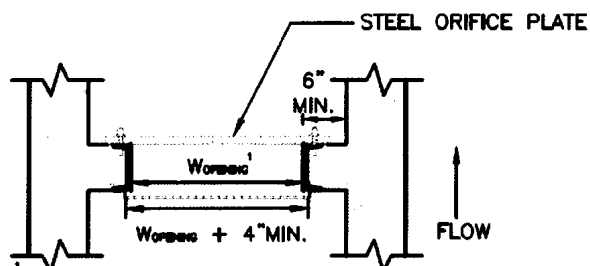

T-12

Outlet Structures

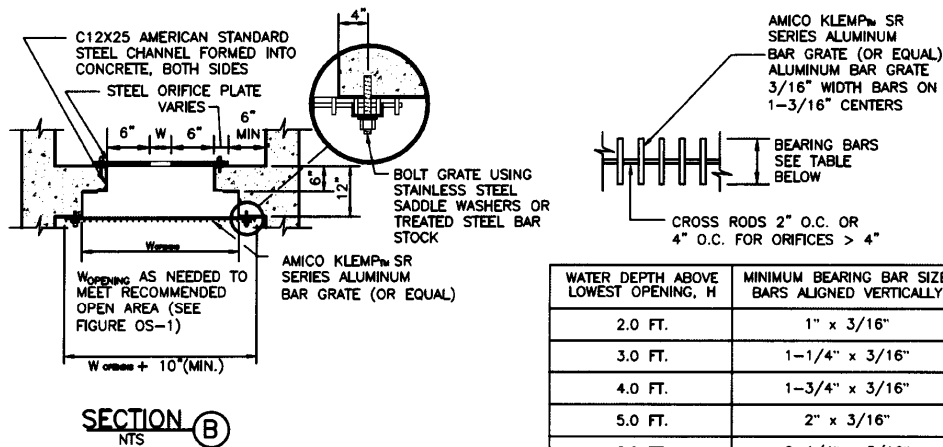
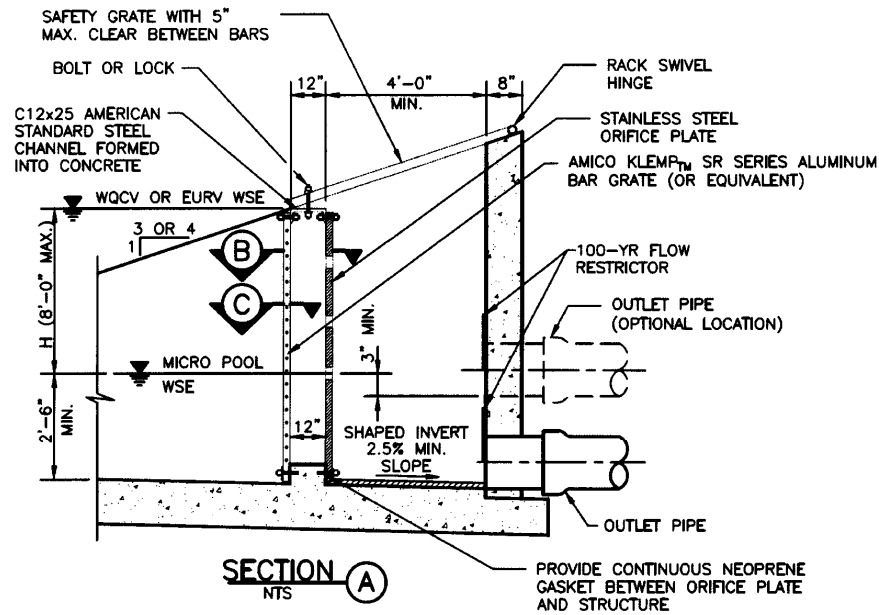

WATER DEPTH ABOVE LOWEST OPENING, H	MINIMUM BEARING BAR SIZE, BARS ALIGNED VERTICALLY
2.0 FT.	1" x 3/16"
3.0 FT.	1-1/4" x 3/16"
4.0 FT.	1-3/4" x 3/16"
5.0 FT.	2" x 3/16"
6.0 FT.	2-1/4" x 3/16"

R VALUE=(NET OPEN AREA)/GROSS RACK AREA
=0.71 FOR CROSS RODS ON 2" CENTERS
=0.77 FOR CROSS RODS ON 4" CENTERS

SECTION C
NTS

Outlet Structures

T-12

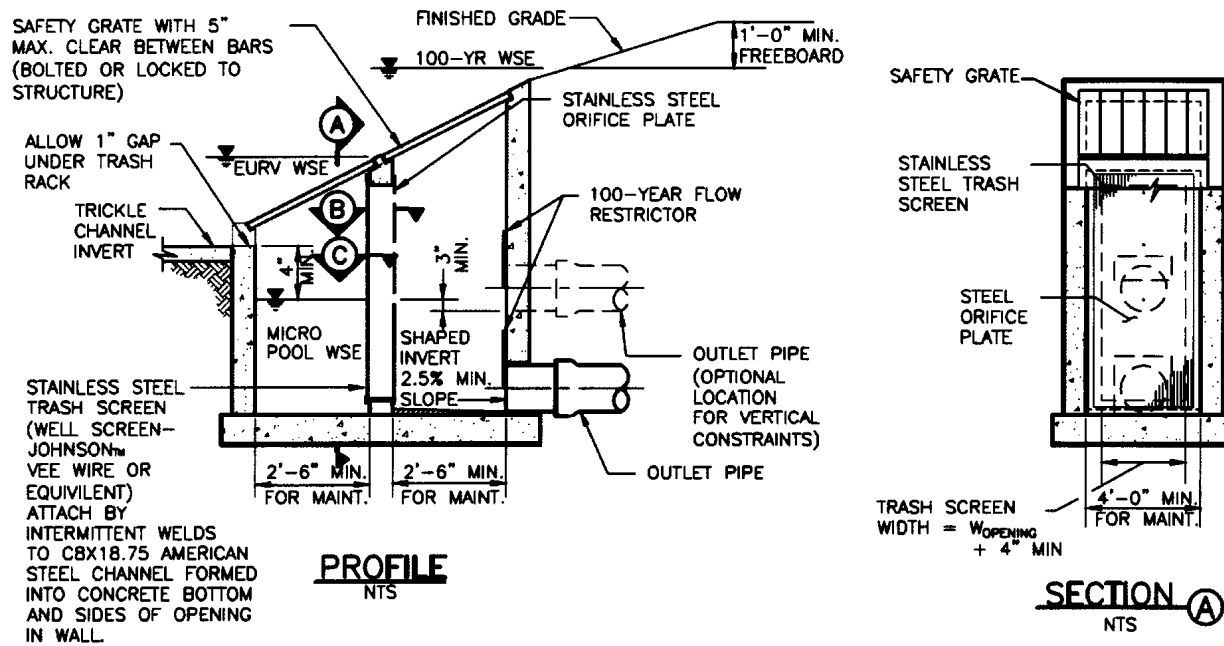

El Paso County, Colorado
(Supp. No. 2)

BOCC Memo Packet
Page 405 of 1032

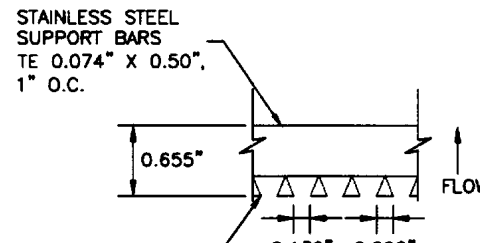
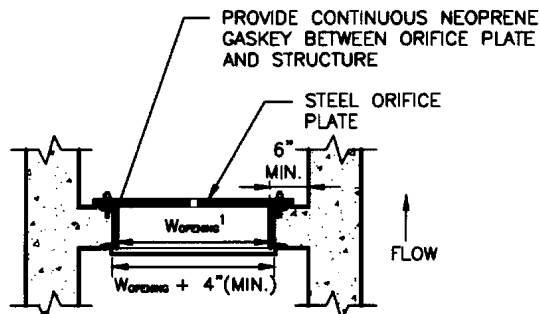

T-12

Outlet Structures

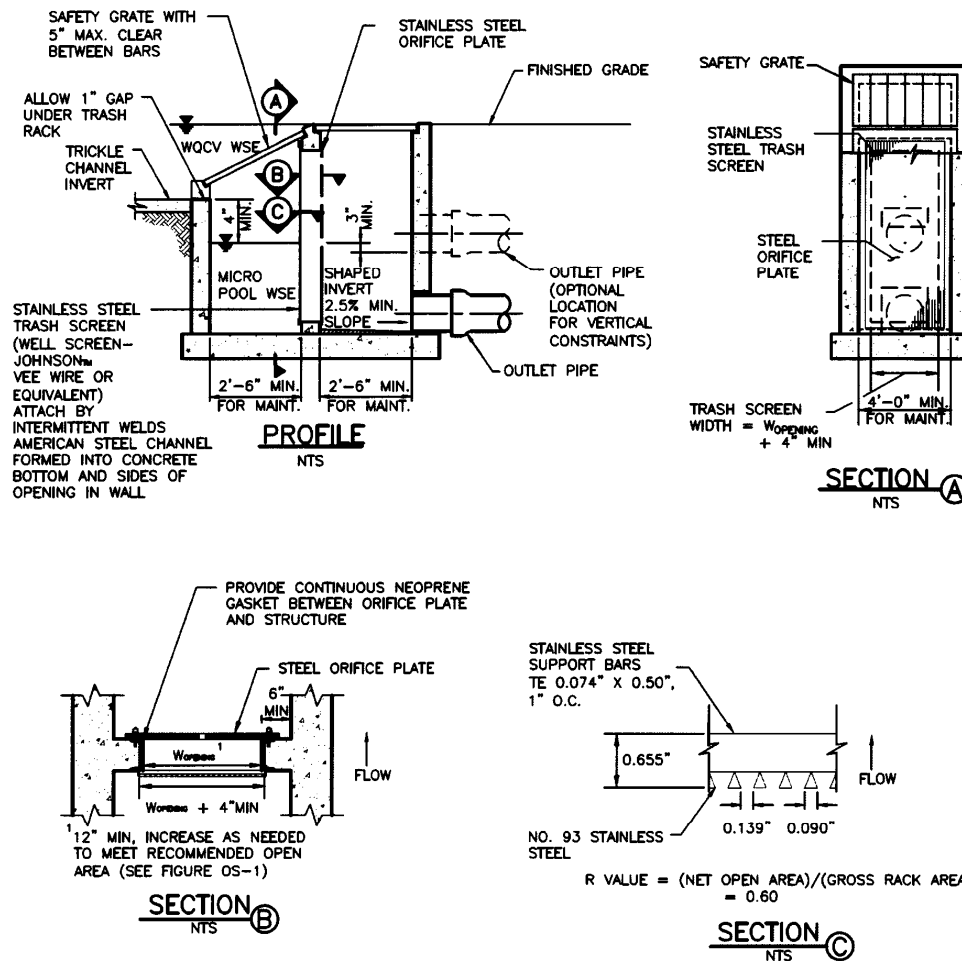

El Paso County, Colorado, Engineerin,
(Supp. No. 2)

FIGURE OS-8

Figure OS-8. WQCV outlet structure for 5-acre impervious area or less

Appendix G STORMWATER BMP MAINTENANCE AGREEMENTS

The El Paso County MS4 permit requires the County to ensure the long-term operation and maintenance of both public and private permanent stormwater quality control measures. To meet this requirement El Paso County developed maintenance agreements for three different types of ownership and maintenance scenarios and provides them for use in this appendix.

Permanent stormwater quality control measures have historically been referred to in this manual as "Post-Construction Best Management Practices (PBMPs)." The two terms may be used interchangeably in this manual.

An applicable development site with multiple permanent control measures may have one or more maintenance and access agreements depending upon ownership and maintenance responsibility. The maintenance agreements shall cover all permanent stormwater quality control measures that are included in a submitted site plan, site development plan, final plat or Grading and Erosion Control Plan. All structures such as Extended Detention Basins and Porous Landscape Detention, plus any additional permanent nonstructural control measures such as Grass Swales & Buffers that are used as part of "Minimizing Directly Connected Impervious Areas" (MDCIA), shall be included in the maintenance agreement.

When submitting a permanent BMP maintenance agreement for review and recordation by the County, the agreement shall include an Operation and Maintenance Manual developed by the engineer of record for each structure type included in a maintenance agreement. Multiple structure types may be included in one maintenance agreement and O&M Manual. The responsible entity shall routinely inspect and provide appropriate long-term maintenance for all structures associated with the permanent stormwater quality control measures as described in the O&M Manual.

(Res. No. 19-245 , 7-2-19)

**DRAFT
PRIVATE STORMWATER QUALITY STRUCTURAL BEST MANAGEMENT
PRACTICE AGREEMENT AND EASEMENT**

This PRIVATE STORMWATER QUALITY STRUCTURAL BEST MANAGEMENT PRACTICE AGREEMENT (Agreement) is made by and between THE BOARD OF COUNTY COMMISSIONERS OF EL PASO COUNTY, COLORADO (Board or County) and _____, a Colorado Corporation (“Developer”) and _____ HOMEOWNERS ASSOCIATION (“Homeowners Association” or “Association”), A Colorado nonprofit corporation. The above may occasionally be referred to herein singularly as “Party” and collectively as “Parties.”

Recitals

1. WHEREAS, Developer is the owner of certain real estate (the Property or Subdivision) in El Paso County, Colorado, which Property is legally described as:

More particularly described as follows:

2. WHEREAS, Developer desires to plat and develop on the Property a subdivision to be known as _____; and

3. WHEREAS, the development of this Subdivision will decrease the quality of the stormwater runoff from the Property, and, therefore, it is in the interest of public health, safety and welfare for the County to condition approval of this subdivision on Developer’s promise to construct adequate drainage and stormwater quality structural Best Management Practices (BMPs) in the subdivision described as

4. WHEREAS, [insert legal citations] as periodically amended, promulgated pursuant to [insert legal citations], as amended, requires the County to condition approval of all subdivisions on a developer’s promise to so construct adequate drainage and BMPs in subdivisions; and

5. WHEREAS, [insert legal citations] provides for a developer’s promise to maintain a subdivision’s BMPs; and

6. WHEREAS, Developer and the Association desire to construct the described BMPs as the means for providing adequate stormwater quality control in the Subdivision; and,

7. WHEREAS, the Association shall be charged in the Subdivision's Covenants with the duty of maintaining all common areas and common structures within the Subdivision, including the BMPs; and

8. WHEREAS, these BMPs when not properly cleaned, maintained, and repaired, threaten the public health, safety and welfare; and

9. WHEREAS, the County in order to so protect the public health, safety and welfare, may be required to expend valuable and limited public resources to so properly clean, maintain, and repair these BMPs when developer and homeowner's association have failed in their responsibilities, and therefore, the County desires the means to recover its costs incurred in the event the burden falls on the County to so clean, maintain and repair the BMPs in this Subdivision; and

10. WHEREAS, the County conditions approval of this Subdivision on the Developer's and the Association's promise to so construct this BMP, and conditions approval on the Association's promise to reimburse the County in the event the burden falls upon the County to so clean, maintain and/or repair the BMP in this Subdivision; and

11. WHEREAS, the County in order to secure performance of the promises contained herein, conditions approval of this Subdivision upon the Developer's grant herein of a perpetual Easement over a portion of the Subdivision for the purpose of allowing the County to periodically access, inspect, and, when so necessary, to clean, maintain and/or repair the BMPs; and

12. WHEREAS, given that the Association could potentially avoid liability hereunder by dissolving and reforming as a different entity, and given the difficulties inherent in collecting an unsecured promise, the County, in order to secure performance of the promises contained herein, conditions approval of this Subdivision upon the Developer's creation, by and through this Agreement, of a covenant running with the land upon each and every lot in the Subdivision.

Agreement

NOW, THEREFORE, in consideration of the mutual Promises contained herein, the sufficiency of which are hereby acknowledged, the Parties agree as follows:

1. Incorporation of Recitals: The Parties incorporated the Recitals above into this Agreement.

2. Covenants Running with the Land and Pro Rata Liability upon Individual Lot Owners: Developer and the Homeowners' Association agree that this entire Agreement and the

performance thereof shall become a covenant running with the land, which land is legally described in Paragraph One (1) of the Recitals set forth above, and that this entire Agreement and the performance thereof shall be binding upon themselves, their respective successors and assigns, including individual lot owners within the Subdivision.

However, any liability imposed under this Agreement against an individual lot owner shall not be joint and several with the Developer and the Association, but shall be prorated on a per-lot basis as determined by the following formula and illustration: each individual lot owner(s) shall be liable for no more than the total monetary amount of liability multiplied by a fraction in which the numerator is the number of lots in the Subdivision owned by a particular lot owner, and the denominator is the total number of lots in the Subdivision. As to any lot(s) owned by more than one person or entity, the liability among co-owners shall be joint and several for the pro rata obligation of that lot. The application of this Paragraph is best illustrated by the following example. Assume the following parameters: total liability is \$10,000; total number of lots in the Subdivision is 100; Lot 1 is owned by persons A and B; person B also owns Lot 2. Liability is as follows: The Developer, \$10,000; the Association, \$10,000; Lot 1 is \$100.00, joint and several as to A and B, Lot 2 is \$100.00 owed solely by B. Thus person A's total liability is \$100.00 and Person B's is \$200.00. Applying the principle that the County cannot collect more than it is owed, and assuming that the County cannot collect anything from the Developer and the Association, if the County collected the whole \$200.00 from B, then it could not collect the \$100.00 from A. Likewise, if the County collected the \$100.00 from A, then it could only collect \$100.00 from B.

3. **Construction:** Developer and the Homeowners' Association agree that they shall construct on [Tract _____ or Lot _____] as indicated on the final plat of the subdivision and as described below a private stormwater quality control BMP _____ [specify BMP] [for multiple BMPs, insert the following here: consisting of _____ () [specify BMP] on Tract or Lot _____ for each type of BMP used in the Subdivision. The Developer and the Homeowners' Association shall not commence construction of the BMPs until the Planning Department and the ECM Administrator have approved in writing the plans and specifications for the BMPs. Failure to obtain such approval shall be a material breach of this Agreement, and shall entitle the County to pursue any remedies available to it at law or in equity to enforce the same. Construction of the BMP must be complete prior to occupation of the site.

In the event construction is not so substantially completed within the occupation, then the County may exercise its discretion to complete the project, and shall have the right to seek reimbursement from the Developer and the Homeowners' Association and their respective successors and assigns, including individual lot owners in the Subdivision, for its actual costs and expenses incurred in the process of completing construction. The term actual costs and expenses shall be liberally construed in favor of the County, and shall include, but shall not be limited to, labor costs, tool and equipment costs, supply costs, and engineering and design costs, regardless of whether the County uses its own personnel, tools, equipment and supplies, etc. to correct the matter. In the event the County initiates any litigation or engages the services of legal

counsel in order to enforce the Provisions arising herein, the County shall be entitled to its damages and costs, including reasonable attorney fees, regardless of whether the County contracts with outside legal counsel or utilizes in-house legal counsel for the same. The scope of liability therefore of the Developer, the Association, and the individual lot owners shall be as set forth in paragraph Two (2) above.

The structural BMP shall be located on the following parcel(s) within the Subdivision:
BMP: _____ Tract: _____ [or Lot: _____]

4. Maintenance: The Developer and the Association agree for themselves, their respective successors and assigns, including individual lot owners within the Subdivision, that they will regularly and routinely inspect, clean and maintain the BMP, and otherwise keep the same in good repair, all at their own cost and expense. No trees or shrubs that will impair the structural integrity of the BMP shall be planted or allowed to grow on the BMP.

5. Creation of Easement: Developer and the Association hereby grant the County a non-exclusive perpetual easement upon the entire Tract(s) [or Lot(s)] describe above. The purpose of the easement is to allow the County to access, inspect, clean, repair and maintain the BMP; however, the creation of the easement does not expressly or implicitly impose on the County a duty to so inspect, clean, repair or maintain the BMP.

6. County's Rights and Obligations: Any time the County determines, in the sole exercise of its discretion, that the BMP is not properly cleaned, maintained and/or otherwise kept in good repair, the County shall give reasonable notice to the Developer, the Association and their respective successors and assigns, including the individual lot owners within the Subdivision, that the BMP needs to be cleaned, maintained and/or otherwise repaired. The notice shall provide a reasonable time to correct the problem(s). Should the responsible parties fail to correct the specified problem(s), the County may enter upon the Property to so correct the specified problem(s). Notice shall be effective to the above by the County's deposit of the same into the regular United States mail, postage pre-paid. However, this Agreement does not expressly impose on the County a duty to so inspect, clean, repair or maintain the BMP.

7. Reimbursement of County's Costs/Covenant Running With the Land: The Developer and the Association agree and covenant, for themselves, their respective successors and assigns, including individual lot owners within the Subdivision, that they will reimburse the County for its costs and expenses incurred in the process of cleaning, maintaining, and/or repairing the BMP. However, the obligation and liability of the Developer hereunder shall only continue until such time as the Developer transfers the entire management and operation of the Association to the individual lot owners within the Subdivision. Notwithstanding the previous

counsel in order to enforce the Provisions arising herein, the County shall be entitled to its damages and costs, including reasonable attorney fees, regardless of whether the County contracts with outside legal counsel or utilizes in-house legal counsel for the same. The scope of liability therefore of the Developer, the Association, and the individual lot owners shall be as set forth in paragraph Two (2) above.

The structural BMP shall be located on the following parcel(s) within the Subdivision:
BMP: _____ Tract: _____ [or Lot: _____]

4. **Maintenance:** The Developer and the Association agree for themselves, their respective successors and assigns, including individual lot owners within the Subdivision, that they will regularly and routinely inspect, clean and maintain the BMP, and otherwise keep the same in good repair, all at their own cost and expense. No trees or shrubs that will impair the structural integrity of the BMP shall be planted or allowed to grow on the BMP.

5. **Creation of Easement:** Developer and the Association hereby grant the County a non-exclusive perpetual easement upon the entire Tract(s) [or Lot(s)] describe above. The purpose of the easement is to allow the County to access, inspect, clean, repair and maintain the BMP; however, the creation of the easement does not expressly or implicitly impose on the County a duty to so inspect, clean, repair or maintain the BMP.

6. **County's Rights and Obligations:** Any time the County determines, in the sole exercise of its discretion, that the BMP is not properly cleaned, maintained and/or otherwise kept in good repair, the County shall give reasonable notice to the Developer, the Association and their respective successors and assigns, including the individual lot owners within the Subdivision, that the BMP needs to be cleaned, maintained and/or otherwise repaired. The notice shall provide a reasonable time to correct the problem(s). Should the responsible parties fail to correct the specified problem(s), the County may enter upon the Property to so correct the specified problem(s). Notice shall be effective to the above by the County's deposit of the same into the regular United States mail, postage pre-paid. However, this Agreement does not expressly impose on the County a duty to so inspect, clean, repair or maintain the BMP.

7. **Reimbursement of County's Costs/Covenant Running With the Land:** The Developer and the Association agree and covenant, for themselves, their respective successors and assigns, including individual lot owners within the Subdivision, that they will reimburse the County for its costs and expenses incurred in the process of cleaning, maintaining, and/or repairing the BMP. However, the obligation and liability of the Developer hereunder shall only continue until such time as the Developer transfers the entire management and operation of the Association to the individual lot owners within the Subdivision. Notwithstanding the previous

sentence, the Association and the individual lot owners within the Subdivision shall always remain obligated and liable hereunder, and as per the provision of Paragraph Two (2) above.

The terms actual costs and expenses shall be liberally constructed in favor of the County, and shall include, but shall not be limited to, labor costs, tools and equipment costs, supply costs, and engineering and design costs, regardless of whether the County uses its own personnel, tools, equipment and supplies, etc. to correct the matter. In the event the County initiates any litigation or engages the services of legal counsel in order to enforce the Provision arising herein, the County shall be entitled to its damages and costs, including reasonable attorney's fees, regardless of whether the County contracts with outside legal counsel or utilizes in-house legal counsel for the same. The scope of liability therefor of the Developer, the Association, and the individual lot owners shall be as set forth in Paragraph Two (2) above.

8. Contingencies of Subdivision Approval: Developer's and the Association's execution of the Agreement is a condition of subdivision approval. Additional conditions of this Agreement include, but are not limited to the following:

- a. Conveyance of Tract(s) _____ from Developer to the Association (which will include a reservation of easement in favor of the County for purposed of accessing, inspecting, cleaning, maintaining, and repairing the BMP), and recording of the Deed for the same; and

[If not a conveyance of a fee interest but merely creating and conveying an easement on the affected lot(s), then substitute the following alternative Paragraph a:]

- a. Conveyance of easements on Lot(s) _____ from the Developer to the Association and to the County for purposes of accessing, inspecting, cleaning, maintaining, and repairing the BMP, and recording of appropriate conveyance documents for the same; and
- b. The County's receipt of a copy of the Articles of Incorporation for the Association, as filed with the Colorado Secretary of State; receipt of the Certificate of Incorporation or other comparable proof for the same from the Colorado Secretary of State; a copy of the Bylaws of the Association; a copy of the organization minutes or other appropriate document of the Association, properly executed and attested, establishing that the Association has adopted this Agreement as an obligation of the Association; and
- c. A copy of the Covenants of the Subdivision establishing that the Association is obligated to inspect, clean, maintain, and repair the BMP; that the Association has adopted this Agreement as an obligation of the Association; and that a funding mechanism is in place whereby individual

lot owners within the Subdivision pay a regular fee to the Association for, among other matters, the inspection, cleaning, maintenance, and repair of the BMP.

- d. A copy of the Covenants of the Subdivision establishing that this Agreement is incorporated into the Covenants, and that such Agreement touches and concerns each every lot within the Subdivision.

The County shall have the right, in the sole exercise of its discretion, to approve or disapprove any documentation submitted to it under the conditions of this Paragraph. The County's rejection of any documentation submitted hereunder shall mean that the appropriate condition of this Agreement has not been fulfilled.

9. Distribution to Lot Purchasers: Upon the initial sale of any lot within the Subdivision, prior to closing on such sale, the Developer shall give a copy of this Agreement to the potential Buyer.

10. Agreement Monitored by Engineering Criteria Manual Administrator: Any and all actions and decisions to be made hereunder by the County shall be made by the Engineering Criteria Manual (ECM) Administrator. Accordingly, any and all documents, submissions, plan approval, inspections, etc. shall be submitted to and shall be made by the ECM Administrator.

11. Indemnification and Hold Harmless: To the extent authorized by law, Developer and the Association agree, for themselves, their respective successors and assigns, including the individual lot owners in the Subdivision, that they will indemnify, defend, and hold the County harmless from any and all loss, costs, damage, injury, liability, claim, lien, demand, action and causes of action whatsoever, whether at law or in equity, arising from or related to their respective intentional or negligent acts, errors, or omissions or that of its agents, officers, servants, employees, invitees and licensees in the construction, operation, inspection, cleaning (including analyzing and disposing of any solid or hazardous wastes as defined by State and/or Federal environmental laws and regulations), maintenance and repair of the BMP, and such obligation arising under this Paragraph shall be joint and several. Nothing in the Paragraph shall be deemed to waive or otherwise limit the defense available to the County pursuant to the Colorado Governmental Immunity Act, Sections 24-10-101, *et seq.* C.R.S. 2001, as amended, or as otherwise provided by law. However, the obligation and liability of the Developer hereunder shall only continue until such time as the Developer transfers the entire management and operation of the Association to the individual lot owners within the Subdivision.

12. Severability: In the event any Court of competent jurisdiction declares any part of this Agreement to be unenforceable, such declaration shall not affect the enforceability of the remaining parts of this agreement.

13. Third Parties: This Agreement does not and shall not be deemed to confer upon or grant to any third party any right to claim damages or to bring any lawsuit, action or other

proceeding against either the County, the Developer or the Association, their respective successors and assigns, including any individual lot owners in the Subdivision, because of any breach hereof or because of any terms, covenants, agreements or conditions contained herein.

14. Solid or Hazardous Wastes: Should any refuse from the BMP be suspected or identified as solid waste and/or hazardous waste, the Developer and the Association shall take all necessary and proper steps to characterize the waste and properly dispose of it in accordance with applicable State and/or Federal environmental laws and regulations, including, but not limited to, the following: Solid Wastes Disposal Sites and Facilities Acts, §§ 30-20-100.5 – 30-20-119, C.R.S. (2001) as amended, Colorado Regulations Pertaining to Solid Waste Disposal Sites and Facilities, 6 C.C.R. 1007-2, *et seq.*, as amended, Solid Waste Disposal Act, 42 U.S.C. §§ 6901-6992k (2001) as amended, and Federal Solid Waste Regulations 40 CFR Ch. I. (2001) as amended. The County shall not be responsible or liable for identifying, characterizing, cleaning up, or disposing of such solid and/or hazardous waste. Notwithstanding the previous sentence, should any refuse cleaned up and disposed of by the County be determined to be solid and/or hazardous waste, the Developer and the Association, but not the County, shall be responsible and liable as the owner, generator, and/or transporter of said solid and/or hazardous waste.

15. Applicable Law and Venue: The laws, rules, and regulations of the State of Colorado and El Paso County shall be applicable in the enforcement, interpretation, and execution of this Agreement, except that Federal law may be applicable regarding solid or hazardous wastes. Venue shall be the El Paso County District Court.

IN WITNESS WHEREOF, the Parties affix their signatures below.

Executed this _____ day of _____, _____, by:
[DEVELOPER'S NAME]:

By: _____
(Insert name) _____, President

The foregoing instrument was acknowledged before me this _____ day of _____, _____, by _____, President, _____.

Witness my hand and official seal.
My commission expires: _____

- ENGINEERING CRITERIA MANUAL
Appendix G STORMWATER BMP MAINTENANCE AGREEMENTS

Notary Public

Executed this _____ day of _____, _____, by:

HOMEOWNERS ASSOCIATION, a Colorado nonprofit corporation.

By: _____
(insert name) _____, President

The foregoing instrument was acknowledged before me this _____ day of _____, _____, by _____, President, _____
Homeowners Association, a Colorado nonprofit corporation.

Witness my hand and official seal.

My commission expires: _____

Notary Public

Executed this _____ day of _____, _____, by:

BOARD OF COUNTY COMMISSIONERS
OF EL PASO COUNTY, COLORADO

By: _____
_____, Chairperson

Attest:

Deputy Clerk

The foregoing instrument was acknowledged before me this _____ day of _____, by _____, Chairperson of the Board of County Commissioners of El Paso County, Colorado, as Attested to by _____, Deputy Clerk to the Board of County Commissioners of El Paso County, Colorado.

Witness my hand and official seal.

My commission expires: _____

Notary Public

Approved as to Content and Form:

Assistant County Attorney

**PRIVATE DETENTION BASIN /
STORMWATER QUALITY BEST MANAGEMENT PRACTICE
MAINTENANCE AGREEMENT AND EASEMENT**

This PRIVATE DETENTION BASIN / STORMWATER QUALITY BEST MANAGEMENT PRACTICE MAINTENANCE AGREEMENT AND EASEMENT (Agreement) is made by and between EL PASO COUNTY by and through THE BOARD OF COUNTY COMMISSIONERS OF EL PASO COUNTY, COLORADO (Board or County) and [Insert Lot Owner/Developer's name] (Owner or Developer). The above may occasionally be referred to herein singularly as "Party" and collectively as "Parties."

Recitals

A. WHEREAS, Developer is the owner of certain real estate (the Property or Subdivision) in El Paso County, Colorado, which Property is legally described in Exhibit A attached hereto and incorporated herein by this reference; and

B. WHEREAS, Developer desires to plat and develop on the Property a subdivision/land use to be known as [Insert proposed subdivision/land use name]; and

C. WHEREAS, the development of this Property will substantially increase the volume of water runoff and will decrease the quality of the stormwater runoff from the Property, and, therefore, it is in the best interest of public health, safety and welfare for the County to condition approval of this subdivision/land use on Developer's promise to construct adequate drainage, water runoff control facilities, and stormwater quality structural Best Management Practices ("BMPs") for the subdivision/land use; and

D. WHEREAS, Chapter 8, Section 8.4.5 of the El Paso County Land Development Code, as periodically amended, promulgated pursuant to Section 30-28-133(1), Colorado Revised Statutes (C.R.S.), requires the County to condition approval of all subdivisions on a developer's promise to so construct adequate drainage, water runoff control facilities, and BMPs in subdivisions; and

E. WHEREAS, the Drainage Criteria Manual, Volume 2, as amended by Appendix I of the El Paso County Engineering Criteria Manual (ECM), as each may be periodically amended, promulgated pursuant to the County's Colorado Discharge Permit System General Permit (MS4 Permit) as required by Phase II of the National Pollutant Discharge Elimination System (NPDES), which MS4 Permit requires that the County take measures to protect the quality of stormwater from sediment and other contaminants, requires subdividers, developers, landowners, and owners of facilities located in the County's rights-of-way or easements to

provide adequate permanent stormwater quality BMPs with new development or significant redevelopment; and

F. WHEREAS, Section 2.9 of the El Paso County Drainage Criteria Manual provides for a developer's promise to maintain a subdivision's drainage facilities in the event the County does not assume such responsibility; and

G. WHEREAS, developers in El Paso County have historically chosen water runoff detention basins as a means to provide adequate drainage and water runoff control in subdivisions, which basins, while effective, are less expensive for developers to construct than other methods of providing drainage and water runoff control; and

H. WHEREAS, Developer desires to construct for the subdivision/land use [insert number of basins/BMPs] detention basin/stormwater quality BMP(s) ("detention basin/BMP(s)") as the means for providing adequate drainage and stormwater runoff control and to meet requirements of the County's MS4 Permit, and to operate, clean, maintain and repair such detention basin/BMP(s); and

I. WHEREAS, Developer desires to construct the detention basin/BMP(s) on property that is or will be platted as [Insert Lot or Tract identifier(s)], as indicated on the final plat of the subdivision, and as set forth on Exhibit B attached hereto; and

J. WHEREAS, Developer shall be charged with the duties of constructing, operating, maintaining and repairing the detention basin/BMP(s) on the Property described in Exhibit B; and

K. WHEREAS, it is the County's experience that subdivision developers and property owners historically have not properly cleaned and otherwise not properly maintained and repaired these detention basins/BMPs, and that these detention basins/BMPs, when not so properly cleaned, maintained, and repaired, threaten the public health, safety and welfare; and

L. WHEREAS, the County, in order to protect the public health, safety and welfare, has historically expended valuable and limited public resources to so properly clean, maintain, and repair these detention basins/BMPs when developers and property owners have failed in their responsibilities, and therefore, the County desires the means to recover its costs incurred in the event the burden falls on the County to so clean, maintain and repair the detention basin/BMP(s) serving this subdivision/land use due to the Developer/Owner's failure to meet its obligations to do the same; and

M. WHEREAS, the County conditions approval of this subdivision/land use on the Developer's promise to so construct the detention basin/BMP(s), and conditions approval on the Owner's promise to reimburse the County in the event the burden falls upon the County to so clean, maintain and/or repair the detention basin/BMP(s) serving this Subdivision; and

N. WHEREAS, the County could condition subdivision/land use approval on the Developer's promise to construct a different and more expensive drainage, water runoff control system and BMPs than those proposed herein, which more expensive system would not create the possibility of the burden of cleaning, maintenance and repair expenses falling on the County; however, the County is willing to forego such right upon the performance of Developer/Owner's promises contained herein; and

O. WHEREAS, the County, in order to secure performance of the promises contained herein, conditions approval of this subdivision/land use upon the Developer's grant herein of a perpetual Easement over a portion of the Property for the purpose of allowing the County to periodically access, inspect, and, when so necessary, to clean, maintain and/or repair the detention basin/BMP(s); and

Agreement

NOW, THEREFORE, in consideration of the mutual Promises contained herein, the sufficiency of which are hereby acknowledged, the Parties agree as follows:

1. Incorporation of Recitals: The Parties incorporate the Recitals above into this Agreement.

2. Covenants Running with the Land: Developer/Owner agrees that this entire Agreement and the performance thereof shall become a covenant running with the land, which land is legally described in Exhibit A attached hereto, and that this entire Agreement and the performance thereof shall be binding upon itself, its successors and assigns.

3. Construction: Developer shall construct on that portion of the Property described in Exhibit B attached hereto and incorporated herein by this reference, [insert number of basins/BMPs] detention basin/BMP(s). Developer shall not commence construction of the detention basin/BMP(s) until the El Paso County Development Services Department (DSD) has approved in writing the plans and specifications for the detention basin/BMP(s) and this Agreement has been signed by all Parties and returned to the DSD. Developer shall complete construction of the detention basin/BMP(s) in substantial compliance with the County-approved plans and specifications for the detention basin/BMP(s). Failure to meet these requirements shall be a material breach of this Agreement, and shall entitle the County to pursue any remedies available to it at law or in equity to enforce the same. Construction of the detention basin/BMP(s) shall be substantially completed within one (1) year (defined as 365 days), which one year period will commence to run on the date the approved plat of this Subdivision is recorded in the records of the El Paso County Clerk and Recorder. In cases where a subdivision is not required, the one year period will commence to run on the date the Erosion and Stormwater Quality Control Permit (ESQCP) is issued. Rough grading of the detention

basin/BMP(s) must be completed and inspected by the El Paso County Development Services Department prior to commencing road construction.

In the event construction is not substantially completed within the one (1) year period, then the County may exercise its discretion to complete the project, and shall have the right to seek reimbursement from the Developer/Owner and its successors and assigns, for its actual costs and expenses incurred in the process of completing construction. The term actual costs and expenses shall be liberally construed in favor of the County, and shall include, but shall not be limited to, labor costs, tool and equipment costs, supply costs, and engineering and design costs, regardless of whether the County uses its own personnel, tools, equipment and supplies, etc. to correct the matter. In the event the County initiates any litigation or engages the services of legal counsel in order to enforce the Provisions arising herein, the County shall be entitled to its damages and costs, including reasonable attorney fees, regardless of whether the County contracts with outside legal counsel or utilizes in-house legal counsel for the same.

4. Maintenance: The Developer/Owner agrees for itself and its successors and assigns, that it will regularly and routinely inspect, clean and maintain the detention basin/BMP(s), and otherwise keep the same in good repair, all at its own cost and expense. No trees or shrubs that will impair the structural integrity of the detention basin/BMP(s) shall be planted or allowed to grow on the detention basin/BMP(s).

5. Creation of Easement: Developer/Owner hereby grants the County a non-exclusive perpetual easement upon and across that portion of the Property described in Exhibit B. The purpose of the easement is to allow the County to access, inspect, clean, repair and maintain the detention basin/BMP(s); however, the creation of the easement does not expressly or implicitly impose on the County a duty to so inspect, clean, repair or maintain the detention basin/BMP(s).

6. County's Rights and Obligations: Any time the County determines, in the sole exercise of its discretion, that the detention basin/BMP(s) is not properly cleaned, maintained and/or otherwise kept in good repair, the County shall give reasonable notice to the Developer/Owner and its successors and assigns, that the detention basin/BMP(s) needs to be cleaned, maintained and/or otherwise repaired. The notice shall provide a reasonable time to correct the problem(s). Should the responsible parties fail to correct the specified problem(s), the County may enter upon the Property to so correct the specified problem(s). Notice shall be effective to the above by the County's deposit of the same into the regular United States mail, postage pre-paid. Notwithstanding the foregoing, this Agreement does not expressly or implicitly impose on the County a duty to so inspect, clean, repair or maintain the detention basin/BMP(s).

7. Reimbursement of County's Costs / Covenant Running With the Land: The Developer/Owner agrees and covenants, for itself, its successors and assigns, that it will reimburse the County for its costs and expenses incurred in the process of completing construction of, cleaning, maintaining, and/or repairing the detention basin/BMP(s) pursuant to the provisions of this Agreement.

The term “actual costs and expenses” shall be liberally construed in favor of the County, and shall include, but shall not be limited to, labor costs, tools and equipment costs, supply costs, and engineering and design costs, regardless of whether the County uses its own personnel, tools, equipment and supplies, etc. to correct the matter. In the event the County initiates any litigation or engages the services of legal counsel in order to enforce the provisions arising herein, the County shall be entitled to its damages and costs, including reasonable attorney’s fees, regardless of whether the County contracts with outside legal counsel or utilizes in-house legal counsel for the same.

8. Contingencies of Land Use/Land Disturbance Approval: Developer/Owner’s execution of this Agreement is a condition of land use/land disturbance approval.

The County shall have the right, in the sole exercise of its discretion, to approve or disapprove any documentation submitted to it under the conditions of this Paragraph, including but not limited to, any separate agreement or amendment, if applicable, identifying any specific maintenance responsibilities not addressed herein. The County’s rejection of any documentation submitted hereunder shall mean that the appropriate condition of this Agreement has not been fulfilled.

9. Agreement Monitored by El Paso County Development Services Department and/or El Paso County Public Services Department: Any and all actions and decisions to be made hereunder by the County shall be made by the Director of the El Paso County Development Services Department and/or the Director of the El Paso County Public Services Department. Accordingly, any and all documents, submissions, plan approvals, inspections, etc. shall be submitted to and shall be made by the Director of the Development Services Department and/or the Director of the El Paso County Public Services Department.

10. Indemnification and Hold Harmless: To the extent authorized by law, Developer/Owner agrees, for itself, its successors and assigns, that it will indemnify, defend, and hold the County harmless from any and all loss, costs, damage, injury, liability, claim, lien, demand, action and causes of action whatsoever, whether at law or in equity, arising from or related to its intentional or negligent acts, errors or omissions or that of its agents, officers, servants, employees, invitees and licensees in the construction, operation, inspection, cleaning (including analyzing and disposing of any solid or hazardous wastes as defined by State and/or Federal environmental laws and regulations), maintenance, and repair of the detention basin/BMP(s), and such obligation arising under this Paragraph shall be joint and several. Nothing in this Paragraph shall be deemed to waive or otherwise limit the defense available to the County pursuant to the Colorado Governmental Immunity Act, Sections 24-10-101, *et seq.* C.R.S., or as otherwise provided by law.

11. Severability: In the event any Court of competent jurisdiction declares any part of this Agreement to be unenforceable, such declaration shall not affect the enforceability of the remaining parts of this Agreement.

12. Third Parties: This Agreement does not and shall not be deemed to confer upon or grant to any third party any right to claim damages or to bring any lawsuit, action or other proceeding against either the County, the Developer/Owner, or their respective successors and assigns, because of any breach hereof or because of any terms, covenants, agreements or conditions contained herein.

13. Solid Waste or Hazardous Materials: Should any refuse from the detention basin/BMP(s) be suspected or identified as solid waste or petroleum products, hazardous substances or hazardous materials (collectively referred to herein as "hazardous materials"), the Developer/Owner shall take all necessary and proper steps to characterize the solid waste or hazardous materials and properly dispose of it in accordance with applicable State and/or Federal environmental laws and regulations, including, but not limited to, the following: Solid Wastes Disposal Sites and Facilities Acts, §§ 30-20-100.5 – 30-20-119, C.R.S., Colorado Regulations Pertaining to Solid Waste Disposal Sites and Facilities, 6 C.C.R. 1007-2, *et seq.*, Solid Waste Disposal Act, 42 U.S.C. §§ 6901-6992k, and Federal Solid Waste Regulations 40 CFR Ch. I. The County shall not be responsible or liable for identifying, characterizing, cleaning up, or disposing of such solid waste or hazardous materials. Notwithstanding the previous sentence, should any refuse cleaned up and disposed of by the County be determined to be solid waste or hazardous materials, the Developer/Owner, but not the County, shall be responsible and liable as the owner, generator, and/or transporter of said solid waste or hazardous materials.

14. Applicable Law and Venue: The laws, rules, and regulations of the State of Colorado and El Paso County shall be applicable in the enforcement, interpretation, and execution of this Agreement, except that Federal law may be applicable regarding solid waste or hazardous materials. Venue shall be in the El Paso County District Court.

IN WITNESS WHEREOF, the Parties affix their signatures below.

Executed this _____ day of _____, 20____, by:

[Insert Developer's company name]

By: _____
[Insert name], [Insert title(President/Manager)]

The foregoing instrument was acknowledged before me this _____ day of _____, 20____, by [Insert name], [Insert title(President/Manager)], [Insert Developer's company name].

- ENGINEERING CRITERIA MANUAL
Appendix G STORMWATER BMP MAINTENANCE AGREEMENTS

Witness my hand and official seal.

My commission expires: _____

Notary Public

Executed this _____ day of _____, 20____, by:

**BOARD OF COUNTY COMMISSIONERS
OF EL PASO COUNTY, COLORADO**

By: _____

_____, Chair

Attest:

County Clerk and Recorder

The foregoing instrument was acknowledged before me this _____ day of _____, 20____, by _____, Chair of the Board of County Commissioners of El Paso County, Colorado, as Attested to by _____, County Clerk and Recorder.

Witness my hand and official seal.

My commission expires: _____

Notary Public

Approved as to Content and Form:

Assistant County Attorney

**PRIVATE DETENTION BASIN /
STORMWATER QUALITY BEST MANAGEMENT PRACTICE
MAINTENANCE AGREEMENT AND EASEMENT**

This PRIVATE DETENTION BASIN / STORMWATER QUALITY BEST MANAGEMENT PRACTICE MAINTENANCE AGREEMENT AND EASEMENT (Agreement) is made by and between EL PASO COUNTY by and through THE BOARD OF COUNTY COMMISSIONERS OF EL PASO COUNTY, COLORADO (Board or County) and [Insert Developer's company name] (Developer) and [Insert first part of Metro District name] METROPOLITAN DISTRICT (Metro District), a quasi-municipal corporation and political subdivision of the State of Colorado. The above may occasionally be referred to herein singularly as "Party" and collectively as "Parties."

Recitals

A. WHEREAS, the District provides various municipal services to certain real property in El Paso County, Colorado referred to as [Insert development name]; and

B. WHEREAS, Developer is the owner of certain real estate (the Property or Subdivision) in El Paso County, Colorado, which Property is legally described in Exhibit A attached hereto and incorporated herein by this reference; and

C. WHEREAS, Developer desires to plat and develop on the Property a subdivision to be known as [Insert proposed subdivision name]; and

D. WHEREAS, the development of this Property will substantially increase the volume of water runoff and will decrease the quality of the stormwater runoff from the Property, and, therefore, it is in the best interest of public health, safety and welfare for the County to condition approval of this subdivision on Developer's promise to construct adequate drainage, water runoff control facilities, and stormwater quality structural Best Management Practices ("BMPs") for the subdivision; and

E. WHEREAS, Chapter 8, Section 8.4.5 of the El Paso County Land Development Code, as periodically amended, promulgated pursuant to Section 30-28-133(1), Colorado Revised Statutes (C.R.S.), requires the County to condition approval of all subdivisions on a developer's promise to so construct adequate drainage, water runoff control facilities, and BMPs in subdivisions; and

F. WHEREAS, the Drainage Criteria Manual, Volume 2, as amended by Appendix I of the El Paso County Engineering Criteria Manual (ECM), as each may be periodically amended, promulgated pursuant to the County's Colorado Discharge Permit System General

Permit (MS4 Permit) as required by Phase II of the National Pollutant Discharge Elimination System (NPDES), which MS4 Permit requires that the County take measures to protect the quality of stormwater from sediment and other contaminants, requires subdividers, developers, landowners, and owners of facilities located in the County's rights-of-way or easements to provide adequate permanent stormwater quality BMPs with new development or significant redevelopment; and

G. WHEREAS, Section 2.9 of the El Paso County Drainage Criteria Manual provides for a developer's promise to maintain a subdivision's drainage facilities in the event the County does not assume such responsibility; and

H. WHEREAS, developers in El Paso County have historically chosen water runoff detention basins as a means to provide adequate drainage and water runoff control in subdivisions, which basins, while effective, are less expensive for developers to construct than other methods of providing drainage and water runoff control; and

I. WHEREAS, Developer desires to construct for the subdivision [insert number of basins/BMPs] detention basin/stormwater quality BMP(s) ("detention basin/BMP(s)") as the means for providing adequate drainage and stormwater runoff control and to meet requirements of the County's MS4 Permit, and to provide for operating, cleaning, maintaining and repairing such detention basin/BMP(s); and

J. WHEREAS, Developer desires to construct the detention basin/BMP(s) on property that is or will be platted as [Insert Lot or Tract identifier(s)], as indicated on the final plat of the subdivision, and as set forth on Exhibit B attached hereto; and

K. WHEREAS, Developer shall be charged with the duty of constructing the detention basin/BMP(s) and the Metro District shall be charged with the duties of operating, maintaining and repairing the detention basin/BMP(s) on the Property described in Exhibit B; and

L. WHEREAS, it is the County's experience that subdivision developers and property owners historically have not properly cleaned and otherwise not properly maintained and repaired these detention basins/BMPs, and that these detention basins/BMPs, when not so properly cleaned, maintained, and repaired, threaten the public health, safety and welfare; and

M. WHEREAS, the County, in order to protect the public health, safety and welfare, has historically expended valuable and limited public resources to so properly clean, maintain, and repair these detention basins/BMPs when developers and property owners have failed in their responsibilities, and therefore, the County desires the means to recover its costs incurred in the event the burden falls on the County to so clean, maintain and repair the detention basin/BMP(s) serving this Subdivision due to the Developer's or the Metro District's failure to meet its obligations to do the same; and

N. WHEREAS, the County conditions approval of this Subdivision on the Developer's promise to so construct the detention basin/BMP(s), and further conditions approval on the Metro District's promise to reimburse the County in the event the burden falls upon the County to so clean, maintain and/or repair the detention basin/BMP(s) serving this Subdivision; and

O. WHEREAS, the County could condition subdivision approval on the Developer's promise to construct a different and more expensive drainage, water runoff control system and BMPs than those proposed herein, which more expensive system would not create the possibility of the burden of cleaning, maintenance and repair expenses falling on the County; however, the County is willing to forego such right upon the performance of Developer's and the Metro District's promises contained herein; and

P. WHEREAS, the County, in order to secure performance of the promises contained herein, conditions approval of this Subdivision upon the Developer's grant herein of a perpetual Easement over a portion of the Property for the purpose of allowing the County to periodically access, inspect, and, when so necessary, to clean, maintain and/or repair the detention basin/BMP(s); and

Q. WHEREAS, Pursuant to Colorado Constitution, Article XIV, Section 18(2) and Section 29-1-203, Colorado Revised Statutes, governmental entities may cooperate and contract with each other to provide any function, services, or facilities lawfully authorized to each.

Agreement

NOW, THEREFORE, in consideration of the mutual Promises contained herein, the sufficiency of which are hereby acknowledged, the Parties agree as follows:

1. Incorporation of Recitals: The Parties incorporate the Recitals above into this Agreement.
2. Covenants Running with the Land: Developer and the Metro District agree that this entire Agreement and the performance thereof shall become a covenant running with the land, which land is legally described in Exhibit A attached hereto, and that this entire Agreement and the performance thereof shall be binding upon themselves, their respective successors and assigns.
3. Construction: Developer shall construct on that portion of the Property described in Exhibit B attached hereto and incorporated herein by this reference, [insert number of basins/BMPs] detention basin/BMP(s). Developer shall not commence construction of the

detention basin/BMP(s) until the El Paso County Development Services Department (DSD) has approved in writing the plans and specifications for the detention basin/BMP(s) and this Agreement has been signed by all Parties and returned to the DSD. Developer shall complete construction of the detention basin/BMP(s) in substantial compliance with the County-approved plans and specifications for the detention basin/BMP(s). Failure to meet these requirements shall be a material breach of this Agreement, and shall entitle the County to pursue any remedies available to it at law or in equity to enforce the same. Construction of the detention basin/BMP(s) shall be substantially completed within one (1) year (defined as 365 days), which one year period will commence to run on the date the approved plat of this Subdivision is recorded in the records of the El Paso County Clerk and Recorder. Rough grading of the detention basin/BMP(s) must be completed and inspected by the El Paso County Development Services Department prior to commencing road construction.

In the event construction is not substantially completed within the one (1) year period, then the County may exercise its discretion to complete the project, and shall have the right to seek reimbursement from the Developer and its respective successors and assigns, for its actual costs and expenses incurred in the process of completing construction. The term actual costs and expenses shall be liberally construed in favor of the County, and shall include, but shall not be limited to, labor costs, tool and equipment costs, supply costs, and engineering and design costs, regardless of whether the County uses its own personnel, tools, equipment and supplies, etc. to correct the matter. In the event the County initiates any litigation or engages the services of legal counsel in order to enforce the Provisions arising herein, the County shall be entitled to its damages and costs, including reasonable attorney fees, regardless of whether the County contracts with outside legal counsel or utilizes in-house legal counsel for the same.

4. Maintenance: The Metro District agrees for itself and its successors and assigns, that it will regularly and routinely inspect, clean and maintain the detention basin/BMP(s), and otherwise keep the same in good repair, all at its own cost and expense. No trees or shrubs that will impair the structural integrity of the detention basin/BMP(s) shall be planted or allowed to grow on the detention basin/BMP(s).

5. Creation of Easement: Developer hereby grants the County and the Metro District a non-exclusive perpetual easement upon and across that portion of the Property described in Exhibit B. The purpose of the easement is to allow the County and the Metro District to access, inspect, clean, repair and maintain the detention basin/BMP(s); however, the creation of the easement does not expressly or implicitly impose on the County a duty to so inspect, clean, repair or maintain the detention basin/BMP(s).

6. County's Rights and Obligations: Any time the County determines, in the sole exercise of its discretion, that the detention basin/BMP(s) is not properly cleaned, maintained and/or otherwise kept in good repair, the County shall give reasonable notice to the Developer, the Metro District and their respective successors and assigns, that the detention basin/BMP(s) needs to be cleaned, maintained and/or otherwise repaired. The notice shall provide a reasonable time to correct the problem(s). Should the responsible parties fail to correct the specified

problem(s), the County may enter upon the Property to so correct the specified problem(s). Notice shall be effective to the above by the County's deposit of the same into the regular United States mail, postage pre-paid. Notwithstanding the foregoing, this Agreement does not expressly or implicitly impose on the County a duty to so inspect, clean, repair or maintain the detention basin/BMP(s).

7. Reimbursement of County's Costs / Covenant Running With the Land: The Developer and the Metro District agree and covenant, for themselves, their respective successors and assigns, that they will reimburse the County for its costs and expenses incurred in the process of completing construction of, cleaning, maintaining, and/or repairing the detention basin/BMP(s) pursuant to the provisions of this Agreement.

The term "actual costs and expenses" shall be liberally construed in favor of the County, and shall include, but shall not be limited to, labor costs, tools and equipment costs, supply costs, and engineering and design costs, regardless of whether the County uses its own personnel, tools, equipment and supplies, etc. to correct the matter. In the event the County initiates any litigation or engages the services of legal counsel in order to enforce the provisions arising herein, the County shall be entitled to its damages and costs, including reasonable attorney's fees, regardless of whether the County contracts with outside legal counsel or utilizes in-house legal counsel for the same.

8. Contingencies of Subdivision Approval: Developer's and the Metro District's execution of this Agreement is a condition of subdivision approval. Additional conditions of this Agreement include, but are not limited to, the following:

- a. Conveyance of [Insert Lot, Tract or easement identifier(s)], as indicated on the final plat of the subdivision, from Developer to the Metro District (which will include a reservation of easement in favor of the County for purposes of accessing, inspecting, cleaning, maintaining, and repairing the detention basin/BMP(s)), and recording of the Deed for the same; and
- b. A copy of the Covenants of the Subdivision, if applicable, establishing that the Metro District is obligated to inspect, clean, maintain, and repair the detention basin/BMP(s).

The County shall have the right, in the sole exercise of its discretion, to approve or disapprove any documentation submitted to it under the conditions of this Paragraph, including but not limited to, any separate agreement or amendment, if applicable, identifying any specific maintenance responsibilities not addressed herein. The County's rejection of any documentation submitted hereunder shall mean that the appropriate condition of this Agreement has not been fulfilled.

9. Agreement Monitored by El Paso County Development Services Department and/or El Paso County Public Services Department: Any and all actions and decisions to be made hereunder by the County shall be made by the Director of the El Paso County Development Services Department and/or the Director of the El Paso County Public Services Department. Accordingly, any and all documents, submissions, plan approvals, inspections, etc. shall be submitted to and shall be made by the Director of the Development Services Department and/or the Director of the El Paso County Public Services Department.

10. Indemnification and Hold Harmless: To the extent authorized by law, Developer and the Metro District agree, for themselves, their respective successors and assigns, that they will indemnify, defend, and hold the County harmless from any and all loss, costs, damage, injury, liability, claim, lien, demand, action and causes of action whatsoever, whether at law or in equity, arising from or related to their respective intentional or negligent acts, errors or omissions or that of their agents, officers, servants, employees, invitees and licensees in the construction, operation, inspection, cleaning (including analyzing and disposing of any solid or hazardous wastes as defined by State and/or Federal environmental laws and regulations), maintenance, and repair of the detention basin/BMP(s), and such obligation arising under this Paragraph shall be joint and several. Nothing in this Paragraph shall be deemed to waive or otherwise limit the defense available to the County pursuant to the Colorado Governmental Immunity Act, Sections 24-10-101, *et seq.* C.R.S., or as otherwise provided by law.

11. Severability: In the event any Court of competent jurisdiction declares any part of this Agreement to be unenforceable, such declaration shall not affect the enforceability of the remaining parts of this Agreement.

12. Third Parties: This Agreement does not and shall not be deemed to confer upon or grant to any third party any right to claim damages or to bring any lawsuit, action or other proceeding against either the County, the Developer, the Metro District, or their respective successors and assigns, because of any breach hereof or because of any terms, covenants, agreements or conditions contained herein.

13. Solid Waste or Hazardous Materials: Should any refuse from the detention basin/BMP(s) be suspected or identified as solid waste or petroleum products, hazardous substances or hazardous materials (collectively referred to herein as “hazardous materials”), the Developer and the Metro District shall take all necessary and proper steps to characterize the solid waste or hazardous materials and properly dispose of it in accordance with applicable State and/or Federal environmental laws and regulations, including, but not limited to, the following: Solid Wastes Disposal Sites and Facilities Acts, §§ 30-20-100.5 – 30-20-119, C.R.S., Colorado Regulations Pertaining to Solid Waste Disposal Sites and Facilities, 6 C.C.R. 1007-2, *et seq.*, Solid Waste Disposal Act, 42 U.S.C. §§ 6901-6992k, and Federal Solid Waste Regulations 40 CFR Ch. I. The County shall not be responsible or liable for identifying, characterizing, cleaning up, or disposing of such solid waste or hazardous materials. Notwithstanding the previous sentence, should any refuse cleaned up and disposed of by the County be determined to be solid waste or hazardous materials, the Developer and the Metro District, but not the County, shall be

responsible and liable as the owner, generator, and/or transporter of said solid waste or hazardous materials.

14. Applicable Law and Venue: The laws, rules, and regulations of the State of Colorado and El Paso County shall be applicable in the enforcement, interpretation, and execution of this Agreement, except that Federal law may be applicable regarding solid waste or hazardous materials. Venue shall be in the El Paso County District Court.

15. Limitation on Developer's Obligation and Liability: The obligation and liability of the Developer hereunder shall only continue until such time as the Final Plat as described in Paragraph Three (3) of the Recitals set forth above is recorded and the Developer completes the construction of the detention basin/BMP(s) and transfers all applicable maintenance and operation responsibilities to the Metro District. By execution of this agreement, the Metro District agrees to accept all responsibilities and to perform all duties assigned to it, including those of the Developer, as specified herein, upon transfer of [Insert Lot, Tract or easement identifier(s)] from Developer to the Metro District.

IN WITNESS WHEREOF, the Parties affix their signatures below.

Executed this _____ day of _____, 20____, by:
[Insert Developer's company name]

By: _____
[Insert name], [Insert title(President/Manager)]

The foregoing instrument was acknowledged before me this _____ day of _____, 20____, by [Insert name], [Insert title(President/Manager)], [Insert Developer's company name].

Witness my hand and official seal.

My commission expires: _____

Notary Public

- ENGINEERING CRITERIA MANUAL
Appendix G STORMWATER BMP MAINTENANCE AGREEMENTS

Executed this _____ day of _____, 20____, by:

[Insert first part of Metro District name] METROPOLITAN DISTRICT

By: _____
[Insert name], President

Attest:

By: _____
[Insert name], [Insert title]

The foregoing instrument was acknowledged before me this _____ day of _____,

20____, by [Insert name], President, and [Insert name], [Insert title], [Insert first part of Metro District name] METROPOLITAN DISTRICT

Witness my hand and official seal.

My commission expires: _____

Notary Public

Executed this _____ day of _____, 20____, by:

**BOARD OF COUNTY COMMISSIONERS
OF EL PASO COUNTY, COLORADO**

By: _____
_____, Chair

Attest:

County Clerk and Recorder

The foregoing instrument was acknowledged before me this _____ day of _____, 20____, by _____, Chair of the Board of County Commissioners of El Paso County, Colorado, as Attested to by _____, County Clerk and Recorder.

Witness my hand and official seal.

My commission expires: _____

Notary Public

Approved as to Content and Form:

Assistant County Attorney

Appendix H PERFORMANCE SURETY

SURETY ESTIMATE FORM

This Surety Estimate Form is located on the El Paso County website at <http://adm.elpasoco.com/Development%20Services/Pages/CollateralSuretyForms.aspx>

The following pages contain typical wording for:

- Defect Surety
- Performance Surety
- Punchlist Inspection Form
- Schedule for Completion of Improvements
- Surety Release Inspection Request

DEFECT SURETY (TYPICAL WORDING)

KNOW ALL MEN BY THESE PRESENTS: That (Owner or Contractor and Address) as Principal and the (Insurance Company) as a (Name of State) corporation authorized to execute an approved form of surety in the State of Colorado, and duly authorized to transact a general surety business in the State of Colorado, as Surety, are held and firmly bound unto County of El Paso, State of Colorado, in the sum of (20% of Contract Price) lawful money of the United States, for the payment of which, well and truly to be made, we bind ourselves, our heirs, executors, administrators, successors and assigns, jointly and severally, firmly by these presents.

THE CONDITION OF THE ABOVE OBLIGATION IS SUCH THAT: WHEREAS (The Principal) has _____, and WHEREAS, the said (Principal) is required to give a form of surety in the amount of (20% Contract Price) to protect the said COUNTY OF EL PASO against the result of faulty materials or workmanship for a period of TWO YEARS from and after the date of completion and preliminary acceptance of said work;

NOW, THEREFORE, if the said (Principal) shall for a period of TWO YEARS from and after the date of completion and acceptance of said work, replace any and all defects arising in said work whether resulting from defective materials or defective workmanship, then the above obligation to be void; otherwise, to remain in full force and effect.

Signed and sealed this _____ day of _____, 20____.

PERFORMANCE SURETY (TYPICAL WORDING)

WHEREAS, the County of El Paso, State of Colorado, and _____
(hereinafter designated as "Principal") have entered into an agreement whereby Principal agrees to install and complete certain designated public and development or subdivision improvements, which said agreement, dated _____, and identified as Project _____ is hereby referred to and made a part hereof; and

WHEREAS, Principal is required under the terms of said agreement to furnish surety for the faithful performance of said agreement;

NOW, THEREFORE, we, the Principal and _____, as Surety, are held firmly bound unto the County of El Paso (hereinafter called "County") in the penal sum of _____ Dollars (\$ _____) of lawful money of the United States, for the payment of which sum well and truly to be made, we bind ourselves, our heirs, executors, administrators, successors and assigns, jointly and severally, firmly by these presents.

The condition of this obligation is such that if the above Principal, his or its heirs, executors, administrators, successors or assigns, shall in all things stand to and abide by, and well and truly keep and perform the covenants, conditions and provisions in said agreement and any alteration thereof made as therein provided, on his or their part, to be kept and performed at the time and in the manner therein specified, and in all respects according to their true intent and meaning, and shall indemnify and save harmless the County, its elected officials, officers, employees, agents, and volunteers, as therein stipulated, then this obligation shall become null and void; otherwise it shall be and remain in full force and effect.

As a part of the obligation secured hereby and in addition to the face amount specified therefore, there shall be included costs and reasonable expenses and fees, including reasonable attorney's fees, incurred by County in successfully enforcing such obligation, all to be taxed as costs and included in any judgment rendered. The surety hereby stipulates and agrees that no change, extension of time, alteration or addition to the terms of the agreement or to the work to be performed thereunder or the specifications accompanying the same shall in manner affect its obligations on this bond, and it does hereby waive notice of any such change, extension of time, alteration or addition to the terms of the agreement or to the work or to the specifications.

IN WITNESS WHEREOF, this instrument has been duly executed by the Principal and Surety above named on _____:

APPROVED AS TO FORM:

COUNTY ATTORNEY

ATTEST:

County Clerk (Seal)

Name of Principal

By: _____
(Seal)

Name of Surety

By: _____
(Seal) Attorney-in-Fact

PUNCHLIST INSPECTION FORM

1.1 **PURPOSE** The purpose of this form is to guide the completion of a preliminary or final acceptance inspection. The completed form is used to provide a comprehensive list of needed corrections.

1.2 **INSPECTION CODES** The following codes shall be used:
NA - not applicable, NI - not installed, WU - work underway

1.3 **DRAINAGE CONDITIONS CONFORM TO PLANS AND AREA ACCEPTABLE:**

- _____ Permanent BMPs
 - _____ Inlet
 - _____ Presedimentation (forebay)
 - _____ Low flow channel
 - _____ Bottom Stage Area
 - _____ Micropool
 - _____ Outlet Structure
 - _____ Vegetative Cover
 - _____ Infiltration Media
 - _____ Underdrain
- _____ Culverts
- _____ Storm Sewers
- _____ Manholes (including risers, steps, and inverts)
- _____ Inlets (including risers, steps, and inverts)
- _____ Drainage Contained Within the Right-of-Way
- _____ Platted Drainage Easement
- _____ Construction BMPs Removed

1.4 **ROADWAY CONDITIONS CONFORM TO PLANS AND ARE ACCEPTABLE:**

- _____ Paved Surface in Acceptable Condition (i.e. free of cracking and potholes)
- _____ Pavement Crown & Super Elevation Acceptable
- _____ Shoulders to Grade and Stabilized
- _____ Roadside Ditches Acceptable
- _____ Cut Slopes to Grade and Stabilized
- _____ Fill Slopes to Grade and Stabilized
- _____ Paved Surface Cleared of Loose Stone

1.5 **RIGHT-OF-WAY:**

- _____ Clear of Vegetation

- _____ Clear of Debris
- _____ Curbing Acceptable
- _____ Sidewalk Acceptable
- _____ Driveway Entrances Properly Installed According to Road Plan or Site Plan
- _____ Driveway Entrances and/or Commercial Entrances Located as shown on Plans
- _____ Guardrail Installed in Correct Location(s)
- _____ Guardrail Installed at Correct Distance from Edge of Pavement
- _____ Proper Guardrail End Sections Installed in Approved Manner
- _____ Grass on Shoulders and Ditches Has Been Mowed
- _____ Dead Trees Removed That Might Fall in Right-of-Way
- _____ Shoulders and Ditches Free of Loose Stone
- _____ Driveway Pipes Clean and Functioning Properly

1.6 **INSPECTION RESULTS** An Inspection Report shall be completed with all items failing to adhere to the approved plans and ECM Standards and specifications. This handwritten punchlist is to be typed, proofed, and then given to the engineer. In addition, the completed Inspection Form shall be put in the project filed.

(Res. No. 19-245 , 7-2-19)

SCHEDULE FOR COMPLETION OF IMPROVEMENTS

1.1 PURPOSE

This form is intended to facilitate the completion of approved improvements in a timely manner by assuring the applicant has a schedule in place for the completion of the improvements, and by providing the County a means to assess the applicant's ability to meet the completion date stated in the approved agreement. The permit holder must provide an estimated completion date for each milestone listed below.

1.2 GENERAL INFORMATION

Date: _____

Applicant: _____

Phone: _____

Tax Map Parcel No.: _____

Project Name (Include phase, section, and other relevant information to clearly identify the project): _____

Date	Milestone
	Start of construction.
	Temporary erosion control systems installed (Initial BMPs).
	Grading, subgrade, and stormwater management activities completed.
	Road base constructed to required grade.
	Asphalt, curb and gutter installation completed.
	End of construction.
Office Use	
	Road Improvements "Preliminary Acceptance Inspection"
	Road Improvements "Final Inspection" (private roads accepted at this point)
	Public Road "Preliminary Acceptance" notification received from BOCC.

1.3 AUTHORIZATION OF REQUEST

Signature of Applicant

Print Applicant Name

Title (if appropriate)

SURETY RELEASE INSPECTION REQUEST

1.1 PURPOSE

This form is used to request that an inspection be scheduled to determine if the following performance sureties can be reduced or released (check below all that apply). Requests are required for either partial or full release of any construction surety. Requests for construction surety reduction will be subject to the following conditions based upon the percentage of work completed and approved by the County, or other authority or agency having jurisdiction over the improvement. The following conditions apply to surety reductions and inspection fees.

- No more than three inspections for surety reductions will be scheduled during any twelve-month period.
- A surety reduction inspection fee must accompany each request for reduction.
- Inspections will be scheduled within 30 days of receipt of the surety reduction inspection request form and applicable fee.
- Reductions will not occur until completion and approval of at least 30% of the proposed improvements.
- 20% of the original construction surety amount will be retained until final completion and preliminary acceptance of all improvements.

Inspections will be scheduled within thirty days of receipt of this request and the required fee.

Inspections must be requested by the permit holder.

1.2 GENERAL INFORMATION

Date: _____

Applicant: _____

Phone: _____

Tax Map Parcel No.: _____

Project Name (Include phase, section, and other relevant information to clearly identify the project): _____

1.3 SURETY RELEASE INFORMATION

Water Protection Performance Surety

Erosion & Sediment Control

Stormwater Management & Water Quality

Identification No.: _____

Description of Release Requested: _____

Amount of Requested Release: _____

- Subdivision/Public Improvement Performance Surety**
 - Roads & Drainage (at least 30% of the work must be satisfactorily completed before requesting an inspection for reduction)***
 - Water & Sewer (at least 30% of the work must be satisfactorily completed before requesting an inspection for reduction)***
 - Other – list below (i.e. landscaping, pedestrian paths)***

Identification No.: _____
Description of Release Requested: _____

Amount of Requested Release: _____

- Work in the Right-of-Way Performance Surety**

Identification No.: _____
Description of Release Requested: _____

Amount of Requested Release: _____

- Site Development Performance Surety**

Identification No.: _____
Description of Release Requested: _____

Amount of Requested Release: _____

1.4 FEE

SUBMIT REQUIRED SURETY INSPECTION FEE - make check payable to the El Paso County and submit with request.

1.5 AUTHORIZATION OF REQUEST

Signature of Permit Holder

Print Permit Holder Name

Title (if appropriate)

Appendix I STORMWATER QUALITY POLICY AND PROCEDURES

I.1. RESERVED

Editor's note(s)—Res. No. 19-245 , adopted July 2, 2019, repealed § I.1, which pertained to title.

I.2. OVERVIEW

As part of the National Pollutant Discharge Elimination System (NPDES)-Phase II program administered by the Colorado Department of Public Health and the Environment, El Paso County has a Colorado General Discharge Permit for Stormwater Discharges Associated with Municipal Separate Storm Sewer Systems (MS4 Permit). This Permit, initially made effective March 10, 2003, was significantly modified and reissued effective on July 1, 2016 and authorizes El Paso County to discharge stormwater from its separate storm sewer system into the waters of the state. The MS4 permit applies to the urbanized areas of unincorporated El Paso County and requires the County to implement control measures to prevent or reduce the discharge of pollutants to waters of the state. The policies and criteria provided in this Appendix and Engineering Criteria Manual apply to the entire county pursuant to Section 1.4 of this Engineering Criteria Manual. A copy of the current MS4 permit area map is available on the El Paso County website. As part of this permit, the County is required to take measures to protect the quality of stormwater from contaminants, including sediment.

The El Paso County Policy Plan, adopted January 20, 1998, includes several policies directly related to protecting the quality of surface water in the County, especially as it relates to stormwater runoff. Policy 2.1.1 commits the County to meeting the requirements of the Clean Water Act.

Directly related to the NPDES programs are:

- Policy 3.3.4 - Implement appropriate measures to protect and/or mitigate effects of point and non-point sources of pollution to surface water,
- Policy 3.3.5 - Regulate or restrict uses that are proven to contribute to contamination of water supplies,

-
- Policy 3.3.6 - Evaluate the consequences to surface water from new development including run off of natural soils, as well as chemical compounds that may result from the proposed uses,
 - Policy 11.1.4 - Require development plans to effectively address both quantitative and qualitative impacts of drainage within the project site,
 - Policy 11.3.3 - Fully evaluate the relative impact of proposed drainage improvements on the maintenance of water quality,
 - Policy 11.3.4 - Promote the effective use of innovative short and long term strategies including sediment ponds, buffer strips, and constructed wetlands as a means of reducing peak flows and improving stormwater quality, and
 - Policy 11.3.6 - Encourage the effective use of control measures to mitigate the short and long term erosion impacts of development.

The following Appendix when combined with: The City of Colorado Springs and El Paso County Drainage Criteria Manual Volume 1; the City of Colorado Springs Drainage Criteria Manual Volume 2; the City of Colorado Springs Drainage Criteria Manual Volume 1 update May 2014, as adopted by El Paso County Resolution No. 15-042; the El Paso County Policy Plan; the El Paso County Land Development Code; the El Paso County Engineering Criteria Manual; and their successors forms the basis for protecting surface water quality in the County. In the event there are conflicts that arise between this Appendix and any of the documents listed above, the requirements of this Appendix shall govern the decisions of the ECM Administrator. It shall be responsibility of the Engineer of Record to identify those conflicts and bring to the attention of the ECM Administrator. The ECM Administrator, at their sole discretion, will determine which specific use of criteria is acceptable for the project under review.

Nothing contained herein relieves any person, corporation, firm or entity from the obligation to comply with any applicable state or federal laws or regulations relating to water quality or water quality standards or any other standards related to land disturbance activities.

(Res. No. 19-245 , 7-2-19)

I.3. ADOPTION OF DRAINAGE CRITERIA MANUALS BY EL PASO COUNTY

In November of 2002, the City of Colorado Springs adopted its Drainage Criteria Manual Volume 2: Stormwater Quality Policies, Procedures and Best Management Practices (BMPs). The goal of this document was to provide guidance and engineering criteria for water quality protection measures during construction and for permanent installations.

The DCM2 was adopted as the County's stormwater quality design criteria. It is supplemented by this Appendix, which provides additions and revisions as applicable to the County in order to expand its scope to cover rural areas and other situations specific to the County. The goal has been to maintain consistency between criteria used in the County and the City of Colorado Springs.

On January 27, 2015, El Paso County adopted certain portions of the revisions made by the City of Colorado Springs to the Drainage Criteria Manual Volume 1, dated May 2014. Specifically, Chapter 6 in its entirety, Sections 3.2.1, 4.1.2, 4.1.3, 4.1.4, 4.2, 4.2.1, 4.2.2, and Figures 13-4a, 13-4b, and 13-5 of Chapter 13 were adopted to update the County criteria to reflect recent advances in hydrology.

To clarify applicability, "El Paso County" will be substituted for "City of Colorado Springs" or a County department or position analogous to one in the City will be used where appropriate unless otherwise specified in this Appendix. Table I-1 summarizes the most common or typical substitutions that shall be used in applying and interpreting DCM2 and DCMV1.

Table I-1. General Substitutions

Text in DCM2	Substitution in DCM2 as Applied in El Paso County
City of Colorado Springs	El Paso County
City	County
City Engineer	County Engineer
City Engineering Inspector	County Inspector
City Inspections	County Inspections
Erosion and Stormwater Quality Control Plan	Stormwater Management Plan
Other Changes	
Hillside Overlay	Remove references to "Hillside Overlay"

(Res. No. 19-245 , 7-2-19)

I.4. EL PASO COUNTY EROSION AND STORMWATER QUALITY CONTROL PERMITS

An overview of the two types of erosion and stormwater quality permits issued by El Paso County is provided in section 5.6 of the ECM. The following section provides specific stormwater permit application requirements and permit holder responsibilities for construction activities that occur within the unincorporated areas of El Paso County.

I.4.1. Erosion and Stormwater Quality Control Permit

An Erosion and Stormwater Quality Control Permit (ESQCP) is required for all applicable construction activities. The ESQCP is the key mechanism for protecting water quality in the County and provides the requirements for the selection, installation, implementation, and maintenance of control measures (BMPs) during construction through final stabilization. Applicable construction activities include construction activities that result in land disturbance of greater than or equal to (\geq) one acre or that is less than ($<$) one acre but is part of a larger common plan of development or sale that would disturb one acre or more of ground surface, unless excluded pursuant to section 5.6.3 of this ECM. Any project involving earth disturbing activity of less than 1 acre but which disturbs more than 500 cubic yards of material (stockpiling, cut and/or fill) may be considered an applicable construction activity at the ECM Administrator's discretion when potential pollutants, site topography, hydraulics or proximity to a surface water body are of significant concern.

Construction activities refers to ground surface disturbing and associated activities that include, but are not limited to: clearing, grading, excavating, demolition, installation of new or improved haul and access roads, staging areas, stockpile, fill and borrow areas. Construction activity occurs from initial ground breaking to final stabilization regardless of ownership of the construction activities.

Activities that include routine maintenance to maintain original line and grade, hydraulic capacity, or original purpose of the facility are not considered construction activities. Activities to conduct repairs that are not part of regular maintenance and activities that are for replacement are considered construction activities and are not considered routine maintenance. Repaving activities where underlying or surrounding soil is cleared, graded, or excavated as part of the repaving operation are construction activities unless they are an excluded pursuant to section 5.6.3 of this ECM.

Temporary construction control measures to protect water quality are to be implemented when needed as determined by an El Paso County Inspector, even if a permit is not required. Refer to Table I-2 for additional criteria to determine applicability of an ESQCP.

Storm Sewer Connections:

An ESQCP may be used as a storm sewer connection permit to allow for a connection to the El Paso County separate storm sewer system. Those cases are limited to entities that possess their own Colorado Discharge Permit System permit for stormwater

Discharges, and are contingent on the hydraulic capacity of the system.

- A. **Application.** Applications for ESQCPs generally are submitted to the El Paso County Planning and Community Development Department as part of a Land Use application. For projects not involved in the Land Use application process, an ESQCP application must be submitted to the Department of Public Works at least ten (10) days prior to the anticipated start of construction. The owner or operator of the construction activity must submit an ESQCP application with all required material listed below to allow for review and approval of the permit.

No work shall begin until the ECM administrator, or his designee, issues a Notice to Proceed. Typically the Notice to Proceed is issued as part of the preconstruction conference.

For projects permitted through the Planning and Community Development Department, during the preconstruction conference a County Inspector will discuss with the permit owner an overview of initial construction control measures expected to be installed prior to the start of construction, as outlined in the grading, erosion, and sediment control plans and/or SWMP. A timeline for completion of initial control measure installation may be determined and the Initial Inspection scheduled during the preconstruction conference. Typically, a Notice to Proceed with initial temporary BMP installation will be given to the permit holder during the preconstruction conference. If an Initial Inspection is not scheduled during the preconstruction conference, upon installation of initial BMPs the permit holder or authorized representative shall request an Initial Inspection. The Initial Inspection must be scheduled with a County Stormwater Inspector at least 48 hours in advance of the proposed inspection time.

For projects permitted through the Department of Public Works, upon approval of the ESQCP a written Notice to Proceed is provided to the permit holder or authorized representative. Upon installation of initial BMPs the permit holder or authorized representative shall request an Initial Inspection. The Initial Inspection must be scheduled with a County Stormwater Inspector at least 48 hours in advance of the proposed inspection time.

Applications for an ESQCP shall include a completed permit application form and any required attachments reasonably necessary to review and evaluate the application or complete the permit. Generally, an application for an ESQCP shall be accompanied by the following:

1. **Stormwater Management Plan.** The purpose of a SWMP is to identify all possible pollutant sources from an applicable construction activity that may contribute to stormwater pollution, and to address the selection, installation, implementation and maintenance of control measures (also known as Best Management Practices (BMPs)) that, when implemented, will prevent pollution or degradation of state waters.

Control measures identified in the SWMP must be appropriate for the specific construction activity, the pollutant sources present, and the phase of construction. There is a wide variety of structural and non-structural control measures that can be used.

The SWMP shall be submitted as a stand-alone document separate from the engineering plan set submitted for review and approval. El Paso County uses a checklist to perform a completeness review of the initially submitted SWMP. Unlike the Grading and Erosion Control Plan, the SWMP is intended to be a dynamic document and must be revised as construction proceeds to accurately reflect the current conditions and control measures in use at the site. Therefore El Paso County does not "approve" the SWMP. A copy of the SWMP review checklist can be found in Appendix E.

During construction the SWMP is the responsibility of the designated Qualified Stormwater Manager or Certified Erosion Control Inspector and shall be located on site at all times during construction and shall be kept up to date with work progress and changes in the field.

2. **Permit Fee.** Permit fees must be paid at the time of application for a permit. If the ESQCP and associated documents are reviewed as part of the Land Use application process, the ESQCP permit fee is included in the fee for plan review. If the ESQCP and associated documents are reviewed by the Public Works Department, a separate permit fee payment must be made. The permit fee shall be in a form acceptable to the ECM Administrator. Permit fees are non-refundable.
3. **Statement of Certification.** Signed statement from owner (applicant) certifying that the SWMP and other terms of the permit will be met.
4. **Operation and Maintenance Plan.** Submitted and approved Operation and Maintenance Manual for Permanent BMPs, if any to be located on site.
5. **Maintenance Agreement.** Submitted and signed Private Detention Basin/Stormwater Quality Best Management Practice Maintenance Agreement and Easement, if any Permanent Best Management Practices are to be located on site.

6.Application Information.

- Property location and legal description.
- Owner Name and Contact Information.
- Contractor Name and Contact Information.
- Project-related information such as: total acres, disturbed acres, brief description of project, and project schedule.
- El Paso County Surety Estimate form that contains cost estimates of Construction and Maintenance of Control Measures for determination of Financial Surety.

Because each permit and site is different with respect to the scope of work and location, additional requirements may be added to address specific concerns relative to the proposed work. Attached to each approved permit will be a list of Special Provisions, if any, which shall govern the work and set forth minimum requirements for disturbing land in the County.

- B. **Permit Holder Responsibilities.** The permit holder shall be responsible for the work authorized under the permit. Should there be any defects or failures in the work that result in erosion or sediment releases, following preliminary acceptance, corrective work shall be performed immediately upon notification from the County Stormwater Staff or County Subdivision Inspector. Failure to respond in a reasonable time frame, as determined by the County Stormwater Staff, shall be just cause for the County Stormwater Staff to take the necessary action to have the defect corrected and to bill the permit holder or draw on the financial assurance for the cost to correct the defect.

The permit holder is responsible for subcontractors and others at the site meeting the provisions of the SWMP. The permit holder is responsible for determining the need for and obtaining other required permits. A State General Permit for Stormwater Discharges from Construction Activities may be required if criteria for an ESQCP is met.

1. **Control Measure Inspection and Maintenance.** Permit holder is required to conduct self-monitoring inspections of the site during construction consistent with Section 1.5.2.A.
2. **Permit Termination.** Upon completion of construction activities and achievement of final stabilization, or upon sale of the permitted property, the permit holder is responsible for

contacting the County in writing to request termination of the permit. Permit Closure will be granted when all of the following conditions are met and an acceptable final inspection has been documented consistent with Section I.5.2.G.

- Construction is complete and final stabilization has been achieved. Final stabilization will be achieved when re-vegetation efforts result in at least 70% of pre-disturbance vegetative cover at the site or equivalent permanent structural erosion and sediment control methods have been employed;
- All temporary BMPs have been removed from the site;
- A copy of the Construction Stormwater Termination Notice, Reassignment form, or Modification form submitted to the Colorado Department of Public Health and Environment is provided to the County.

- C. **Transfer of Property and Permit Holder Responsibilities.** Each successive owner of a property through the land development and building process will obtain its own ESQCP and submit its own permit fees and financial surety until final stabilization is achieved. The new owner of a property that is under an open ESQCP must immediately obtain its own ESQCP. The SWMP from the previous owner may be used, if the previous owner agrees, it covers the phases of work planned by the new owner and it remains relevant to the work to be done. If the new owner will be building single-family residences or duplexes, it may qualify for a BESQCP. The BESQCP is to be obtained immediately following purchase.

When a property is covered by an ESQCP, construction is complete, final stabilization has not occurred, and more than one lot of the covered property is sold to another party (e.g., a home builder or private investor) the previous owner (i.e., current permit holder) is responsible for installing all necessary temporary erosion and sediment control BMP's and informing the new property owner in writing of their responsibility to maintain the temporary BMP's until final stabilization (e.g., landscaping) has been installed. Upon closing of the sale, the previous owner will then be allowed to modify the ESQCP by notifying a county stormwater inspector in writing by providing them with a copy of the "Notice of Reassignment of Permit Coverage and General Permit Application Stormwater Discharges Associated with Construction Activities," which should be provided to the State of Colorado, when applicable. The Stormwater Management Plan must also be revised to account for the change in permit area coverage. Following the transfer and issuance of an ESQCP, the original owner may receive a partial release of the financial assurance proportional to the BMPs on the part of the property that was sold.

In situations where a BMP that provides protection for property that has been sold is located on the property that belongs to the original or other owner, the responsibility for the BMP rests with the owner of the property where it is located.

I.4.2. Builder's Erosion and Stormwater Quality Control Permit

Builders of single family residences may follow a simplified procedure by obtaining a Builder's Erosion and Stormwater Quality Control Permit (BESQCP). A BESQCP is used to protect stormwater on individual, residential building lots with less than one (<1) acre of total disturbed area and is not part of a larger plan of development or sale that does disturb more than one acre of land. A property must be covered by either an ESQCP or BESQCP in order to obtain a building permit.

If the lot has been disturbed previously by construction work but has been final stabilized and any ESQCP on the property has been closed, the lot may be considered undisturbed and not part of a larger plan of development. In these cases a BESQCP may be issued for the single-family residential lot provided no more than one acre of disturbance will occur.

BESQCPs are to be used for land disturbances greater than one (>1) acre on large lot single-family development or agricultural zoned lands with a total area of 2.5 acres or larger and having a total lot imperviousness of less than 10%.

An ESQCP must be used where land disturbance is greater than one (>1) acre on a single-family residential lot or agricultural zoned lands with a total lot size of 2.5 acres or greater and a total site imperviousness between 10% and 20% due to the requirement for a study specific to the watershed where the site is located that demonstrates the expected soil and vegetation conditions are suitable to infiltrate/filtrate 100% of the Water Quality Capture Volume (WQCV).

If a builder acquires single-family residential lots that are covered by an ESQCP owned by a developer (or other party) but are not final stabilized, the builder (i.e. new owner) must obtain a new ESQCP to cover the future construction activity.

- A. **Application.** Applications for a BESQCP shall include a completed permit application form and any required attachments reasonably necessary to review and evaluate the application or complete the permit, a signed statement from the owner (applicant) certifying the terms of the permit will be met, and a permit fee. Financial surety or a SWMP are not required for a BESQCP. However, a site covered by a BESQCP is required to meet stormwater quality protection criteria of preventing pollutants, including sediment, from leaving the site. If a BESQCP is revoked, the applicant will obtain an ESQCP, including the submission of a SWMP and payment of permit fee and financial surety. Initial Inspections and Notices to Proceed are not required for sites with BESQCPs.

Table I-2 provides guidance on which permit is to be obtained for various situations.

Table I-2. ESQCP and BESQCP Permit Applicability Guidance

"X" inside box indicates when each type of permit is required. Refer to section 5.6.3 for exclusions to the applicability provided below.

ESQCP	BESQCP	Description
For Developers		
X		Land Disturbance greater than or equal to (\geq) 1 acre.
X		Land Disturbance less than (<) 1 acre but part of a larger common plan of development or sale that disturbs \geq to 1 acre. See definition of larger common plan of development or sale.
X		New ESQCP required when developer acquires disturbed land currently covered by an ESQCP unless meets criteria for a BESQCP.
For Builders		
No	No	Single-family residence building site with less than (<) 1 acre of disturbance and is not part of a larger common plan of development of sale and is not located in a sensitive area ¹ .
	X	Single-family residence building site with <1 acre of disturbance and is located in an area that is not currently covered by an ESQCP and the site is not located in sensitive area.
	X	Single-family residence building site with <1 acre of disturbance and is not part of a larger common plan of development or sale and the site is located in a sensitive area.
	X	Single-family residence building site with <1 acre of disturbance and is located in an area that is not currently covered by an ESQCP and the site is located in sensitive area.
	X	Single-family residence building site with \geq 1 acre of land disturbance located on a lot or parcel with a total area of greater than or equal to 2.5 acres or

		zoned agriculture land and with a proposed total site imperviousness of less than 10%.
X		Single-family residence building site with ≥1 acre of land disturbance located on a lot or parcel with a total area of greater than or equal to 2.5 acres or zoned agriculture land and with a proposed total site imperviousness of up to 20%.
X		Commercial, industrial or other sites that disturb ≥1 acre of land, unless the activity meets exclusion criteria in Section 5.6.3.
X		Commercial, industrial or other sites that disturb <1 acre of land that are located within a sensitive area or have potential stormwater discharges of concern ² to the ECM Administrator.
NOTES:		
1. Sensitive Areas are defined as those waters identified in Table I-5 of the ECM; and any other areas of concern identified by the ECM Administrator, such as endangered species habitat area, jurisdictional wetlands, flood plains or direct discharges to waters of the state.		
2. "Potential stormwater discharges of concern," include possible discharges from commercial sources with ability to cause water quality violations or acutely toxic conditions in receiving waters. Examples of sources include, but are not limited to, auto salvage yards, auto repair facilities, industrial sources, restaurants.		

- B. **Permit Holder Responsibilities.** The builder permit holder (owner) is responsible for subcontractors and others at the site to meet the provisions requirements of the BESQCP. The permit owner is responsible for determining the need for and obtaining other required permits. A State General Permit for Stormwater Discharges Associated with Construction Activities may be required.

The BESQCP owner is responsible for closure of the BESQCP upon completion of the project. To close a BESQCP all the following requirements must be met:

- Notify a County Inspector in writing that all work under the Building Permit is complete and request closure of the BESQCP;
- The site is stabilized to prevent sediment transport off the lot;
- All temporary BMPs have been removed.

- C. **Transfer of Property and Permit Holder Responsibilities.** If a single residential lot covered by a ESQCP is sold prior to completion of construction and final stabilization of the lot has not been achieved, the new owner must obtain a BESQCP and will become responsible for achieving final stabilization of the lot. Only when a new BESQCP is obtained by the new owner will the ESQCP holder be allowed to modify the ESQCP to remove the sold lot from permit coverage.

- D. **Reassignment of Permit Coverage.** When a property is covered by a ESQCP, construction is complete, final stabilization has not occurred, and the property is sold to a private home owner the current permit holder is responsible for installing all necessary temporary erosion and sediment control BMP's and informing the new property owner, in writing, of their responsibility to maintain the temporary BMP's until final landscaping has been installed. Upon closing of the sale, the previous owner will then be allowed to remove the sold property from the ESQCP coverage by notifying a county stormwater inspector in writing.

(Res. No. 19-245 , 7-2-19)

I.5. EL PASO COUNTY CONSTRUCTION SITE INSPECTIONS

[Replaces DCM2 Section 3.4]

Inspections of construction sites are conducted by the County Inspectors (Stormwater and Subdivision) to ensure compliance with the SWMP and associated county permits.

The focus of construction sites inspections is to ensure construction is in compliance with the approved plans and that BMPs are installed and maintained consistent with the onsite SWMP to prevent erosion, sediment transfer, spillage and leakage, improper sludge or waste disposal, and drainage from raw material storage from leaving the site creating negative public safety, property or stormwater quality impacts.

Inspections also serve as a means of educating owners/owner's representatives, developers, and contractors of the need to minimize negative stormwater quality impacts from the site operations and to assist in complying with the requirements of the County's Stormwater Program. As such County Inspectors will take a compliance assistance approach and will work with and assist the owner/owner's representative and contractor to maintain compliance with its approved plans and erosion and stormwater quality control requirements.

I.5.1. County Engineering and Subdivision Inspections

County Inspections shall be accomplished by County Stormwater Inspectors for the purpose of assuring compliance with the County's Municipal Separate Storm Sewer Systems (MS4) permit. Projects located in the unincorporated areas of El Paso County with an active ESQCP shall be inspected by County Stormwater Inspectors. County construction oversight inspections include the following types of inspections: Initial, Routine, Reduced Frequency, Compliance, Complaint Response and Final inspections, which are described below.

Inspections are not limited to new development and may be performed on any other land-disturbing activities that occur in unincorporated areas of the County. Inspections of individual homes in a residential subdivision, whether construction of the home is finished or not, are only conducted if there are observations or complaints of discharges of sediment from the disturbed area.

For all inspections conducted by County Stormwater Inspectors, a copy of the completed report will be provided to the permit holder (owner) typically within two County work days following the inspection.

I.5.2. Types of Inspections

The following are inspections that may be performed at the construction sites within the unincorporated areas of El Paso County. Not all inspection types will be performed at all sites.

- A. **Self-Monitoring Inspections.** The permit holder or authorized agent shall conduct Self-Monitoring Inspections. The purpose of Self-Monitoring inspections is for the permit holder to ensure that all BMPs are installed according to approved plans, the BMPs are adequate and are being properly maintained, the SWMP is updated to reflect current conditions, and only allowable discharges are occurring off the site. The person performing the inspections may be on the permit holder's staff or a contracted third party. The individual performing the self-monitoring inspections shall be a qualified stormwater manager, which is an individual knowledgeable in the principles and practices of erosion and sediment control and pollution prevention and with the skills to assess conditions at construction sites that could impact stormwater quality and the effectiveness of stormwater controls implemented to meet stormwater permitting requirements. Examples of a qualified stormwater manager include a registered Professional Engineer or an erosion control inspector certified in a regionally recognized erosion and sediment control inspection training program. The person performing inspections should be a person with authority to expend project dollars on erosion and stormwater quality control. There are two

types of Self-Monitoring Inspections allowed in El Paso County: Routine Self-Monitoring and Operator Compliance Inspections.

The permit holder or authorized representative may request an alternative to the 14 day routine self-monitoring inspection cycle discussed above. Self-Monitoring Inspections of stormwater best management practices may be requested for at least once every month (i.e., 30 days) for permitted construction sites when:

- All construction activity is completed except final stabilization because planted vegetative cover has not yet become established;
- All activities for final stabilization have been completed with the exception of seed application which may not have occurred due to seasonal conditions or the necessity to reapply additional seed to augment previous efforts; and
- The SWMP has been updated to locate those areas subject to the reduced inspection frequency. Routine Self-Monitoring Inspections after precipitation events are not required during an approved 30 day inspection cycle.

1. **Routine Self-Monitoring Inspections.** The Routine Self-Monitoring inspections are to be performed and documented at least once every 7 calendar days; or at least once every 14 calendars, if post-storm event inspections are conducted within 24 hours after the end of a precipitation or snow melt event. Post-storm inspections may be used to fulfill the 14 day inspection requirement. In addition to the bi-weekly inspections the owner or representative shall perform post-storm inspections of all BMPs after any precipitation or snowmelt event that causes surface erosion to ensure that the BMPs have operated as designed, to determine if maintenance is needed, and to locate and clean up any areas where materials may have run off site. For those choosing to utilize a 14-day and post-storm inspection frequency, if no construction activities will occur following a storm event, post-storm inspection must be conducted prior to resuming construction activities but no later than 72 hours following a storm event. The delay of any post-storm inspection must be documented in the inspection records included in the SWMP.

The owner or his representative will record the results of all inspections by completing an inspection report or similar inspection checklist included in the SWMP. Completed inspection reports shall be kept on site and available to County Inspectors. The County may require the submission of these inspection reports on a site-specific basis.

2. **Operator Compliance Inspection.** When a Compliance Inspection conducted by a County Stormwater Inspector documents the failure to implement control measures or implementation of inadequate control measures, the County Stormwater Inspector may require the ESQCP owner or their representative to inspect and provide a report to the County that the control measures have been implemented or corrected. The owner or the representative must include date and time stamped photographs of the new, adequate control measures.

- B. **Initial Inspections for Sites Covered by ESQCPs.** County Stormwater Inspectors perform Initial Inspections. The purpose of Initial Inspections is to allow the County the opportunity to confirm that the SWMP is implemented prior to the start of construction. Prior to the Initial Inspection, the initial construction control measures (BMPs) must have been implemented according to the SWMP. At a minimum, perimeter control measures to include vehicle tracking control and access control must be implemented, and no other land disturbing activity shall occur prior to the Initial Inspection.

Initial Inspections will typically be accomplished through the use of a Routine Inspection discussed in Section I.5.2.E. In the event the Routine Inspection identifies a failure to implement adequate

perimeter control measures, the site will be scheduled for a Compliance Inspection discussed in Section I.5.2.C.

Failure to install any initial BMPs or obtain a Notice to Proceed prior to beginning land disturbing activities may result in an immediate Stop Work Order.

Initial Inspections are not required for sites with BESQCPs.

- C. **Compliance Inspections.** Compliance Inspections are inspections conducted by County Stormwater Inspectors in follow up to an illicit discharge, failure to implement a control measure or an inadequate control measure. Typically a Compliance Inspection will occur within 14 days after some other inspection type discussed in this section, unless the necessary corrections were made and observed by the County Stormwater Inspector during the previous inspection when the compliance issue was observed. Compliance Inspections may occur during or immediately after a precipitation event.

During Compliance Inspections the County Stormwater Inspectors verify:

- If the corrections have been completed on sites where an illicit discharge, failure to implement or implementation of an inadequate control measure was documented in the previous inspection;
- BMPs are installed and functioning according to design;
- Only allowable discharges are occurring;
- The required Self-Monitoring Inspections and associated documentation of activities are occurring; and
- The SWMP is revised to reflect current site conditions.

The County Inspectors will examine the SWMP and Self-Monitoring inspection reports and will evaluate installed BMPs and site discharge points to identify any installation, maintenance or effectiveness issues to determine compliance with the ESQCP. One of the following that incorporates this scope of inspection may be performed in lieu of a Compliance Inspection within 14 days of the previous County inspection that identified a failure to implement a control measure or an inadequate control measure:

Routine Inspection in accordance with Section I.5.2.A.1; Reconnaissance Inspection in accordance with Section I.5.2.D; or Operator Compliance Inspection in accordance with Section I.5.2.A.2.

Compliance Inspections are typically conducted for sites that require an ESQCP and are located within the urbanized areas of unincorporated El Paso County. The County uses the Field Inspection Report to document Compliance Inspections.

- D. **Reconnaissance Inspections.** Reconnaissance (Recon) Inspections are indicator inspections that are conducted for the general purpose of determining obvious compliance issues at a site. During a Recon Inspection the site is not fully assessed for the adequacy of control measures, overall site management or record-keeping. Recon Inspections are a reduced scope inspection that may be used by the County to extend the frequency required of routine inspections up to 90 days when all indicators evaluated determine that the control measures observed meet good engineering, hydrologic and pollution control practices. Attention is paid to the perimeter of the site to determine if the site has contributed to offsite transfer of sediment or other pollutants to roads, drainage facilities, or surface water bodies and if any obvious BMP maintenance or implementation is needed.

Recon Inspections are conducted by County Stormwater Inspectors at least every 14 days, are generally performed from adjacent streets or property, and may occur during or immediately after a significant precipitation event. A Routine Inspection must be conducted at least once at a site before a Recon Inspection may be conducted. When a Recon Inspection identifies the need for a Compliance Inspection at a site, a Routine Inspection must occur before the Recon Inspection frequency and scope can be used again. At a minimum a Routine Inspection must be performed at a site every 90 days.

The Recon Inspection will be documented using the Field Inspection Report and a copy of the completed inspection report will be provided to the permit owner.

Recon Inspections are conducted on sites with an ESQCP or BESQCP. A Recon Inspection with cause could result in requiring a site that previously was not permitted to submit a permit application and obtain an ESQCP or BESQCP consistent with enforcement provisions provided in Section I.6.

- E. **Routine Inspections.** Routine Inspections are conducted by County Stormwater staff for the purpose of identifying failures to implement control measures, inadequate control measures and control measures requiring routing maintenance. All sources of pollution including trash will be evaluated to determine if only allowable discharges are occurring. During a Routine Inspection the County Stormwater Inspector will evaluate discharge points from the permitted site to determine if an illicit discharge has occurred.

The removal of pollutants will be required when off-site transfer of pollutants is documented by a Routine Inspection. Results of a Routine Inspection will be provided to the permit owner or representative using the Field Inspection Report.

Routine Inspections are conducted at least once every 45 days, and at least 1 Routine Inspection must occur on a site prior to final stabilization. Routine Inspections do not apply to the reduced site inspections described in Section I.5.2.H.

- F. **Complaint Response Inspections.** Complaint Response Inspections will occur in response to either a citizen complaint or a complaint from another agency. The County Stormwater Inspector will perform a Recon Inspection to determine the validity of the complaint. If the owner or authorized representative of the site is available at the time of the inspection they will be made aware of the complaint and any issues identified during the Recon Inspection, and if necessary, provide recommendations for the implementation, repair, and maintenance of control measures or cleanup of material transferred offsite.

All construction sites are subject to Complaint Response Inspections. In the event a site subject to a Complaint Response Inspection is operating without an applicable permit, the County Stormwater Inspector may pursue appropriate enforcement action described in Section 1.6.

The Complaint Response Inspection will be documented using the Field Inspection Report provided to the owner or authorized representative.

- G. **Final Inspections.** Upon the completion of construction activities for a site, when the ESQCP permit holder (owner) believes conditions for final stabilization are met and a request to close the ESQCP is received in writing by the County, a County Inspector will perform a Final Inspection to verify the conditions required to close the permit are met. If so confirmed during the ESQCP Final Inspection, the County will provide the permit holder (owner) a written notice of permit closure using the Field Inspection Form.

A Final Inspection may be requested in conjunction with a Preliminary Acceptance or Final Acceptance Inspection discussed in Section 5.3.15 of this ECM. During an ESQCP Final Inspection, the following items will be evaluated in addition to the requirements discussed in Sections I.4.1.B.2 and 5.3.15.

- The site has final stabilization equal to a uniform vegetative cover with an individual plant density of at least 70 percent compared to the pre-disturbance levels and such cover is capable of adequately controlling soil erosion, as determined by the County Stormwater Inspector, or equivalent permanent, structural erosion and sediment control methods have been employed.
- Any sediment or other pollutant that may have been transferred off-site has been removed.
- The site shall be free of noxious weeds or treated according to an approved Noxious Weed Control Plan.

-
- All approved permanent (post construction) BMPs have been maintained and are functioning in accordance with the design and with the Operation and Maintenance Manual.
 - Engineering Record Drawings are provided to the County consistent with Section 5.10.6 of this ECM.
 - All temporary construction control measures (BMPs) have been removed from the site.
 - Streets, parking lots and other paved surfaces (on-site and off-site) are free of sediment and debris.
 - Drainage structures such as pipes, inlets and channels are clean and in good service.
 - The site is in compliance with required corrective action identified during previous Inspections.

H. **Reduced Site Inspections.** Reduced site inspections are conducted by County Stormwater Inspectors and must occur at the frequency and include the scope of review indicated below:

1. **Inactive Site Inspections.** Sites where ground disturbing activities are completed and are pending growth of vegetation for final stabilization, or sites where no construction activity has occurred since the previous inspection conducted by the County are eligible for this type of inspection.

Inactive Site Inspections must be conducted by County Stormwater Inspectors at least every 90 days. The purpose of this type of inspection is to identify failure to implement control measures, inadequate control measures or control measures requiring maintenance. The County Stormwater Inspector will evaluate all off-site discharge points to determine if only allowable discharges are occurring. If an illicit discharge is documented, the owner or authorized representative must remove all off-site deposited material when feasible. Results of an Inactive Site Inspection will be documented in the Field Inspection Report.

2. **Stormwater Management System Administrator Program Inspections.** These inspections are for construction activities operated by a participant in a Colorado Department of Public Health and Environment Water Quality Control Division designated Stormwater Management System Administrator's Program in accordance with Article 8 of title 25, Colorado Revised Statutes that has been identified by the Stormwater Management System Administrator to be fully implementing the program and qualified for reduced oversight incentives of the program. To be eligible for this reduced site inspection frequency, the owner or authorized agent must provide verifiable documentation to the County Stormwater Inspector of their participation in this State program. Upon verification of participation with the State, the owner or authorized agent may take advantage this type of reduced frequency inspections.

Upon verification with the State, County Stormwater Inspectors will conduct inspections of the approved site at least every 90 days. The scope of the inspection will include evaluation of all pollutant sources on site, including trash, identification of failure to implement control measures, inadequate control measures, and control measures requiring maintenance to determine if an illicit discharge has occurred. If the site inspection determines an illicit discharge occurred, the permit owner will be required to remove the pollutants immediately when feasible. The results of the inspection will be documented using the Field Inspection Report and provided to the permit holder.

3. **Staff Vacancy Inspections.** This type of inspection is to accommodate a County staff vacancy or leave due to vacation or illness. The minimum frequency for this type of inspection is once every 90 days. The County Inspector will evaluate all pollutant sources on site, including trash, identify failures to implement control measures, inadequate control measures, and control measures requiring maintenance to determine if an illicit discharge has occurred. If the site inspection determines an illicit discharge occurred, the permit owner will be required to remove the pollutants immediately when feasible. The results of the inspection will be documented using the Field Inspection Report and provided to the permit holder.

-
- I. **Permanent Stormwater Quality Control Measure Inspections.** The MS4 permit requires the County to implement inspection and acceptance procedures for all permanent stormwater quality control structures to ensure they are installed and implemented in accordance with approved site plans. The County must also have written procedures in place to ensure the long term operation and maintenance of all permanent stormwater quality control structures, including those owned and maintained by a private or other public entity located within El Paso County jurisdiction. These procedures are described in Section I.7.7 of this Appendix.

During construction, all permanent stormwater management facilities will be inspected as part of the other construction related inspections discussed in this section. Upon satisfactory completion of the Final Inspection for an applicable development site, the County will enter both privately and publicly maintained permanent stormwater quality control structures into an El Paso County Permanent Stormwater Management Facility Inventory. Entry into the County inventory of privately maintained structures does not imply or assume any maintenance responsibility on behalf of El Paso County. Entry into the inventory is for the sole purpose of tracking long term operation, maintenance and enforcement of permanent stormwater quality control structures with Private BMP Maintenance Agreements with the County.

At a minimum a County Stormwater Inspector will inspect all individual permanent stormwater quality management facilities in the inventory at least once every 5 years. During this inspection, the County Stormwater Inspector will evaluate the structures for items that affect the effective operation of the structure, including maintenance needs such as revegetation, mowing, accumulated trash and debris removal, and repairs. Results of the inspection will be documented on a Permanent Stormwater Quality BMP Inspection Form and will be provided to the owner recorded in the Private Detention Basin/Stormwater Quality BMP Maintenance Agreement and Easement.

I.5.3. Site Inspection Exclusions

- A. **Finished Homes in a Residential Subdivision.** Inspections are not routinely conducted on lots that have been conveyed to the homeowner when the following criteria are met:
- i. The lot has been sold to the homeowner for private residential use.
 - ii. The lot has less than one acre of disturbed area.
 - iii. All construction activity associated with grading the lot and building the home is completed.
 - iv. A certificate of occupancy (or equivalent) has been issued to the homeowner.
 - v. The County was notified by the owner and has documented that the lot is subject to this exclusion.
 - vi. The residential development site must have a County-approved site plan and still be inspected by the County under the inspection types described in this section.
- B. **Unfinished Home in a Residential Subdivision.** Inspections are not conducted on residential lots with an unfinished home when all of the following criteria are met:
- i. The lot has less than one acre of disturbed area.
 - ii. The permittee has documented that the lot is subject to this exclusion.
 - iii. The residential development site must have a County-approved site plan and still be inspected by the County under the inspection frequencies described in this section.
- C. **Winter Conditions.** Inspections (self-monitoring and County) are not required at sites where construction activities are temporarily halted, snow cover exists over the entire site for an extended

period, and melting conditions posing a risk of surface erosion do not exist. This exclusion is applicable only during the period where melting conditions do not exist. The following information must be documented for this exclusion:

- Dates when snow cover occurred,
- Date when construction activities ceased, and
- Date that melting conditions began.

Due to typical winter weather conditions along the Front Range, this exemption will rarely be applicable.

(Res. No. 19-245 , 7-2-19)

I.6. CONSTRUCTION STORMWATER ENFORCEMENT

As part of an effective stormwater quality protection program, a process of escalating enforcement measures will be used to ensure compliance with County-issued stormwater permits and the County's MS4 permit.

The County considers the owner of the land the ultimate responsible party for all construction activities. It is the responsibility of the owner to take all necessary measures to ensure that the site is in compliance with the County Construction Permit, Stormwater Management Plan, Erosion and Stormwater Quality Control Permit or Builder's Erosion and Stormwater Quality Control Permit, and Private Detention Basin/Stormwater Quality BMP Maintenance Agreements. In addition to County requirements, the owner must meet State and Federal regulatory requirements for permits, control measures and water rights. The County has tried to make its requirements consistent with State requirements for construction activities (CDPS General Permit - Stormwater Discharges Associated with Construction Activities). Should requirements conflict, it will be the responsibility of the owner to bring these conflicts to the County's attention and propose how to address them.

As mentioned in Section 1.5, El Paso County Stormwater Inspectors will take a compliance assistance approach with project owners and authorized agents during inspections. Failure to adequately respond to non-compliance items documented in Field Inspection Reports provided by the County, however, may result in an enforcement action discussed in this section.

El Paso County is required by its MS4 permit to have an enforcement process and sanctions designed to minimize the occurrence of violations and obtain compliance from chronic and recalcitrant violators of stormwater control requirements. Escalation of enforcement must occur as necessary based upon the severity of the violation and/or the recalcitrance of the violator to ensure that violations of a similar nature are enforced consistently. As a general outline, the following process will be followed up to the point where an adequate response to non-compliance is obtained:

Documented Inspection > Verbal Warning of non-compliance (documented in Field Inspection Report) > Letter of Noncompliance > Stop Work Order > Revocation of Permit > Performance of Remedial Work > Court Order. The County retains its right, however, to exercise its discretion in applying enforcement mechanisms as circumstances warrant.

In cases where the ECM Administrator deems it necessary to address a construction site with more aggressive action, or in cases where no permit is required, the El Paso County Ordinance No. 07-01: Prohibiting Illicit Discharges to the County Storm Sewer System may be used, as appropriate, to address the site. Additional information on the County's Enforcement Procedures is discussed in Section I.6.2 and enforcement options are summarized in Table I-3.

Created: 2021-06-08 11:36:13 [EST]

(Supp. No. 2)

I.6.1. Definitions

- A. **Applicable Construction Activity.** Include construction activities that result in a land disturbance of greater than or equal to one acre or that is less than one acre, but is part of a larger common plan of development or sale that would disturb, or has disturbed since March 2, 2001, one acre or more, unless excluded consistent with Chapter 5, Section 5.6.3, or the disturbed areas have been finally stabilized.
- B. **Applicable Development Site.** "Applicable development sites" are those that result in land disturbance of greater than or equal to one acre, including sites less than one acre that are part of a larger common plan of development or sale, unless excluded consistent with Section 5.6.3 or I.7.1. Applicable development sites include all new development and redevelopment sites for which permanent water quality control measures were required in accordance with an MS4 permit. "New Development" means land disturbing activities, structural development, including construction or installation of a building or structure, creation of impervious surfaces, and land subdivision for a site that does not meet the definition of redevelopment. "Redevelopment" includes a site that is already substantially developed with 35% or more of existing imperviousness; with the creation or addition of impervious area (including removal and/or replacement), to include the expansion of a building footprint or addition or replacement of a structure; structural development including construction, replacement of impervious area that is not part of a routine maintenance activity; and land disturbing activities.
- C. **Control Measure.** Any best management practice (BMP) or other method used to prevent or reduce the discharge of pollutants to waters of the state. Control measures include, but are not limited to best management practices. Control measures can include other methods such as the installation, operation, and maintenance of structural controls and treatment devices. The following requirements apply to all control measures:
1. **Good Engineering, Hydrologic and Pollution Control Practices:** Control measures must be selected, designed, installed, implemented, and maintained in accordance with good engineering, hydrologic, and pollution control practices as defined in this section. "Pollution" is man-made or man-induced, or natural alteration of the physical, chemical, biological, and radiological integrity of water.
 2. **Maintenance:** Control measures must be maintained in effective operating condition.
 3. **Inadequate Control Measures:** Any control measure shall be considered an "inadequate control measure" if it is not designed, implemented, or operating in accordance with the requirements of the permit, including the specific requirements in each program area in Part I.E or requirements for specific permittees in Part III.
 4. **Control Measure Requiring Routine Maintenance:** Any control measure shall be considered a "control measure requiring routine maintenance" if it is still operating in accordance with its design and the requirements of this permit, but requires maintenance to prevent associated potential for failure during a runoff event.
 5. **Minimize:** The term "minimize," for purposes of implementing control measures of this permit, means reduce and/or eliminate to the extent achievable using control measures that are technologically available and economically practicable and achievable in light of best industry practices.
- D. **Final Stabilization.** The condition reached when all ground surface disturbing activities at the site have been completed, and for all areas of ground surface disturbing activities a uniform vegetative cover has been established with an individual plant density of at least 70 percent of pre-disturbance levels, or equivalent permanent, physical erosion reduction methods have been employed.

-
- E. **Good Engineering, Hydrologic and Pollution Control Practices.** Methods, procedures, and practices that:
- Are based on basic scientific facts.
 - Reflect best industry practices and standards.
 - Are appropriate for the conditions and pollutant sources.
 - Provide appropriate solutions to meet the associated permit requirements.
- F. **Inspection.** The term "inspection" refers to an evaluation by a County Inspector of a site for compliance with the ESQCP, BESQCP, SWMP, approved plans, Private Detention Basin/Stormwater Quality BMP Agreement and the Illicit Discharge Ordinance. For the purposes of Appendix I, inspections performed by County Stormwater Inspectors include those inspection types described in Section I.5.2.
- G. **Notice of Noncompliance.** There are two types of notices of noncompliance used by County Stormwater Inspectors: A verbal warning of noncompliance and a letter of noncompliance. Both are defined below.
1. **Verbal Warning of Noncompliance.** During an inspection conducted by a County Stormwater Inspector, the inspector may verbally inform the owner or authorized agent of specific instances of noncompliance with ESQCP or BESQCP. Examples of these instances include failure to implement control measures, inadequate control measures or a control measure needing maintenance. In the event the issues identified as noncompliant are corrected before the termination of the inspection no further action will occur. If the items are not corrected during the inspection, the County Stormwater Inspector will document the findings of noncompliance in the Field Inspection Report and provided to the owner or authorized representative. Once documented in the Field Inspection Report and provided to the owner or authorized agent, this will be considered a "Verbal Warning of Noncompliance."
 2. **Letter of Noncompliance.** A written notice provided by a County Stormwater Inspector to the permit holder (owner) or authorized representative to formally inform them that the permitted project is not in compliance with the ESQCP, BESQCP, SWMP, or other requirements of County criteria, codes or ordinances relating to grading, erosion, and stormwater quality. The letter contains a specific description of the issues of noncompliance and the measures required to bring the site into compliance and a date by which these measures must be implemented.
- H. **Notice to Proceed.** A Notice to Proceed is a written notice provided by the County after an ESQCP is approved. The notice allows for the implementation of initial BMPs and commencement of construction activities upon completion of an Initial Inspection. Construction is authorized only after issuance of a Notice to Proceed.
- I. **Performance or Contracting of Remedial Work.** If the permit holder does not successfully complete all required work or violates any requirement of the permit, the County may take corrective measures and charge the cost of such to the permit holder. Such costs shall include the actual cost of any work deemed necessary by the County plus reasonable administrative and inspection costs and penalties, as established by Resolution adopted by the Board of County Commissioners or by a fee schedule adopted by the ECM Administrator as authorized by the Board of County Commissioners. If the total of such costs exceeds the financial assurance, the permit holder shall be responsible for payment of the remaining balance within thirty calendar days of receipt of an accounting of such from the County.
- J. **Stop Work Order.** A Stop Work Order is a written order to immediately cease construction activity at a site. The Stop Work Order may be issued by the ECM Administrator or County Stormwater staff to the property owner, permit holder or authorized agent of a construction site. An immediate Stop Work Order shall be issued when the property owner has failed to obtain an ESQCP, BESQCP, or a Notice to

Proceed prior to land-disturbing activity. A Stop Work Order may also be issued if the site operator has demonstrated obvious non-compliance with the ESQCP or BESQCP after repeated, documented attempts by the Inspector to bring the site into compliance. When a Stop Work Order is issued, it requires all work on the site to cease. No further land use approvals relative to the site will be allowed by the County, nor will work be allowed to resume, until the owner, permit holder or authorized representative takes the measures necessary to bring the site into compliance, as described in the Stop Work Order. A written notice to resume construction activity will be provided in the Field Inspection Report after Inspection by a County Inspector to verify satisfactory completion of required corrective actions identified in the Stop Work Order.

- K. **Stormwater Management Plan.** A Stormwater Management Plan (SWMP) is a plan developed in compliance with the content requirements in the CDPS General Permit for Stormwater Discharges Associated with Construction Activity (COR040000) and this Appendix I. El Paso County developed a content checklist for use by owners or the authorized representative of applicable construction sites to develop a complete SWMP. A copy of the SWMP Checklist can be found in Appendix E.

The SWMP shall be a stand-alone document separate from the engineering plan set. The purpose of the SWMP is to develop and document a dynamic, systematic approach to identify possible pollutant sources that may contribute pollutants to stormwater, and identify the control measures (BMPs) that, when implemented, will prevent, minimize or eliminate any possible negative water quality impacts. The SWMP must be prepared using good engineering, hydrologic and pollution control practices and shall be implemented prior to beginning ground disturbing activities. The SWMP shall be revised as construction proceeds to accurately reflect the current conditions and practices at the site.

Revisions must be made to the SWMP before changes are made in the field. A map showing the current location, status and changes to the BMPs are required. The owner or his representative shall keep the SWMP on-site while construction activities are occurring and must be implemented as written and updated from the start of construction activity until final stabilization is achieved. During construction, the SWMP must contain records of self-inspections, a map of the BMPs as they are installed or removed, BMP detail sheets with installation and maintenance specifications, and all other items listed in the SWMP checklist found in Appendix E.

Given the dynamic nature of the SWMP, the following guidance is provided for making in-field modifications to BMPs based on Self-Monitoring Inspections. Changes to BMPs identified in the SWMP may be completed in the field without approval from the County when:

- The control measure is a temporary construction BMP.
- The change results in a comparable BMP. Examples include but are not limited to, silt fence replaced with a wattle, rock check dam replaced with straw bale check, erosion control mat used in place of straw mulch, etc.
- Prior to installation, the change is reflected in the on-site SWMP including a BMP detail for the new BMP.

Changes to permanent stormwater quality control measures or any other BMP change that will affect the approved engineering design, hydraulics or hydrology must be approved by the ECM Administrator or designee through the established plan modification process.

- L. **Water Quality Capture Volume (WQCV).** The volume equivalent to the runoff from an 80th percentile storm, meaning that 80 percent of the most frequently occurring storms are fully captured and treated and larger events are partially treated.

I.6.2. Enforcement Procedures

With each inspection the County performs at an active construction site, the County Stormwater Inspector will note any observed violations of the County Construction Permit, Stormwater Management Plan, ESQCP or BESQCP, Private Detention Basin/Stormwater Quality BMP Maintenance Agreement, or any applicable County regulations or ordinances. The owner will remain noncompliant until the violation is corrected. The following enforcement procedures will typically apply. The County reserves its right, however, to exercise its discretion in applying enforcement mechanisms as circumstances warrant.

- A. In the event that control measures have not been implemented, are inadequate or require routine maintenance, the owner must take all necessary steps to minimize or prevent the discharge of pollutants until an adequate control measure is implemented and operational. If it is not feasible to immediately install, repair or perform maintenance on a control measure, the SWMP must be amended to describe the reason such action is infeasible and establish a schedule for installing, repairing, or performing maintenance on the control measure as soon as possible. The owner must also remove and properly dispose of any unauthorized release or discharge (e.g. non-stormwater discharge, trash, sediment, spill or leak) and clean up any contaminated surfaces to minimize future unauthorized discharges.
- B. If corrective action to install, repair, or perform maintenance on a control measure is completed, or if other corrective action is taken to address other types of violations, during the inspection in which the violation is noted, no further enforcement action will occur. If the corrective action is not performed during the inspection, the County Stormwater Inspector will document the violations in the Field Inspection Report provided to the owner. The report will serve as a Verbal Warning of Noncompliance.
- C. The County Stormwater Inspector will conduct a Routine Inspection within 14 days of the inspection that noted the violations. If the violations have not been corrected, a Letter of Noncompliance will be issued to the owner. Failure to subsequently correct the violations will result in the issuance of a Stop Work Order, which may be followed by one or more of the other enforcement options listed in Table I-3.
- D. Accelerated enforcement action or the immediate imposition of stricter remedies may be pursued in certain instances. Factors to be considered include:
 - a. Recurrence of the same problem at a site.
 - b. Occurrence of frequent problems at a site.
 - c. Repeated failure to correct violations at a site.
 - d. A history of noncompliance or recalcitrance.

Permanent stormwater quality control structures are assessed for adequate operation and maintenance. If the County Stormwater Inspector identifies a lack of maintenance or failure or inadequate operation of a permanent stormwater quality control structure, those findings will be documented and provided to the owner or authorized representative using a Permanent Stormwater Quality BMP Inspection Form. In addition to the enforcement mechanisms and process described above, the County will utilize the provisions of the recorded Private Detention Basin/Permanent Stormwater Quality Best Management Practice Agreement and Easement as appropriate to ensure the long term operation and maintenance of permanent stormwater quality control measures.

The County may take other action as deemed appropriate. In cases where deemed appropriate by the ECM Administrator, the El Paso County Ordinance No. 07-01: Prohibiting Illicit Discharges to the County Storm Sewer System may be used to address compliance issues at a site that result in an unauthorized off-site discharge into the County MS4 system.

When an unauthorized discharge of a pollutant or an illicit discharge occurs from an active construction site directly into waters of the state, the County Inspector, at their discretion, may notify the Colorado Department of Public Health and Environment pursuant to the reporting requirements included in the County's MS4 permit or the CDPS General Permit for Stormwater Discharges Associated with Construction Activity.

If an ESQCP is revoked as part of an enforcement action, the owner shall submit a new ESQCP application, SWMP and other required submissions described in Section I.4.1.A to obtain a new ESQCP. When a BESCP is revoked the owner must submit a new ESQCP application and other required submission items. A second BESQCP will not be issued to the same site once revoked.

(Res. No. 19-245 , 7-2-19)

I.7. POST-CONSTRUCTION STORMWATER MANAGEMENT

I.7.1. Post-Construction Stormwater Management Planning

[Replaces DCM2 Section 4.1, pages 4-1 through "Other BMPs" continued on 4-5]

- A. **Overview.** This chapter contains requirements and procedures for the selection, installation, implementation and maintenance of permanent stormwater quality control measures that will remain in operation after construction for new development and significant redevelopment. All applicable development sites must have operational permanent stormwater quality control measures at the completion of the site, unless excluded from the requirements of an applicable development site as described in Section I.7.1.C. All permanent control measures for applicable development sites shall meet one of the "base design standards" described in Section 1.71.D.

In the case where permanent water quality control measures are part of future phasing, the permittee must have a mechanism to ensure that all control measures will be implemented, regardless of completion of future phases or site ownership. In such cases, temporary water quality control measures must be implemented as feasible and maintained until removed or modified. All temporary water quality control measure must meet one of the "base design standards" described in Section I.7.1.D.

A procedure is provided within the context of a flow chart and a four-step process that shall be followed for all applicable development sites. Detailed descriptions, sizing and design criteria, and design procedures for control measures are provided in the New Development BMP Factsheets found in Section 4.2 of the DCMV2.

It is recommended that discussions and collaboration regarding proposed BMPs occur early in each project between the developer's planner and engineer, County Stormwater and County Planning and Community Development staff.

The analysis of the requirements, exclusions and base design standards presented in this Section I.7 shall be incorporated into existing ECM Administrator submittals for review and acceptance including Preliminary/Final Drainage Reports and construction plans, or as otherwise specified by the ECM Administrator.

- B. **Applicable Development Sites: Excluded Sites.** The following types of sites and associated land disturbances are excluded from the requirements of this Section 1.7. Although a site may qualify for an exclusion to Section 1.7 below, the site may still be considered an applicable construction activity subject to the requirements of an ESQCP or BESQCP.

(Supp. No. 2)

Created: 2021-06-08 11:36:13 [EST]

-
1. **Pavement Management Sites.** Sites, or portions of sites, for the rehabilitation, maintenance, and reconstruction of roadway pavement, which includes roadway resurfacing, mill and overlay, white topping, black topping, curb and gutter replacement, concrete panel replacement, and pothole repair. The purpose of the site must be to provide additional years of service life and optimize service and safety. The site also must be limited to the repair and replacement of pavement in a manner that does not result in an increased impervious area, and the infrastructure must not substantially change. The types of sites covered under this exclusion include day-to-day maintenance activities, rehabilitation, and reconstruction of pavement. "Roadways" include roads and bridges that are improved, designed or ordinarily used for vehicular travel and contiguous areas or that are improved, designed or ordinarily used for pedestrian or bicycle traffic, drainage for the roadway, and/or parking along the roadway. Areas primarily used for parking or access to parking are not roadways.
 2. **Excluded Roadway Redevelopment.** Redevelopment sites for existing roadways, when 1 of the following criteria is met:
 - 1) The site adds less than 1 acre of paved area per mile of roadway to an existing roadway, or
 - 2) The site does not add more than 8.25 feet of paved width at any location to the existing roadway.
 3. **Excluded Existing Roadway Areas.** For redevelopment sites for existing roadways, only the area of the existing roadway is excluded from the requirements of an applicable development site when the site does not increase the width by 2 times or more, on average, of the original roadway area. The entire site is not excluded from being considered an applicable development site for this exclusion. The area of the site that is part of the added new roadway area is still an applicable development site.
 4. **Aboveground and Underground Utilities.** Activities for installation or maintenance of underground utilities or infrastructure that does not permanently alter the terrain, ground cover, or drainage patterns from those present prior to the construction activity. This exclusion includes, but is not limited to, activities to install, replace, or maintain utilities under roadways or other paved areas that return the surface to the same condition.
 5. **Large Lot Single Family Sites.** A single-family residential lot, or agricultural zoned lands, greater than or equal to 2.5 acres in size per dwelling and having a total lot impervious area of less than 10 percent. A total lot imperviousness greater than 10 percent is allowed when a study specific to the watershed and/or MS4 shows that expected soil and vegetation conditions are suitable for infiltration/filtration of the WQCV for a typical site, and the permittee accepts such study as applicable within its MS4 boundaries. The maximum total lot impervious covered under this exclusion shall be 20 percent.
 6. **Non-Residential and Non-Commercial Infiltration Conditions.** This exclusion does not apply to residential or commercial sites for buildings. This exclusion applies to applicable development sites for which post-development surface conditions do not result in concentrated stormwater flow during the 80th percentile stormwater runoff event. In addition, post-development surface conditions must not be projected to result in a surface water discharge from the 80th percentile stormwater runoff events. Specifically, the 80th percentile event must be infiltrated and not discharged as concentrated flow. For this exclusion to apply, a study specific to the site, watershed and/or MS4 must be conducted. The study must show rainfall and soil conditions present within the project area, must include allowable slopes, surface conditions, and ratios of impervious area to pervious area, and the County must accept such study as applicable within its MS4 boundaries.

-
7. **Sites with Land Disturbance to Undeveloped Land that will Remain Undeveloped.** Sites with land disturbance to undeveloped land (land with no human-made structures such as buildings or pavement) that will remain undeveloped after the site. Typical examples of this type of site are trails, parks and open space without structures.
 8. **Stream Stabilization Sites.** Construction activity that is solely for the purpose of stream stabilization.
 9. **Trails.** Bike and pedestrian trails. Bike lanes for roadways are not included in this exclusion, unless attached to a roadway that qualifies under another exclusion in this section.
 10. **Oil and Gas Exploration.** Facilities associated with oil and gas exploration, production, processing, or treatment operations, or transmission facilities, including activities necessary to prepare a site for drilling and for the movement and placement of drilling equipment, whether or not such field activities or operations may be considered to be an applicable construction activity.
 11. **County Growth Areas.** The County may exclude the following when they occur within the county growth areas:
 - a. Agricultural facilities and structures on agricultural zoned lands (e.g., barn, stables).
 - b. Residential development site or larger common plans of development for which associated construction activities results in a land disturbance of less than or equal to 10 acres and have a proposed density of less than 1,000 people per square mile.
 - c. Commercial or industrial development site or larger common plans of development for which associated construction activities results in a land disturbance of less than or equal to 10 acres.
- C. **Base Design Standard Requirements.** The "base design standard" is the minimum design standard for new and redevelopment before applying any exclusions or alternative standards. The control measures for applicable development sites shall meet one of the following base design standards:
1. **Water Quality Capture Volume (WQCV) Standard.** The control measures is designed to provide treatment and/or infiltration of the WQCV and:
 - a. 100% of the applicable development site is captured, except the County may exclude up to 20 percent, not to exceed 1 acre, of the applicable development site area when the County has determined that it is not practicable to capture runoff from portions of the site that will not drain towards control measures. In addition, the County must also determine that the implementation of a separate control measure for that portion of the site is not practicable (e.g., driveway access that drains directly to street).
 - b. Evaluation of the minimum drain time shall be based on the pollutant removal mechanism and functionality of the control measure implemented. Consideration of drain time shall include maintaining vegetation necessary for operation of the control measure (e.g., wetland vegetation).
 2. **Pollutant Removal Standard.** The control measures is designed to treat at a minimum the 80th percentile storm event. The control measures shall be designed to treat stormwater runoff in a manner expected to reduce the event mean concentration of total suspended solids (TSS) to a median value of 30 mg/L or less.

100% of the applicable development site must be captured, except the County may exclude up to 20 percent not to exceed 1 acre of the applicable development site area when the County has determined that it is not practicable to capture runoff from portions of the site that will not drain towards control measures. In addition, the County must also determine that the implementation

of a separate control measure for that portion of the site is not practicable (e.g., driveway access that drains directly to street).

3. **Runoff Reduction Standard.** The control measures is designed to infiltrate into the ground where site geology permits, evaporate, or evapotranspire a quantity of water equal to 60% of what the calculated WQCV would be if all impervious area for the applicable development site discharged without infiltration. This base design standard can be met through practices such as green infrastructure. "Green infrastructure" generally refers to control measures that use vegetation, soils, and natural processes or mimic natural processes to manage stormwater. Green infrastructure can be used in place of or in addition to low impact development principles.
4. **Applicable Development Site Draining to a Regional WQCV Control Measure.** The regional WQCV control measure must be designed to accept the drainage from the applicable development site. Stormwater from the site must not discharge to a water of the state before being discharged to the regional WQCV control measure. The regional WQCV control measure must meet the requirements of the WQCV in Part I.7.C.1.
5. **Applicable Development Site Draining to a Regional WQCV Facility.** The regional WQCV facility is designed to accept drainage from the applicable development site. Stormwater from the site may discharge to a water of the state before being discharged to the regional WQCV facility. Before discharging to a water of the state, at least 20 percent of the upstream imperviousness of the applicable development site must be disconnected from the storm drainage system and drain through a receiving pervious area control measure comprising a footprint of at least 10 percent of the upstream disconnected impervious area of the applicable development site. The control measure must be designed in accordance with a design manual identified by the permittee. In addition, the stream channel between the discharge point of the applicable development site and the regional WQCV facility must be stabilized. The regional WQCV facility must meet the following requirements:
 - a. The regional WQCV facility must be implemented, functional, and maintained following good engineering, hydrologic and pollution control practices.
 - b. The regional WQCV facility must be designed and maintained for 100% WQCV for its entire drainage area.
 - c. The regional WQCV facility must have capacity to accommodate the drainage from the applicable development site.
 - d. The regional WQCV facility must be designed and built to comply with all assumptions for the development activities planned by the County within its drainage area, including the imperviousness of its drainage area and the applicable development site.
 - e. Evaluation of the minimum drain time shall be based on the pollutant removal mechanism and functionality of the facility. Consideration of drain time shall include maintaining vegetation necessary for operation of the facility (e.g., wetland vegetation).
 - f. The County shall require site plans and perform a site plan review consistent with the requirements of this ECM to ensure the regional WQCV facility and control measures for the applicable development site plans include:
 - i. Design details for all structural control measures implemented to meet the requirements of Part I.E.4.
 - ii. A narrative reference for all non-structural control measures for the site, if applicable. "Non-structural control measures" are control measures that are not structural control measures and include, but are not limited to, control

measures that prevent or reduce pollutants being introduced to water or that prevent or reduce the generation of runoff or illicit discharges.

- iii. Documentation of operation and maintenance procedures to ensure the long term observation, maintenance, and operation of the control measures. The documentation shall include frequencies for routine inspections and maintenance activities.
 - iv. Documentation regarding easements or other legal means for access of the control measure sites for operation, maintenance, and inspection of control measures.
 - v. Confirmation that control measures meet the requirements of section I.7.C
 - vi. Confirmation that site plans meet the requirements of County's site plan review and approval requirements
- g. The regional WQCV facility must be subject to the County's authority consistent with requirements and actions for a Control Measure in accordance with a base design standard.
- h. Regional Facilities must be designed and implemented with flood control or water quality as the primary use. Recreational ponds and reservoirs may not be considered Regional Facilities. Water bodies listed by name in surface water quality classifications and standards regulations (5 CCR 1002-32 through 5 CCR 1002-38) may not be considered regional facilities.
6. **Constrained Redevelopment Sites Design Standard.** The constrained redevelopment sites standard applies to redevelopment sites meeting the following criteria:
- (a) The applicable redevelopment site is for a site that has greater than 75% impervious area, and
 - (b) The County must determine that it is not practicable to meet any of the base design standards in section I.7.1.C (1), (2), or (3). The County's determination shall include an evaluation of the applicable redevelopment site's ability to install a control measure without reducing surface area covered with the structures.

The control measures is designed to meet one of the following:

- (a) Provide treatment of the WQCV for the area captured. The captured area shall be 50% or more of the impervious area of the applicable redevelopment site. Evaluation of the minimum drain time shall be based on the pollutant removal mechanism and functionality of the control measure implemented,
- (b) The control measures is designed to provide for treatment of the 80th percentile storm event. The control measures shall be designed to treat stormwater runoff in a manner expected to reduce the event mean concentration of total suspended solids (TSS) to a median value of 30 mg/L or less.

A minimum of 50% of the applicable development area including 50% or more of the impervious area of the applicable development area shall drain to the control measures. This standard does not require that 100% of the applicable redevelopment site area be directed to a control measures as long as the overall removal goal is met or exceeded (e.g., providing increased removal for a smaller area), or

-
- (c) Infiltrate, evaporate, or evapotranspire, through practices such as green infrastructure, a quantity of water equal to 30% of what the calculated WQCV would be if all impervious area for the applicable redevelopment site discharged without infiltration.

I.7.2. BMP Selection

The selection of appropriate BMPs is based on the characteristics of the site and potential pollutants. The Four-Step Process provides a method of going through the selection process. Figure I.1 and Figure I.2 with annotations covers site-specific issues to be considered in selecting an effective BMP for each site.

- A. **Four-Step Process.** The following four-step process is recommended for selecting structural BMPs in newly developing and redeveloping urban areas:

Step 1: Employ Runoff Reduction Practices

To reduce runoff peaks and volumes from urbanizing areas, employ a practice generally termed "minimizing directly connected impervious areas" (MDCIA). The principal behind MDCIA is twofold — to reduce impervious areas and to route runoff from impervious surfaces over grassy areas to slow down runoff and promote infiltration. The benefits are less runoff, less stormwater pollution, and less cost for drainage infrastructure. There are several approaches to reduce the effective imperviousness of a development site:

Reduced Pavement Area

Sometimes, creative site layout can reduce the extent of paved areas including parking, thereby saving on initial capital cost of pavement and then saving on pavement maintenance, repair, and replacement over time.

Porous Pavement

The use of modular block porous pavement or reinforced turf in low-traffic zones such as parking areas and low use service drives such as fire lanes can significantly reduce site imperviousness. This practice may reduce the extent and size of the downstream storm sewers and detention.

Grass Buffers

Draining impervious areas over grass buffers slows down runoff and encourages infiltration, in effect reducing the impact of the impervious area.

Grass Swales

The use of grass swales instead of storm sewers slows down runoff, promotes infiltration, and also reducing effective imperviousness. It also may reduce the size and cost of downstream storm sewers and detention.

Implementing these approaches on a new development site is discussed further in the DCM2 section titled Employing Runoff Reduction Techniques. This section provides a procedure for estimating a reduced imperviousness based on the use of grass buffers and swales. The latter three of the approaches for reducing imperviousness are structural BMPs and are described in detail in Section 4.2 of DCM2 (New Development BMP Factsheets):

- Grass Buffer.
- Grass Swale.
- Modular Block Porous Pavement (or Stabilized-Grass Porous Pavement).

Step 2: Stabilize Drainageways

Drainageway, natural and manmade, erosion can be a major source of sediment and associated constituents, such as phosphorus. Natural drainageways are often subject to bed and bank erosion when urbanizing areas increase the frequency, rate, and volume of runoff. Therefore, drainageways are required to be stabilized. One of three basic methods of stabilization may be selected.

Constructed Grass, Riprap, or Concrete-Lined Channel

These methods of channel stabilization have been in practice for some time. The water quality benefit associated with these channels is the reduction of severe bed and bank erosion that can occur in the absence of a stabilized channel. On the other hand, the hard-lined low flow channels that are often used do not offer much in the way of water quality enhancement or wetland habitat. The use of riprap or concrete lined flood conveyance channels is not recommended, unless hydraulic or physical conditions require such an alternative. Rock lined low-flow channels in many cases may be a better alternative.

Stabilized Natural Channel

In practice, many natural drainageways in and adjacent to new developments are frequently left in an undisturbed condition. While this may be positive in terms of retaining desirable riparian vegetation and habitat, urban development may cause the channel to become destabilized. When degradation occurs in these drainageways, significant erosion, loss of riparian and aquatic habitat, and elevated levels of sediment and associated pollutants can result. Therefore, it is recommended that some level of stream stabilization always be considered. Small grade control structures sized for a 5-year or larger runoff event are often an effective means of establishing a mild slope for the baseflow channel and arresting stream degradation. Severe bends or cut banks may also need to be stabilized. Such efforts to stabilize a natural waterway also preserve and promote natural riparian vegetation which can provide paybacks in terms of enhanced aesthetics, habitat, and water quality.

One additional method of drainageway stabilization gives special attention to stormwater quality and is described in Section 4.2 (New Development BMP Factsheets):

- Constructed Wetland Channel.

Step 3: Provide Water Quality Capture Volume (WQCV)

All applicable development sites must have operational permanent stormwater quality control measures at the completion of construction. Designing structures that provide the WQCV is a common preferred approach in El Paso County. Other base design standards discussed earlier may be used if applicable, however. One or more of six types of water quality basins, each draining slowly to provide for long-term settling of sediment particles, may be selected. Information on selecting and configuring for a site one or more of the WQCV facilities listed below is provided in the Section 4.2 of the DCMV2. These six BMPs are also described in detail in the New Development BMP Factsheets found in the DCMV2 Section 4.2.

- Porous Pavement Detention.
- Porous Landscape Detention.
- Extended Detention Basin.
- Sand Filter Extended Detention Basin.
- Constructed Wetland Basin.
- Retention Pond.

Full Spectrum Detention is a newer approach to providing the WQCV. Details on the use, sizing, configuration and maintenance of Full Spectrum Detention structures are located in the DCMV1 update of 2014, sections of which are incorporated by reference into this ECM.

Step 4: Consider Need for Industrial and Commercial BMPs

If a new development or significant redevelopment activity is planned for an industrial or commercial site, the need for specialized BMPs must be considered. Two approaches are described in the New Development BMP Factsheets:

- Covering of Storage/Handling Areas
- Spill Containment and Control

Other Specialized BMPs may also be required

- B. **Other Specialized BMPs.** The Technical Advisory Committee (TAC) selected the above structural BMPs after a comprehensive screening of known structural BMPs. The members of TAC included representatives from many city and County agencies and individuals from the development community. Final selection by TAC was based on the review of documentation on potential effectiveness in a semiarid climate, local applicability, maintenance considerations, and cost.

Development and evaluation of permanent BMPs are continuing processes. Better designs of the BMPs included in DCM2 and designs of new BMPs, including manufactured (proprietary) BMPs, will be developed and tested. To allow for this progress, additional BMPs will be considered on a case-by-case basis by County Stormwater Staff. Design and sizing details and results of independent testing of the BMP in conditions similar to those at the site will be submitted demonstrating that the BMP will meet or exceed the performance of approved BMPs for the site.

To promote improvement in stormwater protection, County Stormwater Staff may approve promising BMPs on an experimental basis. A performance monitoring program to be pre-approved by County Stormwater Staff and an agreement to replace the Experimental System with an approved system should it not function to the required level of performance, both at the owner's expense, will be required. A request to use an "experimental system" must be submitted to El Paso County in the form of a Request for a Deviation from these standards, submitted consistent with the criteria and process described Chapters 1 and 5, respectively. Design of any "experimental system" shall not commence until a Request for Deviation is submitted to and approved by the County.

- C. **Guidance for Selecting and Locating WQCV Facilities.**

[The following section replaces DCM2 Section 4.1 pages 4-19 through 4-23]

Laying out WQCV facilities within a development site and watershed requires thought and planning. This planning and decision-making should occur during a master drainage planning process (Drainage Basin Planning Study or Master Development Drainage Plan) undertaken by local jurisdictions or a developer's engineer. Such plans, studies or other reports may depict a recommended approach for implementing WQCV on a watershed basis. Such reports may call for a few large regional WQCV facilities, smaller sub-regional facilities, or alternatively an onsite approach. It is always a good idea to find out if a master planning study has been completed that addresses water quality and to attempt to follow the Plan's recommendations.

If the master drainage planning process addresses water quality, the following provides supplemental information on the BMPs. If the existing master drainage planning process has not addressed water quality, or if a new master drainage process is underway, this will direct the water quality evaluation.

- D. **Post-Construction Stormwater Quality Control Measure Selection Process.** The BMP selection process is illustrated in Figure I-1 and Figure I-2. These two figures shall be used for all projects except those

that are strictly highway/roadway projects; that is, projects with no plans for building pad sites. Projects that are strictly highway/roadway projects are discussed in a separate section below.

The following process references the use of the permanent control measures (BMPs) and other practices outlined in DCM2 and this Appendix. The use of DCM2 BMPs will promote consistency between the City and County. These BMPs are commonly found in manuals and other literature from municipalities across the country, and they are the accepted best industry practices in stormwater quality control.

As described below, other control measures (which may be relatively new to the field of stormwater management) are acceptable if they can be shown to meet performance criteria provided in this Section 1.7. A Request for a Deviation from these standards submitted consistent with the criteria and process described Chapters 1 and 5, respectively, must be submitted and approved by the County prior to the use of a permanent control measure not included in this ECM, DCMV1, DCMV2 and the DCMV1 Update of 2014.

The following items explain the decision points (i.e., the Boxes) in Figure I-1 and Figure I-2:

Box 1: For all sites, the possibility of incorporating runoff reduction practices must be investigated. Impervious area should be reduced to the maximum extent practicable, per DCM2. DCM2 also provides guidance for MDCIA by routing runoff to pervious areas. This is Step 1 in the Four-Step Process.

Box 2: All drainageways, ditches, and channels shall be stabilized with one of three methods included in Step 2, which include the use of appropriate methods for the type of drainageway as described in the DCM1. Drainageways include:

- Tributaries to creeks that have been left in a relatively natural state,
- Tributaries, channels, and drainageways that are graded or regraded and may include drop or check structures, side slope stabilization, and low-flow channels.
- Roadside ditches that are completely man-made and should only be used to convey runoff from roads and roadway right-of-ways (ROWs).

Box 3: It must be determined if the development and/or redevelopment disturbs an area of land that is 1 acre or larger (or planned to be 1 acre or larger) when all phases are complete.

Box 4: Sites tributary to sensitive waters should consider specialized BMPs to address the parameter of concern as shown in Table I-5. At this time, no special BMPs are required until the County develops an overall strategy to address the parameters of concern, probably if and when a Total Maximum Daily Load (TMDL) is determined.

Figure I-1. BMP Requirements Flowchart for New Development and Redevelopment Sites—For Selecting Post-Construction BMPs in Compliance with El Paso County's Stormwater NPDES Permit

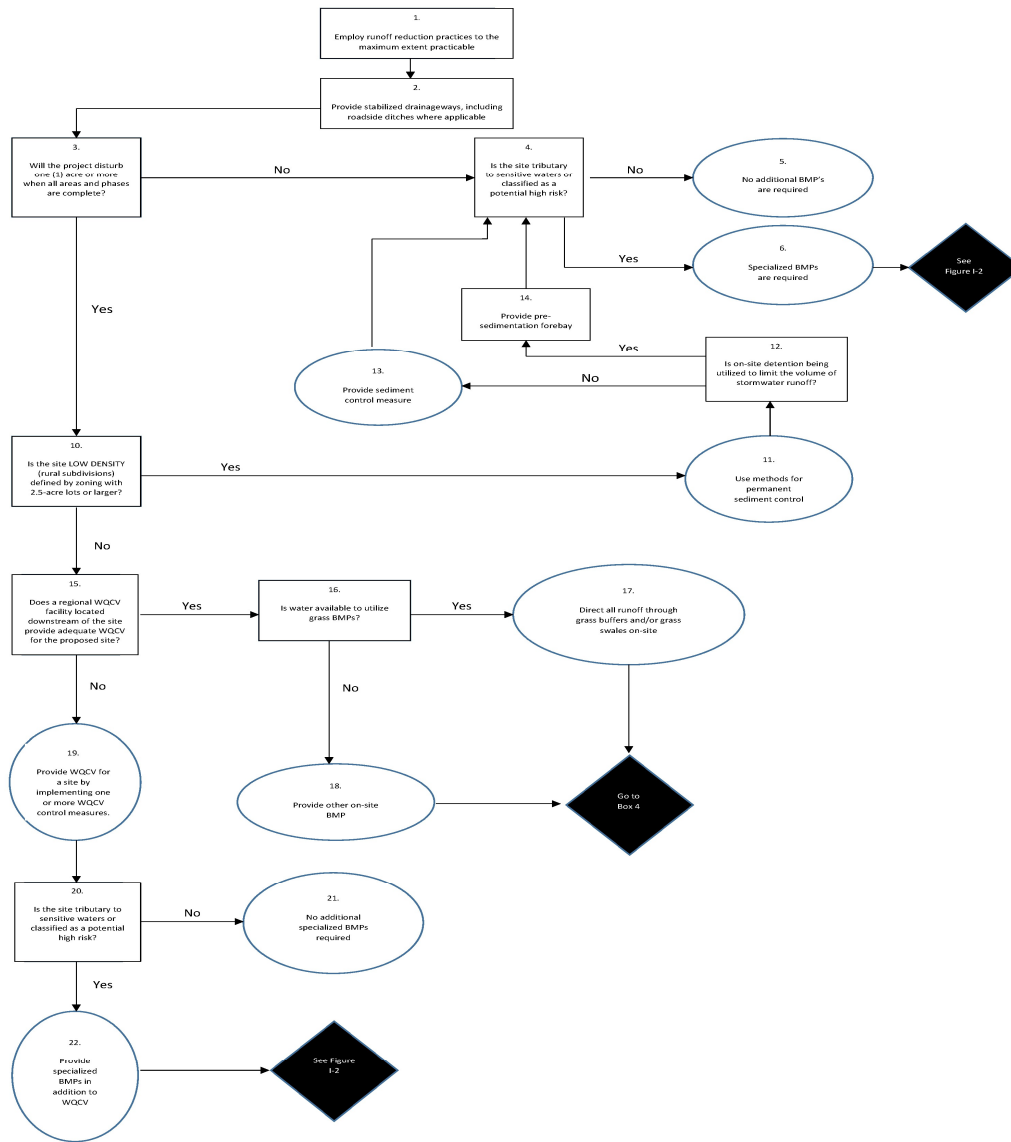

Figure I-2. BMP Requirements Flowchart for New Development and Redevelopment Sites—For Selecting Post-Construction BMPs in Compliance with El Paso County's Stormwater NPDES Permit

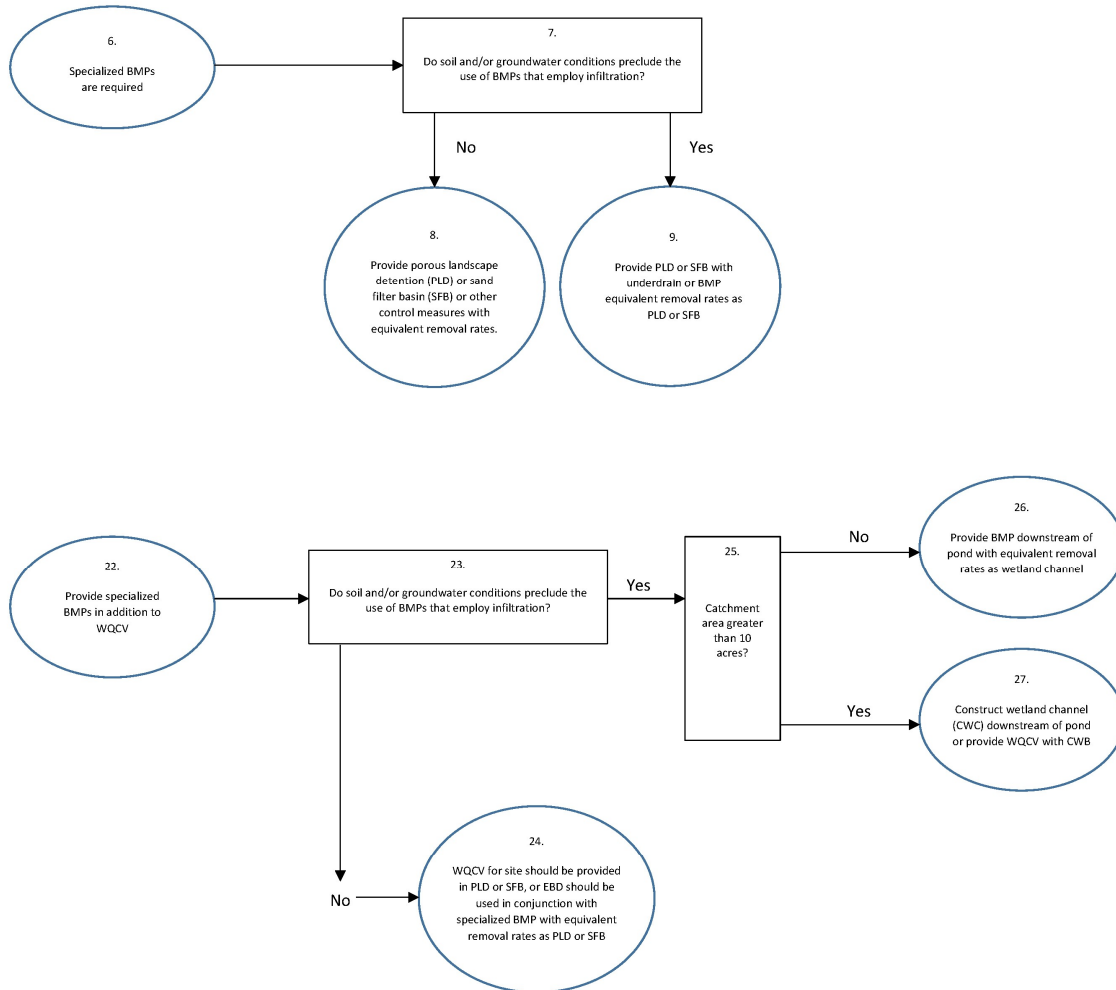

Table I-4. Best Management Practices Abbreviations

Abbreviation	Best Management Practice
CWB	Constructed Wetlands Basin
CWC	Constructed Wetlands Channel - Sedimentation Facility
EDB	Extended Detention Basin - Sedimentation Facility
PLD	Porous Landscape Detention
RP	Retention Pond - Sedimentation Facility
SFB	Sand Filter Extended Detention Basin
WQCV	Water Quality Capture Volume
GB	Grass Buffer
GS	Grass Swale
MBP	Modular Block Porous Pavement
PPD	Porous Pavement Detention

Table I-5. El Paso County Sensitive¹Waters

Stream and Segment	Parameter of Concern	Specialized BMPs Required
Fountain Creek and tributaries above Monument Creek	E. coli and Se	None at this time
Fountain Creek from Monument Creek to Highway 47	E. coli	None at this time
Monument Creek from National Forest to Fountain Creek	Se	None at this time
Willow Springs Pond #1 and #2	PCE	None at this time
¹ CDPHE 2006 303(d) list. Standard agreement forms for Private Detention Basins are in Appendix G. [This list may change in the future. The 303(d) list or equivalent in effect at the time of permitting will apply.]		

Potential high-risk sites must also incorporate specialized BMPs. High-risk sites are defined by two factors:

- Sites with land uses involving the potential for significant deposition of pollutants.
- Sites without practices to eliminate exposure of pollutants to stormwater.

Land uses involving the potential for significant deposition of pollutants include, but are not limited to:

- Vehicle maintenance facilities,
- Gas stations,
- Automobile salvage yards and junk yards,
- Commercial sites with high levels of "in and out" traffic such as fast-food restaurants and convenience stores.

Many industrial facilities are required to obtain coverage under an industrial stormwater permit; these facilities include automobile salvage yards. Practices to eliminate exposure of pollutants to stormwater may or may not be part of an industrial stormwater permit. These practices include coverage of material storage areas, berms around tanks, spill control plans, and other "good housekeeping" measures. For industrial sites where stormwater is not exposed to pollutants, structural BMPs, including detention ponds for water quality and other BMPs discussed below, may not be required.

Because stormwater pollutants are often transported with sediment, erosion protection and sediment control are necessary for stormwater quality protection. This is very important in the County because of the sandy soils in the region. In particular, discharges that may impact sensitive waters or that come from potentially high-risk sites should have a high level of sediment protection. Thus, in addition to the specialized BMPs, sediment control practices such as revegetation, grading to prevent steep side slopes, check dams, slope drains, and sediment basins should be employed where practical.

Box 5: No BMPs are required other than stabilized drainageways and possibly MDCIA.

Box 6: Specialized BMPs are required and therefore proceed to Box 7 on Table I-1.

Box 7: BMPs that employ infiltration include porous landscape detention and sand filter basins without underdrains. Certain conditions preclude the use of these types of BMPs, including close proximity of groundwater or relatively impervious soils to the bottom of the facility. Groundwater levels should be characterized during the season with the highest levels (often late Spring or early Summer). Impervious soils include bedrock as well as soil types C and D. The term "close proximity" means 5 feet or less. If there is less than 5 feet, a study of the hydraulic conductivity of the soils must be conducted to show

that excessive groundwater mounding or direct groundwater contamination will not result from the use of BMPs that employ infiltration.

Box 8: If groundwater or relatively impervious soils are not within 5 feet of the surface, implement porous landscape detention (PLD) or a sand filter basin (SFB) from DCM2. Alternative BMPs can be used if shown to be equally effective as PLD or SFB (see discussion below).

Box 9: Implement PLDs or SFBs with underdrains, or implement a BMP with removal rates equivalent to PLDs or SFBs, including qualifying manufactured BMPs. Qualifying manufactured BMPs are those that have undergone independent tests to verify that the installation, flow volumes, and removal rates will work for the site under consideration.

Box 10: If the site disturbance is larger than one acre and is low density residential, then no WQCV may be required provided the site meets criteria presented in Section I.7.1. If WQCV is not required, the need for a permanent sediment control measure must still be evaluated. If the site is located near and will discharge to a sensitive water, then a "jump" to Box 4 is required for continued evaluation.

Box 11: Sediment is best controlled at the source. That is, rather than using structures to collect soil after it is suspended in stormwater, it is preferable to stabilize soil to prevent suspension from occurring. Sediment source controls must be implemented for all low-density developments and include (but are not limited to):

- Adequately established vegetation per DCM1 criteria,
- Side slopes that are 3 horizontal to 1 vertical or flatter or the use of benched side slopes when slopes are steeper than 3 horizontal to 1 vertical,
- The use of erosion control blankets to aid establishment of vegetation,
- Check dams,
- Slope drains.

Temporary irrigation and maintenance of vegetation until adequately established may be required.

Box 12: In low density (rural) subdivisions, a method for permanent sediment control must be provided. If a detention pond is used, the forebay is to be sized according to the criteria for Extended Detention Basins. If a detention pond/Extended Detention Pond is not required, a sediment basin as described in DCM2, page 3-32 may be used. It should be sized to collect 1,800 cubic feet per acre of disturbed area. Drainage area above a sediment basin can be reduced by use of vegetated swales, buffers, or contour berms.

Box 13: If there are no detention ponds, separate sediment control measure must be located to catch all runoff leaving the disturbed area of the site.

Box 14: In cases where a detention pond is already required for controlling the volume of runoff, a sediment basin can take the form of a forebay to this pond.

Box 15: Regional WQCV facilities may only be used if they meet the requirements of Section I.7.1.C.

Box 16: The site is required to direct all runoff through grass buffers and/or grass swales or provide a similar BMP. (Note that this is required in accordance with the CDPHE guidance manual to afford some protection to state waters in between the site and the downstream WQCV BMP.)

Box 17: Grass buffers require irrigation in almost all cases in the County; swales sometimes require irrigation.

Box 18: "Dry" alternatives may be used if they are shown to have equivalent removal rates as buffers and swales. All of the structural treatment BMPs in DCM2 (Section 4.2) have equivalent removal rates

and may be used. The covering of storage/handling areas and spill containment and control are not structural treatment BMPs, and thus are not substitutes for grass buffers and swales.

Box 19: If there is no regional WQCV facility downstream with adequate capacity to provide the WQCV for the proposed site, then a WQCV control measure must be provided for the site. Examples of potentially acceptable control measures include Extended Detention Basin, Full Spectrum Detention Basin, Sand Filter Basin, Constructed Wetland Basin, or a Retention Pond. For all ponds, issues related to dam construction and potential groundwater infiltration must be considered. Retention Ponds must be considered in the context of additional issues including safety and health (e.g., drowning and mosquito/West Nile virus) and water rights. For all structures that may hold water for more than 72 hours with an exposed water surface, water storage rights must be obtained before a structure (e.g. retention pond) can be proposed for a site. See Sections 3.2.5.F and 3.3.7 of this ECM for additional information regarding water right and permanent stormwater quality control measures.

Box 20: Sites tributary to sensitive waters must meet the requirements as outlined in Table I-5, and potential high-risk sites must have specialized BMPs.

Box 21: No additional BMPs are required other than WQCV-based BMPs. Also, as always, drainageways must be stabilized and runoff should be reduced as much as possible (Boxes 1 and 2).

Box 22: When specialized BMPs are required, proceed to Box 23 on Figure I-2.

Box 23: Two situations apply, one where conditions preclude the installation of BMPS that employ infiltration, and one where they do not. (See Box 7.) If conditions preclude the installation of BMPS that employ infiltration then proceed to Box 25; otherwise proceed to Box 24.

Box 24: Where soil and groundwater conditions are not prohibitive (that is, groundwater or relatively impervious soils are not within 5 feet of the surface), implement PLD or SFB from DCM2. Alternative BMPs can be used if shown to be equally effective as PLD or SFB (see discussion below).

Box 25: Constructed wetlands (either channels or basins) are an effective BMP for sites with drainage areas greater than 10 acres.

Box 26: Provide a BMP downstream of the pond with equivalent removal rates as a wetland channel; this could be a qualifying manufactured BMP or other BMP that meets the criteria below.

Box 27: If the catchment area is greater than 10 acres, provide a constructed wetland channel (CWC) downstream of pond or provide WQCV with CWB.

E. **Projects that are Strictly Roadway Construction.** For projects that entail highway or other roadway construction, there are three basic questions for the applicant:

- Is the road urban or rural?
- That is, does the road have curb and gutter or does it utilize roadside ditches?
- For rural roads, do the ditches require "water turnouts"?
- Is the road a "hot spot" or does it discharge to sensitive waters?

For road construction projects, the applicant must determine if the roadway project is an applicable development site as defined in Section I.7.1.B. Excluded sites do not need to comply with the requirements of this Section I.7. If a roadway construction project is an applicable development site, then the owner must determine which base design standard is appropriate for the project and must design and implement water quality improvement with the project. Requirements for roadway projects included in the DCMV1 may be used provided they do not conflict with other provisions of this Section I.7.

Rural roads, i.e. those roads which utilize roadside ditches for conveyance of runoff from the roadway, do not have sufficient capacity in the roadside ditches to convey much more runoff than that which runs off the road itself. Rural roads (which by definition have roadside ditches) must be stabilized with one of three methods included in DCM2 on pages 4-3 and 4-4. These methods are described in DCMV1. "Water turnouts," which function as spillways which direct flow out of the ditches onto property adjacent to the ROW, are frequently required as a result. Design for the "water turnout" should ensure the turnout discharges into a "suitable outfall" as described in DCM1 along the roadway such as a natural swale. A drainage easement for this runoff must be acquired at these locations. A possible consequence of "water turnouts" is the loading of sediment onto private property. If "water turnouts" will be utilized for the ditches, sediment basins shall be used at these locations. However, there must be sufficient space in the ROW for both the structure itself and for maintenance access, or a specific drainage easement must be provided for the feature and access. Sediment basins can be designed in accordance with the guidelines in DCM2 in the section for construction BMPs. The basin shall be sized to collect 1,800 cubic feet of sediment per acre of drainage area of the roadway.

The term "high risk site" can be defined by traffic volume for a section of roadway. If the road will experience traffic volume of 30,000 average daily traffic (ADT) or more it is likely to contribute high levels of pollutants. For these situations, additional BMPs are required and selection must follow Boxes 6, 7, 8, and 9 in Figure 1b. Additional BMPs may also be required for discharge to sensitive waters. As described above for the general developments (with building pads), these additional requirements will depend on the TMDL process.

- F. **Additional Guidelines for BMP Selection.** Additional Guidelines for selecting among the appropriate BMPs determined from Figure I-1 and Figure I-2. Figure I-3 (Figure ND-7 in DCM2) depicts a decision tree for selecting one of the six WQCV BMPs based on drainage catchment area and whether water is available to satisfy evapotranspiration requirements. Porous pavement and porous landscape detention are generally suited for small drainage areas (i.e. much less than 1.0 acres); however, larger subwatersheds can be subdivided into individual drainage sub-catchment areas meeting the criteria shown in Figure I-3 for these BMPs.

WQCV control measures and Regional WQCV control measures shall be located prior to the stormwater runoff being discharged to State Waters. When using a Regional WQCV facility for a site, the site may discharge to a water of the state before being discharged to the Regional WQCV facility; however, the conditions in Section I.7.1.C.5 shall be met.

Figure I-4 (Figure ND-8 in DCM2) provides an illustration of selection and location options for WQCV facilities based on the principles discussed above.

Figure I-6 (Table ND-1 in DCM2) indicates the BMP options for the four watershed areas shown in Figure I-4.

I.7.3. Incorporating WQCV into Stormwater Detention Structures

Wherever possible, it is recommended that WQCV facilities be incorporated into stormwater quantity detention facilities. This is relatively straightforward for an extended detention basin, constructed wetland basin, and a retention pond. When combined, the 2, 5, 10, and 100-year detention levels are provided above the WQCV and the outlet structure is designed to control two or three different releases. Stormwater quantity detention could be provided above the WQCV for porous pavement and landscape detention provided the drain times for the larger events are kept short.

The following approaches are to be implemented when incorporating WQCV into stormwater quantity detention facilities:

-
1. **Water Quality.** The full WQCV is to be provided according to the design procedures documented in the New Development BMP Factsheets.
 2. **Minor Storm.** The full WQCV plus the full minor storm quantity detention volume is to be provided.
 3. **100-Year Storm.** One-half the WQCV plus the full 100-year detention volume is to be provided.

For linear projects and projects with limited space available for permanent water quality control measures, WQCV may be included in the design of underground detention structures such as sand filter basins (SFB) and proprietary underground detention structures. These systems rely on appropriate soil conditions to infiltrate or evapotranspire the WQCV.

It is extremely important that high sediment loading and compaction of underlying soils in the area to be used for infiltration be controlled to the maximum extent practicable. These structures are best suited to being brought on line at the end of the construction phase where disturbed ground has been stabilized with pavement or vegetation.

Any underground detention facilities proposed for use in the County must meet the good engineering, hydrologic and pollution control practices as defined in this Section I.7. The design of underground detention that incorporates WQCV shall not commence until a Request for Deviation is submitted for review and approved by the ECM Administrator. In addition to the approval criteria for a deviation request provide in Chapters 1 and 5 of this ECM, the owner or authorized agent must provide a structure-specific Operation and Maintenance (O&M) Manual and maintenance agreement for the structures. The Operation and Maintenance Manual shall include specific procedures and equipment that will be used by the owner or authorized representative to operate and maintain the structures. A specification sheet or generic O&M manual provided by the vendor will not satisfy the O&M Manual requirement.

I.7.4. Separate Presedimentation Facilities

The design criteria shown in the New Development BMP Factsheets section shows presedimentation forebays at the upstream end of the extended detention basin, constructed wetland basin, and retention pond. The purpose of the forebay is to settle out coarse sediment and skim off floatables prior to the main body of the facility. An option to this approach is to install a separate facility upstream from the main WQCV facility. If this option is selected, the recommended size is at least 20 percent of the WQCV and the recommended drain time is 1 hour for the presedimentation forebay volume only. Using this approach, any requirement for sediment storage in the main facility may be reduced consistent with the storage capacity of the separated presedimentation forebay, and the forebay within the main facility may be eliminated.

Figure I-3. Decision Tree for WQCV BMP Selection

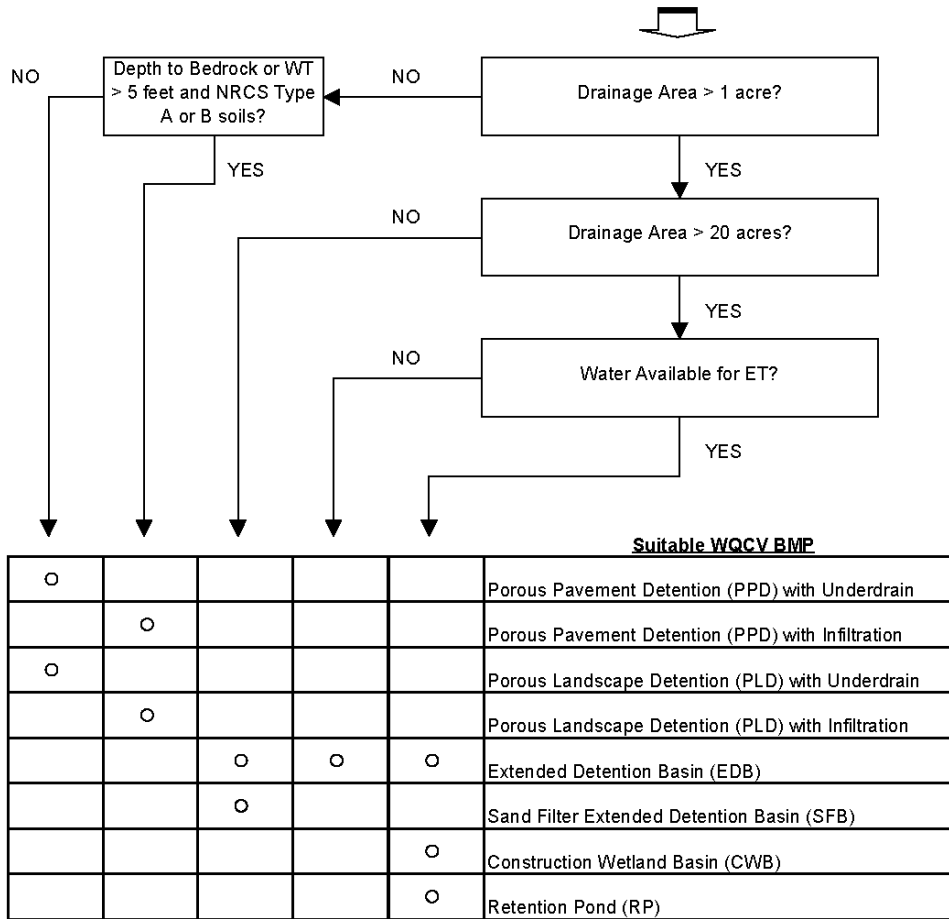

Note: Large drainage areas may be subdivided into areas < 20 acres for use of SFB or < 1 acre for use of PPD or PLD.

Figure I-4. Illustration of Selection and Location Options for WQCV Facilities

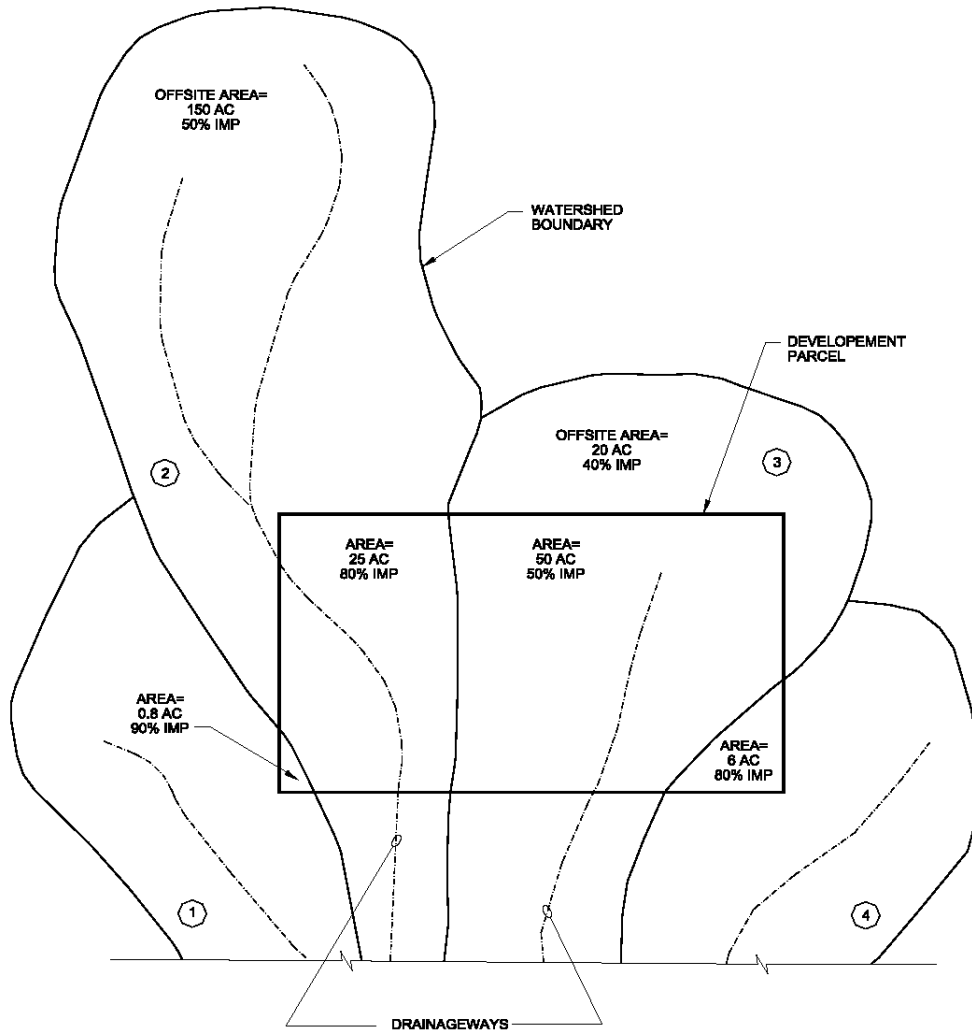

Note: For this example, sufficient make-up water exists for constructed wetlands and retention pond for the watershed areas > 50 acres through irrigation return flows.

Table I-7. Illustration of Selection and Location Options for WQCV Facilities for the Development Parcel on Figure I.4

Watershed Number	Onstream or Offstream	BMP Options	Minimum Number of BMP Installations	Average Drainage Area for Sizing each BMP, acre
1	Offstream	Porous Pavement Detention	1	0.8
		Porous Landscape Detention	1	0.8
2	Offstream	Porous Pavement Detention	24	1
		Porous Landscape Detention	24	1
		Extended Detention Basin	2	12

		Sand Filter Extended Detention Basin	2	12
3	Offstream	Porous Pavement Detention	49	1
		Porous Landscape Detention	49	1
		Extended Detention Basin	2	24
		Sand Filter Extended Detention Basin	3	16
	Onstream	Extended Detention Basin	1	70
		Constructed Wetland Basin	1	70
		Retention Pond	1	70
4	Offstream	Porous Pavement Detention	6	1
		Porous Landscape Detention	6	1
		Extended Detention Basin	1	6
		Sand Filter Extended Detention Basin	1	6

I.7.5. Structural BMP Effectiveness

Table I-7 (Table ND-2 in DCM2) indicates ranges of removal efficiencies reported in literature for a number of structural BMPs. Although combinations of nonstructural/structural BMPs can improve the overall water quality of the runoff, the effectiveness of several BMPs in their ability to reduce influent pollutant concentrations as a group are not directly additive. Table I-7 also shows a most probable range of removal efficiencies for structural BMPs.

I.7.6. Separation Distances

To reduce potential for surface and ground water contamination, permanent water quality BMPs will be located away from wells and Individual Sewage Disposal Systems (ISDS). Rules for separation distances and grouting depths for wells and BMPs will be based on distances between wells and "sources of contamination" in Colorado's Rules and Regulations for Water Well Construction, Pump Installation, and Monitoring and Observation Hole/Well Construction. Permanent BMPs and ISDS will be separated by the same distances specified between the components of the ISDS and "waterways" in the El Paso County ISDS regulations. Additional separation distance may be required when a permanent stormwater quality control measure is located near a water of the state and relies on a vegetated buffer strip as part of the strategy to address WQCV prior to discharge to waters of the state.

Table I-8. BMP Pollutant Removal Ranges for Stormwater Runoff and Most Probable Range for BMPs

Type of BMP	(1)	TSS	TP	TN	TZ	TPb	BOD	Bacteria
Grass Buffer	LRR: EPR	10-50	0-30	0-10	0-10	N/A	N/A	N/A
		10-20	0-10	0-10	0-10	N/A	N/A	N/A
Grass Swale	LRR: EPR	20-60	0-40	0-30	0-40	N/A	N/A	N/A
		20-40	0-15	0-15	0-20	N/A	N/A	N/A
Modular Block Porous Pavement	LRR: EPR	80-95	65	75-85	98	80	80	N/A
		70-90	40-55	10-20	40-80	60-70	N/A	N/A
Porous Pavement Detention	LRR: EPR	8-96	5-92	-130-	10-98	60-80	60-80	N/A
		70-90	40-55	85	40-80	60-70	N/A	N/A
				10-20				

Porous Landscape Detention	LRR: EPR	8-96 70-90	5-92 40-55	-100- 85 20-55	10-98 50-80	60-90 60-80	60-80 N/A	N/A N/A
Extended Detention Basin	LRR: EPR	50-70 55-75	10-20 45-55	10-20 10-20	30-60 30-60	75-90 55-80	N/A N/A	50-90 N/A
Constructed Wetland Basin	LRR: EPR	40-94 50-60	-4-90 40-80	21 20-50	-29-82 30-80	27-94 40-80	18 N/A	N/A N/A
Retention Pond	LRR: EPR	70-91 80-90	0-79 45-70	0-80 20-60	0-71 20-60	9-95 60-80	0-69 N/A	N/A N/A
Sand Filter Extended Detention	LRR: EPR	8-96 80-90	5-92 45-55	-129- 84 35-55	10-98 50-80	60-80 60-80	60-80 60-80	N/A N/A
Constructed Wetland Channel*	LRR: EPR	20-60 30-50	0-40 20-40	0-30 10-30	0-40 20-40	N/A 20-40	N/A N/A	N/A N/A
Ref: Bell et al. (1996), Colorado (1990), Harper & Herr (1992), Lakatos & McNemer (1987), Schueler (1987), Southwest (1995), Strecker et al. (1990), USGS (1986), US EPA (1983), Veenhuis et al. (1989), Whipple and Hunter (1981), Urbonas (1997).								
(1) LRR Literature reported range, EPR—expected probable range of annual performance by DCM2 BMPs.								
N/A Insufficient data to make an assessment.								
* The EPR rates for a Constructed Wetland Channel assume the wetland surface area is equal or greater than 0.5% of the tributary total impervious area.								

I.7.7. Operation and Maintenance of Best Management Practices

A. Long-term Operation and Maintenance of Post-Construction Stormwater Management Structures.

The El Paso County Phase II MS4 Permit requires the County to ensure the long-term operation and maintenance of all post-construction stormwater management control measures constructed by an applicable development site. Part I E.4.a.vi of MS4 permit states:

"vi. Construction Inspection and Acceptance: The County must implement inspection and acceptance procedures to ensure that control measures are installed and implemented in accordance with the site plan and include the following:

- (A) Confirmation that the completed control measure operates in accordance with the approved site plan.
- (B) All applicable development sites must have operational permanent water quality control measures at the completion of the site. In the case where permanent water quality control measures are part of future phasing, the County must have a mechanism to ensure that all control measures will be implemented, regardless of completion of future phases or site ownership. In such cases, temporary water quality control measures must be implemented as feasible and maintained until removed or modified. All temporary water quality control measure must meet one of the design standards in Part I.E.4.a.iv.

For the purpose of this section, completion of a site or phase shall be determined by the issuance of a certificate of occupancy, use of the completed site area according to the site plan, payment marking the completion of a site control measure, the nature of the selected control measure or equivalent determination of completion as appropriate to the nature of the site."

For all structures approved by El Paso County which are not public improvements, the property owner or authorized agent shall be responsible for the operation and maintenance of all permanent

stormwater quality control measures. All temporary control measures required during construction shall be removed after construction activity on the site has been completed and final stabilization of the site is achieved.

Prior to approval of a subdivision, issuance of a Certificate of Occupancy, or closure of the ESQCP for sites that did not go through the subdivision review process that have permanent post-construction stormwater quality control measures, a signed private maintenance agreement for permanent BMPs must be submitted to and recorded by the County. El Paso County uses these agreements as the primary mechanism to ensure the long-term operation and maintenance of post construction stormwater quality control measures. Agreement templates are found in Appendix G.

During construction a County Stormwater Inspector will inspect structures for conformance with approved construction plans and the SWMP. Once the structure has been accepted into the County Permanent Stormwater Quality Control Measure Inventory consistent with Chapter 5, control measures will be inspected at minimum once every five (5) years. All inspections will be conducted as described in Section I.5.

Confirmation that post-construction stormwater quality control measures operate according to approved plans occurs through the use of an inflow hydrograph routed through a basin model. This analysis and the resulting hydrograph shall be performed by the Engineer of Record for the owner or authorized agent of the applicable development site and provided with Final Drainage Report included in the development plan submitted to the County. If the ECM Administrator determines that significant changes to the approved plans are identified in the "as-built" drawings provided in conformance with Section 5.10.6, an additional inflow hydrograph based on the "as-built" changes shall be provided to the County to confirm that the changes made during construction did not negatively alter the effective operation of the control measure.

If during an inspection of a post-construction stormwater quality control structure it is determined and documented by a County Stormwater Inspector that any owner or authorized agent failed to adequately operate and maintain a permanent stormwater quality control measures or remove the temporary control measures, an enforcement action described in Section I.6 shall be pursued.

- B. **Operation and Maintenance Manual.** A detailed Operation and Maintenance Manual covering inspections, operation and maintenance of permanent BMPs will be provided to the party who holds the Private Maintenance Agreement for Permanent BMPs. The Operation and Maintenance Manual will include specifics on frequency of inspections and maintenance; standards for vegetation or structures, such as species of vegetation, mowing height, revegetation of worn or eroded areas, cleaning methods; depth of sediment requiring removal; replacement frequencies; and other relevant topics.

(Res. No. 19-245 , 7-2-19)

I.8. PROCEDURES FOR ASSESSMENT OF STRUCTURAL CONTROLS FOR RETROFITTING WATER QUALITY FEATURES

[Replaces DCM2 Section 4.4, page 4-133]

At some sites, there may be an existing structure for flood control and other water quantity control purposes. It may be possible to retrofit this structure for water quality in addition to the quantity functions. The following procedure will assist in evaluating the potential for retrofitting. In a new or major redevelopment project, new erosion and water quality control BMPs will be required, if retrofitting is not a reasonable option.

Created: 2021-06-08 11:36:14 [EST]

(Supp. No. 2)

The purpose of this document is to outline the procedures for these evaluations. These procedures would then be utilized in conjunction with developing each new Drainage Basin Planning Study (DBPS) to determine the potential and feasibility for retrofitting existing structural controls (detention/retention basins).

The analysis of the structures involves three possible levels of review. The first is a qualitative review to determine if retrofitting of the structure is acceptable. The second element is quantitative to determine the pollutant removal effectiveness of the structure, both with and without water quality elements. Total Suspended Solids (TSS) will normally be the only constituent evaluated, unless other pollutants of concern are specified by the ECM Administrator, based on site-specific information such as draining to sensitive waters or high risk pollution sources. A third element of review involves developing a cost estimate for retrofitting to determine the economic feasibility.

A qualitative assessment evaluates the changes that would occur if the flood-control detention facility was modified for water quality purposes, and determines the extent to which the changes would affect these functions, and if these changes in function are acceptable. The detention pond must first be acceptable under the qualitative criteria, or the evaluation will conclude and not continue to the second level of review. A quantitative analysis involves a determination of whether the percent removal of TSS (or other specified constituent of concern) is significant. For purposes of this assessment, a significant change is defined as the percent removal of the constituent after retrofitting the detention pond is estimated to be at least 20 percent greater than the percent removal of the constituent for the detention pond without the water quality element incorporated. If a significant change is estimated, then the third element of analysis, a cost estimate of the economic feasibility, is conducted. If a significant change is not estimated, then the option to retrofit the detention pond is eliminated.

I.8.1. Final Alternative Selection

The final alternative selection process for drainage improvement options in any new DBPS is based on the evaluation of many factors including costs, safety, environmental issues including water quality, public input, etc. If the selected alternative includes retrofitting structural controls to provide additional pollutant removal, responsibility for implementation would need to be outlined in the study. If the responsibility was determined to be a public (County) responsibility, consideration for funding any such drainage improvement project would be made by the Board of County Commissions during its annual budget approval process in conjunction with all other budget requests. If the responsibility was determined to be a private development responsibility, ECM Administration would decide when implementation would be required in conjunction with the timing of future developments.

I.9. SUPPLEMENTAL INFORMATION: URBAN DRAINAGE FLOOD CONTROL DISTRICT'S HYDROLOGY AND HYDRAULICS DESIGN TOOLS

[Replaces DCM2 Appendix A]

The Urban Drainage and Flood Control District (UDFCD) located in Denver, Colorado developed a number of tools to assist engineers and design professionals develop hydrology, adhere to UDFCD criteria, and perform various analyses. El Paso County allows for the use of these tools on submittals required during the development and construction review and approval process. In the event there are conflicts that arise between the inputs or results of an UDFCD tool and the criteria contained in this ECM, however, it shall be responsibility of the Engineer of Record to identify those conflicts and bring them to the attention of the ECM Administrator. Only the appropriate UDFCD design tools available on the UDFCD website at the time of site plan approval will be acceptable. The ECM Administrator, at their sole discretion, will determine if the specific use of the tool is acceptable for the project under review.

The preparation of final design plans addressing details of structural adequacy, public safety, hydrology, hydraulic functionality, maintainability, and aesthetics remains the sole responsibility of the Engineer of Record.

BY THE USE OF THE URBAN DRAINAGE AND FLOOD CONTROL DISTRICT SUPPLIED DESIGN FORM WORKSHEETS, THE USER AGREES TO THE FOLLOWING: NO LIABILITY FOR CONSEQUENTIAL DAMAGES

To the maximum extent permitted by applicable law, in no event shall the Urban Drainage and Flood Control District or the City of Colorado Springs or El Paso County, their contractors, advisors, reviewers, or their member governmental agencies, be liable for any incidental, special, punitive, exemplary, or consequential damages whatsoever (including, without limitation, damages for loss of business profits, business interruption, loss of business information or other pecuniary loss) arising out of the use or inability to use these products, even if the Urban Drainage and Flood Control District or the City of Colorado Springs or El Paso County, their contractors, advisors, reviewers, or their member governmental agencies have been advised of the possibility of such damages. In any event, the total liability of the Urban Drainage and Flood Control District or El Paso County, their contractors, advisors, reviewers, or their member governmental agencies, and your exclusive remedy, shall not exceed the amount of fees paid by you to the Urban Drainage and Flood Control District for the Product.

NO WARRANTY

The Urban Drainage and Flood Control District or El Paso County, their contractors, advisors, reviewers, or their member governmental agencies do not warrant that the Design Form Worksheets will meet your requirements, or that the use of this product will be uninterrupted or error free.

THIS PRODUCT IS PROVIDED "AS IS" AND THE URBAN DRAINAGE AND FLOOD CONTROL DISTRICT OR EL PASO COUNTY, THEIR CONTRACTORS, ADVISORS, REVIEWERS, AND THEIR MEMBER GOVERNMENTAL AGENCIES DISCLAIM ALL WARRANTIES OF ANY KIND, EITHER EXPRESSED OR IMPLIED, INCLUDING BUT NOT LIMITED TO, ANY WARRANTY OF MERCHANTABILITY, FITNESS FOR A PARTICULAR PURPOSE, PERFORMANCE LEVELS, COURSE OF DEALING OR USAGE IN TRADE.

(Res. No. 19-245 , 7-2-19)

Appendix J ROADWAY INSPECTIONS AND TESTING

J.1. PURPOSE

This appendix presents general requirements for testing and inspecting roadways and ancillary facilities constructed within the County. This appendix presents the minimal standards the ECM Administrator will follow for project inspections and ultimately acceptance of completed improvements.

J.2. GENERAL TESTING AND INSPECTION PROCEDURES

J.2.1. Roadway Testing and Inspection Standards

CDOT Standard Specifications for Road and Bridge Construction, as amended, special provisions and revisions thereto and as amended by the ECM shall apply to roadway testing and inspection requirements.

(Supp. No. 2)

Created: 2021-06-08 11:36:14 [EST]

J.2.2. Submission of Tests

All tests and inspection results performed by the testing firm in the employment of the permit holder shall be submitted directly from the testing agency to ECM Administrator, at the time of field tests, and within 10 working days after the testing or retesting date of laboratory tests.

J.2.3. Testing Required

Any work performed inside the County's RIGHT-OF-WAY or associated easements shall be tested by an approved materials testing firm who must employ a full-time registered professional engineer who directly supervises work of the firm. The costs of testing and associated reporting will be paid by the permit holder. All Material Testing Reports must be from an ECM Administrator-approved lab and must be certified by a Professional Engineer.

J.2.4. Approved Testing Methods

The testing of all materials and construction shall be in conformance with the appropriate AASHTO, ASTM, A.C.I., or CDOT specifications. A partial list of approved testing methods is provided in Table J-1.

Table J-1. Approved Testing Methods

Test Procedures	AASHTO	ASTM
Asphalt Core Densities	T 155 - 78	
Atterberg Limits (LL & PL)	T 89 & T 90	D 4318
Gradation Analysis (except hydrometer)	T 27	D 422
CBR	193	
R-value (subgrade & base)	T 190	D 2844
Rt Value	T 246	D 1560
Compaction Curve (standard)	T 99	D 698
Compaction Curve (modified)	T 180	D 1557
Compaction Curve (CTAB)	T 134	
Field Density Test (Sand Cone)	T 191	D 1556
Field Density Test (Nuclear)	T 238/T 239	D 2922/D 3017
Field Density Test (Balloon)	T 205	D 2167
Concrete Slump	T 119	C 143
Concrete Air Content	T 152	C 231
Concrete Compressive Strength	T 22	C 39
Concrete Sampling	T 141	C 172
Strength of Soil-Lime Mixtures	T 220	---
Asphalt Flow	T 245	D 1559
Air Voids	T 245	D 1559
Profil-o-graph	Colo. Procedure 64-85	
Swell Potential Evaluation		D 4546-96

J.2.5. Scheduling Inspections and Penalties

Any work performed in the County right-of-way must have a valid permit issued by the ECM Administrator. The permit holder must call the ECM Administrator at least 48 hours in advance of commencing work and schedule inspections. If for any reason work is not performed as scheduled, the permit holder must call and cancel the inspection as soon as possible. Failure to cancel the ECM Administrator inspection will result in a

penalty fee. The privilege to work in the County's right-of-way may be revoked by the ECM Administrator for non-conformance with any permit or ECM condition or standard.

J.3. ANCILLARY FACILITIES TESTING AND INSPECTION

J.3.1. Utility Trenches Backfill Testing and Inspection

- A. **Field Moisture Density Testing.** Field moisture-density testing shall be performed during backfill operations beginning 12 inches above the top of the pipe and extending to the finished subgrade elevation. A sufficient number of tests shall be taken at various depths to confirm backfill compaction and moisture content specifications are met. As a minimum, one test shall be taken within 12 inches of manholes, water valves, or other obstacles. Testing shall be done in accordance with Appendix K. Within the roadway area, trench compaction shall be in accordance with AASHTO T-99 or T-180.

J.3.2. Curb, Gutter, Sidewalk, and Minor Drainage Structures Testing and Inspection

- A. **Testing Frequency.** Testing frequency for the subgrade shall be a minimum of each 6-inch lift on replacement materials with one test for every 500 linear feet of structure with more tests taken if necessary for control.
- B. **Slump, Air Content and Unit Weight Tests.** The slump, air content, and unit weight tests for the delivered product shall be carried out on the first load or until compliance for the daily placement and all tests shall be taken at the end of the concrete chute, or, if a "pump truck" is used, at the end of the pump, and thereafter in conformance with Table J-2.

Table J-2. Testing Frequency

Item	Testing Frequency ¹
Sidewalks, Crossspans, Curb Returns	1 set of per class of concrete per project for every 100 cubic yard or fraction thereof of concrete placed
Curbing and Combination Curb, Gutter, and Walk	1 set of per class of concrete per project for every 100 cubic yard or fraction thereof of concrete placed
Note: Testing shall include the slump (T 119), air entrainment (T 152), temperature of concrete at placement, yield and compressive strength of the cylinders (T 22).	
¹ All work done by hand (non-extrusion) shall require a minimum of two (2) sets of tests per day.	

- C. **Core Tests.** At the discretion of the ECM Administrator, the contractor or permit holder will provide core test results of concrete at random intervals, not averaging less than one test in 500 feet, to verify that specified thickness of concrete was installed. If the ECM Administrator has not been given the opportunity to inspect the subgrade or concrete forms prior to placement of the concrete, the contractor or permit holder shall provide core tests.
- D. **Temperature Data and Tests.** When the mean daily temperature is less than 40°F, in accordance with A.C.I. Specifications, or when concrete is placed with ambient temperatures below 40°F, it shall be the contractor or permit holder's responsibility to provide testing lab certified proof that the temperature of the concrete has been maintained at not less than 50°F for a minimum of five (5) days or until at least seventy percent (70%) of the design strength has been attained.

J.4. ROADWAY TESTING AND INSPECTION

J.4.1. Roadway Subgrade Testing and Inspection

- A. **Field Moisture Density Tests.** Field moisture-density tests using acceptance methods will be required at random locations at the rate of one for each 500 lineal feet, or portion thereof, of paving for each travel lane.
- B. **Final Proof Rolling Inspection Notification.** The ECM Administrator shall be notified at least 24 hours before final proof-rolling.
- C. **Review and Approval of Tests.** The results of field density tests and proof-rolling shall be submitted to and reviewed by the ECM Administrator. If testing indicates unsatisfactory work, the necessary reworking, compaction, or replacement will be required prior to continuation of the paving process. If all tests are acceptable, compaction will be approved for the placement of the paving course. The approval is valid for 24 hours. Changes in weather, such as freezing or precipitation, will require reapproval of the subgrade.

J.4.2. Lime Treated Subgrade Testing and Inspection

- A. **Field Moisture Density Tests.** Lime treated subgrade shall be observed and tested on a full-time basis. Field moisture-density tests shall be taken at the rate of one for each 500 lineal feet of travel lane for each lift. Field density shall be compared to the compaction curves (AASHTO T 220) each soil type for percentage compaction determinations. Field compacted 7-day strength and lime content (AASHTO T 232) determinations shall be required for each 500 tons of subgrade treated, with a minimum of one per project.
- B. **Review and Approval of Tests.** The results of field density, lime content, and strength tests shall be submitted and reviewed by the ECM Administrator. Should these tests fail to meet project specifications, the strength reduction will be used to calculate increased pavement layer or overlay thickness required for the design section. If all tests are acceptable, compaction will be approved for the placement of the paving course.

J.4.3. Aggregate Base Course Testing and Inspection

- A. **Verification of Materials Properties.** The contractor or permit holder shall, upon request by the ECM Administrator, provide verification of material properties.
- B. **Gradation and Atterberg Limits Materials Sample Tests.** At least one sample of aggregate base course for each 1,000 tons of materials placed shall be tested to determine gradation and Atterberg Limits. Should these tests indicate the material does not meet specifications, the material shall be removed and replaced.
- C. **Field Moisture Density Tests.** During placement and compaction, compaction curves will be required for each material used. Field moisture-density tests shall be taken of each lift of material at random locations at approximate intervals of 500 feet in each travel lane. At least 20 percent of the tests shall be taken within 12 inches of manholes, valves, and curbs.
- D. **Review and Approval of Tests.** The results of field density tests shall be submitted to and reviewed by the ECM Administrator. Should testing indicate unsatisfactory work, the necessary reworking, compaction, or replacement will be required prior to continuation of the paving process. If all tests are acceptable, compaction will be approved for the placement of the paving course.

J.4.4. Cement Treated Aggregate Base Course Testing and Inspection

- A. **Verification of Materials Properties.** The contractor or permit holder shall provide verification of material properties of the approved mix design.
- B. **Approval of Subgrade.** Materials shall be placed on a subgrade that has been proof-rolled within the past 24 hours and found to be stable and non-yielding and has been approved by the ECM Administrator. Should weather conditions change, such as freezing, precipitation, etc., materials shall not be placed until the subgrade is re-approved by the ECM Administrator.
- C. **Unconfined Compressive Strength, Gradation, and Atterberg Limits Material Test.** At least one sample of cement treated aggregate base course for each 1,000 tons of material placed shall be tested to determine gradation, and Atterberg Limits. Six field prepared proctor mold samples shall be taken for each 500 tons placed and tested at 7 and 28 days to determine unconfined compressive strength.
- D. **Field Moisture Density Tests.** During placement and compaction, compaction curves will be required for each material used in accordance with AASHTO T 134. Field moisture-density test shall be taken of each lift of material at random locations at approximate intervals of 500 feet in each travel lane. At least 20 percent of the tests shall be taken within 12 inches of manholes, valves, and curbs.
- E. **Review and Approval of Tests.** The results of laboratory tests and field density tests shall be submitted to and reviewed by the ECM Administrator. Should testing indicate unsatisfactory work, necessary adjustments will be made to the pavement section to comply with original design strength requirements. If all tests are acceptable, compaction will be approved for the placement of the paving course.

J.4.5. Hot Mix Asphalt (HMA) Testing and Inspection

Hot Mix Asphalt (HMA) materials shall be tested according to the latest edition of the Pikes Peak Region Asphalt Specification. The Pikes Peak Region Asphalt Specification can be obtained online at: <http://adm.elpasoco.com/publicservices/transportation/Pages/default.aspx>.

J.4.6. Portland Cement Concrete Testing and Inspection

- A. **Portland Cement Concrete Requirements.** When the mean daily temperature is less than 40°F, in accordance with A.C.I. Specifications, or when concrete is placed with ambient temperatures below 40°F, it shall be the contractor or permit holder's responsibility to provide testing lab certified proof that the temperature of the concrete has been maintained at not less than 50°F for a minimum of five (5) days or until at least seventy percent (70%) of the design strength has been attained.
- B. **Aggregate Samples.** During placement of Portland cement concrete pavement, observation and testing shall be on a full-time basis. For each day of production or every 400 cubic yards placed (or portion thereof), aggregate samples shall be obtained for gradation of both the coarse and fine aggregates.
- C. **Slump, Air Content, Unit Weight, and Mix Temperature Testing.** Slump, air content, unit weight, and mix temperature shall be tested every 100 cubic yards of pavement placed. The first three loads shall be tested for slump and air content. If any one test fails to meet requirements, slump and air content tests shall continue until three consecutive loads meet requirements. Thereafter, slump and air shall be tested every fifth load.
- D. **Compressive Strength Cylinder Testing.** Six compressive strength cylinders shall be fabricated for each 100 cubic yards placed. Cylinders shall be tested as follows: 1 at 7 days, 2 at 28 days, and 1 for backup, as required by the ECM Administrator. Testing interval may be increased to approximately 1/3 of the daily volume at the discretion of the ECM Administrator.

-
- E. **Certificates of Compliance and Pre-Testing.** Portland cement and fly ash will be accepted on the basis of current certificates of compliance and pre-testing by CDOT. Reinforcing steel, dowels, and tie bars will be accepted by certificate of compliance and mill reports. Water, if not potable, shall be sampled and tested before use. Only CDOT-approved brands of air entraining agents, chemical admixtures, and curing materials may be used and must be documented.
 - F. **Surface Smoothness Tests.** Surface smoothness shall be tested and corrected as necessary according to Section 412.17 CDOT. The profil-o-graph index shall not be more than 14 inches per mile with a deviation of not more than 0.5 inches in 25 feet. Concrete tested with a 10-foot straight edge shall have a deviation of no more than 3/16 inch in 10 feet. This requirement is for all concrete mainline pavements. Surface smoothness shall be tested and corrected as necessary according to CDOT Section 412.16.
 - G. **Concrete Thickness Tests.** Concrete thickness shall be verified by coring after construction at random locations at intervals of approximately 500 feet in each travel lane as determined and marked by the ECM Administrator. The ECM Administrator must be present during actual core drilling or cores will not be accepted. Surface smoothness shall be tested and corrected as necessary according to CDOT Section 412.16.
 - H. **Profil-O-Graph Tests Submitted.** Profil-o-graph tests shall be submitted to, and accepted by, the ECM Administrator prior to beginning the 2-year warranty period.
 - I. **Onsite Test Location.** All on-site air tests shall be taken at the point of placement: at the end of the concrete chute, or, if a "pump truck" is used, at the end of the pump, etc.
 - J. **Review and Approval of Tests.** All test results shall be submitted to, and reviewed by, the ECM Administrator. Should testing indicate unsatisfactory work, removal and replacement or grinding will be required. If all tests are acceptable, the pavement will be accepted and the 2-year warranty period will begin.

J.4.7. Asphalt Tack Coat Testing and Inspection

Asphalt tack coat materials shall be tested according to the latest edition of the Pikes Peak Region Asphalt Specification. The Pikes Peak Region Asphalt Specification can be obtained online at:
<http://adm.elpasoco.com/publicservices/transportation/Pages/default.aspx> .

J.4.8. Cement Stabilized Subgrade Testing and Inspection

- A. **Verification of Materials Properties.** The contractor or permit holder shall provide verification of material properties of the approved mix design.
- B. **Thickness of Stabilized Zone.** Stabilized zone thickness shall be verified by the use of phenolphthalein and shall be performed at intervals of approximately 500 feet in each lane. When the measurement of the thickness is deficient by more than 1 inch from the plan thickness, two additional locations shall be measured randomly within the deficient area and used in determining the average thickness. When the average thickness is deficient by more than 1 inch, the entire area shall be reprocessed to meet the design parameters or the roadway design section must be re-evaluated.
- C. **Unconfined Compressive Strength, Gradation, and Atterberg Limits Material Test.** At least one sample of cement stabilized subgrade for each 1,000 tons of material stabilized shall be tested to determine gradation and Atterberg Limits. The stabilized subgrade must develop a laboratory compressive strength that meets the design compressive strength. Samples shall be molded from stabilized soil within 1.5 hours of final mixing with the material compacted per ASTM D 558 or ASTM D 698, as specified in subgrade stabilization design, at the field moisture content.

- D. **Field Moisture Density Tests.** During placement and compaction, compaction curves will be required for each material used in accordance with AASHTO T 134. Field moisture-density test shall be taken of each lift of material at random locations at approximate intervals of 500 feet in each travel lane. At least 20 percent of the tests shall be taken within 12 inches of manholes, valves, and curbs.
- E. **Review and Approval of Tests.** The results of laboratory tests and field density tests shall be submitted to and reviewed by the ECM Administrator. Should testing indicate unsatisfactory work, necessary adjustments will be made to the pavement section to comply with original design strength requirements. If all tests are acceptable, compaction will be approved for the placement of the paving course.

J.5. TESTING SUMMARY

Table J-3 summarize the testing requirements outlined in Appendix J.

Table J-3. Summary Minimum Testing Requirements

No.	Item	Type Of Test	Minimum Frequency	Min. #	Act. #
1	Utilities: Water, Sewer, Gas, Electric, Phone and Cable Trenches	Moisture/Density	1 per every 250 L.F. or fraction thereof, every 2' elevation. Each structure (manhole, valve, etc.) every 2' elevations. This requirement also applies to every service.		
2	Storm Sewer Trench	Moisture/Density	Same as above. Each structure (manhole, inlet, etc.) every 2' elevations.		
3	Inlets Concrete Testing	Air Slump	First load or until compliance. Minimum 1 per day.		
		Cylinders	1 set (4) per project for every 100 C.Y. or fraction thereof.		
		Steel	Visual and Documentation		
4	Curb and Gutter	Moisture/Density	1 every 250 feet or a minimum of 3 tests, whichever is greater.		
		Proof-Roll	All final subgrade.		
		Air/Slump	First load or until compliance. Minimum 1 per every 2,000 L.F. or fraction thereof.		
		Cylinders	1 set (4) per project every 2,000 L.F. or fraction thereof.		
5	Sidewalk	Moisture/Density	1 per every 250 L.F. or fraction thereof.		
		Air/Slump	First load or until compliance. Minimum 1 per every 1,000 S.Y. or fraction thereof.		
		Cylinders	1 set (4) per project 1,000 S.Y. or fraction thereof.		
6	Roadway Subgrade: Fills and Cuts	Moisture/Density	1 per every 500 Lane Ft. or fraction thereof, every 2' elevation. Cuts to be scarified to a depth of 1', recondition as needed and recompact.		
			All final subgrade.		
7	Roadway (Concrete)	Air/Slump	First 3 loads or until compliance, then every 1,250 C.Y. or fraction thereof.		

Created: 2021-06-08 11:36:14 [EST]

(Supp. No. 2)

		Cylinders	1 set (4) per project for every 1,250 C.Y. or fraction thereof.		
8	Roadways (Base Course)	Moisture/Density	1 per 500 Lane Ft. or fraction thereof.		
		Gradation & Atterberg Limits	1 per 2,000 Tons or fraction thereof.		
		Proof-Roll	Subgrade prior to Base Course placement. Base Course prior to placement of asphalt.		
9	Roadways (Asphalt)	Density	1 per 500 Lane Ft. or fraction thereof, per lift.		
		Extraction/Gradation	1 per 1,000 Tons or fraction thereof.		
10	Roadways (Asphalt & Concrete)	Cores	1 per 1,000 Lane Ft. or fraction thereof.		
		Profil-O-Graph	Minor Arterial classification and above.		

Appendix K ROAD CUT, TRENCHING AND RESTORATION

K.1. ROAD CUTS

K.1.1. General

Placement or repair of subsurface facilities (utilities, culverts, or foundations) within the County roadways shall follow the requirements outlined in the Chapters 3 and 4 and this Appendix. Modifications to these Standards require written approval from the ECM Administrator before beginning work. Emergency repairs for broken pipes, cables etc. is allowed on a case-by-case basis and requires immediate notification of the ECM Administrator. Applicable Trench Notes are provided in Section K.2.

K.1.2. Pavement Cutting

- A. **No Cuts Permitted.** No pavement cuts will be permitted in pavements less than three years old. In the event that a pavement cut is allowed through an approved deviation, restoration requirements may be more extensive than for older pavements. If the a permit holder makes a cut into a pavement less than three years old, which is not an emergency cut, the permit holder shall be liable for restoring the roadway to the satisfaction of ECM Administrator at the permit holder's expense.
- B. **Boring May be Required.** Boring may be required for pipelines to cross roads, instead of trenching, as directed by the ECM Administrator. If sufficient right-of-way exists, the length of the bore shall extend a minimum of 4 feet from edge of pavement. Unused holes or abandoned casings shall be backfilled. Water boring under roadways shall not be permitted. Existing carriers and conduit installed under a roadway shall be physically located prior to boring.
- C. **Pavement Cut Standards.** Pavement shall be cut so the joint line between existing and replacement pavement is straight and neat (i.e., within 5° of vertical and free from horizontal irregularities). All cuts shall be by saw or blade. The cut shall be full depth to allow the pavement to be removed without damage to the remaining pavement. The minimum allowable remaining pavement sections shall not be less than four feet (4') (not including the curb and gutter or concrete pavement) unless it is part of monolithic concrete pavement section that shall be full panel (per existing control joint).
- D. **Removal and Disposal of Pavement.** Removed pavement shall be hauled away and disposed of in a proper manner (recycle or waste facility).

-
- E. **Base Course Storage and Reuse.** Base course material may be removed and stockpiled off of the road surface area for reuse during backfilling if it meets specifications. If not, it is to be hauled away from the right-of-way and disposed of in a proper manner.
- F. **Subbase Material Storage and Reuse.** Sub-base material may be stockpiled parallel to the trench alignment; in such a manner that encroachment upon the non-disturbed portion of the roadway and pedestrian walkways is kept to a minimum. The storage of materials on the non-disturbed portion of the roadway shall not be allowed unless identified in the traffic control plan with appropriate protective measures. Unsuitable material is to be hauled away from the right-of-way, disposed of in a proper manner and replaced with select backfill.
- G. **Storage of Construction Materials in Right-of-Way.** The temporary storage of construction material in the public right-of-way in connection with utility projects is permitted. Material storage shall meet the requirements outlined by the ECM Administrator. Parking of construction or personal vehicles on roadways shall be kept to a minimum.
- H. **Safety Standards.** Safety standards relating to the shoring and stabilization of trench sidewalls should be maintained as prescribed by appropriate safety regulatory agencies (OSHA, State of Colorado). All barricades shall comply with Manual of Uniform Traffic Control Devices (MUTCD).
- I. **Length of Open Trench Limited.** Trenches shall not be opened for a distance of more than one hundred (100) feet at any one time, unless specifically authorized by the ECM Administrator.
- J. **Trench Width and Pavement Cut.** The trench width shall be confined to those minimum dimensions, which will permit proper installation and acceptable pipe loading, as established by current acceptable engineering practices and all OSHA requirements. In no case shall the trench width be less than equal to the diameter of the pipe plus a minimum of 12 inches on each side to ensure adequate compaction by mechanical means.
- All asphalt pavement cuts shall be a minimum of 12 inches in each lateral dimension beyond edge of trench and full panel replacement on all concrete or curb and gutter cuts.
- K. **Open Condition and Traffic Warnings.** No road cuts should be left in an open condition overnight, except for the portion necessary to commence work the following morning. Warning signs, barricades and lights, all in conformance with the MUTCD, shall be used in areas where trenching operations are in public roadways. All work shall have flashing lights used with warning signs and barricades. All barricades, signs and warning devices shall be installed in accordance with the MUTCD.
- L. **Trenching Across the Road and Traffic.** When trenching across the road, no more than one-half (1/2) of the roadway is to be closed to traffic at one time. A traffic signal or flaggers as required by MUTCD shall be provided. The trenched roadway shall be completely backfilled and paved before trenching the other half of the road.
- M. **Road Closure.** Closure of any road, approach, or other access points shall be approved by the ECM Administrator. Upon trenching across facilities, steel running plates, planks or other safe methods shall be used to provide for traffic to enter or leave the road or adjacent property.
- N. **Driveways Closures.** The use of driveways to adjacent properties shall be respected by the permit holder. Every effort shall be made minimize closures and to open and make serviceable those driveways that are closed in the shortest time possible. If closure of driveways is anticipated, the permit holder performing the work shall notify the owners in advance of closure and shall notify the owners of the anticipated time and period of closure. When open, safe access to private driveways shall be provided.

-
- O. **Notice Before Beginning Work.** The ECM Administrator, applicable policing authority and emergency companies shall be informed by the permit holder at least 48 hours in advance of beginning work in the public right-of-way.
 - P. **Accidents.** If traffic accidents or pedestrian incidents occur due to installations or obstructions placed in the right-of-way, the occurrence must immediately be reported to the ECM Administrator and the applicable policing authority by the permit holder.
 - Q. **Access to Fire Hydrants.** Safe access must be maintained at all times to fire hydrants.
 - R. **Restoration of Property.** The permit holder shall take precautions to limit the removal of or damage to existing pavements, sidewalks, curbs, lawns, shrubbery, trees, hedges, walls, fences, buildings, other existing improvements, existing survey monumentation, pavement markings, and signage in the County right-of-way or easement areas to the least practicable amounts and shall replace or restore improvements to their original location and condition after the excavation has been backfilled and compacted.
 - S. **Private Easement Conditions.** The permit holder is responsible for understanding and complying with all specific conditions contained in private easements.
 - T. **Inspection Costs.** All inspection costs shall be borne by the permit holder.
 - U. **Notice of Completed Work.** The permit holder shall notify the ECM Administrator in writing upon completion of work accomplished under the provisions of the permit.

K.1.3. Backfilling

- A. **General.** Once the subsurface facility has been installed or repaired, backfill material shall be placed in accordance with these Standards.
- B. **Backfilling Requirements.**
 - 1. **Preparation of Trench.** The bottom of the trench shall be prepared to provide a firm foundation for the facility in accordance with the bedding conditions specified by the Geotechnical Engineer for the type of facility to be installed. The subgrade of the trench shall be kept free of standing water. Where the trench subgrade material is found to be unsuitable and does not afford a solid foundation, the permit holder shall excavate to depth as necessary to construct a stable foundation. A stable foundation shall be constructed by placing crushed rock or other approved granular material to support the installed facility.
 - 2. **No Deformation or Damage to Facility.** The facility, including backfill, shall be installed in a manner that ensures no deformation, displacement or damage to the facility likely to cause leakage or degradation to the structural integrity of the roadway.
 - 3. **Trench Backfill.** The facility being placed will be properly bedded to at least one foot above the pipe with furnished sand or selected sandy soil free of humus, vegetable or other organic matter, frozen material, clods, sticks and debris. In addition, rock particles and hard earth clods larger than 3 inches will be removed. After the improvements are bedded, the previously removed and stockpiled material shall be replaced and properly compacted to an elevation which facilitates placing pavement. No fill material with a liquid limit greater than 40 and plasticity index greater than 20 percent shall be used within the top two feet of the trench without implementing proper mitigation techniques.
 - 4. **Compaction Tests.** Compaction tests must be performed daily by a Geotechnical Engineer and shall be performed at a minimum of every 250 feet (250') or portion thereof along the trench and

every 12 inches in elevation. Testing intervals may be increased at the discretion of the ECM Administrator.

5. **Compaction.** The subgrade shall conform to the lines, grades and cross-sections as shown on the approved plans. The backfill material shall be compacted in successive layers not to exceed eight inches (8") thick and shall be finished and maintained in a smooth compacted condition. The completed surface shall be free from rutting or other objectionable irregularities.

Within the roadway area, trench compaction shall be in accordance with the following, depending on the site conditions:

- Depths up to 15 feet and cohesive soils (per A.A.S.H.T.O.) - 95 percent of maximum Standard Proctor dry density at moisture contents within 2 percent of optimum (ASTM D698 or AASHTO T99)
- Depths up to 15 feet and non-cohesive soils (per A.A.S.H.T.O.) - 95 percent of maximum Modified Proctor dry density at moisture contents within 2 percent of optimum (ASTM D1557 or AASHTO T180)
- Depths over 15 feet and cohesive soils (per A.A.S.H.T.O.) - 98 percent of maximum Standard Proctor dry density at moisture contents within 2 percent of optimum (ASTM D698 or AASHTO T99)
- Depths over 15 feet and non-cohesive soils (per A.A.S.H.T.O.) - 95 percent of maximum Modified Proctor dry density at moisture contents within 2 percent of optimum (ASTM D1557 or AASHTO T180)

K.1.4. Subbase Preparation

- A. **General.** The term "subbase", for the purpose of trench backfill discussion shall refer to the CDOT Class 1 or Class 2 material that is part of a structural pavement design. There may or may not be a subbase in the pavement section. If there is none, the base course shall all CDOT Class 6.
- B. **Subbase Placement Procedures.**
 1. **Subbase Grade and Cross Sections.** Subbase material shall conform to the lines, grades, cross sections and thickness shown on the approved plans and shall be finished and maintained in an acceptable condition at least one day's progress in advance of base construction.
 2. **Subbase Material.** Subbase material shall be well mixed, free of organic matter and lumps or balls of clay, and shall consist of sound aggregate particles and suitable filler or binding materials which when placed and compacted will result in a firm, dense, unyielding foundation. Subbase material need not be crushed but may be of the pit run variety providing it is graded within the following limits.

Table K-1. Gradation of Subbase Material

Standard Size of Sieve	Percentage of Weight Passing Sieve
2½ inch	100
2 inch	95—100
#4	30—60
#200	5—15
Liquid Limit	35 maximum
Plastic Limit	6 maximum

3. **Subbase Placement.** Subbase shall be deposited and spread, without particle segregation in loose layers not to exceed 6 inches (6") in depth. Each layer shall be thoroughly and individually compacted to 96% proctor (AASHTO T99) density. Wetting or aerating and rolling the material shall be required when ordered by the ECM Administrator. Subbase shall not be placed on soft, spongy, or frozen subgrade or other subgrade, the stability of which, in the opinion of the ECM Administrator, is unsuitable.

K.1.5. Foundation for Base Course

- A. **General.** Foundation preparation shall be completed to ensure proper slopes, grades, shown of project plans are developed.
- B. **Base Course Preparation Requirements.**
 1. **Base Course Grades and Cross Sections.** Base material shall conform to the lines, grades, cross-sections, and thickness shown on the approved plans and shall be finished and maintained in an acceptable condition at least one day's progress in advance of placing prime coat.
 2. **Base Course Material.** Base material shall consist of hard, durable particles or fragments of stone or gravel crushed to the required size and an AP-filler of sand or other finely divided mineral matter. When produced from gravel, not less than 60% by weight of the aggregate retained on a No. 4 sieve shall consist of particles having at least one fractured face. Base material shall be free from vegetable matter and lumps or balls of clay and which when placed and compacted will result in a firm, dense, unyielding foundation. Base material shall meet the following grading requirements:

Table K-2. Gradation Limits for Base Material

Standard Size of Sieve	Percentage of Weight Passing Sieve
¾ inch	100
#4	0—65
#10	25—55
#200	3—12
Liquid Limit	25 maximum
Plastic Limit	6 maximum

3. **Base Course Placement.** Base material shall be deposited and spread without particle segregation in loose layers not to exceed 6 inches in depth. Each layer shall be thoroughly and individually compacted to 95% proctor (AASHTO T180) density. Wetting or aerating and rolling of the material shall be required as ordered by the ECM Administrator following review of all field test results. No base course shall be placed upon a soft, spongy or frozen subgrade or subbase or other subgrade, the stability of which, in the opinion of the ECM Administrator, is unsuitable.
4. **Material Deviations.** Deviation from the gradation limits may be permitted by the ECM Administrator on unpaved roads provided it can be unequivocally demonstrated that the subbase material is not conducive to rutting, raveling or forming a soft yielding surface in the presence of moisture.
5. **Compaction Equipment.** Compaction equipment must be on the job site before excavation is started. Compaction equipment must be capable of compacting within the trench width limits to avoid bridging the ditch.
6. **Existing Untreated Base Course.** If the existing base course is untreated, it shall normally be replaced with CDOT Class 6 aggregate base material and compacted in layers not to exceed 6

inches. The resulting total compacted base thickness shall be 8 inches or to the thickness of the removed base plus 2 inches. A replacement 2 inch thick asphalt surface wearing course, or matching existing, whichever is greater, shall also be used when replacing asphalt treated aggregate.

K.1.6. Trench Cover - Subgrade

- A. **General.** Trench cover placement shall follow the requirements of these Standards. The objectives are to place the material to lines and grades shown on project plans and ensure the compaction requirements are met.
- B. **Trench Cover Placement Requirements.**
 - 1. **Trench Cover Subgrade.** After the backfill has been placed and compacted as specified, it shall be cut and trimmed to the required depth and cross section. Trench cover subgrade shall be free of all rock over 2 ½ inches in size. It shall have a compaction of 95 percent or more, by standard tests at the time of constructing curb, gutter, sidewalk, pavement and/or other permanent trench cover structure.
 - 2. **Disposal and Restoration.** All excess excavated material shall be removed and disposed of outside the legal limits of the right-of-way as the work progresses, unless the approval of the ECM Administrator is obtained for disposal of the material within the legal limits of the right-of-way. All parts of the roadway and various structures disturbed shall be restored to a condition equal to or better than that which existed before starting the work.

K.1.7. Trench Cover - Paved Roads

- A. **General.** Trench cover placement shall follow the requirements of these Standards. The objectives are to place the material to lines and grades shown on project plans for paved surfaces and ensure the compaction requirements are met.
- B. **Temporary Trench Cover Requirements.**
 - 1. **Temporary Cover Required.** All trenches across traffic lanes, where it becomes necessary to remove any existing surfacing or pavement, shall be provided with temporary trench cover.
 - 2. **Temporary Patch Materials.** A temporary patch of cold-mix asphalt shall be placed on all pavement surface cuts immediately after backfilling has been completed and shall be removed at the time a permanent patch is made.

Minimum requirements for temporary trench cover shall be well compacted surfacing material conforming to "Road Mixed Asphalt Surfacing Material" of the CDOT Standard Specifications and shall match the existing asphalt or concrete thickness, or not less than 4 inches thick, whichever is greater. The mineral aggregate shall, with a tolerance of t percent, conform to the grading specified for 3/8-inch maximum aggregate. Bituminous binder to be mixed with the mineral aggregate shall be liquid asphalt, Grade MC-3000 and shall be between 5 ½% and 6% by weight of the dry mineral aggregate.
 - 3. **Material Onsite.** Temporary trench cover surfacing material, other than cold-mix patch, shall be stockpiled on the job site and shall be placed within six hours after completion of trench backfill and compaction.
 - 4. **Temporary Patch Maintenance.** Temporary trench cover shall be properly maintained until permanent trench cover is placed. The surface of the temporary repaving shall be smooth and at the same level as the adjacent undisturbed paved area.

C. **Permanent Trench Cover Requirements.**

1. **Asphalt Replacement Depth.** In the areas where the wearing surface is asphalt concrete, replace the pavement with a full depth asphalt paving of a minimum thickness of 4 inches but in all cases to a thickness of the old surface plus base course plus 1 inch.
2. **PCC Replacement Depth.** In areas where the wearing surface Portland cement concrete, replace the pavement with concrete pavement shall conform to these Standards. Concrete pavement replacement shall be of the same depth as the original pavement, but not less than 6 inches thick on alleys or residential roads, nor less than 8 inches on roads classified as collectives and above.
3. **Other Material Replacement Depth.** In areas where the wearing surface is other than asphalt concrete or Portland cement concrete, replace the pavement and base in kind, or minimum ECM Administrator standards, whichever is greater.
4. **Asphalt Placement.** Where original surface was asphalt concrete, bituminous treatment or mix, or oil mat; Asphalt concrete shall be compacted in layers not to exceed 3 inches to a total compacted thickness of 4 inches or the thickness of the removed pavement plus 1 inch, whichever is greater. On oil mat surfaces or substandard asphalt surfaces, an overlay of Class "EX" asphalt pavement 1 ½ inches thick shall be placed across the entire traffic lane disturbed by the trench and shall be finished as set forth below.
 - Immediately prior to placing the wearing surface, the abutting pavement edges shall be neatly cut.
 - The existing pavement shall be cleaned, removing all loose material and coated with hot liquid asphalt (Grade AC-10) or asphalt emulsion applied cold (Grade CSS-1h) to ensure a bond with the new asphalt surfacing.
 - The restored pavement shall be finished to a smooth riding surface and to the grade of the surrounding undisturbed pavement.
 - Pavement replacement shall commence not more than 7 working days after backfilling, unless approved by the ECM Administrator.
5. **Trench Edges in the Wheel Travel Portion of Roadway.** In the event the trench edges fall in the wheel traveling portion of a traffic lane, existing or proposed, the applicant shall extend the finish surface paving to a point deemed satisfactory by the ECM Administrator. Finish surface paving shall be performed to provide a crown slope equal to that existing prior to excavation, with no ponding of run-off surface water either over the trench or at the joints between the new and original surfaces.
6. **Cuts Impacting More than One Traffic Lane.** When road surface damage involves more than one traffic lane, a full width paving lift may be required. Individual jobs may require negotiations with the ECM Administrator for partial participation in the cost of a full width overlay.

K.1.8. Repair to Gravel Roads and Shoulder

- A. **General.** The repair of disturbed gravel surfaces shall be completed in accordance with these Standards. Placement of the gravel shall be done to ensure a smooth surface is developed and proper compaction is achieved.
- B. **Restoration of Unpaved Areas.**
 1. **Material and Placement.** Where the original surface was crushed rock or gravel for the wearing surface and foundation material, Class 6 aggregate base course shall be used as replacement

material. It shall be placed to a compacted thickness minimum of 8 inches or the thickness of the removed material plus 2 inches, whichever is greater.

2. **Backfill.** In the area from the right-of-way line (fence line/property line) to a point 5 feet outside of the roadside ditch flowline, all trenches shall be backfilled with excavated material and compacted to 90% standard compaction, or to the density of the existing ground, whichever is greater.

In all other areas, including the gravel road, the shoulders and the roadside ditch to a point 5 feet outside of the flowline; all trench compaction shall be completed to a minimum of 90% standard compaction.

3. **Erosion Protection.** During construction and after the trench is backfilled and compacted, erosion protection shall be provided to minimize sediment transport.

K.1.9. General Restoration Requirements

A. Preservation, Restoration and Cleanup.

1. **Conform to Permit.** Where construction has impacted streams, wetlands, fish and wildlife habitat areas or their buffers, full restoration and mitigation shall be performed as required by permit. Restoration methods shall be in accordance with County codes, provisions of the applicable permit, and these Standards.
2. **Unsatisfactory Restoration.** Unsatisfactory restoration of the right-of-way, as determined by the ECM Administrator, shall be promptly corrected by the permit holder. If necessary, unsatisfactory restoration may be corrected by the County and billed to the permit holder.
3. **Protection of Existing Utilities and Facilities.** Reinforcement, protection and security of existing utilities and facilities under construction are the responsibility of the permit holder. In roadway restoration, the design shall consider the protection of existing utilities without sacrificing the geometrics of roadway design.

B. Emergency Repairs. If emergency repairs disturb the right-of-way, the right-of-way shall be restored immediately. Approval of the final restoration of the right-of-way shall be obtained from the ECM Administrator.

C. Striping Replacement. All traffic striping and walkway delineation removed during construction shall be replaced. Temporary striping shall be used on a limited basis and only as approved by the ECM Administrator. All permanent striping and channelization shall be installed by County forces at the expense of the permit holder. If County forces are unavailable to perform the striping installation within an appropriate timeframe, the permit holder shall contract for the striping installation.

D. Final Cleanup.

1. **Roadways Swept.** Roadways shall be cleaned and swept both during and after utility work. Disturbed soils shall be final graded, seeded, and mulched after installation of the utility facilities or equipment. In limited areas, seeding and mulching by hand, or sod placement using approved methods, will be acceptable. Ditches lined with erodible soil and subject to rapid flows may require seeding, jute matting, netting, placement of sod, or rock lining to control erosion. Revegetated areas shall be weed free.
2. **Siltation.** Any silting of downstream drainage facilities, whether ditches, pipes or catchbasins, which results from the utility installation shall be cleaned out and restored to proper operation as part of the site cleanup.

-
3. **Storm Drainage Facilities.** Any existing storm drainage facilities or roadside features damaged during repair or restoration activities shall be replaced with new materials by the permit holder.

K.1.10. Maintenance Period

For a period of two years following the backfilling of any trench in the County's right-of-way or the permanent patching of paved surfaces, the permit holder shall be responsible for the condition of the trench backfill, pavement patches, and adjacent revegetation areas. During that time the permit holder shall, at their own cost, upon request from the ECM Administrator, repair to the County's satisfaction any of the patches that become settled, cracked, broken, or otherwise faulty. Settlement of the replaced road surface of 1/2 inch or more within a 6-foot straight edge shall constitute evidence of improperly compacted backfill material. If test results do not meet the standards for compaction as set forth in this specification, the permit holder shall be responsible for repairs or replacement to meet these standards. Settlement of 3/16 inch or greater with a 10-foot straight edge will be cause for repair in the case of settlement or replacement in the case of unsatisfactory workmanship.

K.2. TRENCHING DETAIL NOTES

- This trench patching detail specifies requirements in addition to those specified in the latest edition of the CDOT's Standard Specifications for Road and Bridge Construction.
- A construction traffic control plan shall be submitted to and approved by ECM Administrator prior to issuance of construction permits in the County right-of-way.
- Trench shall be braced or sheeted as necessary for the safety of the workers and protection of other utilities or structures in accordance with applicable local, state and federal safety regulations.
- The trench width shall be confined to those minimum dimensions, which will permit proper installation and acceptable pipe loading, as established by current local, state and federal safety regulations.
- At the discretion of the ECM Administrator, the pavement may be required to be saw-cut back to maintain a straight edge.
- Backfill compaction requirements: Minimum density will be determined in accordance with AASHTO T99 or T180 as defined by CDOT Standard Specifications Section 203.11 and CDOT 703.03. Except for CLSM.
- Fill depth asphalt can be used as an alternative to base course. A ratio of 3 inches (3") base course to 1 inch (1") of asphalt shall be used in the substitution.
- A temporary cold-mix asphalt patch, 4 inches (4") minimum depth will be required for all road cuts if a permanent hot-mix asphalt patch cannot be applied for any reason, after construction is completed.
- Pavement edges shall be saw-cut straight to within 5 degrees of vertical. Edges shall be tack coated prior to patching.
- If existing road is paved with fabric, a "TEE" trench shall be required. The Contractor shall carefully saw-cut and remove the layer of asphalt above the fabric a minimum of 12" back from the edge of the trench.
- Minimum cover for prefabricated pipe shall be 2 feet (2').
- Changes in design criteria will require compensating change in pipe design.
- When pipe sewer is to be extended or replaced with pipe of different material, the connections shall conform to the detail shown on plans or be approved.
- Spacing for multiple pipe sewer installations shall be ½" inside diameter or span, or 3" maximum.

-
- Trenches over 5 feet (5') in depth shall be either shared or the trench walls shall be sloped to the angle of repose. If sloped, the bottom of the slope shall be a minimum of 1 foot (1') above the bottom of the slope.
 - Shoring will be required when the bottom of the slope is more than 3 feet (3') above the bottom of the trench. Shoring shall extend a minimum of 1 foot (1') above the bottom of the slope.
 - Timber Sheeting or shoring may be cut off 1 foot above the top of the pipe after backfilling is complete.
 - Refer to the City/County DCM and CDOT "M" Standards.

Appendix L DRAINAGE CRITERIA MANUAL 1 ADDENDUM

Addendum

Revised Drainage Basin Fees Based on Impervious Area For Unincorporated El Paso County Only

City of Colorado Springs & El Paso County Drainage Criteria Manual

COORDINATED WITH EL PASO COUNTY STAFF AND DRAINAGE CRITERIA MANUAL REVISIONS TASK FORCE

TECHNICAL WORK BY AYRES ASSOCIATES AND SEC OLSSON ASSOCIATES

DRAINAGE BASIN FEE ADDENDUM CHAPTER 3

This revised fee addendum is intended to supplement Chapter 3 in the Drainage Criteria Manual. It is only effective for use in El Paso County (not in the City of Colorado Springs). Many of the items outlined in Chapter 3 remain applicable to the basin fee calculation process. If a discrepancy exists between this addendum and the original Chapter 3, this addendum shall apply.

3.5a Impetus for Revisions to the Basin Fee

The implementation, maintenance, and improvement of an adequate drainage system in the County were not occurring because of several past problems with assessment and collection of the basin drainage fees. Drainage fees were unreasonably high in some areas, and several land developers had sought and performed "end runs" around the fee payment. Those challenges to the payment of drainage fees had been successful for the following reasons:

- The County's drainage basin fee system did not meet the legal test for proportionality. For stormwater, the proportionality test means that the fee for a development should be roughly proportional to the increase in stormwater runoff that the development generates. Therefore, the fee should not be based on the total acreage of a development (as was in the previous system) but on the number of impervious acres.
- The County's policy for the type of stormwater detention ponds required (regional and/or on-site) was not clear.
- A County policy for implementing regional detention ponds and other regional facilities had not been established.

In the County, a land owner can apply credits earned from one project towards another project within the same basin. However, credits earned in one basin may not be transferred to another basin.

In general, the City of Colorado Springs does not collect fees on replats unless required as a condition of annexation; however, the County does collect fees on replats as explained below.

3.6a History of the Fee Revision Process

El Paso County has levied a basin fee based on acres of development since 1983. Because of the proportionality and general equity issues raised above, the basin fee revision process began in 1998 that culminated in the issuance of a September 21, 1998 draft report entitled "Proposed Revisions - Drainage Basin Fee Program and Policy for New Development, El Paso County, Colorado" along with a subsequent November 17, 1998 Addendum

to clarify on-site detention policy and correct minor typographical errors. A key finding of that report was that basin fees should be based on impervious acres rather than gross developed acres.

Following a review of the above draft, the development community believed that many of the revised basin fees were too high. As such, the developers hired the engineering consulting firm Ayres Associates to investigate the "Prudent Line" approach where applicable in lieu of structural channel improvements in an effort to reduce basin drainage infrastructure costs. The Prudent Line concept allows for an erosion setback and grade control stabilization of natural channels in basins with low-density development. Using the findings of Ayres Associates, including the revised land costs for the Prudent Line approach, a Second Addendum was issued in July 1999, where basin fees were revised significantly downward in many of the basins and a basin fee cap of \$15,000 per impervious acre was recommended. Various credits and reductions were also addressed and illustrated in examples in that addendum.

A Third Addendum was issued in September 1999 to clarify and resolve two objections made by developers following the issuance of the Second Addendum, and to resolve a few additional minor issues that arose as the Third Addendum was being finalized.

The information contained in the original September 1998 report and the three addendums have been used to prepare this revision to the basin fee program in the El Paso County Drainage Criteria Manual (DCM).

3.7a Calculation of the Basin Impervious Area

Impervious area in a basin is calculated for several different reasons. When a drainage basin planning study (DBPS) is completed the imperviousness is estimated to help determine peak runoff rates and runoff volumes under existing and future development conditions. The peak runoff rates and volumes are used to project floodplains and design conveyance and detention improvements. The costs of these improvements are, in turn, used to determine drainage basin fees for new development. Because the costs of improvements are dependent on the estimates of imperviousness in each basin, it is logical to base drainage basin fees on the amount of imperviousness in each development.

This new method is different than the previous method which used the same cost for each acre of development, regardless of the amount of impervious area planned for that acre. This method is still in use in the City of Colorado Springs.

The impervious area can be determined by direct measurements off the final development plan or by calculating the product of total area (both impervious and pervious area) and the percentage of area that is impervious. Table 3-1 shows some typical amounts of impervious area for different types of development. These values are generally consistent with Table 5-1 in the Colorado Springs/El Paso County Drainage Criteria Manual. Four additional single family residential values have been added to Table 3-1 that are not included in Table 5-1. Those values are for the 0.2-acre and the 6,000 square foot sizes for the smaller lots and the 2.5 and 5.0-acre sizes for the larger lots. The percent impervious values for these additions have either been directly computed or estimated from a regression of the existing values in Table 5-1 in the DCM.

Table 3-1. Typical Values of Percent Impervious

Type of Development	Percent Impervious
Commercial	95%
Industrial	85%
Multi-Family	65%
Single Family - 0.1377 acre lots (6,000 SF)	53%
Single-Family - 0.20 acre lots	43%
Single-Family - 0.25 acre lots	40%

Single-Family - 0.33 acre lots	30%
Single-Family - 0.5 acre lots	25%
Single-Family - 1.0 acre lots	20%
Single-Family - 2.5 acre lots	11%
Single-Family - 5 acre lots	7%

The total impervious area may also be determined from direct measurement made by the developer. A developer may wish to do this if the average numbers presented in Table 3-1 do not apply to a specific development. If the developer chooses to do this, all impervious areas within the development should be included. These areas include streets, parking lots, residential, commercial, tax exempt, parks, golf courses, and any other land use within the development. When different land uses are included in a development a composite percent impervious should be used.

3.8a Computation of the Basin Fee

The following example uses the typical impervious area numbers. In the computation of the basin fee, the developer or their representative shall obtain the appropriate basin fee from Exhibit 1 of the September 13, 1999 BOCC Resolution No. 99-383, or more current revision.

Example 1:

What is the fee for a 40-acre residential development in Dirty Woman Creek basin with 0.5-acre lots? The developer is not required to build any reimbursable stormwater facilities in this example and does not qualify for a low-density reduction or an on-site detention pond credit.

From Table 3-1, the percent impervious is 25%.

Calculate the impervious area for the site:

$$25\% \times 40 \text{ acres} = 10 \text{ acres}$$

Calculate the fee for the entire development:

$$\$14,454 \text{ per impervious acre} \times 10 \text{ impervious acres} = \mathbf{\$144,540}$$

Alternatively, the developer in each case could determine impervious area from the property plat, as illustrated in Example 2 below.

Example 2:

What is the fee for a 40-acre residential development in Dirty Woman Creek basin with 0.5-acre lots? The developer is not required to build any reimbursable stormwater facilities in this example and does not qualify for a low-density reduction or an on-site detention pond credit.

The developer has prepared his site plan using AutoCAD, and has instructed his designer to draw all streets, driveways, sidewalks, patios, and building footprints (i.e., all impervious areas) for the entire platted area as closed polylines. The designer can quickly use AutoCAD to compute the total area of those polylines, and determines that those impervious features comprise 22.8% of the platted area.

Thus the measured impervious area for the site is:

$$22.8\% \times 40 \text{ acres} = 9.12 \text{ acres}$$

Calculate the fee for the entire development:

$$\$14,454 \text{ per impervious acre} \times 9.12 \text{ impervious acres} = \mathbf{\$131,820}$$

3.9a Routine Fee Updates

Drainage basin fees are subject to an annual revision based on the current construction cost index. It is important that fees are revised to reflect actual construction costs, otherwise the fees will be inadequate to construct needed improvements to protect residents.

The current drainage and bridge fee schedule in effect shall be attached to the September 13, 1999 BOCC Resolution No. 99-383, and updated annually.

3.10a Credits and Reimbursements

3.10.1a Reductions Versus Reimbursements

Reductions in fees will be made for certain low-density type developments and prudent line land where applicable. Partial reimbursement of construction costs will be made to developers for construction of on-site detention ponds that meet County criteria. Full reimbursement of construction costs will be made to developers for construction of regional facilities in general accordance with the DBPS or as approved by the County prior to construction. Reimbursements for pond construction will only be made if sufficient basin funds are available.

3.10.2a Fee Reductions for Low Density Lots

A reduction in the drainage basin fee is proposed if a development consists of 2.5 or 5.0 acre lots.

A land developer may qualify for a 25 percent reduction in drainage basin fees if he is developing an area into 2.5 acre and/or 5.0 acre lots. The reduction is proposed because a significant portion of the stormwater from these large lots does not flow directly into the County stormwater system, but flows into the yards as sheet flow and infiltrates into the ground. The impervious area on a rural property does not create as much runoff as the same impervious area located in an area with smaller lots and curb and gutter paved roadways. Runoff from these smaller, more urban lots, flows more directly into the County stormwater system. However, the roads serving the larger lot rural areas do create additional stormwater that flows directly into the County system along with some increased flow from the residential lots. Therefore, runoff from these areas shows an increased over the historic conditions. The proposed reductions are based on the 1986 version of the Natural Resources Conservation Services' Technical Release Number 55, which includes a procedure that accounts for "disconnected impervious area".

In a mixed-use development, only the 2.5 acre and/or 5.0 acre area will receive the reduction. Example 3 below illustrates that adjustment.

Example 3:

What is the fee for a 100-acre residential development with 60 acres of 2.5-acre lots and 40 acres of 0.5-acre lots? The development is in the Bennett Ranch basin.

Calculate the fee for the portion of the development with 2.5-acre lots:

$$\text{Impervious area} = 11\% \times 60 \text{ acres} = 6.6 \text{ acres}$$

The developer gets a 25% reduction for the 2.5-acre lots.

$$6.6 \text{ impervious acres} \times 75\% \times \$7,613 \text{ per impervious acre} = \$37,684$$

Calculate the fee for the remaining 40 acres of 0.5-acre lots:

$$\text{Impervious area} = 25\% \times 40 \text{ acres} = 10 \text{ acres}$$

$$10 \text{ impervious acres} \times \$7,613 \text{ per impervious acre} = \$76,130$$

Add the fees for the two areas to get the gross fee:

$$\$37,684 + \$76,130 = \mathbf{\$113,814}$$

3.10.3a Fee Reductions for Land Required to be Dedicated for the Prudent Line

Fee reductions are also available for the cost of land within dedicated Prudent Line easements (outside of the floodplain). Developers that dedicate Prudent Line easements according to a County accepted Prudent Line report can reduce their fees by the value of the easement. The amount of the reduction will be the same as the land cost that was used in the basin fee calculation, which is currently \$5,000 per acre. This reduction rate shall be adjusted whenever the Parkland Dedication Fee is changed. If the reduction exceeds the gross fee, the fee shall be \$0, and the remainder of the easement cost shall be applied as a credit, similar to those discussed below.

Example 4 below is the same as the previous Example 3, with the addition of Prudent Line considerations in the computation of the basin fee.

Example 4:

What is the fee for a 100-acre residential development with 60 acres of 2.5-acre lots and 40 acres of 0.5-acre lots? The development is in the Bennett Ranch basin, and 8 acres of the 2.5-acre lots are within the Prudent Line setback area. The developer is not required to construct grade control structures.

Calculate the fee for the portion of the development with 2.5-acre lots:

$$\text{Impervious area} = 11\% \times 60 \text{ acres} = 6.6 \text{ acres}$$

The developer gets a 25% reduction for the 2.5-acre lots.

$$6.6 \text{ impervious acres} \times 75\% \times \$7,613 \text{ per impervious acre} = \$37,684$$

Calculate the fee for the remaining 40 acres of 0.5-acre lots:

$$\text{Impervious area} = 25\% \times 40 \text{ acres} = 10 \text{ acres}$$

$$10 \text{ impervious acres} \times \$7,613 \text{ per impervious acre} = \$76,130$$

Add the fees for the two areas to get the gross fee:

$$\$37,684 + \$76,130 = \$113,814$$

The fee is reduced by the cost of the land for the Prudent Line setback:

$$\$113,814 - (8 \text{ acres} \times \$5,000 \text{ per acre}) = \mathbf{\$73,814}$$

3.10.4a Reimbursement of Construction Costs for On-Site Ponds

A land developer may qualify for a reimbursement of a portion of the construction costs if he builds on-site detention meeting specific criteria. Recognizing that on-site ponds provide some benefits to the regional system of a basin, 50% of the cost of a small on-site pond may be reimbursed to the developer if the following criteria are met:

1. Allowed only where regional system is not yet in place.
2. The pond is less than 15 acre-feet in volume from the lowest outlet structure to the crest of the emergency spillway.
3. The on-site pond is not part of the regional plan (for approved ponds that are part of the regional plan, developers are given 100% credit).
4. The outlet of the pond must be designed to release at historical levels for all precipitation events from the 2-year storm to the 100-year storm. A smaller outlet may be required by the County if adequate downstream channel improvements are not in place to protect residents from the 2-year storm flows.

5. County approves design and construction.
6. Landowners assume responsibility for maintenance.

The purpose of this reduction is to allow developers to integrate detention into their developments when sites lend themselves to multiple uses such as parks, open space, athletic fields, golf courses or others. Another reason for implementing regional detention on-site is to provide adequate protection to downstream properties that may be threatened from increased flows from the development when regional improvements are not to be implemented within an acceptable time frame. The reason for the 2-year event criteria (or smaller if adequate channels are not in place for 2 year flows) is because of the significant number of smaller events that will pass through a 5-year outlet. Those more frequent events are responsible for much of the erosion and other problems downstream of new developments and the County is left to repair erosion or deal with other problems.

If the above requirements are not met, the on-site detention will not qualify the land developer for a reimbursement of costs. If the developer chooses not to construct an on-site regional pond, he may still have to construct a conventional on-site pond to prevent downstream impacts from his development. It is important to note that reductions for meeting certain on-site detention criteria and for development that consists of 2.5 or 5.0 acre lots (discussed above) cannot both be applied to the same development.

Example 5 below illustrates the reduction in the basin fee for construction of a qualified on-site detention pond.

Example 5:

What is the fee for a 10-acre commercial site with a small on-site detention pond (2 acre-foot pond with estimated construction cost of \$40,000), which meets the County criteria for a pond reimbursement? The fee will be reduced by 50% of the estimated cost of the pond construction, i.e., \$20,000. The site is in the Big Johnson Reservoir/Crews Gulch basin.

Calculate the gross fee:

$$95\% \times 10 \text{ acres} \times \$15,000 \text{ per impervious acre} = \$142,500$$

Calculate the fee after the reduction for the pond:

$$\$142,500 - \$20,000 = \mathbf{\$122,500}$$

3.10.5a Reimbursement of Land and Construction Costs of Other Regional Facilities

The system of credits for the costs of construction of regional structures has not changed from the current system. The current system gives credits to developers for building projects that are listed in the DBPSs. A developer is reimbursed for these credits after the construction is complete and accepted by the County, and when there are sufficient basin funds. Alternatively, credits may be used to reduce the fees for subsequent developments in the same basin.

In addition to regional structures in the DBPSs, credits are given for the following structures:

- Total reimbursement of the construction costs of large on-site ponds that are accepted into the regional system by the County.
- Reimbursement of 50% of the cost of small on-site ponds (less than 15 acre-feet) that meet County criteria. This credit will not exceed the amount of the fee. If the construction cost is more than twice the gross fee, the credit will be equal to the fee.

3.11a Appeals Process

The procedures outlined for basin fee computation are generally straightforward. However, some developments may result in a more complex computation of the basin fee, and the result may be a disagreement between the

developer and the County in the fee computed. The developer and County should attempt to resolve the disputed fee. In the event the attempted resolution is unsuccessful, the developer may elect to appeal the disputed fee amount to the Subdivision Storm Drainage Board. The developer will need to prepare a written appeal detailing the disputed basin fee amount and provide calculations or other evidence supporting his fee calculation. That written appeal is due by 4:00 P.M. on the third Thursday of the month prior to the next month's Drainage Board meeting. The Drainage Board will review the written appeal at their regularly scheduled meeting and render a final decision on the basin fee that will be due.

3.12a New/Revised Drainage Basin Planning Studies

Basin fees may be updated between annual routine fee updates if new or revised DBPSs are prepared for a basin and accepted by the County. These updated fees will be reflected in Exhibit 1 of the September 13, 1999 BOCC Resolution No. 99-383.

3.13a Vacations, Replats, Drainage Districts, and Irrigation Companies

The overriding guideline regarding vacation plats and replats will be whether an increase in impervious land cover would result. A vacation plat occurs when two or more contiguous lots are combined into one lot. A replat of a lot or parcel occurs when it is divided into two or more contiguous lots.

In all cases, a basin drainage fee will be assessed based upon the new impervious acreage if no such fee has been previously paid. If a basin drainage fee has been previously paid, and the vacation plat or replat results in the same or a decrease in the impervious acreage, no additional fee will be assessed, and no refund of previous fees will be given. If a basin drainage fee has been previously paid, and the vacation plat or replat results in an increase in the impervious acreage, a drainage basin fee shall be assessed on the additional impervious acreage at the current applicable fee.

If a developer or landowner enters into any agreement or special arrangement with a drainage district or irrigation company, that individual or company is not relieved of their obligation to pay the County basin and bridge fee. Any drainage improvement made by the land developer has to be identified as a proposed improvement in the Drainage Basin Planning Study (DBPS) for that specific basin in order to be considered for reimbursement of construction cost. If no DBPS exists for the basin or if the land developer proposes a substantial departure from the drainage improvement(s) shown in the existing DBPS, the developer must either fund the preparation a DBPS for the basin (if none exists) or revise the existing DBPS to the satisfaction of the County in order to receive consideration for reimbursement of costs of construction for drainage facilities.

(Res. No. 19-245 , 7-2-19)

Editor's note(s)—Res. No. 19-245, adopted July 2, 2019, repealed the Prudent Line Addendum for Unincorporated El Paso County only.

CODE COMPARATIVE TABLE LEGISLATION

This is a chronological listing of the resolutions of the county used in this Manual. Repealed or superseded resolutions at the time of the publication and any omitted materials are not reflected in the table.

Legislation	Date	Section	Section this Manual
Res. No. 19-245	7- 2-19		1.5
			1.9

El Paso County, Colorado, Engineering Criteria Manual
CODE COMPARATIVE TABLE LEGISLATION

			1.22
			Ch. 3(title)
			3.3(title)
		Added	3.3.7
			3.1.1
			3.1.2, Table 3-1
			3.2.4
			3.2.5 A.
			3.2.5 E.
			3.2.5 F.
			3.3.5
		Added	3.3.6 C.
		Added	3.3.7
			5.1.1
			5.6.1
			5.6.2
			5.6.2
		Added	5.6.3
		Rnbd	5.6.3, 5.6.4
		as	5.6.4, 5.6.5
			5.3.15(title)
			5.3.15 A., B.
			5.3.15 D.1., 2.
			5.3.15 E.1.
			5.3.15 E.3., 4.
		Added	5.9.4
			5.10.4 A.
			5.10.6
			Apps. E.—H.
			App. I.1.
			App. I.2.
			App. I.3.
			App. I.4.1.
			App. I.4.2.
			Table I-2
			App. I.5.—I.7.
			App. I.9.
			App. L.
Res. No. 20-222	6-23-20		1.5
			1.15.2
			1.15.5
			1.22
			2.1.3
			2.2.1
			2.3.2

El Paso County, Colorado, Engineering Criteria Manual
CODE COMPARATIVE TABLE LEGISLATION

			2.3.6
			2.3.7 C.
			2.3.8
			2.5.1 A.
			2.5.2 A.
			2.5.2 B.2.
			2.5.2 B.7., 8.
			2.5.2 C., D.
			2.5.2 F., G.
			2.5.4 C.1.
			2.5.4 C.8.
			2.5.6 A.
			2.5.7 A.12.
			2.5.7 C.13.
			2.5.7 C.19.
			2.6.6 F.1.
		Added	4.2.2 E.
			4.3.5 D.4.
			4.4.5
		Added	6.1—6.4
			App. F

**ENGINEERING CRITERIA MANUAL
COUNTY OF
EL PASO, COLORADO**

Adopted: December 23, 2004

Revised: December 13, 2016

Published in 2018



SUPPLEMENT HISTORY TABLE

The table below allows users of this Manual to quickly and accurately determine what resolutions have been considered for codification in each supplement. Resolutions that are of a general and permanent nature are codified in the Code and are considered "Includes." Resolutions that are not of a general and permanent nature are not codified in the Code and are considered "Omits."

In addition, by adding to this table with each supplement, users of this Manual will be able to gain a more complete picture of the Manual's historical evolution.

Res. No.	Date Adopted	Included/ Omitted	Supp. No.
19-245	7- 2-19	Included	1
Res. No. 20-222	6-23-20	Included	2

Chapter 1 GENERAL PROVISIONS

1.1. TITLE

This document is called the "Engineering Criteria Manual" and shall be referred to throughout the text as the "ECM."

1.2. AUTHORITY

The El Paso Board of County Commissioners (BOCC) has adopted the ECM by resolution pursuant to the authority given by the Colorado Constitution and the following sections of the Colorado Revised Statutes, as amended:

- Article 1 of Title 32 (Special District Act/Provisions),
- Article 1 of Title 34 (Preservation of Commercial Mineral Deposits),
- Article 2 of Title 43 (State, County and Municipal Highways),
- Article 4 of Title 41 (Airports),
- Article 6 of Title 28 (Division of Aviation),
- Article 11 of Title 30 (County Powers and Functions),
- Article 15 of Title 30 (County Regulations under Police Power),
- Article 20 of Title 29 (Local Government Land Use Control Act),
- Article 28 of Title 30 (County Planning and Building Code),
- Article 30.5 of Title 38 (Conservation Easements),
- Article 32 of Title 22 (Zoning, Planning and Building Code Duties of School District Boards),
- Article 65.1 of Title 24 (Areas and Activities of State Interest), and
- Article 68 of Title 24 (Vested Property Rights).

1.3. PURPOSE

The purpose of this ECM is to set standards for designing, constructing, locating, maintaining, choosing materials for, repairing, reconstructing and using public improvements and guiding design and construction of common development improvements in El Paso County (County). The ECM was developed to be consistent with the El Paso County Land Development Code (LDC). The standards are necessary to protect and promote public health, safety, and the general welfare of the public; ensure that public infrastructure meets commonly accepted engineering standards; and maintain consistency and fairness in development review.

The ECM governs the quality of workmanship must be adhered when constructing public and development-related improvements. The ECM also provides standards for County staff to adhere to in reviewing plans and inspecting construction.

1.4. APPLICABILITY

1.4.1. Activities

The provisions of ECM shall apply to the planning, design, construction, enlargement, alteration, relocation, removal, conversion, demolition, repair, excavation and use of any public improvements. The ECM shall also apply as guidance or as specific regulatory standards when required by the LDC to common development improvements. The ECM applies to public and private projects including:

-
- new construction and modification of transportation facilities, storm drainage facilities, utilities, and any facility located in County rights-of-way or easements, whether occurring under permit or franchise, and other transportation facilities, storm drainage facilities, utilities and any facilities mandated by the LDC.
 - facilities outside County rights-of-way (such as private roads or drainage systems), which are regulated through the LDC and County's police power authority to ensure public health, safety, and welfare, and Title 30, Article 15, Colorado Revised Statutes.
 - every new placement and every planned, non-emergency replacement of existing utility poles and other utility structures within the County's rights-of-way.
 - reconstruction, resurfacing, restoration, and rehabilitation of existing transportation facilities, storm drainage facilities, utilities and any other facilities located in County rights-of-way or easements, as well as other transportation facilities, storm drainage facilities, utilities, and facilities mandated by the LDC, as far as practicable and feasible.

1.4.2. Jurisdiction

The ECM applies to all subdividers, developers, landowners, owners of facilities located in the County's rights-of-way or easements and their employees, agents or contractors that design, construct, and maintain facilities or conduct activities subject to review and approval under the provisions of the ECM or where required by the LDC in El Paso County. The ECM further applies to the County and their employees, agents or contractors.

1.5. STANDARDS ADOPTED BY REFERENCE

The BOCC hereby adopts the following documents and standards by reference:

- Colorado Department of Transportation (CDOT) Standard Specifications for Road and Bridge Construction;
- Colorado Department of Transportation (CDOT) State Highway Access Code;
- Colorado Department of Transportation (CDOT) Field Materials Manual;
- Colorado Department of Transportation (CDOT) LRFID Bridge Design Manual;
- American Association of State Highway & Transportation Officials (AASHTO) including Roadway Design Guide and Bicycle Design;
- Institute of Transportation Engineers (ITE) Trip Generation Manual;
- American Society for Testing Materials (ASTM);
- Manual on Uniform Traffic Control Devices (MUTCD);
- Colorado Springs and El Paso County Drainage Criteria Manual Volume 1 (DCM1);
- City of Colorado Springs' Drainage Criteria Manual Volume 2 (DCM2): Stormwater Quality Policies, Procedures and Best Management Practices;
- The State of Colorado, Department of Transportation M&S Standards;
- El Paso County's Road Impact Fee Program;
- ASCE Code of Ethics;
- City of Colorado Springs Drainage Criteria Manual Volume 1, 2014 Update: Chapter 6 and Section 3.2.1 of Chapter 13;

-
- The Urban Drainage and Flood Control District's Urban Storm Drainage Criteria Manual: Volume 3, Chapter 7, Construction BMPs (version applicable at time of project design);
 - United States Access Board, Proposed Guidelines for Pedestrian Facilities in the Public Right-of-Way (PROWAG), 2011;
 - United States Access Board, Proposed Guidelines for Pedestrian Facilities in the Public Right-of-Way; Shared Use Paths Supplement, 2013;
 - United States Department of Justice, 2010 ADA Standards for Accessible Design (ADA Standards), 2010; and
 - United States Department of Justice, Americans with Disabilities Act Title II Regulations (ADA Regulations), 2010.

The referenced documents and standards are enforceable parts of the ECM and may be amended and revised at the discretion of the BOCC in accordance with requirements and processes prescribed by the Colorado Constitution and applicable provisions of the Colorado Revised Statute.

(Res. No. 19-245 , 7-2-19; Res. No. 20-222 , 6-23-20)

1.6. MINIMUM STANDARDS

The standards presented in this ECM are considered the minimum requirements and design values necessary to accomplish the purpose of the ECM. Where minimum values are stated, greater values should be used whenever practical and consistent with State law; where maximum values are stated, lesser values should be used where practical.

Situations might arise where the application of individual standards from the ECM will not ensure the protection of public health, safety, and welfare. Accordingly, the ECM Administrator may impose additional or more stringent standards than those contained in the ECM, or require the modification of plans, specifications or operations to achieve the necessary public health, safety, and welfare. Modifications may include, but are not limited to, scheduling, phasing or timing restrictions. The standards contained herein are not a substitute for sound professional engineering judgment.

1.7. NO STANDARDS SPECIFIC PROVIDED IN ECM

In the case of those improvements that are required by the County, but are not specifically addressed by the ECM, the County will require the owner, permit holder, developer, contractor, and their agents to follow applicable local, state, and federal guidelines or standards promulgated by professional organizations. The ECM Administrator shall be consulted for guidance on proper references.

1.8. MUNICIPAL STANDARDS MAY APPLY IN 3-MILE PLAN AREA

In areas subject to the requirements of C.R.S. § 31-12-105 (3-Mile Plan Areas), the design standards of the municipality may be applied if approved by the ECM Administrator. In cases where ECM standards are more restrictive, the ECM Administrator may require compliance with the ECM.

1.9. DEVIATIONS FROM STANDARDS

The ECM standards represent appropriate practice under most conditions, based on past experience in the County and in other jurisdictions. The Standards are intended to ensure that facilities are safe and appropriate for use in the County.

Engineering design is an endeavor that examines alternative solutions to real world situations. These standards are not intended to limit the introduction of new ideas. Situations will arise where alternatives to these standards may

Created: 2021-06-08 11:35:47 [EST]

(Supp. No. 2)

better accommodate existing conditions, overcome adverse topography or allow for more cost-effective solutions without adversely affecting safety, operations, maintenance or aesthetics.

Accordingly, requests for deviations from these standards will be considered by the ECM Administrator. The request for a deviation may be considered if the request is not based exclusively on financial considerations. The deviation must not be detrimental to public safety or surrounding property. Requests must be submitted and reviewed in accordance with the process outlined in Chapter 5 and include supporting information demonstrating compliance with all of the following criteria:

- The deviation will achieve the intended result with a comparable or superior design and quality of improvement.
- The deviation will not adversely affect safety or operations.
- The deviation will not adversely affect maintenance and its associated cost.
- The deviation will not adversely affect aesthetic appearance.
- The deviation meets the design intent and purpose of these Standards.
- The deviation meets the control measure requirements of Part I.E.3 and Part I.E.4 of the County's MS4 permit, as applicable.

It is recognized that the need for and timing of a deviation request may not be predictable. Requests should be submitted as soon as the need becomes known. No request will be considered until an application for a permit or other approval has been submitted. Known deviation requests that affect lot yield or scope of development must be decided before holding any public hearing or making an official decision on the application. This is important for public notice and participation in the decision process.

Deviations that affect engineering design, to the extent they are known, must be decided before submitting construction plans. This will minimize additional effort in the preparation of plans with non-standard features that cannot be approved.

The ECM Administrator is the final authority on all deviation requests. The ECM Administrator reserves the right to deny a deviation from these Standards, at any time, in the interest of public health, safety, and welfare.

1.9.1. PUD Zoning Districts

The ECM Administrator may establish, on a case-by-case basis, special standards (i.e., deviations) that apply to a project with a Planned Unit Development (PUD) zoning classification. The ECM Administrator, in establishing such standards, shall first find that there are mitigating elements in the design of the project that allow for such special standards and that the special standards are in conformance with the intent and purpose of these Standards.

1.9.2. Alternate Materials and Methods of Construction

The provisions of these Standards are not intended to prevent the use of any material or method of construction not specifically prescribed by these Standards, provided any alternate is approved in writing by the ECM Administrator as a deviation.

The ECM Administrator, as indicated above, shall require that sufficient evidence or proof be submitted to substantiate any request that may be made regarding the alternate method or material.

(Res. No. 19-245 , 7-2-19)

1.10. CONFLICTING PROVISIONS

The following standards shall apply in considering conflicts between provisions of the ECM:

- Whenever any provision of the ECM conflicts with a provision in any federal, state or local law, ordinance, resolution, rule, or regulation, the more restrictive or higher standard shall be used.
- Whenever any provision of the ECM conflicts with another provision of the ECM, the more restrictive or higher standard shall be used.
- Whenever any provision of the ECM conflicts with any provision of the documents and standards adopted by referenced, the provision of the ECM shall be used.

1.11. PERMITS REQUIRED

No owner, permit holder, developer, contractor, and their agents shall do or cause to be done any work governed by the ECM without first having obtained a permit to do the work in accordance with the provisions of Chapter 5. All work shall be done in accordance with the ECM, approved plans, and the conditions of the required permits. In many cases, a Notice to Proceed is also required before beginning work in accordance with the terms and conditions of a permit issued under the provisions of Chapter 5.

Other permits, approvals or agreements may be required by the County or others having jurisdiction before initiating any activities subject to the ECM. It is the responsibility of the owner, permit holder, developer, contractor and their agents to identify and secure all required permits, approvals, or agreements required to do the work.

1.12. PLAN REVIEW PROCEDURES, GENERAL

For County-constructed roads and drainage projects, plan review requirements are governed by the ECM and the policies and procedures of the ECM Administrator. For owner, permit holder, and developer-constructed public improvements and development or subdivision related improvements, all plans, reports, drawings, and specifications that support permit or land use applications are governed by the LDC, ECM and the policies and procedures of the ECM Administrator.

Construction plans are required (sheets shall be 11" x 17" - half size) for all proposed road and drainage-related improvements. Chapter 5 of the ECM outlines the submittal requirements. In some cases, additional engineering data may be required to be submitted. Construction documents will be valid for a period of 2 years from the date signed by the El Paso County Engineer. If construction has not started within 2 years of being signed by the El Paso County Engineer, the plans will need to be resubmitted for approval. Fees for the re-approval will be in accordance with the fee schedule current at the time of plan re-approval.

Engineering Record Drawings (also known as "as-built" plans) for roads and drainage facilities must be submitted before final acceptance of any public facility and release of the required surety.

1.13. PROFESSIONAL QUALIFICATIONS

Professionals in the fields of engineering, architecture, geology or surveying who prepare or are responsible for preparing plans, drawings, specifications, calculations, technical reports, etc., for the purpose of obtaining County permits or approvals, shall be registered or authorized to practice in the state of Colorado. Registration or authorization to practice shall be in the specific technical area pertinent to the documents being prepared. In some cases, specific additional or special professional qualifications are required for preparing specific studies or plans. Any specific additional or special professional qualifications are identified in those sections of the ECM specifically governing preparation of the study or plan.

1.14. ERRORS AND OMISSIONS

At the discretion of the ECM Administrator, any significant errors or omissions in the approved plans or information used as a basis for such approvals may constitute grounds for withdrawal of the approvals and stoppage of any or all permitted work. It is the responsibility of the owner, permit holder, developer, contractor or their agents to demonstrate why work should continue and to make changes in plans that may be required by the ECM Administrator before the plans are re-approved.

1.15. OWNER, PERMIT HOLDER, DEVELOPER, CONTRACTOR AND AGENT RESPONSIBILITIES

1.15.1. Permit and Construction

It is the responsibility of the owner, permit holder, developer, contractor, and their agents to:

- Have an approved set of plans, required permits and Notice to Proceed before commencement of any work governed by the ECM.
- Notify the ECM Administrator in advance of the commencement of any authorized work, in accordance with permit requirements. A pre-construction meeting and field review may be required by the ECM Administrator before the commencement of any work on significant projects.
- Perform all work in accordance with the terms and conditions of the permit, ECM, and all applicable local, state, and federal laws.
- Have an approved set of plans, permits, and a copy of the ECM on the job site wherever work is being accomplished.
- Provide tests to substantiate the adequacy and placement of construction materials if requested by the ECM Administrator.

1.15.2. General Right-of-Way and Site Maintenance

The owner, permit holder, developer, contractor, and their agents shall:

- Schedule and control work so as to comply with all applicable provisions of El Paso County codes and applicable state and federal laws and to prevent any hazards to public safety, health, and welfare.
- Maintain two-way traffic on existing roads for vehicles, bicycles, and pedestrians at all times unless detour plans or lane closures have been approved in advance by the ECM Administrator.
- Keep roads, bridges, bikeways, and pedestrian facilities free of dirt, debris or any obstructions. Paved temporary detour(s) shall be provided when necessary and not detrimental to the abutting properties. See Chapter 6 for providing accessible pedestrian facilities in work zones.
- Maintain pedestrian and vehicular access to occupied buildings, except where written approval from the building owner has been obtained.
- Complete on-site grading in a manner that minimizes off-site erosion and siltation in conformance with all statutory requirements, permits, and approved plans.

1.15.3. Work Conditions

- A. **Action by ECM Administrator to Protect Public or Private Interests.** When the owner, permit holder, developer, contractor, or their agents have not taken sufficient precautions for the safety of the public or the protection of the work, adjacent structures or property, and when, as a result, the ECM Administrator determines a loss-of-life or damage could result, the ECM Administrator, with or without

notice to the owner, permit holder, developer, contractor or their agents, may provide suitable protection by causing work to be done and materials to be furnished and placed as the ECM Administrator may consider necessary to protect the public or any private interest. The cost and expense of the ECM Administrator's action including the cost of labor, equipment and material is the responsibility of the owner, permit holder, developer, contractor, or their agents. All costs shall be paid by the owner, permit holder, developer, contractor, or their agents within 30 calendar days upon receipt of the invoice from the ECM Administrator.

The action performed under the direction of the ECM Administrator shall in no way relieve the owner, permit holder, developer, contractor, or their agents of responsibility for damages that may occur during or after such precaution has been taken.

- B. **Action by Owner to Protect Public or Private Interests.** When an emergency threatening loss of life or damage to the work or an adjoining structure or property is identified by the owner, permit holder, developer, contractor or their agents and the person who identified the emergency is unable to obtain special instructions or authorization from the ECM Administrator, the owner, permit holder, developer, contractor, or their agents are hereby permitted to act to prevent loss of life or damage. The ECM Administrator shall be notified of such emergency work within four hours of the action.
- C. **Final Cleanup.** The owner, permit holder, developer, contractor or their agents shall be responsible for daily clean-up on the project area and shall remove and properly dispose of all surplus and discarded materials, rubbish, and temporary structures from the project area and adjacent areas. They shall, where appropriate, leave the project area swept and in a neat and clean condition. The owner, permit holder, developer, contractor or their agents shall restore all work areas that have been damaged by the operations to general conformity with the specifications for the item or items involved and to the original condition.

The owner, permit holder, developer, contractor or their agents will be responsible for keeping roads free of dirt, mud, and any debris during construction. The work shall conform to the requirements for erosion control, as described in the statutes, ordinances or regulations. The owner, permit holder, developer, contractor or their agents shall be responsible, at their own expense, for keeping on-site roads used as construction routes and rights-of-way clean of mud, rocks, and debris at all times during said construction.

The owner, permit holder, developer, contractor or their agents shall inspect and clean the interior of all manholes and catch basins within the construction limits or impacted by the construction.

The owner, permit holder, developer, contractor or their agents shall, within 24 hours of the ECM Administrator's notification of noncompliance with this section, commence clean-up operations and shall diligently pursue completion of said clean up to the satisfaction of the ECM Administrator. The County may revoke any and all permit approvals until the owner, permit holder, developer, contractor or their agents remedy the problem if:

- the owner, permit holder, developer, contractor or their agents fail to respond within 24 hours, or
- the ECM Administrator is unable to contact the owner, permit holder, developer, contractor or their agents after reasonable effort, or
- the owner, permit holder, developer, contractor or their agents fail to diligently pursue clean-up operations to the satisfaction of the ECM Administrator.

The ECM Administrator may also choose to have the streets and rights-of-way cleaned by County crews or an outside contracted firm and invoice the owner, permit holder, developer, contractor or their agents for all costs. All cost shall be paid by the owner, permit holder, developer, contractor or their agents within thirty days of being invoiced.

-
- D. **Suspension of Work.** In case of suspension of work for any cause whatsoever, the owner, permit holder, developer, contractor or their agents, before leaving the job site, shall take such precautions as may be necessary to prevent damage to the work; provide for proper drainage; and erect any necessary barricades, signs, or other facilities. The owner, permit holder, developer, contractor or their agents will take the above precautions at their own expense, as required by applicable standards.

1.15.4. Protection of Existing Facilities

The owner, permit holder, developer, contractor or their agents shall notify the electric and gas utility, telephone company, cable television, and all other interested parties before beginning work. They shall have their facilities staked and located in the field in order to ensure that there are no interruptions of these services during progress of the work.

Existing power lines, telephone lines, trees, shrubbery, fences, water mains and services, gas mains and services, sewer mains and services, cables, conduits, drainage and irrigation ditches and pipes, embankments, and other structures in the vicinity of the work not authorized to be removed, shall be supported and protected from damage by the owner, permit holder, developer, contractor or their agents during the construction and until completion of work.

The owner, permit holder, developer, contractor or their agents shall preserve intact any underground pipes or other utilities encountered during construction. The owner, permit holder, developer, contractor or their agents shall be liable for all damages done to such existing facilities and structures and shall hold the County harmless from any liability or expense for injuries, damages or repairs to such facilities. The type, size, approximate location and number of all known underground utilities shall be shown on all drawings. It shall be the responsibility of the owner, permit holder, developer, contractor or their agents to verify the existence and location of all underground utilities along the route of the work.

1.15.5. Traffic Control

The flow of traffic on public streets and roadways shall be maintained at all times during construction in accordance with the rules, regulations, and conditions as set forth in the Work in the Right-of-Way Permit issued by the ECM Administrator. Existing pedestrian access routes and circulation paths should be maintained through construction, alterations, and maintenance operations whenever feasible. When the pedestrian access routes and circulation paths must be closed during these operations, an alternate pedestrian access route should be provided. See Section 6.3.11 for more information.

The owner, permit holder, developer, contractor or their agents shall be responsible for the provision of a safe travel-way on all roadways on and adjacent to the job site. The owner, permit holder, developer, contractor or their agents shall erect or cause erection of proper traffic control warning devices around all excavations, embankments, and obstructions. The owner, permit holder, developer, contractor or their agents shall be responsible for the proper maintenance of said erected devices, in accordance with their approved Work in the Right-of-Way permit.

The owner, permit holder, developer, contractor or their agents shall cause suitable warning lights or flares to be provided and kept lighted at night or other times when visibility is limited.

The owner, permit holder, developer, contractor or their agents shall provide flaggers or off-duty police protection, as may be determined by the ECM Administrator, for the protection of the public and workers on the job site.

The owner, permit holder, developer, contractor or their agents shall coordinate with the ECM Administrator so that arrangements may be made by the owner, permit holder, developer, contractor or their agents for detours, parking, and access to property adjacent to work, etc., 48 hours before they are needed.

The owner, permit holder, developer, contractor or their agents shall not work within any portion of a road right-of-way without receiving a Work in the Right-of-Way Permit from the ECM Administrator at least 48 hours before they begin work. Full roadway closures will be reviewed on a case-by-case basis; time of review will vary based on the extent of the closure.

The County reserves the right to refuse to allow full road closures. Requirements for such closures will be determined at the time of issuance of the permit. The owner, permit holder, developer, contractor or their agents will be responsible for all public notices, public meetings, and requirements as outlined in the Work in the Right-of-Way Permit. The owner, permit holder, developer, contractor or their agents shall notify the police and fire departments at least 48 hours before closure and immediately after opening of any street, alley, or fire lane.

The ECM Administrator shall close down work that is not controlled in accordance with approved barricading procedures or on projects that require a Work in the Right-of-Way Permit, but on which one has not been obtained by the owner, permit holder, developer, contractor or their agents.

No work shall be allowed at signalized intersections or on arterial roadways that impedes normal traffic flow from 6:00 a.m. to 8:30 a.m. and 3:30 p.m. to 7:00 p.m., except during emergencies or with prior approval of the ECM Administrator.

1.15.6. Safety

Machinery, equipment, materials, and all hazards shall be guarded or eliminated in accordance with the MAPC and all applicable federal regulations including Office of Safety and Health Administration (OSHA), state, County, and municipal laws and regulations. No blasting shall be done without the prior approval of the County. Safety equipment, devices, and clothing shall be utilized by personnel where required by federal, state, and local laws. The owner, permit holder, developer, contractor or their agents shall strictly comply with MUTCD for temporary and permanent traffic control.

1.15.7. Removal of Unacceptable Work

Work shall be considered unacceptable if it does not conform to the approved plans and specifications or if it results in an inferior or unsatisfactory product. Unacceptable work found to exist prior to the final acceptance of the work shall be immediately removed and replaced or corrected by, and at the expense of, the owner, permit holder, developer, contractor or their agents, whether the unacceptable work is the result of poor workmanship, poor design, use of defective materials, damage through carelessness or any other cause. This expense includes total and complete restoration of any disturbed surface to original or to better than the original condition that existed before the repairs or replacement, regardless of improvements on lands where the repairs or replacement are required.

1.15.8. Control of Materials

- A. **Samples and Tests.** To ascertain whether materials comply with contract requirements, samples shall be taken at the source or at the job destination as often as the ECM Administrator deems necessary. Samples shall be collected in accordance with standard practices, except where methods and procedures for sampling materials are otherwise set forth in this ECM.

The owner, permit holder, developer, contractor or their agents shall furnish, when requested by the ECM Administrator, a written statement of the origin, composition, and sample manufacture process of a material.

Any samples shall be collected and any tests performed shall be done so at the expense of the owner, permit holder, developer, contractor or their agents.

-
- B. **Storage of Material.** Material shall be stored to ensure the preservation of its quality and suitability for the work. Stored material, even though inspected prior to storage, shall be subject to inspection prior to its use in the work and shall meet all requirements of these Standards at the time it is used. Stored material shall be located to facilitate inspection. With the ECM Administrator's approval, the owner, permit holder, developer, contractor or their agents may use portions of the right-of-way for storage purposes. Any additional storage required shall be secured by, and at the expense of, the owner, permit holder, developer, contractor or their agents.
 - C. **Defective Materials.** Materials not in conformance with the requirements of these Standards shall be considered defective and shall be rejected. Rejected materials shall be removed from the job site at the expense of the owner, permit holder, developer, contractor or their agents.

1.15.9. Protection of Public and Utility Interests

- A. **Public Convenience and Safety.** Fire hydrants shall be visible and accessible to the fire district from the road at all times. No permanent or temporary obstructions (including, but not limited to, fencing, street lighting, landscaping, and mailboxes) shall be placed within 6 feet of a fire hydrant.

Unless otherwise specified, the owner, permit holder, developer, contractor or their agents shall give written notice to the proper authorities in charge of streets, gas and water pipes, sanitary and storm sewer facilities, electric service, cable television and other conduits, railroads, poles, manholes, catch basins and all other property that may be affected by the operations, at least 48 hours before breaking ground. The owner, permit holder, developer, contractor or their agents shall not hinder or interfere with any person in the protection of such property or with the operation of utilities at any time. The owner, permit holder, developer, contractor or their agents must obtain all necessary information regarding existing utilities, protect such utilities from damage, and avoid unnecessary exposure so that they shall not cause harm to the public.

The owner, permit holder, developer, contractor or their agents shall obtain all necessary information regarding the planned installation of new utilities and cables, conduits and transformers; make proper provision; and give proper notification so that new utilities and electrical equipment can be installed at the proper time without delay or unnecessary inconvenience. All underground utilities and electrical equipment shall be installed prior to the placement of the final lift of pavement.

When the work involves excavation adjacent to any properties or structures along the work site, the owner, permit holder, developer, contractor or their agents shall give such property owners sufficient written notice thereof, and shall furnish a copy to the ECM Administrator.

- B. **Protection and Restoration of Property and Monuments.** The owner, permit holder, developer, contractor or their agents shall use every precaution to prevent the damage or destruction of public or private property adjacent to or interfering with the work (such as poles; trees; shrubbery; crops; fences; monuments; and all overhead structures, such as wires and cables) within or outside of the right-of-way.

The owner, permit holder, developer, contractor or their agents shall protect and support all water, gas, sanitary sewer, storm sewer, electrical pipes and conduits, railroad tracks, buildings, walls, fences, landscaping, significant wetlands, or other properties that might be damaged during the execution of work. All reasonable and proper precautions shall be taken to protect property, persons, animals, and vehicles from injury. Wherever necessary, fencing or railing shall be placed around any excavation and a sufficient number of amber lights shall be on from twilight until sunrise. One or more guards shall be employed as additional security wherever they are needed or required by the ECM Administrator.

The owner, permit holder, developer, contractor or their agents shall not prevent the flow of water in the gutters of the street and shall use proper means to permit the flow of surface water along the gutters while the work is in progress.

The owner, permit holder, developer, contractor or their agents shall protect and carefully preserve all land boundary and all survey control monuments until the surveyor for the owner, permit holder, developer, contractor or their agents have referenced their location for relocation. All monuments disturbed or removed by the owner, permit holder, developer, contractor or their agents shall be replaced by a licensed surveyor at the expense of the owner, permit holder, developer, contractor or their agents.

The owner, permit holder, developer, contractor or their agents shall be responsible for the damage or destruction of property resulting from neglect, misconduct, or omission in the manner or method of execution or nonexecution of the work, or caused by defective work or the use of unsatisfactory materials. They shall restore such property to a condition similar to or better than existed before such damage or injury was done by repairing, rebuilding, or replacing it as might be directed.

The owner, permit holder, developer, contractor or their agents shall bear the cost of repairing underground pipes, wires, or conduits damaged by the work. The owner, permit holder, developer, contractor or their agents shall be liable for all damage caused by storms and fire. They shall, under no circumstances, start fires without first securing the necessary permits and approval of the authority having jurisdiction, even though they may be ordered or required to do such burning. While burning brush, stumps, or rubbish, care shall be taken not to damage any standing trees, shrubs or other property.

The owner, permit holder, developer, contractor or their agents shall ensure the continued availability of public services including, but not limited to, postal, solid waste collection, emergency services, and public utilities.

- C. **Protection of Streams, Lakes, and Reservoirs.** The owner, permit holder, developer, contractor or their agents shall take all necessary precautions to prevent pollution of streams, lakes, reservoirs, and irrigation ditches with fuels, oils, bitumen, sodium chloride, calcium chloride or other harmful materials. The operations shall be conducted and scheduled to avoid or minimize siltation of streams, lakes, and reservoirs. A plan for erosion protection shall be submitted to the ECM Administrator for approval before starting work and must conform to all local, state, and federal laws and regulations.
- D. **Barricades, Warning Signs, and Flagmen.** Work shall be barricaded as necessary at all times. Between the hours of sunset and sunrise barricades shall be properly lighted to warn all persons. Signs, barricades, lights, and warning devices shall be constructed and used in accordance with the most current version of the MUTCD. These guidelines shall be strictly enforced by the ECM Administrator during the progress of the work.

The owner, permit holder, developer, contractor or their agents shall be responsible for obtaining a Work in the Right-of-Way Permit before beginning work. The owner, permit holder, developer, contractor or their agents shall apply for the permit and submit a traffic control plan for review and approval by the ECM Administrator.

The owner, permit holder, developer, contractor or their agents shall be responsible for all damages to the work due to failure to place barricades, signs, lights, and flaggers and other workers to protect it. Whenever evidence of such damage is found prior to acceptance, the ECM Administrator may order the damaged portion immediately removed and replaced by the owner, permit holder, developer, contractor or their agents.

1.15.10. Warranty

The permit holder is required to warrant Improvements for 2 years, as described in Chapter 5 and the standard Development Agreement and Subdivision Improvement Agreement. The preliminary and final acceptance processes are also described in Chapter 5.

(Res. No. 20-222 , 6-23-20)

1.16. ADMINISTRATION

1.16.1. Discretionary Authority

The ECM Administrator may utilize discretionary authority as it relates to the provisions of the ECM. Judgments will take into consideration the individual situation, but in no instance will safety features or structural integrity prescribed by these Standards be sacrificed. Where the design standards, standard specifications or standard drawings do not cover improvements, the ECM Administrator shall establish appropriate standards.

1.16.2. Delegation and Review of Differences of Opinion

The ECM Administrator may appoint personnel as appropriate to administer these standards. The personnel appointed may only exercise the specific authority delegated to them by the ECM Administrator.

When a difference of opinion occurs between personnel appointed to exercise the authority of the ECM Administrator and an owner, permit holder, developer, contractor or their agents, the owner, permit holder, developer, contractor or their agents are required to obtain a review and decision from the ECM Administrator before appealing an issue to the BOCC. To obtain a review and decision, the owner, permit holder, developer, contractor or their agents shall submit a written request to the ECM Administrator identifying the conflict and describing the unresolved issue. After reviewing all pertinent information, the ECM Administrator will advise those interested parties of the decision relative to the conflict.

1.16.3. Interpretation

Interpretations of this ECM are made by the ECM Administrator. The ECM Administrator's interpretations of provisions may be appealed to the BOCC. The meanings and construction of words and phrases established in this section apply throughout the ECM.

- Words and phrases must be read in context and construed according to the rules of grammar and common usage. Words and phrases that have acquired a technical or particular meaning, whether by definition under the definitions section of the ECM, by legislative declaration or otherwise, must be construed accordingly.
- The particular controls the general.
- Mandatory requirements use the words "shall," "must" or "will" and are sometimes labeled "Standards." Recommendations use the words "may" or "should" and are sometimes labeled "Guidelines" or "Criteria".
- Words used in the present tense include the future, unless the context clearly indicates otherwise.
- Words or provisions apply. The word "or" indicates connected words or that provisions may apply singly or in any combination.
- Words indicating a specific gender apply to all persons and things unless the context clearly indicates otherwise.

(Supp. No. 2)

Created: 2021-06-08 11:35:47 [EST]

-
- A reference to days is to calendar days unless otherwise specified in this code or state statute. If a deadline falls on a weekend or County holiday, the deadline extends to the next working day.
 - When computing a period of days, the first day is excluded and the last day is included. If the last day falls on a weekend or County holiday, the last day is the next working day.

Section and subsection headings are for convenience only. They do not govern, limit or modify the scope, meaning or intent of the ECM.

1.16.4. Revisions to Approved Plans

Work performed within or outside the public right-of-way as mandated by the LDC, ECM or other County codes shall comply with the approved plans, the approved specifications, and these standards. The ECM Administrator must approve any revision to construction plans before the change is implemented.

1.16.5. Enforcement

The ECM Administrator has the authority to enforce the ECM as well as other referenced or pertinent standards and specifications. The ECM Administrator shall appoint personnel as appropriate to inspect work completed pursuant to the ECM standards. Personnel appointed may only exercise the specific authority delegated to them by the ECM Administrator.

Whenever any work is being done contrary to the provisions of these Standards, the ECM Administrator may order the work stopped by a written notice served on any persons engaged in doing the work or causing of the work to be done. Persons shall stop work until authorized by the ECM Administrator to proceed.

1.16.6. Inspection

The ECM Administrator is authorized to inspect all work completed and all material furnished. Inspections may extend to all or any part of the work and to the preparation, fabrication or manufacture of the materials to be used. The ECM Administrator shall notify the owner, permit holder, developer, contractor or their agents of any failure of the work or material conformity with these Standards. The ECM Administrator shall have the authority to reject materials until any questions at issue can be resolved by the ECM Administrator.

The ECM Administrator shall, in no case, act as foreman or perform other duties for, or interfere with the management of work done by, the owner, permit holder, developer, contractor or their agents. Any "advice" that the ECM Administrator might give the owner, permit holder, developer, contractor or their agents shall not be construed as binding upon the County in any way or release the owner, permit holder, developer, contractor or their agents from fulfilling all of the terms of these Standards.

The presence or absence of the ECM Administrator shall not relieve, in any degree, the responsibility or the obligation of the owner, permit holder, developer, contractor or their agents. The ECM Administrator, or an authorized designee, shall, at all times, be provided reasonable and safe access to inspect the work whenever it is in preparation or progress.

1.16.7. Right to Require Additional Tests

Whenever there is insufficient evidence of compliance with any of the provisions of these Standards or evidence that any material or construction does not conform to the requirements herein, the ECM Administrator may require that the owner, permit holder, developer, contractor or their agents, at their expense, provide test results to establish compliance. Such tests shall be as specified by these Standards or by other recognized test standards approved by the ECM Administrator. If there are no recognized and accepted test methods, the ECM Administrator shall determine test procedures. Before testing begins, all tests shall be made by an agency approved by the ECM Administrator. Reports of such test results shall be retained by the County.

1.17. SURETY

Where authorized by the ECM, surety may be required by the ECM Administrator to guarantee the performance of, maintenance of or to correct permitted work. The type and amount of surety shall be per the applicable ECM Standard or, if not specified, at the discretion of the ECM Administrator.

Types of surety include, but are not limited to, cash deposits, assigned savings, and bonds. The ECM Administrator shall release surety upon satisfactory completion of the required work or any previously specified stipulations related to the required work in accordance with the surety release provisions of the ECM.

1.18. PENALTIES

Failure to comply with the ECM will be cause for withholding or withdrawing approval of plans or drawings; withholding of surety, final inspection approval or occupancy certificates; and other penalties as provided by County regulations or state law.

1.19. NO WAIVER OF LEGAL RIGHTS

The County shall not be precluded or stopped by any measurement, estimate, or certificate made either before or after the completion and acceptance of the work from showing:

- The true amount and character of the work performed and materials furnished by the owner, permit holder, developer, contractor or their agents, or
- That any such measurement, estimate or certificate is untrue or incorrectly made, or
- That the work or materials do not conform in fact to these Standards.

1.20. AMENDMENT AND REVISIONS

The ECM may be amended or revised at the sole discretion of the BOCC in accordance with requirements and process prescribed by the Colorado Constitution and applicable provisions of Colorado Revised Statute.

Upon consultation with the County Attorney, the ECM Administrator may make the following changes or corrections to the provisions of the ECM when the changes or corrections do not alter the sense or meaning of its provisions:

- Misspellings. Misspelled words may be corrected.
- Histories. Erroneous legislative histories may be corrected.
- Cross-references. Cross-references may be changed to agree with new, amended, reenacted, renumbered, re-lettered, reallocated or corrected ordinances or resolutions.
- Capitalization. Improper capitalization may be corrected.
- Headings. Descriptive headings of titles, chapters, sections or subsections may be edited or added to briefly and clearly indicate the subject matter of the title, chapter, section or subsection.
- Renumbering; re-lettering. The numbering or lettering of sections, including duplicative numbering or lettering created by conflicting enactments, may be corrected or properly arranged.
- Changed job titles; agency names. References in design standards to specific job titles or agency names that are changed without substantial effect on job or agency responsibilities may be changed to refer to the new job title or agency name.

-
- Punctuation. Punctuation, including hyphenization, may be corrected.
 - Clerical Errors. Typographical or grammatical errors may be corrected.
 - Gender. Gender-specific terms that occur may be changed to gender-neutral terms and necessary grammatical changes to properly use the gender neutral terms may be made.
 - Mandated Changes. Additions, deletions, or revisions to design standards may be made when required for compliance with mandatory regional, state or federal regulations.

Any change or correction made under the authority of this section may not affect the substantive meaning of any enactment of the County. Any erroneous or inadvertent substantive change must be construed as a clerical error and given no effect. If the ECM Administrator or County Attorney is in doubt whether a specific change or correction is authorized by this section, the ECM Administrator may not make the change or correction under authority of this section.

1.21. SEVERABILITY

Except as otherwise provided, a determination by a court that a provision of the ECM is unconstitutional or invalid does not make the remainder of the ECM unconstitutional or invalid. A determination by a court that the application of the ECM to a particular project or parcel of land is unconstitutional or invalid does not apply to any other project or parcel of land.

1.22. TERMS AND DEFINITIONS

Whenever, in these Standards, the words "as ordered", "as directed", "as required", "as permitted", "as allowed", or words or phrases of like meaning are used, it shall be understood that the order, direction, requirement, permission, or allowance of the ECM Administrator is intended. Unless otherwise specified herein, the words "approved", "reasonable", "suitable", "acceptable", "properly", "satisfactory", or words of like meaning shall mean approved, reasonable, suitable, acceptable, proper or satisfactory in the judgment of the ECM Administrator. The following terms, definitions, and acronyms used in the ECM shall be defined as follows (See the LDC for additional definitions of terms not defined in this section):

AASHTO — American Association of State Highway and Transportation Officials.

Acceleration Lane — A speed change lane, including tapered areas, to enable a vehicle entering a roadway to increase its speed to a rate at which it can safely merge with through traffic.

Access — The place, means or way by which vehicles shall have a safe, adequate and usable ingress and egress to a property, use or parking space from a road.

ADA — Americans with Disabilities Act of 1990.

ADT Average daily traffic — The total two-directional volume of traffic during a given time period (in whole days), greater than one day and less than one year, divided by the number of days in that time period.

Alteration— A change to a facility within or adjacent to public roadways that affects or could affect pedestrian access, circulation, or use. Alterations include, but are not limited to, resurfacing, rehabilitation, reconstruction, historic restoration, or changes or rearrangement of structural parts or elements of a facility. Many modifications to traffic signals are also considered alterations.

Applicable Construction Activities — Construction activities that result in a land disturbance of greater than or equal to one acre or that is less than one acre, but is part of a larger common plan of development or sale that would disturb, or has disturbed since March 2, 2001, one acre or more, unless excluded consistent with Chapter 5 or the disturbed areas have been finally stabilized.

Applicant — The individual, firm, business entity, trust, association, syndicate, partnership, or corporation of record or any person designated by the property owner who has applied for or is requesting a permit.

ASTM — American Society for Testing and Materials.

Best Management Practices — Schedules of activities, prohibitions of practices, maintenance procedures, and other management practices to prevent or reduce the pollution of "state surface waters." BMPs also include treatment requirements for and operating procedures and practices to control plant site runoff, spillage or leaks, sludge or waste disposal, or drainage from raw material storage. The term BMP is used interchangeably with the term control measure, and can include other methods such as the installation, operation, and maintenance of structural controls and treatment devices.

Board of County Commissioners or BOCC — The El Paso County legislative board.

CDOT — Colorado Department of Transportation.

Clear Zone — The total roadside border area, starting at the edge of the travel lane, available for safe use by errant vehicles. This area may consist of a shoulder, a recoverable slope, a nonrecoverable slope or a clear runout area.

Common Development Improvement — Improvements under the ownership or control and maintained by a private or public entity other than El Paso County, including greenways, drainage systems and permanent stormwater management facilities.

Common Plan of Development or Sale — A contiguous area where multiple separate and distinct construction activities may be taking place at different times on different schedules, but remain related. "Contiguous" means construction activities located in close proximity to each other (i.e., within ¼ mile). Construction activities are considered to be "related" if they share the same development plan, builder or contractor, equipment, storage areas, etc.

Construction activity — Refers to ground surface disturbing and associated activities (land disturbance), which include, but are not limited to, clearing, grading, excavation, demolition, installation of new or improved haul roads and access roads, staging areas, stockpiling of fill materials, and borrow areas. Construction does not include routine maintenance to maintain the original line and grade, hydraulic capacity, or original purpose of the facility. Activities to conduct repairs that are not part of regular maintenance or for replacement are construction activities and are not routine maintenance. Repaving activities where underlying and/or surrounding soil is cleared, graded, or excavated as part of the repaving operation are considered construction activities unless they are an excluded site described in section 1.7.2.E of this ECM. Construction activity is from initial ground breaking to final stabilization regardless of ownership of the construction activities.

Control Measure — Any best management practice or other method used to prevent or reduce the discharge of pollutants to waters of the state. Control measures include but are not limited to best management practices. Control measures can include other methods such as the installation, operation, and maintenance of structure controls and treatment devices.

Construction Plans — Project drawings subject to County review and approval prior to construction that show the location, character, and dimensions of the proposed work, such as layouts, profiles, cross sections, details, methods, and general notes.

Construction Representative — The person who directly inspects or who directly supervises the inspection of the construction of a project, on behalf of the permit holder, to ensure compliance with the plans and standard specifications. The Construction Representative maintains the Engineering Record Drawings. The Construction Representative is not required to be a registered Professional Engineer, but shall have adequate construction and design experience to perform the work required by these standards.

Contractor — A person, partnership, corporation, subcontractor or other legal entity that undertakes to construct, install, alter, move, demolish, repair, replace, excavate or add to any public improvements covered by these Standards.

County — El Paso County, Colorado.

County Attorney — El Paso County Attorney.

County Engineer — The County Road Engineer for El Paso County with authority and duties as designated in Colorado Revised Statutes or his/her authorized designee.

Deceleration Lane — A speed change lane including tapered areas, to enable a turning vehicle to slow to a safe turning speed after it has left the mainstream of faster moving traffic.

Defect Warranty Period — Shall be the time frame during which the permit holder is held liable for all work performed and materials utilized prior to final acceptance by El Paso County.

Design Engineer — The engineer who directly prepared plans and calculations or who directly supervises the preparation of project plans and calculations. The Design Engineer seals, signs, and dates the plans and calculations certifying that they meet the required standards.

Design Speed — A selected speed used to determine the various geometric design features of the roadway.

Developer — A property owner, or his/her agents or contractors, who are responsible for applying for or receiving a permit or approval for development.

Development Agreement — An agreement with the County which clearly establishes the terms and conditions of the approval, including the applicant's responsibility regarding project phasing, the provision of public and private facilities and improvements, and any other mutually agreed to terms and requirements. The agreement may also serve to implement the site specific development plan which establishes vested rights under Article 68 of Title 24, C.R.S.

Deviation — A technical adjustment from these Standards approved by the ECM Administrator due to unusual circumstances.

Driveway — A physical access that connects a private property or properties to the County road system. These accesses are typically privately owned and privately maintained. El Paso County permits where driveways connect to the public road system and how they connect to the road. All driveway maintenance is the responsibility of the property owner(s).

Easement — A right granted by a property owner to specifically named parties or to the public for the use of certain land for specified purposes. Where appropriate to the context, easement may also refer to the land covered by the grant.

ECM — The El Paso County Engineering Criteria Manual.

ECM Administrator — The County Engineer or his/her authorized designee.

Encroachment —Occupancy of a County right-of-way by non-roadway structures or other objects.

Emergency Work— Construction work that responds to an unforeseen combination of circumstances or the resulting conditions that call for immediate action to restore utility service, pedestrian and traffic flow, or mitigate a safety hazard.

Encroachment — Occupancy of the County right-of-way by non-County-owned non-roadway structures or other objects.

Engineer — A Professional Engineer licensed by the State of Colorado.

EPC DPW — El Paso County Department of Public Works.

FEMA — Federal Emergency Management Agency.

FHWA — Federal Highway Administration.

Final Acceptance — The acknowledgement by the County that the defect warranty period has expired and there are no outstanding items to be corrected under the provisions of the defect warranty.

Franchise — A document granted by the County authorizing the use of County right-of-ways by public or private entities, subject to specified conditions in accordance with State law.

Full Movement Intersection or Access — An intersection or access that allows a full range of turn movements between the two intersecting roads or access.

Inspector — The authorized representative of the County Engineer assigned to make detailed inspection of construction work to assure compliance with these Standards and the plans as approved by the County.

ITE — Institute of Transportation Engineers.

Intersection — The area embraced within the prolongation or connection of the lateral curb lines, or if none, the lateral boundary lines of the roadways of two roads that join one another at, or approximately at, right angles, or the area within which vehicles traveling on different roads that join at any other angle may come into conflict. The junction of an alley or driveway access with a roadway or highway shall not constitute an intersection.

Land Development Code or LDC — The zoning, subdivision, and other land development regulations adopted by the Board of County Commissioners.

Land Disturbing Activity — Any activity that results in a change in the existing land surface (both vegetative and non-vegetative). Land disturbing activities include, but are not limited to clearing, grading, excavation, demolition, installation of new or improved haul roads and access roads, staging areas, stockpiling of fill materials, and borrow areas. Compaction that is associated with stabilization of structures and road construction shall also be considered a land disturbing activity.

Level of Service or LOS — A qualitative measure of traffic flow. Six levels are defined as A through F with A being the best operating conditions and F being the worst (See Highway Capacity Manual).

Manual — El Paso County Engineering Criteria Manual.

Maximum Extent Feasible— Where existing physical constraints make it impracticable for altered elements, spaces, or facilities to fully comply with the ADA and PROWAG requirements for new construction, compliance is required to the extent practicable within the scope of the project. Also referred to as "Maximum Extent Practicable".

MPH — Miles per hour.

MTCP — The El Paso County Major Transportation Corridors Plan.

MUTCD — The Manual on Uniform Traffic Control Devices, published by the U.S. Department of Transportation.

Municipal Separate Storm Sewer System (MS4) — The system of conveyances owned or operated by El Paso County designed or used for collecting or conveying stormwater, including but not limited to roads with drainage systems, inlets, catch basins, curbs, gutters, pipes, man-made channels, ditches, detention and water quality basins, or storm drains.

Neighborhood Path — A local pathway system that may or may not connect to a larger regional trail network.

Notice to Proceed — A document issued by the ECM Administrator authorizing a permit holder to begin construction of common development, subdivision or public improvements in accordance with an approved set of plans.

NPDES — National Pollutant Discharge Elimination System.

Owner — Any individual, corporation, partnership or other legal entity holding controlling title on property that is the subject a permit or improvements covered by these Standards.

PCD — El Paso Planning and Community Development Department.

Pedestrian Access Route— A continuous and unobstructed path of travel provided for pedestrians with disabilities within or coinciding with a Pedestrian Circulation Path. The Pedestrian Access Route shall comply with PROWAG.

Pedestrian Circulation Path— A prepared exterior or interior surface provided for pedestrian travel within or adjacent to public roadways. The Pedestrian Circulation Path does not have to be accessible; however, the Pedestrian Access Route contained within the Pedestrian Circulation Path shall be accessible to those with disabilities.

Permit Holder — Any individual, corporation, partnership or other legal entity holding a valid permit authorized pursuant to the ECM.

Posted Speed — Maximum vehicle speed signed along a roadway.

Preliminary Acceptance — An acknowledgement by the County that, to the best of the County's knowledge, all work has been completed in accordance with the plans and specifications and the defect warranty period should begin.

Public Improvements — Improvements under the ownership or control of the County and maintained by the County including, but not limited to, the components of the street system and storm drainage system covered by these Standards.

Public Utility — Public utility as defined by Section 401103, C.R.S., 1973.

Record Drawings — An approved final revision of a design drawing or plan updated to include information from field inspections showing the true condition or configuration of what has been built. The drawing or plan is designated Record Drawing by stamp or lettering on the drawing.

Regional Trail — A bike or pedestrian facility designated by the County as a regional trail.

Right-of-Way or ROW — All property in which the County has any form of ownership or title and which is held for public purposes, regardless of whether or not any public improvement exists thereon or whether or not it is used, improved, or maintained for public use.

Roads, Private — A road that is owned and maintained by a private individual, organization, or company, other than a government. All roads within private gated communities are considered private roads and shall be maintained by the residents of that gated community. In order to accept a road for maintenance in El Paso County, any road, existing or proposed, must first meet the standards found within the ECM for a public road.

Roads, Public — Any street, highway, or road under the jurisdiction of and maintained by a public authority and opened to public travel.

Standards — The requirements contained in the El Paso County Engineering Criteria Manual.

Subdivision Improvements Agreement — An enforceable agreement between an applicant and El Paso County that serves as the security arrangement to secure the cost of public improvements required by the ECM and LDC.

Surety — A financial guarantee, by the applicant or permit holder and naming El Paso County as beneficiary, that public infrastructure and other common development or subdivision improvements required by the ECM, LDC, or other County rules and regulations will be completed.

Surveyor — A Professional Land Surveyor licensed by the State of Colorado.

Technically Infeasible— With respect to the accessibility of ADA and PROWAG requirements.

Transportation Impact Study or TIS — A report that documents a study of traffic conditions before and after construction of a proposed development. It addresses any deficiencies in the transportation system, either current or after development, and proposes recommended mitigation.

Warrant — A threshold condition that, if found to be satisfied as part of an engineering study, shall result in analysis of other traffic conditions or factors to determine whether a traffic control signal or other transportation system improvement is justified.

(Res. No. 19-245 , 7-2-19; Res. No. 20-222 , 6-23-20)

Chapter 2 TRANSPORTATION FACILITIES

2.1. OVERVIEW

This chapter addresses the standards and technical criteria to be used to plan, design, construct, choose materials, locate, repair, maintain, reconstruct, and use roadways and other transportation facilities and the associated extrinsic structures.

2.1.1. Purpose

The purpose of this chapter is to provide detailed design guidelines and criteria for the preparation of plans for all County-owned and maintained transportation facilities and access to those facilities. These facilities include roadways and their structures, as well as extrinsic structures that support the use of the transportation facility.

2.1.2. Chapter Content and References

Table 2-1 outlines the chapter content and references used as a basis for the standards established in Chapter 2.

Table 2-1. Contents and Basis of Transportation Facility Standards

Intent Use	ECM Content	ECM Section(s)	Reference Document(s)
Planning			
	Roadway	2.2.1 - 2.2.4 and Appendix B	1, 2, 3
	Access	2.2.5	2
	Soils Investigations	2.2.6 and Appendix C and D	
	Pavement Design	2.2.7	8
Design			
	Roadway	2.3.1 - 2.3.9	3, 7, 9, 11, 12, 13
	Access	2.4.1 - 2.4.2	2, 12
	Extrinsic Structures	2.5.1 - 2.5.7	7, 11
	Structures	2.6.1 - 2.6.10	4, 5, 6, 9, 10
Construction			
	Permitting	5.3 and 5.4	1
	Inspections	5.10 and Appendix J	1
	Acceptance	5.3	1

References

1. El Paso County Land Development Code

2. El Paso County Major Transportation Corridor Plan
3. AASHTO, A Policy on Geometric Design of Highways and Roadways
4. AASHTO, Standard Specifications for Highway Bridges
5. AASHTO, LRFD Bridge Design Specifications
6. AASHTO, LRFD Bridge Construction Specifications
7. AASHTO, Roadside Design Guide
8. AASHTO, Standard Specifications Material, Sampling and Testing
9. CDOT, Standard Specifications for Road and Bridge Construction
10. CDOT, Bridge Manual
11. CDOT, M&S Standards
12. US Department of Transportation, Manual on Uniform Traffic Control Devices
13. FHWA, Roundabouts: An Informational Guide

2.1.3. Standard Drawings

Table 2-2 identifies the standard drawings that are enforceable part of these Standards. The Standard Drawing shall be used when designing improvements for County-owned and maintained facilities. Any change to a Standard Drawing shall be approved by the ECM Administrator and noted in the construction plans.

Table 2-2. Standard Drawings

File Name	Detail/Description	Approval Date
SD_2-1	Urban Local Roadway (low volume)	6/23/2020
SD_2-2	Urban Local Roadway	6/23/2020
SD_2-3	Urban NonResidential Collector Roadway	6/23/2020
SD_2-4	Urban Residential Collector Roadway	6/23/2020
SD_2-5	Urban Minor Arterial Roadway	6/23/2020
SD_2-6	Urban Principal 4-Lane Arterial Roadway	6/23/2020
SD_2-7	Urban Principal 6-Lane Arterial Roadway	6/23/2020
SD_2-8	Urban Expressway 4-Lane Roadway	6/23/2020
SD_2-9	Urban Expressway 6-Lane Roadway	6/23/2020
SD-2-10	Rural Gravel Local Roadway	12/31/2005
SD_2-11	Rural Local Roadway	12/31/2005
SD-2-12	Rural Minor Collector Roadway	12/31/2005
SD_2-13	Rural Major Collector Roadway	12/31/2005
SD_2-14	Rural Minor Arterial Roadway	12/31/2005
SD_2-15	Rural Principal 4-Lane Arterial Roadway	12/31/2005
SD_2-16	Rural Principal 6-Lane Arterial Roadway	12/31/2005
SD_2-17	Rural Expressway 4-Lane Roadway	12/31/2005
SD_2-18	Rural Expressway 6-Lane Roadway	12/31/2005
SD_2-20	Typical Curb and Gutter Details	6/23/2020
SD_2-21	Patterned Concrete Median Paving	01/18/2011
SD_2-22	Plowable Median Nose Detail	1/12/2016
SD-2-23	Driveway Cut Detail	08/11/2011

Created: 2021-06-08 11:35:48 [EST]

(Supp. No. 2)

SD-2-24	Driveway Detail w/ Attached Sidewalk	6/23/2020
SD_2-25	Driveway Detail w/ Detached Sidewalk	6/23/2020
SD_2-26	Typical Cross Pan Layout Detail	8/11/2011
SD_2-40	Pedestrian Curb Ramp Detail	6/23/2020
SD_2-41	Pedestrian Curb Ramp Detail	6/23/2020
SD_2-42	Detectable Warning Surface Details	6/23/2020
SD_2-50	Parallel Pedestrian Curb Ramp Detail	6/23/2020
SD_2-70	Type C Aluminum Bridge Railing	08/11/2011
SD_2-71	Oklahoma TR-1 Bridge Railing	08/11/2011
SD_2-72	Nevada Concrete Safety Bridge Railing	08/11/2011
SD_2-73	Safety Shaped Concrete Bridge Railing	08/11/2011
SD_2-74	Texas Type TT Bridge Railing	08/11/2011
SD_2-75	Urban Cul-de-Sac Details	01/01/2008
SD_2-76	Rural Cul-de-Sac Details	01/01/2008
SD_2-77	Urban Knuckle	-approved BoCC date
SD_2-78	Urban Eyebrow	approved BoCC date

2.1.4. Relationship Between ECM and El Paso County Road Impact Fee Program

El Paso County approved a Road Impact Fee Program in 2012 pursuant to Resolution 19-471, as amended. The Fee Program establishes an impact fee applicable to subdivision and certain zoning actions, and it provides a method of establishing credit for the construction of certain transportation improvements identified in the EPC Major Transportation Corridors Plan. Construction of roads that do not meet these criteria may not be eligible for credit under the Road Impact Fee Program.

(Res. No. 20-222 , 6-23-20)

2.2. PLANNING

2.2.1. Basis for Planning

Proper planning of traffic systems helps to provide a safe and effective transportation network to meet existing and future demands within the County. All transportation system components shall be designed to promote:

- Safety - for vehicular and other modes of travel
- Accessibility - to all users, including those with disabilities
- Performance - efficiency of service for all users
- Livability - impacts mitigated by circulation system improvements and coordinates with adjoining land uses
- Economy - of construction and use of land

The goal of planning transportation facilities is to create a network of roadways that connect, enhance circulation, and provide a balanced relationship between all that uses the roadways through coordination with developed land use plans (strategic and small area).

Transportation system planning requires consideration of the following when planning, designing and laying out facilities:

- Adjoining land uses;
- Natural features (topography, creeks, and wooded areas);
- Circulation;
- Impact to traffic;
- Roadway functional classification standards;
- Road way access criteria;
- Soils investigations; and
- Pavement design.

2.2.2. Circulation

Circulation is important in transportation system design for the following reasons:

- Operation of the arterial road system is improved by dispersing local traffic onto multiple roads and access points;
- Local roads are to be used only for accessing developed lots;
- Response time for emergency services is reduced;
- Time and mileage traveled by individuals and service providers, including school bus transportation, mail delivery, utilities, etc., are reduced; and
- Use of transit systems, and pedestrian and bicycle facilities, is promoted.

2.2.3. Transportation Impact Study (TIS)

- General.** The goal of the TIS is to identify the traffic-related issues that result from development and to determine mitigation techniques required to maintain acceptable levels of service, meet the transportation planning goals, and implement the El Paso County Major Transportation Corridors Plan (MTCP).
- TIS Preparation Guidelines.** A TIS shall be prepared in accordance with the general guidelines in Appendix B. A number of specific parameters shall be evaluated in the TIS based on the level of complexity of the development and location within the transportation network. Three levels of analysis are permitted. Prior to assuming a specific level of required analysis, the design engineer should consult with the ECM Administrator to determine what level of analysis is appropriate and desired in support of a specific project proposal.
- Qualifications to Prepare a TIS.** A TIS shall be prepared under the supervision of, and sealed by, a licensed Professional Engineer in the State of Colorado with experience in traffic engineering and transportation planning.

2.2.4. Roadway Functional Classifications and Urban/Rural Designations

Roadway functional classification is one parameter used to determine appropriate road design. The function of a road is determined by the volume of traffic, length of vehicle trips, and whether the road provides service primarily for vehicular movement or access to abutting land uses. For example, arterial roadways

generally carry significantly greater traffic volumes and variety of traffic types at higher speeds than collector roads. Similarly, collector roads will carry greater traffic volumes at higher speeds than local roads.

Roadway functional classifications for regional based facilities are established by the most recently adopted MTCP. Other roadways are classified by the BOCC based on whether the adjoining land uses are rural or urban in nature (i.e. developments with lots greater than or equal to 2.5 acres), along with the existing and projected objectives of the roadway.

The County recognizes six roadway functional classifications within the rural designation: expressways, principal arterials, minor arterials, major collectors, minor collectors, and locals. The County recognizes seven roadway functional classifications within the urban roadway designation: expressways, principal arterials, minor arterials, nonresidential collectors, residential major collectors, residential minor collectors, and locals.

These Standards have been developed in support of the County roadway functional classification system.

A. Rural Roadways.

1. **Expressway.** Expressways serve high-speed and high-volume traffic over long distances. Access is highly controlled and may have both grade-separated interchanges and full movement signalized intersections. Adjacent, existing and future, land uses shall be served by other network roadways, no direct parcel access is permitted (See Figure 2-1 and Figure 2-2).

Figure 2-1. Typical Rural Expressway Partial Cross Section (6 Lane)

Figure 2-2. Typical Rural Expressway Partial Cross Section (4 Lane)

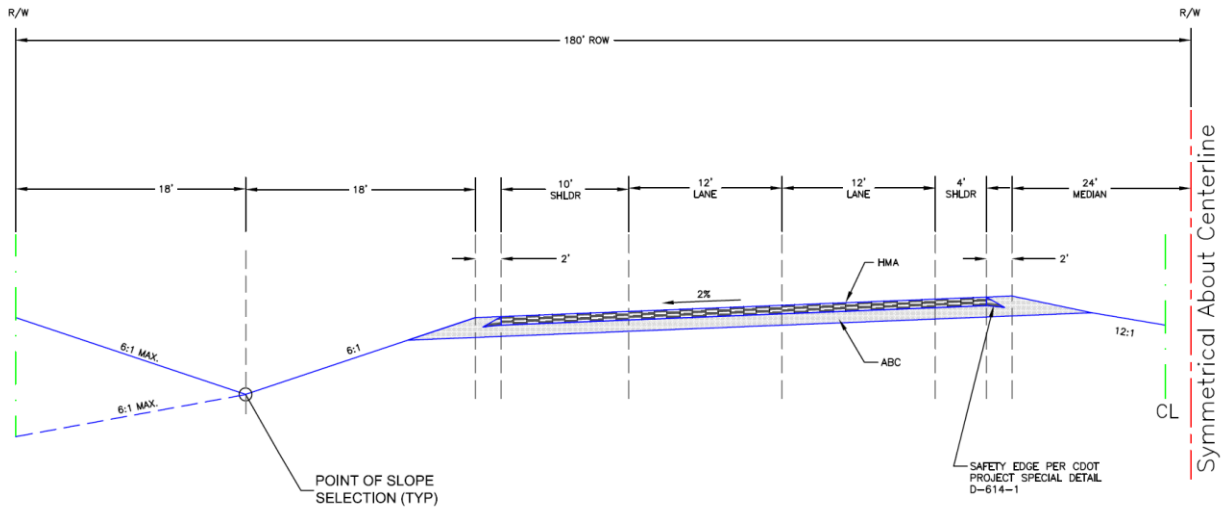

2. **Principal Arterial.** Principal arterials serve high-speed and high-volume traffic over long distances. Access is highly controlled with a limited number of full movement intersections and medians with infrequent openings, and no direct parcel access. Adjacent, existing and future, land uses shall be served by other network roadways, service roads, and inter parcel connections (See Figure 2-3 and Figure 2-4).

Figure 2-3. Typical Rural Principal Arterial Partial Cross Section (6 Lane)

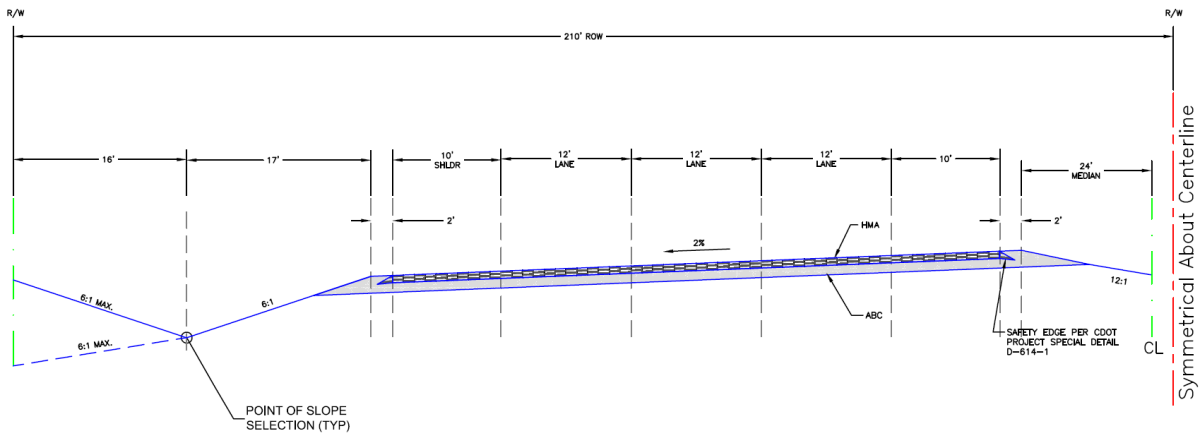
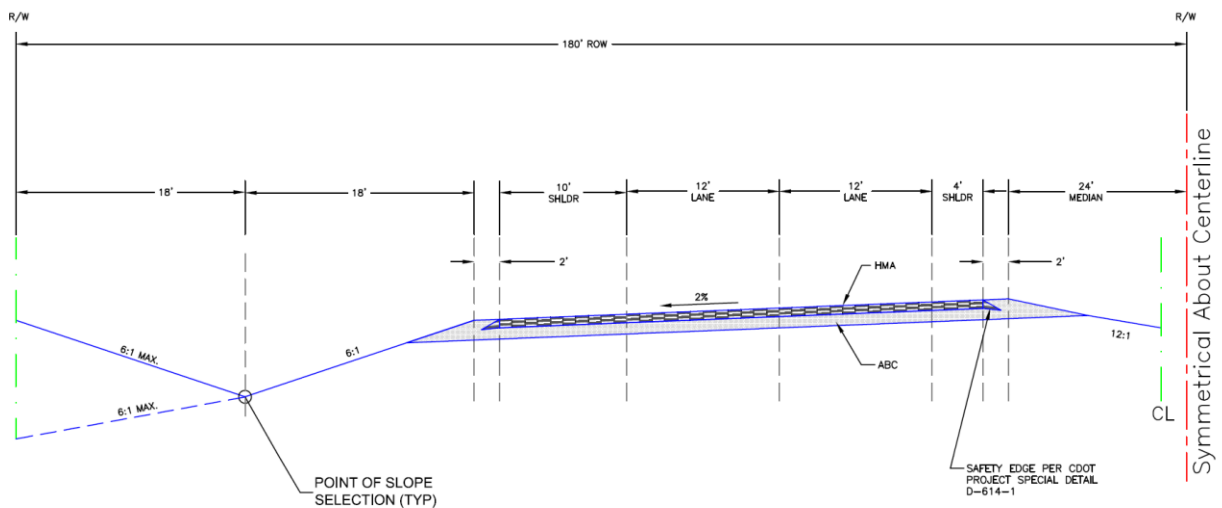
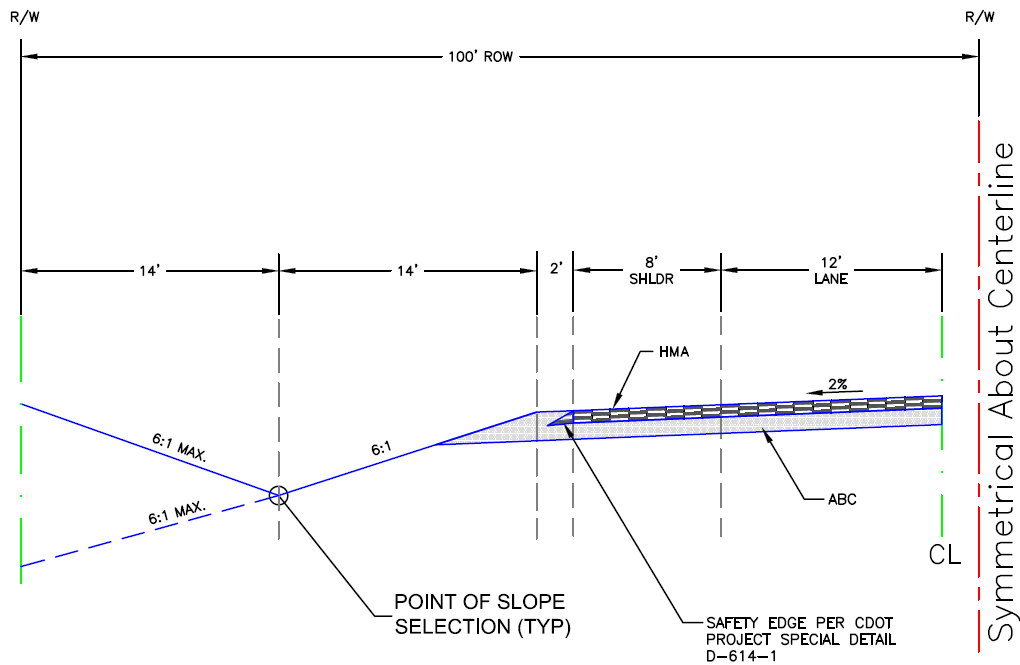

Figure 2-4. Typical Rural Principal Arterial Partial Cross-Section (4 Lane)



3. **Minor Arterial.** Minor arterials serve high-speed and high-volume traffic over medium distances, or are anticipated to serve this kind of traffic within a twenty-year period. Access is restricted through prescribed distances between intersections, use of medians, and no full movement parcel access (See Figure 2-5). Minor arterial status is assigned to rural roadways where the probability of significant travel demand in the future is high. Rights-of-way, easements, setbacks, and access limitations shall be pursued through the land development process on properties adjacent to minor arterials.

Figure 2-5. Typical Rural Minor Arterial Partial Cross Section



4. **Major Collector.** Major collectors serve as links between local access and arterial facilities over medium-to-long distances. Major collectors are managed to maximize the safe operation of through-movements at speed. No full movement access is permitted where the local roadways can be expected to provide access (See Figure 2-6). Where no local public roadway can provide access, temporary direct parcel or partial turn movement access may be permitted, provided the design meets requirements presented in these Standards.

Figure 2-6. Typical Rural Major Collector Cross Section

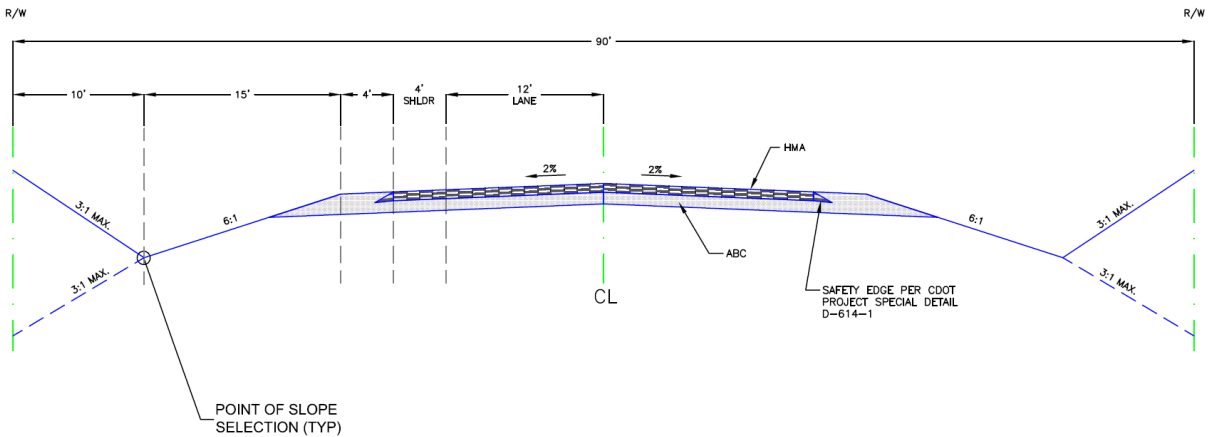

5. **Minor Collector.** Minor collectors link local roadways to major collectors or arterial roadways. No full movement access is permitted where local roadways can be expected to provide access (See Figure 2-7). Where no local public or private roadway can provide access or where lot size is five acres or more, temporary direct parcel or partial turn movement access may be permitted. Access location and design are to be reviewed by the ECM Administrator to ensure roadway objectives are being met.

Figure 2-7. Typical Rural Minor Collector Cross Section

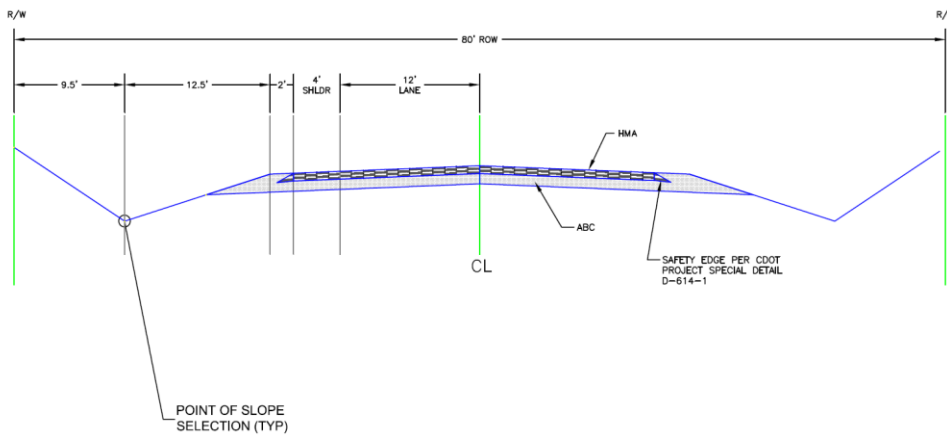

6. **Local.** Local roadways provide direct lot access and deliver lot-generated trips to collector roadways. Although access needs are high, accesses shall not be allowed to compromise the safety, health or welfare of roadway users (See Figure 2-8).

Figure 2-8. Typical Rural Local Cross Section

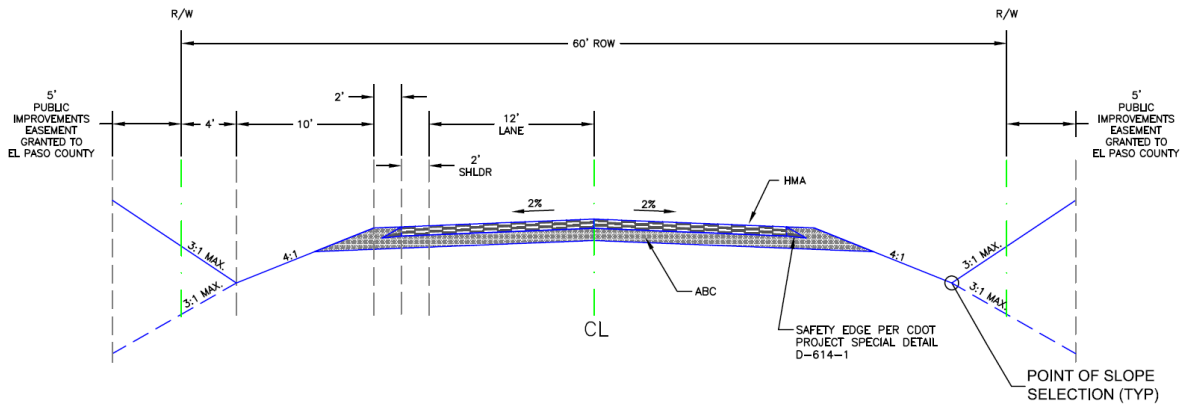

B. Urban Roadways.

1. **Expressway.** Expressways serve high-speed and high-volume traffic over long distances. Access is highly controlled and may have both grade-separated interchanges and full movement signalized intersections. Adjacent, existing and future, land uses shall be served by other network roadways, no direct parcel access is permitted (See Figure 2-9 and Figure 2-10).

Figure 2-9. Typical Urban Expressway Cross Section (6 Lane)

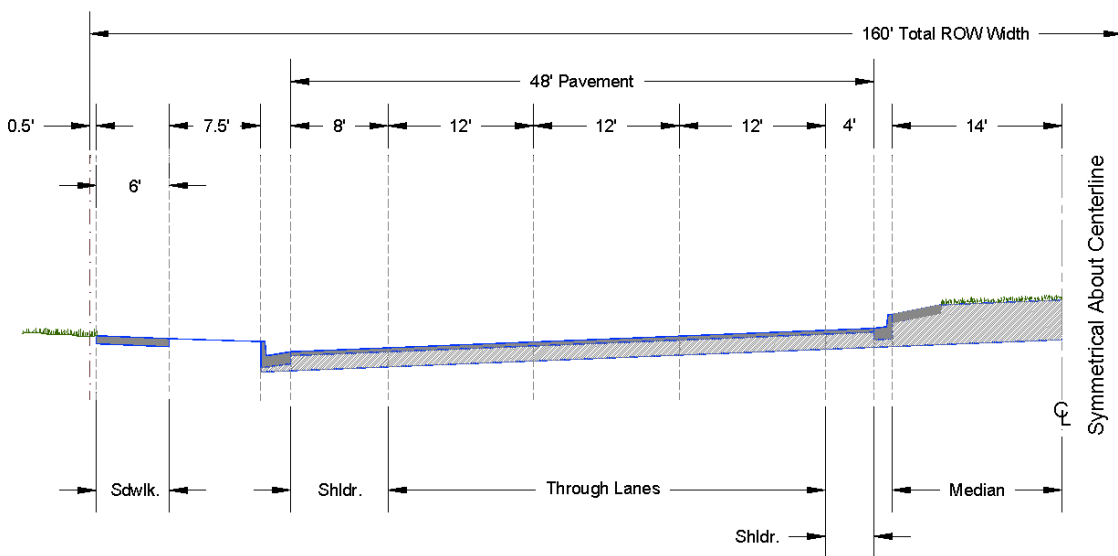

Created: 2021-06-08 11:35:48 [EST]

(Supp. No. 2)

Figure 2-10. Typical Urban Expressway Cross Section (4 Lane)

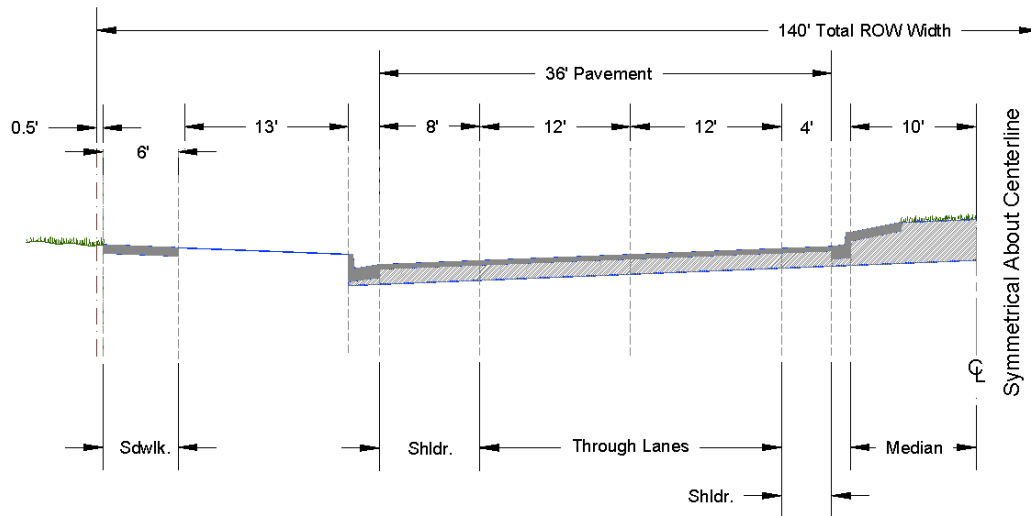

2. **Principal Arterial.** Principal arterials serve high-speed and high-volume traffic over long distances. Access is highly controlled with a limited number of full movement intersections and medians with infrequent openings, and no direct parcel access. Adjacent, existing and future, land uses shall be served by other network roadways, service roads, and inter parcel connections (See Figure 2-11 and 2-12).

Figure 2-11. Typical Urban Principal Arterial Cross Section (6 Lane)

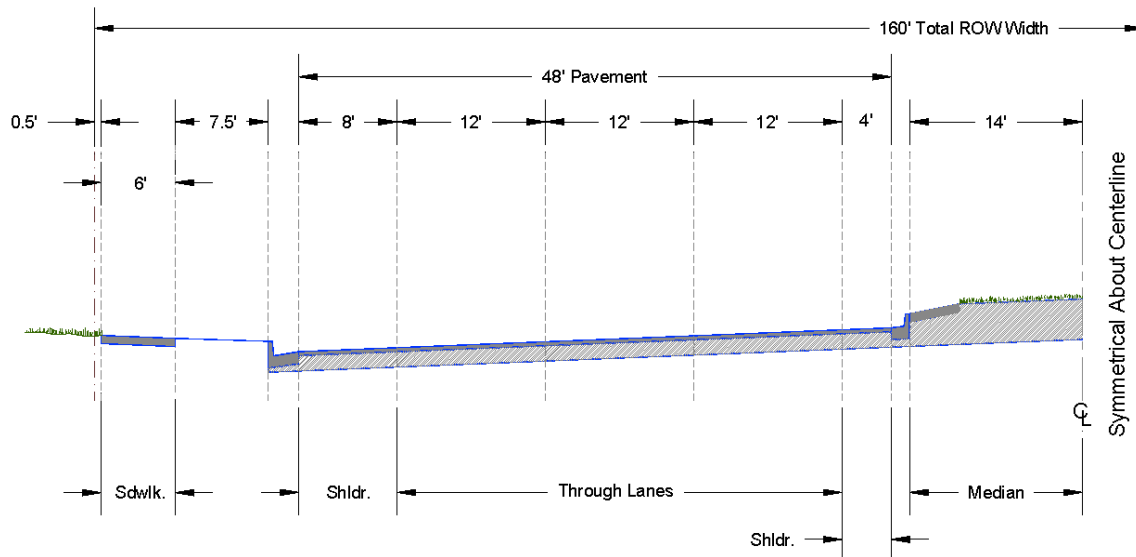
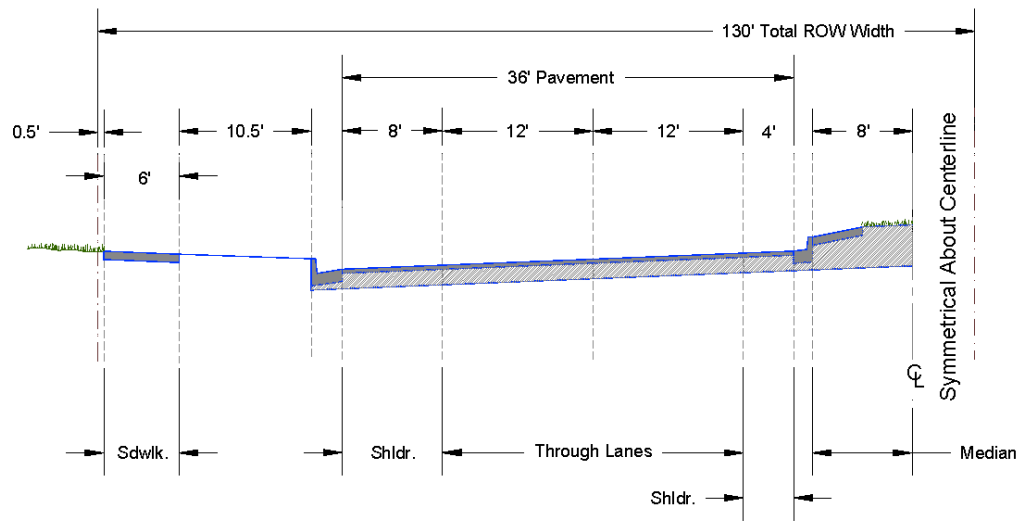
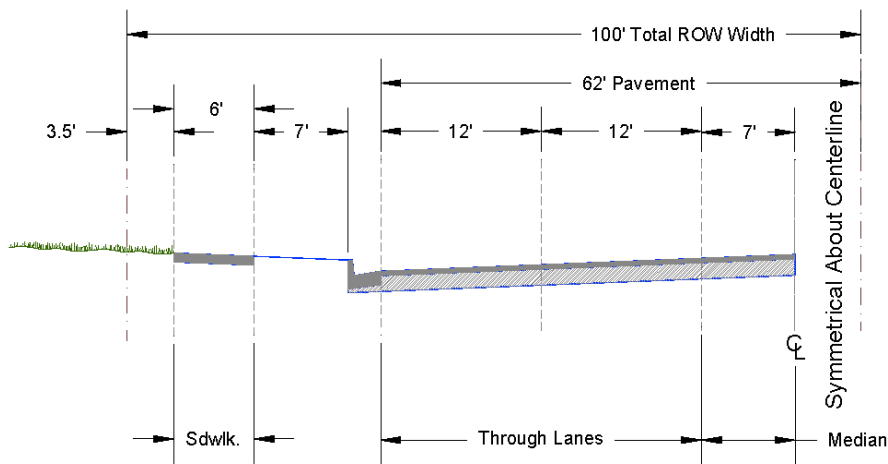

Figure 2-12. Typical Urban Principal Arterial Cross Section (4 Lane)



- Minor Arterial.** Minor arterials serve high-volume traffic over medium distances in developed or developing urban areas. Access is restricted and based on prescribed distances between intersections, use of medians, and no full movement parcel access is permitted where the local roadways can be expected to provide access (See Figure 2-13). Where no local public or private roadway can provide access, temporary lot or partial turn movement access may be permitted, provided the design meets these Standards.

Figure 2-13. Typical Urban Minor Arterial Cross Section



- Nonresidential Collector.** Nonresidential collectors link local roadways and arterial roadways in locations characterized by nonresidential land uses or uncommitted future land uses. Urban nonresidential collectors are intended to accommodate multiple modes of transportation, high-volume turning movements or significant changes in roadway use over time (See Figure 2-14). Urban nonresidential collectors are managed to maximize the safe operation of through-

movements. Intersection and parcel access locations and design are reviewed by the ECM Administrator to ensure roadway objectives are being met.

Figure 2-14. Typical Urban Nonresidential Collector Cross Section

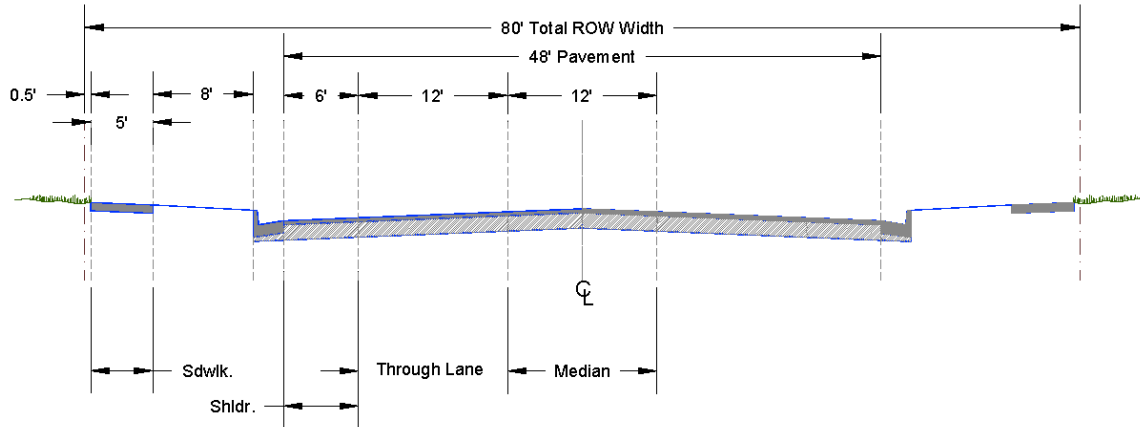

5. **Residential Collector.** Residential collectors link local and arterial roadways in exclusively residential areas where build-out conditions for land development and roadway use can be reasonably forecasted (See Figure 2-15). Residential major collectors are managed to maximize the safe operation of through-movements. No full movement parcel access is permitted where the local roadways can be expected to provide access. Where no local public or private roadways can provide access, partial turn movement access may be permitted. Intersection and access location and design are reviewed by the ECM Administrator to ensure roadway objectives are being met.

Figure 2-15. Typical Urban Residential Collector Cross Section

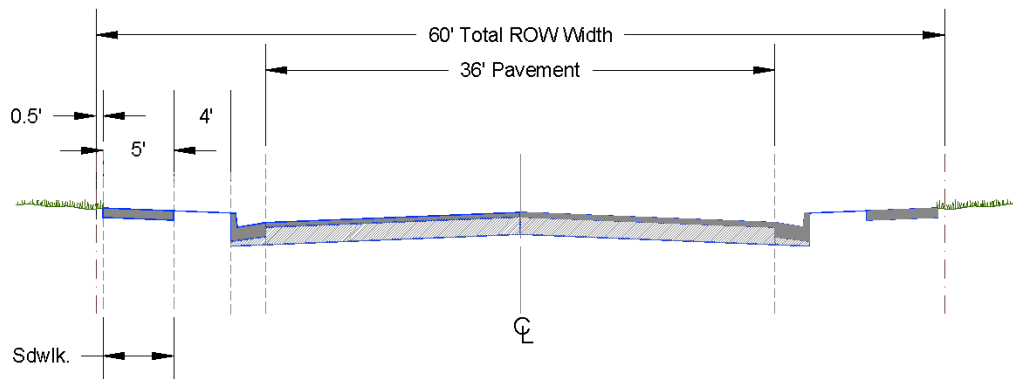

6. **Local.** Local roadways link to collector or arterial roadways. Direct parcel access is permitted provided they meet sight distance and other design requirements presented in these Standards (See Figure 2-16). Intersection and parcel access location and design are reviewed by the ECM Administrator to ensure safe operations.

Figure 2-16. Typical Urban Local Cross Section

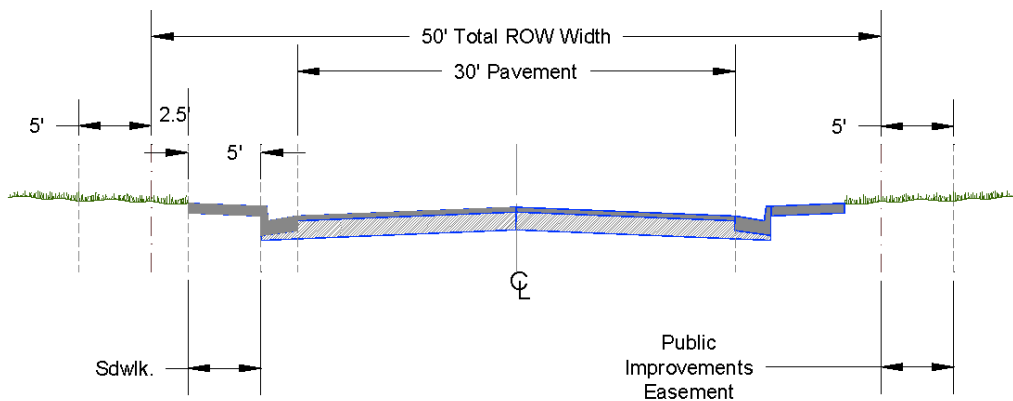

7. **Local (low volume).** Local (low volume) roadways provide direct lot access and deliver lot-generated trips to collector roadways. Although access needs are high, accesses shall not be allowed to compromise the safety, health or welfare of roadway users (See Figure 2-17).

Figure 2-17. Typical Urban Local (low volume) Cross Section

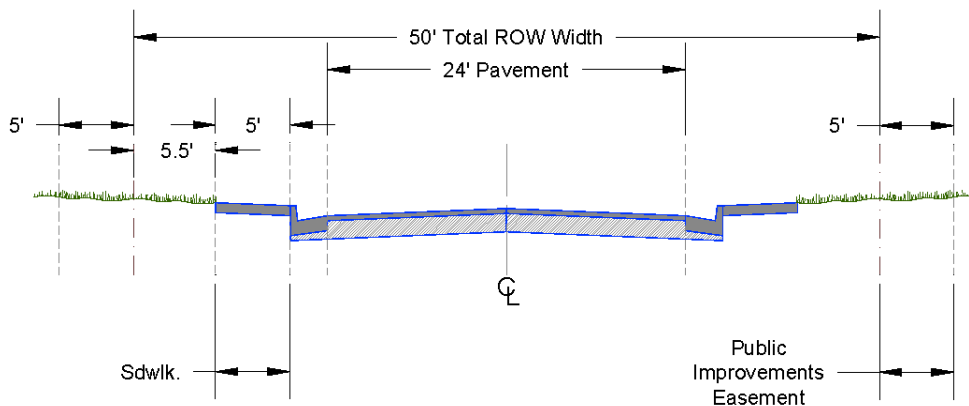

2.2.5. Roadway Access Criteria

All new or modified accesses to the County roadways shall meet the requirements of the ECM. Standards and technical criteria not specifically addressed in the ECM shall follow the provisions of the AASHTO, A Policy on Geometric Design of Highways and Roadways ("Green Book") and the Colorado State Highway Access Code. When CDOT State Highway Access Permit is required, or access is located within the influence zone of an intersection, interchange or as determined by the ECM Administrator, CDOT concurrence shall be provided by the applicant.

A. Rural and Urban Expressway Access Criteria.

1. **Intersection Spacing and General Access Standards.** Full movement intersections and major access spacing shall meet the requirements of this section. Right-in/right-out and three quarter movement accesses may be permitted as a deviation only if they meet the criteria presented in

this section for sight distances, turn lane requirements, grades and do not negatively impact traffic operations or safety.

2. **No Alternative Access to Road System.** Where reasonable access can be obtained from the local roadway system, a temporary direct lot or partial turn movement access may be permitted provided the access meets these Standards or as otherwise required by the ECM Administrator.
 3. **Access and Lot Division.** No additional access right shall accrue and no additional access shall be provided when splitting or dividing of existing lots of land. When an alternative is reasonably available in the opinion of the ECM Administrator, all access to the newly created properties shall be provided internally from the existing access or new access to a roadway of lower functional classification.
 4. **Relocation of Access when Alternative is Available.** All access to an expressway not meeting the minimum one-mile spacing requirement shall be closed in favor of an alternative access when an alternative is reasonably available in the opinion of the ECM Administrator.
- B. Rural and Urban Principal Arterial and Rural Minor Arterial Access Criteria.**
1. **Spacing.** Spacing of roads accessing a principal arterial or rural minor arterial that will result in a full movement intersection shall be planned at one-half mile (one-quarter mile for rural minor arterials). Should the one-half mile spacing not be "viable or practical" for providing access to the adjacent land, a deviation may be considered and approved by the ECM Administrator. If a deviation is granted, only one additional full movement intersection will be permitted by the ECM Administrator. The Applicant shall have the burden of proof that no other "viable or practical" access is available. A deviation request should be supported by a traffic study or memorandum that provides information to assist the ECM Administrator in determining the proposed deviation minimizes negative safety and other operational impacts. If the development is at the intersection of two major corridors, the full movement access should be located on the lower functional classification roadway. The intersection shall only be approved if the intersection and roadway are shown to operate safely and efficiently with buildout design hour/peak hour projected traffic volumes. The intersection must also show a public benefit. An arterial progression through bandwidth percentage of 35 percent or greater must be achieved or the inclusion of a signal at the access must not degrade the existing signal progression. The intersection must not create any queuing or blocking of lane entries or access points. The intersection must be in a location such that any necessary turn, acceleration and deceleration lanes can be accommodated to maintain safe operations and capacity. The analysis should consider all potential future additional requirements for left turn or other exclusive phasing at a signal for which the need is created by traffic generated by land uses on both sides of the roadway.
 2. **Topographic and Other Limitations.** Where topography or other existing conditions make the required spacing inappropriate or unfeasible, location of the access shall be determined with consideration given to topography, established property ownerships, unique physical limitations, pre-existing historical land use patterns, and physical design constraints, with every attempt to achieve an access spacing of one-half mile. The final location shall serve as many properties as possible to reduce the need for additional direct access to the principal arterial or rural minor arterial. In selecting locations for full movement intersections, preference shall be given to roads that meet, or may be reasonably expected to meet, signal warrants in the future.
 3. **Access and Lot Division.** No additional access right shall accrue and no additional access shall be provided when splitting or dividing existing lots of land. When an alternative is reasonably available in the opinion of the ECM Administrator, all access to the newly created properties shall

be provided internally from the existing access or new access to a roadway of lower functional classification.

- C. **Urban Minor Arterial Access Criteria.** Spacing of roads accessing an urban minor arterial that will result in a full movement intersection shall be planned at one-quarter mile. However, one parcel access shall be granted to each existing lot, if it does not create safety or operational problems. The parcel access will provide for right turns only. The access may allow for left turns in (three-quarters movement) if the addition of left turns will improve the operation at an adjacent full movement intersection and meet appropriate design standards.
- D. **Collector Access Standards.** Collector roadways shall intersect another roadway (centerline to centerline) in accordance with the standards in Section 2.3.7. On minor collector roadways, the closest local roadway intersection to an arterial roadway shall be 330 feet (right-of-way line of arterial to centerline of local roadway). On major collector roadways, the closest local roadway intersection to an arterial roadway shall be 660 feet (right-of-way line of arterial to centerline of local roadway). Single-family residence access to major collector roadways is not permitted (even though existing conditions show otherwise).
- E. **Rural and Urban Local Roadways.** Roads shall not intersect urban local roadways closer than 175 feet from each other (centerline to centerline) and shall not intersect a rural local roadway closer than 330 feet from each other. On an urban local roadway, the closest intersection to a collector roadway shall be at least 200 feet (centerline to centerline). To an arterial roadway, the closest intersection shall be 330 feet (arterial right-of-way line to local roadway centerline).

2.2.6. Soils Investigations

- A. **General.** Soil investigations are conducted to help in preparing designs of roadways and other public facilities. The soil investigation report provides detailed information for use in designing facilities to maximize their performance and enhance the lifecycle costs of the asset.
- B. **Reporting Requirements.** As appropriate for the project, the following soil investigation reports shall be developed: (1) Geological Hazards Report, (2) Geotechnical Report, (3) Pavement Design Report, and (4) Inspection and Testing Report. A Professional Geologist or Professional Engineer licensed in the State of Colorado must prepare all soil investigations, as defined by Colorado State Statutes.
- C. **Purpose of Reports.**
 - 1. **Geologic Hazards Report.** This report identifies geologic conditions that may pose hazards to a proposed project.
 - 2. **Geotechnical Report.** This report evaluates the characteristics of the soils and the general issues of groundwater, soil stability, dipping bedrock, and swell/collapse potential that may pose hazards to, or affect the design of, roadway and related improvements within the right-of-way, public easements or slope easements. If groundwater is found within certain parameters, a subsurface water investigation shall be conducted to determine potential impacts to a proposed project.
 - 3. **Pavement Design Report.** This report investigates and details the characteristics of the soil and subsurface conditions affecting the roadway pavement design. The soil investigation associated with this report occurs after the roadways are graded and utilities are installed. The soil investigation associated with this report occurs after the roadways are graded and the deepest utility is installed.
 - 4. **Inspection and Testing Report.** The inspection and testing report is prepared following construction. It is based on the construction inspections and tests performed under the direct

supervision of a Professional Engineer licensed in the State of Colorado, who must sign the report as defined by Colorado State Statutes. Analysis results of all fill material shall be included in the report.

- D. **Report Preparation Guidelines.** All reports shall be prepared in conformance with the guidelines in Appendix C.

2.2.7. Pavement Design

- A. **General.** Pavement design is a critical component of roadway design. Proper pavement design helps to ensure roadway performance and reduce the lifecycle costs associated with maintaining the roadway system.
- B. **Road Paving.** Paved roads meet the paving requirements established by Roadway Functional Classifications in Section 2.2.4.
1. **New Roads.** New roadways shall be paved if it connects to an existing roadway that is paved at the time of final approval of the development or it connects to a roadway internal to the development that is required to be paved. New roadways are not required to be paved where:
 - The new roadway has a projected ADT of less the 200 ADT within the proposed 20-year design life and the new road connects to an existing gravel road or
 - The new road is located in an area of gravel roads and, to reduce the cost of maintenance, the ECM Administrator has determined that a gravel road is the most appropriate application.
 2. **Existing Roads.** Existing roadways shall be paved where:
 - Any development causes an existing gravel road to exceed a projected ADT of 200 (Note: the extent of paving will be determined by the ECM Administrator based on the Transportation Impact Study [Section 2.2.3]).
 - In accordance with the terms and conditions of BoCC Resolution 07-495 regarding the Resident Participation Program.
 3. **New Gravel Roads.** New gravel roads may be permitted in accordance with the allowances in Section 2.2.7B.1 except where:
 - The road is projected to have an ADT of 200 or more. All roads with a projected ADT of 200 or more shall be paved to facilitate compliance with Colorado Air Quality Control Commission Regulation No. 1, Emission Control Regulations for Particulates, Smokes, and Sulfur Oxides for the State of Colorado.
 - The new gravel road would be an extension of an existing paved road.
- C. **Pavement Design Report.** A Pavement Design Report is required to be submitted and approved before paving any County road. The final pavement design may be submitted after the ECM Administrator approval of the associated roadway, profile, drainage, and final construction plans. The Pavement Design Report shall conform to the requirements of Appendix D. The soil investigation associated with this report occurs after the roadways are graded and the deepest utility is installed.
- D. **Safety Edge.** Shoulders should be paved equivalent depth in accordance with the functional or physical characteristic of the roadway. The use of a safety edge (Project Special Detail D-614-1 of the CDOT Standard Plans - M & S Standards) is required in all projects having roadway pavement including but not limited to new construction and modification of transportation facilities, repair, reconstruction, resurfacing, restoration, and rehabilitation of existing transportation facilities. Instead of a vertical drop-off, the safety edge shapes the edge of the pavement to 30 to 35 degrees.

2.3. ROADWAY DESIGN

2.3.1. Roadway Design Criteria

Table 2-3 outlines the general roadway design criteria that shall guide roadway design and layout. All proposed roadway designs and layouts shall conform to the general roadway design criteria; the MTCP; and all other applicable criteria, standards, and regulations.

Table 2-3. Roadway Design Criteria

Criteria	Concern	Guideline
Ensure Vehicular and Pedestrian Access	The primary function of local roads is to serve abutting properties.	Road widths, placement of sidewalks, patterns of roads, and number of intersections are related to safe and efficient access to abutting lands.
Minimize Through Trips	Through traffic on local and collector roads potentially increases the average speed and volume. Therefore increasing the potential for accidents and reducing residential amenities.	Through traffic can be discouraged between neighborhoods and higher volume roads by creating a circuitous route, channeling or controlling median crossings along peripheral routes.
Control Access to Arterials	Local circulation systems and land development patterns should not detract from the efficiency of peripheral arterial facilities. The local roads that intersect arterial systems will tend to have higher volumes since they tend to be primarily exit points.	The number of access points between local circulation systems and adjacent arterial roads should be minimized. Intersections along arterial routes should be properly spaced for efficient signalization and traffic flow.
Discourage Speeding	Residential roads should be designed to discourage fast movement.	Use of curvilinear alignments, traffic calming devices, and circuitous routes in the road system.
Minimize Modal Conflicts (bike, pedestrian, transit, low speed vehicles)	Pedestrian travel from within the area to points outside should require a minimal number of road crossings.	Typical methods include use of cul-de-sacs and looped roads, special pedestrian routes or walkways, and the proper placement of high pedestrian traffic generators. In general, vehicular flow must be outward oriented to the peripheral arterials and pedestrian travel should be inward-oriented to avoid these heavier vehicular flows.
Minimize Space Devoted to Road Use	It is desirable to minimize local road mileage, thereby reducing construction and maintenance costs, as well as permitting the most efficient use of land. Roads should also have an appearance commensurate with their function.	Roads should be designed to complement local character.
Relate Road to Topography	Local roads are more attractive and economical if constructed to closely	The important role that roads play in the overall storm drainage system can be

	adhere to topography (minimize cut and fill).	enhanced by closely following existing topography.
Layout Road to Achieve Optimum Subdivision of Land	The arrangement of roads should allow for economical and practical patterns, shapes, and sizes of adjacent lots. Roads as a function of land use must not unduly hinder the development of land.	Distances between roads, number of roads, and related elements all have a bearing on efficient subdivision of an area. Access to adjoining properties should also be encouraged.

2.3.2. Design Standards by Functional Classification

Section 2.2.4 of these standards identifies the Roadway Functional Classifications recognized and used by the County. Table 2-4 through Table 2-7 summarize many of the minimum roadway design standards by category and functional classification. Detailed road Standard Drawings are provided in Appendix F.

Table 2-4. Roadway Design Standards for Rural Expressways and Arterials

Criteria	Expressways		Arterials		
	6 Lane	4 Lane	6 Lane Principal	4 Lane Principal	Minor
Design Speed/Posted Speed (MPH)	70/65	70/65	70/65	70/65	60/55
Clear Zone	See Table 2-16	See Table 2-16	See Table 2-16	See Table 2-16	See Table 2-16
Minimum Centerline Curve Radius	2,050 ¹	2,050 ¹	2,050 ¹	2,050 ¹	1,505 ¹
Number of Through Lanes	6	4	6	4	2
Lane Width	12'	12'	12'	12'	12'
Right-of-Way	210'	180'	210'	180'	100'
Paved Width (excluding safety edge)	56' ²	38' ²	56' ²	38' ²	40'
Median Width	24'	24'	24'	24'	n/a
Outside Shoulder Width (paved/gravel)	12'(10'/2')	12'(10'/2')	12'(10'/2')	12'(10'/2')	10'(8'/2')
Inside Shoulder Width (paved/gravel)	12'(10'/2')	6'(4'/2')	12'(10'/2')	6'(4'/2')	n/a
Design ADT		48,000		40,000	10,000
Design Vehicle	WB-67	WB-67	WB-67	WB-67	WB-67
Access Permitted	No	No	No	No	No
Access Spacing	n/a	n/a	n/a	n/a	n/a
Intersection Spacing	1 mile	1 mile	½ mile	½ mile	¼ mile
Parking Permitted	No	No	No	No	No
Minimum Flowline Grade	1%	1%	1%	1%	1%
Centerline Grade (Min.—Max.)	1—5%	1—5%	1—5%	1—5%	1—6%
Intersection Grades (Min.—Max.)	1—2%	1—2%	1—3% ³	1—3% ³	1—4% ³
¹ Assumes 4% superelevation, 6% for 70 MPH design speeds					
² Pavement width in each direction for divided roadways					

³ Where pedestrian crosswalks are anticipated at intersections, maximum grade at crosswalks with stop/yield control is 2%

Table 2-5. Roadway Design Standards for Rural Collectors and Locals

Criteria	Collectors		Local	
	Major	Minor	Local	Gravel
Design Speed/Posted Speed (MPH)	50/45	40/35	30/30	30/30 ⁵
Clear Zone	See Table 2-16	See Table 2-16	See Table 2-16	See Table 2-16
Minimum Centerline Curve Radius	930' ²	565'	300'	As Approved
Number of Through Lanes	2	2	2	2
Lane Width	12'	12'	12'	12'
Right of Way	90'	80'	70' ³	70' ³
Paved Width (excluding safety edge)	32'	32'	28'	n/a
Median Width	n/a	n/a	n/a	n/a
Outside Shoulder Width (paved/gravel)	8'(4'/4')	6'(4'/2')	4'(2'/2')	4'(0'/4')
Inside Shoulder Width (paved/gravel)	n/a	n/a	n/a	n/a
Design ADT	3,000	1,500	750	200
Design Vehicle	WB-67	WB-67	WB-50	WB-50
Access Permitted	No	Yes	Yes	Yes
Access Spacing	n/a	Frontage	Frontage	Frontage
Intersection Spacing	¼ mile	660'	330'	330'
Parking Permitted	No	Yes	Yes	No
Minimum Flowline Grade	1%	1%	1%	1%
Centerline Grade (Min.-Max.)	1—8% ¹	1—8% ¹	1—8% ¹	1—8%
Intersection Grades (Min.-Max.)	1—4% ⁴	1—4% ⁴	1—4% ⁴	1—4% ⁴
¹ 10% maximum grade permitted at the discretion of the ECM Administrator				
² Assumes 4% superelevation, 6% for 70 MPH design speeds				
³ 60-foot right-of-way plus two 5-foot Public Improvements Easements granted to El Paso County				
⁴ Where pedestrian crosswalks are anticipated at intersections, maximum grade at crosswalks with stop/yield control is 2%				
⁵ For existing gravel roads, design and posted speeds may exceed this criterion at the ECM Administrator's discretion.				

Table 2-6. Roadway Design Standards for Urban Expressways and Arterials

Criteria	Expressways		Arterials		
	6 Lane	4 Lane	6 Lane Principal	4 Lane Principal	Minor
Design Speed/Posted Speed (MPH)	60/55	60/55	50/45	50/45	40/35
Clear Zone	See Table 2-16	See Table 2-16	See Table 2-16	See Table 2-16	See Table 2-16
Minimum Centerline Curve Radius	1,505' ¹	1,505' ¹	930' ¹	930' ¹	565'

Created: 2021-06-08 11:35:48 [EST]

(Supp. No. 2)

Number of Through Lanes	6	4	6	4	4
Lane Width	12'	12'	12'	12'	12'
Right-of-Way	160'	140'	160'	130'	100'
Paved Width (Excluding Gutter Pan)	48' ²	36' ²	48' ²	36' ²	62'
Median Width (Including Curb & Gutter)	31'	23'	31'	19'	14'
Shoulder Width (Ext., Excluding Gutter)	8'	8'	8'	8'	n/a
Shoulder Width (Int., Excluding Gutter)	4'	4'	4'	4'	n/a
Required Curb/ Gutter Type	6" ramp	6" ramp	6" vertical	6" vertical	6" vertical
Sidewalk Width	6' detached	6' detached	6' detached	6' detached	6' detached
Design ADT		48,000		40,000	20,000
Design Vehicle	WB-67	WB-67	WB-67	WB-67	WB-67
Bike Lanes Permitted	No	No	Yes	Yes	No
Access Permitted	No	No	No	No	No ³
Access Spacing	n/a	n/a	n/a	n/a	See Table 2-35
Intersection Spacing	1 mile	1 mile	½ mile	½ mile	¼ mile
Parking	No	No	No	No	No
Minimum Flowline Grade of Curb	.50%	.50%	.50%	.50%	.50%
Centerline Grade (Min.-Max.)	0.5—5%	0.5—5%	0.5—6%	0.5—6%	0.5—6%
Intersection Grades (Min.-Max.)	0.5—2%	0.5—2%	0.5—3% ⁴	0.5—3% ⁴	0.5—4% ⁴
¹ Assumes 4% superelevation, 6% for 70 MPH design speeds					
² Pavement width in each direction for divided roadways					
³ Where no local public or private roadway can provide access, temporary or partial turn movement parcel access may be permitted					
⁴ Maximum grade at crosswalks with stop/yield control is 2%					

Table 2-7. Roadway Design Standards for Urban Collectors and Locals

Criteria	Collectors		Local	
	Non-Residential	Residential	Local	Local ⁴ (low volume)
Design Speed/Posted Speed (MPH)	40/35	40/35	25/25	20/20
Clear Zone	See Table 2-16	See Table 2-16	See Table 2-16	See Table 2-16
Minimum Centerline Curve Radius	565'	565'	200'	100'
Number of Through Lanes	2	2	2	2
Lane Width	12'	12'	12'	12'
Right-of-Way	80'	60'	60' ³	60' ³
Paved Width (Excluding Gutter Pan)	48'	36'	30'	24'
Median Width (Including Curb & Gutter)	12'	n/a	n/a	n/a

Shoulder Width (Ext., Excluding Gutter)	6'	6'	n/a	n/a
Shoulder Width (Int., Excluding Gutter)	n/a	n/a	n/a	n/a
Required Curb/ Gutter Type (Vertical)	6"	6"	6" (or ramp)	6" (or ramp)
Sidewalk Width (@ from top back of curb when attached)	5' detached	5' detached	5' attached	5' attached
Design ADT	20,000	10,000	3,000	300
Design Vehicle	WB-50	WB-50	WB-50	SU-30
Bike Lanes Permitted	No	Yes	No	No
Access Permitted	No ⁵	No ⁵	Yes	Yes
Access Spacing	See Table 2-35	See Table 2-35	Frontage	Frontage
Intersection Spacing	660' ²	660' ²	175'	150'
Parking Permitted	No	No	Yes	Yes
Minimum Flowline Grade of Curb	.50%	.50%	.50%	.50%
Centerline Grade (Min.-Max.)	0.5—6% ¹	0.5—8% ¹	0.5—8% ¹	0.5—8% ¹
Intersection Grades (Min.-Max.)	0.5—4% ⁶	0.5—4% ⁶	0.5—4% ⁶	0.5—4% ⁶
¹ 10% maximum centerline grade permitted (ADA accessibility requirements shall still be met) at the discretion of the ECM Administrator				
² 330 feet when intersecting local roadways				
³ 50-foot right-of-way plus two 5-foot Public Improvements Easements granted to El Paso County				
⁴ Section can be used for cul-de-sacs, or roads with two ways out having a maximum of 300 ADT and a maximum length of 1,200 feet				
⁵ Where no local public or private roadway can provide access, temporary or partial turn movement parcel access may be permitted				
⁶ Maximum grade at crosswalks with stop/yield control is 2%				

2.3.3. Horizontal Alignment

- A. **General Criteria.** Proper roadway alignment provides for safe and continuous operation at a uniform design speed. Proposed road layouts shall have a logical relationship to existing or platted roads and fit within the overall transportation plan.
- B. **Intersections.** All new roadways must intersect at or nearly at right angles. Modified roadways shall intersect at or nearly at right angles or otherwise allow for safe operation as determined by the ECM Administrator.
- C. **Design Speed.** Design speed is a speed selected to determine the various geometric design features of a roadway. Design speed shall be used to determine stopping sight distance and intersection sight distance requirements for new road facilities. The design speeds by functional classification are provided in Table 2-4 through Table 2-7.
- D. **Superelevation.**
 - 1. **General.** The maximum rate of superelevation is controlled by factors including climate conditions, terrain conditions, land use characteristics (rural or urban), and frequency of slow-moving vehicles. For a given design speed, the superelevation rate applied shall have a logical relationship to the side friction factor.

2. **Establishing the Rate.** Superelevation shall be consistent with Table 2-8, the AASHTO Green Book, and CDOT M & S Standards. However, the maximum rate used for expressways shall be 0.060 and arterial roadways shall be 0.040. Superelevation is not permitted on roadways with design speeds less than 50 MPH.
3. **Adjustments to the Rate.** Standard rates of superelevation must be maintained throughout the curve when possible. In general, roadway intersections, established roadway grades, curb, and adverse drainage conditions may require a reduction in the rate of superelevation or the application of different rates for each half of the roadway to create a safe condition in an urban environment. In areas where pavement warping is required for adverse drainage, superelevations should be avoided.

Table 2-8. Design Values for Rate of Superelevation (e) and Minimum Length of Runoff

R (feet)	V _d =50 MPH			V _d =60 MPH			V _d =70 MPH ¹					
	e (%)	L (feet)		e (%)	L (feet)		e (%)	L (feet)				
		2 Ls	4 Ls		2 Ls	4 Ls		2 Ls	4 Ls			
23,000	NC	0	0	NC	0	0	NC	0	0			
20,000	NC	0	0	NC	0	0	NC	0	0			
17,000	NC	0	0	NC	0	0	NC	0	0			
14,000	NC	0	0	NC	0	0	NC	0	0			
12,000	NC	0	0	NC	0	0	RC	60	90			
10,000	NC	0	0	NC	0	0	2.1	63	95			
8,000	NC	0	0	RC	53	80	2.5	75	113			
6,000	RC	48	72	2.3	61	92	3.2	96	144			
5,000	RC	48	72	2.5	67	100	3.7	111	167			
4,000	2.3	55	83	2.8	75	112	4.4	132	198			
3,500	2.5	60	90	3.0	80	120	4.9	147	221			
3,000	2.7	65	97	3.3	88	132	5.3	159	238			
2,500	2.9	70	104	3.5	93	140	5.8	174	251			
2,000	3.2	77	115	3.8	101	152	R_{min}=2050					
1,800	3.3	79	119	3.9	104	156						
1,600	3.5	84	126	4.0	107	160						
1,400	3.7	89	133	R_{min}=1505								
1,200	3.9	94	140									
1,000	4.0	96	144									
	R_{min}=930											
where:												
e _{max} = 4% (Recommended by the ECM Administrator, must obtain approval for differences)												
R = radius of curve, feet												
V _d = design speed												
e = rate of superelevation												
L = minimum length of runoff (does not include tangent runoff)												
NC = normal crown section												
RC = remove adverse crown, superelevate at normal slope												
¹ e _{max} = 6% for V=70MPH												

- E. **Horizontal Curve Radii.** Horizontal alignment design speed must be consistent with the requirement for vertical alignment design speed. The minimum acceptable design radii are shown in Tables 2-4

through 2-7. Reverse and compound curves should be used only when a single radius curve will not work. For driver safety, compound curves shall have a ratio no greater than 1.5 where the value of the larger radius is divided by the smaller radius.

F. Minimum Tangent Length.

- 1. Intersection.** Whenever a roadway intersects a roadway of higher classification, a tangent length (measured from the nearest gutter flowline of the intersected roadway to the point of curvature in the intersecting roadway) shall be provided for a safe sight distance and traffic operation. The minimum required tangent lengths indicated in Table 2-9 only apply to the roadways with lower functional classifications. The angle of departure shall not exceed 10 degrees for the length of tangent.

Table 2-9. Minimum Tangent Lengths at Intersection

Higher Classification Roadway (below)	Lower Classification Intersecting Roadway			
	Local	Collector	Arterial	Expressway
Expressway	n/a	n/a	250	Special Design ^{1, 2}
Arterial	n/a	200	250 ¹	n/a
Collector	n/a	200 ¹	n/a	n/a
¹ In the case of where each intersecting roadway is of the same classification, the ECM Administrator will designate which roadway takes precedence				
² Use AASHTO, A Policy on Geometric Design of Highways and Roadways for design requirements				

- 2. Reverse Curves.** The tangent between reverse curves shall be no less than the length shown in Table 2-10.
- 3. Broken Back Curves.** Two curves in the same direction (broken back curves) shall be separated by a tangent with a length of at least two times the minimum length shown in Table 2-10. For local roadways, a minimum tangent of 200 feet shall be used to separate all broken back curves.

Table 2-10. Minimum Tangent Lengths between Curves

Roadway Classification	Minimum Tangent Length (Feet)
Expressway	250
Arterial	200
Collector	150

- G. Consistent Radii.** All curves along a roadway shall be designed with radii that are approximately equal to provide consistency and minimize unexpected maneuvers for the driver.
- H. Curves with Small Deflection Angles (10° or less).** High volume roadways using minimum length curves shall be designed with the minimum centerline arc lengths shown in Table 2-11. All other roadways shall be designed for safe travel and to create a smooth appearance.

Table 2-11. Centerline Arc Lengths

Functional Classification	Minimum Centerline Arc Length (feet)
Expressway	500
Arterial	400

-
- I. **Horizontal Curves on Vertical Curves.** Horizontal curves shall not begin near the crest of a vertical curve nor near the bottom of a sag vertical curve.
 - J. **Lane Shifts or Drops.** Transitions for roadways are useful in maintaining the safety, traffic flow, and operations of the roadway and access. When the County requires a lane shift or drop based on information obtained in a TIS, the design, installation, and purchase of the right-of-way to accommodate the required lanes is the responsibility of the owner, applicant or developer.
 - K. **Joining Existing Improvements.** Connection with existing roadways shall be made to match the alignment grade of the existing improvements, in accordance with the horizontal alignment criteria.
 - L. **Effect of Grade.** Grade affects the operating speeds of vehicles and should be recognized as a critical issue in the design of roadways. Where practical, the roadway should be designed for a higher design speed on the downgrade portions and a lower design speed on the upgrade. This variation in design speed will depend on the rate and length of grade and the degrees of curvature, as compared with other curves on the roadway section.
 - M. **Sight Distance on Horizontal Curves.** The proposed horizontal alignment must provide for the minimum stopping distance for the design speed at all points along the roadway. In addition, the design must take into account the visibility at intersections, around curves, and roadside encroachments.
 - N. **Future Extension Confirmation.** When a roadway is designated within the MTCP for future extension, additional survey and preliminary design beyond the current project boundaries may be requested by the ECM Administrator to confirm coordination.

2.3.4. Vertical Alignment

- A. **Vertical Curves.** Vertical curves may either be a crest or sag-type curve (See Figure 2-18).
 - 1. **Crest Vertical Curves.** Figure 2-19 and Table 2-12 show the required lengths of vertical curves for different algebraic differences in grade to provide required stopping sight distances for each design speed.

Design values of crest vertical curves for passing sight distance differ from those for stopping sight distance because of the different height criterion (4.25 feet instead of 0.5 feet). K-values for crest vertical curves based on passing sight distance are shown in Table 2-13.

Figure 2-18. Types of Vertical Curves

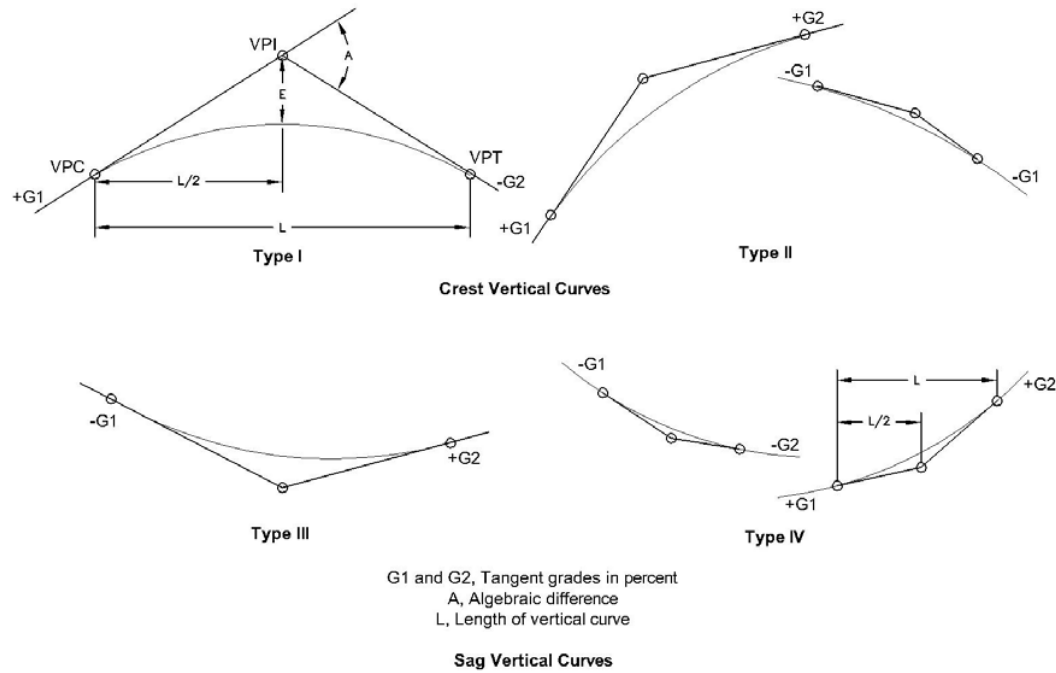

Figure 2-19. Design Controls for Stopping Sight Distances on Crest Vertical Curves

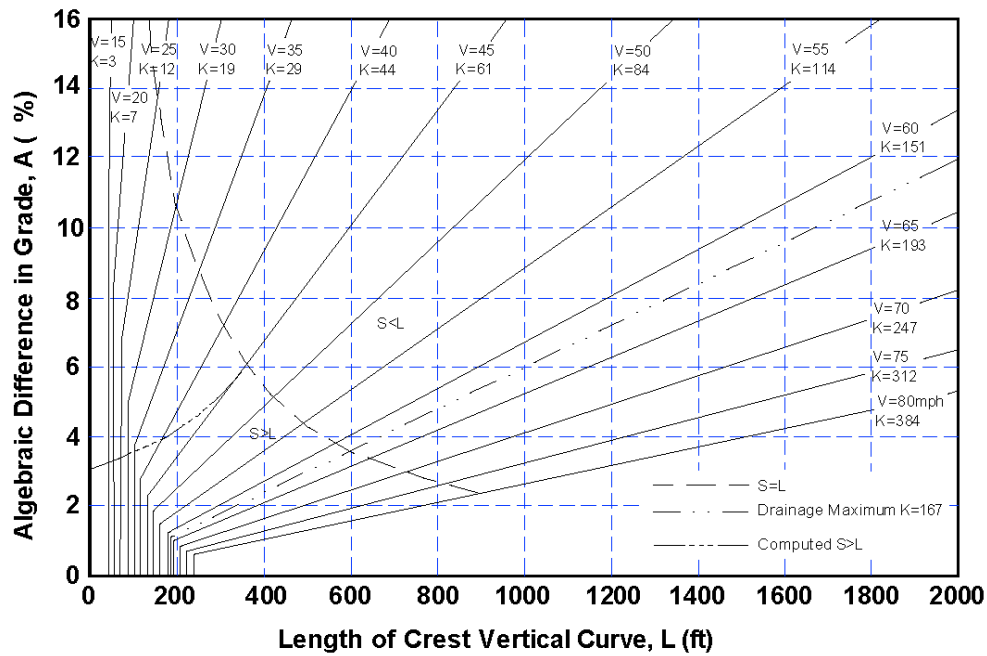

Table 2-12. Design Controls for Stopping Sight Distances on Crest Vertical Curves

Design Speed (MPH)	Stopping Sight Distance (feet)	Rate of Vertical Curvature, K ¹	
		Calculated	Design
25	155	11.1	12
30	200	18.5	19
40	305	43.1	44
50	425	83.7	84
60	570	150.6	151
70	730	246.9	247
¹ Assumes an eye height of 3.5 feet and an object height of 2 feet under open road conditions.			
Where:			
K = rate of vertical curvature $K = L/A$, the length of curve per percent algebraic difference in intersecting grades)			
L = length of vertical curve, feet			
A = algebraic differences in intersecting grades			
S = estimated sight distance, feet			

Table 2-13. Design Controls for Passing Sight Distance on Crest Vertical Curves

Design Speed (MPH)	Minimum Passing Sight Distance (feet)	Rate of Vertical Curvature, K ¹
25	900	289
30	1090	424
40	1470	772
50	1835	1203
60	2135	1628
70	2480	2197
¹ Assumes an eye height of 3.5 feet and an object height of 3.5 feet under open road conditions.		
Where:		
K = rate of vertical curvature ($K = L/A$, the length of curve per percent algebraic difference in intersecting grades)		
L = length of vertical curve, feet		
A = algebraic differences in intersecting grades		
S = estimated sight distance, feet		

2. **Sag Vertical Curves.** Table 2-14 and Figure 2-20 show the required lengths of sag vertical curves for different algebraic differences in grade to provide required stopping sight distances for each design speed.

Figure 2-20. Design Controls for Stopping Distances on Sag Vertical Curves

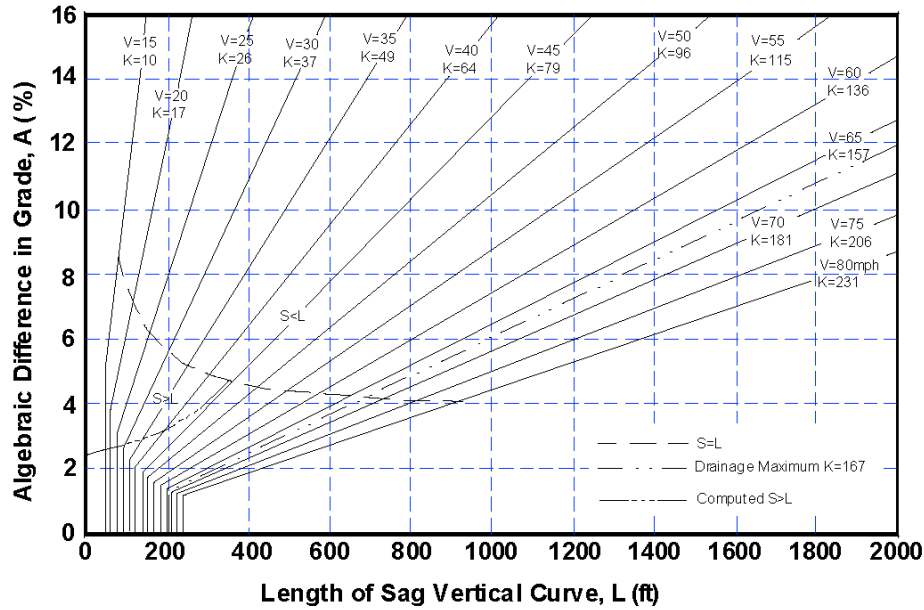

Table 2-14. Design Controls for Stopping Distance on Sag Vertical Curves

Design Speed (MPH)	Stopping Sight Distance (feet)	Rate of Vertical Curvature, K ¹	
		Calculated	Design
25	155	25.5	26
30	200	36.4	37
40	305	63.4	64
50	425	95.7	96
60	570	135.7	136
70	730	180.3	181

¹ Assumes an eye height of 3.5 feet and an object height of 0.5 feet under open road conditions.

Where:

K = rate of vertical curvature ($K = L/A$, the length of curve per percent algebraic difference in intersecting grades)

L = length of vertical curve, feet

A = algebraic differences in intersecting grades

S = estimated sight distance, feet

- B. **Maximum and Minimum Grades for Roadways.** The maximum and minimum grades for specific roadway classifications are shown in Table 2-15. The centerline grade in the bulb of a cul-de-sac shall not exceed 3 percent.

Table 2-15. Minimum and Maximum Roadway Grades

Functional Classification or Facility Type	Maximum Centerline Grade (%)	Minimum Centerline Grade (%)	Minimum Gutter Flowline Grade (%)	Minimum Roadside Ditch Flowline Grade (%)
Expressway (Urban/Rural)	5/5	0.5/1	0.5	1

Arterial (Urban/Rural)	6/5 or 6 (for minor)	0.5/1	0.5	1
Collector (Urban/Rural)	8 ^{1,2} /8 ¹	0.5/1	0.5	1
Local (Urban/Rural)	8 ¹ /8 ¹	0.5/1	0.5	1
Cul-De-Sac	3		1	0.5
¹ 10% maximum grade permitted at the discretion of the ECM Administrator				
² 6% maximum grade permitted for Non-residential Collector				

- C. **Joining Existing Improvements.** Connection with existing roadways shall be made to match the grade of the existing improvements, in accordance with vertical alignment criteria.
- D. **Intersection Approach Grades.** Intersection approach grades can be found in Section 2.3.7C.4.
- E. **Grade Breaks and Vertical Curves.** Vertical curves are required when the algebraic difference in grades is equal to or greater than 1.0%. In addition, the maximum grade break allowed at the point of tangency at a curb return for local and collector roads shall be 2%. Grade breaks of less than 1.0% are permitted.
- F. **Cross Fall.** Except at intersections or where a superelevation is required, roadways must be designed to maintain a level cross slope from top of curb to top of curb (or flowline to flowline). The distance from an intersection where cross-fall will be permitted shall be determined by the ECM Administrator.
- G. **Spiral Curves.** Major and minor arterial roadways may be designed with spiral curves with approval of the ECM Administrator.
- H. **Future Extension Confirmation.** When a roadway is designated within the MTCP for future extension, additional survey and preliminary design beyond the current project boundaries may be requested by the ECM Administrator to confirm coordination.

2.3.5. Clear Zones

Clear zones and recovery areas shall conform to CDOT Highway Access Code, AASHTO Green Book, and AASHTO Roadside Design Guide, as modified by Table 2-16. Where a site-specific investigation indicates a high probability of continuing crashes, or such occurrence are indicated by crash history, the greater clear-zone distances may be required by the ECM Administrator. Clear zones may be limited to 30 feet, when approved by the ECM Administrator, to provide a consistent roadway template if previous experience with similar projects or designs indicates satisfactory performance. In addition, in no case shall a permanent structure, including light poles, fire hydrants or trees be placed within these clear zones or in any other location that would obstruct sight distances without prior approval from the ECM Administrator.

Table 2-16. Clear Zone Distances¹

Design Speed	Design ADT	1V:6H or flatter	Foreslopes 1V:5H to 1V:4H	1V:3H	1V:3H	Backslopes 1V:5H to 1V:4H	1V:6H or flatter
40 mph or less	Under 750	7—10	7—10	²	7—10	7—10	7—10
	750—1,500	10—12	12—14	²	10—12	10—12	10—12
	1,500—6,000	12—14	14—16	²	12—14	12—14	12—14
	Over 6,000	14—16	16—18	²	14—16	14—16	14—16
50 mph	Under 750	10—12	12—14	²	8—10	8—10	10—12
	750—1,500	12—14	16—20	²	10—12	12—14	14—16

Created: 2021-06-08 11:35:48 [EST]

(Supp. No. 2)

	1,500— 6,000	16—18	20—26	²	12—14	14—16	16—18
	Over 6,000	18—20	24—28	²	14—16	18—22	20—22
60 mph	Under 750	16—18	20—24	²	10—12	12—14	14—16
	750—1,500	20—24	26—32*	²	12—14	16—18	20—22
	1,500— 6,000	26—30	32—40*	²	14—18	18—22	24—26
	Over 6,000	30—32*	36—44*	²	20—22	24—26	26—28
70 mph	Under 750	18—20	20—26	²	10—12	14—16	14—16
	750—1,500	24—26	28—36*	²	12—16	18—20	20—22
	1,500— 6,000	28—32*	34—42*	²	16—20	22—24	26—28
	Over 6,000	30—34*	38—46*	²	22—24	26—30	28—30

¹ Distances are provided in feet from the edge of the through lane.

² Since recovery is less likely on the unshielded, traversable 1V:3H slopes, fixed objects should not be present in the vicinity of the toe of these slopes. Recovery of high-speed vehicles that encroach beyond the edge of the shoulder may be expected to occur beyond the toe of the slope. Determination of the width of the recovery area at the toe of slope should take into consideration right-of-way availability, environmental concerns, economic factors, safety needs, and crash histories. Also, the distance between the edge of the through-traveled lane and the beginning of the 1V:3H slope should influence the recovery area provided at the toe of slope.

2.3.6. Sight Distance

Sight distance is the length of roadway that is clearly visible to the driver and is dependent upon the height of the driver's eye above the road surface, the specified object height above the road surface, and the height of sight obstructions within the line of sight. The minimum sight distance available on a roadway should be sufficient to enable a vehicle traveling at or near the design speed to stop before reaching a stationary object. In evaluating the overall performance of a roadway, both the horizontal and vertical sight distances should be considered.

- A. **Sight Distance Calculations.** For general sight distance calculations, the height of the driver's eye is considered to be 3.5 feet above the road surface and the object is considered to be 2 feet above the road surface. However, for passing sight distance calculations, the height of the object is considered to be 4.25 feet above the road surface.

The sight distance design shall assume that a 6-foot-high fence (as measured from actual finish grade) exists at all property lines except where a sight distance easement has been established.

- B. **Stopping Sight Distance on Straight Roadways.** The minimum stopping sight distance is the distance required by the driver of a vehicle traveling at the design speed to bring the vehicle to a stop after an object on the road becomes visible. Stopping sight distance is the sum of the braking distance and the brake reaction time (the interval between the instant that the driver recognizes the existence of an object on the roadway and the instant the driver applies the brakes). The braking distance is related to the initial speed and the coefficient of friction between the tires and the roadway. The wet condition governs the stopping distances for purposes of design. Table 2-17 provides the required minimum stopping sight distances on straight roadways with grades of less than 3%. In no case shall the stopping sight distance be less than as specified in Table 2-17. For grades in excess of 3%, refer to Table 2-18.

Table 2-17. Stopping Sight Distances

Design Speed (MPH)	Brake Reaction Distance (feet) ¹	Braking Distance on Level (feet)	Stopping Sight Distance	
			Calculated (feet)	Design (feet)
25	91.9	60.0	151.9	155
30	110.3	86.4	196.7	200
40	147.0	153.6	300.6	305
50	183.8	240.0	423.8	425
60	220.5	345.5	566.0	570
70	257.3	470.3	727.6	730

¹ Brake reaction distance predicted on a time of 2.5 seconds; deceleration rate of 11.2 feet/second used to determine calculated sight distance.

- C. **Stopping Sight Distance on Horizontal Curve.** Stopping sight distance on horizontal curves is based upon lateral clearance from the inner edge of pavement to sight obstruction, for various radii of inner edge of pavement and design speeds. The position of the driver's eye and the object sighted shall be assumed to be 6 feet from the inner edge of pavement, with the sight distance being measured along this arc. Figure 2-21 is a design chart showing the required middle ordinates for clear sight areas to satisfy stopping sight distances required for curves of various degrees. Figure 2-21 utilizes the stopping sight distance values in Table 2-17. A value at or approaching the upper limit should be used as a minimum wherever conditions permit.

Figure 2-21. Design Controls for Stopping Distance on Horizontal Curve

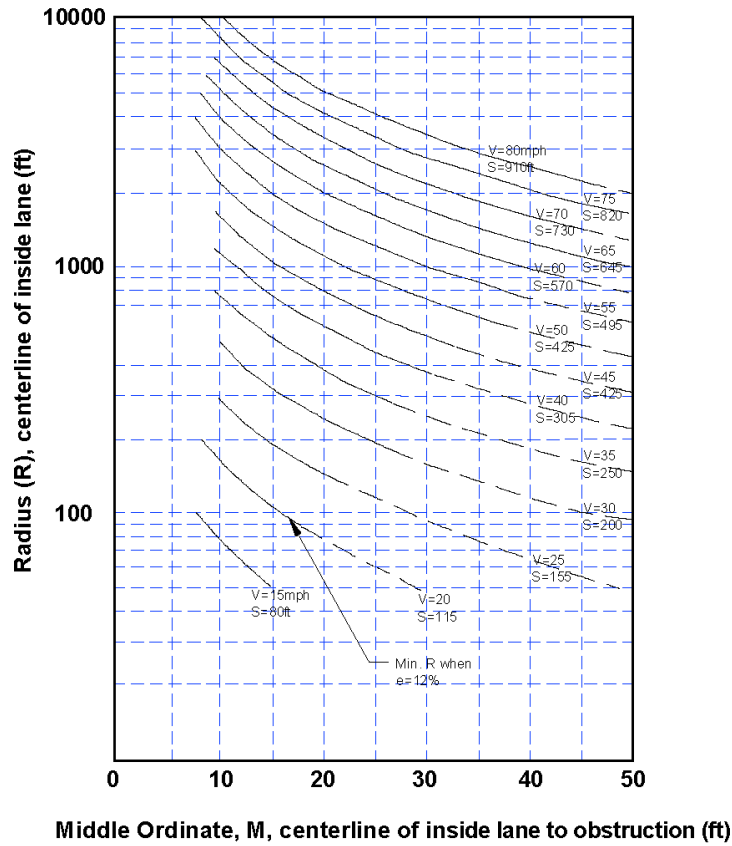

Where:

V=design speed, MPH

M=middle ordinate, centerline of inside lane to obstruction, feet

R=radius of inside lane, feet

S=estimated sight distance, feet (See Table 2-17)

- D. **Stopping Sight Distances at Grade.** When a roadway is constructed on a grade steeper than 3 percent, the braking distance should not only include to the initial speed and coefficient of friction, but also the percent grade (both up and down). Table 2-18 provides the required stopping sight distances at grade in wet conditions.

Table 2-18. Stopping Distance at Grade

Design Speed (MPH)	Downgrades			Design Speed (MPH)	Upgrades		
	Stopping Distance (feet)				Stopping Distance (feet)		
	3%	6%	9%		3%	6%	9%
25	158	165	173	25	147	143	140
30	205	215	227	30	200	184	179
40	315	333	354	40	289	278	269

50	446	474	507	50	405	288	375
60	598	638	686	60	538	515	495
70	771	825	891	70	690	658	631

- E. **Decision Sight Distance in Areas of Visual Noise.** Decision sight distance is defined as the distance it takes for a driver to detect an unexpected or difficult-to-perceive hazard along the roadway that may be visually cluttered, recognize this hazard, select an appropriate speed and path, and complete the required safety maneuver. Based on this definition, these values tend to be greater than stopping sight distances. Interchanges and intersections, locations where unusual or unexpected maneuvers are required, changes in cross section, and areas of "visual noise" are examples of locations where decision sight distances may be needed. Table 2-19 provides the required decision sight distances.

Table 2-19. Decision Sight Distance

Design Speed (MPH)	Decision Sight Distance for Avoidance Maneuver (feet)				
	A	B	C	D	E
30 or less	220	490	450	535	620
40	330	690	600	715	825
50	465	910	750	890	1,030
60	610	1,150	990	1,125	1,280
70	780	1,410	1,105	1,275	1,445
Where:					
Avoidance Maneuver A = stop on rural road (t = 3.0 seconds)					
Avoidance Maneuver B = stop on urban road (t = 9.1 seconds)					
Avoidance Maneuver C = speed/path/direction change on rural road (t = 10.2 - 11.2 seconds)					
Avoidance Maneuver D = speed/path/direction change on suburban road (t = 12.1 - 12.9 seconds)					
Avoidance Maneuver E = speed/path/direction change on urban road (t = 14.0 - 14.5 seconds)					

- F. **Passing Sight Distance for Two-Lane Roads.** Passing sight distance is the minimum distance (traveling at the design speed) that must be available to enable the driver of one vehicle to pass another safely and comfortably without interfering with oncoming traffic. Required passing sight distances are provided in Table 2-20.

Table 2-20. Minimum Passing Sight Distance for Two-Lane Roads

Design Speed (MPH)	Assumed Speeds		Passing Sight Distance (feet)	
	Passed Vehicle (MPH)	Passing Vehicle (MPH)	Figure 2-22	Design
25	22	32	897	900
30	26	36	1,088	1,090
40	34	44	1,470	1,470
50	41	51	1,832	1,835
60	47	57	2,133	2,135
70	54	64	2,479	2,480

Figure 2-22. Total Passing Sight Distance for Two-Lane Roads

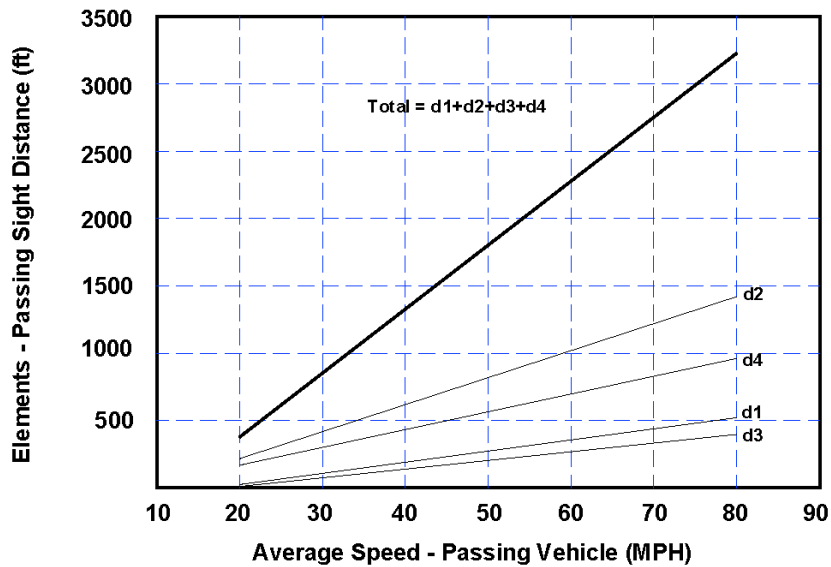

- d1 - distance traversed during perception and reaction time and during initial acceleration to the point of encroachment on the left lane
- d2 - distance traveled while the passing vehicle occupies the left lane
- d3 - distance between the passing vehicle at the end of its maneuver and the opposing vehicle
- d4 - distance traversed by an opposing vehicle for two-thirds of the time the passing vehicle occupies the left lane, or 2/3 of d2

G. **Intersection sight distance.** This section applies to intersections where one public road meets a second public road. The intersection sight distance provides for vehicles to enter traffic and accelerate to the average running speed. Intersection sight distances shall be measured as shown on Figure 2-23. The intersection sight distance shall be per AASHTO Green Book . .

Figure 2-23. Sign Distance Triangle (Stop Controlled) Replace this figure with AASHTO figure

Table 2-21. Intersection Sight Distance

Higher Functional Classification Roadway Design Speed (MPH)	Intersection sight distance (feet) ^{1, 3}
50	555
40	445
30	335 ²
25	280 ²
¹ Intersection sight distance measured from a point on the minor road at 13 feet back from the edge of the major road pavement ("D") and measured from a height of eye at 3.5 feet on the minor road to a height of object at 3.5 feet on the major road.	
² At road intersections only, "D" shall be per AASHTO 9.5.3.	
³ These values only apply to two-lane roads with stop control, all other situations require special design considerations.	

-
1. **Sight Distance Triangles within Easements.** There shall be an unobstructed sight distance along both approaches and both sides at an intersection (within the right-of-way) for distances sufficient to allow the operators of vehicles, approaching simultaneously, to see each other in time to prevent collisions at the intersection.

All sight distance triangles must be within the public right-of-way or a sight distance easement (See Figure 2-23). If the line of sight crosses onto private property, a "Sight Distance Easement" shall be dedicated to provide the required sight distance. The easement or right-of-way shall be dedicated to the County. Maintenance of a sight distance easement shall be the responsibility of the property owner or the homeowners' association unless otherwise approved by the County.

2. **Encroachment into Sight Distance Triangles or Easements.** Any object within the sight distance triangle or easement more than 30 inches above the flowline elevation of the adjacent roadway shall constitute a sight obstruction, and shall be removed or lowered. The objects may include but are not limited to berms, buildings, parked vehicles on private property, cut slopes, hedges, trees, bushes, utility cabinets or tall crops. Trees may be permitted at the discretion of the ECM Administrator if pruned to at least 8 feet above the flowline elevation of the adjacent roadway.

3. **On-Roadway Parking within Sight Distance Triangles.** The ECM Administrator may limit on-street parking to protect visibility and enhance roadway capacity.

2.3.7. Intersections

- A. **Intersection Design Guidelines.** Intersections shall be designed to provide safe movement for all those using roadways within the County (motorists, pedestrians, and bicyclists). By their nature, intersections are conflict locations. Vehicles, pedestrians, and bicycles all cross paths. Each crossing is a conflict point. The basic design of intersections includes the following objectives:

- Minimize points of conflict
- Simplify areas of conflict
- Limit conflict frequency
- Limit conflict severity

- B. **Intersection Spacing and General Access Standards.** Full movement intersections and major accesses spacing shall meet the requirements in Section 2.2.5. While access to a major roadway should be avoided, right-in/right-out and three quarter movement accesses may be permitted as a deviation if they meet the criteria for sight distances, turn lane requirements, grades and do not negatively impact traffic operations or safety. The applicant shall have the burden of proof that no other "viable or practical" property access is available. A deviation request should be supported by a traffic study or memorandum that provides information to assist the ECM Administrator in determining the proposed deviation minimizes negative safety and other operational impacts along upstream and downstream roadway segments. The addition of such an access shall minimize impacts to queuing or blocking of lane entries or access points and minimize impacts to progression. The access must be in a location such that any necessary turn lanes and acceleration/deceleration lanes can be accommodated to maintain safe operations and capacity. The analysis should consider all potential future additional requirements - to accommodate traffic generated by adjacent land uses. Buildout design hour/peak hour projected traffic volumes should be used.

- C. **Intersection Alignment.**

1. **Offset.** All lanes traversing an intersection shall be in alignment. A maximum 2-foot lane offset may be approved by the ECM Administrator if no other alternative exists.
2. **Angle.** Crossing roadways shall intersect at 90 degrees whenever possible. In no case shall roadways be permitted to intersect at less than 80 degrees or more than 100 degrees.
3. **Horizontal Alignment.** The horizontal alignment of roadways through an intersection shall be designed in conformance with this chapter depending on the classification of the roadways intersecting. Intersections may be placed on horizontal curves, provided the minimum tangent lengths shown in Table 2-11 are provided on the lower functional classification roadway and the required sight distance is met.
4. **Vertical Alignment.** The roadway profile grade shall not exceed the value presented in Table 2-22 on the approach to the intersection, as measured along the centerline of the roadway for a minimum distance equal to the grade lengths presented in Table 2-23 for each of the roadway functional classifications.

The grade of the roadway with the higher functional classification shall prevail at intersections. Grading of lower functional classifications, adjacent property, private access shall adapt to the higher functional classification roadway grade.

Where crosswalks are provided at intersections, roadway grades shall be set to provide compliant crosswalk cross slopes. On approaches with stop or yield control, roadway grades shall be 2% maximum. On uncontrolled approaches or at traffic signals designed to permit arrival during the green phase, roadway grades shall be the maximum permitted for that functional classification, but in no case greater than 5%. See Section 6.3.2.

5. **Intersection Sight Distance.** The sight distance at intersections shall be shown geographically on the construction plans. A note shall be added to each leg of the intersection stating that intersection sight distance exceeds the minimum sight distance for ___ mph design speed.

Table 2-22. Intersection Grades by Roadway Functional Classification

Functional Classification	Maximum Intersection Grade (%)	Minimum Intersection Grade (%)
Expressway (Urban/Rural)	2/2	0.5/1
Arterial (Urban/Rural)	3/3 (4 for minor) ¹	0.5/1
Collector (Urban/Rural)	4/4 ¹	0.5/1
Local (Urban/Rural)	4/4 ¹	0.5/1

¹ Maximum grade at crosswalks with stop/yield control is 2%

Table 2-23. Intersection Profile Grade Lengths¹

Higher Classification Roadway (below)	Lower Classification Roadway			
	Local	Collector	Arterial	Expressway
Expressway	n/a	n/a	200	250 ¹
Arterial	n/a	120	200 ¹	n/a
Collector	100	120 ¹	n/a	n/a
Local	100 ¹	n/a	n/a	n/a

¹ In the case of where each intersecting roadway is of the same classification, the ECM Administrator will designate which roadway takes precedence and the distance required.

D. **Turn Lanes Required.**

1. **Exclusive Left Turn Lane Required.** Exclusive left turn lanes shall be provided wherever left turn lanes are specified as being needed by an approved TIS, identified in the MTCP, required by the ECM, or determined to be warranted by the ECM Administrator. Information in the TIS shall be used to determine whether an exclusive left turn lane is warranted. Warrant determinations shall also be based on this chapter, which include:
 - Expressways Left Turn Lane (State Highway Access Code Designation - EX): A left turn lane is required for any access that allows left turn ingress movement, except for field approaches. A left turn acceleration lane may be required if the design would be a benefit to safety and operation of the roadway.
 - Principal Arterials Left Turn Lane (State Highway Access Code Designation - RA for Rural and NR-A for Urban): A left turn lane is required for an access with a projected peak hour left ingress turning volume of 10 VPH or greater. A left turn acceleration lane may be required if it would be a benefit to the safety and operation of the roadway.
 - Minor Arterials (State Highway Access Code Designation - RB for Rural and NR-B for Urban) and Lower Classifications Left Turn Lane: A left turn lane is required for any access with a projected peak hour ingress turning volume of 25 VPH or greater.
2. **Exclusive Right Turn Lanes Required.** Exclusive right turn lanes shall be provided wherever right turn lanes are specified as being needed by an approved TIS, identified in the MTCP, required by the ECM or determined to be warranted by the ECM Administrator. Information in the TIS shall be used to determine whether an exclusive right turn lane is warranted. Warrant determinations shall also be based on this chapter, which include:
 - Expressway Right Turn Lane (State Highway Access Code Designation - EX): A right turn lane is required for any access with a projected peak hour right turn ingress turning volume of 10 VPH or greater. A right turn acceleration lane is required for any access with a projected peak hour right turn egress turning volume of 10 VPH or greater.
 - Principal Arterials Right Turn Lane (State Highway Access Code Designation - RA for Rural and NR-A for Urban): A right turn lane is required for any access with a projected peak hour right ingress turning volume of 25 VPH or greater. A right turn acceleration lane is required for any access with a projected peak hour right turning volume of 50 VPH or greater when the posted speed on the roadway is greater than 40 MPH. A right turn acceleration lane may also be required at a signalized intersection if a free right-turn is needed to maintain an appropriate level of service in the intersection.
 - Minor Arterials (State Highway Access Code Designation - RB for Rural and NR-B for Urban) and Lower Classifications Right Turn Lane: A right turn lane is required for any access with a projected peak hour right turning volume of 50 VPH or greater. An acceleration lane is generally not required.
3. **Acceleration Lanes Required.** Where acceleration lanes are required, deviations may be considered at stop controlled intersections under certain circumstances. As stated in the AASHTO "Green Book" (PGDHS), acceleration lanes are not always desirable. Please refer to the "Green Book" for additional information concerning instances where acceleration lanes may not be desirable. Deviations may also be considered at intersections with traffic signals.
4. **Lane Shifts or Drops Required.** Lane shifts or drops shall be provided wherever redirection of traffic are specified as being needed by an approved traffic control plan, required by the ECM or determined to be warranted by the ECM Administrator.

5. **Conflicts between Exclusive Turn Lanes.** Where two intersections have exclusive turn lanes that overlap, or the ending points of the exclusive turn lanes have less than 300 feet or one-half their length of separation (whichever is shorter) and a significant structure or topographical feature does not preclude widening, a continuous exclusive turn lane shall be established between the intersections to improve roadway consistency, safety, and to maintain edge of pavement continuity.

If restrictive topography allows only one exclusive turn lane, normally a left turn deceleration lane is given first priority. Where a left turn is installed and the travel lanes must be redirected, an overlay of pavement is required.

- E. **Turn Lane Design.** Turn lanes typically consist of a combination of several components (i.e. tapers, lane length, and storage). The use and design of these components varies based on the type of access, roadway classification, and site-specific conditions. Figure 2-24 presents a graphical guide to basic exclusive turn lane elements.

Figure 2-24. Guide to Basic Exclusive Turn Lane Elements

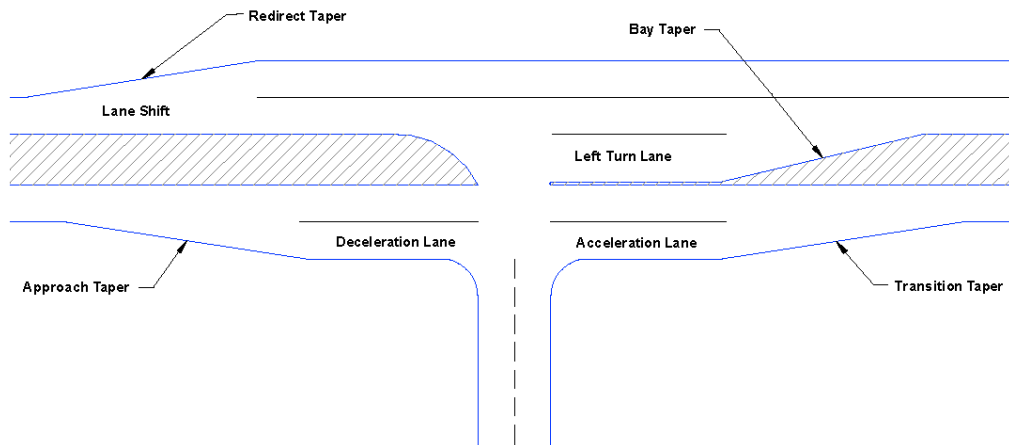

1. **Turn Lane Design Elements.**

- **Left Turn Lane.** The design elements for a left turn lane are the bay taper, lane length, storage length, which in combination makes up the left turn lane. The elements are shown in Figure 2-25. The specific designs for these lanes shall be in accordance with this chapter. For each high volume access and major intersection, both acceleration and deceleration lanes shall be considered in designing an exclusive left turn lane.

Figure 2-25. Design Elements for Left Turn Lanes

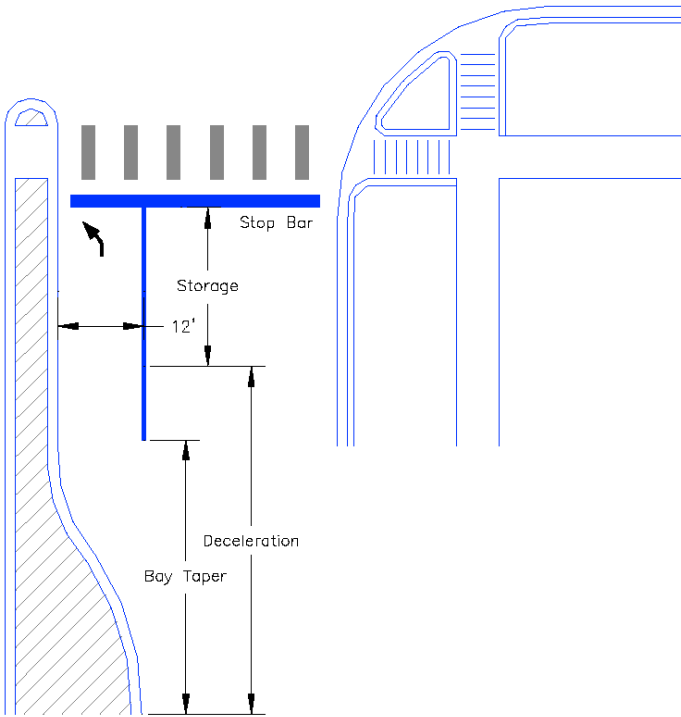

- Right Turn Lane. The design elements for a right turn and deceleration lanes are the approach taper, lane length, storage length, which in combination makes up the right turn lane. The elements are as shown in Figure 2-26. For each high volume access and major intersection, both acceleration and deceleration lanes shall be considered in designing an exclusive right turn lane. The specific designs for these lanes shall be in accordance with this chapter. Specific lane shift and lane drop design criteria can be found in Section 2.3.8J.3.
- Acceleration Lane. The design elements for an acceleration lane are the transition taper and acceleration length. For each high volume access and major intersection, both acceleration and deceleration lanes shall be considered in designing an exclusive right or left turn lane. The specific designs for these lanes shall be in accordance with this chapter.
- Shift or Drop Lane. The design elements for a transition or drop lane are the redirect taper, full width auxiliary lane, and storage length. The use and design of these elements varies based on the roadway classification and site-specific conditions.

Figure 2-26. Design Elements for Right Turn Lanes

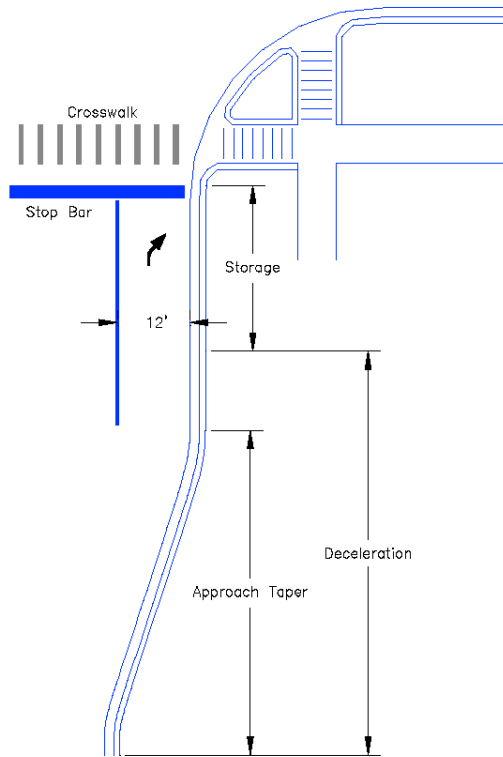

2. Tapers.

- Approach Tapers. The basis for designing a deceleration lane and taper is to provide sufficient length for a vehicle to decelerate and brake primarily outside the through traffic lanes. Table 2-24 provides the required deceleration lane and taper design lengths by design speed. Deceleration lane lengths shall be adjusted for a grade of 3% or more using the factors in Table 2-25. The required length allows a motorist to decelerate in gear for at least 3 seconds followed by safe braking to a complete stop.

Table 2-24. Required Deceleration Lane and Taper Lengths

Design Speed (MPH)	Lane Length (feet)	Approach Taper (feet)	Total Length (feet)
25	115	120	235
30	115	120	235
40	155	160	315
50	235	200	435
60	290	240	530
70	Special Design	Special Design	Special Design

Table 2-25. Deceleration Lane Grade Adjustment Factors

Roadway Grade	Factors
Upgrade	
3% to 4.9%	0.90

5% to 7%	0.80
Downgrade	
3% to 4.9%	1.20
5% to 7%	1.35

- Bay Tapers. Table 2-26 provides the required bay taper length by lane width. A bay taper is designed to direct left-turning vehicles into the turn lane. A minimum taper ratio of 8:1 may be used for tangent bay tapers in constrained locations. Bay tapers should be used (asymmetrical reverse curves) for deceleration transition tapers. Straight transition tapers should be avoided at design speeds above 40, and where a vertical crest or horizontal curve is present. Under these conditions, an immediate bay taper and lane striping should be substituted for a straight transition taper to reduce drifting of the through vehicles into the deceleration lane. Where horizontal or crest vertical curves exist, the ECM Administrator may require the deceleration transition taper to begin with an immediate asymmetrical reverse curve bay taper of 1/3L then 2/3L with the remaining required transition taper length at full lane width. Partial tangent transition tapers, symmetrical reverse curve tapers or asymmetrical reverse curve tapers may be used for transition taper design provided a radius of at least 150 feet is used in curve calculations.

Table 2-26. Required Bay Taper Lengths for 12-foot Lanes (for use with design of left turn deceleration lanes)

Design Speed (MPH)	Lane Length (feet)	Bay Taper (feet)	Total Length (feet)
25	115	80	195
30	115	120	235
40	155	160	315
50	235	200	435
60	290	Special Design	Special Design
70	Special Design	Special Design	Special Design
Taper = $WV/3$			
where: W = lane width, feet, V = design speed, MPH			

- Transition Tapers. The basis for designing an acceleration lane and transition taper is to provide sufficient length for a vehicle to accelerate to the appropriate speed and merge into the through traffic lanes without disrupting traffic flow. Table 2-27 provides the required acceleration lane and transition taper design lengths by design speed. Acceleration lane lengths in Table 2-27 shall be adjusted for a grade of 3% or more using the factors in Table 2-28. The total length of the acceleration lane includes the values of both the lane and transition taper. The length of a transition taper is calculated by multiplying the width of the lane by a standard ratio. The beginning and ending point of all tapers shall be rounded.

Table 2-27. Design Criteria for Acceleration Lanes

Posted Speed Limit (MPH)	25	30	35	40	45	50	55	60	65	70
Acceleration Length (feet)	N/A	190	270	380	550	760	960	1170	1380	1590
Transition Taper Ratio	7.5:1	8:1	10:1	12:1	13.5:1	15:1	18.5:1	25:1	25:1	25:1

Table 2-28. Grade Adjustment Factors for Acceleration Lanes

	Design Speed (MPH)		
	40 to 50	60	70
Upgrade			
3 to 4.9%	1.3	1.5	1.7
5 to 7.5%	1.5	2.0	2.5
Downgrade			
3 to 4.9%	0.7	0.65	0.6
5 to 7.5%	0.6	0.55	0.5

- **Redirect Tapers.** Redirect tapers shall be used where an exclusive turn lane, median or other redirection of vehicles is necessary and where redirection of the flow of traffic is necessary to accommodate the exclusive turn lane or median due to constraints. Redirect tapers required for redirecting through travel lanes shall be installed in conformance with Table 2-29. If the redirect taper would result in a horizontal curve design deficiency for the through movement, the horizontal curve shall be corrected. Redirect taper should be designed as straight tapers with the beginning and ending points rounded.

Table 2-29. Redirect Tapers for Through Lanes

	Design Speed (MPH)				
	30 or less	40	50	60	70
Straight Taper Ratio	15:1	20:1	45:1	55:1	65:1

3. **Storage Lengths.** The basis for designing the length of required storage is to provide sufficient length for vehicles to queue within the lane without affecting other movements. Table 2-30 provides the required storage lengths for stop-controlled intersections. Figure 2-27 provides the required calculated storage lengths for signal-controlled intersections. Where the ECM Administrator determines that meeting the required storage length is impractical or results in an unsafe condition, the minimum storage length shall be based on the mean arrival rate, but in no case shall the minimum storage length be less than 50 feet.

Table 2-30. Required Storage Lengths for Stop-Controlled Intersections

DHV (VPH)	<60	61—120	121—180	181—250	>250
Storage Length (feet)	50—75	100	150	200	250 or more

Figure 2-27. Required Storage Lengths for Signal-Controlled Intersections

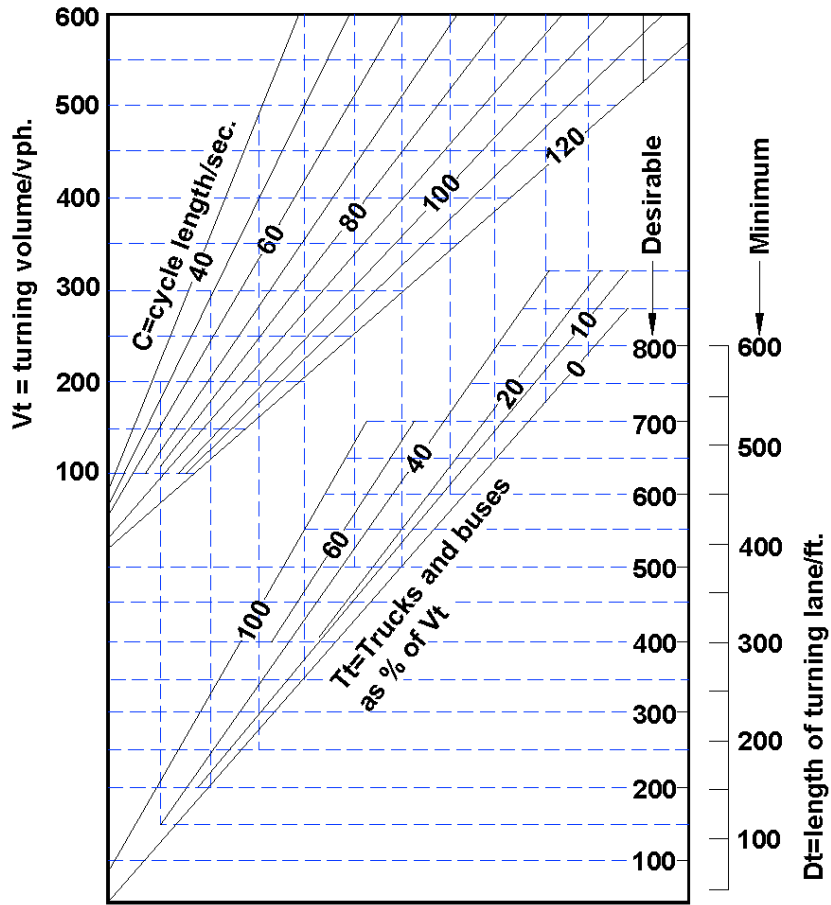

F. Curb Returns.

1. **Radii.** Table 2-31 and Table 2-32 present minimum curb return radii at intersections for each roadway type, rural and urban. A paved shoulder adjacent to an exclusive turn or acceleration lane is required where no curb and gutter exist or are proposed. Shoulders adjacent to an exclusive turn or acceleration lane shall be at least 4 feet wide and paved.

Table 2-31. Minimum Curb Return Radius at Intersection (Urban Roads)

	Local	Collector	Minor Arterial	Principal Arterial	Expressway
Local	20'	25'	30'	30'	Special Design
Collector	25'	25'	30'	40'	Special Design
Minor Arterial	30'	30'	50'	Special Design	Special Design
Principal Arterial	30'	40'	Special Design	Special Design	Special Design
Expressway	Special Design	Special Design	Special Design	Special Design	Special Design

Table 2-32. Minimum Curb Return Radius at Intersections (Rural Roads)

	Local	Collector	Minor Arterial	Principal Arterial	Expressway
Local	20'	30'	40'	40'	Special Design
Collector	30'	30'	40'	40'	Special Design
Minor Arterial	40'	40'	50'	Special Design	Special Design
Principal Arterial	40'	40'	Special Design	Special Design	Special Design
Expressway	Special Design	Special Design	Special Design	Special Design	Special Design

2. **Grades.** The minimum grade for flowlines around the curb return shall be 1%. In some instances, the minimum grade for flowlines around curb returns may be reduced to 0.5% with approval from the ECM Administrator.
- G. **Design Vehicles.** Intersections shall be designed to accommodate the AASHTO design vehicles. The following minimum allowable design vehicle criteria shall apply. For special circumstances, other design vehicles and criteria may be required by the ECM Administrator or proposed by the design engineer where trucking volumes and typical truck sizes suggest an alternative design vehicle would be more appropriate.
1. **SU-30 (Single Unit Truck).** At all intersections, SU-30 vehicles shall be able to turn easily from one roadway to the next and remain in the correct lane for each roadway.
 2. **B-40 (Bus).** At all intersections, B-40 vehicles may use one or more traffic lanes to complete a turn when turning from the correct lane without crossing into opposing traffic lanes and without tracking onto the curb at corners.
 3. **WB-50 (Large Semi Trailer).** WB-50 vehicles may use one or more traffic lanes to complete a turn without tracking onto the curb at corners. In addition, the vehicle must make the turn in one forward maneuver encroaching into opposing traffic lanes. These requirements shall apply to all arterial/arterial, arterial/collector, arterial/local, and collector/collector intersections. For all other intersections, the vehicles may use the entire paved surface of the road to negotiate the turn.
 4. **WB-67 (Large Semi Trailer).** WB-67 vehicles may use one or more traffic lanes to complete a turn without tracking onto the curb at corners. In addition, the vehicle must make the turn in one forward maneuver encroaching into opposing traffic lanes. These requirements shall apply to all arterial/arterial, and arterial/collector intersections. For all other intersections, the vehicles may use the entire paved surface of the road to negotiate the turn.
- H. **Intersection Channelization.** Channelization is intended to separate or regulate conflicting traffic movements into definite paths of travel by the use of pavement markings, raised islands or other suitable means to facilitate the safe and orderly movement of all modes of travel using a particular corridor. See Figure 2-28 for a channelization example associated with a portion of an intersection exclusive right turn lane.

Figure 2-28. Channelization Example

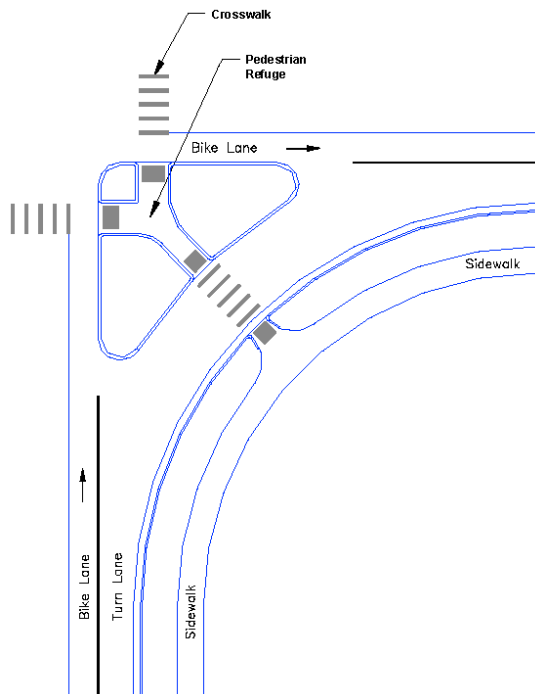

- I. **Roundabouts.** Roundabouts are considered a form of traffic control. Roundabouts shall be considered as two types: (1) modern roundabouts and (2) mini roundabouts.
 1. **Modern Roundabouts Design Guidelines.** Modern roundabouts shall be designed based on site-specific needs for high volume roadways. The use of modern roundabouts may be considered for many reasons; some may include, but not be limited to:
 - Traffic volumes on both roadways are approximately equal (i.e. within 10% of each other), or
 - Where significant percentages (20% or greater) of traffic on the major roadway is conducting left turns, or
 - Where the intersection is expected to warrant signalization within twenty years.Specific guidelines for designing the main elements of a modern roundabout shown in Figure 2-29 include:
 - Modern roundabouts shall be designed to accommodate the largest design vehicle of the intersecting streets.

Figure 2-29. Typical Design Elements of a Modern Roundabout

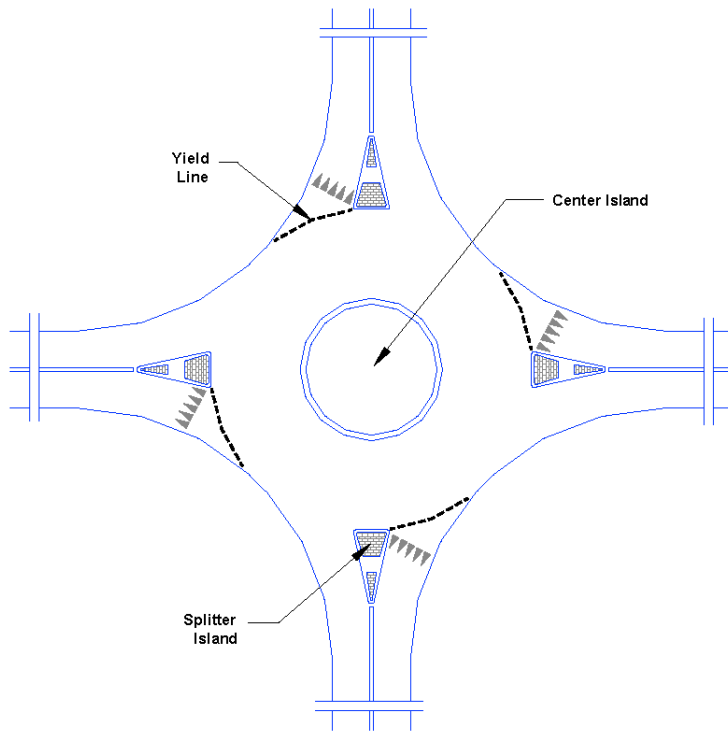

- The design of the center island will be in accordance with the Roundabout Design Guide and approved by the ECM Administrator. Should a truck apron be warranted based on site-specific design parameters, the width shall be selected based on what is appropriate to accommodate the free circulation of the design vehicle.
-
- The roundabout design shall be completed with the aid of computer software. The ECM Administrator is authorized to require the use of a specific software package when warranted by the needs of a specific intersection.
- Roundabout designs shall conform with NCHRP Report 672 – Roundabouts: An Informational Guide, Second Edition (2010), the Wisconsin DOT Facilities Development Manual (FDM) (as amended), found at <https://wisconsin.gov/pages/doing-business/eng-consultants/cnslt-rsrces/rdwy/fdm.aspx>. Any other criteria proposed for use shall be confirmed by the ECM Administrator prior to design. The design process shall be iterative with submittals generally conforming with the Wisconsin DOT design procedures as directed by the ECM Administrator. The Wisconsin DOT details, signing and striping recommendations, and lines of sight, should be utilized to the extent practicable.
- Raised splitter islands are required on all approaches.
- Roundabout signage and markings shall conform with the requirements of the MUTCD.
- Roundabout lighting shall be provided and conform with the 2019 CDOT Lighting Design Guidelines, as amended.

2. **Mini Roundabouts Design Guidelines.** Mini roundabouts may be allowed in a neighborhood setting for traffic calming. Mini roundabouts may be used on urban local roadways. Mini roundabouts are prohibited in areas without curb and gutter. Specific guidelines for designing the main elements of a mini roundabout shown in Figure 2-30 include:
- The design shall conform with the Roundabout Design Guide, FHWA Standards or other design criteria approved by the ECM Administrator.
 - The circular roadway shall be a minimum of 20 feet wide flowline to flowline, and the approach legs shall be a minimum of 16 feet wide.
 - Mini roundabouts shall be designed to accommodate WB-50 vehicles.
 - To enhance truck movement through smaller-diameter roundabouts, a concrete truck apron may be used to assist with tracking.

Figure 2-30. Typical Mini Roundabout Cross Section

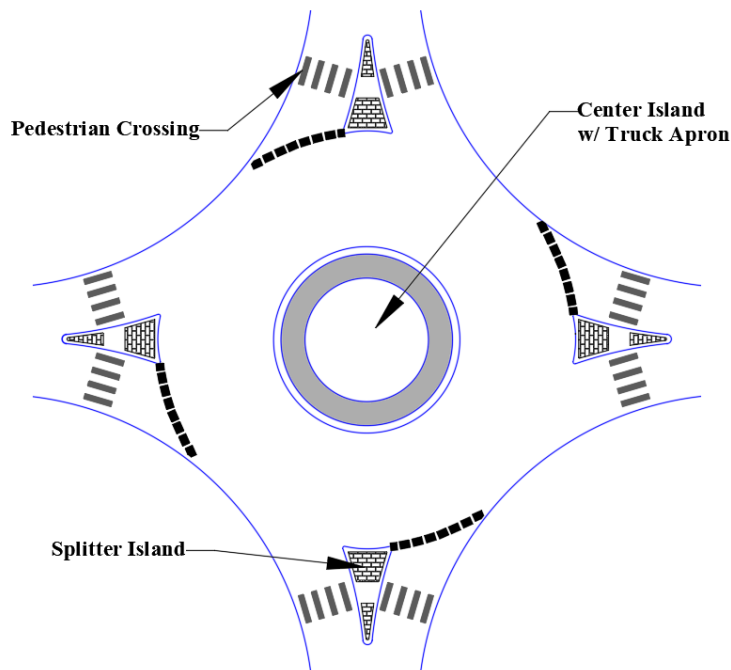

2.3.8. Roadway Terminations

- A. **Cul-de-Sacs.** Cul-de-sacs shall be used only where absolutely necessary. Cul-de-sacs shall have a minimum radius of 45 feet and a maximum length of 750 feet for urban conditions and a minimum radius of 50 feet and a maximum length of 1,600 feet for rural conditions, be designed in conformance with Figure 2-31. The maximum length of cul-de-sac shall be measured from the right-of-way of the intersecting street to the center of the cul-de-sac bulb. Hammerhead turnarounds are not permitted as permanent roadway terminations. The cul-de-sac right-of-way width shall be consistent with the right-of-way associated with the roadway functional classification and provide for the turnaround, sidewalks, utilities, and necessary drainage facilities. A request for a deviation from the maximum length criteria will not be considered without an express written endorsement from the Fire District in which the proposed cul-de-sac is located.

In special cases where a divided 4 lane roadway that terminates adjacent to a subdivision or development, the length of the collector or local roads that intersect the divide 4 lane roadway shall be measured from the point of intersection with the divided 4 lane roadway regardless of the length of the terminated divided 4 lane roadway. In all other cases, the length of the cul-de-sac or terminated road shall be measured from the point at which the road providing access to a site begins.

Figure 2-31. Typical Cul-de-Sac Requirements (Urban and Rural)

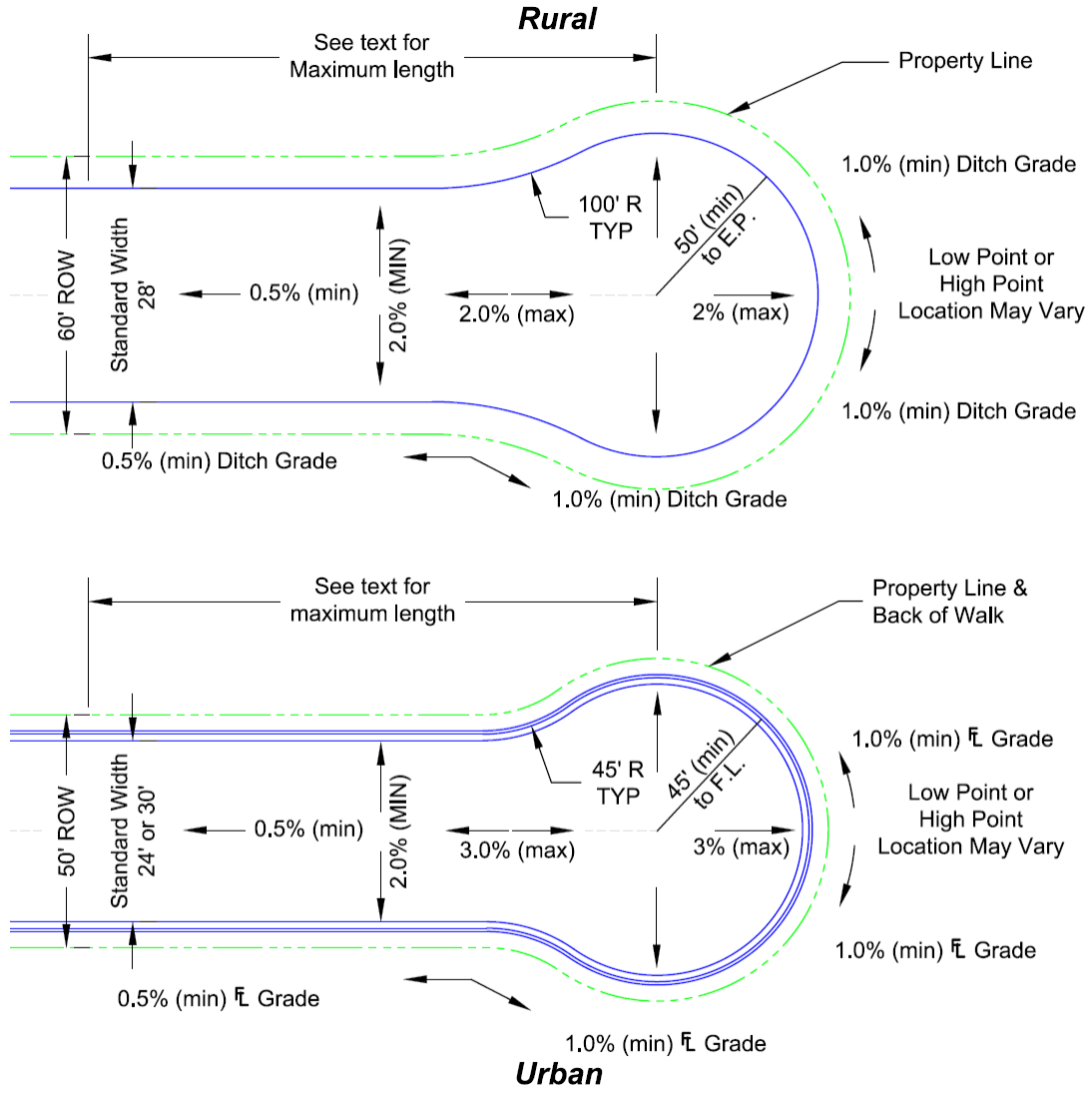

B. **Eyebrows and Knuckles.** Eyebrows and knuckles shall be permitted only on urban local roadways in conformance with Figure 2-32 and detailed standard drawings SD 2-77 and SD 2-78. Eyebrows are permitted if they are in conformance with intersection spacing requirements presented in Table 2-4 through Table 2-26. If the maximum length of the eyebrow is exceeded, the roadway design shall conform to minimum cul-de-sac requirements. Knuckles are permitted at intersections where the intersection angle is between 70-110 degrees and where each street extends in only one direction from the intersection; otherwise the roadway shall be designed in accordance with minimum centerline curve radius.

Figure 2-32. Typical Eyebrow and Knuckle Requirements

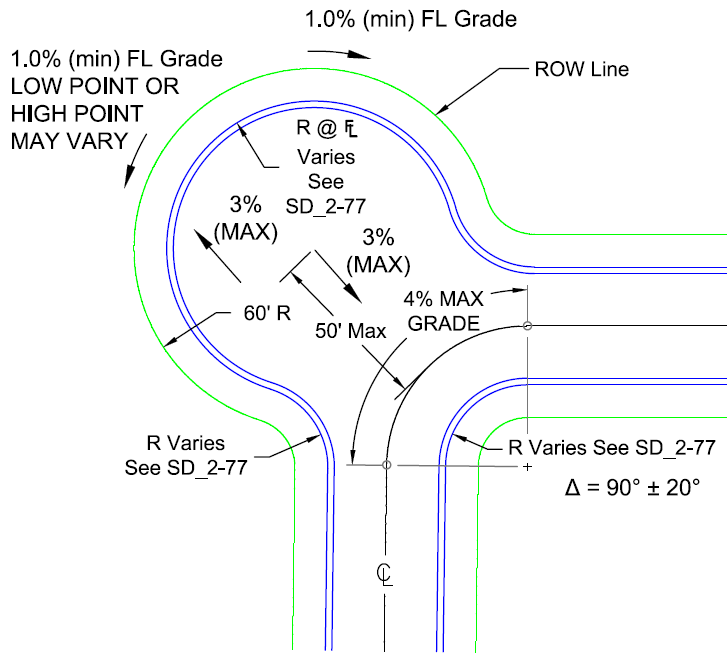
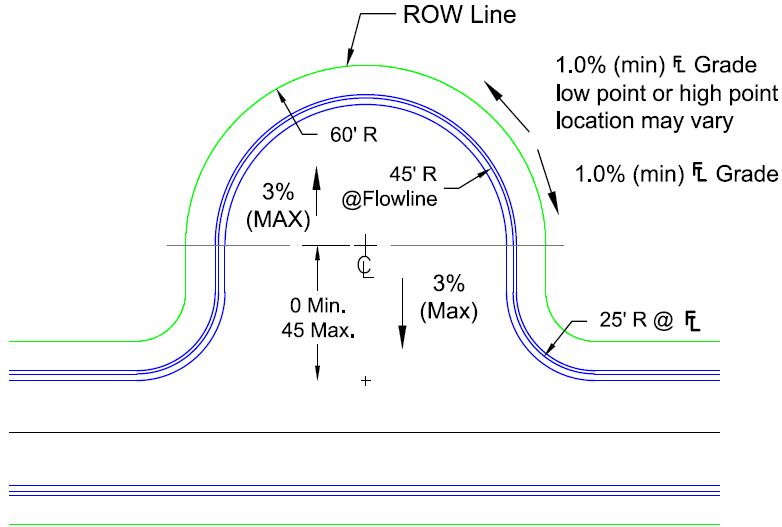

- C. **Temporary Cul-de-Sacs (or Hammerheads).** Where a roadway will be temporarily terminated, a temporary cul-de-sac or hammerhead turnaround shall be constructed in accordance with Figure 2-33 or Figure 2-34. No curb and gutter is required on temporary cul-de-sac or hammerhead turnaround. Temporary turnarounds shall not exceed 600 feet in length except as otherwise approved by the BOCC

in association with a phased development plan. The minimum dimensions for the temporary cul-de-sacs shall follow those of Figure 2-31 in all other respects.

The following criteria language will be required for all easements.

The non-revocable public improvement easement shown at the end of ____ Street cul-de-sac is intended for turn around and emergency response purposes. At such a time that ____ Street is extended by the adjacent property owner/developer and accepted by the County, the non-revocable public improvement easement for the cul-de-sac will be vacated, leaving a standard street ROW and the cul-de-sac improvements will be removed and replaced with a standard street section. The easement vacation, cul-de-sac removal and standard street section construction and site restoration is the responsibility of the owner/developer extending ____ Street.

1. **Cul-de-Sac Terminates Within the Plat.** If the cul-de-sac terminates within the proposed plat, the cul-de-sac shall be dedicated as public right-of-way or non-exclusive public improvement easement. If the road right-of-way is stubbed to an adjacent property for future extension, the right-of-way width at the boundary shall match the proposed street right-of-way width. The cul-de-sac at the end of street is intended as a turn around and also is for emergency response purposes until the road is extended. The cul-de-sac shall meet all current standards. If the street is extended by the adjacent property owner/developer, the cul-de-sac right-of-way or public improvement easement may be vacated, leaving a standard street right-of-way. The cul-de-sac improvements within the right-of-way or public improvement easement will be for public use and publicly maintained.

The lot(s) adjacent to cul-de-sacs may be granted an administrative variance (minor variation during platting) and platted at less than the required minimum acreage. However, the lots will be sized such that if and when the street is extended and the cul-de-sac right-of-way is vacated and the standard street right-of-way is defined, the lots adjacent to the vacated cul-de-sac will meet the minimum zoned acreage requirements that were in place when the plat was approved. No direct access shall be allowed off the anticipated cul-de-sac unless the cul-de-sac is designed to be permanent. The administrative variance would be according to the Land Development Code and is permissive, not mandatory.

When the road is extended at some future time, the responsibility for conversion of the cul-de-sac to the typical road cross section and site restoration shall be the owner/developer requiring the street extension. The same owner/developer will at that time also be responsible for vacation and replat of the lots.

2. **Cul-de-Sac Terminates Outside the Plat of a Phased Development.** If the owner is platting in phases and the cul-de-sac will terminate within the phased development but outside the current subdivision plat, the entire cul-de-sac shall be dedicated as a non-revocable public improvement easement. Where the cul-de-sac will terminate outside the proposed plat, the applicant must provide a copy of the recorded easement for the entire public improvement cul-de-sac easement. The cul-de-sac design shall meet all current standards. Until further land use actions, the non-revocable public improvement easement shall remain in public use and publicly maintained until further resolution or disposition of extension.

When the road is extended at some future time, the developer of the extension at that time shall be responsible for conversion of the cul-de-sac to the typical road cross section and site restoration shall be the responsibility of the owner/developer extending the street. The developer at that time shall also be responsible for vacation of the easements.

3. **Cul-de-Sac Terminates on Property not Owned by the Current Developer.** If the cul-de-sac will terminate on property not owned by the current developer, the developer shall acquire a public improvement easement from the adjacent property owner for the cul-de-sac. The entire cul-de-

sac shall be dedicated as a non-revocable public improvement easement by separate instrument. No direct lot access to the proposed development will be provided off the cul-de-sac turnaround. Where the cul-de-sac will terminate outside the proposed plat, the applicant must provide proof of ownership for the entire cul-de-sac turnaround. The cul-de-sac shall meet all current standards. Until further land use actions, the non-revocable public improvement easement shall remain in public use and publicly maintained until further resolution or disposition of extension.

When the road is extended at some future time, the developer at that time shall be responsible for conversion of the cul-de-sac to the typical road cross section and site restoration shall be the responsibility of the owner/developer extending the street. The developer at that time shall also be responsible for vacation of any public right-of-way.

Figure 2-33. Typical Temporary Cul-de-Sac Requirements

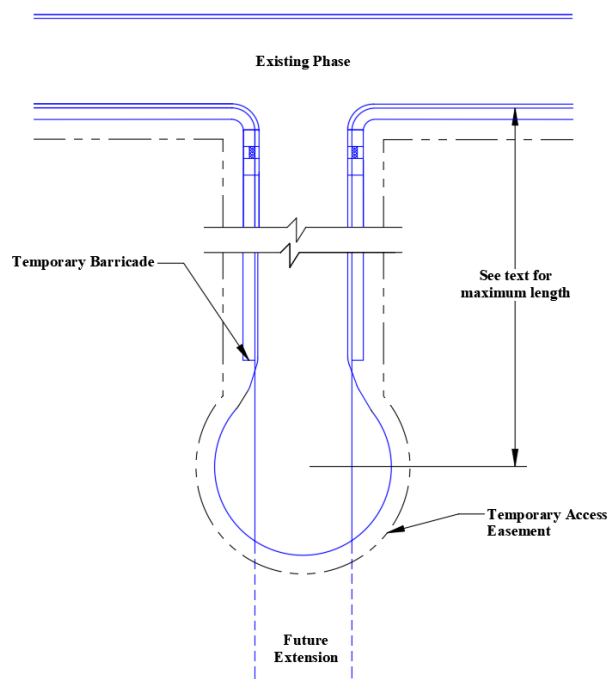
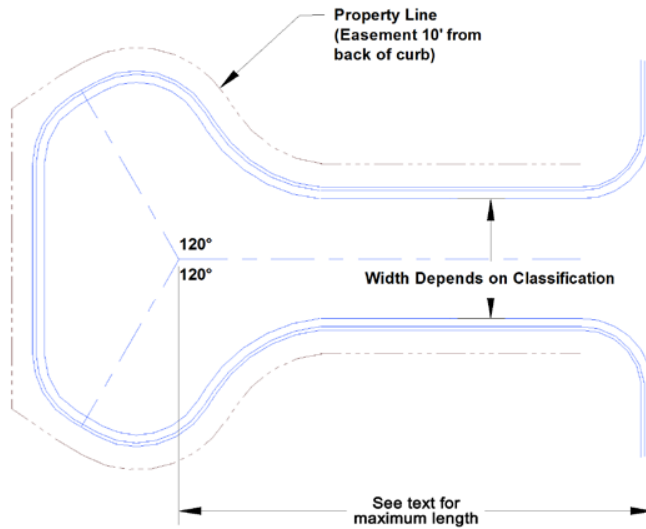

Figure 2-34. Typical Temporary Hammerhead Turnaround Requirements



(Res. No. 20-222 , 6-23-20)

2.4. ROADWAY ACCESS DESIGN

2.4.1. Access Design Criteria

- A. **Access Design Guidelines.** Access points shall be designed to provide safe movement for both those entering and traveling on roadways within the County. Like intersections, access points are conflict locations. The basic design of access points includes the following objectives:
- Adequate spacing
 - Proper alignments
 - Clear sight distances
 - Coordinated widths with its intended use
 - Clearances from intersections
- B. **Access Spacing.** Accesses shall be separated by a distance equal to the entering sight distance values in Table 2-35. When turn lanes are present or will be needed in the future, the accesses shall be separated by a sufficient distance so that exclusive turn lanes including tapers will not overlap. Access shall not be permitted within a turn lane. Warrant criteria, design, and construction of turn lanes shall be governed by the requirements contained in Section 2.3.7D.
- C. **Access Alignment.**
1. **Horizontal Alignment.** Access points shall be aligned at 90 degrees to the adjacent road centerline or along a radial line in a cul-de-sac.
 2. **Vertical Alignment.** Maximum access grades are 4% for commercial and industrial properties with a required 30-foot landing length and a 4% for rural residential and multi-family properties with a required 15-foot landing length. Access point approach grades and configuration shall be

Created: 2021-06-08 11:35:48 [EST]

(Supp. No. 2)

designed and constructed to accommodate the ultimate road standard of the intersecting roadway to prevent major access point reconstruction. Where an access approach will cross an existing sidewalk, the access shall be designed and constructed to match the elevation of the sidewalk where the two intersect. Reverse slope private accesses may be allowed as long as sight distance requirements are met.

D. **Access Sight Distances.** Accesses and specific turn movements shall not be permitted where the sight distance is not adequate to allow the safe movement of a motorist using or passing the access. Any potentially obstructing objects, such as but not limited to advertising signs, structures, trees, and bushes, shall be designed, placed, and maintained at a height not to interfere with the sight distance needed by any vehicle using the access. Reconstruction of the horizontal and vertical curvature along the roadway or side slopes adjacent to the roadway may be necessary to increase sight distances.

1. **Sight Distance Along Roadways.** Horizontal and vertical sight distances shall conform to Table 2-33 for the vehicle traveling on the roadway toward the access. The lengths shown in Table 2-33 shall be adjusted for any grade of 3% or greater using the figures set forth in Table 2-34.

Table 2-33. Minimum Sight Distance Along Roadway (Horizontal and Vertical)

Posted Speed (MPH)	25	30	35	40	45	50	55	60	65	70
Design Sight distance (feet)	150	200	250	325	400	475	550	650	725	850
Minimum Sight distance (feet) ^{1, 2}	150	200	225	275	325	400	450	525	550	625

¹To calculate sight distance at the proposed access location, a height of 3.5 feet shall be used for the driver's eyes of a vehicle on the highway approaching the access location. The driver's eyes shall be assumed to be at the centerline of the inside lane (inside with respect to the curve) for measurement purposes. A height of 3.5 feet shall be used for a vehicle assumed to be on the centerline of the access 5 feet back from the edge of the roadway.

²If an auxiliary lane is present, the entering posted speed for the deceleration lane and the posted speed at the end of the acceleration lane shall be used.

Table 2-34. Sight Distance Adjustment Factors for Roadway Grade

Approach Grade (%)	Design Speed (mph)													
	15	20	25	30	35	40	45	50	55	60	65	70	75	80
-6	1.1	1.1	1.1	1.1	1.1	1.1	1.1	1.2	1.2	1.2	1.2	1.2	1.2	1.2
-5	1.0	1.0	1.1	1.1	1.1	1.1	1.1	1.1	1.1	1.1	1.2	1.2	1.2	1.2
-4	1.0	1.0	1.0	1.1	1.1	1.1	1.1	1.1	1.1	1.1	1.1	1.1	1.1	1.1
-3 to +3	1.0	1.0	1.0	1.0	1.0	1.0	1.0	1.0	1.0	1.0	1.0	1.0	1.0	1.0
+4	1.0	1.0	1.0	1.0	0.9	0.9	0.9	0.9	0.9	0.9	0.9	0.9	0.9	0.9
+5	1.0	1.0	1.0	0.9	0.9	0.9	0.9	0.9	0.9	0.9	0.9	0.9	0.9	0.9
+6	1.0	1.0	0.9	0.9	0.9	0.9	0.9	0.9	0.9	0.9	0.9	0.9	0.9	0.9

Note: Based on ratio of stopping sight distance on specified approach grade to stopping sight distance on level terrain.

- Entering Sight Distance.** This section applies to entering sight distance where a non-public road or driveway meets a public road. The entering sight distance necessary for the entering vehicle shall conform to Table 2-35. These lengths shall be adjusted for any grade of 3% or greater using Table 2-34. The design vehicle used to determine the entering sight distance shall be selected from Table 2-36.

If the median provides at least 20 feet of storage for a crossing or turning vehicle and can safely store the design vehicle, then the sight distance may be calculated assuming a two-stop condition.

Table 2-35. Entering Sight Distance for Driveways (Access Design)

Design Vehicle ³	Posted Speed of Roadway (MPH)				
	25	35	45	55	65
Two Lane Roadway^{1,2}					
Passenger Cars, Pickup Trucks	250	350	450	550	n/a
Single Unit Trucks	325	455	585	715	n/a
Multi-Unit Trucks	425	595	765	935	n/a
Four Lane Roadway^{1,2}					
Passenger Cars, Pickup Trucks	n/a	420	540	660	780
Single Unit Trucks	n/a	525	675	825	975
Multi-Unit Trucks	n/a	700	900	1,100	1,300
Six Lane Roadway^{1,2}					
Passenger Cars, Pickup Trucks	n/a	n/a	585	715	845
Single Unit Trucks	n/a	n/a	765	935	1,105
Multi-Unit Trucks	n/a	n/a	945	1,155	1,365
¹ For calculating sight distance, a height of 3.5 feet shall be used for the driver's eyes at the access location and a height of 3.5 feet for the oncoming vehicle. The entering driver's eyes shall be 10 feet behind the edge of the roadway.					
² If an auxiliary lane is present, the entering posted speed for the deceleration lane and the posted speed at the end of the acceleration lane shall be used.					
³ From Table 2-36.					
⁴ This table is for use for determining entering sight distance for driveways.					

Table 2-36. Design Vehicle Selection

Land Use(s) Served by Access	Design Vehicle
Residential, Non-School Bus Route	Passenger Cars, Pickup Trucks
Residential, School Bus Route	Single Unit Trucks
Office	Single Unit Trucks
Recreational	Single Unit Trucks
Commercial/Retail	Multi-Unit Trucks ¹
Industrial	Multi-Unit Trucks ¹
Agricultural Field Approaches (<1 VPD)	Single Unit Trucks
¹ If less than 2 multi-unit truck trips per day (average), use single-unit truck	

E. Access Width.

1. **Residential Access Points.** Two-way residential access points shall have a 10-foot minimum and a 24-foot maximum width.
2. **One-Way Commercial or Industrial Access Points.** One-way commercial or industrial access points shall have a minimum 15-foot and a maximum 30-foot inbound access, and a minimum 20-foot and maximum 35-foot outbound access width.
3. **Two-Way Commercial or Industrial Access Points.** Two-way commercial or industrial parcel access points shall have:
 - For Nonresidential Collector and Local Roadways: A minimum 25-foot and maximum 40-foot access width.
 - For Minor Arterial Roadways (when approved by the ECM Administrator): A minimum 35-foot and maximum 40-foot access width.
4. **Deviations to Commercial or Industrial Access Point Widths.** Wider commercial or industrial access point widths, where necessary to accommodate buses, trucks or other oversized vehicles, may be approved through deviation. Such parcel access points shall be designed to meet the additional loading and turning radius requirements.

F. Access Clearance from Intersections.

1. **Residential.** Access to residential corner lots shall be located a minimum of 10 feet from the point of curvature or point of tangency of the curb line at the intersection. If no curb exists, access points shall be located not less than 35 feet from where the projected right of way lines intersect. No portion of an access will be permitted within curb returns or curb ramps.
2. **Commercial.** Access to commercial or industrial properties fronting collector or local roads shall be located a minimum of 50 feet from the point of curvature or point of tangency of the curb line at the intersection. Access to commercial or industrial parcels fronting Nonresidential Collector roadways shall be located a minimum of 115 feet from the point of curvature or point of tangency of the curb line at the intersection depending on the sight distance and location with respect to the intersection, intersection control, and posted speed.

In all cases, a minimum corner clearance of 50 feet shall be provided. If the minimum corner clearance cannot be attained, the ECM Administrator may require investigation to determine if left turns should be prohibited into or out of the access point. For proposed access points near stop or signalized intersections, the ECM Administrator will require studies to determine if stopping queues will block the access point and if left turns should be prohibited into or out of the access point.

-
- G. **Construction of Access Points.** Prior to constructing, reconstructing, paving, altering, enlarging, or changing the use of any access point entering a County roadway, an approved Driveway Permit must be obtained. In the case of more complex access projects (i.e. commercial, industrial, or multi-family residential complexes), a Construction Permit may also be required if determined as being warranted through an Engineering Site Plan review. At a minimum, commercial, industrial, or multifamily development shall provide an asphalt or concrete apron for the first fifty (50) feet of the new access when connecting to a paved roadway.

2.5. EXTRINSIC STRUCTURES

2.5.1. Curbs and Gutters

- A. **Curbs and Gutters.** Curbs and gutters shall be designed and installed where required by the functional classification (See Table 2-6 and Table 2-7), the County rules and regulations including the LDC or when required by the ECM Administrator. The curb and gutter will be part of an overall surface water conveyance system. The intent of the system will be to adequately and efficiently control surface water flows during typical storm events (less than 5-year events) while still allowing proper traffic circulation. Gutter slope should be modified to provide compliant counter slope at curb ramps. See Section 6.3.3.
- B. **Curb Cuts and Accesses.** Curb cuts and accesses shall be constructed in accordance with the Standard Drawings. Radius returns are required when the number of parking spaces served by the access exceeds 10.

2.5.2. Pedestrian Facilities

- A. **General.** All pedestrian facilities shall be designed in accordance with Americans with Disabilities Act (ADA) and PROWAG requirements, AASHTO Green Book, and the requirements of these Standards. The standard that results in the greatest overall safety of pedestrians shall prevail when designing and constructing pedestrian facilities. See Chapter 6 for requirements and guidance.
- B. **Sidewalks.** All sidewalks within a development will be designed and constructed by the developer. The design of such sidewalks shall continue to be included within the construction drawings associated with the respective final plat or site development plan, as applicable, and shall comply with the following standards:
 1. **Sidewalk Widths.** Minimum-required sidewalk widths by roadway classifications are specified in Table 2-4 through Table 2-7 and Appendix F. The ECM Administrator may require additional width in activity areas and routes leading to and from these areas. This additional width shall be determined through additional study in higher pedestrian traffic areas.
 2. **Sidewalk Crossings of Accesses.** Access crossings shall be designed in accordance with Standard Drawings SD_2-24 and SD_2-25 in Appendix F. Sidewalk across accesses should be accessible per the requirements of Chapter 6.
 3. **Sidewalks on Both Sides of the Roadway.** Sidewalks shall be installed on both sides of the roadway.
 4. **In-Fill Sidewalk, Curb, and Gutter.** In developed areas, sidewalks, curbs, and gutters may be required to be upgraded to current standards at the ECM Administrator's discretion.
 5. **Sidewalk Widening.** Existing sidewalks shall only be permitted to be widened if the increase in width is 4 feet or more. If an existing sidewalk is required to be widened by less than 4 feet to meet the requirements of the ECM, the existing walk shall be entirely replaced with a sidewalk meeting the minimum width requirements.

-
6. **Concrete Thickness.** All developments within the RS-5000 (Residential Suburban) or RS-6000 (Residential Suburban) zoning districts shall be required to construct sidewalks at a thickness of five inches (5") for all sidewalks along the entire length of any roadway from which temporary or permanent access will be provided. All other sidewalks within either the RS-5000 or RS-6000 zoning districts (e.g., sidewalks in common areas, sidewalks along identified school parcels, sidewalks in open space, etc.) may be designed and constructed to a thickness of five inches (5") but may, at the developer's discretion, be reduced to a thickness no less than four inches (4").

Developments within a Planned Unit Development (PUD) zoning district shall be required to design and construct sidewalks to a thickness of five inches (5") for all sidewalks along the entire length of any roadway from which temporary or permanent access will be provided unless an alternative thickness is approved by the Board of County Commissioners as an element of the associated PUD development standards. Under no circumstances shall any sidewalk be designed and constructed to a thickness of less than four inches (4"). All other sidewalks within a PUD zoning district (e.g., sidewalks in common areas, sidewalks along identified school parcels, sidewalks in open space, etc.) may be designed and constructed to a thickness of five inches (5") but may, at the developer's discretion, be reduced to a thickness no less than four inches (4").

Sidewalks within all other developments not located within the RS-5000 or RS-6000 zoning districts or within a PUD may be designed and constructed to a thickness of five inches (5") but may, at the developer's discretion, be reduced to a thickness no less than four inches (4").

At high volume access or alley crossings, the thickness shall be a minimum of six inches (6"). Sidewalks located at an access for commercial or industrial traffic will be terminated at the edges of the access allowing the access design to set precedence for thickness of pavement.

7. **Sidewalk Slope.**

- Cross Slope: Maximum cross slope for sidewalks shall be 2%. 1.5% typical cross slope is suggested to allow for construction tolerances. See Chapter 6.
- Longitudinal Slope of Attached Sidewalks: Longitudinal slope of attached sidewalks shall be consistent with roadway slopes. Attached sidewalk slopes greater than 5% are only permitted where adjacent roadway slopes are steeper than 5%. See Chapter 6.
- Detached Sidewalks and ADA Requirements: Longitudinal slope of detached sidewalks shall be flatter than 5% wherever feasible. Sidewalk slopes greater than 5% require ramp runs. See Chapter 6.

8. **Sidewalk Clearances.** Horizontal and vertical sidewalk clearances shall meet the requirements of Figure 2-35. See Section 6.3.1 for clearance requirements related to accessibility.

9. **Driveway Option.** Where five inch (5") sidewalks with mountable curb have been installed, the thickness at driveways can remain five inches (5"). As an alternative, the mountable curb and sidewalk at driveways can be poured at six inches (6"). The desired thickness must be identified on the approved construction drawings for the project. Where five inch (5") sidewalks are installed, the Cut Back Swale Standard Drawing (SD_3-88) can be used as an acceptable stormwater BMP along the constructed five inch (5") sidewalk. The proposed stormwater BMPs will need to be provided in detail in the approved erosion control plan for the project.

Where four inch (4") sidewalks are installed, the sidewalks shall be a minimum of 4-inches thick except at driveways, high volume access, or alley crossings where the thickness shall increase to a minimum of six inches (6"). Sidewalks located at an access for commercial or industrial traffic will be terminated at the edges of the access allowing the access design to set precedence for thickness of pavement. The Cut Back Swale Standard Drawing (SD_3-88) is not an acceptable stormwater BMP for any sidewalk that is less than five inches (5") thick.

C. **Accessible Curb Ramps.**

1. **Ramp Requirements.** Accessible curb ramps shall be installed at all intersections where pedestrian routes cross streets and at certain mid-block locations for all new construction and alteration projects to the adjacent roadway. See Chapter 6.
2. **4-Way Intersections.** Curb ramps shall be installed at all intersection corners. Access ramps shall be constructed in accordance with Standard Drawings in Appendix F.
3. **"T" Intersections.** All "T" intersections shall have a minimum of four curb ramps as shown in Figure 2-36. A private access may be used as a curb ramp provided it is designed to meet ramp requirements and it is within the intersection and directly across from other ramps.

Figure 2-35. Sidewalk Clearances

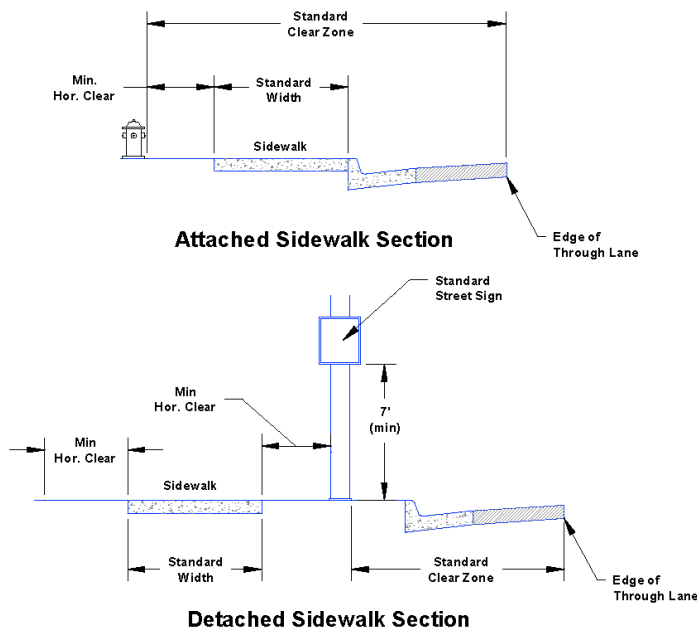
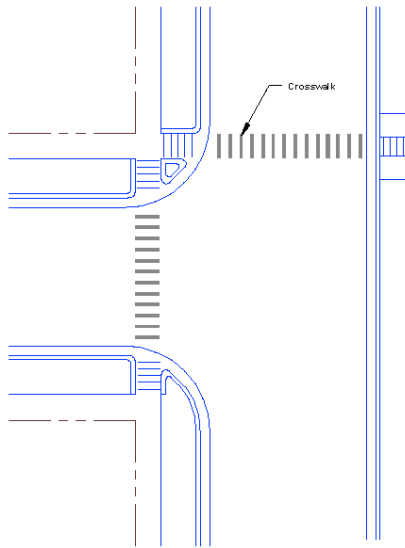

Figure 2-36. Access Ramp Locations at "T" Intersections



4. **Mid-Block Ramps on Local Roadways.** Curb ramps on local roadways shall be spaced no greater than 600 feet apart. Where spacing is greater than 600 feet, mid-block curb ramps shall be provided at spacings that minimize travel distances between curb ramps. Private accesses may be used for these access points where the access is designed to meet curb ramp requirements. The pavement markings and signing required by the ECM and MUTCD shall be provided for mid-block curb ramps.
 5. **Access, Cul-de-Sacs, Knuckles, and Eyebrows.** A curb ramp shall be provided at all accesses, cul-de-sacs and knuckles. Curb ramps are not required for eyebrows unless there are amenities within the eyebrow, however, if they are provided they shall be in accordance with the requirements of ECM 2-6.
 6. **Underwalk Drains (Chases).** Underwalk drains shall not interfere with the pedestrian use. The chase plate shall be flush with the sidewalk surface and be securely fastened, as specified in the Standard Drawing in Appendix F. Underwalk drains shall not be located within a curb ramp, curb cut, or private access.
 7. **Inlets.** Inlets located in a sidewalk shall be integrated with sidewalks. The inlet access shall be flush with the sidewalk surface. No manholes, inlets, or other storm sewer facilities are allowed within curb ramps. Inlets shall be located at or behind the tangent points of a curb return.
- D. **Grade-Separated Roadway Crossings.** The construction of a grade-separated pedestrian crossing may be requested by the ECM Administrator when a regional trail intersects with either an Expressway or Principal Arterial. If available, existing structures should be used to accommodate the proposed grade separation. See Section 6.3.9.
- E. **Rural Roads and Pedestrians.** Rural road sections shall provide sufficient shoulder width for pedestrian travel. Table 2-4 and Table 2-5 outline the requirements for rural roadways.
- F. **Pedestrian Street Crossings (Crosswalks).** All crosswalks shall be properly marked to ensure safe pedestrian movement. Crosswalks will be required at all signalized intersections, school areas, and high pedestrian areas, as determined by the ECM Administrator. See Section 6.3.2.
1. **Crosspans.** Crosswalks shall not be located in crosspans.

-
2. **Maximum Crosswalk Length and Pedestrian Refuge Areas.** The maximum length for any crosswalk shall be 48 feet. Any roadway crossing longer than 48 feet shall be provided with pedestrian refuge areas. Pedestrian refuge areas shall be created in medians or splitter islands to increase pedestrian safety. Vehicle turning radii shall be considered in the design of pedestrian refuge areas.
 3. **Traffic Signals.** All pedestrian traffic signals shall be designed and installed in accordance with MUTCD and an approved TIS. See Section 6.3.6.
- G. **Multi-Use (Shared-Use) Path Width.** Where a multi-use path is proposed, the minimum path width shall be 10 feet wide. See Section 6.3.7.
- H. **Clear Path Pedestrian Minimum.** The minimum horizontal clearance around utility structures, furniture, and other encroachments shall be greater or equal to 4 feet (see Figure 2-35). A Work in the Right-of-Way Permit is required for any private improvements within the right-of-way.

2.5.3. Noise Analysis and Mitigation

A noise study shall be prepared where a new expressway or principal arterial is planned or where roadway construction is planned which will result in changing an existing road classification from a lower classification road to an expressway or principal arterial. Noise mitigation may be required where noise levels exceed or are predicted to exceed 67 dBA Leq or exceed the current Federal Standards.

2.5.4. Bus Shelters

- A. **Location.** The location of a bus shelter shall be determined by the transit provider with the concurrence of the ECM Administrator.
- B. **Visibility.** Bus shelters shall have maximum transparency, and be highly visible from the surrounding area to assure the users' safety. The shelter may not be located within required sight distance triangles.
- C. **Minimum Size and Capacity.**
1. **Opening Size.** Openings shall be at least 48 inches wide and shall meet PROWAG requirements. See Section 6.3.8.
 2. **Capacity and Size.** Capacity shall be based on maximum passenger accumulation at the stop. The shelter size shall be based on approximately 5 square feet per person.
 3. **Placement.** Shelters shall not obstruct pedestrian flow or motorist's sight distance. Minimum pedestrian clear path widths shall be maintained.
 4. **Pad Requirements.** A 6-inch thick concrete pad is required under all bus shelters. The pad shall extend at least 6 inches beyond each edge of the shelter.
 5. **Passenger Loading Area Width and Detached Sidewalks.** Shelters located adjacent to detached sidewalks shall include a fifteen foot wide concrete area between the sidewalk and the curb for passenger loading and unloading.
 6. **Relocation of Shelters.** The ECM Administrator may require a shelter to be relocated or removed in the future to accommodate other needs within the roadway right-of-way at the sole expense of the transit provider.
 7. **Bicycle Racks and Trash Containers.** All shelters are required to provide one trash container and one bicycle rack.

-
8. **Sidewalk Connections.** A sidewalk connection shall be provided between the bus shelter and the existing sidewalk or nearby pedestrian destinations. The minimum width shall be as required in Sections 2.5.2.B.1 and 6.3.8.

2.5.5. Crosspans

- A. **Basic Requirements.** Crosspans for passing storm drainage flow across roadways shall be constructed in accordance with the Standard Drawing in Appendix F.
- B. **Dimensions and Depth.** Crosspans adjacent to local roadways shall be a minimum of 6 feet wide with a typical depth of $\frac{7}{8}$ -inch. Crosspans adjacent to collector roadways shall be a minimum of 8 feet wide with a typical depth of 1 $\frac{1}{4}$ inches. Crosspans adjacent to arterial roadways shall be 10 feet wide with a typical depth of 1 $\frac{1}{2}$ inches.
- C. **Prohibited on Arterial and Collector Roadways.** No crosspans shall cross roadways classified as urban residential collectors and higher.
- D. **Minimum Grade.** The flowline of the crossspan shall have a minimum grade of 0.5%.
- E. **Crosspan Transitions.**
1. **Design Speeds.** Pavement transition from standard crown to crossspan shall be designed using the appropriate design speeds for urban roadways in Table 2-6 and Table 2-7.
 2. **Intersections.** Transitions from standard crown to crossspan at intersections shall be designed in accordance with Figure 2-37.

Figure 2-37. Standard Intersection Crowns

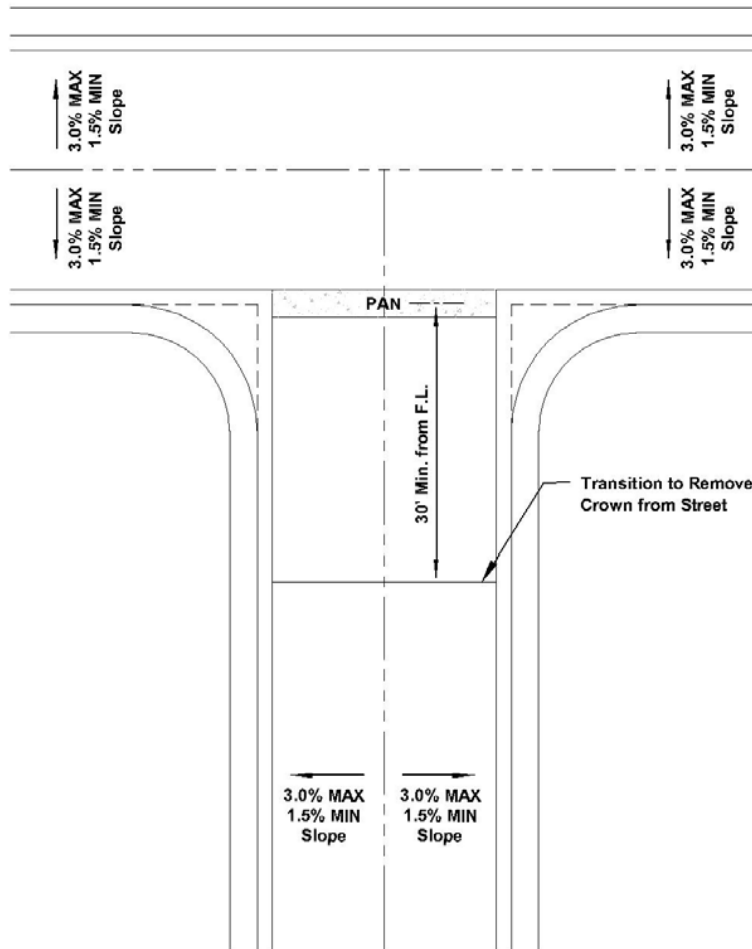

- F. **Pavement Material.** Approaches to crossspans shall be constructed with full depth asphalt wedges on asphalt roadways per the Standard Drawing in Appendix F. If pavement is concrete, crossspans may be poured monolithically with the main line paving process.

2.5.6. Medians and Traffic Islands

- A. **General Requirements.** The design and construction details for medians shall be in accordance with roadway cross sections presented in Appendix F. The minimum width of any raised median shall be 4 feet. See Section 6.3.5 for accessibility requirements.
- B. **Drainage.** Landscaped medians shall be provided with drainage facilities to handle sprinkler runoff and nuisance flows. Sprinklers shall be designed to prevent spray onto the pavement surface. A properly designed drain system shall be required. When low maintenance landscaping is used in conjunction with trickle irrigation, drainage requirements may be waived.
- C. **Curb and Gutter.** If gutters are not needed to handle drainage referenced above, medians may be constructed with outfall curb and gutter. Due to its fragility, glue-down curbs are prohibited.
- D. **Nose.** The position of the median nose shall be placed so that vehicles do not track onto the median. The minimum radius for nose curbs shall be 2 feet to flowline.

-
- E. **Paving.** All non-landscaped areas of medians shall be paved with stamped concrete, colored concrete or exposed aggregate concrete, as determined by the ECM Administrator.
 - F. **Transitions.** The ends of medians shall transition into turn lanes with a minimum radius of 100 feet. A change of direction must be accomplished with the use of radii. Angle points shall not be allowed.
 - G. **Corner Islands Separating Right Turns.** Standard corner islands shall be used in all high capacity intersections to channelize traffic, provide pedestrian refuge or where required by the ECM Administrator.
 - H. **Median Design for Left Turn Lanes.** Where a single left turn lane is necessary, a median area of 16 feet shall be provided. The median area shall consist of a 12-foot turn lane and a 4-foot painted separator. If a barrier median is necessary, the median area should consist of a 12-foot lane exclusive of gutter, and a minimum 6-foot raised median divider.
 - I. **Median Islands Separating Opposing Traffic.** Median islands are required at all high capacity intersections. If raised medians are not required by these standards, the median islands may be raised or painted. The design shall be in accordance with these Standards and as follows:
 - 1. **No Obstruction.** Medians must not obstruct the minimum left turn radius for the design vehicle(s).
 - 2. **Drainage.** Landscaped medians shall include drainage facilities to handle sprinkler run-off and nuisance flows. When low maintenance landscaping is used in conjunction with trickle irrigation, drainage requirements may be waived and outfall curb and gutter should be used.
 - J. **Median Islands on Minor Arterials, Collectors or Local Roadways.** Raised medians may be placed in minor arterial, collector, and all local roadways. If medians are included, they shall be placed in the public right-of-way, and they must meet the following standards for design:
 - 1. **No Obstruction.** The medians may not obstruct the design vehicle turns.
 - 2. **Visibility.** The medians must be placed such that the required visibility in the intersection is not obstructed.
 - 3. **Undiminished Use.** Medians must be placed so they do not diminish the intersection use.
 - 4. **Alignment.** Lanes on one side of the intersection must align with the correct lanes on the opposite side of the intersection.
 - 5. **Median Maintenance.** Maintenance of median landscape will be limited at the discretion of the ECM Administrator.
 - 6. **Public Use.** The ECM Administrator may use these islands for roadway signing and may choose to remove the median if it is deemed necessary by the ECM Administrator.
 - 7. **Additional Right-of-Way.** Any additional right-of-way necessary to accommodate the medians shall be provided.
 - K. **Splitter Islands.** Raised splitter islands for roundabouts shall be designed in accordance with the Roundabout Design Guide, FHWA Standards, or other design criteria approved by the ECM Administrator.

2.5.7. Bicycle Facilities

- A. **General.**

-
1. **Permitted Bicycle Travel Areas.** Bicyclists may share vehicular travel lanes in cases where no designated bike lanes are provided, except in certain cases where bicycle travel may be prohibited or is unsafe.
 2. **Accessibility Requirements.** All design for off-roadway bicycle paths are considered multi-use (shared-use) paths and shall conform to the requirements of Chapter 6.
 3. **Use of Drainage System and Open Space.** The bike path and pathway system may use the drainage and open space system.
 4. **Access Easements.** Where bike paths cross private land or coincide with private access facilities, a public access easement shall be provided.
 5. **Maintenance Responsibility.** Maintenance and operation responsibility for new bike paths will be determined by the ECM Administrator.
- B. On-Roadway Bike Lanes Design Requirements.**
1. **On-Roadway Bike Routes.** Specific roadways may be designated as on-roadway bicycle routes. These routes are on roadways with lower traffic volumes and speeds, wide outside lanes, and minimal stop signs, stop lights, curb cuts, private access, and interference with turning traffic. Roadways designated as on-roadway bicycle routes shall be designed with additional width for bike lanes. Some roadways within new developments or re-developments must also contain additional roadway width for bike lanes.
 2. **One-Way Road Cross Sections.** Bicycle lanes on one-way roadways shall be on the right side of the roadway.
 3. **Signage and Striping.** All designated bike lanes shall be signed and striped in accordance with MUTCD.
 4. **Actuation Loop.** Separate actuation loops are required in bike lanes at signalized intersections.
 5. **Bike Lanes at Intersections.** Where a separate right turn lane exists, the bicycle lane shall transition and be placed between the through lane and the right turn lane. The bike lane width shall remain the same as the approaching bike lane.
- C. Off-Roadway Bicycle Paths Design Requirements.**
1. **General Design Requirements.** The general design of bicycle paths in the County shall meet these Standards. The bicycle path shall be designed to ensure safe, secure, and connected travel for bicyclists and other users of the off-roadway system/facilities.
 2. **Bike Path Location and Easements.** Bike path locations shall be based on safety, circulation, and access considerations. Where needed, a 20-foot minimum easement shall be procured for a 10-foot-wide bike path in accordance with Figure 2-38.
 3. **Preserving Trees.** Where possible, bike paths shall be routed to minimize the loss of trees and disruption of natural environmental conditions.
 4. **Distance from Obstacles.** A minimum of 2 feet is required between the bike path edge and any vertical obstructions such as trees, utility poles, signs, fences, or other obstacles. The ECM Administrator may require greater separation where grades exceed 4%.
 5. **Clearing of Vegetation.** During construction, minimal vegetation will be removed to assist with path installation.
 6. **Overhead Clearance.** All bike paths shall have a minimum of 10 feet clear vertical clearance above the path.

7. **Cross Section.** The typical cross section shown in Figure 2-38 shall be maintained along the entire length of the bike path.
8. **Grade.** Minimum bicycle path grade shall be 0.60% except in sag curves where proper drainage shall be provided by the cross slope. The minimum grade shall be waived if cross slope is 2% and good drainage is provided and unobstructed. A maximum grade of 8% is permitted.
9. **Design Speed.** For paved surfaces, a minimum design speed of 20 MPH shall be used. Where grades exceed 4%, a design speed of 30 MPH shall be used. For unpaved surfaces, a minimum design speed of 10 MPH shall be used. Where grades exceed 4%, a design speed of 20 MPH shall be used.

Figure 2-38. Typical Bicycle Path Cross Section

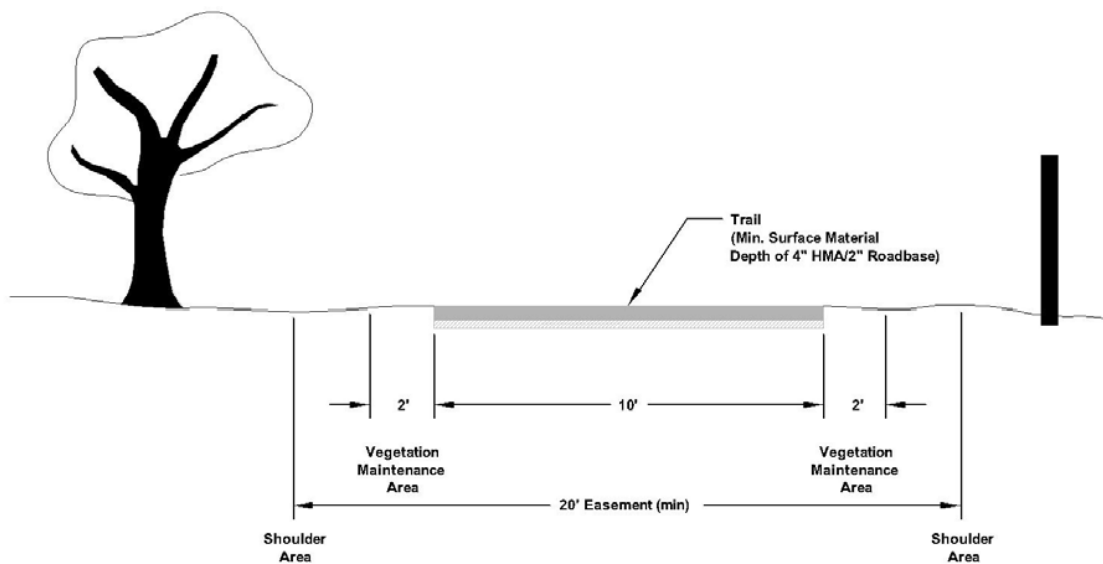

10. **Radius of Curvature.** Based upon a superelevation rate (e) of 2%, the minimum radius of curvature to be used is 95 feet at 20 MPH.

The minimum radius is a limiting value of curvature for a given design speed. At a proposed design speed both the superelevation rate and the assumed value for side friction factor determine the minimum safe radius. The minimum radius of curvature is determined from the following equation:

$$R = V^2 / [5(0.01e + f)]$$

Where:

R = radius of curve, feet

V = vehicle design speed, MPH

e = rate of superelevation, percent (The bicycle path superelevation rate shall be a minimum of 2% and a maximum of 3%.)

f = side friction factor (Friction factors used for design should be selected based upon the point at which centrifugal force causes the bicyclist to recognize a feeling of discomfort and instinctively

act to avoid higher speed. Extrapolating values used in highway design, design friction factors for paved bicycle paths can be assumed to vary from 0.27 at 20 MPH to 0.22 at 30 MPH. Unpaved surface friction factors are to be reduced by 50% to allow a sufficient margin of safety.)

11. **Substandard Radius Curves.** When substandard radius curves must be used on bicycle paths because of right-of-way, topographical or other considerations, standard curve warning signs and supplemental pavement markings shall be installed in accordance with the MUTCD. The negative effects of substandard curves can also be partially offset by widening the pavement through curves.
12. **Sight Distance.** Sight distance requirements shall be in conformance with AASHTO requirements. Figure 2-39, Figure 2-40, Figure 2-41, and Section 2.3.7 provide the required sight distance requirements. Obstructions to the visibility of motorists or bike path users shall be removed or the bike path aligned around the obstruction to maximize visibility. Lateral clearances on horizontal curves should be calculated based on the sum of the stopping sight distance for bicyclists traveling in opposite directions around the curve.

Figure 2-39. Minimum Stopping Sight Distance (Bicycle Paths)

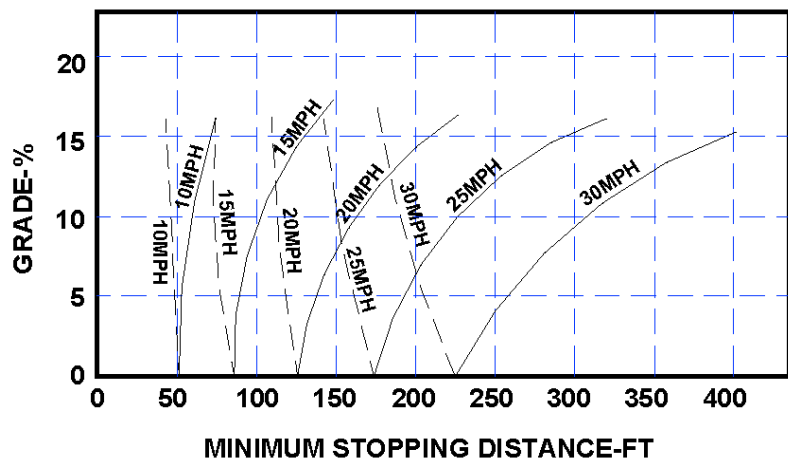

13. **Cross Slope.** The cross slope of multi-use (shared-use) paths shall not exceed 2%. 1.5% Typical cross slope is recommended to allow for variability during construction.
14. **Drainage.** All bicycle paths shall drain freely. Where a bike path is cut into a hillside, a ditch shall be placed along the high side of the bike path to prevent sheet flow across it.
15. **Safety Considerations.** The safety of pedestrians, and others who may use or travel on a bike path, shall be a prime consideration in the bike path design.

Figure 2-40. Minimum Length of Vertical Curves (Bicycle Paths)

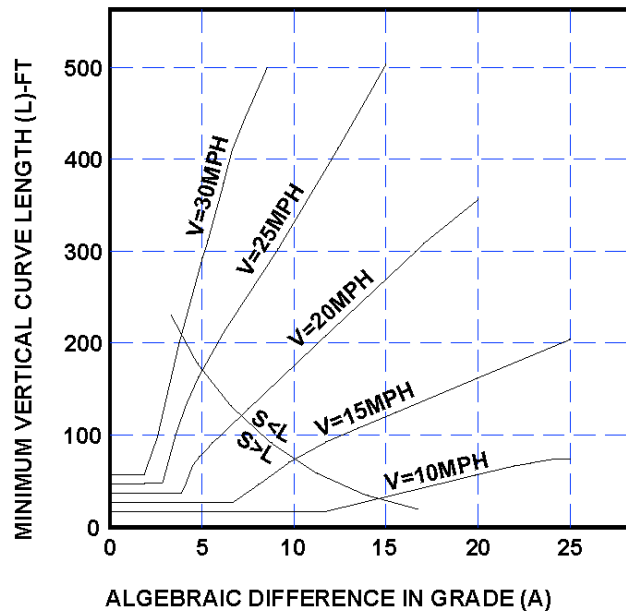
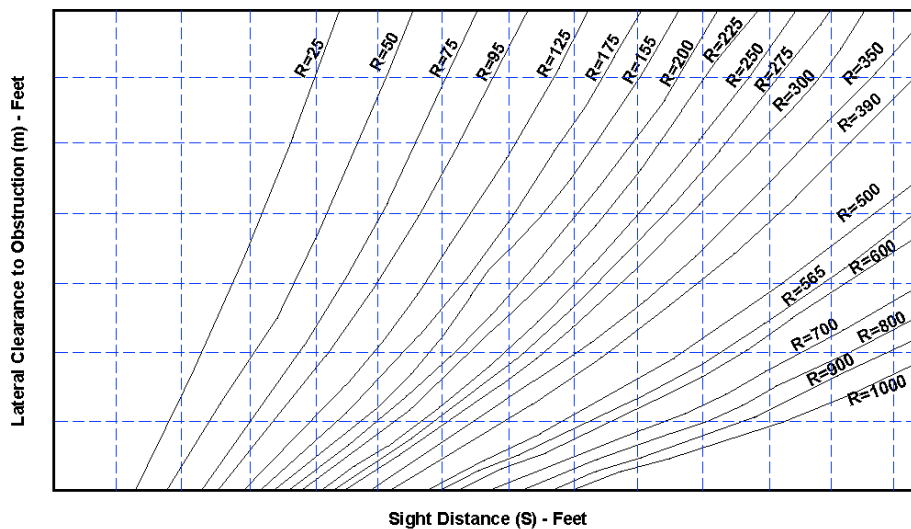

Figure 2-41. Minimum Lateral Clearances on Horizontal Curves (Bicycle Paths)



16. **Barriers and Other Safety Devices.** For bike paths adjacent to roadways with speed limits over 25 MPH, and with slopes greater than 6%, the ECM Administrator may require special safety measures. Examples include barriers or other safety devices between the roadway and bike path, or an increase in the distance between the bike path and highway.
17. **Signs for Hazards and Regulatory Messages.** Standard signage and pavement markings in the MUTCD are required to alert bike path users to hazards and to convey regulatory messages.

-
18. **Intersection Grade.** Maximum grade of the bike path at intersections is 3% extending for 30 feet in each direction from the centerline of the intersection.
 19. **Curb Ramps.** Standard sidewalk curb ramps will be provided at all bike path curb crossings to allow continuity of bike path use by bicyclists and pedestrians. Curb depressions equaling the bike path width shall be used, with the bike path surface sloping to the pavement at 8.3% maximum slope. See Section 6.3.7.
 20. **Water Crossings.** All bike paths require either a bridge or a fair weather crossing. All bridges shall be designed in accordance with the requirements of Section 2.6.
 21. **Grade-Separated Roadway Crossings.** Grade-separated bicycle crossings shall be provided for regional/neighborhood paths and trails that intersect with major roadways as determined by the ECM Administrator.
 22. **Railings, Fences, or Barriers.** Railings, fences, or barriers on both sides of a bicycle path structure shall be a minimum of 4.5 feet high. Smooth, snag-free rub rails should be attached to the barriers at handlebar height of 3.5 feet. Barriers should not impede storm water runoff from the path.
 23. **Bicycle Path Underpasses.** A minimum of 10 feet of vertical clearance from trail surface to underside of bridge shall be provided. Twelve feet of clearance shall be provided if equestrian accommodations are required.
 24. **Trail Surface Elevation and Flooding.** The trail surface elevation shall be at or above the high water mark for the 10-year storm.
 25. **Signage and Pavement Marking.** All signs, except locally adopted bike route signs, shall conform to MUTCD. All curves with restricted sight distances are required to be painted with a centerline to separate traffic. The centerline shall be 4 inches wide and painted yellow.
 26. **Turning Radius at Bike Path Intersections.** The minimum turning radius at bike path intersections shall be 20 feet.

2.5.8. Other Features in the Right-of-Way

- A. **Landscaping.** Landscaping within the County's right-of-way shall provide adequate erosion control for roadside areas; a natural streetscape environment; and safe conditions for motorists, pedestrians, and bicyclists. The landscaping must be appropriate for the conditions and easily maintained by the use of power-mowing equipment.

If plantings are proposed within the County's right-of-way, written approval from the ECM Administrator must be obtained prior to placement and proper maintenance must be performed to ensure that a safety hazard is not created.

- B. **Side Slopes and Grading in Right-of-Way.**
 1. **Cut and Fill Slopes.** Cut and fill slopes should be flattened and rounded to fit with the topography.
 2. **Slope Benches (outside EPC Right-of-Way, inside Easement).** Benches shall be on a slope of no more than 20:1 towards the roadway to prevent ponding of moisture behind the bench, thus creating additional slope blend with geological stratum rather than conforming to any set grade. For ease of maintenance, a 20-foot wide bench is considered satisfactory.

-
3. **Slopes.** The maximum slopes for all areas within or outside of the right-of-way that can affect public improvements shall be a maximum of 3:1. In general, retaining walls are discouraged and not allowed within the right-of-way. Maximum slopes maybe further restricted by clear zones.
 4. **Off-Site Fill Material.** Any material from an off-site location to be used in right-of-way or areas within the influence area of the right-of-way must be tested to ensure these Standards are being met.

C. **Roadside Ditches.** Roadside ditches shall be designed to the following criteria.

- Ditches shall have a minimum depth of 24 inches to accommodate driveway culverts.
- If 100-year flows require ditches to be greater than 24 inches deep, additional rights-of-way must be provided to accommodate the ditch.
- Ditches shall be stabilized with vegetation, stone or concrete paving where velocities will erode natural soils. Asphalt paving of ditches is prohibited.
- Ditches with steep flow lines shall be interrupted with dikes (ditch checks) at such intervals to maintain a velocity not to exceed what is appropriate for the ditch material.
- Type C Grate Inlets are not permitted in roadside ditch applications.
- Ditches shall have a minimum grade of 1.0% or as dictated by the roadway grade and surrounding slopes.
- Side slopes of ditches shall be designed to minimize drifting snow onto the roadway.

D. **Design Features to Prevent Snow Drifting.** Many areas of El Paso County have problems with drifting snow. Snow drifting on El Paso County roads is a dangerous problem for the traveling public and snow removal crews. Snow drifting has left motorists stranded, has created the need for rescue efforts for stuck motorists, impedes emergency vehicles, and has even caused deaths in El Paso County. Snow drifting increases the snow removal costs to allow motorists and emergency vehicles access to subdivisions. Therefore, subdivision applicants shall address the issue of drifting snow on El Paso County roads early in the subdivision planning and design process.

A map has been developed by snow removal crews for roads that have recurring snow drifting problems. The map is shown in Figure 2-42. Snow drifting along applicable arterial roads must be addressed when the subdivision:

- Is in a rural area.
- Consist of lot sizes 2.5 acres or larger, and
- Occurs along a road with snow drifting problems according to Figure 2-42

When all previous conditions are met, the subdivision applicant shall:

- Provide written documentation of measures taken to minimize snow drifting on identified El Paso County roads adjacent to the subdivision.
- Provide a 150 foot building setback to accommodate snow fencing/storage along the applicable arterial road.
- Provide plat notes that discuss setbacks, necessary easements, and maintenance responsibilities. El Paso County will maintain the snow fence if there is an easement and the plat notes identify that El Paso County is responsible for maintenance.

- Identify the type of snow fence to be used. The preferred snow fence is an earthen berm. Other acceptable snow fence types include a living snow fence, vertical slat fence, Wyoming snow fence (with horizontal slats) and other approved snow fence types.
- Identify the primary direction of wind and snow drifting. Typically, a snow fence will be required on the windward side of the arterial and a snow storage area will be required on the leeward side of the arterial.

Figure 2-42. Roads with Snow Drifting Problems

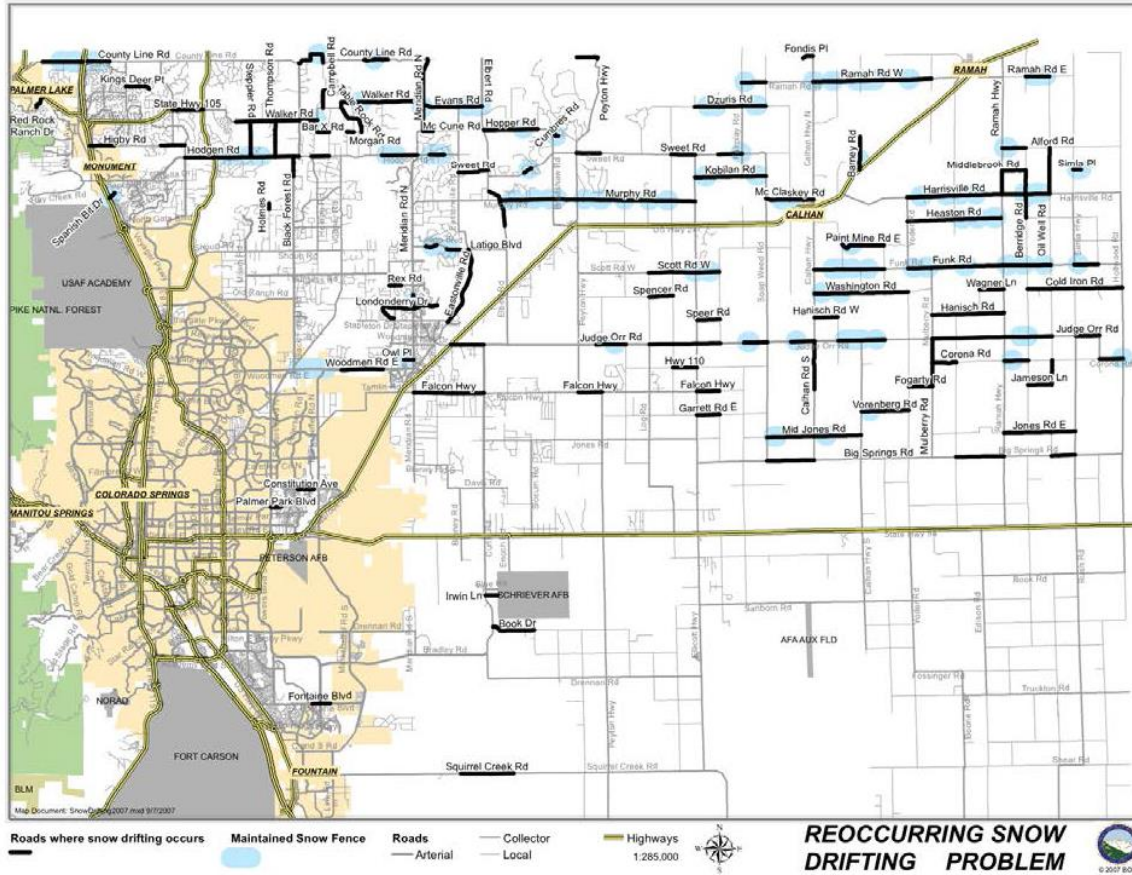

(Res. No. 20-222 , 6-23-20)

2.6. STRUCTURE DESIGN

2.6.1. Structures That Must Conform to the Standards

All culvert pipe, box culverts, guardrails, and bridges that will be owned and maintained by the County shall conform to these standards.

(Supp. No. 2)

Created: 2021-06-08 11:35:49 [EST]

2.6.2. Drainage Capacity and Erosion Control

Bridges and major drainage structures shall be designed to conform to the hydraulic requirements presented in Chapter 3. The design of all structures shall include measures to control bank erosion and bridge scour.

2.6.3. Design Criteria

Designs of structures shall conform to these Standards and the criteria contained in the following documents.

Structural Standards:

- AASHTO, Standard Specifications for Highway Bridges
- AASHTO, LRFD Bridge Design Specifications
- AASHTO, LRFD Bridge Construction Specifications
- AASHTO, A Policy on Geometric Design of Highways and Roadways
- AASHTO, Roadside Design Guide
- CDOT, Bridge Manual, Volumes I and II
- CDOT, Standard Specifications for Road and Bridge Construction
- CDOT, M&S Standards

Borings and Soils Tests:

- Borings and soils tests shall conform to the requirements for Soils Investigations in Appendix C

2.6.4. Design Approach

Load and Resistance Factor Design (LRFD) is the recognized design approach for structures.

2.6.5. Deflection Control

Designs of three-sided concrete drainage structures shall include deflection control.

2.6.6. Bridges (Major Structures)

- Design Life.** All bridges shall have a minimum design life of 50 years.
- Sufficiency Rating.** All major structures shall be rated for structural sufficiency prior to approval of the plans by the County. The design shall conform to Federal Bridge Rating Guidelines for new bridges.
- Basic Construction Parameters.** Bridges shall be constructed of reinforced concrete or steel. Bridges constructed of timber are prohibited.
- Span Construction Types.** Typical span types and approximate acceptable span limitations are shown in Table 2-37.

Table 2-37. Bridge Span Types

Span Type	Approximate Limitations
Reinforced Concrete Slab	<40 feet
Prestressed Concrete Slab	<50 feet
Prestressed Concrete Double Tee Girders	<120 feet
Prestressed Concrete Box Girders	<140 feet

Created: 2021-06-08 11:35:50 [EST]

(Supp. No. 2)

Prestressed Concrete B-T Girders (Bulb Tee)	<160 feet
Rolled Beams	<100 feet; with cover plate up to 120 feet
Plate Girders	<70 feet
Trusses	>140 feet

- E. **Vehicular Bridges.** Vehicular bridges shall be designed to carry vehicles, pedestrians, and bicycles.
- Design Loads.** All vehicular bridges shall be designed for vehicle loadings of HS-15 or higher. A pedestrian load of 85 psf shall be applied to all sidewalks wider than 2 feet, in combination with vehicular design live load. Sidewalks in this case include wide curbs or other structures that may be used by pedestrians.
 - Deflection.** Maximum deflection on a vehicular bridge shall be:

$$D_{max} = S/1000$$
Where:
 D_{max} = deflection, feet
S = span, feet
 - Clear Width.** The clear width for bridges on roadways with curbed approaches shall meet or exceed the curb-to-curb width of the roadway approaches. For roadways with shoulders and no curbs, the clear width should be the same as the approach roadway width.
 - Sidewalks.** Sidewalks conforming to the roadway cross sections shall be provided on both sides of a bridge. Sidewalk and bike path widths will match those of the approaching roadway segments. If no sidewalks or bike paths currently exist, sidewalks conforming to the roadway functional classification shall be provided (See Table 2-4 through Table 2-7).
- F. **Pedestrian, Equestrian, and Bicycle Bridges (PEB bridges).**
- Design Approach.** PEB bridges shall be designed with the LFD method, as provided by AASHTO Standard Specifications for Highway Bridges. PEB bridges shall be designed to comply with the accessibility requirements of Chapter 6.
 - Vehicle Design Loads.** The minimum design vehicle loading for a PEB bridge follows the H-truck configuration loading. Table 2-38 presents specific H-truck loading based upon clear deck width for PEB bridges.

Table 2-38. H-Truck Loading for PEB Bridges

PEB Bridge Width (feet)	H- Truck Loading
6—10	H-5 Truck Configuration (10,000 lb)
>10	H-10 truck configuration (20,000 lb)
>6	Not wide enough for any vehicles

- Pedestrians and Bicycle Design Loads.** The pedestrian live load for the main member shall be 85 psf. When the deck influence area, A_1 , is greater than 400 square feet, a reduction may be made per the following equation:
Pedestrian live load = $85/[0.25 + (15/A_1^{1/2})]$
At no time shall the pedestrian live load of the main member be less than 65 psf.
The design live load for the secondary member shall be 85 psf.

4. **Equestrian Design Loads.** A concentrated load of $P = 1,000$ lb shall be used when horse traffic is present.
5. **Wind.** Wind load is a horizontal load. There is no required combination of wind on live loads (pedestrian or vehicular). For wind overturning force, see AASHTO Standard Specifications for Highway Bridges. Table 2-39 presents a listing of design wind loads applicable to the vertical area of PEB bridge members.

Table 2-39. Design Wind Load for PEB Bridges

Member Type	Design Wind Load (psf)
Truss and Arches	75
Girders and Beams	50
Open Truss	35

6. **Deflection.** Maximum deflection on a PEB bridge shall be as follows:

$$D_{\max} = S/1000$$

where:

D_{\max} = deflection, feet

S = span, feet

7. **Vibrations for PEB Bridge without Live Load.** When the PEB bridge has no vehicular or pedestrian traffic, the frequency shall be greater than 3 Hz to avoid the first harmonic.
8. **Vibrations for PEB Bridge with Live Load.** When the PEB bridge has a live load (e.g., running and jumping), the frequency shall be greater than 5 Hz to avoid the second harmonic.
9. **Allowable Fatigue Stress.** Fatigue provisions are not required for pedestrian live load stresses where heavy pedestrian loads are infrequent. Fatigue provisions shall be included for wind loads.
10. **Half-through Truss Spans.** Half-through truss spans shall be designed per AASHTO Guide Specifications for Design of Pedestrian Bridges.

2.6.7. Railings

- A. **Using Rigid Railings.** Railing systems can be rigid or they can allow deflection to reduce penetration. Highway structures normally warrant the use of a rigid railing.
- B. **Criteria.** Railings used on any bridge structure in the County shall comply with AASHTO and CDOT Criteria.
- C. **Traffic Railing.**
 1. **Accepted Bridge Railing Types.** Bridge railings must handle vehicles on the bridge under impact conditions. Vehicles and impact conditions are specified in the design. Table 2-40 presents the acceptable bridge railings for bridges in the County.

Table 2-40. Acceptable Bridge Railing Types

Type of Railing	Reference(s)
CDOT Railing Types 3, 7, 8 and 10	CDOT Standards
Oklahoma Modified TR-1	AASHTO and Appendix F
BR1 Type C Aluminum Bridge Railing	AASHTO and Appendix F

Safety-Shaped Concrete Bridge Railing	AASHTO and Appendix F
Nevada Concrete Safety Shape (w/ Steel Rails)	AASHTO and Appendix F
Texas Type HT (Heavy Truck)	AASHTO and Appendix F
Texas Type TT (Tank Truck)	AASHTO and Appendix F

2. **Using Other Types of Railing.** Other railings may be proposed for review and approval by the ECM Administrator. Structural calculations or crash test results shall be submitted with such proposals.
 3. **Transitions.** Transitions shall be provided when a semi-rigid roadside guardrail meets a rigid bridge railing.
 4. **Gradual Stiffening.** The transition shall provide a gradual stiffening of the approach by adjusting the post spacing or rail strength or by transitioning to a different, stiffer barrier.
 5. **Flexible Bridge Railings.** Transitions may not be necessary when bridge railings have some flexibility. Any design without a transition shall satisfy AASHTO criteria.
 6. **Alternatives in Congested Areas.** In urban areas or where roadways and sidewalks prevent installation of approach guardrail transitions, one or more of the following alternatives shall be followed:
 - Extend the guardrail or bridge rail in a manner that prevents encroachment of vehicle onto any roadway system below the bridge. A tapered end section parallel to the roadway may be an option.
 - Provide a barrier curb.
 - Restrict speed. The ECM Administrator approval is required for this option.
 - Provide a recovery area.
 7. **Placement and Lateral Clearance.** The rail system shall be placed 2 feet beyond the useable shoulder.
- D. **Roadside Barrier Railing.**
1. **Required Barriers.** Barriers are required only when the warrants in the AASHTO Roadside Design Guide are met.
 2. **Acceptable Roadside Barriers.** Roadside barriers are flexible, semi-rigid or rigid. Table 2-41 presents the acceptable roadside barriers in the County.

Table 2-41. Acceptable Roadside Barriers

Category	Type of Barrier	Reference
Semi-Rigid Systems	Blocked-Out W-Beam (Strong Post)	Refer to M & S Standards
	Blocked-Out Three-Beam (Strong Post0)	Refer to M & S Standards
	Modified Three-Beam	Refer to M & S Standards
Rigid Systems	Concrete Safety Shape	Refer to M & S Standards
	Stone Masonry Wall	Refer to M & S Standards

3. **Transitions.** In the case of roadside barriers, the gradual stiffening shall decrease from structure to roadway.

4. **Lateral Offset from the Edge-of-Traveled Way.** Roadside barriers shall be placed as far from the through lane as conditions allow. A roadside barrier shall not be placed beyond the shy line offset given in Table 2-42.

Table 2-42. Shy Line Offset Values

Design Speed (MPH)	Shy Line Offset Ls (feet)
70	9.2
60	7.9
50	6.6
40	4.6
30	3.6
25	3.0

5. **Deflection Distance.** If a rail is installed along the face of an exposed pier, abutment or wall, sufficient clearance shall be provided to allow dynamic lateral deflection. This will enable the rail to cushion and deflect an errant vehicle. Figure 2-43 provides the barrier-to-obstruction distance.

Figure 2-43. Deflection Distance

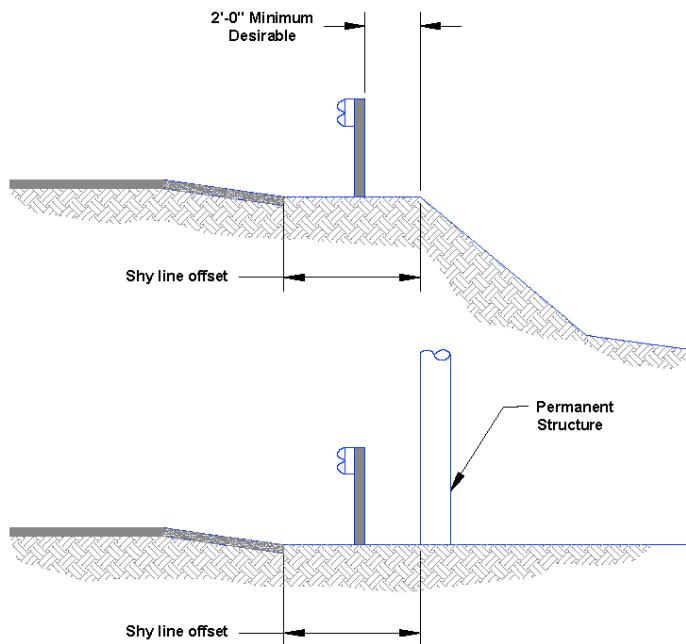

6. **Terrain Effect.** Most roadside barriers are designed and tested on level terrain. Caution must be taken when slopes are 1:6 or more. Figure 2-44 shows recommended barrier location on a 1:6 slope.

Figure 2-44. Terrain Effects Barrier Location on a 1:6 Slope

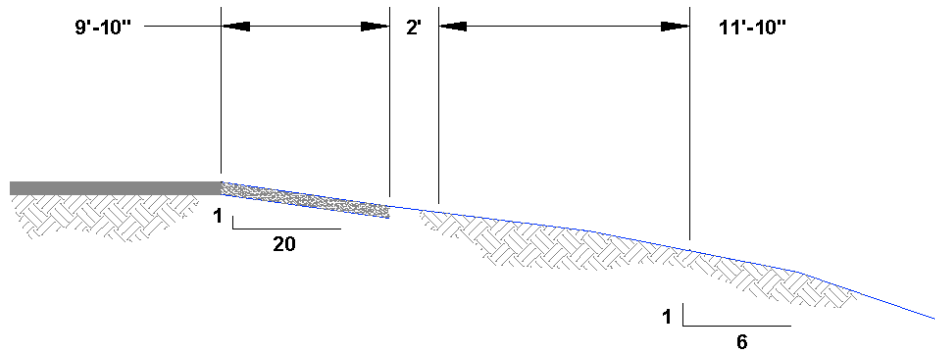

7. **Length of Need.** AASHTO Roadside Design Guide shall be used to determine the length of need requirements.
- E. **Pedestrian Railing.**
1. **Pedestrian Railing Required.** A pedestrian railing shall be used at all locations where pedestrians are adjacent to a 2:1 or steeper drop-off equal to or greater than 30 inches high.
 2. **Placement.** The railing shall be placed on the outer edge of the sidewalk when pedestrian traffic is separated from vehicular traffic by a traffic railing.
 3. **Height and Openings.** Pedestrian railing height shall be a minimum of 42 inches, measured from the walkway surface (See Figure 2-45). Railings shall not have openings large enough to pass a 4-inch sphere.

Figure 2-45. Typical Pedestrian Railing

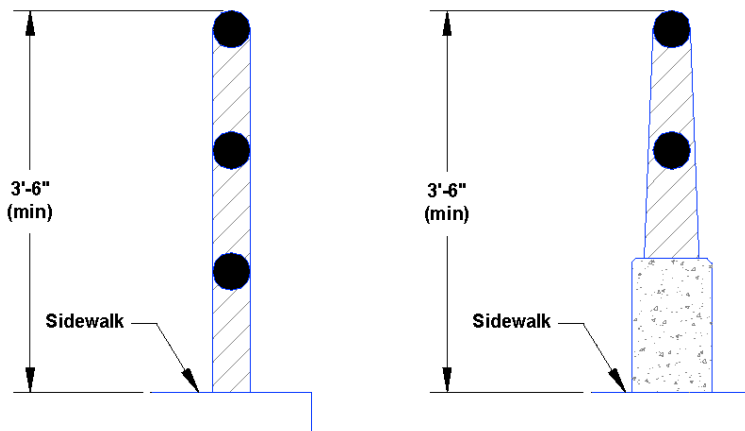

4. **Construction Material.** A pedestrian railing shall be constructed of metal fabric, chain link (vinyl clad only), metal rails only or metal rails placed above a concrete parapet.
5. **Metal Rail Design Loads.** The design live loading shall be 0.050 kips per Linear Foot, both transversely and vertically, acting simultaneously on each longitudinal element. A concentrated load of 0.20 kips, acting on the top rail and simultaneous with the design live loading can be considered at any point and in any direction.

6. **Chain Link/Metal Fabric Design Loads.** The design live load shall be 0.015 Kips per Square Foot acting normal to the entire surface.

F. **Bicycle Railing.**

1. **Bicycle Railing Required.** A bicycle railing shall be used wherever bicycle lanes are adjacent to the edge of a bridge or hazard. The railing shall be warranted when the roadway has designated bike lanes.
2. **Placement.** The bicycle railing shall be placed on the outer edge of the bike lane.
3. **Height and Rub Rail.** Bicycle railing height shall be a minimum of 54 inches, measured from the riding surface. Smooth, snag-free rub rail shall be attached to the railings at the handlebar height of 3.5 feet (See Figure 2-46).

Figure 2-46. Typical Bicycle Railing

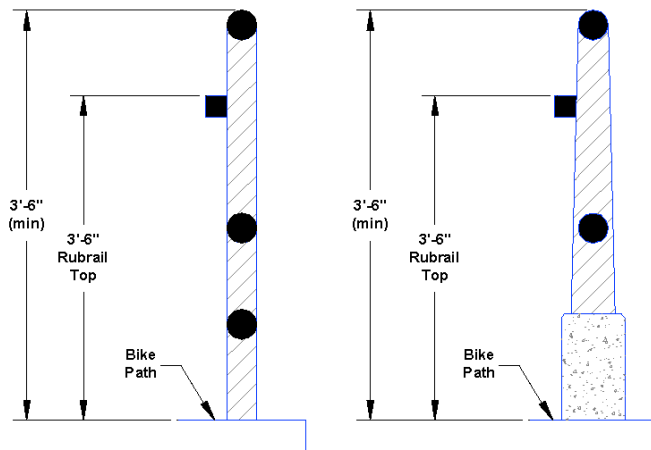

4. **Construction Materials.** A bicycle railing shall be constructed of metal rails only, metal rails above a concrete parapet, chain link or metal fabric.
 5. **Design loads.** Design loads shall conform to pedestrian railing design loads in Section 2.6.7E.
- G. **Combination Pedestrian, Vehicle or Bicycle Traffic Barrier.**
1. **Conditions for Use.** The combination barrier shall be provided for structures whenever a raised curb and an attached sidewalk exist.
 2. **Placement.** The combination barrier shall be installed adjacent to the roadway with either a pedestrian or bicycle railing, as appropriate. The combination barrier shall be placed on the outboard side as shown in Figure 2-47.

Figure 2-47. Typical Combination Barrier

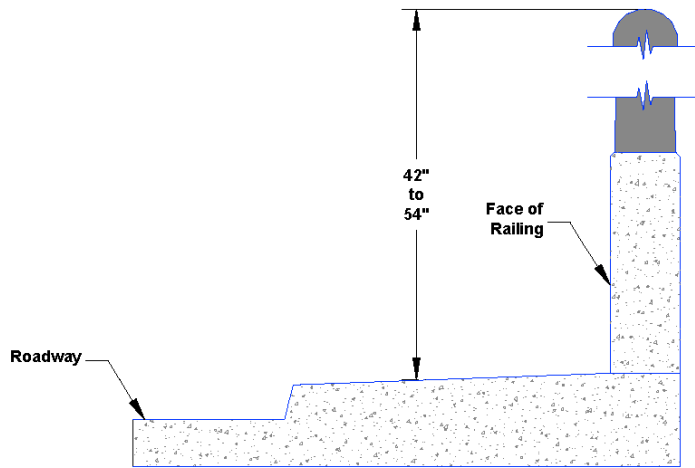

3. **Height.** If the sidewalk width is 6 feet or greater, the railing height shall be between 42 and 54 inches, measured from the sidewalk surface.

2.6.8. Retaining Walls and Abutments

A. General requirements.

1. **Accepted Retaining Walls.** Four types of retaining wall systems are accepted by the County: conventional retaining walls and abutments, anchored walls, mechanically stabilized earth walls, and prefabricated modular walls.
2. **Backfill Materials.** The backfill materials used shall be granular and free-draining.
3. **Drainage.** Drainage shall be provided to reduce hydrostatic pressure behind the wall.
4. **Design Life.** All retaining walls shall have a minimum design life of 50 years.

B. Conventional Retaining Walls and Abutments.

1. **Design Basis.** Conventional retaining walls and abutments are proportioned to provide stability against bearing capacity failure, overturning, and sliding.
2. **Avoid Placement in Right-of-Way.** Retaining walls are discouraged within the public right-of-way. They will be allowed only when necessary to support public improvements and when approved by the ECM Administrator.
3. **Requirements When Beyond Right-of-Way.** Retaining walls needed to support private improvements shall not be located in the public right-of-way. However, if the failure of a related retaining wall could threaten any improvements or safety within the right-of-way, the retaining wall shall be designed to ECM standards.
4. **Loading.** Design of conventional retaining walls and abutments shall satisfy the following loading factors:
 - Lateral earth and water pressures including any live and dead load surcharges,
 - The weight of the wall,
 - Temperature and shrinkage effects, and

-
- Seismic loads.

C. **Anchored Walls.**

1. **Design Basis.** Anchored walls provide additional lateral resistance with the use of anchors. Their design is based on the suitability of the subsurface soil and rock conditions.
2. **Loading.** Design of conventional retaining walls and abutments shall satisfy the following loading factors:
 - Lateral earth and water pressures including any live and dead load surcharges,
 - The weight of the wall, and
 - Seismic loads.

D. **Mechanically Stabilized Earth Walls.**

1. **Design Basis.** Mechanically Stabilized Earth Walls (MSEW) are flexible composites of granular soil and tensile inclusions that behave as earth embankments with vertical or nearly vertical faces. MSEW are proportioned to provide stability against overturning and sliding. Bearing pressure generally governs design.
2. **Loading.** Design of conventional retaining walls and abutments shall satisfy the following loading factors:
 - Lateral earth and water pressures including any live and dead load surcharges,
 - The weight of the wall, and
 - Seismic loads.
3. **Application for MSEW.** An MSEW should be used where substantial total and differential settlement is expected. This type of wall may also be used where conventional gravity, cantilever or counterforted concrete retaining walls are considered.
4. **Unacceptable Uses of MSEW.** An MSEW shall not be used in any of the following conditions:
 - Where utilities other than highway drainage are to be constructed within the reinforced zone,
 - Where floodplain erosion or scour may undermine the reinforced fill zone or any supporting footing, and
 - Where surface or groundwater contaminated by acid mine drainage or other industrial pollutants is present.

E. **Prefabricated Modular Walls.**

1. **Design Basis.** Prefabricated modular walls employ soil-filled interlocking modules to resist earth pressures. Stability of modular walls depends upon the weight and strength of the fill soil. Each module level shall be investigated for sliding and overturning.
2. **Loading.** Design of conventional retaining walls and abutments shall satisfy the following loading factors:
 - Lateral earth and water pressures including any live and dead load surcharges,
 - The weight of the wall, and
 - Seismic loads.

-
3. **Earth Pressure and Lateral Thrust Calculations.** Earth pressure shall be computed on a plane surface where modules form an irregular, stepped surface. K_a , used to compute lateral thrust, shall be computed based on the friction angle of the backfill behind the modules.
 4. **Application for Prefabricated Modular Wall.** A prefabricated modular wall may be used where conventional gravity, cantilever or counterforted concrete retaining walls are considered.
 5. **Unacceptable Uses of Prefabricated Modular Wall.** A prefabricated modular wall shall not be used in any of the following conditions:
 - On curves with radii less than 800 feet, unless the chord can be substituted with a series of chords and
 - Where groundwater or surface runoff is contaminated with acid.
- F. **Placement of Walls.**
1. **Clear Zone Placement.** Walls shall not be placed within the clear zone. Walls located in the clear zone shall be snag-proof and crash resistant or include an AASHTO barrier.
 2. **Relationship to Shoulder.** Full or partial height walls shall not be located closer than the outer edge of the shoulder.
 3. **Retaining Wall at Roadway Level.** When the top of the retaining wall is at the level of a roadway, the face of the parapet wall or rail shall be at least 4 feet from the edge of the traveled way.

2.6.9. Buried Structures

- A. **Materials.** Buried structures may be constructed of precast or cast-in-place concrete, aluminum, or steel materials.
- B. **Design Life.** The design life for buried structures shall be a minimum of 100 years.
- C. **Non-Vehicular Loads.**
 1. **Load Factors.** Buried structures shall be designed for force effects resulting from horizontal and vertical earth pressure, pavement load, live load, and vehicular dynamic load.
 2. **Other Load Factors.** When relevant for site or construction conditions, earth and live load surcharges and downdrag loads shall also be evaluated.
 3. **Water Buoyancy Loads.** Water buoyancy loads shall be analyzed for buried structures with inverts below the water table.
- D. **Vehicular Loads.**
 1. **Wheel Loads.** Where depth of fill is greater than 2 feet, wheel loads may be considered uniformly distributed over a rectangular area equal to the dimensions of the tire contact area.
For depth of fill 2 feet or less, wheel loads shall be increased by 1.15 times the depth of fill in select granular backfill.
 2. **Recreational Trails.** The minimum design vehicular loading for buried structures supporting recreational trails shall accommodate maintenance traffic. The minimum design loading shall be H-15.
 3. **All Other Traffic.** Buried structures below traffic other than recreational traffic shall be designed for vehicular loadings of HS-20 or higher.

4. **Sidewalks.** A pedestrian load of 85 psf shall be applied to all sidewalks, where warranted for location above buried structures, wider than 2 feet, and considered simultaneously with vehicular design live load.
- E. **Embankment Installation.** The soil envelope shall be wide enough to ensure lateral restraint for the buried structure. In no cases shall the width of the soil envelope on each side of the buried structure be less than the values specified in Table 2-43.

Table 2-43. Minimum Width of Soil Envelope around Buried Structures

Diameter, S (inches)	Minimum Envelope Width (feet)
<24	S/12
24–144	2.0
>144	5.0

- F. **Minimum Soil Cover.** The depth of cover of a well compacted granular sub-base, taken from the top of rigid pavement or the bottom of flexible pavement, shall be no less than the values specified in Table 2-44 and Table 2-45.

Table 2-44. Minimum Soil Cover for Buried Structures

Type	Condition	Minimum Cover
Structural Plate Pipe Structures		$S/8 \geq 12.0$ inches
Long Span Structural Plate Pipe Structures		Table 2-45
Structural Plate Box Structures		1.4 to 5.0 feet
Reinforced Concrete Pipe	Unpaved areas and under flexible pavement	$B/8$ or $B'/8 \geq 12.0$ inches (whichever is greater)
	Compacted granular fill under rigid pavement	9.0 inches
Where:		
S = diameter of pipe, inches		
B = outside diameter or width of the structure, feet		
B' = out-to-out vertical rise to pipe, feet		
ID = inside diameter, inches		

Table 2-45. Minimum Soil Cover for Buried Long Span Plate Pipe Structures

Steel Thickness Without Ribs (inches)	Top Radius (feet)				
	≥ 15.0	15–17	17–20	20–23	23–25
0.111	2.5	-	-	-	-
0.140	2.5	3.0	-	-	-
0.170	2.5	3.0	3.0	-	-
0.188	2.5	3.0	3.0	-	-
0.218	2.0	2.5	2.5	3.0	-
0.249	2.0	2.0	2.5	3.0	4.0
0.280	2.0	2.0	2.5	3.0	4.0

- G. **Multiple pipe crossings.** Due to maintenance issues, parallel culverts (a.k.a. culvert batteries) are not permitted except in areas where low headwater is unavoidable, areas where approach velocity is supercritical, or in the vicinity of a bend immediately upstream. Refer to Chapter 9 of the CDOT Drainage Design Manual for additional information.
- H. **Structural Plate Box Structures.**
1. **Design.** The shallow covers and extreme shapes of box culverts require special design procedures. Flexural requirements of metal box culverts govern the choice of section in all cases.
 2. **Geometric Requirements.** Table 2-46 and Figure 2-48 provide the geometric requirements for structural plate box structures.

Table 2-46. Geometric Requirements for Structural Plate Boxes

Parameter	Required Range
Span, S	8'9" to 25'5"
Rise, R	2'6" to 10'6"
Radius of crown, r^c	<24'9½"
Radius of haunch, r^h	>2'6"
Haunch radius included angle, Δ	50 to 70 degrees
Length of leg, D	4¾" to 71"
Minimum length of rib of leg, L	19"; D - 3"; or within 3" of top of footing (whichever is lowest)

Figure 2-48. Typical Structural Plate Box

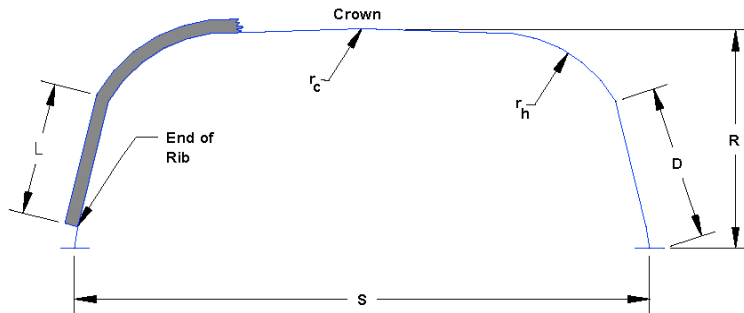

3. **Embankment Installation.** The combined width of the soil envelope and embankment beyond shall be adequate to support all the loads on the culvert.
 4. **Live Loads.** Live load distribution for culvert tops may be based on provisions for deck slabs spanning parallel to traffic.
 5. **Maximum Soil Cover.** Maximum soil cover for structural plate box structures shall be limited to a depth of cover of 5 feet.
 6. **Concrete Relieving Slabs.** Concrete relieving slabs may be used to reduce flexural moments in box culverts. The length of the concrete relieving slab shall project at least 1 foot beyond the haunch on each side of the culvert.
- I. **Reinforced Concrete Pipe.**

1. **Design.** Buried reinforced concrete pipes shall be designed to resist structural failure due to flexure, thrust, shear, and radial tension. The dimensions of the pipe sections shall be determined with either the direct or indirect design method as outlined in the AASHTO standards referenced.
2. **Trench and Embankment Installations.** Both trench and embankment installations shall be designed for embankment loads and pressure distribution. The earth pressure distribution shall be the Hedger pressure distribution as shown in Figure 2-49 and Table 2-47.

Table 2-47. Coefficients for Use with Figure 2-48

Coefficient	Installation Type			
	1	2	3	4
VAF	1.35	1.4	1.4	1.45
HAF	0.45	0.4	0.37	0.3
A1	0.62	.85	1.05	1.45
A2	0.73	0.55	0.35	0.0
A3	1.35	1.4	1.4	1.45
A4	0.19	0.15	0.1	0.0
A5	0.08	0.08	0.1	0.11
A6	0.18	0.17	0.17	0.19
A	1.4	1.45	1.45	1.45
B	0.4	0.4	0.36	0.3
C	0.18	0.19	0.2	0.25
E	0.08	0.1	0.12	0.0
F	0.05	0.05	0.05	-
U	0.8	0.82	0.85	0.9
V	0.8	0.7	0.6	-

Figure 2-49. Hedger Pressure Distribution

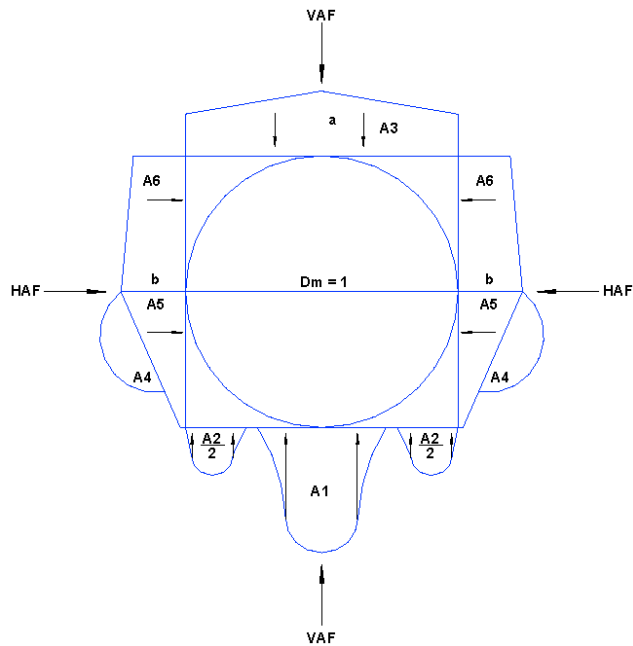

3. **Live Loads.** For standard installations, the live load on the pipe shall be assumed to have a uniform vertical distribution across the top of the pipe and the same distribution across the bottom of the pipe.
- J. **Reinforced Concrete Cast-in-Place and Precast Arches and Box Culverts.**
1. **Trench and Embankment Installations.** Trenches or embankments shall be constructed according to these Standards.
 2. **Other Installations.** Other installation methods (such as partial positive projection, 0.0 projection, negative projection, induced trench, and jacked installations) may be used to reduce the loads on a culvert.
 3. **Vehicular Live Loads.** All vehicular box culverts shall be designed for vehicular loadings of HS-20 or higher. For single-span culverts, the effects of live load may be neglected where the depth of fill is more than 8 feet and exceeds the span length. For multiple span culverts, the effects of live load may be neglected when depth of fill exceeds the distance between faces of end walls.
 4. **Less Than Two Feet of Soil Cover.** Distribution of wheel loads and concentrated loads for culverts with less than 2 feet of cover shall be as specified for slab-type superstructures.
 5. **No Soil Cover.** If soil cover is not provided, the top of reinforced concrete box structures shall be designed for direct application of vehicular and pedestrian loads.
 6. **Crack Width Control.** Steel reinforcement shall be well distributed over the zone of maximum concrete tension to control flexural cracking.
- K. **Thermoplastic Pipe.** Thermoplastic pipe shall not be used in El Paso County right-of-way or in any publicly maintained easements.
- L. **Precast Reinforced Concrete Three-Sided Structures.**

-
1. **Design.** Design of three-sided structures shall be based on a pinned connection at the footing and shall take into account anticipated footing movement. Each precast, three-sided structure shall be analyzed independently with no shear or stress transfer assumed between sections.
 2. **Geometric Requirements.** Wall thickness shall be a minimum of 8.0 inches for spans under 24 feet and 10 inches for spaces 24 feet and longer.
 3. **Shear Key.** Flat top structures with shallow cover shall be provided with shear keys in the top surface.
 4. **Minimum Reinforcement.** The flexural reinforcement in the direction of span shall provide a ratio of reinforcement/gross concrete area ≥ 0.002 . This minimum reinforcement shall be provided at all cross sections subject to flexural tension, at the inside face of walls, and in each direction at the top of slabs of three-sided sections with less than 2.0 feet of fill.
 5. **Deflection Control.** Deflection criteria shall be addressed in the design of all precast reinforced concrete, three-sided structures.

2.6.10. Subdrains

- A. **Controlling Groundwater.** Subdrains used for the purpose of controlling groundwater on private property may be constructed within the County's right-of-way if certain criteria are met. The system shall be private and must be maintained by viable private parties and approved with a Work in the Right-of-Way Permit.
- B. **Protecting Right-of-Way Improvements.** Subdrains constructed for the purpose of protecting public improvements may be installed only if other means are not possible. Subdrains installed for the protection of public improvements shall be maintained by the County.
- C. **Design Criteria.**
 1. **Positive Outfall.** A subdrain shall have a positive outfall for gravity drainage.
 2. **Adequate Engineering.** The subdrain shall be designed in consideration of site-specific groundwater conditions, soil properties, topography, and layout of proposed development.
 3. **Sanitary Sewer Kept Dry.** The subdrain system shall maintain adequate flow capacity under peak hydraulic loading rates to keep groundwater below the invert of the sanitary sewer.
 4. **No Offsite Transport.** The subdrain shall neither receive groundwater inflow from additional upstream developments, nor transfer collected groundwater to downstream developments without first recording legally binding documents of the agreements established between multiple owners.
 5. **Water Rights.** The subdrain shall not injure existing water rights.
 6. **Monitoring after Construction.** The subdrain shall incorporate provisions to allow monitoring of groundwater levels to confirm that it is functioning as designed.
 7. **Design for Seasonal High Water.** The subdrain shall be designed in consideration of seasonal high groundwater levels.
 8. **Groundwater Barriers.** The subdrain shall be designed with clay cutoff walls to preclude hydraulic communication with offsite utility trenches either upstream or downstream.
 9. **Filter Fabric.** The subdrain trench shall be lined with a filter fabric specifically selected to minimize the invasion of fine soil particles into the bedding gravel.

10. **Pipe Diameter.** The minimum subdrain pipe diameter is 4 inches for mains and 3 inches for laterals or as determined by a completed geotechnical analysis.
11. **Subdrain Placement and Cleanouts.** The Standard Drawings in Appendix F show general requirements for subdrain placement, location of cleanouts, and service.

(Res. No. 20-222 , 6-23-20)

Chapter 3 STORMWATER MANAGEMENT

3.1. OVERVIEW

This chapter provides policies and procedures to attain reasonable standardization of drainage design throughout the County.

3.1.1. Purpose

The purpose of this chapter is to discuss specific drainage and grading related criteria for projects that disturb surface soils within the unincorporated areas of the County. In addition, with the issuance of a County-wide National Pollutant Discharge Elimination System (NPDES) permit, this chapter and adopted Addendum presented in Appendix I provide specific criteria and standards for the management and protection of surface water quality.

The most current version of the Drainage Criteria Manual Volume 1 (DCM1) can be found here:

<https://publicworks.elpasoco.com/policies-manuals/>

The most current version of the drainage fees and bridge fees can be found at the following website under Fees:

<https://publicworks.elpasoco.com/road-bridge-planning/>

3.1.2. Chapter Content and References

Table 3-1 outlines the chapter content and references used as a basis for the standards established in Chapter 3.

Table 3-1. Contents and Basis of Drainage Facility Standards

Intent Use	ECM Content	ECM Section(s)	Reference Document(s)
Planning			
	Plan Basis	3.2.1 - 3.2.3	2
	Plan Objectives and Policies	3.2.4 - 3.2.8 and Appendix I	2, 3
Design			
	Storm Sewers	3.3.2	2, 3
	Culverts	3.3.3	2, 3
	Open Channels	3.3.4	2, 3
	Drainage Ditches	3.3.5	2, 3
	Roadways	3.3.6	2, 3
	Permanent Stormwater Management Facilities	3.3.7	n/a
Construction			

Created: 2021-06-08 11:35:50 [EST]

(Supp. No. 2)

	Permitting	5.3, 5.6 and Appendix I	1, 3
	Inspections	5.11 and Appendix I	1, 3
	Acceptance	5.3 and Appendix I	1, 3
	Site Grading	3.3.4	2.3

References

1. El Paso County Land Development Code.
2. City of Colorado Springs Drainage Criteria Manual Volume 1 (DCM 1).
3. City of Colorado Springs Drainage Criteria Manual Volume 2 (DCM 2).
4. City of Colorado Springs Drainage Criteria Manual 2014 Update: Chapter 6 and Section 3.2.1 of Chapter 13.
5. Urban Drainage and Flood Control District Criteria Manual Volume 3, Chapter 7.

3.1.3. Standard Drawings

Table 3-2 identifies the standard drawings that are included in Appendix F as an enforceable part of these Standards. The standard drawings shall be used in all applications for which a public improvement is to be designed. Any change to a standard drawing shall be approved by the ECM Administrator and noted on the construction plans.

Table 3-2. Standard Drawings

File Name	Detail/Description	Approval Date
SD_3-1	Storm Sewer Manhole Detail Type I	07/09/2009
SD-3-2	Storm Sewer Manhole Detail Type II	11/10/2004
SD_3-3	Storm Sewer Manhole Detail Type III	08/11/2011
SD_3-5	Storm Sewer Manhole Lid Detail	09/16/2010
SD_3-7	Storm Sewer Manhole Riser and Cover Detail	08/11/2011
SD-3-8	Grate Inlet for Common Areas (guidance)	08/11/2011
SD_3-14	Driveway Access on Rural Local Roadway	08/11/2011
SD_3-24	Sidewalk Underdrain w/ Curb Outlet Detail	08/11/2011
SD_3-25	Curb Opening w/ Drainage Chase Detail 1 of 2	08/11/2011
SD_3-25A	Curb Opening w/ Drainage Chase Detail 2 of 2	08/11/2011
SD_3-30	Desilting Basin Outlet	08/11/2011
SD_3-31	Temporary Desilting Basin at Inlet	08/11/2011
SD_3-32	Temporary Desilting Basin at Sump	08/11/2011
SD_3-33	On Street Temporary Desilting Basin Detail	
SD_3-34	Temporary Desilting Basin Detail (guidance)	08/11/2011
SD_3-35	Debris Cage for Desilting Basin Riser	08/11/2011
SD_3-36	Desilting Basin Riser Detail	08/11/2011
SD_3-41	Lined Ditch Splashwall Detail (plan and section)	08/11/2011
SD_3-44	Lined Ditch Behind Retaining Wall Detail	08/11/2011
SD_3-48	Beehive Grate Detail (guidance)	08/11/2011
SD_3-60	Temporary Street Sandbag Detail and Section	08/11/2011
SD_3-62	Typical Check Dam Detail	08/11/2011
SD_3-71	Canyon Subdrain Detail	08/11/2011

Created: 2021-06-08 11:35:50 [EST]

(Supp. No. 2)

SD_3-81	Lug Connection Detail (cast in place concrete pipe)	08/11/2011
SD_3-82	Plan and Section of an Extended Detention Basin Sedimentation Facility	01/01/08
SD_3-83	Typical WQCV Outlet Structure Profiles Including 100-Year Detention	01/01/08
SD_3-84	Concrete Washout Structure	01/01/08
SD_3-85	Erosion Log Check Dams	01/01/08
SD_3-86	Culvert Inlet and Outlet Protection Erosion Logs Above Inlets and Outlets for Slope 3:1 or Steeper	01/01/08
SD_3-87	Erosion Log Barrier	01/01/08
SD_3-88	Cut Back Swale	12/13/2016

(Res. No. 19-245 , 7-2-19)

3.2. PLANNING

3.2.1. Developing a Plan for Drainage

All drainage systems being designed in the County shall take into account both minor intensity and major intensity storms. The objective of drainage system planning for minor intensity storms reoccurrence interval is to allow for the proper design of minor drainage systems (i.e., curb and gutters, storm sewers, culverts, open channels, and detention ponds) while minimizing minor damage and maintenance costs. The objective of drainage planning for major intensity storms (100-year reoccurrence interval) is to allow for proper design of major drainage systems (i.e., bridges, storm sewers, open channels, and detention ponds) while minimizing the possibility of major damage and/or loss of life.

It is the design engineer's responsibility to develop, justify, and submit values and calculations used in the preparation of drainage for county review and approval.

3.2.2. Natural and Artificial Systems

Conveyance systems include drainage facilities, both natural and artificial, that collect, contain, and convey stormwater runoff. Natural conveyance systems include, but are not limited to, swales, wetlands, drainage courses, streams, and rivers. Artificial conveyance systems include, but are not limited to, gutters, ditches, pipes, catch basins, manholes, constructed wetlands, open channels, and swales. Requirements for artificial conveyance systems, where natural systems already exist, shall not be interpreted to supersede County requirements for protection of natural systems.

3.2.3. Requirements of Adequate Drainage Systems Required

Adequate drainage designs shall provide for removal of runoff from the roadway or the upstream end of any development, and for carrying runoff water from the upstream side to the downstream side. These functions shall be accomplished without causing objectionable backwater, causing excessive or increased velocities, creating damages to downstream ownerships, unduly affecting the safe operation of traffic on the roadway, damaging the roadway or damaging water quality.

3.2.4. Suitable Outfall Location Definition

A suitable outfall location refers to a stream which is a hydraulically adequate historic natural stream or channel segment which developed conveyance systems (i.e. storm drain systems, channels, and detention

basin outlets) shall utilize for ultimate discharge of stormwater runoff from development. A suitable outfall stream may be a perennial or ephemeral stream in its previously undeveloped, natural condition. The other choice for a new stormwater outfall is a connection to an existing hydrologically and hydraulically adequate man-made system.

Any and all proposed man-made systems for stormwater conveyance shall outfall to a location as identified above, which is capable of receiving developed flows without negative impacts to streambed stability and/or natural sediment transport functions. Man-made conveyance systems are not limited to storm drain systems, detention basin outlets, and lined channels, but also include any change in the land configuration by grading which results in a new runoff pattern in terms of flow direction and quantity of runoff.

All suitable outfall streams as defined above shall be defined on a map of the basin and included in the applicable drainage basin planning study. In the event an older planning study does not define a suitable discharge point for a new stormwater discharge in the basin, the above criteria shall still apply.

3.2.5. Basic Objectives

The purpose of the drainage system is to collect, transmit, and discharge drainage consistent with the following objectives:

- A. **Space Planning.** Adequate space shall be provided and properly allocated for drainage facilities to ensure that downstream water quality impacts are minimized. When topography of a site dictates the need for addressing water quality near State Waters, adequate space must be provided for the location of permanent water quality structures prior to the discharge to State Waters. At no time shall concentrated flows be allowed from developed lots to discharge directly to State Waters.

Up to 20 percent, not to exceed one (1) acre, of an applicable development site may be excluded from Water Quality Capture Volume (WQCV) calculations when it has been determined that it is not practicable to capture runoff from portions of the site that will not drain towards a permanent control measure. The Owner must determine that implementation of a separate control measure for that portion of the site is not practicable and such determination shall be reviewed and approved by the ECM Administrator. See Appendix I for additional information.
- B. **Multi-Use Resource.** Stormwater runoff shall be treated as a multi-use resource and the design of storm drainage management facilities shall be planned to ensure that the multi-use aspects of drainage facilities are maintained.
- C. **Jurisdictional Boundaries and Master Planning.** Drainage boundaries are non-jurisdictional and regional cooperation is required to receive approval of facilities that have potential multi-jurisdictional and regional impacts through the preparation of a new or use of an existing Drainage Basin Planning Study.
- D. **Floodplain Management.** The design of drainage facilities shall consider the general purpose of the County's Floodplain Regulations and reduce the hazard of floods to life and property, protect and preserve hydraulic characteristics of water courses used for conveyance of floodwaters, protect the public from the extraordinary financial expenditures for flood control and relief, and promote the multi-use resource concept with the intent to provide and preserve quality open space, trails, and tree lines.
- E. **Stormwater Quantity and Quality.** Land disturbance activities shall properly manage and mitigate both stormwater quantity and quality related impacts. Quantity related impacts shall be mitigated in a manner that controls possible damage caused by the amount of surface water being transported to any one design point. Quality related impacts shall be mitigated using the design standards and permanent BMP selection process discussed in Appendix I.

All applicable development sites must have operational permanent stormwater quality control measures at the completion of the site. In the case where permanent water quality control measures are part of future phasing, the permittee must have a mechanism to ensure that all control measures will be implemented, regardless of completion of future phases or site ownership. In such cases, temporary water quality control measures must be implemented as feasible and maintained until removed or modified. All temporary water quality control measure must meet one of the design standards discussed in Appendix I.

- F. **Water Rights.** When proposed drainage systems interfere with existing water rights, the value and use of the water are affected; therefore, the design of any proposed stormwater drainage system incorporating retention shall identify the impact to water rights, and shall be approved by the State Engineer as appropriate.

Colorado Revised Statute (CRS) § 37-92-602(8) provides legal protection for any regional or individual site stormwater detention and infiltration facility in Colorado, except those in the Fountain Creek watershed, that are not required by or operated in compliance with a Municipal Separate Storm Sewer System (MS4) permit, provided it meets the following criteria:

1. It is owned or operated by a governmental entity or is subject to oversight by a governmental entity (e.g., required under an MS4 permit).
2. It continuously releases or infiltrates at least 97% of all of the runoff from a rainfall event that is less than or equal to a 5-year storm within 72 hours after the end of the event.
3. It continuously releases or infiltrates as quickly as practicable, but in all cases releases or infiltrates at least 99% of the runoff within 120 hours after the end of events greater than a 5-year storm.
4. It operates passively and does not subject the stormwater runoff to any active treatment process (e.g., coagulation, flocculation, disinfection, etc.).
5. The runoff treated in stormwater detention and infiltration facilities shall not be used for any other purpose by the owner/operator/overseer (or that entity's assignees).
6. The run off shall not be released for subsequent diversion or storage by the owner/operator/overseer (or that entity's assignees).
7. It shall not be the basis for a water right or credit.

Most stormwater detention and infiltration facilities constructed in unincorporated El Paso County are subject to the oversight of El Paso County and are required by an MS4 permit. Thus, El Paso County developed a registration process to meet the requirements of CRS § 37-92-602(8). Please refer to Section 3.3.7 for required information to be submitted during plan review to allow for facilities to be protected under the provisions of the statute.

3.2.6. County Policy on Drainage Diversion

Colorado drainage law recognizes the inequity in transferring the burden of managing storm drainage from one location or property to another. Liability questions may also arise when the historic drainage continuum is altered. Therefore, diversion of stormwater runoff from one basin to another is discouraged unless specific and prudent reasons justify such a transfer without impacting the historical drainage paths within the basin and the appropriate legal agreements have been recorded.

3.2.7. County Roadside Ditches

Consistent with Section 3.2.5, the County's existing roadside ditch and ditch systems shall not be used as an outfall conveyance for developed runoff. The main purpose of these ditch systems is to collect and properly convey stormwater from adjacent public roadways. Roadside ditches should not be considered as a suitable outfall for conveyance of developed runoff. Should a roadside ditch be the only true option, downstream capture and storage of sediment shall be planned for and provided for in the construction plans.

3.2.8. Hydrology

- A. **Design Storm Criteria.** Design storm flows shall be calculated based on appropriate criteria and guidelines presented in the DCM 1 to assure minimum design standards and that a regional drainage solution is developed. Information presented in these Standards do not replace information presented in the other referenced standards, but instead should be considered as additional criteria and shall be used in determining design storm runoff for both on-site and off-site flows.
- B. **Peak Volumes and Times of Concentration.** Peak volumes and times of concentrations shall consider fully developed land use scenarios to determine runoff coefficients and changes in flow patterns (from the undeveloped site conditions). Estimated times of concentration shall be based on proposed grading. The proposed project or developed land use shall not change historical runoff values, cause downstream damage or adversely impact adjacent properties.
- C. **Entire Project Area.** Phased or partial development analysis will not be accepted. The entire project area shall be analyzed based on full build-out to properly site and size storage areas and conveyance systems.
- D. **Off-Site Runoff.** The analysis of off-site runoff is dependent on regional drainage characteristics, the existing/proposed land use, and topographic features. If an existing storm drainage master plan is available for the area, the storm drainage master plan shall be used as a baseline document and updated with proposed information. Should no off-site information be available for fully developed flows, the design engineer must perform a regional analysis to ensure that the project does not change historic runoff values, cause downstream damage or adversely impact adjacent properties.
- E. **Design Runoff.** Design runoff shall be based on the following information:
- The 5-year minor design storm may be used in accordance with City of Colorado Springs adopted revisions to DCM 1.
 - Within floodplain and floodplain fringe areas, as defined by the FEMA, the runoff criteria shall be based on a 100-year frequency storm.
 - For all drainage channels and storm drain systems, which will convey drainage from a tributary area equal to and greater than one square mile, the runoff criteria shall be based on a 100-year frequency storm.
 - For tributary areas under one square mile, (1) the storm drain system shall be designed so that the combination of storm drain system capacity and overflow will be able to carry the 100-year frequency storm without damage to or flooding of adjacent existing buildings or potential building sites, and (2) the runoff criteria for the minor storm and underground storm drain systems shall be based upon a frequency storm consistent with DCM 1 and 2.
- F. **Design Runoff Methods.** Storm discharge flows shall be based on the adopted storm drainage master plan. If no established storm discharge flows are available, the storm drainage flows shall be based on the following:

- Design flows for watersheds less than 100 acres shall be developed using the Rational Method. Methods other than Rational Method shall not be accepted for watersheds less than 100 acres in size.
- Design flows for watersheds greater than 100 acres shall be developed using Soil Conservation Service (SCS) Methods, tabular or computer modeling or U.S. Army Corps of Engineers HEC I or HEC HMS computational methods.
- When determining design flows for floodplain management and flood proofing, design runoff shall be based upon existing conditions in accordance with the Regional Building Development's Floodplain Management Requirements and FEMA Regulations.

G. **Design Points.** Basin delineation within a development or specific design area is problematic with relation to the design of proper drainage systems and the long-range management of discharge quantities. Therefore, specific design points shall be analyzed in the design process. Discharge volumes for minor and major storm events shall be calculated at all design points. Examples of typical design points include:

- Curb inlets/catch basin;
- Area drains;
- Discharge points: pipes, swales, channels, detention basins, and sedimentation basins to a suitable outfall (existing or natural system);
- Transition points: pipe to channel or swale, crosspans, at any location where developed runoff exits the project boundary and at any point where off-site runoff enters the project boundary;
- Ditchout locations;
- Intersections; and
- Inflow and outflow from sedimentation basins and detention basins.

3.2.9. Site Grading

A. **Basic Objectives.** The goal of site grading is to develop features that direct and store surface water in a manner consistent with the following objectives:

- Assist in directing surface away from existing and proposed structures and towards well-developed conveyance/storage systems to minimize property damage;
- Minimize the amount of surface erosion and sediment transport by limiting steep grades in excess of 4:1 through terracing and using applicable permanent BMPs;
- Site grading shall be designed in a manner that minimizes the use of retaining walls and limits severe transitions at property boundaries;
- Storing surface runoff on site to minimize downstream impacts and control discharge flows; and
- Enhance surface water quality through the use of BMPs designed to remove constituents of concern collected during smaller storm events.

Site grading should imitate natural landforms and work effectively with the developed drainage plan to minimize erosion. The overall area being graded should be kept to a minimum per provisions presented in an approved ESQCP. Once construction is complete, all disturbed areas must be revegetated or other permanent BMPs must be installed.

B. **County Policy on Site Grading.** Site grading shall be designed to the level of detail necessary to ensure that the developed drainage plan is followed for each parcel or lot. In most cases, this will require lot

templates to be developed showing the direction of overall lot drainage, key drainage features/structures, slopes exceeding 10 percent, and approved discharge points. Lot templates are recommended for all commercial development and proposed residential development densities of one unit per acre or more. Where drainage conditions across individual lots are critical to the function of the overall drainage systems or where otherwise required by the ECM Administrator, lot templates shall be developed.

3.2.10. Major Drainageways/Floodplain Management

- A. **Permitting and Regulations.** All construction within the 100-year floodplain must comply with applicable local, state, and federal regulations. The Floodplain Administrator and ECM Administrator shall be consulted prior to submitting any formal proposal that requires or will potentially cause a change in base flood elevations in designated floodplains. Proposed modifications to the 100-year floodplain must be approved through the FEMA map revision process.

The preservation and enhancement of natural floodplains is encouraged whenever feasible. Filling floodplain fringes is generally discouraged because discharge and flood storage capacity will be impacted, affecting water surface elevations, velocity of flow, and downstream peak flows. All construction in the floodplain should be undertaken with caution and in accordance with applicable regulations.

Wetland regulations and permitting issues are also relevant to the major drainage system. A permit under Section 404 of the federal Clean Water Act (CWA) is required for any activities impacting waters of the U.S. and jurisdictional wetlands.

- B. **Embankments and Levees.** Permanent earth embankments, roadway embankments, walls or other structures along a water course for the purpose of flood control are not allowed as provisions for new development or redevelopment. Any existing or proposed roadway embankment that could be considered a levee or "non-levee embankment" providing flood control shall meet County, State, and FEMA requirements prior to development or redevelopment of an area potentially impacted by the subject floodplain.

(Res. No. 19-245 , 7-2-19)

3.3. DESIGN¹

3.3.1. Storm Sewers

- A. **Design Basis.** The installation of storm sewer systems is required when the other parts of the minor system (i.e., curb, gutter, and roadside ditches) no longer have capacity for additional runoff and required spread widths are exceeded.

The design of storm sewers shall be done in accordance with these Standards, the DCM1 and 2, and other references cited for additional discussion and basic design concepts. Hydraulics, debris and detritus, maintenance, inlet conditions, outlet conditions, safety, the effects on traffic, property, economics, and aesthetics shall be considered in the design of all underground storm drainage conduits.

¹Editor's note(s)—Res. No. 19-245 , adopted July 2, 2019, changed the title of § 3.3 to read as herein set out. Formerly, such section pertained to Stormwater Design.

B. **Service Life.**

1. **Minimum Service Life.** The minimum design service life for storm sewer systems shall be 50 years.
2. **Extended Service Life Required.** The service life for storm sewer systems shall be increased to 100 years when:
 - The depth of cover exceeds 15 feet,
 - A portion of the system is or may be located under a structure or the overhang of a structure,
 - The system is located within the traveled way of 4-lane or major and minor arterial roadways (rural and urban),
 - The centerline of a storm sewer pipe is located 15 feet or less horizontally from a structure, or
 - A storm sewer pipe is under a pressure head (typically caused by an installation on a steep slope).

- C. **Minimum Pipe Size.** Storm sewers shall be designed and sized to convey the minor storm runoff peaks without surcharging the sewer. To ensure that this objective is achieved, the hydraulic and energy grade lines shall be estimated by calculating both the major and minor losses (i.e., friction, expansion, contraction, bend, and junction losses). The final energy grade line shall be at or below the proposed ground surface.

The minimum allowable pipe size for storm sewers is dependent upon the estimated flows and a practical diameter from a maintenance standpoint. The minimum pipe size shall have a cross sectional area equivalent to an 18" circular pipe.

- D. **Minimum Gradient.** The minimum gradient shall be 0.5% or a minimum velocity of 4 feet per second (fps) with the pipe flowing one quarter full. Storm sewer pipes shall be designed to flow full and free of pressure heads except for short runs where the grade changes and a small pressure head cannot be avoided. Where it is necessary to design for a pressure head, it shall be approved by the ECM Administrator and shall use pressure pipe with watertight joints with a 100-year service life.

- E. **Vertical Alignment.** The storm sewer grade shall withstand AASHTO HS-20 or higher loading on the pipe. The minimum cover depends upon the pipe size, type and class, and soil bedding condition.

The minimum clearances between the proposed storm sewer, water main, and sanitary sewer (either above or below) shall be in accordance with the applicable district standards and Chapter 4.

- F. **Horizontal Alignment.** In most cases, the curvilinear storm sewer shall be avoided. Where a demonstrated need exists and where the pipe will have a diameter of 48-inches or less, a curvilinear alignment may be approved. The limitations on the radius for pulled-joint pipe are dependent on the pipe length and diameter, and the amount of opening permitted in the joint per the pipe manufacturer's recommendations.

- G. **Manholes.** Maximum spacing and locations of manholes and cleanouts are to be installed per requirements described in DCM 1, except as modified by Section 3.3.1.J.2. Manholes shall be installed 1/8" below the surface of the pavement on the lowest side of the manhole.

- H. **Inlets.** The capacities of standard inlets under various flow conditions shall be calculated or obtained from the DCM Volumes I and II.

- I. **Angle of Confluence.** In no case shall a component of lateral velocity oppose the mainline velocity by an angle of confluence. The angle of confluence shall be 90° or less, except where lateral measures 36 inches in diameter or more, in which case the angle of confluence shall be 60° or less. The change in energy gradient in the cleanout or junction shall not exceed 3 feet. In no case shall the energy gradient

exceed the elevation of 6 inches below the gutter grade on inlets, grate for grated inlets, or 6 inches below the bottom of the roof slab on cleanouts.

J. **Design Criteria Summary.**

1. **Minimum Class of Pipe.** All storm sewers within the County's right-of-way (right-of-way) are required to be RCP (minimum Class 3, Wall B). Other materials for storm pipe may be allowed, assuming a comparable service life can be achieved and the design criteria presented in this section are met. Pipe must maintain its original manufactured dimensions after installation.
2. **Changes in Conduit Size.** Where the conduit size increases, the inside top slopes of the conduits shall be continuous in elevation. Change in conduit sizes shall be accomplished in a reinforced concrete manhole or cleanout structure only.
3. **Consistent with Plans.** All pipes in the storm sewer system shall have size and slope indicated in the profiles on the plans.
4. **Stationing.** Storm sewer stationing shall run upgrade from the lower end of the drain. When a storm sewer runs longitudinally in a roadway, the stationing may be the roadway stationing.
5. **Minimum and Maximum Cover.** Minimum and maximum cover for storm pipes shall be determined based on loading, type and class of pipe, manufacturer's recommendations, and soil bedding conditions. Should a design warrant a cover depth of greater than 15 feet, an extended service life shall be accommodated (see Section 3.3.1 B2).
6. **Alignment Priority.** Drainage alignment priority shall be given to the larger of any two connecting storm drain systems. Pipes larger than 36 inches shall not run into and out of storm drain inlets in lieu of manholes without a specially designed inlet structure.
7. **Changes in Flow from Supercritical to Subcritical.** Hydraulic calculations shall be provided when the flow changes from supercritical to subcritical flow.
8. **Maximum Velocity.** The maximum storm sewer velocity shall be 18 fps.
9. **No Diversions of Drainage.** Diversion of drainage to other than an approved storm system is not permitted.
10. **Concrete Cutoff Walls and Anchoring.** Reinforced cast-in-place concrete cutoff walls shall be installed at intervals of no greater than 30 feet (horizontally) for all pipes placed in slopes where there is the possibility of erosion of the pipe trench on the slope. In addition, anchoring shall be installed at intervals of no greater than 30 feet for all culvert pipe placed on or within slopes 3:1 or steeper.
11. **Special Bedding Requirements.** When other pipe materials are proposed, the bedding of the pipe will be performed in a manner that is consistent with the material manufacturer's recommendations to achieve the required service life and meet the design criteria presented within these Standards.

K. **Storm Sewer Easements.**

1. **Minimum Widths.** Table 3-3 is a general guide for establishing minimum easement widths, although special conditions, such as deep locations, may require additional widths. The minimum easement width should be as shown in the table or twice the pipe depth plus the pipe diameter (rounded to the nearest 5 feet), whichever is larger. In general, storm sewer pipes should be centered in the easement.

Table 3-3. Easement Width Minimums

Pipe Diameter or Equivalent (inches)	Minimum Width (feet)
18—35	15
36—60	15
Over 61	30

2. **Location.** Storm sewers and easements are to be placed on one side of the lot ownership lines in a new development and in existing developments where conditions will permit.
3. **Joint Easements Permitted and Separations.** In general, storm sewer easements are to be established exclusively for drainage facilities. Joint use easements will be permitted, such as sewer, water, non-motorized public access, where necessary. Each underground line shall be separated by a minimum of 10 feet horizontally.
4. **Access to Storm Sewer.** Physical access shall be provided to all storm sewer easements. Should special access to storm sewer easements be required because of grade differential, a minimum access easement of 15 feet shall be established. A 15-foot wide access road shall be provided within the access easement. The access road shall have a maximum grade of 15 percent. Maintenance vehicle access is required every 1,500 feet or more often if site conditions demand. Joint use for non-motorized public use access may be permitted.
5. **Surface Use.** In areas to be improved over a storm sewer easement, only at-grade parking lots or fences may be constructed. Permanent structures are not permitted over or within storm sewer easements.

3.3.2. Culverts

- A. **Selection of Culvert.** The selection of a culvert for installation shall be based on information outlined in the DCM1. The required pipe strength shall be determined from the actual depth of cover, true load, and proposed field conditions. See also Section 2.6.9.G for restrictions on the number of culverts.
- B. **Service Life.** The minimum design service life for all culverts shall follow the design service life for storm sewer systems outlined in Section 3.3.1B.
- C. **Minimum Pipe Size.** The minimum allowable culvert size shall follow the minimum size criteria for storm sewer systems in Section 3.3.1C. The minimum culvert size shall have a cross-sectional area equivalent to an 18-inch circular pipe.
- D. **Minimum Gradient.** In designing culverts, both the minimum and maximum velocities must be considered. A flow velocity greater than approximately 3 fps during the initial storm is required to ensure that self-cleaning conditions exist. A velocity less than approximately 7 to 12 fps (subcritical flow regime) minimizes possible culvert damage due to scouring and downstream channel erosion.
- E. **Culvert Entrances.**
 1. **Entrances.** Entrances shall be rounded, beveled or expanded, whichever is appropriate, to increase the capacity of the culvert, whether the outlet is free or submerged and whether the slope is above or below critical.
 2. **Flared End Sections Required.** Flared end sections are required for outlets and inlets of culverts that do not have headwalls (except for private driveway culverts).
 3. **Inlet Aprons.** Inlet aprons shall be used as transitions between the culvert and an improved approach channel, and may be used between the culvert and a natural approach channel. These shall be designed to prevent grade cutting of natural channels and to provide for a more efficient entrance condition.

-
- F. **Outlet Dissipater.** A suitable energy dissipater shall be installed to reduce discharge velocities to non-erodible levels at each culvert outlet.
- G. **Slope Drains.**
1. **Defined.** A slope drain is a culvert placed on a grade of 5:1 (20%) or greater that does not fall within a road right-of-way. Slope drains may be permanent installations or temporary drains for a future extension of a permanent installation, above or below ground.
 2. **Concealed.** Any slope drain that would be conspicuous or placed in landscaped areas shall be concealed.
 3. **Concrete Encasement.** For installations on steep slopes or difficult topography, 6-inch concrete shall completely encase the pipe.
 4. **Watertight Joints.** All slope drains shall have positive watertight joint connections in conformance with manufacturer's recommendations.
- H. **Debris and Silt Control Facilities.**
1. **Flows Transporting Debris.** When determined or observed by the ECM Administrator that flows are likely to carry floating debris, sediment or other abrasive materials in sufficient size to block or obstruct the conduit, a trash fence, rack or deflector is required. Vehicular access shall be provided to accommodate maintenance activities. These facilities shall be constructed upstream of the inlet so they will not obstruct the entrance.
 2. **Flows Transporting Silt.** Where temporary drainage flows will be transporting silt, a temporary desilting basin shall be required to prevent silting of the culvert.
- I. **Design Criteria Summary.**
1. **Minimum Class of Pipe.** All culverts within the County's right-of-way are required to be RCP (minimum Class 3). Other materials for storm pipe may be allowed, assuming a comparable service life can be achieved and the design criteria presented in this section are met. Pipe must maintain its manufactured dimensions after installation.
 2. **Consistent with Plans.** Culverts in the storm drain system shall have classification indicated in the profiles on the plans.
 3. **Stationing.** Culvert stationing shall run upgrade from the lower end of the drain. When a culvert runs longitudinally in a roadway, the stationing may be the roadway stationing.
 4. **Discharge Areas.** Culvert outfalls shall extend to the nearest well-defined natural drainage channel that can adequately convey the discharge. Downstream conditions shall be investigated to verify the appropriateness of the point of discharge. This may require off-site storm drains or channel stabilization measures.
 5. **Abrasive Load.** When the culvert is expected to carry a large amount of abrasive material, such as rocks and boulders, a special design to protect the full length of invert area (the lower 90°) and walls within curves to the spring line is required.
 6. **Superelevation Sections.** Drainage must be picked up prior to reversing superelevation sections to prevent cross flows from one side of the roadway to the other side or median.
 7. **Minimum and Maximum Cover.** Minimum and maximum cover for culverts shall be determined based on loading, type and class of pipe, manufacturer's recommendation, and soil bedding conditions. Should a design warrant a cover depth of greater than 15 feet, an extended service life shall be accommodated (see Section 3.3.1.B.2).

-
8. **Changes in Flow from Supercritical to Subcritical.** Hydraulic calculations shall be provided when the flow changes from supercritical to subcritical.
 9. **Special Bedding Requirements.** When other culvert materials are proposed, the bedding of the culvert will be performed in a manner that is consistent with the material manufacturer's recommendations to achieve the required service life and meet the design criteria presented within these Standards.

3.3.3. Open Channels

- A. **Design Options.** Due to the complexities of open channels, there are a wide range of design options available. Therefore, this section only covers those issues that are particularly useful in the design of a channel and have the greatest effect on the performance and costs. The exact method of analysis and design shall be clearly documented.
- B. **Conformance with Standards.** All open channels shall conform to these Standards and the DCM1 and 2.
- C. **Channel Types.**
 1. **Soft-Lined Channels.** Soft-lined channels may be used where the following conditions exist:
 - A fully improved channel section is determined to be economically unfeasible.
 - Adequate bank protection, where necessary, is to be installed for alignment control and for safeguarding adjacent property.
 - Channel work will not significantly alter the watercourse or cause detrimental effects on adjacent property.
 - Planted wetlands are not allowed within the lowest portion of a newly constructed channel.
 - The channel conforms to the permissible velocities contained in the DCM1 and 2.
 - A low-flow channel is required because the main channel grade has been determined to result in ponding during low flows.
 - Drop structures will be used to accommodate changes in channel grades.
 2. **Hard-Lined Channels.** Hard-lined channels shall be used where the conditions required for soft-lined channels do not exist. Concrete or other lining materials used in hard-lined channels shall be designed to withstand all loads including hydrostatic uplift, lateral earth pressures, velocities and debris loads, truck subcharge, and possible wheel loads.
- D. **Minimum Channel Gradient.** The minimum gradient shall be dictated by the calculated hydraulics for the estimated channel low flows (2 to 5 year storm events). In addition, soft-lined channels will be designed to accommodate low flow events by armoring the lowest portion of the channel. This armoring will allow these low flow events to be accommodated within the channel without causing excessive erosion or sediment transport.
- E. **Channel Alignment.**
 1. **Bends.** A bend in channel alignment should be located where the velocity is lowest. The degree of bend shall be as minimal as practicable.
 2. **Radius of Curvature.** The minimum radius of curvature of the centerline of a channel shall be at least 3 times the width of a rectangular channel or 2 times the top width of a trapezoidal channel to minimize development of spiral flow.
- F. **Channel Transitions.**

-
1. **Change in Channel Shape.** Transitions between two different shaped channels shall be designed to produce a smooth, low-head-loss transfer of flow. The water surface level of the downstream channel must be set below the water surface level of the upstream channel by at least the sum of the increase in velocity head, plus transition and friction losses.
 2. **Downstream of a Conduit.** The channel downstream of a conduit shall have a water surface far enough below the conduit to prevent a submerged outlet for a design storm.
 3. **Maximum Angle of Deviation.** The maximum angle of deviation in any transition shall be 12.5°.
- G. **Angle of Confluence.**
1. **Determined by Downstream Flow.** The angle of confluence shall be determined by the downstream flow characteristics. The angle shall be designed to produce a smooth, low-head-loss transfer of flow and shall consider flow-rate changes, roughness, shape, and slope.
 2. **Lateral and Main Velocity.** In no case shall a component of lateral velocity oppose the mainline velocity by an angle of confluence.
 3. **Conduit Connection to Channel.** A conduit connection to a channel shall be made at an elevation at the top of the channel water surface and the angle of confluence shall produce a smooth low-head-loss transfer of flow.
- H. **Cutoff Walls.**
1. **Lined Channels.** Lined channels shall have a cutoff wall constructed at each end of the lining along the full width of section. Intermediate cutoff walls shall be provided at 250-foot intervals.
 2. **Unlined Channels.** Graded, unlined channels, or channels with rock slope protection, shall have a rock or other type of suitable cutoff wall at each end along the full width or section.
- I. **Debris and Silt Control Facilities.**
1. **Flows Transporting Debris.** When determined or observed by the ECM Administrator that flows into a channel are likely to carry floating debris or rocks in any quantity, a trash fence, rack or deflector is required upstream of the channel. This facility shall be designed and located to prevent an obstruction or blockage of the channel entrance. Maintenance access to debris/rock racks is required. The channel entrance and upstream area shall be designed to provide for overtopping of the rack without overtopping the channel or damaging adjacent property.
 2. **Flows Transporting Silt.** Where flows will be transporting significant quantities of silt, a temporary or permanent desilting basin shall be required to prevent silting in the channel or downstream from the channel.
- J. **Outlet Dissipater.** A suitable energy dissipater for all open channel flow shall be installed to reduce velocities to pre-improved conditions where:
- Channels discharge into an unimproved or natural channel and the velocities exceed those permissible for the material involved; and
 - Roadway gutters discharge onto natural ground with velocities exceeding those permissible for the material involved.
- K. **Open Channel Easements and Access.**
1. **Minimum Width and Access Road.** All easements shall be wide enough to provide for the channel structure and adequate maintenance access.
 - For channels 30 feet or more in top width, a minimum access road width of 15 feet shall be provided on each side of the channel.

-
- For channels with a top width of less than 30 feet, a minimum access road width of 15 feet shall be provided on one side of the channel and 4 feet on the opposite side.
 - The minimum width of any channel easement shall be the top width of channel plus 4 feet on each side of the channel.
 - For channels with a depth greater than 10 feet and a length longer than 1,000 feet, access to the bottom of the channel in the form of a vehicular ramp shall be provided at an interval of 500 feet.
 - Easement and maintenance access provisions shall be made for public road discharge (i.e., ditch outs) and for cross-lot drainage in subdivisions.
2. **Exclusion of Access Road.** When the lack of an access road is not considered detrimental to the maintenance and integrity of the channel, the access road can be omitted under the following conditions:
 - Where suitable exit-entry ramps are provided to intermediate channels with a minimum bottom width of 8 feet at roadway crossings and at other approved, needed locations to facilitate travel or maintenance of emergency vehicles in the channel bottom. At a minimum, one access ramp must be provided at each end of a channel.
 - Where vehicular access to the channel on a maximum spacing of 1,000 feet and at other approved, needed locations is provided to small channels with a bottom width of less than 8 feet.
 3. **Easement Location.**
 - Easements shall be placed on one side of a lot or parcel lines in new developments and where conditions permit in existing developments.
 - Easements for public road discharge and capture of created sediment shall be located where appropriate based on topography and available property.
 4. **Fencing.** Fencing is required for all channels abutting residential developments, schools, parks, and pedestrian walkways based on the following criteria:
 - All concrete-lined or rip-rapped channels where the design frequency storm provides a velocity that exceeds 5 feet per second and 2 feet in depth, or a combination thereof, for a factor of ten. Fencing is not required for right-of-way ditches.
 - All constructed channels steeper than 4:1 where the design frequency storm provides a velocity that exceeds 5 feet per second and 2 feet in depth, or a combination thereof.
 - Fencing shall be installed on both sides of the channel easement, with gate openings at all access points.
 - Fencing shall be located at a minimum of 6 inches inside the easement boundary lines.
 - All new fences shall be chain link, a minimum of 6 feet in height with a top rail and vinyl-coated for natural color compatibility (green or brown).

3.3.4. Drainage Ditches

- A. **Application of Standards.** A ditch located within a development, not including roadside ditches, that conveys less than 15 cubic feet per second of public drainage is considered a drainage ditch. The requirements for open channels shall apply to drainage ditches.

In rural subdivisions where no overlot site grading will be performed, and "natural" drainageways will be conveying developed runoff, the easement width for increased capacity of these drainage channels will be determined by the engineer. Typical lot line easements designated as drainage and utility easements are generally not adequate for the purpose of runoff control. The size of the drainage channel easement shall be large enough to accommodate the developed design runoff without impact to adjacent lots or public improvements. The engineer must determine the easement width for these drainage channels early in the subdivision planning and design process. The easement size must also meet the requirements in the Land Development Code.

- B. **Right-of-way and Terrace Ditches.** A right-of-way or terrace ditch is one that is located along the top of a slope and is designed to convey surface water towards designated down drain locations. The following standards shall apply to right-of-way and terrace ditches.
1. **Minimum Grade.** Minimum grade shall be 2 percent or a grade that will produce a minimum velocity of 6 fps when flowing full and 4 fps when a quarter full.
 2. **Minimum Freeboard.** Minimum freeboard shall be 0.5 foot. Where energy gradients necessitate, more freeboard is required.
 3. **Angle of Confluence.** The maximum angle of confluence on any ditch connection shall be 60°. Connections at any angle of confluence may require some means to contain the drainage flow within the ditches (splash aprons, splash walls, etc.).
 4. **Downdrains.** Downdrains may be either ditch or pipe. All drainage flow in an open ditch down drain shall be totally contained within the ditch.
 5. **Outfall.** Right-of-way ditch drainage must outfall either into a constructed channel within the development or a well-defined natural channel. An energy dissipater will be required upstream of the outfall in a natural channel.
 6. **Single Lot Right-of-way Ditches.** Single lot right-of-way ditches may terminate at the toe of the slope within the lot, with an adequate energy dissipater.
- C. **Toe Ditches.** Toe ditches shall be required at the toe of fill slopes where any drainage is directed toward or along the slope. Right-of-way or terrace ditch sections may be used as toe ditches if they have adequate capacity for the drainage flow.

3.3.5. Roadways

When the drainage in the roadway exceeds allowable limits, a storm sewer or an open channel system is required to convey the excess flows. The primary function of roadways is for traffic movement. Therefore, the drainage function is subservient to the traffic objective. Design criteria for the collection, conveyance, and protection of surface water runoff on public roadways shall meet the requirements of these Standards and the DCM1 and 2 CDOT M&S Standards.

3.3.6. Subsurface Drainage

When localized groundwater impacts the design of public improvements, a subsurface drainage system may be constructed, provided an acceptable subsurface drain system from the drainage system to the point of connection within the County's right-of-way is provided.

- A. **Subsurface Drainage Required.** Subsurface drainage systems shall be provided in the following situations:
- Where necessary for stability and protection of adjacent properties from the influence of groundwater on cut and fill slopes.

-
- Where natural or artificially introduced groundwater (i.e., derived from meteoric or landscape irrigation and similar sources, respectively) affects or is likely to affect the project in a potentially unstable, hazardous or otherwise deleterious manner.

B. Design Requirements.

1. **Minimum Pipe Size.** The minimum size of a collector line within the County's right-of-way shall be 6 inches.
2. **Materials.** Polyvinyl chloride (PVC) pipe shall be allowable conduit for seepage collector lines within the County's right-of-way.
3. **Cleanout.** A suitable cleanout or manhole shall be located in the seepage collector line on 350-foot spacing for straight runs of pipe, and at each break in alignment or grade.
4. **Outlets.** All discharge outlets for new construction on existing lots or newly developed lots shall be taken to the nearest existing underground public storm drain system. Discharge from a sump pump shall not be directly onto a County road. Prior to connecting to the County's system, an approved Encroachment Permit must be obtained from the ECM Administrator.
5. **Minimum Grade.** The minimum allowable grade of seepage collector pipes shall be 0.5%.
6. **Depth and Spacing.** Depth and spacing of the collection system will depend upon the permeability of the soil, the elevation of the water table, and the quantity of water encountered.

C. Permitting Requirement.

1. **Construction Dewatering Permit.** Dewatering associated with construction activity is allowed when performed consistent with the Colorado Department of Public Health and Environment Low Risk Discharge Policy for Discharges of Uncontaminated Groundwater to Land. The discharge of groundwater that will leave the permitted site in the form of surface runoff requires additional permit coverage by an appropriate CDPS Construction Dewatering Permit. The discharge of construction dewatering into the MS4 shall not occur without prior notification to and approval from El Paso County Department of Public Works and shall only be approved when done consistent with the Low Risk Discharge Policy or approved CDPS Construction Dewatering Permit.
2. **NPDES Permit.** In the event no other option exists but to "day light" a subsurface discharge, thereby transforming ground water flow into surface water flow, an NPDES permit may be required by the Colorado Department of Public Health and Environment. It shall be the responsibility of the applicant and/or owner to apply for and maintain any required NPDES permit.
3. **Well Permit.** The Colorado Division of Water Resources may require a Well Permit for any subsurface discharge that meets the definition of "well," found in CRS § 37-91-102(4.5).

(Res. No. 19-245 , 7-2-19)

3.3.7. Permanent Stormwater Management Facilities

Post construction stormwater management often relies on facilities designed for detention or infiltration of stormwater from developed areas with a goal to release accumulated runoff at levels that mimic historic levels. There are specific notification requirements that apply to all new stormwater detention and infiltration facilities, including individual site facilities built by private parties as a development requirement. For any stormwater detention and infiltration facility constructed after August 5, 2015 and seeking protection under the new statute, the "entity that owns, operates, or has oversight for" shall, prior to operation of the facility, provide notice to all parties on the substitute water supply plan notification email list maintained by the State Engineer.

Created: 2021-06-08 11:35:50 [EST]

(Supp. No. 2)

El Paso County developed a Post Construction Stormwater Detention Facility Documentation Form and procedure to assist applicants in the process of registering stormwater detention and infiltration facilities pursuant to the provisions of CRS § 37-92-602(8). This documentation form can be found in Appendix E, Checklists and Permits.

With submission of a Final Drainage Report for a project, the design engineer must include for each detention and infiltration facility proposed for the project:

1. A completed Post Construction Stormwater Detention Facility Documentation Form.
2. A completed Stormwater Detention and Infiltration Facility Design Data Sheet for each facility included in the project.
3. An Operations and Maintenance Manual.
4. A Private Detention Basin/Stormwater Quality Best Management Practice Maintenance Agreement and Easement.

The Stormwater Detention and Infiltration Facility Design Data Sheet can be downloaded from the statewide notification and compliance portal at: <https://maperture.digitaldataservices.com/gvh/?viewer=cswdif>, or by contacting the El Paso County Project Engineer assigned to the project.

El Paso County Planning and Community Development Project Engineers will review the submitted documentation forms for completeness and accuracy. Upon verification of completed and accurate documentation and data sheets, El Paso County staff will upload each facility into the statewide reporting portal once the facility become operational.

(Res. No. 19-245 , 7-2-19)

3.4. GRADING AND EROSION CONTROL PLANS

The intent of the Grading and Erosion Control (GEC) Plan is to provide for overall subdivision or development grading design as part of the engineering required for review and approval by the County. This plan is done at the time subdivision or development construction drawings are prepared by the Professional Engineer working for the developer. This is complex work whereby cuts and fills are analyzed for balance and slopes and contours are proposed as an integral part of the engineering design. A second important purpose of the GEC Plan is to estimate the cost of the overall grading and erosion control measures known as Best Management Practices (BMPs) or control measures, and of ultimate site stabilization. The County subdivision regulations require that collateral for these activities be posted prior to any land disturbing activity. It is therefore important that the GEC Plan be completed and approved at the time of subdivision construction drawing approval so that these costs can be accurately estimated and included with the required subdivision collateral.

The Board of Commissioners of El Paso County passed Resolution No. 07-279 on June 28, 2007 "Authorizing a Joint Policy Statement on Clarifications to Previously Approved Regulations Concerning Grading, Erosion Control, and Dust." The clarifications include definitions and checklists of required components of GEC Plans and Stormwater Management Plans (SWMP) and Standard Notes for the GEC Plans, SWMP and construction plans. The checklists and standard notes can be found in Appendix E of this manual. These checklists and standard notes replace the requirements in City of Colorado Springs/El Paso County Drainage Criteria Manual for GEC Plans and the City of Colorado Springs Drainage Criteria Manual, Volume 2: Stormwater Quality Policies, Procedures, and Best Management Practices (BMPs) (DCM2) for SWMP.

A checklist was developed to assist in the development and review of GEC Plans submitted for review and approval. The checklist shall be used by applicants (i.e. Engineer of Record) to ensure the submitted GEC Plan contains all the required elements. The same checklist is used by El Paso County Project Engineers to guide the review of submitted plans. A copy of a completed review checklist is signed and dated by the Project Engineer

Created: 2021-06-08 11:35:50 [EST]

(Supp. No. 2)

upon completion of a submittal review. The signed and dated checklist is kept with all other project documents in an electronic database.

At the time of GEC Plan approval, the exact timing and phasing of the work is not always known because the start date may be delayed or the earthwork contractor, who has expertise in planning and phasing the land disturbing activity, may not yet be under contract. Detailed phasing of the work and the proposed construction schedule shall be deferred to the required SWMP.

El Paso County also developed a checklist to guide the development and review of the SWMP to ensure all the required elements are. Given that SWMPs are intended to be dynamic documents to reflect onsite conditions at all times, El Paso County does not approve the submitted SWMP. Rather it performs a completeness review to ensure the applicant has at the time of project commencement a SWMP on site that addresses all the required elements of Part I.E.3.a.iv.B of the MS4 permit. The SWMP Checklist is used by El Paso County Project Engineers to perform the completeness review of a submitted SWMP. The completed SWMP Checklist is signed and dated by the Project Engineer and is included with other project records in an electronic database to document the review process.

Per Section 1.12 of this ECM, GEC Plans shall expire if site construction or land disturbance has not commenced within 24 months of plan approval, and the plans must be resubmitted for re-approval. Previously approved plans shall also be resubmitted for re-approval when any of the following occur:

- Change in ownership of the property to be disturbed;
- Development design changes that alter hydrology or hydraulics of permanent drainage systems; or
- Grading design changes that affect 1 or more acres of land.

(Res. No. 19-245 , 7-2-19)

Chapter 4 UTILITIES AND OTHER RIGHT-OF-WAY USES

4.1. OVERVIEW

All activities using the County's rights-of-way for other than transportation are subject to the Standards in this chapter, which regulates these activities through the Work in the Right-of-Way Permit processes. Detailed permit requirements are contained in Chapter 5 Permits and Inspections.

4.1.1. Purpose

The purpose of this chapter is to provide guidelines for those proposing to perform work or place a privately owned structure within the County's right-of-way. The main focus of the criteria within this chapter is on utilities, however, it also discusses the importance of coordination and the expectation of those performing any and all work within the County's right-of-way.

4.1.2. Chapter Content and References

Table 4-1 outlines the chapter content and references used as a basis for the standards established in Chapter 4.

Table 4-1. Contents and Basis of Utility and Other Right-of-Way Uses

Intent Use	ECM Content	ECM Section(s)	Reference Document(s)
Planning			
	Rights	4.2.1	1
	Uses	4.2.2	1

Created: 2021-06-08 11:35:50 [EST]

(Supp. No. 2)

Design			
	Requirements and Standards	4.3.1 - 4.3.4	1
	Utility Locations	4.3.5	2
	Installation Standards	4.3.6 - 4.3.8	2, 3
	Mailboxes	4.4	1
Construction			
	Permitting	5.3, 5.5 and 5.7	1
	Inspections	5.11 and Appendix K	1
	Acceptance	5.3 and 5.5	1

References

1. El Paso County Land Development Code
2. Utility District (location dependent) Installation Standards/Specifications
3. US Department of Transportation, Manual on Uniform Traffic Control Devices

4.1.3. Standard Drawings

Table 4-2 identifies the standard drawings that are included in Appendix F as an enforceable part of these Standards. The Standard Drawing shall be used in all applications for which a public improvement is to be designed. Any deviations from a Standard Drawing shall be approved by the ECM Administrator and noted in the construction plans.

Table 4-2. Standard Drawings

Figure Name	Detail/Description	Approval Date
SD_4-1	Urban Local Roadway - Utility Placement	08/11/2011
SD_4-2	Urban Residential Minor Collector Roadway - Utility Placement	08/11/2011
SD_4-3	Urban NonResidential Collector Roadway - Utility Placement	08/11/2011
SD_4-4	Urban Residential Major Collector Roadway - Utility Placement	08/11/2011
SD_4-5 & 4-5A	Urban Minor Arterial Roadway - Utility Placement	08/11/2011
SD_4-6 & 4-6A	Urban Principal 4-Lane Arterial Roadway - Utility Placement	08/11/2011
SD_4-7 & 4-7A	Urban Principal 6-Lane Arterial Roadway - Utility Placement	08/11/2011
SD_4-8 & 4-8A	Urban Expressway 4-Lane Roadway - Utility Placement	08/11/2011
SD_4-9 & 4-9A	Urban Expressway 6-Lane Roadway - Utility Placement	08/11/2011
SD-4-10	Rural Gravel Local Roadway- Utility Placement	08/11/2011
SD_4-11	Rural Local Roadway - Utility Placement	08/11/2011
SD-4-12	Rural Minor Collector Roadway - Utility Placement	08/11/2011
SD_4-13	Rural Major Collector Roadway - Utility Placement	08/11/2011
SD_4-14 & 4-14A	Rural Minor Arterial Roadway - Utility Placement	08/11/2011
SD_4-15 & 4-15A	Rural Principal 4-Lane Arterial Roadway - Utility Placement	08/11/2011
SD_4-16 & 4-16A	Rural Principal 6-Lane Arterial Roadway - Utility Placement	08/11/2011
SD_4-17 & 4-17A	Rural Expressway 4-Lane Roadway - Utility Placement	08/11/2011
SD_4-18 & 4-18A	Rural Expressway 6-Lane Roadway - Utility Placement	08/11/2011
SD_4-20	Utility Trench Repair Detail (asphalt pavement)	08/11/2011
SD_4-21	Utility Trench Repair Detail (newly overlaid pavement)	08/11/2011
SD_4-22	Utility Trench Repair Detail (concrete pavement)	08/11/2011

Created: 2021-06-08 11:35:50 [EST]

(Supp. No. 2)

SD_4-23	Utility Trench Repair Detail (flowable fill)	08/11/2011
---------	--	------------

4.2. PLANNING

4.2.1. Rights of Utilities

Section 38-5-101, Colorado Revised Statutes, authorizes the placement of utilities within the County's right-of-way. While the County is obligated to allow the public right-of-way to be used to provide development with sanitary and storm sewers, water mains and service lines, gas mains and service lines, electrical main lines and service lines, telephone cable lines and service lines, etc., the County must establish and enforce these Standards for design, installation, and maintenance of utilities and other facilities within the right-of-way. The County must enforce these Standards to protect the value and use of the right-of-way and roadways for transportation.

4.2.2. Use of Right-of-Way Policy

- A. **Coordination with Roadway Improvements.** Every attempt shall be made to coordinate proposed utility and facility installations with existing conditions and other proposed construction activities, such as utility main lines and service lines to all lots, tracts or parcels of land shall be placed prior to completion of roadways.
- B. **No Disturbance of Roadway Surface.** When roadway construction is completed, utility and facility placement shall not disturb the roadway surfaces, except for an emergency repair. Jacking or boring under the surface will be required for new utility placement in hard surfaced roadways. The size of disturbed area necessary to install a utility or facility shall be kept to a minimum.
- C. **Coordination with Other Utilities.** Each utility company or district must coordinate with the other utility companies in the location of its utility; that is, the companies shall mutually ascertain the most satisfactory location of their utility.
- D. **Impact Traffic Operations and Safety.** Accommodation of utilities and other facilities within the County's right-of-way shall not materially degrade or adversely affect traffic operations, safety, maintenance or the structural integrity of the roadway.
- E. **Impact on Accessibility.** Accommodation of utilities and other facilities within the County's right-of-way shall not materially degrade or affect accessibility of pedestrian facilities. See Chapter 6.

(Res. No. 20-222 , 6-23-20)

4.3. UTILITY DESIGN

4.3.1. Permit Required

A Work in the Right-of-Way Permit shall be obtained from the ECM Administrator for the placement of utilities within the County's right-of-way. The installation of utilities in dedicated right-of-way in new subdivisions will be exempt from requiring a Work in the Right-of-Way Permit, but such installations shall obtain approval of a layout plan showing proposed utility locations prior to beginning construction. The approved layout plan(s) shall be submitted as part of the Construction Permit.

A Work in the Right-of-Way Permit shall be obtained from the ECM Administrator for the maintenance of utilities within the County's right-of-way.

Created: 2021-06-08 11:35:50 [EST]

(Supp. No. 2)

4.3.2. Damages Caused by Utility Installations

Any damage to existing installations caused by the installation of utilities shall be repaired or replaced at the expense of the permit holder, contractor or utility company making the installation. Examples of existing installations include culverts damaged or cut, sidewalks cut or undermined, curbs or gutters cut or undermined, fencing cut or damaged, vegetation destroyed, hard surface cut or undermined.

4.3.3. Adjustment or Relocation Cost Obligations

Utilities are deemed acceptable to the ECM Administrator if they are installed per plans showing horizontal and elevation control, within the County's right-of-way, and approved by the ECM Administrator. In the case where utilities are installed prior to or without plan approval, the utility company will cover expenses for relocation and adjustments due to road improvements or reconstruction.

4.3.4. General Standards

- A. **Existing Utility Districts.** Where a utility district exists and has adopted installation standards, the utility district's requirements shall be followed and used in preparing the utility design.
- B. **Area Not Currently in a Utility District.** In areas not covered by a utility district, the standards contained in this section shall be used in preparing the utility design. These standards generally follow industry codes that are used by the utility companies for design and installation of their facilities.

4.3.5. Utility Location

- A. **Minimize Relocation and Disruption of Traffic.** Utility facilities shall be located to minimize the need for future relocation, to accommodate roadway improvements, and to provide service access to such facilities with minimum disruption to roadway traffic.
- B. **Minimize Disruption of Other Utilities.** Utility equipment or facilities to be installed in the County's right-of-way shall not disrupt the operation of existing utilities. Other utilities, including but not limited to electrical, telephone, cable TV, and fiber optic lines, are preferred for underground installation at locations compatible with other utilities, storm drains, and future roadway construction.
- C. **Precedence of Gravity Systems.** Gravity systems, whether sanitary sewer or storm drainage, shall have precedence over other systems in design and construction.
- D. **Aboveground Utilities.**
 - 1. **Compatibility.** The location of poles, vaults, boxes or other aboveground utility objects shall be compatible with driveways, intersections, and other roadway features. They shall not interfere with sight distance, signage, traffic signals, drainage facilities, etc. Where possible, utilities shall share facilities to minimize the number of obstructions in the County's right-of-way.
 - 2. **Clear Zone.** The placement of aboveground utility facilities or equipment within the County's right-of-way shall conform to the "clear zone" guidelines in Chapter 2. Utility poles and other aboveground utility equipment shall be placed outside of clear zone areas unless a deviation is approved by the ECM Administrator and provisions for vehicular safety are installed.
 - 3. **Roadway Vertical Clearances.** A 19-foot minimum vertical clearance for overhead lines shall be maintained over all County roadways. The minimum vertical clearance for overhead power and communication lines above the roadway and the minimum lateral and vertical clearance from bridges shall comply with state and federal standards.
 - 4. **Pedestrian and Bike Path Clearances.** Utility poles and equipment shall not be placed in pedestrian or bicycle facilities, or protrude into the vertical space over sidewalks, walkways or

bikeways. As specified in Chapter 2, there shall be an unobstructed vertical clearance of at least 7 feet above the surface of any sidewalk and 10 feet above any bike path. A 2-foot horizontal clearance shall be maintained between the edge of any bike path and any vertical utility obstruction. See Chapter 6.

E. Underground Utilities.

1. **Scoping Meeting.** A Scoping Meeting is required with the ECM Administrator for all proposals to install underground utilities in the right-of-way of any arterial or expressway roadway or in more than 2,000 feet of right-of-way of non-arterial roadway. Final approval of all utility installations within the road right-of-way rests with the ECM Administrator even if the utility ownership falls within an existing utility district.
2. **Longitudinal Placement.** Longitudinal placement of underground utilities in the County's right-of-way shall comply with the typical utility locations shown in the utility Standard Drawing in Appendix F. When determining the planned longitudinal placements of utilities, the design engineer shall consider the roadway functional classification in the Major Transportation Corridors Plan to try to anticipate future roadway alterations and limit the need for relocation of utilities in the future.
3. **Lateral Placement.** Lateral placement of underground utilities across a County right-of-way shall be as near a right angle to the road centerline as practicable. Utility crossings should avoid deep cuts, bridge footings and retaining walls, or locations where roadway drainage would be affected. Utility crossings may be designated by the ECM Administrator.

4.3.6. Underground Utilities Standards

A. Cover and Separation. Cover over underground utilities and the separation between underground utilities shall conform to applicable federal and state regulations, these Standards, and the Standard Drawings in Appendix F.

1. Water Lines.

- **Water Mains:** At no time shall a water main be placed less than 5 feet in depth measured perpendicularly to the ground line at any point of the road cross section.
- **Water Service Lines:** At no time shall water service lines be placed less than 5 feet in depth measured perpendicularly to the ground line, at any point of the road cross section, to the right-of-way line.
- **Meter and Stop Boxes:** Meter and stop boxes shall be set at the inside edge of the right-of-way line, but not within curb ramps. Where a utility easement exists adjacent and parallel to the right-of-way, meter and stop boxes shall be placed in the utility easement.
- **Fire Hydrants:** Fire Districts must be contacted to determine location, spacing, and equipment standards.

2. Sanitary Sewer Lines.

- **Sewer Mains:** At no time shall a sewer main be placed less than 5 feet in depth measured perpendicularly to the ground line at any point of the road cross section.
- **Sanitary Sewer Service Lines:** At no time shall sewer service lines be placed at a depth of less than 5 feet measured perpendicularly to the ground line at any point of the road cross section, to the right-of-way line.

3. Storm Sewer Lines.

-
- Storm Sewer Lines: At no time shall storm sewer lines be placed less than 2 feet in depth measured perpendicularly to the finished road surface. When placed outside the road, at no time shall the storm sewer lines be placed less than 1 foot in depth from the ground surface.

- Storm Sewer Lines: Include pipe culverts, box culverts, and manholes, excluding the risers.

4. **Gas.**

- Gas Mains: At no time shall the depth of gas mains be less than 3 feet as measured perpendicularly to the ground line at any point of the road cross section.
- Gas Service Lines: At no time shall the depth of gas service lines be less than 2.5 feet, as measured perpendicularly to the ground line at any point of the road cross section, to the right-of-way line.

5. **Electrical Lines.**

- Main Lines: At no time shall the depth of electrical main lines be less than 4 feet as measured perpendicularly to the ground line at any point of the road cross section.
- Service Lines: At no time shall the depth of electrical service lines be less than 2.5 feet, as measured perpendicularly to the ground line at any point of the road cross section, to the right-of-way line.

6. **Telephone and Cable TV.**

- Telephone Cable TV Main Lines: At no time shall the depth of telephone main cables be less than 2.5 feet, as measured perpendicularly to the ground line at any point of the road cross section.
- Telephone and Cable TV Service Lines: At no time shall the depth of telephone service lines be less than 2.5 feet, as measured perpendicularly to the ground line at any point of the road cross section, to the right-of-way line.

B. **Casings.**

1. **When Required.** Casings shall be installed for roadway crossings when required by appropriate industry codes or by the ECM Administrator. Casings may be required in the following situations:

- To facilitate the insertion, removal, replacement or maintenance of a carrier line crossing or other circumstances where it is necessary to avoid open trench construction.
- To protect carrier lines from external loads or shock during or after construction of a road.
- To protect jacked or bored installation of coated carrier lines unless assurance is provided that no damage will result.

2. **Type and Sizing.** The type of casing used shall meet industry and applicable state and federal standards and shall be designed to withstand road loading. The casing shall be sized to accommodate other compatible utilities and future needs.

3. **Extension.** Within the County's right-of-way, casing pipes shall extend to the outside of curbs or ditches or beyond the toe of fill slopes.

4. **Ends Sealed.** Casing pipes shall be sealed at both ends, except for necessary vents or drains.

- C. **Carrier Pipes.** Carrier pipes, i.e., pipes that directly enclose a transmitted fluid or gas, shall conform to the material and design requirements of the appropriate utility industry and state and federal codes and specifications.

Carrier pipes shall be designed to withstand road loading plus all loads imposed under all ranges of operating pressure from zero to maximum internal pressure.

- D. **Marking.** Location markers and emergency information shall be provided by the utility when required by applicable state and federal standards.
- E. **Appurtenances.** To avoid damage to appurtenances by snowplows and other maintenance activities, all appurtenances shall be installed below the roadway surface. Damage to appurtenances that occurs during maintenance activities will be the responsibility of the utility owner.

The depth of the appurtenance will depend on the surface type. Appurtenances installed within a paved roadway shall be installed a minimum of 1/8" below the pavement surface.

Appurtenances installed within a gravel roadway shall be installed a minimum of 8" below the gravel surface and shall be covered with gravel. A concrete collar shall be installed around the appurtenance for protection. A strip of tape shall be placed above the appurtenance to help identify the location of the appurtenance.

1. **Vents.** Vents may be required for casings, tunnels, and galleries enclosing carriers of fluids or gases in accordance with state and federal standards. Vent standpipes shall be located as close to the right-of-way line as possible to minimize interference with road operation and maintenance, and shall not be concealed by vegetation.
2. **Drains.** Drains may be required for casings, tunnels or galleries enclosing carriers of fluids or gases in accordance with state and federal standards. Drains for carriers of hazardous materials shall be directed to artificial holding areas to prevent possible surface or groundwater contamination. Drains for which only water or other non-hazardous liquids may discharge may be directed into roadway drainage systems at locations approved by the ECM Administrator. The drainage outfall shall not be used as a waste way for routine purging of the carrier pipe unless specifically authorized by the ECM Administrator.
3. **Manholes.** Manholes shall be designed and located in a manner that will cause the least interference to other utilities or future road expansion.

4.3.7. Underground Utility Installation Standards

- A. **General.** All utility installation, maintenance, and repair shall conform to these Standards and Appendices F and K.
- B. **Logistical Planning.** Logistical planning shall be coordinated with and approved by the ECM Administrator as part of an approved Work in the Right-of-Way Permit. Logistics plans shall include requirements for advance warning signs, directional signs, flagmen, lighting, and all such standard traffic control devices deemed necessary. Upon approval of the logistics and construction plans, implementation of logistics plans shall be complied with by the utility company performing the work to best guarantee the safety of the motorist, pedestrian, workers, and equipment.
- C. **Maintenance during Peak Traffic Periods.** Utility construction maintenance activities on heavily traveled roadways are prohibited during the peak traffic volume periods. The ECM Administrator shall establish appropriate work hours for all projects. The closing of any lane to traffic shall have written approval from the ECM Administrator.
- D. **Alternative Installation Methods.**
 1. **Plowing.** Plowing of communication and electrical lines on or adjacent to existing roads by means of a vibratory plow may be allowed by the ECM Administrator provided the structural integrity of

the roadway will not be impaired. Plowing may be no closer than 4 feet from the pavement. Use of a "static" type plow is not allowed.

2. **Boring.** Boring may be required for pipelines or conduits to cross roads, instead of trenching, as directed by the ECM Administrator. If sufficient right-of-way exists, the length of the bore shall extend a minimum of 4 feet from the edge of the pavement. Unused holes or abandoned casings shall be backfilled. Water boring under roadways shall not be permitted. Existing carriers and conduit installed under a roadway shall be physically located prior to boring.

4.3.8. Utility Installation on Roadway Structures

- A. **General.** Attachment of utility lines to a roadway structure, including bridges, may be allowed where such attachment conforms to sound engineering practice for preserving the roadway structure and ensuring its safe operation, maintenance, and appearance. Attachment of any utility to any bridge within the County's right-of-way requires the approval of the ECM Administrator.

Attachment of a utility shall not be considered unless the structure is designed to support the additional load and can accommodate the utility facility without limiting features such as ease of maintenance.

- B. **Placement of Utility Features.** Utility features, such as manholes or access panels, shall not be placed within the roadway portion of the structure.
- C. **Hazardous Substance.** A pipeline carrying a hazardous substance shall not be attached to a roadway structure unless specifically approved by the ECM Administrator.
- D. **Clearance Requirements.** The utility attachment shall not reduce any clearance requirement of the structure. Attachment to the outside of a structure shall be avoided unless there are no reasonable alternatives.
- E. **Vibration and Noise.** Utility mountings shall be of a type that does not create noise from vibration.
- F. **Sleeves Required.** Any hole created in a structure abutment shall be sleeved, be of a minimum size necessary to accommodate the utility line, and be sealed to prevent any leakage of water or backfill material.
- G. **Alignment.** A utility line behind an abutment shall curve or angle out to align outside the roadbed area in as short a distance as is operationally practicable.
- H. **Communication and Electric Lines.** Communication and electrical power line attachments shall be suitably insulated, grounded, and preferably carried in protective conduit or pipe from point of exit from the ground to re-entry. Carrier pipe and casing pipe shall be properly isolated from electric power line attachments.

(Res. No. 20-222 , 6-23-10)

4.4. MAILBOXES

4.4.1. United States Postal Service (USPS) Coordination

The applicant shall provide USPS approval of mailbox type and location prior to approval of the construction plans. Discussions with the local postmaster early in the project design process are important to ensure proper coordination.

Created: 2021-06-08 11:35:50 [EST]

(Supp. No. 2)

4.4.2. Mail Box Types

To assist in clarifying the differences between the types of mailboxes typically installed within the County's right-of-ways, the following three descriptions were developed:

- Type 1 is a typical post mounted individual mail box
- Type 2 is an individual mail box that has been modified by the owner through the addition of a larger/permanent supportive structure
- Type 3 relates to cluster boxes (CBUs) or mailbox kiosks (multiple CBUs at one location).

These descriptions are only applicable to this section and were primarily developed to assist in determining the different levels of actions required for locating and installing these types of mailboxes within the County's right-of-way.

4.4.3. Work in the Right-of-Way Permit Required

A Work in the Right-of-Way Permit shall be obtained from the ECM Administrator to locate either Type 2 or 3 mailboxes within the County's right-of-way.

4.4.4. Mailbox Construction Plans

Construction plans shall clearly show the proposed location or relocation of either Type 2 or 3 mailboxes. The applicant shall provide a statement that the postmaster has approved the proposed mailbox type(s) and location(s). The statement shall be signed and dated by the local postmaster or authorized representative prior to obtaining approval of construction drawings or a Work in the Right-of-Way Permit.

The relocation of Type 1 mail boxes will be done so through direct coordination between the owner and local postal carrier.

4.4.5. Location and Installation

Pullouts for mail delivery vehicles shall be installed to serve cluster mailbox units located along arterial or collector roads, or any road with a posted speed of 35 MPH or above.

- Lower Functional Classification Roadway.** Where a choice of roadway locations exists, mailboxes shall be located on the lower functional classification roadway.
- Not Impede Access or Sight Distance.** Mailboxes shall be located so as not to impede access or sight distance visibility.
- Clear Zone Placement.** Type 1 mailboxes located within a roadway clear zone shall have breakaway features. Type 2 and Type 3 mailboxes shall not be located in the clear zone.
- Temporary Relocation.** If it becomes necessary to remove or otherwise disturb existing mailboxes, the mailboxes shall be temporarily placed so their function will not be impaired. The boxes shall be reinstalled in accordance with the local postal carrier's requirements.
- Type 3 Mailbox Placement.** Type 3 mailboxes and the pullout for the mailbox shall be located within the public right-of-way or in a public improvement easement but outside the roadway clear zone. If in an easement, the easement must allow for access by the United States Postal Service. A license agreement with provisions for the structure to remain within the right-of-way is required. The Type 3 mailbox and associated structures shall be maintained by a private entity in accordance with the license agreement. Figures 4-1 and 4-2 show the required right-of-way and clear zone. The following conditions also apply:

- The Type 3 mailbox must be within the right-of-way so additional right-of-way dedication is required
- Provisions shall include the ability to park vehicles temporarily outside the clear zone and a minimum of thirty-six (36) feet shall be provided for parking queue.
- Pullout tapers shall be designed and constructed in accordance with Table 2-27.
- The pavement section of the pullout shall match the pavement section for the roadway and the pavement grade shall slope away from the centerline of the road.
- Signage (R7-6) shall be provided for the pullout area to limit extended parking in accordance with the MUTCD.
- Attached sidewalk is allowed in the pullout area to include the pullout tapers.
- Discussions with Growth Management or the local Postmaster are required for mailbox location, concrete specifications, and mailbox type.
- Mailboxes shall be located along accessible pedestrian route in compliance with the requirements of Chapter 6. See Section 6.3.10.

Figure 4-1. Mailbox Pad Pullout Area Detail, Urban Application

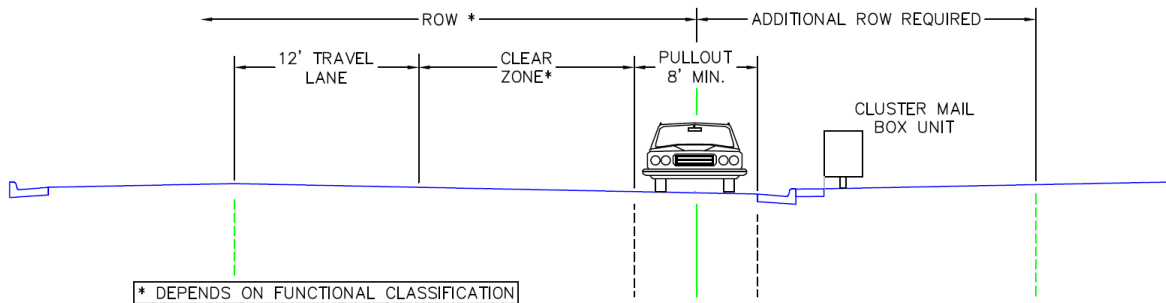
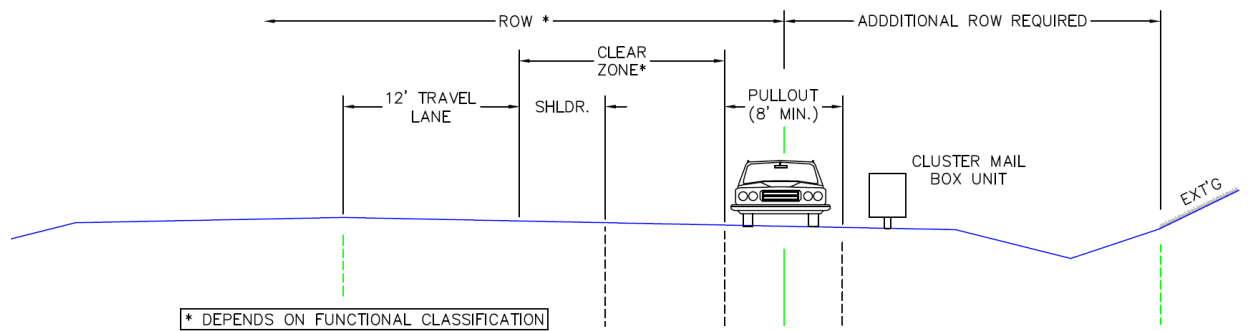

Figure 4-2. Mailbox Pad Pullout Area Detail, Rural Application



(Res. No. 20-222 , 6-23-20)

Chapter 5 PERMITS AND INSPECTIONS

5.1. OVERVIEW

This chapter addresses the review, permitting and inspection process for projects involving the use, construction, enlargement, alteration, relocation, removal, conversion, demolition, repair, maintenance and excavation of any public improvements; work within a County right-of-way (right-of-way) or easement, transport of over dimensional loads on County roads; removal of trees or plants from the County's right-of-way or easements; the discharge of stormwater from a construction site or land development activity to , deviations from ECM standards, and the construction, enlargement, alteration, relocation, removal, conversion, demolition, repair and maintenance of common development improvements governed by the ECM or LDC.

5.1.1. Purpose

The purpose of this chapter is to identify permit and inspection requirements and standards for activities associated with the construction, enlargement, alteration, relocation, removal, conversion, demolition, repair, maintenance and excavation of public infrastructure or common development improvements, the use of or work within a County right-of-way or easement, the discharge of stormwater to County drainage facilities or water bodies located within El Paso County, and requests for deviations from these standards. The chapter also establishes the acceptance process for public infrastructure and common development improvements.

5.1.2. Chapter Content and References

Table 5-1 outlines the chapter content and references used as a basis for the standards established in Chapter 5.

Table 5-1. Contents and Basis of Permits and Inspections

Intent Use	ECM Content	ECM Section(s)	Reference Document(s)
Permits			
	Construction	5.3	
	Driveway	5.4 and Appendix B	
	Work in right-of-way	5.5 and Appendix K	
	Erosion and Sediment Quality Control	5.6 and Appendix I	
	Special Transport	5.7	
Deviation from Standards			
	Process to gain approval	5.8	1
Site Development Plan Review			
	Process to gain approval	5.9	1
Construction Control and Inspections			
	Inspections	5.10.2 - 5.10.4	
	Monumenting Roadways	5.10.5	
	Record Drawings	5.10.6	

References

1. El Paso County Land Development Code.
(Res. No. 19-245 , 7-2-19)

5.2. PERMITS

5.2.1. Permit Required

It shall be unlawful for any person, owner, firm or corporation or other legal entity to construct, enlarge, alter, repair, move, improve, remove, excavate, convert or demolish any public improvements, work or locate any facility in a County right-of-way or easement, transport over dimensional loads on a County road, remove or place trees or vegetation in a County right-of-way or easement, or to construct, enlarge, alter, repair, move, improve, remove, excavate, convert or demolish any common development improvements regulated by the ECM or the LDC without first obtaining the required permits for the activity.

5.2.2. Permit Administration

The ECM Administrator is hereby authorized to administer, approve, and enforce the permit requirements of these Standards; develop procedures for the administration, approval and enforcement of the permit requirements of these Standards; and delegate the authority for the administration, approval and enforcement of the permit requirements of these Standards.

The ECM Administrator shall administer, approve and enforce all permits in a manner consistent with the general purpose and intent of the ECM.

The ECM Administrator shall have the authority to review and approve the following permit types:

- Construction Permits.
- Driveway Permits (Access Permits).

-
- Work in Right-of-Way Permits including (1) Excavation Permits, (2) Temporary Obstruction Permits, and (3) Encroachment Permits.
 - Erosion and Stormwater Quality Control Permits including (1) Erosion and Stormwater Quality Control Permits (ESQCP), and (2) Building Erosion and Stormwater Quality Control Permits (BESQCP).
 - Special Transport Permits.
 - Annual Maintenance Permits.

5.2.3. Conditions of Approval

The ECM Administrator is authorized to impose any reasonable conditions upon a permit necessary to carry out the general purpose and intent of the ECM. Conditions shall be directly related to the impacts of the proposed action and shall be roughly proportional in both extent and amount to the anticipated impacts of the action.

5.2.4. Simultaneous Processing of Applications

Where possible and without creating an undue administrative burden on the County's decision-making bodies and staff, the ECM intends to accommodate the simultaneous processing of applications for different County permits and approvals that may be required for the same project or activity in order to expedite the overall review process. Review and decision-making bodies and staff considering applications submitted simultaneously shall render separate reports, recommendations, and decisions on each application based on the specific standards applicable to each permit or approval.

Some permits depend on the applicant having previously received another permit or approval, or require the applicant to take particular action within some time period following the issuance of a permit or approval in order to avoid having the permit or approval lapse. Therefore, even though this ECM intends to accommodate simultaneous processing of County required permits or approvals, applicants should note that each of the permits or approvals set forth in the ECM, LDC and other County regulations has its own timing and review process.

5.2.5. Pre-Application Conferences

The purpose of a pre-application conference is to familiarize the applicant and the staff with the applicable provisions of the ECM that are required to permit the proposed project or activity. This conference is not required, but is recommended particularly for complex projects. The conference should be held prior to developing a detailed plan for the project or activity to ensure that the plan will address all applicable requirements of the ECM.

Any potential applicant may request a pre-application conference. Prior to the pre-application conference, the applicant shall provide to the ECM Administrator a description of the character, location, and magnitude of the proposed project or activity and any other supporting documents such as maps, drawings, models, and a description of the project or activity for which a permit or approval is sought.

The ECM Administrator shall schedule a pre-application conference after receipt of a request. At the conference, the applicant, the ECM Administrator, and any other persons the ECM Administrator deems appropriate to attend shall discuss the proposed activity. As a result of the pre-application conference, the ECM Administrator may eliminate or expand the list of required application submittals by providing the applicant with an amended application checklist.

5.2.6. Responsibility for Damage

The County and its officers and employees, including but not limited to the ECM Administrator, shall not be answerable or accountable in any manner, for injury to or death of any person, including but not limited to a permit holder, persons employed by the permit holder, persons acting in behalf of the permit holder, or for damage to property resulting from any activities undertaken by a permit holder or under the direction of a permit holder. The permit holder shall be responsible for any liability imposed by law and for injuries to or death of any person, including but not limited to the permit holder, persons employed by the permit holder, persons acting in behalf of the permit holder, or damage to property arising out of work or other activity permitted and done by the permit holder under a permit, or arising out of the failure on the permit holder's part to perform the obligations under any permit in respect to maintenance or any other obligations, or resulting from defects or obstructions, or from any cause whatsoever during the progress of the work, or other activity, or at any subsequent time work or other activity is being performed under the obligations provided by and contemplated by the permit.

To the extent allowed by law, the permit holder shall indemnify, save, and hold harmless the County and its officers and employees, including but not limited to the BOCC and ECM Administrator, from all claims, suits or actions of every name, kind and description brought for or on account of injuries to or death of any person, including but not limited to the permit holder, persons employed by the permit holder, persons acting in behalf of the permit holder and the public, or damage to property resulting from the performance of work or other activity under the permit, or arising out of the failure on the permit holder's part to perform his obligations under any permit in respect to maintenance or any other obligations, or resulting from defects or obstructions, or from any cause whatsoever during the progress of the work, or other activity or at any subsequent time work or other activity is being performed under the obligations provided by and contemplated by the permit, except as otherwise provided by state law. The permit holder waives any and all rights to any type of expressed or implied indemnity against the County, its officers or employees.

5.2.7. Contractor Certification

- A. **General Requirements.** Any contractor performing work in a County right-of-way or easement must be certified by the County to be knowledgeable of the specifications, testing, inspection, and other procedures required by the ECM. To become certified, a person must take, and pass, a written test given by the ECM Administrator.
- B. **Testing.** A written test will be conducted by the ECM Administrator to ensure that every contractor responsible for work performed within a County right-of-way or easement is knowledgeable of the requirements of the County for that work. The person being certified may pick one or all of the 3 following areas of testing: (1) earthwork, (2) concrete work, and (3) asphalt work. The ECM Administrator shall develop a standardized written test and shall determine the minimum grade that will be required before a contractor is certified to perform work.
- C. **Work Performed Under a Contractor Certification.** Each contractor who is issued a contractor certification may designate other persons who are authorized to perform work on behalf of the certified contractor. The certified contractor holder is still responsible for the work even though the work is performed by an authorized representative. The certified contractor or authorized representative must be on the site of the work at all times during construction. If a certified contractor or an authorized representative is not present at the construction site during construction activity, a stop work order for all work on the site may be issued until a certified contractor or an authorized representative arrives on site.
- D. **Expiration.** Contractor Certification is good for a period of 2 years. At the end of 2 years, the certified contractor must pay a renewal fee to renew the certification. The ECM Administrator may require the contractor to retest before issuing the renewal when significant changes in the specifications, testing,

inspection, and other procedures required by the ECM have occurred during the certification period or where the certified contractor has had a history of substandard performance or violations during the certification period.

- E. **Revocation of Certification.** If it is found that work performed by a certified contractor is repeatedly substandard according to the requirements and specifications of the ECM, the ECM Administrator may revoke the contractor's certification. A contractor's certification cannot be revoked unless the ECM Administrator determines that allowing the certified contractor to continue to perform work on public property would be detrimental to the health, safety and welfare of the general public. If revoked, the contractor shall not be granted a new certification for one-year. Prior to revoking the certification, the ECM Administrator shall provide 7 days written notice to the certified contractor and allow the certified contractor to provide materials documenting the certified contractor's performance and the reasons that certification should not be revoked. The ECM Administrator shall consider the materials presented by the certified contractor prior to rendering a decision concerning revocation of the contractor's certification. The certified contractor may appeal the decision of the ECM Administrator to the BOCC.
- F. **Obligation of Contractors Performing Work in the County Right-of-Way.** Before any certified contractor shall perform work within a County right-of-way or easement that requires a permit under the ECM, the certified contractor shall have on file with the ECM Administrator general permit bond in the minimum amount of \$20,000.00. Such bond shall be for the benefit of the BOCC of El Paso County by and through the ECM Administrator and shall assure recovery by the County of any expense incurred by the County in completing work begun, but not finished, by the certified contractor in accordance with these Standards. Such bond shall remain in place for at least 2 years after completion of the work.

Before any certified contractor shall perform work within a County right-of-way or easement, the certified contractor shall show evidence of a valid and enforceable bodily injury and property damage liability insurance policy, with minimum limits of \$1,000,000.00 combined single limit coverage. Such policy shall be for the protection of the County from all suits, actions or claims of any type for injuries or damages allegedly sustained by any person or property as a result of the operations or completed operations of the work. Such policy shall specifically cover the acts and operations of any subcontractors or independent contractors of the certified contractor.

- G. **Special Districts, Utilities and Municipalities.** Special districts, utilities governed by the State Public Utilities Commission, and municipalities are not be required to be certified contractors, but when using a contractor to perform work within a County right-of-way or easement shall be required to use only certified contractors. Special districts, utilities governed by the State Public Utilities Commission, and municipalities, by obtaining a permit, do agree to accept liabilities for their work in within a County right-of-way or easement.

5.2.8. Surety from Public Agency, Public Utilities and Quasi-Governmental Agencies

Appropriate surety or collateral is required for all new construction associated with development.

When obtaining a work in the right-of-way permit, municipalities, quasigovernmental agencies, special districts, mutual companies, electric, gas and communication utilities, may provide a Letter of Responsibility in lieu of posting the required surety in a form acceptable to the ECM Administrator. This Letter of Responsibility in lieu of posting the required surety does not apply to any new development. The Letter of Responsibility used in obtaining a work in the right-of-way permit does not relieve the Public Agency, Public Utility, or Quasi-Governmental Agency from their responsibility to complete the project as planned. Every entity is required to assure that they have the financial ability to fund the entire project. Acceptable documentation verifying assets adequate to assure construction should be included in District

documentation and may be verified. They must also show that they have the ability to obtain required surety for the project, even if a Letter of Responsibility is used in lieu of the surety. Special districts, metro districts, or other districts specifically created for construction or financing of improvements cannot provide a Letter of Responsibility in lieu of posting the required financial assurance.

5.2.9. Nonexclusive Remedy

The remedies provided in the ECM are not exclusive or in lieu of other rights and remedies that the County may have at law or in equity. The County is hereby authorized to seek legal and equitable relief for actual or threatened injury to the public rights-of-way or County-owned infrastructure, including, but not limited to, damages to the right-of-way, roads, sidewalks, bridges, or drainageways whether or not caused by a violation of any of the provisions of the ECM.

5.3. CONSTRUCTION PERMIT

5.3.1. General

Construction Permits are a tool to:

- provide for the administration of the orderly construction, alteration or reconstruction of public improvements within a County right-of-way or easement; and
- protect the public interest and safety in the development of private property by providing general review and oversight of the construction, alteration and reconstruction of common development and subdivision improvements regulated by the ECM and LDC.

5.3.2. Construction Permit Required

Construction Permits are required for:

- construction, alteration or reconstruction of public improvements within any County right-of-way or easement; and
- construction, alteration or reconstruction of common development improvements covered by the ECM, LDC, development agreement, or subdivision improvement agreement.
- site preparation activities including grading, stripping of soil or vegetation, depositing fill material, and trenching or excavating.

5.3.3. Notice to Proceed Required

No work shall begin under an approved Construction Permit until the ECM Administrator has also issued a Notice to Proceed.

5.3.4. Construction Permit Not Required

Construction Permits are not required for the following activities:

- Grading in an area of one acre or less which is isolated and self-contained. When a negative impact is identified by the ECM Administrator, a permit shall be required.
- An excavation below finished grade for basements and footing of a building, retaining wall or other structure authorized by a valid building permit including any fill using material from such excavation.
- Routine agricultural uses of agricultural land.

-
- Exploratory excavations of less than 500 square feet (excluding mining activity) being performed at the direction of a professional soils engineer or engineering geologist or utility locates.
 - A fill less than one foot in depth and placed on natural terrain with a slope flatter than 5 horizontal feet to 1 vertical foot, or less than 3 feet in depth, not intended to support structures, which does not exceed 50 cubic yards on any one lot and does not obstruct a drainage course.

Even if a Construction Permit is not required, any clearing, grading, or land disturbance activities shall be in accordance with these Standards and may require an ESQCP, BESQCP or other County permits.

5.3.5. Relationship to Other ECM Permits

In most cases, construction of public facilities within any County right-of-way or easement or the construction of common development improvements covered by a development agreement or subdivision improvement agreement will often require that the applicant obtain other County permits or approvals including an ESQCP or BESQCP. A Construction Permit will not be issued by the ECM Administrator until all other required County permits and approvals have been obtained.

5.3.6. Relationship to LDC Approvals

A Construction Permit is generally required in connection with subdivision approvals and complex development approvals including some site development plan approvals, planned unit development approvals, and commercial and multifamily residential development approvals governed by the LDC. In most cases, construction plans are required as part of the development review process which are reviewed and approved by the ECM Administrator. Therefore, the necessary construction plans to obtain a Construction Permit have often already been prepared by the applicant, and reviewed and approved by the ECM Administrator. If a complete set of construction drawings have been approved by the ECM Administrator in connection with a subdivision or development review application reviewed and approved by the BOCC, no additional plan review is necessary to obtain a construction permit.

5.3.7. Application for Permit

A. Complete Application Required

1. **General.** Applicants shall file a complete application for a Construction Permit. Each application shall:
 - Identify and describe the work to be covered by the permit for which the application is made.
 - Describe the land on which the proposed work is to be done, by legal description, street address, or similar description that readily identifies and definitively locates the proposed work location.
 - Be accompanied by plans, diagrams, computations and specifications, and other data as required in these Standards.
 - State the valuation of the work to be performed.
 - Identify all other required County permits or approvals including permit or approval type, permit number (if permit has been approved by the ECM Administrator) or case number, date of approval (or date of application if approval has not been received), and description of work for which the permit or approval was sought.
 - Include all other materials requested by the ECM Administrator including those identified in the ECM Administrator approved checklist.

-
2. **Traffic Control.** Construction activities shall not interfere with traffic on the adjacent roadways. If interference with traffic is required, a traffic control plan shall be submitted and approved by the ECM Administrator as part of the Construction Permit application. All traffic control shall conform to MUTCD standards.
 3. **Signed by Applicant.** All applications for Construction Permit shall be signed by the applicant, or an authorized agent, who may be required to submit evidence to indicate their authority.
 4. **Determination of Application Completeness.** An application will be considered complete if it is submitted in the required form, including all mandatory information and supporting materials specified by the ECM Administrator, and is accompanied by the applicable fee. If an application is determined to be incomplete, the ECM Administrator shall provide notice to the applicant along with an explanation of the application's deficiencies. No further processing of the application shall occur until the deficiencies are corrected in the resubmittal. An application which is determined to be incomplete may or may not retain its same processing cycle.

B. Construction Plan Submittal Requirements.

1. **General.** Submittal requirements consist of application, design plans, grading plans (where required), erosion control plans (where required), drainage calculations, and other information as required by the ECM Administrator. An application for Construction Permit and checklist provided by the ECM Administrator shall accompany all submittals. The application form and checklist are subject to change at the discretion of the ECM Administrator. Therefore, the applicant is advised to contact the ECM Administrator to ensure that the most current form and checklist are used.
2. **Signed and Sealed by PE.** The seal of the design engineer shall appear on each plan sheet. The design engineer shall be a registered Colorado Registered Professional Engineer.

5.3.8. Construction Permit Review and Issuance

- A. **Review Process.** The application, checklist, plans, specifications, and other data filed by an applicant for a Construction Permit shall be reviewed by the ECM Administrator. The plans may also be reviewed by other departments or agencies to verify compliance with any applicable laws.

As discussed in 5.3.6, construction plan review is often conducted as part of the subdivision and development approvals. Upon completion of the detailed review by the ECM Administrator and any other departments or agencies, the ECM Administrator will return written comments and may provide one set of plans with "Red Line" comments. More than one review and "Red Line" comments may be required. All applicable "Red Line" plans shall be returned to the ECM Administrator with the revised plan set. After the design engineer has completed all revisions, final revised plans shall be submitted to the ECM Administrator for signoff and the latest set of "Red Line" plans shall be returned to the ECM Administrator. Current review procedures are provided in the Land Development Code Procedures Manual.

- B. **Criteria for Approval.** If the ECM Administrator finds that the work described in an application for a Construction Permit and the plans and other data conform to the requirements of these Standards and other pertinent laws regulations or ordinances and that all required fees have been paid, a Construction Permit may be issued to the applicant.

A Construction Permit may only be approved if it meets the criteria set forth below:

- The construction plan complies with all applicable requirements of the ECM;
- The applicant has obtained an ESQCP and all other required County permits and approvals for the project;

-
- All approvals required by the LDC have been obtained, the construction plans are consistent with the approvals obtained, and all conditions associated with any LDC approvals have been met;
 - All required review and permit fees have been paid; and
 - The required surety has been provided in a form acceptable to the ECM Administrator.

Any Construction Permit application that in the opinion of the ECM Administrator fails to meet the criteria for approval listed above may be denied a Construction Permit by the ECM Administrator. In denying a Construction Permit, the ECM Administrator shall provide a statement outlining the reasons for denial of the permit.

- C. **Authority to Deny Permit to Applicant in Violation of ECM.** The ECM Administrator may deny a Construction Permit to any applicant where the applicant, or any parent or subsidiary corporation (if the applicant is a corporation) has:
- Failed to substantially comply with local regulations adopted in support of the El Paso County's Colorado Discharge Permit System General Permit (See Appendix I);
 - Conducted or is conducting land-disturbing activity without an approved Construction Permit, ESQCP, or any other permit required by the ECM;
 - Failed to pay a civil penalty assessed pursuant to the ECM for failure to comply with the applicable sedimentation and erosion control requirements, where the payment is due and no appeal regarding the penalty is pending.
- D. **Approved Plans.** When issuing a Construction Permit, the ECM Administrator shall approve the plans by signing the appropriate approval block. The approved plans shall be attached to and become an enforceable part of the Construction Permit.
- E. **Valid Permit and Notice to Proceed.** A Construction Permit is valid once issued, but work may not proceed until a Notice to Proceed is issued by the ECM Administrator. Generally, a Notice to Proceed will be provided to the permit holder following the preconstruction meeting. A Notice to Proceed may be issued concurrently with the Construction Permit where the ECM Administrator has determined that a preconstruction meeting is not required.
- F. **Preconstruction Meeting.** The ECM Administrator may require a preconstruction meeting prior to issuing a Notice to Proceed. The ECM Administrator shall specify in the approved permit whether or not a preconstruction meeting is required and who is required to attend. The applicant is responsible for scheduling the meeting with the ECM Administrator.
- G. **Onsite Quality Control.** The permit holder shall provide onsite quality control by an experienced construction representative during all phases of construction. All quality control and inspections shall meet the requirements presented in Section 5.11. Field changes made during the construction process that modifies the overall design intent as permitted or do not meet minimum County standards shall be considered a change to the permit and shall be approved by the design engineer and ECM Administrator. No adjustment to the surety is warranted unless extensive redesign is required.
- H. **Change in Approved Plan.** The approved plans and specifications shall not be changed, modified, or altered without written authorization from the ECM Administrator. All work shall be done in conformance with the approved permit, plans, specifications, and these Standards.
- I. **Approved Plans and Copy of ECM at Work Site.** One set of approved plans, a copy of the Construction Permit and any conditions of approval, and a copy of the ECM shall be maintained at the work site at all times during construction activities.
- J. **No Violation of Standards.** The issuing and granting of a Construction Permit shall not be construed to be a permit for, or an approval of, any violation of any of the provisions of these Standards or of any

regulations of the County. No permit presuming to give authority to violate or cancel the provisions of these Standards shall be valid unless a deviation has been expressly and specifically approved by the ECM Administrator.

- K. **Limit of Plan Review and Permit Approval.** Construction Permit approval means that the plans have been reviewed for reasonableness and compliance with minimum ECM Standards. Construction Permit approval does not relieve the design engineer from responsibility for errors, omissions, or deficiencies in the plans
- L. **Correction of Errors.** The issuance of a Construction Permit based on plans, specifications or other data shall not prevent the ECM Administrator from requiring the correction of errors in the plans, specifications and other data, or from stopping construction operations being conducted in violation of these Standards or any other regulations of the County.

5.3.9. Construction Permit Suspension or Revocation

The ECM Administrator may suspend or revoke any Construction Permit, in writing, issued under the provisions of these Standards whenever the Construction Permit is issued in error or on the basis of incorrect information supplied by the applicant or whenever the permit may have been issued in violation of any provision of these Standards. In the event a permit is suspended or revoked, no refund of permit fees shall be made unless the permit was issued by the ECM Administrator in error.

5.3.10. Violations

Construction Permits may be enforced by injunction, including both the enjoining of actions or inactions in violation of the ECM, and a mandatory injunction to require the action accomplished without, or in violation of the terms of, a Construction Permit. In any such injunctive action the County shall be entitled to an award of its costs of suit and any costs incurred in the correcting any action undertaken in violation of the provisions of the information presented herein.

The County shall be entitled to recover its attorney's fees incurred in bringing action to compel compliance with the provisions of these regulations or to compel compliance with any plan approved hereunder.

5.3.11. Construction Permit Fees

Construction Permit fees shall be paid in full prior to any pre-construction conference or notice to proceed. The fee for Construction Permits shall be determined by resolution of the Board of County Commissioners.

5.3.12. County Inspections

- A. **General Requirements.** All work performed under a Construction Permit shall be subject to inspection by the ECM Administrator. The permit holder shall notify the ECM Administrator when work is ready for inspection. The ECM Administrator shall require that every request for inspection be filed at least 48 hours before the inspection is desired. The request may be in writing, email or by telephone. It is understood that in some cases it may not be possible to give 48 hours' notice. However, every attempt shall be made to provide the ECM Administrator with at least 48 hours' notice. Where the ECM Administrator determines that a permit holder consistently fails to provide adequate notice, the ECM Administrator may issue a stop work order or suspend the permit.

It shall be the responsibility of the permit holder to provide access to and means for proper inspection of all regulated construction activities.

5.3.13. Permit Holder Inspections

In accordance with the provisions of Section 5.11, the permit holder shall provide inspection services of all public improvements and common development improvements. All improvements shall be inspected by a construction representative or a qualified individual under the supervision of a construction representative. All inspection costs, including the services of the construction representative and required testing, shall be paid by the permit holder. Copies of all inspections and required testing shall be provided to the ECM Administrator.

5.3.14. Insurance

Before any permit holder shall perform work under a Construction Permit, the permit holder shall show evidence of a valid and enforceable bodily injury and property damage liability insurance policy, with minimum limits of \$1,000,000.00 combined single limit coverage. Such policy shall be for the protection of the County from all suits, actions or claims of any type for injuries or damages allegedly sustained by any person or property as a result of the operations or completed operations of the work. Such policy shall specifically cover the acts and operations of any subcontractors or independent contractors of the permit holder, in addition to the permit holder's employees or agents.

In addition to the insurance described above, the permit holder personally, by obtaining an approved Construction Permit, agrees to be liable to the County for any expenses incurred by the County because of the permit holder's acts of omissions relating to the work, and the permit holder shall hold the County harmless from any claims of anyone else arising from or relating to the work.

5.3.15. Construction Surety, Warranties, and Acceptance of Public and Common Development Improvements

- A. **General.** The purpose of this section is to set forth the policies and procedural guidelines for providing an acceptable guarantee of performance and compliance with County and State requirements for the acceptance of public and common development improvements.
- B. **Requirements of Applicant.** The applicant shall be required to submit construction surety in a form acceptable to the ECM Administrator prior to the issuance of a Construction Permit. The construction surety shall be released in accordance with the provisions of Section 5.3.16.E or as otherwise allowed by any approved development agreement or subdivision improvements agreement. Two-year defect warranty surety shall be posted by the permit holder for public and common development improvements prior to preliminary acceptance and release of any portion of the construction surety.
- C. **Construction Surety Default.** The ECM Administrator may demand payment on construction surety if the applicant fails to:
- Renew the construction surety at least 30 days in advance of the expiration; or
 - Comply with a written notice of violation or correction within the time specified in the notice.
- D. **Construction Surety Requirements.**
1. **Types of Surety.** The applicant is required to ensure the construction of all public and common development improvements and utilities are in accordance with the Construction Permit, approved plans and drawings, the standards of this ECM, and any development or subdivision improvements agreement. The construction surety must be posted prior to issuance of a Construction Permit for the proposed work or recording of the final plat in the case of a subdivision.

-
2. **Surety Estimates.** All surety estimates will be prepared based on unit prices for new public or private sector construction in the County. The applicant shall complete and submit a Construction Surety Estimate to the ECM Administrator. The ECM Administrator will review the surety estimate for public and common development improvements and will coordinate with the appropriate utility providers to review the surety estimate for water, sewer, and other utilities.
 3. **Forms of Acceptable Construction Surety.** The acceptable forms of surety guarantee for construction surety are: Performance Bond from a bond or insurance company authorized to do business in the State of Colorado, Letter of Credit from a financial institution authorized to do business in the State of Colorado, cash, or Certified or Cashier's Check. Other forms or construction surety such as a plat restriction or deeds of trust may be approved by the Board of County Commissioners.
 4. **Posting Construction Surety.** The applicant shall provide all construction surety in a form acceptable to the ECM Administrator. Surety forms shall be completed, executed and then submitted, along with any other required supporting documentation, to the ECM Administrator for approval prior to the issuance of a Construction Permit or recording a final plat in the case of a subdivision.
 - Surety with a Bonding Company: The applicable "Performance Bond with Surety" form is completed by the applicant and the surety company. An original power of attorney for the individual signing for the surety company shall be attached to the bond. The bond shall be signed or countersigned by a Colorado Resident Agent of the surety. Once the bond is completed and executed, the original is submitted for approval.
 - Collateral Assignment of Certificate of Deposit: The applicable "Performance Bond with Certificate of Deposit" form shall be completed and executed by the applicant. Both the applicant and the financial institution must complete the "collateral assignment" form. The original of the completed and executed bond and collateral assignment, along with the certificate of deposit or an original receipt for the certificate of deposit, are submitted for approval.
 - Certified or Cashier's Check: The applicable "Performance Bond with Cash Escrow" form and the "Request for Taxpayer Identification Number (Form W-9)" shall be completed and executed by the applicant. The check shall be made payable to the El Paso County. The cashier's check and the original of the completed and executed bond and Form W-9 are submitted for approval. Checks are cashed and the funds placed in an interest bearing performance bond account maintained by the County.
 - Letter of Credit from an Insured Lending Institution: The applicable "Irrevocable Letter of Credit" form shall be completed by the lending institution and be in favor of the BOCC, and shall guarantee construction of the improvements according to the approved plans and specifications. This Letter of Credit shall be automatically extended for additional periods of one year from the present or future expiration date, unless the bank notifies the ECM Administrator and the "Customer" via courier or certified mail at least 120 calendar days prior to the then expiration date that the bank has elected not to renew the Letter of Credit. 30 days after receipt of such notice, the County may draw on the Letter of Credit by presentation of the .Letter of Credit, and a demand in writing signed by a person who has been duly authorized to sign on the County's behalf.

Under no circumstances shall the required performance bond, collateral assignment of certificate of deposit, certified or cashier's check or irrevocable letter of credit be tied to or be considered a portion of the developer's financing for the development.
 5. **Construction Surety Term.** The construction surety shall have minimum term of one year.

E. Preliminary Acceptance, Surety Reductions and Inspection.

1. **General.** The permit holder seeking preliminary acceptance shall notify the ECM Administrator that the public and common development improvements are complete and ready to be accepted by the County. The permit holder shall schedule a preliminary acceptance walk-through. The ECM Administrator shall develop a punch list of items to be corrected prior to preliminary acceptance and noncritical items which must only be completed prior to final acceptance. The walk-through shall involve at a minimum the ECM Administrator and the construction representative.

Upon satisfactory completion of punch list items required for preliminary acceptance and a determination by the ECM Administrator that the installed improvements meet all applicable Standards, a preliminary acceptance recommendation shall be forwarded by the ECM Administrator to the BOCC for action. If the BOCC approve preliminary acceptance of an improvement, then construction surety shall be released in accordance with Sections 5.3.16E.3 and 5.3.16E.4 upon receipt of a defect warranty bond (See Section 5.3.16F).

Upon preliminary acceptance by the BOCC and release of the construction surety by the ECM Administrator, the facilities to be publicly maintained will be included in the County system for maintenance. A roads system maintenance acceptance form and drainage facility maintenance form shall be prepared by the BOCC identifying the systems to be added into the maintenance system.

A determination concerning final acceptance will not be made for 2 years from the date of preliminary acceptance.

2. **Preliminary Acceptance Limitation.** The preliminary acceptance of an improvement shall in no way constitute an assumption by the County of liability for defects in the improvement due to workmanship or materials. By accepting the improvement, the County does not warrant or guarantee that the improvement has been properly designed or constructed. Any errors or omission of the permit holder, design engineer, or construction engineer shall not be the responsibility of the County.

The permit holder shall be responsible for making any repair of facility failures that occur during the 2-year defect warranty period.

3. **Surety Reductions and Inspections.** Once the initial surety estimate is prepared, to request any reduction in surety the permit holder shall submit an approved "Surety Inspection Request Form" to the ECM Administrator.

Requests for construction surety reduction will be subject to the following conditions based upon the percentage of work completed and approved by the County, or other authority or agency having jurisdiction over the improvement. The following conditions apply to surety reductions and inspection fees.

- No more than 3 inspections for surety reductions will be scheduled during any twelve-month period. Additional inspections for surety reductions can be requested and will be scheduled and conducted based on staff availability but shall be scheduled only after regular inspections are completed.
- A surety reduction inspection fee must accompany each request for reduction.
- Inspections will be scheduled within 30 days of receipt of the surety reduction inspection request form and applicable fee.
- Reductions will not occur until completion and approval of at least 30% of the public and common development improvements.

Twenty percent of the original construction surety amount will be retained until final completion and preliminary acceptance of all public and common development improvements. Preliminary acceptance will not begin until the applicable defect warranty surety is posted.

4. **Release of Construction Surety.** Construction surety shall be released upon completion and preliminary acceptance of all public and common development improvements and posting of defect warranty surety. A county public improvement is deemed to be complete when it is preliminarily accepted and taken over for maintenance by the County. Other public improvements are deemed to be complete when approved by the public authority or state agency responsible for maintaining and operating the improvement. A common development improvement is deemed to be approved once the ECM Administrator determines that the improvements are complete and operates in accordance with the approved plans. For common development improvements that include permanent stormwater quality control measures, additional final inspection criteria are provided in Appendix I.

Engineering Record Drawings are required at the time of preliminary acceptance in accordance with Section 5.10.6. However, any field modifications made to the site contrary to the accepted drawings during the warranty period will be documented during inspections, and an addendum must be submitted to revise the Engineering Record Drawings prior to receiving Final Acceptance.

F. Warranty Requirements.

1. **General.** The permit holder is required to warranty all improvements against defects in materials or workmanship. This warranty must be posted prior to preliminary acceptance by the County or the release of any portion of the construction surety except as otherwise provided. The amount of the defect warranty shall be equal to 20% of those items as identified in the approved surety estimate.
2. **Form of Defect Warranty Surety.** The permit holder shall provide a defect warranty in a form acceptable to the ECM Administrator. The approved Defect Warranty Form shall be completed, executed and then submitted, along with any required supporting documentation, to the ECM Administrator for approval prior to the preliminary acceptance.
3. **Defect Warranty Period.** The permit holder is required to warrant improvements for 2 years.
4. **Permit Holder Responsibilities During Defect Warranty Period.** The permit holder shall repair or correct any deficiencies or defects in workmanship or materials that may occur before final acceptance is granted. Any repairs or correction shall be noted and a copy of the repair description and action shall be provided to the ECM Administrator.

G. Final Acceptance, Inspection and Release of Defect Warranty.

1. **General.** The permit holder seeking final acceptance shall notify the ECM Administrator to schedule a final walk-through inspection at least 30 days and no more than 90 days before the end of the defect warranty period. The final walk-through inspection shall include the permit holder (or representative), the construction representative (if different than the permit holder representative), and the ECM Administrator. The ECM Administrator may invite additional County or outside agency representatives. The ECM Administrator will generate a punch list of items for repair or correction.

Once all items identified on the punch list have been repaired or corrected to the satisfaction of the ECM Administrator and the ECM Administrator determines that the installed improvements meet all applicable Standards, the ECM Administrator shall prepare and schedule final acceptance documents for public improvements for Board of County Commissioner hearing and

approval. The defect warranty may be released by the ECM Administrator upon action of the BOCC to accept the public improvements.

2. **Final Acceptance Certification.** Prior to scheduling final acceptance for BOCC approval, the final punch list certification shall be signed by the ECM Administrator, construction representative, and permit holder stating that all items identified in the punch list have been repaired, corrected or completed.
3. **Final Acceptance and Release of Defect Warranty.** Upon final acceptance of the improvements by the BOCC, the ECM Administrator shall release the defect warranty.
4. **Failure to Make Repairs or Corrections.** If the permit holder fails to make the required repairs or corrections identified during the final walk-through inspection within 6 months, the ECM Administrator may draw on the defect warranty in order to perform the required repairs or corrections.

(Res. No. 19-245 , 7-2-19)

5.4. DRIVEWAY PERMIT

5.4.1. General

For the safety of the general public, the County has determined the minimum requirements and technical standards for driveways, and associated culverts and drainage structures constructed within the County right-of-way. The Driveway Permit is a tool to help the County regulate the location and construction of driveways that will intersect any County road, determine compliance with general access standards, and determine whether or not an access will intersect a county road. This section provides an orderly procedure for obtaining a Driveway Permit.

5.4.2. Driveway Permit Required

Driveway Permits are required to construct, reconstruct, pave, alter, enlarge or change the use of any driveway intersecting a County road; install, re-install, replace, or move a culvert associated with a driveway intersecting a County road; or verify a driveway location is on a private road before issuing a building permit. Where a new driveway is to be constructed in conjunction with the construction of a new principal structure, the Driveway Permit shall be issued as a condition for obtaining a building permit. Where the use of a principal structure or property is proposed to change, a new Driveway Permit may be required prior to the use conversion.

No person shall commence work on any driveway or culvert within a County right-of-way before the Driveway Permit has been issued.

5.4.3. Restrictions on Locations

All driveways shall meet the criteria for access outlined in Chapter 2 of the ECM. In addition, accesses shall be subject to any subdivision plat restrictions.

5.4.4. Application

- A. **Complete Application Required.** Applicants shall file a complete application for a Driveway Permit on forms provided by the ECM Administrator. Based on the proposal, additional submissions may be required to provide the ECM Administrator with sufficient information to provide for review of the application.

Created: 2021-06-08 11:35:50 [EST]

(Supp. No. 2)

The ECM Administrator may allow Driveway Permits to be processed in groups within a common development or subdivision to reduce the administrative burden on applicants requesting permits concurrently for multiple lots.

- B. **Additional Requirements for Commercial or Multifamily Driveways.** All commercial and multifamily driveways are subject to site development plan review. Due to the higher complexity and possible impacts, a transportation impact study may be required to support review and approval of a Driveway Permit application for a driveway serving commercial and multifamily development. Where the transportation impact study determines or these Standards require public improvements such as acceleration and deceleration lanes, exclusive left or right hand turn lanes, or a traffic signal, the applicant shall also be required to obtain a Construction Permit to construct, reconstruct, alter, or enlarge the necessary public improvements.
- C. **Signed by Applicant.** All applications for Driveway Permit shall be signed by the applicant, or an authorized agent, who may be required to submit evidence to indicate their authority.
- D. **Proposed Driveway Location to be Marked.** For access onto a County public road with open ditch drainage (not curb and gutter), the applicant may be required by the ECM Administrator to stake the proposed location of the driveway at the point of intersection with County road. If staking is required, the driveway location shall be staked with 2 stakes marked "driveway" placed along the edge of the County right-of-way, and shall be clearly visible from the road. In evaluating the Driveway Permit application, the ECM Administrator may conduct a field inspection of the location of the proposed driveway. If the location has not been staked in accordance with this section, the Driveway Permit may be denied by the ECM Administrator or a reinspection fee may be assessed prior to reinspecting the location and issuing the Driveway Permit.
- E. **Determination of Application Completeness.** An application will be considered complete if it is submitted in the required form, includes all mandatory information, including all supporting materials specified by the ECM Administrator, and is accompanied by the applicable fee. If an application is determined to be incomplete, the ECM Administrator shall provide notice to the applicant along with an explanation of the application's deficiencies. No further processing of the application shall occur until the deficiencies are corrected in a future resubmittal. An application which is determined to be incomplete may or may not retain its same processing cycle.
- F. **Application for Second Driveway Access.** In some situations, El Paso County will consider a second driveway access for a lot, if requested. If a second driveway access is requested, all driveway criteria must be met for both driveways.

5.4.5. Driveway Permit Review and Issuance

- A. **Review Process.** The application and other data filed by an applicant for a Driveway Permit shall be reviewed by the ECM Administrator. The application may also be reviewed by other departments or agencies to verify compliance with any applicable laws.

If the ECM Administrator finds that the work described in an application for a Driveway Permit conform to the requirements of these Standards and other pertinent laws regulations or ordinances and that all required fees have been paid, a Driveway Permit shall be issued to the applicant.

- B. **Criteria for Approval.** A Driveway Permit may only be approved if it meets the criteria set forth below:
 - The submitted application complies with all applicable requirements of the ECM;
 - The ECM Administrator determines that the access will not create an unsafe condition for the traveling public;

-
- All required review and permit fees have been paid and any required construction surety has been posted in a form acceptable to the ECM Administrator.

Any Driveway Permit application that in the opinion of the ECM Administrator fails to meet the criteria for approval listed above may be denied a Driveway Permit by the ECM Administrator. In denying a Driveway Permit, the ECM Administrator shall provide a statement outlining the reasons for denial of the permit.

- C. **Change in Approved Permit.** The approved permit shall not be changed, modified, or altered without written authorization from the ECM Administrator. All work shall be done in conformance with the approved permit and these Standards.
- D. **Violation of Standards.** The issuing and granting of a Driveway Permit shall not be construed to be a permit for, or an approval of, any violation of any of the provisions of these Standards or of any regulations of the County. No permit presuming to give authority to violate or cancel the provisions of these Standards shall be valid, unless expressly and specifically varied by the ECM Administrator.
- E. **Limit of Permit Approval.** Driveway Permit approval means that the permit has been reviewed for reasonableness and compliance with minimum ECM Standards. The Driveway Permit does not guarantee that if the permit specifications are met and construction complies with the standards outlined in the ECM and on the Driveway Permit, the permit holder will not be liable for damages to the County road after construction is completed.
- F. **County Authority Preserved.** The County, notwithstanding the issuance of any permit or construction of any driveway, reserves the right to make any changes, additions, repairs or relocation of any part of a driveway within the dedicated right-of-way at any time, including but not limited to, in connection with the relocation, reconstruction, widening and maintaining the road or right-of-way, without compensating the owner of the driveway for the damages to or destruction of the driveway.

5.4.6. Driveway Permit Holder Responsibilities

- A. **Maintenance Responsibility.** The property owner is responsible for maintaining the driveway approaches, culvert and ditch to permit free and unobstructed flow of water. The County does not assume any responsibility for repair or replacement of concrete or decorative pavement, decorative endwalls/headwalls, the removal or clearance of snow or ice, or the opening of windrows of such material, upon any portion of the driveway within the County right-of-way.
- B. **Utility Locates.** The permit holder shall be responsible for contacting the Utility Notification Center of Colorado for utility locates at least 48 hours in advance of the driveway construction if excavation is required.
- C. **Traffic Control.** Driveway construction activities shall not interfere with traffic on the adjacent roadway. If interference with traffic is required, a traffic control plan shall be submitted and approved by the ECM Administrator as part of the permit application. All traffic control shall conform to MUTCD standards.
- D. **Drainage Interference.** A permit holder shall not obstruct the natural free and clear passage of water along the gutters or other waterways. If surface drainage is to be affected, the permit holder is responsible for the proper disposition of the runoff.
- E. **Responsibility for Clean Up and Restoration.** The permit holder shall assume all responsibility for removing all debris and slash from the County's right-of-way associated with the driveway construction activities. If, upon inspection, the ECM Administrator determines that debris and slash have not been removed from the County right-of-way, the ECM Administrator shall notify the permit holder of the violation of the permit conditions. The permit holder, upon notification from the ECM Administrator

shall correct all work to the extent necessary, using the method required by the ECM Administrator. The work shall be completed within the time period specified in the notice from the ECM Administrator.

If the permit holder fails to restore the right-of-way in the manner and to the condition required by the ECM Administrator, the ECM Administrator may have the County perform the restorations. In that event, the permit holder shall pay to the County, within 30 days of billing, the cost of restoring the right-of-way.

5.4.7. Driveway Permit Expiration

Every Driveway Permit issued by the ECM Administrator shall expire if a building permit is not obtained within 90-days, the work authorized by the permit is not substantially begun within one year from the date of the permit or if the construction of work authorized by the permit is suspended or abandoned for a period of one year at any time after the work is begun. Before work can begin or be resumed, the Driveway Permit shall be reissued by the ECM Administrator.

5.4.8. Driveway Permit Suspension or Revocation

The ECM Administrator may suspend or revoke any Driveway Permit, in writing, issued under the provisions of these Standards whenever the Driveway Permit is issued in error or on the basis of incorrect information supplied by the applicant or whenever the Driveway Permit may have been issued in violation of any provisions of these Standards. In the event a Driveway Permit is suspended or revoked, no refund of permit fees shall be made unless issued in error by the ECM Administrator.

5.4.9. Driveway Permit Fees

Driveway Permit fees shall be paid in full at the time of the driveway permit application. The fee for Driveway Permits shall be as determined by resolution of the BOCC.

5.4.10. Inspections

The ECM Administrator may conduct an inspection of the driveway to ensure full compliance with all provisions of the ECM and terms of the permit.

5.4.11. Driveway Construction Surety

When determined necessary by the ECM Administrator, the applicant shall be required to submit driveway construction surety in a form and amount acceptable to the ECM Administrator prior to the issuance of a Driveway Permit. Surety shall be released upon final completion and approval of the ECM Administrator.

5.5. WORK IN THE RIGHT-OF-WAY PERMIT

5.5.1. General

The County holds public right-of-way and easement as an asset in trust for its citizens and manages the use of the right-of-way and other uses for public purposes, including use by public utilities pursuant to Section 38-5-101 of the Colorado Revised Statutes. To provide for the health, safety and welfare of its citizens and to ensure the structural integrity of its roads and the appropriate use of right-of-way, the County strives to keep its right-of-way in a state of good repair and free from unnecessary encumbrances.

The Work in the Right-of-Way Permit is a tool to help regulate obstructions of, excavations in, and the use of the County's right-of-way and easements by, among other things, granting a permit holder authority to

obstruct, excavate, or install facilities within the right-of-way or easement, and provide for the subsequent restoration of the County's right-of-way, easement, and public improvements located therein.

5.5.2. Work in the Right-of-Way Permit and Notice to Proceed Required

- A. **General Requirements.** A Work in the Right-of-Way Permit is required for obstructing or excavating within any public right-of-way or easement, and for encroaching upon any County right-of-way or easement.

No person may obstruct or excavate any right-of-way or easement, or encroach upon any County right-of-way or easement without first having obtained the appropriate Work in the Right-of-Way Permit from the ECM Administrator. In addition, no person may excavate or obstruct the right-of-way or easement beyond the date or dates specified in the permit unless: (1) the person requests a permit extension before the expiration of the initial permit, and (2) a new permit or permit extension is granted.

No work shall begin until a Work in the Right-of-Way Permit has been issued.

- B. **Work in the Right-of-Way Permit Types.**

1. **Excavation in the Right-of-Way.** A Work in the Right-of-Way Permit is required to excavate that part of the right-of-way described in the permit to the extent and for the duration specified in the permit including, but not limited to:

- Grade, trench, cut, or change the elevation of the surface of a County right-of-way or easement including any road, drainageway, ditch, drainage facility, and reservoir/catch basin or drainage structure located within a County right-of-way or easement.

2. **Temporary Obstruction of the Right-of-Way.** A Work in the Right-of-Way Permit is required to hinder free and open passage over a specified portion of right-of-way by placing equipment or materials in the right-of-way or conducting an approved activity within the right-of-way for the duration specified therein including, but not limited to:

- Place within a County right-of-way or easement any rubbish, brush, earth, or other material of any nature whatsoever;
- Place any equipment, barrier, sign, detour, post or bollard so as to change the flow of vehicular or pedestrian traffic in a County right-of-way or easement.

3. **Encroachment in the Right-of-Way.** A Work in the Right-of-Way Permit is required to locate, erect or maintain any structure, including but not limited to driveway monuments, flag, banner, post, sign, pole, fence, guardrail, wall, loading platform, gang mailbox, pipe, drainage ditch or facility, conduit, irrigation facility, utility, or wire on, over, or under a County right-of-way or easement.

All Work in the Right-of-Way Permits for encroachments shall require the owner of the encroachment to fulfill the registrant requirements of Section 5.5.8 and file an Encroachment Removal Agreement.

4. **Annual Maintenance Permit.** This permit is approved by the El Paso County Board of County Commissioners. The following conditions apply:

- The Annual Maintenance Permit is for maintenance of existing utilities requiring only access to vaults, cabinets, manholes, etc.
- No excavation is permitted

- C. **Working Without a Permit - Registrants.**

-
1. **Registrant Identified Emergencies.** When a condition arises where emergency work must be performed on a facility located within the County right-of-way (i.e., existing approved encroachment), the registrant shall immediately notify the ECM Administrator of the event regarding its facilities which it considers to be an emergency. The registrant may proceed to take whatever actions are necessary in order to respond to the emergency in accordance with approved Standards. Within 2 business days after the occurrence of the emergency, the registrant shall apply for the necessary permits, pay the associated fees and fulfill the rest of the requirements necessary to comply with the ECM for the actions the registrant took in response to the emergency.
 2. **ECM Administrator Identified Emergencies.** In the event that the ECM Administrator becomes aware of an emergency regarding a registrant's equipment or facilities located in the County right-of-way or easement, the ECM Administrator shall attempt to contact the local representative of each registrant affected, or potentially affected, by the emergency. The ECM Administrator may take whatever action deemed necessary in order to respond to the emergency, the cost of which shall be borne by the registrant whose equipment or facilities occasioned the emergency.
- D. **Working Without a Permit - Non-Registrants.**
1. **General.** Non-registrants shall not work in the County right-of-way without a valid Work in the Right-of-Way Permit except as otherwise permitted.
 2. **Emergency Repair of Service Lines.** When a condition arises where emergency work must be performed on a service line located within the County right-of-way, the property owner shall immediately notify the ECM Administrator of the event regarding the emergency. The property owner may proceed to take whatever actions are necessary in order to respond to the emergency provided a contractor certified and bonded with the ECM Administrator or registrant performs all work within the County right-of-way. Within 2 business days after the occurrence of the emergency, the property owner shall apply for the necessary permits, pay the associated fees and fulfill the rest of the requirements necessary to bring the action into compliance with the ECM.
 3. **Mailboxes and Other Exceptions.** A property owner may erect a single mailbox in accordance with USPS standards, maintain and mow areas of vegetation within the County right-of-way, maintain roadside ditches, and maintain that portion of the driveway located within the County right-of-way without obtaining a Work in the Right-of-Way Permit. Caution should be used when working in the County right-of-way. Although a permit is not required, all activities shall conform to these Standards.

5.5.3. Application for Permit

- A. **Complete Application Required.**
1. **General.** Applicants shall file a complete application for a Work in the Right-of-Way Permit. Each application shall:
 - Identify and describe the work to be covered by the permit for which the application is made.
 - Describe the land on which the proposed work is to be done, by legal description, street address, or similar description that shall readily identify and definitively locate the proposed work location.
 - Be accompanied by plans, diagrams, computations and specifications, and other data as required by these Standards and the approved application and permit checklists.

-
- Be accompanied by a traffic management plan that clearly describes the traffic management to be implemented and maintained during excavation, obstruction or placement of the encroachment.
 - Identify in detail the activities including proposed dates and times of operation, schedule for start and completion.
 - Include all other materials requested by the ECM Administrator.
2. **Signed by Applicant.** All applications for Work in the Right-of-Way Permit shall be signed by the applicant, or an authorized agent, who may be required to submit evidence to indicate their authority.
 3. **Joint Applications.** Applicants may jointly make application for permits to excavate, obstruct or encroach on the County right-of-way at the same place and time. The ECM Administrator may reduce the disruption and degradation portions of the permit fee for applicants who join in during a scheduled obstruction, excavation, or encroachment action whether or not it is a joint application by 2 or more applicants or a single application.
 4. **Encroachment Removal Agreement.** An approved executed Encroachment Removal Agreement is required for any planned encroachment into the County right-of-way or easement. A metes and bounds easement for the encroachment shall be provided to the ECM Administrator with a statement of justification as to why the appurtenance must remain in the County right-of-way or easement.

In the event the County performs work in this area which requires removal of the encroachment, the registrant shall at their own cost remove and relocate the appurtenance, or the ECM Administrator may have the encroachment removed at the County's expense and invoice the registrant.

5. **Supplemental Applications.** A Work in the Right-of-Way Permit is valid only for the area of the right-of-way or easement specified in the permit. No permit holder may perform any work outside the area specified in the permit, except as provided. Any permit holder that determines an area greater than that specified in the permit must be obstructed, excavated or encroached upon must, before working in that greater area: (1) make application for a permit modification and pay any additional fees, and (2) be granted a new permit or permit modification.

A Work in the Right-of-Way Permit is valid only for the dates specified in the permit. No permit holder may begin its work before the permit start date or, except as provided herein, continue working after the end date. If a permit holder does not finish the work by the permit end date, the permit holder must: (1) make application for a permit extension for the additional time needed before the permit expires, and (2) receive the extension before working after the end date of the previous permit.

6. **Determination of Application Completeness.** An application will be considered complete if it is submitted in the required form and includes all mandatory information, including all supporting materials specified by the ECM Administrator. If an application is determined to be incomplete, the ECM Administrator shall provide notice to the applicant along with an explanation of the application's deficiencies. No further processing of the application shall occur until the deficiencies are corrected in a resubmittal. An application which is determined to be incomplete may or may not retain its same processing cycle.

B. Plan Submittal Requirements.

1. **General.** Plans for any work or activity within the County right-of-way or easement shall be submitted to the ECM Administrator for approval. For minor installations such as service lines,

drops, etc., simple sketch plans with pertinent information as to location and depth may suffice as the plans.

For complex applications and if requested on the application, the following shall be provided:

- Engineering scale drawings showing the location of all facilities and improvements proposed.
 - Location and approximate depth of the subject and related facilities and any other facilities in the immediate vicinity.
 - A description of the methods that will be used in the work.
 - The County road and associated right-of-way affected by the work.
 - Offset distances from the roadway centerline to the back of curb or edge of pavement surface and the associated right-of-way line.
 - A legend explaining symbols, characters, abbreviations, scale, north arrow, and other data.
 - The location of any public streets, trails, walks or alleys and private property accesses that will be temporarily closed to use during the work.
 - Any facilities to be abandoned, if applicable.
 - Any other information required by the ECM Administrator.
2. **Traffic Control.** Work within the County right-of-way shall not interfere with traffic. If interference with traffic is require, a traffic control plan shall be submitted and approved by the ECM Administrator as part of the permit application. All traffic control shall conform to MUTCD standards.
 3. **Signed and Sealed by PE.** The seal of the design engineer shall appear on each sheet. The design engineer shall be a registered Colorado Registered Professional Engineer.

5.5.4. Work in the Right-of-Way Permit Review and Issuance

- A. **Review Process.** The application, plans, specifications, and other data filed by an applicant for a Work in the Right-of-Way Permit shall be reviewed by the ECM Administrator. The plans may also be reviewed by other departments or agencies to verify compliance with any applicable laws.

Upon completion of the detailed review by the ECM Administrator and any other departments or agencies, the ECM Administrator will return one set of plans with "Red Line" comments. More than one review may be required. All successive sets of "Red Line" plans shall be returned to the ECM Administrator with the corresponding revised set of plans. After the design engineer has completed all revisions, final revised plans shall be submitted to the ECM Administrator for signoff and the most recent set of "Red Line" plans shall be returned to the ECM Administrator. Plan review priority will be given to plans submitted for final review over plans submitted for initial or intermediate review.

If the ECM Administrator finds that the work described in an application for a Work in the Right-of-Way Permit and the plans and other data conform to the requirements of these Standards and other pertinent laws regulations or ordinances and that all required fees have been paid, a Work in the Right-of-Way Permit may be issued to the applicant at the discretion of the ECM Administrator.

A Work in the Right-of-Way Permit is valid once issued, but the ECM Administrator might require a preconstruction meeting.

- B. **Authority of ECM Administrator.** The ECM Administrator shall have the discretionary authority to issue or deny a permit. A Work in the Right-of-Way Permit is considered a privilege. The ECM Administrator will decide all questions that may arise as to the quality and acceptability of materials furnished and

work performed. The ECM Administrator shall have the authority to suspend work, wholly or in part, because of the failure of the permit holder to properly execute the work in accordance with these Standards. The ECM Administrator may undertake the inspection of the material at the source and shall have full entry at all times to those areas where the manufacture or production of the materials is taking place. The ECM Administrator shall also have the authority to waive, wholly or in part, the requirements presented in these Standards, dealing with individual projects, for reasons deemed to be in the public's interest.

- C. **Permit Conditions.** The ECM Administrator may impose reasonable conditions upon the issuance of the permit and the performance of the permit holder in order to protect the public health, safety and welfare, to insure the structural integrity of the right-of-way, to protect the property and safety of other users of the right-of-way, and to minimize the disruption and inconvenience to the traveling public. In addition, the ECM Administrator may develop permit conditions that provide reasonable assurance that utilities and their contractors working in the right-of-way are competent and qualified. These permit conditions may include, but not be limited to, instruction in state and local laws, including one-call, construction zone traffic safety, and construction standards, including restoration standards.
- D. **Criteria for Approval.** A Work in the Right-of-Way Permit may only be approved if it meets the criteria set forth below:
- The proposal complies with all applicable requirements of the ECM or a deviation has been granted;
 - All required review and permit fees have been paid; and
 - The required insurance and surety has been provided in a form acceptable to the ECM Administrator.

Any Work in the Right-of-Way Permit application that in the opinion of the ECM Administrator fails to meet the criteria for approval listed above may be denied a Work in the Right-of-Way Permit by the ECM Administrator. In denying a Work in the Right-of-Way Permit, the ECM Administrator shall provide a statement outlining the reasons for denial of the permit.

- E. **Authority to Deny Permit.**
1. **Mandatory Denial.** Except in the case of an emergency, the ECM Administrator shall deny a Work in the Right-of-Way Permit to any applicant, or any parent or subsidiary corporation (if the applicant is a corporation) where the applicant:
 - has failed within the past 3 years to comply, or is presently not in full compliance, with the requirements of the ECM;
 - where grounds exist for the revocation of an existing permit.
 - has outstanding debt owed to the County that is in arrears, due, owing and unpaid.
 2. **Permissive Denial.** The ECM Administrator may deny a permit in order to protect the public health, safety and welfare, to prevent interference with the safety and convenience of ordinary travel over the County right-of-way, would cause a conflict or interfere with an exhibition, celebration, festival, or any other event, or when necessary to protect the County right-of-way and its users. The ECM Administrator may consider one or more of the following factors: the extent to which right-of-way space where the permit is sought is available; the competing demands for the particular space in the County right-of-way; the availability of other locations in the County right-of-way or in other right-of-way for the facilities of the permit applicant; the applicability of standards or other regulations of the County right-of-way that affect location of facilities in the County right-of-way; the degree of compliance of the applicant with the terms and conditions of its franchise, if any; the degree of disruption to surrounding communities and businesses that will result from the use of that part of the County right-of-way; the condition and

age of the right-of-way, and whether and when it is scheduled for total or partial reconstruction; and the balancing of the costs of disruption to the public and damage to the County right-of-way, against the benefits to that part of the public served by the expansion into additional parts of the County right-of-way.

To protect health, safety, and welfare or when necessary to protect the County right-of-way and its current use, the ECM Administrator shall have the power to prohibit or limit the placement and location of new or additional facilities within the County's right-of-way.

- F. **Approved Plans.** When issuing a Work in the Right-of-Way Permit, the ECM Administrator shall endorse the plans in writing or by stamping the plans and specifications "Approved, El Paso County ECM Administrator". The approved plans shall be attached to and become an enforceable part of the Work in the Right-of-Way Permit.
- G. **Preconstruction Meeting.** The ECM Administrator may require a preconstruction meeting prior to issuing a Notice to Proceed. The ECM Administrator shall specify in the approved permit whether or not a preconstruction meeting is required and who is required to attend. The applicant is responsible for scheduling the meeting with the ECM Administrator.
- H. **Change in Approved Plan.** The approved plans and specifications shall not be changed, modified, or altered without written authorization from the ECM Administrator. All work shall be done in conformance with the approved permit, plans, specifications, and these Standards.
- I. **Approved Plans at Work Site.** One set of approved plans, a copy of the Work in the Right-of-Way Permit and any conditions of approval shall be maintained at the work site at all times during the progress of the work or activity.
- J. **Maintenance of Drainage Within Right-of-Way.** A permit holder shall not obstruct the natural free and clear passage of water along the gutters or other waterways. If surface drainage is to be affected, the permit holder is responsible for the proper disposition of the runoff.
- K. **Utility Locates.** The permit holder shall be responsible for contacting the Utility Notification Center of Colorado for utility locates at least 48 hours in advance of the work that requires the ground to be disturbed.
- L. **Violation of Standards.** The issuing and granting of a Work in the Right-of-Way Permit shall not be construed to be a permit for, or an approval of, any violation of any of the provisions of these Standards or of any regulations of the County. No permit presuming to give authority to violate or cancel the provisions of these Standards shall be valid unless a deviation has been unless expressly and specifically approved by the ECM Administrator.
- M. **Limit of Plan Review and Permit Approval.** Work in the Right-of-Way Permit approval means that the plans have been reviewed for reasonableness and compliance with minimum ECM Standards. Work in the Right-of-Way Permit approval does not relieve the design engineer from responsibility for errors, omissions, or deficiencies in the plans.

Permits issued by the ECM Administrator pertain only to work within the County-owned right-of-way and in no way allow a permit holder to enter onto private property adjacent to County-owned right-of-way nor to alter or disturb any facilities or installations that exist within the County-owned right-of-way that are owned by others unless expressly and specifically approved.
- N. **Correction of Errors.** The issuance of a Work in the Right-of-Way Permit based on plans, specifications or other data shall not prevent the ECM Administrator from requiring the correction of errors in the plans, specifications and other data, or from stopping construction operations being conducted in violation of these Standards or any other regulations of the County.
- O. **Right-of-Way Patching and Restoration.**

-
1. **General.** The work to be done under the Work in the Right-of-Way Permit, and the required patching and restoration of the County's right-of-way must be completed within the dates specified in the permit, increased by as many days as work could not be done because of circumstances constituting force majeure or when work was prohibited as unseasonal or unreasonable. In addition to patching their work, the permit holder must restore the general area of the work, and the surrounding areas, including the paving and its foundations, to the same condition that existed before the commencement of the work.
 2. **Patching and Restoration Methods.** The permit holder shall perform excavation, backfilling, patching and restoration according to the Standards and with the materials specified by the ECM Administrator. The ECM Administrator shall have the authority to prescribe the manner and extent of the restoration in written procedures of general application or on a case-by-case basis. Methods of restoration may include, but are not limited to, patching, replacement of the base, and milling and overlay of the affected area of the County roadway. The permit holder shall at the time of application of permit post construction surety when required by the ECM Administrator.
 3. **Defects and Repair.** The permit holder shall correct defects in patching, or restoration performed by the permit holder or its agents for up to 2 years following restoration. The permit holder, upon notification from the ECM Administrator shall correct all restoration work to the extent necessary, using the method required by the ECM Administrator. The work shall be completed within the timeframe specified by the ECM Administrator.
 4. **County Action to Restore or Correct.** If the permit holder fails to restore the County's right-of-way in the manner and to the condition required by the ECM Administrator, or fails to satisfactorily and timely complete all restorations required by the ECM Administrator, the ECM Administrator may have the County perform the restorations. In that event, the permit holder shall pay to the County, within 30 days of billing, the cost of restoring the right-of-way plus an additional degradation fee established by the ECM Administrator

5.5.5. Work in the Right-of-Way Permit Expiration and Extension

- A. **Expiration.** Every Work in the Right-of-Way Permit issued by the ECM Administrator shall expire if the work authorized by the permit is not substantially begun within one year from the date of the permit or if the construction of work authorized by the permit is suspended or abandoned for a period of one year at any time after the work is begun. The permit will also expire if it is not picked up within 90 days of the permit being issued. Before such work can be resumed, the Work in the Right-of-Way Permit shall be reissued by the ECM Administrator. The fee for a reissued Work in the Right-of-Way Permit shall be one-fourth of the amount required for a new Work in the Right-of-Way Permit for the work, provided no changes have been made or are required by the ECM Administrator in the originally approved plans and specifications. A copy of the permit must be available at the site for review at all times.
- B. **Extension.** Any permit holder with an unexpired Work in the Right-of-Way Permit may apply for an extension of the time within which work may begin under that permit if the permit holder is unable to begin work within the time required for good cause, and that the cause is acceptable to the ECM Administrator. There shall be an extension fee assessed to cover administrative costs.

5.5.6. Work in the Right-of-Way Permit Suspension or Revocation

- A. **Permit Issued in Error or Violation of ECM.** The ECM Administrator may suspend or revoke any Work in the Right-of-Way Permit, in writing, whenever the Work in the Right-of-Way Permit is issued in error or on the basis of incorrect information supplied by the applicant or whenever the permit may have

been issued in violation of any provisions of these Standards. In the event a permit is suspended or revoked, no refund of permit fees shall be made unless the permit was issued by the ECM Administrator in error.

B. **Breach of Permit Terms and Conditions.** Permit holders hold Work in the Right-of-Way Permits as a privilege. The County reserves its right to revoke any Work in the Right-of-Way Permit, without fee refund, in the event of a substantial breach of the terms and conditions of any statute, ordinance, standard, rule or regulation, or any condition of the permit. A substantial breach by the permit holder shall include, but shall not be limited to, the following:

- The violation of any material provision of the Work in the Right-of-Way Permit;
- An evasion or attempt to evade any material provision of the Work in the Right-of-Way Permit, or the perpetration or attempt to perpetrate any fraud or deceit upon the County or its citizens;
- Any material misrepresentation of fact in the application for a Work in the Right-of-Way Permit;
- The failure to maintain the required bonds or insurance;
- The failure to complete the work in a timely manner;
- The failure to correct a condition indicated on an order of the ECM Administrator;
- Hiring illegal aliens;
- Failing to report damage to other utilities; or
- Failing to report injuries.

If the ECM Administrator determines that the permit holder has committed a substantial breach of a term or condition of any statute, ordinance, rule, regulation or any condition of the permit, the ECM Administrator shall make a written demand upon the permit holder to remedy the violation. The demand shall state that continued violations may be cause for revocation of the permit. Further, a substantial breach will allow the ECM Administrator to place additional or revised conditions on the permit.

Within 48 hours of receiving notification of the breach, the permit holder shall contact the ECM Administrator with a plan, acceptable to the ECM Administrator, for correction. The permit holder's failure to contact the ECM Administrator, or the failure to submit an acceptable plan, or failure to reasonably implement the approved plan, shall be cause for immediate revocation of the permit. Further, the permit holder's failure to contact the ECM Administrator, or failure to submit an acceptable plan, or failure to implement the approved plan, shall automatically place the permit holder on probation for one full year. Permit fees may increase while an applicant is on probation.

- C. **Violation of Permit Conditions.** From time to time, the ECM Administrator may establish a list of permit conditions which, if breached, will automatically place the permit holder on probation for one full year, such as, but not limited to, working out of the allotted time period, working on right-of-way grossly outside of the permit, failing to report utility hits, failing to report injuries or hiring illegal aliens.
- D. **Breach of Permit While on Probation.** If a permit holder, while on probation, commits a breach as outlined above, the permit holder's permit will automatically be revoked and permit holder will not be allowed further permits for one full year, except for emergency repairs.
- E. **Reimbursement of County Costs for Revoked Permit.** If a permit is revoked, the permit holder shall reimburse the County for the County's reasonable costs, including restoration costs and the costs of collection and reasonable attorneys' fees incurred in connection with revocation.

5.5.7. Fees

A. General.

1. **Excavation.** The excavation fee shall be in an amount sufficient to recover the following costs if applicable:
 - The County management and administrative cost;
 - The traffic management fee;
 - The degradation cost;
 - The trench fee for trenches over 1,320 linear feet; and
 - The incentive/disincentive.
2. **Temporary Obstruction Fee.** The obstruction fee shall be in an amount sufficient to recover the following costs if applicable:
 - The County management and administrative cost; and
 - The traffic management fee.
3. **Encroachment.** The encroachment fee shall be in an amount sufficient to recover the following costs if applicable:
 - The County management and administrative cost;
 - The traffic management fee;
 - The registration and monitoring costs;
 - The degradation cost;
 - The incentive/disincentive; and
 - The trench fee for trenches over 1,320 linear feet.
4. **Annual Maintenance Permit (\$600.00 currently).**
 - The County management and administration cost.

- B. **Work in the Right-of-Way Permit Review Fees.** The Work in the Right-of-Way Permit review fee shall be paid in full at the time the Work in the Right-of-Way Permit application is submitted for approval to the ECM Administrator. The permit review fees shall be determined by resolution of the BOCC. Applications for which no Work in the Right-of-Way Permit is issued within one year following the date of the original application shall expire; and plans and other data submitted for review may be returned to the applicant or destroyed by the ECM Administrator. The ECM Administrator may extend the time for action by the applicant for a period not exceeding one year upon request by the applicant showing that circumstances beyond the control of the applicant have prevented action from being taken. No application shall be extended more than once. In order to renew action on an application after expiration, the applicant shall resubmit plans and pay a new plan review fee.

All resubmittals or incomplete applications are subject to re-review fees. Re-review fees shall be established by resolution the BOCC. A re-review fee may be assessed at the discretion of the ECM Administrator for each plan review when the redlines are not corrected or when resubmittal materials are not complete. The purpose of the re-review fee shall not to be interpreted as requiring re-review fees the first time a submittal is rejected for failure to comply with the requirements of these Standards, but rather as controlling the practice of not making required plan corrections or submitting complete materials.

-
- C. **Work in the Right-of-Way Permit Fees.** The fee for Work in the Right-of-Way Permit shall be as determined by resolution of the BOCC plus any mapping, registration and monitoring, degradation or traffic management costs assessed by the ECM Administrator. Work in the Right-of-Way Permit fees shall be paid in full at the time the plans and specifications have been approved by the ECM Administrator and the Work in the Right-of-Way Permit is issued. The ECM Administrator may allow the registrants to pay permit fees within 30 days of billing.
1. **Computation of Traffic Management Fee.** The ECM Administrator shall determine the traffic management fee component of the fees for excavation, obstruction or encroachments, and in doing so shall have the purpose of providing a financial incentive to permit holders to minimize their obstruction and use of the right-of-way and to get in and get out of the right-of-way as quickly as possible. In aid of that purpose, the ECM Administrator shall use in the computation of the traffic management fee, to the extent practicable, economic and accounting principles relating to the quantification of the social costs resulting from road obstructions, including (1) losses to businesses and merchants which would not have occurred but for the obstructions, and (2) social costs to the users of the County's right-of-way resulting from traffic delays, diversions, disruption in services, missed or delayed appointments, and decline in quality of life. Fees may vary from one location to another based on the size of the area to be obstructed; the duration that the County right-of-way or parts of it will be unavailable for public use and travel; the proximity of businesses and enterprises which rely in whole or in part on access by members of the public or the delivery of supplies or raw materials; the importance of the particular right-of-way as to the traveling public; the use of the particular right-of-way for emergency vehicles and the availability of alternate routes; the traffic volumes carried by the particular right-of-way; and the amount of vehicular, bicycle, and pedestrian traffic that is reasonably likely to be disrupted. The methodology used to establish the fee shall be approved by the BOCC.
 2. **Computation of Degradation Fees.** The ECM Administrator shall determine the degradation fee component of the fees for excavation, obstruction or encroachments. The degradation fee shall have the purpose of providing a financial incentive for permit holders to minimize their damage to public improvements and to coordinate their new construction, repair and replacement programs with County maintenance and capital improvement programs. The ECM Administrator shall use in the computation of the degradation fee, to the extent practicable, economic and accounting principles relating to the decrease in the useful life of the County's right-of-way and impact public improvements caused by excavation in or disturbance of the County right-of-way or those improvements, resulting in the need to reconstruct improvements earlier than would be required if the excavation or disturbance did not occur. The degradation fee shall consider:
 - The number, size, depth and duration of the excavations, disruptions or damage to the County's right-of-way;
 - The traffic volume carried within the County's right-of-way and the character of the neighborhood surrounding the County right-of-way;
 - The pre-existing condition of the County's right-of-way and the remaining useful life of the County's right-of-way affected by the excavation;
 - Whether the relative cost of the method of restoration to the permit holder is in reasonable balance with the prevention of an accelerated depreciation of the County's right-of-way that would otherwise result from the work, disturbance or damage to the County's right-of-way; and
 - The likelihood that the particular method of restoration would be effective in slowing the depreciation of the County's right-of-way that would otherwise take place.The methodology used to establish the fee shall be approved by the BOCC.

3. **Incentive/Disincentive.**

- Earn 1 point for each item successfully completed per permit
- Track running average* of points earned for each permit holder
- Post averages on Transportation website

Five Rating Categories

- 24-hours minimum notification of start and completion of project
- Proper setup and continual maintenance of work zone per approved traffic control plan
- Submit all required compaction test per ECM at time of project completion
- Perform all patch work and restoration per ECM
- Completed project within time period specified on the permit (weather allowance is considered)

Permit costs using the incentive/disincentive points earned:

POINTS EARNED	PERMIT COST
0	200%
1	150%
2	125%
3	100%
4	90%
5	75%

* Running averages will be rounded up or down to the nearest whole number

4. **Computation of Registration and Monitoring Fees.** The ECM Administrator may assess a registration and monitoring fee to all encroachment and registration renewal applications to cover the cost of maintaining the registry and monitoring County right-of-way information. The methodology used to establish the fee shall be approved by the BOCC.

D. **Investigation Fees (Working without a Permit/Notice to Proceed).** Whenever any work for which a Work in the Right-of-Way Permit is required by these Standards is begun without the required Work in the Right-of-Way Permit or Notice to Proceed, a special investigation shall be made before a Work in the Right-of-Way Permit or the Notice to Proceed may be issued for the work. All work shall cease immediately upon written notice by the ECM Administrator.

An investigation fee shall be collected whether or not a permit is then or subsequently issued. The investigation fee shall be as determined by resolution of the BOCC. The payment of investigation fees shall not exempt any person from compliance with all other provisions of these Standards nor from any penalty prescribed by law.

E. **Delay Penalty.** The ECM Administrator may impose a delay penalty for unreasonable delays in right-of-way excavation, obstruction, patching, or restoration by the permit holder. The delay penalty shall be proposed by the ECM Administrator and established by resolution of the BOCC. The delay penalty may also include a traffic management fee at the discretion of the ECM Administrator calculated in accordance with Section 5.5.7C.1.

F. **Fee Refunds.** The ECM Administrator may authorize the refunding of any fee which was erroneously paid or collected. In addition, upon written request from the permit holder, the ECM Administrator

may authorize the refunding of not more than eighty percent of the Work in the Right-of-Way Permit fee when no work has been done under a Work in the Right-of-Way Permit issued in accordance with these procedures. The ECM Administrator shall not refund any fee except upon written request filed by the original permit holder. The written request must be filed not later than one year after the date of the fee payment.

5.5.8. Registration and Right-of-Way Occupancy

- A. **Registration.** Any person, agency, corporation, or other entity who occupies or seeks to occupy the right-of-way or place any equipment or facilities in or on the right-of-way, including those with installation and maintenance responsibilities by lease, sublease or assignment, must register with the ECM Administrator.

Registration is not intended to apply to or require the following persons to register with the ECM Administrator: (1) property owners maintaining service lines solely for the purpose of connecting to utility service facilities located in the County's right-of-way or those facilities not subject to an Work in the right-of-way Permit; and (2) agents, contractors or subcontractors of a right-of-way user who has registered with the ECM Administrator.

- B. **Registration Prior to Work.** No person, agency, corporation, or other entity may construct, install, repair, remove, relocate, or perform any other work on, or use any non-county-owned facilities installed in any County right-of-way without first being registered with the ECM Administrator.
- C. **Annual Registration Renewal.** Registration is required on an annual basis to maintain facilities within the County right-of-way. If a registrant fails to renew their registration, the ECM Administrator shall assume that the registrant's facilities are abandoned and any facilities of the registrant's found in a County right-of-way shall be deemed to be a nuisance. The ECM Administrator may exercise any remedies or rights it has at law or in equity, to abate or correct the nuisance, including, but not limited to, abating the nuisance or taking possession of the facilities and restoring the County's right-of-way to a useable condition, and the registrant shall reimburse the County for all costs incurred.
- D. **Failure to Register.** One year after the passage of this section, any facilities of a person, agency, corporation, or other entity found in a County right-of-way that have not been registered shall be deemed to be a nuisance. The ECM Administrator may exercise any remedies or rights it has at law or in equity, to abate or correct such nuisance, including, but not limited to, abating the nuisance or taking possession of the facilities and restoring the County's right-of-way to a useable condition, and the person, agency, corporation, or other entity who owns said facilities shall reimburse the County for all costs incurred.
- E. **Registration Information.**
1. **Information Required.** The information provided to the ECM Administrator at the time of registration shall include, but not be limited to:
 - Each registrant's name, Utility Notification Center of Colorado registration number, address and e-mail address if applicable, and telephone and facsimile numbers.
 - The name, address and e-mail address, if applicable, and telephone and facsimile numbers of a local representative. The local representative or designee shall be available at all times. Current information regarding how to contact the local representative in an emergency shall be provided at the time of registration.
 - A certificate of insurance or self-insurance: (1) Verifying that an insurance policy has been issued to the registrant by an insurance company licensed to do business in the State of Colorado, or a form of self-insurance acceptable to the ECM Administrator; (2) Verifying

that the registrant is insured against claims for personal injury, including death, as well as claims for property damage arising out of the: (i) use and occupancy of the County's right-of-way by the registrant, its officers, agents, and employees, and (ii) placement and use of facilities and equipment in the County's right-of-way by the registrant, its officers, agents, and employees, including, but not limited to, protection against liability arising from completed operations, damage of underground facilities and collapse of property; Naming the County as an additional insured as to whom the coverages required herein are in force and applicable and for whom defense will be provided as to all such coverages; Requiring that the County be notified 30 days in advance of cancellation of the policy or material modification of a coverage term; Indicating comprehensive liability coverage, automobile liability coverage, workers compensation and umbrella coverage established by the County in amounts sufficient to protect the County and the public and to carry out the purposes and policies of this section. The ECM Administrator may require a copy of the actual insurance policies.

- An acknowledgment by the registrant of the indemnification of the County.
 - A copy of the registrant's order granting a certificate of authority from the Colorado Public Utilities Commission or other applicable state or federal agency, where the person, agency, corporation, or other entity is lawfully required to have such certificate from the commission or other state or federal agency.
2. **Notice of Changes.** The registrant shall keep all of the information listed above current at all times by providing the ECM Administrator information as to changes within fifteen days following the date on which the registrant has knowledge of any change.

F. Reporting Obligations.

1. **Mapping Data for New and Replaced Facilities.** Registrants shall provide mapping information for all new or replaced facilities in a format approved by the ECM Administrator. Registrants shall provide the mapping information required by the ECM Administrator including:
- Location and approximate depth of registrant's mains, cables, conduits, switches, and related equipment and facilities, with the location based on: (1) Offsets from property lines, distances from the centerline of the County's right-of-way, and curb lines as determined by the County; (2) Coordinates derived from the coordinate system being used by the County; or (3) Any other system agreed upon by the registrant and the ECM Administrator.
 - The type and size of the facility;
 - A description showing above ground appurtenances;
 - A legend explaining symbols, characters, abbreviations, scale, and other data shown on the map; and
 - Any facilities to be abandoned, if applicable.
2. **Data on Existing Facilities.** At the request of the ECM Administrator, a registrant shall provide existing data on its existing facilities within the County's right-of-way in the form maintained by the registrant at the time the request is made, if available.
3. **Construction and Maintenance Plans.** Each registrant shall, at the time of registration and by December 1 of each year, file a construction and major maintenance plan for underground facilities with the ECM Administrator (in this paragraph, a "plan"). The plan shall be submitted using a format designated by the ECM Administrator and shall contain the information determined by the ECM Administrator to be necessary to facilitate the coordination and reduction in the frequency of excavations and obstructions of the County right-of-way.

The plan shall include, but not be limited to, the following information:

- The locations and the estimated beginning and ending dates of all projects for facilities to be constructed in the County's right-of-way to be commenced during the next calendar year (in this paragraph, a "next year project"); and
 - To the extent known, the tentative locations and estimated beginning and ending dates for all projects for facilities to be constructed in the County's right-of-way contemplated for the 5 years following the next calendar year (in this paragraph, a "5-year project"). The term "project" in this paragraph shall include both next year projects and 5-year projects.
4. **Availability of Plans.** The ECM Administrator will have available for inspection in the ECM Administrator's office a list of all plans submitted by registrants. All registrants are responsible for keeping themselves informed of the current status of this list and the plans filed with the ECM Administrator.
 5. **Changes in Next Year Projects and Coordination.** Thereafter, by February 1, each registrant may change any project in its list of next year projects, and must notify the ECM Administrator and all other registrants of all changes. A registrant may at any time join in a next year project of another registrant listed by the other registrant, subject to the prior consent of such other registrant. Where registrants join in a next year project to reduce disruption and degradation of the County's right-of-ways and infrastructure, the ECM Administrator may reduce the disruption and degradation fees. In cases where registrants join in a County next year road construction, reconstruction or resurfacing project, disruption and degradation fees may be waived by the ECM Administrator.
 6. **Additional Next Year Projects.** Failure by a registrant to include a project in a plan submitted to the ECM Administrator shall not, in and of itself, constitute grounds for denial of a permit if the registrant has used commercially reasonable efforts to anticipate and plan for the project.
 7. **Utility Coordination Committee.** The ECM Administrator may create an advisory utility coordination committee. Participation on the committee is voluntary. It will be composed of any registrants that wish to assist the County in obtaining information and by making recommendations regarding the use of the County's right-of-way, and to improve the process of performing construction work therein. The ECM Administrator may determine the size of such committee and shall appoint members from a list of registrants that have expressed a desire to assist the County.
- G. **Relocation of Facilities.**
1. **Responsibility of the Registrant.** The registrant must promptly and at its own expense, with due regard for seasonal working conditions, permanently remove and relocate its facilities in the right-of-way whenever it is necessary to prevent interference, and not merely for the convenience of the County, in connection with: (1) A present or future use of the County's right-of-way for a public project; (2) The public health or safety; or (3) The safety and convenience of ordinary travel over the County's right-of-way.
 2. **Relocation Notification Procedure.** The ECM Administrator shall notify the registrant at least six months in advance of the need to relocate existing facilities so the registrant can plan the relocation. The ECM Administrator shall provide a second notification to the registrant one month before the registrant needs to begin the relocation. The registrant shall begin relocation of the facilities within one week of the second notification. All facilities shall be relocated within one month. The ECM Administrator may allow a different schedule if it does not interfere with the County's project. The registrant shall diligently work to relocate the facilities within the above schedule.

-
3. **Delay to County Project.** The ECM Administrator shall notify the registrant if the registrant's progress will not meet the relocation schedule.
- H. **Interference By Other Facilities.** When the County does work in the right-of-way as part of its governmental right-of-way management function and finds it necessary to maintain, support, or move a registrant's facilities to carry out the work without damaging the registrant's facilities, the ECM Administrator shall notify the registrant's local representative as early as is reasonably possible. The County costs associated will be billed to the registrant and must be paid within 30 days from the date of billing.
- Each registrant shall be responsible for the cost of repairing any facilities in the County right-of-way which it or its facilities damage.
- I. **Right-of-Way Vacation.** If the County vacates a right-of-way that contains the facilities of a registrant, the registrant's rights in the vacated County right-of-way are governed by state law.
- J. **Abandoned Facilities.** A registrant shall notify the County when facilities are to be abandoned in County right-of-way. A registrant that has abandoned facilities in a County right-of-way shall remove them from that right-of-way if required in conjunction with other County right-of-way repair, excavation or construction, unless this requirement is waived by the ECM Administrator.
- K. **Indemnification and Liability.** By registering with the County, a registrant agrees to defend and indemnify the County in accordance with Section 5.2.6.

5.5.9. Insurance, Bonding, Construction Surety and Warranty Requirements

- A. **Permit Holder Insurance.** Before any permit holder shall perform work within the County's right-of-way under a Work in the Right-of-Way Permit, the permit holder shall show evidence of a valid and enforceable bodily injury and property damage liability insurance policy, with minimum limits of \$1,000,000.00 combined single limit coverage. Such policy shall be for the protection of the County from all suits, actions or claims of any type for injuries or damages allegedly sustained by any person or property as a result of the encroachments. Such policy shall specifically cover the acts and operations of any subcontractors or independent contractors of the permit holder, in addition to the permit holder's employees or agents. Special districts, utilities governed by State Public Utilities Commission, and municipalities, by obtaining a permit, do agree to accept liabilities for their work in the County's right-of-way.
- In addition to the insurance described above, the permit holder personally, by working under an approved Work in the Right-of-Way Permit, agrees to be liable to the County for any expenses incurred by the County because of the permit holder's acts of omissions relating to the work, and the permit holder shall hold the County harmless from any claims of anyone else arising from or relating to the work.
- B. **Indemnification and Liability.** By accepting a Work in the Right-of-Way Permit, a permit holder agrees to defend and indemnify the County in accordance with Section 5.2.6.
- C. **Defect Warranty.** The permit holder shall warrantee all restoration work and its maintenance for 2 years following its completion and approval by the ECM Administrator. The permit holder shall post a defect warranty prior to the release of any portion of the construction surety. The amount of the defect warranty shall be based on an estimate of the percentage cost of roads construction, drainage facilities construction, utilities, and erosion control and revegetation damaged by the action. During the 2 year warrantee period the permit holder shall, upon notification from the ECM Administrator, correct all defective restoration to the extent necessary within the time period specified in the notice, using the method required by the ECM Administrator. If the defective work is not corrected by the permit holder, and the County does the work and sends a bill to the permit holder, who fails to pay for

such work, the County may exercise its rights under the defect warranty. The following are exempt from having to file a defect warranty: special districts, utilities governed by the State Public Utilities Commission, and municipalities.

5.5.10. Inspections, Corrections and Project Closeout

- A. **Progress Inspections and Orders.** Inspections during the construction period will be made by the ECM Administrator to ensure that work is progressing in compliance with the permit and ECM. The permit holder shall make the work-site available to the ECM Administrator and to all others as authorized by law for inspection at all reasonable times during the execution and upon completion of the work. At the time of inspection the ECM Administrator may order the immediate cessation of any work which poses a serious threat to the life, health, safety or well-being of the public.

The ECM Administrator may issue an order to the permit holder for any work which does not conform to the applicable standards, approved plans and specifications, or permit conditions. The order shall state that failure to correct the violation will be cause for revocation of the permit. Within 10 days after issuance of the order, the permit holder shall present proof to the ECM Administrator that the violation has been corrected. If such proof has not been presented within the required time, the ECM Administrator may revoke the permit.

- B. **Inspection Before Pavement Placement.** Before a pavement section is replaced (patched) the contractor shall notify the ECM Administrator as to the date such work is proposed. Failure to notify the ECM Administrator may result in a request to have work re-done in order to pass a final inspection.
- C. **Completion Certificate and Project Closeout.** When the work under a Work in the Right-of-Way Permit is completed, the permit holder shall submit a completion certificate to the ECM Administrator within 5 days following completion. The completion statement, signed by the permit holder, shall show the completion date for the work performed, identify the installer and design engineer, and certify that the work was completed according to the requirements of the ECM Administrator. If the work involved the placement of any permanent facilities, record drawings meeting the requirements of Section 5.11.6 shall be submitted.

5.6. EROSION AND STORMWATER QUALITY CONTROL

5.6.1. General

The Erosion and Stormwater Quality Control Permit (ESQCP) and Builder's Erosion and Stormwater Quality Control Permit (BESQCP) are established tools to: protect water quality in the County; provide for the enforcement of specific stormwater control measures (also known as Best Management Practices (BMPs)) during construction through final stabilization; and implement control measures required by the County's MS4 Permit. The permits and associated standards are intended to minimize soil erosion and sedimentation during and after construction and to control non-point source pollution by requiring the implementation of soil erosion, sedimentation, and runoff control measures for protection of water quality. Refer to Appendix I for specific application and permit holder responsibilities for ESQCPs and BESQCPs.

5.6.2. ESQCP Permit and Notice to Proceed Required

An ESQCP is required for construction activities that result in land disturbance of greater than or equal to 1 acre or that is less than one acre, but is part of a larger common plan of development or sale that would disturb 1 acre or more, unless the activity meets exclusion criteria in Section 5.6.3. Any project involving land disturbing activity of less than 1 acre but which disturbs more than 500 cubic yards of material (stockpiling, cut and/or fill) may be considered an applicable construction activity at the ECM Administrator's discretion

when potential pollutants, site topography, hydraulics or proximity to a surface water body are of significant concern.

For builders of single residential homes that are not part of a larger common plan of development or sale, and that will disturb less than 1 acre of land, a BESQCP may be obtained following a simplified procedure. ;b1; No work shall begin under an approved ESQCP or BESQCP until the ECM Administrator has issued a Notice to Proceed under an approved Construction Permit or until issuance of a Building Permit.

5.6.3. [Activities not subject to ESQCP or BESQCP requirements]

The following construction activities are not subject to ESQCP or BESQCP requirements:

- A. Construction activities that qualify for the R-Factor waiver provided in Colorado Regulation No. 61, 5 CCR 1002-61, Section 61.3(2)(f)(ii)(B).
- B. Large lot single family home construction when land disturbance greater than 1 acre occurs on a single-family residential lot or agricultural zoned land with a parcel size greater than or equal to 2.5 acres and a total site impervious area less than or equal to 10 percent. Up to 20% impervious area may be allowed when a study specific to the watershed and/or parcel is conducted by the owner and approved by the ECM Administrator which demonstrates that expected soil and vegetation are suitable to infiltrate 100% of the Water Quality Capture Volume (WQCV). See Appendix I for information on WQCV.
- C. Facilities associated with oil and gas exploration, production, processing, or treatment operations, or transmission facilities, whether or not such field activities or operations may be considered construction activity.

5.6.4. Relationship to Other ECM Permits

In most cases, construction of public facilities within any County right-of-way or easement or the construction of common development improvements including grading will require that the applicant obtain an ESQCP. In cases where a submitted drainage report demonstrates the need for permanent stormwater quality management, a grading and erosion control plan may be required in cases where land disturbance is less than 1 acre.

5.6.5. Application, Review, Approval, Inspections and Enforcement

Application, review, approval, inspections, and enforcement for ESQCP or BESQCP shall conform to the requirements of Appendix I.

(Res. No. 19-245 , 7-2-19)

5.7. SPECIAL TRANSPORT PERMIT

5.7.1. General

The ECM Administrator is responsible for ensuring the long-term structural stability of roads and bridges in the County has established a Special Transport Permit as a tool to allow over dimensional loads and vehicles to be routed along County routes with adequate capacity to accommodate the proposed load or vehicle dimensions, ensure adequate safety provisions are provided to protect the traveling public, reduce damage to County facilities, track over dimensional loads, and obtain reasonable fees to provide for the administration of permits and impacts to County facilities. This section provides an orderly procedure for obtaining a Special Transport Permit.

There are two types of Special Transport Permits:

1. **Annual.**
 - For vehicles and fleets moving multiple oversize/overweight loads during the year.
 - Maximum width of 17', pilot cars required per Section 5.8.6.
 - Maximum length of 110', pilot cars requirements per Section 5.8.6.
 - Maximum height of 16', pilot cars requirements per Section 5.8.6.
 - Maximum weight of 200,000 lbs; pilot cars requirements per Section 5.8.6.
2. **Oversize/Overweight (Special).**
 - Single oversize/overweight loads exceeding Annual Permit maximum dimensions or weights.
 - Requires 1 or more pilot cars.

5.7.2. Special Transport Permit Required

Pursuant to the laws of the State of Colorado, the County requires that a Special Transport Permit be obtained from the ECM Administrator, when transporting a load or vehicle on a County road where overall dimensions or weight of the load or vehicle exceed 1 or more of the following limits:

- Overall height (Total distance from ground to top part of load): 13 feet.
- Overall width: 8.5 feet.
- Overall length for single vehicles: 45 feet.
- Overall length for combination vehicles: 75 feet.
- Overhang: 4 feet front and 10 feet rear.
- Overall weight for combination vehicles: 85,000 lbs.
- Overall weight for single vehicles (3 or more axles): 54,000 lbs.
- Overall weight for single vehicles (2 axles): 36,000 lbs.
- Weight on Any Single Axle (with low-pressure tires): 20,000 lbs. per single axle, 36,000 lbs. for tandem axle and 54,000 lbs. for tridem axles.

5.7.3. Prohibited Loads or Vehicles

The following over dimensional loads and vehicles are prohibited on the County roads:

- Front overhangs exceeding 32 feet.
- Rear overhangs exceeding 35 feet.
- Five and Six-axle vehicles carry more than 74.5 tons.

5.7.4. Application

- A. **Complete Application Required.** Applicants shall file a complete application for a Special Transport Permit on forms provided by the ECM Administrator. Application for permits shall be made not less than 5 days in advance of the time transport is to be done. The application shall fully describe the load dimensions and proposed route including when the transport will occur.

-
- B. **Signed by Applicant.** All applications for Special Transport Permit shall be signed by the applicant, or an authorized agent, who may be required to submit evidence to indicate their authority.
 - C. **Determination of Application Completeness.** An application will be considered complete if it is submitted in the required form, includes all mandatory information, including all supporting materials specified by the ECM Administrator, and is accompanied by the applicable fee. If an application is determined to be incomplete, the ECM Administrator shall provide notice to the applicant along with an explanation of the application's deficiencies. No further processing of the application shall occur until the deficiencies are corrected in a future resubmittal. An application which is determined to be incomplete may or may not retain its same processing cycle.

5.7.5. Special Transport Permit Review and Issuance

- A. **Review Process.** The application and other data filed by an applicant for a Special Transport Permit shall be reviewed by the ECM Administrator.

If the ECM Administrator finds that the transport described in an application for a Special Transport Permit and other data conform to the requirements of these Standards and other pertinent laws regulations or ordinances and that all required fees have been paid, a Special Transport Permit may be issued to the applicant. A Special Transport Permit is valid once issued and transport may proceed in accordance with the dates prescribed in the permit.
- B. **Criteria for Approval.** The ECM Administrator may issue a Special Transport Permit if the proposed transport meets these Standards, no alternative routes are available that would limit transport of the over dimensional load over County roads, and the proposed method is satisfactory.
- C. **Conditions of Approval.** The ECM Administrator shall have the authority to affix reasonable conditions to the granting of a Special Transport Permit.

5.7.6. Special Transport Permit Standards and Permit Holder Responsibilities

- A. **Pilot Car Required.** One pilot car is required when the overall dimensions/weight of load/vehicle fall within one or more of the following limits:
 - Overall height equals or exceeds 16 feet.
 - Overall width equals or exceeds 11 feet but less than 14 feet.
 - Overall length exceeds 45 feet for single vehicles or exceeds 75 feet for combination vehicles, but less than 100 feet.
 - Front overhang equals or exceeds 25 feet in length.
 - Rear overhang equals or exceeds 20 feet in length.
 - Overall weight equals or exceeds 75 tons.

2 pilot cars, fore and aft, are required when the overall dimensions/weight of load/vehicle fall within one or more of the following limits:

- Overall width equals or exceeds 14 feet.
- Overall length equals or exceeds 100 feet.

A pilot car shall be a single vehicle with a minimum width of 60 inches, and may operate with a nondestructive vertical clearance-measuring device suitable for measuring heights in excess of 14 feet.

A pilot car shall be equipped with one stop/slow paddle, one orange vest, one (18" × 18" minimum) red hand-flag, 2-way radio to communicate with transporting vehicle, top-mount flashing amber warning-light and the proper load signs.

A single pilot car shall precede the load/vehicle on 2 or 3-lane roads and follow on 4 or more lane highways and divided highways. When 2 pilot cars are required, one shall precede and one shall follow.

Pilot cars and transporting vehicle shall remain to the right of the roadway centerline, and along the most right lane, at all times, unless it is absolutely necessary to stay left.

- A pilot car shall not:
- Preempt opposing traffic.
- Tow another vehicle.
- Display the stop/slow sign paddle out of its window when moving.
- Stop opposing traffic, except in extreme emergencies.
- Convoy more than one load/vehicle at the same time.

Pilot cars shall accompany the extralegal load/vehicle at all times during the transportation operation. Pilot cars shall maintain proper intervals from the vehicle, to allow passing by other traffic.

B. Signs. All signs shall:

- be neat, clean, legible and securely mounted.
- have black letters on a bright yellow background.
- be illuminated for night moves, or be constructed of reflectorized material that is clearly visible to traffic.
- read "oversize load" or "overweight load", as appropriate.
- have lettering a minimum of 10 inches in height with a 2 inch minimum brushstroke and a minimum 1 inch margin all around.
- be posted on the front and rear of the vehicle.
- mounted at least 18 inches for vehicles and 48 inches for pilot cars, above road surface, and shall be visible from straight-ahead or behind and to 45 degrees either side thereof.
- be posted on the front of the pilot car, when leading, and on rear, when following.
- have a minimum sign area of 440 square inches for a pilot car.

C. Flagmen. A flagman is required whenever 2 pilot cars are in use. Flagging shall be done in accordance with CDOT requirements.

D. Manufactured Housing. Axle weight for manufactured housing unit shall not exceed 6,000 pounds per axle. Tractor units towing manufactured housing unit that exceeds legal width, up to 12 feet, shall be equipped with dual rear wheels and shall have an unladen weight of not less than 6,500 pounds. Tractor units towing manufactured housing unit exceeding 12 feet in width, shall be equipped with dual rear wheels and shall have an unladen weight, as of not less than 9,500 pounds.

Manufactured housing units open on one side shall be covered with plywood or other approved rigid material. Approved flexible material billowing or flapping less than six inches, may be substituted for rigid material. Manufactured housing units, open on both sides, need not be covered if transported empty.

-
- E. **Transport During Inclement Weather Prohibited.** The permit holder shall ensure that the transportation of an over dimensional load/vehicle does not occur during inclement weather conditions, including snow, rain, fog and wind. The permit holder shall ensure that the transportation of an over dimensional load/vehicle does not occur when the pavement surface is hazardous due to inclement weather conditions. The permit holder shall ensure that no transportation of an over dimensional load/vehicle occurs when the visibility is less than 1000 feet. Any accident caused by the transportation of an over dimensional load/vehicle during inclement weather conditions, shall be considered a violation and shall constitute grounds for revoking the permit.
- F. **Vehicle Requirements.** The permit holder shall check the load/vehicle to ensure compliance with all applicable requirements and shall ensure that actual axle weights do not exceed those shown on the permit. The permit holder shall further ensure that permitted axle or axle group weights do not exceed the rated capacity of the vehicle tires. A permit holder shall use neither booster axles nor joe dog axles in transporting overweight loads.
- G. **Check Clearance.** The permit holder shall check all underpasses, bridges, mast arms of lighting and traffic signals, overhead wires and all other structures, for impaired vertical clearance. The permit holder shall arrange for either a bypass or a clearance at such locations.
- H. **Repair Damage.** The permit holder shall repair, at permit holder's sole cost, any damage to any public or private property, and pertinent improvements, resulting from transporting the permit holder's load/vehicle, to the satisfaction of the ECM Administrator. Any damage shall be reported to the ECM Administrator, in writing, within 72 hours. Failure to file a report will result in the cancellation of all future permit privileges, pending a satisfactory arrangement with the ECM Administrator to repair the damage.
- I. **Hours for Transport.** The transportation of an over dimensional load/vehicle shall strictly occur between the hours 11:00 p.m. and 5:00 a.m. and shall not occur from 5:00 a.m. on Saturday until 11:00 p.m. on Sunday, when the overall dimensions of the load/vehicle fall within one or more of the following limits:
- Overall height equals or exceeds 18 feet.
 - Overall width equals or exceeds 15 feet.
 - Overall length equals or exceeds 110 feet.

Unless specifically authorized by the permit, no transportation of any over dimensional load/vehicle shall occur during the following times or holidays:

- 7:00 a.m. to 9:00 a.m. Monday through Friday.
- 4:00 p.m. to 6:00 p.m. Monday through Friday.
- Christmas Evening and Day.
- New Year's Evening and Day.
- Memorial Day.
- Independence Day.
- Labor Day.
- Thanksgiving Day.
- Any other national/state holiday.

- J. **Permit Available for Surrender.** The Special Transport Permit is the property of the County, and must be surrendered upon demand, to any law enforcement officer or the County employee charged with the care and protection of the County's right-of-way.
- K. **Insurance, Subrogation and Indemnity.** The permit holder shall maintain on file with the ECM Administrator, throughout the term of the permit, a County-approved general liability insurance policy and endorsement naming the County additional insured on primary basis. Insurers must be admitted to do business in the State of Colorado.

Signing the Special Transport Permit is prima facie evidence that the permit holder waives permit holder's right of subrogation against the County, its officers, elected and appointed officials, employees and volunteers for any loss, liability, damage, or cost sustained by any person or property, arising out of work or operations performed by or on behalf of the permit holder, including materials, parts, or equipment furnished in connection with such work or operations.

Signing the Special Transport Permit is prima facie evidence that the permit holder agrees to indemnify, defend and hold harmless the County, its officers, elected and appointed officials, employees and volunteers against any loss, liability, damage, or cost sustained by any person or property, arising out of work or operations performed by or on behalf of the permit holder, including materials, parts, or equipment furnished in connection with such work or operations.

5.7.7. Special Transport Permit Expiration and Extension

- A. **Expiration.** The date of expiration shall be identified in the Special Transport Permit. Transport shall be completed in the time allowed on the permit and in the manner as therein described.
- B. **Extension.** Any permit holder with an unexpired Special Transport Permit may apply for an extension of the time within which complete transport under that permit if the permit holder is unable to transport the load within the time required for good cause, and that the cause is acceptable to the ECM Administrator.

5.7.8. Fees

- A. **Special Transport Permit.** Special Transport Permit fees shall be paid in full at the time of permit issuance. The fee for Special Transport Permit shall be as determined by resolution of the BOCC.
1. Annual permit (fleet) costs:
 - 5 times oversize/overweight permit plus 5% of Annual permit cost per vehicle to be permitted
 - No security deposit
 - If any of the maximum limits in Section 5.7.1 are exceeded, each vehicle exceeding the limit must have its own annual permit and cannot be included in the fleet annual permit.
 2. Oversize
 - Fee to be set by resolution of the BOCC
 - Security deposit based on load dimensions. The security deposit will be determined for both width and height. The security deposit required will be determined based on the greater deposit of width and height.

Width of Load	Height of Load	Deposit
≤14'	≤14'	\$0.00
>14' ≤20'	>14' ≤15'	\$100.00
>20' ≤28'	>15' ≤18'	\$250.00

>28' ≤36'	>18' ≤22'	\$1,000.00
>36'	>22'	\$2,500.00

- B. **Investigation Fees (Working without a Permit/Notice to Proceed).** Whenever any transport for which a Special Transport Permit is required by these Standards is begun without the required Special Transport Permit, a special investigation shall be made before a Special Transport Permit may be issued. Transport shall cease immediately upon notice by the ECM Administrator of failure to obtain a permit.

An investigation fee shall be collected whether or not a Special Transport Permit is then or subsequently issued. The investigation fees shall be determined by resolution of the BOCC. The payment of investigation fees shall not exempt any person from compliance with all other provisions of these Standards nor from any penalty prescribed by law.

5.7.9. Special Transport Permit Suspension or Revocation

The ECM Administrator may suspend or revoke any Special Transport Permit, in writing, issued under the provisions of these Standards whenever the Special Transport Permit is issued in error or on the basis of incorrect information supplied by the applicant or whenever the Special Transport Permit may have been issued in violation of any provisions of these Standards. In the event a Special Transport Permit is suspended or revoked, no refund of permit fees shall be made.

5.7.10. Voidance of Special Transport Permit

The Special Transport Permit is void if one of the following occurs:

- permit is not carried on the permitted vehicle.
- any part of the permit is not legible, or has been altered.
- permit is not signed by an authorized representative of the County.
- permit is presented without pertinent attachments.
- permit is used on state or city highways.
- route includes roads and bridges that have posted weight limits.
- permitted dimensions/weight of an extralegal load/vehicle can be reduced to legal limits by repositioning and/or practical removal of a part, portion or unit.
- permit is used to represent proper authority for transporting a load/vehicle that is not specifically described on the permit.
- permit is used to represent proper authority for transporting a load/vehicle by an entity not specifically named on the permit, or organizationally related to the permit holder.
- permit is used to represent proper authority for transporting a load/vehicle before or after the times and dates authorized by the permit.

5.8. DEVIATIONS FROM STANDARDS

5.8.1. General

The ECM establishes uniform standards for the design and construction of public improvements and common development improvements. These standards were established to promote consistent construction

practices, and safeguard the interests of the County, its citizens, and the general public by ensuring that all improvements are designed and constructed in conformance with sound engineering principles and accepted standards. It is recognized that site conditions or a specific design or construction problem may require a design engineer to deviate from the adopted Standards. In cases where the design engineer can demonstrate, in writing, with engineering rationale and data that a provision of these Standards, if strictly adhered to, would cause unnecessary hardship or unsafe design because of topographical or other conditions particular to the site, and that a departure may be made without destroying the intent of such provision, the ECM Administrator may approve a deviation of the required Standard.

5.8.2. Deviation for Specific Projects

The ECM Administrator may make project-specific revisions to standard drawings and other BOCC promulgated technical engineering standards for use in any project, whether privately or publicly funded, in accordance with the procedures outlined in this section.

5.8.3. Submittal for Requested Deviation

A design engineer may request that the ECM Administrator deviate from a Standard relating to, and only for, a specific project by submitting a written request for such deviation to the ECM Administrator. The written request shall state the desired deviation, the reason for the requested deviation, the condition authorizing consideration of the request from Section 5.9.6 that apply to the desired deviation, a comparison between the County's existing standard and the proposed deviation; and a detailed statement addressing each of the Criteria for Approval in Section 5.9.7.

Any request for deviation of a Standard for a specific project shall be supported with reference to pertinent nationally accepted specifications or standards. Refer to the Deviation Form for more information.

5.8.4. Review of Requested Deviation

After completing a review of the information submitted, the ECM Administrator shall:

- Approve the request as proposed,
- Approve the request with conditions, or
- Deny the request.

The ECM Administrator's decision shall be documented in writing. A denial of a request shall be accompanied with a brief explanation of the reason for the denial.

The ECM Administrator may consult with others to assist in determination of whether to approve, approve with conditions, or deny a request to modify a Standard for a specific project.

5.8.5. Affect of Request on Development Review and Permits

A request for deviation constitutes permission to delay processing the all associated development applications for up to 21 calendar days to allow analysis and decision by the ECM Administrator. The ECM Administrator may advise the Development Services Department to add the time between receiving this request and the decision being made to the project timeline.

5.8.6. Limits of Consideration

The ECM Administrator may only consider a project-specific deviation to an existing Standard when one of the following conditions is met:

- The ECM standard is inapplicable to a particular situation.

-
- Topography, right-of-way, or other geographical conditions or impediments impose an undue economic hardship on the applicant, and an equivalent alternative that can accomplish the same design objective is available and does not compromise public safety or accessibility.
 - A change to a standard is required to address a specific design or construction problem, and if not modified, the standard will impose an undue hardship on the applicant with little or no material benefit to the public.

5.8.7. Criteria for Approval

In approving a request for deviation, the deviation must not be detrimental to public safety or injurious to surrounding property. No deviation shall be approved unless it is demonstrated that:

- The request for a deviation is not based exclusively on financial considerations;
- The deviation will achieve the intended result with a comparable or superior design and quality of improvement;
- The deviation will not adversely affect safety or operations;
- The deviation will not adversely affect maintenance and its associated cost; and
- The deviation will not adversely affect aesthetic appearance.

5.8.8. Limits of Approval

Whether a request for deviation is approved as proposed or with conditions, the approval is for project-specific use and shall not constitute a precedent or general deviation from these Standards.

5.8.9. Review Fees

A Deviation Review Fee shall be paid in full at the time of submission of a request for deviation. The fee for Deviation Review shall be as determined by resolution of the BOCC.

5.8.10. Tracking Approved Deviations

The ECM Administrator shall track all approved deviations to review in coordination with the annual evaluation of potential amendments to the ECM.

5.9. SITE DEVELOPMENT PLAN REVIEW

5.9.1. Overview

Submission of a Site Development Plan (SDP) for review by the ECM Administrator is required for all multifamily, commercial and industrial development within unincorporated the County in accordance with the requirements of the ECM. Obtaining approval of the SDP is required as part of El Paso County's Site Development Plan Review process and must occur prior to issuance of a building permit from the Regional Building Department. The SDP is to be reviewed by the ECM Administrator for compliance with applicable ECM Standards and ensure coordination between proposed and existing improvements.

5.9.2. Review Process

In most cases where site development is occurring within El Paso County, an applicant must submit applicable information for review and acceptance by the ECM Administrator through the Site Development Plan review process outlined in the LDC. In many cases, the review process may require the submission of

certain engineered plans and documents to allow complete review and approval of the proposed development. Submissions will vary with the level of complexity and impact of the project but may include:

- Grading and Erosion Control Plan.
- Drainage Report.
- Traffic Impact Study.
- Site Utility Plan.
- Specific Plans for Proposed Public Improvements.
- Traffic Control Devices Plans (i.e. signalization, signing and pavement marking, traffic control plans).
- Other submissions typically required by the ECM.

Guidance concerning submission requirements is provided by the LDC and will be clarified during the Early Assistance meeting outlined in the LDC.

5.9.3. Standards

Proposed public improvements shall meet the requirements of these Standards. The ECM standards will be used as guidance in the review of the SDP and accompanying reports and plans for private improvements should use the ECM to provide guidance.

5.9.4. Application Requirements

Engineering drawings submitted for approval with site development plans shall be prepared, stamped and signed by a Professional Engineer licensed to practice in the State of Colorado. Engineering drawings submitted for the initial application submission and subsequent reviews shall be provided in .PDF file format and are not required to be stamped and signed by the engineer of record.

On or after July 1, 2019, all construction drawings and final plat base drawings submitted for final signature approval by the ECM Administrator shall be provided in .PDF and CAD file format (.DWG) 2016 or newer version. Included with the CAD file submitted for final approval shall be at least two survey reference points to allow the County to move, fit and rotate the project file to the survey coordinate system used by El Paso County.

(Res. No. 19-245 , 7-2-19)

5.10. CONSTRUCTION CONTROL AND INSPECTION

5.10.1. General

- Work Done in Accordance with Approved Plans.** Work performed in the construction or improvement of County roads, storm drainage facilities or other public facilities shall be done to the satisfaction of the ECM Administrator in accordance with approved plans. No work may be started until required permits and a Notice to Proceed are obtained. Revisions to construction plans shall be approved by the ECM Administrator prior to implementation.
- Construction Plans Onsite.** A copy of the approved construction plans and a copy of the El Paso County ECM are required to be on the construction site at all times.
- Test Reports.** It is the responsibility of the permit holder to provide the ECM Administrator with test reports, certified by a Professional Engineer licensed in the State of Colorado, to verify compliance of materials used in the project. Sampling and testing shall be at a frequency and magnitude determined

Created: 2021-06-08 11:35:51 [EST]

(Supp. No. 2)

by the ECM Administrator. All costs incurred for sampling and testing shall be the responsibility of the permit holder.

5.10.2. Inspection

- A. **Permit Holder Inspection Services.** The permit holder is fully responsible for providing onsite inspection of all public improvements by a construction representative. The ECM Administrator will not authorize work to begin without designation of the permit holder's construction representative at the preconstruction meeting.
- B. **Construction Inspection Services and Conflict of Interest.** Individuals or firms serving as the construction representative for a project, and all employees of such firms, must be financially independent of the permit holder. It is the sole responsibility of the permit holder to ensure the requirements of this paragraph are met.
- C. **County Policies Concerning Inspection Services.** The County's policies on inspection services for privately-funded site improvements and privately-funded public infrastructure improvements are as follows:
- Permit holder Inspection Services: Permit holder inspection services required by the County are the primary inspection services on a project, are more comprehensive and intensive than County inspection services, and are the responsibility of the permit holder and designated construction representative.
 - County Inspection Services: It is the policy of El Paso County to provide only "spot check" (oversight) inspection services. The County's inspection services are only secondary inspection services and do not relieve the permit holder or construction representative of responsibility for proper construction and compliance with the requirements of these Standards, nor do County inspection services constitute approval of any modification to the approved construction plans.
- D. **County Inspection Activities.** Inspecting services provided by the County shall include:
- Acting as a liaison between the designated construction representative, and the County.
 - Monitoring both work progress and performance testing results.
 - The performance of administrative and coordination activities as required to support the processing and completion of the project.
 - Maintaining a completion file containing the following: (1) The original of the project completion certification; (2) A copy of any portions of the log book determined to be important to the County initialed by the construction representative; (3) The results of material tests, compaction tests, and soil analysis as detailed in the log book.
 - Inform the Development Services Department of all proposed plan changes, material changes, stop work orders, or errors or omissions in the approved plans or specifications as soon as practical.
- E. **Construction Engineer's Activities.** The following represents the standard onsite construction representative's activities the County believes are necessary to provide quality onsite control. This list is not all inclusive and the permit holder will ensure the activities match the site conditions and the activities being performed:
- Maintain a project log book of daily inspection reports which contain the following information: (1) job number and name of design engineer and designees; (2) permit number; (3) date and time (arrival and departure) of site visits; (4) weather conditions, including temperature; (5) a description of construction activities; (6) statements of directions to change plans, specifications, stop work, reject materials, or other work quality actions; (7) public agency contacts which result

Created: 2021-06-08 11:35:51 [EST]

(Supp. No. 2)

in plan changes or other significant actions; (8) perceived problems and action taken; (9) final and staged inspections; (10) record all material and soil types and conditions; (11) test results; (12) record all pavement grade and depth measurements by stationing; (13) general remarks including citizen contact or complaints.

- All active site development projects will be required to make inspection reports available to the ECM Administrator during construction.
- Obtain and use a copy of County-approved construction plans, specifications, and a copy of this manual. The construction representative shall document any changes to the plans which may arise during construction in accordance with Section 5.11.6.
- Inspect and approve all materials such as pipe, aggregate, portland cement concrete, asphaltic concrete, and other products used onsite to ensure their compliance with the approved plans and specifications.
- Approve all plan or specification changes in writing and obtain ECM Administrator approval of changes for which a change in design intent is to be made prior to the commencement of work affected by the revision.
- Monitor construction activities to ensure end products meet approved plans and specifications.
- Perform (or have performed) material, composition, and other tests required to ensure compliance with approved specifications.
- For pavement construction, perform the following stage inspections and record date of each: (1) curbs are built to line and grade; (2) subgrade meets grade and compaction specifications; (3) base course meets depth/thickness, grade, and compaction specifications; (4) leveling course meets depth/thickness, grade, and compaction specifications; and (5) wearing course meets depth/thickness, grade, and compaction specifications.
- Provide the ECM Administrator with 48-hour notice of impending stage inspections.

5.10.3. Haul Route Agreements

Haul route agreements may be required for new or expanded hauling within the right-of-way for activities such as development construction that are anticipated to cause extraordinary damage or accelerated deterioration to County roads.

If required by the ECM Administrator, the permit applicant shall submit a proposed haul route for review by the ECM Administrator prior to the start of hauling activities. Based on review of the proposed haul route, the ECM Administrator may require a haul route agreement.

5.10.4. Subdivision and Commercial Development Inspection

- A. **General.** The County shall inspect all public improvements relating to subdivision and commercial development. Construction events that require notification of the ECM Administrator by the permit holder include those general items listed below. Adequate notice is required to ensure the ECM Administrator as reasonable opportunity to inspect. For additional information on sites subject to Erosion and Stormwater Quality Control Permit (ESQCP) inspections please refer to Appendix I. Change: "as" to "has" in last sentence.
1. **Preconstruction Meeting.** A preconstruction meeting shall precede the start of construction and the issuance of a notice to proceed if required by the ECM Administrator. The meeting shall include the contractor, design or construction engineer, utilities, and other parties affected.

Approved plans, including the traffic control plan, and all permits are required to be obtained prior to the meeting.

2. **Temporary Erosion Control Inspection (Initial ESQCP Inspection).** Forty-eight hours' notice is required prior to land disturbance to allow inspection of initial site work involving drainage and initial BMPs required by the Stormwater Management Plan.
 3. **Grading, Subgrade and Stormwater Management Inspection.** Forty-eight hours' notice is required prior to trenching and placing of utilities or placement of road base to allow inspection of final grading and stormwater facilities.
 4. **Road Base Approval.** Forty-eight hours' notice is required prior to placement of asphalt or curb to allow for inspection of underground utilities and placement of road base. Inspection shall include review and approval of any density tests and certifications submitted in accordance with Appendix J.
 5. **Asphalt and Curb Placement.** Forty-eight hours' notice is required following placement of road surface treatment and curb to allow for inspection of road and curb.
- B. **Failure to Notify For Inspection.** Notification of the ECM Administrator by the permit holder of the construction events described above is essential for verification of compliance with these Standards. Failure to notify in a timely manner may require the County to arrange appropriate sampling and testing after-the-fact, with certification by a qualified private testing laboratory or by the ECM Administrator. The cost of such testing and certification shall be borne by the permit holder. The ECM Administrator may prohibit or limit further work on development construction until all required tests have been completed and corrections made to the satisfaction of the ECM Administrator. If necessary, the County may take further action as permitted by law.

5.10.5. Monumentation of Roadways

- A. **Not Offset.** Monuments within and adjacent to the County's right-of-way shall not be offset unless prior approval from the ECM Administrator is received in writing.
- B. **Centerline Monumentation.** Center line monumentation shall be installed. If the monument is located within a hard surfaced road, the monument shall be located in a valve box with cover at grade. If the monument is located within a gravel surfaced road, the monument shall be placed in a valve box 3 to 6 inches below road grade.
- C. **Monument Caps and Data.** All monuments shall be metallic caps stamped with the registered business name or the letters "L.S." followed by the registration number of the surveyor in charge. All monuments shall include state plane coordinate and elevation information meeting County GIS Standards along with any information required by State law.
- D. **Replacement of Disturbed Monuments.** The permit holder is responsible for replacement of any disturbed monumentation previously present. All disturbed monumentation including property corners shall be reset per state statute.

5.10.6. Engineering Record Drawings

- A. **Record Drawing Required.** Engineering Record Drawings are required for all projects that include public improvements or common development improvements, including but not limited to roadway improvements, public sidewalks and trails, storm drainage facilities, and utility infrastructure on public property or on private property within public easements or rights-of-way. Engineering Record Drawings are necessary for inclusion of public improvements into the El Paso County Asset Management System, to serve as a basis to plan and design future projects in the same area, to demonstrate ADA compliance, and to document

compliance with permitting requirements such as the County's MS4 permit. Engineering Record Drawings shall be submitted in an electronic format acceptable to the ECM Administrator as described below in Section 5.10.6.D.

- B. Reflect Changes to Construction Plans.** Engineering Record Drawings are a record of any substantial variations or changes to the original intended physical product of the approved construction plans, based upon visual field observations or field survey data. The revisions shall be shown on a copy of the original approved construction plans that are filed with the County. Engineering Record Drawings submitted for County review may be the same drawings as the original approved plan drawing if no substantial variation to the original approved design occurred. Engineering Record Drawings shall be accompanied by a certification letter from the Engineer of Record which shall state that the site and adjacent properties (as affected by work performed under the County permit) are stable with respect to settlement and subsidence, sloughing of cut and fill slopes, revegetation or other ground cover, and that the improvements (public improvements, common development improvements, site grading and paving) meet or exceed the minimum design requirements.

For sites including detention and/or water quality facilities, the certification letter shall include a statement that the facilities provide the required storage volume and will meet the required release rates, as documented by an attached UDFCD design form submitted with the original application, the stage areas, elevations and outlet dimensions. If the detention/WQCV facility cannot be modeled with UDFCD spreadsheets due to a large contributing area, other verified stage/storage/discharge tables for the applicable design storms shall be provided with the certification letter.

At the initiation of the Preliminary Acceptance process, Engineering Record Drawings shall be submitted for review and approval by the ECM Administrator.

- C. Record Drawings Approval Process.** To facilitate the approval process of Engineering Record drawings, the following procedure shall be followed:
- The permit holder's engineer of record shall submit the Engineering Record Drawings for ECM Administrator review in the applicable formats specified below.
 - The ECM Administrator will review the drawings and redline any necessary changes. The engineer of record shall update the drawings and resubmit the drawings for approval.
 - Upon ECM Administrator approval of the final Engineering Record Drawings, the drawings will be uploaded to the El Paso County Planning and Community Development (PCD) Electronic Development Application Review Program (EDARP). If there are multiple hardcopy sets the County will retain one set.
 - The Engineering Record Drawings shall clearly indicate the completed state of construction for the project. Each sheet of the record drawings shall be designated as "Engineering Record Drawings" and signed and dated by the engineer of record.
 - Financial assurances for the Engineering Record Drawings line item in the project Financial Assurance Estimate will not be released until the Engineering Record Drawings are submitted, verified and approved, nor will partial releases of any line item be reduced to less than 20%. It is recommended that the required format of drawings and certification letter be submitted at least one month prior to the developer's request for Preliminary Acceptance to expedite the County acceptance process.
- D. Required Engineering Record Drawings Format**
1. A complete construction plan set, including the plat or parcel boundaries as applicable, conforming to the minimum requirements in this section is required. Hard copy drawings will only be accepted in special cases as approved by the ECM Administrator.
 2. For projects submitted on or after July 1, 2019, Electronic CAD files shall be in AutoCAD format (.DWG) 2016 or newer or in .PDF file format.

Survey/GIS Reference Links:

State monument records:

https://www.colorado.gov/pacific/dora/AES_Monument_Records

<http://www.cp-db.com/kml/ElPasoCountyMonumentRecordsNetworkLink.kmz> (KMZ file)

Vertical benchmark data: <https://www.ngs.noaa.gov/NGSDataExplorer/>

CSU Survey control points

(GIS):

<https://maps.csu.org/ArcFMWebViewer27/index.html?viewer=GISPublic&runWorkflow=CSUDisclaimer&inTheme>

<http://desktop.arcgis.com/en/arcmap/10.3/map/working-with-arcmap/creating-a-map-package.htm>

<https://helpx.adobe.com/acrobat/using/geospatial-pdfs.html>

<https://thecadgeek.com/blog/2008/09/georeferenced-dwf-files/>

**BUILDERS EROSION AND STORMWATER QUALITY CONTROL PERMIT (BESQCP)
EL PASO COUNTY APPLICATION AND PERMIT**

PERMIT NUMBER:

Applicant Information	
Property Owner	
Applicant Name (Permit Holder)	
Company	
Position of Applicant	
Address (physical address, not PO Box)	
City	
State	
Zip Code	
Phone	

Contractor Information	
Name (person of responsibility)	
Company	
Position of Applicant	
Address	
City	
State	
Zip Code	
Phone	

Project Specifications	
Name and Legal Description	
Name of Subdivision Filing	
Address (or nearest major cross streets)	
Acreage (total and disturbed)	
Schedule (start and finish and date of final stabilization)	
Description of Project	
Tax Schedule Number	

FOR OFFICE USE ONLY

The following signature from the ECM Administrator signifies the approval of this BESQCP. All work shall be performed in accordance with the permit and the El Paso County ECM Standards.

Signature of ECM Administrator: _____ Date _____

Rev. 7/2019

1.1 REQUIRED SUBMISSIONS

In addition to this completed and signed application, all permit fees must be submitted to obtain a BESQCP. Submission and review of a Stormwater Management Plan and posting of financial sureties are not required for a BESQCP.

1.2 RESPONSIBILITY FOR DAMAGE

The County and its officers and employees, including but not limited to the ECM Administrator, shall not be answerable or accountable in any manner for damage to property or for injury to or death of any person, including but not limited to a permit holder, persons employed by the permit holder, or persons acting in behalf of the permit holder, from any cause. The permit holder shall be responsible for any liability imposed by law and for damage to property or injuries to or death of any person, including but not limited to the permit holder, persons employed by the permit holder, persons acting in behalf of the permit holder, arising out of work or other activity permitted and done under a permit, or arising out of the failure to perform the obligations under any permit with respect to maintenance or any other obligations, or resulting from defects or obstructions, or from any cause whatsoever during the progress of the work or other activity, or at any subsequent time work or other activity is being performed under the obligations provided by and contemplated by the permit.

The permit holder shall indemnify, save, and hold harmless the County and its officers and employees, including but not limited to the BOCC and ECM Administrator, from all claims, suits or actions of every name, kind and description brought for or on account of damage to property or injuries to or death of any person, including but not limited to the permit holder, persons employed by the permit holder, persons acting in behalf of the permit holder and the public, resulting from the performance of work or other activity under the permit, or arising out of a failure to perform obligations under any permit with respect to maintenance or any other obligations, or resulting from defects or obstructions, or from any cause whatsoever during the progress of the work or other activity, or at any subsequent time work or other activity is being performed under the obligations provided by and contemplated by the permit, except as otherwise provided by state law. The permit holder waives any and all rights to any type of expressed or implied indemnity against the County, its officers or employees. It is the intent of the parties that the permit holder will indemnify, save, and hold harmless the County, its officers and employees from any and all claims, suits or actions as set forth above regardless of the existence or degree of fault or negligence, whether active or passive, primary or secondary, on the part of the County, the permit holder, persons employed by the permit holder, or persons acting in behalf of the permit holder.

1.3 APPLICATION CERTIFICATION

I, as the Applicant or the representative of the Applicant, hereby certify that this application is correct and complete as per the requirements presented in this application, the El Paso County Engineering Criteria Manual, and the Drainage Criteria Manual, Volume 2 and El Paso County Addendum.

Rev.7/2019

Created: 2021-06-08 11:35:51 [EST]

(Supp. No. 2)

I understand that stormwater control measures are to be implemented on the site and maintained as necessary to protect stormwater quality as the project progresses. The site and adjacent areas will be self-inspected to be sure that control measures are installed correctly and functioning for each stage of construction and following each rain event.

Installation and maintenance of control measures include, but are not limited to:

- Source control and physical barriers that prevent pollutants, including sediment, from leaving the site, especially into waterways or storm drain systems. Pollutants are also to be kept off of roadways, including roadside ditches, and adjacent properties.
- Protection of downstream storm drains, channels, ponds, or waterways.
- Immediate cleanup of sediment and other pollutants that are tracked or otherwise leave the permitted site.

Examples of pollutants that must be contained and cleaned up are:

- Sediment (mud or dirt)
- Excavated or imported soil, aggregate, or rock
- Landscaping materials, including topsoil
- Concrete washout water
- Stucco
- Paints
- Solvents
- Fuels and lubricants
- Pesticides and fertilizers
- Cleaning products
- Other chemicals
- Trash, litter, garbage
- Sanitary waste (e.g. portable toilets), other animal waste

Note: El Paso County does not require that a Stormwater Management Plan (SWMP) be reviewed for a BESQCP. It is recommended, however, that a SWMP be prepared and site personnel be trained in the procedures necessary to protect stormwater quality. The measures in the City of Colorado Springs' Drainage Criteria Manual, Volume 2, Chapter 3, and the El Paso County approved Addendum provide guidance on stormwater control measures for construction sites. **Sites covered by BESQCPs are still subject** to any other relevant regulations such as the Colorado Discharge Permit System regulations. The permit holder is responsible for subcontractors onsite complying with the terms of the permit holder's BESQCP.

_____ Date: _____
Signature of Applicant or Representative

Rev.7/2019

Chapter 6 ACCESSIBILITY

6.1. OVERVIEW

This chapter addresses the standards and technical criteria to be used to plan, design, construct, choose materials for, locate, repair, maintain, reconstruct, and use accessible pedestrian facilities within and adjacent to public roadways, whether such pedestrian facilities are located within the public right-of-way, easements, or tracts, and on Shared Use Paths.

Design criteria and requirements presented in this chapter shall apply to pedestrian facilities within and adjacent to public roadways, whether such pedestrian facilities are located within right-of-way, easements, or tracts, and whether such public roadways are dedicated to use by the public or in fact used by the general public, regardless of the entity responsible for operation and maintenance. Other pedestrian facilities outside of the public right-of-

way or easements or tracts adjacent thereto may be required, however, to comply with ADA Standards and requirements based on other codes and regulations.

All pedestrian facilities shall be designed and constructed in accordance with current Proposed Guidelines for Pedestrian Facilities in the Public Right-of-Way (PROWAG), including the Shared Use Paths Supplement.

This chapter provides key design criteria for ADA Compliance. All new construction and alterations shall adhere to all PROWAG criteria to the maximum extent feasible. All new construction and alterations shall meet the requirements of this chapter unless a deviation request detailing the specific existing site constraints and technical infeasibility is approved by the ECM Administrator. Traditional maintenance activities that do not affect the public's access to or usability of the roadway are not required to comply with requirements of this chapter.

6.1.1. Purpose

The purpose of this chapter is to provide detailed design guidelines and criteria relating to accessibility for the preparation of plans for and access to all roadways dedicated to use by the public or in fact used by the general public, regardless of the entity responsible for operation and maintenance. These facilities include sidewalks, curb ramps, street crossings, and other elements within and adjacent to public roadways.

6.1.2. Chapter Content and References

Table 6-1 outlines the chapter content and references used as a basis for the standards established in Chapter 6.

Table 6-1. Contents and Basis of Accessibility Standards

Intent Use	ECM Content	ECM Section(s)	Reference Document(s)
Design			
	Sidewalks	6.3.1	1, 8
	Pedestrian Street Crossings	6.3.2	1
	Curb Ramps/Blended Transitions	6.3.3	1, 9
	Detectable Warning Surfaces	6.3.4	1, 9
	Medians/Pedestrian Refuge Islands	6.3.5	1
	Pedestrian Signals/Pushbuttons	6.3.6	1, 3, 4, 9
	Shared Use Paths	6.3.7	1, 2, 3, 4, 7
	Transit Stops	6.3.8	1
	Pedestrian Over/Underpasses	6.3.9	1
	Ancillary Elements	6.3.10	1, 3, 4, 8
	Pedestrian Access in Work Zones	6.3.11	1, 3, 4, 9
Construction			
	Inspections	Ch. 5, 6.4, App. J	1, 3, 4
	Acceptance	Ch. 5, 6.4	1, 3, 4

References

1. United States Access Board, Proposed Guidelines for Pedestrian Facilities in the Public Right-of-Way (PROWAG), 2011
2. United States Access Board, Proposed Guidelines for Pedestrian Facilities in the Public Right-of-Way; Shared Use Paths Supplement, 2013
3. FHWA, Manual on Uniform Traffic Control Devices for Streets and Highways (MUTCD), 2009 with Revisions 1 and 2, 2012
4. CDOT, Supplement to the Federal Manual on Uniform Traffic Control Devices, 2009
5. United States Department of Justice, 2010 ADA Standards for Accessible Design (ADA Standards), 2010
6. United States Department of Justice, Americans With Disabilities Act Title II Regulations (ADA Regulations), 2010
7. AASHTO, AASHTO Guide for the Development of Bicycle Facilities, 2012
8. AASHTO, AASHTO Roadside Design Guide, 4th Edition, 2011
9. CDOT, M&S Standards
10. CDOT, Roadway Design Guide, 2018

6.1.3. Standard Drawings

Table 6-2 identifies the standard drawings that are included in Appendix F as an enforceable part of these Standards. The Standard Drawings shall be used when designing improvements for County-owned and maintained facilities. Any change to a Standard Drawing shall be approved by the ECM Administrator and noted in the construction plans. CDOT standard drawings adopted in the ECM are also applicable to the design of pedestrian facilities. Where noted in this chapter, El Paso County standard drawings supersede CDOT standard drawings.

Table 6-2. Standard Drawings

File Name	Detail/Description	Approval Date
SD_2-1	Urban Local Roadway (low volume)	6/23/2020
SD_2-2	Urban Local Roadway	6/23/2020
SD_2-3	Urban Nonresidential Collector Roadway	6/23/2020
SD_2-4	Urban Residential Collector Roadway	6/23/2020
SD_2-5	Urban Minor Arterial Roadway	6/23/2020
SD_2-6	Urban Principal 4-Lane Arterial Roadway	6/23/2020
SD_2-7	Urban Principal 6-Lane Arterial Roadway	6/23/2020
SD_2-8	Urban Expressway 4-Lane Roadway	6/23/2020
SD_2-9	Urban Expressway 6-Lane Roadway	6/23/2020
SD_2-20	Typical Curb and Gutter Details	6/23/2020
SD-2-24	Driveway Detail w/ Attached Sidewalk	6/23/2020
SD_2-25	Driveway Detail w/ Detached Sidewalk	6/23/2020
SD_2-40	Pedestrian Curb Ramp Detail	6/23/2020
SD_2-41	Pedestrian Curb Ramp Detail	6/23/2020
SD_2-42	Detectable Warning Surface Details	6/23/2020
SD_2-50	Parallel Pedestrian Curb Ramp Detail	6/23/2020

6.1.4. Relationship between ECM, ADA, and PROWAG

The Americans with Disabilities Act (ADA) of 1990 is the civil rights law that prohibits discrimination against individuals with disabilities and is the basis for creating accessibility in the private and state and local government sectors. It is often referred to as the ADA Regulations. The ADA Standards establish the design requirements for the construction and alteration of facilities, including sites and buildings. Although they are related and based on similar concepts, these standards are not directly applicable to the public rights-of-way. In order to address elements within and adjacent to public roadways, the United States Access Board created the Proposed Guidelines for Pedestrian Facilities in the Public Right-of-Way (PROWAG). These guidelines establish the design requirements for construction and alteration of elements within and adjacent to public roadways. The United States Access Board has also created a supplement to PROWAG to address specific design requirements for Shared Use Paths.

El Paso County requires that all pedestrian facilities within and adjacent to public roadways be designed and constructed in accordance with current PROWAG requirements, including the Shared Use Paths Supplement. The design criteria and requirements presented in this chapter are taken directly from PROWAG. Recommendations and best practices are provided to facilitate compliance during design and construction. Where additional guidance is required beyond what is presented in the ECM, refer to the ADA Regulations, 2010 ADA Standards, PROWAG (2011) with Shared Use Path Supplement (2013), MUTCD (2009 with revisions and Colorado Supplement), and other guidance and resources provided by the United States Access Board.

(Res. No. 20-222 , 6-23-20)

6.2. PLANNING AND APPLICABILITY

6.2.1. Definitions and Building Blocks of Accessible Design

A. Definitions.

Pedestrian Circulation Path: A prepared exterior or interior surface provided for pedestrian travel within or adjacent to public roadways. The Pedestrian Circulation Path does not have to be accessible; however, the Pedestrian Access Route contained within the Pedestrian Circulation Path shall be accessible to those with disabilities.

Pedestrian Access Route: A continuous and unobstructed path of travel provided for pedestrians with disabilities within or coinciding with a Pedestrian Circulation Path. The Pedestrian Access Route shall comply with PROWAG.

Alteration: A change to a facility within or adjacent to public roadways that affects or could affect pedestrian access, circulation, or use. Alterations include, but are not limited to, resurfacing, rehabilitation, reconstruction, historic restoration, or changes or rearrangement of structural parts or elements of a facility. Many modifications to traffic signals are also considered alterations. See Section 6.3.6.

Maximum Extent Feasible: Where existing physical constraints make it impracticable for altered elements, spaces, or facilities to fully comply with the requirements for new construction, compliance is required to the extent practicable within the scope of the project. Also referred to as "Maximum Extent Practicable".

Technically Infeasible: With respect to an alteration of a facility within or adjacent to public roadways, something that has little likelihood of being accomplished because existing physical or site constraints

Created: 2021-06-08 11:35:51 [EST]

(Supp. No. 2)

prohibit modification or addition of elements, spaces, or features that are in full and strict compliance with minimum requirements.

- B. **Construction Tolerances.** The requirements and guidance provided in this chapter recognize the conventional tolerances associated with construction within or adjacent to public roadways. In accordance with PROWAG R103, "Dimensions are subject to conventional industry tolerances except where dimensions are stated as a range" and "Conventional industry tolerances include tolerances for field conditions and tolerances that may be a necessary consequence of a particular manufacturing process. Conventional industry tolerances do not apply to design work."

6.2.2. Accessibility for New Construction

All new construction projects, where pedestrian access is included, shall be accessible and compliant with the Engineering Criteria Manual.

6.2.3. Accessibility for Alteration Projects

Whenever existing facilities are altered, they shall meet accessibility requirements within the scope and limits of the project as determined by the ECM Administrator. Alterations include projects such as reconstruction, rehabilitation, resurfacing, widening, and projects of similar scope and scale. For example, if a project requires resurfacing of an intersection, then the curb ramps and sidewalks within the project limits shall be updated to comply with the requirements contained in the ECM.

- A. **Transitional Segments.** Transitional segments of Pedestrian Access Routes shall connect to existing unaltered segments of Pedestrian Circulation Paths and shall comply with Section 6.3.1 to the maximum extent practicable.
- B. **Reduction in Access Prohibited.** An alteration shall not decrease or have the effect of decreasing the accessibility of a facility or an accessible connection to an adjacent building or site below the requirements for new construction in effect at the time of the alteration.
- C. **Technical Infeasibility.** In alterations, it can be infeasible to make facilities fully compliant with the requirements of the ECM due to existing site constraints. Improvements at certain locations may be deemed "Technically Infeasible" when engineering judgement is used and the County concurs. If full compliance with the ECM is deemed technically infeasible, facilities being altered shall be made accessible to the maximum extent practicable. If full compliance cannot be achieved, a deviation request shall be made to the County in accordance with ECM Section 1.9 and Section 5.8. In the Deviation Request and Decision Form, the designer should fully and specifically document the existing site constraints that result in technical infeasibility and the efforts made to comply to the maximum extent practicable.

Examples of site constraints that may make it technically infeasible to make a facility fully compliant include:

- Underground structures or utilities that would need to be altered to make a facility compliant and would expand the project scope.
- Adjacent development or buildings that would need to be moved or altered to make a facility fully compliant.
- Required improvements that would alter the status of a Historic property.
- Drainage that could not be maintained if an area is made fully accessible.

-
- Underlying terrain that would require significant expansion of the project scope to achieve full compliance. An example would be altering an existing roadway profile to make the cross slope of a crosswalk fully compliant.

Project scope, not cost, shall determine when existing constraints make it technically infeasible to make a facility accessible. For example, if a roadway resurfacing project that does not include utility relocations would require relocating underground utilities to make a curb ramp accessible, then making the curb ramp fully accessible could be considered technically infeasible. If, however, a project requires relocation of utilities and widening of a roadway, then that same curb ramp should be made fully accessible.

- D. **Projects Solely to Improve Accessibility.** If the sole purpose of a project is to improve accessibility, the scope of the project is not required to be expanded to make other adjacent portions of the Pedestrian Access Route and/or Pedestrian Circulation Path accessible. For example, a project whose sole purpose is to repair and replace sidewalk in poor condition would not be required to be expanded to fix adjacent noncompliant curb ramps. In these cases, documentation of the sole purpose to improve accessibility shall be documented during project development and written approval obtained from the ECM Administrator.

6.2.4. Accessibility for Maintenance Projects

Traditional maintenance activities do not require that the adjacent pedestrian facilities be made accessible. These activities include crack sealing, graveling, chip sealing, cover coating, pavement patching, restriping, and similar activities meant to seal and protect the road surface and improve friction and that do not significantly affect the public's access to or usability of the road.

(Res. No. 20-222 , 6-23-20)

6.3. ACCESSIBLE DESIGN

6.3.1. Sidewalks (Pedestrian Access Routes/Pedestrian Circulation Paths)

- A. **General Requirements.** Accessible sidewalks provide a safe route and continuous path for users with disabilities. All new sidewalk and sidewalk that is being replaced as part of an alteration project shall comply with the requirements contained within this section. Pedestrian Access Routes shall be provided within Pedestrian Circulation Paths to connect with accessible elements, spaces, and facilities within and adjacent to public roadways.
- B. **Clear Width.** Minimum-required sidewalk widths by roadway classification are specified in Table 2-4 through Table 2-7 and Appendix F. The minimum clear width of accessible sidewalk is 4 feet in all cases, excluding the width of the curb. If the designer chooses to use a 4 ft. wide sidewalk, then 5 ft. x 5 ft. passing spaces are required to be included and spaced a maximum of every 200 feet, as shown in Figure 6-1. Utilizing a 5 ft. wide (or wider) sidewalk eliminates the need for passing spaces. When sidewalk wider than the minimum 4 ft. width is provided (for example in an urban commercial area), only part of the sidewalk area is classified as the Pedestrian Access Route and must comply with the requirements of Section 6.3.1. Providing at least the minimum width accessible Pedestrian Access Route ensures that persons with disabilities can access all accessible elements, spaces, and features along the roadway. If approved by the ECM Administrator, the remainder (classified as Pedestrian Circulation Path) may have street furniture, utility poles, etc. that would not be acceptable in the Pedestrian Access Route. Designers shall ensure that, where approved by the ECM Administrator, street furniture and other elements in the Pedestrian Circulation Path are detectable and will not present a hazard to pedestrians. All protruding objects within the Pedestrian Circulation Path shall

Created: 2021-06-08 11:35:51 [EST]

(Supp. No. 2)

meet the requirements of Section 6.3.1.F.6. Where feasible, designers are also encouraged to comply with slope and other requirements to improve the accessibility of the sidewalk area.

Figure 6-1. Passing Spaces

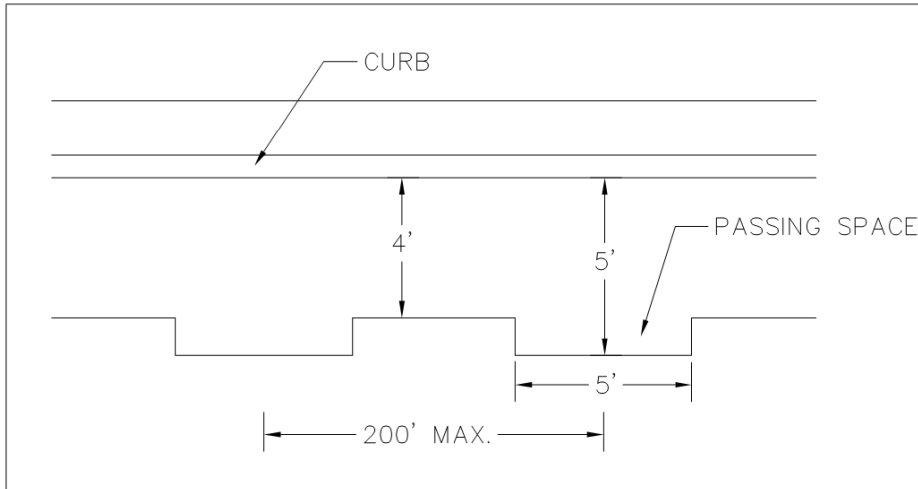

- C. **Vertical Alignment.** The vertical alignment of all elements within a Pedestrian Access Route (sidewalks, curb ramps, blended transitions, turning spaces, and gutter areas, etc.) shall be planar. Grade breaks shall be flush.
- D. **Grade.** The grade of Pedestrian Access Routes within and adjacent to public roadways shall not exceed 5%. When, however, the grade of the adjacent street is greater than 5%, the grade of adjacent Pedestrian Access Routes shall not exceed the general grade of the adjacent street or highway. In these cases, the Pedestrian Access Route is not considered a ramp even though its grade exceeds 5%. In all other areas, Pedestrian Access Routes with grades between 5% and 8.3% must comply with the requirements of Section 6.3.1.G.
- E. **Cross Slope.** The cross slope of all sidewalk contained within the Pedestrian Access Route shall not exceed 2%. Typical sidewalk cross slope of 1.5% is recommended for design to allow for construction tolerance.
- F. **Surface.**
 - 1. **General.** The surface of all elements contained within the Pedestrian Access Route shall be firm, stable, and slip resistant (e.g. concrete sidewalk with broom finish or slip-resistant plate over a drainage chase). Soft loose surfaces such as sand, gravel, or cobblestones can make it difficult for people using wheelchairs to move with ease.
 - 2. **Level Change.** The maximum level change for a non-beveled surface is 0.25 inches. The maximum level change for a beveled surface is 0.50 inches. The beveled surface shall have a slope not steeper than 50% (2:1 H:V). See Figure 6-2.

Figure 6-2. Vertical Surface Discontinuities

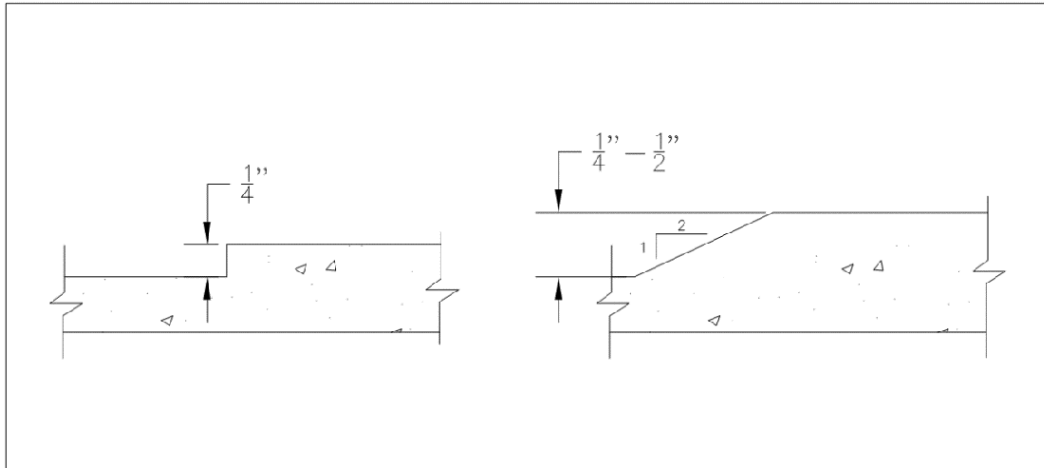

3. **Horizontal Opening (Grates and Joints).** The maximum horizontal openings in gratings and joints shall not permit passage of a 0.50-inch diameter sphere. Elongated openings in grating shall be oriented such that the long dimension is perpendicular to the main direction of travel. See Figure 6-3.

Figure 6-3. Horizontal Openings

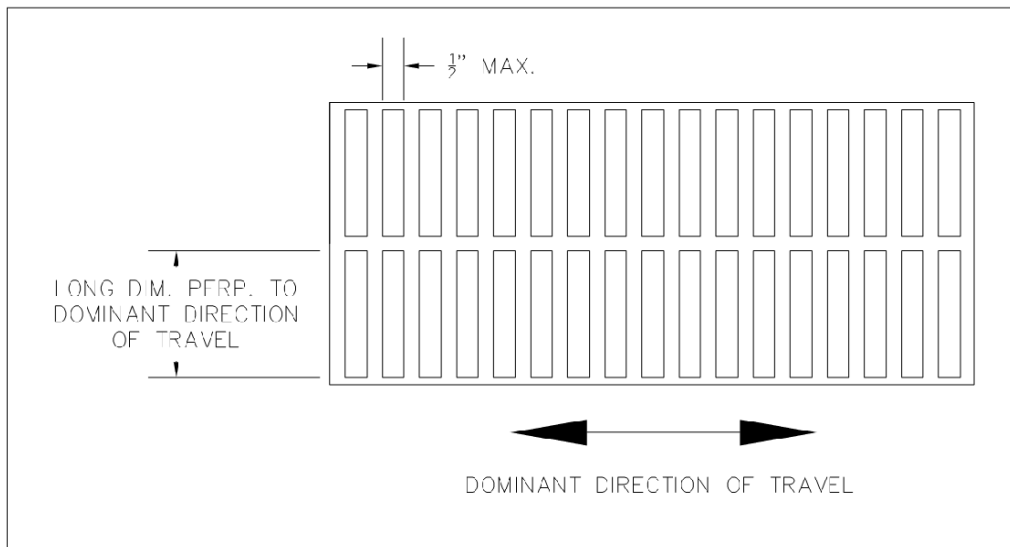

4. **Surface Obstructions.** Utility vaults, covers, frames, and other elements should be located outside of Pedestrian Access Routes, curb ramps, and turning spaces whenever possible. Over time, differential settlement at these interfaces can lead to vertical discontinuities.
5. **Railroad Crossings.** Railroad crossings shall be level with the top of rail.
 - The flangeway gap for a non-freight train rail shall not exceed 2.5 inches. See Figure 6-4.
 - The flangeway gap for a freight train rail shall not exceed 3 inches. See Figure 6-4.

Figure 6-4. Flangeway Gaps

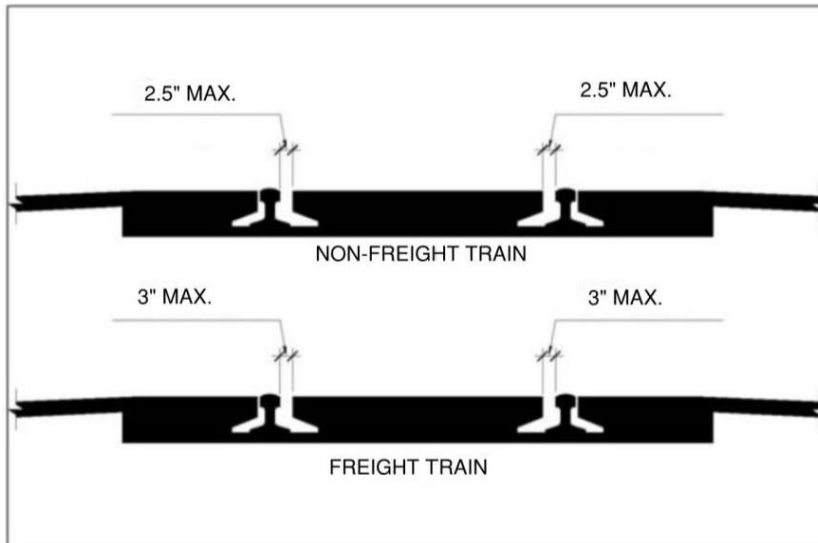

6. **Protruding Objects.** Roadside objects shall not be permitted to encroach upon or protrude into pedestrian routes including Pedestrian Access Routes and Pedestrian Circulation Paths. In cases where it is infeasible to locate objects outside of these pedestrian routes, a deviation must be approved by the ECM Administrator and these objects must be designed to be detectable and not present a hazard to pedestrians or vehicles. Objects include, but are not limited to, signs, street furniture, landscaping, and above ground utility poles and boxes. See Section 2.5.2.B.8 and Figure 2-35 for horizontal and vertical clearance requirements.
 - **General:** Requirements for protruding objects extend along the entire width of the Pedestrian Circulation Path. Protruding objects shall not decrease the minimum required clear width of the Pedestrian Access Route.
 - **Protrusion Limits:** Objects with leading edges more than 2.25 ft. and not more than 6.7 ft. above the finished surface shall not protrude more than 4 inches maximum into the Pedestrian Circulation Path. See Figure 6-5.

Figure 6-5. Protrusion Limits

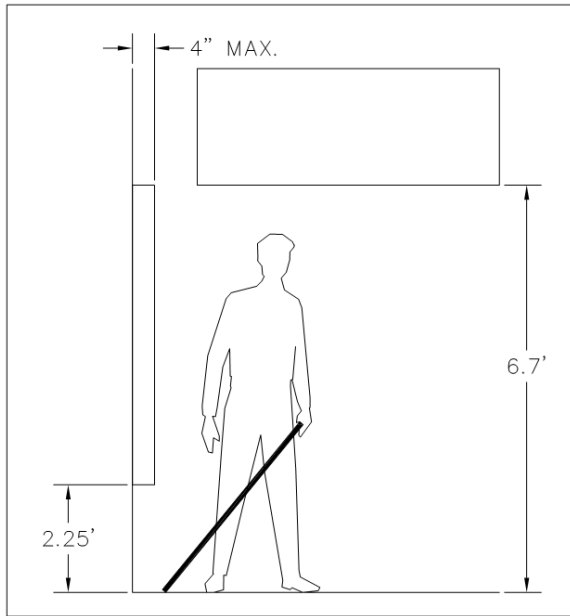

- **Post-Mounted Objects:** When objects are mounted on free-standing posts or pylons and the object is between 2.25 ft. and 6.7 ft. above the finished surface, the maximum protrusion into the Pedestrian Circulation Path is 4 in., measured horizontally from the outside edge of the post or pylon.

Where objects are mounted between 2 or more posts or pylons and the clear distance between the posts is 1 ft. or greater, the lowest edge of the object shall be 2.25 ft. maximum or 6.7 ft. minimum above the finished grade. See Figure 6-6.

Figure 6-6. Protrusion Limits for Post-Mounted Objects

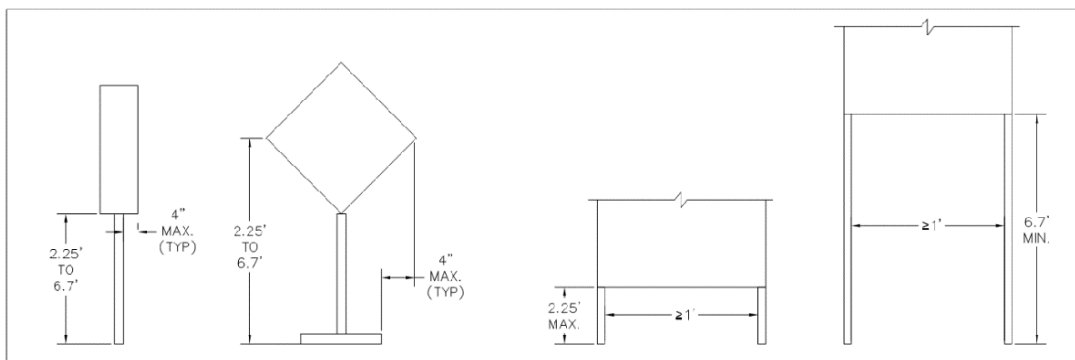

- **Reduced Vertical Clearance:** Railing or other barriers to pedestrian travel shall be provided where the vertical clearance is less than 6.7 ft. high. The leading edge of the railing or barrier shall be located 2.25 ft. maximum above the finished surface. See Figure 6-7.

Figure 6-7. Reduced Vertical Clearance

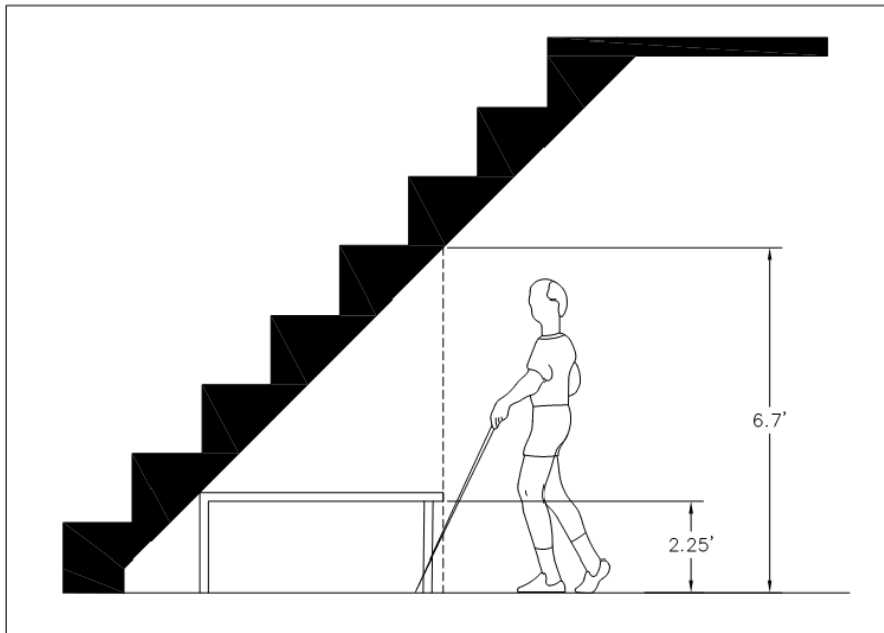

- G. **Ramps.** Ramps (not to be confused with curb ramps) include ramp runs and landings. See Figure 6-8. Ramps are required where the running slope of the sidewalk within a Pedestrian Access Route exceeds 5%.
1. **Running Slope.** The running slope of ramp runs is between 5% and 8.3%. Utilize the flattest slope feasible on ramp runs. A suggested maximum running slope of 7.5% is recommended for design to allow for variability during construction, since no construction tolerance is allowed.
 2. **Cross Slope.** The cross slope of ramps within the Pedestrian Access Route shall not exceed 2%. Typical ramp cross slope of 1.5% is recommended for design to allow for construction tolerance.
 3. **Clear Width.** The minimum clear width of ramps is 4 ft. if handrails are not provided. If handrails are provided, the minimum clear width of ramps between handrails is 3 ft.
 4. **Rise.** The maximum rise of a ramp run is limited to 2.5 ft. There is no limit to the number of consecutive ramp runs a Pedestrian Access Route may have, as long as intermediate landings are provided.
 5. **Landings.** Landings shall be provided at the top and bottom of every ramp run, and intermediate landings shall be provided for every 2.5 ft. of ramp rise. The slope of the landing in any direction shall not exceed 2%. It is recommended that the slopes of the landing be designed with a 1.5% slope to allow for construction tolerance. The clear width of the landing shall be at least as wide as the ramp run leading to the landing. The length of the landing shall be 5 ft. minimum. For ramps that change direction between runs, landings shall have minimum dimensions of 5 ft. x 5 ft. See Figure 6-8.

Figure 6-8. Landing Requirements in Ramps

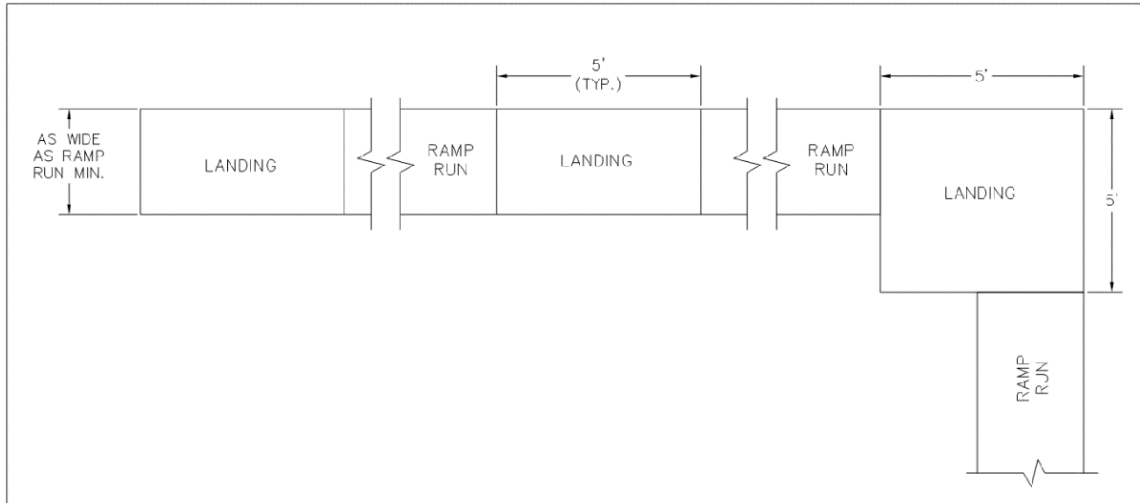

6. **Edge Protection.** Edge protection is required on all ramps and ramp landings. Edge protection can be provided by either extending the width of the ramp and landings 1 ft. minimum beyond the inside face of the handrails or providing a curb or barrier that prevents the passage of a 4 in. diameter sphere, where any portion of the sphere is within 4 in. of the finished surface.
 7. **Handrails.** PROWAG compliant handrails are required on all ramps that have a ramp rise of 6 in. or greater. Handrails should be continuous the full length of the ramp and shall be between 2.8 ft and 3.2 ft above the finished surface of the ramp. Handrails shall extend 1 ft. beyond the top and bottom of the ramp runs. See PROWAG Section R409 for additional physical requirements for handrails including, but not limited to, height, cross section, and extensions. Handrails should be designed and located in accordance with requirements of the AASHTO Roadside Design Guide. Where required, handrails should be located outside of the roadway clear zone whenever feasible. When they cannot be located outside of the clear zone, the designer should refer to the methodology of the AASHTO Roadside Design Guide to reduce the likelihood and severity of the obstacle being struck.
 8. **Stairs.** As a best practice, providing stairways along with ramps, where possible, benefits pedestrians with heart disease, limited stamina, and others for whom distance presents a greater barrier than steps. Stairs should be designed and located in accordance with requirements of the AASHTO Roadside Design Guide. Where required, stairs should be located outside of the roadway clear zone whenever feasible. When they cannot be located outside of the clear zone, the designer should refer to the methodology of the AASHTO Roadside Design Guide to reduce the likelihood and severity of the obstacle being struck.
- H. **Sidewalk at Driveways.**
1. **General.** Sidewalk across driveways shall comply with the general requirements for accessible sidewalk (running slope, cross slope, surface, clear width). Accessible sidewalk configurations at driveways are shown in Standard Drawings SD_2-24 and SD_2-25.

6.3.2. Pedestrian Street Crossings (Crosswalks)

- A. **General.** Pedestrian street crossings are roadway crossings that connect Pedestrian Access Routes on opposite sides of a roadway. A Pedestrian Access Route shall be provided where pedestrian access

across a roadway is permitted. Where pedestrian street crossings are deemed to be unsafe or unsuitable for all pedestrians, the designer should consider measures to prohibit pedestrian crossings, such as signage, landscaping, and pedestrian barriers.

- B. **Running Slope.** Where Pedestrian Access Routes are contained within the pedestrian street crossing, the running slope of the Pedestrian Access Route shall not exceed 5%. This is generally equal to the roadway cross slope in perpendicular crossings.
- C. **Cross Slope.** The cross slope of pedestrian street crossings is generally equal to the roadway profile in perpendicular crossings. Designers should consider this requirement for initial, interim, and ultimate configurations when setting roadway grades to allow for compliant pedestrian crossings. For example, if an intersection is initially constructed as a Two-Way-Stop-Controlled intersection but expected to ultimately be converted to an All-Way-Stop-Controlled intersection, all roadway grades must be set at 2% or flatter to accommodate compliant crosswalks in the ultimate condition.
 - 1. **Yield or stop controlled intersections:** The cross slope of a pedestrian street crossing at an intersection with yield or stop control that is within the Pedestrian Access Route shall not exceed 2%. A cross slope of 1.8% is recommended for design to allow for construction tolerance. This requirement may require the roadway profile to be "tabled" across the pedestrian street crossing. See Figure 6-9.
 - 2. **Intersections without yield or stop control:** The cross slope of a pedestrian street crossing at an intersection without yield or stop control or at a signalized intersection that is within the Pedestrian Access Route shall not exceed 5%. When traffic signals are designed to allow for arrival during the green phase on an approach, that approach is considered to be without stop or yield control because vehicles could traverse the intersection without slowing or stopping. See Figure 6-9.
 - 3. **Midblock crossings:** Where a midblock crosswalk is approved by the ECM Administrator, the cross slope of the midblock pedestrian street crossing within the Pedestrian Access Route shall not exceed the profile grade of the street or highway.

Figure 6-9. Example Street Intersection

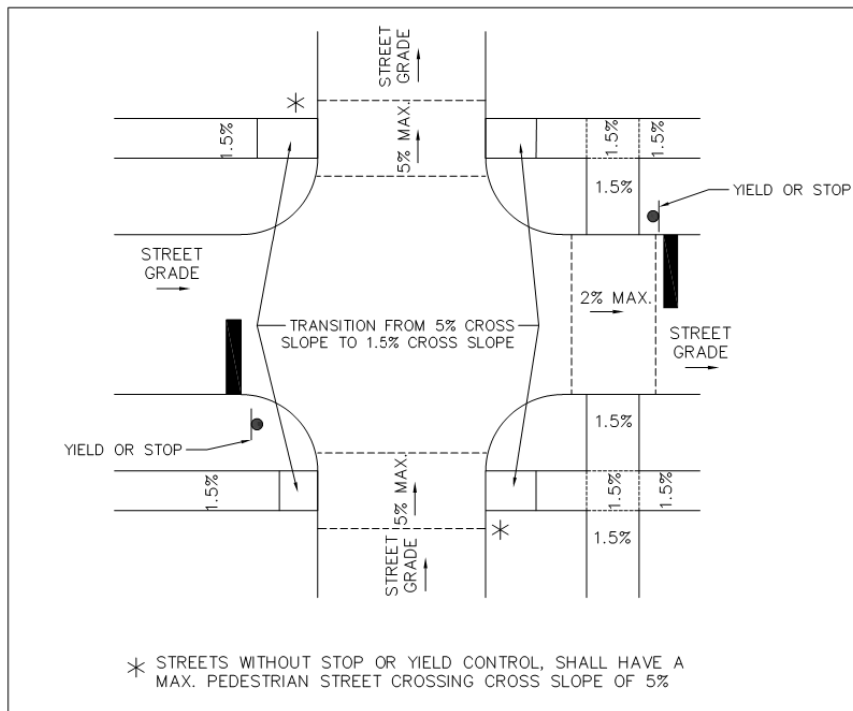

- D. **Roundabouts.** Design of accessible Pedestrian Access Routes at roundabouts requires careful design to provide guidance to pedestrians who are blind or have low vision because the crossings are located off to the side of the Pedestrian Circulation Path around the street or highway. Water fountains and other features that produce background noise should not be used in the middle of the roundabouts as pedestrians who are blind or have low vision rely on audible cues to help detect gaps in traffic.

Designers should refer to PROWAG R306.3 and other roundabout guidance when designing pedestrian facilities. Care should be taken to provide directional cues, separating the Pedestrian Access Route from the roadway with a landscape buffer, and locating the pedestrian street crossings set-back from the central island. Roundabouts with multi-lane approaches involve an increased risk of pedestrian exposure to accident when compared to those with single-lane approaches.

6.3.3. Curb Ramps/Blended Transitions

Curb ramps and blended transitions are used to transition the Pedestrian Access Route (sidewalk) to a pedestrian street crossing (crosswalk). Curb ramps and blended transitions shall comply with the requirements of this section. Selection of the type of curb ramp to be used at a given location should be based on:

- Intersection geometry
- Attached or detached sidewalk configuration
- Drainage
- Coordination with utilities and other roadside elements

Designers should design curb ramps individually, check critical slopes, ensure drainage does not pond in ramps, and consider directionality of the crossing. Designers are encouraged to use flatter slopes, where

possible, to allow for flexibility during construction. Designers should use ramps conforming with standard drawings SD_2-40, SD_2-41, SD_2-42, and SD_2-50 whenever feasible. When physical constraints prevent the application of these standard ramp designs, the designer should develop a design that fits project constraints and conforms with the requirements of this section to be approved by the ECM Administrator on a case-by-case basis. Designers are advised to see CDOT M-608-1 standard drawings for guidance in these cases.

A. Common Requirements for Curb Ramps and Blended Transitions.

1. **Clear Width.** The minimum clear width of curb ramps, blended transitions, and turning spaces is 4 ft. Widths should generally match the approaching sidewalk.
2. **Grade Breaks.** Grade breaks at the top and bottom of curb ramps shall be perpendicular to the direction of the ramp running slope. Grade breaks are not permitted within curb ramps and turning spaces. Surface slopes that meet at grade breaks shall be flush.
3. **Counter Slope.** The maximum counter slope of the gutter or street at the bottom of a curb ramp, blended transition, or turning space is 5%.
4. **Clear Space.** A minimum clear space of 4 ft. x 4 ft. shall be provided at the bottom of all curb ramps and blended transitions. The clear space shall be contained within the width of the pedestrian street crossing and be completely outside of the parallel vehicle travel lane. The cross slope of the clear space shall be equal to the street or highway grade. The maximum running slope of the clear space is 5% to comply with counter slope requirements.

B. Perpendicular Curb Ramps.

1. **General.** Perpendicular curb ramps have a running slope that cuts through or is built up to the gutter grade break at right angles.
2. **Running Slope.** Provide the flattest running slope possible on curb ramps, while maintaining adequate drainage. The running slope of a curb ramp is between 5% and 8.3%, but shall not require the ramp length to exceed 15 ft. A maximum running slope of 7.5% is recommended for design to allow for variability during construction, since construction tolerance is not allowed.
3. **Cross Slope.** The cross slope of curb ramps within the Pedestrian Access Route and at a stop or yield-controlled intersection shall not exceed 2%. A cross slope of 1.5% is recommended for design to allow for construction tolerance. The cross slope at intersections without stop or yield control shall not exceed 5%. The cross slope at midblock crossings can match the street or highway running slope. Where the ramp cross slope must exceed 2% in order to match a roadway grade greater than 2% at the end of the ramp, transition the ramp above the clear space to match the roadway grade. Spread the transition evenly over the length of the ramp. See Figure 6-10.

Figure 6-10. Transitioning Cross Slope Across Curb Ramp

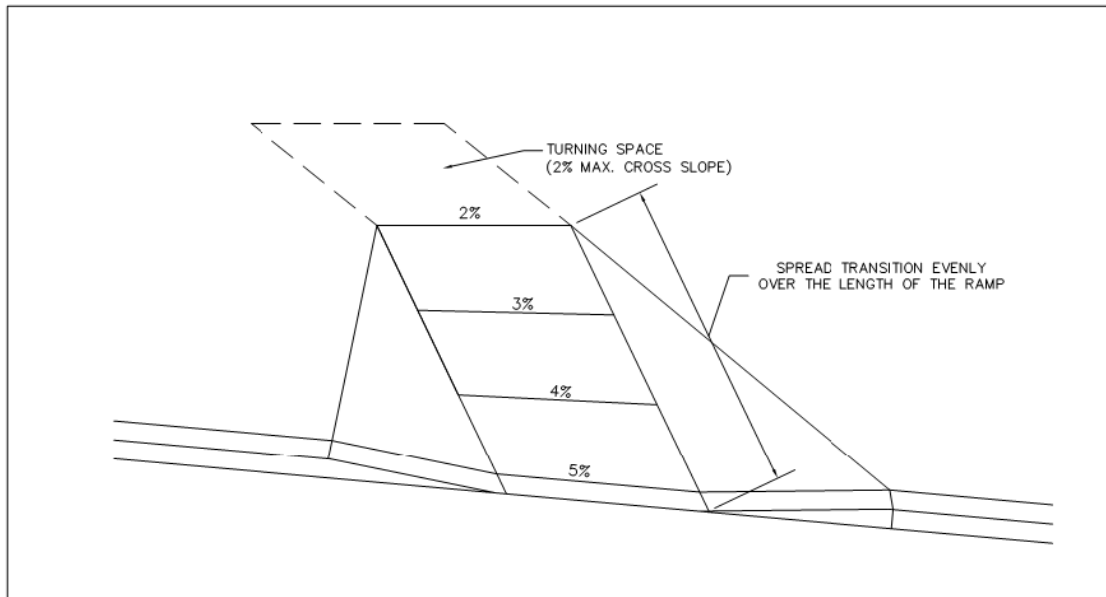

4. **Turning Space.** A 4 ft. x 4 ft. minimum turning space shall be provided at the top of the curb ramp and may overlap other turning and clear spaces. If the turning space is constrained at the back of the sidewalk, the turning space shall be 4 ft. x 5 ft. minimum. The 5 ft. dimension shall be provided in the direction of the ramp running slope. The maximum running slope of a turning space is 2%. Use 1.5% where practicable to allow for construction tolerance.
 5. **Flared Sides and Returned Curbs.** Where the Pedestrian Circulation Path crosses the curb ramp, the slope of the side flares shall not exceed 10%. A side flare slope of 9.5% is recommended to allow for construction tolerance. If the sides of a perpendicular ramp are not contained within the Pedestrian Circulation Path (e.g., detached sidewalk configurations) and are protected from cross travel by landscaping, street furniture, or other elements, 1'-6" flared sides should be used as shown in the standard drawings. Returned curbs in lieu of 1'-6" flared sides may be approved by the ECM Administrator on a case-by-case basis if the directional cues they provide to pedestrians who are blind or have low vision are important in the design.
- C. **Parallel Curb Ramps.**
1. **General.** Parallel curb ramps have a running slope that is aligned with the direction of sidewalk travel and lower the sidewalk to a level turning space where a turn is made to enter the pedestrian street crossing.
 2. **Running Slope.** Provide the flattest running slope possible on curb ramps, while maintaining adequate drainage. The running slope of a curb ramp is between 5% and 8.3%, but shall not require the ramp length to exceed 15 ft. A recommended maximum running slope of 7.5% is recommended for design to allow for variability during construction, since construction tolerance is not allowed.
 3. **Cross Slope.** The cross slope of parallel curb ramps within the Pedestrian Access Route shall not exceed 2%. A typical cross slope of 1.5% is recommended for design to allow for construction tolerance.
 4. **Turning Space.** A 4 ft. x 4 ft. minimum (5 ft. x width of sidewalk is preferred) turning space shall be provided between the parallel ramps to allow the pedestrian to turn and cross the

street. The maximum running slope of the turning space is 2%. A running slope of 1.5% is recommended for design to allow for construction tolerance. The maximum cross slope of the turning space at a stop or yield-controlled intersection is 2%. The cross slope at intersections without stop or yield control shall not exceed 5%. The cross slope of the turning space at midblock crossings can match the street or highway running slope. If the turning space is confined (by a building or other adjacent feature that would impact a pedestrian turning) on two or more sides, the turning space shall be 4 ft. x 5 ft. minimum. The 5 ft. dimensions shall be provided in the direction of the pedestrian street crossing.

D. Blended Transitions.

1. **General.** Blended transitions are raised pedestrian street crossings, depressed corners, or similar connections at the level of the sidewalk and the pedestrian street crossing that have a running slope of 5% or less.
2. **Running Slope.** Provide the flattest running slope possible on blended transitions, while maintaining adequate drainage. The maximum running slope of blended transitions is 5%.
3. **Cross Slope.** The cross slope of blended transitions within the Pedestrian Access Route and at a stop or yield-controlled intersection shall not exceed 2%. A cross slope of 1.5% is recommended for design to allow for construction tolerance. The cross slope at intersections without stop or yield control shall not exceed 5%. The cross slope at midblock crossings can match the street or highway running slope. When the blended transition cross slope must exceed 2% in order to match a roadway grade greater than 2% at the end of the blended transition, transition the blended transition to match the roadway grade. Spread the transition evenly over the length of the blended transition. See Figure 6-10.

- E. **Diagonal Curb Ramps.** A single diagonal curb ramp is not permitted to serve two pedestrian street crossings on a corner. Single diagonal curb ramps must be approved by the ECM Administrator and will only be considered as part of an alteration project where existing physical site constraints prevent two curb ramps from being installed. Diagonal curb ramps are not desirable because they can provide directional cues that lead pedestrians, especially those that are blind or have low vision, into the middle of an unsafe intersection.

6.3.4. Detectable Warning Surfaces (DWS)

Detectable warning surfaces shall consist of truncated domes aligned in a square or radial grid pattern. Detectable warning surfaces shall be provided where a curb ramp, landing, or Shared Use Path connects to a pedestrian street crossing, railroad crossing, traffic island or median. Detectable warning surfaces shall be made of cast iron with a patina natural finish and in accordance with the requirements of PROWAG Section R305. See SD_2-40, SD_2-41, SD_2-42, and SD_2-50 for details. See CDOT standard drawings M-608-1 for location and placement of DWS.

6.3.5. Medians/Pedestrian Refuge Islands

- A. **Clear Width.** The minimum clear width of Pedestrian Access Routes contained within a median or pedestrian refuge island is 5 feet.
- B. **Grade.** The grade of the Pedestrian Access Route through medians and pedestrian refuge islands shall comply with the running slope requirements for crosswalks. See Section 6.3.2.
- C. **Cross Slope.** The cross slope of the Pedestrian Access Route through medians and pedestrian refuge islands shall comply with the cross slope requirements for crosswalks. See Section 6.3.2.

-
- D. **Curb Ramps.** Curb ramps and blended transitions in medians and pedestrian refuge islands shall meet the requirements of Section 6.3.3.
 - E. **Detectable Warning Surfaces.** When a cut-through pedestrian refuge island is 6 feet wide or greater from the face of curb to face of curb, Detectable Warning Surfaces shall be installed. When installed, the Detectable Warning Surfaces must be separated by a surface without Detectable Warning Surface that is a minimum of 2 feet in length (parallel to pedestrian travel). If this 2-foot space cannot be provided, Detectable Warning Surfaces shall not be installed because the island is not wide enough to be considered a pedestrian refuge island.
 - F. **Pedestrian Signals.** Where pedestrian signals are provided and the pedestrian crossing phase is not designed to be long enough to permit crossing across the entire street, additional pushbuttons complying with Section 6.3.6 should be provided in the pedestrian refuge islands to actuate the pedestrian phase in order for pedestrians to complete the crossing.

6.3.6. Pedestrian Signals/Pushbuttons

- A. **General Requirements.** Requirements for application of pedestrian signals shall be in accordance with Section 4.03 of the MUTCD. Where installed, including at Shared Use Path crossings, all accessible pedestrian signals and pushbuttons shall be designed in accordance with Sections 4E.08 through 4E.13 of the latest version of the Manual on Uniform Traffic Control Devices for Streets and Highways (MUTCD). See CDOT standard drawings S-614-45 for guidance on location of pedestrian pushbuttons.
- B. **Applicability in Alterations.** Per PROWAG requirements, if the existing signal controller and software are altered, or if the existing signal head is replaced, the pedestrian pushbuttons and pedestrian signal heads shall be updated to meet the accessible pedestrian signal requirements contained in this section, unless a deviation is approved by the ECM Administrator.
- C. **Pedestrian Signal Phase Timing.** All pedestrian signal timing shall be based on a pedestrian clearance time that is calculated using a pedestrian walking speed of 3.5 ft/s or less and a crossing distance from the end of the curb ramp to the far side of the traveled way or the near side of a pedestrian refuge island with secondary pushbutton.
- D. **Pushbutton Separation.** Pedestrian pushbuttons shall be spaced a minimum of 10 feet apart to allow for pedestrians who are blind or have low vision to identify the correct crosswalk. If it is not feasible for the pedestrian pushbuttons to be spaced 10 feet apart, they may be placed closer than 10 ft apart or on the same pole. In these cases, the accessible pedestrian signals shall use speech messages. See Section 6.3.6.G.
- E. **Pushbutton Locations.** Pushbuttons should be located as close as possible to the curb ramp they are servicing and be adjacent to a clear and level (< 2% slope in all directions) platform. The pushbutton should be located within 5 ft. of the edge of the far crosswalk line and between 1.5 ft. to 6 ft. from the face of the curb or edge of pavement. Where there are physical constraints that make locating the pushbutton within 6 feet from the face of curb or edge of pavement infeasible, they should not be located farther than 10 feet from the face of curb or edge of pavement.
- F. **Pushbutton Mounting Heights and Reach Length.** Pushbuttons shall be mounted between 42 inches and 48 inches above the surface of the accessible route. The preferred mounting height is 42 inches. The pushbutton should not require a pedestrian to reach more than 10 inches to activate it. See Section 6.3.10.B.2.
- G. **Accessible Pedestrian Signals (APS).** Accessible Pedestrian Signals shall have audible and vibrotactile walk indications located on the pushbutton, locator tones, and tactile arrows.

-
1. Where pedestrian pushbuttons on one corner are separated by at least 10 feet, the audible walk indication shall be a percussive tone. Where two accessible pedestrian signals on one corner are on the same pole or separated by less than 10 feet, the audible walk indication shall be a speech message patterned after the model, "Broadway. Walk sign is on to cross Broadway."

6.3.7. Shared Use Paths

Shared Use Paths are facilities on separate right-of-way, easements, or tracts or otherwise physically separated from roadways that are designed for use by bicycles, pedestrians, and other non-automotive modes of recreation and transportation. Because these facilities are used by pedestrians, they shall be accessible and in compliance with the requirements of this chapter. Shared Use Paths are also called Multi-Use Paths in other ECM Chapters. The two terms are synonymous.

- A. **General.** Design of accessible Shared Use Paths should comply with the requirements in the ECM. Designers should also refer to the current version of the AASHTO Guide for the Development of Bicycle Facilities for additional design guidance.
- B. **Clear Width.** The requirements of a Pedestrian Access Route shall be met for the full width of the Shared Use Path, i.e. the entire width of the Shared Use Path must be fully accessible. The minimum clear width of a Shared Use Path is 10 ft. See Section 2.5.7.
- C. **Grade.** The grade of a Shared Use Path within or adjacent to public roadways shall be less than or equal to the adjacent street grade. Whenever feasible, the grade of the Shared Use Path shall be less than or equal to 5%.
- D. **Cross Slope.** The cross slope of Shared Use Paths shall not exceed 2%. A cross slope of 1.5% is recommended for design to allow for variability during construction.
- E. **Curb Ramps.** Curb ramps on Shared Use Paths shall meet the requirements of Section 6.3.3, except that the width of the curb ramp shall be equal to the full width of the Shared Use Path.

6.3.8. Transit Stops

Transit stops and facilities shall comply with requirements of Section 2.5.4 and those of the transit provider.

- A. **Boarding and Alighting Areas.**
 1. **Location.** Wherever feasible, transit stops should be located where the adjacent street grade is less than 2.5% to facilitate passenger boarding. Bollards and other potential obstructions shall be located so as not to protrude into the boarding and alighting area or Pedestrian Access Route or obstruct the boarding process.
 2. **Surface.** The surface of transit stops shall meet the requirements of Section 6.3.1.F.
 3. **Connectivity.** Transit platforms, shelters, and boarding/alighting areas shall be connected to streets, sidewalks, and Pedestrian Circulation Paths by accessible Pedestrian Access Routes.
 4. **Dimensions.** Boarding and alighting areas shall provide a minimum clear length of 8 ft. measured perpendicular to the curb and a minimum clear width of 5 ft. measured parallel to the roadway. See Figure 6-11.
 5. **Slope.** The slope of the boarding and alighting area parallel to the roadway should be the same as the roadway grade. The maximum running slope of the boarding and alighting area perpendicular to the roadway is 2%. A running slope of 1.5% is recommended for design to allow for construction tolerance. See Figure 6-11.

6. **Detectable Warning Surfaces.** Detectable warning surfaces are not required at boarding and alighting areas for bus-only transit stops. They are required for boarding and alighting areas for rail vehicles and buses AND rail vehicles.
- B. **Transit Shelters.** Transit shelters shall be connected to boarding and alighting areas by Pedestrian Access Routes. The boarding and alighting area may be located either within or outside of the shelter. Transit shelters shall provide a minimum 2.5 ft. x 4 ft. clear space entirely within the shelter. If seating is provided within the shelter, the clear space shall be located at one end of the seating or shall not overlap the area within 1.5 ft. of the front of the seating. The clear space shall have a running slope consistent with the grade of the adjacent Pedestrian Access Route and cross slope of 2% maximum. See Figure 6-11.

Figure 6-11. Boarding and Alighting Area Connection to Transit Shelter

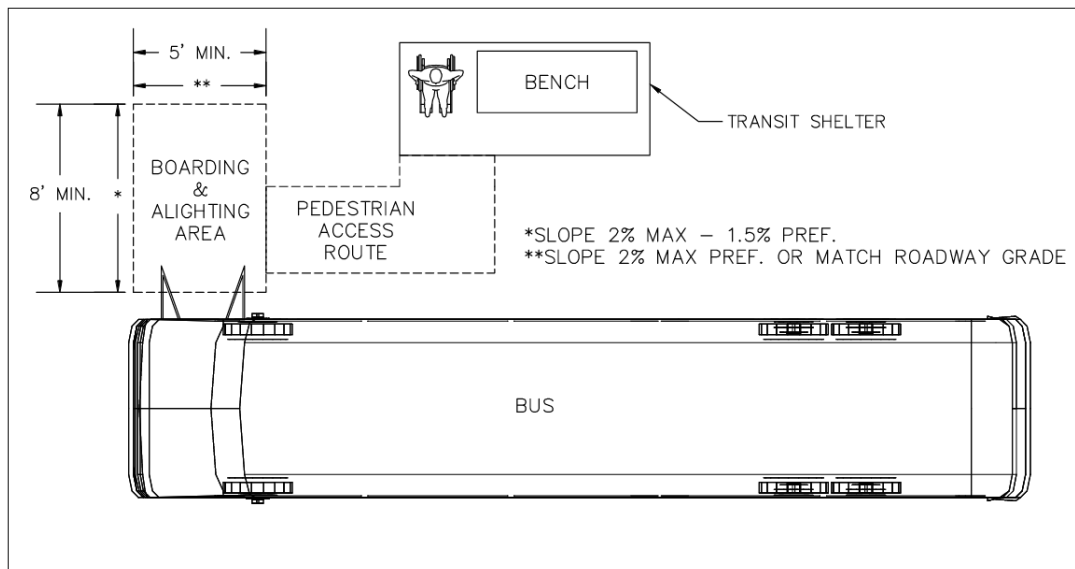

6.3.9. Pedestrian Over/Underpasses

- A. **General.** Provide Pedestrian Access Routes on overpasses and underpasses to connect with Pedestrian Access Routes on both sides of the structure. If pedestrian bridges over waterways are installed as part of Pedestrian Access Routes or Shared Use Paths, they shall comply with the requirements of a Pedestrian Access Route.
- B. **Ramps, Lifts, Elevators.** If the approach slopes of the overpass or underpass exceed 5%, then a ramp, lift, or elevator shall be provided to provide access.

6.3.10. Ancillary Elements

- A. **Signage (Pedestrians).** Signs providing directions, warnings, or other information for pedestrians only, excluding transit signs, shall comply with PROWAG R410 in addition to the MUTCD with revisions and supplements.
- B. **Operable Parts.** Operable parts consist of pedestrian signals, pushbuttons, and other similar elements that are to be operated by pedestrians.

1. **Clear Space.** Provide a 2.5 ft. x 4 ft. minimum clear space adjacent to the operable part. The cross slope of all sidewalk contained within the Pedestrian Access Route shall not exceed 2%. A cross slope of 1.5% is recommended for design to allow for construction tolerance. The running slope of the clear space shall match the grade of the adjacent Pedestrian Access Route.
2. **Height/Reach Ranges.**
 - **Forward Reach:** An operable part shall be located between 15 in. and 48 in. above the finished surface when a forward reach is required to activate the operable part. An obstruction is not allowed between the operable part and the clear space. See Figure 6-12.

Figure 6-12. Forward Reach Range

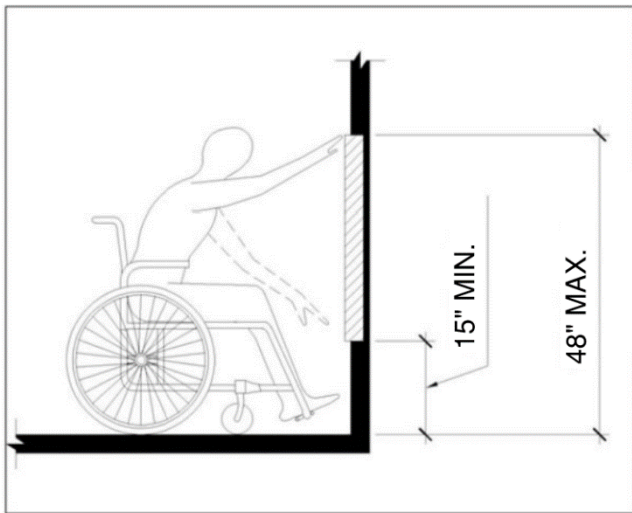

- **Side Reach:** An operable part shall be located between 15 in. and 48 in. above the finished surface when a side reach is required to activate the operable part. An obstruction is allowed between the operable part and the clear space if the obstruction protrudes less than 10 inches from the operable part. See Figure 6-13.

Figure 6-13. Side Reach Range

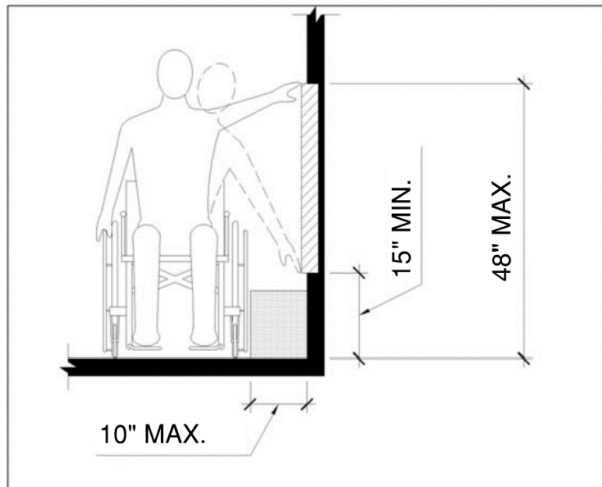

3. **Operation.** Operable parts shall be able to be operated with one hand and shall not require tight grasping, pinching, or twisting of the wrist. The maximum force required to operate the operable parts is 5 pounds.
4. **Mailboxes.** Both single and cluster mailboxes shall be located along an accessible Pedestrian Access Route within accessible reach ranges and with clear spaces in accordance with the requirements of this section. Mailbox locations must also comply with U.S. Postal Service and other requirements. See Section 4.4.
5. **Elements not Permitted in ECM.** The items listed below are not permitted by the ECM without a deviation approved by the ECM Administrator. If a deviation is approved, the designer shall refer to PROWAG for specific accessibility requirements.
 - Street furniture other than at transit stops
 - On-Street Parking (Marked or Metered)
 - Access Aisles (Marked or Metered On-Street Parking or Passenger Loading Zones)
 - Parking Meters and Pay Stations
 - Passenger Loading Zones
 - Stairs, Elevators, Escalators, and Lifts
 - Doors, Doorways, and Gates

6.3.11. Pedestrian Access Routes in Work Zones during Construction and Maintenance

Pedestrian access in Work Zones and Temporary Traffic Control (TTC) Zones shall be provided in accordance with MUTCD Section 6D.01.04, *"If the TTC zone affects the movement of pedestrians, adequate pedestrian access and walkways shall be provided. If the TTC zone affects an accessible and detectable pedestrian facility, the accessibility and detectability shall be maintained along the alternate pedestrian route."* Pedestrian accommodation in TTC zones shall not conflict with adopted CDOT Traffic Control Standards.

- A. **Planning for Pedestrians in Temporary Traffic Control (TTC) Zones.** Planning for pedestrians should be incorporated in the development of Traffic Control Plans for all projects within or adjacent to public roadways. In some cases, pedestrian demand will be low and accommodation measures will be

minimal. In other cases where pedestrian demand is high, dedicated temporary pedestrian facilities will be required. In accordance with MUTCD Section 6D.01.07, *"The following three items should be considered when planning for pedestrians in TTC zones:*

1. *Pedestrians should not be led into conflicts with vehicles, equipment, and operations.*
2. *Pedestrians should not be led into conflicts with vehicles moving through or around the worksite.*
3. *Pedestrians should be provided with a convenient and accessible path that replicates as nearly as practical the most desirable characteristics of the existing sidewalk(s) or footpath(s)."*

- B. **Approaches to accommodating pedestrians in work zones.** Technical requirements of Pedestrian Access Routes are also applicable in temporary work zones to the extent feasible. In order, the preferred methods for maintaining or providing Pedestrian Access Routes in TTC Zones are:
1. Maintain the existing pedestrian facilities (sidewalks, footpaths, etc.) whenever feasible.
 2. When the existing Pedestrian Access Route must be closed or blocked, develop an Alternate Pedestrian Route and Pedestrian Circulation Path parallel to the existing pedestrian facility on the same side of the street.
 3. When a parallel alternative Pedestrian Access Route cannot be developed on the same side of the street, an alternative pedestrian route (detour) may be provided on the other side of the street or outside of the TTC zone.

- C. **Traffic Control Devices.** All barricades, signs, and other temporary traffic control devices used to protect and direct pedestrians in TTC Zones shall be compliant with the MUTCD. The temporary facilities shall be detectable and include accessibility features consistent with the features of the existing pedestrian facilities. Pedestrian barriers and channelizing devices shall be detectable.

Pedestrian barricades should be placed between the Pedestrian Access Route and the work site in a location that protects pedestrians from hazards and provides guidance to the location of the alternate pedestrian route.

- D. **Short Duration Monitoring.** For short durations, such as those required for moving equipment or traffic control set-up and phase changes, the Pedestrian Access Route may be monitored by construction personnel who can provide guidance and direction to pedestrians until the Pedestrian Access Route through the work zone is restored or completed.

(Res. No. 20-222 , 6-23-20)

6.4. INSPECTION AND ACCEPTANCE

Inspection and acceptance of all accessible pedestrian facilities shall be based on the requirements in this chapter and in accordance with Chapter 5 and Appendix J. According to the ADA and PROWAG, all portions of the Pedestrian Access Route and associated elements must be accessible. Pedestrian facilities may be inspected at one or more locations, as determined by the project inspector, to verify that the facilities meet the requirements of this chapter. Standard Pedestrian Access Route and Curb Ramp Inspection Forms will be used for inspection and acceptance.

Table 6-3 summarizes the requirements for the most common accessible pedestrian elements. In no case shall the minimum, maximum, or ranges be deviated from in design without a deviation approved by the ECM Administrator. The construction tolerances shown are ONLY applicable during construction. Designers are encouraged to utilize design values greater than the minimums and less than the maximums to reduce noncompliant and unacceptable work during construction.

Table 6-3. - Common Design Values and Construction Tolerances

Created: 2021-06-08 11:35:51 [EST]

(Supp. No. 2)

Element	Design Values			Construction Tolerance
	Minimum	Maximum	Range	
P.A.R. Width	4 ft. ¹	—	—	- ¼"
P.A.R. Grade	N/A ²	5.0% ³	—	+0.5%
P.A.R. Cross Slope	N/A ²	2.0%	—	+0.5%
Ramp Run Slope	—	—	5.0—8.3%	None
Ramp Run Rise	N/A	2.5 ft. ⁴	—	+ ¼"
Ped. Street Crossing Cross Slope	N/A ²	2.0% ⁵ 5.0% ⁶ Adj. Str. Gr. ⁷	—	+0.5%
Ped. Street Crossing Running Slope	N/A ²	5.0%	—	+0.5%
Curb Ramp Width	4 ft. ^{8,13}	—	—	- ¼"
Curb Ramp Cross Slope	N/A ²	2.0% ⁹	—	+0.5%
Curb Ramp Running Slope	—	—	5.0—8.3%	None
Curb Ramp Counter Slope	N/A ²	5.0%	—	+0.5%
Curb Ramp Turning Space Slopes	N/A ²	2.0% ¹⁰	—	+0.5%
Curb Ramp Flare Slope	N/A	1'-6" Flare ¹¹ 10.0% ¹²	—	+0.5% ¹²
Shared Use Path Width	10 ft.	—	—	- ¼"
Shared Use Path Grade	N/A ²	5.0% ³	—	+0.5%
Shared Use Path Cross Slope	N/A ²	2.0%	—	+0.5%

NOTES:

1. Minimum width for Pedestrian Access Route. Design minimum should be per design criteria in Chapter 2.
2. No minimum slope or grade specified. But positive drainage without ponding should be ensured through combination of grade and cross slope.
3. Where adjacent street grade is greater than 5.0%, P.A.R. grade may equal adjacent street grade.
4. Consecutive Ramp Runs with 2.5 ft. maximum rise may be separated by landings.
5. At intersections/approaches with stop or yield control.
6. At intersections/approaches without stop or yield control, including traffic signals.
7. At mid-block crossings.
8. Minimum for accessibility. Should also be equal to approach sidewalk widths.
9. At top of curb ramp. Transition to match compliant crosswalk cross slope at bottom of ramp.
10. Slope in any direction. May match adjacent street grade at bottom of ramps.

Created: 2021-06-08 11:35:52 [EST]

(Supp. No. 2)

-
11. Where curb ramp flare is protected from cross travel (detached sidewalks).
 12. Where curb ramp flare is in Pedestrian Circulation Path (attached sidewalks).
 13. For Shared Use Paths, curb ramp width equals the full Shared Use Path width.

(Res. No. 20-222 , 6-23-20)

Appendix A REFERENCES

Adams County, Colorado: "Development Standards and Regulations", January 2004.

American Association of State Highway and Transportation Officials: "A Policy on Geometric Design of Rural Highways"

American Association of State Highway and Transportation Officials: "Guide Specifications for Design of Pedestrian Bridges"

American Association of State Highway and Transportation Officials: "Standard Specifications for Highway Bridges"

American Association of State Highway and Transportation Officials: "LRFD Bridge Design Specifications"

American Association of State Highway and Transportation Officials: "LRFD Bridge Construction Specifications"

American Association of State Highway and Transportation Officials: "Roadside Design Guide"

American Association of State Highway and Transportation Officials: "Standard Specifications for Transportation Material and Method of Sampling and Testing, Parts I and II"

City of Colorado Springs, Colorado: "Drainage Criteria Manual, Volumes 1 and 2"

City of Colorado Springs, Colorado: "Standard Specification Manual"

City of Colorado Springs, Colorado: "Subdivision Policy Manual"

City of Fort Collins, Colorado: "Storm Drainage Design Criteria and Construct Standards", May 1984

Colorado Department of Transportation: "Standard Specifications for Road and Bridge Construction"

Colorado Department of Transportation: "Bridge Manual, Volumes I and II"

Colorado Department of Transportation: "M&S Standards"

Douglas County, Colorado: "Roadway Design and Construction Standards", July 2003

El Paso County, Colorado: "Major Transportation Corridor Plan", August 3, 2004

Federal Highway Administration: "Roundabouts: An Informational Guide", 2010

Jefferson County, Colorado "Roadway Design and Construction Manual", February 2000

Larimer County, Colorado: "Road Manual", January 2000

U.S. Department of Transportation: "Manual on Uniform Traffic Control Devices (MUTCD)"

Soil Conservation Service (SCS): "Procedure for Determining Peak Flows in Colorado"

The American Society for Testing and Material (ASTM): "The Annual Book of ASTM Standards"

Appendix B TRANSPORTATION IMPACT STUDY GUIDELINES

(Supp. No. 2)

Created: 2021-06-08 11:35:52 [EST]

B.1. GENERAL

These Transportation Impact Study (TIS) guidelines are established to help ensure a standard process, set of assumptions, set of analytic techniques, and presentation format to be used in the preparation of the TIS. All TISs prepared for the County shall be prepared in conformance with these guidelines.

B.1.1. Types of Study

- A. **Master TIS.** Where large, complex projects (big box retail or residential developments over 100 acres) are planned or a project is phased over a multi-year build-out, it may be appropriate to prepare a Master TIS for the initial action followed by periodic updates for specific phases. The Master TIS must include overall phasing of improvements to coincide with project phasing.
- B. **Individual Site TIS.** An individual site TIS is prepared for a project that stands alone or is a phase of a master development. It can be for a new use in an existing or remodeled building, the construction of a new building (either single occupant or multi-user), construction of multiple buildings, or the construction of new residential development.

B.1.2. Levels of Analysis

For an Individual Site TIS, the following levels of analysis apply:

- A. **Full TIS.** A full TIS is required if one or more of the following conditions occur:
 - Vehicular Traffic: The site-generated traffic exceeds 1,000 trips/day or 100 peak-hour trips, or new high-volume access to an arterial roadway or State Highway is proposed.
 - Pedestrian Traffic: Paved pedestrian facilities exist or will be constructed on or adjacent to the site, or the proposed use will generate an increase in new pedestrian traffic.
 - Bicycle Traffic: Paved bicycle lanes or paths exist or will be constructed on or adjacent to the site, or the proposed use will generate an increase in new bicycle traffic.
 - When the site plan does not significantly comply with the Comprehensive Plan or the MTCP.
- B. **Intermediate TIS.** An Intermediate TIS may be considered instead of a Full TIS if all the following requirements are met:
 - Vehicular Traffic: Daily vehicle trip-end generation is between 501 and 1,000 inclusive, the peak hour trip generation is between 51 and 100, no high volume access to arterials or State Highways are proposed, and the Level of Service (LOS) of the adjacent facility when the development is completed equals or exceeds the minimum allowable LOS standard established for that facility.
 - Pedestrian Traffic: No paved pedestrian facilities exist or will be constructed on or adjacent to the site, or the proposed use will not generate any new pedestrian traffic.
 - Bicycle Traffic: No paved bicycle lanes or paths exist or will be constructed on or adjacent to the site, or the proposed use will not generate any new bicycle traffic.
- C. **Transportation Memorandum.** A Traffic Memorandum may be considered if all the following requirements are met:
 - Vehicular Traffic: Daily vehicle trip-end generation is less than or equal to 500, or the peak hour trip generation is between 21 and 50, and the proposed access is for local roadways or minor collector roadways only.

-
- Pedestrian Traffic: Paved pedestrian facilities exist or will be constructed on, or adjacent to, the site; or, the proposed use will not generate an increase in new pedestrian traffic.
 - Bicycle Traffic: Paved bicycle lanes or paths exist or will be constructed on, or adjacent to, the site; or, the proposed use will not generate an increase in new bicycle traffic.

D. **No TIS Required.** No TIS is required if all of the criteria below are satisfied:

- Vehicular Traffic: (1) Daily vehicle trip-end generation is less than 100 or the peak hour trip generation is less than 10; (2) there are no additional proposed minor or major roadway intersections on major collectors, arterials, or State Highways; (3) the increase in the number of vehicular trips does not exceed the existing trip generation by more than 10 peak hour trips or 100 daily trip ends; (4) the change in the type of traffic to be generated (i.e., the addition of truck traffic) does not adversely affect the traffic currently planned for and accommodated within, and adjacent to, the property; (5) acceptable LOS on the adjacent public roadways, accesses, and intersections will be maintained; (6) no roadway or intersection in the immediate vicinity has a history of safety or accident problems; and (7) there is no change of land use with access to a State Highway.
- Pedestrian Traffic: Paved pedestrian facilities exist or will be constructed on, or adjacent to, the site; or, the proposed use will not generate any new pedestrian traffic.
- Bicycle Traffic: Paved bicycle lanes or paths exist or will be constructed on, or adjacent to, the site; or, the proposed use will not generate any new bicycle traffic.

B.1.3. Revisions and Updates

An approved TIS that has been prepared in the last three years may be revised or updated where a proposed access is changed or a change in the proposed action may result in new trip generation that exceeds the original trip generation estimates. An amendment letter addressing the changes may be accepted provided the letter adequately addresses: (1) an estimate of site trip generation, (2) existing site trip generations, (3) the differences between anticipated estimates and existing trip generation, and (4) changes to the bicycle or pedestrian facilities. If the original TIS is older than three years, an entirely new TIS shall be prepared.

B.2. TIS PARAMETERS

A TIS shall include the following information.

B.2.1. Project Description

A description of the proposed project shall be prepared and include the type of land use and size of the proposed project (e.g., number of dwelling units of building square footage, etc.). Any proposed phasing shall be discussed and the anticipated completion date established. A figure depicting the proposed site plan shall also be included and the proposed vehicular access location shall be described. This section of the TIS shall also include a description of how pedestrians and bicycle travel will be accommodated within the proposed site plan. This shall include a discussion of types of sidewalks (attached/detached), pathways, and connections to local and perimeter destinations.

B.2.2. Analysis Horizons

Three study horizons are required for a Master TIS analysis: the existing (current), the short-range (short-range) and the long-range build-out (20-25 years). An Individual TIS analysis shall be based on build-out.

- A. **Existing Horizon.** The intent of completing an analysis of the existing (current) study horizon is to establish a baseline of traffic conditions.

-
- B. **Short-Range Horizon.** The intent of the short-range planning horizon is to investigate the immediate impacts of the completed, proposed project on the existing and committed roadway network. The short-range planning horizon year is defined as one year after the full occupancy of the project. If the project is proposed to occur over multiple phases, each phase shall be evaluated for impacts one year after the occupancy of the phase for the short-range analysis.
- C. **Long-Range Horizon.** The third planning horizon is the long-range planning horizon. It shall be based on the current MTCP planning horizon and related modeling. The model shall be updated based on existing counts where necessary. In such situations, the current counts shall be increased by application of a growth rate established by the ECM Administrator. The intent of the long-range planning horizon is to evaluate the implications of the fully developed project on the long-range traffic condition. This study horizon is for the ECM Administrator's use as an indicator of traffic for planning purposes and the determination of the necessary right-of-way.

B.2.3. Study Area

The limits of the transportation network to be studied shall be based on the size and extent of the proposed development, the existing and future land uses, and traffic conditions on and near the site.

The limits of the study area shall be agreed to by the ECM Administrator before preparing the TIS. The Master TIS shall generally establish the study area for all subsequent Individual TISs.

A. **Study Area Basis for Master TIS.**

- All adjacent and internal collector and arterial roadways;
- Offsite collector and arterial links within the study area that are impacted by 10 percent or more by the project;
- Continuity and adequacy of pedestrian and bicycle facilities to the nearest attraction (existing or planned);
- Access to the most direct public transportation services facility or public transportation services route where public transportation services are available; or
- Any pedestrian routes within 2 miles of a school.

B. **Study Area Basis for Individual Full TIS.**

- All adjacent roadways, intersections, and high-volume accesses;
- Nearest offsite major intersection(s);
- Offsite collector and arterial links within the study area that have impacted intersections as defined below or provide the primary connections between the project and urban services;
- Internal public roads, including establishing the road classification;
- Additional offsite major intersections where: the project contributes a 10 percent impact (during either the A.M. or P.M. peak hour) to any approach leg of the intersection where the intersection is operating at a LOS of C or better in the Short-Range Horizon, or the project contributes a 5 percent impact (during either the A.M. or P.M. peak hour) to any approach leg of the intersection where the intersection is operating at a LOS of D or worse in the Short-Range Horizon;
- Additional offsite minor intersection where the project contributes a 30 percent increase in volume (during either the A.M. or P.M. peak hour) to any approach leg of the intersection where any existing leg of the intersection is currently operating at a LOS of E or worse;
- Pedestrian and bicyclist destinations (existing or planned) to the nearest attraction;

-
- Access to the most direct public transportation services facility or public transportation services route (existing or planned) within 1,320 feet of the site where public transportation services are available; or
 - Any pedestrian routes within 2 miles of a school (residential land uses only).

C. Study Area Basis for Individual Intermediate TIS.

- All adjacent roadways, intersections, and high-volume accesses;
- The nearest offsite major intersection(s) only if: the project contributes a 10 percent impact (during either the A.M. or P.M. peak hour) to any approach leg of the intersection where the intersection is operating at a LOS of C or better in the Short-Range Horizon, or the project contributes a 5 percent impact (during either the A.M. or P.M. peak hour) to any approach leg of the intersection where the intersection is operating at a LOS of D or worse in the Short-Range Horizon,
- Offsite collector and arterial links within the study area that have impacted intersections;
- Internal public roads, including establishing the road classification;
- Pedestrian and bicyclist destinations (existing or planned) to the nearest attraction;
- Access to public transportation services where available; or
- Any pedestrian routes within 2 miles of a school (residential land uses only).

D. Traffic Memorandum.

- All adjacent roadways, intersections, and high-volume accesses;
- Internal public roads, including establishing the road classifications;
- Continuity and adequacy of pedestrian and bicycle facilities adjacent to the site; or
- Access to the most direct public transportation services facility or public transportation services route adjacent to the site.

B.2.4. Evaluation Elements

- A. **Evaluation Elements for a Master TIS.** The purpose of the Master TIS is to provide a general sense of the overall impacts to the transportation system and to identify the larger scale improvement needs necessitated by the proposed zoning (i.e., widening of arterials, connecting key gaps in the roadway system, etc.). For example, for a large development plan with a multi-phase build-out, the Master TIS would not only address the overall project, but also identify key measurable criteria that would trigger the construction of some incremental portion of the overall infrastructure improvement plan. Typically, with each phase of the project a new individual site TIS specific to that phase would be prepared. This new study would verify the accuracy of the original traffic projections, both on site and background, and check the criteria identified for infrastructure improvements and other pertinent information.

The key elements of the project impact assessment for a Master TIS shall include the following minimum evaluations:

- Conformity with the adopted MTCP and ECM;
- Peak hour link volume and LOS;
- Appropriateness of access locations;
- Multi-modal and Transportation Demand Management (TDM) opportunities;
- Pedestrian/bicycle requirements and improvements;

-
- Safety and accident analysis. Other items requested by the ECM Administrator in the Scoping Meeting; and
 - Neighborhood and public input issues.

In cases where a developer seeks vesting with a Site Specific Development Plan, the Master TIS is required to present all the detailed information required in an Individual Site Transportation Impact Study.

B. Evaluation Elements for a Full TIS. The key elements of the project impact assessment shall be specified by the ECM Administrator from the following list:

- Conformity with the adopted MTCP and ECM;
- Peak hour link volume and LOS;
- Peak hour intersection and access LOS;
- Appropriateness of access locations;
- Location and requirements for turn lanes or acceleration/deceleration lanes at accesses or intersections, including recommendations for taper lengths, storage length, acceleration/deceleration lengths, and other geometric design requirements;
- Sight distance evaluations and recommendations (intersection, stopping, passing);
- Multi-modal and TDM opportunities;
- Continuity and adequacy of pedestrian and bicycle facilities to the nearest attraction (existing or planned) within the study area;
- Recommended traffic control devices for intersections which may include two-way stop control, four-way stop control or yield signs, school flashes, school crossing guards, crosswalks, traffic signals, or roundabouts;
- Traffic Signal and stop sign warrants;
- Progression analysis for signalized intersections;
- Appropriateness of the existing roadway signing and striping;
- Safety and accident analysis;
- Other items as requested by the ECM Administrator in the Scoping Meeting; and
- Neighborhood and public input issues.

C. Evaluation Elements for an Intermediate TIS.

- The key elements of the project impact assessment shall be specified by The ECM Administrator from the following list:
- Conformity with the adopted MTCP and ECM;
- Peak hour link volume and LOS;
- Peak hour intersection and access LOS;
- Appropriateness of access locations;
- Location and requirements for turn lanes or acceleration/deceleration lanes at accesses or intersections, including recommendations for taper lengths, storage length, acceleration/deceleration lengths, and other geometric design requirements;

-
- Sight distance evaluations and recommendations (intersection, stopping, passing);
 - Continuity and adequacy of pedestrian and bicycle facilities to the nearest attraction (existing or planned) within the study area;
 - Recommended traffic control devices for intersections, which may include two-way stop control, four-way stop control or yield signs, school flashers, school crossing guards, crosswalks, traffic signals, or roundabouts;
 - Traffic signal and stop sign warrants;
 - Progression analysis for signalized intersections;
 - Appropriateness of the existing roadway signing and striping;
 - Safety and accident analysis;
 - Other items as requested by the ECM Administrator in the Scoping Meeting; and
 - Neighborhood and public input issues.
- D. **Traffic Memorandum.** The key elements of the project impact assessment shall be specified by the ECM Administrator from the following list:
- Peak hour link volume and LOS;
 - Peak hour access LOS;
 - Appropriateness of access locations;
 - Location and requirements for turn lanes or acceleration/deceleration lanes at the access, including recommendations for taper lengths, storage length, acceleration/deceleration lengths, and other geometric design requirements;
 - Sight distance evaluations and recommendations (intersection, stopping, passing);
 - Continuity and adequacy of pedestrian and bicycle facilities within the study area;
 - Appropriateness of the existing roadway signing and striping;
 - Other items as requested by the ECM Administrator in consultation with the applicant's traffic engineer; and
 - Neighborhood and public input issues.
- E. **Board of County Commissioners Rights Reserved.** The BOCC reserves the right and ability to review the cumulative impacts created by the proposed development and to require improvements to mitigate the impacts.

B.3. ASSESS TRAFFIC VOLUMES

B.3.1. Existing Traffic

- A. **Roadway Traffic Volumes/Traffic Counts.** Current A.M. and P.M. peak hour traffic counts as specified by the ECM Administrator shall be obtained for the roadways within the study area for one, non-holiday Tuesday, Wednesday, or Thursday. Each peak hour count shall be conducted over a two-hour period and shall include fifteen (15)-minute count data to clearly identify the peak hours.

Weekend counts and average daily counts on local roadways may also be required where appropriate when requested by the ECM Administrator. The DOT or CDOT average weekday traffic (AWT) counts

may be used when available. Pedestrian counts and bicycle usage should be obtained. Vehicle classification counts may be required.

In any case, these volumes shall be no more than one year old (from the date of application submittal). The source(s) of each of the existing traffic volumes shall be explicitly stated. Summaries of current traffic counts shall be provided. The ECM Administrator may require the use of seasonal adjustment factors depending on when data was collected and if the project is considered to be in an area of higher risk for lower levels of services (i.e., Tourism).

- B. **Intersection LOS.** A.M. and P.M. peak hour intersection LOS shall be determined for the existing collector and arterial signalized and unsignalized intersections within the transportation network to be studied. The analysis shall use procedures described in the Highway Capacity Manual. Factors for intersections will be by approach and those used for roadways will be by facility unless otherwise directed by the ECM Administrator.
 - 1. **Existing and Short-Range Horizon.** Use calculated peak hour factors or 0.85, whichever is higher, and
 - 2. **Long-Range Horizon.** A peak hour factor of 0.95 may be used for the Long-Range Horizon. Greater values may be used if approved by the ECM Administrator.
- C. **Roadway Links.** Roadway links shall be analyzed. Acceptable maximum traffic volumes allowed for the specific class of roadway are shown in Table B-1.

Table B-1. Threshold Capacity

Facility Type	Lanes	ADT Threshold Capacity (Urban/Rural)
Local (low volume)/Local (rural)	2	300/750
Collector-Non-Residential	2	20,000
Local (urban)/Minor Collector (rural)	2	3,000/1,500
Major Collector	2	10,000/3,000
Minor Arterial	4	20,000/10,000
Principal Arterial (4-lane)	4	40,000/40,000
Principal Arterial (6-lane)	6	40,000/40,000
Expressway (4-lane)	4	48,000/48,000
Expressway (6-lane)	6	48,000/48,000

B.3.2. Background Traffic

- A. **Short-Range Volume Projections.** The traffic forecast for the short-range planning horizon shall be the sum of existing traffic volumes plus cumulative development traffic from approved land use actions (projects with reserved intersection capacity established through a certified Full TIS), plus background growth (as adjusted to avoid duplicative consideration of the identified development traffic from the approved land use already considered). The cumulative development traffic shall be based, in part, on the A.M. and P.M. peak hour and (ADT) data established and accepted from planned and approved land use actions within and near the study area. The assumed baseline surface transportation network shall reflect existing facilities (without the proposed project improvements) plus any committed improvements within the study area.

The short-range planning horizon background traffic growth rate shall be based:

-
- Straight line projection for the build-out year between the existing traffic volumes and the MTCP model forecast, CDOT rates;
 - Historical traffic counts projected to the build-out year (at least three years of traffic data should be used for this); or
 - Area-wide traffic count analysis that considers traffic volume trends in the study area's circulation system and uses proportion/extrapolation methods.

B. Long-Range Volume Projection.

- Straight line projection for the build-out year between the existing traffic volumes and the MTCP model forecast, CDOT rates;
- Historical traffic counts projected to the build-out year (at least three years of traffic data should be used for this);
- Area-wide traffic count analysis which considers traffic volume trends in the study area's circulation system and uses proportion/extrapolation methods; or
- Growth rate agreed upon with the ECM Administrator.

B.3.3. Project Traffic

- A. **Trip Generation Rate.** Trip generation shall be calculated from the latest data contained within the Institute of Transportation Engineers' Trip Generation Manual. Other industry publications (such as the ITE Journal or other sources) may be approved by the ECM Administrator. Data limitations, data age, choice of peak hours (for the land use or adjacent roadway traffic), choice of independent variables, and choice of average rate versus statistically significant modification shall be discussed in the study when appropriate. When data is not available for a proposed land use or a modification is proposed, the Applicant must conduct a local trip generation study following procedures prescribed in the ITE Trip Generation Manual and provide sufficient justification for the proposed generation rate. This rate must be approved by the ECM Administrator prior to its use in the written study.
- B. **Preliminary Land Use Assumptions.** The trip generation values contained in studies submitted prior to the establishment of a site-specific development plan shall be based on the maximum number of dwelling units permitted for the approved land uses or the maximum trip generation rates for the non-residential development proposed land use action. When a TIS is being developed for a project with an established site-specific development plan, trip generation shall be based on actual dwelling unit counts and square footage(s) proposed on the final plan.
- C. **Trip Generation Table.** A Trip Generation Table, listing each type of land use within the site at build-out, the size and unit of measure for each land use, trip generation rates (total daily traffic, A.M. and P.M. peaks), directional splits for each in/out access, and the resultant total trips generated shall be provided. The data source shall include ITE land use code. Build-out land uses and trip generations shall be used for both the short-range and long-range planning horizons.
- D. **Committed Trips/Capacity.** The trip generation stated in the TIS will establish the maximum number of trips permitted entering and exiting the development. If the number of committed trips is reached prior to full occupancy, the ECM Administrator reserves the right to require from the sponsor, at the sponsor's expense, supplemental traffic analyses prior to the issuance of additional building permits. This information shall demonstrate that uncommitted capacity is available on the transportation network to serve the excessive trips, or that additional transportation mitigation improvements can be reasonably installed to maintain compliant operation with the excessive trips. If no additional capacity is available, or no reasonable mitigation conforming to the requirements of these roadway standards can be implemented, the owner shall obtain an exception from the ECM Administrator for the non-

conformity or scale back the intensity of the proposed land uses as needed to achieve compliance. If the project is fully occupied and it is determined that the approved land use action's traffic exceeds that which was included in the approved TIS, the ECM Administrator is authorized to require the property to conduct additional traffic analysis and provide additional mitigation measures.

- E. **Adjustments to Trip Generation.** Trip-making reduction factors may be used after first generating trips at full ITE rates. These factors fall into two categories: those that reassign some portion of generated trips to the background stream of traffic, and those that remove or move generated trips. In all cases, the underlying assumptions of the ITE trip generation rates must be recognized and considered before any reductions are used in the TIS. Two specific situations will be closely reviewed. The first is when the traffic study assumes rates where the collection of mixed uses, such as at a shopping center, result in lower peak hour trips than when applying individual rates to each land use. The second is when reductions in the trip generation rates are assumed based on reductions due to travel demand management.
1. **Pass-by Trips.** This first category may be considered when trips to the proposed development currently exist as part of the background traffic stream, referred to as a pass-by trip. Pass-by percentages identified in the ITE Trip Generation Manual will be considered with appropriate explanation and documentation. Pass-by traffic must remain assigned to driveways and access points, but should not be added to the background traffic stream. A technical appendix, table, or map that illustrates the re-division of pass-by trips is required.
 2. **Internal Site Trips/ Transportation Demand Management (TDM).** Analytic support documentation of internal site trips, public transportation services use, and TDM actions shall be provided to show how trip adjustments are derived. Optimistic assumptions regarding public transportation use and TDM actions will not be accepted unless accompanied by specific implementation proposals that will become a condition of approval. Such implementation proposals must have a high expectation of realization within a 5-year period after projection initiation.
- F. **Trip Distribution.** Trip Distribution must be documented in the TIS. It may be based on the professional engineer's judgment applied to one or more of the following: MTCP traffic volume projections, gravity model, market analysis, existing traffic flows, or applied census data. Regardless of the basis of the estimates, the procedures and rationale used in determining the trip distributions must be fully explained, documented, and approved by the ECM Administrator.
- G. **Trip Assignment.** The project traffic will be assigned to the roadway system according to the trip distribution. The resulting project site-generated traffic and total site traffic will be depicted on figures for each analysis horizon. These figures will include peak hour traffic volume information, plus daily traffic volume information. Separate maps or values are required when the trip distribution differs by more than 10 percent between the short-and long-range analysis horizons.

B.3.4. Total Traffic

The total traffic projections will be determined for each of the analysis horizons identified in the base assumptions. The total traffic projections will include the existing traffic, plus the future background traffic, plus the project generated traffic. The future total traffic projections will be depicted on figures for each study year. Based upon the total traffic projections, roadway standards, and MTCP, the applicant shall provide roadway functional classification recommendations.

B.4. ASSESS PROJECT IMPACTS

B.4.1. Project Impact Assessment

The key elements of the project impact assessment include evaluations of issues outlined for a specific Analysis Level.

A. **Project Impacts.** The key elements of the project impact analysis include:

- Generalized Daily Traffic Volume Level of Service
- Using the daily traffic volumes forecast and general daily level of service thresholds, a general evaluation should be made of the arterial roadway system for the short term and long-term horizon years. Incremental differences attributable to the land use action should be identified. A map showing generalized levels of service should be presented for each design year.
- For unsignalized intersections of 2 lane (and rarely on 4-lane) roads, where traffic on the main road is not stop controlled, an evaluation for the need for auxiliary speed change lanes is to be provided (reference Section 2.3.7.D).
- Peak Hour Intersection Level of Service
- An a.m. and p.m. peak hour intersection level of service analysis shall be conducted for each intersection, based on procedures specified in the Highway Capacity Manual. All level of service analysis worksheets shall be included in the Appendix.
- The principal objective of the intersection level of service traffic impact analysis is to identify whether the traffic from the proposed project when added to the existing plus short and long term planning horizon traffic will result in a significant impact and an unacceptable LOS. For definitional purposes, the threshold for acceptable LOS is not less than LOS D for peak hours.
- Significance for signalized intersections is defined as when the added project traffic causes an intersection to fail the minimum acceptable LOS standard; or when the background traffic conditions (without project traffic) causes an intersection to fail the minimum acceptable LOS standards; and when the project traffic causes more than a 2 percent increase in the intersection delay. Significance for unsignalized intersections is defined when backstacking to adjacent intersections would create impeded traffic flows and/or excessive congestion; when added project traffic is determined to create potential safety problems.

B. **Traffic Signals and Access Locations.** Traffic signals warranted by the land use action a signal warrant analysis (based on the MUTCD) shall be identified. The acceptability of the signal locations must be demonstrated through a signal progression (time-space) analysis. The analysis shall consider any existing access or intersection or a possible future signal location along the arterial for a distance of at least one mile in each direction of the proposed signal. A cycle length of between 80 and 120 seconds should be selected and agreed to by the ECM Administrator. A travel speed of 45 mph on majors and 35 mph on minors, unless the existing posted speed limit is less, must be used. A major arterial bandwidth of 50 percent and a minor arterial bandwidth of 40 percent are considered desirable, and must be used where existing conditions allow. Where intersections or other accesses have no signals presently, but are expected to have signals, a 60 percent mainline, 40 percent cross roadway, and cycle split should be assumed. Where more detailed information is available from turning movement projections, other split assumptions may be made.

Any access where a signal would reduce the desirable bandwidth shall be identified. In general terms, that access should remain unsignalized and have turning movements limited by access design or median islands, unless the impacts to traffic operation and safety are made worse. The implications of

the land use action upon the adequacy of the signal locations for each design year shall be provided. Distances between signalized intersections (centerline) shall be indicated. Signal progression worksheets (time-space diagrams) shall be included in the TIS Appendix.

The following signalization and access parameters shall also be addressed:

- Turn lane storage needs shall be identified for the "necessary" situation, based on projected turning volumes and AASHTO analytic techniques. Appropriate documentation of the calculations must be provided;
- The identification of project sight distance at the project entrances and all internal roadways shall be conducted. Line of sight triangles for determining sight distances and landscape restrictions shall be prepared and submitted.
- Appropriateness of acceleration or deceleration lanes.
- All proposed project entrances on arterials shall be evaluated as to whether they require acceleration lanes or deceleration lanes per the requirements presented in these Standards.

C. **Pedestrian and Bicycle Impact Evaluations.** Pedestrian and bicycle facility demand shall be identified and related items for discussion shall include:

- School routing plans shall be developed per the MUTCD between the project and all schools within 2 miles of the project boundary.
- The demand for pedestrian and bicycle facilities to serve high pedestrian activity areas with the land use shall be evaluated and properly accommodated for the planning of the project.
- The need for links of bicycle or pedestrian facilities to neighboring land uses or attractions (trails, etc.) within 1,320 feet or greater if applicable to unique pedestrian-oriented destinations) of the project site.
- Existing and proposed sidewalk width, separation from traffic, and space available for trees, public transportation services stops (if any), or other related elements (if any).
- Geometric improvements and recommended traffic control devices to accommodate pedestrians and bicyclists.

D. **Pedestrian and Bicycle Level of Service.** Existing and proposed pedestrian and bicycle facilities shall be evaluated for compliance with the following elements:

1. **Directness.** Walking distance to destinations like public transportation services stops, schools, parks, and commercial or activity areas shall be direct. Measurement of directness is the ratio of the actual distance to a destination via a sidewalk or pathway divided by the minimum distance characterized by a grid roadway system,
2. **Continuity.** The sidewalk/walkway system shall be complete, without gaps. The pedestrian corridor shall be integrated with the activities along the corridor and shall provide continuous access to destinations,
3. **Roadway Crossings.** Safety and comfort is essential while crossing roadways, intersections, and mid-block crossings. Factors that affect safety include number of lanes to cross, crossing delay for pedestrians, signal indication, cross-walks, lighting, raised medians, visibility, curb ramps, pedestrian buttons, convenience, comfort, and security,
4. **Visual Interest and Amenity.** Pedestrians enjoy visually appealing environments that are compatible with local architecture and include roadway lighting, fountains, and benches.

-
5. **Security.** Pedestrians shall be visible to motorists, separated from motor vehicles and bicycles, and under adequate roadway lighting.
 6. **Surface Condition.** Pedestrian facilities shall be free from obstructions, cracks, and interruptions.
- E. **Special Studies.** This section provides the ECM Administrator with opportunities to require specific focused traffic analyses that may be unique to the proposed land use action. The ECM Administrator will determine if special studies are required in a Scoping Meeting. These may include, but are not limited to, the following:
1. **Access Management.**
 - If a development is proposing a new access location on an arterial and an Access Management Plan does not exist, the ECM Administrator may require an Access Management Plan. Proposals to access roads classified as arterials and above shall require review through the Major Thoroughfares Task Force Process;
 - Access spacing;
 - Accident/safety concerns (accident statistics);
 - Truck routing;
 - Emergency and snow routes; and
 - Hazardous materials routes.
 2. **Neighborhood Transportation Impact Evaluation.** The TIS may be required to include a focused analysis of the potential project-related impacts on adjacent residential neighborhood quality of life issues, such as potential cut-through traffic and speeding/volume concerns. If it is determined that a neighborhood transportation impact evaluation is required, the following procedure shall be followed:
 - Examine existing transportation conditions within the neighborhood following the procedure as set forth for the transportation impact analysis. Daily and peak hour traffic volumes shall be collected for the local roadways to be included in the analysis;
 - Determine project-generated traffic for all modes within the neighborhood and show on a figure;
 3. **Determine total traffic projections for the local roadways.** This shall follow the same procedures as described earlier, including other projects and area-wide growth, if applicable:
 - Determine if the proposed project would create significant impacts to the residential roadways;
 - If necessary, develop measures including, but not limited to, traffic calming techniques, to mitigate any significant impacts; and
 - The neighborhood TIS shall also discuss how pedestrians and bicyclists would access the proposed project from the adjacent neighborhood(s), and the need for special facilities to enhance direct pedestrian and bicycle connectivity.
 4. **Sight Distance.** Sight distance concerns that are anticipated or observed which may impact access, intersection, or roadway operation and safety need to be discussed in the TIS. Recommendations regarding stopping sight distance, intersection sight distance, and passing sight distance needs shall be provided for detailing on the final development, site plan, or final construction plans.

B.5. DEVELOP MITIGATION MEASURES

When a project's vehicular impacts do not meet the minimum acceptable LOS standard, the TIS shall include feasible measures, which would mitigate the project's impacts. The mitigation measures are intended to be in addition to the minimum required improvements necessary to meet these standards. One goal of the mitigation measure(s) should be to minimize the demand for trips by single occupant vehicles and to increase the use of the alternative modes.

The intersection LOS shall be recalculated to reflect the effectiveness of the proposed mitigation measures and show that the project-related impacts have been reduced to an acceptable LOS. The LOS findings shall be shown in tabular form. The following mitigation categories are not listed in order of priority.

B.5.1. Transportation Demand Management Measures

Transportation Demand Management measures are designed to facilitate the use of alternate transportation modes in an effort to decrease demand on the roadway system by single occupant vehicles. A detailed description of the proposed TDM measures and implementation plan must be included in the TIS for any project seeking TDM-related trip reductions. If the TDM program is acceptable to The ECM Administrator, the total project vehicle trips may be reduced by an amount commensurate with applicable trip reduction policies.

A. Examples of TDM Measures.

- Vehicle trip reduction incentives and services offered by employers to encourage employees to utilize alternative modes of travel, such as carpooling, vanpooling, riding public transportation services, bicycling, walking, telecommuting, etc.;
- Vehicle trip reduction incentives and services affecting visitors to the project, such as shoppers, clients, patrons, etc.;
- Financial support for the capital or operating costs of enhanced public transportation services or vanpool service to the project;
- Provision of a mix of land uses in close proximity, facilitating trip making by walking, bicycling, or local shuttles;
- Provision of on-site facilities that encourage the use of alternate forms of transportation, such as bicycle lanes and amenities, enhanced pedestrian connections, telecommuting facilities, etc.; and
- Site trip cap and/or parking cap including trip-monitoring agreements.

B.5.2. Public Transportation Service

Suggested elements of a public transportation services program include:

- Contributions of equipment or funds to increase the capacity of existing public transportation systems,
- Public transportation shuttles provided by Applicant (e.g., bus, taxicab, van, etc.), and
- Contributions toward park and ride lots, public transportation services stations or centers.

B.5.3. Traffic Control

There are many ways to control traffic and enhance safety and mobility for motorists, pedestrians and bicyclists. Each component of a traffic control system must be viewed as a single unit in an overall network.

-
- A. **Medians.** Medians are grouped into three general types (i.e., raised, depressed, and flush) and are designed for both through traffic and access control.
 - B. **Signals.** Design of all traffic signals shall be in accordance with the MUTCD and the CDOT Standards and Specifications. Traffic signal plans shall be submitted to and approved by the ECM Administrator prior to initiating installation.
 - C. **Signing and Striping.** Signing and Striping plans are required for signing/striping of new roadways and re-signing/striping of existing roadways. All plans shall be prepared in accordance with the MUTCD and included with the final construction plans for review and approval.
 - D. **Traffic Control Plans.** Traffic control during construction shall be planned and performed in accordance with the MUTCD and be included with the final construction plans for review and approval.

B.5.4. Roadway Widening and Other Physical Improvements

Mitigation measures, which include roadway widening, and other physical improvements must be demonstrated to be physically feasible and must meet minimum ECM standards.

B.5.5. Roadway Restriping and Parking Regulations

The ECM Administrator must approve proposed striping and parking regulation mitigation(s). Generally, roadway restriping is not a preferred mitigation due to resulting parking impact. Therefore, any parking impacts should be clearly identified and proposed for mitigation to the extent feasible.

B.5.6. Geometric Improvements

Turn lanes and other auxiliary lane needs shall be identified for each access.

B.5.7. Traffic Calming

This section presents acceptable methods of neighborhood traffic calming for urban collector or rural minor collectors and local roads. This section also provides for specific design criteria for a number of traffic calming methods.

- A. **Intended Use.** The necessity or desire for traffic safety and calming stems from the perception that local and minor collector roadways are not always functioning as intended. These roadways should be low traffic volume roadways used for direct access to property. They are also intended as a system that is shared by vehicular, bicycle, and pedestrian traffic, in a manner that minimally impacts residents in these areas.

Traffic calming measures are intended to minimize these issues and return the quality of life to the neighborhood. Care must be taken by the designer so that the installation of traffic calming devices does not create unintended hazards that delay emergency response or jeopardize the safety of bicyclists, pedestrians, or motorists.

- B. **Traffic Calming for New Roadway Design.** New local and minor collectors roadways are to be designed to minimize cut-through traffic, high volumes, and high-speed operation and to maximize the efficiency of the roadway to provide vehicular access and bicycle and pedestrian traffic.
- C. **Roundabouts and Mini Roundabouts.** Roundabouts and Mini roundabouts are considered traffic control measures. These traffic control measures may be used in new or existing roadway design if the appropriate criteria are met.
- D. **Traffic Calming Design Criteria.** Table B-2 presents a brief list of traffic calming solutions and their intended uses. Traffic calming devices may only be used on local and minor collector roadways.

Table B-2. Traffic Calming Solutions

Device	Intended Use	Reference
Signals, Signs, and Striping	Creates a system that calms traffic through warnings, progression control, and highlighting surrounding land uses	Chapter 2, Transportation Facilities
Mini Roundabouts	An intersection device that can slow traffic through the use of specialized roadway geometry	Chapter 2, Transportation Facilities
Neckdowns	An intersection device that slows traffic through the use of narrowed roadway geometry	Standard Detail
Drop Off Zone for Schools	Creates a traffic calming condition by highlighting school bus operations, the presence of pedestrians and changes in roadway section	Standard Detail
Realigned Intersections	Creates a disruption in travel patterns by offsetting the standard intersection geometry	Chapter 2, Transportation Facilities

B.6. RECOMMENDATIONS AND REPORT CONCLUSIONS

B.6.1. Recommended Improvements

The findings of the TIS shall be provided in summary format, including the identification of any areas of significant impacts and recommended improvements/mitigation measures to achieve LOS standards.

- A. **Geometric Improvements.** The TIS shall include recommendations for all geometric improvements, such as pavement markings, signs, adding through or turn lanes, adding project access and assorted turn lanes, acceleration lanes, and changes in medians. Sufficient dimensions/data shall be identified to facilitate review. Anticipated right-of-way needs shall be identified.
- B. **Responsibility.** The location, nature, and extent of all transportation improvements recommended to achieve the required LOS for each analysis horizon shall be identified. In addition, the sponsor responsible to complete the improvements shall be identified.
- C. **Proposed Transportation Demand Management.** If TDM measures are recommended to mitigate the traffic impact of the proposed land use action, a specific TDM Implementation Proposal shall be developed and presented to the ECM Administrator. If accepted, this Implementation Proposal will become a condition of approval of the land use action requested. Each TDM Implementation Proposal shall be developed in conformance with the ECM Administrator's and the PPACG's Transportation Demand Management Program.
- D. **Summary Presentation.** A Recommended Improvements Summary Table shall be prepared. The recommended improvements identified on the Recommended Improvement Table shall be categorized as Master Planned, Background Committed, or Project Committed. Each project shall include a description of its location, the type of project, right-of-way needs (for roadways), and signal or turn lane improvements (for intersections). Commitment to funding and constructing each of the improvements shall be identified.

B.7. SIGNATURE AND APPROVAL BLOCK

El Paso County: County report review is provided only for general conformance with County standards and design criteria. The County is not responsible for the accuracy and adequacy of the data, analysis, or conclusions. The County through the approval of this document assumes not responsibility for completeness and/or accuracy of this document.

B.8. TRAFFIC REPORT STANDARDS

Traffic reports shall include the following unless the review engineer specifically waives them:

- Proposed classifications of all proposed internal roadways (e.g. "rural local road", "rural local low volume road", "urban minor arterial", etc.)
- Classification of all adjacent or impacted roadways per the MTCP. (e.g. "rural local road", "rural local low volume road", "urban minor arterial", etc.)
- Trigger points for the construction of all required future improvements including but not limited to turn lanes, signals, widenings, and openings or closings of accesses. ("Trigger points" are the conditions that, when met, will call for the construction of said improvements.) Cost estimates and escrow amounts can be determined at the final plat stage.
- For final plats, state definitively what improvements the developer will be constructing with the project.
- Clearly state in text and in supporting documents what the ADT and peak hour traffic levels are at all accesses currently, at full development, and long term (twenty years out.) Include intermediate stages for phased development.
- State whether or not any improvements affected by the project are reimbursable under the current Major Transportation Corridors Plan (MTCP).
- State whether the MTCP or other approved corridor study calls for the construction of improvements in the immediate area.
- List ECM criteria for stacking, storage, and taper for every affected auxiliary lane and access and state whether this access can be met. If it cannot be met, state the required modifications so that it can be met.
- State what the sight distance is for every affected access and whether it can be met. If it cannot be met, state the required modifications so that it can be met.
- State what the current applicable Transportation Impact Fees are and what option the developer will be selecting for payment. If the site is in a special district, so state and summarize the applicable fees.
- List other traffic studies by the consultant in the area of study within the past five years, in addition to any reports identified by County staff or that the applicant is aware of. State whether the current study is consistent with those studies and explain any discrepancies.
- List all deviations from the County Engineering Criteria that the applicant will be making. Include supporting information, together with a signed and stamped deviation request form.
- Include LOS for all affected intersections.
- Show total traffic generated by the proposed development using ITE trip generation figures.
- If an intersection does not meet LOS D or better, discuss what steps can be taken to bring the intersection to a satisfactory level.

-
- Include an engineer's certification page with the engineer's stamp, signature, and date. The statement must read as follows:
 - "The attached traffic report and supporting information were prepared under my responsible charge and they comport with the standard of care. So far as is consistent with the standard of care, said report was prepared in general conformance with the criteria established by the County for traffic reports."
 - Include a developer's statement on the certification page. The statement must read as follows:
"I, the Developer, have read and will comply with all commitments made on my behalf within this report." Include a printed or typed developer name and address as well as a signature block.

Appendix C SOILS INVESTIGATION REPORTS AND MITIGATION

C.1. PURPOSE

This appendix provides the minimum requirements for soils investigations associated with new and improved County infrastructure. In addition, it provides guidelines for the documentation to be developed for summarizing the results of these investigations.

C.2. GEOLOGIC HAZARDS REPORT

C.2.1. General Requirements

These guidelines outline the minimum information that shall be presented and evaluated in a Geologic Hazard Report. These guidelines are not intended to be a rigid framework of requirements, nor a specific format for each report submitted for County review. The level of detail and emphasis may vary due to unique or particular geologic conditions or due to the type of project.

C.2.2. Report Guidelines

- A. **Overall Project Information.** A general project description shall be included with each report and in a clear manner present at a minimum the following list of items:
- Size and location of the project;
 - Existing site land uses;
 - Proposed site land uses; and,
 - Identification of the person who prepared the study and his/her qualifications for conducting the study.
- B. **Study Overview.** A general overview of the report objectives, contents, methods, level of investigation, and findings should be provided:
- State the objective(s) and level of investigation for the study;
 - Cite the previous publicly available geologic reports which were reviewed or referenced in the course of preparing the geologic hazard study and indicate the author(s), firm, and date of each report;
 - List the methods of investigation as well as professional firm(s) who participated;
 - If the level of investigation varies within the subject area, describe in the text and show on the maps areas of concentration or exclusion;

- Describe the general physiographic setting of the project and its relationship to local topographic features;
- Describe the general geologic setting of the project and indicate any lithologic, tectonic, geomorphic, or soils problems specific to the area; and,
- Describe the general surface and groundwater conditions.

C. **Site Evaluation Techniques.** The most appropriate site evaluation techniques shall be determined by the geologist/geotechnical engineer based on site conditions and the activities being proposed for the site. However, the list below presents typical methodologies and techniques used to evaluate the potential geological hazards of a site. Based on their applicability to the site being investigated, the information listed under each technique shall be included with the submitted report unless otherwise indicated to not be required. A detailed explanation is necessary for exclusion of minimum requirements listed.

1. **Extent.** State the extent and method of surface and subsurface geologic studies.
2. **Geologic Mapping.** The geologic mapping shall:
 - Show important details corresponding to the size, extent and degree of the investigation on the project topographic map;
 - Show the abundance of distributions of earth materials and structural elements exposed or inferred in the subject area. Observed and inferred features or relationships should be so designated on the geologic map;
 - Portray all geologic information at a scale that is appropriate for readability and interpretation. When different sources are used. "Tie-points" between the sources shall be presented, and,
 - Indicate the geologic base map use, date, and significant additions and modifications to previous work.
3. **Aerial Photographs and Remote-Sensing Imagery.** When aerial photographs or imagery are used, the report shall:
 - Present the source(s) of photographs or images, if available;
 - Indicate data and scale of photographs or imagery; and,
 - Highlight critical points and their relationship to the project.
4. **Geophysical Investigations.** Geophysical investigation information shall:
 - Indicate the type and objectives of the geophysical investigation(s) (if any), quality of the data, and limitations of geophysical techniques;
 - Describe the information used to correlate the geophysical data and geologic conditions; and,
 - Display the geophysical data on the topographic/geologic maps and cross section.
5. **Drill-Hole Data.** Drill-hole data information shall:
 - Describe the specific investigative methods, tests conducted, drilling, and date of investigation;
 - Show the location of all borings on the topographic or geologic map; and,
 - Show boring logs, geophysical logs, or profiles obtained in the investigation.
6. **Test Pits and Trenches.** The test pit and trench information shall:

-
- Describe the location and dimensions of all pits and trenches and date of investigation;
 - Indicate the location of all excavations on the topographic/geologic map and profiles;
 - Provide a large scale descriptive log with sufficient detail; and,
 - Show sample location if supplemental laboratory tests were conducted.
7. **Field and Laboratory Tests.** The field and laboratory tests information shall:
- Describe the type of any tests conducted in the field or laboratory;
 - Describe the sample method and test procedures; and,
 - Show the test results on the data work sheets or on summary tables.
8. **Monitoring Programs.** The monitoring program information shall:
- Describe the type, objectives, and location of all monitoring programs in the subject area; and,
 - State the monitoring period, the firm(s) or individuals responsible for the care and disposal of the installations.
- D. **Geologic Descriptions.** As appropriate for site conditions, the report should provide the following general geologic description information.
1. **Bedrock Units.**
- Rock type and bedding attitude or foliation;
 - Age of and correlation with recognized formations;
 - Dimensional characteristics such as thickness and extent;
 - Distribution and extent of the weathered zone;
 - Physical characteristics; and,
 - Response of bedrock materials to natural processes.
2. **Surficial Deposits.**
- Distribution, occurrence, and age;
 - Identification of material types and sources;
 - Dimensional characteristics such as thickness and extent;
 - Surface expression and relationships with present topography;
 - Physical and chemical characteristics; and,
 - Distributions and extent of altered zones.
3. **Geomorphic Features.** Geomorphic features resulting from landslides, earthflows, debris flows, mudflows, rockfalls, debris avalanches, fault scarps, soil creep, erosion scarps, avalanched paths, and subsidence phenomenon.
- Locations and distribution;
 - Dimensional characteristics;
 - Age of feature and history of activity;
 - Recurrence interval for geomorphic process; and,

-
- Physical characteristics.
4. **Structural Features.** Structural features include joints, faults, shear zones, folds, schistosity, and foliation.
 - Occurrence, distribution, and proximity to site;
 - Dimensional and displacement characteristics of faults;
 - Orientation and changes in orientation;
 - Physical characteristics such as brecciation, slickensides, gouge zones, sand boils, sag ponds, springs alignment;
 - Disrupted drainages, or ground-water barriers;
 - Nature of offset(s) and timing of movement(s); and,
 - Absolute or relative age of latest movement.
 5. **Surface Drainage.**
 - Distributions;
 - Relation to topography (drainage patterns);
 - Relation to areas of vegetations;
 - Relation to geologic features;
 - Source permanence, and variation in amount of surface water;
 - Evidence of earlier occurrence of water localities now dry;
 - Estimated peak flows an physiographic flood plain of drainages;
 - Probable maximum or 100-year flood limits, including flash and debris floods; and,
 - Outfall.
 6. **Ground Water.**
 - Distributions and occurrence;
 - Hydraulic gradients;
 - Relation to topography;
 - Relations to geologic features; and,
 - Seasonal variations.
- E. **Geologic Interpretation.** The report shall include interpretations and detailed descriptions of the following:
1. **Geologic Hazards.** Geologic hazards include landslides, avalanche, rockfall, mudflows, debris flows, radioactivity, etc.
 - Geomorphic and structural features/processes present in the area;
 - Man-induced features/processes;
 - Age and activity of the features/processes;
 - Natural contentions affecting the features/processes;

-
- Susceptibility to man-induced changes;
 - Potential impact of hazard(s) and risk to project;
 - Amenability of adverse conditions for adequate mitigation;
 - Long-term lateral and vertical stability of earth materials; and,
 - Impact of project on materials stability.
2. **Geologic Constraints.** Geologic constraints include expansive soil or rock, potentially unstable slopes, high groundwater levels, soil creep, hydrocompaction, shallow bedrock, erosion, etc.
- Soil, surface and ground water, and geomorphic conditions;
 - Man-induced conditions;
 - Activity of conditions
 - Effect of natural or man-induced changes;
 - Potential impact of conditions and risk to project;
 - Amenability of adverse conditions for adequate mitigation; and,
 - Impact of project on long-term project stability.
- F. **Relationship of Geologic Factors on the Proposed Action.** This topic normally constitutes the principal contribution of the report. It involves both the affects of geologic features upon the proposed grading, construction, and land use; and the effects of these proposed modifications upon future geological processes in the area. The following checklist includes the topics that ordinarily should be considered as part of the findings, conclusions, and recommendations of the geologic reports:
1. **Compatibility.** General compatibility of natural features with proposed action that should be discussed includes:
- Topography;
 - Lateral stability of earth materials;
 - Problems of flood inundation, erosion, and deposition;
 - Problems caused by features or conditions in adjacent properties; and,
 - Other general problems.
2. **Proposed Cuts.** A description of proposed cuts and the relationship to the activities being proposed including:
- Prediction of what materials and structural features will be encountered;
 - Prediction of stability based on geologic factors;
 - Problems of excavation (e.g. unusually hard or massive rock, excessive flow of groundwater); and,
 - Recommendations for reorientation or repositioning of cuts, reductions of cut slopes, development of compound cut slopes, special stripping above daylight lines, buttressing, protections against erosion, handling of seepage water, setbacks for structures above cuts, etc.
3. **Proposed Fill.** A description of proposed fill and the relationship to the action including:
- General evaluation of planning with respect of canyon-filling and sidehill masses of fill; and

-
- Comment on suitability of existing natural materials for fill.
4. **Recommendations for Fill.** Recommendations concerning the positioning of fill masses, provision for underdrainage, buttressing, special protection against erosion including:
 - Recommendations for subsurface testing and exploration; and
 - Cuts and test holed needed for additional geologic information.
 5. **Special Recommendations.** Details concerning any unique or unusual recommendations concerning the action including recommendations about:
 - Areas to be left as natural ground;
 - Removal or buttressing of existing slide masses;
 - Flood protection;
 - Problem of groundwater level fluctuation;
 - Position of structures, with respect to active faults;
 - Problems associated with radon gas and soil radioactivity; and,
 - Problems caused by natural gases, such as methane and hydrogen sulfide, radon, and,
 - Protection of existing and proposed utility facilities.
- G. **Conclusions.** The report shall provide detailed conclusions of the analysis including:
1. **Land Compatibility.** State generally whether the intended use of the land is compatible with the investigated site conditions; and if mitigation measures are necessary. In addition, depict those areas where "no building" is recommended.
 2. **Construction Planning.** Discuss critical construction planning aspects that may need further consideration by the contractor including the stability of earth materials, grading plans and the need for selective location of project facilities.
 3. **Geologic Basis.** The report shall clearly state the geologic basis for all conclusions.
- H. **Recommendations.** The report shall provide recommendations to be used in later stages of the project based on this preliminary analysis of the project site including:
1. **Mitigation Procedures.** Discuss the development of mitigation procedures or design changed necessary to minimize or abate any hazardous condition requires a recommendation.
 2. **Long-term Project Objectives.** Recommendations should focus upon the long-term stability and safety of the proposed project.

C.3. GEOTECHNICAL REPORT

C.3.1. General Requirements

These guidelines outline the minimum information that shall be presented and evaluated in a Geotechnical Report. These guidelines are not intended to be a rigid framework of requirements, nor a specific format for all reports. The level of detail and emphasis may vary due to unique or particular conditions or due to the type of project. The Geotechnical Report shall generally show results from the applicable testing. The report shall also include a description of site characteristics, e.g., topography, drainage features, etc.

C.3.2. Detailed Report Requirements

A. **Required Items.** The following items are required to be included in all Geotechnical Reports:

- Site location and description
- Boring location diagram
- Laboratory test reports with evaluations (classification tests) (See Table C-1)

Table C-1. Applicable Geotechnical Laboratory Tests

Applicable Laboratory Tests
Visual classification
Liquid limit - AASHTO T89 or ASTM D4318
Plastic limit - AASHTO T90 or ASTM D4318
Plasticity Index
In-situ moisture content
Percent passing No. 200 sieve - AASHTO T11 or ASTM C117-90
Gradation of granular (sand & gravel) materials - AASHTO T27, ASTM D422 or ASTM C136
AASHTO classification and group index - AASHTO M145
Standard Penetrations Test
Swell Potential Evaluation - ASTM D4546-96

- Boring logs, to include but not limited to the following: (1) Date, Strata Elevation, Depth of Boring; (2) Natural moisture content, blow count and dry density of each undisturbed sample; and (3) Water table elevation
- Seasonal variations in soil and groundwater conditions to include the expected seasonal groundwater elevation variation shall be summarized.
- Shallow bedrock depth and description including mitigation requirements if bedrock is within 3 feet of subgrade.
- Percentage of soluble sulfates.
- Backfill and fill evaluation including any additional tests required for trench backfill evaluation, fill evaluation, etc.
- Groundwater evaluation including the elevation of groundwater encountered in each boring at time of drilling and at 24 to 48 hours after drilling. If deemed necessary, the boring may remain open for up to 7 days if required for further assessment.

B. **Recommendations and Mitigation Plans.** The report shall include recommendations and mitigation concerning but not limited to the following:

- Allowable soil pressure
- Foundation types
- Groundwater
- Maximum stable slopes (cut, fill, and natural)
- Retaining wall information (if applicable)
- Detention pond design and construction (if applicable)

-
- Cut and fill criteria (such as compaction, moisture content, benching)
- C. **Engineer Seal.** All Geotechnical Reports shall be signed and seal by a professional engineer registered or authorized to practice in the State of Colorado.

C.3.3. Boring Standards

The following represent the minimum boring standards and guidelines for conducting borings for Geotechnical Reports.

A. **Timing of Soil Borings.**

1. **Initial Borings.** The information from the initial soil borings shall be summarized in the Geotechnical Report. The entire site shall be sampled for initial testing. This is required to evaluate soil and groundwater conditions and for evaluating roadway locations that may not yet be determined or may change.
2. **Structures.** Soil borings for design of transportation structures shall be taken prior to the design of the structure.
3. **Fill for Right-of-Way Grading.** Testing shall be provided for all proposed fill material. All proposed fill material shall be approved by The ECM Administrator prior to placement. The material shall meet minimum requirements and be equal to or better than existing conditions. No fill material with a liquid limit greater than 40 and plasticity index greater than 20 shall be used in the upper 2-feet of the pavement subbase without implementing proper mitigation techniques.

B. **Frequency of Borings.** The following represent the minimum number of borings that are required based on a typical improvements project. The number of borings may be increased based on the geotechnical engineer's recommendations or at the request of the ECM Administrator.

- A minimum of 2 borings for each project with public improvements shall be performed.
- A minimum 1 boring for each SCS (NRCS) soil type within a development shall be performed.
- A minimum of 1 boring shall be performed for each 10 acres of development up to 100 acres. One additional boring shall be performed for every 25 acres of development above the 100 acres.

C. **Borings for Structures.** The boring frequency for transportation structures shall satisfy AASHTO Bridge Design requirements and CDOT Materials Testing requirements.

D. **Depth of Borings.** Borings shall be performed to a minimum depth of 20 feet. In areas where the cut depths are expected to exceed 8 feet, borings shall be extended to a minimum of 15 feet below proposed finished grade. Borings shall extend deeper if needed to determine if bedrock or high groundwater levels are design concerns. Samples for structures shall be taken to a minimum depth of 10 feet below the footing elevation. Additional depth may be required for piers or piles.

It should be noted that boring depths will ultimately be determined by the geotechnical engineer based on site conditions. However, when depths different than those presented is performed, documentation as to the difference must be presented in the submitted report.

C.3.4. Testing

The following represent a listing of the minimum testing requirements and procedures for Geotechnical Reports. The actual numbers and types of tests will be based on the site and the activities being proposed.

A. **Applicable Tests.**

- Visual Classification

-
- Liquid Limit
 - Plastic Limit
 - Plasticity Index
 - Moisture Content
 - Percent Passing 200
 - Gradation (Granular Soils)
 - AASHTO Classification
 - Swell Potential Evaluation
 - Percentage of Soluble Sulfates
 - Standard Penetration/California Test
 - Corrosion Potential Resistivity
- B. **Classification Testing.** Soils shall be classified visually and representative samples tested to determine the soil properties. Sands and gravel samples shall be analyzed for gradation where needed to comply with classification requirements.

C.3.5. Soil Mitigation

Mitigation measures for soil problems revealed by the soils investigation shall be included in the Geotechnical Report. The following specific factors shall be addressed:

- A. **Mitigation Measures and Approval.** All special problems found in soils investigation (e.g., expansion, frost, soluble sulfates, shallow bedrock, heave, groundwater, soil instability, utility backfill, etc.) shall be addressed in the mitigation plans. All proposed mitigation shall be approved by the ECM Administrator.
- B. **Swell Criteria.** If the average swell is 2.0 percent or greater, the pavement design report must provide mitigation measures. The mitigation measures shall reduce destructive swell potential under the public improvements, including landscaping, to an acceptable level of less than 2.0 percent. The swell test report shall specify sample conditions, surcharge pressures, and other key testing factors.
- C. **Swell Mitigation Measures.** Some commonly accepted mitigation measures for swell include: (1) over excavation; (2) chemical treatment; and (3) moisture treatments. Other procedures may be proposed for approval by the ECM Administrator. The selected method must work for the full life expectancy of the improvements.
- D. **Mitigation of Unstable Subgrade.** Some commonly accepted mitigation measures for unstable subgrade include: (1) over-excavation; and (2) chemical treatment. Other procedures may be proposed for approval by The ECM Administrator. The selected method of mitigation must work for the full life expectancy of the improvements.
- E. **Mitigation Recommendations.**
1. **Extent of Mitigation.** Soil treatment shall extend to the back of curb, or to the back of walk for attached or monolithic walk. For detached walk, separate mitigation procedures may be required. A combination of mitigation methods may be required to sufficiently mitigate a soil problem.

-
2. **Approval of Chemical Treatment.** Mitigation procedures that alter existing soil conditions (such as lime, fly ash, or cement treatment) shall follow an approved mix design process. Additional testing is required to verify that no swell is introduced in the chemical treatment.

C.4. PAVEMENT DESIGN REPORT

The Pavement Design Report must be submitted and approved prior to any nonstructural concrete or paving installation. See Appendix D for specific requirements for the Pavement Design Report information.

C.5. INSPECTION AND TESTING REPORTS

All tests and inspection results performed by the sponsor's testing firm shall be submitted directly from the testing agency to the ECM Administrator at the time of field tests, and within ten (10) working days after the testing or retesting date of laboratory test (See Chapter 5 and Appendix J, Roadway and Ancillary Facility Inspections and Testing, for more detailed information).

C.6. SUBSURFACE WATER INVESTIGATION REPORT

C.6.1. When Required

If groundwater is encountered within 5 feet of the original ground surface, a Subsurface Water Investigation Report shall be submitted for approval by the ECM Administrator. This report is required to ensure mitigation of high groundwater effects upon public improvements within the right-of-way. This information may be a separate report or may be included in the Geotechnical Report. This report is not required for temporary dewatering activity needed to facilitate construction of buried utilities. However, all applicable state and federal requirements shall be followed.

C.6.2. Report Requirements

The subsurface water investigation report shall include the following information.

- A. **Site Location.** Site location and description including locations of any irrigation ditches and wetlands.
- B. **Groundwater.** Elevation of water table and seasonal high water level shall be presented within the report and critical issues pertaining to groundwater highlighted.
- C. **Additional Subsurface Information.** Other relevant subsurface information such as water ownership (water rights), groundwater quality (contamination or other undesirable characteristics).
- D. **Subsurface Drainage.** Subsurface drainage recommendations, including its effects on all conditions, including sensitive habitat.
- E. **Control Measures and Designs.**
 1. **Subsurface Drains.** Should subsurface drains be recommended, the drains must have a gravity discharge without any possibility of back flow or blockage of the outlet. Any subsurface drain system shall be owned and maintained by the Applicant or the Applicant's assigned successor(s). These drains may discharge into the ECM Administrator's storm drainage system, including inlets or detention ponds, upon appropriate submitted design and approval by the ECM Administrator. Anticipated impacts to the groundwater table on adjacent properties must be quantified.
 2. **Drain Lines.** Drain lines may be installed in the sanitary sewer trench, at an elevation of one sewer diameter lower than the sanitary sewer line.

-
3. **Drain Line Separation from Sewer.** Drain line separation from sewer shall be marked to specifically distinguish the drain from the sanitary sewer line.
 4. **Pipe Materials.** Pipe Materials shall be an approved material pipe, for long-term 100 years minimum design life, with appropriate cleanouts.
 5. **Drain Outlet.** Drain Outlet into an inlet structure or detention pond shall be designed to prevent any possibility of backflow and blockage of the drain line.
- F. **Engineer Seal.** All Subsurface Water Investigation Reports shall be signed and seal by a professional engineer registered or authorized to practice in the State of Colorado.

Appendix D PAVEMENT DESIGN CRITERIA AND REPORT

D.1. PURPOSE

This appendix provides the basic criteria, design procedures, and report guidelines for roadway pavements. Asphalt and Portland Cement Concrete (PCC) methodologies generally follow the CDOT methodology.

D.2. SUBGRADE INVESTIGATION

D.2.1. Field Investigation

The field investigation shall consist of borings or other suitable methods of sampling subgrade soils for visual classification to a depth of at least 5 feet below proposed subgrade elevation, at spacings of not more than 500 feet. A minimum of one boring shall be obtained for any roadway segment. Every fifth hole shall be 10 feet deep. The ECM Administrator may require more frequent testing or additional borings that extend deeper should bedrock or high groundwater be a design concern. All borings shall be field logged and visually classified. Samples shall be obtained from each soil type in the upper 24 inches of subgrade for testing and evaluation. The soil investigation associated with this report occurs after the roadways are graded and the deepest utility is installed. Multiple samples shall be taken alternating among lanes and shall be evenly spaced.

D.2.2. Classification Testing

Each boring location shall be tested to determine Liquid Limit, Plastic Limit, Plasticity Index, and the percentage passing the U.S. Standard No. 200 sieve. Samples of sands and gravels will require gradation analysis for classification determination. These data shall be determined using the following methods:

- Liquid Limit - AASHTO T 89 (ASTM D 4318)
- Plastic Limit - AASHTO T 90 (ASTM D 4318)
- % Passing No. 200 - AASHTO T 11 (ASTM C 117)
- Gradation - AASHTO T 27 (ASTM D 422)

The results of these tests shall be used to calculate the AASHTO Classification and Group Index using AASHTO M 145.

Additional testing that shall be performed include:

- Moisture Content - AASHTO T 265
- Water Soluble Sulfates (for rigid pavements only) - AASHTO T 290

D.2.3. Soil Grouping

Soil samples collected in the field investigation can be combined to form soil groups. These groups determined by laboratory testing shall be based upon the AASHTO Classification, Group Index and location within the area investigated. Groupings shall not consist of samples with different AASHTO Classifications. Composite samples can be manufactured by combining small portions of each subgrade sample contained within the group and mixing to provide a uniform composite sample of the soil group. Soils are to be grouped based on the AASHTO classification of the bulk materials. When significant disparities in Group Index (greater than 7) are noted, the subgrade soil groups shall be subdivided into two or more groups.

D.2.4. Subgrade Support Testing

Individual subgrade or composite samples shall be tested to determine the subgrade support value using either California Bearing Ratio (CBR) or Hveem Stabilometer (R-value) testing. In addition, a swell potential evaluation shall be performed when the plasticity index (PI) is greater than 10 or as deemed appropriate. These values shall be used in the design of pavement sections. Tests shall be conducted in accordance with the procedures listed below.

- A. **CBR Tests.** California Bearing Ratio tests shall be conducted in accord with AASHTO T 193 with the following modifications:
- Note 4 of AASHTO T 193 shall not apply. A 3-point CBR evaluation is required.
 - Surcharge shall be calculated using a unit weight of 140 pcf for Mix Asphalt and 135 pcf for untreated aggregate base course.
 - The design CBR value shall be determined from the CBR - Dry Density Curve and shall be the CBR value at 95 percent compaction.
 - In addition to the values requested in AASHTO T 193, Stress - Penetration curves for each sample, a CBR - Dry Density curve and Proctor Compaction test results shall be reported.
- B. **R-Value Tests.** Hveem Stabilometer tests shall be conducted in accordance with AASHTO T190. The design R-value shall be at 300 psi exudation pressure. The reported data shall consist of:
- Dry density and moisture content for each sample.
 - Expansion pressure for each sample.
 - Exudation Pressure - corrected R-value curve showing the 300-psi design R-value.
- C. **Swell Test.** The results of a swell potential evaluation (ASTM D4546-96) shall be presented in the Pavement Design Reports where the PI of the existing material is greater than 10.

If the swell (at an overburden pressure of 100-150 psf, at specified compaction per CDOT and at optimum moisture content) is 2.0% or greater, the Pavement Design Report must provide mitigative measures to minimize the destructive swell potential. Since the pavement is not placed on the soils until after the soil has been scarified, moisture treated, and compacted to optimum, the "% swell" shall be measured from the point after the overburden pressure is applied, to the point after water is added.

D.3. PAVEMENT DESIGN CRITERIA

This section provides the input data used for the design of pavements for El Paso County roads.

D.3.1. ESAL

Equivalent Single Axle Loads (ESAL) are considered equivalent units based on 20-year design criteria and an 18-kip axle loading. All data and design nomographs use ESAL units for pavement loading repetitions. ESAL criteria shall conform to Table D-2.

D.3.2. Design Serviceability

Design values in Table D-1 shall be used for all County roadways.

Table D-1. Pavement Design Values

Roadway Functional Classification	Serviceability Index, SI	Lanes	Directional Distribution Factor, DD	Lane Distribution Factor, DL	Truck (%)	Reliability (%)
Rural						
Local	2.0	2.0	0.5	1.0	3.0	75
Minor Collector	2.5	2.0	0.5	1.0	4.0	80
Major Collector	2.5	2.0	0.5	1.0	5.0	80
Minor Arterial	2.5	4.0	0.5	0.9	7.0	80
Principal Arterial, 4-lane	2.5	4.0	0.5	0.9	8.0	85
Principal Arterial, 6-lane	2.5	6.0	0.5	0.7	9.0	85
Expressway, 4-lane	2.5	4.0	0.5	0.9	8.0	90
Expressway, 6-lane	2.5	6.0	0.5	0.7	10.0	90
Urban						
Local (low volume)	2.0	2.0	0.5	1.0	3.0	80
Local	2.0	2.0	0.5	1.0	4.0	80
Residential Collector	2.5	2.0	0.5	1.0	5.0	85
Nonresidential Collector	2.5	2.0	0.5	1.0	15.0	85
Minor Arterial	2.5	2.0	0.5	1.0	6.0	85
Principal Arterial, 4-lane	2.5	4.0	0.5	0.9	8.0	90
Principal Arterial, 6-lane	2.5	6.0	0.5	0.7	8.0	90
Expressway, 4-lane	2.5	4.0	0.5	0.9	8.0	95
Expressway, 6-lane	2.5	6.0	0.5	0.7	8.0	95

D.3.3. Minimum Pavement Section

Table D-2 provides the minimum acceptable pavement sections for County roadways. Final pavement designs must be based on actual subgrade support test results and the Transportation Impact Study (TIS).

Table D-2. Minimum Pavement Sections

Roadway Functional Classification	ESAL	Composite Sections ¹		Portland Cement Concrete (in)
		Asphalt (in)	Base (in)	
Rural				
Local	36,500	3.0	4.0	5.0
Minor Collector	109,500	3.0	6.0	5.0
Major Collector	273,750	3.0	8.0	6.0

Minor Arterial	689,850	4.0	8.0	6.0
Principal Arterial, 4-lane	2,628,000	5.0	8.0	6.0
Principal Arterial, 6-lane	9,198,000	6.5	8.0	6.0
Expressway, 4-lane	3,942,000	6.5	10.0	6.0
Expressway, 6-lane	12,264,000	6.5	10.0	7.0
Urban				
Local (low volume)	36,500	3.0	4.0	5.0
Local	292,000	3.0	8.0	5.0
Residential Collector	821,000	4.0	8.0	6.0
Nonresidential Collector	821,000	4.0	8.0	6.0
Minor Arterial	1,971,000	5.0	8.0	6.0
Principal Arterial, 4-lane	5,256,000	5.0	8.0	6.0
Principal Arterial, 6-lane	8,176,000	6.5	8.0	6.0
Expressway, 4-lane	7,884,000	6.5	8.0	6.0
Expressway, 6-lane	9,811,000	6.5	10.0	7.0

D.3.4. Flexible Pavement Strength Coefficients

The standard design coefficients for pavement materials are provided in Table D-3. Design values shall be verified by predesign mix test data and supported by daily construction tests.

D.3.5. Portland Cement Concrete Working Stress (f_t)

The working stress (f_t) shall be 75% of that provided by third-point beam loading which shall have minimum laboratory 28-day strength of 650 psi based on actual tests of materials to be used.

D.3.6. Gravel Roads

A minimum thickness of 6 inches shall be used on all newly constructed gravel roads meeting material specifications presented in Table D-7.

D.4. PAVEMENT DESIGN PROCEDURE

D.4.1. Flexible Pavements

The following procedure shall be used in determining the Structural Number (SN) and thickness of the pavement being designed.

- A. **Define ESAL.** Determine ESAL from Table D-2. The ESAL calculated from the traffic volumes in the Traffic Impact Study shall be used whenever they exceed the minimum ESAL values given in Table D-2.
- B. **Define Serviceability Index (SI).** Determine the SI of the roadway classification from Table D-1 and use it in Figure D-1 or use AASHTO pavement design software.
- C. **Resilient Modulus Usage (M_R) and CBR.** Using the resilient modulus and ESAL, determine the SN from the appropriate design nomograph. The appropriate reliability value from Table D-1 and an overall deviation of 0.45 shall be used for flexible pavements. Resilient modulus shall be calculated using the following equations:

$$S_1 = [(R - 5) / 11.29] + 3$$

$$M_R = 10^{[(S_1 + 18.72) / 6.24]}$$

$$M_R = 1,500 * CBR$$

Where:

M_R = resilient modulus (psi)

S_1 = the soil support value

R = R-value obtained from the Hveem stabilometer

CBR = California Bearing Ratio

- D. **Pavement Design Thickness.** The design thickness for the pavement structure can be determined by the general equation:

$$SN = a_1 D_1 + a_2 D_2 + a_3 D_3 + \dots$$

Where:

a_1 = Hot Mix Asphalt (HMA) strength coefficients

a_2, a_3, a_n = strength coefficients of additional pavement components

D_1 = thickness of Hot Mix Asphalt (HMA) (inches)

D_2, D_3, D_n = thickness of additional pavement component sections

The strength coefficients for various components of the pavement structures are given in Table D-3. The component thickness selected must meet two conditions.

Pavement layer thickness shall be rounded up to the nearest 1/4 inch.

Table D-3. Strength Coefficients

Pavement Structure Component	Strength Coefficients	Limiting Test Criteria
Conventional Materials		
Hot Mix Asphalt	0.44	See Section D.5.4
Existing Bituminous Pavement	0.20-0.40 ¹	N/A
Aggregate Base Course/Recycled Concrete ²	0.11	(CBR 80+ or R 78+)
Existing Aggregate Base Course/Existing Recycled Concrete ²	0.09	(CBR 50+ or R 69+)
Granular Subbase Course	0.07	(CBR 15 or R 50+)
Treated Materials		
Cement Treated Aggregate Base	0.23	(7 day, 640-1000 psi)
Fly Ash	0.10	(7 day, 150 psi @ 70°±)
Lime Treated Subgrade	0.14	(7 day, 160 psi, PI < 6)
Kiln Dust	0.10	(7 day, 150 psi, PI < 6)
Cement Stabilized Subgrade ³	0.11	(7 day, 125 psi)
Cement Stabilized Subgrade ³	0.12	(7 day, 200 psi)
¹ An average value of 0.30 can be used, unless analysis of existing pavement dictates a more representative coefficient.		
² Materials must meet the requirements in Section D.5.5.1.		
³ If testing during construction shows the Cement Stabilized Subgrade strength is greater than 275 psi, the subgrade shall be micro fractured prior to paving.		
⁴ Crushed concrete shall not be used as a driving surface, even as a temporary driving surface during construction.		

- E. **Total HMA Thickness.** Total HMA thickness selected cannot be less than the minimum specified in Table D-2 for the roadway classification.
- F. **Base Course Thickness.** The base course thickness selected cannot exceed 2.5 times the HMA thickness selected. A composite section of asphalt over aggregate base must be used.
- G. **Swelling Soils.** The design must reference any mitigation measures required when the subgrade contains swelling soils. Pavement Design Reports recommending permeable layers such as untreated aggregate base course in the pavement system, must present the measures to be used to ensure adequate drainage of such layers, and to maintain segregation of the layers from the swelling soils.

D.4.2. Rigid Pavement

The design of rigid pavements is a function of structural quality of the subgrade soil (R-value or CBR), traffic (ESAL), and the strength of the concrete (working stress). In comparison to the strength of the concrete slab, the structural contributions of underlying layers to the capacity of the pavement are relatively insignificant. Therefore, the use of thick bases or subbases under concrete pavement to achieve greater structural capacity is considered to be uneconomical and is not recommended. The following procedure should be used in determining the thickness of rigid pavement.

- A. **Define ESAL.** Determine roadway classification and corresponding ESAL from Table D-2. The ESAL calculated from the traffic volumes in the traffic impact study shall be used whenever they exceed the minimum ESAL values given in Table D-2.
- B. **Define Serviceability Index (SI) and Other Variables.** Determine design Serviceability Index (SI) of the roadway from Table D-1. For the purposes of design, the Concrete Elastic Modulus (E_c) shall be 3.4, the Mean Concrete Modulus of Rupture (S'_c) shall be 650 psi, the Load Transfer Coefficient (J) shall depend on the whether the shoulders are tied or non-tied and doweled or non-doweled (The J's shall be used. 2.8 for tied shoulders and doweled pavement, 4.2 for non-tied shoulders and non-doweled pavement. All other combinations shall be 3.6), and the Drainage Coefficient (C_d) shall be assumed to be 1.0 unless there is justification for a different number.
- C. **Effective Modulus of Subgrade Reaction (k) Determination.** The Effective Modulus of Subgrade Reaction (k) shall be calculated using AASHTO. In most cases where there is no subbase, k can be calculated using the following equations:

$$S_1 = [(R - 5) / 11.29] + 3$$

$$M_R = 10^{[(S_1 + 18.72) / 6.24]}$$

$$M_R = 1,500 * CBR$$

$$k = M_R / 19.4$$

Where:

M_R = resilient modulus (psi)

S_1 = the soil support value

R = R-value obtained from the Hveem stabilometer

CBR = California Bearing Ratio

- D. **Software or Nomograph Used.** Determine the structural numbers using AASHTO pavement design software. Nomographs of the AASHTO parameters may be used instead (Figures D-2 and D-3). If the nomographs are used, copies of the nomograph determinations must be included with the design

submission. The appropriate reliability from Table D-1 and an overall deviation of 0.35 shall be used for rigid pavements.

- E. **Slab Thickness.** Use the slab thickness or the minimum thickness from Table D-2, whichever is greater.
- F. **Swelling Soils.** The design must reference any mitigation measures required when the subgrade contains swelling soils. Pavement Design Reports recommending permeable layers such as untreated aggregate base course in the pavement system must present the measures to be used to ensure adequate drainage of such layers, and to maintain segregation of the layers from the swelling soils.

Figure D-1. Flexible Pavement Nomograph

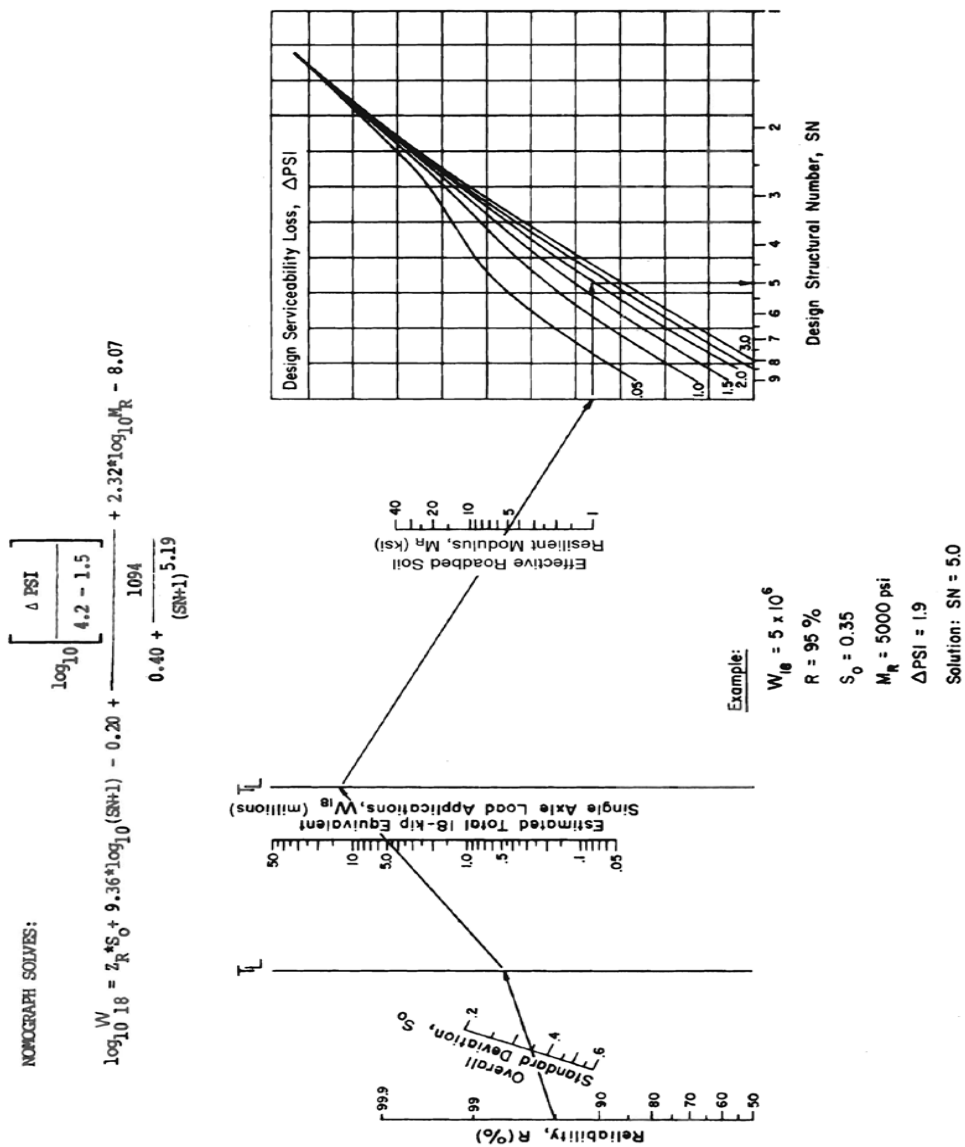

Figure D-2. Rigid Pavement Nomograph

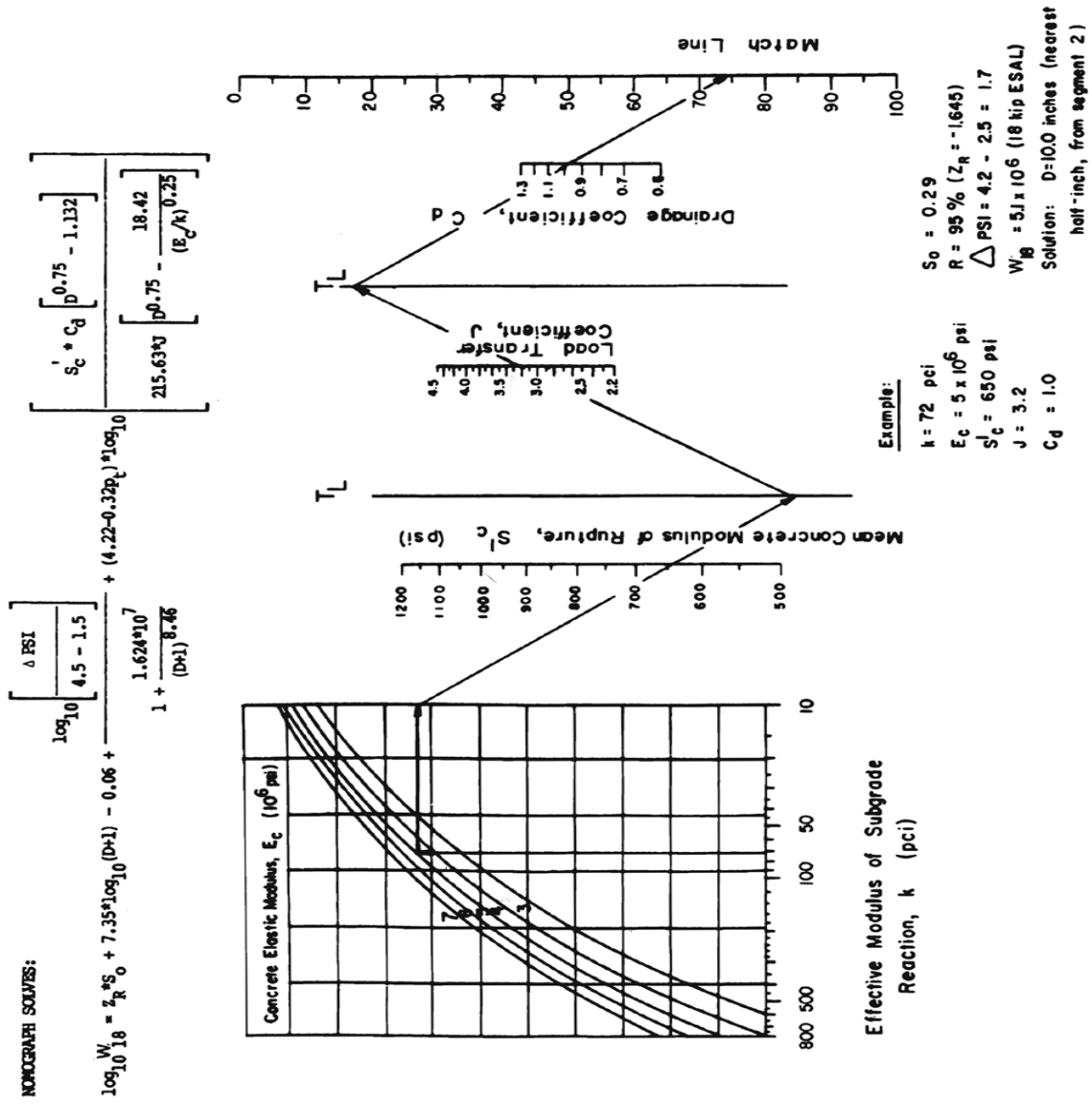
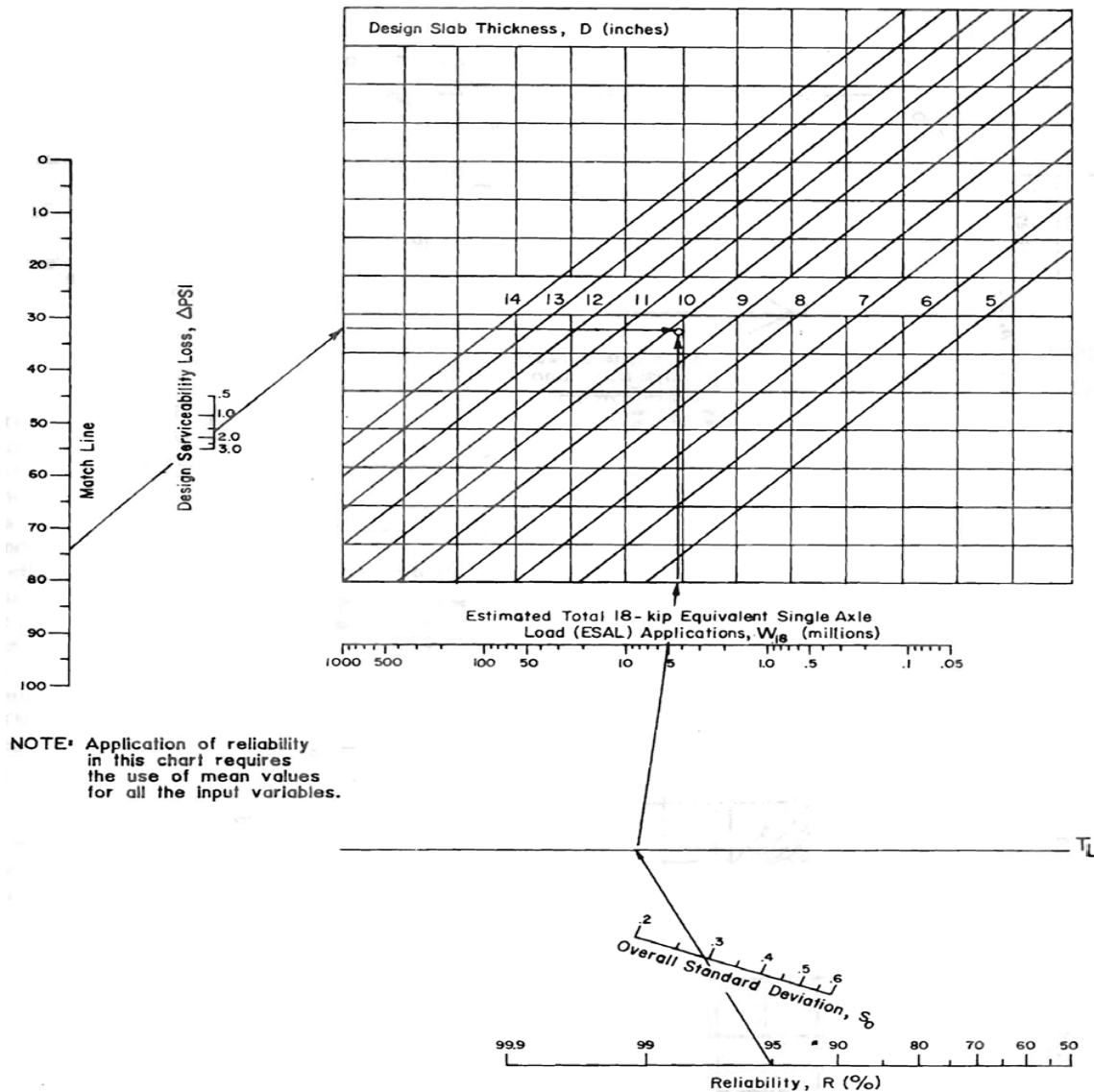

Figure D-3. Rigid Pavement Nomograph Cont.



D.5. MATERIAL SPECIFICATIONS

D.5.1. General

The material specifications presented are performance oriented. All sources of mined or manufactured materials used in public improvement construction must be annually approved by the ECM Administrator as having met the appropriate materials performance specifications.

D.5.2. Procedure for Material Source Approval

On or before April 1st of each year, or a minimum of 14 calendar days before construction, a material supplier for any public improvements may supply written documentation and material test results from a competent materials testing laboratory that describes:

- Material(s) being tested to meet the ECM Administrator specifications.
- The test procedures employed.
- The supplier's manufacturing, mining or treating process by which the tested materials were created.
- The material test results.

A signed statement shall be provided by the material supplier certifying the materials tested are representative of the materials to be provided for public improvements during the coming 365-day period.

D.5.3. Violations of Approval Conditions

Any and all material used to construct public improvements that is not from a certified source, or that is from a certified source and fails random material tests ordered by the ECM Administrator, may be subject to complete removal as a condition of the ECM Administrator acceptance of that public improvement. Additional tests will be required to confirm the existence and extent of the sub-standard material prior to the initiation of remedial action. The extent of the material to be removed will be at the discretion of the ECM Administrator.

D.5.4. Hot Mix Asphalt (HMA)

Hot mix asphalt (HMA) materials shall meet the requirements of and be placed according to the latest edition of the Pikes Peak Region Asphalt Specification. The Pikes Peak Region Asphalt Specification can be obtained online at: <http://adm.elpasoco.com/NR/rdonlyres/A8D006F3-BB2B-4FC1-AD65-32180CF4F2E6/0/PikesPeakRegionAsphaltPavingSpecs1106.pdf>.

D.5.5. Portland Cement Concrete Pavement

This material shall consist of a mixture of coarse and fine aggregates, Portland Cement, water and other materials or admixtures as required. Colorado Department of Transportation Class "P" mix may be used. The only alternatives to "P" shall be according to Section 412.03 of CDOT Standard Specifications. Other high-strength concretes may be used where special conditions warrant, subject to written approval by the ECM Administrator.

- Cement Requirements.** Portland cement shall comply with the CDOT requirements and the type of cement shall be Type II, unless sulfate conditions dictate otherwise. Table 2.2.3 in Chapter 2.2 of ACI 201, indicates recommendations for sulfate resistance.
- Fine Aggregates.** Fine aggregates shall meet CDOT Section 703.01 requirements and gradation as shown in Table D-4.

Table D-4. Fine Aggregates for Portland Cement Concrete

Sieve Size Or Test Procedure	Percent Passing By Weight Or Test Requirement
3/8"	100
#4	95—100
#16	45—80
#50	10—30
#100	2—10

Created: 2021-06-08 11:35:53 [EST]

(Supp. No. 2)

#200	3, Maximum
Friable Particles, %	1.0, Maximum
Coal & Lignite, %	1.0, Maximum
Deleterious Material (AASHTO T-11), %	3.0, Maximum
Sand Equivalent (AASHTO T-176), %	80.0, Minimum
Fineness Modulus	2.50—3.50
Sodium Sulfate Soundness, %	20.0, Maximum

- C. **Coarse Aggregate.** Coarse aggregates shall meet CDOT Section 703.02 requirements and gradation as shown in Table D-5.

Table D-5. Coarse Aggregates for Portland Cement Concrete

Sieve Size Or Test Procedure	Percent Passing By Weight Or Test Requirement
2"	100
1½"	95—100
¾"	35—70
⅜"	10—30
#4	0—5
#200	1, Maximum (1.5% if crushed fines)
% Wear	45.0, Maximum
Clay Lumps & Friable Particles, %	2.0, Maximum
Coal & Lignite, %	0.5, Maximum
Sodium Sulfate Soundness, %	12.0, Maximum

- D. **Fly Ash.** Fly Ash shall comply with CDOT Section 701.02.
- E. **Water.** Water shall meet the requirements of CDOT Section 712.01.
- F. **Air Entraining and Chemical Admixtures.** Air entraining and chemical admixtures shall meet the requirements of CDOT Sections 711.02 and 711.03. No additive manufactured with the purposeful addition of chloride shall be permitted. Water-reducing admixtures are used when concrete temperatures are as follows: Type A is used with ambient temperature range of 50 to 90 degrees inclusive; Type D is used when ambient temperature is over 90 degrees.
- G. **Reinforcement.** Reinforcing steel shall meet the requirements of CDOT Section 709.01, grade 40 minimum.
- H. **Laboratory Design Strength.** Minimum compressive laboratory design strength shall be 3,750 psi; minimum modulus of rupture or flexural strength shall be 650 psi.
- I. **Aggregate Base Course Material.** This material shall consist of hard, durable particles or fragments of stone or gravel, crushed to required sizes, containing an appropriate quantity of sand or other finely-divided mineral matter which conform to the requirements of AASHTO M 147, and CDOT Section 703.03. In addition, the material must have an R-value of 72 or greater, or a CBR of 80+, and must be moisture stable.

The materials to be used in construction shall be tested and a mix design submitted to The ECM Administrator for approval. Only aggregate from approved sources shall be used. As a minimum, the mix design report shall contain documented gradation, Atterberg limits, and CBR/R-value testing.

Two types of crushed aggregate base course are acceptable. The gradation specifications for these two types of base course are listed in Table D-6.

D.5.6. Gravel for Gravel Roads

Gravel described in this section shall be used for gravel shoulders, repairing gravel surfaces, or in cases where gravel roads are allowed. The gradation specification for this material is listed in Table D-7.

Table D-6. Aggregate Base Course Materials

Sieve Designation	Percent Passing By Weight	
	Class 5	Class 6
1½"	100	
1"	95—100	
¾"		100
#4	30—70	30—65
#8		25—55
#200	3—15 ¹	3—12
Liquid Limit (LL)	30, Maximum	30, Maximum
¹ ASTM C-117		

Table D-7. Gravel for Gravel Roads

Sieve Designation	Percent Passing by Weight
¾"	100
#4	50—78
#8	37—67
#40	13—35
#200	4—15
Plastic Index (PI)	4—12

D.5.7. Cement Treated Aggregate Base Course

This material shall consist of a mixture of aggregate materials, Portland cement and water as outlined in CDOT Section 308. Acceptable aggregates include CDOT Classes 4, 5, and 6.

The materials to be used in construction shall be tested and a mix design submitted to the ECM Administrator for approval. As a minimum, the mix design report shall contain a description of material sources, gradations, and Atterberg limits of aggregates, cement type, Proctor compaction curves and unconfined compressive strength results for each mix, strength versus cement content curves, a design mix, and special construction procedures recommended. Testing shall be in accordance with appropriate AASHTO specifications.

The mix shall have a 7-day compressive strength of at least 650 psi, and no more than 1000 psi. The minimum acceptable cement content shall be 5 percent by weight. Only approved mix designs shall be used. Approvals are required on a project basis or an annual basis for suppliers. Mixes shall be approved, prior to issuance of a Construction Permit.

D.5.8. Class C Fly Ash Treated Subgrade

This material consists of a mixture of native or imported soils, Class C fly ash, and water, as outlined by ASTM C 618 or AASHTO M-295. Minimum in-place thickness for this material shall be eight (8) inches.

The materials to be used in construction shall be tested and a mix design submitted to the ECM Administrator for approval. As a minimum, the mix design report shall contain a description of material sources, gradations, and Atterberg limits of the native soils, fly ash type, Proctor compaction curves and unconfined compressive strength results for each mix, strength versus fly ash content curves, a design mix, and special construction procedures recommended. Testing shall be in accordance with appropriate AASHTO specifications.

To be approved, the mix shall have a minimum 7-day compressive strength of 150 psi. Only approved mix designs shall be used. Approvals are required on a project basis prior to issuance of a Construction Permit.

D.5.9. Lime Treated Subgrade

This material consists of a mixture of native or imported soils, hydrated or quick lime and water, as outlined by ASTM Specification C 977 or AASHTO M216. Minimum in-place thickness for this material shall be eight (8) inches.

The materials to be used in construction shall be tested and a mix design submitted to the ECM Administrator for approval. As a minimum, the mix design report shall contain a description of material sources, gradation and Atterberg limits of native soils, Atterberg limits and 7-day unconfined compressive test results for each mix, strength versus lime content curves, a design mix and special construction procedures recommended. Testing shall be in accordance with appropriate AASHTO methods.

The mix shall have a minimum 7-day compressive strength of 160 psi. In addition, the Plasticity Index of the treated soil shall not exceed 6. The minimum acceptable hydrated lime content shall be 4 percent by weight.

Only approved mix designs shall be used. Approvals are required on a project basis prior to issuance of a Construction Permit.

D.5.10. Kiln Dust Treated Subgrade

This material consists of a mixture of native or imported soils, kiln dust and water, as outlined by ASTM and AASHTO Specifications. Minimum in-place thickness for this material shall be eight (8) inches.

The materials to be used in construction shall be tested and a mix design submitted to the ECM Administrator for approval. As a minimum, the mix design report shall contain a description of material sources, gradation and Atterberg limits of native soils, Atterberg limits and 7-day unconfined compressive test results for each mix, strength versus kiln dust content curves, a design mix and special construction procedures recommended. Testing shall be in accordance with appropriate AASHTO methods.

The mix shall have a minimum 7-day compressive strength of 150 psi. In addition, the Plasticity Index of the treated soil shall not exceed 6.

Only approved mix designs shall be used. Approvals are required on a project basis prior to issuance of a Construction Permit.

D.6. PAVEMENT DESIGN REPORT

The Pavement Design Report shall be prepared by or under the supervision of and signed and seal by a professional engineer registered or authorized to practice in the State of Colorado. The Pavement Design Report shall include the following information:

- Vicinity map to locate the investigated area.
- Scaled drawings showing the location of borings.
- Scaled drawings showing the estimated extent of subgrade soil types and ESAL for each roadway.
- Pavement design alternatives for each roadway on a scaled drawing.
- Tabular listing of sample designation, sample depth, Group Number, Liquid Limit, Plasticity Index, percent passing the No. 200 sieve, AASHTO Classification, Group Index, soil description, and moisture content. Percent soluble sulfate will also be necessary for rigid pavements.
- Identification of any samples that were consolidated to create composite samples for testing purposes.
- CBR or R-value test results of each soil type used in the design.
- Pavement design nomographs properly drawn to show Soil Support - ESAL - SN and/or output from an approved AASHTO pavement design program.
- Design calculations including all design assumptions.
- A discussion regarding potential subgrade soil problems including, but not limited to: soils with swelling potential, frost susceptible soils, ground water, drainage considerations (surface and subsurface), cold weather construction (if appropriate), soluble sulfates in the subgrade, and other factors or properties that could affect the design or performance of the pavement system.
- Recommendations to alleviate or mitigate the impact of problems discussed in Item I.
- Pavement Mix Types to be used for the project.

Appendix E CHECKLISTS AND PERMITS

As described in Appendix I, an Erosion and Stormwater Quality Control Permit (ESQCP) is required for all applicable construction activity of this ECM. A Builder's Erosion and Stormwater Quality Control Permit (BESQCP) is used to protect stormwater quality on individual residential building lots that have less than one (<1) acre of total disturbed area and are not part of a larger plan of development or sale. BESQCPs are also required for large lot (>2.5 acres) single family home construction when more than one acre of disturbance occurs. Either an ESQCP or a BESQCP will be required for all applicable construction activity, unless excluded pursuant to Section 5.6.3 of this ECM.

Projects that go through any part of the development review process (land use applications including subdivision, site development plan, site plan, grading plan, grading and erosion control plan, location approval, etc.), shall obtain the ESQCP from the Planning and Community Development Department. Applicable construction activity that is not associated with a land use application shall obtain the ESQCP through the Department of Public Works Stormwater Program. As a general practice, applicable construction activity limited primarily to County Right-of-Way will make an ESQCP application to the Department of Public Works.

To assist in the preparation of Grading and Erosion Control Plans and Stormwater Management Plans, the County in conjunction with local stakeholders developed checklists to guide the completion and review of submitted plans. Standard Notes for Grading and Erosion Control Plans are also provided in this Appendix. The checklists provided in this Appendix are to be completed by the Engineer of Record and certified as to the completeness of the submitted plans required for ESQCP approval.

Permit Applications

Erosion and Stormwater Quality Control Permit

Builders Erosion and Stormwater Quality Control Permit

Checklists and Standard Notes

El Paso County Stormwater Management Plan Checklist

El Paso County Grading and Erosion Control Plan Submittal Checklist

Standard Notes for El Paso County Grading and Erosion Control Plans

(Res. No. 19-245 , 7-2-19)

**EROSION AND STORMWATER QUALITY CONTROL PERMIT (ESQCP)
EL PASO COUNTY APPLICATION AND PERMIT**

APPLICANT INFORMATION	PERMIT NUMBER
Owner Information	
Property Owner	
Applicant Name (Permit Holder)	
Company/Agency	
Position of Applicant	
Address (physical address, not PO Box)	
City	
State	
Zip Code	
Mailing address, if different from above	
Telephone	
FAX number	
Email Address	
Cellular Phone number	
Contractor/Operator Information	
Name (person of responsibility)	
Company	
Address (physical address, not PO Box)	
City	
State	
Zip Code	
Mailing address, if different from above	
Telephone	
FAX number	
Email Address	
Cellular Phone number	
Erosion Control Supervisor (ECS)*	
ECS Phone number*	
ECS Cellular Phone number*	

*Required for all applicants. May be provided at later date pending securing a contract when applicable.

- ENGINEERING CRITERIA MANUAL
Appendix E CHECKLISTS AND PERMITS

PROJECT INFORMATION

Project Information	
Project Name	
Legal Description	
Address (or nearest major cross streets)	
Acreage (total and disturbed)	Total: acres Disturbed: acres
Schedule	Start of Construction: Completion of Construction: Final Stabilization:
Project Purpose	
Description of Project	
Tax Schedule Number	

FOR OFFICE USE ONLY

The following signature from the ECM Administrator signifies the approval of this ESQCP. All work shall be performed in accordance with the permit, the El Paso County Engineering Criteria Manual (ECM) Standards, City of Colorado Springs Drainage Criteria Manual, Volume 2 (DCM2) as adopted by the El Paso County Addendum, approved plans, and any attached conditions. The approved plans are an enforceable part of the ESQCP. Construction activity, except for the installation of initial construction BMPs, is not permitted until issuance of a Construction Permit and Notice to Proceed.

Signature of ECM Administrator: _____ Date _____

1.1 REQUIRED SUBMISSIONS

In addition to this completed and signed application, the following items must be submitted to obtain an ESQCP:

- Permit fees;
- Stormwater Management Plan (SWMP) meeting the requirements of DCM2 and ECM either as part of the plan set or as a separate document;
- Operation and Maintenance Plan for any proposed permanent stormwater control measures; and
- Signed Private Detention Basin/Stormwater Quality Best Management Practice Maintenance Agreement and Easement, if any permanent stormwater control measures are to be constructed.

1.2 RESPONSIBILITY FOR DAMAGE

The County and its officers and employees, including but not limited to the ECM Administrator, shall not be answerable or accountable in any manner for damage to property or for injury to or death of any person, including but not limited to a permit holder, persons employed by the permit holder, or persons acting in behalf of the permit holder, from any cause. . The permit holder shall be responsible for any liability imposed by law and for damage to property or injuries to or death of any person, including but not limited to the permit holder, persons employed by the permit holder, persons acting in behalf of the permit holder, arising out of work or other activity permitted and done under a permit, or arising out of the failure to perform the obligations under any permit with respect to maintenance or any other obligations, or resulting from defects or obstructions, or from any cause whatsoever during the progress of the work or other activity, or at any subsequent time work or other activity is being performed under the obligations provided by and contemplated by the permit.

The permit holder shall indemnify, save, and hold harmless the County and its officers and employees, including but not limited to the BOCC and ECM Administrator, from all claims, suits or actions of every name, kind and description brought for or on account of damage to property or injuries to or death of any person, including but not limited to the permit holder, persons employed by the permit holder, persons acting in behalf of the permit holder and the public, resulting from the performance of work or other activity under the permit, or arising out of the failure to perform obligations under any permit with respect to maintenance or any other obligations, or resulting from defects or obstructions, or from any cause whatsoever during the progress of the work or other activity, or at any subsequent time work or other activity is being performed under the obligations provided by and contemplated by the permit, except as otherwise provided by state law. The permit holder waives any and all rights to any type of expressed or implied indemnity against the County, its officers or employees. It is the intent of the parties that the permit holder will indemnify, save, and hold harmless the County, its officers and employees from any and all claims, suits or actions as set forth above regardless of the existence or degree of fault of or negligence, whether active or passive, primary or secondary, on the part of the County, the permit holder, persons employed by the permit holder, or persons acting in behalf of the permit holder.

- ENGINEERING CRITERIA MANUAL
Appendix E CHECKLISTS AND PERMITS

1.3 APPLICATION CERTIFICATION

We, as the Applicants or the representative of the Applicants, hereby certify that this application is correct and complete as per the requirements presented in this application, the El Paso County Engineering Criteria Manual, and Drainage Criteria Manual, Volume 2 and El Paso County Addendum.

We, as the Applicants or the representatives of the Applicants, have read and will comply with all of the requirements of the specified Stormwater Management Plan and any other documents specifying stormwater best management practices to be used on the site, including permit conditions that may be required by the ECM Administrator. We understand that the stormwater control measures are to be maintained on the site and revised as necessary to protect stormwater quality as the project progresses. We further understand that a Construction Permit must be obtained and all necessary stormwater quality control measures are to be installed in accordance with the SWMP, the El Paso County Engineering Criteria Manual, Drainage Criteria Manual, Volume 2 and El Paso County Addendum before land disturbance begins and that failure to comply will result in a Stop Work Order and may result in other penalties as allowed by law. We further understand and agree to indemnify, save, and hold harmless the County and its officers and employees, including but not limited to the BOCC and ECM Administrator, from all claims, suits or actions of every name, kind and description as outlined in Section 1.2 Responsibility for Damage.

Signature of Owner or Representative

Date: _____

Print Name of Owner or Representative

Signature of Operator or Representative

Date: _____

Print Name of Operator or Representative

Permit Fee	\$ _____	
Surcharge	\$ _____	
Financial Surety	\$ _____	Type of Surety _____
Total	\$ _____	

- ENGINEERING CRITERIA MANUAL
Appendix E CHECKLISTS AND PERMITS



2880 International Circle, Suite 110
Colorado Springs, CO 80910
Phone 719-520-6300
Fax 719-520-6695
www.elpasoco.com

**EL PASO COUNTY PLANNING AND
COMMUNITY DEVELOPMENT
DEPARTMENT**

STORMWATER MANAGEMENT PLAN CHECKLIST

Revised: July 2019		Applicant	PCD
1. STORMWATER MANAGEMENT PLAN (SWMP)			
1	Applicant (owner/designated operator), SWMP Preparer, Qualified Stormwater Manager, and Contractor Information. (On cover/title sheet)		
2	Table of Contents		
3	Site description and location to include: vicinity map with nearest street/crossroads description.		
4	Narrative description of construction activities proposed (e.g., may include clearing and grubbing, temporary stabilization, road grading, utility / storm installation, final grading, final stabilization, and removal of temporary control measures)		
5	Phasing plan – may require separate drawings indicating initial, interim, and final site phases for larger projects. Provide "living maps" that can be revised in the field as conditions dictate.		
6	Proposed sequence for major activities: Provide a construction schedule of anticipated starting and completion dates for each stage of land-disturbing activity depicting conservation measures anticipated, including the expected date on which the final stabilization will be completed.		
7	Estimates of the total site area and area to undergo disturbance; current area of disturbance must be updated on the SWMP as changes occur.		
8	Soil erosion potential and impacts on discharge that includes a summary of the data used to determine soil erosion potential		
9	A description of existing vegetation at the site and percent ground cover and method used to determine ground cover		
10	Location and description of all potential pollution sources including but not limited to: disturbed and stored soils; vehicle tracking; management of contaminated soils; loading and unloading operations; outdoor storage of materials; vehicle and equipment maintenance and fueling; significant dust generating process; routine maintenance activities involving fertilizers, pesticides, herbicides, detergents, fuels, solvents, oils, etc.; on-site waste management; concrete truck/equipment washing; dedicated asphalt, concrete batch plants and masonry mixing stations; non-industrial waste such as trash and portable toilets		
11	Material handling to include spill prevention and response plan and procedures.		
12	Spill prevention and pollution controls for dedicated batch plants		
13	Other SW pollutant control measures to include waste disposal and off site soil tracking		
14	Location and description of any anticipated allowable non-stormwater discharge (ground water, springs, irrigation, discharge covered by CDPHE Low Risk Guidance, etc.)		
15	Name(s) of ultimate receiving waters; size, type and location of stormwater outfall or storm sewer system discharge		
16	Description of all stream crossings located within the project area or statement that no streams cross the project area		
17	SWMP Map to include:		
17a	construction site boundaries		
17b	flow arrows to depict stormwater flow directions		
17c	all areas of disturbance		
17d	areas of cut and fill		
17e	areas used for storage of building materials, soils (stockpiles) or wastes		
17f	location of any dedicated asphalt / concrete batch plants		

- ENGINEERING CRITERIA MANUAL
Appendix E CHECKLISTS AND PERMITS



2880 International Circle, Suite 110
Colorado Springs, CO 80910
Phone 719-520-6300
Fax 719-520-6695
www.elpasoco.com

**EL PASO COUNTY PLANNING AND
COMMUNITY DEVELOPMENT
DEPARTMENT**

STORMWATER MANAGEMENT PLAN CHECKLIST

Revised: July 2019		Applicant	PCD
17g	location of all structural control measures		
17h	location of all non-structural control measures		
17i	springs, streams, wetlands and other surface waters, including areas that require maintenance of pre-existing vegetation within 50 feet of a receiving water		
18	Narrative description of all structural control measures to be used. Modifications to EPC standard control measures must meet or exceed County-approved details.		
19	Description of all non-structural control measures to be used including seeding, mulching, protection of existing vegetation, site watering, sod placement, etc.		
20	Technical drawing details for all control measure installation and maintenance; custom or other jurisdiction's details used must meet or exceed EPC standards		
21	Procedure describing how the SWMP is to be revised		
22	Description of Final Stabilization and Long-term Stormwater Quality (describe nonstructural and structural measures to control SW pollutants after construction operations have been completed, including detention, water quality control measure etc.)		
23	Specification that final vegetative cover density is to be 70% of pre-disturbed levels		
24	Outline of permit holder inspection procedures to install, maintain, and effectively operate control measures to manage erosion and sediment		
25	Record keeping procedures identified to include signature on inspection logs and location of SWMP records on-site		
26	If this project relies on control measures owned or operated by another entity, a documented agreement must be included in the SWMP that identifies location, installation and design specifications, and maintenance requirements and responsibility of the control measure(s). Please note: all items above must be addressed. If not applicable, explain why, simply identifying "not applicable" will not satisfy CDPHE requirement of explanation.		
2. ADDITIONAL REPORTS/PERMITS/DOCUMENTS			
a	Grading and Erosion Control Plan (signed)		
b	Erosion and Stormwater Quality Control Permit (ESQCP) (signed)		
3. Applicant Comments:			
a			
b			
c			
4. Checklist Review Certifications:			



2880 International Circle, Suite 110
Colorado Springs, CO 80910
Phone 719-520-6300
Fax 719-520-6695
www.elpasoco.com

**EL PASO COUNTY PLANNING AND
COMMUNITY DEVELOPMENT
DEPARTMENT**

STORMWATER MANAGEMENT PLAN CHECKLIST

Revised: July 2019

		Applicant	PCD
a	<p>Engineer of Record: The Stormwater Management Plan was prepared under my direction and supervision and is correct to the best of my knowledge and belief. Said Plan has been prepared according to the criteria established by the County and State for Stormwater Management Plans.</p>		
	<p>_____ Date _____ Engineer of Record Signature</p>		
b	<p>Review Engineer: The Stormwater Management Plan was reviewed and found to meet the checklist requirements except where otherwise noted or allowed by an approved deviation request.</p>		
	<p>_____ Date _____ Review Engineer</p>		

- ENGINEERING CRITERIA MANUAL
Appendix E CHECKLISTS AND PERMITS



2880 International Circle, Suite 110
Colorado Springs, CO 80910
Phone 719-520-6300
Fax 719-520-6695
www.elpasoco.com

**EL PASO COUNTY PLANNING AND
COMMUNITY DEVELOPMENT
DEPARTMENT**

GRADING AND EROSION CONTROL PLAN CHECKLIST

Revised: July 2019		Applicant	PCD
1. GRADING AND EROSION CONTROL PLAN			
a	Vicinity map.		
b	Adjacent city/town/jurisdictional boundaries, subdivision names, and property parcel numbers labeled.		
c	North arrow and acceptable scale (1"=20' to 1"=100').		
d	Legend for all symbols used in the plan.		
e	Existing and proposed property lines. Proposed subdivision boundary for subdivision projects.		
f	All existing structures.		
g	All existing utilities.		
h	Construction site boundaries.		
i	Existing vegetation (notes are acceptable in cases where there is no notable vegetation, only grasses/weeds, or site has already been stripped).		
j	FEMA 100-yr floodplain.		
k	Existing and proposed water courses including springs, streams, wetlands, detention ponds, stormwater quality structures, roadside ditches, irrigation ditches and other water surfaces. Show maintenance of pre-existing vegetation within 50 feet of a receiving water.		
l	Existing and proposed contours 2 feet or less (except for hillside).		
m	Limits of disturbance delineating all anticipated areas of soil disturbance.		
n	Identify and protect areas outside of the construction site boundary with existing fencing, construction fencing or other methods as appropriate.		
o	Offsite grading clearly shown and called out.		
p	Areas of cut and fill identified.		
q	Conclusions from soils/geotechnical report and geologic hazards report incorporated in grading design (slopes, embankments, materials, mitigation, etc.)		
r	Proposed slopes steeper than 3:1 with top and toe of slope delineated. Erosion control blanketing or other protective covering required.		
s	Stormwater flow direction arrows.		
t	Location of any dedicated asphalt / concrete batch plants.		
u	Areas used for staging, storage of building materials, soils (stockpiles) or wastes. The use of construction office trailers requires PCD permitting.		
v	All proposed temporary construction control measures, structural and non-structural. Temporary construction control measures shall be identified by phase of implementation to include "initial," "interim," and "final" or shown on separate phased maps identifying each phase.		
w	Vehicle tracking provided at all construction entrances/exits. Construction fencing, barricades, and/or signage provided at access points not to be used for construction.		
x	Temporary sediment ponds provided for disturbed drainage areas greater than 1 acre.		
y	Dewatering operations to include locations of diversion, pump and discharge(s) as anticipated at time of design.		
z	All proposed temporary construction control measure details. Custom or other jurisdiction's details used must meet or exceed EPC standards.		

- ENGINEERING CRITERIA MANUAL
Appendix E CHECKLISTS AND PERMITS



2880 International Circle, Suite 110
Colorado Springs, CO 80910
Phone 719-520-6300
Fax 719-520-6695
www.elpasoco.com

**EL PASO COUNTY PLANNING AND
COMMUNITY DEVELOPMENT
DEPARTMENT**

GRADING AND EROSION CONTROL PLAN CHECKLIST

Revised: July 2019		Applicant	PCD
aa	Any offsite stormwater control measure proposed for use by the project and not under the direct control or ownership of the Owner or Operator.		
bb	Existing and proposed permanent storm water management facilities, including areas proposed for stormwater infiltration or subsurface detention.		
cc	Existing and proposed easements (permanent and construction) including required off site easements.		
dd	Retaining walls (not to be located in County ROW unless approved via license agreement). Design by P.E. and building permit from Regional Building Department required for walls greater than or equal to 4 feet in height, series of walls, or walls supporting a surcharge.		
ee	Plan certified by a Colorado Registered P.E., with EPC standard signature blocks for Engineer, Owner and EPC.		
ff	Engineer's Statement (for standalone GEC Plan): This Grading and Erosion Control Plan was prepared under my direction and supervision and is correct to the best of my knowledge and belief. Said Plan has been prepared according to the criteria established by the County for Grading and Erosion Control Plans. I accept responsibility for any liability caused by any negligent acts, errors or omissions on my part in preparing this plan. _____ Engineer of Record Signature Date		
gg	Engineer's Statement (for GEC Plan within Construction Drawing set): These detailed plans and specifications were prepared under my direction and supervision. Said plans and specifications have been prepared according to the criteria established by the County for detailed roadway, drainage, grading and erosion control plans and specifications, and said plans and specifications are in conformity with applicable master drainage plans and master transportation plans. Said plans and specifications meet the purposes for which the particular roadway and drainage facilities are designed and are correct to the best of my knowledge and belief. I accept responsibility for any liability caused by any negligent acts, errors or omissions on my part in preparation of these detailed plans and specifications. _____ Engineer of Record Signature Date		
hh	Owner's Statement (for standalone GEC Plan): I, the owner/developer have read and will comply with the requirements of the Grading and Erosion Control Plan. _____ Owner Signature Date		
ii	Owner's Statement (for GEC Plan within Construction Drawing set): I, the owner/developer have read and will comply with the requirements of the grading and erosion control plan and all of the requirements specified in these detailed plans and specifications. _____ Owner Signature Date		

- ENGINEERING CRITERIA MANUAL
Appendix E CHECKLISTS AND PERMITS



2880 International Circle, Suite 110
Colorado Springs, CO 80910
Phone 719-520-6300
Fax 719-520-6695
www.elpasoco.com

**EL PASO COUNTY PLANNING AND
COMMUNITY DEVELOPMENT
DEPARTMENT**

GRADING AND EROSION CONTROL PLAN CHECKLIST

Revised: July 2019		Applicant	PCD
<p>El Paso County (standalone GEC Plan): County plan review is provided only for general conformance with County Design Criteria. The County is not responsible for the accuracy and adequacy of the design, dimensions, and/ or elevations which shall be confirmed at the job site. The County through the approval of this document assumes no responsibility for completeness and/ or accuracy of this document. Filed in accordance with the requirements of the El Paso County Land Development Code, Drainage Criteria Manual Volumes 1 and 2, and Engineering Criteria Manual, as amended.</p> <p>ij In accordance with ECM Section 1.12, these construction documents will be valid for construction for a period of 2 years from the date signed by the El Paso County Engineer. If construction has not started within those 2 years, the plans will need to be resubmitted for approval, including payment of review fees at the Planning and Community Development Director's discretion.</p> <p>_____</p> <p>County Project Engineer Signature Date</p>			
2. ADDITIONAL REPORTS/PERMITS/DOCUMENTS			
a	Soils report / geotechnical investigation as appropriate for grading/utilities/drainage/road construction.		
b	Use Agreement/easement between the Owner or Operator and other third party for use of all offsite grading or stormwater control measures, used by the owner or operator but not under their direct control or ownership.		
c	Floodplain Development Permit		
d	USACE 404/wetlands permit/mitigation plan		
e	FEMA CLOMR		
f	State Engineer's permit/Notice Of Intent to Construct		
g	Stormwater Management Plan (SWMP)		
h	Financial Assurance Estimate (FAE) (signed)		
i	Erosion and Stormwater Quality Control Permit (ESQCP) (signed)		
j	Pre-Development Site Grading Acknowledgement and Right of Access Form (signed)		
k	Conditions of Approval met?		
3. STANDARD NOTES FOR EL PASO COUNTY GRADING AND EROSION CONTROL PLANS			
1	Stormwater discharges from construction sites shall not cause or threaten to cause pollution, contamination, or degradation of State Waters. All work and earth disturbance shall be done in a manner that minimizes pollution of any on-site or off-site waters, including wetlands.		
2	Notwithstanding anything depicted in these plans in words or graphic representation, all design and construction related to roads, storm drainage and erosion control shall conform to the standards and requirements of the most recent version of the relevant adopted El Paso County standards, including the Land Development Code, the Engineering Criteria Manual, the Drainage Criteria Manual, and the Drainage Criteria Manual Volume 2. Any deviations from regulations and standards must be requested, and approved, in writing.		

- ENGINEERING CRITERIA MANUAL
Appendix E CHECKLISTS AND PERMITS



2880 International Circle, Suite 110
Colorado Springs, CO 80910
Phone 719-520-6300
Fax 719-520-6695
www.elpasoco.com

**EL PASO COUNTY PLANNING AND
COMMUNITY DEVELOPMENT
DEPARTMENT**

GRADING AND EROSION CONTROL PLAN CHECKLIST

Revised: July 2019		Applicant	PCD
3	A separate Stormwater Management Plan (SMWP) for this project shall be completed and an Erosion and Stormwater Quality Control Permit (ESQCP) issued prior to commencing construction. Management of the SWMP during construction is the responsibility of the designated Qualified Stormwater Manager or Certified Erosion Control Inspector. The SWMP shall be located on site at all times during construction and shall be kept up to date with work progress and changes in the field.		
4	Once the ESQCP is approved and a "Notice to Proceed" has been issued, the contractor may install the initial stage erosion and sediment control measures as indicated on the approved GEC. A Preconstruction Meeting between the contractor, engineer, and El Paso County will be held prior to any construction. It is the responsibility of the applicant to coordinate the meeting time and place with County staff.		
5	Control measures must be installed prior to commencement of activities that could contribute pollutants to stormwater. Control measures for all slopes, channels, ditches, and disturbed land areas shall be installed immediately upon completion of the disturbance.		
6	All temporary sediment and erosion control measures shall be maintained and remain in effective operating condition until permanent soil erosion control measures are implemented and final stabilization is established. All persons engaged in land disturbance activities shall assess the adequacy of control measures at the site and identify if changes to those control measures are needed to ensure the continued effective performance of the control measures. All changes to temporary sediment and erosion control measures must be incorporated into the Stormwater Management Plan.		
7	Temporary stabilization shall be implemented on disturbed areas and stockpiles where ground disturbing construction activity has permanently ceased or temporarily ceased for longer than 14 days.		
8	Final stabilization must be implemented at all applicable construction sites. Final stabilization is achieved when all ground disturbing activities are complete and all disturbed areas either have a uniform vegetative cover with individual plant density of 70 percent of pre-disturbance levels established or equivalent permanent alternative stabilization method is implemented. All temporary sediment and erosion control measures shall be removed upon final stabilization and before permit closure.		
9	All permanent stormwater management facilities shall be installed as designed in the approved plans. Any proposed changes that effect the design or function of permanent stormwater management structures must be approved by the ECM Administrator prior to implementation.		
10	Earth disturbances shall be conducted in such a manner so as to effectively minimize accelerated soil erosion and resulting sedimentation. All disturbances shall be designed, constructed, and completed so that the exposed area of any disturbed land shall be limited to the shortest practical period of time. Pre-existing vegetation shall be protected and maintained within 50 horizontal feet of a waters of the state unless shown to be infeasible and specifically requested and approved.		
11	Compaction of soil must be prevented in areas designated for infiltration control measures or where final stabilization will be achieved by vegetative cover. Areas designated for infiltration control measures shall also be protected from sedimentation during construction until final stabilization is achieved. If compaction prevention is not feasible due to site constraints, all areas designated for infiltration and vegetation control measures must be loosened prior to installation of the control measure(s).		
12	Any temporary or permanent facility designed and constructed for the conveyance of stormwater around, through, or from the earth disturbance area shall be a stabilized conveyance designed to minimize erosion and the discharge of sediment off site.		

- ENGINEERING CRITERIA MANUAL
Appendix E CHECKLISTS AND PERMITS



2880 International Circle, Suite 110
Colorado Springs, CO 80910
Phone 719-520-6300
Fax 719-520-6695
www.elpasoco.com

**EL PASO COUNTY PLANNING AND
COMMUNITY DEVELOPMENT
DEPARTMENT**

GRADING AND EROSION CONTROL PLAN CHECKLIST

Revised: July 2019		Applicant	PCD
13	Concrete wash water shall be contained and disposed of in accordance with the SWMP. No wash water shall be discharged to or allowed to enter State Waters, including any surface or subsurface storm drainage system or facilities. Concrete washouts shall not be located in an area where shallow groundwater may be present, or within 50 feet of a surface water body, creek or stream.		
14	During dewatering operations of uncontaminated ground water may be discharged on site, but shall not leave the site in the form of surface runoff unless an approved State dewatering permit is in place.		
15	Erosion control blanketing or other protective covering shall be used on slopes steeper than 3:1.		
16	Contractor shall be responsible for the removal of all wastes from the construction site for disposal in accordance with local and State regulatory requirements. No construction debris, tree slash, building material wastes or unused building materials shall be buried, dumped, or discharged at the site.		
17	Waste materials shall not be temporarily placed or stored in the street, alley, or other public way, unless in accordance with an approved Traffic Control Plan. control measures may be required by El Paso County Engineering if deemed necessary, based on specific conditions and circumstances.		
18	Tracking of soils and construction debris off-site shall be minimized. Materials tracked off-site shall be cleaned up and properly disposed of immediately.		
19	The owner/developer shall be responsible for the removal of all construction debris, dirt, trash, rock, sediment, soil, and sand that may accumulate in roads, storm drains and other drainage conveyance systems and stormwater appurtenances as a result of site development.		
20	The quantity of materials stored on the project site shall be limited, as much as practical, to that quantity required to perform the work in an orderly sequence. All materials stored on-site shall be stored in a neat, orderly manner, in their original containers, with original manufacturer's labels.		
21	No chemical(s) having the potential to be released in stormwater are to be stored or used onsite unless permission for the use of such chemical(s) is granted in writing by the ECM Administrator. In granting approval for the use of such chemical(s), special conditions and monitoring may be required.		
22	Bulk storage of allowed petroleum products or other allowed liquid chemicals in excess of 55 gallons shall require adequate secondary containment protection to contain all spills onsite and to prevent any spilled materials from entering State Waters, any surface or subsurface storm drainage system or other facilities.		
23	No person shall cause the impediment of stormwater flow in the curb and gutter or ditch except with approved sediment control measures.		
24	Owner/developer and their agents shall comply with the "Colorado Water Quality Control Act" (Title 25, Article 8, CRS), and the "Clean Water Act" (33 USC 1344), in addition to the requirements of the Land Development Code, DCM Volume II and the ECM Appendix I. All appropriate permits must be obtained by the contractor prior to construction (1041, NPDES, Floodplain, 404, fugitive dust, etc.). In the event of conflicts between these requirements and other laws, rules, or regulations of other Federal, State, local, or County agencies, the most restrictive laws, rules, or regulations shall apply.		
25	All construction traffic must enter/exit the site only at approved construction access points.		
26	Prior to construction the permittee shall verify the location of existing utilities.		
27	A water source shall be available on site during earthwork operations and shall be utilized as required to minimize dust from earthwork equipment and wind.		

- ENGINEERING CRITERIA MANUAL
Appendix E CHECKLISTS AND PERMITS



2880 International Circle, Suite 110
Colorado Springs, CO 80910
Phone 719-520-6300
Fax 719-520-6695
www.elpasoco.com

**EL PASO COUNTY PLANNING AND
COMMUNITY DEVELOPMENT
DEPARTMENT**

GRADING AND EROSION CONTROL PLAN CHECKLIST

Revised: July 2019

		Applicant	PCD
28	The soils report for this site has been prepared by _____ and shall be considered a part of these plans.		
29	At least ten (10) days prior to the anticipated start of construction, for projects that will disturb one (1) acre or more, the owner or operator of construction activity shall submit a permit application for stormwater discharge to the Colorado Department of Public Health and Environment, Water Quality Division. The application contains certification of completion of a stormwater management plan (SWMP), of which this Grading and Erosion Control Plan may be a part. For information or application materials contact: Colorado Department of Public Health and Environment Water Quality Control Division WQCD – Permits 4300 Cherry Creek Drive South Denver, CO 80246-1530 Attn: Permits Unit		
4. Applicant Comments:			
a			
b			
c			
5. Checklist Review Certifications:			
a	Engineer of Record: The Grading and Erosion Control Plan was prepared under my direction and supervision and is complete and correct to the best of my knowledge and belief. Said Plan has been prepared according to the criteria established by the County for Grading and Erosion Control Plans.		
	_____ Engineer of Record Signature		
	_____ Date		

- ENGINEERING CRITERIA MANUAL
Appendix E CHECKLISTS AND PERMITS



2880 International Circle, Suite 110
Colorado Springs, CO 80910
Phone 719-520-6300
Fax 719-520-6695
www.elpasoco.com

**EL PASO COUNTY PLANNING AND
COMMUNITY DEVELOPMENT
DEPARTMENT**

GRADING AND EROSION CONTROL PLAN CHECKLIST

		Applicant	PCD
Revised: July 2019	Review Engineer: The Grading and Erosion Control Plan was reviewed and found to meet the checklist requirements except where otherwise noted or allowed by an approved deviation request.		
b			

	Review Engineer		
	Date		

Appendix F STANDARD DRAWINGS & SPECIFICATIONS

Note: Drawings are listed by chapter and then sequential (intentional gaps in the numbering have been placed to allow for future additions). EPC Standard Drawings remain products in progress and will continue to be updated as necessary through an administrative process. Only those with listed Approval Dates shall be considered a standard and all others are presented for "reference" purposes only until such date that they are fully accepted by the ECM Administrator. EPC Standard Specifications remain products in progress and will continue to be updated as necessary through an administrative process. Only those with listed Approval Dates shall be considered a standard and all others are presented for "reference" purposes only until such date that they are fully accepted by the ECM Administrator.

EPC Standard Drawings

File Name	Detail/Description	Approval Date
SD_2-1	Urban Local Roadway (low volume)	06/23/2020
SD_2-2	Urban Local Roadway	06/23/2020
SD_2-3	Urban NonResidential Collector Roadway	06/23/2020
SD_2-4	Urban Residential Collector Roadway	06/23/2020
SD_2-5	Urban Minor Arterial Roadway	06/23/2020
SD_2-6	Urban Principal 4-Lane Arterial Roadway	06/23/2020
SD_2-7	Urban Principal 6-Lane Arterial Roadway	06/23/2020
SD_2-8	Urban Expressway 4-Lane Roadway	06/23/2020
SD_2-9	Urban Expressway 6-Lane Roadway	06/23/2020
SD-2-10	Rural Gravel Local Roadway	12/31/2005
SD_2-11	Rural Local Roadway	BOCC Approval Date
SD-2-12	Rural Minor Collector Roadway	BOCC Approval Date
SD_2-13	Rural Major Collector Roadway	BOCC Approval Date
SD_2-14	Rural Minor Arterial Roadway	BOCC Approval Date
SD_2-15	Rural Principal 4-Lane Arterial Roadway	BOCC Approval Date
SD_2-16	Rural Principal 6-Lane Arterial Roadway	BOCC Approval Date
SD_2-17	Rural Expressway 4-Lane Roadway	BOCC Approval Date
SD_2-18	Rural Expressway 6-Lane Roadway	BOCC Approval Date
SD_2-20	Typical Curb and Gutter Details	BOCC Approval Date
SD_2-21	Patterned Concrete Median Paving	01/18/2011
SD_2-22	Plowable Median Nose Detail	1/12/2016

- ENGINEERING CRITERIA MANUAL
Appendix F STANDARD DRAWINGS & SPECIFICATIONS

SD-2-23	Driveway Cut Detail	08/11/2011
SD-2-24	Driveway Detail w/Attached Sidewalk	06/23/2020
SD_2-25	Driveway Detail w/Detached Sidewalk	06/23/2020
SD_2-26	Typical Cross Pan Layout Detail	08/11/2011
SD_2-40	Pedestrian Curb Ramp Detail	06/23/2020
SD_2-41	Pedestrian Curb Ramp Detail	06/23/2020
SD_2-42	Detectable Warning Surface Details	06/23/2020
SD_2-50	Parallel Pedestrian Curb Ramp Detail	06/23/2020
SD_2-70	Type C Aluminum Bridge Railing	08/11/2011
SD_2-71	Oklahoma TR-1 Bridge Railing	08/11/2011
SD_2-72	Nevada Concrete Safety Bridge Railing	08/11/2011
SD_2-73	Safety Shaped Concrete Bridge Railing	08/11/2011
SD_2-74	Texas Type TT Bridge Railing	08/11/2011
SD_2-75	Urban Cul-de-Sac Details	01/01/2008
SD_2-76	Rural Cul-de-Sac Details	BOCC Approval Date
SD_2-77	Urban Knuckle	BOCC Approval Date
SD_2-78	Urban Eyebrow	BoCC Approval Date
SD_3-1	Storm Sewer Manhole Detail Type I	07/09/2009
SD-3-2	Storm Sewer Manhole Detail Type II	11/10/2004
SD_3-3	Storm Sewer Manhole Detail Type III	08/11/2011
SD_3-5	Storm Sewer Manhole Lid Detail	09/16/2010
SD_3-7	Storm Sewer Manhole Riser and Cover Detail	08/11/2011
SD-3-8	Grate Inlet for Common Areas (guidance)	08/11/2011
SD_3-14	Driveway Access on Rural Local Roadway	08/11/2011
SD_3-24	Sidewalk Underdrain w/ Curb Outlet Detail	08/11/2011
SD_3-25	Curb Opening w/ Drainage Chase Detail 1 of 2	08/11/2011
SD_3-25A	Curb Opening w/ Drainage Chase Detail 2 of 2	08/11/2011
SD_3-30	Desilting Basin Outlet	08/11/2011
SD_3-31	Temporary Desilting Basin at Inlet	08/11/2011
SD_3-32	Temporary Desilting Basin at Sump	08/11/2011
SD_3-33	On Street Temporary Desilting Basin Detail	
SD_3-34	Temporary Desilting Basin Detail (guidance)	08/11/2011
SD_3-35	Debris Cage for Desilting Basin Riser	08/11/2011
SD_3-36	Desilting Basin Riser Detail	08/11/2011
SD_3-41	Lined Ditch Splashwall Detail (plan and section)	08/11/2011
SD_3-44	Lined Ditch Behind Retaining Wall Detail	08/11/2011
SD_3-48	Beehive Grate Detail (guidance)	08/11/2011
SD_3-60	Temporary Street Sandbag Detail and Section	08/11/2011
SD_3-62	Typical Check Dam Detail	08/11/2011
SD_3-71	Canyon Subdrain Detail	08/11/2011
SD_3-81	Lug Connection Detail (cast in place concrete pipe)	08/11/2011
SD_3-82	Plan and Section of an Extended Detention Basin Sedimentation Facility	01/01/08

- ENGINEERING CRITERIA MANUAL
Appendix F STANDARD DRAWINGS & SPECIFICATIONS

SD_3-83	Typical WQCV Outlet Structure Profiles Including 100-Year Detention	01/01/08
SD_3-84	Concrete Washout Structure	01/01/08
SD_3-85	Erosion Log Check Dams	01/01/08
SD_3-86	Culvert Inlet and Outlet Protection Erosion Logs Above Inlets and Outlets for Slope 3:1 or Steeper	01/01/08
SD_3-87	Erosion Log Barrier	01/01/08
SD_3-88	Cut Back Swale	12/13/2016
SD_4-1	Urban Local Roadway - Utility Placement	08/11/2011
SD_4-2	Urban Residential Minor Collector Roadway - Utility Placement	08/11/2011
SD_4-3	Urban NonResidential Collector Roadway - Utility Placement	08/11/2011
SD_4-4	Urban Residential Major Collector Roadway - Utility Placement	08/11/2011
SD_4-5 & 4-5A	Urban Minor Arterial Roadway - Utility Placement	08/11/2011
SD_4-6 & 4-6A	Urban Principal 4-Lane Arterial Roadway - Utility Placement	08/11/2011
SD_4-7 & 4-7A	Urban Principal 6-Lane Arterial Roadway - Utility Placement	08/11/2011
SD_4-8 & 4-8A	Urban Expressway 4-Lane Roadway - Utility Placement	08/11/2011
SD_4-9 & 4-9A	Urban Expressway 6-Lane Roadway - Utility Placement	08/11/2011
SD-4-10	Rural Gravel Local Roadway - Utility Placement	08/11/2011
SD_4-11	Rural Local Roadway - Utility Placement	08/11/2011
SD-4-12	Rural Minor Collector Roadway - Utility Placement	08/11/2011
SD_4-13	Rural Major Collector Roadway - Utility Placement	08/11/2011
SD_4-14 & 4-14A	Rural Minor Arterial Roadway - Utility Placement	08/11/2011
SD_4-15 & 4-15A	Rural Principal 4-Lane Arterial Roadway - Utility Placement	08/11/2011
SD_4-16 & 4-16A	Rural Principal 6-Lane Arterial Roadway - Utility Placement	08/11/2011
SD_4-17 & 4-17A	Rural Expressway 4-Lane Roadway - Utility Placement	08/11/2011
SD_4-18 & 4-18A	Rural Expressway 6-Lane Roadway - Utility Placement	08/11/2011
SD_4-20	Utility Trench Repair Detail (asphalt pavement)	08/11/2011
SD_4-21	Utility Trench Repair Detail (newly overlaid pavement)	08/11/2011
SD_4-22	Utility Trench Repair Detail (concrete pavement)	08/11/2011
SD_4-23	Utility Trench Repair Detail (flowable fill)	08/11/2011

(Res. No. 20-222 , 6-23-20)

EPC Standard Specifications

- ENGINEERING CRITERIA MANUAL
Appendix F STANDARD DRAWINGS

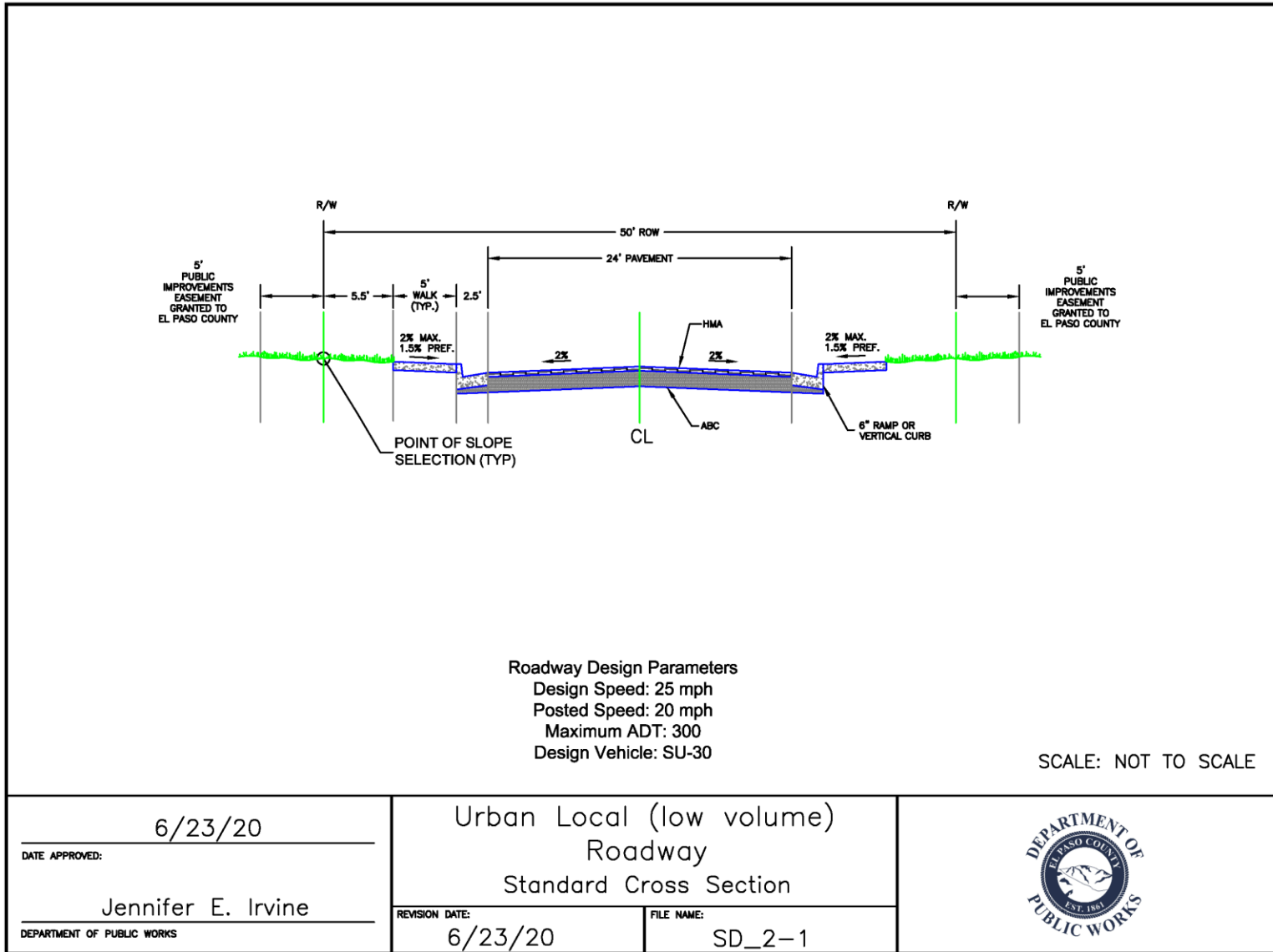

- ENGINEERING CRITERIA MANUAL
Appendix F STANDARD DRAWINGS

(Res. No. 20-222 , 6-23-20)

- ENGINEERING CRITERIA MANUAL
Appendix F STANDARD DRAWINGS

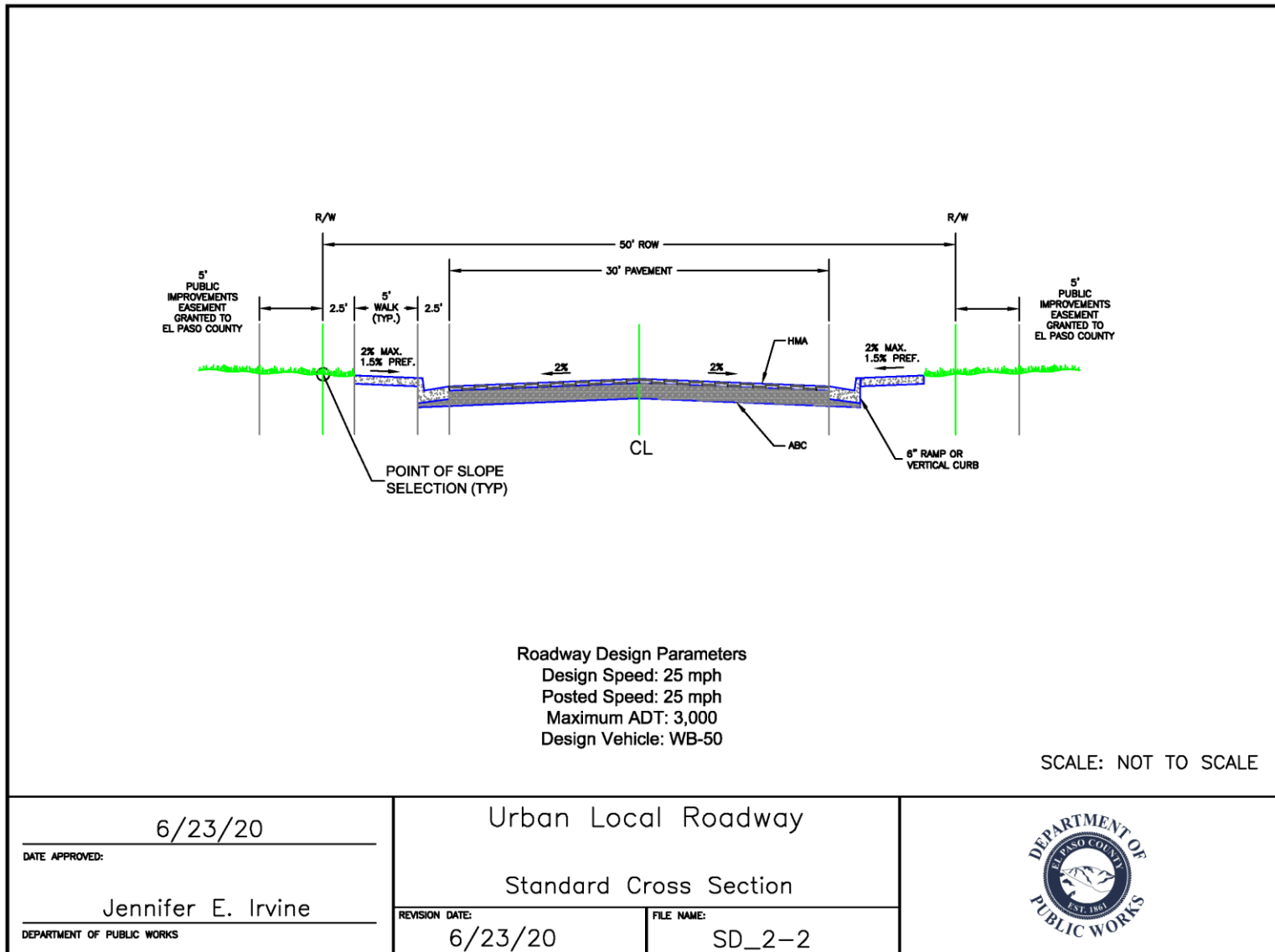

- ENGINEERING CRITERIA MANUAL
Appendix F STANDARD DRAWINGS

(Res. No. 20-222 , 6-23-20)

- ENGINEERING CRITERIA MANUAL
Appendix F STANDARD DRAWINGS

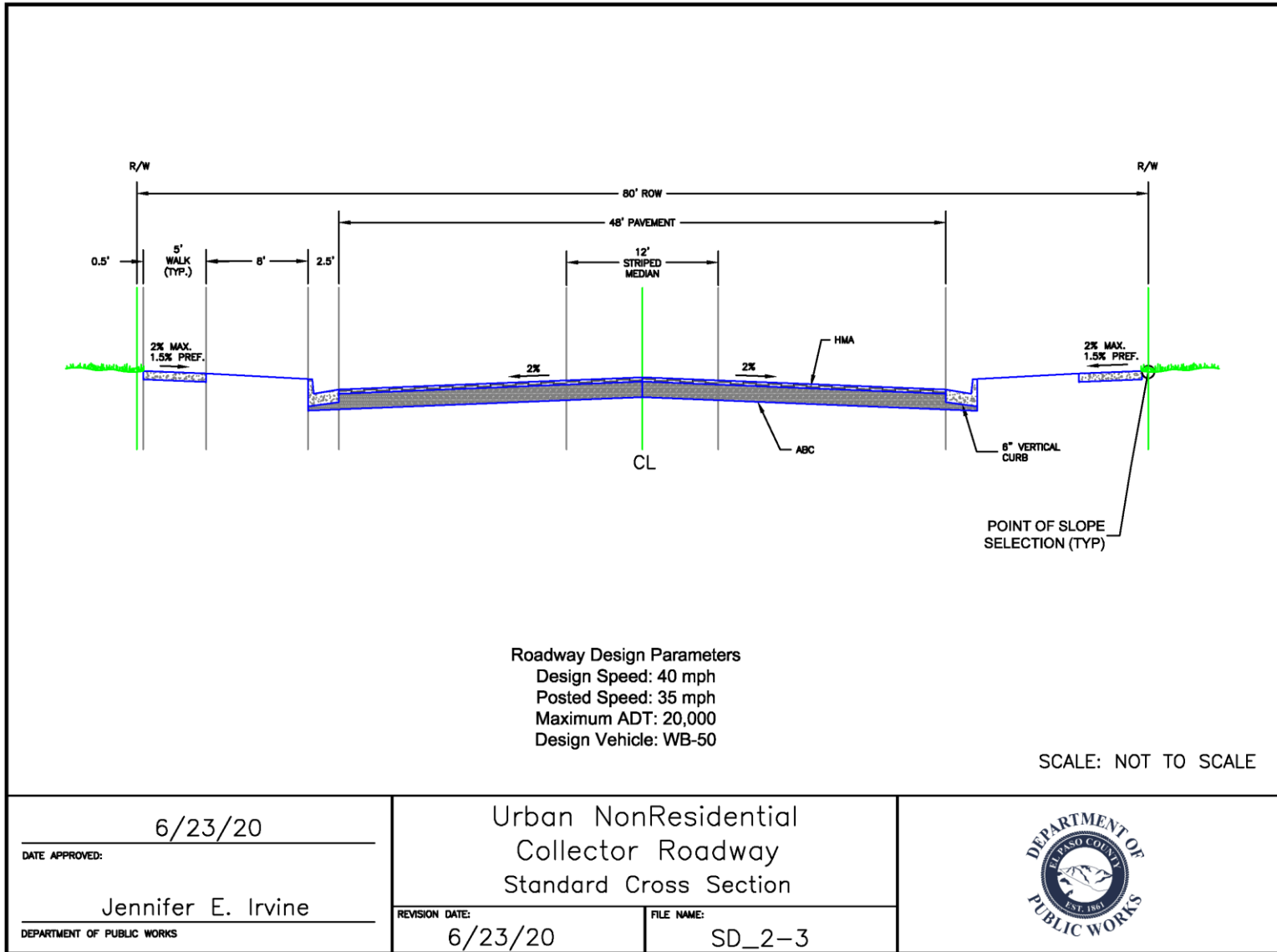

- ENGINEERING CRITERIA MANUAL
Appendix F STANDARD DRAWINGS

(Res. No. 20-222 , 6-23-20)

- ENGINEERING CRITERIA MANUAL
Appendix F STANDARD DRAWINGS

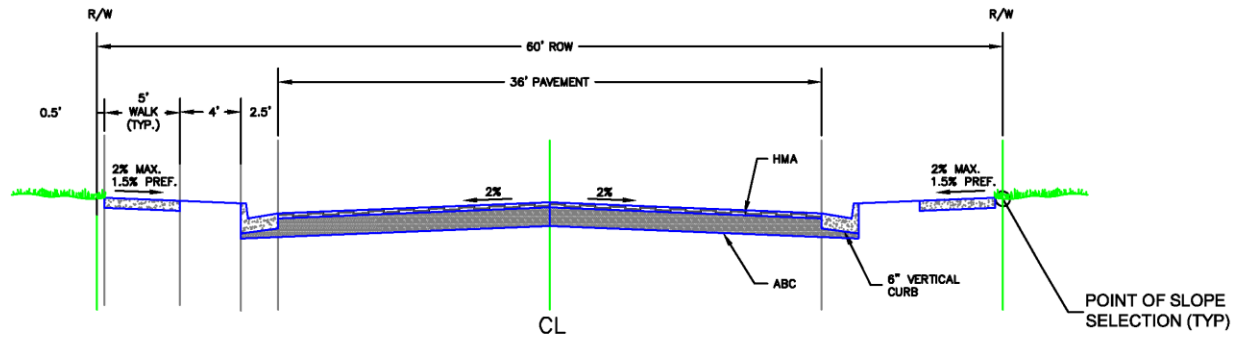

Roadway Design Parameters
 Design Speed: 40 mph
 Posted Speed: 35 mph
 Maximum ADT: 10,000
 Design Vehicle: WB-50

SCALE: NOT TO SCALE

DATE APPROVED: 6/23/20
 Jennifer E. Irvine
 DEPARTMENT OF PUBLIC WORKS

Urban Residential
 Collector Roadway
 Standard Cross Section

REVISION DATE: 6/23/20 FILE NAME: SD_2-4



- ENGINEERING CRITERIA MANUAL
Appendix F STANDARD DRAWINGS

(Res. No. 20-222 , 6-23-20)

- ENGINEERING CRITERIA MANUAL
Appendix F STANDARD DRAWINGS

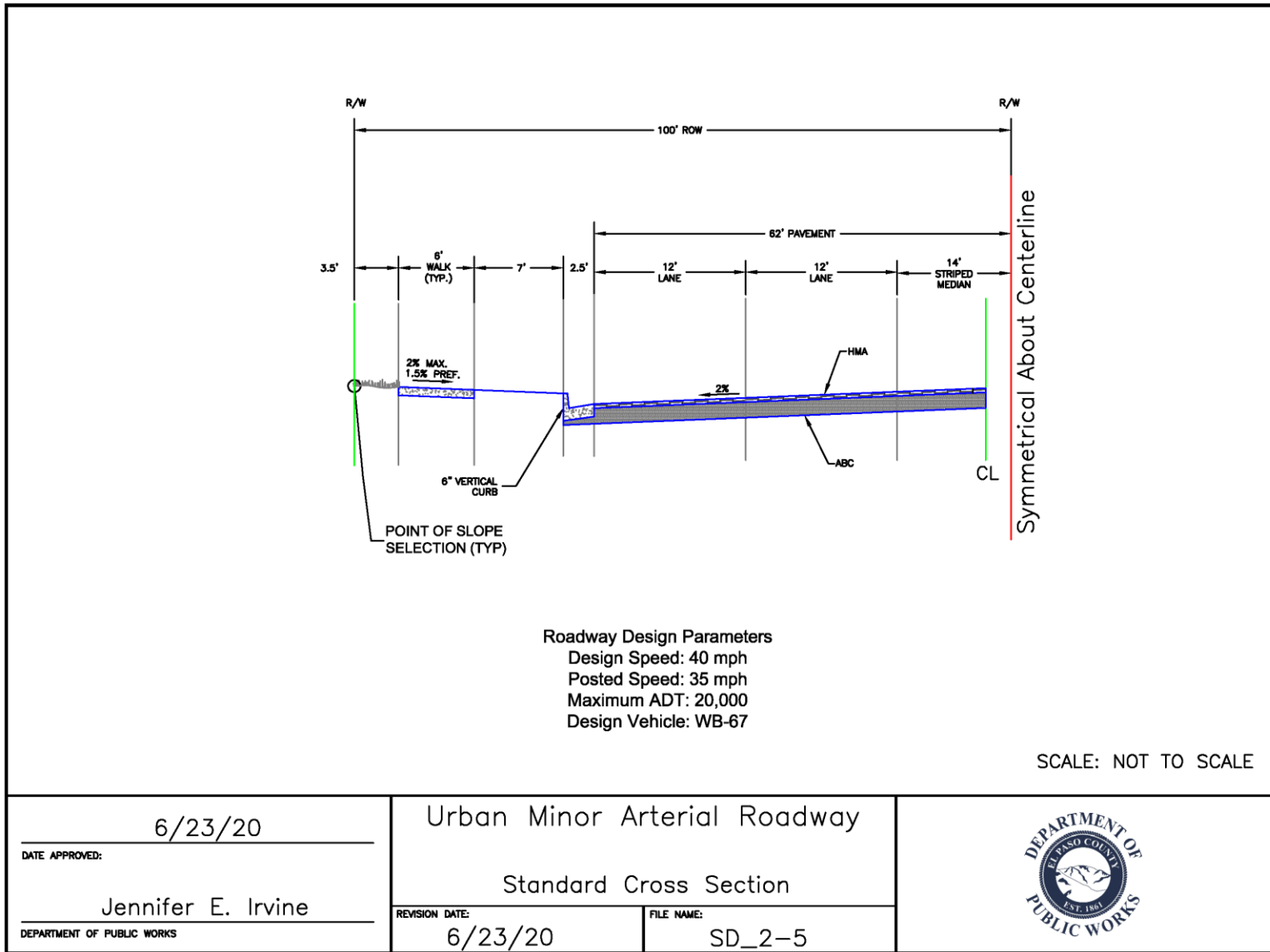

- ENGINEERING CRITERIA MANUAL
Appendix F STANDARD DRAWINGS

(Res. No. 20-222 , 6-23-20)

- ENGINEERING CRITERIA MANUAL
Appendix F STANDARD DRAWINGS

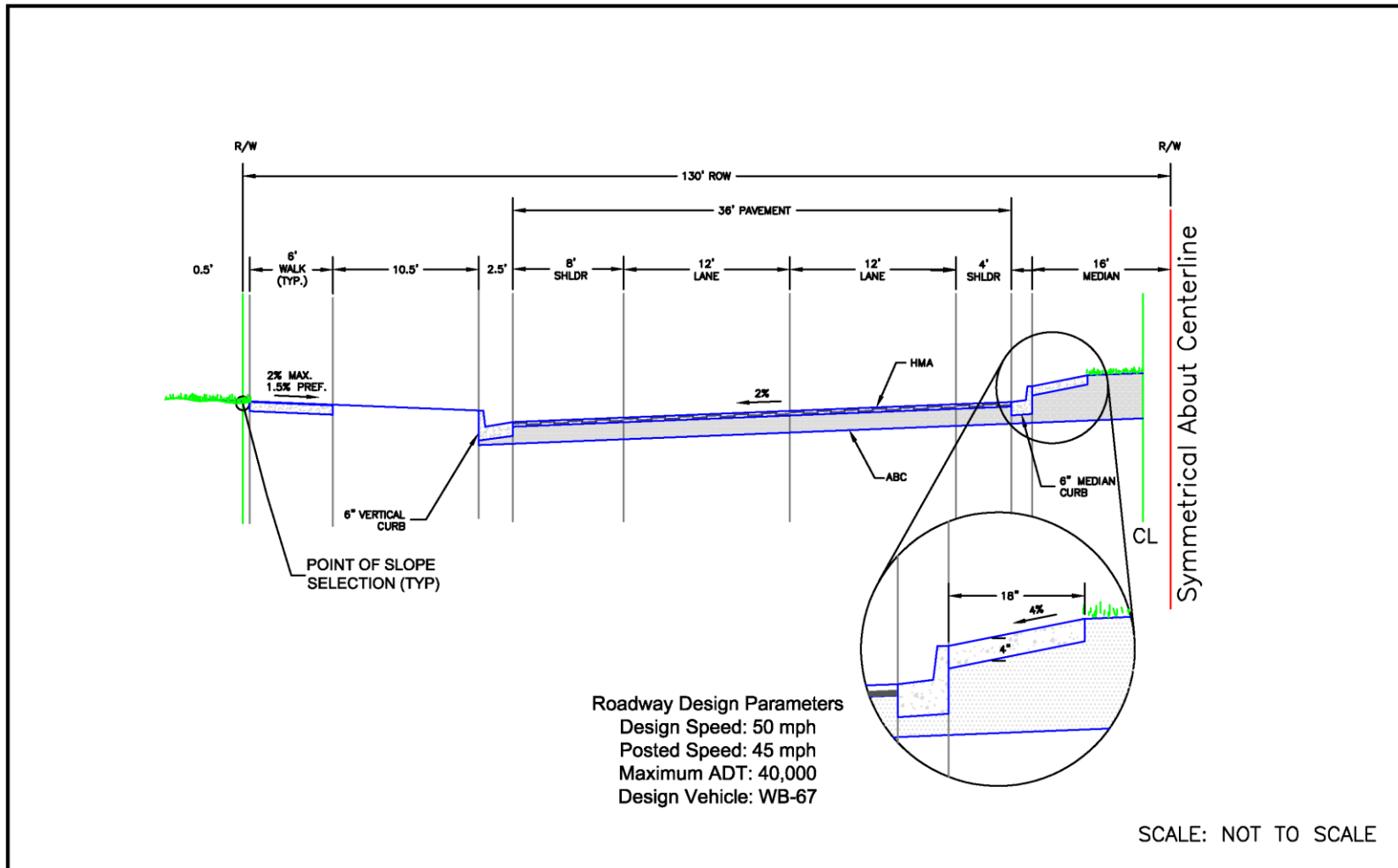

6/23/20
 DATE APPROVED:
 Jennifer E. Irvine
 DEPARTMENT OF PUBLIC WORKS

Urban Principal 4-Lane
 Arterial Roadway
 Standard Cross Section

REVISION DATE: 6/23/20 FILE NAME: SD_2-6



El Paso
 (Supp. No. 2)

- ENGINEERING CRITERIA MANUAL
Appendix F STANDARD DRAWINGS

(Res. No. 20-222 , 6-23-20)

- ENGINEERING CRITERIA MANUAL
Appendix F STANDARD DRAWINGS

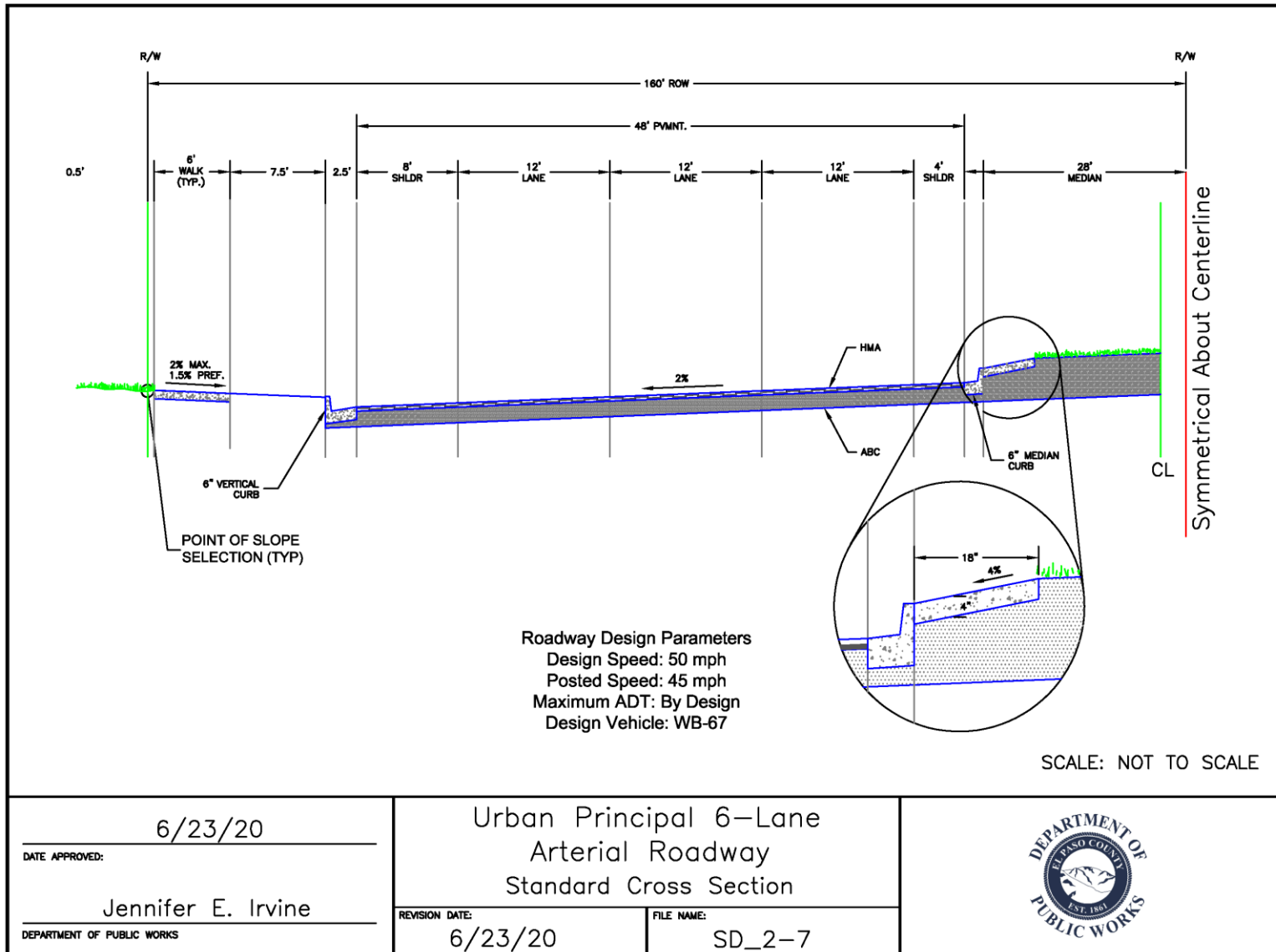

- ENGINEERING CRITERIA MANUAL
Appendix F STANDARD DRAWINGS

(Res. No. 20-222 , 6-23-20)

- ENGINEERING CRITERIA MANUAL
Appendix F STANDARD DRAWINGS

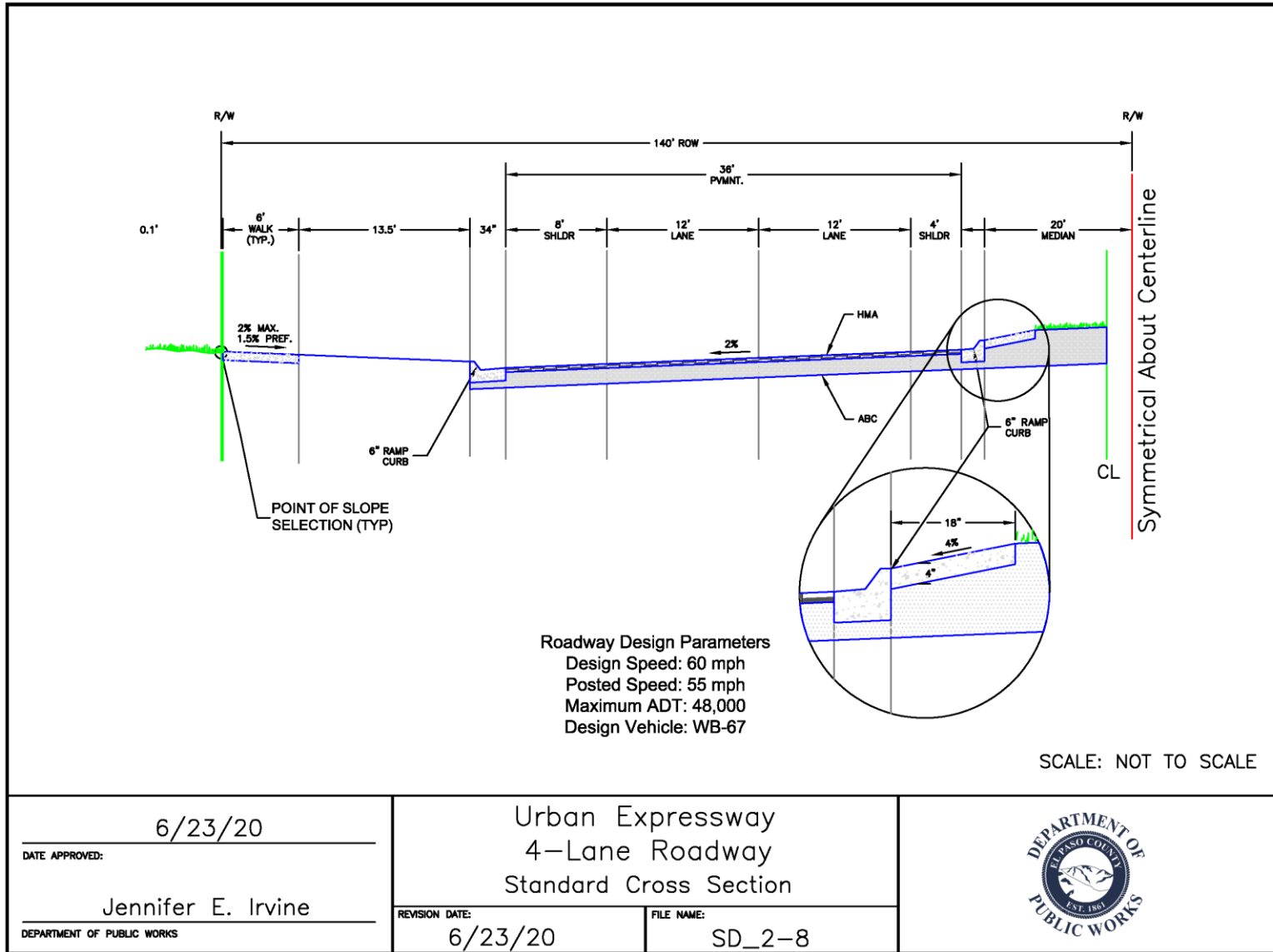

- ENGINEERING CRITERIA MANUAL
Appendix F STANDARD DRAWINGS

(Res. No. 20-222 , 6-23-20)

- ENGINEERING CRITERIA MANUAL
Appendix F STANDARD DRAWINGS

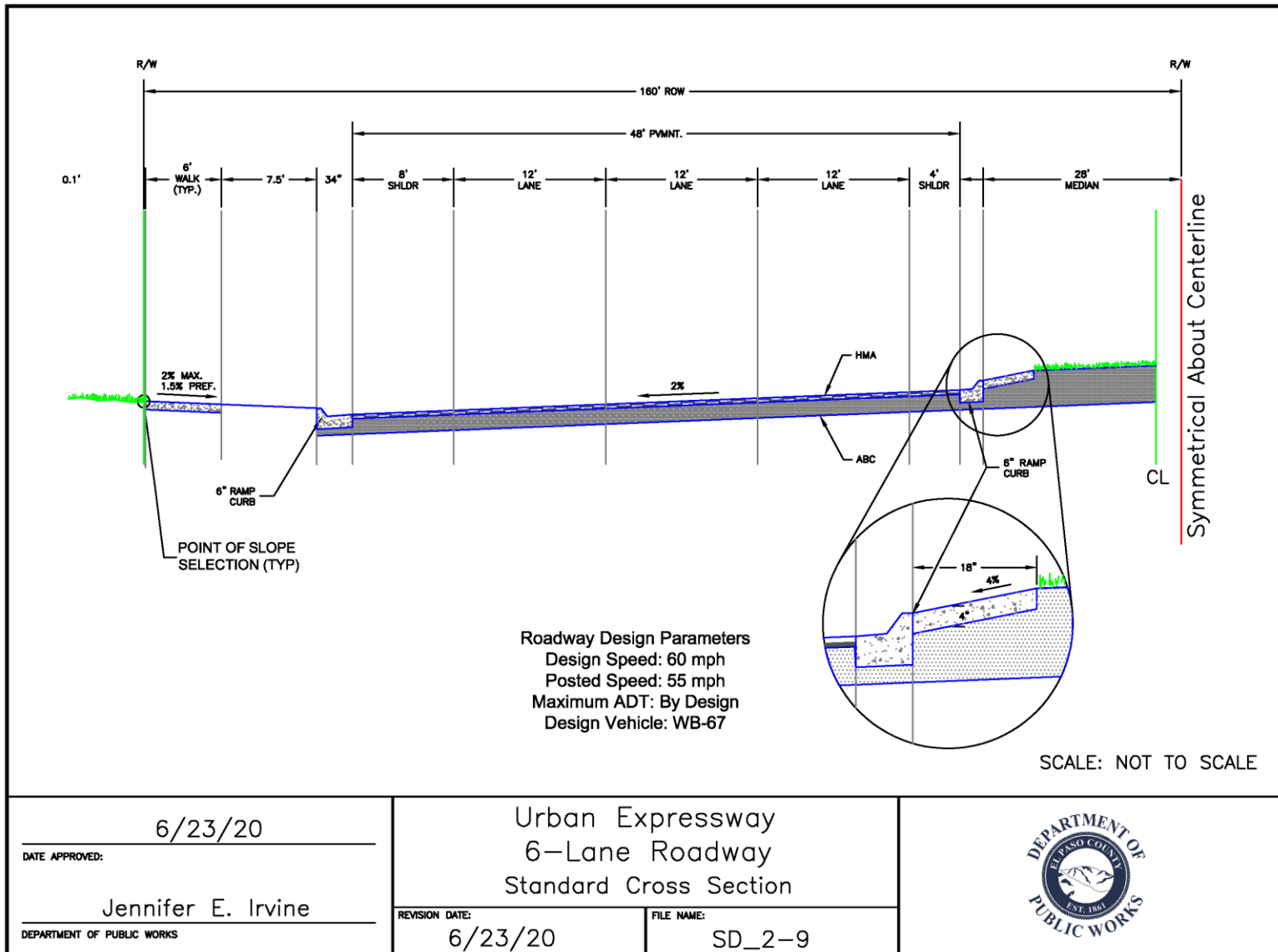

- ENGINEERING CRITERIA MANUAL
Appendix F STANDARD DRAWINGS

(Res. No. 20-222 , 6-23-20)

- ENGINEERING CRITERIA MANUAL
Appendix F STANDARD DRAWINGS

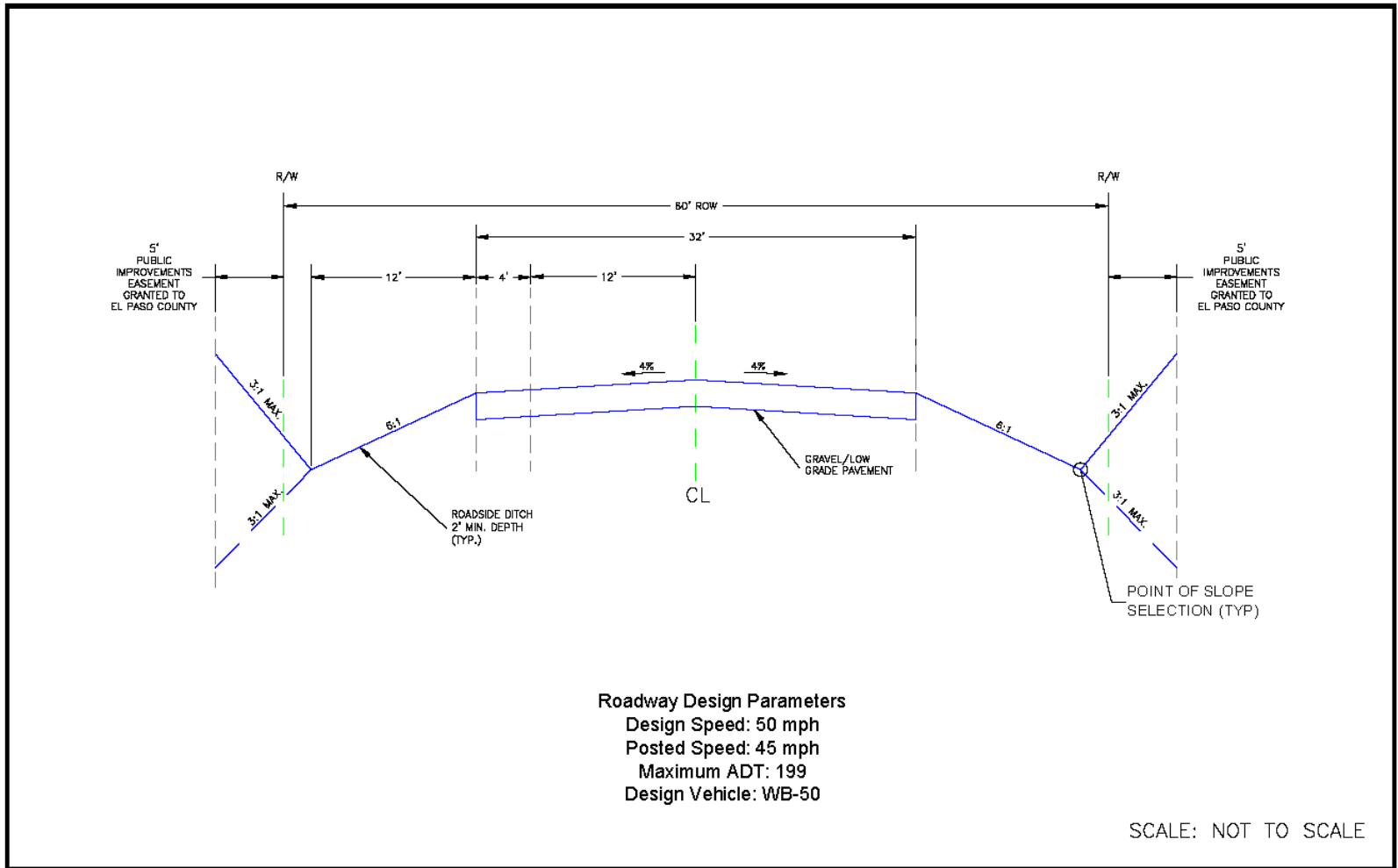

9/16/10
 DATE APPROVED:
 André P. Brackin
 DEPARTMENT OF TRANSPORTATION

Rural Gravel Local Roadway

Standard Cross Section

REVISION DATE: 12/8/15 FILE NAME: SD_2-10



El Pas
 (Supp. No. 2)

- ENGINEERING CRITERIA MANUAL
Appendix F STANDARD DRAWINGS

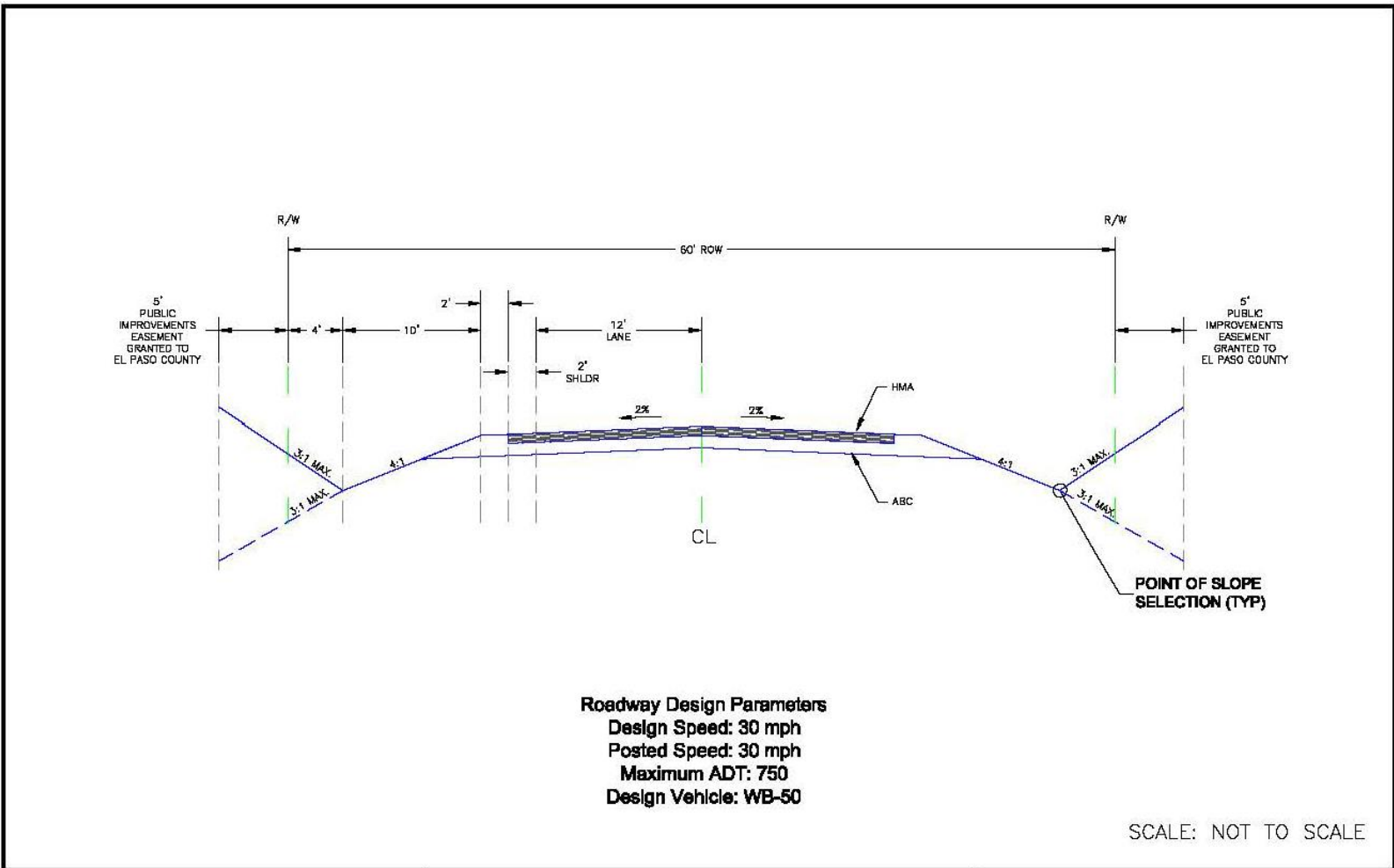

<p align="center">12/31/05</p> <p>DATE APPROVED:</p> <p align="center">John A. McCarty</p> <p>DEPARTMENT OF TRANSPORTATION</p>	<p align="center">Rural Local Roadway</p> <p align="center">Standard Cross Section</p> <p>REVISION DATE: 12/22/05</p> <p>FILE NAME: SD_2-11</p>	
--	---	---

El Paso
(Supp. No. 2)

- ENGINEERING CRITERIA MANUAL
Appendix F STANDARD DRAWINGS

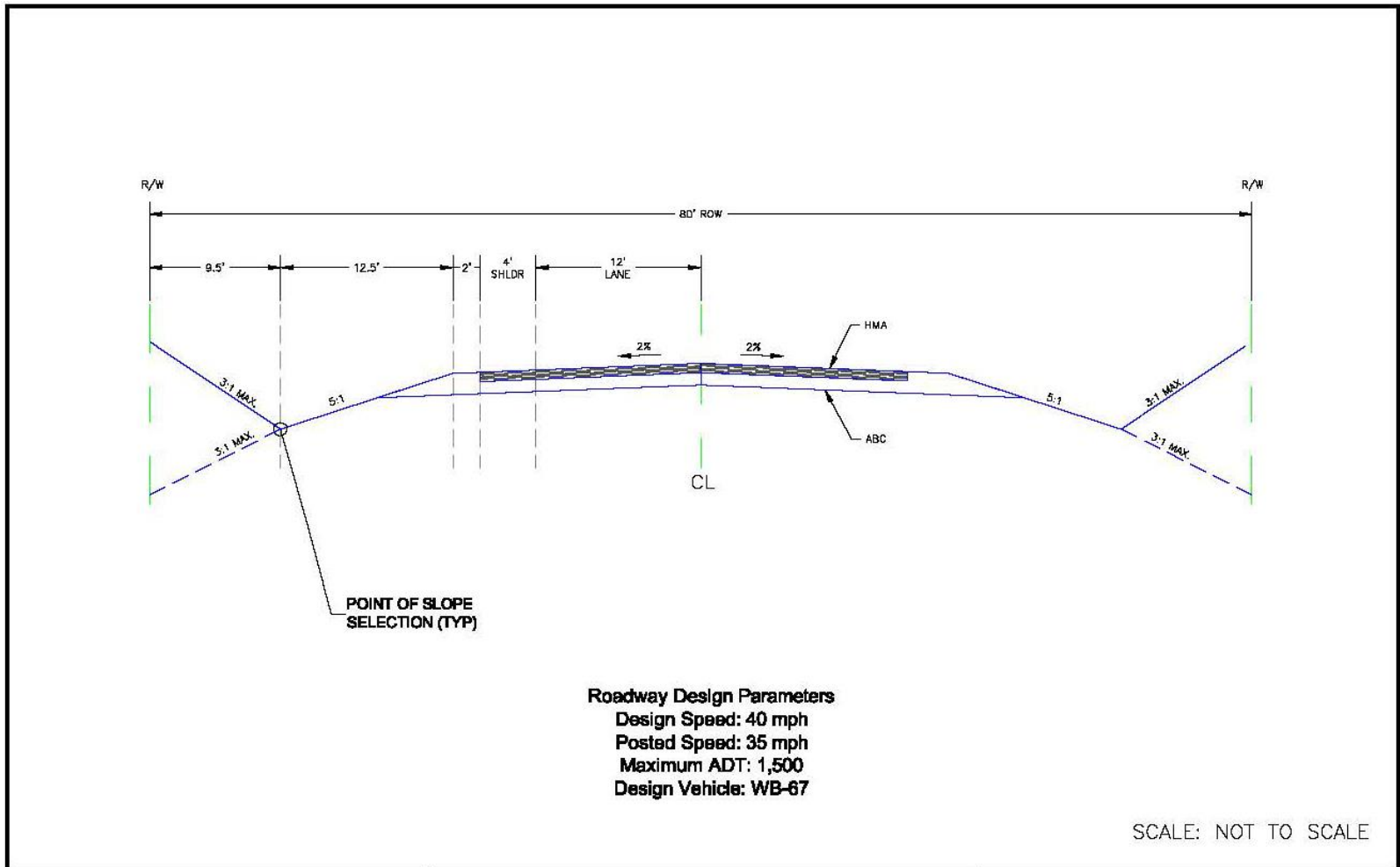

<p style="text-align: center; font-size: 1.2em;">12/31/05</p> <p><small>DATE APPROVED:</small></p> <p style="text-align: center; font-size: 1.1em;">John A. McCarty</p> <p><small>DEPARTMENT OF TRANSPORTATION</small></p>	<p style="text-align: center; font-size: 1.1em;">Rural Minor Collector Roadway</p> <p style="text-align: center; font-size: 1.1em;">Standard Cross Section</p> <p><small>REVISION DATE:</small> 12/22/05 <small>FILE NAME:</small> SD_2-12</p>	
--	---	---

El Paso
(Supp. No. 2)

- ENGINEERING CRITERIA MANUAL
Appendix F STANDARD DRAWINGS

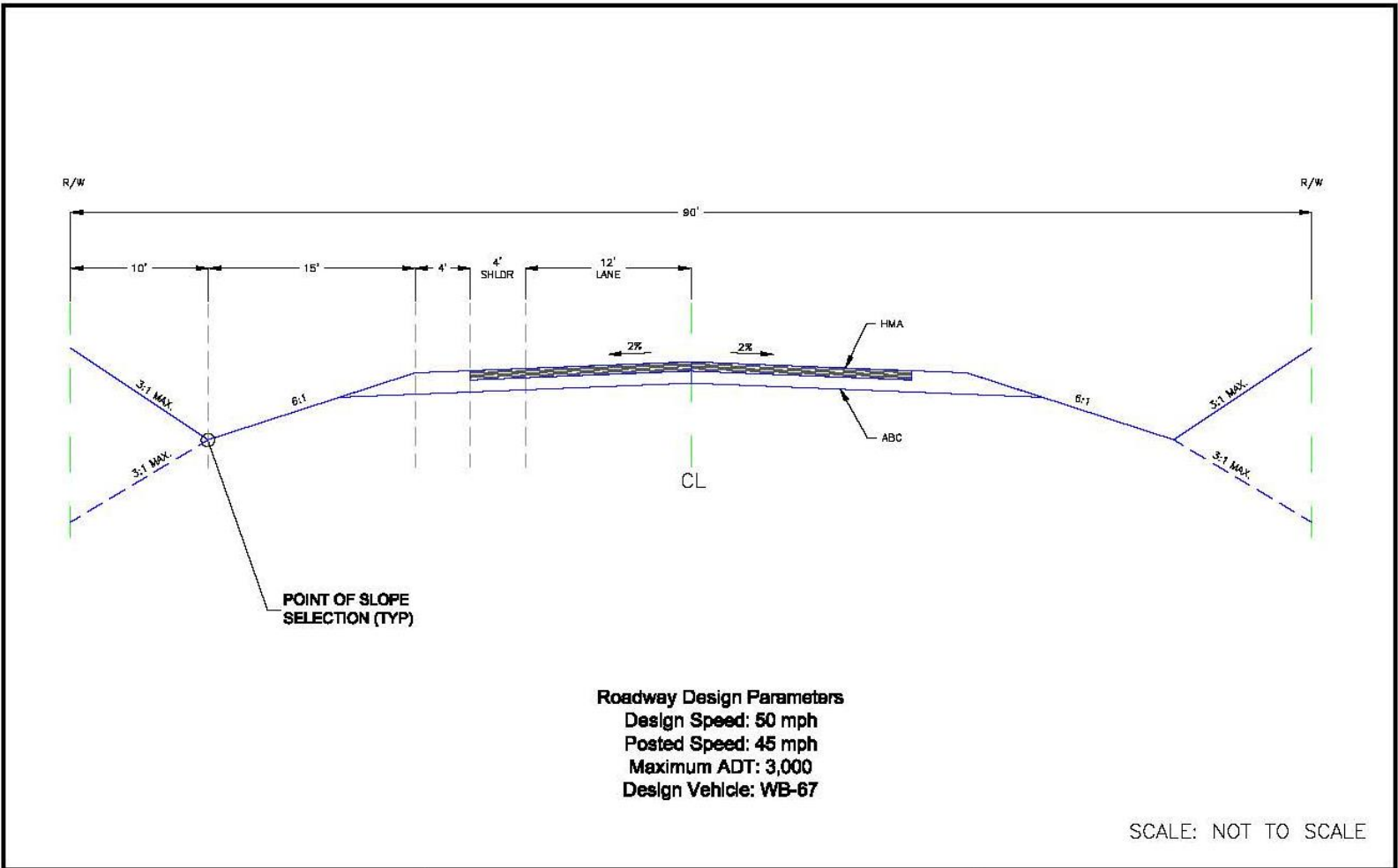

<p>12/31/05</p> <p>DATE APPROVED:</p> <p>John A. McCarty</p> <p>DEPARTMENT OF TRANSPORTATION</p>	<p>Rural Major Collector Roadway</p> <p>Standard Cross Section</p> <p>REVISION DATE: 12/22/05</p> <p>FILE NAME: SD_2-13</p>	
--	---	---

El Pasco
(Supp. No. 2)

- ENGINEERING CRITERIA MANUAL
Appendix F STANDARD DRAWINGS

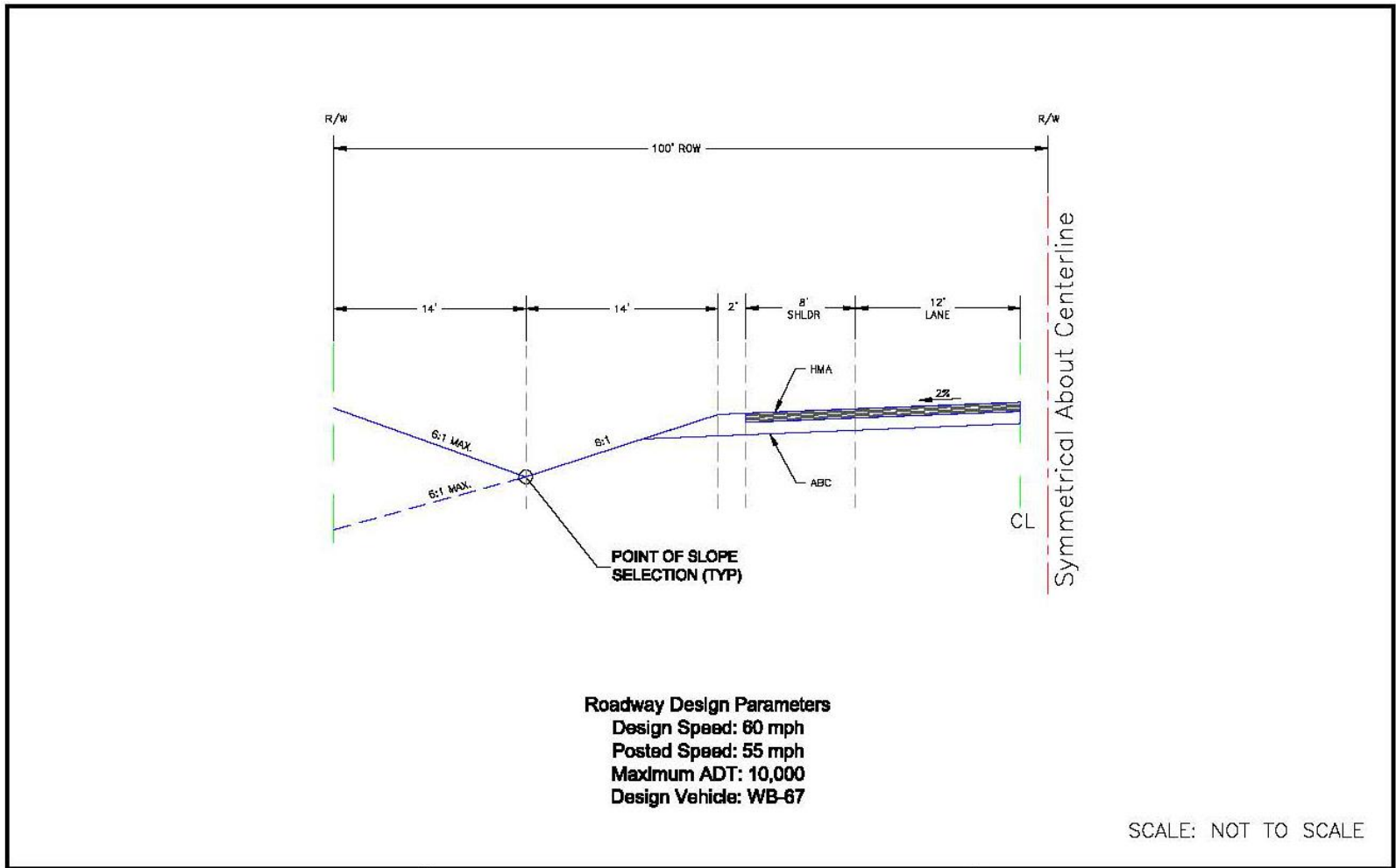

12/31/05 <small>DATE APPROVED:</small>	Rural Minor Arterial Roadway	
John A. McCarty <small>DEPARTMENT OF TRANSPORTATION</small>	Standard Cross Section	
	<small>REVISION DATE:</small> 12/22/05	<small>FILE NAME:</small> SD_2-14

El Paso
(Supp. No. 2)

- ENGINEERING CRITERIA MANUAL
Appendix F STANDARD DRAWINGS

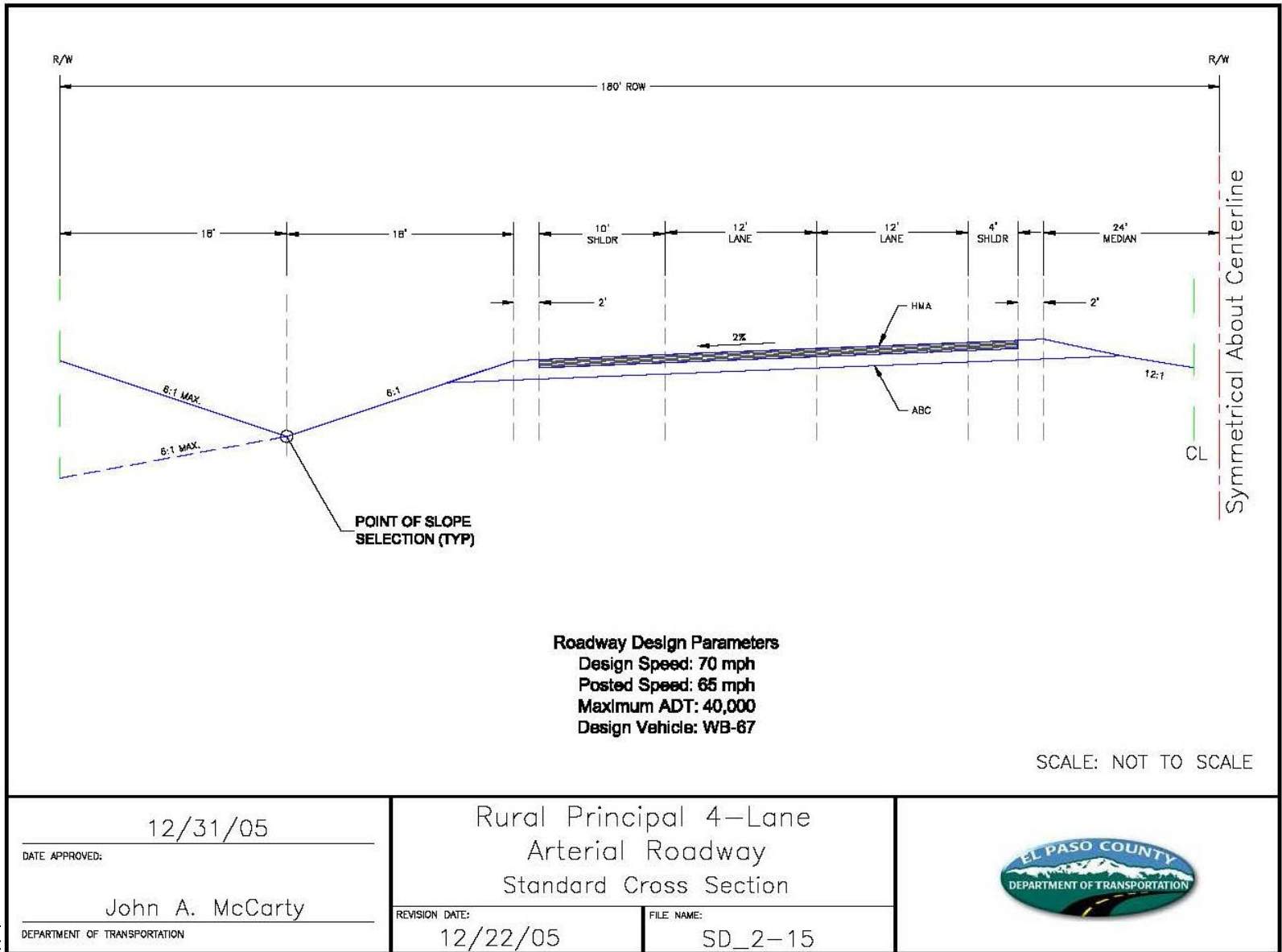

El Paso
(Supp. No. 2)

- ENGINEERING CRITERIA MANUAL
Appendix F STANDARD DRAWINGS

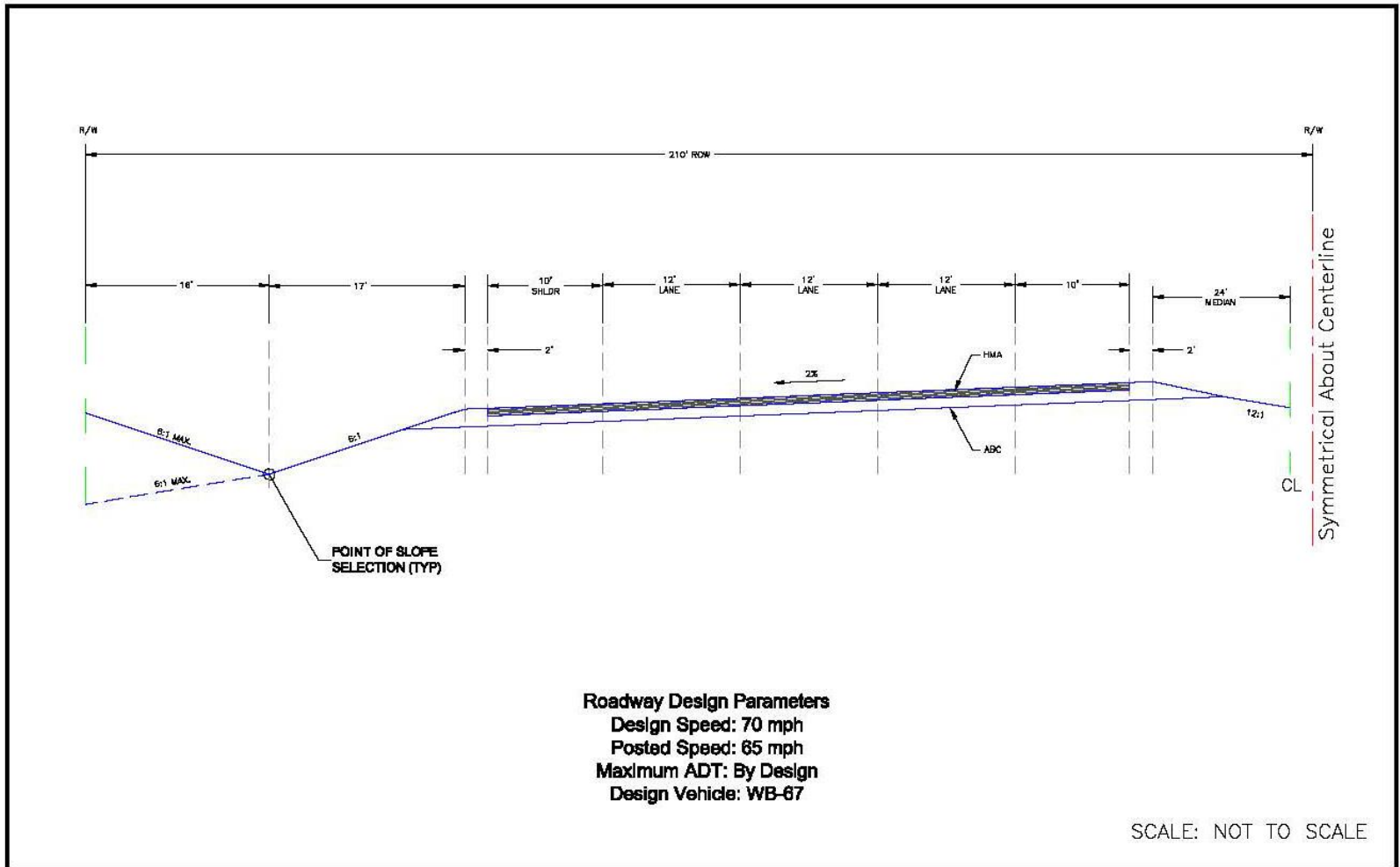

<p align="center">12/31/05</p> <p>DATE APPROVED:</p> <p align="center">John A. McCarty</p> <p>DEPARTMENT OF TRANSPORTATION</p>	<p align="center">Rural Principal 6-Lane Arterial Roadway Standard Cross Section</p> <p>REVISION DATE: 12/22/05</p> <p>FILE NAME: SD_2-16</p>	
--	---	---

El Paso
(Supp. No. 2)

- ENGINEERING CRITERIA MANUAL
Appendix F STANDARD DRAWINGS

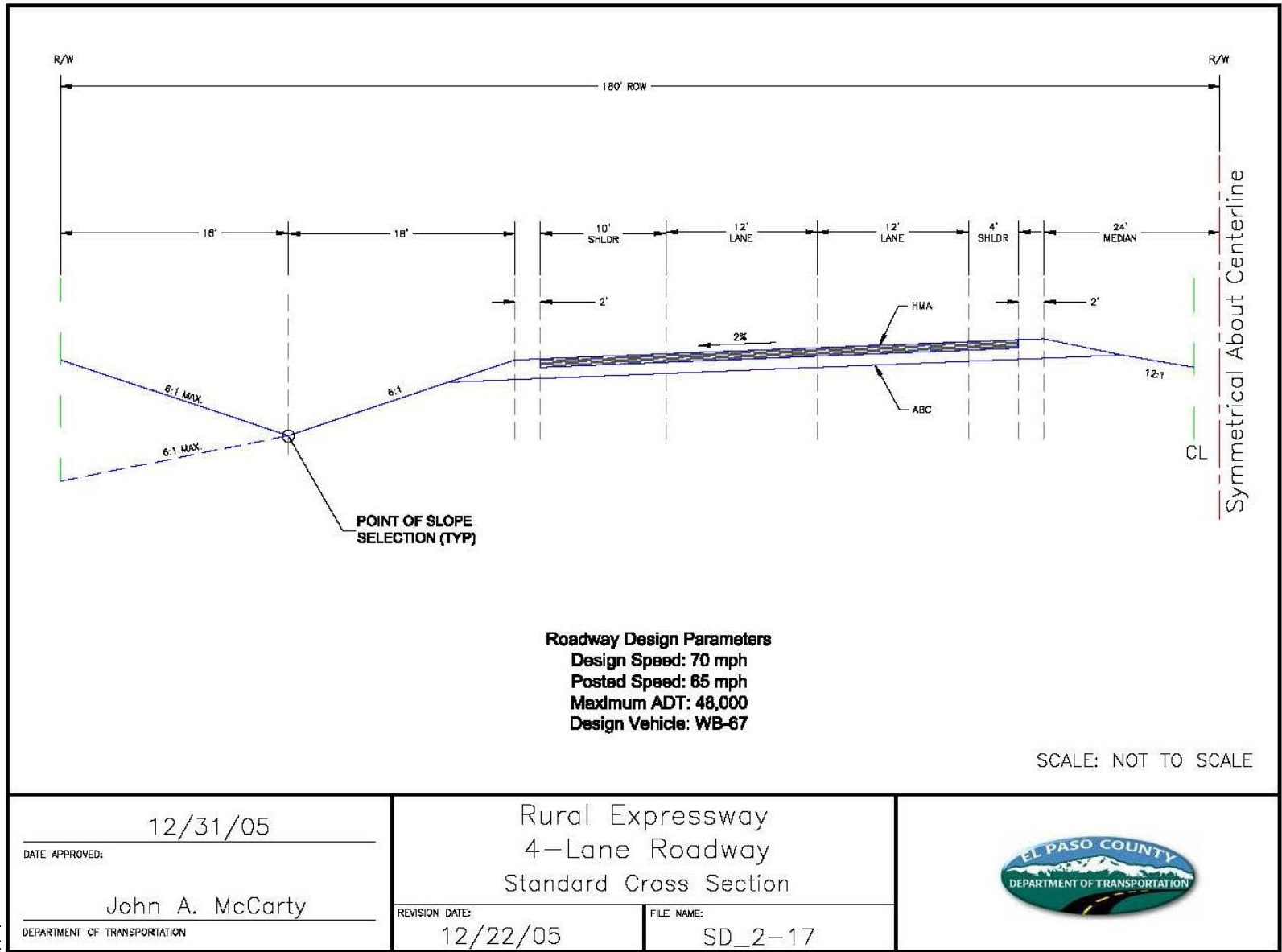

El Paso
(Supp. No. 2)

- ENGINEERING CRITERIA MANUAL
Appendix F STANDARD DRAWINGS

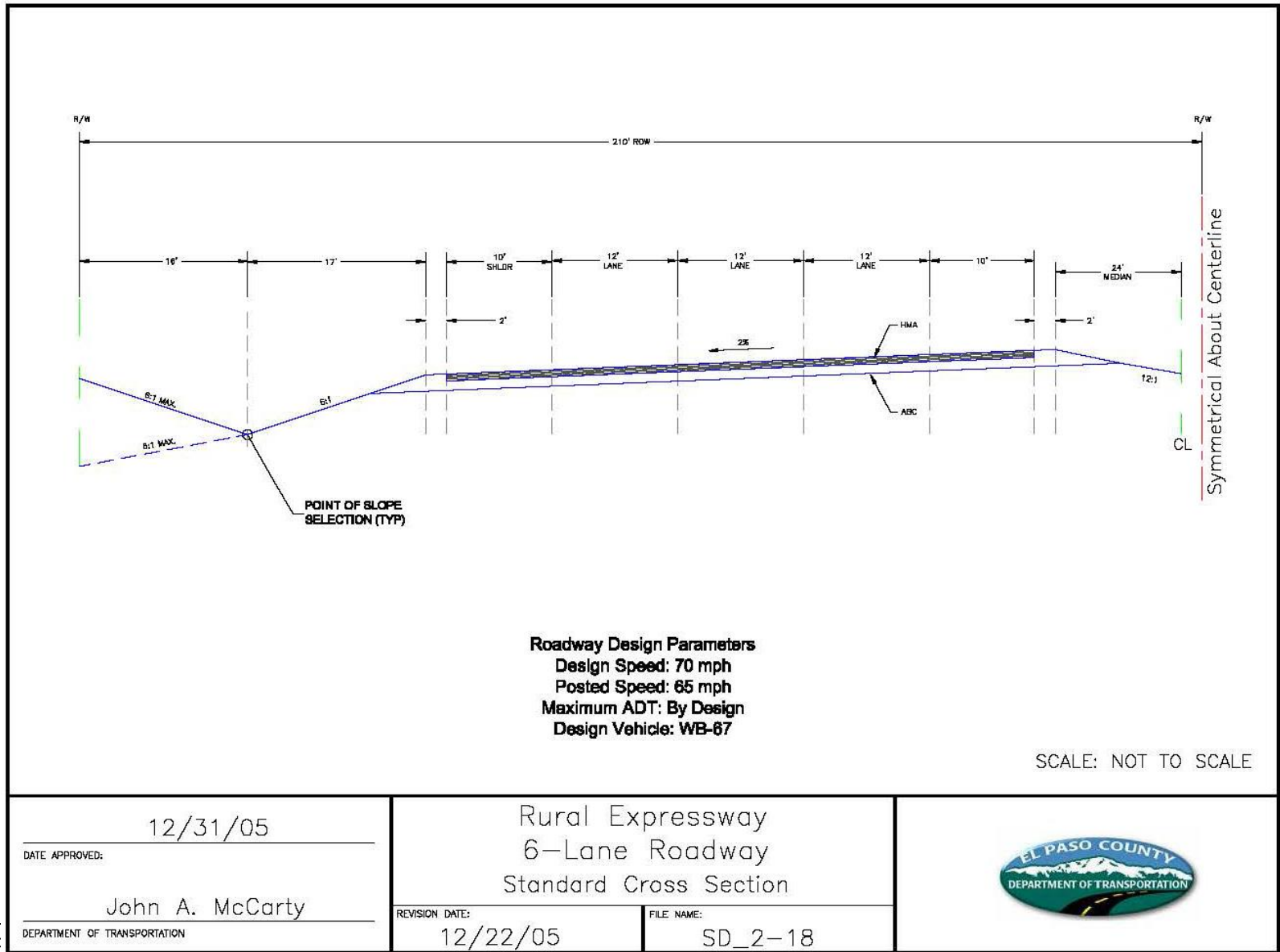

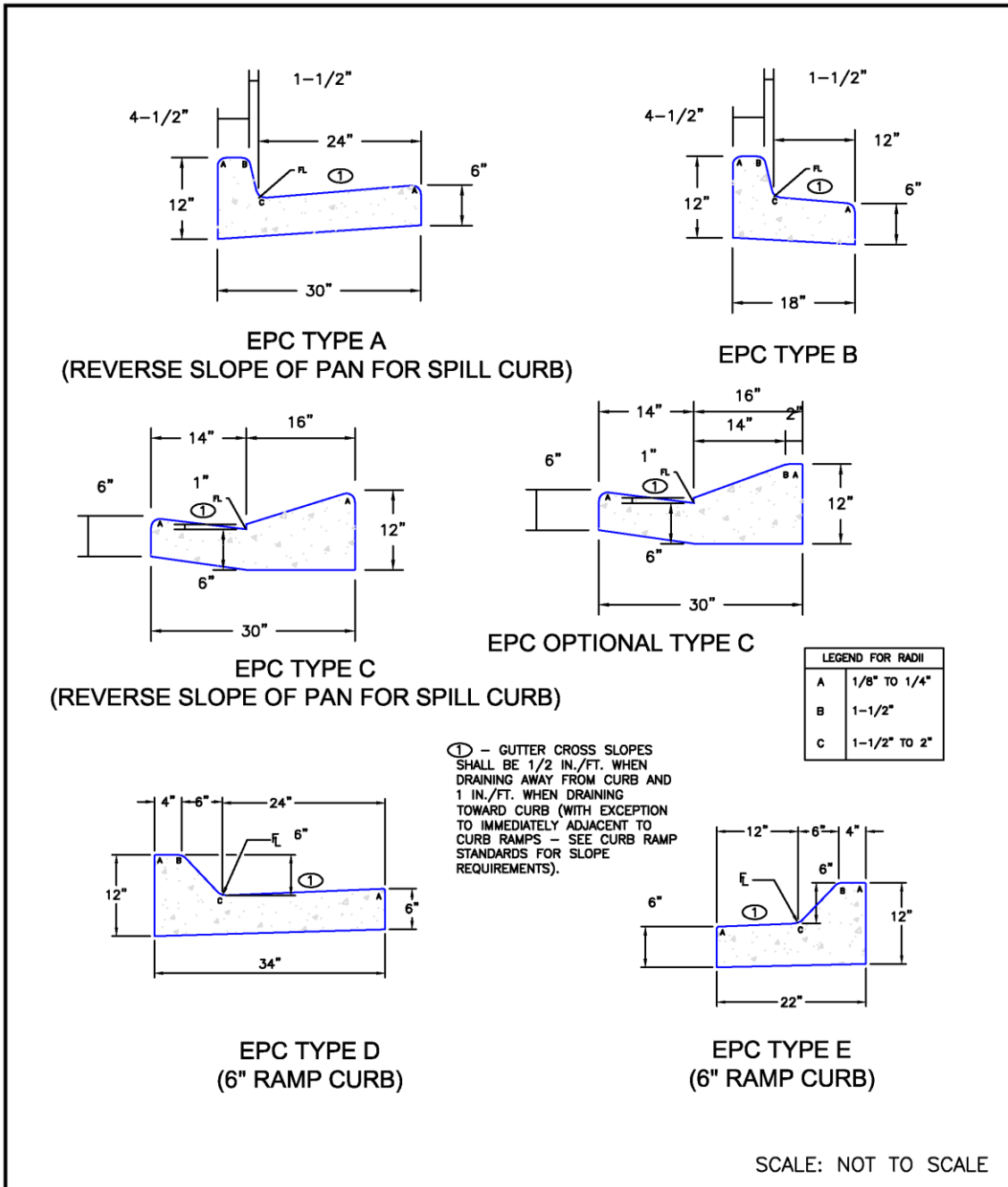

El Paso County, Colorado, Eng
(Supp. No. 2)

(Res. No. 20-222 , 6-23-20)

- ENGINEERING CRITERIA MANUAL
Appendix F STANDARD DRAWINGS

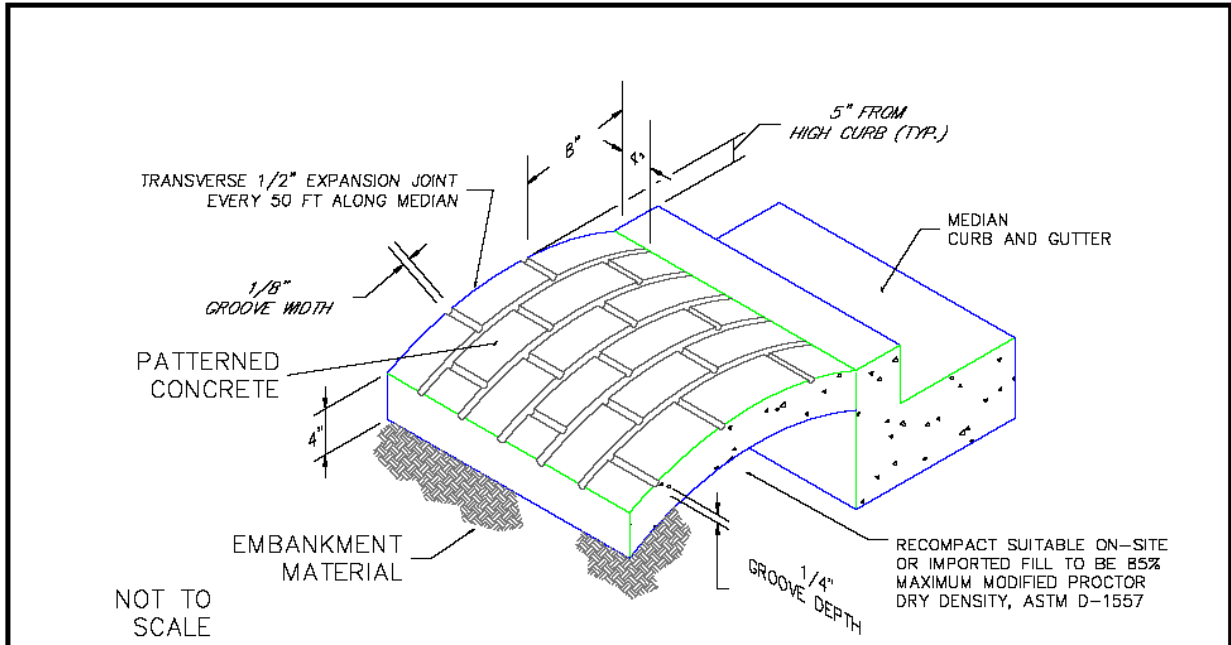

- NOTES:**
- A) The median paving shall be constructed with 4 inch thick, integrally colored concrete, embossed with a running bond 4" x 8" brick pattern as shown.
 - B) Install 1/2" x 4" expansion material at median noses, fixed objects, and at transverse joints at 50 ft. intervals (maximum) along the median.
 - C) The color additive shall be an approved commercially pure or synthetic mineral pigment, factory formulated and packaged in cubic yard dosage increments. The mixture shall be "Chromix" as manufactured by L.M. Scofield Company, "Davis Colors" as manufactured by Davis Color Company, Pigment No. 678, 5 lbs/sack, or an approved equal.
 - D) Patterned concrete to be colored L.M. Scofield Company "Santa Barbara Brown, C-35", Davis Color Company, Pigment No. 678, 5 lbs/sack, or an approved equal.
 - E) The Matching curing compound shall be a blend of waxes and pigments in a solvent emulsion base and conform to the requirements of ASTM C-309. The curing compound shall be "Lithochrome Colorwax" as manufactured by L.M. Scofield Company, Davis Color-Seal, as manufactured by Davis Color Company, or approved equal.
 - F) The concrete mix design shall conform to the requirements of the color admixture manufacturer and shall meet CDOT Class B concrete requirements, unless otherwise approved.
 - G) For weed control prior to median paving, apply a pre-emergent herbicide to median subgrade area per manufacturer's specifications for paving under Barrier 50 label (pbi Gordon). Trifluralin is labeled for use under asphalt under the Treflan 4EC label (Elanco).

SCALE: NOT TO SCALE

<p align="center">7/9/09</p> <p>DATE APPROVED:</p> <p align="center">André P. Brackin</p> <p align="center">DEPARTMENT OF TRANSPORTATION</p>	<p>Patterned Concrete Median Paving Standard Drawing</p>	
	<p>REVISION DATE:</p> <p align="center">1/18/11</p>	<p>FILE NAME:</p> <p align="center">SD_2-21</p>

(Supp. No. 2)

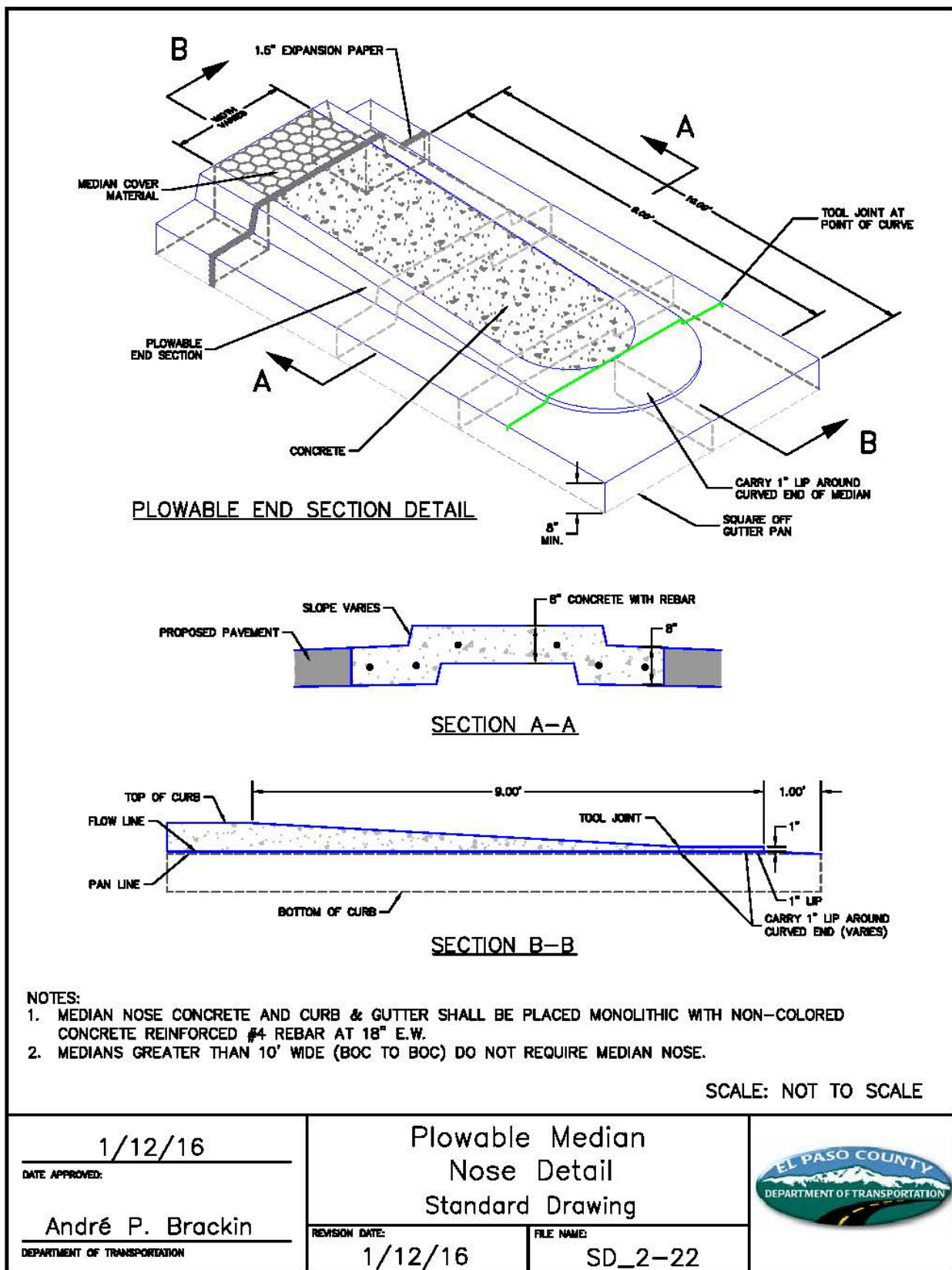

(Supp. No. 2)

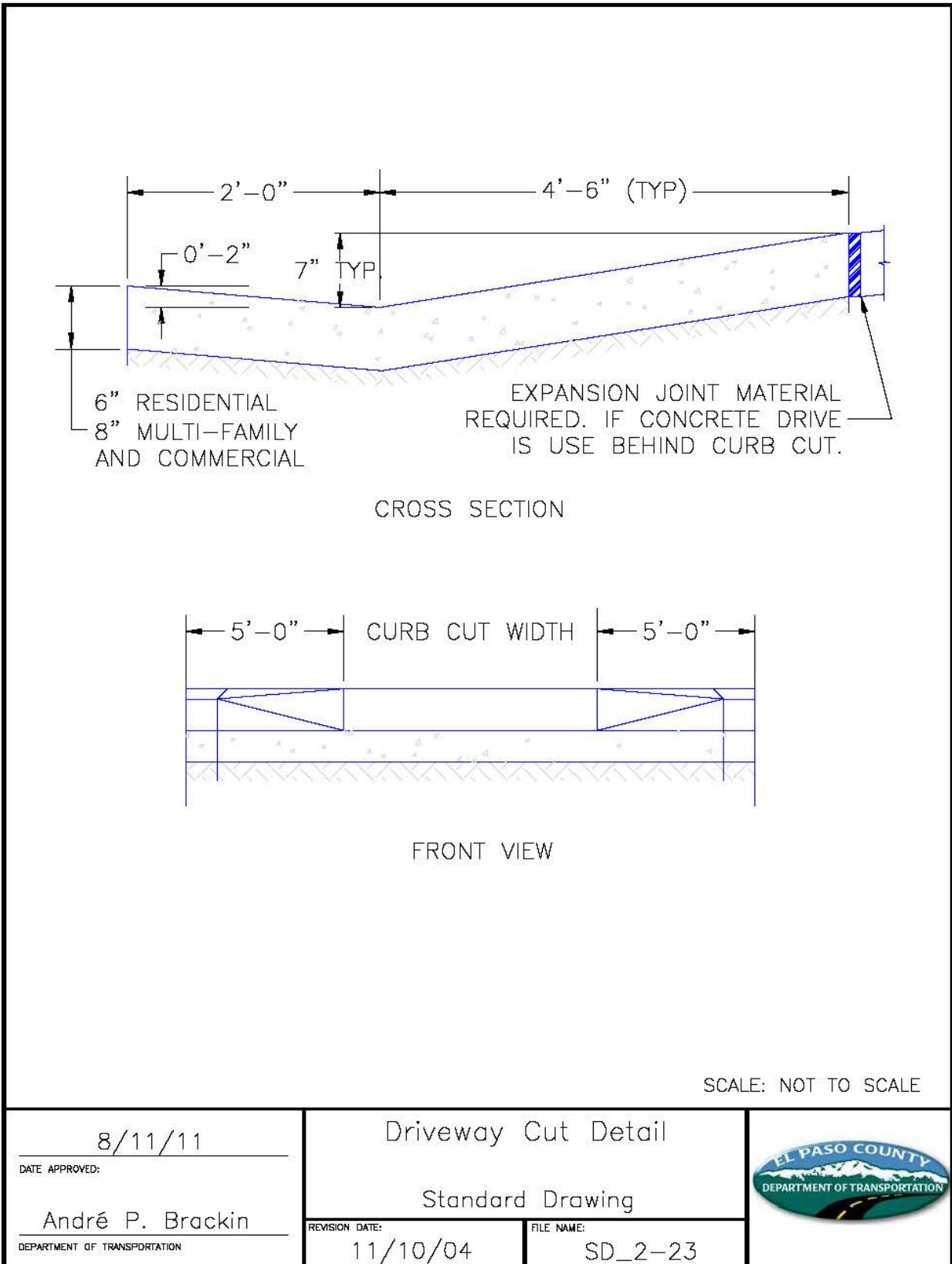

(Supp. No. 2)

- ENGINEERING CRITERIA MANUAL
Appendix F STANDARD DRAWINGS

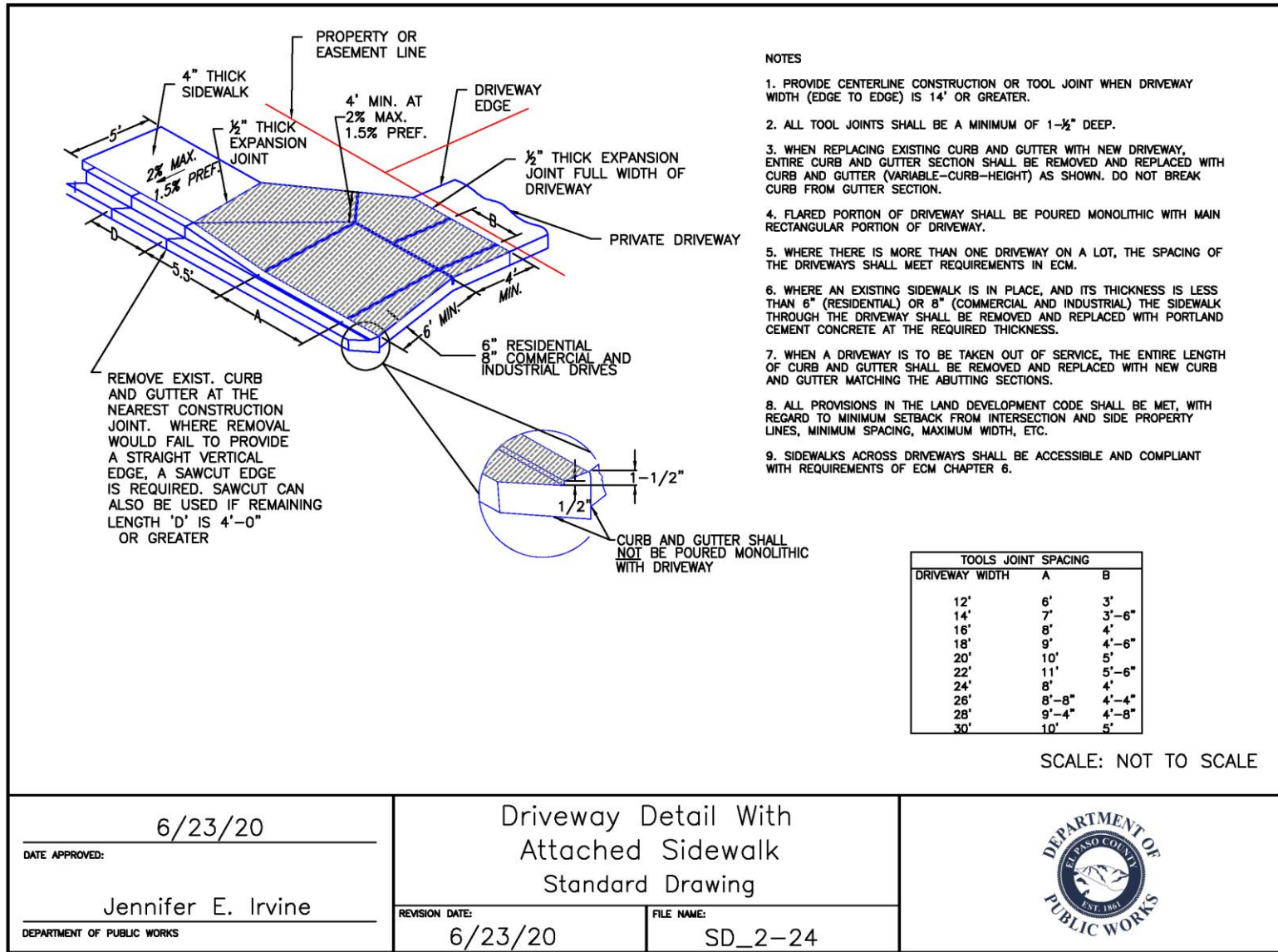

- ENGINEERING CRITERIA MANUAL
Appendix F STANDARD DRAWINGS

(Res. No. 20-222 , 6-23-20)

- ENGINEERING CRITERIA MANUAL
Appendix F STANDARD DRAWINGS

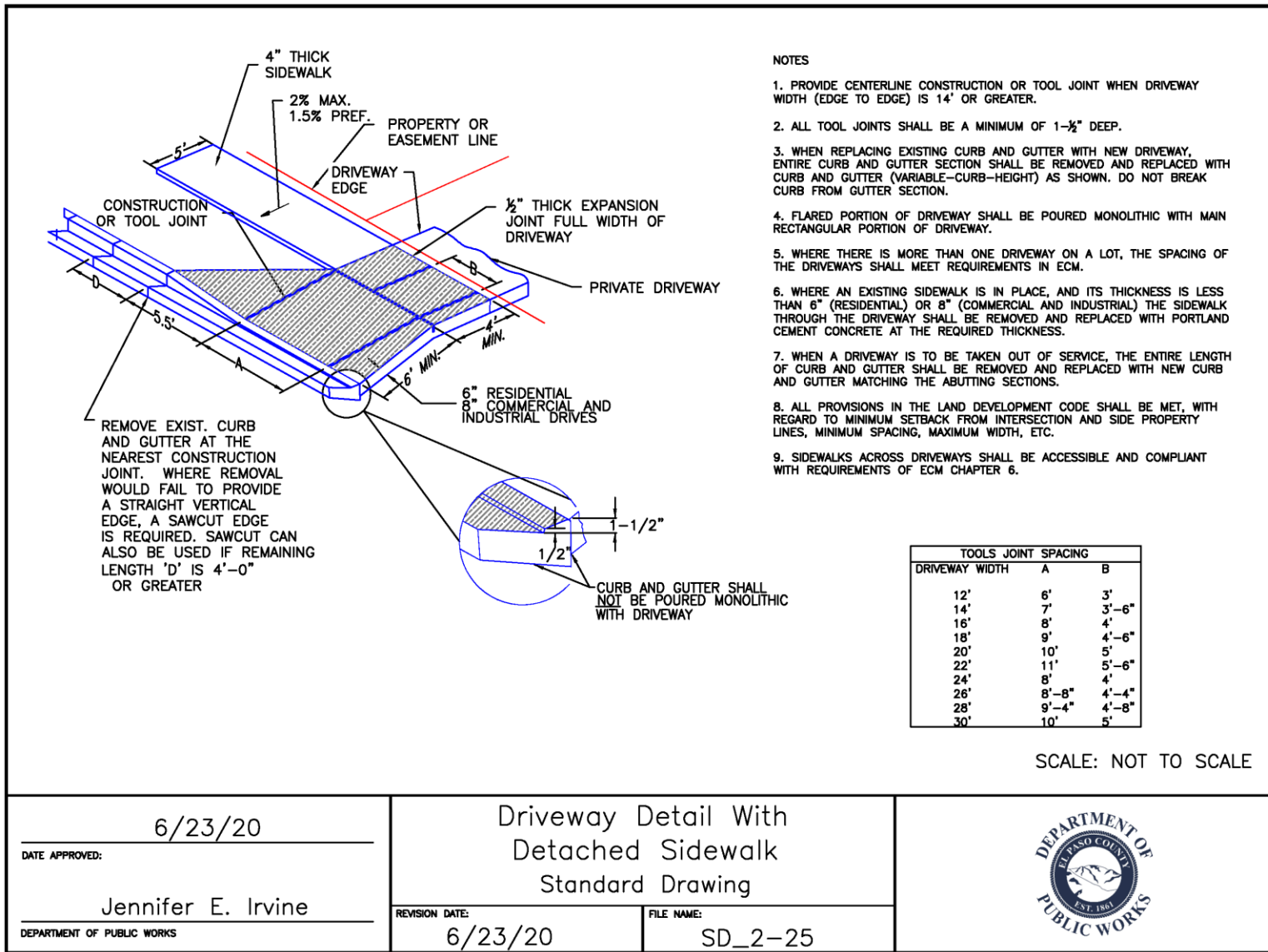

- ENGINEERING CRITERIA MANUAL
Appendix F STANDARD DRAWINGS

(Res. No. 20-222 , 6-23-20)

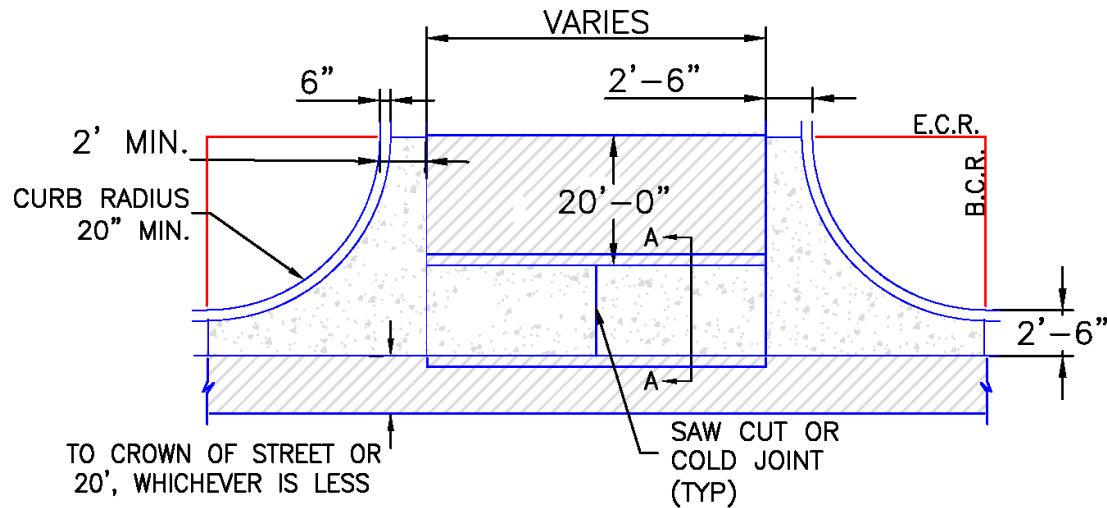

PLAN VIEW

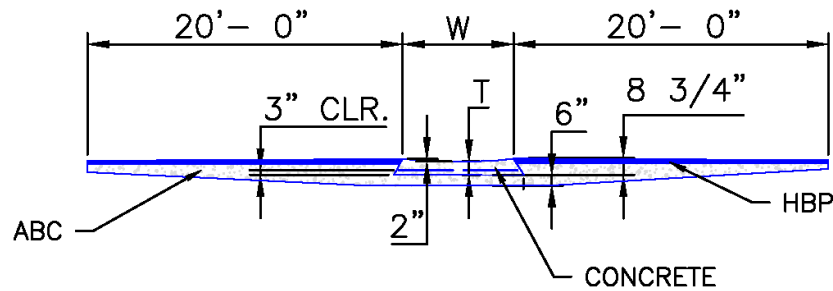

SECTION A-A

NOTES

1. W - WIDTH SHALL BE 6' FOR LOCAL, 8' FOR COLLECTORS, AND 10' FOR ARTERIAL ROADS.
2. T - SQUARED-OFF RETURN TO BE POURED MONOLITHICALLY, 8" PCC FOR LOCAL ROADS, 9" FOR COLLECTORS WITH 6x6 - 4.4 W.W.F. OR #4 REINFORCING BAR @ 18" EACH WAY.
3. = 3" MINIMUM ASPHALT DEPTH (2 LIFTS).
4. DESIGN TO SPECIFY ELEVATIONS AT PI AND PCR.

- ENGINEERING CRITERIA MANUAL
Appendix F STANDARD DRAWINGS

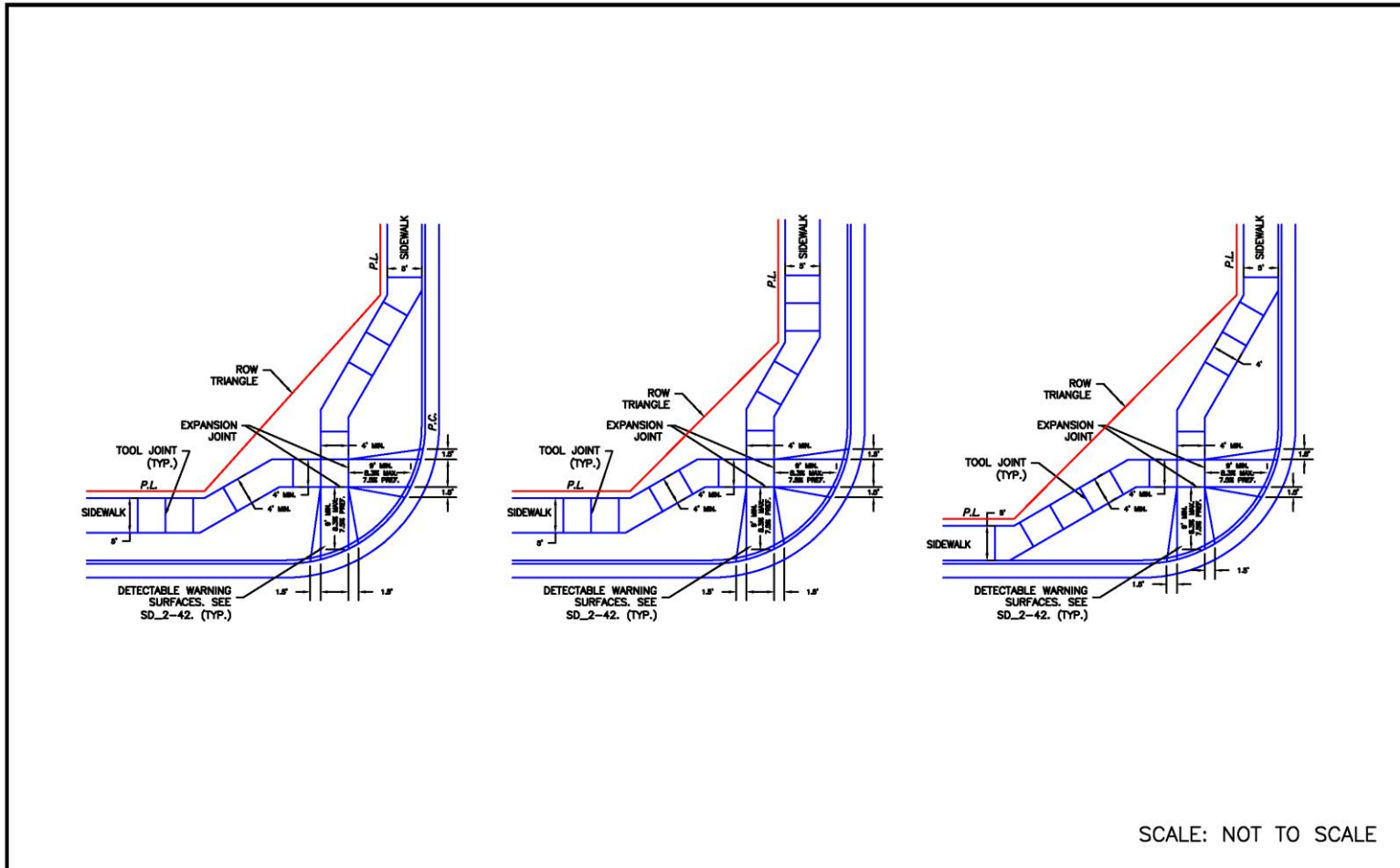

SCALE: NOT TO SCALE

<p>DATE APPROVED:</p> <p>6/23/20</p> <p>Jennifer E. Irvine</p> <p>DEPARTMENT OF PUBLIC WORKS</p>	<p>Pedestrian Curb Ramp Detail Standard Drawing</p>	
	<p>REVISION DATE:</p> <p>6/23/20</p>	<p>FILE NAME:</p> <p>SD_2-40</p>

(Res. No. 20-222 , 6-23-20)

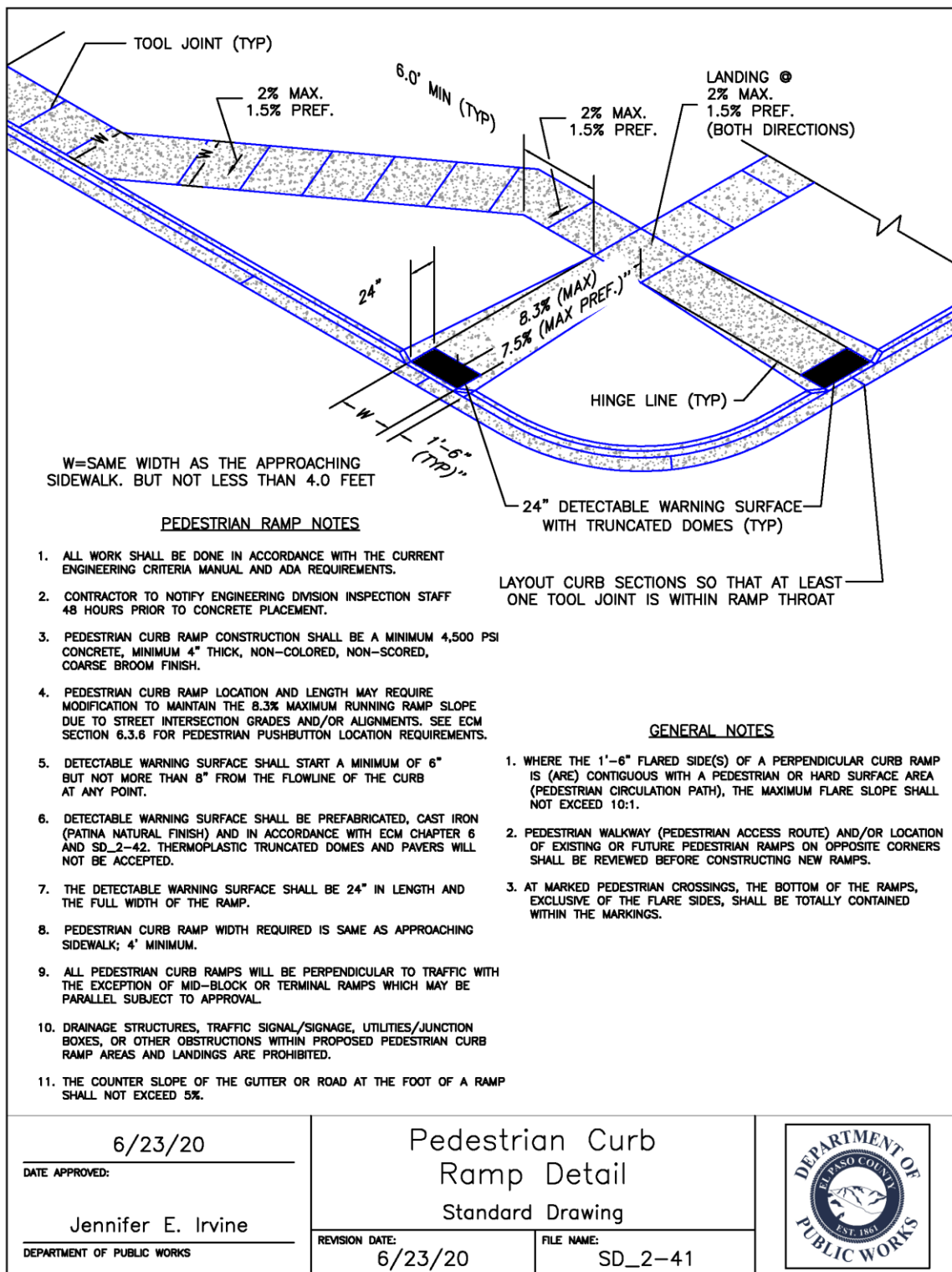

(Res. No. 20-222 , 6-23-20)

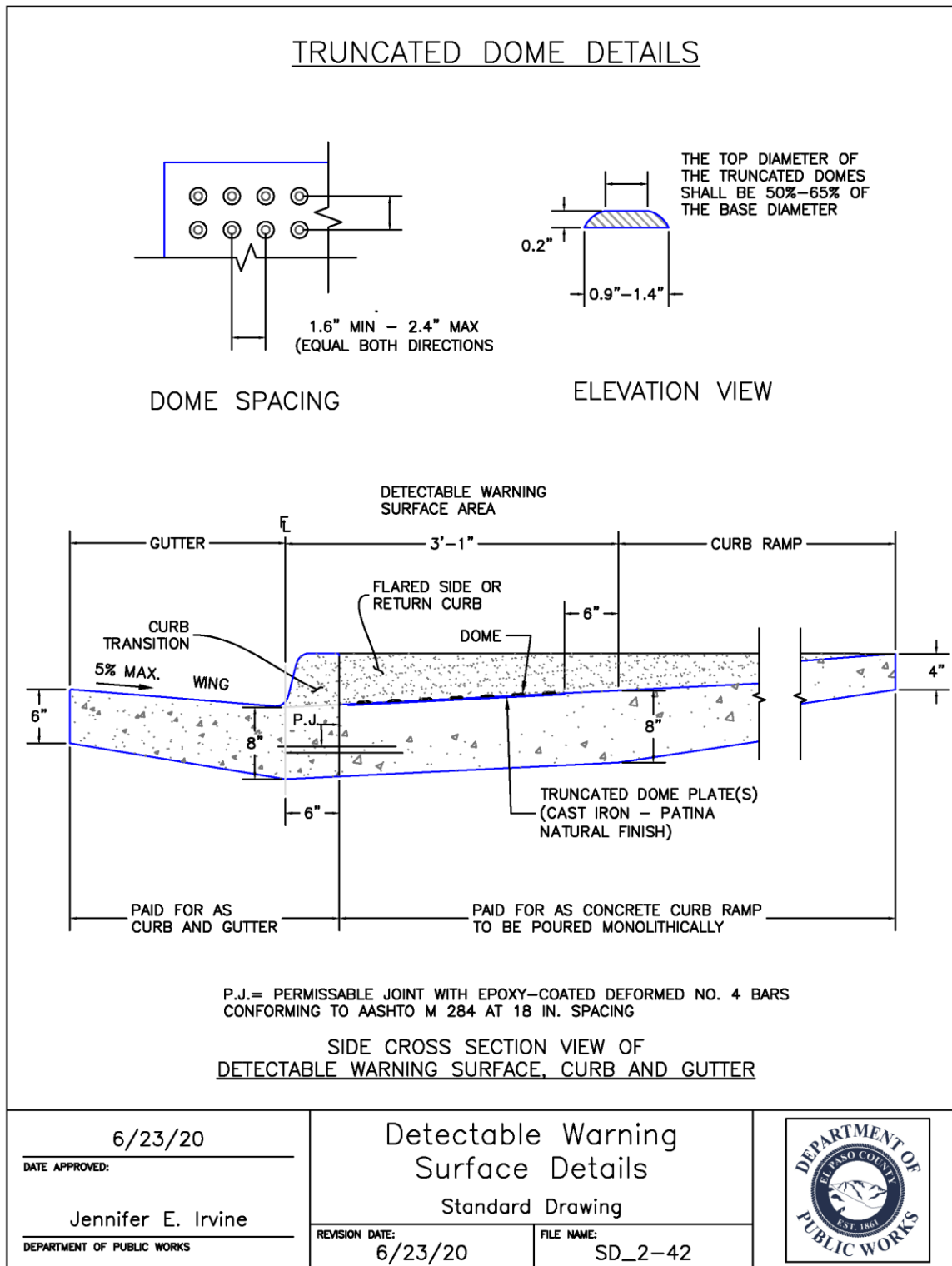

(Res. No. 20-222 , 6-23-20)

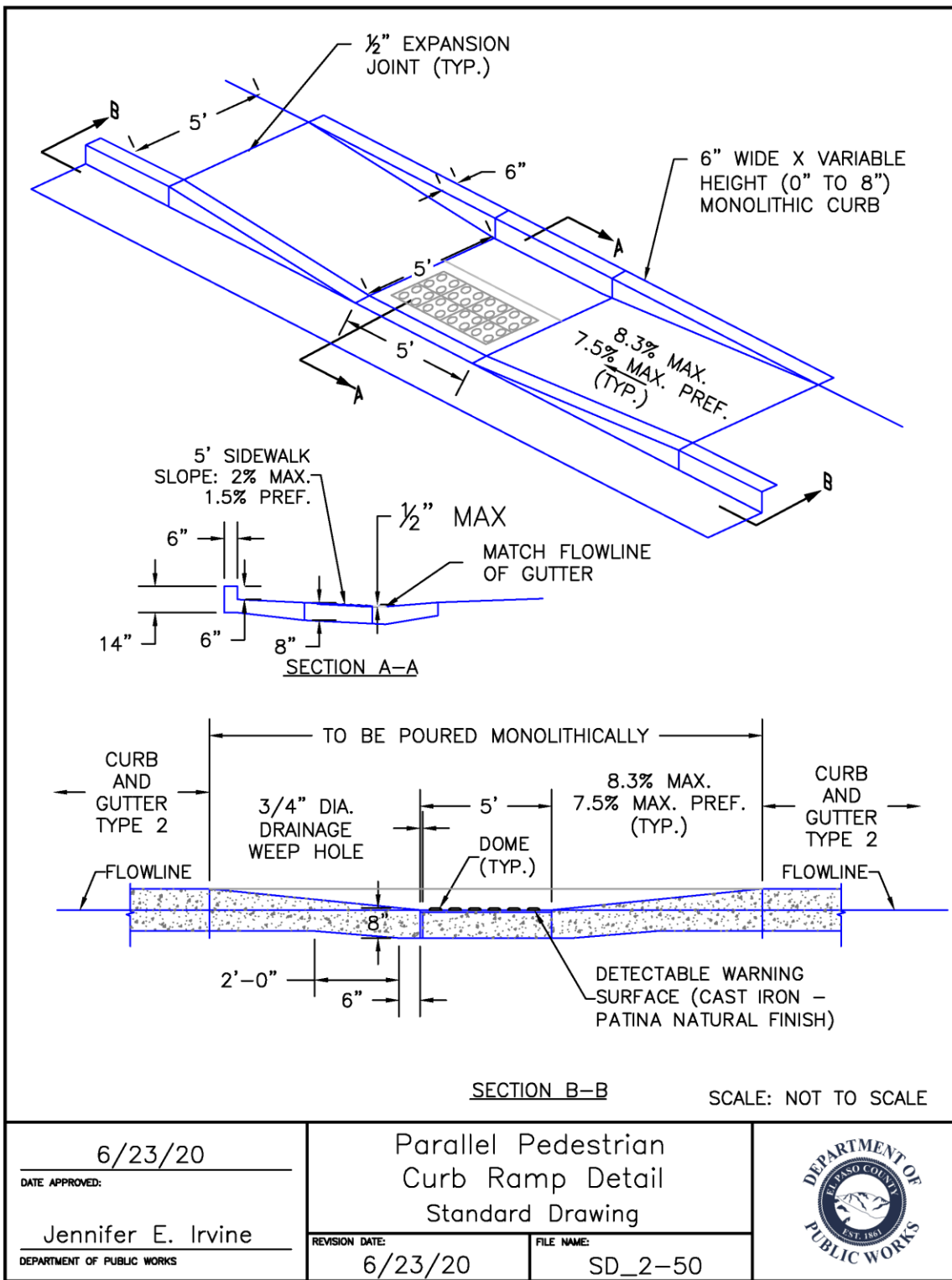

(Res. No. 20-222, 6-23-20)

- ENGINEERING CRITERIA MANUAL
Appendix F STANDARD DRAWINGS

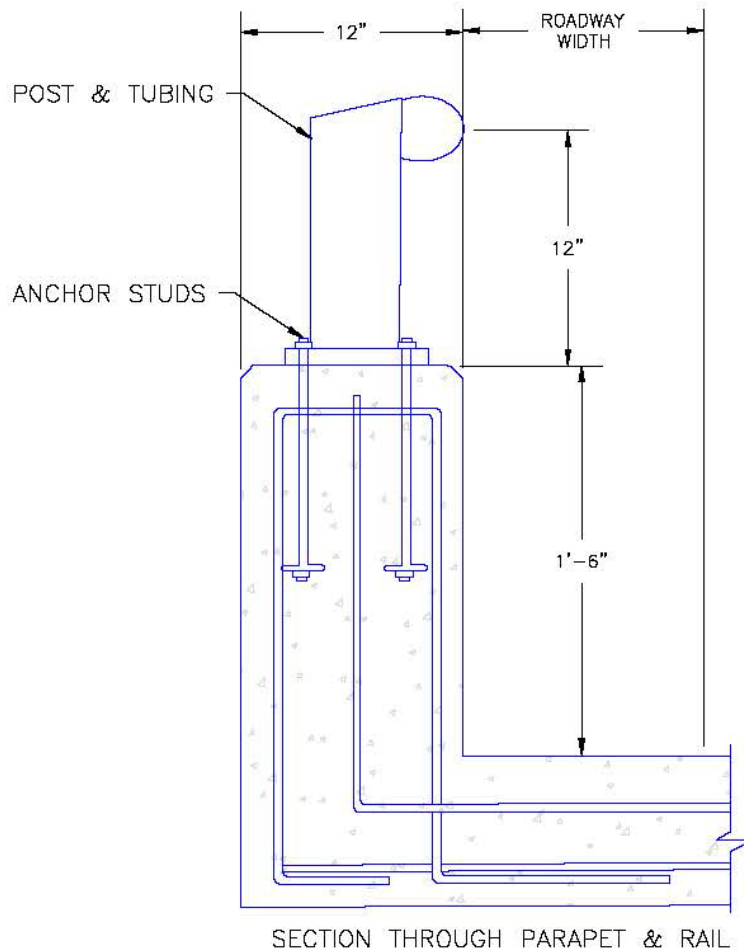

SECTION THROUGH PARAPET & RAIL

RAIL HEIGHT (IN.)	32"		
TEST VEHICLE (LB.)	1900-CAR	4660 - CAR	20,000-BUS
IMPACT SPEED (MPH)	60	60	57
IMPACT ANGLE (DEGREES)	18.8	25.0	14.8

FROM AASHTO ROADWAY GUIDELINE

SCALE: NOT TO SCALE

<p align="center">8/11/11</p> <p>DATE APPROVED:</p> <p align="center">André P. Brackin</p> <p>DEPARTMENT OF TRANSPORTATION</p>	<p align="center">Type C Aluminum Bridge Railing Standard Drawing</p> <p>REVISION DATE: 11/10/04</p> <p>FILE NAME: SD_2-70</p>	
--	--	---

(Supp. No. 2)

- ENGINEERING CRITERIA MANUAL
Appendix F STANDARD DRAWINGS

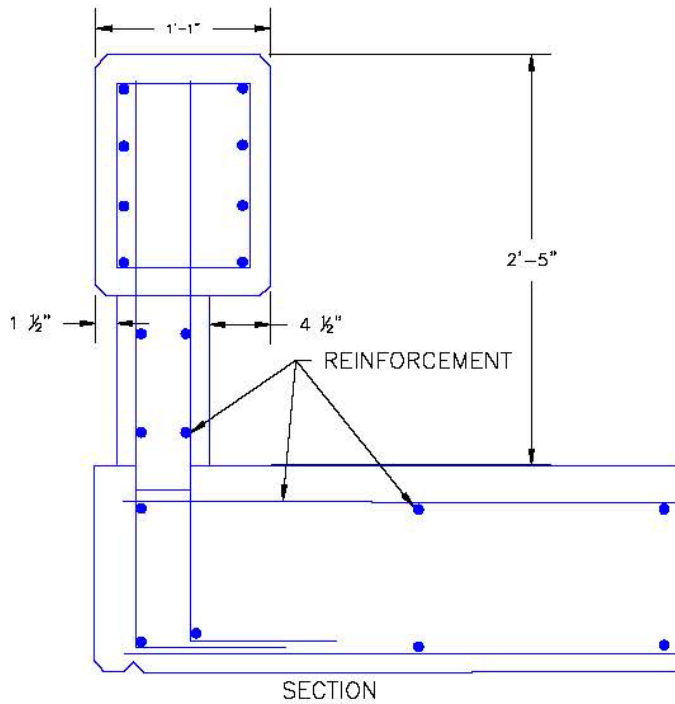
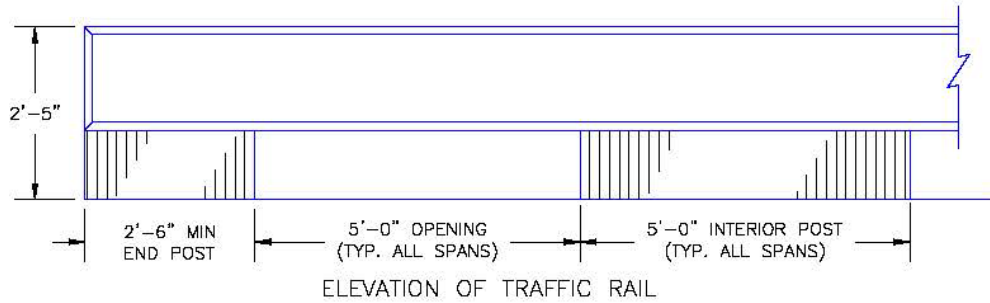

RAIL HEIGHT (IN.)	29	
TEST VEHICLE (LB.)	1980#-CAR	4660# - CAR
IMPACT SPEED (MPH)	59	59
IMPACT ANGLE (DEGREES)	18.9	25.4

FROM AASHTO ROADWAY GUIDELINE

SCALE: NOT TO SCALE

<p align="center">8/11/11</p> <p>DATE APPROVED:</p> <p align="center">André P. Brackin</p> <p>DEPARTMENT OF TRANSPORTATION</p>	<p align="center">Oklahoma TR-1 Bridge Railing Standard Drawing</p> <p>REVISION DATE: 11/10/04</p> <p>FILE NAME: SD_2-71</p>	
--	--	---

(Supp. No. 2)

- ENGINEERING CRITERIA MANUAL
Appendix F STANDARD DRAWINGS

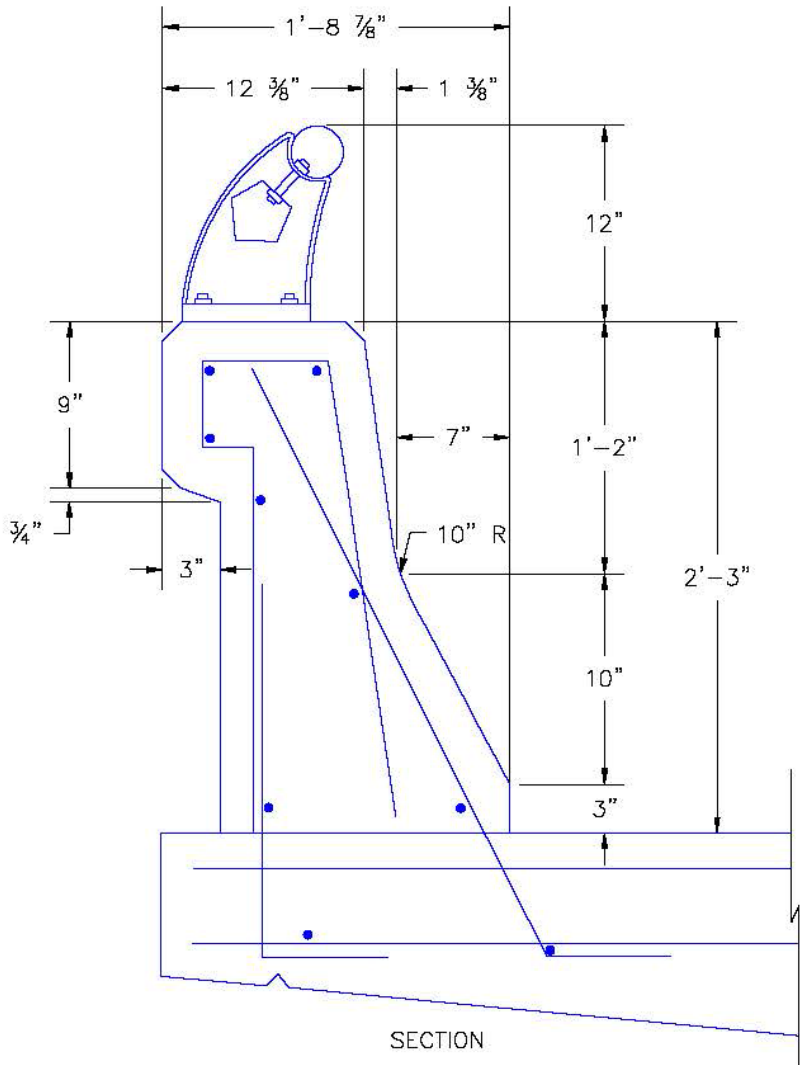

SECTION

RAIL HEIGHT (IN.)	39		
TEST VEHICLE (LB.)	1900-CAR	4660 - CAR	40,000-BUS
IMPACT SPEED (MPH)	61	62	59
IMPACT ANGLE (DEGREES)	19.3	24.9	16.4

FROM AASHTO ROADWAY GUIDELINE

SCALE: NOT TO SCALE

<p align="center">8/11/11</p> <p>DATE APPROVED:</p> <p align="center">André P. Brackin</p> <p>DEPARTMENT OF TRANSPORTATION</p>	<p>Nevada Concrete Safety Shape Bridge Railing Standard Drawing</p>		
	<p>REVISION DATE:</p> <p align="center">11/10/04</p>	<p>FILE NAME:</p> <p align="center">SD_2-72</p>	

(Supp. No. 2)

- ENGINEERING CRITERIA MANUAL
Appendix F STANDARD DRAWINGS

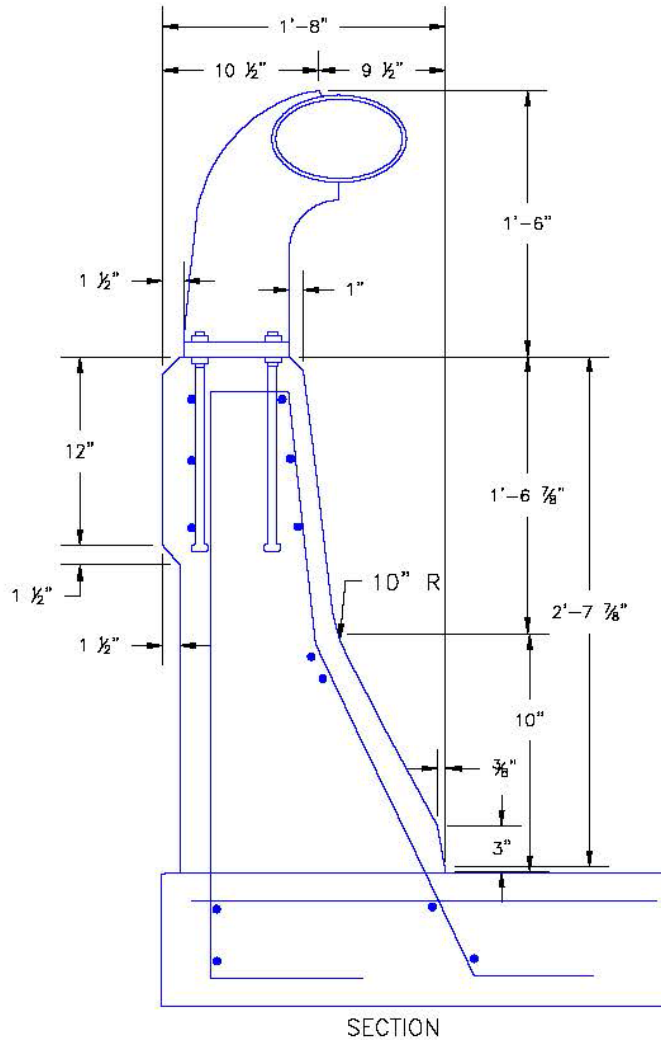

RAIL HEIGHT (IN.)	50
TEST VEHICLE (LB.)	80,150 – TRUCK
IMPACT SPEED (MPH)	48
IMPACT ANGLE (DEGREES)	14.5

FROM AASHTO ROADWAY GUIDELINE

SCALE: NOT TO SCALE

<p align="center">8/11/11</p> <p>DATE APPROVED:</p> <p align="center">André P. Brackin</p> <p>DEPARTMENT OF TRANSPORTATION</p>	<p align="center">Safety Shaped Concrete Bridge Railing Standard Drawing</p> <p>REVISION DATE: 11/10/04</p> <p>FILE NAME: SD_2-73</p>	
--	---	--

(Supp. No. 2)

- ENGINEERING CRITERIA MANUAL
Appendix F STANDARD DRAWINGS

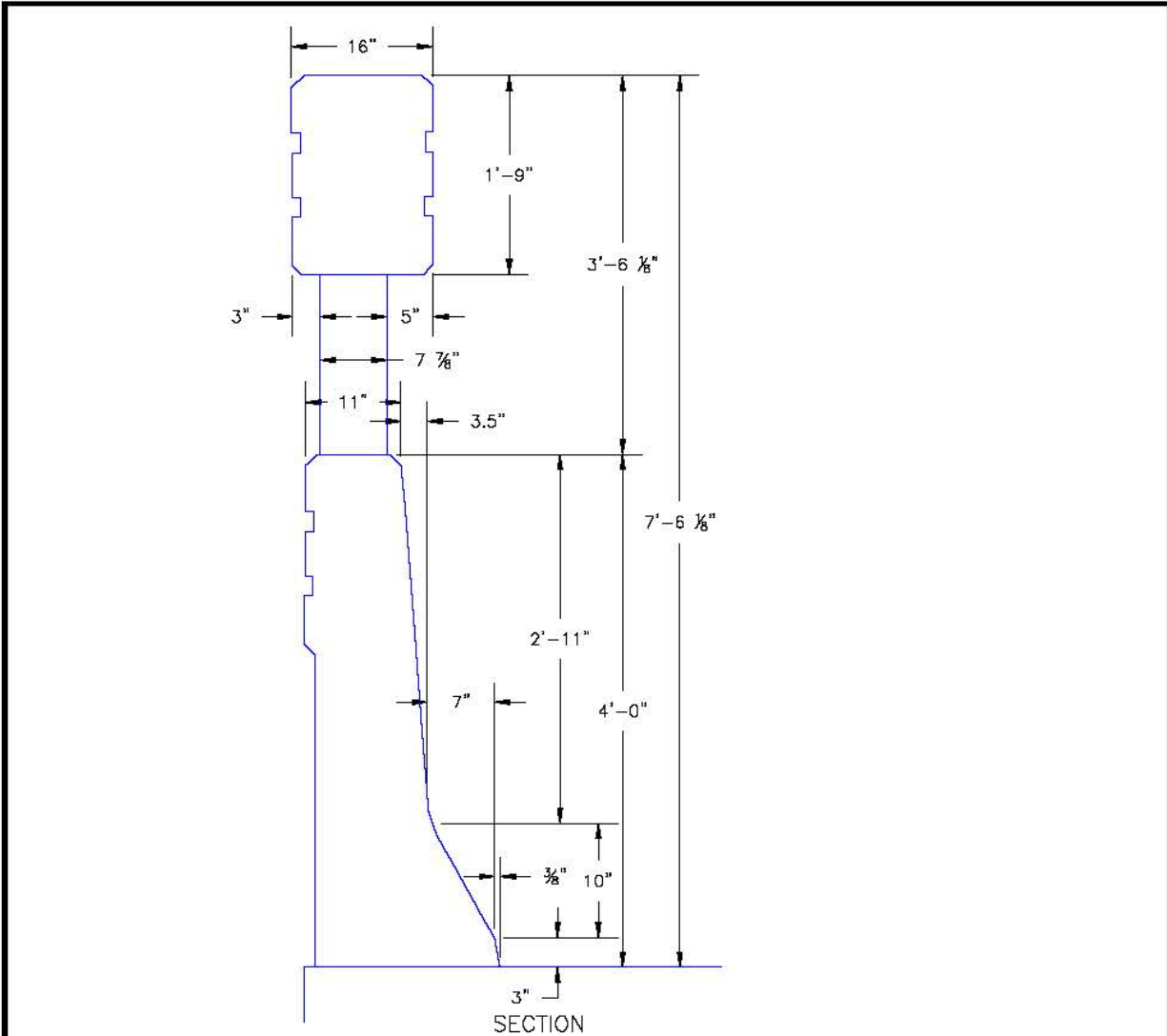

SECTION

RAIL HEIGHT (IN.)	90
TEST VEHICLE (LB.)	80,190 – TANK TYPE TRACTOR–TRAILER
IMPACT SPEED (MPH)	52
IMPACT ANGLE (DEGREES)	15.0

FROM AASHTO ROADWAY GUIDELINE

SCALE: NOT TO SCALE

<p align="center">8/11/11</p> <p>DATE APPROVED:</p> <p align="center">André P. Brackin</p> <p>DEPARTMENT OF TRANSPORTATION</p>	<p align="center">Texas Type TT Bridge Railing Standard Drawing</p>	
<p>REVISION DATE:</p> <p align="center">11/10/04</p>	<p>FILE NAME:</p> <p align="center">SD_2-74</p>	

(Supp. No. 2)

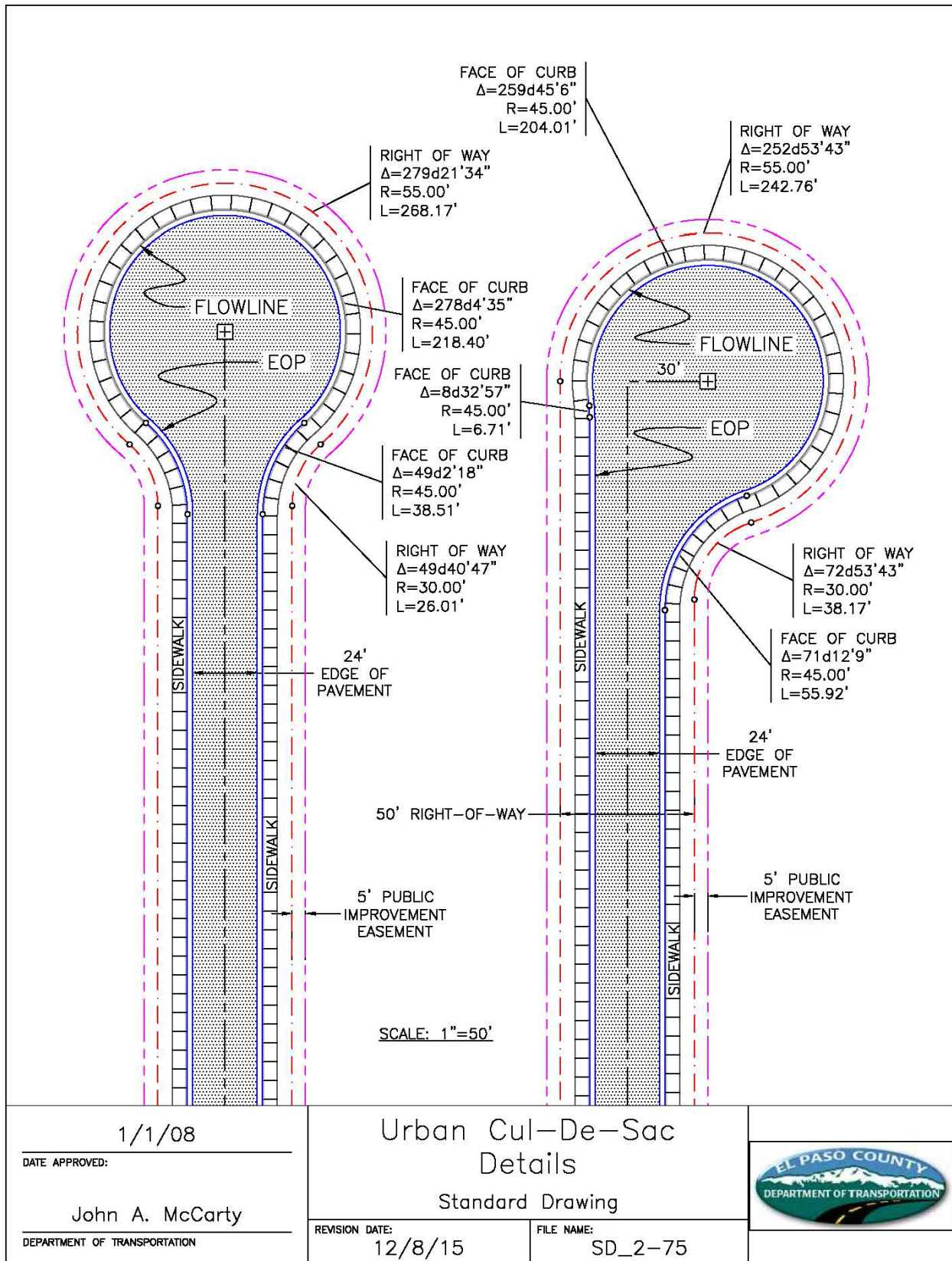

(Supp. No. 2)

- ENGINEERING CRITERIA MANUAL
Appendix F STANDARD DRAWINGS

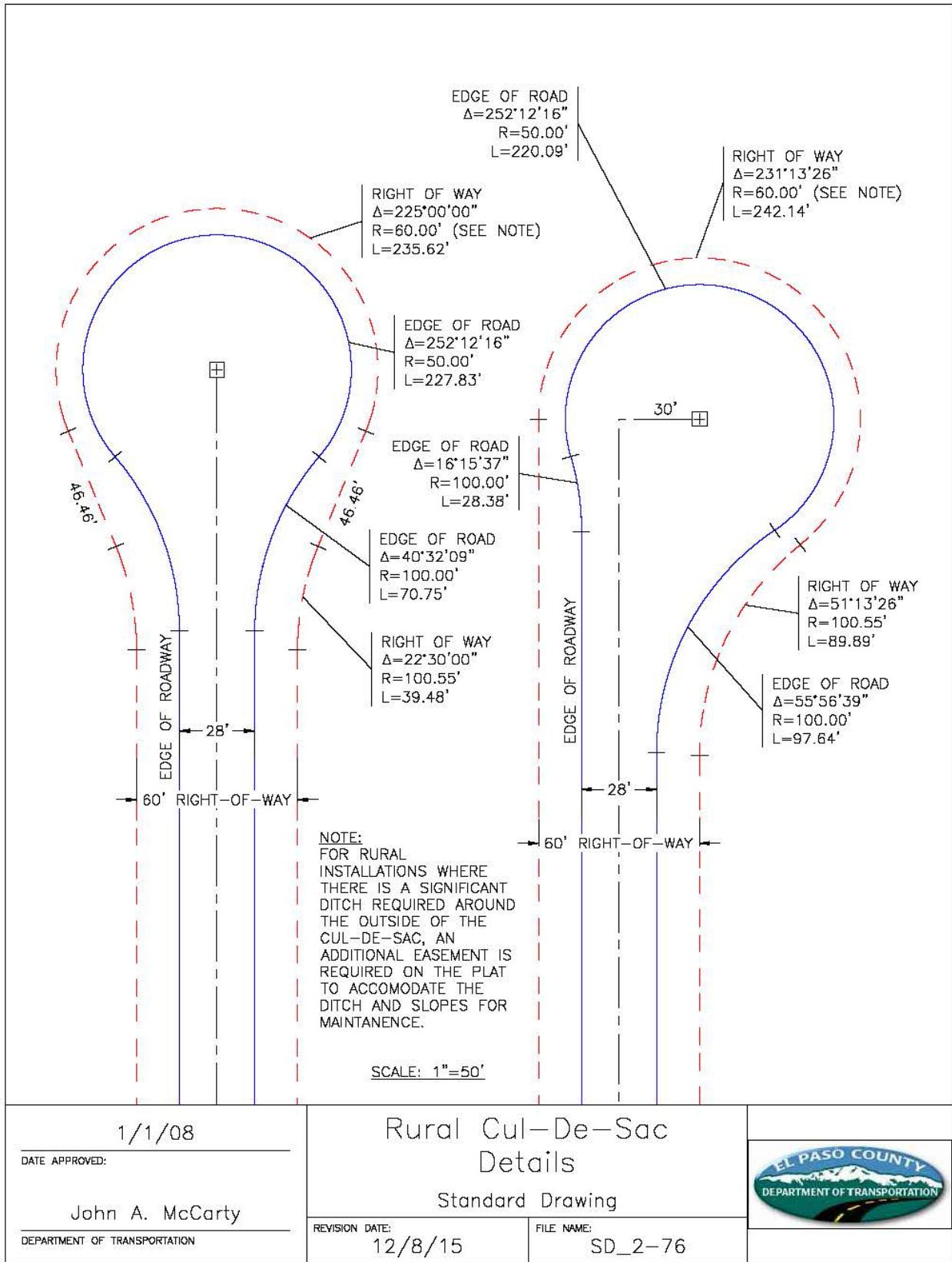

1/1/08
 DATE APPROVED:
 John A. McCarty
 DEPARTMENT OF TRANSPORTATION

Rural Cul-De-Sac
 Details
 Standard Drawing

REVISION DATE: 12/8/15
 FILE NAME: SD_2-76



(Supp. No. 2)

URBAN LOCAL KNUCKLE DETAILS

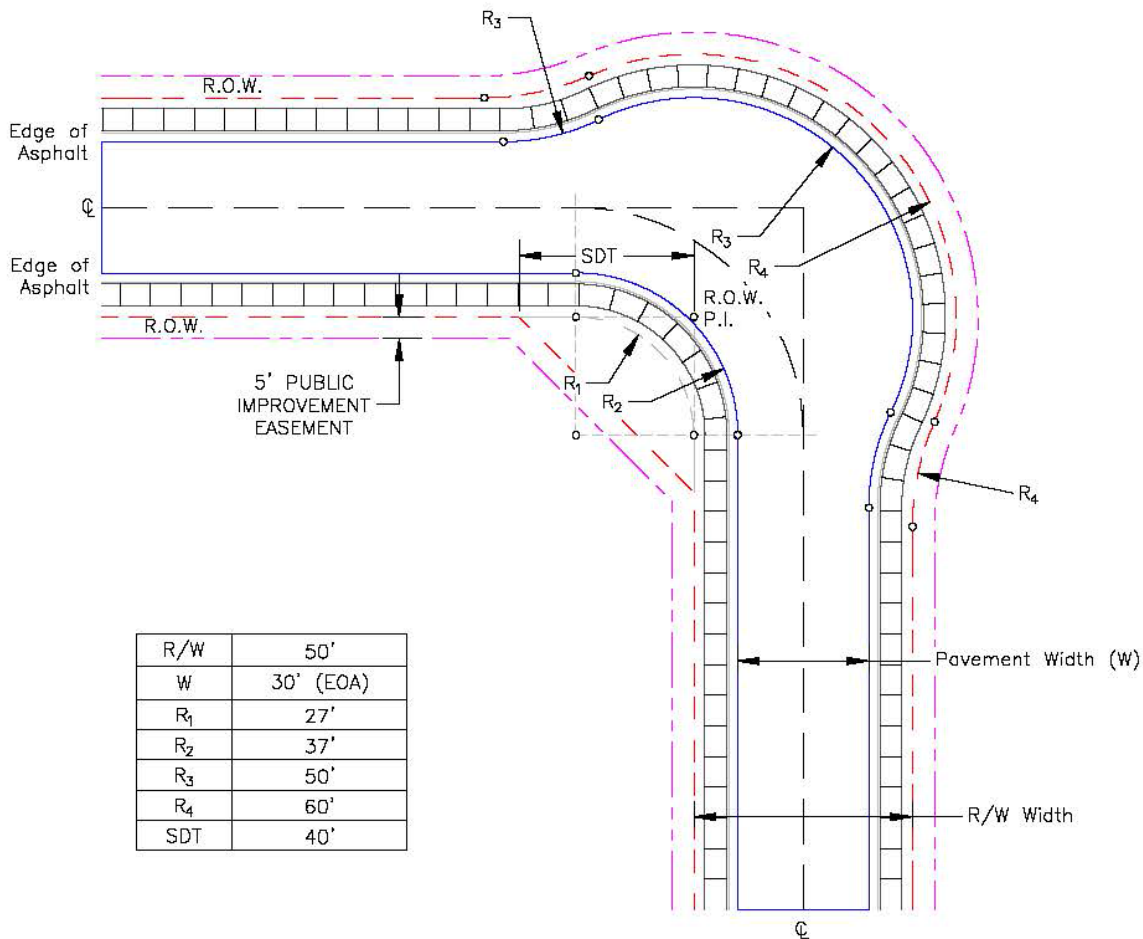

SDT = SIGHT DISTANCE TRIANGLE
DESIGN SPEED = 25 MPH

<p align="center">7/9/09</p> <p>DATE APPROVED:</p> <p align="center">André Brackin</p> <p>DEPARTMENT OF TRANSPORTATION</p>	<p align="center">Urban Local Knuckle</p> <p align="center">Standard Drawing</p> <p>REVISION DATE: 12/8/15</p> <p>FILE NAME: SD_2-77</p>	
--	--	---

(Supp. No. 2)

URBAN LOCAL LOW-VOLUME KNUCKLE DETAILS

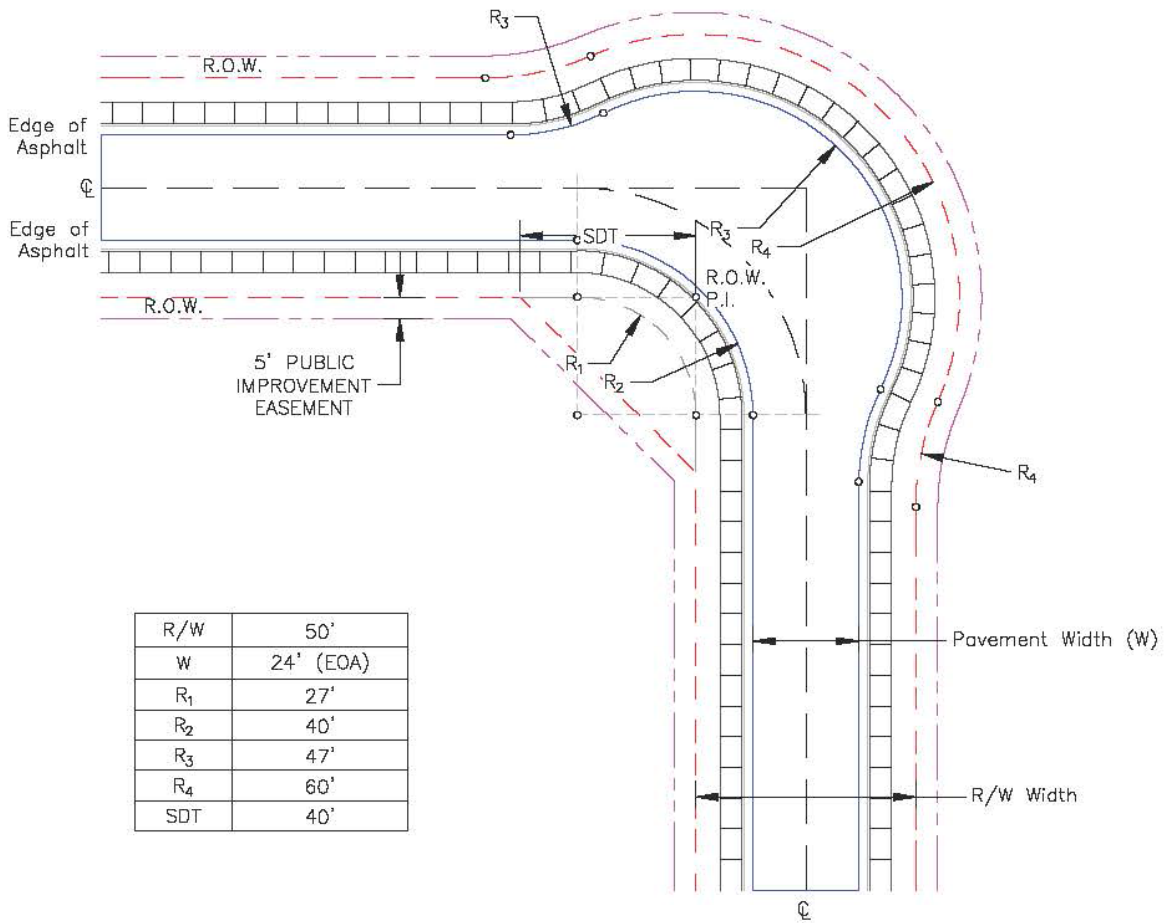

SDT = SIGHT DISTANCE TRIANGLE
DESIGN SPEED = 20 MPH

<p align="center">7/9/09</p> <p>DATE APPROVED:</p> <p align="center">André Brackin</p> <p>DEPARTMENT OF TRANSPORTATION</p>	<p>Urban Local Low-Volume Knuckle Standard Drawing</p>	
	<p>REVISION DATE:</p> <p align="center">7/9/09</p>	<p>FILE NAME:</p> <p align="center">SD_2-78</p>

(Supp. No. 2)

- ENGINEERING CRITERIA MANUAL
Appendix F STANDARD DRAWINGS

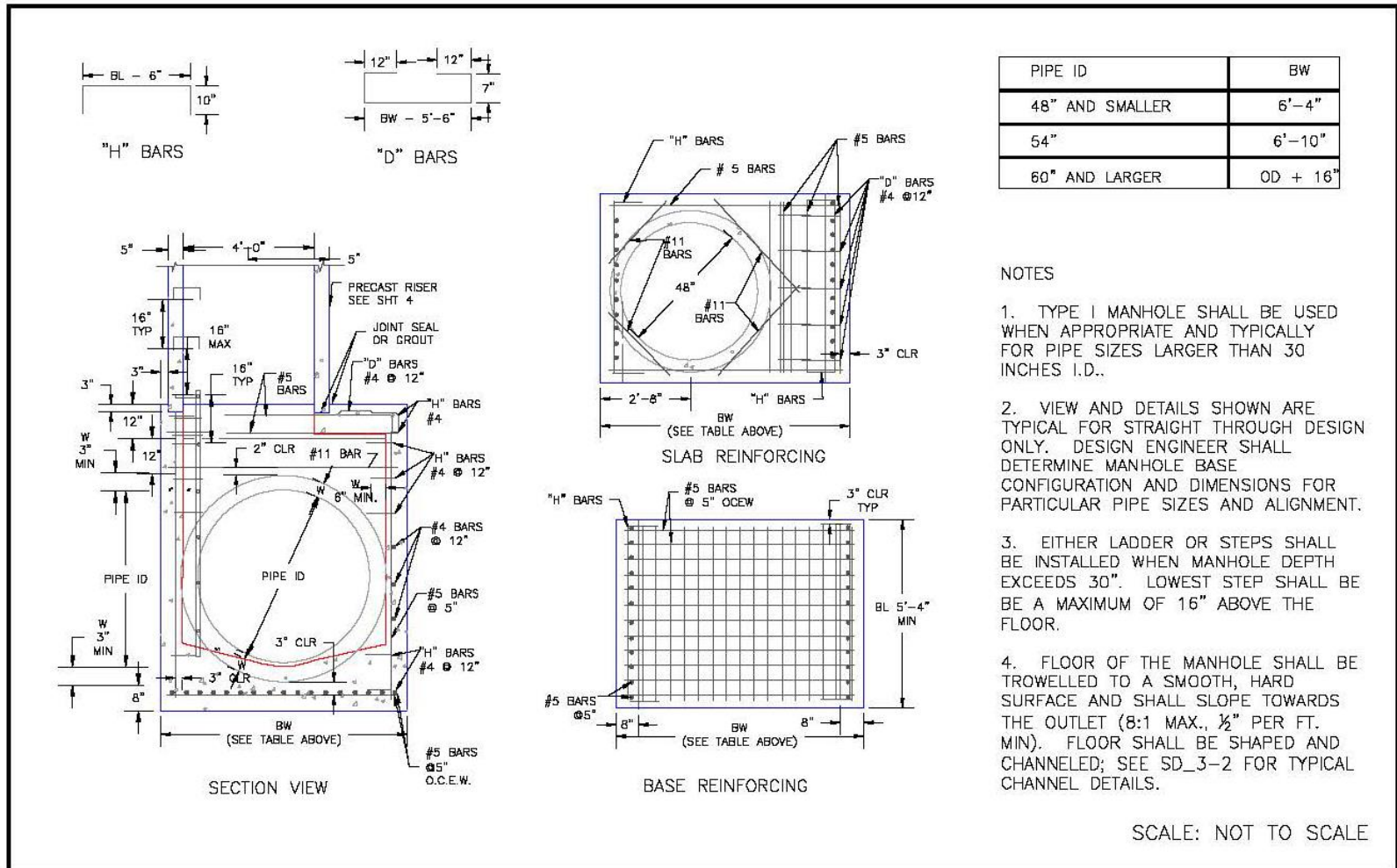

7/9/09
DATE APPROVED:
André Brackin
DEPARTMENT OF TRANSPORTATION

Storm Sewer Manhole Detail
Type I
Standard Drawing
REVISION DATE: 7/9/09
FILE NAME: SD_3-1



El Paso
(Supp. No. 2)

- ENGINEERING CRITERIA MANUAL
Appendix F STANDARD DRAWINGS

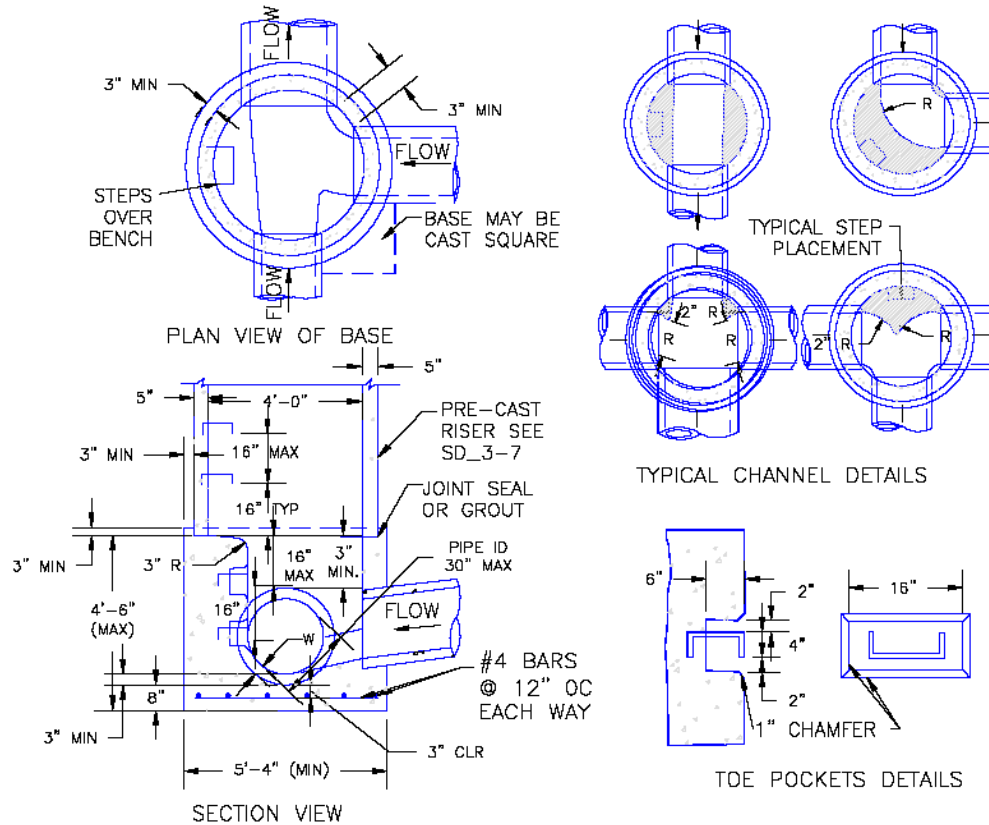

NOTES

1. TYPE II MANHOLES SHALL BE USED WHEN APPROPRIATE AND TYPICALLY WHEN THE PIPE SIZES ARE 30" OR LESS INSIDE DIAMETER.
2. VIEW AND DETAILS ARE TYPICAL. DESIGN ENGINEER SHALL DETERMINE MANHOLE BASE CONFIGURATION AND DIMENSIONS FOR PARTICULAR PIPE SIZES AND ALIGNMENT.
3. EITHER LADDER OF STEPS SHALL BE INSTALLED WHEN MANHOLE DEPTH EXCEEDS 30". STEPS IN BASE SHALL BE INSTALLED IN "TOE POCKETS" (SEE DETAIL THIS SHEET). LOWEST STEP SHALL BE A MAXIMUM OF 16" ABOVE THE FLOOR.
4. PIPES SHALL BE TRIMMED TO FINAL SHAPE AND SET BEFORE MANHOLE IS POURED.
5. BENCH SHALL BE SLOPED TOWARD CENTER OF MANHOLE BASE (4:1 MAX., 1/2" PER FOOT. MIN.).
6. FLOOR OF MANHOLE SHALL BE TROWELLED TO A SMOOTH, HARD SURFACE AND SHALL SLOPE TOWARDS THE OUTLET (8:1., 1/2" PER FT. MIN.) . FLOOR SHALL BE SHAPED AND CHANNELED; SEE DETAILS THIS SHEET.

- ENGINEERING CRITERIA MANUAL
Appendix F STANDARD DRAWINGS

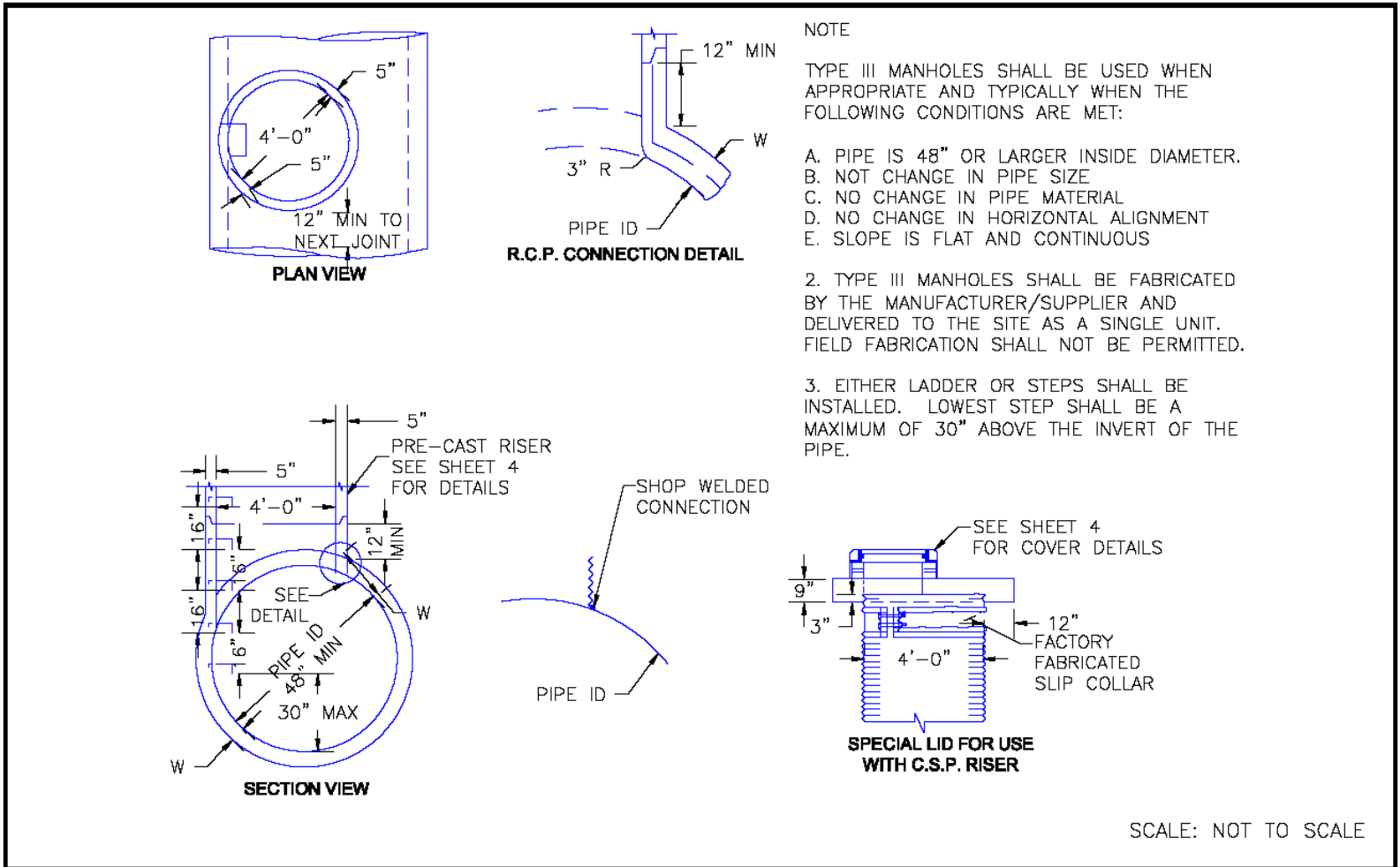

SCALE: NOT TO SCALE

<p align="center">8/11/11</p> <p>DATE APPROVED:</p> <p align="center">André P. Brackin</p> <p>DEPARTMENT OF TRANSPORTATION</p>	<p align="center">Storm Sewer Manhole Detail Type III Standard Drawing</p> <p>REVISION DATE: 11/10/04</p> <p>FILE NAME: SD_3-3</p>	
--	--	---

El Paso
(Supp. No. 2)

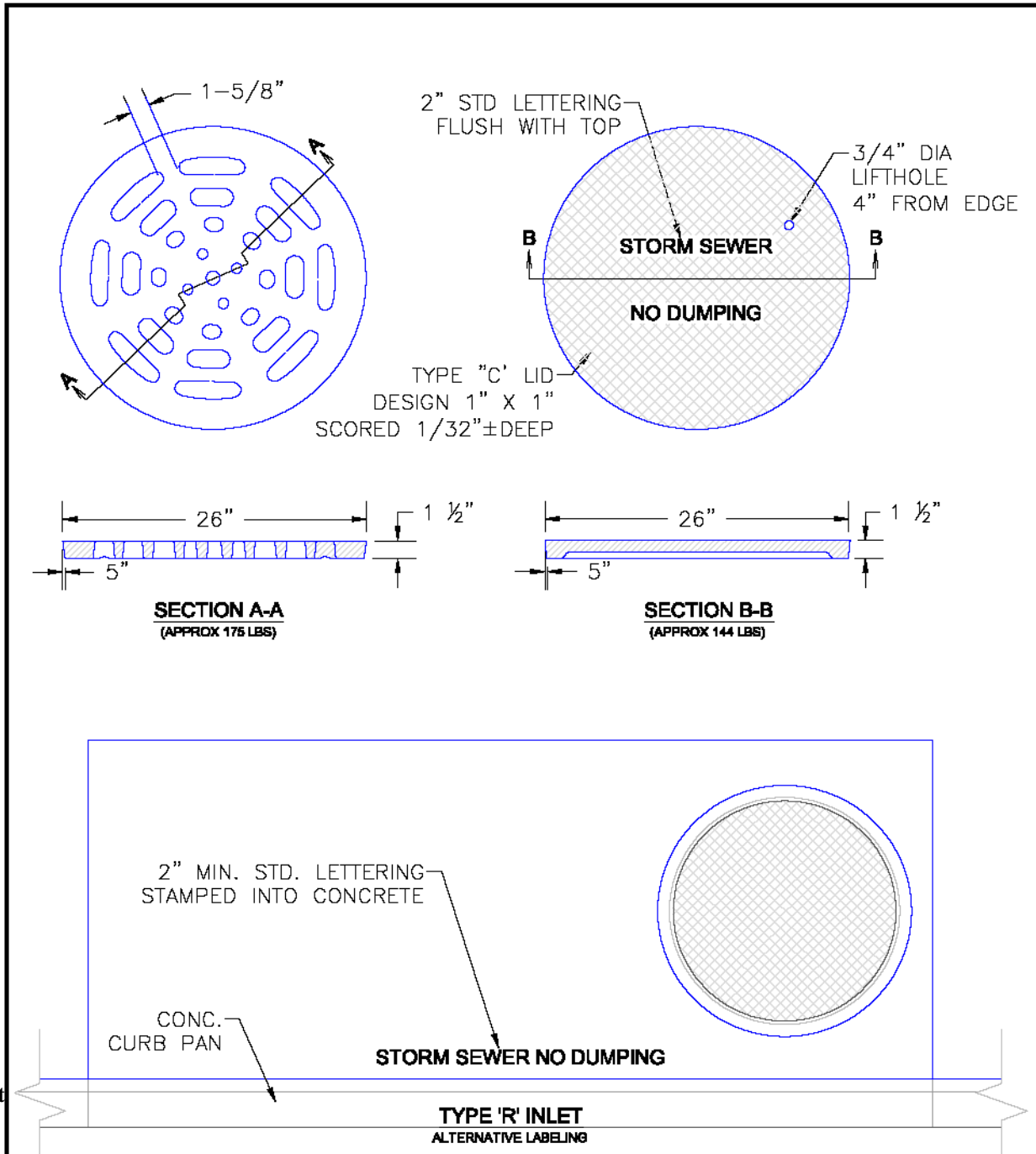

- ENGINEERING CRITERIA MANUAL
Appendix F STANDARD DRAWINGS

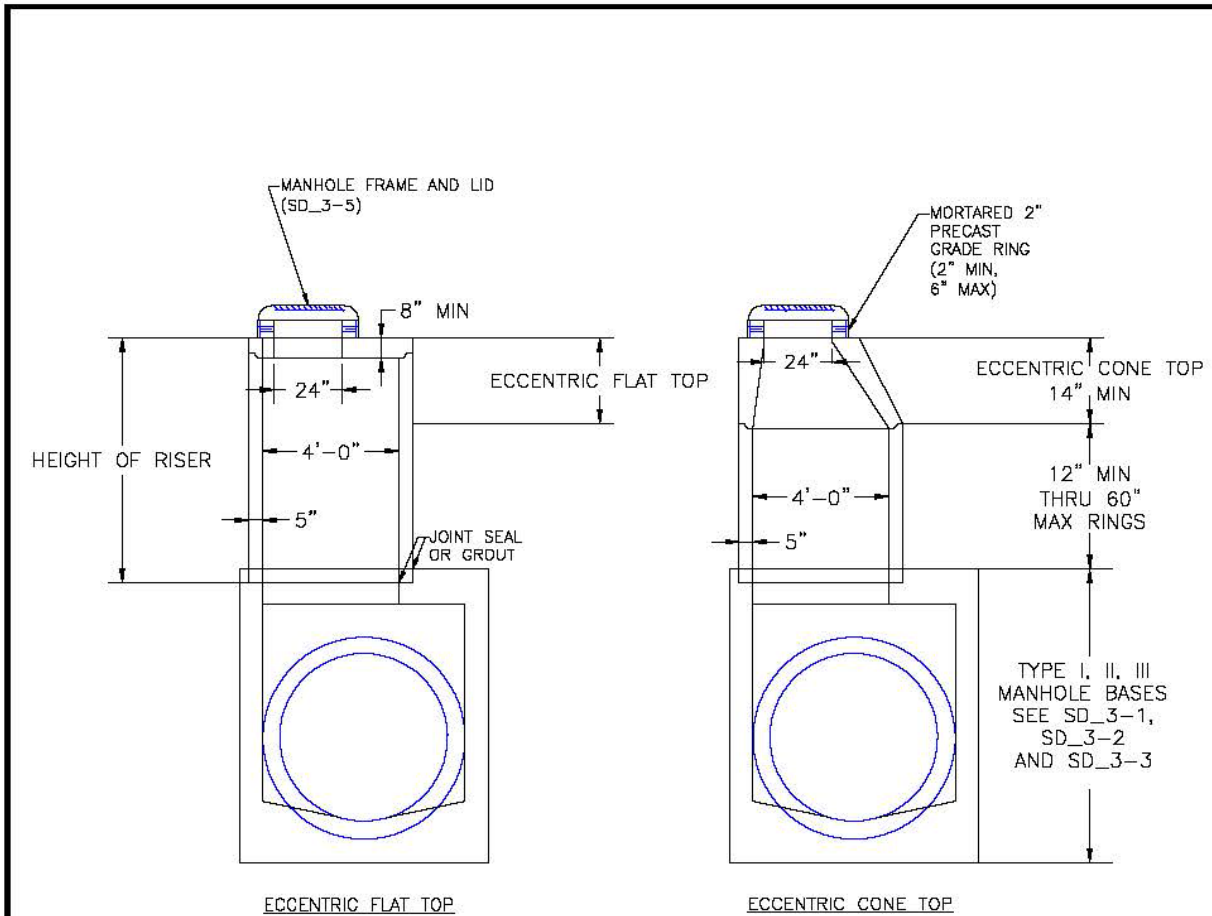

NOTES

1. ALL WORK SHALL BE DONE IN ACCORDANCE WITH THE STANDARD AND SUPPLEMENTAL SPECIFICATIONS APPLICABLE TO THE PROJECT.
2. PRECAST RISERS SHALL CONFORM TO ASTM C478.
3. STEPS SHALL BE INSTALLED WHEN MANHOLE DEPTH EXCEEDS 30". STEPS SHALL BE CAST IRON OR EXTRUDED ALUMINUM, 1000 LB CAPACITY, 12" WIDE WITH NON-SKID GROOVES AND DROP FRONT ON SAFETY NOSES, IN ACCORDANCE WITH APPROVED OSHA REQUIREMENTS.

- ENGINEERING CRITERIA MANUAL
Appendix F STANDARD DRAWINGS

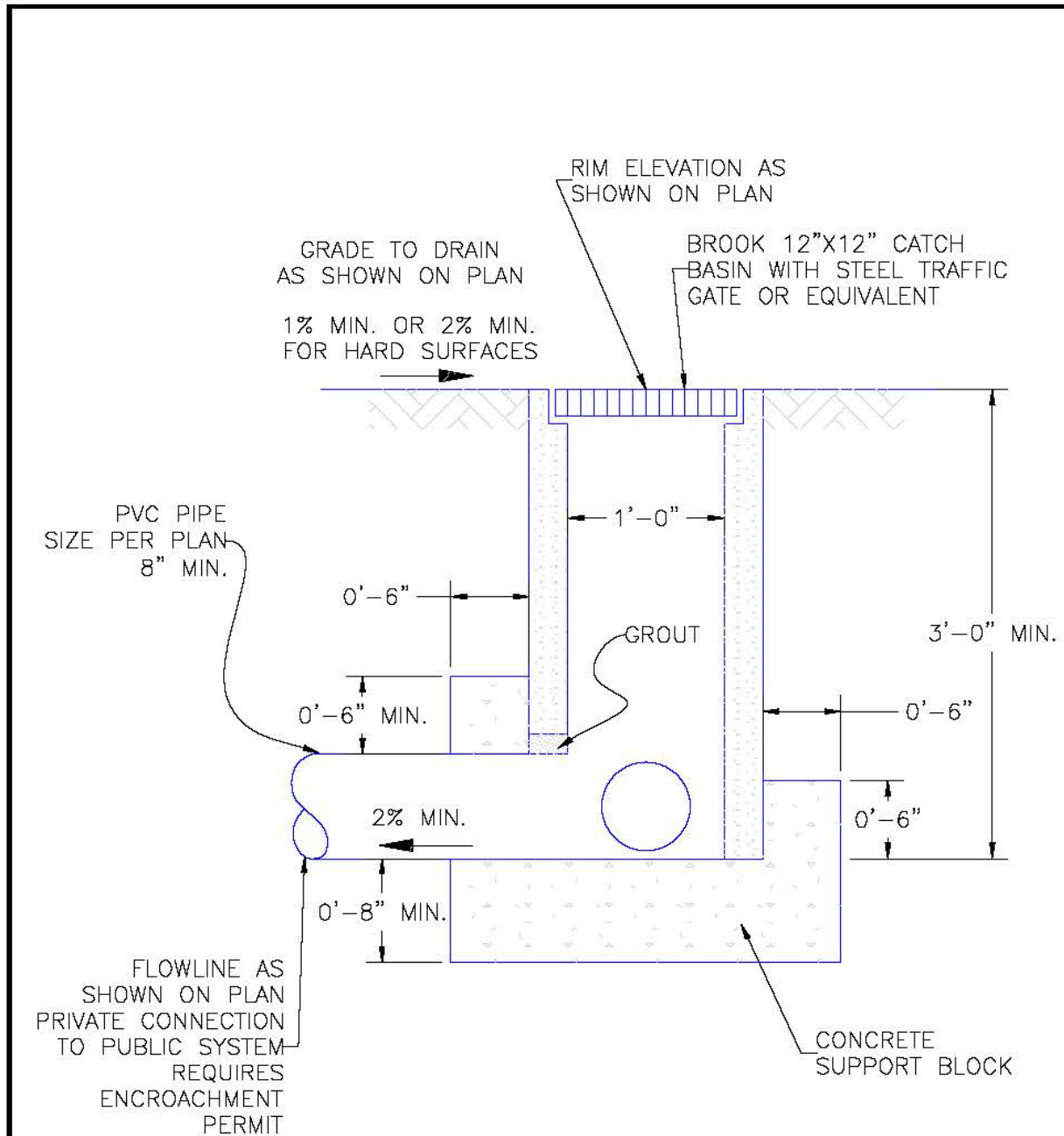

- ENGINEERING CRITERIA MANUAL
Appendix F STANDARD DRAWINGS

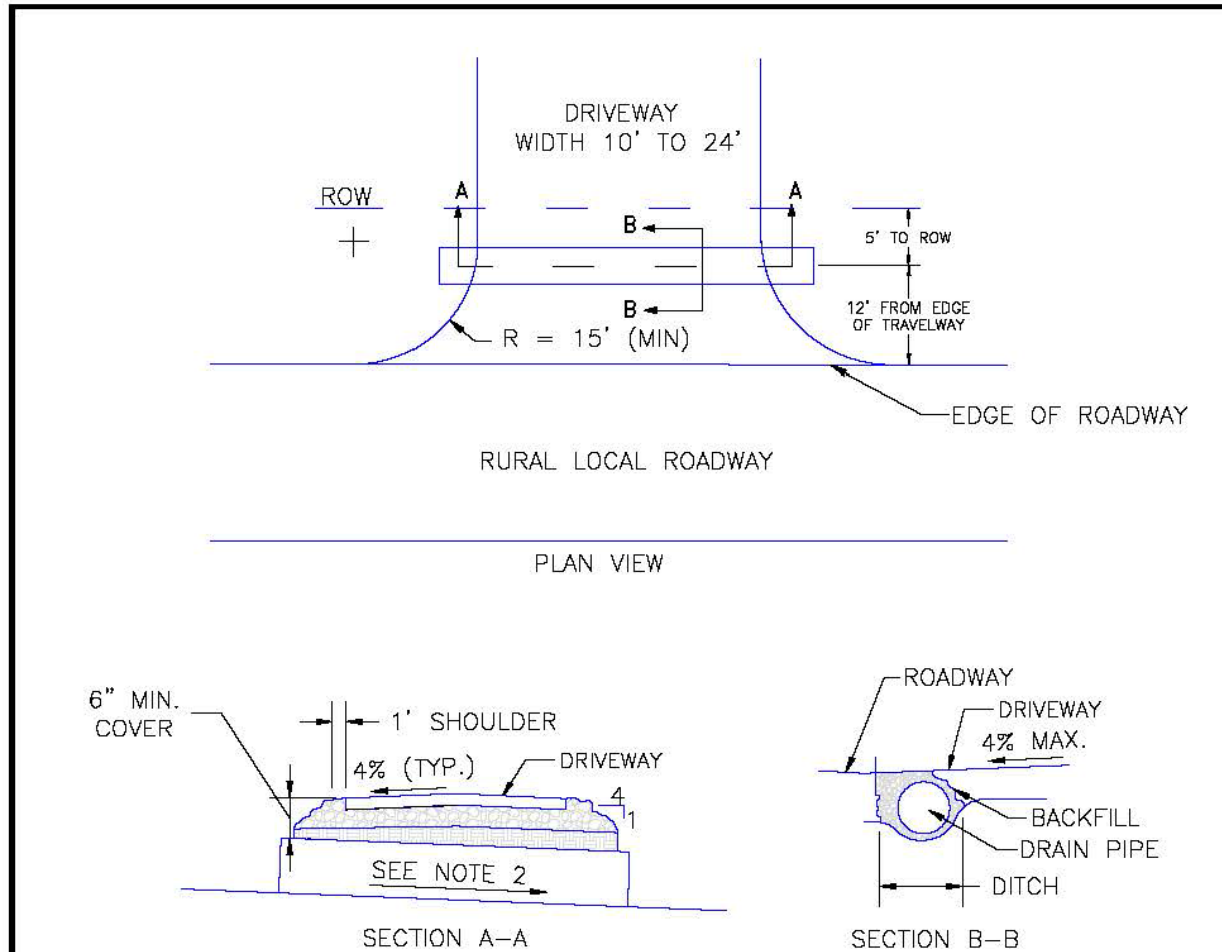

NOTES

1. SURFACE TREATMENT OF DRIVEWAY TO MATCH SURFACE TREATMENT OF ROAD WITHIN THE ROW.
2. DRAIN PIPE TO BE 18" DIAMETER CMP MINIMUM.
3. PIPE SLOPE TO BE CONSISTENT WITH FLOWLINE OF DITCH, MINIMUM OF 1% PREFERRED.
4. ALL DRIVEWAYS SHALL HAVE A 4 PERCENT CROWN.
5. WHEN SLOPING TOWARDS ROAD, DRIVEWAYS SHALL HAVE A MAXIMUM GRADE OF 4 PERCENT FOR A MINIMUM OF 20 FEET WHERE THE SITE ALLOWS.

- ENGINEERING CRITERIA MANUAL
Appendix F STANDARD DRAWINGS

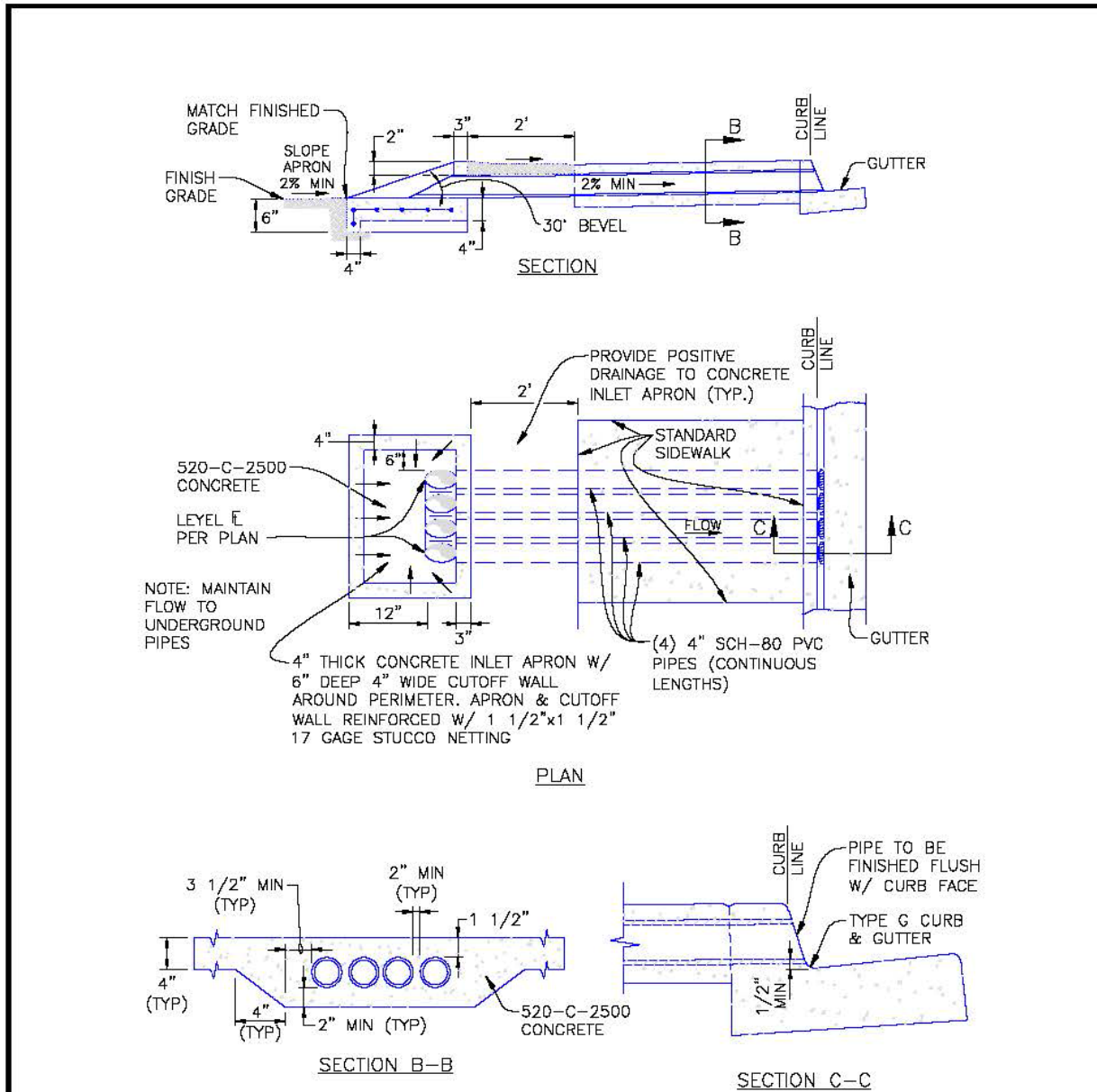

El Paso County, Colorado
(Supp. No. 2)

- ENGINEERING CRITERIA MANUAL
Appendix F STANDARD DRAWINGS

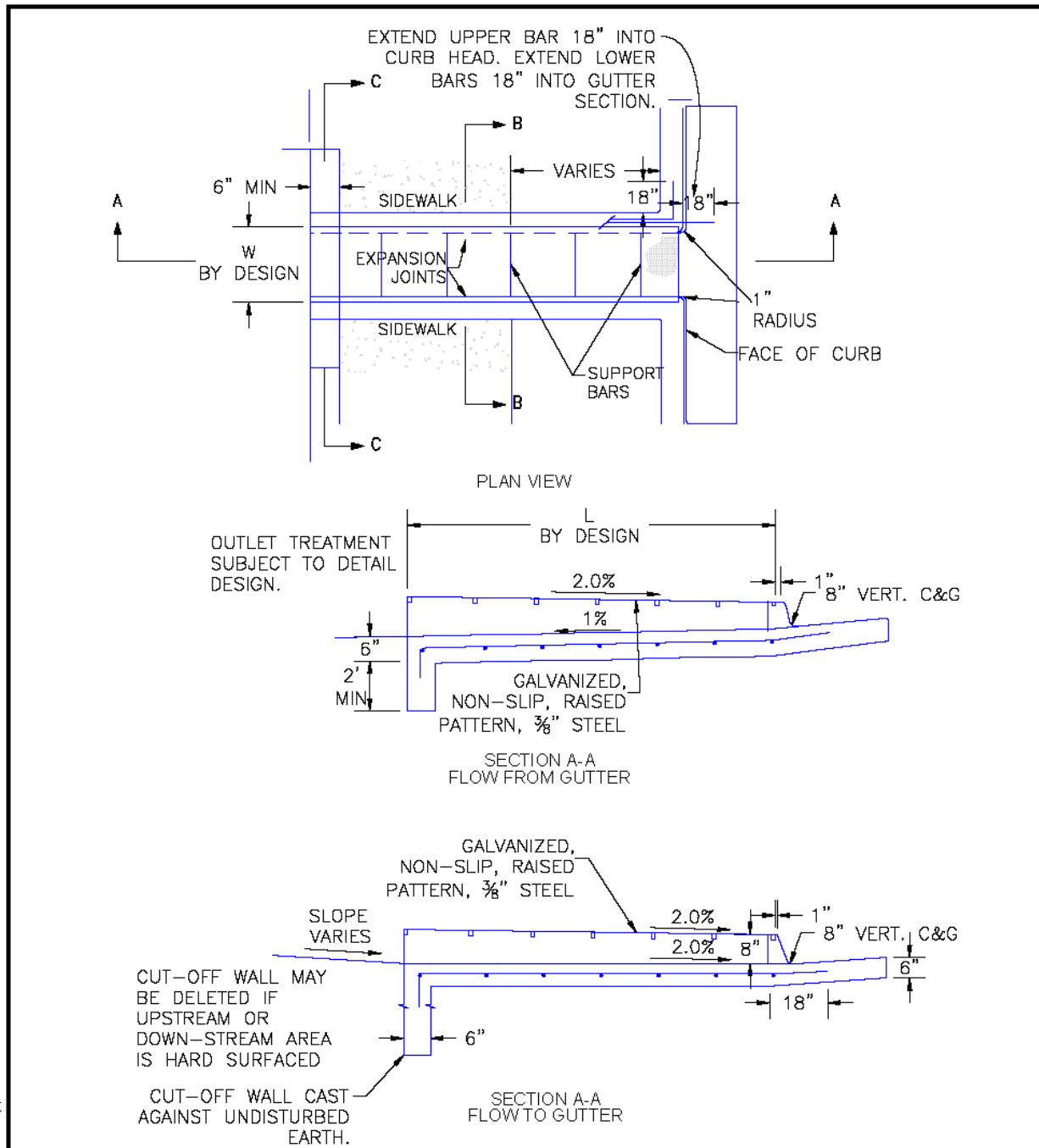

El Paso County, Colorado
(Supp. No. 2)

- ENGINEERING CRITERIA MANUAL
Appendix F STANDARD DRAWINGS

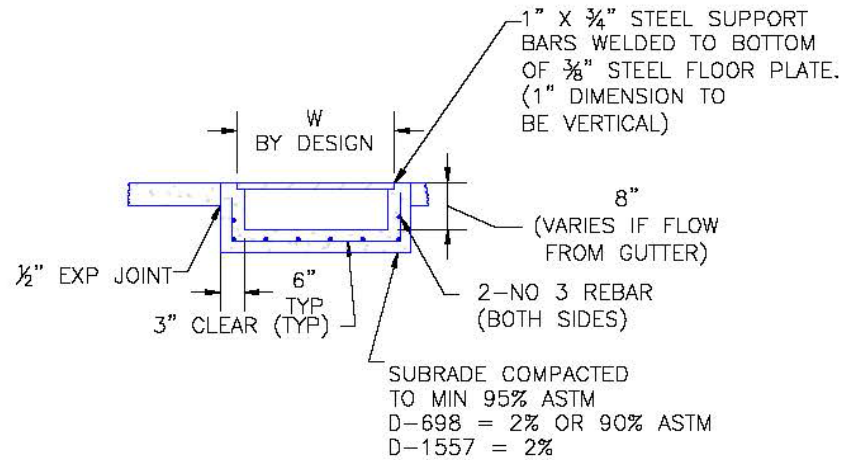

SECTION B-B

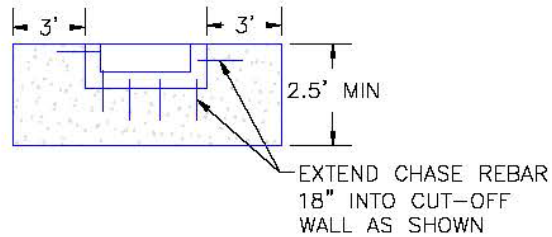

SECTION C-C

- ENGINEERING CRITERIA MANUAL
Appendix F STANDARD DRAWINGS

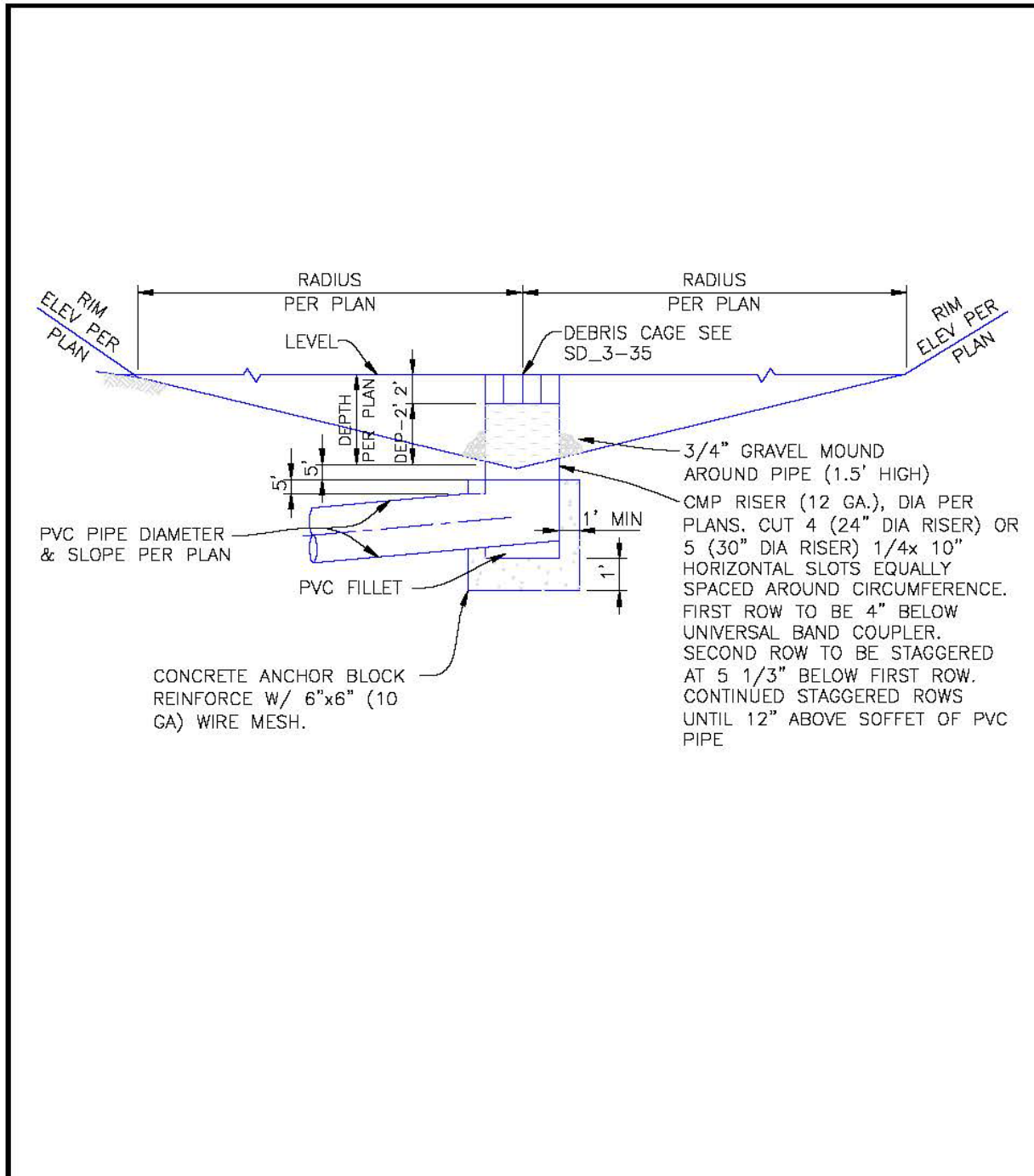

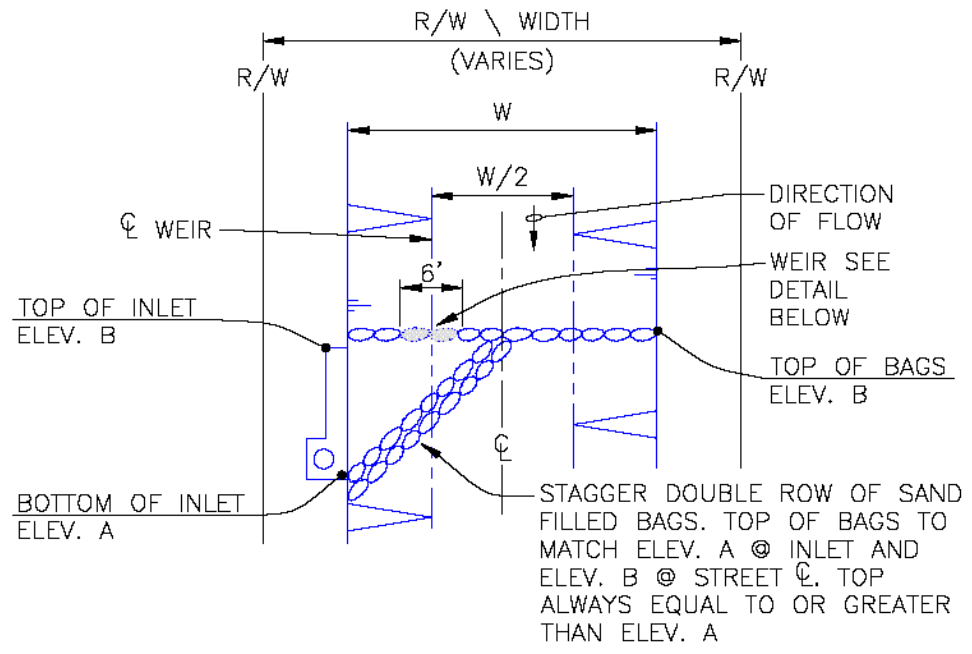

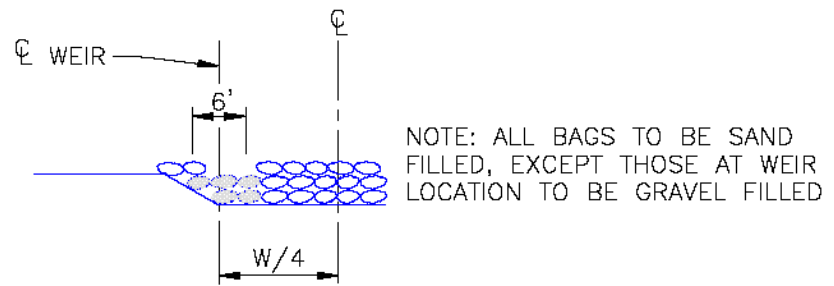

PLAN



NOTE: ALL BAGS TO BE SAND FILLED, EXCEPT THOSE AT WEIR LOCATION TO BE GRAVEL FILLED

WEIR ELEVATION

LEGEND:
GRAVEL FILLED BAG.. 
SAND FILLED BAG..... 

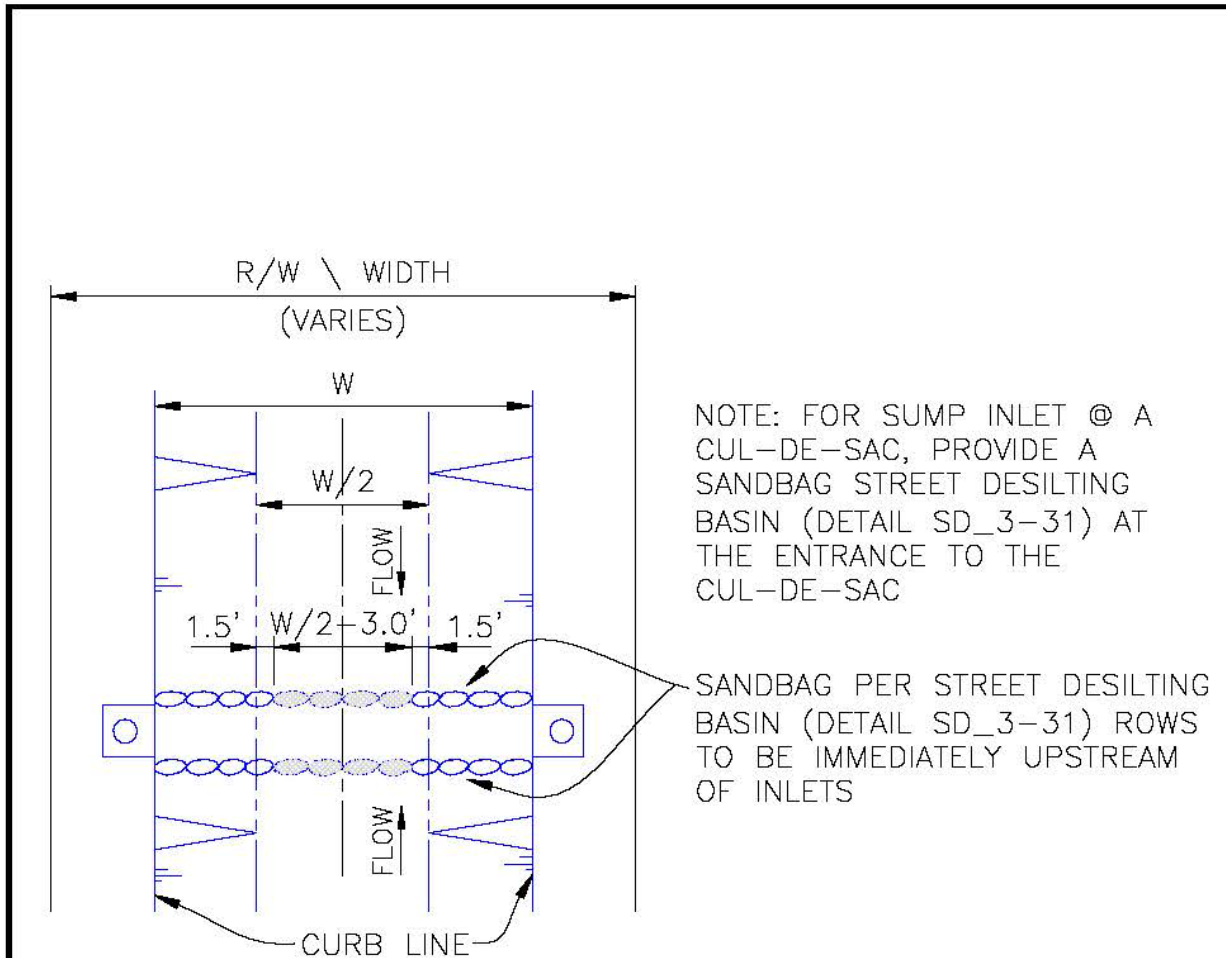

TEMP. DESILTING BASIN @ SUMP
NO SCALE

LEGEND:

GRAVEL FILLED BAG.. 

SAND FILLED BAG..... 

- ENGINEERING CRITERIA MANUAL
Appendix F STANDARD DRAWINGS

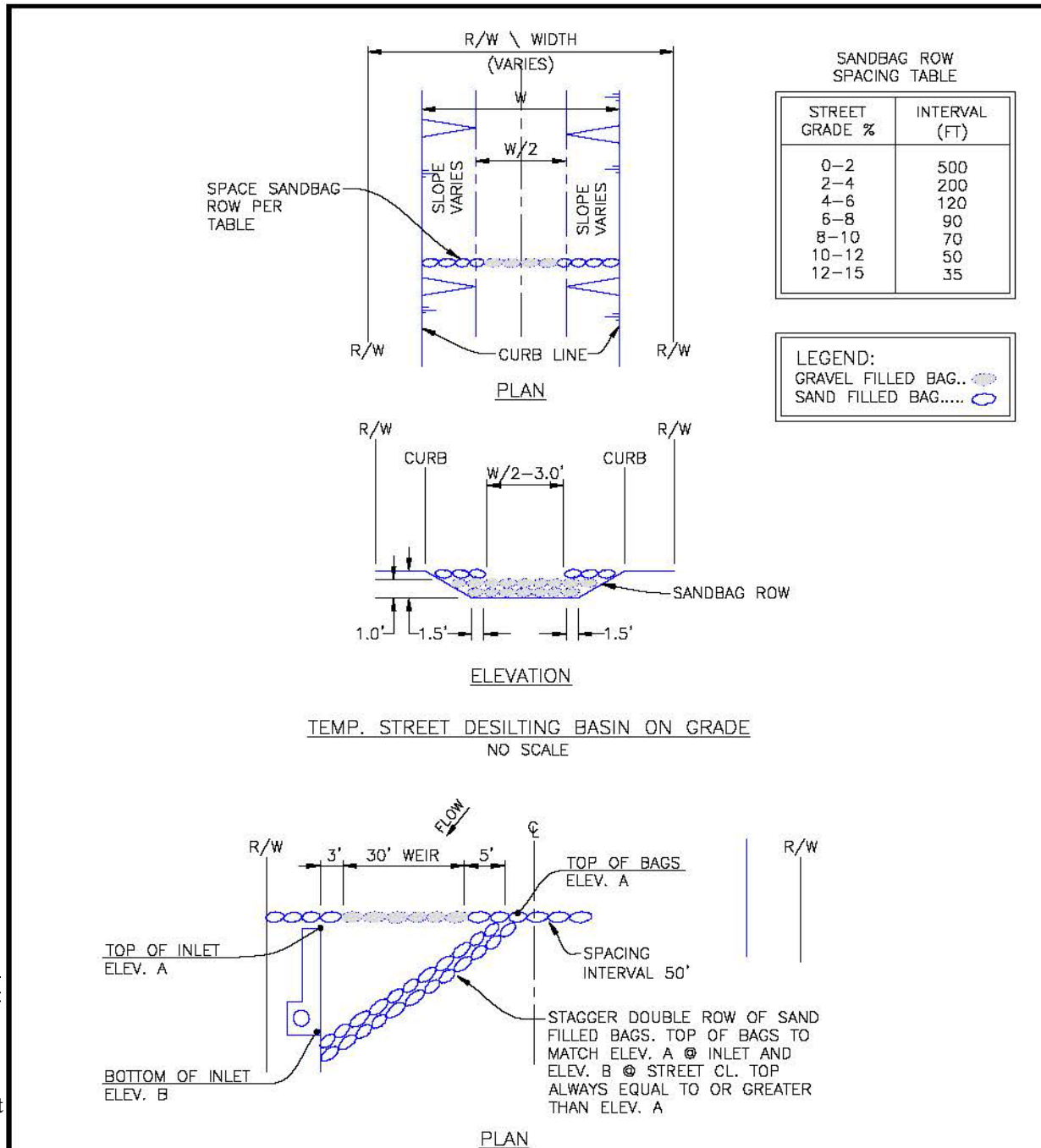

- ENGINEERING CRITERIA MANUAL
Appendix F STANDARD DRAWINGS

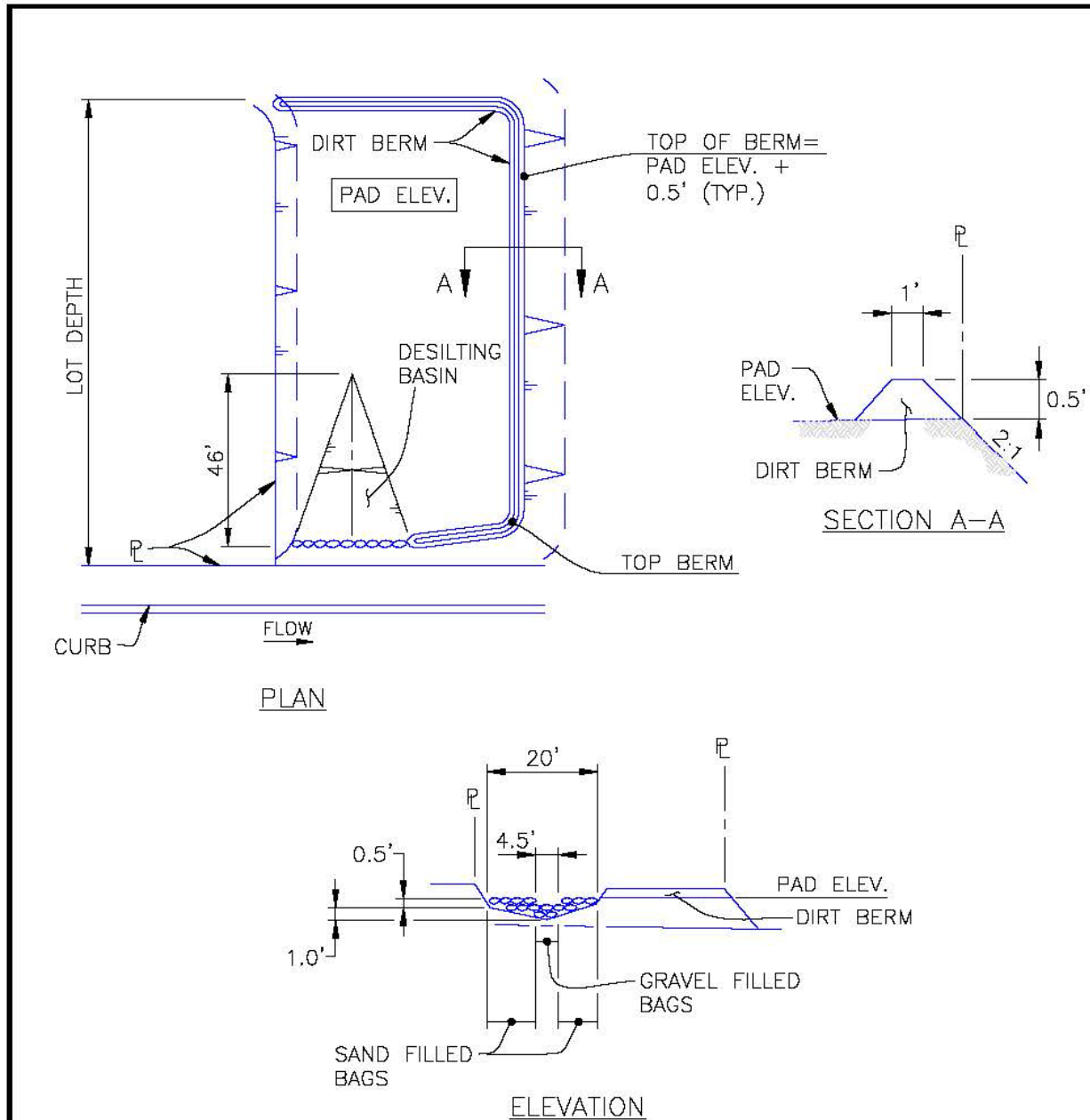

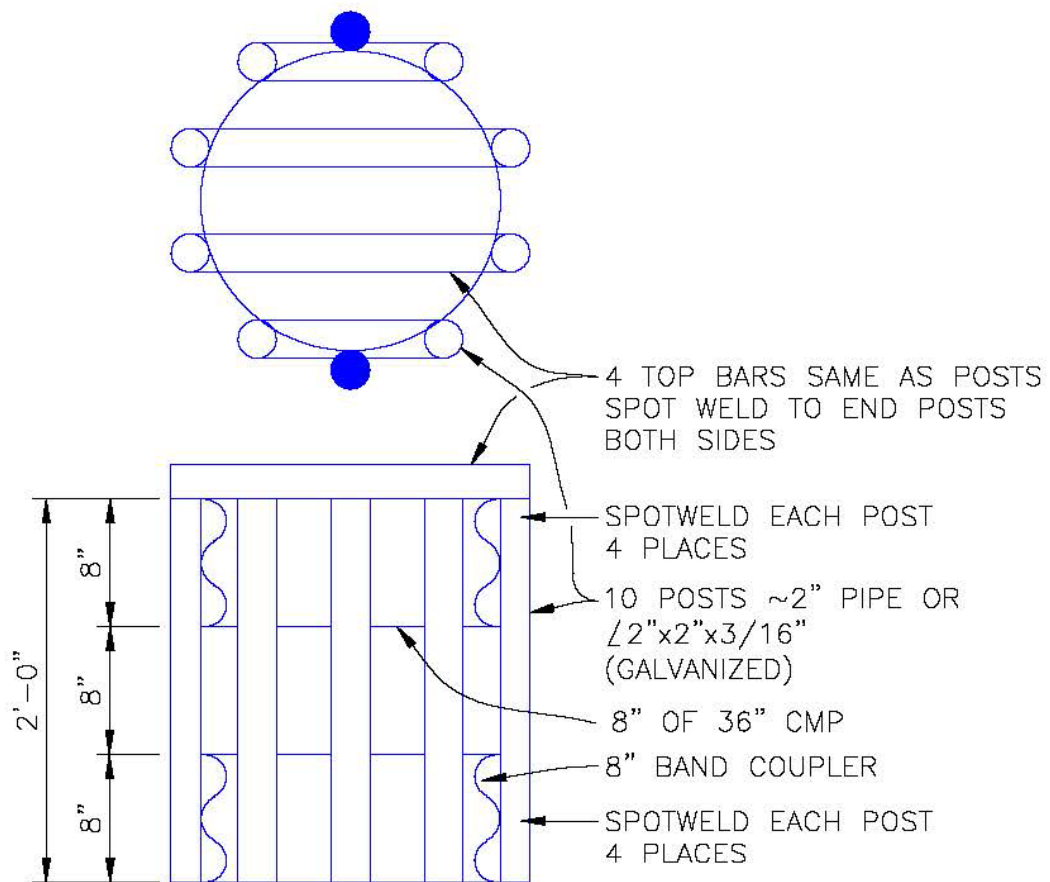

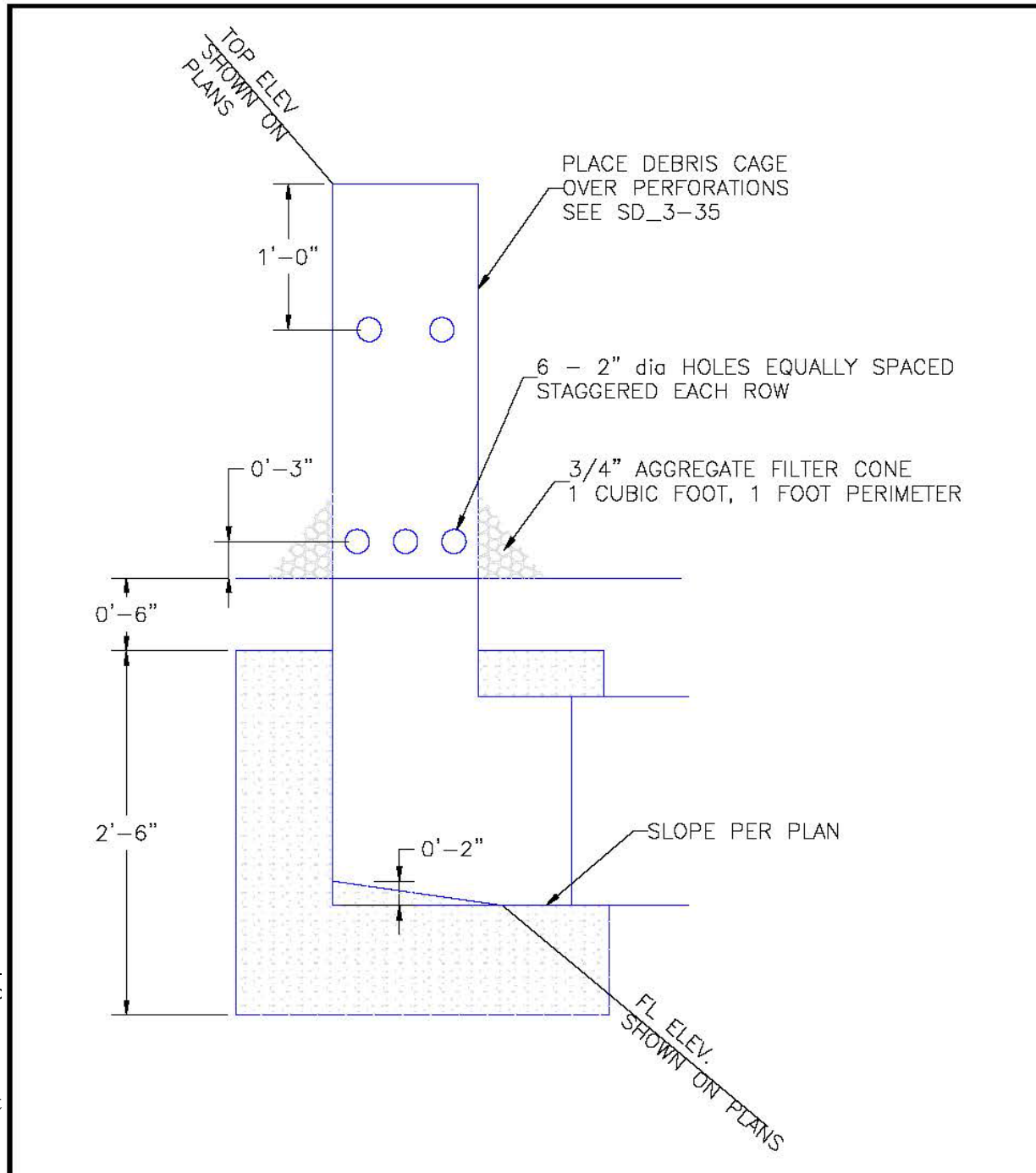

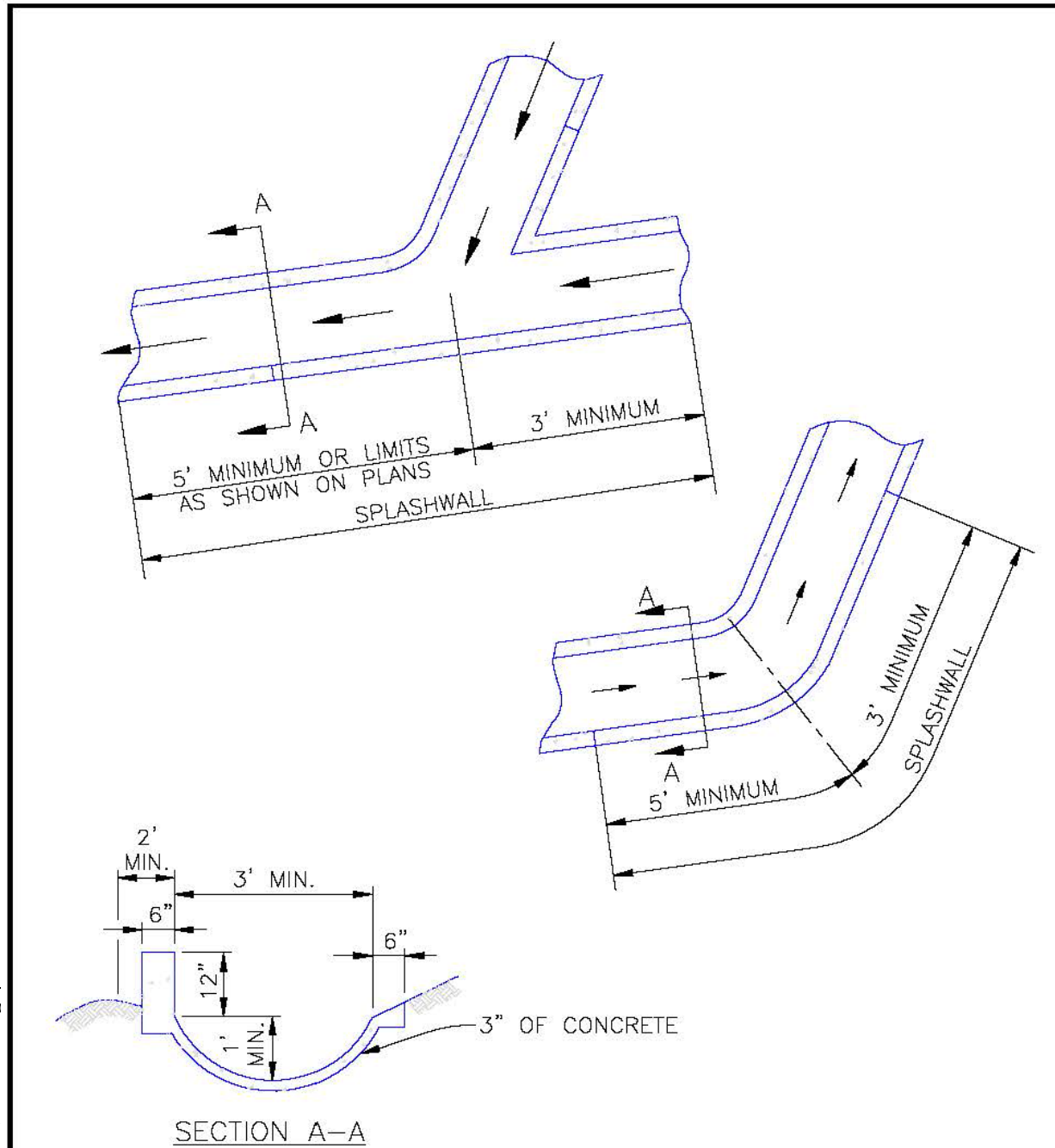

- ENGINEERING CRITERIA MANUAL
Appendix F STANDARD DRAWINGS

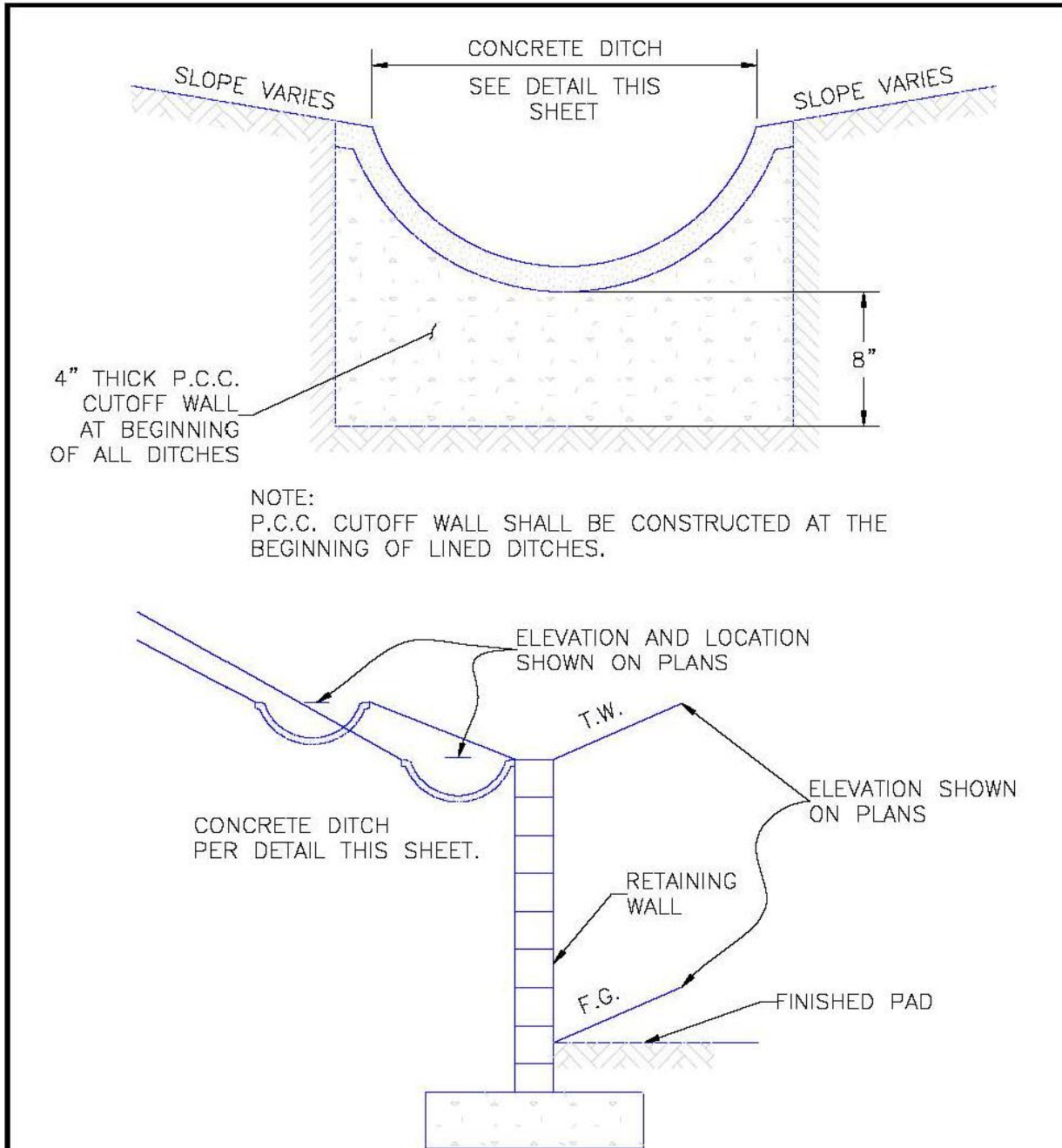

- ENGINEERING CRITERIA MANUAL
Appendix F STANDARD DRAWINGS

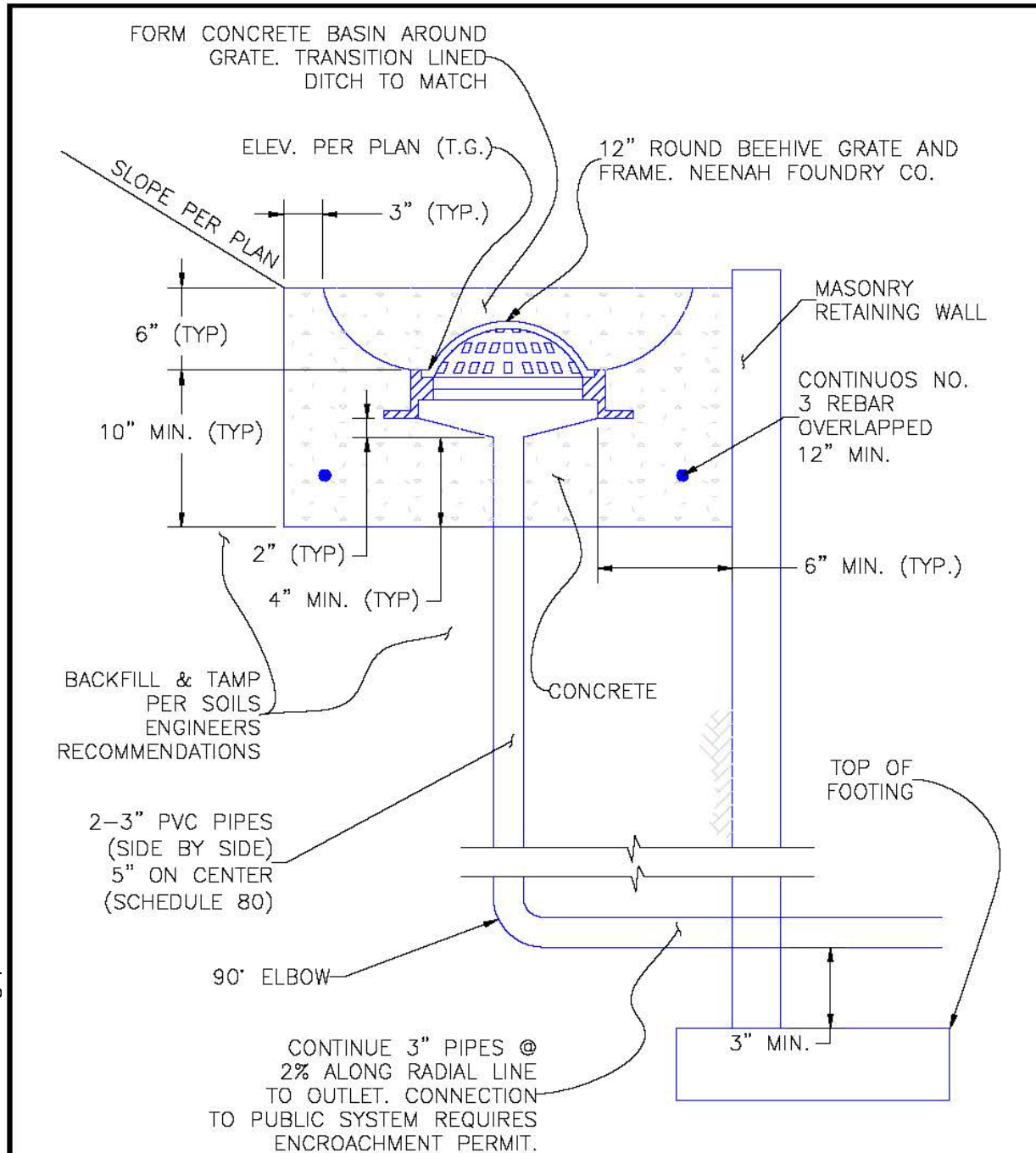

El Paso County, Colorado
(Supp. No. 2)

- ENGINEERING CRITERIA MANUAL
Appendix F STANDARD DRAWINGS

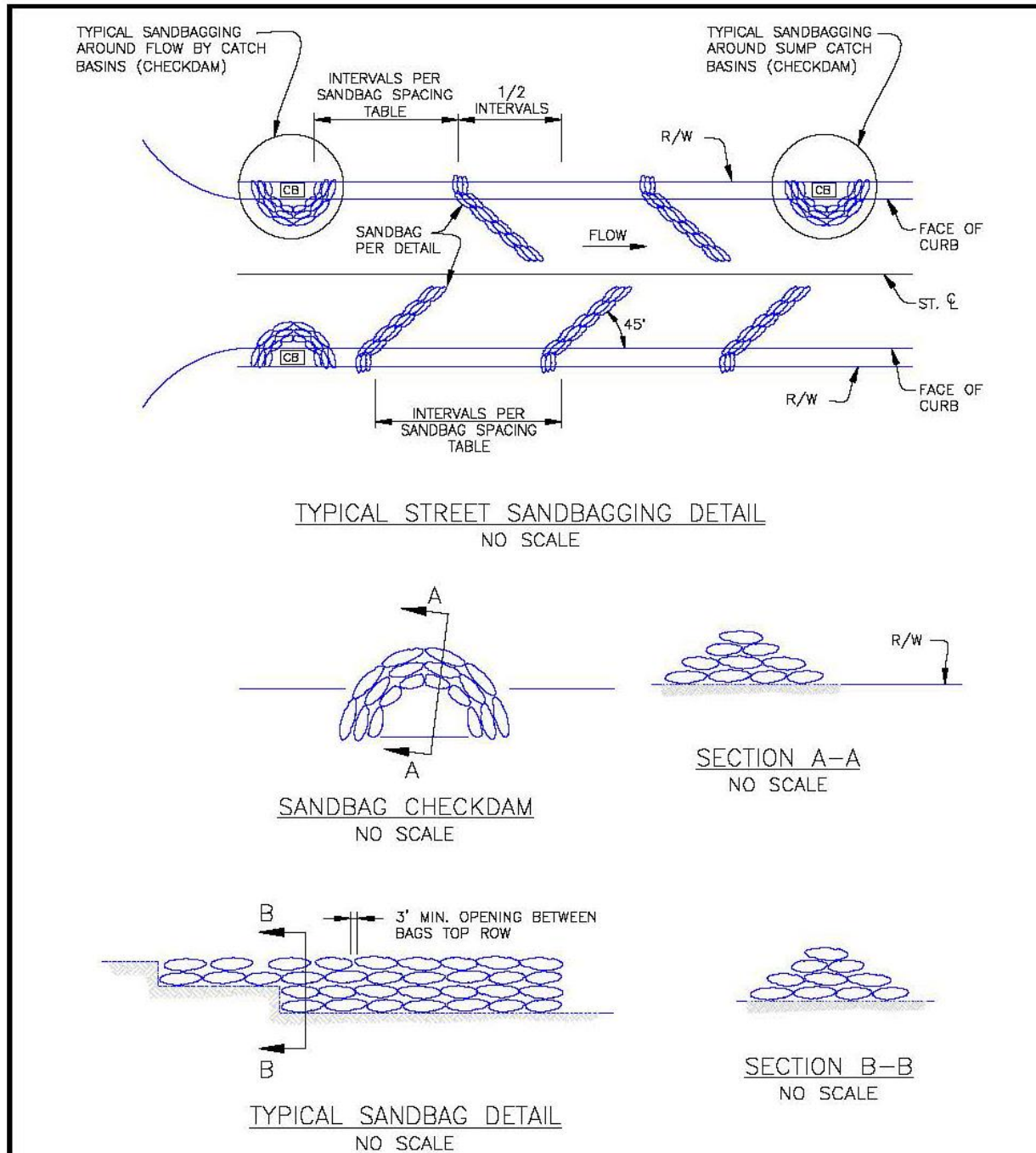

- ENGINEERING CRITERIA MANUAL
Appendix F STANDARD DRAWINGS

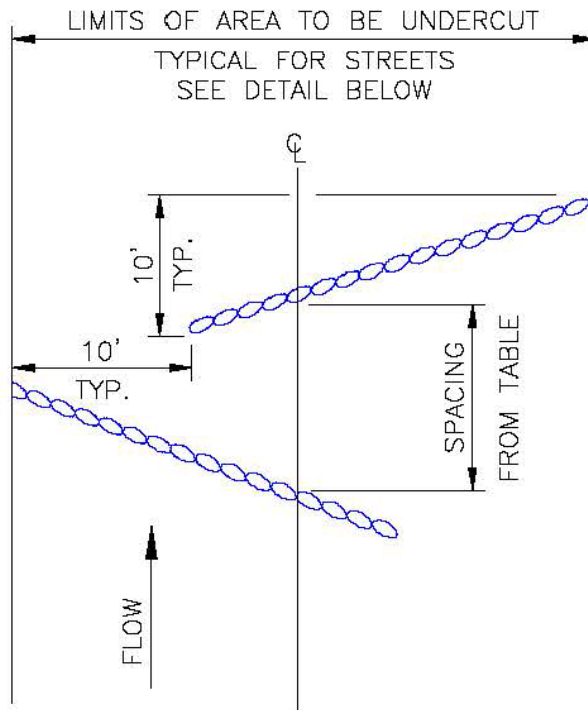

SANDBAG ROW
SPACING TABLE

STREET GRADE %	INTERVAL (FT)
0-2	500
2-4	200
4-6	120
6-8	90
8-10	70
10-12	50
12-15	35

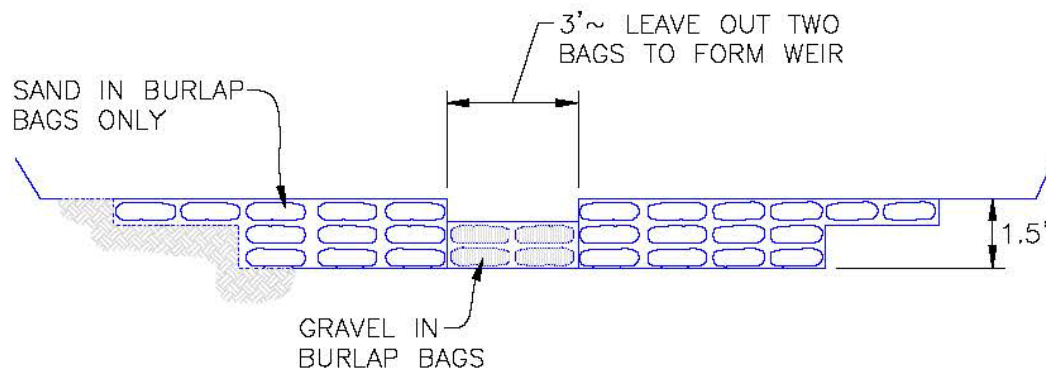

- ENGINEERING CRITERIA MANUAL
Appendix F STANDARD DRAWINGS

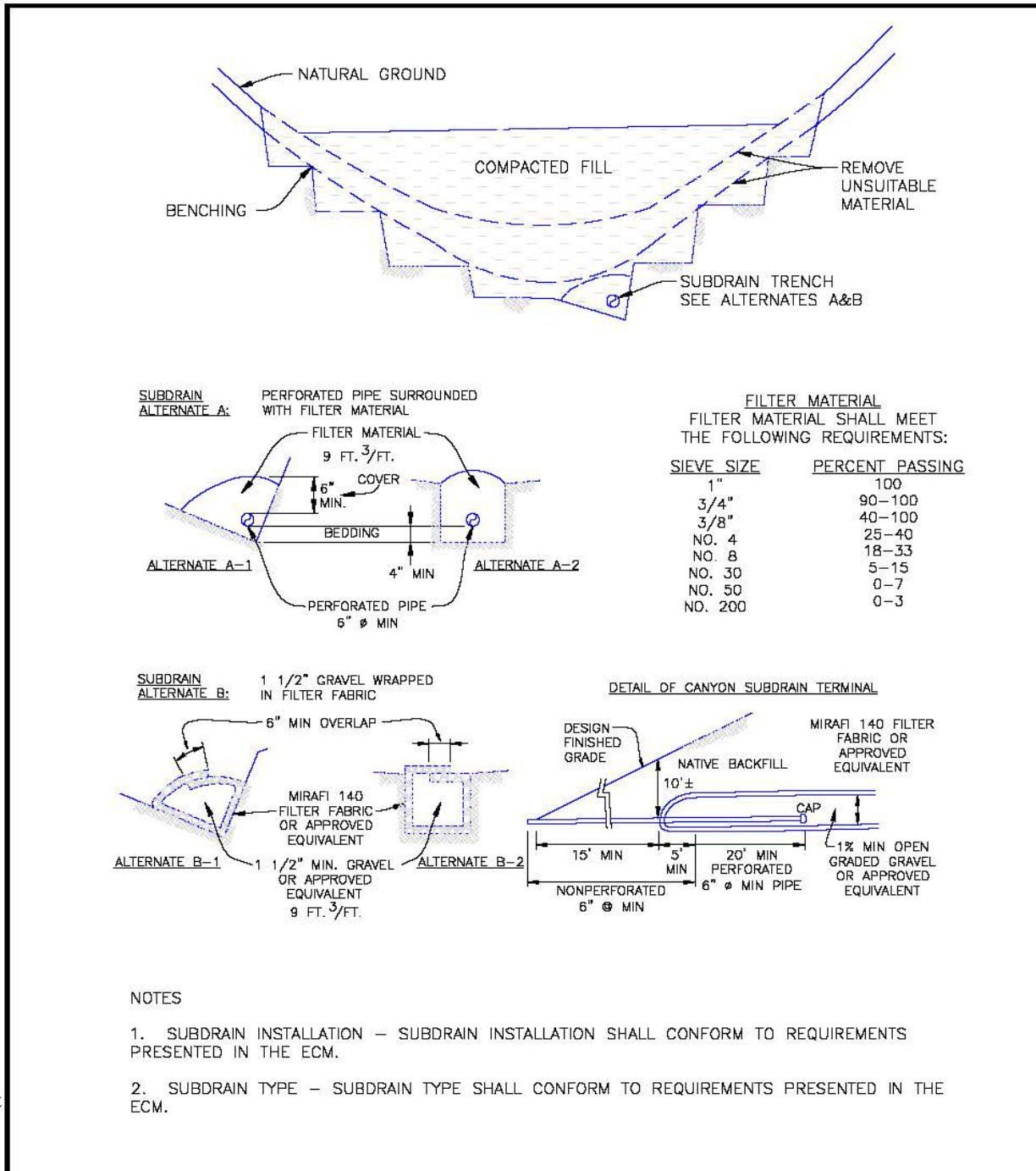

NOTES

1. SUBDRAIN INSTALLATION – SUBDRAIN INSTALLATION SHALL CONFORM TO REQUIREMENTS PRESENTED IN THE ECM.
2. SUBDRAIN TYPE – SUBDRAIN TYPE SHALL CONFORM TO REQUIREMENTS PRESENTED IN THE ECM.

- ENGINEERING CRITERIA MANUAL
Appendix F STANDARD DRAWINGS

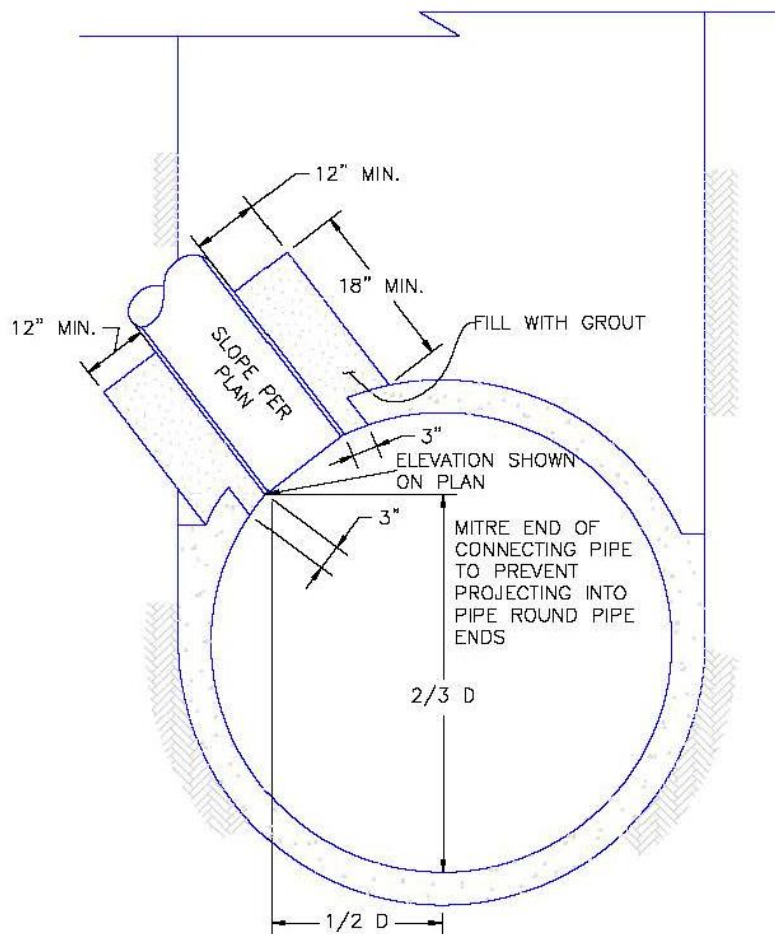

NOTE:

1. THE COMPRESSIVE STRENGTH OF CONCRETE MUST BE 4,000 PSI AT 28 DAYS OR BETTER.
2. MAXIMUM SLUMP SHALL BE 2".
3. TRENCH SIDES MUST STAND VERTICAL FROM THE BOTTOM OF THE TRENCH TO TWO FEET ABOVE THE TOP OF PIPE.
4. FULL TIME INSPECTION MUST BE PROVIDED TO ASSURE FULL COMPLIANCE.
5. 95% RELATIVE COMPACTION SHALL BE ACHIVED AND VERIFIED IN THE PIPE CONTACT SUPPORT AREA OF THE TRENCH.

- ENGINEERING CRITERIA MANUAL
Appendix F STANDARD DRAWINGS

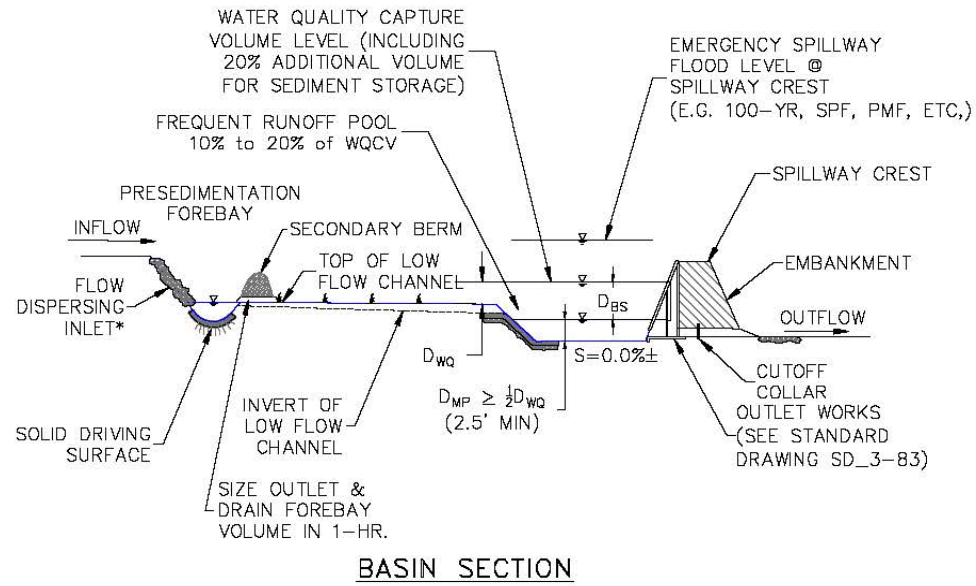
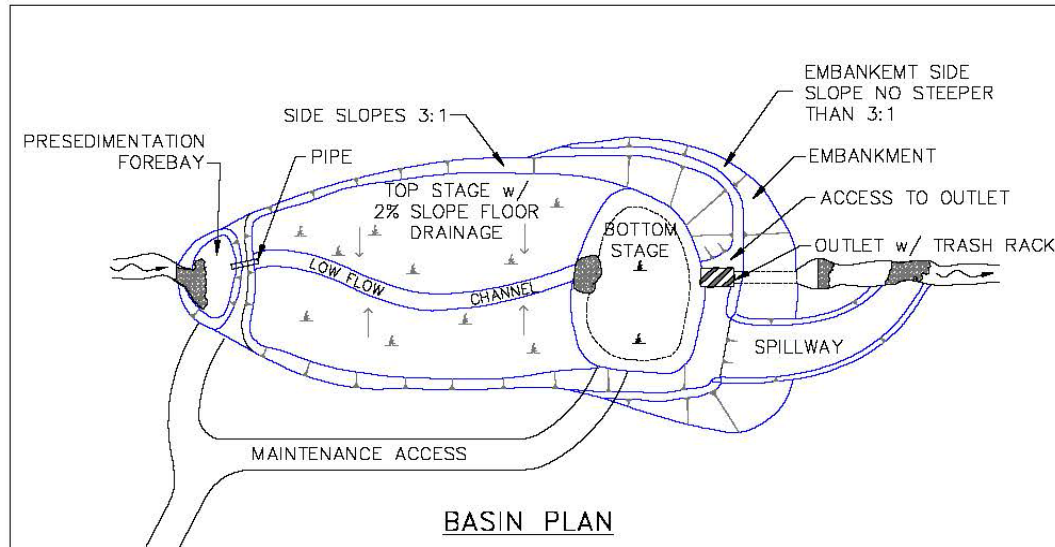

*COULD BE IMPACT BASIN, GSB DROP, CONCRETE RUNDOWN, OTHER HARDENED RUNDOWN

El Paso County, Colorado, Engine
(Supp. No. 2)

DATE APPROVED:
1/1/08
John A. McCarty

Plan & Section of an Extended
Detention Basin Sedimentation Facility
Standard Drawing



Maintenance access shall be designed and constructed to not contribute additional flow or sediment load directly to the forebay or outlet works.

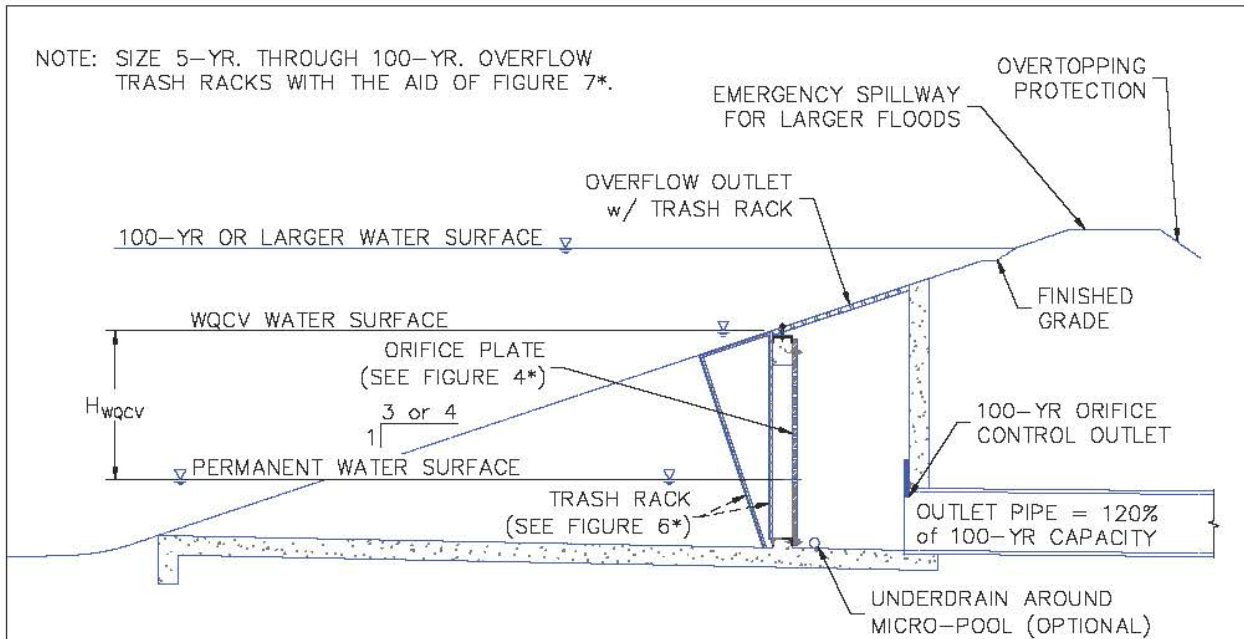

DROP BOX OUTLET OPTION

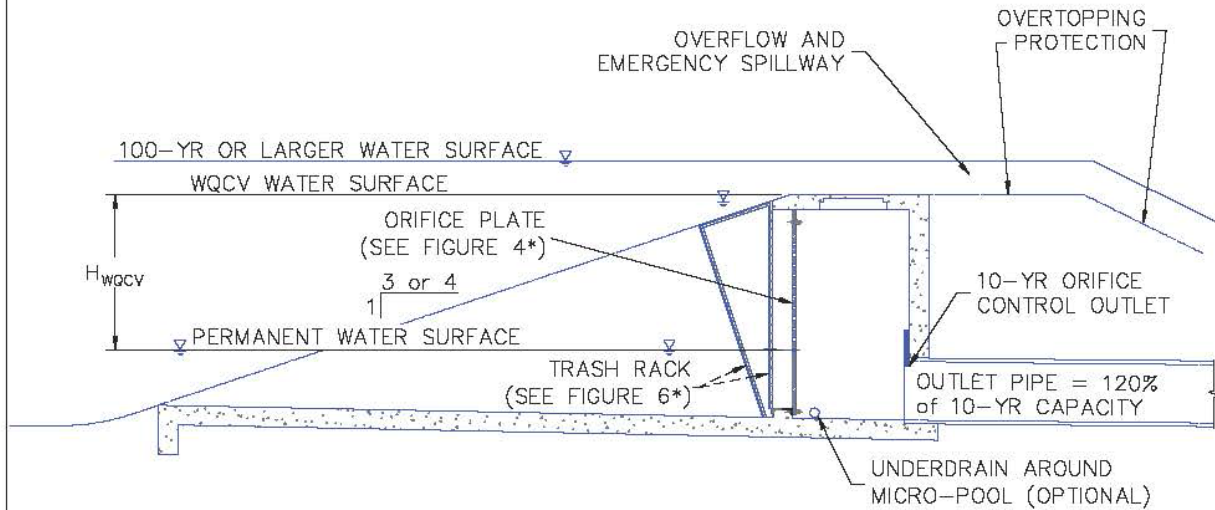

OVERTOPPING SPILLWAY OPTION

*FIGURES 4, 6 and 7 ARE IN THE CITY OF COLORADO SPRINGS ENGINEERING DIVISION'S DRAINAGE CRITERIA MANUAL, VOLUME 2.

<p align="center">1/1/08</p> <p>DATE APPROVED:</p> <p align="center">John A. McCarty</p> <p>DEPARTMENT OF TRANSPORTATION</p>	<p align="center">Typical WQCV Outlet Structure Profiles Including 100-Year Detention</p> <p align="center">Standard Drawing</p>	
	<p>REVISION DATE:</p> <p align="center">7/16/07</p>	

(Supp. No. 2)

- ENGINEERING CRITERIA MANUAL
Appendix F STANDARD DRAWINGS

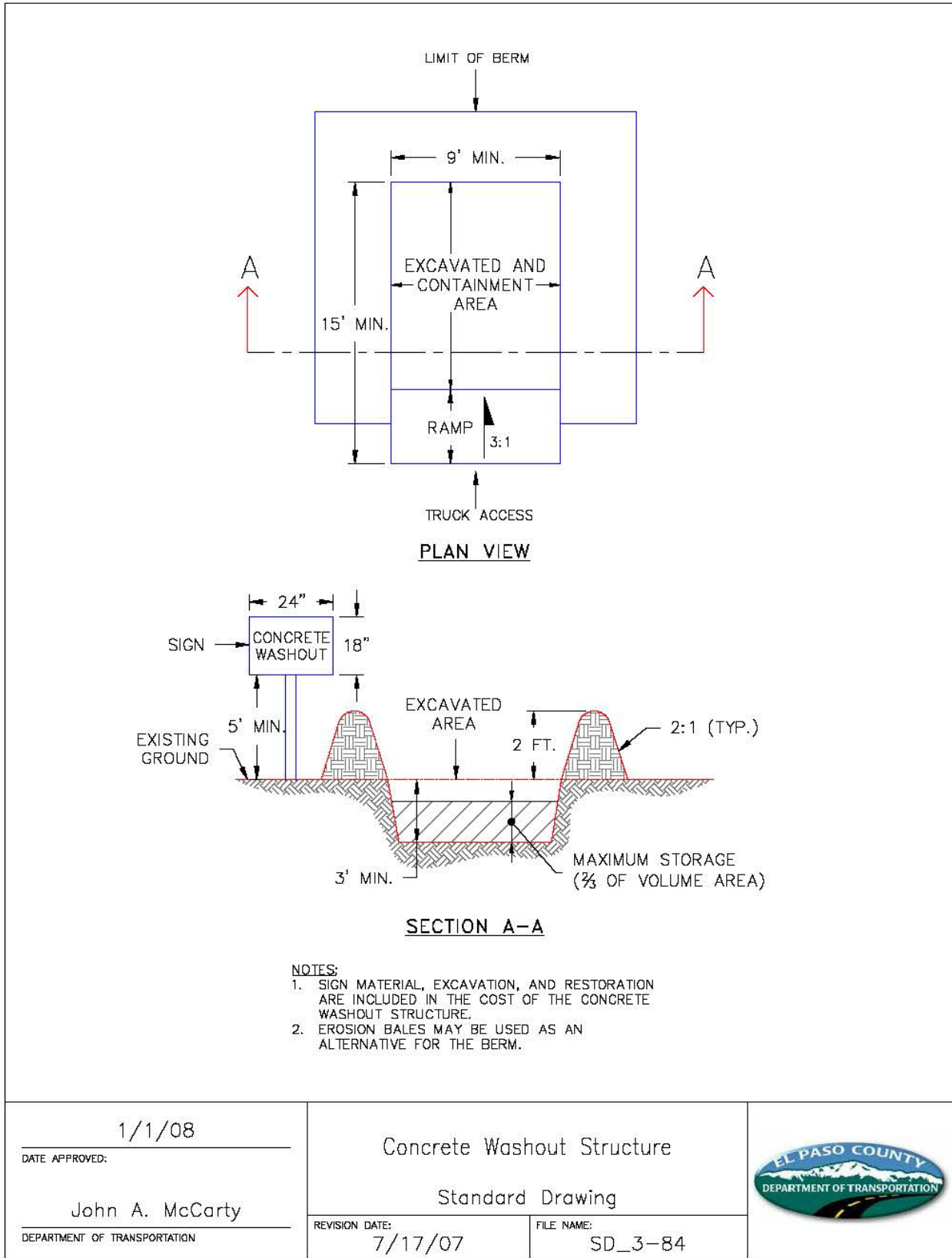

<p align="center">1/1/08</p> <p>DATE APPROVED:</p> <p align="center">John A. McCarty</p> <p>DEPARTMENT OF TRANSPORTATION</p>	<p align="center">Concrete Washout Structure</p> <p align="center">Standard Drawing</p>	
	<p>REVISION DATE:</p> <p align="center">7/17/07</p>	<p>FILE NAME:</p> <p align="center">SD_3-84</p>

(Supp. No. 2)

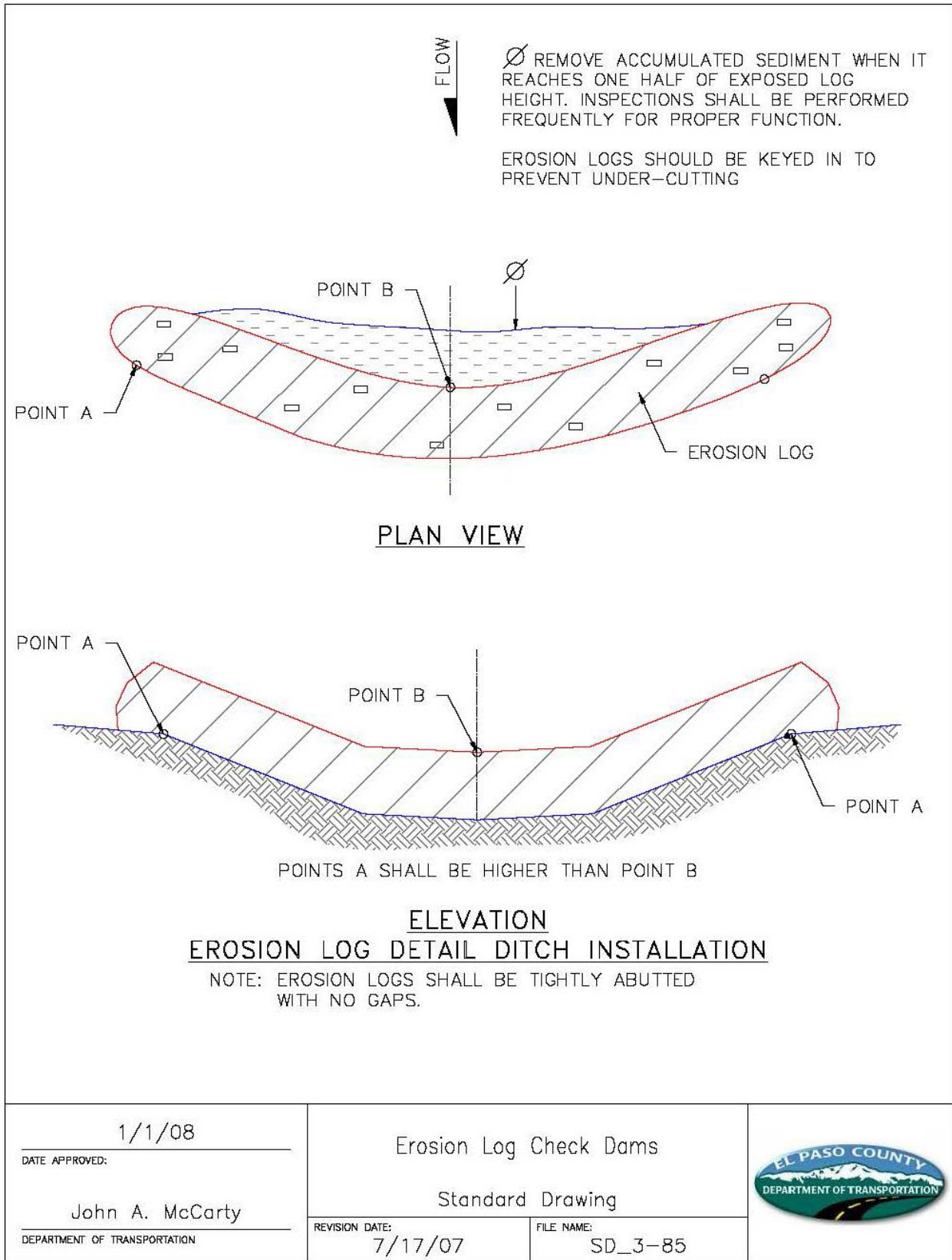

(Supp. No. 2)

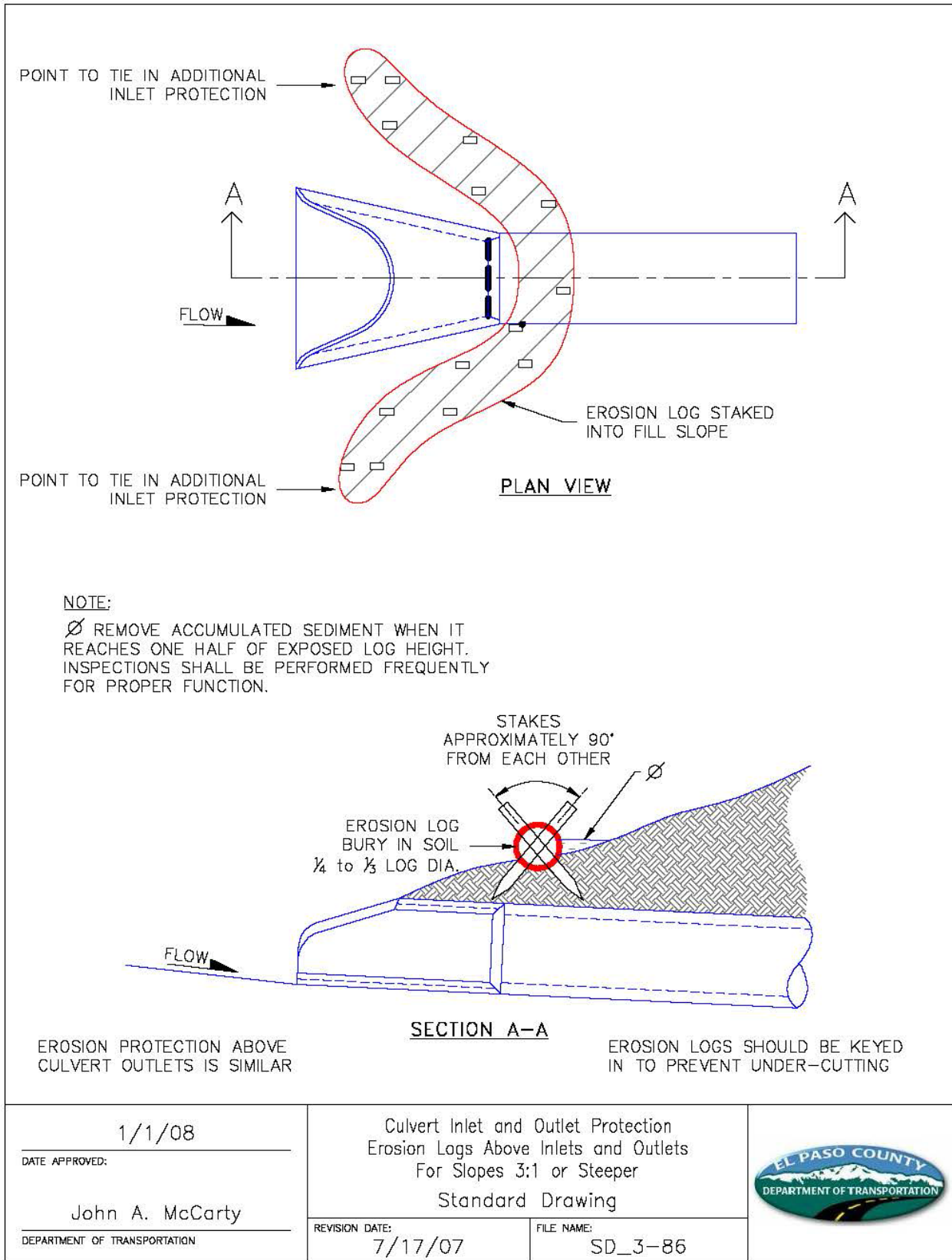

(Supp. No. 2)

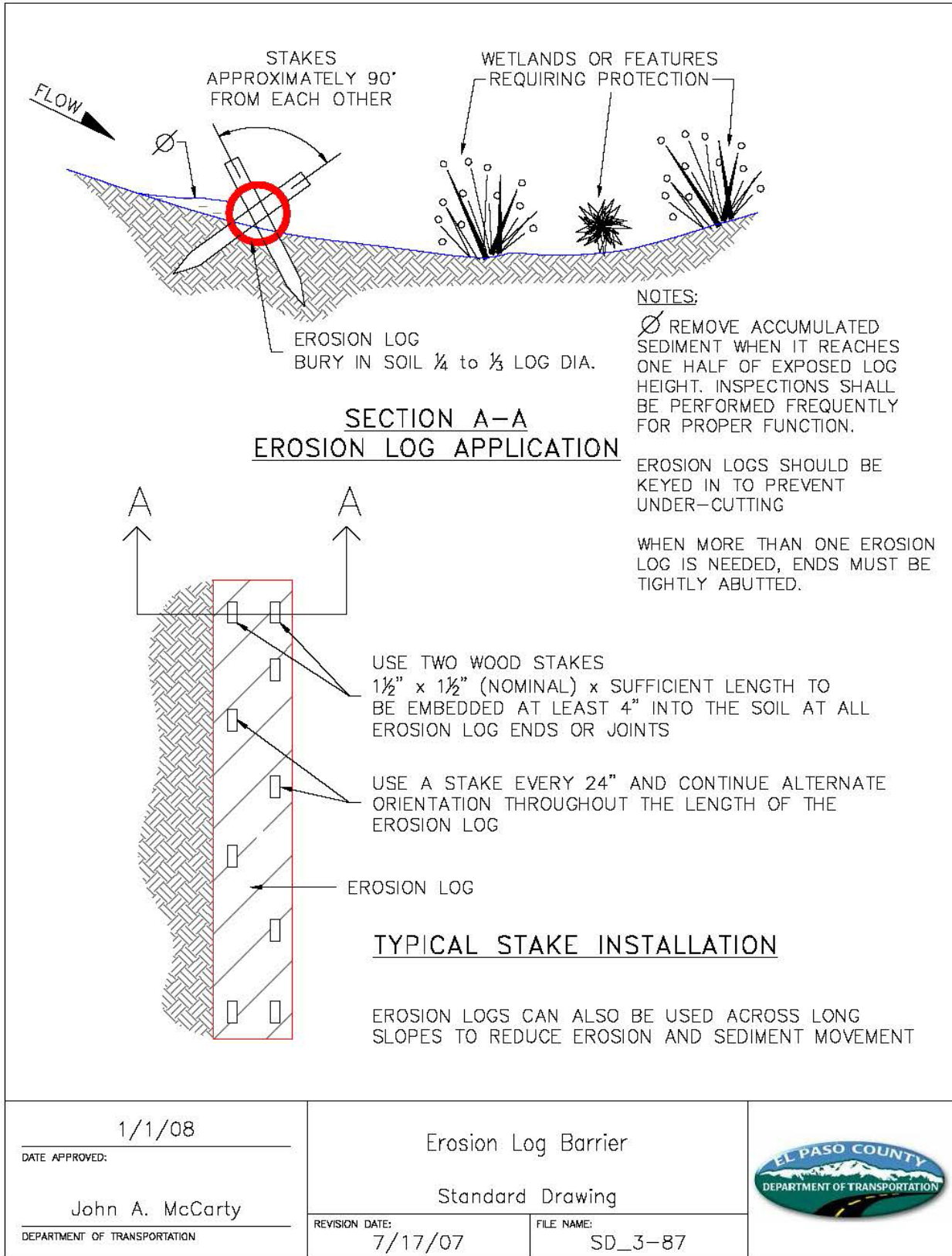

(Supp. No. 2)

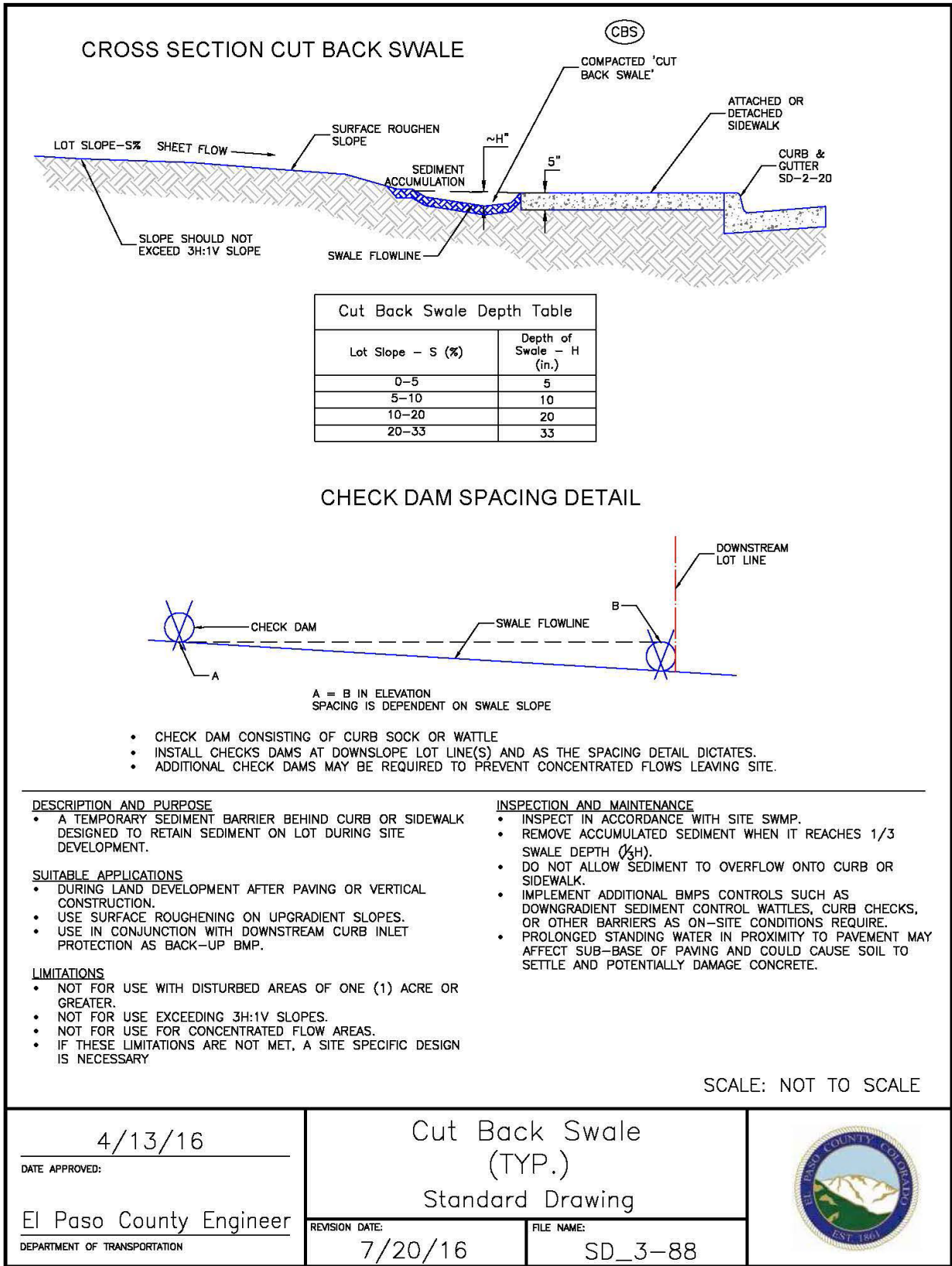

DESCRIPTION AND PURPOSE

- A TEMPORARY SEDIMENT BARRIER BEHIND CURB OR SIDEWALK DESIGNED TO RETAIN SEDIMENT ON LOT DURING SITE DEVELOPMENT.

SUITABLE APPLICATIONS

- DURING LAND DEVELOPMENT AFTER PAVING OR VERTICAL CONSTRUCTION.
- USE SURFACE ROUGHENING ON UPGRADIENT SLOPES.
- USE IN CONJUNCTION WITH DOWNSTREAM CURB INLET PROTECTION AS BACK-UP BMP.

LIMITATIONS

- NOT FOR USE WITH DISTURBED AREAS OF ONE (1) ACRE OR GREATER.
- NOT FOR USE EXCEEDING 3H:1V SLOPES.
- NOT FOR USE FOR CONCENTRATED FLOW AREAS.
- IF THESE LIMITATIONS ARE NOT MET, A SITE SPECIFIC DESIGN IS NECESSARY

INSPECTION AND MAINTENANCE

- INSPECT IN ACCORDANCE WITH SITE SWMP.
- REMOVE ACCUMULATED SEDIMENT WHEN IT REACHES 1/3 SWALE DEPTH ($\frac{1}{3}H$).
- DO NOT ALLOW SEDIMENT TO OVERFLOW ONTO CURB OR SIDEWALK.
- IMPLEMENT ADDITIONAL BMPs CONTROLS SUCH AS DOWNGRADIENT SEDIMENT CONTROL WATTLES, CURB CHECKS, OR OTHER BARRIERS AS ON-SITE CONDITIONS REQUIRE.
- PROLONGED STANDING WATER IN PROXIMITY TO PAVEMENT MAY AFFECT SUB-BASE OF PAVING AND COULD CAUSE SOIL TO SETTLE AND POTENTIALLY DAMAGE CONCRETE.

4/13/16
DATE APPROVED:
El Paso County Engineer
DEPARTMENT OF TRANSPORTATION

Cut Back Swale
(TYP.)
Standard Drawing

REVISION DATE: 7/20/16
FILE NAME: SD_3-88



- ENGINEERING CRITERIA MANUAL
Appendix F STANDARD DRAWINGS

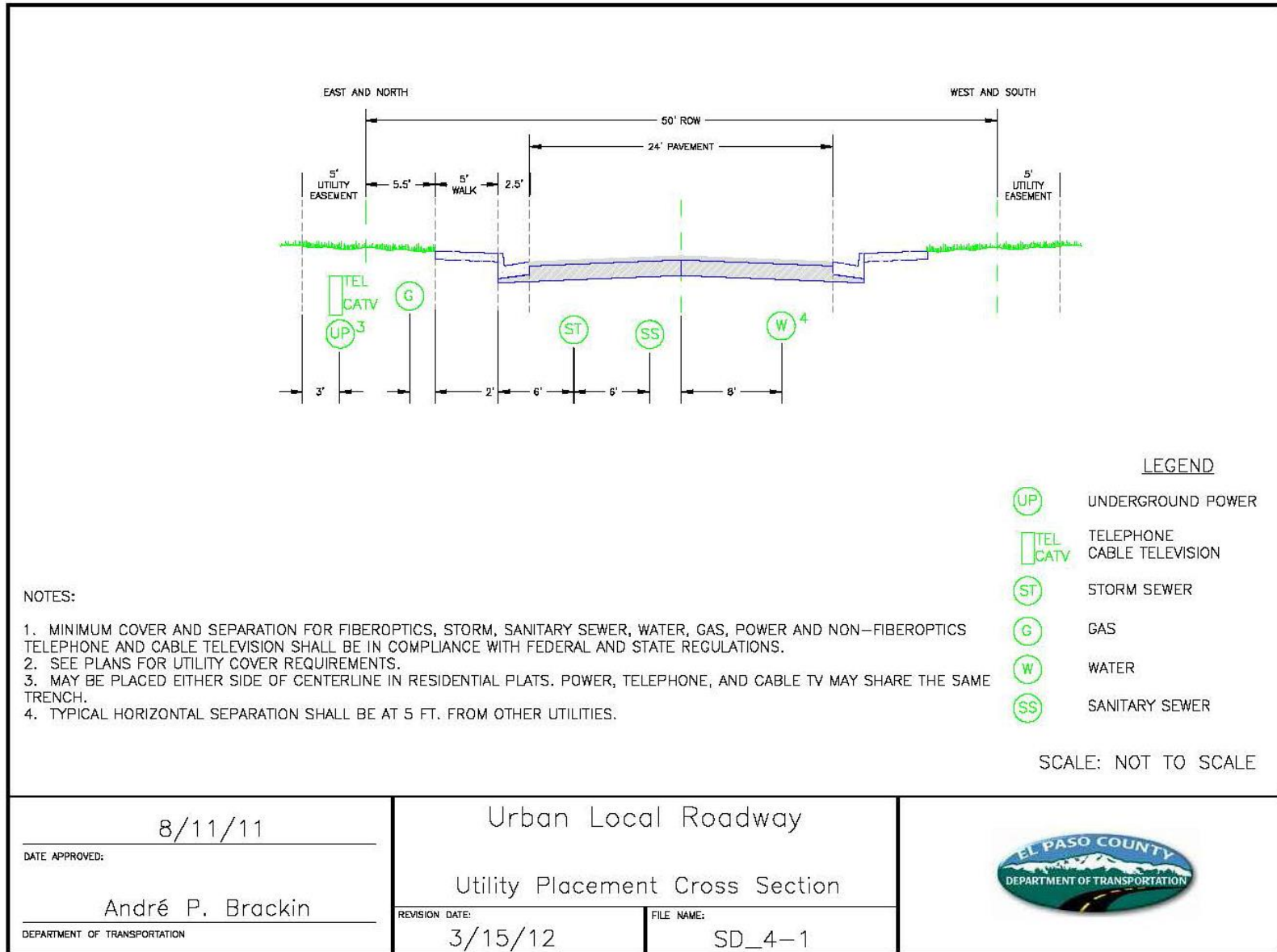

El Paso
(Supp. No. 2)

- ENGINEERING CRITERIA MANUAL
Appendix F STANDARD DRAWINGS

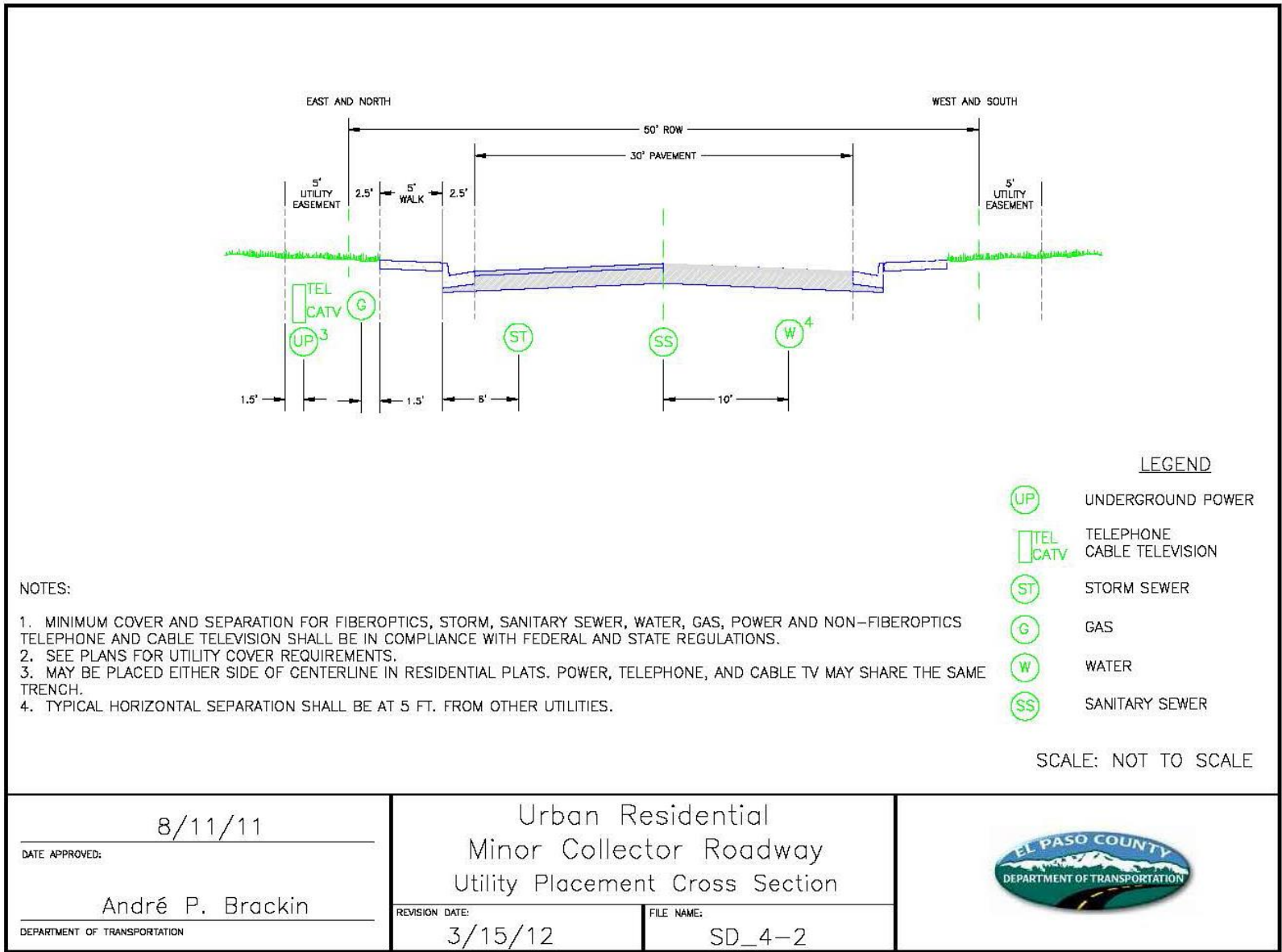

El Paso
(Supp. No. 2)

- ENGINEERING CRITERIA MANUAL
Appendix F STANDARD DRAWINGS

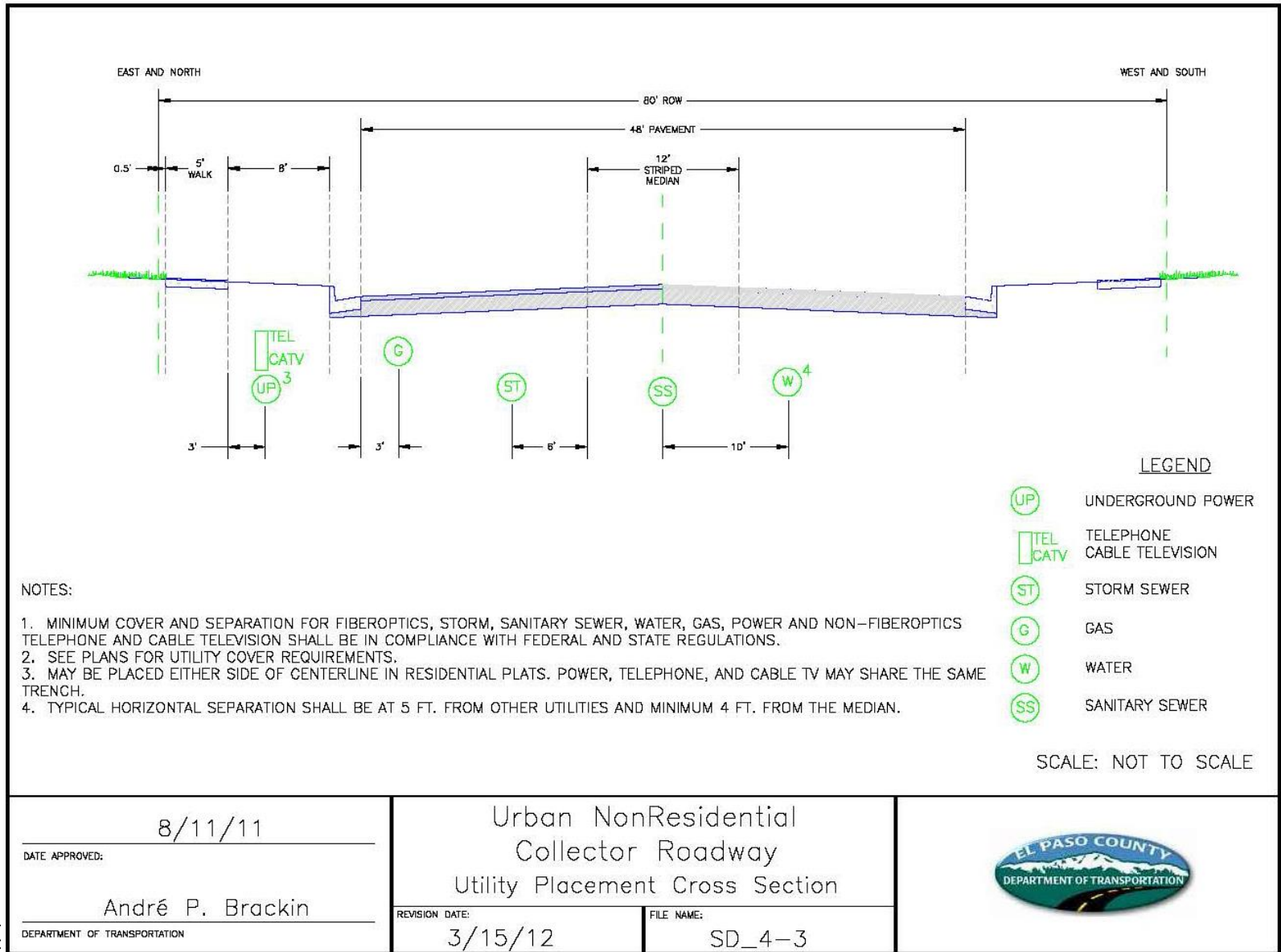

El Paso
(Supp. No. 2)

- ENGINEERING CRITERIA MANUAL
Appendix F STANDARD DRAWINGS

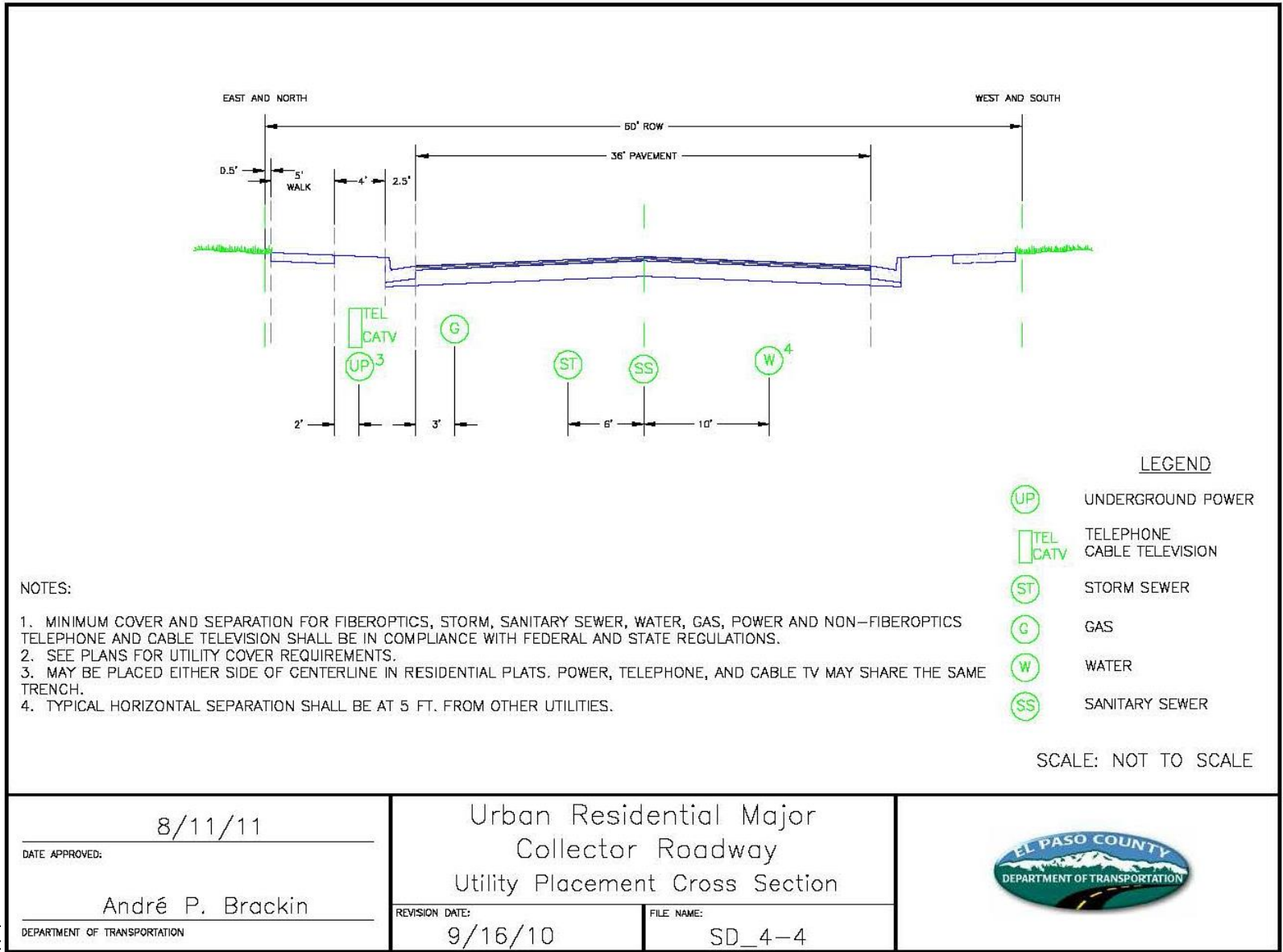

El Paso
(Supp. No. 2)

- ENGINEERING CRITERIA MANUAL
Appendix F STANDARD DRAWINGS

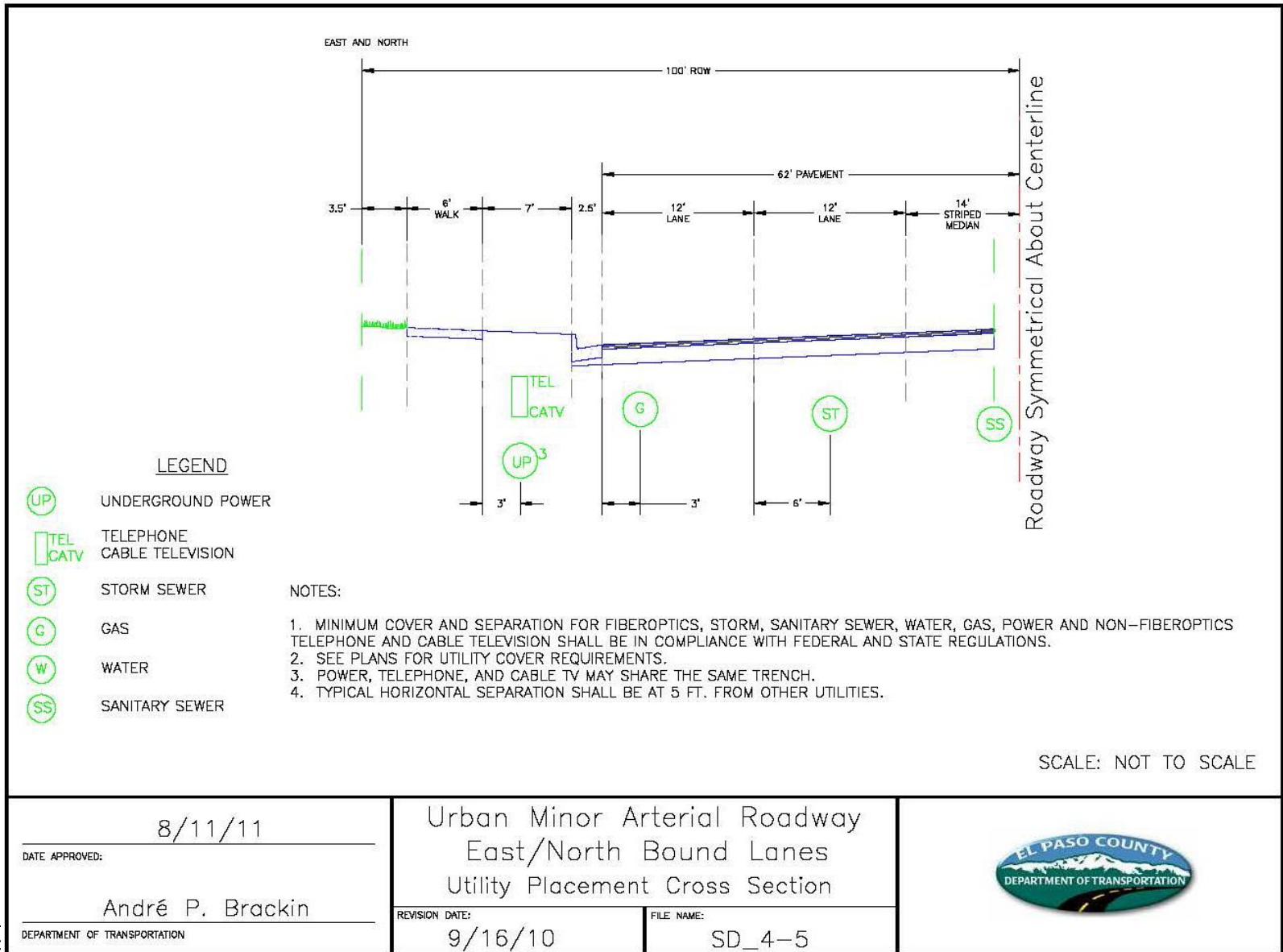

8/11/11

DATE APPROVED:

André P. Brackin

DEPARTMENT OF TRANSPORTATION

Urban Minor Arterial Roadway
East/North Bound Lanes
Utility Placement Cross Section

REVISION DATE: 9/16/10

FILE NAME: SD_4-5



El Pas
(Supp. No. 2)

- ENGINEERING CRITERIA MANUAL
Appendix F STANDARD DRAWINGS

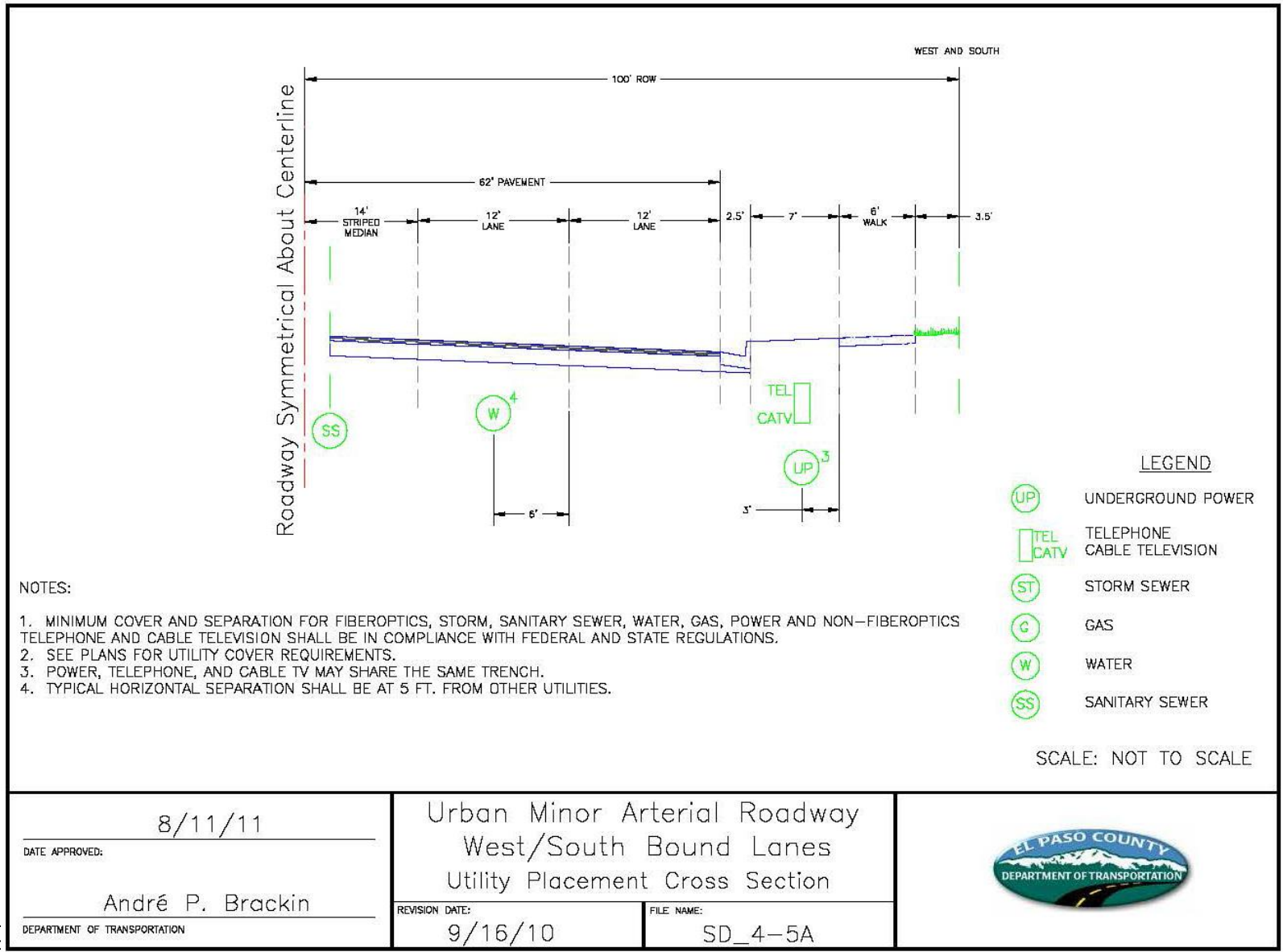

El Paso
(Supp. No. 2)

- ENGINEERING CRITERIA MANUAL
Appendix F STANDARD DRAWINGS

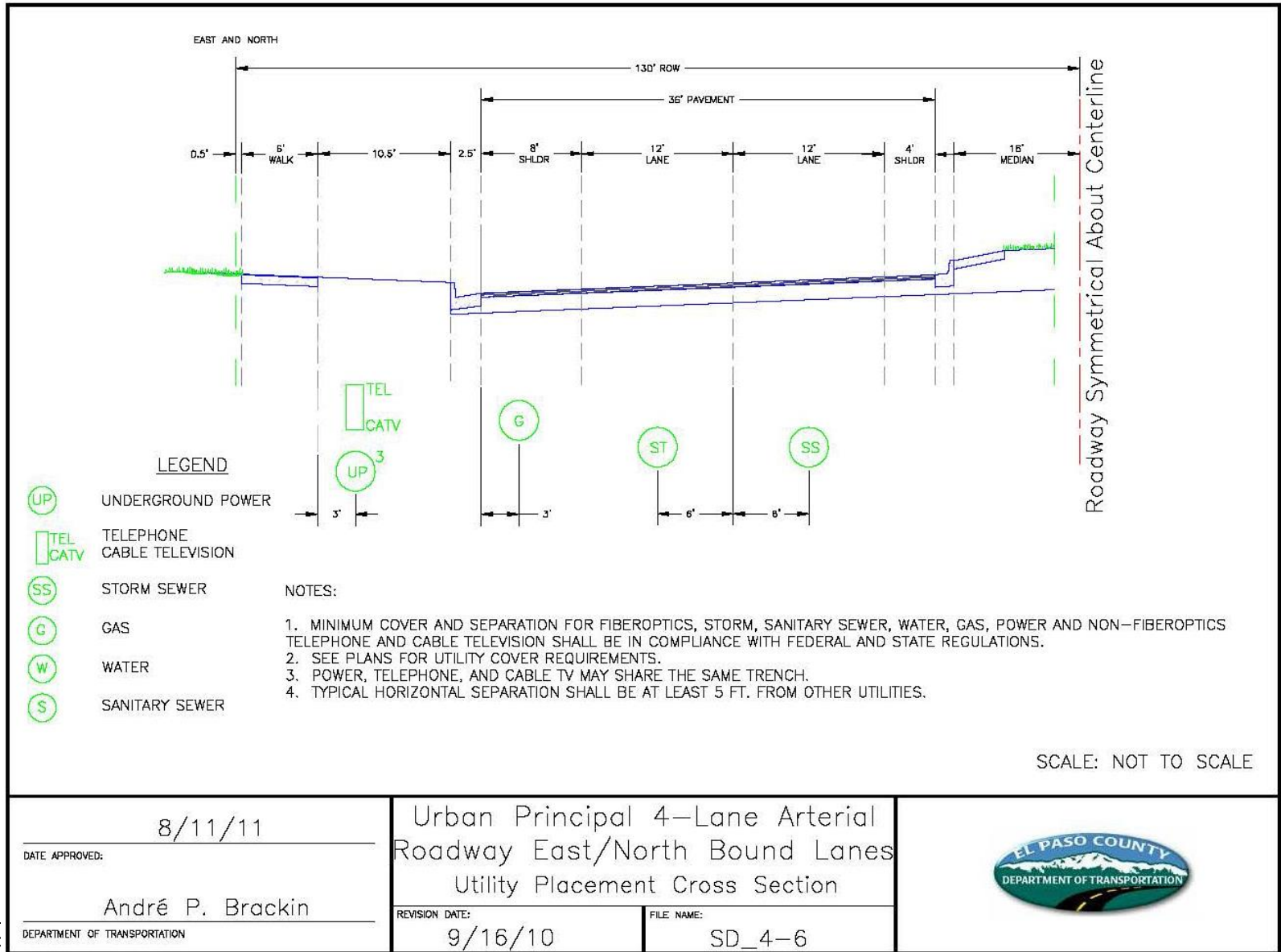

El Pas
(Supp. No. 2)

- ENGINEERING CRITERIA MANUAL
Appendix F STANDARD DRAWINGS

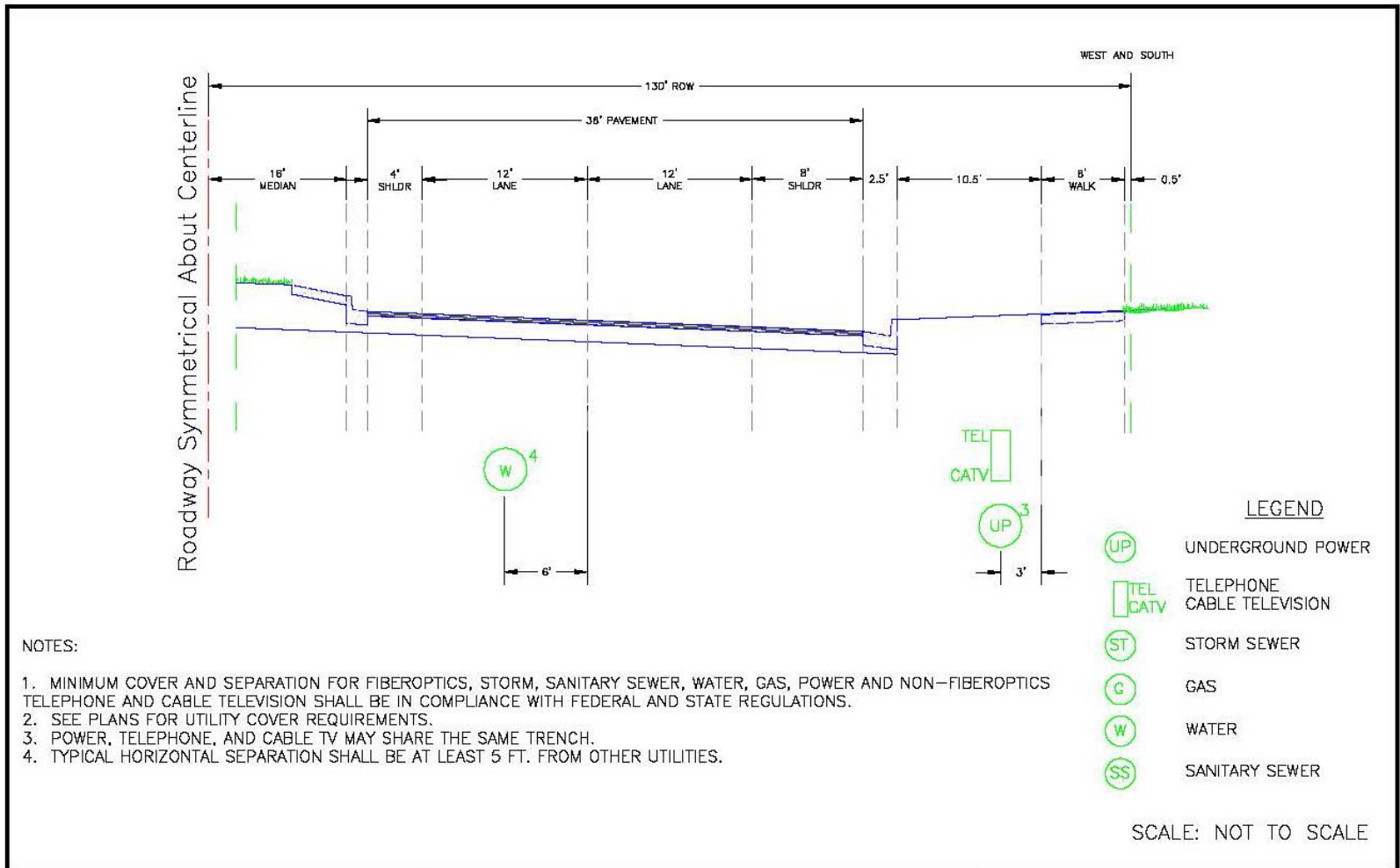

NOTES:

1. MINIMUM COVER AND SEPARATION FOR FIBEROPTICS, STORM, SANITARY SEWER, WATER, GAS, POWER AND NON-FIBEROPTICS TELEPHONE AND CABLE TELEVISION SHALL BE IN COMPLIANCE WITH FEDERAL AND STATE REGULATIONS.
2. SEE PLANS FOR UTILITY COVER REQUIREMENTS.
3. POWER, TELEPHONE, AND CABLE TV MAY SHARE THE SAME TRENCH.
4. TYPICAL HORIZONTAL SEPARATION SHALL BE AT LEAST 5 FT. FROM OTHER UTILITIES.

<p align="center">8/11/11</p> <p>DATE APPROVED:</p> <p align="center">André P. Brackin</p> <p>DEPARTMENT OF TRANSPORTATION</p>	<p align="center">Urban Principal 4-Lane Arterial Roadway West/South Bound Lanes Utility Placement Cross Section</p> <p>REVISION DATE: 9/16/10</p> <p>FILE NAME: SD_4-6A</p>	
--	--	---

El Paso
(Supp. No. 2)

- ENGINEERING CRITERIA MANUAL
Appendix F STANDARD DRAWINGS

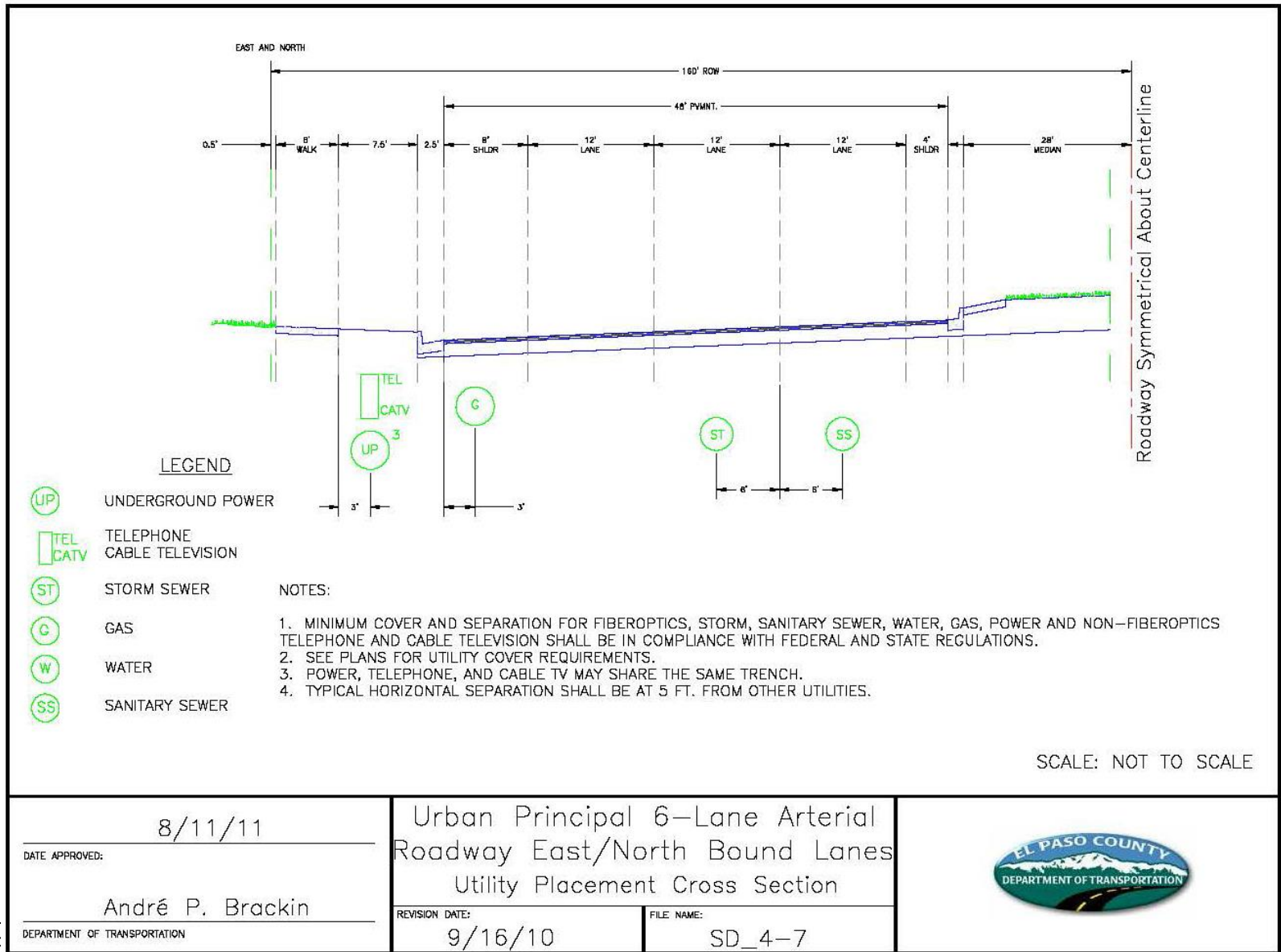

El Pas
(Supp. No. 2)

- ENGINEERING CRITERIA MANUAL
Appendix F STANDARD DRAWINGS

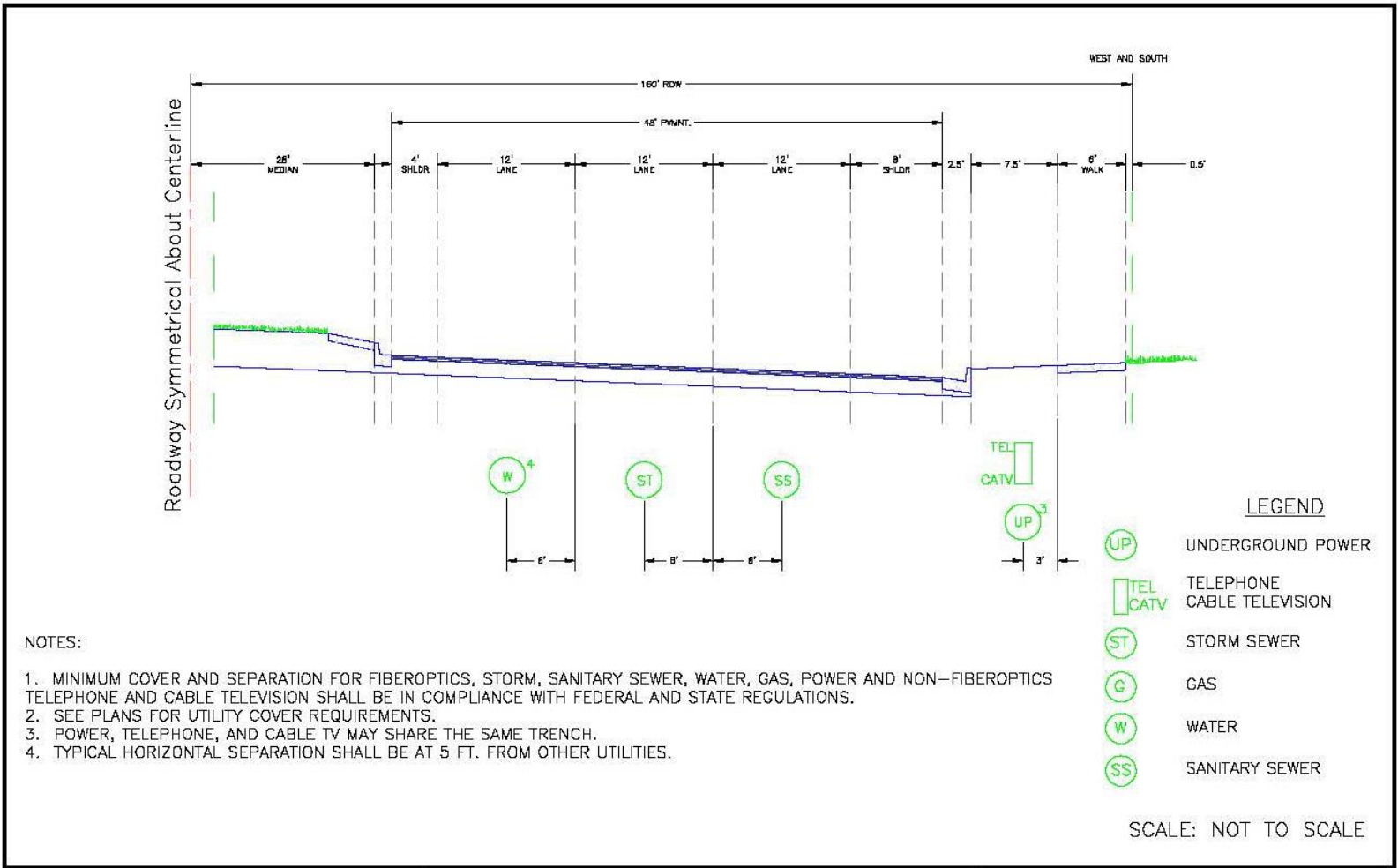

NOTES:

1. MINIMUM COVER AND SEPARATION FOR FIBEROPTICS, STORM, SANITARY SEWER, WATER, GAS, POWER AND NON-FIBEROPTICS TELEPHONE AND CABLE TELEVISION SHALL BE IN COMPLIANCE WITH FEDERAL AND STATE REGULATIONS.
2. SEE PLANS FOR UTILITY COVER REQUIREMENTS.
3. POWER, TELEPHONE, AND CABLE TV MAY SHARE THE SAME TRENCH.
4. TYPICAL HORIZONTAL SEPARATION SHALL BE AT 5 FT. FROM OTHER UTILITIES.

<p align="center">8/11/11</p> <p>DATE APPROVED:</p> <p align="center">André P. Brackin</p> <p>DEPARTMENT OF TRANSPORTATION</p>	<p align="center">Urban Principal 6-Lane Arterial Roadway West/South Bound Lanes Utility Placement Cross Section</p> <p>REVISION DATE: 9/16/10</p> <p>FILE NAME: SD_4-7A</p>	
--	--	---

El Paso
(Supp. No. 2)

- ENGINEERING CRITERIA MANUAL
Appendix F STANDARD DRAWINGS

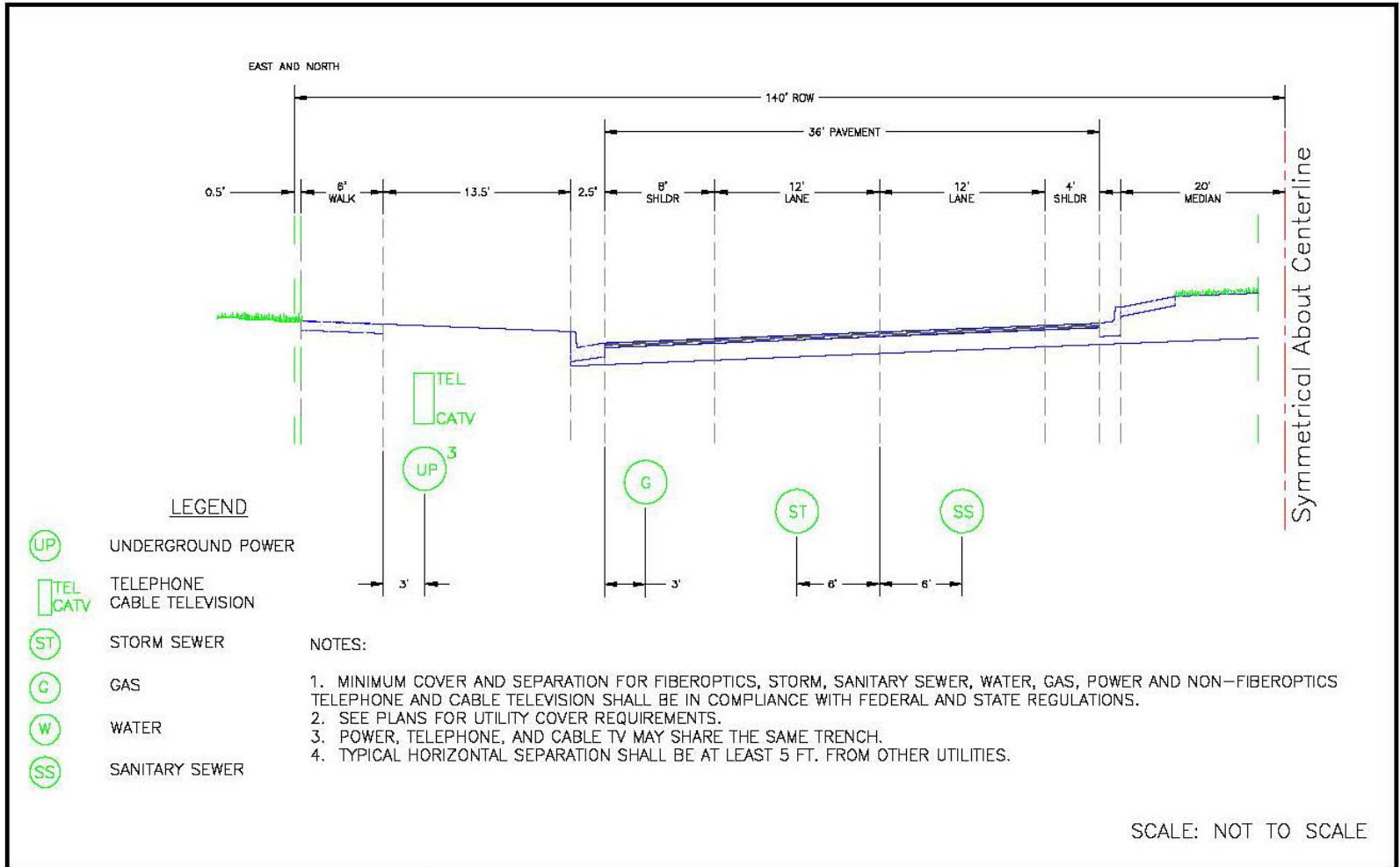

<p align="center">8/11/11</p> <p>DATE APPROVED:</p> <p align="center">André P. Brackin</p> <p>DEPARTMENT OF TRANSPORTATION</p>	<p align="center">Urban Expressway 4-Lane Roadway East/North Bound Lanes Utility Placement Cross Section</p>	
<p>REVISION DATE: 9/16/10</p>	<p>FILE NAME: SD_4-8</p>	

El Paso
(Supp. No. 2)

- ENGINEERING CRITERIA MANUAL
Appendix F STANDARD DRAWINGS

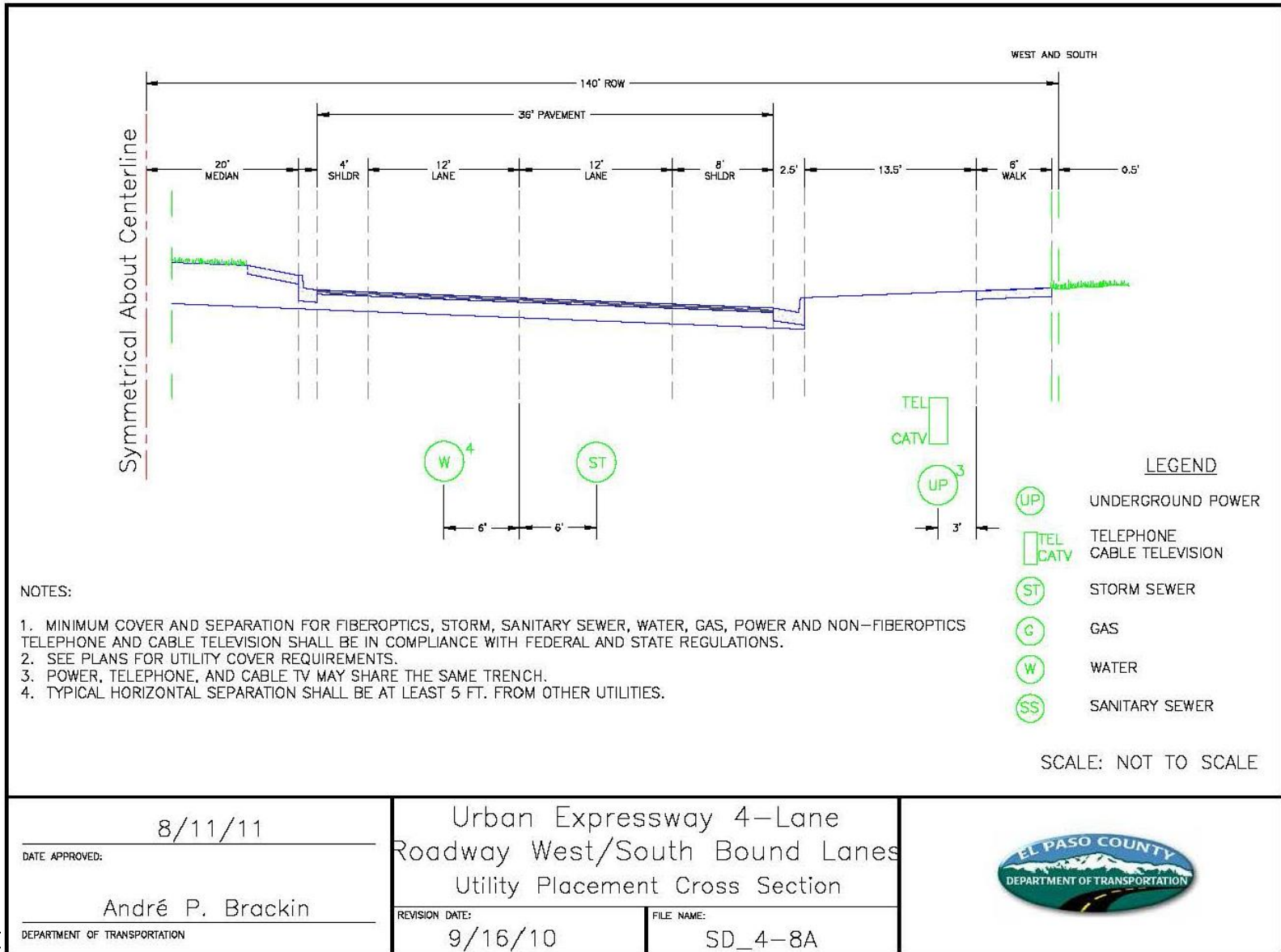

El Paso
(Supp. No. 2)

- ENGINEERING CRITERIA MANUAL
Appendix F STANDARD DRAWINGS

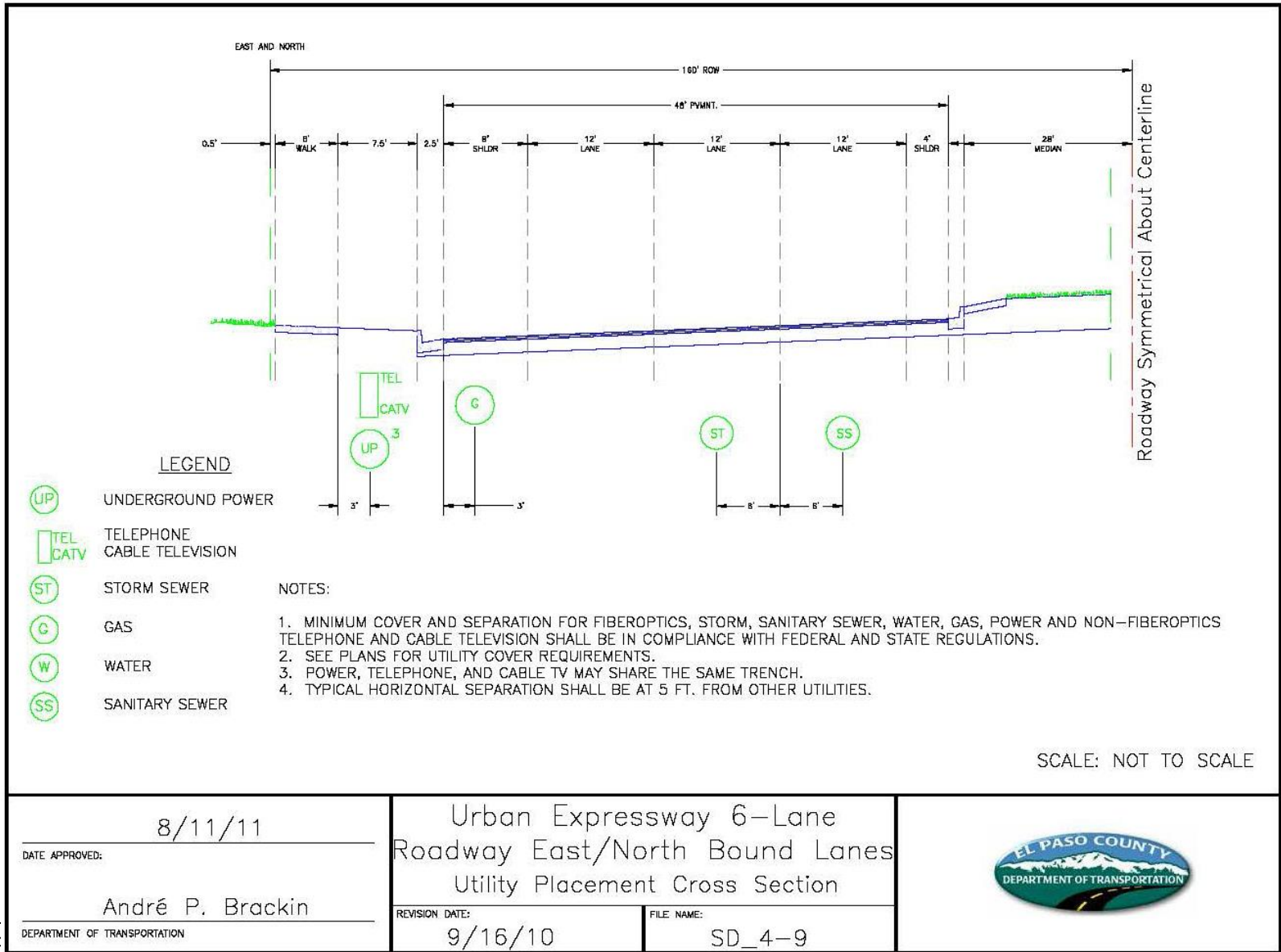

El Pas
(Supp. No. 2)

- ENGINEERING CRITERIA MANUAL
Appendix F STANDARD DRAWINGS

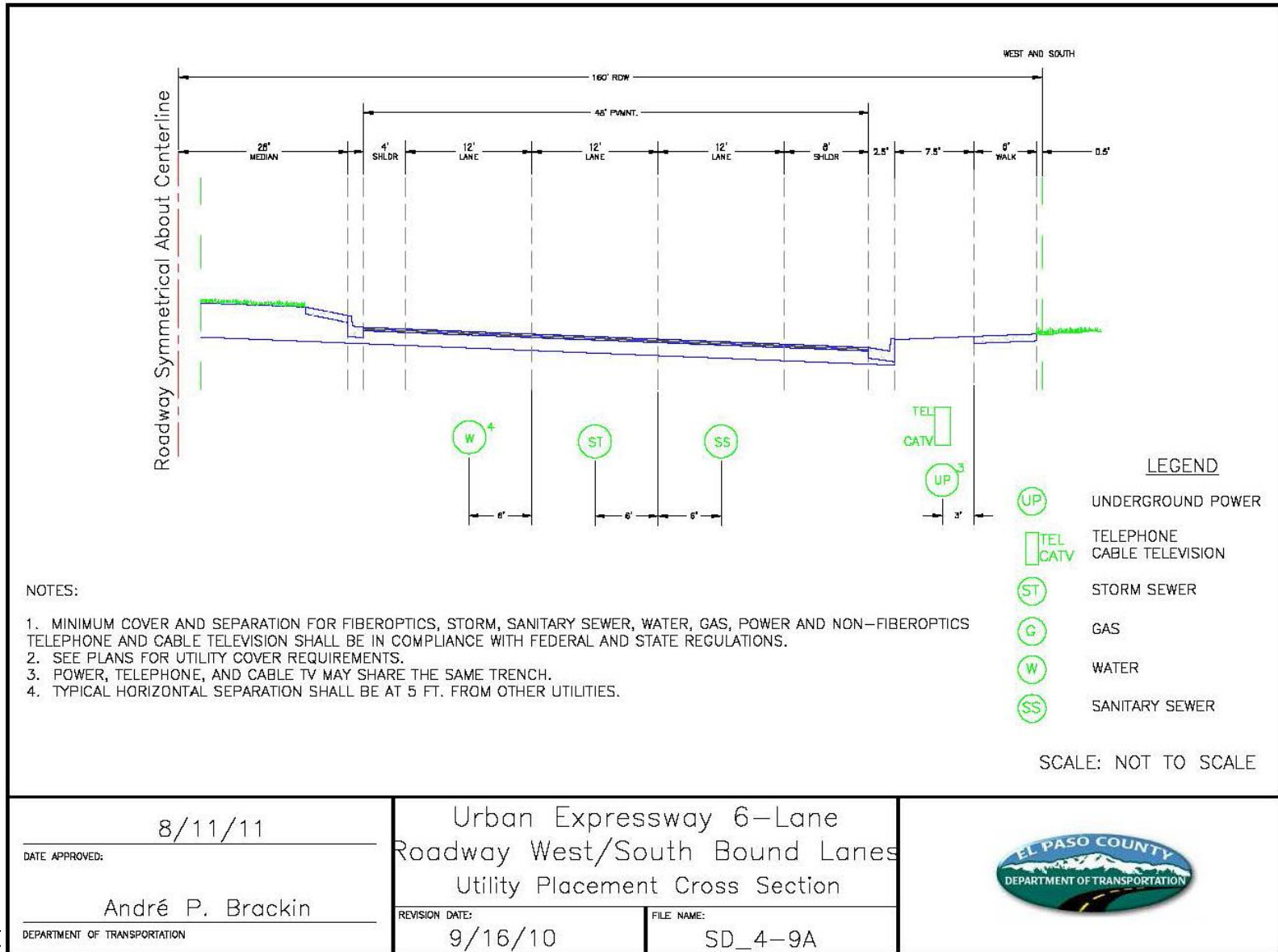

El Paso
(Supp. No. 2)

- ENGINEERING CRITERIA MANUAL
Appendix F STANDARD DRAWINGS

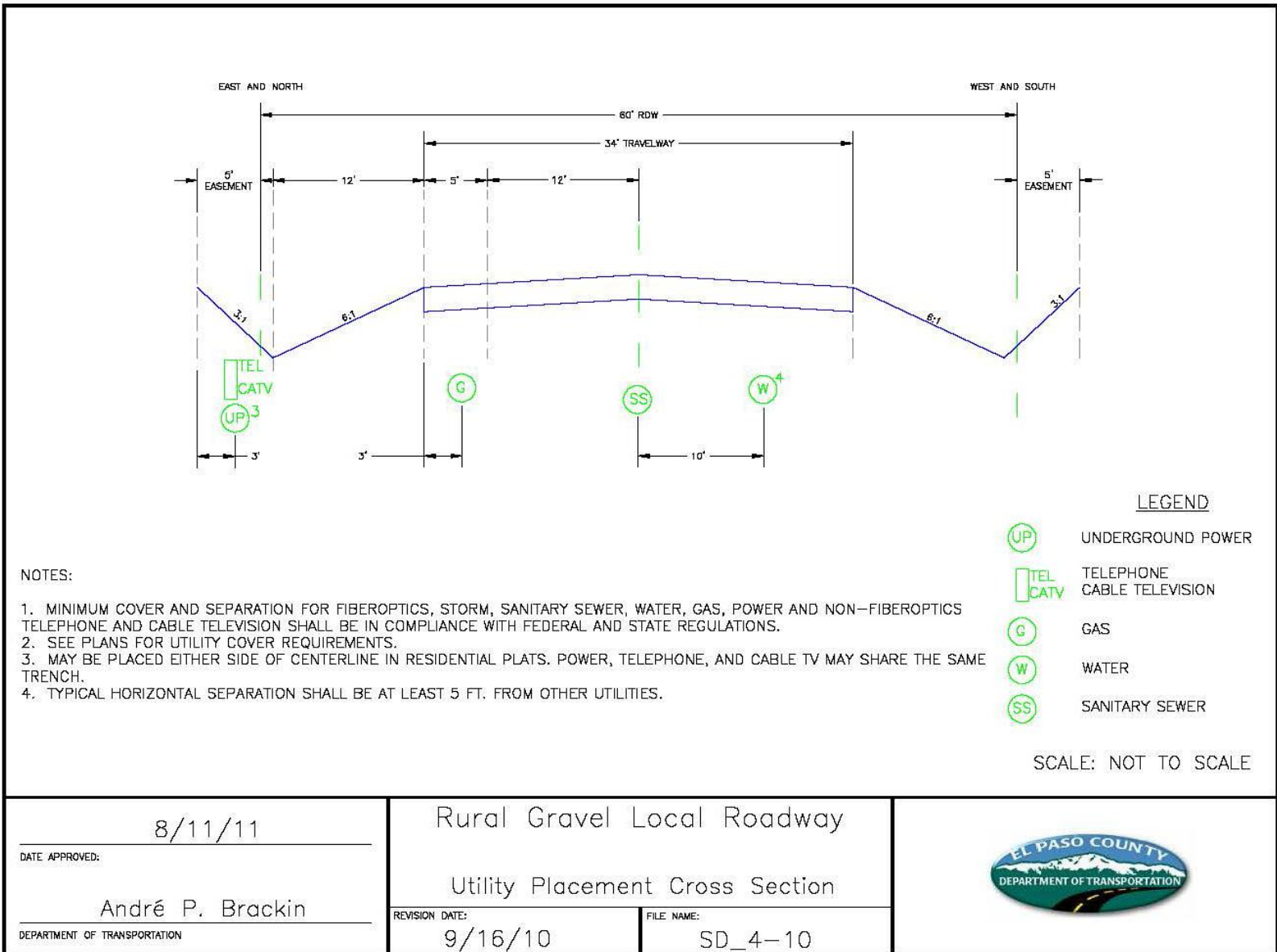

El Paso
(Supp. No. 2)

- ENGINEERING CRITERIA MANUAL
Appendix F STANDARD DRAWINGS

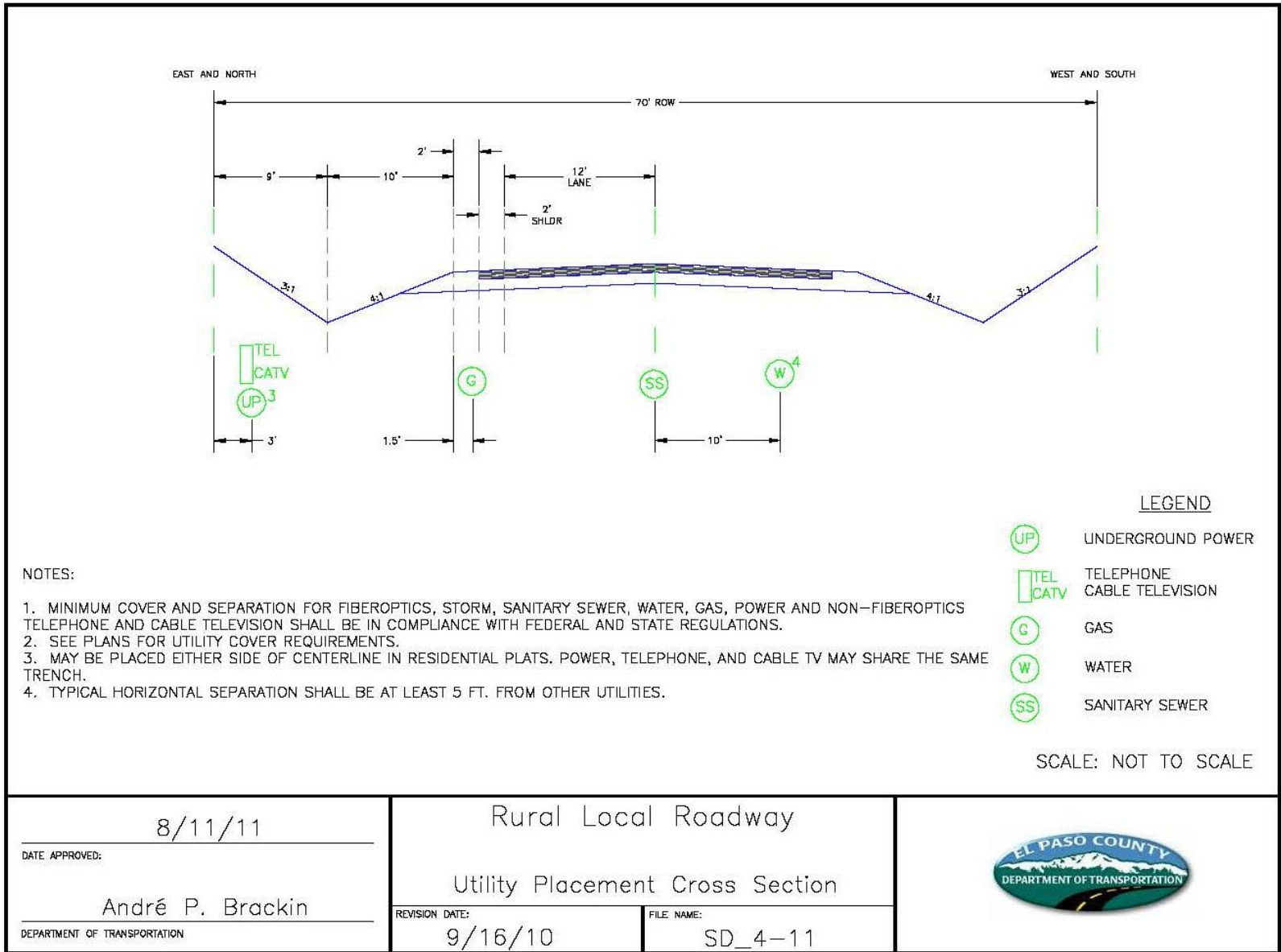

El Paso
(Supp. No. 2)

- ENGINEERING CRITERIA MANUAL
Appendix F STANDARD DRAWINGS

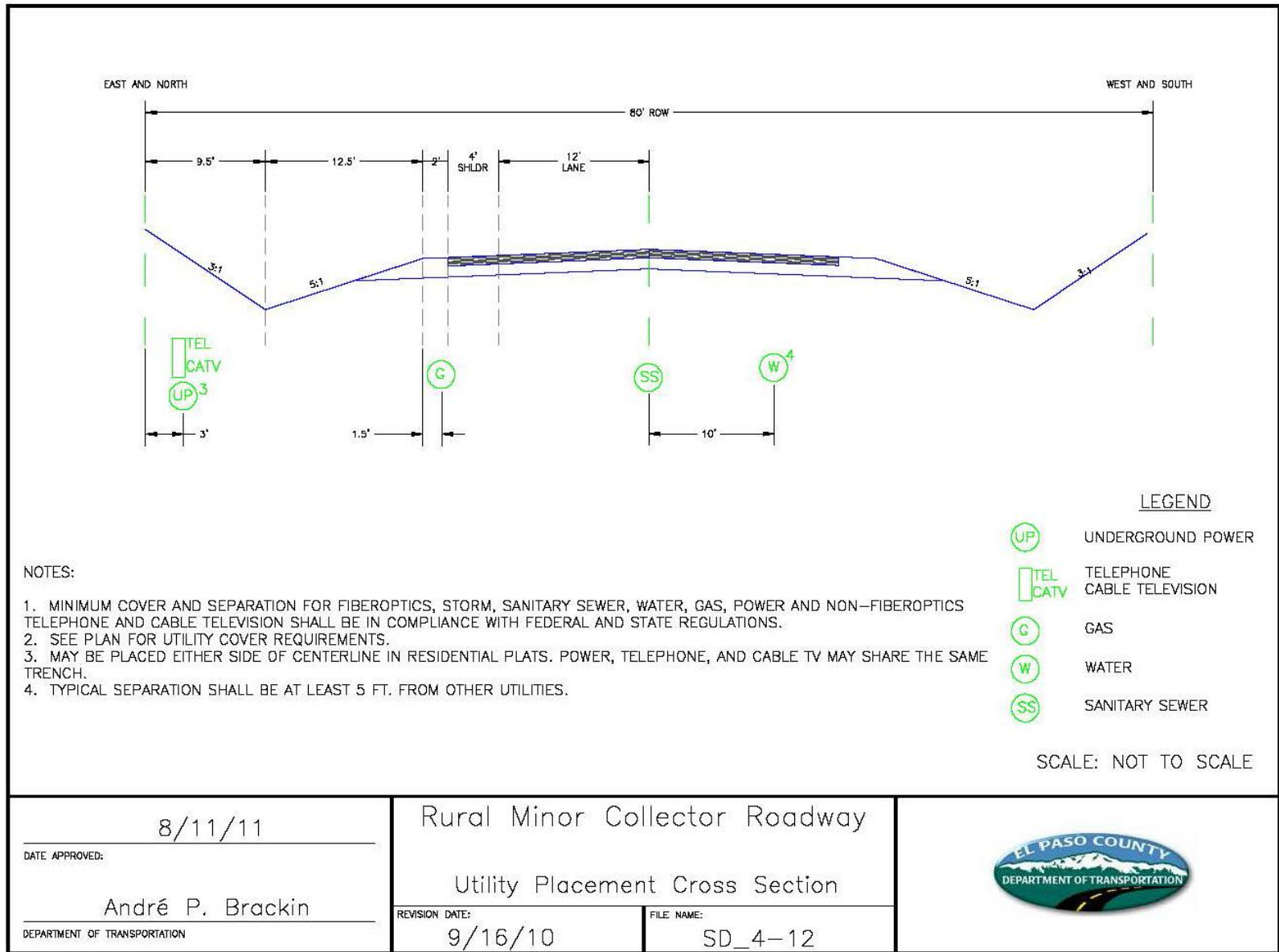

El Paso
(Supp. No. 2)

- ENGINEERING CRITERIA MANUAL
Appendix F STANDARD DRAWINGS

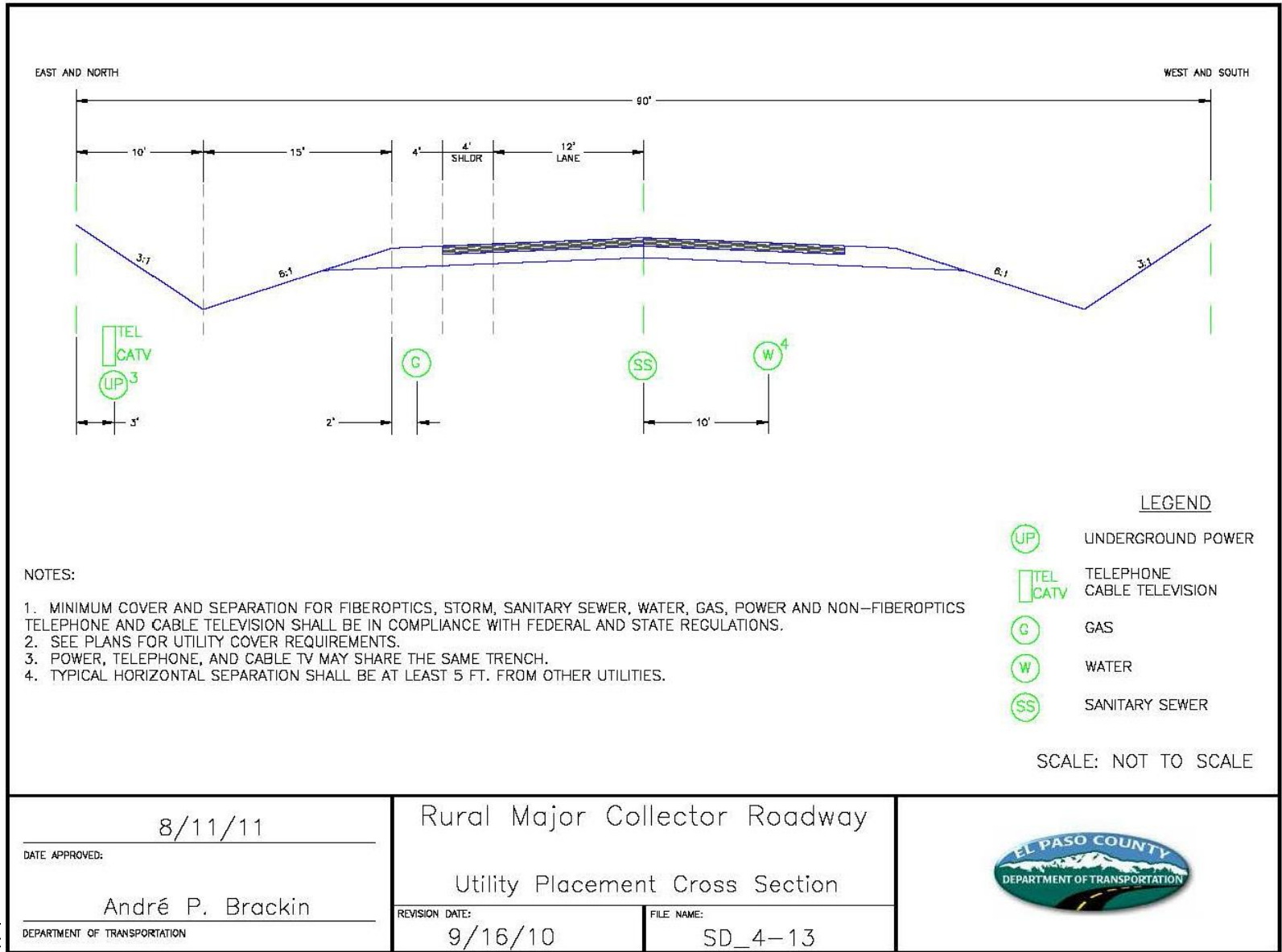

El Paso
(Supp. No. 2)

- ENGINEERING CRITERIA MANUAL
Appendix F STANDARD DRAWINGS

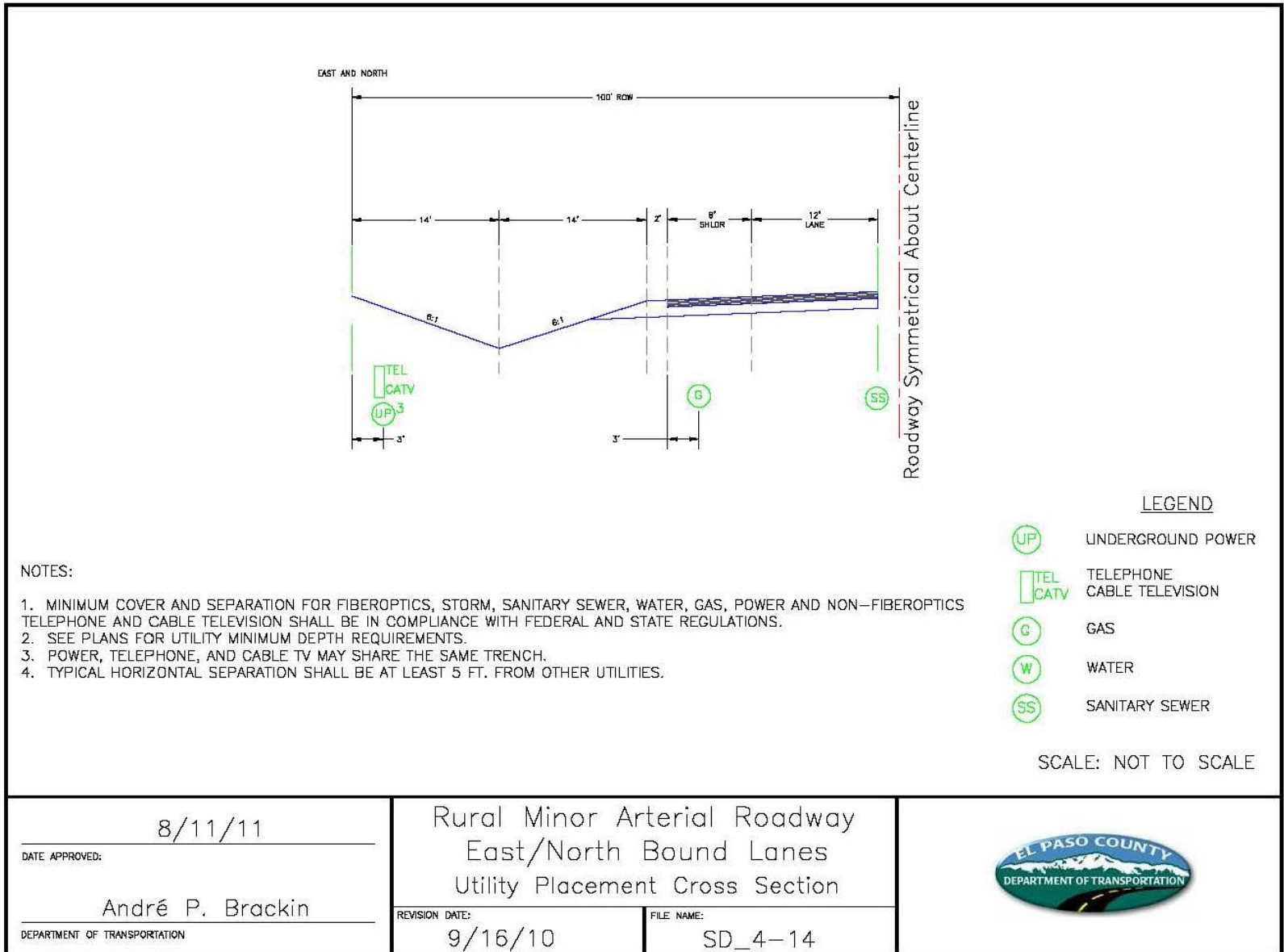

- ENGINEERING CRITERIA MANUAL
Appendix F STANDARD DRAWINGS

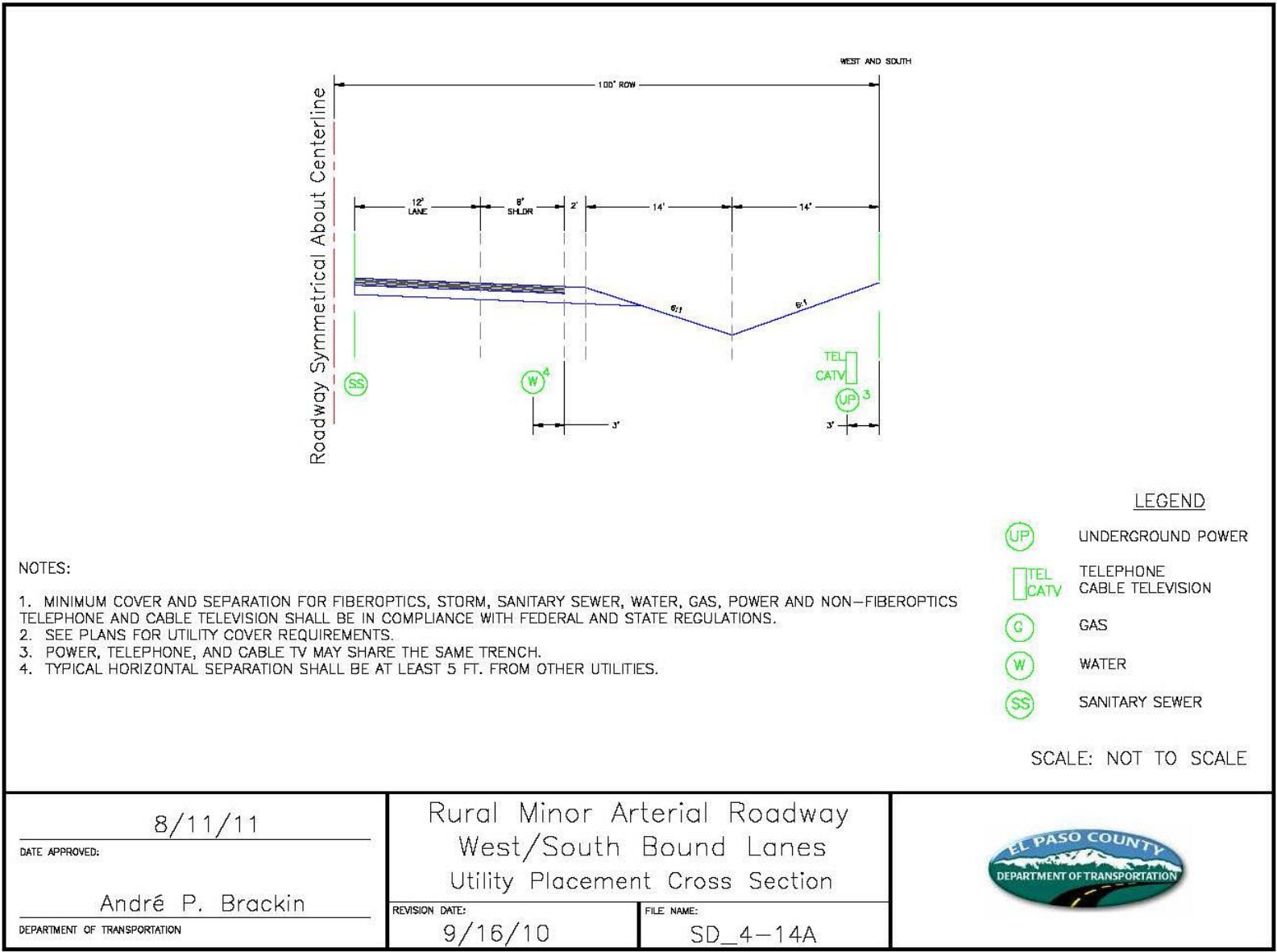

El Paso
(Supp. No. 2)

- ENGINEERING CRITERIA MANUAL
Appendix F STANDARD DRAWINGS

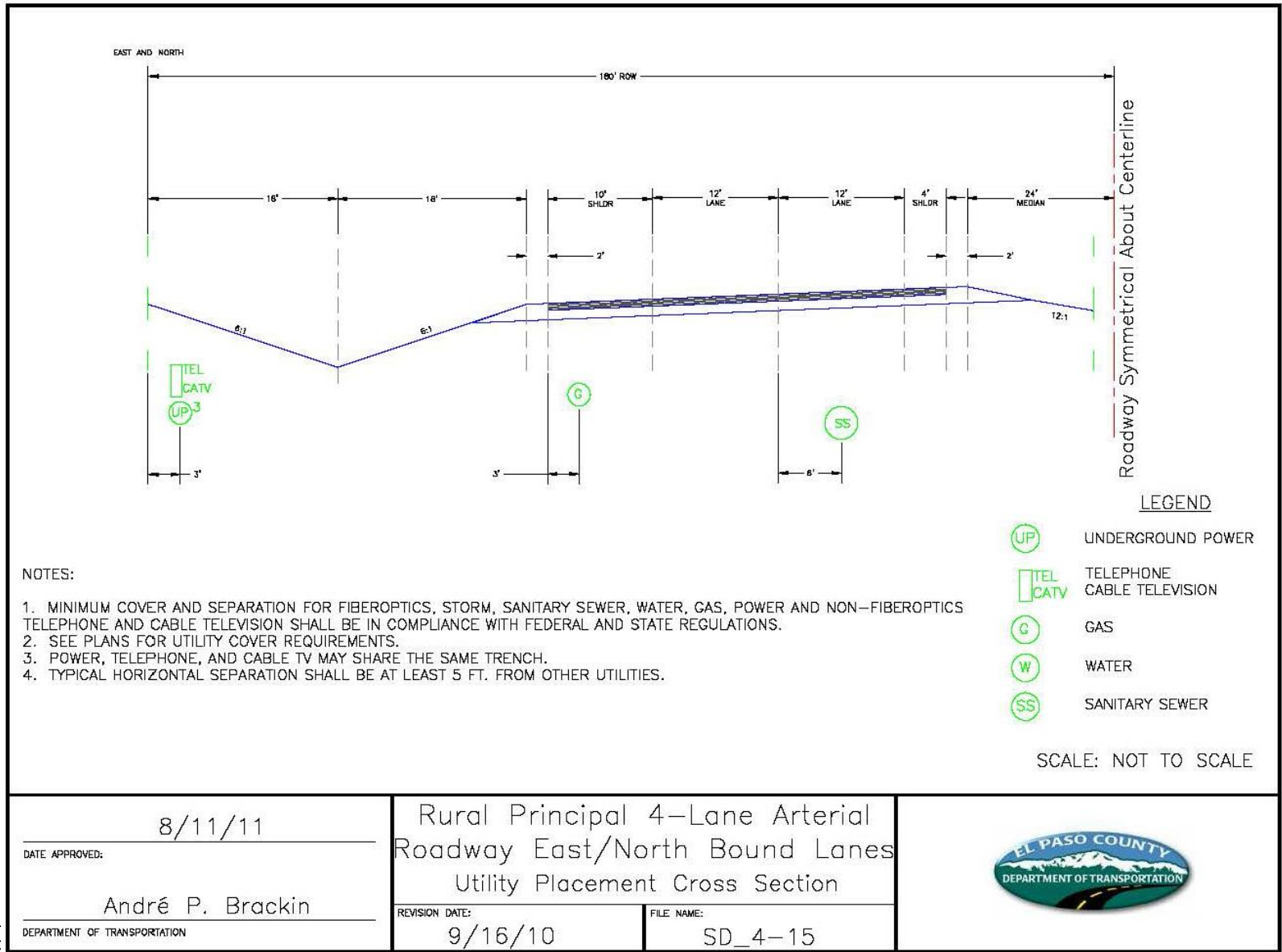

El Paso
(Supp. No. 2)

- ENGINEERING CRITERIA MANUAL
Appendix F STANDARD DRAWINGS

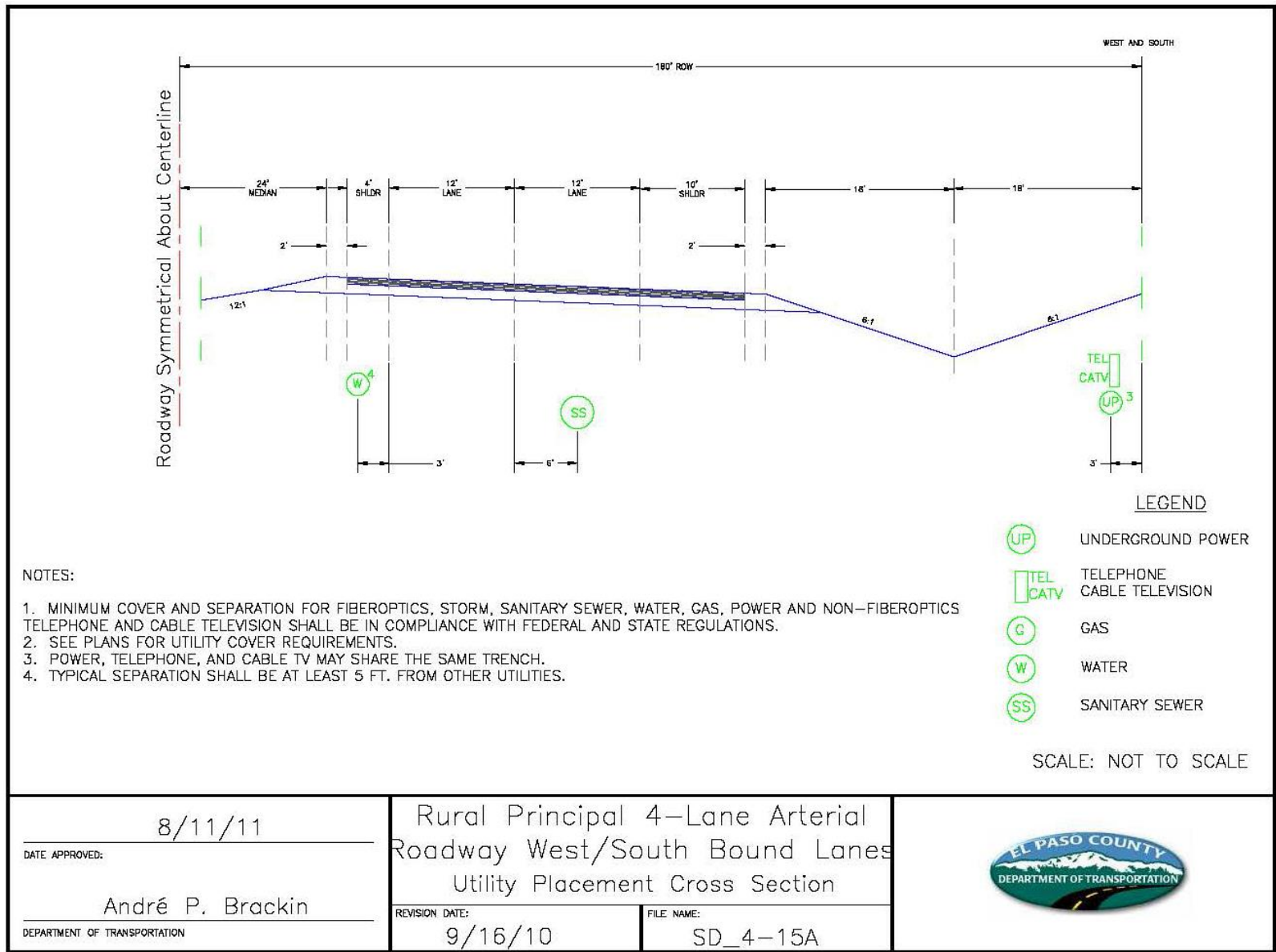

El Paso
(Supp. No. 2)

- ENGINEERING CRITERIA MANUAL
Appendix F STANDARD DRAWINGS

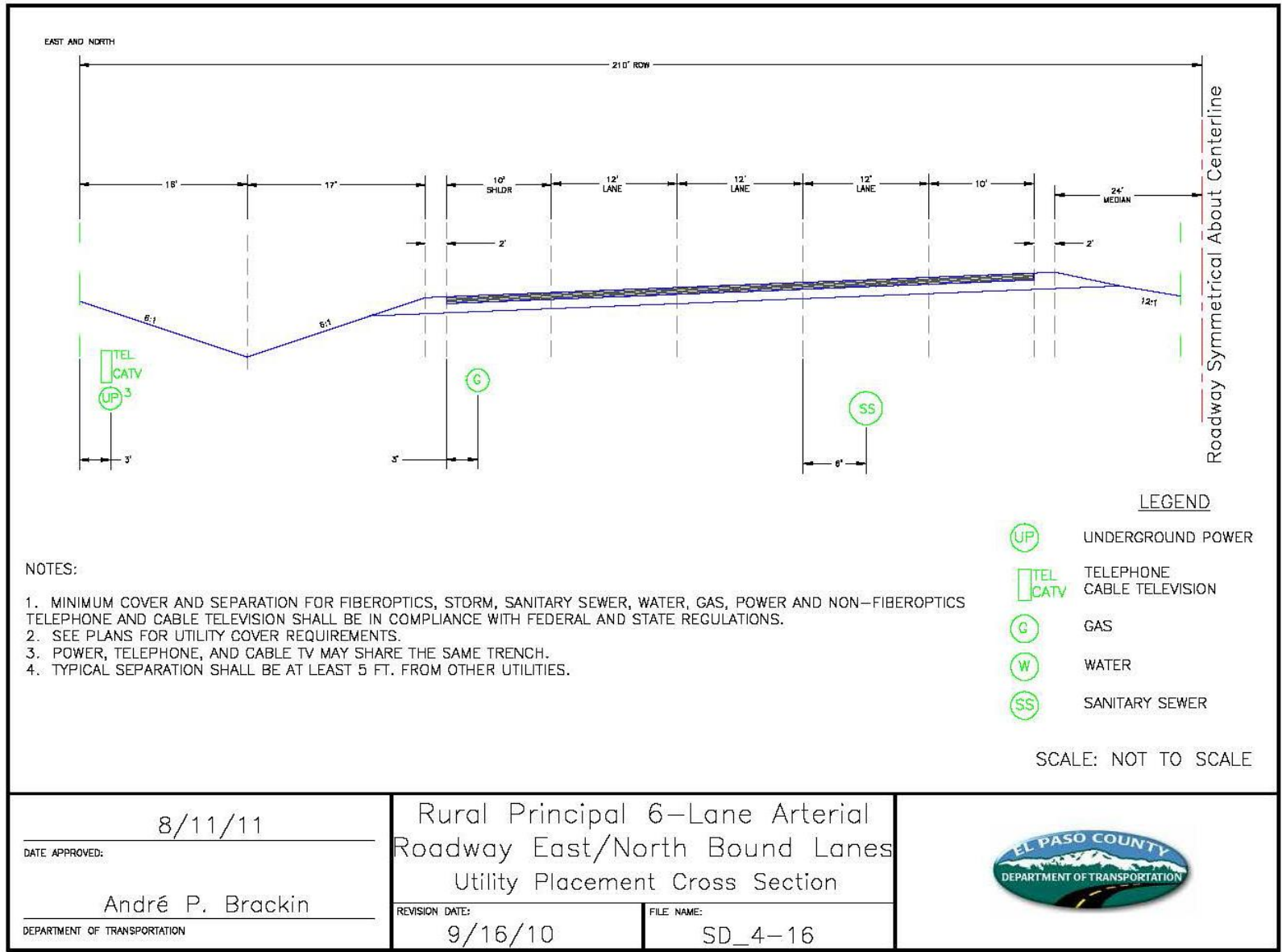

El Paso
(Supp. No. 2)

- ENGINEERING CRITERIA MANUAL
Appendix F STANDARD DRAWINGS

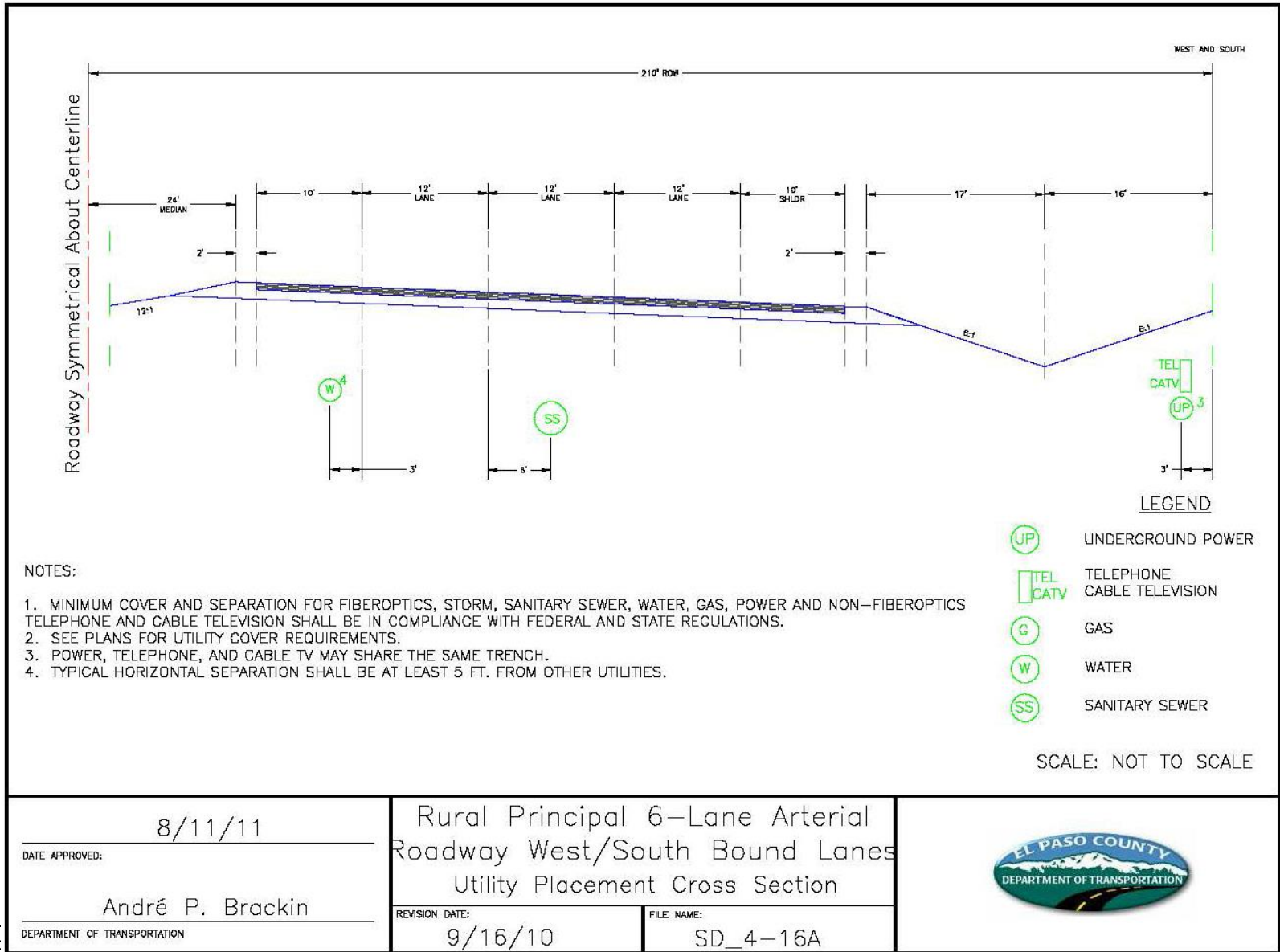

El Paso
(Supp. No. 2)

- ENGINEERING CRITERIA MANUAL
Appendix F STANDARD DRAWINGS

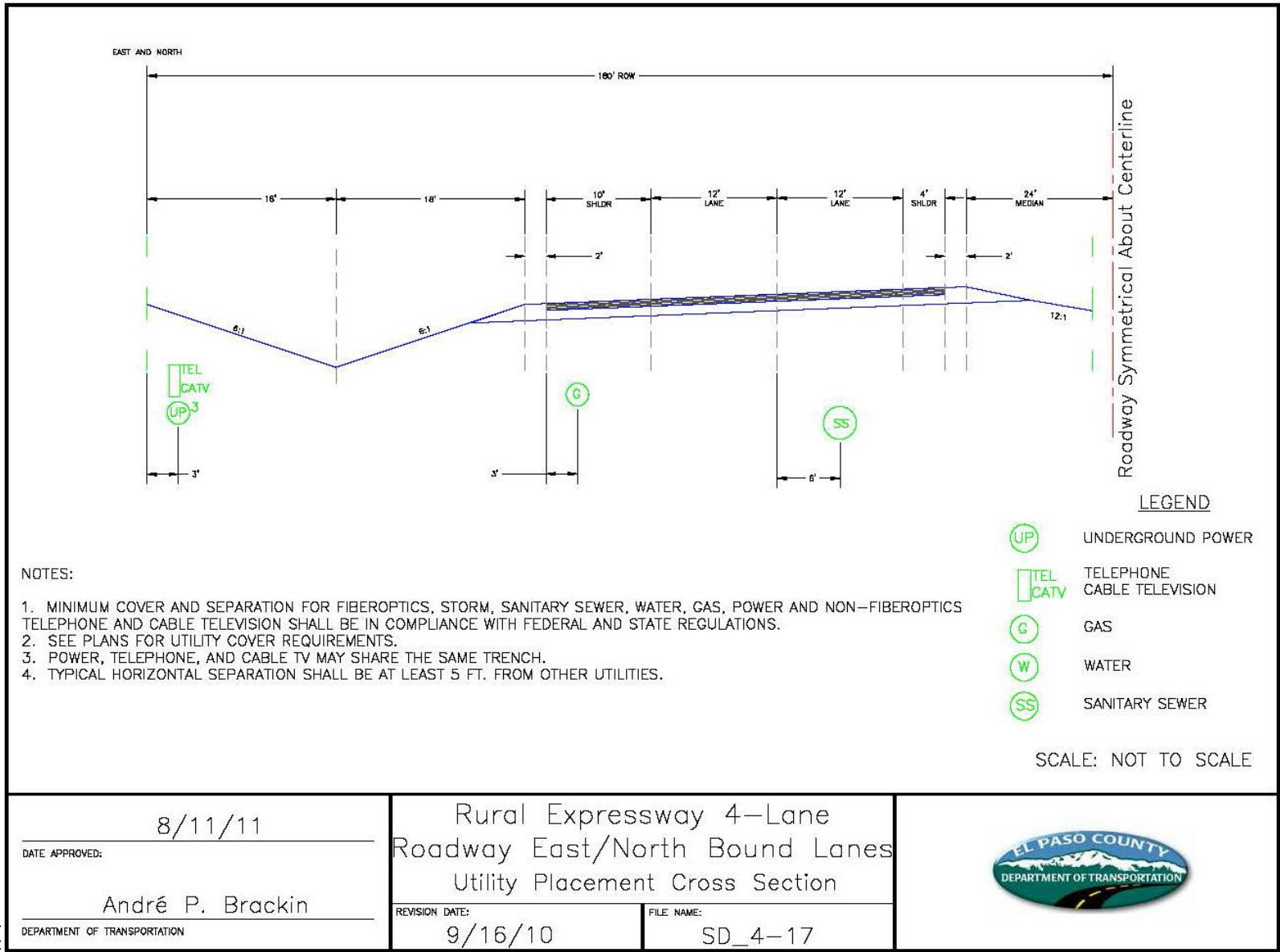

El Paso
(Supp. No. 2)

- ENGINEERING CRITERIA MANUAL
Appendix F STANDARD DRAWINGS

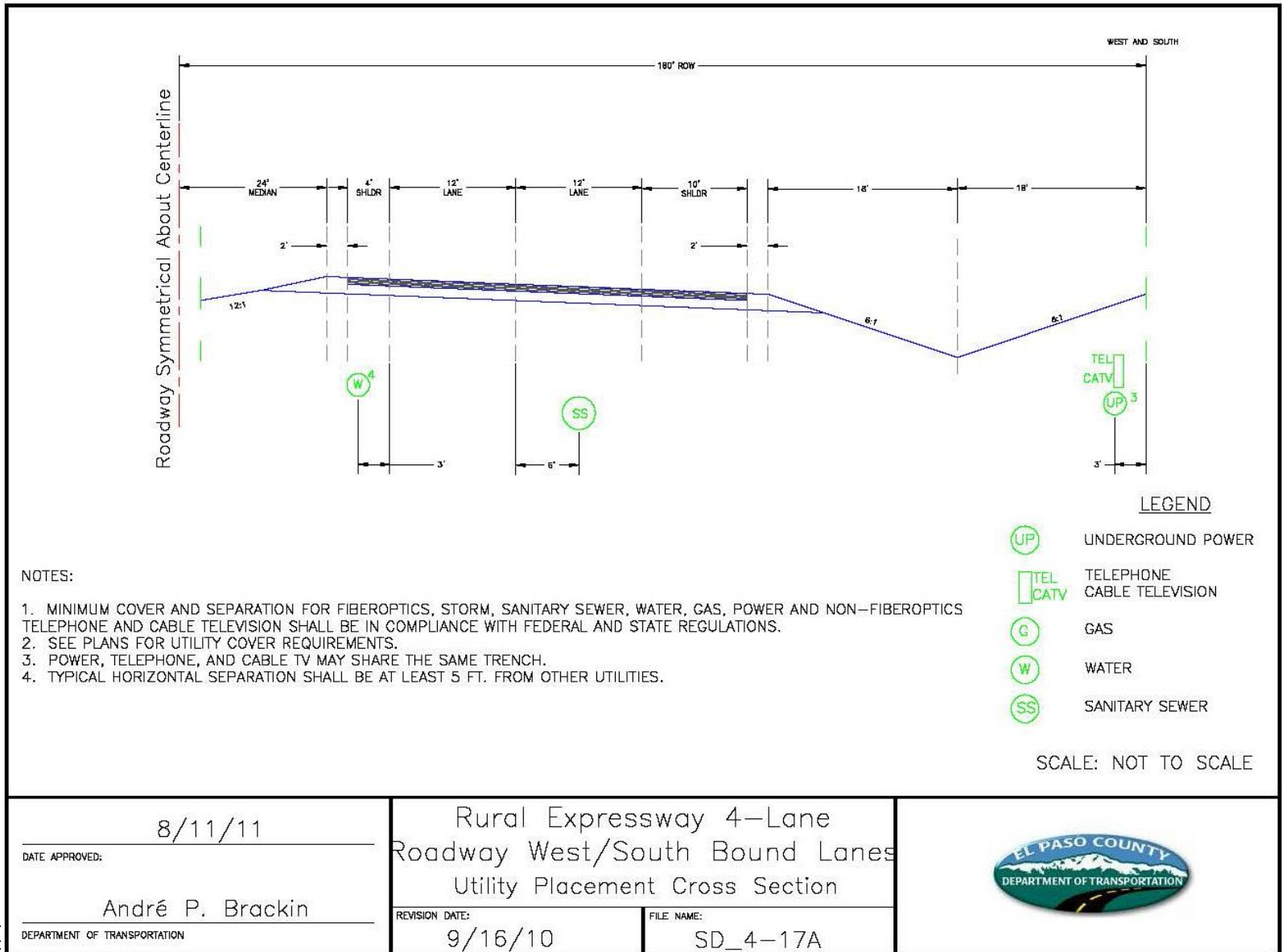

El Paso
(Supp. No. 2)

- ENGINEERING CRITERIA MANUAL
Appendix F STANDARD DRAWINGS

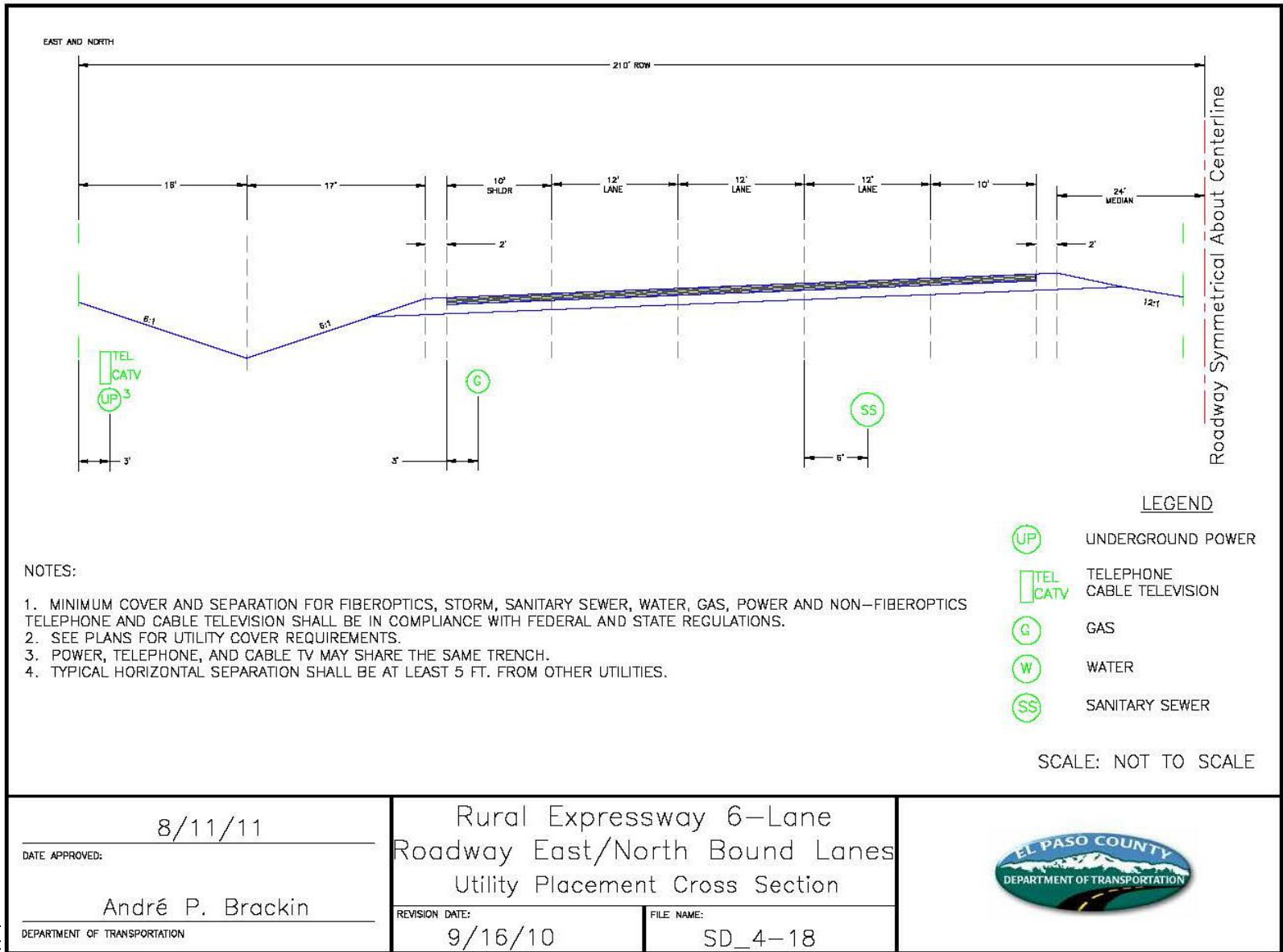

El Paso
(Supp. No. 2)

- ENGINEERING CRITERIA MANUAL
Appendix F STANDARD DRAWINGS

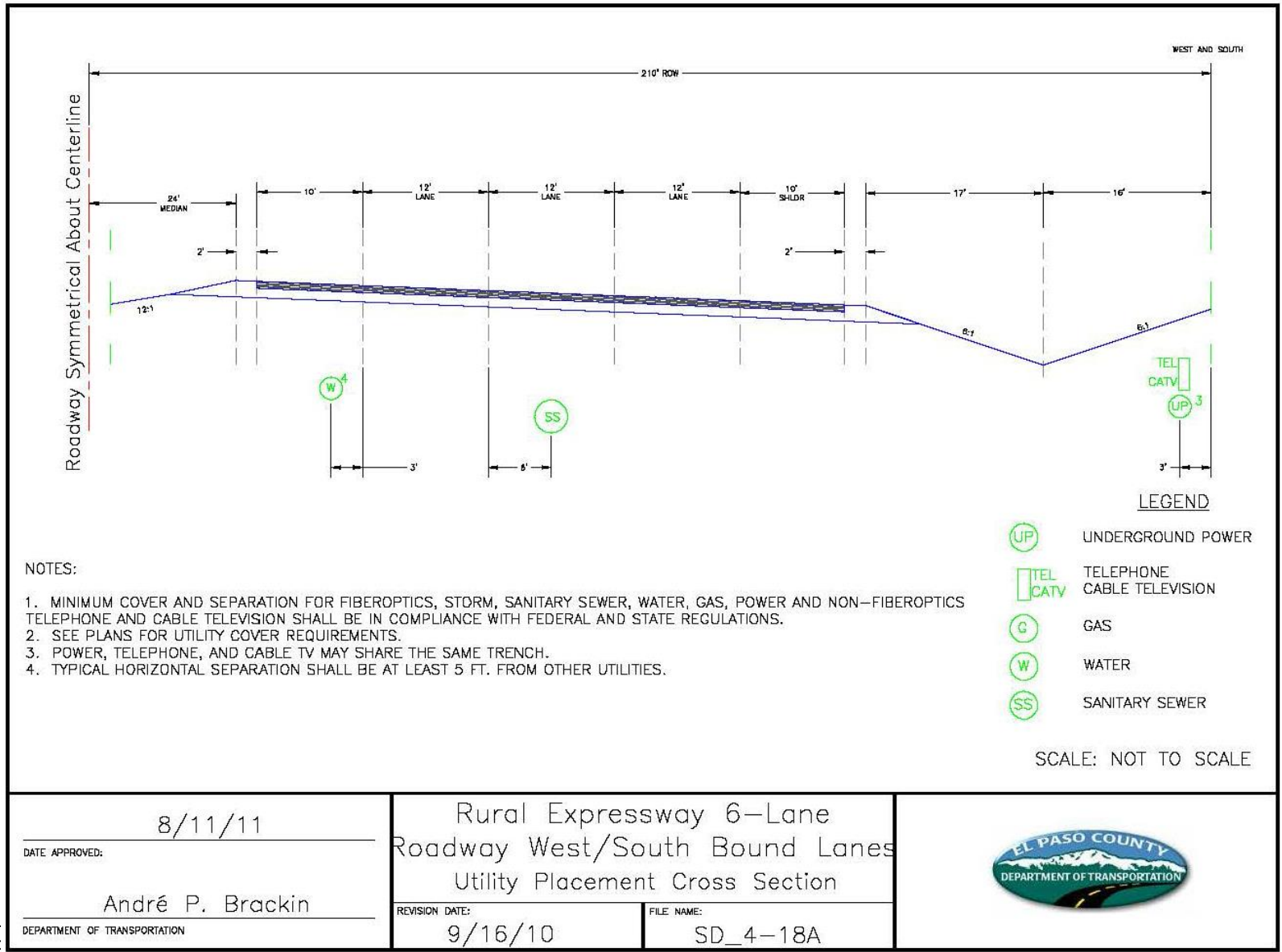

El Paso
(Supp. No. 2)

- ENGINEERING CRITERIA MANUAL
Appendix F STANDARD DRAWINGS

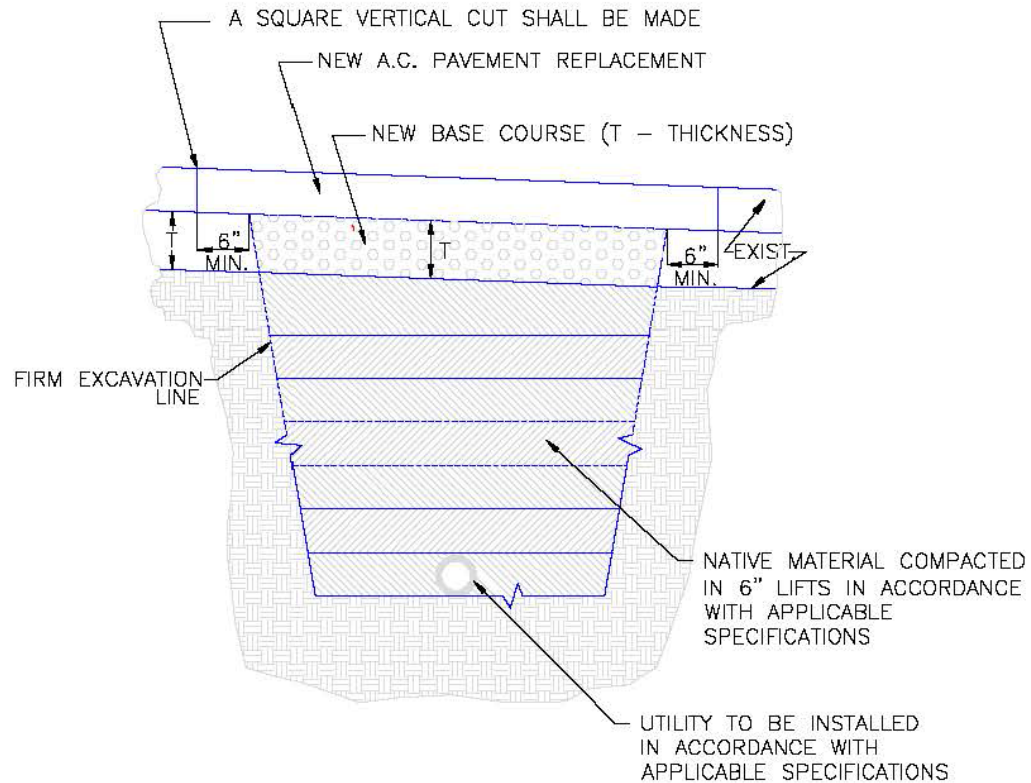

NOTES:

1. THIS DETAIL MAY BE USED FOR PAVEMENT CUTS LESS THAN 200 SQ. FT.
2. EXISTING PAVEMENT MAY BE ROUGH CUT INITIALLY IN CONJUNCTION WITH TRENCHING.
3. A SQUARE VERTICAL CUT SHALL BE MADE IN THE EXISTING A.C. PAVEMENT AFTER PLACEMENT OF BACKFILL PRIOR TO PAVEMENT REPLACEMENT.
4. THICKNESS OF NEW A.C. PAVEMENT REPLACEMENT SHALL MATCH EXISTING (4" MIN.)
5. THICKNESS OF NEW BASE COURSE SHALL BE MINIMUM OF 6" OR EQUAL TO EXISTING, WHICHEVER IS GREATER.

- ENGINEERING CRITERIA MANUAL
Appendix F STANDARD DRAWINGS

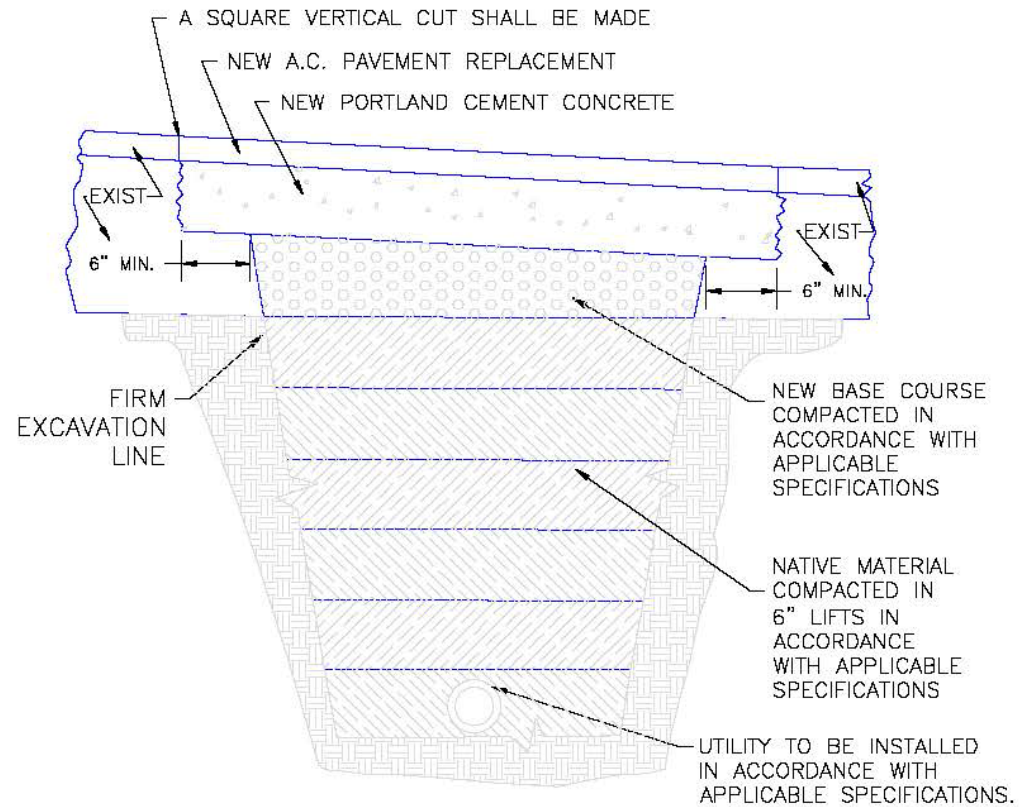

NOTES

1. THIS DETAIL MAY BE USED FOR PAVEMENT CUT LESS THAN 200 SQ. FT.
2. EXISTING PAVEMENT MAY BE ROUGH CUT INITIALLY IN CONJUNCTION WITH TRENCHING.
3. A SQUARE VERTICAL CUT SHALL BE MADE IN THE EXISTING A.C. PAVEMENT AFTER PLACEMENT OF BACKFILL AND PRIOR TO PAVEMENT REPLACEMENT.
4. THICKNESS OF NEW A.C. PAVEMENT REPLACEMENT SHALL MATCH EXISTING.
5. THICKNESS OF PORTLAND CEMENT CONCRETE SHALL BE A MINIMUM OF 6" WITH A 4000 PSI COMPRESSIVE STRENGTH AT 28 DAYS.
6. THICKNESS OF NEW BASE COURSE SHALL BE A MINIMUM OF 6" WHEN THE EXISTING BASE COURSE EXCEEDS 12" IN DEPTH. STREETS WITH LESS THAN 12" OF EXISTING BASE COURSE REQUIRE NO NEW BASE COURSE.

- ENGINEERING CRITERIA MANUAL
Appendix F STANDARD DRAWINGS

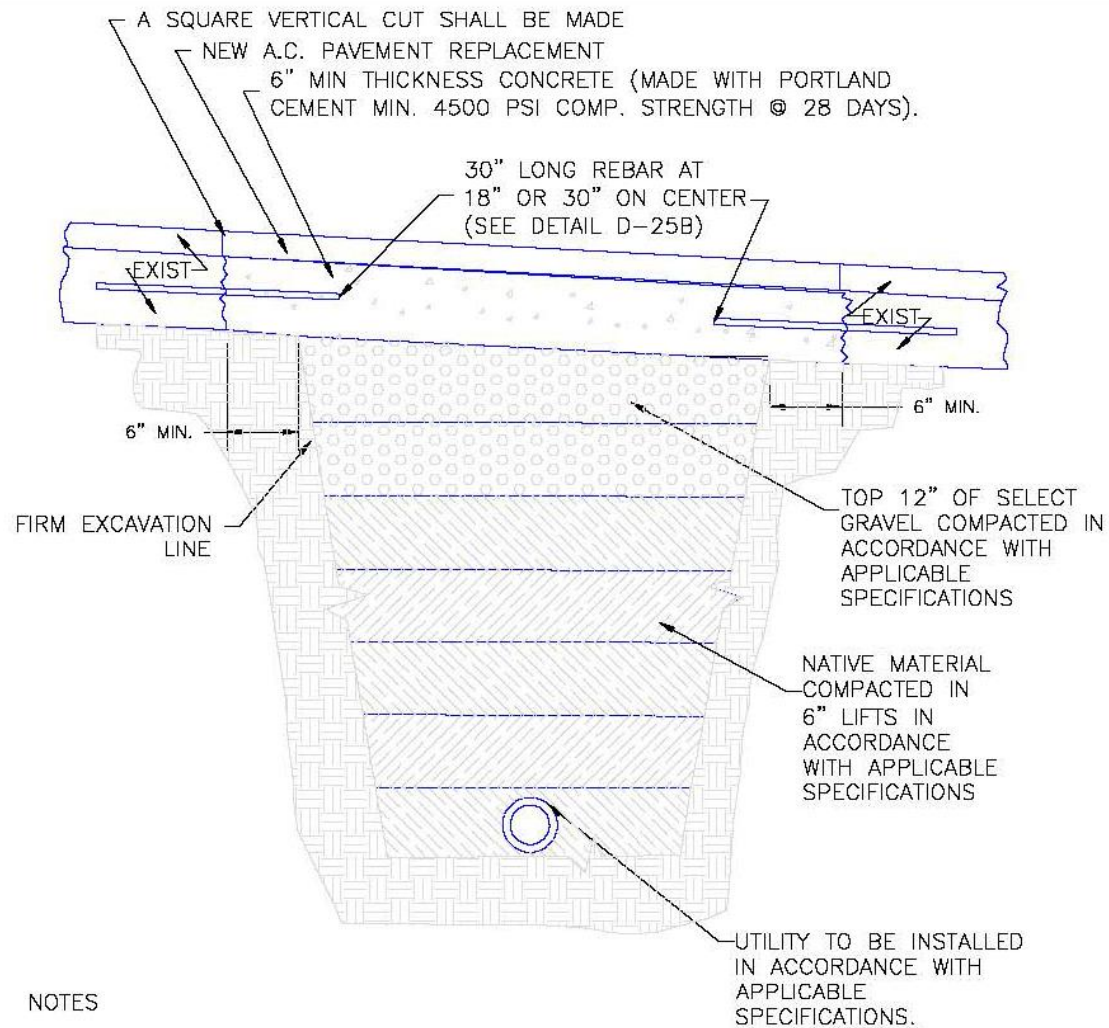

NOTES

1. EXISTING PAVEMENT MAY BE ROUGH CUT INITIALLY IN CONJUNCTION WITH TRENCHING.
2. A SQUARE, VERTICAL CUT SHALL BE MADE IN THE EXISTING A.C. PAVEMENT AFTER PLACEMENT OF BACKFILL AND PRIOR TO PAVEMENT REPLACEMENT.
3. THICKNESS OF CONCRETE AND A.C. SHALL BE EQUAL TO EXISTING CONCRETE AND A.C. THICKNESS WITH MINIMUM AS SHOWN.
4. DRILL AND EPOXY 30" LONG REBARS 15" DEEP INTO EXISTING CONCRETE PAVEMENT IN ACCORDANCE WITH DETAIL D-25B FOR TRANSVERSE AND LONGITUDINAL JOINTS.

- ENGINEERING CRITERIA MANUAL
Appendix F STANDARD DRAWINGS

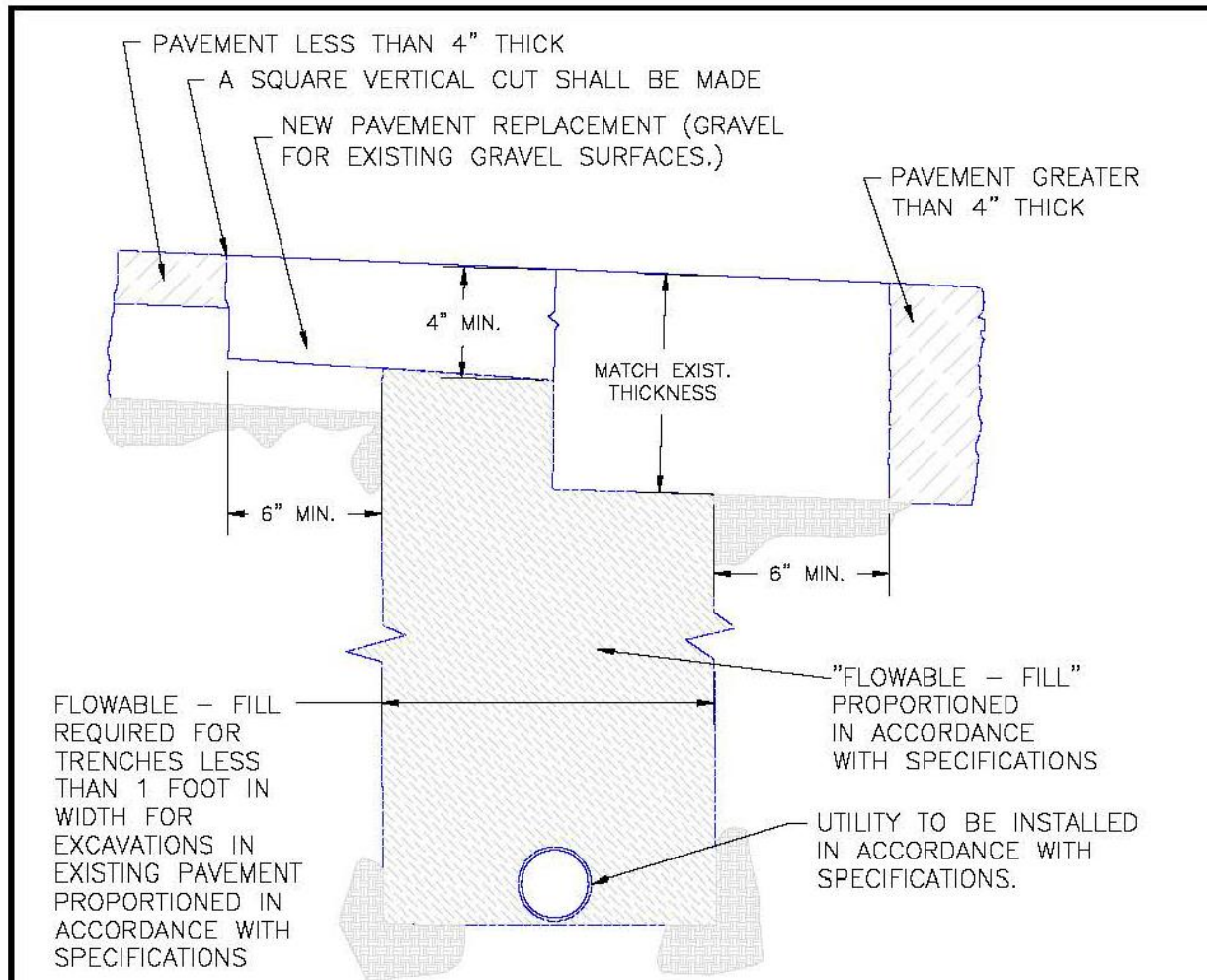

FLOWABLE - FILL
REQUIRED FOR
TRENCHES LESS
THAN 1 FOOT IN
WIDTH FOR
EXCAVATIONS IN
EXISTING PAVEMENT
PROPORTIONED IN
ACCORDANCE WITH
SPECIFICATIONS

"FLOWABLE - FILL"
PROPORTIONED
IN ACCORDANCE
WITH SPECIFICATIONS

UTILITY TO BE INSTALLED
IN ACCORDANCE WITH
SPECIFICATIONS.

NOTES

1. EXISTING PAVEMENT MAY BE ROUGH CUT INITIALLY IN CONJUNCTION WITH TRENCHING.
2. A SQUARE, VERTICAL CUT SHALL BE MADE IN THE EXISTING A.C. PAVEMENT AFTER PLACEMENT OF BACKFILL AND PRIOR TO PAVEMENT REPLACEMENT.
3. THICKNESS OF NEW A.C. PAVEMENT REPLACEMENT SHALL MATCH EXISTING OR 4" MINIMUM, WHICHEVER IS GREATER.

Synthetic Sediment Control Log with Tailpiece

Description and Purpose

A synthetic sediment control log. Outer cover of silt filtration fabric surrounding an inner core of full rebound foam covered by a 6 mil plastic sleeve. Designed to be used where hard surfaces contact disturbed areas for pounding and on-site soil retention.

The Heavyweight Wattle

Suitable Applications — The Heavyweight Wattle may be suitable:

- Where hard surfaces contact soil.

Limitations

- The Heavyweight Wattle is not effective when the flap is not properly pinned and backfilled.
- The Heavyweight Wattle has a limited sediment capture zone and should only be used for lower volume sheet flows.
- The Heavyweight Wattle is not a substitute for adequate tracking pads and construction egress.

Installation



The Heavyweight™ Wattle

SIDEWALK Installation

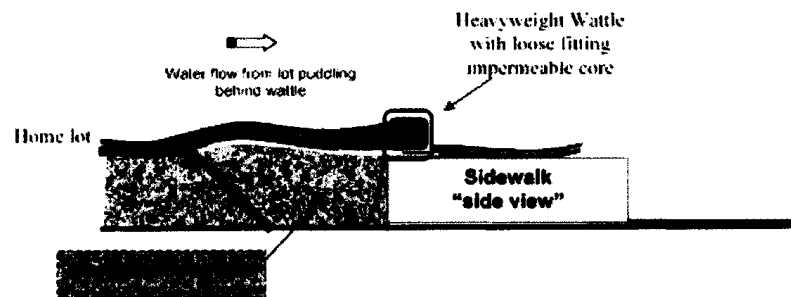

While crews remove concrete forms, install wattle immediately afterwards.

Wattle to be installed upon removal of concrete forms:

1. Lay the Heavyweight wattle directly on top of sidewalk, dropping tail of wattle behind sidewalk area.
2. Connect wattle together to form a continuous barrier.
3. Pin tail section into soil with fasteners behind sidewalk approximately every three feet.
4. Overlap the connection points and use two fasteners in this area.
5. Back-fill area behind sidewalk.
6. Site in compliance.

Fastener Recommendation: Use 60d nails or The Heavyweight wattle pins

Synthetic Stabilized Construction Entrance FODS TRACKOUT CONTROL SYSTEM INSTALLATION GUIDE

THE PURPOSE AND DESIGN OF THE FODS TRACKOUT CONTROL SYSTEM IS TO EFFECTIVELY REMOVE MOST SEDIMENT FROM VEHICLE TIRES AS THEY EXIT A DISTURBED LAND AREA ONTO A PAVED STREET. THIS MANUAL IS A PLATFORM FROM WHICH TO INSTALL A FODS TRACKOUT CONTROL SYSTEM (NOTE: THIS IS NOT A ONE SIZE FITS ALL GUIDE.) THE INSTALLATION MAY NEED TO BE MODIFIED TO MEET THE EXISTING CONDITIONS, EXPECTATIONS, OR DEMANDS OF A PARTICULAR SITE. THIS IS A GUIDELINE. ULTIMATELY THE FODS TRACKOUT CONTROL SYSTEM SHOULD BE INSTALLED SAFELY WITH PROPER ANCHORING AND SIGNS PLACED AROUND THE ENTRANCE AND EXIT TO CAUTION USERS AND OTHERS.

KEY NOTES:

- A. FODS TRACKOUT CONTROL SYSTEM MAT.
- B. FODS SAFETY SIGN.
- C. ANCHOR POINT.
- D. SILT OR ORANGE CONSTRUCTION FENCE.

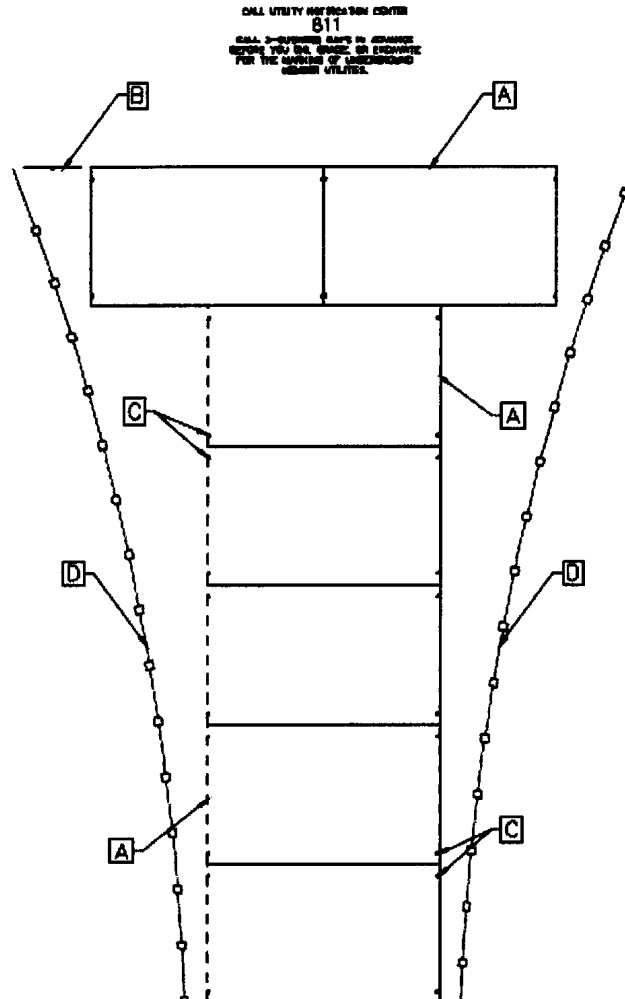

INSTALLATION:

1. THE SITE WHERE THE FODS TRACKOUT CONTROL SYSTEM IS TO BE PLACED SHOULD CORRESPOND TO BEST MANAGEMENT PRACTICES AS MUCH AS POSSIBLE. THE SITE WHERE FODS TRACKOUT CONTROL SYSTEM SHOULD ALSO MEET OR EXCEED THE LOCAL JURISDICTION OR STORM WATER POLLUTION PREVENTION PLAN (SWPPP) REQUIREMENTS.
2. CALL FOR UTILITY LOCATES 3 BUSINESS DAYS IN ADVANCE OF THE FODS TRACKOUT CONTROL SYSTEM INSTALLATION FOR THE MARKING OF UNDERGROUND MEMBER UTILITIES. CALL THE UTILITY NOTIFICATION CENTER AT 811.
3. ONCE THE SITE IS ESTABLISHED WHERE FODS TRACKOUT CONTROL SYSTEM IS TO BE PLACED, ANY EXCESSIVE UNEVEN TERRAIN SHOULD BE LEVELED OUT OR REMOVED SUCH AS LARGE ROCKS, LANDSCAPING MATERIALS, SUDDEN ABRUPT CHANGES IN ELEVATION, AND SIMILAR. FODS WILL SPAN AND SUPPORT OVER MOST OBSTACLES, BUT THE FLATTER AND SMOOTHER THE TERRAIN UNDER THE FODS TRACKOUT CONTROL SYSTEM WILL BE MORE EFFICIENT AND SAFER.
4. NEXT THE INDIVIDUAL MATS CAN START TO BE PLACED IN POSITION. THE FIRST MAT SHOULD BE PLACED NEXT TO THE PAVED SURFACE AND/OR CURB AT THE CLOSEST POINT OF EGRESS. THIS WILL ENSURE THAT THE VEHICLE WILL EXIT STRAIGHT FROM THE SITE TO THE PAVED SURFACE, FROM THE SITE TO THE PAVED SURFACE.
5. AFTER THE FIRST MAT IS PLACED DOWN IN ITS PROPER LOCATION, AN H BRACKET SHOULD BE PLACED AT THE END OF THE FIRST MAT, BEFORE ANOTHER MAT IS POSITIONED ADJACENT TO THE FIRST MAT.
6. ONCE THE SECOND MAT IS PLACED ADJACENT TO THE FIRST MAT, MAKE SURE THE H BRACKET IS CORRECTLY SITUATED BETWEEN THE TWO MATS.
7. NEXT, THE CONNECTOR STRAP SHOULD BE INSTALLED TO CONNECT THE TWO MATS TOGETHER.
8. AFTER THE FIRST MAT IS PLACED DOWN IN ITS PROPER LOCATION, IT SHOULD BE ANCHORED TO PREVENT THE POTENTIAL MOVEMENT WHILE THE ADJOINING MATS ARE INSTALLED NEXT. ANCHORS SHOULD BE PLACED AT EVERY ANCHOR POINT (IF FEASIBLE) TO HELP MAINTAIN THE MAT IN ITS CURRENT POSITION.
9. ONCE THE FIRST MAT IS ANCHORED DOWN, THE SUCCESSIVE MATS CAN THEN BE PLACED TO CREATE THE FODS TRACKOUT CONTROL SYSTEM.
10. UPON PLACEMENT OF EACH NEW MAT IN THE SYSTEM, THAT MAT SHOULD BE ANCHORED AT EVERY ANCHOR POINT TO HELP STABILIZE THE MAT AND ENSURE THE SYSTEM IS CONTINUOUS WITH NO GAPS IN BETWEEN THE MATS.
11. AFTER INSTALLATION OF THE FODS TRACKOUT CONTROL SYSTEM, FODS SAFETY SIGNS SHOULD BE PLACED AT THE ENTRANCE AND EXIT SIDES OF THE FODS TRACKOUT CONTROL SYSTEM.
12. A SILT FENCE OR ORANGE CONSTRUCTION FENCE SHOULD ALSO BE INSTALLED ON THE SIDES OF THE FODS TRACKOUT CONTROL SYSTEM TO DIRECT VEHICLES DOWN THE MATS AND BARRICADE PEDESTRIANS FROM CROSSING THE MATS. PEDESTRIANS SHOULD ALSO USE EXTREME CAUTION WHEN CROSSING THE MATS AS THE SURFACE IS UNEVEN AND MAY BE DIFFICULT TO WALK ON.

USE AND MAINTENANCE:

1. VEHICLES SHOULD TRAVEL DOWN THE LENGTH OF THE FODS TRACKOUT CONTROL SYSTEM AND NOT CUT ACROSS THE MATS.
2. DRIVERS SHOULD TURN THE WHEEL OF THEIR VEHICLES SUCH THAT THE VEHICLE WILL TAKE A SERPENTINE ROUTE DOWN THE LENGTH OF THE FODS TRACKOUT CONTROL SYSTEM.
3. MATS SHOULD BE CLEANED ONCE THE VOIDS BETWEEN THE PYRAMIDS BECOME FULL OF SEDIMENT. TYPICALLY THIS TASK WILL NEED TO BE PERFORMED WITHIN TWO WEEKS AFTER A STORM EVENT. BRUSHING IS THE PREFERRED METHOD OF CLEANING, EITHER MANUALLY OR MECHANICALLY.
4. THE USE OF ICE MELT, ROCK SALT, SNOW MELT, DEICER, ETC. SHOULD BE UTILIZED AS NECESSARY DURING THE WINTER MONTHS AND AFTER A SNOW EVENT.

Single Lot Access Vehicle Tracking Control Mats

Single Lot Access VTC (Mud Mats)

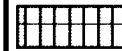

Description and Purpose

A stabilized construction access is defined by a point of entrance/exit to a construction site that is stabilized to reduce the tracking of mud and dirt onto public roads by construction vehicles.

Suitable Applications

Use at construction sites:

- Where dirt or mud can be tracked onto public roads.
- Where a single family lot needs a temporary access point.

Limitations

- Entrances and exits require periodic cleaning and maintenance.
- This BMP should be used in conjunction with street sweeping on adjacent public right of way
- Entrances and exits should be constructed on level ground only or sloping away from paved surfaces.

Implementation

- Construct on level ground or sloping down and away from paved surfaces where possible.
- For individual lots VTC perimeter may be reduced to minimum 8' x 15' due to space limitation. This is for access to single family lots only.)
- Limit the points of entrance/exit to the construction site.
- Properly grade each construction entrance/exit to prevent runoff from leaving the construction site.
- Route runoff from stabilized entrances/exits through a sediment trapping device before discharge.
- Require that all employees, subcontractors, and suppliers to utilize the stabilized construction access when lot access is necessary.
- Educate all employees, subcontractors, and suppliers on keeping vehicles off-site whenever possible.
- Limit access to only access that is absolutely necessary.

Inspection and Maintenance

- Inspect and verify that activity-based BMPs are in place prior to the commencement of associated activities. While activities associated with the BMPs are under way, inspect in accordance with the specified inspection schedule in the site SWMP.
- Visually inspect local roads adjacent to the site daily. Sweep or vacuum to remove visible accumulated sediment.
- Check for damage and repair as needed.
- Remove accumulated sediment as needed.
- Reset and restake as needed.
- Remove any sediment deposited on paved roadways immediately.

Lot Access-VTC (mud mats)

AGES Mud Mat Specifications

Each mat is made up of a double layer of high strength woven fabric that is stitched in such a way to encapsulate the reinforcing members that run perpendicular to the direction of traffic. These reinforcing ribs are secured individually within each pocket. There are approx. 24-26 pockets that each holds 1 bamboo post of approx. 2" diameter. This combination of reinforcing member and confining fabric result in a portable mat that can be rolled up for transport and ease of deployment. AGES Mud Mats can be used in construction site access, agriculture, golf & parks, other soft or sensitive ground condition areas where vehicle access is required.

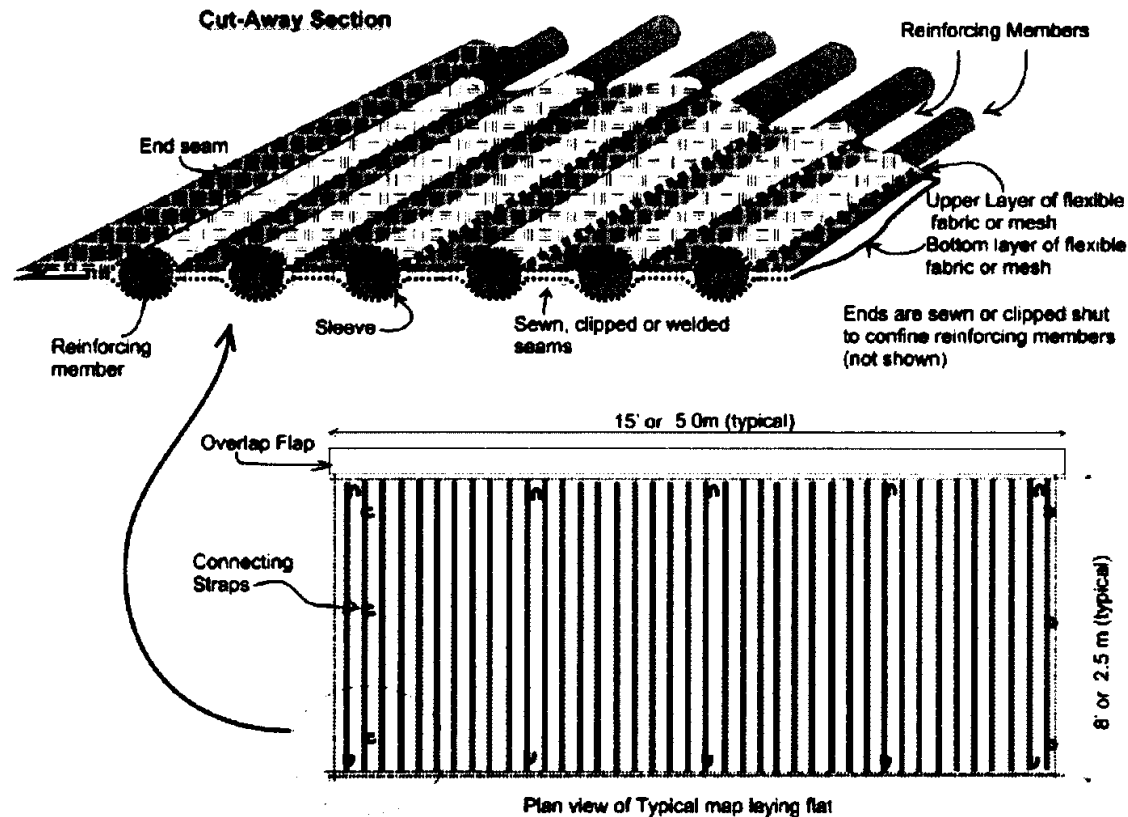

El Paso County, Colorado
(Supp. No. 2)

BOCC Memo Packet
Page 894 of 1032

PROPERTY	TEST PROCEDURE	VALUE
Grab Tensile Strength	ASTM D4832	802.6 lbs
Apparent Breaking Elongation	ASTM D4832	25% / 18%
Trapezoid Tearing Strength	ASTM D4833	807 lbs
Puncture Resistance	ASTM D4833	374.3 lbs
Mullen Burst	ASTM D3786	456.88 psi
Apparent Opening Size	ASTM D4751	70 US Sieve / 0.212mm
Constant Head Permittivity	ASTM D4491	20.16 gm/m ²

APPROXIMATE DIMENSIONS PER MAT	
Size Deployed (approx.)	15' x 8'
Shipping Size (rolled)	1.5' dia x 8.5' long
Weight (approx.)	60 lbs

5 carabeneer clips for each mat (Side connection and end connection straps)

Rubber Vehicle Tracking Control Pads

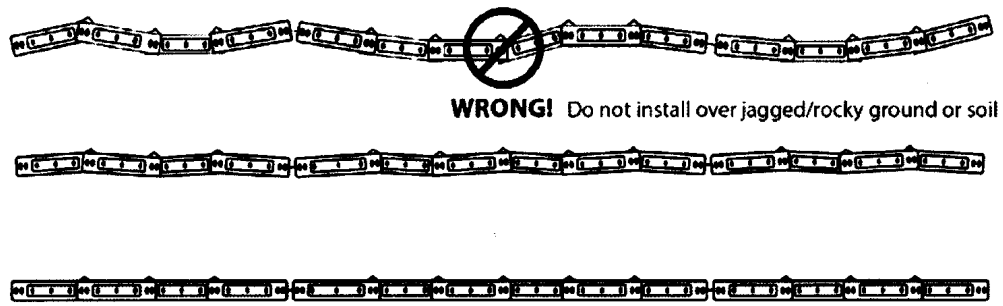
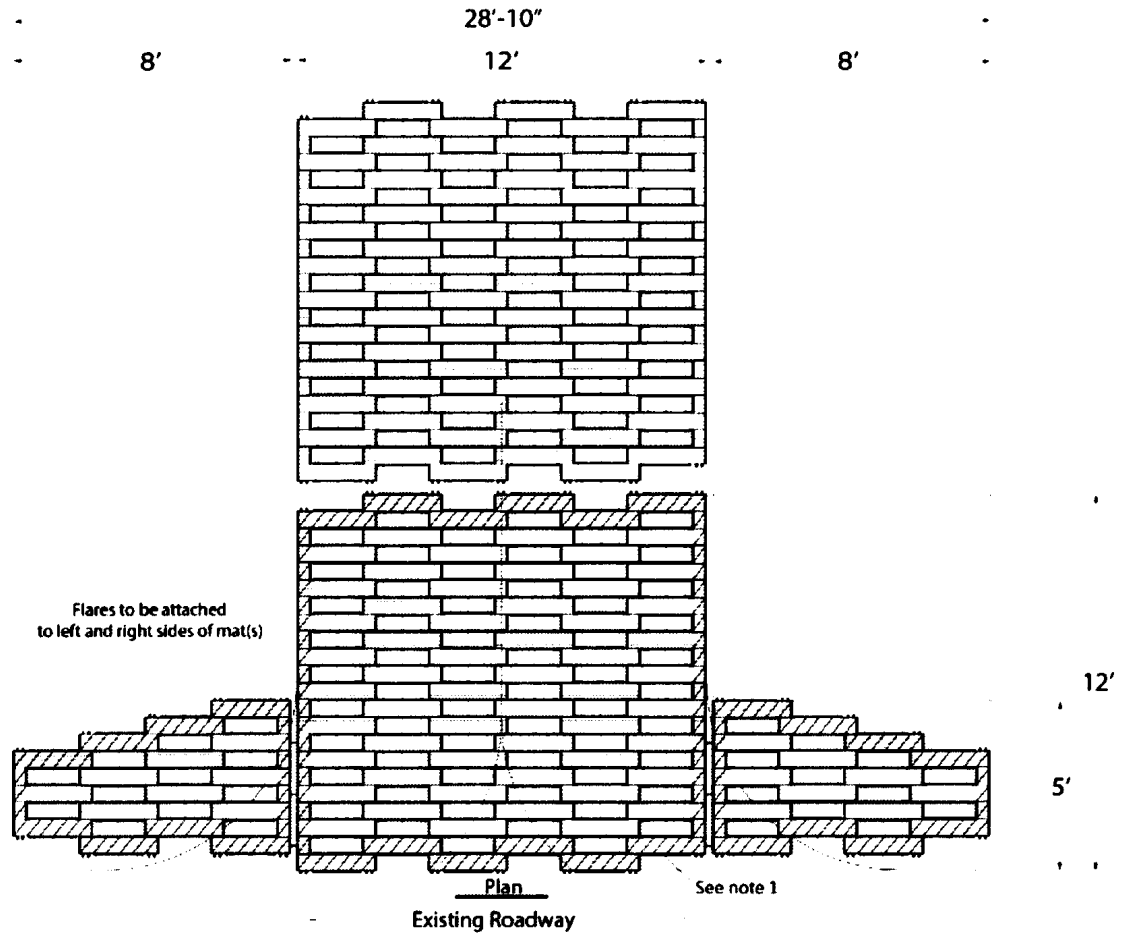

Outlet Structures

T-12

Description

This section provides guidance and details for outlet structures for the use primarily with BMPs utilizing sedimentation, (i.e., extended detention basins, retention ponds and constructed wetland ponds). The information provided in this section includes guidance for different size watersheds as well as for incorporating full spectrum detention as described in the *Storage* chapter of Volume 2.

The details contained in this Fact Sheet are intended to provide a starting point for design. UDFCD recommends that design details for outlet structures be specific for each site with structural details drawn to scale. The details provided in this Fact Sheet are not intended to be used without modification or additional detail.

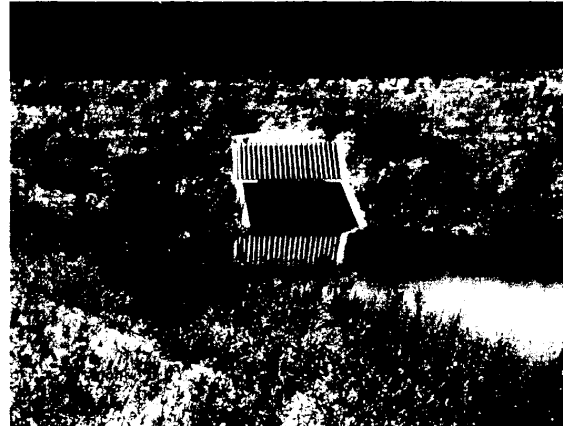

Photograph OS-1. Although each site is different, most sedimentation BMPs have similar outlet structures. Each structure should include a partially submerged orifice plate with a screen (or grate) protecting the orifice plate from clogging, and an overflow weir for flows exceeding the WQCV or excess urban runoff volume (EURV), when full spectrum detention is used.

Outlet Design

Large Watershed Considerations

UDFCD recommends that water quality treatment be provided close to the pollutant source. This is a fundamental concept of Low Impact Development (LID). Although flood control facilities, including full spectrum detention facilities, have been shown to be very effective for watersheds exceeding one square mile, this is not the case for water quality facilities. One reason for this is that the baseflow associated with a larger watershed will vary and can be difficult to estimate. The orifice plate should be designed to pass the baseflow while detaining the water quality capture volume (WQCV) for approximately 40 hours. When the baseflow is overestimated, the WQCV is not detained for the recommended time, passing through without treatment. When the baseflow is underestimated, the elevation of the permanent pool will be higher than designed, causing maintenance issues as well as reducing the volume available for detention of the WQCV, which also allows for a portion of this volume to pass through without treatment. For this reason, UDFCD recommends that facilities designed for both water quality and flood control be limited, where possible, to watersheds without a baseflow. The maximum recommended watershed for combined facilities is one square mile. Additional discussion on designing for baseflows is provided in the EDB BMP Fact Sheet (T-5).

Designing for Maintenance

Rather than using the minimum criteria, consider maximizing the width of the trash rack to the geometry of the outlet. This will reduce clogging and frequency of maintenance. Reduced clogging in EDB outlet structures will preserve the initial surcharge volume thus reducing frequency of inundation in the bottom of the basin. This will benefit the grasses and reduce long-term EDB maintenance requirements (including sediment removal in the grassed area) and may

T-12

Outlet Structures

Orifice Plates, Trash Racks, and Safety Grates

An orifice plate is used to release the WQCV slowly over 40 hours. For full spectrum detention, the orifice plate is extended to drain a larger volume, the EURV, over approximately 72 hours. The figures and tables in this section provide recommendations for orifice configurations and trash rack type and size. Guidance is provided for plates using both circular and rectangular orifices.

Orifice Sizing

Follow the design steps included in the BMP Fact Sheet for the appropriate BMP. The UD-Detention workbook, available at www.udfcd.org, can be used to route flows and calculate the required orifice sizes. UDFCD recommends a total of three orifices to maximize the orifice size and avoid clogging of the orifice plate. A detail showing the recommended orifice configuration is provided in Figure OS-4.

Trash Rack Sizing

Once the size of the orifice has been determined, this information, along with the total orifice area in the water quality plate, is used to determine the total open area of the grate. See Figure OS-1 and use the dashed line to size the trash rack. Include the portion of the trash rack that is inundated by the micropool in total open area of the grate.

Be aware, Figures OS-5, OS-6, OS-7, and OS-8 dimension the minimum width clear for the trash rack frame. It is also important to provide adequate width for attachment to the outlet structure (see Photos OS-2 and OS-3). Also, consider maximizing the width of the trash rack to the geometry of the outlet. This will reduce clogging and maintenance requirements associated with cleaning the trash rack. This Fact Sheet also

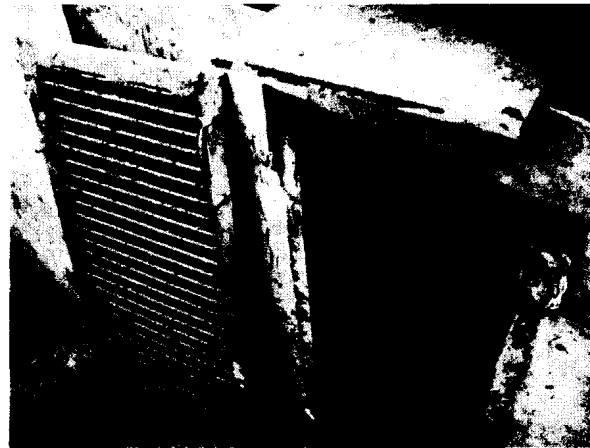

Photograph OS-2. This trash rack could not be properly



Outlet Structures

T-12

Safety Grates

Safety grates are intended to keep people and animals from inadvertently entering a storm drain. They are sometimes required even when debris entering a storm drain is not a concern. The grate on top of the outlet drop box is considered a safety grate and should be designed accordingly. The danger associated with outlet structures is the potential associated with pinning a person or animal to unexposed outlet pipe or grate. See the *Culverts and Bridges* chapter of Volume 2 of this manual for design criteria related to safety grates.

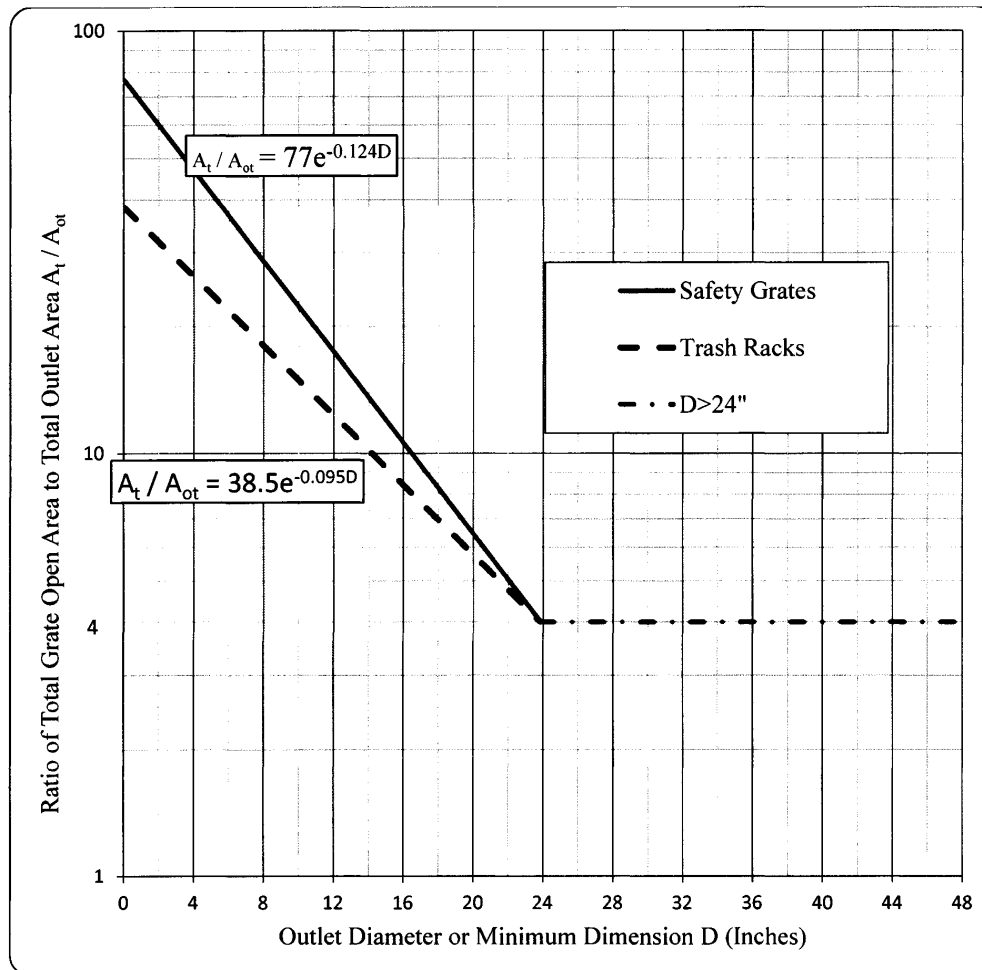

El Paso County, Colorado, Engineerin
(Supp. No. 2)

Figure OS-1. Trash Rack Sizing

T-12

Outlet Structures

Outlet Geometry

Outlets for small watersheds will typically be sized for maintenance operations while the geometry of outlets for larger watersheds may be determined based on the required size of the trash rack. For all watershed sizes, the outlet should be set back into the embankment of the pond to better allow access to the structure. This also provides a more attractive BMP. For larger watersheds, this will require wing walls. Wing walls are frequently cast-in-place concrete, although other materials, such as grouted boulders, may be used where appropriate. Consider safety, aesthetics, and maintenance when selecting materials and determining the geometry. A safety rail should be included for vertical drops of 3 feet or more. Depending on the location of the structure in relation to pedestrian trails, safety rails may also be required for lesser drops. Stepped grouted boulders can be used to reduce the height of vertical drops.

As shown in Figures EDB-1 and EDB-2 provided in BMP Fact Sheet T-5, wing walls can be flared or parallel. There are advantages to both configurations. Parallel wing walls may be more aesthetic; however, depending on the geometry of the pond, may limit accessibility to the trash rack. Flared wing walls can call attention to the structure but provide better accessibility and sometimes a vertical barrier from the micropool of an EDB, which can increase safety of the structure. Parallel walls can also be used with a second trash rack that is secured flush with the top of the wall as shown in Photo OS-4. This eliminates the need for a safety rail and may provide additional protection from clogging:

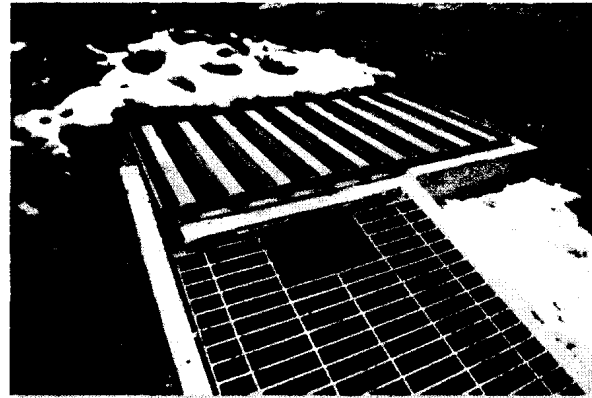

Photograph OS-4. Maintenance access to the water quality trash rack was compromised by the location of a secondary trash rack on this outlet. This may have been included as a safety rack or as additional protection from clogging. The owner modified the structure for better access. A safety rail would have been a better solution.

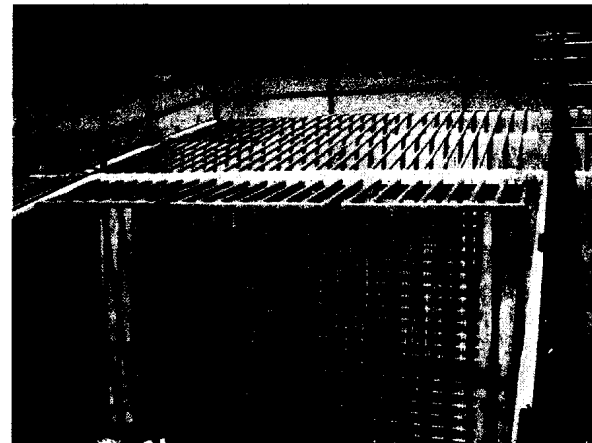

Photograph OS-5. Interruptions in the horizontal members of this trash rack and the spacing of the vertical members

Outlet Structures

T-12

Micropools within the Outlet Structure

The micropool of an EDB may be placed inside the structure when desired. This is becoming increasingly common for smaller watersheds and near airfields where large bird populations can be problematic. When designing this type of structure, consider maintenance of the water quality trash rack. The secondary trash rack should be designed to allow maintenance of the water quality trash rack similar to that shown in Photo OS-5. This concept can easily be incorporated into smaller outlet structures (see Figures OS-7 and OS-8 for details).

Outlet Structure Details

A number of details are presented in this section to assist designers with detailing outlet structures. Table OS-1 provides a list of details available at www.udfcd.org. These details are not intended to be used in construction plans without proper modifications as indicated in this table.

Table OS-1. Summary of Outlet Structure Details and Use

Figure	Detail	Use of Detail
OS-2	Typical outlet structure for full spectrum detention	Conceptual.
OS-3	Typical outlet structure for WQCV treatment and attenuation	Conceptual.
OS-4	Orifice plate and trash rack detail and notes	Outlet section. Modify per true structure geometry and concrete reinforcement. Modify notes per actual design.
OS-5	Typical outlet structure with well screen trash rack	Outlet sections. Modify per true structure geometry and concrete reinforcement. Add additional sections and detailing as necessary. Modify notes per actual design.
OS-6	Typical outlet structure with bar grate trash rack	Outlet sections. Modify per true structure geometry and concrete reinforcement. Add additional sections and detailing as necessary. Modify notes per actual design.
OS-7	Full spectrum detention outlet structure for 5-acre impervious area or less	Outlet profile and section. Modify per true EURV elevation and concrete reinforcement. Add additional sections and detailing as necessary.
OS-8	WQCV outlet structure for 5-acre impervious area or less	Outlet sections. Modify per true WQCV elevation and concrete reinforcement. Add additional sections and detailing as necessary.

T-12

Outlet Structures

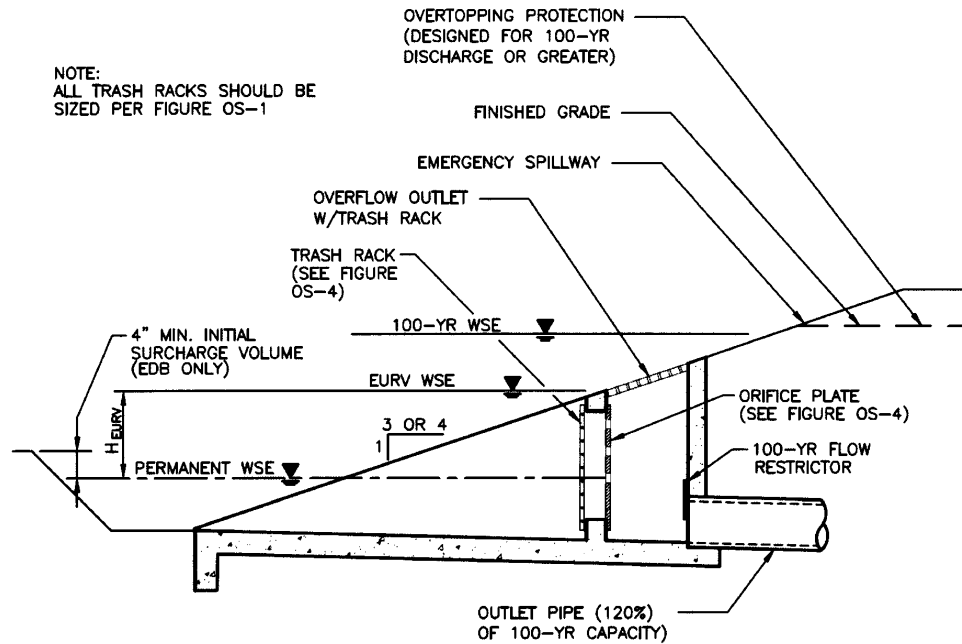

Figure OS-2. Typical outlet structure for full spectrum detention

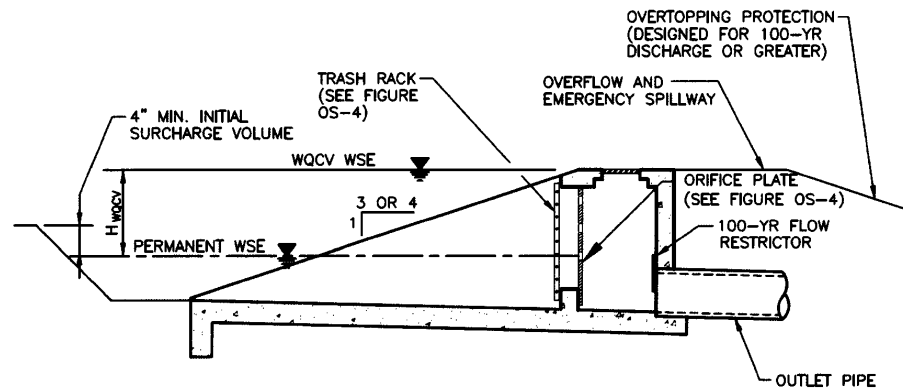
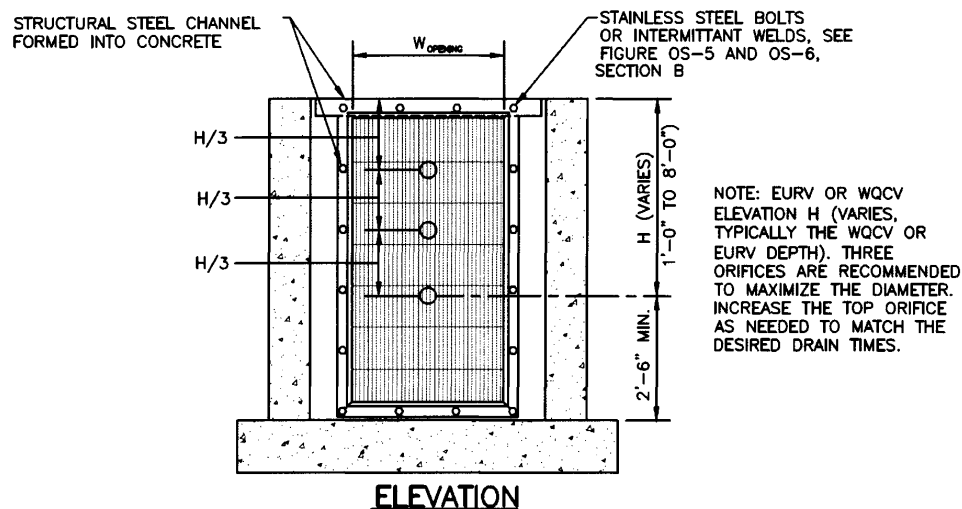

Figure OS-3. Typical outlet structure for WQCV treatment and attenuation

Outlet Structures

T-12



ORIFICE PLATE NOTES:

1. PROVIDE CONTINUOUS NEOPRENE GASKET MATERIAL BETWEEN THE ORIFICE PLATE AND CONCRETE.
2. BOLT PLATE TO CONCRETE 12" MAX. ON CENTER. SEE TABLE OS-2 FOR PLATE THICKNESS.

EURV AND WQCV TRASH RACKS:

1. WELL-SCREEN TRASH RACKS SHALL BE STAINLESS STEEL AND SHALL BE ATTACHED BY INTERMITTENT WELDS ALONG THE EDGE OF THE MOUNTING FRAME.
2. BAR GATE TRASH RACKS SHALL BE ALUMINUM AND SHALL BE BOLTED USING STAINLESS STEEL HARDWARE.
3. TRASH RACK OPEN AREAS ARE FOR SPECIFIED TRASH RACK MATERIALS. TOTAL TRASH RACK SIZE MAY NEED TO BE ADJUSTED FOR MATERIALS HAVING DIFFERENT OPEN AREA/GROSS AREA RATIO (R VALUE).
4. STRUCTURAL DESIGN OF TRASH RACKS SHALL BE BASED ON FULL HYDROSTATIC HEAD WITH ZERO HEAD DOWNSTREAM OF THE RACK.

OVERFLOW SAFETY GRATES:

1. ALL SAFETY GRATES SHALL BE MOUNTED USING STAINLESS STEEL HARDWARE AND PROVIDED WITH HINGED AND LOCKABLE OR BOLTABLE ACCESS PANELS.
2. SAFETY GRATES SHALL BE STAINLESS STEEL, ALUMINUM, OR STEEL. STEEL GRATES SHALL BE HOT DIP GALVANIZED AND MAY BE HOT POWDER COATED AFTER GALVANIZING.
3. SAFETY GRATES SHALL BE DESIGNED SUCH THAT THE DIAGONAL DIMENSION OF EACH OPENING IS SMALLER THAN THE DIAMETER OF THE OUTLET PIPE.
4. STRUCTURAL DESIGN OF SAFETY GRATES SHALL BE BASED ON FULL HYDROSTATIC HEAD WITH ZERO HEAD DOWNSTREAM OF THE RACK.

T-12

Outlet Structures

Table OS-2. Thickness of steel water quality plate

Steel plate thickness (in inches) based on design depth and span of plate											
		Head (feet)									
		3	4	5	6	7	8	9	10	11	12
Span (feet)	1	0.1875	0.1875	0.1875	0.1875	0.1875	0.1875	0.1875	0.1875	0.1875	0.1875
	2	0.1875	0.2500	0.2500	0.2500	0.2500	0.2500	0.2500	0.2500	0.2500	0.2500
	3	0.2500	0.2500	0.3750	0.3750	0.3750	0.3750	0.3750	0.3750	0.3750	0.5000
	4	0.2500	0.3750	0.3750	0.3750	0.3750	0.5000	0.5000	0.5000	0.5000	0.5000

Outlet Structures

T-12

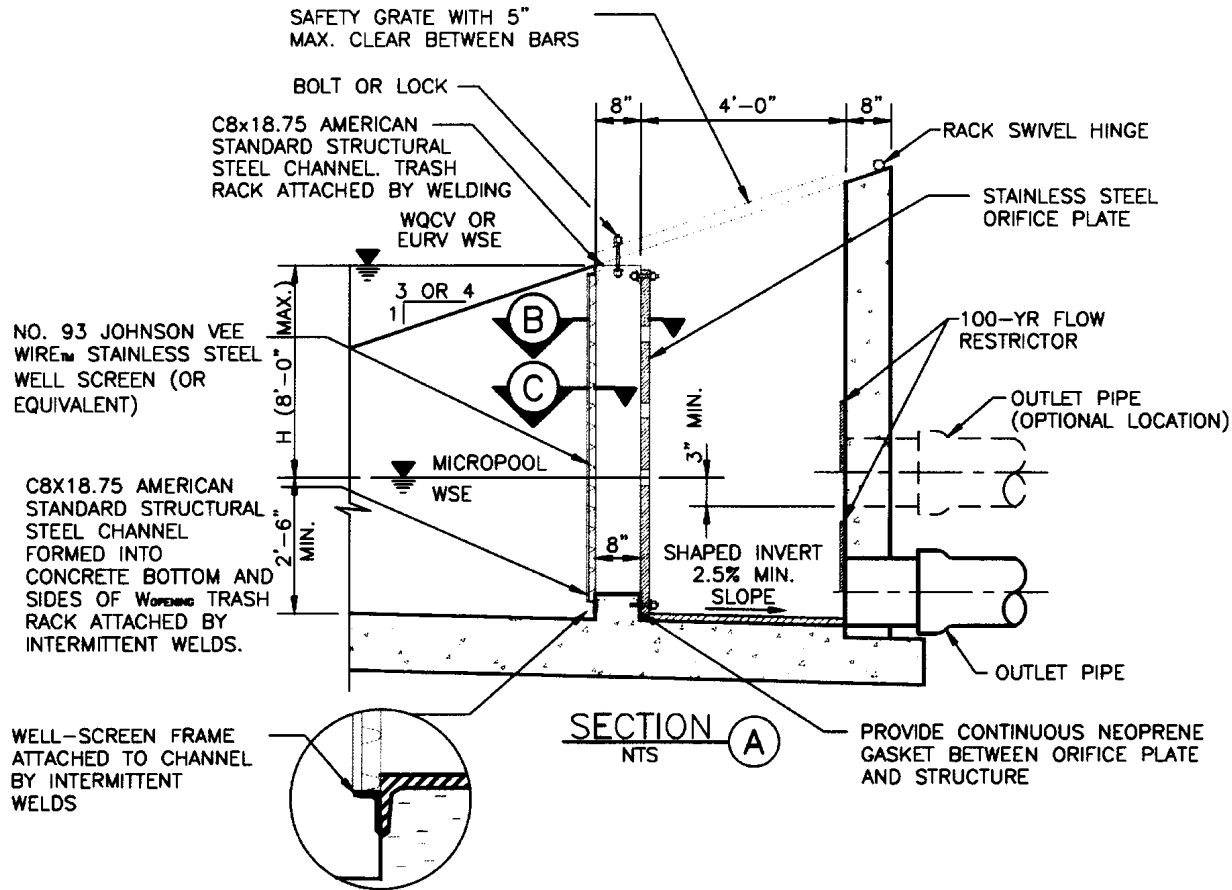

El Paso County, Colorado
(Supp. No. 2)

BOCC Memo Packet
Page 904 of 1032

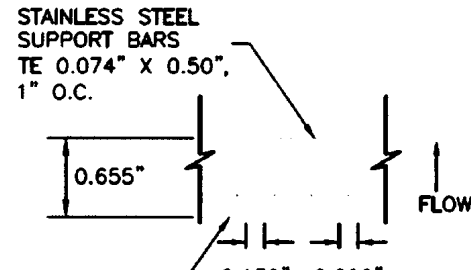
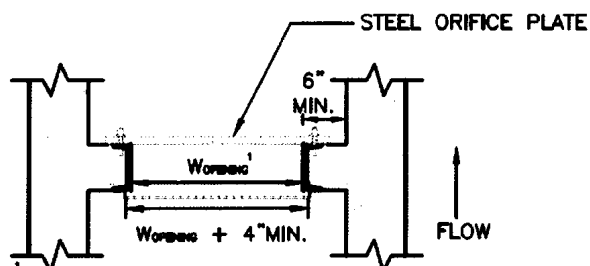

T-12

Outlet Structures

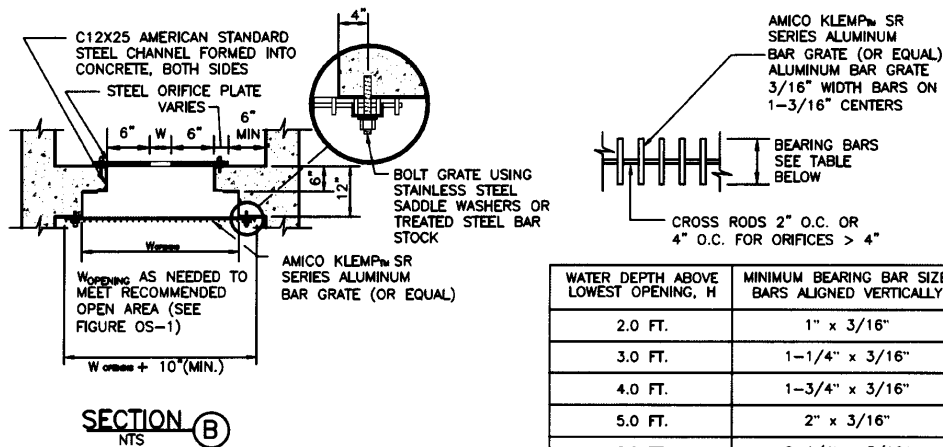
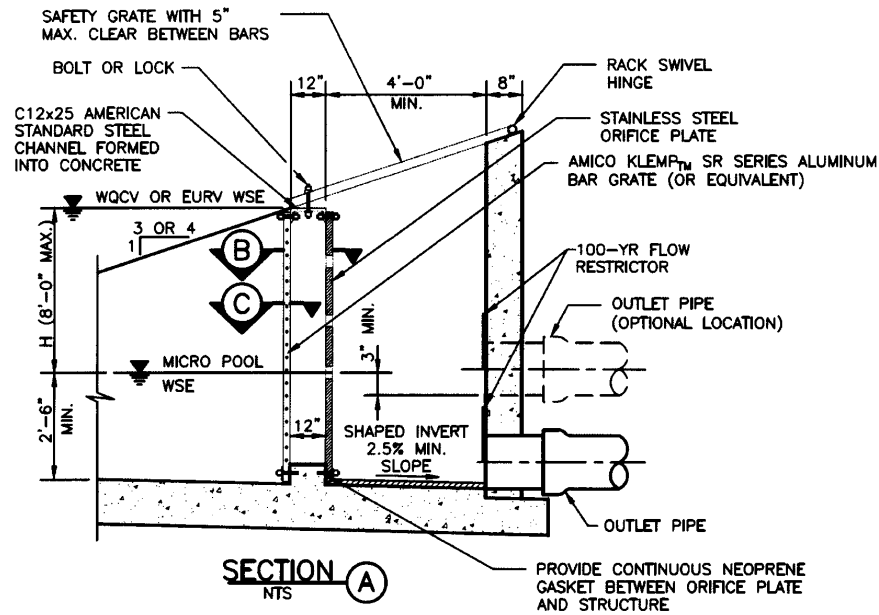

WATER DEPTH ABOVE LOWEST OPENING, H	MINIMUM BEARING BAR SIZE, BARS ALIGNED VERTICALLY
2.0 FT.	1" x 3/16"
3.0 FT.	1-1/4" x 3/16"
4.0 FT.	1-3/4" x 3/16"
5.0 FT.	2" x 3/16"
6.0 FT.	2-1/4" x 3/16"

R VALUE=(NET OPEN AREA)/GROSS RACK AREA)
=0.71 FOR CROSS RODS ON 2" CENTERS
=0.77 FOR CROSS RODS ON 4" CENTERS

SECTION C
NTS

Outlet Structures

T-12

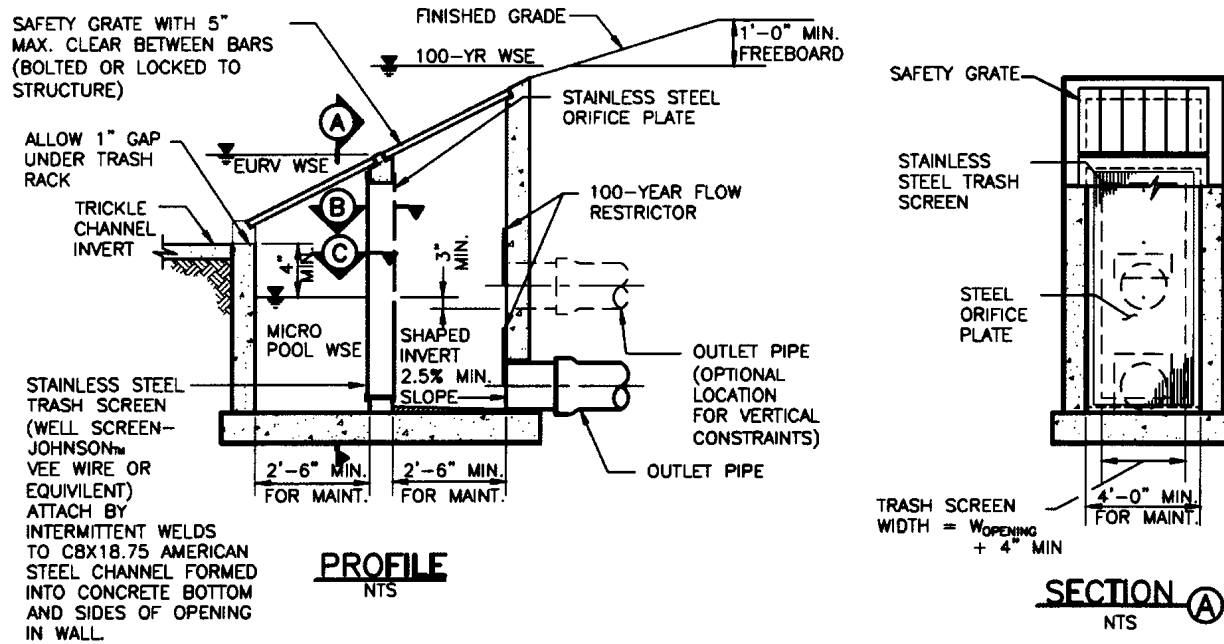

El Paso County, Colorado
(Supp. No. 2)

BOCC Memo Packet
Page 906 of 1032

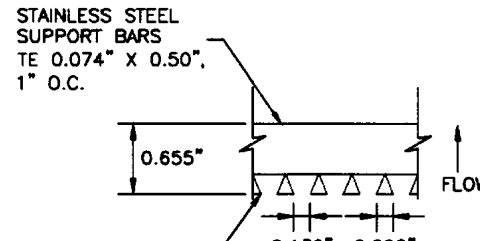
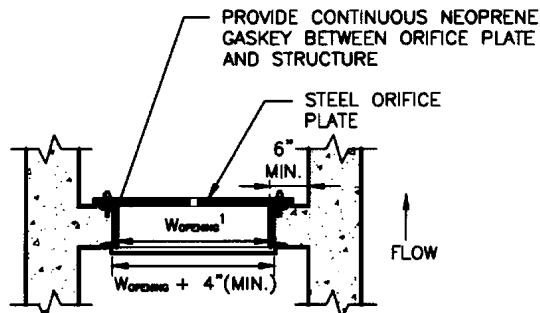

T-12

Outlet Structures

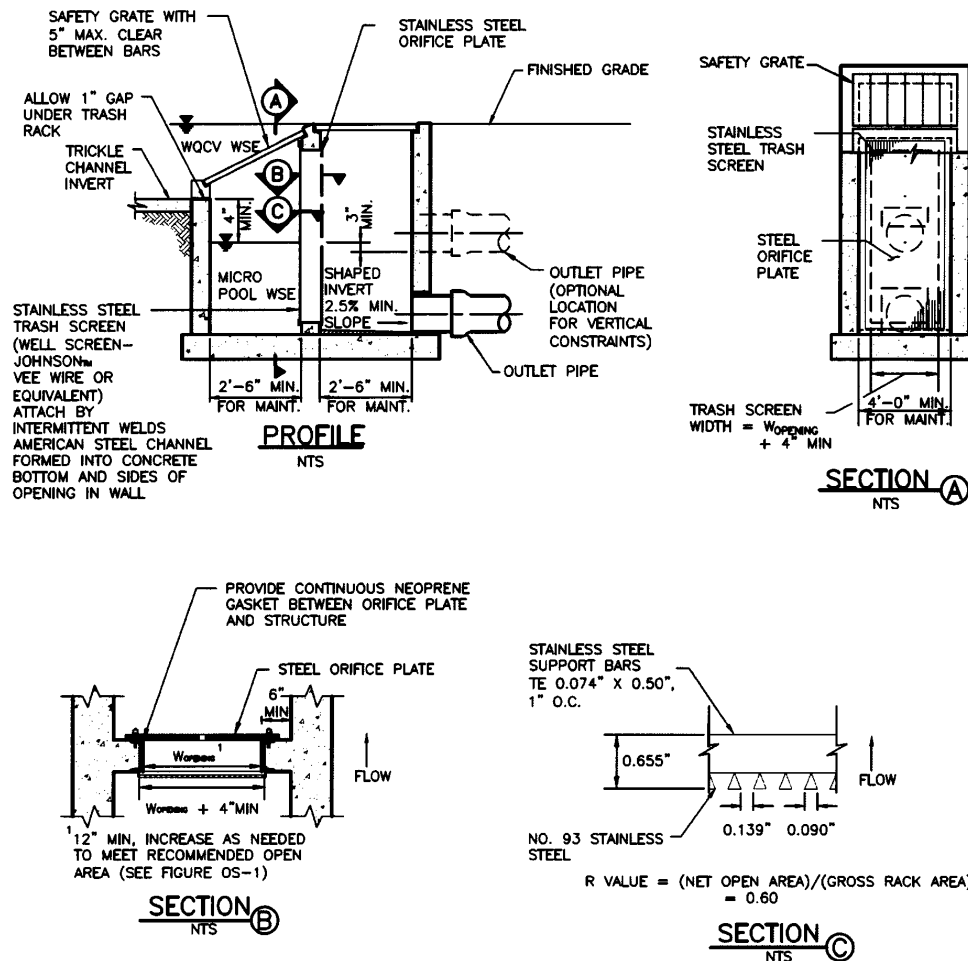

El Paso County, Colorado, Engineerin;
(Supp. No. 2)

FIGURE OS-8

Figure OS-8. WQCV outlet structure for 5-acre impervious area or less

Appendix G STORMWATER BMP MAINTENANCE AGREEMENTS

The El Paso County MS4 permit requires the County to ensure the long-term operation and maintenance of both public and private permanent stormwater quality control measures. To meet this requirement El Paso County developed maintenance agreements for three different types of ownership and maintenance scenarios and provides them for use in this appendix.

Permanent stormwater quality control measures have historically been referred to in this manual as "Post-Construction Best Management Practices (PBMPs)." The two terms may be used interchangeably in this manual.

An applicable development site with multiple permanent control measures may have one or more maintenance and access agreements depending upon ownership and maintenance responsibility. The maintenance agreements shall cover all permanent stormwater quality control measures that are included in a submitted site plan, site development plan, final plat or Grading and Erosion Control Plan. All structures such as Extended Detention Basins and Porous Landscape Detention, plus any additional permanent nonstructural control measures such as Grass Swales & Buffers that are used as part of "Minimizing Directly Connected Impervious Areas" (MDCIA), shall be included in the maintenance agreement.

When submitting a permanent BMP maintenance agreement for review and recordation by the County, the agreement shall include an Operation and Maintenance Manual developed by the engineer of record for each structure type included in a maintenance agreement. Multiple structure types may be included in one maintenance agreement and O&M Manual. The responsible entity shall routinely inspect and provide appropriate long-term maintenance for all structures associated with the permanent stormwater quality control measures as described in the O&M Manual.

(Res. No. 19-245 , 7-2-19)

**DRAFT
PRIVATE STORMWATER QUALITY STRUCTURAL BEST MANAGEMENT
PRACTICE AGREEMENT AND EASEMENT**

This PRIVATE STORMWATER QUALITY STRUCTURAL BEST MANAGEMENT PRACTICE AGREEMENT (Agreement) is made by and between THE BOARD OF COUNTY COMMISSIONERS OF EL PASO COUNTY, COLORADO (Board or County) and _____, a Colorado Corporation (“Developer”) and _____ HOMEOWNERS ASSOCIATION (“Homeowners Association” or “Association”), A Colorado nonprofit corporation. The above may occasionally be referred to herein singularly as “Party” and collectively as “Parties.”

Recitals

1. WHEREAS, Developer is the owner of certain real estate (the Property or Subdivision) in El Paso County, Colorado, which Property is legally described as:

More particularly described as follows:

2. WHEREAS, Developer desires to plat and develop on the Property a subdivision to be known as _____; and

3. WHEREAS, the development of this Subdivision will decrease the quality of the stormwater runoff from the Property, and, therefore, it is in the interest of public health, safety and welfare for the County to condition approval of this subdivision on Developer’s promise to construct adequate drainage and stormwater quality structural Best Management Practices (BMPs) in the subdivision described as

4. WHEREAS, [insert legal citations] as periodically amended, promulgated pursuant to [insert legal citations], as amended, requires the County to condition approval of all subdivisions on a developer’s promise to so construct adequate drainage and BMPs in subdivisions; and

5. WHEREAS, [insert legal citations] provides for a developer’s promise to maintain a subdivision’s BMPs; and

6. WHEREAS, Developer and the Association desire to construct the described BMPs as the means for providing adequate stormwater quality control in the Subdivision; and,

7. WHEREAS, the Association shall be charged in the Subdivision's Covenants with the duty of maintaining all common areas and common structures within the Subdivision, including the BMPs; and

8. WHEREAS, these BMPs when not properly cleaned, maintained, and repaired, threaten the public health, safety and welfare; and

9. WHEREAS, the County in order to so protect the public health, safety and welfare, may be required to expend valuable and limited public resources to so properly clean, maintain, and repair these BMPs when developer and homeowner's association have failed in their responsibilities, and therefore, the County desires the means to recover its costs incurred in the event the burden falls on the County to so clean, maintain and repair the BMPs in this Subdivision; and

10. WHEREAS, the County conditions approval of this Subdivision on the Developer's and the Association's promise to so construct this BMP, and conditions approval on the Association's promise to reimburse the County in the event the burden falls upon the County to so clean, maintain and/or repair the BMP in this Subdivision; and

11. WHEREAS, the County in order to secure performance of the promises contained herein, conditions approval of this Subdivision upon the Developer's grant herein of a perpetual Easement over a portion of the Subdivision for the purpose of allowing the County to periodically access, inspect, and, when so necessary, to clean, maintain and/or repair the BMPs; and

12. WHEREAS, given that the Association could potentially avoid liability hereunder by dissolving and reforming as a different entity, and given the difficulties inherent in collecting an unsecured promise, the County, in order to secure performance of the promises contained herein, conditions approval of this Subdivision upon the Developer's creation, by and through this Agreement, of a covenant running with the land upon each and every lot in the Subdivision.

Agreement

NOW, THEREFORE, in consideration of the mutual Promises contained herein, the sufficiency of which are hereby acknowledged, the Parties agree as follows:

1. Incorporation of Recitals: The Parties incorporated the Recitals above into this Agreement.

2. Covenants Running with the Land and Pro Rata Liability upon Individual Lot Owners: Developer and the Homeowners' Association agree that this entire Agreement and the

performance thereof shall become a covenant running with the land, which land is legally described in Paragraph One (1) of the Recitals set forth above, and that this entire Agreement and the performance thereof shall be binding upon themselves, their respective successors and assigns, including individual lot owners within the Subdivision.

However, any liability imposed under this Agreement against an individual lot owner shall not be joint and several with the Developer and the Association, but shall be prorated on a per-lot basis as determined by the following formula and illustration: each individual lot owner(s) shall be liable for no more than the total monetary amount of liability multiplied by a fraction in which the numerator is the number of lots in the Subdivision owned by a particular lot owner, and the denominator is the total number of lots in the Subdivision. As to any lot(s) owned by more than one person or entity, the liability among co-owners shall be joint and several for the pro rata obligation of that lot. The application of this Paragraph is best illustrated by the following example. Assume the following parameters: total liability is \$10,000; total number of lots in the Subdivision is 100; Lot 1 is owned by persons A and B; person B also owns Lot 2. Liability is as follows: The Developer, \$10,000; the Association, \$10,000; Lot 1 is \$100.00, joint and several as to A and B, Lot 2 is \$100.00 owed solely by B. Thus person A's total liability is \$100.00 and Person B's is \$200.00. Applying the principle that the County cannot collect more than it is owed, and assuming that the County cannot collect anything from the Developer and the Association, if the County collected the whole \$200.00 from B, then it could not collect the \$100.00 from A. Likewise, if the County collected the \$100.00 from A, then it could only collect \$100.00 from B.

3. **Construction:** Developer and the Homeowners' Association agree that they shall construct on [Tract _____ or Lot _____] as indicated on the final plat of the subdivision and as described below a private stormwater quality control BMP _____ [specify BMP] [for multiple BMPs, insert the following here: consisting of _____ () [specify BMP] on Tract or Lot _____ for each type of BMP used in the Subdivision. The Developer and the Homeowners' Association shall not commence construction of the BMPs until the Planning Department and the ECM Administrator have approved in writing the plans and specifications for the BMPs. Failure to obtain such approval shall be a material breach of this Agreement, and shall entitle the County to pursue any remedies available to it at law or in equity to enforce the same. Construction of the BMP must be complete prior to occupation of the site.

In the event construction is not so substantially completed within the occupation, then the County may exercise its discretion to complete the project, and shall have the right to seek reimbursement from the Developer and the Homeowners' Association and their respective successors and assigns, including individual lot owners in the Subdivision, for its actual costs and expenses incurred in the process of completing construction. The term actual costs and expenses shall be liberally construed in favor of the County, and shall include, but shall not be limited to, labor costs, tool and equipment costs, supply costs, and engineering and design costs, regardless of whether the County uses its own personnel, tools, equipment and supplies, etc. to correct the matter. In the event the County initiates any litigation or engages the services of legal

counsel in order to enforce the Provisions arising herein, the County shall be entitled to its damages and costs, including reasonable attorney fees, regardless of whether the County contracts with outside legal counsel or utilizes in-house legal counsel for the same. The scope of liability therefore of the Developer, the Association, and the individual lot owners shall be as set forth in paragraph Two (2) above.

The structural BMP shall be located on the following parcel(s) within the Subdivision:
BMP: _____ Tract: _____ [or Lot: _____]

4. Maintenance: The Developer and the Association agree for themselves, their respective successors and assigns, including individual lot owners within the Subdivision, that they will regularly and routinely inspect, clean and maintain the BMP, and otherwise keep the same in good repair, all at their own cost and expense. No trees or shrubs that will impair the structural integrity of the BMP shall be planted or allowed to grow on the BMP.

5. Creation of Easement: Developer and the Association hereby grant the County a non-exclusive perpetual easement upon the entire Tract(s) [or Lot(s)] describe above. The purpose of the easement is to allow the County to access, inspect, clean, repair and maintain the BMP; however, the creation of the easement does not expressly or implicitly impose on the County a duty to so inspect, clean, repair or maintain the BMP.

6. County's Rights and Obligations: Any time the County determines, in the sole exercise of its discretion, that the BMP is not properly cleaned, maintained and/or otherwise kept in good repair, the County shall give reasonable notice to the Developer, the Association and their respective successors and assigns, including the individual lot owners within the Subdivision, that the BMP needs to be cleaned, maintained and/or otherwise repaired. The notice shall provide a reasonable time to correct the problem(s). Should the responsible parties fail to correct the specified problem(s), the County may enter upon the Property to so correct the specified problem(s). Notice shall be effective to the above by the County's deposit of the same into the regular United States mail, postage pre-paid. However, this Agreement does not expressly impose on the County a duty to so inspect, clean, repair or maintain the BMP.

7. Reimbursement of County's Costs/Covenant Running With the Land: The Developer and the Association agree and covenant, for themselves, their respective successors and assigns, including individual lot owners within the Subdivision, that they will reimburse the County for its costs and expenses incurred in the process of cleaning, maintaining, and/or repairing the BMP. However, the obligation and liability of the Developer hereunder shall only continue until such time as the Developer transfers the entire management and operation of the Association to the individual lot owners within the Subdivision. Notwithstanding the previous

counsel in order to enforce the Provisions arising herein, the County shall be entitled to its damages and costs, including reasonable attorney fees, regardless of whether the County contracts with outside legal counsel or utilizes in-house legal counsel for the same. The scope of liability therefore of the Developer, the Association, and the individual lot owners shall be as set forth in paragraph Two (2) above.

The structural BMP shall be located on the following parcel(s) within the Subdivision:
BMP: _____ Tract: _____ [or Lot: _____]

4. Maintenance: The Developer and the Association agree for themselves, their respective successors and assigns, including individual lot owners within the Subdivision, that they will regularly and routinely inspect, clean and maintain the BMP, and otherwise keep the same in good repair, all at their own cost and expense. No trees or shrubs that will impair the structural integrity of the BMP shall be planted or allowed to grow on the BMP.

5. Creation of Easement: Developer and the Association hereby grant the County a non-exclusive perpetual easement upon the entire Tract(s) [or Lot(s)] describe above. The purpose of the easement is to allow the County to access, inspect, clean, repair and maintain the BMP; however, the creation of the easement does not expressly or implicitly impose on the County a duty to so inspect, clean, repair or maintain the BMP.

6. County's Rights and Obligations: Any time the County determines, in the sole exercise of its discretion, that the BMP is not properly cleaned, maintained and/or otherwise kept in good repair, the County shall give reasonable notice to the Developer, the Association and their respective successors and assigns, including the individual lot owners within the Subdivision, that the BMP needs to be cleaned, maintained and/or otherwise repaired. The notice shall provide a reasonable time to correct the problem(s). Should the responsible parties fail to correct the specified problem(s), the County may enter upon the Property to so correct the specified problem(s). Notice shall be effective to the above by the County's deposit of the same into the regular United States mail, postage pre-paid. However, this Agreement does not expressly impose on the County a duty to so inspect, clean, repair or maintain the BMP.

7. Reimbursement of County's Costs/Covenant Running With the Land: The Developer and the Association agree and covenant, for themselves, their respective successors and assigns, including individual lot owners within the Subdivision, that they will reimburse the County for its costs and expenses incurred in the process of cleaning, maintaining, and/or repairing the BMP. However, the obligation and liability of the Developer hereunder shall only continue until such time as the Developer transfers the entire management and operation of the Association to the individual lot owners within the Subdivision. Notwithstanding the previous

sentence, the Association and the individual lot owners within the Subdivision shall always remain obligated and liable hereunder, and as per the provision of Paragraph Two (2) above.

The terms actual costs and expenses shall be liberally constructed in favor of the County, and shall include, but shall not be limited to, labor costs, tools and equipment costs, supply costs, and engineering and design costs, regardless of whether the County uses its own personnel, tools, equipment and supplies, etc. to correct the matter. In the event the County initiates any litigation or engages the services of legal counsel in order to enforce the Provision arising herein, the County shall be entitled to its damages and costs, including reasonable attorney's fees, regardless of whether the County contracts with outside legal counsel or utilizes in-house legal counsel for the same. The scope of liability therefor of the Developer, the Association, and the individual lot owners shall be as set forth in Paragraph Two (2) above.

8. Contingencies of Subdivision Approval: Developer's and the Association's execution of the Agreement is a condition of subdivision approval. Additional conditions of this Agreement include, but are not limited to the following:

- a. Conveyance of Tract(s) _____ from Developer to the Association (which will include a reservation of easement in favor of the County for purposed of accessing, inspecting, cleaning, maintaining, and repairing the BMP), and recording of the Deed for the same; and

[If not a conveyance of a fee interest but merely creating and conveying an easement on the affected lot(s), then substitute the following alternative Paragraph a:]

- a. Conveyance of easements on Lot(s) _____ from the Developer to the Association and to the County for purposes of accessing, inspecting, cleaning, maintaining, and repairing the BMP, and recording of appropriate conveyance documents for the same; and
- b. The County's receipt of a copy of the Articles of Incorporation for the Association, as filed with the Colorado Secretary of State; receipt of the Certificate of Incorporation or other comparable proof for the same from the Colorado Secretary of State; a copy of the Bylaws of the Association; a copy of the organization minutes or other appropriate document of the Association, properly executed and attested, establishing that the Association has adopted this Agreement as an obligation of the Association; and
- c. A copy of the Covenants of the Subdivision establishing that the Association is obligated to inspect, clean, maintain, and repair the BMP; that the Association has adopted this Agreement as an obligation of the Association; and that a funding mechanism is in place whereby individual

lot owners within the Subdivision pay a regular fee to the Association for, among other matters, the inspection, cleaning, maintenance, and repair of the BMP.

- d. A copy of the Covenants of the Subdivision establishing that this Agreement is incorporated into the Covenants, and that such Agreement touches and concerns each every lot within the Subdivision.

The County shall have the right, in the sole exercise of its discretion, to approve or disapprove any documentation submitted to it under the conditions of this Paragraph. The County's rejection of any documentation submitted hereunder shall mean that the appropriate condition of this Agreement has not been fulfilled.

9. Distribution to Lot Purchasers: Upon the initial sale of any lot within the Subdivision, prior to closing on such sale, the Developer shall give a copy of this Agreement to the potential Buyer.

10. Agreement Monitored by Engineering Criteria Manual Administrator: Any and all actions and decisions to be made hereunder by the County shall be made by the Engineering Criteria Manual (ECM) Administrator. Accordingly, any and all documents, submissions, plan approval, inspections, etc. shall be submitted to and shall be made by the ECM Administrator.

11. Indemnification and Hold Harmless: To the extent authorized by law, Developer and the Association agree, for themselves, their respective successors and assigns, including the individual lot owners in the Subdivision, that they will indemnify, defend, and hold the County harmless from any and all loss, costs, damage, injury, liability, claim, lien, demand, action and causes of action whatsoever, whether at law or in equity, arising from or related to their respective intentional or negligent acts, errors, or omissions or that of its agents, officers, servants, employees, invitees and licensees in the construction, operation, inspection, cleaning (including analyzing and disposing of any solid or hazardous wastes as defined by State and/or Federal environmental laws and regulations), maintenance and repair of the BMP, and such obligation arising under this Paragraph shall be joint and several. Nothing in the Paragraph shall be deemed to waive or otherwise limit the defense available to the County pursuant to the Colorado Governmental Immunity Act, Sections 24-10-101, *et seq.* C.R.S. 2001, as amended, or as otherwise provided by law. However, the obligation and liability of the Developer hereunder shall only continue until such time as the Developer transfers the entire management and operation of the Association to the individual lot owners within the Subdivision.

12. Severability: In the event any Court of competent jurisdiction declares any part of this Agreement to be unenforceable, such declaration shall not affect the enforceability of the remaining parts of this agreement.

13. Third Parties: This Agreement does not and shall not be deemed to confer upon or grant to any third party any right to claim damages or to bring any lawsuit, action or other

proceeding against either the County, the Developer or the Association, their respective successors and assigns, including any individual lot owners in the Subdivision, because of any breach hereof or because of any terms, covenants, agreements or conditions contained herein.

14. Solid or Hazardous Wastes: Should any refuse from the BMP be suspected or identified as solid waste and/or hazardous waste, the Developer and the Association shall take all necessary and proper steps to characterize the waste and properly dispose of it in accordance with applicable State and/or Federal environmental laws and regulations, including, but not limited to, the following: Solid Wastes Disposal Sites and Facilities Acts, §§ 30-20-100.5 – 30-20-119, C.R.S. (2001) as amended, Colorado Regulations Pertaining to Solid Waste Disposal Sites and Facilities, 6 C.C.R. 1007-2, *et seq.*, as amended, Solid Waste Disposal Act, 42 U.S.C. §§ 6901-6992k (2001) as amended, and Federal Solid Waste Regulations 40 CFR Ch. I. (2001) as amended. The County shall not be responsible or liable for identifying, characterizing, cleaning up, or disposing of such solid and/or hazardous waste. Notwithstanding the previous sentence, should any refuse cleaned up and disposed of by the County be determined to be solid and/or hazardous waste, the Developer and the Association, but not the County, shall be responsible and liable as the owner, generator, and/or transporter of said solid and/or hazardous waste.

15. Applicable Law and Venue: The laws, rules, and regulations of the State of Colorado and El Paso County shall be applicable in the enforcement, interpretation, and execution of this Agreement, except that Federal law may be applicable regarding solid or hazardous wastes. Venue shall be the El Paso County District Court.

IN WITNESS WHEREOF, the Parties affix their signatures below.

Executed this _____ day of _____, _____, by:
[DEVELOPER'S NAME]:

By: _____
(Insert name) _____, President

The foregoing instrument was acknowledged before me this _____ day of _____, _____, by _____, President, _____.

Witness my hand and official seal.
My commission expires: _____

- ENGINEERING CRITERIA MANUAL
Appendix G STORMWATER BMP MAINTENANCE AGREEMENTS

Notary Public

Executed this _____ day of _____, _____, by:

HOMEOWNERS ASSOCIATION, a Colorado nonprofit corporation.

By: _____
(insert name) _____, President

The foregoing instrument was acknowledged before me this _____ day of _____, _____, by _____, President, _____
Homeowners Association, a Colorado nonprofit corporation.

Witness my hand and official seal.

My commission expires: _____

Notary Public

Executed this _____ day of _____, _____, by:

BOARD OF COUNTY COMMISSIONERS
OF EL PASO COUNTY, COLORADO

By: _____
_____, Chairperson

Attest:

Deputy Clerk

The foregoing instrument was acknowledged before me this _____ day of _____, by _____, Chairperson of the Board of County Commissioners of El Paso County, Colorado, as Attested to by _____, Deputy Clerk to the Board of County Commissioners of El Paso County, Colorado.

Witness my hand and official seal.

My commission expires: _____

Notary Public

Approved as to Content and Form:

Assistant County Attorney

**PRIVATE DETENTION BASIN /
STORMWATER QUALITY BEST MANAGEMENT PRACTICE
MAINTENANCE AGREEMENT AND EASEMENT**

This PRIVATE DETENTION BASIN / STORMWATER QUALITY BEST MANAGEMENT PRACTICE MAINTENANCE AGREEMENT AND EASEMENT (Agreement) is made by and between EL PASO COUNTY by and through THE BOARD OF COUNTY COMMISSIONERS OF EL PASO COUNTY, COLORADO (Board or County) and [Insert Lot Owner/Developer's name] (Owner or Developer). The above may occasionally be referred to herein singularly as "Party" and collectively as "Parties."

Recitals

A. WHEREAS, Developer is the owner of certain real estate (the Property or Subdivision) in El Paso County, Colorado, which Property is legally described in Exhibit A attached hereto and incorporated herein by this reference; and

B. WHEREAS, Developer desires to plat and develop on the Property a subdivision/land use to be known as [Insert proposed subdivision/land use name]; and

C. WHEREAS, the development of this Property will substantially increase the volume of water runoff and will decrease the quality of the stormwater runoff from the Property, and, therefore, it is in the best interest of public health, safety and welfare for the County to condition approval of this subdivision/land use on Developer's promise to construct adequate drainage, water runoff control facilities, and stormwater quality structural Best Management Practices ("BMPs") for the subdivision/land use; and

D. WHEREAS, Chapter 8, Section 8.4.5 of the El Paso County Land Development Code, as periodically amended, promulgated pursuant to Section 30-28-133(1), Colorado Revised Statutes (C.R.S.), requires the County to condition approval of all subdivisions on a developer's promise to so construct adequate drainage, water runoff control facilities, and BMPs in subdivisions; and

E. WHEREAS, the Drainage Criteria Manual, Volume 2, as amended by Appendix I of the El Paso County Engineering Criteria Manual (ECM), as each may be periodically amended, promulgated pursuant to the County's Colorado Discharge Permit System General Permit (MS4 Permit) as required by Phase II of the National Pollutant Discharge Elimination System (NPDES), which MS4 Permit requires that the County take measures to protect the quality of stormwater from sediment and other contaminants, requires subdividers, developers, landowners, and owners of facilities located in the County's rights-of-way or easements to

provide adequate permanent stormwater quality BMPs with new development or significant redevelopment; and

F. WHEREAS, Section 2.9 of the El Paso County Drainage Criteria Manual provides for a developer's promise to maintain a subdivision's drainage facilities in the event the County does not assume such responsibility; and

G. WHEREAS, developers in El Paso County have historically chosen water runoff detention basins as a means to provide adequate drainage and water runoff control in subdivisions, which basins, while effective, are less expensive for developers to construct than other methods of providing drainage and water runoff control; and

H. WHEREAS, Developer desires to construct for the subdivision/land use [insert number of basins/BMPs] detention basin/stormwater quality BMP(s) ("detention basin/BMP(s)") as the means for providing adequate drainage and stormwater runoff control and to meet requirements of the County's MS4 Permit, and to operate, clean, maintain and repair such detention basin/BMP(s); and

I. WHEREAS, Developer desires to construct the detention basin/BMP(s) on property that is or will be platted as [Insert Lot or Tract identifier(s)], as indicated on the final plat of the subdivision, and as set forth on Exhibit B attached hereto; and

J. WHEREAS, Developer shall be charged with the duties of constructing, operating, maintaining and repairing the detention basin/BMP(s) on the Property described in Exhibit B; and

K. WHEREAS, it is the County's experience that subdivision developers and property owners historically have not properly cleaned and otherwise not properly maintained and repaired these detention basins/BMPs, and that these detention basins/BMPs, when not so properly cleaned, maintained, and repaired, threaten the public health, safety and welfare; and

L. WHEREAS, the County, in order to protect the public health, safety and welfare, has historically expended valuable and limited public resources to so properly clean, maintain, and repair these detention basins/BMPs when developers and property owners have failed in their responsibilities, and therefore, the County desires the means to recover its costs incurred in the event the burden falls on the County to so clean, maintain and repair the detention basin/BMP(s) serving this subdivision/land use due to the Developer/Owner's failure to meet its obligations to do the same; and

M. WHEREAS, the County conditions approval of this subdivision/land use on the Developer's promise to so construct the detention basin/BMP(s), and conditions approval on the Owner's promise to reimburse the County in the event the burden falls upon the County to so clean, maintain and/or repair the detention basin/BMP(s) serving this Subdivision; and

N. WHEREAS, the County could condition subdivision/land use approval on the Developer's promise to construct a different and more expensive drainage, water runoff control system and BMPs than those proposed herein, which more expensive system would not create the possibility of the burden of cleaning, maintenance and repair expenses falling on the County; however, the County is willing to forego such right upon the performance of Developer/Owner's promises contained herein; and

O. WHEREAS, the County, in order to secure performance of the promises contained herein, conditions approval of this subdivision/land use upon the Developer's grant herein of a perpetual Easement over a portion of the Property for the purpose of allowing the County to periodically access, inspect, and, when so necessary, to clean, maintain and/or repair the detention basin/BMP(s); and

Agreement

NOW, THEREFORE, in consideration of the mutual Promises contained herein, the sufficiency of which are hereby acknowledged, the Parties agree as follows:

1. Incorporation of Recitals: The Parties incorporate the Recitals above into this Agreement.

2. Covenants Running with the Land: Developer/Owner agrees that this entire Agreement and the performance thereof shall become a covenant running with the land, which land is legally described in Exhibit A attached hereto, and that this entire Agreement and the performance thereof shall be binding upon itself, its successors and assigns.

3. Construction: Developer shall construct on that portion of the Property described in Exhibit B attached hereto and incorporated herein by this reference, [insert number of basins/BMPs] detention basin/BMP(s). Developer shall not commence construction of the detention basin/BMP(s) until the El Paso County Development Services Department (DSD) has approved in writing the plans and specifications for the detention basin/BMP(s) and this Agreement has been signed by all Parties and returned to the DSD. Developer shall complete construction of the detention basin/BMP(s) in substantial compliance with the County-approved plans and specifications for the detention basin/BMP(s). Failure to meet these requirements shall be a material breach of this Agreement, and shall entitle the County to pursue any remedies available to it at law or in equity to enforce the same. Construction of the detention basin/BMP(s) shall be substantially completed within one (1) year (defined as 365 days), which one year period will commence to run on the date the approved plat of this Subdivision is recorded in the records of the El Paso County Clerk and Recorder. In cases where a subdivision is not required, the one year period will commence to run on the date the Erosion and Stormwater Quality Control Permit (ESQCP) is issued. Rough grading of the detention

basin/BMP(s) must be completed and inspected by the El Paso County Development Services Department prior to commencing road construction.

In the event construction is not substantially completed within the one (1) year period, then the County may exercise its discretion to complete the project, and shall have the right to seek reimbursement from the Developer/Owner and its successors and assigns, for its actual costs and expenses incurred in the process of completing construction. The term actual costs and expenses shall be liberally construed in favor of the County, and shall include, but shall not be limited to, labor costs, tool and equipment costs, supply costs, and engineering and design costs, regardless of whether the County uses its own personnel, tools, equipment and supplies, etc. to correct the matter. In the event the County initiates any litigation or engages the services of legal counsel in order to enforce the Provisions arising herein, the County shall be entitled to its damages and costs, including reasonable attorney fees, regardless of whether the County contracts with outside legal counsel or utilizes in-house legal counsel for the same.

4. Maintenance: The Developer/Owner agrees for itself and its successors and assigns, that it will regularly and routinely inspect, clean and maintain the detention basin/BMP(s), and otherwise keep the same in good repair, all at its own cost and expense. No trees or shrubs that will impair the structural integrity of the detention basin/BMP(s) shall be planted or allowed to grow on the detention basin/BMP(s).

5. Creation of Easement: Developer/Owner hereby grants the County a non-exclusive perpetual easement upon and across that portion of the Property described in Exhibit B. The purpose of the easement is to allow the County to access, inspect, clean, repair and maintain the detention basin/BMP(s); however, the creation of the easement does not expressly or implicitly impose on the County a duty to so inspect, clean, repair or maintain the detention basin/BMP(s).

6. County's Rights and Obligations: Any time the County determines, in the sole exercise of its discretion, that the detention basin/BMP(s) is not properly cleaned, maintained and/or otherwise kept in good repair, the County shall give reasonable notice to the Developer/Owner and its successors and assigns, that the detention basin/BMP(s) needs to be cleaned, maintained and/or otherwise repaired. The notice shall provide a reasonable time to correct the problem(s). Should the responsible parties fail to correct the specified problem(s), the County may enter upon the Property to so correct the specified problem(s). Notice shall be effective to the above by the County's deposit of the same into the regular United States mail, postage pre-paid. Notwithstanding the foregoing, this Agreement does not expressly or implicitly impose on the County a duty to so inspect, clean, repair or maintain the detention basin/BMP(s).

7. Reimbursement of County's Costs / Covenant Running With the Land: The Developer/Owner agrees and covenants, for itself, its successors and assigns, that it will reimburse the County for its costs and expenses incurred in the process of completing construction of, cleaning, maintaining, and/or repairing the detention basin/BMP(s) pursuant to the provisions of this Agreement.

The term “actual costs and expenses” shall be liberally construed in favor of the County, and shall include, but shall not be limited to, labor costs, tools and equipment costs, supply costs, and engineering and design costs, regardless of whether the County uses its own personnel, tools, equipment and supplies, etc. to correct the matter. In the event the County initiates any litigation or engages the services of legal counsel in order to enforce the provisions arising herein, the County shall be entitled to its damages and costs, including reasonable attorney’s fees, regardless of whether the County contracts with outside legal counsel or utilizes in-house legal counsel for the same.

8. Contingencies of Land Use/Land Disturbance Approval: Developer/Owner’s execution of this Agreement is a condition of land use/land disturbance approval.

The County shall have the right, in the sole exercise of its discretion, to approve or disapprove any documentation submitted to it under the conditions of this Paragraph, including but not limited to, any separate agreement or amendment, if applicable, identifying any specific maintenance responsibilities not addressed herein. The County’s rejection of any documentation submitted hereunder shall mean that the appropriate condition of this Agreement has not been fulfilled.

9. Agreement Monitored by El Paso County Development Services Department and/or El Paso County Public Services Department: Any and all actions and decisions to be made hereunder by the County shall be made by the Director of the El Paso County Development Services Department and/or the Director of the El Paso County Public Services Department. Accordingly, any and all documents, submissions, plan approvals, inspections, etc. shall be submitted to and shall be made by the Director of the Development Services Department and/or the Director of the El Paso County Public Services Department.

10. Indemnification and Hold Harmless: To the extent authorized by law, Developer/Owner agrees, for itself, its successors and assigns, that it will indemnify, defend, and hold the County harmless from any and all loss, costs, damage, injury, liability, claim, lien, demand, action and causes of action whatsoever, whether at law or in equity, arising from or related to its intentional or negligent acts, errors or omissions or that of its agents, officers, servants, employees, invitees and licensees in the construction, operation, inspection, cleaning (including analyzing and disposing of any solid or hazardous wastes as defined by State and/or Federal environmental laws and regulations), maintenance, and repair of the detention basin/BMP(s), and such obligation arising under this Paragraph shall be joint and several. Nothing in this Paragraph shall be deemed to waive or otherwise limit the defense available to the County pursuant to the Colorado Governmental Immunity Act, Sections 24-10-101, *et seq.* C.R.S., or as otherwise provided by law.

11. Severability: In the event any Court of competent jurisdiction declares any part of this Agreement to be unenforceable, such declaration shall not affect the enforceability of the remaining parts of this Agreement.

12. Third Parties: This Agreement does not and shall not be deemed to confer upon or grant to any third party any right to claim damages or to bring any lawsuit, action or other proceeding against either the County, the Developer/Owner, or their respective successors and assigns, because of any breach hereof or because of any terms, covenants, agreements or conditions contained herein.

13. Solid Waste or Hazardous Materials: Should any refuse from the detention basin/BMP(s) be suspected or identified as solid waste or petroleum products, hazardous substances or hazardous materials (collectively referred to herein as "hazardous materials"), the Developer/Owner shall take all necessary and proper steps to characterize the solid waste or hazardous materials and properly dispose of it in accordance with applicable State and/or Federal environmental laws and regulations, including, but not limited to, the following: Solid Wastes Disposal Sites and Facilities Acts, §§ 30-20-100.5 – 30-20-119, C.R.S., Colorado Regulations Pertaining to Solid Waste Disposal Sites and Facilities, 6 C.C.R. 1007-2, *et seq.*, Solid Waste Disposal Act, 42 U.S.C. §§ 6901-6992k, and Federal Solid Waste Regulations 40 CFR Ch. I. The County shall not be responsible or liable for identifying, characterizing, cleaning up, or disposing of such solid waste or hazardous materials. Notwithstanding the previous sentence, should any refuse cleaned up and disposed of by the County be determined to be solid waste or hazardous materials, the Developer/Owner, but not the County, shall be responsible and liable as the owner, generator, and/or transporter of said solid waste or hazardous materials.

14. Applicable Law and Venue: The laws, rules, and regulations of the State of Colorado and El Paso County shall be applicable in the enforcement, interpretation, and execution of this Agreement, except that Federal law may be applicable regarding solid waste or hazardous materials. Venue shall be in the El Paso County District Court.

IN WITNESS WHEREOF, the Parties affix their signatures below.

Executed this _____ day of _____, 20____, by:

[Insert Developer's company name]

By: _____
[Insert name], [Insert title(President/Manager)]

The foregoing instrument was acknowledged before me this _____ day of _____, 20____, by [Insert name], [Insert title(President/Manager)], [Insert Developer's company name].

- ENGINEERING CRITERIA MANUAL
Appendix G STORMWATER BMP MAINTENANCE AGREEMENTS

Witness my hand and official seal.

My commission expires: _____

Notary Public

Executed this _____ day of _____, 20____, by:

**BOARD OF COUNTY COMMISSIONERS
OF EL PASO COUNTY, COLORADO**

By: _____

_____, Chair

Attest:

County Clerk and Recorder

The foregoing instrument was acknowledged before me this _____ day of _____, 20____, by _____, Chair of the Board of County Commissioners of El Paso County, Colorado, as Attested to by _____, County Clerk and Recorder.

Witness my hand and official seal.

My commission expires: _____

Notary Public

Approved as to Content and Form:

Assistant County Attorney

**PRIVATE DETENTION BASIN /
STORMWATER QUALITY BEST MANAGEMENT PRACTICE
MAINTENANCE AGREEMENT AND EASEMENT**

This PRIVATE DETENTION BASIN / STORMWATER QUALITY BEST MANAGEMENT PRACTICE MAINTENANCE AGREEMENT AND EASEMENT (Agreement) is made by and between EL PASO COUNTY by and through THE BOARD OF COUNTY COMMISSIONERS OF EL PASO COUNTY, COLORADO (Board or County) and [Insert Developer's company name] (Developer) and [Insert first part of Metro District name] METROPOLITAN DISTRICT (Metro District), a quasi-municipal corporation and political subdivision of the State of Colorado. The above may occasionally be referred to herein singularly as "Party" and collectively as "Parties."

Recitals

A. WHEREAS, the District provides various municipal services to certain real property in El Paso County, Colorado referred to as [Insert development name]; and

B. WHEREAS, Developer is the owner of certain real estate (the Property or Subdivision) in El Paso County, Colorado, which Property is legally described in Exhibit A attached hereto and incorporated herein by this reference; and

C. WHEREAS, Developer desires to plat and develop on the Property a subdivision to be known as [Insert proposed subdivision name]; and

D. WHEREAS, the development of this Property will substantially increase the volume of water runoff and will decrease the quality of the stormwater runoff from the Property, and, therefore, it is in the best interest of public health, safety and welfare for the County to condition approval of this subdivision on Developer's promise to construct adequate drainage, water runoff control facilities, and stormwater quality structural Best Management Practices ("BMPs") for the subdivision; and

E. WHEREAS, Chapter 8, Section 8.4.5 of the El Paso County Land Development Code, as periodically amended, promulgated pursuant to Section 30-28-133(1), Colorado Revised Statutes (C.R.S.), requires the County to condition approval of all subdivisions on a developer's promise to so construct adequate drainage, water runoff control facilities, and BMPs in subdivisions; and

F. WHEREAS, the Drainage Criteria Manual, Volume 2, as amended by Appendix I of the El Paso County Engineering Criteria Manual (ECM), as each may be periodically amended, promulgated pursuant to the County's Colorado Discharge Permit System General

Permit (MS4 Permit) as required by Phase II of the National Pollutant Discharge Elimination System (NPDES), which MS4 Permit requires that the County take measures to protect the quality of stormwater from sediment and other contaminants, requires subdividers, developers, landowners, and owners of facilities located in the County's rights-of-way or easements to provide adequate permanent stormwater quality BMPs with new development or significant redevelopment; and

G. WHEREAS, Section 2.9 of the El Paso County Drainage Criteria Manual provides for a developer's promise to maintain a subdivision's drainage facilities in the event the County does not assume such responsibility; and

H. WHEREAS, developers in El Paso County have historically chosen water runoff detention basins as a means to provide adequate drainage and water runoff control in subdivisions, which basins, while effective, are less expensive for developers to construct than other methods of providing drainage and water runoff control; and

I. WHEREAS, Developer desires to construct for the subdivision [insert number of basins/BMPs] detention basin/stormwater quality BMP(s) ("detention basin/BMP(s)") as the means for providing adequate drainage and stormwater runoff control and to meet requirements of the County's MS4 Permit, and to provide for operating, cleaning, maintaining and repairing such detention basin/BMP(s); and

J. WHEREAS, Developer desires to construct the detention basin/BMP(s) on property that is or will be platted as [Insert Lot or Tract identifier(s)], as indicated on the final plat of the subdivision, and as set forth on Exhibit B attached hereto; and

K. WHEREAS, Developer shall be charged with the duty of constructing the detention basin/BMP(s) and the Metro District shall be charged with the duties of operating, maintaining and repairing the detention basin/BMP(s) on the Property described in Exhibit B; and

L. WHEREAS, it is the County's experience that subdivision developers and property owners historically have not properly cleaned and otherwise not properly maintained and repaired these detention basins/BMPs, and that these detention basins/BMPs, when not so properly cleaned, maintained, and repaired, threaten the public health, safety and welfare; and

M. WHEREAS, the County, in order to protect the public health, safety and welfare, has historically expended valuable and limited public resources to so properly clean, maintain, and repair these detention basins/BMPs when developers and property owners have failed in their responsibilities, and therefore, the County desires the means to recover its costs incurred in the event the burden falls on the County to so clean, maintain and repair the detention basin/BMP(s) serving this Subdivision due to the Developer's or the Metro District's failure to meet its obligations to do the same; and

N. WHEREAS, the County conditions approval of this Subdivision on the Developer's promise to so construct the detention basin/BMP(s), and further conditions approval on the Metro District's promise to reimburse the County in the event the burden falls upon the County to so clean, maintain and/or repair the detention basin/BMP(s) serving this Subdivision; and

O. WHEREAS, the County could condition subdivision approval on the Developer's promise to construct a different and more expensive drainage, water runoff control system and BMPs than those proposed herein, which more expensive system would not create the possibility of the burden of cleaning, maintenance and repair expenses falling on the County; however, the County is willing to forego such right upon the performance of Developer's and the Metro District's promises contained herein; and

P. WHEREAS, the County, in order to secure performance of the promises contained herein, conditions approval of this Subdivision upon the Developer's grant herein of a perpetual Easement over a portion of the Property for the purpose of allowing the County to periodically access, inspect, and, when so necessary, to clean, maintain and/or repair the detention basin/BMP(s); and

Q. WHEREAS, Pursuant to Colorado Constitution, Article XIV, Section 18(2) and Section 29-1-203, Colorado Revised Statutes, governmental entities may cooperate and contract with each other to provide any function, services, or facilities lawfully authorized to each.

Agreement

NOW, THEREFORE, in consideration of the mutual Promises contained herein, the sufficiency of which are hereby acknowledged, the Parties agree as follows:

1. Incorporation of Recitals: The Parties incorporate the Recitals above into this Agreement.
2. Covenants Running with the Land: Developer and the Metro District agree that this entire Agreement and the performance thereof shall become a covenant running with the land, which land is legally described in Exhibit A attached hereto, and that this entire Agreement and the performance thereof shall be binding upon themselves, their respective successors and assigns.
3. Construction: Developer shall construct on that portion of the Property described in Exhibit B attached hereto and incorporated herein by this reference, [insert number of basins/BMPs] detention basin/BMP(s). Developer shall not commence construction of the

detention basin/BMP(s) until the El Paso County Development Services Department (DSD) has approved in writing the plans and specifications for the detention basin/BMP(s) and this Agreement has been signed by all Parties and returned to the DSD. Developer shall complete construction of the detention basin/BMP(s) in substantial compliance with the County-approved plans and specifications for the detention basin/BMP(s). Failure to meet these requirements shall be a material breach of this Agreement, and shall entitle the County to pursue any remedies available to it at law or in equity to enforce the same. Construction of the detention basin/BMP(s) shall be substantially completed within one (1) year (defined as 365 days), which one year period will commence to run on the date the approved plat of this Subdivision is recorded in the records of the El Paso County Clerk and Recorder. Rough grading of the detention basin/BMP(s) must be completed and inspected by the El Paso County Development Services Department prior to commencing road construction.

In the event construction is not substantially completed within the one (1) year period, then the County may exercise its discretion to complete the project, and shall have the right to seek reimbursement from the Developer and its respective successors and assigns, for its actual costs and expenses incurred in the process of completing construction. The term actual costs and expenses shall be liberally construed in favor of the County, and shall include, but shall not be limited to, labor costs, tool and equipment costs, supply costs, and engineering and design costs, regardless of whether the County uses its own personnel, tools, equipment and supplies, etc. to correct the matter. In the event the County initiates any litigation or engages the services of legal counsel in order to enforce the Provisions arising herein, the County shall be entitled to its damages and costs, including reasonable attorney fees, regardless of whether the County contracts with outside legal counsel or utilizes in-house legal counsel for the same.

4. Maintenance: The Metro District agrees for itself and its successors and assigns, that it will regularly and routinely inspect, clean and maintain the detention basin/BMP(s), and otherwise keep the same in good repair, all at its own cost and expense. No trees or shrubs that will impair the structural integrity of the detention basin/BMP(s) shall be planted or allowed to grow on the detention basin/BMP(s).

5. Creation of Easement: Developer hereby grants the County and the Metro District a non-exclusive perpetual easement upon and across that portion of the Property described in Exhibit B. The purpose of the easement is to allow the County and the Metro District to access, inspect, clean, repair and maintain the detention basin/BMP(s); however, the creation of the easement does not expressly or implicitly impose on the County a duty to so inspect, clean, repair or maintain the detention basin/BMP(s).

6. County's Rights and Obligations: Any time the County determines, in the sole exercise of its discretion, that the detention basin/BMP(s) is not properly cleaned, maintained and/or otherwise kept in good repair, the County shall give reasonable notice to the Developer, the Metro District and their respective successors and assigns, that the detention basin/BMP(s) needs to be cleaned, maintained and/or otherwise repaired. The notice shall provide a reasonable time to correct the problem(s). Should the responsible parties fail to correct the specified

problem(s), the County may enter upon the Property to so correct the specified problem(s). Notice shall be effective to the above by the County's deposit of the same into the regular United States mail, postage pre-paid. Notwithstanding the foregoing, this Agreement does not expressly or implicitly impose on the County a duty to so inspect, clean, repair or maintain the detention basin/BMP(s).

7. Reimbursement of County's Costs / Covenant Running With the Land: The Developer and the Metro District agree and covenant, for themselves, their respective successors and assigns, that they will reimburse the County for its costs and expenses incurred in the process of completing construction of, cleaning, maintaining, and/or repairing the detention basin/BMP(s) pursuant to the provisions of this Agreement.

The term "actual costs and expenses" shall be liberally construed in favor of the County, and shall include, but shall not be limited to, labor costs, tools and equipment costs, supply costs, and engineering and design costs, regardless of whether the County uses its own personnel, tools, equipment and supplies, etc. to correct the matter. In the event the County initiates any litigation or engages the services of legal counsel in order to enforce the provisions arising herein, the County shall be entitled to its damages and costs, including reasonable attorney's fees, regardless of whether the County contracts with outside legal counsel or utilizes in-house legal counsel for the same.

8. Contingencies of Subdivision Approval: Developer's and the Metro District's execution of this Agreement is a condition of subdivision approval. Additional conditions of this Agreement include, but are not limited to, the following:

- a. Conveyance of [Insert Lot, Tract or easement identifier(s)], as indicated on the final plat of the subdivision, from Developer to the Metro District (which will include a reservation of easement in favor of the County for purposes of accessing, inspecting, cleaning, maintaining, and repairing the detention basin/BMP(s)), and recording of the Deed for the same; and
- b. A copy of the Covenants of the Subdivision, if applicable, establishing that the Metro District is obligated to inspect, clean, maintain, and repair the detention basin/BMP(s).

The County shall have the right, in the sole exercise of its discretion, to approve or disapprove any documentation submitted to it under the conditions of this Paragraph, including but not limited to, any separate agreement or amendment, if applicable, identifying any specific maintenance responsibilities not addressed herein. The County's rejection of any documentation submitted hereunder shall mean that the appropriate condition of this Agreement has not been fulfilled.

9. Agreement Monitored by El Paso County Development Services Department and/or El Paso County Public Services Department: Any and all actions and decisions to be made hereunder by the County shall be made by the Director of the El Paso County Development Services Department and/or the Director of the El Paso County Public Services Department. Accordingly, any and all documents, submissions, plan approvals, inspections, etc. shall be submitted to and shall be made by the Director of the Development Services Department and/or the Director of the El Paso County Public Services Department.

10. Indemnification and Hold Harmless: To the extent authorized by law, Developer and the Metro District agree, for themselves, their respective successors and assigns, that they will indemnify, defend, and hold the County harmless from any and all loss, costs, damage, injury, liability, claim, lien, demand, action and causes of action whatsoever, whether at law or in equity, arising from or related to their respective intentional or negligent acts, errors or omissions or that of their agents, officers, servants, employees, invitees and licensees in the construction, operation, inspection, cleaning (including analyzing and disposing of any solid or hazardous wastes as defined by State and/or Federal environmental laws and regulations), maintenance, and repair of the detention basin/BMP(s), and such obligation arising under this Paragraph shall be joint and several. Nothing in this Paragraph shall be deemed to waive or otherwise limit the defense available to the County pursuant to the Colorado Governmental Immunity Act, Sections 24-10-101, *et seq.* C.R.S., or as otherwise provided by law.

11. Severability: In the event any Court of competent jurisdiction declares any part of this Agreement to be unenforceable, such declaration shall not affect the enforceability of the remaining parts of this Agreement.

12. Third Parties: This Agreement does not and shall not be deemed to confer upon or grant to any third party any right to claim damages or to bring any lawsuit, action or other proceeding against either the County, the Developer, the Metro District, or their respective successors and assigns, because of any breach hereof or because of any terms, covenants, agreements or conditions contained herein.

13. Solid Waste or Hazardous Materials: Should any refuse from the detention basin/BMP(s) be suspected or identified as solid waste or petroleum products, hazardous substances or hazardous materials (collectively referred to herein as “hazardous materials”), the Developer and the Metro District shall take all necessary and proper steps to characterize the solid waste or hazardous materials and properly dispose of it in accordance with applicable State and/or Federal environmental laws and regulations, including, but not limited to, the following: Solid Wastes Disposal Sites and Facilities Acts, §§ 30-20-100.5 – 30-20-119, C.R.S., Colorado Regulations Pertaining to Solid Waste Disposal Sites and Facilities, 6 C.C.R. 1007-2, *et seq.*, Solid Waste Disposal Act, 42 U.S.C. §§ 6901-6992k, and Federal Solid Waste Regulations 40 CFR Ch. I. The County shall not be responsible or liable for identifying, characterizing, cleaning up, or disposing of such solid waste or hazardous materials. Notwithstanding the previous sentence, should any refuse cleaned up and disposed of by the County be determined to be solid waste or hazardous materials, the Developer and the Metro District, but not the County, shall be

responsible and liable as the owner, generator, and/or transporter of said solid waste or hazardous materials.

14. Applicable Law and Venue: The laws, rules, and regulations of the State of Colorado and El Paso County shall be applicable in the enforcement, interpretation, and execution of this Agreement, except that Federal law may be applicable regarding solid waste or hazardous materials. Venue shall be in the El Paso County District Court.

15. Limitation on Developer's Obligation and Liability: The obligation and liability of the Developer hereunder shall only continue until such time as the Final Plat as described in Paragraph Three (3) of the Recitals set forth above is recorded and the Developer completes the construction of the detention basin/BMP(s) and transfers all applicable maintenance and operation responsibilities to the Metro District. By execution of this agreement, the Metro District agrees to accept all responsibilities and to perform all duties assigned to it, including those of the Developer, as specified herein, upon transfer of [Insert Lot, Tract or easement identifier(s)] from Developer to the Metro District.

IN WITNESS WHEREOF, the Parties affix their signatures below.

Executed this _____ day of _____, 20____, by:
[Insert Developer's company name]

By: _____
[Insert name], [Insert title(President/Manager)]

The foregoing instrument was acknowledged before me this _____ day of _____, 20____, by [Insert name], [Insert title(President/Manager)], [Insert Developer's company name].

Witness my hand and official seal.

My commission expires: _____

Notary Public

- ENGINEERING CRITERIA MANUAL
Appendix G STORMWATER BMP MAINTENANCE AGREEMENTS

Executed this _____ day of _____, 20____, by:

[Insert first part of Metro District name] METROPOLITAN DISTRICT

By: _____
[Insert name], President

Attest:

By: _____
[Insert name], [Insert title]

The foregoing instrument was acknowledged before me this _____ day of _____,

20____, by [Insert name], President, and [Insert name], [Insert title], [Insert first part of Metro District name] METROPOLITAN DISTRICT

Witness my hand and official seal.

My commission expires: _____

Notary Public

Executed this _____ day of _____, 20____, by:

**BOARD OF COUNTY COMMISSIONERS
OF EL PASO COUNTY, COLORADO**

By: _____
_____, Chair

Attest:

County Clerk and Recorder

The foregoing instrument was acknowledged before me this _____ day of _____, 20____, by _____, Chair of the Board of County Commissioners of El Paso County, Colorado, as Attested to by _____, County Clerk and Recorder.

Witness my hand and official seal.

My commission expires: _____

Notary Public

Approved as to Content and Form:

Assistant County Attorney

Appendix H PERFORMANCE SURETY

SURETY ESTIMATE FORM

This Surety Estimate Form is located on the El Paso County website at <http://adm.elpasoco.com/Development%20Services/Pages/CollateralSuretyForms.aspx>

The following pages contain typical wording for:

- Defect Surety
- Performance Surety
- Punchlist Inspection Form
- Schedule for Completion of Improvements
- Surety Release Inspection Request

DEFECT SURETY (TYPICAL WORDING)

KNOW ALL MEN BY THESE PRESENTS: That (Owner or Contractor and Address) as Principal and the (Insurance Company) as a (Name of State) corporation authorized to execute an approved form of surety in the State of Colorado, and duly authorized to transact a general surety business in the State of Colorado, as Surety, are held and firmly bound unto County of El Paso, State of Colorado, in the sum of (20% of Contract Price) lawful money of the United States, for the payment of which, well and truly to be made, we bind ourselves, our heirs, executors, administrators, successors and assigns, jointly and severally, firmly by these presents.

THE CONDITION OF THE ABOVE OBLIGATION IS SUCH THAT: WHEREAS (The Principal) has _____, and WHEREAS, the said (Principal) is required to give a form of surety in the amount of (20% Contract Price) to protect the said COUNTY OF EL PASO against the result of faulty materials or workmanship for a period of TWO YEARS from and after the date of completion and preliminary acceptance of said work;

NOW, THEREFORE, if the said (Principal) shall for a period of TWO YEARS from and after the date of completion and acceptance of said work, replace any and all defects arising in said work whether resulting from defective materials or defective workmanship, then the above obligation to be void; otherwise, to remain in full force and effect.

Signed and sealed this _____ day of _____, 20____.

PERFORMANCE SURETY (TYPICAL WORDING)

WHEREAS, the County of El Paso, State of Colorado, and _____
(hereinafter designated as "Principal") have entered into an agreement whereby Principal agrees to install and complete certain designated public and development or subdivision improvements, which said agreement, dated _____, and identified as Project _____ is hereby referred to and made a part hereof; and

WHEREAS, Principal is required under the terms of said agreement to furnish surety for the faithful performance of said agreement;

NOW, THEREFORE, we, the Principal and _____, as Surety, are held firmly bound unto the County of El Paso (hereinafter called "County") in the penal sum of _____ Dollars (\$ _____) of lawful money of the United States, for the payment of which sum well and truly to be made, we bind ourselves, our heirs, executors, administrators, successors and assigns, jointly and severally, firmly by these presents.

The condition of this obligation is such that if the above Principal, his or its heirs, executors, administrators, successors or assigns, shall in all things stand to and abide by, and well and truly keep and perform the covenants, conditions and provisions in said agreement and any alteration thereof made as therein provided, on his or their part, to be kept and performed at the time and in the manner therein specified, and in all respects according to their true intent and meaning, and shall indemnify and save harmless the County, its elected officials, officers, employees, agents, and volunteers, as therein stipulated, then this obligation shall become null and void; otherwise it shall be and remain in full force and effect.

As a part of the obligation secured hereby and in addition to the face amount specified therefore, there shall be included costs and reasonable expenses and fees, including reasonable attorney's fees, incurred by County in successfully enforcing such obligation, all to be taxed as costs and included in any judgment rendered. The surety hereby stipulates and agrees that no change, extension of time, alteration or addition to the terms of the agreement or to the work to be performed thereunder or the specifications accompanying the same shall in manner affect its obligations on this bond, and it does hereby waive notice of any such change, extension of time, alteration or addition to the terms of the agreement or to the work or to the specifications.

IN WITNESS WHEREOF, this instrument has been duly executed by the Principal and Surety above named on _____:

APPROVED AS TO FORM:

COUNTY ATTORNEY

ATTEST:

County Clerk (Seal)

Name of Principal

By: _____
(Seal)

Name of Surety

By: _____
(Seal) Attorney-in-Fact

PUNCHLIST INSPECTION FORM

- 1.1 **PURPOSE** The purpose of this form is to guide the completion of a preliminary or final acceptance inspection. The completed form is used to provide a comprehensive list of needed corrections.
- 1.2 **INSPECTION CODES** The following codes shall be used:
NA - not applicable, NI - not installed, WU - work underway
- 1.3 **DRAINAGE CONDITIONS CONFORM TO PLANS AND AREA ACCEPTABLE:**
- _____ Permanent BMPs
 - _____ Inlet
 - _____ Presedimentation (forebay)
 - _____ Low flow channel
 - _____ Bottom Stage Area
 - _____ Micropool
 - _____ Outlet Structure
 - _____ Vegetative Cover
 - _____ Infiltration Media
 - _____ Underdrain
 - _____ Culverts
 - _____ Storm Sewers
 - _____ Manholes (including risers, steps, and inverts)
 - _____ Inlets (including risers, steps, and inverts)
 - _____ Drainage Contained Within the Right-of-Way
 - _____ Platted Drainage Easement
 - _____ Construction BMPs Removed
- 1.4 **ROADWAY CONDITIONS CONFORM TO PLANS AND ARE ACCEPTABLE:**
- _____ Paved Surface in Acceptable Condition (i.e. free of cracking and potholes)
 - _____ Pavement Crown & Super Elevation Acceptable
 - _____ Shoulders to Grade and Stabilized
 - _____ Roadside Ditches Acceptable
 - _____ Cut Slopes to Grade and Stabilized
 - _____ Fill Slopes to Grade and Stabilized
 - _____ Paved Surface Cleared of Loose Stone
- 1.5 **RIGHT-OF-WAY:**
- _____ Clear of Vegetation

- _____ Clear of Debris
- _____ Curbing Acceptable
- _____ Sidewalk Acceptable
- _____ Driveway Entrances Properly Installed According to Road Plan or Site Plan
- _____ Driveway Entrances and/or Commercial Entrances Located as shown on Plans
- _____ Guardrail Installed in Correct Location(s)
- _____ Guardrail Installed at Correct Distance from Edge of Pavement
- _____ Proper Guardrail End Sections Installed in Approved Manner
- _____ Grass on Shoulders and Ditches Has Been Mowed
- _____ Dead Trees Removed That Might Fall in Right-of-Way
- _____ Shoulders and Ditches Free of Loose Stone
- _____ Driveway Pipes Clean and Functioning Properly

1.6 **INSPECTION RESULTS** An Inspection Report shall be completed with all items failing to adhere to the approved plans and ECM Standards and specifications. This handwritten punchlist is to be typed, proofed, and then given to the engineer. In addition, the completed Inspection Form shall be put in the project filed.

(Res. No. 19-245 , 7-2-19)

SCHEDULE FOR COMPLETION OF IMPROVEMENTS

1.1 PURPOSE

This form is intended to facilitate the completion of approved improvements in a timely manner by assuring the applicant has a schedule in place for the completion of the improvements, and by providing the County a means to assess the applicant's ability to meet the completion date stated in the approved agreement. The permit holder must provide an estimated completion date for each milestone listed below.

1.2 GENERAL INFORMATION

Date: _____

Applicant: _____

Phone: _____

Tax Map Parcel No.: _____

Project Name (Include phase, section, and other relevant information to clearly identify the project): _____

Date	Milestone
	Start of construction.
	Temporary erosion control systems installed (Initial BMPs).
	Grading, subgrade, and stormwater management activities completed.
	Road base constructed to required grade.
	Asphalt, curb and gutter installation completed.
	End of construction.
Office Use	
	Road Improvements "Preliminary Acceptance Inspection"
	Road Improvements "Final Inspection" (private roads accepted at this point)
	Public Road "Preliminary Acceptance" notification received from BOCC.

1.3 AUTHORIZATION OF REQUEST

Signature of Applicant

Print Applicant Name

Title (if appropriate)

SURETY RELEASE INSPECTION REQUEST

1.1 PURPOSE

This form is used to request that an inspection be scheduled to determine if the following performance sureties can be reduced or released (check below all that apply). Requests are required for either partial or full release of any construction surety. Requests for construction surety reduction will be subject to the following conditions based upon the percentage of work completed and approved by the County, or other authority or agency having jurisdiction over the improvement. The following conditions apply to surety reductions and inspection fees.

- No more than three inspections for surety reductions will be scheduled during any twelve-month period.
- A surety reduction inspection fee must accompany each request for reduction.
- Inspections will be scheduled within 30 days of receipt of the surety reduction inspection request form and applicable fee.
- Reductions will not occur until completion and approval of at least 30% of the proposed improvements.
- 20% of the original construction surety amount will be retained until final completion and preliminary acceptance of all improvements.

Inspections will be scheduled within thirty days of receipt of this request and the required fee.

Inspections must be requested by the permit holder.

1.2 GENERAL INFORMATION

Date: _____

Applicant: _____

Phone: _____

Tax Map Parcel No.: _____

Project Name (Include phase, section, and other relevant information to clearly identify the project): _____

1.3 SURETY RELEASE INFORMATION

Water Protection Performance Surety

Erosion & Sediment Control

Stormwater Management & Water Quality

Identification No.: _____

Description of Release Requested: _____

Amount of Requested Release: _____

- Subdivision/Public Improvement Performance Surety**
 - Roads & Drainage (at least 30% of the work must be satisfactorily completed before requesting an inspection for reduction)***
 - Water & Sewer (at least 30% of the work must be satisfactorily completed before requesting an inspection for reduction)***
 - Other – list below (i.e. landscaping, pedestrian paths)***

Identification No.: _____
Description of Release Requested: _____

Amount of Requested Release: _____

- Work in the Right-of-Way Performance Surety**

Identification No.: _____
Description of Release Requested: _____

Amount of Requested Release: _____

- Site Development Performance Surety**

Identification No.: _____
Description of Release Requested: _____

Amount of Requested Release: _____

1.4 FEE

SUBMIT REQUIRED SURETY INSPECTION FEE - make check payable to the El Paso County and submit with request.

1.5 AUTHORIZATION OF REQUEST

Signature of Permit Holder

Print Permit Holder Name

Title (if appropriate)

Appendix I STORMWATER QUALITY POLICY AND PROCEDURES

I.1. RESERVED

Editor's note(s)—Res. No. 19-245 , adopted July 2, 2019, repealed § I.1, which pertained to title.

I.2. OVERVIEW

As part of the National Pollutant Discharge Elimination System (NPDES)-Phase II program administered by the Colorado Department of Public Health and the Environment, El Paso County has a Colorado General Discharge Permit for Stormwater Discharges Associated with Municipal Separate Storm Sewer Systems (MS4 Permit). This Permit, initially made effective March 10, 2003, was significantly modified and reissued effective on July 1, 2016 and authorizes El Paso County to discharge stormwater from its separate storm sewer system into the waters of the state. The MS4 permit applies to the urbanized areas of unincorporated El Paso County and requires the County to implement control measures to prevent or reduce the discharge of pollutants to waters of the state. The policies and criteria provided in this Appendix and Engineering Criteria Manual apply to the entire county pursuant to Section 1.4 of this Engineering Criteria Manual. A copy of the current MS4 permit area map is available on the El Paso County website. As part of this permit, the County is required to take measures to protect the quality of stormwater from contaminants, including sediment.

The El Paso County Policy Plan, adopted January 20, 1998, includes several policies directly related to protecting the quality of surface water in the County, especially as it relates to stormwater runoff. Policy 2.1.1 commits the County to meeting the requirements of the Clean Water Act.

Directly related to the NPDES programs are:

- Policy 3.3.4 - Implement appropriate measures to protect and/or mitigate effects of point and non-point sources of pollution to surface water,
- Policy 3.3.5 - Regulate or restrict uses that are proven to contribute to contamination of water supplies,

-
- Policy 3.3.6 - Evaluate the consequences to surface water from new development including run off of natural soils, as well as chemical compounds that may result from the proposed uses,
 - Policy 11.1.4 - Require development plans to effectively address both quantitative and qualitative impacts of drainage within the project site,
 - Policy 11.3.3 - Fully evaluate the relative impact of proposed drainage improvements on the maintenance of water quality,
 - Policy 11.3.4 - Promote the effective use of innovative short and long term strategies including sediment ponds, buffer strips, and constructed wetlands as a means of reducing peak flows and improving stormwater quality, and
 - Policy 11.3.6 - Encourage the effective use of control measures to mitigate the short and long term erosion impacts of development.

The following Appendix when combined with: The City of Colorado Springs and El Paso County Drainage Criteria Manual Volume 1; the City of Colorado Springs Drainage Criteria Manual Volume 2; the City of Colorado Springs Drainage Criteria Manual Volume 1 update May 2014, as adopted by El Paso County Resolution No. 15-042; the El Paso County Policy Plan; the El Paso County Land Development Code; the El Paso County Engineering Criteria Manual; and their successors forms the basis for protecting surface water quality in the County. In the event there are conflicts that arise between this Appendix and any of the documents listed above, the requirements of this Appendix shall govern the decisions of the ECM Administrator. It shall be responsibility of the Engineer of Record to identify those conflicts and bring to the attention of the ECM Administrator. The ECM Administrator, at their sole discretion, will determine which specific use of criteria is acceptable for the project under review.

Nothing contained herein relieves any person, corporation, firm or entity from the obligation to comply with any applicable state or federal laws or regulations relating to water quality or water quality standards or any other standards related to land disturbance activities.

(Res. No. 19-245 , 7-2-19)

I.3. ADOPTION OF DRAINAGE CRITERIA MANUALS BY EL PASO COUNTY

In November of 2002, the City of Colorado Springs adopted its Drainage Criteria Manual Volume 2: Stormwater Quality Policies, Procedures and Best Management Practices (BMPs). The goal of this document was to provide guidance and engineering criteria for water quality protection measures during construction and for permanent installations.

The DCM2 was adopted as the County's stormwater quality design criteria. It is supplemented by this Appendix, which provides additions and revisions as applicable to the County in order to expand its scope to cover rural areas and other situations specific to the County. The goal has been to maintain consistency between criteria used in the County and the City of Colorado Springs.

On January 27, 2015, El Paso County adopted certain portions of the revisions made by the City of Colorado Springs to the Drainage Criteria Manual Volume 1, dated May 2014. Specifically, Chapter 6 in its entirety, Sections 3.2.1, 4.1.2, 4.1.3, 4.1.4, 4.2, 4.2.1, 4.2.2, and Figures 13-4a, 13-4b, and 13-5 of Chapter 13 were adopted to update the County criteria to reflect recent advances in hydrology.

To clarify applicability, "El Paso County" will be substituted for "City of Colorado Springs" or a County department or position analogous to one in the City will be used where appropriate unless otherwise specified in this Appendix. Table I-1 summarizes the most common or typical substitutions that shall be used in applying and interpreting DCM2 and DCMV1.

Table I-1. General Substitutions

Text in DCM2	Substitution in DCM2 as Applied in El Paso County
City of Colorado Springs	El Paso County
City	County
City Engineer	County Engineer
City Engineering Inspector	County Inspector
City Inspections	County Inspections
Erosion and Stormwater Quality Control Plan	Stormwater Management Plan
Other Changes	
Hillside Overlay	Remove references to "Hillside Overlay"

(Res. No. 19-245 , 7-2-19)

I.4. EL PASO COUNTY EROSION AND STORMWATER QUALITY CONTROL PERMITS

An overview of the two types of erosion and stormwater quality permits issued by El Paso County is provided in section 5.6 of the ECM. The following section provides specific stormwater permit application requirements and permit holder responsibilities for construction activities that occur within the unincorporated areas of El Paso County.

I.4.1. Erosion and Stormwater Quality Control Permit

An Erosion and Stormwater Quality Control Permit (ESQCP) is required for all applicable construction activities. The ESQCP is the key mechanism for protecting water quality in the County and provides the requirements for the selection, installation, implementation, and maintenance of control measures (BMPs) during construction through final stabilization. Applicable construction activities include construction activities that result in land disturbance of greater than or equal to (\geq) one acre or that is less than ($<$) one acre but is part of a larger common plan of development or sale that would disturb one acre or more of ground surface, unless excluded pursuant to section 5.6.3 of this ECM. Any project involving earth disturbing activity of less than 1 acre but which disturbs more than 500 cubic yards of material (stockpiling, cut and/or fill) may be considered an applicable construction activity at the ECM Administrator's discretion when potential pollutants, site topography, hydraulics or proximity to a surface water body are of significant concern.

Construction activities refers to ground surface disturbing and associated activities that include, but are not limited to: clearing, grading, excavating, demolition, installation of new or improved haul and access roads, staging areas, stockpile, fill and borrow areas. Construction activity occurs from initial ground breaking to final stabilization regardless of ownership of the construction activities.

Activities that include routine maintenance to maintain original line and grade, hydraulic capacity, or original purpose of the facility are not considered construction activities. Activities to conduct repairs that are not part of regular maintenance and activities that are for replacement are considered construction activities and are not considered routine maintenance. Repaving activities where underlying or surrounding soil is cleared, graded, or excavated as part of the repaving operation are construction activities unless they are an excluded pursuant to section 5.6.3 of this ECM.

Temporary construction control measures to protect water quality are to be implemented when needed as determined by an El Paso County Inspector, even if a permit is not required. Refer to Table I-2 for additional criteria to determine applicability of an ESQCP.

Storm Sewer Connections:

An ESQCP may be used as a storm sewer connection permit to allow for a connection to the El Paso County separate storm sewer system. Those cases are limited to entities that possess their own Colorado Discharge Permit System permit for stormwater

Discharges, and are contingent on the hydraulic capacity of the system.

- A. **Application.** Applications for ESQCPs generally are submitted to the El Paso County Planning and Community Development Department as part of a Land Use application. For projects not involved in the Land Use application process, an ESQCP application must be submitted to the Department of Public Works at least ten (10) days prior to the anticipated start of construction. The owner or operator of the construction activity must submit an ESQCP application with all required material listed below to allow for review and approval of the permit.

No work shall begin until the ECM administrator, or his designee, issues a Notice to Proceed. Typically the Notice to Proceed is issued as part of the preconstruction conference.

For projects permitted through the Planning and Community Development Department, during the preconstruction conference a County Inspector will discuss with the permit owner an overview of initial construction control measures expected to be installed prior to the start of construction, as outlined in the grading, erosion, and sediment control plans and/or SWMP. A timeline for completion of initial control measure installation may be determined and the Initial Inspection scheduled during the preconstruction conference. Typically, a Notice to Proceed with initial temporary BMP installation will be given to the permit holder during the preconstruction conference. If an Initial Inspection is not scheduled during the preconstruction conference, upon installation of initial BMPs the permit holder or authorized representative shall request an Initial Inspection. The Initial Inspection must be scheduled with a County Stormwater Inspector at least 48 hours in advance of the proposed inspection time.

For projects permitted through the Department of Public Works, upon approval of the ESQCP a written Notice to Proceed is provided to the permit holder or authorized representative. Upon installation of initial BMPs the permit holder or authorized representative shall request an Initial Inspection. The Initial Inspection must be scheduled with a County Stormwater Inspector at least 48 hours in advance of the proposed inspection time.

Applications for an ESQCP shall include a completed permit application form and any required attachments reasonably necessary to review and evaluate the application or complete the permit. Generally, an application for an ESQCP shall be accompanied by the following:

1. **Stormwater Management Plan.** The purpose of a SWMP is to identify all possible pollutant sources from an applicable construction activity that may contribute to stormwater pollution, and to address the selection, installation, implementation and maintenance of control measures (also known as Best Management Practices (BMPs)) that, when implemented, will prevent pollution or degradation of state waters.

Control measures identified in the SWMP must be appropriate for the specific construction activity, the pollutant sources present, and the phase of construction. There is a wide variety of structural and non-structural control measures that can be used.

The SWMP shall be submitted as a stand-alone document separate from the engineering plan set submitted for review and approval. El Paso County uses a checklist to perform a completeness review of the initially submitted SWMP. Unlike the Grading and Erosion Control Plan, the SWMP is intended to be a dynamic document and must be revised as construction proceeds to accurately reflect the current conditions and control measures in use at the site. Therefore El Paso County does not "approve" the SWMP. A copy of the SWMP review checklist can be found in Appendix E.

During construction the SWMP is the responsibility of the designated Qualified Stormwater Manager or Certified Erosion Control Inspector and shall be located on site at all times during construction and shall be kept up to date with work progress and changes in the field.

2. **Permit Fee.** Permit fees must be paid at the time of application for a permit. If the ESQCP and associated documents are reviewed as part of the Land Use application process, the ESQCP permit fee is included in the fee for plan review. If the ESQCP and associated documents are reviewed by the Public Works Department, a separate permit fee payment must be made. The permit fee shall be in a form acceptable to the ECM Administrator. Permit fees are non-refundable.
3. **Statement of Certification.** Signed statement from owner (applicant) certifying that the SWMP and other terms of the permit will be met.
4. **Operation and Maintenance Plan.** Submitted and approved Operation and Maintenance Manual for Permanent BMPs, if any to be located on site.
5. **Maintenance Agreement.** Submitted and signed Private Detention Basin/Stormwater Quality Best Management Practice Maintenance Agreement and Easement, if any Permanent Best Management Practices are to be located on site.

6.Application Information.

- Property location and legal description.
- Owner Name and Contact Information.
- Contractor Name and Contact Information.
- Project-related information such as: total acres, disturbed acres, brief description of project, and project schedule.
- El Paso County Surety Estimate form that contains cost estimates of Construction and Maintenance of Control Measures for determination of Financial Surety.

Because each permit and site is different with respect to the scope of work and location, additional requirements may be added to address specific concerns relative to the proposed work. Attached to each approved permit will be a list of Special Provisions, if any, which shall govern the work and set forth minimum requirements for disturbing land in the County.

- B. **Permit Holder Responsibilities.** The permit holder shall be responsible for the work authorized under the permit. Should there be any defects or failures in the work that result in erosion or sediment releases, following preliminary acceptance, corrective work shall be performed immediately upon notification from the County Stormwater Staff or County Subdivision Inspector. Failure to respond in a reasonable time frame, as determined by the County Stormwater Staff, shall be just cause for the County Stormwater Staff to take the necessary action to have the defect corrected and to bill the permit holder or draw on the financial assurance for the cost to correct the defect.

The permit holder is responsible for subcontractors and others at the site meeting the provisions of the SWMP. The permit holder is responsible for determining the need for and obtaining other required permits. A State General Permit for Stormwater Discharges from Construction Activities may be required if criteria for an ESQCP is met.

1. **Control Measure Inspection and Maintenance.** Permit holder is required to conduct self-monitoring inspections of the site during construction consistent with Section 1.5.2.A.
2. **Permit Termination.** Upon completion of construction activities and achievement of final stabilization, or upon sale of the permitted property, the permit holder is responsible for

contacting the County in writing to request termination of the permit. Permit Closure will be granted when all of the following conditions are met and an acceptable final inspection has been documented consistent with Section I.5.2.G.

- Construction is complete and final stabilization has been achieved. Final stabilization will be achieved when re-vegetation efforts result in at least 70% of pre-disturbance vegetative cover at the site or equivalent permanent structural erosion and sediment control methods have been employed;
- All temporary BMPs have been removed from the site;
- A copy of the Construction Stormwater Termination Notice, Reassignment form, or Modification form submitted to the Colorado Department of Public Health and Environment is provided to the County.

- C. **Transfer of Property and Permit Holder Responsibilities.** Each successive owner of a property through the land development and building process will obtain its own ESQCP and submit its own permit fees and financial surety until final stabilization is achieved. The new owner of a property that is under an open ESQCP must immediately obtain its own ESQCP. The SWMP from the previous owner may be used, if the previous owner agrees, it covers the phases of work planned by the new owner and it remains relevant to the work to be done. If the new owner will be building single-family residences or duplexes, it may qualify for a BESQCP. The BESQCP is to be obtained immediately following purchase.

When a property is covered by an ESQCP, construction is complete, final stabilization has not occurred, and more than one lot of the covered property is sold to another party (e.g., a home builder or private investor) the previous owner (i.e., current permit holder) is responsible for installing all necessary temporary erosion and sediment control BMP's and informing the new property owner in writing of their responsibility to maintain the temporary BMP's until final stabilization (e.g., landscaping) has been installed. Upon closing of the sale, the previous owner will then be allowed to modify the ESQCP by notifying a county stormwater inspector in writing by providing them with a copy of the "Notice of Reassignment of Permit Coverage and General Permit Application Stormwater Discharges Associated with Construction Activities," which should be provided to the State of Colorado, when applicable. The Stormwater Management Plan must also be revised to account for the change in permit area coverage. Following the transfer and issuance of an ESQCP, the original owner may receive a partial release of the financial assurance proportional to the BMPs on the part of the property that was sold.

In situations where a BMP that provides protection for property that has been sold is located on the property that belongs to the original or other owner, the responsibility for the BMP rests with the owner of the property where it is located.

I.4.2. Builder's Erosion and Stormwater Quality Control Permit

Builders of single family residences may follow a simplified procedure by obtaining a Builder's Erosion and Stormwater Quality Control Permit (BESQCP). A BESQCP is used to protect stormwater on individual, residential building lots with less than one (<1) acre of total disturbed area and is not part of a larger plan of development or sale that does disturb more than one acre of land. A property must be covered by either an ESQCP or BESQCP in order to obtain a building permit.

If the lot has been disturbed previously by construction work but has been final stabilized and any ESQCP on the property has been closed, the lot may be considered undisturbed and not part of a larger plan of development. In these cases a BESQCP may be issued for the single-family residential lot provided no more than one acre of disturbance will occur.

BESQCPs are to be used for land disturbances greater than one (>1) acre on large lot single-family development or agricultural zoned lands with a total area of 2.5 acres or larger and having a total lot imperviousness of less than 10%.

An ESQCP must be used where land disturbance is greater than one (>1) acre on a single-family residential lot or agricultural zoned lands with a total lot size of 2.5 acres or greater and a total site imperviousness between 10% and 20% due to the requirement for a study specific to the watershed where the site is located that demonstrates the expected soil and vegetation conditions are suitable to infiltrate/filtrate 100% of the Water Quality Capture Volume (WQCV).

If a builder acquires single-family residential lots that are covered by an ESQCP owned by a developer (or other party) but are not final stabilized, the builder (i.e. new owner) must obtain a new ESQCP to cover the future construction activity.

- A. **Application.** Applications for a BESQCP shall include a completed permit application form and any required attachments reasonably necessary to review and evaluate the application or complete the permit, a signed statement from the owner (applicant) certifying the terms of the permit will be met, and a permit fee. Financial surety or a SWMP are not required for a BESQCP. However, a site covered by a BESQCP is required to meet stormwater quality protection criteria of preventing pollutants, including sediment, from leaving the site. If a BESQCP is revoked, the applicant will obtain an ESQCP, including the submission of a SWMP and payment of permit fee and financial surety. Initial Inspections and Notices to Proceed are not required for sites with BESQCPs.

Table I-2 provides guidance on which permit is to be obtained for various situations.

Table I-2. ESQCP and BESQCP Permit Applicability Guidance

"X" inside box indicates when each type of permit is required. Refer to section 5.6.3 for exclusions to the applicability provided below.

ESQCP	BESQCP	Description
For Developers		
X		Land Disturbance greater than or equal to (\geq) 1 acre.
X		Land Disturbance less than (<) 1 acre but part of a larger common plan of development or sale that disturbs \geq to 1 acre. See definition of larger common plan of development or sale.
X		New ESQCP required when developer acquires disturbed land currently covered by an ESQCP unless meets criteria for a BESQCP.
For Builders		
No	No	Single-family residence building site with less than (<) 1 acre of disturbance and is not part of a larger common plan of development of sale and is not located in a sensitive area ¹ .
	X	Single-family residence building site with <1 acre of disturbance and is located in an area that is not currently covered by an ESQCP and the site is not located in sensitive area.
	X	Single-family residence building site with <1 acre of disturbance and is not part of a larger common plan of development or sale and the site is located in a sensitive area.
	X	Single-family residence building site with <1 acre of disturbance and is located in an area that is not currently covered by an ESQCP and the site is located in sensitive area.
	X	Single-family residence building site with \geq 1 acre of land disturbance located on a lot or parcel with a total area of greater than or equal to 2.5 acres or

		zoned agriculture land and with a proposed total site imperviousness of less than 10%.
X		Single-family residence building site with ≥1 acre of land disturbance located on a lot or parcel with a total area of greater than or equal to 2.5 acres or zoned agriculture land and with a proposed total site imperviousness of up to 20%.
X		Commercial, industrial or other sites that disturb ≥1 acre of land, unless the activity meets exclusion criteria in Section 5.6.3.
X		Commercial, industrial or other sites that disturb <1 acre of land that are located within a sensitive area or have potential stormwater discharges of concern ² to the ECM Administrator.
NOTES:		
1. Sensitive Areas are defined as those waters identified in Table I-5 of the ECM; and any other areas of concern identified by the ECM Administrator, such as endangered species habitat area, jurisdictional wetlands, flood plains or direct discharges to waters of the state.		
2. "Potential stormwater discharges of concern," include possible discharges from commercial sources with ability to cause water quality violations or acutely toxic conditions in receiving waters. Examples of sources include, but are not limited to, auto salvage yards, auto repair facilities, industrial sources, restaurants.		

B. **Permit Holder Responsibilities.** The builder permit holder (owner) is responsible for subcontractors and others at the site to meet the provisions requirements of the BESQCP. The permit owner is responsible for determining the need for and obtaining other required permits. A State General Permit for Stormwater Discharges Associated with Construction Activities may be required.

The BESQCP owner is responsible for closure of the BESQCP upon completion of the project. To close a BESQCP all the following requirements must be met:

- Notify a County Inspector in writing that all work under the Building Permit is complete and request closure of the BESQCP;
- The site is stabilized to prevent sediment transport off the lot;
- All temporary BMPs have been removed.

C. **Transfer of Property and Permit Holder Responsibilities.** If a single residential lot covered by a ESQCP is sold prior to completion of construction and final stabilization of the lot has not been achieved, the new owner must obtain a BESQCP and will become responsible for achieving final stabilization of the lot. Only when a new BESQCP is obtained by the new owner will the ESQCP holder be allowed to modify the ESQCP to remove the sold lot from permit coverage.

D. **Reassignment of Permit Coverage.** When a property is covered by a ESQCP, construction is complete, final stabilization has not occurred, and the property is sold to a private home owner the current permit holder is responsible for installing all necessary temporary erosion and sediment control BMP's and informing the new property owner, in writing, of their responsibility to maintain the temporary BMP's until final landscaping has been installed. Upon closing of the sale, the previous owner will then be allowed to remove the sold property from the ESQCP coverage by notifying a county stormwater inspector in writing.

(Res. No. 19-245 , 7-2-19)

I.5. EL PASO COUNTY CONSTRUCTION SITE INSPECTIONS

[Replaces DCM2 Section 3.4]

Inspections of construction sites are conducted by the County Inspectors (Stormwater and Subdivision) to ensure compliance with the SWMP and associated county permits.

The focus of construction sites inspections is to ensure construction is in compliance with the approved plans and that BMPs are installed and maintained consistent with the onsite SWMP to prevent erosion, sediment transfer, spillage and leakage, improper sludge or waste disposal, and drainage from raw material storage from leaving the site creating negative public safety, property or stormwater quality impacts.

Inspections also serve as a means of educating owners/owner's representatives, developers, and contractors of the need to minimize negative stormwater quality impacts from the site operations and to assist in complying with the requirements of the County's Stormwater Program. As such County Inspectors will take a compliance assistance approach and will work with and assist the owner/owner's representative and contractor to maintain compliance with its approved plans and erosion and stormwater quality control requirements.

I.5.1. County Engineering and Subdivision Inspections

County Inspections shall be accomplished by County Stormwater Inspectors for the purpose of assuring compliance with the County's Municipal Separate Storm Sewer Systems (MS4) permit. Projects located in the unincorporated areas of El Paso County with an active ESQCP shall be inspected by County Stormwater Inspectors. County construction oversight inspections include the following types of inspections: Initial, Routine, Reduced Frequency, Compliance, Complaint Response and Final inspections, which are described below.

Inspections are not limited to new development and may be performed on any other land-disturbing activities that occur in unincorporated areas of the County. Inspections of individual homes in a residential subdivision, whether construction of the home is finished or not, are only conducted if there are observations or complaints of discharges of sediment from the disturbed area.

For all inspections conducted by County Stormwater Inspectors, a copy of the completed report will be provided to the permit holder (owner) typically within two County work days following the inspection.

I.5.2. Types of Inspections

The following are inspections that may be performed at the construction sites within the unincorporated areas of El Paso County. Not all inspection types will be performed at all sites.

- A. **Self-Monitoring Inspections.** The permit holder or authorized agent shall conduct Self-Monitoring Inspections. The purpose of Self-Monitoring inspections is for the permit holder to ensure that all BMPs are installed according to approved plans, the BMPs are adequate and are being properly maintained, the SWMP is updated to reflect current conditions, and only allowable discharges are occurring off the site. The person performing the inspections may be on the permit holder's staff or a contracted third party. The individual performing the self-monitoring inspections shall be a qualified stormwater manager, which is an individual knowledgeable in the principles and practices of erosion and sediment control and pollution prevention and with the skills to assess conditions at construction sites that could impact stormwater quality and the effectiveness of stormwater controls implemented to meet stormwater permitting requirements. Examples of a qualified stormwater manager include a registered Professional Engineer or an erosion control inspector certified in a regionally recognized erosion and sediment control inspection training program. The person performing inspections should be a person with authority to expend project dollars on erosion and stormwater quality control. There are two

types of Self-Monitoring Inspections allowed in El Paso County: Routine Self-Monitoring and Operator Compliance Inspections.

The permit holder or authorized representative may request an alternative to the 14 day routine self-monitoring inspection cycle discussed above. Self-Monitoring Inspections of stormwater best management practices may be requested for at least once every month (i.e., 30 days) for permitted construction sites when:

- All construction activity is completed except final stabilization because planted vegetative cover has not yet become established;
- All activities for final stabilization have been completed with the exception of seed application which may not have occurred due to seasonal conditions or the necessity to reapply additional seed to augment previous efforts; and
- The SWMP has been updated to locate those areas subject to the reduced inspection frequency. Routine Self-Monitoring Inspections after precipitation events are not required during an approved 30 day inspection cycle.

1. **Routine Self-Monitoring Inspections.** The Routine Self-Monitoring inspections are to be performed and documented at least once every 7 calendar days; or at least once every 14 calendars, if post-storm event inspections are conducted within 24 hours after the end of a precipitation or snow melt event. Post-storm inspections may be used to fulfill the 14 day inspection requirement. In addition to the bi-weekly inspections the owner or representative shall perform post-storm inspections of all BMPs after any precipitation or snowmelt event that causes surface erosion to ensure that the BMPs have operated as designed, to determine if maintenance is needed, and to locate and clean up any areas where materials may have run off site. For those choosing to utilize a 14-day and post-storm inspection frequency, if no construction activities will occur following a storm event, post-storm inspection must be conducted prior to resuming construction activities but no later than 72 hours following a storm event. The delay of any post-storm inspection must be documented in the inspection records included in the SWMP.

The owner or his representative will record the results of all inspections by completing an inspection report or similar inspection checklist included in the SWMP. Completed inspection reports shall be kept on site and available to County Inspectors. The County may require the submission of these inspection reports on a site-specific basis.

2. **Operator Compliance Inspection.** When a Compliance Inspection conducted by a County Stormwater Inspector documents the failure to implement control measures or implementation of inadequate control measures, the County Stormwater Inspector may require the ESQCP owner or their representative to inspect and provide a report to the County that the control measures have been implemented or corrected. The owner or the representative must include date and time stamped photographs of the new, adequate control measures.

- B. **Initial Inspections for Sites Covered by ESQCPs.** County Stormwater Inspectors perform Initial Inspections. The purpose of Initial Inspections is to allow the County the opportunity to confirm that the SWMP is implemented prior to the start of construction. Prior to the Initial Inspection, the initial construction control measures (BMPs) must have been implemented according to the SWMP. At a minimum, perimeter control measures to include vehicle tracking control and access control must be implemented, and no other land disturbing activity shall occur prior to the Initial Inspection.

Initial Inspections will typically be accomplished through the use of a Routine Inspection discussed in Section I.5.2.E. In the event the Routine Inspection identifies a failure to implement adequate

perimeter control measures, the site will be scheduled for a Compliance Inspection discussed in Section I.5.2.C.

Failure to install any initial BMPs or obtain a Notice to Proceed prior to beginning land disturbing activities may result in an immediate Stop Work Order.

Initial Inspections are not required for sites with BESQCPs.

- C. **Compliance Inspections.** Compliance Inspections are inspections conducted by County Stormwater Inspectors in follow up to an illicit discharge, failure to implement a control measure or an inadequate control measure. Typically a Compliance Inspection will occur within 14 days after some other inspection type discussed in this section, unless the necessary corrections were made and observed by the County Stormwater Inspector during the previous inspection when the compliance issue was observed. Compliance Inspections may occur during or immediately after a precipitation event.

During Compliance Inspections the County Stormwater Inspectors verify:

- If the corrections have been completed on sites where an illicit discharge, failure to implement or implementation of an inadequate control measure was documented in the previous inspection;
- BMPs are installed and functioning according to design;
- Only allowable discharges are occurring;
- The required Self-Monitoring Inspections and associated documentation of activities are occurring; and
- The SWMP is revised to reflect current site conditions.

The County Inspectors will examine the SWMP and Self-Monitoring inspection reports and will evaluate installed BMPs and site discharge points to identify any installation, maintenance or effectiveness issues to determine compliance with the ESQCP. One of the following that incorporates this scope of inspection may be performed in lieu of a Compliance Inspection within 14 days of the previous County inspection that identified a failure to implement a control measure or an inadequate control measure:

Routine Inspection in accordance with Section I.5.2.A.1; Reconnaissance Inspection in accordance with Section I.5.2.D; or Operator Compliance Inspection in accordance with Section I.5.2.A.2.

Compliance Inspections are typically conducted for sites that require an ESQCP and are located within the urbanized areas of unincorporated El Paso County. The County uses the Field Inspection Report to document Compliance Inspections.

- D. **Reconnaissance Inspections.** Reconnaissance (Recon) Inspections are indicator inspections that are conducted for the general purpose of determining obvious compliance issues at a site. During a Recon Inspection the site is not fully assessed for the adequacy of control measures, overall site management or record-keeping. Recon Inspections are a reduced scope inspection that may be used by the County to extend the frequency required of routine inspections up to 90 days when all indicators evaluated determine that the control measures observed meet good engineering, hydrologic and pollution control practices. Attention is paid to the perimeter of the site to determine if the site has contributed to offsite transfer of sediment or other pollutants to roads, drainage facilities, or surface water bodies and if any obvious BMP maintenance or implementation is needed.

Recon Inspections are conducted by County Stormwater Inspectors at least every 14 days, are generally performed from adjacent streets or property, and may occur during or immediately after a significant precipitation event. A Routine Inspection must be conducted at least once at a site before a Recon Inspection may be conducted. When a Recon Inspection identifies the need for a Compliance Inspection at a site, a Routine Inspection must occur before the Recon Inspection frequency and scope can be used again. At a minimum a Routine Inspection must be performed at a site every 90 days.

The Recon Inspection will be documented using the Field Inspection Report and a copy of the completed inspection report will be provided to the permit owner.

Recon Inspections are conducted on sites with an ESQCP or BESQCP. A Recon Inspection with cause could result in requiring a site that previously was not permitted to submit a permit application and obtain an ESQCP or BESQCP consistent with enforcement provisions provided in Section I.6.

- E. **Routine Inspections.** Routine Inspections are conducted by County Stormwater staff for the purpose of identifying failures to implement control measures, inadequate control measures and control measures requiring routing maintenance. All sources of pollution including trash will be evaluated to determine if only allowable discharges are occurring. During a Routine Inspection the County Stormwater Inspector will evaluate discharge points from the permitted site to determine if an illicit discharge has occurred.

The removal of pollutants will be required when off-site transfer of pollutants is documented by a Routine Inspection. Results of a Routine Inspection will be provided to the permit owner or representative using the Field Inspection Report.

Routine Inspections are conducted at least once every 45 days, and at least 1 Routine Inspection must occur on a site prior to final stabilization. Routine Inspections do not apply to the reduced site inspections described in Section I.5.2.H.

- F. **Complaint Response Inspections.** Complaint Response Inspections will occur in response to either a citizen complaint or a complaint from another agency. The County Stormwater Inspector will perform a Recon Inspection to determine the validity of the complaint. If the owner or authorized representative of the site is available at the time of the inspection they will be made aware of the complaint and any issues identified during the Recon Inspection, and if necessary, provide recommendations for the implementation, repair, and maintenance of control measures or cleanup of material transferred offsite.

All construction sites are subject to Complaint Response Inspections. In the event a site subject to a Complaint Response Inspection is operating without an applicable permit, the County Stormwater Inspector may pursue appropriate enforcement action described in Section 1.6.

The Complaint Response Inspection will be documented using the Field Inspection Report provided to the owner or authorized representative.

- G. **Final Inspections.** Upon the completion of construction activities for a site, when the ESQCP permit holder (owner) believes conditions for final stabilization are met and a request to close the ESQCP is received in writing by the County, a County Inspector will perform a Final Inspection to verify the conditions required to close the permit are met. If so confirmed during the ESQCP Final Inspection, the County will provide the permit holder (owner) a written notice of permit closure using the Field Inspection Form.

A Final Inspection may be requested in conjunction with a Preliminary Acceptance or Final Acceptance Inspection discussed in Section 5.3.15 of this ECM. During an ESQCP Final Inspection, the following items will be evaluated in addition to the requirements discussed in Sections I.4.1.B.2 and 5.3.15.

- The site has final stabilization equal to a uniform vegetative cover with an individual plant density of at least 70 percent compared to the pre-disturbance levels and such cover is capable of adequately controlling soil erosion, as determined by the County Stormwater Inspector, or equivalent permanent, structural erosion and sediment control methods have been employed.
- Any sediment or other pollutant that may have been transferred off-site has been removed.
- The site shall be free of noxious weeds or treated according to an approved Noxious Weed Control Plan.

-
- All approved permanent (post construction) BMPs have been maintained and are functioning in accordance with the design and with the Operation and Maintenance Manual.
 - Engineering Record Drawings are provided to the County consistent with Section 5.10.6 of this ECM.
 - All temporary construction control measures (BMPs) have been removed from the site.
 - Streets, parking lots and other paved surfaces (on-site and off-site) are free of sediment and debris.
 - Drainage structures such as pipes, inlets and channels are clean and in good service.
 - The site is in compliance with required corrective action identified during previous Inspections.

H. **Reduced Site Inspections.** Reduced site inspections are conducted by County Stormwater Inspectors and must occur at the frequency and include the scope of review indicated below:

1. **Inactive Site Inspections.** Sites where ground disturbing activities are completed and are pending growth of vegetation for final stabilization, or sites where no construction activity has occurred since the previous inspection conducted by the County are eligible for this type of inspection.

Inactive Site Inspections must be conducted by County Stormwater Inspectors at least every 90 days. The purpose of this type of inspection is to identify failure to implement control measures, inadequate control measures or control measures requiring maintenance. The County Stormwater Inspector will evaluate all off-site discharge points to determine if only allowable discharges are occurring. If an illicit discharge is documented, the owner or authorized representative must remove all off-site deposited material when feasible. Results of an Inactive Site Inspection will be documented in the Field Inspection Report.

2. **Stormwater Management System Administrator Program Inspections.** These inspections are for construction activities operated by a participant in a Colorado Department of Public Health and Environment Water Quality Control Division designated Stormwater Management System Administrator's Program in accordance with Article 8 of title 25, Colorado Revised Statutes that has been identified by the Stormwater Management System Administrator to be fully implementing the program and qualified for reduced oversight incentives of the program. To be eligible for this reduced site inspection frequency, the owner or authorized agent must provide verifiable documentation to the County Stormwater Inspector of their participation in this State program. Upon verification of participation with the State, the owner or authorized agent may take advantage this type of reduced frequency inspections.

Upon verification with the State, County Stormwater Inspectors will conduct inspections of the approved site at least every 90 days. The scope of the inspection will include evaluation of all pollutant sources on site, including trash, identification of failure to implement control measures, inadequate control measures, and control measures requiring maintenance to determine if an illicit discharge has occurred. If the site inspection determines an illicit discharge occurred, the permit owner will be required to remove the pollutants immediately when feasible. The results of the inspection will be documented using the Field Inspection Report and provided to the permit holder.

3. **Staff Vacancy Inspections.** This type of inspection is to accommodate a County staff vacancy or leave due to vacation or illness. The minimum frequency for this type of inspection is once every 90 days. The County Inspector will evaluate all pollutant sources on site, including trash, identify failures to implement control measures, inadequate control measures, and control measures requiring maintenance to determine if an illicit discharge has occurred. If the site inspection determines an illicit discharge occurred, the permit owner will be required to remove the pollutants immediately when feasible. The results of the inspection will be documented using the Field Inspection Report and provided to the permit holder.

-
- I. **Permanent Stormwater Quality Control Measure Inspections.** The MS4 permit requires the County to implement inspection and acceptance procedures for all permanent stormwater quality control structures to ensure they are installed and implemented in accordance with approved site plans. The County must also have written procedures in place to ensure the long term operation and maintenance of all permanent stormwater quality control structures, including those owned and maintained by a private or other public entity located within El Paso County jurisdiction. These procedures are described in Section I.7.7 of this Appendix.

During construction, all permanent stormwater management facilities will be inspected as part of the other construction related inspections discussed in this section. Upon satisfactory completion of the Final Inspection for an applicable development site, the County will enter both privately and publicly maintained permanent stormwater quality control structures into an El Paso County Permanent Stormwater Management Facility Inventory. Entry into the County inventory of privately maintained structures does not imply or assume any maintenance responsibility on behalf of El Paso County. Entry into the inventory is for the sole purpose of tracking long term operation, maintenance and enforcement of permanent stormwater quality control structures with Private BMP Maintenance Agreements with the County.

At a minimum a County Stormwater Inspector will inspect all individual permanent stormwater quality management facilities in the inventory at least once every 5 years. During this inspection, the County Stormwater Inspector will evaluate the structures for items that affect the effective operation of the structure, including maintenance needs such as revegetation, mowing, accumulated trash and debris removal, and repairs. Results of the inspection will be documented on a Permanent Stormwater Quality BMP Inspection Form and will be provided to the owner recorded in the Private Detention Basin/Stormwater Quality BMP Maintenance Agreement and Easement.

I.5.3. Site Inspection Exclusions

- A. **Finished Homes in a Residential Subdivision.** Inspections are not routinely conducted on lots that have been conveyed to the homeowner when the following criteria are met:
- i. The lot has been sold to the homeowner for private residential use.
 - ii. The lot has less than one acre of disturbed area.
 - iii. All construction activity associated with grading the lot and building the home is completed.
 - iv. A certificate of occupancy (or equivalent) has been issued to the homeowner.
 - v. The County was notified by the owner and has documented that the lot is subject to this exclusion.
 - vi. The residential development site must have a County-approved site plan and still be inspected by the County under the inspection types described in this section.
- B. **Unfinished Home in a Residential Subdivision.** Inspections are not conducted on residential lots with an unfinished home when all of the following criteria are met:
- i. The lot has less than one acre of disturbed area.
 - ii. The permittee has documented that the lot is subject to this exclusion.
 - iii. The residential development site must have a County-approved site plan and still be inspected by the County under the inspection frequencies described in this section.
- C. **Winter Conditions.** Inspections (self-monitoring and County) are not required at sites where construction activities are temporarily halted, snow cover exists over the entire site for an extended

period, and melting conditions posing a risk of surface erosion do not exist. This exclusion is applicable only during the period where melting conditions do not exist. The following information must be documented for this exclusion:

- Dates when snow cover occurred,
- Date when construction activities ceased, and
- Date that melting conditions began.

Due to typical winter weather conditions along the Front Range, this exemption will rarely be applicable.

(Res. No. 19-245 , 7-2-19)

I.6. CONSTRUCTION STORMWATER ENFORCEMENT

As part of an effective stormwater quality protection program, a process of escalating enforcement measures will be used to ensure compliance with County-issued stormwater permits and the County's MS4 permit.

The County considers the owner of the land the ultimate responsible party for all construction activities. It is the responsibility of the owner to take all necessary measures to ensure that the site is in compliance with the County Construction Permit, Stormwater Management Plan, Erosion and Stormwater Quality Control Permit or Builder's Erosion and Stormwater Quality Control Permit, and Private Detention Basin/Stormwater Quality BMP Maintenance Agreements. In addition to County requirements, the owner must meet State and Federal regulatory requirements for permits, control measures and water rights. The County has tried to make its requirements consistent with State requirements for construction activities (CDPS General Permit - Stormwater Discharges Associated with Construction Activities). Should requirements conflict, it will be the responsibility of the owner to bring these conflicts to the County's attention and propose how to address them.

As mentioned in Section 1.5, El Paso County Stormwater Inspectors will take a compliance assistance approach with project owners and authorized agents during inspections. Failure to adequately respond to non-compliance items documented in Field Inspection Reports provided by the County, however, may result in an enforcement action discussed in this section.

El Paso County is required by its MS4 permit to have an enforcement process and sanctions designed to minimize the occurrence of violations and obtain compliance from chronic and recalcitrant violators of stormwater control requirements. Escalation of enforcement must occur as necessary based upon the severity of the violation and/or the recalcitrance of the violator to ensure that violations of a similar nature are enforced consistently. As a general outline, the following process will be followed up to the point where an adequate response to non-compliance is obtained:

Documented Inspection > Verbal Warning of non-compliance (documented in Field Inspection Report) > Letter of Noncompliance > Stop Work Order > Revocation of Permit > Performance of Remedial Work > Court Order. The County retains its right, however, to exercise its discretion in applying enforcement mechanisms as circumstances warrant.

In cases where the ECM Administrator deems it necessary to address a construction site with more aggressive action, or in cases where no permit is required, the El Paso County Ordinance No. 07-01: Prohibiting Illicit Discharges to the County Storm Sewer System may be used, as appropriate, to address the site. Additional information on the County's Enforcement Procedures is discussed in Section I.6.2 and enforcement options are summarized in Table I-3.

Created: 2021-06-08 11:36:13 [EST]

(Supp. No. 2)

I.6.1. Definitions

- A. **Applicable Construction Activity.** Include construction activities that result in a land disturbance of greater than or equal to one acre or that is less than one acre, but is part of a larger common plan of development or sale that would disturb, or has disturbed since March 2, 2001, one acre or more, unless excluded consistent with Chapter 5, Section 5.6.3, or the disturbed areas have been finally stabilized.
- B. **Applicable Development Site.** "Applicable development sites" are those that result in land disturbance of greater than or equal to one acre, including sites less than one acre that are part of a larger common plan of development or sale, unless excluded consistent with Section 5.6.3 or I.7.1. Applicable development sites include all new development and redevelopment sites for which permanent water quality control measures were required in accordance with an MS4 permit. "New Development" means land disturbing activities, structural development, including construction or installation of a building or structure, creation of impervious surfaces, and land subdivision for a site that does not meet the definition of redevelopment. "Redevelopment" includes a site that is already substantially developed with 35% or more of existing imperviousness; with the creation or addition of impervious area (including removal and/or replacement), to include the expansion of a building footprint or addition or replacement of a structure; structural development including construction, replacement of impervious area that is not part of a routine maintenance activity; and land disturbing activities.
- C. **Control Measure.** Any best management practice (BMP) or other method used to prevent or reduce the discharge of pollutants to waters of the state. Control measures include, but are not limited to best management practices. Control measures can include other methods such as the installation, operation, and maintenance of structural controls and treatment devices. The following requirements apply to all control measures:
1. **Good Engineering, Hydrologic and Pollution Control Practices:** Control measures must be selected, designed, installed, implemented, and maintained in accordance with good engineering, hydrologic, and pollution control practices as defined in this section. "Pollution" is man-made or man-induced, or natural alteration of the physical, chemical, biological, and radiological integrity of water.
 2. **Maintenance:** Control measures must be maintained in effective operating condition.
 3. **Inadequate Control Measures:** Any control measure shall be considered an "inadequate control measure" if it is not designed, implemented, or operating in accordance with the requirements of the permit, including the specific requirements in each program area in Part I.E or requirements for specific permittees in Part III.
 4. **Control Measure Requiring Routine Maintenance:** Any control measure shall be considered a "control measure requiring routine maintenance" if it is still operating in accordance with its design and the requirements of this permit, but requires maintenance to prevent associated potential for failure during a runoff event.
 5. **Minimize:** The term "minimize," for purposes of implementing control measures of this permit, means reduce and/or eliminate to the extent achievable using control measures that are technologically available and economically practicable and achievable in light of best industry practices.
- D. **Final Stabilization.** The condition reached when all ground surface disturbing activities at the site have been completed, and for all areas of ground surface disturbing activities a uniform vegetative cover has been established with an individual plant density of at least 70 percent of pre-disturbance levels, or equivalent permanent, physical erosion reduction methods have been employed.

-
- E. **Good Engineering, Hydrologic and Pollution Control Practices.** Methods, procedures, and practices that:
- Are based on basic scientific facts.
 - Reflect best industry practices and standards.
 - Are appropriate for the conditions and pollutant sources.
 - Provide appropriate solutions to meet the associated permit requirements.
- F. **Inspection.** The term "inspection" refers to an evaluation by a County Inspector of a site for compliance with the ESQCP, BESQCP, SWMP, approved plans, Private Detention Basin/Stormwater Quality BMP Agreement and the Illicit Discharge Ordinance. For the purposes of Appendix I, inspections performed by County Stormwater Inspectors include those inspection types described in Section I.5.2.
- G. **Notice of Noncompliance.** There are two types of notices of noncompliance used by County Stormwater Inspectors: A verbal warning of noncompliance and a letter of noncompliance. Both are defined below.
1. **Verbal Warning of Noncompliance.** During an inspection conducted by a County Stormwater Inspector, the inspector may verbally inform the owner or authorized agent of specific instances of noncompliance with ESQCP or BESQCP. Examples of these instances include failure to implement control measures, inadequate control measures or a control measure needing maintenance. In the event the issues identified as noncompliant are corrected before the termination of the inspection no further action will occur. If the items are not corrected during the inspection, the County Stormwater Inspector will document the findings of noncompliance in the Field Inspection Report and provided to the owner or authorized representative. Once documented in the Field Inspection Report and provided to the owner or authorized agent, this will be considered a "Verbal Warning of Noncompliance."
 2. **Letter of Noncompliance.** A written notice provided by a County Stormwater Inspector to the permit holder (owner) or authorized representative to formally inform them that the permitted project is not in compliance with the ESQCP, BESQCP, SWMP, or other requirements of County criteria, codes or ordinances relating to grading, erosion, and stormwater quality. The letter contains a specific description of the issues of noncompliance and the measures required to bring the site into compliance and a date by which these measures must be implemented.
- H. **Notice to Proceed.** A Notice to Proceed is a written notice provided by the County after an ESQCP is approved. The notice allows for the implementation of initial BMPs and commencement of construction activities upon completion of an Initial Inspection. Construction is authorized only after issuance of a Notice to Proceed.
- I. **Performance or Contracting of Remedial Work.** If the permit holder does not successfully complete all required work or violates any requirement of the permit, the County may take corrective measures and charge the cost of such to the permit holder. Such costs shall include the actual cost of any work deemed necessary by the County plus reasonable administrative and inspection costs and penalties, as established by Resolution adopted by the Board of County Commissioners or by a fee schedule adopted by the ECM Administrator as authorized by the Board of County Commissioners. If the total of such costs exceeds the financial assurance, the permit holder shall be responsible for payment of the remaining balance within thirty calendar days of receipt of an accounting of such from the County.
- J. **Stop Work Order.** A Stop Work Order is a written order to immediately cease construction activity at a site. The Stop Work Order may be issued by the ECM Administrator or County Stormwater staff to the property owner, permit holder or authorized agent of a construction site. An immediate Stop Work Order shall be issued when the property owner has failed to obtain an ESQCP, BESQCP, or a Notice to

Proceed prior to land-disturbing activity. A Stop Work Order may also be issued if the site operator has demonstrated obvious non-compliance with the ESQCP or BESQCP after repeated, documented attempts by the Inspector to bring the site into compliance. When a Stop Work Order is issued, it requires all work on the site to cease. No further land use approvals relative to the site will be allowed by the County, nor will work be allowed to resume, until the owner, permit holder or authorized representative takes the measures necessary to bring the site into compliance, as described in the Stop Work Order. A written notice to resume construction activity will be provided in the Field Inspection Report after Inspection by a County Inspector to verify satisfactory completion of required corrective actions identified in the Stop Work Order.

- K. **Stormwater Management Plan.** A Stormwater Management Plan (SWMP) is a plan developed in compliance with the content requirements in the CDPS General Permit for Stormwater Discharges Associated with Construction Activity (COR040000) and this Appendix I. El Paso County developed a content checklist for use by owners or the authorized representative of applicable construction sites to develop a complete SWMP. A copy of the SWMP Checklist can be found in Appendix E.

The SWMP shall be a stand-alone document separate from the engineering plan set. The purpose of the SWMP is to develop and document a dynamic, systematic approach to identify possible pollutant sources that may contribute pollutants to stormwater, and identify the control measures (BMPs) that, when implemented, will prevent, minimize or eliminate any possible negative water quality impacts. The SWMP must be prepared using good engineering, hydrologic and pollution control practices and shall be implemented prior to beginning ground disturbing activities. The SWMP shall be revised as construction proceeds to accurately reflect the current conditions and practices at the site.

Revisions must be made to the SWMP before changes are made in the field. A map showing the current location, status and changes to the BMPs are required. The owner or his representative shall keep the SWMP on-site while construction activities are occurring and must be implemented as written and updated from the start of construction activity until final stabilization is achieved. During construction, the SWMP must contain records of self-inspections, a map of the BMPs as they are installed or removed, BMP detail sheets with installation and maintenance specifications, and all other items listed in the SWMP checklist found in Appendix E.

Given the dynamic nature of the SWMP, the following guidance is provided for making in-field modifications to BMPs based on Self-Monitoring Inspections. Changes to BMPs identified in the SWMP may be completed in the field without approval from the County when:

- The control measure is a temporary construction BMP.
- The change results in a comparable BMP. Examples include but are not limited to, silt fence replaced with a wattle, rock check dam replaced with straw bale check, erosion control mat used in place of straw mulch, etc.
- Prior to installation, the change is reflected in the on-site SWMP including a BMP detail for the new BMP.

Changes to permanent stormwater quality control measures or any other BMP change that will affect the approved engineering design, hydraulics or hydrology must be approved by the ECM Administrator or designee through the established plan modification process.

- L. **Water Quality Capture Volume (WQCV).** The volume equivalent to the runoff from an 80th percentile storm, meaning that 80 percent of the most frequently occurring storms are fully captured and treated and larger events are partially treated.

I.6.2. Enforcement Procedures

With each inspection the County performs at an active construction site, the County Stormwater Inspector will note any observed violations of the County Construction Permit, Stormwater Management Plan, ESQCP or BESQCP, Private Detention Basin/Stormwater Quality BMP Maintenance Agreement, or any applicable County regulations or ordinances. The owner will remain noncompliant until the violation is corrected. The following enforcement procedures will typically apply. The County reserves its right, however, to exercise its discretion in applying enforcement mechanisms as circumstances warrant.

- A. In the event that control measures have not been implemented, are inadequate or require routine maintenance, the owner must take all necessary steps to minimize or prevent the discharge of pollutants until an adequate control measure is implemented and operational. If it is not feasible to immediately install, repair or perform maintenance on a control measure, the SWMP must be amended to describe the reason such action is infeasible and establish a schedule for installing, repairing, or performing maintenance on the control measure as soon as possible. The owner must also remove and properly dispose of any unauthorized release or discharge (e.g. non-stormwater discharge, trash, sediment, spill or leak) and clean up any contaminated surfaces to minimize future unauthorized discharges.
- B. If corrective action to install, repair, or perform maintenance on a control measure is completed, or if other corrective action is taken to address other types of violations, during the inspection in which the violation is noted, no further enforcement action will occur. If the corrective action is not performed during the inspection, the County Stormwater Inspector will document the violations in the Field Inspection Report provided to the owner. The report will serve as a Verbal Warning of Noncompliance.
- C. The County Stormwater Inspector will conduct a Routine Inspection within 14 days of the inspection that noted the violations. If the violations have not been corrected, a Letter of Noncompliance will be issued to the owner. Failure to subsequently correct the violations will result in the issuance of a Stop Work Order, which may be followed by one or more of the other enforcement options listed in Table I-3.
- D. Accelerated enforcement action or the immediate imposition of stricter remedies may be pursued in certain instances. Factors to be considered include:
 - a. Recurrence of the same problem at a site.
 - b. Occurrence of frequent problems at a site.
 - c. Repeated failure to correct violations at a site.
 - d. A history of noncompliance or recalcitrance.

Permanent stormwater quality control structures are assessed for adequate operation and maintenance. If the County Stormwater Inspector identifies a lack of maintenance or failure or inadequate operation of a permanent stormwater quality control structure, those findings will be documented and provided to the owner or authorized representative using a Permanent Stormwater Quality BMP Inspection Form. In addition to the enforcement mechanisms and process described above, the County will utilize the provisions of the recorded Private Detention Basin/Permanent Stormwater Quality Best Management Practice Agreement and Easement as appropriate to ensure the long term operation and maintenance of permanent stormwater quality control measures.

The County may take other action as deemed appropriate. In cases where deemed appropriate by the ECM Administrator, the El Paso County Ordinance No. 07-01: Prohibiting Illicit Discharges to the County Storm Sewer System may be used to address compliance issues at a site that result in an unauthorized off-site discharge into the County MS4 system.

When an unauthorized discharge of a pollutant or an illicit discharge occurs from an active construction site directly into waters of the state, the County Inspector, at their discretion, may notify the Colorado Department of Public Health and Environment pursuant to the reporting requirements included in the County's MS4 permit or the CDPS General Permit for Stormwater Discharges Associated with Construction Activity.

If an ESQCP is revoked as part of an enforcement action, the owner shall submit a new ESQCP application, SWMP and other required submissions described in Section I.4.1.A to obtain a new ESQCP. When a BESCP is revoked the owner must submit a new ESQCP application and other required submission items. A second BESQCP will not be issued to the same site once revoked.

(Res. No. 19-245 , 7-2-19)

I.7. POST-CONSTRUCTION STORMWATER MANAGEMENT

I.7.1. Post-Construction Stormwater Management Planning

[Replaces DCM2 Section 4.1, pages 4-1 through "Other BMPs" continued on 4-5]

- A. **Overview.** This chapter contains requirements and procedures for the selection, installation, implementation and maintenance of permanent stormwater quality control measures that will remain in operation after construction for new development and significant redevelopment. All applicable development sites must have operational permanent stormwater quality control measures at the completion of the site, unless excluded from the requirements of an applicable development site as described in Section I.7.1.C. All permanent control measures for applicable development sites shall meet one of the "base design standards" described in Section 1.71.D.

In the case where permanent water quality control measures are part of future phasing, the permittee must have a mechanism to ensure that all control measures will be implemented, regardless of completion of future phases or site ownership. In such cases, temporary water quality control measures must be implemented as feasible and maintained until removed or modified. All temporary water quality control measure must meet one of the "base design standards" described in Section I.7.1.D.

A procedure is provided within the context of a flow chart and a four-step process that shall be followed for all applicable development sites. Detailed descriptions, sizing and design criteria, and design procedures for control measures are provided in the New Development BMP Factsheets found in Section 4.2 of the DCMV2.

It is recommended that discussions and collaboration regarding proposed BMPs occur early in each project between the developer's planner and engineer, County Stormwater and County Planning and Community Development staff.

The analysis of the requirements, exclusions and base design standards presented in this Section I.7 shall be incorporated into existing ECM Administrator submittals for review and acceptance including Preliminary/Final Drainage Reports and construction plans, or as otherwise specified by the ECM Administrator.

- B. **Applicable Development Sites: Excluded Sites.** The following types of sites and associated land disturbances are excluded from the requirements of this Section 1.7. Although a site may qualify for an exclusion to Section 1.7 below, the site may still be considered an applicable construction activity subject to the requirements of an ESQCP or BESQCP.

Created: 2021-06-08 11:36:13 [EST]

(Supp. No. 2)

-
1. **Pavement Management Sites.** Sites, or portions of sites, for the rehabilitation, maintenance, and reconstruction of roadway pavement, which includes roadway resurfacing, mill and overlay, white topping, black topping, curb and gutter replacement, concrete panel replacement, and pothole repair. The purpose of the site must be to provide additional years of service life and optimize service and safety. The site also must be limited to the repair and replacement of pavement in a manner that does not result in an increased impervious area, and the infrastructure must not substantially change. The types of sites covered under this exclusion include day-to-day maintenance activities, rehabilitation, and reconstruction of pavement. "Roadways" include roads and bridges that are improved, designed or ordinarily used for vehicular travel and contiguous areas or that are improved, designed or ordinarily used for pedestrian or bicycle traffic, drainage for the roadway, and/or parking along the roadway. Areas primarily used for parking or access to parking are not roadways.
 2. **Excluded Roadway Redevelopment.** Redevelopment sites for existing roadways, when 1 of the following criteria is met:
 - 1) The site adds less than 1 acre of paved area per mile of roadway to an existing roadway, or
 - 2) The site does not add more than 8.25 feet of paved width at any location to the existing roadway.
 3. **Excluded Existing Roadway Areas.** For redevelopment sites for existing roadways, only the area of the existing roadway is excluded from the requirements of an applicable development site when the site does not increase the width by 2 times or more, on average, of the original roadway area. The entire site is not excluded from being considered an applicable development site for this exclusion. The area of the site that is part of the added new roadway area is still an applicable development site.
 4. **Aboveground and Underground Utilities.** Activities for installation or maintenance of underground utilities or infrastructure that does not permanently alter the terrain, ground cover, or drainage patterns from those present prior to the construction activity. This exclusion includes, but is not limited to, activities to install, replace, or maintain utilities under roadways or other paved areas that return the surface to the same condition.
 5. **Large Lot Single Family Sites.** A single-family residential lot, or agricultural zoned lands, greater than or equal to 2.5 acres in size per dwelling and having a total lot impervious area of less than 10 percent. A total lot imperviousness greater than 10 percent is allowed when a study specific to the watershed and/or MS4 shows that expected soil and vegetation conditions are suitable for infiltration/filtration of the WQCV for a typical site, and the permittee accepts such study as applicable within its MS4 boundaries. The maximum total lot impervious covered under this exclusion shall be 20 percent.
 6. **Non-Residential and Non-Commercial Infiltration Conditions.** This exclusion does not apply to residential or commercial sites for buildings. This exclusion applies to applicable development sites for which post-development surface conditions do not result in concentrated stormwater flow during the 80th percentile stormwater runoff event. In addition, post-development surface conditions must not be projected to result in a surface water discharge from the 80th percentile stormwater runoff events. Specifically, the 80th percentile event must be infiltrated and not discharged as concentrated flow. For this exclusion to apply, a study specific to the site, watershed and/or MS4 must be conducted. The study must show rainfall and soil conditions present within the project area, must include allowable slopes, surface conditions, and ratios of impervious area to pervious area, and the County must accept such study as applicable within its MS4 boundaries.

-
7. **Sites with Land Disturbance to Undeveloped Land that will Remain Undeveloped.** Sites with land disturbance to undeveloped land (land with no human-made structures such as buildings or pavement) that will remain undeveloped after the site. Typical examples of this type of site are trails, parks and open space without structures.
 8. **Stream Stabilization Sites.** Construction activity that is solely for the purpose of stream stabilization.
 9. **Trails.** Bike and pedestrian trails. Bike lanes for roadways are not included in this exclusion, unless attached to a roadway that qualifies under another exclusion in this section.
 10. **Oil and Gas Exploration.** Facilities associated with oil and gas exploration, production, processing, or treatment operations, or transmission facilities, including activities necessary to prepare a site for drilling and for the movement and placement of drilling equipment, whether or not such field activities or operations may be considered to be an applicable construction activity.
 11. **County Growth Areas.** The County may exclude the following when they occur within the county growth areas:
 - a. Agricultural facilities and structures on agricultural zoned lands (e.g., barn, stables).
 - b. Residential development site or larger common plans of development for which associated construction activities results in a land disturbance of less than or equal to 10 acres and have a proposed density of less than 1,000 people per square mile.
 - c. Commercial or industrial development site or larger common plans of development for which associated construction activities results in a land disturbance of less than or equal to 10 acres.
- C. **Base Design Standard Requirements.** The "base design standard" is the minimum design standard for new and redevelopment before applying any exclusions or alternative standards. The control measures for applicable development sites shall meet one of the following base design standards:
1. **Water Quality Capture Volume (WQCV) Standard.** The control measures is designed to provide treatment and/or infiltration of the WQCV and:
 - a. 100% of the applicable development site is captured, except the County may exclude up to 20 percent, not to exceed 1 acre, of the applicable development site area when the County has determined that it is not practicable to capture runoff from portions of the site that will not drain towards control measures. In addition, the County must also determine that the implementation of a separate control measure for that portion of the site is not practicable (e.g., driveway access that drains directly to street).
 - b. Evaluation of the minimum drain time shall be based on the pollutant removal mechanism and functionality of the control measure implemented. Consideration of drain time shall include maintaining vegetation necessary for operation of the control measure (e.g., wetland vegetation).
 2. **Pollutant Removal Standard.** The control measures is designed to treat at a minimum the 80th percentile storm event. The control measures shall be designed to treat stormwater runoff in a manner expected to reduce the event mean concentration of total suspended solids (TSS) to a median value of 30 mg/L or less.

100% of the applicable development site must be captured, except the County may exclude up to 20 percent not to exceed 1 acre of the applicable development site area when the County has determined that it is not practicable to capture runoff from portions of the site that will not drain towards control measures. In addition, the County must also determine that the implementation

of a separate control measure for that portion of the site is not practicable (e.g., driveway access that drains directly to street).

3. **Runoff Reduction Standard.** The control measures is designed to infiltrate into the ground where site geology permits, evaporate, or evapotranspire a quantity of water equal to 60% of what the calculated WQCV would be if all impervious area for the applicable development site discharged without infiltration. This base design standard can be met through practices such as green infrastructure. "Green infrastructure" generally refers to control measures that use vegetation, soils, and natural processes or mimic natural processes to manage stormwater. Green infrastructure can be used in place of or in addition to low impact development principles.
4. **Applicable Development Site Draining to a Regional WQCV Control Measure.** The regional WQCV control measure must be designed to accept the drainage from the applicable development site. Stormwater from the site must not discharge to a water of the state before being discharged to the regional WQCV control measure. The regional WQCV control measure must meet the requirements of the WQCV in Part I.7.C.1.
5. **Applicable Development Site Draining to a Regional WQCV Facility.** The regional WQCV facility is designed to accept drainage from the applicable development site. Stormwater from the site may discharge to a water of the state before being discharged to the regional WQCV facility. Before discharging to a water of the state, at least 20 percent of the upstream imperviousness of the applicable development site must be disconnected from the storm drainage system and drain through a receiving pervious area control measure comprising a footprint of at least 10 percent of the upstream disconnected impervious area of the applicable development site. The control measure must be designed in accordance with a design manual identified by the permittee. In addition, the stream channel between the discharge point of the applicable development site and the regional WQCV facility must be stabilized. The regional WQCV facility must meet the following requirements:
 - a. The regional WQCV facility must be implemented, functional, and maintained following good engineering, hydrologic and pollution control practices.
 - b. The regional WQCV facility must be designed and maintained for 100% WQCV for its entire drainage area.
 - c. The regional WQCV facility must have capacity to accommodate the drainage from the applicable development site.
 - d. The regional WQCV facility must be designed and built to comply with all assumptions for the development activities planned by the County within its drainage area, including the imperviousness of its drainage area and the applicable development site.
 - e. Evaluation of the minimum drain time shall be based on the pollutant removal mechanism and functionality of the facility. Consideration of drain time shall include maintaining vegetation necessary for operation of the facility (e.g., wetland vegetation).
 - f. The County shall require site plans and perform a site plan review consistent with the requirements of this ECM to ensure the regional WQCV facility and control measures for the applicable development site plans include:
 - i. Design details for all structural control measures implemented to meet the requirements of Part I.E.4.
 - ii. A narrative reference for all non-structural control measures for the site, if applicable. "Non-structural control measures" are control measures that are not structural control measures and include, but are not limited to, control

measures that prevent or reduce pollutants being introduced to water or that prevent or reduce the generation of runoff or illicit discharges.

- iii. Documentation of operation and maintenance procedures to ensure the long term observation, maintenance, and operation of the control measures. The documentation shall include frequencies for routine inspections and maintenance activities.
 - iv. Documentation regarding easements or other legal means for access of the control measure sites for operation, maintenance, and inspection of control measures.
 - v. Confirmation that control measures meet the requirements of section I.7.C
 - vi. Confirmation that site plans meet the requirements of County's site plan review and approval requirements
- g. The regional WQCV facility must be subject to the County's authority consistent with requirements and actions for a Control Measure in accordance with a base design standard.
- h. Regional Facilities must be designed and implemented with flood control or water quality as the primary use. Recreational ponds and reservoirs may not be considered Regional Facilities. Water bodies listed by name in surface water quality classifications and standards regulations (5 CCR 1002-32 through 5 CCR 1002-38) may not be considered regional facilities.
6. **Constrained Redevelopment Sites Design Standard.** The constrained redevelopment sites standard applies to redevelopment sites meeting the following criteria:
- (a) The applicable redevelopment site is for a site that has greater than 75% impervious area, and
 - (b) The County must determine that it is not practicable to meet any of the base design standards in section I.7.1.C (1), (2), or (3). The County's determination shall include an evaluation of the applicable redevelopment site's ability to install a control measure without reducing surface area covered with the structures.

The control measures is designed to meet one of the following:

- (a) Provide treatment of the WQCV for the area captured. The captured area shall be 50% or more of the impervious area of the applicable redevelopment site. Evaluation of the minimum drain time shall be based on the pollutant removal mechanism and functionality of the control measure implemented,
- (b) The control measures is designed to provide for treatment of the 80th percentile storm event. The control measures shall be designed to treat stormwater runoff in a manner expected to reduce the event mean concentration of total suspended solids (TSS) to a median value of 30 mg/L or less.

A minimum of 50% of the applicable development area including 50% or more of the impervious area of the applicable development area shall drain to the control measures. This standard does not require that 100% of the applicable redevelopment site area be directed to a control measures as long as the overall removal goal is met or exceeded (e.g., providing increased removal for a smaller area), or

-
- (c) Infiltrate, evaporate, or evapotranspire, through practices such as green infrastructure, a quantity of water equal to 30% of what the calculated WQCV would be if all impervious area for the applicable redevelopment site discharged without infiltration.

I.7.2. BMP Selection

The selection of appropriate BMPs is based on the characteristics of the site and potential pollutants. The Four-Step Process provides a method of going through the selection process. Figure I.1 and Figure I.2 with annotations covers site-specific issues to be considered in selecting an effective BMP for each site.

- A. **Four-Step Process.** The following four-step process is recommended for selecting structural BMPs in newly developing and redeveloping urban areas:

Step 1: Employ Runoff Reduction Practices

To reduce runoff peaks and volumes from urbanizing areas, employ a practice generally termed "minimizing directly connected impervious areas" (MDCIA). The principal behind MDCIA is twofold — to reduce impervious areas and to route runoff from impervious surfaces over grassy areas to slow down runoff and promote infiltration. The benefits are less runoff, less stormwater pollution, and less cost for drainage infrastructure. There are several approaches to reduce the effective imperviousness of a development site:

Reduced Pavement Area

Sometimes, creative site layout can reduce the extent of paved areas including parking, thereby saving on initial capital cost of pavement and then saving on pavement maintenance, repair, and replacement over time.

Porous Pavement

The use of modular block porous pavement or reinforced turf in low-traffic zones such as parking areas and low use service drives such as fire lanes can significantly reduce site imperviousness. This practice may reduce the extent and size of the downstream storm sewers and detention.

Grass Buffers

Draining impervious areas over grass buffers slows down runoff and encourages infiltration, in effect reducing the impact of the impervious area.

Grass Swales

The use of grass swales instead of storm sewers slows down runoff, promotes infiltration, and also reducing effective imperviousness. It also may reduce the size and cost of downstream storm sewers and detention.

Implementing these approaches on a new development site is discussed further in the DCM2 section titled Employing Runoff Reduction Techniques. This section provides a procedure for estimating a reduced imperviousness based on the use of grass buffers and swales. The latter three of the approaches for reducing imperviousness are structural BMPs and are described in detail in Section 4.2 of DCM2 (New Development BMP Factsheets):

- Grass Buffer.
- Grass Swale.
- Modular Block Porous Pavement (or Stabilized-Grass Porous Pavement).

Step 2: Stabilize Drainageways

Drainageway, natural and manmade, erosion can be a major source of sediment and associated constituents, such as phosphorus. Natural drainageways are often subject to bed and bank erosion when urbanizing areas increase the frequency, rate, and volume of runoff. Therefore, drainageways are required to be stabilized. One of three basic methods of stabilization may be selected.

Constructed Grass, Riprap, or Concrete-Lined Channel

These methods of channel stabilization have been in practice for some time. The water quality benefit associated with these channels is the reduction of severe bed and bank erosion that can occur in the absence of a stabilized channel. On the other hand, the hard-lined low flow channels that are often used do not offer much in the way of water quality enhancement or wetland habitat. The use of riprap or concrete lined flood conveyance channels is not recommended, unless hydraulic or physical conditions require such an alternative. Rock lined low-flow channels in many cases may be a better alternative.

Stabilized Natural Channel

In practice, many natural drainageways in and adjacent to new developments are frequently left in an undisturbed condition. While this may be positive in terms of retaining desirable riparian vegetation and habitat, urban development may cause the channel to become destabilized. When degradation occurs in these drainageways, significant erosion, loss of riparian and aquatic habitat, and elevated levels of sediment and associated pollutants can result. Therefore, it is recommended that some level of stream stabilization always be considered. Small grade control structures sized for a 5-year or larger runoff event are often an effective means of establishing a mild slope for the baseflow channel and arresting stream degradation. Severe bends or cut banks may also need to be stabilized. Such efforts to stabilize a natural waterway also preserve and promote natural riparian vegetation which can provide paybacks in terms of enhanced aesthetics, habitat, and water quality.

One additional method of drainageway stabilization gives special attention to stormwater quality and is described in Section 4.2 (New Development BMP Factsheets):

- Constructed Wetland Channel.

Step 3: Provide Water Quality Capture Volume (WQCV)

All applicable development sites must have operational permanent stormwater quality control measures at the completion of construction. Designing structures that provide the WQCV is a common preferred approach in El Paso County. Other base design standards discussed earlier may be used if applicable, however. One or more of six types of water quality basins, each draining slowly to provide for long-term settling of sediment particles, may be selected. Information on selecting and configuring for a site one or more of the WQCV facilities listed below is provided in the Section 4.2 of the DCMV2. These six BMPs are also described in detail in the New Development BMP Factsheets found in the DCMV2 Section 4.2.

- Porous Pavement Detention.
- Porous Landscape Detention.
- Extended Detention Basin.
- Sand Filter Extended Detention Basin.
- Constructed Wetland Basin.
- Retention Pond.

Full Spectrum Detention is a newer approach to providing the WQCV. Details on the use, sizing, configuration and maintenance of Full Spectrum Detention structures are located in the DCMV1 update of 2014, sections of which are incorporated by reference into this ECM.

Step 4: Consider Need for Industrial and Commercial BMPs

If a new development or significant redevelopment activity is planned for an industrial or commercial site, the need for specialized BMPs must be considered. Two approaches are described in the New Development BMP Factsheets:

- Covering of Storage/Handling Areas
- Spill Containment and Control

Other Specialized BMPs may also be required

- B. **Other Specialized BMPs.** The Technical Advisory Committee (TAC) selected the above structural BMPs after a comprehensive screening of known structural BMPs. The members of TAC included representatives from many city and County agencies and individuals from the development community. Final selection by TAC was based on the review of documentation on potential effectiveness in a semiarid climate, local applicability, maintenance considerations, and cost.

Development and evaluation of permanent BMPs are continuing processes. Better designs of the BMPs included in DCM2 and designs of new BMPs, including manufactured (proprietary) BMPs, will be developed and tested. To allow for this progress, additional BMPs will be considered on a case-by-case basis by County Stormwater Staff. Design and sizing details and results of independent testing of the BMP in conditions similar to those at the site will be submitted demonstrating that the BMP will meet or exceed the performance of approved BMPs for the site.

To promote improvement in stormwater protection, County Stormwater Staff may approve promising BMPs on an experimental basis. A performance monitoring program to be pre-approved by County Stormwater Staff and an agreement to replace the Experimental System with an approved system should it not function to the required level of performance, both at the owner's expense, will be required. A request to use an "experimental system" must be submitted to El Paso County in the form of a Request for a Deviation from these standards, submitted consistent with the criteria and process described Chapters 1 and 5, respectively. Design of any "experimental system" shall not commence until a Request for Deviation is submitted to and approved by the County.

- C. **Guidance for Selecting and Locating WQCV Facilities.**

[The following section replaces DCM2 Section 4.1 pages 4-19 through 4-23]

Laying out WQCV facilities within a development site and watershed requires thought and planning. This planning and decision-making should occur during a master drainage planning process (Drainage Basin Planning Study or Master Development Drainage Plan) undertaken by local jurisdictions or a developer's engineer. Such plans, studies or other reports may depict a recommended approach for implementing WQCV on a watershed basis. Such reports may call for a few large regional WQCV facilities, smaller sub-regional facilities, or alternatively an onsite approach. It is always a good idea to find out if a master planning study has been completed that addresses water quality and to attempt to follow the Plan's recommendations.

If the master drainage planning process addresses water quality, the following provides supplemental information on the BMPs. If the existing master drainage planning process has not addressed water quality, or if a new master drainage process is underway, this will direct the water quality evaluation.

- D. **Post-Construction Stormwater Quality Control Measure Selection Process.** The BMP selection process is illustrated in Figure I-1 and Figure I-2. These two figures shall be used for all projects except those

that are strictly highway/roadway projects; that is, projects with no plans for building pad sites. Projects that are strictly highway/roadway projects are discussed in a separate section below.

The following process references the use of the permanent control measures (BMPs) and other practices outlined in DCM2 and this Appendix. The use of DCM2 BMPs will promote consistency between the City and County. These BMPs are commonly found in manuals and other literature from municipalities across the country, and they are the accepted best industry practices in stormwater quality control.

As described below, other control measures (which may be relatively new to the field of stormwater management) are acceptable if they can be shown to meet performance criteria provided in this Section 1.7. A Request for a Deviation from these standards submitted consistent with the criteria and process described Chapters 1 and 5, respectively, must be submitted and approved by the County prior to the use of a permanent control measure not included in this ECM, DCMV1, DCMV2 and the DCMV1 Update of 2014.

The following items explain the decision points (i.e., the Boxes) in Figure I-1 and Figure I-2:

Box 1: For all sites, the possibility of incorporating runoff reduction practices must be investigated. Impervious area should be reduced to the maximum extent practicable, per DCM2. DCM2 also provides guidance for MDCIA by routing runoff to pervious areas. This is Step 1 in the Four-Step Process.

Box 2: All drainageways, ditches, and channels shall be stabilized with one of three methods included in Step 2, which include the use of appropriate methods for the type of drainageway as described in the DCM1. Drainageways include:

- Tributaries to creeks that have been left in a relatively natural state,
- Tributaries, channels, and drainageways that are graded or regraded and may include drop or check structures, side slope stabilization, and low-flow channels.
- Roadside ditches that are completely man-made and should only be used to convey runoff from roads and roadway right-of-ways (ROWs).

Box 3: It must be determined if the development and/or redevelopment disturbs an area of land that is 1 acre or larger (or planned to be 1 acre or larger) when all phases are complete.

Box 4: Sites tributary to sensitive waters should consider specialized BMPs to address the parameter of concern as shown in Table I-5. At this time, no special BMPs are required until the County develops an overall strategy to address the parameters of concern, probably if and when a Total Maximum Daily Load (TMDL) is determined.

Figure I-1. BMP Requirements Flowchart for New Development and Redevelopment Sites—For Selecting Post-Construction BMPs in Compliance with El Paso County's Stormwater NPDES Permit

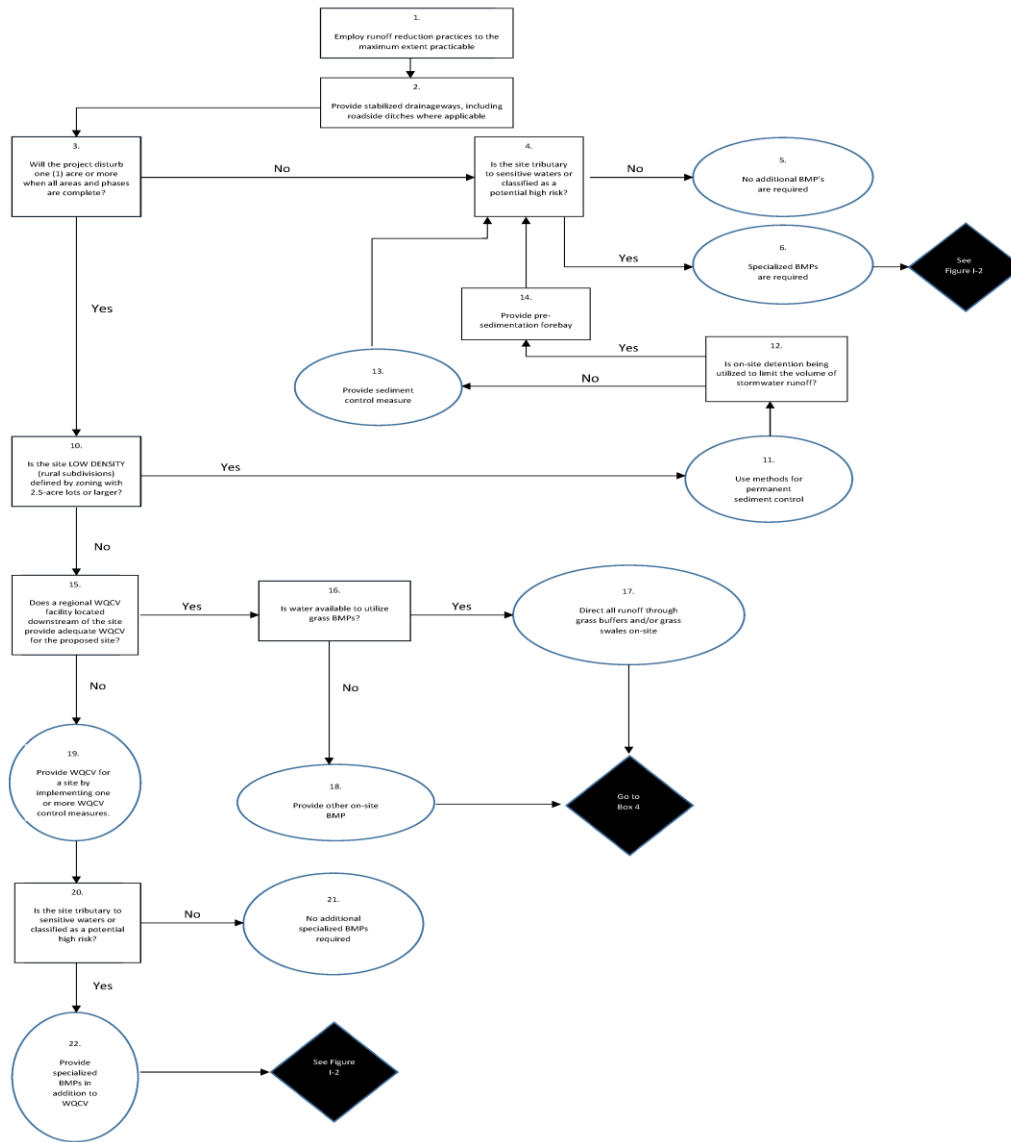

Figure I-2. BMP Requirements Flowchart for New Development and Redevelopment Sites—For Selecting Post-Construction BMPs in Compliance with El Paso County's Stormwater NPDES Permit

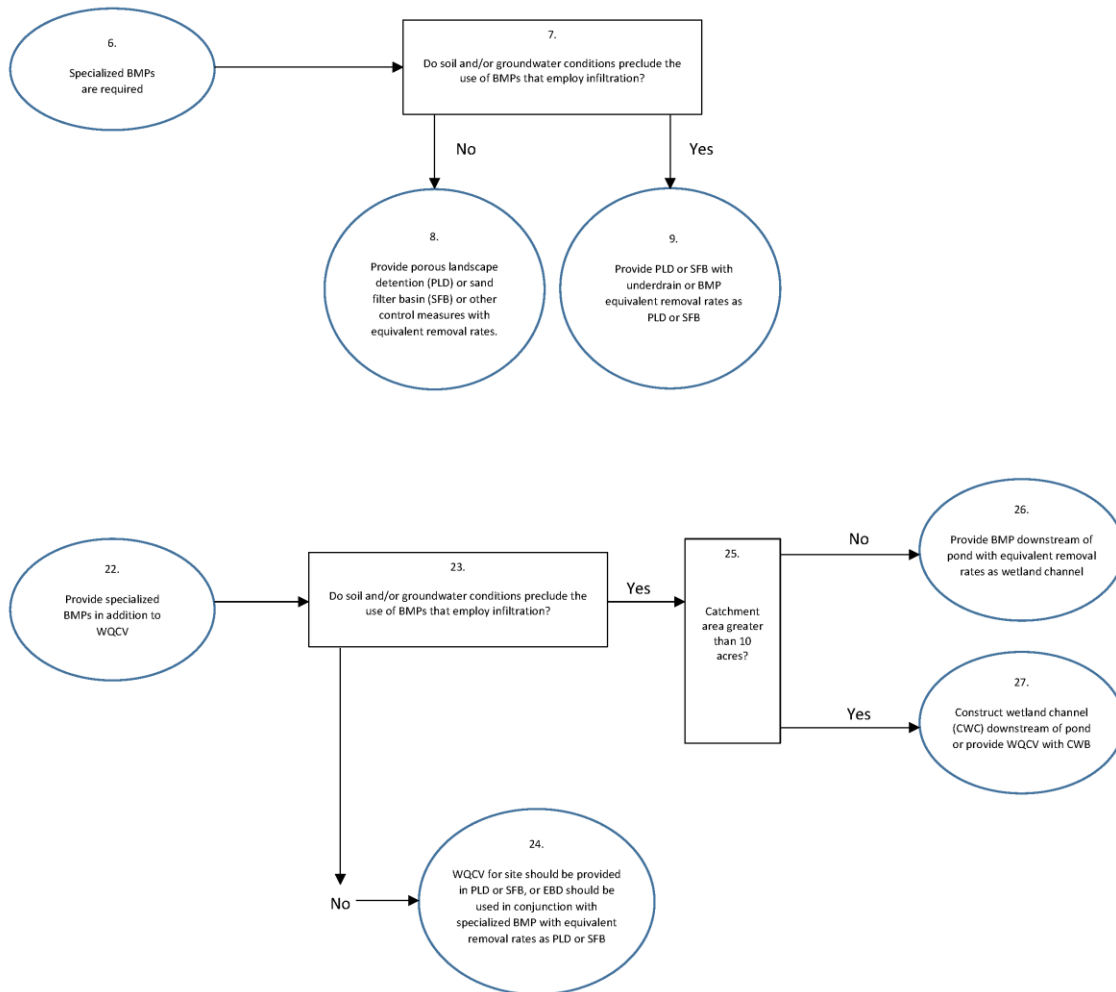

Table I-4. Best Management Practices Abbreviations

Abbreviation	Best Management Practice
CWB	Constructed Wetlands Basin
CWC	Constructed Wetlands Channel - Sedimentation Facility
EDB	Extended Detention Basin - Sedimentation Facility
PLD	Porous Landscape Detention
RP	Retention Pond - Sedimentation Facility
SFB	Sand Filter Extended Detention Basin
WQCV	Water Quality Capture Volume
GB	Grass Buffer
GS	Grass Swale
MBP	Modular Block Porous Pavement
PPD	Porous Pavement Detention

Table I-5. El Paso County Sensitive¹Waters

Stream and Segment	Parameter of Concern	Specialized BMPs Required
Fountain Creek and tributaries above Monument Creek	E. coli and Se	None at this time
Fountain Creek from Monument Creek to Highway 47	E. coli	None at this time
Monument Creek from National Forest to Fountain Creek	Se	None at this time
Willow Springs Pond #1 and #2	PCE	None at this time
¹ CDPHE 2006 303(d) list. Standard agreement forms for Private Detention Basins are in Appendix G. [This list may change in the future. The 303(d) list or equivalent in effect at the time of permitting will apply.]		

Potential high-risk sites must also incorporate specialized BMPs. High-risk sites are defined by two factors:

- Sites with land uses involving the potential for significant deposition of pollutants.
- Sites without practices to eliminate exposure of pollutants to stormwater.

Land uses involving the potential for significant deposition of pollutants include, but are not limited to:

- Vehicle maintenance facilities,
- Gas stations,
- Automobile salvage yards and junk yards,
- Commercial sites with high levels of "in and out" traffic such as fast-food restaurants and convenience stores.

Many industrial facilities are required to obtain coverage under an industrial stormwater permit; these facilities include automobile salvage yards. Practices to eliminate exposure of pollutants to stormwater may or may not be part of an industrial stormwater permit. These practices include coverage of material storage areas, berms around tanks, spill control plans, and other "good housekeeping" measures. For industrial sites where stormwater is not exposed to pollutants, structural BMPs, including detention ponds for water quality and other BMPs discussed below, may not be required.

Because stormwater pollutants are often transported with sediment, erosion protection and sediment control are necessary for stormwater quality protection. This is very important in the County because of the sandy soils in the region. In particular, discharges that may impact sensitive waters or that come from potentially high-risk sites should have a high level of sediment protection. Thus, in addition to the specialized BMPs, sediment control practices such as revegetation, grading to prevent steep side slopes, check dams, slope drains, and sediment basins should be employed where practical.

Box 5: No BMPs are required other than stabilized drainageways and possibly MDCIA.

Box 6: Specialized BMPs are required and therefore proceed to Box 7 on Table I-1.

Box 7: BMPs that employ infiltration include porous landscape detention and sand filter basins without underdrains. Certain conditions preclude the use of these types of BMPs, including close proximity of groundwater or relatively impervious soils to the bottom of the facility. Groundwater levels should be characterized during the season with the highest levels (often late Spring or early Summer). Impervious soils include bedrock as well as soil types C and D. The term "close proximity" means 5 feet or less. If there is less than 5 feet, a study of the hydraulic conductivity of the soils must be conducted to show

that excessive groundwater mounding or direct groundwater contamination will not result from the use of BMPs that employ infiltration.

Box 8: If groundwater or relatively impervious soils are not within 5 feet of the surface, implement porous landscape detention (PLD) or a sand filter basin (SFB) from DCM2. Alternative BMPs can be used if shown to be equally effective as PLD or SFB (see discussion below).

Box 9: Implement PLDs or SFBs with underdrains, or implement a BMP with removal rates equivalent to PLDs or SFBs, including qualifying manufactured BMPs. Qualifying manufactured BMPs are those that have undergone independent tests to verify that the installation, flow volumes, and removal rates will work for the site under consideration.

Box 10: If the site disturbance is larger than one acre and is low density residential, then no WQCV may be required provided the site meets criteria presented in Section I.7.1. If WQCV is not required, the need for a permanent sediment control measure must still be evaluated. If the site is located near and will discharge to a sensitive water, then a "jump" to Box 4 is required for continued evaluation.

Box 11: Sediment is best controlled at the source. That is, rather than using structures to collect soil after it is suspended in stormwater, it is preferable to stabilize soil to prevent suspension from occurring. Sediment source controls must be implemented for all low-density developments and include (but are not limited to):

- Adequately established vegetation per DCM1 criteria,
- Side slopes that are 3 horizontal to 1 vertical or flatter or the use of benched side slopes when slopes are steeper than 3 horizontal to 1 vertical,
- The use of erosion control blankets to aid establishment of vegetation,
- Check dams,
- Slope drains.

Temporary irrigation and maintenance of vegetation until adequately established may be required.

Box 12: In low density (rural) subdivisions, a method for permanent sediment control must be provided. If a detention pond is used, the forebay is to be sized according to the criteria for Extended Detention Basins. If a detention pond/Extended Detention Pond is not required, a sediment basin as described in DCM2, page 3-32 may be used. It should be sized to collect 1,800 cubic feet per acre of disturbed area. Drainage area above a sediment basin can be reduced by use of vegetated swales, buffers, or contour berms.

Box 13: If there are no detention ponds, separate sediment control measure must be located to catch all runoff leaving the disturbed area of the site.

Box 14: In cases where a detention pond is already required for controlling the volume of runoff, a sediment basin can take the form of a forebay to this pond.

Box 15: Regional WQCV facilities may only be used if they meet the requirements of Section I.7.1.C.

Box 16: The site is required to direct all runoff through grass buffers and/or grass swales or provide a similar BMP. (Note that this is required in accordance with the CDPHE guidance manual to afford some protection to state waters in between the site and the downstream WQCV BMP.)

Box 17: Grass buffers require irrigation in almost all cases in the County; swales sometimes require irrigation.

Box 18: "Dry" alternatives may be used if they are shown to have equivalent removal rates as buffers and swales. All of the structural treatment BMPs in DCM2 (Section 4.2) have equivalent removal rates

and may be used. The covering of storage/handling areas and spill containment and control are not structural treatment BMPs, and thus are not substitutes for grass buffers and swales.

Box 19: If there is no regional WQCV facility downstream with adequate capacity to provide the WQCV for the proposed site, then a WQCV control measure must be provided for the site. Examples of potentially acceptable control measures include Extended Detention Basin, Full Spectrum Detention Basin, Sand Filter Basin, Constructed Wetland Basin, or a Retention Pond. For all ponds, issues related to dam construction and potential groundwater infiltration must be considered. Retention Ponds must be considered in the context of additional issues including safety and health (e.g., drowning and mosquito/West Nile virus) and water rights. For all structures that may hold water for more than 72 hours with an exposed water surface, water storage rights must be obtained before a structure (e.g. retention pond) can be proposed for a site. See Sections 3.2.5.F and 3.3.7 of this ECM for additional information regarding water right and permanent stormwater quality control measures.

Box 20: Sites tributary to sensitive waters must meet the requirements as outlined in Table I-5, and potential high-risk sites must have specialized BMPs.

Box 21: No additional BMPs are required other than WQCV-based BMPs. Also, as always, drainageways must be stabilized and runoff should be reduced as much as possible (Boxes 1 and 2).

Box 22: When specialized BMPs are required, proceed to Box 23 on Figure I-2.

Box 23: Two situations apply, one where conditions preclude the installation of BMPS that employ infiltration, and one where they do not. (See Box 7.) If conditions preclude the installation of BMPS that employ infiltration then proceed to Box 25; otherwise proceed to Box 24.

Box 24: Where soil and groundwater conditions are not prohibitive (that is, groundwater or relatively impervious soils are not within 5 feet of the surface), implement PLD or SFB from DCM2. Alternative BMPs can be used if shown to be equally effective as PLD or SFB (see discussion below).

Box 25: Constructed wetlands (either channels or basins) are an effective BMP for sites with drainage areas greater than 10 acres.

Box 26: Provide a BMP downstream of the pond with equivalent removal rates as a wetland channel; this could be a qualifying manufactured BMP or other BMP that meets the criteria below.

Box 27: If the catchment area is greater than 10 acres, provide a constructed wetland channel (CWC) downstream of pond or provide WQCV with CWB.

E. **Projects that are Strictly Roadway Construction.** For projects that entail highway or other roadway construction, there are three basic questions for the applicant:

- Is the road urban or rural?
- That is, does the road have curb and gutter or does it utilize roadside ditches?
- For rural roads, do the ditches require "water turnouts"?
- Is the road a "hot spot" or does it discharge to sensitive waters?

For road construction projects, the applicant must determine if the roadway project is an applicable development site as defined in Section I.7.1.B. Excluded sites do not need to comply with the requirements of this Section I.7. If a roadway construction project is an applicable development site, then the owner must determine which base design standard is appropriate for the project and must design and implement water quality improvement with the project. Requirements for roadway projects included in the DCMV1 may be used provided they do not conflict with other provisions of this Section I.7.

Rural roads, i.e. those roads which utilize roadside ditches for conveyance of runoff from the roadway, do not have sufficient capacity in the roadside ditches to convey much more runoff than that which runs off the road itself. Rural roads (which by definition have roadside ditches) must be stabilized with one of three methods included in DCM2 on pages 4-3 and 4-4. These methods are described in DCMV1. "Water turnouts," which function as spillways which direct flow out of the ditches onto property adjacent to the ROW, are frequently required as a result. Design for the "water turnout" should ensure the turnout discharges into a "suitable outfall" as described in DCM1 along the roadway such as a natural swale. A drainage easement for this runoff must be acquired at these locations. A possible consequence of "water turnouts" is the loading of sediment onto private property. If "water turnouts" will be utilized for the ditches, sediment basins shall be used at these locations. However, there must be sufficient space in the ROW for both the structure itself and for maintenance access, or a specific drainage easement must be provided for the feature and access. Sediment basins can be designed in accordance with the guidelines in DCM2 in the section for construction BMPs. The basin shall be sized to collect 1,800 cubic feet of sediment per acre of drainage area of the roadway.

The term "high risk site" can be defined by traffic volume for a section of roadway. If the road will experience traffic volume of 30,000 average daily traffic (ADT) or more it is likely to contribute high levels of pollutants. For these situations, additional BMPs are required and selection must follow Boxes 6, 7, 8, and 9 in Figure 1b. Additional BMPs may also be required for discharge to sensitive waters. As described above for the general developments (with building pads), these additional requirements will depend on the TMDL process.

- F. **Additional Guidelines for BMP Selection.** Additional Guidelines for selecting among the appropriate BMPs determined from Figure I-1 and Figure I-2. Figure I-3 (Figure ND-7 in DCM2) depicts a decision tree for selecting one of the six WQCV BMPs based on drainage catchment area and whether water is available to satisfy evapotranspiration requirements. Porous pavement and porous landscape detention are generally suited for small drainage areas (i.e. much less than 1.0 acres); however, larger subwatersheds can be subdivided into individual drainage sub-catchment areas meeting the criteria shown in Figure I-3 for these BMPs.

WQCV control measures and Regional WQCV control measures shall be located prior to the stormwater runoff being discharged to State Waters. When using a Regional WQCV facility for a site, the site may discharge to a water of the state before being discharged to the Regional WQCV facility; however, the conditions in Section I.7.1.C.5 shall be met.

Figure I-4 (Figure ND-8 in DCM2) provides an illustration of selection and location options for WQCV facilities based on the principles discussed above.

Figure I-6 (Table ND-1 in DCM2) indicates the BMP options for the four watershed areas shown in Figure I-4.

I.7.3. Incorporating WQCV into Stormwater Detention Structures

Wherever possible, it is recommended that WQCV facilities be incorporated into stormwater quantity detention facilities. This is relatively straightforward for an extended detention basin, constructed wetland basin, and a retention pond. When combined, the 2, 5, 10, and 100-year detention levels are provided above the WQCV and the outlet structure is designed to control two or three different releases. Stormwater quantity detention could be provided above the WQCV for porous pavement and landscape detention provided the drain times for the larger events are kept short.

The following approaches are to be implemented when incorporating WQCV into stormwater quantity detention facilities:

-
1. **Water Quality.** The full WQCV is to be provided according to the design procedures documented in the New Development BMP Factsheets.
 2. **Minor Storm.** The full WQCV plus the full minor storm quantity detention volume is to be provided.
 3. **100-Year Storm.** One-half the WQCV plus the full 100-year detention volume is to be provided.

For linear projects and projects with limited space available for permanent water quality control measures, WQCV may be included in the design of underground detention structures such as sand filter basins (SFB) and proprietary underground detention structures. These systems rely on appropriate soil conditions to infiltrate or evapotranspire the WQCV.

It is extremely important that high sediment loading and compaction of underlying soils in the area to be used for infiltration be controlled to the maximum extent practicable. These structures are best suited to being brought on line at the end of the construction phase where disturbed ground has been stabilized with pavement or vegetation.

Any underground detention facilities proposed for use in the County must meet the good engineering, hydrologic and pollution control practices as defined in this Section 1.7. The design of underground detention that incorporates WQCV shall not commence until a Request for Deviation is submitted for review and approved by the ECM Administrator. In addition to the approval criteria for a deviation request provide in Chapters 1 and 5 of this ECM, the owner or authorized agent must provide a structure-specific Operation and Maintenance (O&M) Manual and maintenance agreement for the structures. The Operation and Maintenance Manual shall include specific procedures and equipment that will be used by the owner or authorized representative to operate and maintain the structures. A specification sheet or generic O&M manual provided by the vendor will not satisfy the O&M Manual requirement.

I.7.4. Separate Presedimentation Facilities

The design criteria shown in the New Development BMP Factsheets section shows presedimentation forebays at the upstream end of the extended detention basin, constructed wetland basin, and retention pond. The purpose of the forebay is to settle out coarse sediment and skim off floatables prior to the main body of the facility. An option to this approach is to install a separate facility upstream from the main WQCV facility. If this option is selected, the recommended size is at least 20 percent of the WQCV and the recommended drain time is 1 hour for the presedimentation forebay volume only. Using this approach, any requirement for sediment storage in the main facility may be reduced consistent with the storage capacity of the separated presedimentation forebay, and the forebay within the main facility may be eliminated.

Figure I-3. Decision Tree for WQCV BMP Selection

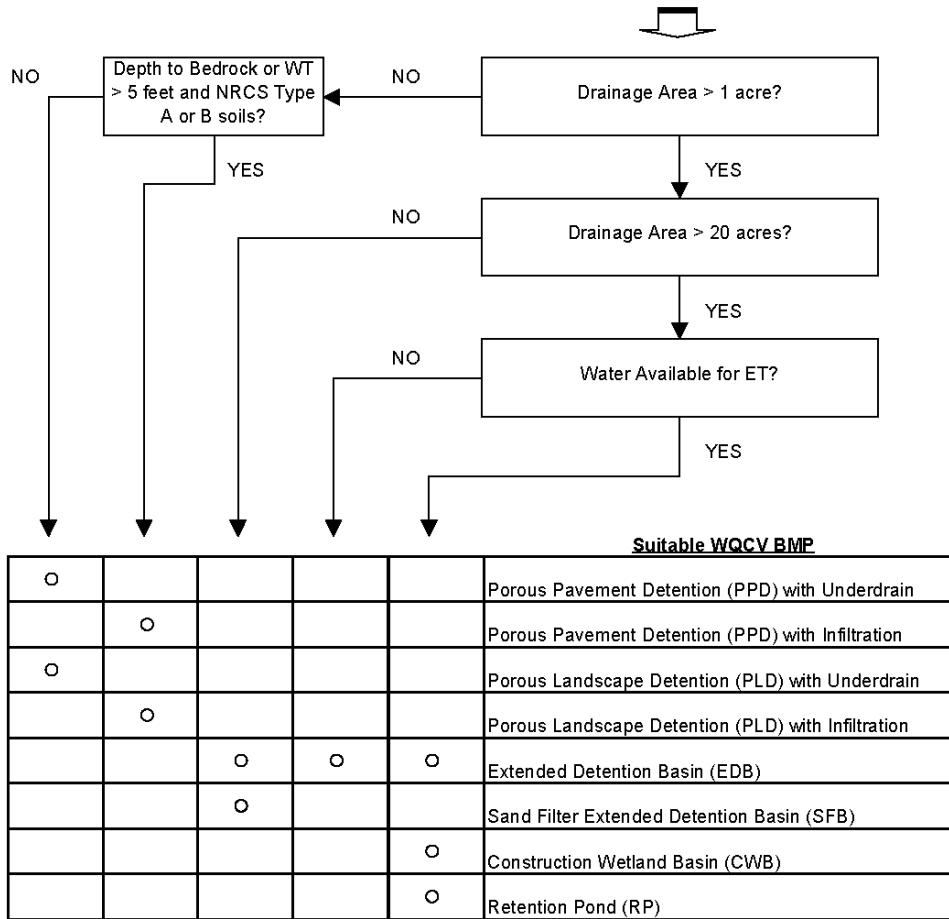

Note: Large drainage areas may be subdivided into areas < 20 acres for use of SFB or < 1 acre for use of PPD or PLD.

Figure I-4. Illustration of Selection and Location Options for WQCV Facilities

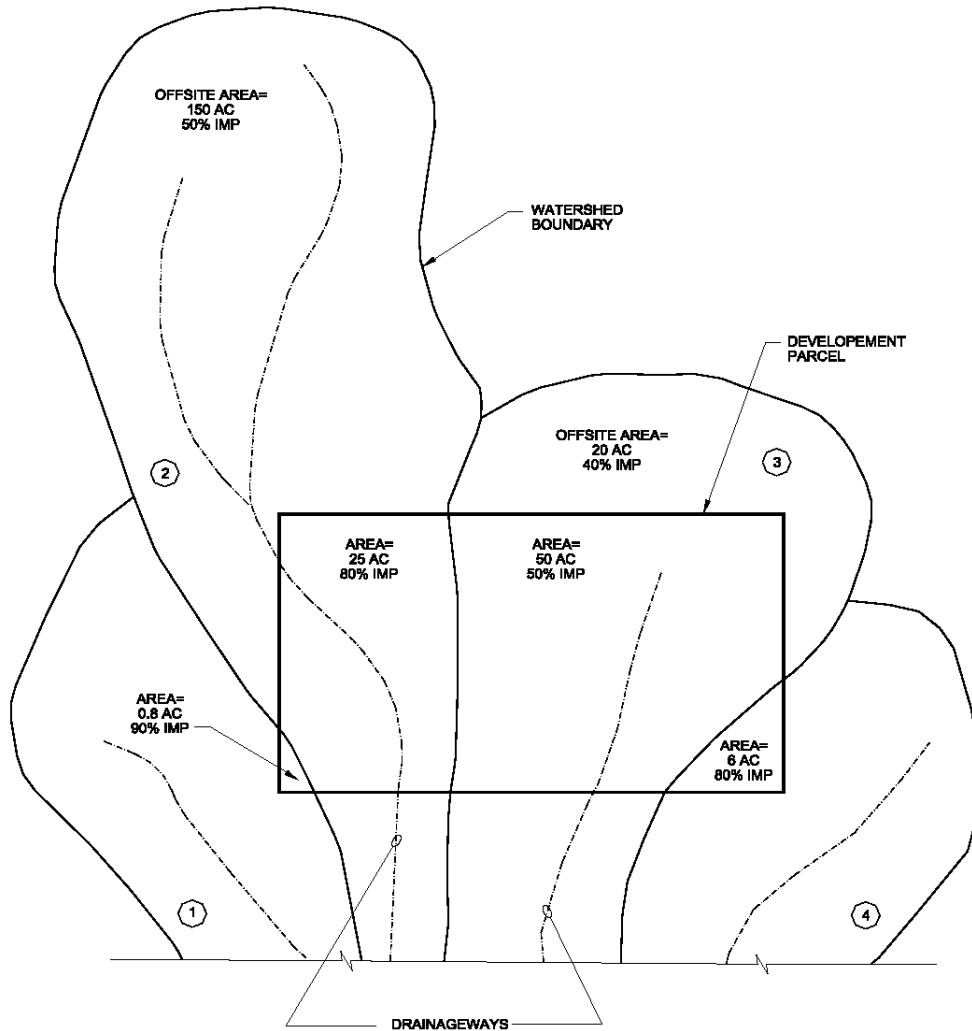

Note: For this example, sufficient make-up water exists for constructed wetlands and retention pond for the watershed areas > 50 acres through irrigation return flows.

Table I-7. Illustration of Selection and Location Options for WQCV Facilities for the Development Parcel on Figure I.4

Watershed Number	Onstream or Offstream	BMP Options	Minimum Number of BMP Installations	Average Drainage Area for Sizing each BMP, acre
1	Offstream	Porous Pavement Detention	1	0.8
		Porous Landscape Detention	1	0.8
2	Offstream	Porous Pavement Detention	24	1
		Porous Landscape Detention	24	1
		Extended Detention Basin	2	12

		Sand Filter Extended Detention Basin	2	12
3	Offstream	Porous Pavement Detention	49	1
		Porous Landscape Detention	49	1
		Extended Detention Basin	2	24
		Sand Filter Extended Detention Basin	3	16
	Onstream	Extended Detention Basin	1	70
		Constructed Wetland Basin	1	70
		Retention Pond	1	70
4	Offstream	Porous Pavement Detention	6	1
		Porous Landscape Detention	6	1
		Extended Detention Basin	1	6
		Sand Filter Extended Detention Basin	1	6

I.7.5. Structural BMP Effectiveness

Table I-7 (Table ND-2 in DCM2) indicates ranges of removal efficiencies reported in literature for a number of structural BMPs. Although combinations of nonstructural/structural BMPs can improve the overall water quality of the runoff, the effectiveness of several BMPs in their ability to reduce influent pollutant concentrations as a group are not directly additive. Table I-7 also shows a most probable range of removal efficiencies for structural BMPs.

I.7.6. Separation Distances

To reduce potential for surface and ground water contamination, permanent water quality BMPs will be located away from wells and Individual Sewage Disposal Systems (ISDS). Rules for separation distances and grouting depths for wells and BMPs will be based on distances between wells and "sources of contamination" in Colorado's Rules and Regulations for Water Well Construction, Pump Installation, and Monitoring and Observation Hole/Well Construction. Permanent BMPs and ISDS will be separated by the same distances specified between the components of the ISDS and "waterways" in the El Paso County ISDS regulations. Additional separation distance may be required when a permanent stormwater quality control measure is located near a water of the state and relies on a vegetated buffer strip as part of the strategy to address WQCV prior to discharge to waters of the state.

Table I-8. BMP Pollutant Removal Ranges for Stormwater Runoff and Most Probable Range for BMPs

Type of BMP	(1)	TSS	TP	TN	TZ	TPb	BOD	Bacteria
Grass Buffer	LRR: EPR	10-50	0-30	0-10	0-10	N/A	N/A	N/A
		10-20	0-10	0-10	0-10	N/A	N/A	N/A
Grass Swale	LRR: EPR	20-60	0-40	0-30	0-40	N/A	N/A	N/A
		20-40	0-15	0-15	0-20	N/A	N/A	N/A
Modular Block Porous Pavement	LRR: EPR	80-95	65	75-85	98	80	80	N/A
		70-90	40-55	10-20	40-80	60-70	N/A	N/A
Porous Pavement Detention	LRR: EPR	8-96	5-92	-130-	10-98	60-80	60-80	N/A
		70-90	40-55	85	40-80	60-70	N/A	N/A
				10-20				

Porous Landscape Detention	LRR: EPR	8-96 70-90	5-92 40-55	-100- 85 20-55	10-98 50-80	60-90 60-80	60-80 N/A	N/A N/A
Extended Detention Basin	LRR: EPR	50-70 55-75	10-20 45-55	10-20 10-20	30-60 30-60	75-90 55-80	N/A N/A	50-90 N/A
Constructed Wetland Basin	LRR: EPR	40-94 50-60	-4-90 40-80	21 20-50	-29-82 30-80	27-94 40-80	18 N/A	N/A N/A
Retention Pond	LRR: EPR	70-91 80-90	0-79 45-70	0-80 20-60	0-71 20-60	9-95 60-80	0-69 N/A	N/A N/A
Sand Filter Extended Detention	LRR: EPR	8-96 80-90	5-92 45-55	-129- 84 35-55	10-98 50-80	60-80 60-80	60-80 60-80	N/A N/A
Constructed Wetland Channel*	LRR: EPR	20-60 30-50	0-40 20-40	0-30 10-30	0-40 20-40	N/A 20-40	N/A N/A	N/A N/A
Ref: Bell et al. (1996), Colorado (1990), Harper & Herr (1992), Lakatos & McNemer (1987), Schueler (1987), Southwest (1995), Strecker et al. (1990), USGS (1986), US EPA (1983), Veenhuis et al. (1989), Whipple and Hunter (1981), Urbonas (1997).								
(1) LRR Literature reported range, EPR—expected probable range of annual performance by DCM2 BMPs.								
N/A Insufficient data to make an assessment.								
* The EPR rates for a Constructed Wetland Channel assume the wetland surface area is equal or greater than 0.5% of the tributary total impervious area.								

I.7.7. Operation and Maintenance of Best Management Practices

A. Long-term Operation and Maintenance of Post-Construction Stormwater Management Structures.

The El Paso County Phase II MS4 Permit requires the County to ensure the long-term operation and maintenance of all post-construction stormwater management control measures constructed by an applicable development site. Part I E.4.a.vi of MS4 permit states:

"vi. Construction Inspection and Acceptance: The County must implement inspection and acceptance procedures to ensure that control measures are installed and implemented in accordance with the site plan and include the following:

- (A) Confirmation that the completed control measure operates in accordance with the approved site plan.
- (B) All applicable development sites must have operational permanent water quality control measures at the completion of the site. In the case where permanent water quality control measures are part of future phasing, the County must have a mechanism to ensure that all control measures will be implemented, regardless of completion of future phases or site ownership. In such cases, temporary water quality control measures must be implemented as feasible and maintained until removed or modified. All temporary water quality control measure must meet one of the design standards in Part I.E.4.a.iv.

For the purpose of this section, completion of a site or phase shall be determined by the issuance of a certificate of occupancy, use of the completed site area according to the site plan, payment marking the completion of a site control measure, the nature of the selected control measure or equivalent determination of completion as appropriate to the nature of the site."

For all structures approved by El Paso County which are not public improvements, the property owner or authorized agent shall be responsible for the operation and maintenance of all permanent

stormwater quality control measures. All temporary control measures required during construction shall be removed after construction activity on the site has been completed and final stabilization of the site is achieved.

Prior to approval of a subdivision, issuance of a Certificate of Occupancy, or closure of the ESQCP for sites that did not go through the subdivision review process that have permanent post-construction stormwater quality control measures, a signed private maintenance agreement for permanent BMPs must be submitted to and recorded by the County. El Paso County uses these agreements as the primary mechanism to ensure the long-term operation and maintenance of post construction stormwater quality control measures. Agreement templates are found in Appendix G.

During construction a County Stormwater Inspector will inspect structures for conformance with approved construction plans and the SWMP. Once the structure has been accepted into the County Permanent Stormwater Quality Control Measure Inventory consistent with Chapter 5, control measures will be inspected at minimum once every five (5) years. All inspections will be conducted as described in Section I.5.

Confirmation that post-construction stormwater quality control measures operate according to approved plans occurs through the use of an inflow hydrograph routed through a basin model. This analysis and the resulting hydrograph shall be performed by the Engineer of Record for the owner or authorized agent of the applicable development site and provided with Final Drainage Report included in the development plan submitted to the County. If the ECM Administrator determines that significant changes to the approved plans are identified in the "as-built" drawings provided in conformance with Section 5.10.6, an additional inflow hydrograph based on the "as-built" changes shall be provided to the County to confirm that the changes made during construction did not negatively alter the effective operation of the control measure.

If during an inspection of a post-construction stormwater quality control structure it is determined and documented by a County Stormwater Inspector that any owner or authorized agent failed to adequately operate and maintain a permanent stormwater quality control measures or remove the temporary control measures, an enforcement action described in Section I.6 shall be pursued.

- B. **Operation and Maintenance Manual.** A detailed Operation and Maintenance Manual covering inspections, operation and maintenance of permanent BMPs will be provided to the party who holds the Private Maintenance Agreement for Permanent BMPs. The Operation and Maintenance Manual will include specifics on frequency of inspections and maintenance; standards for vegetation or structures, such as species of vegetation, mowing height, revegetation of worn or eroded areas, cleaning methods; depth of sediment requiring removal; replacement frequencies; and other relevant topics.

(Res. No. 19-245 , 7-2-19)

I.8. PROCEDURES FOR ASSESSMENT OF STRUCTURAL CONTROLS FOR RETROFITTING WATER QUALITY FEATURES

[Replaces DCM2 Section 4.4, page 4-133]

At some sites, there may be an existing structure for flood control and other water quantity control purposes. It may be possible to retrofit this structure for water quality in addition to the quantity functions. The following procedure will assist in evaluating the potential for retrofitting. In a new or major redevelopment project, new erosion and water quality control BMPs will be required, if retrofitting is not a reasonable option.

(Supp. No. 2)

Created: 2021-06-08 11:36:14 [EST]

The purpose of this document is to outline the procedures for these evaluations. These procedures would then be utilized in conjunction with developing each new Drainage Basin Planning Study (DBPS) to determine the potential and feasibility for retrofitting existing structural controls (detention/retention basins).

The analysis of the structures involves three possible levels of review. The first is a qualitative review to determine if retrofitting of the structure is acceptable. The second element is quantitative to determine the pollutant removal effectiveness of the structure, both with and without water quality elements. Total Suspended Solids (TSS) will normally be the only constituent evaluated, unless other pollutants of concern are specified by the ECM Administrator, based on site-specific information such as draining to sensitive waters or high risk pollution sources. A third element of review involves developing a cost estimate for retrofitting to determine the economic feasibility.

A qualitative assessment evaluates the changes that would occur if the flood-control detention facility was modified for water quality purposes, and determines the extent to which the changes would affect these functions, and if these changes in function are acceptable. The detention pond must first be acceptable under the qualitative criteria, or the evaluation will conclude and not continue to the second level of review. A quantitative analysis involves a determination of whether the percent removal of TSS (or other specified constituent of concern) is significant. For purposes of this assessment, a significant change is defined as the percent removal of the constituent after retrofitting the detention pond is estimated to be at least 20 percent greater than the percent removal of the constituent for the detention pond without the water quality element incorporated. If a significant change is estimated, then the third element of analysis, a cost estimate of the economic feasibility, is conducted. If a significant change is not estimated, then the option to retrofit the detention pond is eliminated.

I.8.1. Final Alternative Selection

The final alternative selection process for drainage improvement options in any new DBPS is based on the evaluation of many factors including costs, safety, environmental issues including water quality, public input, etc. If the selected alternative includes retrofitting structural controls to provide additional pollutant removal, responsibility for implementation would need to be outlined in the study. If the responsibility was determined to be a public (County) responsibility, consideration for funding any such drainage improvement project would be made by the Board of County Commissions during its annual budget approval process in conjunction with all other budget requests. If the responsibility was determined to be a private development responsibility, ECM Administration would decide when implementation would be required in conjunction with the timing of future developments.

I.9. SUPPLEMENTAL INFORMATION: URBAN DRAINAGE FLOOD CONTROL DISTRICT'S HYDROLOGY AND HYDRAULICS DESIGN TOOLS

[Replaces DCM2 Appendix A]

The Urban Drainage and Flood Control District (UDFCD) located in Denver, Colorado developed a number of tools to assist engineers and design professionals develop hydrology, adhere to UDFCD criteria, and perform various analyses. El Paso County allows for the use of these tools on submittals required during the development and construction review and approval process. In the event there are conflicts that arise between the inputs or results of an UDFCD tool and the criteria contained in this ECM, however, it shall be responsibility of the Engineer of Record to identify those conflicts and bring them to the attention of the ECM Administrator. Only the appropriate UDFCD design tools available on the UDFCD website at the time of site plan approval will be acceptable. The ECM Administrator, at their sole discretion, will determine if the specific use of the tool is acceptable for the project under review.

The preparation of final design plans addressing details of structural adequacy, public safety, hydrology, hydraulic functionality, maintainability, and aesthetics remains the sole responsibility of the Engineer of Record.

BY THE USE OF THE URBAN DRAINAGE AND FLOOD CONTROL DISTRICT SUPPLIED DESIGN FORM WORKSHEETS, THE USER AGREES TO THE FOLLOWING: NO LIABILITY FOR CONSEQUENTIAL DAMAGES

To the maximum extent permitted by applicable law, in no event shall the Urban Drainage and Flood Control District or the City of Colorado Springs or El Paso County, their contractors, advisors, reviewers, or their member governmental agencies, be liable for any incidental, special, punitive, exemplary, or consequential damages whatsoever (including, without limitation, damages for loss of business profits, business interruption, loss of business information or other pecuniary loss) arising out of the use or inability to use these products, even if the Urban Drainage and Flood Control District or the City of Colorado Springs or El Paso County, their contractors, advisors, reviewers, or their member governmental agencies have been advised of the possibility of such damages. In any event, the total liability of the Urban Drainage and Flood Control District or El Paso County, their contractors, advisors, reviewers, or their member governmental agencies, and your exclusive remedy, shall not exceed the amount of fees paid by you to the Urban Drainage and Flood Control District for the Product.

NO WARRANTY

The Urban Drainage and Flood Control District or El Paso County, their contractors, advisors, reviewers, or their member governmental agencies do not warrant that the Design Form Worksheets will meet your requirements, or that the use of this product will be uninterrupted or error free.

THIS PRODUCT IS PROVIDED "AS IS" AND THE URBAN DRAINAGE AND FLOOD CONTROL DISTRICT OR EL PASO COUNTY, THEIR CONTRACTORS, ADVISORS, REVIEWERS, AND THEIR MEMBER GOVERNMENTAL AGENCIES DISCLAIM ALL WARRANTIES OF ANY KIND, EITHER EXPRESSED OR IMPLIED, INCLUDING BUT NOT LIMITED TO, ANY WARRANTY OF MERCHANTABILITY, FITNESS FOR A PARTICULAR PURPOSE, PERFORMANCE LEVELS, COURSE OF DEALING OR USAGE IN TRADE.

(Res. No. 19-245 , 7-2-19)

Appendix J ROADWAY INSPECTIONS AND TESTING

J.1. PURPOSE

This appendix presents general requirements for testing and inspecting roadways and ancillary facilities constructed within the County. This appendix presents the minimal standards the ECM Administrator will follow for project inspections and ultimately acceptance of completed improvements.

J.2. GENERAL TESTING AND INSPECTION PROCEDURES

J.2.1. Roadway Testing and Inspection Standards

CDOT Standard Specifications for Road and Bridge Construction, as amended, special provisions and revisions thereto and as amended by the ECM shall apply to roadway testing and inspection requirements.

(Supp. No. 2)

Created: 2021-06-08 11:36:14 [EST]

J.2.2. Submission of Tests

All tests and inspection results performed by the testing firm in the employment of the permit holder shall be submitted directly from the testing agency to ECM Administrator, at the time of field tests, and within 10 working days after the testing or retesting date of laboratory tests.

J.2.3. Testing Required

Any work performed inside the County's RIGHT-OF-WAY or associated easements shall be tested by an approved materials testing firm who must employ a full-time registered professional engineer who directly supervises work of the firm. The costs of testing and associated reporting will be paid by the permit holder. All Material Testing Reports must be from an ECM Administrator-approved lab and must be certified by a Professional Engineer.

J.2.4. Approved Testing Methods

The testing of all materials and construction shall be in conformance with the appropriate AASHTO, ASTM, A.C.I., or CDOT specifications. A partial list of approved testing methods is provided in Table J-1.

Table J-1. Approved Testing Methods

Test Procedures	AASHTO	ASTM
Asphalt Core Densities	T 155 - 78	
Atterberg Limits (LL & PL)	T 89 & T 90	D 4318
Gradation Analysis (except hydrometer)	T 27	D 422
CBR	193	
R-value (subgrade & base)	T 190	D 2844
Rt Value	T 246	D 1560
Compaction Curve (standard)	T 99	D 698
Compaction Curve (modified)	T 180	D 1557
Compaction Curve (CTAB)	T 134	
Field Density Test (Sand Cone)	T 191	D 1556
Field Density Test (Nuclear)	T 238/T 239	D 2922/D 3017
Field Density Test (Balloon)	T 205	D 2167
Concrete Slump	T 119	C 143
Concrete Air Content	T 152	C 231
Concrete Compressive Strength	T 22	C 39
Concrete Sampling	T 141	C 172
Strength of Soil-Lime Mixtures	T 220	—
Asphalt Flow	T 245	D 1559
Air Voids	T 245	D 1559
Profil-o-graph	Colo. Procedure 64-85	
Swell Potential Evaluation		D 4546-96

J.2.5. Scheduling Inspections and Penalties

Any work performed in the County right-of-way must have a valid permit issued by the ECM Administrator. The permit holder must call the ECM Administrator at least 48 hours in advance of commencing work and schedule inspections. If for any reason work is not performed as scheduled, the permit holder must call and cancel the inspection as soon as possible. Failure to cancel the ECM Administrator inspection will result in a

penalty fee. The privilege to work in the County's right-of-way may be revoked by the ECM Administrator for non-conformance with any permit or ECM condition or standard.

J.3. ANCILLARY FACILITIES TESTING AND INSPECTION

J.3.1. Utility Trenches Backfill Testing and Inspection

- A. **Field Moisture Density Testing.** Field moisture-density testing shall be performed during backfill operations beginning 12 inches above the top of the pipe and extending to the finished subgrade elevation. A sufficient number of tests shall be taken at various depths to confirm backfill compaction and moisture content specifications are met. As a minimum, one test shall be taken within 12 inches of manholes, water valves, or other obstacles. Testing shall be done in accordance with Appendix K. Within the roadway area, trench compaction shall be in accordance with AASHTO T-99 or T-180.

J.3.2. Curb, Gutter, Sidewalk, and Minor Drainage Structures Testing and Inspection

- A. **Testing Frequency.** Testing frequency for the subgrade shall be a minimum of each 6-inch lift on replacement materials with one test for every 500 linear feet of structure with more tests taken if necessary for control.
- B. **Slump, Air Content and Unit Weight Tests.** The slump, air content, and unit weight tests for the delivered product shall be carried out on the first load or until compliance for the daily placement and all tests shall be taken at the end of the concrete chute, or, if a "pump truck" is used, at the end of the pump, and thereafter in conformance with Table J-2.

Table J-2. Testing Frequency

Item	Testing Frequency ¹
Sidewalks, Crossspans, Curb Returns	1 set of per class of concrete per project for every 100 cubic yard or fraction thereof of concrete placed
Curbing and Combination Curb, Gutter, and Walk	1 set of per class of concrete per project for every 100 cubic yard or fraction thereof of concrete placed
Note: Testing shall include the slump (T 119), air entrainment (T 152), temperature of concrete at placement, yield and compressive strength of the cylinders (T 22).	
¹ All work done by hand (non-extrusion) shall require a minimum of two (2) sets of tests per day.	

- C. **Core Tests.** At the discretion of the ECM Administrator, the contractor or permit holder will provide core test results of concrete at random intervals, not averaging less than one test in 500 feet, to verify that specified thickness of concrete was installed. If the ECM Administrator has not been given the opportunity to inspect the subgrade or concrete forms prior to placement of the concrete, the contractor or permit holder shall provide core tests.
- D. **Temperature Data and Tests.** When the mean daily temperature is less than 40°F, in accordance with A.C.I. Specifications, or when concrete is placed with ambient temperatures below 40°F, it shall be the contractor or permit holder's responsibility to provide testing lab certified proof that the temperature of the concrete has been maintained at not less than 50°F for a minimum of five (5) days or until at least seventy percent (70%) of the design strength has been attained.

J.4. ROADWAY TESTING AND INSPECTION

J.4.1. Roadway Subgrade Testing and Inspection

- A. **Field Moisture Density Tests.** Field moisture-density tests using acceptance methods will be required at random locations at the rate of one for each 500 lineal feet, or portion thereof, of paving for each travel lane.
- B. **Final Proof Rolling Inspection Notification.** The ECM Administrator shall be notified at least 24 hours before final proof-rolling.
- C. **Review and Approval of Tests.** The results of field density tests and proof-rolling shall be submitted to and reviewed by the ECM Administrator. If testing indicates unsatisfactory work, the necessary reworking, compaction, or replacement will be required prior to continuation of the paving process. If all tests are acceptable, compaction will be approved for the placement of the paving course. The approval is valid for 24 hours. Changes in weather, such as freezing or precipitation, will require reapproval of the subgrade.

J.4.2. Lime Treated Subgrade Testing and Inspection

- A. **Field Moisture Density Tests.** Lime treated subgrade shall be observed and tested on a full-time basis. Field moisture-density tests shall be taken at the rate of one for each 500 lineal feet of travel lane for each lift. Field density shall be compared to the compaction curves (AASHTO T 220) each soil type for percentage compaction determinations. Field compacted 7-day strength and lime content (AASHTO T 232) determinations shall be required for each 500 tons of subgrade treated, with a minimum of one per project.
- B. **Review and Approval of Tests.** The results of field density, lime content, and strength tests shall be submitted and reviewed by the ECM Administrator. Should these tests fail to meet project specifications, the strength reduction will be used to calculate increased pavement layer or overlay thickness required for the design section. If all tests are acceptable, compaction will be approved for the placement of the paving course.

J.4.3. Aggregate Base Course Testing and Inspection

- A. **Verification of Materials Properties.** The contractor or permit holder shall, upon request by the ECM Administrator, provide verification of material properties.
- B. **Gradation and Atterberg Limits Materials Sample Tests.** At least one sample of aggregate base course for each 1,000 tons of materials placed shall be tested to determine gradation and Atterberg Limits. Should these tests indicate the material does not meet specifications, the material shall be removed and replaced.
- C. **Field Moisture Density Tests.** During placement and compaction, compaction curves will be required for each material used. Field moisture-density tests shall be taken of each lift of material at random locations at approximate intervals of 500 feet in each travel lane. At least 20 percent of the tests shall be taken within 12 inches of manholes, valves, and curbs.
- D. **Review and Approval of Tests.** The results of field density tests shall be submitted to and reviewed by the ECM Administrator. Should testing indicate unsatisfactory work, the necessary reworking, compaction, or replacement will be required prior to continuation of the paving process. If all tests are acceptable, compaction will be approved for the placement of the paving course.

J.4.4. Cement Treated Aggregate Base Course Testing and Inspection

- A. **Verification of Materials Properties.** The contractor or permit holder shall provide verification of material properties of the approved mix design.
- B. **Approval of Subgrade.** Materials shall be placed on a subgrade that has been proof-rolled within the past 24 hours and found to be stable and non-yielding and has been approved by the ECM Administrator. Should weather conditions change, such as freezing, precipitation, etc., materials shall not be placed until the subgrade is re-approved by the ECM Administrator.
- C. **Unconfined Compressive Strength, Gradation, and Atterberg Limits Material Test.** At least one sample of cement treated aggregate base course for each 1,000 tons of material placed shall be tested to determine gradation, and Atterberg Limits. Six field prepared proctor mold samples shall be taken for each 500 tons placed and tested at 7 and 28 days to determined unconfined compressive strength.
- D. **Field Moisture Density Tests.** During placement and compaction, compaction curves will be required for each material used in accordance with AASHTO T 134. Field moisture-density test shall be taken of each lift of material at random locations at approximate intervals of 500 feet in each travel lane. At least 20 percent of the tests shall be taken within 12 inches of manholes, valves, and curbs.
- E. **Review and Approval of Tests.** The results of laboratory tests and field density tests shall be submitted to and reviewed by the ECM Administrator. Should testing indicate unsatisfactory work, necessary adjustments will be made to the pavement section to comply with original design strength requirements. If all tests are acceptable, compaction will be approved for the placement of the paving course.

J.4.5. Hot Mix Asphalt (HMA) Testing and Inspection

Hot Mix Asphalt (HMA) materials shall be tested according to the latest edition of the Pikes Peak Region Asphalt Specification. The Pikes Peak Region Asphalt Specification can be obtained online at: <http://adm.elpasoco.com/publicservices/transportation/Pages/default.aspx>.

J.4.6. Portland Cement Concrete Testing and Inspection

- A. **Portland Cement Concrete Requirements.** When the mean daily temperature is less than 40°F, in accordance with A.C.I. Specifications, or when concrete is placed with ambient temperatures below 40°F, it shall be the contractor or permit holder's responsibility to provide testing lab certified proof that the temperature of the concrete has been maintained at not less than 50°F for a minimum of five (5) days or until at least seventy percent (70%) of the design strength has been attained.
- B. **Aggregate Samples.** During placement of Portland cement concrete pavement, observation and testing shall be on a full-time basis. For each day of production or every 400 cubic yards placed (or portion thereof), aggregate samples shall be obtained for gradation of both the coarse and fine aggregates.
- C. **Slump, Air Content, Unit Weight, and Mix Temperature Testing.** Slump, air content, unit weight, and mix temperature shall be tested every 100 cubic yards of pavement placed. The first three loads shall be tested for slump and air content. If any one test fails to meet requirements, slump and air content tests shall continue until three consecutive loads meet requirements. Thereafter, slump and air shall be tested every fifth load.
- D. **Compressive Strength Cylinder Testing.** Six compressive strength cylinders shall be fabricated for each 100 cubic yards placed. Cylinders shall be tested as follows: 1 at 7 days, 2 at 28 days, and 1 for backup, as required by the ECM Administrator. Testing interval may be increased to approximately 1/3 of the daily volume at the discretion of the ECM Administrator.

-
- E. **Certificates of Compliance and Pre-Testing.** Portland cement and fly ash will be accepted on the basis of current certificates of compliance and pre-testing by CDOT. Reinforcing steel, dowels, and tie bars will be accepted by certificate of compliance and mill reports. Water, if not potable, shall be sampled and tested before use. Only CDOT-approved brands of air entraining agents, chemical admixtures, and curing materials may be used and must be documented.
 - F. **Surface Smoothness Tests.** Surface smoothness shall be tested and corrected as necessary according to Section 412.17 CDOT. The profil-o-graph index shall not be more than 14 inches per mile with a deviation of not more than 0.5 inches in 25 feet. Concrete tested with a 10-foot straight edge shall have a deviation of no more than 3/16 inch in 10 feet. This requirement is for all concrete mainline pavements. Surface smoothness shall be tested and corrected as necessary according to CDOT Section 412.16.
 - G. **Concrete Thickness Tests.** Concrete thickness shall be verified by coring after construction at random locations at intervals of approximately 500 feet in each travel lane as determined and marked by the ECM Administrator. The ECM Administrator must be present during actual core drilling or cores will not be accepted. Surface smoothness shall be tested and corrected as necessary according to CDOT Section 412.16.
 - H. **Profil-O-Graph Tests Submitted.** Profil-o-graph tests shall be submitted to, and accepted by, the ECM Administrator prior to beginning the 2-year warranty period.
 - I. **Onsite Test Location.** All on-site air tests shall be taken at the point of placement: at the end of the concrete chute, or, if a "pump truck" is used, at the end of the pump, etc.
 - J. **Review and Approval of Tests.** All test results shall be submitted to, and reviewed by, the ECM Administrator. Should testing indicate unsatisfactory work, removal and replacement or grinding will be required. If all tests are acceptable, the pavement will be accepted and the 2-year warranty period will begin.

J.4.7. Asphalt Tack Coat Testing and Inspection

Asphalt tack coat materials shall be tested according to the latest edition of the Pikes Peak Region Asphalt Specification. The Pikes Peak Region Asphalt Specification can be obtained online at:
<http://adm.elpasoco.com/publicservices/transportation/Pages/default.aspx> .

J.4.8. Cement Stabilized Subgrade Testing and Inspection

- A. **Verification of Materials Properties.** The contractor or permit holder shall provide verification of material properties of the approved mix design.
- B. **Thickness of Stabilized Zone.** Stabilized zone thickness shall be verified by the use of phenolphthalein and shall be performed at intervals of approximately 500 feet in each lane. When the measurement of the thickness is deficient by more than 1 inch from the plan thickness, two additional locations shall be measured randomly within the deficient area and used in determining the average thickness. When the average thickness is deficient by more than 1 inch, the entire area shall be reprocessed to meet the design parameters or the roadway design section must be re-evaluated.
- C. **Unconfined Compressive Strength, Gradation, and Atterberg Limits Material Test.** At least one sample of cement stabilized subgrade for each 1,000 tons of material stabilized shall be tested to determine gradation and Atterberg Limits. The stabilized subgrade must develop a laboratory compressive strength that meets the design compressive strength. Samples shall be molded from stabilized soil within 1.5 hours of final mixing with the material compacted per ASTM D 558 or ASTM D 698, as specified in subgrade stabilization design, at the field moisture content.

- D. **Field Moisture Density Tests.** During placement and compaction, compaction curves will be required for each material used in accordance with AASHTO T 134. Field moisture-density test shall be taken of each lift of material at random locations at approximate intervals of 500 feet in each travel lane. At least 20 percent of the tests shall be taken within 12 inches of manholes, valves, and curbs.
- E. **Review and Approval of Tests.** The results of laboratory tests and field density tests shall be submitted to and reviewed by the ECM Administrator. Should testing indicate unsatisfactory work, necessary adjustments will be made to the pavement section to comply with original design strength requirements. If all tests are acceptable, compaction will be approved for the placement of the paving course.

J.5. TESTING SUMMARY

Table J-3 summarize the testing requirements outlined in Appendix J.

Table J-3. Summary Minimum Testing Requirements

No.	Item	Type Of Test	Minimum Frequency	Min. #	Act. #
1	Utilities: Water, Sewer, Gas, Electric, Phone and Cable Trenches	Moisture/Density	1 per every 250 L.F. or fraction thereof, every 2' elevation. Each structure (manhole, valve, etc.) every 2' elevations. This requirement also applies to every service.		
2	Storm Sewer Trench	Moisture/Density	Same as above. Each structure (manhole, inlet, etc.) every 2' elevations.		
3	Inlets Concrete Testing	Air Slump	First load or until compliance. Minimum 1 per day.		
		Cylinders	1 set (4) per project for every 100 C.Y. or fraction thereof.		
		Steel	Visual and Documentation		
4	Curb and Gutter	Moisture/Density	1 every 250 feet or a minimum of 3 tests, whichever is greater.		
		Proof-Roll	All final subgrade.		
		Air/Slump	First load or until compliance. Minimum 1 per every 2,000 L.F. or fraction thereof.		
		Cylinders	1 set (4) per project every 2,000 L.F. or fraction thereof.		
5	Sidewalk	Moisture/Density	1 per every 250 L.F. or fraction thereof.		
		Air/Slump	First load or until compliance. Minimum 1 per every 1,000 S.Y. or fraction thereof.		
		Cylinders	1 set (4) per project 1,000 S.Y. or fraction thereof.		
6	Roadway Subgrade: Fills and Cuts	Moisture/Density	1 per every 500 Lane Ft. or fraction thereof, every 2' elevation. Cuts to be scarified to a depth of 1', recondition as needed and recompact.		
			All final subgrade.		
7	Roadway (Concrete)	Air/Slump	First 3 loads or until compliance, then every 1,250 C.Y. or fraction thereof.		

Created: 2021-06-08 11:36:14 [EST]

(Supp. No. 2)

		Cylinders	1 set (4) per project for every 1,250 C.Y. or fraction thereof.		
8	Roadways (Base Course)	Moisture/Density	1 per 500 Lane Ft. or fraction thereof.		
		Gradation & Atterberg Limits	1 per 2,000 Tons or fraction thereof.		
		Proof-Roll	Subgrade prior to Base Course placement. Base Course prior to placement of asphalt.		
9	Roadways (Asphalt)	Density	1 per 500 Lane Ft. or fraction thereof, per lift.		
		Extraction/Gradation	1 per 1,000 Tons or fraction thereof.		
10	Roadways (Asphalt & Concrete)	Cores	1 per 1,000 Lane Ft. or fraction thereof.		
		Profil-O-Graph	Minor Arterial classification and above.		

Appendix K ROAD CUT, TRENCHING AND RESTORATION

K.1. ROAD CUTS

K.1.1. General

Placement or repair of subsurface facilities (utilities, culverts, or foundations) within the County roadways shall follow the requirements outlined in the Chapters 3 and 4 and this Appendix. Modifications to these Standards require written approval from the ECM Administrator before beginning work. Emergency repairs for broken pipes, cables etc. is allowed on a case-by-case basis and requires immediate notification of the ECM Administrator. Applicable Trench Notes are provided in Section K.2.

K.1.2. Pavement Cutting

- A. **No Cuts Permitted.** No pavement cuts will be permitted in pavements less than three years old. In the event that a pavement cut is allowed through an approved deviation, restoration requirements may be more extensive than for older pavements. If the a permit holder makes a cut into a pavement less than three years old, which is not an emergency cut, the permit holder shall be liable for restoring the roadway to the satisfaction of ECM Administrator at the permit holder's expense.
- B. **Boring May be Required.** Boring may be required for pipelines to cross roads, instead of trenching, as directed by the ECM Administrator. If sufficient right-of-way exists, the length of the bore shall extend a minimum of 4 feet from edge of pavement. Unused holes or abandoned casings shall be backfilled. Water boring under roadways shall not be permitted. Existing carriers and conduit installed under a roadway shall be physically located prior to boring.
- C. **Pavement Cut Standards.** Pavement shall be cut so the joint line between existing and replacement pavement is straight and neat (i.e., within 5° of vertical and free from horizontal irregularities). All cuts shall be by saw or blade. The cut shall be full depth to allow the pavement to be removed without damage to the remaining pavement. The minimum allowable remaining pavement sections shall not be less than four feet (4') (not including the curb and gutter or concrete pavement) unless it is part of monolithic concrete pavement section that shall be full panel (per existing control joint).
- D. **Removal and Disposal of Pavement.** Removed pavement shall be hauled away and disposed of in a proper manner (recycle or waste facility).

-
- E. **Base Course Storage and Reuse.** Base course material may be removed and stockpiled off of the road surface area for reuse during backfilling if it meets specifications. If not, it is to be hauled away from the right-of-way and disposed of in a proper manner.
- F. **Subbase Material Storage and Reuse.** Sub-base material may be stockpiled parallel to the trench alignment; in such a manner that encroachment upon the non-disturbed portion of the roadway and pedestrian walkways is kept to a minimum. The storage of materials on the non-disturbed portion of the roadway shall not be allowed unless identified in the traffic control plan with appropriate protective measures. Unsuitable material is to be hauled away from the right-of-way, disposed of in a proper manner and replaced with select backfill.
- G. **Storage of Construction Materials in Right-of-Way.** The temporary storage of construction material in the public right-of-way in connection with utility projects is permitted. Material storage shall meet the requirements outlined by the ECM Administrator. Parking of construction or personal vehicles on roadways shall be kept to a minimum.
- H. **Safety Standards.** Safety standards relating to the shoring and stabilization of trench sidewalls should be maintained as prescribed by appropriate safety regulatory agencies (OSHA, State of Colorado). All barricades shall comply with Manual of Uniform Traffic Control Devices (MUTCD).
- I. **Length of Open Trench Limited.** Trenches shall not be opened for a distance of more than one hundred (100) feet at any one time, unless specifically authorized by the ECM Administrator.
- J. **Trench Width and Pavement Cut.** The trench width shall be confined to those minimum dimensions, which will permit proper installation and acceptable pipe loading, as established by current acceptable engineering practices and all OSHA requirements. In no case shall the trench width be less than equal to the diameter of the pipe plus a minimum of 12 inches on each side to ensure adequate compaction by mechanical means.
- All asphalt pavement cuts shall be a minimum of 12 inches in each lateral dimension beyond edge of trench and full panel replacement on all concrete or curb and gutter cuts.
- K. **Open Condition and Traffic Warnings.** No road cuts should be left in an open condition overnight, except for the portion necessary to commence work the following morning. Warning signs, barricades and lights, all in conformance with the MUTCD, shall be used in areas where trenching operations are in public roadways. All work shall have flashing lights used with warning signs and barricades. All barricades, signs and warning devices shall be installed in accordance with the MUTCD.
- L. **Trenching Across the Road and Traffic.** When trenching across the road, no more than one-half (1/2) of the roadway is to be closed to traffic at one time. A traffic signal or flaggers as required by MUTCD shall be provided. The trenched roadway shall be completely backfilled and paved before trenching the other half of the road.
- M. **Road Closure.** Closure of any road, approach, or other access points shall be approved by the ECM Administrator. Upon trenching across facilities, steel running plates, planks or other safe methods shall be used to provide for traffic to enter or leave the road or adjacent property.
- N. **Driveways Closures.** The use of driveways to adjacent properties shall be respected by the permit holder. Every effort shall be made minimize closures and to open and make serviceable those driveways that are closed in the shortest time possible. If closure of driveways is anticipated, the permit holder performing the work shall notify the owners in advance of closure and shall notify the owners of the anticipated time and period of closure. When open, safe access to private driveways shall be provided.

-
- O. **Notice Before Beginning Work.** The ECM Administrator, applicable policing authority and emergency companies shall be informed by the permit holder at least 48 hours in advance of beginning work in the public right-of-way.
 - P. **Accidents.** If traffic accidents or pedestrian incidents occur due to installations or obstructions placed in the right-of-way, the occurrence must immediately be reported to the ECM Administrator and the applicable policing authority by the permit holder.
 - Q. **Access to Fire Hydrants.** Safe access must be maintained at all times to fire hydrants.
 - R. **Restoration of Property.** The permit holder shall take precautions to limit the removal of or damage to existing pavements, sidewalks, curbs, lawns, shrubbery, trees, hedges, walls, fences, buildings, other existing improvements, existing survey monumentation, pavement markings, and signage in the County right-of-way or easement areas to the least practicable amounts and shall replace or restore improvements to their original location and condition after the excavation has been backfilled and compacted.
 - S. **Private Easement Conditions.** The permit holder is responsible for understanding and complying with all specific conditions contained in private easements.
 - T. **Inspection Costs.** All inspection costs shall be borne by the permit holder.
 - U. **Notice of Completed Work.** The permit holder shall notify the ECM Administrator in writing upon completion of work accomplished under the provisions of the permit.

K.1.3. Backfilling

- A. **General.** Once the subsurface facility has been installed or repaired, backfill material shall be placed in accordance with these Standards.
- B. **Backfilling Requirements.**
 - 1. **Preparation of Trench.** The bottom of the trench shall be prepared to provide a firm foundation for the facility in accordance with the bedding conditions specified by the Geotechnical Engineer for the type of facility to be installed. The subgrade of the trench shall be kept free of standing water. Where the trench subgrade material is found to be unsuitable and does not afford a solid foundation, the permit holder shall excavate to depth as necessary to construct a stable foundation. A stable foundation shall be constructed by placing crushed rock or other approved granular material to support the installed facility.
 - 2. **No Deformation or Damage to Facility.** The facility, including backfill, shall be installed in a manner that ensures no deformation, displacement or damage to the facility likely to cause leakage or degradation to the structural integrity of the roadway.
 - 3. **Trench Backfill.** The facility being placed will be properly bedded to at least one foot above the pipe with furnished sand or selected sandy soil free of humus, vegetable or other organic matter, frozen material, clods, sticks and debris. In addition, rock particles and hard earth clods larger than 3 inches will be removed. After the improvements are bedded, the previously removed and stockpiled material shall be replaced and properly compacted to an elevation which facilitates placing pavement. No fill material with a liquid limit greater than 40 and plasticity index greater than 20 percent shall be used within the top two feet of the trench without implementing proper mitigation techniques.
 - 4. **Compaction Tests.** Compaction tests must be performed daily by a Geotechnical Engineer and shall be performed at a minimum of every 250 feet (250') or portion thereof along the trench and

every 12 inches in elevation. Testing intervals may be increased at the discretion of the ECM Administrator.

5. **Compaction.** The subgrade shall conform to the lines, grades and cross-sections as shown on the approved plans. The backfill material shall be compacted in successive layers not to exceed eight inches (8") thick and shall be finished and maintained in a smooth compacted condition. The completed surface shall be free from rutting or other objectionable irregularities.

Within the roadway area, trench compaction shall be in accordance with the following, depending on the site conditions:

- Depths up to 15 feet and cohesive soils (per A.A.S.H.T.O.) - 95 percent of maximum Standard Proctor dry density at moisture contents within 2 percent of optimum (ASTM D698 or AASHTO T99)
- Depths up to 15 feet and non-cohesive soils (per A.A.S.H.T.O.) - 95 percent of maximum Modified Proctor dry density at moisture contents within 2 percent of optimum (ASTM D1557 or AASHTO T180)
- Depths over 15 feet and cohesive soils (per A.A.S.H.T.O.) - 98 percent of maximum Standard Proctor dry density at moisture contents within 2 percent of optimum (ASTM D698 or AASHTO T99)
- Depths over 15 feet and non-cohesive soils (per A.A.S.H.T.O.) - 95 percent of maximum Modified Proctor dry density at moisture contents within 2 percent of optimum (ASTM D1557 or AASHTO T180)

K.1.4. Subbase Preparation

- A. **General.** The term "subbase", for the purpose of trench backfill discussion shall refer to the CDOT Class 1 or Class 2 material that is part of a structural pavement design. There may or may not be a subbase in the pavement section. If there is none, the base course shall all CDOT Class 6.
- B. **Subbase Placement Procedures.**
 1. **Subbase Grade and Cross Sections.** Subbase material shall conform to the lines, grades, cross sections and thickness shown on the approved plans and shall be finished and maintained in an acceptable condition at least one day's progress in advance of base construction.
 2. **Subbase Material.** Subbase material shall be well mixed, free of organic matter and lumps or balls of clay, and shall consist of sound aggregate particles and suitable filler or binding materials which when placed and compacted will result in a firm, dense, unyielding foundation. Subbase material need not be crushed but may be of the pit run variety providing it is graded within the following limits.

Table K-1. Gradation of Subbase Material

Standard Size of Sieve	Percentage of Weight Passing Sieve
2½ inch	100
2 inch	95—100
#4	30—60
#200	5—15
Liquid Limit	35 maximum
Plastic Limit	6 maximum

Created: 2021-06-08 11:36:15 [EST]

(Supp. No. 2)

3. **Subbase Placement.** Subbase shall be deposited and spread, without particle segregation in loose layers not to exceed 6 inches (6") in depth. Each layer shall be thoroughly and individually compacted to 96% proctor (AASHTO T99) density. Wetting or aerating and rolling the material shall be required when ordered by the ECM Administrator. Subbase shall not be placed on soft, spongy, or frozen subgrade or other subgrade, the stability of which, in the opinion of the ECM Administrator, is unsuitable.

K.1.5. Foundation for Base Course

- A. **General.** Foundation preparation shall be completed to ensure proper slopes, grades, shown of project plans are developed.
- B. **Base Course Preparation Requirements.**
 1. **Base Course Grades and Cross Sections.** Base material shall conform to the lines, grades, cross-sections, and thickness shown on the approved plans and shall be finished and maintained in an acceptable condition at least one day's progress in advance of placing prime coat.
 2. **Base Course Material.** Base material shall consist of hard, durable particles or fragments of stone or gravel crushed to the required size and an AP-filler of sand or other finely divided mineral matter. When produced from gravel, not less than 60% by weight of the aggregate retained on a No. 4 sieve shall consist of particles having at least one fractured face. Base material shall be free from vegetable matter and lumps or balls of clay and which when placed and compacted will result in a firm, dense, unyielding foundation. Base material shall meet the following grading requirements:

Table K-2. Gradation Limits for Base Material

Standard Size of Sieve	Percentage of Weight Passing Sieve
¾ inch	100
#4	0—65
#10	25—55
#200	3—12
Liquid Limit	25 maximum
Plastic Limit	6 maximum

3. **Base Course Placement.** Base material shall be deposited and spread without particle segregation in loose layers not to exceed 6 inches in depth. Each layer shall be thoroughly and individually compacted to 95% proctor (AASHTO T180) density. Wetting or aerating and rolling of the material shall be required as ordered by the ECM Administrator following review of all field test results. No base course shall be placed upon a soft, spongy or frozen subgrade or subbase or other subgrade, the stability of which, in the opinion of the ECM Administrator, is unsuitable.
4. **Material Deviations.** Deviation from the gradation limits may be permitted by the ECM Administrator on unpaved roads provided it can be unequivocally demonstrated that the subbase material is not conducive to rutting, raveling or forming a soft yielding surface in the presence of moisture.
5. **Compaction Equipment.** Compaction equipment must be on the job site before excavation is started. Compaction equipment must be capable of compacting within the trench width limits to avoid bridging the ditch.
6. **Existing Untreated Base Course.** If the existing base course is untreated, it shall normally be replaced with CDOT Class 6 aggregate base material and compacted in layers not to exceed 6

inches. The resulting total compacted base thickness shall be 8 inches or to the thickness of the removed base plus 2 inches. A replacement 2 inch thick asphalt surface wearing course, or matching existing, whichever is greater, shall also be used when replacing asphalt treated aggregate.

K.1.6. Trench Cover - Subgrade

- A. **General.** Trench cover placement shall follow the requirements of these Standards. The objectives are to place the material to lines and grades shown on project plans and ensure the compaction requirements are met.
- B. **Trench Cover Placement Requirements.**
 - 1. **Trench Cover Subgrade.** After the backfill has been placed and compacted as specified, it shall be cut and trimmed to the required depth and cross section. Trench cover subgrade shall be free of all rock over 2 ½ inches in size. It shall have a compaction of 95 percent or more, by standard tests at the time of constructing curb, gutter, sidewalk, pavement and/or other permanent trench cover structure.
 - 2. **Disposal and Restoration.** All excess excavated material shall be removed and disposed of outside the legal limits of the right-of-way as the work progresses, unless the approval of the ECM Administrator is obtained for disposal of the material within the legal limits of the right-of-way. All parts of the roadway and various structures disturbed shall be restored to a condition equal to or better than that which existed before starting the work.

K.1.7. Trench Cover - Paved Roads

- A. **General.** Trench cover placement shall follow the requirements of these Standards. The objectives are to place the material to lines and grades shown on project plans for paved surfaces and ensure the compaction requirements are met.
- B. **Temporary Trench Cover Requirements.**
 - 1. **Temporary Cover Required.** All trenches across traffic lanes, where it becomes necessary to remove any existing surfacing or pavement, shall be provided with temporary trench cover.
 - 2. **Temporary Patch Materials.** A temporary patch of cold-mix asphalt shall be placed on all pavement surface cuts immediately after backfilling has been completed and shall be removed at the time a permanent patch is made.

Minimum requirements for temporary trench cover shall be well compacted surfacing material conforming to "Road Mixed Asphalt Surfacing Material" of the CDOT Standard Specifications and shall match the existing asphalt or concrete thickness, or not less than 4 inches thick, whichever is greater. The mineral aggregate shall, with a tolerance of t percent, conform to the grading specified for 3/8-inch maximum aggregate. Bituminous binder to be mixed with the mineral aggregate shall be liquid asphalt, Grade MC-3000 and shall be between 5 ½% and 6% by weight of the dry mineral aggregate.
 - 3. **Material Onsite.** Temporary trench cover surfacing material, other than cold-mix patch, shall be stockpiled on the job site and shall be placed within six hours after completion of trench backfill and compaction.
 - 4. **Temporary Patch Maintenance.** Temporary trench cover shall be properly maintained until permanent trench cover is placed. The surface of the temporary repaving shall be smooth and at the same level as the adjacent undisturbed paved area.

C. **Permanent Trench Cover Requirements.**

1. **Asphalt Replacement Depth.** In the areas where the wearing surface is asphalt concrete, replace the pavement with a full depth asphalt paving of a minimum thickness of 4 inches but in all cases to a thickness of the old surface plus base course plus 1 inch.
2. **PCC Replacement Depth.** In areas where the wearing surface Portland cement concrete, replace the pavement with concrete pavement shall conform to these Standards. Concrete pavement replacement shall be of the same depth as the original pavement, but not less than 6 inches thick on alleys or residential roads, nor less than 8 inches on roads classified as collectives and above.
3. **Other Material Replacement Depth.** In areas where the wearing surface is other than asphalt concrete or Portland cement concrete, replace the pavement and base in kind, or minimum ECM Administrator standards, whichever is greater.
4. **Asphalt Placement.** Where original surface was asphalt concrete, bituminous treatment or mix, or oil mat; Asphalt concrete shall be compacted in layers not to exceed 3 inches to a total compacted thickness of 4 inches or the thickness of the removed pavement plus 1 inch, whichever is greater. On oil mat surfaces or substandard asphalt surfaces, an overlay of Class "EX" asphalt pavement 1 ½ inches thick shall be placed across the entire traffic lane disturbed by the trench and shall be finished as set forth below.
 - Immediately prior to placing the wearing surface, the abutting pavement edges shall be neatly cut.
 - The existing pavement shall be cleaned, removing all loose material and coated with hot liquid asphalt (Grade AC-10) or asphalt emulsion applied cold (Grade CSS-1h) to ensure a bond with the new asphalt surfacing.
 - The restored pavement shall be finished to a smooth riding surface and to the grade of the surrounding undisturbed pavement.
 - Pavement replacement shall commence not more than 7 working days after backfilling, unless approved by the ECM Administrator.
5. **Trench Edges in the Wheel Travel Portion of Roadway.** In the event the trench edges fall in the wheel traveling portion of a traffic lane, existing or proposed, the applicant shall extend the finish surface paving to a point deemed satisfactory by the ECM Administrator. Finish surface paving shall be performed to provide a crown slope equal to that existing prior to excavation, with no ponding of run-off surface water either over the trench or at the joints between the new and original surfaces.
6. **Cuts Impacting More than One Traffic Lane.** When road surface damage involves more than one traffic lane, a full width paving lift may be required. Individual jobs may require negotiations with the ECM Administrator for partial participation in the cost of a full width overlay.

K.1.8. Repair to Gravel Roads and Shoulder

- A. **General.** The repair of disturbed gravel surfaces shall be completed in accordance with these Standards. Placement of the gravel shall be done to ensure a smooth surface is developed and proper compaction is achieved.
- B. **Restoration of Unpaved Areas.**
 1. **Material and Placement.** Where the original surface was crushed rock or gravel for the wearing surface and foundation material, Class 6 aggregate base course shall be used as replacement

material. It shall be placed to a compacted thickness minimum of 8 inches or the thickness of the removed material plus 2 inches, whichever is greater.

2. **Backfill.** In the area from the right-of-way line (fence line/property line) to a point 5 feet outside of the roadside ditch flowline, all trenches shall be backfilled with excavated material and compacted to 90% standard compaction, or to the density of the existing ground, whichever is greater.

In all other areas, including the gravel road, the shoulders and the roadside ditch to a point 5 feet outside of the flowline; all trench compaction shall be completed to a minimum of 90% standard compaction.

3. **Erosion Protection.** During construction and after the trench is backfilled and compacted, erosion protection shall be provided to minimize sediment transport.

K.1.9. General Restoration Requirements

A. Preservation, Restoration and Cleanup.

1. **Conform to Permit.** Where construction has impacted streams, wetlands, fish and wildlife habitat areas or their buffers, full restoration and mitigation shall be performed as required by permit. Restoration methods shall be in accordance with County codes, provisions of the applicable permit, and these Standards.
2. **Unsatisfactory Restoration.** Unsatisfactory restoration of the right-of-way, as determined by the ECM Administrator, shall be promptly corrected by the permit holder. If necessary, unsatisfactory restoration may be corrected by the County and billed to the permit holder.
3. **Protection of Existing Utilities and Facilities.** Reinforcement, protection and security of existing utilities and facilities under construction are the responsibility of the permit holder. In roadway restoration, the design shall consider the protection of existing utilities without sacrificing the geometrics of roadway design.

- B. **Emergency Repairs.** If emergency repairs disturb the right-of-way, the right-of-way shall be restored immediately. Approval of the final restoration of the right-of-way shall be obtained from the ECM Administrator.

- C. **Striping Replacement.** All traffic striping and walkway delineation removed during construction shall be replaced. Temporary striping shall be used on a limited basis and only as approved by the ECM Administrator. All permanent striping and channelization shall be installed by County forces at the expense of the permit holder. If County forces are unavailable to perform the striping installation within an appropriate timeframe, the permit holder shall contract for the striping installation.

D. Final Cleanup.

1. **Roadways Swept.** Roadways shall be cleaned and swept both during and after utility work. Disturbed soils shall be final graded, seeded, and mulched after installation of the utility facilities or equipment. In limited areas, seeding and mulching by hand, or sod placement using approved methods, will be acceptable. Ditches lined with erodible soil and subject to rapid flows may require seeding, jute matting, netting, placement of sod, or rock lining to control erosion. Revegetated areas shall be weed free.
2. **Siltation.** Any silting of downstream drainage facilities, whether ditches, pipes or catchbasins, which results from the utility installation shall be cleaned out and restored to proper operation as part of the site cleanup.

-
3. **Storm Drainage Facilities.** Any existing storm drainage facilities or roadside features damaged during repair or restoration activities shall be replaced with new materials by the permit holder.

K.1.10. Maintenance Period

For a period of two years following the backfilling of any trench in the County's right-of-way or the permanent patching of paved surfaces, the permit holder shall be responsible for the condition of the trench backfill, pavement patches, and adjacent revegetation areas. During that time the permit holder shall, at their own cost, upon request from the ECM Administrator, repair to the County's satisfaction any of the patches that become settled, cracked, broken, or otherwise faulty. Settlement of the replaced road surface of 1/2 inch or more within a 6-foot straight edge shall constitute evidence of improperly compacted backfill material. If test results do not meet the standards for compaction as set forth in this specification, the permit holder shall be responsible for repairs or replacement to meet these standards. Settlement of 3/16 inch or greater with a 10-foot straight edge will be cause for repair in the case of settlement or replacement in the case of unsatisfactory workmanship.

K.2. TRENCHING DETAIL NOTES

- This trench patching detail specifies requirements in addition to those specified in the latest edition of the CDOT's Standard Specifications for Road and Bridge Construction.
- A construction traffic control plan shall be submitted to and approved by ECM Administrator prior to issuance of construction permits in the County right-of-way.
- Trench shall be braced or sheeted as necessary for the safety of the workers and protection of other utilities or structures in accordance with applicable local, state and federal safety regulations.
- The trench width shall be confined to those minimum dimensions, which will permit proper installation and acceptable pipe loading, as established by current local, state and federal safety regulations.
- At the discretion of the ECM Administrator, the pavement may be required to be saw-cut back to maintain a straight edge.
- Backfill compaction requirements: Minimum density will be determined in accordance with AASHTO T99 or T180 as defined by CDOT Standard Specifications Section 203.11 and CDOT 703.03. Except for CLSM.
- Fill depth asphalt can be used as an alternative to base course. A ratio of 3 inches (3") base course to 1 inch (1") of asphalt shall be used in the substitution.
- A temporary cold-mix asphalt patch, 4 inches (4") minimum depth will be required for all road cuts if a permanent hot-mix asphalt patch cannot be applied for any reason, after construction is completed.
- Pavement edges shall be saw-cut straight to within 5 degrees of vertical. Edges shall be tack coated prior to patching.
- If existing road is paved with fabric, a "TEE" trench shall be required. The Contractor shall carefully saw-cut and remove the layer of asphalt above the fabric a minimum of 12" back from the edge of the trench.
- Minimum cover for prefabricated pipe shall be 2 feet (2').
- Changes in design criteria will require compensating change in pipe design.
- When pipe sewer is to be extended or replaced with pipe of different material, the connections shall conform to the detail shown on plans or be approved.
- Spacing for multiple pipe sewer installations shall be ½" inside diameter or span, or 3" maximum.

-
- Trenches over 5 feet (5') in depth shall be either shared or the trench walls shall be sloped to the angle of repose. If sloped, the bottom of the slope shall be a minimum of 1 foot (1') above the bottom of the slope.
 - Shoring will be required when the bottom of the slope is more than 3 feet (3') above the bottom of the trench. Shoring shall extend a minimum of 1 foot (1') above the bottom of the slope.
 - Timber Sheeting or shoring may be cut off 1 foot above the top of the pipe after backfilling is complete.
 - Refer to the City/County DCM and CDOT "M" Standards.

Appendix L DRAINAGE CRITERIA MANUAL 1 ADDENDUM

Addendum

Revised Drainage Basin Fees Based on Impervious Area For Unincorporated El Paso County Only

City of Colorado Springs & El Paso County Drainage Criteria Manual

COORDINATED WITH EL PASO COUNTY STAFF AND DRAINAGE CRITERIA MANUAL REVISIONS TASK FORCE

TECHNICAL WORK BY AYRES ASSOCIATES AND SEC OLSSON ASSOCIATES

DRAINAGE BASIN FEE ADDENDUM CHAPTER 3

This revised fee addendum is intended to supplement Chapter 3 in the Drainage Criteria Manual. It is only effective for use in El Paso County (not in the City of Colorado Springs). Many of the items outlined in Chapter 3 remain applicable to the basin fee calculation process. If a discrepancy exists between this addendum and the original Chapter 3, this addendum shall apply.

3.5a Impetus for Revisions to the Basin Fee

The implementation, maintenance, and improvement of an adequate drainage system in the County were not occurring because of several past problems with assessment and collection of the basin drainage fees. Drainage fees were unreasonably high in some areas, and several land developers had sought and performed "end runs" around the fee payment. Those challenges to the payment of drainage fees had been successful for the following reasons:

- The County's drainage basin fee system did not meet the legal test for proportionality. For stormwater, the proportionality test means that the fee for a development should be roughly proportional to the increase in stormwater runoff that the development generates. Therefore, the fee should not be based on the total acreage of a development (as was in the previous system) but on the number of impervious acres.
- The County's policy for the type of stormwater detention ponds required (regional and/or on-site) was not clear.
- A County policy for implementing regional detention ponds and other regional facilities had not been established.

In the County, a land owner can apply credits earned from one project towards another project within the same basin. However, credits earned in one basin may not be transferred to another basin.

In general, the City of Colorado Springs does not collect fees on replats unless required as a condition of annexation; however, the County does collect fees on replats as explained below.

3.6a History of the Fee Revision Process

El Paso County has levied a basin fee based on acres of development since 1983. Because of the proportionality and general equity issues raised above, the basin fee revision process began in 1998 that culminated in the issuance of a September 21, 1998 draft report entitled "Proposed Revisions - Drainage Basin Fee Program and Policy for New Development, El Paso County, Colorado" along with a subsequent November 17, 1998 Addendum

to clarify on-site detention policy and correct minor typographical errors. A key finding of that report was that basin fees should be based on impervious acres rather than gross developed acres.

Following a review of the above draft, the development community believed that many of the revised basin fees were too high. As such, the developers hired the engineering consulting firm Ayres Associates to investigate the "Prudent Line" approach where applicable in lieu of structural channel improvements in an effort to reduce basin drainage infrastructure costs. The Prudent Line concept allows for an erosion setback and grade control stabilization of natural channels in basins with low-density development. Using the findings of Ayres Associates, including the revised land costs for the Prudent Line approach, a Second Addendum was issued in July 1999, where basin fees were revised significantly downward in many of the basins and a basin fee cap of \$15,000 per impervious acre was recommended. Various credits and reductions were also addressed and illustrated in examples in that addendum.

A Third Addendum was issued in September 1999 to clarify and resolve two objections made by developers following the issuance of the Second Addendum, and to resolve a few additional minor issues that arose as the Third Addendum was being finalized.

The information contained in the original September 1998 report and the three addendums have been used to prepare this revision to the basin fee program in the El Paso County Drainage Criteria Manual (DCM).

3.7a Calculation of the Basin Impervious Area

Impervious area in a basin is calculated for several different reasons. When a drainage basin planning study (DBPS) is completed the imperviousness is estimated to help determine peak runoff rates and runoff volumes under existing and future development conditions. The peak runoff rates and volumes are used to project floodplains and design conveyance and detention improvements. The costs of these improvements are, in turn, used to determine drainage basin fees for new development. Because the costs of improvements are dependent on the estimates of imperviousness in each basin, it is logical to base drainage basin fees on the amount of imperviousness in each development.

This new method is different than the previous method which used the same cost for each acre of development, regardless of the amount of impervious area planned for that acre. This method is still in use in the City of Colorado Springs.

The impervious area can be determined by direct measurements off the final development plan or by calculating the product of total area (both impervious and pervious area) and the percentage of area that is impervious. Table 3-1 shows some typical amounts of impervious area for different types of development. These values are generally consistent with Table 5-1 in the Colorado Springs/El Paso County Drainage Criteria Manual. Four additional single family residential values have been added to Table 3-1 that are not included in Table 5-1. Those values are for the 0.2-acre and the 6,000 square foot sizes for the smaller lots and the 2.5 and 5.0-acre sizes for the larger lots. The percent impervious values for these additions have either been directly computed or estimated from a regression of the existing values in Table 5-1 in the DCM.

Table 3-1. Typical Values of Percent Impervious

Type of Development	Percent Impervious
Commercial	95%
Industrial	85%
Multi-Family	65%
Single Family - 0.1377 acre lots (6,000 SF)	53%
Single-Family - 0.20 acre lots	43%
Single-Family - 0.25 acre lots	40%

Single-Family - 0.33 acre lots	30%
Single-Family - 0.5 acre lots	25%
Single-Family - 1.0 acre lots	20%
Single-Family - 2.5 acre lots	11%
Single-Family - 5 acre lots	7%

The total impervious area may also be determined from direct measurement made by the developer. A developer may wish to do this if the average numbers presented in Table 3-1 do not apply to a specific development. If the developer chooses to do this, all impervious areas within the development should be included. These areas include streets, parking lots, residential, commercial, tax exempt, parks, golf courses, and any other land use within the development. When different land uses are included in a development a composite percent impervious should be used.

3.8a Computation of the Basin Fee

The following example uses the typical impervious area numbers. In the computation of the basin fee, the developer or their representative shall obtain the appropriate basin fee from Exhibit 1 of the September 13, 1999 BOCC Resolution No. 99-383, or more current revision.

Example 1:

What is the fee for a 40-acre residential development in Dirty Woman Creek basin with 0.5-acre lots? The developer is not required to build any reimbursable stormwater facilities in this example and does not qualify for a low-density reduction or an on-site detention pond credit.

From Table 3-1, the percent impervious is 25%.

Calculate the impervious area for the site:

$$25\% \times 40 \text{ acres} = 10 \text{ acres}$$

Calculate the fee for the entire development:

$$\text{\$14,454 per impervious acre} \times 10 \text{ impervious acres} = \text{\$144,540}$$

Alternatively, the developer in each case could determine impervious area from the property plat, as illustrated in Example 2 below.

Example 2:

What is the fee for a 40-acre residential development in Dirty Woman Creek basin with 0.5-acre lots? The developer is not required to build any reimbursable stormwater facilities in this example and does not qualify for a low-density reduction or an on-site detention pond credit.

The developer has prepared his site plan using AutoCAD, and has instructed his designer to draw all streets, driveways, sidewalks, patios, and building footprints (i.e., all impervious areas) for the entire platted area as closed polylines. The designer can quickly use AutoCAD to compute the total area of those polylines, and determines that those impervious features comprise 22.8% of the platted area.

Thus the measured impervious area for the site is:

$$22.8\% \times 40 \text{ acres} = 9.12 \text{ acres}$$

Calculate the fee for the entire development:

$$\text{\$14,454 per impervious acre} \times 9.12 \text{ impervious acres} = \text{\$131,820}$$

3.9a Routine Fee Updates

Drainage basin fees are subject to an annual revision based on the current construction cost index. It is important that fees are revised to reflect actual construction costs, otherwise the fees will be inadequate to construct needed improvements to protect residents.

The current drainage and bridge fee schedule in effect shall be attached to the September 13, 1999 BOCC Resolution No. 99-383, and updated annually.

3.10a Credits and Reimbursements

3.10.1a Reductions Versus Reimbursements

Reductions in fees will be made for certain low-density type developments and prudent line land where applicable. Partial reimbursement of construction costs will be made to developers for construction of on-site detention ponds that meet County criteria. Full reimbursement of construction costs will be made to developers for construction of regional facilities in general accordance with the DBPS or as approved by the County prior to construction. Reimbursements for pond construction will only be made if sufficient basin funds are available.

3.10.2a Fee Reductions for Low Density Lots

A reduction in the drainage basin fee is proposed if a development consists of 2.5 or 5.0 acre lots.

A land developer may qualify for a 25 percent reduction in drainage basin fees if he is developing an area into 2.5 acre and/or 5.0 acre lots. The reduction is proposed because a significant portion of the stormwater from these large lots does not flow directly into the County stormwater system, but flows into the yards as sheet flow and infiltrates into the ground. The impervious area on a rural property does not create as much runoff as the same impervious area located in an area with smaller lots and curb and gutter paved roadways. Runoff from these smaller, more urban lots, flows more directly into the County stormwater system. However, the roads serving the larger lot rural areas do create additional stormwater that flows directly into the County system along with some increased flow from the residential lots. Therefore, runoff from these areas shows an increased over the historic conditions. The proposed reductions are based on the 1986 version of the Natural Resources Conservation Services' Technical Release Number 55, which includes a procedure that accounts for "disconnected impervious area".

In a mixed-use development, only the 2.5 acre and/or 5.0 acre area will receive the reduction. Example 3 below illustrates that adjustment.

Example 3:

What is the fee for a 100-acre residential development with 60 acres of 2.5-acre lots and 40 acres of 0.5-acre lots? The development is in the Bennett Ranch basin.

Calculate the fee for the portion of the development with 2.5-acre lots:

$$\text{Impervious area} = 11\% \times 60 \text{ acres} = 6.6 \text{ acres}$$

The developer gets a 25% reduction for the 2.5-acre lots.

$$6.6 \text{ impervious acres} \times 75\% \times \$7,613 \text{ per impervious acre} = \$37,684$$

Calculate the fee for the remaining 40 acres of 0.5-acre lots:

$$\text{Impervious area} = 25\% \times 40 \text{ acres} = 10 \text{ acres}$$

$$10 \text{ impervious acres} \times \$7,613 \text{ per impervious acre} = \$76,130$$

Add the fees for the two areas to get the gross fee:

$$\$37,684 + \$76,130 = \mathbf{\$113,814}$$

3.10.3a Fee Reductions for Land Required to be Dedicated for the Prudent Line

Fee reductions are also available for the cost of land within dedicated Prudent Line easements (outside of the floodplain). Developers that dedicate Prudent Line easements according to a County accepted Prudent Line report can reduce their fees by the value of the easement. The amount of the reduction will be the same as the land cost that was used in the basin fee calculation, which is currently \$5,000 per acre. This reduction rate shall be adjusted whenever the Parkland Dedication Fee is changed. If the reduction exceeds the gross fee, the fee shall be \$0, and the remainder of the easement cost shall be applied as a credit, similar to those discussed below.

Example 4 below is the same as the previous Example 3, with the addition of Prudent Line considerations in the computation of the basin fee.

Example 4:

What is the fee for a 100-acre residential development with 60 acres of 2.5-acre lots and 40 acres of 0.5-acre lots? The development is in the Bennett Ranch basin, and 8 acres of the 2.5-acre lots are within the Prudent Line setback area. The developer is not required to construct grade control structures.

Calculate the fee for the portion of the development with 2.5-acre lots:

$$\text{Impervious area} = 11\% \times 60 \text{ acres} = 6.6 \text{ acres}$$

The developer gets a 25% reduction for the 2.5-acre lots.

$$6.6 \text{ impervious acres} \times 75\% \times \$7,613 \text{ per impervious acre} = \$37,684$$

Calculate the fee for the remaining 40 acres of 0.5-acre lots:

$$\text{Impervious area} = 25\% \times 40 \text{ acres} = 10 \text{ acres}$$

$$10 \text{ impervious acres} \times \$7,613 \text{ per impervious acre} = \$76,130$$

Add the fees for the two areas to get the gross fee:

$$\$37,684 + \$76,130 = \$113,814$$

The fee is reduced by the cost of the land for the Prudent Line setback:

$$\$113,814 - (8 \text{ acres} \times \$5,000 \text{ per acre}) = \mathbf{\$73,814}$$

3.10.4a Reimbursement of Construction Costs for On-Site Ponds

A land developer may qualify for a reimbursement of a portion of the construction costs if he builds on-site detention meeting specific criteria. Recognizing that on-site ponds provide some benefits to the regional system of a basin, 50% of the cost of a small on-site pond may be reimbursed to the developer if the following criteria are met:

1. Allowed only where regional system is not yet in place.
2. The pond is less than 15 acre-feet in volume from the lowest outlet structure to the crest of the emergency spillway.
3. The on-site pond is not part of the regional plan (for approved ponds that are part of the regional plan, developers are given 100% credit).
4. The outlet of the pond must be designed to release at historical levels for all precipitation events from the 2-year storm to the 100-year storm. A smaller outlet may be required by the County if adequate downstream channel improvements are not in place to protect residents from the 2-year storm flows.

5. County approves design and construction.
6. Landowners assume responsibility for maintenance.

The purpose of this reduction is to allow developers to integrate detention into their developments when sites lend themselves to multiple uses such as parks, open space, athletic fields, golf courses or others. Another reason for implementing regional detention on-site is to provide adequate protection to downstream properties that may be threatened from increased flows from the development when regional improvements are not to be implemented within an acceptable time frame. The reason for the 2-year event criteria (or smaller if adequate channels are not in place for 2 year flows) is because of the significant number of smaller events that will pass through a 5-year outlet. Those more frequent events are responsible for much of the erosion and other problems downstream of new developments and the County is left to repair erosion or deal with other problems.

If the above requirements are not met, the on-site detention will not qualify the land developer for a reimbursement of costs. If the developer chooses not to construct an on-site regional pond, he may still have to construct a conventional on-site pond to prevent downstream impacts from his development. It is important to note that reductions for meeting certain on-site detention criteria and for development that consists of 2.5 or 5.0 acre lots (discussed above) cannot both be applied to the same development.

Example 5 below illustrates the reduction in the basin fee for construction of a qualified on-site detention pond.

Example 5:

What is the fee for a 10-acre commercial site with a small on-site detention pond (2 acre-foot pond with estimated construction cost of \$40,000), which meets the County criteria for a pond reimbursement? The fee will be reduced by 50% of the estimated cost of the pond construction, i.e., \$20,000. The site is in the Big Johnson Reservoir/Crews Gulch basin.

Calculate the gross fee:

$$95\% \times 10 \text{ acres} \times \$15,000 \text{ per impervious acre} = \$142,500$$

Calculate the fee after the reduction for the pond:

$$\$142,500 - \$20,000 = \mathbf{\$122,500}$$

3.10.5a Reimbursement of Land and Construction Costs of Other Regional Facilities

The system of credits for the costs of construction of regional structures has not changed from the current system. The current system gives credits to developers for building projects that are listed in the DBPSs. A developer is reimbursed for these credits after the construction is complete and accepted by the County, and when there are sufficient basin funds. Alternatively, credits may be used to reduce the fees for subsequent developments in the same basin.

In addition to regional structures in the DBPSs, credits are given for the following structures:

- Total reimbursement of the construction costs of large on-site ponds that are accepted into the regional system by the County.
- Reimbursement of 50% of the cost of small on-site ponds (less than 15 acre-feet) that meet County criteria. This credit will not exceed the amount of the fee. If the construction cost is more than twice the gross fee, the credit will be equal to the fee.

3.11a Appeals Process

The procedures outlined for basin fee computation are generally straightforward. However, some developments may result in a more complex computation of the basin fee, and the result may be a disagreement between the

developer and the County in the fee computed. The developer and County should attempt to resolve the disputed fee. In the event the attempted resolution is unsuccessful, the developer may elect to appeal the disputed fee amount to the Subdivision Storm Drainage Board. The developer will need to prepare a written appeal detailing the disputed basin fee amount and provide calculations or other evidence supporting his fee calculation. That written appeal is due by 4:00 P.M. on the third Thursday of the month prior to the next month's Drainage Board meeting. The Drainage Board will review the written appeal at their regularly scheduled meeting and render a final decision on the basin fee that will be due.

3.12a New/Revised Drainage Basin Planning Studies

Basin fees may be updated between annual routine fee updates if new or revised DBPSs are prepared for a basin and accepted by the County. These updated fees will be reflected in Exhibit 1 of the September 13, 1999 BOCC Resolution No. 99-383.

3.13a Vacations, Replats, Drainage Districts, and Irrigation Companies

The overriding guideline regarding vacation plats and replats will be whether an increase in impervious land cover would result. A vacation plat occurs when two or more contiguous lots are combined into one lot. A replat of a lot or parcel occurs when it is divided into two or more contiguous lots.

In all cases, a basin drainage fee will be assessed based upon the new impervious acreage if no such fee has been previously paid. If a basin drainage fee has been previously paid, and the vacation plat or replat results in the same or a decrease in the impervious acreage, no additional fee will be assessed, and no refund of previous fees will be given. If a basin drainage fee has been previously paid, and the vacation plat or replat results in an increase in the impervious acreage, a drainage basin fee shall be assessed on the additional impervious acreage at the current applicable fee.

If a developer or landowner enters into any agreement or special arrangement with a drainage district or irrigation company, that individual or company is not relieved of their obligation to pay the County basin and bridge fee. Any drainage improvement made by the land developer has to be identified as a proposed improvement in the Drainage Basin Planning Study (DBPS) for that specific basin in order to be considered for reimbursement of construction cost. If no DBPS exists for the basin or if the land developer proposes a substantial departure from the drainage improvement(s) shown in the existing DBPS, the developer must either fund the preparation a DBPS for the basin (if none exists) or revise the existing DBPS to the satisfaction of the County in order to receive consideration for reimbursement of costs of construction for drainage facilities.

(Res. No. 19-245 , 7-2-19)

Editor's note(s)—Res. No. 19-245, adopted July 2, 2019, repealed the Prudent Line Addendum for Unincorporated El Paso County only.

**CODE COMPARATIVE TABLE
LEGISLATION**

This is a chronological listing of the resolutions of the county used in this Manual. Repealed or superseded resolutions at the time of the publication and any omitted materials are not reflected in the table.

Legislation	Date	Section	Section this Manual
Res. No. 19-245	7- 2-19		1.5
			1.9

El Paso County, Colorado, Engineering Criteria Manual
CODE COMPARATIVE TABLE LEGISLATION

			1.22
			Ch. 3(title)
			3.3(title)
		Added	3.3.7
			3.1.1
			3.1.2, Table 3-1
			3.2.4
			3.2.5 A.
			3.2.5 E.
			3.2.5 F.
			3.3.5
		Added	3.3.6 C.
		Added	3.3.7
			5.1.1
			5.6.1
			5.6.2
			5.6.2
		Added	5.6.3
		Rnbd	5.6.3, 5.6.4
		as	5.6.4, 5.6.5
			5.3.15(title)
			5.3.15 A., B.
			5.3.15 D.1., 2.
			5.3.15 E.1.
			5.3.15 E.3., 4.
		Added	5.9.4
			5.10.4 A.
			5.10.6
			Apps. E.—H.
			App. I.1.
			App. I.2.
			App. I.3.
			App. I.4.1.
			App. I.4.2.
			Table I-2
			App. I.5.—I.7.
			App. I.9.
			App. L.
Res. No. 20-222	6-23-20		1.5
			1.15.2
			1.15.5
			1.22
			2.1.3
			2.2.1
			2.3.2

El Paso County, Colorado, Engineering Criteria Manual
CODE COMPARATIVE TABLE LEGISLATION

			2.3.6
			2.3.7 C.
			2.3.8
			2.5.1 A.
			2.5.2 A.
			2.5.2 B.2.
			2.5.2 B.7., 8.
			2.5.2 C., D.
			2.5.2 F., G.
			2.5.4 C.1.
			2.5.4 C.8.
			2.5.6 A.
			2.5.7 A.12.
			2.5.7 C.13.
			2.5.7 C.19.
			2.6.6 F.1.
		Added	4.2.2 E.
			4.3.5 D.4.
			4.4.5
		Added	6.1—6.4
			App. F

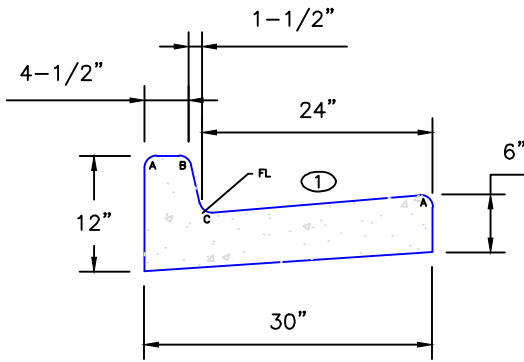

EPC TYPE A
(REVERSE SLOPE OF PAN FOR SPILL CURB)

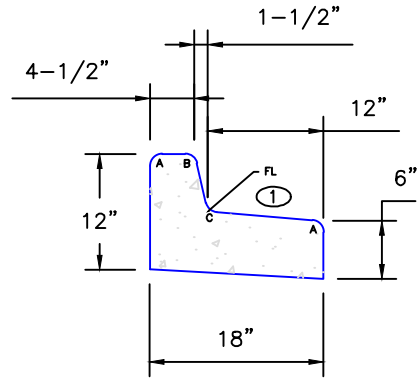

EPC TYPE B

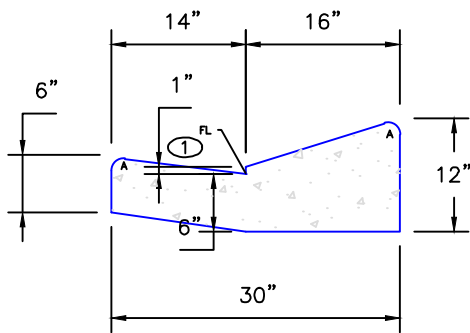

EPC TYPE C
(REVERSE SLOPE OF PAN FOR SPILL CURB)

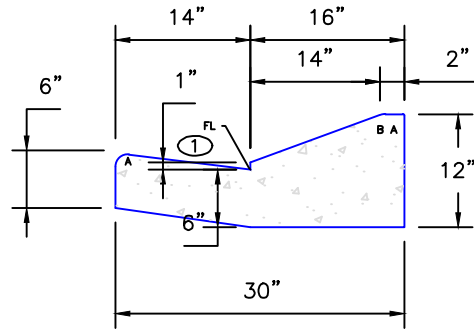

EPC OPTIONAL TYPE C

LEGEND FOR RADII	
A	1/8" TO 1/4"
B	1-1/2"
C	1-1/2" TO 2"

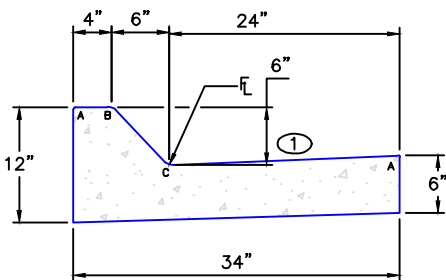

EPC TYPE D
(6" RAMP CURB)

① - GUTTER CROSS SLOPES SHALL BE 1/2 IN./FT. WHEN DRAINING AWAY FROM CURB AND 1 IN./FT. WHEN DRAINING TOWARD CURB.

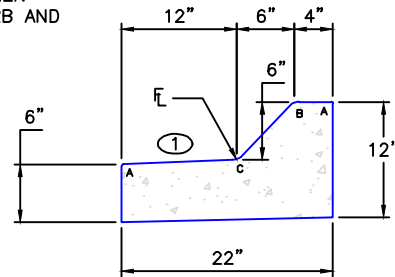

EPC TYPE E
(6" RAMP CURB)

NOTE: SIDEWALK/CURB & GUTTER SHALL NOT BE POURED MONOLITHICALLY

SCALE: NOT TO SCALE

6/23/20
DATE APPROVED:
Jennifer I. Irvine
DEPARTMENT OF PUBLIC WORKS

Typical Curb and Gutter Details	
Standard Drawing	
REVISION DATE:	FILE NAME:
6/23/20	SD_2-20



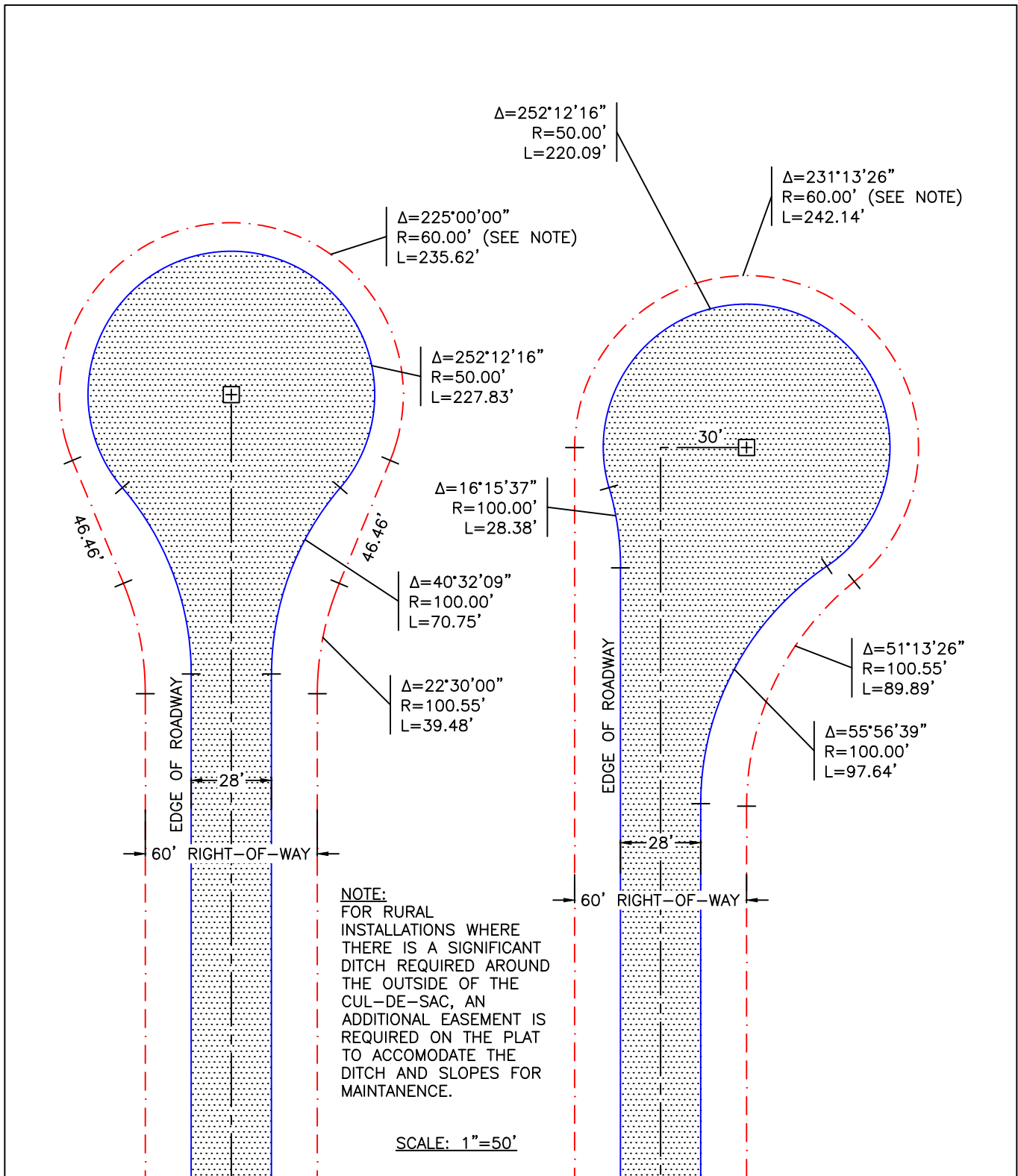

<p>1/1/08</p>	<p>Rural Cul-De-Sac Details</p>		
<p>DATE APPROVED:</p> <p>Joshua J. Palmer</p> <p>DEPARTMENT OF PUBLIC WORKS</p>			
<p>REVISION DATE:</p> <p>xx/xx/xx</p>	<p>FILE NAME:</p> <p>SD_2-76</p>		

URBAN LOCAL & LOW-VOLUME LOCAL KNUCKLE DETAILS

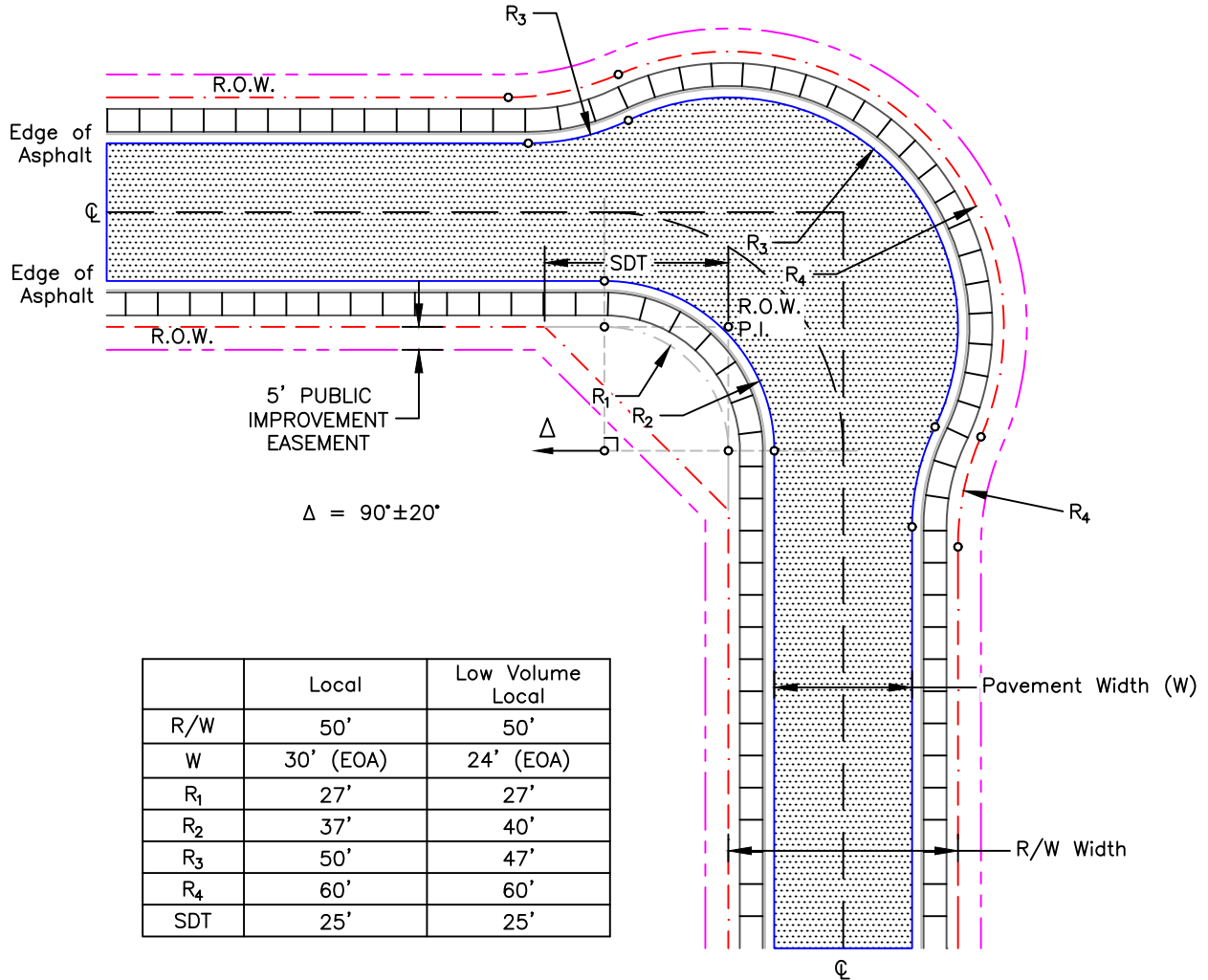

	Local	Low Volume Local
R/W	50'	50'
W	30' (EOA)	24' (EOA)
R ₁	27'	27'
R ₂	37'	40'
R ₃	50'	47'
R ₄	60'	60'
SDT	25'	25'

SDT = SIGHT DISTANCE TRIANGLE
DESIGN SPEED = 15 MPH

7/9/09

DATE APPROVED:

Joshua J. Palmer

DEPARTMENT OF PUBLIC WORKS

Urban Local & Low-Volume
Local Knuckle
Standard Drawing

REVISION DATE:

xx/xx/xx

FILE NAME:

SD_2-77



URBAN LOCAL & LOW-VOLUME LOCAL EYEBROW DETAILS

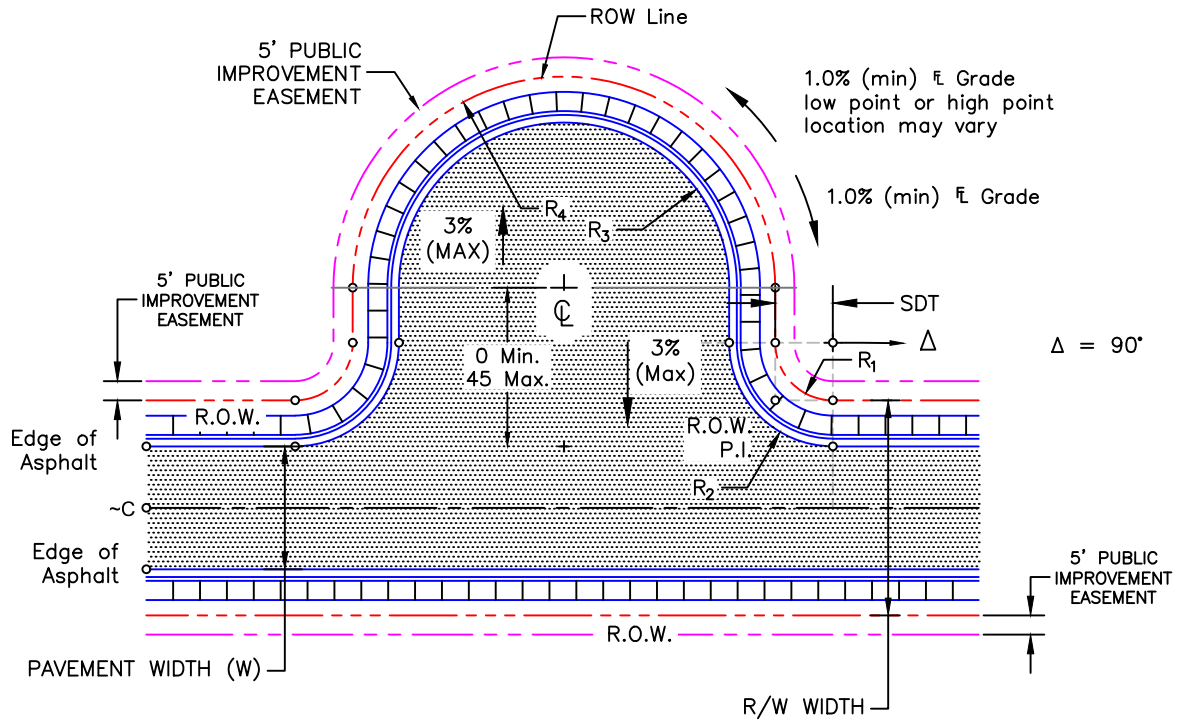

	Local	Low Volume Local
R/W	50'	50'
W	30' (EOA)	24' (EOA)
R ₁	15'	15'
R ₂	25'	25'
R ₃	45'	45'
R ₄	60'	60'
SDT	25'	25'

SDT = SIGHT DISTANCE TRIANGLE
 URBAN LOCAL DESIGN SPEED 25MPH
 URBAN LOCAL LOW VOLUME DESIGN SPEED 20MPH

<p style="text-align: center;">xx/xx/xx</p> <p>DATE APPROVED:</p> <p style="text-align: center; font-weight: bold;">Joshua J. Palmer</p> <p>DEPARTMENT OF PUBLIC WORKS</p>	<h2 style="margin: 0;">Urban Local & Low-Volume Local Eyebrow</h2> <p style="margin: 0;">Standard Drawing</p>	
	REVISION DATE: xx/xx/xx	FILE NAME: SD_2-78

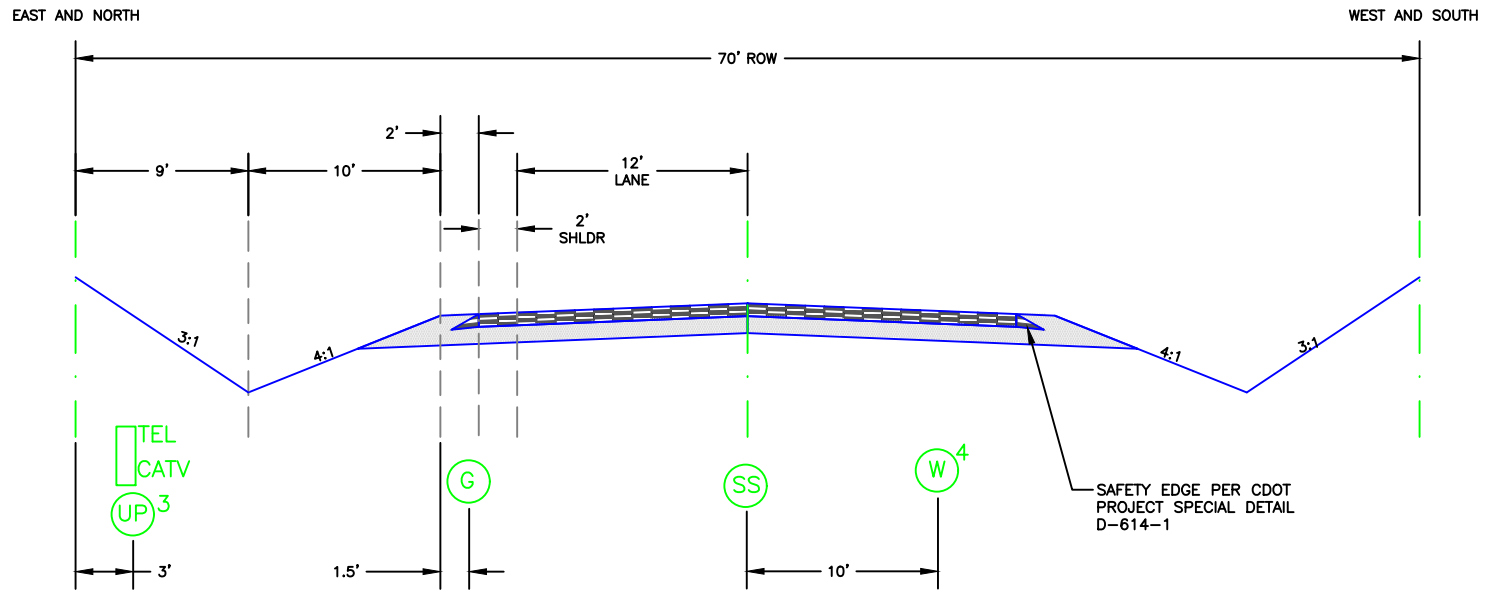

NOTES:

1. MINIMUM COVER AND SEPARATION FOR FIBEROPTICS, STORM, SANITARY SEWER, WATER, GAS, POWER AND NON-FIBEROPTICS TELEPHONE AND CABLE TELEVISION SHALL BE IN COMPLIANCE WITH FEDERAL AND STATE REGULATIONS.
2. SEE PLANS FOR UTILITY COVER REQUIREMENTS.
3. MAY BE PLACED EITHER SIDE OF CENTERLINE IN RESIDENTIAL PLATS. POWER, TELEPHONE, AND CABLE TV MAY SHARE THE SAME TRENCH.
4. TYPICAL HORIZONTAL SEPARATION SHALL BE AT LEAST 5 FT. FROM OTHER UTILITIES.

LEGEND

- UNDERGROUND POWER
- TELEPHONE CABLE TELEVISION
- GAS
- WATER
- SANITARY SEWER

SCALE: NOT TO SCALE

8/11/11
 DATE APPROVED:
 Joshua J. Palmer
 DEPARTMENT OF PUBLIC WORKS

Rural Local Roadway
 Utility Placement Cross Section
 REVISION DATE: xx/xx/xx
 FILE NAME: SD_4-11



EAST AND NORTH

WEST AND SOUTH

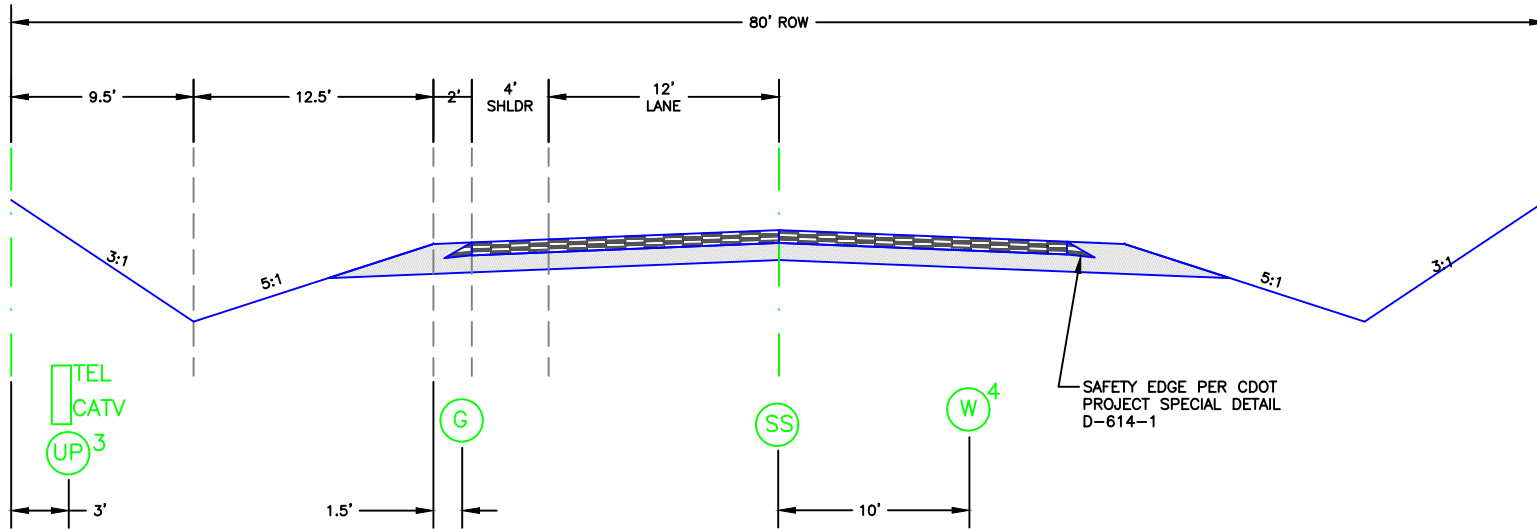

NOTES:

1. MINIMUM COVER AND SEPARATION FOR FIBEROPTICS, STORM, SANITARY SEWER, WATER, GAS, POWER AND NON-FIBEROPTICS TELEPHONE AND CABLE TELEVISION SHALL BE IN COMPLIANCE WITH FEDERAL AND STATE REGULATIONS.
2. SEE PLAN FOR UTILITY COVER REQUIREMENTS.
3. MAY BE PLACED EITHER SIDE OF CENTERLINE IN RESIDENTIAL PLATS. POWER, TELEPHONE, AND CABLE TV MAY SHARE THE SAME TRENCH.
4. TYPICAL SEPARATION SHALL BE AT LEAST 5 FT. FROM OTHER UTILITIES.

LEGEND

- UNDERGROUND POWER
- TELEPHONE CABLE TELEVISION
- GAS
- WATER
- SANITARY SEWER

SCALE: NOT TO SCALE

8/11/11

DATE APPROVED:

Joshua P. Palmer

DEPARTMENT OF PUBLIC WORKS

Rural Minor Collector Roadway

Utility Placement Cross Section

REVISION DATE:

xx/xx/xx

FILE NAME:

SD_4-12



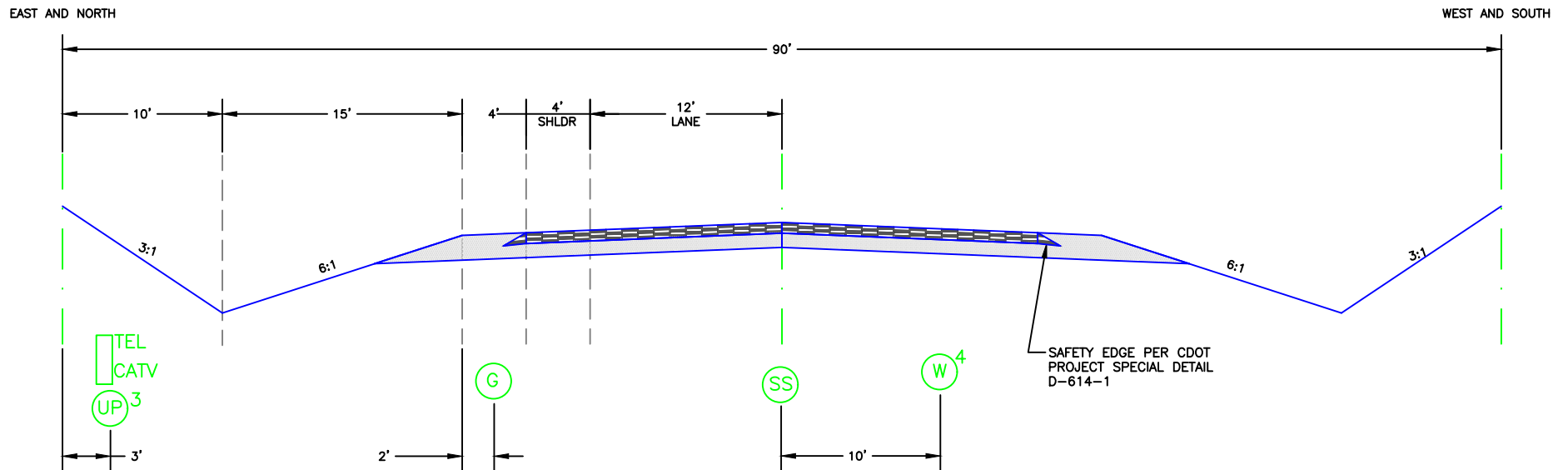

NOTES:

1. MINIMUM COVER AND SEPARATION FOR FIBEROPTICS, STORM, SANITARY SEWER, WATER, GAS, POWER AND NON-FIBEROPTICS TELEPHONE AND CABLE TELEVISION SHALL BE IN COMPLIANCE WITH FEDERAL AND STATE REGULATIONS.
2. SEE PLANS FOR UTILITY COVER REQUIREMENTS.
3. POWER, TELEPHONE, AND CABLE TV MAY SHARE THE SAME TRENCH.
4. TYPICAL HORIZONTAL SEPARATION SHALL BE AT LEAST 5 FT. FROM OTHER UTILITIES.

LEGEND

- UNDERGROUND POWER
- TELEPHONE CABLE TELEVISION
- GAS
- WATER
- SANITARY SEWER

SCALE: NOT TO SCALE

8/11/11
 DATE APPROVED:
 Joshua J. Palmer
 DEPARTMENT OF PUBLIC WORKS

Rural Major Collector Roadway

Utility Placement Cross Section

REVISION DATE:
 xx/xx/xx

FILE NAME:
 SD_4-13



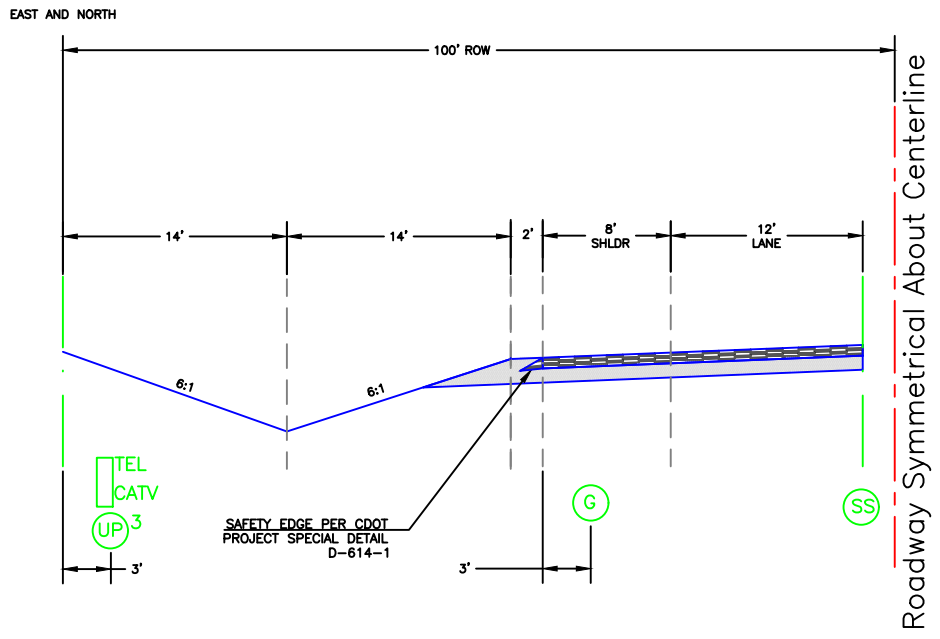

NOTES:

1. MINIMUM COVER AND SEPARATION FOR FIBEROPTICS, STORM, SANITARY SEWER, WATER, GAS, POWER AND NON-FIBEROPTICS TELEPHONE AND CABLE TELEVISION SHALL BE IN COMPLIANCE WITH FEDERAL AND STATE REGULATIONS.
2. SEE PLANS FOR UTILITY MINIMUM DEPTH REQUIREMENTS.
3. POWER, TELEPHONE, AND CABLE TV MAY SHARE THE SAME TRENCH.
4. TYPICAL HORIZONTAL SEPARATION SHALL BE AT LEAST 5 FT. FROM OTHER UTILITIES.

LEGEND

- UNDERGROUND POWER
- TELEPHONE CABLE TELEVISION
- GAS
- WATER
- SANITARY SEWER

SCALE: NOT TO SCALE

8/11/11
 DATE APPROVED:
 Joshua J. Palmer
 DEPARTMENT OF PUBLIC WORKS

Rural Minor Arterial Roadway
 East/North Bound Lanes
 Utility Placement Cross Section

REVISION DATE: xx/xx/xx FILE NAME: SD_4-14



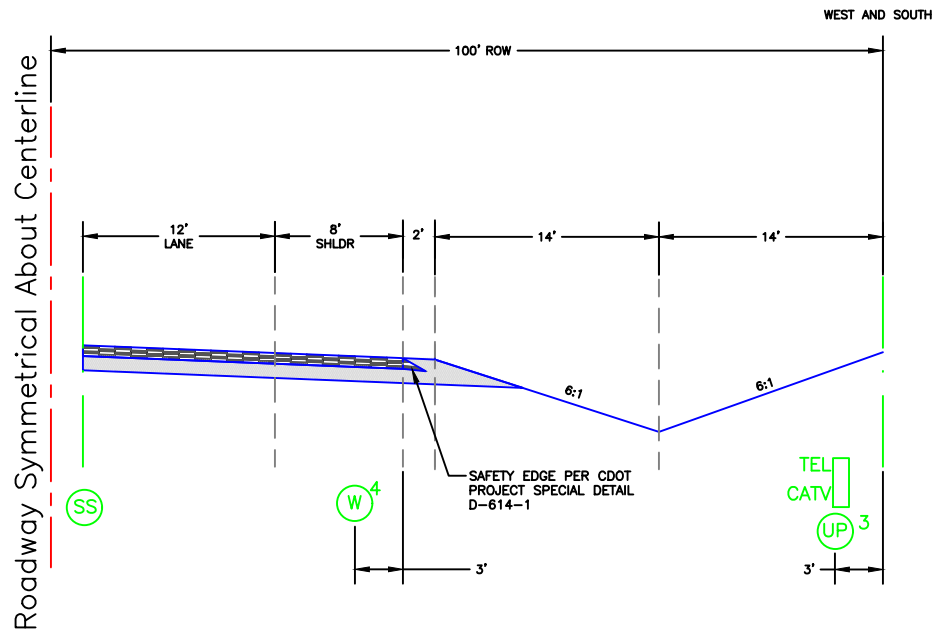

NOTES:

1. MINIMUM COVER AND SEPARATION FOR FIBEROPTICS, STORM, SANITARY SEWER, WATER, GAS, POWER AND NON-FIBEROPTICS TELEPHONE AND CABLE TELEVISION SHALL BE IN COMPLIANCE WITH FEDERAL AND STATE REGULATIONS.
2. SEE PLANS FOR UTILITY COVER REQUIREMENTS.
3. POWER, TELEPHONE, AND CABLE TV MAY SHARE THE SAME TRENCH.
4. TYPICAL HORIZONTAL SEPARATION SHALL BE AT LEAST 5 FT. FROM OTHER UTILITIES.

LEGEND

- UNDERGROUND POWER
- TELEPHONE CABLE TELEVISION
- GAS
- WATER
- SANITARY SEWER

SCALE: NOT TO SCALE

8/11/11
 DATE APPROVED:
 Joshua J. Palmer
 DEPARTMENT OF PUBLIC WORKS

Rural Minor Arterial Roadway
 West/South Bound Lanes
 Utility Placement Cross Section





REVISION DATE: xx/xx/xx FILE NAME: SD_4-14A

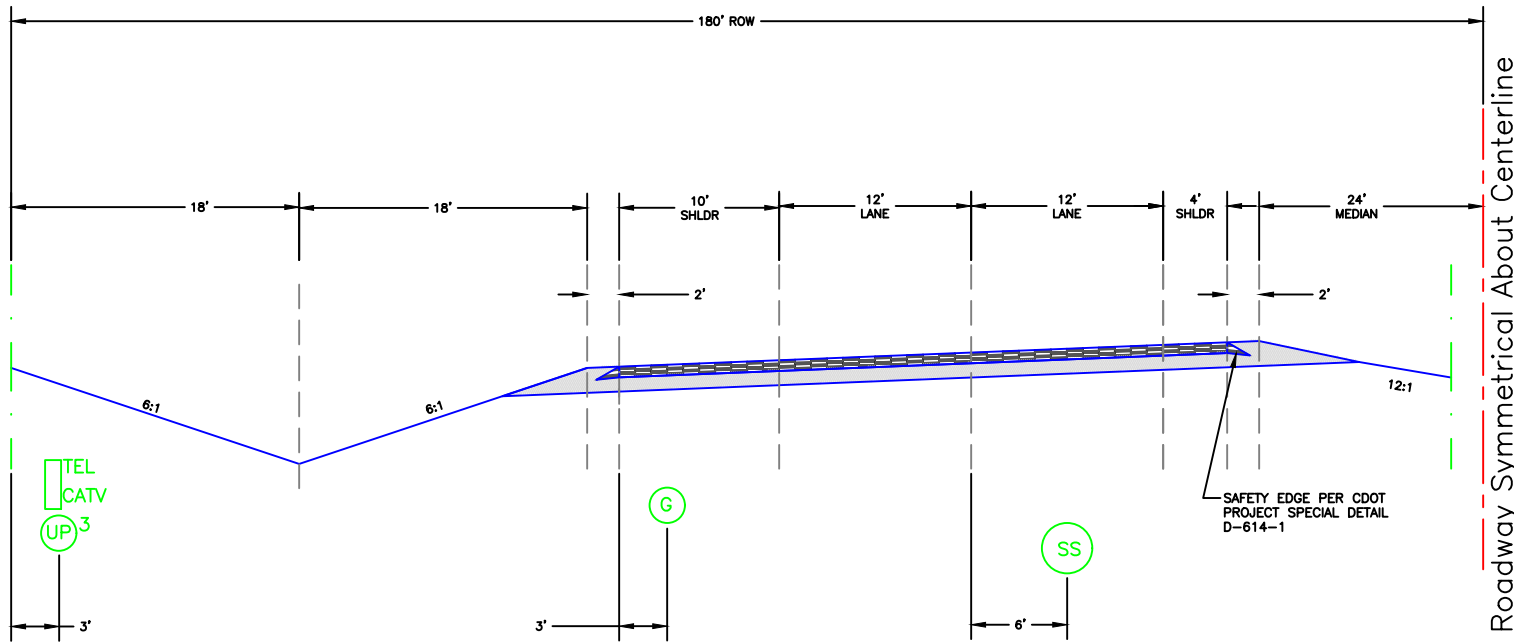

EAST AND NORTH



LEGEND

-  UNDERGROUND POWER
-  TELEPHONE CABLE TELEVISION
-  GAS
-  WATER
-  SANITARY SEWER

SCALE: NOT TO SCALE

NOTES:

1. MINIMUM COVER AND SEPARATION FOR FIBEROPTICS, STORM, SANITARY SEWER, WATER, GAS, POWER AND NON-FIBEROPTICS TELEPHONE AND CABLE TELEVISION SHALL BE IN COMPLIANCE WITH FEDERAL AND STATE REGULATIONS.
2. SEE PLANS FOR UTILITY COVER REQUIREMENTS.
3. POWER, TELEPHONE, AND CABLE TV MAY SHARE THE SAME TRENCH.
4. TYPICAL HORIZONTAL SEPARATION SHALL BE AT LEAST 5 FT. FROM OTHER UTILITIES.

8/11/11
 DATE APPROVED:
 Joshua J. Palmer
 DEPARTMENT OF PUBLIC WORKS

Rural Principal 4-Lane Arterial
 Roadway East/North Bound Lanes
 Utility Placement Cross Section

REVISION DATE: xx/xx/xx FILE NAME: SD_4-15



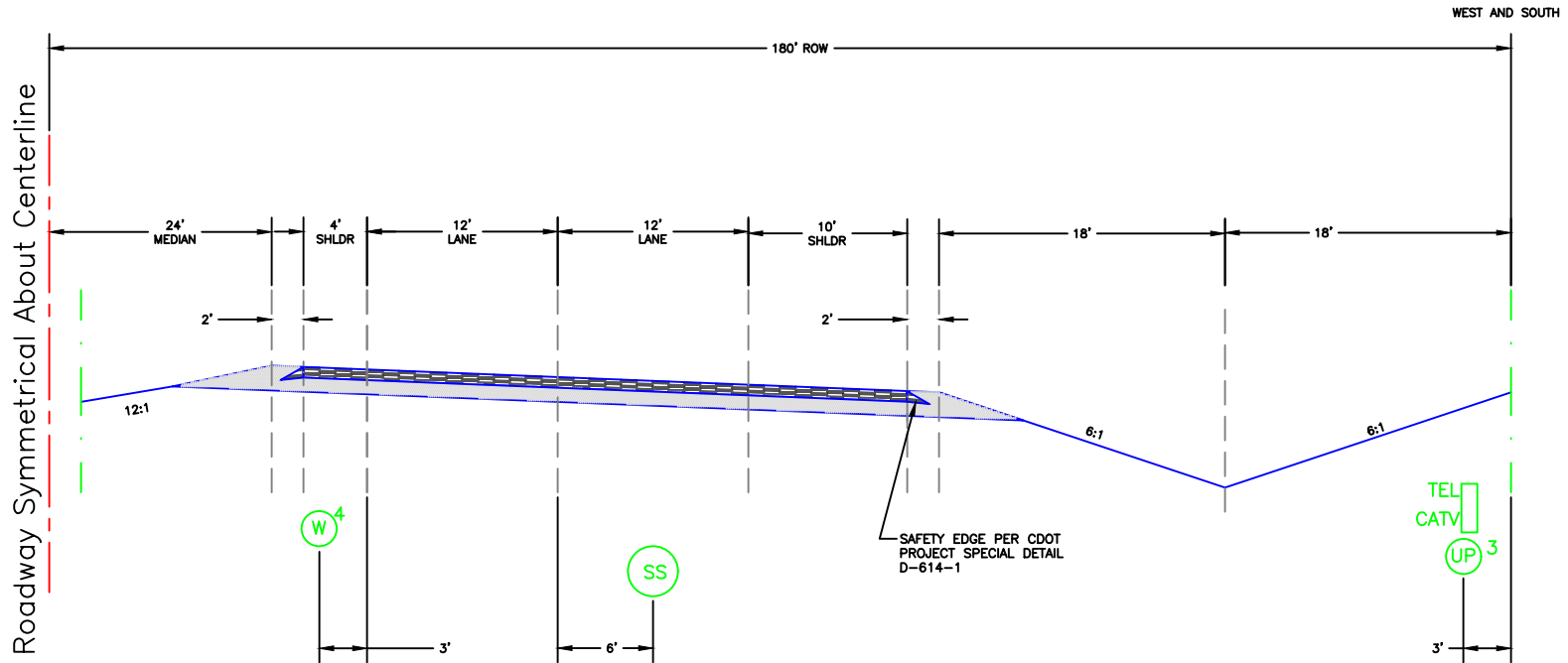

NOTES:

1. MINIMUM COVER AND SEPARATION FOR FIBEROPTICS, STORM, SANITARY SEWER, WATER, GAS, POWER AND NON-FIBEROPTICS TELEPHONE AND CABLE TELEVISION SHALL BE IN COMPLIANCE WITH FEDERAL AND STATE REGULATIONS.
2. SEE PLANS FOR UTILITY COVER REQUIREMENTS.
3. POWER, TELEPHONE, AND CABLE TV MAY SHARE THE SAME TRENCH.
4. TYPICAL SEPARATION SHALL BE AT LEAST 5 FT. FROM OTHER UTILITIES.

LEGEND

- UNDERGROUND POWER
- TELEPHONE CABLE TELEVISION
- GAS
- WATER
- SANITARY SEWER

SCALE: NOT TO SCALE

8/11/11
 DATE APPROVED:
 Joshua J. Palmer
 DEPARTMENT OF PUBLIC WORKS

Rural Principal 4-Lane Arterial
 Roadway West/South Bound Lanes
 Utility Placement Cross Section

REVISION DATE: xx/xx/xx FILE NAME: SD_4-15A



EAST AND NORTH

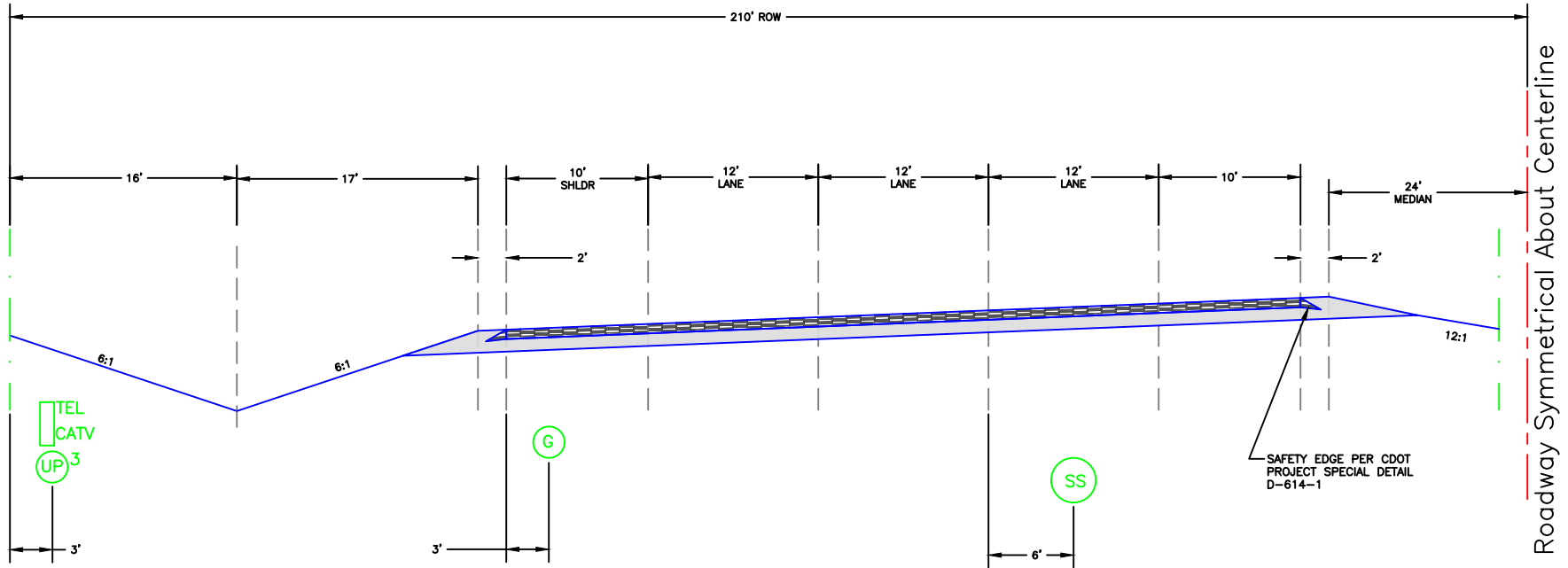

Roadway Symmetrical About Centerline

NOTES:

1. MINIMUM COVER AND SEPARATION FOR FIBEROPTICS, STORM, SANITARY SEWER, WATER, GAS, POWER AND NON-FIBEROPTICS TELEPHONE AND CABLE TELEVISION SHALL BE IN COMPLIANCE WITH FEDERAL AND STATE REGULATIONS.
2. SEE PLANS FOR UTILITY COVER REQUIREMENTS.
3. POWER, TELEPHONE, AND CABLE TV MAY SHARE THE SAME TRENCH.
4. TYPICAL SEPARATION SHALL BE AT LEAST 5 FT. FROM OTHER UTILITIES.

LEGEND

- UNDERGROUND POWER
- TELEPHONE CABLE TELEVISION
- GAS
- WATER
- SANITARY SEWER

SCALE: NOT TO SCALE

8/11/11
 DATE APPROVED:
 Joshua J. Palmer
 DEPARTMENT OF PUBLIC WORKS



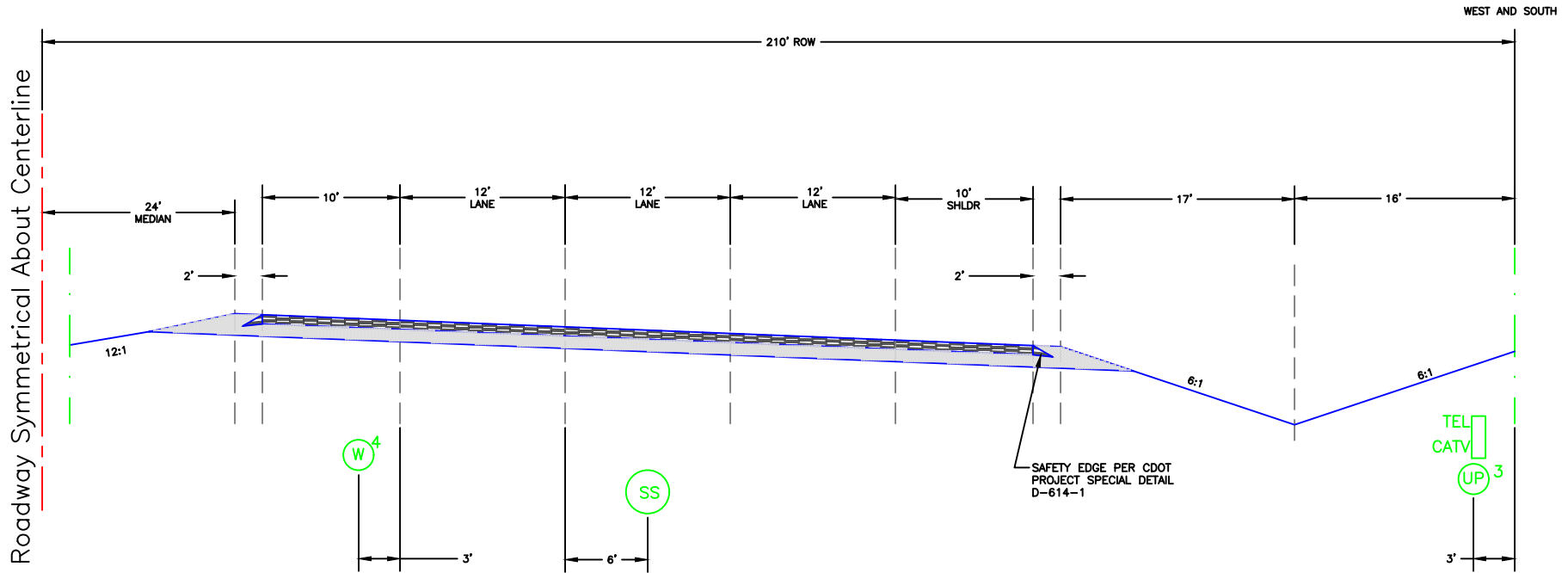

Rural Principal 6-Lane Arterial
 Roadway East/North Bound Lanes
 Utility Placement Cross Section

REVISION DATE: xx/xx/xx FILE NAME: SD_4-16





LEGEND

-  UNDERGROUND POWER
-  TELEPHONE CABLE TELEVISION
-  GAS
-  WATER
-  SANITARY SEWER

SCALE: NOT TO SCALE

NOTES:

1. MINIMUM COVER AND SEPARATION FOR FIBEROPTICS, STORM, SANITARY SEWER, WATER, GAS, POWER AND NON-FIBEROPTICS TELEPHONE AND CABLE TELEVISION SHALL BE IN COMPLIANCE WITH FEDERAL AND STATE REGULATIONS.
2. SEE PLANS FOR UTILITY COVER REQUIREMENTS.
3. POWER, TELEPHONE, AND CABLE TV MAY SHARE THE SAME TRENCH.
4. TYPICAL HORIZONTAL SEPARATION SHALL BE AT LEAST 5 FT. FROM OTHER UTILITIES.



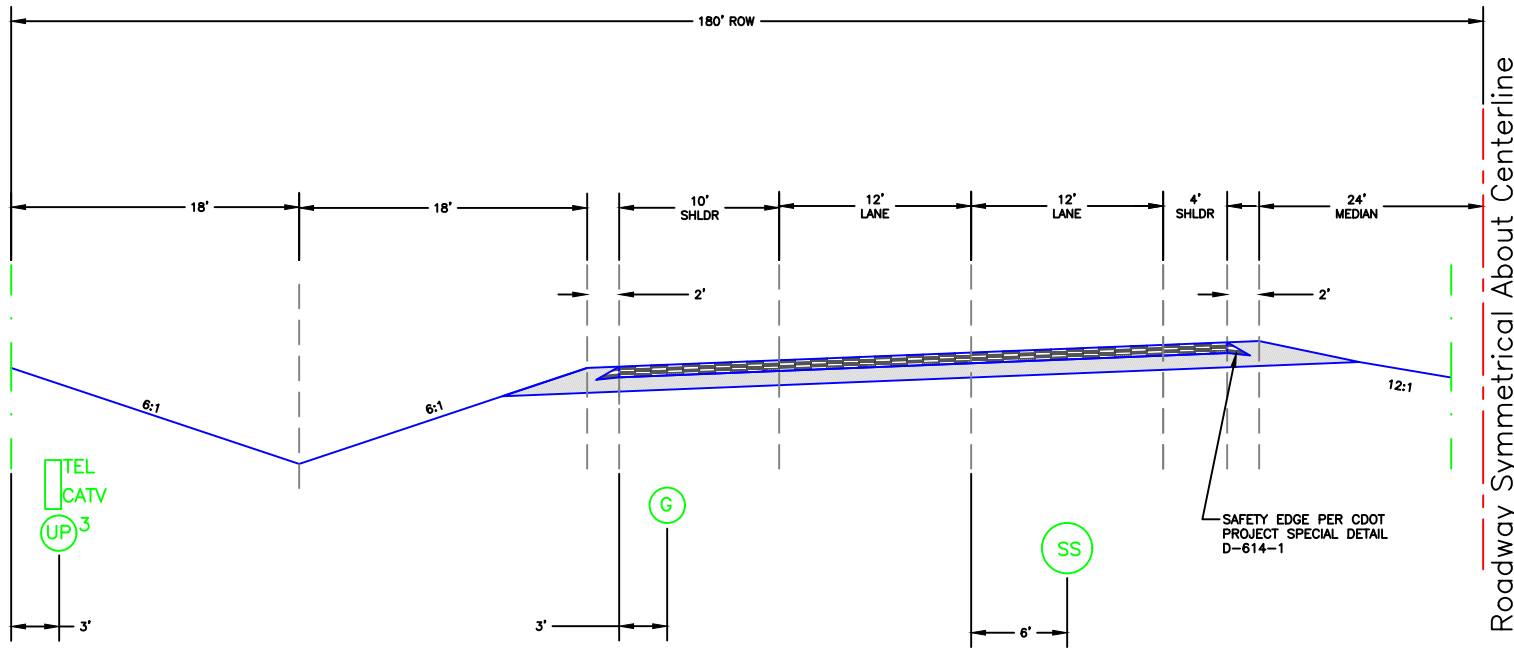

<p style="text-align: center; font-size: 1.2em;">8/11/11</p> <p>DATE APPROVED:</p> <p style="text-align: center; font-size: 1.1em;">Joshua J. Palmer</p> <p>DEPARTMENT OF PUBLIC WORKS</p>	<p style="font-size: 1.1em;">Rural Principal 6-Lane Arterial Roadway West/South Bound Lanes Utility Placement Cross Section</p>	
<p>REVISION DATE:</p> <p style="text-align: center; font-size: 1.1em;">xx/xx/xx</p>	<p>FILE NAME:</p> <p style="text-align: center; font-size: 1.1em;">SD_4-16A</p>	

EAST AND NORTH



Roadway Symmetrical About Centerline

LEGEND

-  UNDERGROUND POWER
-  TELEPHONE CABLE TELEVISION
-  GAS
-  WATER
-  SANITARY SEWER

SCALE: NOT TO SCALE

NOTES:

1. MINIMUM COVER AND SEPARATION FOR FIBEROPTICS, STORM, SANITARY SEWER, WATER, GAS, POWER AND NON-FIBEROPTICS TELEPHONE AND CABLE TELEVISION SHALL BE IN COMPLIANCE WITH FEDERAL AND STATE REGULATIONS.
2. SEE PLANS FOR UTILITY COVER REQUIREMENTS.
3. POWER, TELEPHONE, AND CABLE TV MAY SHARE THE SAME TRENCH.
4. TYPICAL HORIZONTAL SEPARATION SHALL BE AT LEAST 5 FT. FROM OTHER UTILITIES.

8/11/11
 DATE APPROVED:
 Joshua J. Palmer
 DEPARTMENT OF PUBLIC WORKS

Rural Expressway 4-Lane
 Roadway East/North Bound Lanes
 Utility Placement Cross Section

REVISION DATE: xx/xx/xx FILE NAME: SD_4-17



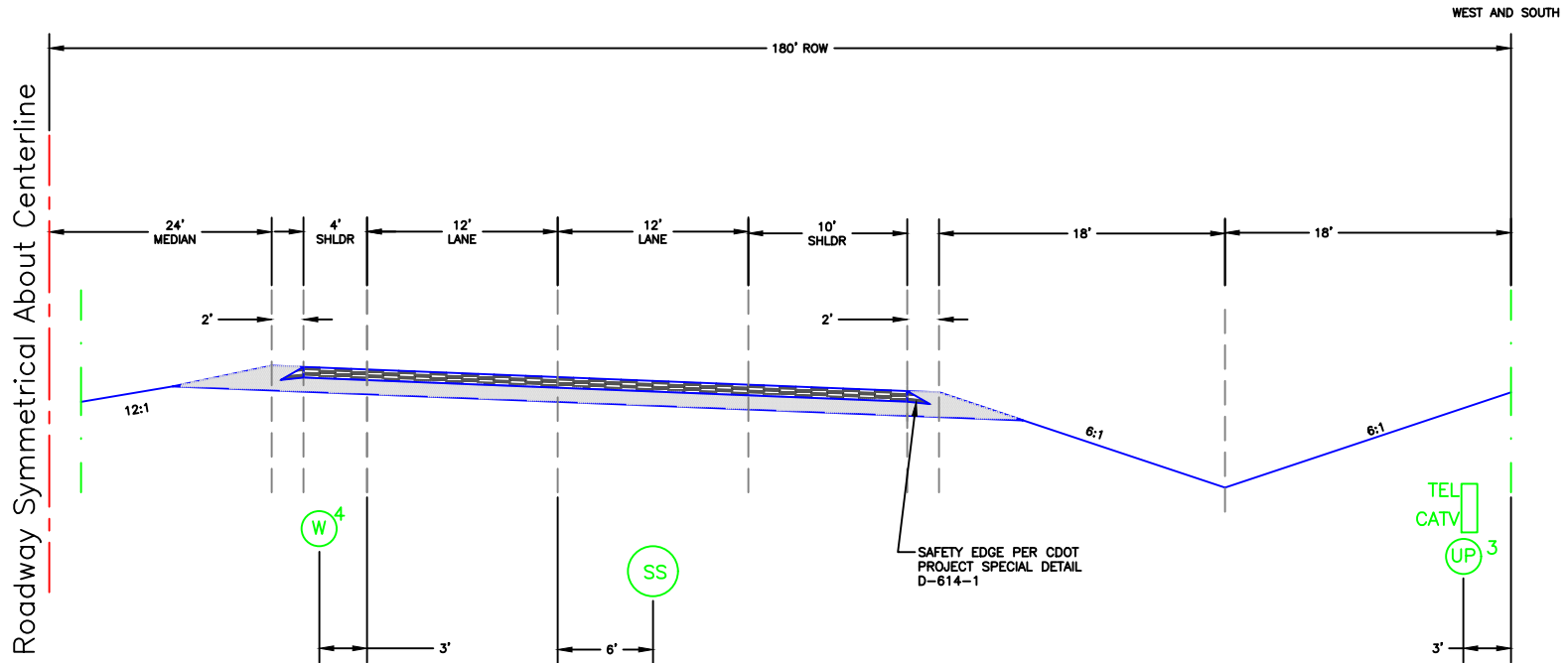

NOTES:

1. MINIMUM COVER AND SEPARATION FOR FIBEROPTICS, STORM, SANITARY SEWER, WATER, GAS, POWER AND NON-FIBEROPTICS TELEPHONE AND CABLE TELEVISION SHALL BE IN COMPLIANCE WITH FEDERAL AND STATE REGULATIONS.
2. SEE PLANS FOR UTILITY COVER REQUIREMENTS.
3. POWER, TELEPHONE, AND CABLE TV MAY SHARE THE SAME TRENCH.
4. TYPICAL HORIZONTAL SEPARATION SHALL BE AT LEAST 5 FT. FROM OTHER UTILITIES.

LEGEND

- UNDERGROUND POWER
- TELEPHONE CABLE TELEVISION
- GAS
- WATER
- SANITARY SEWER

SCALE: NOT TO SCALE

8/11/11
 DATE APPROVED:
 Joshua J. Palmer
 DEPARTMENT OF PUBLIC WORKS

Rural Expressway 4-Lane
 Roadway West/South Bound Lanes
 Utility Placement Cross Section

REVISION DATE: xx/xx/xx FILE NAME: SD_4-17A



EAST AND NORTH

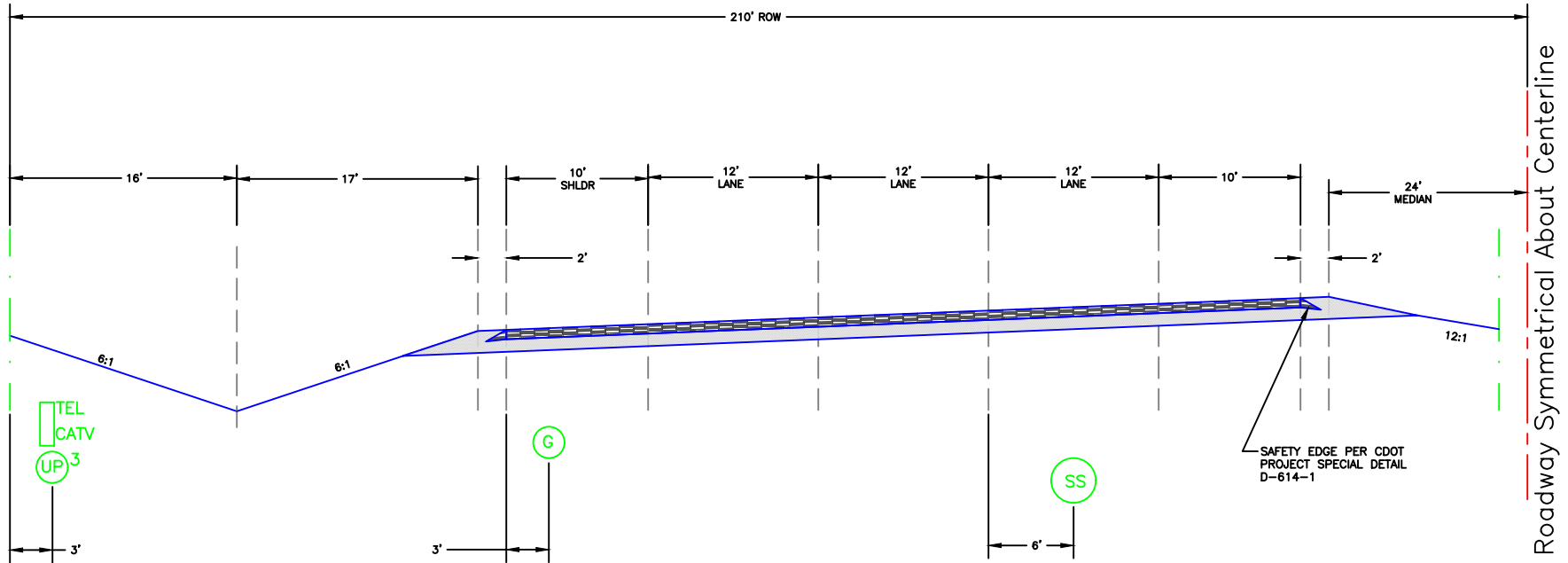

NOTES:

1. MINIMUM COVER AND SEPARATION FOR FIBEROPTICS, STORM, SANITARY SEWER, WATER, GAS, POWER AND NON-FIBEROPTICS TELEPHONE AND CABLE TELEVISION SHALL BE IN COMPLIANCE WITH FEDERAL AND STATE REGULATIONS.
2. SEE PLANS FOR UTILITY COVER REQUIREMENTS.
3. POWER, TELEPHONE, AND CABLE TV MAY SHARE THE SAME TRENCH.
4. TYPICAL HORIZONTAL SEPARATION SHALL BE AT LEAST 5 FT. FROM OTHER UTILITIES.

LEGEND

- UNDERGROUND POWER
- TELEPHONE CABLE TELEVISION
- GAS
- WATER
- SANITARY SEWER

SCALE: NOT TO SCALE

<p>8/11/11</p> <p>DATE APPROVED:</p> <p>Joshua J. Palmer</p> <p>DEPARTMENT OF PUBLIC WORKS</p>	<p>Rural Expressway 6-Lane Roadway East/North Bound Lanes Utility Placement Cross Section</p>	
	<p>REVISION DATE: xx/xx/xx</p> <p>FILE NAME: SD_4-18</p>	

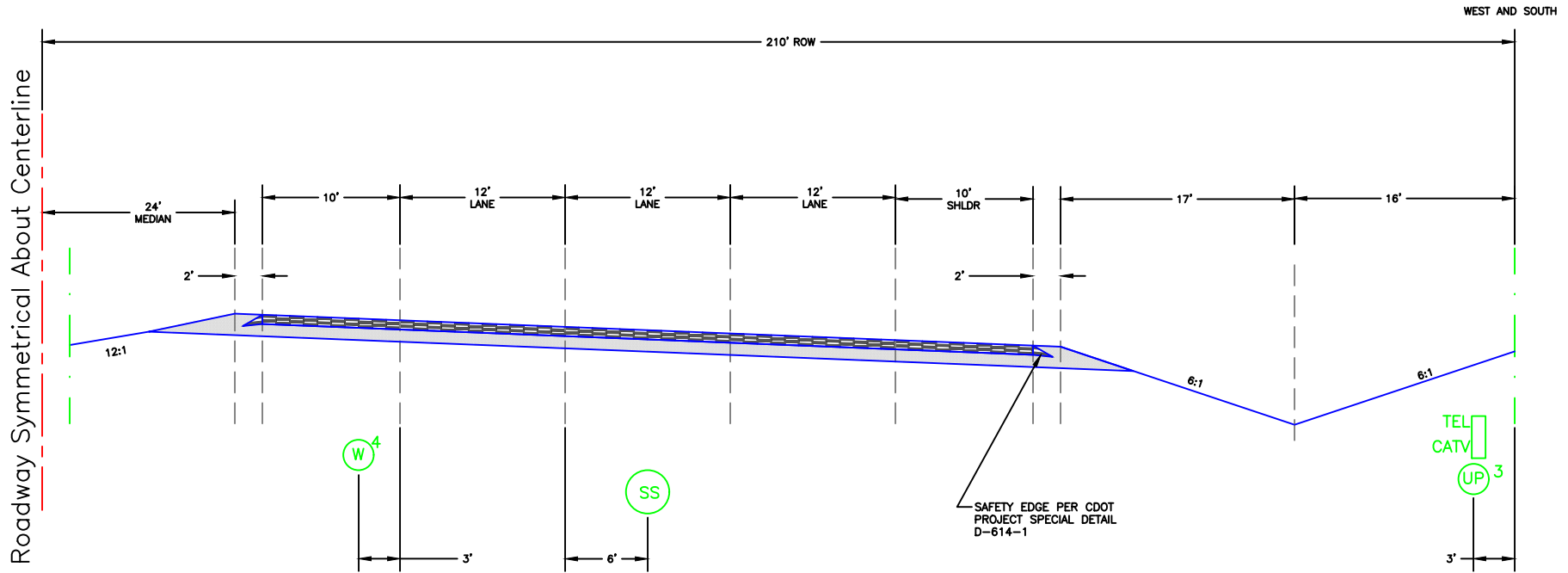

NOTES:

1. MINIMUM COVER AND SEPARATION FOR FIBEROPTICS, STORM, SANITARY SEWER, WATER, GAS, POWER AND NON-FIBEROPTICS TELEPHONE AND CABLE TELEVISION SHALL BE IN COMPLIANCE WITH FEDERAL AND STATE REGULATIONS.
2. SEE PLANS FOR UTILITY COVER REQUIREMENTS.
3. POWER, TELEPHONE, AND CABLE TV MAY SHARE THE SAME TRENCH.
4. TYPICAL HORIZONTAL SEPARATION SHALL BE AT LEAST 5 FT. FROM OTHER UTILITIES.

LEGEND

- UNDERGROUND POWER
- TELEPHONE CABLE TELEVISION
- GAS
- WATER
- SANITARY SEWER

SCALE: NOT TO SCALE

<p>8/11/11</p> <p>DATE APPROVED:</p> <p>Joshua J. Palmer</p> <p>DEPARTMENT OF PUBLIC WORKS</p>	<p>Rural Expressway 6-Lane Roadway West/South Bound Lanes Utility Placement Cross Section</p>	
	<p>REVISION DATE: xx/xx/xx</p> <p>FILE NAME: SD_4-18A</p>	



HOUSING & BUILDING
ASSOCIATION
OF COLORADO SPRINGS

4585 Hilton Parkway Suite 100, Colorado Springs, CO 80907
Phone: 719-592-1800 • CSHBA.com

MEMO

To: Elizabeth Nijkamp, Deputy County Engineer

From: Jon Romero, Land Use Chair

Date: May 25, 2023

Subject: Engineering Criteria Manual Updates, Revision #9

On behalf of the Housing & Building Association of Colorado Springs (CSHBA), we would like to thank you for working with us on much needed updates to the Engineering Criteria Manual (ECM). The efforts from both EPC staff and HBA members in 2021 generated the revisions outlined in the #9 document to include chapters 1, 2 & 4 of the ECM.

After a quick re-review from our members, we support the updates outlined; apart from the determination for section 2.3.8.A & 2.3.8.B regarding clarification on cul-de-sac lengths and turnarounds. The industry is a proponent of alternative improvements for cul-de-sac terminations in place of a turnaround. We would like to add this item to the current list of revisions for further discussion and consideration.

We understand that updates to the ECM are a process, and we appreciate staff's efforts to document items for discussion and review. Moving forward, the HBA respectfully asks for consideration of an annual review, policy clarification process and, if applicable, an update of the ECM for items identified by both agency and industry. Our members and HBA staff can track change requests on our side and share those requests with EPC's engineering team at any time for group discussions. In support of the great partnerships with EPC staff, we hope that the proposal for an annual review of EMC items moving forward would assist with the potential for more concise applications and processing moving forward.

Thank you for your collaboration on these important updates. We look forward to working with EPC on the next round of updates.

Thank you,

Jon Romero

2023 HBA Land Use Chair

Department of Public Works

Engineering Division
719-520-6460
Chuck Brown Transportation Complex
3275 Akers Drive
Colorado Springs, CO 80922
www.ElPasoCo.com

Board of County Commissioners
Holly Williams, District 1
Carrie Geitner, District 2
Stan VanderWerf, District 3
Longinos Gonzalez, Jr., District 4
Cami Bremer, District 5

TO: El Paso County Planning Commission

FROM: Joshua J. Palmer P.E., County Engineer

**RE: ECM-23-001 Engineering Criteria Manual Amendment
Various Portions of the El Paso County Engineering Criteria Manual**

Commissioner District: All Commissioner Districts

Planning Commission Hearing Date:	6/1/2023
Board of County Commissioners Hearing Date:	7/18/2023

EXECUTIVE SUMMARY

A request by the El Paso County Department of Public Works (DPW) for approval of various amendments to the El Paso County Engineering Criteria Manual (ECM). The request also includes the ability to administratively approve amendments necessary to carry out the intent of the proposed amendments. The ECM was completed in 2004 and revisions were made in 2006, 2007, 2009, 2011, 2015, 2016, 2019, and 2020.

A. BACKGROUND

The El Paso County Engineering Criteria Manual (ECM) is routinely amended to respond to current engineering trends, recurring issues, changes in legislation, and/or errors/oversights. The Department of Public Works maintains a running list of necessary and recommended revisions to the ECM as issues arise. El Paso County is a statutory County, which requires the County regulations to align with those rules and regulations included within the Colorado Revised Statutes (C.R.S.). The C.R.S., in most instances, is



flexible enough to allow each jurisdiction the ability to customize their rules and regulations in ways that best suit the needs of the local community as well as those challenges present in each community.

B. REQUEST

A request by the El Paso County Public Works Department to amend the El Paso County Engineering Criteria Manual include:

- Amending Chapters 1, 2, and 4 of the ECM to remove incorrect references, add correct references, update definitions, reflect current practices already in use, and clarify design requirements, and;
- Amending Appendix F of the ECM to add El Paso County Standard Specifications and moving El Paso County Standard Specifications and Standard Drawings as stand-alone document(s). In addition, the amendment would include the ability to revise the El Paso County Standard Specifications administratively (as currently allowed with the Standard Drawings). Note that the County Engineer would coordinate with stakeholders concerning El Paso County Standard Drawings and Specifications through a formal process of notification along with appropriate review and comment procedures/process.

C. MASTER PLAN ANALYSIS

The purpose of the ECM is to set standards for designing, constructing, locating, maintaining, choosing materials for, repairing, reconstructing, and using public improvements and guiding design and construction of common development improvements in El Paso County (County). The ECM governs the quality of workmanship must be adhered when constructing public and development-related improvements. The ECM also provides standards for County staff to adhere to in reviewing plans and inspecting construction.

The ECM was developed to be consistent with the El Paso County Land Development Code (LDC). The standards are necessary to protect and promote public health, safety, and the general welfare of the public; ensure that public infrastructure meets commonly accepted engineering standards; and maintain consistency and fairness in development review.

The County's Engineering Criteria Manual also provides a framework implementing the County Master Plan's recommendations. The purpose of the County's Engineering Criteria Manual is to protect and promote public health, safety, and the general welfare of the



public; ensure that public infrastructure meets commonly accepted engineering standards; and maintain consistency and fairness in development review, and to:

- Implement the Master Plan and related elements including but not limited to the elements such as the El Paso County Major Transportation Corridors Plan and the Drainage Master Plans.
- Promote predictability, consistency, and efficiency in the land development process for residents, neighborhoods, businesses, agricultural and development interests.
- Ensure appropriate opportunities for participation and involvement in the development process by all affected parties.
- Be fair to all by ensuring due consideration is given to protecting private property rights, the rights of individuals and the rights of the community as a whole.
- Guide the future growth and development of the County in accordance with the Master Plan.

D. APPLICABLE RESOLUTIONS

See Attached Resolution.

E. STATUS OF MAJOR ISSUES

There are no major issues.

F. RECOMMENDED CONDITIONS AND NOTATIONS

No conditions or notations.

G. PUBLIC COMMENT AND NOTICE

A summary of the proposed ECM amendments and the date of the Board of County Commissioner hearing have been published in The Gazette pursuant to Colorado Revised Statute 30-28-116. A copy of this publication will be included in the backup materials for the Board of County Commissioners hearing.

H. ATTACHMENTS

Proposed Changes to the El Paso County Engineering Criteria Manual (redline version)
Proposed Changes to the El Paso County Engineering Criteria Manual (clean version)
Proposed Changes to the El Paso County Engineering Criteria Manual Standard Drawings (clean version)
Draft Planning Commission Resolution El Paso County Engineering Criteria Manual



Meggan Herington, AICP, Executive Director
El Paso County Planning & Community Development

O: 719-520-6300
MegganHerington@elpasoco.com
2880 International Circle, Suite 110
Colorado Springs, CO 80910

Board of County Commissioners

Holly Williams, District 1
Carrie Geitner, District 2
Stan VanderWerf, District 3
Longinos Gonzalez, Jr., District 4
Cami Bremer, District 5

EL PASO COUNTY PLANNING COMMISSION

MEETING RESULTS (UNOFFICIAL RESULTS)

Planning Commission (PC) Meeting

Thursday, June 1, 2023

El Paso County Planning and Community Development Department

2880 International Circle – Second Floor Hearing Room

Colorado Springs, Colorado

REGULAR HEARING, 9:00 A.M.

PC MEMBERS PRESENT AND VOTING: THOMAS BAILEY, JAY CARLSON, BRANDY MERRIAM, ERIC MORAES, BRYCE SCHUETTPELZ, TIM TROWBRIDGE, AND CHRISTOPHER WHITNEY (Joined the meeting 5A onward).

PC MEMBERS VIRTUAL AND VOTING: NONE.

PC MEMBERS PRESENT AND NOT VOTING: NONE.

PC MEMBERS ABSENT: SARAH BRITAIN JACK, BECKY FULLER, KARA OFFNER, AND JOSHUA PATTERSON.

STAFF PRESENT: MEGGAN HERINGTON, JUSTIN KILGORE, ELIZABETH NIJKAMP, JENNIFER IRVINE, MIRANDA BENSON, AND EL PASO COUNTY ATTORNEY LORI SEAGO.

OTHERS PRESENT AND SPEAKING: NONE.

1. REPORT ITEMS

A. Planning Department. Next PC Hearing is Thursday, June 15, 2023, at 9:00 A.M.

2. CALL FOR PUBLIC COMMENT FOR ITEMS NOT ON THE HEARING AGENDA. NONE.

3. CONSENT ITEMS

A. Adoption of Minutes of meeting held May 18, 2023.

PC ACTION: THE MINUTES WERE APPROVED AS PRESENTED BY UNANIMOUS CONSENT (6-0).

4. CALLED-UP CONSENT ITEMS. NONE.

5. REGULAR ITEMS

A. ECM231

MASTIN/PALMER

**EL PASO COUNTY ENGINEERING CRITERIA MANUAL
REVISION TO VARIOUS ENGINEERING STANDARDS
(A LEGISLATIVE ACTION BY THE BOARD OF COUNTY COMMISSIONERS)**

A request by the El Paso County Department of Public Works (DPW) for approval of amendments to the El Paso County Engineering Criteria Manual (ECM). The ECM was completed in 2004 and revisions were made in 2006, 2007, 2009, 2011, 2015, 2016, 2019, and 2020. The El Paso County Department of Public Works requests approval of amendments to the El Paso County Engineering Criteria Manual (ECM) to provide clarification of various engineering requirements. The request also includes the ability to administratively approve amendments necessary to carry out the intent of the proposed amendments.

APPLICANT PRESENTATION & DISCUSSION

Mr. Trowbridge asked Ms. Seago for her opinion on a statement from the presentation slideshow: *"The request also includes the ability to administratively approve amendments necessary to carry out the intent of the proposed amendments."* He asked if the first use of the word amendments is correct.

Ms. Seago requested time to research.

Mr. Bailey asked if each revision would be presented individually.

Ms. Nijkamp, Deputy County Engineer, presenting in lieu of Mr. Palmer, answered that she did not plan to go through each change individually. Next time they make proposed changes, they will include a summary. Most of the changes are administrative.

Mr. Trowbridge thinks the wording should be modified on page 36 of 504, section 2.2.5.

Ms. Nijkamp explained that the applicant must go to CDOT to get CDOT's concurrence. She thinks the way it is currently worded explains to an applicant what they need to do. After discussion, she suggested modifying the sentence to read *"... CDOT concurrence shall be provided by the applicant."*

Mr. Moraes commented that the confusion comes from using the passive voice style of writing.

Mr. Trowbridge asked for an explanation of the term "safety edge" found on page 41 of 504. He asked for further clarification on paved vs. unpaved.

Ms. Nijkamp explained what a safety edge is and further explained that the shoulder portion of the asphalt changes based on the safety edge.

Mr. Carlson clarified that the amendment concerns an addition to the paved width which excludes the safety edge.

Mr. Bailey further clarified that the proposed addition is a definition of safety edge and declares that they are required. The table provides dimensions.

Ms. Nijkamp stated that is correct.

Mr. Bailey asked for clarification regarding the change proposed within Table 2-7 on page 43 of 504 regarding sidewalk width (from top back of curb when attached).

Ms. Nijkamp explained that the chart conveys how wide a sidewalk should be (5 feet). The criteria previously stated, "sidewalk width at flowline". The delta between the flowline and the top back of the curb is 6 inches, so the sidewalks could have been 4.5 feet wide. Sidewalks will now be a full 5 feet wide. This amendment was a correction to avoid confusion.

Mr. Trowbridge asked if further notation of the AASHTO Green Book was needed on page 55 of 504.

Ms. Nijkamp stated she doesn't think a specific citation is necessary. She stated the AASHTO Green Book's sole purpose is designing roads.

Ms. Seago added that she doesn't think further reference would be necessary because the ECM would then need to be amended every time the section or paragraph changes.

Mr. Bailey stated the added sentence in section 4.4.1 on page 134 of 504 seems redundant.

Ms. Nijkamp explained that the difference between the first and last sentences of that paragraph is that approval from USPS must take place prior to approval of the construction drawings. After discussion, she suggested combining the first and last sentences.

Ms. Seago recommended the proposed change read, "*The applicant shall provide USPS approval of mailbox type and location prior to approval of the construction plans.*" She addressed Mr. Trowbridge's earlier question. Page 15 of 504 of the ECM, section 1.20, lists the specific items that may be changed or corrected administratively. It also states that they shall not change the substance of the regulations. The wording of the request that will go to the BOCC does not give her concern, but the PC can add wording to their resolution like "as specifically set forth in Chapter 1 of the ECM" if they would like. The PC can also direct staff to use the term *changes and corrections* instead of *amendments* when drafting the BOCC resolution. That doesn't need to be part of the motion during this hearing, however.

NO PUBLIC COMMENT

PC ACTION: TROWBRIDGE MOVED / MORAES SECONDED TO RECOMMEND APPROVAL OF REGULAR ITEM NUMBER 5A, ECM-23-001, FOR REVISION TO VARIOUS ENGINEERING STANDARDS (A LEGISLATIVE ACTION BY THE BOARD OF COUNTY COMMISSIONERS), WITH THE RESOLUTION ATTACHED TO THE STAFF REPORT TO INCLUDE THE DISCUSSED RECOMMENDATIONS, WITH NO (0) CONDITIONS OR NOTATIONS, THAT THIS ITEM BE FORWARDED TO THE BOARD OF COUNTY COMMISSIONERS FOR THEIR CONSIDERATION. THE MOTION WAS APPROVED (7-0).

6. NON-ACTION ITEMS. NONE.

MEETING ADJOURNED at 10:28 A.M.

Minutes Prepared By: Miranda Benson

AMENDMENT TO THE EL PASO COUNTY ENGINEERING CRITERIA MANUAL (RECOMMEND APPROVAL)

Mr. Trowbridge moved that the following Resolution be adopted:

BEFORE THE PLANNING COMMISSION

OF THE COUNTY OF EL PASO

STATE OF COLORADO

RESOLUTION NO. ECM-23-001
REVISION TO VARIOUS ENGINEERING STANDARDS

WHEREAS, the Public Works Department of El Paso County requests approval of Amendment(s) as described below:

- Amending Chapters 1, 2, and 4 of the ECM to remove incorrect references, add correct references, update definitions, reflect current practices already in use, and clarify design requirements; and.
- Amending Appendix F of the ECM to add El Paso County Standard Specifications and moving El Paso County Standard Specifications and Standard Specifications as stand-alone document(s). In addition, the amendment would include the ability to revise the El Paso County Standard Specifications administratively (as currently allowed with the Standard Drawings). Note that the County Engineer would coordinate with stakeholders concerning El Paso County Standard Drawings and Specifications through a formal process of notification along with appropriate review and comment procedures/process.

WHEREAS, a public hearing was held by this Commission on June 1, 2023; and

WHEREAS, based on the evidence, testimony, exhibits, consideration of the master plan for the unincorporated area of the County, presentation and comments of the El Paso County Department of Public Works and other County representatives, comments of public officials and agencies, comments from all interested persons, comments by the general public, and comments by the Planning Commission Members during the hearing, this Commission finds as follows:

1. The proposed amendment(s) to the El Paso Engineering Criteria Manual was properly submitted for consideration by the Planning Commission.
2. Proper publication and public notice were provided as required by law for the hearing before the Planning Commission.
3. The hearing before the Planning Commission was extensive and complete, that all pertinent facts, matters and issues were submitted and that all interested persons were heard at that hearing.

4. All data, surveys, analyses, and studies, as are required by the State of Colorado and El Paso County have been submitted, reviewed, and were recieved into evidence and found to meet the intent of the El Paso County Engineering Criteria Manual.
5. For the above-stated and other reasons, the proposed Amendment(s) are in the best interest of the health, safety, morals, convenience, order, prosperity and welfare of the citizens of El Paso County.

NOW, THEREFORE, BE IT RESOLVED that the El Paso County Planning Commission recommends approval of the proposed amendment(s) as describe above of the El Paso County Engineering Criteria Manual, including other conforming amendments throughout the Manual as presented at the public hearing held by this Commission on June 1, 2023;

AND BE IT FURTHER RESOLVED that, in the case of any inconsistency with these amendment(s) and any previous Criteria Manuals, these revision(s) shall prevail;

AND BE IT FURTHER RESOLVED that this Resolution and the recommendations contained herein be forwarded to the El Paso County Board of County Commissioners for its consideration.

Mr. Moraes seconded the adoption of the foregoing Resolution.

The roll having been called, the vote was as follows: (circle one)

Thomas Bailey	<input checked="" type="radio"/> aye / no / non-voting / absent / recused
Sarah Brittain Jack	aye / no / non-voting / <input checked="" type="radio"/> absent / recused
Jay Carlson	<input checked="" type="radio"/> aye / no / non-voting / absent / recused
Becky Fuller	aye / no / non-voting / <input checked="" type="radio"/> absent / recused
Brandy Merriam	<input checked="" type="radio"/> aye / no / non-voting / absent / recused
Eric Moraes	<input checked="" type="radio"/> aye / no / non-voting / absent / recused
Kara Offner	aye / no / non-voting / <input checked="" type="radio"/> absent / recused
Joshua Patterson	aye / no / non-voting / <input checked="" type="radio"/> absent / recused
Bryce Schuettpeiz	<input checked="" type="radio"/> aye / no / non-voting / absent / recused
Tim Trowbridge	<input checked="" type="radio"/> aye / no / non-voting / absent / recused
Christopher Whitney	<input checked="" type="radio"/> aye / no / non-voting / absent / recused

The Resolution was adopted by a vote of 7 to 0 by the El Paso County Planning Commission, State of Colorado.

DONE THIS 1st day of June 2023, at Colorado Springs, Colorado.

EL PASO COUNTY PLANNING COMMISSION

By: 
Thomas Bailey, Chair

RESOLUTION NO. 23-

BOARD OF COUNTY COMMISSIONERS
COUNTY OF EL PASO, STATE OF COLORADO

RESOLUTION TO APPROVE VARIOUS AMENDMENTS TO THE EL PASO COUNTY
ENGINEERING CRITERIA MANUAL AND ADOPTION FOR IMPLEMENTATION
(ECM-23-001)

WHEREAS, Colorado Revised Statutes, Article 28 of Title 30, authorize the State of Colorado and its political subdivisions to enact subdivision regulations in the unincorporated areas of the County through planning and building codes, and other regulatory documents or references as necessary; and

WHEREAS, El Paso County has adopted an Engineering Criteria Manual (ECM) for the purpose of setting and revising standards for the design and construction of public improvements and common subdivision or private development improvements to serve new development, and for repair and reconstruction of existing public improvements, finding that these standards are necessary to protect and promote health, safety, and general welfare of the public, ensure that public infrastructure meets commonly accepted engineering standards, and provide for consistency and fairness in development review; and

WHEREAS, the purposes of the ECM amendments attached hereto are to:

- Amend Chapters 1, 2 and 4 of the ECM to remove incorrect references, add correct references, update definitions, reflect current practices already in use, and clarify design requirements; and
- Amend Appendix F of the ECM to add El Paso County Standard Specifications and moving El Paso County Standard Specifications and Standard Specifications as stand-alone document(s). In addition, the amendment would include the ability to revise the El Paso County Standard Specifications administratively (as currently allowed with the Standard Drawings). ; and

WHEREAS, the ECM applies to all subdividers, developers, landowners, owners of facilities located in El Paso County rights-of-way, tracts or easements, and El Paso County, and their employees, agents, or contractors designing, constructing, and maintaining facilities or conducting activities subject to review and approval under the provisions of the ECM in unincorporated El Paso County; and

WHEREAS, the responsible authority for setting these standards and providing revisions to the standards is the Board of County Commissioners, who may delegate authority to apply and interpret these standards to the County Engineer in his or her capacity as the ECM Administrator; and

WHEREAS, the responsible authority for application of these standards is the County Engineer, who may delegate responsible authority for the application of these standards pursuant to Section 1.16.2 of the ECM; and

WHEREAS, the standards presented within the ECM are the minimum requirements necessary to accomplish the purposes of the ECM, and when situations arise where the application of individual standards from the ECM will not ensure the protection of public health, safety and welfare, the ECM Administrator may require the modification of plans, specifications or operations to achieve the necessary public health, safety, and welfare; and

WHEREAS, the proposed changes were endorsed by the Colorado Springs Housing and Building Association on May 25, 2023; and

WHEREAS, the proposed amendments were presented to and endorsed by the El Paso County Planning Commission on June 1, 2023.

NOW, THEREFORE, BE IT RESOLVED by the Board of County Commissioners of El Paso County, Colorado that the amendments to the El Paso County Engineering Criteria Manual attached hereto are acceptable, authorized, and hereby adopted for implementation.

BE IT FURTHER RESOLVED that County staff is authorized to edit the revisions as necessary to correct any non-substantive errors or to reformat text.

BE IT FURTHER RESOLVED, this Resolution shall become effective immediately upon approval by the El Paso County Board of Commissioners.

DONE THIS 18th day of July 2023 at Colorado Springs, Colorado.

ATTEST:

BOARD OF COUNTY COMMISSIONERS
OF EL PASO COUNTY, COLORADO

Steve Schleiker
County Clerk & Recorder

By: _____
Cami Bremer, Chair