

**MASTER DEVELOPMENT DRAINAGE PLAN &
FINAL DRAINAGE REPORT**

for

MONUMENT ACADEMY

Prepared for:

Monument Academy Foundation

1150 Village Ridge Point
Monument, CO 80132

February 8, 2019
Revised April 30, 2019
Revised June 20, 2019
Revised July 12, 2019
Revised April 9, 2020

Prepared by:

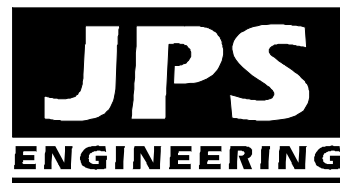

19 E. Willamette Avenue
Colorado Springs, CO 80903
(719)-477-9429
www.jpsengr.com

**JPS Project No. 040201
PCD File No. PPR-19-009 / CDR-19-001 / CDR-20-001**

MONUMENT ACADEMY - FINAL DRAINAGE REPORT
TABLE OF CONTENTS

	<u>PAGE</u>
EXECUTIVE SUMMARY	i
DRAINAGE STATEMENT.....	ii
I. GENERAL LOCATION AND DESCRIPTION	1
II. DRAINAGE BASINS AND SUB-BASINS	4
III. DRAINAGE DESIGN CRITERIA.....	5
IV. DRAINAGE PLANNING FOUR STEP PROCESS	6
V. GENERAL DRAINAGE RECOMMENDATIONS	7
VI. DRAINAGE FACILITY DESIGN	7
VII. EROSION / SEDIMENT CONTROL	18
VIII. COST ESTIMATE AND DRAINAGE FEES	18
IX. SUMMARY.....	18

APPENDICES

APPENDIX A	Soils Information
APPENDIX B	Hydrologic Calculations
APPENDIX C1	Hydraulic Calculations – Channels
APPENDIX C2	Hydraulic Calculations – Storm Sewer System
APPENDIX D1	Detention Pond Calculations – Pond C14
APPENDIX D2	Detention Pond Calculations – Pond M3
APPENDIX D3	Water Quality Facility Calculations
APPENDIX E	Drainage Cost Estimate
APPENDIX F	Figures
Figure A1	Vicinity Map
Figure FM1	Floodplain Map
Figure EX1	Major Basin / Historic Drainage Plan
Figure EX2	Historic Drainage Plan
Figure D1	Developed Drainage Plan
Sheet C2.1	North Site Grading & Erosion Control Plan
Sheet C2.2	South Site Grading & Erosion Control Plan
Sheet C3.1	Detention Pond C14 Plan & Details
Sheet C3.2	Detention Pond M3 Plan & Details

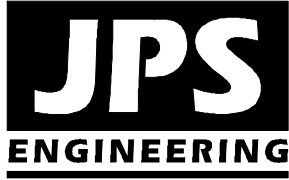

MONUMENT ACADEMY FINAL DRAINAGE REPORT - EXECUTIVE SUMMARY

A. Background

- Monument Academy is planning to construct a new Middle School / High School campus on approximately 21.2 acres of the vacant 42.3-acre parcel at the southeast corner of SH83 and Walker Road.
- Walden Corporation has future plans for development of the adjoining property with a mixture of commercial and residential land uses.
- The project site is located near the upstream limit of the West Cherry Creek Drainage Basin, which comprises a total drainage area in excess of 30 square miles.

B. General Drainage Plan

- Developed drainage will be conveyed to suitable outfalls through paved parking areas with curb and gutter, streets with roadside ditches, storm sewer facilities, and drainage channels.
- Developed flows from the site will be detained to historic levels through on-site stormwater detention and water quality ponds.

C. Drainage Impacts

- Drainage facilities will be designed and constructed to El Paso County standards.
- Drainage facilities within public road rights-of-way will be dedicated to the County for maintenance. The proposed stormwater detention ponds will be privately owned and maintained by the Walden Corporation or Property Owners Association.
- The proposed detention ponds will release historic flows at the downstream property boundaries, ensuring no significant adverse drainage impact on downstream properties.

DRAINAGE STATEMENTS

Engineer's Statement:

The attached drainage plan and report were prepared under my direction and supervision and are correct to the best of my knowledge and belief. Said drainage report has been prepared according to the criteria established by the County for drainage reports and said report is in conformity with the master plan of the drainage basin. I accept responsibility for liability caused by negligent acts, errors or omissions on my part in preparing this report.



John P. Schwab, P.E. #29891



Developer's Statement:

I, the developer have read and will comply with all of the requirements specified in this drainage report and plan.

By:

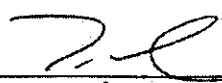

Printed Name: MARK A. McWilliams



Date

Monument Academy Foundation
1150 Village Ridge Point
Monument, CO 80132

El Paso County's Statement:

Filed in accordance with the requirements of the El Paso County Land Development Code, Drainage Criteria Manual, Volumes 1 and 2, and Engineering Criteria Manual as amended.

Jennifer Irvine, P.E.
County Engineer / ECM Administrator

Date

Conditions:

I. GENERAL LOCATION AND DESCRIPTION

A. Background

Monument Academy is planning to construct a new school campus on a 42.3-acre property located at the southeast corner of State Highway 83 (SH83) and Walker Road in northern of El Paso County, Colorado (see Figure A1, Appendix F). The proposed school site is a vacant, unplatted property (El Paso County Assessor's Parcel No. 61000-00-533). The site is zoned Rural Residential (RR-5), and the proposed school is a permitted use.

Monument Academy is planning to construct the new school campus on approximately 20 acres in the northeasterly part of the property. Walden Corporation has future plans for development of the balance of the adjoining property with a mixture of commercial and residential land uses. Site development activities will include site grading, utilities, a new school building, internal roads, parking lots, landscaping, and related site improvements.

Monument Academy, a Colorado Charter School authorized by the Lewis-Palmer School District No. 38, desires to construct a new middle/high school serving grades 6-12. The school intends to open in the fall of 2020 with approximately 480 students and anticipates growing its enrollment to 1,000 students at full build out. The school, as proposed, would consist of a two-story building of approximately 55,000 SF built in phase one, and an additional 30,000 SF to be constructed in a future phase. The school will contain all customary program spaces such as academic spaces, athletic and gymnasium spaces, band, vocal music, art, drama and typical support spaces such as administrative and counseling spaces. While most of these functions would be constructed in the first phase, the second phase would likely expand the athletic and performance arts spaces including a multi-purpose performance venue.

In addition to the school functions, the YMCA of the Pikes Peak Region, the largest non-profit community support organization serving El Paso County, has potential plans to occupy approximately 12,000 SF of space that would be co-located with the school. The YMCA program would consist of athletic spaces such as a healthy living center, group exercise class space, personal training, and other similar functions. As with the school, the YMCA would also require typical support spaces for administrative, child-care, and other functions. As with the school, the YMCA envisions constructing their program space in phases, and phase two could include an expanded healthy living center, additional group exercise spaces, and potentially a competition aquatics venue. If all these envisioned uses are eventually constructed, future phases would total approximately 40,000 SF of additional space.

Primary access to the site will be provided by a new roadway extending south from Walker Road into the site. Based on the Traffic Study and coordination with CDOT, a roundabout is proposed at the intersection of Walker Road and the new north-south roadway (Jane Lundeen Drive) entering the site. An additional right-in access is planned to extend from State Highway 83 easterly into the site. This access will extend east-west across the property, connecting with the

future extension of Pinehurst Circle planned through the adjoining Walden Preserve 2 PUD southeast of the school site. Both Jane Lundeen Drive and Pinehurst Circle will be constructed to County standards with the intention of dedication as public roadways in conjunction with a future subdivision application.

B. Scope

In support of the El Paso County Site Development Plan and Minor Subdivision Plat submittals for this project, this report is intended to meet the requirements of a Master Development Drainage Plan (MDDP) and Final Drainage Report (FDR) in accordance with El Paso County drainage criteria. This report will provide a summary of site drainage issues impacting the proposed development. The report will analyze impacts from upstream drainage patterns, site-specific developed drainage patterns, and impacts on downstream facilities. This report is based on the guidelines and criteria presented in the City of Colorado Springs and El Paso County “Drainage Criteria Manual.”

This Final Drainage Report provides final drainage analysis and design for the Monument Academy campus and associated public road improvements. Additional Final Drainage Reports will be required in support of detailed development plans for the anticipated future commercial and residential development areas.

C. Site Location and Description

The property is described as the East Half of the Northwest Quarter of Section 15, Township 11 South, Range 66 West of the 6th Principal Meridian, with exceptions as detailed in the legal description. The site has historically been a vacant forest and meadow tract.

The Monument Academy parcel is bordered by Walker Road to the north, State Highway 83 to the west, a rural residential parcel to the south, and the existing Walden Wastewater Treatment Facility to the east. The adjoining property to the north, west, and south is zoned rural residential (RR5).

The east boundary of the site adjoins the Walden Preserve 2 PUD. The Walden Preserve PUD and adjoining Walden Subdivision (Zoned RR1) include a range of 0.5-acre to 1-acre residential lots served by the Walden central water and wastewater systems.

Ground elevations within the parcel range from a low point of approximately 7,365 feet above mean sea level at the southwest corner of the property to a high point of 7,440 feet along the ridge within the site.

Surface drainage from this site flows into tributary channels draining to the main channel of West Cherry Creek. The terrain is rolling with slopes ranging from 1% to 10%. Existing vegetation is typical eastern Colorado prairie grass in the meadow areas and evergreen pines in the forest areas.

D. General Soil Conditions

According to the Soil Survey of El Paso County prepared by the Soil Conservation Service, the majority of the parcel is classified as “Tomah-Crowfoot” series loamy sands, and characterized as hydrologic soils group B. On-site soils are comprised primarily of the following soil types (see Appendix A):

- Type 26 – “Elbeth sandy loam”: slow to medium surface runoff, moderate erosion hazard (Hydrologic group B)
- Type 71 – “Pring coarse sandy loam”: medium surface runoff, moderate erosion hazard (Hydrologic Group B)
- Type 92 - “Tomah-Crowfoot loamy sands”: slow surface runoff, slight to moderate erosion hazard (Hydrologic Group B)

E. References

City of Colorado Springs & El Paso County “Drainage Criteria Manual,” revised October 12, 1994.

City of Colorado Springs “Drainage Criteria Manual, Volumes 1 and 2,” revised May, 2014.

CDOT, “CDOT Drainage Design Manual,” July, 1995.

El Paso County “Engineering Criteria Manual,” January 9, 2006.

Guenther Polok, “Drainage Report, Walden III, Filings 5, 6, and 7,” July, 1983.

JPS Engineering, Inc., “Final Drainage Report for Walden Pines Subdivision,” March 24, 2004.

JPS Engineering, Inc., “Final Drainage Report for Walden Preserve 2 Filings No. 1 and 2,” November 13, 2014.

JPS Engineering, Inc., “Final Drainage Report for Walden Preserve 2 Filing No. 4,” September 30, 2019 (approved October 30, 2019).

JPS Engineering, Inc., “Final Drainage Report for Walden Preserve Subdivision Filing No. 1,” May 11, 2005.

JPS Engineering, Inc., “Master Development Drainage Plan (MDDP) and Preliminary Drainage Report for Walden Preserve Subdivision,” December 10, 2004.

JPS Engineering, Inc., “Master Development Drainage Plan (MDDP) and Preliminary Drainage Report for Walden Preserve 2 PUD,” September 17, 2014 (approved November 6, 2014).

JPS Engineering, Inc., "Preliminary Drainage Report for Walden Pines Subdivision," December 29, 2003.

II. DRAINAGE BASINS AND SUB-BASINS

A. Major Basin Description

The proposed development lies within the West Cherry Creek Drainage Basin (CYCY 0400) as classified by El Paso County. Drainage from the east side of this site flows northerly to an eastern tributary of West Cherry Creek, which flows to a confluence with the main channel north of Walker Road. Drainage from the west side of this site flows westerly to several culverts crossing SH83, and then flowing northwesterly to the main channel of West Cherry Creek. Downstream agricultural areas generally drain northerly towards the main channel of West Cherry Creek.

The major drainage basins lying in and around the proposed development are depicted in Figure EX1. The Walden area is located near the southerly limits of the West Cherry Creek Basin, which comprises a total drainage area in excess of 30 square miles.

B. Floodplain Impacts

The proposed development area is located beyond the limits of any 100-year floodplain delineated by the Federal Emergency Management Agency (FEMA). The floodplain limits in the vicinity of the site are shown in Flood Insurance Rate Map (FIRM) Number 08041C0285G dated December 7, 2018, as shown in Figure FM1 (Appendix F). As shown on Figure FM1, the FEMA floodplain limit extends slightly south of Walker Road in the vicinity of the existing culvert crossing east of this site.

C. Sub-Basin Description

The existing drainage basins lying in and around the proposed development are depicted in Figure EX1 and EX2 (Appendix F). The property is located along a ridge, so there are no significant off-site drainage basins impacting the site. The existing on-site topography has been delineated as five drainage basins. Basin C14 drains northeasterly to a tributary channel of West Cherry Creek which crosses Walker Road east of the site. Basins M1-M5 drain westerly to existing culverts crossing SH83 and flowing northwesterly to the main channel of West Cherry Creek.

The developed drainage basins lying within the proposed development are depicted on Figure D1 (Appendix F). The interior site layout has been divided into drainage basins based on the site layout and proposed topography. The natural drainage patterns will be impacted through development by site grading and concentration of runoff in roadside ditches and channels.

Developed flows from the MA site will be routed through on-site stormwater Detention Ponds designed to release historic flows to the existing downstream culverts. In addition to the Detention Ponds, temporary Water Quality Ponds will be constructed at two locations along the west boundary of the site to provide interim water quality mitigation until permanent detention ponds are constructed during future phases of development. Additionally, two Rain Gardens will be constructed as permanent water quality Best Management Practices (BMP's) along the north side of Walker Road to mitigate developed drainage impacts. The limited area of roadway improvements excluded from water quality measures along Walker Road is less than one acre and within the allowable ECM limits in the County ECM.

III. DRAINAGE DESIGN CRITERIA

A. Development Criteria Reference

No Drainage Basin Planning Study (DBPS) has been completed for the West Cherry Creek Drainage Basin. JPS Engineering, Inc. prepared the "Master Development Drainage Plan (MDDP) and Preliminary Drainage Report for Walden Preserve 2 PUD" dated September 17, 2014, which was approved by El Paso County on November 6, 2014 in support of the Walden Preserve 2 PUD and Preliminary Plan.

B. Hydrologic Criteria

Recognizing that all tributary drainage basins impacting this site are less than 100 acres, Rational Method procedures were utilized for calculation of peak flows within the on-site drainage basins. Rational Method hydrologic calculations were based on the following assumptions:

• Design storm (minor)	5-year	
• Design storm (major)	100-year	
• Rainfall Intensities	El Paso County I-D-F Curve	
• Hydrologic soil type	B	
	<u>C5</u>	<u>C100</u>
• Runoff Coefficients - undeveloped:		
Existing meadow / forest areas	0.08	0.35
• Runoff Coefficients - developed:		
Proposed buildings / pavement areas	0.90	0.96
Future neighborhood business areas	0.49	0.62
Future residential areas (0.5-acre lots)	0.22	0.46
Future residential areas (1-acre lots)	0.20	0.44

Hydrologic calculations are detailed in Appendix B, and peak design flows are identified on the drainage plan drawings in Appendix F.

IV. DRAINAGE PLANNING FOUR STEP PROCESS

El Paso County Drainage Criteria require drainage planning to include a Four Step Process for receiving water protection that focuses on reducing runoff volumes, treating the water quality capture volume (WQCV), stabilizing drainageways, and implementing long-term source controls. The Four Step Process is applicable to all new and re-development projects with construction activities that disturb 1 acre or greater or that disturb less than 1 acre but are part of a larger common plan of development. The Four Step Process has been implemented as follows in the planning of this project:

Step 1: Employ Runoff Reduction Practices

- **Minimize Impacts:** The proposed school development includes significant open space, play areas, and a future athletic field, resulting in a moderate level of impervious site development. The proposed school campus development generates less impervious area and less intensive drainage impacts in comparison to multi-family residential, commercial, or industrial land uses.
- **Minimize Directly Connected Impervious Areas (MDCIA):** The Walden community has developed as a rural residential development with roadside ditches along subdivision roads, providing for impervious areas to drain across pervious areas. Based on the roadside ditches throughout the subdivision, the subdivision is classified as MDCIA Level One.
- **Reduce Pavement Area:** The proposed school site layout has been designed to provide pavement areas as required to meet the functional needs of the school campus while minimizing excessive paved areas.
- **Grass Swales:** The proposed drainage plan incorporates roadside ditches and grass-lined swales in selected locations to encourage stormwater infiltration while providing positive drainage through the site.

Step 2: Stabilize Drainageways

- Proper erosion control measures will be implemented along the roadside ditches and grass-lined drainage channels to provide stabilized drainageways within the site.

Step 3: Provide Water Quality Capture Volume (WQCV)

- **Detention Ponds:** The developed site will drain through stormwater detention ponds which will capture and slowly release the WQCV over an extended release period.
- **Temporary Sediment Basins:** Sediment basins will be installed to provide water quality treatment for segments of roadways and other impervious areas that are not routed through detention ponds. A deviation has been requested for interim use of temporary sediment basins as non-standard BMPs in two locations where developed flow impacts are minimal during interim conditions prior to construction of permanent detention pond facilities with the adjoining future development phase.

Step 4: Consider Need for Industrial and Commercial BMPs

- No industrial land uses are proposed within this development. Future commercial development areas will need to consider the potential need for Commercial BMPs.
- Low Impact Development (LID) features will be considered for implementation in site design of future commercial areas.
- On-site drainage will be routed through private detention ponds to minimize introduction of contaminants to the County's public drainage system.

V. GENERAL DRAINAGE RECOMMENDATIONS

The developed drainage plan for the site is to provide and maintain positive drainage away from structures and conform to the established drainage patterns for the overall site. JPS Engineering recommends that positive drainage be established and maintained away from all structures within the site in conformance with applicable building codes and geotechnical engineering recommendations.

Site grading and drainage improvements performed as a part of subdivision infrastructure development includes overlot grading and subdivision drainage improvements depicted on the subdivision construction drawings. Individual lot grading is the sole responsibility of the individual builders and property owners. Final grading of each building site should establish proper protective slopes and positive drainage in accordance with HUD guidelines and building codes.

In general, we recommend a minimum of 6 inches clearance from the top of concrete foundation walls to adjacent finished site grades. Positive drainage slopes should be maintained away from all structures, with a minimum recommended slope of 5 percent for the first 10 feet away from buildings in landscaped areas, a minimum recommended slope of 2 percent for the first 10 feet away from buildings in paved areas, and a minimum slope of 1 percent for paved areas beyond buildings.

VI. DRAINAGE FACILITY DESIGN

A. General Concept

Development of the Monument Academy site will require site grading and paving, resulting in additional impervious areas throughout the site. The general drainage pattern will consist of grading away from building sites to a system of drainage swales, storm sewers, and roadside ditches conveying runoff flows through the site.

The stormwater management concept for the Monument Academy development will be to provide a system of storm sewers, roadside ditches, and grass-lined swales as required to safely convey developed drainage through the site to on-site and off-site detention ponds, discharging to the existing natural outfalls.

Grading of individual development sites will provide positive drainage away from buildings and direct developed flows into the system of storm sewers, roadside ditches, and drainage swales running through the subdivision.

B. Specific Details

1. Existing Drainage Conditions

Historic drainage conditions within the site are depicted on Figure EX1 and EX2. The Monument Academy site is located along a north-south ridge along the east side of SH83, so there are no significant off-site drainage basins impacting the site. Surface drainage from the site generally flows northerly to tributary channels feeding into West Cherry Creek.

The northeasterly part of the site has been delineated as Basin C14, which sheet flows northeasterly to Design Point #C16.1 at the northeast corner of the property, with historic peak flows calculated as $Q_5 = 4.2$ cfs and $Q_{100} = 30.7$ cfs. Drainage from Design Point #C16.1 continues flowing easterly across the adjoining Walden Wastewater Treatment Facility site to an existing culvert crossing Walker Road at the northern boundary of the Walden property. According to the Master Development Drainage Plan for Walden Preserve 2 PUD," historic peak flows at the existing culvert crossing Walker Road have been calculated as $Q_5 = 222.5$ cfs and $Q_{100} = 582.9$ cfs (SCS Method), so the relative contribution of flow from Monument Academy Basin C14 to this design point is very small.

As tabulated in Appendix C2, the capacity of the existing 18-inch Corrugated Metal Pipe (CMP) driveway culvert immediately downstream of Design Point C16.1 is approximately 11 cfs, and the capacity of the existing 43"x27" CMP crossing Walker Road at Walden Design Point #4 is approximately 55 cfs. As discussed in the Walden MDDP, the existing culvert crossing Walker Road is undersized based on historic flows at this location and would be expected to overtop during major storm events. However, we are not aware of any significant historic drainage concerns at this crossing.

The westerly and southerly part of the site has been delineated as Basins M1-M4, flowing westerly to existing culverts crossing SH83 and Walker Road. Basin M1 comprises the northwest corner of the property, which sheet flows northwesterly to Design Point #M1, with historic peak flows calculated as $Q_5 = 2.0$ cfs and $Q_{100} = 14.3$ cfs. An existing 18-inch CMP culvert (Culvert M6) conveys the flow from Design Point #M1 northerly across Walker Road. The capacity of the existing 18-inch CMP culvert is approximately 13 cfs.

Basin M3 comprises most of the middle area on the west side of the property, which sheet flows to an existing culvert crossing SH83. Historic peak flows at Design Point #M3 are calculated as $Q_5 = 2.7$ cfs and $Q_{100} = 19.8$ cfs. An existing 24-inch CMP culvert conveys the flow from Basin M3 westerly across SH83. The capacity of the existing 24-inch CMP culvert is approximately 26 cfs.

Basin M4 comprises another small basin on the west side of the property, which sheet flows to an existing 24-inch culvert crossing SH83. Historic peak flows at Design Point #M4 are calculated as $Q_5 = 1.8$ cfs and $Q_{100} = 13.6$ cfs. The capacity of the existing 24-inch CMP culvert at Design Point M4 is approximately 24 cfs.

Design Point #M3.1 represents the combined flow from Basins M3 and M4. Historic peak flows at Design Point #M3.1 are calculated as $Q_5 = 4.2$ cfs and $Q_{100} = 31.0$ cfs.

Basin M5 comprises the south end of the property, which sheet flows to the southwest corner of the site. Basin OM1 is a small off-site drainage basin contributing flow to the southeast corner of Basin M5. Off-site flow from Basin OM1 enters the southeast corner of Basin M5 and flows westerly in an existing natural drainage swale through Basin M5. Flows from Basin OM1 and M5 combine at Design Point #M5.1, with historic peak flows calculated as $Q_5 = 5.8$ cfs and $Q_{100} = 42.4$ cfs. An existing 24-inch CMP culvert conveys the flow from DP-M5.1 westerly across SH83. The capacity of the existing 24-inch CMP culvert is approximately 30 cfs (see Appendix C2).

2. Developed Drainage Conditions

As shown on the enclosed Developed Drainage Plan (Figure D1, Appendix F), the property has been delineated as five on-site drainage basins flowing across the property. Developed flows have been calculated based on the impervious areas associated with the proposed building and parking areas and anticipated future land uses.

Hydrologic calculations for the school site are detailed in the attached tables (Appendix B), and peak flows are identified on Figures EX1 and D1 (Appendix F).

a) School Campus

The majority of the school site has been delineated as Basins C14 and M2. Basin C14 drains northeasterly across the property to a proposed stormwater detention pond at the northeast corner of the site. Basin M2 drains westerly across the site to a proposed stormwater detention pond along the western boundary of the property.

The proposed school building pad will be graded with protective slopes to provide positive drainage away from the building. Private storm sewer systems will be extended across the parking areas, and site grades around the school campus will slope to storm inlets at selected locations, collecting surface drainage and conveying stormwater to the proposed extended detention basins (EDB).

Basins C14-C16

The northeasterly part of the developed School Site has been delineated as Basin C14, which will flow northeasterly to Design Point #C14 following historic drainage patterns. Developed peak flows at Design Point #C14 are calculated as $Q_5 = 13.8$ cfs and $Q_{100} = 42.3$ cfs. An 18"-24" storm sewer system will collect surface drainage from Basin C14 and convey developed flows northeasterly to Detention Pond C14 at the northeast corner of the site. Detention pond design parameters are detailed in Section D of this report.

Basins C15 and C16 comprise the north end of Jane Lundeen Drive, which drains northerly to a public storm sewer system which also flows to Detention Pond C14. Developed peak flows at Design Point #C15 (west side of Jane Lundeen Drive) are calculated as $Q_5 = 1.6$ cfs and $Q_{100} = 2.6$ cfs, and these flows will be intercepted in a Public 5' Type R Inlet (Inlet C15) at the southwest corner of Jane Lundeen Drive and Walker Road.

Developed peak flows at Design Point #C16 (east side of Jane Lundeen Drive) are calculated as $Q_5 = 2.6$ cfs and $Q_{100} = 4.3$ cfs, and these flows will be intercepted in a 5' Type R Inlet (Public) at the southeast corner of Jane Lundeen Drive and Walker Road. Storm Sewer C15 (18" RCP) will convey the flow from DP-C15 easterly to Inlet C16, and Storm Sewer C16 (18" RCP) will convey the combined flow northeasterly to the ditch along the south side of Walker Road, flowing easterly to Detention Pond C14. The outlet of Storm Sewer C16 will discharge into the ditch along the south side of Walker Road (Channel C16.1), which will be armored with ECB lining. The ditch will flow easterly to the northeast corner of the MA property and then turn southeasterly, flowing down a riprap rundown (Channel C16.2) into Pond C14.

The east edge of the southerly parking lot will flow northeasterly to Private Storm Inlet C14.1 (10' Type R Inlet) on the east side of the school building. Private Storm Sewer C14.1 (18" HDPE) will convey the flow from Inlet C14.1 northerly to Private Storm Inlet C14.2 at the northeast corner of the northerly parking lot.

Private Storm Sewer C14.2 (24" HDPE) will convey the flow from Inlet C14.2 northerly to Storm Manhole C14.3 (Type C) at the northeast corner of the athletic field. Private Storm Sewer C14.3 (24" HDPE) will convey the flow from Manhole C14.3 easterly into Private Detention Pond C14. Future construction of the athletic field will include a field drainage system with storm drain piping connected to Storm Manhole C14.3.

Developed flows from Basins C14-C16 combine at Design Point #C16.1, with peak flows calculated as $Q_5 = 16.9$ cfs and $Q_{100} = 47.1$ cfs. Stormwater detention and water quality for Basins C14-C16 will be provided by routing developed flows through Detention Pond C14, which will release detained flows of $Q_5 = 0.3$ cfs and $Q_{100} = 16.9$ cfs.

Basin M2

The southwesterly part of the developed School Site has been delineated as Basin M2, which flows westerly across the south parking lot to Design Point #M2, with developed peak flows calculated as $Q_5 = 19.4$ cfs and $Q_{100} = 40.0$ cfs. An 18"-24" storm sewer system will collect surface drainage from Basin M2 and convey developed flows westerly to a grass-lined channel on the west side of Jane Lundeen Drive flowing to Detention Pond M3 at the western property boundary. While no initial development is proposed within Basin M3 and M4, the volume of Detention Pond M3 has been sized to account for future commercial development of Basins M3 and M4 as well.

The majority of the east side of the southerly parking lot will flow northwesterly to Inlet M2.1 (10' Type R Inlet) on the south side of the school building. Storm Inlet M2.1 will intercept surface drainage from the southeasterly parking lot, and roof drains from the south side of the building will flow into a roof drain collection line feeding into Storm Sewer M2.1. Private Storm Sewer M2.1 (18" HDPE) will convey the flow from Inlet M2.1 to Public Inlet M2.3 (10' Type R) on the east side of Jane Lundeen Drive, southwest of the school building.

Public Storm Inlets M2.2A and M2.2B will intercept roadway drainage from the low point at the northeast corner of Pinehurst Circle and Jane Lundeen Drive, and Public Storm Sewer M2.2A (15" RCP) and M2.2B (18" RCP) will convey this flow northerly to the junction Inlet M2.3. Public Storm Sewer M2.3 (30" RCP) will convey the combined flow from Inlet M2.3 westerly across Jane Lundeen Drive to daylight in an open channel flowing northwesterly into Private Detention Pond M3.

Developed flows from Basins M2-M4 combine at Design Point #M3.1, with interim peak flows calculated as $Q_5 = 19.4$ cfs and $Q_{100} = 53.4$ cfs. Stormwater detention and water quality will be provided by routing developed flows through Detention Pond M3, which will release detained flows of $Q_5 = 0.3$ cfs and $Q_{100} = 23.2$ cfs.

During the initial phase of interim development, stormwater quality for the roadway improvements within Basin M4 and M5 will be provided by constructing Temporary Sediment Basins (TSB) M4 and M5. Interim developed peak flows at Design Point M4 are calculated as $Q_5 = 2.2$ cfs and $Q_{100} = 8.2$ cfs. Interim developed peak flows at Design Point M5.1 are calculated as $Q_5 = 7.4$ cfs and $Q_{100} = 46.3$ cfs.

b) Future Development Areas

Basin M1

The northwesterly part of the overall site has been delineated as Basin M1, which flows to Design Point #M1 at the northwest corner of the property. Assuming future commercial development characterized as “neighborhood business,” the future developed peak flows at Design Point #M1 are calculated as $Q_5 = 10.7$ cfs and $Q_{100} = 22.6$ cfs. A future detention and water quality pond will be required to mitigate developed drainage impacts at Design Point #M1. There will be no significant developed drainage impact within Basin M1 during the initial phase of Monument Academy site development.

Basins M3 and M4

The central area on the west side of the property has been delineated as developed Basin M3, which flows westerly to Detention Pond M3. Assuming future commercial development characterized as “neighborhood business,” the future developed peak flows from Basin M3 are calculated as $Q_5 = 11.0$ cfs and $Q_{100} = 25.7$ cfs.

Developed Basin M4 consists of the small area on the northwest side of Pinehurst Circle and Road A. Assuming future commercial development characterized as “neighborhood business,” the future developed peak flows from Basin M4 are calculated as $Q_5 = 6.3$ cfs and $Q_{100} = 13.5$ cfs. The future developed flows from Basin M4 will be routed northwesterly into Detention Pond M3.

Developed flows from Basins B2-B4 will ultimately combine at Design Point #M3.1, with peak flows calculated as $Q_5 = 34.0$ cfs and $Q_{100} = 73.6$ cfs. Detention Pond M3 will be constructed with the initial phase of development, so no additional detention volume will be required for Basins M2-M4 assuming the future development is consistent with the assumptions in this report.

There will be no significant developed drainage impact within Basins M3 and M4 during the initial phase of Monument Academy site development. Within Basin M4, the limited drainage impact from the north side of the Pinehurst Circle roadway and west side of Jane Lundeen Drive will be mitigated by routing flows through Temporary Sediment Basin (TSB) M4. At the time of future development within Basin M4, developed flows will be routed northwesterly into Detention Pond M3. The interim Temporary Sediment Basin M4 can be removed in the future when developed flows from Basin M4 are conveyed into Pond M3.

Basin M5

The south end of the overall site has been delineated as Basin M5, which flows to Design Point #M5 at the southwest corner of the property. Off-site flows from Basin OM1 will continue to combine with Basin M5 at Design Point M5.1.

Assuming future residential development of Basin OM1 with 1-acre lots, and future residential development of Basin M5 with a mixture of 0.5-acre to 1-acre lot sizes, the future developed peak flows at Design Point #M5.1 are calculated as $Q_5 = 16.4$ cfs and $Q_{100} = 59.1$ cfs. A future detention and water quality pond will be required to mitigate developed drainage impacts at Design Point #M5.

There will be no significant developed drainage impact within Basin M5 during the initial phase of Monument Academy site development. The limited drainage impact from the south side of the Pinehurst Circle roadway will be mitigated by routing flows through Temporary Sediment Basin (TSB) M5.

At the time of future development within Basin M5, Detention Pond M5 will need to be constructed as a permanent stormwater detention and water quality facility, and developed flows from Basin M5 will be routed through Detention Pond M5. Construction of the ultimate Detention Pond M5 will entail replacing the interim Temporary Sediment Basin M5 with a significantly larger permanent facility.

c) Walker Road Improvements

The MA project will include construction of roadway improvements to Walker Road along the north boundary of the site. The road improvements will include a new roundabout, along with re-alignment of Walker Road on each side of the new roundabout, with associated curb and gutter and paving improvements.

The new roundabout will be located at the existing high point in Walker Road, and roadway drainage conditions will remain consistent with historic conditions, with the easterly segment of Walker Road draining east to the existing downstream tributary channel, and the westerly segment of Walker Road draining west to the existing culverts at the northeast and southeast corners of the intersection with SH83.

As shown on Sh. D1, the southeast segment of Walker Road has been included as a part of Basin C14, and this segment of road will flow easterly along the south curb and gutter to a curb chase draining to the riprap rundown entering Detention Pond C14.

The drainage area flowing along the northeast segment of Walker Road has been delineated as Basin OM2, and this small drainage area will flow easterly along the north curb and gutter to the existing ditch along the north side of Walker Road. Historic peak

flows at Design Point #OM2 are calculated as $Q_5 = 0.8$ cfs and $Q_{100} = 2.1$ cfs. Developed peak flows at Design Point #OM2 are calculated as $Q_5 = 1.4$ cfs and $Q_{100} = 4.2$ cfs, indicating a minor increase in developed flows. The roadway improvements within Basin OM2 will have no significant developed drainage impact in comparison to historic conditions. Rain Garden OM2 will be constructed along the north side of Walker Road to provide water quality mitigation for Basin OM2.

The drainage area flowing along the southwest segment of Walker Road has been delineated as Basin M6, which includes the off-site area along the east side of SH83 approaching the southeast corner of the intersection at Walker Road. The segment of Walker Road within Basin M6 will flow westerly along the south curb and gutter to a curb chase flowing into the existing 18" culvert (Culvert M6) at the southeast corner of the intersection. Flows from Basin M1 at the northwest corner of the Monument Academy site combine with roadway flows from Basin M6 at Design Point #M6.1. Historic peak flows at Design Point #M6.1 are calculated as $Q_5 = 5.6$ cfs and $Q_{100} = 15.8$ cfs. Developed peak flows at Design Point #M6.1 are calculated as $Q_5 = 2.4$ cfs and $Q_{100} = 12.9$ cfs, representing a minor reduction in flow (reduced basin area due to roundabout offset to the south). As shown in the Existing Culvert Summary table in Appendix C2, the existing Culvert M6 has adequate capacity to convey the developed flows.

The drainage area flowing along the northwest segment of Walker Road has been delineated as Basin OM3, and this drainage area will flow westerly along the north curb and gutter to the existing 24" culvert at the northeast corner of the intersection of Walker Road and SH83. Flows from Basins M1, M6, and OM3 combine at Design Point #OM3.1 (northeast corner of the intersection). Historic peak flows at Design Point #OM3.1 are calculated as $Q_5 = 3.2$ cfs and $Q_{100} = 19.3$ cfs. Developed peak flows (interim conditions) at Design Point #OM3.1 are calculated as $Q_5 = 3.7$ cfs and $Q_{100} = 18.0$ cfs, generally consistent with historic conditions. Future design of Detention Pond M1 will ensure that detained flows at Design Point #OM3.1 remain consistent with historic conditions. While Pond M1 is shown conceptually on the enclosed Developed Drainage Plan (Sh. D1), the final design and location of this pond will be refined during future development of the adjoining area. As shown in the Existing Culvert Summary table in Appendix C2, the existing Culvert OM3 has adequate capacity to convey the developed flows.

C. Comparison of Developed to Historic Discharges

Based on the hydrologic calculations in Appendix B, the proposed development will result in developed flows exceeding historic flows from the parcel. The increase in developed flows will be mitigated through on-site stormwater detention facilities.

The comparison of developed to historic discharges at key design points is summarized as follows:

Design Point	Historic Flow			Developed Flow			Comparison of Developed to Historic Flow (Q _{5%} /Q _{100%})
	Area (ac)	Q ₅ (cfs)	Q ₁₀₀ (cfs)	Area (ac)	Q ₅ (cfs)	Q ₁₀₀ (cfs)	
C16.1(Developed Ph. 1)	19.4	4.2	30.7	18.1	17.1	47.6	407% / 155% (increase)
C16.1(Developed Ult.)	19.4	4.2	30.7	18.1	17.1	47.6	407% / 155% (increase)
C16.1 (Detained)	19.4	4.2	30.7	18.1	0.3	16.9	7% / 55% (decrease)
M3.1 (Developed Ph. 1)	16.4	4.2	31.0	17.8	19.4	53.4	462% / 172% (increase)
M3.1 (Developed Ult.)	16.4	4.2	31.0	17.8	34.0	73.6	424% / 237% (increase)
M3.1 (Detained)	16.4	4.2	31.0	18.4	0.3	23.2	11% / 80% (decrease)

* Appendix B provides calculations for both Interim (Phase 1) and Ultimate Developed Flow Conditions

D. Detention Ponds

The total developed storm runoff downstream of the site will be maintained at historic levels by routing flows through the proposed detention ponds. Detention Ponds C14 and M3 will be constructed with the initial phase of development, and these ponds have been designed as “full-spectrum” detention ponds to mitigate developed drainage and water quality impacts from the school campus and associated roadway improvements.

The proposed pond outlet structures have been designed as Extended Detention Basins (EDB), providing for a 40-hour release of the WQCV, and outlet structure sizing to maintain maximum allowable release rates from the pond. The detention ponds will have grass-lined bottoms and riprap infiltration zones in front of the pond outlet structures to encourage infiltration of stormwater prior to discharging into the downstream drainage system. Buried riprap spillways will be provided as emergency overflow paths from each pond to the adjoining roadside ditches.

Final pond design calculations utilizing the Denver Urban Drainage and Flood Control District (UDFCD) “UD-Detention_v3.07” software package are enclosed in Appendix D1 and D2.

Pond C14 has been designed for ultimate development of the MA School Site. Pond M3 has been designed to provide the 100-year detention storage volume for the ultimate site development, including anticipated future commercial development within Basins M3 and M4. However, the outlet structure for Pond M3 has been designed based on the Interim Phase 1 developed conditions (school site only). A future outlet structure upgrade will need to be evaluated with the drainage report for future development of Basins M3 and M4, and an upgrade of the orifice plate will likely be required at the time of future development.

Design parameters for the detention ponds are summarized as follows:

Pond	Required 100-Year Detention Volume (ac-ft)	Design Volume (ac-ft)	100-Year Inflow (cfs)	100-Year Outflow (cfs)
C14	1.1	1.3	37.1	16.9
M3	2.0	2.2	47.6	23.2

The proposed detention ponds will be owned and maintained by the Walden Corporation, and maintenance access will be provided from the adjacent parking lots, access drives, and public roads. Easements are provided in the PDP/BMP maintenance agreement.

Design calculations for the Water Quality Capture Volume (WQCV) used in sizing the interim Temporary Sediment Basins (TSB) M4 and M5 are enclosed in Appendix D3.

In addition to the on-site detention ponds, two Rain Gardens will be constructed along the north side of Walker Road to provide water quality mitigation for the associated roadway improvements. Rain Garden OM2 will be constructed on the east of the roundabout and Rain Garden OM3 will be constructed on the west side of the roundabout. Design calculations for these permanent water quality Best Management Practices (BMP's) are also enclosed in Appendix D3.

E. On-Site Drainage Facility Design

Developed sub-basins and proposed drainage improvements are depicted on the enclosed Drainage Plan (Sheet D1). On-site drainage facilities will consist of roadside ditches, grass-lined channels, and culverts. Hydraulic calculations for sizing of site drainage facilities are enclosed in Appendix C, and design criteria are summarized as follows:

1. Culverts and Storm Sewers

The internal road system will be graded to drain roadside ditches to low points along the road profile, where cross-culverts will convey developed flows into grass-lined channels following historic drainage paths. Culvert pipes have been specified as reinforced concrete pipe (RCP) or High-Density Polyethylene (HDPE) with a minimum diameter of 18-inches. Final design will ensure that culverts meet County criteria for allowable headwater depths and overtopping. Riprap outlet protection will be provided at all culverts.

Calculations for the capacity of the existing culverts adjoining the site are enclosed in Appendix C2.

Proposed Storm Inlets have been sized using the "UD-Inlet" software package, and the proposed Storm Sewer systems have been designed based on allowable hydraulic grade line design criteria using the "UD-Sewer" software package (see Appendix C2).

2. Open Channels

Drainage easements will be dedicated along major drainage channels following historic drainage paths through the subdivision. Proposed channel improvements have generally been designed as grass-lined channels designed to convey 100-year flows, with a trapezoidal cross-section, variable bottom width and depth, 4:1 maximum side slopes, one-foot freeboard, and a minimum slope of 0.5 percent.

The proposed drainage channels have been sized utilizing Manning's equation for open channel flow, assuming a friction factor ("n") of 0.030 for dry-land grass channels. Maximum allowable velocities have been evaluated based on El Paso County drainage criteria, typically allowing for a maximum 100-year velocity of 4 feet per second for native grass channels. Erosion control mats have been specified for channel segments with maximum 100-year velocities up to 9 feet per second. The proposed channels will generally be seeded with native grasses for erosion control. Permanent Erosion Control Blanket (ECB) lining will be provided where required based on erosive velocities. Ditch flows will be diverted to drainage channels at the nearest practical location to minimize excessive roadside ditch sizes.

F. Analysis of Existing and Proposed Downstream Facilities

The general concept of the proposed drainage plan is to mitigate developed drainage impacts by routing developed flows through on-site detention ponds. There is no evidence of erosion concerns in the existing natural drainage swales immediately downstream of the site. Appendix C2 provides a tabulation of the capacity of the existing culverts adjoining the site. Recognizing that on-site detention ponds are being constructed to mitigate developed drainage impacts, there is no need for off-site drainage improvements.

As discussed in the previously approved Walden Preserve MDDP, the existing culvert crossing Walker Road on the north side of the Walden Wastewater Facility is undersized based on historic flows, and the culvert would be expected to overtop during major storm events. However, we are not aware of any significant historic drainage concerns at this crossing, and we are not aware of any County plans for replacement of the existing culvert crossing.

G. Anticipated Drainage Problems and Solutions

Stormwater detention ponds have been designed to mitigate the impacts of developed drainage from the Monument Academy project. The overall drainage plan for the subdivision includes a system of storm sewer facilities, roadside ditches, channels, and culverts to convey developed flows through the site. The primary drainage problems anticipated within this development will consist of maintenance of these drainage pipes, channels, culverts, and detention pond facilities. Care will need to be taken to implement proper erosion control measures in the proposed roadside ditches, channels, and swales.

Ditches have been designed to meet maximum allowable velocity criteria. Erosion control mats will be installed where necessary to minimize erosion concerns. Proper construction and maintenance of the proposed detention and water quality facilities will minimize downstream drainage impacts.

VII. EROSION / SEDIMENT CONTROL

The Contractor will be required to implement Best Management Practices (BMP's) for erosion control through the course of construction. Sediment control measures will include installation of silt fence at the toe of disturbed slopes and hay bales protecting drainage ditches. Cut slopes will be stabilized during excavation as necessary and vegetation will be established for stabilization of disturbed areas as soon as possible. All ditches will be designed to meet El Paso County criteria for slope and velocity.

VIII. COST ESTIMATE AND DRAINAGE FEES

A cost estimate for proposed drainage improvements is enclosed in Appendix E.

The developer will finance all construction costs for proposed roadway and drainage improvements, and public facilities will be owned and maintained by El Paso County upon final acceptance. The proposed detention ponds will be privately owned and maintained by the property owners or owners association.

This parcel is located in the West Cherry Creek drainage basin. No drainage and bridge fees will be due at time of recordation of the final plat as the subject site is not located in a fee basin.

IX. SUMMARY

The developed drainage patterns associated with the proposed Monument Academy campus and surrounding site development will remain consistent with historic conditions, and new drainage facilities constructed to El Paso County standards will safely convey runoff to suitable outfalls. Developed flows from the site will drain through on-site stormwater detention ponds prior to discharging to the existing downstream drainage system.

The proposed stormwater detention and water quality facilities have been designed to mitigate developed flow impacts and meet the County's stormwater quality requirements. Construction and proper maintenance of the proposed stormwater facilities and detention basins, in conjunction with proper erosion control practices, will ensure that this developed site has no significant adverse drainage impact on downstream or surrounding areas.

APPENDIX A
SOILS INFORMATION

Hydrologic Soil Group—El Paso County Area, Colorado
(Monument Academy Site)

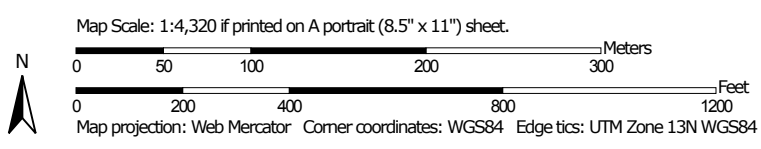
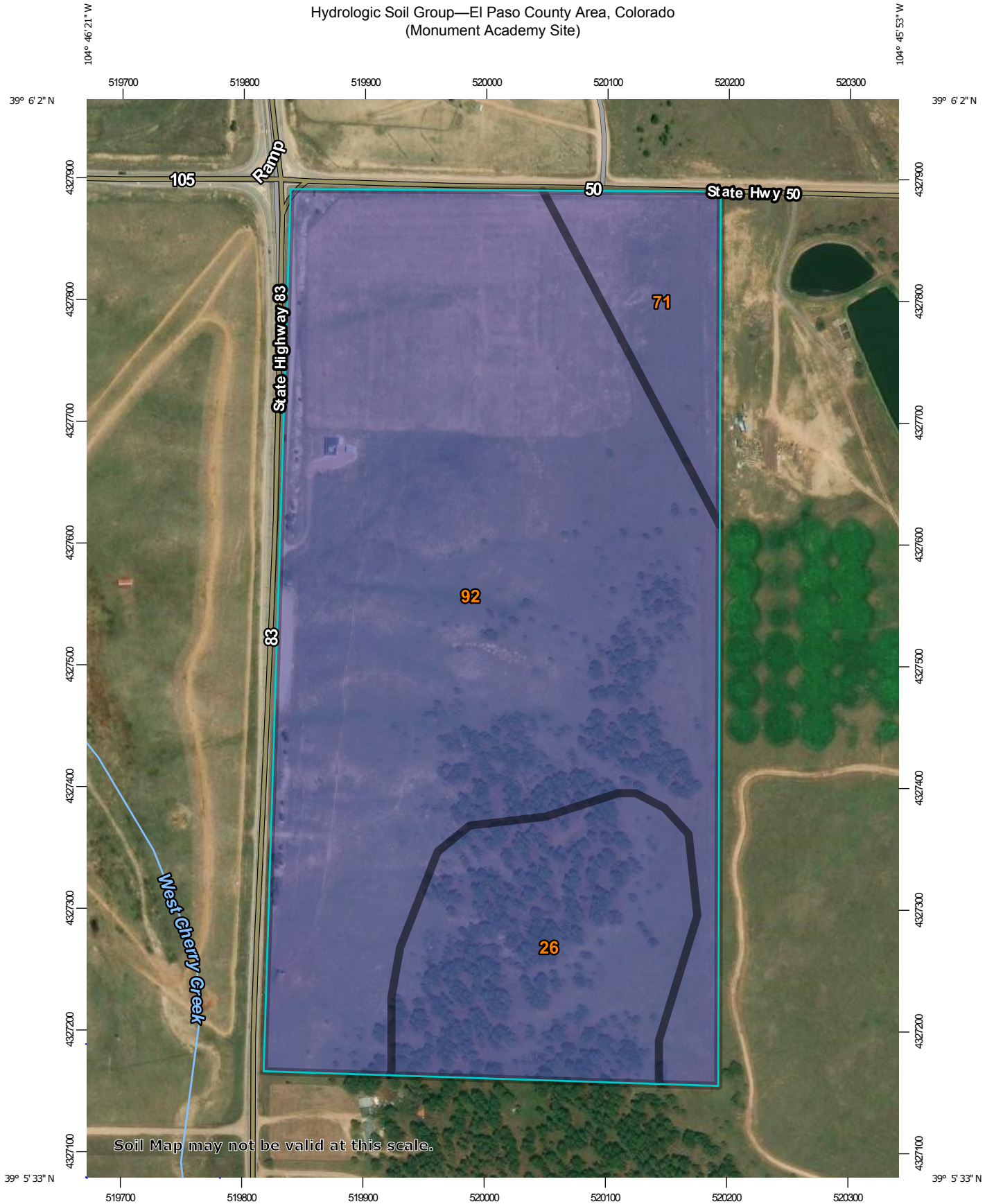

MAP LEGEND

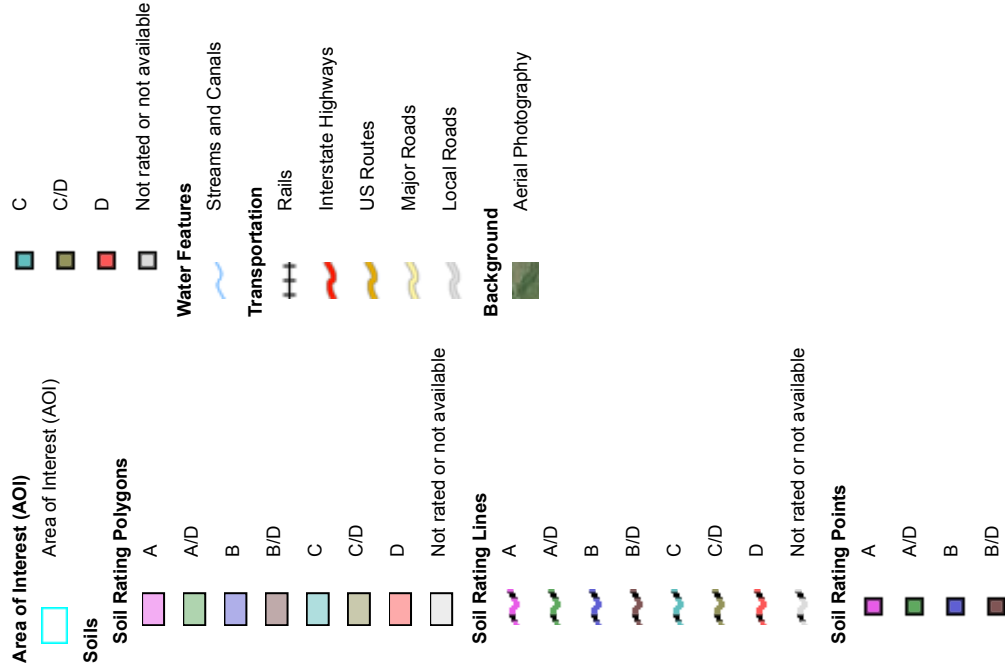

MAP INFORMATION

The soil surveys that comprise your AOI were mapped at 1:24,000.

Warning: Soil Map may not be valid at this scale.

Enlargement of maps beyond the scale of mapping can cause misunderstanding of the detail of mapping and accuracy of soil line placement. The maps do not show the small areas of contrasting soils that could have been shown at a more detailed scale.

Please rely on the bar scale on each map sheet for map measurements.

Source of Map: Natural Resources Conservation Service
 Web Soil Survey URL:
 Coordinate System: Web Mercator (EPSG:3857)

Maps from the Web Soil Survey are based on the Web Mercator projection, which preserves direction and shape but distorts distance and area. A projection that preserves area, such as the Albers equal-area conic projection, should be used if more accurate calculations of distance or area are required.

This product is generated from the USDA-NRCS certified data as of the version date(s) listed below.

Soil Survey Area: El Paso County Area, Colorado
 Survey Area Data: Version 16, Sep 10, 2018

Soil map units are labeled (as space allows) for map scales 1:50,000 or larger.

Date(s) aerial images were photographed: Jul 4, 2010—Oct 16, 2017

The orthophoto or other base map on which the soil lines were compiled and digitized probably differs from the background imagery displayed on these maps. As a result, some minor shifting of map unit boundaries may be evident.

Hydrologic Soil Group

Map unit symbol	Map unit name	Rating	Acres in AOI	Percent of AOI
26	Elbeth sandy loam, 8 to 15 percent slopes	B	12.1	18.4%
71	Pring coarse sandy loam, 3 to 8 percent slopes	B	5.0	7.6%
92	Tomah-Crowfoot loamy sands, 3 to 8 percent slopes	B	48.9	74.1%
Totals for Area of Interest			66.1	100.0%

Description

Hydrologic soil groups are based on estimates of runoff potential. Soils are assigned to one of four groups according to the rate of water infiltration when the soils are not protected by vegetation, are thoroughly wet, and receive precipitation from long-duration storms.

The soils in the United States are assigned to four groups (A, B, C, and D) and three dual classes (A/D, B/D, and C/D). The groups are defined as follows:

Group A. Soils having a high infiltration rate (low runoff potential) when thoroughly wet. These consist mainly of deep, well drained to excessively drained sands or gravelly sands. These soils have a high rate of water transmission.

Group B. Soils having a moderate infiltration rate when thoroughly wet. These consist chiefly of moderately deep or deep, moderately well drained or well drained soils that have moderately fine texture to moderately coarse texture. These soils have a moderate rate of water transmission.

Group C. Soils having a slow infiltration rate when thoroughly wet. These consist chiefly of soils having a layer that impedes the downward movement of water or soils of moderately fine texture or fine texture. These soils have a slow rate of water transmission.

Group D. Soils having a very slow infiltration rate (high runoff potential) when thoroughly wet. These consist chiefly of clays that have a high shrink-swell potential, soils that have a high water table, soils that have a claypan or clay layer at or near the surface, and soils that are shallow over nearly impervious material. These soils have a very slow rate of water transmission.

If a soil is assigned to a dual hydrologic group (A/D, B/D, or C/D), the first letter is for drained areas and the second is for undrained areas. Only the soils that in their natural condition are in group D are assigned to dual classes.

Rating Options

Aggregation Method: Dominant Condition

Component Percent Cutoff: None Specified

Tie-break Rule: Higher



United States
Department of
Agriculture

NRCS

Natural
Resources
Conservation
Service

A product of the National
Cooperative Soil Survey,
a joint effort of the United
States Department of
Agriculture and other
Federal agencies, State
agencies including the
Agricultural Experiment
Stations, and local
participants

Custom Soil Resource Report for El Paso County Area, Colorado



Preface

Soil surveys contain information that affects land use planning in survey areas. They highlight soil limitations that affect various land uses and provide information about the properties of the soils in the survey areas. Soil surveys are designed for many different users, including farmers, ranchers, foresters, agronomists, urban planners, community officials, engineers, developers, builders, and home buyers. Also, conservationists, teachers, students, and specialists in recreation, waste disposal, and pollution control can use the surveys to help them understand, protect, or enhance the environment.

Various land use regulations of Federal, State, and local governments may impose special restrictions on land use or land treatment. Soil surveys identify soil properties that are used in making various land use or land treatment decisions. The information is intended to help the land users identify and reduce the effects of soil limitations on various land uses. The landowner or user is responsible for identifying and complying with existing laws and regulations.

Although soil survey information can be used for general farm, local, and wider area planning, onsite investigation is needed to supplement this information in some cases. Examples include soil quality assessments (<http://www.nrcs.usda.gov/wps/portal/nrcs/main/soils/health/>) and certain conservation and engineering applications. For more detailed information, contact your local USDA Service Center (<https://offices.sc.egov.usda.gov/locator/app?agency=nrcs>) or your NRCS State Soil Scientist (http://www.nrcs.usda.gov/wps/portal/nrcs/detail/soils/contactus/?cid=nrcs142p2_053951).

Great differences in soil properties can occur within short distances. Some soils are seasonally wet or subject to flooding. Some are too unstable to be used as a foundation for buildings or roads. Clayey or wet soils are poorly suited to use as septic tank absorption fields. A high water table makes a soil poorly suited to basements or underground installations.

The National Cooperative Soil Survey is a joint effort of the United States Department of Agriculture and other Federal agencies, State agencies including the Agricultural Experiment Stations, and local agencies. The Natural Resources Conservation Service (NRCS) has leadership for the Federal part of the National Cooperative Soil Survey.

Information about soils is updated periodically. Updated information is available through the NRCS Web Soil Survey, the site for official soil survey information.

The U.S. Department of Agriculture (USDA) prohibits discrimination in all its programs and activities on the basis of race, color, national origin, age, disability, and where applicable, sex, marital status, familial status, parental status, religion, sexual orientation, genetic information, political beliefs, reprisal, or because all or a part of an individual's income is derived from any public assistance program. (Not all prohibited bases apply to all programs.) Persons with disabilities who require

alternative means for communication of program information (Braille, large print, audiotape, etc.) should contact USDA's TARGET Center at (202) 720-2600 (voice and TDD). To file a complaint of discrimination, write to USDA, Director, Office of Civil Rights, 1400 Independence Avenue, S.W., Washington, D.C. 20250-9410 or call (800) 795-3272 (voice) or (202) 720-6382 (TDD). USDA is an equal opportunity provider and employer.

Contents

Preface	2
How Soil Surveys Are Made	5
Soil Map	8
Soil Map.....	9
Legend.....	10
Map Unit Legend.....	11
Map Unit Descriptions.....	11
El Paso County Area, Colorado.....	13
26—Elbeth sandy loam, 8 to 15 percent slopes.....	13
71—Pring coarse sandy loam, 3 to 8 percent slopes.....	14
92—Tomah-Crowfoot loamy sands, 3 to 8 percent slopes.....	15
References	17

How Soil Surveys Are Made

Soil surveys are made to provide information about the soils and miscellaneous areas in a specific area. They include a description of the soils and miscellaneous areas and their location on the landscape and tables that show soil properties and limitations affecting various uses. Soil scientists observed the steepness, length, and shape of the slopes; the general pattern of drainage; the kinds of crops and native plants; and the kinds of bedrock. They observed and described many soil profiles. A soil profile is the sequence of natural layers, or horizons, in a soil. The profile extends from the surface down into the unconsolidated material in which the soil formed or from the surface down to bedrock. The unconsolidated material is devoid of roots and other living organisms and has not been changed by other biological activity.

Currently, soils are mapped according to the boundaries of major land resource areas (MLRAs). MLRAs are geographically associated land resource units that share common characteristics related to physiography, geology, climate, water resources, soils, biological resources, and land uses (USDA, 2006). Soil survey areas typically consist of parts of one or more MLRA.

The soils and miscellaneous areas in a survey area occur in an orderly pattern that is related to the geology, landforms, relief, climate, and natural vegetation of the area. Each kind of soil and miscellaneous area is associated with a particular kind of landform or with a segment of the landform. By observing the soils and miscellaneous areas in the survey area and relating their position to specific segments of the landform, a soil scientist develops a concept, or model, of how they were formed. Thus, during mapping, this model enables the soil scientist to predict with a considerable degree of accuracy the kind of soil or miscellaneous area at a specific location on the landscape.

Commonly, individual soils on the landscape merge into one another as their characteristics gradually change. To construct an accurate soil map, however, soil scientists must determine the boundaries between the soils. They can observe only a limited number of soil profiles. Nevertheless, these observations, supplemented by an understanding of the soil-vegetation-landscape relationship, are sufficient to verify predictions of the kinds of soil in an area and to determine the boundaries.

Soil scientists recorded the characteristics of the soil profiles that they studied. They noted soil color, texture, size and shape of soil aggregates, kind and amount of rock fragments, distribution of plant roots, reaction, and other features that enable them to identify soils. After describing the soils in the survey area and determining their properties, the soil scientists assigned the soils to taxonomic classes (units). Taxonomic classes are concepts. Each taxonomic class has a set of soil characteristics with precisely defined limits. The classes are used as a basis for comparison to classify soils systematically. Soil taxonomy, the system of taxonomic classification used in the United States, is based mainly on the kind and character of soil properties and the arrangement of horizons within the profile. After the soil

Custom Soil Resource Report

scientists classified and named the soils in the survey area, they compared the individual soils with similar soils in the same taxonomic class in other areas so that they could confirm data and assemble additional data based on experience and research.

The objective of soil mapping is not to delineate pure map unit components; the objective is to separate the landscape into landforms or landform segments that have similar use and management requirements. Each map unit is defined by a unique combination of soil components and/or miscellaneous areas in predictable proportions. Some components may be highly contrasting to the other components of the map unit. The presence of minor components in a map unit in no way diminishes the usefulness or accuracy of the data. The delineation of such landforms and landform segments on the map provides sufficient information for the development of resource plans. If intensive use of small areas is planned, onsite investigation is needed to define and locate the soils and miscellaneous areas.

Soil scientists make many field observations in the process of producing a soil map. The frequency of observation is dependent upon several factors, including scale of mapping, intensity of mapping, design of map units, complexity of the landscape, and experience of the soil scientist. Observations are made to test and refine the soil-landscape model and predictions and to verify the classification of the soils at specific locations. Once the soil-landscape model is refined, a significantly smaller number of measurements of individual soil properties are made and recorded. These measurements may include field measurements, such as those for color, depth to bedrock, and texture, and laboratory measurements, such as those for content of sand, silt, clay, salt, and other components. Properties of each soil typically vary from one point to another across the landscape.

Observations for map unit components are aggregated to develop ranges of characteristics for the components. The aggregated values are presented. Direct measurements do not exist for every property presented for every map unit component. Values for some properties are estimated from combinations of other properties.

While a soil survey is in progress, samples of some of the soils in the area generally are collected for laboratory analyses and for engineering tests. Soil scientists interpret the data from these analyses and tests as well as the field-observed characteristics and the soil properties to determine the expected behavior of the soils under different uses. Interpretations for all of the soils are field tested through observation of the soils in different uses and under different levels of management. Some interpretations are modified to fit local conditions, and some new interpretations are developed to meet local needs. Data are assembled from other sources, such as research information, production records, and field experience of specialists. For example, data on crop yields under defined levels of management are assembled from farm records and from field or plot experiments on the same kinds of soil.

Predictions about soil behavior are based not only on soil properties but also on such variables as climate and biological activity. Soil conditions are predictable over long periods of time, but they are not predictable from year to year. For example, soil scientists can predict with a fairly high degree of accuracy that a given soil will have a high water table within certain depths in most years, but they cannot predict that a high water table will always be at a specific level in the soil on a specific date.

After soil scientists located and identified the significant natural bodies of soil in the survey area, they drew the boundaries of these bodies on aerial photographs and

Custom Soil Resource Report

identified each as a specific map unit. Aerial photographs show trees, buildings, fields, roads, and rivers, all of which help in locating boundaries accurately.

Soil Map

The soil map section includes the soil map for the defined area of interest, a list of soil map units on the map and extent of each map unit, and cartographic symbols displayed on the map. Also presented are various metadata about data used to produce the map, and a description of each soil map unit.

Custom Soil Resource Report Soil Map



Map Scale: 1:4,320 if printed on A portrait (8.5" x 11") sheet.

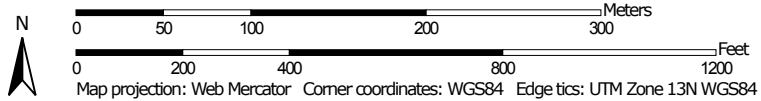

Map projection: Web Mercator Corner coordinates: WGS84 Edge tics: UTM Zone 13N WGS84

MAP LEGEND

- Area of Interest (AOI)**
-  Area of Interest (AOI)
- Soils**
-  Soil Map Unit Polygons
-  Soil Map Unit Lines
-  Soil Map Unit Points
- Special Point Features**
-  Blowout
-  Borrow Pit
-  Clay Spot
-  Closed Depression
-  Gravel Pit
-  Gravelly Spot
-  Landfill
-  Lava Flow
-  Marsh or swamp
-  Mine or Quarry
-  Miscellaneous Water
-  Perennial Water
-  Rock Outcrop
-  Saline Spot
-  Sandy Spot
-  Severely Eroded Spot
-  Sinkhole
-  Slide or Slip
-  Sodic Spot
-  Spoil Area
-  Stony Spot
-  Very Stony Spot
-  Wet Spot
-  Other
-  Special Line Features
- Water Features**
-  Streams and Canals
- Transportation**
-  Rails
-  Interstate Highways
-  US Routes
-  Major Roads
-  Local Roads
- Background**
-  Aerial Photography

MAP INFORMATION

The soil surveys that comprise your AOI were mapped at 1:24,000.

Warning: Soil Map may not be valid at this scale.

Enlargement of maps beyond the scale of mapping can cause misunderstanding of the detail of mapping and accuracy of soil line placement. The maps do not show the small areas of contrasting soils that could have been shown at a more detailed scale.

Please rely on the bar scale on each map sheet for map measurements.

Source of Map: Natural Resources Conservation Service
 Web Soil Survey URL:
 Coordinate System: Web Mercator (EPSG:3857)

Maps from the Web Soil Survey are based on the Web Mercator projection, which preserves direction and shape but distorts distance and area. A projection that preserves area, such as the Albers equal-area conic projection, should be used if more accurate calculations of distance or area are required.

This product is generated from the USDA-NRCS certified data as of the version date(s) listed below.

Soil Survey Area: El Paso County Area, Colorado
 Survey Area Data: Version 16, Sep 10, 2018

Soil map units are labeled (as space allows) for map scales 1:50,000 or larger.

Date(s) aerial images were photographed: Jul 4, 2010—Oct 16, 2017

The orthophoto or other base map on which the soil lines were compiled and digitized probably differs from the background imagery displayed on these maps. As a result, some minor shifting of map unit boundaries may be evident.

Map Unit Legend

Map Unit Symbol	Map Unit Name	Acres in AOI	Percent of AOI
26	Elbeth sandy loam, 8 to 15 percent slopes	12.1	18.4%
71	Pring coarse sandy loam, 3 to 8 percent slopes	5.0	7.6%
92	Tomah-Crowfoot loamy sands, 3 to 8 percent slopes	48.9	74.1%
Totals for Area of Interest		66.1	100.0%

Map Unit Descriptions

The map units delineated on the detailed soil maps in a soil survey represent the soils or miscellaneous areas in the survey area. The map unit descriptions, along with the maps, can be used to determine the composition and properties of a unit.

A map unit delineation on a soil map represents an area dominated by one or more major kinds of soil or miscellaneous areas. A map unit is identified and named according to the taxonomic classification of the dominant soils. Within a taxonomic class there are precisely defined limits for the properties of the soils. On the landscape, however, the soils are natural phenomena, and they have the characteristic variability of all natural phenomena. Thus, the range of some observed properties may extend beyond the limits defined for a taxonomic class. Areas of soils of a single taxonomic class rarely, if ever, can be mapped without including areas of other taxonomic classes. Consequently, every map unit is made up of the soils or miscellaneous areas for which it is named and some minor components that belong to taxonomic classes other than those of the major soils.

Most minor soils have properties similar to those of the dominant soil or soils in the map unit, and thus they do not affect use and management. These are called noncontrasting, or similar, components. They may or may not be mentioned in a particular map unit description. Other minor components, however, have properties and behavioral characteristics divergent enough to affect use or to require different management. These are called contrasting, or dissimilar, components. They generally are in small areas and could not be mapped separately because of the scale used. Some small areas of strongly contrasting soils or miscellaneous areas are identified by a special symbol on the maps. If included in the database for a given area, the contrasting minor components are identified in the map unit descriptions along with some characteristics of each. A few areas of minor components may not have been observed, and consequently they are not mentioned in the descriptions, especially where the pattern was so complex that it was impractical to make enough observations to identify all the soils and miscellaneous areas on the landscape.

The presence of minor components in a map unit in no way diminishes the usefulness or accuracy of the data. The objective of mapping is not to delineate pure taxonomic classes but rather to separate the landscape into landforms or

Custom Soil Resource Report

landform segments that have similar use and management requirements. The delineation of such segments on the map provides sufficient information for the development of resource plans. If intensive use of small areas is planned, however, onsite investigation is needed to define and locate the soils and miscellaneous areas.

An identifying symbol precedes the map unit name in the map unit descriptions. Each description includes general facts about the unit and gives important soil properties and qualities.

Soils that have profiles that are almost alike make up a *soil series*. Except for differences in texture of the surface layer, all the soils of a series have major horizons that are similar in composition, thickness, and arrangement.

Soils of one series can differ in texture of the surface layer, slope, stoniness, salinity, degree of erosion, and other characteristics that affect their use. On the basis of such differences, a soil series is divided into *soil phases*. Most of the areas shown on the detailed soil maps are phases of soil series. The name of a soil phase commonly indicates a feature that affects use or management. For example, Alpha silt loam, 0 to 2 percent slopes, is a phase of the Alpha series.

Some map units are made up of two or more major soils or miscellaneous areas. These map units are complexes, associations, or undifferentiated groups.

A *complex* consists of two or more soils or miscellaneous areas in such an intricate pattern or in such small areas that they cannot be shown separately on the maps. The pattern and proportion of the soils or miscellaneous areas are somewhat similar in all areas. Alpha-Beta complex, 0 to 6 percent slopes, is an example.

An *association* is made up of two or more geographically associated soils or miscellaneous areas that are shown as one unit on the maps. Because of present or anticipated uses of the map units in the survey area, it was not considered practical or necessary to map the soils or miscellaneous areas separately. The pattern and relative proportion of the soils or miscellaneous areas are somewhat similar. Alpha-Beta association, 0 to 2 percent slopes, is an example.

An *undifferentiated group* is made up of two or more soils or miscellaneous areas that could be mapped individually but are mapped as one unit because similar interpretations can be made for use and management. The pattern and proportion of the soils or miscellaneous areas in a mapped area are not uniform. An area can be made up of only one of the major soils or miscellaneous areas, or it can be made up of all of them. Alpha and Beta soils, 0 to 2 percent slopes, is an example.

Some surveys include *miscellaneous areas*. Such areas have little or no soil material and support little or no vegetation. Rock outcrop is an example.

El Paso County Area, Colorado

26—Elbeth sandy loam, 8 to 15 percent slopes

Map Unit Setting

National map unit symbol: 367y
Elevation: 7,300 to 7,600 feet
Farmland classification: Not prime farmland

Map Unit Composition

Elbeth and similar soils: 85 percent
Estimates are based on observations, descriptions, and transects of the mapunit.

Description of Elbeth

Setting

Landform: Hills
Landform position (three-dimensional): Side slope
Down-slope shape: Linear
Across-slope shape: Linear
Parent material: Alluvium derived from arkose

Typical profile

A - 0 to 3 inches: sandy loam
E - 3 to 23 inches: loamy sand
Bt - 23 to 68 inches: sandy clay loam
C - 68 to 74 inches: sandy clay loam

Properties and qualities

Slope: 8 to 15 percent
Depth to restrictive feature: More than 80 inches
Natural drainage class: Well drained
Runoff class: Medium
Capacity of the most limiting layer to transmit water (Ksat): Moderately high (0.20 to 0.60 in/hr)
Depth to water table: More than 80 inches
Frequency of flooding: None
Frequency of ponding: None
Available water storage in profile: Moderate (about 7.1 inches)

Interpretive groups

Land capability classification (irrigated): None specified
Land capability classification (nonirrigated): 4e
Hydrologic Soil Group: B
Hydric soil rating: No

Minor Components

Other soils

Percent of map unit:
Hydric soil rating: No

Pleasant

Percent of map unit:
Landform: Depressions
Hydric soil rating: Yes

71—Pring coarse sandy loam, 3 to 8 percent slopes

Map Unit Setting

National map unit symbol: 369k
Elevation: 6,800 to 7,600 feet
Farmland classification: Not prime farmland

Map Unit Composition

Pring and similar soils: 85 percent
Estimates are based on observations, descriptions, and transects of the mapunit.

Description of Pring

Setting

Landform: Hills
Landform position (three-dimensional): Side slope
Down-slope shape: Linear
Across-slope shape: Linear
Parent material: Arkosic alluvium derived from sedimentary rock

Typical profile

A - 0 to 14 inches: coarse sandy loam
C - 14 to 60 inches: gravelly sandy loam

Properties and qualities

Slope: 3 to 8 percent
Depth to restrictive feature: More than 80 inches
Natural drainage class: Well drained
Runoff class: Low
Capacity of the most limiting layer to transmit water (Ksat): High (2.00 to 6.00 in/hr)
Depth to water table: More than 80 inches
Frequency of flooding: None
Frequency of ponding: None
Available water storage in profile: Low (about 6.0 inches)

Interpretive groups

Land capability classification (irrigated): None specified
Land capability classification (nonirrigated): 3e
Hydrologic Soil Group: B
Ecological site: Loamy Park (R048AY222CO)
Hydric soil rating: No

Minor Components

Pleasant

Percent of map unit:
Landform: Depressions
Hydric soil rating: Yes

Other soils

Percent of map unit:
Hydric soil rating: No

92—Tomah-Crowfoot loamy sands, 3 to 8 percent slopes

Map Unit Setting

National map unit symbol: 36b9
Elevation: 7,300 to 7,600 feet
Farmland classification: Not prime farmland

Map Unit Composition

Tomah and similar soils: 50 percent
Crowfoot and similar soils: 30 percent
Estimates are based on observations, descriptions, and transects of the mapunit.

Description of Tomah

Setting

Landform: Alluvial fans, hills
Landform position (three-dimensional): Side slope, crest
Down-slope shape: Linear
Across-slope shape: Linear
Parent material: Alluvium derived from arkose and/or residuum weathered from arkose

Typical profile

A - 0 to 10 inches: loamy sand
E - 10 to 22 inches: coarse sand
C - 48 to 60 inches: coarse sand

Properties and qualities

Slope: 3 to 8 percent
Depth to restrictive feature: More than 80 inches
Natural drainage class: Well drained
Runoff class: Medium
Capacity of the most limiting layer to transmit water (Ksat): Moderately high to high (0.60 to 2.00 in/hr)
Depth to water table: More than 80 inches
Frequency of flooding: None
Frequency of ponding: None
Available water storage in profile: Very low (about 2.0 inches)

Interpretive groups

Land capability classification (irrigated): None specified
Land capability classification (nonirrigated): 4e
Hydrologic Soil Group: B
Ecological site: Sandy Divide (R049BY216CO)
Hydric soil rating: No

Description of Crowfoot

Setting

Landform: Alluvial fans, hills
Landform position (three-dimensional): Side slope, crest
Down-slope shape: Linear
Across-slope shape: Linear
Parent material: Alluvium

Typical profile

A - 0 to 12 inches: loamy sand
E - 12 to 23 inches: sand
Bt - 23 to 36 inches: sandy clay loam
C - 36 to 60 inches: coarse sand

Properties and qualities

Slope: 3 to 8 percent
Depth to restrictive feature: More than 80 inches
Natural drainage class: Well drained
Runoff class: Medium
Capacity of the most limiting layer to transmit water (Ksat): Moderately high to high (0.60 to 2.00 in/hr)
Depth to water table: More than 80 inches
Frequency of flooding: None
Frequency of ponding: None
Available water storage in profile: Low (about 4.7 inches)

Interpretive groups

Land capability classification (irrigated): None specified
Land capability classification (nonirrigated): 4e
Hydrologic Soil Group: B
Ecological site: Sandy Divide (R049BY216CO)
Hydric soil rating: No

Minor Components

Other soils

Percent of map unit:
Hydric soil rating: No

Pleasant

Percent of map unit:
Landform: Depressions
Hydric soil rating: Yes

References

- American Association of State Highway and Transportation Officials (AASHTO). 2004. Standard specifications for transportation materials and methods of sampling and testing. 24th edition.
- American Society for Testing and Materials (ASTM). 2005. Standard classification of soils for engineering purposes. ASTM Standard D2487-00.
- Cowardin, L.M., V. Carter, F.C. Golet, and E.T. LaRoe. 1979. Classification of wetlands and deep-water habitats of the United States. U.S. Fish and Wildlife Service FWS/OBS-79/31.
- Federal Register. July 13, 1994. Changes in hydric soils of the United States.
- Federal Register. September 18, 2002. Hydric soils of the United States.
- Hurt, G.W., and L.M. Vasilas, editors. Version 6.0, 2006. Field indicators of hydric soils in the United States.
- National Research Council. 1995. Wetlands: Characteristics and boundaries.
- Soil Survey Division Staff. 1993. Soil survey manual. Soil Conservation Service. U.S. Department of Agriculture Handbook 18. http://www.nrcs.usda.gov/wps/portal/nrcs/detail/national/soils/?cid=nrcs142p2_054262
- Soil Survey Staff. 1999. Soil taxonomy: A basic system of soil classification for making and interpreting soil surveys. 2nd edition. Natural Resources Conservation Service, U.S. Department of Agriculture Handbook 436. http://www.nrcs.usda.gov/wps/portal/nrcs/detail/national/soils/?cid=nrcs142p2_053577
- Soil Survey Staff. 2010. Keys to soil taxonomy. 11th edition. U.S. Department of Agriculture, Natural Resources Conservation Service. http://www.nrcs.usda.gov/wps/portal/nrcs/detail/national/soils/?cid=nrcs142p2_053580
- Tiner, R.W., Jr. 1985. Wetlands of Delaware. U.S. Fish and Wildlife Service and Delaware Department of Natural Resources and Environmental Control, Wetlands Section.
- United States Army Corps of Engineers, Environmental Laboratory. 1987. Corps of Engineers wetlands delineation manual. Waterways Experiment Station Technical Report Y-87-1.
- United States Department of Agriculture, Natural Resources Conservation Service. National forestry manual. http://www.nrcs.usda.gov/wps/portal/nrcs/detail/soils/home/?cid=nrcs142p2_053374
- United States Department of Agriculture, Natural Resources Conservation Service. National range and pasture handbook. <http://www.nrcs.usda.gov/wps/portal/nrcs/detail/national/landuse/rangepasture/?cid=stelprdb1043084>

Custom Soil Resource Report

United States Department of Agriculture, Natural Resources Conservation Service. National soil survey handbook, title 430-VI. http://www.nrcs.usda.gov/wps/portal/nrcs/detail/soils/scientists/?cid=nrcs142p2_054242

United States Department of Agriculture, Natural Resources Conservation Service. 2006. Land resource regions and major land resource areas of the United States, the Caribbean, and the Pacific Basin. U.S. Department of Agriculture Handbook 296. http://www.nrcs.usda.gov/wps/portal/nrcs/detail/national/soils/?cid=nrcs142p2_053624

United States Department of Agriculture, Soil Conservation Service. 1961. Land capability classification. U.S. Department of Agriculture Handbook 210. http://www.nrcs.usda.gov/Internet/FSE_DOCUMENTS/nrcs142p2_052290.pdf

APPENDIX B
HYDROLOGIC CALCULATIONS

Table 6-6. Runoff Coefficients for Rational Method

(Source: UDFCD 2001)

Land Use or Surface Characteristics	Percent Impervious	Runoff Coefficients											
		2-year		5-year		10-year		25-year		50-year		100-year	
		HSG A&B	HSG C&D	HSG A&B	HSG C&D	HSG A&B	HSG C&D	HSG A&B	HSG C&D	HSG A&B	HSG C&D	HSG A&B	HSG C&D
Business													
Commercial Areas	95	0.79	0.80	0.81	0.82	0.83	0.84	0.85	0.87	0.87	0.88	0.88	0.89
Neighborhood Areas	70	0.45	0.49	0.49	0.53	0.53	0.57	0.58	0.62	0.60	0.65	0.62	0.68
Residential													
1/8 Acre or less	65	0.41	0.45	0.45	0.49	0.49	0.54	0.54	0.59	0.57	0.62	0.59	0.65
1/4 Acre	40	0.23	0.28	0.30	0.35	0.36	0.42	0.42	0.50	0.46	0.54	0.50	0.58
1/3 Acre	30	0.18	0.22	0.25	0.30	0.32	0.38	0.39	0.47	0.43	0.52	0.47	0.57
1/2 Acre	25	0.15	0.20	0.22	0.28	0.30	0.36	0.37	0.46	0.41	0.51	0.46	0.56
1 Acre	20	0.12	0.17	0.20	0.26	0.27	0.34	0.35	0.44	0.40	0.50	0.44	0.55
Industrial													
Light Areas	80	0.57	0.60	0.59	0.63	0.63	0.66	0.66	0.70	0.68	0.72	0.70	0.74
Heavy Areas	90	0.71	0.73	0.73	0.75	0.75	0.77	0.78	0.80	0.80	0.82	0.81	0.83
Parks and Cemeteries	7	0.05	0.09	0.12	0.19	0.20	0.29	0.30	0.40	0.34	0.46	0.39	0.52
Playgrounds	13	0.07	0.13	0.16	0.23	0.24	0.31	0.32	0.42	0.37	0.48	0.41	0.54
Railroad Yard Areas	40	0.23	0.28	0.30	0.35	0.36	0.42	0.42	0.50	0.46	0.54	0.50	0.58
Undeveloped Areas													
Historic Flow Analysis-- Greenbelts, Agriculture	2	0.03	0.05	0.09	0.16	0.17	0.26	0.26	0.38	0.31	0.45	0.36	0.51
Pasture/Meadow	0	0.02	0.04	0.08	0.15	0.15	0.25	0.25	0.37	0.30	0.44	0.35	0.50
Forest	0	0.02	0.04	0.08	0.15	0.15	0.25	0.25	0.37	0.30	0.44	0.35	0.50
Exposed Rock	100	0.89	0.89	0.90	0.90	0.92	0.92	0.94	0.94	0.95	0.95	0.96	0.96
Offsite Flow Analysis (when landuse is undefined)	45	0.26	0.31	0.32	0.37	0.38	0.44	0.44	0.51	0.48	0.55	0.51	0.59
Streets													
Paved	100	0.89	0.89	0.90	0.90	0.92	0.92	0.94	0.94	0.95	0.95	0.96	0.96
Gravel	80	0.57	0.60	0.59	0.63	0.63	0.66	0.66	0.70	0.68	0.72	0.70	0.74
Drive and Walks	100	0.89	0.89	0.90	0.90	0.92	0.92	0.94	0.94	0.95	0.95	0.96	0.96
Roofs	90	0.71	0.73	0.73	0.75	0.75	0.77	0.78	0.80	0.80	0.82	0.81	0.83
Lawns	0	0.02	0.04	0.08	0.15	0.15	0.25	0.25	0.37	0.30	0.44	0.35	0.50

3.2 Time of Concentration

One of the basic assumptions underlying the Rational Method is that runoff is a function of the average rainfall rate during the time required for water to flow from the hydraulically most remote part of the drainage area under consideration to the design point. However, in practice, the time of concentration can be an empirical value that results in reasonable and acceptable peak flow calculations.

For urban areas, the time of concentration (t_c) consists of an initial time or overland flow time (t_i) plus the travel time (t_r) in the storm sewer, paved gutter, roadside drainage ditch, or drainage channel. For non-urban areas, the time of concentration consists of an overland flow time (t_i) plus the time of travel in a concentrated form, such as a swale or drainageway. The travel portion (t_r) of the time of concentration can be estimated from the hydraulic properties of the storm sewer, gutter, swale, ditch, or drainageway. Initial time, on the other hand, will vary with surface slope, depression storage, surface cover, antecedent rainfall, and infiltration capacity of the soil, as well as distance of surface flow. The time of concentration is represented by Equation 6-7 for both urban and non-urban areas.

$$t_c = t_i + t_t \quad (\text{Eq. 6-7})$$

Where:

t_c = time of concentration (min)

t_i = overland (initial) flow time (min)

t_t = travel time in the ditch, channel, gutter, storm sewer, etc. (min)

3.2.1 Overland (Initial) Flow Time

The overland flow time, t_i , may be calculated using Equation 6-8.

$$t_i = \frac{0.395(1.1 - C_5)\sqrt{L}}{S^{0.33}} \quad (\text{Eq. 6-8})$$

Where:

t_i = overland (initial) flow time (min)

C_5 = runoff coefficient for 5-year frequency (see Table 6-6)

L = length of overland flow (300 ft maximum for non-urban land uses, 100 ft maximum for urban land uses)

S = average basin slope (ft/ft)

Note that in some urban watersheds, the overland flow time may be very small because flows quickly concentrate and channelize.

3.2.2 Travel Time

For catchments with overland and channelized flow, the time of concentration needs to be considered in combination with the travel time, t_t , which is calculated using the hydraulic properties of the swale, ditch, or channel. For preliminary work, the overland travel time, t_t , can be estimated with the help of Figure 6-25 or Equation 6-9 (Guo 1999).

$$V = C_v S_w^{0.5} \quad (\text{Eq. 6-9})$$

Where:

V = velocity (ft/s)

C_v = conveyance coefficient (from Table 6-7)

S_w = watercourse slope (ft/ft)

Table 6-7. Conveyance Coefficient, C_v

Type of Land Surface	C_v
Heavy meadow	2.5
Tillage/field	5
Riprap (not buried)*	6.5
Short pasture and lawns	7
Nearly bare ground	10
Grassed waterway	15
Paved areas and shallow paved swales	20

* For buried riprap, select C_v value based on type of vegetative cover.

The travel time is calculated by dividing the flow distance (in feet) by the velocity calculated using Equation 6-9 and converting units to minutes.

The time of concentration (t_c) is then the sum of the overland flow time (t_i) and the travel time (t_t) per Equation 6-7.

3.2.3 First Design Point Time of Concentration in Urban Catchments

Using this procedure, the time of concentration at the first design point (typically the first inlet in the system) in an urbanized catchment should not exceed the time of concentration calculated using Equation 6-10. The first design point is defined as the point where runoff first enters the storm sewer system.

$$t_c = \frac{L}{180} + 10 \quad (\text{Eq. 6-10})$$

Where:

t_c = maximum time of concentration at the first design point in an urban watershed (min)

L = waterway length (ft)

Equation 6-10 was developed using the rainfall-runoff data collected in the Denver region and, in essence, represents regional “calibration” of the Rational Method. Normally, Equation 6-10 will result in a lesser time of concentration at the first design point and will govern in an urbanized watershed. For subsequent design points, the time of concentration is calculated by accumulating the travel times in downstream drainageway reaches.

3.2.4 Minimum Time of Concentration

If the calculations result in a t_c of less than 10 minutes for undeveloped conditions, it is recommended that a minimum value of 10 minutes be used. The minimum t_c for urbanized areas is 5 minutes.

3.2.5 Post-Development Time of Concentration

As Equation 6-8 indicates, the time of concentration is a function of the 5-year runoff coefficient for a drainage basin. Typically, higher levels of imperviousness (higher 5-year runoff coefficients) correspond to shorter times of concentration, and lower levels of imperviousness correspond to longer times of

Figure 6-5. Colorado Springs Rainfall Intensity Duration Frequency

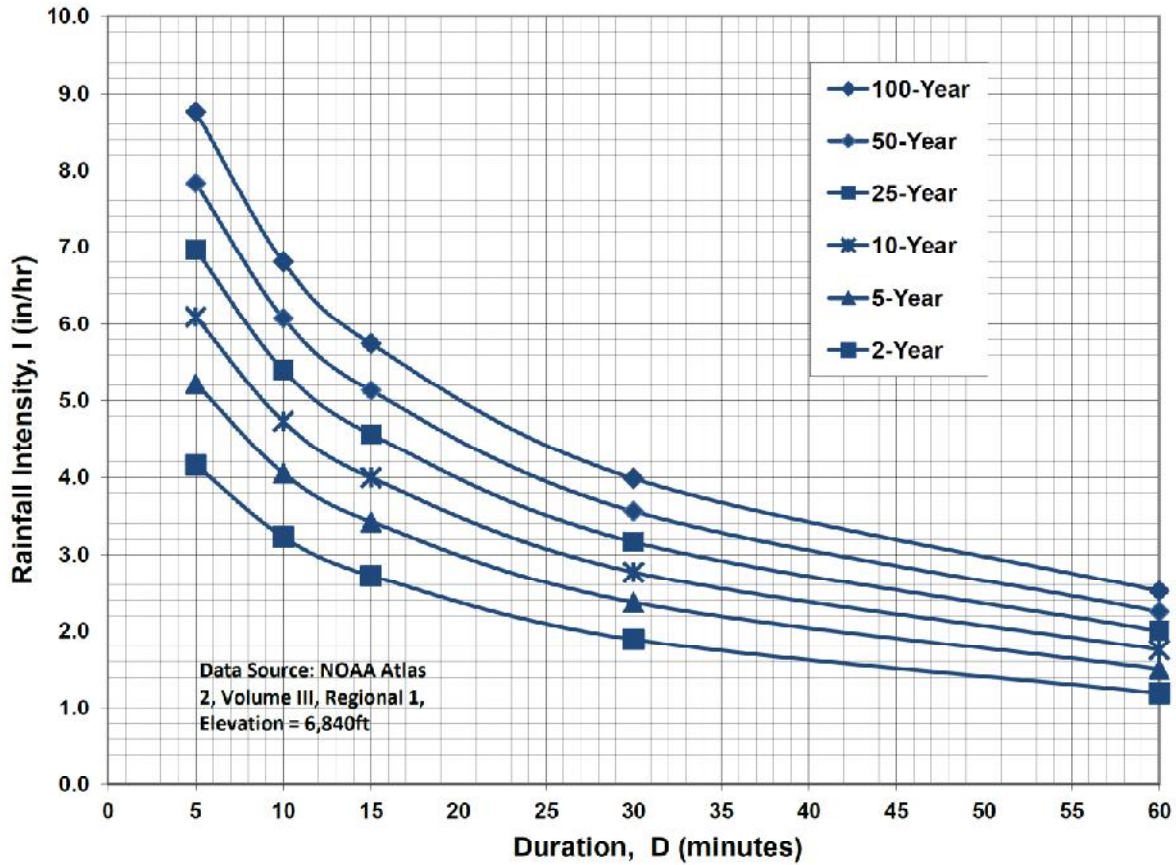

IDF Equations

$$I_{100} = -2.52 \ln(D) + 12.735$$

$$I_{50} = -2.25 \ln(D) + 11.375$$

$$I_{25} = -2.00 \ln(D) + 10.111$$

$$I_{10} = -1.75 \ln(D) + 8.847$$

$$I_5 = -1.50 \ln(D) + 7.583$$

$$I_2 = -1.19 \ln(D) + 6.035$$

Note: Values calculated by equations may not precisely duplicate values read from figure.

MONUMENT ACADEMY
RATIONAL METHOD

HISTORIC FLOWS

BASIN	DESIGN POINT	AREA (AC)	C		Overland Flow			Channel flow					TOTAL Tc ⁽⁴⁾ (MIN)		INTENSITY ⁽⁵⁾		PEAK FLOW	
			5-YEAR	100-YEAR	LENGTH (FT)	SLOPE (FT/FT)	Tco ⁽¹⁾ (MIN)	CHANNEL LENGTH (FT)	CONVEYANCE COEFFICIENT C	SLOPE (FT/FT)	SCS ⁽²⁾ VELOCITY (FT/S)	Tt ⁽³⁾ (MIN)	TOTAL Tc ⁽⁴⁾ (MIN)	5-YR (IN/HR)	100-YR (IN/HR)	Q5 ⁽⁶⁾ (CFS)	Q100 ⁽⁶⁾ (CFS)	
MA SITE:																		
C14	C16.1	19.42	0.080	0.350	300	0.050	18.9	1350	15	0.044	3.15	7.2	26.1	2.69	4.52	4.2	30.7	
M1	M1	8.38	0.080	0.350	300	0.037	20.9	400	15	0.075	4.11	1.6	22.5	2.91	4.88	2.0	14.3	
M3	M3	9.22	0.080	0.350	100	0.050	10.9	660	15	0.065	3.82	2.9	13.8	3.65	6.12	2.7	19.8	
M4	M4	7.20	0.080	0.350	300	0.080	16.2	560	15	0.075	4.11	2.3	18.5	3.21	5.39	1.8	13.6	
M3,M4	M3.1	16.42	0.080	0.350									18.5	3.21	5.39	4.2	31.0	
OM1	OM1	2.90	0.080	0.350	300	0.073	16.7	0	15	0.055	3.52	6.4	16.7	3.36	5.64	0.8	5.7	
M5	M5	22.19	0.080	0.350			0.0	1350	15				6.4	4.80	8.06	8.5	62.6	
OM1,M5	M5.1	25.09	0.080	0.350									23.1	2.87	4.82	5.8	42.4	
WALKER ROAD & SH63:																		
OM2	OM2	0.50	0.333	0.538	30	0.067	4.1	560	15	0.043	3.11	3.0	7.1	4.65	7.80	0.8	2.1	
M6	M6	1.10	0.214	0.450	30	0.320	2.8	620	15	0.014	1.77	5.8	8.6	4.35	7.31	1.0	3.6	
M1,M6	M6.1	9.48	0.214	0.362				350	15	0.023	2.27	2.6	25.1	2.75	4.61	5.6	15.8	
OM3	OM3	2.20	0.134	0.390	30	0.067	5.1	510	15	0.047	3.25	2.6	7.8	4.51	7.57	1.3	6.5	
M1,M6,OM3	OM3.1	11.68	0.103	0.367				120	20	0.009	1.90	1.1	26.2	2.69	4.51	3.2	19.3	

1) OVERLAND FLOW Tco = (0.395*(1.1-RUNOFF COEFFICIENT)*(OVERLAND FLOW LENGTH^0.5)/(SLOPE^0.333))

2) SCS VELOCITY = C * ((SLOPE(FT/FT))^0.5)

C = 2.5 FOR HEAVY MEADOW

C = 5 FOR TILLAGE/FIELD

C = 7 FOR SHORT PASTURE AND LAWNS

C = 10 FOR NEARLY BARE GROUND

C = 15 FOR GRASSED WATERWAY

C = 20 FOR PAVED AREAS AND SHALLOW PAVED SWALES

3) MANNING'S CHANNEL TRAVEL TIME = LV (WHEN CHANNEL VELOCITY IS KNOWN)

4) Tc = Tco + Tt

*** IF TOTAL TIME OF CONCENTRATION IS LESS THAN 5 MINUTES, THEN 5 MINUTES IS USED

5) INTENSITY BASED ON I-D-F EQUATIONS IN CITY OF COLORADO SPRINGS DRAINAGE CRITERIA MANUAL

$$I_5 = -1.5 * \ln(Tc) + 7.583$$

$$I_{100} = -2.52 * \ln(Tc) + 12.735$$

6) Q = CIA

MONUMENT ACADEMY COMPOSITE RUNOFF COEFFICIENTS									
DEVELOPED CONDITIONS - INTERIM (PHASE 1 DEVELOPMENT)									
5-YEAR C VALUES									
BASIN	TOTAL AREA (AC)	SUB-AREA 1 DEVELOPMENT/ COVER (AC)	C	AREA (AC)	SUB-AREA 2 DEVELOPMENT/ COVER (AC)	C	AREA (AC)	SUB-AREA 3 DEVELOPMENT/ COVER (AC)	WEIGHTED C VALUE
C14	15.85	3.68	0.90	12.17	LANDSCAPED	0.08			0.270
C15	1.26	0.39	0.90	0.87	ROADWAY	0.08			0.334
C16	1.03	0.62	0.90	0.41	ROADWAY	0.08			0.574
C14-C16	18.14								0.292
M1	7.06	7.06	0.08		MEADOW				0.080
M2	7.48	4.78	0.90	2.70	BUILDING / PAVEMENT	0.08			0.604
M2.2A	0.18	0.10	0.90	0.08	PAVEMENT	0.08			0.536
M3	7.73	0.23	0.90	7.50	ROADWAY	0.08			0.104
M4	3.02	0.34	0.90	2.68	ROADWAY	0.08			0.172
M2.M3.M4	18.41								0.323
OM1	2.00	2.00	0.08		MEADOW				0.080
M5	21.24	0.49	0.90	20.75	ROADWAY	0.08			0.099
OM1.M5	23.24								0.097
100-YEAR C VALUES									
BASIN	TOTAL AREA (AC)	SUB-AREA 1 DEVELOPMENT/ COVER (AC)	C	AREA (AC)	SUB-AREA 2 DEVELOPMENT/ COVER (AC)	C	AREA (AC)	SUB-AREA 3 DEVELOPMENT/ COVER (AC)	WEIGHTED C VALUE
C14	15.85	3.68	0.96	12.17	LANDSCAPED	0.35			0.492
C15	1.26	0.39	0.90	0.87	ROADWAY	0.08			0.334
C16	1.03	0.62	0.90	0.41	ROADWAY	0.08			0.574
C14-C16	18.14								0.485
M1	7.06	7.06	0.35		MEADOW				0.350
M2	7.48	4.78	0.96	2.70	BUILDING / PAVEMENT	0.35			0.740
M2.2A	0.18	0.10	0.96	0.08	PAVEMENT	0.35			0.689
M3	7.73	0.23	0.96	7.50	ROADWAY	0.35			0.368
M4	3.02	0.34	0.96	2.68	ROADWAY	0.35			0.419
M2.M3.M4	18.41								0.531
OM1	2.00	2.00	0.35		MEADOW				0.350
M5	21.24	0.49	0.96	20.75	ROADWAY	0.35			0.364
OM1.M5	23.24								0.363

MONUMENT ACADEMY COMPOSITE RUNOFF COEFFICIENTS											
DEVELOPED CONDITIONS - ULTIMATE											
5-YEAR C VALUES											
BASIN	TOTAL AREA (AC)	(AC)	SUB-AREA 1 DEVELOPMENT/ COVER	C	AREA (AC)	SUB-AREA 2 DEVELOPMENT/ COVER	C	(AC)	SUB-AREA 3 DEVELOPMENT/ COVER	C	WEIGHTED C VALUE
C14	15.85	3.68	BUILDING / PAVEMENT	0.90	12.17	LANDSCAPED	0.08				0.270
C15	1.26	0.39	ROADWAY	0.90	0.87	LANDSCAPED	0.08				0.334
C16	1.03	0.62	ROADWAY	0.90	0.41	LANDSCAPED	0.08				0.574
C14-C16	18.14										0.292
M1	7.06	7.06	NH BUSINESS	0.49							0.490
M2	7.48	4.78	BUILDING / PAVEMENT	0.90	2.70	LANDSCAPED	0.08				0.604
M2,2A	0.18	0.10	PAVEMENT	0.90	0.08	LANDSCAPED	0.08				0.536
M3	7.73	6.08	NH BUSINESS	0.49	1.65	POND / LANDSCAPE	0.08				0.402
M4	3.02	3.02	NH BUSINESS	0.49							0.490
M2,M3,M4	18.41										0.500
OM1	2.00	2.00	RESIDENTIAL-1-AC	0.20							0.200
M5	21.24	10.62	RESIDENTIAL-0.5-AC	0.22	10.62	RESIDENTIAL-1-AC	0.2				0.210
OM1,M5	23.24										0.209
100-YEAR C VALUES											
BASIN	TOTAL AREA (AC)	(AC)	SUB-AREA 1 DEVELOPMENT/ COVER	C	AREA (AC)	SUB-AREA 2 DEVELOPMENT/ COVER	C	(AC)	SUB-AREA 3 DEVELOPMENT/ COVER	C	WEIGHTED C VALUE
C14	15.85	3.68	BUILDING / PAVEMENT	0.96	12.17	LANDSCAPED	0.35				0.492
C15	1.26	0.39	ROADWAY	0.90	0.87	LANDSCAPED	0.08				0.334
C16	1.03	0.62	ROADWAY	0.90	0.41	LANDSCAPED	0.08				0.574
C14-C16	18.14										0.485
M1	7.06	7.06	NH BUSINESS	0.62							0.620
M2	7.48	4.78	BUILDING / PAVEMENT	0.96	2.70	LANDSCAPED	0.35				0.740
M2,2A	0.18	0.10	PAVEMENT	0.96	0.08	LANDSCAPED	0.35				0.689
M3	7.73	6.08	NH BUSINESS	0.62	1.65	POND / LANDSCAPE	0.35				0.562
M4	3.02	3.02	NH BUSINESS	0.62							0.620
M2,M3,M4	18.41										0.645
OM1	2.00	2.00	RESIDENTIAL-1-AC	0.44							0.440
M5	21.24	10.62	RESIDENTIAL-0.5-AC	0.46	10.62	RESIDENTIAL-1-AC	0.44				0.450
OM1,M5	23.24										0.449

MA - WALKER ROAD DRAINAGE ANALYSIS
COMPOSITE RUNOFF COEFFICIENTS

HISTORIC CONDITIONS										
5-YEAR C VALUES										
BASIN	TOTAL AREA (AC)	SUB-AREA 1 DEVELOPMENT/ COVER (AC)	C	AREA (AC)	SUB-AREA 2 DEVELOPMENT/ COVER	C	(AC)	SUB-AREA 3 DEVELOPMENT/ COVER	C	WEIGHTED C VALUE
OM2	0.50	0.15	0.90	0.35	MEADOW	0.08			0.08	0.333
M1	8.38	8.38	0.08		MEADOW					0.080
M6	1.10	0.18	0.90	0.92	MEADOW	0.08			0.08	0.214
M1.M6	9.48									0.096
OM3	2.20	0.15	0.90	2.05	MEADOW	0.08			0.08	0.134
M1.M6.OM3	11.68									0.103

100-YEAR C VALUES										
BASIN	TOTAL AREA (AC)	SUB-AREA 1 DEVELOPMENT/ COVER (AC)	C	AREA (AC)	SUB-AREA 2 DEVELOPMENT/ COVER	C	(AC)	SUB-AREA 3 DEVELOPMENT/ COVER	C	WEIGHTED C VALUE
OM2	0.50	0.15	0.96	0.35	MEADOW	0.35			0.35	0.538
M1	8.38	8.38	0.35		MEADOW					0.350
M6	1.10	0.18	0.96	0.92	MEADOW	0.35			0.35	0.450
M1.M6	9.48									0.362
OM3	2.20	0.15	0.96	2.05	MEADOW	0.35			0.35	0.390
M1.M6.OM3	11.68									0.367

DEVELOPED CONDITIONS										
5-YEAR C VALUES										
BASIN	TOTAL AREA (AC)	SUB-AREA 1 DEVELOPMENT/ COVER (AC)	C	AREA (AC)	SUB-AREA 2 DEVELOPMENT/ COVER	C	(AC)	SUB-AREA 3 DEVELOPMENT/ COVER	C	WEIGHTED C VALUE
OM2	1.10	0.26	0.90	0.84	MEADOW	0.08			0.08	0.272
M1	5.94	5.94	0.08		DETAINED POND M1					0.080
M6	1.46	0.36	0.90	1.10	MEADOW	0.08			0.08	0.280
M1.M6	7.40									0.119
OM3	2.80	0.33	0.90	2.47	MEADOW	0.08			0.08	0.175
M1.M6.OM3	10.20									0.135

100-YEAR C VALUES										
BASIN	TOTAL AREA (AC)	SUB-AREA 1 DEVELOPMENT/ COVER (AC)	C	AREA (AC)	SUB-AREA 2 DEVELOPMENT/ COVER	C	(AC)	SUB-AREA 3 DEVELOPMENT/ COVER	C	WEIGHTED C VALUE
OM2	1.10	0.26	0.96	0.84	MEADOW	0.35			0.35	0.493
M1	5.94	5.94	0.35		DETAINED POND M1					0.350
M6	1.46	0.36	0.96	1.10	MEADOW	0.35			0.35	0.499
M1.M6	7.40									0.379
OM3	2.80	0.33	0.96	2.47	MEADOW	0.35			0.35	0.421
M1.M6.OM3	10.20									0.391

MONUMENT ACADEMY
RATIONAL METHOD
DEVELOPED FLOWS - INTERIM CONDITIONS (PHASE 1)

BASIN	DESIGN POINT	AREA (AC)	C		Overland Flow			Channel flow					TOTAL			INTENSITY ⁽⁶⁾		PEAK FLOW	
			5-YEAR	100-YEAR	LENGTH (FT)	SLOPE (FT/FT)	T _{co} ⁽¹⁾ (MIN)	CHANNEL LENGTH (FT)	CONVEYANCE COEFFICIENT C	SLOPE (FT/FT)	SCS ⁽²⁾ VELOCITY (FT/S)	T _t ⁽³⁾ (MIN)	T _c ⁽⁴⁾ (MIN)	5-YR (IN/HR)	100-YR (IN/HR)	Q5 ⁽⁶⁾ (CFS)	Q100 ⁽⁶⁾ (CFS)		
MA SITE:																			
C14	C14	15.81	0.270	0.492	100	0.020	12.1	1550											
C15	C15	1.20	0.334	0.334	20	0.020	5.0	760	0.028	3.35	3.8	8.8	8.8	4.33	7.27	1.7	2.9		
C16	C16	1.09	0.574	0.574	30	0.020	4.2	870	0.028	3.35	4.3	8.5	8.5	4.37	7.34	2.7	4.6		
C14-C16	C16.1	18.10	0.292	0.485								18.2	18.2	3.23	5.42	17.1	47.6		
M1	M1	5.94	0.080	0.350	300	0.037	20.9	400		4.11	1.6	22.5	22.5	2.91	4.88	1.4	10.2		
M2	M2	7.48	0.604	0.740	100	0.040	5.7	670	0.031	3.52	3.2	8.9	8.9	4.30	7.23	19.4	40.0		
M2.2A	M2.2A	0.18	0.536	0.689	25	2.000	0.9	165	0.010	2.00	1.4	2.3	5.0	5.17	8.68	0.5	1.1		
M3	M3	7.14	0.104	0.368	100	0.020	14.5	600	0.053	4.60	2.2	16.6	16.6	3.36	5.65	2.5	14.8		
M4	M4	3.02	0.172	0.419	100	0.020	13.5	450	0.084	4.35	1.7	15.2	15.2	3.50	5.88	1.8	7.4		
M2,M3,M4	M3.1	17.82	0.323	0.531								16.6	16.6	3.36	5.65	19.4	53.4		
OM1	OM1	2.90	0.080	0.350	100	0.060	10.3	450	0.053	3.45	2.2	12.5	12.5	3.80	6.38	0.9	6.5		
M5	M5	21.24	0.099	0.364			0.0	1350	0.049	3.32	6.8	6.8	6.8	4.71	7.91	9.9	61.2		
OM1,M5	M5.1	24.14	0.097	0.363								19.2	19.2	3.15	5.28	7.4	46.3		
WALKER ROAD & SH83:																			
OM2	OM2	1.10	0.272	0.493	30	0.067	4.4	560	0.043	3.11	3.0	7.4	7.4	4.58	7.69	1.4	4.2		
M6	M6	1.46	0.280	0.499	30	0.320	2.6	620	0.014	1.77	5.8	8.4	8.4	4.39	7.37	1.8	5.4		
M1,M6	M6.1	7.40	0.119	0.379				350	0.023	2.27	2.6	25.1	25.1	2.75	4.61	2.4	12.9		
OM3	OM3	2.80	0.175	0.421	30	0.067	4.9	510	0.047	3.25	2.6	7.5	7.5	4.55	7.65	2.2	9.0		
M1,M6,OM3	OM3.1	10.20	0.135	0.391				120	0.009	1.90	1.1	26.2	26.2	2.69	4.51	3.7	18.0		

1) OVERLAND FLOW T_{co} = (0.395^(1.1-RUNOFF COEFFICIENT)*(OVERLAND FLOW LENGTH^(0.5))/(SLOPE^(0.333))

2) SCS VELOCITY = C * ((SLOPE/FT)*0.5)

C = 2.5 FOR HEAVY MEADOW

C = 5 FOR TILLAGE/FIELD

C = 7 FOR SHORT PASTURE AND LAWNS

C = 10 FOR NEARLY BARE GROUND

C = 15 FOR GRASSED WATERWAY

C = 20 FOR PAVED AREAS AND SHALLOW PAVED SWALES

3) MANNINGS CHANNEL TRAVEL TIME = L/V (WHEN CHANNEL VELOCITY IS KNOWN)

4) T_c = T_{co} + T_t

*** IF TOTAL TIME OF CONCENTRATION IS LESS THAN 5 MINUTES, THEN 5 MINUTES IS USED

5) INTENSITY BASED ON I-D-F EQUATIONS IN CITY OF COLORADO SPRINGS DRAINAGE CRITERIA MANUAL

$$I_5 = -1.5 * \ln(I_1(T_c) + 7.583)$$

$$I_{100} = -2.52 * \ln(T_c) + 12.735$$

$$Q = C/I_A$$

MONUMENT ACADEMY
RATIONAL METHOD

DEVELOPED FLOWS - ULTIMATE CONDITIONS

BASIN	DESIGN POINT	AREA (AC)	C		Overland Flow			Channel flow									
			5-YEAR	100-YEAR	LENGTH (FT)	SLOPE (FT/FT)	T _{co} ⁽¹⁾ (MIN)	CHANNEL LENGTH (FT)	CONVEYANCE COEFFICIENT C	SLOPE (FT/FT)	SCS ⁽²⁾ VELOCITY (FT/S)	T _t ⁽³⁾ (MIN)	TOTAL T _c ⁽⁴⁾ (MIN)	5-YR (IN/HR)	100-YR (IN/HR)	PEAK FLOW Q5 ⁽⁶⁾ (CFS)	PEAK FLOW Q100 ⁽⁶⁾ (CFS)
MA SITE:																	
C14	C14	15.81	0.270	0.492	100	0.020	12.1	1550	20	0.044	4.20	6.2	18.2	3.23	5.42	13.8	42.2
C15	C15	1.20	0.334	0.334	20	0.020	5.0	760	20	0.028	3.35	3.8	8.8	4.33	7.27	1.7	2.9
C16	C16	1.09	0.574	0.574	30	0.020	4.2	870	20	0.028	3.35	4.3	8.5	4.37	7.34	2.7	4.6
C14-C16	C16.1	18.10	0.292	0.485									18.2	3.23	5.42	17.1	47.6
M1	M1	5.94	0.490	0.620	100	0.010	11.2	680	20	0.052	4.56	2.5	13.7	3.66	6.15	10.7	22.6
M2	M2	7.48	0.604	0.740	100	0.040	5.7	670	20	0.031	3.52	3.2	8.9	4.30	7.23	19.4	40.0
M2.2A	M2.2A	0.18	0.536	0.689	25	2.000	0.9	165	20	0.010	2.00	1.4	2.3	5.17	8.68	0.5	1.1
M3	M3	7.14	0.402	0.562	100	0.020	10.1	600	20	0.053	4.60	2.2	12.3	3.82	6.41	11.0	25.7
M4	M4	3.02	0.490	0.620	100	0.020	8.9	450	15	0.084	4.35	1.7	10.6	4.04	6.79	6.0	12.7
M2,M3,M4	M3.1	17.82	0.500	0.645									12.3	3.82	6.41	34.0	73.6
OM1	OM1	2.90	0.200	0.440	100	0.060	9.1	450	15	0.053	3.45	2.2	11.2	3.95	6.64	2.3	8.5
M5	M5	21.24	0.210	0.450	0		0.0	1350	15	0.049	3.32	6.8	6.8	4.71	7.91	21.0	75.6
OM1,M5	M5.1	24.14	0.209	0.449									18.0	3.25	5.45	16.4	59.1
WALKER ROAD & SH83:																	
OM2	OM2	1.10	0.272	0.493	30	0.130	3.5	540	15	0.039	2.96	3.0	6.6	4.76	7.99	1.4	4.3
M6	M6	1.46	0.280	0.499	30	0.320	2.6	620	15	0.014	1.77	5.8	8.4	4.39	7.37	1.8	5.4
M1,M6	M6.1	7.40	0.119	0.379				100	20	0.100	6.32	0.3	13.9	3.63	6.10	3.2	17.1
OM3	OM3	2.80	0.175	0.421	30	0.067	4.9	510	15	0.047	3.25	2.6	7.5	4.55	7.65	2.2	9.0
M1,M6,OM3	OM3.1	10.20	0.135	0.391				120	20	0.009	1.90	1.1	15.0	3.52	5.92	4.9	23.6

1) OVERLAND FLOW T_{co} = (0.395*(1.1-RUNOFF COEFFICIENT)*(OVERLAND FLOW LENGTH^0.5))/(SLOPE^(0.333))

2) SCS VELOCITY = C * ((SLOPE(FT/FT))^0.5)

C = 2.5 FOR HEAVY MEADOW

C = 5 FOR TILLAGE/FIELD

C = 7 FOR SHORT PASTURE AND LAWNS

C = 10 FOR NEARLY BARE GROUND

C = 15 FOR GRASSED WATERWAY

C = 20 FOR PAVED AREAS AND SHALLOW PAVED SWALES

3) MANNING'S CHANNEL TRAVEL TIME = L/V (WHEN CHANNEL VELOCITY IS KNOWN)

4) T_c = T_{co} + T_t

*** IF TOTAL TIME OF CONCENTRATION IS LESS THAN 5 MINUTES, THEN 5 MINUTES IS USED

5) INTENSITY BASED ON I-D-F EQUATIONS IN CITY OF COLORADO SPRINGS DRAINAGE CRITERIA MANUAL

$$I_5 = -1.5 * \ln(T_c) + 7.583$$

$$I_{100} = -2.52 * \ln(T_c) + 12.735$$

6) Q = CIA









APPENDIX C1

HYDRAULIC CALCULATIONS - CHANNELS

**ALLOWABLE VELOCITY AND MAXIMUM SHEAR STRESS
Streambank and Shoreland Protection Code 580**

Type of Treatment	Allowable Shear lb/sq ft	Velocity ft/sec
Brush Mattresses¹		
Staked only w/ rock riprap toe (initial)	0.8 - 4.1	5
Staked only w/ rock riprap toe (grown)	4.0 - 8.0	12
Coir Geotextile Roll²		
Roll with coir rope mesh staked only without rock riprap toe	0.2 - 0.8	< 5
Roll with Polypropylene rope mesh staked only without rock riprap toe	0.8 - 3.0	< 8
Roll with Polypropylene rope mesh staked and with rock riprap toe	3.0 - 4.0	< 12
Live Fascine³		
LF Bundle w/ rock riprap toe	2.0 - 3.1	8
Soils⁴		
Fine colloidal sand	0.02-0.03	1.5
Sandy loam (noncolloidal)	0.03-0.04	1.75
Alluvial silt (noncolloidal)	0.045-0.05	2
Silty loam (noncolloidal)	0.045-0.05	1.75-2.25
Firm loam	0.075	2.5
Fine gravels	0.075	2.5
Stiff clay	0.26	3-4.5
Alluvial silt (colloidal)	0.26	3.75
Graded loam to cobbles	0.38	3.75
Graded silts to cobbles	0.43	4
Shales and hardpan	0.67	6
Gravel/Cobble⁴		
1-inch	0.33	2.5-5
2-inch	0.67	3-6
6-inch	2	4-7.5
12-inch	4	5.5-12
Vegetation⁴		
Class A turf (ret class)	3.7	6-8
Class B turf (ret class)	2.1	4-7
Class C turf (ret class)	1	3.5
Retardance Class D	0.6	Design of roadside channels HEC-15
Retardance Class E	0.35	
Long native grasses	1.2-1.7	4-6
Short native and bunch grass	0.7-0.95	3-4



TEMPORARY					
	Product Description	Longevity	Applications	Design Permissible Shear Stress lbs/ft ² (Pa)	Design Permissible Velocity ft/s (m/s)
BIONET CONT'D					
 C125BN	9.3 lb., leno woven biodegradable jute top net, 100% coconut fiber matrix, 7.7 lb., woven biodegradable jute bottom net	24 mo.	High Flow Channels 1:1 and Greater Slopes	Unvegetated 2.35 (112)	Unvegetated 10.0 (3.05)
 C700BN	143 lb., (700 g) woven biodegradable coir top net, 100% coconut fiber matrix, 7.7 lb., woven biodegradable jute bottom net	36 mo.	High Flow Channels 1:1 and Greater Slopes	Unvegetated 2.35 (112)	Unvegetated 10.0 (3.05)
PERMANENT					
ERONET					
 P300	5.0 lb., UV-stable polypropylene top net, 100% polypropylene fiber matrix, 3.0 lb., UV-stable polypropylene bottom net	Permanent	High Flow Channels 1:1 Slopes	Unvegetated 3.0 (144) Vegetated 8.0 (388)	Unvegetated 9.0 (2.7) Vegetated 16.0 (4.9)
VMAX					
 SC250	5.0 lb., UV-stable polypropylene top & bottom nets, 24.0 lb., UV-stable polypropylene corrugated center net, 70% straw/30% coconut fiber matrix	Permanent	High Flow Channels 1:1 and Greater Slopes	Unvegetated 3.0 (144) Vegetated 10.0 (480)	Unvegetated 9.5 (2.9) Vegetated 15.0 (4.6)
 C350	8.0 lb., UV-stable polypropylene top & bottom nets, 24.0 lb., UV-stable polypropylene corrugated center net, 100% coconut fiber matrix	Permanent	High Flow Channels 1:1 and Greater Slopes	Unvegetated 3.2 (153) Vegetated 12.0 (576)	Unvegetated 10.5 (3.2) Vegetated 20.0 (6.0)
 P550	24.0 lb., UV-stable polypropylene top & bottom nets, 24.0 lb., UV-stable polypropylene corrugated center net, 100% polypropylene fiber matrix	Permanent	Extreme High Flow Channels 1:1 and Greater Slopes	Unvegetated 4.0 (191) Vegetated 14.0 (672)	Unvegetated 12.5 (3.8) Vegetated 25.0 (7.6)
 TMax	100% UV-stable polypropylene monofilament yarns, woven into a 3-D structure	Permanent	Extreme High Flow Channels 1:1 and Greater Slopes	Vegetated 15.0 (718)	Vegetated 25.0 (7.6)
 W3000	100% UV-stable polypropylene monofilament yarns, woven into a 3-D structure	Permanent	Extreme High Flow Channels 1:1 and Greater Slopes	Vegetated 16.0 (766)	Vegetated 25.0 (7.6)

MONUMENT ACADEMY
DITCH CALCULATION SUMMARY

PROPOSED ROADSIDE DITCHES

ROADWAY	FROM STA	TO STA	SIDE	PROPOSED SLOPE (%)	SIDE SLOPE (Z)	CHANNEL DEPTH (FT)	FRICTION FACTOR (n)	ROW WIDTH (ft)	BASIN	Q100 FLOW (CFS)	DITCH FLOW % OF BASIN	DITCH FLOW (CFS)	Q100 DEPTH (FT)	Q100 VELOCITY (FT/S)	DITCH LINING
PINEHURST CIRCLE	11+00	13+63	S	7.72	4:1/3:1	2.5	0.030	60	M5	61.2	5	3.1	0.4	4.8	GRASS / ECB
WALKER ROAD (NW)	19+20	20+20	N	5.61	4:1/3:1	2.5	0.030	60	OM3	9.0	100	9.0	0.7	5.6	GRASS / ECB

- 1) Channel flow calculations based on Manning's Equation
- 2) n = 0.03 for grass-lined non-irrigated channels
- 3) Vmax = 4.0 fps for 100-year flows w/ native grass-lined channels (per ECM Table 10-4 & NRCS Companion Document 580-10)
- 4) Vmax = 8.0 fps for 100-year flows w/ Erosion Control Blankets (Tensar Eronet P300 or equal)

Hydraulic Analysis Report

Project Data

Project Title: Project-MA-Ditches
Designer: JPS
Project Date: Tuesday, February 5, 2019
Project Units: U.S. Customary Units
Notes:

Channel Analysis: Pinehurst-1100-1363-S

Notes:

Input Parameters

Channel Type: Triangular
Side Slope 1 (Z1): 4.0000 ft/ft
Side Slope 2 (Z2): 3.0000 ft/ft
Longitudinal Slope: 0.0772 ft/ft
Manning's n: 0.0300
Flow: 3.1000 cfs

Result Parameters

Depth: 0.4294 ft
Area of Flow: 0.6452 ft²
Wetted Perimeter: 3.1280 ft
Hydraulic Radius: 0.2063 ft
Average Velocity: 4.8046 ft/s * Use ECB Lining *
Top Width: 3.0055 ft
Froude Number: 1.8274
Critical Depth: 0.5487 ft
Critical Velocity: 2.9418 ft/s
Critical Slope: 0.0209 ft/ft
Critical Top Width: 3.92 ft
Calculated Max Shear Stress: 2.0683 lb/ft²
Calculated Avg Shear Stress: 0.9937 lb/ft²

Channel Analysis: Walker-1920-2020-N

Notes:

Input Parameters

Channel Type: Triangular
Side Slope 1 (Z1): 4.0000 ft/ft
Side Slope 2 (Z2): 3.0000 ft/ft
Longitudinal Slope: 0.0561 ft/ft
Manning's n: 0.0300
Flow: 9.0000 cfs

Result Parameters

Depth: 0.6798 ft
Area of Flow: 1.6175 ft²
Wetted Perimeter: 4.9528 ft
Hydraulic Radius: 0.3266 ft
Average Velocity: 5.5640 ft/s * Use ECB Lining *
Top Width: 4.7587 ft
Froude Number: 1.6818
Critical Depth: 0.8404 ft
Critical Velocity: 3.6407 ft/s
Critical Slope: 0.0181 ft/ft
Critical Top Width: 6.01 ft
Calculated Max Shear Stress: 2.3798 lb/ft²
Calculated Avg Shear Stress: 1.1433 lb/ft²

MONUMENT ACADEMY
CHANNEL CALCULATIONS
DEVELOPED FLOWS

PROPOSED CHANNELS

CHANNEL	DESIGN POINT	PROPOSED SLOPE (%)	BOTTOM WIDTH (B, FT)	SIDE SLOPE (Z)	CHANNEL DEPTH (FT)	FRICTION FACTOR (n)	EASEMENT WIDTH (ft)	Q100 FLOW (CFS)	Q100 DEPTH (FT)	Q100 VELOCITY (FT/S)	CHANNEL LINING
M2.3A	M2	7.1	12	4:1	2.0	0.030	30	40.0	0.43	6.86	GRASS / ECB
M2.3B (RR RUNDOWN)	M2	33.3	8	3:1	2.0	0.040		40.0	0.47	9.06	RIPRAP
C16.1 (WALKER RD DITCH)	C16	6.0	0	4:1/3:1	2.0	0.030		7.4	0.62	5.43	GRASS / ECB
C16.2 (RR RUNDOWN)	C16	25.0	0	4:1	1.0	0.040		7.4	0.50	7.27	RIPRAP

- 1) Channel flow calculations based on Manning's Equation
- 2) Channel depth includes 1' minimum freeboard
- 3) n = 0.03 for grass-lined non-irrigated channels (minimum)
- 4) n = 0.04 for riprap-lined channels
- 5) Vmax = 4.0 fps for 100-year flows w/ native grass-lined channels
- 6) Vmax = 8.0 fps for 100-year flows w/ Erosion Control Blankets (Tensar Eronet P300 or equal)

Hydraulic Analysis Report

Project Data

Project Title: Monument Academy - Channels
Designer: JPS
Project Date: Thursday, February 7, 2019
Project Units: U.S. Customary Units
Notes:

Channel Analysis: Channel Analysis - Channel M2.3A

Notes:

Input Parameters

Channel Type: Trapezoidal
Side Slope 1 (Z1): 4.0000 ft/ft
Side Slope 2 (Z2): 4.0000 ft/ft
Channel Width: 12.0000 ft
Longitudinal Slope: 0.0710 ft/ft
Manning's n: 0.0300
Flow: 40.0000 cfs

Result Parameters

Depth: 0.4251 ft
Area of Flow: 5.8239 ft²
Wetted Perimeter: 15.5054 ft
Hydraulic Radius: 0.3756 ft
Average Velocity: 6.8682 ft/s
Top Width: 15.4007 ft
Froude Number: 1.9683
Critical Depth: 0.6499 ft
Critical Velocity: 4.2160 ft/s
Critical Slope: 0.0162 ft/ft
Critical Top Width: 17.20 ft
Calculated Max Shear Stress: 1.8833 lb/ft²
Calculated Avg Shear Stress: 1.6641 lb/ft²

Channel Analysis: Channel Analysis - Channel M2.3B (Rundown)

Notes:

Input Parameters

Channel Type: Trapezoidal
Side Slope 1 (Z1): 3.0000 ft/ft
Side Slope 2 (Z2): 3.0000 ft/ft
Channel Width: 8.0000 ft
Longitudinal Slope: 0.2000 ft/ft
Manning's n: 0.0400
Lining Type: Rock Riprap - 300 mm (12-inch)
Flow: 40.0000 cfs

Result Parameters

Depth: 0.4695 ft
Area of Flow: 4.4168 ft²
Wetted Perimeter: 10.9691 ft
Hydraulic Radius: 0.4027 ft
Average Velocity: 9.0564 ft/s
Top Width: 10.8167 ft
Froude Number: 2.4976
Critical Depth: 0.8242 ft
Critical Velocity: 4.6343 ft/s
Critical Slope: 0.0275 ft/ft
Critical Top Width: 12.95 ft
Calculated Max Shear Stress: 5.8587 lb/ft²
Calculated Avg Shear Stress: 5.0251 lb/ft²

Channel Analysis: Channel Analysis - Channel C16.1 (Walker Rd Ditch)

Notes:

Input Parameters

Channel Type: Triangular
Side Slope 1 (Z1): 4.0000 ft/ft
Side Slope 2 (Z2): 3.0000 ft/ft
Longitudinal Slope: 0.0600 ft/ft
Manning's n: 0.0300
Flow: 7.4000 cfs

Result Parameters

Depth: 0.6238 ft
Area of Flow: 1.3619 ft²
Wetted Perimeter: 4.5446 ft
Hydraulic Radius: 0.2997 ft
Average Velocity: 5.4335 ft/s
Top Width: 4.3666 ft
Froude Number: 1.7145
Critical Depth: 0.7771 ft
Critical Velocity: 3.5009 ft/s
Critical Slope: 0.0186 ft/ft
Critical Top Width: 5.55 ft
Calculated Max Shear Stress: 2.3355 lb/ft²
Calculated Avg Shear Stress: 1.1220 lb/ft²

Channel Analysis: Channel Analysis - Channel C16.2 (Rundown)

Notes:

Input Parameters

Channel Type: Triangular
Side Slope 1 (Z1): 4.0000 ft/ft
Side Slope 2 (Z2): 4.0000 ft/ft
Longitudinal Slope: 0.2500 ft/ft
Manning's n: 0.0400
Flow: 7.4000 cfs

Result Parameters

Depth: 0.5045 ft
Area of Flow: 1.0182 ft²
Wetted Perimeter: 4.1605 ft
Hydraulic Radius: 0.2447 ft
Average Velocity: 7.2676 ft/s
Top Width: 4.0363 ft
Froude Number: 2.5500
Critical Depth: 0.7337 ft
Critical Velocity: 3.4369 ft/s
Critical Slope: 0.0339 ft/ft
Critical Top Width: 5.87 ft
Calculated Max Shear Stress: 7.8707 lb/ft²
Calculated Avg Shear Stress: 3.8179 lb/ft²

PROJECT: MONUMENT ACADEMY
CHANNEL: M2.3B (RIPRAP RUNDOWN INTO POND M3)

RIPRAP SIZING:

$$d_{50} > [(VS^{0.17}) / (4.5(Gs - 1)^{0.66})]^2 \quad \text{(USDCM EQUATION 8-11)}$$

ASSUMPTIONS:

V =	9.06 FPS	MEAN CHANNEL VELOCITY
S =	0.2 FT/FT	LONGITUDINAL SLOPE PER CHANNEL PROFILE
Gs =	2.5	SPECIFIC GRAVITY OF STONE
d ₅₀ =		CALCULATED MEAN ROCK SIZE

CALCULATED RIPRAP SIZE:

d ₅₀ =	1.37 FT
d ₅₀ =	16.48 INCHES

SELECTED MEAN RIPRAP SIZE = 18 INCHES (TYPE H RIPRAP)

PROJECT: MONUMENT ACADEMY
CHANNEL: C16.2 (RIPRAP RUNDOWN INTO POND C14)

RIPRAP SIZING:

$$d_{50} > [(VS^{0.17}) / (4.5(Gs - 1)^{0.66})]^2 \quad \text{(USDCM EQUATION 8-11)}$$

ASSUMPTIONS:

V =	7.3 FPS	MEAN CHANNEL VELOCITY
S =	0.25 FT/FT	LONGITUDINAL SLOPE PER CHANNEL PROFILE
Gs =	2.5	SPECIFIC GRAVITY OF STONE
d ₅₀ =		CALCULATED MEAN ROCK SIZE

CALCULATED RIPRAP SIZE:

d ₅₀ =	0.96 FT
d ₅₀ =	11.54 INCHES

SELECTED MEAN RIPRAP SIZE = 12 INCHES (TYPE H RIPRAP)

8.1 Riprap Sizing

Procedures for sizing rock to be used in soil riprap, void-filled riprap, and riprap over bedding are the same.

8.1.1 Mild Slope Conditions

When subcritical flow conditions occur and/or slopes are mild (less than 2 percent), UDFCD recommends the following equation (Hughes, et al, 1983):

$$d_{50} \geq \left[\frac{VS^{0.17}}{4.5(G_s - 1)^{0.66}} \right]^2 \quad \text{Equation 8-11}$$

Where:

V = mean channel velocity (ft/sec)

S = longitudinal channel slope (ft/ft)

d_{50} = mean rock size (ft)

G_s = specific gravity of stone (minimum = 2.50, typically 2.5 to 2.7), Note: In this equation ($G_s - 1$) considers the buoyancy of the water, in that the specific gravity of water is subtracted from the specific gravity of the rock.

Note that Equation 8-11 is applicable for sizing riprap for channel lining with a longitudinal slope of no more than 2%. This equation is not intended for use in sizing riprap for steep slopes (typically in excess of 2 percent), rundowns, or protection downstream of culverts. Information on rundowns is provided in Section 7.0 of the *Hydraulic Structures* chapter of the USDCM, and protection downstream of culverts is discussed in the *Culverts and Bridges* chapter. For channel slopes greater than 2% use one of the methods presented in 8.1.2.

Rock size does not need to be increased for steeper channel side slopes, provided the side slopes are no steeper than 2.5H:1V (UDFCD 1982). Channel side slopes steeper than 2.5H:1V are not recommended because of stability, safety, and maintenance considerations. See Figure 8-34 for riprap placement specifications. At the upstream and downstream termination of a riprap lining, the thickness should be increased 50% for at least 3 feet to prevent undercutting.

8.1.2 Steep Slope Conditions

Steep slope rock sizing equations are used for applications where the slope is greater than 2 percent and/or flows are in the supercritical flow regime. The following rock sizing equations may be referred to for riprap design analysis on steep slopes:

- CSU Equation, *Development of Riprap Design Criteria by Riprap Testing in Flumes: Phase II* (prepared by S.R. Abt, et al, Colorado State University, 1988). This method was developed for steep slopes from 2 to 20 percent.
- USDA- Agricultural Research Service Equations, *Design of Rock Chutes* (by K.M. Robinson, et al, USDA- ARS, 1998 Transactions of ASAE) and *An Excel Program to Design Rock Chutes for Grade*

APPENDIX C2

HYDRAULIC CALCULATIONS – STORM SEWER SYSTEM

**MONUMENT ACADEMY SITE
EXISTING CULVERT SUMMARY**

CULVERT	DESIGN POINT	Q5 FLOW (CFS)	Q100 FLOW (CFS)	CULVERT SIZE (IN)	HEADWATER DEPTH (FT)	HW/D	CULVERT CAPACITY (CFS)
DP4 (WALKER RD)	4	222.5	582.9	43"X27" CMP	4.7	2.1	55
C16.1	C16.1	4.2	30.7	18	3.0	2.0	11
M3	M3	2.7	19.8	24	4.8	2.4	26
M4	M4	1.8	13.6	24	4.2	2.1	24
M5	M5	5.0	36.4	24	5.8	2.9	30
M6	M6.1	2.4	12.9	18	3.6	2.4	13
OM3	OM3.1	3.7	18.0	24	4.0	2.0	24

ASSUMPTIONS:

- 1) Culvert Capacity based on Inlet Control Nomographs (DCM Fig. 9-37 & 9-38)

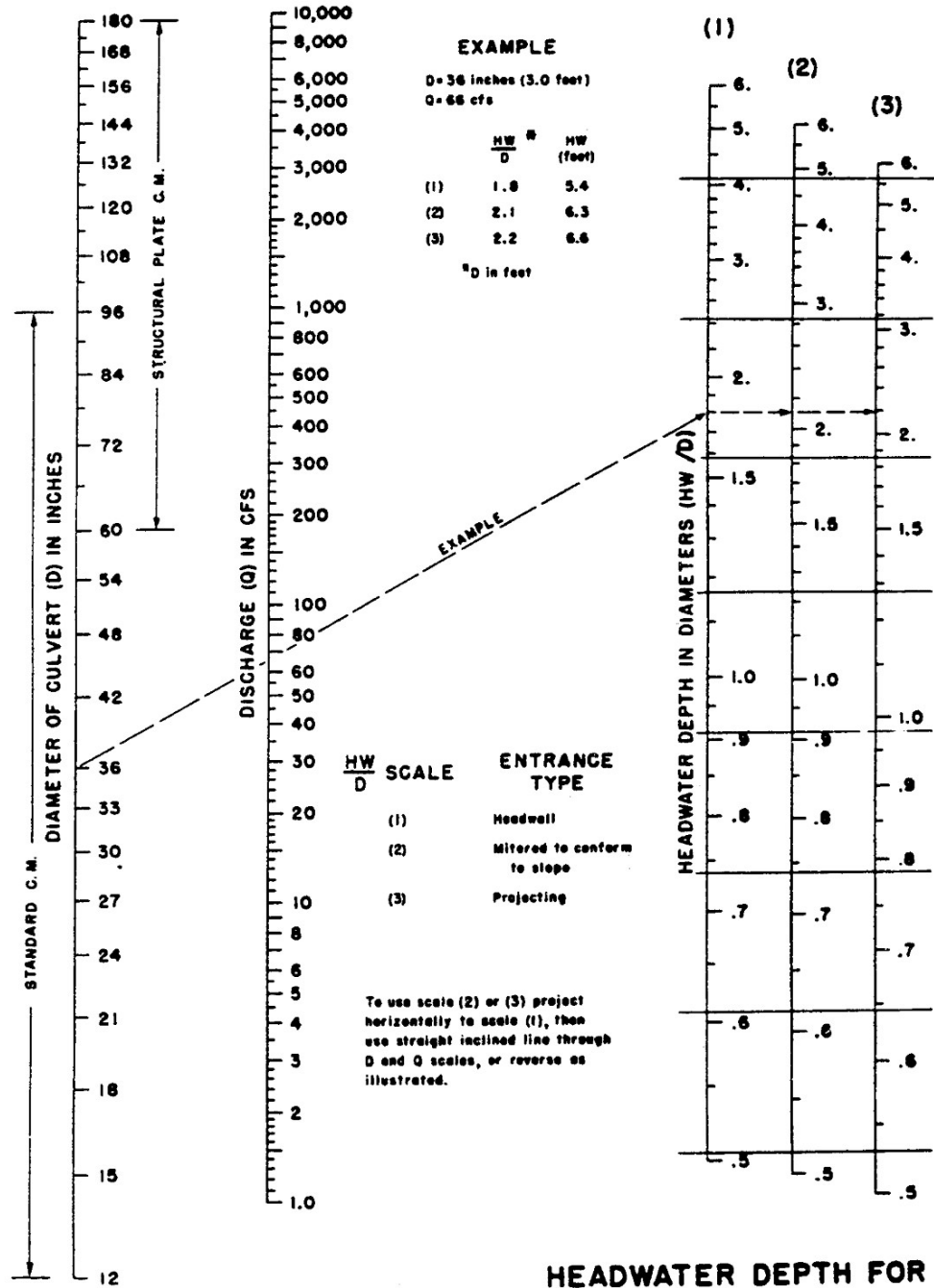

**HEADWATER DEPTH FOR
 C. M. PIPE CULVERTS
 WITH INLET CONTROL**

BUREAU OF PUBLIC ROADS JAN. 1963



HDR Infrastructure, Inc.
 A Centerra Company

The City of Colorado Springs / El Paso County
 Drainage Criteria Manual

Date
OCT. 1987
 Figure
 9-37

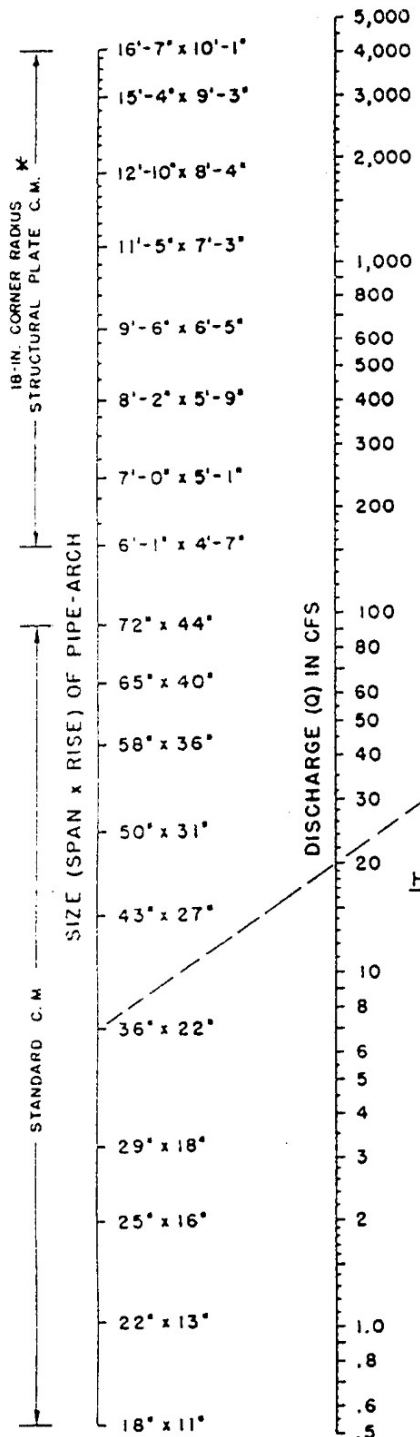

EXAMPLE
 Size: 36" x 22"
 Q = 20 cfs

	$\frac{HW}{D}$	HW (feet)
(1)	1.10	2.0
(2)	1.15	2.1
(3)	1.22	2.2

*D in feet

$\frac{HW}{D}$ SCALE	ENTRANCE TYPE
(1)	Headwall
(2)	Mitered to conform to slope
(3)	Projecting

To use scale (2) or (3) project horizontally to scale (1), then use straight inclined line through D and Q scales, or reverse as illustrated.

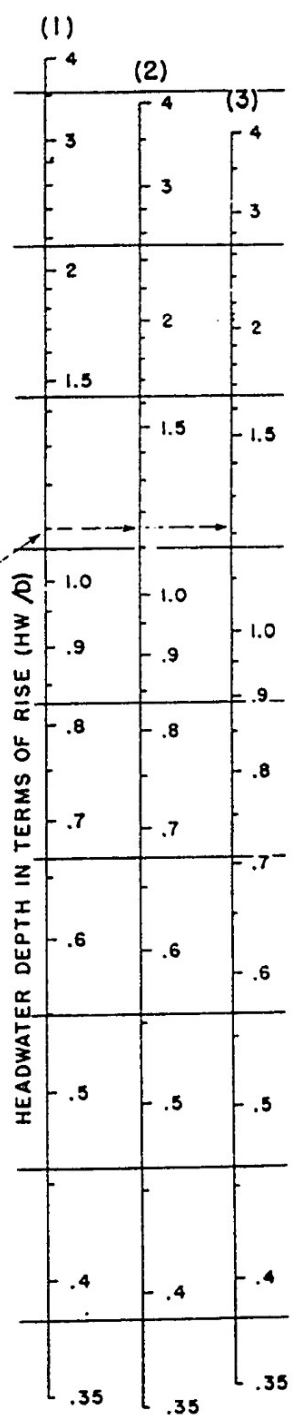
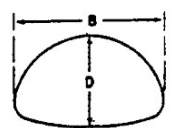

* ADDITIONAL SIZES NOT DIMENSIONED ARE LISTED IN FABRICATOR'S CATALOG

HEADWATER DEPTH FOR C. M. PIPE-ARCH CULVERTS WITH INLET CONTROL

BUREAU OF PUBLIC ROADS JAN. 1963

The City of Colorado Springs / El Paso County Drainage Criteria Manual	Date 9-30-90
	Figure 9-38

MONUMENT ACADEMY
STORM INLET SIZING SUMMARY

INLET	BASIN FLOW			INLET FLOW				INLET CONDITION / TYPE	INLET SIZE	INLET CAPACITY (CFS)
	DP	Q5 FLOW (CFS) ¹	Q100 FLOW (CFS)	INLET FLOW % OF BASIN	Q5 FLOW (CFS)	Q100 FLOW (CFS)				
M2.1	M2	19.4	40.0	40	7.8	16.0		10	25.5	
M2.2A	M2.2A	0.5	1.1	100	0.5	1.1		5	3.7	
M2.2B	M2	19.4	40.0	10	1.9	4.0		5	8.9	
M2.3	M2	19.4	40.0	50	9.7	20.0		10	25.5	
C14.1	C14	13.8	42.3	15	2.1	6.3		5	12.3	
C14.2	C14	13.8	42.3	35	4.8	14.8		10	25.5	
C14.3	C14	13.8	42.3	30	4.1	12.7		SINGLE	7.3 ^b	
C16	C16	2.6	4.3	100	2.6	4.3		5	8.9	

^a REFER TO RATIONAL METHOD HYDROLOGY CALCULATIONS FOR CONTRIBUTING BASINS & DEVELOPED FLOW CALCULATIONS

^b ADDITIONAL INLETS AND DRAIN SYSTEM TO BE PROVIDED WITH ULTIMATE ATHLETIC FIELD CONSTRUCTION

ASSUMPTIONS:

1. ALLOWABLE SUMP INLET CAPACITY FOR D10R INLETS BASED ON EPC-DCM FIG 7-11 (ADJUSTED FOR CLOGGING FACTOR)
2. MAXIMUM ALLOWABLE DEPTH AT Q5 = 0.75' (9")
3. MAXIMUM ALLOWABLE DEPTH AT Q100 = 1.0' (12")

ALLOWABLE CAPACITY FOR ONE-HALF OF STREET (Minor & Major Storm)

(Based on Regulated Criteria for Maximum Allowable Flow Depth and Spread)

Project:

Monument Academy - Inlet M2.1 (Sump Condition)

Inlet ID:

Inlet M2.1

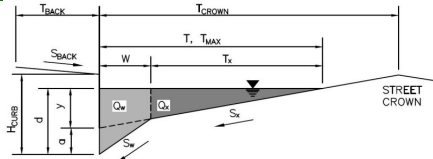

Gutter Geometry (Enter data in the blue cells)

Maximum Allowable Width for Spread Behind Curb
 Side Slope Behind Curb (leave blank for no conveyance credit behind curb)
 Manning's Roughness Behind Curb (typically between 0.012 and 0.020)
 Height of Curb at Gutter Flow Line
 Distance from Curb Face to Street Crown
 Gutter Width
 Street Transverse Slope
 Gutter Cross Slope (typically 2 inches over 24 inches or 0.083 ft/ft)
 Street Longitudinal Slope - Enter 0 for sump condition
 Manning's Roughness for Street Section (typically between 0.012 and 0.020)

$T_{BACK} = 4.0$ ft
 $S_{BACK} = 0.020$ ft/ft
 $n_{BACK} = 0.020$
 $H_{CURB} = 6.00$ inches
 $T_{CROWN} = 50.0$ ft
 $W = 2.00$ ft
 $S_X = 0.020$ ft/ft
 $S_W = 0.083$ ft/ft
 $S_D = 0.000$ ft/ft
 $n_{STREET} = 0.016$

Max. Allowable Spread for Minor & Major Storm
 Max. Allowable Depth at Gutter Flowline for Minor & Major Storm
 Check boxes are not applicable in SUMP conditions

	Minor Storm	Major Storm	
$T_{MAX} =$	50.0	50.0	ft
$d_{MAX} =$	6.0	12.0	inches
	<input type="checkbox"/>	<input type="checkbox"/>	

MINOR STORM Allowable Capacity is based on Depth Criterion
MAJOR STORM Allowable Capacity is based on Depth Criterion

$Q_{allow} =$

Minor Storm	Major Storm	
SUMP	SUMP	cfs

INLET IN A SUMP OR SAG LOCATION

Version 4.05 Released March 2017

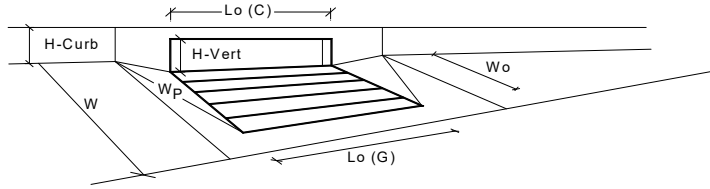

Design Information (Input)	MINOR		MAJOR		
	CDOT Type R Curb Opening				
Type of Inlet	CDOT Type R Curb Opening				
Local Depression (additional to continuous gutter depression 'a' from above)					
Number of Unit Inlets (Grate or Curb Opening)					
Water Depth at Flowline (outside of local depression)					
Grate Information					
Length of a Unit Grate	L _g (G) =		N/A	N/A	feet
Width of a Unit Grate	W _g =		N/A	N/A	feet
Area Opening Ratio for a Grate (typical values 0.15-0.90)	A _{ratio} =		N/A	N/A	
Clogging Factor for a Single Grate (typical value 0.50 - 0.70)	C _f (G) =		N/A	N/A	
Grate Weir Coefficient (typical value 2.15 - 3.60)	C _w (G) =		N/A	N/A	
Grate Orifice Coefficient (typical value 0.60 - 0.80)	C _o (G) =		N/A	N/A	
Curb Opening Information					
Length of a Unit Curb Opening	L _c (C) =		10.00	10.00	feet
Height of Vertical Curb Opening in Inches	H _{vert} =		6.00	6.00	inches
Height of Curb Orifice Throat in Inches	H _{throat} =		6.00	6.00	inches
Angle of Throat (see USDCM Figure ST-5)	Theta =		63.40	63.40	degrees
Side Width for Depression Pan (typically the gutter width of 2 feet)	W _p =		2.00	2.00	feet
Clogging Factor for a Single Curb Opening (typical value 0.10)	C _f (C) =		0.10	0.10	
Curb Opening Weir Coefficient (typical value 2.3-3.7)	C _w (C) =		3.60	3.60	
Curb Opening Orifice Coefficient (typical value 0.60 - 0.70)	C _o (C) =		0.67	0.67	
Low Head Performance Reduction (Calculated)					
Depth for Grate Midwidth	d _{grate} =		N/A	N/A	ft
Depth for Curb Opening Weir Equation	d _{curb} =		0.33	0.83	ft
Combination Inlet Performance Reduction Factor for Long Inlets	RF _{Combination} =		0.57	1.00	
Curb Opening Performance Reduction Factor for Long Inlets	RF _{Curb} =		0.93	1.00	
Grated Inlet Performance Reduction Factor for Long Inlets	RF _{Grate} =		N/A	N/A	
Total Inlet Interception Capacity (assumes clogged condition)					
Inlet Capacity IS GOOD for Minor and Major Storms(>Q PEAK)	Q _a =		8.3	25.5	cfs
	Q _{PEAK REQUIRED} =		7.8	16.0	cfs

ALLOWABLE CAPACITY FOR ONE-HALF OF STREET (Minor & Major Storm)

(Based on Regulated Criteria for Maximum Allowable Flow Depth and Spread)

Project: Monument Academy - Inlet M2.2A (Sump Condition)
 Inlet ID: Inlet M2.2A

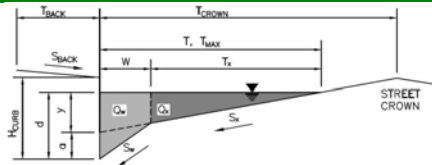

Gutter Geometry (Enter data in the blue cells)																	
Maximum Allowable Width for Spread Behind Curb	$T_{BACK} = $ <input style="width: 50px;" type="text" value="13.0"/> ft																
Side Slope Behind Curb (leave blank for no conveyance credit behind curb)	$S_{BACK} = $ <input style="width: 50px;" type="text" value="0.020"/> ft/ft																
Manning's Roughness Behind Curb (typically between 0.012 and 0.020)	$n_{BACK} = $ <input style="width: 50px;" type="text" value="0.020"/>																
Height of Curb at Gutter Flow Line	$H_{CURB} = $ <input style="width: 50px;" type="text" value="6.00"/> inches																
Distance from Curb Face to Street Crown	$T_{CROWN} = $ <input style="width: 50px;" type="text" value="15.0"/> ft																
Gutter Width	$W = $ <input style="width: 50px;" type="text" value="2.00"/> ft																
Street Transverse Slope	$S_X = $ <input style="width: 50px;" type="text" value="0.020"/> ft/ft																
Gutter Cross Slope (typically 2 inches over 24 inches or 0.083 ft/ft)	$S_W = $ <input style="width: 50px;" type="text" value="0.083"/> ft/ft																
Street Longitudinal Slope - Enter 0 for sump condition	$S_O = $ <input style="width: 50px;" type="text" value="0.000"/> ft/ft																
Manning's Roughness for Street Section (typically between 0.012 and 0.020)	$n_{STREET} = $ <input style="width: 50px;" type="text" value="0.016"/>																
Max. Allowable Spread for Minor & Major Storm	<table style="width: 100%; border-collapse: collapse;"> <thead> <tr> <th style="width: 50%;"></th> <th style="width: 25%; text-align: center;">Minor Storm</th> <th style="width: 25%; text-align: center;">Major Storm</th> <th style="width: 10%;"></th> </tr> </thead> <tbody> <tr> <td>$T_{MAX} =$</td> <td style="text-align: center;"><input style="width: 40px;" type="text" value="15.0"/></td> <td style="text-align: center;"><input style="width: 40px;" type="text" value="15.0"/></td> <td style="text-align: right;">ft</td> </tr> <tr> <td>$d_{MAX} =$</td> <td style="text-align: center;"><input style="width: 40px;" type="text" value="6.0"/></td> <td style="text-align: center;"><input style="width: 40px;" type="text" value="12.0"/></td> <td style="text-align: right;">inches</td> </tr> <tr> <td></td> <td style="text-align: center;"><input type="checkbox"/></td> <td style="text-align: center;"><input type="checkbox"/></td> <td></td> </tr> </tbody> </table>		Minor Storm	Major Storm		$T_{MAX} = $	<input style="width: 40px;" type="text" value="15.0"/>	<input style="width: 40px;" type="text" value="15.0"/>	ft	$d_{MAX} = $	<input style="width: 40px;" type="text" value="6.0"/>	<input style="width: 40px;" type="text" value="12.0"/>	inches		<input type="checkbox"/>	<input type="checkbox"/>	
	Minor Storm	Major Storm															
$T_{MAX} = $	<input style="width: 40px;" type="text" value="15.0"/>	<input style="width: 40px;" type="text" value="15.0"/>	ft														
$d_{MAX} = $	<input style="width: 40px;" type="text" value="6.0"/>	<input style="width: 40px;" type="text" value="12.0"/>	inches														
	<input type="checkbox"/>	<input type="checkbox"/>															
Max. Allowable Depth at Gutter Flowline for Minor & Major Storm																	
Check boxes are not applicable in SUMP conditions																	
MINOR STORM Allowable Capacity is based on Depth Criterion																	
MAJOR STORM Allowable Capacity is based on Depth Criterion																	
$Q_{allow} = $	<table style="width: 100%; border-collapse: collapse;"> <thead> <tr> <th style="width: 50%;"></th> <th style="width: 25%; text-align: center;">Minor Storm</th> <th style="width: 25%; text-align: center;">Major Storm</th> <th style="width: 10%;"></th> </tr> </thead> <tbody> <tr> <td></td> <td style="text-align: center;"><input style="width: 40px;" type="text" value="SUMP"/></td> <td style="text-align: center;"><input style="width: 40px;" type="text" value="SUMP"/></td> <td style="text-align: right;">cfs</td> </tr> </tbody> </table>		Minor Storm	Major Storm			<input style="width: 40px;" type="text" value="SUMP"/>	<input style="width: 40px;" type="text" value="SUMP"/>	cfs								
	Minor Storm	Major Storm															
	<input style="width: 40px;" type="text" value="SUMP"/>	<input style="width: 40px;" type="text" value="SUMP"/>	cfs														

INLET IN A SUMP OR SAG LOCATION

Version 4.05 Released March 2017

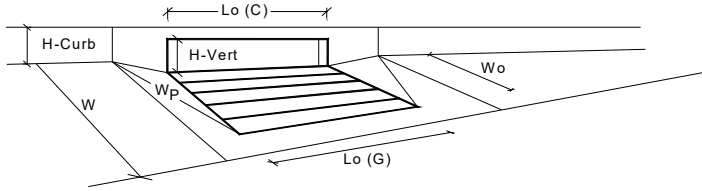

Design Information (Input)	MINOR	MAJOR	
Type of Inlet	CDOT Type R Curb Opening		
Local Depression (additional to continuous gutter depression 'a' from above)	3.00	3.00	inches
Number of Unit Inlets (Grate or Curb Opening)	1	1	
Water Depth at Flowline (outside of local depression)	5.1	5.1	inches
Grate Information	MINOR	MAJOR	<input type="checkbox"/> Override Depths
Length of a Unit Grate	N/A	N/A	feet
Width of a Unit Grate	N/A	N/A	feet
Area Opening Ratio for a Grate (typical values 0.15-0.90)	N/A	N/A	
Clogging Factor for a Single Grate (typical value 0.50 - 0.70)	N/A	N/A	
Grate Weir Coefficient (typical value 2.15 - 3.60)	N/A	N/A	
Grate Orifice Coefficient (typical value 0.60 - 0.80)	N/A	N/A	
Curb Opening Information	MINOR	MAJOR	
Length of a Unit Curb Opening	5.00	5.00	feet
Height of Vertical Curb Opening in Inches	6.00	6.00	inches
Height of Curb Orifice Throat in Inches	6.00	6.00	inches
Angle of Throat (see USDCM Figure ST-5)	63.40	63.40	degrees
Side Width for Depression Pan (typically the gutter width of 2 feet)	2.00	2.00	feet
Clogging Factor for a Single Curb Opening (typical value 0.10)	0.10	0.10	
Curb Opening Weir Coefficient (typical value 2.3-3.7)	3.60	3.60	
Curb Opening Orifice Coefficient (typical value 0.60 - 0.70)	0.67	0.67	
Low Head Performance Reduction (Calculated)	MINOR	MAJOR	
Depth for Grate Midwidth	N/A	N/A	ft
Depth for Curb Opening Weir Equation	0.26	0.26	ft
Combination Inlet Performance Reduction Factor for Long Inlets	0.66	0.66	
Curb Opening Performance Reduction Factor for Long Inlets	1.00	1.00	
Grated Inlet Performance Reduction Factor for Long Inlets	N/A	N/A	
Total Inlet Interception Capacity (assumes clogged condition)	MINOR	MAJOR	
Q_a	3.7	3.7	cfs
Q_{PEAK REQUIRED}	0.5	1.1	cfs

Inlet Capacity IS GOOD for Minor and Major Storms(>Q PEAK)

ALLOWABLE CAPACITY FOR ONE-HALF OF STREET (Minor & Major Storm)

(Based on Regulated Criteria for Maximum Allowable Flow Depth and Spread)

Project: Monument Academy - Inlet M2.2B (Sump Condition)
 Inlet ID: Inlet M2.2B

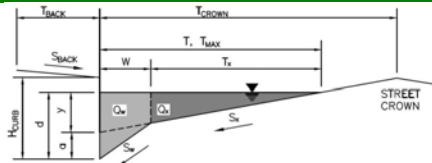

Gutter Geometry (Enter data in the blue cells)							
Maximum Allowable Width for Spread Behind Curb	$T_{BACK} = $ <input style="width: 50px;" type="text" value="13.0"/> ft						
Side Slope Behind Curb (leave blank for no conveyance credit behind curb)	$S_{BACK} = $ <input style="width: 50px;" type="text" value="0.020"/> ft/ft						
Manning's Roughness Behind Curb (typically between 0.012 and 0.020)	$n_{BACK} = $ <input style="width: 50px;" type="text" value="0.020"/>						
Height of Curb at Gutter Flow Line	$H_{CURB} = $ <input style="width: 50px;" type="text" value="6.00"/> inches						
Distance from Curb Face to Street Crown	$T_{CROWN} = $ <input style="width: 50px;" type="text" value="26.0"/> ft						
Gutter Width	$W = $ <input style="width: 50px;" type="text" value="2.00"/> ft						
Street Transverse Slope	$S_X = $ <input style="width: 50px;" type="text" value="0.020"/> ft/ft						
Gutter Cross Slope (typically 2 inches over 24 inches or 0.083 ft/ft)	$S_W = $ <input style="width: 50px;" type="text" value="0.083"/> ft/ft						
Street Longitudinal Slope - Enter 0 for sump condition	$S_O = $ <input style="width: 50px;" type="text" value="0.000"/> ft/ft						
Manning's Roughness for Street Section (typically between 0.012 and 0.020)	$n_{STREET} = $ <input style="width: 50px;" type="text" value="0.016"/>						
Max. Allowable Spread for Minor & Major Storm	<table border="1" style="display: inline-table; border-collapse: collapse;"> <thead> <tr> <th style="width: 50px;">Minor Storm</th> <th style="width: 50px;">Major Storm</th> <th style="width: 20px;">ft</th> </tr> </thead> <tbody> <tr> <td style="text-align: center;">$T_{MAX} =$ <input style="width: 40px;" type="text" value="26.0"/></td> <td style="text-align: center;"><input style="width: 40px;" type="text" value="26.0"/></td> <td></td> </tr> </tbody> </table>	Minor Storm	Major Storm	ft	$T_{MAX} = $ <input style="width: 40px;" type="text" value="26.0"/>	<input style="width: 40px;" type="text" value="26.0"/>	
Minor Storm	Major Storm	ft					
$T_{MAX} = $ <input style="width: 40px;" type="text" value="26.0"/>	<input style="width: 40px;" type="text" value="26.0"/>						
Max. Allowable Depth at Gutter Flowline for Minor & Major Storm	<table border="1" style="display: inline-table; border-collapse: collapse;"> <thead> <tr> <th style="width: 50px;">Minor Storm</th> <th style="width: 50px;">Major Storm</th> <th style="width: 20px;">inches</th> </tr> </thead> <tbody> <tr> <td style="text-align: center;">$d_{MAX} =$ <input style="width: 40px;" type="text" value="6.0"/></td> <td style="text-align: center;"><input style="width: 40px;" type="text" value="12.0"/></td> <td></td> </tr> </tbody> </table>	Minor Storm	Major Storm	inches	$d_{MAX} = $ <input style="width: 40px;" type="text" value="6.0"/>	<input style="width: 40px;" type="text" value="12.0"/>	
Minor Storm	Major Storm	inches					
$d_{MAX} = $ <input style="width: 40px;" type="text" value="6.0"/>	<input style="width: 40px;" type="text" value="12.0"/>						
Check boxes are not applicable in SUMP conditions	<table style="display: inline-table; border-collapse: collapse;"> <tr> <td style="text-align: center; width: 20px;"><input type="checkbox"/></td> <td style="text-align: center; width: 20px;"><input type="checkbox"/></td> </tr> </table>	<input type="checkbox"/>	<input type="checkbox"/>				
<input type="checkbox"/>	<input type="checkbox"/>						
MINOR STORM Allowable Capacity is based on Depth Criterion							
MAJOR STORM Allowable Capacity is based on Depth Criterion							
Q _{allow} =	<table border="1" style="display: inline-table; border-collapse: collapse;"> <thead> <tr> <th style="width: 50px;">Minor Storm</th> <th style="width: 50px;">Major Storm</th> <th style="width: 20px;">cfs</th> </tr> </thead> <tbody> <tr> <td style="text-align: center;">SUMP</td> <td style="text-align: center;">SUMP</td> <td></td> </tr> </tbody> </table>	Minor Storm	Major Storm	cfs	SUMP	SUMP	
Minor Storm	Major Storm	cfs					
SUMP	SUMP						

INLET IN A SUMP OR SAG LOCATION

Version 4.05 Released March 2017

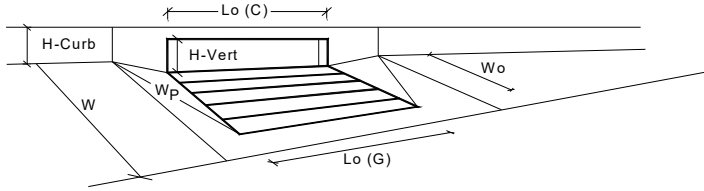

Design Information (Input)	MINOR	MAJOR	
Type of Inlet	CDOT Type R Curb Opening		
Local Depression (additional to continuous gutter depression 'a' from above)	3.00	3.00	inches
Number of Unit Inlets (Grate or Curb Opening)	1	1	
Water Depth at Flowline (outside of local depression)	6.0	7.8	inches
Grate Information	MINOR	MAJOR	<input type="checkbox"/> Override Depths
Length of a Unit Grate	N/A	N/A	feet
Width of a Unit Grate	N/A	N/A	feet
Area Opening Ratio for a Grate (typical values 0.15-0.90)	N/A	N/A	
Clogging Factor for a Single Grate (typical value 0.50 - 0.70)	N/A	N/A	
Grate Weir Coefficient (typical value 2.15 - 3.60)	N/A	N/A	
Grate Orifice Coefficient (typical value 0.60 - 0.80)	N/A	N/A	
Curb Opening Information	MINOR	MAJOR	
Length of a Unit Curb Opening	5.00	5.00	feet
Height of Vertical Curb Opening in Inches	6.00	6.00	inches
Height of Curb Orifice Throat in Inches	6.00	6.00	inches
Angle of Throat (see USDCM Figure ST-5)	63.40	63.40	degrees
Side Width for Depression Pan (typically the gutter width of 2 feet)	2.00	2.00	feet
Clogging Factor for a Single Curb Opening (typical value 0.10)	0.10	0.10	
Curb Opening Weir Coefficient (typical value 2.3-3.7)	3.60	3.60	
Curb Opening Orifice Coefficient (typical value 0.60 - 0.70)	0.67	0.67	
Low Head Performance Reduction (Calculated)	MINOR	MAJOR	
Depth for Grate Midwidth	N/A	N/A	ft
Depth for Curb Opening Weir Equation	0.33	0.48	ft
Combination Inlet Performance Reduction Factor for Long Inlets	0.77	0.99	
Curb Opening Performance Reduction Factor for Long Inlets	1.00	1.00	
Grated Inlet Performance Reduction Factor for Long Inlets	N/A	N/A	
Total Inlet Interception Capacity (assumes clogged condition)	MINOR	MAJOR	
Q_a	5.4	8.9	cfs
Q _{PEAK REQUIRED}	1.9	4.0	cfs

Inlet Capacity IS GOOD for Minor and Major Storms(>Q PEAK)

ALLOWABLE CAPACITY FOR ONE-HALF OF STREET (Minor & Major Storm)

(Based on Regulated Criteria for Maximum Allowable Flow Depth and Spread)

Project:

Monument Academy - Inlet M2.3 (Sump Condition)

Inlet ID:

Inlet M2.3

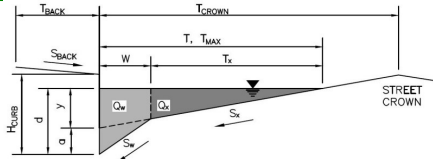

Gutter Geometry (Enter data in the blue cells)

Maximum Allowable Width for Spread Behind Curb
 Side Slope Behind Curb (leave blank for no conveyance credit behind curb)
 Manning's Roughness Behind Curb (typically between 0.012 and 0.020)

$T_{BACK} = 13.0$ ft
 $S_{BACK} = 0.020$ ft/ft
 $n_{BACK} = 0.020$

Height of Curb at Gutter Flow Line
 Distance from Curb Face to Street Crown
 Gutter Width
 Street Transverse Slope
 Gutter Cross Slope (typically 2 inches over 24 inches or 0.083 ft/ft)
 Street Longitudinal Slope - Enter 0 for sump condition
 Manning's Roughness for Street Section (typically between 0.012 and 0.020)

$H_{CURB} = 6.00$ inches
 $T_{CROWN} = 26.0$ ft
 $W = 2.00$ ft
 $S_X = 0.020$ ft/ft
 $S_W = 0.083$ ft/ft
 $S_D = 0.000$ ft/ft
 $n_{STREET} = 0.016$

Max. Allowable Spread for Minor & Major Storm
 Max. Allowable Depth at Gutter Flowline for Minor & Major Storm
 Check boxes are not applicable in SUMP conditions

	Minor Storm	Major Storm	
$T_{MAX} =$	26.0	26.0	ft
$d_{MAX} =$	6.0	12.0	inches
	<input type="checkbox"/>	<input type="checkbox"/>	

MINOR STORM Allowable Capacity is based on Depth Criterion
MAJOR STORM Allowable Capacity is based on Depth Criterion

$Q_{allow} =$

Minor Storm	Major Storm	
SUMP	SUMP	cfs

INLET IN A SUMP OR SAG LOCATION

Version 4.05 Released March 2017

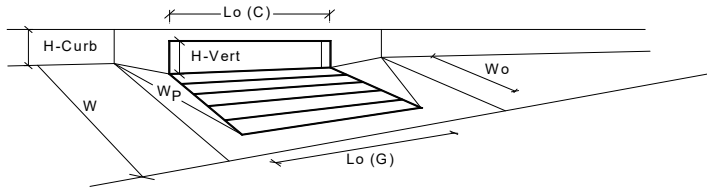

Design Information (Input)	MINOR	MAJOR	
Type of Inlet	CDOT Type R Curb Opening		
Local Depression (additional to continuous gutter depression 'a' from above)			
Number of Unit Inlets (Grate or Curb Opening)			
Water Depth at Flowline (outside of local depression)			
Grate Information	MINOR	MAJOR	
Length of a Unit Grate	L _g (G) =	N/A	feet
Width of a Unit Grate	W _g =	N/A	feet
Area Opening Ratio for a Grate (typical values 0.15-0.90)	A _{ratio} =	N/A	
Clogging Factor for a Single Grate (typical value 0.50 - 0.70)	C _f (G) =	N/A	
Grate Weir Coefficient (typical value 2.15 - 3.60)	C _w (G) =	N/A	
Grate Orifice Coefficient (typical value 0.60 - 0.80)	C _o (G) =	N/A	
Curb Opening Information	MINOR	MAJOR	
Length of a Unit Curb Opening	L _c (C) =	10.00	feet
Height of Vertical Curb Opening in Inches	H _{vert} =	6.00	inches
Height of Curb Orifice Throat in Inches	H _{throat} =	6.00	inches
Angle of Throat (see USDCM Figure ST-5)	Theta =	63.40	degrees
Side Width for Depression Pan (typically the gutter width of 2 feet)	W _p =	2.00	feet
Clogging Factor for a Single Curb Opening (typical value 0.10)	C _f (C) =	0.10	
Curb Opening Weir Coefficient (typical value 2.3-3.7)	C _w (C) =	3.60	
Curb Opening Orifice Coefficient (typical value 0.60 - 0.70)	C _o (C) =	0.67	
Low Head Performance Reduction (Calculated)	MINOR	MAJOR	
Depth for Grate Midwidth	d _{grate} =	N/A	ft
Depth for Curb Opening Weir Equation	d _{curb} =	0.33	ft
Combination Inlet Performance Reduction Factor for Long Inlets	RF _{Combination} =	0.57	
Curb Opening Performance Reduction Factor for Long Inlets	RF _{Curb} =	0.93	
Grated Inlet Performance Reduction Factor for Long Inlets	RF _{Grate} =	N/A	
Total Inlet Interception Capacity (assumes clogged condition)	MINOR	MAJOR	
Q_a =	8.3	25.5	cfs
Q_{PEAK REQUIRED} =	9.7	20.0	cfs

Total Inlet Interception Capacity (assumes clogged condition)

WARNING: Inlet Capacity less than Q Peak for Minor Storm

ALLOWABLE CAPACITY FOR ONE-HALF OF STREET (Minor & Major Storm)

(Based on Regulated Criteria for Maximum Allowable Flow Depth and Spread)

Project:

Monument Academy - Inlet C14.1 (Sump Condition)

Inlet ID:

Inlet C14.1

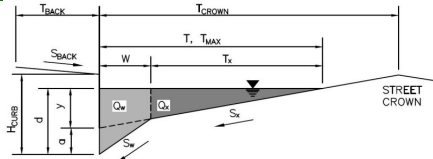

Gutter Geometry (Enter data in the blue cells)

Maximum Allowable Width for Spread Behind Curb
 Side Slope Behind Curb (leave blank for no conveyance credit behind curb)
 Manning's Roughness Behind Curb (typically between 0.012 and 0.020)
 Height of Curb at Gutter Flow Line
 Distance from Curb Face to Street Crown
 Gutter Width
 Street Transverse Slope
 Gutter Cross Slope (typically 2 inches over 24 inches or 0.083 ft/ft)
 Street Longitudinal Slope - Enter 0 for sump condition
 Manning's Roughness for Street Section (typically between 0.012 and 0.020)

$T_{BACK} = 4.0$ ft
 $S_{BACK} = 0.020$ ft/ft
 $n_{BACK} = 0.020$
 $H_{CURB} = 6.00$ inches
 $T_{CROWN} = 50.0$ ft
 $W = 2.00$ ft
 $S_X = 0.020$ ft/ft
 $S_W = 0.083$ ft/ft
 $S_D = 0.000$ ft/ft
 $n_{STREET} = 0.016$

Max. Allowable Spread for Minor & Major Storm
 Max. Allowable Depth at Gutter Flowline for Minor & Major Storm
 Check boxes are not applicable in SUMP conditions

	Minor Storm	Major Storm	
$T_{MAX} =$	50.0	50.0	ft
$d_{MAX} =$	6.0	12.0	inches
	<input type="checkbox"/>	<input type="checkbox"/>	

MINOR STORM Allowable Capacity is based on Depth Criterion
MAJOR STORM Allowable Capacity is based on Depth Criterion

	Minor Storm	Major Storm	
$Q_{allow} =$	SUMP	SUMP	cfs

ALLOWABLE CAPACITY FOR ONE-HALF OF STREET (Minor & Major Storm)

(Based on Regulated Criteria for Maximum Allowable Flow Depth and Spread)

Project: **Monument Academy - Inlet C14.2 (Sump Condition)**
 Inlet ID: **Inlet C14.2**

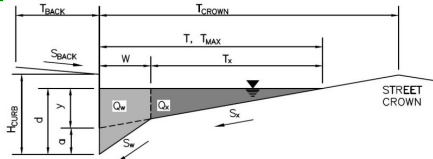

Gutter Geometry (Enter data in the blue cells)

Maximum Allowable Width for Spread Behind Curb
 Side Slope Behind Curb (leave blank for no conveyance credit behind curb)
 Manning's Roughness Behind Curb (typically between 0.012 and 0.020)
 Height of Curb at Gutter Flow Line
 Distance from Curb Face to Street Crown
 Gutter Width
 Street Transverse Slope
 Gutter Cross Slope (typically 2 inches over 24 inches or 0.083 ft/ft)
 Street Longitudinal Slope - Enter 0 for sump condition
 Manning's Roughness for Street Section (typically between 0.012 and 0.020)

$T_{BACK} = 4.0$ ft
 $S_{BACK} = 0.020$ ft/ft
 $n_{BACK} = 0.020$

$H_{CURB} = 6.00$ inches
 $T_{CROWN} = 50.0$ ft
 $W = 2.00$ ft
 $S_X = 0.020$ ft/ft
 $S_W = 0.083$ ft/ft
 $S_D = 0.000$ ft/ft
 $n_{STREET} = 0.016$

Max. Allowable Spread for Minor & Major Storm
 Max. Allowable Depth at Gutter Flowline for Minor & Major Storm
 Check boxes are not applicable in SUMP conditions

	Minor Storm	Major Storm	
$T_{MAX} =$	50.0	50.0	ft
$d_{MAX} =$	6.0	12.0	inches
	<input type="checkbox"/>	<input type="checkbox"/>	

MINOR STORM Allowable Capacity is based on Depth Criterion
MAJOR STORM Allowable Capacity is based on Depth Criterion

$Q_{allow} =$

Minor Storm	Major Storm	
SUMP	SUMP	cfs

ALLOWABLE CAPACITY FOR ONE-HALF OF STREET (Minor & Major Storm)

(Based on Regulated Criteria for Maximum Allowable Flow Depth and Spread)

Project: **Monument Academy - Inlet C14.3 (Sump Condition)**
 Inlet ID: **Inlet C14.3**

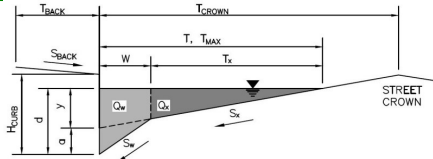

Gutter Geometry (Enter data in the blue cells)

Maximum Allowable Width for Spread Behind Curb
 Side Slope Behind Curb (leave blank for no conveyance credit behind curb)
 Manning's Roughness Behind Curb (typically between 0.012 and 0.020)
 Height of Curb at Gutter Flow Line
 Distance from Curb Face to Street Crown
 Gutter Width
 Street Transverse Slope
 Gutter Cross Slope (typically 2 inches over 24 inches or 0.083 ft/ft)
 Street Longitudinal Slope - Enter 0 for sump condition
 Manning's Roughness for Street Section (typically between 0.012 and 0.020)

T_{BACK} =	50.0	ft
S_{BACK} =	0.010	ft/ft
n_{BACK} =	0.020	
H_{CURB} =	0.00	inches
T_{CROWN} =	50.0	ft
W =	3.00	ft
S_X =	0.010	ft/ft
S_W =	0.083	ft/ft
S_D =	0.000	ft/ft
n_{STREET} =	0.020	
T_{MAX} =	Minor Storm: 50.0 Major Storm: 50.0	ft
d_{MAX} =	Minor Storm: 6.0 Major Storm: 12.0	inches
	<input type="checkbox"/>	<input type="checkbox"/>

Warning 02

Max. Allowable Spread for Minor & Major Storm
 Max. Allowable Depth at Gutter Flowline for Minor & Major Storm
 Check boxes are not applicable in SUMP conditions

MINOR STORM Allowable Capacity is based on Depth Criterion
MAJOR STORM Allowable Capacity is based on Depth Criterion

Q_{allow} =	Minor Storm: SUMP Major Storm: SUMP	cfs
---------------	--	-----

INLET IN A SUMP OR SAG LOCATION

Version 4.05 Released March 2017

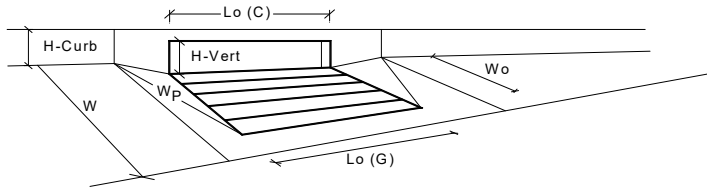

Design Information (Input)	MINOR	MAJOR	
Type of Inlet	CDOT Type C Grate		
Local Depression (additional to continuous gutter depression 'a' from above)	0.00	0.00	inches
Number of Unit Inlets (Grate or Curb Opening)	1	1	
Water Depth at Flowline (outside of local depression)	6.0	12.0	inches
Grate Information	MINOR	MAJOR	<input checked="" type="checkbox"/> Override Depths
Length of a Unit Grate	2.92	2.92	feet
Width of a Unit Grate	2.92	2.92	feet
Area Opening Ratio for a Grate (typical values 0.15-0.90)	0.70	0.70	
Clogging Factor for a Single Grate (typical value 0.50 - 0.70)	0.50	0.50	
Grate Weir Coefficient (typical value 2.15 - 3.60)	2.41	2.41	
Grate Orifice Coefficient (typical value 0.60 - 0.80)	0.67	0.67	
Curb Opening Information	MINOR	MAJOR	
Length of a Unit Curb Opening	N/A	N/A	feet
Height of Vertical Curb Opening in Inches	N/A	N/A	inches
Height of Curb Orifice Throat in Inches	N/A	N/A	inches
Angle of Throat (see USDCM Figure ST-5)	N/A	N/A	degrees
Side Width for Depression Pan (typically the gutter width of 2 feet)	N/A	N/A	feet
Clogging Factor for a Single Curb Opening (typical value 0.10)	N/A	N/A	
Curb Opening Weir Coefficient (typical value 2.3-3.7)	N/A	N/A	
Curb Opening Orifice Coefficient (typical value 0.60 - 0.70)	N/A	N/A	
Low Head Performance Reduction (Calculated)	MINOR	MAJOR	
Depth for Grate Midwidth	0.379	0.879	ft
Depth for Curb Opening Weir Equation	N/A	N/A	ft
Combination Inlet Performance Reduction Factor for Long Inlets	N/A	N/A	
Curb Opening Performance Reduction Factor for Long Inlets	N/A	N/A	
Grated Inlet Performance Reduction Factor for Long Inlets	0.95	1.00	
Total Inlet Interception Capacity (assumes clogged condition)	MINOR	MAJOR	
Q_a	2.0	7.3	cfs
Q_{PEAK REQUIRED}	4.1	12.7	cfs

WARNING: Inlet Capacity less than Q Peak for Minor and Major Storms

ALLOWABLE CAPACITY FOR ONE-HALF OF STREET (Minor & Major Storm)

(Based on Regulated Criteria for Maximum Allowable Flow Depth and Spread)

Project:

Monument Academy - Inlet C16 (Sump Condition)

Inlet ID:

Inlet C16

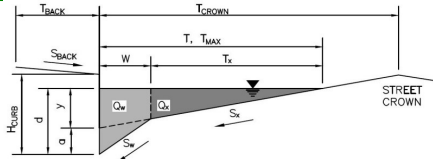

Gutter Geometry (Enter data in the blue cells)

Maximum Allowable Width for Spread Behind Curb
 Side Slope Behind Curb (leave blank for no conveyance credit behind curb)
 Manning's Roughness Behind Curb (typically between 0.012 and 0.020)
 Height of Curb at Gutter Flow Line
 Distance from Curb Face to Street Crown
 Gutter Width
 Street Transverse Slope
 Gutter Cross Slope (typically 2 inches over 24 inches or 0.083 ft/ft)
 Street Longitudinal Slope - Enter 0 for sump condition
 Manning's Roughness for Street Section (typically between 0.012 and 0.020)

$T_{BACK} = 13.0$ ft
 $S_{BACK} = 0.020$ ft/ft
 $n_{BACK} = 0.020$
 $H_{CURB} = 6.00$ inches
 $T_{CROWN} = 26.0$ ft
 $W = 2.00$ ft
 $S_X = 0.020$ ft/ft
 $S_W = 0.083$ ft/ft
 $S_D = 0.000$ ft/ft
 $n_{STREET} = 0.016$

Max. Allowable Spread for Minor & Major Storm
 Max. Allowable Depth at Gutter Flowline for Minor & Major Storm
 Check boxes are not applicable in SUMP conditions

	Minor Storm	Major Storm	
$T_{MAX} =$	26.0	26.0	ft
$d_{MAX} =$	6.0	12.0	inches
	<input type="checkbox"/>	<input type="checkbox"/>	

MINOR STORM Allowable Capacity is based on Depth Criterion
MAJOR STORM Allowable Capacity is based on Depth Criterion

$Q_{allow} =$

Minor Storm	Major Storm	
SUMP	SUMP	cfs

INLET IN A SUMP OR SAG LOCATION

Version 4.05 Released March 2017

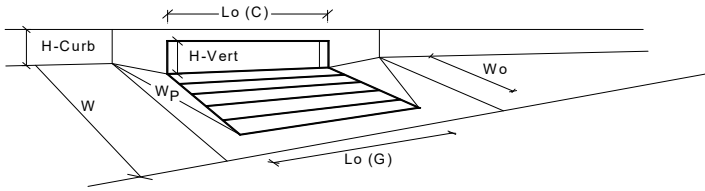

Design Information (Input)	MINOR		MAJOR																																																																																																																																													
Type of Inlet	CDOT Type R Curb Opening																																																																																																																																															
Local Depression (additional to continuous gutter depression 'a' from above)																																																																																																																																																
Number of Unit Inlets (Grate or Curb Opening)																																																																																																																																																
Water Depth at Flowline (outside of local depression)																																																																																																																																																
Grate Information																																																																																																																																																
Length of a Unit Grate																																																																																																																																																
Width of a Unit Grate																																																																																																																																																
Area Opening Ratio for a Grate (typical values 0.15-0.90)																																																																																																																																																
Clogging Factor for a Single Grate (typical value 0.50 - 0.70)																																																																																																																																																
Grate Weir Coefficient (typical value 2.15 - 3.60)																																																																																																																																																
Grate Orifice Coefficient (typical value 0.60 - 0.80)																																																																																																																																																
Curb Opening Information																																																																																																																																																
Length of a Unit Curb Opening																																																																																																																																																
Height of Vertical Curb Opening in Inches																																																																																																																																																
Height of Curb Orifice Throat in Inches																																																																																																																																																
Angle of Throat (see USDCM Figure ST-5)																																																																																																																																																
Side Width for Depression Pan (typically the gutter width of 2 feet)																																																																																																																																																
Clogging Factor for a Single Curb Opening (typical value 0.10)																																																																																																																																																
Curb Opening Weir Coefficient (typical value 2.3-3.7)																																																																																																																																																
Curb Opening Orifice Coefficient (typical value 0.60 - 0.70)																																																																																																																																																
Low Head Performance Reduction (Calculated)																																																																																																																																																
Depth for Grate Midwidth																																																																																																																																																
Depth for Curb Opening Weir Equation																																																																																																																																																
Combination Inlet Performance Reduction Factor for Long Inlets																																																																																																																																																
Curb Opening Performance Reduction Factor for Long Inlets																																																																																																																																																
Grated Inlet Performance Reduction Factor for Long Inlets																																																																																																																																																
Total Inlet Interception Capacity (assumes clogged condition)																																																																																																																																																
Inlet Capacity IS GOOD for Minor and Major Storms(>Q PEAK)																																																																																																																																																
<table border="1" style="margin-left: auto; margin-right: auto;"> <thead> <tr> <th></th> <th style="text-align: center;">MINOR</th> <th style="text-align: center;">MAJOR</th> <th></th> </tr> </thead> <tbody> <tr> <td>Type =</td> <td colspan="2" style="text-align: center;">CDOT Type R Curb Opening</td> <td></td> </tr> <tr> <td>ϕ_{local} =</td> <td style="text-align: center;">3.00</td> <td style="text-align: center;">3.00</td> <td>inches</td> </tr> <tr> <td>No =</td> <td style="text-align: center;">1</td> <td style="text-align: center;">1</td> <td></td> </tr> <tr> <td>Ponding Depth =</td> <td style="text-align: center;">6.0</td> <td style="text-align: center;">7.8</td> <td>inches</td> </tr> <tr> <td colspan="5" style="text-align: center;"> <table border="1" style="margin-left: auto; margin-right: auto;"> <thead> <tr> <th></th> <th style="text-align: center;">MINOR</th> <th style="text-align: center;">MAJOR</th> <th></th> </tr> </thead> <tbody> <tr> <td>L_o (G) =</td> <td style="text-align: center;">N/A</td> <td style="text-align: center;">N/A</td> <td>feet</td> </tr> <tr> <td>W_o =</td> <td style="text-align: center;">N/A</td> <td style="text-align: center;">N/A</td> <td>feet</td> </tr> <tr> <td>A_{ratio} =</td> <td style="text-align: center;">N/A</td> <td style="text-align: center;">N/A</td> <td></td> </tr> <tr> <td>C_l (G) =</td> <td style="text-align: center;">N/A</td> <td style="text-align: center;">N/A</td> <td></td> </tr> <tr> <td>C_w (G) =</td> <td style="text-align: center;">N/A</td> <td style="text-align: center;">N/A</td> <td></td> </tr> <tr> <td>C_o (G) =</td> <td style="text-align: center;">N/A</td> <td style="text-align: center;">N/A</td> <td></td> </tr> <tr> <td colspan="5" style="text-align: center;"> <table border="1" style="margin-left: auto; margin-right: auto;"> <thead> <tr> <th></th> <th style="text-align: center;">MINOR</th> <th style="text-align: center;">MAJOR</th> <th></th> </tr> </thead> <tbody> <tr> <td>L_o (C) =</td> <td style="text-align: center;">5.00</td> <td style="text-align: center;">5.00</td> <td>feet</td> </tr> <tr> <td>H_{vert} =</td> <td style="text-align: center;">6.00</td> <td style="text-align: center;">6.00</td> <td>inches</td> </tr> <tr> <td>H_{throat} =</td> <td style="text-align: center;">6.00</td> <td style="text-align: center;">6.00</td> <td>inches</td> </tr> <tr> <td>Theta =</td> <td style="text-align: center;">63.40</td> <td style="text-align: center;">63.40</td> <td>degrees</td> </tr> <tr> <td>W_p =</td> <td style="text-align: center;">2.00</td> <td style="text-align: center;">2.00</td> <td>feet</td> </tr> <tr> <td>C_l (C) =</td> <td style="text-align: center;">0.10</td> <td style="text-align: center;">0.10</td> <td></td> </tr> <tr> <td>C_w (C) =</td> <td style="text-align: center;">3.60</td> <td style="text-align: center;">3.60</td> <td></td> </tr> <tr> <td>C_o (C) =</td> <td style="text-align: center;">0.67</td> <td style="text-align: center;">0.67</td> <td></td> </tr> <tr> <td colspan="5" style="text-align: center;"> <table border="1" style="margin-left: auto; margin-right: auto;"> <thead> <tr> <th></th> <th style="text-align: center;">MINOR</th> <th style="text-align: center;">MAJOR</th> <th></th> </tr> </thead> <tbody> <tr> <td>d_{grate} =</td> <td style="text-align: center;">N/A</td> <td style="text-align: center;">N/A</td> <td>ft</td> </tr> <tr> <td>d_{curb} =</td> <td style="text-align: center;">0.33</td> <td style="text-align: center;">0.48</td> <td>ft</td> </tr> <tr> <td>$RF_{combination}$ =</td> <td style="text-align: center;">0.77</td> <td style="text-align: center;">0.99</td> <td></td> </tr> <tr> <td>RF_{curb} =</td> <td style="text-align: center;">1.00</td> <td style="text-align: center;">1.00</td> <td></td> </tr> <tr> <td>RF_{grate} =</td> <td style="text-align: center;">N/A</td> <td style="text-align: center;">N/A</td> <td></td> </tr> <tr> <td colspan="5" style="text-align: center;"> <table border="1" style="margin-left: auto; margin-right: auto;"> <thead> <tr> <th></th> <th style="text-align: center;">MINOR</th> <th style="text-align: center;">MAJOR</th> <th></th> </tr> </thead> <tbody> <tr> <td>Q_a =</td> <td style="text-align: center;">5.4</td> <td style="text-align: center;">8.9</td> <td>cfs</td> </tr> <tr> <td>$Q_{PEAK REQUIRED}$ =</td> <td style="text-align: center;">2.6</td> <td style="text-align: center;">4.3</td> <td>cfs</td> </tr> </tbody> </table> </td> </tr> </tbody> </table> </td> </tr> </tbody> </table> </td></tr></tbody></table></td></tr></tbody></table>						MINOR	MAJOR		Type =	CDOT Type R Curb Opening			ϕ_{local} =	3.00	3.00	inches	No =	1	1		Ponding Depth =	6.0	7.8	inches	<table border="1" style="margin-left: auto; margin-right: auto;"> <thead> <tr> <th></th> <th style="text-align: center;">MINOR</th> <th style="text-align: center;">MAJOR</th> <th></th> </tr> </thead> <tbody> <tr> <td>L_o (G) =</td> <td style="text-align: center;">N/A</td> <td style="text-align: center;">N/A</td> <td>feet</td> </tr> <tr> <td>W_o =</td> <td style="text-align: center;">N/A</td> <td style="text-align: center;">N/A</td> <td>feet</td> </tr> <tr> <td>A_{ratio} =</td> <td style="text-align: center;">N/A</td> <td style="text-align: center;">N/A</td> <td></td> </tr> <tr> <td>C_l (G) =</td> <td style="text-align: center;">N/A</td> <td style="text-align: center;">N/A</td> <td></td> </tr> <tr> <td>C_w (G) =</td> <td style="text-align: center;">N/A</td> <td style="text-align: center;">N/A</td> <td></td> </tr> <tr> <td>C_o (G) =</td> <td style="text-align: center;">N/A</td> <td style="text-align: center;">N/A</td> <td></td> </tr> <tr> <td colspan="5" style="text-align: center;"> <table border="1" style="margin-left: auto; margin-right: auto;"> <thead> <tr> <th></th> <th style="text-align: center;">MINOR</th> <th style="text-align: center;">MAJOR</th> <th></th> </tr> </thead> <tbody> <tr> <td>L_o (C) =</td> <td style="text-align: center;">5.00</td> <td style="text-align: center;">5.00</td> <td>feet</td> </tr> <tr> <td>H_{vert} =</td> <td style="text-align: center;">6.00</td> <td style="text-align: center;">6.00</td> <td>inches</td> </tr> <tr> <td>H_{throat} =</td> <td style="text-align: center;">6.00</td> <td style="text-align: center;">6.00</td> <td>inches</td> </tr> <tr> <td>Theta =</td> <td style="text-align: center;">63.40</td> <td style="text-align: center;">63.40</td> <td>degrees</td> </tr> <tr> <td>W_p =</td> <td style="text-align: center;">2.00</td> <td style="text-align: center;">2.00</td> <td>feet</td> </tr> <tr> <td>C_l (C) =</td> <td style="text-align: center;">0.10</td> <td style="text-align: center;">0.10</td> <td></td> </tr> <tr> <td>C_w (C) =</td> <td style="text-align: center;">3.60</td> <td style="text-align: center;">3.60</td> <td></td> </tr> <tr> <td>C_o (C) =</td> <td style="text-align: center;">0.67</td> <td style="text-align: center;">0.67</td> <td></td> </tr> <tr> <td colspan="5" style="text-align: center;"> <table border="1" style="margin-left: auto; margin-right: auto;"> <thead> <tr> <th></th> <th style="text-align: center;">MINOR</th> <th style="text-align: center;">MAJOR</th> <th></th> </tr> </thead> <tbody> <tr> <td>d_{grate} =</td> <td style="text-align: center;">N/A</td> <td style="text-align: center;">N/A</td> <td>ft</td> </tr> <tr> <td>d_{curb} =</td> <td style="text-align: center;">0.33</td> <td style="text-align: center;">0.48</td> <td>ft</td> </tr> <tr> <td>$RF_{combination}$ =</td> <td style="text-align: center;">0.77</td> <td style="text-align: center;">0.99</td> <td></td> </tr> <tr> <td>RF_{curb} =</td> <td style="text-align: center;">1.00</td> <td style="text-align: center;">1.00</td> <td></td> </tr> <tr> <td>RF_{grate} =</td> <td style="text-align: center;">N/A</td> <td style="text-align: center;">N/A</td> <td></td> </tr> <tr> <td colspan="5" style="text-align: center;"> <table border="1" style="margin-left: auto; margin-right: auto;"> <thead> <tr> <th></th> <th style="text-align: center;">MINOR</th> <th style="text-align: center;">MAJOR</th> <th></th> </tr> </thead> <tbody> <tr> <td>Q_a =</td> <td style="text-align: center;">5.4</td> <td style="text-align: center;">8.9</td> <td>cfs</td> </tr> <tr> <td>$Q_{PEAK REQUIRED}$ =</td> <td style="text-align: center;">2.6</td> <td style="text-align: center;">4.3</td> <td>cfs</td> </tr> </tbody> </table> </td> </tr> </tbody> </table> </td> </tr> </tbody> </table> </td></tr></tbody></table>						MINOR	MAJOR		L_o (G) =	N/A	N/A	feet	W_o =	N/A	N/A	feet	A_{ratio} =	N/A	N/A		C_l (G) =	N/A	N/A		C_w (G) =	N/A	N/A		C_o (G) =	N/A	N/A		<table border="1" style="margin-left: auto; margin-right: auto;"> <thead> <tr> <th></th> <th style="text-align: center;">MINOR</th> <th style="text-align: center;">MAJOR</th> <th></th> </tr> </thead> <tbody> <tr> <td>L_o (C) =</td> <td style="text-align: center;">5.00</td> <td style="text-align: center;">5.00</td> <td>feet</td> </tr> <tr> <td>H_{vert} =</td> <td style="text-align: center;">6.00</td> <td style="text-align: center;">6.00</td> <td>inches</td> </tr> <tr> <td>H_{throat} =</td> <td style="text-align: center;">6.00</td> <td style="text-align: center;">6.00</td> <td>inches</td> </tr> <tr> <td>Theta =</td> <td style="text-align: center;">63.40</td> <td style="text-align: center;">63.40</td> <td>degrees</td> </tr> <tr> <td>W_p =</td> <td style="text-align: center;">2.00</td> <td style="text-align: center;">2.00</td> <td>feet</td> </tr> <tr> <td>C_l (C) =</td> <td style="text-align: center;">0.10</td> <td style="text-align: center;">0.10</td> <td></td> </tr> <tr> <td>C_w (C) =</td> <td style="text-align: center;">3.60</td> <td style="text-align: center;">3.60</td> <td></td> </tr> <tr> <td>C_o (C) =</td> <td style="text-align: center;">0.67</td> <td style="text-align: center;">0.67</td> <td></td> </tr> <tr> <td colspan="5" style="text-align: center;"> <table border="1" style="margin-left: auto; margin-right: auto;"> <thead> <tr> <th></th> <th style="text-align: center;">MINOR</th> <th style="text-align: center;">MAJOR</th> <th></th> </tr> </thead> <tbody> <tr> <td>d_{grate} =</td> <td style="text-align: center;">N/A</td> <td style="text-align: center;">N/A</td> <td>ft</td> </tr> <tr> <td>d_{curb} =</td> <td style="text-align: center;">0.33</td> <td style="text-align: center;">0.48</td> <td>ft</td> </tr> <tr> <td>$RF_{combination}$ =</td> <td style="text-align: center;">0.77</td> <td style="text-align: center;">0.99</td> <td></td> </tr> <tr> <td>RF_{curb} =</td> <td style="text-align: center;">1.00</td> <td style="text-align: center;">1.00</td> <td></td> </tr> <tr> <td>RF_{grate} =</td> <td style="text-align: center;">N/A</td> <td style="text-align: center;">N/A</td> <td></td> </tr> <tr> <td colspan="5" style="text-align: center;"> <table border="1" style="margin-left: auto; margin-right: auto;"> <thead> <tr> <th></th> <th style="text-align: center;">MINOR</th> <th style="text-align: center;">MAJOR</th> <th></th> </tr> </thead> <tbody> <tr> <td>Q_a =</td> <td style="text-align: center;">5.4</td> <td style="text-align: center;">8.9</td> <td>cfs</td> </tr> <tr> <td>$Q_{PEAK REQUIRED}$ =</td> <td style="text-align: center;">2.6</td> <td style="text-align: center;">4.3</td> <td>cfs</td> </tr> </tbody> </table> </td> </tr> </tbody> </table> </td> </tr> </tbody> </table>						MINOR	MAJOR		L_o (C) =	5.00	5.00	feet	H_{vert} =	6.00	6.00	inches	H_{throat} =	6.00	6.00	inches	Theta =	63.40	63.40	degrees	W_p =	2.00	2.00	feet	C_l (C) =	0.10	0.10		C_w (C) =	3.60	3.60		C_o (C) =	0.67	0.67		<table border="1" style="margin-left: auto; margin-right: auto;"> <thead> <tr> <th></th> <th style="text-align: center;">MINOR</th> <th style="text-align: center;">MAJOR</th> <th></th> </tr> </thead> <tbody> <tr> <td>d_{grate} =</td> <td style="text-align: center;">N/A</td> <td style="text-align: center;">N/A</td> <td>ft</td> </tr> <tr> <td>d_{curb} =</td> <td style="text-align: center;">0.33</td> <td style="text-align: center;">0.48</td> <td>ft</td> </tr> <tr> <td>$RF_{combination}$ =</td> <td style="text-align: center;">0.77</td> <td style="text-align: center;">0.99</td> <td></td> </tr> <tr> <td>RF_{curb} =</td> <td style="text-align: center;">1.00</td> <td style="text-align: center;">1.00</td> <td></td> </tr> <tr> <td>RF_{grate} =</td> <td style="text-align: center;">N/A</td> <td style="text-align: center;">N/A</td> <td></td> </tr> <tr> <td colspan="5" style="text-align: center;"> <table border="1" style="margin-left: auto; margin-right: auto;"> <thead> <tr> <th></th> <th style="text-align: center;">MINOR</th> <th style="text-align: center;">MAJOR</th> <th></th> </tr> </thead> <tbody> <tr> <td>Q_a =</td> <td style="text-align: center;">5.4</td> <td style="text-align: center;">8.9</td> <td>cfs</td> </tr> <tr> <td>$Q_{PEAK REQUIRED}$ =</td> <td style="text-align: center;">2.6</td> <td style="text-align: center;">4.3</td> <td>cfs</td> </tr> </tbody> </table> </td> </tr> </tbody> </table>						MINOR	MAJOR		d_{grate} =	N/A	N/A	ft	d_{curb} =	0.33	0.48	ft	$RF_{combination}$ =	0.77	0.99		RF_{curb} =	1.00	1.00		RF_{grate} =	N/A	N/A		<table border="1" style="margin-left: auto; margin-right: auto;"> <thead> <tr> <th></th> <th style="text-align: center;">MINOR</th> <th style="text-align: center;">MAJOR</th> <th></th> </tr> </thead> <tbody> <tr> <td>Q_a =</td> <td style="text-align: center;">5.4</td> <td style="text-align: center;">8.9</td> <td>cfs</td> </tr> <tr> <td>$Q_{PEAK REQUIRED}$ =</td> <td style="text-align: center;">2.6</td> <td style="text-align: center;">4.3</td> <td>cfs</td> </tr> </tbody> </table>						MINOR	MAJOR		Q_a =	5.4	8.9	cfs	$Q_{PEAK REQUIRED}$ =	2.6	4.3	cfs
	MINOR	MAJOR																																																																																																																																														
Type =	CDOT Type R Curb Opening																																																																																																																																															
ϕ_{local} =	3.00	3.00	inches																																																																																																																																													
No =	1	1																																																																																																																																														
Ponding Depth =	6.0	7.8	inches																																																																																																																																													
<table border="1" style="margin-left: auto; margin-right: auto;"> <thead> <tr> <th></th> <th style="text-align: center;">MINOR</th> <th style="text-align: center;">MAJOR</th> <th></th> </tr> </thead> <tbody> <tr> <td>L_o (G) =</td> <td style="text-align: center;">N/A</td> <td style="text-align: center;">N/A</td> <td>feet</td> </tr> <tr> <td>W_o =</td> <td style="text-align: center;">N/A</td> <td style="text-align: center;">N/A</td> <td>feet</td> </tr> <tr> <td>A_{ratio} =</td> <td style="text-align: center;">N/A</td> <td style="text-align: center;">N/A</td> <td></td> </tr> <tr> <td>C_l (G) =</td> <td style="text-align: center;">N/A</td> <td style="text-align: center;">N/A</td> <td></td> </tr> <tr> <td>C_w (G) =</td> <td style="text-align: center;">N/A</td> <td style="text-align: center;">N/A</td> <td></td> </tr> <tr> <td>C_o (G) =</td> <td style="text-align: center;">N/A</td> <td style="text-align: center;">N/A</td> <td></td> </tr> <tr> <td colspan="5" style="text-align: center;"> <table border="1" style="margin-left: auto; margin-right: auto;"> <thead> <tr> <th></th> <th style="text-align: center;">MINOR</th> <th style="text-align: center;">MAJOR</th> <th></th> </tr> </thead> <tbody> <tr> <td>L_o (C) =</td> <td style="text-align: center;">5.00</td> <td style="text-align: center;">5.00</td> <td>feet</td> </tr> <tr> <td>H_{vert} =</td> <td style="text-align: center;">6.00</td> <td style="text-align: center;">6.00</td> <td>inches</td> </tr> <tr> <td>H_{throat} =</td> <td style="text-align: center;">6.00</td> <td style="text-align: center;">6.00</td> <td>inches</td> </tr> <tr> <td>Theta =</td> <td style="text-align: center;">63.40</td> <td style="text-align: center;">63.40</td> <td>degrees</td> </tr> <tr> <td>W_p =</td> <td style="text-align: center;">2.00</td> <td style="text-align: center;">2.00</td> <td>feet</td> </tr> <tr> <td>C_l (C) =</td> <td style="text-align: center;">0.10</td> <td style="text-align: center;">0.10</td> <td></td> </tr> <tr> <td>C_w (C) =</td> <td style="text-align: center;">3.60</td> <td style="text-align: center;">3.60</td> <td></td> </tr> <tr> <td>C_o (C) =</td> <td style="text-align: center;">0.67</td> <td style="text-align: center;">0.67</td> <td></td> </tr> <tr> <td colspan="5" style="text-align: center;"> <table border="1" style="margin-left: auto; margin-right: auto;"> <thead> <tr> <th></th> <th style="text-align: center;">MINOR</th> <th style="text-align: center;">MAJOR</th> <th></th> </tr> </thead> <tbody> <tr> <td>d_{grate} =</td> <td style="text-align: center;">N/A</td> <td style="text-align: center;">N/A</td> <td>ft</td> </tr> <tr> <td>d_{curb} =</td> <td style="text-align: center;">0.33</td> <td style="text-align: center;">0.48</td> <td>ft</td> </tr> <tr> <td>$RF_{combination}$ =</td> <td style="text-align: center;">0.77</td> <td style="text-align: center;">0.99</td> <td></td> </tr> <tr> <td>RF_{curb} =</td> <td style="text-align: center;">1.00</td> <td style="text-align: center;">1.00</td> <td></td> </tr> <tr> <td>RF_{grate} =</td> <td style="text-align: center;">N/A</td> <td style="text-align: center;">N/A</td> <td></td> </tr> <tr> <td colspan="5" style="text-align: center;"> <table border="1" style="margin-left: auto; margin-right: auto;"> <thead> <tr> <th></th> <th style="text-align: center;">MINOR</th> <th style="text-align: center;">MAJOR</th> <th></th> </tr> </thead> <tbody> <tr> <td>Q_a =</td> <td style="text-align: center;">5.4</td> <td style="text-align: center;">8.9</td> <td>cfs</td> </tr> <tr> <td>$Q_{PEAK REQUIRED}$ =</td> <td style="text-align: center;">2.6</td> <td style="text-align: center;">4.3</td> <td>cfs</td> </tr> </tbody> </table> </td> </tr> </tbody> </table> </td> </tr> </tbody> </table> </td></tr></tbody></table>						MINOR	MAJOR		L_o (G) =	N/A	N/A	feet	W_o =	N/A	N/A	feet	A_{ratio} =	N/A	N/A		C_l (G) =	N/A	N/A		C_w (G) =	N/A	N/A		C_o (G) =	N/A	N/A		<table border="1" style="margin-left: auto; margin-right: auto;"> <thead> <tr> <th></th> <th style="text-align: center;">MINOR</th> <th style="text-align: center;">MAJOR</th> <th></th> </tr> </thead> <tbody> <tr> <td>L_o (C) =</td> <td style="text-align: center;">5.00</td> <td style="text-align: center;">5.00</td> <td>feet</td> </tr> <tr> <td>H_{vert} =</td> <td style="text-align: center;">6.00</td> <td style="text-align: center;">6.00</td> <td>inches</td> </tr> <tr> <td>H_{throat} =</td> <td style="text-align: center;">6.00</td> <td style="text-align: center;">6.00</td> <td>inches</td> </tr> <tr> <td>Theta =</td> <td style="text-align: center;">63.40</td> <td style="text-align: center;">63.40</td> <td>degrees</td> </tr> <tr> <td>W_p =</td> <td style="text-align: center;">2.00</td> <td style="text-align: center;">2.00</td> <td>feet</td> </tr> <tr> <td>C_l (C) =</td> <td style="text-align: center;">0.10</td> <td style="text-align: center;">0.10</td> <td></td> </tr> <tr> <td>C_w (C) =</td> <td style="text-align: center;">3.60</td> <td style="text-align: center;">3.60</td> <td></td> </tr> <tr> <td>C_o (C) =</td> <td style="text-align: center;">0.67</td> <td style="text-align: center;">0.67</td> <td></td> </tr> <tr> <td colspan="5" style="text-align: center;"> <table border="1" style="margin-left: auto; margin-right: auto;"> <thead> <tr> <th></th> <th style="text-align: center;">MINOR</th> <th style="text-align: center;">MAJOR</th> <th></th> </tr> </thead> <tbody> <tr> <td>d_{grate} =</td> <td style="text-align: center;">N/A</td> <td style="text-align: center;">N/A</td> <td>ft</td> </tr> <tr> <td>d_{curb} =</td> <td style="text-align: center;">0.33</td> <td style="text-align: center;">0.48</td> <td>ft</td> </tr> <tr> <td>$RF_{combination}$ =</td> <td style="text-align: center;">0.77</td> <td style="text-align: center;">0.99</td> <td></td> </tr> <tr> <td>RF_{curb} =</td> <td style="text-align: center;">1.00</td> <td style="text-align: center;">1.00</td> <td></td> </tr> <tr> <td>RF_{grate} =</td> <td style="text-align: center;">N/A</td> <td style="text-align: center;">N/A</td> <td></td> </tr> <tr> <td colspan="5" style="text-align: center;"> <table border="1" style="margin-left: auto; margin-right: auto;"> <thead> <tr> <th></th> <th style="text-align: center;">MINOR</th> <th style="text-align: center;">MAJOR</th> <th></th> </tr> </thead> <tbody> <tr> <td>Q_a =</td> <td style="text-align: center;">5.4</td> <td style="text-align: center;">8.9</td> <td>cfs</td> </tr> <tr> <td>$Q_{PEAK REQUIRED}$ =</td> <td style="text-align: center;">2.6</td> <td style="text-align: center;">4.3</td> <td>cfs</td> </tr> </tbody> </table> </td> </tr> </tbody> </table> </td> </tr> </tbody> </table>						MINOR	MAJOR		L_o (C) =	5.00	5.00	feet	H_{vert} =	6.00	6.00	inches	H_{throat} =	6.00	6.00	inches	Theta =	63.40	63.40	degrees	W_p =	2.00	2.00	feet	C_l (C) =	0.10	0.10		C_w (C) =	3.60	3.60		C_o (C) =	0.67	0.67		<table border="1" style="margin-left: auto; margin-right: auto;"> <thead> <tr> <th></th> <th style="text-align: center;">MINOR</th> <th style="text-align: center;">MAJOR</th> <th></th> </tr> </thead> <tbody> <tr> <td>d_{grate} =</td> <td style="text-align: center;">N/A</td> <td style="text-align: center;">N/A</td> <td>ft</td> </tr> <tr> <td>d_{curb} =</td> <td style="text-align: center;">0.33</td> <td style="text-align: center;">0.48</td> <td>ft</td> </tr> <tr> <td>$RF_{combination}$ =</td> <td style="text-align: center;">0.77</td> <td style="text-align: center;">0.99</td> <td></td> </tr> <tr> <td>RF_{curb} =</td> <td style="text-align: center;">1.00</td> <td style="text-align: center;">1.00</td> <td></td> </tr> <tr> <td>RF_{grate} =</td> <td style="text-align: center;">N/A</td> <td style="text-align: center;">N/A</td> <td></td> </tr> <tr> <td colspan="5" style="text-align: center;"> <table border="1" style="margin-left: auto; margin-right: auto;"> <thead> <tr> <th></th> <th style="text-align: center;">MINOR</th> <th style="text-align: center;">MAJOR</th> <th></th> </tr> </thead> <tbody> <tr> <td>Q_a =</td> <td style="text-align: center;">5.4</td> <td style="text-align: center;">8.9</td> <td>cfs</td> </tr> <tr> <td>$Q_{PEAK REQUIRED}$ =</td> <td style="text-align: center;">2.6</td> <td style="text-align: center;">4.3</td> <td>cfs</td> </tr> </tbody> </table> </td> </tr> </tbody> </table>						MINOR	MAJOR		d_{grate} =	N/A	N/A	ft	d_{curb} =	0.33	0.48	ft	$RF_{combination}$ =	0.77	0.99		RF_{curb} =	1.00	1.00		RF_{grate} =	N/A	N/A		<table border="1" style="margin-left: auto; margin-right: auto;"> <thead> <tr> <th></th> <th style="text-align: center;">MINOR</th> <th style="text-align: center;">MAJOR</th> <th></th> </tr> </thead> <tbody> <tr> <td>Q_a =</td> <td style="text-align: center;">5.4</td> <td style="text-align: center;">8.9</td> <td>cfs</td> </tr> <tr> <td>$Q_{PEAK REQUIRED}$ =</td> <td style="text-align: center;">2.6</td> <td style="text-align: center;">4.3</td> <td>cfs</td> </tr> </tbody> </table>						MINOR	MAJOR		Q_a =	5.4	8.9	cfs	$Q_{PEAK REQUIRED}$ =	2.6	4.3	cfs																									
	MINOR	MAJOR																																																																																																																																														
L_o (G) =	N/A	N/A	feet																																																																																																																																													
W_o =	N/A	N/A	feet																																																																																																																																													
A_{ratio} =	N/A	N/A																																																																																																																																														
C_l (G) =	N/A	N/A																																																																																																																																														
C_w (G) =	N/A	N/A																																																																																																																																														
C_o (G) =	N/A	N/A																																																																																																																																														
<table border="1" style="margin-left: auto; margin-right: auto;"> <thead> <tr> <th></th> <th style="text-align: center;">MINOR</th> <th style="text-align: center;">MAJOR</th> <th></th> </tr> </thead> <tbody> <tr> <td>L_o (C) =</td> <td style="text-align: center;">5.00</td> <td style="text-align: center;">5.00</td> <td>feet</td> </tr> <tr> <td>H_{vert} =</td> <td style="text-align: center;">6.00</td> <td style="text-align: center;">6.00</td> <td>inches</td> </tr> <tr> <td>H_{throat} =</td> <td style="text-align: center;">6.00</td> <td style="text-align: center;">6.00</td> <td>inches</td> </tr> <tr> <td>Theta =</td> <td style="text-align: center;">63.40</td> <td style="text-align: center;">63.40</td> <td>degrees</td> </tr> <tr> <td>W_p =</td> <td style="text-align: center;">2.00</td> <td style="text-align: center;">2.00</td> <td>feet</td> </tr> <tr> <td>C_l (C) =</td> <td style="text-align: center;">0.10</td> <td style="text-align: center;">0.10</td> <td></td> </tr> <tr> <td>C_w (C) =</td> <td style="text-align: center;">3.60</td> <td style="text-align: center;">3.60</td> <td></td> </tr> <tr> <td>C_o (C) =</td> <td style="text-align: center;">0.67</td> <td style="text-align: center;">0.67</td> <td></td> </tr> <tr> <td colspan="5" style="text-align: center;"> <table border="1" style="margin-left: auto; margin-right: auto;"> <thead> <tr> <th></th> <th style="text-align: center;">MINOR</th> <th style="text-align: center;">MAJOR</th> <th></th> </tr> </thead> <tbody> <tr> <td>d_{grate} =</td> <td style="text-align: center;">N/A</td> <td style="text-align: center;">N/A</td> <td>ft</td> </tr> <tr> <td>d_{curb} =</td> <td style="text-align: center;">0.33</td> <td style="text-align: center;">0.48</td> <td>ft</td> </tr> <tr> <td>$RF_{combination}$ =</td> <td style="text-align: center;">0.77</td> <td style="text-align: center;">0.99</td> <td></td> </tr> <tr> <td>RF_{curb} =</td> <td style="text-align: center;">1.00</td> <td style="text-align: center;">1.00</td> <td></td> </tr> <tr> <td>RF_{grate} =</td> <td style="text-align: center;">N/A</td> <td style="text-align: center;">N/A</td> <td></td> </tr> <tr> <td colspan="5" style="text-align: center;"> <table border="1" style="margin-left: auto; margin-right: auto;"> <thead> <tr> <th></th> <th style="text-align: center;">MINOR</th> <th style="text-align: center;">MAJOR</th> <th></th> </tr> </thead> <tbody> <tr> <td>Q_a =</td> <td style="text-align: center;">5.4</td> <td style="text-align: center;">8.9</td> <td>cfs</td> </tr> <tr> <td>$Q_{PEAK REQUIRED}$ =</td> <td style="text-align: center;">2.6</td> <td style="text-align: center;">4.3</td> <td>cfs</td> </tr> </tbody> </table> </td> </tr> </tbody> </table> </td> </tr> </tbody> </table>						MINOR	MAJOR		L_o (C) =	5.00	5.00	feet	H_{vert} =	6.00	6.00	inches	H_{throat} =	6.00	6.00	inches	Theta =	63.40	63.40	degrees	W_p =	2.00	2.00	feet	C_l (C) =	0.10	0.10		C_w (C) =	3.60	3.60		C_o (C) =	0.67	0.67		<table border="1" style="margin-left: auto; margin-right: auto;"> <thead> <tr> <th></th> <th style="text-align: center;">MINOR</th> <th style="text-align: center;">MAJOR</th> <th></th> </tr> </thead> <tbody> <tr> <td>d_{grate} =</td> <td style="text-align: center;">N/A</td> <td style="text-align: center;">N/A</td> <td>ft</td> </tr> <tr> <td>d_{curb} =</td> <td style="text-align: center;">0.33</td> <td style="text-align: center;">0.48</td> <td>ft</td> </tr> <tr> <td>$RF_{combination}$ =</td> <td style="text-align: center;">0.77</td> <td style="text-align: center;">0.99</td> <td></td> </tr> <tr> <td>RF_{curb} =</td> <td style="text-align: center;">1.00</td> <td style="text-align: center;">1.00</td> <td></td> </tr> <tr> <td>RF_{grate} =</td> <td style="text-align: center;">N/A</td> <td style="text-align: center;">N/A</td> <td></td> </tr> <tr> <td colspan="5" style="text-align: center;"> <table border="1" style="margin-left: auto; margin-right: auto;"> <thead> <tr> <th></th> <th style="text-align: center;">MINOR</th> <th style="text-align: center;">MAJOR</th> <th></th> </tr> </thead> <tbody> <tr> <td>Q_a =</td> <td style="text-align: center;">5.4</td> <td style="text-align: center;">8.9</td> <td>cfs</td> </tr> <tr> <td>$Q_{PEAK REQUIRED}$ =</td> <td style="text-align: center;">2.6</td> <td style="text-align: center;">4.3</td> <td>cfs</td> </tr> </tbody> </table> </td> </tr> </tbody> </table>						MINOR	MAJOR		d_{grate} =	N/A	N/A	ft	d_{curb} =	0.33	0.48	ft	$RF_{combination}$ =	0.77	0.99		RF_{curb} =	1.00	1.00		RF_{grate} =	N/A	N/A		<table border="1" style="margin-left: auto; margin-right: auto;"> <thead> <tr> <th></th> <th style="text-align: center;">MINOR</th> <th style="text-align: center;">MAJOR</th> <th></th> </tr> </thead> <tbody> <tr> <td>Q_a =</td> <td style="text-align: center;">5.4</td> <td style="text-align: center;">8.9</td> <td>cfs</td> </tr> <tr> <td>$Q_{PEAK REQUIRED}$ =</td> <td style="text-align: center;">2.6</td> <td style="text-align: center;">4.3</td> <td>cfs</td> </tr> </tbody> </table>						MINOR	MAJOR		Q_a =	5.4	8.9	cfs	$Q_{PEAK REQUIRED}$ =	2.6	4.3	cfs																																																										
	MINOR	MAJOR																																																																																																																																														
L_o (C) =	5.00	5.00	feet																																																																																																																																													
H_{vert} =	6.00	6.00	inches																																																																																																																																													
H_{throat} =	6.00	6.00	inches																																																																																																																																													
Theta =	63.40	63.40	degrees																																																																																																																																													
W_p =	2.00	2.00	feet																																																																																																																																													
C_l (C) =	0.10	0.10																																																																																																																																														
C_w (C) =	3.60	3.60																																																																																																																																														
C_o (C) =	0.67	0.67																																																																																																																																														
<table border="1" style="margin-left: auto; margin-right: auto;"> <thead> <tr> <th></th> <th style="text-align: center;">MINOR</th> <th style="text-align: center;">MAJOR</th> <th></th> </tr> </thead> <tbody> <tr> <td>d_{grate} =</td> <td style="text-align: center;">N/A</td> <td style="text-align: center;">N/A</td> <td>ft</td> </tr> <tr> <td>d_{curb} =</td> <td style="text-align: center;">0.33</td> <td style="text-align: center;">0.48</td> <td>ft</td> </tr> <tr> <td>$RF_{combination}$ =</td> <td style="text-align: center;">0.77</td> <td style="text-align: center;">0.99</td> <td></td> </tr> <tr> <td>RF_{curb} =</td> <td style="text-align: center;">1.00</td> <td style="text-align: center;">1.00</td> <td></td> </tr> <tr> <td>RF_{grate} =</td> <td style="text-align: center;">N/A</td> <td style="text-align: center;">N/A</td> <td></td> </tr> <tr> <td colspan="5" style="text-align: center;"> <table border="1" style="margin-left: auto; margin-right: auto;"> <thead> <tr> <th></th> <th style="text-align: center;">MINOR</th> <th style="text-align: center;">MAJOR</th> <th></th> </tr> </thead> <tbody> <tr> <td>Q_a =</td> <td style="text-align: center;">5.4</td> <td style="text-align: center;">8.9</td> <td>cfs</td> </tr> <tr> <td>$Q_{PEAK REQUIRED}$ =</td> <td style="text-align: center;">2.6</td> <td style="text-align: center;">4.3</td> <td>cfs</td> </tr> </tbody> </table> </td> </tr> </tbody> </table>						MINOR	MAJOR		d_{grate} =	N/A	N/A	ft	d_{curb} =	0.33	0.48	ft	$RF_{combination}$ =	0.77	0.99		RF_{curb} =	1.00	1.00		RF_{grate} =	N/A	N/A		<table border="1" style="margin-left: auto; margin-right: auto;"> <thead> <tr> <th></th> <th style="text-align: center;">MINOR</th> <th style="text-align: center;">MAJOR</th> <th></th> </tr> </thead> <tbody> <tr> <td>Q_a =</td> <td style="text-align: center;">5.4</td> <td style="text-align: center;">8.9</td> <td>cfs</td> </tr> <tr> <td>$Q_{PEAK REQUIRED}$ =</td> <td style="text-align: center;">2.6</td> <td style="text-align: center;">4.3</td> <td>cfs</td> </tr> </tbody> </table>						MINOR	MAJOR		Q_a =	5.4	8.9	cfs	$Q_{PEAK REQUIRED}$ =	2.6	4.3	cfs																																																																																																			
	MINOR	MAJOR																																																																																																																																														
d_{grate} =	N/A	N/A	ft																																																																																																																																													
d_{curb} =	0.33	0.48	ft																																																																																																																																													
$RF_{combination}$ =	0.77	0.99																																																																																																																																														
RF_{curb} =	1.00	1.00																																																																																																																																														
RF_{grate} =	N/A	N/A																																																																																																																																														
<table border="1" style="margin-left: auto; margin-right: auto;"> <thead> <tr> <th></th> <th style="text-align: center;">MINOR</th> <th style="text-align: center;">MAJOR</th> <th></th> </tr> </thead> <tbody> <tr> <td>Q_a =</td> <td style="text-align: center;">5.4</td> <td style="text-align: center;">8.9</td> <td>cfs</td> </tr> <tr> <td>$Q_{PEAK REQUIRED}$ =</td> <td style="text-align: center;">2.6</td> <td style="text-align: center;">4.3</td> <td>cfs</td> </tr> </tbody> </table>						MINOR	MAJOR		Q_a =	5.4	8.9	cfs	$Q_{PEAK REQUIRED}$ =	2.6	4.3	cfs																																																																																																																																
	MINOR	MAJOR																																																																																																																																														
Q_a =	5.4	8.9	cfs																																																																																																																																													
$Q_{PEAK REQUIRED}$ =	2.6	4.3	cfs																																																																																																																																													

**MONUMENT ACADEMY
STORM SEWER SIZING SUMMARY**

		PIPE FLOW		PIPE CAPACITY		
PIPE	INLETS	Q5 FLOW (CFS)	Q100 FLOW (CFS)	PIPE SIZE	MIN. PIPE SLOPE	FULL PIPE CAPACITY (CFS)
M2.1	M2.1	7.8	16.0	18	4.1%	21.3
M2.2A	M2.2A	0.5	1.1	15	0.5%	4.6
M2.2B	M2.2A.,2.2B	2.4	5.1	18	2.0%	14.9
M2.3	M2.1-M2.3	19.9	41.1	30	4.9%	90.8
C14.1	C14.1	2.1	6.3	18	2.0%	14.9
C14.2	C14.1-C14.2	6.9	21.2	24	1.0%	22.6
C14.3	C14.1-C14.3	11.0	33.8	24	18.0%	96.0
C15	C15	1.8	3.1	18	1.0%	10.5
C16	C15,C16	4.4	7.4	18	2.5%	16.6

ASSUMPTIONS:

1. STORM DRAIN PIPE ASSUMED TO BE RCP OR HDPE

Hydraulic Analysis Report

Project Data

Project Title: MA
Designer: JPS
Project Date: Tuesday, January 29, 2019
Project Units: U.S. Customary Units
Notes:

Channel Analysis: SD-M2.1

Notes:

Input Parameters

Channel Type: Circular
Pipe Diameter: 1.5000 ft
Longitudinal Slope: 0.0410 ft/ft
Manning's n: 0.0130
Depth: 1.5000 ft

Result Parameters

Flow: 21.2697 cfs
Area of Flow: 1.7671 ft²
Wetted Perimeter: 4.7124 ft
Hydraulic Radius: 0.3750 ft
Average Velocity: 12.0362 ft/s
Top Width: 0.0000 ft
Froude Number: 0.0000
Critical Depth: 1.4744 ft
Critical Velocity: 12.0818 ft/s
Critical Slope: 0.0370 ft/ft
Critical Top Width: 0.39 ft
Calculated Max Shear Stress: 3.8376 lb/ft²
Calculated Avg Shear Stress: 0.9594 lb/ft²

Channel Analysis: SD-M2.2A

Notes:

Input Parameters

Channel Type: Circular
Pipe Diameter: 1.2500 ft
Longitudinal Slope: 0.0050 ft/ft
Manning's n: 0.0130
Depth: 1.2500 ft

Result Parameters

Flow: 4.5678 cfs
Area of Flow: 1.2272 ft²
Wetted Perimeter: 3.9270 ft
Hydraulic Radius: 0.3125 ft
Average Velocity: 3.7221 ft/s
Top Width: 0.0000 ft
Froude Number: 0.0000
Critical Depth: 0.8661 ft
Critical Velocity: 5.0344 ft/s
Critical Slope: 0.0073 ft/ft
Critical Top Width: 1.15 ft
Calculated Max Shear Stress: 0.3900 lb/ft²
Calculated Avg Shear Stress: 0.0975 lb/ft²

Channel Analysis: SD-M2.2B

Notes:

Input Parameters

Channel Type: Circular
Pipe Diameter: 1.5000 ft
Longitudinal Slope: 0.0200 ft/ft
Manning's n: 0.0130
Depth: 1.5000 ft

Result Parameters

Flow: 14.8554 cfs
Area of Flow: 1.7671 ft²
Wetted Perimeter: 4.7124 ft
Hydraulic Radius: 0.3750 ft
Average Velocity: 8.4064 ft/s
Top Width: 0.0000 ft
Froude Number: 0.0000
Critical Depth: 1.4026 ft
Critical Velocity: 8.6445 ft/s
Critical Slope: 0.0173 ft/ft
Critical Top Width: 0.74 ft
Calculated Max Shear Stress: 1.8720 lb/ft²
Calculated Avg Shear Stress: 0.4680 lb/ft²

Channel Analysis: SD-M2.3

Notes:

Input Parameters

Channel Type: Circular
Pipe Diameter: 2.5000 ft
Longitudinal Slope: 0.0490 ft/ft
Manning's n: 0.0130
Depth: 2.5000 ft

Result Parameters

Flow: 90.7953 cfs
Area of Flow: 4.9087 ft²
Wetted Perimeter: 7.8540 ft
Hydraulic Radius: 0.6250 ft
Average Velocity: 18.4967 ft/s
Top Width: 0.0000 ft
Froude Number: 0.0000
Critical Depth: 2.4786 ft
Critical Velocity: 18.5214 ft/s
Critical Slope: 0.0454 ft/ft
Critical Top Width: 0.46 ft
Calculated Max Shear Stress: 7.6440 lb/ft²
Calculated Avg Shear Stress: 1.9110 lb/ft²

Channel Analysis: SD-C14.1

Notes:

Input Parameters

Channel Type: Circular
Pipe Diameter: 1.5000 ft
Longitudinal Slope: 0.0200 ft/ft
Manning's n: 0.0130
Depth: 1.5000 ft

Result Parameters

Flow: 14.8554 cfs
Area of Flow: 1.7671 ft²
Wetted Perimeter: 4.7124 ft
Hydraulic Radius: 0.3750 ft
Average Velocity: 8.4064 ft/s
Top Width: 0.0000 ft
Froude Number: 0.0000
Critical Depth: 1.4026 ft
Critical Velocity: 8.6445 ft/s
Critical Slope: 0.0173 ft/ft
Critical Top Width: 0.74 ft
Calculated Max Shear Stress: 1.8720 lb/ft²
Calculated Avg Shear Stress: 0.4680 lb/ft²

Channel Analysis: SD-C14.2

Notes:

Input Parameters

Channel Type: Circular
Pipe Diameter: 2.0000 ft
Longitudinal Slope: 0.0100 ft/ft
Manning's n: 0.0130
Depth: 2.0000 ft

Result Parameters

Flow: 22.6224 cfs
Area of Flow: 3.1416 ft²
Wetted Perimeter: 6.2832 ft
Hydraulic Radius: 0.5000 ft
Average Velocity: 7.2009 ft/s
Top Width: 0.0000 ft
Froude Number: 0.0000
Critical Depth: 1.6953 ft
Critical Velocity: 7.9674 ft/s
Critical Slope: 0.0095 ft/ft
Critical Top Width: 1.44 ft
Calculated Max Shear Stress: 1.2480 lb/ft²
Calculated Avg Shear Stress: 0.3120 lb/ft²

Channel Analysis: SD-C14.3

Notes:

Input Parameters

Channel Type: Circular
Pipe Diameter: 2.0000 ft
Longitudinal Slope: 0.1800 ft/ft
Manning's n: 0.0130
Depth: 2.0000 ft

Result Parameters

Flow: 95.9787 cfs
Area of Flow: 3.1416 ft²
Wetted Perimeter: 6.2832 ft
Hydraulic Radius: 0.5000 ft
Average Velocity: 30.5510 ft/s
Top Width: 0.0000 ft
Froude Number: 0.0000
Critical Depth: 1.9985 ft
Critical Velocity: 30.5520 ft/s
Critical Slope: 0.1759 ft/ft
Critical Top Width: 0.11 ft
Calculated Max Shear Stress: 22.4640 lb/ft²
Calculated Avg Shear Stress: 5.6160 lb/ft²

Channel Analysis: SD-C15

Notes:

Input Parameters

Channel Type: Circular

Pipe Diameter: 1.5000 ft

Longitudinal Slope: 0.0100 ft/ft

Manning's n: 0.0130

Depth: 1.5000 ft

Result Parameters

Flow: 10.5043 cfs

Area of Flow: 1.7671 ft²

Wetted Perimeter: 4.7124 ft

Hydraulic Radius: 0.3750 ft

Average Velocity: 5.9442 ft/s

Top Width: 0.0000 ft

Froude Number: 0.0000

Critical Depth: 1.2451 ft

Critical Velocity: 6.6989 ft/s

Critical Slope: 0.0098 ft/ft

Critical Top Width: 1.13 ft

Calculated Max Shear Stress: 0.9360 lb/ft²

Calculated Avg Shear Stress: 0.2340 lb/ft²

Channel Analysis: SD-C16

Notes:

Input Parameters

Channel Type: Circular

Pipe Diameter: 1.5000 ft

Longitudinal Slope: 0.0250 ft/ft

Manning's n: 0.0130

Depth: 1.5000 ft

Result Parameters

Flow: 16.6088 cfs

Area of Flow: 1.7671 ft²

Wetted Perimeter: 4.7124 ft

Hydraulic Radius: 0.3750 ft

Average Velocity: 9.3987 ft/s

Top Width: 0.0000 ft

Froude Number: 0.0000

Critical Depth: 1.4341 ft

Critical Velocity: 9.5460 ft/s

Critical Slope: 0.0217 ft/ft

Critical Top Width: 0.61 ft

Calculated Max Shear Stress: 2.3400 lb/ft²

Calculated Avg Shear Stress: 0.5850 lb/ft²

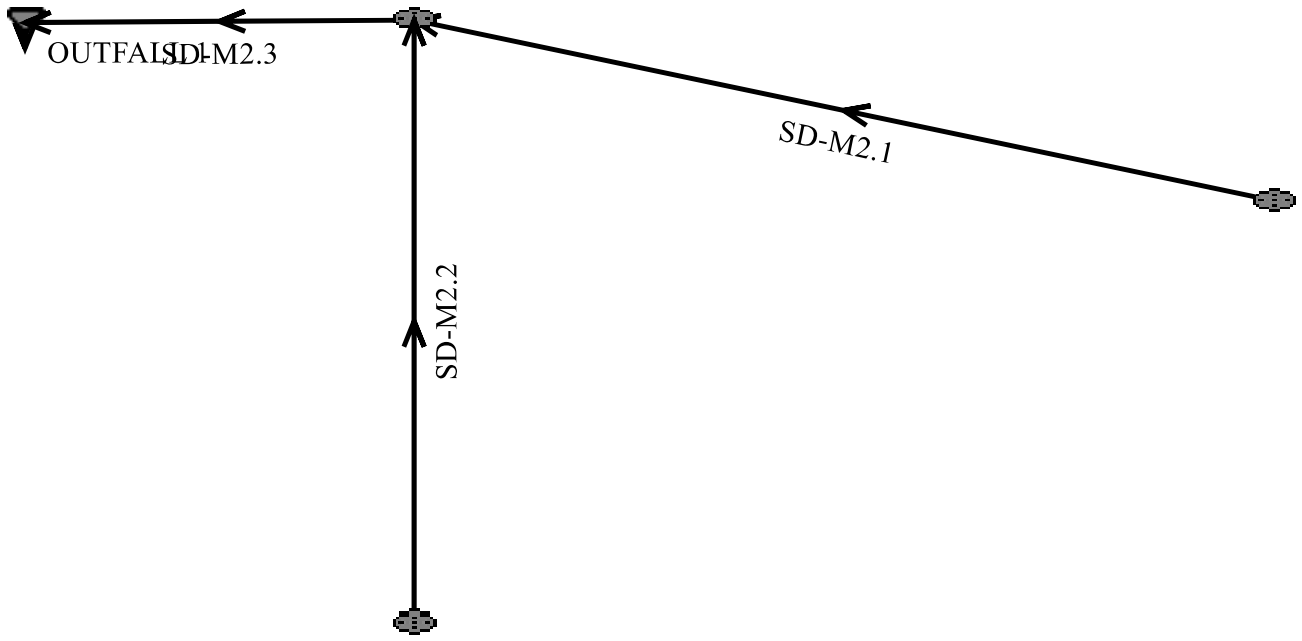

UDSewer Results Summary

Project Title: MA - Storm Sewer M2 – 100-Year Analysis
Project Description: Default system

Table of Contents

[Top](#)

[System Input](#)

[Manhole Input](#)

[Manhole Output](#)

[Sewer Input](#)

[Sewer Flow](#)

[Sewer Sizing](#)

[EGL/HGL Summary](#)

[Excavation Estimate](#)

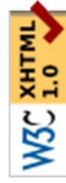

System Input Summary

Rainfall Parameters

Rainfall Return Period: 100
Rainfall Calculation Method: Formula

One Hour Depth (in): 2.52
Rainfall Constant "A": 28.5
Rainfall Constant "B": 10
Rainfall Constant "C": 0.786

Rational Method Constraints

Minimum Urban Runoff Coeff.: 0.20
Maximum Rural Overland Len. (ft): 500
Maximum Urban Overland Len. (ft): 300
Used UDFCD Tc. Maximum: Yes

Sizer Constraints

Minimum Sewer Size (in): 12.00
Maximum Depth to Rise Ratio: 0.90
Maximum Flow Velocity (fps): 18.0
Minimum Flow Velocity (fps): 2.0

Backwater Calculations:

Tailwater Elevation (ft): 7398.10

Sewer Input Summary:

Element Name	Elevation			Loss Coefficients			Given Dimensions			
	Sewer Length (ft)	Downstream Invert (ft)	Slope (%)	Upstream Invert (ft)	Manning's n	Bend Loss	Lateral Loss	Cross Section	Rise (ft or in)	Span (ft or in)
SD-M2.3	88.56	7397.70	4.9	7402.00	0.013	0.03	1.00	CIRCULAR	30.00 in	30.00 in
SD-M2.1	309.57	7403.00	4.1	7415.70	0.013	0.11	1.00	CIRCULAR	18.00 in	18.00 in
SD-M2.2	277.68	7402.00	2.0	7407.50	0.013	1.32	1.00	CIRCULAR	18.00 in	18.00 in

Sewer Flow Summary:

Element Name	Full Flow Capacity			Critical Flow			Normal Flow			Surcharged Length (ft)	Comment
	Flow (cfs)	Velocity (fps)	Depth (in)	Depth (in)	Velocity (fps)	Flow Condition	Flow (cfs)	Froude Number	Velocity (fps)		
SD-M2.3	90.62	18.46	25.55	13.95	17.89	Supercritical	40.00	3.33	0.00		
SD-M2.1	21.33	12.07	17.09	11.63	13.25	Supercritical	16.00	2.54	0.00		
SD-M2.2	14.82	8.39	9.18	6.39	7.12	Supercritical Jump	4.00	2.01	155.64		

- A Froude number of 0 indicates that pressured flow occurs (adverse slope or undersized pipe).
- If the sewer is not pressurized, full flow represents the maximum gravity flow in the sewer.
- If the sewer is pressurized, full flow represents the pressurized flow conditions.

Sewer Sizing Summary:

Element Name	Peak Flow (cfs)	Cross Section	Existing		Calculated		Used			Area (ft ²)	Comment
			Rise	Span	Rise	Span	Rise	Span	Area (ft ²)		
SD-M2.3	40.00	CIRCULAR	30.00 in	30.00 in	24.00 in	24.00 in	30.00 in	30.00 in	4.91		
SD-M2.1	16.00	CIRCULAR	18.00 in	18.00 in	18.00 in	18.00 in	18.00 in	18.00 in	1.77		
SD-M2.2	4.00	CIRCULAR	18.00 in	18.00 in	12.00 in	12.00 in	18.00 in	18.00 in	1.77		

- Calculated diameter was determined by sewer hydraulic capacity rounded up to the nearest commercially available size.
- Sewer sizes should not decrease downstream.
- All hydraulics were calculated using the 'Used' parameters.

Grade Line Summary:

Tailwater Elevation (ft): 7398.10

Element Name	Invert Elev.		Downstream Manhole Losses			HGL		EGL	
	Downstream (ft)	Upstream (ft)	Bend Loss (ft)	Lateral Loss (ft)	Downstream (ft)	Upstream (ft)	Downstream (ft)	Friction Loss (ft)	Upstream (ft)
SD-M2.3	7397.70	7402.00	0.00	0.00	7398.86	7404.13	7403.83	1.55	7405.38
SD-M2.1	7403.00	7415.70	0.14	0.00	7404.27	7417.12	7406.69	11.75	7418.45
SD-M2.2	7402.00	7407.50	0.11	0.95	7406.36	7408.27	7406.44	2.13	7408.57

- Bend and Lateral losses only apply when there is an outgoing sewer. The system outfall, sewer #0, is not considered a sewer.
- Bend loss = $\text{Bend } K * V_{fi}^2 / (2 * g)$
- Lateral loss = $V_{fo}^2 / (2 * g)$ - Junction Loss $K * V_{fi}^2 / (2 * g)$.
- Friction loss is always Upstream EGL - Downstream EGL.

SD-M2.1-OUTFALL-PROFILE-100-YR

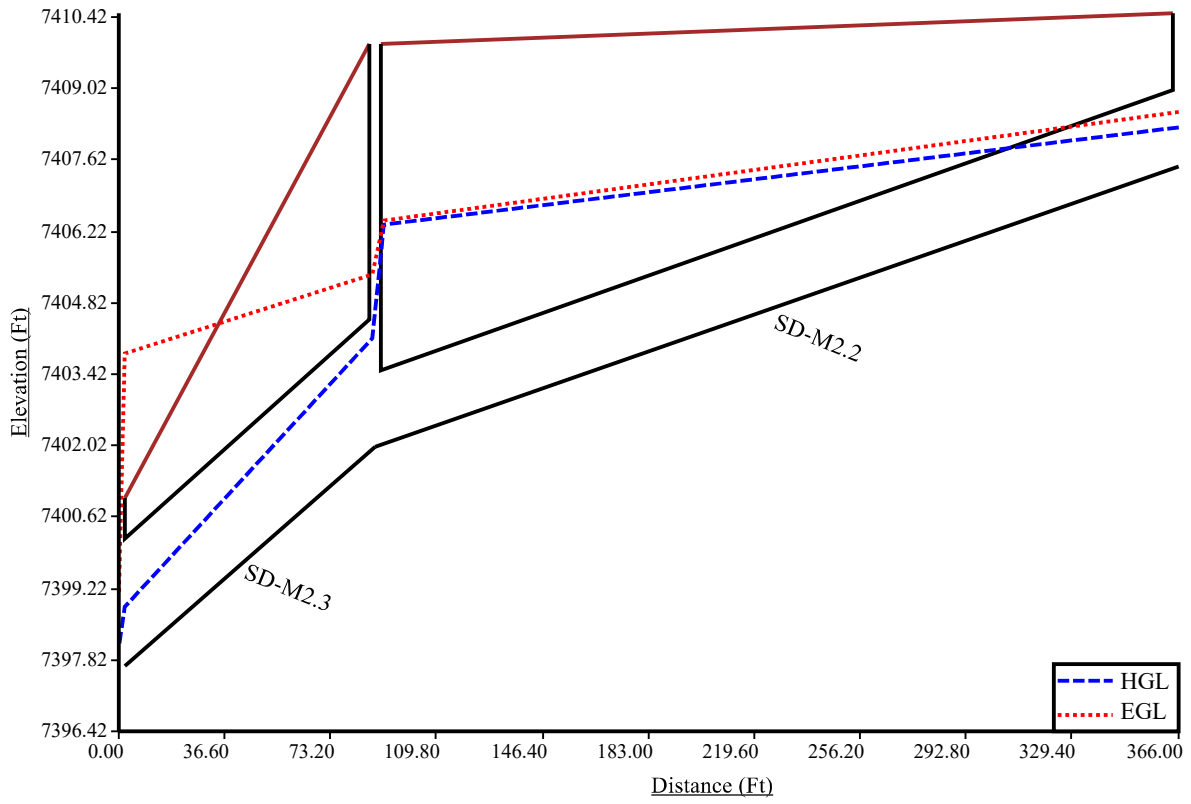

SD-M2.2-OUTFALL-PROFILE-100-YR

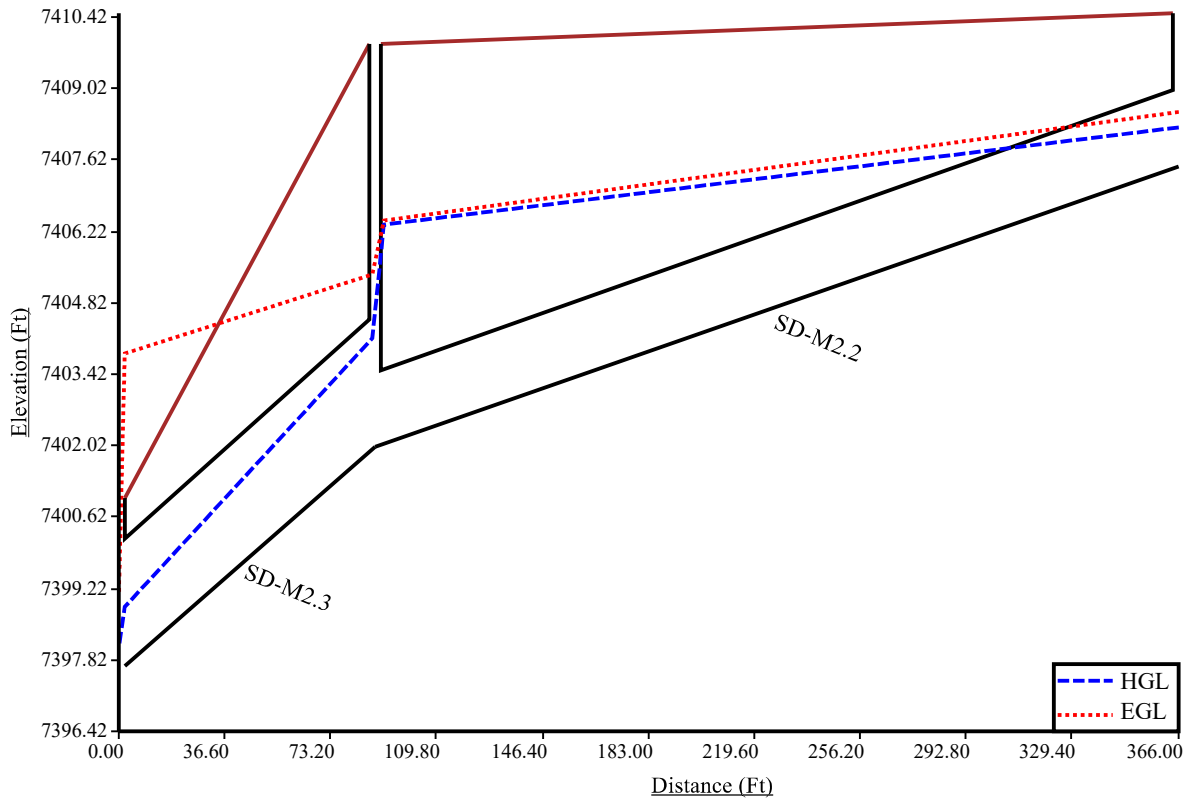

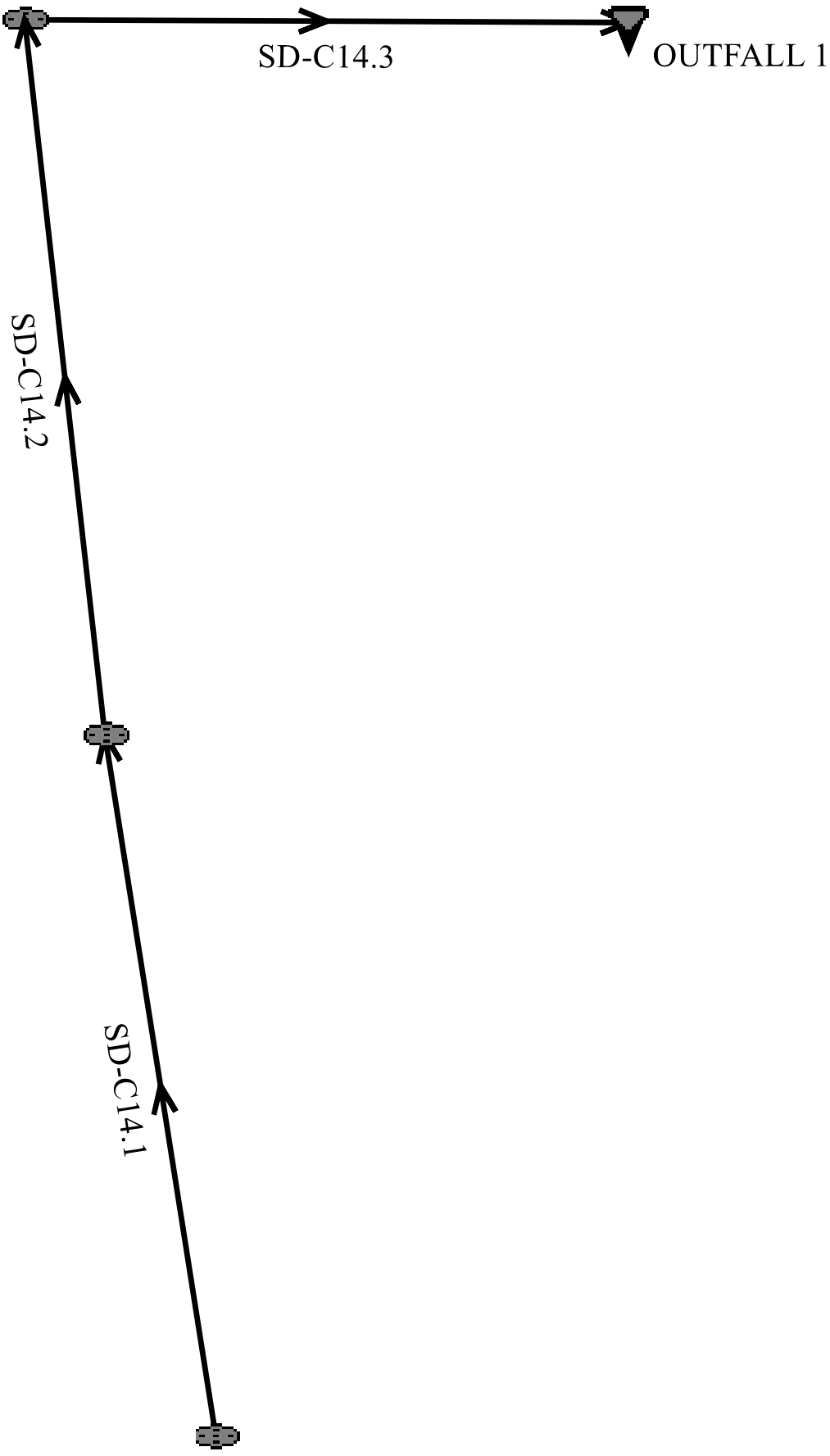

UDSewer Results Summary

Project Title: MA - Storm Sewer C14 – 100-Year Analysis
Project Description: Default system

Table of Contents

[Top](#)

[System Input](#)

[Manhole Input](#)

[Manhole Output](#)

[Sewer Input](#)

[Sewer Flow](#)

[Sewer Sizing](#)

[EGL/HGL Summary](#)

[Excavation Estimate](#)



System Input Summary

Rainfall Parameters

Rainfall Return Period: 100
Rainfall Calculation Method: Formula

One Hour Depth (in): 2.52
Rainfall Constant "A": 28.5
Rainfall Constant "B": 10
Rainfall Constant "C": 0.786

Rational Method Constraints

Minimum Urban Runoff Coeff.: 0.20
Maximum Rural Overland Len. (ft): 500
Maximum Urban Overland Len. (ft): 300
Used UDFCD Tc. Maximum: Yes

Sizer Constraints

Minimum Sewer Size (in): 12.00
Maximum Depth to Rise Ratio: 0.90
Maximum Flow Velocity (fps): 18.0
Minimum Flow Velocity (fps): 2.0

Backwater Calculations:

Tailwater Elevation (ft): 7367.50

Sewer Input Summary:

Element Name	Elevation			Loss Coefficients			Given Dimensions			
	Sewer Length (ft)	Downstream Invert (ft)	Slope (%)	Upstream Invert (ft)	Mannings n	Bend Loss	Lateral Loss	Cross Section	Rise (ft or in)	Span (ft or in)
SD-C14.3	197.40	7362.00	14.2	7390.02	0.013	0.03	1.00	CIRCULAR	24.00 in	24.00 in
SD-C14.2	543.90	7390.12	3.1	7406.90	0.013	1.32	1.00	CIRCULAR	24.00 in	24.00 in
SD-C14.1	458.00	7407.00	1.6	7414.13	0.013	0.08	1.00	CIRCULAR	18.00 in	18.00 in

Sewer Flow Summary:

Element Name	Full Flow Capacity		Critical Flow		Normal Flow					Surcharged Length (ft)	Comment
	Flow (cfs)	Velocity (fps)	Depth (in)	Velocity (fps)	Velocity (fps)	Depth (in)	Froude Number	Flow Condition	Flow (cfs)		
SD-C14.3	85.46	27.20	22.91	10.94	25.61	10.49	5.53	Supercritical Jump	33.80	29.23	Velocity is Too High
SD-C14.2	39.84	12.68	19.78	7.65	12.88	12.45	2.50	Supercritical Jump	21.20	134.87	
SD-C14.1	13.14	7.44	11.64	5.21	7.36	8.78	1.72	Supercritical Jump	6.30	107.27	

- A Froude number of 0 indicates that pressured flow occurs (adverse slope or undersized pipe).
- If the sewer is not pressurized, full flow represents the maximum gravity flow in the sewer.
- If the sewer is pressurized, full flow represents the pressurized flow conditions.

Sewer Sizing Summary:

Element Name	Peak Flow (cfs)	Cross Section	Existing			Calculated			Used			Area (ft ²)	Comment
			Rise	Span		Rise	Span		Rise	Span			
SD-C14.3	33.80	CIRCULAR	24.00 in	24.00 in	18.00 in	18.00 in	24.00 in	24.00 in	24.00 in	24.00 in	3.14		
SD-C14.2	21.20	CIRCULAR	24.00 in	24.00 in	21.00 in	21.00 in	24.00 in	24.00 in	24.00 in	24.00 in	3.14		
SD-C14.1	6.30	CIRCULAR	18.00 in	18.00 in	15.00 in	15.00 in	18.00 in	18.00 in	18.00 in	18.00 in	1.77		

- Calculated diameter was determined by sewer hydraulic capacity rounded up to the nearest commercially available size.
- Sewer sizes should not decrease downstream.
- All hydraulics were calculated using the 'Used' parameters.

Grade Line Summary:

Tailwater Elevation (ft): 7367.50

Element Name	Invert Elev.		Downstream Manhole Losses		HGL		EGL		
	Downstream (ft)	Upstream (ft)	Bend Loss (ft)	Lateral Loss (ft)	Downstream (ft)	Upstream (ft)	Downstream (ft)	Friction Loss (ft)	Upstream (ft)
SD-C14.3	7362.00	7390.02	0.00	0.00	7367.50	7391.93	7369.30	24.49	7393.79
SD-C14.2	7390.12	7406.90	0.93	1.09	7395.10	7408.55	7395.81	13.65	7409.46
SD-C14.1	7407.00	7414.13	0.02	0.51	7409.79	7415.10	7409.98	5.54	7415.52

- Bend and Lateral losses only apply when there is an outgoing sewer. The system outfall, sewer #0, is not considered a sewer.
- Bend loss = $\text{Bend } K * V_{fi}^2 / (2 * g)$
- Lateral loss = $V_{fo}^2 / (2 * g)$ - Junction Loss $K * V_{fi}^2 / (2 * g)$.
- Friction loss is always Upstream EGL - Downstream EGL.

SD-C14-100-Year

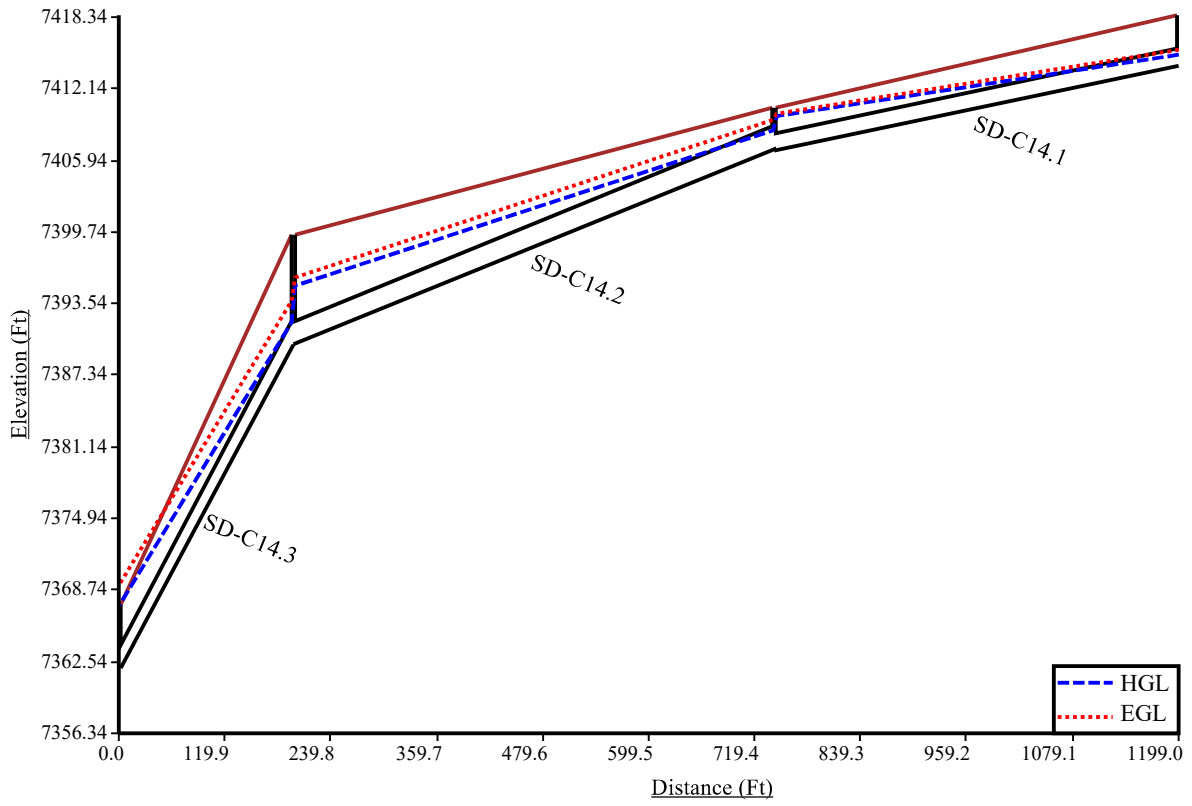

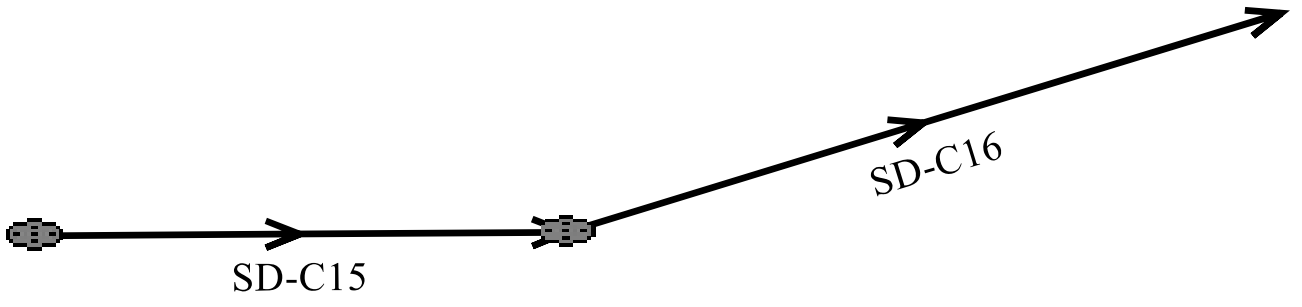

UDSewer Results Summary

Project Title: MA - Storm Sewer C15 – 100-Year Analysis
Project Description: Default system

Table of Contents

[Top](#)

[System Input](#)

[Manhole Input](#)

[Manhole Output](#)

[Sewer Input](#)

[Sewer Flow](#)

[Sewer Sizing](#)

[EGL/HGL Summary](#)

[Excavation Estimate](#)

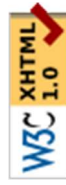

System Input Summary

Rainfall Parameters

Rainfall Return Period: 100
Rainfall Calculation Method: Formula

One Hour Depth (in): 2.52
Rainfall Constant "A": 28.5
Rainfall Constant "B": 10
Rainfall Constant "C": 0.786

Rational Method Constraints

Minimum Urban Runoff Coeff.: 0.20
Maximum Rural Overland Len. (ft): 500
Maximum Urban Overland Len. (ft): 300
Used UDFCD Tc. Maximum: Yes

Sizer Constraints

Minimum Sewer Size (in): 12.00
Maximum Depth to Rise Ratio: 0.90
Maximum Flow Velocity (fps): 18.0
Minimum Flow Velocity (fps): 2.0

Backwater Calculations:

Tailwater Elevation (ft): 7387.50

Sewer Input Summary:

Element Name	Elevation			Loss Coefficients			Given Dimensions			
	Sewer Length (ft)	Downstream Invert (ft)	Slope (%)	Upstream Invert (ft)	Mannings n	Bend Loss	Lateral Loss	Cross Section	Rise (ft or in)	Span (ft or in)
SD-C16	211.39	7386.72	0.6	7388.06	0.013	0.11	1.00	CIRCULAR	18.00 in	18.00 in
SD-C15	59.50	7388.16	0.5	7388.46	0.013	0.11	1.00	CIRCULAR	18.00 in	18.00 in

Sewer Flow Summary:

Element Name	Full Flow Capacity			Critical Flow			Normal Flow					
	Flow (cfs)	Velocity (fps)	Depth (in)	Depth (in)	Velocity (fps)	Depth (in)	Velocity (fps)	Froude Number	Flow Condition	Flow (cfs)	Surcharged Length (ft)	Comment
SD-C16	8.39	4.75	12.64	12.64	5.58	13.13	5.36	0.93	Subcritical	7.40	0.00	
SD-C15	7.48	4.23	8.04	8.04	4.06	8.08	4.03	0.99	Subcritical Surcharged	3.10	31.21	

- A Froude number of 0 indicates that pressurized flow occurs (adverse slope or undersized pipe).
- If the sewer is not pressurized, full flow represents the maximum gravity flow in the sewer.
- If the sewer is pressurized, full flow represents the pressurized flow conditions.

Sewer Sizing Summary:

Element Name	Peak Flow (cfs)	Cross Section	Existing			Calculated			Used			Area (ft ²)	Comment
			Rise	Span		Rise	Span		Rise	Span			
SD-C16	7.40	CIRCULAR	18.00 in	18.00 in	18.00 in	18.00 in	18.00 in	18.00 in	18.00 in	18.00 in	18.00 in	1.77	
SD-C15	3.10	CIRCULAR	18.00 in	18.00 in	15.00 in	15.00 in	15.00 in	18.00 in	18.00 in	18.00 in	18.00 in	1.77	

- Calculated diameter was determined by sewer hydraulic capacity rounded up to the nearest commercially available size.
 - Sewer sizes should not decrease downstream.
 - All hydraulics where calculated using the 'Used' parameters.
-

Grade Line Summary:

Tailwater Elevation (ft): 7387.50

Element Name	Invert Elev.		Downstream Manhole Losses			HGL		EGL	
	Downstream (ft)	Upstream (ft)	Bend Loss (ft)	Lateral Loss (ft)	Downstream (ft)	Upstream (ft)	Downstream (ft)	Friction Loss (ft)	Upstream (ft)
SD-C16	7386.72	7388.06	0.00	0.00	7387.77	7389.20	7388.26	1.35	7389.61
SD-C15	7388.16	7388.46	0.01	0.22	7389.79	7389.84	7389.84	0.05	7389.89

- Bend and Lateral losses only apply when there is an outgoing sewer. The system outfall, sewer #0, is not considered a sewer.
- Bend loss = $Bend\ K * V_fi^2 / (2 * g)$
- Lateral loss = $V_fo^2 / (2 * g) - Junction\ Loss\ K * V_fi^2 / (2 * g)$.
- Friction loss is always Upstream EGL - Downstream EGL.

SD-C16-Profile-100-Year

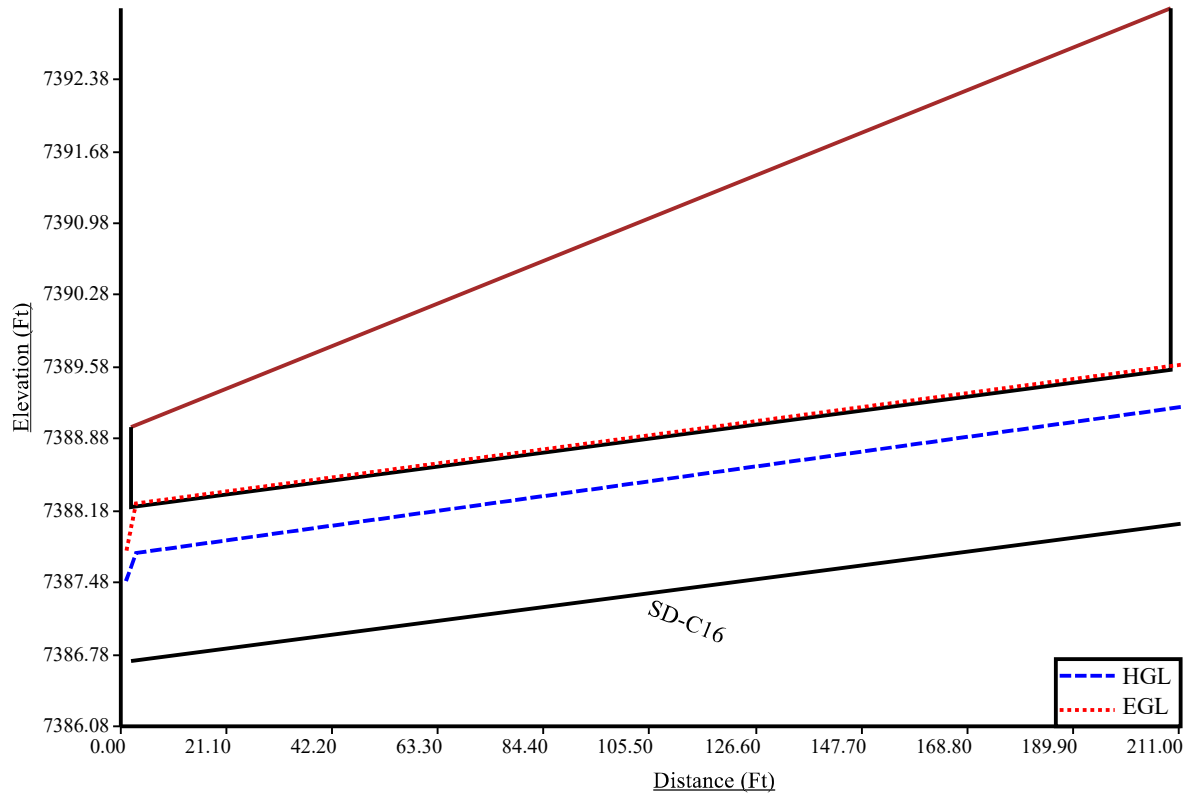

APPENDIX D1

DETENTION POND CALCULATIONS – POND C14

MONUMENT ACADEMY DEVELOPED IMPERVIOUS AREAS											
IMPERVIOUS AREAS - INTERIM (PHASE 1) DEVELOPMENT											
BASIN	TOTAL AREA (AC)	(AC)	SUB-AREA 1 DEVELOPMENT/ COVER	PERCENT IMPERVIOUS	AREA (AC)	SUB-AREA 2 DEVELOPMENT/ COVER	PERCENT IMPERVIOUS	(AC)	SUB-AREA 3 DEVELOPMENT/ COVER	PERCENT IMPERVIOUS	WEIGHTED % IMP
C14	15.85	3.68	BUILDING / PAVEMENT	100	12.17	LANDSCAPED	0				23.218
C15	1.26	0.39	ROADWAY	100	0.87	LANDSCAPED	0				30.952
C16	1.03	0.62	ROADWAY	100	0.41	LANDSCAPED	0				60.194
C14-C16	18.14										25.854
M1	7.06	7.06	NH BUSINESS	70							70.000
M2	7.48	4.78	BUILDING / PAVEMENT	100	2.70	LANDSCAPED	0				63.904
M3	7.73	0.23	ROADWAY	100	7.50	POND / LANDSCAPE	0				2.975
M4	3.20	0.44	ROADWAY	100	2.76	POND / LANDSCAPE	0				13.750
M2,M3,M4	18.41										29.603
OM1	2.00	2.00	MEADOW	0							0.000
M5	21.24	0.49	ROADWAY	100	20.75	FOREST / MEADOW	0				2.307
OM1,M5	23.24										2.108
IMPERVIOUS AREAS - ULTIMATE DEVELOPMENT											
BASIN	TOTAL AREA (AC)	(AC)	SUB-AREA 1 DEVELOPMENT/ COVER	PERCENT IMPERVIOUS	AREA (AC)	SUB-AREA 2 DEVELOPMENT/ COVER	PERCENT IMPERVIOUS	(AC)	SUB-AREA 3 DEVELOPMENT/ COVER	PERCENT IMPERVIOUS	WEIGHTED % IMP
C14	15.85	3.68	BUILDING / PAVEMENT	100	12.17	LANDSCAPED	0				23.218
C15	1.26	0.39	ROADWAY	100	0.87	LANDSCAPED	0				30.952
C16	1.03	0.62	ROADWAY	100	0.41	LANDSCAPED	0				60.194
C14-C16	18.14										25.854
M1	7.06	7.06	NH BUSINESS	70							70.000
M2	7.48	4.78	BUILDING / PAVEMENT	100	2.70	LANDSCAPED	0				63.904
M3	7.73	6.08	NH BUSINESS	70	1.65	POND / LANDSCAPE	0				55.058
M4	3.20	3.20	NH BUSINESS	70							70.000
M2,M3,M4	18.41										61.249
OM1	2.00	2.00	RESIDENTIAL-1-AC	20							20.000
M5	21.24	10.62	RESIDENTIAL-0.5-AC	25	10.62	RESIDENTIAL-1-AC	20				22.500
OM1,M5	23.24										22.285

Detention Basin Outlet Structure Design

UD-Detention, Version 3.07 (February 2017)

Project: Walden NW / Monument Academy

Basin ID: C14

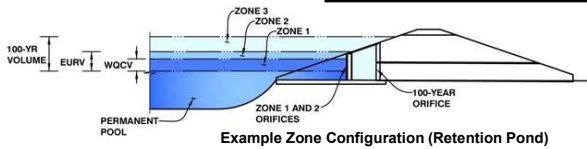

Example Zone Configuration (Retention Pond)

	Stage (ft)	Zone Volume (ac-ft)	Outlet Type
Zone 1 (WQCV)	2.06	0.208	Orifice Plate
Zone 2 (EURV)	3.82	0.267	Orifice Plate
Zone 3 (100-year)	6.31	0.626	Weir&Pipe (Restrict)
		1.101	Total

User Input: Orifice at Underdrain Outlet (typically used to drain WQCV in a Filtration BMP)

Underdrain Orifice Invert Depth =	N/A	ft (distance below the filtration media surface)
Underdrain Orifice Diameter =	N/A	inches

Calculated Parameters for Underdrain

Underdrain Orifice Area =	N/A	ft ²
Underdrain Orifice Centroid =	N/A	feet

User Input: Orifice Plate with one or more orifices or Elliptical Slot Weir (typically used to drain WQCV and/or EURV in a sedimentation BMP)

Invert of Lowest Orifice =	0.00	ft (relative to basin bottom at Stage = 0 ft)
Depth at top of Zone using Orifice Plate =	3.82	ft (relative to basin bottom at Stage = 0 ft)
Orifice Plate: Orifice Vertical Spacing =	15.30	inches
Orifice Plate: Orifice Area per Row =	1.60	sq. inches (diameter = 1-7/16 inches)

Calculated Parameters for Plate

WQ Orifice Area per Row =	1.111E-02	ft ²
Elliptical Half-Width =	N/A	feet
Elliptical Slot Centroid =	N/A	feet
Elliptical Slot Area =	N/A	ft ²

User Input: Stage and Total Area of Each Orifice Row (numbered from lowest to highest)

	Row 1 (required)	Row 2 (optional)	Row 3 (optional)	Row 4 (optional)	Row 5 (optional)	Row 6 (optional)	Row 7 (optional)	Row 8 (optional)
Stage of Orifice Centroid (ft)	0.00	1.27	2.55					
Orifice Area (sq. inches)	1.60	1.60	1.60					
	Row 9 (optional)	Row 10 (optional)	Row 11 (optional)	Row 12 (optional)	Row 13 (optional)	Row 14 (optional)	Row 15 (optional)	Row 16 (optional)
Stage of Orifice Centroid (ft)								
Orifice Area (sq. inches)								

User Input: Vertical Orifice (Circular or Rectangular)

	Not Selected	Not Selected	
Invert of Vertical Orifice =	N/A	N/A	ft (relative to basin bottom at Stage = 0 ft)
Depth at top of Zone using Vertical Orifice =	N/A	N/A	ft (relative to basin bottom at Stage = 0 ft)
Vertical Orifice Diameter =	N/A	N/A	inches

Calculated Parameters for Vertical Orifice

	Not Selected	Not Selected	
Vertical Orifice Area =	N/A	N/A	ft ²
Vertical Orifice Centroid =	N/A	N/A	feet

User Input: Overflow Weir (Dropbox) and Grate (Flat or Sloped)

	Zone 3 Weir	Not Selected	
Overflow Weir Front Edge Height, Ho =	5.00	N/A	ft (relative to basin bottom at Stage = 0 ft)
Overflow Weir Front Edge Length =	4.00	N/A	feet
Overflow Weir Slope =	0.00	N/A	H:V (enter zero for flat grate)
Horiz. Length of Weir Sides =	4.00	N/A	feet
Overflow Grate Open Area % =	70%	N/A	% grate open area/total area
Debris Clogging % =	50%	N/A	%

Calculated Parameters for Overflow Weir

	Zone 3 Weir	Not Selected	
Height of Grate Upper Edge, H _g =	5.00	N/A	feet
Over Flow Weir Slope Length =	4.00	N/A	feet
Grate Open Area / 100-yr Orifice Area =	9.90	N/A	should be ≥ 4
Overflow Grate Open Area w/o Debris =	11.20	N/A	ft ²
Overflow Grate Open Area w/ Debris =	5.60	N/A	ft ²

User Input: Outlet Pipe w/ Flow Restriction Plate (Circular Orifice, Restrictor Plate, or Rectangular Orifice)

	Zone 3 Restrictor	Not Selected	
Depth to Invert of Outlet Pipe =	0.00	N/A	ft (distance below basin bottom at Stage = 0 ft)
Outlet Pipe Diameter =	18.00	N/A	inches
Restrictor Plate Height Above Pipe Invert =	11.00		inches

Calculated Parameters for Outlet Pipe w/ Flow Restriction Plate

	Zone 3 Restrictor	Not Selected	
Outlet Orifice Area =	1.13	N/A	ft ²
Outlet Orifice Centroid =	0.52	N/A	feet
Half-Central Angle of Restrictor Plate on Pipe =	1.79	N/A	radians

User Input: Emergency Spillway (Rectangular or Trapezoidal)

Spillway Invert Stage =	6.50	ft (relative to basin bottom at Stage = 0 ft)
Spillway Crest Length =	2.00	feet
Spillway End Slopes =	4.00	H:V
Freeboard above Max Water Surface =	1.00	feet

Calculated Parameters for Spillway

Spillway Design Flow Depth =	1.49	feet
Stage at Top of Freeboard =	8.99	feet
Basin Area at Top of Freeboard =	0.41	acres

Routed Hydrograph Results

	WQCV	EURV	2 Year	5 Year	10 Year	25 Year	50 Year	100 Year	500 Year
Design Storm Return Period =									
One-Hour Rainfall Depth (in) =	0.53	1.07	1.19	1.50	1.75	2.00	2.25	2.52	3.14
Calculated Runoff Volume (acre-ft) =	0.208	0.476	0.359	0.517	0.823	1.462	1.876	2.418	3.492
OPTIONAL Override Runoff Volume (acre-ft) =									
Inflow Hydrograph Volume (acre-ft) =	0.208	0.475	0.359	0.518	0.824	1.462	1.876	2.419	3.494
Predevelopment Unit Peak Flow, q (cfs/acre) =	0.00	0.00	0.01	0.02	0.18	0.61	0.85	1.15	1.70
Predevelopment Peak Q (cfs) =	0.0	0.0	0.2	0.3	3.3	11.1	15.4	20.8	30.8
Peak Inflow Q (cfs) =	3.3	7.4	5.6	8.1	12.8	22.6	28.9	37.1	53.4
Peak Outflow Q (cfs) =	0.1	0.2	0.2	0.3	0.9	12.2	12.9	16.9	33.8
Ratio Peak Outflow to Predevelopment Q =	N/A	N/A	N/A	0.7	0.3	1.1	0.8	0.8	1.1
Structure Controlling Flow =	Plate	Plate	Plate	Plate	Overflow Gate 1	Outlet Plate 1	Outlet Plate 1	Spillway	Spillway
Max Velocity through Gate 1 (fps) =	N/A	N/A	N/A	N/A	0.0	1.1	1.1	1.2	1.3
Max Velocity through Gate 2 (fps) =	N/A	N/A	N/A	N/A	N/A	N/A	N/A	N/A	N/A
Time to Drain 97% of Inflow Volume (hours) =	38	53	48	55	63	58	55	52	45
Time to Drain 99% of Inflow Volume (hours) =	40	57	51	58	69	66	65	64	61
Maximum Ponding Depth (ft) =	1.93	3.62	2.94	3.84	5.06	5.50	6.08	6.95	7.60
Area at Maximum Ponding Depth (acres) =	0.14	0.18	0.14	0.19	0.26	0.27	0.29	0.33	0.35
Maximum Volume Stored (acre-ft) =	0.190	0.440	0.331	0.481	0.753	0.867	1.034	1.301	1.525

Detention Basin Outlet Structure Design

UD-Detention, Version 3.07 (February 2017)

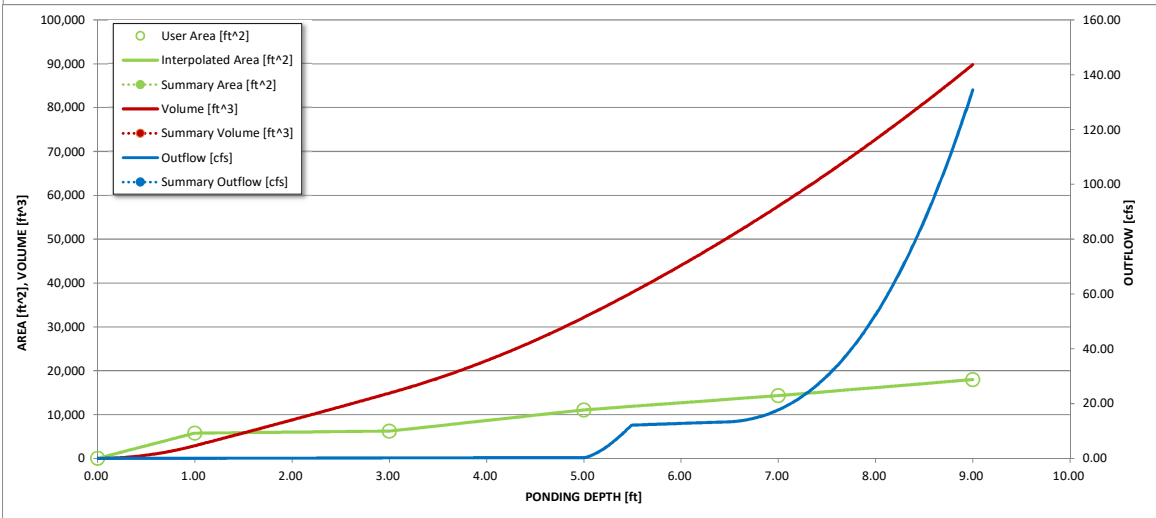
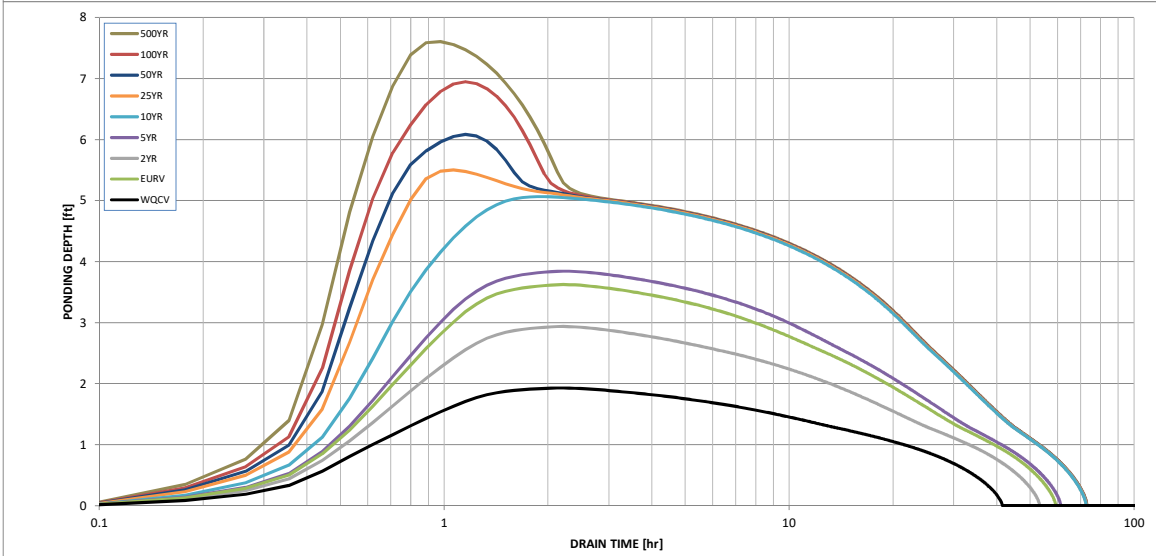
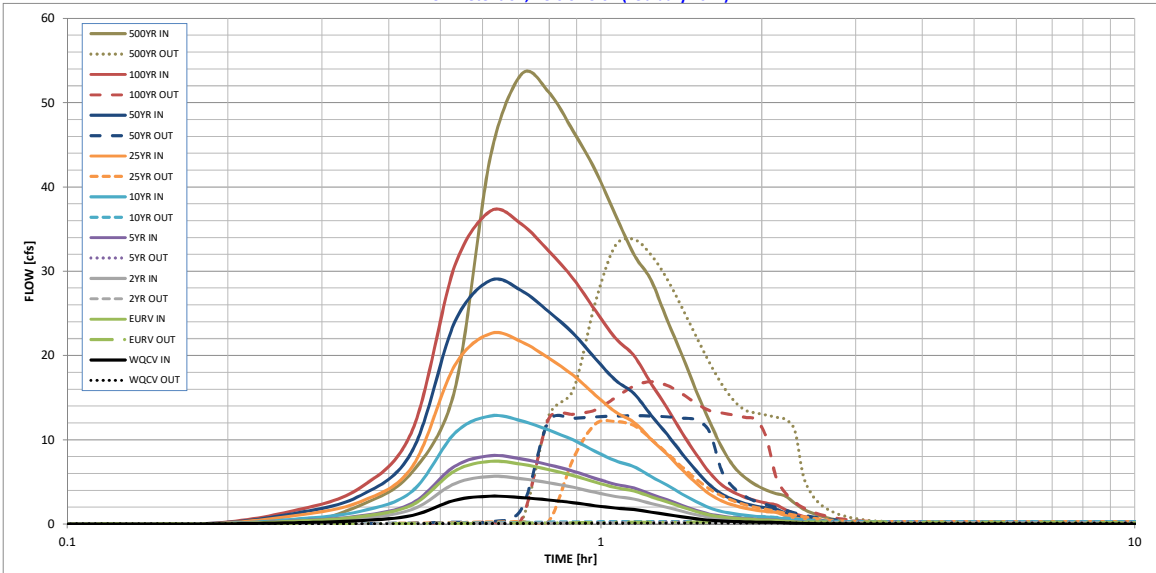

S-A-V-D Chart Axis Override

	X-axis	Left Y-Axis	Right Y-Axis
minimum bound			
maximum bound			

Design Procedure Form: Extended Detention Basin (EDB)

UD-BMP (Version 3.06, November 2016)

Sheet 1 of 4

Designer: JPS
Company: JPS
Date: April 23, 2019
Project: MONUMENT ACADEMY
Location: DETENTION POND C14

<p>1. Basin Storage Volume</p> <p>A) Effective Imperviousness of Tributary Area, I_a</p> <p>B) Tributary Area's Imperviousness Ratio ($i = I_a / 100$)</p> <p>C) Contributing Watershed Area</p> <p>D) For Watersheds Outside of the Denver Region, Depth of Average Runoff Producing Storm</p> <p>E) Design Concept (Select EURV when also designing for flood control)</p> <p>F) Design Volume (WQCV) Based on 40-hour Drain Time ($V_{DESIGN} = (1.0 * (0.91 * i^3 - 1.19 * i^2 + 0.78 * i)) / 12 * Area$)</p> <p>G) For Watersheds Outside of the Denver Region, Water Quality Capture Volume (WQCV) Design Volume ($V_{WQCV\ OTHER} = (d_6 * V_{DESIGN} / 0.43)$)</p> <p>H) User Input of Water Quality Capture Volume (WQCV) Design Volume (Only if a different WQCV Design Volume is desired)</p> <p>I) Predominant Watershed NRCS Soil Group</p> <p>J) Excess Urban Runoff Volume (EURV) Design Volume For HSG A: $EURV_A = 1.68 * i^{1.28}$ For HSG B: $EURV_B = 1.36 * i^{1.08}$ For HSG C/D: $EURV_{C/D} = 1.20 * i^{1.06}$ </p>	<p>$I_a =$ <u>25.9</u> %</p> <p>$i =$ <u>0.259</u></p> <p>Area = <u>18.140</u> ac</p> <p>$d_6 =$ _____ in</p> <p>Choose One</p> <p><input type="radio"/> Water Quality Capture Volume (WQCV)</p> <p><input checked="" type="radio"/> Excess Urban Runoff Volume (EURV)</p> <p>$V_{DESIGN} =$ <u>0.208</u> ac-ft</p> <p>$V_{DESIGN\ OTHER} =$ _____ ac-ft</p> <p>$V_{DESIGN\ USER} =$ _____ ac-ft</p> <p>Choose One</p> <p><input type="radio"/> A</p> <p><input checked="" type="radio"/> B</p> <p><input type="radio"/> C / D</p> <p>EURV = <u>0.477</u> ac-ft</p>
<p>2. Basin Shape: Length to Width Ratio (A basin length to width ratio of at least 2:1 will improve TSS reduction.)</p>	<p>L : W = <u>2.0</u> : 1</p>
<p>3. Basin Side Slopes</p> <p>A) Basin Maximum Side Slopes (Horizontal distance per unit vertical, 4:1 or flatter preferred)</p>	<p>Z = <u>4.00</u> ft / ft</p>
<p>4. Inlet</p> <p>A) Describe means of providing energy dissipation at concentrated inflow locations:</p>	<p>Concrete Forebay</p> <hr/> <hr/> <hr/>

Design Procedure Form: Extended Detention Basin (EDB)

Designer: JPS
Company: JPS
Date: April 23, 2019
Project: MONUMENT ACADEMY
Location: DETENTION POND C14

<p>5. Forebay</p> <p>A) Minimum Forebay Volume ($V_{MIN} =$ <u>2%</u> of the WQCV)</p> <p>B) Actual Forebay Volume</p> <p>C) Forebay Depth ($D_F =$ <u>18</u> inch maximum)</p> <p>D) Forebay Discharge</p> <p style="padding-left: 20px;">i) Undetained 100-year Peak Discharge</p> <p style="padding-left: 20px;">ii) Forebay Discharge Design Flow ($Q_F = 0.02 * Q_{100}$)</p> <p>E) Forebay Discharge Design</p> <p style="padding-left: 20px;">Choose One <input type="radio"/> Berm With Pipe <input checked="" type="radio"/> Wall with Rect. Notch <input type="radio"/> Wall with V-Notch Weir</p> <p>F) Discharge Pipe Size (minimum 8-inches)</p> <p>G) Rectangular Notch Width</p>	<p>$V_{MIN} =$ <u>0.004</u> ac-ft</p> <p>$V_F =$ <u>0.005</u> ac-ft</p> <p>$D_F =$ <u>18.0</u> in</p> <p>$Q_{100} =$ <u>47.70</u> cfs</p> <p>$Q_F =$ <u>0.95</u> cfs</p> <p style="text-align: right; color: blue;">(flow too small for berm w/ pipe)</p> <p>Calculated $D_p =$ <u> </u> in</p> <p>Calculated $W_N =$ <u>5.5</u> in</p>
<p>6. Trickle Channel</p> <p>A) Type of Trickle Channel</p> <p>F) Slope of Trickle Channel</p>	<p style="padding-left: 20px;">Choose One <input checked="" type="radio"/> Concrete <input type="radio"/> Soft Bottom</p> <p>$S =$ <u>0.0050</u> ft / ft</p>
<p>7. Micropool and Outlet Structure</p> <p>A) Depth of Micropool (2.5-foot minimum)</p> <p>B) Surface Area of Micropool (10 ft² minimum)</p> <p>C) Outlet Type</p> <p style="padding-left: 20px;">Choose One <input checked="" type="radio"/> Orifice Plate <input type="radio"/> Other (Describe): _____ _____ _____</p> <p>D) Smallest Dimension of Orifice Opening Based on Hydrograph Routing (Use UD-Detention)</p> <p>E) Total Outlet Area</p>	<p>$D_M =$ <u>2.5</u> ft</p> <p>$A_M =$ <u>10</u> sq ft</p> <p>$D_{orifice} =$ <u>1.44</u> inches</p> <p>$A_{ot} =$ <u>4.80</u> square inches</p>

Design Procedure Form: Extended Detention Basin (EDB)

Designer: JPS
Company: JPS
Date: April 23, 2019
Project: MONUMENT ACADEMY
Location: DETENTION POND C14

<p>8. Initial Surcharge Volume</p> <p>A) Depth of Initial Surcharge Volume (Minimum recommended depth is 4 inches)</p> <p>B) Minimum Initial Surcharge Volume (Minimum volume of 0.3% of the WQCV)</p> <p>C) Initial Surcharge Provided Above Micropool</p>	<p>$D_{IS} = 6$ in</p> <p>$V_{IS} =$ <input style="width: 50px;" type="text" value=""/> cu ft</p> <p>$V_s = 5.0$ cu ft</p>
<p>9. Trash Rack</p> <p>A) Water Quality Screen Open Area: $A_t = A_{ot} * 38.5 * (e^{-0.095D})$</p> <p>B) Type of Screen (If specifying an alternative to the materials recommended in the USDCM, indicate "other" and enter the ratio of the total open are to the total screen are for the material specified.)</p> <p align="center">Other (Y/N): <input style="width: 50px;" type="text" value="N"/></p> <p>C) Ratio of Total Open Area to Total Area (only for type 'Other')</p> <p>D) Total Water Quality Screen Area (based on screen type)</p> <p>E) Depth of Design Volume (EURV or WQCV) (Based on design concept chosen under 1E)</p> <p>F) Height of Water Quality Screen (H_{TR})</p> <p>G) Width of Water Quality Screen Opening ($W_{opening}$) (Minimum of 12 inches is recommended)</p>	<p>$A_t = 161$ square inches</p> <p><i>Aluminum Amico-Klemp SR Series with Cross Rods 2" O.C.</i></p> <hr/> <hr/> <p>User Ratio =</p> <p>$A_{total} = 227$ sq. in.</p> <p>$H = 3.82$ feet</p> <p>$H_{TR} = 73.84$ inches</p> <p>$W_{opening} = 12.0$ inches</p>

Design Procedure Form: Extended Detention Basin (EDB)

Designer: JPS
Company: JPS
Date: April 23, 2019
Project: MONUMENT ACADEMY
Location: DETENTION POND C14

<p>10. Overflow Embankment</p> <p>A) Describe embankment protection for 100-year and greater overtopping:</p> <p>B) Slope of Overflow Embankment (Horizontal distance per unit vertical, 4:1 or flatter preferred)</p>	<p><u>Buried Riprap</u></p> <p><u>4.00</u></p>
<p>11. Vegetation</p>	<p>Choose One</p> <p><input type="radio"/> Irrigated</p> <p><input checked="" type="radio"/> Not Irrigated</p>
<p>12. Access</p> <p>A) Describe Sediment Removal Procedures</p>	<p><u>Periodic inspection and maintenance by property owner as required</u></p> <p><u>Ramp provided for skid-loader access to pond bottom</u></p>
<p>Notes: _____</p> <p>_____</p> <p>_____</p>	

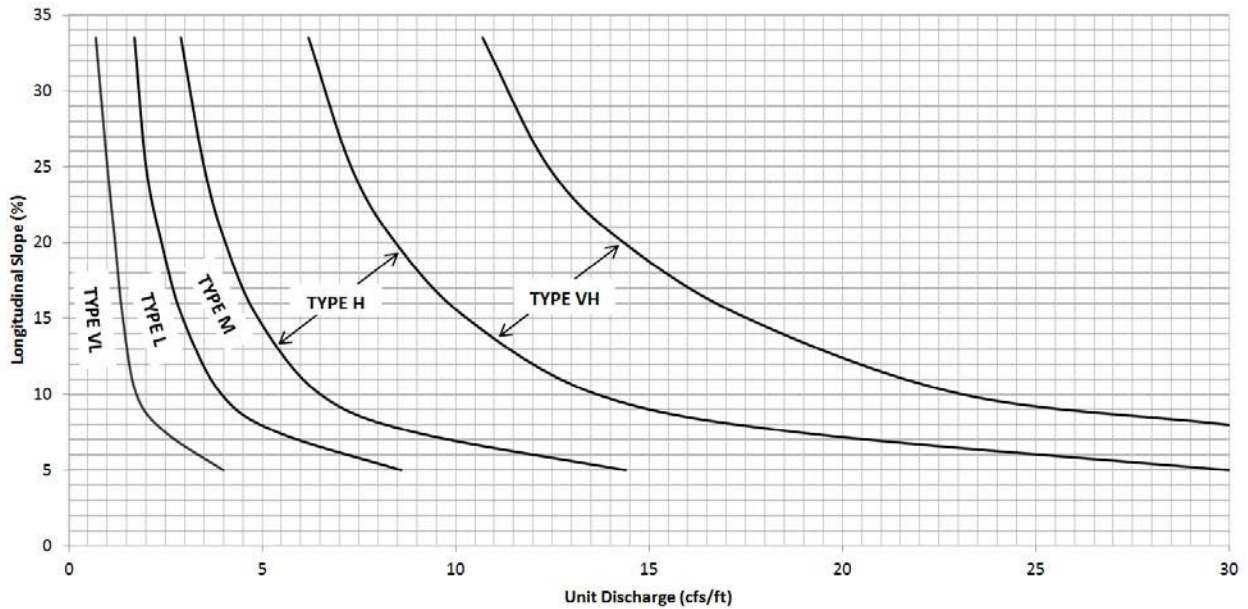
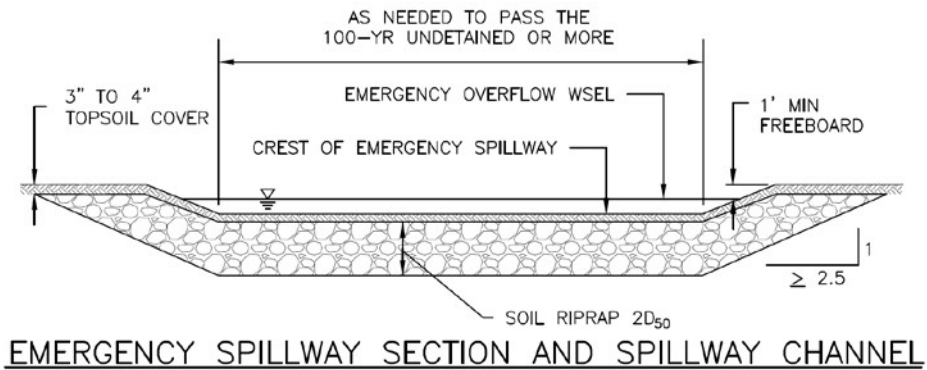
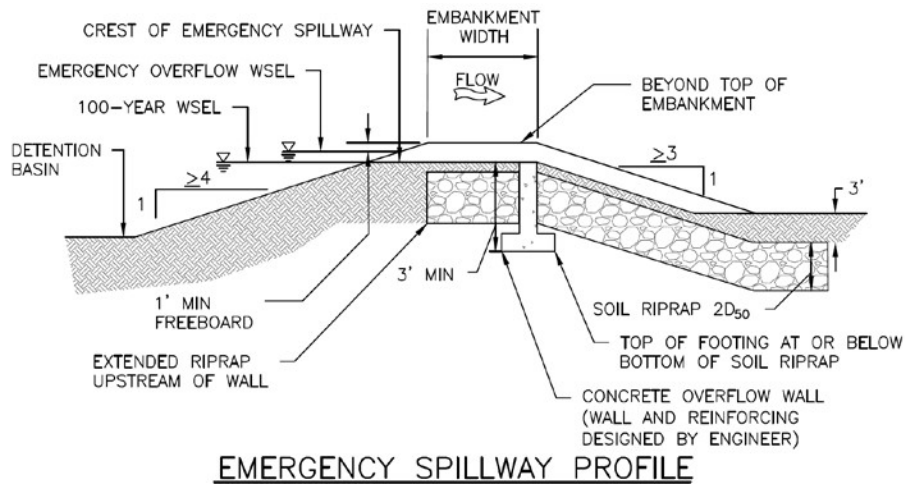

Figure 12-21. Embankment protection details and rock sizing chart (adapted from Arapahoe County)

POND C14: UNIT DISCHARGE = (47.7 CFS / 12.0 FT) = 4.0; SLOPE = 25.0%
 USE TYPE H RIPRAP

APPENDIX D2

DETENTION POND CALCULATIONS – POND M3

MONUMENT ACADEMY DEVELOPED IMPERVIOUS AREAS										
IMPERVIOUS AREAS - INTERIM (PHASE 1) DEVELOPMENT										
BASIN	TOTAL AREA (AC)	(AC)	SUB-AREA 1 DEVELOPMENT/ COVER	PERCENT IMPERVIOUS	AREA (AC)	SUB-AREA 2 DEVELOPMENT/ COVER	PERCENT IMPERVIOUS	(AC)	SUB-AREA 3 DEVELOPMENT/ COVER	WEIGHTED % IMP
C14	15.85	3.68	BUILDING / PAVEMENT	100	12.17	LANDSCAPED	0			23.218
C15	1.26	0.39	ROADWAY	100	0.87	LANDSCAPED	0			30.952
C16	1.03	0.62	ROADWAY	100	0.41	LANDSCAPED	0			60.194
C14-C16	18.14									25.854
M1	7.06	7.06	NH BUSINESS	70						70.000
M2	7.48	4.78	BUILDING / PAVEMENT	100	2.70	LANDSCAPED	0			63.904
M3	7.73	0.23	ROADWAY	100	7.50	POND / LANDSCAPE	0			2.975
M4	3.20	0.44	ROADWAY	100	2.76	POND / LANDSCAPE	0			13.750
M2,M3,M4	18.41									29.603
OM1	2.00	2.00	MEADOW	0						0.000
M5	21.24	0.49	ROADWAY	100	20.75	FOREST / MEADOW	0			2.307
OM1,M5	23.24									2.108

IMPERVIOUS AREAS - ULTIMATE DEVELOPMENT										
BASIN	TOTAL AREA (AC)	(AC)	SUB-AREA 1 DEVELOPMENT/ COVER	PERCENT IMPERVIOUS	AREA (AC)	SUB-AREA 2 DEVELOPMENT/ COVER	PERCENT IMPERVIOUS	(AC)	SUB-AREA 3 DEVELOPMENT/ COVER	WEIGHTED % IMP
C14	15.85	3.68	BUILDING / PAVEMENT	100	12.17	LANDSCAPED	0			23.218
C15	1.26	0.39	ROADWAY	100	0.87	LANDSCAPED	0			30.952
C16	1.03	0.62	ROADWAY	100	0.41	LANDSCAPED	0			60.194
C14-C16	18.14									25.854
M1	7.06	7.06	NH BUSINESS	70						70.000
M2	7.48	4.78	BUILDING / PAVEMENT	100	2.70	LANDSCAPED	0			63.904
M3	7.73	6.08	NH BUSINESS	70	1.65	POND / LANDSCAPE	0			55.058
M4	3.20	3.20	NH BUSINESS	70						70.000
M2,M3,M4	18.41									61.249
OM1	2.00	2.00	RESIDENTIAL-1-AC	20						20.000
M5	21.24	10.62	RESIDENTIAL-0.5-AC	25	10.62	RESIDENTIAL-1-AC	20			22.500
OM1,M5	23.24									22.285

DETENTION BASIN STAGE-STORAGE TABLE BUILDER

UD-Detention, Version 3.07 (February 2017)

Project: **Walden NW / Monument Academy**

Basin ID: **M3 - ULTIMATE CONDITIONS**

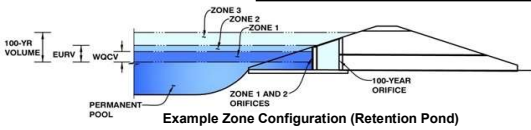

Required Volume Calculation

Selected BMP Type =	EDB
Watershed Area =	18.41 acres
Watershed Length =	1,220 ft
Watershed Slope =	0.046 ft/ft
Watershed Imperviousness =	61.25% percent
Percentage Hydrologic Soil Group A =	0.0% percent
Percentage Hydrologic Soil Group B =	100.0% percent
Percentage Hydrologic Soil Groups C/D =	0.0% percent
Desired WQCV Drain Time =	40.0 hours
Location for 1-hr Rainfall Depths =	User Input
Water Quality Capture Volume (WQCV) =	0.369 acre-feet
Excess Urban Runoff Volume (EURV) =	1.225 acre-feet
2-yr Runoff Volume (P1 = 1.19 in.) =	1.008 acre-feet
5-yr Runoff Volume (P1 = 1.5 in.) =	1.354 acre-feet
10-yr Runoff Volume (P1 = 1.75 in.) =	1.759 acre-feet
25-yr Runoff Volume (P1 = 2 in.) =	2.304 acre-feet
50-yr Runoff Volume (P1 = 2.25 in.) =	2.696 acre-feet
100-yr Runoff Volume (P1 = 2.52 in.) =	3.209 acre-feet
500-yr Runoff Volume (P1 = 3.14 in.) =	4.281 acre-feet
Approximate 2-yr Detention Volume =	0.944 acre-feet
Approximate 5-yr Detention Volume =	1.272 acre-feet
Approximate 10-yr Detention Volume =	1.635 acre-feet
Approximate 25-yr Detention Volume =	1.766 acre-feet
Approximate 50-yr Detention Volume =	1.841 acre-feet
Approximate 100-yr Detention Volume =	2.005 acre-feet

**Optional User Override
1-hr Precipitation**

1.19	inches
1.50	inches
1.75	inches
2.00	inches
2.25	inches
2.52	inches
3.14	inches

Stage-Storage Calculation

Zone 1 Volume (WQCV) =	0.369	acre-feet
Zone 2 Volume (EURV - Zone 1) =	0.856	acre-feet
Zone 3 Volume (100-year - Zones 1 & 2) =	0.779	acre-feet
Total Detention Basin Volume =	2.005	acre-feet

Depth Increment = ft

Stage - Storage Description	Stage (ft)	Optional Override Stage (ft)	Length (ft)	Width (ft)	Area (ft²)	Optional Override Area (ft²)	Area (acre)	Volume (ft³)	Volume (ac-ft)
Top of Micropool	--	0.00	--	--	--	10	0.000		
Bot EL=7372.0	--	1.00	--	--	--	9,098	0.209	4,463	0.102
	--	3.00	--	--	--	13,383	0.307	27,035	0.621
	--	5.00	--	--	--	17,945	0.412	58,363	1.340
Spillway=7377.5	--	7.00	--	--	--	22,827	0.524	99,135	2.276
Top EL=7380.0	--	9.00	--	--	--	28,025	0.643	149,987	3.443

Detention Basin Outlet Structure Design

UD-Detention, Version 3.07 (February 2017)

Project: **MONUMENT ACADEMY**
 Basin ID: **M3 - INTERIM (PHASE 1) CONDITIONS**

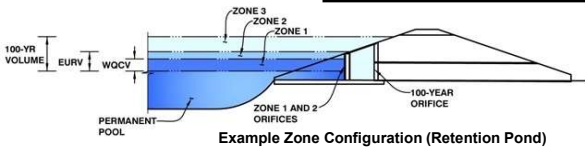

	Stage (ft)	Zone Volume (ac-ft)	Outlet Type
Zone 1 (WQCV)	1.57	0.230	Orifice Plate
Zone 2 (EURV)	2.80	0.328	Orifice Plate
Zone 3 (100-year)	4.69	0.654	Weir&Pipe (Restrict)
		1.213	Total

User Input: Orifice at Underdrain Outlet (typically used to drain WQCV in a Filtration BMP)

Underdrain Orifice Invert Depth =	N/A	ft (distance below the filtration media surface)
Underdrain Orifice Diameter =	N/A	inches

Calculated Parameters for Underdrain

Underdrain Orifice Area =	N/A	ft ²
Underdrain Orifice Centroid =	N/A	feet

User Input: Orifice Plate with one or more orifices or Elliptical Slot Weir (typically used to drain WQCV and/or EURV in a sedimentation BMP)

Invert of Lowest Orifice =	0.00	ft (relative to basin bottom at Stage = 0 ft)
Depth at top of Zone using Orifice Plate =	2.80	ft (relative to basin bottom at Stage = 0 ft)
Orifice Plate: Orifice Vertical Spacing =	11.20	inches
Orifice Plate: Orifice Area per Row =	1.87	sq. inches (diameter = 1-1/2 inches)

Calculated Parameters for Plate

WQ Orifice Area per Row =	1.299E-02	ft ²
Elliptical Half-Width =	N/A	feet
Elliptical Slot Centroid =	N/A	feet
Elliptical Slot Area =	N/A	ft ²

User Input: Stage and Total Area of Each Orifice Row (numbered from lowest to highest)

	Row 1 (required)	Row 2 (optional)	Row 3 (optional)	Row 4 (optional)	Row 5 (optional)	Row 6 (optional)	Row 7 (optional)	Row 8 (optional)
Stage of Orifice Centroid (ft)	0.00	0.93	1.87					
Orifice Area (sq. inches)	1.87	1.87	1.87					
	Row 9 (optional)	Row 10 (optional)	Row 11 (optional)	Row 12 (optional)	Row 13 (optional)	Row 14 (optional)	Row 15 (optional)	Row 16 (optional)
Stage of Orifice Centroid (ft)								
Orifice Area (sq. inches)								

User Input: Vertical Orifice (Circular or Rectangular)

	Not Selected	Not Selected	
Invert of Vertical Orifice =	N/A	N/A	ft (relative to basin bottom at Stage = 0 ft)
Depth at top of Zone using Vertical Orifice =	N/A	N/A	ft (relative to basin bottom at Stage = 0 ft)
Vertical Orifice Diameter =	N/A	N/A	inches

Calculated Parameters for Vertical Orifice

	Not Selected	Not Selected	
Vertical Orifice Area =	N/A	N/A	ft ²
Vertical Orifice Centroid =	N/A	N/A	feet

User Input: Overflow Weir (Dropbox) and Grate (Flat or Sloped)

	Zone 3 Weir	Not Selected	
Overflow Weir Front Edge Height, Ho =	5.50	N/A	ft (relative to basin bottom at Stage = 0 ft)
Overflow Weir Front Edge Length =	13.00	N/A	feet
Overflow Weir Slope =	0.00	N/A	H:V (enter zero for flat grate)
Horiz. Length of Weir Sides =	13.00	N/A	feet
Overflow Grate Open Area % =	70%	N/A	% grate open area/total area
Debris Clogging % =	50%	N/A	%

Calculated Parameters for Overflow Weir

	Zone 3 Weir	Not Selected	
Height of Grate Upper Edge, H _g =	5.50	N/A	feet
Over Flow Weir Slope Length =	13.00	N/A	feet
Grate Open Area / 100-yr Orifice Area =	53.17	N/A	should be ≥ 4
Overflow Grate Open Area w/o Debris =	118.30	N/A	ft ²
Overflow Grate Open Area w/ Debris =	59.15	N/A	ft ²

User Input: Outlet Pipe w/ Flow Restriction Plate (Circular Orifice, Restrictor Plate, or Rectangular Orifice)

	Zone 3 Restrictor	Not Selected	
Depth to Invert of Outlet Pipe =	0.00	N/A	ft (distance below basin bottom at Stage = 0 ft)
Outlet Pipe Diameter =	24.00	N/A	inches
Restrictor Plate Height Above Pipe Invert =	16.00		inches

Calculated Parameters for Outlet Pipe w/ Flow Restriction Plate

	Zone 3 Restrictor	Not Selected	
Outlet Orifice Area =	2.22	N/A	ft ²
Outlet Orifice Centroid =	0.75	N/A	feet
Half-Central Angle of Restrictor Plate on Pipe =	1.91	N/A	radians

User Input: Emergency Spillway (Rectangular or Trapezoidal)

Spillway Invert Stage =	6.50	ft (relative to basin bottom at Stage = 0 ft)
Spillway Crest Length =	8.00	feet
Spillway End Slopes =	4.00	H:V
Freeboard above Max Water Surface =	1.00	feet

Calculated Parameters for Spillway

Spillway Design Flow Depth =	1.21	feet
Stage at Top of Freeboard =	8.71	feet
Basin Area at Top of Freeboard =	0.63	acres

Routed Hydrograph Results

	WQCV	EURV	2 Year	5 Year	10 Year	25 Year	50 Year	100 Year	500 Year
Design Storm Return Period =									
One-Hour Rainfall Depth (in) =	0.53	1.07	1.19	1.50	1.75	2.00	2.25	2.52	3.14
Calculated Runoff Volume (acre-ft) =	0.230	0.559	0.428	0.609	0.934	1.570	1.988	2.534	3.622
OPTIONAL Override Runoff Volume (acre-ft) =									
Inflow Hydrograph Volume (acre-ft) =	0.230	0.558	0.428	0.610	0.934	1.571	1.989	2.536	3.625
Predevelopment Unit Peak Flow, q (cfs/acre) =	0.00	0.00	0.01	0.02	0.24	0.77	1.07	1.43	2.10
Predevelopment Peak Q (cfs) =	0.0	0.0	0.3	0.4	4.4	14.2	19.6	26.3	38.7
Peak Inflow Q (cfs) =	4.5	10.7	8.2	11.6	17.8	29.7	37.5	47.6	67.7
Peak Outflow Q (cfs) =	0.1	0.2	0.2	0.3	0.3	0.4	0.9	23.2	28.2
Ratio Peak Outflow to Predevelopment Q =	N/A	N/A	N/A	0.6	0.1	0.0	0.5	0.9	0.7
Structure Controlling Flow =	Plate	Plate	Plate	Plate	Plate	Plate	Overflow Grate 1	Outlet Plate 1	Spillway
Max Velocity through Grate 1 (fps) =	N/A	N/A	N/A	N/A	N/A	N/A	0.1	0.2	0.2
Max Velocity through Grate 2 (fps) =	N/A	N/A	N/A	N/A	N/A	N/A	N/A	N/A	N/A
Time to Drain 97% of Inflow Volume (hours) =	38	56	51	58	69	85	84	80	74
Time to Drain 99% of Inflow Volume (hours) =	40	60	54	62	75	94	94	92	89
Maximum Ponding Depth (ft) =	1.50	2.69	2.25	2.86	3.83	5.42	5.69	5.85	6.69
Area at Maximum Ponding Depth (acres) =	0.23	0.29	0.27	0.30	0.35	0.43	0.45	0.46	0.51
Maximum Volume Stored (acre-ft) =	0.213	0.528	0.401	0.575	0.890	1.513	1.637	1.706	2.111

Detention Basin Outlet Structure Design

UD-Detention, Version 3.07 (February 2017)

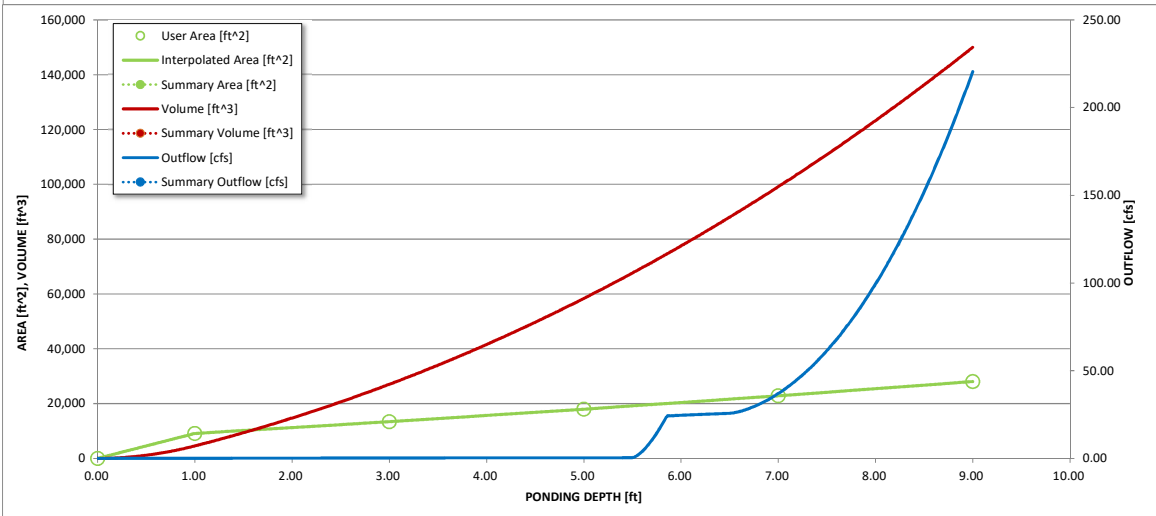
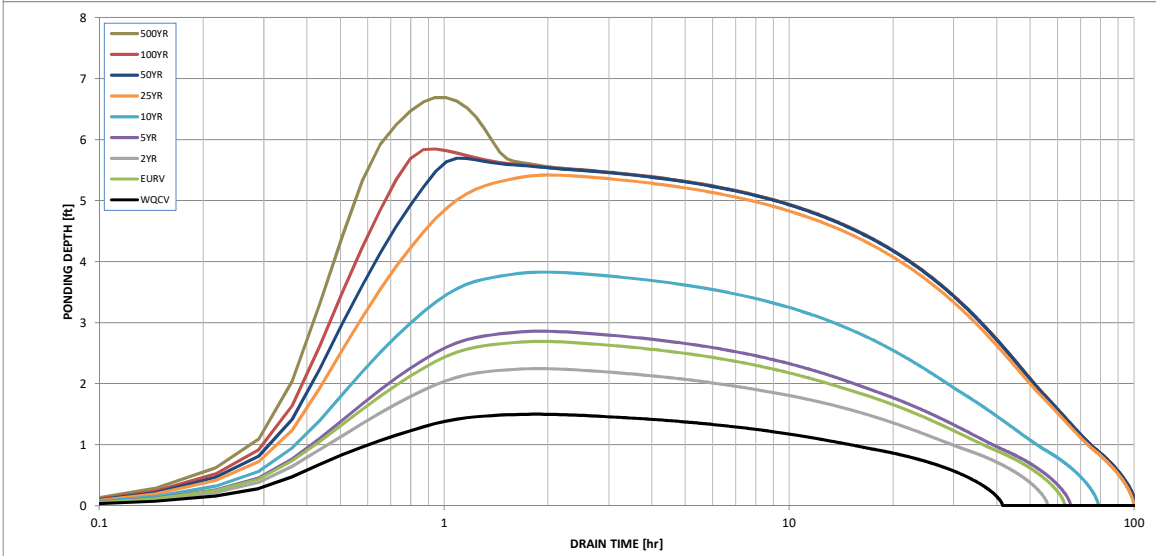
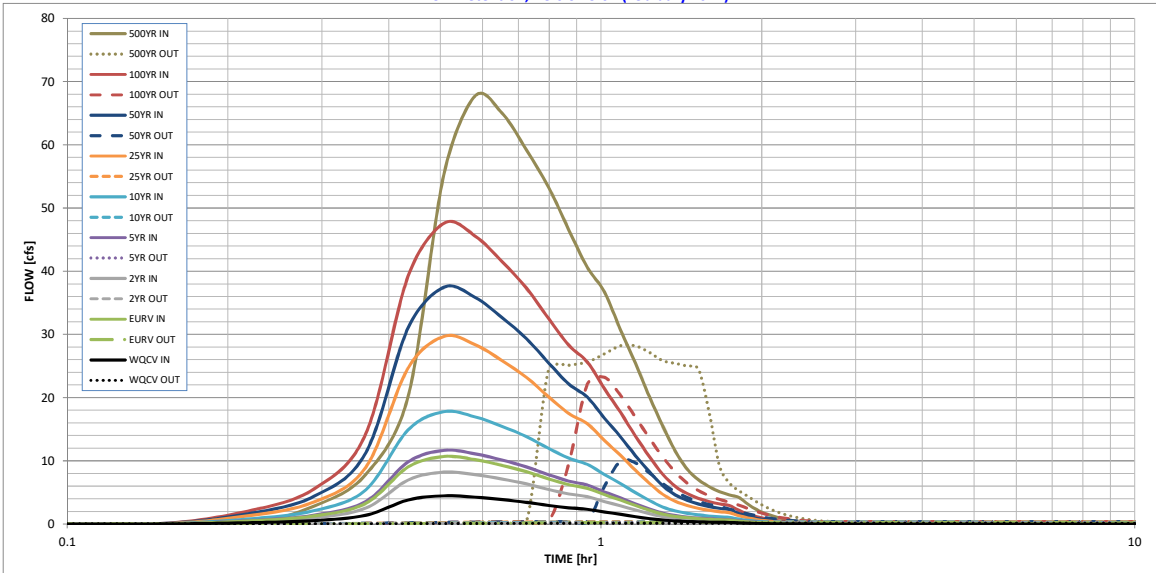

S-A-V-D Chart Axis Override

	X-axis	Left Y-Axis	Right Y-Axis
minimum bound			
maximum bound			

Design Procedure Form: Extended Detention Basin (EDB)

UD-BMP (Version 3.06, November 2016)

Sheet 1 of 4

Designer: JPS
Company: JPS
Date: April 23, 2019
Project: MONUMENT ACADEMY
Location: DETENTION POND M3 - INTERIM (PHASE 1) CONDITIONS

<p>1. Basin Storage Volume</p> <p>A) Effective Imperviousness of Tributary Area, I_a</p> <p>B) Tributary Area's Imperviousness Ratio ($i = I_a / 100$)</p> <p>C) Contributing Watershed Area</p> <p>D) For Watersheds Outside of the Denver Region, Depth of Average Runoff Producing Storm</p> <p>E) Design Concept (Select EURV when also designing for flood control)</p> <p>F) Design Volume (WQCV) Based on 40-hour Drain Time ($V_{DESIGN} = (1.0 * (0.91 * i^3 - 1.19 * i^2 + 0.78 * i)) / 12 * Area$)</p> <p>G) For Watersheds Outside of the Denver Region, Water Quality Capture Volume (WQCV) Design Volume ($V_{WQCV\ OTHER} = (d_6 * (V_{DESIGN} / 0.43))$)</p> <p>H) User Input of Water Quality Capture Volume (WQCV) Design Volume (Only if a different WQCV Design Volume is desired)</p> <p>I) Predominant Watershed NRCS Soil Group</p> <p>J) Excess Urban Runoff Volume (EURV) Design Volume For HSG A: $EURV_A = 1.68 * i^{1.28}$ For HSG B: $EURV_B = 1.36 * i^{1.08}$ For HSG C/D: $EURV_{C/D} = 1.20 * i^{1.06}$ </p>	<p>$I_a =$ <u>29.6</u> %</p> <p>$i =$ <u>0.296</u></p> <p>Area = <u>18.410</u> ac</p> <p>$d_6 =$ _____ in</p> <p>Choose One</p> <p><input type="radio"/> Water Quality Capture Volume (WQCV)</p> <p><input checked="" type="radio"/> Excess Urban Runoff Volume (EURV)</p> <p>$V_{DESIGN} =$ <u>0.230</u> ac-ft</p> <p>$V_{DESIGN\ OTHER} =$ _____ ac-ft</p> <p>$V_{DESIGN\ USER} =$ _____ ac-ft</p> <p>Choose One</p> <p><input type="radio"/> A</p> <p><input checked="" type="radio"/> B</p> <p><input type="radio"/> C / D</p> <p>EURV = <u>0.560</u> ac-ft</p>
<p>2. Basin Shape: Length to Width Ratio (A basin length to width ratio of at least 2:1 will improve TSS reduction.)</p>	<p>L : W = <u>4.0</u> : 1</p>
<p>3. Basin Side Slopes</p> <p>A) Basin Maximum Side Slopes (Horizontal distance per unit vertical, 4:1 or flatter preferred)</p>	<p>Z = <u>3.00</u> ft / ft</p> <p align="center">DIFFICULT TO MAINTAIN, INCREASE WHERE POSSIBLE</p>
<p>4. Inlet</p> <p>A) Describe means of providing energy dissipation at concentrated inflow locations:</p>	<p>Concrete Forebay</p> <hr/> <hr/> <hr/>

Design Procedure Form: Extended Detention Basin (EDB)

Designer: JPS
Company: JPS
Date: April 23, 2019
Project: MONUMENT ACADEMY
Location: DETENTION POND M3 - INTERIM (PHASE 1) CONDITIONS

<p>5. Forebay</p> <p>A) Minimum Forebay Volume ($V_{FMIN} =$ <u>3%</u> of the WQCV)</p> <p>B) Actual Forebay Volume</p> <p>C) Forebay Depth ($D_F =$ <u>18</u> inch maximum)</p> <p>D) Forebay Discharge</p> <p style="padding-left: 20px;">i) Undetained 100-year Peak Discharge</p> <p style="padding-left: 20px;">ii) Forebay Discharge Design Flow ($Q_F = 0.02 * Q_{100}$)</p> <p>E) Forebay Discharge Design</p> <p style="padding-left: 20px;">Choose One <input type="radio"/> Berm With Pipe <input checked="" type="radio"/> Wall with Rect. Notch <input type="radio"/> Wall with V-Notch Weir</p> <p>F) Discharge Pipe Size (minimum 8-inches)</p> <p>G) Rectangular Notch Width</p>	<p>$V_{FMIN} =$ <u>0.007</u> ac-ft</p> <p>$V_F =$ <u>0.007</u> ac-ft</p> <p>$D_F =$ <u>18.0</u> in</p> <p>$Q_{100} =$ <u>67.80</u> cfs</p> <p>$Q_F =$ <u>1.36</u> cfs</p> <p style="color: blue; font-size: small;">(flow too small for berm w/ pipe)</p> <p>Calculated $D_p =$ <u> </u> in</p> <p>Calculated $W_N =$ <u>6.3</u> in</p>
<p>6. Trickle Channel</p> <p>A) Type of Trickle Channel</p> <p>F) Slope of Trickle Channel</p>	<p style="padding-left: 20px;">Choose One <input checked="" type="radio"/> Concrete <input type="radio"/> Soft Bottom</p> <p>$S =$ <u>0.0050</u> ft / ft</p>
<p>7. Micropool and Outlet Structure</p> <p>A) Depth of Micropool (2.5-foot minimum)</p> <p>B) Surface Area of Micropool (10 ft² minimum)</p> <p>C) Outlet Type</p> <p style="padding-left: 20px;">Choose One <input checked="" type="radio"/> Orifice Plate <input type="radio"/> Other (Describe): _____ _____ _____</p> <p>D) Smallest Dimension of Orifice Opening Based on Hydrograph Routing (Use UD-Detention)</p> <p>E) Total Outlet Area</p>	<p>$D_M =$ <u>2.5</u> ft</p> <p>$A_M =$ <u>10</u> sq ft</p> <p>$D_{orifice} =$ <u>1.50</u> inches</p> <p>$A_{ot} =$ <u>5.61</u> square inches</p>

Design Procedure Form: Extended Detention Basin (EDB)

Sheet 3 of 4

Designer: JPS
Company: JPS
Date: April 23, 2019
Project: MONUMENT ACADEMY
Location: DETENTION POND M3 - INTERIM (PHASE 1) CONDITIONS

<p>8. Initial Surcharge Volume</p> <p>A) Depth of Initial Surcharge Volume (Minimum recommended depth is 4 inches)</p> <p>B) Minimum Initial Surcharge Volume (Minimum volume of 0.3% of the WQCV)</p> <p>C) Initial Surcharge Provided Above Micropool</p>	<p>$D_{IS} = 6$ in</p> <p>$V_{IS} = 30.1$ cu ft</p> <p>$V_s = 5.0$ cu ft</p>
<p>9. Trash Rack</p> <p>A) Water Quality Screen Open Area: $A_t = A_{ot} * 38.5 * (e^{-0.095D})$</p> <p>B) Type of Screen (If specifying an alternative to the materials recommended in the USDCM, indicate "other" and enter the ratio of the total open are to the total screen are for the material specified.)</p> <p align="center">Other (Y/N): N</p> <p>C) Ratio of Total Open Area to Total Area (only for type 'Other')</p> <p>D) Total Water Quality Screen Area (based on screen type)</p> <p>E) Depth of Design Volume (EURV or WQCV) (Based on design concept chosen under 1E)</p> <p>F) Height of Water Quality Screen (H_{TR})</p> <p>G) Width of Water Quality Screen Opening ($W_{opening}$) (Minimum of 12 inches is recommended)</p>	<p>$A_t = 187$ square inches</p> <p><i>Aluminum Amico-Klemp SR Series with Cross Rods 2" O.C.</i></p> <hr/> <hr/> <p>User Ratio =</p> <p>$A_{total} = 264$ sq. in.</p> <p>$H = 2.8$ feet</p> <p>$H_{TR} = 61.6$ inches</p> <p>$W_{opening} = 12.0$ inches</p>

Design Procedure Form: Extended Detention Basin (EDB)

Designer: JPS
Company: JPS
Date: April 23, 2019
Project: MONUMENT ACADEMY
Location: DETENTION POND M3 - INTERIM (PHASE 1) CONDITIONS

<p>10. Overflow Embankment</p> <p>A) Describe embankment protection for 100-year and greater overtopping:</p> <p>B) Slope of Overflow Embankment (Horizontal distance per unit vertical, 4:1 or flatter preferred)</p>	<p>Buried Riprap</p> <hr/> <hr/> <hr/>
<p>11. Vegetation</p>	<p>Choose One</p> <p><input type="radio"/> Irrigated</p> <p><input checked="" type="radio"/> Not Irrigated</p>
<p>12. Access</p> <p>A) Describe Sediment Removal Procedures</p>	<p>Periodic inspection and maintenance by property owner as required</p> <p>Ramp provided for skid-loader access to pond bottom</p> <hr/> <hr/> <hr/> <hr/>
<p>Notes: _____</p> <hr/> <hr/> <hr/>	

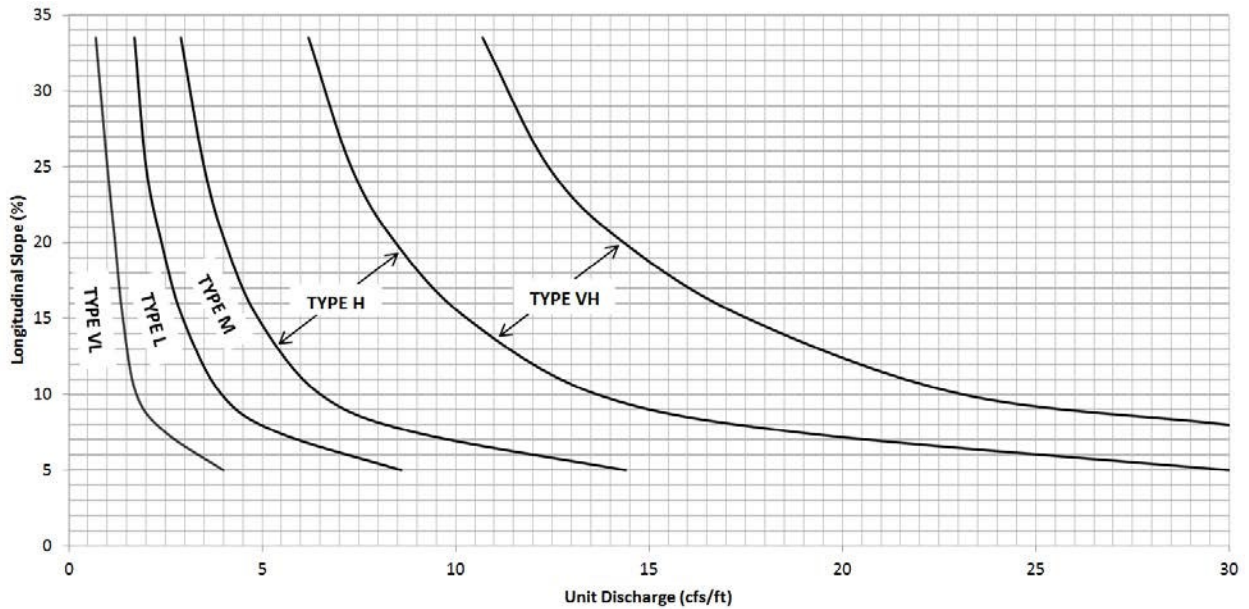
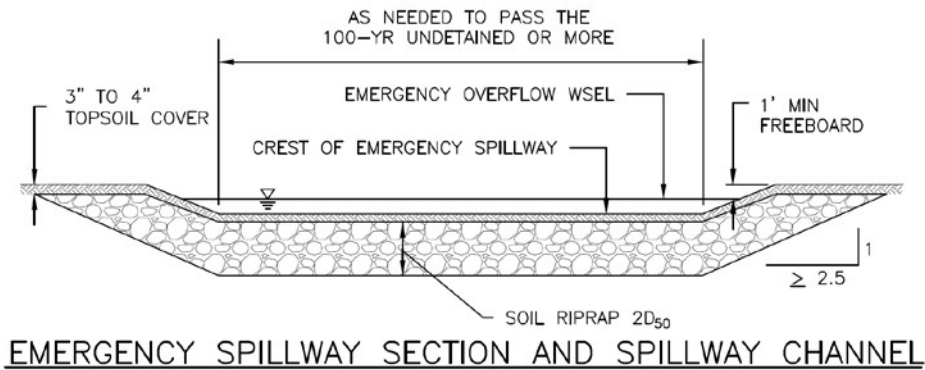
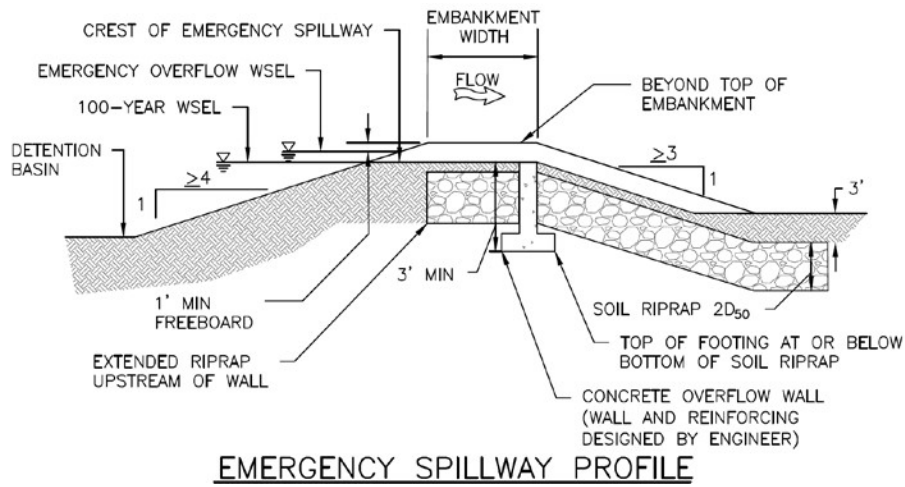

Figure 12-21. Embankment protection details and rock sizing chart (adapted from Arapahoe County)

POND M3: UNIT DISCHARGE = (76.0 CFS / 18.0 FT) = 4.2; SLOPE = 33.3%
 USE TYPE H RIPRAP

APPENDIX D3

WATER QUALITY FACILITY CALCULATIONS

MONUMENT ACADEMY DEVELOPED IMPERVIOUS AREAS										
IMPERVIOUS AREAS - INTERIM (PHASE 1) DEVELOPMENT										
BASIN	TOTAL AREA (AC)	(AC)	SUB-AREA 1 DEVELOPMENT/ COVER	PERCENT IMPERVIOUS	AREA (AC)	SUB-AREA 2 DEVELOPMENT/ COVER	PERCENT IMPERVIOUS	(AC)	SUB-AREA 3 DEVELOPMENT/ COVER	WEIGHTED % IMP
C14	15.85	3.68	BUILDING / PAVEMENT	100	12.17	LANDSCAPED	0			23.218
C15	1.26	0.39	ROADWAY	100	0.87	LANDSCAPED	0			30.952
C16	1.03	0.62	ROADWAY	100	0.41	LANDSCAPED	0			60.194
C14-C16	18.14									25.854
M1	7.06	7.06	NH BUSINESS	70						70.000
M2	7.48	4.78	BUILDING / PAVEMENT	100	2.70	LANDSCAPED	0			63.904
M3	7.73	0.23	ROADWAY	100	7.50	POND / LANDSCAPE	0			2.975
M4	3.20	0.44	ROADWAY	100	2.76	POND / LANDSCAPE	0			13.750
M2,M3,M4	18.41									29.603
OM1	2.00	2.00	MEADOW	0						0.000
M5	21.24	0.49	ROADWAY	100	20.75	FOREST / MEADOW	0			2.307
OM1,M5	23.24									2.108
IMPERVIOUS AREAS - ULTIMATE DEVELOPMENT										
BASIN	TOTAL AREA (AC)	(AC)	SUB-AREA 1 DEVELOPMENT/ COVER	PERCENT IMPERVIOUS	AREA (AC)	SUB-AREA 2 DEVELOPMENT/ COVER	PERCENT IMPERVIOUS	(AC)	SUB-AREA 3 DEVELOPMENT/ COVER	WEIGHTED % IMP
C14	15.85	3.68	BUILDING / PAVEMENT	100	12.17	LANDSCAPED	0			23.218
C15	1.26	0.39	ROADWAY	100	0.87	LANDSCAPED	0			30.952
C16	1.03	0.62	ROADWAY	100	0.41	LANDSCAPED	0			60.194
C14-C16	18.14									25.854
M1	7.06	7.06	NH BUSINESS	70						70.000
M2	7.48	4.78	BUILDING / PAVEMENT	100	2.70	LANDSCAPED	0			63.904
M3	7.73	6.08	NH BUSINESS	70	1.65	POND / LANDSCAPE	0			55.058
M4	3.20	3.20	NH BUSINESS	70						70.000
M2,M3,M4	18.41									61.249
OM1	2.00	2.00	RESIDENTIAL-1-AC	20						20.000
M5	21.24	10.62	RESIDENTIAL-0.5-AC	25	10.62	RESIDENTIAL-1-AC	20			22.500
OM1,M5	23.24									22.285

Design Procedure Form: Extended Detention Basin (EDB)

UD-BMP (Version 3.06, November 2016)

Sheet 1 of 4

Designer: JPS
Company: JPS
Date: May 1, 2019
Project: MONUMENT ACADEMY
Location: WQ POND M4 (INTERIM PHASE 1 CONDITIONS)

<p>1. Basin Storage Volume</p> <p>A) Effective Imperviousness of Tributary Area, I_a</p> <p>B) Tributary Area's Imperviousness Ratio ($i = I_a / 100$)</p> <p>C) Contributing Watershed Area</p> <p>D) For Watersheds Outside of the Denver Region, Depth of Average Runoff Producing Storm</p> <p>E) Design Concept (Select EURV when also designing for flood control)</p> <p>F) Design Volume (WQCV) Based on 40-hour Drain Time ($V_{DESIGN} = (1.0 * (0.91 * i^3 - 1.19 * i^2 + 0.78 * i)) / 12 * Area$)</p> <p>G) For Watersheds Outside of the Denver Region, Water Quality Capture Volume (WQCV) Design Volume ($V_{WQCV\ OTHER} = (d_6 * V_{DESIGN} / 0.43)$)</p> <p>H) User Input of Water Quality Capture Volume (WQCV) Design Volume (Only if a different WQCV Design Volume is desired)</p> <p>I) Predominant Watershed NRCS Soil Group</p> <p>J) Excess Urban Runoff Volume (EURV) Design Volume For HSG A: $EURV_A = 1.68 * i^{1.28}$ For HSG B: $EURV_B = 1.36 * i^{1.08}$ For HSG C/D: $EURV_{C/D} = 1.20 * i^{1.08}$ </p>	<p>$I_a =$ <u>13.8</u> %</p> <p>$i =$ <u>0.138</u></p> <p>Area = <u>3.200</u> ac</p> <p>$d_6 =$ _____ in</p> <p>Choose One</p> <p><input checked="" type="radio"/> Water Quality Capture Volume (WQCV)</p> <p><input type="radio"/> Excess Urban Runoff Volume (EURV)</p> <p>$V_{DESIGN} =$ <u>0.023</u> ac-ft</p> <p>$V_{DESIGN\ OTHER} =$ _____ ac-ft</p> <p>$V_{DESIGN\ USER} =$ _____ ac-ft</p> <p>Choose One</p> <p><input type="radio"/> A</p> <p><input type="radio"/> B</p> <p><input type="radio"/> C / D</p> <p style="color: blue;">WQCV selected. Soil group not required.</p> <p>EURV = _____ ac-ft</p>
<p>2. Basin Shape: Length to Width Ratio (A basin length to width ratio of at least 2:1 will improve TSS reduction.)</p>	<p>L : W = <u>2.0</u> : 1</p>
<p>3. Basin Side Slopes</p> <p>A) Basin Maximum Side Slopes (Horizontal distance per unit vertical, 4:1 or flatter preferred)</p>	<p>Z = <u>4.00</u> ft / ft</p>
<p>4. Inlet</p> <p>A) Describe means of providing energy dissipation at concentrated inflow locations:</p>	<p>_____</p> <p>_____</p> <p>_____</p> <p>_____</p>

Design Procedure Form: Extended Detention Basin (EDB)

UD-BMP (Version 3.06, November 2016)

Sheet 1 of 4

Designer: JPS
Company: JPS
Date: June 20, 2019
Project: MONUMENT ACADEMY
Location: WQ POND M5 (INTERIM PHASE 1 CONDITIONS)

<p>1. Basin Storage Volume</p> <p>A) Effective Imperviousness of Tributary Area, I_a</p> <p>B) Tributary Area's Imperviousness Ratio ($i = I_a / 100$)</p> <p>C) Contributing Watershed Area</p> <p>D) For Watersheds Outside of the Denver Region, Depth of Average Runoff Producing Storm</p> <p>E) Design Concept (Select EURV when also designing for flood control)</p> <p>F) Design Volume (WQCV) Based on 40-hour Drain Time ($V_{DESIGN} = (1.0 * (0.91 * i^3 - 1.19 * i^2 + 0.78 * i)) / 12 * Area$)</p> <p>G) For Watersheds Outside of the Denver Region, Water Quality Capture Volume (WQCV) Design Volume ($V_{WQCV\ OTHER} = (d_6 * V_{DESIGN} / 0.43)$)</p> <p>H) User Input of Water Quality Capture Volume (WQCV) Design Volume (Only if a different WQCV Design Volume is desired)</p> <p>I) Predominant Watershed NRCS Soil Group</p> <p>J) Excess Urban Runoff Volume (EURV) Design Volume For HSG A: $EURV_A = 1.68 * i^{1.28}$ For HSG B: $EURV_B = 1.36 * i^{1.08}$ For HSG C/D: $EURV_{C/D} = 1.20 * i^{1.08}$ </p>	<p>$I_a =$ <u>2.1</u> %</p> <p>$i =$ <u>0.021</u></p> <p>Area = <u>23.200</u> ac</p> <p>$d_6 =$ _____ in</p> <p>Choose One</p> <p><input checked="" type="radio"/> Water Quality Capture Volume (WQCV)</p> <p><input type="radio"/> Excess Urban Runoff Volume (EURV)</p> <p>$V_{DESIGN} =$ <u>0.031</u> ac-ft</p> <p>$V_{DESIGN\ OTHER} =$ _____ ac-ft</p> <p>$V_{DESIGN\ USER} =$ _____ ac-ft</p> <p>Choose One</p> <p><input type="radio"/> A</p> <p><input type="radio"/> B</p> <p><input type="radio"/> C / D</p> <p>WQCV selected. Soil group not required.</p> <p>EURV = _____ ac-ft</p>
<p>2. Basin Shape: Length to Width Ratio (A basin length to width ratio of at least 2:1 will improve TSS reduction.)</p>	<p>L : W = <u>2.0</u> : 1</p>
<p>3. Basin Side Slopes</p> <p>A) Basin Maximum Side Slopes (Horizontal distance per unit vertical, 4:1 or flatter preferred)</p>	<p>Z = <u>4.00</u> ft / ft</p>
<p>4. Inlet</p> <p>A) Describe means of providing energy dissipation at concentrated inflow locations:</p>	<p>_____</p> <p>_____</p> <p>_____</p> <p>_____</p>

MA - WALKER ROAD DRAINAGE ANALYSIS
IMPERVIOUS AREAS

DEVELOPED CONDITIONS											
BASIN	TOTAL AREA (AC)	(AC)	SUB-AREA 1 DEVELOPMENT/ COVER	PERCENT IMPERVIOUS	AREA (AC)	SUB-AREA 2 DEVELOPMENT/ COVER	PERCENT IMPERVIOUS	(AC)	SUB-AREA 3 DEVELOPMENT/ COVER	PERCENT IMPERVIOUS	WEIGHTED % IMP
OM2	1.10	0.26	ASPHALT PAVEMENT	100.00	0.84	MEADOW	0				23.364
M1	5.94	5.94	DETAINED POND M1	0.00							0.000
M6	1.46	0.36	ASPHALT PAVEMENT	100.00	1.10	MEADOW	0				24.384
M1,M6	7.40										4.811
OM3	2.80	0.33	ASPHALT PAVEMENT	100.00	2.47	MEADOW	0				11.643
M1,M6,OM3	10.20										6.686

Design Procedure Form: Rain Garden (RG)

UD-BMP (Version 3.06, November 2016)

Sheet 1 of 2

Designer: JPS
Company: JPS
Date: April 7, 2020
Project: MONUMENT ACADEMY
Location: WALKER ROAD - BASIN OM2

<p>1. Basin Storage Volume</p> <p>A) Effective Imperviousness of Tributary Area, I_a (100% if all paved and roofed areas upstream of rain garden)</p> <p>B) Tributary Area's Imperviousness Ratio ($i = I_a/100$)</p> <p>C) Water Quality Capture Volume (WQCV) for a 12-hour Drain Time ($WQCV = 0.8 * (0.91 * i^3 - 1.19 * i^2 + 0.78 * i)$)</p> <p>D) Contributing Watershed Area (including rain garden area)</p> <p>E) Water Quality Capture Volume (WQCV) Design Volume $Vol = (WQCV / 12) * Area$</p> <p>F) For Watersheds Outside of the Denver Region, Depth of Average Runoff Producing Storm</p> <p>G) For Watersheds Outside of the Denver Region, Water Quality Capture Volume (WQCV) Design Volume</p> <p>H) User Input of Water Quality Capture Volume (WQCV) Design Volume (Only if a different WQCV Design Volume is desired)</p>	<p>$I_a =$ <u>23.4</u> %</p> <p>$i =$ <u>0.234</u></p> <p>WQCV = <u>0.10</u> watershed inches</p> <p>Area = <u>47,916</u> sq ft</p> <p>$V_{WQCV} =$ <u>412</u> cu ft</p> <p>$d_e =$ _____ in</p> <p>$V_{WQCV\ OTHER} =$ _____ cu ft</p> <p>$V_{WQCV\ USER} =$ _____ cu ft</p>
<p>2. Basin Geometry</p> <p>A) WQCV Depth (12-inch maximum)</p> <p>B) Rain Garden Side Slopes ($Z = 4$ min., horiz. dist per unit vertical) (Use "0" if rain garden has vertical walls)</p> <p>C) Minimum Flat Surface Area</p> <p>D) Actual Flat Surface Area</p> <p>E) Area at Design Depth (Top Surface Area)</p> <p>F) Rain Garden Total Volume ($V_T = ((A_{Top} + A_{Actual}) / 2) * Depth$)</p>	<p>$D_{WQCV} =$ <u>12</u> in</p> <p>$Z =$ <u>4.00</u> ft / ft</p> <p>$A_{Min} =$ <u>224</u> sq ft</p> <p>$A_{Actual} =$ <u>236</u> sq ft</p> <p>$A_{Top} =$ <u>600</u> sq ft</p> <p>$V_T =$ <u>418</u> cu ft</p>
<p>3. Growing Media</p>	<p>Choose One _____</p> <p><input checked="" type="radio"/> 18" Rain Garden Growing Media</p> <p><input type="radio"/> Other (Explain): _____</p>
<p>4. Underdrain System</p> <p>A) Are underdrains provided?</p> <p>B) Underdrain system orifice diameter for 12 hour drain time</p> <p style="margin-left: 20px;">i) Distance From Lowest Elevation of the Storage Volume to the Center of the Orifice</p> <p style="margin-left: 20px;">ii) Volume to Drain in 12 Hours</p> <p style="margin-left: 20px;">iii) Orifice Diameter, 3/8" Minimum</p>	<p>Choose One _____</p> <p><input checked="" type="radio"/> YES</p> <p><input type="radio"/> NO</p> <p>$y =$ <u>2.0</u> ft</p> <p>$Vol_{12} =$ <u>412</u> cu ft</p> <p>$D_o =$ <u>1/2</u> in</p>

Design Procedure Form: Rain Garden (RG)

Sheet 2 of 2

Designer: JPS
Company: JPS
Date: April 7, 2020
Project: MONUMENT ACADEMY
Location: WALKER ROAD - BASIN OM2

5. Impermeable Geomembrane Liner and Geotextile Separator Fabric

A) Is an impermeable liner provided due to proximity of structures or groundwater contamination?

Choose One

YES

NO

6. Inlet / Outlet Control

A) Inlet Control

Choose One

Sheet Flow- No Energy Dissipation Required

Concentrated Flow- Energy Dissipation Provided

7. Vegetation

Choose One

Seed (Plan for frequent weed control)

Plantings

Sand Grown or Other High Infiltration Sod

8. Irrigation

A) Will the rain garden be irrigated?

Choose One

YES

NO

Notes: _____

Design Procedure Form: Rain Garden (RG)

UD-BMP (Version 3.06, November 2016)

Sheet 1 of 2

Designer: JPS
Company: JPS
Date: April 7, 2020
Project: MONUMENT ACADEMY
Location: WALKER ROAD - BASIN OM3

<p>1. Basin Storage Volume</p> <p>A) Effective Imperviousness of Tributary Area, I_a (100% if all paved and roofed areas upstream of rain garden)</p> <p>B) Tributary Area's Imperviousness Ratio ($i = I_a/100$)</p> <p>C) Water Quality Capture Volume (WQCV) for a 12-hour Drain Time ($WQCV = 0.8 * (0.91 * i^3 - 1.19 * i^2 + 0.78 * i)$)</p> <p>D) Contributing Watershed Area (including rain garden area)</p> <p>E) Water Quality Capture Volume (WQCV) Design Volume $Vol = (WQCV / 12) * Area$</p> <p>F) For Watersheds Outside of the Denver Region, Depth of Average Runoff Producing Storm</p> <p>G) For Watersheds Outside of the Denver Region, Water Quality Capture Volume (WQCV) Design Volume</p> <p>H) User Input of Water Quality Capture Volume (WQCV) Design Volume (Only if a different WQCV Design Volume is desired)</p>	<p>$I_a =$ <u>11.6</u> %</p> <p>$i =$ <u>0.116</u></p> <p>WQCV = <u>0.06</u> watershed inches</p> <p>Area = <u>121,968</u> sq ft</p> <p>$V_{WQCV} =$ <u>617</u> cu ft</p> <p>$d_e =$ _____ in</p> <p>$V_{WQCV\ OTHER} =$ _____ cu ft</p> <p>$V_{WQCV\ USER} =$ _____ cu ft</p>
<p>2. Basin Geometry</p> <p>A) WQCV Depth (12-inch maximum)</p> <p>B) Rain Garden Side Slopes ($Z = 4$ min., horiz. dist per unit vertical) (Use "0" if rain garden has vertical walls)</p> <p>C) Minimum Flat Surface Area</p> <p>D) Actual Flat Surface Area</p> <p>E) Area at Design Depth (Top Surface Area)</p> <p>F) Rain Garden Total Volume ($V_T = ((A_{Top} + A_{Actual}) / 2) * Depth$)</p>	<p>$D_{WQCV} =$ <u>12</u> in</p> <p>$Z =$ <u>4.00</u> ft / ft</p> <p>$A_{Min} =$ <u>283</u> sq ft</p> <p>$A_{Actual} =$ <u>308</u> sq ft</p> <p>$A_{Top} =$ <u>949</u> sq ft</p> <p>$V_T =$ <u>629</u> cu ft</p>
<p>3. Growing Media</p>	<p>Choose One _____</p> <p><input checked="" type="radio"/> 18" Rain Garden Growing Media</p> <p><input type="radio"/> Other (Explain): _____</p>
<p>4. Underdrain System</p> <p>A) Are underdrains provided?</p> <p>B) Underdrain system orifice diameter for 12 hour drain time</p> <p style="margin-left: 20px;">i) Distance From Lowest Elevation of the Storage Volume to the Center of the Orifice</p> <p style="margin-left: 20px;">ii) Volume to Drain in 12 Hours</p> <p style="margin-left: 20px;">iii) Orifice Diameter, 3/8" Minimum</p>	<p>Choose One _____</p> <p><input checked="" type="radio"/> YES</p> <p><input type="radio"/> NO</p> <p>$y =$ <u>2.0</u> ft</p> <p>$Vol_{12} =$ <u>617</u> cu ft</p> <p>$D_o =$ <u>4/7</u> in</p>

Design Procedure Form: Rain Garden (RG)

Designer: JPS
Company: JPS
Date: April 7, 2020
Project: MONUMENT ACADEMY
Location: WALKER ROAD - BASIN OM3

<p>5. Impermeable Geomembrane Liner and Geotextile Separator Fabric</p> <p>A) Is an impermeable liner provided due to proximity of structures or groundwater contamination?</p>	<p>Choose One</p> <p><input type="radio"/> YES</p> <p><input checked="" type="radio"/> NO</p>
<p>6. Inlet / Outlet Control</p> <p>A) Inlet Control</p>	<p>Choose One</p> <p><input type="radio"/> Sheet Flow- No Energy Dissipation Required</p> <p><input checked="" type="radio"/> Concentrated Flow- Energy Dissipation Provided</p>
<p>7. Vegetation</p>	<p>Choose One</p> <p><input checked="" type="radio"/> Seed (Plan for frequent weed control)</p> <p><input type="radio"/> Plantings</p> <p><input type="radio"/> Sand Grown or Other High Infiltration Sod</p>
<p>8. Irrigation</p> <p>A) Will the rain garden be irrigated?</p>	<p>Choose One</p> <p><input type="radio"/> YES</p> <p><input type="radio"/> NO</p>

Notes: _____

APPENDIX E
DRAINAGE COST ESTIMATE

**MONUMENT ACADEMY
DRAINAGE IMPROVEMENTS COST ESTIMATE**

Item No.	Description	Quantity	Unit	Unit Cost (\$\$\$)	Total Cost (\$\$\$)
PUBLIC DRAINAGE IMPROVEMENTS (NON-REIMBURSABLE)					
	Rain Garden	130	CY	\$20	\$2,600
	15" RCP Storm Sewer	45	LF	\$69	\$3,105
	18" RCP Storm Sewer	880	LF	\$69	\$60,720
	30" RCP Storm Sewer	89	LF	\$94	\$8,366
	Curb Inlet, 5' Type R	5	EA	\$3,791	\$18,955
	Curb Inlet, 10' Type R	1	EA	\$5,528	\$5,528
	Permanent Erosion Control Blanket Ditch Lining	320	SY	\$6	\$1,920
	18" RCP Flared End Section	5	EA	\$414	\$2,070
	30" RCP Flared End Section	1	EA	\$564	\$564
	Riprap (d ₅₀ = 12")	20	CY	\$98	\$1,960
	SUBTOTAL				\$105,788
	Contingency @ 15%				\$15,868
	TOTAL				\$121,656
PRIVATE DRAINAGE IMPROVEMENTS (NON-REIMBURSABLE)					
	18" HDPE Storm Sewer	1420	LF	\$69	\$97,980
	24" HDPE Storm Sewer	810	LF	\$84	\$68,040
	Curb Inlet, 5' Type R	1	EA	\$3,791	\$3,791
	Curb Inlet, 10' Type R	2	EA	\$5,528	\$11,056
	18" RCP Flared End Section	1	EA	\$414	\$414
	24" RCP Flared End Section	1	EA	\$504	\$504
	Riprap (d ₅₀ = 12")	10	CY	\$98	\$980
	Permanent Erosion Control Blanket Channel Lining	622	SY	\$6	\$3,732
	Channel Lining, Riprap	85	CY	\$98	\$8,330
	Detention Pond Outlet Structure	2	EA	\$8,000	\$16,000
	Detention Pond Spillway	2	EA	\$3,000	\$6,000
	SUBTOTAL				\$216,827
	Contingency @ 15%				\$32,524
	TOTAL				\$249,351
	TOTAL DRAINAGE IMPROVEMENTS				\$371,007
	Note: This estimate does not include costs for street improvements (curb & gutter, crosspans, etc.)				

The cost estimate submitted herein is based on time-honored practices within the construction industry. As such the engineer does not control the cost of labor, materials, equipment or a contractor's method of determining prices and competitive bidding practices or market conditions. The estimate represents our best judgement as design professionals using current information available at the time of the preparation. The engineer cannot guarantee that proposals, bids and/or construction costs will not vary from this cost estimate.

APPENDIX F

FIGURES

Z:\040201.walden\dwg\civi\WALDEN PRESERVE 2\MONUMENT ACADEMY\FIGURE A1.dwg, 2/8/2019 6:27:56 PM, DWG To PDF.pc3

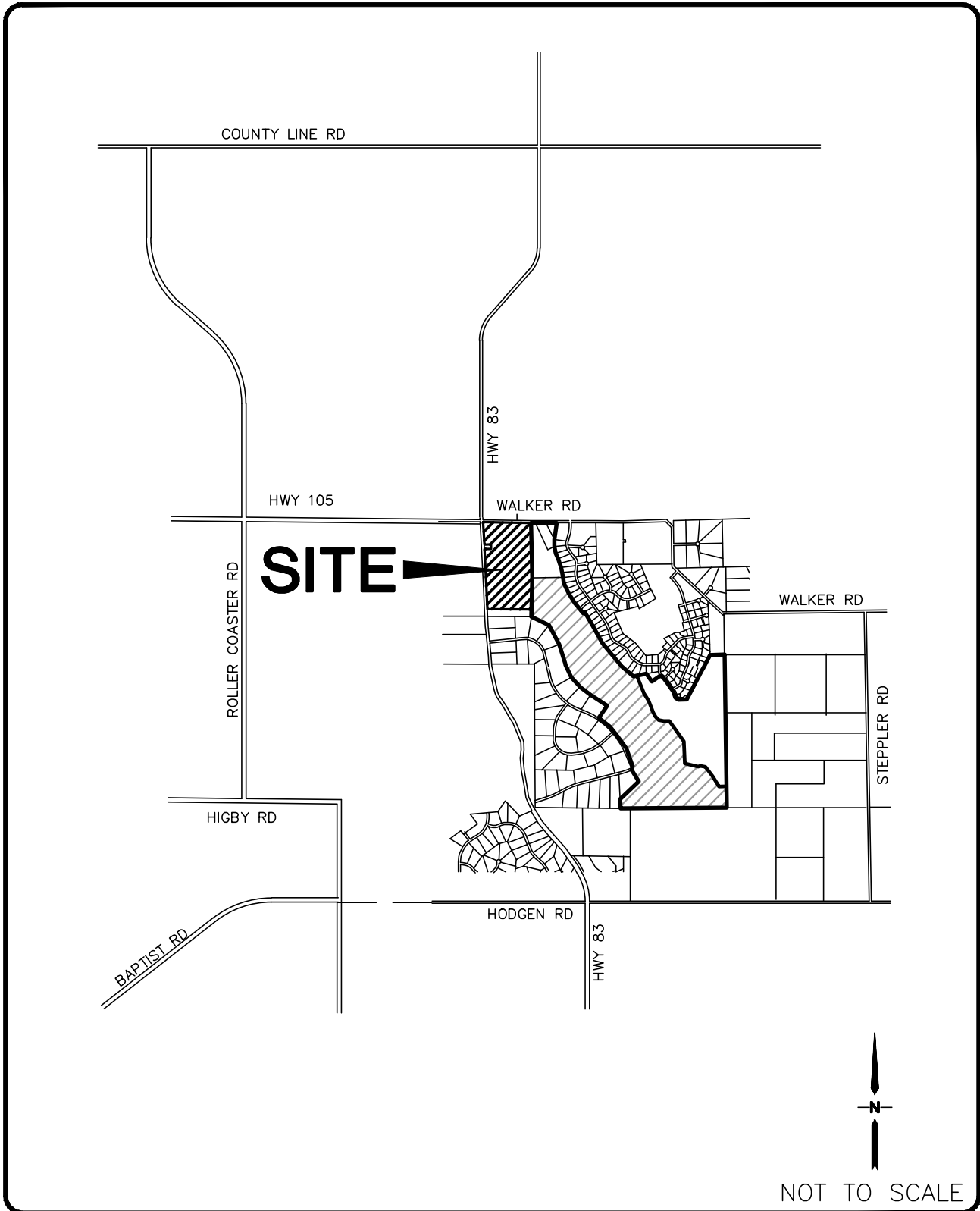

VICINITY MAP

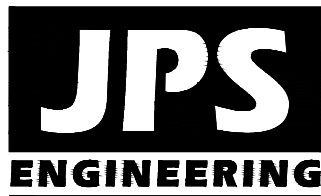

MONUMENT ACADEMY

FIGURE A1

JPS PROJ NO. 040201

National Flood Hazard Layer FIRMette



Legend

SEE FIS REPORT FOR DETAILED LEGEND AND INDEX MAP FOR FIRM PANEL LAYOUT

SPECIAL FLOOD HAZARD AREAS		Without Base Flood Elevation (BFE) Zone A, V, A99
		With BFE or Depth Zone AE, AO, AH, VE, AR
		Regulatory Floodway
OTHER AREAS OF FLOOD HAZARD		0.2% Annual Chance Flood Hazard, Areas of 1% annual chance flood with average depth less than one foot or with drainage areas of less than one square mile Zone X
		Future Conditions 1% Annual Chance Flood Hazard Zone X
		Area with Reduced Flood Risk due to Levee. See Notes. Zone X
		Area with Flood Risk due to Levee Zone D
OTHER AREAS		NO SCREEN Area of Minimal Flood Hazard Zone X
		Effective LOMRs
		Area of Undetermined Flood Hazard Zone D
GENERAL STRUCTURES		Channel, Culvert, or Storm Sewer
		Levee, Dike, or Floodwall
OTHER FEATURES		Cross Sections with 1% Annual Chance Water Surface Elevation
		Coastal Transect
		Base Flood Elevation Line (BFE)
		Limit of Study
		Jurisdiction Boundary
		Coastal Transect Baseline
		Profile Baseline
MAP PANELS		Digital Data Available
		No Digital Data Available
		Unmapped



The pin displayed on the map is an approximate point selected by the user and does not represent an authoritative property location.

This map complies with FEMA's standards for the use of digital flood maps if it is not void as described below. The basemap shown complies with FEMA's basemap accuracy standards

The flood hazard information is derived directly from the authoritative NFHL web services provided by FEMA. This map was exported on **2/8/2019 at 7:27:28 PM** and does not reflect changes or amendments subsequent to this date and time. The NFHL and effective information may change or become superseded by new data over time.

This map image is void if the one or more of the following map elements do not appear: basemap imagery, flood zone labels, legend, scale bar, map creation date, community identifiers, FIRM panel number, and FIRM effective date. Map images for unmapped and unmodernized areas cannot be used for regulatory purposes.

104°46'25.02"W
39°6'6.61"N

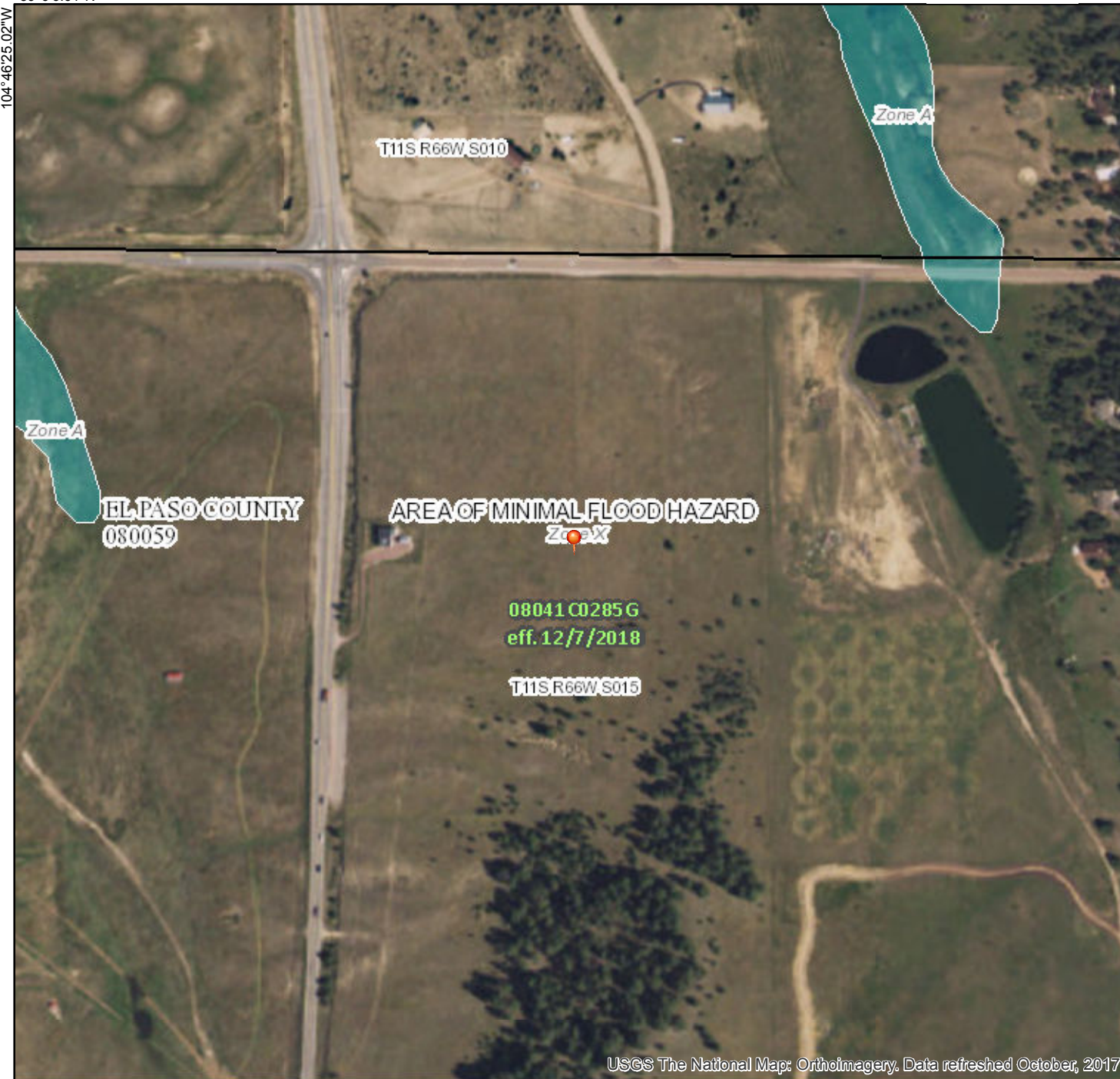

USGS The National Map: Orthoimagery. Data refreshed October, 2017.

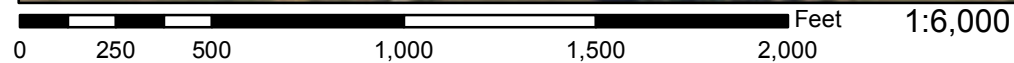

39°5'38.69"N
104°45'47.57"W

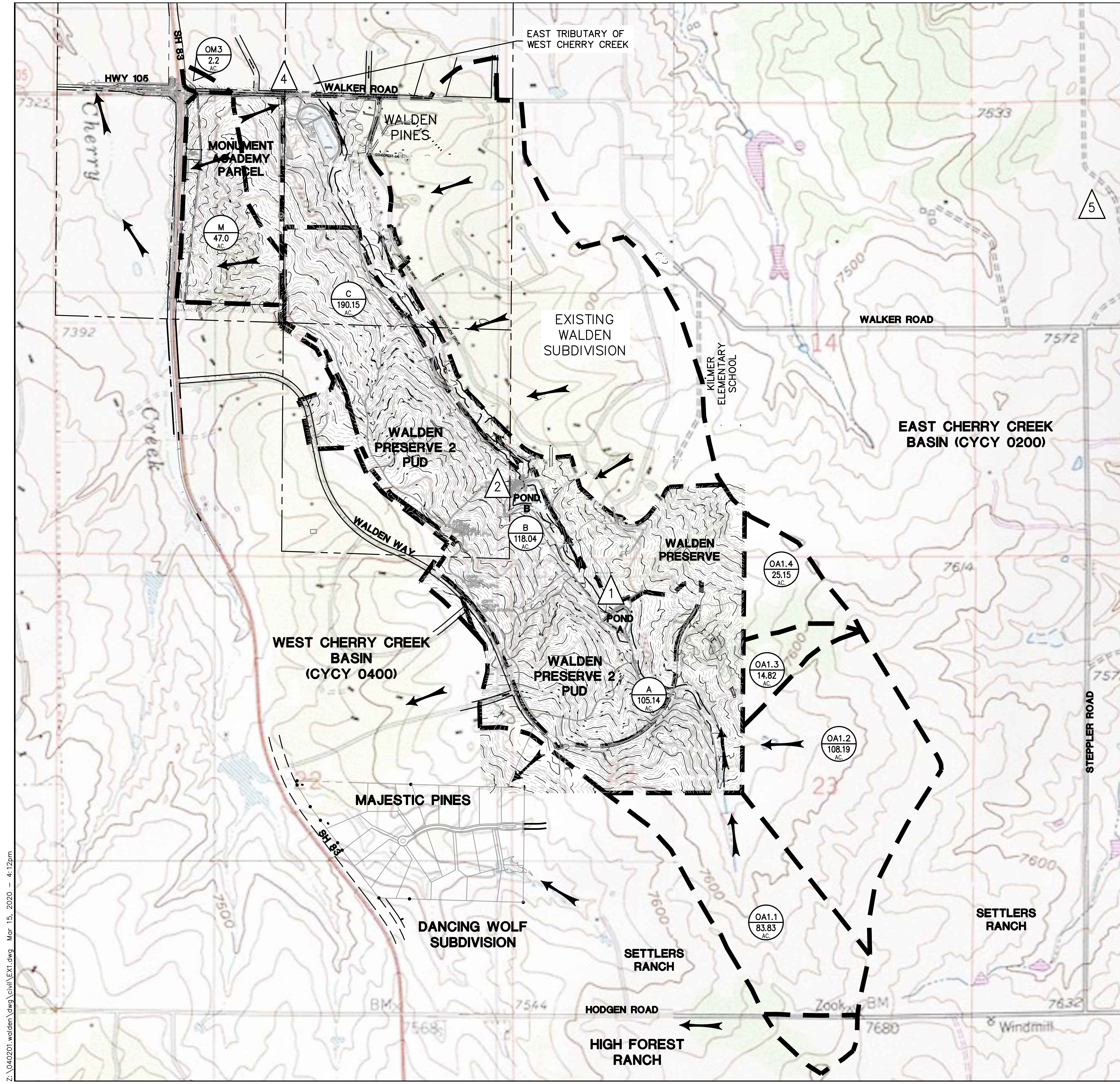

LEGEND

- FILING LIMITS
- MAJOR BASIN BOUNDARY
- EXISTING CONTOUR
- FLOWLINE
- DESIGN POINT (FROM "WALDEN PRESERVE MDDP")
- BASIN DESIGNATION
- BASIN AREA (ACRES)

SUMMARY HYDROLOGY TABLE

DESIGN POINT	Q5 (CFS)	Q100 (CFS)
1	39.4	240.8
2	73.4	321.3
4	234.8	620.0

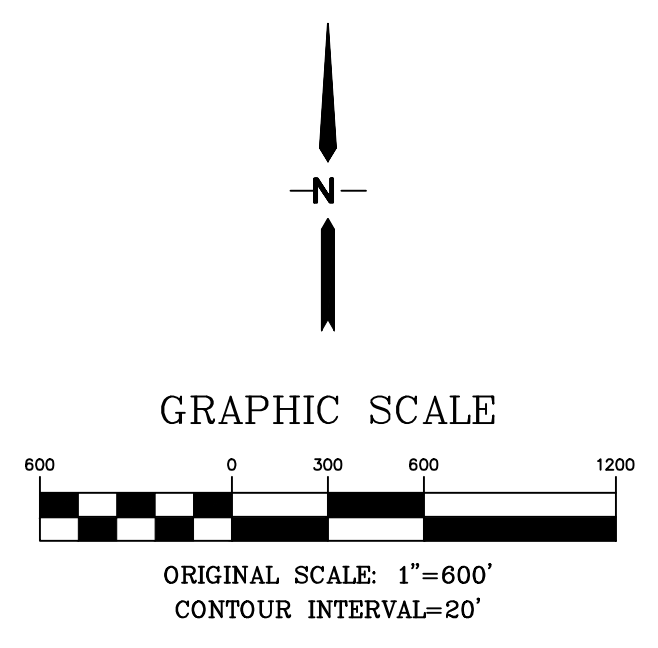

WALDEN PRESERVE SUBDIVISION

MAJOR BASIN / HISTORIC DRAINAGE PLAN

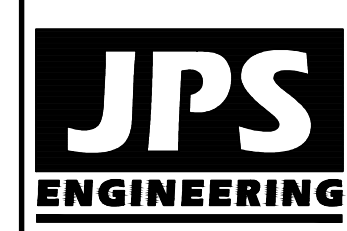

19 E. Willamette Ave.
Colorado Springs, CO
80903
PH: 719-477-9429
FAX: 719-471-0766
www.jpsegr.com



CALL UTILITY NOTIFICATION
CENTER OF COLORADO
1-800-922-1987
CALL OR VISIT www.cocolorado.com
BEFORE YOU DIG, GRADE, OR EXCAVATE
FOR THE MARKING OF UNDERGROUND
MEMBER UTILITIES

No.	REVISION	BY	DATE

HORZ. SCALE: 1"=600'	DRAWN: MJP
VERT. SCALE: N/A	DESIGNED: JPS
SURVEYED: PINNACLE	CHECKED: JPS
CREATED: 7/22/02	LAST MODIFIED: 3/15/20
PROJECT NO: 040201	MODIFIED BY: BJJ

SHEET: EX1

Z:\040201\walden_dwg\civil\EX1.dwg Mar 15, 2020 - 4:12pm

Z:\040201\walden.dwg 2:MONUMENT_ACADEMY_EX2.dwg Mar 16, 2020 - 5:09pm

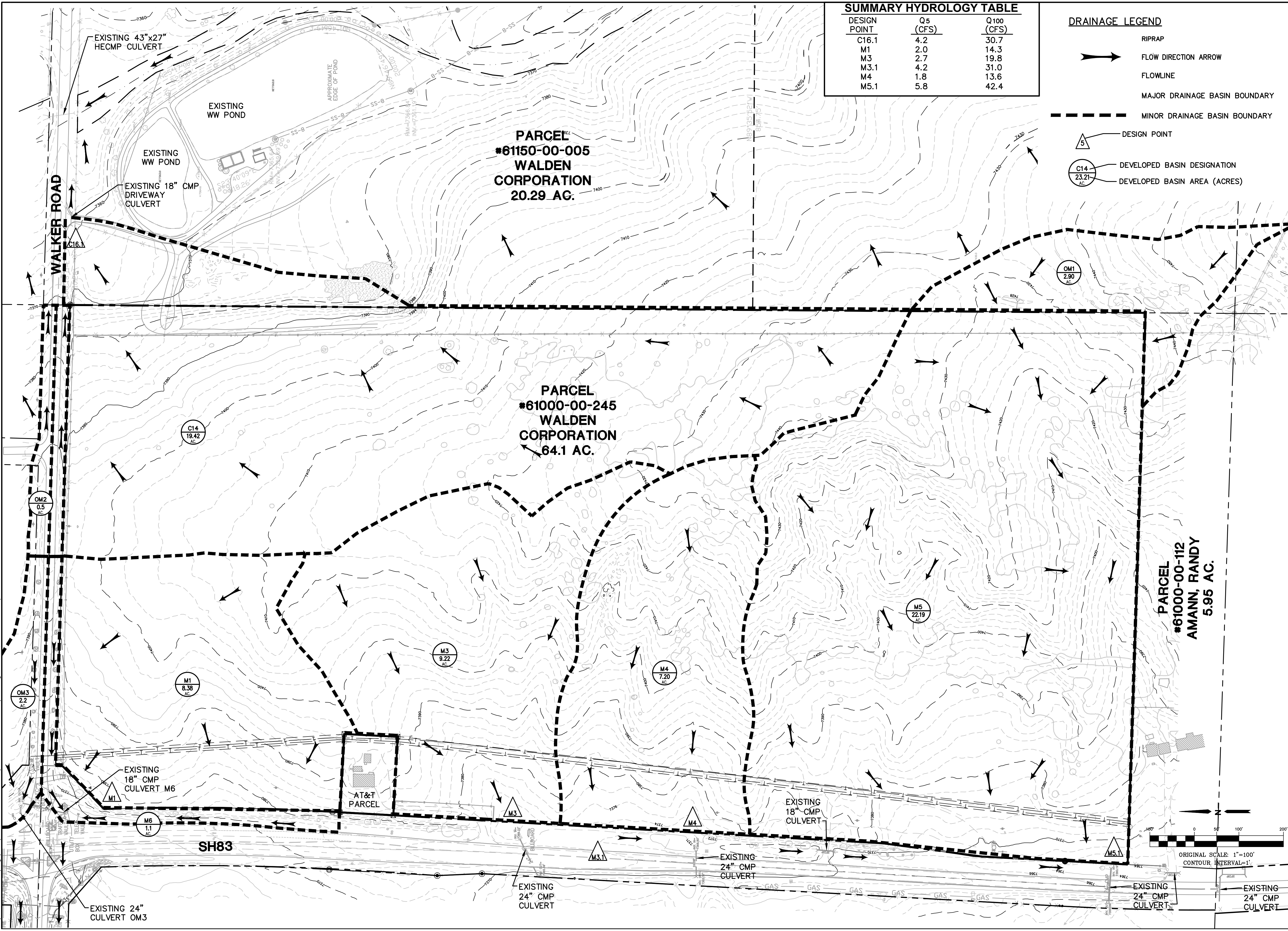

DESIGN POINT	Q5 (CFS)	Q100 (CFS)
C16.1	4.2	30.7
M1	2.0	14.3
M3	2.7	19.8
M3.1	4.2	31.0
M4	1.8	13.6
M5.1	5.8	42.4

- DRAINAGE LEGEND**
- RIPRAP
 - FLOW DIRECTION ARROW
 - FLOWLINE
 - MAJOR DRAINAGE BASIN BOUNDARY
 - MINOR DRAINAGE BASIN BOUNDARY
 - DESIGN POINT
 - DEVELOPED BASIN DESIGNATION
 - DEVELOPED BASIN AREA (ACRES)

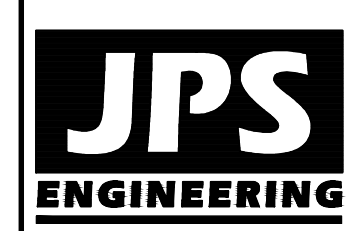

19 E. Willamette Ave.
Colorado Springs, CO
80903
PH: 719-477-9429
FAX: 719-471-0766
www.jpsegr.com



CALL UTILITY NOTIFICATION
CENTER OF COLORADO
1-800-922-1987
CALL OR VISIT US ONLINE IN ADVANCE
BEFORE YOU DIG, GRADE, OR EXCAVATE
FOR THE MARKING OF UNDERGROUND
MEMBER UTILITIES.

MONUMENT ACADEMY

NO.	REVISION	BY	DATE

HISTORIC DRAINAGE PLAN

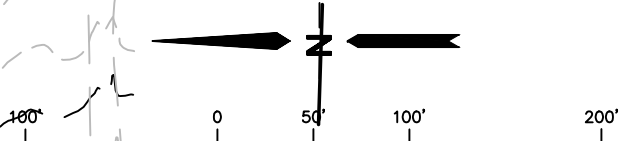

HORZ. SCALE: 1"=100'	DRAWN: BJJ
VERT. SCALE: N/A	DESIGNED: JPS
SURVEYED: RAMPART	CHECKED: JPS
CREATED: 2/08/19	LAST MODIFIED: 3/13/20
PROJECT NO: 040201	MODIFIED BY: BJJ
SHEET:	

EX2

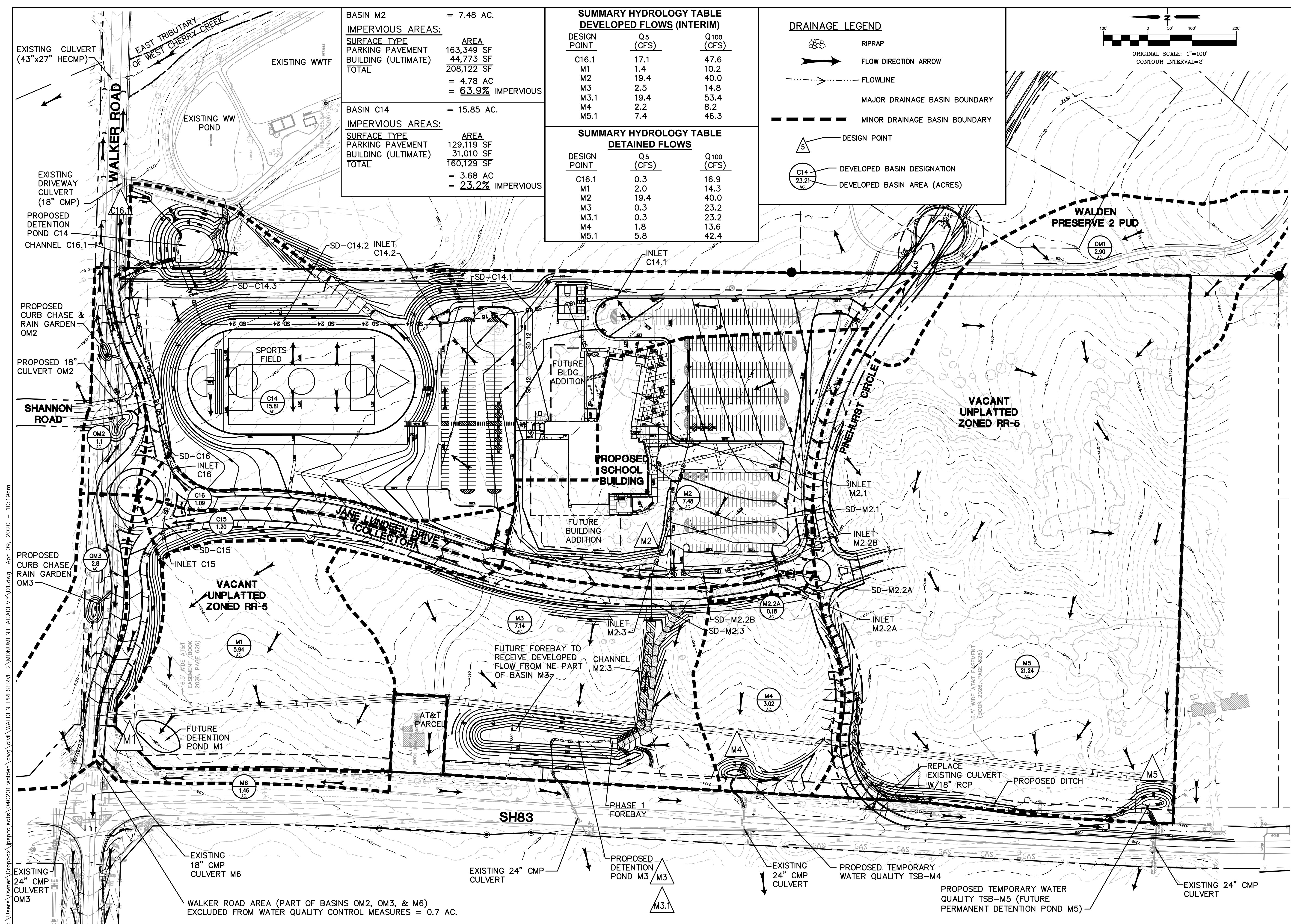

BASIN M2		= 7.48 AC.
IMPERVIOUS AREAS:		
SURFACE TYPE	AREA	
PARKING PAVEMENT	163,349 SF	
BUILDING (ULTIMATE)	44,773 SF	
TOTAL	208,122 SF	
	= 4.78 AC	
	= 63.9% IMPERVIOUS	
BASIN C14		= 15.85 AC.
IMPERVIOUS AREAS:		
SURFACE TYPE	AREA	
PARKING PAVEMENT	129,119 SF	
BUILDING (ULTIMATE)	31,010 SF	
TOTAL	160,129 SF	
	= 3.68 AC	
	= 23.2% IMPERVIOUS	

SUMMARY HYDROLOGY TABLE DEVELOPED FLOWS (INTERIM)		
DESIGN POINT	Q5 (CFS)	Q100 (CFS)
C16.1	17.1	47.6
M1	1.4	10.2
M2	19.4	40.0
M3	2.5	14.8
M3.1	19.4	53.4
M4	2.2	8.2
M5.1	7.4	46.3
SUMMARY HYDROLOGY TABLE DETAINED FLOWS		
DESIGN POINT	Q5 (CFS)	Q100 (CFS)
C16.1	0.3	16.9
M1	2.0	14.3
M2	19.4	40.0
M3	0.3	23.2
M3.1	0.3	23.2
M4	1.8	13.6
M5.1	5.8	42.4

DRAINAGE LEGEND

- RIPRAP
- FLOW DIRECTION ARROW
- FLOWLINE
- MAJOR DRAINAGE BASIN BOUNDARY
- MINOR DRAINAGE BASIN BOUNDARY
- DESIGN POINT
- DEVELOPED BASIN DESIGNATION
- DEVELOPED BASIN AREA (ACRES)

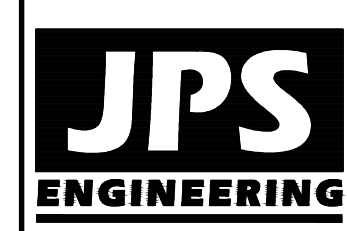
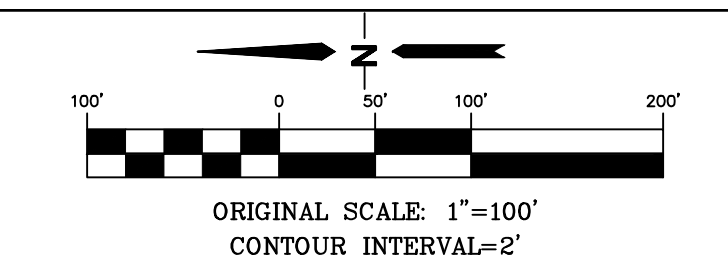

19 E. Willamette Ave.
Colorado Springs, CO
80903
PH: 719-477-9429
FAX: 719-471-0766
www.jpsegr.com



CALL UTILITY NOTIFICATION
CENTER OF COLORADO
1-800-922-1987
CALL BEFORE YOU DIG. IN ADVANCE
BEFORE YOU DIG, GRADE, OR EXCAVATE
FOR THE MARKING OF UNDERGROUND
MEMBER UTILITIES.

MONUMENT ACADEMY

NO.	REVISION	BY	DATE

DEVELOPED DRAINAGE PLAN

HORZ. SCALE: 1"=100'	DRAWN: BJJ
VERT. SCALE: N/A	DESIGNED: JPS
SURVEYED: RAMPART	CHECKED: JPS
CREATED: 11/29/18	LAST MODIFIED: 4/08/20
PROJECT NO: 040201	MODIFIED BY: BJJ
SHEET:	

D1

C:\Users\Owner\Desktop\psprojects\040201\walden_preserve_2\monument_academy.dwg, Apr. 09, 2020 - 10:19am

MONUMENT ACADEMY HIGH SCHOOL

FOR CONSTRUCTION

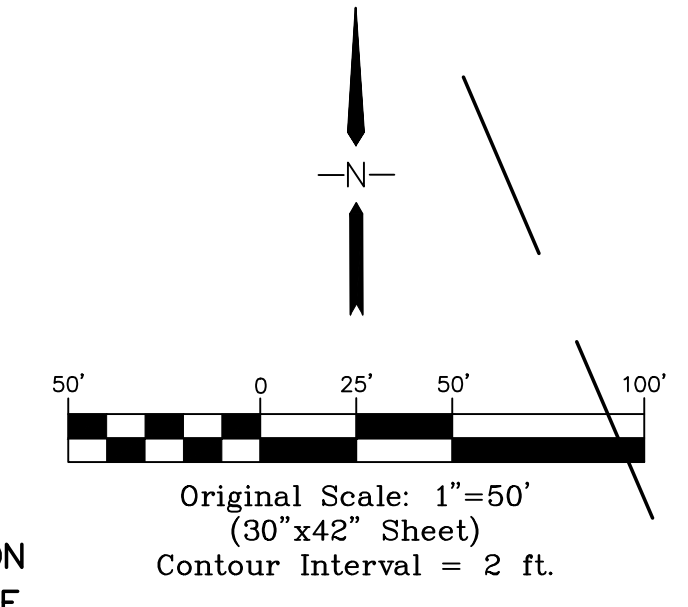
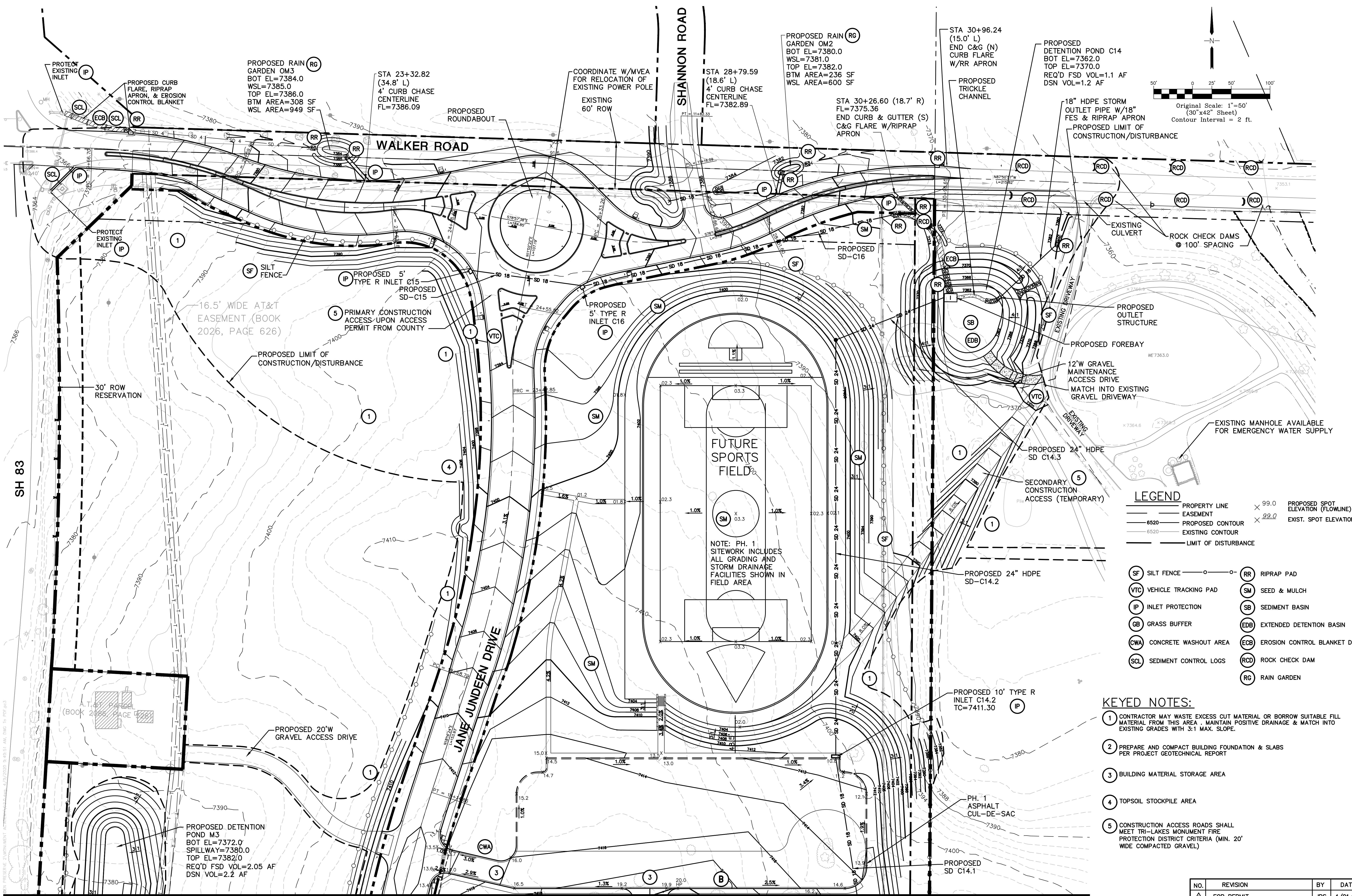

LEGEND

—	PROPERTY LINE	X 99.0	PROPOSED SPOT ELEVATION (FLOWLINE)
- - -	EASEMENT	X 99.0	EXIST. SPOT ELEVATION
— 6520	PROPOSED CONTOUR		
- - - 6520	EXISTING CONTOUR		
- - - - -	LIMIT OF DISTURBANCE		

(SF)	SILT FENCE	(RR)	RIPRAP PAD
(VTC)	VEHICLE TRACKING PAD	(SM)	SEED & MULCH
(IP)	INLET PROTECTION	(SB)	SEDIMENT BASIN
(GB)	GRASS BUFFER	(EDB)	EXTENDED DETENTION BASIN
(CWA)	CONCRETE WASHOUT AREA	(ECB)	EROSION CONTROL BLANKET DITCH LINING
(SCL)	SEDIMENT CONTROL LOGS	(RCD)	ROCK CHECK DAM
		(RG)	RAIN GARDEN

- KEYED NOTES:**
- CONTRACTOR MAY WASTE EXCESS CUT MATERIAL OR BORROW SUITABLE FILL MATERIAL FROM THIS AREA, MAINTAIN POSITIVE DRAINAGE & MATCH INTO EXISTING GRADES WITH 3:1 MAX. SLOPE.
 - PREPARE AND COMPACT BUILDING FOUNDATION & SLABS PER PROJECT GEOTECHNICAL REPORT
 - BUILDING MATERIAL STORAGE AREA
 - TOPSOIL STOCKPILE AREA
 - CONSTRUCTION ACCESS ROADS SHALL MEET TRI-LAKES MONUMENT FIRE PROTECTION DISTRICT CRITERIA (MIN. 20' WIDE COMPACTED GRAVEL)

NO.	REVISION	BY	DATE
1	FOR PERMIT	JPS	4/01/19
2	COUNTY COMMENTS	JPS	4/29/19
3	COUNTY COMMENTS	JPS	6/20/19
4	COUNTY COMMENTS	JPS	7/23/19
5	ROUNDABOUT REVISION	JPS	12/19/19
6	PH. 1B GEC PLANS	JPS	3/04/20
7	COUNTY COMMENTS	JPS	4/08/20

BENCHMARK:
BENCHMARK 4 BB RESET 1984
NAVD 88 DATUM ELEV.=7570.80
FOUND BRASS CAP IN CONCRETE
INT HWY 83 & HODGEN RD.

MATCH LINE
SEE SHT. C2.2

JPS ENGINEERING

19 E. Willamette Ave.
Colorado Springs, CO
80903

PH: 719-477-9429
FAX: 719-471-0766
www.jpsegr.com

OWNERSHIP OF INSTRUMENTS OF SERVICE:
ALL REPORTS, PLANS, SPECIFICATIONS, COMPUTER FILES, FIELD DATA, NOTES AND OTHER DOCUMENTS AND INSTRUMENTS PREPARED BY DESIGN PROFESSIONAL AS INSTRUMENTS OF SERVICE SHALL REMAIN THE PROPERTY OF THE DESIGN PROFESSIONAL. THE DESIGN PROFESSIONAL SHALL RETAIN ALL COMMON LAW STATUTORY AND OTHER RESERVED RIGHTS INCLUDING THE COPYRIGHT THEREON.

CRP ARCHITECTS AIA
100 E. St. Vrain, Suite 300
Colorado Springs, Colorado 80903

NORTH SITE GRADING & EROSION CONTROL PLAN

SCALE : 1"=50'

NORTH

DATE: 12/20/18
DRAWN BY: BJJ
CHECKED BY: JPS
REVISED: 4/08/20

MONUMENT ACADEMY HIGH SCHOOL

FOR CONSTRUCTION

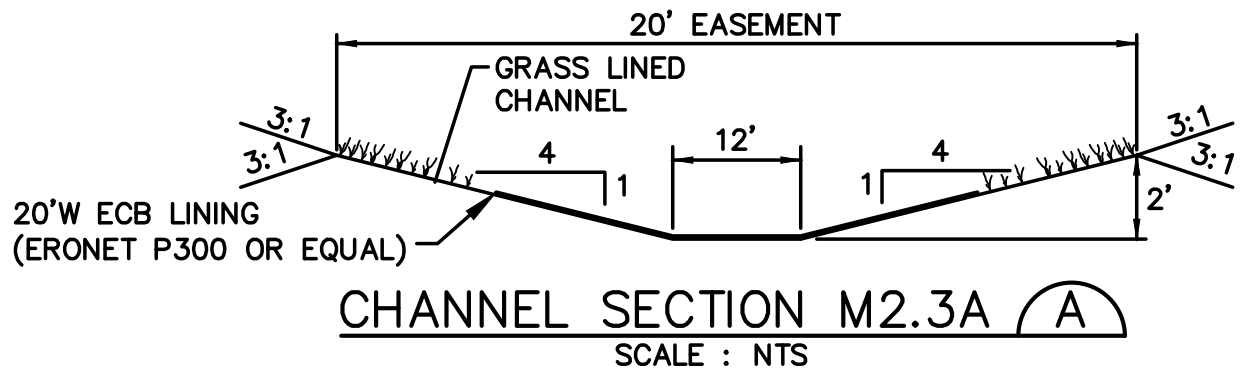
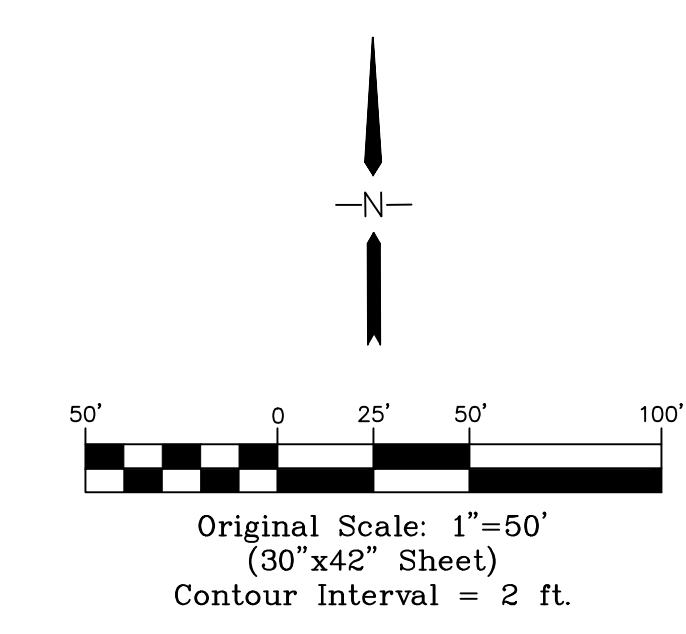

LEGEND

- PROPERTY LINE
- LIMITS OF DISTURBANCE
- EASEMENT
- 6520 PROPOSED CONTOUR
- 6520 EXISTING CONTOUR
- 99.0 PROPOSED SPOT ELEVATION (FLOWLINE)
- 99.0 EXIST. SPOT ELEVATION
- SF SILT FENCE
- VTC VEHICLE TRACKING PAD
- IP INLET PROTECTION
- GB GRASS BUFFER
- CWA CONCRETE WASHOUT AREA
- RR RIPRAP PAD
- SM SEED & MULCH
- SB SEDIMENT BASIN
- EDB EXTENDED DETENTION BASIN
- ECB EROSION CONTROL BLANKET DITCH LINING (ERONET P300 OR EQUAL)

NOTE: ALL EROSION CONTROL MEASURES SHALL CONFORM TO CITY OF COLORADO SPRINGS DRAINAGE CRITERIA MANUAL, VOLUME 2 REQUIREMENTS.

KEYED NOTES:

- 1 CONTRACTOR MAY EXCESS CUT MATERIAL OR BORROW SUITABLE FILL MATERIAL FROM THIS AREA. MAINTAIN POSITIVE DRAINAGE & MATCH INTO EXISTING GRADES WITH 3:1 MAX. SLOPE.
- 2 PREPARE AND COMPACT BUILDING FOUNDATION & SLABS PER PROJECT GEOTECHNICAL REPORT
- 3 HEAVY DUTY PAVEMENT: 5" HBP OVER 5" ABC (REFER TO GEOTECH REPORT)
- 4 LIGHT DUTY PAVEMENT: 4" HBP OVER 5" ABC (REFER TO GEOTECH REPORT)
- 5 2' CURB CHASE
- 6 BUILDING MATERIAL STORAGE AREA
- 7 TOPSOIL STOCKPILE AREA

NO.	REVISION	BY	DATE
1	FOR PERMIT	JPS	4/01/19
2	COUNTY COMMENTS	JPS	4/29/19
3	COUNTY COMMENTS	JPS	6/20/19
4	COUNTY COMMENTS	JPS	8/23/19
5	ROUNDBOUT REVISIONS	JPS	11/29/19
6	COUNTY COMMENTS	JPS	2/27/20
7	PH. 1B GEC PLANS	JPS	3/04/20
8	COUNTY COMMENTS	JPS	4/08/20

BENCHMARK:
BENCHMARK 4 BB RESET 1984 NAVD 88 DATUM
ELEV.=7570.80 FOUND BRASS CAP IN CONCRETE
INT HWY 83 & HODGEN RD.

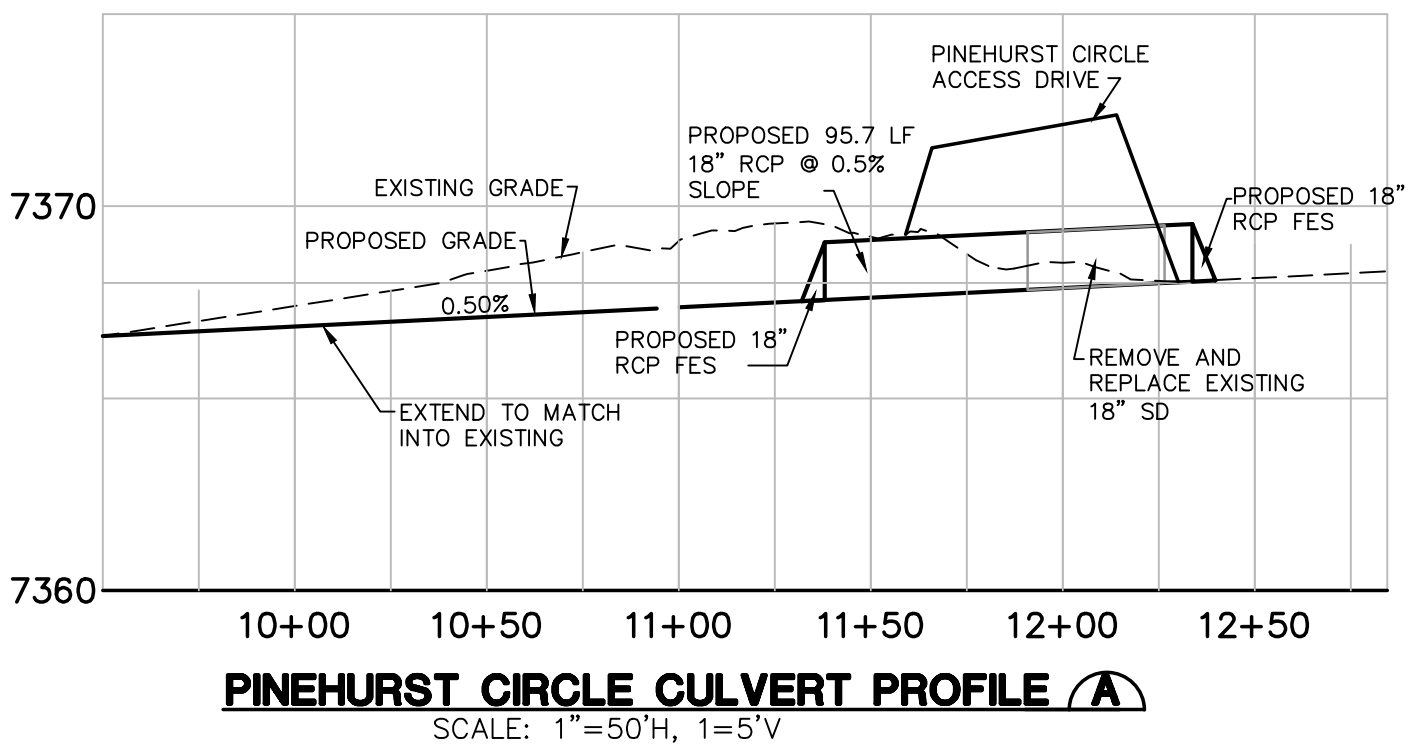

PINEHURST CIRCLE CULVERT PROFILE (A)
SCALE: 1"=50H, 1"=5'V

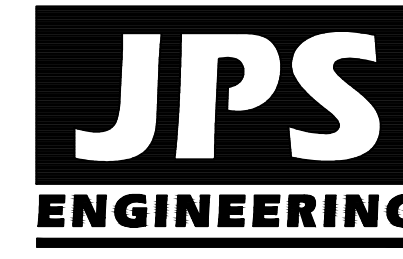

19 E. Willamette Ave.
Colorado Springs, CO
80903

PH: 719-477-9429
FAX: 719-471-0766
www.jpsegr.com

OWNERSHIP OF INSTRUMENTS OF SERVICE:
ALL REPORTS, PLANS, SPECIFICATIONS, COMPUTER FILES, FIELD DATA, NOTES AND OTHER DOCUMENTS AND INSTRUMENTS PREPARED BY DESIGN PROFESSIONAL AS INSTRUMENTS OF SERVICE SHALL REMAIN THE PROPERTY OF THE DESIGN PROFESSIONAL. THE DESIGN PROFESSIONAL SHALL RETAIN ALL COMMON LAW STATUTORY AND OTHER RESERVED RIGHTS INCLUDING THE COPYRIGHT THERE TO.

CRP ARCHITECTS AIA
100 E. St. Vrain, Suite 300
Colorado Springs, Colorado 80903

SOUTH SITE GRADING & EROSION CONTROL PLAN

SCALE: 1"=50'

NORTH
DATE: 12/20/18
DRAWN BY: BJJ
CHECKED BY: JPS
REVISED: 4/08/20

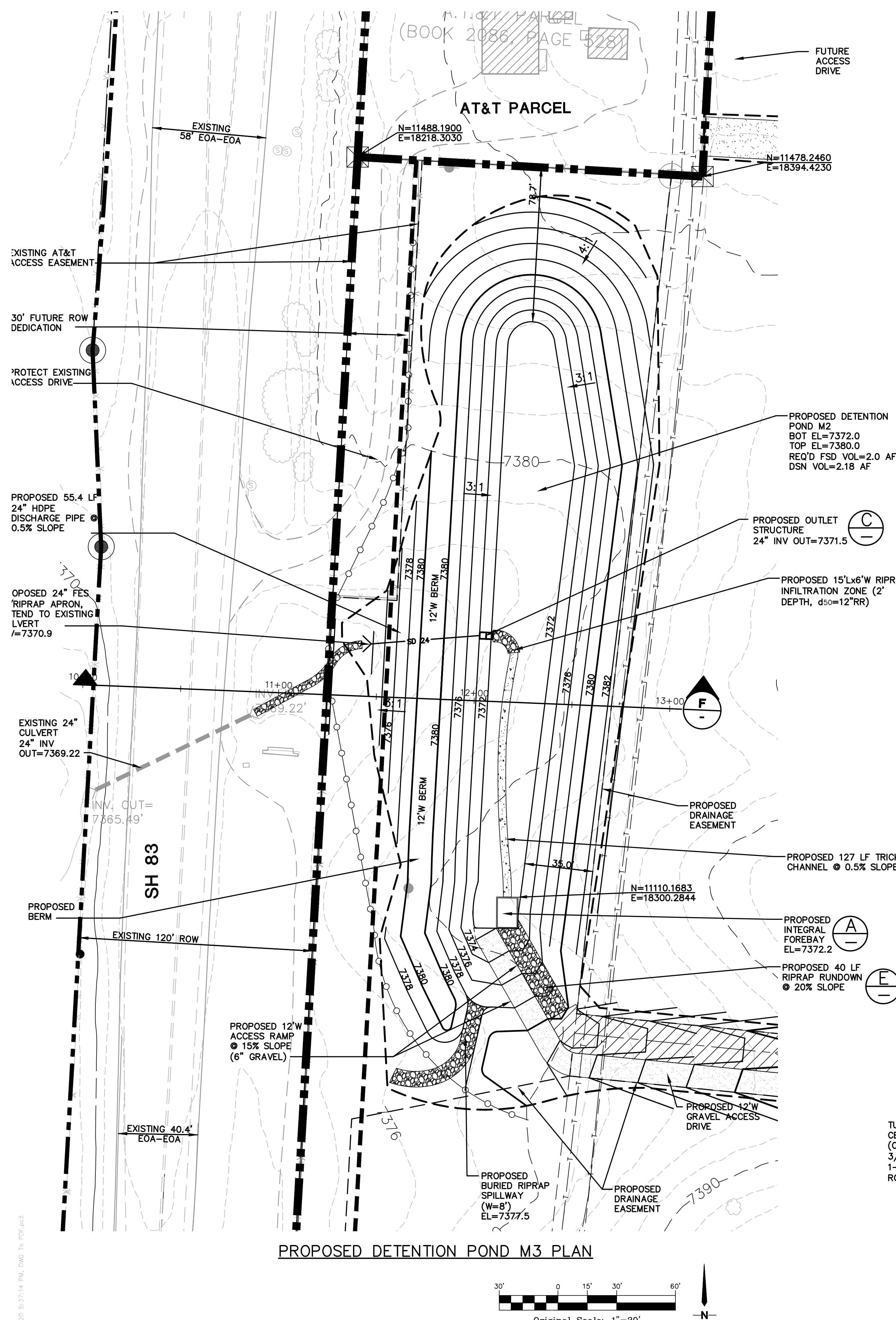

PROPOSED DETENTION POND M3 PLAN

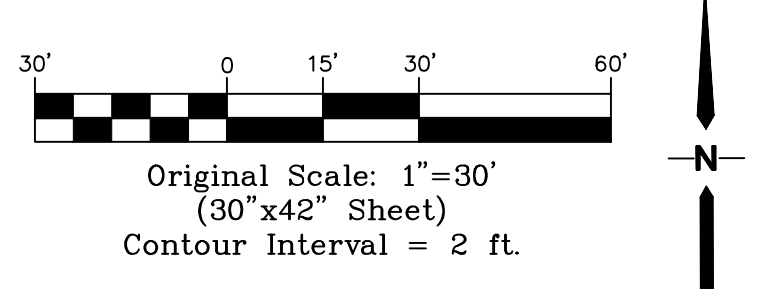

EMBANKMENT CONSTRUCTION NOTES:

1. COMPLY WITH RECOMMENDATIONS IN PROJECT GEOTECHNICAL REPORT BY KUMAR.
2. PROVIDE EMBANKMENT KEY-IN BY OVER-EXCAVATING & RE-COMPACTING MIN. 2' DEPTH & 12' WIDTH AT BASE OF EMBANKMENT.
3. COMPACT FILL MATERIAL TO 100% MAX. STANDARD PROCTOR DENSITY.
4. PROVIDE CONCRETE COLLAR ON POND DISCHARGE PIPE AT CENTER OF EMBANKMENT (MIN. 8\"/>

VERTICAL CONTROL POINT

BENCHMARK:
BENCHMARK 4 BB RESET 1984 NAVD 88 DATUM
ELEV.=7570.80 FOUND BRASS CAP IN CONCRETE
INT HWY 83 & HODGEN RD.

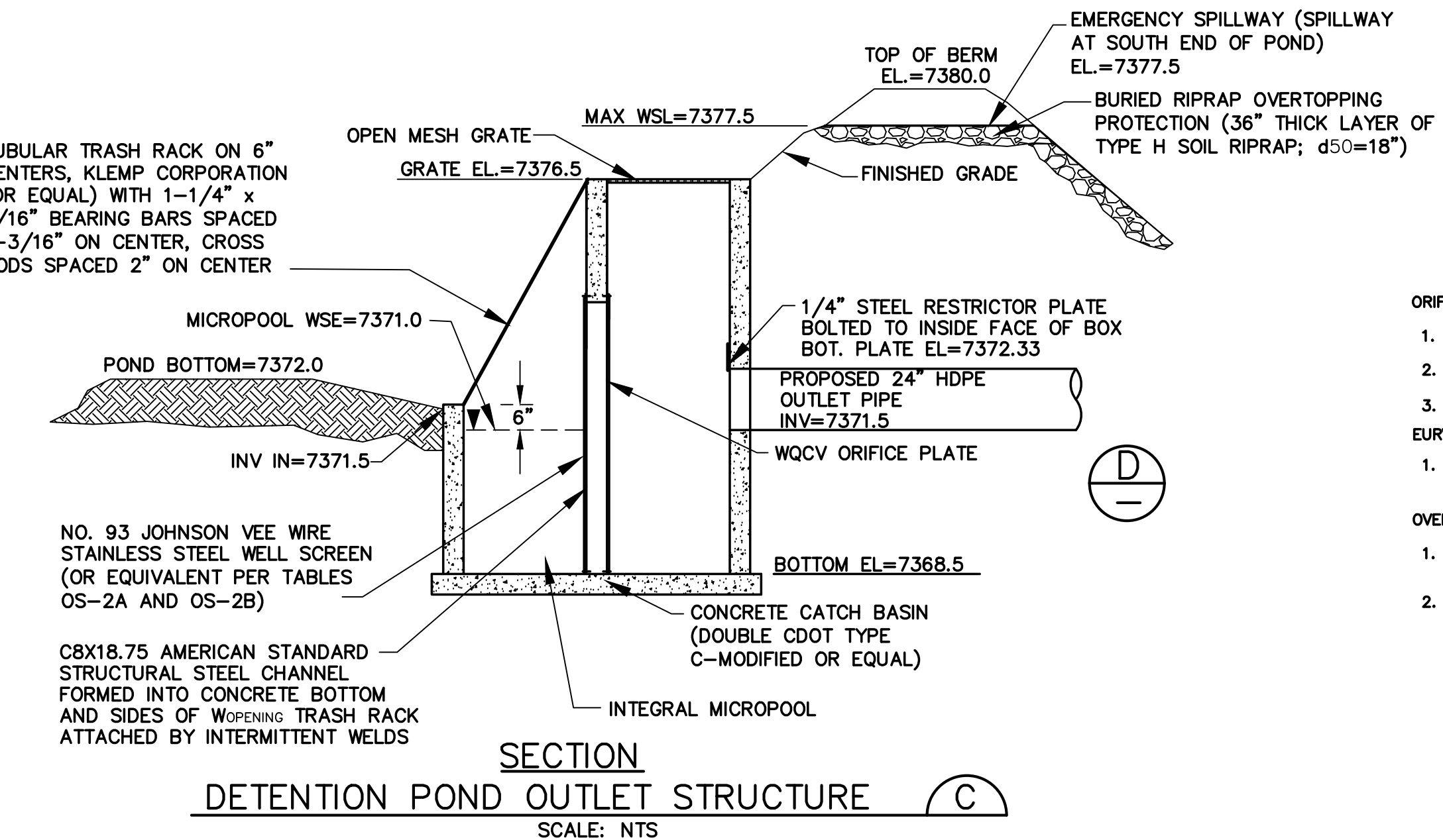
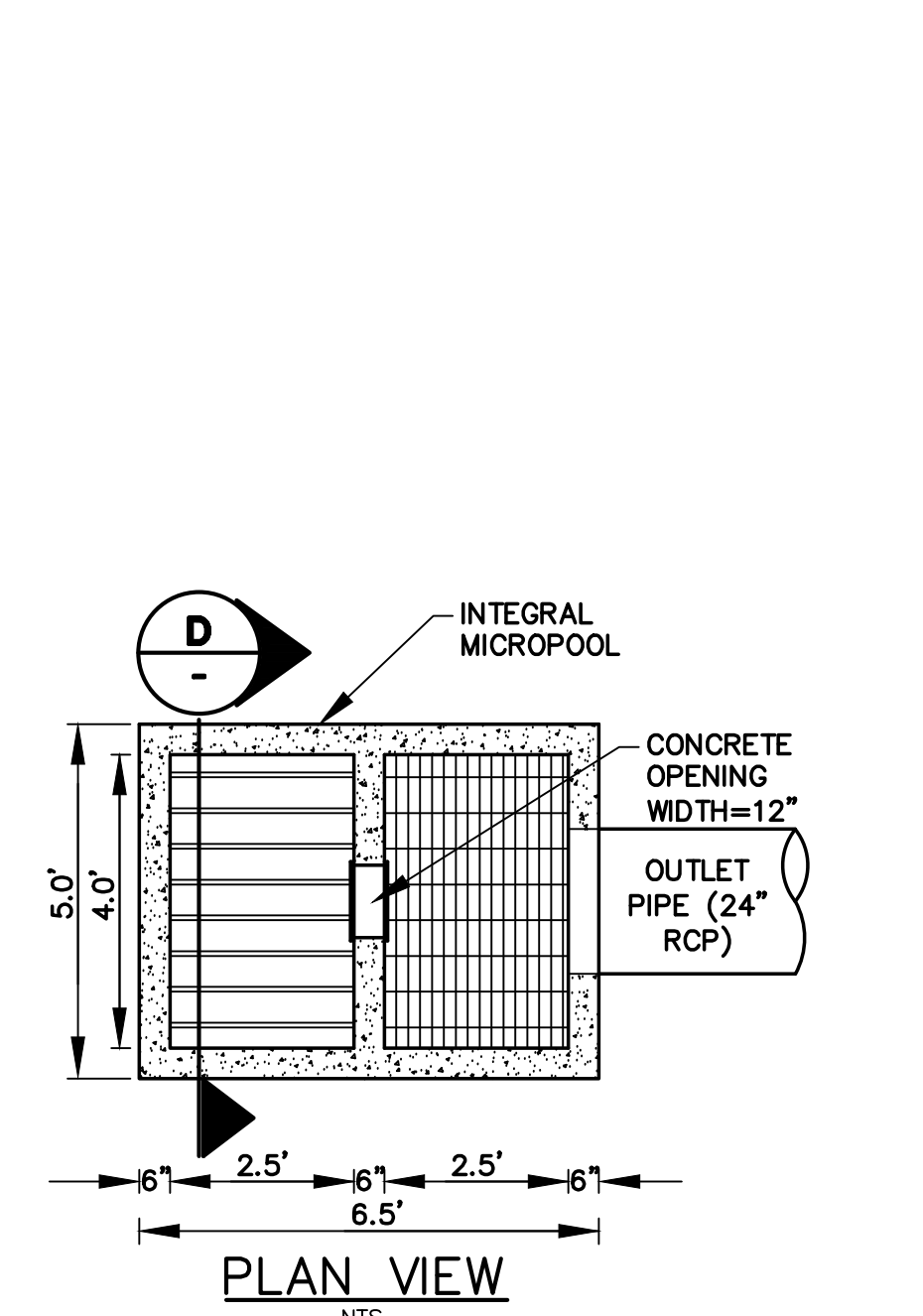
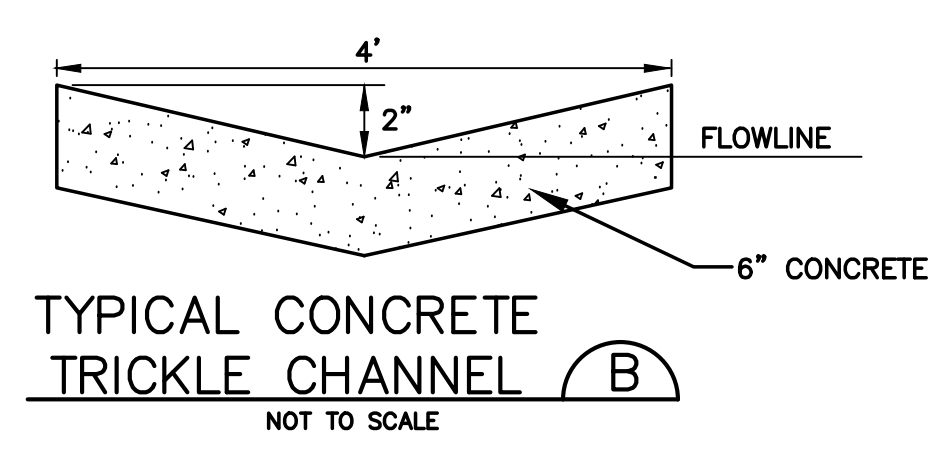
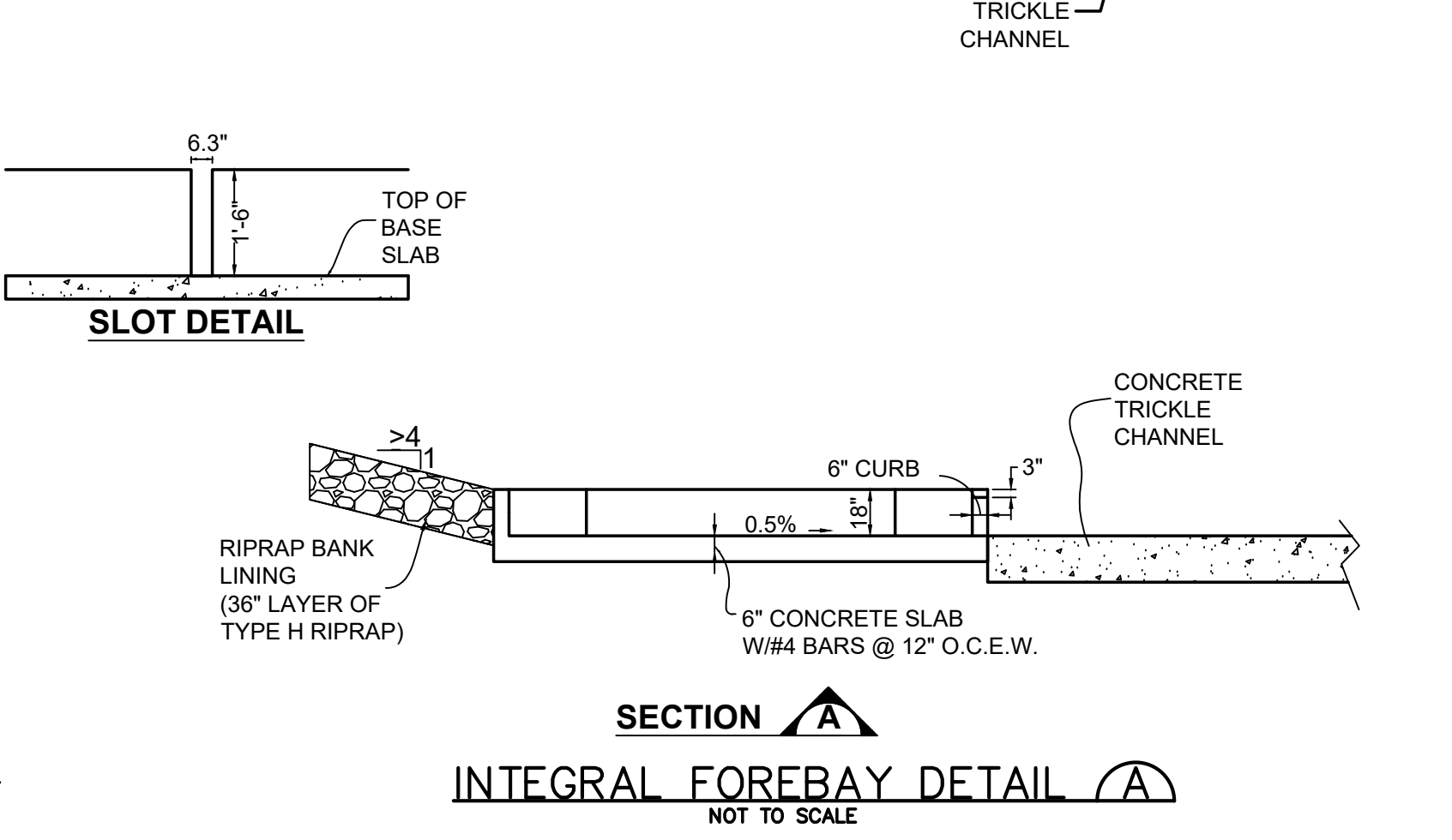
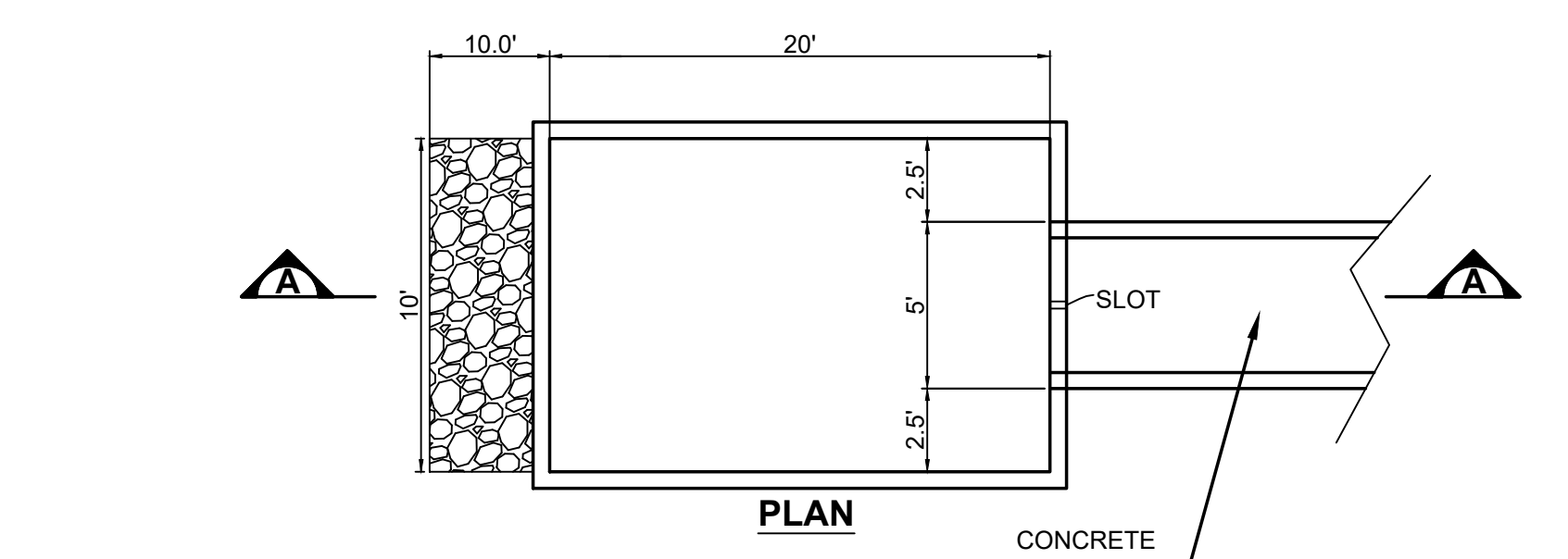

SECTION DETENTION POND OUTLET STRUCTURE

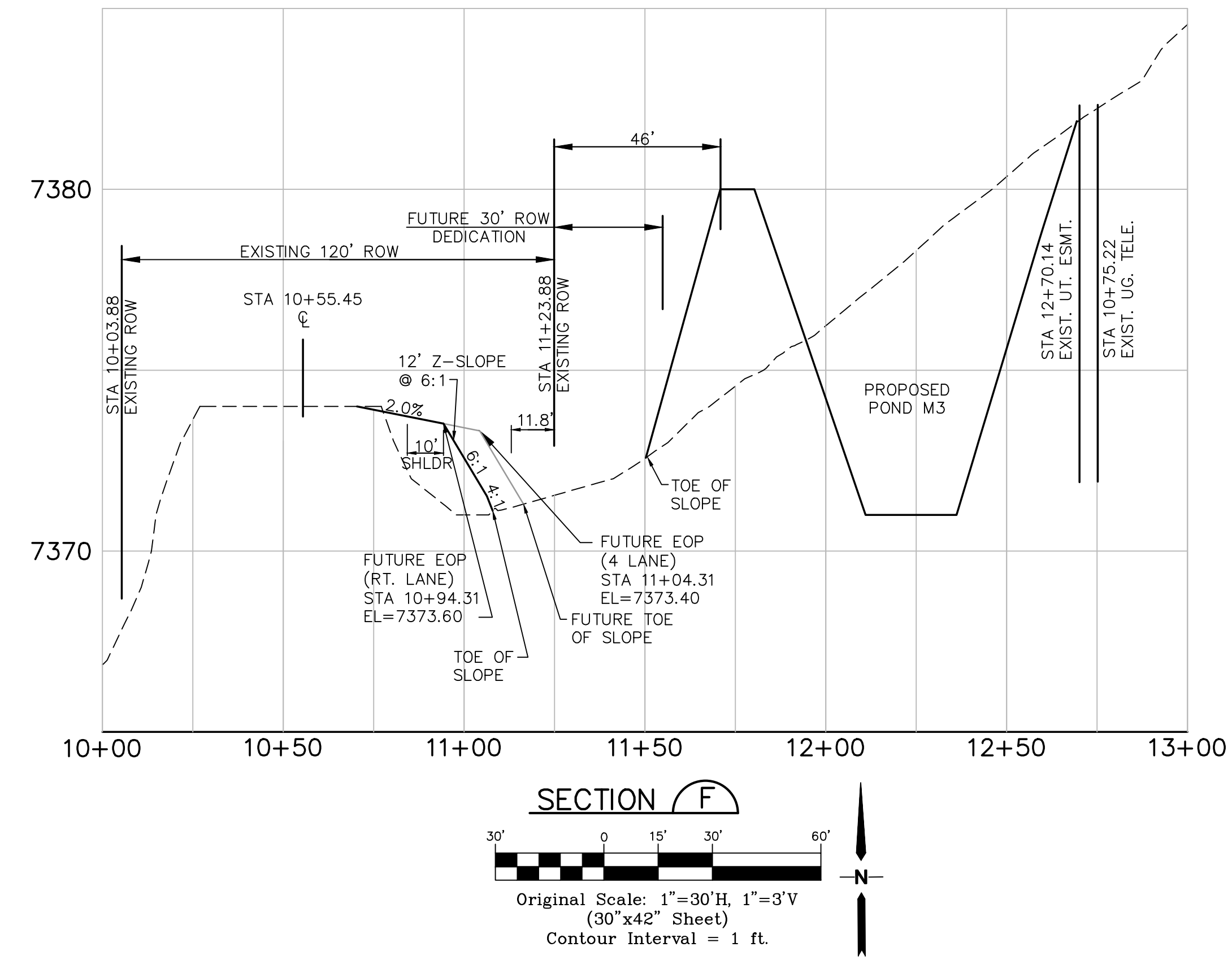

SECTION F
Original Scale: 1\"/>

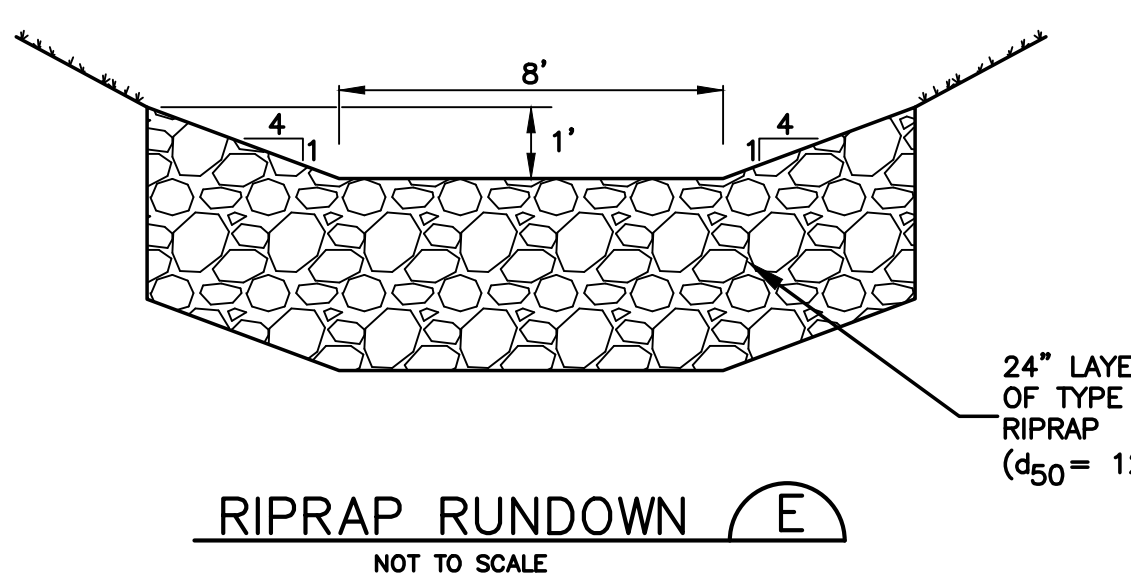

RIPRAP RUNDOWN

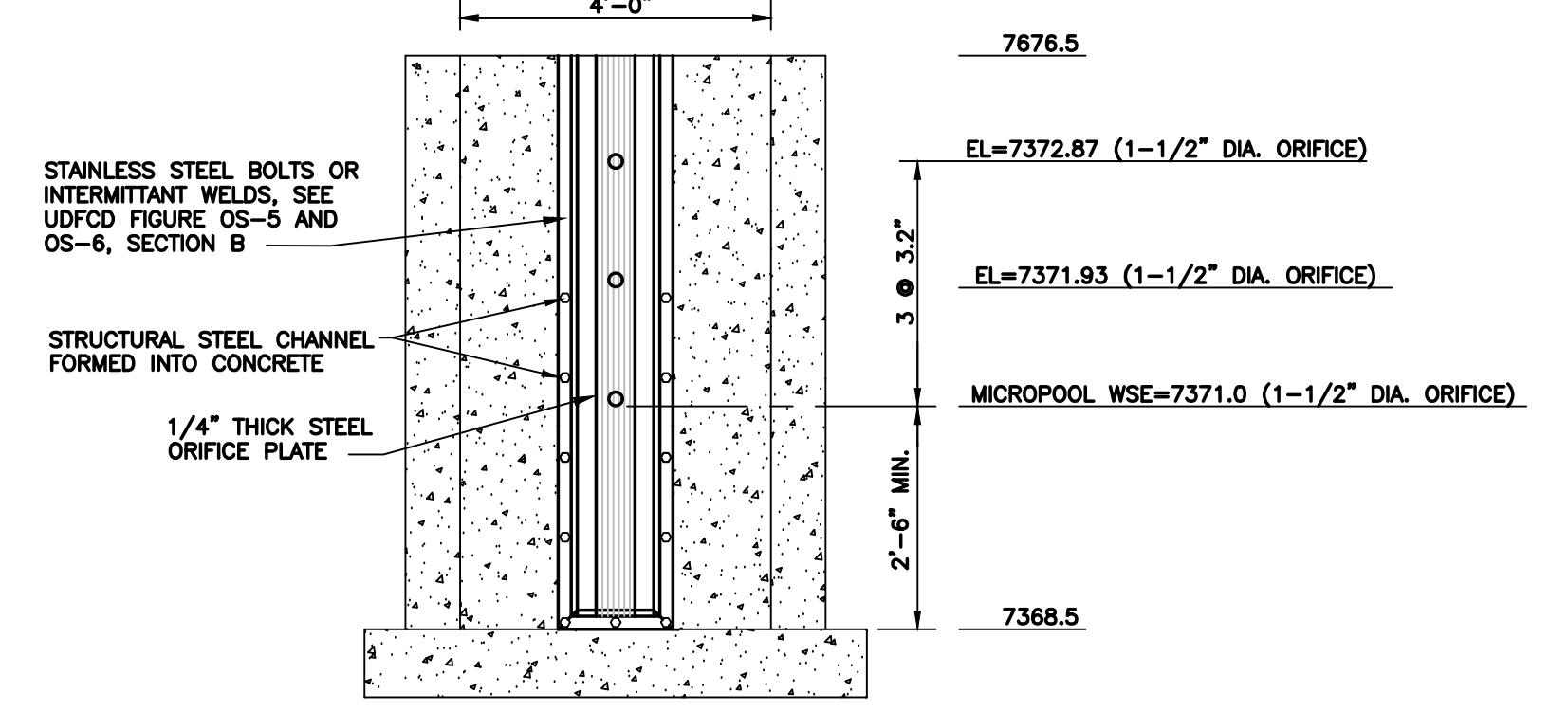

ELEVATION

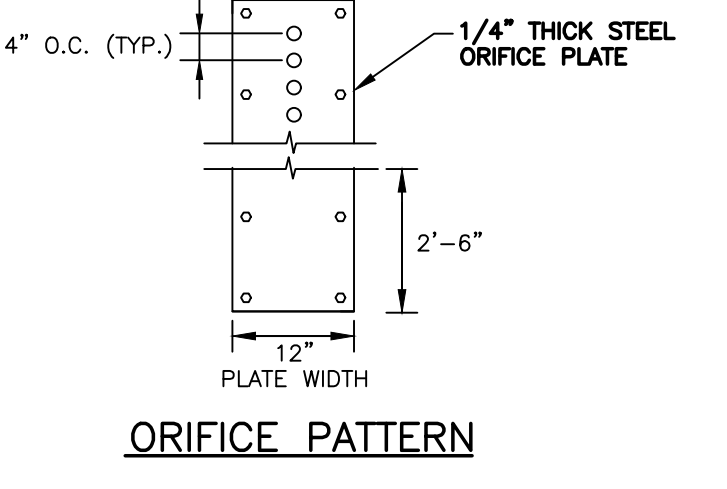

ORIFICE PATTERN

ORIFICE PLATE NOTES:

1. MINIMIZE THE NUMBER OF COLUMNS.
 2. PROVIDE GASKET MATERIAL BETWEEN THE ORIFICE PLATE AND CONCRETE.
 3. BOLT PLATE TO CONCRETE 12\"/>
- EMERGENCY SPILLWAY TRASH RACKS:
1. WELL-SCREEN TRASH RACKS (FOR CIRCULAR ORIFICES) SHALL BE STAINLESS STEEL AND SHALL BE ATTACHED BY INTERMITTENT WELDS ALONG THE EDGE OF THE MOUNTING FRAME.
- OVERFLOW TRASH RACKS:
1. ALL TRASH RACKS SHALL BE MOUNTED USING STAINLESS STEEL HARDWARE AND PROVIDED WITH HINGED AND LOCKABLE OR BOLTABLE ACCESS PANELS.
 2. TRASH RACKS SHALL BE STAINLESS STEEL, ALUMINUM, OR STEEL. STEEL TRASH RACKS SHALL BE HOT DIP GALVANIZED AND MAY BE HOT POWDER COATED AFTER GALVANIZING.

TYPICAL WQCV ORIFICE PLATE DETAIL

NO.	REVISION	BY	DATE
1	FOR PERMIT	JPS	4/17/19
2	COUNTY COMMENTS	JPS	4/29/19
3	COUNTY/CDOT COMMENTS	JPS	7/23/19
4	PH. 1B GEC PLANS	JPS	3/04/20

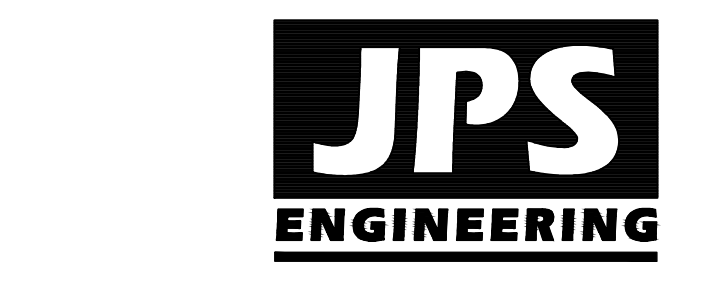

19 E. Willamette Ave.
Colorado Springs, CO
80903
PH: 719-477-9429
FAX: 719-471-0766
www.jpsegr.com

OWNERSHIP OF INSTRUMENTS OF SERVICE:
ALL REPORTS, PLANS, SPECIFICATIONS, COMPUTER FILES, FIELD DATA, NOTES AND OTHER DOCUMENTS AND INSTRUMENTS PREPARED BY DESIGN PROFESSIONAL AS INSTRUMENTS OF SERVICE SHALL REMAIN THE PROPERTY OF THE DESIGN PROFESSIONAL. THE DESIGN PROFESSIONAL SHALL RETAIN ALL COMMON LAW STATUTORY AND OTHER RESERVED RIGHTS INCLUDING THE COPYRIGHT THEREON.

CRP ARCHITECTS AIA
100 E. St. Vrain, Suite 300
Colorado Springs, Colorado 80903

DETENTION POND M3
PLAN & DETAILS
SCALE: AS SHOWN

NORTH
DATE: 12/20/18
DRAWN BY: BJJ
CHECKED BY: JPS
REVISED: 3/04/20

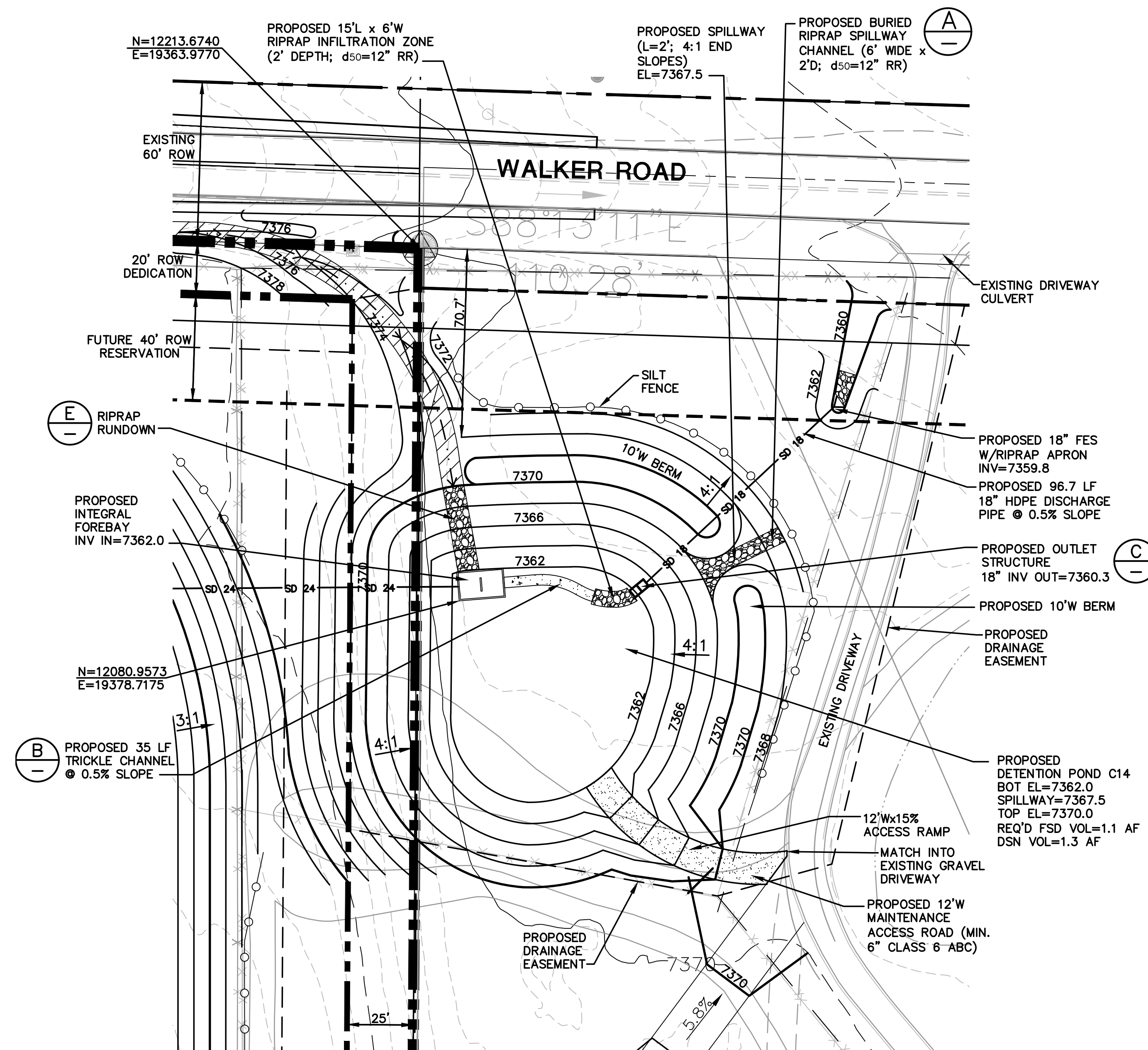

ENLARGED DETENTION POND C14 PLAN

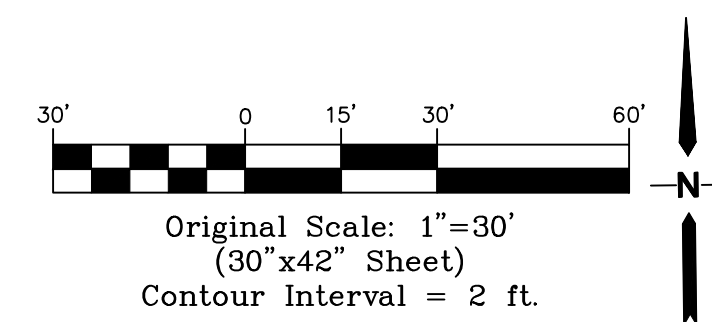

VERTICAL CONTROL POINT

EMBANKMENT CONSTRUCTION NOTES:

1. COMPLY WITH RECOMMENDATIONS IN PROJECT GEOTECHNICAL REPORT BY KUMAR.
2. PROVIDE EMBANKMENT KEY-IN BY OVER-EXCAVATING & RE-COMPACTING MIN. 2' DEPTH & 12' WIDTH AT BASE OF EMBANKMENT.
3. COMPACT FILL MATERIAL TO 100% MAX. STANDARD PROCTOR DENSITY.
4. PROVIDE CONCRETE COLLAR ON POND DISCHARGE PIPE AT CENTER OF EMBANKMENT (MIN. 8" BEYOND PIPE O.D.; MIN. 12" THICK)

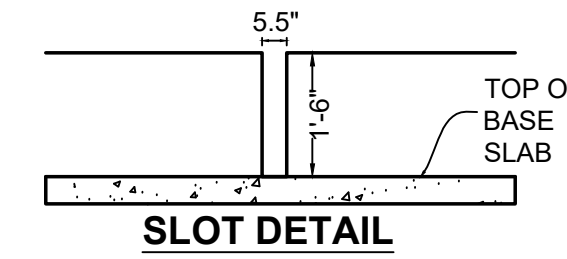
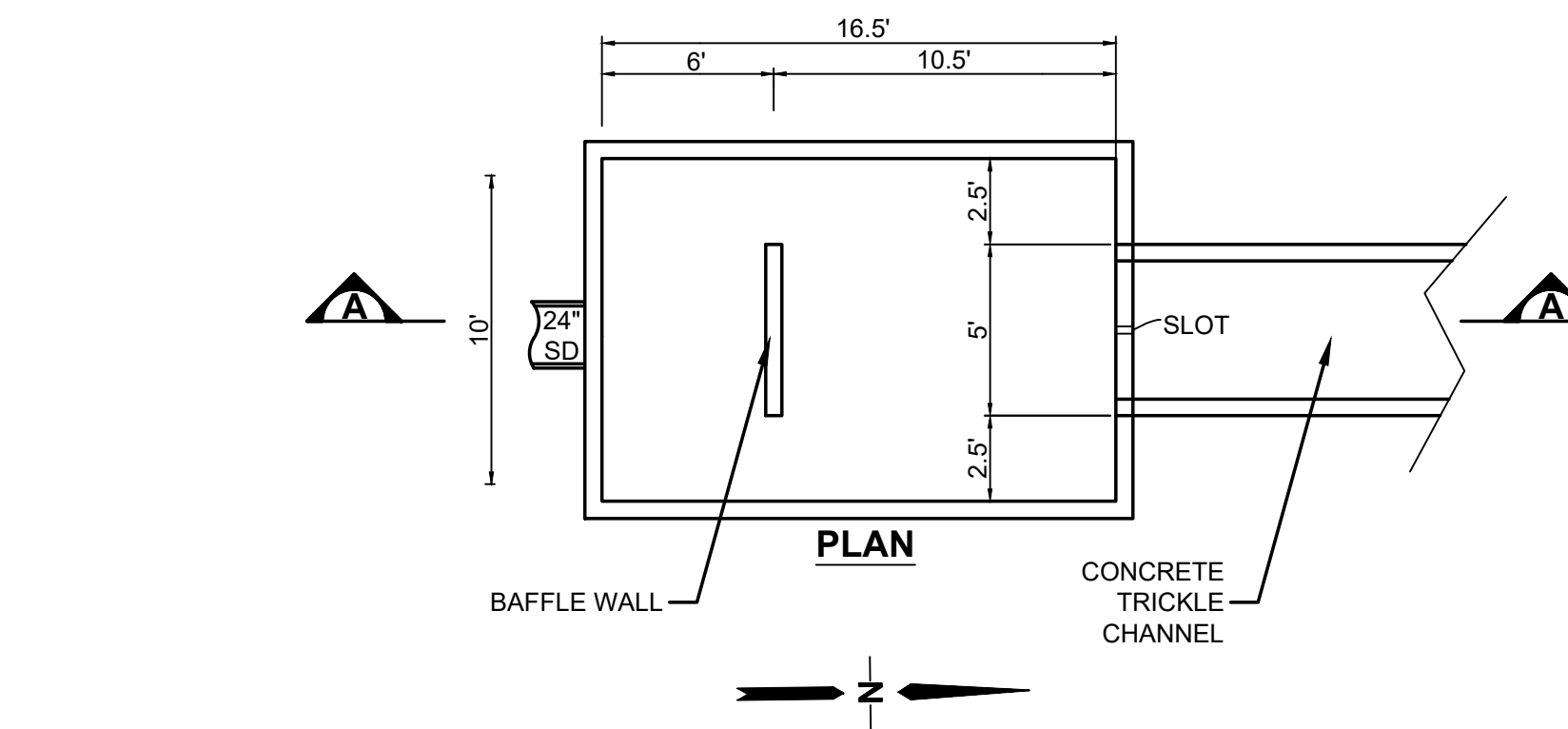

SECTION A
INTEGRAL FOREBAY DETAIL A
NOT TO SCALE

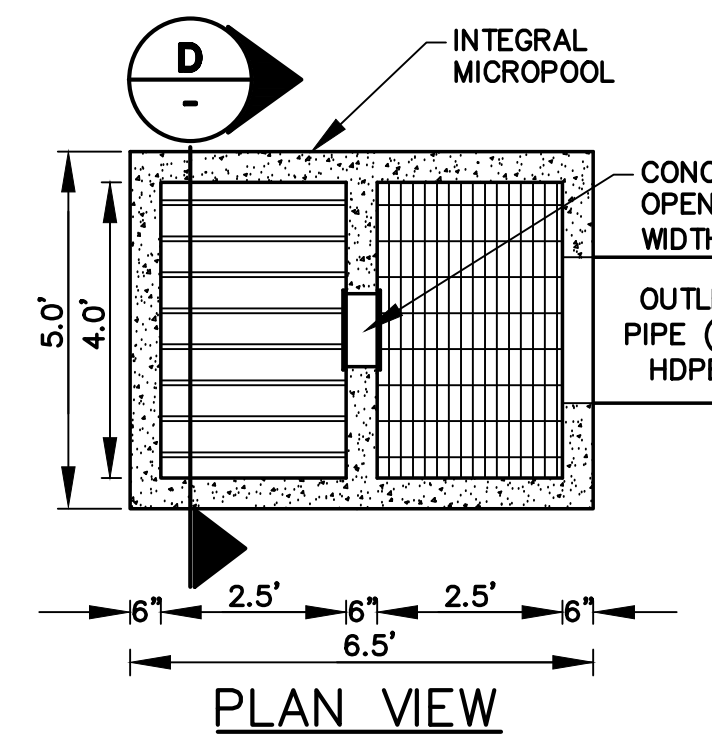
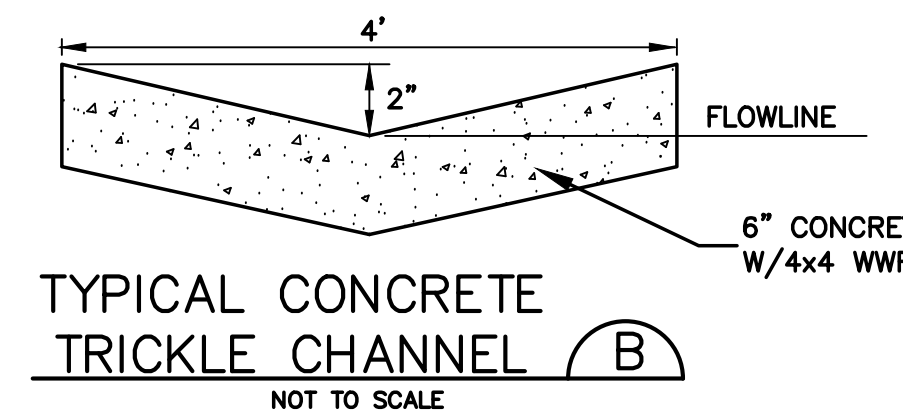

PLAN VIEW
NTS

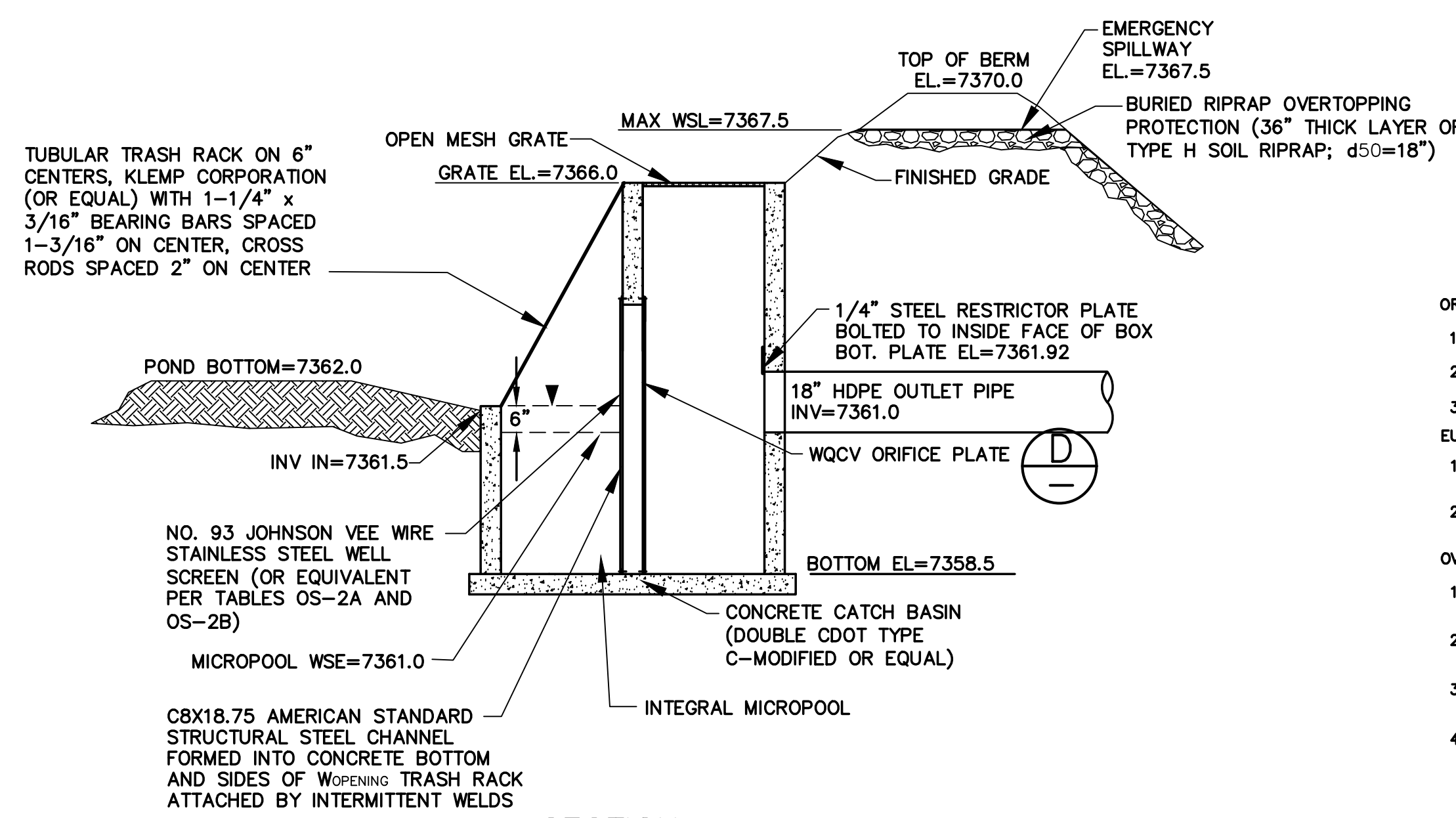

SECTION C
DETENTION POND OUTLET STRUCTURE C
SCALE: NTS

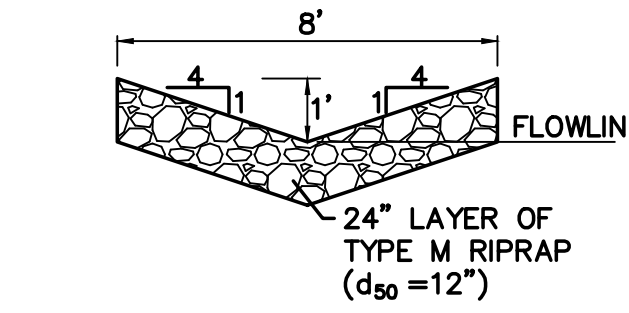

RIPRAP RUNDOWN E
NOT TO SCALE

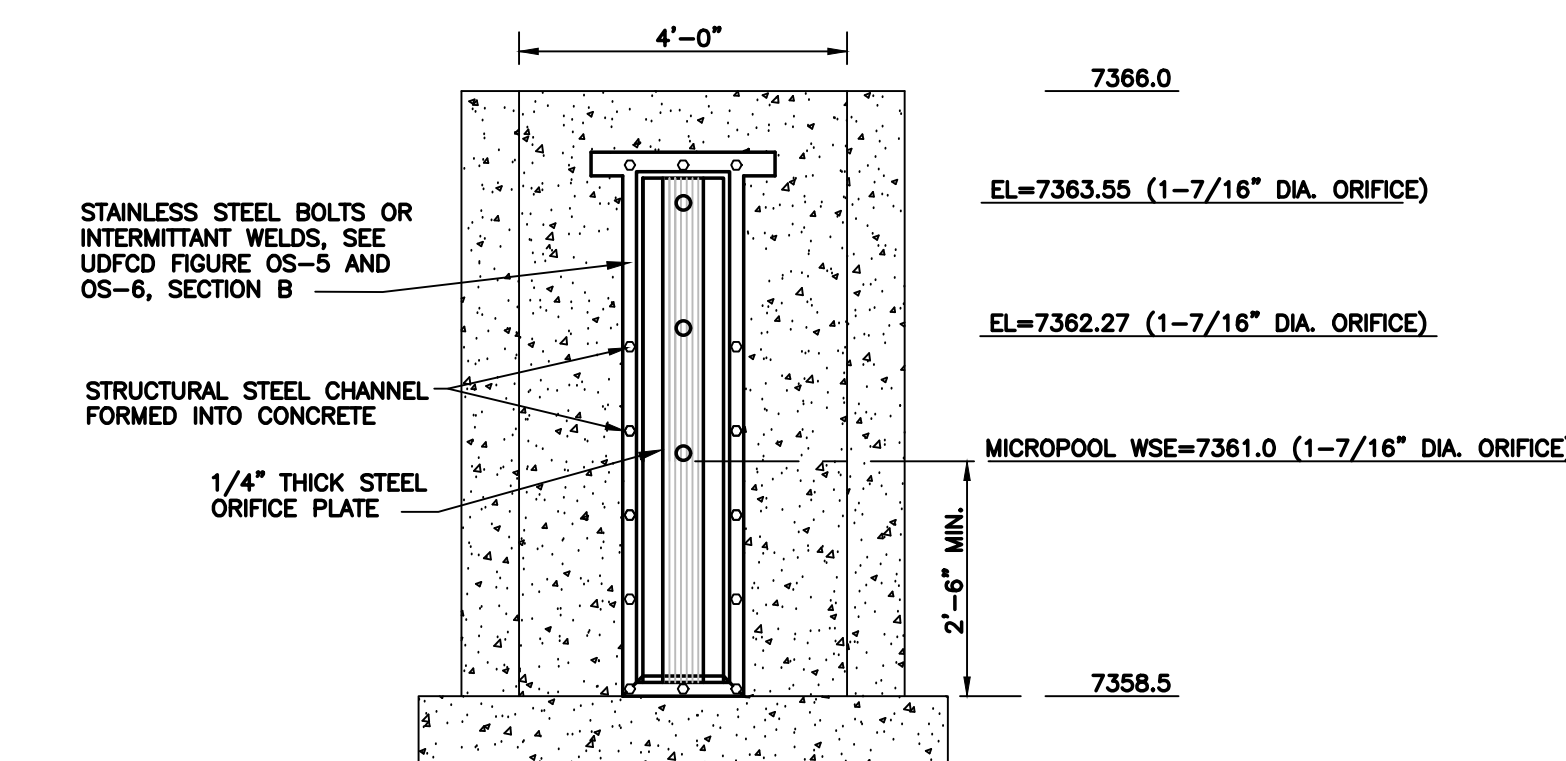

ELEVATION

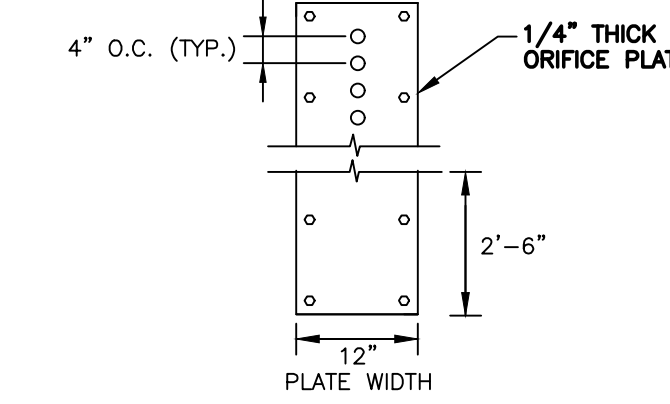

ORIFICE PATTERN

ORIFICE PLATE NOTES:

1. MINIMIZE THE NUMBER OF COLUMNS.
 2. PROVIDE GASKET MATERIAL BETWEEN THE ORIFICE PLATE AND CONCRETE.
 3. BOLT PLATE TO CONCRETE 12" MAX. ON CENTER.
- EURV AND WQCV TRASH RACKS:
1. WELL-SCREEN TRASH RACKS (FOR CIRCULAR ORIFICES) SHALL BE STAINLESS STEEL AND SHALL BE ATTACHED BY INTERMITTENT WELDS ALONG THE EDGE OF THE MOUNTING FRAME.
 2. STRUCTURAL DESIGN OF TRASH RACKS SHALL BE BASED ON FULL HYDROSTATIC HEAD WITH ZERO HEAD DOWNSTREAM OF THE RACK.
- OVERFLOW TRASH RACKS:
1. ALL TRASH RACKS SHALL BE MOUNTED USING STAINLESS STEEL HARDWARE AND PROVIDED WITH HINGED AND LOCKABLE OR BOLTABLE ACCESS PANELS.
 2. TRASH RACKS SHALL BE STAINLESS STEEL, ALUMINUM, OR STEEL. STEEL TRASH RACKS SHALL BE HOT DIP GALVANIZED AND MAY BE HOT POWDER COATED AFTER GALVANIZING.
 3. TRASH RACKS SHALL BE DESIGNED SUCH THAT THE DIAGONAL DIMENSION OF EACH OPENING IS SMALLER THAN THE DIAMETER OF THE OUTLET PIPE.
 4. STRUCTURAL DESIGN OF TRASH RACKS SHALL BE BASED ON FULL HYDROSTATIC HEAD WITH ZERO HEAD DOWNSTREAM OF THE RACK.

TYPICAL WQCV ORIFICE PLATE DETAIL D
SCALE: NTS

NO.	REVISION	BY	DATE
1	FOR PERMIT	JPS	4/17/19
2	COUNTY COMMENTS	JPS	4/29/19
3	COUNTY COMMENTS	JPS	6/20/19
4	COUNTY COMMENTS	JPS	7/11/19

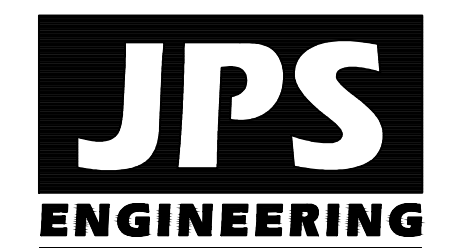

19 E. Willamette Ave.
Colorado Springs, CO
80903

PH: 719-477-9429
FAX: 719-471-0766
www.jpsegr.com

OWNERSHIP OF INSTRUMENTS OF SERVICE:

ALL REPORTS, PLANS, SPECIFICATIONS, COMPUTER FILES, FIELD DATA, NOTES AND OTHER DOCUMENTS AND INSTRUMENTS PREPARED BY DESIGN PROFESSIONAL AS INSTRUMENTS OF SERVICE SHALL REMAIN THE PROPERTY OF THE DESIGN PROFESSIONAL. THE DESIGN PROFESSIONAL SHALL RETAIN ALL COMMON LAW STATUTORY AND OTHER RESERVED RIGHTS INCLUDING THE COPYRIGHT THEREON.

CRP ARCHITECTS AIA
100 E. St. Vrain, Suite 300
Colorado Springs, Colorado 80903

DETENTION POND C14 PLAN & DETAILS

SCALE : AS SHOWN

NORTH	DATE:	12/20/18
	DRAWN BY:	BJJ
	CHECKED BY:	JPS
	REVISED:	7/11/19