

**FINAL DRAINAGE REPORT FOR
WATERBURY FILING NO. 1
EL PASO COUNTY, COLORADO**

**PCD FILE NO:
PUDSP-21-005**

FEBRUARY 2023

Prepared For:

Prepared for:
4-WAY RANCH JOINT VENTURE
P.O. BOX 50223
COLORADO SPRINGS, CO 80949
Contact: Peter Martz

Prepared By:

TERRA NOVA ENGINEERING, INC.
721 S. 23rd ST.
Colorado Springs, CO 80904

Job No. 1715.00

**FINAL DRAINAGE REPORT FOR
WATERBURY FILING NO. 1
EL PASO COUNTY, COLORADO**

TABLE OF CONTENTS

ENGINEER’S STATEMENT	PAGE 3
INTRODUCTION	PAGE 4
PROJECT CHARACTERISTICS	PAGE 5
FLOODPLAINS STATEMENT	PAGE 6
HYDROLOGIC ANALYSIS FOR MDDP	PAGE 6
Existing Condition Analysis for MDDP	PAGE 7
Early Grading Analysis for MDDP	PAGE 9
Proposed Condition Analysis for MDDP	PAGE 11
HYDRAULIC ANALYSIS FOR MDDP	PAGE 26
HYDROLOGIC ANALYSIS FOR FILING 1 FDR	PAGE 31
DRAINAGE FEES	PAGE 35
SUMMARY	PAGE 36
BIBLIOGRAPHY	PAGE 37

REQUIRED MAPS AND DRAWINGS

VICINITY MAP

S.C.S. SOILS MAP

FEMA FIRM MAP

HYDROLOGIC CALCULATIONS

HYDRUALIC CALCULATIONS

FULL SPECTRUM & WATER QUALITY CALCULATIONS

HEC-RAS ANALYSIS

DRAINAGE MAPS

**FINAL DRAINAGE REPORT FOR
WATERBURY FILING NO. 1
EL PASO COUNTY, COLORADO**

DESIGN ENGINEER’S STATEMENT:

The attached drainage plan and report were prepared under my direction and supervision and are correct to the best of my knowledge and belief. Said drainage report has been prepared according to the criteria established by the County for drainage reports and said report is in conformity with the applicable master plan of the drainage basin. I accept responsibility for any liability caused by any negligent acts, errors or omissions on my part in preparing this report.

Quentin Armijo, P.E. 37170
On behalf of Terra Nova Engineering, Inc.

Date

OWNER/DEVELOPER’S STATEMENT:

I, the owner/developer have read and will comply with all of the requirements specified in this drainage report and plan.

Authorized Signature

Date

Printed Name, Title

Business Name

Address

EL PASO COUNTY:

Filed in accordance with the requirements of the Drainage Criteria Manual, Volumes 1 and 2, El Paso County Engineering Criteria Manual and Land Development Code as amended.

Joshua Palmer, P.E.
County Engineer / ECM Administrator
Conditions:

Date

**FINAL DRAINAGE REPORT FOR
WATERBURY FILING NO. 1
EL PASO COUNTY, COLORADO**

INTRODUCTION

PURPOSE

The purpose of this Final Drainage Report is to identify and analyze the proposed drainage patterns, determine proposed runoff quantities, size drainage structures for conveyance of developed runoff based upon the overall development of single-family homes along with all the supporting infrastructure, while following the guidelines of the 4-step process.

This site was previously submitted as Waterbury Phase 1 Preliminary Plan with 3 separate filings by Classic Consulting Engineers & Surveyors, LLC. The Final Drainage Report for Filing 1 along with the construction drawings were approved in September of 2016 by EL Paso County Development Services and the Final Drainage Report for Filing 2 along with the construction drawings were submitted for review in September of 2017 and comments given back in September of 2017. Filing 3 had been preliminary designed but nothing submitted to EL Paso County. Since this time the owner has revised the lot layout and removed the alleys shown in Filings 1 & 2. All the public roadways have remained the same with the exception of the ROW for Saybrook Road from Stapleton to Bayshore Way, where the it changed from 65' to 89'. With these changes El Paso County Development Services requested that we submit a new Preliminary Plan and the associated MDDP for these revisions. An Early Grading Permit was also submitted. These have been approved and this Final Drainage Report is being submitted with the Final Plat and Construction drawings. The site will now be developed and platted in 1 Filing. The overall proposed drainage patterns do not differ much and follow the previous studies closely.

The Waterbury site lies within the Geick Ranch and the Haegler Drainage Basins, storm runoff drains southerly via 2 existing natural waterways, one bordering the site on the west (Haegler Drainage Basin) and one on the east (Geick Ranch Drainage Basin). The "Haegler Drainage Basin Planning Study" was prepared by URS and approved in June of 2009. Drexel Barrel & Co prepared the "Geick Ranch Drainage Basin Planning Study" submitted for approval February 2008 but it has yet to be approved by El Paso County, and therefore there are no drainage fees in this basin. In the Haegler DBPS it is noted that "a portion of the Haegler Ranch as delineated by the County map was found to

be part of the Geick Ranch Drainage Basin at Judge Orr Road, due to a lack of a roadway culvert at the crossing. This is excluded from the Haegler Ranch DBPS and is included as part of the Geick Ranch DBPS, per the County.” These 2 channels eventually drain to Black Squirrel Creek and ultimately the Arkansas River.

PROJECT CHARACTERISTICS

Waterbury Filings 1 & 2 consists of 61.88 acres and is part of a larger development of 322.0 acres to be developed over time and in multiple filings. A PUD Development Plan, Zoning and Conceptual plans have all been previously processed and approved with El Paso County. Filing 1 is 29.44 acres with 115 single family units, while Filing 2 is 32.44 acres 83 single family lots.

The site is in the SW 1/4 of Sections 28, SE ¼ 29 & NW 1/4 33, Township 12 South, Range 64 West of the 6th Principal Meridian within El Paso County, Colorado. The site is bounded to the west by natural channel and 4-Way Ranch Filing No. 1. To the south by Stapleton Drive. To the north by unplatted land consisting of future Waterbury Filings, and to the west by a natural channel unplatted land consisting of future Waterbury Filings (See vicinity map, Appendix A).

The site consists of 100% Columbine Gravelly (19) per the USDA, NRCS web soil survey. The hydrologic soil group “A” was used to represent the soil types and determine the onsite basin overland flow. (See map in appendix)

The study area consists of undeveloped land that has existing vegetation consisting of established native grasses. A ridge running north to south splits the site with the west 1/3 draining southwest with average slopes of 0% to 3% and the remaining 2/3 drains southwest with average slopes of 0% to 3%. There are no existing on-site improvements.

The site has been analyzed in several approved studies including the following “Revision to the MDDP for Meridian Ranch, EL Paso County, Colorado”, approved October 2005, and prepared by PBS&J. “Final Drainage Report for 4-Way Ranch Phase 1” by JR Engineering Dated March 2006. The “Geick Ranch Drainage Basin Planning Study” dated February 2008, and prepared by Drexel Barrel & Co. The “Preliminary/Final Drainage Report for Meridian Ranch filing No. 3” by Tech Contractors, November 2011. The “Master Development Drainage Plan, 4-Way Ranch – Phase 1” by

Advanced Design Professionals, Inc. dated January 2012. The “Preliminary Drainage Report for Waterbury (Phase 1 Preliminary Plan) dated June 2013 by Classic Consulting analyzes this area in more detail and then Classic followed up with the “Final Drainage Report for Waterbury Filing No. 1” dated September 2016 which studied a portion of the area now being developed. Kiowa Engineering also prepared a 2004 LOMR (04-08-0012).

As-built field survey data is the basis for the design of the drainage basins.

FLOODPLAIN STATEMENT

A portion of this site along the western edge is within a designated F.E.M.A. floodplain, as determined by Flood Insurance Rate Map No. 08041C0552G December 7, 2018 (see appendix). The floodplain is shown on the proposed Drainage Map in the appendix along with the FEMA Firmette. Lots from Filings 1 & 2 abut the channel with rear lots lines, but are set to be outside of the floodplain. As mentioned in the previously approved “Final Drainage Report for Waterbury Filing 1” dated September 2016 prepared by Classic Consulting Engineering & Surveying the floodplain was determined by Kiowa Engineering in a 2004 LOMR (04-08-0012) using a HEC-RAS analysis modeling developed flows along the channel from the 3-42” culverts under Eastonville Road south to the existing stock pond (Design Point 13) south of Stapleton Drive with proposed and existing improvements such as the proposed 42” dual culverts located at the Gilbert Road crossing and existing dual 4’ x 8’ box culverts at Stapleton Drive (see appendix for HEC-RAS model). The Base Floodplain Elevations are shown on the Final Plat.

HYDROLOGIC ANALYSIS

The El Paso County Drainage Criteria Manual (EPCDCM), dated May 1994 was the resource used in this analysis with the exception for calculating the 5-year and 100-year design storm events. Chapter 6 of the City of Colorado Springs Drainage Criteria Manual (CSDCM) was referenced in determining rainfall and runoff for the proposed drainage system per the EPC DCM1 Update resolution. Runoff was calculated using the Rational Method for developed conditions (see appendix). Runoff coefficients were calculated using weighted impervious values for each specific basin base upon Table 6.6 of the CSDCM. Table 6.5 was used for calculating intensity (see appendix).

EXISTING CONDITIONS

In the existing condition runoff from Filing 2 sheet flows south onto Filing 1 and from here the runoff is directed southwest and southeast overland to the existing channels on the west and east side of the site. Below is a description of the existing condition's Design Points, Basins and site runoff.

There are 4 offsite basins that drain existing runoff onto the site from the north under Eastonville Road through culverts. There is also unplatted open space just north of the proposed Waterbury Filing No. 1 & 2.

At Design Point 10A 3-42" RCP that routes runoff from a temporary sediment pond south onto the property (Basin OS-5). The "Preliminary/Final Drainage Report for Meridian Ranch Filing No. 3" and shows flows of $Q_5 = 28$ cfs, $Q_{100} = 153$ cfs while the Meridian Ranch MDDP shows a 100-year flow of 185 cfs. This larger flow of 185 cfs is used in the HEC-RAS model for downstream channel analysis and culvert design. As mentioned above in the Floodplain Statement section the natural channel along the west side of the site is a recognized FEMA floodplain. This channel in the Haegler Creek Basin drains south to Stapleton Drive where dual 4' high x 8' wide concrete box culverts route the water south in its natural path.

Design Point EX1 consist of onsite Basin EXA's 9.62 acres and offsite Basin OS-5's 6.74 acres, which both consist of undeveloped open space prairie and the FEMA flood channel and the runoff from Design Point EX10A mentioned above travel in the channel south to the southern boundary of our site. The combined flow from these upstream basins and our onsite basins that contribute to the flow is $Q_5 = 38$ cfs, $Q_{100} = 219$ cfs. This report does not analyze the flow coming from the adjacent Subdivision as the culverts were previously sized and installed in the approved Classic Consulting "Final Drainage Report for Waterbury Filing No. 1" dated September 2016.

Design Point EX2 is a point at the southern boundary of Filing 1 where runoff ($Q_5 = 1$ cfs, $Q_{100} = 9$ cfs) from Basin EXB's 4.09 acres of undeveloped prairie flow into Stapleton Road.

Design Point EX3 consists of a shallow swale that leave the site at the south east boundary. Runoff ($Q_5 = 0$ cfs, $Q_{100} = 1$ cfs) from Basin OS-4's 0.29 acres is directed south onto Basin EXC. The runoff

($Q_5 = 7$ cfs, $Q_{100} = 45$ cfs) from Basin EXC's 24.80 acres is combined with the Basin's OS-4. The combined runoff ($Q_5 = 7$ cfs, $Q_{100} = 45$ cfs) is directed offsite and shortly later in the existing channel in the Geick Ranch Basin.

Design Point EX4 is a point at the eastern boundary of Filing 1 where runoff ($Q_5 = 0$ cfs, $Q_{100} = 2$ cfs) from Basin OS-3's 1.11 acres of undeveloped prairie flows south onto Basin EXD's 15.87 acres ($Q_5 = 5$ cfs, $Q_{100} = 31$ cfs). The combined flow ($Q_5 = 5$ cfs, $Q_{100} = 33$ cfs) travels south and drains into the existing channel along the eastern boundary.

At Design Point EX10 a 36" CMP culvert (corresponds to DP10 in the MDDP) that drains from north to south under Eastonville Road (Basin OS-8) onto the undeveloped open space north (Basin OS-2) of the proposed Filing 2 layout. The Meridian Ranch MDDP states the runoff is $Q_5 = 5$ cfs, $Q_{100} = 11$ cfs.

Design Point EX5 consists of a swale that leave the site at the south east boundary. Runoff ($Q_5 = 3$ cfs, $Q_{100} = 22$ cfs) from Basin OS-2's 11.40 acres and Design Point EX10 is directed south onto Basin EXE. The runoff ($Q_5 = 2$ cfs, $Q_{100} = 14$ cfs) from Basin EXE's 5.83 acres is combined with Basin's OS-2 & Design Point EX10. The combined runoff ($Q_5 = 10$ cfs, $Q_{100} = 44$ cfs) of the 3 basins is directed offsite and into the existing channel in the Geick Ranch Basin.

At Design Point EX9 (Basin OS-9) is another 36" DONE culvert (corresponds to DP9 in the MDDP) that routes the runoff ($Q_5 = 8$ cfs, $Q_{100} = 19$ cfs) under Eastonville Road and onto the open space in Basin OS-1. The runoff ($Q_5 = 13$ cfs, $Q_{100} = 85$ cfs) from Basin OS-1's 45.02 acres is routed south via the existing channel located in the Geick Ranch Basin. An analysis found that this drainage channel is a jurisdictional waters of the U.S. with associated jurisdictional wetland habitat. Basin EXF's 1.62 acres is a small area consisting of open space prairies located at the north east corner of the site. Runoff ($Q_5 = 1$ cfs, $Q_{100} = 4$ cfs) from Basin EXF is directed onto Basin OS-1 along the eastern boundary at Design Point EX6.

Design Point EX7 is a point in the channel that corresponds to the proposed Design Point 30. The combined flow of Basin OS-1, Design Points EX5, EX6, & EX9 at DP EX7 is $Q_5 = 31$ cfs, $Q_{100} =$

151 cfs).

Design Point EX7A is a point in the eastern channel that lines up with the beginning of the Waterbury Filing 1 & 2 development. The combined flow of Basin OS-1 & EX9 at DP EX7 is $Q_5 = 21$ cfs, $Q_{100} = 104$ cfs).

Design Point 13 in this report corresponds to Design Point 13 in Classic Consulting's previously approved "Final Drainage Report for Waterbury Filing 1" dated September 2016. Design Point 13 is an existing Stormwater Quality Pond 3 (SWQ Pond 3) that was an existing stock pond south of Stapleton Drive that has been converted to an EDB and treat 40.4 acres of 4-Way Ranch Filing No. 1 from their Basins OS-5, OS-6, D, E, N 40% of L, 50% of O, Q & basins I, J & N of Waterbury Filing No. 1. The EDB was designed using a 4' x 4' outlet set at 6907.50 with an orifice plate with 1 column of 8-1/8" diameter holes spaced 4" apart. The forebay top is set at 6915.00 with the bottom at 6914.75. The required volume was calculated to be 0.66 ac-ft and the design volume shown is 1.20 ac-ft. The release out of the pond was calculated to be $Q_5 = 69$ cfs, $Q_{100} = 396$ cfs (See Classic Consulting Drainage Map in Appendix). This online EDB is no longer considered a viable solution to treating for WQCV for Waterbury Filing 1 & 2 basins I, J & N.

PROPOSED CONDITIONS

The overall site will be developed in several Filings with each filing requiring its own final drainage report. The Proposed Major Basin Descriptions below is for Waterbury Filings 1 & 2 development and the preliminary layout of the future filings to the north tributary to the storm drain system and detention ponds in Filings 1 & 2. This future area is shown as fully developed to analyze the ultimate storm drain capacity and pond volumes. In the section below labeled Hydrologic Analysis for Filing 1 FDR the interim condition will be discussed and how runoff is captured and routed safely to the proposed private EDB for Filings 1 & 2 construction. See the Proposed MDDP Drainage Map in the appendix for a visual representation of the below Basin descriptions.

Design Point 1 is a proposed public 10' CDOT TYPE R sump inlet located in the west flowline of Saybrook drive just north of the roundabout. Basin A's 3.39 acres consists of roadway and single-family development. Runoff ($Q_5 = 5$ cfs, $Q_{100} = 12$ cfs) sheet flows into street sections and then is routed south via c&g where the inlet captures all the flow.

Design Point 2 is a proposed public 5' CDOT TYPE R sump inlet located in the west flowline of Saybrook drive opposite of DP 1. Basin C's 0.86 acres is comprised of roadway and single-family development. Runoff ($Q_5 = 2$ cfs, $Q_{100} = 4$ cfs) drains overland to the street and then to the inlet where it is fully captured. Pipe run 1 an 18" RCP routes the flow to a junction at DP 1. Pipe Run 2 a public 24" RCP routes the combined flow ($Q_5 = 7$ cfs, $Q_{100} = 15$ cfs) of DP 1 & 2 down Saybrook Road and then down Bayshore Drive over to manhole junction in Sandy Neck Way.

Design Point 3 is a proposed public 5' CDOT TYPE R sump inlet located in the east flowline of Sandy Neck Way. Basin B1's 2.30 acres consists of roadway and single-family development. Runoff ($Q_5 = 4$ cfs, $Q_{100} = 8$ cfs) is directed south to Design Point 3. The 5' CDOT TYPE R sump inlet captures the entire flow. Pipe run 3 an 18" public RCP storm sewer routes the flow west to a manhole junction with Pipe run 4.

Design Point 4 is a proposed public 10' CDOT TYPE R sump inlet located in the west flowline of Sandy Neck Way opposite of DP 3. Basin B2's 3.58 acres consists of roadway and single-family development. Runoff ($Q_5 = 6$ cfs, $Q_{100} = 13$ cfs) is routed to Design Point 4. The 10' CDOT TYPE R sump inlet captures the entire flow. Pipe run 4 a 24" public RCP storm sewer routes the flow west to a manhole junction with Pipe run 3. Pipe run 5 a 24" RCP routes the combined ($Q_5 = 9$ cfs, $Q_{100} = 21$ cfs) flow of Pipe runs 3 & 4 south down Sandy Neck Way to the manhole junction with Pipe run 2. Pipe run 6 a public 36" RCP then routes the combined ($Q_5 = 16$ cfs, $Q_{100} = 35$ cfs) flow of Pipe runs 2 & 5 south down Sandy Neck Way to a junction at Design Point 5.

Design Point 5 is a proposed public 10' CDOT TYPE R sump inlet located in the flowline of Sandy Neck Way cul-de-sac. Runoff ($Q_5 = 4$ cfs, $Q_{100} = 9$ cfs) from Basin F's 2.18 acres consisting of single-family development is directed to the east flow line of Sandy Neck Way and then south to the cul-de-sac bulb low point. Runoff ($Q_5 = 3$ cfs, $Q_{100} = 6$ cfs) from Basin H's 1.46 acres consisting of single-family development is directed to the west flow line of Sandy Neck Way and then south to the cul-de-sac bulb low point. The combined flow ($Q_5 = 7$ cfs, $Q_{100} = 16$ cfs) at DP 5 is captured in the 10' CDOT TYPE R sump inlet and then is routed to the pond along with the flow from Pipe Run 6 via a proposed 36" public RCP storm sewer (Pipe run 7, $Q_5 = 22$ cfs, $Q_{100} = 48$ cfs) to Design Point 8. If

this inlet were blocked, runoff would overtop the curb and flow down the storm drain tract and into the proposed FSD Pond 1 (Design Point 8).

Design Point 6 is a proposed public 5' CDOT TYPE R sump inlet located in the west flowline of Saybrook Road. Runoff ($Q_5 = 4$ cfs, $Q_{100} = 8$ cfs) from Basin D's 2.11 acres consisting of single-family development is directed to the low point in Saybrook Road where the entire flow is captured. It is then routed via a proposed 18" public RCP storm sewer (Pipe run 8) to a manhole junction with Pipe run 9.

Design Point 7 is a proposed public 5' CDOT TYPE R sump inlet located opposite of DP 6 in Saybrook Road. Runoff ($Q_5 = 4$ cfs, $Q_{100} = 8$ cfs) from Basin E's 2.18 acres consisting of roadway and single-family lots is directed via side lot line swales and C&G to the proposed inlet. The 5' inlet captures all of the flow and Pipe run 9 a public 18" diameter RCP storm sewer routes the flow to a manhole junction at with Pipe run 8. The combined flows ($Q_5 = 7$ cfs, $Q_{100} = 15$ cfs) of Pipe runs 8 & 9 are routed south down Saybrook Road in Pipe run 10 a public 24' diameter RCP to a junction with Pipe Run 10A.

Design Point 7A is a proposed public 5' CDOT TYPE R at-grade inlet located in the east flowline of Saybrook Road at the south boundary. Runoff ($Q_5 = 1$ cfs, $Q_{100} = 2$ cfs) from Basin G1's 0.39 acres consisting of single-family development is directed to the at-grade inlet. The entire flow is captured. It is then routed via a proposed 15" public RCP storm sewer (Pipe run 10A) to a Design Point 7B.

Design Point 7B is a proposed public 5' CDOT TYPE R at-grade inlet located opposite of DP 7A in Saybrook Road. Runoff ($Q_5 = 1$ cfs, $Q_{100} = 3$ cfs) from Basin G2's 0.60 acres consisting of roadway and single-family lots is directed via side lot line swales and C&G to the proposed inlet. The 5' inlet captures all of the flow and Pipe run 10B a public 24" diameter RCP storm sewer routes the combined flows ($Q_5 = 9$ cfs, $Q_{100} = 19$ cfs) of Pipe runs 10, 10A & Design Point 7B are routed west to the proposed FSD Pond 1 Design (Design Point 8).

Design Point 8 is a proposed private Full Spectrum Detention Basin called FSD Pond 1. Design Points 1-7B are routed to the pond and treated for Water Quality and Detention along with Basin K's 3.06

acres consisting mainly of the EDB area and rear yards. Runoff ($Q_5 = 3$ cfs, $Q_{100} = 11$ cfs) sheet flows into the EDB. The basins tributary to Design Point 8 are Basins A, B1, B2, C, D, E, F, G1, G2, H & K with a total area of 21.12 acres. The 100-year effective impervious area of 55.5% was calculated using UD-BMP Version 3.07 IRF spreadsheet. This information was entered into the UD-Detention_v4.03 spreadsheet and the calculation yielded a required a WQCV of 0.394 ac-ft, a EURV of 0.957 ac-ft and a 100-year total required volume of 2.127 ac-ft. The top of pond is set at 6930.00, with a bottom of pond at 6923.50. The pipes and swales to the pond discharge into 2 concrete forebays (3% WQCV see calcs in appendix) with 18" high walls and a 3" notch to release minor flows into 2' wide concrete tickle channel. The trickle channel directs runoff to the proposed concrete micro-pool at the surcharge elevation of 6923.83. The bottom of the micro-pool is set at 6921.00 and the top set at 6923.50. A proposed 4' x 4' grate set at 6926.90 on top of a concrete outlet box, an outlet plate on the front to meet the 3-orifice requirement and an 18" outlet pipe with a restrictor plate set 12" above the invert will route all runoff from the pond. The metal plate will have 1 column containing 3 rows of 1-15/16" diameter orifice holes spaced 13.80" apart starting at 6923.50. The WQCV release is 0.20 cfs with a ponding elevation of 6925.29 and takes 40 hours to release. The EURV release is 0.5 cfs, with an elevation of 6926.94 and takes 73 hours to release. The 100-year detention release is 14.5 cfs, with an elevation of 6927.60 and takes 74 hours to release. A 30' long riprap emergency spillway set at 6928.00 will allow the 100-year developed peak in flow ($Q_{100} = 60.0$ cfs) with a depth of 0.73' (top of water = 6928.73) to be routed west into the natural channel. 1.00' freeboard is provided (see appendix for all pond calcs). The spillway and downhill slope will be armored with d50= VH 24" riprap. Pipe Run 10C a private 24" RCP will route the pond release into the existing natural channel. (See Pond Calculations in appendix).

Design Point 9 is an existing 36" RCP culvert under Eastonville Road where Offsite Basin OS-9 discharges onto offsite Basin OS-2. Runoff ($Q_5 = 8$ cfs, $Q_{100} = 19$ cfs) from Basin OS-9's 11.80 acres consists of historic flow based upon upstream detention. Further breakdown of this flow will be discussed with analysis of Design Point 29 and the discussion for Tributary flow to the FSD Pond 3.

Design Point 10 is an existing 36" RCP culvert under Eastonville Road south of the existing High School Pond where Offsite Basin OS-8 discharges onto a future Waterbury Filing. Runoff ($Q_5 = 5$ cfs, $Q_{100} = 11$ cfs) from Basin OS-10's 2.56 acres consists of historic flow based upon upstream

detention. In the ultimate buildout this flow will be piped west to the existing natural channel along the westside of Waterbury and to Offsite Basin OS-5. Until the future filings are built this flow will follow its natural channel south to the existing channel located along the eastern boundary of Filings 1 & 2. This will be discussed again in the Preliminary Drainage Report section below.

Design Point 10A is where existing 3-42" RCP culverts from the temporary Meridian Ranch Pond cross under Eastonville Road per the "Preliminary/Final Drainage Report for Meridian Ranch Filing No. 3" and shows flows of $Q_5 = 28$ cfs, $Q_{100} = 153$ cfs while the Meridian Ranch MDDP shows a 100-year flow of 185 cfs. The pipes discharge onto Offsite Basin OS-5. Offsite Basin OS-5's 5.64 acres consists of future Waterbury rear lots, open space and the natural channel. Runoff ($Q_5 = 10$ cfs, $Q_{100} = 23$ cfs) from OS-5 sheet flows to the channel. The flow is then routed south to Design Point 11.

Design Point 13 in this report corresponds to Design Point 13 in Classic Consulting's previously approved "Final Drainage Report for Waterbury Filing 1" dated September 2016. Design Point 13 is an existing Stormwater Quality Pond 3 (SWQ Pond 3) that was an existing stock pond south of Stapleton Drive that has been converted to an EDB and treat 40.4 acres of 4-Way Ranch Filing No. 1 from their Basins OS-5, OS-6, D, E, N 40% of L, 50% of O, Q & basins I, J & N of Waterbury Filing No. 1. The EDB was designed using a 4' x 4' outlet set at 6907.50 with an orifice plate with 1 column of 8-1/8" diameter holes spaced 4" apart. The forebay top is set at 6915.00 with the bottom at 6914.75. The required volume was calculated to be 0.66 ac-ft and the design volume shown is 1.20 ac-ft. The release out of the pond was calculated to be $Q_5 = 69$ cfs, $Q_{100} = 396$ cfs (See Classic Consulting Drainage Map in Appendix). This online EDB is no longer considered a viable solution to treating for WQCV for Waterbury Filing 1 & 2 basins I, J & N.

Design Point 11 is a proposed crossing under the proposed continuation of Gilbert Drive with dual 42" RCP culverts. Basin I's 4.97 acres consists of rear lots of 131-137, & 150-162 and the natural channel. Runoff ($Q_5 = 4$ cfs, $Q_{100} = 14$ cfs) sheet flows to the channel and is directed south to Design Points 11. As mentioned above Kiowas Engineering did a HEC-RAS analysis modeling developed flows along the channel. Tera Nova Engineering has done a new HEC-RAS analysis modeling developed flows. This information can be found under the Hydraulic analysis section below. The

combined flow of Design Point 10A along with Basins OS-5 and I is $Q_5 = 34$ cfs, $Q_{100} = 216$ cfs. This flow is routed south under Gilbert drive and onto Basin J. Basin I's runoff as mentioned above was intended to be treated downstream in the existing EDB at Design Point 13. This online EDB is no longer considered a viable solution to treating for WQCV due to new regulations. Basin I's rear 20' of several lots consists of the rear setback where no structure can be built with this restriction the entire acreage consists of undeveloped pervious area. Therefore, this Basin is listed as excluded from Water Quality per the exclusion in ECM Appendix I.7.1.B.7 - Sites with Land Disturbance to Undeveloped Land that will Remain Undeveloped.

Design Point 12 is a proposed 18" RCP culvert under Gilbert Drive that routes the runoff ($Q_5 = 2$ cfs, $Q_{100} = 4$ cfs) from offsite Basin OS-6's 1.06 acres that is comprised of the eastern half of Thatcher Court located in 4-Way Ranch Filing 1 to the existing natural channel.

Basin J's 1.44 acres is comprised of the 20' of rear lots of 156-162 and the existing channel along the west boundary. Runoff ($Q_5 = 3$ cfs, $Q_{100} = 6$ cfs) sheet flows into the channel and then is routed south to Design Point 13, an on-line existing stock pond that was converted to an EDB to provide water quality for part of 4-Way Ranch Filing No. 1 and Waterbury Basins I, J & N. As mentioned above this online EDB is no longer considered a viable solution to treating for WQCV. Basin I's rear 20' of several lots consists of the rear setback where no structure can be built with this restriction the entire acreage consists of undeveloped pervious area. Therefore, this Basin is listed as excluded from Water Quality per the exclusion in ECM Appendix I.7.1.B.7 - Sites with Land Disturbance to Undeveloped Land that will Remain Undeveloped .

Design Point 11A is a point at the south end of the property used to show the total flow in the west channel. The total runoff ($Q_5 = 37$ cfs, $Q_{100} = 222$ cfs) from Basin J's area and Design Point 11 is used in modeling analysis of the stream in Hydraulic section below.

Basin N's 0.22 acres is comprised of the proposed extension of Gilbert Road from 4-Way Ranch into Waterbury. Runoff ($Q_5 = 1$ cfs, $Q_{100} = 1$ cfs) sheet flows into the channel and then is routed south to Design Point 13, an on-line existing stock pond that is being converted to an EDB to provide water quality for part of 4-Way Ranch Filing No. 1 and Waterbury Basins I, J & N. Once again, this online

EDB is no longer considered a viable solution to treating for WQCV. Therefore, the UD-BMP Version 3.07 Runoff Reduction was used to show that this area can be treated using Runoff Reduction. The results show that we have a 100% WQCV reduction for Basin N. A Drainage Easement will need to be placed over these areas on the Final Plat with the note *“No lots shall have any impervious improvements constructed within the rear setback (i.e. patios, hardscape, recreational facilities, etc.) for Lots 40-42, 156, & Tract C”*. The area will be vegetated with the final GEC plan. The Preliminary Plan/PUD also places impervious restrictions on this Basin area and the O and M manual also lists how to maintain this space. This acreage of 0.35 is within the allowable limits.

In the previously approved “Final Drainage Report for Waterbury Filing No. 1” by Classic Consulting it was stated that there were 3 Stormwater Quality Ponds that needed to be provided for the adjacent 4-Way Ranch per conditions set forth by the Board of County Commissioners at approval of the Waterbury PUD Development Plan. Because there have been no changes to the tributary areas to these 3 Ponds and they have already been designed and constructed. The original approved calculations and results can be found in the appendix of the original report by Classic Consulting along with the Basin Exhibit Map.

Basin M1’s 1.05 acres is comprised of the rear yards of lots 35-39 & open space tract along Stapleton Drive along. Runoff ($Q_5 = 2$ cfs, $Q_{100} = 4$ cfs) sheet flows over the 20’ back yard setback and open space tract onto Stapleton Drive and then is routed east via curb & gutter to an existing storm drain system from here it is routed to the eastern channel located in the Geick Ranch Basin. Basin M1 contains the rear 20’ of several lots which consists of the rear setback where no structure can be built. The entire acreage consists of undeveloped pervious area. Therefore, this Basin is listed as excluded from Water Quality per the exclusion in ECM Appendix I.7.1.B.7 - Sites with Land Disturbance to Undeveloped Land that will Remain Undeveloped.

Basin M2’s 0.35 acres is comprised of the rear yards of lots 40-42 adjacent to undeveloped land east of the site. Runoff ($Q_5 = 1$ cfs, $Q_{100} = 2$ cfs) sheet flows from the back yard onto the undeveloped land. This rear lot area is not treated for water quality but is pervious area. The UD-BMP Version 3.07 Runoff Reduction was used to show that this area has 100% WQCV reduction based upon the Unconnected Impervious Area being routed over the Receiving Pervious Area. Only developed land

in Basin M2 is the rear 40' which 20' of that consists of the rear setback where no structure can be built. A Drainage Easement will need to be placed over these areas on the Final Plat with the note "*No lots shall have any impervious improvements constructed within the rear setback (i.e. patios, hardscape, recreational facilities, etc.) for Lots 40-42, 156, & Tract C*". The area will be vegetated with the final GEC plan. The Preliminary Plan/PUD also places impervious restrictions on this Basin area and the O and M manual also lists how to maintain this space. This acreage of 0.35 is within the allowable limits.

Basin M3's 0.20 acres is comprised of Saybrook Road public ROW that cannot be captured by the onsite storm sewer system Stapleton Drive. Runoff ($Q_5 = 0$ cfs, $Q_{100} = 1$ cfs) is directed by curb and gutter onto Stapleton Drive and then is routed east via curb & gutter to an existing storm drain system from here it is routed to the eastern channel located in the Geick Ranch Basin. This Basin is listed as excluded from Water Quality per the exclusion in ECM Appendix I.7.1.C.1.A - less than 1 acre of developed roadway area.

Basin P's 0.70 acres is comprised of open space Tract I adjacent to undeveloped land east of the site. Runoff ($Q_5 = 0$ cfs, $Q_{100} = 2$ cfs) sheet flows from the open space onto the undeveloped land. The entire acreage consists of undeveloped pervious area. Therefore, this Basin is listed as excluded from Water Quality per the exclusion in ECM Appendix I.7.1.B.7 - Sites with Land Disturbance to Undeveloped Land that will Remain Undeveloped.

Design Point 14 is a low point in the knuckle of Beech Creek Drive with a proposed public 10' CDOT TYPE R sump inlet. Runoff ($Q_5 = 6$ cfs, $Q_{100} = 13$ cfs) from Basin L1's 3.79 acres consisting of roadway and single-family lots is directed via side lot line swales and C&G to the proposed inlet. The 10' inlet captures all of the flow and Pipe run 11 a public 24" diameter RCP storm sewer routes the flow to a manhole junction with Pipe run 12.

Design Point 15 is a proposed public 5' CDOT TYPE R sump inlet opposite of DP 14 in Beech Creek Drive Runoff ($Q_5 = 3$ cfs, $Q_{100} = 7$ cfs) from Basin L2's 2.00 acres consisting of roadway and single-family lots is directed via side lot line swales and C&G to the proposed inlet. The 5' inlet captures all of the flow and Pipe run 12 a public 24" diameter RCP storm sewer routes the flow to a manhole

junction with Pipe run 11. Pipe run 13 a 30" RCP routes the combined flow ($Q_5 = 9$ cfs, $Q_{100} = 19$ cfs) of Pipe Runs 11 & 12 north in Beech Creek Drive to a manhole junction with Pipe run 14.

Design Point 16 is a proposed public 10' CDOT TYPE R sump inlet located in the proposed western half of the private street of Beech Creek Drive. Runoff ($Q_5 = 5$ cfs, $Q_{100} = 10$ cfs) from Basin O1's 2.82 acres consisting of roadway and single-family lots is directed via side lot line swales and C&G to the proposed inlet. The 5' inlet captures all of the flow and Pipe run 14 a public 30" diameter RCP storm sewer routes the flow to a manhole junction with Pipe run 13. Pipe run 15 a 30" RCP routes the combined flow ($Q_5 = 13$ cfs, $Q_{100} = 29$ cfs) of Pipe Runs 13 & 14 west to a manhole junction with Pipe run 16.

Design Point 17 is a proposed public 5' CDOT TYPE R sump inlet located opposite of DP 16 in Beech Creek Drive. Runoff ($Q_5 = 1$ cfs, $Q_{100} = 2$ cfs) from Basin O2's 0.71 acres consisting of roadway, parking, roof and landscape area sheet flows to the east flowline of Beech Creek Drive and to the proposed inlet. After all the flow is captured by the inlet Pipe run 16 routes the runoff to a junction with Pipe run 15. Pipe run 17 routes the combined flows ($Q_5 = 15$ cfs, $Q_{100} = 34$ cfs) of Pipe runs 15, 16, 39 & 40 and is routed west offsite via a private 36" diameter RCP to Design Point 18 a proposed private temporary EDB to be in place until future final design of a pond accommodates the new Waterbury development tributary to this pond. This is the FSD Pond 2.

Design Point 33 consists of 4-18" diameter area inlets located at the rear lot line in the downhill side yard swale. A 1' high berm along the back of Lots 46-49 in Basin O3's 0.45 acres will keep runoff ($Q_5 = 1$ cfs, $Q_{100} = 2$ cfs) from back yards and rear lot downspouts from sheet flowing into the existing wetlands untreated. Each area inlet can capture 1.40 cfs based upon a head of 0.25'. Therefore the 4 inlets can capture all of the flow. Pipe run 39 a 15" HDPE will route the captured flow to pipe run 17.

Design Point 34 consists of 3-18" diameter area inlets located at the rear lot line in the downhill side yard swale. A 1' high berm along the back of Lots 43-45 in Basin O4's 0.38 acres will keep runoff ($Q_5 = 1$ cfs, $Q_{100} = 2$ cfs) from back yards and rear lot downspouts from sheet flowing into the existing wetlands untreated. Each area inlet can capture 1.40 cfs based upon a head of 0.25'. Therefore the 3 inlets can capture all of the flow. Pipe run 40 a 15" HDPE will route the captured flow to pipe run 17.

Design Point 18 is a proposed temporary private Full Spectrum Detention Basin called FSD Pond 2. This pond will be replaced and resized when future filings to the east are final designed. There are no set time frames at this time to when the final design of the permanent pond will happen. Design Points 14-17 are routed to the pond and treated for Water Quality and Detention along with the Basin OS-4's 10.90 acres consisting of the EDB area and undeveloped upstream tributary area. Runoff ($Q_5 = 2$ cfs, $Q_{100} = 16$ cfs) from Basin OS-4 sheet flows into the EDB. The basins tributary to Design Point 18 are L1, L2, O1, O2 and OS-4 with a total area of 20.54 acres. The 100-year effective impervious area of 27.2% was calculated using UD-BMP Version 3.07 IRF spreadsheet. This information was entered into the UD-Detention_v4.03 spreadsheet and the calculation yielded a required a WQCV of 0.241 ac-ft, a EURV of 0.278 ac-ft and a 100-year detention total required volume of 1.027 ac-ft. The top of pond is set at 6906.00, with a bottom of pond at 6899.00. The pipes and swales to the pond discharge into a concrete forebay (3% WQCV see calcs in appendix) with 18" high walls and a 3" notch to release minor flows into 2' wide concrete trickle channel. The trickle channel directs runoff to the proposed concrete micro-pool at the surcharge elevation of 6899.33. The bottom of the micro-pool is set at 6896.50 and the top set at 6899.00. A proposed 4' x 4' grate set at 6902.15 on top of a concrete outlet box, an outlet plate on the front to meet the 3-orifice requirement and an 18" outlet pipe with no restrictor plate will route all runoff from the pond. The metal plate will have 1 column containing 3 rows of 1-5/16" diameter orifice holes spaced 12.4" apart starting at 6899.00. The WQCV release is 0.10 cfs with a ponding elevation of 6901.21 and takes 40 hours to release. The EURV release is 0.2 cfs, with an elevation of 6902.09 and takes 59 hours to release. The 100-year detention release is 15.1 cfs, with an elevation of 6902.71 and takes 58 hours to release. A 20' long riprap emergency spillway set at 6904.00 will allow the 100-year developed peak in flow ($Q_{100} = 29.30$ cfs) with a depth of 0.59' (top of water = 6904.59) to be routed west into the natural channel. 1.00' freeboard is provided (see appendix). The spillway and downhill slope will be armored with d50= VH 24" riprap. Pipe Run 17A a private 18" RCP will route the pond release into the existing natural channel. (See Pond Calculations in appendix). When future filings are developed this temporary Pond 2 will be replaced with a permanent Pond as shown in the "Conceptual Drainage Report for Waterbury PUD Plan" prepared by Classic Consulting and dated November 2012.

Design Point 19 is a proposed 10' CDOT TYPE R sump inlet located in the south curb of Muddy

Pond Street. Runoff ($Q_5 = 0$ cfs, $Q_{100} = 1$ cfs) from Basin OS-Q1's 0.33 acres consists of undeveloped land and will sheet flow onto Basin Q1. Runoff ($Q_5 = 3$ cfs, $Q_{100} = 6$ cfs) from Basin Q1's 1.48 acres is directed to the 8' inlet. The combined flow ($Q_5 = 3$ cfs, $Q_{100} = 6$ cfs) is captured in the inlet and Pipe run 18 a 24" RCP diameter storm routes the flows to a manhole junction with Pipe run 19.

Design Point 20 is a proposed 5' CDOT TYPE R sump inlet located opposite of DP 19. Runoff ($Q_5 = 0$ cfs, $Q_{100} = 1$ cfs) from Basin OS-Q2's 0.22 acres consists of undeveloped land and will sheet flow onto Basin Q2. Runoff ($Q_5 = 2$ cfs, $Q_{100} = 4$ cfs) from Basin Q2's 0.96 acres is directed to the 4' inlet. The combined flow ($Q_5 = 2$ cfs, $Q_{100} = 5$ cfs) is fully captured in the inlet and Pipe run 19 an 18" RCP diameter storm routes the flows to a manhole junction with Pipe run 18. Pipe Run 20 a 24" RCP storm routes the combined flow ($Q_5 = 4$ cfs, $Q_{100} = 10$ cfs) of Pipe runs 19 & 20 east down Muddy Pond Street to a manhole junction with Pipe run 21.

Design Point 21 is a proposed 10' CDOT TYPE R at-grade inlet located in the north curb of Muddy Pond Street just east of Masonboro Way intersection. Runoff ($Q_5 = 0$ cfs, $Q_{100} = 2$ cfs) from Basin OS-R's 1.04 acres consists of undeveloped land and will sheet flow onto Basin R. Runoff ($Q_5 = 2$ cfs, $Q_{100} = 4$ cfs) from Basin R's 1.02 acres is directed to the 10' inlet. The combined flow ($Q_5 = 2$ cfs, $Q_{100} = 6$ cfs) is routed to the inlet and the flow is fully captured. Pipe run 21 an 18" RCP diameter storm routes the captured flow to a manhole junction with Pipe run 20. Pipe run 22 routes the combined flow ($Q_5 = 6$ cfs, $Q_{100} = 16$ cfs) of Pipe runs 20 & 21 east down Muddy Pond Street to a manhole junction with Pipe run 25. The bypass flow ($Q_5 = 0$ cfs, $Q_{100} = 1$ cfs) at DP 21 travels in the north flow line of Muddy Pond Street to Design Point 22.

Design Point 22 is a proposed 10' CDOT TYPE R sump inlet located in the west curb of Megansett Way. Runoff ($Q_5 = 0$ cfs, $Q_{100} = 1$ cfs) from Basin OS-S1's 0.31 acres consists of undeveloped land and will sheet flow onto Basin S1. Runoff ($Q_5 = 3$ cfs, $Q_{100} = 7$ cfs) from Basin S1's 1.55 acres is directed to the 10' inlet. The combined flow ($Q_5 = 3$ cfs, $Q_{100} = 7$ cfs) of Basins OS-S1 & S1 is routed via Pipe run 23 to a junction with Pipe run 24.

Design Point 23 is a proposed 10' CDOT TYPE R sump inlet located opposite of DP 22. Runoff ($Q_5 = 0$ cfs, $Q_{100} = 0$ cfs) from Basin OS-S2's 0.13 acres consists of future single-family development and

will be directed via lot line swales and c&g onto Basin S2. Runoff ($Q_5 = 0$ cfs, $Q_{100} = 1$ cfs) from Basin S2's 0.13 acres is directed to the 10' inlet. The combined flow at DP 23 is $Q_5 = 0$ cfs, $Q_{100} = 1$ cfs. Pipe run 24 a 24" RCP diameter storm routes the flow ($Q_5 = 0$ cfs, $Q_{100} = 1$ cfs) from the inlet at DP 22 to a manhole junction with Pipe run 23. Pipe Run 25 a 30" RCP routes the combined flow ($Q_5 = 3$ cfs, $Q_{100} = 7$ cfs) of Pipe runs 23 & 24 south to a manhole junction with Pipe run 22 in Muddy Pond Street. Pipe run 26 a 36" RCP then routes the combined flow ($Q_5 = 9$ cfs, $Q_{100} = 23$ cfs) of Pipe runs 22 & 25 east in Muddy Pond to a manhole junction with Pipe runs 27 & 28.

Design Point 24 is a proposed 5' CDOT TYPE R sump inlet located in the south curb of Muddy Pond Street. Runoff ($Q_5 = 3$ cfs, $Q_{100} = 6$ cfs) from Basin T1's 1.42 acres consists of single-family development and will be directed via lot line swales and c&g to the 5' inlet. Pipe run 27 an 18" RCP diameter storm routes the flow from the inlet to a manhole junction with Pipe runs 26 & 28.

Design Point 25 is a proposed 5' CDOT TYPE R sump inlet located opposite of DP 24. Runoff ($Q_5 = 0$ cfs, $Q_{100} = 1$ cfs) from Basin OS-T2's 0.30 acres consists of future single-family development and will be directed via lot line swales and c&g onto Basin T2. Runoff ($Q_5 = 2$ cfs, $Q_{100} = 5$ cfs) from Basin T2's 1.23 acres is directed to the 4' inlet. The combined flow at DP 25 is $Q_5 = 2$ cfs, $Q_{100} = 5$ cfs. Pipe run 28 an 18" RCP diameter storm routes the flow from the inlet to a manhole junction with Pipe runs 27 & 28. Pipe run 29 a 36" RCP then routes the combined flow ($Q_5 = 13$ cfs, $Q_{100} = 34$ cfs) of Pipe runs 26, 27 & 28 east in Muddy Pond Street and then south down Fish Camp Circle to a manhole junction with Pipe run 30.

Design Point 26 is a proposed 10' CDOT TYPE R sump inlet located in the west curb of Fish Camp Circle near the Knuckle. Runoff ($Q_5 = 7$ cfs, $Q_{100} = 16$ cfs) from Basin U1's 4.38 acres consists of single-family development and will be directed via lot line swales and c&g to the 10' inlet. Pipe run 30 a 24" RCP diameter storm routes the flow from the inlet to a manhole junction with Pipe run 29. Pipe run 31 a 42" RCP transports the combined flow ($Q_5 = 20$ cfs, $Q_{100} = 48$ cfs) of Pipe runs 29 & 30.

Design Point 27 is a proposed 5' CDOT TYPE R sump inlet located opposite of DP 26. Runoff ($Q_5 = 3$ cfs, $Q_{100} = 7$ cfs) from Basin U2's 1.89 acres consists of future single-family development and

will be directed via lot line swales to the 6' inlet. Pipe run 32 an 18" RCP diameter storm routes the flow from the inlet to a manhole junction with Pipe runs 31. Pipe run 33 a 42" RCP then routes the combined flow ($Q_5 = 24$ cfs, $Q_{100} = 57$ cfs) of Pipe runs 31 & 32 east through a Drainage Tract to FSD Pond 3.

Design Point E-E is a proposed 4' wide swale, 2' deep with 4:1 side slopes. Offsite Basin OS-8's 2.56 acres flow ($Q_5 = 5$ cfs, $Q_{100} = 11$ cfs) under Eastonville Road via a 36" CMP culvert onto Basin OS-2. Offsite Basin OS-2's 12.02 undeveloped acres flow ($Q_5 = 3$ cfs, $Q_{100} = 23$ cfs) south into the existing stock pond. The combined flow ($Q_5 = 8$ cfs, $Q_{100} = 33$ cfs) of the 2 basins will be routed overland in a proposed Diversion Swale E-E north of the Filing 2 Boundary to the existing channel that runs along the eastern boundary, while keeping it from entering the proposed development. The swale is a 8' wide bottom 2' deep swale with 5:1 side slopes set in a proposed Drainage Easement. This followed the guideline set forth in MHFD chapter 8 design criteria for stabilized swales. The 100-Y highwater depth in the swale is 0.72' (See Appendix for calcs). This swale has velocities of 4.00 fps for a grassed water way. This is below the allowable 5 fps. It is recommended that the swale be Permanently Seeded and mulched once installed in the Initial Phase of grading to establish a dense grass bottom and side slopes. The swale will be maintained by the 4-Way Ranch Metro District based upon the recommendations in the Operations and Maintenance Manual. Access to maintain the swale can be made from the temporary turnarounds at the end of Megansett Way and Masonboro Way. The swale is located in a proposed Access and Drainage Easement (see Drainage Maps).

Design Point 28 are 2 proposed 10' CDOT TYPE R sump inlets located in the north and south curb of Sunken Meadow Road. These inlets are offsite in a future phase and will be built within a proposed drainage easement. The offsite curb and gutter in this area is being built along with some asphalt to direct runoff to the 10' inlets. Runoff ($Q_5 = 8$ cfs, $Q_{100} = 18$ cfs) from Basin W's 5.20 acres is assumed to be evenly split between the 2 inlets and fully captured by them. Pipe run 34 a 24" RCP routes the captured runoff ($Q_5 = 4$ cfs, $Q_{100} = 9$ cfs) from the south inlet to the north inlet. Pipe run 34A a 30" RCP routes the combined flow from Design Points 28 & 32, described below via Pipe run 34A a 30" RCP.

Design Point 31 consists of 3-18" diameter area inlets located at the rear lot line in the downhill side

yard swale. A 1' high berm along the back of Lots 90-92 in Basin V's 0.54 acres will keep runoff ($Q_5 = 1$ cfs, $Q_{100} = 3$ cfs) from back yards and rear lot downspouts from sheet flowing into the existing wetlands untreated. Each area inlet can capture 1.40 cfs based upon a head of 0.25'. Therefore the 3 inlets can capture all of the flow. Pipe run 37 a 15" HDPE will route the captured flow to pipe run 33. Pipe run 33 a 42" RCP then routes the combined flow ($Q_5 = 44$ cfs, $Q_{100} = 92$ cfs) of Pipe runs 31, 32 & 37 east through a Drainage Tract to FSD Pond 3.

Design Point 32 consists of 2-18" diameter area inlets located at the rear lot line in the downhill side yard swale. A 1' high berm along the back of Lots 88-89 in Basin X's 0.43 acres will keep runoff ($Q_5 = 1$ cfs, $Q_{100} = 2$ cfs) from back yards and rear lot downspouts from sheet flowing into the existing wetlands untreated. Each area inlet can capture 1.40 cfs based upon a head of 0.25'. Therefore the 2 inlets can capture all of the flow. Pipe run 38 a 15" HDPE will route the fully captured flow to Design point 28. Pipe run 34 a 30" RCP will route the combined flow ($Q_5 = 9$ cfs, $Q_{100} = 20$ cfs) of Design Point 28 and Pipe run 32 to FSD Pond 3.

Basin Y's 0.35 acres is comprised of undeveloped open space Tracts adjacent to the existing natural channel along the east side of the site. Runoff ($Q_5 = 1$ cfs, $Q_{100} = 2$ cfs) from Basin Y sheet flows east into the channel. The entire acreage consists of undeveloped pervious area. Therefore, this Basin is listed as excluded from Water Quality per the exclusion in ECM Appendix I.7.1.B.7 - Sites with Land Disturbance to Undeveloped Land that will Remain Undeveloped and I.7.1.C.1.a – Less than 1 acres of developed roadway area.

The following Basins are for future Waterbury Filings to the north and east that will be tributary to FSD Pond 3. All the basin descriptions are the same, they are comprised of future single-family development and will be directed via lot line swales and c&g to future storm drain systems the future drain systems will be routed to FSD Pond 3. The exact routes and design have not been finalized at this time but will be with a future Final Drainage Report at the time of development. Below is the summary of the flow and acreage.

Basin OS-1: 11.81 acres, Runoff ($Q_5 = 18$ cfs, $Q_{100} = 41$ cfs)

Basin OS-2: 11.53 acres Runoff ($Q_5 = 16$ cfs, $Q_{100} = 36$ cfs)

Basin OS-3A: 0.79 acres Runoff ($Q_5 = 1$ cfs, $Q_{100} = 3$ cfs)

Basin OS-3B: 5.66 acres Runoff ($Q_5 = 9$ cfs, $Q_{100} = 20$ cfs)

As mentioned above Design Point 9 is an existing 36" CMP culvert under Eastonville Road where Offsite Basin OS-9 discharges onto Offsite Basin OS-2. Runoff ($Q_5 = 8$ cfs, $Q_{100} = 19$ cfs) from Basin OS-9's 11.80 acres consists of historic flow based upon upstream detention. Runoff will be directed through the future Waterbury filings and into FSD Pond 3.

Design Point 29 is a proposed private Full Spectrum Detention Basin called FSD Pond 3. Design Points 19-28 and Offsite Basins OS-1, OS-2, OS-3A, OS-3B, & OS-9 along with Basin OS-7's 2.82 acres consisting of the EDB area. Runoff ($Q_5 = 1$ cfs, $Q_{100} = 9$ cfs) sheet flows into the EDB with a total area of 82.02 acres routed to the pond and treated for Water Quality and Detention. The 100-year effective impervious area of 49.3% was calculated using UD-BMP Version 3.07 IRF spreadsheet. This information was entered into the UD-Detention_v4.03 spreadsheet and the calculation yielded a required a WQCV of 1.398 ac-ft, a EURV of 3.231 ac-ft and a 100-year total required detention volume of 7.398 ac-ft. The top of pond is set at 6930.00, with a bottom of pond at 6922.00. The pipes and swales to the pond discharge into a concrete forebay (3% WQCV see calcs in appendix) with 18" high walls and a 3" notch to release minor flows into 2' wide concrete tickle channel. The trickle channel directs runoff to the proposed concrete micro-pool at the surcharge elevation of 6922.33. The bottom of the micro-pool is set at 6919.50 and the top set at 6922.00. A proposed 10' x 4' grate set at 6926.84 on top of a concrete outlet box, an outlet plate on the front to meet the 3-orifice requirement and a 36" outlet pipe with a restrictor plate set 26.10" above the invert will route all runoff from the pond. The metal plate will have 1 column containing 3 rows of 2.62" x 2.62" orifice holes spaced 19.4" apart starting at 6922.00. The WQCV release is 0.70 cfs with a ponding elevation of 6925.04 and takes 40 hours to release. The EURV release is 1.2 cfs, with an elevation of 6926.84 and takes 78 hours to release. The 100-year detention release is 58.0 cfs, with an elevation of 6927.93 and takes 79 hours to release. A 80' long riprap emergency spillway set at 6928.10 will allow the 100-year developed peak in flow ($Q_{100} = 247.2$ cfs) with a depth of 0.99' (top of water = 6928.98) to be routed west into the natural channel. 0.91' freeboard is provided (see appendix). The spillway and downhill slope will be armored with d50= VH 24" riprap. Pipe Run 35 a private 36" RCP will route the pond release into the existing natural channel. (See Pond Calculations

in appendix).

Design Point 30 is a triple 36" RCP culvert crossing under Sunken Meadow Road. Offsite Basin OS-9 discharges onto Offsite Basin OS-1. Runoff ($Q_5 = 8$ cfs, $Q_{100} = 19$ cfs) from Basin OS-9's 11.80 acres consists of historic flow based upon upstream detention. Offsite Basin OS-1's 41.09 acres consists of undeveloped land and open space containing the natural channel. Runoff ($Q_5 = 11$ cfs, $Q_{100} = 73$ cfs) from Basin OS-1 is directed south through the wetlands to the culverts. Basin Y's 0.35 acres is comprised of undeveloped open space Tracts adjacent to the existing natural channel along the east side of the site. Runoff ($Q_5 = 1$ cfs, $Q_{100} = 2$ cfs) from Basin Y sheet flows east into the channel. The entire acreage consists of undeveloped pervious area. Therefore, this Basin is listed as excluded from Water Quality per the exclusion in ECM Appendix I.7.1.B.7 - Sites with Land Disturbance to Undeveloped Land that will Remain Undeveloped. Also entering the channel is the runoff from Diversion Swale E-E that routes Basin OS-2's flow mentioned above. The combined flow ($Q_5 = 36$ cfs, $Q_{100} = 120$ cfs) at DP 30 of Basins OS-1, OS-2, OS-8, OS-9, & Y will be safely routed through the triple 36" RCP culverts (See appendix).

In an effort to protect receiving water and as part of the "four step process to minimize adverse impacts of urbanization" this site was analyzed in the following manner:

1. Reduce Runoff- The proposed impervious areas on the site are surrounded by landscaping and green space areas. Additionally, the new improvements and impervious areas on the site will be routed to a proposed private Extended Detention Basin. These items will reduce the volume of runoff using ponding and infiltration.
2. Stabilize Drainageways- There are 2 existing drainageways onsite. The westerly channel has been studied in HEC-RAS model and based upon calculations velocities are within the range for stabilized flow. The easterly channel has wetlands that allow the channel to stay stabilized.
3. Provide Water Quality Capture Volume (WQCV)- The 3 Extended Detention Basin have been sized and designed to sufficiently capture the required WQCV and slowly release it though the three-hole outlet, thereby allowing solids and contaminants to settle out.
4. Consider Need for Industrial and Commercial BMPs- The proposed development is single family site; therefore, no Industrial and Commercial BMPs have been proposed.

HYDRAULIC ANALYSIS

As mentioned above there are 2 major drainage ways on the east and west side of the site. In the previously approved “Final Drainage Report for Waterbury Filing 1” dated September 2016 prepared by Classic Consulting Engineering & Surveying the floodplain along the west side of the site was determined by Kiowa Engineering in a 2004 LOMR (04-08-0012) using a HEC-RAS analysis modeling developed flows along the channel from the 3-42” culverts under Eastonville Road south to the existing stock pond (Design Point 13) south of Stapleton Drive with proposed and existing improvements such as the proposed 42” dual culverts located at the Gilbert Road crossing and existing dual 4’ x 8’ box culverts at Stapleton Drive. Terra Nova engineering has done a new HEC-RAS study for the floodplain to establish base flood elevations (see appendix for HEC-RAS model). These channels will be contained in proposed Tracts dedicated to drainage that will allow the 4-Way Ranch Metro District to provide maintenance.

As part of the revised Preliminary Plan submittal for the site revisions an analysis of the eastern channel by ECO Systems found that this drainage channel is a jurisdictional water of the U.S. with associated jurisdictional wetland habitat. Therefore, to comply with Section 404 of the Clean Water Act, we must meet the 404(b)(1) project review criteria, which include impact avoidance and minimization. The option the client plan to take is to minimize Project-wide impacts to 0.5-acre or less such that the pre-approved Nationwide Permits (NWP) may be used. No channel grading or redesign is proposed for the channels; with the exception of the Sunken Meadow Crossing where 3-36” culverts are being placed and additional flow is routed into the channel further upstream (Design Point E-E on the PDR Map). The rest of the channel is to remain natural at this time until verified with final design review.

For the analysis of the channels the Manning’s Roughness Coefficients were selected based upon investigation of the channels from site visits and the Natural features and Wetlands report for the site done by Ecosystems services. Both channels have a very substantial amount of vegetative cover containing cattails and Palustrine Emergent wetland vegetation (see attached exhibits & photos in appendix). Both channels show no sign of erosion but do have standing pools of water 1”to 6” deep in most areas along the reach.

The Manning's n values were taken from Table 10-2 for a stream on a plain with sluggish reaches, weedy and deep pools.

The west channel has more significant vegetation (cattails and brush) along the southern reach (RS x-sections 0 to 1500) than the northern part (RS x-sections 1500 to 2600) where it has more grasses and no cattails. For the existing condition in the southern part of the channel a Manning's n of 0.07 was used. While in the northern part a Manning's n of 0.05 was used. In the proposed condition we used a Manning's n value of 0.07 for the whole channel as we are proposing planting some cattails and other tall grasses in the northern part to help with critical RS x-sections that were shown with the results of the existing conditions.

The east channel has significant vegetation (cattails and brush) along the whole reach (RS x-sections 0 to 2600) and is denser than the west channel. Therefore, a Manning's n value of 0.08 was used in the HEC-RAS model. This is the upper limit for Table 10-2 for a stream on a plain with sluggish reaches, weedy and deep pools.

For shear stress the Retardance Class ranges from Class A to Class C were used based upon the SCS Retardance Class of Vegetal Retardance Curve See Table 8.9 and eq. 8.32 in appendix the values for allowable shear stress which based upon the index conversion the values are Class A: 10.0 lb/sq ft, Class B: 7.64 lb/sq ft and Class C 5.60 lb/sq ft.

A HEC-RAS analysis was done of the east channel using the existing topo and the proposed contours sampled from these AutoCAD files along with the developed 100-year flow of 120 cfs. This flow is taken from the Preliminary Drainage report calculations shown below and is the biggest flow the channel will see once development starts. This happens after development of Filings 1 & 2 and before there is development upstream in the future phases where onsite storm will route most flows in storm drain to detention/water quality ponds and not in the existing channel. The flow in the future fully developed condition is only 9 cfs (Design Point 30 MDDP Calcs) from RS x-section 2010.09 to 1200. While from RS x-sections 1000 to 400, 67 cfs is the flow (Design Point 30A MDDP Calcs). These may change in the future based upon the final design upstream. The 100-Y-HWL and finished floor lot elevations shown on the HECRAS exhibit are based upon the 120 cfs. The output information

shows that the channel velocities are in the range of 0.46 fps to 3.60 fps. This is below the suggested velocities of 5 fps from the DCM Manual Chapter 10 for 100-year event. The Froude # vary from 0.05 to 0.76. The shear stress varies from 0.01 to 2.59 lbs/q ft, which is well under the above-mentioned limits. As mentioned above this is an existing channel that is not being altered with the exception of the road crossing with the 3-36" culverts and the diversion of flows from Basin OS-2 to a point higher in the channel. This channel also contains wetlands that we should avoid disturbing as the HECRAS results show that the channel is stable as is, with no needed improvements. At RS x-section 1200 just upstream of the culvert crossing is shown as critical flow and but the velocity is 0.46 fps, the Froude number is 0.05 and the shear stress is 1.43 lbs/sq ft, all below the requirements. There is proposed Type M d50=12" riprap with a bury depth of 24" just downstream of the RS x-section 1200 as shown on the construction drawings and this will help to stabilize the channel. The only other on-site RS x-section shown to be critical is RS x-section 1600. This RS x-section has a velocity of 2.59 fps, the Froude number is 0.58 and the shear stress is 0.03 lbs/sq ft. It is respectfully requested that no improvements be done in this area as all the results show the channel is in conformance with the maximum design values and this RS x-section is in the middle of the widest part of the existing wetlands and any proposed stabilization would be more detrimental than helpful. RS x-section 400 which is downstream of our site and on someone else's property is also critical. RS x-section 400 is the last station which is always critical due to no downstream RS x-section to properly run calculations in HECRAS analysis. The 4-Way Ranch Metro District will provide maintenance on the channel using access from the end of the Public ROW of Sunken Meadow Road and Muddy Pond Street and Megansett Way. There is a proposed Drainage-Maintenance Easement along the whole channel abutting Waterbury Filing 1 & 2 and to the proposed FSD Pond 2.

A HEC-RAS analysis was also done of the West channel for the proposed conditions using the existing topo and the proposed contours. The channel was sampled from these AutoCAD files to obtain the RS x-sections data for the HECRAS analysis. The developed 100-year flow of 216 cfs was used for RS x-section 2500 to the proposed 42" dual culvert RS x-section at 1042.5. From RS x-section 900 to 100, 222 cfs was entered into the program. These flows are the based upon the MDDP drainage calculations for Design Points 11 & 11A respectively. As mentioned above the northern part of the channel has a manning's n of 0.05 and the southern part a 0.07 in the current condition but we are using a manning's n value of 0.07 for the whole channel as we are proposing planting cattails and

other tall grasses in the northern part to help improve the critical RS x-sections that were shown with the results of the existing conditions. In the proposed analysis of the west channel the HECRAS output shows that the channel velocities are in the range of 0.71 fps to 5.13 fps. This is below the suggested velocities of 7.00 fps from the DCM Manual Chapter 10 for 100-year event. The shear stress varies from 0.05 to 3.94 lbs/sq ft, which is under the above-mentioned limits for Class A, B & C Retardance. The Froude #'s vary from 0.10 to 1.02. There are 3 locations where the Froude # is above the 0.90 maximum. The first one is at the RS x-section 1420 just upstream of a proposed check structure. We are adding selective riprap bank stabilization from station 1500 to station 1350. The second and third RS x-sections are at 500 & 300. They both have a Froude # of 1.01. These 2 RS x-sections are also shown as Critical Water Surface locations therefore, we are adding selective riprap bank stabilization from station 550 to station 250. RS x-section 1200 just upstream of the culvert crossing is also shown as Critical Water Surface. The velocity at is 0.71 fps, the Froude # is 0.07 and the shear stress is 0.05 lbs/sq ft. This shows that the crossing is not detrimental to the channel. There are 6 critical water surface RS x-sections listed in the HECRAS table, RS x-sections 1900, 1420, 1200, 500, 300, & 0. The velocity at RS x-section 1900 is 2.94 fps, the Froude # is 0.61 and the shear stress is at 1.33 lbs/sq ft. The results are all below the allowable ranges and by armoring with selective riprap bank stabilization from station 1950 to station 1850 and planting cattails & other tall grasses we believe this will keep the channel stable. At the time of the Final Drainage Report and Construction Drawings a check structure with a more detailed analysis of this cross section will be looked at to help change this from a critical water surface. A check structure has been added at RS x-section 1400 to shallow out the channel slope downstream. This causes a Critical Water Surface at RS x-section 1420. RS x-section 1400 has a velocity of 4.54 fps, a Froude # of 1.02 and s shear stress of 3.36 lbs/sq ft. As mentioned above we are adding selective riprap bank stabilization from station 1500 to station 1350 in order to stabilize the channel. At RS x-section 1200 the velocity is 0.60 fps, the Froude # is 0.05 and the shear stress is 0.04 lbs/sq ft. This demonstrates that this RS x-section will be stable in the 100-Y event and no alternate stabilization is needed. As mentioned above RS x-sections are 500 & 300 are both at Critical Water Surface. It is proposed to armor with selective riprap bank stabilization from station 550 to station 250 and leave the bottom as is with the existing dense cattails and other tall grasses. RS x-section 0 is the last station which is always critical due to no downstream RS x-section to properly run calculations in HECRAS analysis. The 4-Way Ranch Metro District will provide maintenance on the channel using access from the Public ROW of the abutting Thatcher

Court, Gilbert Drive and Stapleton Drive. The Housemen Easement is also being used to gain access from Bandenero Drive

A HEC-RAS analysis was also done of the West channel for the existing conditions using the existing topo. This was analyzed so we could compare the existing 100-Y HWL to the proposed 100-Y HWL. The channel was sampled from these AutoCAD files using the same reach alignment and RS x-sections. The developed 100-year flow of 219 cfs was used for RS x-section 2600 to the proposed to RS x-section at 0. There was no rise above 0.50' (see table WEST CHANNEL EXISTING VS PROPOSED HWL in appendix for comparison) and therefore we met the requirement from the EL Paso County Floodplain Director *“that the cumulative effect of the proposed development, when combined with all other existing and anticipated development, will not increase the water surface elevation of the base flood more than one-half (1/2) foot at any point within the community.”*

The 100-year high water elevations and limits for the east and west channels were checked against the adjacent proposed lots and the finished grade. All lot grades are set above the adjacent 100-year highwater elevation by 1 foot on the Preliminary Plan /PUD. The proposed lots in Waterbury Filing 1 & 2 along the east and west channel are all set out side of the FEMA Floodplain and the calculated 100-year high water elevations and limits. The existing Lots 35 & 36 of the adjacent subdivision 4-Way Ranch Filing No. 1 to the west are shown to have the current FEMA floodplain study from December of 2018 encroach onto them. In the HECRAS analysis of the existing conditions flows from this MDDP study the 100-Y HWL encroaches onto their property in the existing condition at RS-x-sections 600, 700, 800, & 900 (see EXISTING 100-Y FLOODPLAIN EXHIBIT in Appendix under HECRAS ANALYSIS). The encroachment of the 100-Y HWL occurs across the rear yards of the house. This encroachment is shown to be more than the current FEMA floodplain study form December of 2018. This is an existing condition and the Waterbury Development is not initiating this concern. In the proposed condition for this MDDP study the 100-Y HWL is pulled in closer to the channel at RS x-sections 800 & 900, but at RS x-sections 600 & 700 the 100-Y HWL still encroaches onto Lots 35 & 36 (see PROPOSED 100-Y FLOODPLAIN EXHIBIT in Appendix under HECRAS ANALYSIS). The HECRAS model show that the proposed condition limits the encroachment as compared to the existing condition analysis.

FILING 1 CONSTRUCTION COST OPINION

Private Drainage Facilities Improvements, Non-Reimbursable

	<u>Item</u>	<u>Quantity</u>	<u>Unit Price</u>	<u>Cost</u>
1.	12" HDPE	1126 LF	\$ 50/LF	\$ 56,300
2.	18" DIA INLET	12 EA	\$ 500/EA	\$ 6,000
3.	18" RCP	70 LF	\$ 76/LF	\$ 5,320
4.	24" RCP	47 LF	\$ 91/LF	\$ 4,277
5.	36" RCP	567 LF	\$ 114/LF	\$ 64,638
6.	42" RCP	254 LF	\$ 140/LF	\$ 35,560
7.	18" FES	3 EA	\$ 456/EA	\$ 1,368
8.	24" FES	1 EA	\$ 546/EA	\$ 546
9.	36" FES	1 EA	\$ 684/EA	\$ 684
10.	HEADWALL	2 EA	\$ 2000/EA	\$ 4,000
11	WINGWALL	4 EA	\$ 2000/EA	\$ 8,000
12.	SWALE	565 LF	\$ 30/LF	\$ 16,950
13.	RIPRAP	426 TONS	\$ 97/TONS	\$ 41,322
			Total	<u>\$ 244,965</u>

Public Drainage Facilities Improvements, Non-Reimbursable

	<u>Item</u>	<u>Quantity</u>	<u>Unit Price</u>	<u>Cost</u>
1.	15" RCP	66 LF	\$ 61/LF	\$ 4,026
2.	18" RCP	364 LF	\$ 76/LF	\$ 27,664
3.	24" RCP	1,218 LF	\$ 91/LF	\$ 110,838
4.	30" RCP	674 LF	\$ 114/LF	\$ 76,836
5.	36" RCP	2,098 LF	\$ 140/LF	\$ 293,720
6.	18" FES	2 EA	\$ 456/EA	\$ 912
7.	24" FES	2 EA	\$ 546/EA	\$ 1,092
8.	36" FES	1 EA	\$ 684/EA	\$ 684
9.	42" FES	1 EA	1,112/EA	\$ 1,112
10.	5' Type R Inlet<5'	10 EA	\$ 6,703/EA	\$ 67,030
11.	5' Type R Inlet>5'	4 EA	\$ 8,715/EA	\$ 34,860

12.	10' Type R Inlet<10'	6 EA	\$ 9,224/EA	\$ 55,344
13.	10' Type R Inlet>10'	4 EA	\$ 9,507/EA	\$ 38,028
14	MH Slab Base	18 EA	\$ 7,734/EA	\$ 139,212
Total				<u>\$ 851,368</u>

Private Permanent BMPs, Non-Reimbursable

	<u>Description</u>	<u>Quantity</u>	<u>Unit Price</u>	<u>Cost</u>
1.	3-Extended Detention Basins			
	- Earthwork	32,000 CY	\$ 2	\$ 64,000
	- Forebays	5 EA	\$ 10,000	\$ 50,000
	- Trickle Channel	985 LF	\$ 50	\$ 49,250
	- Outlet Structures (4'x4')	2 EA	\$ 6,000	\$ 12,000
	- Outlet Structures (6'x6')	1 EA	\$ 10,000	\$ 10,000
	- Access Roads	3 EA	\$ 5,000	\$ 15,000
	- Stabilization	3 EA	\$ 5,000	<u>\$ 15,000</u>
	- Emergency Spillways	Included in Private Non Reimbursable		\$ 0
Total				<u>\$ 215,250</u>

DRAINAGE FEES WATERBURY FILING NO. 1

This site lies within the Haegler Ranch Drainage Basin Diversion and Geick Ranch Basin. There is no approved Drainage Basin Planning study on file done with fees for Geick Ranch Basin. Drainage and Bridge fees for the part of the site that lies within the Haegler Ranch (diversion to Geick) Basin 28 will not need to pay fees at the time of Final Plat

Total acreage of:

$$61.88 \text{ ac} / 198 = 0.31 \text{ ac} / \text{lot}$$

(Per El Paso County% impervious Chart 40%)

$$61.88 \times 40\% = 24.75 \text{ Impervious acres}$$

The following calculations are based upon the 2022 Drainage & Bridge fees:

Drainage Fees: $\$11,891 \times 24.75 = \mathbf{\$294,302}$
Bridge Fees: $\$1,755 \times 24.75 = \mathbf{\$43,436}$

Fee Reduction (Assumed 50% construction costs for Detention Facilities)

FSD Detention Pond 1, 2 & 3 $\$215,250 \times 50\% = \$107,625$

Total Deduction = \$107,625 (Actual costs may vary this will be finalized prior to approval)

Filing 1 Drainage Fee Total: $\$294,302 - \$107,625 = \mathbf{\$186,677}$

Filing 1 Bridge Fee Total: $\mathbf{\$43,436}$

SUMMARY

Site runoff and storm drain and appurtenances associated with the development of the Waterbury Filing No. 1 & 2 site will not adversely affect the surrounding and downstream developments. Runoff will be routed to the existing and proposed detention basins and reduce the runoff to be at or below historic rates mentioned above in the report via Full Spectrum Detention while slowly treating the water quality capture volume and in turn helping to stabilize the downstream channel banks. Terra Nova Engineering requests that this report satisfy the submittal requirements for the drainage analysis for Waterbury. This report and findings are in general conformance with all previously approved reports for this site.

PREPARED BY:
TERRA NOVA ENGINEERING, INC.

Quentin N. Armijo, P.E.
Vice President
Jobs/1715.00/drainage/1715.00FDR

BIBLIOGRAPHY

“City of Colorado Springs Drainage Criteria Manual Volume 1”, approved May 2014 and prepared by City of Colorado Springs

“Drainage Criteria Manual County of El Paso, Colorado Volume 1” approved October 2018 and prepared by El Paso County

“Drainage Criteria Manual County of El Paso, Colorado Volume 2” approved October 2018 and prepared by El Paso County

“Drainage Criteria Manual County of El Paso, Colorado Volume 1 update Chapter 6” approved October 2018 and prepared by El Paso County

“El Paso County Stormwater Drainage Facilities Maintenance Policy” approved October 2018 and prepared by El Paso County

NRCS Soils Map for El Paso County

“Revision to the MDDP for Meridian Ranch, EL Paso County, Colorado”, approved October 2005, and prepared by PBS&J

“Final Drainage Report for 4-Way Ranch Phase 1” approved March 2006 prepared by JR Engineering

The “Geick Ranch Drainage Basin Planning Study” approved February 2008, prepared by Drexel Barrel & Co

“Preliminary/Final Drainage Report for Meridian Ranch filing No. 3” approved November 2011 prepared by Tech Contractors

“Master Development Drainage Plan, 4-Way Ranch – Phase 1” approved January 2012 prepared by Advanced Design Professionals, Inc.

“Preliminary Drainage Report for Waterbury (Phase 1 Preliminary Plan) approved June 2013 prepared by Classic Consulting

“Final Drainage Report for Waterbury Filing No. 1” approved September 2016 prepared by Classic Consulting

APPENDIX

VICINTY MAP

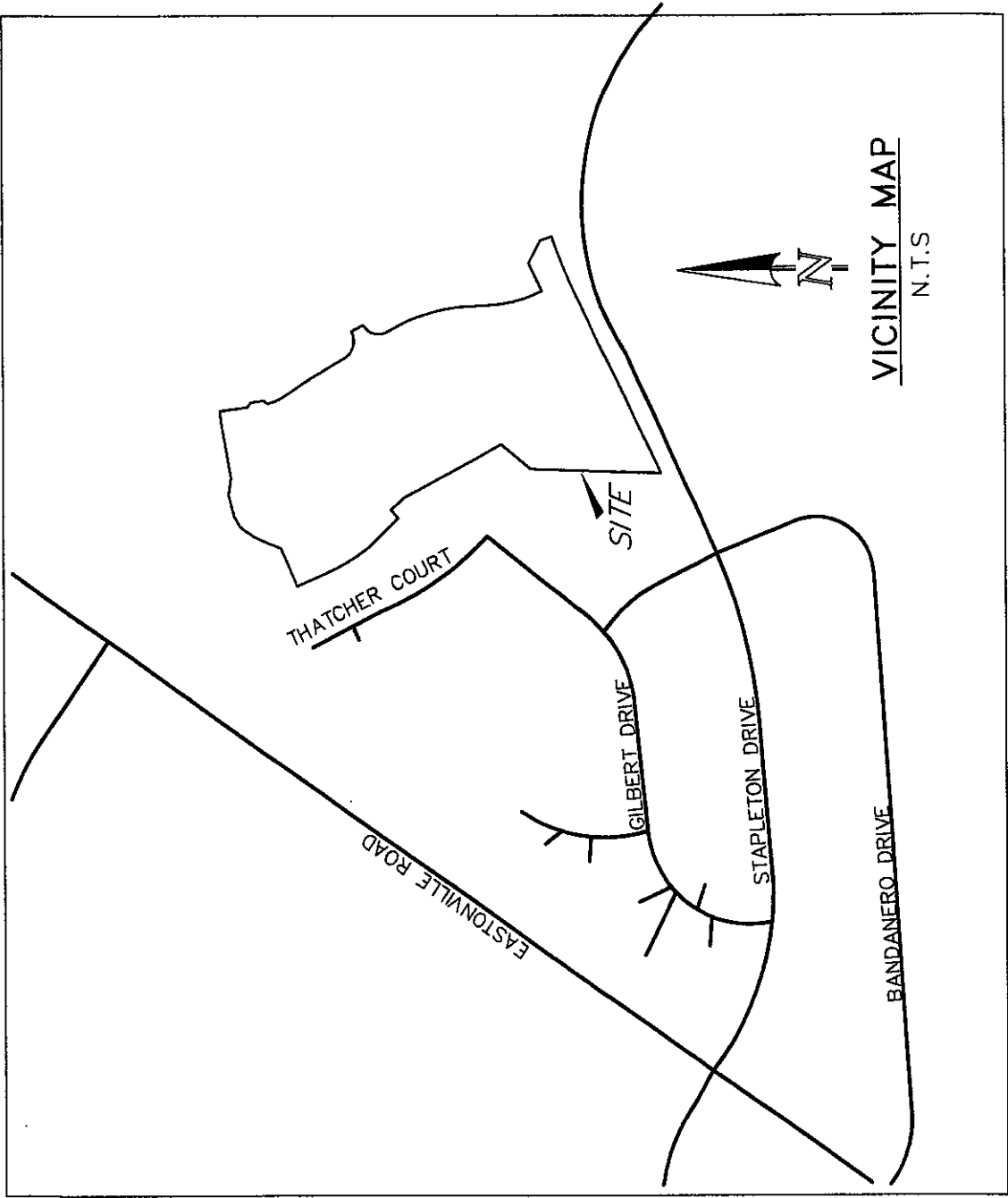

VICINITY MAP
N.T.S.



SITE

THATCHER COURT

GILBERT DRIVE

STAPLETON DRIVE

EASTONVILLE ROAD

BANDANFRO DRIVE



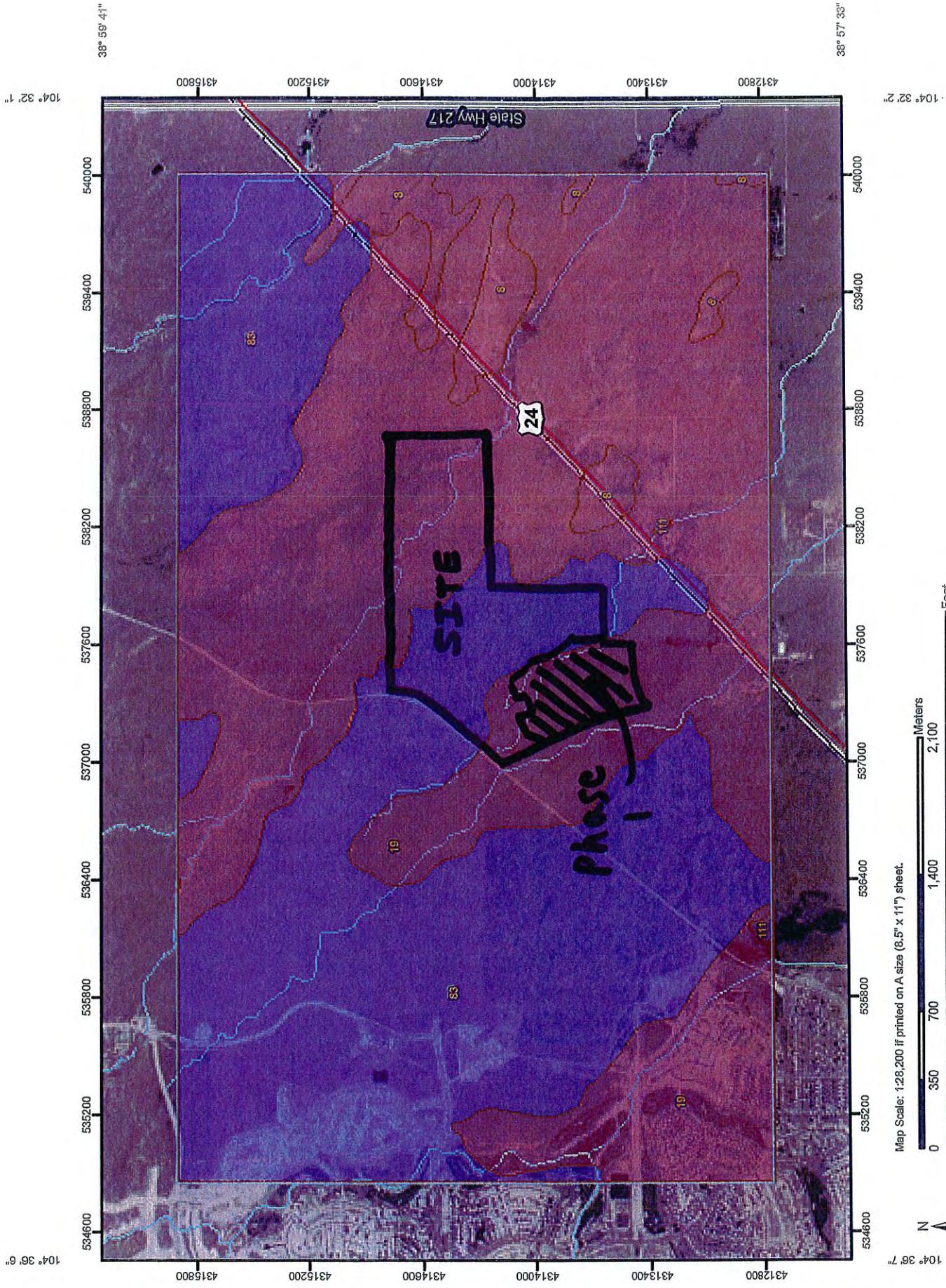



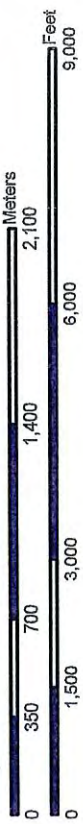









NRCS SOILS MAP



Map Scale: 1:28,200 if printed on A size (8.5" x 11") sheet.



MAP LEGEND

- Area of Interest (AOI)**
 -  Area of Interest (AOI)
- Soils**
 -  Soil Map Units
- Soil Ratings**
 -  A
 -  A/D
 -  B
 -  B/D
 -  C
 -  C/D
 -  D
 -  Not rated or not available
- Political Features**
 -  Cities
- Water Features**
 -  Streams and Canals
- Transportation**
 -  Rails
 -  Interstate Highways
 -  US Routes
 -  Major Roads
 -  Local Roads

MAP INFORMATION

Map Scale: 1:28,200 if printed on A size (8.5" x 11") sheet.
 The soil surveys that comprise your AOI were mapped at 1:24,000.
 Please rely on the bar scale on each map sheet for accurate map measurements.
 Source of Map: Natural Resources Conservation Service
 Web Soil Survey URL: <http://websoilsurvey.nrcs.usda.gov>
 Coordinate System: UTM Zone 13N NAD83
 This product is generated from the USDA-NRCS certified data as of the version date(s) listed below.
 Soil Survey Area: El Paso County Area, Colorado
 Survey Area Data: Version 8, Apr 6, 2011
 Date(s) aerial images were photographed: 7/29/2005; 8/17/2005; 7/2/2005
 The orthophoto or other base map on which the soil lines were compiled and digitized probably differs from the background imagery displayed on these maps. As a result, some minor shifting of map unit boundaries may be evident.

Hydrologic Soil Group

Hydrologic Soil Group— Summary by Map Unit — El Paso County Area, Colorado (CO625)				
Map unit symbol	Map unit name	Rating	Acres in AOI	Percent of AOI
8	Blakeland loamy sand, 1 to 9 percent slopes	A	155.7	3.9%
19	Columbine gravelly sandy loam, 0 to 3 percent slopes	A	2,095.1	52.1%
83	Stapleton sandy loam, 3 to 8 percent slopes	B	1,768.2	44.0%
111	Water		3.8	0.1%
Totals for Area of Interest			4,022.9	100.0%

Description

Hydrologic soil groups are based on estimates of runoff potential. Soils are assigned to one of four groups according to the rate of water infiltration when the soils are not protected by vegetation, are thoroughly wet, and receive precipitation from long-duration storms.

The soils in the United States are assigned to four groups (A, B, C, and D) and three dual classes (A/D, B/D, and C/D). The groups are defined as follows:

Group A. Soils having a high infiltration rate (low runoff potential) when thoroughly wet. These consist mainly of deep, well drained to excessively drained sands or gravelly sands. These soils have a high rate of water transmission.

Group B. Soils having a moderate infiltration rate when thoroughly wet. These consist chiefly of moderately deep or deep, moderately well drained or well drained soils that have moderately fine texture to moderately coarse texture. These soils have a moderate rate of water transmission.

Group C. Soils having a slow infiltration rate when thoroughly wet. These consist chiefly of soils having a layer that impedes the downward movement of water or soils of moderately fine texture or fine texture. These soils have a slow rate of water transmission.

Group D. Soils having a very slow infiltration rate (high runoff potential) when thoroughly wet. These consist chiefly of clays that have a high shrink-swell potential, soils that have a high water table, soils that have a claypan or clay layer at or near the surface, and soils that are shallow over nearly impervious material. These soils have a very slow rate of water transmission.

If a soil is assigned to a dual hydrologic group (A/D, B/D, or C/D), the first letter is for drained areas and the second is for undrained areas. Only the soils that in their natural condition are in group D are assigned to dual classes.

FEMA FIRM MAP

National Flood Hazard Layer FIRMMette



104°34'31"W 38°58'31"N

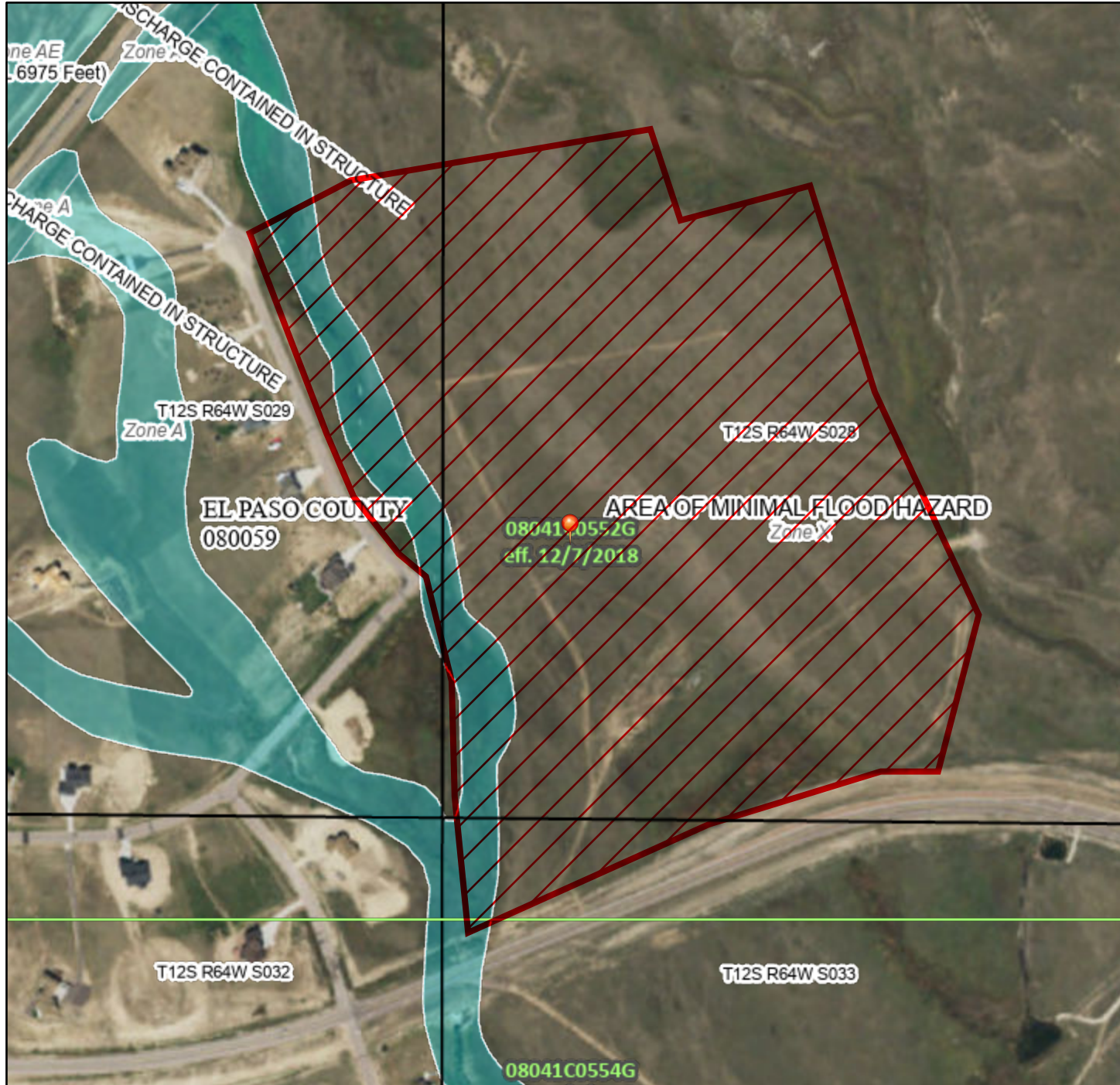

Legend

SEE FIS REPORT FOR DETAILED LEGEND AND INDEX MAP FOR FIRM PANEL LAYOUT

SPECIAL FLOOD HAZARD AREAS		Without Base Flood Elevation (BFE) Zone A, V, A99
		With BFE or Depth Zone AE, AO, AH, VE, AR
		Regulatory Floodway

OTHER AREAS OF FLOOD HAZARD		0.2% Annual Chance Flood Hazard, Areas of 1% annual chance flood with average depth less than one foot or with drainage areas of less than one square mile Zone X
		Future Conditions 1% Annual Chance Flood Hazard Zone X
		Area with Reduced Flood Risk due to Levee. See Notes. Zone X
		Area with Flood Risk due to Levee Zone D

OTHER AREAS		NO SCREEN Area of Minimal Flood Hazard Zone X
		Effective LOMRs
		Area of Undetermined Flood Hazard Zone D

GENERAL STRUCTURES		Channel, Culvert, or Storm Sewer
		Levee, Dike, or Floodwall

OTHER FEATURES		20.2 Cross Sections with 1% Annual Chance Water Surface Elevation
		17.5 Coastal Transect
		Base Flood Elevation Line (BFE)
		Limit of Study
		Jurisdiction Boundary
		Coastal Transect Baseline
		Profile Baseline
		Hydrographic Feature

MAP PANELS		Digital Data Available
		No Digital Data Available
		Unmapped

The pin displayed on the map is an approximate point selected by the user and does not represent an authoritative property location.

This map complies with FEMA's standards for the use of digital flood maps if it is not void as described below. The basemap shown complies with FEMA's basemap accuracy standards

The flood hazard information is derived directly from the authoritative NFHL web services provided by FEMA. This map was exported on 8/27/2021 at 4:44 PM and does not reflect changes or amendments subsequent to this date and time. The NFHL and effective information may change or become superseded by new data over time.

This map image is void if the one or more of the following map elements do not appear: basemap imagery, flood zone labels, legend, scale bar, map creation date, community identifiers, FIRM panel number, and FIRM effective date. Map images for unmapped and unmodernized areas cannot be used for regulatory purposes.



Federal Emergency Management Agency
Washington, D.C. 20472

FEB 19 2004

CERTIFIED MAIL
RETURN RECEIPT REQUESTED

The Honorable Chuck Brown
Chairman, El Paso County
Board of Commissioners
27 East Vermijo Avenue
Colorado Springs, CO 80903-2208

IN REPLY REFER TO:

Case No.: 04-08-0012P
Community Name: El Paso County, CO
Community No.: 080059
Effective Date of
This Revision: **MAR 19 2004**

Dear Mr. Brown:

The Flood Insurance Rate Map for your community has been revised by this Letter of Map Revision (LOMR). Please use the enclosed annotated map panel(s) revised by this LOMR for floodplain management purposes and for all flood insurance policies and renewals issued in your community.

Additional documents are enclosed which provide information regarding this LOMR. Please see the List of Enclosures below to determine which documents are included. Other attachments specific to this request may be included as referenced in the Determination Document. If you have any questions regarding floodplain management regulations for your community or the National Flood Insurance Program (NFIP) in general, please contact the Consultation Coordination Officer for your community. If you have any technical questions regarding this LOMR, please contact the Director, Federal Insurance and Mitigation Division of the Department of Homeland Security's Federal Emergency Management Agency (FEMA) in Denver, Colorado, at (303) 235-4830, or the FEMA Map Assistance Center toll free at 1-877-336-2627 (1-877-FEMA MAP). Additional information about the NFIP is available on our website at <http://www.fema.gov/nfip>.

Sincerely,

Kevin C. Long, CFM, Project Engineer
Hazard Identification Section
Mitigation Division
Emergency Preparedness
and Response Directorate

For: Doug Bellomo, P.E., CFM, Acting Chief
Hazard Identification Section
Mitigation Division
Emergency Preparedness
and Response Directorate

List of Enclosures:

Letter of Map Revision Determination Document
Annotated Flood Insurance Rate Map

cc: Mr. Kevin Stilson, P.E., CFM
Floodplain Administrator
Pikes Peak Regional Building Department

Mr. Richard N. Wray, P.E.
Principal
Kiowa Engineering Corporation



Federal Emergency Management Agency

Washington, D.C. 20472

LETTER OF MAP REVISION DETERMINATION DOCUMENT

COMMUNITY AND REVISION INFORMATION		PROJECT DESCRIPTION	BASIS OF REQUEST
COMMUNITY	El Paso County Colorado (Unincorporated Areas)	NO PROJECT	HYDROLOGIC ANALYSIS HYDRAULIC ANALYSIS NEW TOPOGRAPHIC DATA
	COMMUNITY NO.: 080059		
IDENTIFIER	Fourway Ranch Letter of Map Revision	APPROXIMATE LATITUDE & LONGITUDE: 39.974, -104.566 SOURCE: USGS QUADRANGLE DATUM: NAD 83	
FLOODING SOURCE(S) & REVISED REACH(ES)	Haegler Ranch Tributary 1 – from approximately 1,200 feet upstream of the Cadillac and Lake City Railroad to just upstream of Eastonville Road Haegler Ranch Tributary 1A – from the confluence with Haegler Ranch Tributary 1 to just upstream of Eastonville Road Haegler Ranch Tributary 2 – from the confluence with Haegler Ranch Tributary 1 to just upstream of Eastonville Road Geick Ranch Tributary 1 – from approximately 600 feet upstream to approximately 4,000 feet upstream of the Cadillac and Lake City Railroad Geick Ranch Tributary 2 – from approximately 600 feet upstream to approximately 2,600 feet upstream of the Cadillac and Lake City Railroad		

SUMMARY OF REVISIONS

Effective Flooding: Zone A

Revised Flooding: Zone A

Increases: YES

Decreases: YES

* BFEs – Base Flood Elevations

ANNOTATED MAPPING ENCLOSURES	ANNOTATED STUDY ENCLOSURES
TYPE: FIRM* NO.: 08041C0575 F Date: March 17, 1997	NO REVISION TO THE FLOOD INSURANCE STUDY REPORT

* FIRM – Flood Insurance Rate Map; ** FBFM – Flood Boundary and Floodway Map; *** FHBM – Flood Hazard Boundary Map

DETERMINATION

This document provides the determination from the Department of Homeland Security's Federal Emergency Management Agency (FEMA) regarding a request for a Letter of Map Revision (LOMR) for the area described above. Using the information submitted, we have determined that a revision to the flood hazards depicted in the Flood Insurance Study (FIS) report and/or National Flood Insurance Program (NFIP) map is warranted. This document revises the effective NFIP map, as indicated in the attached documentation. Please use the enclosed annotated map panels revised by this LOMR for floodplain management purposes and for all flood insurance policies and renewals in your community.

This determination is based on the flood data presently available. The enclosed documents provide additional information regarding this determination. If you have any questions about this document, please contact the FEMA Map Assistance Center toll free at 1-877-336-2677 (1-877-FEMA MAP) or by letter addressed to the LOMR Depot, 3601 Eisenhower Avenue, Alexandria, VA 22304. Additional information about the NFIP is available on our website at <http://www.fema.gov/nfip>.

Doug Bellomo, P.E., CFM, Acting Chief
Hazard Identification Section
Mitigation Division

Emergency Preparedness and Response Directorate 102061 D.A04080012 102IC



Federal Emergency Management Agency
Washington, D.C. 20472

**LETTER OF MAP REVISION
DETERMINATION DOCUMENT (CONTINUED)**

COMMUNITY INFORMATION

APPLICABLE NFIP REGULATIONS/COMMUNITY OBLIGATION

We have made this determination pursuant to Section 206 of the Flood Disaster Protection Act of 1973 (P.L. 93-234) and in accordance with the National Flood Insurance Act of 1968, as amended (Title XIII of the Housing and Urban Development Act of 1968, P.L. 90-448), 42 U.S.C. 4001-4128, and 44 CFR Part 65. Pursuant to Section 1361 of the National Flood Insurance Act of 1968, as amended, communities participating in the NFIP are required to adopt and enforce floodplain management regulations that meet or exceed NFIP criteria. These criteria, including adoption of the FIS report and FIRM, and the modifications made by this LOMR, are the minimum requirements for continued NFIP participation and do not supersede more stringent State/Commonwealth or local requirements to which the regulations apply.

COMMUNITY REMINDERS

We based this determination on the 1-percent-annual-chance discharges computed in the submitted hydrologic model. Future development of projects upstream could cause increased discharges, which could cause increased flood hazards. A comprehensive restudy of your community's flood hazards would consider the cumulative effects of development on discharges and could, therefore, indicate that greater flood hazards exist in this area.

Your community must regulate all proposed floodplain development and ensure that permits required by Federal and/or State/Commonwealth law have been obtained. State/Commonwealth or community officials, based on knowledge of local conditions and in the interest of safety, may set higher standards for construction or may limit development in floodplain areas. If your State/Commonwealth or community has adopted more restrictive or comprehensive floodplain management criteria, those criteria take precedence over the minimum NFIP requirements.

We will not print and distribute this LOMR to primary users, such as local insurance agents or mortgage lenders; instead, the community will serve as a repository for the new data. We encourage you to disseminate the information in this LOMR by preparing a news release for publication in your community's newspaper that describes the revision and explains how your community will provide the data and help interpret the NFIP maps. In that way, interested persons, such as property owners, insurance agents, and mortgage lenders, can benefit from the information.

This determination is based on the flood data presently available. The enclosed documents provide additional information regarding this determination. If you have any questions about this document, please contact the FEMA Map Assistance Center toll free at 1-877-336-2677 (1-877-FEMA MAP) or by letter addressed to the LOMR Depot, 3601 Eisenhower Avenue, Alexandria, VA 22304. Additional information about the NFIP is available on our website at <http://www.fema.gov/nfip>.

Doug Bellomo, P.E., CFM, Acting Chief
Hazard Identification Section
Mitigation Division
Emergency Preparedness and Response Directorate

102061 D.A04080012 1021C

**Federal Emergency Management Agency**

Washington, D.C. 20472

**LETTER OF MAP REVISION
DETERMINATION DOCUMENT (CONTINUED)****COMMUNITY INFORMATION (CONTINUED)**

We have designated a Consultation Coordination Officer (CCO) to assist your community. The CCO will be the primary liaison between your community and FEMA. For information regarding your CCO, please contact:

Mr. Steve L. Olsen
Director, Federal Insurance and Mitigation Division
Federal Emergency Management Agency, Region VIII
Denver Federal Center, Building 710
P.O. Box 25267
Denver, CO 80225-0267
(303) 235-4830

STATUS OF THE COMMUNITY NFIP MAPS

We will not physically revise and republish the FIRM and FIS report for your community to reflect the modifications made by this LOMR at this time. When changes to the previously cited FIRM panel and FIS report warrant physical revision and republication in the future, we will incorporate the modifications made by this LOMR at that time.

This determination is based on the flood data presently available. The enclosed documents provide additional information regarding this determination. If you have any questions about this document, please contact the FEMA Map Assistance Center toll free at 1-877-336-2677 (1-877-FEMA MAP) or by letter addressed to the LOMR Depot, 3601 Eisenhower Avenue, Alexandria, VA 22304. Additional information about the NFIP is available on our website at <http://www.fema.gov/nfip>.

Doug Bellomo, P.E., CFM, Acting Chief
Hazard Identification Section
Mitigation Division
Emergency Preparedness and Response Directorate

102061 D.A04080012 1021C



Federal Emergency Management Agency

Washington, D.C. 20472

LETTER OF MAP REVISION DETERMINATION DOCUMENT (CONTINUED)

PUBLIC NOTIFICATION OF REVISION

This revision will become effective 30 days from the date of this letter. Any requests to review or alter this determination should be made within 30 days and must be based on scientific or technical data.

This determination is based on the flood data presently available. The enclosed documents provide additional information regarding this determination. If you have any questions about this document, please contact the FEMA Map Assistance Center toll free at 1-877-338-2677 (1-877-FEMA MAP) or by letter addressed to the LOMR Depot, 3601 Eisenhower Avenue, Alexandria, VA 22304. Additional information about the NFIP is available on our website at <http://www.fema.gov/nfip>.

A handwritten signature in black ink, appearing to read "Doug Bellomo".

Doug Bellomo, P.E., CFM, Acting Chief
Hazard Identification Section
Mitigation Division

Emergency Preparedness and Response Directorate 102061 D.A04080012 102IC

HYDROLOGIC CALCULATIONS

EXISTING CONDITIONS

JOB NAME: WATERBURY MDDP
 JOB NUMBER: 1715.00
 DATE: 2/6/23
 CALCULATED BY: QNA

DRAINAGE REPORT ~ EXISTING BASIN RUNOFF COEFFICIENT SUMMARY

BASIN	TOTAL AREA (AC)	IMPERVIOUS / DEVELOPED AREA			NONIMPERVIOUS / UNDEVELOPED AREA			WEIGHTED		WEIGHTED CA	
		AREA (AC)	C(5)	C(100)	AREA (AC)	C(5)	C(100)	C(5)	C(100)	CA(5)	CA(100)
EXA	9.62	0.00	0.45	0.59	9.62	0.09	0.36	0.09	0.36	0.87	3.46
EXB	4.09	0.00	0.45	0.59	4.09	0.09	0.36	0.09	0.36	0.37	1.47
EXC	24.80	0.00	0.45	0.59	24.80	0.09	0.36	0.09	0.36	2.23	8.93
EXD	15.87	0.00	0.45	0.59	15.87	0.09	0.36	0.09	0.36	1.43	5.71
EXE	5.83	0.00	0.45	0.59	5.83	0.09	0.36	0.09	0.36	0.52	2.10
EXF	1.62	0.00	0.45	0.59	1.62	0.09	0.36	0.09	0.36	0.15	0.58
OS-1	45.02	0.00	0.45	0.59	45.02	0.09	0.36	0.09	0.36	4.05	16.21
OS-2	11.40	0.00	0.45	0.59	11.40	0.09	0.36	0.09	0.36	1.03	4.11
OS-3	1.11	0.00	0.45	0.59	1.11	0.09	0.36	0.09	0.36	0.10	0.40
OS-4	0.29	0.00	0.45	0.59	0.29	0.09	0.36	0.09	0.36	0.03	0.11
OS-5	6.74	0.00	0.45	0.59	6.74	0.09	0.36	0.09	0.36	0.61	2.43
OS-8	2.56	FLOW TAKEN FROM MERIDAIN RANCH MDDP									
OS-9	11.80	FLOW TAKEN FROM MERIDAIN RANCH MDDP									
OS-10A	12.80	FLOW TAKEN FROM MERIDAIN RANCH MDDP									

JOB NAME: WATERBURY MDDP
 JOB NUMBER: 1715.00
 DATE: 2/6/23
 CALC'D BY: QNA

EXISTING BASIN RUNOFF SUMMARY

BASIN	WEIGHTED		OVERLAND				STREET / CHANNEL FLOW				Tc	INTENSITY		TOTAL FLOWS	
	CA(5)	CA(100)	C(5)	Length (ft)	Height (ft)	Tc (min)	Length (ft)	Slope (%)	Velocity (fps)	Tc (min)	TOTAL (min)	I(5) (in/hr)	I(100) (in/hr)	Q(5) (cfs)	Q(100) (cfs)
EXA	0.87	3.46	0.25	100	3	11.1	1193	1.7%	4.5	4.4	15.4	3.43	5.81	3	20
EXB	0.37	1.47	0.25	100	2	12.6	623	2.2%	5.2	2.0	14.6	3.51	5.96	1	9
EXC	2.23	8.93	0.25	100	2.5	11.7	2420	1.7%	4.6	8.9	20.6	3.01	5.01	7	45
EXD	1.43	5.71	0.25	100	2	12.6	1615	2.6%	5.6	4.8	17.4	3.25	5.47	5	31
EXE	0.52	2.10	0.25	100	8	8.0	1063	2.1%	5.0	3.5	11.5	3.86	6.66	2	14
EXF	0.15	0.58	0.25	100	6	8.8	400	2.5%	5.5	1.2	10.0	4.06	7.07	1	4
OS-1	4.05	16.21	0.25	100	6	8.8	3219	2.3%	5.3	10.1	18.9	3.13	5.24	13	85
OS-2	1.03	4.11	0.25	100	2	12.6	1203	1.0%	3.5	5.7	18.4	3.17	5.32	3	22
OS-3	0.10	0.40	0.25	100	2	12.6	330	2.6%	5.6	1.0	13.6	3.61	6.17	0	2
OS-4	0.03	0.11	0.25	100	2	12.6	230	2.6%	5.7	0.7	13.3	3.64	6.23	0	1
OS-5	0.61	2.43	0.25	80	5	7.8	1000	2.5%	5.5	3.0	10.8	3.96	6.85	2	17
OS-8	FLOW TAKEN FROM MERIDAIN RANCH MDDP													5	11
OS-9	FLOW TAKEN FROM MERIDAIN RANCH MDDP													8	19

JOB NAME: WATERBURY MDDP
 JOB NUMBER: 1715.00
 DATE: 2/6/23
 CALCULATED BY: QNA

EXISTING SURFACE ROUTING SUMMARY

Design Point(s)	Contributing Basins	Area (AC)	Equivalent CA(5)	Equivalent CA(100)	Maximum Tc	Intensity		Flow		Facility Size
						I(5)	I(100)	Q(5)	Q(100)	
EX1	EXA, OS-5, & DP-EX10A	18.92	1.47	5.89	15.4	3.43	5.81	33	219	3-42" CULVERTS
EX2	EXB	4.09	0.37	1.47	14.6	3.51	5.96	1	9	STAPLETON ROAD
EX3	EXC & OS-4	25.10	2.26	9.03	20.6	3.01	5.01	7	45	EAST BOUNDARY
EX4	EXD & OS-3	16.98	1.53	6.11	17.4	3.25	5.47	5	33	EAST BOUNDARY
EX5	EXE, OS-2 & OS-8	17.23	1.55	6.20	18.4	3.17	5.32	10	44	EAST BOUNDARY
EX6	EXF	1.62	0.15	0.58	13.8	3.59	6.12	1	4	EAST BOUNDARY
EX7A	OS-1 & OS-9	56.82	4.05	16.21	18.9	3.13	5.24	21	104	POINT ALONG CHANNEL
EX7	EXE, EXF, OS-1, OS-2, OS-8 & OS-9	78.24	5.75	23.00	18.9	3.13	5.24	31	151	DP 30 PROP CONDITION
EX9	OS-9	11.80						8	19	EX 36" RCP Culvert
EX10	OS-8	2.56						5	11	EX 36" RCP Culvert
EX10A	MERIDIAN POND E RELEASE	Meridaian Ranch Filing 3 FDR Calculated Flows						28	185	EX 3-42" RCP Culverts
13	TOTAL OFFSITE EX. STOCK POND INFLOW	Per "Final Drainage Report for Waterbury Filing No. 1" dated September 2016, by Classic Consulting						69	396	EX STOCK POND

PROPOSED CONDITION

JOB NAME: WATERBURY FDR
 JOB NUMBER: 1715.00
 DATE: 02/06/23
 CALCULATED BY: QNA

FINAL DRAINAGE REPORT ~ BASIN RUNOFF COEFFICIENT SUMMARY

BASIN	TOTAL AREA (AC)	IMPERVIOUS / DEVELOPED AREA			NONIMPERVIOUS / UNDEVELOPED AREA			WEIGHTED		WEIGHTED CA	
		AREA (AC)	C(5)	C(100)	AREA (AC)	C(5)	C(100)	C(5)	C(100)	CA(5)	CA(100)
A	3.39	3.39	0.45	0.59	0.00	0.09	0.36	0.45	0.59	1.52	2.00
B1	2.30	2.30	0.45	0.59	0.00	0.09	0.36	0.45	0.59	1.03	1.36
B2	3.58	3.58	0.45	0.59	0.00	0.09	0.36	0.45	0.59	1.61	2.11
C	0.86	0.86	0.45	0.59	0.00	0.09	0.36	0.45	0.59	0.39	0.51
D	2.11	2.11	0.45	0.59	0.00	0.09	0.36	0.45	0.59	0.95	1.24
E	2.18	2.18	0.45	0.59	0.00	0.09	0.36	0.45	0.59	0.98	1.29
F	2.18	2.18	0.45	0.59	0.00	0.09	0.36	0.45	0.59	0.98	1.29
G1	0.39	0.39	0.45	0.59	0.00	0.09	0.36	0.45	0.59	0.17	0.23
G2	0.60	0.60	0.45	0.59	0.00	0.09	0.36	0.45	0.59	0.27	0.35
H	1.46	1.46	0.45	0.59	0.00	0.09	0.36	0.45	0.59	0.66	0.86
I	4.97	1.45	0.45	0.59	3.53	0.09	0.36	0.19	0.43	0.97	2.12
J	1.44	1.44	0.45	0.59	0.00	0.09	0.36	0.45	0.59	0.65	0.85
K	3.06	1.14	0.45	0.59	1.92	0.09	0.36	0.22	0.45	0.69	1.37
L1	3.79	3.79	0.45	0.59	0.00	0.09	0.36	0.45	0.59	1.71	2.24
L2	2.00	2.00	0.45	0.59	0.00	0.09	0.36	0.45	0.59	0.90	1.18
M1	1.05	1.05	0.45	0.59	0.00	0.09	0.36	0.45	0.59	0.47	0.62
M2	0.35	0.35	0.45	0.59	0.00	0.09	0.36	0.45	0.59	0.16	0.21
M3	0.20	0.20	0.45	0.59	0.00	0.09	0.36	0.45	0.59	0.09	0.12
N	0.22	0.22	0.45	0.59	0.00	0.09	0.36	0.45	0.59	0.10	0.13
O1	2.82	2.82	0.45	0.59	0.00	0.09	0.36	0.45	0.59	1.27	1.66
O2	0.71	0.71	0.45	0.59	0.00	0.09	0.36	0.45	0.59	0.32	0.42

JOB NAME: WATERBURY FDR
 JOB NUMBER: 1715.00
 DATE: 02/06/23
 CALCULATED BY: QNA

FINAL DRAINAGE REPORT ~ BASIN RUNOFF COEFFICIENT SUMMARY

BASIN	TOTAL AREA (AC)	IMPERVIOUS / DEVELOPED AREA			NONIMPERVIOUS / UNDEVELOPED AREA			WEIGHTED		WEIGHTED CA	
		AREA (AC)	C(5)	C(100)	AREA (AC)	C(5)	C(100)	C(5)	C(100)	CA(5)	CA(100)
O3	0.45	0.45	0.45	0.59	0.00	0.09	0.36	0.45	0.59	0.20	0.27
O4	0.38	0.38	0.45	0.59	0.00	0.09	0.36	0.45	0.59	0.17	0.23
P	0.70	0.00	0.45	0.59	0.70	0.09	0.36	0.09	0.36	0.06	0.25
Q1	1.48	1.48	0.45	0.59	0.00	0.09	0.36	0.45	0.59	0.66	0.87
Q2	0.96	0.96	0.45	0.59	0.00	0.09	0.36	0.45	0.59	0.43	0.56
R	1.02	1.02	0.45	0.59	0.00	0.09	0.36	0.45	0.59	0.46	0.60
S1	1.55	1.55	0.45	0.59	0.00	0.09	0.36	0.45	0.59	0.70	0.91
S2	0.13	0.13	0.45	0.59	0.00	0.09	0.36	0.45	0.59	0.06	0.08
T1	1.42	1.42	0.45	0.59	0.00	0.09	0.36	0.45	0.59	0.64	0.84
T2	1.23	1.23	0.45	0.59	0.00	0.09	0.36	0.45	0.59	0.55	0.73
U1	4.38	4.38	0.45	0.59	0.00	0.09	0.36	0.45	0.59	1.97	2.58
U2	1.89	1.89	0.45	0.59	0.00	0.09	0.36	0.45	0.59	0.85	1.11
V	0.54	0.54	0.45	0.59	0.00	0.09	0.36	0.45	0.59	0.24	0.32
W	5.20	5.20	0.45	0.59	0.00	0.09	0.36	0.45	0.59	2.34	3.07
X	0.43	0.43	0.45	0.59	0.00	0.09	0.36	0.45	0.59	0.19	0.25
Y	0.35	0.35	0.45	0.59	0.00	0.09	0.36	0.45	0.59	0.16	0.21
OS-1	41.09	0.00	0.45	0.59	41.09	0.09	0.36	0.09	0.36	3.70	14.79
OS-2	12.02	0.00	0.45	0.59	12.02	0.09	0.36	0.09	0.36	1.08	4.33
OS-4	10.90	0.00	0.45	0.59	10.90	0.09	0.36	0.09	0.36	0.98	3.92
OS-5	5.64	0.00	0.45	0.59	5.64	0.09	0.36	0.09	0.36	0.51	2.03
OS-6	1.06	1.06	0.45	0.59	0.00	0.09	0.36	0.45	0.59	0.48	0.63
OS-7	2.82	0.00	0.45	0.59	2.82	0.09	0.36	0.09	0.36	0.25	1.01
OS-8	2.56	FLOW TAKEN FROM MERIDAIN RANCH MDDP									
OS-9	11.80	FLOW TAKEN FROM MERIDAIN RANCH MDDP									
OS-Q1	0.33	0.00	0.45	0.59	0.33	0.09	0.36	0.09	0.36	0.03	0.12
OS-Q2	0.22	0.00	0.45	0.59	0.22	0.09	0.36	0.09	0.36	0.02	0.08
OS-R	1.04	0.00	0.45	0.59	1.04	0.09	0.36	0.09	0.36	0.09	0.38
OS-S1	0.31	0.00	0.45	0.59	0.31	0.09	0.36	0.09	0.36	0.03	0.11
OS-S2	0.13	0.00	0.45	0.59	0.13	0.09	0.36	0.09	0.36	0.01	0.05
OS-T2	0.30	0.00	0.45	0.59	0.30	0.09	0.36	0.09	0.36	0.03	0.11

JOB NAME: WATERBURY FDR
 JOB NUMBER: 1715.00
 DATE: 02/06/23
 CALC'D BY: QNA

FINAL DRAINAGE REPORT ~ BASIN RUNOFF SUMMARY

BASIN	WEIGHTED		OVERLAND				STREET / CHANNEL FLOW				Tc	INTENSITY		TOTAL FLOWS	
	CA(5)	CA(100)	C(5)	Length (ft)	Height (ft)	Tc (min)	Length (ft)	Slope (%)	Velocity (fps)	Tc (min)	TOTAL (min)	I(5) (in/hr)	I(100) (in/hr)	Q(5) (cfs)	Q(100) (cfs)
A	1.52	2.00	0.25	100	2	12.6	420	1.5%	4.3	1.6	14.3	3.54	6.03	5	12
B1	1.03	1.36	0.25	100	2	12.6	400	1.5%	4.3	1.6	14.2	3.55	6.05	4	8
B2	1.61	2.11	0.25	100	2	12.6	550	1.5%	4.3	2.1	14.8	3.49	5.93	6	13
C	0.39	0.51	0.25	20	0.5	5.3	500	2.0%	4.9	1.7	6.9	4.58	8.14	2	4
D	0.95	1.24	0.25	80	2	10.5	300	2.5%	5.5	0.9	11.4	3.87	6.69	4	8
E	0.98	1.29	0.25	100	2	12.6	400	2.5%	5.5	1.2	13.8	3.59	6.12	4	8
F	0.98	1.29	0.25	50	2	7.1	620	1.5%	4.3	2.4	9.5	4.14	7.22	4	9
G1	0.17	0.23	0.25								5.0	5.00	9.06	1	2
G2	0.27	0.35	0.25								5.0	5.00	9.06	1	3
H	0.66	0.86	0.25	50	2	7.1	525	1.5%	4.3	2.0	9.2	4.19	7.33	3	6
I	0.97	2.12	0.25	80	4	8.4	250	2.0%	4.9	0.8	9.2	4.18	7.32	4	16
J	0.65	0.85	0.25	90	6	8.1	850	2.0%	4.9	2.9	10.9	3.94	6.81	3	6
K	0.69	1.37	0.25	100	18	6.1	80	1.0%	3.5	0.4	6.5	4.67	8.33	3	11
L1	1.71	2.24	0.25	100	2	12.6	860	1.4%	4.1	3.5	16.1	3.36	5.69	6	13
L2	0.90	1.18	0.25	55	1.1	9.4	860	1.4%	4.1	3.5	12.8	3.70	6.34	3	7
M1	0.47	0.62	0.25	70	1.5	10.3	200	2.0%	4.9	0.7	11.0	3.92	6.79	2	4
M2	0.16	0.21	0.25	65	3	7.7	0	0.0%	0.0	0.0	7.7	4.43	7.83	1	2
M3	0.09	0.12	0.25								5.0	5.00	9.06	0	1
N	0.10	0.13	0.25								5.0	5.00	9.06	1	1
O1	1.27	1.66	0.25	100	2.5	11.7	460	1.5%	4.3	1.8	13.5	3.62	6.19	5	10
O2	0.32	0.42	0.25	100	2	12.6	850	2.0%	4.9	2.9	15.5	3.42	5.80	1	2
O3	0.20	0.27	0.25								5.0	5.00	9.06	1	2
O4	0.17	0.23	0.25								5.0	5.00	9.06	1	2
P	0.06	0.25	0.25								5.0	5.00	9.06	0	2

JOB NAME: WATERBURY FDR
 JOB NUMBER: 1715.00
 DATE: 02/06/23
 CALC'D BY: QNA

FINAL DRAINAGE REPORT ~ BASIN RUNOFF SUMMARY

BASIN	WEIGHTED		OVERLAND				STREET / CHANNEL FLOW				Tc	INTENSITY		TOTAL FLOWS	
	CA(5)	CA(100)	C(5)	Length (ft)	Height (ft)	Tc (min)	Length (ft)	Slope (%)	Velocity (fps)	Tc (min)	TOTAL (min)	I(5) (in/hr)	I(100) (in/hr)	Q(5) (cfs)	Q(100) (cfs)
Q1	0.66	0.87	0.25	55	1.3	8.9	445	2.0%	5.0	1.5	10.4	4.01	6.97	3	6
Q2	0.43	0.56	0.25	55	1.3	8.9	445	2.0%	5.0	1.5	10.4	4.01	6.97	2	4
R	0.46	0.60	0.25	100	4	10.1	700	2.0%	4.9	2.4	12.4	3.75	6.44	2	4
S1	0.70	0.91	0.25	100	6	8.8	175	2.0%	4.9	0.6	9.4	4.16	7.26	3	7
S2	0.06	0.08	0.25								5.0	5.00	9.06	0	1
T1	0.64	0.84	0.25	55	1.1	9.4	390	2.0%	4.9	1.3	10.7	3.97	6.88	3	6
T2	0.55	0.73	0.25	100	2	12.6	245	2.0%	5.0	0.8	13.5	3.63	6.20	2	5
U1	1.97	2.58	0.25	100	2	12.6	520	2.3%	5.3	1.6	14.3	3.54	6.03	7	16
U2	0.85	1.11	0.25	100	2	12.6	385	2.3%	5.4	1.2	13.8	3.59	6.12	3	7
V	0.24	0.32	0.25								5.0	5.00	9.06	1	3
W	2.34	3.07	0.25	100	2	12.6	630	1.6%	4.4	2.4	15.0	3.47	5.89	8	18
X	0.19	0.25	0.25								5.0	5.00	9.06	1	2
Y	0.16	0.21	0.25								5.0	5.00	9.06	1	2
OS-1	3.70	14.79	0.25	100	2	12.6	2700	2.3%	5.3	8.5	21.1	2.97	4.94	11	73
OS-2	1.08	4.33	0.25	100	2	12.6	1203	1.0%	3.5	5.7	18.4	3.17	5.32	3	23
OS-4	0.98	3.92	0.25	800	26	30.5					30.5	2.46	4.01	2	16
OS-5	0.51	2.03	0.25	80	5	7.8					7.8	4.42	7.82	2	16
OS-6	0.48	0.63	0.25	30	0.6	6.9	900	1.8%	4.7	3.2	10.1	4.05	7.04	2	4
OS-7	0.25	1.01	0.25								5.0	5.00	9.06	1	9
OS-8	FLOW TAKEN FROM MERIDAIN RANCH MDDP													5	11
OS-9	FLOW TAKEN FROM MERIDAIN RANCH MDDP													8	19
OS-Q1	0.03	0.12	0.25	100	2	12.6	135	1.5%	4.3	0.5	13.2	3.66	6.27	0	1
OS-Q2	0.02	0.08	0.25	50	1	8.9	135	1.5%	4.3	0.5	9.5	4.14	7.24	0	1
OS-R	0.09	0.38	0.25	100	2	12.6	50	2.7%	5.8	0.1	12.8	3.70	6.35	0	2
OS-S1	0.03	0.11	0.25								5.0	5.00	9.06	0	1
OS-S2	0.01	0.05	0.25								5.0	5.00	9.06	0	0
OS-T2	0.03	0.11	0.25								5.0	5.00	9.06	0	1

JOB NAME: WATERBURY FDR
 JOB NUMBER: 1715.00
 DATE: 02/06/23
 CALCULATED BY: QNA

FINAL DRAINAGE REPORT ~ SURFACE ROUTING SUMMARY

Design Point(s)	Contributing Basins	Area (AC)	Equivalent CA(5)	Equivalent CA(100)	Maximum Tc	Intensity		Flow		Facility Size
						I(5)	I(100)	Q(5)	Q(100)	
1	A	3.39	1.52	2.00	14.3	3.54	6.03	5	12	10' Type R Sump Inlet
2	C	0.86	0.39	0.51	6.9	4.58	8.14	2	4	5' Type R Sump Inlet
3	B1	2.30	1.03	1.36	14.2	3.55	6.05	4	8	5' Type R Sump Inlet
4	B2	3.58	1.61	2.11	14.8	3.49	5.93	6	13	10' Type R Sump Inlet
5	F & H	3.65	1.64	2.15	9.5	4.14	7.22	7	16	10' Type R Sump Inlet
6	D	2.11	0.95	1.24	11.4	3.87	6.69	4	8	5' Type R Sump Inlets
7	E	2.18	0.98	1.29	13.8	3.59	6.12	4	8	5' Type R Sump Inlets
7A	G1	0.39	0.17	0.23	5.0	5.00	9.06	1	2	5' Type R At-grade Inlet
7B	G2	0.60	0.27	0.35	5.0	5.00	9.06	1	3	5' Type R At-grade Inlet
8	DESIGN POINTS 1-7 & K	22.11	8.13	10.66	14.8	3.49	5.93	28	63	FSD Pond 1
9	OS-9	11.80						8	19	EX 36" RCP Culvert
10	OS-8	2.56						5	11	EX 36" RCP Culvert
10A	MERIDIAN POND E RELEASE	Meridaian Ranch Filing 3 FDR Calculated Flows						28	185	EX 3-42" RCP Culverts
11	OS-5, I, OS-& MERIDIAN POND E RELEASE	Sum of Basins						34	216	PR 2-42" RCP Culverts
11A	DP 11 & BASIN J	Sum of Basins						37	222	PR 2-42" RCP Culverts
12	OS-6	1.06	0.48	0.63	10.1	4.05	7.04	2	4	18" RCP Culvert
13	TOTAL OFFSITE EX. STOCK POND INFLOW	Per "Final Drainage Report for Waterbury Filing No. 1" dated September 2016, by Classic Consulting						69	396	EX STOCK POND

JOB NAME: WATERBURY FDR
 JOB NUMBER: 1715.00
 DATE: 02/06/23
 CALCULATED BY: QNA

FINAL DRAINAGE REPORT ~ SURFACE ROUTING SUMMARY

Design Point(s)	Contributing Basins	Area (AC)	Equivalent CA(5)	Equivalent CA(100)	Maximum Tc	Intensity		Flow		Facility Size
						I(5)	I(100)	Q(5)	Q(100)	
14	L1	3.79	1.71	2.24	16.1	3.36	5.69	6	13	10' Type R Sump Inlet
15	L2	2.00	0.90	1.18	16.1	3.36	5.69	3	7	5' Type R Sump Inlet
16	O1	2.82	1.27	1.66	13.5	3.62	6.19	5	10	10' Type R Sump Inlet
17	O2	0.71	0.32	0.42	15.5	3.42	5.80	1	2	5' Type R Sump Inlet
18	DESIGN POINTS 14-17 & BASIN OS-4	20.23	5.18	5.50	16.1	3.36	5.69	17	31	Interim FSD Pond 2
19	Q1 & OS-Q1	1.81	0.69	0.99	13.2	3.66	6.27	3	6	10' Type R Sump Inlet
20	Q2 & OS-Q2	1.18	0.45	0.65	9.5	4.14	7.24	2	5	5' Type R Sump Inlet
21	R & OS-R	2.06	0.55	0.98	12.4	3.75	6.44	2	6	10' Type R At-grade Inlet
22	S1 & OS-S1	1.86	0.72	1.02	12.4	3.75	6.44	3	7	10' Type R Sump Inlet
23	S2 & OS-S2	0.27	0.07	0.13	5.0	5.00	9.06	0	1	10' Type R Sump Inlet
24	T1	1.42	0.64	0.84	10.7	3.97	6.88	3	6	5' Type R Sump Inlets
25	T2 & OS-T2	1.54	0.58	0.84	13.5	3.63	6.20	2	5	5' Type R Sump Inlets
26	U1	4.38	1.97	2.58	14.3	3.54	6.03	7	16	10' Type R Sump Inlets
27	U2	1.89	0.85	1.11	13.8	3.59	6.12	3	7	5' Type R Sump Inlets
28	W	5.20	2.34	3.07	15.0	3.47	5.89	8	18	2-10' Type R Sump Inlets
29	DESIGN POINTS 19-28 & OS-7	24.41	9.13	13.21	15.0	3.47	5.89	32	78	FSD POND 3
E-E	OS-2 & OS-8	14.58	2.66	6.20	18.4	3.17	5.32	8	33	DIVERSION SWALE E-E
30	Y, OS-1, OS-2, OS-8 & OS-9	67.82	9.32	20.34	21.1	2.97	4.94	36	120	Triple 36" RCP Culverts
31	V	0.54	0.24	0.32	5.0	5.00	9.06	1	3	18" DIA INLETS
32	X	0.43	0.19	0.25	5.0	5.00	9.06	1	2	18" DIA INLETS
33	O-3	0.45	0.20	0.27	5.0	5.00	9.06	1	2	18" DIA INLETS
34	O-4	0.38	0.17	0.23	5.0	5.00	9.06	1	2	18" DIA INLETS

JOB NAME: WATERBURY FDR
 JOB NUMBER: 1715.00
 DATE: 02/06/23
 CALCULATED BY: QNA

* PIPES ARE LISTED AT MAXIMUM SIZE REQUIRED TO ACCOMMODATE Q100 FLOWS AT MINIMUM GRADE.
 REFER TO INDIVIDUAL PIPE SHEETS FOR HYDRAULIC INFORMATION.

FINAL DRAINAGE REPORT ~ PIPE ROUTING SUMMARY

Pipe Run	Contributing Design Points/Basins	Equivalent CA(5)	Equivalent CA(100)	Maximum Tc	Intensity		Flow		Pipe Size
					I(5)	I(100)	Q(5)	Q(100)	
1	DP 2	0.39	0.51	6.9	4.58	8.14	2	4	18" RCP
2	DP 1 & 2	1.91	2.51	14.3	3.54	6.03	7	15	24" RCP
3	DP 3	1.03	1.36	14.2	3.55	6.05	4	8	18" RCP
4	DP-4	1.61	2.11	14.8	3.49	5.93	6	13	18" RCP
5	DP 3 & 4	2.64	3.47	14.8	3.49	5.93	9	21	24" RCP
6	DP 1-4	4.56	5.97	14.8	3.49	5.93	16	35	36" RCP
7	DP-1-5	6.20	8.12	14.8	3.49	5.93	22	48	36" RCP
8	DP-6	0.95	1.24	11.4	3.87	6.69	4	8	18" RCP
9	DP-7	0.98	1.29	13.8	3.59	6.12	4	8	18" RCP
10	DP-6 & 7	1.93	2.53	13.8	3.59	6.12	7	15	24" RCP
10A	DP-7A	0.17	0.23	5.0	5.00	9.06	1	2	15" RCP
23	DP-6, 7, 7A & 7B	2.37	3.11	13.8	3.59	6.12	9	19	24" RCP
10C	Pond 1 Release						0.4	14.5	18" RCP
11	DP-14	1.71	2.24	16.1	3.36	5.69	6	13	24" RCP

JOB NAME: WATERBURY FDR
 JOB NUMBER: 1715.00
 DATE: 02/06/23
 CALCULATED BY: QNA

* PIPES ARE LISTED AT MAXIMUM SIZE REQUIRED TO ACCOMMODATE Q100 FLOWS AT MINIMUM GRADE.
 REFER TO INDIVIDUAL PIPE SHEETS FOR HYDRAULIC INFORMATION.

FINAL DRAINAGE REPORT ~ PIPE ROUTING SUMMARY

Pipe Run	Contributing Design Points/Basins	Equivalent CA(5)	Equivalent CA(100)	Maximum Tc	Intensity		Flow		Pipe Size
					I(5)	I(100)	Q(5)	Q(100)	
12	DP-15	0.90	1.18	16.1	3.36	5.69	3	7	18" RCP
13	DP 14 & 15	2.61	3.42	16.1	3.36	5.69	9	19	30" RCP
14	DP 16	1.27	1.66	13.5	3.62	6.19	5	10	24" RCP
15	DP 14, 15 & 16	3.88	5.08	16.1	3.36	5.69	13	29	36" RCP
16	DP 17	0.32	0.42	15.5	3.42	5.80	1	2	18" RCP
17	DP 14, 15, 16, & 17	4.57	6.00	16.1	3.36	5.69	15	34	36" RCP
17A	Pond 2 Release						1.1	2.4	18" RCP
18	DP 19	0.69	0.99	13.2	3.66	6.27	3	6	24" RCP
19	DP 20	0.45	0.65	9.5	4.14	7.24	2	5	18" RCP
20	DP 19 & 20	1.15	1.64	13.2	3.66	6.27	4	10	24" RCP
21	DP 21 PICK UP						2	6	18" RCP
22	DP 19, 20 & 21	1.69	2.59	13.2	3.66	6.27	6	16	30" RCP
23	DP 22	0.72	1.02	12.4	3.75	6.44	3	7	24" RCP
24	DP 23	0.07	0.13	5.0	5.00	9.06	0	1	24" RCP

JOB NAME: WATERBURY FDR
 JOB NUMBER: 1715.00
 DATE: 02/06/23
 CALCULATED BY: QNA

* PIPES ARE LISTED AT MAXIMUM SIZE REQUIRED TO ACCOMMODATE Q100 FLOWS AT MINIMUM GRADE.
 REFER TO INDIVIDUAL PIPE SHEETS FOR HYDRAULIC INFORMATION.

FINAL DRAINAGE REPORT ~ PIPE ROUTING SUMMARY

Pipe Run	Contributing Design Points/Basins	Equivalent CA(5)	Equivalent CA(100)	Maximum Tc	Intensity		Flow		Pipe Size
					I(5)	I(100)	Q(5)	Q(100)	
25	DP 22 & 23	0.80	1.15	12.4	3.75	6.44	3	7	30" RCP
26	DP 19 -23	2.49	3.74	13.2	3.66	6.27	9	23	36" RCP
27	DP 24	0.64	0.84	10.7	3.97	6.88	3	6	18" RCP
28	DP 25	0.58	0.84	13.5	3.63	6.20	2	5	18" RCP
29	DP 19-25	3.71	5.42	13.5	3.63	6.20	13	34	36" RCP
30	DP 26	1.97	2.58	14.3	3.54	6.03	7	16	24" RCP
31	DP 19-26	5.68	8.00	14.3	3.54	6.03	20	48	42" RCP
32	DP 27	0.85	1.11	13.8	3.59	6.12	3	7	18" RCP
33	DP 19-27 & 31	6.77	9.43	14.3	3.54	6.03	24	57	42" RCP
34	DP 28 SPLIT FLOW	2.34	3.07	15.03	3.47	5.89	4	9	24" RCP
34A	28 & 32	2.53	3.32	15.0	3.47	5.89	9	20	24" RCP
35	Pond 3 Release	MHFD UD-DETENTION POND RELEASE					1	58	36" RCP
36	DP 30	SUM OF BASINS					36	120	TRIPLE 36" RCP
37	DP 31	0.24	0.32	5.00	5.00	9.06	1	3	15" HDPE
38	DP 32	0.19	0.25	5.00	5.00	9.06	1	2	15" HDPE
39	DP 33	0.20	0.27	5.00	5.00	9.06	1	2	15" HDPE
40	DP 34	0.17	0.23	5.00	5.00	9.06	1	2	15" HDPE

HYDRAULIC CALCULATIONS

MDDP
INLET CALCULATIONS

Figure 8-11. Inlet Capacity Chart Sump Conditions , Curb Opening (Type R) Inlet

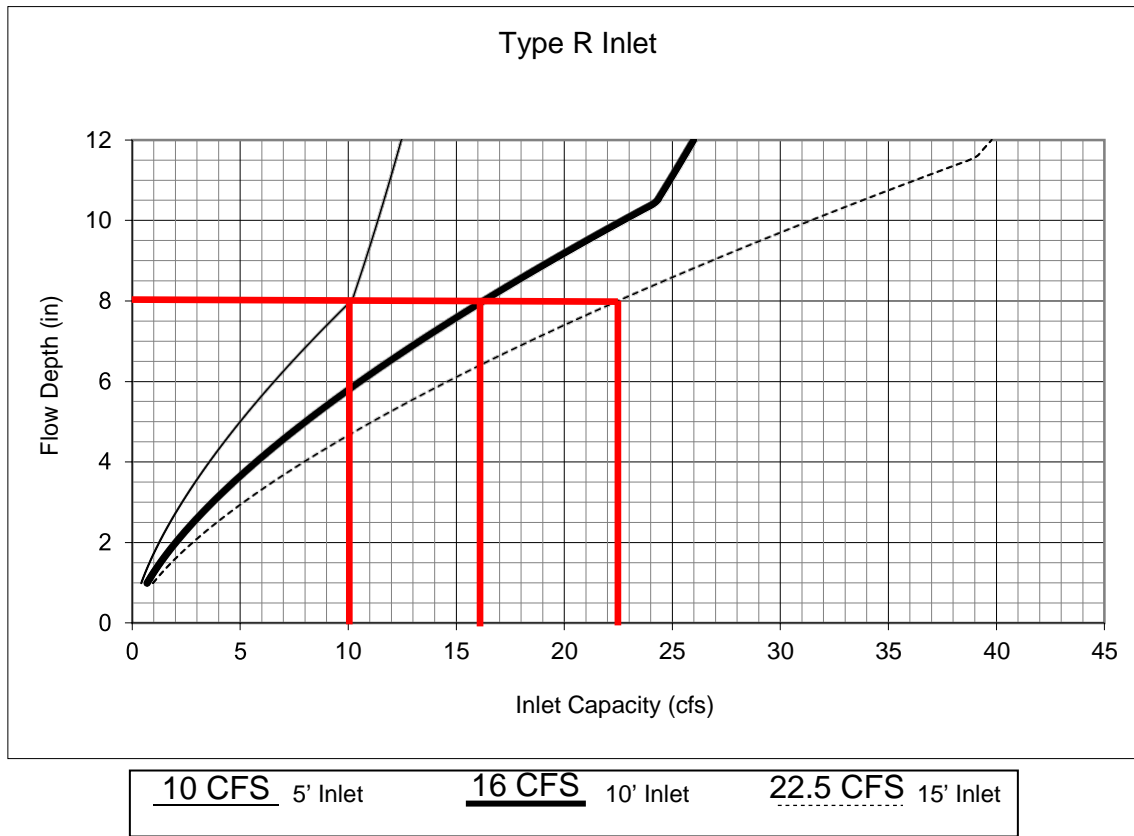

- DP1: Q100=12 CFS ---> 10' INLET
- DP2: Q100= 4 CFS ---> 5' INLET
- DP3: Q100= 8 CFS ---> 5' INLET
- DP4: Q100=13 CFS ---> 10' INLET
- DP5: Q100=16 CFS ---> 10' INLET
- DP6: Q100= 8 CFS ---> 5' INLET
- DP7: Q100= 8 CFS ---> 5' INLET
- DP14: Q100=13 CFS ---> 10' INLET
- DP15: Q100= 7 CFS ---> 5' INLET
- DP16: Q100= 10 CFS ---> 10' INLET
- DP17: Q100= 2 CFS ---> 10' INLET

- DP19: Q100=6 CFS ---> 10' INLET
- DP20: Q100=5 CFS ---> 5' INLET
- DP22: Q100=7 CFS ---> 5' INLET
- DP23: Q100=1 CFS ---> 10' INLET
- DP24: Q100=6 CFS ---> 10' INLET
- DP25: Q100=5 CFS ---> 5' INLET
- DP26: Q100=16 CFS ---> 10' INLET
- DP27: Q100=7 CFS ---> 10' INLET
- DP28: Q100=18/2 CFS --->2-10' INLETS

Notes:

1. The standard inlet parameters must apply to use this chart.

DP7A 5' At-Grade Inlet
 $Q_s = 1 \text{ cfs}$ $Q_{100} = 2 \text{ cfs}$
 Soapbrook slope = 4.45%

Figure 8-7. Inlet Capacity Chart Continuous Grade Conditions, Residential (Local)
 (Attached and Detached Sidewalk)

Street Section Data: Street Width Flowline to Flowline = 34'
 Type of Curb and Gutter: D-10-R = 8" vertical
 Type 16 = 6" vertical

Minor Storm

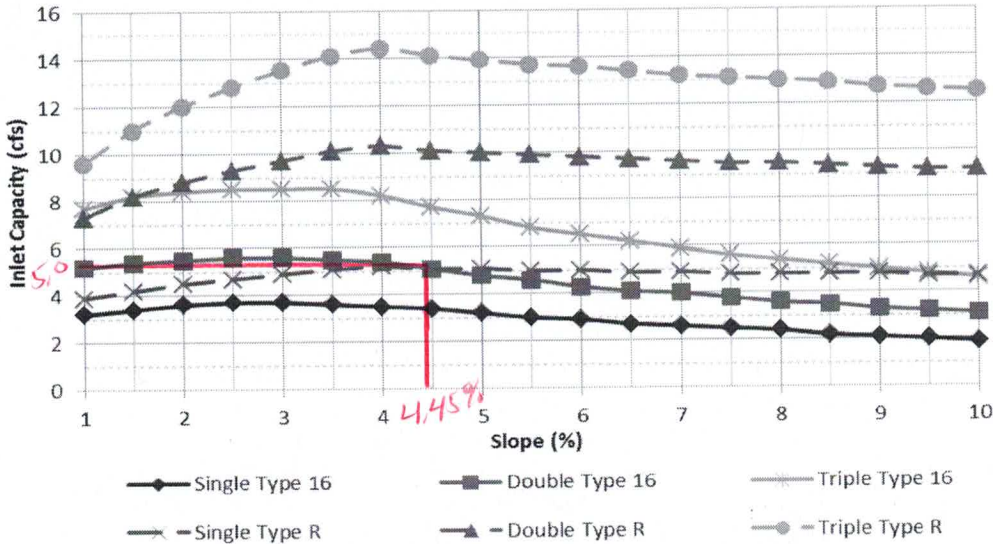

Major Storm

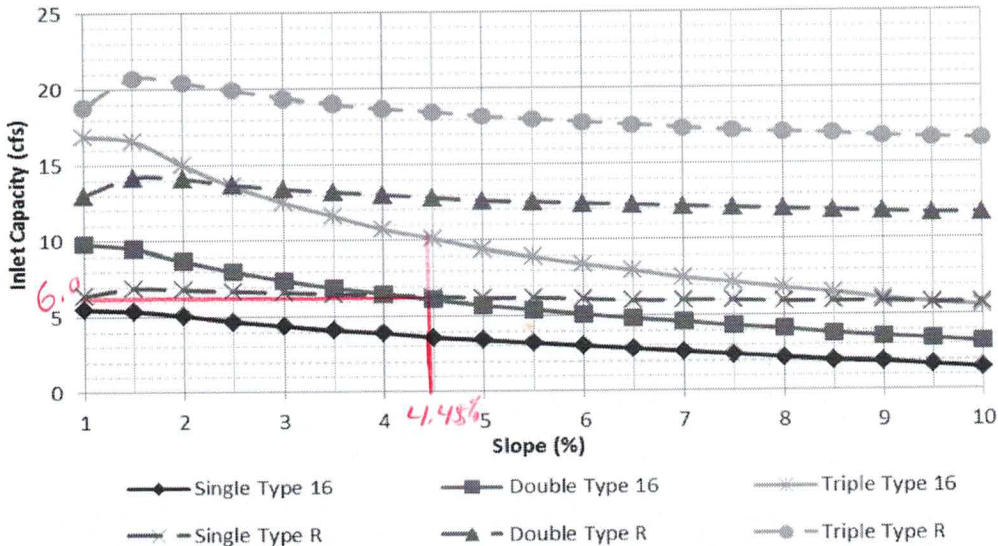

The standard street section parameters as defined in Chapter 7 must apply to use these charts. For non-standard sections, the inlet capacity shall be calculated using the UDFCD spreadsheets. The maximum spread width is limited by the curb height based on no curb overtopping during a minor storm and flow being contained within the public right-of-way during the major storm. Calculations were done using UD-Inlet 3.00.xls, Mar., 2011 with the default clogging factors.

*PP 7B 5' At-Grade Inlet
 Q₅ = 1 cfs Q₁₀₀ = 3 cfs
 Sag brook Slope = 4.45%*

Figure 8-7. Inlet Capacity Chart Continuous Grade Conditions, Residential (Local)
 (Attached and Detached Sidewalk)

Street Section Data: Street Width Flowline to Flowline = 34'
 Type of Curb and Gutter: D-10-R = 8" vertical
 Type 16 = 6" vertical

Minor Storm

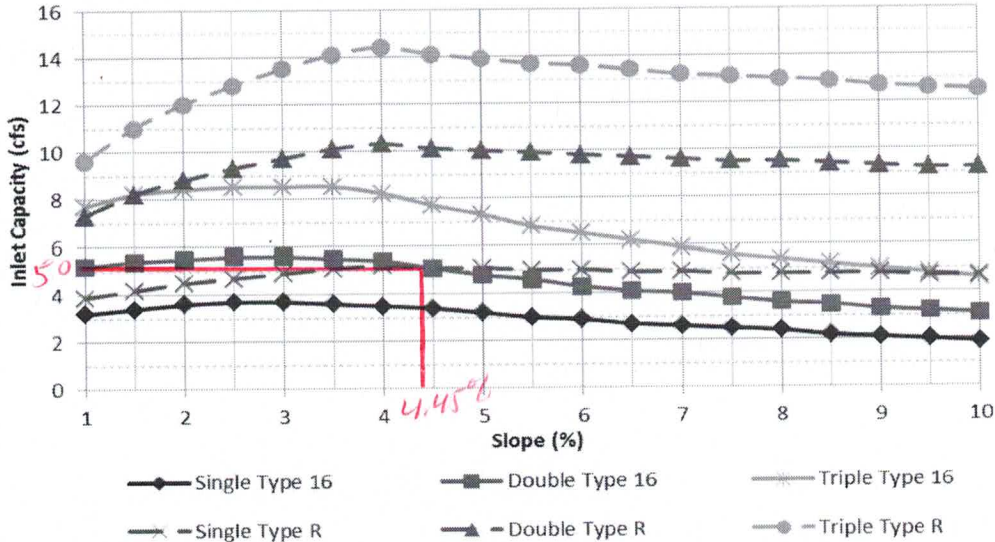

Major Storm

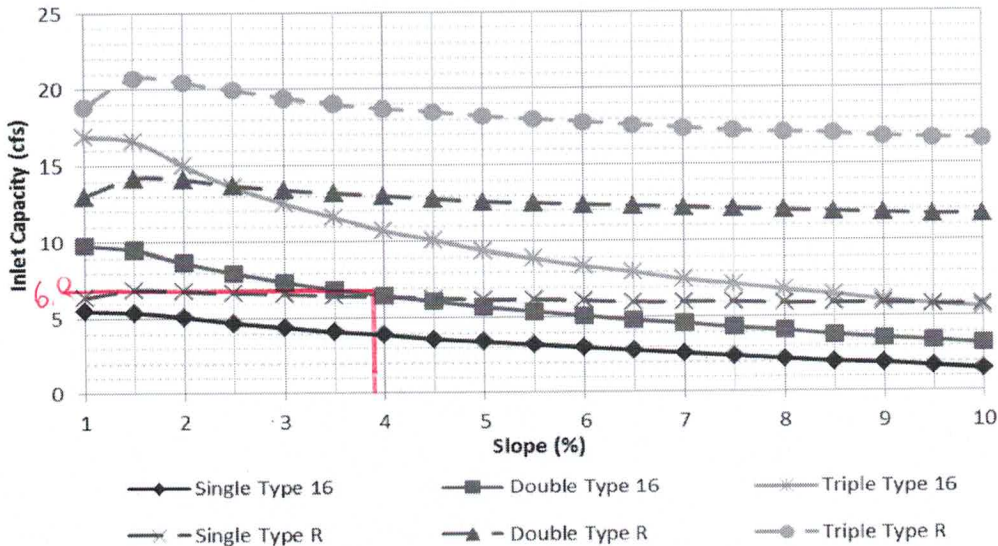

The standard street section parameters as defined in Chapter 7 must apply to use these charts. For non-standard sections, the inlet capacity shall be calculated using the UDFCD spreadsheets. The maximum spread width is limited by the curb height based on no curb overtopping during a minor storm and flow being contained within the public right-of-way during the major storm. Calculations were done using UD-Inlet 3.00.xls, Mar., 2011 with the default clogging factors.

*DP 21 10' Type R At-Grade
 Q₅ = 2 cfs Q₁₀₀ = 6 cfs
 Muddy Pond Slope = 1.75%*

Figure 8-7. Inlet Capacity Chart Continuous Grade Conditions, Residential (Local)
 (Attached and Detached Sidewalk)

Street Section Data: Street Width Flowline to Flowline = 34'
 Type of Curb and Gutter: D-10-R = 8" vertical
 Type 16 = 6" vertical

Minor Storm

*8 cfs > 2 cfs
 ok
 Fully Captured*

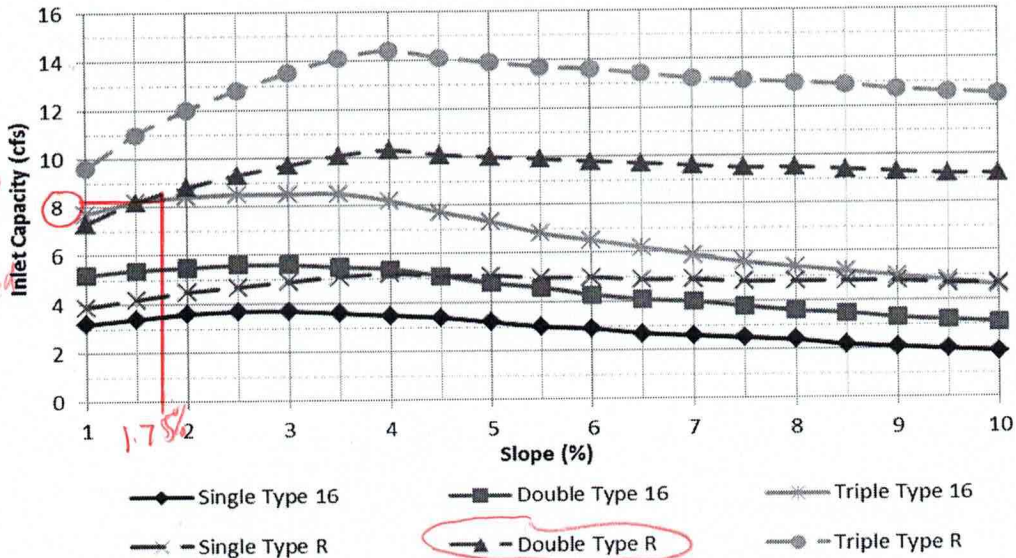

Major Storm

*14 cfs > 6 cfs
 ok
 Fully Captured*

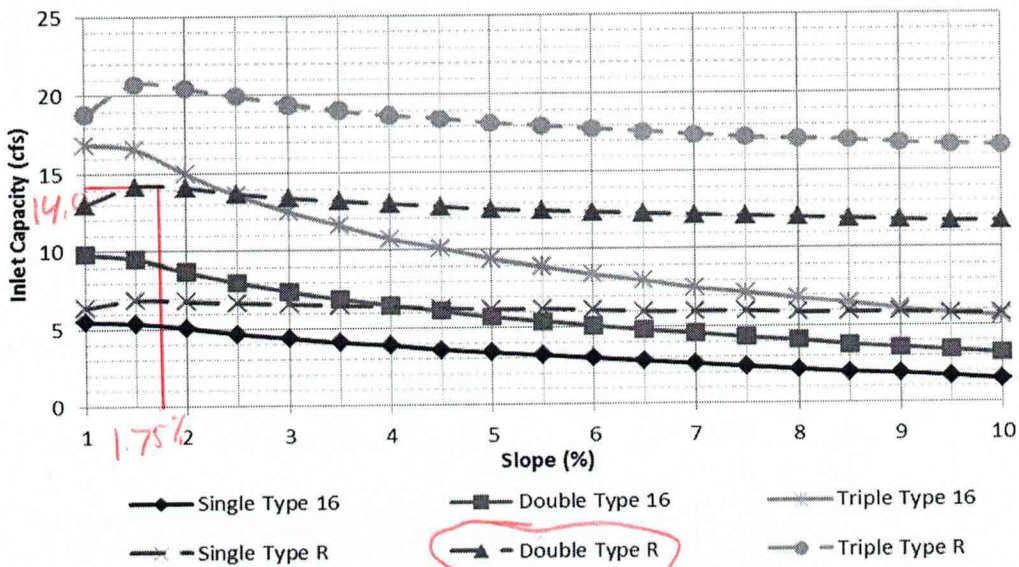

The standard street section parameters as defined in Chapter 7 must apply to use these charts. For non-standard sections, the inlet capacity shall be calculated using the UDFCD spreadsheets. The maximum spread width is limited by the curb height based on no curb overtopping during a minor storm and flow being contained within the public right-of-way during the major storm. Calculations were done using UD-Inlet 3.00.xls, Mar., 2011 with the default clogging factors.

Nyloplast 18" Drop In Grate Inlet Capacity Chart

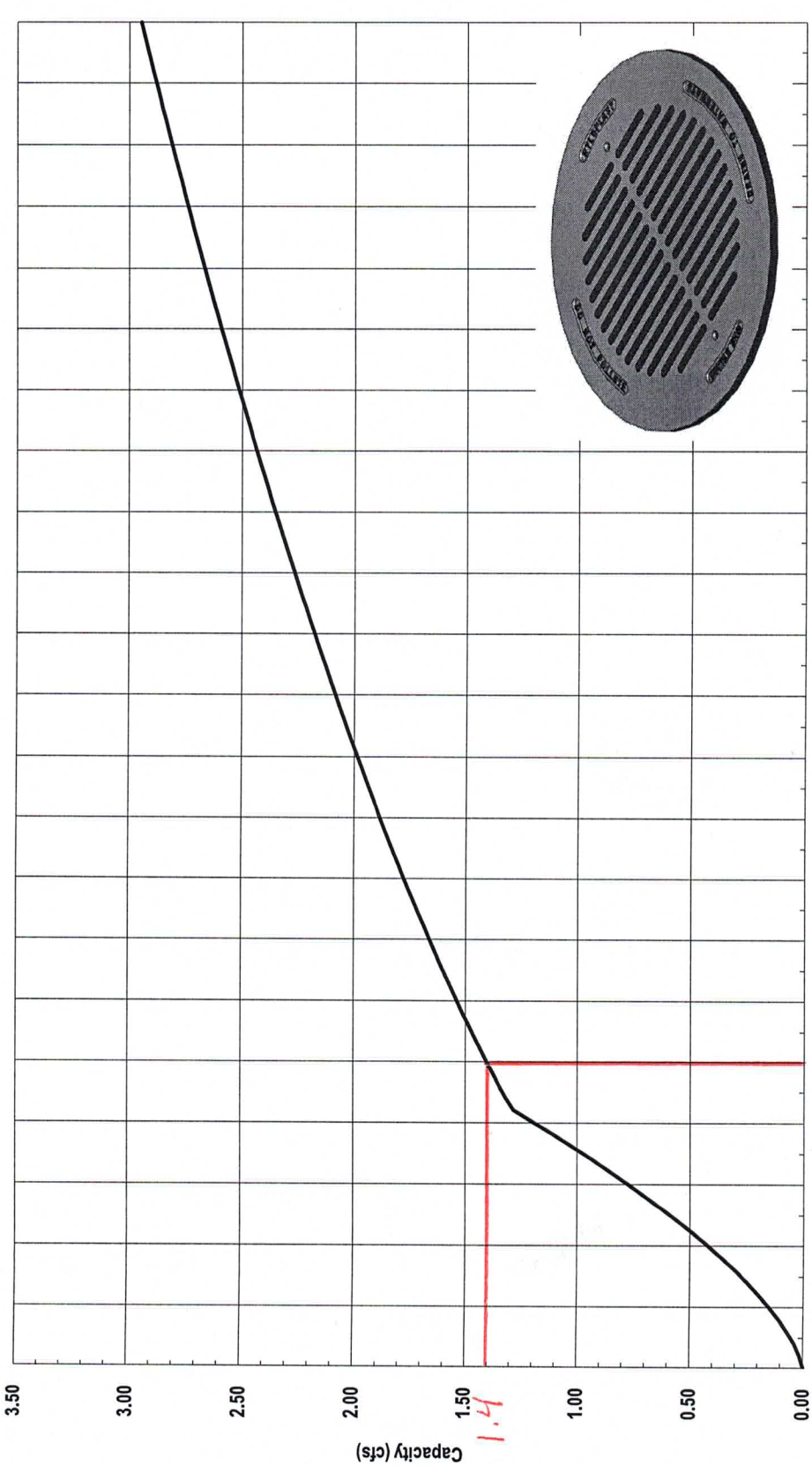

DP 33 $Q_{100} = 2 \text{ cfs}$ 4 in/let
 DP 34 $Q_{100} = 2 \text{ cfs}$ 3 in/let
 DP 31 $Q_{100} = 2 \text{ cfs}$ 3 in/let
 DP 32 $Q_{100} = 3 \text{ cfs}$ 3 in/let

 Capacity = $4 \times 1.4 = 5.6 \text{ cfs}$
 Capacity = $3 \times 1.4 = 4.2 \text{ cfs}$
 Capacity = $2 \times 1.4 = 2.8 \text{ cfs}$
 Capacity = $3 \times 1.4 = 4.2 \text{ cfs}$



Nyloplast

3130 Verona Avenue • Buford, GA 30518
 (866) 888-8479 / (770) 932-2443 • Fax: (770) 932-2490
 © Nyloplast Inlet Capacity Charts June 2012

HGL CALCULATIONS

PIPERUNS 1-7

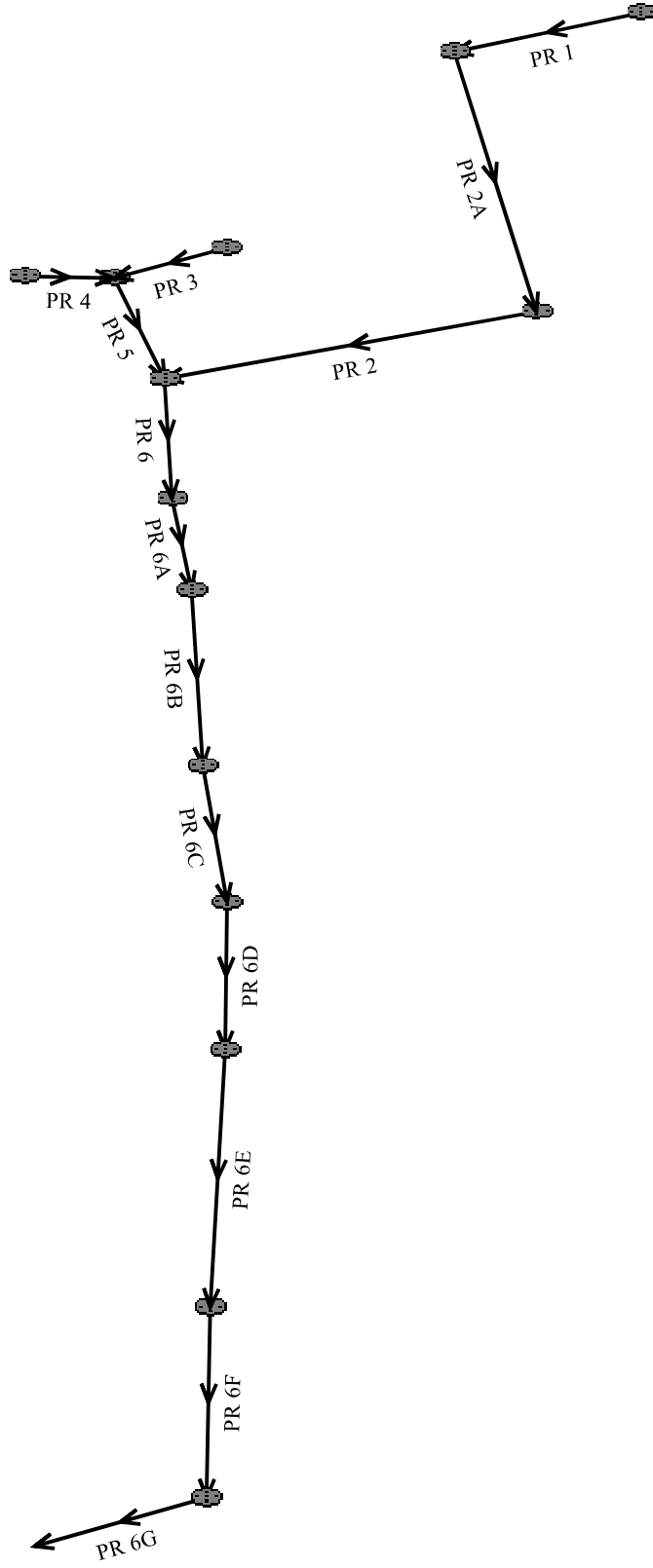

Program:
UDSEWER Math
Model Interface
2.1.1.4
Run Date:
2/3/2023 12:01:21
PM

UDSewer Results Summary

Project Title: New UDSEWER System Module
Project Description: Default system

PIPERUNS 1-7 100-Y

System Input Summary

Rainfall Parameters

Rainfall Return Period: 100
Rainfall Calculation Method: Formula

One Hour Depth (in): 2.52
Rainfall Constant "A": 28.5
Rainfall Constant "B": 10
Rainfall Constant "C": 0.786

Rational Method Constraints

Minimum Urban Runoff Coeff.: 0.20
Maximum Rural Overland Len. (ft): 500
Maximum Urban Overland Len. (ft): 300
Used UDFCD Tc. Maximum: Yes

Sizer Constraints

Minimum Sewer Size (in): 18.00
Maximum Depth to Rise Ratio: 0.90
Maximum Flow Velocity (fps): 18.0
Minimum Flow Velocity (fps): 2.0

Backwater Calculations:

Tailwater Elevation (ft): 6927.70

Manhole Input Summary:

		Given Flow		Sub Basin Information						
Element Name	Ground Elevation (ft)	Total Known Flow (cfs)	Local Contribution (cfs)	Drainage Area (Ac.)	Runoff Coefficient	5yr Coefficient	Overland Length (ft)	Overland Slope (%)	Gutter Length (ft)	Gutter Velocity (fps)
FSD 1	6925.50	0.00	0.00	0.00	0.00	0.00	0.00	0.00	0.00	0.00
PR 7	6932.90	48.00	0.00	0.00	0.00	0.00	0.00	0.00	0.00	0.00

PR 6G	6933.90	35.00	0.00	0.00	0.00	0.00	0.00	0.00	0.00	0.00
PR 6F	6936.71	35.00	0.00	0.00	0.00	0.00	0.00	0.00	0.00	0.00
PR 6E	6938.56	35.00	0.00	0.00	0.00	0.00	0.00	0.00	0.00	0.00
PR 6D	6939.06	35.00	0.00	0.00	0.00	0.00	0.00	0.00	0.00	0.00
PR 6C	6939.59	35.00	0.00	0.00	0.00	0.00	0.00	0.00	0.00	0.00
PR 6B	6940.10	35.00	0.00	0.00	0.00	0.00	0.00	0.00	0.00	0.00
PR 6A	6941.78	35.00	0.00	0.00	0.00	0.00	0.00	0.00	0.00	0.00
PR 6	6941.39	35.00	0.00	0.00	0.00	0.00	0.00	0.00	0.00	0.00
PR 2	6941.19	15.00	0.00	0.00	0.00	0.00	0.00	0.00	0.00	0.00
PR 2A	6943.36	15.00	0.00	0.00	0.00	0.00	0.00	0.00	0.00	0.00
PR 1	6943.36	4.00	0.00	0.00	0.00	0.00	0.00	0.00	0.00	0.00
PR 5	6940.83	21.00	0.00	0.00	0.00	0.00	0.00	0.00	0.00	0.00
PR 3	6941.09	8.00	0.00	0.00	0.00	0.00	0.00	0.00	0.00	0.00
PR 4	6941.09	13.00	0.00	0.00	0.00	0.00	0.00	0.00	0.00	0.00

Manhole Output Summary:

Element Name	Local Contribution					Total Design Flow				Comment
	Overland Time (min)	Gutter Time (min)	Basin Tc (min)	Intensity (in/hr)	Local Contrib (cfs)	Coeff. Area	Intensity (in/hr)	Manhole Tc (min)	Peak Flow (cfs)	
FSD 1	0.00	0.00	0.00	0.00	0.00	0.00	0.00	0.00	48.00	Surface Water Present (Upstream)
PR 7	0.00	0.00	0.00	0.00	0.00	0.00	0.00	0.00	48.00	Surface Water Present (Downstream)
PR 6G	0.00	0.00	0.00	0.00	0.00	0.00	0.00	0.00	35.00	
PR 6F	0.00	0.00	0.00	0.00	0.00	0.00	0.00	0.00	35.00	
PR 6E	0.00	0.00	0.00	0.00	0.00	0.00	0.00	0.00	35.00	
PR 6D	0.00	0.00	0.00	0.00	0.00	0.00	0.00	0.00	35.00	
PR 6C	0.00	0.00	0.00	0.00	0.00	0.00	0.00	0.00	35.00	
PR 6B	0.00	0.00	0.00	0.00	0.00	0.00	0.00	0.00	35.00	
PR 6A	0.00	0.00	0.00	0.00	0.00	0.00	0.00	0.00	35.00	
PR 6	0.00	0.00	0.00	0.00	0.00	0.00	0.00	0.00	35.00	
PR 2	0.00	0.00	0.00	0.00	0.00	0.00	0.00	0.00	15.00	
PR 2A	0.00	0.00	0.00	0.00	0.00	0.00	0.00	0.00	15.00	
PR 1	0.00	0.00	0.00	0.00	0.00	0.00	0.00	0.00	4.00	
PR 5	0.00	0.00	0.00	0.00	0.00	0.00	0.00	0.00	21.00	
PR 3	0.00	0.00	0.00	0.00	0.00	0.00	0.00	0.00	8.00	
PR 4	0.00	0.00	0.00	0.00	0.00	0.00	0.00	0.00	13.00	

Sewer Input Summary:

	Elevation	Loss Coefficients	Given Dimensions
--	------------------	--------------------------	-------------------------

Element Name	Sewer Length (ft)	Downstream Invert (ft)	Slope (%)	Upstream Invert (ft)	Mannings n	Bend Loss	Lateral Loss	Cross Section	Rise (ft or in)	Span (ft or in)
PR 7	158.59	6925.50	0.7	6926.68	0.013	0.03	0.00	CIRCULAR	36.00 in	36.00 in
PR 6G	32.50	6927.18	1.0	6927.50	0.013	0.12	0.00	CIRCULAR	36.00 in	36.00 in
PR 6F	205.18	6928.00	1.2	6930.52	0.013	0.85	0.00	CIRCULAR	36.00 in	36.00 in
PR 6E	120.81	6930.52	1.2	6932.00	0.013	0.05	0.00	CIRCULAR	36.00 in	36.00 in
PR 6D	30.31	6932.52	0.7	6932.73	0.013	0.05	0.00	CIRCULAR	36.00 in	36.00 in
PR 6C	32.90	6932.73	0.7	6932.96	0.013	0.05	0.00	CIRCULAR	36.00 in	36.00 in
PR 6B	32.35	6932.96	0.7	6933.19	0.013	0.05	0.00	CIRCULAR	36.00 in	36.00 in
PR 6A	116.94	6933.19	0.7	6934.01	0.013	0.05	0.00	CIRCULAR	36.00 in	36.00 in
PR 6	54.42	6934.01	0.7	6934.39	0.013	0.05	0.00	CIRCULAR	36.00 in	36.00 in
PR 2	300.04	6934.89	0.6	6936.69	0.013	1.32	0.00	CIRCULAR	30.00 in	30.00 in
PR 2A	159.48	6937.19	0.6	6938.15	0.013	1.32	0.00	CIRCULAR	30.00 in	30.00 in
PR 1	38.58	6938.69	1.0	6939.07	0.013	1.32	0.00	CIRCULAR	18.00 in	18.00 in
PR 5	52.76	6935.39	1.5	6936.18	0.013	0.05	0.00	CIRCULAR	24.00 in	24.00 in
PR 3	26.98	6935.18	2.0	6935.72	0.013	1.32	0.00	CIRCULAR	18.00 in	18.00 in
PR 4	5.25	6936.68	1.9	6936.78	0.013	1.32	0.00	CIRCULAR	18.00 in	18.00 in

Sewer Flow Summary:

Element Name	Full Flow Capacity		Critical Flow		Normal Flow				Flow (cfs)	Surcharged Length (ft)	Comment
	Flow (cfs)	Velocity (fps)	Depth (in)	Velocity (fps)	Depth (in)	Velocity (fps)	Froude Number	Flow Condition			
PR 7	57.69	8.16	27.07	8.42	25.08	9.13	1.17	Supercritical	48.00	0.00	
PR 6G	66.34	9.39	23.07	7.32	18.58	9.51	1.51	Supercritical	35.00	0.00	
PR 6F	74.12	10.49	23.07	7.32	17.41	10.34	1.71	Supercritical	35.00	0.00	
PR 6E	74.02	10.47	23.07	7.32	17.42	10.33	1.71	Supercritical	35.00	0.00	
PR 6D	55.66	7.87	23.07	7.32	20.70	8.32	1.23	Supercritical	35.00	0.00	
PR 6C	55.95	7.92	23.07	7.32	20.63	8.35	1.24	Supercritical	35.00	0.00	
PR 6B	56.39	7.98	23.07	7.32	20.53	8.40	1.25	Supercritical	35.00	0.00	
PR 6A	56.00	7.92	23.07	7.32	20.62	8.36	1.24	Supercritical	35.00	0.00	
PR 6	55.91	7.91	23.07	7.32	20.64	8.35	1.24	Supercritical	35.00	0.00	
PR 2	31.85	6.49	15.67	5.78	14.48	6.39	1.16	Supercritical	15.00	0.00	
PR 2A	31.91	6.50	15.67	5.78	14.47	6.40	1.16	Supercritical	15.00	0.00	
PR 1	10.45	5.91	9.18	4.41	7.72	5.52	1.39	Supercritical	4.00	0.00	
PR 5	27.78	8.84	19.70	7.61	15.59	9.72	1.61	Supercritical	21.00	0.00	
PR 3	14.90	8.43	13.15	5.78	9.39	8.58	1.92	Pressurized	8.00	26.98	
PR 4	14.52	8.22	16.21	7.76	13.29	9.29	1.59	Pressurized	13.00	5.25	

- A Froude number of 0 indicates that pressurized flow occurs (adverse slope or undersized pipe).
- If the sewer is not pressurized, full flow represents the maximum gravity flow in the sewer.
- If the sewer is pressurized, full flow represents the pressurized flow conditions.

Sewer Sizing Summary:

Element Name	Peak Flow (cfs)	Cross Section	Existing		Calculated		Used			Comment
			Rise	Span	Rise	Span	Rise	Span	Area (ft ²)	
PR 7	48.00	CIRCULAR	36.00 in	36.00 in	36.00 in	36.00 in	36.00 in	36.00 in	7.07	
PR 6G	35.00	CIRCULAR	36.00 in	36.00 in	30.00 in	30.00 in	36.00 in	36.00 in	7.07	
PR 6F	35.00	CIRCULAR	36.00 in	36.00 in	30.00 in	30.00 in	36.00 in	36.00 in	7.07	
PR 6E	35.00	CIRCULAR	36.00 in	36.00 in	30.00 in	30.00 in	36.00 in	36.00 in	7.07	
PR 6D	35.00	CIRCULAR	36.00 in	36.00 in	33.00 in	33.00 in	36.00 in	36.00 in	7.07	
PR 6C	35.00	CIRCULAR	36.00 in	36.00 in	33.00 in	33.00 in	36.00 in	36.00 in	7.07	
PR 6B	35.00	CIRCULAR	36.00 in	36.00 in	33.00 in	33.00 in	36.00 in	36.00 in	7.07	
PR 6A	35.00	CIRCULAR	36.00 in	36.00 in	33.00 in	33.00 in	36.00 in	36.00 in	7.07	
PR 6	35.00	CIRCULAR	36.00 in	36.00 in	33.00 in	33.00 in	36.00 in	36.00 in	7.07	
PR 2	15.00	CIRCULAR	30.00 in	30.00 in	24.00 in	24.00 in	30.00 in	30.00 in	4.91	
PR 2A	15.00	CIRCULAR	30.00 in	30.00 in	24.00 in	24.00 in	30.00 in	30.00 in	4.91	
PR 1	4.00	CIRCULAR	18.00 in	18.00 in	18.00 in	18.00 in	18.00 in	18.00 in	1.77	
PR 5	21.00	CIRCULAR	24.00 in	24.00 in	24.00 in	24.00 in	24.00 in	24.00 in	3.14	
PR 3	8.00	CIRCULAR	18.00 in	18.00 in	18.00 in	18.00 in	18.00 in	18.00 in	1.77	
PR 4	13.00	CIRCULAR	18.00 in	18.00 in	18.00 in	18.00 in	18.00 in	18.00 in	1.77	

- Calculated diameter was determined by sewer hydraulic capacity rounded up to the nearest commercially available size.
- Sewer sizes should not decrease downstream.
- All hydraulics were calculated using the 'Used' parameters.

Grade Line Summary:

Tailwater Elevation (ft): 6927.70

Element Name	Invert Elev.		Downstream Manhole Losses		HGL		EGL		
	Downstream (ft)	Upstream (ft)	Bend Loss (ft)	Lateral Loss (ft)	Downstream (ft)	Upstream (ft)	Downstream (ft)	Friction Loss (ft)	Upstream (ft)
PR 7	6925.50	6926.68	0.00	0.00	6927.70	6928.94	6928.88	1.15	6930.04
PR 6G	6927.18	6927.50	0.05	0.00	6928.98	6929.42	6930.13	0.12	6930.25
PR 6F	6928.00	6930.52	0.32	0.00	6929.75	6932.44	6931.11	2.16	6933.27
PR 6E	6930.52	6932.00	0.02	0.00	6932.46	6933.92	6933.63	1.13	6934.75
PR 6D	6932.52	6932.73	0.02	0.00	6934.24	6934.65	6935.32	0.16	6935.48
PR 6C	6932.73	6932.96	0.02	0.00	6934.67	6934.88	6935.53	0.18	6935.71
PR 6B	6932.96	6933.19	0.02	0.00	6934.90	6935.11	6935.77	0.18	6935.94

PR 6A	6933.19	6934.01	0.02	0.00	6935.13	6935.93	6935.99	0.77	6936.76
PR 6	6934.01	6934.39	0.02	0.00	6935.95	6936.31	6936.81	0.33	6937.14
PR 2	6934.89	6936.69	0.19	0.00	6937.18	6938.00	6937.33	1.18	6938.52
PR 2A	6937.19	6938.15	0.19	0.00	6938.40	6939.46	6939.03	0.94	6939.98
PR 1	6938.69	6939.07	0.11	0.00	6939.99	6939.99	6940.08	0.10	6940.18
PR 5	6935.39	6936.18	0.03	0.00	6936.69	6937.82	6938.16	0.57	6938.72
PR 3	6935.18	6935.72	0.42	0.00	6938.82	6938.98	6939.14	0.16	6939.30
PR 4	6936.68	6936.78	1.11	0.00	6938.99	6939.07	6939.83	0.08	6939.91

- Bend and Lateral losses only apply when there is an outgoing sewer. The system outfall, sewer #0, is not considered a sewer.
- Bend loss = Bend K * V_{fi} ^ 2/(2*g)
- Lateral loss = V_{fo} ^ 2/(2*g)- Junction Loss K * V_{fi} ^ 2/(2*g).
- Friction loss is always Upstream EGL - Downstream EGL.

Excavation Estimate:

The trench side slope is 1.0 ft/ft

The minimum trench width is 2.00 ft

Element Name	Length (ft)	Wall (in)	Bedding (in)	Bottom Width (ft)	Downstream			Upstream			Volume (cu. yd)	Comment
					Top Width (ft)	Trench Depth (ft)	Cover (ft)	Top Width (ft)	Trench Depth (ft)	Cover (ft)		
PR 7	158.59	4.00	6.00	6.67	0.00	0.83	0.00	10.44	7.05	2.89	164.87	Sewer Too Shallow
PR 6G	32.50	4.00	6.00	6.67	9.44	6.55	2.39	10.80	7.23	3.07	59.04	
PR 6F	205.18	4.00	6.00	6.67	9.80	6.73	2.57	10.38	7.02	2.86	370.89	
PR 6E	120.81	4.00	6.00	6.67	10.38	7.02	2.86	11.12	7.39	3.23	233.83	
PR 6D	30.31	4.00	6.00	6.67	10.08	6.87	2.71	10.66	7.16	3.00	56.40	
PR 6C	32.90	4.00	6.00	6.67	10.66	7.16	3.00	11.26	7.46	3.30	65.05	
PR 6B	32.35	4.00	6.00	6.67	11.26	7.46	3.30	11.82	7.74	3.58	67.87	
PR 6A	116.94	4.00	6.00	6.67	11.82	7.74	3.58	13.54	8.60	4.44	275.95	
PR 6	54.42	4.00	6.00	6.67	13.54	8.60	4.44	12.00	7.83	3.67	129.50	
PR 2	300.04	3.50	6.00	6.08	11.50	7.29	3.71	7.50	5.29	1.71	468.86	Sewer Too Shallow
PR 2A	159.48	3.50	6.00	6.08	6.50	4.79	1.21	8.92	6.00	2.42	199.98	Sewer Too Shallow
PR 1	38.58	2.50	4.00	4.92	8.84	5.21	2.96	8.08	4.83	2.58	39.81	
PR 5	52.76	3.00	4.00	5.50	11.00	6.58	3.75	8.30	5.23	2.40	72.82	
PR 3	26.98	2.50	4.00	4.92	10.80	6.19	3.94	10.24	5.91	3.66	37.59	
PR 4	5.25	2.50	4.00	4.92	7.80	4.69	2.44	8.12	4.85	2.60	5.01	

Total earth volume for sewer trenches = 2247 cubic yards.

- The trench was estimated to have a bottom width equal to the outer pipe diameter plus 36 inches.
- If the calculated width of the trench bottom is less than the minimum acceptable width, the minimum acceptable width was used.
- The sewer wall thickness is equal to: (equivalent diameter in inches/12)+1 inches
- The sewer bedding thickness is equal to:

PR 1-7 100-Y PROF

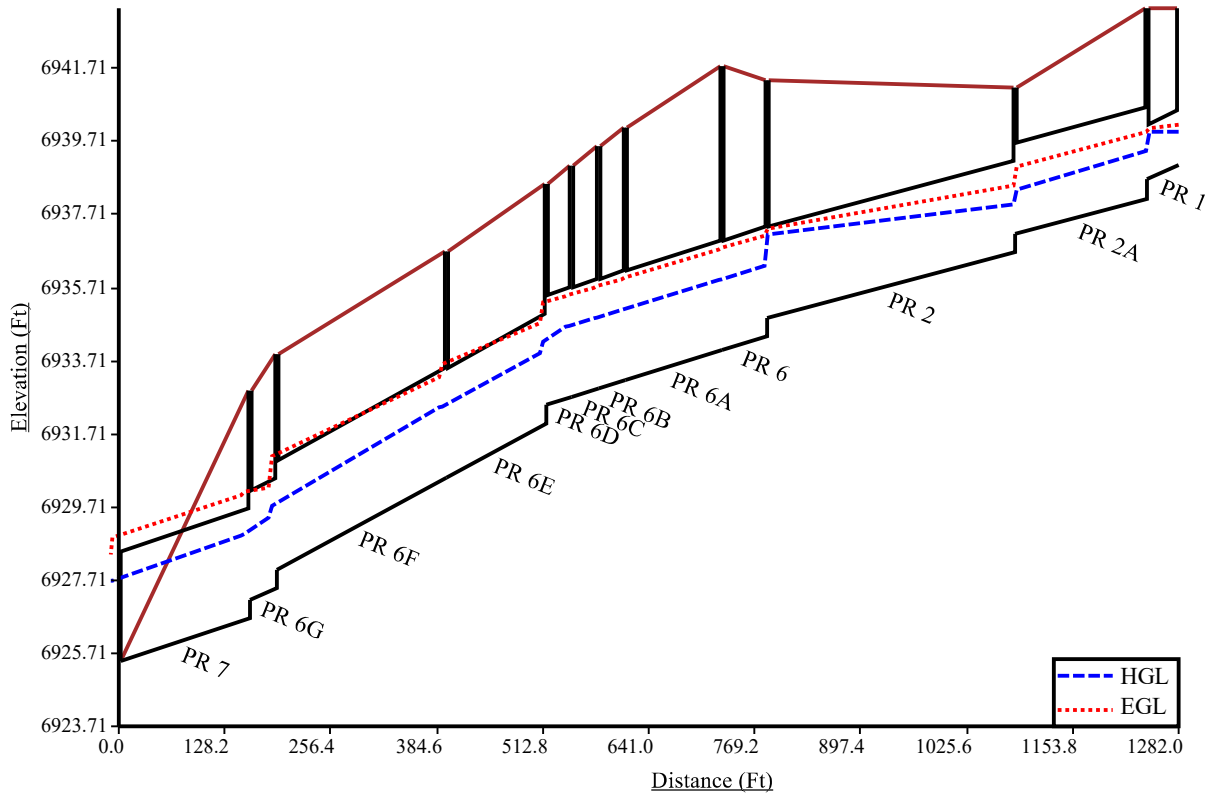

PR 3 100-Y PROF

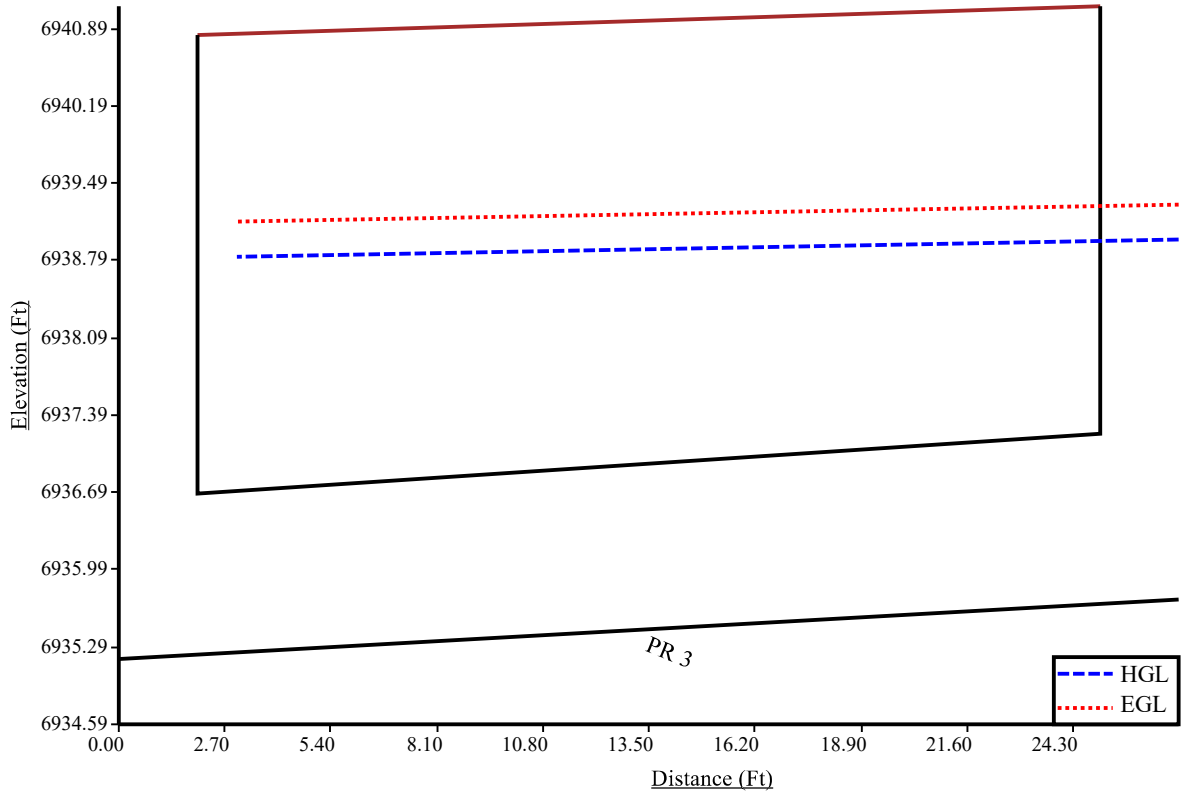

PR 4-5 100-Y PROF

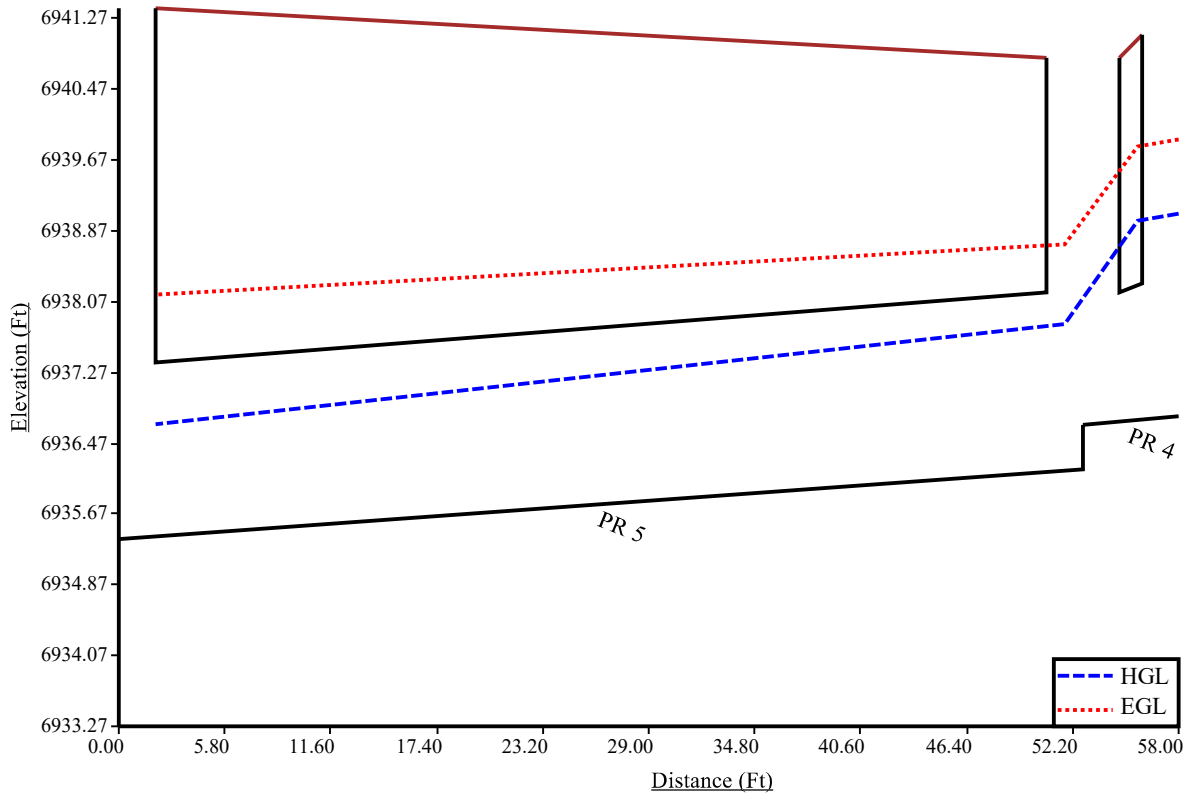

PIPERUNS 8-10B

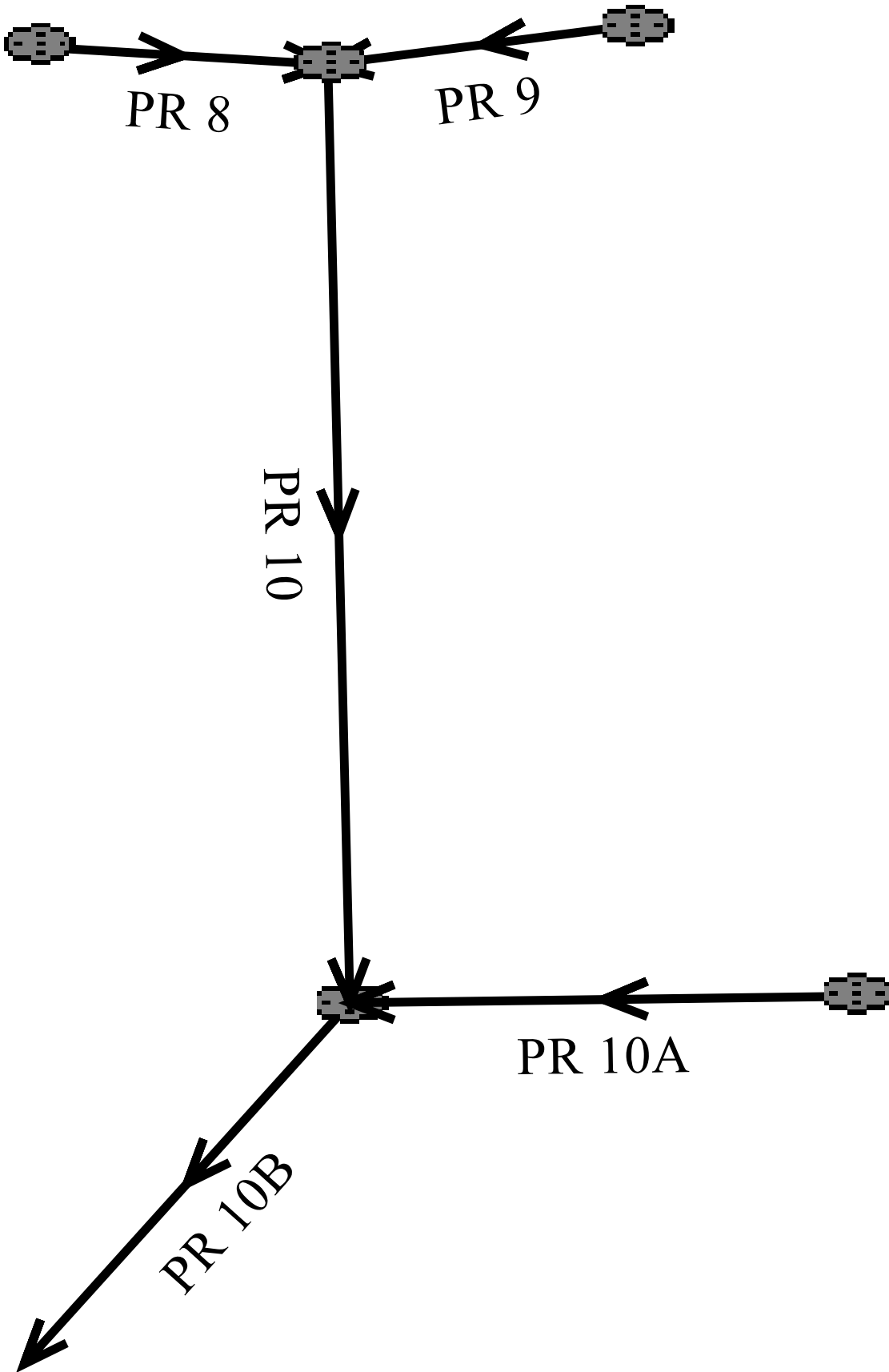

Program:
UDSEWER Math
Model Interface
2.1.1.4
Run Date:
2/3/2023 2:04:13 PM

UDSewer Results Summary

Project Title: New UDSEWER System Module
Project Description: Default system

PIPERUNS 8-10B 100-Y

System Input Summary

Rainfall Parameters

Rainfall Return Period: 100
Rainfall Calculation Method: Formula

One Hour Depth (in):
Rainfall Constant "A": 28.5
Rainfall Constant "B": 10
Rainfall Constant "C": 0.786

Rational Method Constraints

Minimum Urban Runoff Coeff.: 0.20
Maximum Rural Overland Len. (ft): 500
Maximum Urban Overland Len. (ft): 300
Used UDFCD Tc. Maximum: Yes

Sizer Constraints

Minimum Sewer Size (in): 18.00
Maximum Depth to Rise Ratio: 0.90
Maximum Flow Velocity (fps): 18.0
Minimum Flow Velocity (fps): 2.0

Backwater Calculations:

Tailwater Elevation (ft): 6927.70

Manhole Input Summary:

		Given Flow		Sub Basin Information						
Element Name	Ground Elevation (ft)	Total Known Flow (cfs)	Local Contribution (cfs)	Drainage Area (Ac.)	Runoff Coefficient	5yr Coefficient	Overland Length (ft)	Overland Slope (%)	Gutter Length (ft)	Gutter Velocity (fps)
FSD 1	6927.00	0.00	0.00	0.00	0.00	0.00	0.00	0.00	0.00	0.00
PR 10B	6931.50	15.00	0.00	0.00	0.00	0.00	0.00	0.00	0.00	0.00

PR 10A	6930.05	2.00	0.00	0.00	0.00	0.00	0.00	0.00	0.00	0.00
PR 10	6933.86	15.00	0.00	0.00	0.00	0.00	0.00	0.00	0.00	0.00
PR 9	6933.88	8.00	0.00	0.00	0.00	0.00	0.00	0.00	0.00	0.00
PR 8	6933.98	8.00	0.00	0.00	0.00	0.00	0.00	0.00	0.00	0.00

Manhole Output Summary:

Element Name	Local Contribution					Total Design Flow				Comment
	Overland Time (min)	Gutter Time (min)	Basin Tc (min)	Intensity (in/hr)	Local Contrib (cfs)	Coeff. Area	Intensity (in/hr)	Manhole Tc (min)	Peak Flow (cfs)	
FSD 1	0.00	0.00	0.00	0.00	0.00	0.00	0.00	0.00	0.00	Surface Water Present (Upstream)
PR 10B	0.00	0.00	0.00	0.00	0.00	0.00	0.00	0.00	15.00	Surface Water Present (Downstream)
PR 10A	0.00	0.00	0.00	0.00	0.00	0.00	0.00	0.00	2.00	
PR 10	0.00	0.00	0.00	0.00	0.00	0.00	0.00	0.00	15.00	
PR 9	0.00	0.00	0.00	0.00	0.00	0.00	0.00	0.00	8.00	
PR 8	0.00	0.00	0.00	0.00	0.00	0.00	0.00	0.00	8.00	

Sewer Input Summary:

Element Name	Sewer Length (ft)	Elevation			Loss Coefficients			Given Dimensions		
		Downstream Invert (ft)	Slope (%)	Upstream Invert (ft)	Mannings n	Bend Loss	Lateral Loss	Cross Section	Rise (ft or in)	Span (ft or in)
PR 10B	50.50	6926.00	0.6	6926.30	0.013	0.03	0.00	CIRCULAR	24.00 in	24.00 in
PR 10A	66.37	6927.05	0.5	6927.38	0.013	0.38	0.00	CIRCULAR	15.00 in	15.00 in
PR 10	245.24	6926.50	1.0	6928.83	0.013	0.38	0.00	CIRCULAR	24.00 in	24.00 in
PR 9	56.05	6929.33	1.0	6929.88	0.013	1.32	0.00	CIRCULAR	18.00 in	18.00 in
PR 8	12.46	6929.33	1.0	6929.46	0.013	1.32	0.00	CIRCULAR	18.00 in	18.00 in

Sewer Flow Summary:

Element Name	Full Flow Capacity		Critical Flow		Normal Flow				Flow (cfs)	Surcharged Length (ft)	Comment
	Flow (cfs)	Velocity (fps)	Depth (in)	Velocity (fps)	Depth (in)	Velocity (fps)	Froude Number	Flow Condition			
PR 10B	17.48	5.56	16.75	6.41	17.13	6.25	0.96	Subcritical	15.00	0.00	
PR 10A	4.57	3.72	6.76	3.73	6.94	3.60	0.95	Subcritical Surcharged	2.00	8.55	
PR 10	22.11	7.04	16.75	6.41	14.49	7.56	1.32	Supercritical	15.00	0.00	
PR 9	10.43	5.90	13.15	5.78	11.81	6.51	1.23	Supercritical Jump	8.00	33.38	

PR 8	10.75	6.09	13.15	5.78	11.57	6.67	1.29	Pressurized	8.00	12.46	
------	-------	------	-------	------	-------	------	------	-------------	------	-------	--

- A Froude number of 0 indicates that pressured flow occurs (adverse slope or undersized pipe).
- If the sewer is not pressurized, full flow represents the maximum gravity flow in the sewer.
- If the sewer is pressurized, full flow represents the pressurized flow conditions.

Sewer Sizing Summary:

			Existing		Calculated		Used			
Element Name	Peak Flow (cfs)	Cross Section	Rise	Span	Rise	Span	Rise	Span	Area (ft ²)	Comment
PR 10B	15.00	CIRCULAR	24.00 in	24.00 in	24.00 in	24.00 in	24.00 in	24.00 in	3.14	
PR 10A	2.00	CIRCULAR	15.00 in	15.00 in	18.00 in	18.00 in	15.00 in	15.00 in	1.23	Height is too small. Width is too small. Existing height is smaller than the suggested height. Existing width is smaller than the suggested width.
PR 10	15.00	CIRCULAR	24.00 in	24.00 in	21.00 in	21.00 in	24.00 in	24.00 in	3.14	
PR 9	8.00	CIRCULAR	18.00 in	18.00 in	18.00 in	18.00 in	18.00 in	18.00 in	1.77	
PR 8	8.00	CIRCULAR	18.00 in	18.00 in	18.00 in	18.00 in	18.00 in	18.00 in	1.77	

- Calculated diameter was determined by sewer hydraulic capacity rounded up to the nearest commercially available size.
- Sewer sizes should not decrease downstream.
- All hydraulics were calculated using the 'Used' parameters.

Grade Line Summary:

Tailwater Elevation (ft): 6927.70

Element Name	Invert Elev.		Downstream Manhole Losses		HGL		EGL		
	Downstream (ft)	Upstream (ft)	Bend Loss (ft)	Lateral Loss (ft)	Downstream (ft)	Upstream (ft)	Downstream (ft)	Friction Loss (ft)	Upstream (ft)
PR 10B	6926.00	6926.30	0.00	0.00	6927.70	6927.84	6928.13	0.23	6928.36
PR 10A	6927.05	6927.38	0.02	0.00	6928.33	6928.38	6928.38	0.06	6928.44
PR 10	6926.50	6928.83	0.13	0.00	6927.98	6930.23	6928.60	2.27	6930.86
PR 9	6929.33	6929.88	0.42	0.00	6930.97	6930.98	6931.28	0.21	6931.50
PR 8	6929.33	6929.46	0.42	0.00	6930.97	6931.04	6931.28	0.07	6931.36

- Bend and Lateral losses only apply when there is an outgoing sewer. The system outfall, sewer #0, is not considered a sewer.
- Bend loss = Bend K * V_{fi}² / (2 * g)
- Lateral loss = V_{fo}² / (2 * g) - Junction Loss K * V_{fi}² / (2 * g).

- Friction loss is always Upstream EGL - Downstream EGL.

Excavation Estimate:

The trench side slope is 1.0 ft/ft

The minimum trench width is 2.00 ft

				Downstream				Upstream				
Element Name	Length (ft)	Wall (in)	Bedding (in)	Bottom Width (ft)	Top Width (ft)	Trench Depth (ft)	Cover (ft)	Top Width (ft)	Trench Depth (ft)	Cover (ft)	Volume (cu. yd)	Comment
PR 10B	50.50	3.00	4.00	5.50	0.00	1.58	0.00	9.40	5.78	2.95	41.45	Sewer Too Shallow
PR 10A	66.37	2.25	4.00	4.63	8.65	4.97	3.01	5.09	3.19	1.23	51.44	Sewer Too Shallow
PR 10	245.24	3.00	4.00	5.50	9.00	5.58	2.75	9.06	5.61	2.78	307.97	
PR 9	56.05	2.50	4.00	4.92	8.56	5.07	2.82	7.50	4.54	2.29	54.23	
PR 8	12.46	2.50	4.00	4.92	8.56	5.07	2.82	8.54	5.06	2.81	13.02	

Total earth volume for sewer trenches = 468 cubic yards.

- The trench was estimated to have a bottom width equal to the outer pipe diameter plus 36 inches.
- If the calculated width of the trench bottom is less than the minimum acceptable width, the minimum acceptable width was used.
- The sewer wall thickness is equal to: (equivalent diameter in inches/12)+1 inches
- The sewer bedding thickness is equal to:
 - Four inches for pipes less than 33 inches.
 - Six inches for pipes less than 60 inches.
 - Eight inches for all larger sizes.

PR 8-10B 100-Y PROF

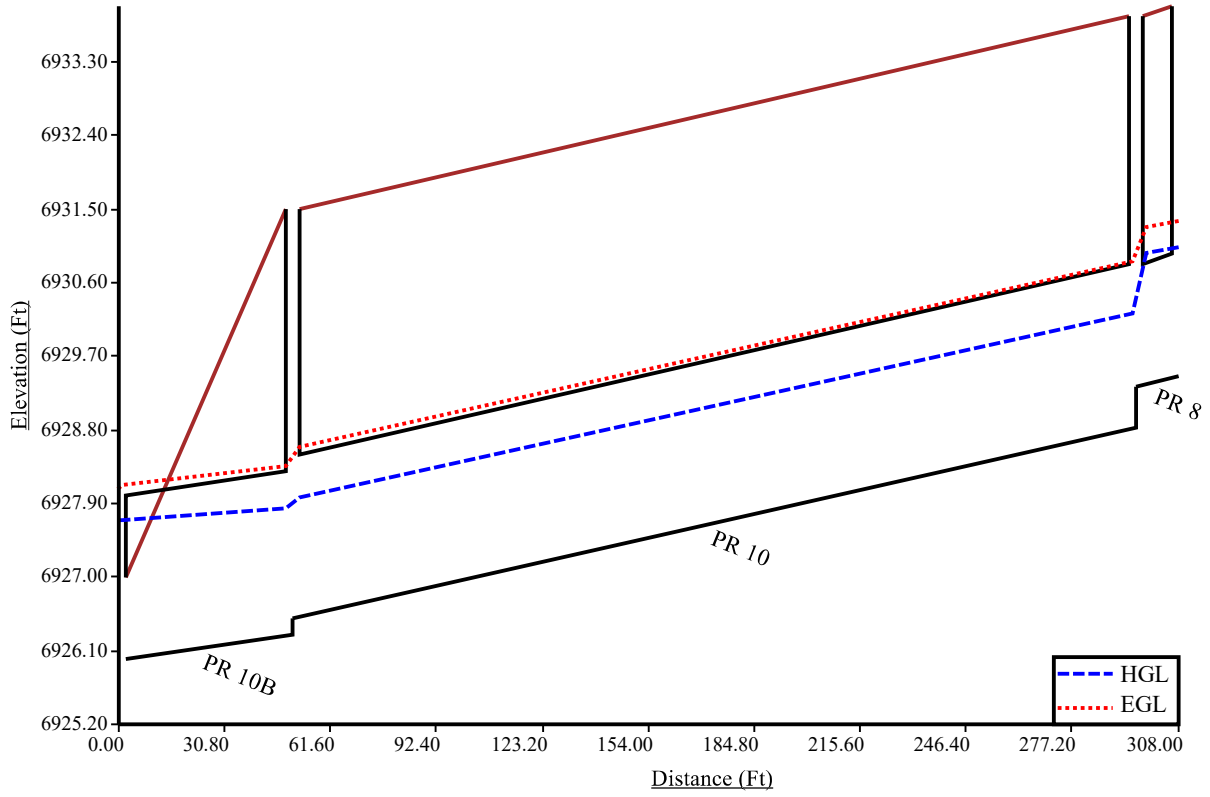

PR 9 100-Y PROF

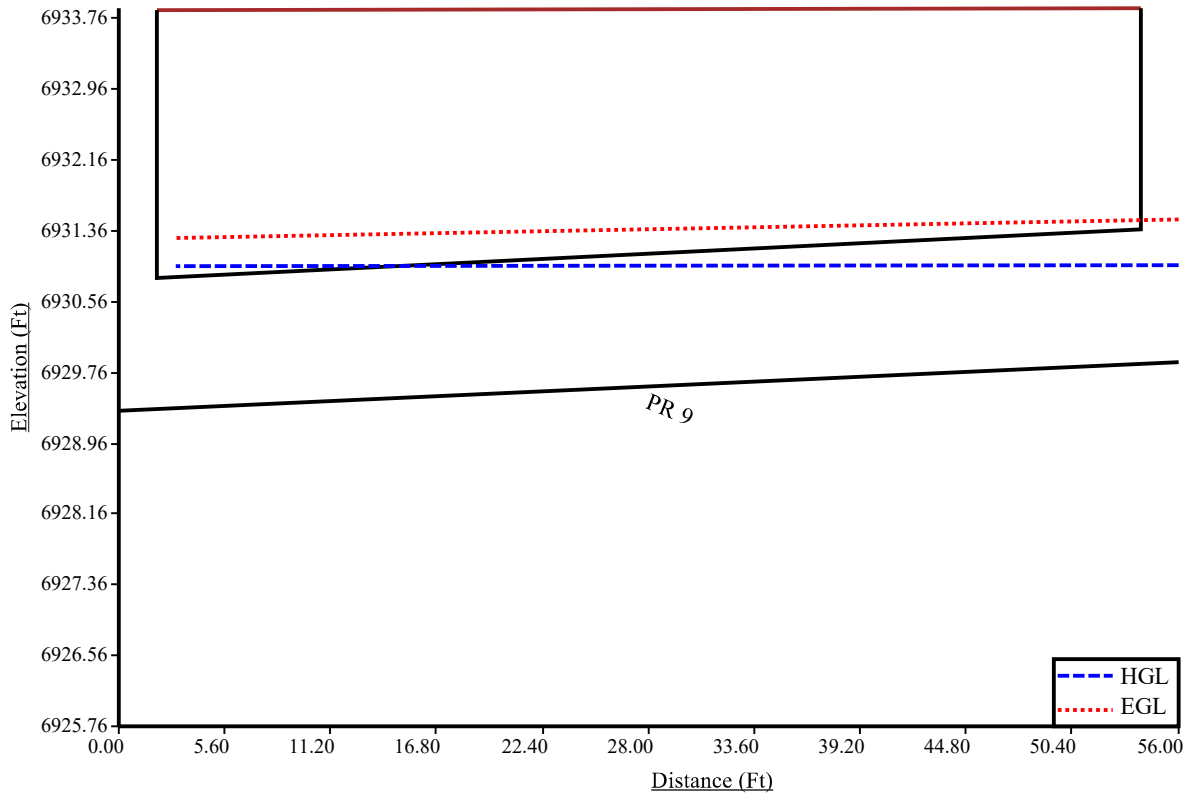

PR 10A 100-Y PROF

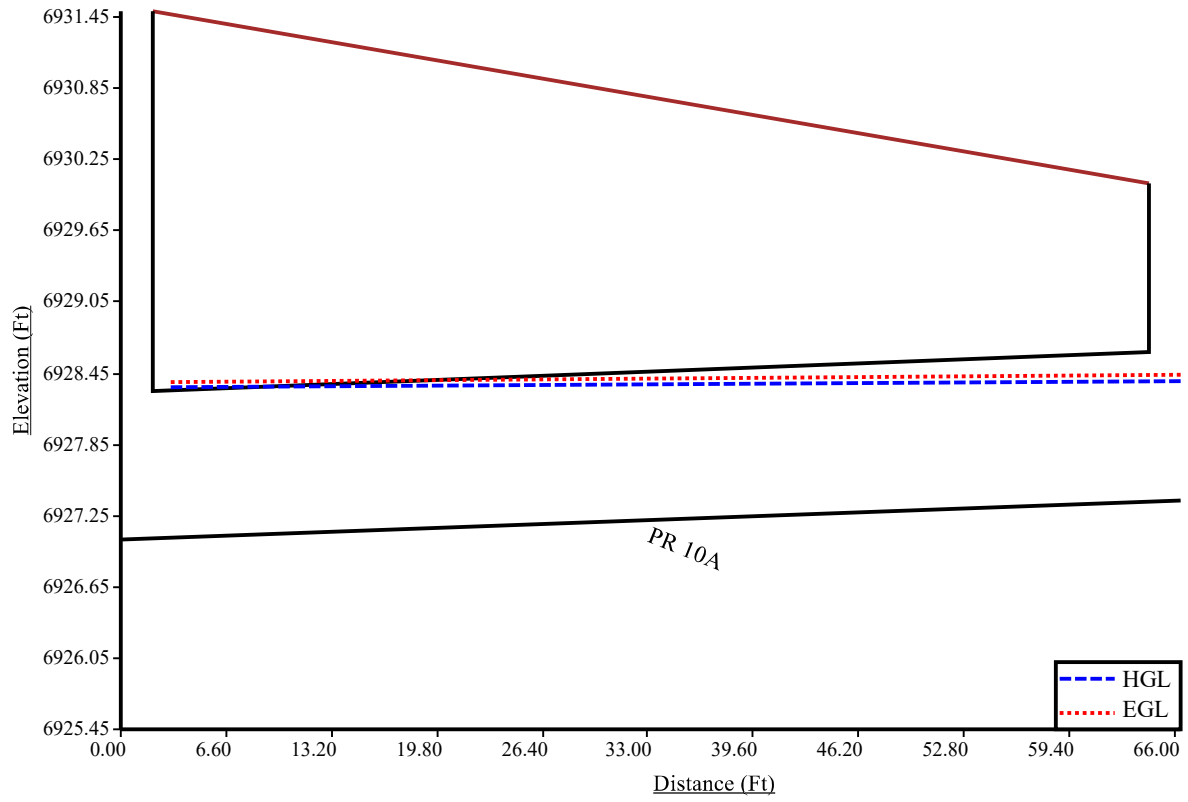

PIPERUNS 11-17

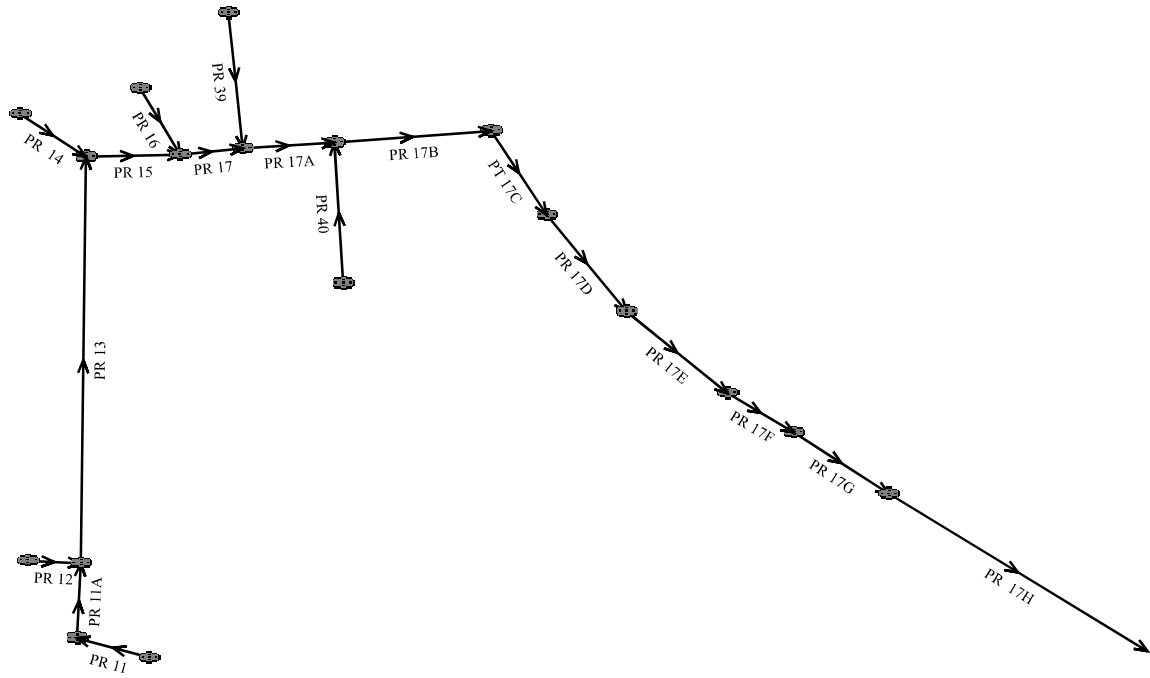

Program:
UDSEWER Math
Model Interface
2.1.1.4
Run Date:
2/3/2023 2:37:17 PM

UDSewer Results Summary

Project Title: New UDSEWER System Module
Project Description: Default system

PIPERUNS 11-17 100-Y

System Input Summary

Rainfall Parameters

Rainfall Return Period: 100
Rainfall Calculation Method: Formula

One Hour Depth (in):
Rainfall Constant "A": 28.5
Rainfall Constant "B": 10
Rainfall Constant "C": 0.786

Rational Method Constraints

Minimum Urban Runoff Coeff.: 0.20
Maximum Rural Overland Len. (ft): 500
Maximum Urban Overland Len. (ft): 300
Used UDFCD Tc. Maximum: Yes

Sizer Constraints

Minimum Sewer Size (in): 18.00
Maximum Depth to Rise Ratio: 0.90
Maximum Flow Velocity (fps): 18.0
Minimum Flow Velocity (fps): 2.0

Backwater Calculations:

Tailwater Elevation (ft): 6902.71

Manhole Input Summary:

		Given Flow		Sub Basin Information						
Element Name	Ground Elevation (ft)	Total Known Flow (cfs)	Local Contribution (cfs)	Drainage Area (Ac.)	Runoff Coefficient	5yr Coefficient	Overland Length (ft)	Overland Slope (%)	Gutter Length (ft)	Gutter Velocity (fps)
FSD 2	6899.00	0.00	0.00	0.00	0.00	0.00	0.00	0.00	0.00	0.00
PR 17I	6907.90	31.00	0.00	0.00	0.00	0.00	0.00	0.00	0.00	0.00

PR 17H	6911.55	31.00	0.00	0.00	0.00	0.00	0.00	0.00	0.00	0.00
PR 17G	6912.25	31.00	0.00	0.00	0.00	0.00	0.00	0.00	0.00	0.00
PR 17F	6913.00	31.00	0.00	0.00	0.00	0.00	0.00	0.00	0.00	0.00
PR 17E	6914.00	31.00	0.00	0.00	0.00	0.00	0.00	0.00	0.00	0.00
PR 17D	6914.75	31.00	0.00	0.00	0.00	0.00	0.00	0.00	0.00	0.00
PT 17C	6916.00	31.00	0.00	0.00	0.00	0.00	0.00	0.00	0.00	0.00
PR 17B	6921.50	31.00	0.00	0.00	0.00	0.00	0.00	0.00	0.00	0.00
PR 40	6918.00	2.00	0.00	0.00	0.00	0.00	0.00	0.00	0.00	0.00
PR 17A	6923.25	31.00	0.00	0.00	0.00	0.00	0.00	0.00	0.00	0.00
PR 17	6923.00	31.00	0.00	0.00	0.00	0.00	0.00	0.00	0.00	0.00
PR 16	6922.51	2.00	0.00	0.00	0.00	0.00	0.00	0.00	0.00	0.00
PR 15	6922.35	29.00	0.00	0.00	0.00	0.00	0.00	0.00	0.00	0.00
PR 13	6922.07	19.00	0.00	0.00	0.00	0.00	0.00	0.00	0.00	0.00
PR 12	6922.18	7.00	0.00	0.00	0.00	0.00	0.00	0.00	0.00	0.00
PR 11A	6921.65	13.00	0.00	0.00	0.00	0.00	0.00	0.00	0.00	0.00
PR 11	6921.81	13.00	0.00	0.00	0.00	0.00	0.00	0.00	0.00	0.00
PR 14	6922.51	10.00	0.00	0.00	0.00	0.00	0.00	0.00	0.00	0.00
PR 39	6918.00	2.00	0.00	0.00	0.00	0.00	0.00	0.00	0.00	0.00

Manhole Output Summary:

Element Name	Local Contribution					Total Design Flow				Comment
	Overland Time (min)	Gutter Time (min)	Basin Tc (min)	Intensity (in/hr)	Local Contrib (cfs)	Coeff. Area	Intensity (in/hr)	Manhole Tc (min)	Peak Flow (cfs)	
FSD 2	0.00	0.00	0.00	0.00	0.00	0.00	0.00	0.00	0.00	Surface Water Present (Upstream)
PR 17I	0.00	0.00	0.00	0.00	0.00	0.00	0.00	0.00	31.00	Surface Water Present (Downstream)
PR 17H	0.00	0.00	0.00	0.00	0.00	0.00	0.00	0.00	31.00	
PR 17G	0.00	0.00	0.00	0.00	0.00	0.00	0.00	0.00	31.00	
PR 17F	0.00	0.00	0.00	0.00	0.00	0.00	0.00	0.00	31.00	
PR 17E	0.00	0.00	0.00	0.00	0.00	0.00	0.00	0.00	31.00	
PR 17D	0.00	0.00	0.00	0.00	0.00	0.00	0.00	0.00	31.00	
PT 17C	0.00	0.00	0.00	0.00	0.00	0.00	0.00	0.00	31.00	
PR 17B	0.00	0.00	0.00	0.00	0.00	0.00	0.00	0.00	31.00	
PR 40	0.00	0.00	0.00	0.00	0.00	0.00	0.00	0.00	2.00	
PR 17A	0.00	0.00	0.00	0.00	0.00	0.00	0.00	0.00	31.00	
PR 17	0.00	0.00	0.00	0.00	0.00	0.00	0.00	0.00	31.00	
PR 16	0.00	0.00	0.00	0.00	0.00	0.00	0.00	0.00	2.00	
PR 15	0.00	0.00	0.00	0.00	0.00	0.00	0.00	0.00	29.00	
PR 13	0.00	0.00	0.00	0.00	0.00	0.00	0.00	0.00	19.00	
PR 12	0.00	0.00	0.00	0.00	0.00	0.00	0.00	0.00	7.00	

PR 11A	0.00	0.00	0.00	0.00	0.00	0.00	0.00	0.00	13.00	
PR 11	0.00	0.00	0.00	0.00	0.00	0.00	0.00	0.00	13.00	
PR 14	0.00	0.00	0.00	0.00	0.00	0.00	0.00	0.00	10.00	
PR 39	0.00	0.00	0.00	0.00	0.00	0.00	0.00	0.00	2.00	

Sewer Input Summary:

Element Name	Sewer Length (ft)	Elevation			Loss Coefficients			Given Dimensions		
		Downstream Invert (ft)	Slope (%)	Upstream Invert (ft)	Mannings n	Bend Loss	Lateral Loss	Cross Section	Rise (ft or in)	Span (ft or in)
PR 17I	153.11	6901.00	0.7	6902.07	0.013	0.03	0.00	CIRCULAR	36.00 in	36.00 in
PR 17H	248.15	6902.17	0.7	6903.91	0.013	0.05	0.00	CIRCULAR	36.00 in	36.00 in
PR 17G	75.41	6904.01	0.7	6904.54	0.013	0.05	0.00	CIRCULAR	36.00 in	36.00 in
PR 17F	23.28	6904.54	0.7	6904.70	0.013	0.06	0.00	CIRCULAR	36.00 in	36.00 in
PR 17E	40.75	6904.69	0.7	6904.98	0.013	0.06	0.00	CIRCULAR	36.00 in	36.00 in
PR 17D	40.75	6904.98	0.7	6905.27	0.013	0.06	0.00	CIRCULAR	36.00 in	36.00 in
PT 17C	40.26	6905.27	0.7	6905.55	0.013	0.06	0.00	CIRCULAR	36.00 in	36.00 in
PR 17B	231.50	6905.65	0.7	6907.27	0.013	1.32	0.00	CIRCULAR	36.00 in	36.00 in
PR 40	8.08	6909.00	3.1	6909.25	0.012	1.32	0.00	CIRCULAR	12.00 in	12.00 in
PR 17A	50.50	6907.26	9.7	6912.16	0.013	0.05	0.00	CIRCULAR	36.00 in	36.00 in
PR 17	28.17	6912.16	1.0	6912.44	0.013	0.05	0.00	CIRCULAR	36.00 in	36.00 in
PR 16	15.44	6913.19	17.8	6915.94	0.013	0.38	0.00	CIRCULAR	18.00 in	18.00 in
PR 15	31.83	6912.44	1.0	6912.76	0.013	0.05	0.00	CIRCULAR	36.00 in	36.00 in
PR 13	277.53	6913.26	1.0	6916.04	0.013	1.32	0.00	CIRCULAR	36.00 in	36.00 in
PR 12	21.44	6917.91	1.0	6918.12	0.013	1.32	0.00	CIRCULAR	18.00 in	18.00 in
PR 11A	29.17	6916.44	1.0	6916.73	0.013	0.05	0.00	CIRCULAR	24.00 in	24.00 in
PR 11	16.92	6916.90	1.0	6917.07	0.013	1.32	0.00	CIRCULAR	24.00 in	24.00 in
PR 14	15.96	6917.60	1.0	6917.76	0.013	0.05	0.00	CIRCULAR	24.00 in	24.00 in
PR 39	172.21	6911.64	0.8	6913.03	0.012	1.32	0.00	CIRCULAR	12.00 in	12.00 in

Sewer Flow Summary:

Element Name	Full Flow Capacity		Critical Flow		Normal Flow				Flow (cfs)	Surcharged Length (ft)	Comment
	Flow (cfs)	Velocity (fps)	Depth (in)	Velocity (fps)	Depth (in)	Velocity (fps)	Froude Number	Flow Condition			
PR 17I	55.95	7.92	21.66	6.98	19.14	8.12	1.27	Supercritical	31.00	0.00	
PR 17H	55.95	7.92	21.66	6.98	19.14	8.12	1.27	Supercritical	31.00	0.00	
PR 17G	55.95	7.92	21.66	6.98	19.14	8.12	1.27	Supercritical	31.00	0.00	
PR 17F	55.95	7.92	21.66	6.98	19.14	8.12	1.27	Supercritical	31.00	0.00	
PR 17E	55.95	7.92	21.66	6.98	19.14	8.12	1.27	Supercritical	31.00	0.00	

PR 17D	55.95	7.92	21.66	6.98	19.14	8.12	1.27	Supercritical	31.00	0.00	
PT 17C	55.95	7.92	21.66	6.98	19.14	8.12	1.27	Supercritical	31.00	0.00	
PR 17B	55.95	7.92	21.66	6.98	19.14	8.12	1.27	Supercritical	31.00	0.00	
PR 40	6.81	8.67	7.24	4.04	4.46	7.53	2.53	Supercritical	2.00	0.00	
PR 17A	208.29	29.47	21.66	6.98	9.39	21.15	5.00	Supercritical	31.00	0.00	Velocity is Too High
PR 17	66.88	9.46	21.66	6.98	17.22	9.28	1.55	Supercritical	31.00	0.00	
PR 16	44.44	25.15	6.40	3.55	2.60	12.70	5.79	Supercritical	2.00	0.00	
PR 15	66.88	9.46	20.92	6.81	16.57	9.12	1.56	Supercritical	29.00	0.00	
PR 13	66.88	9.46	16.76	5.89	13.13	8.15	1.60	Supercritical	19.00	0.00	
PR 12	10.53	5.96	12.29	5.45	10.72	6.38	1.30	Supercritical	7.00	0.00	
PR 11A	22.68	7.22	15.56	6.03	13.02	7.47	1.41	Supercritical	13.00	0.00	
PR 11	22.68	7.22	15.56	6.03	13.02	7.47	1.41	Supercritical	13.00	0.00	
PR 14	22.68	7.22	13.58	5.46	11.15	6.99	1.46	Supercritical	10.00	0.00	
PR 39	3.48	4.43	7.24	4.04	6.53	4.58	1.22	Pressurized	2.00	172.21	

- A Froude number of 0 indicates that pressurized flow occurs (adverse slope or undersized pipe).
- If the sewer is not pressurized, full flow represents the maximum gravity flow in the sewer.
- If the sewer is pressurized, full flow represents the pressurized flow conditions.

Sewer Sizing Summary:

Element Name	Peak Flow (cfs)	Cross Section	Existing		Calculated		Used			Comment
			Rise	Span	Rise	Span	Rise	Span	Area (ft ²)	
PR 17I	31.00	CIRCULAR	36.00 in	36.00 in	30.00 in	30.00 in	36.00 in	36.00 in	7.07	
PR 17H	31.00	CIRCULAR	36.00 in	36.00 in	30.00 in	30.00 in	36.00 in	36.00 in	7.07	
PR 17G	31.00	CIRCULAR	36.00 in	36.00 in	30.00 in	30.00 in	36.00 in	36.00 in	7.07	
PR 17F	31.00	CIRCULAR	36.00 in	36.00 in	30.00 in	30.00 in	36.00 in	36.00 in	7.07	
PR 17E	31.00	CIRCULAR	36.00 in	36.00 in	30.00 in	30.00 in	36.00 in	36.00 in	7.07	
PR 17D	31.00	CIRCULAR	36.00 in	36.00 in	30.00 in	30.00 in	36.00 in	36.00 in	7.07	
PT 17C	31.00	CIRCULAR	36.00 in	36.00 in	30.00 in	30.00 in	36.00 in	36.00 in	7.07	
PR 17B	31.00	CIRCULAR	36.00 in	36.00 in	30.00 in	30.00 in	36.00 in	36.00 in	7.07	
PR 40	2.00	CIRCULAR	12.00 in	12.00 in	18.00 in	18.00 in	12.00 in	12.00 in	0.79	Height is too small. Width is too small. Existing height is smaller than the suggested height. Existing width is smaller than the suggested width.
PR 17A	31.00	CIRCULAR	36.00 in	36.00 in	18.00 in	18.00 in	36.00 in	36.00 in	7.07	
PR 17	31.00	CIRCULAR	36.00 in	36.00 in	30.00 in	30.00 in	36.00 in	36.00 in	7.07	
PR 16	2.00	CIRCULAR	18.00 in	18.00 in	18.00 in	18.00 in	18.00 in	18.00 in	1.77	
PR 15	29.00	CIRCULAR	36.00 in	36.00 in	27.00 in	27.00 in	36.00 in	36.00 in	7.07	
PR 13	19.00	CIRCULAR	36.00 in	36.00 in	24.00 in	24.00 in	36.00 in	36.00 in	7.07	

PR 12	7.00	CIRCULAR	18.00 in	18.00 in	18.00 in	18.00 in	18.00 in	18.00 in	1.77	
PR 11A	13.00	CIRCULAR	24.00 in	24.00 in	21.00 in	21.00 in	24.00 in	24.00 in	3.14	
PR 11	13.00	CIRCULAR	24.00 in	24.00 in	21.00 in	21.00 in	24.00 in	24.00 in	3.14	
PR 14	10.00	CIRCULAR	24.00 in	24.00 in	18.00 in	18.00 in	24.00 in	24.00 in	3.14	
PR 39	2.00	CIRCULAR	12.00 in	12.00 in	18.00 in	18.00 in	12.00 in	12.00 in	0.79	Height is too small. Width is too small. Existing height is smaller than the suggested height. Existing width is smaller than the suggested width.

- Calculated diameter was determined by sewer hydraulic capacity rounded up to the nearest commercially available size.
- Sewer sizes should not decrease downstream.
- All hydraulics were calculated using the 'Used' parameters.

Grade Line Summary:

Tailwater Elevation (ft): 6902.71

Element Name	Invert Elev.		Downstream Manhole Losses		HGL		EGL		
	Downstream (ft)	Upstream (ft)	Bend Loss (ft)	Lateral Loss (ft)	Downstream (ft)	Upstream (ft)	Downstream (ft)	Friction Loss (ft)	Upstream (ft)
PR 17I	6901.00	6902.07	0.00	0.00	6902.71	6903.87	6903.62	1.01	6904.63
PR 17H	6902.17	6903.91	0.01	0.00	6903.89	6905.71	6904.79	1.68	6906.47
PR 17G	6904.01	6904.54	0.01	0.00	6905.73	6906.34	6906.63	0.47	6907.10
PR 17F	6904.54	6904.70	0.02	0.00	6906.36	6906.50	6907.16	0.11	6907.26
PR 17E	6904.69	6904.98	0.02	0.00	6906.52	6906.78	6907.31	0.23	6907.54
PR 17D	6904.98	6905.27	0.02	0.00	6906.80	6907.07	6907.60	0.23	6907.83
PT 17C	6905.27	6905.55	0.02	0.00	6907.09	6907.35	6907.89	0.22	6908.11
PR 17B	6905.65	6907.27	0.39	0.00	6908.12	6909.07	6908.51	1.33	6909.83
PR 40	6909.00	6909.25	0.13	0.00	6909.37	6910.14	6910.25	0.00	6910.25
PR 17A	6907.26	6912.16	0.01	0.00	6909.09	6914.59	6914.99	0.00	6914.99
PR 17	6912.16	6912.44	0.01	0.00	6914.61	6914.61	6915.00	0.11	6915.11
PR 16	6913.19	6915.94	0.01	0.00	6914.62	6916.47	6915.91	0.76	6916.67
PR 15	6912.44	6912.76	0.01	0.00	6914.73	6914.73	6915.12	0.15	6915.27
PR 13	6913.26	6916.04	0.15	0.00	6915.17	6917.44	6915.42	2.56	6917.98
PR 12	6917.91	6918.12	0.32	0.00	6918.80	6919.14	6919.43	0.17	6919.60
PR 11A	6916.44	6916.73	0.01	0.00	6917.52	6918.03	6918.39	0.20	6918.59
PR 11	6916.90	6917.07	0.35	0.00	6918.63	6918.63	6918.94	0.07	6919.01
PR 14	6917.60	6917.76	0.01	0.00	6918.53	6918.89	6919.29	0.06	6919.35
PR 39	6911.64	6913.03	0.13	0.00	6915.02	6915.48	6915.12	0.46	6915.58

- Bend and Lateral losses only apply when there is an outgoing sewer. The system outfall, sewer #0, is not considered a sewer.
- Bend loss = Bend $K * V_{fi}^2 / (2 * g)$
- Lateral loss = $V_{fo}^2 / (2 * g)$ - Junction Loss $K * V_{fi}^2 / (2 * g)$.
- Friction loss is always Upstream EGL - Downstream EGL.

Excavation Estimate:

The trench side slope is 1.0 ft/ft

The minimum trench width is 2.00 ft

Element Name	Length (ft)	Wall (in)	Bedding (in)	Bottom Width (ft)	Downstream			Upstream			Volume (cu. yd)	Comment
					Top Width (ft)	Trench Depth (ft)	Cover (ft)	Top Width (ft)	Trench Depth (ft)	Cover (ft)		
PR 17I	153.11	4.00	6.00	6.67	0.00	0.00	0.00	9.66	6.66	2.50	132.30	Sewer Too Shallow
PR 17H	248.15	4.00	6.00	6.67	9.45	6.56	2.39	13.28	8.47	4.31	519.74	
PR 17G	75.41	4.00	6.00	6.67	13.08	8.37	4.20	13.42	8.54	4.38	187.74	
PR 17F	23.28	4.00	6.00	6.67	13.43	8.55	4.38	14.60	9.13	4.97	62.52	
PR 17E	40.75	4.00	6.00	6.67	14.61	9.14	4.97	16.04	9.85	5.69	124.03	
PR 17D	40.75	4.00	6.00	6.67	16.03	9.85	5.68	16.96	10.31	6.15	137.96	
PT 17C	40.26	4.00	6.00	6.67	16.96	10.32	6.15	18.90	11.28	7.12	155.01	
PR 17B	231.50	4.00	6.00	6.67	18.70	11.18	7.02	26.46	15.06	10.90	1325.26	
PR 40	8.08	2.00	4.00	4.33	25.00	13.00	11.33	17.50	9.25	7.58	36.89	
PR 17A	50.50	4.00	6.00	6.67	26.48	15.07	10.91	20.18	11.92	7.76	302.75	
PR 17	28.17	4.00	6.00	6.67	20.18	11.93	7.76	19.12	11.39	7.23	125.15	
PR 16	15.44	2.50	4.00	4.92	19.12	10.35	8.10	12.64	7.11	4.86	43.22	
PR 15	31.83	4.00	6.00	6.67	19.12	11.39	7.22	17.18	10.42	6.26	124.85	
PR 13	277.53	4.00	6.00	6.67	16.17	9.92	5.75	10.06	6.86	2.70	705.85	
PR 12	21.44	2.50	4.00	4.92	7.83	4.71	2.46	7.62	4.60	2.35	19.74	
PR 11A	29.17	3.00	4.00	5.50	10.26	6.22	3.38	8.84	5.50	2.67	39.39	
PR 11	16.92	3.00	4.00	5.50	8.50	5.33	2.50	8.48	5.32	2.49	19.76	
PR 14	15.96	3.00	4.00	5.50	8.50	5.33	2.50	8.50	5.33	2.50	18.67	
PR 39	172.21	2.00	4.00	4.33	23.22	12.11	10.44	9.94	5.47	3.80	552.37	

Total earth volume for sewer trenches = 4633 cubic yards.

- The trench was estimated to have a bottom width equal to the outer pipe diameter plus 36 inches.
- If the calculated width of the trench bottom is less than the minimum acceptable width, the minimum acceptable width was used.
- The sewer wall thickness is equal to: (equivalent diameter in inches/12)+1 inches
- The sewer bedding thickness is equal to:
 - Four inches for pipes less than 33 inches.
 - Six inches for pipes less than 60 inches.
 - Eight inches for all larger sizes.

PR 11-17 100-Y PROF

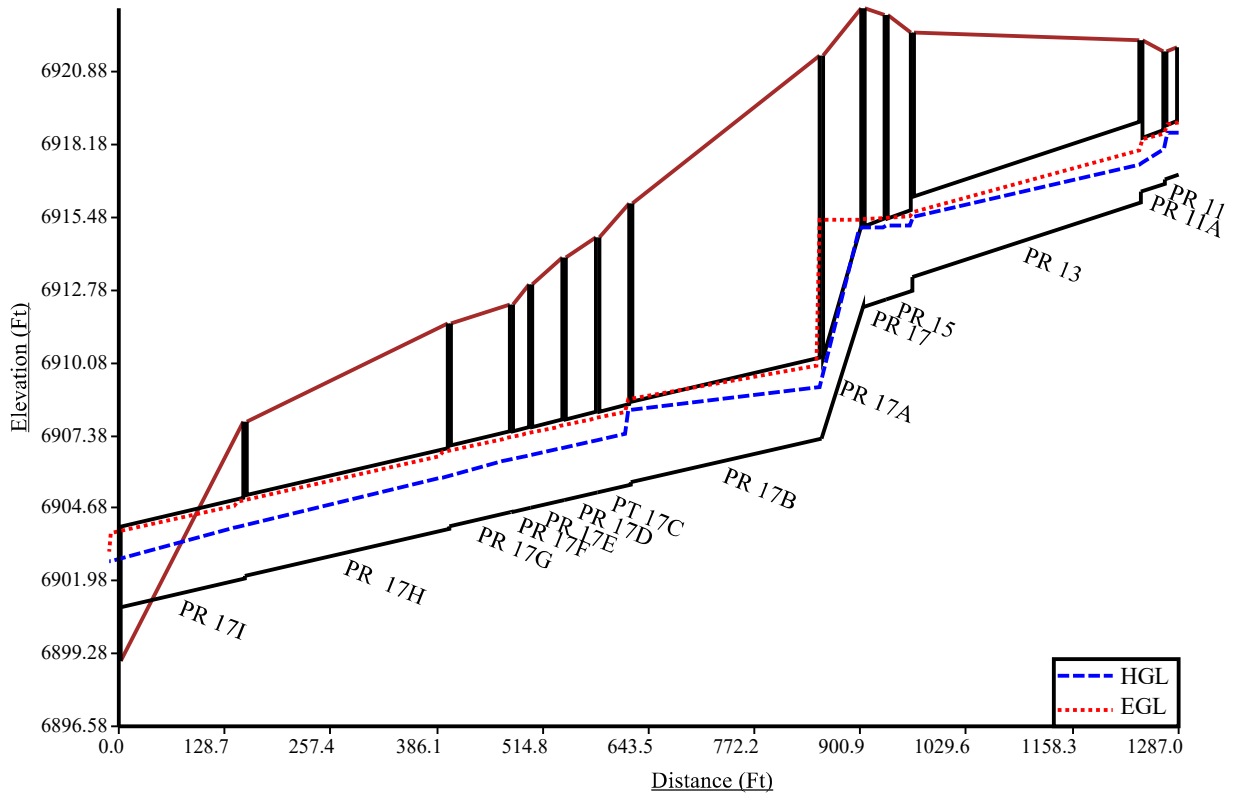

PR 12 100-Y PROF

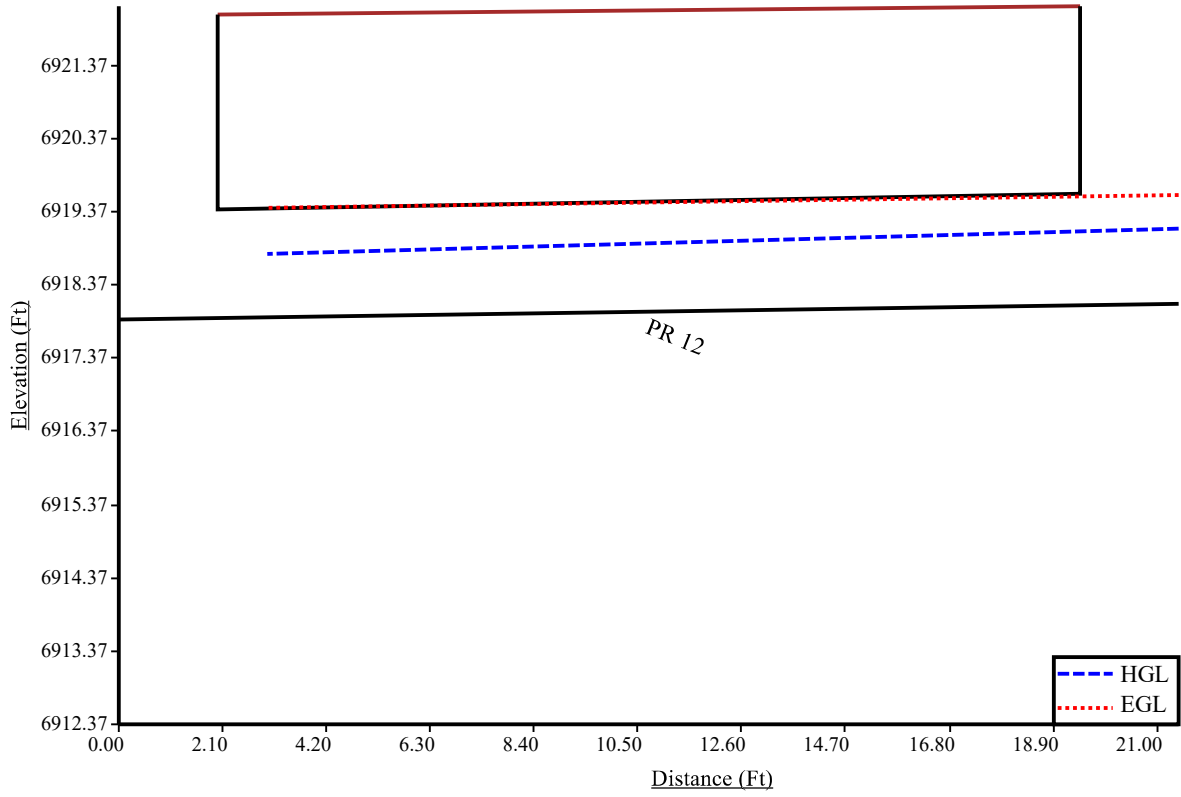

PR 14 100-Y PROF

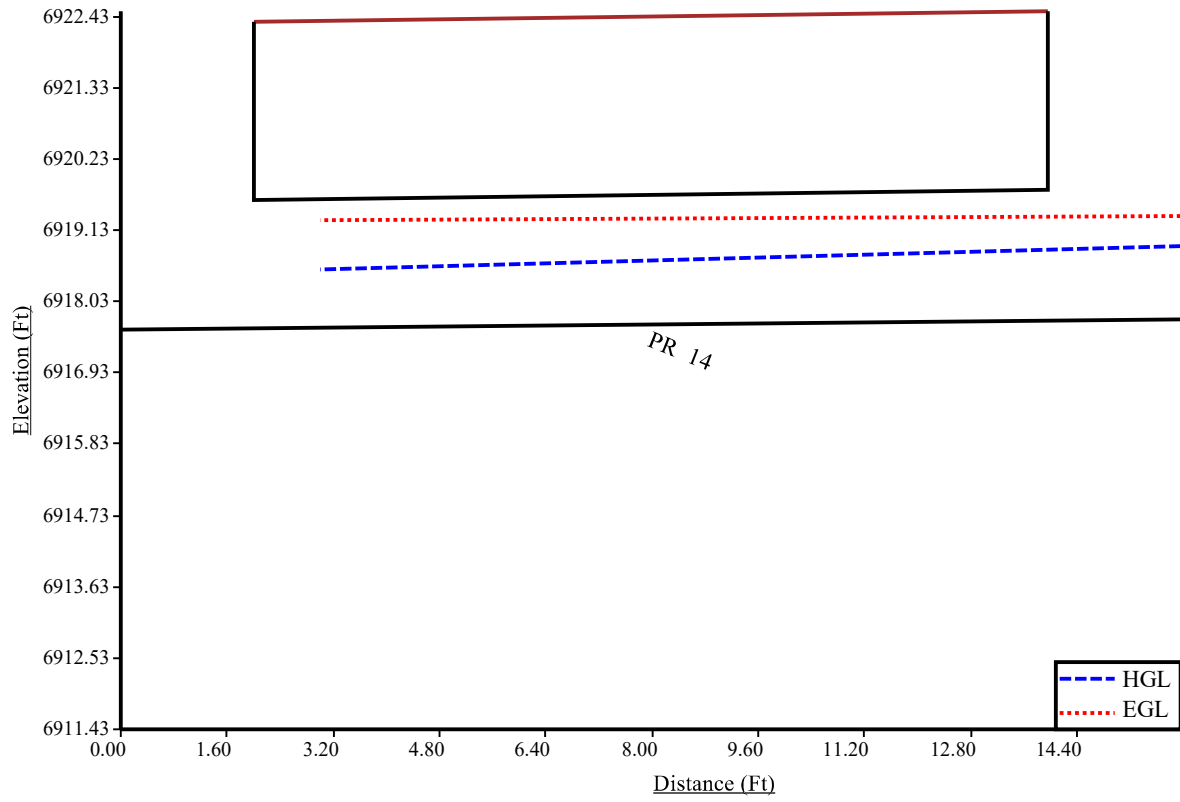

PIPERUNS 19-33

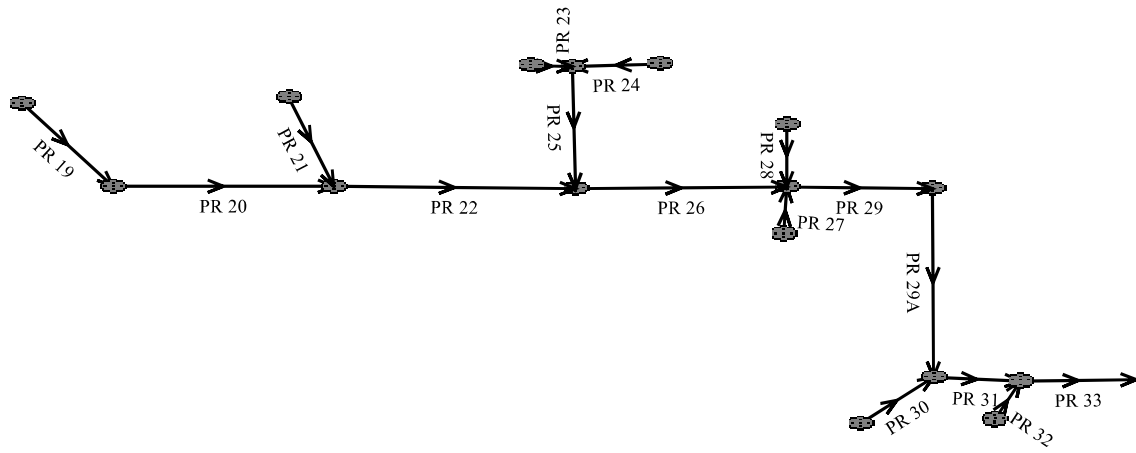

<p>Program: UDSEWER Math Model Interface 2.1.1.4</p> <p>Run Date: 2/4/2023 12:53:05 PM</p>	<h1 style="margin: 0;">UDSewer Results Summary</h1> <p>Project Title: New UDSEWER System Module Project Description: Default system</p> <h2 style="margin: 20px 0 0 0;">PIPERUNS 19-33 100-Y</h2>
--	---

System Input Summary

Rainfall Parameters

Rainfall Return Period: 100
Rainfall Calculation Method: Formula

One Hour Depth (in):
Rainfall Constant "A": 28.5
Rainfall Constant "B": 10
Rainfall Constant "C": 0.786

Rational Method Constraints

Minimum Urban Runoff Coeff.: 0.20
Maximum Rural Overland Len. (ft): 500
Maximum Urban Overland Len. (ft): 300
Used UDFCD Tc. Maximum: Yes

Sizer Constraints

Minimum Sewer Size (in): 18.00
Maximum Depth to Rise Ratio: 0.90
Maximum Flow Velocity (fps): 18.0
Minimum Flow Velocity (fps): 2.0

Backwater Calculations:

Tailwater Elevation (ft): 6927.75

Manhole Input Summary:

		Given Flow		Sub Basin Information						
Element Name	Ground Elevation (ft)	Total Known Flow (cfs)	Local Contribution (cfs)	Drainage Area (Ac.)	Runoff Coefficient	5yr Coefficient	Overland Length (ft)	Overland Slope (%)	Gutter Length (ft)	Gutter Velocity (fps)
FSD 3	6924.25	0.00	0.00	0.00	0.00	0.00	0.00	0.00	0.00	0.00
PR 33A	6932.00	57.00	0.00	0.00	0.00	0.00	0.00	0.00	0.00	0.00

PR 33	6932.20	57.00	0.00	0.00	0.00	0.00	0.00	0.00	0.00	0.00
PR 32	6935.06	7.00	0.00	0.00	0.00	0.00	0.00	0.00	0.00	0.00
PR 31	6934.70	48.00	0.00	0.00	0.00	0.00	0.00	0.00	0.00	0.00
PR 29A	6941.90	34.00	0.00	0.00	0.00	0.00	0.00	0.00	0.00	0.00
PR 29	6941.40	34.00	0.00	0.00	0.00	0.00	0.00	0.00	0.00	0.00
PR 28	6941.66	5.00	0.00	0.00	0.00	0.00	0.00	0.00	0.00	0.00
PR 26	6947.10	23.00	0.00	0.00	0.00	0.00	0.00	0.00	0.00	0.00
PR 25	6945.70	7.00	0.00	0.00	0.00	0.00	0.00	0.00	0.00	0.00
PR 24	6945.95	7.00	0.00	0.00	0.00	0.00	0.00	0.00	0.00	0.00
PR 24	6945.98	1.00	0.00	0.00	0.00	0.00	0.00	0.00	0.00	0.00
PR 22	6952.18	16.00	0.00	0.00	0.00	0.00	0.00	0.00	0.00	0.00
PR 20	6952.70	10.00	0.00	0.00	0.00	0.00	0.00	0.00	0.00	0.00
PR 19	6953.14	5.00	0.00	0.00	0.00	0.00	0.00	0.00	0.00	0.00
PR 21	6952.84	6.00	0.00	0.00	0.00	0.00	0.00	0.00	0.00	0.00
PR 27	6941.66	6.00	0.00	0.00	0.00	0.00	0.00	0.00	0.00	0.00
PR 30	6935.06	16.00	0.00	0.00	0.00	0.00	0.00	0.00	0.00	0.00

Manhole Output Summary:

Element Name	Local Contribution					Total Design Flow				Comment
	Overland Time (min)	Gutter Time (min)	Basin Tc (min)	Intensity (in/hr)	Local Contrib (cfs)	Coeff. Area	Intensity (in/hr)	Manhole Tc (min)	Peak Flow (cfs)	
FSD 3	0.00	0.00	0.00	0.00	0.00	0.00	0.00	0.00	0.00	Surface Water Present (Upstream)
PR 33A	0.00	0.00	0.00	0.00	0.00	0.00	0.00	0.00	57.00	Surface Water Present (Downstream)
PR 33	0.00	0.00	0.00	0.00	0.00	0.00	0.00	0.00	57.00	
PR 32	0.00	0.00	0.00	0.00	0.00	0.00	0.00	0.00	7.00	
PR 31	0.00	0.00	0.00	0.00	0.00	0.00	0.00	0.00	48.00	
PR 29A	0.00	0.00	0.00	0.00	0.00	0.00	0.00	0.00	34.00	
PR 29	0.00	0.00	0.00	0.00	0.00	0.00	0.00	0.00	34.00	
PR 28	0.00	0.00	0.00	0.00	0.00	0.00	0.00	0.00	5.00	
PR 26	0.00	0.00	0.00	0.00	0.00	0.00	0.00	0.00	23.00	
PR 25	0.00	0.00	0.00	0.00	0.00	0.00	0.00	0.00	7.00	
PR 24	0.00	0.00	0.00	0.00	0.00	0.00	0.00	0.00	7.00	
PR 24	0.00	0.00	0.00	0.00	0.00	0.00	0.00	0.00	1.00	
PR 22	0.00	0.00	0.00	0.00	0.00	0.00	0.00	0.00	16.00	
PR 20	0.00	0.00	0.00	0.00	0.00	0.00	0.00	0.00	10.00	
PR 19	0.00	0.00	0.00	0.00	0.00	0.00	0.00	0.00	5.00	
PR 21	0.00	0.00	0.00	0.00	0.00	0.00	0.00	0.00	6.00	
PR 27	0.00	0.00	0.00	0.00	0.00	0.00	0.00	0.00	6.00	
PR 30	0.00	0.00	0.00	0.00	0.00	0.00	0.00	0.00	16.00	

Sewer Input Summary:

Element Name	Sewer Length (ft)	Elevation			Loss Coefficients			Given Dimensions		
		Downstream Invert (ft)	Slope (%)	Upstream Invert (ft)	Mannings n	Bend Loss	Lateral Loss	Cross Section	Rise (ft or in)	Span (ft or in)
PR 33A	163.90	6924.25	1.0	6925.89	0.013	0.03	0.00	CIRCULAR	42.00 in	42.00 in
PR 33	126.20	6925.89	1.0	6927.15	0.013	0.05	0.00	CIRCULAR	42.00 in	42.00 in
PR 32	11.86	6928.15	11.7	6929.54	0.013	0.38	0.00	CIRCULAR	18.00 in	18.00 in
PR 31	35.39	6927.15	1.0	6927.50	0.013	0.05	0.00	CIRCULAR	42.00 in	42.00 in
PR 29A	274.51	6928.06	1.6	6932.56	0.013	1.32	0.00	CIRCULAR	36.00 in	36.00 in
PR 29	83.18	6932.95	1.6	6934.30	0.013	1.32	0.00	CIRCULAR	36.00 in	36.00 in
PR 28	25.17	6935.80	3.0	6936.55	0.013	1.32	0.00	CIRCULAR	18.00 in	18.00 in
PR 26	345.95	6934.60	1.3	6939.25	0.013	0.05	0.00	CIRCULAR	36.00 in	36.00 in
PR 25	105.89	6939.75	1.0	6940.81	0.013	1.32	0.00	CIRCULAR	30.00 in	30.00 in
PR 24	5.99	6941.31	1.0	6941.37	0.013	1.32	0.00	CIRCULAR	24.00 in	24.00 in
PR 24	25.67	6941.31	1.0	6941.57	0.013	1.32	0.00	CIRCULAR	24.00 in	24.00 in
PR 22	289.94	6940.25	1.8	6945.61	0.013	0.05	0.00	CIRCULAR	30.00 in	30.00 in
PR 20	174.56	6946.11	1.0	6947.86	0.013	0.05	0.00	CIRCULAR	24.00 in	24.00 in
PR 19	26.19	6948.36	1.0	6948.62	0.013	0.38	0.00	CIRCULAR	18.00 in	18.00 in
PR 21	26.19	6946.61	2.1	6947.17	0.013	0.38	0.00	CIRCULAR	18.00 in	18.00 in
PR 27	5.17	6935.80	2.9	6935.95	0.013	1.32	0.00	CIRCULAR	18.00 in	18.00 in
PR 30	12.69	6929.00	4.3	6929.54	0.013	0.38	0.00	CIRCULAR	24.00 in	24.00 in

Sewer Flow Summary:

Element Name	Full Flow Capacity		Critical Flow		Normal Flow				Flow (cfs)	Surcharged Length (ft)	Comment
	Flow (cfs)	Velocity (fps)	Depth (in)	Velocity (fps)	Depth (in)	Velocity (fps)	Froude Number	Flow Condition			
PR 33A	100.88	10.49	28.37	8.24	22.60	10.80	1.55	Supercritical	57.00	0.00	
PR 33	100.88	10.49	28.37	8.24	22.60	10.80	1.55	Supercritical	57.00	0.00	
PR 32	36.03	20.39	12.29	5.45	5.38	15.79	4.90	Supercritical	7.00	0.00	
PR 31	100.88	10.49	25.96	7.69	20.40	10.36	1.59	Supercritical	48.00	0.00	
PR 29A	85.63	12.11	22.72	7.23	15.77	11.42	2.01	Supercritical	34.00	0.00	
PR 29	85.19	12.05	22.72	7.23	15.81	11.37	2.00	Supercritical	34.00	0.00	
PR 28	18.18	10.29	10.32	4.77	6.45	8.78	2.46	Supercritical	5.00	0.00	
PR 26	77.54	10.97	18.53	6.27	13.44	9.56	1.85	Supercritical	23.00	0.00	
PR 25	41.15	8.38	10.53	4.55	8.37	6.25	1.56	Supercritical	7.00	0.00	
PR 24	22.71	7.23	11.26	4.83	9.15	6.37	1.49	Supercritical	7.00	0.00	
PR 24	22.82	7.26	4.13	2.77	3.42	3.64	1.45	Supercritical	1.00	0.00	
PR 22	55.92	11.39	16.21	5.91	10.98	9.83	2.11	Supercritical	16.00	0.00	
PR 20	22.71	7.23	13.58	5.46	11.15	7.00	1.46	Supercritical	10.00	0.00	

PR 19	10.53	5.96	10.32	4.77	8.73	5.88	1.38	Supercritical	5.00	0.00	
PR 21	15.40	8.72	11.35	5.11	7.80	8.17	2.05	Supercritical	6.00	0.00	
PR 27	17.96	10.17	11.35	5.11	7.17	9.15	2.41	Supercritical	6.00	0.00	
PR 30	46.79	14.89	17.30	6.60	9.68	13.49	3.06	Supercritical	16.00	0.00	

- A Froude number of 0 indicates that pressured flow occurs (adverse slope or undersized pipe).
- If the sewer is not pressurized, full flow represents the maximum gravity flow in the sewer.
- If the sewer is pressurized, full flow represents the pressurized flow conditions.

Sewer Sizing Summary:

Element Name	Peak Flow (cfs)	Cross Section	Existing		Calculated		Used			Comment
			Rise	Span	Rise	Span	Rise	Span	Area (ft ²)	
PR 33A	57.00	CIRCULAR	42.00 in	42.00 in	36.00 in	36.00 in	42.00 in	42.00 in	9.62	
PR 33	57.00	CIRCULAR	42.00 in	42.00 in	36.00 in	36.00 in	42.00 in	42.00 in	9.62	
PR 32	7.00	CIRCULAR	18.00 in	18.00 in	18.00 in	18.00 in	18.00 in	18.00 in	1.77	
PR 31	48.00	CIRCULAR	42.00 in	42.00 in	33.00 in	33.00 in	42.00 in	42.00 in	9.62	
PR 29A	34.00	CIRCULAR	36.00 in	36.00 in	27.00 in	27.00 in	36.00 in	36.00 in	7.07	
PR 29	34.00	CIRCULAR	36.00 in	36.00 in	27.00 in	27.00 in	36.00 in	36.00 in	7.07	
PR 28	5.00	CIRCULAR	18.00 in	18.00 in	18.00 in	18.00 in	18.00 in	18.00 in	1.77	
PR 26	23.00	CIRCULAR	36.00 in	36.00 in	24.00 in	24.00 in	36.00 in	36.00 in	7.07	
PR 25	7.00	CIRCULAR	30.00 in	30.00 in	18.00 in	18.00 in	30.00 in	30.00 in	4.91	
PR 24	7.00	CIRCULAR	24.00 in	24.00 in	18.00 in	18.00 in	24.00 in	24.00 in	3.14	
PR 24	1.00	CIRCULAR	24.00 in	24.00 in	18.00 in	18.00 in	24.00 in	24.00 in	3.14	
PR 22	16.00	CIRCULAR	30.00 in	30.00 in	21.00 in	21.00 in	30.00 in	30.00 in	4.91	
PR 20	10.00	CIRCULAR	24.00 in	24.00 in	18.00 in	18.00 in	24.00 in	24.00 in	3.14	
PR 19	5.00	CIRCULAR	18.00 in	18.00 in	18.00 in	18.00 in	18.00 in	18.00 in	1.77	
PR 21	6.00	CIRCULAR	18.00 in	18.00 in	18.00 in	18.00 in	18.00 in	18.00 in	1.77	
PR 27	6.00	CIRCULAR	18.00 in	18.00 in	18.00 in	18.00 in	18.00 in	18.00 in	1.77	
PR 30	16.00	CIRCULAR	24.00 in	24.00 in	18.00 in	18.00 in	24.00 in	24.00 in	3.14	

- Calculated diameter was determined by sewer hydraulic capacity rounded up to the nearest commercially available size.
- Sewer sizes should not decrease downstream.
- All hydraulics were calculated using the 'Used' parameters.

Grade Line Summary:

Tailwater Elevation (ft): 6927.75

Invert Elev.	Downstream Manhole Losses	HGL	EGL

Element Name	Downstream (ft)	Upstream (ft)	Bend Loss (ft)	Lateral Loss (ft)	Downstream (ft)	Upstream (ft)	Downstream (ft)	Friction Loss (ft)	Upstream (ft)
PR 33A	6924.25	6925.89	0.00	0.00	6927.75	6928.25	6928.30	1.01	6929.31
PR 33	6925.89	6927.15	0.03	0.00	6928.28	6929.51	6929.58	0.99	6930.57
PR 32	6928.15	6929.54	0.09	0.00	6929.61	6932.23	6932.47	0.00	6932.47
PR 31	6927.15	6927.50	0.02	0.00	6930.12	6930.12	6930.59	0.13	6930.72
PR 29A	6928.06	6932.56	0.47	0.00	6930.59	6934.45	6931.40	3.87	6935.27
PR 29	6932.95	6934.30	0.47	0.00	6934.93	6936.19	6936.28	0.73	6937.01
PR 28	6935.80	6936.55	0.16	0.00	6936.36	6937.41	6937.54	0.23	6937.76
PR 26	6934.60	6939.25	0.01	0.00	6936.20	6940.79	6937.14	4.27	6941.41
PR 25	6939.75	6940.81	0.04	0.00	6941.38	6941.69	6941.45	0.56	6942.01
PR 24	6941.31	6941.37	0.10	0.00	6942.15	6942.31	6942.63	0.04	6942.67
PR 24	6941.31	6941.57	0.00	0.00	6941.99	6941.99	6942.01	0.05	6942.06
PR 22	6940.25	6945.61	0.01	0.00	6941.17	6946.96	6942.67	4.84	6947.50
PR 20	6946.11	6947.86	0.01	0.00	6947.04	6948.99	6947.80	1.65	6949.45
PR 19	6948.36	6948.62	0.05	0.00	6949.09	6949.48	6949.62	0.21	6949.83
PR 21	6946.61	6947.17	0.07	0.00	6947.26	6948.12	6948.30	0.22	6948.52
PR 27	6935.80	6935.95	0.24	0.00	6936.43	6937.52	6937.70	0.00	6937.70
PR 30	6929.00	6929.54	0.15	0.00	6930.27	6932.23	6932.63	0.00	6932.63

- Bend and Lateral losses only apply when there is an outgoing sewer. The system outfall, sewer #0, is not considered a sewer.
- Bend loss = Bend K * V_{fi} ^ 2/(2*g)
- Lateral loss = V_{fo} ^ 2/(2*g)- Junction Loss K * V_{fi} ^ 2/(2*g).
- Friction loss is always Upstream EGL - Downstream EGL.

Excavation Estimate:

The trench side slope is 1.0 ft/ft
 The minimum trench width is 2.00 ft

Element Name	Length (ft)	Wall (in)	Bedding (in)	Downstream				Upstream			Volume (cu. yd)	Comment
				Bottom Width (ft)	Top Width (ft)	Trench Depth (ft)	Cover (ft)	Top Width (ft)	Trench Depth (ft)	Cover (ft)		
PR 33A	163.90	4.50	6.00	7.25	0.00	0.87	0.00	9.72	6.99	2.24	177.57	Sewer Too Shallow
PR 33	126.20	4.50	6.00	7.25	9.72	6.99	2.24	7.60	5.93	1.18	222.42	Sewer Too Shallow
PR 32	11.86	2.50	4.00	4.92	7.60	4.59	2.34	10.54	6.06	3.81	13.63	
PR 31	35.39	4.50	6.00	7.25	7.61	5.93	1.18	11.90	8.08	3.33	70.10	Sewer Too Shallow
PR 29A	274.51	4.00	6.00	6.67	11.28	7.47	3.31	16.68	10.17	6.01	752.52	
PR 29	83.18	4.00	6.00	6.67	15.90	9.78	5.62	12.20	7.93	3.77	226.55	
PR 28	25.17	2.50	4.00	4.92	10.70	6.14	3.89	9.72	5.65	3.40	33.61	
PR 26	345.95	4.00	6.00	6.67	11.60	7.63	3.47	13.70	8.68	4.52	815.08	
PR 25	105.89	3.50	6.00	6.08	13.20	8.14	4.56	8.28	5.68	2.10	192.09	

PR 24	5.99	3.00	4.00	5.50	7.78	4.97	2.14	8.16	5.16	2.33	6.52	
PR 24	25.67	3.00	4.00	5.50	7.78	4.97	2.14	7.82	4.99	2.16	27.31	
PR 22	289.94	3.50	6.00	6.08	12.20	7.64	4.06	11.64	7.36	3.78	581.71	
PR 20	174.56	3.00	4.00	5.50	11.14	6.65	3.82	8.68	5.42	2.59	248.59	
PR 19	26.19	2.50	4.00	4.92	8.18	4.88	2.63	8.54	5.06	2.81	26.60	
PR 21	26.19	2.50	4.00	4.92	10.64	6.11	3.86	10.84	6.21	3.96	37.61	
PR 27	5.17	2.50	4.00	4.92	10.70	6.14	3.89	10.92	6.25	4.00	7.50	
PR 30	12.69	3.00	4.00	5.50	10.40	6.28	3.45	10.04	6.10	3.27	18.63	

Total earth volume for sewer trenches = 3458 cubic yards.

- The trench was estimated to have a bottom width equal to the outer pipe diameter plus 36 inches.
- If the calculated width of the trench bottom is less than the minimum acceptable width, the minimum acceptable width was used.
- The sewer wall thickness is equal to: (equivalent diameter in inches/12)+1 inches
- The sewer bedding thickness is equal to:
 - Four inches for pipes less than 33 inches.
 - Six inches for pipes less than 60 inches.
 - Eight inches for all larger sizes.

PR 19-33 100-Y PROF

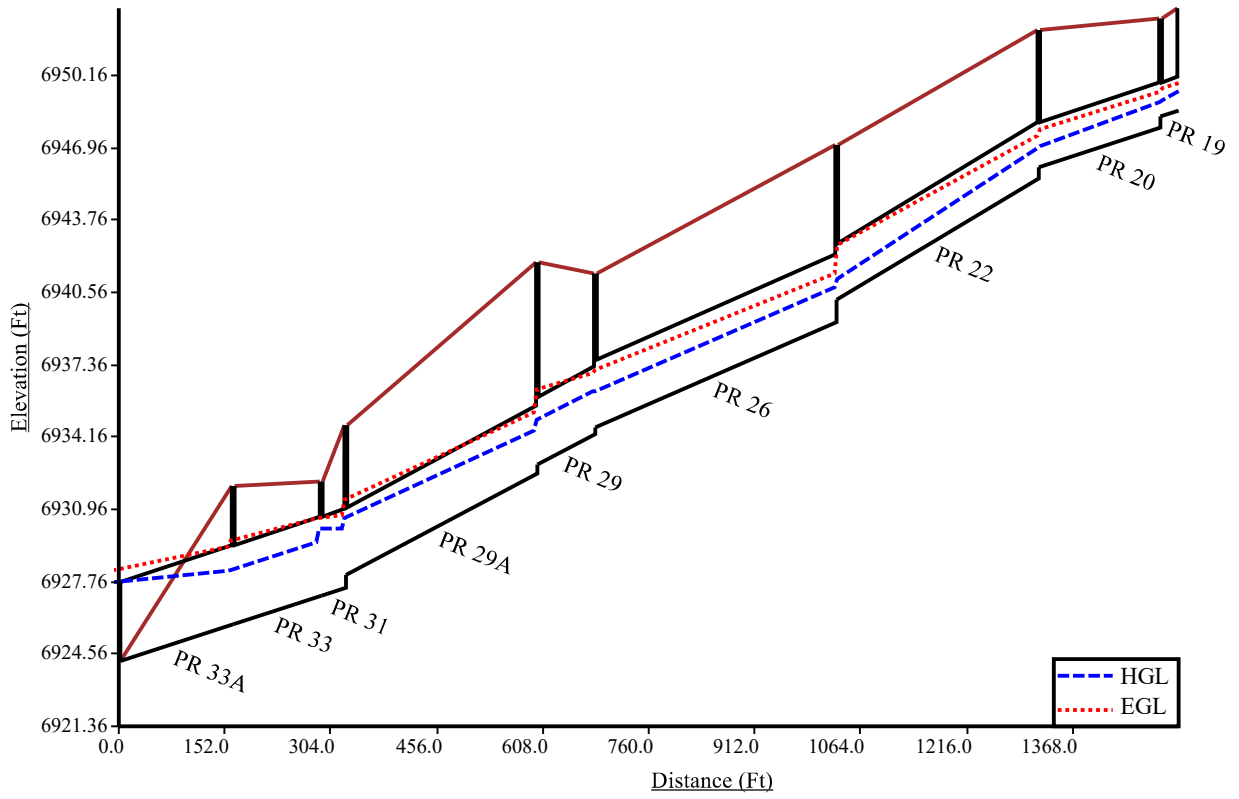

PR 21 100-Y PROF

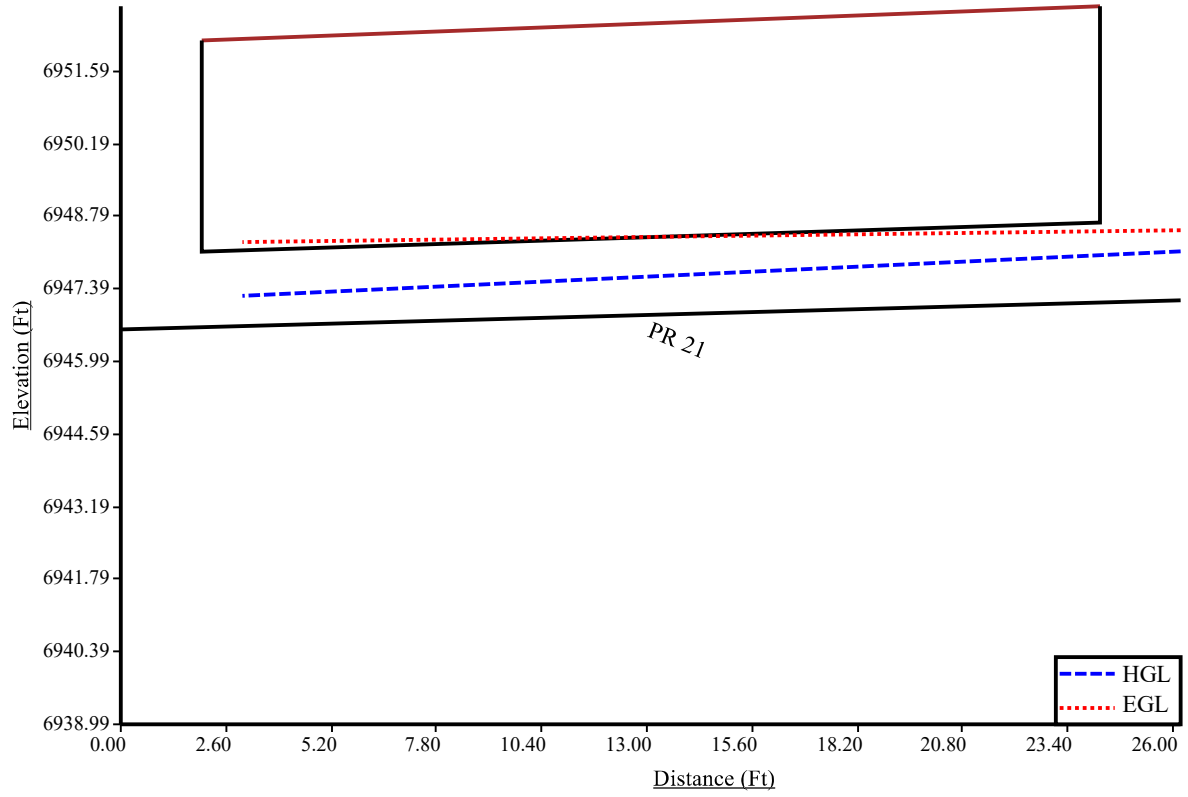

PR 25-23 100-Y PROF

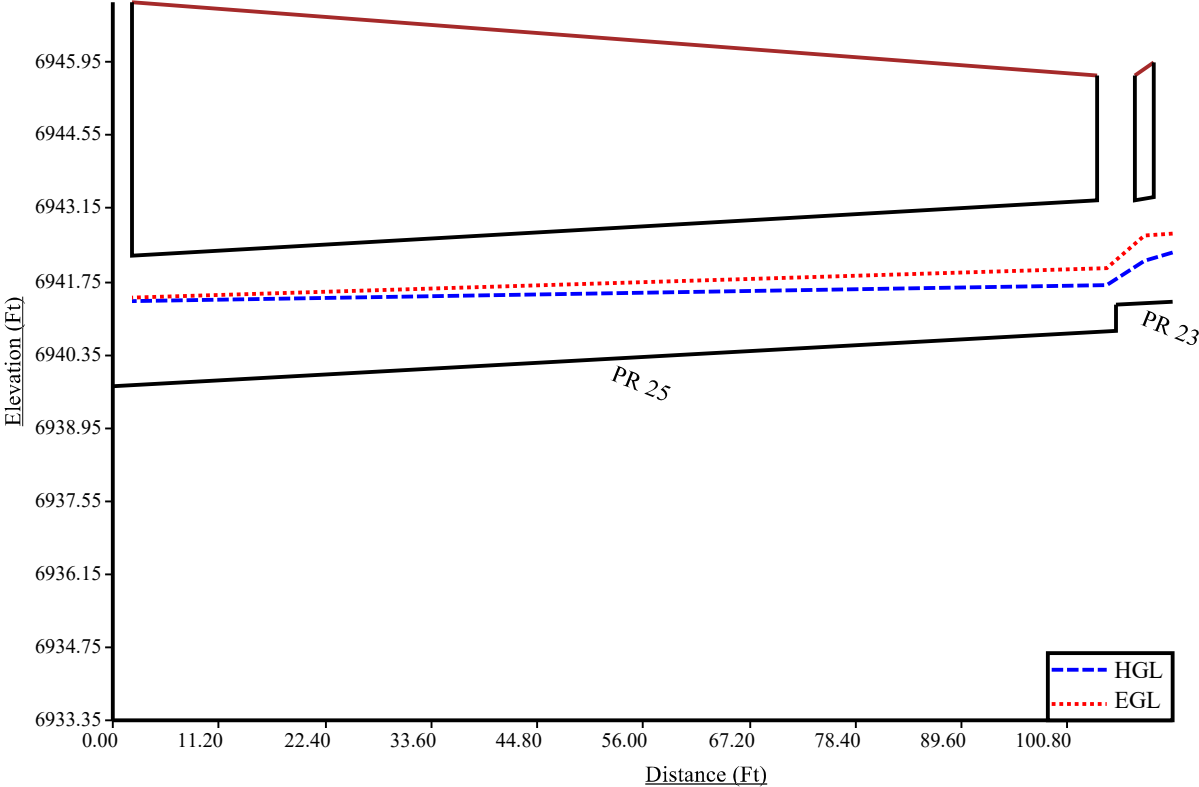

PR 24 100-Y PROF

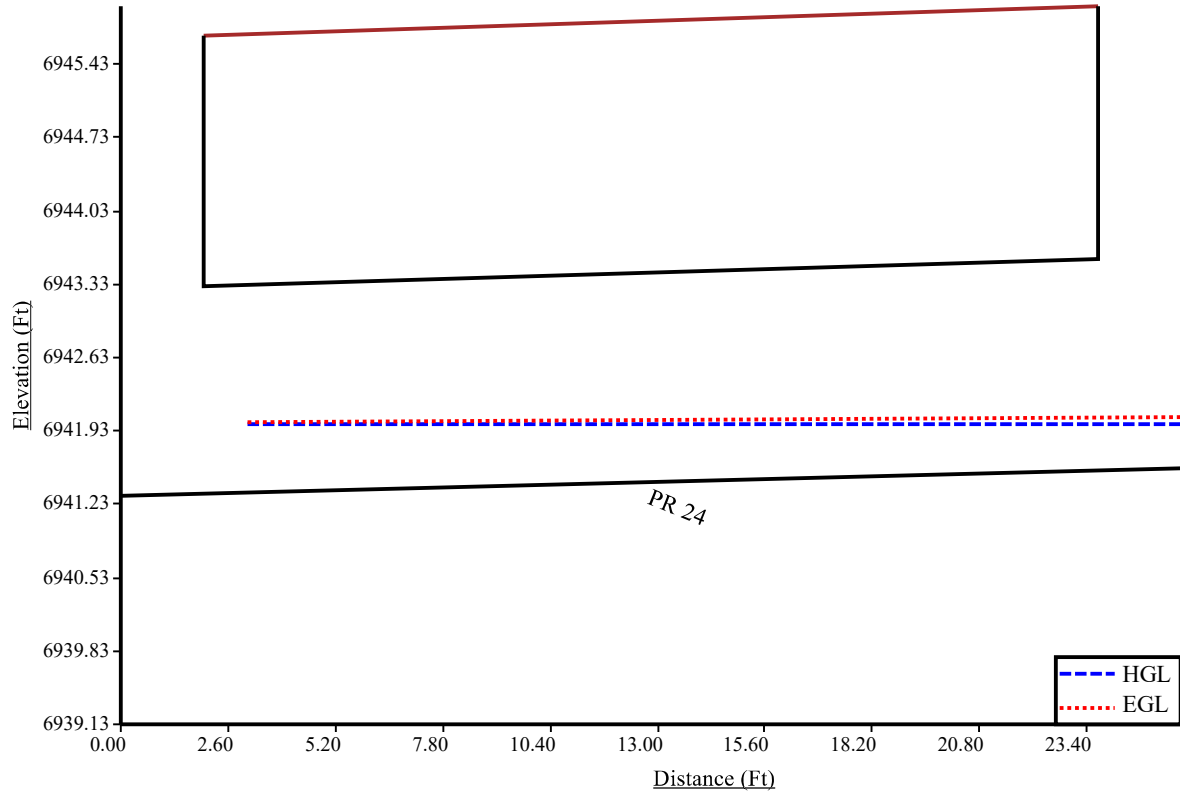

PR 27 100-Y PROF

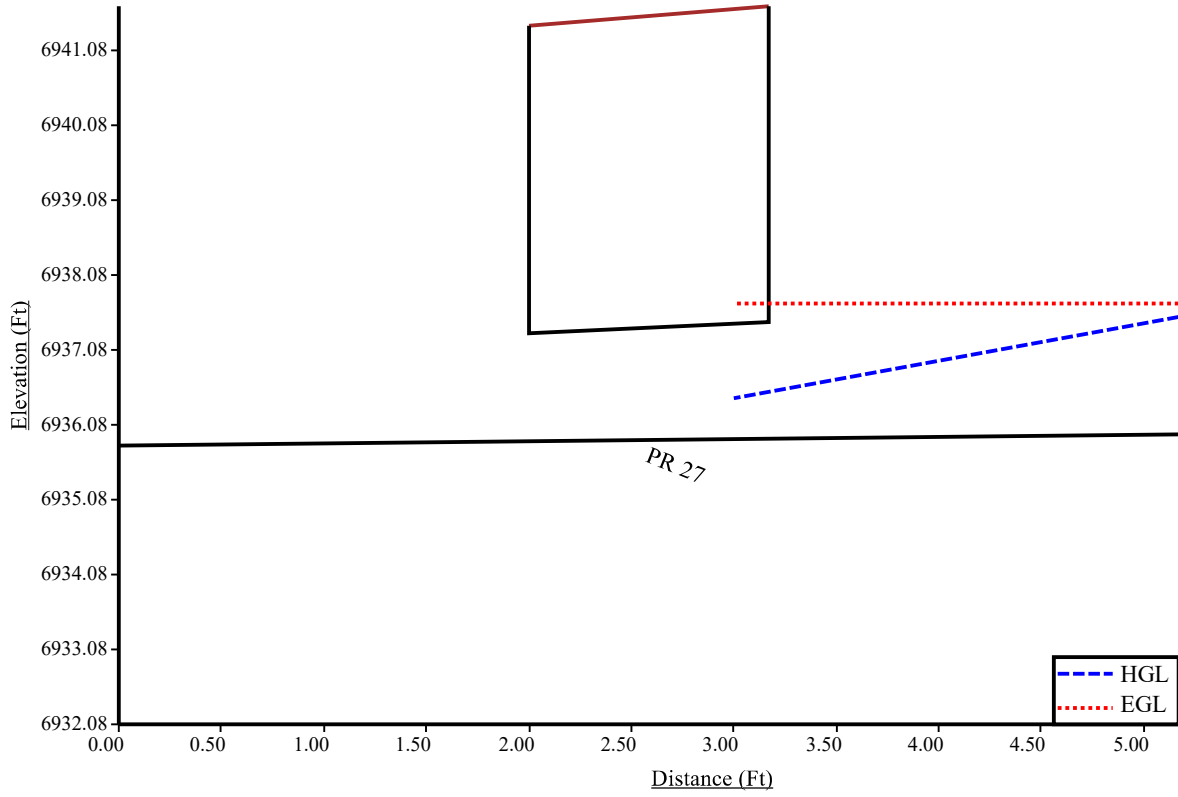

PR 28 100-Y PROF

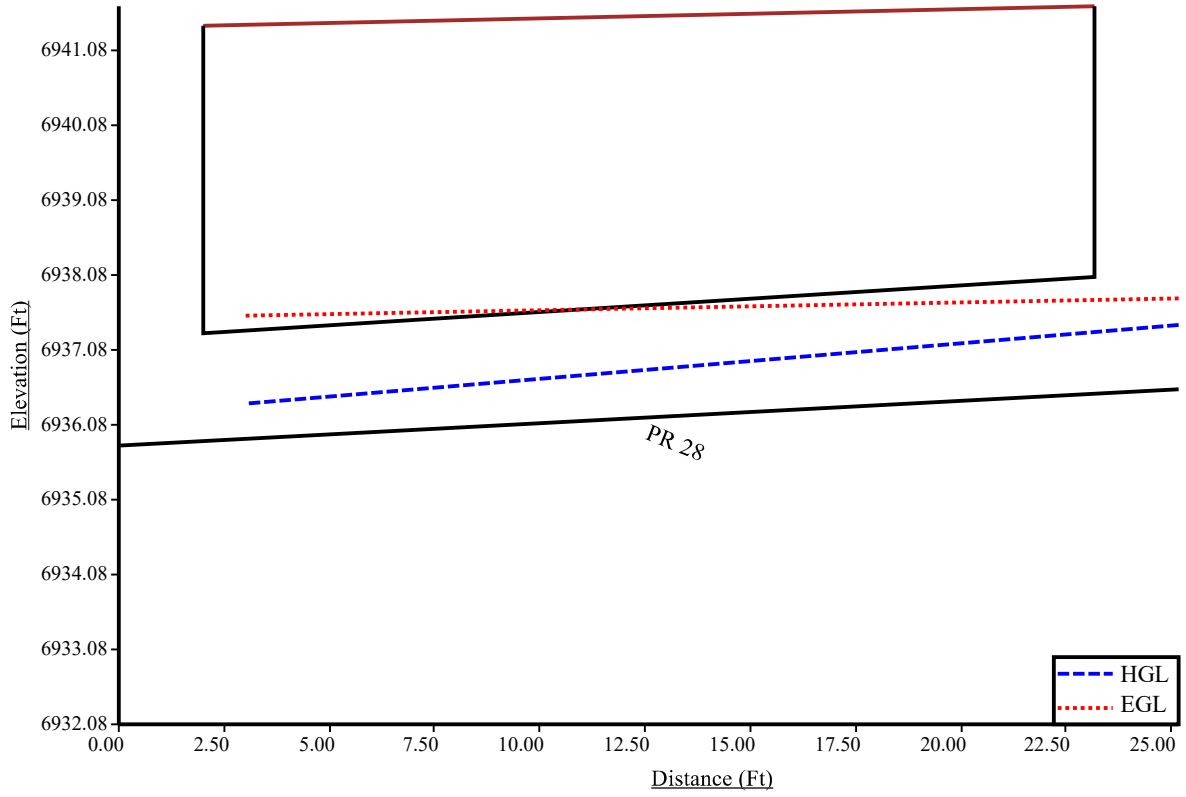

PR 30 100-Y PROF

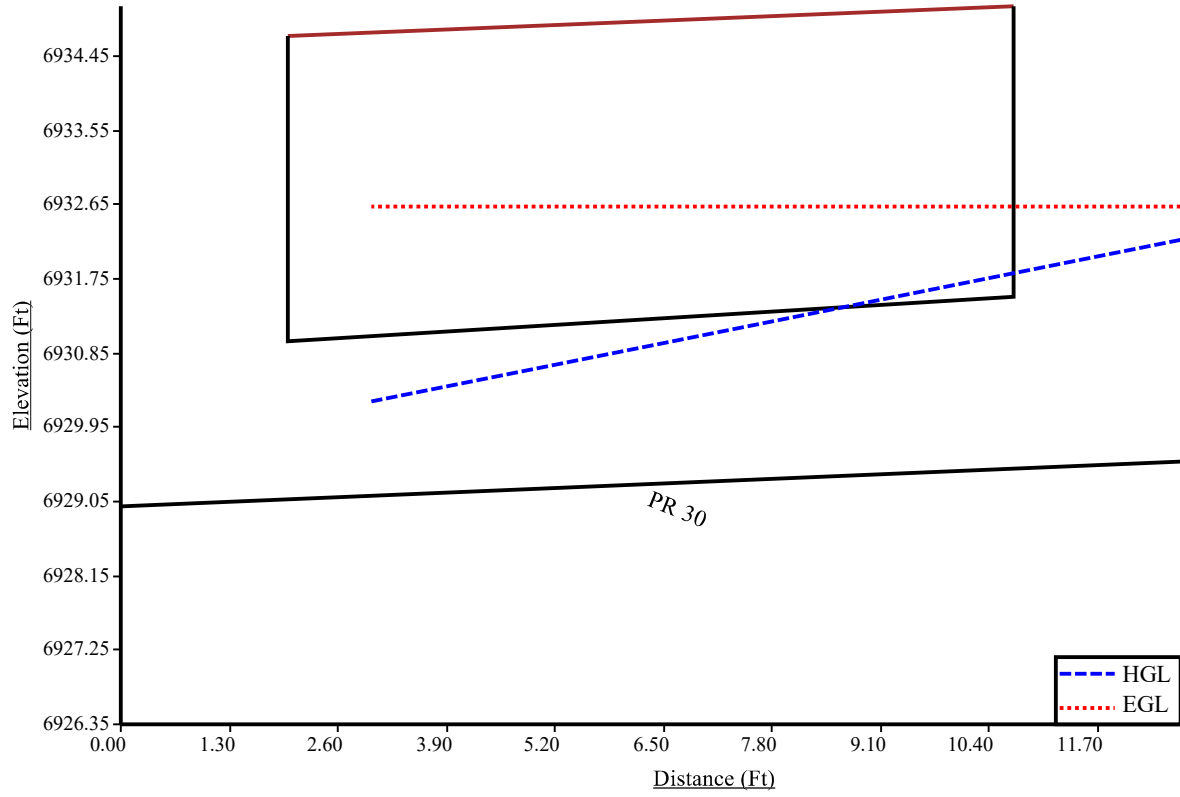

PR 32 100-Y PROF

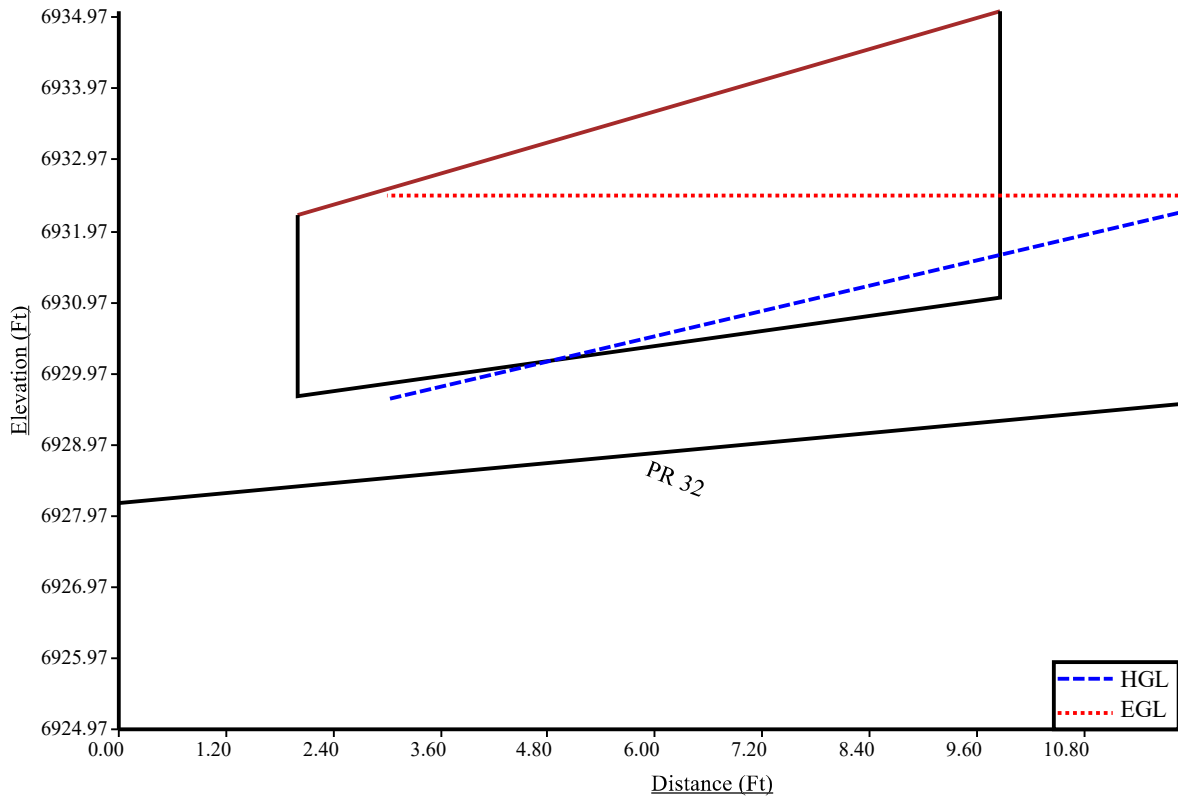

CULVERT CALCULATIONS

CULVERT STAGE-DISCHARGE SIZING (INLET vs. OUTLET CONTROL WITH TAILWATER EFFECTS)

Project: **WATERBURY FILING 1**
 Basin ID: **Design Point 11- Dual 42" RCP Culverts**
 Status: _____

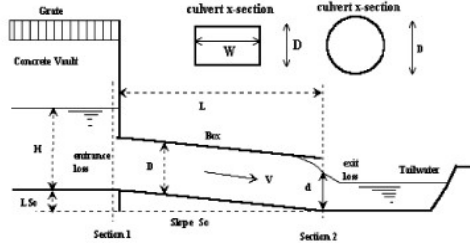

Design Information (Input):

Circular Culvert: Barrel Diameter in Inches D = inches
 Inlet Edge Type (choose from pull-down list)

OR:

Box Culvert: Barrel Height (Rise) in Feet Height (Rise) = ft.
 Barrel Width (Span) in Feet Width (Span) = ft.
 Inlet Edge Type (choose from pull-down list)

Number of Barrels No =
 Inlet Elevation at Culvert Invert Inlet Elev = ft. elev.
 Outlet Elevation at Culvert Invert **OR** Slope of Culvert (ft v./ft h.) Outlet Elev = ft. elev.
 Culvert Length in Feet L = ft.
 Manning's Roughness n =
 Bend Loss Coefficient K_b =
 Exit Loss Coefficient K_x =

Design Information (calculated):

Entrance Loss Coefficient K_e =
 Friction Loss Coefficient K_f =
 Sum of All Loss Coefficients K_s =
 Orifice Inlet Condition Coefficient C_d =
 Minimum Energy Condition Coefficient KE_{bw} =

Calculations of Culvert Capacity (output):

Water Surface Elevation (ft., linked)	Tailwater Surface Elevation ft	Culvert Inlet-Control Flowrate cfs	Culvert Outlet-Control Flowrate cfs	Controlling Culvert Flowrate cfs (output)	Inlet Equation Used:	Flow Control Used
6939.32		113.80	142.47	113.80	Regression Eqn.	INLET
6939.57		125.60	152.60	125.60	Regression Eqn.	INLET
6939.82		136.80	162.28	136.80	Regression Eqn.	INLET
6940.07		147.20	171.28	147.20	Regression Eqn.	INLET
6940.32		157.00	180.05	157.00	Regression Eqn.	INLET
6940.57		166.20	188.25	166.20	Regression Eqn.	INLET
6940.82		175.00	196.11	175.00	Regression Eqn.	INLET
6941.07		183.20	203.85	183.20	Regression Eqn.	INLET
6941.32		191.00	211.14	191.00	Regression Eqn.	INLET
6941.57		198.60	218.20	198.60	Regression Eqn.	INLET
6941.82		205.80	225.15	205.80	Regression Eqn.	INLET
6942.07		212.60	231.86	212.60	Regression Eqn.	INLET
6942.32		219.40	238.36	219.40	Regression Eqn.	INLET
6942.57		225.80	244.62	225.80	Regression Eqn.	INLET
6942.82		232.00	250.88	232.00	Regression Eqn.	INLET
6943.07		238.20	256.81	238.20	Regression Eqn.	INLET
6943.32		244.20	262.73	244.20	Regression Eqn.	INLET
6943.57		250.00	268.42	250.00	Regression Eqn.	INLET
6943.82		255.60	274.12	255.60	Regression Eqn.	INLET
6944.07		261.20	279.58	261.20	Regression Eqn.	INLET
6944.32		266.60	285.05	266.60	Regression Eqn.	INLET
6944.57		272.00	290.40	272.00	Regression Eqn.	INLET
6944.82		277.20	295.64	277.20	Regression Eqn.	INLET
6945.07		282.40	300.76	282.40	Regression Eqn.	INLET
6945.32		287.40	305.77	287.40	Regression Eqn.	INLET
6945.57		292.40	310.67	292.40	Regression Eqn.	INLET
6945.82		297.40	315.57	297.40	Regression Eqn.	INLET
6946.07		302.20	320.35	302.20	Regression Eqn.	INLET
6946.32		307.00	325.13	307.00	Regression Eqn.	INLET
6946.57		311.40	329.80	311.40	Orifice Eqn.	INLET

Processing Time: 27.79 Seconds

CULVERT STAGE-DISCHARGE SIZING (INLET vs. OUTLET CONTROL WITH TAILWATER EFFECTS)

Project: WATERBURY FILING 1
Basin ID: Design Point 11- Dual 42" RCP Culverts

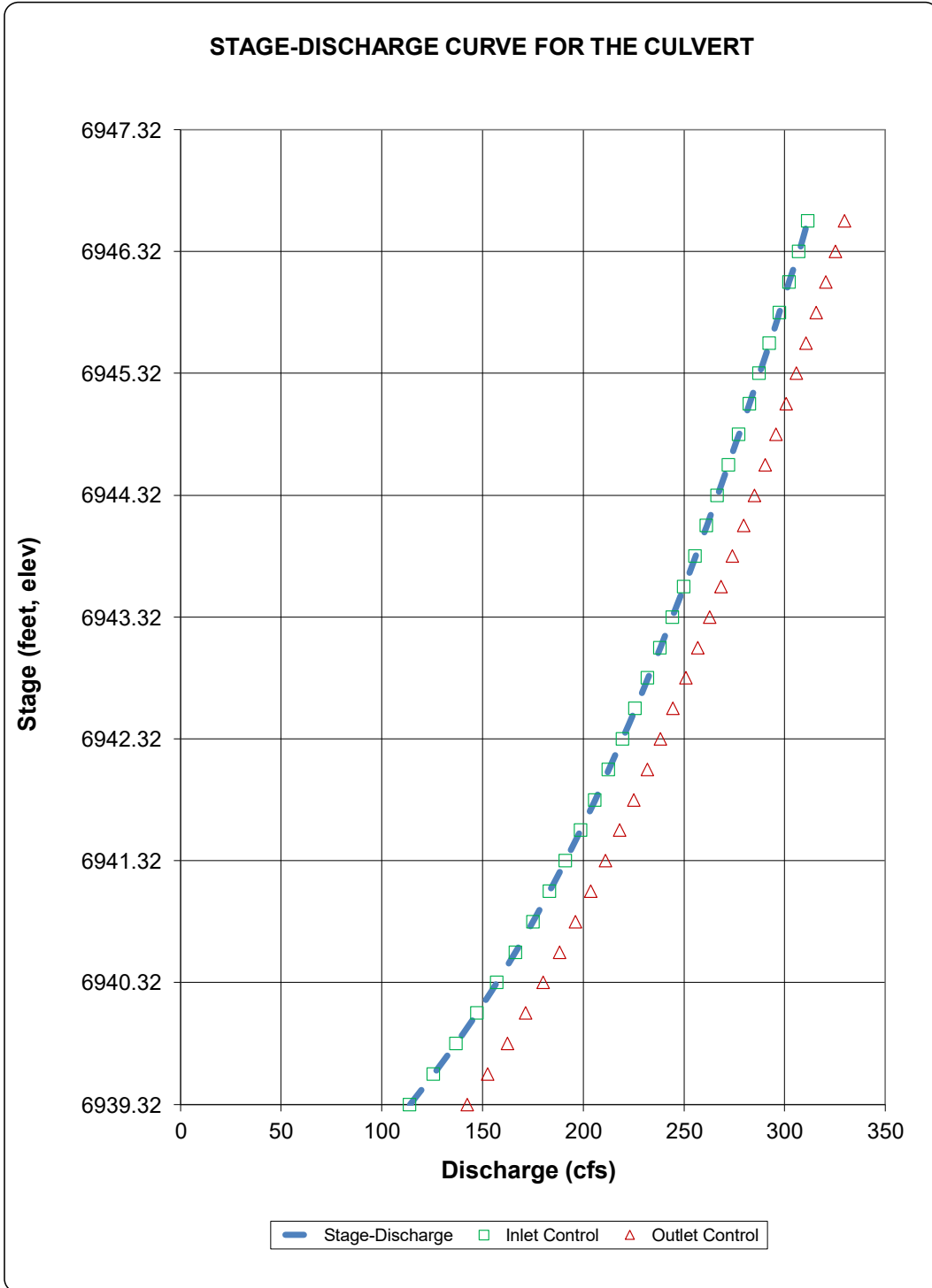

Determination of Culvert Headwater and Outlet Protection

Project: **WATERBURY FILING 1**
 Basin ID: **Design Point 11- Dual 42" RCP Culverts**

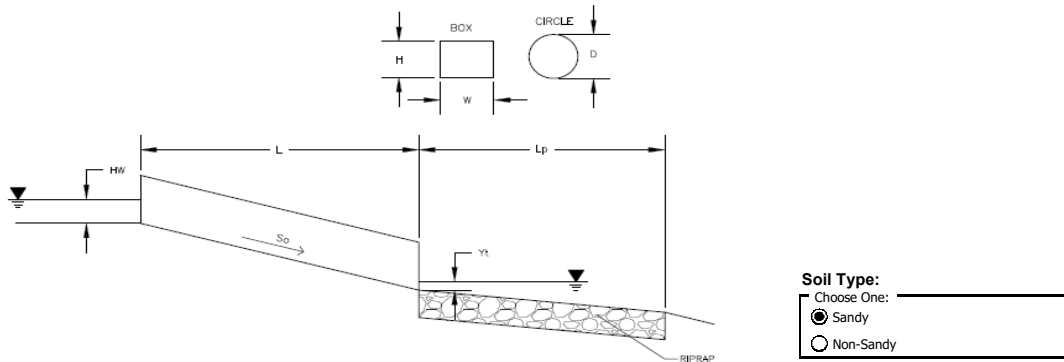

Supercritical Flow! Using Da to calculate protection type.

Design Information (Input):	
Design Discharge	Q = <input style="width: 100px;" type="text" value="216"/> cfs
Circular Culvert:	
Barrel Diameter in Inches	D = <input style="width: 100px;" type="text" value="42"/> inches
Inlet Edge Type (Choose from pull-down list)	Grooved End Projection <input type="text" value=""/>
Box Culvert:	OR
Barrel Height (Rise) in Feet	Height (Rise) = <input style="width: 100px;" type="text"/>
Barrel Width (Span) in Feet	Width (Span) = <input style="width: 100px;" type="text"/>
Inlet Edge Type (Choose from pull-down list)	<input type="text" value=""/>
Number of Barrels	No = <input style="width: 100px;" type="text" value="2"/>
Inlet Elevation	Elev IN = <input style="width: 100px;" type="text" value="6935.82"/> ft
Outlet Elevation OR Slope	Elev OUT = <input style="width: 100px;" type="text" value="6934.18"/> ft
Culvert Length	L = <input style="width: 100px;" type="text" value="128"/> ft
Manning's Roughness	n = <input style="width: 100px;" type="text" value="0.013"/>
Bend Loss Coefficient	k_b = <input style="width: 100px;" type="text" value="0"/>
Exit Loss Coefficient	k_x = <input style="width: 100px;" type="text" value="1"/>
Tailwater Surface Elevation	Elev Y_t = <input style="width: 100px;" type="text"/>
Max Allowable Channel Velocity	V = <input style="width: 100px;" type="text" value="5"/> ft/s
Required Protection (Output):	
Tailwater Surface Height	Y_t = <input style="width: 100px;" type="text" value="1.40"/> ft
Flow Area at Max Channel Velocity	A_t = <input style="width: 100px;" type="text" value="21.64"/> ft ²
Culvert Cross Sectional Area Available	A = <input style="width: 100px;" type="text" value="9.62"/> ft ²
Entrance Loss Coefficient	k_e = <input style="width: 100px;" type="text" value="0.20"/>
Friction Loss Coefficient	k_f = <input style="width: 100px;" type="text" value="0.75"/>
Sum of All Losses Coefficients	k_s = <input style="width: 100px;" type="text" value="1.95"/> ft
Culvert Normal Depth	Y_n = <input style="width: 100px;" type="text" value="2.72"/> ft
Culvert Critical Depth	Y_c = <input style="width: 100px;" type="text" value="3.15"/> ft
Tailwater Depth for Design	d = <input style="width: 100px;" type="text" value="3.33"/> ft
Adjusted Diameter OR Adjusted Rise	D_a = <input style="width: 100px;" type="text" value="3.11"/> ft
Expansion Factor	$1/(2*\tan(\theta))$ = <input style="width: 100px;" type="text" value="3.27"/>
Flow/Diameter ^{2.5} OR Flow/(Span * Rise ^{1.5})	$Q/D^{2.5}$ = <input style="width: 100px;" type="text" value="4.72"/> ft ^{0.5} /s
Froude Number	Fr = <input style="width: 100px;" type="text" value="1.44"/> Supercritical!
Tailwater/Adjusted Diameter OR Tailwater/Adjusted Rise	Y_t/D = <input style="width: 100px;" type="text" value="0.45"/>
Inlet Control Headwater	HW_i = <input style="width: 100px;" type="text" value="6.39"/> ft
Outlet Control Headwater	HW_o = <input style="width: 100px;" type="text" value="5.52"/> ft
Design Headwater Elevation	HW = <input style="width: 100px;" type="text" value="6,942.21"/> ft
Headwater/Diameter OR Headwater/Rise Ratio	HW/D = <input style="width: 100px;" type="text" value="1.83"/> HW/D > 1.5!
Minimum Theoretical Riprap Size	d_{50} = <input style="width: 100px;" type="text" value="14"/> in
Nominal Riprap Size	d_{50} = <input style="width: 100px;" type="text" value="18"/> in
UDFCD Riprap Type	Type = <input style="width: 100px;" type="text" value="H"/>
Length of Protection	L_p = <input style="width: 100px;" type="text" value="35"/> ft
Width of Protection	T = <input style="width: 100px;" type="text" value="15"/> ft

CULVERT STAGE-DISCHARGE SIZING (INLET vs. OUTLET CONTROL WITH TAILWATER EFFECTS)

Project: **WATERBURY FILING 1**
 Basin ID: **Design Point 12- 18" RCP Culvert**
 Status: _____

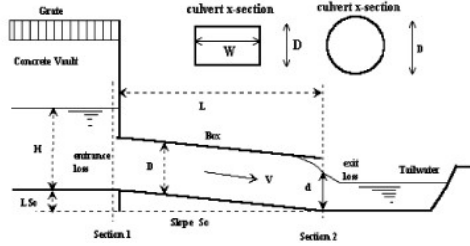

Design Information (Input):

Circular Culvert: Barrel Diameter in Inches D = inches
 Inlet Edge Type (choose from pull-down list)

OR:

Box Culvert: Barrel Height (Rise) in Feet Height (Rise) = ft.
 Barrel Width (Span) in Feet Width (Span) = ft.
 Inlet Edge Type (choose from pull-down list)

Number of Barrels No =
 Inlet Elevation at Culvert Invert Inlet Elev = ft. elev.
 Outlet Elevation at Culvert Invert **OR** Slope of Culvert (ft v./ft h.) Outlet Elev = ft. elev.
 Culvert Length in Feet L = ft.
 Manning's Roughness n =
 Bend Loss Coefficient K_b =
 Exit Loss Coefficient K_x =

Design Information (calculated):

Entrance Loss Coefficient K_e =
 Friction Loss Coefficient K_f =
 Sum of All Loss Coefficients K_s =
 Orifice Inlet Condition Coefficient C_d =
 Minimum Energy Condition Coefficient KE_{bw} =

Calculations of Culvert Capacity (output):

Water Surface Elevation (ft., linked)	Tailwater Surface Elevation ft	Culvert Inlet-Control Flowrate cfs	Culvert Outlet-Control Flowrate cfs	Controlling Culvert Flowrate cfs (output)	Inlet Equation Used:	Flow Control Used
6942.02		7.20	20.76	7.20	Regression Eqn.	INLET
6942.27		8.70	21.16	8.70	Regression Eqn.	INLET
6942.52		10.10	21.54	10.10	Regression Eqn.	INLET
6942.77		11.20	21.93	11.20	Regression Eqn.	INLET
6943.02		12.30	22.32	12.30	Regression Eqn.	INLET
6943.27		13.20	22.68	13.20	Regression Eqn.	INLET
6943.52		14.10	23.05	14.10	Regression Eqn.	INLET
6943.77		15.00	23.41	15.00	Regression Eqn.	INLET
6944.02		15.80	23.76	15.80	Regression Eqn.	INLET
6944.27		16.50	24.10	16.50	Regression Eqn.	INLET
6944.52		17.20	24.45	17.20	Regression Eqn.	INLET
6944.77		17.90	24.80	17.90	Regression Eqn.	INLET
6945.02		18.60	25.13	18.60	Regression Eqn.	INLET
6945.27		19.30	25.45	19.30	Orifice Eqn.	INLET
6945.52		19.90	25.78	19.90	Orifice Eqn.	INLET
6945.77		20.40	26.10	20.40	Orifice Eqn.	INLET
6946.02		21.00	26.42	21.00	Orifice Eqn.	INLET
6946.27		21.50	26.73	21.50	Orifice Eqn.	INLET
6946.52		22.10	27.05	22.10	Orifice Eqn.	INLET
6946.77		22.60	27.36	22.60	Orifice Eqn.	INLET
6947.02		23.10	27.65	23.10	Orifice Eqn.	INLET
6947.27		23.60	27.96	23.60	Orifice Eqn.	INLET
6947.52		24.10	28.25	24.10	Orifice Eqn.	INLET
6947.77		24.50	28.55	24.50	Orifice Eqn.	INLET
6948.02		25.00	28.84	25.00	Orifice Eqn.	INLET
6948.27		25.50	29.13	25.50	Orifice Eqn.	INLET
6948.52		25.90	29.41	25.90	Orifice Eqn.	INLET
6948.77		26.40	29.69	26.40	Orifice Eqn.	INLET
6949.02		26.80	29.97	26.80	Orifice Eqn.	INLET
6949.27		27.20	30.25	27.20	Orifice Eqn.	INLET

Processing Time: 26.66 Seconds

CULVERT STAGE-DISCHARGE SIZING (INLET vs. OUTLET CONTROL WITH TAILWATER EFFECTS)

Project: WATERBURY FILING 1
Basin ID: Design Point 12- 18" RCP Culvert

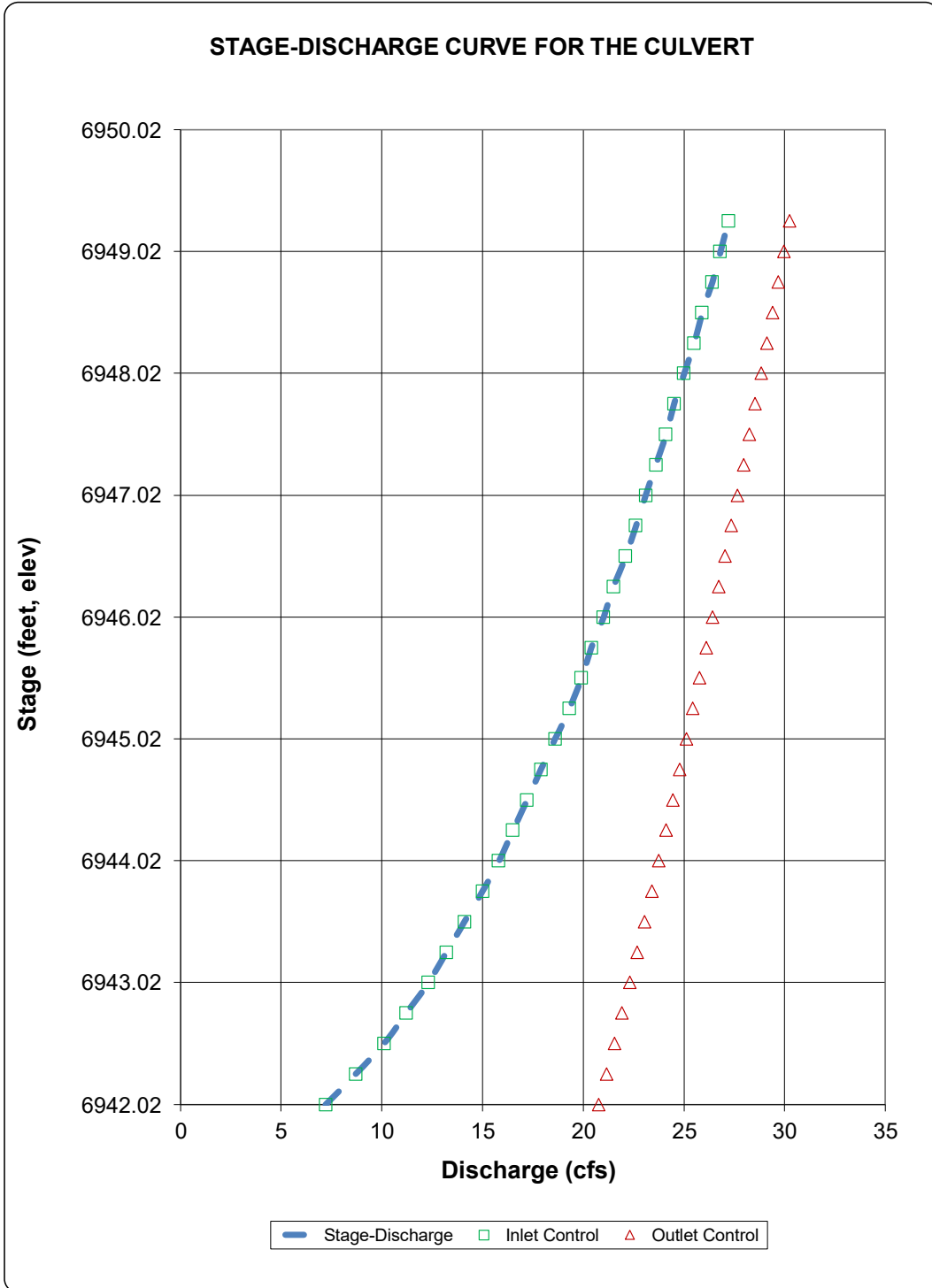

Determination of Culvert Headwater and Outlet Protection

Project: **WATERBURY FILING 1**
 Basin ID: **Design Point 12- 18" RCP Culvert**

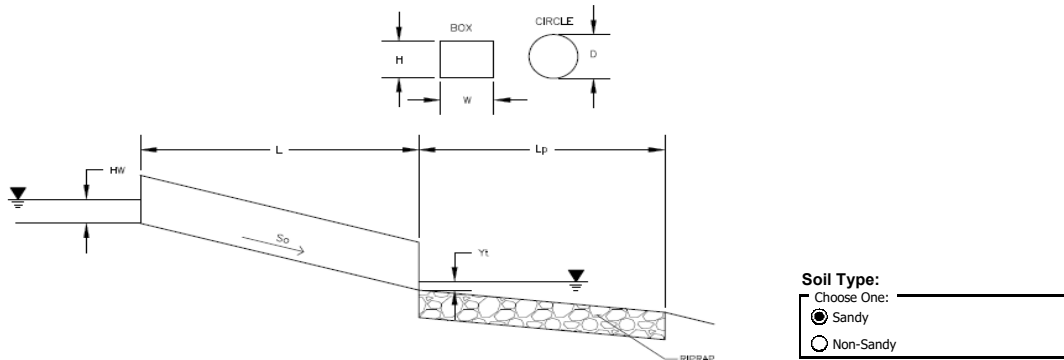

Soil Type:
 Choose One: Sandy Non-Sandy

Supercritical Flow! Using D_a to calculate protection type.

Design Information (Input):	
Design Discharge	Q = <input style="width: 50px;" type="text" value="4"/> cfs
Circular Culvert:	
Barrel Diameter in Inches	D = <input style="width: 50px;" type="text" value="18"/> inches
Inlet Edge Type (Choose from pull-down list)	Grooved End Projection <input type="text" value=""/>
Box Culvert:	OR
Barrel Height (Rise) in Feet	Height (Rise) = <input style="width: 50px;" type="text"/>
Barrel Width (Span) in Feet	Width (Span) = <input style="width: 50px;" type="text"/>
Inlet Edge Type (Choose from pull-down list)	<input type="text" value=""/>
Number of Barrels	No = <input style="width: 50px;" type="text" value="1"/>
Inlet Elevation	Elev IN = <input style="width: 50px;" type="text" value="6940.52"/> ft
Outlet Elevation OR Slope	Elev OUT = <input style="width: 50px;" type="text" value="6934.07"/> ft
Culvert Length	L = <input style="width: 50px;" type="text" value="100"/> ft
Manning's Roughness	n = <input style="width: 50px;" type="text" value="0.013"/>
Bend Loss Coefficient	k_b = <input style="width: 50px;" type="text" value="0"/>
Exit Loss Coefficient	k_x = <input style="width: 50px;" type="text" value="1"/>
Tailwater Surface Elevation	Elev Y_t = <input style="width: 50px;" type="text"/>
Max Allowable Channel Velocity	V = <input style="width: 50px;" type="text" value="5"/> ft/s

Required Protection (Output):	
Tailwater Surface Height	Y_t = <input style="width: 50px;" type="text" value="0.60"/> ft
Flow Area at Max Channel Velocity	A_f = <input style="width: 50px;" type="text" value="0.88"/> ft ²
Culvert Cross Sectional Area Available	A = <input style="width: 50px;" type="text" value="1.77"/> ft ²
Entrance Loss Coefficient	k_e = <input style="width: 50px;" type="text" value="0.20"/>
Friction Loss Coefficient	k_f = <input style="width: 50px;" type="text" value="1.81"/>
Sum of All Losses Coefficients	k_s = <input style="width: 50px;" type="text" value="3.01"/> ft
Culvert Normal Depth	Y_n = <input style="width: 50px;" type="text" value="0.41"/> ft
Culvert Critical Depth	Y_c = <input style="width: 50px;" type="text" value="0.80"/> ft
Tailwater Depth for Design	d = <input style="width: 50px;" type="text" value="1.15"/> ft
Adjusted Diameter OR Adjusted Rise	D_a = <input style="width: 50px;" type="text" value="0.96"/> ft
Expansion Factor	$1/(2*\tan(\theta))$ = <input style="width: 50px;" type="text" value="6.70"/>
Flow/Diameter ^{2.5} OR Flow/(Span * Rise ^{1.5})	$Q/D^{2.5}$ = <input style="width: 50px;" type="text" value="1.60"/> ft ^{0.5} /s
Froude Number	Fr = <input style="width: 50px;" type="text" value="3.63"/> Supercritical!
Tailwater/Adjusted Diameter OR Tailwater/Adjusted Rise	Y_t/D = <input style="width: 50px;" type="text" value="0.63"/>
Inlet Control Headwater	H_{w1} = <input style="width: 50px;" type="text" value="1.11"/> ft
Outlet Control Headwater	H_{w0} = <input style="width: 50px;" type="text" value="-5.01"/>
Design Headwater Elevation	HW = <input style="width: 50px;" type="text" value="6,941.63"/> ft
Headwater/Diameter OR Headwater/Rise Ratio	HW/D = <input style="width: 50px;" type="text" value="0.74"/>
Minimum Theoretical Riprap Size	d_{50} = <input style="width: 50px;" type="text" value="2"/> in
Nominal Riprap Size	d_{50} = <input style="width: 50px;" type="text" value="6"/> in
UDFCD Riprap Type	Type = <input style="width: 50px;" type="text" value="VL"/>
Length of Protection	L_p = <input style="width: 50px;" type="text" value="5"/> ft
Width of Protection	T = <input style="width: 50px;" type="text" value="3"/> ft

CULVERT STAGE-DISCHARGE SIZING (INLET vs. OUTLET CONTROL WITH TAILWATER EFFECTS)

Project: **WATERBURY FILING 1**
 Basin ID: **Design Point 30- Triple 36" RCP Culverts**
 Status: _____

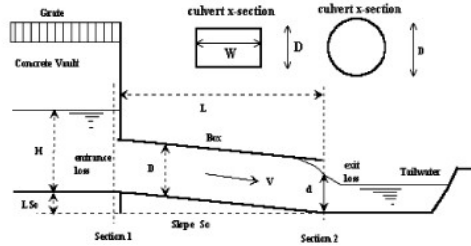

Design Information (Input):

Circular Culvert: Barrel Diameter in Inches D = inches
 Inlet Edge Type (choose from pull-down list)

OR:

Box Culvert: Barrel Height (Rise) in Feet Height (Rise) = ft.
 Barrel Width (Span) in Feet Width (Span) = ft.
 Inlet Edge Type (choose from pull-down list)

Number of Barrels No =
 Inlet Elevation at Culvert Invert Inlet Elev = ft. elev.
 Outlet Elevation at Culvert Invert **OR** Slope of Culvert (ft v./ft h.) Outlet Elev = ft. elev.
 Culvert Length in Feet L = ft.
 Manning's Roughness n =
 Bend Loss Coefficient K_b =
 Exit Loss Coefficient K_x =

Design Information (calculated):

Entrance Loss Coefficient K_e =
 Friction Loss Coefficient K_f =
 Sum of All Loss Coefficients K_s =
 Orifice Inlet Condition Coefficient C_d =
 Minimum Energy Condition Coefficient K_{E_{bw}} =

Calculations of Culvert Capacity (output):

Water Surface Elevation (ft., linked)	Tailwater Surface Elevation ft	Culvert Inlet-Control Flowrate cfs	Culvert Outlet-Control Flowrate cfs	Controlling Culvert Flowrate cfs (output)	Inlet Equation Used:	Flow Control Used
6920.00		0.00	0.00	0.00	No Flow (WS < inlet)	N/A
6920.25		0.90	65.46	0.90	Min. Energy Eqn.	INLET
6920.50		3.60	66.25	3.60	Min. Energy Eqn.	INLET
6920.75		9.90	67.92	9.90	Min. Energy Eqn.	INLET
6921.00		16.80	70.46	16.80	Min. Energy Eqn.	INLET
6921.25		25.80	74.06	25.80	Min. Energy Eqn.	INLET
6921.50		36.00	78.71	36.00	Min. Energy Eqn.	INLET
6921.75		46.50	84.33	46.50	Regression Eqn.	INLET
6922.00		58.50	90.82	58.50	Regression Eqn.	INLET
6922.25		71.70	97.66	71.70	Regression Eqn.	INLET
6922.50		86.10	104.77	86.10	Regression Eqn.	INLET
6922.75		101.10	111.79	101.10	Regression Eqn.	INLET
6923.00		115.80	118.55	115.80	Regression Eqn.	INLET
6923.25		129.90	131.45	129.90	Regression Eqn.	INLET
6923.50		142.80	143.38	142.80	Regression Eqn.	INLET
6923.75		155.10	154.08	154.08	Regression Eqn.	OUTLET
6924.00		166.20	164.79	164.79	Regression Eqn.	OUTLET
6924.25		176.70	174.79	174.79	Regression Eqn.	OUTLET
6924.50		186.60	184.18	184.18	Regression Eqn.	OUTLET
6924.75		195.90	193.22	193.22	Regression Eqn.	OUTLET
6925.00		204.90	201.82	201.82	Regression Eqn.	OUTLET
6925.25		213.30	209.98	209.98	Regression Eqn.	OUTLET
6925.50		221.40	217.97	217.97	Regression Eqn.	OUTLET
6925.75		229.20	225.60	225.60	Regression Eqn.	OUTLET
6926.00		236.70	232.97	232.97	Regression Eqn.	OUTLET
6926.25		243.90	240.17	240.17	Regression Eqn.	OUTLET
6926.50		250.80	247.10	247.10	Regression Eqn.	OUTLET
6926.75		257.70	253.85	253.85	Regression Eqn.	OUTLET
6927.00		264.30	260.52	260.52	Regression Eqn.	OUTLET
6927.25		270.90	266.93	266.93	Regression Eqn.	OUTLET

Processing Time: 00.91 Seconds

CULVERT STAGE-DISCHARGE SIZING (INLET vs. OUTLET CONTROL WITH TAILWATER EFFECTS)

Project: WATERBURY FILING 1
Basin ID: Design Point 30- Triple 36" RCP Culverts

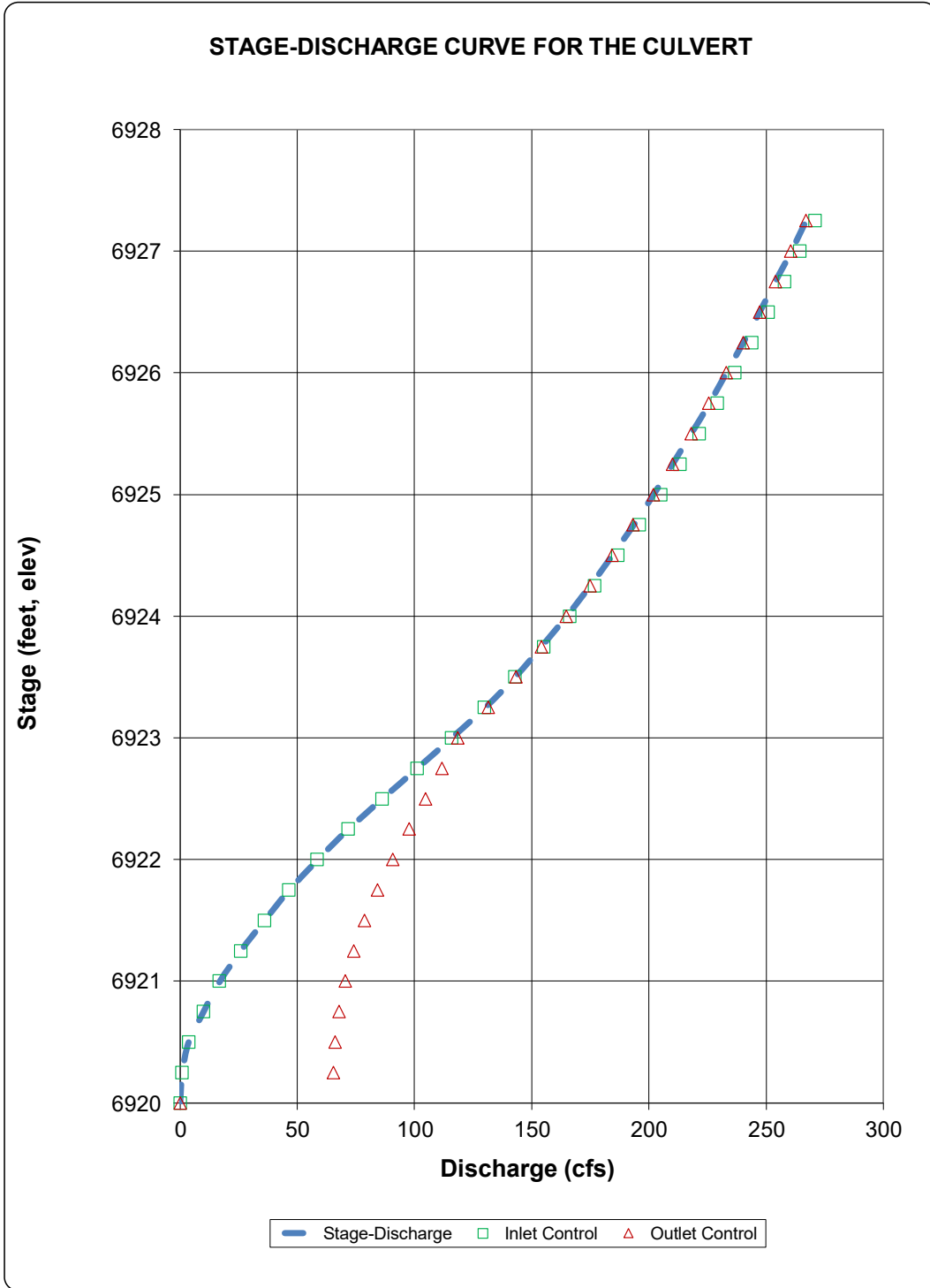

Determination of Culvert Headwater and Outlet Protection

Project: **WATERBURY FILING 1**
 Basin ID: **Design Point 30- Triple 36" RCP Culverts**

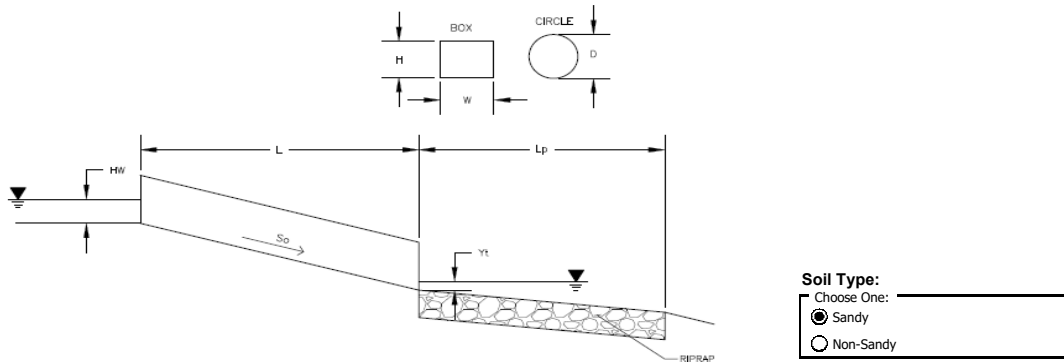

Soil Type:
 Choose One: Sandy Non-Sandy

Design Information (Input):

Design Discharge	Q =	<input type="text" value="247"/>	cfs
Circular Culvert:			
Barrel Diameter in Inches	D =	<input type="text" value="36"/>	inches
Inlet Edge Type (Choose from pull-down list)	Grooved End Projection	<input type="text"/>	
Box Culvert:			
Barrel Height (Rise) in Feet	Height (Rise) =	<input type="text"/>	ft
Barrel Width (Span) in Feet	Width (Span) =	<input type="text"/>	ft
Inlet Edge Type (Choose from pull-down list)			
Number of Barrels	No =	<input type="text" value="3"/>	
Inlet Elevation	Elev IN =	<input type="text" value="6920"/>	ft
Outlet Elevation OR Slope	Elev OUT =	<input type="text" value="6919"/>	ft
Culvert Length	L =	<input type="text" value="133.5"/>	ft
Manning's Roughness	n =	<input type="text" value="0.013"/>	
Bend Loss Coefficient	k_b =	<input type="text" value="0"/>	
Exit Loss Coefficient	k_x =	<input type="text" value="1"/>	
Tailwater Surface Elevation	Elev Y_t =	<input type="text" value="6920"/>	ft
Max Allowable Channel Velocity	V =	<input type="text" value="5"/>	ft/s

Required Protection (Output):

Tailwater Surface Height	Y_t =	<input type="text" value="1.00"/>	ft
Flow Area at Max Channel Velocity	A_t =	<input type="text" value="16.48"/>	ft ²
Culvert Cross Sectional Area Available	A =	<input type="text" value="7.07"/>	ft ²
Entrance Loss Coefficient	k_e =	<input type="text" value="0.20"/>	
Friction Loss Coefficient	k_f =	<input type="text" value="0.96"/>	
Sum of All Losses Coefficients	k_s =	<input type="text" value="2.16"/>	
Culvert Normal Depth	Y_n =	<input type="text" value="1.64"/>	ft
Culvert Critical Depth	Y_c =	<input type="text" value="2.79"/>	ft
Tailwater Depth for Design	d =	<input type="text" value="2.90"/>	ft
Adjusted Diameter OR Adjusted Rise	D_a =	<input type="text" value="-"/>	ft
Expansion Factor	$1/(2*\tan(\theta))$ =	<input type="text" value="1.69"/>	
Flow/Diameter ^{2.5} OR Flow/(Span * Rise ^{1.5})	Q/D ^{2.5} =	<input type="text" value="5.29"/>	ft ^{0.5} /s
Froude Number	Fr =	<input type="text" value="-"/>	Pressure flow!
Tailwater/Adjusted Diameter OR Tailwater/Adjusted Rise	Y_t/D =	<input type="text" value="0.33"/>	
Inlet Control Headwater	HW_i =	<input type="text" value="6.37"/>	ft
Outlet Control Headwater	HW_o =	<input type="text" value="6.45"/>	ft
Design Headwater Elevation	HW =	<input type="text" value="6,926.45"/>	ft
Headwater/Diameter OR Headwater/Rise Ratio	HW/D =	<input type="text" value="2.15"/>	HW/D > 1.5!
Minimum Theoretical Riprap Size	d_{50} =	<input type="text" value="16"/>	in
Nominal Riprap Size	d_{50} =	<input type="text" value="18"/>	in
UDFCD Riprap Type	Type =	<input type="text" value="H"/>	
Length of Protection	L_p =	<input type="text" value="23"/>	ft
Width of Protection	T =	<input type="text" value="17"/>	ft

FDR SWALE CALCULATIONS

MANNING'S EQUATION for OPEN CHANNEL FLOW

Project: **WATERBURY 1&2 MDP/PDR**

Location: **DP-PRE5 DIVERSIONS SWALE E-E**

By: **QNA**

Date: **7/14/2022**

Chk By:

Date:

version 12-2004

Mannings Formula

$$Q = (1.486/n)AR_n^{2/3}S^{1/2}$$

$$R = A/P$$

A = cross sectional area

P= wetted perimeter

S = slope of channel

n = Manning's roughness coefficient

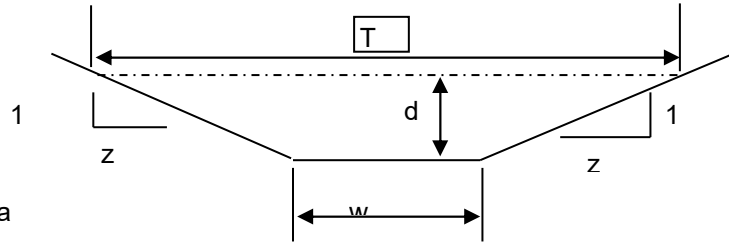

$$V = (1.49/n)R_n^{2/3}S^{1/2}$$

$$Q = V \times A$$

INPUT

z (sideslope)=	5
z (sideslope)=	5
b (btm width, ft)=	8
d (depth, ft)=	0.72
S (slope, ft/ft)	0.02
n low =	0.025
n high =	0.035

Clear Data
Entry Cells

Depth, ft	Area, sf	Wetted Perimeter, ft	Hydraulic Radius, ft	Low N		High N		T =	Dm =
				Velocity, fps	Flow, cfs	Velocity, fps	Flow, cfs		
0.72	8.35	15.34	0.54	5.60419065	46.8062	4.002993	33.433	15.2	0.549
Sc low =				0.0112	Sc high =		0.0220		
.7 Sc				0.0079	1.3 Sc		0.0146		
.7 Sc				0.0154	1.3 Sc		0.0287		

s_c = critical slope ft / ft

T = top width of the stream

d_m = a/T = mean depth of flow

FULL SPECTRUM DETENTION & WATER QUALITY CALCULATIONS

POND TRIBUTARY AREA

POND 1 TRIB AREA (DP 8)	22.34 AC	BASINS A, B1, B2, C, D, E, F, H, G1, G2, & K	DCIA	5.03
			UIA	6.92
			RPA	2.46
			SPA	7.94
			Total	22.34
POND 2 TRIB AREA (DP 18)	21.06 AC	BASINS L1, L2, O1, O2, O-3, O-4 & OS-4	DCIA	2.34
			UIA	3.23
			RPA	0.94
			SPA	14.55
			Total	21.06
POND 3 TRIB AREA (DP 29)	82.44 AC	BASINS Q1, Q2, R, S1, S2, T1, T2, U1, U2, V, W, X, OS-1, OS-2, OS-3A, OS-3B, OS-Q1, OS-Q2, OS-4, OS-S1, OS-S2, OS-T2, OS-7, & OS-9	DCIA	19.50
			UIA	22.09
			RPA	9.10
			SPA	31.74
			Total	82.44

Site-Level Low Impact Development (LID) Design Effective Impervious Calculator

LID Credit by Impervious Reduction Factor (IRF) Method

UD-BMP (Version 3.06, November 2016)

User Input	
Calculated cells	
***Design Storm: 1-Hour Rain Depth	WQCV Event: 0.43 inches
***Minor Storm: 1-Hour Rain Depth	5-Year Event: 1.50 inches
***Major Storm: 1-Hour Rain Depth	100-Year Event: 2.52 inches
Optional User Defined Storm	CUHP
(CUHP) NOAA 1 Hour Rainfall Depth and Frequency for User Defined Storm	100-Year Event
Max Intensity for Optional User Defined Storm	0

Designer: QNA
Company: Terra Nova Engineering
Date: June 16, 2022
Project: WATERBURY FILING 1 POND 1
Location: POND 1 Design Point 8 Full Spectrum Detention

SITE INFORMATION (USER-INPUT)												
Sub-basin Identifier	DP 8 FSD											
Receiving Pervious Area Soil Type	Loamy Sand											
Total Area (ac, Sum of DCIA, UIA, RPA, & SPA)	22.34											
Directly Connected Impervious Area (DCIA, acres)	5.03											
Unconnected Impervious Area (UIA, acres)	6.92											
Receiving Pervious Area (RPA, acres)	2.46											
Separate Pervious Area (SPA, acres)	7.94											
RPA Treatment Type: Conveyance (C), Volume (V), or Permeable Pavement (PP)	C											

CALCULATED RESULTS (OUTPUT)												
Total Calculated Area (ac, check against input)	22.343											
Directly Connected Impervious Area (DCIA, %)	22.5%											
Unconnected Impervious Area (UIA, %)	31.0%											
Receiving Pervious Area (RPA, %)	11.0%											
Separate Pervious Area (SPA, %)	35.5%											
A_p (RPA / UIA)	0.355											
I_p Check	0.740											
f / I for WQCV Event:	4.5											
f / I for 5-Year Event:	0.5											
f / I for 100-Year Event:	0.4											
f / I for Optional User Defined Storm CUHP:												
IRF for WQCV Event:	0.74											
IRF for 5-Year Event:	0.93											
IRF for 100-Year Event:	0.95											
IRF for Optional User Defined Storm CUHP:												
Total Site Imperviousness: I_{total}	53.5%											
Effective Imperviousness for WQCV Event:	45.5%											
Effective Imperviousness for 5-Year Event:	51.3%											
Effective Imperviousness for 100-Year Event:	51.9%											
Effective Imperviousness for Optional User Defined Storm CUHP:												

LID / EFFECTIVE IMPERVIOUSNESS CREDITS												
WQCV Event CREDIT: Reduce Detention By:	10.0%	N/A	N/A	N/A	N/A	N/A	N/A	N/A	N/A	N/A	N/A	N/A
This line only for 10-Year Event	N/A	N/A	N/A	N/A	N/A	N/A	N/A	N/A	N/A	N/A	N/A	N/A
100-Year Event CREDIT**:	2.9%	N/A	N/A	N/A	N/A	N/A	N/A	N/A	N/A	N/A	N/A	N/A
User Defined CUHP CREDIT: Reduce Detention By:												

Total Site Imperviousness:	53.5%
Total Site Effective Imperviousness for WQCV Event:	45.5%
Total Site Effective Imperviousness for 5-Year Event:	51.3%
Total Site Effective Imperviousness for 100-Year Event:	51.9%
Total Site Effective Imperviousness for Optional User Defined Storm CUHP:	

Notes:

- * Use Green-Ampt average infiltration rate values from Table 3-3.
- ** Flood control detention volume credits based on empirical equations from Storage Chapter of USDCM.
- *** Method assumes that 1-hour rainfall depth is equivalent to 1-hour intensity for calculation purposed

DETENTION BASIN STAGE-STORAGE TABLE BUILDER

MHFD-Detention, Version 4.03 (May 2020)

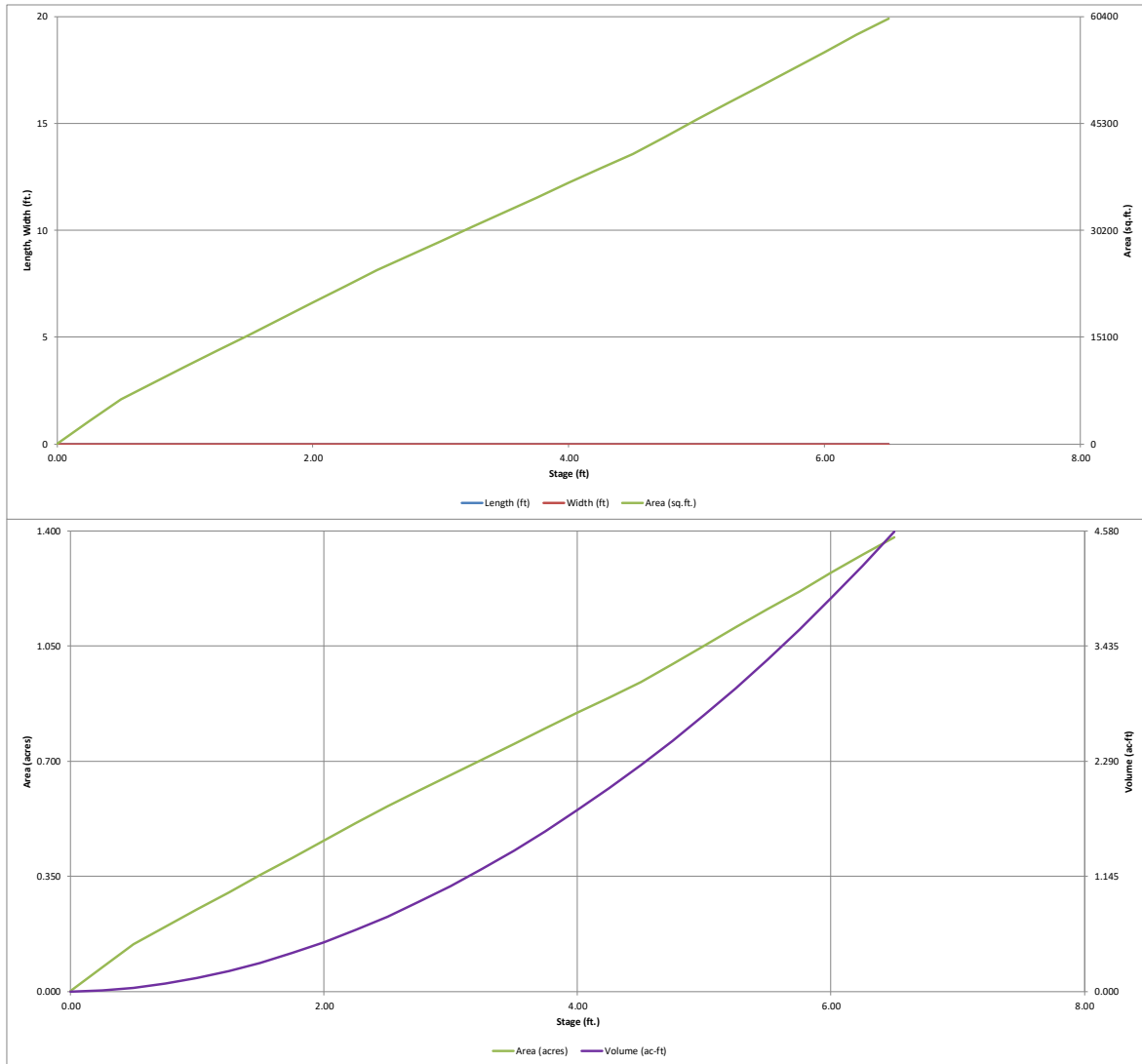

DETENTION BASIN OUTLET STRUCTURE DESIGN

MHFD-*Detention, Version 4.03 (May 2020)*

Project: WATERBURY
Basin ID: POND 1 DP 8

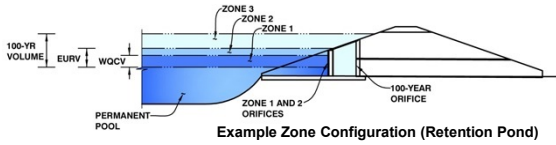

	Estimated Stage (ft)	Estimated Volume (ac-ft)	Outlet Type
Zone 1 (WQCV)	1.79	0.394	Orifice Plate
Zone 2 (EURV)	3.44	0.957	Orifice Plate
Zone 3 (100-year)	4.37	0.775	Weir&Pipe (Restrict)
Total (all zones)		2.127	

User Input: Orifice at Underdrain Outlet (typically used to drain WQCV in a Filtration BMP)

Underdrain Orifice Invert Depth = ft (distance below the filtration media surface)
Underdrain Orifice Diameter = inches

Calculated Parameters for Underdrain
Underdrain Orifice Area = ft²
Underdrain Orifice Centroid = feet

User Input: Orifice Plate with one or more orifices or Elliptical Slot Weir (typically used to drain WQCV and/or EURV in a sedimentation BMP)

Invert of Lowest Orifice = 0.00 ft (relative to basin bottom at Stage = 0 ft)
Depth at top of Zone using Orifice Plate = 3.44 ft (relative to basin bottom at Stage = 0 ft)
Orifice Plate: Orifice Vertical Spacing = 13.80 inches
Orifice Plate: Orifice Area per Row = 3.04 sq. inches (diameter = 1-15/16 inches)

Calculated Parameters for Plate
WQ Orifice Area per Row = 2.111E-02 ft²
Elliptical Half-Width = N/A feet
Elliptical Slot Centroid = N/A feet
Elliptical Slot Area = N/A ft²

User Input: Stage and Total Area of Each Orifice Row (numbered from lowest to highest)

	Row 1 (required)	Row 2 (optional)	Row 3 (optional)	Row 4 (optional)	Row 5 (optional)	Row 6 (optional)	Row 7 (optional)	Row 8 (optional)
Stage of Orifice Centroid (ft)	0.00	1.15	2.29					
Orifice Area (sq. inches)	3.04	3.04	3.04					

	Row 9 (optional)	Row 10 (optional)	Row 11 (optional)	Row 12 (optional)	Row 13 (optional)	Row 14 (optional)	Row 15 (optional)	Row 16 (optional)
Stage of Orifice Centroid (ft)								
Orifice Area (sq. inches)								

User Input: Vertical Orifice (Circular or Rectangular)

Invert of Vertical Orifice = Not Selected Not Selected ft (relative to basin bottom at Stage = 0 ft)
Depth at top of Zone using Vertical Orifice = N/A N/A ft (relative to basin bottom at Stage = 0 ft)
Vertical Orifice Diameter = N/A N/A inches

Calculated Parameters for Vertical Orifice
Vertical Orifice Area = Not Selected Not Selected ft²
Vertical Orifice Centroid = N/A N/A feet

User Input: Overflow Weir (Dropbox with Flat or Sloped Grate and Outlet Pipe OR Rectangular/Trapezoidal Weir (and No Outlet Pipe))

Overflow Weir Front Edge Height, Ho = 3.44 N/A ft (relative to basin bottom at Stage = 0 ft)
Overflow Weir Front Edge Length = 4.00 N/A feet
Overflow Weir Grate Slope = 0.00 N/A H:V
Horiz. Length of Weir Sides = 4.00 N/A feet
Overflow Grate Open Area % = 70% N/A %, grate open area/total area
Debris Clogging % = 50% N/A %

Calculated Parameters for Overflow Weir
Height of Grate Upper Edge, H_g = 3.44 N/A feet
Overflow Weir Slope Length = 4.00 N/A feet
Grate Open Area / 100-yr Orifice Area = 7.13 N/A
Overflow Grate Open Area w/o Debris = 11.20 N/A ft²
Overflow Grate Open Area w/ Debris = 5.60 N/A ft²

User Input: Outlet Pipe w/ Flow Restriction Plate (Circular Orifice, Restrictor Plate, or Rectangular Orifice)

Depth to Invert of Outlet Pipe = 0.10 N/A ft (distance below basin bottom at Stage = 0 ft)
Outlet Pipe Diameter = 24.00 N/A inches
Restrictor Plate Height Above Pipe Invert = 12.00 N/A inches

Calculated Parameters for Outlet Pipe w/ Flow Restriction Plate
Outlet Orifice Area = 1.57 N/A ft²
Outlet Orifice Centroid = 0.58 N/A feet
Half-Central Angle of Restrictor Plate on Pipe = 1.57 N/A radians

User Input: Emergency Spillway (Rectangular or Trapezoidal)

Spillway Invert Stage = 4.50 ft (relative to basin bottom at Stage = 0 ft)
Spillway Crest Length = 30.00 feet
Spillway End Slopes = 3.00 H:V
Freeboard above Max Water Surface = 1.00 feet

Calculated Parameters for Spillway
Spillway Design Flow Depth = 0.73 feet
Stage at Top of Freeboard = 6.23 feet
Basin Area at Top of Freeboard = 1.32 acres
Basin Volume at Top of Freeboard = 4.21 acre-ft

Routed Hydrograph Results

The user can override the default CUHP hydrographs and runoff volumes by entering new values in the Inflow Hydrographs table (Columns W through AF).

	WQCV	EURV	2 Year	5 Year	10 Year	25 Year	50 Year	100 Year	500 Year
Design Storm Return Period	N/A	N/A	1.19	1.50	1.75	2.00	2.25	2.52	3.00
One-Hour Rainfall Depth (in)	N/A	N/A	0.000	0.000	0.000	0.000	0.000	0.000	0.000
CUHP Runoff Volume (acre-ft)	0.394	1.351	0.000	0.000	0.000	0.000	0.000	0.000	0.000
Inflow Hydrograph Volume (acre-ft)	N/A	N/A	0.974	1.292	1.546	1.939	2.321	2.805	3.607
CUHP Predevelopment Peak Q (cfs)	N/A	N/A	0.0	0.0	0.0	0.0	0.0	0.0	0.0
OPTIONAL Override Predevelopment Peak Q (cfs)	N/A	N/A	0.2	0.4	0.6	5.3	10.4	17.1	27.3
Predevelopment Unit Peak Flow, q (cfs/acre)	N/A	N/A	0.01	0.02	0.03	0.24	0.47	0.77	1.22
Peak Inflow Q (cfs)	N/A	N/A	18.4	24.5	28.9	38.8	47.6	60.0	77.2
Peak Outflow Q (cfs)	0.2	0.5	0.4	0.4	1.7	5.1	10.3	14.5	21.9
Ratio Peak Outflow to Predevelopment Q	N/A	N/A	N/A	1.1	2.8	1.0	1.0	0.8	0.8
Structure Controlling Flow	Plate	Overflow Weir 1	Plate	Plate	Overflow Weir 1	Overflow Weir 1	Overflow Weir 1	Outlet Plate 1	Spillway
Max Velocity through Grate 1 (fps)	N/A	N/A	N/A	N/A	0.1	0.4	0.9	1.2	1.3
Max Velocity through Grate 2 (fps)	N/A	N/A	N/A	N/A	N/A	N/A	N/A	N/A	N/A
Time to Drain 97% of Inflow Volume (hours)	38	68	59	67	71	69	67	65	62
Time to Drain 99% of Inflow Volume (hours)	40	73	63	72	76	75	75	74	73
Maximum Ponding Depth (ft)	1.79	3.44	2.80	3.26	3.55	3.70	3.87	4.16	4.67
Area at Maximum Ponding Depth (acres)	0.41	0.74	0.62	0.71	0.76	0.79	0.82	0.88	0.98
Maximum Volume Stored (acre-ft)	0.398	1.358	0.916	1.220	1.433	1.557	1.694	1.940	2.403

DETENTION BASIN OUTLET STRUCTURE DESIGN

MHFD-Detention, Version 4.00 (December 2019)

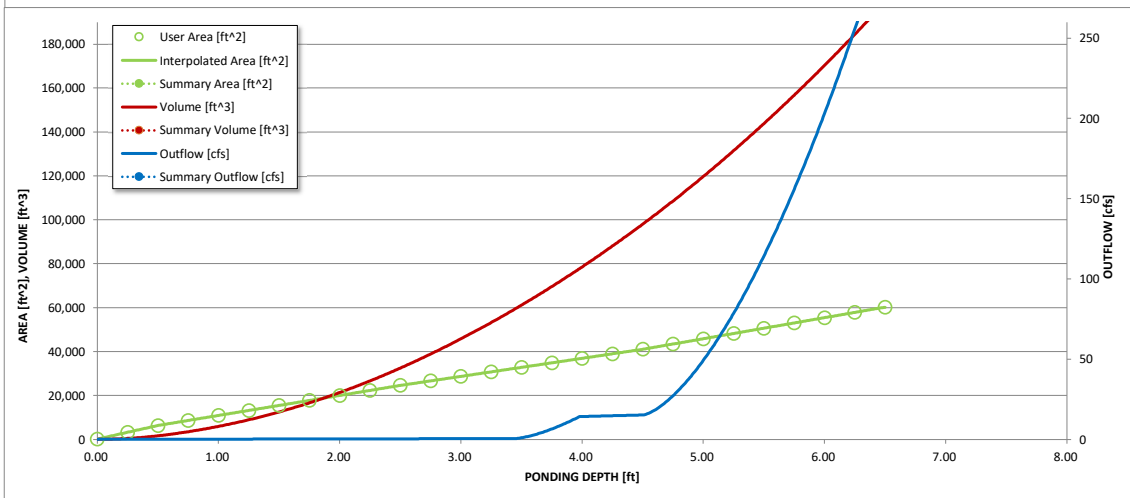
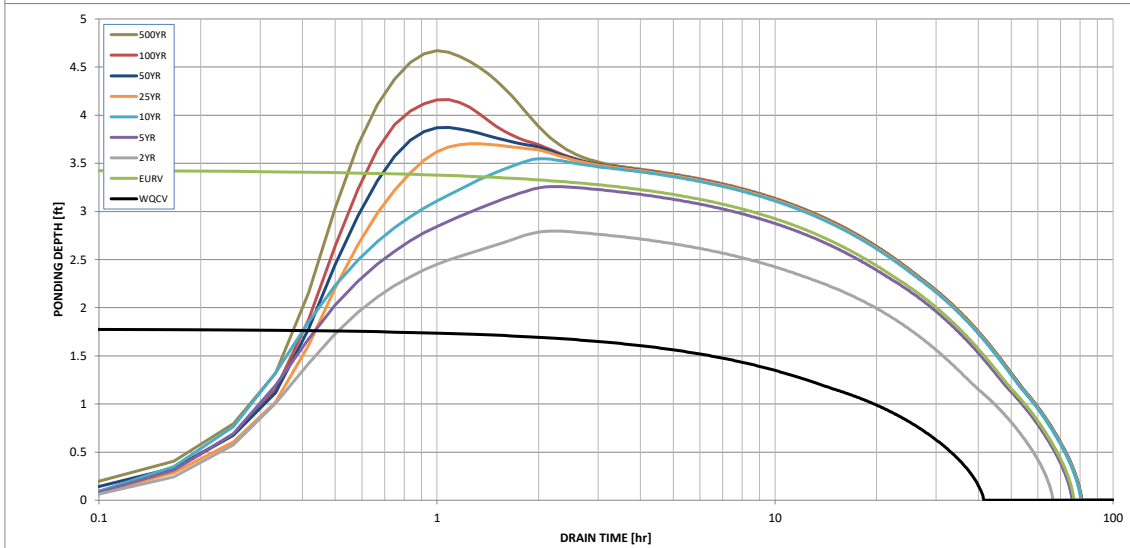
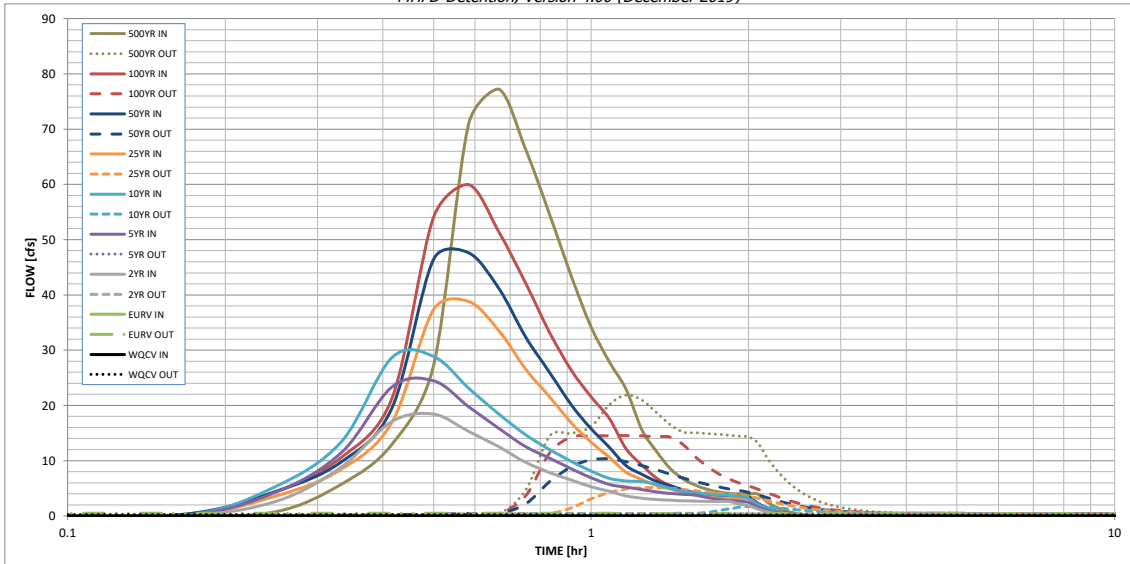

S-A-V-D Chart Axis Override	X-axis	Left Y-Axis	Right Y-Axis
minimum bound			
maximum bound			

DETENTION BASIN OUTLET STRUCTURE DESIGN

Outflow Hydrograph Workbook Filename: _____

Inflow Hydrographs

The user can override the calculated inflow hydrographs from this workbook with inflow hydrographs developed in a separate program.

Time Interval	SOURCE	CUHP	CUHP	CUHP	CUHP	CUHP	CUHP	CUHP	CUHP	CUHP
TIME	WQCV [cfs]	EURV [cfs]	2 Year [cfs]	5 Year [cfs]	10 Year [cfs]	25 Year [cfs]	50 Year [cfs]	100 Year [cfs]	500 Year [cfs]	CUHP
5.00 min	0:00:00	0.00	0.00	0.00	0.00	0.00	0.00	0.00	0.00	0.00
	0:05:00	0.00	0.00	0.00	0.00	0.00	0.00	0.00	0.00	0.00
	0:10:00	0.00	0.00	0.00	0.00	0.00	0.00	0.30	0.03	0.76
	0:15:00	0.00	0.00	2.64	4.30	5.34	3.60	4.44	4.39	5.74
	0:20:00	0.00	0.00	8.87	11.46	13.44	8.45	9.79	10.59	12.98
	0:25:00	0.00	0.00	17.10	23.36	28.66	16.99	19.58	21.33	27.27
	0:30:00	0.00	0.00	18.41	24.45	28.87	37.34	46.49	54.12	70.90
	0:35:00	0.00	0.00	15.27	19.79	23.15	38.82	47.62	59.97	77.19
	0:40:00	0.00	0.00	12.50	15.81	18.41	33.51	41.16	51.36	66.26
	0:45:00	0.00	0.00	9.68	12.52	14.67	26.53	32.33	42.08	54.59
	0:50:00	0.00	0.00	7.85	10.45	11.98	21.55	25.98	33.20	43.37
	0:55:00	0.00	0.00	6.47	8.52	9.88	16.80	20.08	26.35	34.19
	1:00:00	0.00	0.00	5.29	6.90	8.11	13.33	15.77	21.53	27.87
	1:05:00	0.00	0.00	4.45	5.70	6.79	10.59	12.42	17.63	22.92
	1:10:00	0.00	0.00	3.63	5.20	6.33	7.90	9.10	12.19	15.65
	1:15:00	0.00	0.00	3.21	4.77	6.20	6.60	7.54	9.22	11.69
	1:20:00	0.00	0.00	2.96	4.34	5.69	5.50	6.24	6.86	8.58
	1:25:00	0.00	0.00	2.82	4.06	4.97	4.86	5.49	5.41	6.66
	1:30:00	0.00	0.00	2.73	3.88	4.49	4.16	4.69	4.56	5.55
	1:35:00	0.00	0.00	2.67	3.77	4.17	3.73	4.21	3.99	4.81
	1:40:00	0.00	0.00	2.63	3.31	3.96	3.45	3.89	3.62	4.33
	1:45:00	0.00	0.00	2.61	2.99	3.82	3.27	3.68	3.42	4.07
	1:50:00	0.00	0.00	2.61	2.78	3.72	3.17	3.57	3.35	3.99
	1:55:00	0.00	0.00	2.16	2.65	3.53	3.11	3.50	3.32	3.95
	2:00:00	0.00	0.00	1.86	2.47	3.16	3.08	3.47	3.32	3.95
	2:05:00	0.00	0.00	1.22	1.61	2.07	2.02	2.27	2.17	2.58
	2:10:00	0.00	0.00	0.77	1.02	1.33	1.30	1.46	1.40	1.66
	2:15:00	0.00	0.00	0.48	0.63	0.83	0.82	0.92	0.88	1.04
	2:20:00	0.00	0.00	0.28	0.38	0.50	0.49	0.55	0.52	0.62
	2:25:00	0.00	0.00	0.15	0.23	0.28	0.29	0.33	0.31	0.36
	2:30:00	0.00	0.00	0.06	0.11	0.13	0.14	0.16	0.15	0.18
	2:35:00	0.00	0.00	0.02	0.04	0.04	0.05	0.05	0.05	0.05
	2:40:00	0.00	0.00	0.00	0.00	0.00	0.00	0.00	0.00	0.00
	2:45:00	0.00	0.00	0.00	0.00	0.00	0.00	0.00	0.00	0.00
	2:50:00	0.00	0.00	0.00	0.00	0.00	0.00	0.00	0.00	0.00
	2:55:00	0.00	0.00	0.00	0.00	0.00	0.00	0.00	0.00	0.00
	3:00:00	0.00	0.00	0.00	0.00	0.00	0.00	0.00	0.00	0.00
	3:05:00	0.00	0.00	0.00	0.00	0.00	0.00	0.00	0.00	0.00
	3:10:00	0.00	0.00	0.00	0.00	0.00	0.00	0.00	0.00	0.00
	3:15:00	0.00	0.00	0.00	0.00	0.00	0.00	0.00	0.00	0.00
	3:20:00	0.00	0.00	0.00	0.00	0.00	0.00	0.00	0.00	0.00
	3:25:00	0.00	0.00	0.00	0.00	0.00	0.00	0.00	0.00	0.00
	3:30:00	0.00	0.00	0.00	0.00	0.00	0.00	0.00	0.00	0.00
	3:35:00	0.00	0.00	0.00	0.00	0.00	0.00	0.00	0.00	0.00
	3:40:00	0.00	0.00	0.00	0.00	0.00	0.00	0.00	0.00	0.00
	3:45:00	0.00	0.00	0.00	0.00	0.00	0.00	0.00	0.00	0.00
	3:50:00	0.00	0.00	0.00	0.00	0.00	0.00	0.00	0.00	0.00
	3:55:00	0.00	0.00	0.00	0.00	0.00	0.00	0.00	0.00	0.00
	4:00:00	0.00	0.00	0.00	0.00	0.00	0.00	0.00	0.00	0.00
	4:05:00	0.00	0.00	0.00	0.00	0.00	0.00	0.00	0.00	0.00
	4:10:00	0.00	0.00	0.00	0.00	0.00	0.00	0.00	0.00	0.00
	4:15:00	0.00	0.00	0.00	0.00	0.00	0.00	0.00	0.00	0.00
	4:20:00	0.00	0.00	0.00	0.00	0.00	0.00	0.00	0.00	0.00
	4:25:00	0.00	0.00	0.00	0.00	0.00	0.00	0.00	0.00	0.00
	4:30:00	0.00	0.00	0.00	0.00	0.00	0.00	0.00	0.00	0.00
	4:35:00	0.00	0.00	0.00	0.00	0.00	0.00	0.00	0.00	0.00
	4:40:00	0.00	0.00	0.00	0.00	0.00	0.00	0.00	0.00	0.00
	4:45:00	0.00	0.00	0.00	0.00	0.00	0.00	0.00	0.00	0.00
	4:50:00	0.00	0.00	0.00	0.00	0.00	0.00	0.00	0.00	0.00
	4:55:00	0.00	0.00	0.00	0.00	0.00	0.00	0.00	0.00	0.00
	5:00:00	0.00	0.00	0.00	0.00	0.00	0.00	0.00	0.00	0.00
	5:05:00	0.00	0.00	0.00	0.00	0.00	0.00	0.00	0.00	0.00
	5:10:00	0.00	0.00	0.00	0.00	0.00	0.00	0.00	0.00	0.00
	5:15:00	0.00	0.00	0.00	0.00	0.00	0.00	0.00	0.00	0.00
	5:20:00	0.00	0.00	0.00	0.00	0.00	0.00	0.00	0.00	0.00
	5:25:00	0.00	0.00	0.00	0.00	0.00	0.00	0.00	0.00	0.00
	5:30:00	0.00	0.00	0.00	0.00	0.00	0.00	0.00	0.00	0.00
	5:35:00	0.00	0.00	0.00	0.00	0.00	0.00	0.00	0.00	0.00
	5:40:00	0.00	0.00	0.00	0.00	0.00	0.00	0.00	0.00	0.00
	5:45:00	0.00	0.00	0.00	0.00	0.00	0.00	0.00	0.00	0.00
	5:50:00	0.00	0.00	0.00	0.00	0.00	0.00	0.00	0.00	0.00
	5:55:00	0.00	0.00	0.00	0.00	0.00	0.00	0.00	0.00	0.00
	6:00:00	0.00	0.00	0.00	0.00	0.00	0.00	0.00	0.00	0.00

DETENTION BASIN STAGE-STORAGE TABLE BUILDER

MHFD-Detention, Version 4.03 (May 2020)

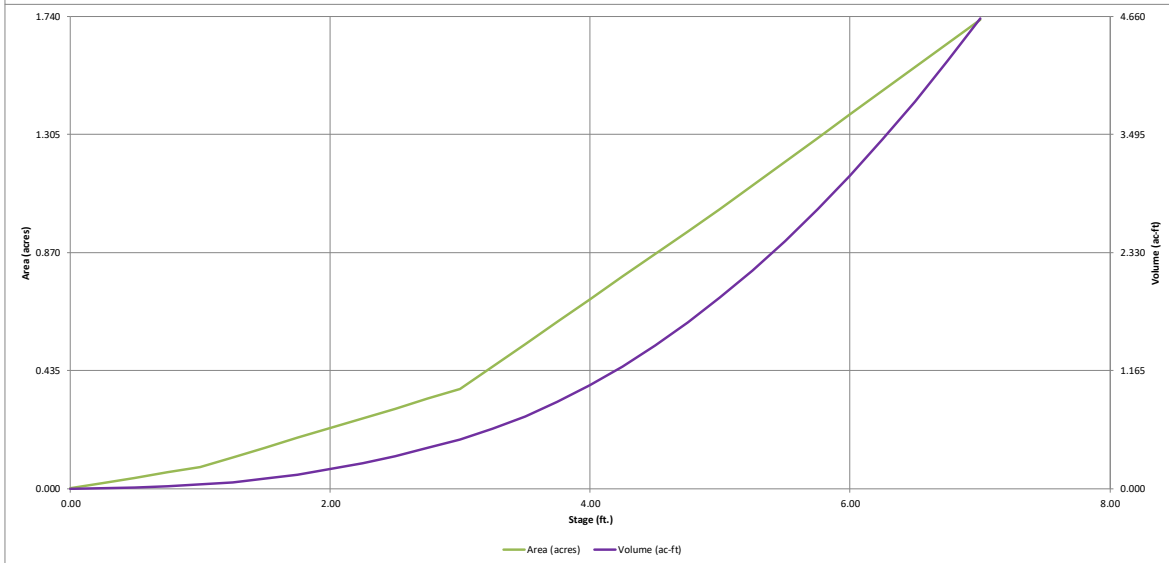
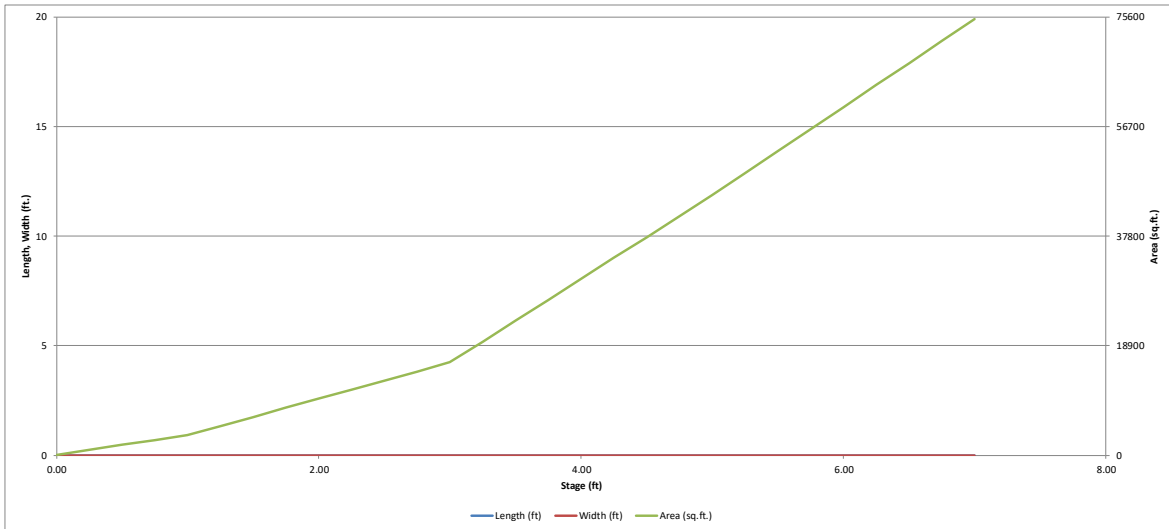

DETENTION BASIN OUTLET STRUCTURE DESIGN

MHFD-Detention, Version 4.03 (May 2020)

Project: WATERBURY

Basin ID: TEMPORARY POND 2 DP 18

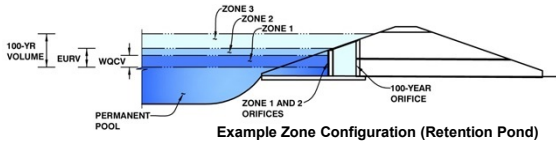

	Estimated Stage (ft)	Estimated Volume (ac-ft)	Outlet Type
Zone 1 (WQCV)	2.21	0.241	Orifice Plate
Zone 2 (EURV)	3.09	0.278	Orifice Plate
Zone 3 (100-year)	4.01	0.508	Weir&Pipe (Restrict)
Total (all zones)		1.027	

User Input: Orifice at Underdrain Outlet (typically used to drain WQCV in a Filtration BMP)

Underdrain Orifice Invert Depth =	N/A	ft (distance below the filtration media surface)
Underdrain Orifice Diameter =	N/A	inches

Calculated Parameters for Underdrain		
Underdrain Orifice Area =	N/A	ft ²
Underdrain Orifice Centroid =	N/A	feet

User Input: Orifice Plate with one or more orifices or Elliptical Slot Weir (typically used to drain WQCV and/or EURV in a sedimentation BMP)

Invert of Lowest Orifice =	0.00	ft (relative to basin bottom at Stage = 0 ft)
Depth at top of Zone using Orifice Plate =	3.09	ft (relative to basin bottom at Stage = 0 ft)
Orifice Plate: Orifice Vertical Spacing =	12.40	inches
Orifice Plate: Orifice Area per Row =	1.34	sq. inches (diameter = 1-5/16 inches)

Calculated Parameters for Plate		
WQ Orifice Area per Row =	9.306E-03	ft ²
Elliptical Half-Width =	N/A	feet
Elliptical Slot Centroid =	N/A	feet
Elliptical Slot Area =	N/A	ft ²

User Input: Stage and Total Area of Each Orifice Row (numbered from lowest to highest)

	Row 1 (required)	Row 2 (optional)	Row 3 (optional)	Row 4 (optional)	Row 5 (optional)	Row 6 (optional)	Row 7 (optional)	Row 8 (optional)
Stage of Orifice Centroid (ft)	0.00	1.03	2.06					
Orifice Area (sq. inches)	1.34	1.34	1.34					

	Row 9 (optional)	Row 10 (optional)	Row 11 (optional)	Row 12 (optional)	Row 13 (optional)	Row 14 (optional)	Row 15 (optional)	Row 16 (optional)
Stage of Orifice Centroid (ft)								
Orifice Area (sq. inches)								

User Input: Vertical Orifice (Circular or Rectangular)

	Not Selected	Not Selected	
Invert of Vertical Orifice =	N/A	N/A	ft (relative to basin bottom at Stage = 0 ft)
Depth at top of Zone using Vertical Orifice =	N/A	N/A	ft (relative to basin bottom at Stage = 0 ft)
Vertical Orifice Diameter =	N/A	N/A	inches

Calculated Parameters for Vertical Orifice		
Vertical Orifice Area =	N/A	ft ²
Vertical Orifice Centroid =	N/A	feet

User Input: Overflow Weir (Dropbox with Flat or Sloped Grate and Outlet Pipe OR Rectangular/Trapezoidal Weir (and No Outlet Pipe))

	Zone 3 Weir	Not Selected	
Overflow Weir Front Edge Height, H _o =	3.09	N/A	ft (relative to basin bottom at Stage = 0 ft)
Overflow Weir Front Edge Length =	4.00	N/A	feet
Overflow Weir Grate Slope =	0.00	N/A	H:V
Horiz. Length of Weir Sides =	4.00	N/A	feet
Overflow Grate Open Area % =	70%	N/A	%, grate open area/total area
Debris Clogging % =	50%	N/A	%

Calculated Parameters for Overflow Weir		
Height of Grate Upper Edge, H _u =	3.09	N/A
Overflow Weir Slope Length =	4.00	N/A
Grate Open Area / 100-yr Orifice Area =	6.34	N/A
Overflow Grate Open Area w/o Debris =	11.20	N/A
Overflow Grate Open Area w/ Debris =	5.60	N/A

User Input: Outlet Pipe w/ Flow Restriction Plate (Circular Orifice, Restrictor Plate, or Rectangular Orifice)

	Zone 3 Restrictor	Not Selected	
Depth to Invert of Outlet Pipe =	0.20	N/A	ft (distance below basin bottom at Stage = 0 ft)
Outlet Pipe Diameter =	18.00	N/A	inches
Restrictor Plate Height Above Pipe Invert =	18.00		inches

Calculated Parameters for Outlet Pipe w/ Flow Restriction Plate		
Outlet Orifice Area =	1.77	ft ²
Outlet Orifice Centroid =	0.75	feet
Half-Central Angle of Restrictor Plate on Pipe =	3.14	radians

User Input: Emergency Spillway (Rectangular or Trapezoidal)

Spillway Invert Stage =	5.00	ft (relative to basin bottom at Stage = 0 ft)
Spillway Crest Length =	20.00	feet
Spillway End Slopes =	3.00	H:V
Freeboard above Max Water Surface =	1.00	feet

Calculated Parameters for Spillway		
Spillway Design Flow Depth =	0.59	feet
Stage at Top of Freeboard =	6.59	feet
Basin Area at Top of Freeboard =	1.58	acres
Basin Volume at Top of Freeboard =	3.96	acre-ft

Routed Hydrograph Results

The user can override the default CUHP hydrographs and runoff volumes by entering new values in the Inflow Hydrographs table (Columns W through AF).

	WQCV	EURV	2 Year	5 Year	10 Year	25 Year	50 Year	100 Year	500 Year
Design Storm Return Period	N/A	N/A	1.19	1.50	1.75	2.00	2.25	2.52	3.00
One-Hour Rainfall Depth (in)	N/A	N/A	0.344	0.481	0.601	0.939	1.255	1.681	2.377
CUHP Runoff Volume (acre-ft)	N/A	N/A	0.344	0.481	0.601	0.939	1.255	1.681	2.377
Inflow Hydrograph Volume (acre-ft)	N/A	N/A	0.2	0.5	0.6	5.6	10.8	17.5	27.9
CUHP Predevelopment Peak Q (cfs)	N/A	N/A							
OPTIONAL Override Predevelopment Peak Q (cfs)	N/A	N/A							
Predevelopment Unit Peak Flow, q (cfs/acre)	N/A	N/A	0.01	0.02	0.03	0.26	0.51	0.83	1.32
Peak Inflow Q (cfs)	N/A	N/A	5.3	7.7	9.5	15.9	21.7	29.3	40.9
Peak Outflow Q (cfs)	0.1	0.2	0.2	0.2	0.7	5.2	9.8	15.1	16.4
Ratio Peak Outflow to Predevelopment Q	N/A	N/A	N/A	0.4	1.2	0.9	0.9	0.9	0.6
Structure Controlling Flow	Plate	Overflow Weir 1	Plate	Plate	Overflow Weir 1	Overflow Weir 1	Overflow Weir 1	Outlet Plate 1	Outlet Plate 1
Max Velocity through Grate 1 (fps)	N/A	N/A	N/A	N/A	0.0	0.5	0.9	1.3	1.4
Max Velocity through Grate 2 (fps)	N/A	N/A	N/A	N/A	N/A	N/A	N/A	N/A	N/A
Time to Drain 97% of Inflow Volume (hours)	38	55	45	54	58	55	52	49	45
Time to Drain 99% of Inflow Volume (hours)	40	59	48	57	62	61	60	58	56
Maximum Ponding Depth (ft)	2.21	3.09	2.49	2.90	3.15	3.37	3.52	3.71	4.25
Area at Maximum Ponding Depth (acres)	0.25	0.40	0.29	0.35	0.42	0.49	0.54	0.60	0.78
Maximum Volume Stored (acre-ft)	0.243	0.522	0.316	0.448	0.547	0.641	0.718	0.826	1.198

DETENTION BASIN OUTLET STRUCTURE DESIGN

MHFD-Detention, Version 4.00 (December 2019)

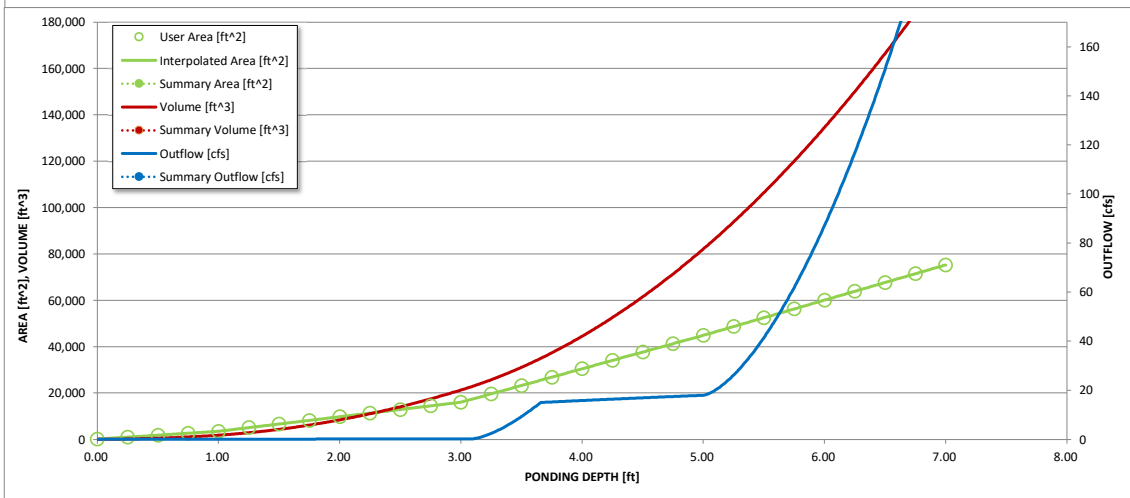
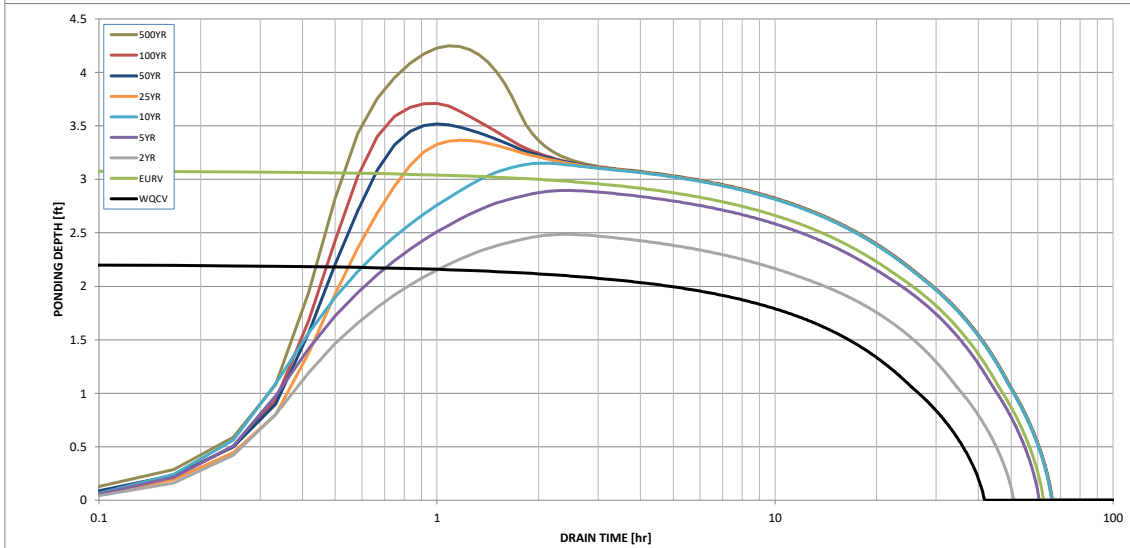
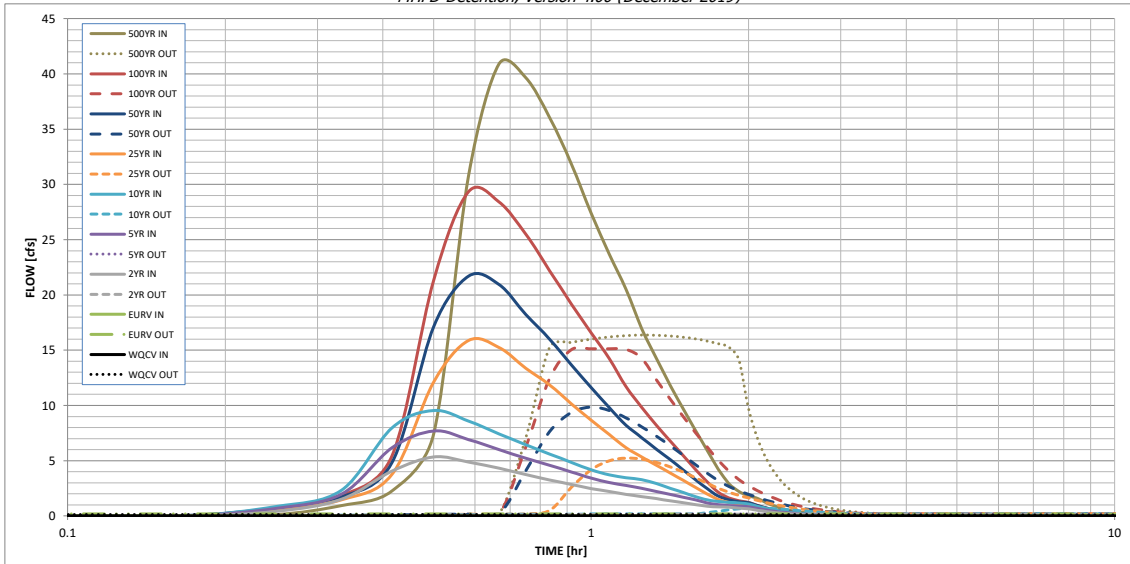

S-A-V-D Chart Axis Override	X-axis	Left Y-Axis	Right Y-Axis
minimum bound			
maximum bound			

DETENTION BASIN OUTLET STRUCTURE DESIGN

Outflow Hydrograph Workbook Filename: _____

Inflow Hydrographs

The user can override the calculated inflow hydrographs from this workbook with inflow hydrographs developed in a separate program.

Time Interval	SOURCE	CUHP	CUHP	CUHP	CUHP	CUHP	CUHP	CUHP	CUHP	CUHP
	TIME	WQCV [cfs]	EURV [cfs]	2 Year [cfs]	5 Year [cfs]	10 Year [cfs]	25 Year [cfs]	50 Year [cfs]	100 Year [cfs]	500 Year [cfs]
5.00 min	0:00:00	0.00	0.00	0.00	0.00	0.00	0.00	0.00	0.00	0.00
	0:05:00	0.00	0.00	0.00	0.00	0.00	0.00	0.00	0.00	0.00
	0:10:00	0.00	0.00	0.00	0.00	0.00	0.00	0.05	0.00	0.12
	0:15:00	0.00	0.00	0.42	0.68	0.85	0.57	0.71	0.70	0.94
	0:20:00	0.00	0.00	1.50	1.97	2.32	1.47	1.72	1.84	2.28
	0:25:00	0.00	0.00	4.07	6.19	7.98	3.76	4.83	5.45	7.42
	0:30:00	0.00	0.00	5.34	7.70	9.55	12.10	17.11	21.32	30.78
	0:35:00	0.00	0.00	4.88	6.92	8.59	15.87	21.71	29.34	40.89
	0:40:00	0.00	0.00	4.31	6.01	7.43	15.25	20.95	28.41	39.65
	0:45:00	0.00	0.00	3.74	5.22	6.44	13.37	18.23	25.50	36.05
	0:50:00	0.00	0.00	3.26	4.59	5.61	11.86	16.00	22.20	31.86
	0:55:00	0.00	0.00	2.85	3.98	4.85	10.15	13.68	19.18	27.41
	1:00:00	0.00	0.00	2.48	3.42	4.17	8.66	11.61	16.58	23.68
	1:05:00	0.00	0.00	2.20	3.01	3.72	7.36	9.80	14.23	20.51
	1:10:00	0.00	0.00	1.96	2.75	3.47	6.18	8.21	11.70	16.95
	1:15:00	0.00	0.00	1.75	2.49	3.28	5.33	7.09	9.84	14.26
	1:20:00	0.00	0.00	1.56	2.22	2.92	4.58	6.05	8.21	11.83
	1:25:00	0.00	0.00	1.38	1.95	2.51	3.90	5.09	6.77	9.68
	1:30:00	0.00	0.00	1.20	1.69	2.11	3.22	4.16	5.46	7.75
	1:35:00	0.00	0.00	1.03	1.45	1.75	2.58	3.27	4.22	5.92
	1:40:00	0.00	0.00	0.89	1.18	1.45	1.99	2.46	3.07	4.25
	1:45:00	0.00	0.00	0.82	1.03	1.31	1.49	1.79	2.14	2.94
	1:50:00	0.00	0.00	0.79	0.95	1.24	1.23	1.46	1.64	2.22
	1:55:00	0.00	0.00	0.71	0.89	1.17	1.10	1.28	1.38	1.83
	2:00:00	0.00	0.00	0.63	0.83	1.08	1.03	1.19	1.22	1.57
	2:05:00	0.00	0.00	0.51	0.66	0.86	0.81	0.93	0.93	1.18
	2:10:00	0.00	0.00	0.40	0.52	0.67	0.62	0.71	0.69	0.87
	2:15:00	0.00	0.00	0.31	0.41	0.52	0.48	0.55	0.52	0.63
	2:20:00	0.00	0.00	0.24	0.31	0.40	0.37	0.42	0.38	0.46
	2:25:00	0.00	0.00	0.19	0.24	0.30	0.28	0.32	0.29	0.35
	2:30:00	0.00	0.00	0.14	0.18	0.23	0.21	0.24	0.22	0.26
	2:35:00	0.00	0.00	0.11	0.14	0.17	0.16	0.18	0.17	0.20
	2:40:00	0.00	0.00	0.08	0.10	0.13	0.12	0.13	0.13	0.15
	2:45:00	0.00	0.00	0.06	0.07	0.10	0.09	0.10	0.10	0.11
	2:50:00	0.00	0.00	0.04	0.05	0.07	0.06	0.07	0.07	0.08
	2:55:00	0.00	0.00	0.02	0.03	0.04	0.04	0.05	0.04	0.05
	3:00:00	0.00	0.00	0.01	0.02	0.02	0.03	0.03	0.03	0.03
	3:05:00	0.00	0.00	0.01	0.01	0.01	0.01	0.01	0.01	0.01
	3:10:00	0.00	0.00	0.00	0.00	0.00	0.00	0.00	0.00	0.00
	3:15:00	0.00	0.00	0.00	0.00	0.00	0.00	0.00	0.00	0.00
	3:20:00	0.00	0.00	0.00	0.00	0.00	0.00	0.00	0.00	0.00
	3:25:00	0.00	0.00	0.00	0.00	0.00	0.00	0.00	0.00	0.00
	3:30:00	0.00	0.00	0.00	0.00	0.00	0.00	0.00	0.00	0.00
	3:35:00	0.00	0.00	0.00	0.00	0.00	0.00	0.00	0.00	0.00
	3:40:00	0.00	0.00	0.00	0.00	0.00	0.00	0.00	0.00	0.00
	3:45:00	0.00	0.00	0.00	0.00	0.00	0.00	0.00	0.00	0.00
	3:50:00	0.00	0.00	0.00	0.00	0.00	0.00	0.00	0.00	0.00
	3:55:00	0.00	0.00	0.00	0.00	0.00	0.00	0.00	0.00	0.00
	4:00:00	0.00	0.00	0.00	0.00	0.00	0.00	0.00	0.00	0.00
	4:05:00	0.00	0.00	0.00	0.00	0.00	0.00	0.00	0.00	0.00
	4:10:00	0.00	0.00	0.00	0.00	0.00	0.00	0.00	0.00	0.00
	4:15:00	0.00	0.00	0.00	0.00	0.00	0.00	0.00	0.00	0.00
	4:20:00	0.00	0.00	0.00	0.00	0.00	0.00	0.00	0.00	0.00
	4:25:00	0.00	0.00	0.00	0.00	0.00	0.00	0.00	0.00	0.00
	4:30:00	0.00	0.00	0.00	0.00	0.00	0.00	0.00	0.00	0.00
	4:35:00	0.00	0.00	0.00	0.00	0.00	0.00	0.00	0.00	0.00
	4:40:00	0.00	0.00	0.00	0.00	0.00	0.00	0.00	0.00	0.00
	4:45:00	0.00	0.00	0.00	0.00	0.00	0.00	0.00	0.00	0.00
	4:50:00	0.00	0.00	0.00	0.00	0.00	0.00	0.00	0.00	0.00
	4:55:00	0.00	0.00	0.00	0.00	0.00	0.00	0.00	0.00	0.00
	5:00:00	0.00	0.00	0.00	0.00	0.00	0.00	0.00	0.00	0.00
	5:05:00	0.00	0.00	0.00	0.00	0.00	0.00	0.00	0.00	0.00
	5:10:00	0.00	0.00	0.00	0.00	0.00	0.00	0.00	0.00	0.00
	5:15:00	0.00	0.00	0.00	0.00	0.00	0.00	0.00	0.00	0.00
	5:20:00	0.00	0.00	0.00	0.00	0.00	0.00	0.00	0.00	0.00
	5:25:00	0.00	0.00	0.00	0.00	0.00	0.00	0.00	0.00	0.00
	5:30:00	0.00	0.00	0.00	0.00	0.00	0.00	0.00	0.00	0.00
	5:35:00	0.00	0.00	0.00	0.00	0.00	0.00	0.00	0.00	0.00
	5:40:00	0.00	0.00	0.00	0.00	0.00	0.00	0.00	0.00	0.00
	5:45:00	0.00	0.00	0.00	0.00	0.00	0.00	0.00	0.00	0.00
	5:50:00	0.00	0.00	0.00	0.00	0.00	0.00	0.00	0.00	0.00
	5:55:00	0.00	0.00	0.00	0.00	0.00	0.00	0.00	0.00	0.00
	6:00:00	0.00	0.00	0.00	0.00	0.00	0.00	0.00	0.00	0.00

Site-Level Low Impact Development (LID) Design Effective Impervious Calculator

LID Credit by Impervious Reduction Factor (IRF) Method

UD-BMP (Version 3.06, November 2016)

User Input	
Calculated cells	
***Design Storm: 1-Hour Rain Depth	WQCV Event: 0.43 inches
***Minor Storm: 1-Hour Rain Depth	5-Year Event: 1.50 inches
***Major Storm: 1-Hour Rain Depth	100-Year Event: 2.52 inches
Optional User Defined Storm	CUHP
(CUHP) NOAA 1 Hour Rainfall Depth and Frequency for User Defined Storm	100-Year Event
Max Intensity for Optional User Defined Storm	0

Designer: QNA
Company: Terra Nova Engineering
Date: June 16, 2022
Project: WATERBURY FILING 1 POND 3
Location: POND 3 Design Point 29 Full Spectrum Detention

SITE INFORMATION (USER-INPUT)												
Sub-basin Identifier	DP 29 FSD											
Receiving Pervious Area Soil Type	Loamy Sand											
Total Area (ac., Sum of DCIA, UIA, RPA, & SPA)	82.44											
Directly Connected Impervious Area (DCIA, acres)	19.50											
Unconnected Impervious Area (UIA, acres)	22.09											
Receiving Pervious Area (RPA, acres)	9.10											
Separate Pervious Area (SPA, acres)	31.74											
RPA Treatment Type: Conveyance (C), Volume (V), or Permeable Pavement (PP)	C											

CALCULATED RESULTS (OUTPUT)												
Total Calculated Area (ac, check against input)	82.435											
Directly Connected Impervious Area (DCIA, %)	23.7%											
Unconnected Impervious Area (UIA, %)	26.8%											
Receiving Pervious Area (RPA, %)	11.0%											
Separate Pervious Area (SPA, %)	38.5%											
A_p (RPA / UIA)	0.412											
I_s Check	0.710											
f / I for WQCV Event:	4.5											
f / I for 5-Year Event:	0.5											
f / I for 100-Year Event:	0.4											
f / I for Optional User Defined Storm CUHP:												
IRF for WQCV Event:	0.73											
IRF for 5-Year Event:	0.93											
IRF for 100-Year Event:	0.94											
IRF for Optional User Defined Storm CUHP:												
Total Site Imperviousness: I_{total}	50.5%											
Effective Imperviousness for WQCV Event:	43.1%											
Effective Imperviousness for 5-Year Event:	48.5%											
Effective Imperviousness for 100-Year Event:	49.0%											
Effective Imperviousness for Optional User Defined Storm CUHP:												

LID / EFFECTIVE IMPERVIOUSNESS CREDITS												
WQCV Event CREDIT: Reduce Detention By:	9.4%	N/A	N/A	N/A	N/A	N/A	N/A	N/A	N/A	N/A	N/A	N/A
This line only for 10-Year Event	N/A	N/A	N/A	N/A	N/A	N/A	N/A	N/A	N/A	N/A	N/A	N/A
100-Year Event CREDIT**:	2.9%	N/A	N/A	N/A	N/A	N/A	N/A	N/A	N/A	N/A	N/A	N/A
User Defined CUHP CREDIT: Reduce Detention By:												

Total Site Imperviousness: 50.5%
Total Site Effective Imperviousness for WQCV Event: 43.1%
Total Site Effective Imperviousness for 5-Year Event: 48.5%
Total Site Effective Imperviousness for 100-Year Event: 49.0%
Total Site Effective Imperviousness for Optional User Defined Storm CUHP:

Notes:
 * Use Green-Ampt average infiltration rate values from Table 3-3.
 ** Flood control detention volume credits based on empirical equations from Storage Chapter of USDCM.
 *** Method assumes that 1-hour rainfall depth is equivalent to 1-hour intensity for calculation purposed

DETENTION BASIN STAGE-STORAGE TABLE BUILDER

MHFD-Detention, Version 4.03 (May 2020)

Project: **WATERBURY**
 Basin ID: **POND 3 DP 29**

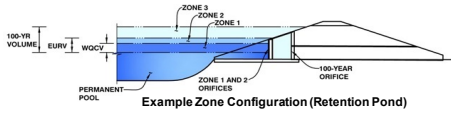

Watershed Information

Selected BMP Type =	EDB
Watershed Area =	82.44 acres
Watershed Length =	1,900 ft
Watershed Length to Centroid =	450 ft
Watershed Slope =	0.026 ft/ft
Watershed Imperviousness =	48.98% percent
Percentage Hydrologic Soil Group A =	100.0% percent
Percentage Hydrologic Soil Group B =	0.0% percent
Percentage Hydrologic Soil Groups C/D =	0.0% percent
Target WQC Drain Time =	40.0 hours
Location for 1-hr Rainfall Depths =	User Input

After providing required inputs above including 1-hour rainfall depths, click "Run CUHP" to generate runoff hydrographs using the embedded Colorado Urban Hydrograph Procedure.

Water Quality Capture Volume (WQCV) =	1,398 acre-feet
Excess Urban Runoff Volume (EURV) =	4,629 acre-feet
2-yr Runoff Volume (P1 = 1.19 in.) =	3,415 acre-feet
5-yr Runoff Volume (P1 = 1.5 in.) =	4,541 acre-feet
10-yr Runoff Volume (P1 = 1.75 in.) =	5,445 acre-feet
25-yr Runoff Volume (P1 = 2 in.) =	6,891 acre-feet
50-yr Runoff Volume (P1 = 2.25 in.) =	8,301 acre-feet
100-yr Runoff Volume (P1 = 2.52 in.) =	10,096 acre-feet
500-yr Runoff Volume (P1 = 3 in.) =	13,064 acre-feet
Approximate 2-yr Detention Volume =	2,974 acre-feet
Approximate 5-yr Detention Volume =	3,917 acre-feet
Approximate 10-yr Detention Volume =	4,785 acre-feet
Approximate 25-yr Detention Volume =	5,861 acre-feet
Approximate 50-yr Detention Volume =	6,549 acre-feet
Approximate 100-yr Detention Volume =	7,398 acre-feet

Optional User Overrides

	acre-feet
	acre-feet
	1.19 inches
	1.50 inches
	1.75 inches
	2.00 inches
	2.25 inches
	2.52 inches
	3.00 inches

Define Zones and Basin Geometry

Zone 1 Volume (WQCV) =	1,398 acre-feet
Zone 2 Volume (EURV - Zone 1) =	3,231 acre-feet
Zone 3 Volume (100-year - Zones 1 & 2) =	2,769 acre-feet
Total Detention Basin Volume =	7,398 acre-feet
Initial Surcharge Volume (ISV) =	user ft ³
Initial Surcharge Depth (ISD) =	user ft
Total Available Detention Depth (H _{total}) =	user ft
Depth of Trickle Channel (H _{TC}) =	user ft
Slope of Trickle Channel (S _{TC}) =	user ft/ft
Slopes of Main Basin Sides (S _{main}) =	user H:V
Basin Length-to-Width Ratio (R _{L/W}) =	user
Initial Surcharge Area (A _{ISV}) =	user ft ²
Surcharge Volume Length (L _{ISV}) =	user ft
Surcharge Volume Width (W _{ISV}) =	user ft
Depth of Basin Floor (H _{FLOOR}) =	user ft
Length of Basin Floor (L _{FLOOR}) =	user ft
Width of Basin Floor (W _{FLOOR}) =	user ft
Area of Basin Floor (A _{FLOOR}) =	user ft ²
Volume of Basin Floor (V _{FLOOR}) =	user ft ³
Depth of Main Basin (H _{MAIN}) =	user ft
Length of Main Basin (L _{MAIN}) =	user ft
Width of Main Basin (W _{MAIN}) =	user ft
Area of Main Basin (A _{MAIN}) =	user ft ²
Volume of Main Basin (V _{MAIN}) =	user ft ³
Calculated Total Basin Volume (V _{total}) =	user acre-feet

Stage - Storage Description	Stage (ft)	Optional Override Stage (ft)	Length (ft)	Width (ft)	Area (ft ²)	Optional Override Area (ft ²)	Area (acre)	Volume (ft ³)	Volume (ac-ft)
Top of Micropool	--	0.00	--	--	--	100	0.002		
6922.25	--	0.25	--	--	--	2,785	0.064	360	0.008
6922.50	--	0.50	--	--	--	5,470	0.126	1,392	0.032
6922.75	--	0.75	--	--	--	8,155	0.187	3,095	0.071
6923.00	--	1.00	--	--	--	10,844	0.249	5,470	0.126
6923.25	--	1.25	--	--	--	13,525	0.310	8,516	0.196
6923.50	--	1.50	--	--	--	16,210	0.372	12,233	0.281
6923.75	--	1.75	--	--	--	18,895	0.434	16,621	0.382
6924.00	--	2.00	--	--	--	21,580	0.495	21,681	0.498
6924.25	--	2.25	--	--	--	29,550	0.678	28,072	0.644
6924.50	--	2.50	--	--	--	37,520	0.861	36,456	0.837
6924.75	--	2.75	--	--	--	45,490	1.044	46,832	1.075
6925.00	--	3.00	--	--	--	53,460	1.227	59,201	1.359
6925.25	--	3.25	--	--	--	61,430	1.410	73,562	1.689
6925.50	--	3.50	--	--	--	69,399	1.593	89,915	2.064
6925.75	--	3.75	--	--	--	77,369	1.776	108,261	2.485
6926.00	--	4.00	--	--	--	85,339	1.959	128,600	2.952
6926.25	--	4.25	--	--	--	93,305	2.142	150,081	3.445
6926.50	--	4.50	--	--	--	101,275	2.325	171,853	3.945
6926.75	--	4.75	--	--	--	109,245	2.508	193,860	4.450
6927.00	--	5.00	--	--	--	117,215	2.691	216,160	4.962
6927.25	--	5.25	--	--	--	125,185	2.874	238,807	5.482
6927.50	--	5.50	--	--	--	133,155	3.057	261,746	6.009
6927.75	--	5.75	--	--	--	141,125	3.240	284,976	6.542
6928.00	--	6.00	--	--	--	149,095	3.423	308,498	7.082
6928.25	--	6.25	--	--	--	157,065	3.606	332,316	7.629
6928.50	--	6.50	--	--	--	165,035	3.789	356,434	8.183
6928.75	--	6.75	--	--	--	173,005	3.972	380,910	8.744
6929.00	--	7.00	--	--	--	180,975	4.155	405,685	9.313
6929.25	--	7.25	--	--	--	188,945	4.338	430,705	9.888
6929.50	--	7.50	--	--	--	196,915	4.521	456,025	10.469
6929.75	--	7.75	--	--	--	204,885	4.704	481,645	11.057
6930.00	--	8.00	--	--	--	212,855	4.887	507,566	11.652

DETENTION BASIN STAGE-STORAGE TABLE BUILDER

MHFD-Detention, Version 4.03 (May 2020)

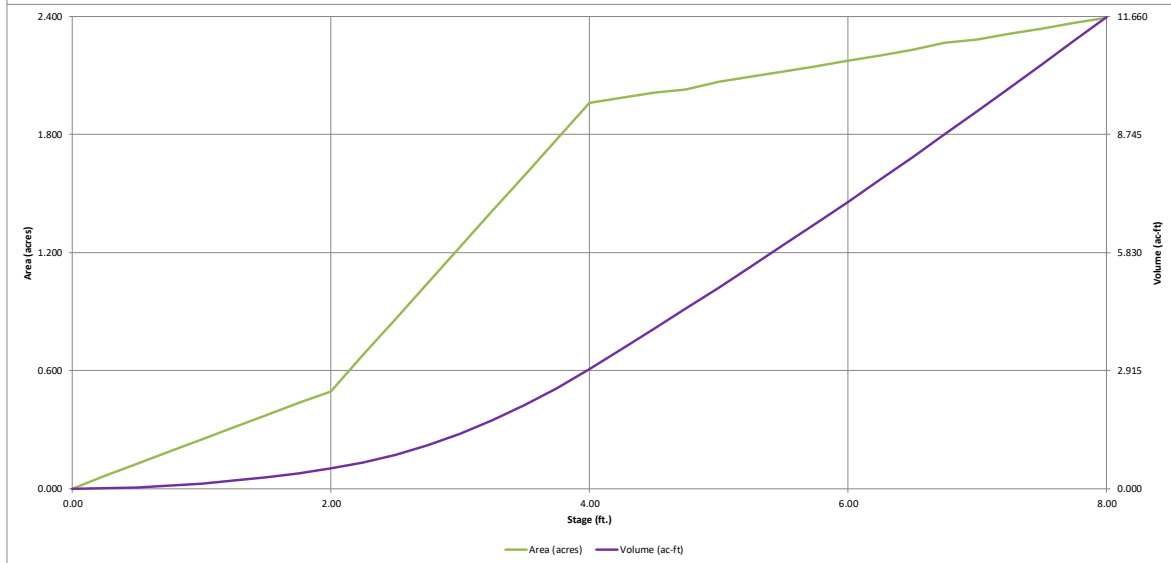
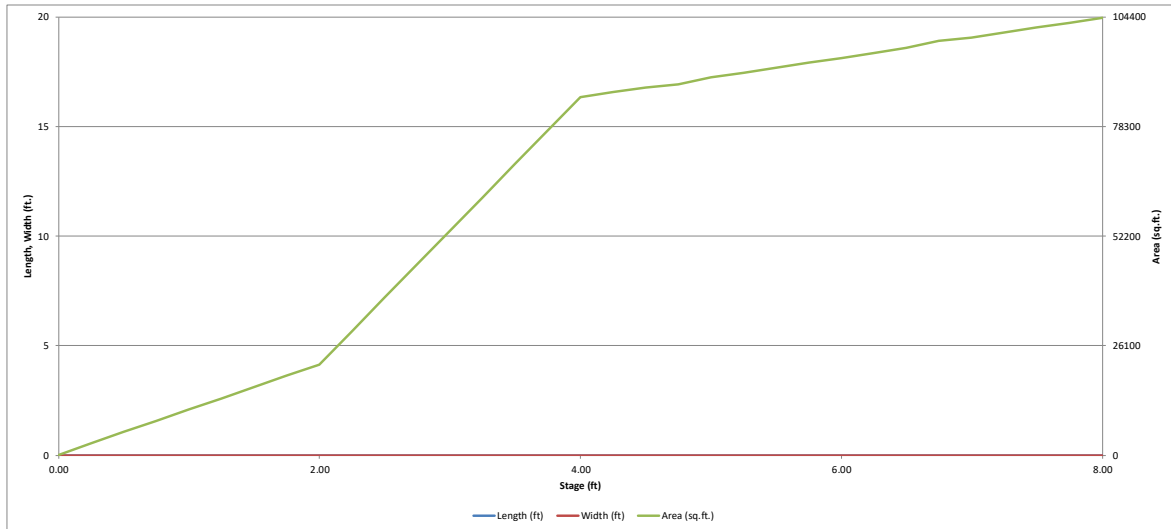

DETENTION BASIN OUTLET STRUCTURE DESIGN

MHFD-*Detention, Version 4.03 (May 2020)*

Project: WATERBURY
Basin ID: POND 3 DP 29

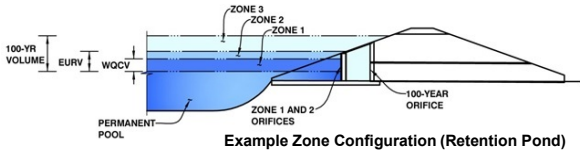

Example Zone Configuration (Retention Pond)

	Estimated Stage (ft)	Estimated Volume (ac-ft)	Outlet Type
Zone 1 (WQCV)	3.04	1.398	Orifice Plate
Zone 2 (EURV)	4.84	3.231	Orifice Plate
Zone 3 (100-year)	6.15	2.769	Weir&Pipe (Restrict)
Total (all zones)		7.398	

User Input: Orifice at Underdrain Outlet (typically used to drain WQCV in a Filtration BMP)

Underdrain Orifice Invert Depth = ft (distance below the filtration media surface)
 Underdrain Orifice Diameter = inches

Calculated Parameters for Underdrain
 Underdrain Orifice Area = ft²
 Underdrain Orifice Centroid = feet

User Input: Orifice Plate with one or more orifices or Elliptical Slot Weir (typically used to drain WQCV and/or EURV in a sedimentation BMP)

Invert of Lowest Orifice = ft (relative to basin bottom at Stage = 0 ft)
 Depth at top of Zone using Orifice Plate = ft (relative to basin bottom at Stage = 0 ft)
 Orifice Plate: Orifice Vertical Spacing = inches
 Orifice Plate: Orifice Area per Row = sq. inches (use rectangular openings)

Calculated Parameters for Plate
 WQ Orifice Area per Row = ft²
 Elliptical Half-Width = feet
 Elliptical Slot Centroid = feet
 Elliptical Slot Area = ft²

User Input: Stage and Total Area of Each Orifice Row (numbered from lowest to highest)

	Row 1 (required)	Row 2 (optional)	Row 3 (optional)	Row 4 (optional)	Row 5 (optional)	Row 6 (optional)	Row 7 (optional)	Row 8 (optional)
Stage of Orifice Centroid (ft)	0.00	1.62	3.23					
Orifice Area (sq. inches)	6.88	6.88	6.88					

	Row 9 (optional)	Row 10 (optional)	Row 11 (optional)	Row 12 (optional)	Row 13 (optional)	Row 14 (optional)	Row 15 (optional)	Row 16 (optional)
Stage of Orifice Centroid (ft)								
Orifice Area (sq. inches)								

User Input: Vertical Orifice (Circular or Rectangular)

	Not Selected	Not Selected	
Invert of Vertical Orifice =	<input type="text" value="N/A"/>	<input type="text" value="N/A"/>	ft (relative to basin bottom at Stage = 0 ft)
Depth at top of Zone using Vertical Orifice =	<input type="text" value="N/A"/>	<input type="text" value="N/A"/>	ft (relative to basin bottom at Stage = 0 ft)
Vertical Orifice Diameter =	<input type="text" value="N/A"/>	<input type="text" value="N/A"/>	inches

Calculated Parameters for Vertical Orifice

	Not Selected	Not Selected	
Vertical Orifice Area =	<input type="text" value="N/A"/>	<input type="text" value="N/A"/>	ft ²
Vertical Orifice Centroid =	<input type="text" value="N/A"/>	<input type="text" value="N/A"/>	feet

User Input: Overflow Weir (Dropbox with Flat or Sloped Gate and Outlet Pipe OR Rectangular/Trapezoidal Weir (and No Outlet Pipe))

	Zone 3 Weir	Not Selected	
Overflow Weir Front Edge Height, Ho =	<input type="text" value="4.85"/>	<input type="text" value="N/A"/>	ft (relative to basin bottom at Stage = 0 ft)
Overflow Weir Front Edge Length =	<input type="text" value="10.00"/>	<input type="text" value="N/A"/>	feet
Overflow Weir Gate Slope =	<input type="text" value="0.00"/>	<input type="text" value="N/A"/>	H:V
Horiz. Length of Weir Sides =	<input type="text" value="4.00"/>	<input type="text" value="N/A"/>	feet
Overflow Gate Open Area % =	<input type="text" value="70%"/>	<input type="text" value="N/A"/>	%, gate open area/total area
Debris Clogging % =	<input type="text" value="50%"/>	<input type="text" value="N/A"/>	%

Calculated Parameters for Overflow Weir

	Zone 3 Weir	Not Selected	
Height of Gate Upper Edge, H ₁ =	<input type="text" value="4.85"/>	<input type="text" value="N/A"/>	feet
Overflow Weir Slope Length =	<input type="text" value="4.00"/>	<input type="text" value="N/A"/>	feet
Gate Open Area / 100-yr Orifice Area =	<input type="text" value="5.10"/>	<input type="text" value="N/A"/>	
Overflow Gate Open Area w/o Debris =	<input type="text" value="28.00"/>	<input type="text" value="N/A"/>	ft ²
Overflow Gate Open Area w/ Debris =	<input type="text" value="14.00"/>	<input type="text" value="N/A"/>	ft ²

User Input: Outlet Pipe w/ Flow Restriction Plate (Circular Orifice, Restrictor Plate, or Rectangular Orifice)

	Zone 3 Restrictor	Not Selected	
Depth to Invert of Outlet Pipe =	<input type="text" value="0.10"/>	<input type="text" value="N/A"/>	ft (distance below basin bottom at Stage = 0 ft)
Outlet Pipe Diameter =	<input type="text" value="36.00"/>	<input type="text" value="N/A"/>	inches
Restrictor Plate Height Above Pipe Invert =	<input type="text" value="26.10"/>	<input type="text" value="N/A"/>	inches

Calculated Parameters for Outlet Pipe w/ Flow Restriction Plate

	Zone 3 Restrictor	Not Selected	
Outlet Orifice Area =	<input type="text" value="5.49"/>	<input type="text" value="N/A"/>	ft ²
Outlet Orifice Centroid =	<input type="text" value="1.21"/>	<input type="text" value="N/A"/>	feet
Half-Central Angle of Restrictor Plate on Pipe =	<input type="text" value="2.04"/>	<input type="text" value="N/A"/>	radians

User Input: Emergency Spillway (Rectangular or Trapezoidal)

Spillway Invert Stage =	<input type="text" value="6.10"/>	ft (relative to basin bottom at Stage = 0 ft)
Spillway Crest Length =	<input type="text" value="80.00"/>	feet
Spillway End Slopes =	<input type="text" value="3.00"/>	H:V
Freeboard above Max Water Surface =	<input type="text" value="0.89"/>	feet

Calculated Parameters for Spillway

Spillway Design Flow Depth =	<input type="text" value="0.99"/>	feet
Stage at Top of Freeboard =	<input type="text" value="7.98"/>	feet
Basin Area at Top of Freeboard =	<input type="text" value="2.39"/>	acres
Basin Volume at Top of Freeboard =	<input type="text" value="11.58"/>	acre-ft

Routed Hydrograph Results

The user can override the default CUHP hydrographs and runoff volumes by entering new values in the Inflow Hydrographs table (Columns W through AF).

	WQCV	EURV	2 Year	5 Year	10 Year	25 Year	50 Year	100 Year	500 Year
Design Storm Return Period =	N/A	N/A	1.19	1.50	1.75	2.00	2.25	2.52	3.00
One-Hour Rainfall Depth (in) =	1.398	4.629	3.415	4.541	5.445	6.891	8.301	10.096	13.064
CUHP Runoff Volume (acre-ft) =	N/A	N/A	3.415	4.541	5.445	6.891	8.301	10.096	13.064
Inflow Hydrograph Volume (acre-ft) =	N/A	N/A	1.1	2.3	3.1	27.2	53.4	86.5	137.6
CUHP Predevelopment Peak Q (cfs) =	N/A	N/A	N/A	N/A	N/A	N/A	N/A	N/A	N/A
OPTIONAL Override Predevelopment Peak Q (cfs) =	N/A	N/A	N/A	N/A	N/A	N/A	N/A	N/A	N/A
Predevelopment Unit Peak Flow, q (cfs/acre) =	N/A	N/A	0.01	0.03	0.04	0.33	0.65	1.05	1.67
Peak Inflow Q (cfs) =	N/A	N/A	72.9	99.5	122.8	160.6	202.7	247.2	319.2
Peak Outflow Q (cfs) =	0.7	1.2	1.1	1.2	6.7	17.7	35.1	58.0	116.6
Ratio Peak Outflow to Predevelopment Q =	N/A	N/A	N/A	0.5	2.2	0.7	0.7	0.7	0.8
Structure Controlling Flow =	Plate	Plate	Plate	Plate	Overflow Weir 1	Overflow Weir 1	Overflow Weir 1	Outlet Plate 1	Spillway
Max Velocity through Gate 1 (fps) =	N/A	N/A	N/A	N/A	0.2	0.6	1.2	2.0	2.1
Max Velocity through Gate 2 (fps) =	N/A	N/A	N/A	N/A	N/A	N/A	N/A	N/A	N/A
Time to Drain 97% of Inflow Volume (hours) =	38	73	62	72	76	74	72	70	67
Time to Drain 99% of Inflow Volume (hours) =	40	78	66	78	82	81	80	79	78
Maximum Ponding Depth (ft) =	3.04	4.84	4.16	4.71	5.05	5.27	5.53	5.93	6.47
Area at Maximum Ponding Depth (acres) =	1.26	2.04	1.98	2.03	2.07	2.10	2.12	2.17	2.23
Maximum Volume Stored (acre-ft) =	1.409	4.634	3.247	4.349	5.066	5.524	6.051	6.930	8.116

DETENTION BASIN OUTLET STRUCTURE DESIGN

MHFD-Detention, Version 4.00 (December 2019)

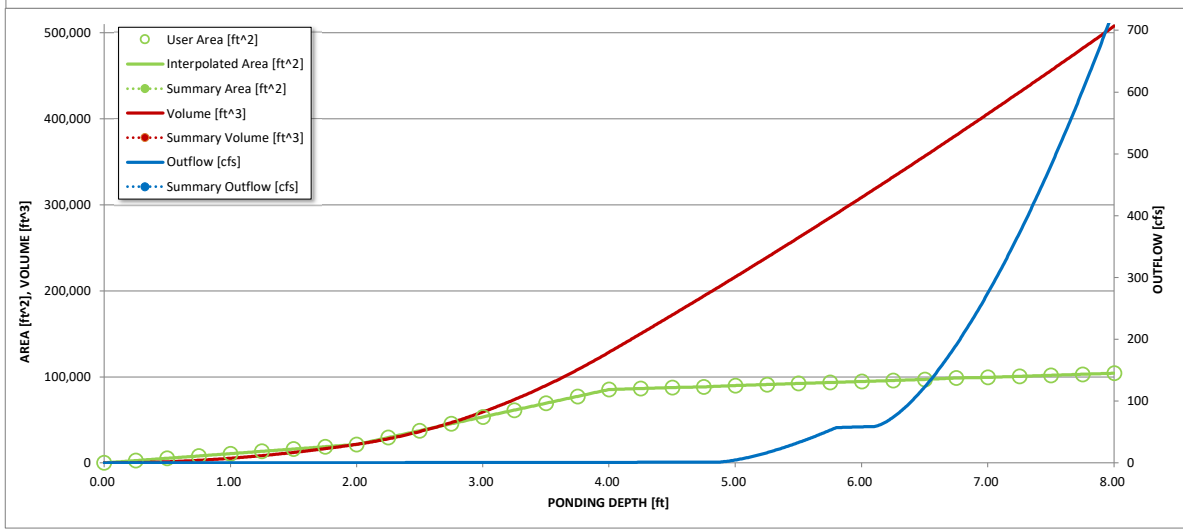
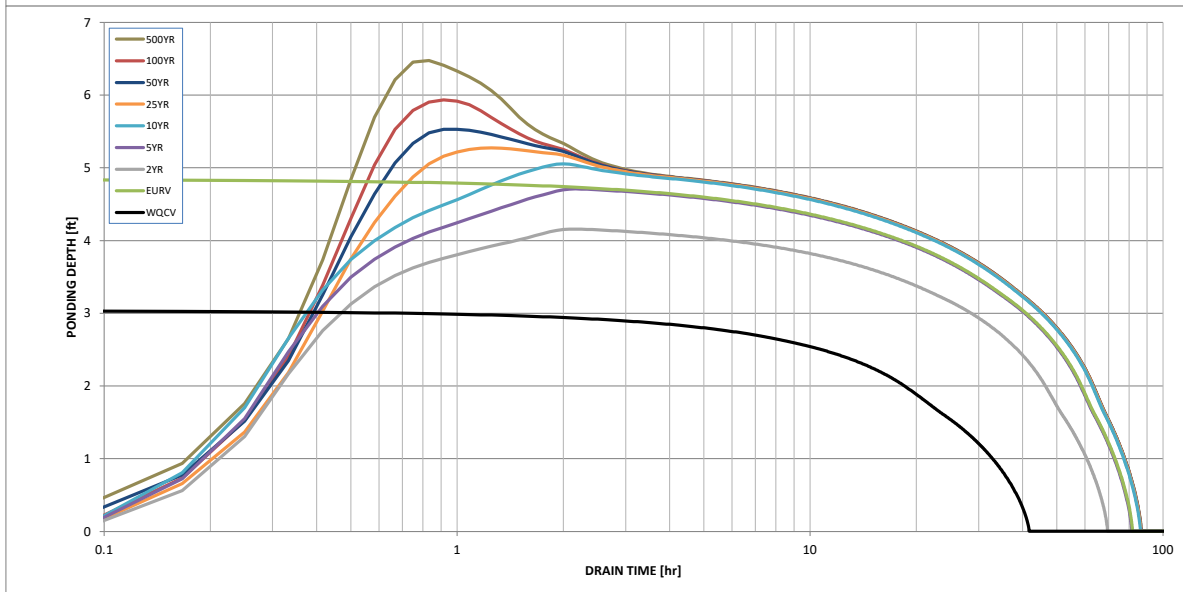
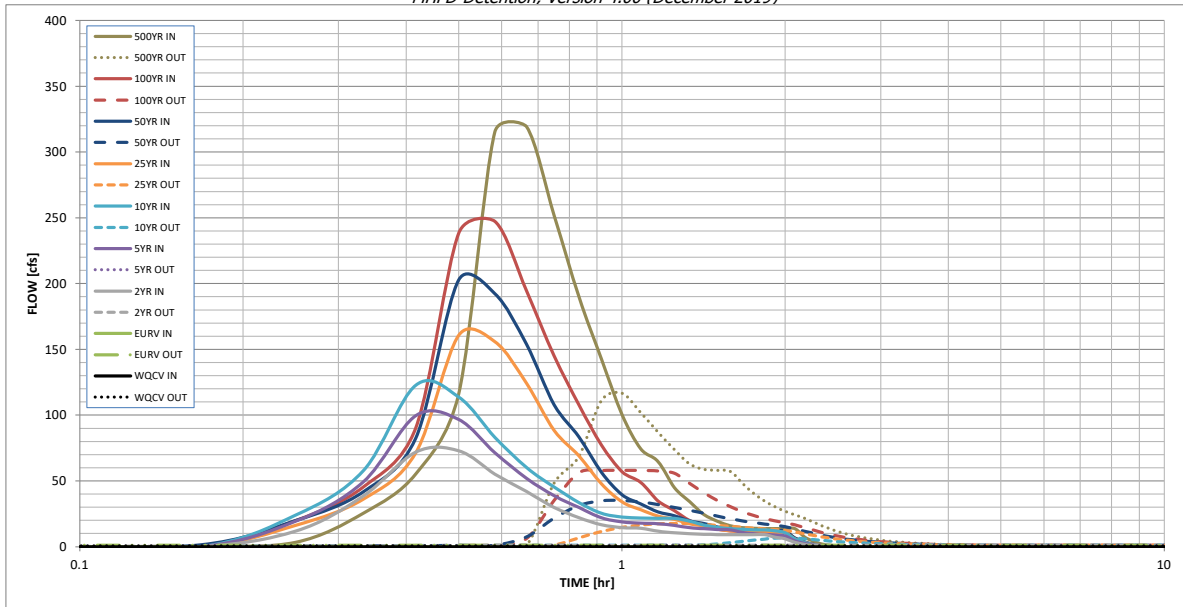

S-A-V-D Chart Axis Override	X-axis	Left Y-Axis	Right Y-Axis
minimum bound			
maximum bound			

DETENTION BASIN OUTLET STRUCTURE DESIGN

Outflow Hydrograph Workbook Filename: _____

Inflow Hydrographs

The user can override the calculated inflow hydrographs from this workbook with inflow hydrographs developed in a separate program.

Time Interval	SOURCE	CUHP	CUHP	CUHP	CUHP	CUHP	CUHP	CUHP	CUHP	CUHP
	TIME	WQCV [cfs]	EURV [cfs]	2 Year [cfs]	5 Year [cfs]	10 Year [cfs]	25 Year [cfs]	50 Year [cfs]	100 Year [cfs]	500 Year [cfs]
5.00 min	0:00:00	0.00	0.00	0.00	0.00	0.00	0.00	0.00	0.00	0.00
	0:05:00	0.00	0.00	0.00	0.00	0.00	0.00	0.00	0.00	0.00
	0:10:00	0.00	0.00	0.00	0.00	0.00	0.00	1.35	0.14	3.40
	0:15:00	0.00	0.00	11.84	19.24	23.93	16.13	19.76	19.71	25.41
	0:20:00	0.00	0.00	38.47	49.26	57.67	36.15	41.70	45.37	55.31
	0:25:00	0.00	0.00	71.90	99.51	122.76	71.44	82.68	90.48	116.27
	0:30:00	0.00	0.00	72.87	96.62	113.69	160.63	202.71	238.31	315.30
	0:35:00	0.00	0.00	55.17	71.29	83.09	155.84	192.39	247.17	319.17
	0:40:00	0.00	0.00	41.86	52.06	60.13	124.23	153.76	194.38	251.85
	0:45:00	0.00	0.00	29.85	38.68	45.34	88.38	108.00	144.98	189.78
	0:50:00	0.00	0.00	21.98	29.77	33.50	68.94	83.41	107.69	142.73
	0:55:00	0.00	0.00	16.71	22.00	25.41	47.81	56.67	77.35	100.69
	1:00:00	0.00	0.00	14.54	18.88	22.56	34.08	39.57	57.15	74.42
	1:05:00	0.00	0.00	13.90	17.89	21.84	28.04	32.52	48.85	64.68
	1:10:00	0.00	0.00	11.69	17.49	21.54	23.14	26.47	34.78	44.87
	1:15:00	0.00	0.00	10.54	16.06	21.44	20.71	23.51	27.30	34.27
	1:20:00	0.00	0.00	9.84	14.50	19.40	17.34	19.60	19.81	24.41
	1:25:00	0.00	0.00	9.47	13.63	16.46	15.68	17.70	15.86	19.30
	1:30:00	0.00	0.00	9.23	13.13	14.73	13.32	15.00	13.38	16.05
	1:35:00	0.00	0.00	9.11	12.84	13.74	12.03	13.52	12.17	14.48
	1:40:00	0.00	0.00	9.11	10.93	13.16	11.32	12.73	11.77	14.01
	1:45:00	0.00	0.00	9.11	9.87	12.83	10.96	12.33	11.59	13.80
	1:50:00	0.00	0.00	9.11	9.26	12.73	10.80	12.15	11.59	13.80
	1:55:00	0.00	0.00	7.13	8.93	12.15	10.73	12.07	11.59	13.80
	2:00:00	0.00	0.00	5.98	8.22	10.64	10.73	12.07	11.59	13.80
	2:05:00	0.00	0.00	3.31	4.59	5.96	6.02	6.76	6.47	7.68
	2:10:00	0.00	0.00	1.79	2.53	3.25	3.32	3.72	3.55	4.21
	2:15:00	0.00	0.00	0.85	1.29	1.63	1.69	1.89	1.80	2.12
	2:20:00	0.00	0.00	0.36	0.63	0.75	0.82	0.91	0.87	1.02
	2:25:00	0.00	0.00	0.12	0.20	0.22	0.26	0.28	0.27	0.31
	2:30:00	0.00	0.00	0.00	0.00	0.00	0.00	0.00	0.00	0.00
	2:35:00	0.00	0.00	0.00	0.00	0.00	0.00	0.00	0.00	0.00
	2:40:00	0.00	0.00	0.00	0.00	0.00	0.00	0.00	0.00	0.00
	2:45:00	0.00	0.00	0.00	0.00	0.00	0.00	0.00	0.00	0.00
	2:50:00	0.00	0.00	0.00	0.00	0.00	0.00	0.00	0.00	0.00
	2:55:00	0.00	0.00	0.00	0.00	0.00	0.00	0.00	0.00	0.00
	3:00:00	0.00	0.00	0.00	0.00	0.00	0.00	0.00	0.00	0.00
	3:05:00	0.00	0.00	0.00	0.00	0.00	0.00	0.00	0.00	0.00
	3:10:00	0.00	0.00	0.00	0.00	0.00	0.00	0.00	0.00	0.00
	3:15:00	0.00	0.00	0.00	0.00	0.00	0.00	0.00	0.00	0.00
	3:20:00	0.00	0.00	0.00	0.00	0.00	0.00	0.00	0.00	0.00
	3:25:00	0.00	0.00	0.00	0.00	0.00	0.00	0.00	0.00	0.00
	3:30:00	0.00	0.00	0.00	0.00	0.00	0.00	0.00	0.00	0.00
	3:35:00	0.00	0.00	0.00	0.00	0.00	0.00	0.00	0.00	0.00
	3:40:00	0.00	0.00	0.00	0.00	0.00	0.00	0.00	0.00	0.00
	3:45:00	0.00	0.00	0.00	0.00	0.00	0.00	0.00	0.00	0.00
	3:50:00	0.00	0.00	0.00	0.00	0.00	0.00	0.00	0.00	0.00
	3:55:00	0.00	0.00	0.00	0.00	0.00	0.00	0.00	0.00	0.00
	4:00:00	0.00	0.00	0.00	0.00	0.00	0.00	0.00	0.00	0.00
	4:05:00	0.00	0.00	0.00	0.00	0.00	0.00	0.00	0.00	0.00
	4:10:00	0.00	0.00	0.00	0.00	0.00	0.00	0.00	0.00	0.00
	4:15:00	0.00	0.00	0.00	0.00	0.00	0.00	0.00	0.00	0.00
	4:20:00	0.00	0.00	0.00	0.00	0.00	0.00	0.00	0.00	0.00
	4:25:00	0.00	0.00	0.00	0.00	0.00	0.00	0.00	0.00	0.00
	4:30:00	0.00	0.00	0.00	0.00	0.00	0.00	0.00	0.00	0.00
	4:35:00	0.00	0.00	0.00	0.00	0.00	0.00	0.00	0.00	0.00
	4:40:00	0.00	0.00	0.00	0.00	0.00	0.00	0.00	0.00	0.00
	4:45:00	0.00	0.00	0.00	0.00	0.00	0.00	0.00	0.00	0.00
	4:50:00	0.00	0.00	0.00	0.00	0.00	0.00	0.00	0.00	0.00
	4:55:00	0.00	0.00	0.00	0.00	0.00	0.00	0.00	0.00	0.00
	5:00:00	0.00	0.00	0.00	0.00	0.00	0.00	0.00	0.00	0.00
	5:05:00	0.00	0.00	0.00	0.00	0.00	0.00	0.00	0.00	0.00
	5:10:00	0.00	0.00	0.00	0.00	0.00	0.00	0.00	0.00	0.00
	5:15:00	0.00	0.00	0.00	0.00	0.00	0.00	0.00	0.00	0.00
	5:20:00	0.00	0.00	0.00	0.00	0.00	0.00	0.00	0.00	0.00
	5:25:00	0.00	0.00	0.00	0.00	0.00	0.00	0.00	0.00	0.00
	5:30:00	0.00	0.00	0.00	0.00	0.00	0.00	0.00	0.00	0.00
	5:35:00	0.00	0.00	0.00	0.00	0.00	0.00	0.00	0.00	0.00
	5:40:00	0.00	0.00	0.00	0.00	0.00	0.00	0.00	0.00	0.00
	5:45:00	0.00	0.00	0.00	0.00	0.00	0.00	0.00	0.00	0.00
	5:50:00	0.00	0.00	0.00	0.00	0.00	0.00	0.00	0.00	0.00
	5:55:00	0.00	0.00	0.00	0.00	0.00	0.00	0.00	0.00	0.00
	6:00:00	0.00	0.00	0.00	0.00	0.00	0.00	0.00	0.00	0.00

FSD POND 1 FORBAY VOLUMES

Required Forbay Volume = 3% of WQCV

WQCV = 0.394 ac-ft
 WQCV = 17,155 cu-ft
 3% of WQCV = 0.01 ac-ft
 3% of WQCV = 514.65 cu-ft

POND PR 7

<i>ELEV</i>	<i>AREA</i>	<i>AREA AVG.</i>	<i>DELTA ELEV.</i>	<i>VOLUME</i>	<i>VOLUME TOTAL</i>
6925.50	198	198	1.5	297	
6927.00	198				297

End Area Method: 297 C.F.
0.007 A.F.

POND PR 10

<i>ELEV</i>	<i>AREA</i>	<i>AREA AVG.</i>	<i>DELTA ELEV.</i>	<i>VOLUME</i>	<i>VOLUME TOTAL</i>
6927.00	198	198	1.5	297	
6928.50	198				297

End Area Method: 297 C.F.
0.007 A.F.

TOTAL 594.000 A.F.
TOTAL 0.014 A.F.

FSD POND 2 FORBAY VOLUMES

Required Forbay Volume = 3% of WQCV

WQCV = 0.241 ac-ft
 WQCV = 10,513 cu-ft
 3% of WQCV = 0.01 ac-ft
 3% of WQCV = 315.38 cu-ft

POND PR 17

<i>ELEV</i>	<i>AREA</i>	<i>AREA AVG.</i>	<i>DELTA ELEV.</i>	<i>VOLUME</i>	<i>VOLUME TOTAL</i>
6900.25	382	382	1.5	573	
6901.75	382				573

End Area Method: 573 C.F.
0.013 A.F.

FSD POND 3 FORBAY VOLUMES

Required Forbay Volume = 3% of WQCV

WQCV = 1.398 ac-ft
 WQCV = 60,894 cu-ft
 3% of WQCV = 0.04 ac-ft
 3% of WQCV = 1826.82 cu-ft

POND PR 33

<i>ELEV</i>	<i>AREA</i>	<i>AREA AVG.</i>	<i>DELTA ELEV.</i>	<i>VOLUME</i>	<i>VOLUME TOTAL</i>
6900.25	900				
		900	1.5	1350	
6901.75	900				1350

End Area Method: 1350 C.F.
0.031 A.F.

POND PR 34A

<i>ELEV</i>	<i>AREA</i>	<i>AREA AVG.</i>	<i>DELTA ELEV.</i>	<i>VOLUME</i>	<i>VOLUME TOTAL</i>
6900.25	425				
		425	1.5	638	
6901.75	425				638

End Area Method: 638 C.F.
0.015 A.F.

TOTAL 1987.500 A.F.
TOTAL 0.046 A.F.

**RUNOFF REDUCTION
& EXCLUDED UNDEVELOPED PERVIOUS AREA**

Design Procedure Form: Runoff Reduction

UD-BMP (Version 3.07, March 2018)

Sheet 1 of 1

Designer: QUENTIN ARMJJO
Company: TERRA NOVA ENGINEERING, INC.
Date: November 19, 2022
Project: WATERBURY FILING 1 & 2
Location: BASIN M2 EASTERN CHANNEL DIRECT RELEASE

SITE INFORMATION (User Input in Blue Cells)

WQCV Rainfall Depth = 0.60 inches
 Depth of Average Runoff Producing Storm, d_6 = 0.43 inches (for Watersheds Outside of the Denver Region, Figure 3-1 in USDCM Vol. 3)

Area Type	UIA:RPA																		
Area ID	M2																		
Downstream Design Point ID	EAST CH																		
Downstream BMP Type	None																		
DCIA (ft ²)	--																		
UIA (ft ²)	5,300																		
RPA (ft ²)	7,000																		
SPA (ft ²)	--																		
HSG A (%)	100%																		
HSG B (%)	0%																		
HSG C/D (%)	0%																		
Average Slope of RPA (ft/ft)	0.020																		
UIA:RPA Interface Width (ft)	60.00																		

CALCULATED RUNOFF RESULTS

Area ID	M2																		
UIA:RPA Area (ft ²)	12,300																		
L / W Ratio	3.42																		
UIA / Area	0.4309																		
Runoff (in)	0.00																		
Runoff (ft ³)	0																		
Runoff Reduction (ft ³)	221																		

CALCULATED WQCV RESULTS

Area ID	M2																		
WQCV (ft ³)	221																		
WQCV Reduction (ft ³)	221																		
WQCV Reduction (%)	100%																		
Untreated WQCV (ft ³)	0																		

CALCULATED DESIGN POINT RESULTS (sums results from all columns with the same Downstream Design Point ID)

Downstream Design Point ID	EAST CH																		
DCIA (ft ²)	0																		
UIA (ft ²)	5,300																		
RPA (ft ²)	7,000																		
SPA (ft ²)	0																		
Total Area (ft ²)	12,300																		
Total Impervious Area (ft ²)	5,300																		
WQCV (ft ³)	221																		
WQCV Reduction (ft ³)	221																		
WQCV Reduction (%)	100%																		
Untreated WQCV (ft ³)	0																		

CALCULATED SITE RESULTS (sums results from all columns in worksheet)

Total Area (ft ²)	12,300
Total Impervious Area (ft ²)	5,300
WQCV (ft ³)	221
WQCV Reduction (ft ³)	221
WQCV Reduction (%)	100%
Untreated WQCV (ft ³)	0

Design Procedure Form: Runoff Reduction

UD-BMP (Version 3.07, March 2018)

Sheet 1 of 1

Designer: Quentin Armijo
Company: Terra Nova Engineering, Inc.
Date: November 19, 2022
Project: Waterbury Filings 1 & 2
Location: *BASIN N WESTERN CHANNEL DIRECT RELEASE.

SITE INFORMATION (User Input in Blue Cells)

WQCV Rainfall Depth = 0.60 inches
 Depth of Average Runoff Producing Storm, d_6 = 0.43 inches (for Watersheds Outside of the Denver Region, Figure 3-1 in USDCM Vol. 3)

Area Type	UIA:RPA																		
Area ID	N																		
Downstream Design Point ID	WEST CH																		
Downstream BMP Type	None																		
DCIA (ft ²)	--																		
UIA (ft ²)	1,105																		
RPA (ft ²)	1,895																		
SPA (ft ²)	--																		
HSG A (%)	100%																		
HSG B (%)	0%																		
HSG C/D (%)	0%																		
Average Slope of RPA (ft/ft)	0.020																		
UIA:RPA Interface Width (ft)	60.00																		

CALCULATED RUNOFF RESULTS

Area ID	N																		
UIA:RPA Area (ft ²)	3,000																		
L / W Ratio	0.83																		
UIA / Area	0.3683																		
Runoff (in)	0.00																		
Runoff (ft ³)	0																		
Runoff Reduction (ft ³)	46																		

CALCULATED WQCV RESULTS

Area ID	N																		
WQCV (ft ³)	46																		
WQCV Reduction (ft ³)	46																		
WQCV Reduction (%)	100%																		
Untreated WQCV (ft ³)	0																		

CALCULATED DESIGN POINT RESULTS (sums results from all columns with the same Downstream Design Point ID)

Downstream Design Point ID	WEST CH																		
DCIA (ft ²)	0																		
UIA (ft ²)	1,105																		
RPA (ft ²)	1,895																		
SPA (ft ²)	0																		
Total Area (ft ²)	3,000																		
Total Impervious Area (ft ²)	1,105																		
WQCV (ft ³)	46																		
WQCV Reduction (ft ³)	46																		
WQCV Reduction (%)	100%																		
Untreated WQCV (ft ³)	0																		

CALCULATED SITE RESULTS (sums results from all columns in worksheet)

Total Area (ft ²)	3,000
Total Impervious Area (ft ²)	1,105
WQCV (ft ³)	46
WQCV Reduction (ft ³)	46
WQCV Reduction (%)	100%
Untreated WQCV (ft ³)	0

HEC-RAS ANALYSIS

TABLE 10-1

COMPOSITE ROUGHNESS COEFFICIENTS FOR UNLINED OPEN CHANNELS
 (Reference: Chow, Ven Te, 1959; Open-Channel Hydraulics)

$$n = (n_0 + n_1 + n_2 + n_3 + n_4)m \quad (10-2)$$

	<u>Channel Conditions</u>	<u>Value</u>
Material Type n_0	Earth	0.020
	Fine Gravel	0.024
	Coarse Gravel	0.028
Degree of Irregularity n_1	Smooth	0.000
	Minor	0.005
	Moderate	0.010
	Severe	0.020
Variation of Channel Cross Section n_2	Gradual	0.000
	Alternating Occasionally	0.005
	Alternating Frequently	0.010 - 0.015
Relative Effect of Obstructions n_3	Negligible	0.000
	Minor	0.010 - 0.015
	Appreciable	0.020 - 0.030
	Severe	0.040 - 0.060
Vegetation n_4	Low	0.005 - 0.010
	Medium	0.010 - 0.025
	High	0.025 - 0.050
	Very High	0.050 - 0.100
Degree of Meandering m	Minor	1.000 - 1.200
	Appreciable	1.200 - 1.500
	Severe	1.500

TABLE 10-2 (Continued)

TYPICAL ROUGHNESS COEFFICIENTS FOR OPEN CHANNELS

<u>Type of Channel and Description</u>	<u>Minimum</u>	<u>Normal</u>	<u>Maximum</u>
NATURAL STREAMS			
Minor streams (top width at flood stage 100 ft)			
a. Streams on plain			
1. Clean, straight, full stage, no rifts or deep pools	0.025	0.030	0.033
2. Same as above, but more stones and weeds	0.030	0.035	0.040
3. Clean, winding, some pools and shoals	0.033	0.040	0.045
4. Same as above, but some weeds and stones	0.035	0.045	0.050
5. Same as above, lower stages, more ineffective slopes and sections	0.040	0.048	0.055
6. Same as 4, but more stones	0.045	0.050	0.060
7. Sluggish reaches, weedy, deep pools	0.050	0.070	0.080
8. Very weedy reaches, deep pools, or floodways with heavy stand of timber and underbrush	0.075	0.100	0.150
LINED OR BUILT-UP CHANNELS			
a. Corrugated Metal	0.021	0.025	0.030
b. Concrete			
1. Trowel finish	0.011	0.013	0.015
2. Float finish	0.013	0.015	0.016
3. Finished, with gravel on bottom	0.015	0.017	0.020
4. Unfinished	0.014	0.017	0.020
5. Gunite, good section	0.016	0.019	0.023
6. Gunite, wavy section	0.018	0.022	0.025
7. On good excavated rock	0.017	0.020	
8. On irregular excavated rock	0.022	0.027	

Table 3. Adjustment values for factors that affect roughness of flood plains

[Modified from Aldridge and Garrett, 1973, table 2]

Flood-plain conditions		<i>n</i> value adjustment	Example
Degree of irregularity (<i>n</i> ₁)	Smooth	0.000	Compares to the smoothest, flattest flood plain attainable in a given bed material.
	Minor	0.001–0.005	Is a flood plain slightly irregular in shape. A few rises and dips or sloughs may be visible on the flood plain.
	Moderate	0.006–0.010	Has more rises and dips. Sloughs and hummocks may occur.
	Severe	0.011–0.020	Flood plain very irregular in shape. Many rises and dips or sloughs are visible. Irregular ground surfaces in pastureland and furrows perpendicular to the flow are also included.
Variation of flood-plain cross section (<i>n</i> ₂)		0.0	Not applicable.
Effect of obstructions (<i>n</i> ₃)	Negligible	0.000–0.004	Few scattered obstructions, which include debris deposits, stumps, exposed roots, logs, or isolated boulders, occupy less than 5 percent of the cross-sectional area.
	Minor	0.005–0.019	Obstructions occupy less than 15 percent of the cross-sectional area.
	Appreciable	0.020–0.030	Obstructions occupy from 15 to 50 percent of the cross-sectional area.
Amount of vegetation (<i>n</i> ₄)	Small	0.001–0.010	Dense growth of flexible turf grass, such as Bermuda, or weeds growing where the average depth of flow is at least two times the height of the vegetation, or supple tree seedlings such as willow, cottonwood, arrowweed, or saltcedar growing where the average depth of flow is at least three times the height of the vegetation.
	Medium	0.011–0.025	Turf grass growing where the average depth of flow is from one to two times the height of the vegetation, or moderately dense stemmy grass, weeds, or tree seedlings growing where the average depth of flow is from two to three times the height of the vegetation; brushy, moderately dense vegetation, similar to 1- to 2-year-old willow trees in the dormant season.
	Large	0.025–0.050	Turf grass growing where the average depth of flow is about equal to the height of the vegetation, or 8- to 10-year-old willow or cottonwood trees intergrown with some weeds and brush (none of the vegetation in foliage) where the hydraulic radius exceeds 2 ft, or mature row crops such as small vegetables, or mature field crops where depth of flow is at least twice the height of the vegetation.
	Very large	0.050–0.100	Turf grass growing where the average depth of flow is less than half the height of the vegetation, or moderate to dense brush, or heavy stand of timber with few down trees and little undergrowth where depth of flow is below branches, or mature field crops where depth of flow is less than the height of the vegetation.
	Extreme	0.100–0.200	Dense bushy willow, mesquite, and saltcedar (all vegetation in full foliage), or heavy stand of timber, few down trees, depth of flow reaching branches.
Degree of meander (<i>m</i>)		1.0	Not applicable.

Chow (1959) presents a table showing minimum, normal, and maximum values of *n* for flood plains covered by pasture and crops. These values are helpful for comparing the roughness values of flood plains having similar vegetation.

Vegetation-Density Method

For a wooded flood plain, the vegetation-density method can be used as an alternative to the previous method for determining *n* values for flood plains. In a wooded flood plain, where the tree diameters can be measured, the vegetation density of the flood plain can be determined.

Determining the vegetation density is an effective way of relating plant height and density characteristics, as a function of depth of flow, to the flow resistance of vegetation. Application of the flow-resistance model presented below requires an estimate of the vegetation density as a function of depth of flow. The procedure requires a direct or indirect determination of vegetation density at a given depth. If the change in *n* value through a range in depth is required, then an estimation of vegetation density through that range is necessary.

Techniques for Determining Vegetation Density

Petryk and Bosmajian (1975) developed a method of analysis of the vegetation density to determine the rough-

Classification of Vegetal Covers

Retardance Class	Cover	Condition
A	Weeping lovegrass	Excellent stand, tall, average 30 in.
	Yellow bluestem <i>Ischaemum</i>	Excellent stand, tall, average 36 in.
B	Bermuda grass	Good stand, tall, average 12 in.
	Native grass mixture (little bluestem, bluestem, blue gamma, and other long and short Midwest grasses)	Good stand, unmowed
	Weeping lovegrass	Good stand, tall, average 24 in.
	Lespedeza serica	Good stand, not woody, tall, average 19 in.
	Alfalfa	Good stand uncut, average 11 in.
	Weeping lovegrass	Good stand, unmowed, average 13 in.
	Kudzu	Dense growth, uncut
C	Blue gamma	Good stand, uncut, average 13 in.
	Crabgrass	Fair stand, uncut, avg. 10 in.
	Bermuda grass	Good stand, mowed, average 6 in.
	Common lespedeza	Good stand, uncut, average 11 in.
	Grass-legume mixture - summer (orchard grass, redtop Italian ryegrass, and common lespedeza)	Good stand, uncut, average 6 to 8 in.
	Centipede grass	Very dense cover, average 6 in.
	Kentucky Bluegrass	Good stand, headed, 6 to 12 in.
D	Bermuda grass	Good stand, cut to 2.5 in. height
	Common lespedeza	Excellent stand, uncut, average 4.5 in.
	Buffalo Grass	Good stand, uncut, 3 to 6 in.
	Grass-legume mixture - fall (orchard grass, redtop Italian ryegrass, and common lespedeza)	Good stand, uncut, 3 to 5 in.
	Lespedeza serica	After cutting to 2 in. height, good stand before cutting
E	Bermuda grass	Good stand, cut to average 1.5 in. height
	Bermuda grass	Burned stubble

Note: Covers classified have been tested in experimental channels. Covers were green and generally uniform.

Source: HEC-15



Coefficients for Roughness of Grass-Lined Channels

SCS Retardance Class	C _n
A	0.605
B	0.418
C	0.220
D	0.147
E	0.093

Source: HEC-15

Composite Roughness

Culverts using different materials for portions of the perimeter such as embedded culverts or culverts with an invert liner should use a composite Manning's n value. A weighted n value based on the materials can be derived using the following equation:

$$n_c = \left[\frac{\sum(p_i n_i^{1.5})}{p} \right]^{0.67}$$

Where:

- n_c = Composite/weighted Manning's n.
- p_i = Wetted perimeter for the material, ft.
- n_i = Manning's n value for the material.
- p = Total wetted perimeter, ft.

750.1.4.1.2 Hydraulic Radius

The hydraulic radius is a characteristic depth of flow and is defined as the cross-sectional area of flow divided by the wetted perimeter of the channel. The hydraulic radius is computed as follows:

$$R = \frac{A}{P}$$

where:

- R = hydraulic radius, ft
- A = cross-sectional area of flow, ft²
- P = wetted perimeter of the channel cross section, ft

750.1.4.1.3 Slope

Table 8-8 Characteristics of selected grass species for use in channels and waterways

Grass species	Height at maturity	
	(ft)	(m)
Cool-season grasses		
Creeping foxtail	3-4	0.9-1.2
Crested wheatgrass	2-3	0.6-0.9
Green needlegrass	3-4	0.9-1.2
Russian wild rye	3-4	0.9-1.2
Smooth brome grass	3-4	0.9-1.2
Tall fescue	3-4	0.9-1.2
Tall wheatgrass		1.2-1.5
Western wheatgrass	2-3	0.6-0.9
Warm-season grasses		
Bermudagrass	3/4-2	0.2-0.6
Big bluestem	4-6	1.2-1.8
Blue grama	1-2	0.3-0.6
Buffalograss	1/3-1	0.1-0.3
Green spangle top	3-4	0.9-1.2
Indiangrass	5-6	1.5-1.8
Klein grass	3-4	0.9-1.2
Little bluestem	3-4	0.9-1.2
Plains bristlegrass	1-2	0.3-0.6
Sand bluestem	5-6	1.5-1.8
Sideoats grama	2-3	0.6-0.9
Switchgrass	4-5	1.2-1.5
Vine mesquitegrass	1-2	0.3-0.6
Weeping lovegrass	3-4	0.9-1.2
Old World bluestems		
Caucasian bluestem	4-5	1.2-1.5
Ganada yellow bluestem	3-4	0.9-1.2

Table 8-9 Retardance curve index by SCS retardance class

SCS retardance class	Retardance curve index
A	10.0
B	7.64
C	5.60
D	4.44
E	2.88

this table were obtained from a review of the available qualitative descriptions and stem counts reported by researchers studying channel resistance and stability.

Since cover conditions vary from year to year and season to season, it is recommended that an upper and lower bound be determined for C_F . The lower bound should be used in stability computations, and the upper bound should be used to determine channel capacity. Some practitioners find that the use of SCS retardance class (table 8-9) is a preferable approach.

The vegetal cover index, C_F , depends primarily on the density and uniformity of density in the immediate vicinity of the soil boundary. Because this parameter is associated with the prevention of local erosion damage which may lead to channel unraveling, the cover factor should represent the weakest area in a reach, rather than the average for the cover species. Recommended values for the cover factor are presented in table 8-10. Values in this table do not account for such considerations as maintenance practices or uniformity of soil fertility or moisture. Therefore, appropriate engineering judgment should be used in its application.

Table 8-10 Properties of grass channel linings values (apply to good uniform stands of each cover)

Cover factor (C_F)	Covers tested	Reference stem density (stems/ft ²)	Reference stem density (stems/m ²)
0.90	Bermudagrass	500	5,380
	Centipede grass	500	5,380
0.87	Buffalograss	400	4,300
	Kentucky bluegrass	350	3,770
0.75	Blue grama	350	3,770
	Grass mixture	200	2,150
0.50	Weeping lovegrass	350	3,770
	Yellow bluestem	250	2,690
0.50	Alfalfa	500	5,380
	Lespedeza sericea	300	3,280
0.50	Common lespedeza	150	1,610
	Sudangrass	50	538

Multiply the stem densities given by 1/3, 2/3, 1, 4/3, and 5/3 for poor, fair, good, very good, and excellent covers, respectively. Reduce the C_F by 20% for fair stands and 50% for poor stands.

Two soil parameters are required for application of effective stress concepts to the stability design of lined or unlined channels having an erodible soil boundary: soil grain roughness, n_s , and allowable effective stress, τ_a . When the effective stress approach is used, the soil parameters are the same for both lined and unlined channels with negligible bed-material sediment transport.

Soil grain roughness is defined as the roughness associated with particles or aggregates of a size that can be independently moved by the flow at incipient channel failure. For noncohesive soils, the soil grain roughness and effective shear stress are both a function of the D_{75} grain size. When D_{75} is greater than 1.3 millimeter, the soil is considered coarse grained. When D_{75} is less than 1.3 millimeter, the soil is considered fine grained. Fine-grained roughness is considered to have a constant value of 0.0156. Fine-grained effective shear stress is taken to have a constant value of 0.02 pound per square foot. Coarse-grained shear stress and roughness are given in figures 8-21 and 8-22.

A soil grain roughness of 0.0156 is assigned to all cohesive soils. The allowable effective stresses are a function of the unified soil classification system soil type, the plasticity index, and the void ratio. The basic allowable shear stress, τ_{ab} , is determined from the plasticity index and soil classification, and then adjusted by the void ratio correction factor, C_e , using the following equation:

$$\tau_a = \tau_{ab} C_e^2 \quad (\text{eq. 8-29})$$

The basic allowable effective stress can be determined from figure 8-23 and the void ratio correction factor from figure 8-24. These two figures were developed directly from the allowable velocity curves in AH 667. Stress partitioning (slope partitioning) is essential to application of figures 8-21 to 8-24, with or without vegetation (Temple et al. 1987).

(e) General design procedure

Use the basic shear stress equation to determine effective shear stress on the soil beneath the vegetation. Use any consistent units of measurement.

$$\tau_e = \gamma d S (1 - C_f) \left(\frac{n_s}{n} \right)^2 \quad (\text{eq. 8-30})$$

where:

- τ_e = effective shear stress exerted on the soil beneath vegetation (lb/ft² or N/m²)
- γ = specific weight of water (lb/ft³ or N/m³)
- d = maximum depth of flow in the cross section (ft or m)
- S = energy slope, dimensionless
- C_f = vegetation cover factor (0 for unlined channel), dimensionless
- n_s = grain roughness of underlying soil, typically taken as dimensionless
- n = roughness coefficient of vegetation, typically taken as dimensionless

The flow depth is used instead of the hydraulic radius because this will result in the maximum local shear stress, rather than the average shear stress. The cover factor is a function of the grass and stem density. Roughness coefficients are standard Manning's roughness values; n_s can be determined from figure 8-22, n can be determined from the old SCS curves (fig. 8-20) or from the following equation.

$$n_r = \exp \left\{ C_1 \left[0.0133 (\ln R_v)^2 - 0.0954 \ln R_v + 0.297 \right] - 4.16 \right\} \quad (\text{eq. 8-31})$$

where:

- R_v = $(VR/v) \times 10^{-5}$ (this dimensionless term reduces to VR for practical application in English units)
- V = channel velocity (ft/s or m/s)
- R = hydraulic radius (ft or m)
- Limited to $0.0025 C_1^{2.5} < R_v < 36$

A reference value of Manning's resistance coefficient, n_r , is applicable to vegetation established on relatively smoothly graded fine-grained soil.

If vegetated channel liner mats are used, manufacturer-supplied roughness coefficients for particular mats may be used in the equation.



Maximum allowable shear stress, τ_{va} , in pound per square foot is determined as a function of the retardance curve index, C_r . Very little information is available for vegetal performance under very high stresses and this relation is believed to be conservative.

$$\tau_{va} = 0.75 C_r \quad (\text{eq. 8-32})$$

Table 8-3. Design parameters for naturalized channels

Design Parameter	Design Value	Reuslts East Channel	Reuslts West Channel
Maximum 100-year depth outside of bankfull channel	5 ft	< than 5 ft	< than 5 ft
Roughness values Per Table 8-5 used <i>Herbaceous wetlands (few or no willows)</i>	0.06 to 0.08	0.6 to 0.8	0.6 to 0.7
Maximum 100-year velocity, main channel (within bankfull channel width) (ft/s)	7 ft/s	3.6 ft/s	5.13 ft/s
Froude No., 100-year, main channel (within bankfull channel width)	0.8	0.76	0.81 (1.02)*
Maximum shear stress, 100-year, main channel (within bankfull channel width) <i>using shear retardancce</i>	Class A:10.0lb/sq ft Class B: 7.46 lb/sq ft Class C: 5.6 lb/sq ft	2.59 lb/sq ft	3.94 lb/sq ft*
Minimum bankfull capacity of bankfull channel (based on future development conditions)	70% of 2-year discharge or 10% of 100-yr discharge, whichever is greater	NA Exist. doesn't have bankfull channel	NA Exist. doesn't have bankfull channel
Minimum bankfull channel geometry	Per Table 8-2	NA Exist. doesn't have bankfull channel	NA Exist. doesn't have bankfull channel
Minimum bankfull channel width/depth ratio (Equation 8-3)	9	NA Exist. doesn't have bankfull channel	NA Exist. doesn't have bankfull channel
Minimum entrenchment ratio (Equation 8-4)	3	NA Exist. Channel geometry	NA Exist. Channel geometry
Maximum longitudinal slope of low flow channel (assuming unlined, unvegetated low flow channel)	0.20%	6.06%**	7.91%**
Bankfull channel sinuosity (Equation 8-5)	1.1 to 1.3	NA Exist. doesn't have bankfull channel	NA Exist. doesn't have bankfull channel
Maximum overbank side slope	4(H):1(v)	NA Exist. Channel geometry	NA Exist. Channel geometry
Maximum bankfull side slope	2.5(H):1(V)	NA Exist. doesn't have bankfull channel	NA Exist. doesn't have bankfull channel
Minimum radius of curvature	2.5 times top width	R=90'	R=200'

* critical water surface cross sections with existing or proposed stabilization

**Slope is Existing condition. Drop Structure may need to be added at time of Final Drainage Report and Construction Drawings.



Figure 3

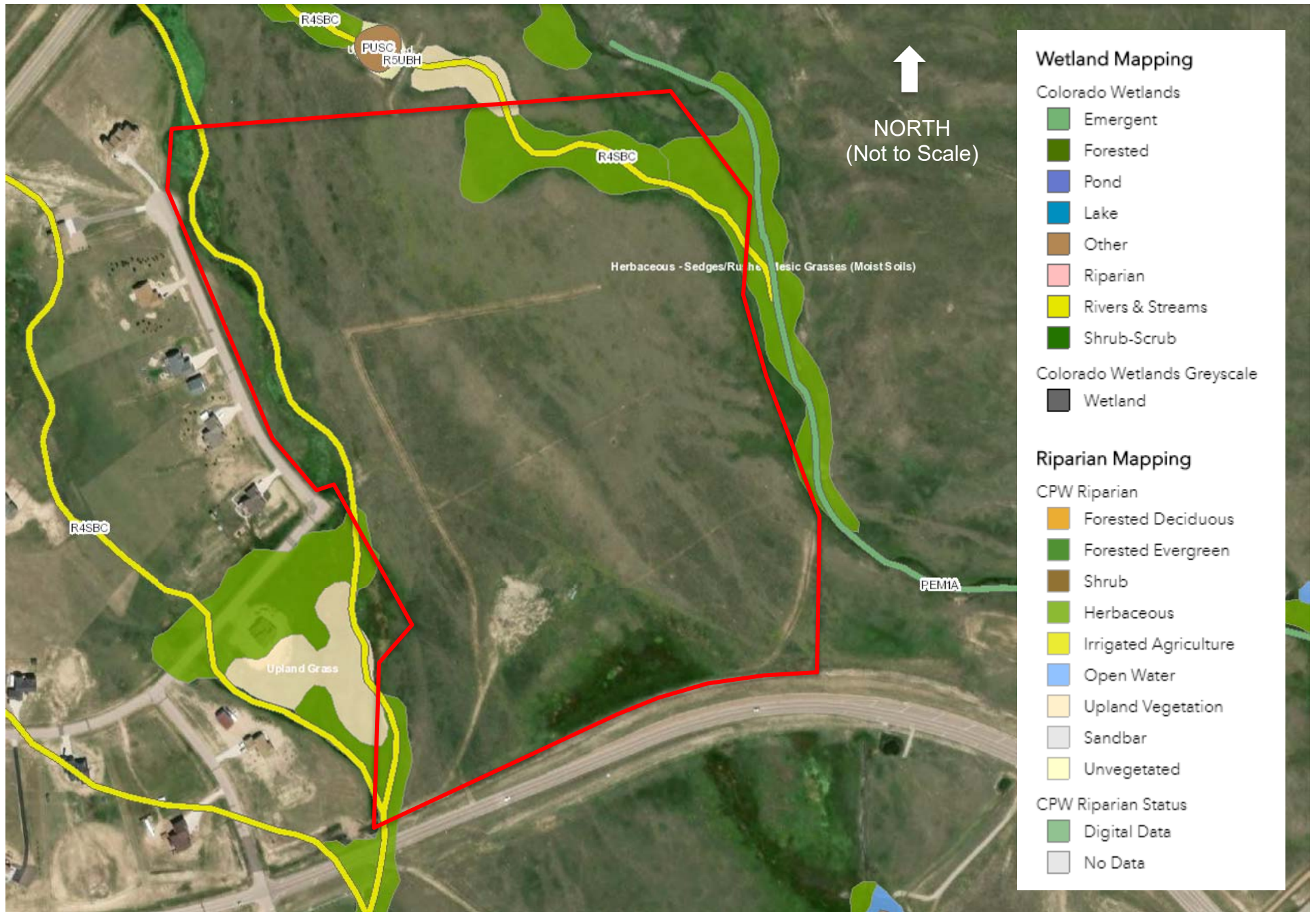

Figure 4



PHOTO LOCATION MAP



PP1 - DRAINAGE A, C-D UPLAND BREAK (LOOKING UPSTREAM FROM LAZOR POINT DRIVE)



PP1 - DRAINAGE A, C-D UPLAND BREAK (LOOKING DOWNSTREAM FROM LAZOR POINT DRIVE)



PP2 - DRAINAGE A, C-D UPLAND BREAK (LOOKING UPSTREAM FROM LAZOR POINT PRIVATE DRIVE)



PP2 - DRAINAGE A, C-D UPLAND BREAK (LOOKING DOWNSTREAM FROM LAZOR POINT PRIVATE DRIVE)



PP3 – WETLAND/CHANNEL B (FROM UPSTREAM END LOOKING SOUTH)



PP4 – WETLAND/CHANNEL B (LOOKING UPSTREAM)



PP4 – WETLAND/CHANNEL B (LOOKING DOWNSTREAM)



PP5- WETLAND/CHANNEL B (LOOKING UPSTREAM)



PP5- WETLAND/CHANNEL B (LOOKING DOWNSTREAM)



PP6- WETLAND/CHANNEL B (LOOKING UPSTREAM)



PP6- WETLAND/CHANNEL B (LOOKING DOWNSTREAM)



PP7- WETLAND/CHANNEL B (LOOKING UPSTREAM)



PP7 - WETLAND/CHANNEL B (LOOKING DOWNSTREAM)



PP8 – WETLAND/CHANNEL B (LOOKING UPSTREAM)



PP8 – WETLAND/CHANNEL B (LOOKING DOWNSTREAM)



PP9 – SITE OVERVIEW FROM SOUTHEAST CORNER (LOOKING WEST)



PP9 – SITE OVERVIEW FROM SOUTHEAST CORNER (LOOKING NORTH)



PP10 – SITE OVERVIEW FROM SOUTHWEST CORNER (LOOKING NORTH)



PP10 – SITE OVERVIEW FROM SOUTHWEST CORNER (LOOKING WEST)



PP11 – SITE OVERVIEW FROM NORTHWEST CORNER (LOOKING EAST)



PP11 – SITE OVERVIEW FROM NORTHWEST CORNER (LOOKING SOUTH)



PP12 – SITE OVERVIEW FROM NORTHEASTCORNER (LOOKING WEST)



PP12 – SITE OVERVIEW FROM NORTHEASTCORNER CORNER (LOOKING SOUTH)



SAMPLE POINT B1 – WETLAND PHOTO (LOOKING UPSTREAM)



SAMPLE POINT B1 – WETLAND PHOTO (LOOKING DOWNSTREAM)



SAMPLE POINT B2 – WETLAND PHOTO (LOOKING UPSTREAM)



SAMPLE POINT B2 – WETLAND PHOTO (LOOKING DOWNSTREAM)

WEST CHANNEL
RS X-SECTION 0 LOOKING NORTH

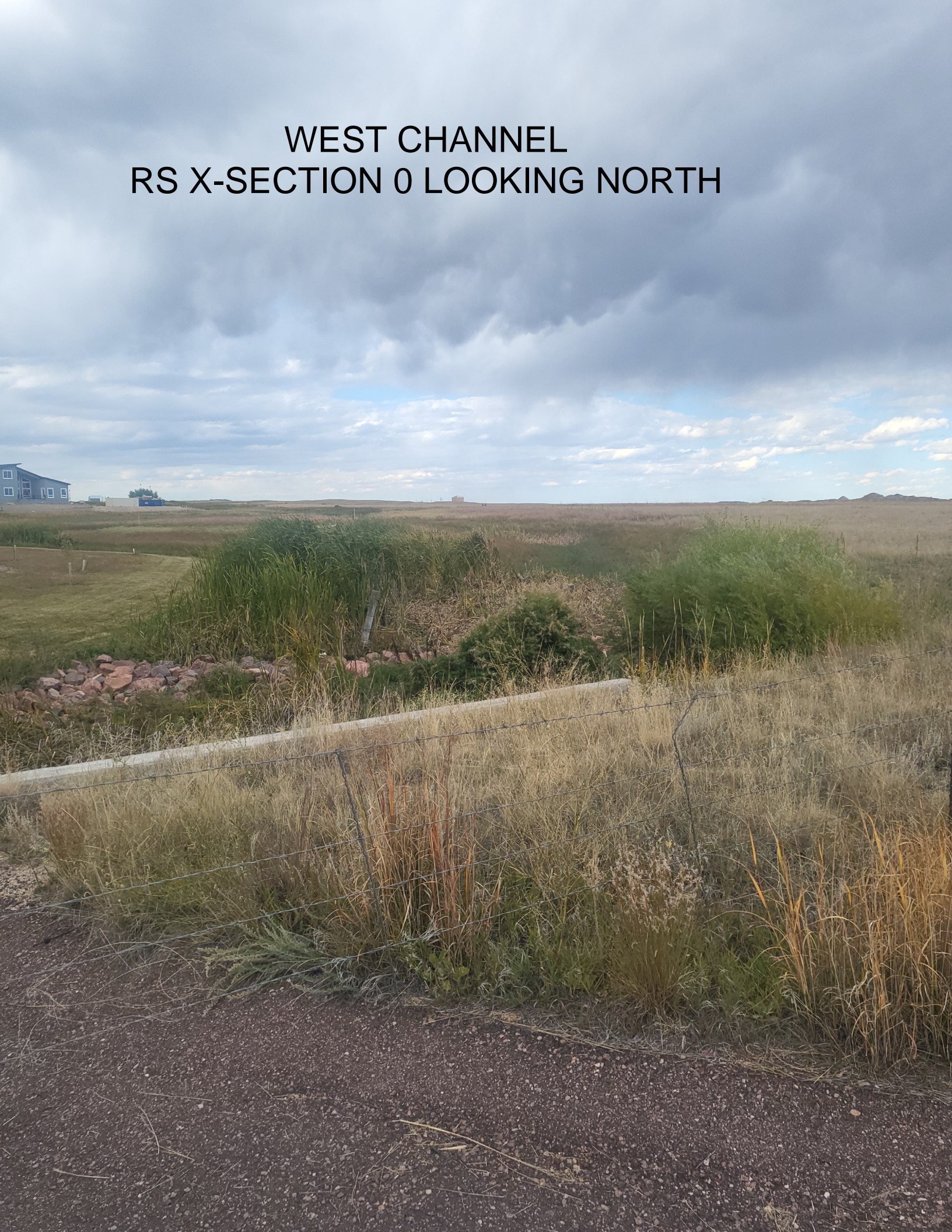

WEST CHANNEL
RS X-SECTION 900 LOOKING SOUTH



WEST CHANNEL
RS X-SECTION 900 LOOKING EAST



WEST CHANNEL
RS X-SECTION 1500 LOOKING NORTH



WEST CHANNEL EXISTING CONDITIONS

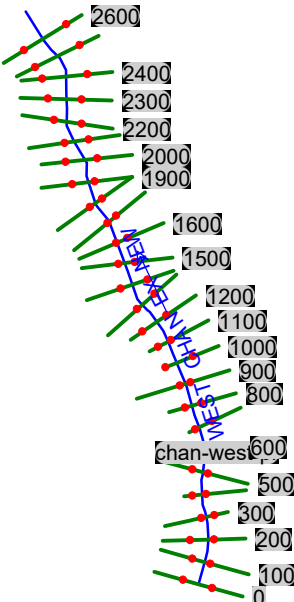

HEC-RAS Plan: Plan 02 River: WEST CHAN EX NEW Reach: chan-west-pr Profile: PF 1

Reach	River Sta	Profile	Q Total (cfs)	Min Ch El (ft)	W.S. Elev (ft)	Crit W.S. (ft)	E.G. Elev (ft)	E.G. Slope (ft/ft)	Vel Chnl (ft/s)	Flow Area (sq ft)	Top Width (ft)	Froude # Chl
chan-west-pr	2600	PF 1	219.00	6966.83	6967.79	6967.63	6967.90	0.017799	2.60	84.18	158.35	0.63
chan-west-pr	2500	PF 1	219.00	6964.90	6965.71		6965.85	0.023298	3.05	71.69	129.71	0.72
chan-west-pr	2400	PF 1	219.00	6963.25	6964.24		6964.32	0.010700	2.29	95.59	148.56	0.50
chan-west-pr	2300	PF 1	219.00	6961.27	6962.31	6962.27	6962.50	0.037650	3.51	62.47	131.69	0.90
chan-west-pr	2200	PF 1	219.00	6958.46	6959.77		6959.91	0.018663	2.93	74.69	122.50	0.66
chan-west-pr	2100	PF 1	219.00	6955.98	6957.46		6957.72	0.025643	4.03	54.39	69.81	0.80
chan-west-pr	2000	PF 1	219.00	6954.57	6956.18		6956.28	0.008732	2.59	84.54	93.75	0.48
chan-west-pr	1900	PF 1	219.00	6952.76	6954.43	6954.40	6954.68	0.037613	4.02	54.59	95.18	0.93
chan-west-pr	1800	PF 1	219.00	6949.31	6951.77	6951.52	6952.02	0.019694	4.05	54.04	55.99	0.73
chan-west-pr	1700	PF 1	219.00	6947.11	6949.36		6949.76	0.025882	5.06	43.31	39.34	0.85
chan-west-pr	1600	PF 1	219.00	6945.84	6948.18		6948.34	0.008240	3.19	69.18	60.82	0.49
chan-west-pr	1500	PF 1	219.00	6944.91	6946.88		6947.04	0.023605	3.14	70.67	83.82	0.57
chan-west-pr	1400	PF 1	219.00	6943.78	6945.45		6945.51	0.010305	2.00	109.73	123.80	0.37
chan-west-pr	1300	PF 1	219.00	6942.19	6943.64		6943.80	0.033144	3.22	68.07	89.53	0.65
chan-west-pr	1200	PF 1	219.00	6940.78	6943.03		6943.06	0.002970	1.34	169.08	153.77	0.21
chan-west-pr	1100	PF 1	219.00	6940.72	6942.48	6942.14	6942.55	0.010638	2.35	113.09	166.20	0.39
chan-west-pr	1000	PF 1	219.00	6939.66	6940.98		6941.09	0.020399	2.69	81.46	97.46	0.52
chan-west-pr	900	PF 1	219.00	6937.05	6938.39	6938.33	6938.52	0.033426	3.38	90.46	227.78	0.66
chan-west-pr	800	PF 1	219.00	6934.82	6936.10		6936.19	0.016993	2.64	99.24	178.51	0.48
chan-west-pr	700	PF 1	219.00	6932.96	6934.12		6934.23	0.022819	2.81	87.83	153.26	0.55
chan-west-pr	600	PF 1	219.00	6930.96	6932.22		6932.30	0.015704	2.46	116.29	250.13	0.46
chan-west-pr	500	PF 1	219.00	6928.39	6929.71	6929.55	6929.93	0.039549	3.71	60.15	82.77	0.72
chan-west-pr	400	PF 1	219.00	6924.96	6927.52		6927.65	0.014470	2.91	78.16	77.13	0.46
chan-west-pr	300	PF 1	219.00	6923.02	6924.34	6924.34	6924.79	0.075333	5.37	40.78	45.95	1.01
chan-west-pr	200	PF 1	219.00	6919.08	6920.46		6920.57	0.016608	2.65	82.52	86.27	0.48
chan-west-pr	100	PF 1	219.00	6917.36	6920.09		6920.12	0.001886	1.42	154.70	85.42	0.18
chan-west-pr	0	PF 1	219.00	6918.00	6919.64	6919.12	6919.72	0.012995	2.23	98.31	111.26	0.42

Plan: Plan 02 WEST CHAN EX NEW chan-west-pr RS: 2600 Profile: PF 1

E.G. Elev (ft)	6967.90	Element	Left OB	Channel	Right OB
Vel Head (ft)	0.11	Wt. n-Val.		0.050	
W.S. Elev (ft)	6967.79	Reach Len. (ft)	108.00	100.00	88.00
Crit W.S. (ft)	6967.63	Flow Area (sq ft)		84.18	
E.G. Slope (ft/ft)	0.017799	Area (sq ft)		84.18	
Q Total (cfs)	219.00	Flow (cfs)		219.00	
Top Width (ft)	158.35	Top Width (ft)		158.35	
Vel Total (ft/s)	2.60	Avg. Vel. (ft/s)		2.60	
Max Chl Dpth (ft)	0.96	Hydr. Depth (ft)		0.53	
Conv. Total (cfs)	1641.5	Conv. (cfs)		1641.5	
Length Wtd. (ft)	100.00	Wetted Per. (ft)		158.37	
Min Ch El (ft)	6966.83	Shear (lb/sq ft)		0.59	
Alpha	1.00	Stream Power (lb/ft s)		1.54	
Frctn Loss (ft)	2.03	Cum Volume (acre-ft)	0.26	4.50	0.25
C & E Loss (ft)	0.00	Cum SA (acres)	0.81	5.20	0.91

Plan: Plan 02 WEST CHAN EX NEW chan-west-pr RS: 2500 Profile: PF 1

E.G. Elev (ft)	6965.85	Element	Left OB	Channel	Right OB
Vel Head (ft)	0.15	Wt. n-Val.		0.050	
W.S. Elev (ft)	6965.71	Reach Len. (ft)	132.00	100.00	59.00
Crit W.S. (ft)		Flow Area (sq ft)		71.69	
E.G. Slope (ft/ft)	0.023298	Area (sq ft)		71.69	
Q Total (cfs)	219.00	Flow (cfs)		219.00	
Top Width (ft)	129.71	Top Width (ft)		129.71	
Vel Total (ft/s)	3.05	Avg. Vel. (ft/s)		3.05	
Max Chl Dpth (ft)	0.81	Hydr. Depth (ft)		0.55	
Conv. Total (cfs)	1434.8	Conv. (cfs)		1434.8	
Length Wtd. (ft)	100.00	Wetted Per. (ft)		129.73	
Min Ch El (ft)	6964.90	Shear (lb/sq ft)		0.80	
Alpha	1.00	Stream Power (lb/ft s)		2.46	
Frctn Loss (ft)	1.52	Cum Volume (acre-ft)	0.26	4.32	0.25
C & E Loss (ft)	0.02	Cum SA (acres)	0.81	4.87	0.91

Plan: Plan 02 WEST CHAN EX NEW chan-west-pr RS: 2400 Profile: PF 1

E.G. Elev (ft)	6964.32	Element	Left OB	Channel	Right OB
Vel Head (ft)	0.08	Wt. n-Val.		0.050	
W.S. Elev (ft)	6964.24	Reach Len. (ft)	113.00	100.00	91.00
Crit W.S. (ft)		Flow Area (sq ft)		95.59	
E.G. Slope (ft/ft)	0.010700	Area (sq ft)		95.59	
Q Total (cfs)	219.00	Flow (cfs)		219.00	
Top Width (ft)	148.56	Top Width (ft)		148.56	
Vel Total (ft/s)	2.29	Avg. Vel. (ft/s)		2.29	
Max Chl Dpth (ft)	0.99	Hydr. Depth (ft)		0.64	
Conv. Total (cfs)	2117.2	Conv. (cfs)		2117.2	
Length Wtd. (ft)	100.00	Wetted Per. (ft)		148.59	
Min Ch El (ft)	6963.25	Shear (lb/sq ft)		0.43	
Alpha	1.00	Stream Power (lb/ft s)		0.98	
Frctn Loss (ft)	1.82	Cum Volume (acre-ft)	0.26	4.13	0.25
C & E Loss (ft)	0.01	Cum SA (acres)	0.81	4.55	0.91

Plan: Plan 02 WEST CHAN EX NEW chan-west-pr RS: 2300 Profile: PF 1

E.G. Elev (ft)	6962.50	Element	Left OB	Channel	Right OB
Vel Head (ft)	0.19	Wt. n-Val.		0.050	
W.S. Elev (ft)	6962.31	Reach Len. (ft)	107.00	100.00	97.00
Crit W.S. (ft)	6962.27	Flow Area (sq ft)		62.47	
E.G. Slope (ft/ft)	0.037650	Area (sq ft)		62.47	
Q Total (cfs)	219.00	Flow (cfs)		219.00	
Top Width (ft)	131.69	Top Width (ft)		131.69	
Vel Total (ft/s)	3.51	Avg. Vel. (ft/s)		3.51	
Max Chl Dpth (ft)	1.03	Hydr. Depth (ft)		0.47	
Conv. Total (cfs)	1128.7	Conv. (cfs)		1128.7	
Length Wtd. (ft)	100.00	Wetted Per. (ft)		131.78	
Min Ch El (ft)	6961.27	Shear (lb/sq ft)		1.11	
Alpha	1.00	Stream Power (lb/ft s)		3.91	
Frctn Loss (ft)	2.57	Cum Volume (acre-ft)	0.26	3.95	0.25
C & E Loss (ft)	0.02	Cum SA (acres)	0.81	4.23	0.91

Plan: Plan 02 WEST CHAN EX NEW chan-west-pr RS: 2200 Profile: PF 1

E.G. Elev (ft)	6959.91	Element	Left OB	Channel	Right OB
Vel Head (ft)	0.13	Wt. n-Val.	0.050	0.050	
W.S. Elev (ft)	6959.77	Reach Len. (ft)	74.00	100.00	110.00
Crit W.S. (ft)		Flow Area (sq ft)	0.01	74.68	
E.G. Slope (ft/ft)	0.018663	Area (sq ft)	0.01	74.68	
Q Total (cfs)	219.00	Flow (cfs)	0.00	219.00	
Top Width (ft)	122.50	Top Width (ft)	0.97	121.54	
Vel Total (ft/s)	2.93	Avg. Vel. (ft/s)	0.18	2.93	
Max Chl Dpth (ft)	1.31	Hydr. Depth (ft)	0.01	0.61	
Conv. Total (cfs)	1603.1	Conv. (cfs)	0.0	1603.1	
Length Wtd. (ft)	100.00	Wetted Per. (ft)	0.97	121.66	
Min Ch El (ft)	6958.46	Shear (lb/sq ft)	0.01	0.72	
Alpha	1.00	Stream Power (lb/ft s)	0.00	2.10	
Frctn Loss (ft)	2.17	Cum Volume (acre-ft)	0.26	3.79	0.25
C & E Loss (ft)	0.01	Cum SA (acres)	0.81	3.94	0.91

Plan: Plan 02 WEST CHAN EX NEW chan-west-pr RS: 2100 Profile: PF 1

E.G. Elev (ft)	6957.72	Element	Left OB	Channel	Right OB
Vel Head (ft)	0.25	Wt. n-Val.		0.050	
W.S. Elev (ft)	6957.46	Reach Len. (ft)	92.00	100.00	83.00
Crit W.S. (ft)		Flow Area (sq ft)		54.39	
E.G. Slope (ft/ft)	0.025643	Area (sq ft)		54.39	
Q Total (cfs)	219.00	Flow (cfs)		219.00	
Top Width (ft)	69.81	Top Width (ft)		69.81	
Vel Total (ft/s)	4.03	Avg. Vel. (ft/s)		4.03	
Max Chl Dpth (ft)	1.48	Hydr. Depth (ft)		0.78	
Conv. Total (cfs)	1367.6	Conv. (cfs)		1367.6	
Length Wtd. (ft)	100.00	Wetted Per. (ft)		69.88	
Min Ch El (ft)	6955.98	Shear (lb/sq ft)		1.25	
Alpha	1.00	Stream Power (lb/ft s)		5.02	
Frctn Loss (ft)	1.39	Cum Volume (acre-ft)	0.26	3.65	0.25
C & E Loss (ft)	0.04	Cum SA (acres)	0.81	3.72	0.91

Plan: Plan 02 WEST CHAN EX NEW chan-west-pr RS: 2000 Profile: PF 1

E.G. Elev (ft)	6956.28	Element	Left OB	Channel	Right OB
Vel Head (ft)	0.10	Wt. n-Val.		0.050	
W.S. Elev (ft)	6956.18	Reach Len. (ft)	101.00	100.00	102.00
Crit W.S. (ft)		Flow Area (sq ft)		84.54	
E.G. Slope (ft/ft)	0.008732	Area (sq ft)		84.54	
Q Total (cfs)	219.00	Flow (cfs)		219.00	
Top Width (ft)	93.75	Top Width (ft)		93.75	
Vel Total (ft/s)	2.59	Avg. Vel. (ft/s)		2.59	
Max Chl Dpth (ft)	1.61	Hydr. Depth (ft)		0.90	
Conv. Total (cfs)	2343.6	Conv. (cfs)		2343.6	
Length Wtd. (ft)	100.00	Wetted Per. (ft)		93.82	
Min Ch El (ft)	6954.57	Shear (lb/sq ft)		0.49	
Alpha	1.00	Stream Power (lb/ft s)		1.27	
Frctn Loss (ft)	1.59	Cum Volume (acre-ft)	0.26	3.49	0.25
C & E Loss (ft)	0.01	Cum SA (acres)	0.81	3.53	0.91

Plan: Plan 02 WEST CHAN EX NEW chan-west-pr RS: 1900 Profile: PF 1

E.G. Elev (ft)	6954.68	Element	Left OB	Channel	Right OB
Vel Head (ft)	0.25	Wt. n-Val.		0.050	0.050
W.S. Elev (ft)	6954.43	Reach Len. (ft)	81.00	100.00	134.00
Crit W.S. (ft)	6954.40	Flow Area (sq ft)		54.50	0.09
E.G. Slope (ft/ft)	0.037613	Area (sq ft)		54.50	0.09
Q Total (cfs)	219.00	Flow (cfs)		218.92	0.08
Top Width (ft)	95.18	Top Width (ft)		93.52	1.66
Vel Total (ft/s)	4.01	Avg. Vel. (ft/s)		4.02	0.84
Max Chl Dpth (ft)	1.67	Hydr. Depth (ft)		0.58	0.06
Conv. Total (cfs)	1129.2	Conv. (cfs)		1128.8	0.4
Length Wtd. (ft)	100.01	Wetted Per. (ft)		93.67	1.66
Min Ch El (ft)	6952.76	Shear (lb/sq ft)		1.37	0.13
Alpha	1.00	Stream Power (lb/ft s)		5.49	0.11
Frctn Loss (ft)	2.65	Cum Volume (acre-ft)	0.26	3.33	0.25
C & E Loss (ft)	0.00	Cum SA (acres)	0.81	3.31	0.91

Plan: Plan 02 WEST CHAN EX NEW chan-west-pr RS: 1800 Profile: PF 1

E.G. Elev (ft)	6952.02	Element	Left OB	Channel	Right OB
Vel Head (ft)	0.26	Wt. n-Val.		0.050	
W.S. Elev (ft)	6951.77	Reach Len. (ft)	97.00	100.00	124.00
Crit W.S. (ft)	6951.52	Flow Area (sq ft)		54.04	
E.G. Slope (ft/ft)	0.019694	Area (sq ft)		54.04	
Q Total (cfs)	219.00	Flow (cfs)		219.00	
Top Width (ft)	55.99	Top Width (ft)		55.99	
Vel Total (ft/s)	4.05	Avg. Vel. (ft/s)		4.05	
Max Chl Dpth (ft)	2.46	Hydr. Depth (ft)		0.97	
Conv. Total (cfs)	1560.6	Conv. (cfs)		1560.6	
Length Wtd. (ft)	100.00	Wetted Per. (ft)		56.41	
Min Ch El (ft)	6949.31	Shear (lb/sq ft)		1.18	
Alpha	1.00	Stream Power (lb/ft s)		4.77	
Frctn Loss (ft)	2.25	Cum Volume (acre-ft)	0.26	3.20	0.25
C & E Loss (ft)	0.01	Cum SA (acres)	0.81	3.14	0.91

Plan: Plan 02 WEST CHAN EX NEW chan-west-pr RS: 1700 Profile: PF 1

E.G. Elev (ft)	6949.76	Element	Left OB	Channel	Right OB
Vel Head (ft)	0.40	Wt. n-Val.		0.050	
W.S. Elev (ft)	6949.36	Reach Len. (ft)	110.00	100.00	96.00
Crit W.S. (ft)		Flow Area (sq ft)		43.31	
E.G. Slope (ft/ft)	0.025882	Area (sq ft)		43.31	
Q Total (cfs)	219.00	Flow (cfs)		219.00	
Top Width (ft)	39.34	Top Width (ft)		39.34	
Vel Total (ft/s)	5.06	Avg. Vel. (ft/s)		5.06	
Max Chl Dpth (ft)	2.25	Hydr. Depth (ft)		1.10	
Conv. Total (cfs)	1361.3	Conv. (cfs)		1361.3	
Length Wtd. (ft)	100.00	Wetted Per. (ft)		39.83	
Min Ch El (ft)	6947.11	Shear (lb/sq ft)		1.76	
Alpha	1.00	Stream Power (lb/ft s)		8.88	
Frctn Loss (ft)	1.35	Cum Volume (acre-ft)	0.26	3.09	0.25
C & E Loss (ft)	0.07	Cum SA (acres)	0.81	3.03	0.91

Plan: Plan 02 WEST CHAN EX NEW chan-west-pr RS: 1600 Profile: PF 1

E.G. Elev (ft)	6948.34	Element	Left OB	Channel	Right OB
Vel Head (ft)	0.16	Wt. n-Val.	0.050	0.050	0.050
W.S. Elev (ft)	6948.18	Reach Len. (ft)	109.00	100.00	92.00
Crit W.S. (ft)		Flow Area (sq ft)	0.09	68.50	0.60
E.G. Slope (ft/ft)	0.008240	Area (sq ft)	0.09	68.50	0.60
Q Total (cfs)	219.00	Flow (cfs)	0.04	218.63	0.34
Top Width (ft)	60.82	Top Width (ft)	1.51	53.00	6.31
Vel Total (ft/s)	3.17	Avg. Vel. (ft/s)	0.40	3.19	0.56
Max Chl Dpth (ft)	2.34	Hydr. Depth (ft)	0.06	1.29	0.09
Conv. Total (cfs)	2412.6	Conv. (cfs)	0.4	2408.5	3.7
Length Wtd. (ft)	99.99	Wetted Per. (ft)	1.51	53.22	6.32
Min Ch El (ft)	6945.84	Shear (lb/sq ft)	0.03	0.66	0.05
Alpha	1.02	Stream Power (lb/ft s)	0.01	2.11	0.03
Frctn Loss (ft)	1.30	Cum Volume (acre-ft)	0.26	2.96	0.25
C & E Loss (ft)	0.00	Cum SA (acres)	0.80	2.93	0.90

Plan: Plan 02 WEST CHAN EX NEW chan-west-pr RS: 1500 Profile: PF 1

E.G. Elev (ft)	6947.04	Element	Left OB	Channel	Right OB
Vel Head (ft)	0.15	Wt. n-Val.	0.070	0.070	0.070
W.S. Elev (ft)	6946.88	Reach Len. (ft)	95.00	100.00	109.00
Crit W.S. (ft)		Flow Area (sq ft)	0.58	69.26	0.84
E.G. Slope (ft/ft)	0.023605	Area (sq ft)	0.58	69.26	0.84
Q Total (cfs)	219.00	Flow (cfs)	0.48	217.81	0.71
Top Width (ft)	83.82	Top Width (ft)	4.58	73.00	6.24
Vel Total (ft/s)	3.10	Avg. Vel. (ft/s)	0.82	3.14	0.85
Max Chl Dpth (ft)	1.97	Hydr. Depth (ft)	0.13	0.95	0.13
Conv. Total (cfs)	1425.4	Conv. (cfs)	3.1	1417.7	4.6
Length Wtd. (ft)	100.01	Wetted Per. (ft)	4.58	73.14	6.25
Min Ch El (ft)	6944.91	Shear (lb/sq ft)	0.19	1.40	0.20
Alpha	1.02	Stream Power (lb/ft s)	0.15	4.39	0.17
Frctn Loss (ft)	1.49	Cum Volume (acre-ft)	0.26	2.80	0.25
C & E Loss (ft)	0.03	Cum SA (acres)	0.80	2.78	0.89

Plan: Plan 02 WEST CHAN EX NEW chan-west-pr RS: 1400 Profile: PF 1

E.G. Elev (ft)	6945.51	Element	Left OB	Channel	Right OB
Vel Head (ft)	0.06	Wt. n-Val.	0.000	0.070	0.000
W.S. Elev (ft)	6945.45	Reach Len. (ft)	69.00	100.00	114.80
Crit W.S. (ft)		Flow Area (sq ft)	0.00	109.72	0.00
E.G. Slope (ft/ft)	0.010305	Area (sq ft)	0.00	109.72	0.00
Q Total (cfs)	219.00	Flow (cfs)	0.00	219.00	0.00
Top Width (ft)	123.80	Top Width (ft)	0.47	123.00	0.33
Vel Total (ft/s)	2.00	Avg. Vel. (ft/s)	0.07	2.00	0.11
Max Chl Dpth (ft)	1.67	Hydr. Depth (ft)	0.01	0.89	0.01
Conv. Total (cfs)	2157.3	Conv. (cfs)	0.0	2157.3	0.0
Length Wtd. (ft)	100.00	Wetted Per. (ft)	0.47	123.09	0.33
Min Ch El (ft)	6943.78	Shear (lb/sq ft)		0.57	
Alpha	1.00	Stream Power (lb/ft s)		1.14	
Frctn Loss (ft)	1.70	Cum Volume (acre-ft)	0.26	2.60	0.25
C & E Loss (ft)	0.01	Cum SA (acres)	0.79	2.56	0.88

Plan: Plan 02 WEST CHAN EX NEW chan-west-pr RS: 1300 Profile: PF 1

E.G. Elev (ft)	6943.80	Element	Left OB	Channel	Right OB
Vel Head (ft)	0.16	Wt. n-Val.		0.070	
W.S. Elev (ft)	6943.64	Reach Len. (ft)	108.00	100.00	101.00
Crit W.S. (ft)		Flow Area (sq ft)		68.07	
E.G. Slope (ft/ft)	0.033144	Area (sq ft)		68.07	
Q Total (cfs)	219.00	Flow (cfs)		219.00	
Top Width (ft)	89.53	Top Width (ft)		89.53	
Vel Total (ft/s)	3.22	Avg. Vel. (ft/s)		3.22	
Max Chl Dpth (ft)	1.45	Hydr. Depth (ft)		0.76	
Conv. Total (cfs)	1202.9	Conv. (cfs)		1202.9	
Length Wtd. (ft)	100.05	Wetted Per. (ft)		89.60	
Min Ch El (ft)	6942.19	Shear (lb/sq ft)		1.57	
Alpha	1.00	Stream Power (lb/ft s)		5.06	
Frctn Loss (ft)	0.70	Cum Volume (acre-ft)	0.26	2.39	0.25
C & E Loss (ft)	0.04	Cum SA (acres)	0.79	2.31	0.88

Plan: Plan 02 WEST CHAN EX NEW chan-west-pr RS: 1200 Profile: PF 1

E.G. Elev (ft)	6943.06	Element	Left OB	Channel	Right OB
Vel Head (ft)	0.03	Wt. n-Val.	0.070	0.070	0.070
W.S. Elev (ft)	6943.03	Reach Len. (ft)	110.00	100.00	95.00
Crit W.S. (ft)		Flow Area (sq ft)	4.34	158.54	6.20
E.G. Slope (ft/ft)	0.002970	Area (sq ft)	4.34	158.54	6.20
Q Total (cfs)	219.00	Flow (cfs)	2.49	212.42	4.09
Top Width (ft)	153.77	Top Width (ft)	12.42	127.00	14.36
Vel Total (ft/s)	1.30	Avg. Vel. (ft/s)	0.57	1.34	0.66
Max Chl Dpth (ft)	2.25	Hydr. Depth (ft)	0.35	1.25	0.43
Conv. Total (cfs)	4018.7	Conv. (cfs)	45.7	3897.9	75.1
Length Wtd. (ft)	100.87	Wetted Per. (ft)	12.44	127.18	14.38
Min Ch El (ft)	6940.78	Shear (lb/sq ft)	0.06	0.23	0.08
Alpha	1.04	Stream Power (lb/ft s)	0.04	0.31	0.05
Frctn Loss (ft)	0.51	Cum Volume (acre-ft)	0.26	2.13	0.24
C & E Loss (ft)	0.00	Cum SA (acres)	0.78	2.07	0.86

Plan: Plan 02 WEST CHAN EX NEW chan-west-pr RS: 1100 Profile: PF 1

E.G. Elev (ft)	6942.55	Element	Left OB	Channel	Right OB
Vel Head (ft)	0.07	Wt. n-Val.	0.070	0.070	0.070
W.S. Elev (ft)	6942.48	Reach Len. (ft)	119.00	100.00	95.00
Crit W.S. (ft)	6942.14	Flow Area (sq ft)	32.13	71.23	9.73
E.G. Slope (ft/ft)	0.010638	Area (sq ft)	32.13	71.23	9.73
Q Total (cfs)	219.00	Flow (cfs)	42.23	167.36	9.42
Top Width (ft)	166.20	Top Width (ft)	69.09	64.00	33.11
Vel Total (ft/s)	1.94	Avg. Vel. (ft/s)	1.31	2.35	0.97
Max Chl Dpth (ft)	1.76	Hydr. Depth (ft)	0.47	1.11	0.29
Conv. Total (cfs)	2123.3	Conv. (cfs)	409.4	1622.6	91.3
Length Wtd. (ft)	101.72	Wetted Per. (ft)	69.11	64.07	33.12
Min Ch El (ft)	6940.72	Shear (lb/sq ft)	0.31	0.74	0.20
Alpha	1.22	Stream Power (lb/ft s)	0.41	1.73	0.19
Frctn Loss (ft)	1.46	Cum Volume (acre-ft)	0.21	1.87	0.23
C & E Loss (ft)	0.00	Cum SA (acres)	0.67	1.85	0.81

Plan: Plan 02 WEST CHAN EX NEW chan-west-pr RS: 1000 Profile: PF 1

E.G. Elev (ft)	6941.09	Element	Left OB	Channel	Right OB
Vel Head (ft)	0.11	Wt. n-Val.		0.070	
W.S. Elev (ft)	6940.98	Reach Len. (ft)	114.00	100.00	102.00
Crit W.S. (ft)		Flow Area (sq ft)		81.46	
E.G. Slope (ft/ft)	0.020399	Area (sq ft)		81.46	
Q Total (cfs)	219.00	Flow (cfs)		219.00	
Top Width (ft)	97.46	Top Width (ft)		97.46	
Vel Total (ft/s)	2.69	Avg. Vel. (ft/s)		2.69	
Max Chl Dpth (ft)	1.32	Hydr. Depth (ft)		0.84	
Conv. Total (cfs)	1533.4	Conv. (cfs)		1533.4	
Length Wtd. (ft)	100.50	Wetted Per. (ft)		97.56	
Min Ch El (ft)	6939.66	Shear (lb/sq ft)		1.06	
Alpha	1.00	Stream Power (lb/ft s)		2.86	
Frctn Loss (ft)	2.58	Cum Volume (acre-ft)	0.17	1.69	0.22
C & E Loss (ft)	0.00	Cum SA (acres)	0.58	1.66	0.77

Plan: Plan 02 WEST CHAN EX NEW chan-west-pr RS: 900 Profile: PF 1

E.G. Elev (ft)	6938.52	Element	Left OB	Channel	Right OB
Vel Head (ft)	0.12	Wt. n-Val.	0.070	0.070	0.070
W.S. Elev (ft)	6938.39	Reach Len. (ft)	102.00	100.00	99.00
Crit W.S. (ft)	6938.33	Flow Area (sq ft)	2.90	39.12	48.44
E.G. Slope (ft/ft)	0.033426	Area (sq ft)	2.90	39.12	48.44
Q Total (cfs)	219.00	Flow (cfs)	3.82	132.15	83.03
Top Width (ft)	227.78	Top Width (ft)	14.69	48.00	165.09
Vel Total (ft/s)	2.42	Avg. Vel. (ft/s)	1.32	3.38	1.71
Max Chl Dpth (ft)	1.34	Hydr. Depth (ft)	0.20	0.81	0.29
Conv. Total (cfs)	1197.9	Conv. (cfs)	20.9	722.8	454.1
Length Wtd. (ft)	99.86	Wetted Per. (ft)	14.69	48.17	165.12
Min Ch El (ft)	6937.05	Shear (lb/sq ft)	0.41	1.69	0.61
Alpha	1.37	Stream Power (lb/ft s)	0.54	5.73	1.05
Frctn Loss (ft)	2.31	Cum Volume (acre-ft)	0.16	1.56	0.16
C & E Loss (ft)	0.01	Cum SA (acres)	0.56	1.49	0.58

Plan: Plan 02 WEST CHAN EX NEW chan-west-pr RS: 800 Profile: PF 1

E.G. Elev (ft)	6936.19	Element	Left OB	Channel	Right OB
Vel Head (ft)	0.09	Wt. n-Val.	0.070	0.070	0.070
W.S. Elev (ft)	6936.10	Reach Len. (ft)	92.00	100.00	105.00
Crit W.S. (ft)		Flow Area (sq ft)	11.81	68.88	18.56
E.G. Slope (ft/ft)	0.016993	Area (sq ft)	11.81	68.88	18.56
Q Total (cfs)	219.00	Flow (cfs)	16.41	181.67	20.92
Top Width (ft)	178.51	Top Width (ft)	33.19	74.00	71.33
Vel Total (ft/s)	2.21	Avg. Vel. (ft/s)	1.39	2.64	1.13
Max Chl Dpth (ft)	1.28	Hydr. Depth (ft)	0.36	0.93	0.26
Conv. Total (cfs)	1680.0	Conv. (cfs)	125.9	1393.6	160.4
Length Wtd. (ft)	99.70	Wetted Per. (ft)	33.19	74.01	71.37
Min Ch El (ft)	6934.82	Shear (lb/sq ft)	0.38	0.99	0.28
Alpha	1.24	Stream Power (lb/ft s)	0.52	2.60	0.31
Frctn Loss (ft)	1.95	Cum Volume (acre-ft)	0.15	1.43	0.08
C & E Loss (ft)	0.00	Cum SA (acres)	0.50	1.35	0.31

Plan: Plan 02 WEST CHAN EX NEW chan-west-pr RS: 700 Profile: PF 1

E.G. Elev (ft)	6934.23	Element	Left OB	Channel	Right OB
Vel Head (ft)	0.11	Wt. n-Val.	0.070	0.070	0.070
W.S. Elev (ft)	6934.12	Reach Len. (ft)	123.00	100.00	93.00
Crit W.S. (ft)		Flow Area (sq ft)	11.63	67.24	8.96
E.G. Slope (ft/ft)	0.022819	Area (sq ft)	11.63	67.24	8.96
Q Total (cfs)	219.00	Flow (cfs)	19.68	188.88	10.44
Top Width (ft)	153.26	Top Width (ft)	30.33	82.00	40.93
Vel Total (ft/s)	2.49	Avg. Vel. (ft/s)	1.69	2.81	1.16
Max Chl Dpth (ft)	1.16	Hydr. Depth (ft)	0.38	0.82	0.22
Conv. Total (cfs)	1449.8	Conv. (cfs)	130.3	1250.4	69.1
Length Wtd. (ft)	102.46	Wetted Per. (ft)	30.34	82.01	40.96
Min Ch El (ft)	6932.96	Shear (lb/sq ft)	0.55	1.17	0.31
Alpha	1.15	Stream Power (lb/ft s)	0.92	3.28	0.36
Frctn Loss (ft)	1.92	Cum Volume (acre-ft)	0.12	1.28	0.05
C & E Loss (ft)	0.01	Cum SA (acres)	0.44	1.17	0.18

Plan: Plan 02 WEST CHAN EX NEW chan-west-pr RS: 600 Profile: PF 1

E.G. Elev (ft)	6932.30	Element	Left OB	Channel	Right OB
Vel Head (ft)	0.07	Wt. n-Val.	0.070	0.070	0.070
W.S. Elev (ft)	6932.22	Reach Len. (ft)	106.00	100.00	82.00
Crit W.S. (ft)		Flow Area (sq ft)	33.96	63.31	19.02
E.G. Slope (ft/ft)	0.015704	Area (sq ft)	33.96	63.31	19.02
Q Total (cfs)	219.00	Flow (cfs)	37.99	155.98	25.03
Top Width (ft)	250.13	Top Width (ft)	124.46	71.00	54.67
Vel Total (ft/s)	1.88	Avg. Vel. (ft/s)	1.12	2.46	1.32
Max Chl Dpth (ft)	1.26	Hydr. Depth (ft)	0.27	0.89	0.35
Conv. Total (cfs)	1747.6	Conv. (cfs)	303.2	1244.7	199.7
Length Wtd. (ft)	99.48	Wetted Per. (ft)	124.50	71.02	54.70
Min Ch El (ft)	6930.96	Shear (lb/sq ft)	0.27	0.87	0.34
Alpha	1.34	Stream Power (lb/ft s)	0.30	2.15	0.45
Frctn Loss (ft)	2.35	Cum Volume (acre-ft)	0.06	1.13	0.02
C & E Loss (ft)	0.01	Cum SA (acres)	0.22	1.00	0.08

Plan: Plan 02 WEST CHAN EX NEW chan-west-pr RS: 500 Profile: PF 1

E.G. Elev (ft)	6929.93	Element	Left OB	Channel	Right OB
Vel Head (ft)	0.21	Wt. n-Val.	0.070	0.070	0.070
W.S. Elev (ft)	6929.71	Reach Len. (ft)	91.00	100.00	115.00
Crit W.S. (ft)	6929.55	Flow Area (sq ft)	0.99	58.54	0.63
E.G. Slope (ft/ft)	0.039549	Area (sq ft)	0.99	58.54	0.63
Q Total (cfs)	219.00	Flow (cfs)	1.18	217.18	0.64
Top Width (ft)	82.77	Top Width (ft)	6.49	71.00	5.28
Vel Total (ft/s)	3.64	Avg. Vel. (ft/s)	1.20	3.71	1.02
Max Chl Dpth (ft)	1.32	Hydr. Depth (ft)	0.15	0.82	0.12
Conv. Total (cfs)	1101.2	Conv. (cfs)	5.9	1092.1	3.2
Length Wtd. (ft)	99.90	Wetted Per. (ft)	6.50	71.04	5.28
Min Ch El (ft)	6928.39	Shear (lb/sq ft)	0.37	2.03	0.29
Alpha	1.03	Stream Power (lb/ft s)	0.45	7.55	0.30
Frctn Loss (ft)	2.24	Cum Volume (acre-ft)	0.01	0.99	0.00
C & E Loss (ft)	0.03	Cum SA (acres)	0.06	0.84	0.02

Plan: Plan 02 WEST CHAN EX NEW chan-west-pr RS: 400 Profile: PF 1

E.G. Elev (ft)	6927.65	Element	Left OB	Channel	Right OB
Vel Head (ft)	0.13	Wt. n-Val.	0.070	0.070	0.070
W.S. Elev (ft)	6927.52	Reach Len. (ft)	172.00	100.00	180.00
Crit W.S. (ft)		Flow Area (sq ft)	4.46	73.61	0.09
E.G. Slope (ft/ft)	0.014470	Area (sq ft)	4.46	73.61	0.09
Q Total (cfs)	219.00	Flow (cfs)	4.98	213.99	0.03
Top Width (ft)	77.13	Top Width (ft)	15.45	60.00	1.68
Vel Total (ft/s)	2.80	Avg. Vel. (ft/s)	1.12	2.91	0.37
Max Chl Dpth (ft)	2.56	Hydr. Depth (ft)	0.29	1.23	0.05
Conv. Total (cfs)	1820.6	Conv. (cfs)	41.4	1778.9	0.3
Length Wtd. (ft)	100.82	Wetted Per. (ft)	15.46	60.60	1.68
Min Ch El (ft)	6924.96	Shear (lb/sq ft)	0.26	1.10	0.05
Alpha	1.06	Stream Power (lb/ft s)	0.29	3.19	0.02
Frctn Loss (ft)	2.82	Cum Volume (acre-ft)	0.01	0.83	0.00
C & E Loss (ft)	0.03	Cum SA (acres)	0.03	0.69	0.01

Plan: Plan 02 WEST CHAN EX NEW chan-west-pr RS: 300 Profile: PF 1

E.G. Elev (ft)	6924.79	Element	Left OB	Channel	Right OB
Vel Head (ft)	0.45	Wt. n-Val.		0.070	
W.S. Elev (ft)	6924.34	Reach Len. (ft)	106.00	100.00	108.00
Crit W.S. (ft)	6924.34	Flow Area (sq ft)		40.78	
E.G. Slope (ft/ft)	0.075333	Area (sq ft)		40.78	
Q Total (cfs)	219.00	Flow (cfs)		219.00	
Top Width (ft)	45.95	Top Width (ft)		45.95	
Vel Total (ft/s)	5.37	Avg. Vel. (ft/s)		5.37	
Max Chl Dpth (ft)	1.32	Hydr. Depth (ft)		0.89	
Conv. Total (cfs)	797.9	Conv. (cfs)		797.9	
Length Wtd. (ft)	100.00	Wetted Per. (ft)		46.07	
Min Ch El (ft)	6923.02	Shear (lb/sq ft)		4.16	
Alpha	1.00	Stream Power (lb/ft s)		22.35	
Frctn Loss (ft)	3.08	Cum Volume (acre-ft)	0.00	0.70	0.00
C & E Loss (ft)	0.10	Cum SA (acres)	0.00	0.56	0.01

Plan: Plan 02 WEST CHAN EX NEW chan-west-pr RS: 200 Profile: PF 1

E.G. Elev (ft)	6920.57	Element	Left OB	Channel	Right OB
Vel Head (ft)	0.11	Wt. n-Val.		0.070	
W.S. Elev (ft)	6920.46	Reach Len. (ft)	81.00	100.00	107.00
Crit W.S. (ft)		Flow Area (sq ft)		82.52	
E.G. Slope (ft/ft)	0.016608	Area (sq ft)		82.52	
Q Total (cfs)	219.00	Flow (cfs)		219.00	
Top Width (ft)	86.27	Top Width (ft)		86.27	
Vel Total (ft/s)	2.65	Avg. Vel. (ft/s)		2.65	
Max Chl Dpth (ft)	1.38	Hydr. Depth (ft)		0.96	
Conv. Total (cfs)	1699.4	Conv. (cfs)		1699.4	
Length Wtd. (ft)	100.00	Wetted Per. (ft)		86.37	
Min Ch El (ft)	6919.08	Shear (lb/sq ft)		0.99	
Alpha	1.00	Stream Power (lb/ft s)		2.63	
Frctn Loss (ft)	0.42	Cum Volume (acre-ft)	0.00	0.56	0.00
C & E Loss (ft)	0.02	Cum SA (acres)	0.00	0.41	0.01

Plan: Plan 02 WEST CHAN EX NEW chan-west-pr RS: 100 Profile: PF 1

E.G. Elev (ft)	6920.12	Element	Left OB	Channel	Right OB
Vel Head (ft)	0.03	Wt. n-Val.	0.070	0.070	0.070
W.S. Elev (ft)	6920.09	Reach Len. (ft)	101.00	100.00	107.00
Crit W.S. (ft)		Flow Area (sq ft)	0.15	154.43	0.11
E.G. Slope (ft/ft)	0.001886	Area (sq ft)	0.15	154.43	0.11
Q Total (cfs)	219.00	Flow (cfs)	0.02	218.96	0.01
Top Width (ft)	85.42	Top Width (ft)	2.15	80.70	2.56
Vel Total (ft/s)	1.42	Avg. Vel. (ft/s)	0.16	1.42	0.11
Max Chl Dpth (ft)	2.73	Hydr. Depth (ft)	0.07	1.91	0.04
Conv. Total (cfs)	5042.9	Conv. (cfs)	0.6	5042.0	0.3
Length Wtd. (ft)	100.00	Wetted Per. (ft)	2.16	80.96	2.57
Min Ch El (ft)	6917.36	Shear (lb/sq ft)	0.01	0.22	0.01
Alpha	1.00	Stream Power (lb/ft s)	0.00	0.32	0.00
Frctn Loss (ft)	0.40	Cum Volume (acre-ft)	0.00	0.29	0.00
C & E Loss (ft)	0.00	Cum SA (acres)	0.00	0.22	0.00

Plan: Plan 02 WEST CHAN EX NEW chan-west-pr RS: 0 Profile: PF 1

E.G. Elev (ft)	6919.72	Element	Left OB	Channel	Right OB
Vel Head (ft)	0.08	Wt. n-Val.		0.070	
W.S. Elev (ft)	6919.64	Reach Len. (ft)			
Crit W.S. (ft)	6919.12	Flow Area (sq ft)		98.31	
E.G. Slope (ft/ft)	0.012995	Area (sq ft)		98.31	
Q Total (cfs)	219.00	Flow (cfs)		219.00	
Top Width (ft)	111.26	Top Width (ft)		111.26	
Vel Total (ft/s)	2.23	Avg. Vel. (ft/s)		2.23	
Max Chl Dpth (ft)	1.64	Hydr. Depth (ft)		0.88	
Conv. Total (cfs)	1921.1	Conv. (cfs)		1921.1	
Length Wtd. (ft)		Wetted Per. (ft)		111.31	
Min Ch El (ft)	6918.00	Shear (lb/sq ft)		0.72	
Alpha	1.00	Stream Power (lb/ft s)		1.60	
Frctn Loss (ft)		Cum Volume (acre-ft)			
C & E Loss (ft)		Cum SA (acres)			

WEST CHAN EX NEW Plan: Plan 02 11/22/2022
River = WEST CHAN EX NEW Reach = chan-west-pr RS = 2600

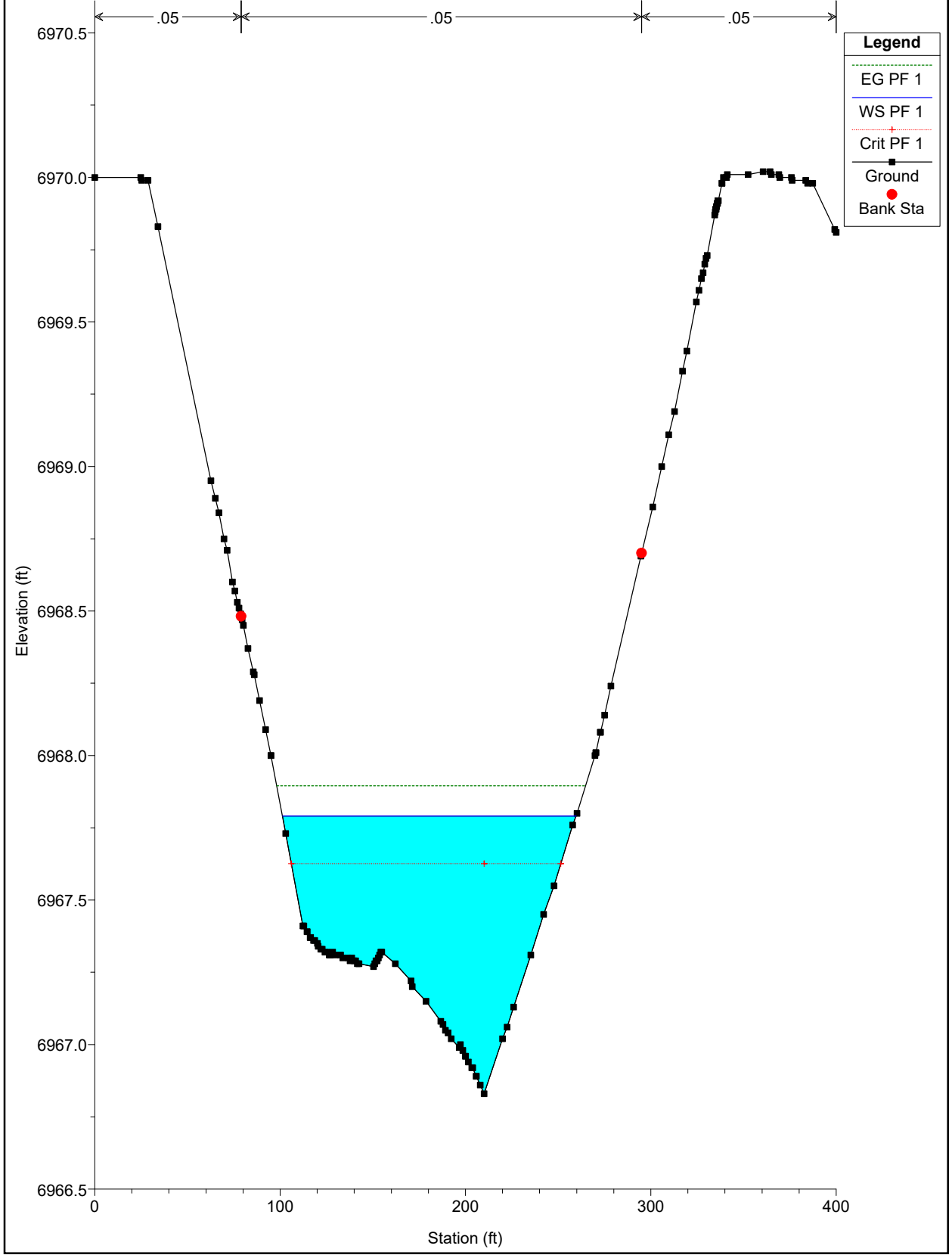

WEST CHAN EX NEW Plan: Plan 02 11/22/2022
River = WEST CHAN EX NEW Reach = chan-west-pr RS = 2500

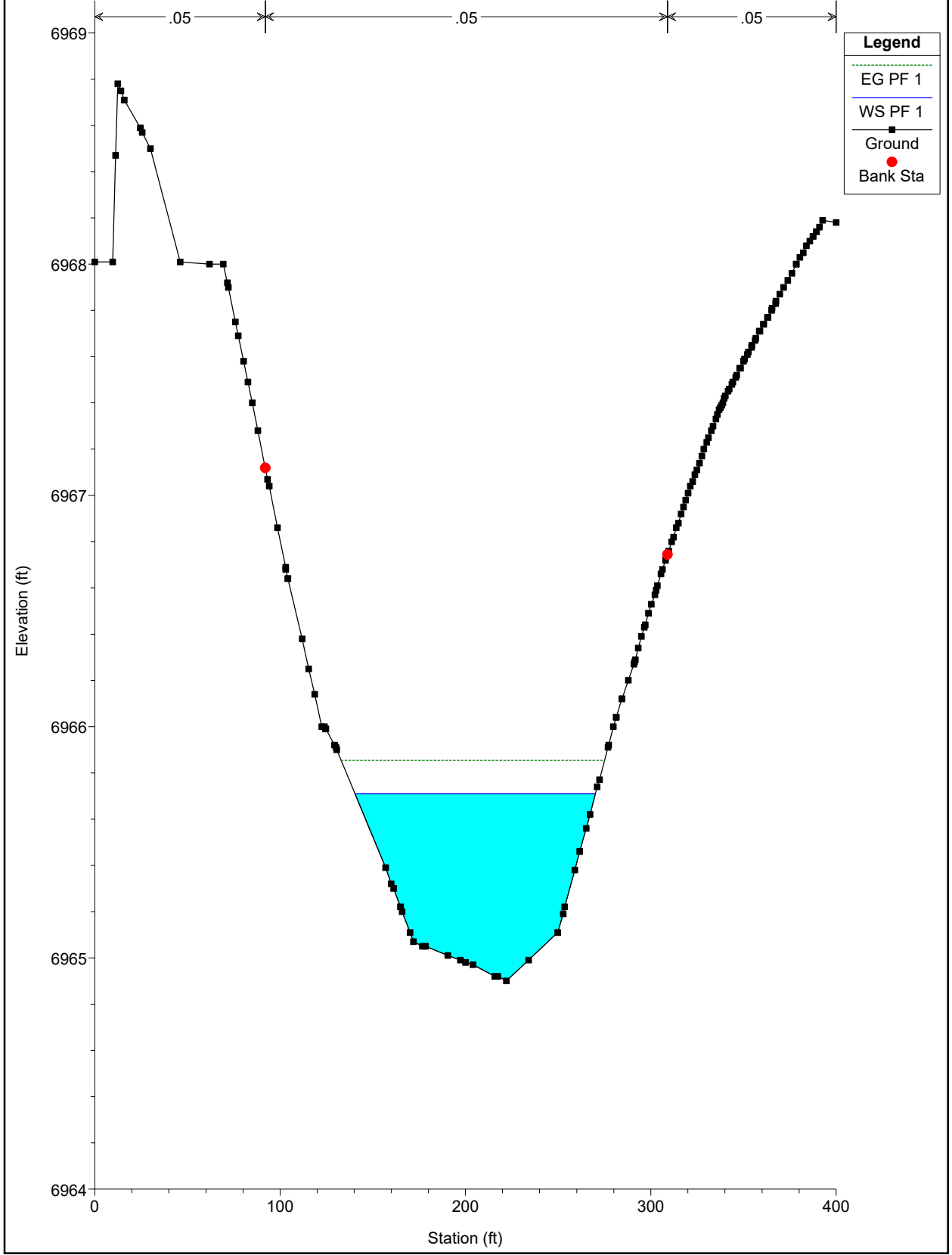

WEST CHAN EX NEW Plan: Plan 02 11/22/2022
River = WEST CHAN EX NEW Reach = chan-west-pr RS = 2400

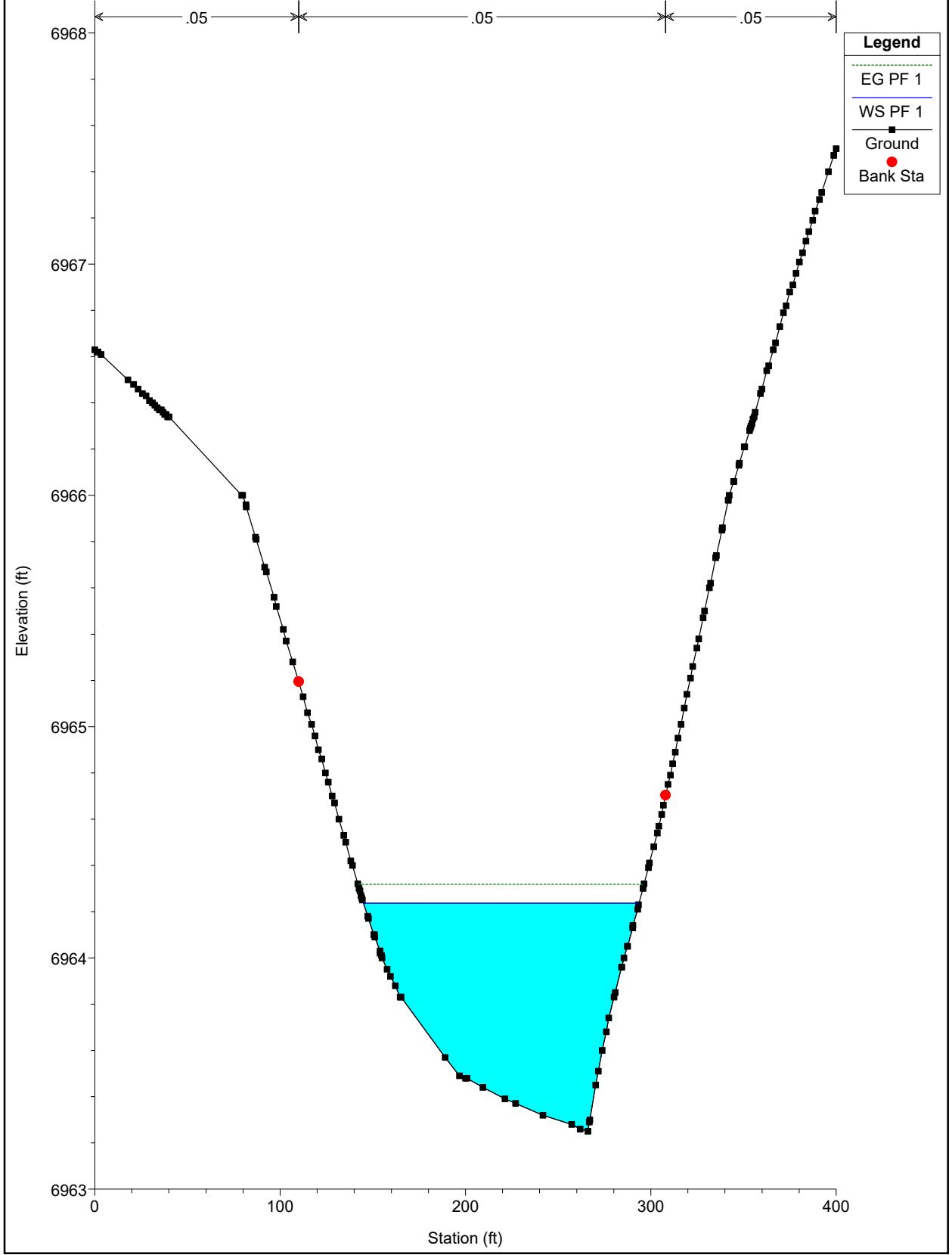

WEST CHAN EX NEW Plan: Plan 02 11/22/2022
River = WEST CHAN EX NEW Reach = chan-west-pr RS = 2300

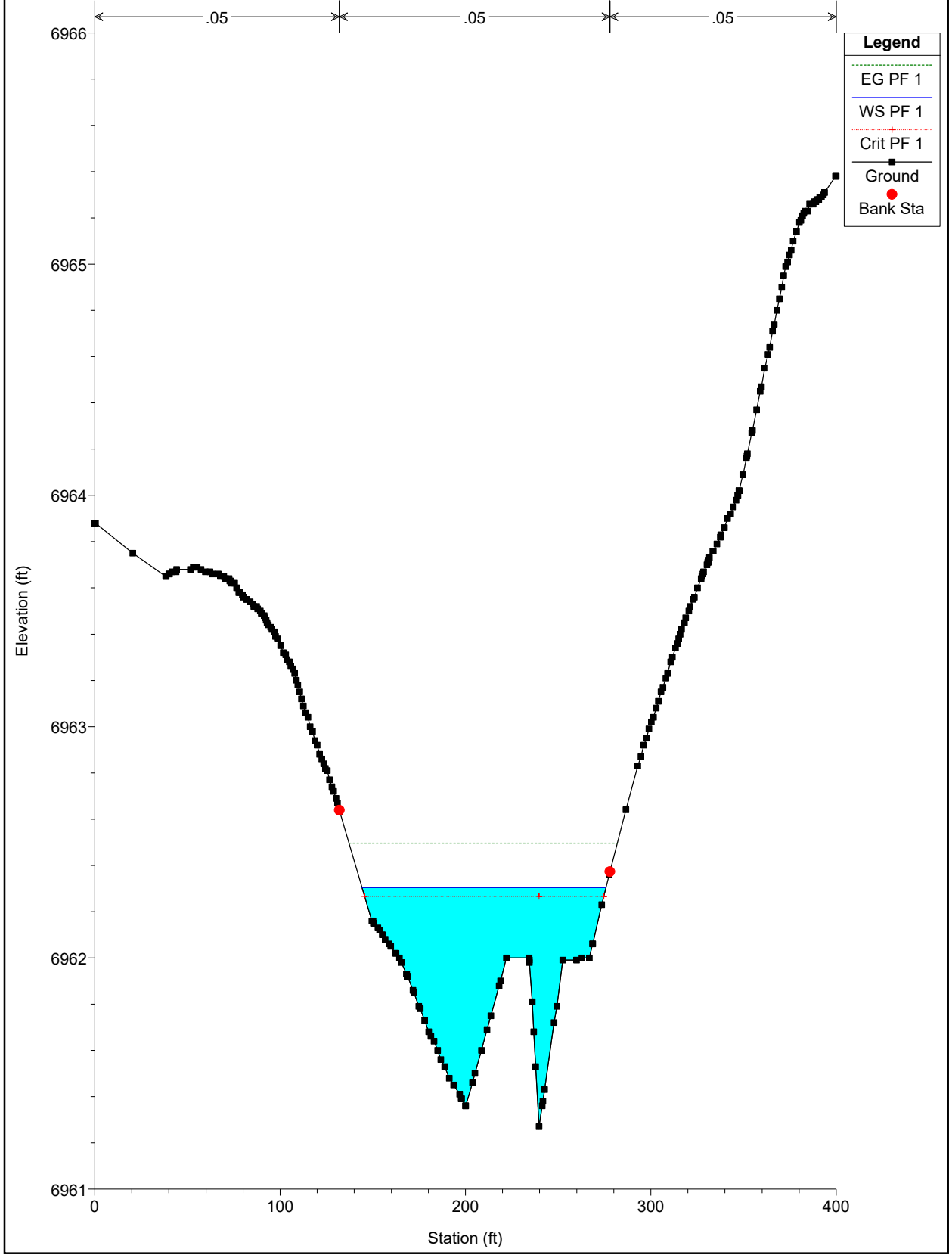

WEST CHAN EX NEW Plan: Plan 02 11/22/2022
River = WEST CHAN EX NEW Reach = chan-west-pr RS = 2200

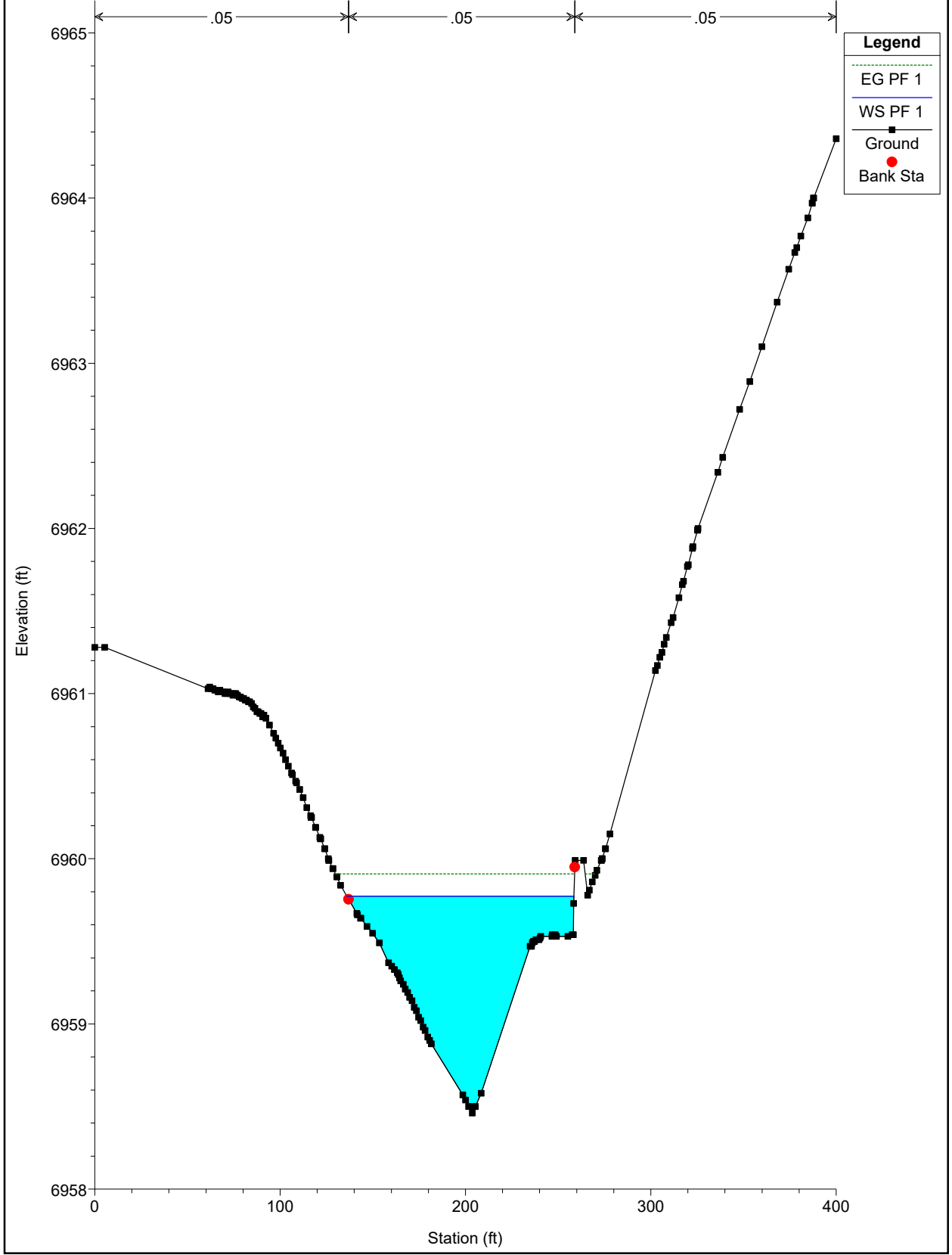

WEST CHAN EX NEW Plan: Plan 02 11/22/2022
River = WEST CHAN EX NEW Reach = chan-west-pr RS = 2100

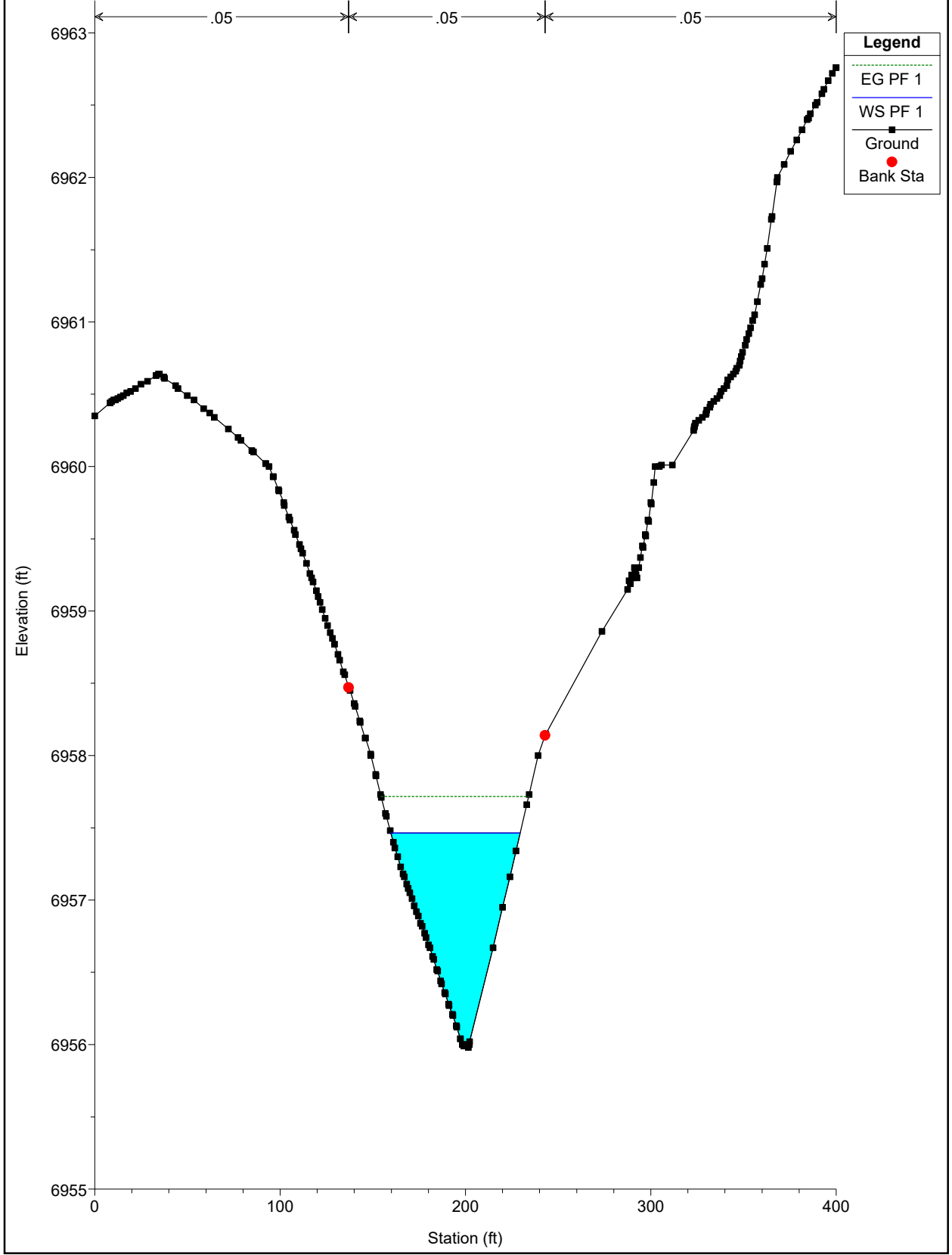

WEST CHAN EX NEW Plan: Plan 02 11/22/2022
River = WEST CHAN EX NEW Reach = chan-west-pr RS = 2000

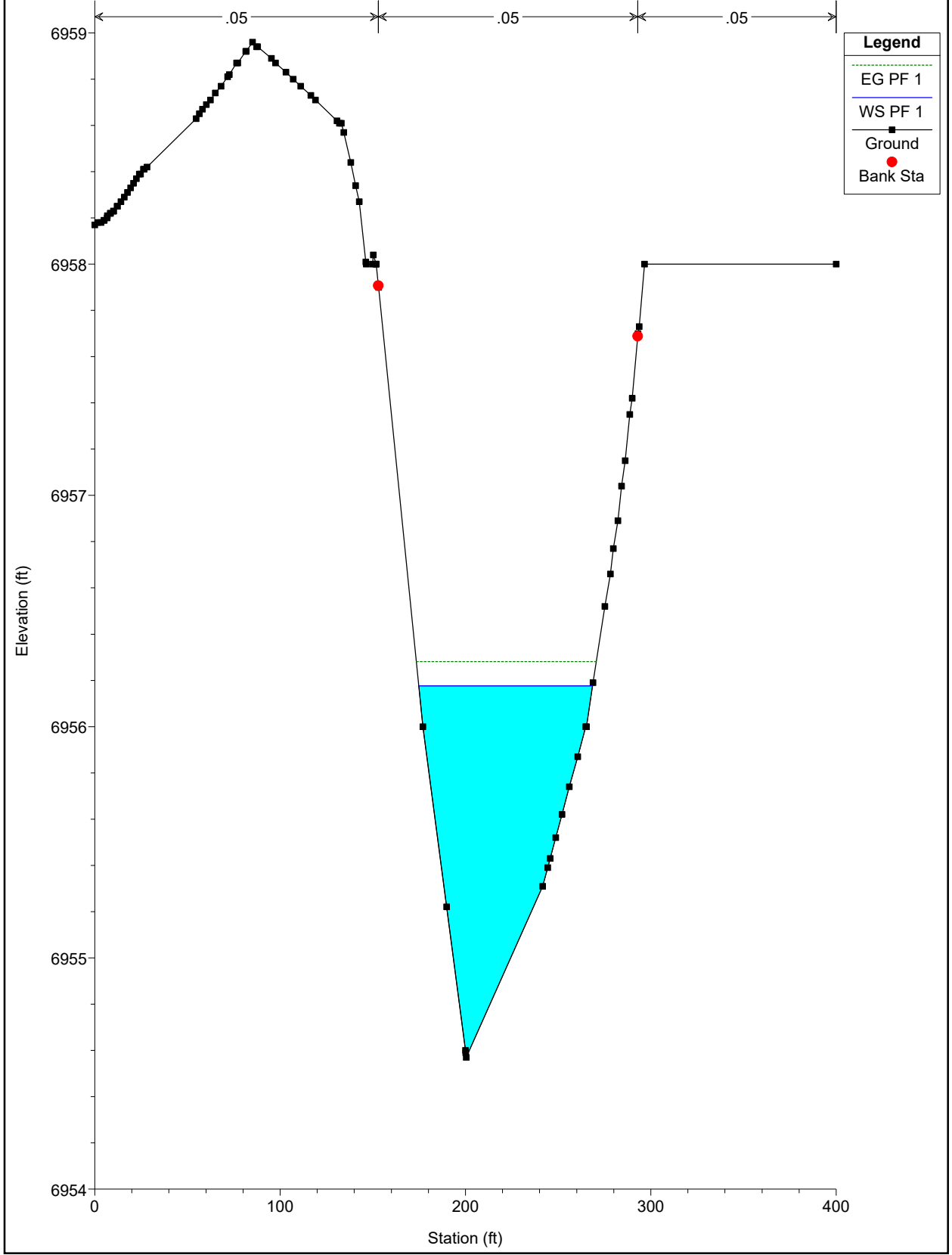

WEST CHAN EX NEW Plan: Plan 02 11/22/2022
River = WEST CHAN EX NEW Reach = chan-west-pr RS = 1900

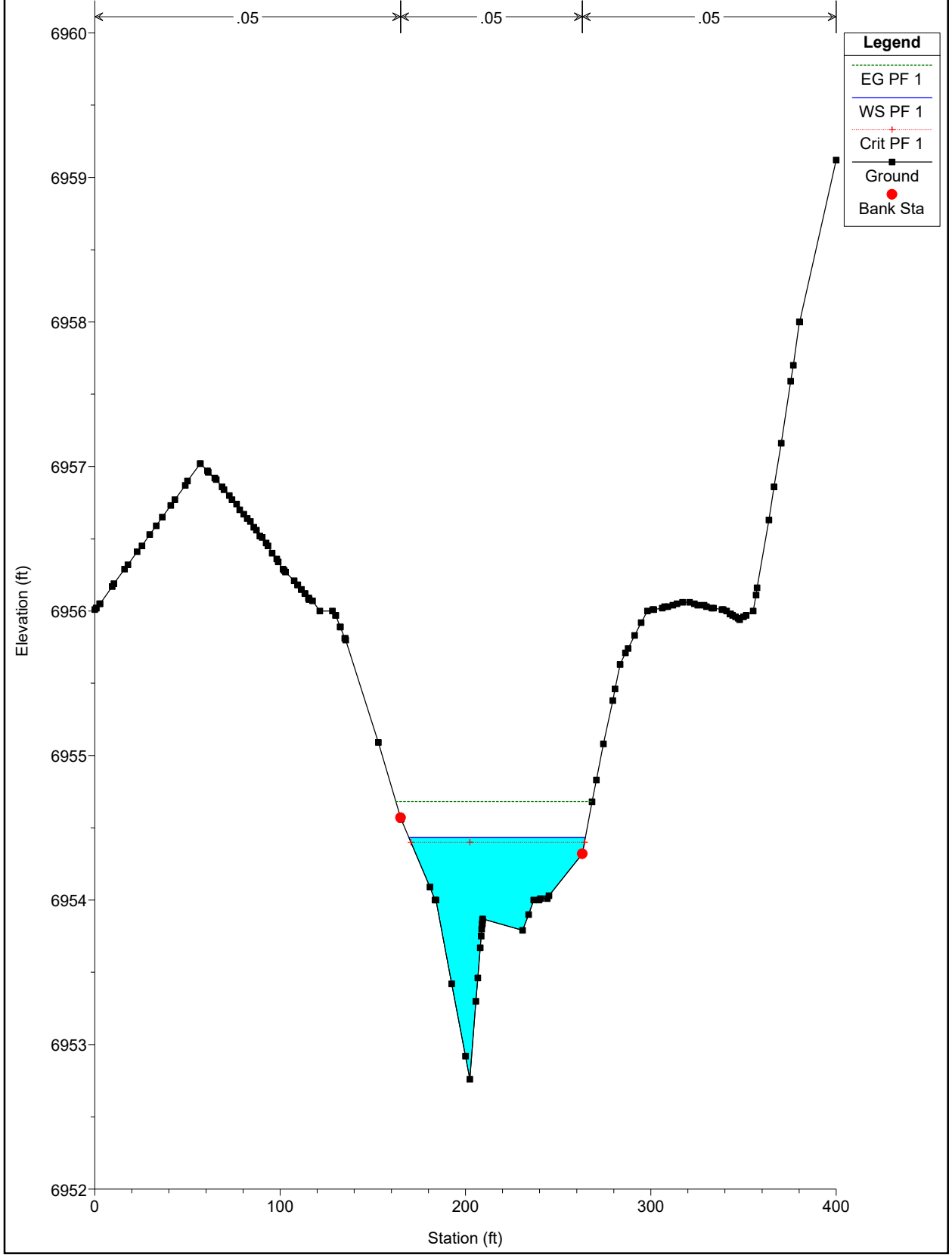

WEST CHAN EX NEW Plan: Plan 02 11/22/2022
River = WEST CHAN EX NEW Reach = chan-west-pr RS = 1800

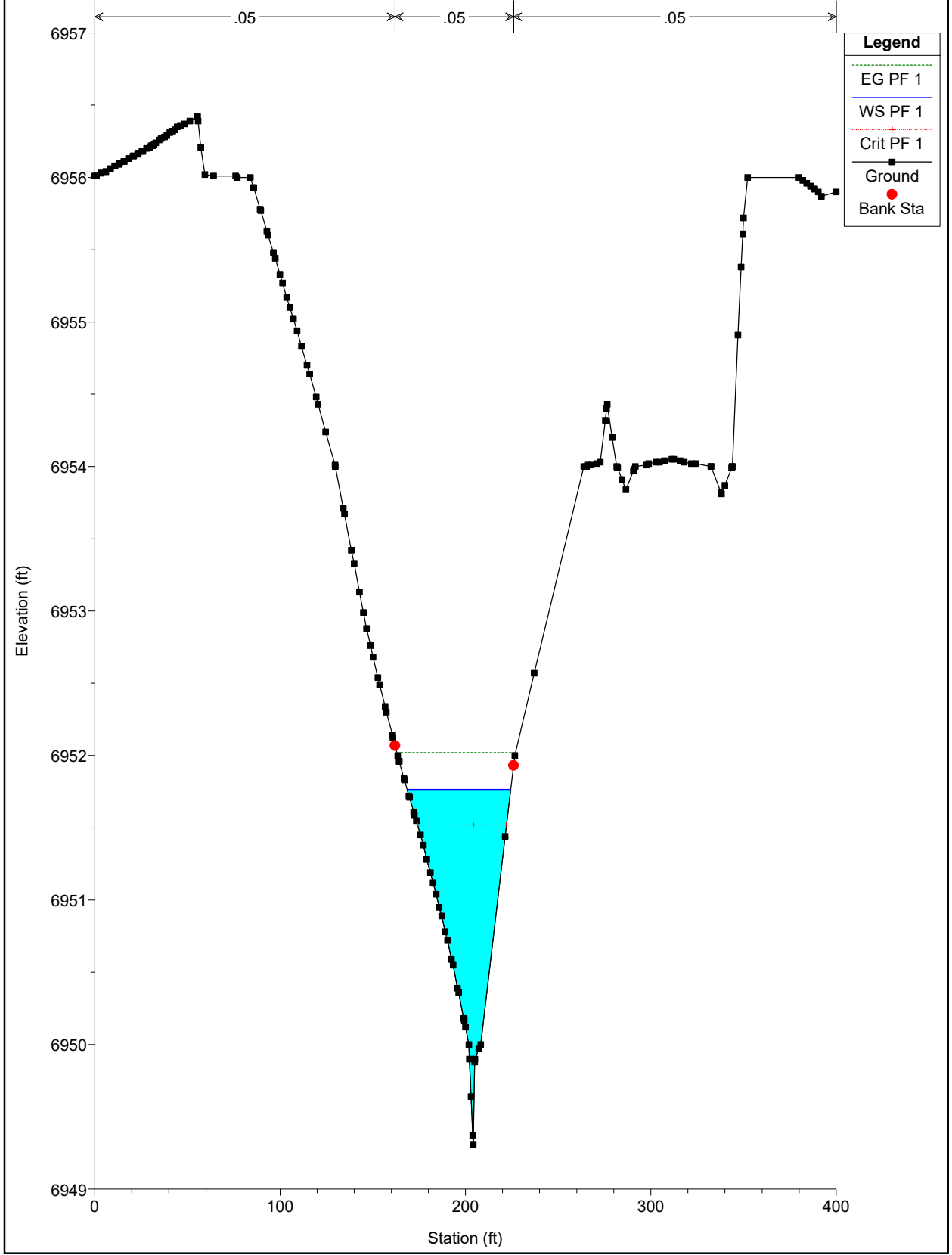

WEST CHAN EX NEW Plan: Plan 02 11/22/2022
River = WEST CHAN EX NEW Reach = chan-west-pr RS = 1700

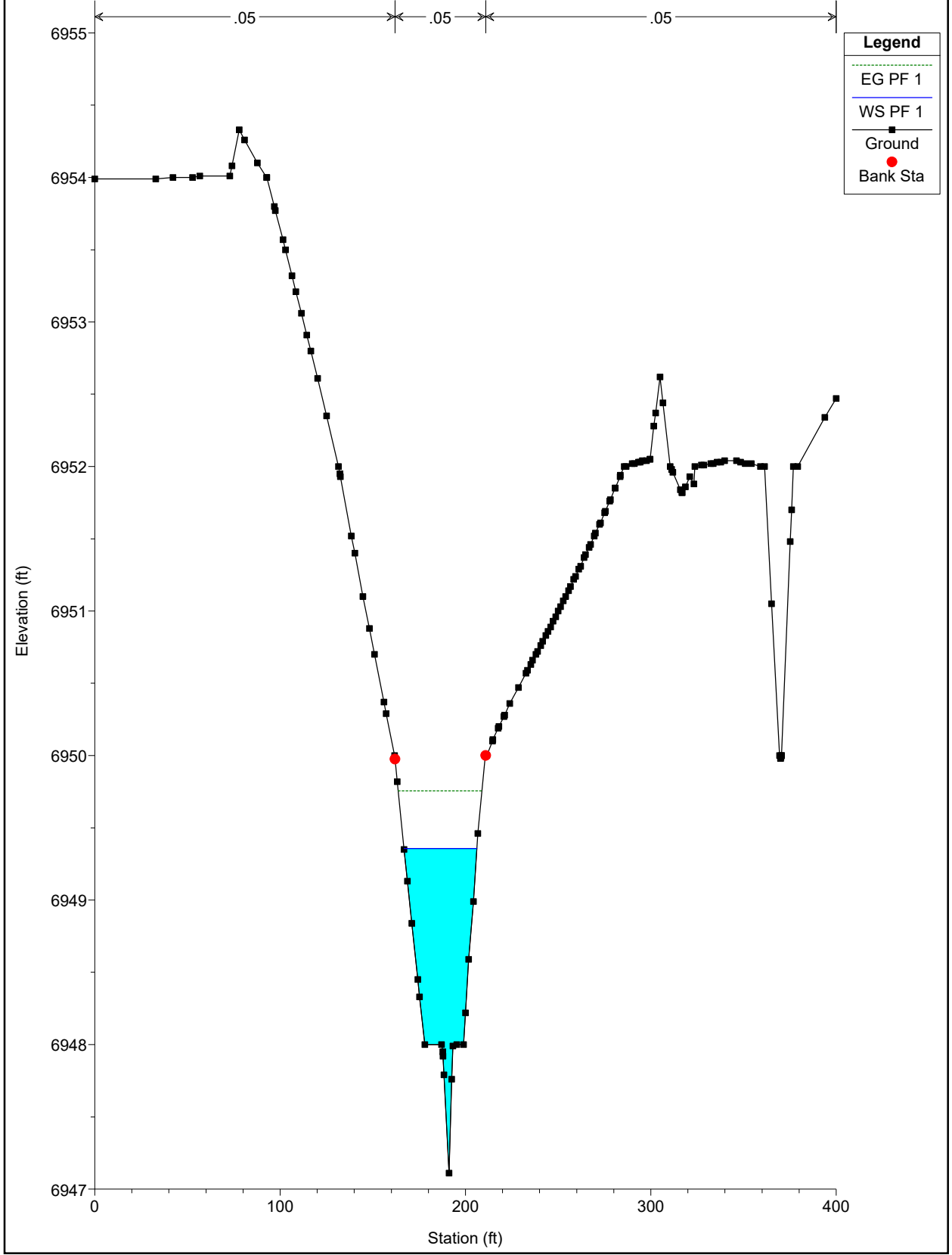

WEST CHAN EX NEW Plan: Plan 02 11/22/2022
River = WEST CHAN EX NEW Reach = chan-west-pr RS = 1600

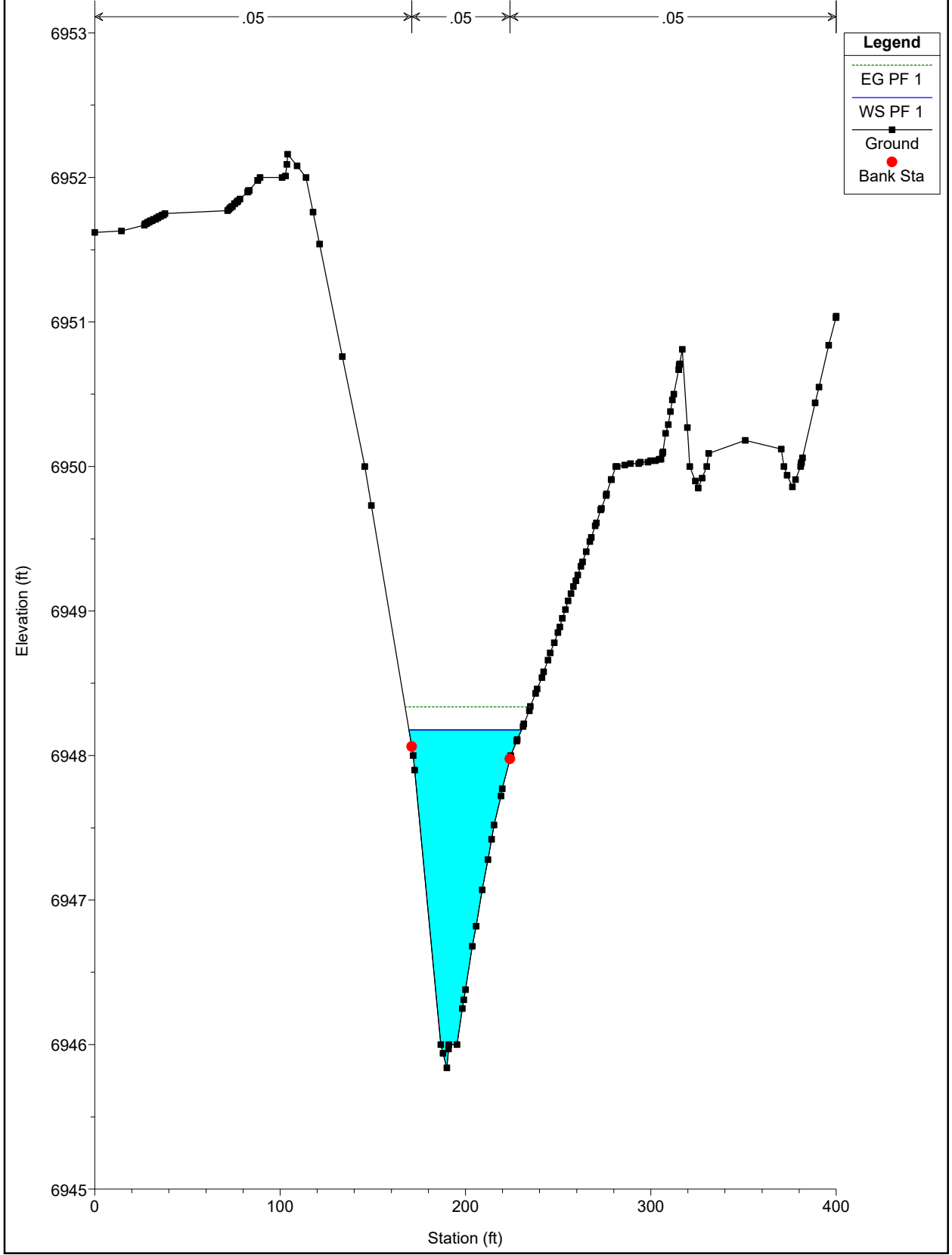

WEST CHAN EX NEW Plan: Plan 02 11/22/2022
River = WEST CHAN EX NEW Reach = chan-west-pr RS = 1500

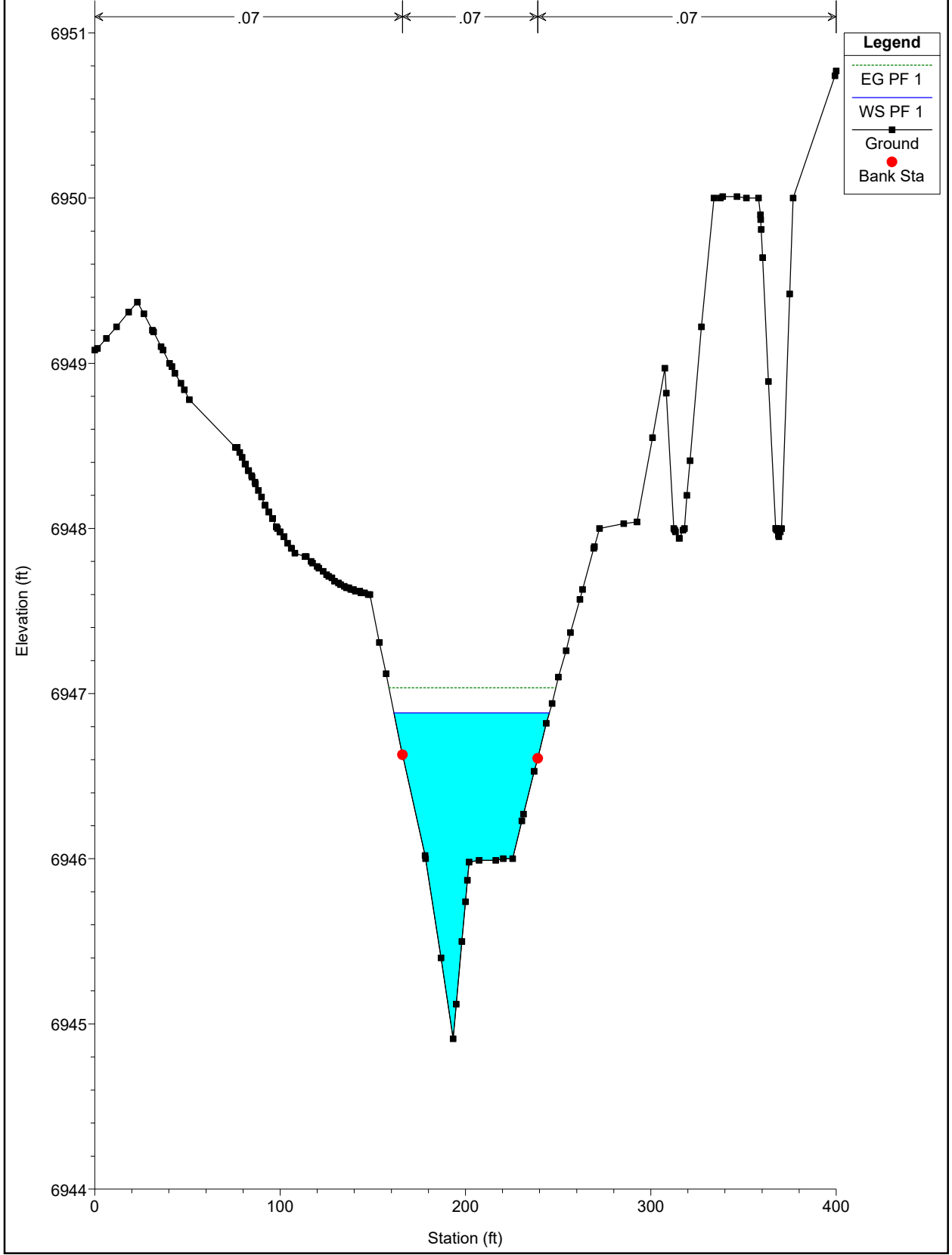

WEST CHAN EX NEW Plan: Plan 02 11/22/2022
River = WEST CHAN EX NEW Reach = chan-west-pr RS = 1400

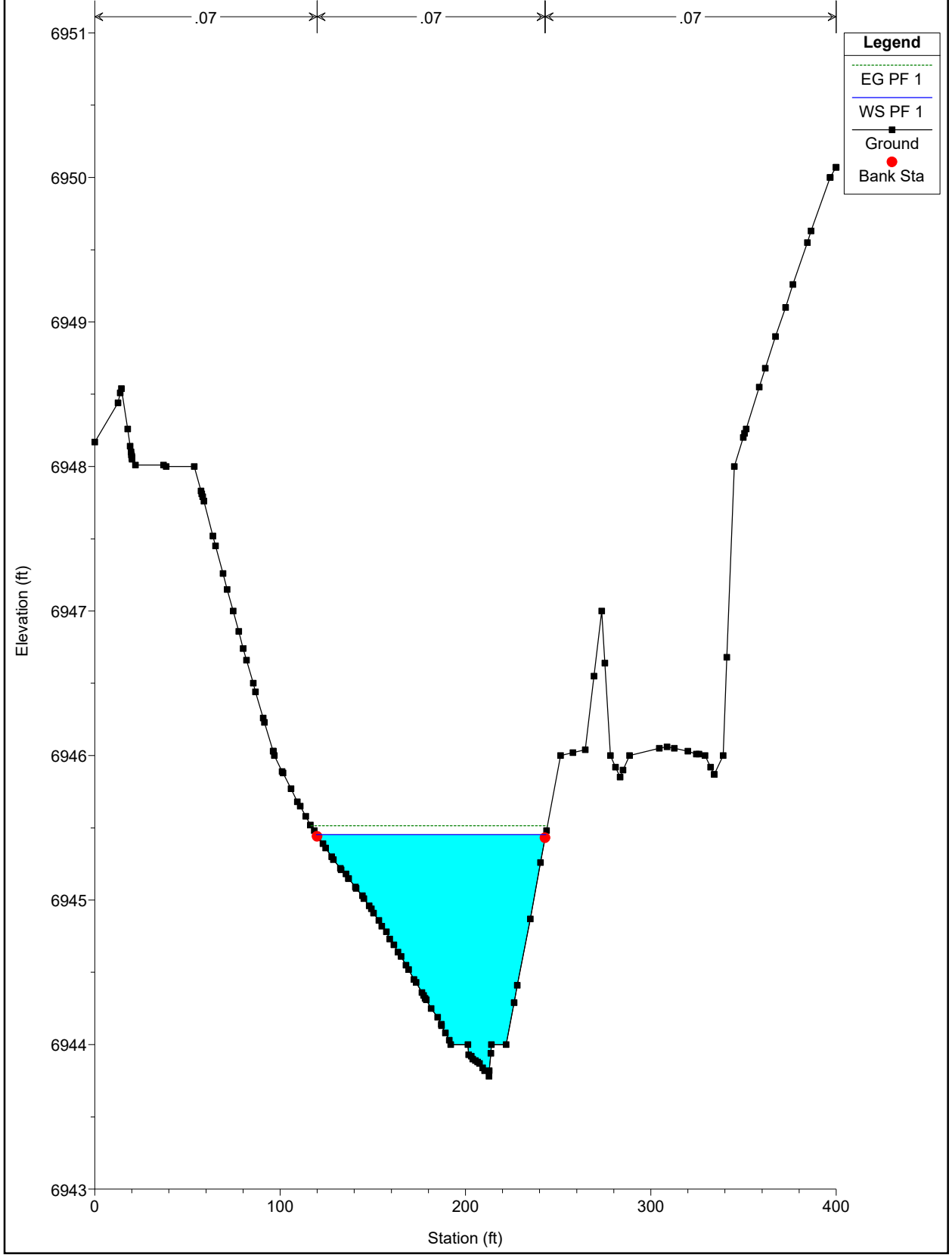

WEST CHAN EX NEW Plan: Plan 02 11/22/2022
River = WEST CHAN EX NEW Reach = chan-west-pr RS = 1300

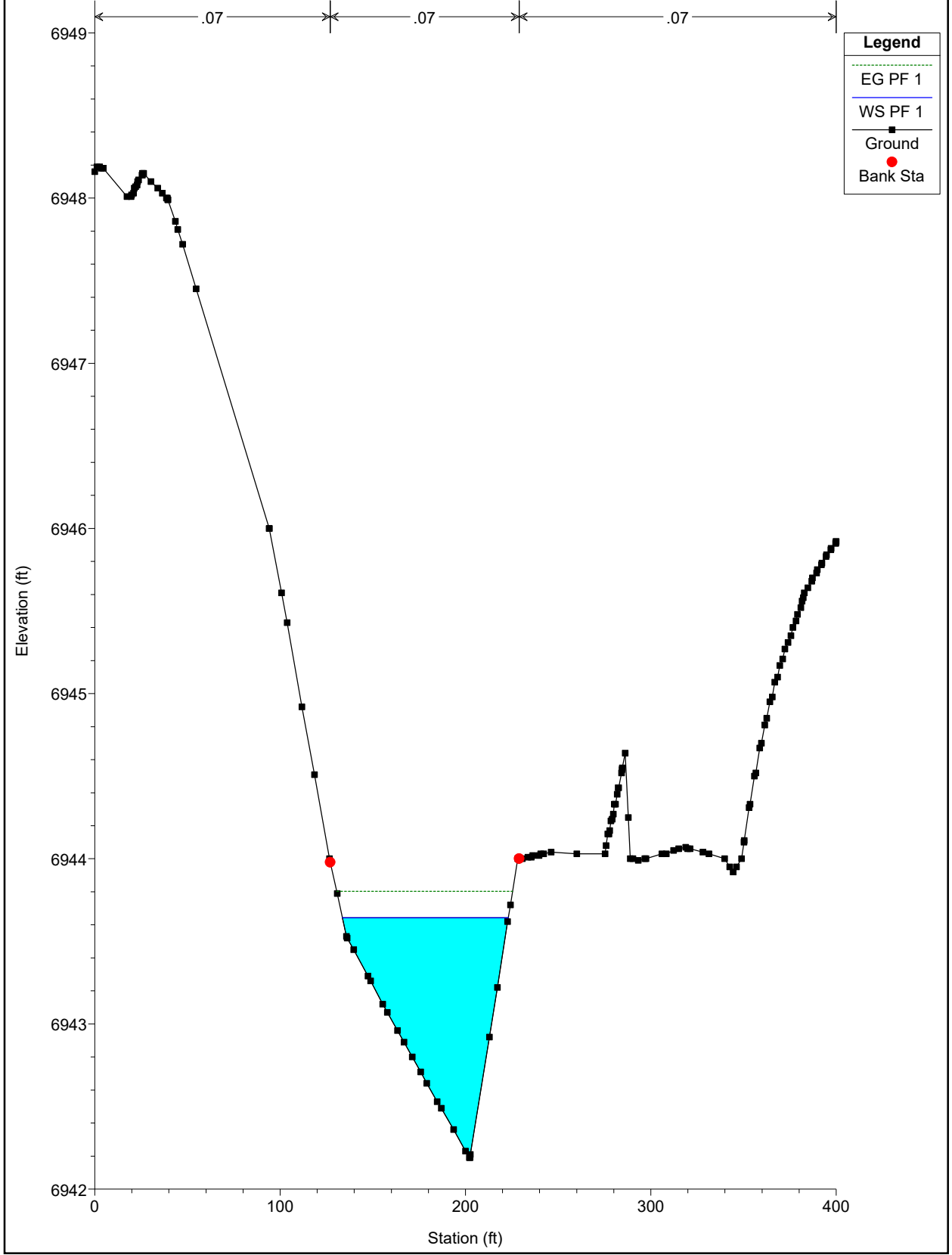

WEST CHAN EX NEW Plan: Plan 02 11/22/2022
River = WEST CHAN EX NEW Reach = chan-west-pr RS = 1200

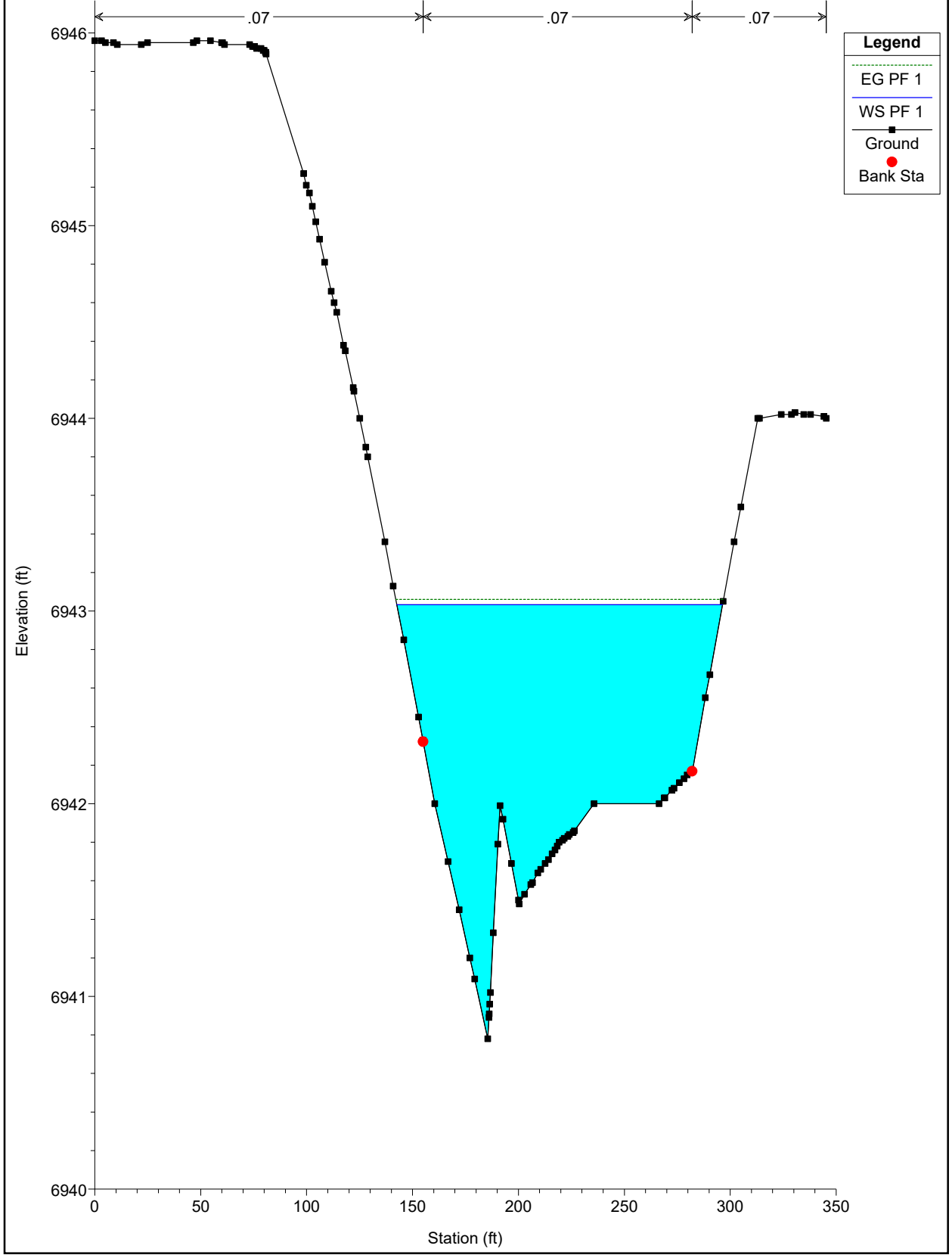

WEST CHAN EX NEW Plan: Plan 02 11/22/2022
River = WEST CHAN EX NEW Reach = chan-west-pr RS = 1100

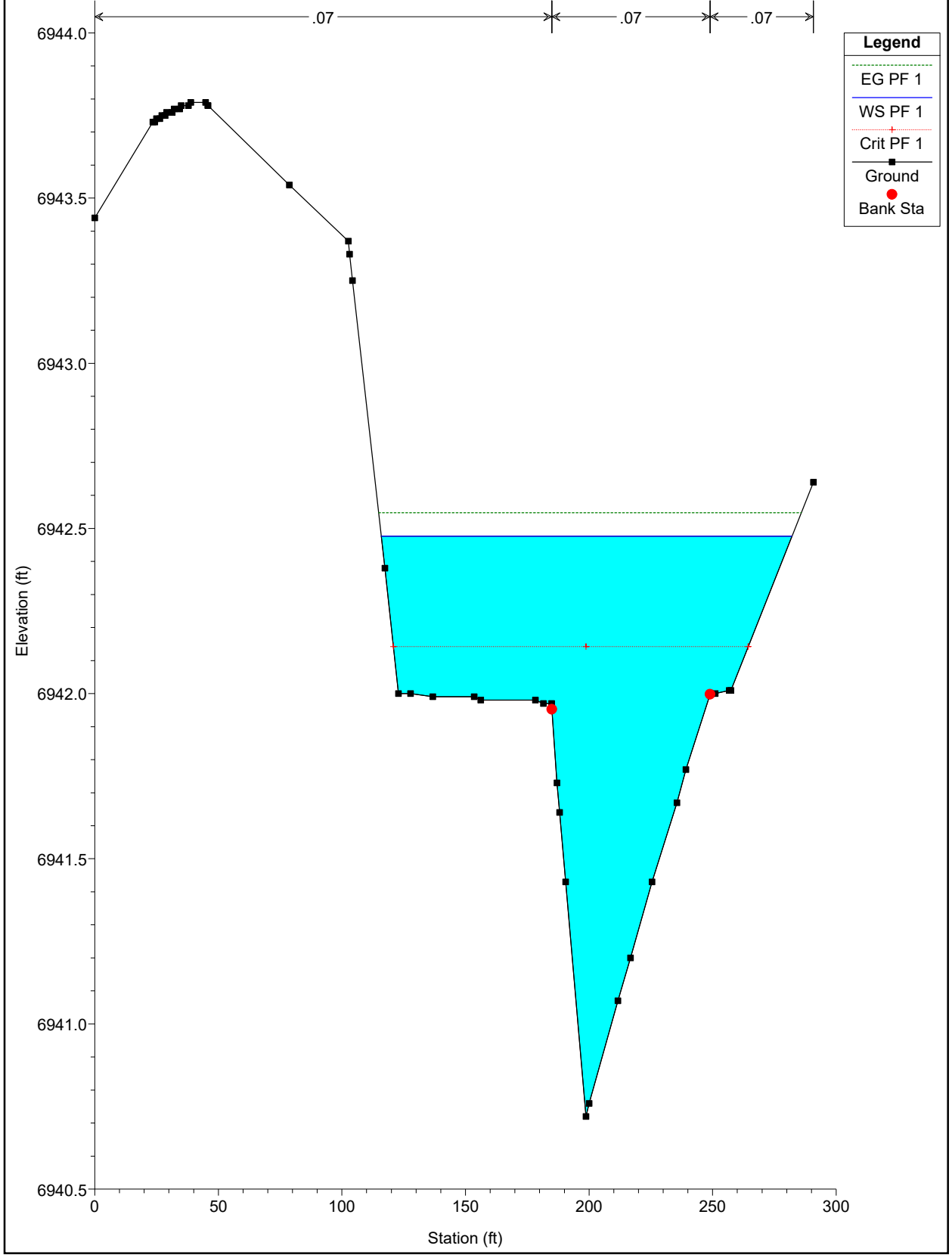

WEST CHAN EX NEW Plan: Plan 02 11/22/2022
River = WEST CHAN EX NEW Reach = chan-west-pr RS = 1000

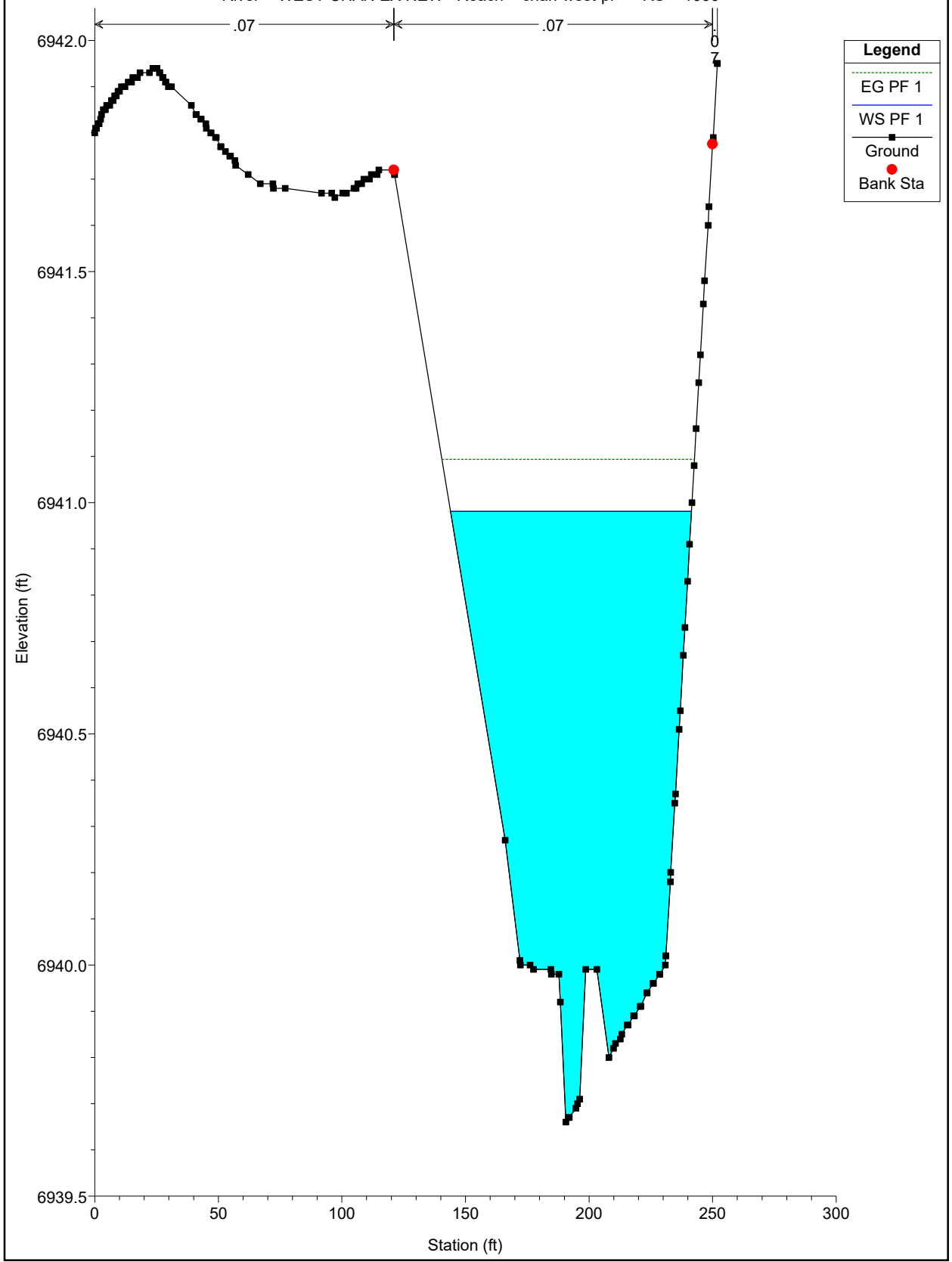

Legend	
EG PF 1	(Dashed green line)
WS PF 1	(Blue line)
Ground	(Black squares)
Bank Sta	(Red dot)

WEST CHAN EX NEW Plan: Plan 02 11/22/2022
River = WEST CHAN EX NEW Reach = chan-west-pr RS = 900

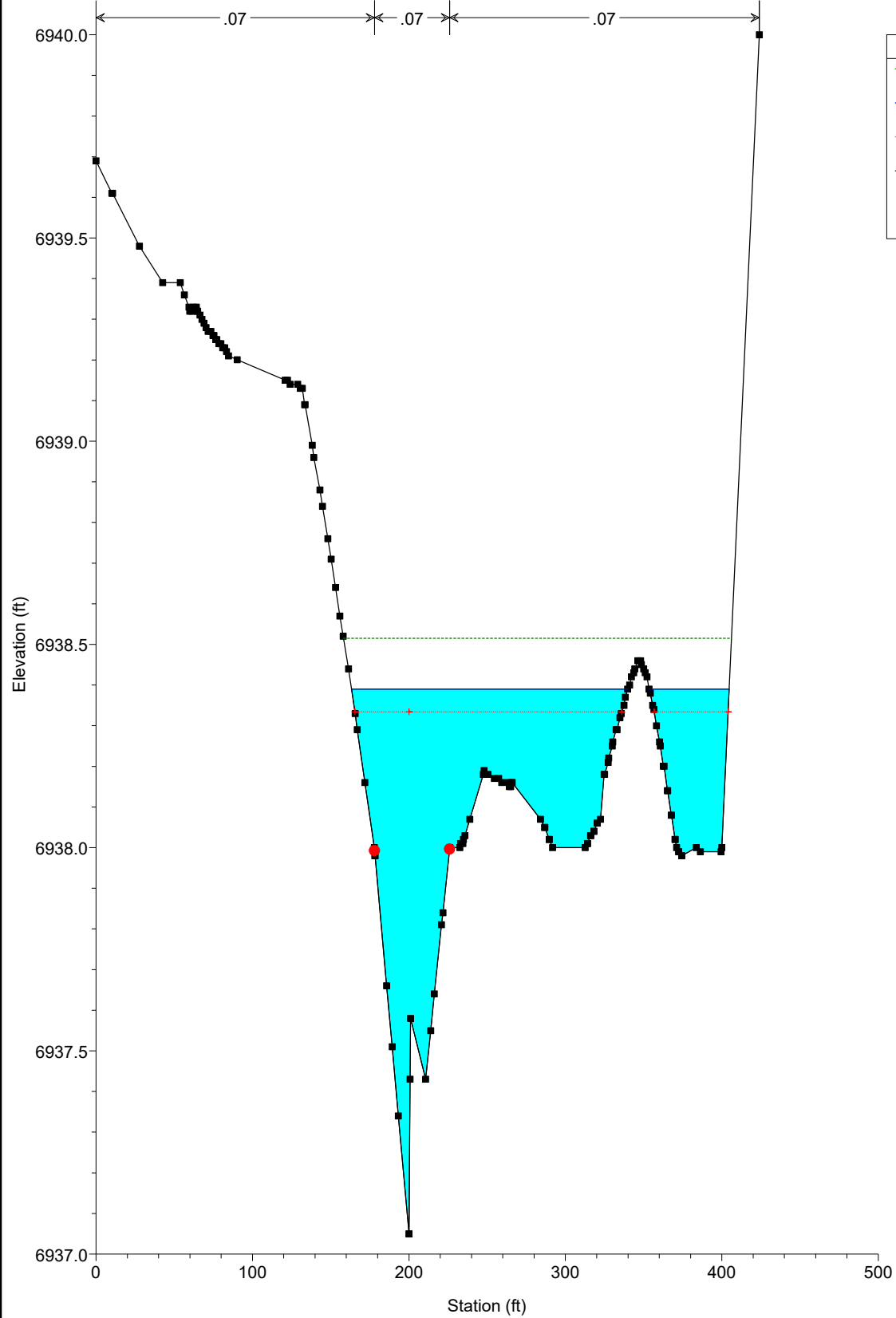

Legend	
EG PF 1	(Green dashed line)
WS PF 1	(Blue solid line)
Crit PF 1	(Red dotted line with plus markers)
Ground	(Black line with square markers)
Bank Sta	(Red dot)

WEST CHAN EX NEW Plan: Plan 02 11/22/2022
River = WEST CHAN EX NEW Reach = chan-west-pr RS = 800

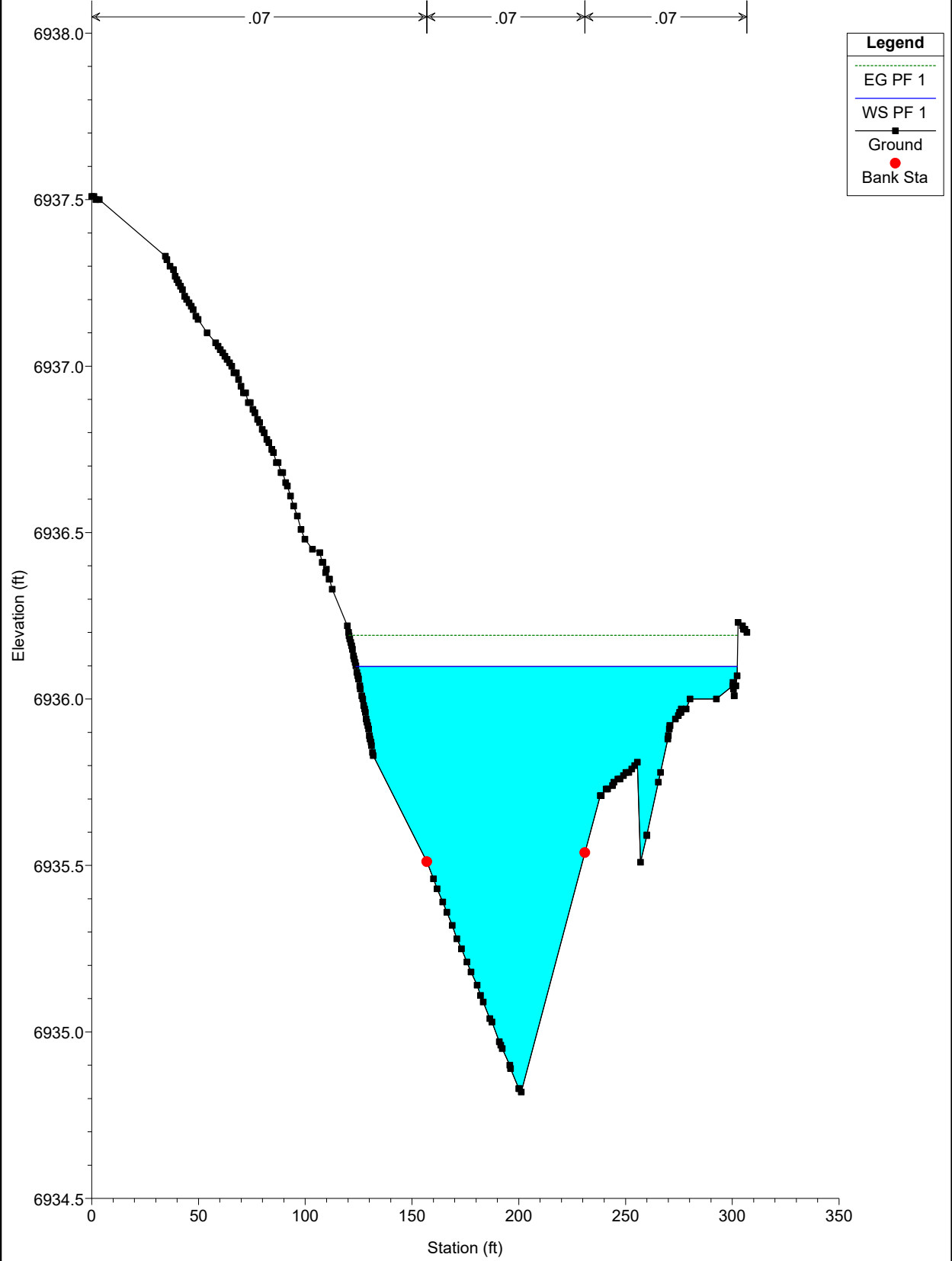

WEST CHAN EX NEW Plan: Plan 02 11/22/2022
River = WEST CHAN EX NEW Reach = chan-west-pr RS = 700

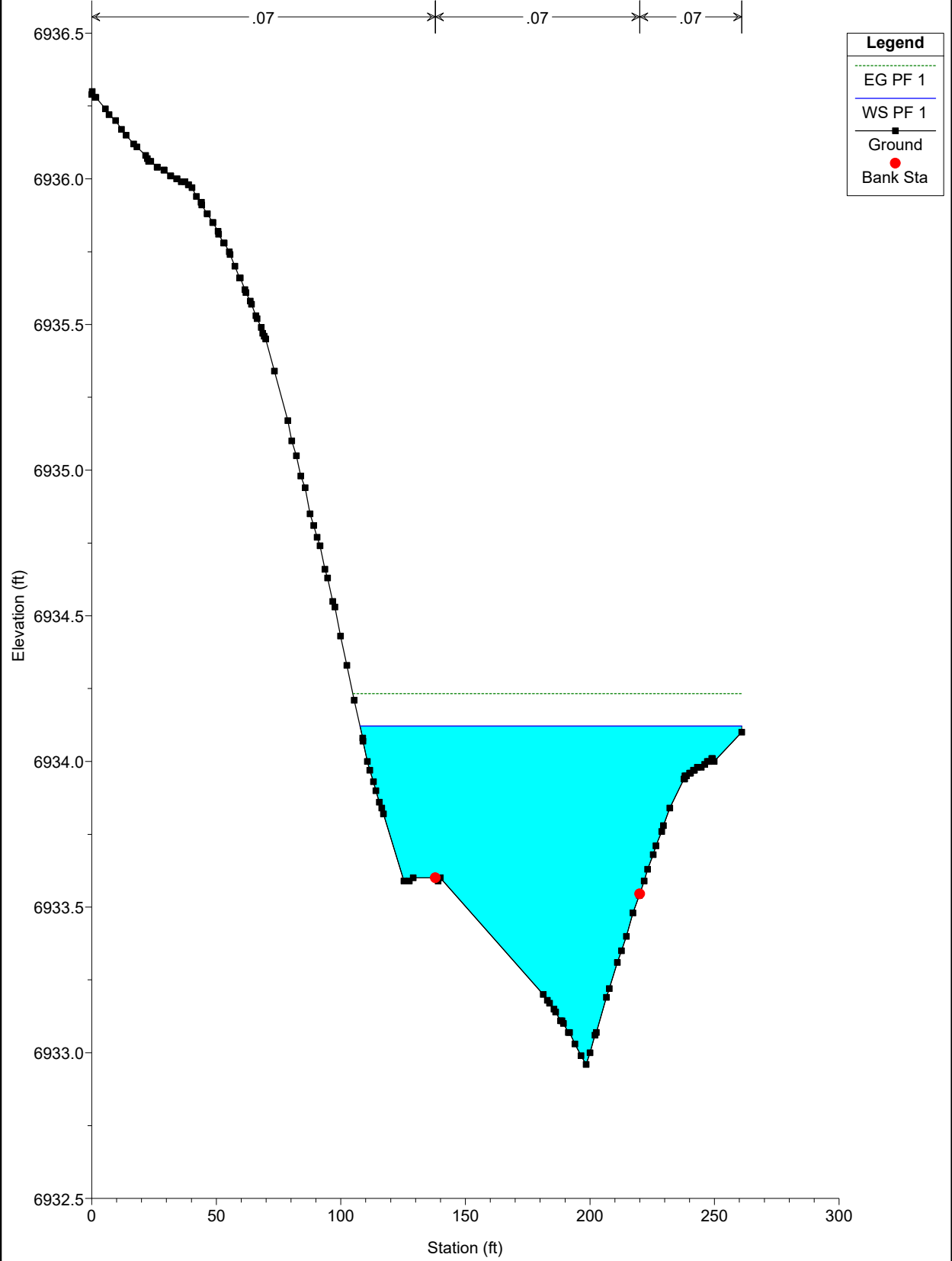

WEST CHAN EX NEW Plan: Plan 02 11/22/2022
River = WEST CHAN EX NEW Reach = chan-west-pr RS = 600

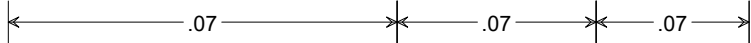

Legend	
EG PF 1	
WS PF 1	
Ground	
Bank Sta	

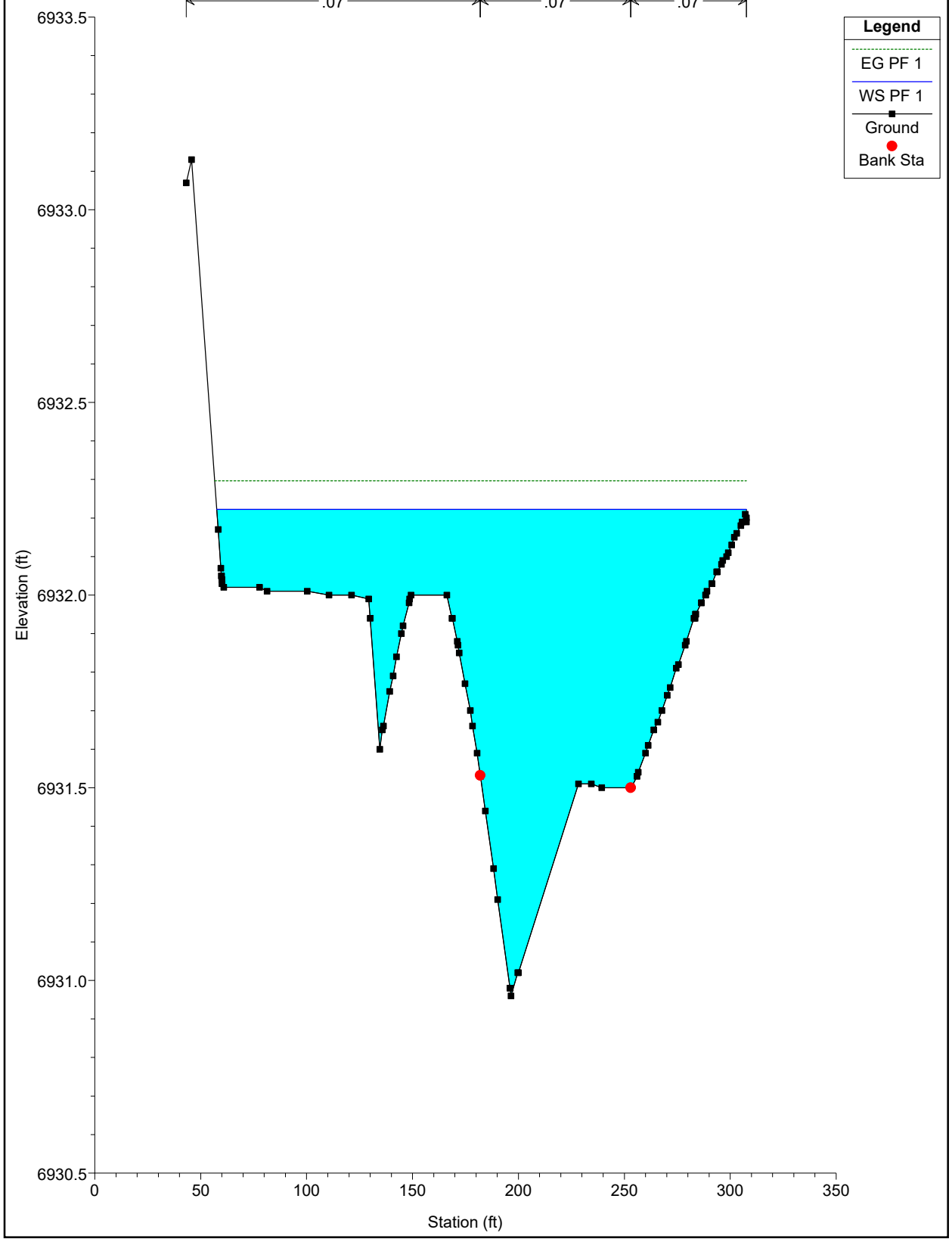

WEST CHAN EX NEW Plan: Plan 02 11/22/2022
River = WEST CHAN EX NEW Reach = chan-west-pr RS = 500

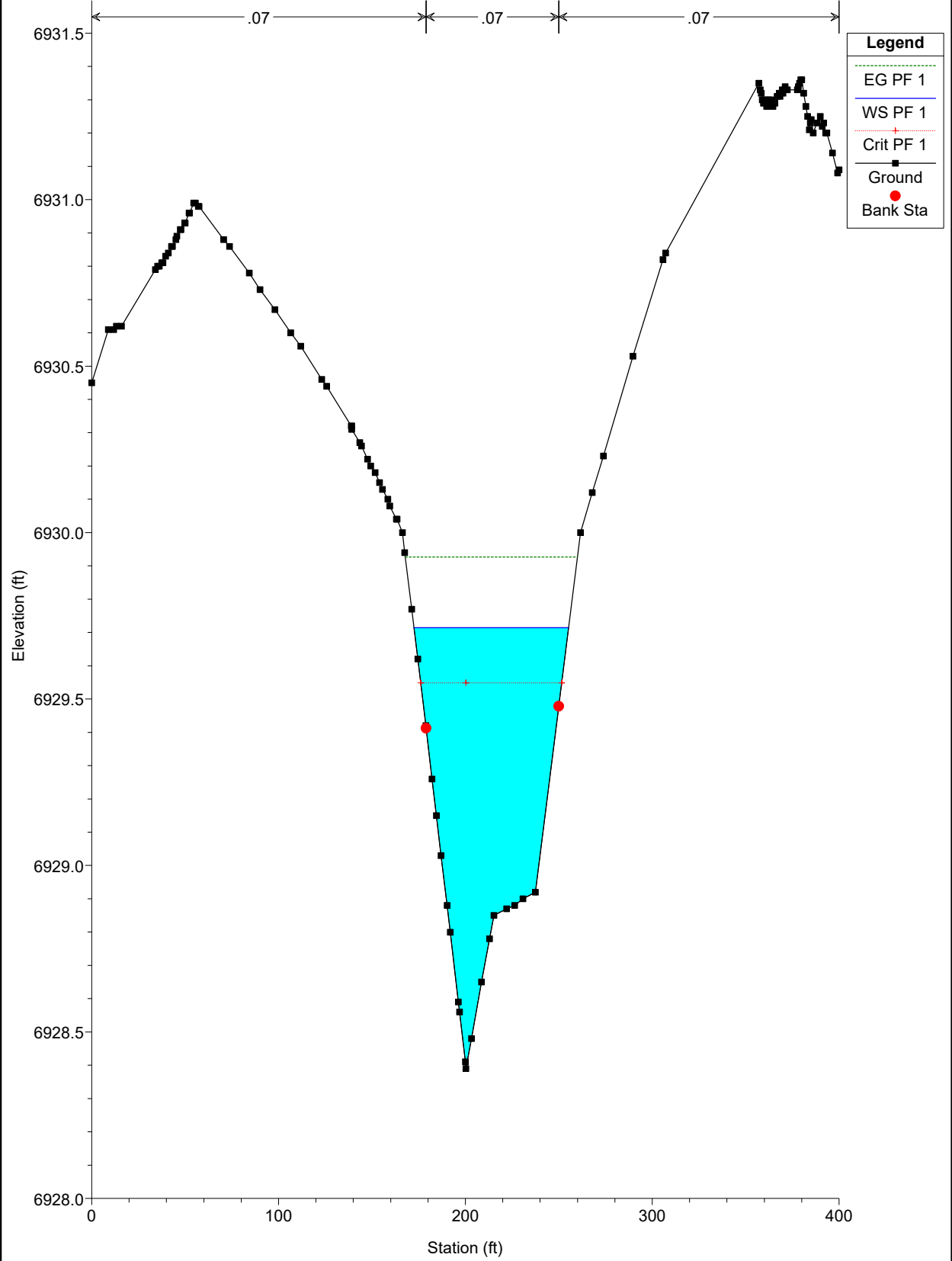

WEST CHAN EX NEW Plan: Plan 02 11/22/2022
River = WEST CHAN EX NEW Reach = chan-west-pr RS = 400

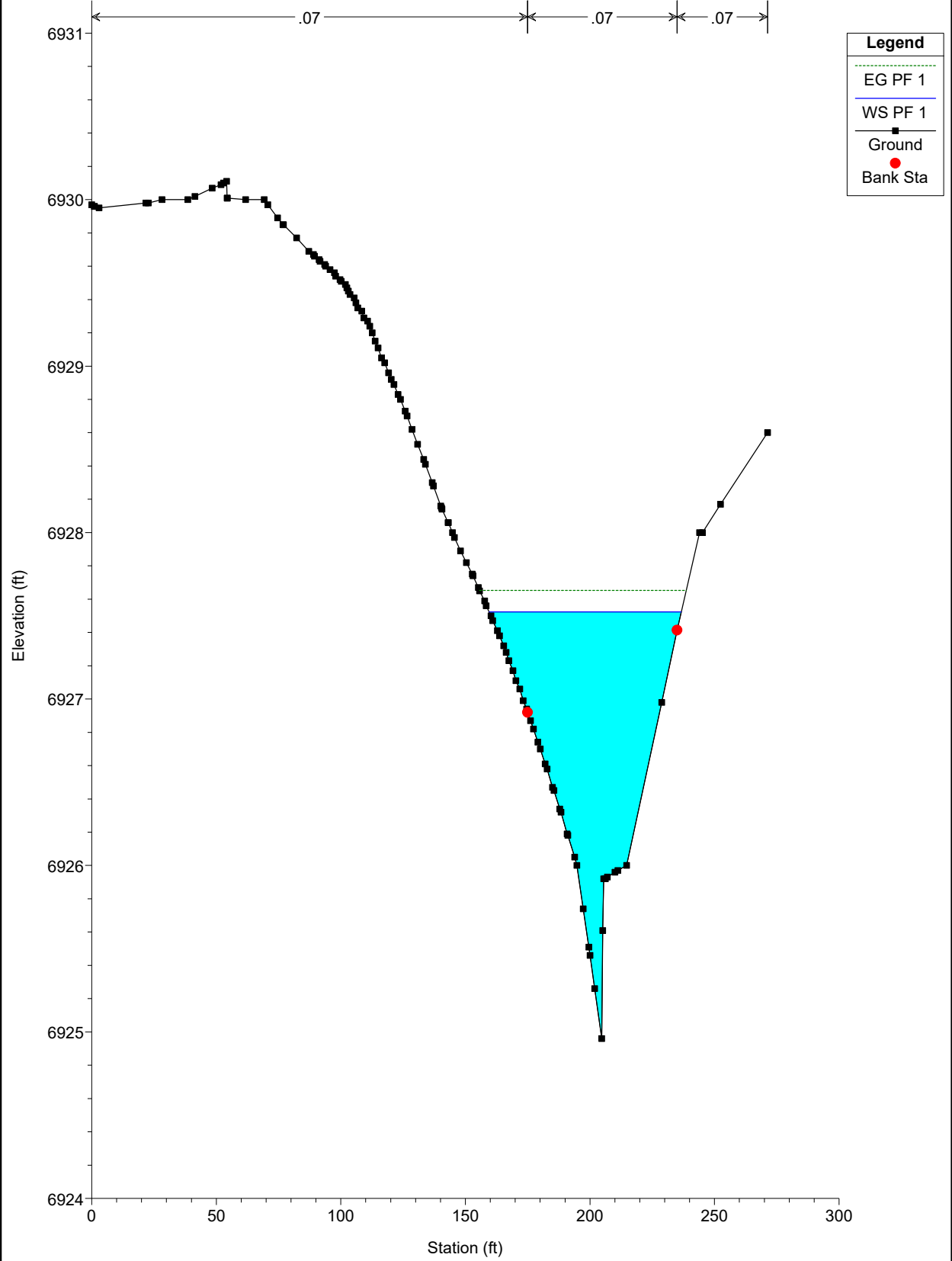

WEST CHAN EX NEW Plan: Plan 02 11/22/2022
River = WEST CHAN EX NEW Reach = chan-west-pr RS = 300

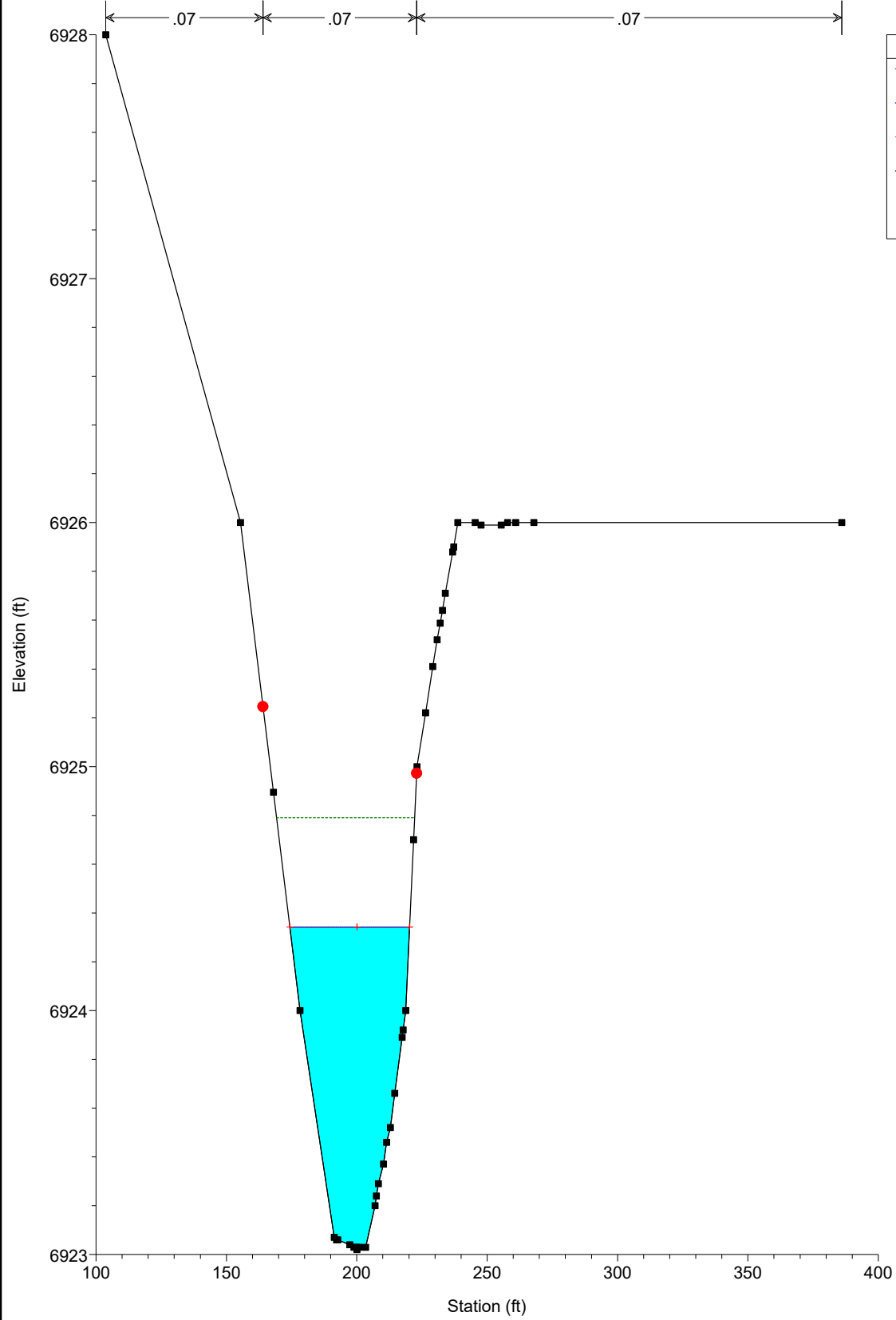

Legend	
EG PF 1	(Green dashed line)
WS PF 1	(Blue solid line)
Crit PF 1	(Red dotted line with cross)
Ground	(Black solid line with square)
Bank Sta	(Red solid circle)

WEST CHAN EX NEW Plan: Plan 02 11/22/2022
River = WEST CHAN EX NEW Reach = chan-west-pr RS = 200

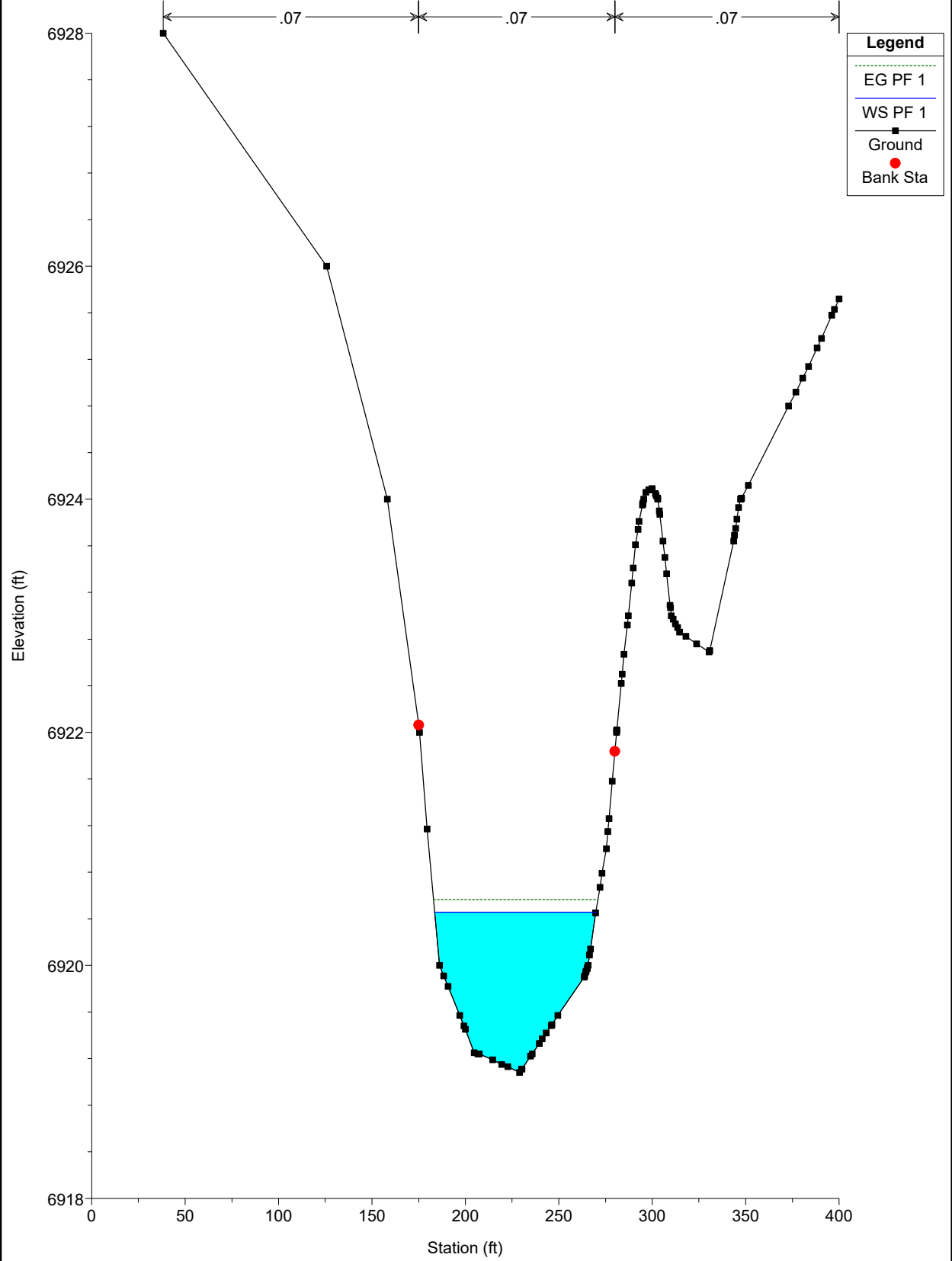

WEST CHAN EX NEW Plan: Plan 02 11/22/2022
River = WEST CHAN EX NEW Reach = chan-west-pr RS = 100

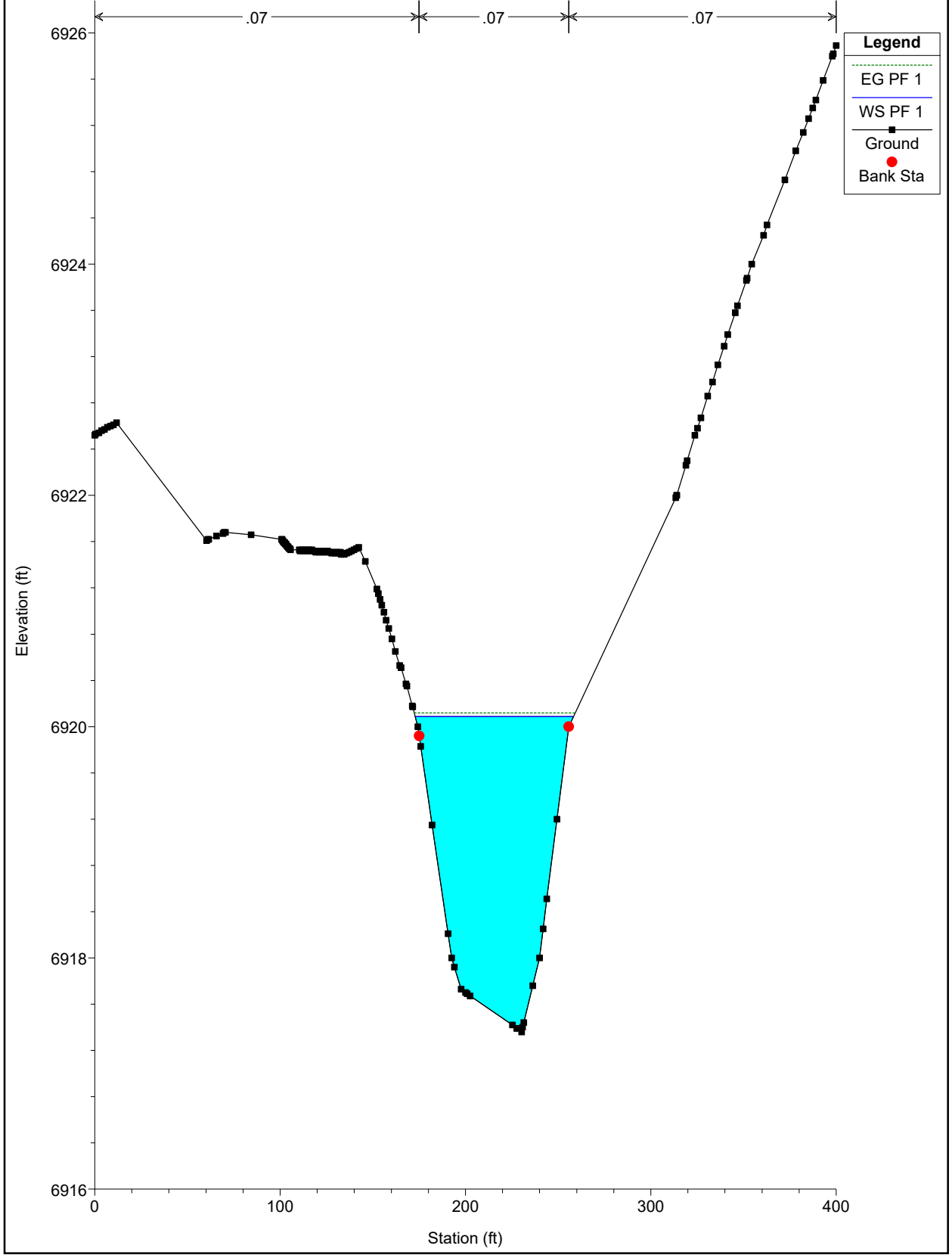

Legend	
EG PF 1	(Dotted line)
WS PF 1	(Blue line)
Ground	(Black square)
Bank Sta	(Red circle)

WEST CHAN EX NEW Plan: Plan 02 11/22/2022
River = WEST CHAN EX NEW Reach = chan-west-pr RS = 0

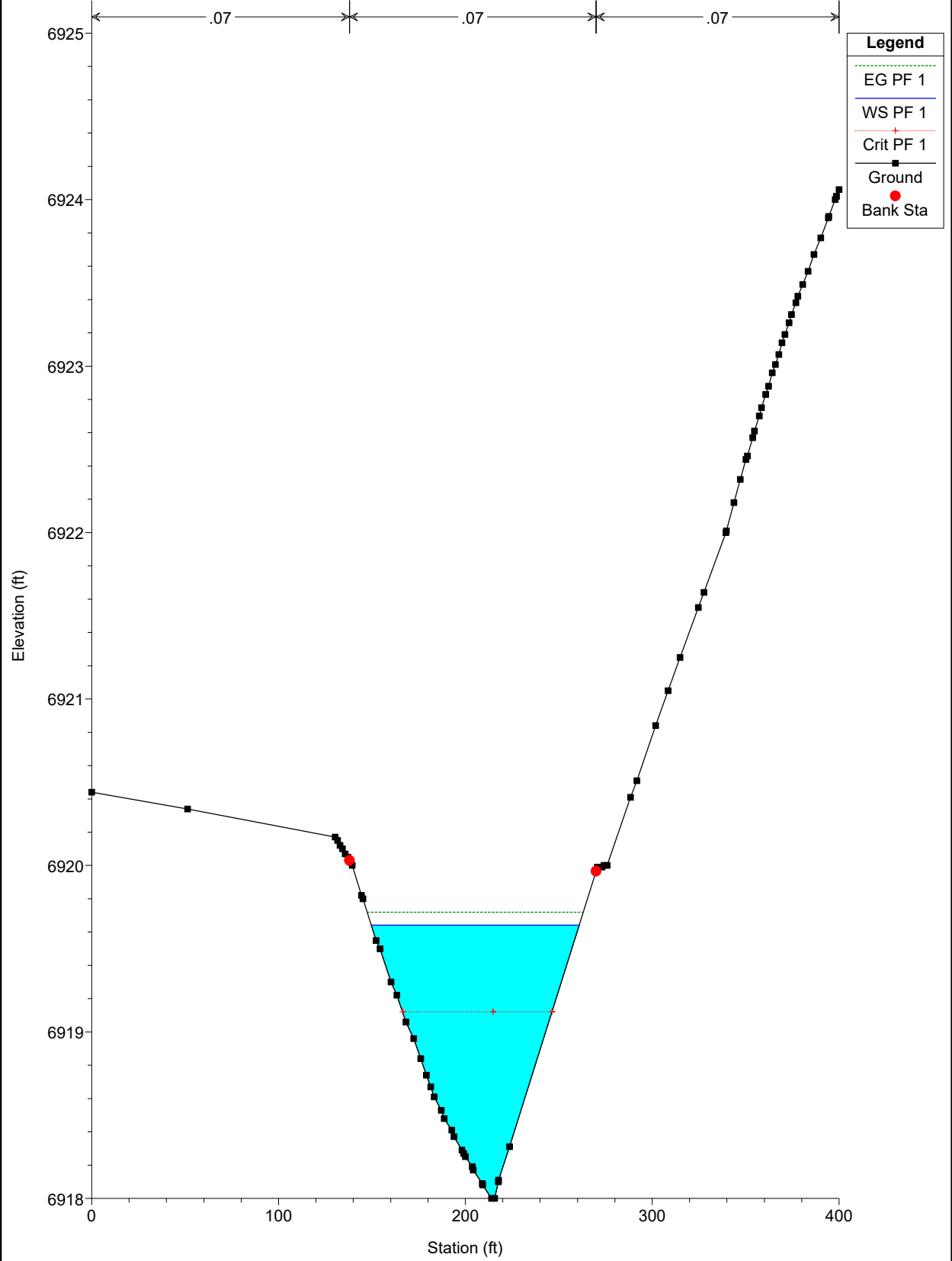

WEST CHANNEL PROPOSED CONDITIONS

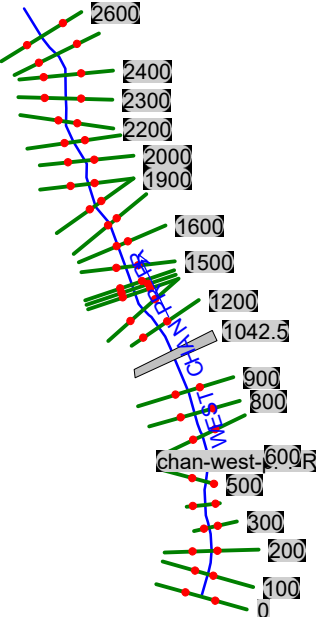

HEC-RAS Plan: PR River: WEST CHAN PR PR Reach: chan-west-pr-PR Profile: PF 1

Reach	River Sta	Profile	Q Total (cfs)	Min Ch El (ft)	W.S. Elev (ft)	Crit W.S. (ft)	E.G. Elev (ft)	E.G. Slope (ft/ft)	Vel Chnl (ft/s)	Flow Area (sq ft)	Top Width (ft)	Froude # Chl
chan-west-pr-PR	2600	PF 1	216.00	6966.83	6967.90		6967.97	0.019637	2.13	101.24	166.66	0.48
chan-west-pr-PR	2500	PF 1	216.00	6964.90	6965.87		6965.96	0.020519	2.29	94.20	143.85	0.50
chan-west-pr-PR	2400	PF 1	216.00	6963.25	6964.36		6964.41	0.011893	1.89	114.26	157.09	0.39
chan-west-pr-PR	2300	PF 1	216.00	6961.27	6962.44		6962.55	0.033352	2.67	80.77	140.86	0.62
chan-west-pr-PR	2200	PF 1	216.00	6958.46	6959.84		6959.96	0.020704	2.82	83.08	128.60	0.53
chan-west-pr-PR	2100	PF 1	216.00	6955.98	6957.72		6957.86	0.021346	2.93	73.61	79.89	0.54
chan-west-pr-PR	2000	PF 1	216.00	6954.57	6956.33		6956.41	0.010386	2.17	99.43	98.73	0.38
chan-west-pr-PR	1900	PF 1	216.00	6952.76	6954.62	6954.40	6954.76	0.029802	2.94	73.62	103.72	0.61
chan-west-pr-PR	1800	PF 1	216.00	6949.31	6951.93		6952.11	0.023436	3.40	63.64	61.03	0.58
chan-west-pr-PR	1700	PF 1	216.00	6947.11	6949.76		6949.96	0.019687	3.58	60.34	45.25	0.55
chan-west-pr-PR	1600	PF 1	216.00	6945.84	6948.25		6948.39	0.012697	2.99	73.63	63.87	0.45
chan-west-pr-PR	1500	PF 1	216.00	6944.91	6947.20		6947.28	0.009609	2.17	99.60	97.23	0.37
chan-west-pr-PR	1420.03	PF 1	216.00	6944.06	6945.20	6945.20	6945.52	0.087553	4.54	47.55	77.24	1.02
chan-west-pr-PR	1400	PF 1	216.00	6942.00	6942.89		6942.97	0.014054	2.29	94.34	108.30	0.43
chan-west-pr-PR	1379.97	PF 1	216.00	6941.43	6942.26		6942.45	0.058666	3.51	61.47	108.72	0.82
chan-west-pr-PR	1300	PF 1	216.00	6939.98	6942.24		6942.25	0.000570	0.82	262.35	126.12	0.10
chan-west-pr-PR	1200	PF 1	216.00	6938.82	6942.20	6939.60	6942.21	0.000285	0.71	306.22	110.15	0.07
chan-west-pr-PR	1042.5		Culvert									
chan-west-pr-PR	900	PF 1	222.00	6934.00	6936.26		6936.33	0.010413	2.14	103.57	104.79	0.38
chan-west-pr-PR	800	PF 1	222.00	6934.00	6935.46		6935.51	0.006641	1.68	132.03	137.92	0.30
chan-west-pr-PR	700	PF 1	222.00	6932.83	6934.09	6933.92	6934.23	0.032794	3.00	77.93	145.79	0.64
chan-west-pr-PR	600	PF 1	222.00	6930.96	6932.31		6932.37	0.011526	2.21	120.32	190.99	0.40
chan-west-pr-PR	500	PF 1	222.00	6928.39	6929.57	6929.57	6929.89	0.084942	4.57	48.57	76.43	1.01
chan-west-pr-PR	400	PF 1	222.00	6924.96	6927.00		6927.10	0.011696	2.57	86.30	72.60	0.42
chan-west-pr-PR	300	PF 1	222.00	6923.02	6924.22	6924.22	6924.63	0.079058	5.13	43.26	54.15	1.01
chan-west-pr-PR	200	PF 1	222.00	6919.08	6920.47		6920.58	0.016461	2.66	83.49	86.46	0.48
chan-west-pr-PR	100	PF 1	222.00	6917.36	6920.10		6920.13	0.001900	1.43	155.59	84.58	0.18
chan-west-pr-PR	0	PF 1	222.00	6918.00	6919.65	6919.14	6919.73	0.012996	2.24	99.29	111.76	0.42

Plan: PR WEST CHAN PR PR chan-west-pr-PR RS: 2600 Profile: PF 1

E.G. Elev (ft)	6967.97	Element	Left OB	Channel	Right OB
Vel Head (ft)	0.07	Wt. n-Val.		0.070	
W.S. Elev (ft)	6967.90	Reach Len. (ft)	100.00	100.00	100.00
Crit W.S. (ft)		Flow Area (sq ft)		101.24	
E.G. Slope (ft/ft)	0.019637	Area (sq ft)		101.24	
Q Total (cfs)	216.00	Flow (cfs)		216.00	
Top Width (ft)	166.66	Top Width (ft)		166.66	
Vel Total (ft/s)	2.13	Avg. Vel. (ft/s)		2.13	
Max Chl Dpth (ft)	1.07	Hydr. Depth (ft)		0.61	
Conv. Total (cfs)	1541.4	Conv. (cfs)		1541.4	
Length Wtd. (ft)	100.00	Wetted Per. (ft)		166.68	
Min Ch El (ft)	6966.83	Shear (lb/sq ft)		0.74	
Alpha	1.00	Stream Power (lb/ft s)		1.59	
Frctn Loss (ft)	2.01	Cum Volume (acre-ft)	0.09	5.41	0.06
C & E Loss (ft)	0.00	Cum SA (acres)	0.32	5.80	0.20

Plan: PR WEST CHAN PR PR chan-west-pr-PR RS: 2500 Profile: PF 1

E.G. Elev (ft)	6965.96	Element	Left OB	Channel	Right OB
Vel Head (ft)	0.08	Wt. n-Val.		0.070	
W.S. Elev (ft)	6965.87	Reach Len. (ft)	126.00	100.00	64.00
Crit W.S. (ft)		Flow Area (sq ft)		94.20	
E.G. Slope (ft/ft)	0.020519	Area (sq ft)		94.20	
Q Total (cfs)	216.00	Flow (cfs)		216.00	
Top Width (ft)	143.85	Top Width (ft)		143.85	
Vel Total (ft/s)	2.29	Avg. Vel. (ft/s)		2.29	
Max Chl Dpth (ft)	0.97	Hydr. Depth (ft)		0.65	
Conv. Total (cfs)	1507.9	Conv. (cfs)		1507.9	
Length Wtd. (ft)	100.00	Wetted Per. (ft)		143.87	
Min Ch El (ft)	6964.90	Shear (lb/sq ft)		0.84	
Alpha	1.00	Stream Power (lb/ft s)		1.92	
Frctn Loss (ft)	1.53	Cum Volume (acre-ft)	0.09	5.18	0.06
C & E Loss (ft)	0.01	Cum SA (acres)	0.32	5.44	0.20

Plan: PR WEST CHAN PR PR chan-west-pr-PR RS: 2400 Profile: PF 1

E.G. Elev (ft)	6964.41	Element	Left OB	Channel	Right OB
Vel Head (ft)	0.06	Wt. n-Val.		0.070	0.070
W.S. Elev (ft)	6964.36	Reach Len. (ft)	110.00	100.00	106.00
Crit W.S. (ft)		Flow Area (sq ft)		114.16	0.11
E.G. Slope (ft/ft)	0.011893	Area (sq ft)		114.16	0.11
Q Total (cfs)	216.00	Flow (cfs)		215.97	0.03
Top Width (ft)	157.09	Top Width (ft)		154.49	2.60
Vel Total (ft/s)	1.89	Avg. Vel. (ft/s)		1.89	0.28
Max Chl Dpth (ft)	1.11	Hydr. Depth (ft)		0.74	0.04
Conv. Total (cfs)	1980.6	Conv. (cfs)		1980.4	0.3
Length Wtd. (ft)	100.00	Wetted Per. (ft)		154.52	2.60
Min Ch El (ft)	6963.25	Shear (lb/sq ft)		0.55	0.03
Alpha	1.00	Stream Power (lb/ft s)		1.04	0.01
Frctn Loss (ft)	1.86	Cum Volume (acre-ft)	0.09	4.94	0.06
C & E Loss (ft)	0.01	Cum SA (acres)	0.32	5.10	0.20

Plan: PR WEST CHAN PR PR chan-west-pr-PR RS: 2300 Profile: PF 1

E.G. Elev (ft)	6962.55	Element	Left OB	Channel	Right OB
Vel Head (ft)	0.11	Wt. n-Val.		0.070	
W.S. Elev (ft)	6962.44	Reach Len. (ft)	105.00	100.00	95.00
Crit W.S. (ft)		Flow Area (sq ft)		80.77	
E.G. Slope (ft/ft)	0.033352	Area (sq ft)		80.77	
Q Total (cfs)	216.00	Flow (cfs)		216.00	
Top Width (ft)	140.86	Top Width (ft)		140.86	
Vel Total (ft/s)	2.67	Avg. Vel. (ft/s)		2.67	
Max Chl Dpth (ft)	1.17	Hydr. Depth (ft)		0.57	
Conv. Total (cfs)	1182.8	Conv. (cfs)		1182.8	
Length Wtd. (ft)	99.93	Wetted Per. (ft)		140.96	
Min Ch El (ft)	6961.27	Shear (lb/sq ft)		1.19	
Alpha	1.00	Stream Power (lb/ft s)		3.19	
Frctn Loss (ft)	2.59	Cum Volume (acre-ft)	0.09	4.72	0.06
C & E Loss (ft)	0.00	Cum SA (acres)	0.32	4.76	0.19

Plan: PR WEST CHAN PR PR chan-west-pr-PR RS: 2200 Profile: PF 1

E.G. Elev (ft)	6959.96	Element	Left OB	Channel	Right OB
Vel Head (ft)	0.12	Wt. n-Val.	0.070	0.070	0.070
W.S. Elev (ft)	6959.84	Reach Len. (ft)	79.00	100.00	99.60
Crit W.S. (ft)		Flow Area (sq ft)	4.44	71.16	7.48
E.G. Slope (ft/ft)	0.020704	Area (sq ft)	4.44	71.16	7.48
Q Total (cfs)	216.00	Flow (cfs)	4.62	200.98	10.40
Top Width (ft)	128.60	Top Width (ft)	22.35	80.00	26.25
Vel Total (ft/s)	2.60	Avg. Vel. (ft/s)	1.04	2.82	1.39
Max Chl Dpth (ft)	1.38	Hydr. Depth (ft)	0.20	0.89	0.28
Conv. Total (cfs)	1501.2	Conv. (cfs)	32.1	1396.8	72.3
Length Wtd. (ft)	99.77	Wetted Per. (ft)	22.35	80.03	26.36
Min Ch El (ft)	6958.46	Shear (lb/sq ft)	0.26	1.15	0.37
Alpha	1.12	Stream Power (lb/ft s)	0.27	3.25	0.51
Frctn Loss (ft)	2.10	Cum Volume (acre-ft)	0.08	4.54	0.05
C & E Loss (ft)	0.00	Cum SA (acres)	0.29	4.51	0.16

Plan: PR WEST CHAN PR PR chan-west-pr-PR RS: 2100 Profile: PF 1

E.G. Elev (ft)	6957.86	Element	Left OB	Channel	Right OB
Vel Head (ft)	0.13	Wt. n-Val.		0.070	
W.S. Elev (ft)	6957.72	Reach Len. (ft)	91.60	100.00	83.00
Crit W.S. (ft)		Flow Area (sq ft)		73.61	
E.G. Slope (ft/ft)	0.021346	Area (sq ft)		73.61	
Q Total (cfs)	216.00	Flow (cfs)		216.00	
Top Width (ft)	79.89	Top Width (ft)		79.89	
Vel Total (ft/s)	2.93	Avg. Vel. (ft/s)		2.93	
Max Chl Dpth (ft)	1.74	Hydr. Depth (ft)		0.92	
Conv. Total (cfs)	1478.4	Conv. (cfs)		1478.4	
Length Wtd. (ft)	100.00	Wetted Per. (ft)		79.97	
Min Ch El (ft)	6955.98	Shear (lb/sq ft)		1.23	
Alpha	1.00	Stream Power (lb/ft s)		3.60	
Frctn Loss (ft)	1.44	Cum Volume (acre-ft)	0.08	4.38	0.04
C & E Loss (ft)	0.02	Cum SA (acres)	0.27	4.32	0.13

Plan: PR WEST CHAN PR PR chan-west-pr-PR RS: 2000 Profile: PF 1

E.G. Elev (ft)	6956.41	Element	Left OB	Channel	Right OB
Vel Head (ft)	0.07	Wt. n-Val.		0.070	
W.S. Elev (ft)	6956.33	Reach Len. (ft)	99.00	100.00	100.50
Crit W.S. (ft)		Flow Area (sq ft)		99.43	
E.G. Slope (ft/ft)	0.010386	Area (sq ft)		99.43	
Q Total (cfs)	216.00	Flow (cfs)		216.00	
Top Width (ft)	98.73	Top Width (ft)		98.73	
Vel Total (ft/s)	2.17	Avg. Vel. (ft/s)		2.17	
Max Chl Dpth (ft)	1.76	Hydr. Depth (ft)		1.01	
Conv. Total (cfs)	2119.5	Conv. (cfs)		2119.5	
Length Wtd. (ft)	100.00	Wetted Per. (ft)		98.81	
Min Ch El (ft)	6954.57	Shear (lb/sq ft)		0.65	
Alpha	1.00	Stream Power (lb/ft s)		1.42	
Frctn Loss (ft)	1.64	Cum Volume (acre-ft)	0.08	4.18	0.04
C & E Loss (ft)	0.01	Cum SA (acres)	0.27	4.12	0.13

Plan: PR WEST CHAN PR PR chan-west-pr-PR RS: 1900 Profile: PF 1

E.G. Elev (ft)	6954.76	Element	Left OB	Channel	Right OB
Vel Head (ft)	0.13	Wt. n-Val.	0.070	0.070	
W.S. Elev (ft)	6954.62	Reach Len. (ft)	82.00	100.00	268.00
Crit W.S. (ft)	6954.40	Flow Area (sq ft)	0.03	73.58	
E.G. Slope (ft/ft)	0.029802	Area (sq ft)	0.03	73.58	
Q Total (cfs)	216.00	Flow (cfs)	0.01	215.99	
Top Width (ft)	103.72	Top Width (ft)	1.24	102.49	
Vel Total (ft/s)	2.93	Avg. Vel. (ft/s)	0.33	2.94	
Max Chl Dpth (ft)	1.86	Hydr. Depth (ft)	0.03	0.72	
Conv. Total (cfs)	1251.2	Conv. (cfs)	0.1	1251.1	
Length Wtd. (ft)	100.00	Wetted Per. (ft)	1.24	102.64	
Min Ch El (ft)	6952.76	Shear (lb/sq ft)	0.05	1.33	
Alpha	1.00	Stream Power (lb/ft s)	0.02	3.92	
Frctn Loss (ft)	2.63	Cum Volume (acre-ft)	0.08	3.98	0.04
C & E Loss (ft)	0.00	Cum SA (acres)	0.27	3.89	0.13

Plan: PR WEST CHAN PR PR chan-west-pr-PR RS: 1800 Profile: PF 1

E.G. Elev (ft)	6952.11	Element	Left OB	Channel	Right OB
Vel Head (ft)	0.18	Wt. n-Val.	0.070	0.070	
W.S. Elev (ft)	6951.93	Reach Len. (ft)	98.00	100.00	103.00
Crit W.S. (ft)		Flow Area (sq ft)	0.10	63.54	
E.G. Slope (ft/ft)	0.023436	Area (sq ft)	0.10	63.54	
Q Total (cfs)	216.00	Flow (cfs)	0.04	215.96	
Top Width (ft)	61.03	Top Width (ft)	2.05	58.97	
Vel Total (ft/s)	3.39	Avg. Vel. (ft/s)	0.43	3.40	
Max Chl Dpth (ft)	2.62	Hydr. Depth (ft)	0.05	1.08	
Conv. Total (cfs)	1410.9	Conv. (cfs)	0.3	1410.7	
Length Wtd. (ft)	100.00	Wetted Per. (ft)	2.06	59.41	
Min Ch El (ft)	6949.31	Shear (lb/sq ft)	0.07	1.56	
Alpha	1.00	Stream Power (lb/ft s)	0.03	5.32	
Frctn Loss (ft)	2.14	Cum Volume (acre-ft)	0.08	3.82	0.04
C & E Loss (ft)	0.00	Cum SA (acres)	0.27	3.70	0.13

Plan: PR WEST CHAN PR PR chan-west-pr-PR RS: 1700 Profile: PF 1

E.G. Elev (ft)	6949.96	Element	Left OB	Channel	Right OB
Vel Head (ft)	0.20	Wt. n-Val.		0.070	
W.S. Elev (ft)	6949.76	Reach Len. (ft)	109.00	100.00	96.00
Crit W.S. (ft)		Flow Area (sq ft)		60.34	
E.G. Slope (ft/ft)	0.019687	Area (sq ft)		60.34	
Q Total (cfs)	216.00	Flow (cfs)		216.00	
Top Width (ft)	45.25	Top Width (ft)		45.25	
Vel Total (ft/s)	3.58	Avg. Vel. (ft/s)		3.58	
Max Chl Dpth (ft)	2.65	Hydr. Depth (ft)		1.33	
Conv. Total (cfs)	1539.5	Conv. (cfs)		1539.5	
Length Wtd. (ft)	100.01	Wetted Per. (ft)		45.80	
Min Ch El (ft)	6947.11	Shear (lb/sq ft)		1.62	
Alpha	1.00	Stream Power (lb/ft s)		5.80	
Frctn Loss (ft)	1.56	Cum Volume (acre-ft)	0.08	3.68	0.04
C & E Loss (ft)	0.02	Cum SA (acres)	0.27	3.58	0.13

Plan: PR WEST CHAN PR PR chan-west-pr-PR RS: 1600 Profile: PF 1

E.G. Elev (ft)	6948.39	Element	Left OB	Channel	Right OB
Vel Head (ft)	0.14	Wt. n-Val.	0.070	0.070	0.070
W.S. Elev (ft)	6948.25	Reach Len. (ft)	11.00	100.00	93.00
Crit W.S. (ft)		Flow Area (sq ft)	0.80	71.71	1.12
E.G. Slope (ft/ft)	0.012697	Area (sq ft)	0.80	71.71	1.12
Q Total (cfs)	216.00	Flow (cfs)	0.60	214.69	0.70
Top Width (ft)	63.87	Top Width (ft)	4.44	51.00	8.44
Vel Total (ft/s)	2.93	Avg. Vel. (ft/s)	0.76	2.99	0.62
Max Chl Dpth (ft)	2.41	Hydr. Depth (ft)	0.18	1.41	0.13
Conv. Total (cfs)	1916.9	Conv. (cfs)	5.4	1905.3	6.2
Length Wtd. (ft)	99.86	Wetted Per. (ft)	4.46	51.21	8.44
Min Ch El (ft)	6945.84	Shear (lb/sq ft)	0.14	1.11	0.11
Alpha	1.04	Stream Power (lb/ft s)	0.11	3.32	0.07
Frctn Loss (ft)	1.10	Cum Volume (acre-ft)	0.08	3.53	0.04
C & E Loss (ft)	0.02	Cum SA (acres)	0.26	3.47	0.13

Plan: PR WEST CHAN PR PR chan-west-pr-PR RS: 1500 Profile: PF 1

E.G. Elev (ft)	6947.28	Element	Left OB	Channel	Right OB
Vel Head (ft)	0.07	Wt. n-Val.	0.070	0.070	0.070
W.S. Elev (ft)	6947.20	Reach Len. (ft)	69.00	79.97	89.00
Crit W.S. (ft)		Flow Area (sq ft)	0.05	99.39	0.15
E.G. Slope (ft/ft)	0.009609	Area (sq ft)	0.05	99.39	0.15
Q Total (cfs)	216.00	Flow (cfs)	0.01	215.94	0.05
Top Width (ft)	97.23	Top Width (ft)	1.43	93.00	2.80
Vel Total (ft/s)	2.17	Avg. Vel. (ft/s)	0.24	2.17	0.30
Max Chl Dpth (ft)	2.29	Hydr. Depth (ft)	0.04	1.07	0.05
Conv. Total (cfs)	2203.5	Conv. (cfs)	0.1	2202.9	0.5
Length Wtd. (ft)	79.97	Wetted Per. (ft)	1.43	93.16	2.81
Min Ch El (ft)	6944.91	Shear (lb/sq ft)	0.02	0.64	0.03
Alpha	1.00	Stream Power (lb/ft s)	0.01	1.39	0.01
Frctn Loss (ft)	1.73	Cum Volume (acre-ft)	0.08	3.33	0.04
C & E Loss (ft)	0.02	Cum SA (acres)	0.26	3.31	0.11

Plan: PR WEST CHAN PR PR chan-west-pr-PR RS: 1420.03 Profile: PF 1

E.G. Elev (ft)	6945.52	Element	Left OB	Channel	Right OB
Vel Head (ft)	0.32	Wt. n-Val.		0.070	
W.S. Elev (ft)	6945.20	Reach Len. (ft)	29.00	20.03	20.00
Crit W.S. (ft)	6945.20	Flow Area (sq ft)		47.55	
E.G. Slope (ft/ft)	0.087553	Area (sq ft)		47.55	
Q Total (cfs)	216.00	Flow (cfs)		216.00	
Top Width (ft)	77.24	Top Width (ft)		77.24	
Vel Total (ft/s)	4.54	Avg. Vel. (ft/s)		4.54	
Max Chl Dpth (ft)	1.14	Hydr. Depth (ft)		0.62	
Conv. Total (cfs)	730.0	Conv. (cfs)		730.0	
Length Wtd. (ft)	20.03	Wetted Per. (ft)		77.29	
Min Ch El (ft)	6944.06	Shear (lb/sq ft)		3.36	
Alpha	1.00	Stream Power (lb/ft s)		15.28	
Frctn Loss (ft)	0.57	Cum Volume (acre-ft)	0.08	3.20	0.04
C & E Loss (ft)	0.07	Cum SA (acres)	0.26	3.15	0.11

Plan: PR WEST CHAN PR PR chan-west-pr-PR RS: 1400 Profile: PF 1

E.G. Elev (ft)	6942.97	Element	Left OB	Channel	Right OB
Vel Head (ft)	0.08	Wt. n-Val.		0.070	
W.S. Elev (ft)	6942.89	Reach Len. (ft)	20.00	20.03	20.03
Crit W.S. (ft)		Flow Area (sq ft)		94.34	
E.G. Slope (ft/ft)	0.014054	Area (sq ft)		94.34	
Q Total (cfs)	216.00	Flow (cfs)		216.00	
Top Width (ft)	108.30	Top Width (ft)		108.30	
Vel Total (ft/s)	2.29	Avg. Vel. (ft/s)		2.29	
Max Chl Dpth (ft)	0.89	Hydr. Depth (ft)		0.87	
Conv. Total (cfs)	1822.0	Conv. (cfs)		1822.0	
Length Wtd. (ft)	20.03	Wetted Per. (ft)		108.72	
Min Ch El (ft)	6942.00	Shear (lb/sq ft)		0.76	
Alpha	1.00	Stream Power (lb/ft s)		1.74	
Frctn Loss (ft)	0.51	Cum Volume (acre-ft)	0.08	3.17	0.04
C & E Loss (ft)	0.01	Cum SA (acres)	0.26	3.11	0.11

Plan: PR WEST CHAN PR PR chan-west-pr-PR RS: 1379.97 Profile: PF 1

E.G. Elev (ft)	6942.45	Element	Left OB	Channel	Right OB
Vel Head (ft)	0.19	Wt. n-Val.		0.070	
W.S. Elev (ft)	6942.26	Reach Len. (ft)	51.00	79.97	105.00
Crit W.S. (ft)		Flow Area (sq ft)		61.47	
E.G. Slope (ft/ft)	0.058666	Area (sq ft)		61.47	
Q Total (cfs)	216.00	Flow (cfs)		216.00	
Top Width (ft)	108.72	Top Width (ft)		108.72	
Vel Total (ft/s)	3.51	Avg. Vel. (ft/s)		3.51	
Max Chl Dpth (ft)	0.83	Hydr. Depth (ft)		0.57	
Conv. Total (cfs)	891.8	Conv. (cfs)		891.8	
Length Wtd. (ft)	79.97	Wetted Per. (ft)		108.80	
Min Ch El (ft)	6941.43	Shear (lb/sq ft)		2.07	
Alpha	1.00	Stream Power (lb/ft s)		7.27	
Frctn Loss (ft)	0.15	Cum Volume (acre-ft)	0.08	3.13	0.04
C & E Loss (ft)	0.05	Cum SA (acres)	0.26	3.06	0.11

Plan: PR WEST CHAN PR PR chan-west-pr-PR RS: 1300 Profile: PF 1

E.G. Elev (ft)	6942.25	Element	Left OB	Channel	Right OB
Vel Head (ft)	0.01	Wt. n-Val.		0.070	
W.S. Elev (ft)	6942.24	Reach Len. (ft)	107.00	100.00	89.00
Crit W.S. (ft)		Flow Area (sq ft)		262.35	
E.G. Slope (ft/ft)	0.000570	Area (sq ft)		262.35	
Q Total (cfs)	216.00	Flow (cfs)		216.00	
Top Width (ft)	126.12	Top Width (ft)		126.12	
Vel Total (ft/s)	0.82	Avg. Vel. (ft/s)		0.82	
Max Chl Dpth (ft)	2.26	Hydr. Depth (ft)		2.08	
Conv. Total (cfs)	9049.4	Conv. (cfs)		9049.4	
Length Wtd. (ft)	100.00	Wetted Per. (ft)		126.66	
Min Ch El (ft)	6939.98	Shear (lb/sq ft)		0.07	
Alpha	1.00	Stream Power (lb/ft s)		0.06	
Frctn Loss (ft)	0.04	Cum Volume (acre-ft)	0.08	2.83	0.04
C & E Loss (ft)	0.00	Cum SA (acres)	0.26	2.84	0.11

Plan: PR WEST CHAN PR PR chan-west-pr-PR RS: 1200 Profile: PF 1

E.G. Elev (ft)	6942.21	Element	Left OB	Channel	Right OB
Vel Head (ft)	0.01	Wt. n-Val.		0.070	
W.S. Elev (ft)	6942.20	Reach Len. (ft)	323.00	300.00	288.00
Crit W.S. (ft)	6939.60	Flow Area (sq ft)		306.22	
E.G. Slope (ft/ft)	0.000285	Area (sq ft)		306.22	
Q Total (cfs)	216.00	Flow (cfs)		216.00	
Top Width (ft)	110.15	Top Width (ft)		110.15	
Vel Total (ft/s)	0.71	Avg. Vel. (ft/s)		0.71	
Max Chl Dpth (ft)	3.38	Hydr. Depth (ft)		2.78	
Conv. Total (cfs)	12804.6	Conv. (cfs)		12804.6	
Length Wtd. (ft)	300.00	Wetted Per. (ft)		110.76	
Min Ch El (ft)	6938.82	Shear (lb/sq ft)		0.05	
Alpha	1.00	Stream Power (lb/ft s)		0.03	
Frctn Loss (ft)		Cum Volume (acre-ft)	0.08	2.18	0.04
C & E Loss (ft)		Cum SA (acres)	0.26	2.57	0.11

Plan: PR WEST CHAN PR PR chan-west-pr-PR RS: 900 Profile: PF 1

E.G. Elev (ft)	6936.33	Element	Left OB	Channel	Right OB
Vel Head (ft)	0.07	Wt. n-Val.		0.070	
W.S. Elev (ft)	6936.26	Reach Len. (ft)	105.00	100.00	99.00
Crit W.S. (ft)		Flow Area (sq ft)		103.57	
E.G. Slope (ft/ft)	0.010413	Area (sq ft)		103.57	
Q Total (cfs)	222.00	Flow (cfs)		222.00	
Top Width (ft)	104.79	Top Width (ft)		104.79	
Vel Total (ft/s)	2.14	Avg. Vel. (ft/s)		2.14	
Max Chl Dpth (ft)	2.26	Hydr. Depth (ft)		0.99	
Conv. Total (cfs)	2175.5	Conv. (cfs)		2175.5	
Length Wtd. (ft)	100.00	Wetted Per. (ft)		105.21	
Min Ch El (ft)	6934.00	Shear (lb/sq ft)		0.64	
Alpha	1.00	Stream Power (lb/ft s)		1.37	
Frctn Loss (ft)	0.82	Cum Volume (acre-ft)	0.08	1.83	0.04
C & E Loss (ft)	0.01	Cum SA (acres)	0.26	1.83	0.11

Plan: PR WEST CHAN PR PR chan-west-pr-PR RS: 800 Profile: PF 1

E.G. Elev (ft)	6935.51	Element	Left OB	Channel	Right OB
Vel Head (ft)	0.04	Wt. n-Val.	0.070	0.070	
W.S. Elev (ft)	6935.46	Reach Len. (ft)	90.00	100.00	110.00
Crit W.S. (ft)		Flow Area (sq ft)	0.03	132.01	
E.G. Slope (ft/ft)	0.006641	Area (sq ft)	0.03	132.01	
Q Total (cfs)	222.00	Flow (cfs)	0.01	221.99	
Top Width (ft)	137.92	Top Width (ft)	0.41	137.51	
Vel Total (ft/s)	1.68	Avg. Vel. (ft/s)	0.26	1.68	
Max Chl Dpth (ft)	1.46	Hydr. Depth (ft)	0.06	0.96	
Conv. Total (cfs)	2724.1	Conv. (cfs)	0.1	2724.0	
Length Wtd. (ft)	99.87	Wetted Per. (ft)	0.43	137.72	
Min Ch El (ft)	6934.00	Shear (lb/sq ft)	0.02	0.40	
Alpha	1.00	Stream Power (lb/ft s)	0.01	0.67	
Frctn Loss (ft)	1.26	Cum Volume (acre-ft)	0.08	1.56	0.04
C & E Loss (ft)	0.01	Cum SA (acres)	0.26	1.55	0.11

Plan: PR WEST CHAN PR PR chan-west-pr-PR RS: 700 Profile: PF 1

E.G. Elev (ft)	6934.23	Element	Left OB	Channel	Right OB
Vel Head (ft)	0.14	Wt. n-Val.	0.070	0.070	0.070
W.S. Elev (ft)	6934.09	Reach Len. (ft)	122.00	100.00	83.00
Crit W.S. (ft)	6933.92	Flow Area (sq ft)	5.69	71.76	0.48
E.G. Slope (ft/ft)	0.032794	Area (sq ft)	5.69	71.76	0.48
Q Total (cfs)	222.00	Flow (cfs)	6.21	215.36	0.44
Top Width (ft)	145.79	Top Width (ft)	37.69	104.00	4.10
Vel Total (ft/s)	2.85	Avg. Vel. (ft/s)	1.09	3.00	0.91
Max Chl Dpth (ft)	1.26	Hydr. Depth (ft)	0.15	0.69	0.12
Conv. Total (cfs)	1225.9	Conv. (cfs)	34.3	1189.2	2.4
Length Wtd. (ft)	100.74	Wetted Per. (ft)	37.71	104.03	4.19
Min Ch El (ft)	6932.83	Shear (lb/sq ft)	0.31	1.41	0.23
Alpha	1.08	Stream Power (lb/ft s)	0.34	4.24	0.21
Frctn Loss (ft)	1.83	Cum Volume (acre-ft)	0.07	1.32	0.04
C & E Loss (ft)	0.02	Cum SA (acres)	0.22	1.28	0.11

Plan: PR WEST CHAN PR PR chan-west-pr-PR RS: 600 Profile: PF 1

E.G. Elev (ft)	6932.37	Element	Left OB	Channel	Right OB
Vel Head (ft)	0.06	Wt. n-Val.	0.070	0.070	0.070
W.S. Elev (ft)	6932.31	Reach Len. (ft)	110.00	100.00	80.00
Crit W.S. (ft)		Flow Area (sq ft)	24.44	74.61	21.27
E.G. Slope (ft/ft)	0.011526	Area (sq ft)	24.44	74.61	21.27
Q Total (cfs)	222.00	Flow (cfs)	29.94	165.05	27.01
Top Width (ft)	190.99	Top Width (ft)	61.98	78.00	51.01
Vel Total (ft/s)	1.85	Avg. Vel. (ft/s)	1.22	2.21	1.27
Max Chl Dpth (ft)	1.35	Hydr. Depth (ft)	0.39	0.96	0.42
Conv. Total (cfs)	2067.8	Conv. (cfs)	278.9	1537.4	251.6
Length Wtd. (ft)	99.46	Wetted Per. (ft)	62.03	78.02	51.11
Min Ch El (ft)	6930.96	Shear (lb/sq ft)	0.28	0.69	0.30
Alpha	1.19	Stream Power (lb/ft s)	0.35	1.52	0.38
Frctn Loss (ft)	2.45	Cum Volume (acre-ft)	0.03	1.16	0.02
C & E Loss (ft)	0.03	Cum SA (acres)	0.08	1.07	0.05

Plan: PR WEST CHAN PR PR chan-west-pr-PR RS: 500 Profile: PF 1

E.G. Elev (ft)	6929.89	Element	Left OB	Channel	Right OB
Vel Head (ft)	0.32	Wt. n-Val.		0.070	
W.S. Elev (ft)	6929.57	Reach Len. (ft)	85.00	100.00	119.00
Crit W.S. (ft)	6929.57	Flow Area (sq ft)		48.57	
E.G. Slope (ft/ft)	0.084942	Area (sq ft)		48.57	
Q Total (cfs)	222.00	Flow (cfs)		222.00	
Top Width (ft)	76.43	Top Width (ft)		76.43	
Vel Total (ft/s)	4.57	Avg. Vel. (ft/s)		4.57	
Max Chl Dpth (ft)	1.18	Hydr. Depth (ft)		0.64	
Conv. Total (cfs)	761.7	Conv. (cfs)		761.7	
Length Wtd. (ft)	100.00	Wetted Per. (ft)		76.48	
Min Ch El (ft)	6928.39	Shear (lb/sq ft)		3.37	
Alpha	1.00	Stream Power (lb/ft s)		15.39	
Frctn Loss (ft)	2.49	Cum Volume (acre-ft)	0.00	1.02	0.00
C & E Loss (ft)	0.07	Cum SA (acres)	0.00	0.89	0.01

Plan: PR WEST CHAN PR PR chan-west-pr-PR RS: 400 Profile: PF 1

E.G. Elev (ft)	6927.10	Element	Left OB	Channel	Right OB
Vel Head (ft)	0.10	Wt. n-Val.		0.070	
W.S. Elev (ft)	6927.00	Reach Len. (ft)	94.00	100.00	108.00
Crit W.S. (ft)		Flow Area (sq ft)		86.30	
E.G. Slope (ft/ft)	0.011696	Area (sq ft)		86.30	
Q Total (cfs)	222.00	Flow (cfs)		222.00	
Top Width (ft)	72.60	Top Width (ft)		72.60	
Vel Total (ft/s)	2.57	Avg. Vel. (ft/s)		2.57	
Max Chl Dpth (ft)	2.04	Hydr. Depth (ft)		1.19	
Conv. Total (cfs)	2052.7	Conv. (cfs)		2052.7	
Length Wtd. (ft)	100.00	Wetted Per. (ft)		72.76	
Min Ch El (ft)	6924.96	Shear (lb/sq ft)		0.87	
Alpha	1.00	Stream Power (lb/ft s)		2.23	
Frctn Loss (ft)	2.44	Cum Volume (acre-ft)	0.00	0.86	0.00
C & E Loss (ft)	0.03	Cum SA (acres)	0.00	0.72	0.01

Plan: PR WEST CHAN PR PR chan-west-pr-PR RS: 300 Profile: PF 1

E.G. Elev (ft)	6924.63	Element	Left OB	Channel	Right OB
Vel Head (ft)	0.41	Wt. n-Val.		0.070	
W.S. Elev (ft)	6924.22	Reach Len. (ft)	106.00	100.00	109.00
Crit W.S. (ft)	6924.22	Flow Area (sq ft)		43.26	
E.G. Slope (ft/ft)	0.079058	Area (sq ft)		43.26	
Q Total (cfs)	222.00	Flow (cfs)		222.00	
Top Width (ft)	54.15	Top Width (ft)		54.15	
Vel Total (ft/s)	5.13	Avg. Vel. (ft/s)		5.13	
Max Chl Dpth (ft)	1.20	Hydr. Depth (ft)		0.80	
Conv. Total (cfs)	789.5	Conv. (cfs)		789.5	
Length Wtd. (ft)	100.00	Wetted Per. (ft)		54.26	
Min Ch El (ft)	6923.02	Shear (lb/sq ft)		3.94	
Alpha	1.00	Stream Power (lb/ft s)		20.19	
Frctn Loss (ft)	3.10	Cum Volume (acre-ft)	0.00	0.71	0.00
C & E Loss (ft)	0.09	Cum SA (acres)	0.00	0.57	0.01

Plan: PR WEST CHAN PR PR chan-west-pr-PR RS: 200 Profile: PF 1

E.G. Elev (ft)	6920.58	Element	Left OB	Channel	Right OB
Vel Head (ft)	0.11	Wt. n-Val.		0.070	
W.S. Elev (ft)	6920.47	Reach Len. (ft)	107.00	100.00	81.00
Crit W.S. (ft)		Flow Area (sq ft)		83.49	
E.G. Slope (ft/ft)	0.016461	Area (sq ft)		83.49	
Q Total (cfs)	222.00	Flow (cfs)		222.00	
Top Width (ft)	86.46	Top Width (ft)		86.46	
Vel Total (ft/s)	2.66	Avg. Vel. (ft/s)		2.66	
Max Chl Dpth (ft)	1.39	Hydr. Depth (ft)		0.97	
Conv. Total (cfs)	1730.3	Conv. (cfs)		1730.3	
Length Wtd. (ft)	100.00	Wetted Per. (ft)		86.55	
Min Ch El (ft)	6919.08	Shear (lb/sq ft)		0.99	
Alpha	1.00	Stream Power (lb/ft s)		2.64	
Frctn Loss (ft)	0.42	Cum Volume (acre-ft)	0.00	0.57	0.00
C & E Loss (ft)	0.02	Cum SA (acres)	0.00	0.41	0.01

Plan: PR WEST CHAN PR PR chan-west-pr-PR RS: 100 Profile: PF 1

E.G. Elev (ft)	6920.13	Element	Left OB	Channel	Right OB
Vel Head (ft)	0.03	Wt. n-Val.	0.070	0.070	0.070
W.S. Elev (ft)	6920.10	Reach Len. (ft)	107.00	100.00	90.60
Crit W.S. (ft)		Flow Area (sq ft)	0.11	155.34	0.14
E.G. Slope (ft/ft)	0.001900	Area (sq ft)	0.11	155.34	0.14
Q Total (cfs)	222.00	Flow (cfs)	0.02	221.96	0.02
Top Width (ft)	84.58	Top Width (ft)	0.99	80.70	2.89
Vel Total (ft/s)	1.43	Avg. Vel. (ft/s)	0.21	1.43	0.12
Max Chl Dpth (ft)	2.74	Hydr. Depth (ft)	0.11	1.92	0.05
Conv. Total (cfs)	5092.4	Conv. (cfs)	0.6	5091.4	0.4
Length Wtd. (ft)	100.00	Wetted Per. (ft)	1.01	80.96	2.89
Min Ch El (ft)	6917.36	Shear (lb/sq ft)	0.01	0.23	0.01
Alpha	1.00	Stream Power (lb/ft s)	0.00	0.33	0.00
Frctn Loss (ft)	0.40	Cum Volume (acre-ft)	0.00	0.29	0.00
C & E Loss (ft)	0.00	Cum SA (acres)	0.00	0.22	0.00

Plan: PR WEST CHAN PR PR chan-west-pr-PR RS: 0 Profile: PF 1

E.G. Elev (ft)	6919.73	Element	Left OB	Channel	Right OB
Vel Head (ft)	0.08	Wt. n-Val.		0.070	
W.S. Elev (ft)	6919.65	Reach Len. (ft)			
Crit W.S. (ft)	6919.14	Flow Area (sq ft)		99.29	
E.G. Slope (ft/ft)	0.012996	Area (sq ft)		99.29	
Q Total (cfs)	222.00	Flow (cfs)		222.00	
Top Width (ft)	111.76	Top Width (ft)		111.76	
Vel Total (ft/s)	2.24	Avg. Vel. (ft/s)		2.24	
Max Chl Dpth (ft)	1.65	Hydr. Depth (ft)		0.89	
Conv. Total (cfs)	1947.4	Conv. (cfs)		1947.4	
Length Wtd. (ft)		Wetted Per. (ft)		111.81	
Min Ch El (ft)	6918.00	Shear (lb/sq ft)		0.72	
Alpha	1.00	Stream Power (lb/ft s)		1.61	
Frctn Loss (ft)		Cum Volume (acre-ft)			
C & E Loss (ft)		Cum SA (acres)			

WEST CHAN PR NEW Plan: PR-PR 11/22/2022
River = WEST CHAN PR PR Reach = chan-west-pr-PR RS = 2600

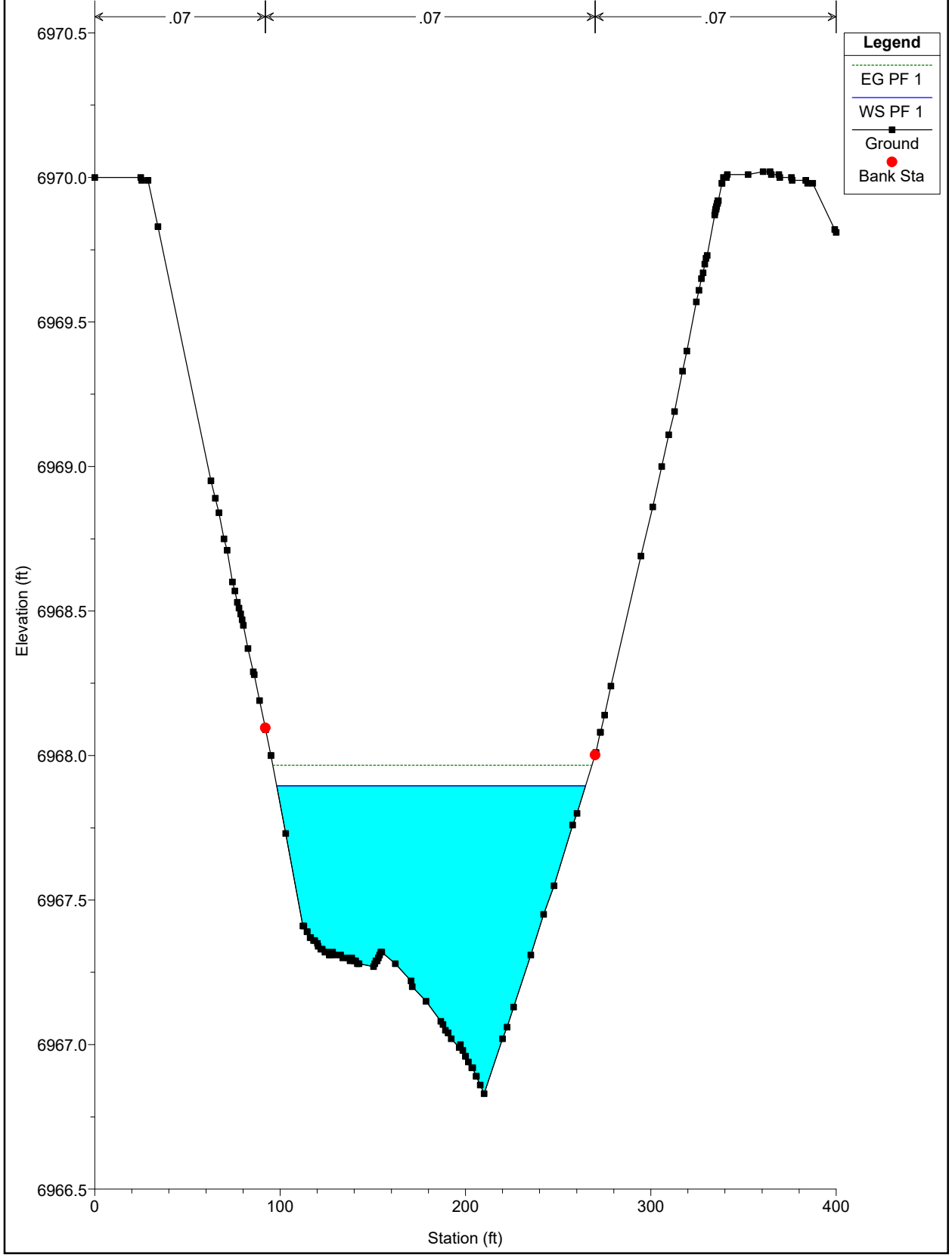

WEST CHAN PR NEW Plan: PR-PR 11/22/2022
River = WEST CHAN PR PR Reach = chan-west-pr-PR RS = 2500

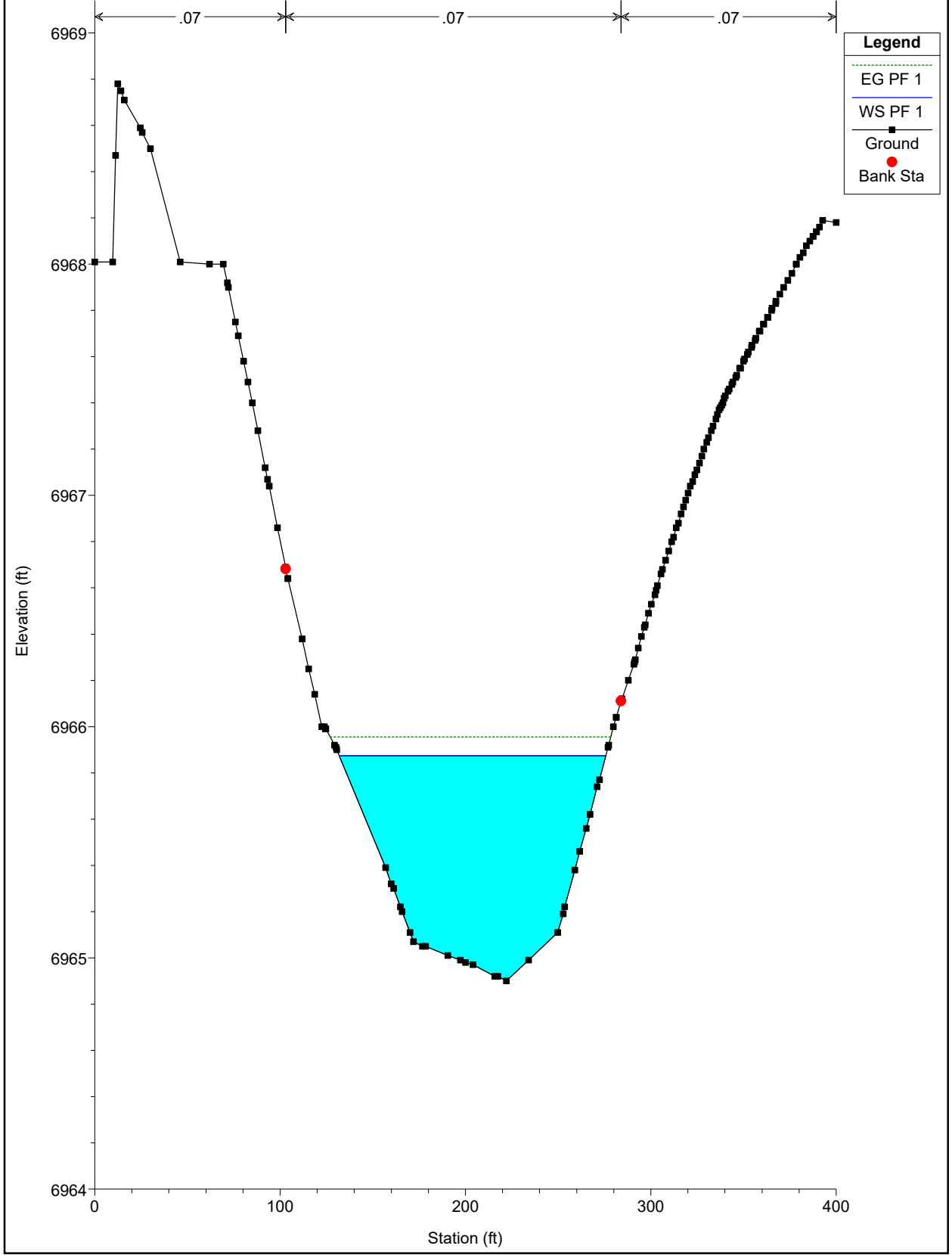

WEST CHAN PR NEW Plan: PR-PR 11/22/2022
River = WEST CHAN PR PR Reach = chan-west-pr-PR RS = 2400

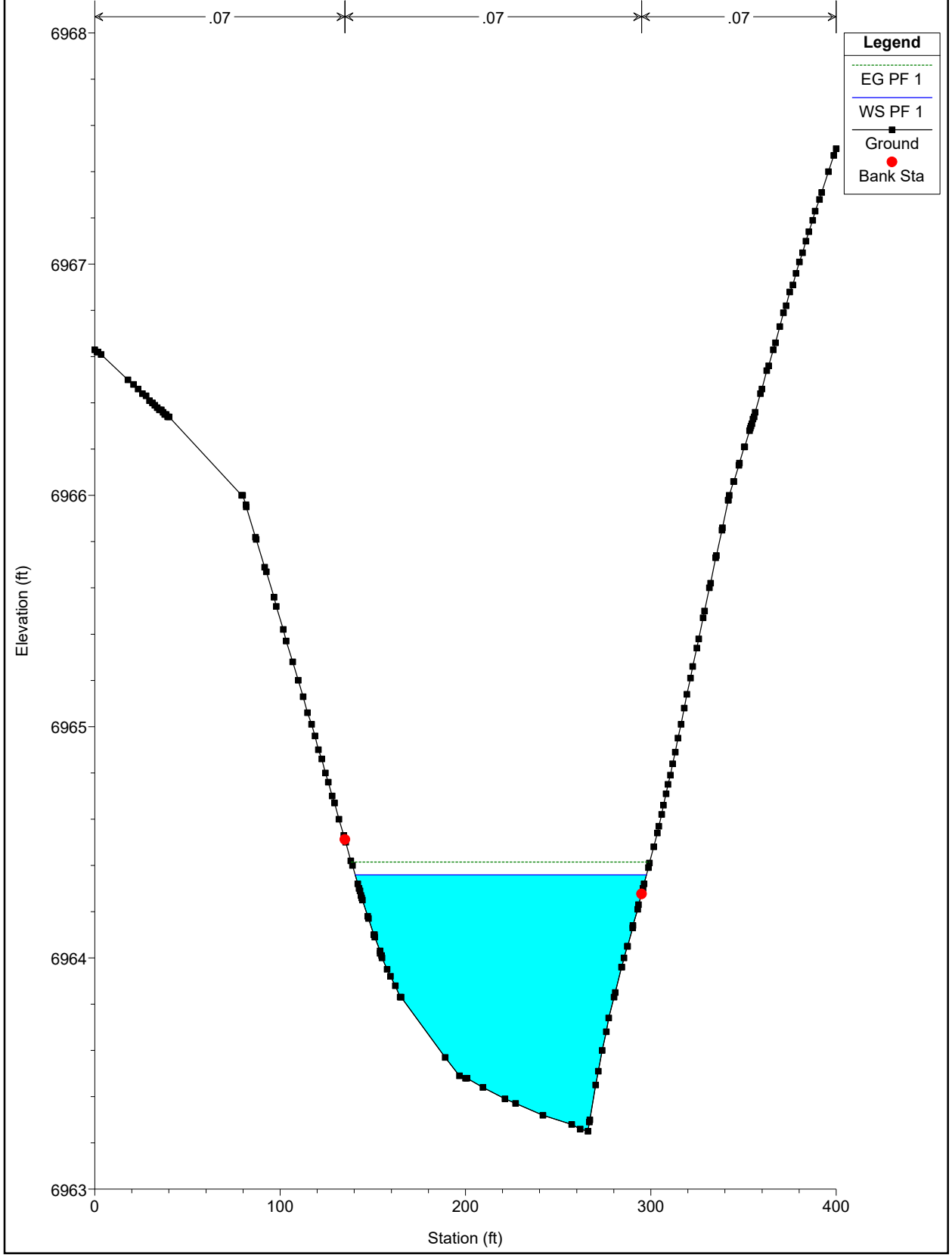

WEST CHAN PR NEW Plan: PR-PR 11/22/2022
River = WEST CHAN PR PR Reach = chan-west-pr-PR RS = 2300

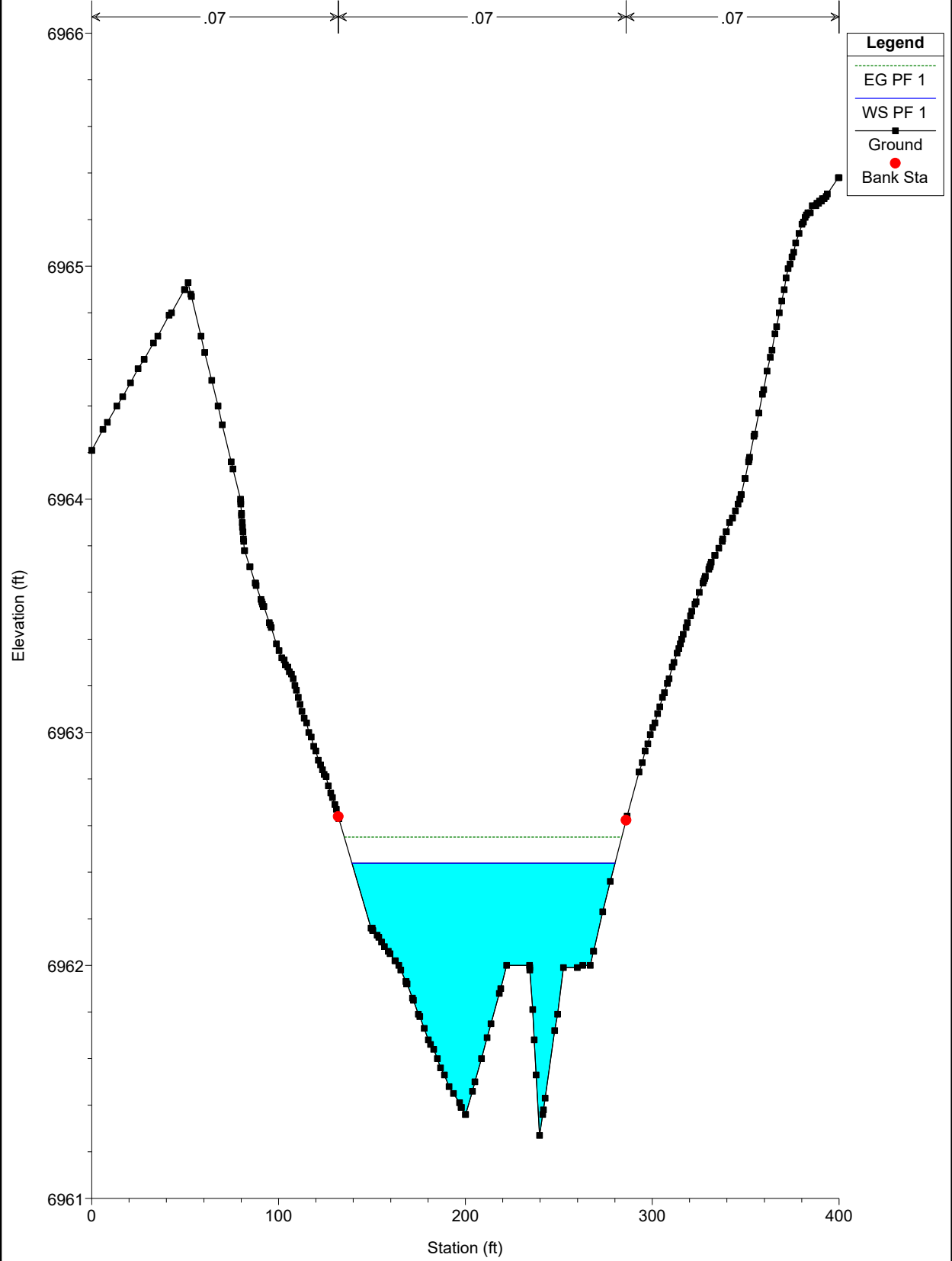

WEST CHAN PR NEW Plan: PR-PR 11/22/2022
River = WEST CHAN PR PR Reach = chan-west-pr-PR RS = 2200

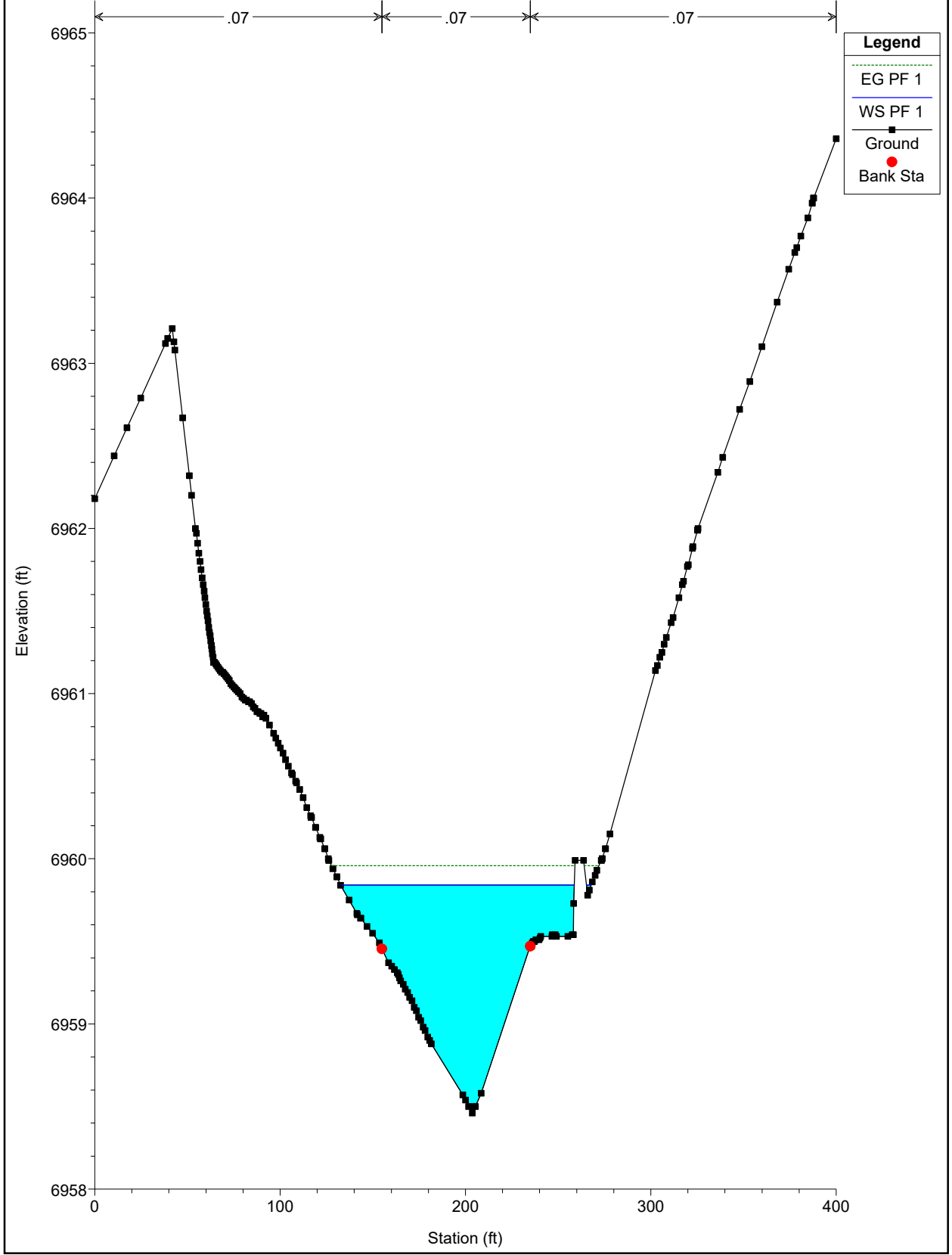

WEST CHAN PR NEW Plan: PR-PR 11/22/2022
River = WEST CHAN PR PR Reach = chan-west-pr-PR RS = 2100

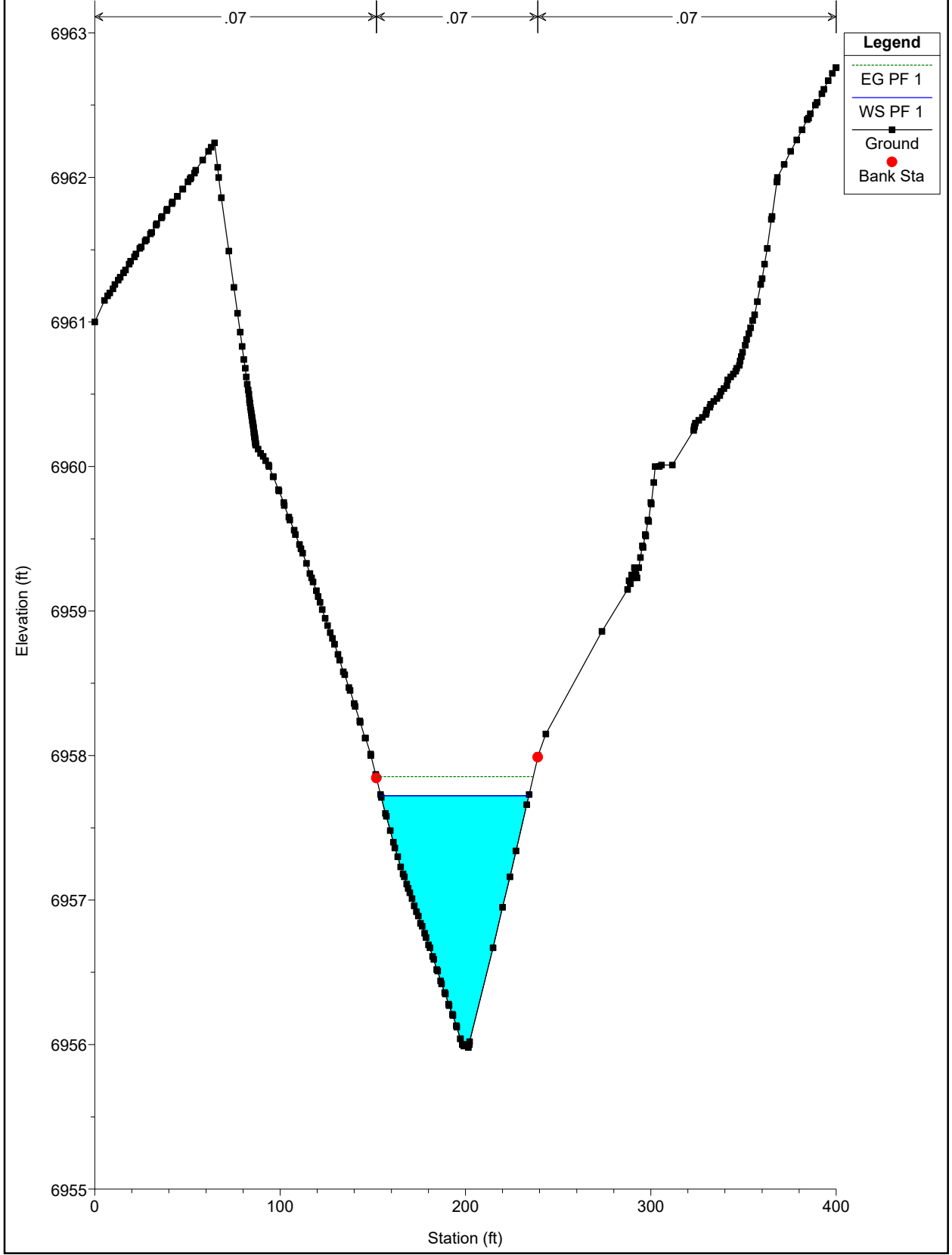

WEST CHAN PR NEW Plan: PR-PR 11/22/2022
River = WEST CHAN PR PR Reach = chan-west-pr-PR RS = 2000

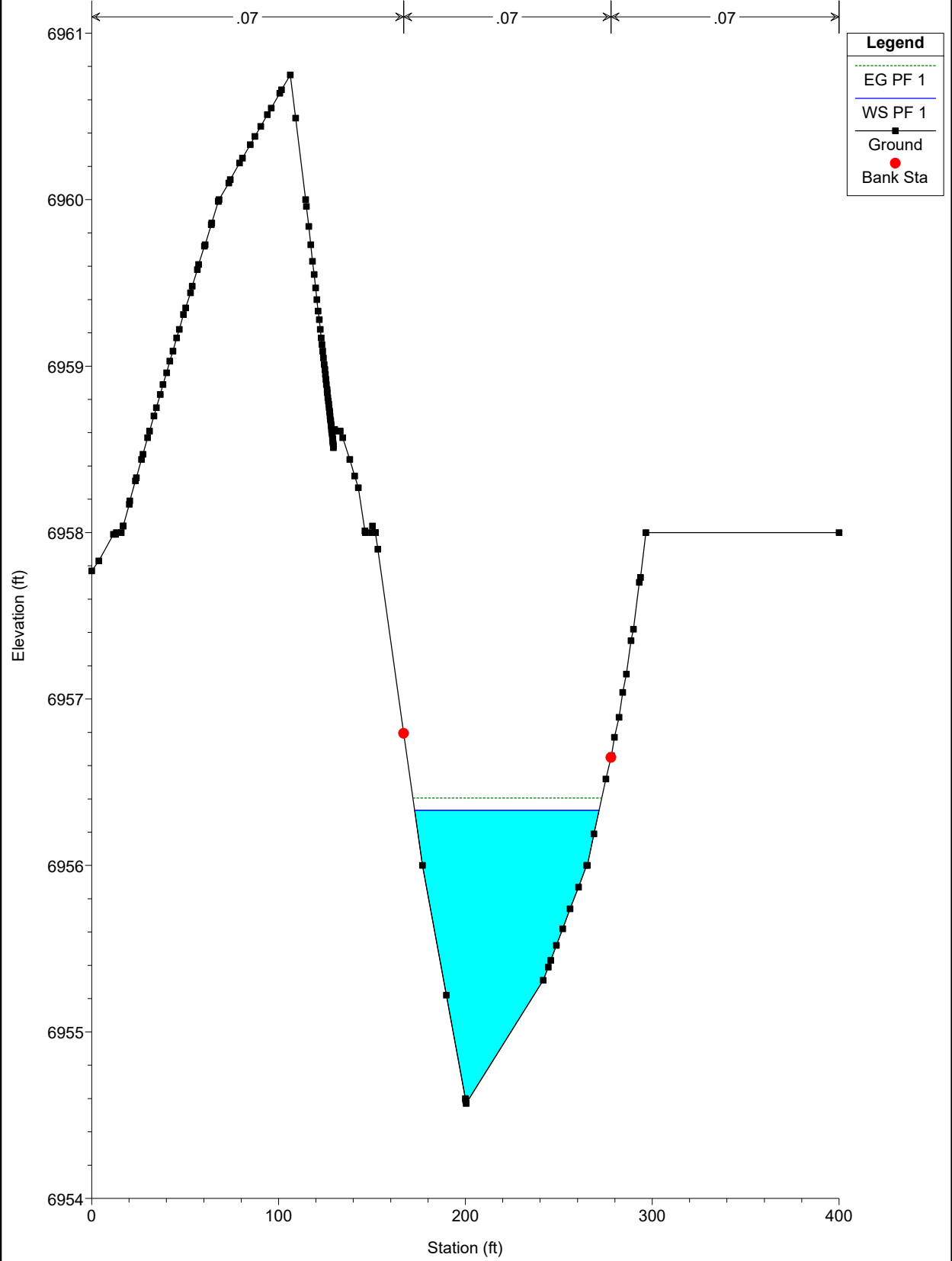

WEST CHAN PR NEW Plan: PR-PR 11/22/2022
River = WEST CHAN PR PR Reach = chan-west-pr-PR RS = 1900

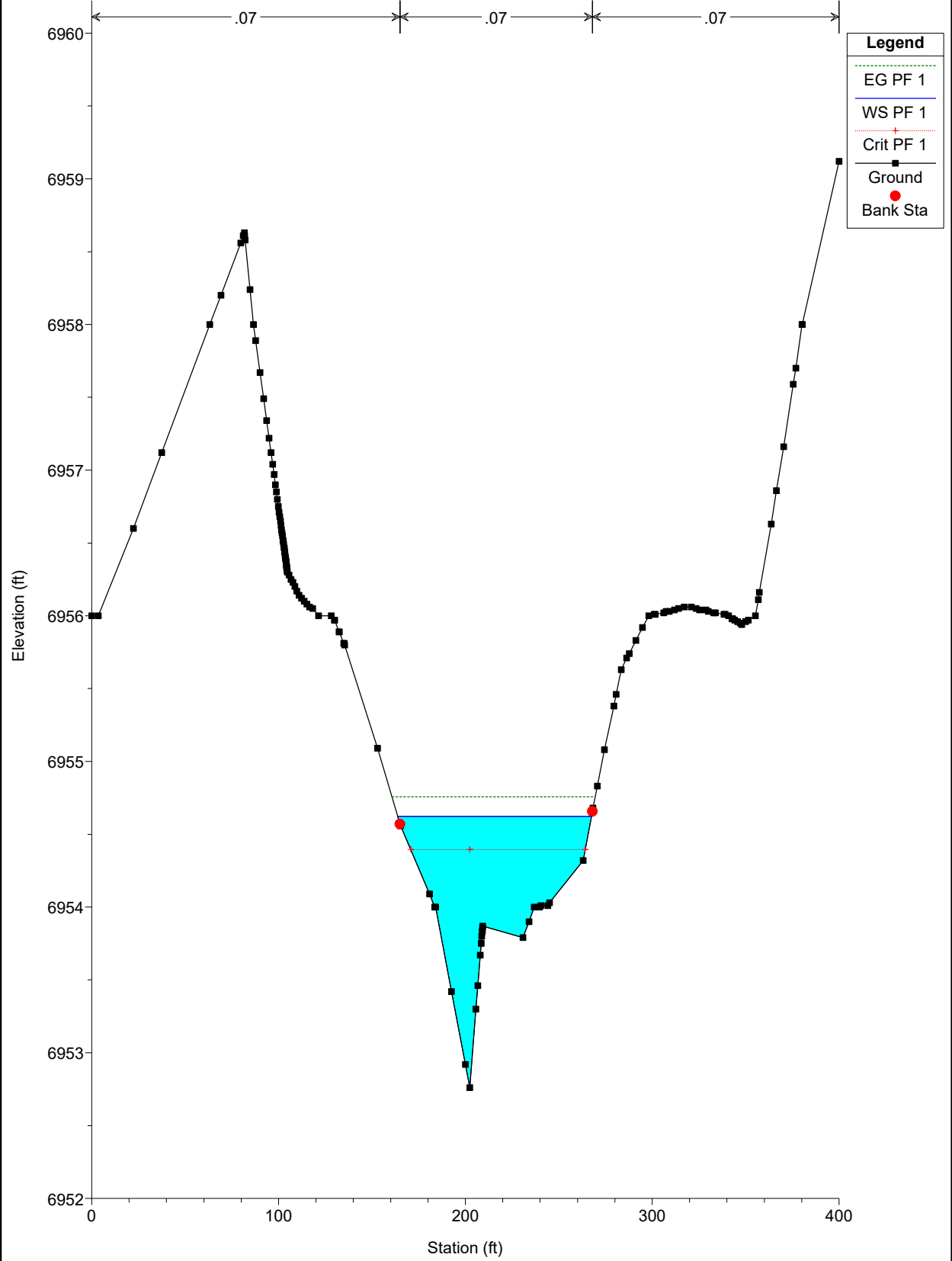

WEST CHAN PR NEW Plan: PR-PR 11/22/2022
River = WEST CHAN PR PR Reach = chan-west-pr-PR RS = 1800

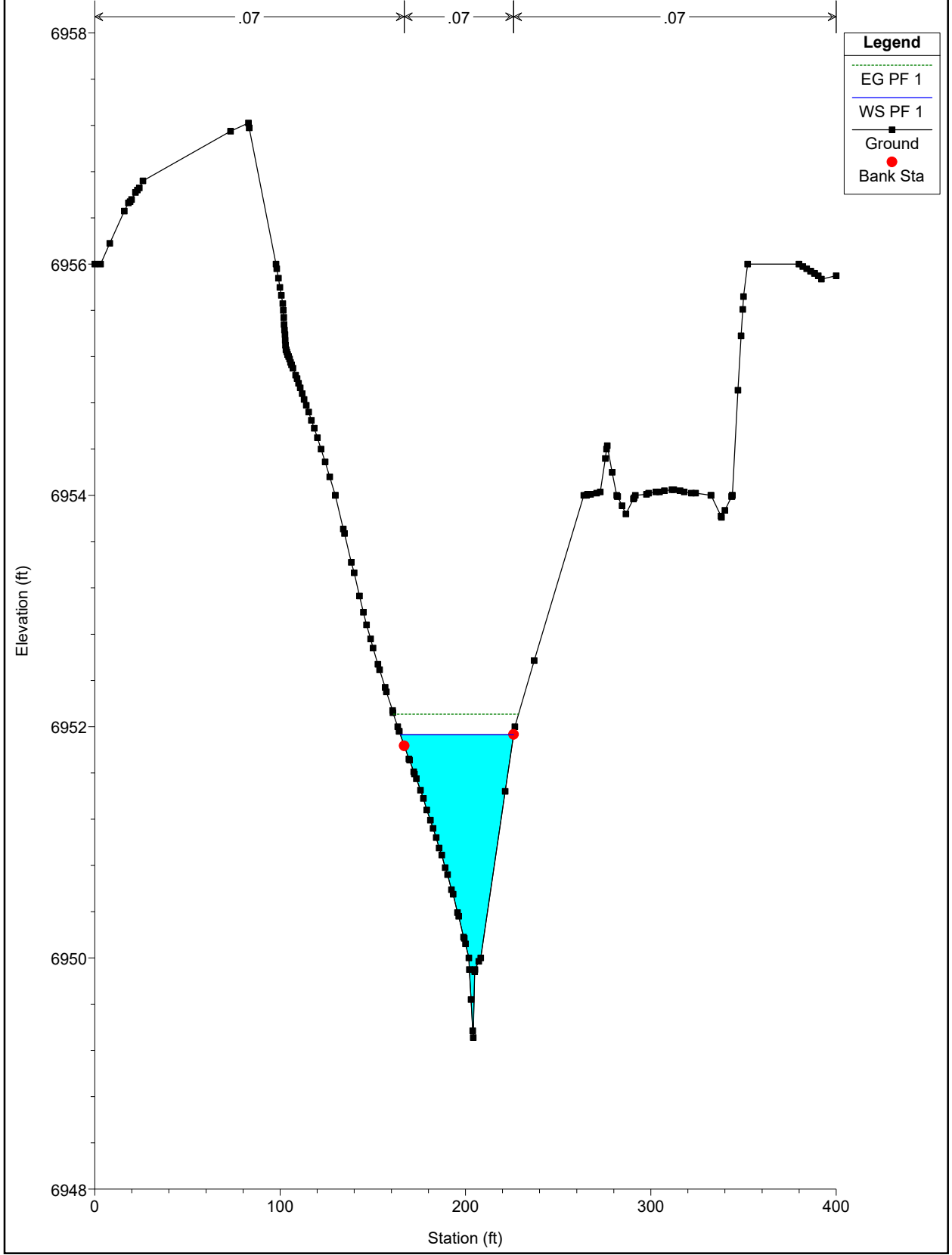

WEST CHAN PR NEW Plan: PR-PR 11/22/2022
River = WEST CHAN PR PR Reach = chan-west-pr-PR RS = 1700

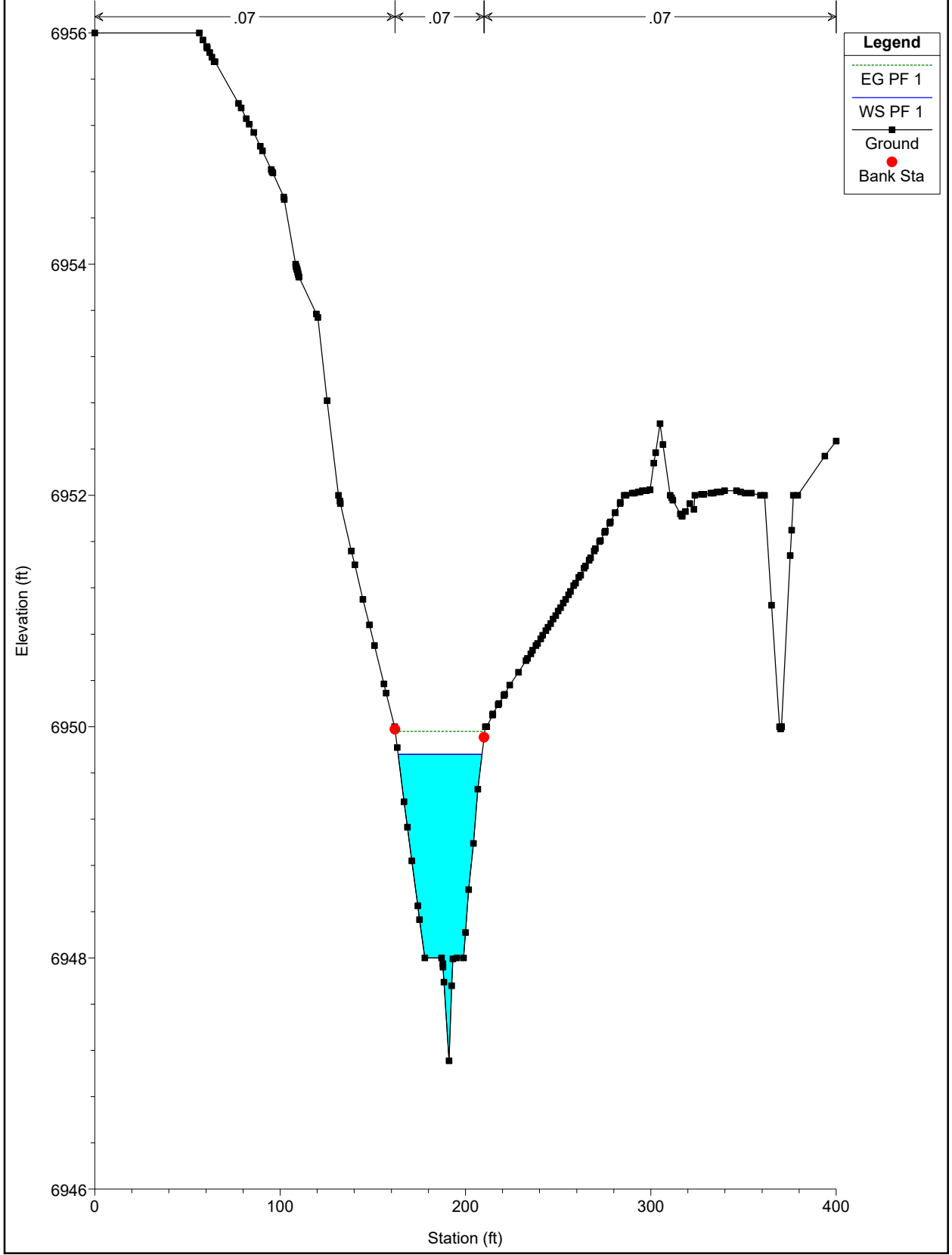

WEST CHAN PR NEW Plan: PR-PR 11/22/2022
River = WEST CHAN PR PR Reach = chan-west-pr-PR RS = 1600

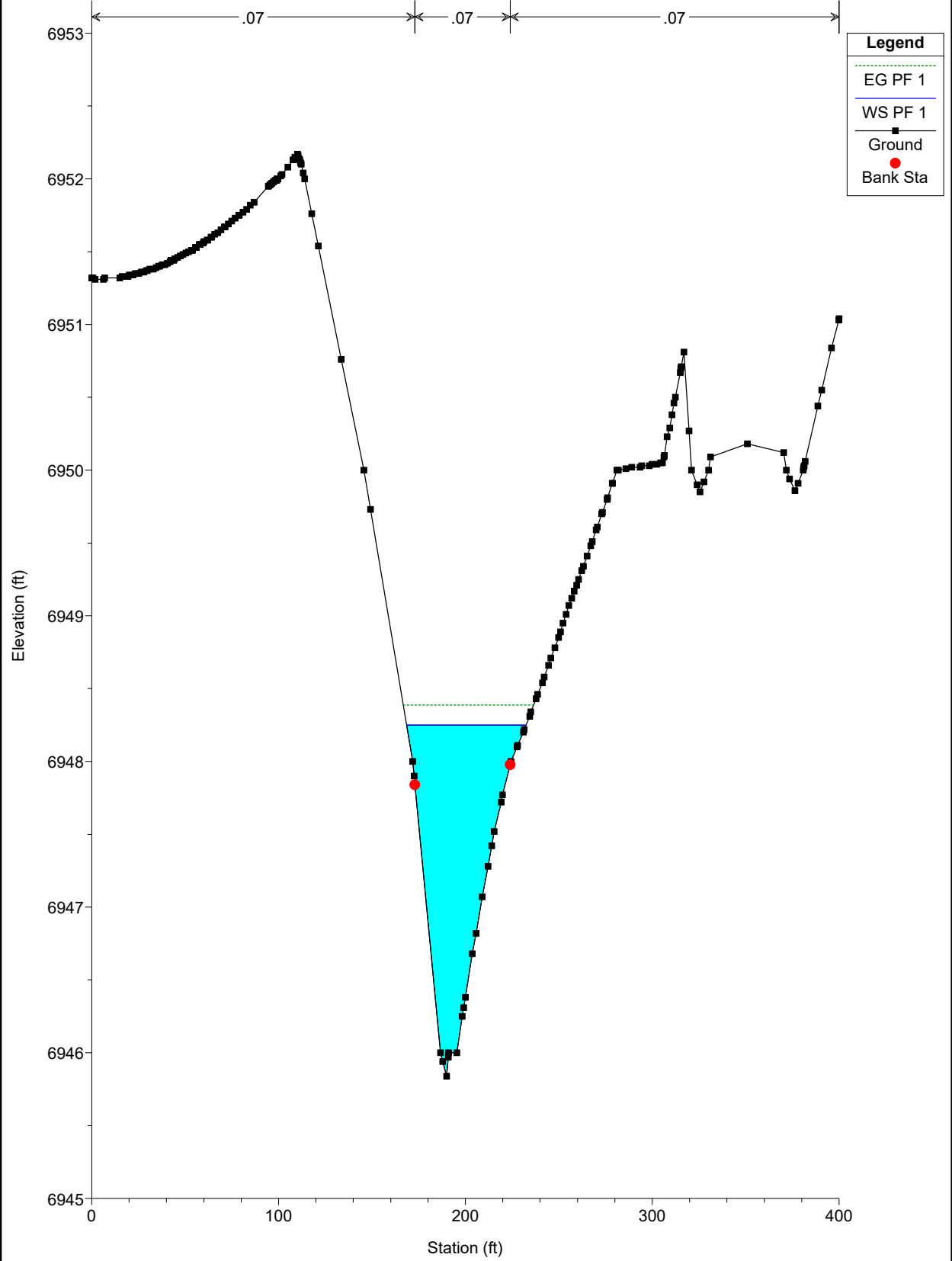

WEST CHAN PR NEW Plan: PR-PR 11/22/2022
River = WEST CHAN PR PR Reach = chan-west-pr-PR RS = 1500

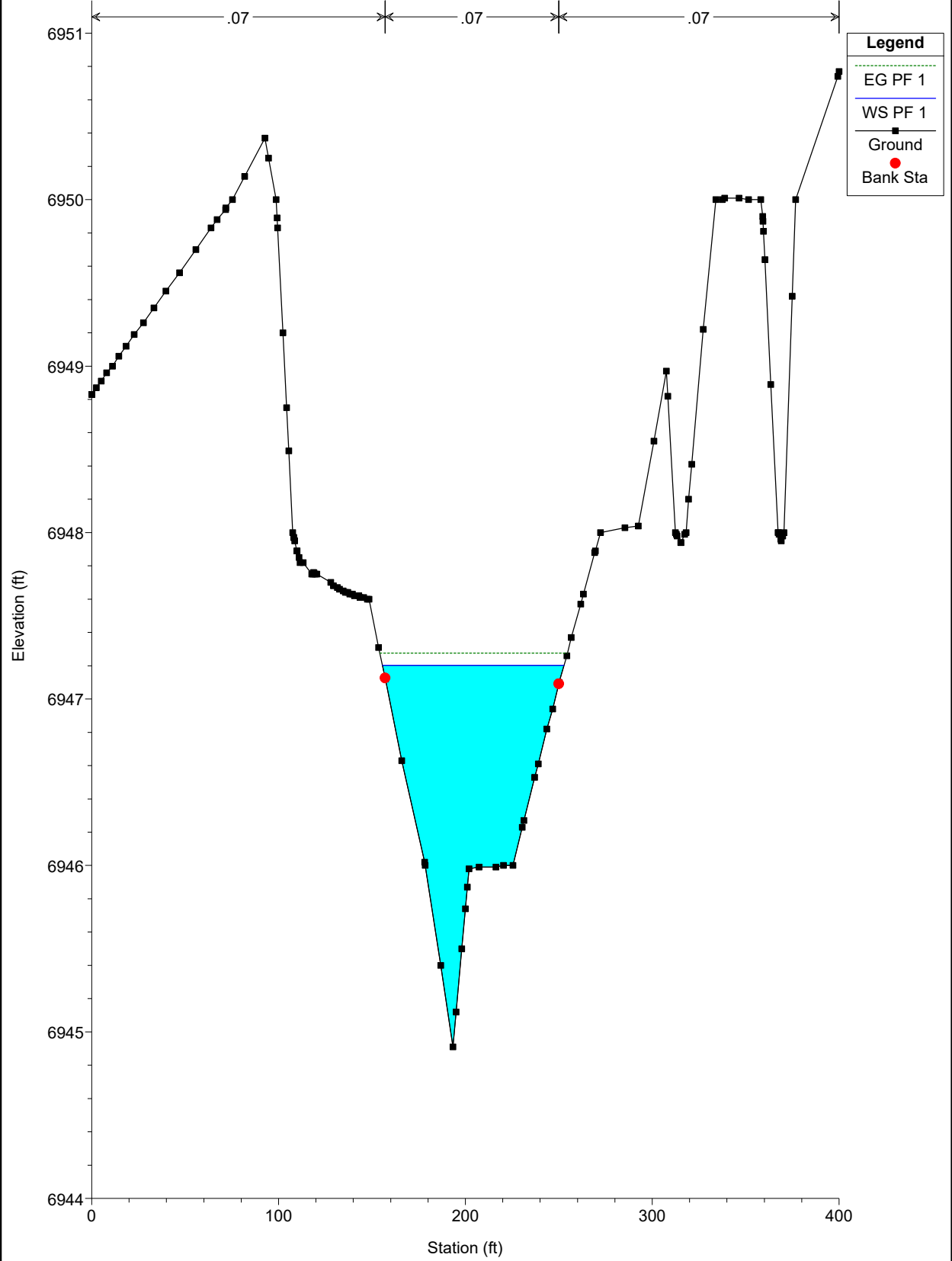

WEST CHAN PR NEW Plan: PR-PR 11/22/2022
River = WEST CHAN PR PR Reach = chan-west-pr-PR RS = 1420.03

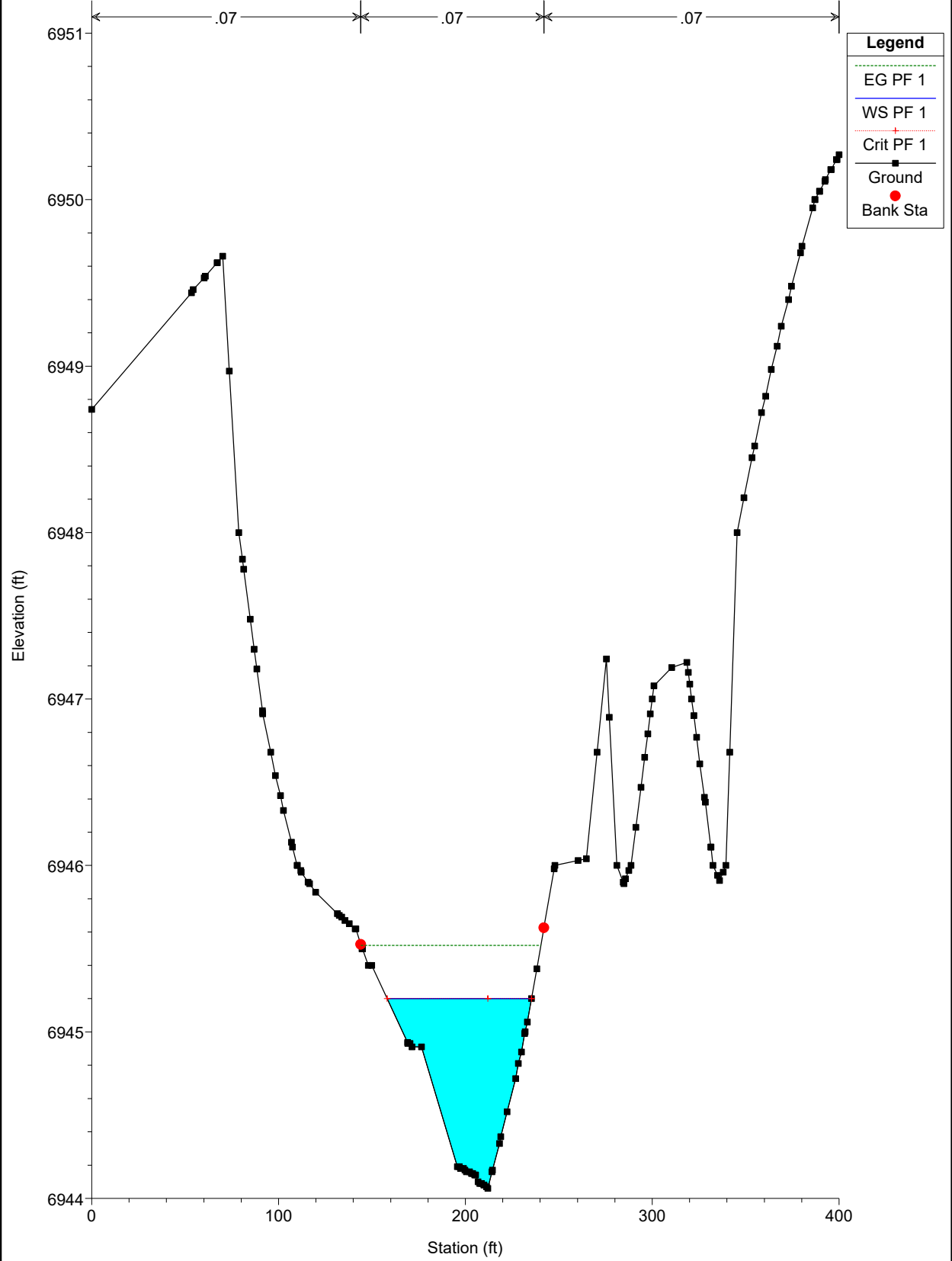

WEST CHAN PR NEW Plan: PR-PR 11/22/2022
River = WEST CHAN PR PR Reach = chan-west-pr-PR RS = 1400

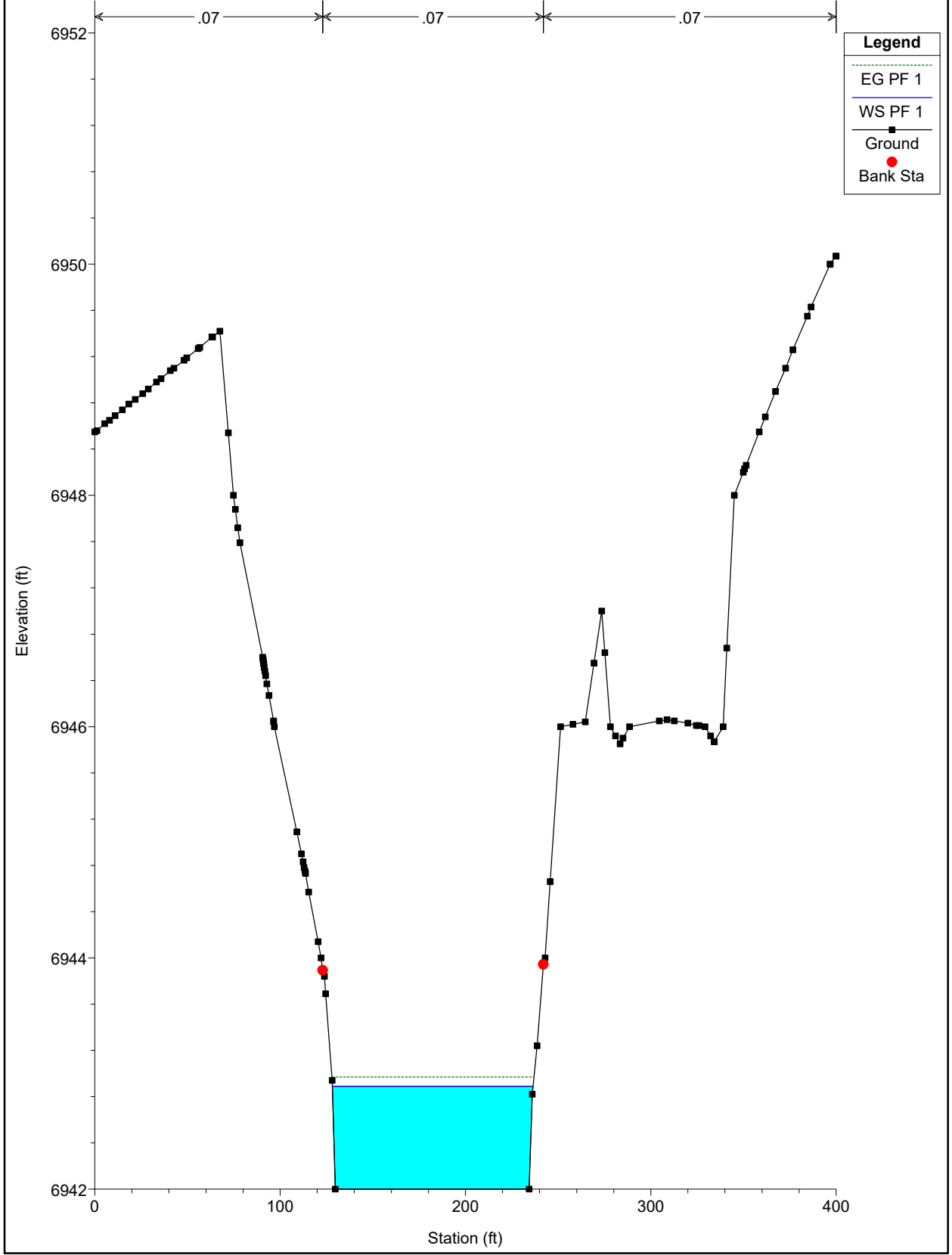

WEST CHAN PR NEW Plan: PR-PR 11/22/2022

River = WEST CHAN PR PR Reach = chan-west-pr-PR RS = 1379.97

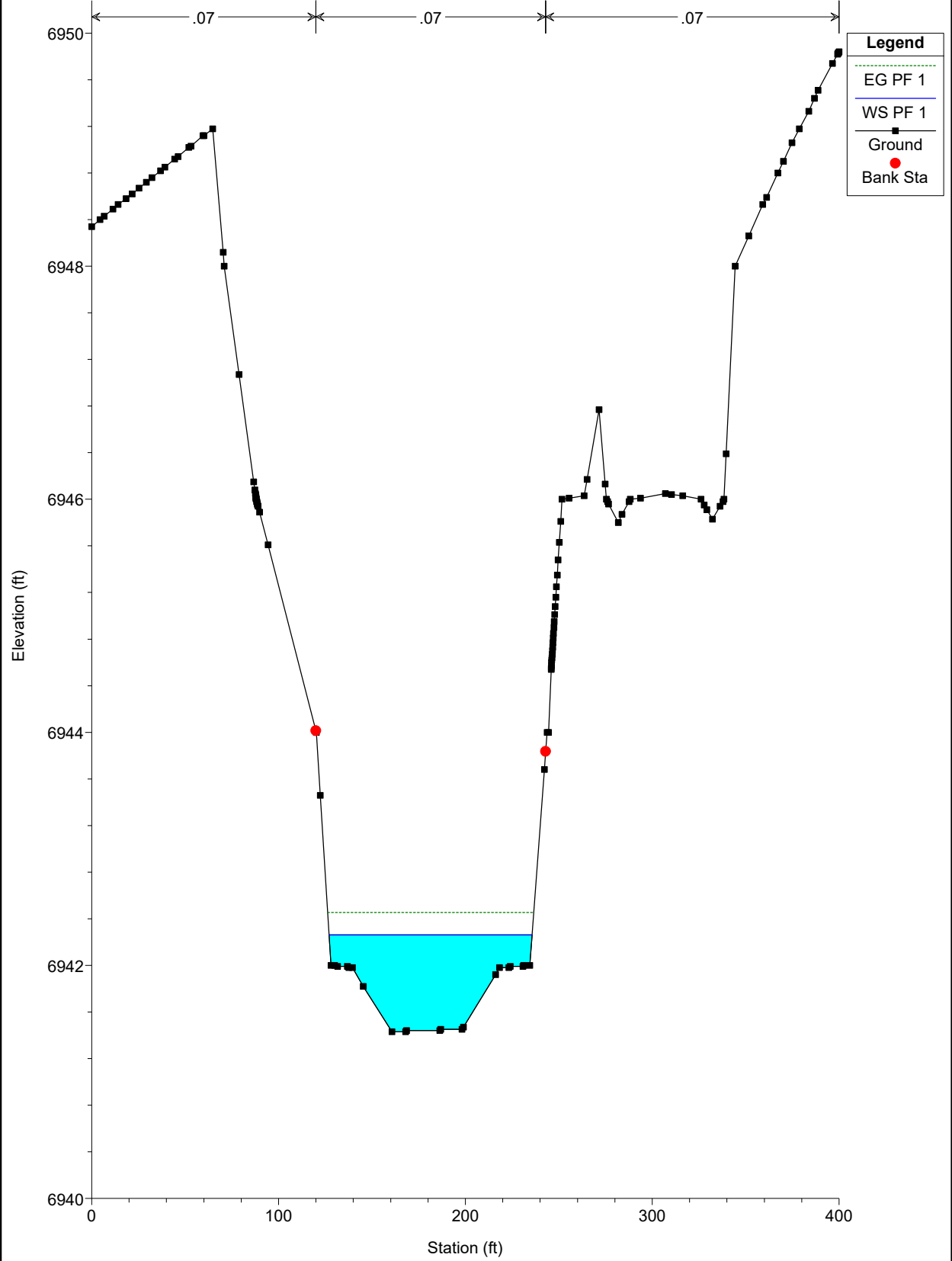

WEST CHAN PR NEW Plan: PR-PR 11/22/2022
River = WEST CHAN PR PR Reach = chan-west-pr-PR RS = 1300

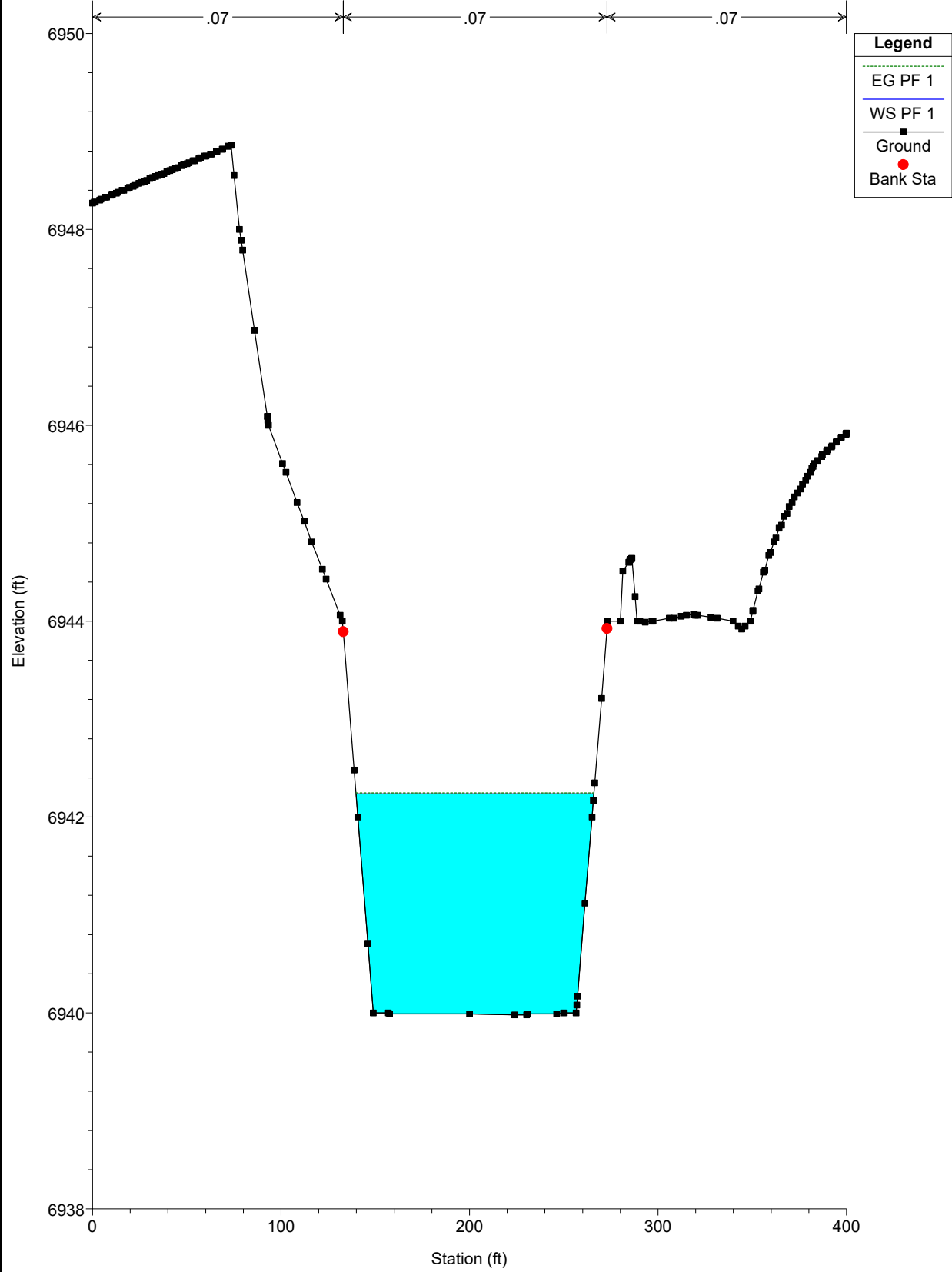

WEST CHAN PR NEW Plan: PR-PR 11/22/2022
River = WEST CHAN PR PR Reach = chan-west-pr-PR RS = 1200

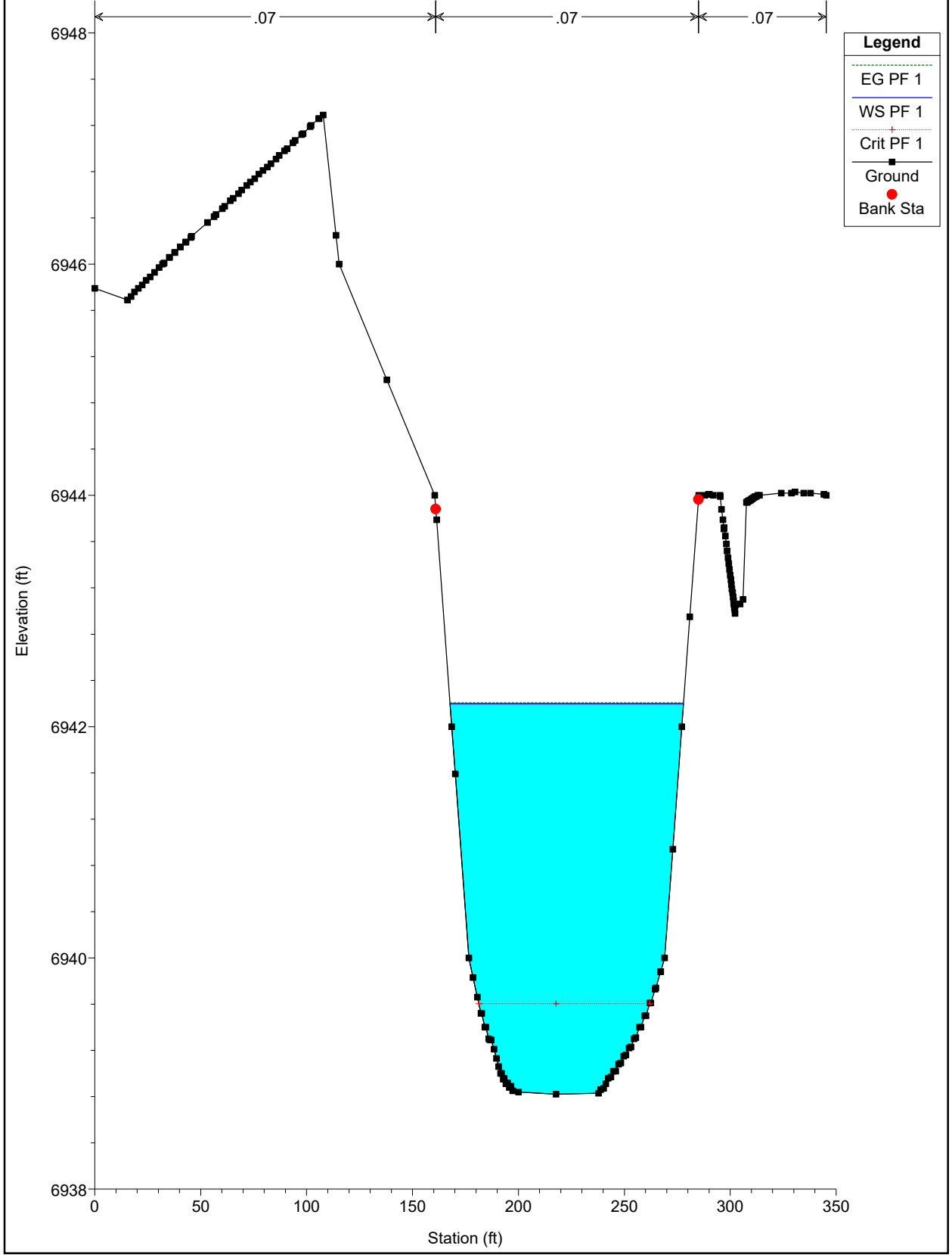

WEST CHAN PR NEW Plan: PR-PR 11/22/2022

River = WEST CHAN PR PR Reach = chan-west-pr-PR RS = 1042.5 Culv

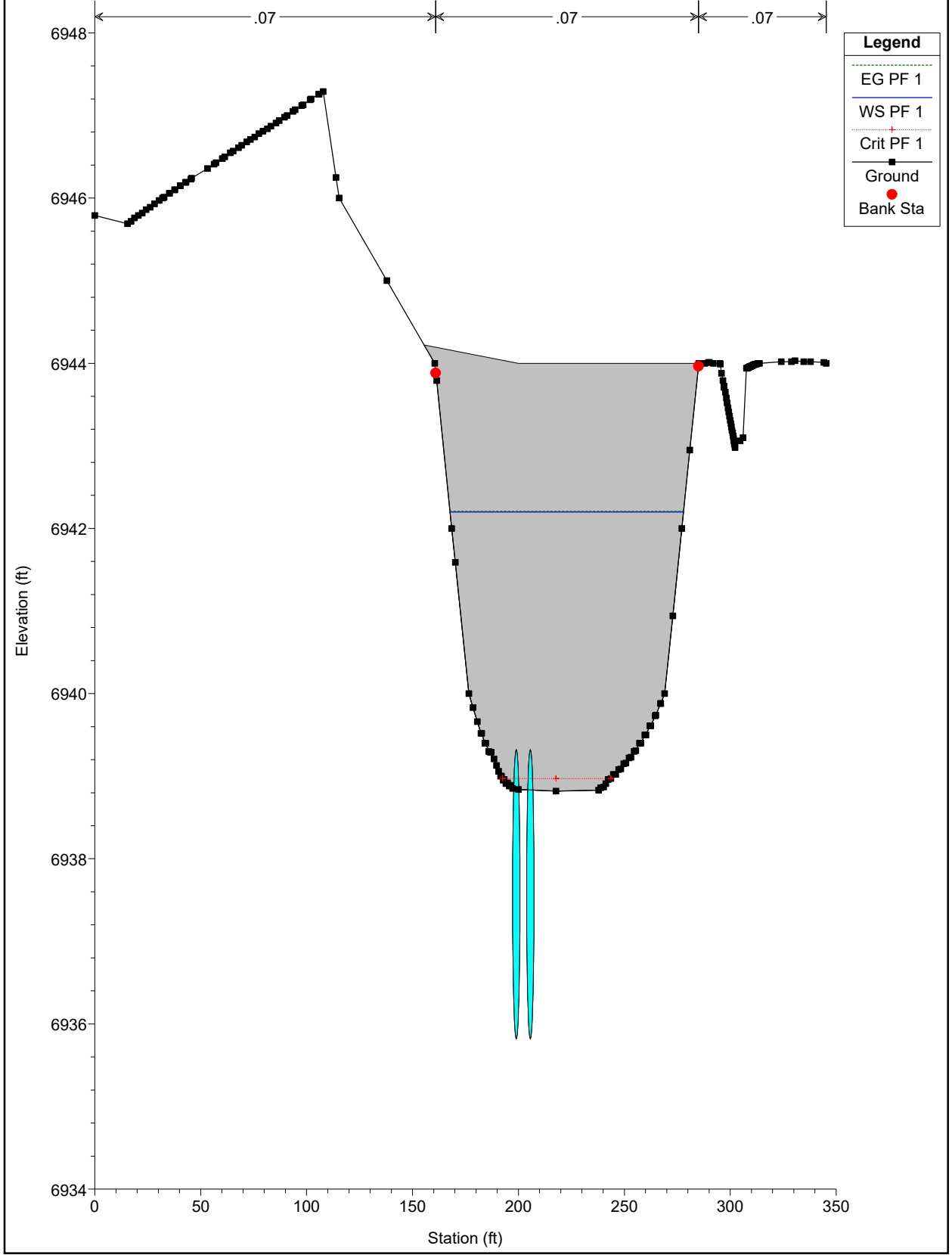

WEST CHAN PR NEW Plan: PR-PR 11/22/2022
River = WEST CHAN PR PR Reach = chan-west-pr-PR RS = 900

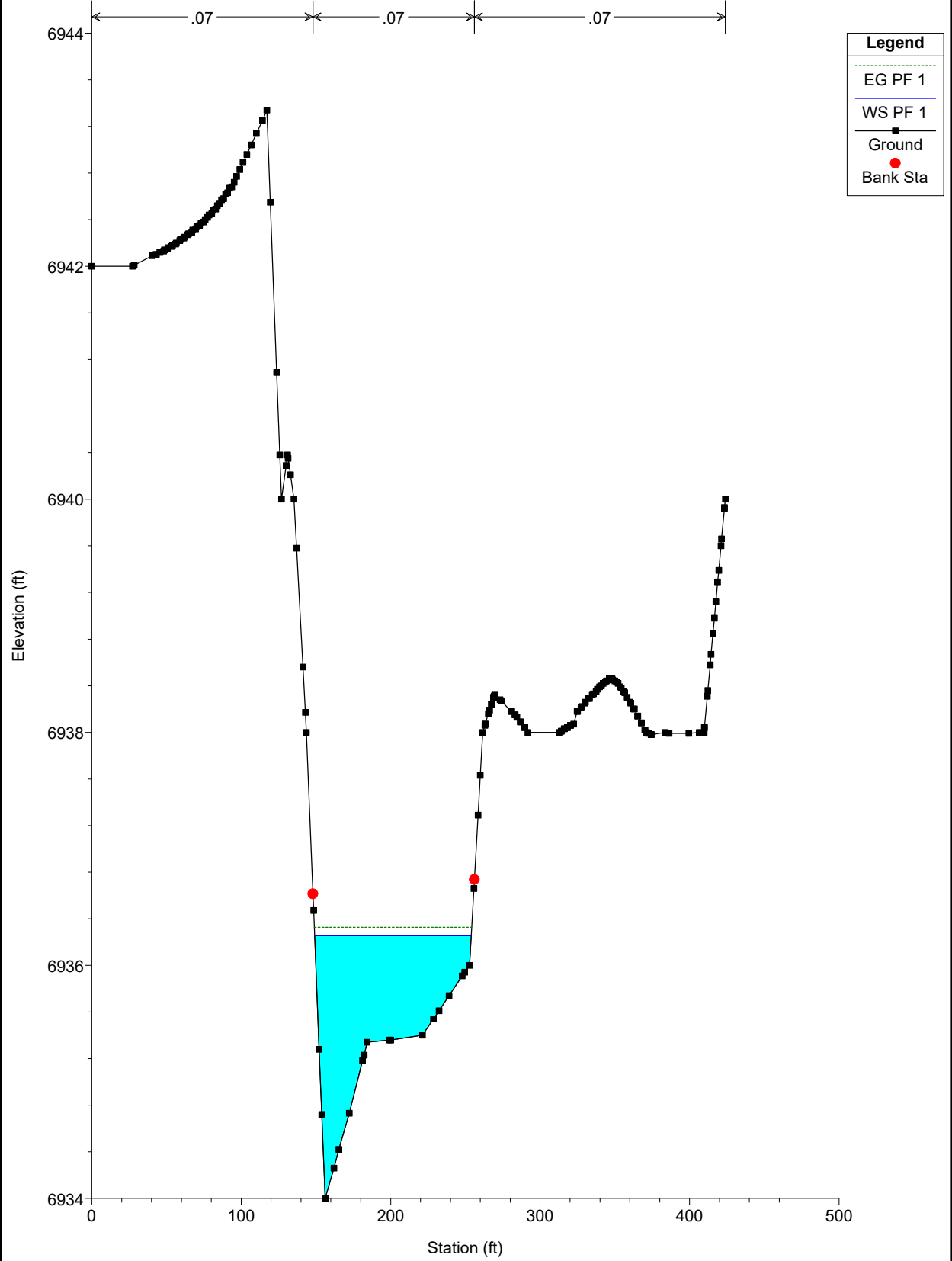

WEST CHAN PR NEW Plan: PR-PR 11/22/2022
River = WEST CHAN PR PR Reach = chan-west-pr-PR RS = 800

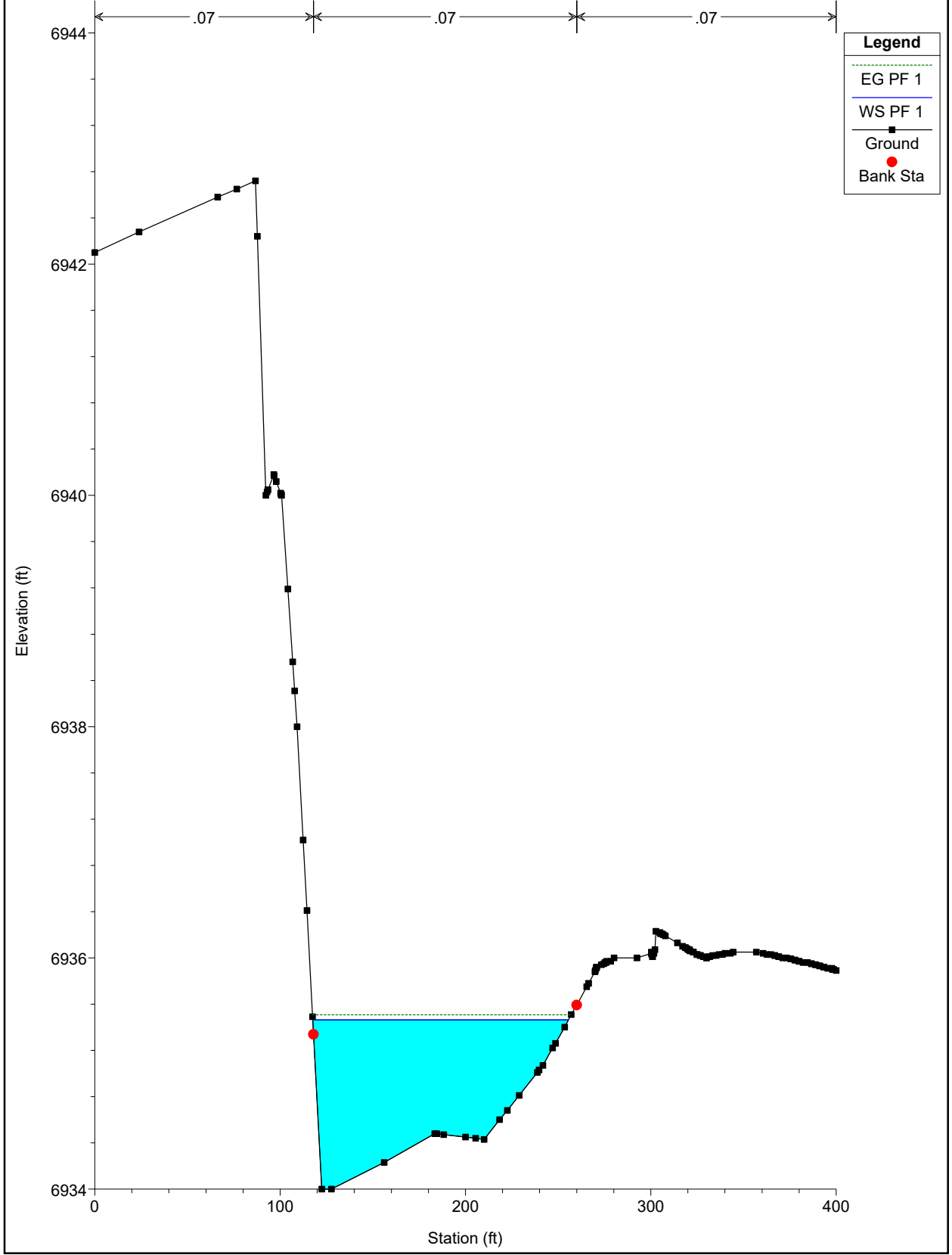

WEST CHAN PR NEW Plan: PR-PR 11/22/2022
River = WEST CHAN PR PR Reach = chan-west-pr-PR RS = 700

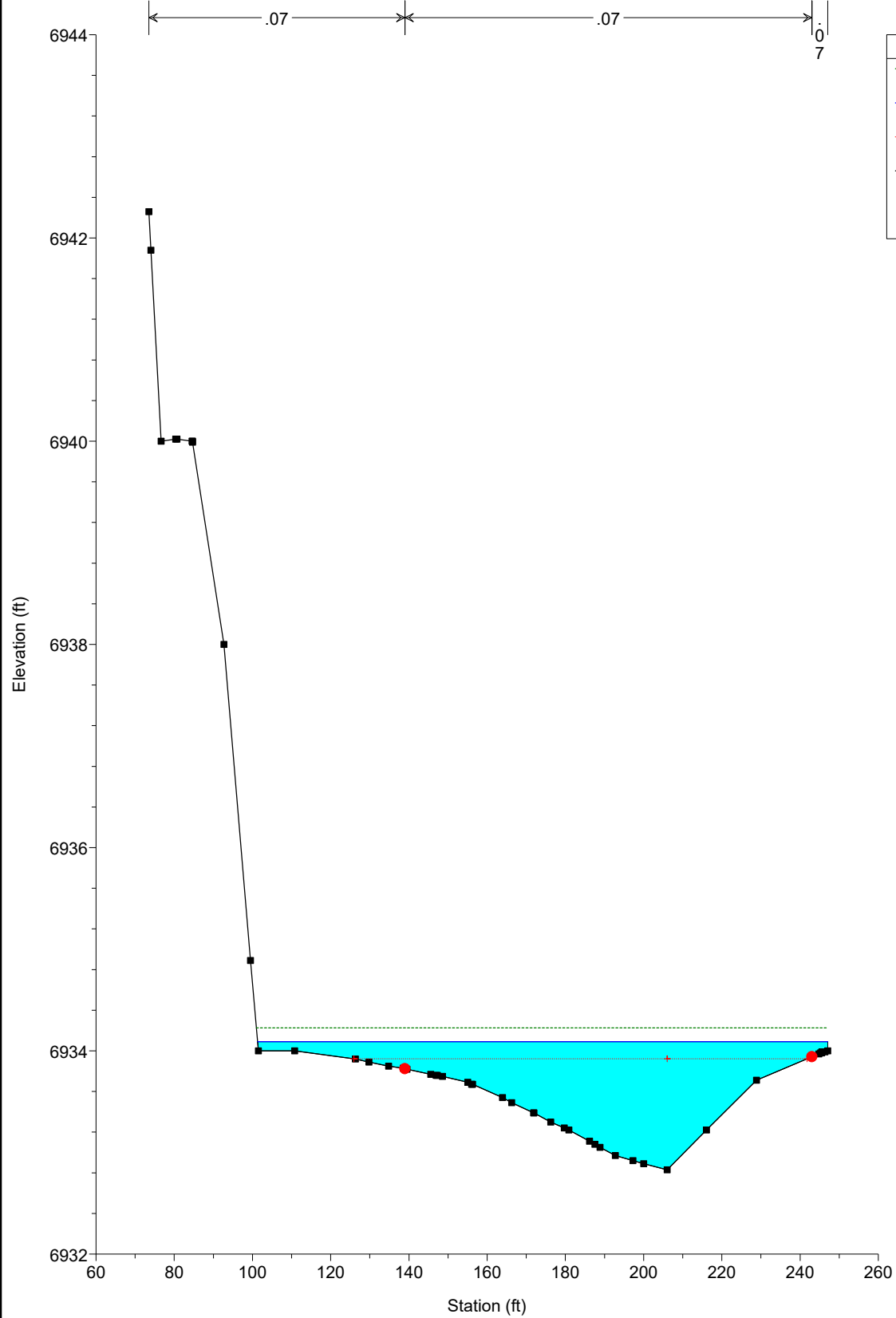

WEST CHAN PR NEW Plan: PR-PR 11/22/2022

River = WEST CHAN PR PR Reach = chan-west-pr-PR RS = 600

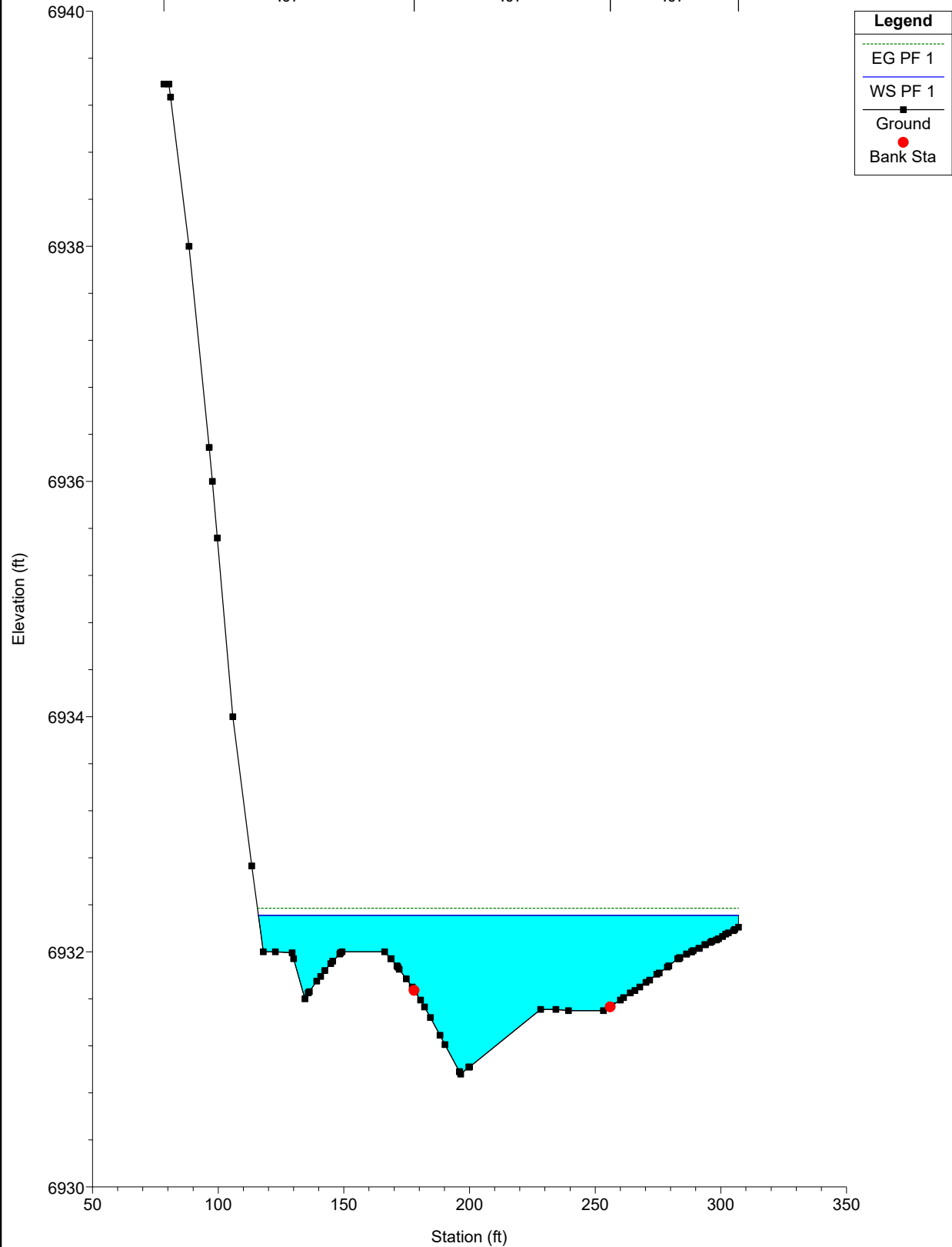
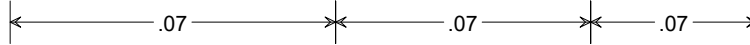

WEST CHAN PR NEW Plan: PR-PR 11/22/2022
River = WEST CHAN PR PR Reach = chan-west-pr-PR RS = 500

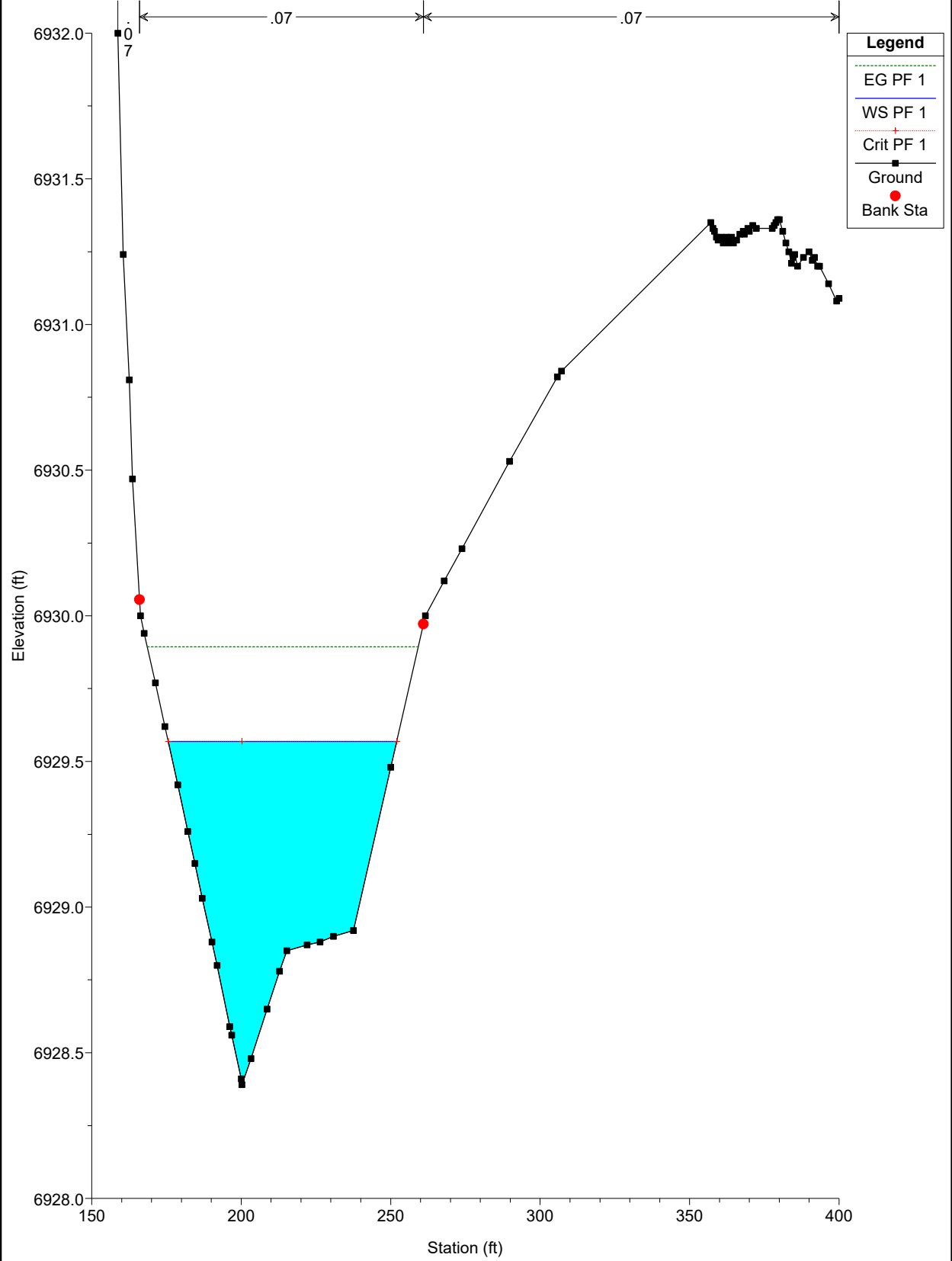

WEST CHAN PR NEW Plan: PR-PR 11/22/2022

River = WEST CHAN PR PR Reach = chan-west-pr-PR RS = 400

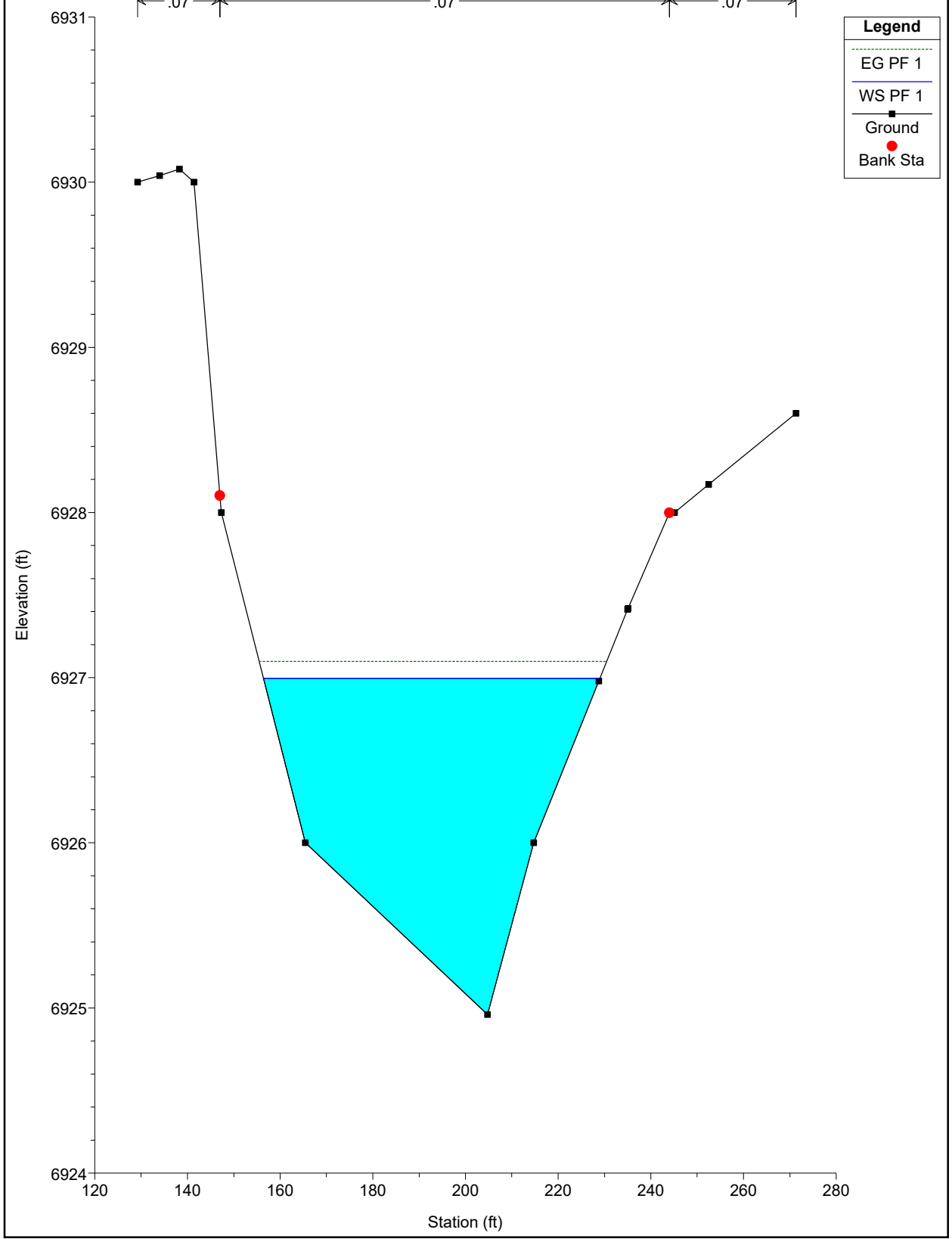
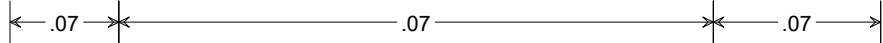

WEST CHAN PR NEW Plan: PR-PR 11/22/2022

River = WEST CHAN PR PR Reach = chan-west-pr-PR RS = 300

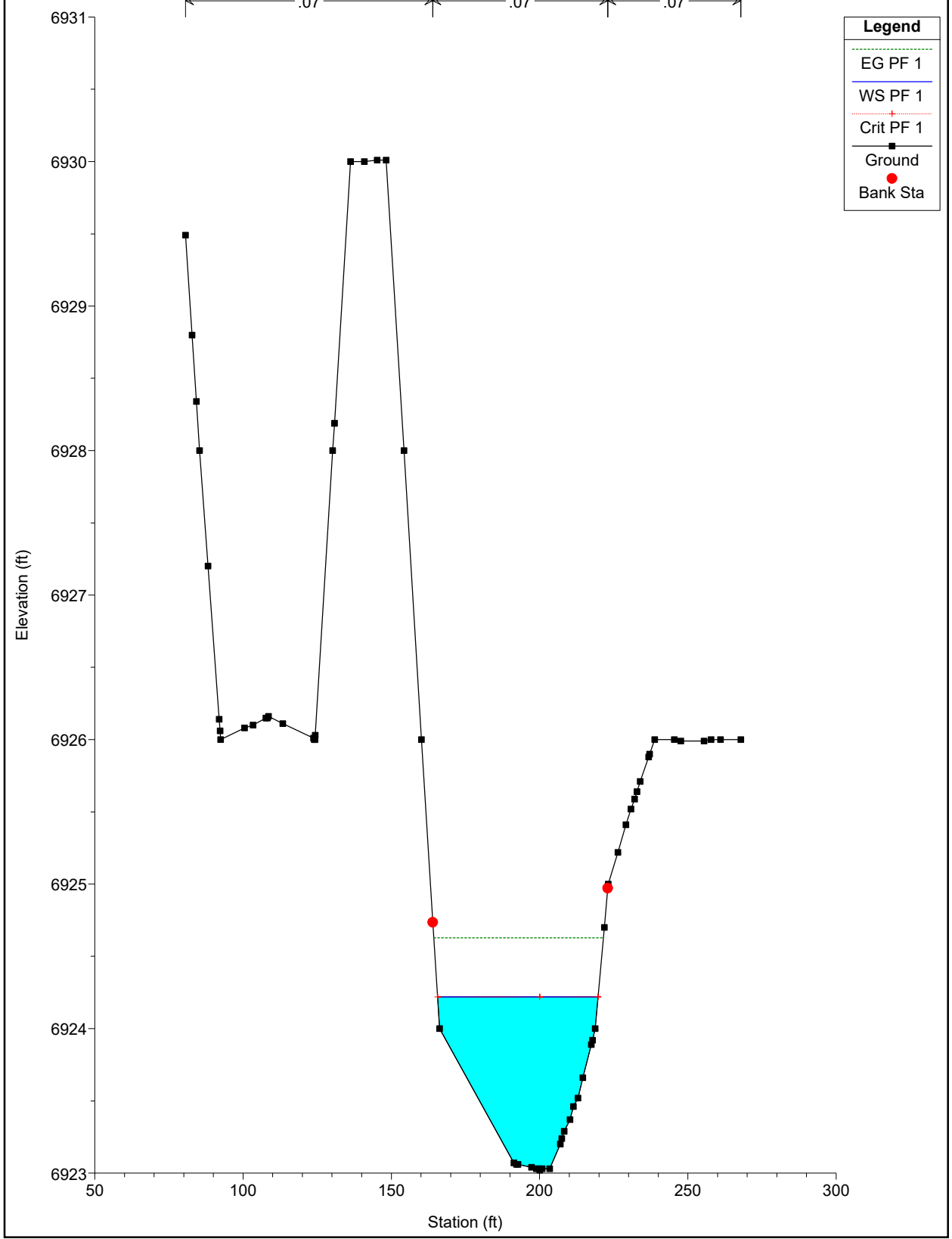

WEST CHAN PR NEW Plan: PR-PR 11/22/2022
River = WEST CHAN PR PR Reach = chan-west-pr-PR RS = 200

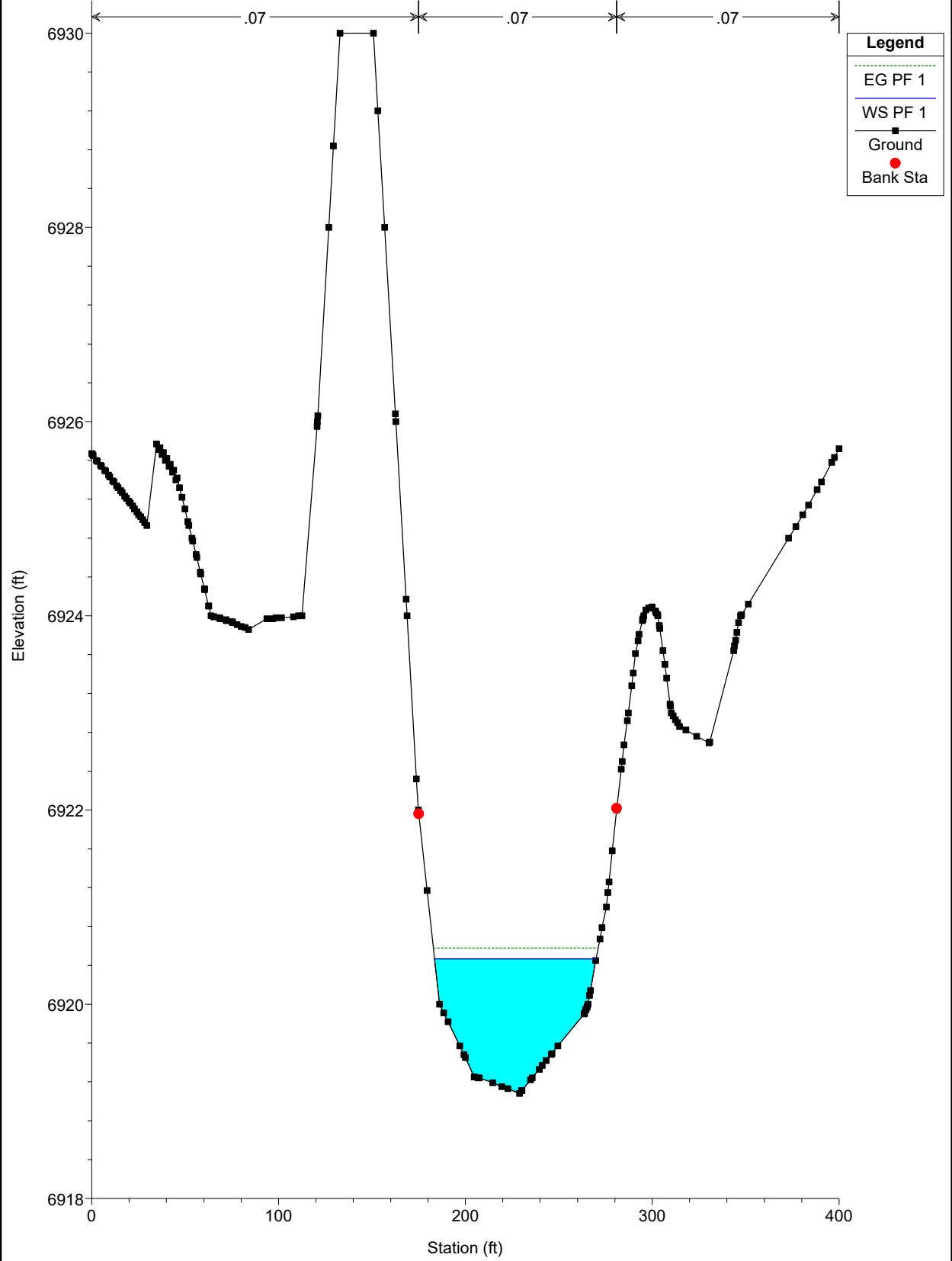

WEST CHAN PR NEW Plan: PR-PR 11/22/2022
River = WEST CHAN PR PR Reach = chan-west-pr-PR RS = 100

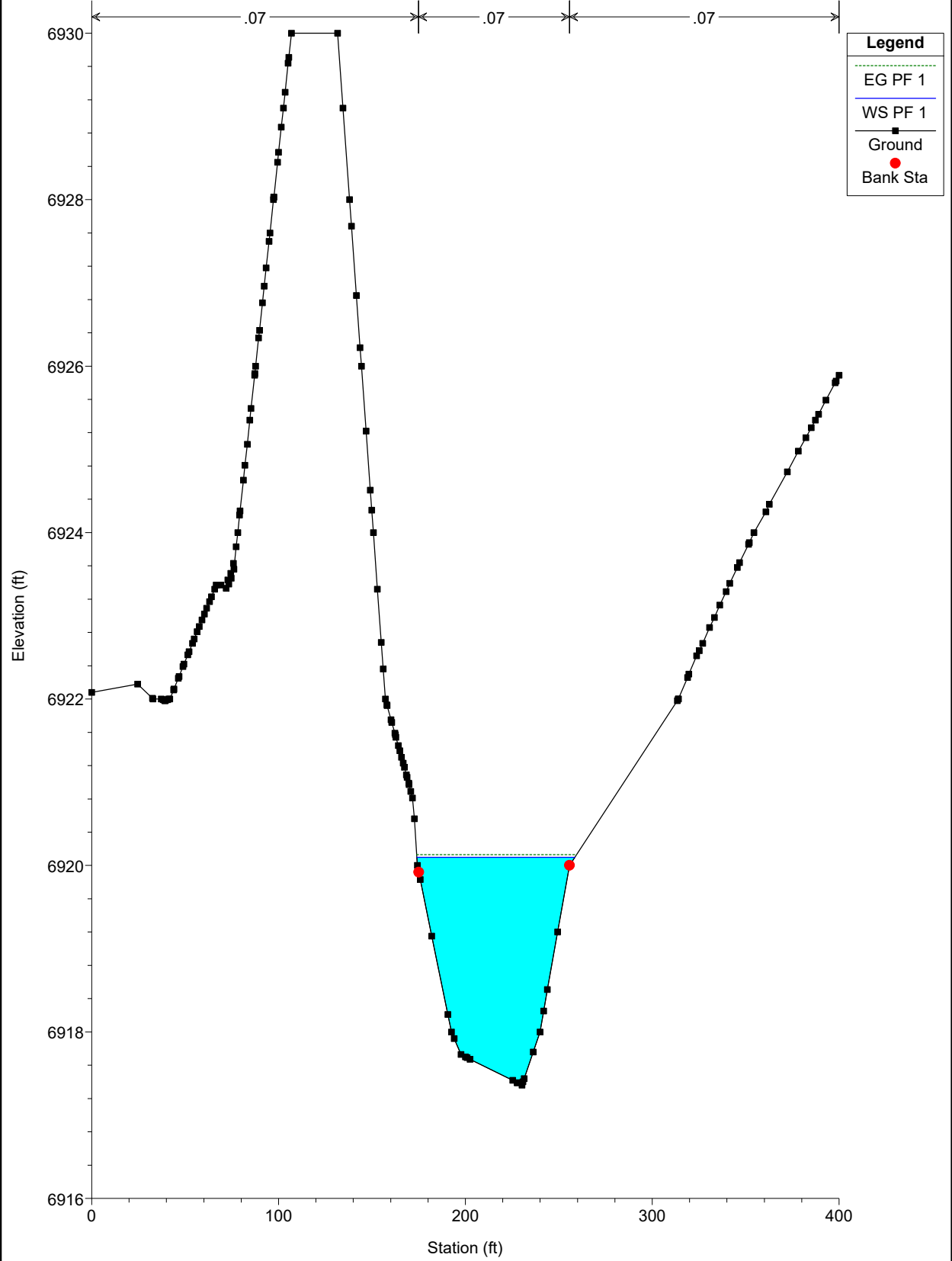

WEST CHAN PR NEW Plan: PR-PR 11/22/2022
River = WEST CHAN PR PR Reach = chan-west-pr-PR RS = 0

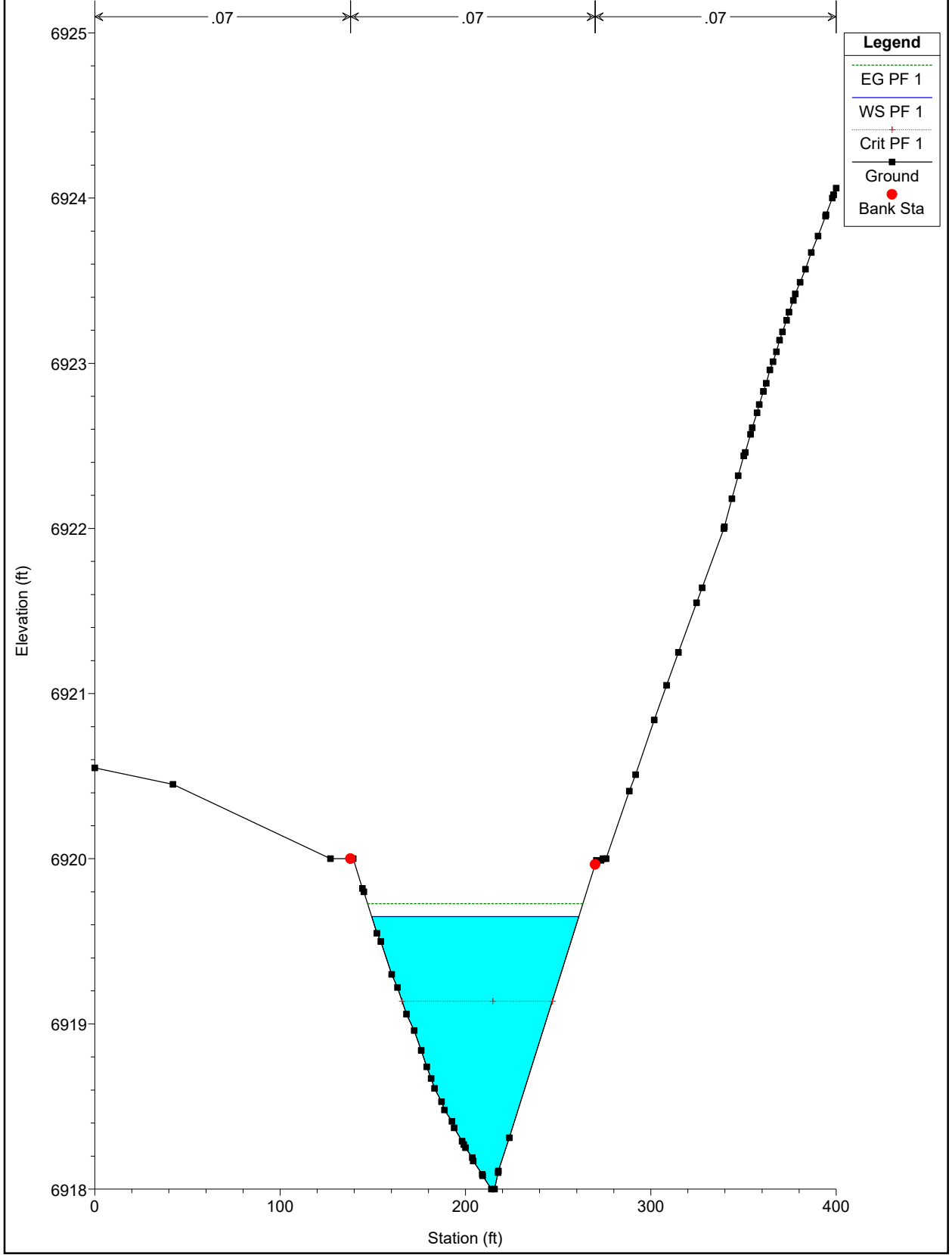

EAST CHANNEL PROPOSED CONDITIONS

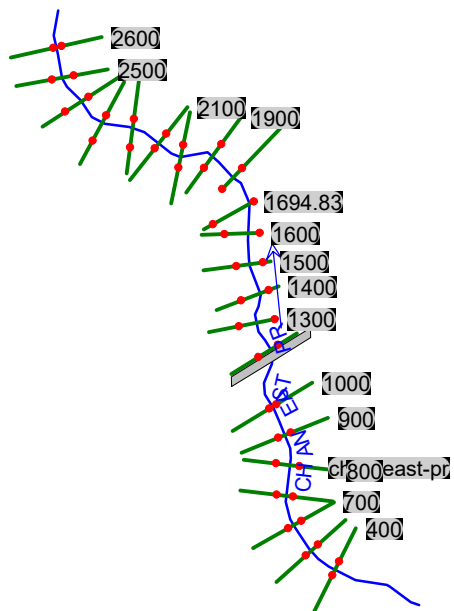

HEC-RAS Plan: Plan 01 River: CHAN EAST PR Reach: chan-east-pr Profile: PF 1

Reach	River Sta	Profile	Q Total (cfs)	Min Ch El (ft)	W.S. Elev (ft)	Crit W.S. (ft)	E.G. Elev (ft)	E.G. Slope (ft/ft)	Vel Chnl (ft/s)	Flow Area (sq ft)	Top Width (ft)	Froude # Chl
chan-east-pr	2600	PF 1	120.00	6942.53	6944.39		6944.48	0.019970	2.84	55.31	96.02	0.47
chan-east-pr	2500	PF 1	120.00	6941.18	6942.95		6943.00	0.011213	1.82	69.79	107.49	0.34
chan-east-pr	2400	PF 1	120.00	6939.95	6941.49		6941.57	0.018928	2.20	54.51	68.07	0.43
chan-east-pr	2300	PF 1	120.00	6938.19	6939.32		6939.41	0.024903	2.36	50.83	70.26	0.49
chan-east-pr	2200	PF 1	120.00	6936.58	6938.20		6938.24	0.006720	1.44	83.98	96.95	0.26
chan-east-pr	2100	PF 1	120.00	6935.13	6937.32		6937.39	0.010706	2.12	56.69	48.29	0.34
chan-east-pr	2010.45	PF 1	120.00	6933.88	6935.28		6935.48	0.060124	3.54	33.95	51.85	0.75
chan-east-pr	1900	PF 1	120.00	6931.88	6933.67		6933.70	0.007046	1.53	78.58	80.97	0.27
chan-east-pr	1801.17	PF 1	120.00	6931.01	6932.38		6932.46	0.028688	2.26	53.11	87.19	0.51
chan-east-pr	1694.83	PF 1	120.00	6929.94	6930.91		6930.93	0.008419	1.30	92.65	139.75	0.28
chan-east-pr	1600	PF 1	120.00	6928.36	6929.36	6929.13	6929.46	0.037429	2.59	46.35	75.77	0.58
chan-east-pr	1500	PF 1	120.00	6924.52	6926.32		6926.45	0.024682	2.92	41.13	40.91	0.51
chan-east-pr	1400	PF 1	120.00	6922.11	6924.60		6924.66	0.013218	2.04	58.94	63.00	0.37
chan-east-pr	1300	PF 1	120.00	6921.11	6923.45		6923.51	0.010011	1.94	61.98	57.78	0.33
chan-east-pr	1200	PF 1	120.00	6919.19	6923.45	6920.42	6923.45	0.000130	0.46	284.35	116.74	0.05
chan-east-pr	1111.15		Culvert									
chan-east-pr	1000	PF 1	120.00	6916.11	6918.62		6918.73	0.011875	2.69	49.46	50.50	0.38
chan-east-pr	900	PF 1	120.00	6915.02	6917.38		6917.48	0.013156	2.50	48.04	37.27	0.39
chan-east-pr	800	PF 1	120.00	6913.85	6916.41		6916.48	0.007767	2.04	58.68	41.67	0.30
chan-east-pr	700	PF 1	120.00	6913.13	6915.68		6915.73	0.007063	1.87	64.05	48.08	0.29
chan-east-pr	600	PF 1	120.00	6912.13	6914.18		6914.38	0.034817	3.60	33.30	31.11	0.61
chan-east-pr	500	PF 1	120.00	6909.89	6912.63		6912.72	0.009428	2.35	51.05	33.77	0.34
chan-east-pr	400	PF 1	120.00	6908.81	6911.50	6910.69	6911.61	0.013008	2.68	44.70	30.55	0.39

Plan: Plan 01 CHAN EAST PR chan-east-pr RS: 2600 Profile: PF 1

E.G. Elev (ft)	6944.48	Element	Left OB	Channel	Right OB
Vel Head (ft)	0.10	Wt. n-Val.	0.080	0.080	0.080
W.S. Elev (ft)	6944.39	Reach Len. (ft)	103.00	100.00	103.00
Crit W.S. (ft)		Flow Area (sq ft)	1.09	30.69	23.52
E.G. Slope (ft/ft)	0.019970	Area (sq ft)	1.09	30.69	23.52
Q Total (cfs)	120.00	Flow (cfs)	0.96	87.15	31.89
Top Width (ft)	96.02	Top Width (ft)	5.66	27.00	63.36
Vel Total (ft/s)	2.17	Avg. Vel. (ft/s)	0.88	2.84	1.36
Max Chl Dpth (ft)	1.85	Hydr. Depth (ft)	0.19	1.14	0.37
Conv. Total (cfs)	849.2	Conv. (cfs)	6.8	616.7	225.7
Length Wtd. (ft)	100.45	Wetted Per. (ft)	5.67	27.28	63.37
Min Ch EI (ft)	6942.53	Shear (lb/sq ft)	0.24	1.40	0.46
Alpha	1.35	Stream Power (lb/ft s)	0.21	3.98	0.63
Frctn Loss (ft)	1.47	Cum Volume (acre-ft)	0.02	2.89	0.09
C & E Loss (ft)	0.01	Cum SA (acres)	0.14	3.03	0.26

Plan: Plan 01 CHAN EAST PR chan-east-pr RS: 2500 Profile: PF 1

E.G. Elev (ft)	6943.00	Element	Left OB	Channel	Right OB
Vel Head (ft)	0.05	Wt. n-Val.	0.080	0.080	0.080
W.S. Elev (ft)	6942.95	Reach Len. (ft)	83.00	100.00	112.00
Crit W.S. (ft)		Flow Area (sq ft)	3.26	64.09	2.44
E.G. Slope (ft/ft)	0.011213	Area (sq ft)	3.26	64.09	2.44
Q Total (cfs)	120.00	Flow (cfs)	1.90	116.49	1.61
Top Width (ft)	107.49	Top Width (ft)	22.95	72.00	12.54
Vel Total (ft/s)	1.72	Avg. Vel. (ft/s)	0.58	1.82	0.66
Max Chl Dpth (ft)	1.77	Hydr. Depth (ft)	0.14	0.89	0.19
Conv. Total (cfs)	1133.2	Conv. (cfs)	17.9	1100.1	15.2
Length Wtd. (ft)	99.95	Wetted Per. (ft)	23.07	72.15	12.54
Min Ch EI (ft)	6941.18	Shear (lb/sq ft)	0.10	0.62	0.14
Alpha	1.09	Stream Power (lb/ft s)	0.06	1.13	0.09
Frctn Loss (ft)	1.43	Cum Volume (acre-ft)	0.02	2.78	0.06
C & E Loss (ft)	0.00	Cum SA (acres)	0.10	2.91	0.17

Plan: Plan 01 CHAN EAST PR chan-east-pr RS: 2400 Profile: PF 1

E.G. Elev (ft)	6941.57	Element	Left OB	Channel	Right OB
Vel Head (ft)	0.08	Wt. n-Val.		0.080	
W.S. Elev (ft)	6941.49	Reach Len. (ft)	83.00	100.00	128.00
Crit W.S. (ft)		Flow Area (sq ft)		54.51	
E.G. Slope (ft/ft)	0.018928	Area (sq ft)		54.51	
Q Total (cfs)	120.00	Flow (cfs)		120.00	
Top Width (ft)	68.07	Top Width (ft)		68.07	
Vel Total (ft/s)	2.20	Avg. Vel. (ft/s)		2.20	
Max Chl Dpth (ft)	1.54	Hydr. Depth (ft)		0.80	
Conv. Total (cfs)	872.2	Conv. (cfs)		872.2	
Length Wtd. (ft)	100.00	Wetted Per. (ft)		68.16	
Min Ch EI (ft)	6939.95	Shear (lb/sq ft)		0.94	
Alpha	1.00	Stream Power (lb/ft s)		2.08	
Frctn Loss (ft)	2.16	Cum Volume (acre-ft)	0.01	2.65	0.06
C & E Loss (ft)	0.00	Cum SA (acres)	0.08	2.75	0.15

Plan: Plan 01 CHAN EAST PR chan-east-pr RS: 2300 Profile: PF 1

E.G. Elev (ft)	6939.41	Element	Left OB	Channel	Right OB
Vel Head (ft)	0.09	Wt. n-Val.		0.080	
W.S. Elev (ft)	6939.32	Reach Len. (ft)	90.00	100.00	123.00
Crit W.S. (ft)		Flow Area (sq ft)		50.83	
E.G. Slope (ft/ft)	0.024903	Area (sq ft)		50.83	
Q Total (cfs)	120.00	Flow (cfs)		120.00	
Top Width (ft)	70.26	Top Width (ft)		70.26	
Vel Total (ft/s)	2.36	Avg. Vel. (ft/s)		2.36	
Max Chl Dpth (ft)	1.13	Hydr. Depth (ft)		0.72	
Conv. Total (cfs)	760.4	Conv. (cfs)		760.4	
Length Wtd. (ft)	99.99	Wetted Per. (ft)		70.31	
Min Ch El (ft)	6938.19	Shear (lb/sq ft)		1.12	
Alpha	1.00	Stream Power (lb/ft s)		2.65	
Frctn Loss (ft)	1.16	Cum Volume (acre-ft)	0.01	2.52	0.06
C & E Loss (ft)	0.02	Cum SA (acres)	0.08	2.59	0.15

Plan: Plan 01 CHAN EAST PR chan-east-pr RS: 2200 Profile: PF 1

E.G. Elev (ft)	6938.24	Element	Left OB	Channel	Right OB
Vel Head (ft)	0.03	Wt. n-Val.	0.080	0.080	
W.S. Elev (ft)	6938.20	Reach Len. (ft)	115.00	100.00	80.00
Crit W.S. (ft)		Flow Area (sq ft)	0.51	83.47	
E.G. Slope (ft/ft)	0.006720	Area (sq ft)	0.51	83.47	
Q Total (cfs)	120.00	Flow (cfs)	0.15	119.85	
Top Width (ft)	96.95	Top Width (ft)	5.96	90.98	
Vel Total (ft/s)	1.43	Avg. Vel. (ft/s)	0.30	1.44	
Max Chl Dpth (ft)	1.62	Hydr. Depth (ft)	0.09	0.92	
Conv. Total (cfs)	1463.8	Conv. (cfs)	1.8	1462.0	
Length Wtd. (ft)	100.01	Wetted Per. (ft)	5.97	91.15	
Min Ch El (ft)	6936.58	Shear (lb/sq ft)	0.04	0.38	
Alpha	1.01	Stream Power (lb/ft s)	0.01	0.55	
Frctn Loss (ft)	0.84	Cum Volume (acre-ft)	0.01	2.37	0.06
C & E Loss (ft)	0.00	Cum SA (acres)	0.07	2.41	0.15

Plan: Plan 01 CHAN EAST PR chan-east-pr RS: 2100 Profile: PF 1

E.G. Elev (ft)	6937.39	Element	Left OB	Channel	Right OB
Vel Head (ft)	0.07	Wt. n-Val.		0.080	
W.S. Elev (ft)	6937.32	Reach Len. (ft)	65.00	89.55	98.00
Crit W.S. (ft)		Flow Area (sq ft)		56.69	
E.G. Slope (ft/ft)	0.010706	Area (sq ft)		56.69	
Q Total (cfs)	120.00	Flow (cfs)		120.00	
Top Width (ft)	48.29	Top Width (ft)		48.29	
Vel Total (ft/s)	2.12	Avg. Vel. (ft/s)		2.12	
Max Chl Dpth (ft)	2.19	Hydr. Depth (ft)		1.17	
Conv. Total (cfs)	1159.7	Conv. (cfs)		1159.7	
Length Wtd. (ft)	89.55	Wetted Per. (ft)		49.05	
Min Ch El (ft)	6935.13	Shear (lb/sq ft)		0.77	
Alpha	1.00	Stream Power (lb/ft s)		1.64	
Frctn Loss (ft)	1.90	Cum Volume (acre-ft)	0.01	2.21	0.06
C & E Loss (ft)	0.01	Cum SA (acres)	0.07	2.25	0.15

Plan: Plan 01 CHAN EAST PR chan-east-pr RS: 2010.45 Profile: PF 1

E.G. Elev (ft)	6935.48	Element	Left OB	Channel	Right OB
Vel Head (ft)	0.19	Wt. n-Val.		0.080	0.080
W.S. Elev (ft)	6935.28	Reach Len. (ft)	123.00	110.45	82.00
Crit W.S. (ft)		Flow Area (sq ft)		33.90	0.05
E.G. Slope (ft/ft)	0.060124	Area (sq ft)		33.90	0.05
Q Total (cfs)	120.00	Flow (cfs)		119.98	0.02
Top Width (ft)	51.85	Top Width (ft)		49.38	2.48
Vel Total (ft/s)	3.53	Avg. Vel. (ft/s)		3.54	0.35
Max Chl Dpth (ft)	1.40	Hydr. Depth (ft)		0.69	0.02
Conv. Total (cfs)	489.4	Conv. (cfs)		489.3	0.1
Length Wtd. (ft)	110.45	Wetted Per. (ft)		49.47	2.48
Min Ch El (ft)	6933.88	Shear (lb/sq ft)		2.57	0.08
Alpha	1.00	Stream Power (lb/ft s)		9.10	0.03
Frctn Loss (ft)	1.73	Cum Volume (acre-ft)	0.01	2.12	0.06
C & E Loss (ft)	0.05	Cum SA (acres)	0.07	2.15	0.15

Plan: Plan 01 CHAN EAST PR chan-east-pr RS: 1900 Profile: PF 1

E.G. Elev (ft)	6933.70	Element	Left OB	Channel	Right OB
Vel Head (ft)	0.04	Wt. n-Val.		0.080	
W.S. Elev (ft)	6933.67	Reach Len. (ft)	102.00	98.83	89.00
Crit W.S. (ft)		Flow Area (sq ft)		78.58	
E.G. Slope (ft/ft)	0.007046	Area (sq ft)		78.58	
Q Total (cfs)	120.00	Flow (cfs)		120.00	
Top Width (ft)	80.97	Top Width (ft)		80.97	
Vel Total (ft/s)	1.53	Avg. Vel. (ft/s)		1.53	
Max Chl Dpth (ft)	1.79	Hydr. Depth (ft)		0.97	
Conv. Total (cfs)	1429.5	Conv. (cfs)		1429.5	
Length Wtd. (ft)	98.83	Wetted Per. (ft)		81.06	
Min Ch El (ft)	6931.88	Shear (lb/sq ft)		0.43	
Alpha	1.00	Stream Power (lb/ft s)		0.65	
Frctn Loss (ft)	1.25	Cum Volume (acre-ft)	0.01	1.97	0.06
C & E Loss (ft)	0.00	Cum SA (acres)	0.07	1.98	0.15

Plan: Plan 01 CHAN EAST PR chan-east-pr RS: 1801.17 Profile: PF 1

E.G. Elev (ft)	6932.46	Element	Left OB	Channel	Right OB
Vel Head (ft)	0.08	Wt. n-Val.		0.080	
W.S. Elev (ft)	6932.38	Reach Len. (ft)	114.00	106.34	118.00
Crit W.S. (ft)		Flow Area (sq ft)		53.11	
E.G. Slope (ft/ft)	0.028688	Area (sq ft)		53.11	
Q Total (cfs)	120.00	Flow (cfs)		120.00	
Top Width (ft)	87.19	Top Width (ft)		87.19	
Vel Total (ft/s)	2.26	Avg. Vel. (ft/s)		2.26	
Max Chl Dpth (ft)	1.37	Hydr. Depth (ft)		0.61	
Conv. Total (cfs)	708.5	Conv. (cfs)		708.5	
Length Wtd. (ft)	106.34	Wetted Per. (ft)		87.27	
Min Ch El (ft)	6931.01	Shear (lb/sq ft)		1.09	
Alpha	1.00	Stream Power (lb/ft s)		2.46	
Frctn Loss (ft)	1.51	Cum Volume (acre-ft)	0.01	1.82	0.06
C & E Loss (ft)	0.02	Cum SA (acres)	0.07	1.79	0.15

Plan: Plan 01 CHAN EAST PR chan-east-pr RS: 1694.83 Profile: PF 1

E.G. Elev (ft)	6930.93	Element	Left OB	Channel	Right OB
Vel Head (ft)	0.03	Wt. n-Val.		0.080	
W.S. Elev (ft)	6930.91	Reach Len. (ft)	103.00	94.83	49.00
Crit W.S. (ft)		Flow Area (sq ft)		92.65	
E.G. Slope (ft/ft)	0.008419	Area (sq ft)		92.65	
Q Total (cfs)	120.00	Flow (cfs)		120.00	
Top Width (ft)	139.75	Top Width (ft)		139.75	
Vel Total (ft/s)	1.30	Avg. Vel. (ft/s)		1.30	
Max Chl Dpth (ft)	0.97	Hydr. Depth (ft)		0.66	
Conv. Total (cfs)	1307.8	Conv. (cfs)		1307.8	
Length Wtd. (ft)	94.83	Wetted Per. (ft)		139.85	
Min Ch El (ft)	6929.94	Shear (lb/sq ft)		0.35	
Alpha	1.00	Stream Power (lb/ft s)		0.45	
Frctn Loss (ft)	1.47	Cum Volume (acre-ft)	0.01	1.65	0.06
C & E Loss (ft)	0.01	Cum SA (acres)	0.07	1.52	0.15

Plan: Plan 01 CHAN EAST PR chan-east-pr RS: 1600 Profile: PF 1

E.G. Elev (ft)	6929.46	Element	Left OB	Channel	Right OB
Vel Head (ft)	0.10	Wt. n-Val.		0.080	
W.S. Elev (ft)	6929.36	Reach Len. (ft)	96.00	100.00	108.00
Crit W.S. (ft)	6929.13	Flow Area (sq ft)		46.35	
E.G. Slope (ft/ft)	0.037429	Area (sq ft)		46.35	
Q Total (cfs)	120.00	Flow (cfs)		120.00	
Top Width (ft)	75.77	Top Width (ft)		75.77	
Vel Total (ft/s)	2.59	Avg. Vel. (ft/s)		2.59	
Max Chl Dpth (ft)	1.00	Hydr. Depth (ft)		0.61	
Conv. Total (cfs)	620.3	Conv. (cfs)		620.3	
Length Wtd. (ft)	100.00	Wetted Per. (ft)		75.81	
Min Ch El (ft)	6928.36	Shear (lb/sq ft)		1.43	
Alpha	1.00	Stream Power (lb/ft s)		3.70	
Frctn Loss (ft)	3.01	Cum Volume (acre-ft)	0.01	1.49	0.06
C & E Loss (ft)	0.00	Cum SA (acres)	0.07	1.28	0.15

Plan: Plan 01 CHAN EAST PR chan-east-pr RS: 1500 Profile: PF 1

E.G. Elev (ft)	6926.45	Element	Left OB	Channel	Right OB
Vel Head (ft)	0.13	Wt. n-Val.		0.080	
W.S. Elev (ft)	6926.32	Reach Len. (ft)	91.00	100.00	112.00
Crit W.S. (ft)		Flow Area (sq ft)		41.13	
E.G. Slope (ft/ft)	0.024682	Area (sq ft)		41.13	
Q Total (cfs)	120.00	Flow (cfs)		120.00	
Top Width (ft)	40.91	Top Width (ft)		40.91	
Vel Total (ft/s)	2.92	Avg. Vel. (ft/s)		2.92	
Max Chl Dpth (ft)	1.80	Hydr. Depth (ft)		1.01	
Conv. Total (cfs)	763.8	Conv. (cfs)		763.8	
Length Wtd. (ft)	100.00	Wetted Per. (ft)		41.13	
Min Ch El (ft)	6924.52	Shear (lb/sq ft)		1.54	
Alpha	1.00	Stream Power (lb/ft s)		4.50	
Frctn Loss (ft)	1.76	Cum Volume (acre-ft)	0.01	1.39	0.06
C & E Loss (ft)	0.02	Cum SA (acres)	0.07	1.15	0.15

Plan: Plan 01 CHAN EAST PR chan-east-pr RS: 1400 Profile: PF 1

E.G. Elev (ft)	6924.66	Element	Left OB	Channel	Right OB
Vel Head (ft)	0.06	Wt. n-Val.		0.080	
W.S. Elev (ft)	6924.60	Reach Len. (ft)	96.00	100.00	83.00
Crit W.S. (ft)		Flow Area (sq ft)		58.94	
E.G. Slope (ft/ft)	0.013218	Area (sq ft)		58.94	
Q Total (cfs)	120.00	Flow (cfs)		120.00	
Top Width (ft)	63.00	Top Width (ft)		63.00	
Vel Total (ft/s)	2.04	Avg. Vel. (ft/s)		2.04	
Max Chl Dpth (ft)	2.49	Hydr. Depth (ft)		0.94	
Conv. Total (cfs)	1043.8	Conv. (cfs)		1043.8	
Length Wtd. (ft)	100.00	Wetted Per. (ft)		63.31	
Min Ch El (ft)	6922.11	Shear (lb/sq ft)		0.77	
Alpha	1.00	Stream Power (lb/ft s)		1.56	
Frctn Loss (ft)	1.14	Cum Volume (acre-ft)	0.01	1.28	0.06
C & E Loss (ft)	0.00	Cum SA (acres)	0.07	1.03	0.15

Plan: Plan 01 CHAN EAST PR chan-east-pr RS: 1300 Profile: PF 1

E.G. Elev (ft)	6923.51	Element	Left OB	Channel	Right OB
Vel Head (ft)	0.06	Wt. n-Val.		0.080	
W.S. Elev (ft)	6923.45	Reach Len. (ft)	83.00	100.00	118.00
Crit W.S. (ft)		Flow Area (sq ft)		61.98	
E.G. Slope (ft/ft)	0.010011	Area (sq ft)		61.98	
Q Total (cfs)	120.00	Flow (cfs)		120.00	
Top Width (ft)	57.78	Top Width (ft)		57.78	
Vel Total (ft/s)	1.94	Avg. Vel. (ft/s)		1.94	
Max Chl Dpth (ft)	2.34	Hydr. Depth (ft)		1.07	
Conv. Total (cfs)	1199.3	Conv. (cfs)		1199.3	
Length Wtd. (ft)	100.55	Wetted Per. (ft)		58.28	
Min Ch El (ft)	6921.11	Shear (lb/sq ft)		0.66	
Alpha	1.00	Stream Power (lb/ft s)		1.29	
Frctn Loss (ft)	0.04	Cum Volume (acre-ft)	0.01	1.14	0.06
C & E Loss (ft)	0.02	Cum SA (acres)	0.07	0.89	0.15

Plan: Plan 01 CHAN EAST PR chan-east-pr RS: 1200 Profile: PF 1

E.G. Elev (ft)	6923.45	Element	Left OB	Channel	Right OB
Vel Head (ft)	0.00	Wt. n-Val.	0.080	0.080	0.080
W.S. Elev (ft)	6923.45	Reach Len. (ft)	191.00	200.00	169.00
Crit W.S. (ft)	6920.42	Flow Area (sq ft)	10.33	237.81	36.21
E.G. Slope (ft/ft)	0.000130	Area (sq ft)	10.33	237.81	36.21
Q Total (cfs)	120.00	Flow (cfs)	1.77	109.27	8.95
Top Width (ft)	116.74	Top Width (ft)	14.09	74.00	28.65
Vel Total (ft/s)	0.42	Avg. Vel. (ft/s)	0.17	0.46	0.25
Max Chl Dpth (ft)	4.26	Hydr. Depth (ft)	0.73	3.21	1.26
Conv. Total (cfs)	10505.3	Conv. (cfs)	155.3	9566.0	783.9
Length Wtd. (ft)	200.00	Wetted Per. (ft)	14.18	74.61	28.78
Min Ch El (ft)	6919.19	Shear (lb/sq ft)	0.01	0.03	0.01
Alpha	1.11	Stream Power (lb/ft s)	0.00	0.01	0.00
Frctn Loss (ft)		Cum Volume (acre-ft)	0.00	0.80	0.01
C & E Loss (ft)		Cum SA (acres)	0.05	0.74	0.11

Plan: Plan 01 CHAN EAST PR chan-east-pr RS: 1000 Profile: PF 1

E.G. Elev (ft)	6918.73	Element	Left OB	Channel	Right OB
Vel Head (ft)	0.11	Wt. n-Val.	0.080	0.080	0.080
W.S. Elev (ft)	6918.62	Reach Len. (ft)	103.00	100.00	98.00
Crit W.S. (ft)		Flow Area (sq ft)	2.06	41.94	5.45
E.G. Slope (ft/ft)	0.011875	Area (sq ft)	2.06	41.94	5.45
Q Total (cfs)	120.00	Flow (cfs)	1.93	112.90	5.17
Top Width (ft)	50.50	Top Width (ft)	6.54	27.00	16.96
Vel Total (ft/s)	2.43	Avg. Vel. (ft/s)	0.93	2.69	0.95
Max Chl Dpth (ft)	2.51	Hydr. Depth (ft)	0.32	1.55	0.32
Conv. Total (cfs)	1101.2	Conv. (cfs)	17.7	1036.0	47.5
Length Wtd. (ft)	99.98	Wetted Per. (ft)	6.57	27.35	16.98
Min Ch El (ft)	6916.11	Shear (lb/sq ft)	0.23	1.14	0.24
Alpha	1.17	Stream Power (lb/ft s)	0.22	3.06	0.23
Frctn Loss (ft)	1.25	Cum Volume (acre-ft)	0.00	0.69	0.01
C & E Loss (ft)	0.00	Cum SA (acres)	0.01	0.51	0.02

Plan: Plan 01 CHAN EAST PR chan-east-pr RS: 900 Profile: PF 1

E.G. Elev (ft)	6917.48	Element	Left OB	Channel	Right OB
Vel Head (ft)	0.10	Wt. n-Val.		0.080	
W.S. Elev (ft)	6917.38	Reach Len. (ft)	111.00	100.00	84.00
Crit W.S. (ft)		Flow Area (sq ft)		48.04	
E.G. Slope (ft/ft)	0.013156	Area (sq ft)		48.04	
Q Total (cfs)	120.00	Flow (cfs)		120.00	
Top Width (ft)	37.27	Top Width (ft)		37.27	
Vel Total (ft/s)	2.50	Avg. Vel. (ft/s)		2.50	
Max Chl Dpth (ft)	2.36	Hydr. Depth (ft)		1.29	
Conv. Total (cfs)	1046.2	Conv. (cfs)		1046.2	
Length Wtd. (ft)	100.00	Wetted Per. (ft)		37.85	
Min Ch El (ft)	6915.02	Shear (lb/sq ft)		1.04	
Alpha	1.00	Stream Power (lb/ft s)		2.60	
Frctn Loss (ft)	0.99	Cum Volume (acre-ft)		0.58	
C & E Loss (ft)	0.01	Cum SA (acres)		0.43	

Plan: Plan 01 CHAN EAST PR chan-east-pr RS: 800 Profile: PF 1

E.G. Elev (ft)	6916.48	Element	Left OB	Channel	Right OB
Vel Head (ft)	0.06	Wt. n-Val.		0.080	
W.S. Elev (ft)	6916.41	Reach Len. (ft)	100.50	100.00	100.00
Crit W.S. (ft)		Flow Area (sq ft)		58.68	
E.G. Slope (ft/ft)	0.007767	Area (sq ft)		58.68	
Q Total (cfs)	120.00	Flow (cfs)		120.00	
Top Width (ft)	41.67	Top Width (ft)		41.67	
Vel Total (ft/s)	2.04	Avg. Vel. (ft/s)		2.04	
Max Chl Dpth (ft)	2.56	Hydr. Depth (ft)		1.41	
Conv. Total (cfs)	1361.6	Conv. (cfs)		1361.6	
Length Wtd. (ft)	100.00	Wetted Per. (ft)		42.03	
Min Ch El (ft)	6913.85	Shear (lb/sq ft)		0.68	
Alpha	1.00	Stream Power (lb/ft s)		1.38	
Frctn Loss (ft)	0.74	Cum Volume (acre-ft)		0.46	
C & E Loss (ft)	0.00	Cum SA (acres)		0.34	

Plan: Plan 01 CHAN EAST PR chan-east-pr RS: 700 Profile: PF 1

E.G. Elev (ft)	6915.73	Element	Left OB	Channel	Right OB
Vel Head (ft)	0.05	Wt. n-Val.		0.080	
W.S. Elev (ft)	6915.68	Reach Len. (ft)	82.00	100.00	114.00
Crit W.S. (ft)		Flow Area (sq ft)		64.05	
E.G. Slope (ft/ft)	0.007063	Area (sq ft)		64.05	
Q Total (cfs)	120.00	Flow (cfs)		120.00	
Top Width (ft)	48.08	Top Width (ft)		48.08	
Vel Total (ft/s)	1.87	Avg. Vel. (ft/s)		1.87	
Max Chl Dpth (ft)	2.55	Hydr. Depth (ft)		1.33	
Conv. Total (cfs)	1427.8	Conv. (cfs)		1427.8	
Length Wtd. (ft)	100.00	Wetted Per. (ft)		48.70	
Min Ch El (ft)	6913.13	Shear (lb/sq ft)		0.58	
Alpha	1.00	Stream Power (lb/ft s)		1.09	
Frctn Loss (ft)	1.34	Cum Volume (acre-ft)		0.32	
C & E Loss (ft)	0.01	Cum SA (acres)		0.24	

Plan: Plan 01 CHAN EAST PR chan-east-pr RS: 600 Profile: PF 1

E.G. Elev (ft)	6914.38	Element	Left OB	Channel	Right OB
Vel Head (ft)	0.20	Wt. n-Val.		0.080	
W.S. Elev (ft)	6914.18	Reach Len. (ft)	94.00	100.00	104.00
Crit W.S. (ft)		Flow Area (sq ft)		33.30	
E.G. Slope (ft/ft)	0.034817	Area (sq ft)		33.30	
Q Total (cfs)	120.00	Flow (cfs)		120.00	
Top Width (ft)	31.11	Top Width (ft)		31.11	
Vel Total (ft/s)	3.60	Avg. Vel. (ft/s)		3.60	
Max Chl Dpth (ft)	2.05	Hydr. Depth (ft)		1.07	
Conv. Total (cfs)	643.1	Conv. (cfs)		643.1	
Length Wtd. (ft)	100.00	Wetted Per. (ft)		31.40	
Min Ch El (ft)	6912.13	Shear (lb/sq ft)		2.30	
Alpha	1.00	Stream Power (lb/ft s)		8.31	
Frctn Loss (ft)	1.63	Cum Volume (acre-ft)		0.21	
C & E Loss (ft)	0.03	Cum SA (acres)		0.15	

Plan: Plan 01 CHAN EAST PR chan-east-pr RS: 500 Profile: PF 1

E.G. Elev (ft)	6912.72	Element	Left OB	Channel	Right OB
Vel Head (ft)	0.09	Wt. n-Val.		0.080	
W.S. Elev (ft)	6912.63	Reach Len. (ft)	87.00	100.00	107.00
Crit W.S. (ft)		Flow Area (sq ft)		51.05	
E.G. Slope (ft/ft)	0.009428	Area (sq ft)		51.05	
Q Total (cfs)	120.00	Flow (cfs)		120.00	
Top Width (ft)	33.77	Top Width (ft)		33.77	
Vel Total (ft/s)	2.35	Avg. Vel. (ft/s)		2.35	
Max Chl Dpth (ft)	2.74	Hydr. Depth (ft)		1.51	
Conv. Total (cfs)	1235.9	Conv. (cfs)		1235.9	
Length Wtd. (ft)	100.00	Wetted Per. (ft)		34.30	
Min Ch El (ft)	6909.89	Shear (lb/sq ft)		0.88	
Alpha	1.00	Stream Power (lb/ft s)		2.06	
Frctn Loss (ft)	1.10	Cum Volume (acre-ft)		0.11	
C & E Loss (ft)	0.00	Cum SA (acres)		0.07	

Plan: Plan 01 CHAN EAST PR chan-east-pr RS: 400 Profile: PF 1

E.G. Elev (ft)	6911.61	Element	Left OB	Channel	Right OB
Vel Head (ft)	0.11	Wt. n-Val.		0.080	
W.S. Elev (ft)	6911.50	Reach Len. (ft)			
Crit W.S. (ft)	6910.69	Flow Area (sq ft)		44.70	
E.G. Slope (ft/ft)	0.013008	Area (sq ft)		44.70	
Q Total (cfs)	120.00	Flow (cfs)		120.00	
Top Width (ft)	30.55	Top Width (ft)		30.55	
Vel Total (ft/s)	2.68	Avg. Vel. (ft/s)		2.68	
Max Chl Dpth (ft)	2.69	Hydr. Depth (ft)		1.46	
Conv. Total (cfs)	1052.2	Conv. (cfs)		1052.2	
Length Wtd. (ft)		Wetted Per. (ft)		31.33	
Min Ch El (ft)	6908.81	Shear (lb/sq ft)		1.16	
Alpha	1.00	Stream Power (lb/ft s)		3.11	
Frctn Loss (ft)		Cum Volume (acre-ft)			
C & E Loss (ft)		Cum SA (acres)			

EAST CHAN PR NEW Plan: Plan 01 11/22/2022
River = CHAN EAST PR Reach = chan-east-pr RS = 2600

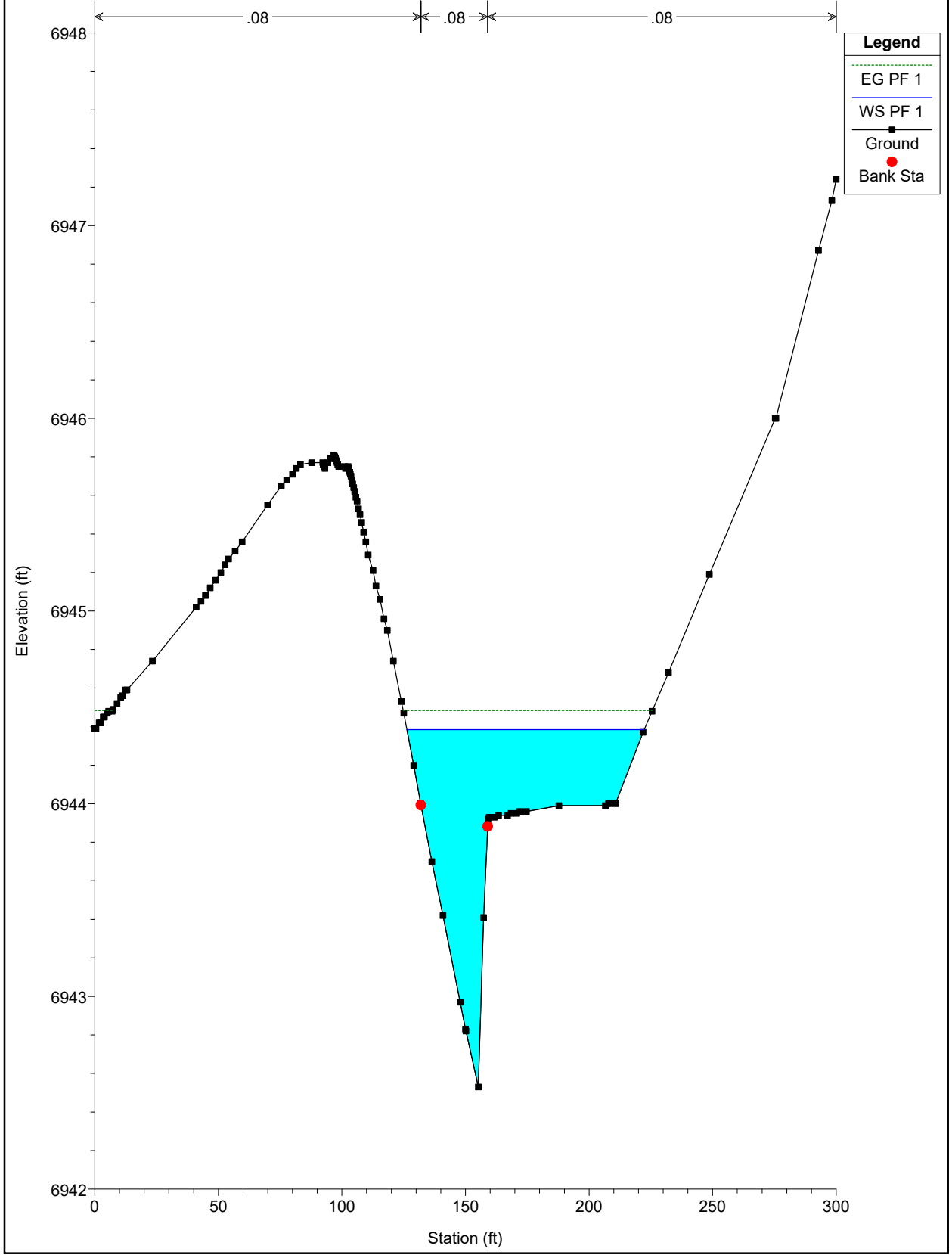

EAST CHAN PR NEW Plan: Plan 01 11/22/2022
River = CHAN EAST PR Reach = chan-east-pr RS = 2500

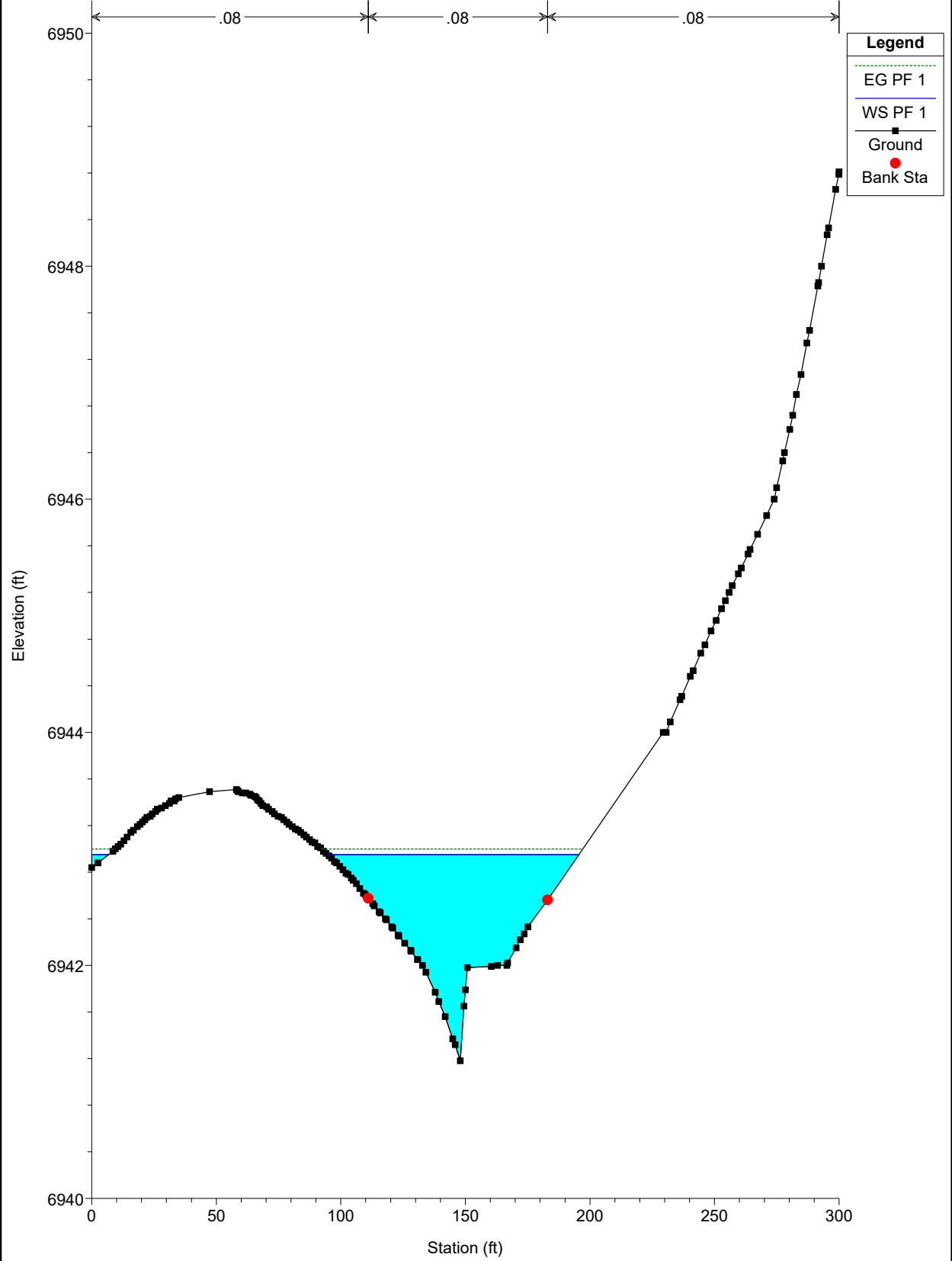

EAST CHAN PR NEW Plan: Plan 01 11/22/2022
River = CHAN EAST PR Reach = chan-east-pr RS = 2400

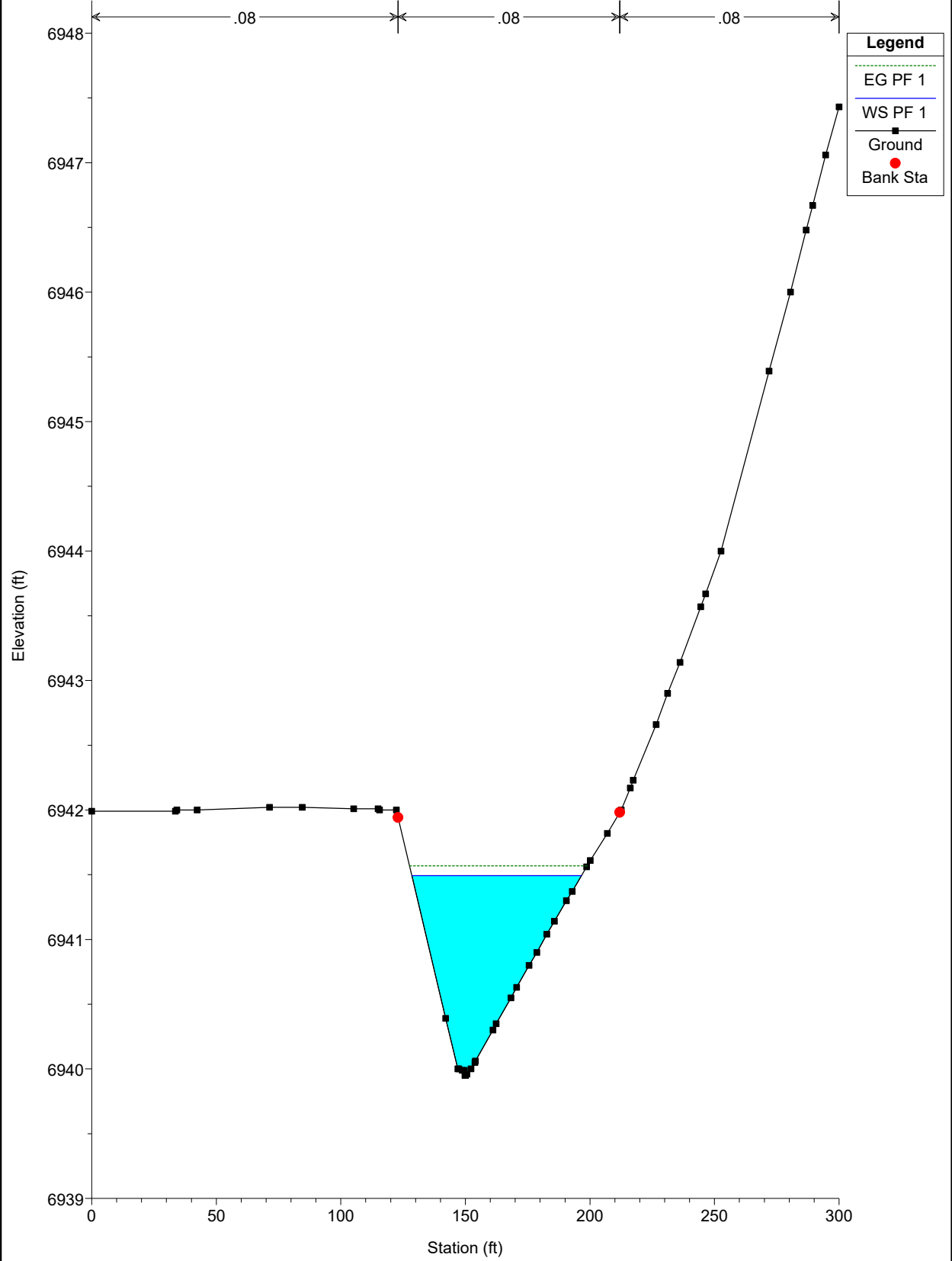

EAST CHAN PR NEW Plan: Plan 01 11/22/2022
River = CHAN EAST PR Reach = chan-east-pr RS = 2300

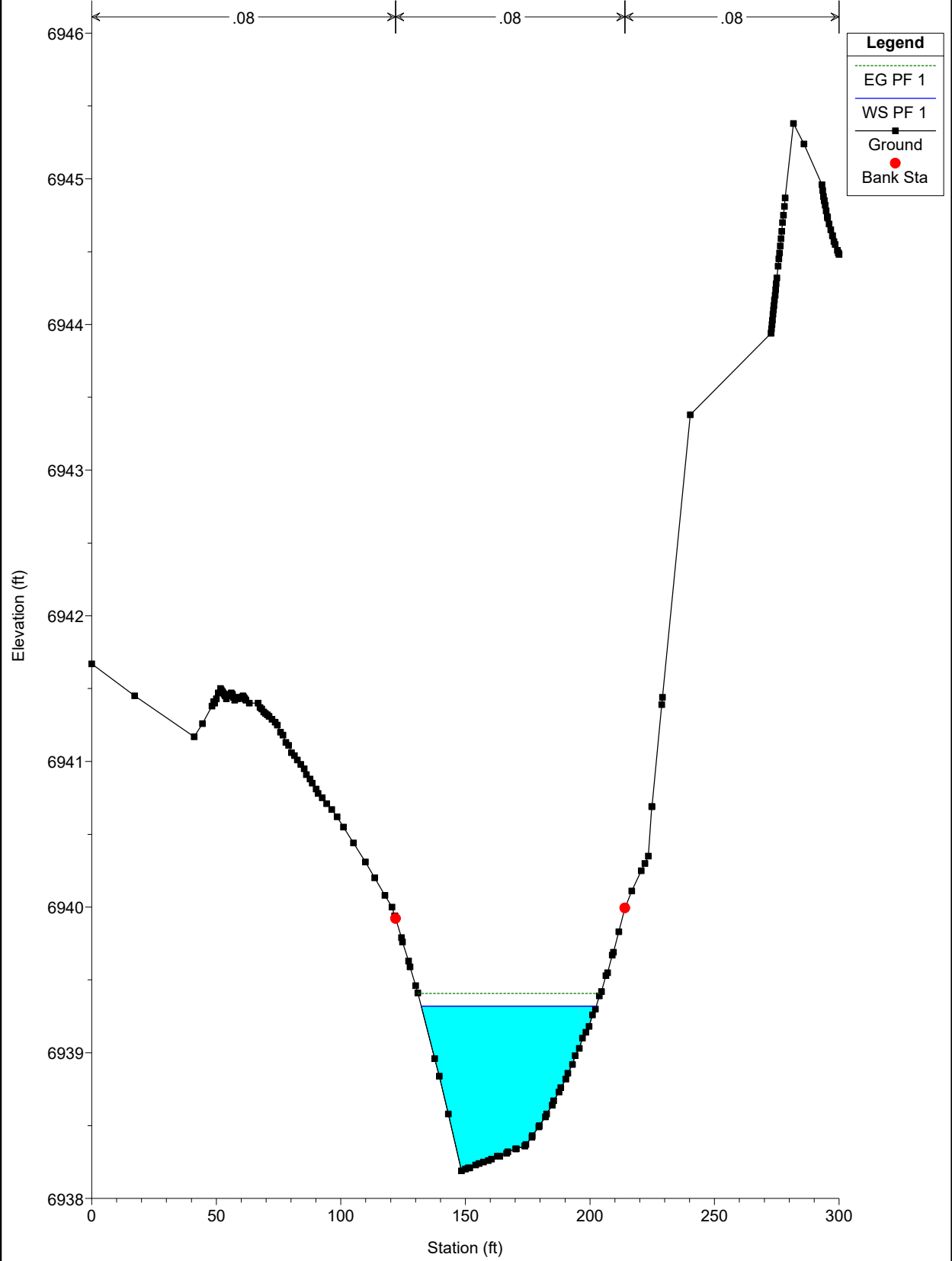

EAST CHAN PR NEW Plan: Plan 01 11/22/2022
River = CHAN EAST PR Reach = chan-east-pr RS = 2200

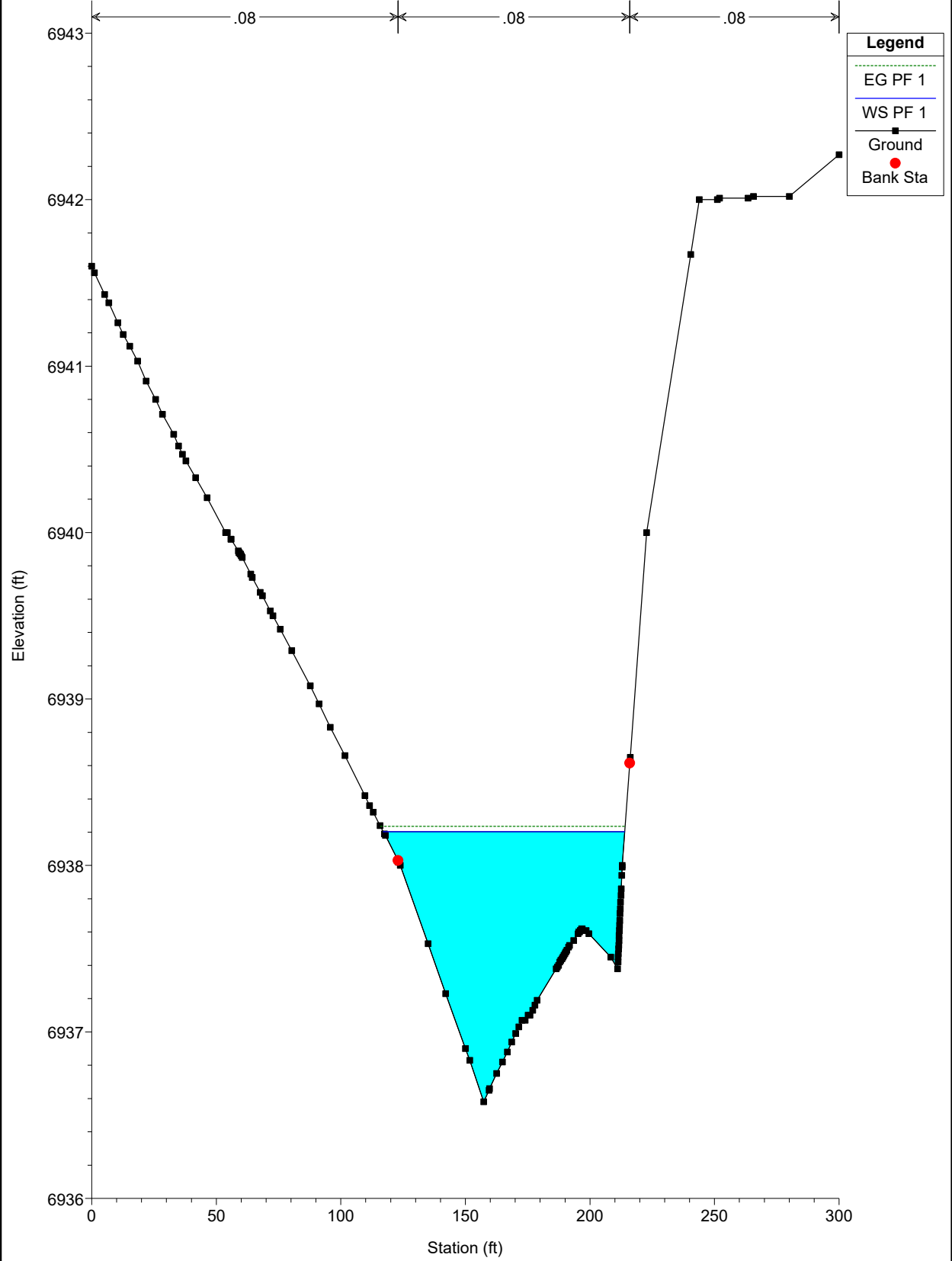

EAST CHAN PR NEW Plan: Plan 01 11/22/2022
River = CHAN EAST PR Reach = chan-east-pr RS = 2100

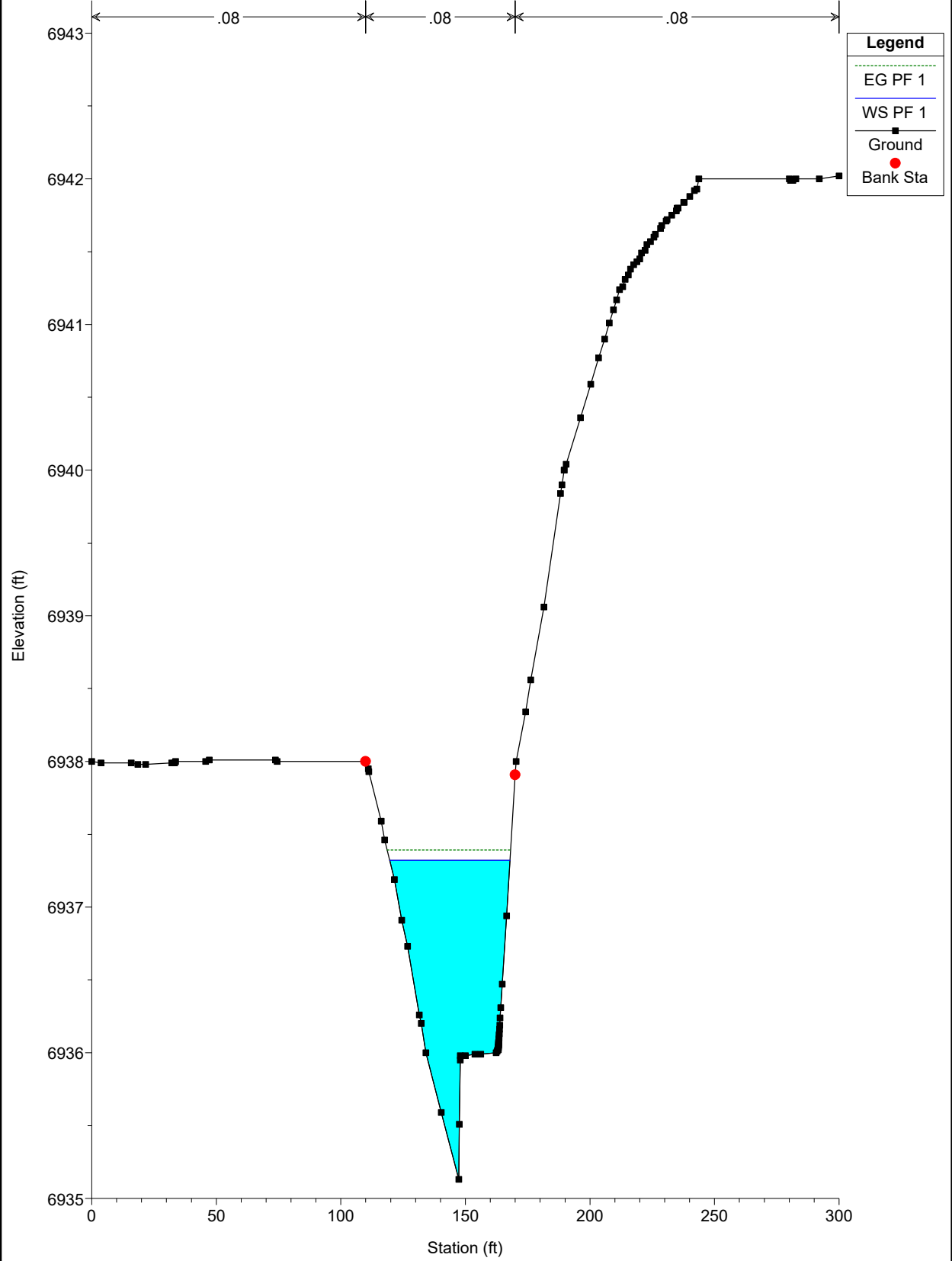

EAST CHAN PR NEW Plan: Plan 01 11/22/2022
River = CHAN EAST PR Reach = chan-east-pr RS = 2010.45

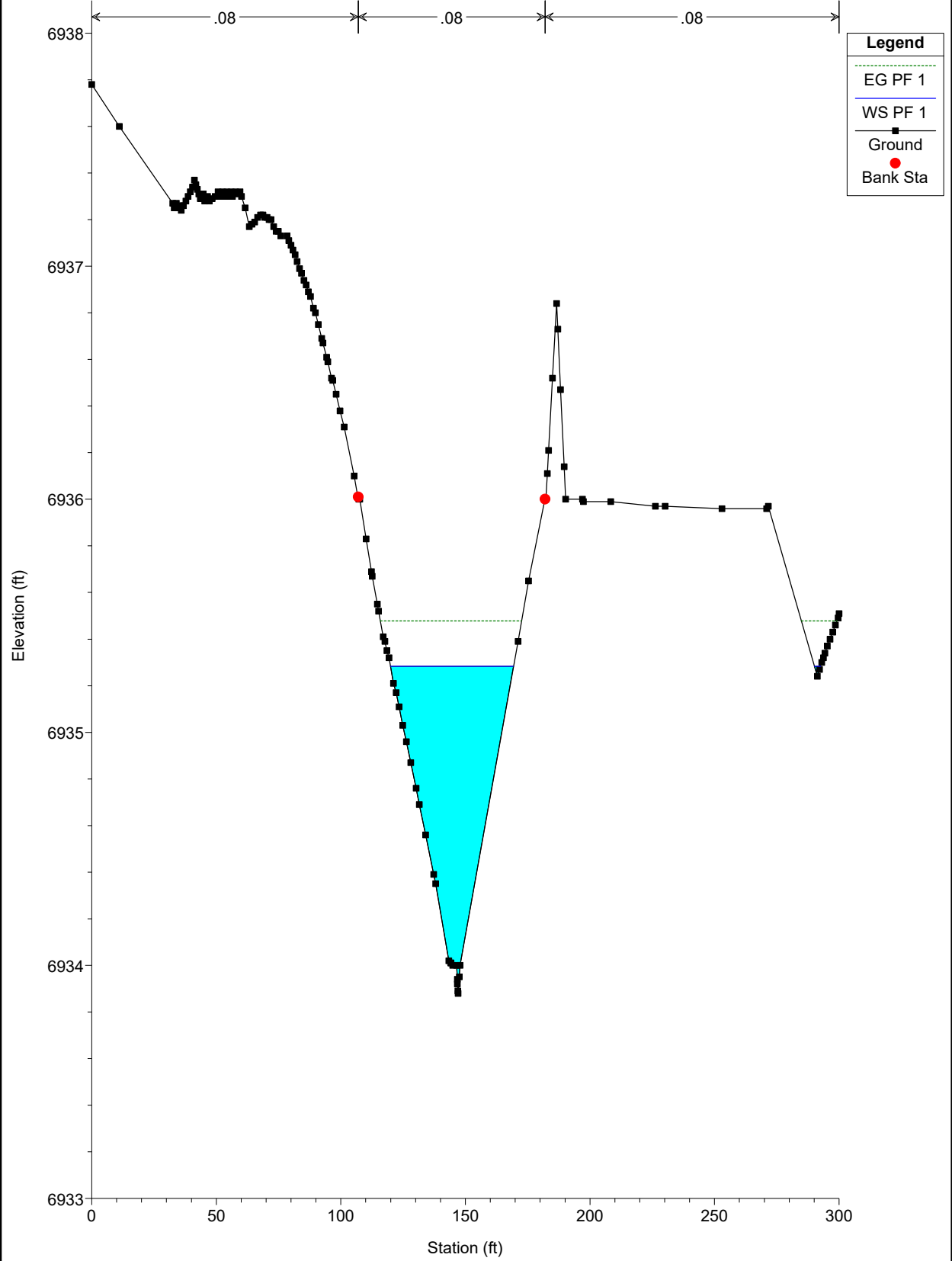

EAST CHAN PR NEW Plan: Plan 01 11/22/2022
River = CHAN EAST PR Reach = chan-east-pr RS = 1900

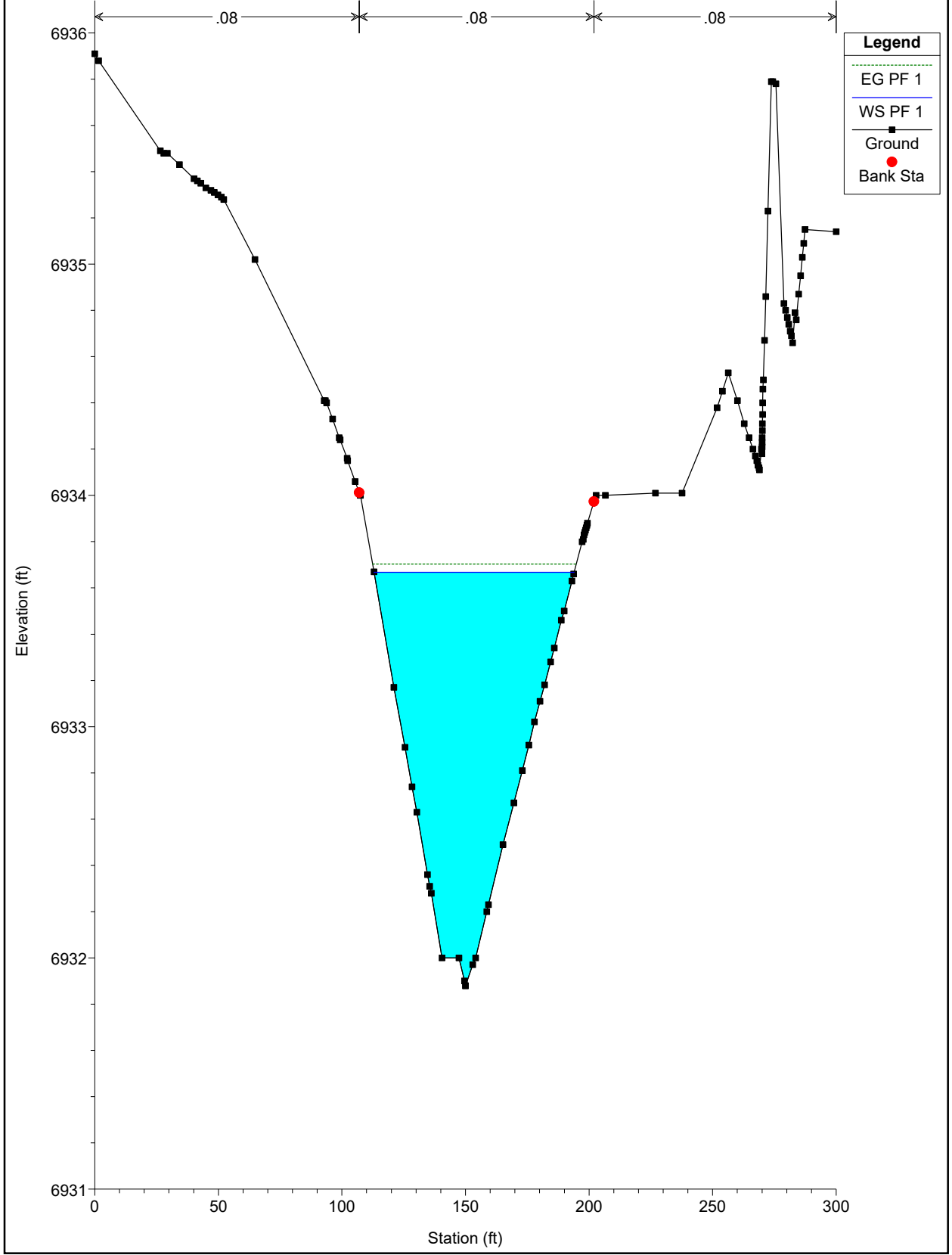

EAST CHAN PR NEW Plan: Plan 01 11/22/2022
River = CHAN EAST PR Reach = chan-east-pr RS = 1801.17

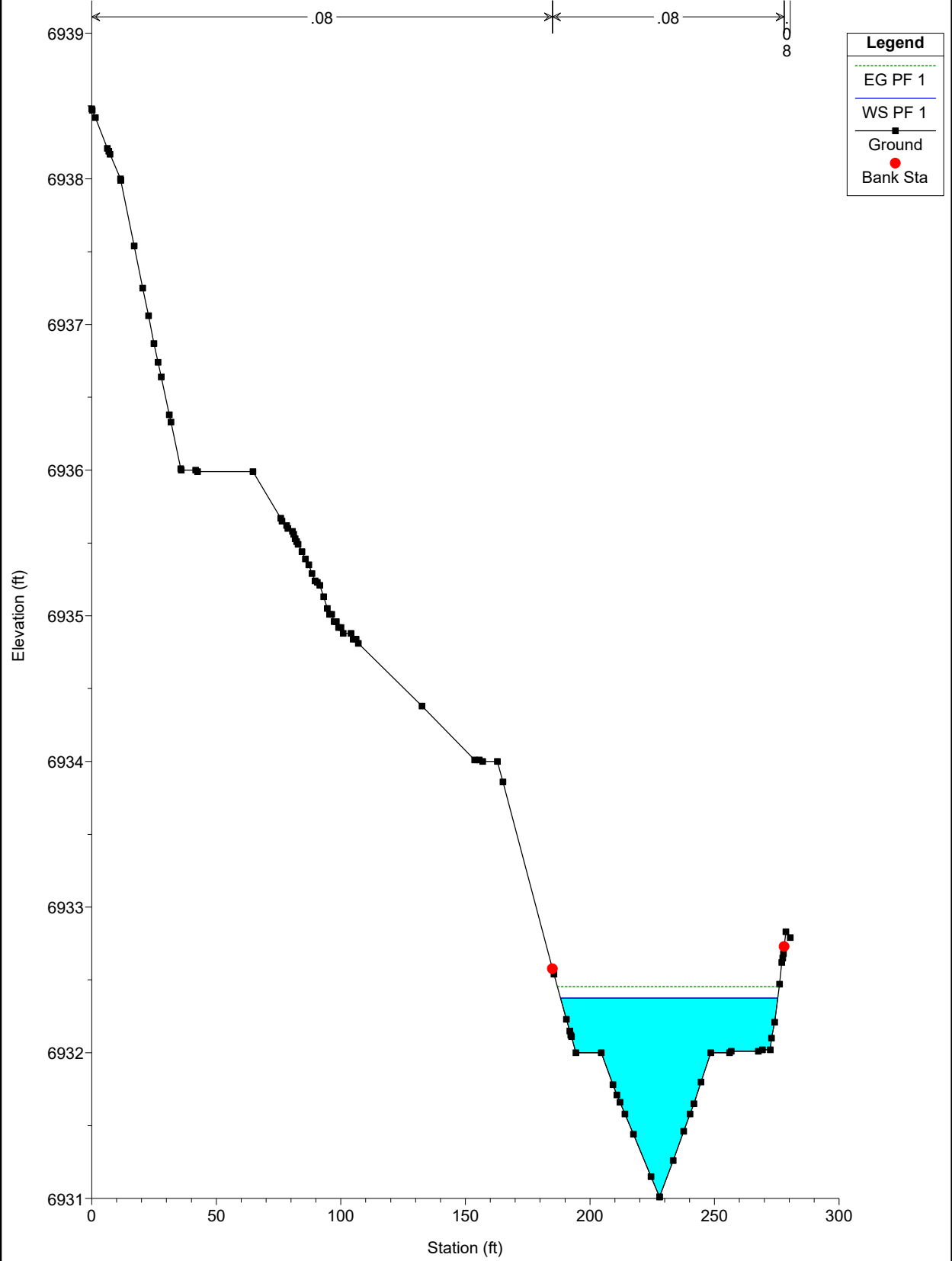

EAST CHAN PR NEW Plan: Plan 01 11/22/2022
River = CHAN EAST PR Reach = chan-east-pr RS = 1694.83

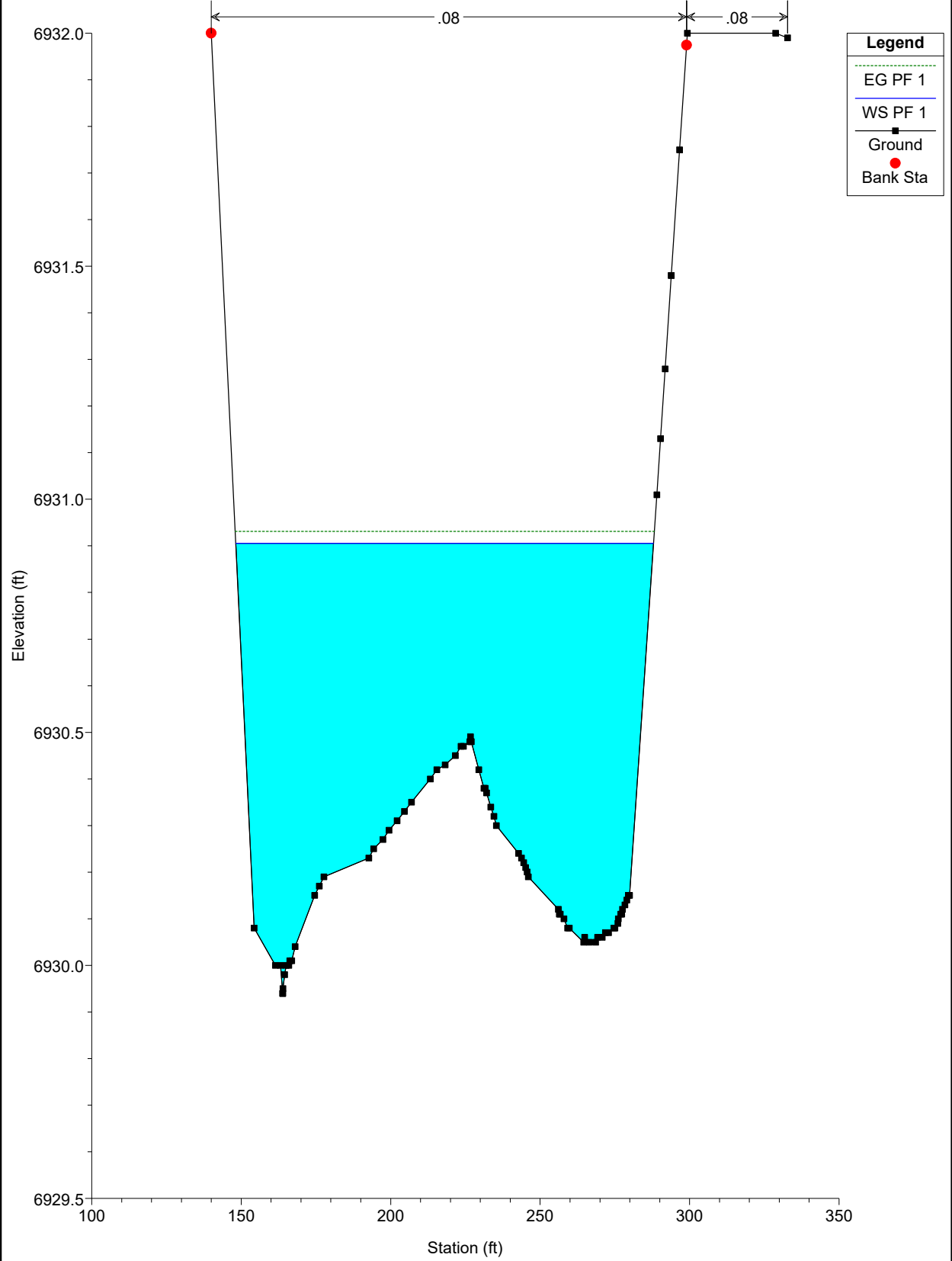

EAST CHAN PR NEW Plan: Plan 01 11/22/2022
River = CHAN EAST PR Reach = chan-east-pr RS = 1600

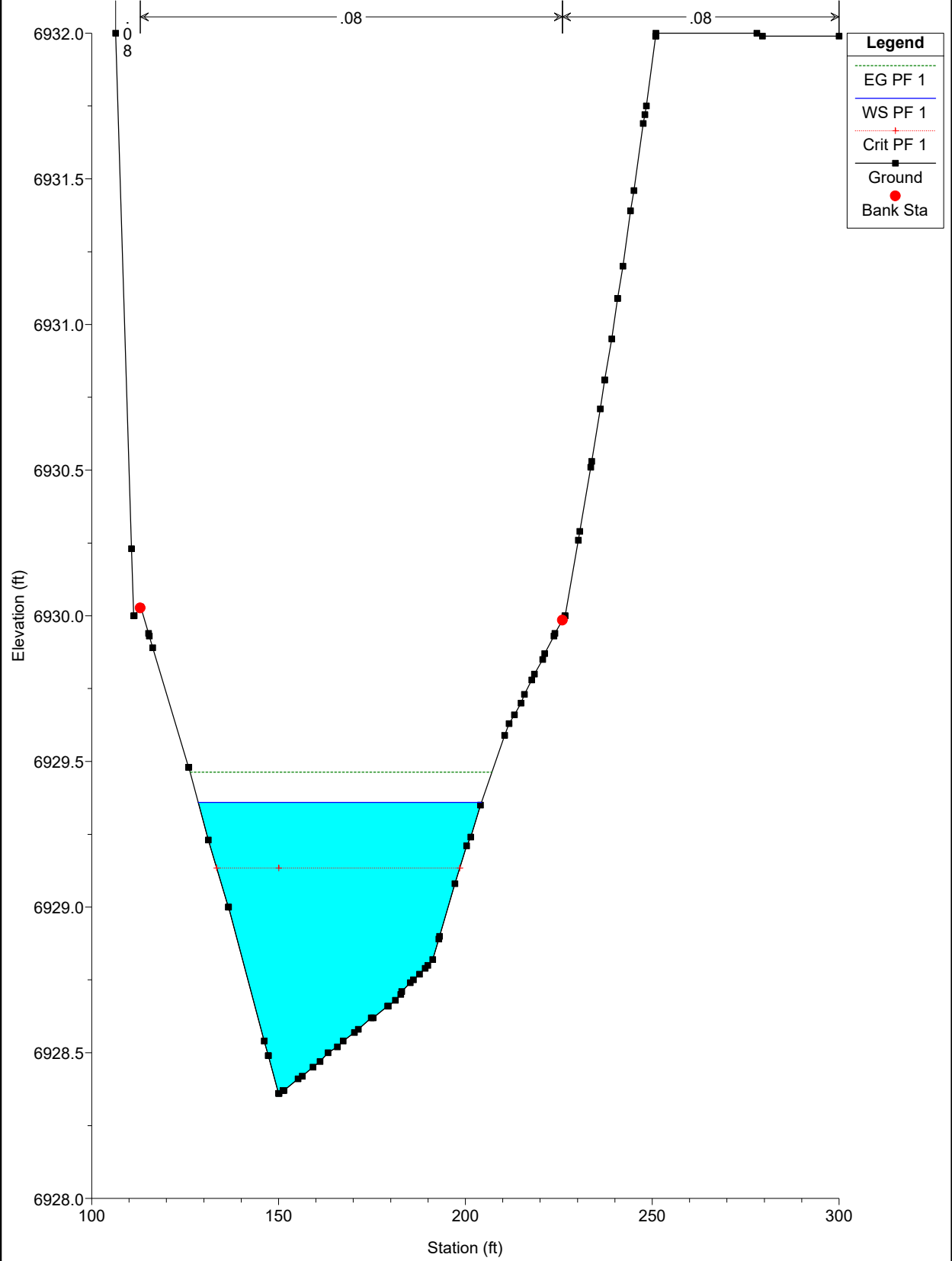

EAST CHAN PR NEW Plan: Plan 01 11/22/2022
River = CHAN EAST PR Reach = chan-east-pr RS = 1500

← .08 → .08 .08 →

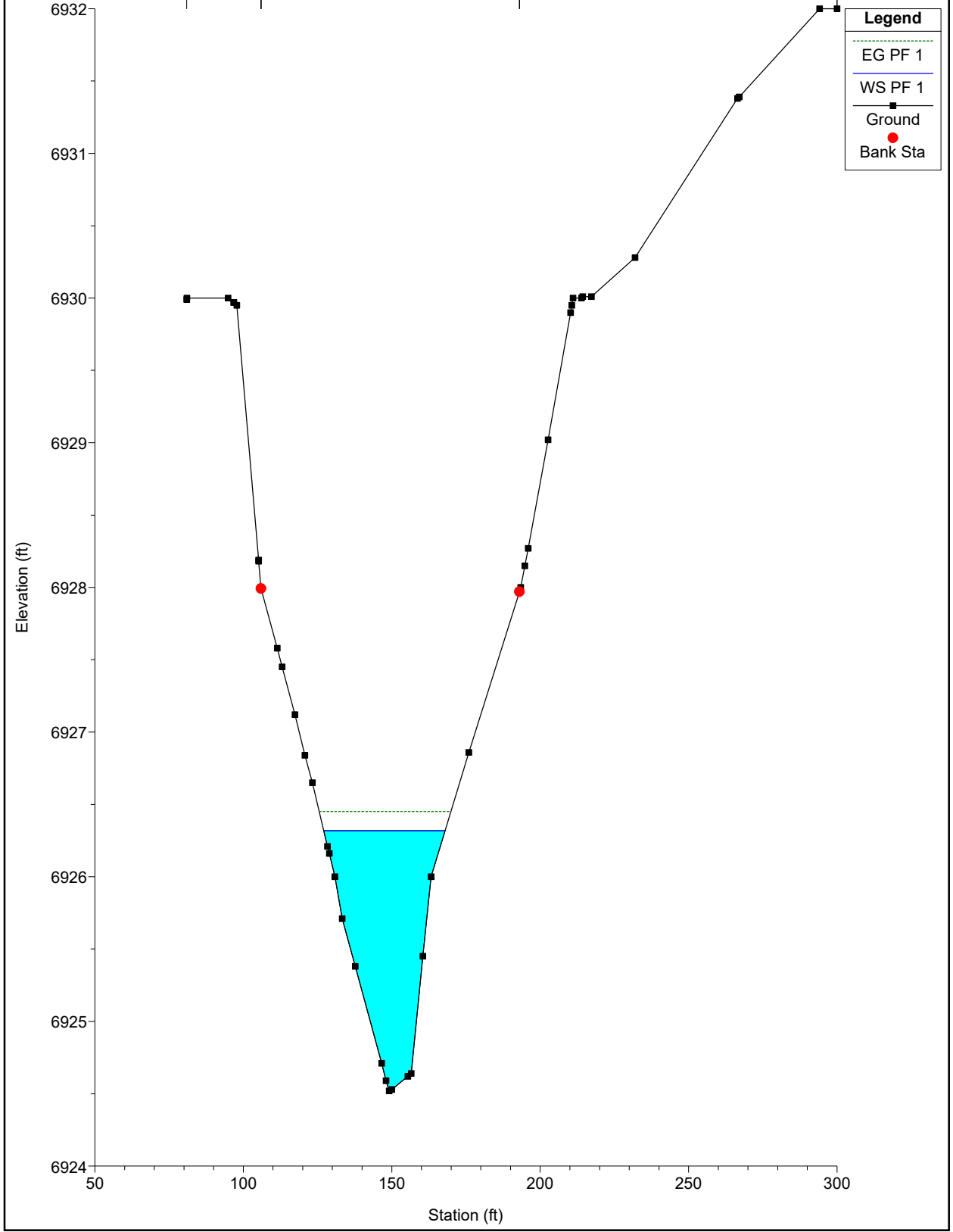

EAST CHAN PR NEW Plan: Plan 01 11/22/2022

River = CHAN EAST PR Reach = chan-east-pr RS = 1400

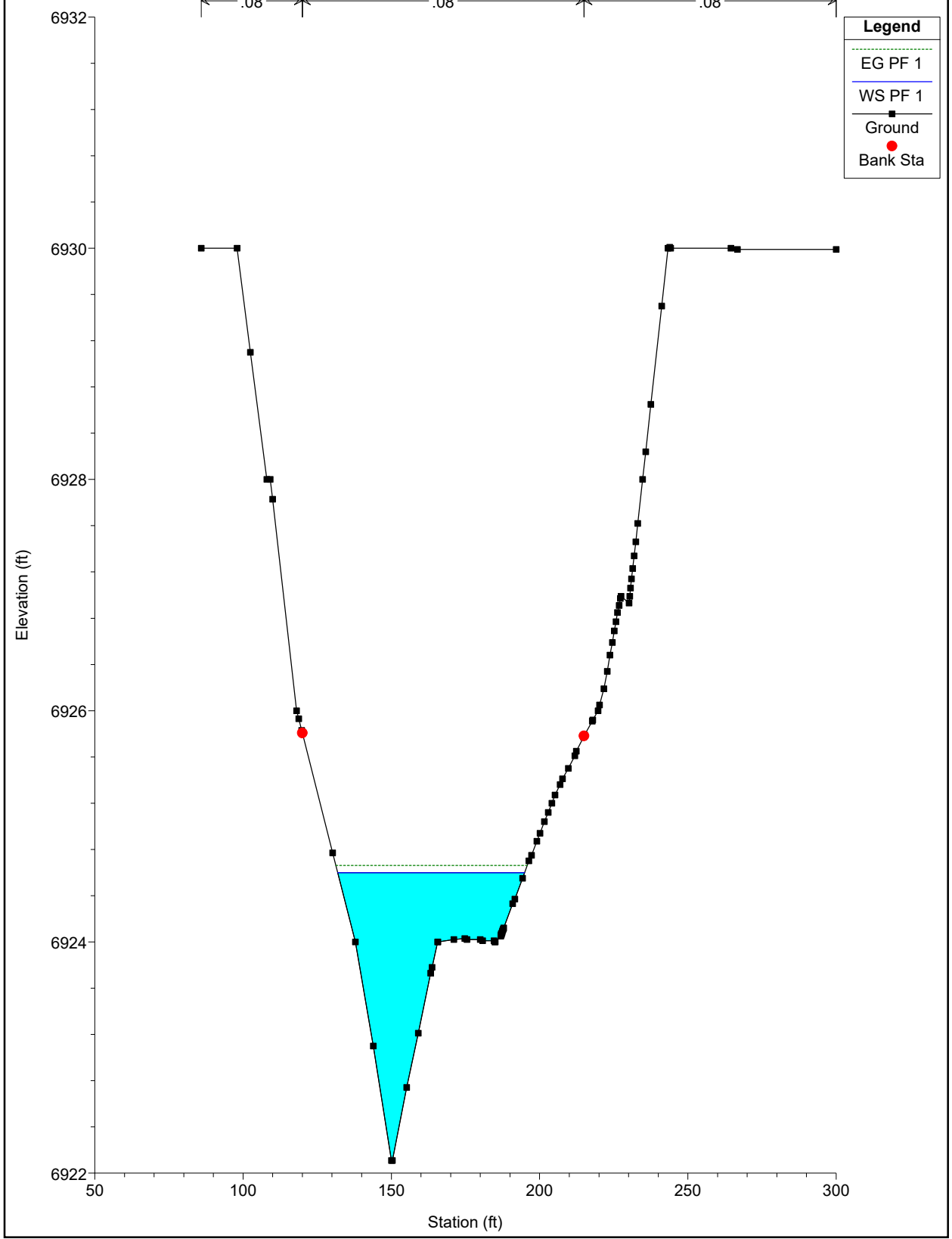

EAST CHAN PR NEW Plan: Plan 01 11/22/2022
River = CHAN EAST PR Reach = chan-east-pr RS = 1300

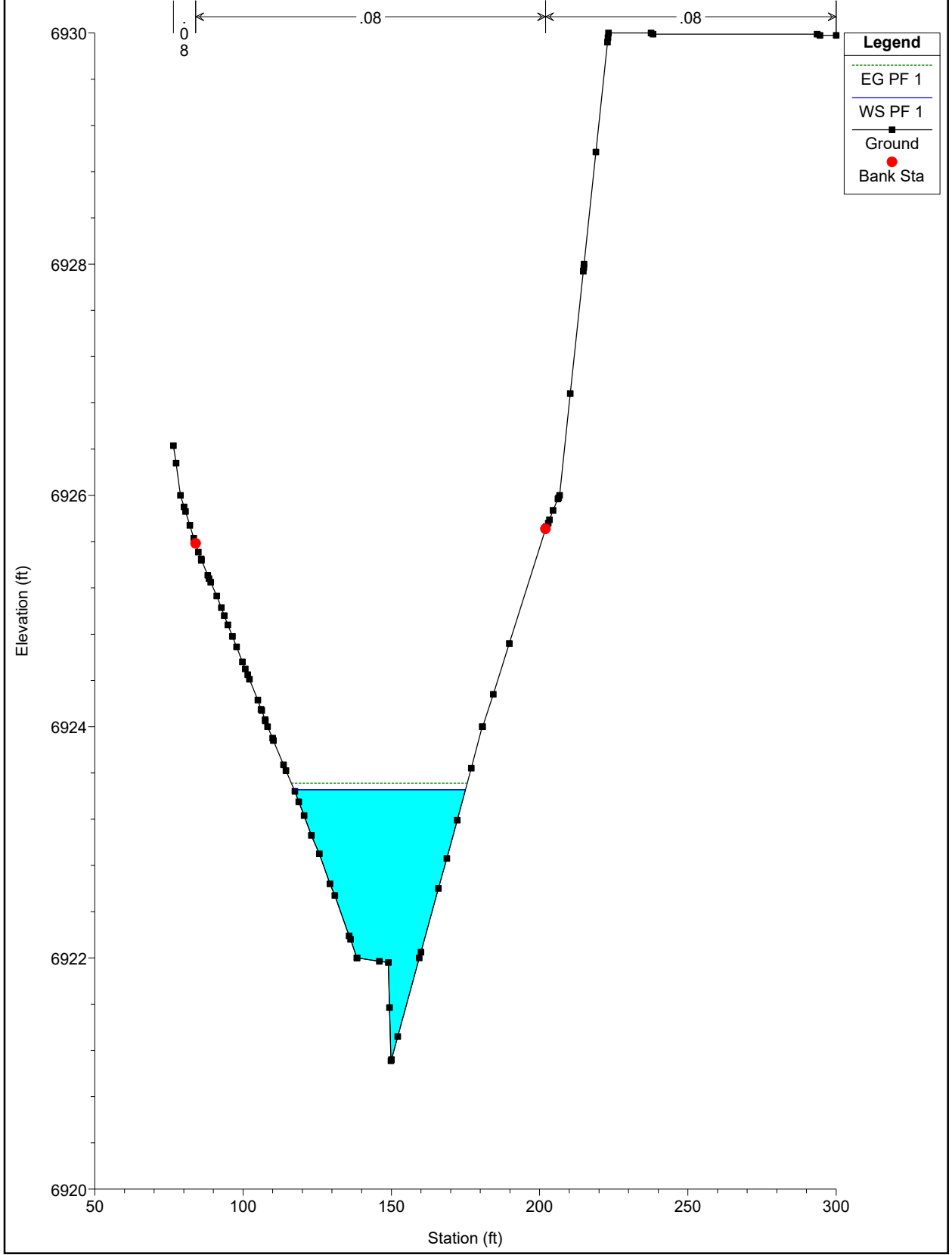

EAST CHAN PR NEW Plan: Plan 01 11/22/2022
River = CHAN EAST PR Reach = chan-east-pr RS = 1200

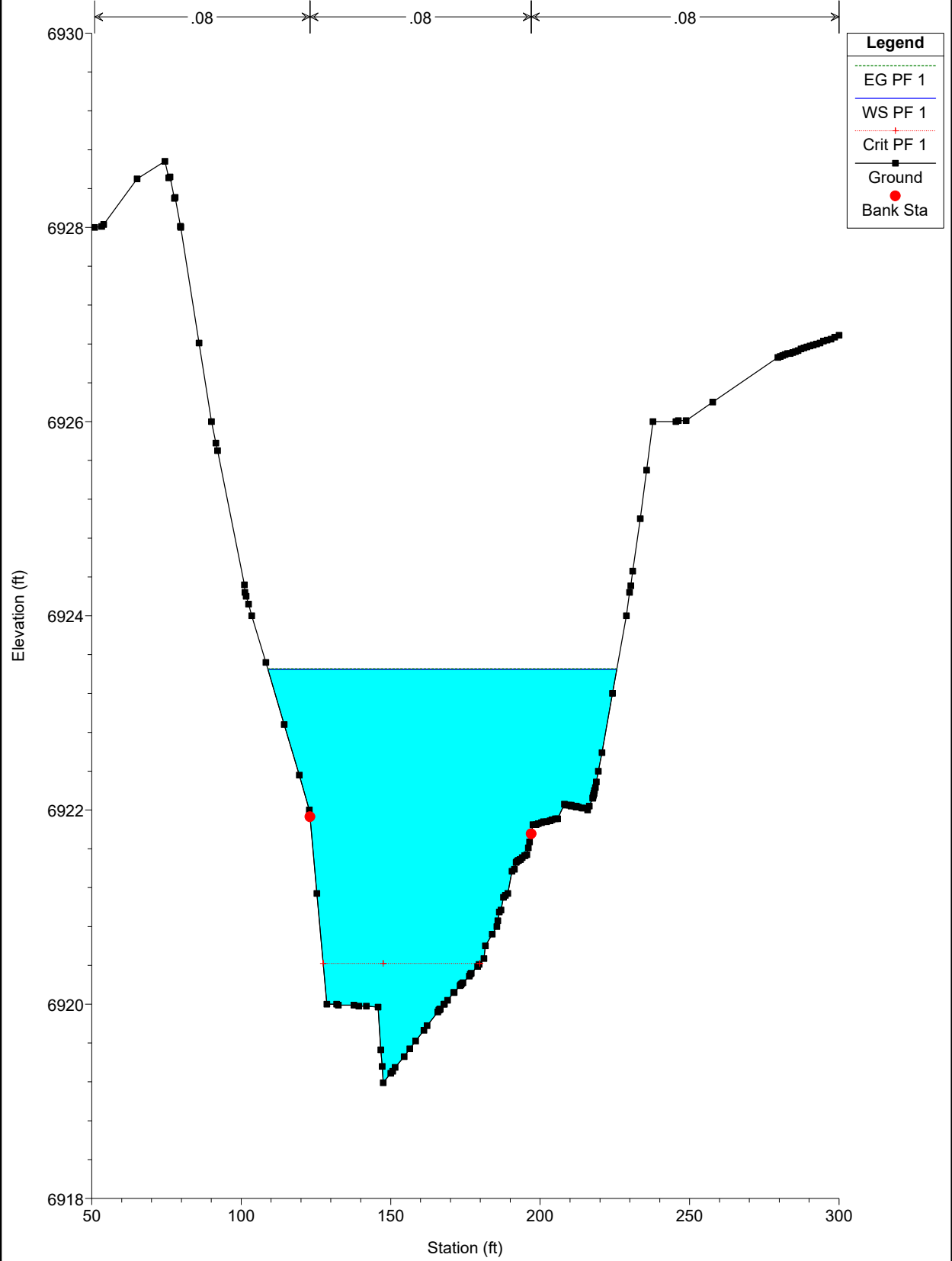

EAST CHAN PR NEW Plan: Plan 01 11/22/2022
River = CHAN EAST PR Reach = chan-east-pr RS = 1111.15 Culv

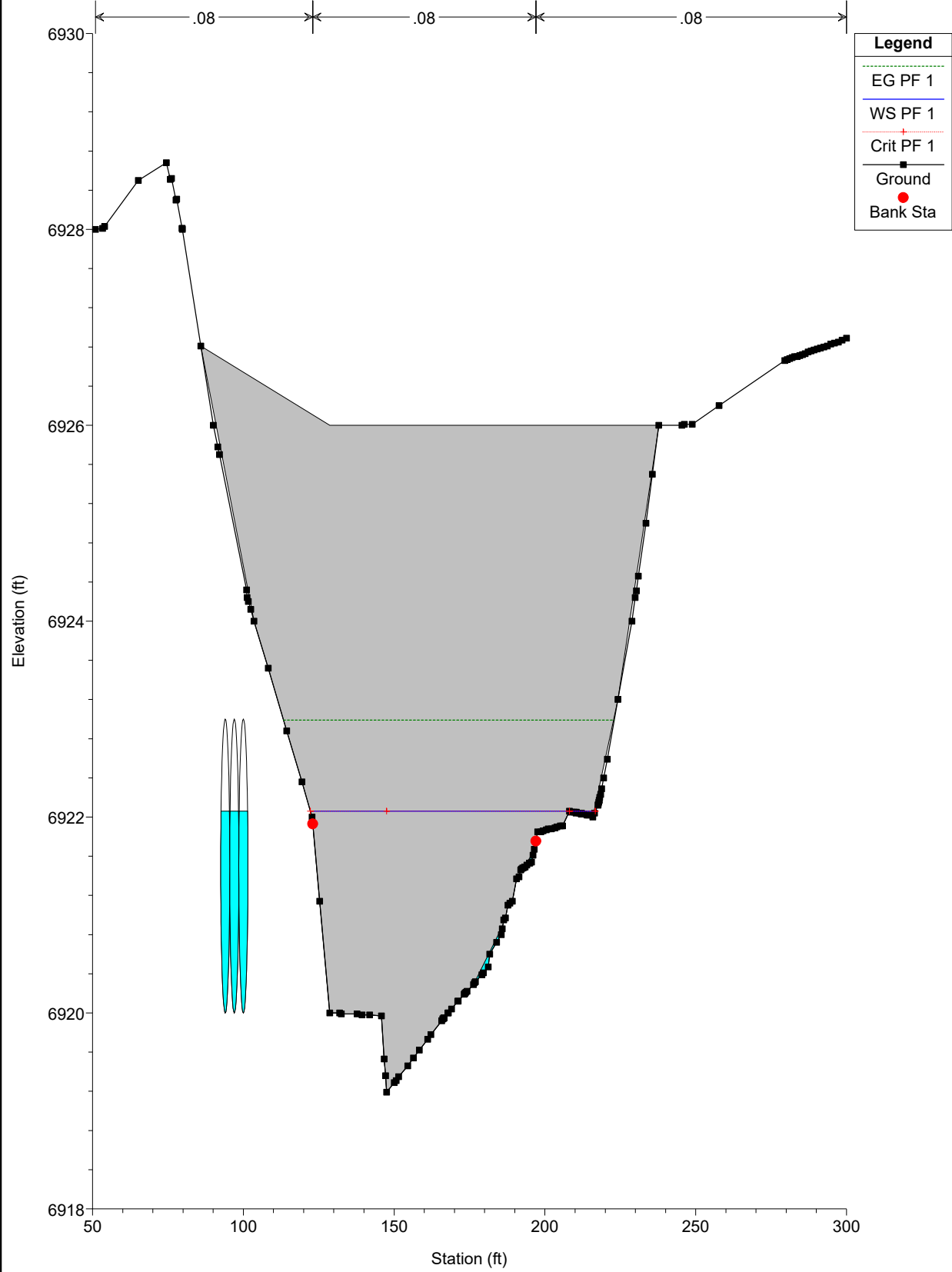

EAST CHAN PR NEW Plan: Plan 01 11/22/2022
River = CHAN EAST PR Reach = chan-east-pr RS = 1000

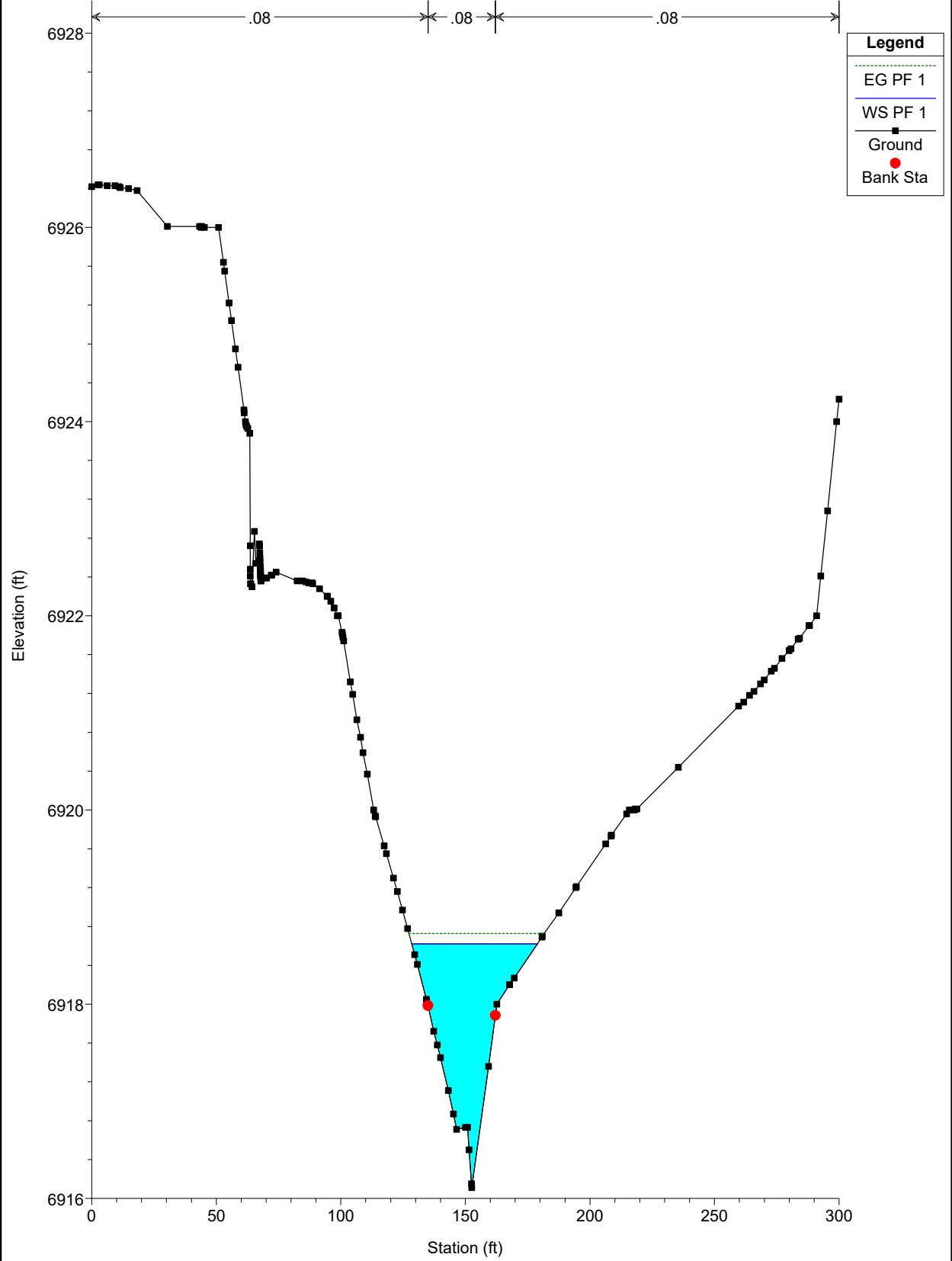

EAST CHAN PR NEW Plan: Plan 01 11/22/2022
River = CHAN EAST PR Reach = chan-east-pr RS = 900

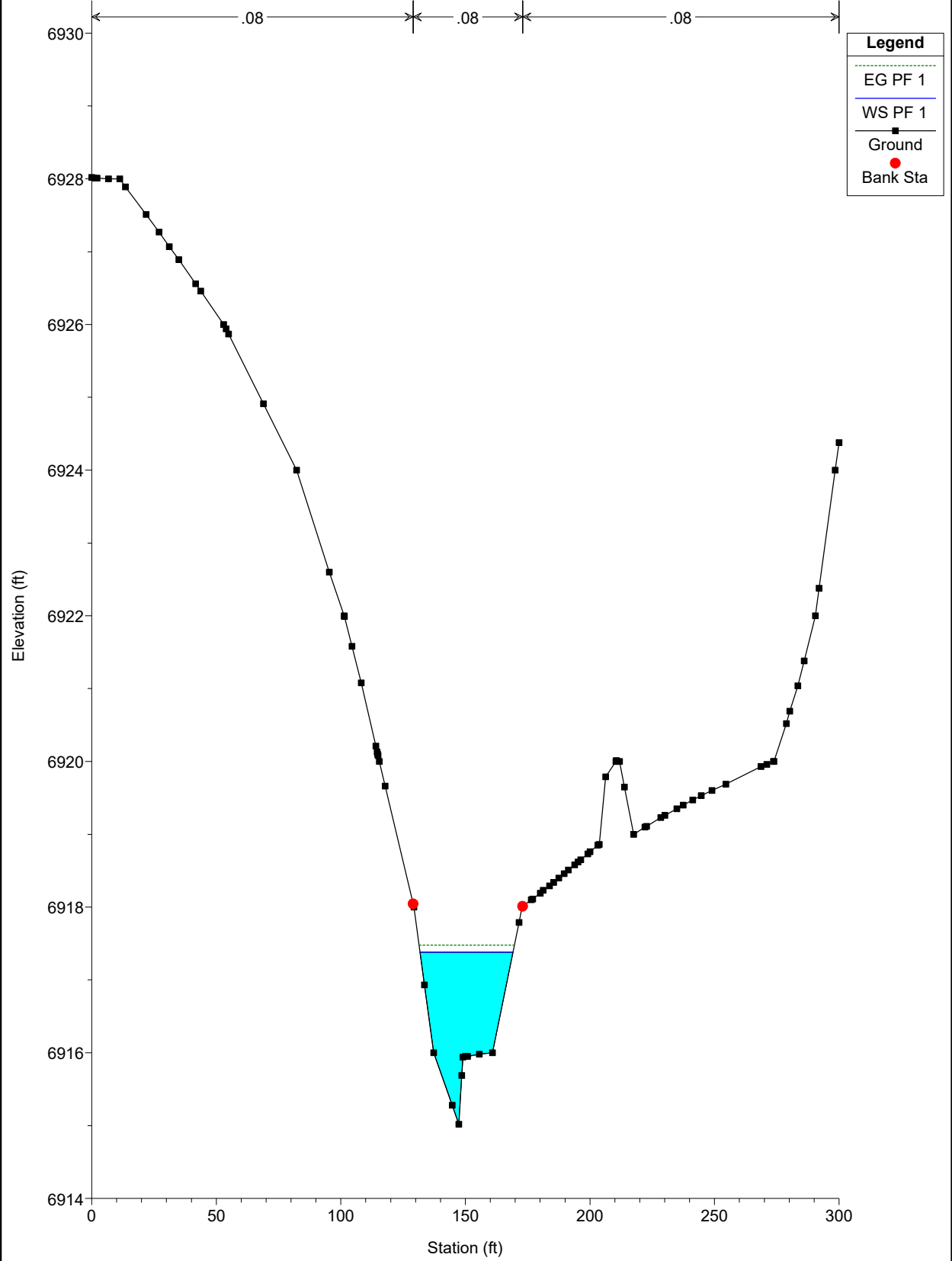

EAST CHAN PR NEW Plan: Plan 01 11/22/2022
River = CHAN EAST PR Reach = chan-east-pr RS = 800

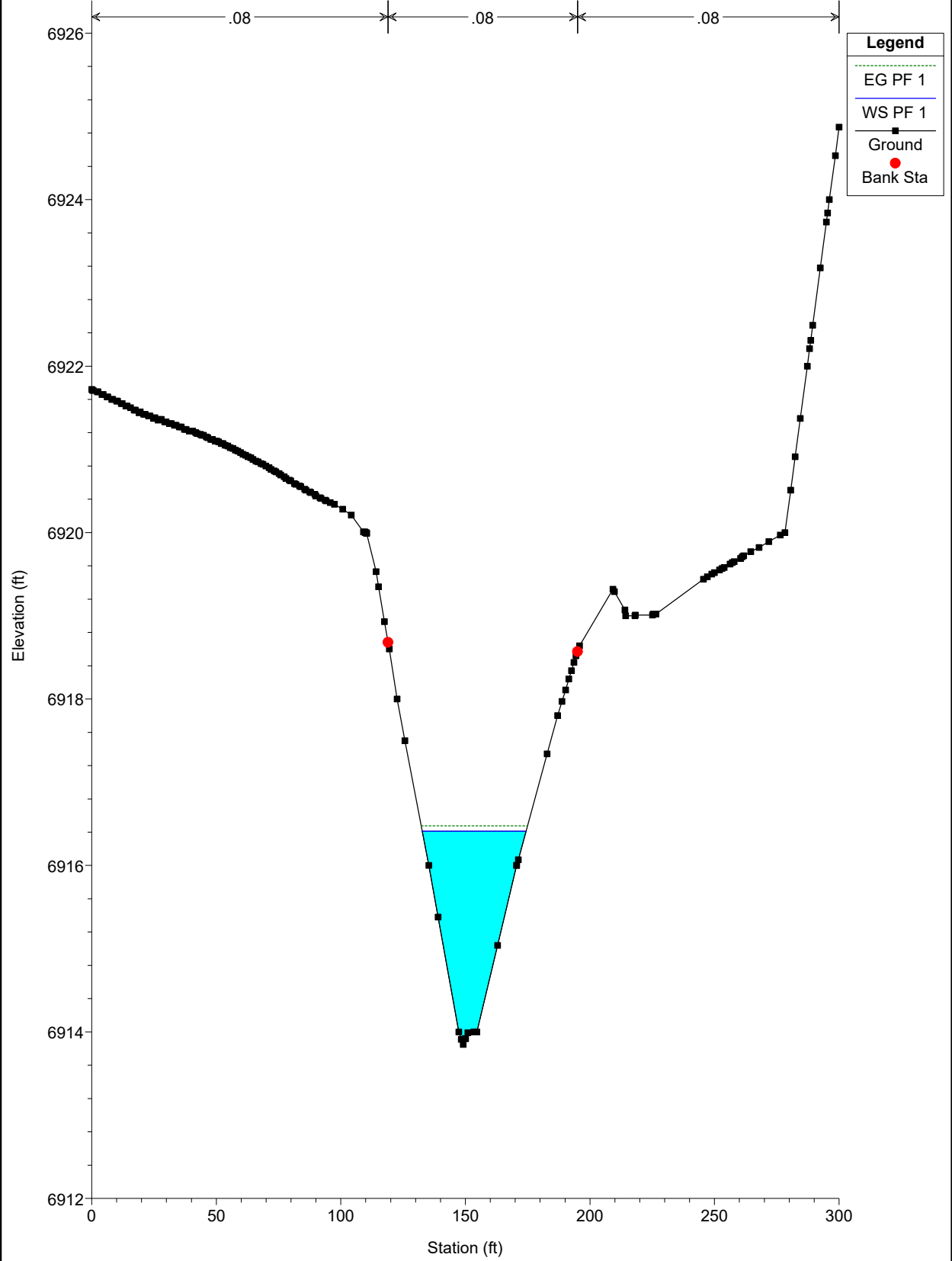

EAST CHAN PR NEW Plan: Plan 01 11/22/2022
River = CHAN EAST PR Reach = chan-east-pr RS = 700

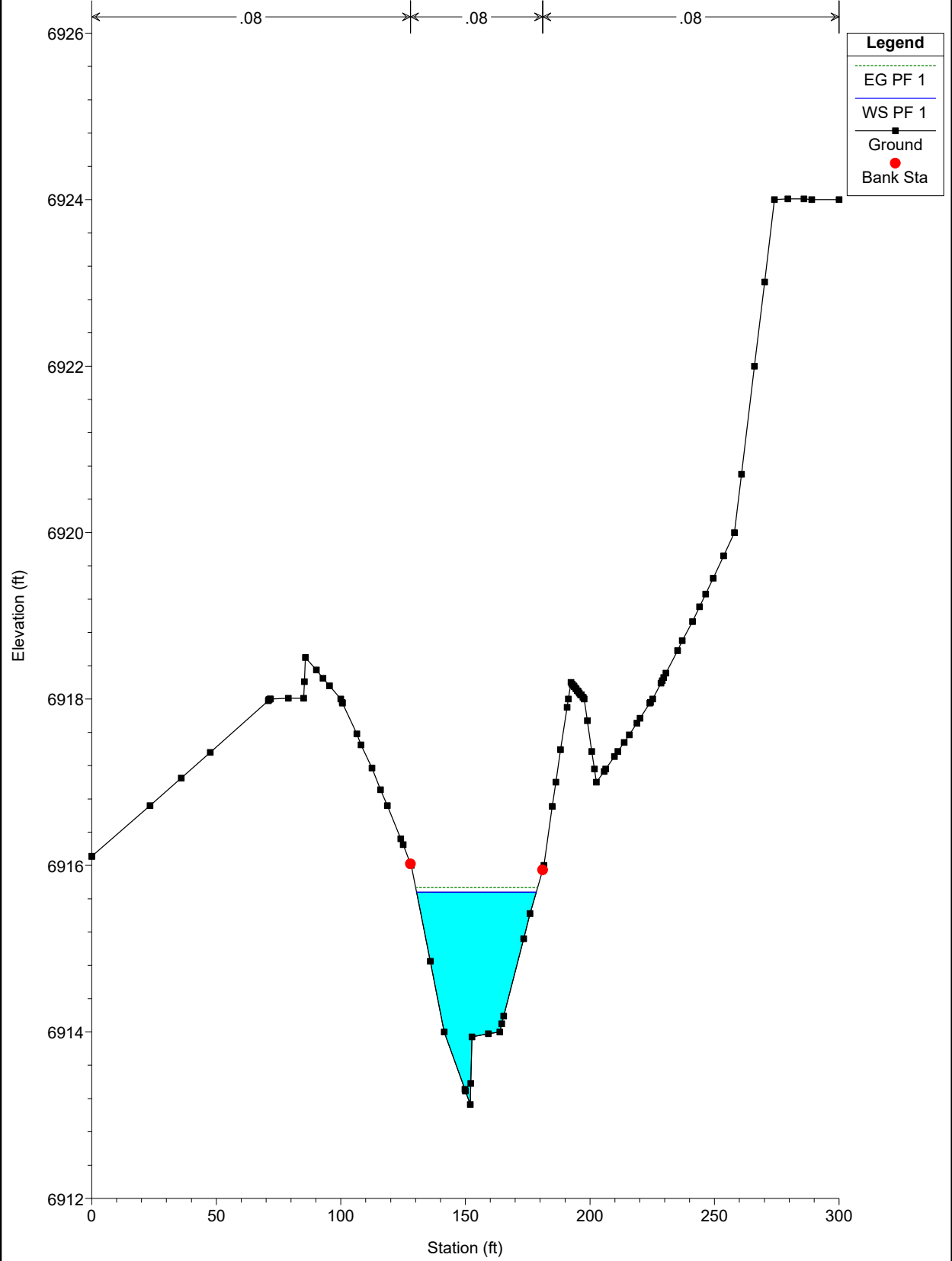

EAST CHAN PR NEW Plan: Plan 01 11/22/2022
River = CHAN EAST PR Reach = chan-east-pr RS = 600

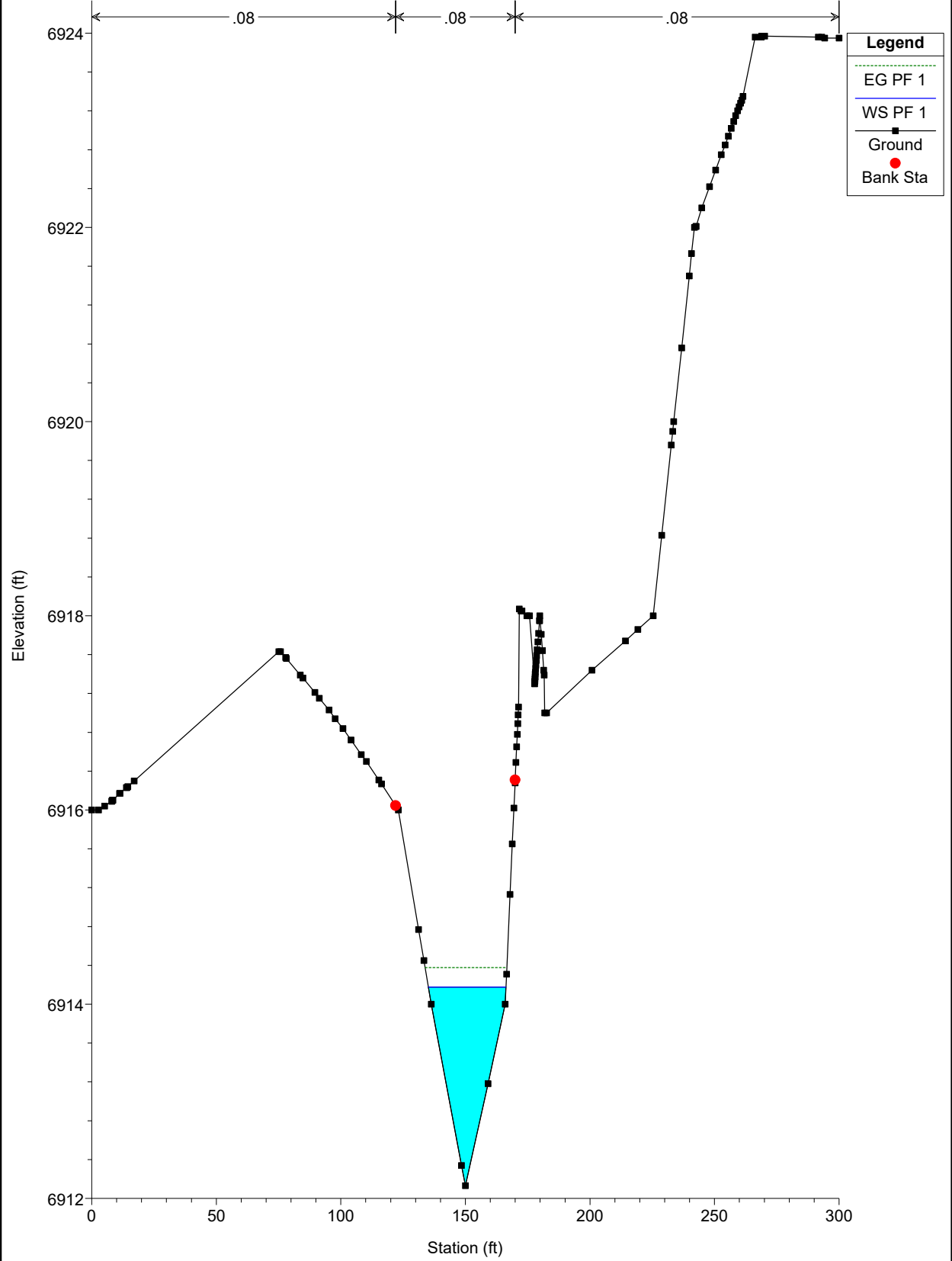

EAST CHAN PR NEW Plan: Plan 01 11/22/2022
River = CHAN EAST PR Reach = chan-east-pr RS = 500

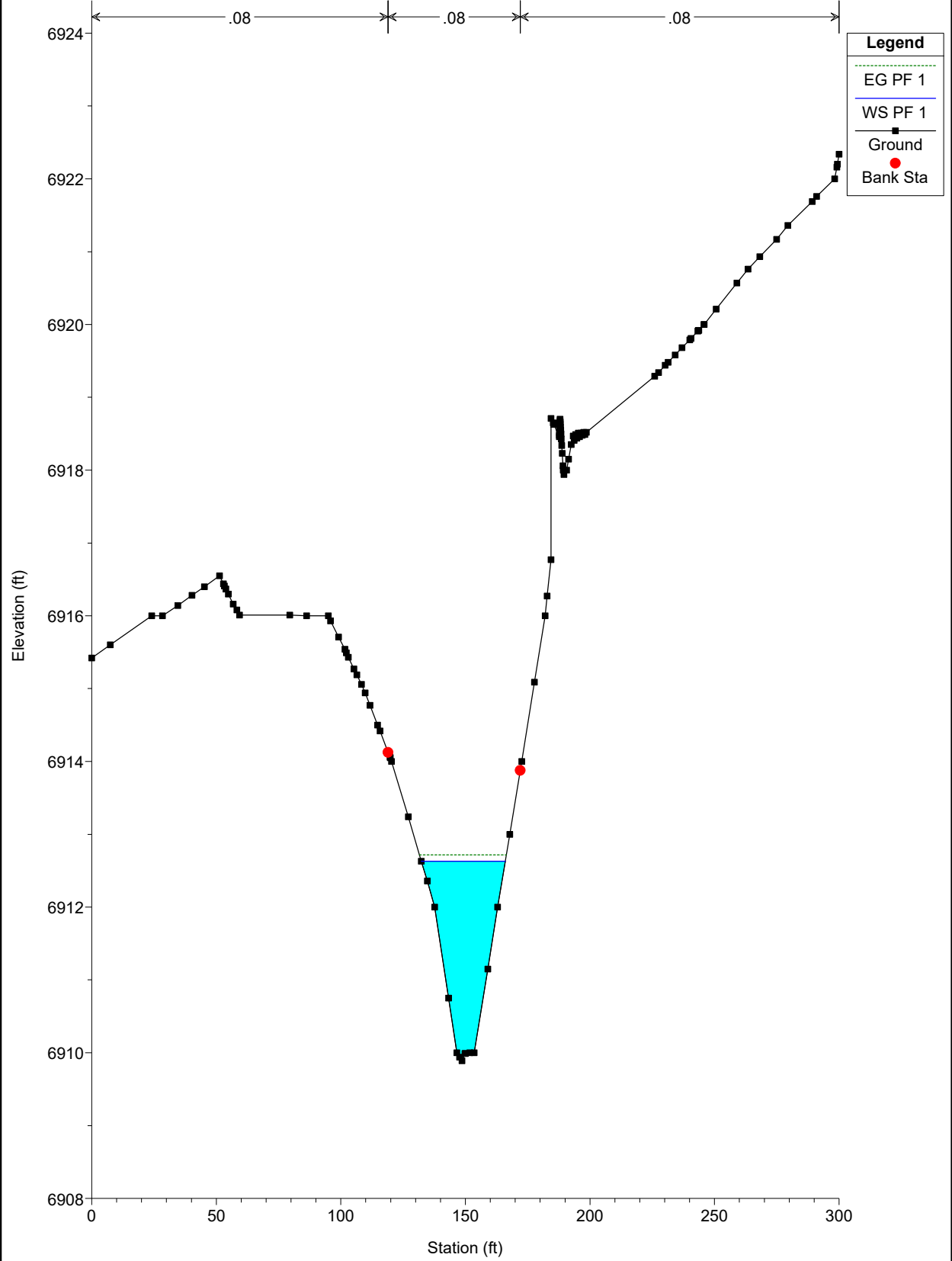

EAST CHAN PR NEW Plan: Plan 01 11/22/2022
River = CHAN EAST PR Reach = chan-east-pr RS = 400

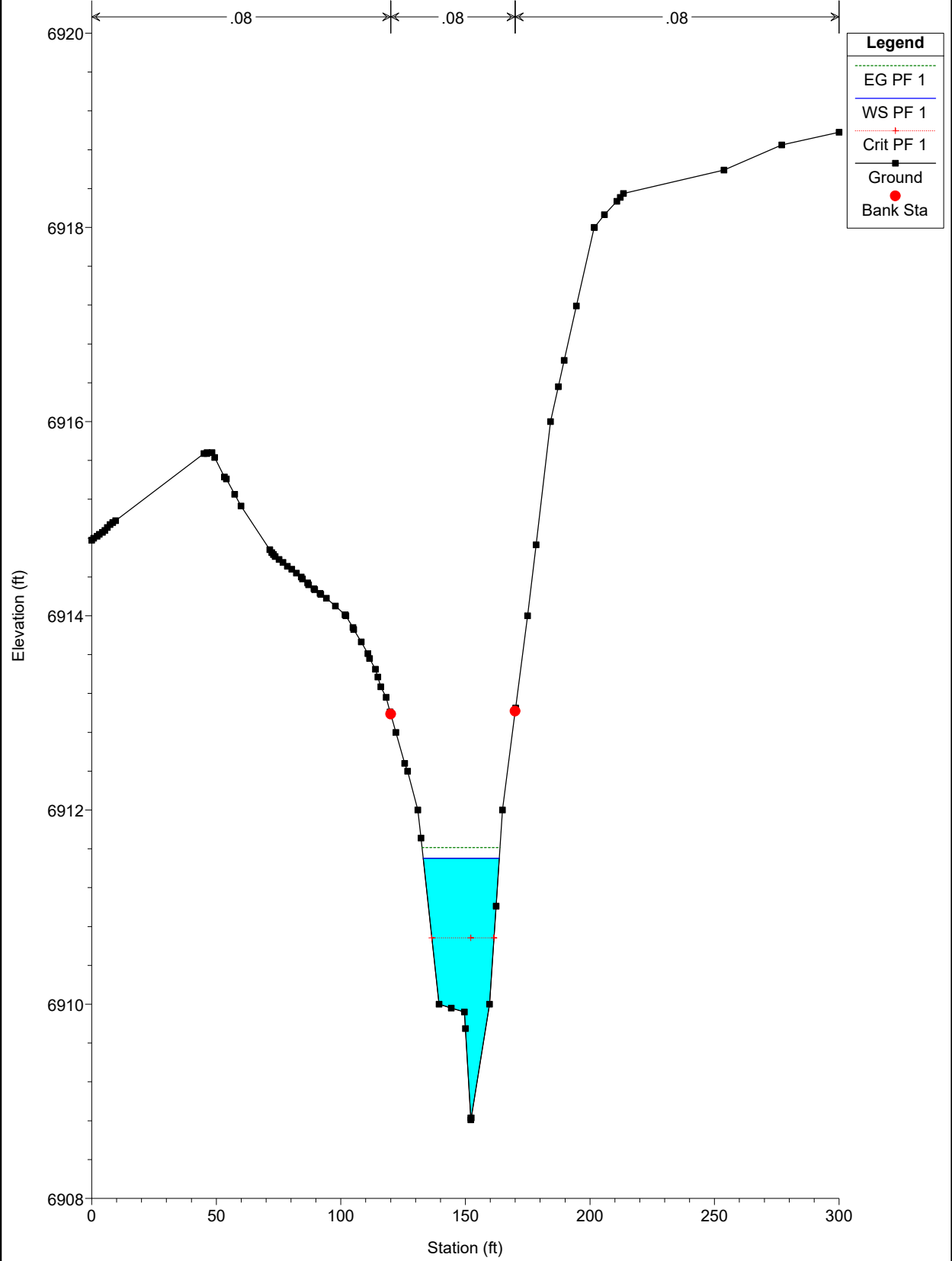

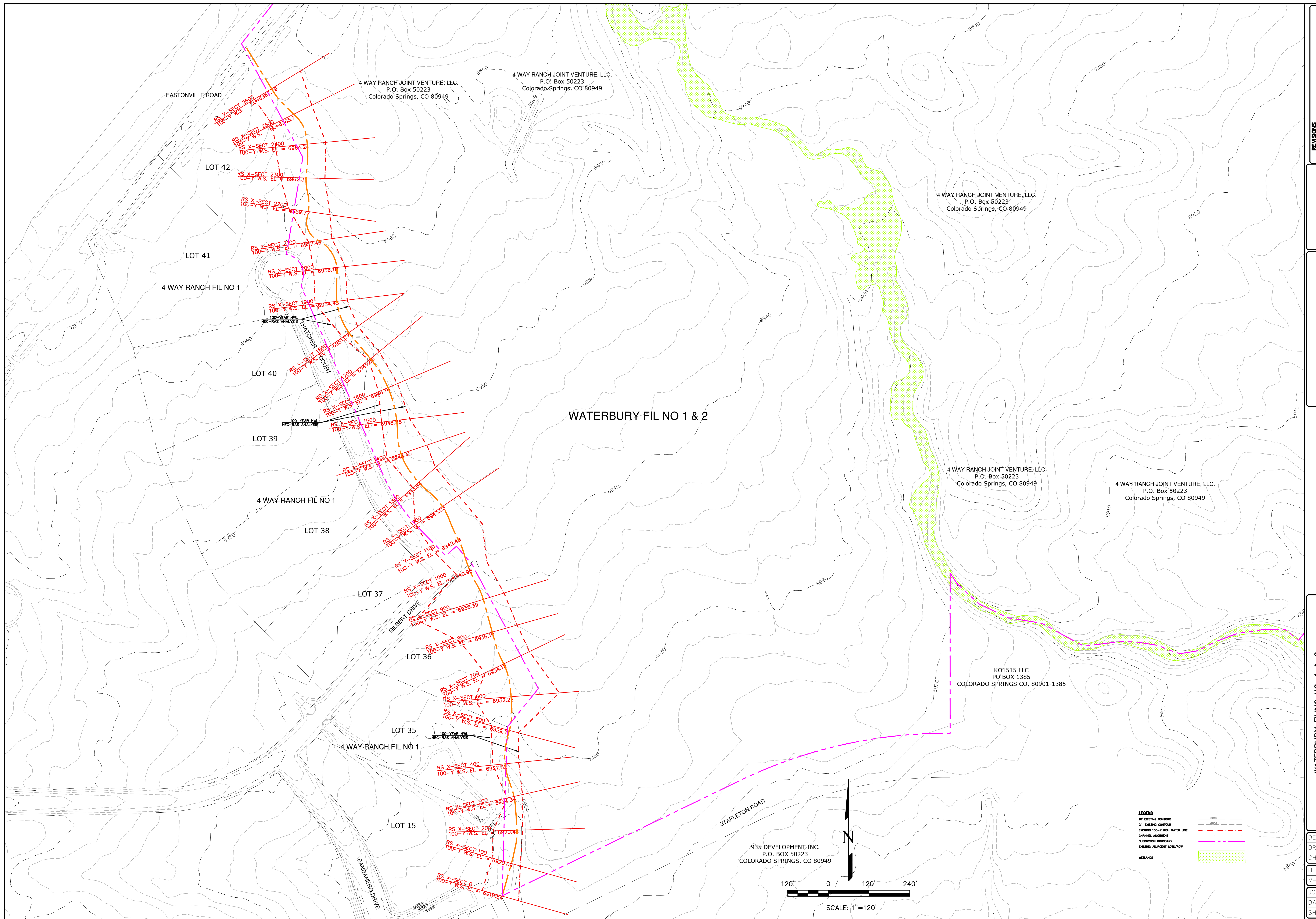

LEGEND

1/2" EXISTING CONTOUR	---
2" EXISTING CONTOUR	- - - -
EXISTING 100-YR HIGH WATER LINE	---
CHANNEL ALIGNMENT	---
SUBDIVISION BOUNDARY	---
EXISTING ADJACENT LOTS/ROW	---
WETLANDS	---

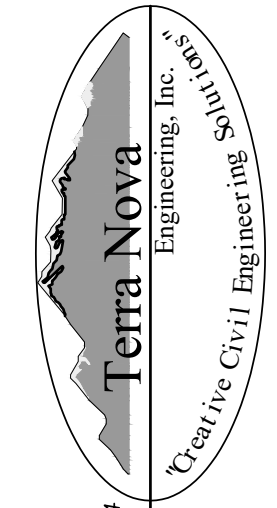
REVISIONS	DATE
NO.	DESCRIPTION
UNTIL SUCH TIME AS THESE DRAWINGS ARE APPROVED BY REVIEWING AGENCIES, TERRA NOVA ENGINEERING, INC. APPROVES THEIR USE ONLY FOR THE PROJECT AND FOR THE USE INTENDED BY WRITTEN AUTHORIZATION.	
PREPARED FOR: 4-WAY RANCH JOINT VENTURE ATTN: PETER MARTZ P.O. BOX 50223 COLORADO SPRINGS, CO 80949 719-491-3150	
	
721 S. Z3RD STREET COLORADO SPRINGS, CO 80904 OFFICE: 719-635-6422 FAX: 719-635-6426 www.tnec.com	
WATERBURY FILING NO. 1 & 2 EXISTING 100-YR FLOODPLAIN EXHIBIT WEST CHANNEL ONLY	
DESIGNED BY DLF DRAWN BY QNA CHECKED BY QNA	
H-SCALE 1" = 120' V-SCALE N/A	
JOB NO. 1715.00 DATE ISSUED 11/22/22 SHEET NO. 1 OF 2	

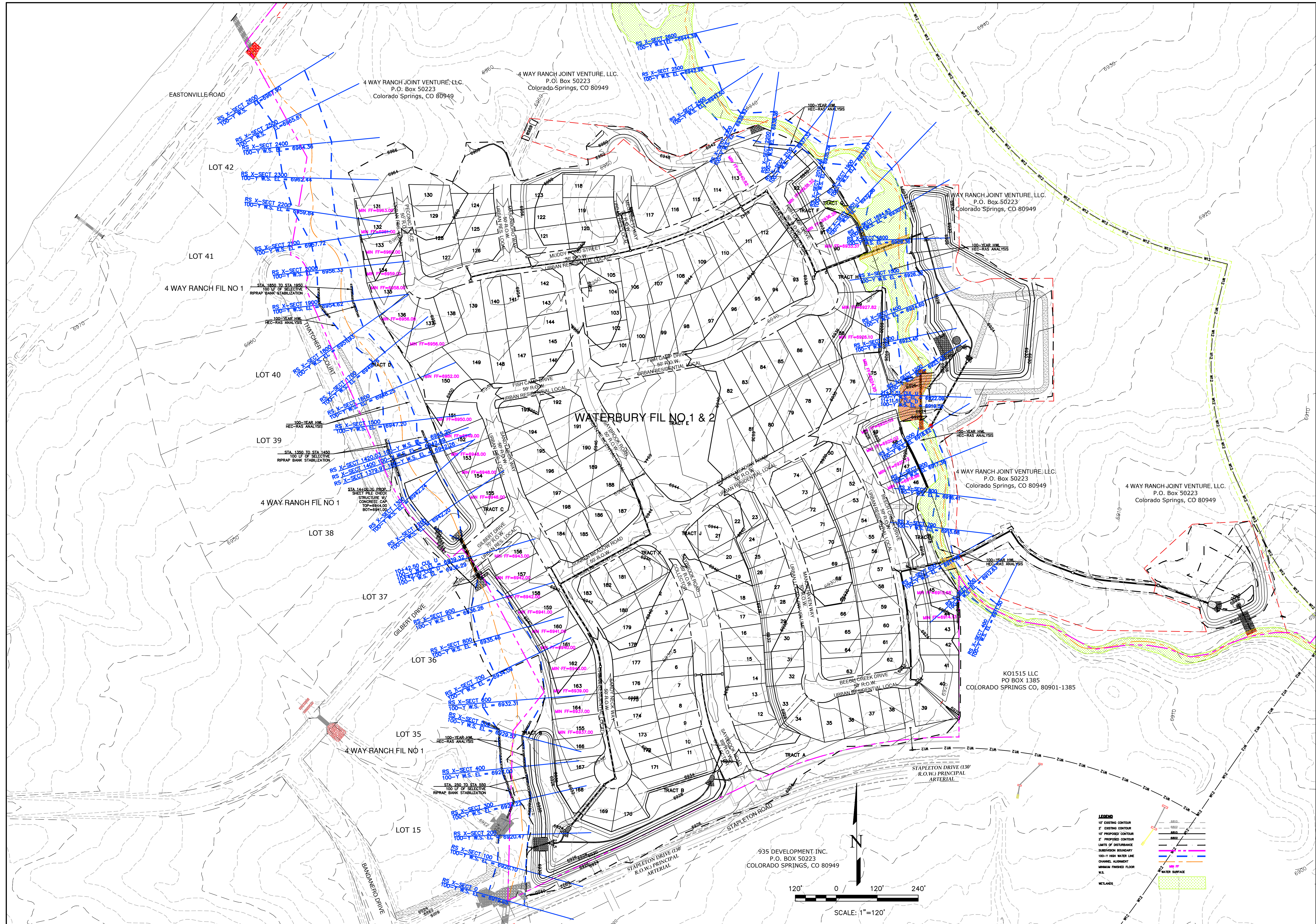

DESIGNED BY DLF DRAWN BY QNA CHECKED BY QNA	
H-SCALE 1" = 100' V-SCALE N/A	
JOB NO. 1715.00 DATE ISSUED 11/22/22 SHEET NO. 2 OF 2	
WATERBURY FILING NO. 1 & 2 PROPOSED 100-Y FLOODPLAIN EXHIBIT	
721 S. ZABO STREET COLORADO SPRINGS, CO 80904 OFFICE: 719-635-6422 FAX: 719-635-6426 www.terra-nova.com	
PREPARED FOR: 4-WAY RANCH JOINT VENTURE ATTN: PETER MARTZ P.O. BOX 50223 COLORADO SPRINGS, CO 80949 719-491-3150	
UNTIL SUCH TIME AS THESE DRAWINGS ARE APPROVED BY THE ENGINEERING BOARD OF TERRA NOVA ENGINEERING, INC. APPROVES THEIR USE ONLY FOR THE PROJECT AND FOR THE PURPOSES AUTHORIZED BY WRITTEN AUTHORIZATION.	
REVISIONS NO. _____ DESCRIPTION _____ DATE _____	DATE _____

DRAINAGE MAPS

DRAINAGE REPORT - EXISTING BASIN RUNOFF COEFFICIENT SUMMARY											
BASIN	TOTAL AREA (AC)	IMPERVIOUS / DEVELOPED AREA			NONIMPERVIOUS / UNDEVELOPED AREA			WEIGHTED		WEIGHTED CA	
		AREA (AC)	C(5)	C(100)	AREA (AC)	C(5)	C(100)	C(5)	C(100)	CA(5)	CA(100)
EXA	9.62	0.00	0.45	0.59	9.62	0.09	0.36	0.09	0.36	0.87	3.46
EXB	4.09	0.00	0.45	0.59	4.09	0.09	0.36	0.09	0.36	0.37	1.47
EXC	24.80	0.00	0.45	0.59	24.80	0.09	0.36	0.09	0.36	2.23	8.93
EXD	15.87	0.00	0.45	0.59	15.87	0.09	0.36	0.09	0.36	1.43	5.71
EXE	5.83	0.00	0.45	0.59	5.83	0.09	0.36	0.09	0.36	0.52	2.10
EXF	1.62	0.00	0.45	0.59	1.62	0.09	0.36	0.09	0.36	0.15	0.58
OS-1	45.02	0.00	0.45	0.59	45.02	0.09	0.36	0.09	0.36	4.05	16.21
OS-2	11.40	0.00	0.45	0.59	11.40	0.09	0.36	0.09	0.36	1.03	4.11
OS-3	1.11	0.00	0.45	0.59	1.11	0.09	0.36	0.09	0.36	0.10	0.40
OS-4	0.29	0.00	0.45	0.59	0.29	0.09	0.36	0.09	0.36	0.03	0.11
OS-5	6.74	0.00	0.45	0.59	6.74	0.09	0.36	0.09	0.36	0.61	2.43
OS-8	2.56										
OS-9	11.80										
OS-10A	12.80										

EXISTING BASIN RUNOFF SUMMARY															
BASIN	WEIGHTED CA		C(5)	OVERLAND Length (ft)	OVERLAND Height (ft)	OVERLAND Tc (min)	STREET / CHANNEL FLOW Length (ft)	STREET / CHANNEL FLOW Slope (%)	STREET / CHANNEL FLOW Velocity (ft/s)	STREET / CHANNEL FLOW Tc (min)	INTENSITY TOTAL FLOWS I(5) (in/hr)	INTENSITY TOTAL FLOWS I(100) (in/hr)	TOTAL FLOWS Q(5) (cfs)	TOTAL FLOWS Q(100) (cfs)	
	CA(5)	CA(100)													
EXA	0.87	3.46	0.25	100	3	11.1	1193	1.7%	4.5	4.4	15.4	3.43	5.81	3	20
EXB	0.37	1.47	0.25	100	2	12.6	823	2.2%	5.2	2.0	14.6	3.51	5.96	1	9
EXC	2.23	8.93	0.25	100	2.5	11.7	2420	1.7%	4.6	8.9	20.6	3.01	5.01	7	45
EXD	1.43	5.71	0.25	100	2	12.6	1615	2.6%	5.6	4.8	17.4	3.25	5.47	5	31
EXE	0.52	2.10	0.25	100	8	8.0	1063	2.1%	5.0	3.5	11.5	3.86	6.66	2	14
EXF	0.15	0.58	0.25	100	6	8.8	400	2.5%	5.5	1.2	10.0	4.06	7.07	1	4
OS-1	4.05	16.21	0.25	100	6	8.8	3219	2.3%	5.3	10.1	18.9	3.13	5.24	13	85
OS-2	1.03	4.11	0.25	100	2	12.6	1263	1.0%	3.5	5.7	18.4	3.17	5.32	3	22
OS-3	0.10	0.40	0.25	100	2	12.6	330	2.6%	5.6	1.0	13.6	3.61	6.17	0	2
OS-4	0.03	0.11	0.25	100	2	12.6	230	2.6%	5.7	0.7	13.3	3.64	6.23	0	1
OS-5	0.61	2.43	0.25	80	5	7.8	1000	2.5%	5.5	3.0	10.8	3.96	6.85	2	17
OS-8														5	11
OS-9														8	19

EXISTING SURFACE ROUTING SUMMARY											
Design Point(s)	Contributing Basins	Area (AC)	Equivalent CA(5)	Equivalent CA(100)	Maximum Tc	Intensity			Flow		Facility Size
						I(5)	I(100)	Q(5)	Q(100)		
EX1	EXA, OS-5, & DP-EX10A	18.92	1.47	5.89	15.4	3.43	5.81	33	219	3-42" CULVERTS	
EX2	EXB	4.09	0.37	1.47	14.6	3.51	5.96	1	9	STAPLETON ROAD	
EX3	EXC & OS-4	25.10	2.26	9.03	20.6	3.01	5.01	7	45	EAST BOUNDARY	
EX4	EXD & OS-3	16.98	1.53	6.11	17.4	3.25	5.47	5	33	EAST BOUNDARY	
EX5	EXE, OS-2 & OS-8	17.23	1.55	6.20	18.4	3.17	5.32	10	44	EAST BOUNDARY	
EX6	EXF	1.62	0.15	0.58	13.8	3.59	6.12	1	4	EAST BOUNDARY	
EX7A	OS-1 & OS-9	56.82	4.05	16.21	18.9	3.13	5.24	21	104	POINT ALONG CHANNEL	
EX7	EXE, EXF, OS-1, OS-2, OS-8 & OS-9	78.24	5.75	23.00	18.9	3.13	5.24	31	151	DP 30 PROP CONDITION	
EX9	OS-9	11.80						8	19	EX 36" RCP Culvert	
EX10	OS-8	2.56						5	11	EX 36" RCP Culvert	
EX10A	MERIDIAN POND E RELEASE				Meridian Ranch Filing 3 FDR Calculated Flows			28	185	EX 3-42" RCP Culverts	
13	TOTAL OFFSITE EX. STOCK POND INFLOW				Per "Final Drainage Report for Waterbury Filing No. 1" dated September 2016, by Classic Consulting			69	396	EX STOCK POND	

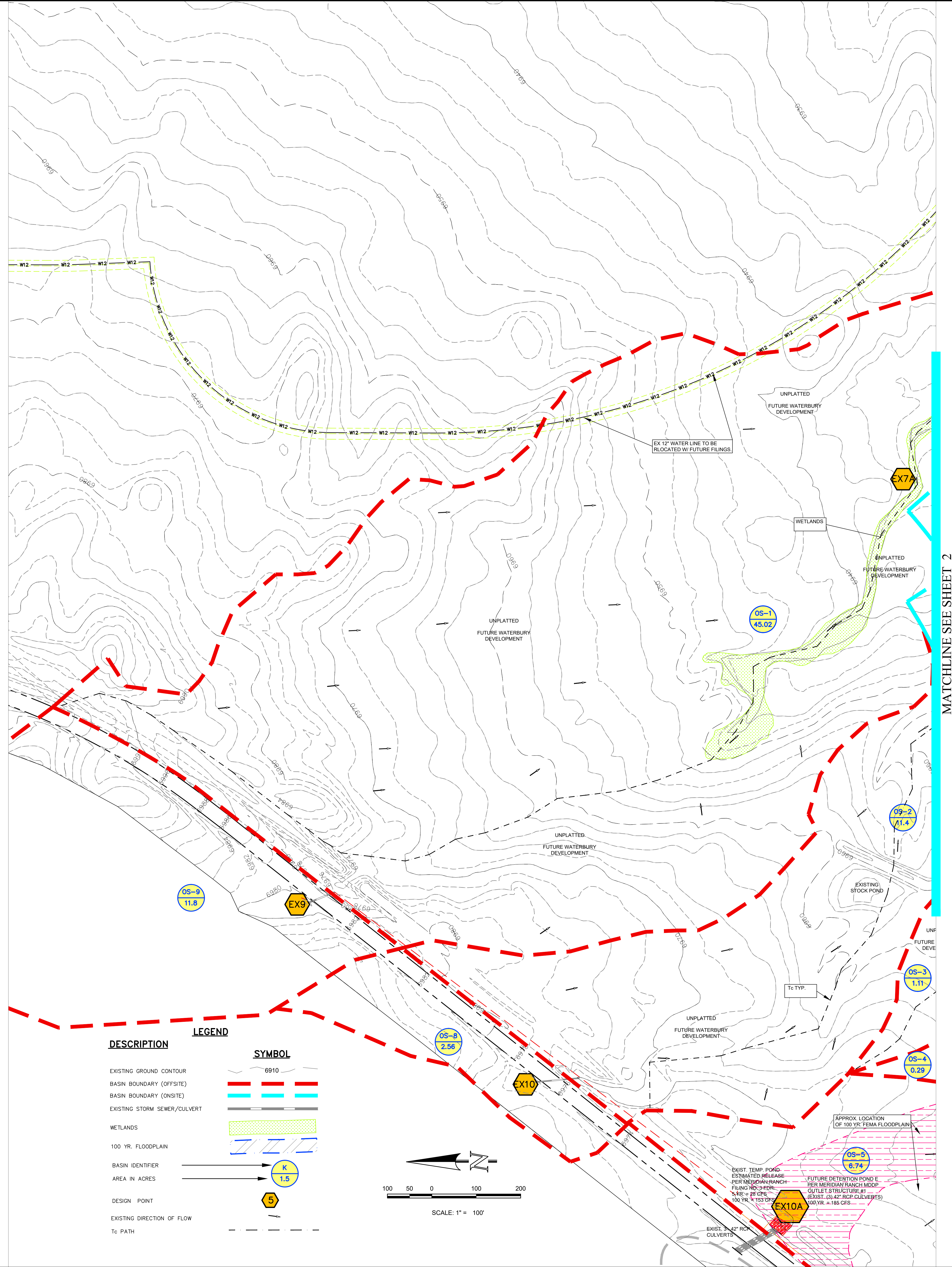

REVISIONS

NO.	DESCRIPTION	DATE

UNTIL SUCH TIME AS THESE REVISIONS ARE INCORPORATED BY THE APPROPRIATE REVIEWING AGENCIES AND SURVEYING, INC. APPROVES THEIR USE, ONLY DESIGNATED BY WRITTEN AUTHORIZATION.

PREPARED FOR:
4-WAY RANCH JOINT VENTURES
 ATTN: PETER MARTZ
 PO BOX 50223
 COLORADO SPRINGS, CO 80949
 719-471-3150

721 S. 23RD STREET
 COLORADO SPRINGS, CO 80904
 OFFICE: 719-635-4422
 FAX: 719-635-6426
 www.tnra.com

Terra Nova
 Engineering, Inc.
 Professional Engineer
 License No. 100000000

WATERBURY FILING 1
 EXISTING MDDP DRAINAGE MAP 1
 OFFSITE MAP

DESIGNED BY: QNA
 DRAWN BY: QNA
 CHECKED BY: QNA

H-SCALE: 1"=100'
 V-SCALE: 1"=100'

JOB NO. 1715.00
 DATE ISSUED 2/6/23
 SHEET NO. 1 OF 2

FINAL DRAINAGE REPORT - SURFACE RUNOFF SUMMARY										
Design Point(s)	Contributing Basins	Area (AC)	Equivalent CA			Intensity		Flow		Facility Size
			CA(5)	CA(100)	Maximum Tc	I(5)	I(100)	Q(5)	Q(100)	
1	A	3.39	1.52	2.00	14.3	3.54	6.03	5	12	10" Type R Sump Inlet
2	C	0.86	0.39	0.51	6.9	4.8	8.14	2	4	5" Type R Sump Inlet
3	B1	2.30	1.03	1.36	14.2	3.55	6.06	4	8	5" Type R Sump Inlet
4	B2	3.58	1.61	2.11	14.8	3.49	5.93	6	13	10" Type R Sump Inlet
5	F & H	3.65	1.64	2.15	9.5	4.14	7.22	7	16	10" Type R Sump Inlet
6	D	2.11	0.95	1.24	11.4	3.87	6.09	4	8	5" Type R Sump Inlet
7	E	2.18	0.98	1.29	13.8	3.99	6.12	4	8	5" Type R Sump Inlet
7A	G1	0.38	0.17	0.23	5.0	5.00	9.06	1	2	5" Type R Algrade Inlet
7B	G2	0.60	0.27	0.35	5.0	5.00	9.06	1	3	5" Type R Algrade Inlet
8	DESIGN POINTS 1-7 & K	22.11	8.13	10.66	14.8	3.49	5.93	28	63	FSD Pond 1
9	OS-9	11.80						8	19	EX 36" RCP Culvert
10	OS-6	2.56						5	11	EX 36" RCP Culvert
10A	MERIDIAN POND E RELEASE							28	185	EX 3-42" RCP Culverts
11	OS-5, 1, OS-6 & MERIDIAN POND E RELEASE							34	216	PR 2-42" RCP Culverts
11A	DP 11 & BASIN J							37	222	PR 2-42" RCP Culverts
12	OS-6	1.06	0.48	0.63	10.1	4.05	7.04	2	4	18" RCP Culvert
13	TOTAL OFFSITE EX. STOCK POND INFLOW							69	396	EX STOCK POND
14	L1	3.79	1.71	2.24	16.1	3.36	5.69	6	13	10" Type R Sump Inlet
15	L2	2.00	0.90	1.18	16.1	3.36	5.69	3	7	5" Type R Sump Inlet
16	O1	2.82	1.27	1.66	13.5	3.62	6.19	5	10	10" Type R Sump Inlet
17	O2	0.71	0.32	0.42	15.5	3.42	5.80	1	2	5" Type R Sump Inlet
18	DESIGN POINTS 14-17 & BASIN OS-4	20.23	5.18	5.50	16.1	3.36	5.69	17	31	Interim FSD Pond 2
19	Q1 & OS-Q1	1.61	0.69	0.99	13.2	3.66	6.27	3	6	10" Type R Sump Inlet
20	Q2 & OS-Q2	1.18	0.45	0.65	9.5	4.14	7.24	2	5	5" Type R Sump Inlet
21	R & OS-R	2.06	0.55	0.88	12.4	3.75	6.44	2	6	10" Type R Algrade Inlet
22	S1 & OS-S1	1.86	0.72	1.02	12.4	3.75	6.44	3	7	10" Type R Sump Inlet
23	S2 & OS-S2	0.27	0.07	0.13	5.0	5.00	9.06	0	1	10" Type R Sump Inlet
24	T1	1.42	0.64	0.84	10.7	3.97	6.88	3	6	5" Type R Sump Inlet
25	T2 & OS-T2	1.54	0.58	0.84	13.5	3.63	6.20	2	5	5" Type R Sump Inlet
26	U1	4.38	1.97	2.58	14.3	3.54	6.03	7	16	10" Type R Sump Inlet
27	U2	1.89	0.85	1.11	13.8	3.99	6.12	3	7	5" Type R Sump Inlet
28	W	5.20	2.34	3.07	15.0	3.47	5.89	8	18	2-10" Type R Sump Inlets
29	DESIGN POINTS 19-26 & OS-7	24.41	9.13	13.21	15.0	3.47	5.89	32	78	FSD Pond 3
E-E	OS-2 & OS-8	14.58	2.66	6.20	18.4	3.17	5.32	8	33	DIVERSION SWALE E-E
30	Y, OS-1, OS-2, OS-8 & OS-9	67.82	9.32	20.34	21.1	2.97	4.84	36	100	Triple 36" RCP Culverts
31	V	0.54	0.24	0.32	5.0	5.00	9.06	1	3	18" DIA INLETS
32	X	0.43	0.19	0.25	5.0	5.00	9.06	1	2	18" DIA INLETS
33	O-3	0.45	0.20	0.27	5.0	5.00	9.06	1	2	18" DIA INLETS
34	O-4	0.38	0.17	0.23	5.0	5.00	9.06	1	2	18" DIA INLETS

FINAL DRAINAGE REPORT - PIPE ROUTING SUMMARY										
Pipe Run	Contributing Design Points/Basins	Equivalent CA			Intensity		Flow		Pipe Size	
		CA(5)	CA(100)	Maximum Tc	I(5)	I(100)	Q(5)	Q(100)		
1	DP-2	0.39	0.51	6.9	4.98	8.14	2	4	18" RCP	
2	DP 1 & 2	1.91	2.51	14.3	3.54	6.03	7	15	24" RCP	
3	DP-3	1.03	1.36	14.2	3.55	6.06	4	8	18" RCP	
4	DP-4	1.61	2.11	14.8	3.49	5.93	6	13	18" RCP	
5	DP 3 & 4	2.64	3.47	14.8	3.49	5.93	9	21	24" RCP	
6	DP-1.4	4.56	5.97	14.8	3.49	5.93	16	35	36" RCP	
7	DP-1.5	6.20	8.12	14.8	3.49	5.93	22	48	36" RCP	
8	DP-6	0.95	1.24	11.4	3.87	6.09	4	8	18" RCP	
9	DP-7	0.98	1.29	13.8	3.99	6.12	4	8	18" RCP	
10	DP-6 & 7	1.93	2.53	13.8	3.99	6.12	7	15	24" RCP	
10A	DP-7A	0.17	0.23	5.0	5.00	9.06	1	2	15" RCP	
23	DP-6, 7, 7A & 7B	2.37	3.11	13.8	3.99	6.12	9	19	24" RCP	
10C	Pond 1 Release						0.4	14.5	18" RCP	
11	DP-14	1.71	2.24	16.1	3.36	5.69	6	13	24" RCP	
12	DP-15	0.90	1.18	16.1	3.36	5.69	3	7	18" RCP	
13	DP-14 & 15	2.61	3.42	16.1	3.36	5.69	9	19	30" RCP	
14	DP-16	1.27	1.66	13.5	3.62	6.19	5	10	24" RCP	
15	DP-14, 15 & 16	3.88	5.08	16.1	3.36	5.69	13	29	36" RCP	
16	DP-17	0.32	0.42	15.5	3.42	5.80	1	2	18" RCP	
17	DP-14, 15, 16, & 17	4.57	6.00	16.1	3.36	5.69	15	34	36" RCP	
17A	Pond 2 Release						1.1	24	18" RCP	
18	DP-19	0.69	0.99	13.2	3.66	6.27	3	6	24" RCP	
19	DP-20	0.45	0.65	9.5	4.14	7.24	2	5	18" RCP	
20	DP-19 & 20	1.15	1.64	13.2	3.66	6.27	4	10	24" RCP	
21	DP-21 PICK UP						2	6	18" RCP	
22	DP-19, 20 & 21	1.69	2.59	13.2	3.66	6.27	6	16	30" RCP	
23	DP-22	0.72	1.02	12.4	3.75	6.44	3	7	24" RCP	
24	DP-23	0.07	0.13	5.0	5.00	9.06	0	1	24" RCP	
25	DP-22 & 23	0.80	1.15	12.4	3.75	6.44	3	7	30" RCP	
26	DP-19-23	2.49	3.74	13.2	3.66	6.27	9	23	36" RCP	
27	DP-24	0.64	0.84	10.7	3.97	6.88	3	6	18" RCP	
28	DP-25	0.58	0.84	13.5	3.63	6.20	2	5	18" RCP	
29	DP-19-25	3.71	5.42	13.5	3.63	6.20	13	34	36" RCP	
30	DP-26	1.97	2.58	14.3	3.54	6.03	7	16	24" RCP	
31	DP-19-26	5.68	8.00	14.3	3.54	6.03	20	48	42" RCP	
32	DP-27	0.85	1.11	13.8	3.99	6.12	3	7	18" RCP	
33	DP-19-27 & 31	6.77	9.43	14.3	3.54	6.03	24	57	42" RCP	
34	DP-28 SPLIT FLOW	2.34	3.07	15.03	3.47	5.89	4	9	24" RCP	
34A	28 & 32	2.53	3.32	15.0	3.47	5.89	9	20	24" RCP	
35	Pond 3 Release						1	58	36" RCP	
36	DP-30						36	120	TRIPLE 36" RCP	
37	DP-31	0.24	0.32	5.00	5.00	9.06	1	3	15" HDPE	
38	DP-32	0.19	0.25	5.00	5.00	9.06	1	2	15" HDPE	
39	DP-33	0.20	0.27	5.00	5.00	9.06	1	2	15" HDPE	
40	DP-34	0.17	0.23	5.00	5.00	9.06	1	2	15" HDPE	

FINAL DRAINAGE REPORT - BASIN RUNOFF SUMMARY															
BASIN	WEIGHTED CA(5)	WEIGHTED CA(100)	OVERLAND		STREET / CHANNEL FLOW		TOTAL		INTENSITY		TOTAL FLOWS				
			Length (ft)	Height (ft)	Length (ft)	Velocity (ft/s)	Length (ft)	Velocity (ft/s)	I(5)	I(100)	Q(5)	Q(100)			
A	1.52	2.00	0.25	100	2	12.6	400	1.9%	4.3	1.6	14.3	3.54	6.03	5	12
B1	1.03	1.36	0.25	100	2	12.6	400	1.9%	4.3	1.6	14.2	3.55	6.06	4	8
B2	1.61	2.11	0.25	100	2	12.6	550	1.9%	4.3	2.1	14.8	3.49	5.93	6	13
C	0.39	0.51	0.25	20	0.5	5.3	500	2.0%	4.9	1.7	6.9	4.98	8.14	2	4
D	0.95	1.24	0.25	80	2	10.5	300	2.5%	5.5	0.9	11.4	3.87	6.09	4	8
E	0.98	1.29	0.25	100	2	12.6	400	2.5%	5.5	1.2	13.8	3.99	6.12	4	8
F	0.98	1.29	0.25	50	2	11	600	1.9%	4.3	2.4	9.5	4.14	7.22	4	8
G1	0.17	0.23	0.25								5.0	5.00	9.06	1	2
G2	0.27	0.35	0.25								5.0	5.00	9.06	1	3
H	0.66	0.86	0.25	50	2	11	600	1.9%	4.3	2.0	9.2	4.19	7.33	3	6
I	0.97	1.24	0.25	80	4	8.4	200	2.0%	4.9	0.8	9.2	4.18	7.32	4	16
J	0.65	0.85	0.25	90	6	8.1	800	2.0%	4.9	2.9	10.9	3.84	6.81	3	6
K	0.69	0.92	0.25	100	18	6.1	80	1.0%	3.5	0.4	6.5	4.67	8.33	3	11
L1	1.71	2.24	0.25	100	2	12.6	800	1.4%	4.1	3.5	16.1	3.36	5.69	6	13
L2	0.90	1.18	0.25	95	1.1	9.4	800	1.4%	4.1	3.5	12.8	3.70	6.34	3	7
M1	0.47	0.62	0.25	70	1.5	10.3	200	2.0%	4.9	0.7	11.0	3.52	6.79	2	4
M2	0.16	0.21	0.25	65	3	7.7	0	0.0%	0.0	0.0	7.7	4.43	7.83	1	2
M3	0.09	0.12	0.25								5.0	5.00	9.06	0	1
N	0.10	0.13	0.25								5.0	5.00	9.06	1	1
O1	1.27	1.66	0.25	100	2.5	11.7	400	1.9%	4.3	1.8	13.5	3.62	6.19	5	12
O2	0.32	0.42	0.25	100	2	12.6	850	2.0%	4.9	2.9	16.5	3.42	5.80	1	2
O3	0.20	0.27	0.25								5.0	5.00	9.06	1	2
O4	0.17	0.23	0.25								5.0	5.00	9.06	1	2
P	0.06	0.08	0.25								5.0	5.00	9.06	0	1
Q1	0.66	0.87	0.25	55	1.3	8.9	445	2.0%	5.0	1.5	10.4	4.01	6.97	3	6
Q2	0.43	0.56	0.25	55	1.3	8.9	445	2.0%	5.0	1.5	10.4	4.01	6.97	2	4
R	0.46	0.60	0.25	100	4	10.1	700	2.0%	4.9	2.4	12.4	3.75	6.44	2	4
S1	0.70	0.91	0.25	100	6	8.8	175	2.0%	4.9	0.6	9.4	4.16	7.25	3	7
S2	0.06	0.08	0.25								5.0	5.00	9.06	0	1
T1	0.64	0.84	0.25	55	1.1	9.4	300	2.0%	4.9	1.3	10.7	3.97	6.88	3	6
T2	0.56	0.73	0.25	100	2	12.6	245	2.0%	5.0	0.8	13.5	3.63	6.20	2	5
U1	1.97														

MATCHLINE SEE SHEET 1

RUNOFF REDUCTION LEGEND

UNCONNECTED IMPERVIOUS AREA
RECEIVING PERVIOUS AREA
EXCLUDED UNDEVELOPED IMPERVIOUS AREA PER THE EXCLUSION IN ECM APPENDIX 17.1.B.7 - SITES WITH LAND DISTURBANCE TO UNDEVELOPED LAND THAT WILL REMAIN UNDEVELOPED
EXCLUDED IMPERVIOUS AREA PER THE EXCLUSION IN ECM APPENDIX 17.1.C.1.A - LESS THAN 1 ACRE OF DEVELOPED ROADWAY AREA

DESCRIPTION

EXISTING GROUND CONTOUR
PROPOSED FINISHED CONTOUR
BASIN BOUNDARY (TRIB- TO POND)
BASIN BOUNDARY (OFFSITE)
BASIN BOUNDARY (ONSITE)
STORM SEWER
WETLANDS
100-YR FLOODPLAIN
100-Y HWL PER HEC-RAS ANALYSIS

LEGEND

SYMBOL
6910
6910
K
5
17

FDR PBMP SUMMARY TABLE

BASINS	PBMP TRIB. AREA (AC)	PBMP
A, B1, B2, C, D, E, F, G1, G2, H, & K	22.11	FSD POND 1
L1, L2, O1, O2, O3 O4, & OS-4	20.23	FSD POND 2
O1, OS-O1, O2, OS-O2, R, OS-R, S1, OS-S1, U2, OS-U2, T1, T2, OS-T2, U1, U2, V, X, W, & OS-7	24.41	FSD POND 3
I, J, M1, P, & Y	8.51	EXCLUDED*
M2 & N	0.58	RUNOFF REDUCTION**
M3	0.20	EXCLUDED***

*EXCLUDED UNDEVELOPED IMPERVIOUS AREA PER THE EXCLUSION IN ECM APPENDIX 17.1.B.7 - SITES WITH LAND DISTURBANCE TO UNDEVELOPED LAND THAT WILL REMAIN UNDEVELOPED
**UD-BMP VERSION 3.07 RUNOFF REDUCTION WAS USED TO SHOW THAT THIS AREA HAS 100% WQV REDUCTION BASED UPON THE UNCONNECTED IMPERVIOUS AREA BEING ROUTED OVER THE RECEIVING PERVIOUS AREA
***EXCLUDED IMPERVIOUS AREA PER THE EXCLUSION IN ECM APPENDIX 17.1.C.1.A - LESS THAN 1 ACRE OF DEVELOPED ROADWAY AREA

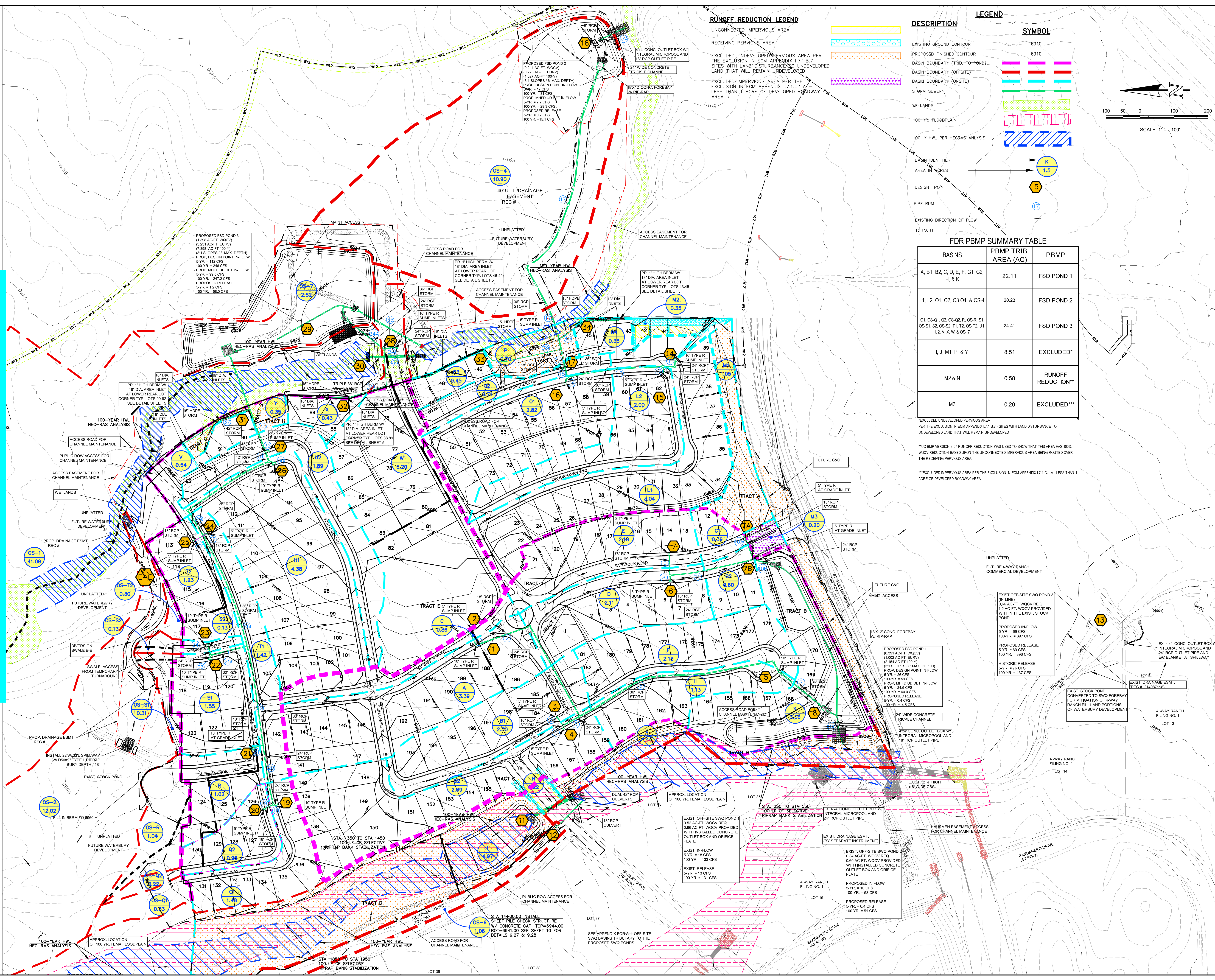
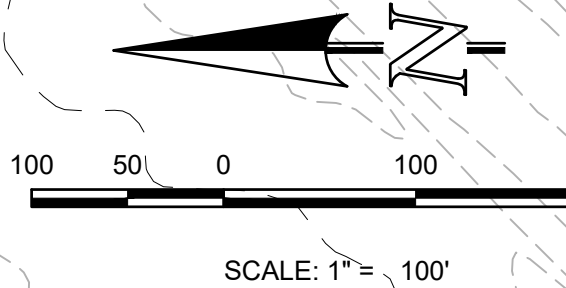

UNLESS SUCH TIME AS THESE ARE PROVIDED BY THE APPLICANT, THE APPLICANT SHALL BE RESPONSIBLE FOR OBTAINING ALL NECESSARY PERMITS AND APPROVALS FROM THE APPROPRIATE AGENCIES AND AGENCIES OF THE STATE OF COLORADO. THE APPLICANT'S USE OF THIS MAP IS LIMITED TO THE PROJECT AND SITE DESIGNATED BY THE APPLICANT.

PREPARED FOR:
4-WAY RANCH JOINT VENTURE
ATTN: PETER MARTZ
PO BOX 50223
COLORADO SPRINGS, CO 80949
719-471-3150

Terra Nova
Engineering, Inc.
721 S. 23RD STREET
COLORADO SPRINGS, CO 80904
OFFICE: 719-634-6422
FAX: 719-635-6426
www.terrano.com

WATERBURY FILING NO. 1
FINAL
PROPOSED DRAINAGE MAP
ON-SITE
DESIGNED BY QNA
DRAWN BY QNA
CHECKED BY
H-SCALE 1"=100'
V-SCALE NA
JOB NO. 1715.00
DATE ISSUED 2/1/23
SHEET NO. 2 OF 2