

**PRIVATE STORMWATER FACILITY
MAINTENANCE AGREEMENT AND EASEMENT**

This PRIVATE STORMWATER FACILITY MAINTENANCE AGREEMENT AND EASEMENT (Agreement) is made by and between EL PASO COUNTY by and through THE BOARD OF COUNTY COMMISSIONERS OF EL PASO COUNTY, COLORADO (County), ACM ALF VIII JV Sub II LLC (Developer), and Waterbury Metropolitan District No. 1 (Metro District), a quasi-municipal corporation and political subdivision of the State of Colorado. The above may occasionally be referred to herein singularly as “Party” and collectively as “Parties.”

Recitals

A. WHEREAS, the Metro District provides various municipal services to certain real property in El Paso County, Colorado referred to as Waterbury Filing 1; and

B. WHEREAS, Developer is the owner of certain real estate (the Subject Property) in El Paso County, Colorado, which Property is legally described in Exhibit A attached hereto and incorporated herein by this reference; and

C. WHEREAS, Developer desires to plat and develop on the Subject Property a Subdivision to be known as Waterbury Filing No. 1 (the Development); and

D. WHEREAS, the development of the Subject Property will materially increase the volume and decrease the quality of stormwater runoff from the Property; therefore, it is in the best interest of the public health, safety and welfare for the County to condition approval of this Development on Developer’s promise to construct adequate stormwater control facilities for the Development; and

E. WHEREAS, the El Paso County Land Development Code, as periodically amended, requires the construction and maintenance of drainage facilities adequate to maintain historic stormwater flow patterns, protect natural and man-made drainage conveyances, and prevent property damage in connection with land development and subdivisions, and further requires that developers enter into maintenance agreements and easements with the County for such drainage facilities; and

F. WHEREAS, Section 2.9 of the El Paso County Drainage Criteria Manual, Volume I provides for a developer’s promise to maintain a development’s drainage facilities in the event the County does not assume such responsibility; and

G. WHEREAS, Developer desires to construct for the Development drainage conveyance facilities and to preserve existing vegetated drainageways (collectively, “Stormwater Facilities”) as the means for providing adequate drainage and stormwater runoff control and to meet the requirements of the County’s MS4 Permit, and to operate, clean, maintain and repair such Stormwater Facilities; and

H. WHEREAS, Developer desires to construct and preserve the Stormwater Facilities on property as set forth on Exhibit B1, B2, & B3 attached hereto and incorporated herein by this reference (the Stormwater Facilities Area); and

I. WHEREAS, Developer also desires to maintain wetlands on property in the areas set forth on Exhibit B1, B2, & B3 attached hereto and incorporated herein by this reference in conjunction with the Development, as may be required by the County, U.S. Army Corps of Engineers or the State of Colorado; and

J. WHEREAS, Developer shall be charged with the duty of constructing and preserving the Stormwater Facilities and, upon completion of the construction and transfer of property to the Metro District, the Metro District shall be charged with the duties of operating, maintaining and repairing the Stormwater Facilities and any appurtenant improvements and maintaining any wetlands on the property described in Exhibit B1, B2, & B3; and

K. WHEREAS, the County, in order to protect the public health, safety and welfare, desires the means to access, construct, maintain, and repair the Stormwater Facilities and to recover its costs incurred in connection therewith in the event the Developer or District fails to meet their obligations to do the same; and

L. WHEREAS, the County conditions approval of this Development on the Developer's promise to construct and preserve the Stormwater Facilities as applicable, and further conditions approval on the Metro District's promise to clean, maintain and repair the Stormwater Facilities and maintain any wetlands, and on the Metro District's promise to reimburse the County in the event the burden falls upon the County to construct, clean, maintain or repair the Stormwater Facilities serving this Development; and

M. WHEREAS, the County, in order to secure performance of the promises contained herein, conditions approval of this Development upon Developer's grant herein of a perpetual Easement over the Stormwater Facilities Area as described in Exhibit B1, B2, & B3 for the purpose of allowing the Metro District access to construct, upgrade, clean, maintain and/or repair the Stormwater Facilities and wetlands thereon, and allowing the County to periodically access and inspect the Stormwater Facilities and, when necessary, to construct, clean, maintain or repair the Stormwater Facilities; and

N. WHEREAS, Pursuant to Colorado Constitution, Article XIV, Section 18(2) and Section 29-1-203, Colorado Revised Statutes, governmental entities may cooperate and contract with each other to provide any function, services, or facilities lawfully authorized to each.

Agreement

NOW, THEREFORE, in consideration of the mutual Promises contained herein, the sufficiency of which are hereby acknowledged, the Parties agree as follows:

1. Incorporation of Recitals: The Parties incorporate the Recitals above into this Agreement.

2. Covenants Running with the Land: Developer agrees that this entire Agreement and the performance thereof shall become a covenant running with the land, which land is legally described in Exhibit A attached hereto, and that this entire Agreement and the performance thereof shall be binding upon itself and its successors and assigns.

3. Construction: Developer shall construct the following Stormwater Facilities on the Stormwater Facilities Area described in Exhibit B1, B2, & B3: channel grading and culverts and appurtenant improvements in accordance with construction drawings titled "Waterbury Filing No. 1 Construction Set", dated _____ 2026. Developer shall not commence construction of the Stormwater Facilities until the County has approved in writing the plans and specifications for the Stormwater Facilities and this Agreement has been signed by all Parties and returned to the Planning and Community Development Department. Developer shall complete construction of the Stormwater Facilities in substantial compliance with the County-approved plans and specifications for the Stormwater Facilities and shall provide certification from a Colorado registered Professional Engineer that the Stormwater Facilities were constructed in compliance with and provide the volume and capacity required by such plans and specifications in accordance with ECM requirements. Failure to meet these requirements shall be a material breach of this Agreement and shall entitle the County to pursue any remedies available to it at law or in equity to enforce the same. Construction of the Stormwater Facilities shall be substantially completed within one (1) year (defined as 365 days), which one-year period will commence to run on the date the Erosion and Stormwater Quality Control Permit (ESQCP) and associated Construction Permit are issued.

In the event construction of the Stormwater Facilities is not substantially completed within the one (1) year period, or if the Development is in violation of its ESQCP terms and conditions and Developer has not made an effort to remedy the violation in a reasonable amount of time as determined by the County, then the County may exercise its discretion to complete the Stormwater Facilities and shall have the right to seek reimbursement from the Developer and its respective successors and assigns for its actual costs and expenses incurred in the process of completing construction.

If Developer is required by the U.S. Army Corps of Engineers or other agency to construct and/or mitigate wetlands on the Stormwater Facilities Area in conjunction with the Development, the wetlands mitigation plan shall be provided to the County after completion of construction, representing the as-built conditions.

4. Maintenance of Stormwater Facilities and Wetlands: The Developer and the Metro District agree for themselves and their respective successors and assigns that they will regularly and routinely inspect, clean and maintain the Stormwater Facilities and properly manage the grasses, wetlands and other vegetation in the Stormwater Facility Area in compliance with the "Routine Maintenance Activities" specified in Exhibit D, attached hereto and incorporated herein by this reference, and otherwise keep the same in good repair, all at their own cost and expense.

No trees or shrubs that will impair the structural integrity of the Stormwater Facilities shall be planted or allowed to grow within or adjacent to the Stormwater Facilities.

5. Creation of Easements: Developer hereby grants the County and the Metro District a non-exclusive perpetual easement upon and across the property described in Exhibit B1, B2, & B3. The purpose of the easement is to allow the County and the Metro District to access, inspect, clean, repair and maintain the Stormwater Facilities and to allow the Metro District to access and maintain any wetlands; however, the creation of the easement does not expressly or implicitly impose on the County a duty to so inspect, clean, repair or maintain the Stormwater Facilities or any appurtenant improvements.

6. County's Rights and Obligations: Any time the County determines, in the sole exercise of its discretion, that the Stormwater Facilities have not been properly cleaned, maintained, or otherwise kept in good repair, the County shall give reasonable notice of such to the responsible Party and its successors and assigns. The notice shall provide a reasonable time to correct the problems. Should the responsible Parties fail to correct the specified problems, the County may enter upon the properties described in Exhibit B1, B2, & B3 to perform the needed work and shall have the right to seek reimbursement from the responsible Parties for its actual costs and expenses in performing the work. Notice shall be effective to the above by the County's deposit of the same into the regular United States mail, postage pre-paid. Notwithstanding the foregoing, this Agreement does not expressly or implicitly impose on the County a duty to inspect, construct, clean, repair or maintain the Stormwater Facilities.

7. Actual Costs and Expenses: The Developer and the Metro District agree and covenant, for themselves and their successors and assigns, that they will reimburse the County for its actual costs and expenses incurred in the process of completing construction of, cleaning, maintaining, or repairing the Stormwater Facilities or vegetated areas pursuant to the provisions of this Agreement.

The term "actual costs and expenses" as used in this Agreement shall be liberally construed in favor of the County, and shall include, but shall not be limited to, labor costs, tools and equipment costs, supply costs, engineering and design costs, and costs to contract with specialized professionals or consultants, including but not limited to wetlands scientists, regardless of whether the County uses its own personnel, tools, equipment and supplies, etc. to perform the work. In the event the County initiates any litigation or engages the services of legal counsel in order to enforce the provisions arising herein, the County shall be entitled to its damages and costs, including reasonable attorney's fees, regardless of whether the County contracts with outside legal counsel or utilizes in-house legal counsel for the same.

8. Contingencies of Land Use/Land Disturbance Approval: Developer's and the Metro District's execution of this Agreement is a condition of subdivision, land use, or land disturbance approval. Additional conditions of this Agreement include, but are not limited to, the following:

- a. Conveyance of all applicable tracts identified on the Waterbury Filing No. 1 Final Plat from Developer to the Metro District (which will include a reservation of

easement in favor of the County for purposes of accessing, inspecting, cleaning, maintaining, and repairing the Stormwater Facilities), and recording of the Deed for the same; and

- b. A copy of the Covenants of the Subdivision, if applicable, establishing that the Metro District is obligated to inspect, clean, maintain, and repair the Stormwater Facilities.

The County shall have the right, in the sole exercise of its discretion, to approve or disapprove any documentation submitted to it under the conditions of this Paragraph, including but not limited to, any separate agreement or amendment, if applicable, identifying any specific maintenance responsibilities not addressed herein. The County's rejection of any documentation submitted hereunder shall mean that the appropriate condition of this Agreement has not been fulfilled.

9. Agreement Monitored by El Paso County Planning and Community Development Department and/or El Paso County Department of Public Works: Any and all actions and decisions to be made hereunder by the County shall be made by the Executive Director of the El Paso County Planning and Community Development Department and/or the Executive Director of the El Paso County Department of Public Works. Accordingly, any and all documents, submissions, plan approvals, inspections, etc. shall be submitted to and shall be made by the Executive Director of the Planning and Community Development Department and/or the Executive Director of the El Paso County Department of Public Works.

10. Indemnification and Hold Harmless: Developer and the Metro District agree, for themselves, their successors and assigns, that they will, to the extent permitted by law indemnify, defend, and hold the County harmless from any and all loss, costs, damage, injury, liability, claim, lien, demand, action and causes of action whatsoever, whether at law or in equity, arising from or related to their intentional or negligent acts, errors or omissions or that of their agents, officers, servants, employees, invitees and licensees in the construction, operation, inspection, cleaning (including analyzing and disposing of any solid or hazardous wastes as defined by State and/or Federal environmental laws and regulations), maintenance, and repair of the Stormwater Facilities and such obligation arising under this Paragraph shall be joint and several. Nothing in this Paragraph shall be deemed to waive or otherwise limit the defense available to the County or the Metro District pursuant to the Colorado Governmental Immunity Act, Sections 24-10-101, *et seq.* C.R.S., or as otherwise provided by law.

11. Subject to Annual Appropriation: The Metro District does not intend hereby to create a multiple-fiscal year direct or indirect debt or other financial obligation whatsoever. The performance of those obligations of the Metro District pursuant to this Agreement requiring budgeting and appropriation of funds are subject to annual budgeting and appropriations. The County and the Developer expressly understands and agrees that the Metro District's obligations under this Agreement shall extend only to monies appropriated for the purposes of this Agreement by the Metro District Board and shall not constitute a mandatory charge, requirement or liability in any ensuing fiscal year beyond the then-current fiscal year. No provision of this Agreement shall be construed or interpreted as a delegation of governmental powers by the Metro District, or as creating a multiple-fiscal year direct or indirect debt or other financial

obligation whatsoever of the Metro District or statutory debt limitation, including, without limitation, Article X, Section 20 or Article XI, Section 6 of the Constitution of the State of Colorado. No provision of this Agreement shall be construed to pledge or to create a lien on any class or source of Metro District funds. The Metro District's obligations under this Agreement exist subject to annual budgeting and appropriations and shall remain subject to the same for the entire term of this Agreement.

12. Severability: In the event any Court of competent jurisdiction declares any part of this Agreement to be unenforceable, such declaration shall not affect the enforceability of the remaining parts of this Agreement.

13. Third Parties: This Agreement does not and shall not be deemed to confer upon or grant to any third party any right to claim damages or to bring any lawsuit, action or other proceeding against the County, the Developer, the Metro District, or their respective successors and assigns, because of any breach hereof or because of any terms, covenants, agreements or conditions contained herein.

14. Solid Waste or Hazardous Materials: Should any refuse from the Stormwater Facilities be suspected or identified as solid waste or petroleum products, hazardous substances or hazardous materials (collectively referred to herein as "hazardous materials"), the Developer and the Metro District shall take all necessary and proper steps to characterize the solid waste or hazardous materials and properly dispose of it in accordance with applicable State and/or Federal environmental laws and regulations, including, but not limited to, the following: Solid Wastes Disposal Sites and Facilities Acts, §§ 30-20-100.5 – 30-20-119, C.R.S., Colorado Regulations Pertaining to Solid Waste Disposal Sites and Facilities, 6 C.C.R. 1007-2, *et seq.*, Solid Waste Disposal Act, 42 U.S.C. §§ 6901-6992k, and Federal Solid Waste Regulations 40 CFR Ch. I. The County shall not be responsible or liable for identifying, characterizing, cleaning up, or disposing of such solid waste or hazardous materials. Notwithstanding the previous sentence, should any refuse cleaned up and disposed of by the County be determined to be solid waste or hazardous materials, the Developer and the Metro District, but not the County, shall be responsible and liable as the owner, generator, and/or transporter of said solid waste or hazardous materials.

15. Applicable Law and Venue: The laws, rules, and regulations of the State of Colorado and El Paso County shall be applicable in the enforcement, interpretation, and execution of this Agreement, except that Federal law may be applicable regarding solid waste or hazardous materials. Venue shall be in the El Paso County District Court.

16. Limitation on Developer's Obligation and Liability: The obligation and liability of the Developer hereunder shall only continue until such time as the Final Plat as described in the third paragraph (Paragraph C) of the Recitals set forth above is recorded (if applicable) and the Developer completes the construction of the Stormwater Facilities and transfers all applicable maintenance and operation responsibilities to the Metro District. By execution of this agreement, the Metro District agrees to accept all responsibilities and to perform all duties assigned to it, including those of the Developer, as specified herein, upon transfer of maintenance responsibilities for the Stormwater Facilities and any wetlands from Developer to the Metro District.

[Remainder of page intentionally left blank]

IN WITNESS WHEREOF, the Parties affix their signatures below.

Executed this 15th day of May, 2026, by:

ACM ALF VIII JV Sub II LLC

By: [Signature]
Andrew R. ~~Klein~~, [Authorized Representative]
Klein

The foregoing instrument was acknowledged before me this 15 day of May, 2026, by Andrew R. Klein, Authorized Representative, ACM ALF VIII JV Sub II LLC.

Witness my hand and official seal.

My commission expires: 07-23-2028

[Signature]

Notary Public

HARRISON GRANT COHEN
Notary Public
State of Colorado
Notary ID # 20244027480
My Commission Expires 07-23-2028

Executed this 15th day of May, 2026, by: Waterbury Metropolitan District No. 1

By: [Signature]
Jason D.W. Peck, Title Director

The foregoing instrument was acknowledged before me this 15 day of May, 2026, by Jason D.W. Peck Title Director, Waterbury Metropolitan District No. 1

Witness my hand and official seal.

My commission expires: 07-23-2028

[Signature]

Notary Public

HARRISON GRANT COHEN
Notary Public
State of Colorado
Notary ID # 20244027480
My Commission Expires 07-23-2028

BOARD OF COUNTY COMMISSIONERS
OF EL PASO COUNTY, COLORADO

By: _____

Gilbert LaForce, Engineering Manager

Development Services, Department of Public Works

Designee of Joshua Palmer, County Engineer

Authorized signatory pursuant to Resolution No. 24-145

The foregoing instrument was acknowledged before me this _____ day of _____, 20__, by _____, Engineering Manager, El Paso County Department of Public Works.

Witness my hand and official seal.

My commission expires: _____

Notary Public

Approved as to Content and Form:

Lori L. Seago

Assistant County Attorney

EXHIBIT A

WATERBURY FILING1

A PARCEL OF LAND BEING A PORTION OF SOUTHWEST QUARTER OF SECTION 28, A PORTION OF THE SOUTHEAST QUARTER OF SECTION 29, AND A PORTION OF THE NORTHWEST QUARTER OF SECTION 33, TOWNSHIP 12 SOUTH, RANGE 64 WEST OF THE SIXTH PRINCIPAL MERIDIAN, EL PASO COUNTY, COLORADO, BEING MORE PARTICULARLY DESCRIBED AS FOLLOWS:

BASIS OF BEARINGS: THE NORTH LINE OF SECTION 28, TOWNSHIP 12 SOUTH, RANGE 64 WEST OF THE SIXTH PRINCIPAL MERIDIAN, EL PASO COUNTY, COLORADO, BEING MONUMENTED AT EACH END BY A 3-1/4" ALUMINUM SURVEYOR'S CAP STAMPED "PSINC LS 30087" AND ASSUMED TO BEAR S89°47'04"E A DISTANCE OF 5,285.07 FEET.

COMMENCING AT THE SOUTHEASTERLY CORNER OF LOT 15 AS PLATTED IN 4 WAY RANCH FILING NO. 1, RECORDED UNDER RECEPTION NO. 206712416, RECORDS OF EL PASO COUNTY, COLORADO, SAID POINT BEING ON THE WESTERLY RIGHT OF WAY LINE OF STAPLETON DRIVE AS DESCRIBED IN THE DOCUMENT RECORDED UNDER RECEPTION NO. 212064636; THENCE N01°31'24"E, ON THE EASTERLY BOUNDARY OF SAID LOT 15 AND THE SAID WESTERLY RIGHT-OF-WAY LINE, A DISTANCE OF 5.63 FEET TO A POINT ON THE NORTHERLY RIGHT OF WAY LINE OF SAID STAPLETON ROAD SAID POINT BEING THE POINT OF BEGINNING;

THENCE ON THE EASTERLY BOUNDARY OF SAID 4 WAY RANCH FILING NO. 1, THE FOLLOWING TWELVE (12) COURSES;

1. N01°31'24"E, A DISTANCE OF 230.23 FEET;
2. N01°58'45"E, A DISTANCE OF 267.96 FEET;
3. N38°56'07"E, A DISTANCE OF 145.18 FEET;
4. N28°06'29"W, A DISTANCE OF 415.84 FEET;
5. N40°37'02"W, A DISTANCE OF 70.00 FEET TO A POINT ON CURVE;
6. ON THE ARC OF CURVE TO THE LEFT WHOSE CENTER BEARS S40°37'02"E, HAVING A DELTA OF 02°07'07", A RADIUS OF 1,135.00 FEET, A DISTANCE OF 41.97 FEET TO A POINT ON CURVE;
7. N44°30'10"W, A DISTANCE OF 104.01 FEET TO A POINT OF CURVE;
8. ON THE ARC OF CURVE TO THE RIGHT, HAVING A DELTA OF 21°00'17", A RADIUS OF 565.00 FEET, A DISTANCE OF 207.13 FEET TO A POINT OF TANGENT;
9. N23°29'53"W, A DISTANCE OF 586.57 FEET TO A POINT OF CURVE;

10. ON THE ARC OF A CURVE TO THE RIGHT HAVING A DELTA OF 41°24'35", A RADIUS OF 40.00 FEET AND A DISTANCE OF 28.91 FEET TO A POINT OF REVERSE CURVE;

11. ON THE ARC OF A CURVE TO THE LEFT HAVING A DELTA OF 98°17'54", A RADIUS OF 60.00 FEET, A DISTANCE OF 102.94 FEET TO A POINT ON CURVE;

12. N09°36'47"E, A DISTANCE OF 181.35 FEET;

THENCE S84°51'41"E, A DISTANCE OF 156.95 FEET, THENCE N81°05'30"E, A DISTANCE OF 114.50 FEET; THENCE N08°54'30"W, A DISTANCE OF 13.30 FEET TO A POINT OF CURVE; THENCE ON THE ARC OF A CURVE TO THE LEFT, HAVING A DELTA OF 00°22'06", A RADIUS OF 475.00 FEET, A DISTANCE OF 3.05 FEET TO A POINT ON CURVE; THENCE N80°43'23"E, A DISTANCE OF 50.00 FEET; THENCE S88°55'30"E, A DISTANCE OF 118.82 FEET; THENCE S09°08'33"E, A DISTANCE OF 24.43 FEET; THENCE N89°59'53"E, A DISTANCE OF 125.65 FEET TO A POINT ON CURVE, THENCE ON THE ARC OF A CURVE TO THE RIGHT WHOSE CENTER BEARS N89°59'53"E, HAVING A DELTA OF 01°10'07", A RADIUS OF 225.00 FEET, A DISTANCE OF 4.59 FEET TO A POINT OF TANGENT; THENCE N01°10'00"E, A DISTANCE OF 22.47 FEET, THENCE S88°50'00"E, A DISTANCE OF 50.00 FEET; THENCE N89°55'04"E, A DISTANCE OF 152.16 FEET; THENCE N00°04'56"W, A DISTANCE OF 30.14 FEET; THENCE S88°15'00"E, A DISTANCE OF 201.01 FEET; THENCE S01°45'00"W, A DISTANCE OF 27.39 FEET; THENCE S88°35'57"E, A DISTANCE OF 70.97 FEET; THENCE N68°36'47"E, A DISTANCE OF 62.85 FEET; THENCE N65°20'20"E, A DISTANCE OF 62.85 FEET; THENCE N62°03'54"E, A DISTANCE OF 62.85 FEET; THENCE N58°57'56"E, A DISTANCE OF 65.28 FEET; THENCE S32°58'22"E, A DISTANCE OF 124.73 FEET TO A POINT ON CURVE; THENCE ON THE ARC OF A CURVE TO THE LEFT WHOSE CENTER BEARS N32°58'22"W, HAVING A DELTA OF 08°00'18", A RADIUS OF 1,225.00 FEET, A DISTANCE OF 171.15 FEET TO A POINT ON CURVE; THENCE S41°02'14"E, A DISTANCE OF 144.45 FEET; THENCE S34°05'25"E, A DISTANCE OF 72.65 FEET; THENCE S30°56'30"E, A DISTANCE OF 81.87 FEET; THENCE S21°08'32"E, A DISTANCE OF 89.56 FEET; THENCE S19°08'47"E, A DISTANCE OF 73.79 FEET; THENCE S03°18'02"W, A DISTANCE OF 205.74 FEET; THENCE S17°29'03"E, A DISTANCE OF 124.83 FEET; THENCE S16°09'50"E, A DISTANCE OF 50.00 FEET; THENCE S16°07'17"E, A DISTANCE OF 73.88 FEET; THENCE S27°50'37"E, A DISTANCE OF 65.16 FEET; THENCE S25°07'25"E, A DISTANCE OF 66.02 FEET; THENCE S22°21'31"E, A DISTANCE OF 66.20 FEET; THENCE S19°54'11"E, A DISTANCE OF 51.22 FEET; THENCE S16°26'35"E, A DISTANCE OF 114.20 FEET; THENCE S21°00'38"E, A DISTANCE OF 85.08 FEET TO A POINT ON THE BOUNDARY LINE OF THE PARCEL DESCRIBED IN THE WARRANTY DEED RECORDED UNDER RECEPTION NUMBER 214007733, RECORDS OF EL PASO COUNTY, COLORADO; THENCE S00°00'00"E ON SAID BOUNDARY LINE, A DISTANCE OF 472.54 FEET TO A POINT ON CURVE, SAID POINT BEING ON THE NORTHERLY RIGHT-OF-WAY LINE OF STAPLETON DRIVE AS DESCRIBED IN THE DOCUMENT RECORDED UNDER RECEPTION NO. 212064636; THENCE ON SAID RIGHT-OF-WAY LINE THE FOLLOWING TWO (2) COURSES:

1. ON THE ARC OF A CURVE TO THE LEFT WHOSE CENTER BEARS S00°23'33"W, HAVING A DELTA OF 26°14'01", A RADIUS OF 1,405.00 FEET, A DISTANCE OF 643.30 FEET TO A POINT OF TANGENT,
2. S64°09'32"W, A DISTANCE OF 777.32 FEET TO THE POINT OF BEGINNING.

CONTAINING A CALCULATED AREA OF 2,694,934 SQUARE FEET OR 61.867 ACRES.



EXHIBIT B1

LEGAL DESCRIPTION: DRAINAGE EASEMENT

A TRACT OF LAND BEING A PORTION OF SOUTHWEST QUARTER OF SECTION 28 AND A PORTION OF THE SOUTHEAST QUARTER OF SECTION 29, TOWNSHIP 12 SOUTH, RANGE 64 WEST OF THE 6TH P.M., EL PASO COUNTY, STATE OF COLORADO, BEING MORE PARTICULARLY DESCRIBED AS FOLLOWS:

BASIS OF BEARINGS: THE NORTH LINE OF SAID SECTION 28, BEING MONUMENTED AT EACH END BY A 3-1/4" ALUMINUM SURVEYOR'S CAP STAMPED "PSINC LS 30087" AND ASSUMED TO BEAR S89°47'04"E, A DISTANCE OF 5,285.07 FEET.

EASEMENT NO. 1

COMMENCING AT THE NORTHEAST CORNER OF GILBERT DRIVE AS PLATTED IN 4 WAY RANCH FILING NO. 1, RECORDED UNDER RECEPTION NUMBER 206712416, RECORDS OF EL PASO COUNTY, COLORADO, SAID POINT BEING THE POINT OF BEGINNING; THENCE ON THE EASTERLY BOUNDARY OF SAID 4 WAY RANCH FILING NO. 1, THE FOLLOWING SEVEN (7) COURSES:

1. ON THE ARC OF CURVE TO THE LEFT WHOSE CENTER BEARS S40°37'02"E, HAVING A DELTA OF 02°07'07", A RADIUS OF 1,135.00 FEET, A DISTANCE OF 41.97 FEET TO A POINT ON CURVE;
2. N44°30'10"W, A DISTANCE OF 104.01 FEET TO A POINT OF CURVE;
3. ON THE ARC OF CURVE TO THE RIGHT, HAVING A DELTA OF 21°00'17", A RADIUS OF 565.00 FEET, A DISTANCE OF 207.13 FEET TO A POINT OF TANGENT;
4. N23°29'53"W, A DISTANCE OF 586.57 FEET;
5. ON THE ARC OF A CURVE TO THE RIGHT HAVING A DELTA OF 41°24'35", A RADIUS OF 40.00 FEET AND A DISTANCE OF 28.91 FEET TO A POINT OF REVERSE CURVE;
6. ON THE ARC OF A CURVE TO THE LEFT HAVING A DELTA OF 98°17'54", A RADIUS OF 60.00 FEET, A DISTANCE OF 102.94 FEET TO A POINT ON CURVE;
7. N09°36'47"E, A DISTANCE OF 181.35 FEET;



THENCE S84°51'41"E A DISTANCE OF 156.95 FEET; THENCE S07°57'13"E A DISTANCE OF 60.01 FEET; THENCE S09°22'41"E A DISTANCE OF 60.99 FEET; THENCE S08°30'28"E A DISTANCE OF 59.94 FEET; THENCE S08°28'55"E A DISTANCE OF 69.06 FEET; THENCE S20°14'40"E A DISTANCE OF 105.14 FEET; THENCE S31°38'07"E A DISTANCE OF 143.03 FEET; THENCE S40°59'51"E A DISTANCE OF 18.23 FEET; THENCE S21°55'47"E A DISTANCE OF 132.00 FEET; THENCE S20°59'40"E A DISTANCE OF 99.72 FEET; THENCE S22°50'54"E A DISTANCE OF 60.00 FEET; THENCE S29°54'41"E A DISTANCE OF 121.04 FEET; THENCE S28°11'27"E A DISTANCE OF 60.31 FEET; THENCE S26°07'36"E A DISTANCE OF 61.20 FEET; THENCE S49°04'39"W A DISTANCE OF 92.13 FEET TO THE POINT OF BEGINNING.

CONTAINING A CALCULATED AREA OF 196,438 SQUARE FEET OR 4.510 ACRES.

LEGAL DESCRIPTION STATEMENT

I, JONATHAN W. TESSIN, A REGISTERED PROFESSIONAL LAND SURVEYOR IN THE STATE OF COLORADO, DO HEREBY STATE THAT THE ABOVE LEGAL DESCRIPTION WAS PREPARED UNDER MY RESPONSIBLE CHARGE AND ON THE BASIS OF MY KNOWLEDGE, INFORMATION, AND BELIEF IS CORRECT.

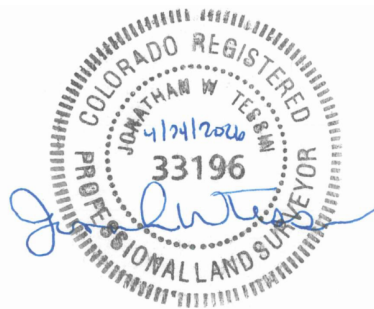

JONATHAN W. TESSIN, PROFESSIONAL LAND SURVEYOR
COLORADO PLS NO. 33196
FOR AND ON BEHALF OF EDWARD-JAMES SURVEYING, INC.

EXHIBIT C1

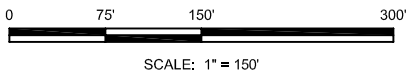
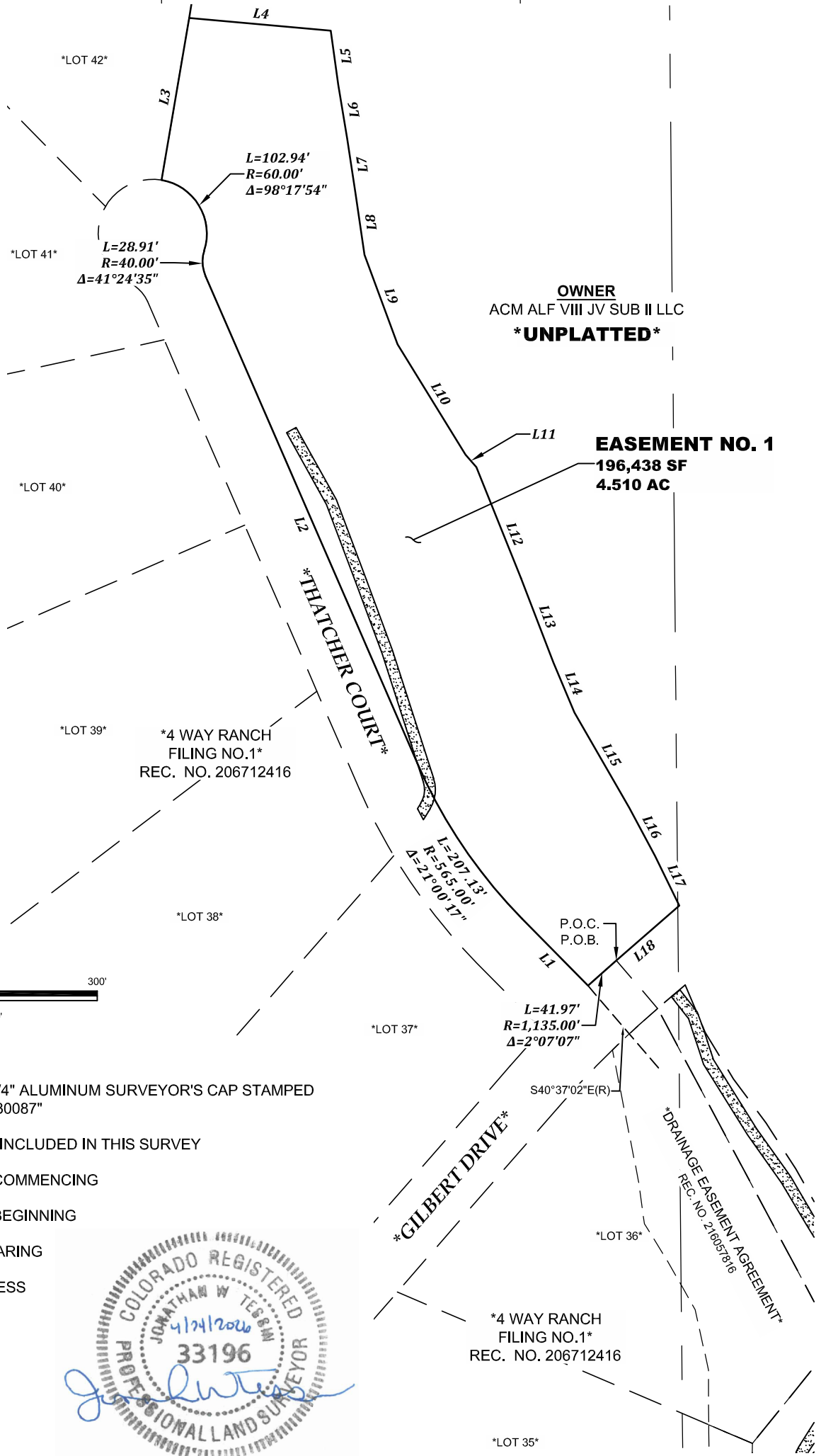
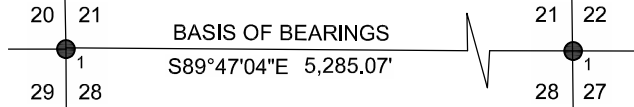

LEGEND:

- 1 FOUND 3-1/4" ALUMINUM SURVEYOR'S CAP STAMPED "PSINC LS 30087"
- * AREA NOT INCLUDED IN THIS SURVEY
- P.O.C POINT OF COMMENCING
- P.O.B. POINT OF BEGINNING
- (R) RADIAL BEARING
- ROAD ACCESS

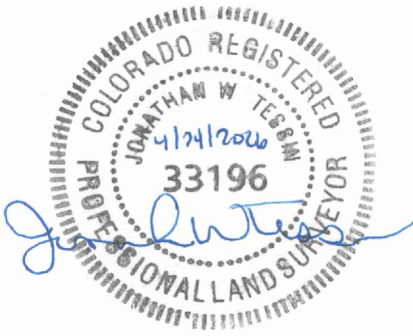

EDWARD-JAMES SURVEYING, INC.
 926 Elkton Dr. 4732 Eagleridge Circle
 Colorado Springs, CO 80907 Pueblo, CO 81008
 (719) 576-1216 (719) 545-6240
 4-20-2026 JOB NO. 2117-00
DRAINAGE EASEMENT 1 SHEET 3 OF 4

THIS DRAWING DOES NOT REPRESENT A MONUMENTED LAND SURVEY AND IS ONLY INTENDED TO DEPICT THE LEGAL DESCRIPTION.

EXHIBIT C1 LINE TABLE

LINE TABLE EASEMENT 1		
NO.	BEARING	LENGTH
L1	N44°30'10"W	104.01'
L2	N23°29'53"W	586.57'
L3	N09°36'47"E	181.35'
L4	S84°51'41"E	156.95'
L5	S07°57'13"E	60.01'
L6	S09°22'41"E	60.99'
L7	S08°30'28"E	59.94'
L8	S08°28'55"E	69.06'
L9	S20°14'40"E	105.14'
L10	S31°38'07"E	143.03'
L11	S40°59'51"E	18.23'
L12	S21°55'47"E	132.00'
L13	S20°59'40"E	99.72'
L14	S22°50'54"E	60.00'
L15	S29°54'41"E	121.04'
L16	S28°11'27"E	60.31'
L17	S26°07'36"E	61.20'
L18	S49°04'39"W	92.13'

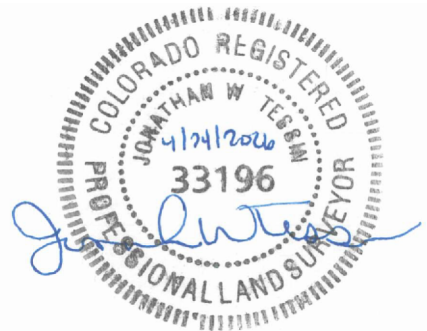

**THIS DRAWING DOES NOT REPRESENT A
MONUMENTED LAND SURVEY AND IS ONLY
INTENDED TO DEPICT THE LEGAL DESCRIPTION.**



EDWARD-JAMES SURVEYING, INC.
 926 Elkton Dr. 4732 Eagleridge Circle
 Colorado Springs, CO 80907 Pueblo, CO 81008
 (719) 576-1216 (719) 545-6240
 4-20-2026 JOB NO. 2117-00
DRAINAGE EASEMENT 2 SHEET 4 OF 4



EXHIBIT B2

LEGAL DESCRIPTION: DRAINAGE EASEMENT

A TRACT OF LAND BEING A PORTION OF SOUTHEAST QUARTER OF SECTION 29, A PORTION OF THE SOUTHWEST QUARTER OF SECTION 28 AND A PORTION OF THE NORTHWEST QUARTER OF SECTION 33, TOWNSHIP 12 SOUTH, RANGE 64 WEST OF THE 6TH P.M., EL PASO COUNTY, STATE OF COLORADO, BEING MORE PARTICULARLY DESCRIBED AS FOLLOWS:

BASIS OF BEARINGS: THE NORTH LINE OF SAID SECTION 28, BEING MONUMENTED AT EACH END BY A 3-1/4" ALUMINUM SURVEYOR'S CAP STAMPED "PSINC LS 30087" AND ASSUMED TO BEAR S89°47'04"E, A DISTANCE OF 5,285.07 FEET.

EASEMENT NO. 2

COMMENCING AT THE SOUTHEAST CORNER OF GILBERT DRIVE AS PLATTED IN 4 WAY RANCH FILING NO. 1, RECORDED UNDER RECEPTION NUMBER 206712416, RECORDS OF EL PASO COUNTY, COLORADO, SAID POINT BEING THE POINT OF BEGINNING; THENCE N49°22'58"E A DISTANCE OF 40.19 FEET; THENCE S22°44'36"E A DISTANCE OF 56.87 FEET; THENCE S31°19'55"E A DISTANCE OF 60.05 FEET; THENCE S36°28'03"E A DISTANCE OF 60.53 FEET; THENCE S32°52'52"E A DISTANCE OF 60.15 FEET; THENCE S29°25'32"E A DISTANCE OF 60.00 FEET; THENCE S26°30'01"E A DISTANCE OF 60.05 FEET; THENCE S07°00'09"E A DISTANCE OF 44.70 FEET; THENCE S02°30'00"E A DISTANCE OF 120.39 FEET THENCE S04°21'40"E A DISTANCE OF 194.43 FEET; THENCE S30°14'06"E A DISTANCE OF 101.64 FEET; THENCE N39°00'00"E A DISTANCE OF 120.00 FEET TO A POINT ON CURVE; THENCE ON THE ARC OF A CURVE TO THE LEFT, WHOSE CENTER BEARS N42°07'45"E, HAVING A DELTA OF 21°07'52", A RADIUS OF 55.00 FEET A DISTANCE OF 20.28 FEET TO A POINT ON CURVE; THENCE S39°00'00"W A DISTANCE OF 120.00 FEET; THENCE S68°08'53"E A DISTANCE OF 97.61 FEET; THENCE N69°11'02"E A DISTANCE OF 116.63 FEET; THENCE N33°09'46"W A DISTANCE OF 77.79 FEET; THENCE N74°01'31"E A DISTANCE OF 262.92 FEET; THENCE S25°50'28"E A DISTANCE OF 35.96 FEET; THENCE S19°07'42"W A DISTANCE OF 49.52 FEET TO A POINT ON THE NORTHERLY RIGHT-OF-WAY LINE OF STAPLETON DRIVE AS DESCRIBED IN THE DOCUMENT RECORDED UNDER RECEPTION NO. 212064636; THENCE S64°09'32"W ON SAID NORTHERLY RIGHT-OF-WAY LINE A DISTANCE OF 691.61 FEET TO A POINT ON THE EASTERLY LINE OF LOT 15 AS PLATTED IN SAID 4 WAY RANCH FILING NO. 1; THENCE ON THE EASTERLY LINE OF SAID 4 WAY RANCH FILING NO. 1 THE FOLLOWING FOUR (4) COURSES:



1. N01°31'24"E, A DISTANCE OF 230.23 FEET;
2. N01°58'45"E, A DISTANCE OF 267.96 FEET;
3. N38°56'07"E, A DISTANCE OF 145.18 FEET;
4. N28°06'29"W, A DISTANCE OF 415.84 FEET TO THE POINT OF OF BEGINNING.

CONTAINING A CALCULATED AREA OF 141,164 SQUARE FEET OR 3.241 ACRES.

LEGAL DESCRIPTION STATEMENT

I, JONATHAN W. TESSIN, A REGISTERED PROFESSIONAL LAND SURVEYOR IN THE STATE OF COLORADO, DO HEREBY STATE THAT THE ABOVE LEGAL DESCRIPTION WAS PREPARED UNDER MY RESPONSIBLE CHARGE AND ON THE BASIS OF MY KNOWLEDGE, INFORMATION, AND BELIEF IS CORRECT.

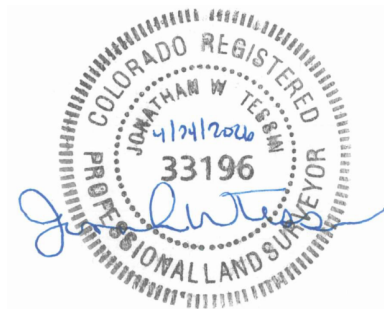

JONATHAN W. TESSIN, PROFESSIONAL LAND SURVEYOR
COLORADO PLS NO. 33196
FOR AND ON BEHALF OF EDWARD-JAMES SURVEYING, INC.

EXHIBIT C2

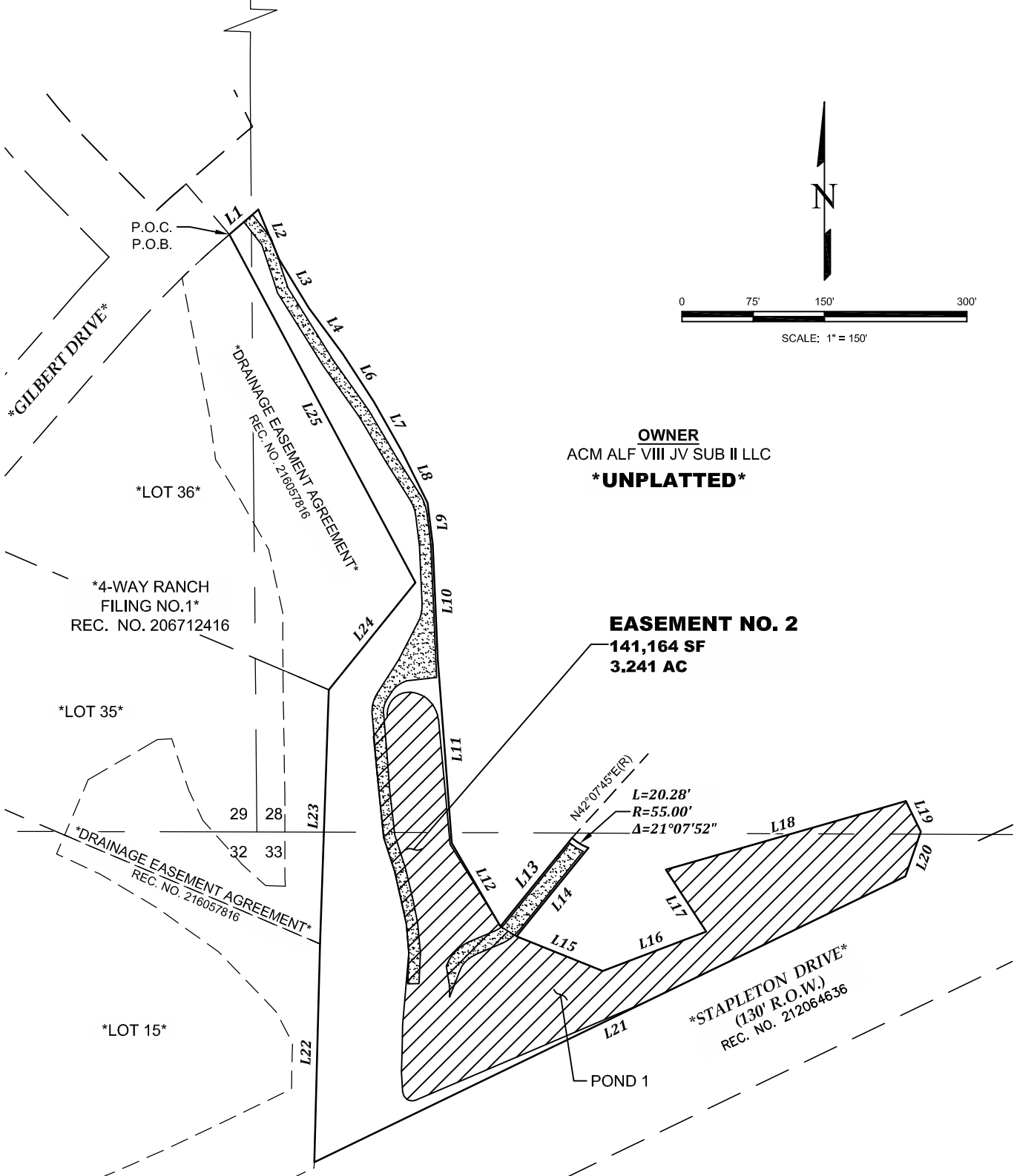
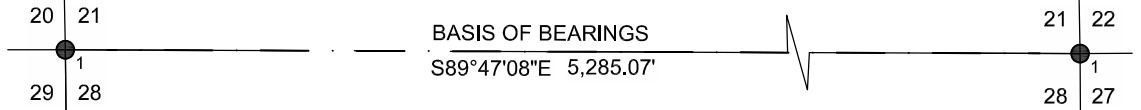



OWNER
ACM ALF VIII JV SUB II LLC
UNPLATTED

EASEMENT NO. 2
141,164 SF
3.241 AC

$N42^{\circ}07'45\"/>$

LEGEND:

- 1 FOUND 3-1/4" ALUMINUM SURVEYOR'S CAP STAMPED "PSINC LS 30087"
- * AREA NOT INCLUDED IN THIS SURVEY
- P.O.C POINT OF COMMENCING
- P.O.B. POINT OF BEGINNING
- (R) RADIAL BEARING
-  ROAD ACCESS
-  POND AREA

THIS DRAWING DOES NOT REPRESENT A MONUMENTED LAND SURVEY AND IS ONLY INTENDED TO DEPICT THE LEGAL DESCRIPTION.

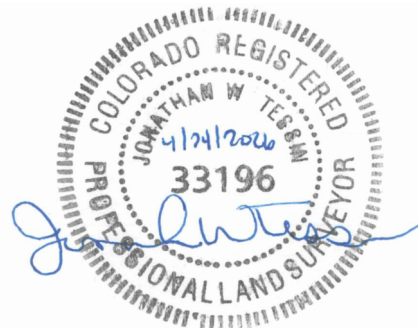

EDWARD-JAMES SURVEYING, INC.
926 Elkton Dr. 4732 Eagleridge Circle
Colorado Springs, CO 80907 Pueblo, CO 81008
(719) 576-1216 (719) 545-6240
4-20-2026 JOB NO. 2117-00
DRAINAGE EASEMENT 2 SHEET 3 OF 4

EXHIBIT C2 LINE TABLE

LINE TABLE EASEMENT NO. 2		
NO.	BEARING	LENGTH
L1	N49°22'58"E	40.19'
L2	S22°44'36"E	56.87'
L3	S31°19'55"E	60.05'
L4	S36°28'03"E	60.53'
L6	S32°52'52"E	60.15'
L7	S29°25'32"E	60.00'
L8	S26°30'01"E	60.05'
L9	S07°00'09"E	44.70'
L10	S02°30'00"E	120.39'
L11	S04°21'40"E	194.43'
L12	S30°14'06"E	101.64'
L13	N39°00'00"E	120.00'
L14	S39°00'00"W	120.00'
L15	S68°08'53"E	97.61'
L16	N69°11'02"E	116.63'
L17	N33°09'46"W	77.79'
L18	N74°01'31"E	262.92'
L19	S25°50'28"E	35.96'
L20	S19°07'42"W	49.52'
L21	S64°09'32"W	691.61'
L22	N01°31'24"E	230.23'
L23	N01°58'45"E	267.96'
L24	N38°56'07"E	145.18'
L25	N28°06'29"W	415.84'



THIS DRAWING DOES NOT REPRESENT A
MONUMENTED LAND SURVEY AND IS ONLY
INTENDED TO DEPICT THE LEGAL DESCRIPTION.



EDWARD-JAMES SURVEYING, INC.
 926 Elkton Dr. 4732 Eagleridge Circle
 Colorado Springs, CO 80907 Pueblo, CO 81008
 (719) 576-1216 (719) 545-6240
 4-20-2026 JOB NO. 2117-00
DRAINAGE EASEMENT 2 SHEET 4 OF 4



EXHIBIT B3

LEGAL DESCRIPTION: DRAINAGE EASEMENT

A TRACT OF LAND BEING A PORTION OF SOUTHWEST QUARTER OF SECTION 28, TOWNSHIP 12 SOUTH, RANGE 64 WEST OF THE 6TH P.M., EL PASO COUNTY, STATE OF COLORADO, BEING MORE PARTICULARLY DESCRIBED AS FOLLOWS:

BASIS OF BEARINGS: THE NORTH LINE OF SAID SECTION 28, BEING MONUMENTED AT EACH END BY A 3-1/4" ALUMINUM SURVEYOR'S CAP STAMPED "PSINC LS 30087" AND ASSUMED TO BEAR S89°47'04"E, A DISTANCE OF 5,285.07 FEET.

EASEMENT NO. 3

COMMENCING AT THE NORTHWEST CORNER OF SAID SECTION 28; THENCE S02°57'46"E, A DISTANCE OF 3,337.73 FEET TO THE POINT OF BEGINNING; THENCE S84°07'01"E, A DISTANCE OF 223.34 FEET; THENCE S87°26'34"E, A DISTANCE OF 63.00 FEET; THENCE S71°11'29"E, A DISTANCE OF 45.82 FEET; THENCE S41°52'53"E, A DISTANCE OF 75.23 FEET; THENCE S74°50'57"E, A DISTANCE OF 62.49 FEET; THENCE N67°40'48"E, A DISTANCE OF 371.53 FEET; THENCE S44°11'17"E A DISTANCE OF 147.36; THENCE N43°58'27"E A DISTANCE OF 80.21 FEET; THENCE S47°22'50"E A DISTANCE OF 145.02 FEET; THENCE N44°19'19"E A DISTANCE OF 22.14 FEET; THENCE S81°05'02"E A DISTANCE OF 190.87 FEET TO A POINT ON CURVE; THENCE ON THE ARC OF A CURVE TO THE LEFT, WHOSE CENTER BEARS N78°37'57"E, HAVING A DELTA OF 116°05'55", A RADIUS OF 55.00 FEET A DISTANCE OF 111.45 FEET TO A POINT ON CURVE; THENCE S00°26'19"E A DISTANCE OF 103.59 FEET; THENCE N89°33'41"E A DISTANCE OF 65.00 FEET; THENCE S00°26'19"E A DISTANCE OF 152.50 FEET; THENCE S48°19'16"E A DISTANCE OF 96.59 FEET; THENCE N89°32'58"E A DISTANCE OF 53.92 FEET; THENCE S00°27'02"E, A DISTANCE OF 345.12 FEET; THENCE S89°34'31"W, A DISTANCE OF 190.82 FEET; THENCE S13°38'53"W, A DISTANCE OF 3.14 FEET TO A POINT OF CURVE; THENCE ON THE ARC OF A CURVE TO THE RIGHT HAVING A DELTA OF 46°12'58", A RADIUS OF 86.00 FEET, A DISTANCE OF 69.37 FEET TO A POINT OF TANGENT; THENCE S59°51'51"W, A DISTANCE OF 42.97 FEET TO A POINT OF CURVE; THENCE ON THE ARC OF A CURVE TO THE LEFT HAVING A DELTA OF 79°02'13", A RADIUS OF 20.00 FEET A DISTANCE OF 27.59 FEET TO A POINT OF TANGENT; THENCE S19°10'22"E A DISTANCE OF 109.24 FEET TO A POINT OF CURVE; THENCE ON THE ARC OF A CURVE TO THE LEFT HAVING A DELTA OF 28°28'21", A RADIUS OF 20.00 FEET A DISTANCE OF 9.94 FEET TO A POINT OF TANGENT; THENCE S47°38'44"E A DISTANCE OF 225.96 FEET; THENCE S73°16'59"E A DISTANCE OF 83.70 FEET; THENCE N44°58'19"E A DISTANCE OF 148.45 FEET; THENCE S45°01'41"E A DISTANCE OF 104.00 FEET; THENCE S44°58'19"W A DISTANCE OF 144.85 FEET; THENCE S64°59'02"E A DISTANCE OF 23.80 FEET TO A POINT OF CURVE; THENCE ON THE ARC OF A CURVE TO THE LEFT HAVING A DELTA OF 18°36'46", A RADIUS OF 20.00 FEET A DISTANCE OF 6.50 FEET TO A POINT OF TANGENT; THENCE S83°35'47"E A DISTANCE OF 150.10 FEET; THENCE N47°33'57"E A DISTANCE OF 193.25 FEET; THENCE N86°51'25"E A DISTANCE OF 167.64 FEET; THENCE S24°23'26"E A DISTANCE OF 50.77 FEET; THENCE S17°37'46"E A DISTANCE OF 294.28 FEET TO A POINT ON THE NORTHERLY BOUNDARY OF A SPECIAL WARRANTY DEED RECORDED AT RECEPTION NO. 208025323 OF THE RECORDS OF SAID EL PASO COUNTY;



THENCE ON SAID NORTHERLY BOUNDARY THE FOLLOWING SIXTEEN (16) COURSES:

1. N90°00'00"W, A DISTANCE OF 36.51 FEET;
2. S81°21'20"W, A DISTANCE OF 79.00 FEET;
3. S69°17'32"W, A DISTANCE OF 67.16 FEET;
4. S62°43'20"W, A DISTANCE OF 59.22 FEET;
5. S80°50'46"W, A DISTANCE OF 53.31 FEET;
6. N72°21'55"W, A DISTANCE OF 39.19 FEET;
7. N65°00'13"W, A DISTANCE OF 28.10 FEET;
8. N80°32'47"W, A DISTANCE OF 61.96 FEET;
9. N88°09'15"W, A DISTANCE OF 52.66 FEET;
10. S82°46'11"W, A DISTANCE OF 108.65 FEET;
11. N61°19'38"W, A DISTANCE OF 141.06 FEET;
12. N80°48'35"W, A DISTANCE OF 101.84 FEET;
13. N64°09'57"W, A DISTANCE OF 94.87 FEET;
14. N47°17'41"W, A DISTANCE OF 86.33 FEET;
15. N33°21'54"W, A DISTANCE OF 38.41 FEET;
16. S00°00'00"E, A DISTANCE OF 472.53 FEET TO A POINT ON THE NORTHERLY RIGHT-OF-WAY LINE OF STAPLETON DRIVE;

THENCE N19°11'11"W A DISTANCE OF 75.54 FEET; THENCE N48°10'00"W A DISTANCE OF 39.62 FEET; THENCE N41°45'56"E A DISTANCE OF 10.02 FEET; THENCE S48°07'44"E A DISTANCE OF 37.15 FEET; THENCE N00°00'00"E A DISTANCE OF 104.03 FEET; THENCE N90°00'00"W A DISTANCE OF 32.25 FEET; THENCE N00°00'00"E A DISTANCE OF 10.00 FEET; THENCE N90°00'00"E A DISTANCE OF 32.25 FEET; THENCE N00°00'00"E A DISTANCE OF 40.82 FEET; THENCE S90°00'00"W A DISTANCE OF 32.24 FEET; THENCE N00°04'28"W A DISTANCE OF 10.00 FEET; THENCE N90°00'00"E A DISTANCE OF 32.25 FEET; THENCE N00°00'00"E A DISTANCE OF 38.31 FEET; THENCE N90°00'00"W A DISTANCE OF 76.09 FEET; THENCE N03°30'47"W A DISTANCE OF 10.02 FEET; THENCE N90°00'00"E A DISTANCE OF 91.65 FEET; THENCE N00°00'47"W A DISTANCE OF 137.46 FEET; THENCE N56°21'42"W A DISTANCE OF 54.38 FEET; THENCE S76°54'43"W A DISTANCE OF 86.50 FEET TO A POINT ON CURVE; THENCE ON THE ARC OF A CURVE TO THE LEFT, WHOSE CENTER BEARS S79°41'47"W, HAVING A DELTA OF 11°30'28", A RADIUS OF 1,250.00 FEET A DISTANCE OF 251.06 FEET TO A POINT ON CURVE; THENCE N67°18'17"E A DISTANCE OF 119.72 FEET; THENCE N22°28'23"E A DISTANCE OF 7.09 FEET; THENCE N22°21'31"W A DISTANCE OF 38.57 FEET; THENCE N25°07'25"W A DISTANCE OF 66.02 FEET; THENCE N27°50'37"W A DISTANCE OF 65.16 FEET, THENCE N16°07'17"W A DISTANCE OF 73.88 FEET; THENCE N16°09'50"W A DISTANCE OF 50.00 FEET; THENCE N17°29'03"W A DISTANCE OF 124.83 FEET; THENCE N03°18'02"E, A DISTANCE OF 205.74 FEET; THENCE N19°08'47"W A DISTANCE OF 73.79 FEET; THENCE N21°08'32"W A DISTANCE OF 89.56 FEET; THENCE N30°56'30", A DISTANCE OF 81.87 FEET; THENCE N34°05'25"W A DISTANCE OF 72.65 FEET; THENCE N41°02'14"W A DISTANCE OF 144.45 FEET TO A POINT ON CURVE; THENCE ON THE ARC OF A CURVE TO THE RIGHT, WHOSE CENTER BEARS N40°58'40"W, HAVING A DELTA OF 08°00'18", A RADIUS OF 1,225.00 FEET, A DISTANCE OF 171.15 FEET TO A POINT ON CURVE; THENCE N32°58'22"W A DISTANCE OF 124.73 FEET; THENCE S58°57'56"W A DISTANCE OF 65.28 FEET; THENCE S62°03'54"W A DISTANCE OF 62.85 FEET; THENCE S65°20'20"W A DISTANCE OF 62.85 FEET; THENCE S68°36'47"W A DISTANCE OF 62.85 FEET;



April 19, 2026
Job No. 2117-01
Page 3 of 6

THENCE N88°35'57"W A DISTANCE OF 70.92 FEET; THENCE N00°21'55"E A DISTANCE OF 132.98 FEET; THENCE N83°07'18"W A DISTANCE OF 22.85 FEET; THENCE S46°16'35"W A DISTANCE OF 59.47 FEET; THENCE S72°34'31"W A DISTANCE OF 64.44 FEET; THENCE N71°47'57"W A DISTANCE OF 205.75; THENCE N23°23'58"E A DISTANCE OF 63.18 FEET; FEET TO THE POINT OF BEGINNING.

CONTAINING A CALCULATED AREA OF 808,370 SQUARE FEET OR 18.558 ACRES, MORE OR LESS.

LEGAL DESCRIPTION STATEMENT

I, JONATHAN W. TESSIN, A REGISTERED PROFESSIONAL LAND SURVEYOR IN THE STATE OF COLORADO, DO HEREBY STATE THAT THE ABOVE LEGAL DESCRIPTION WAS PREPARED UNDER MY RESPONSIBLE CHARGE AND ON THE BASIS OF MY KNOWLEDGE, INFORMATION, AND BELIEF IS CORRECT.

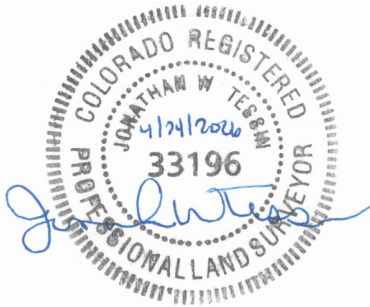

JONATHAN W. TESSIN, PROFESSIONAL LAND SURVEYOR
COLORADO PLS NO. 33196
FOR AND ON BEHALF OF EDWARD-JAMES SURVEYING, INC.

EXHIBIT C3

OWNER
ACM ALF VIII JV SUB II LLC

UNPLATTED

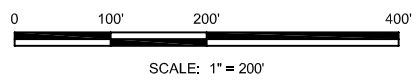
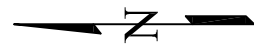
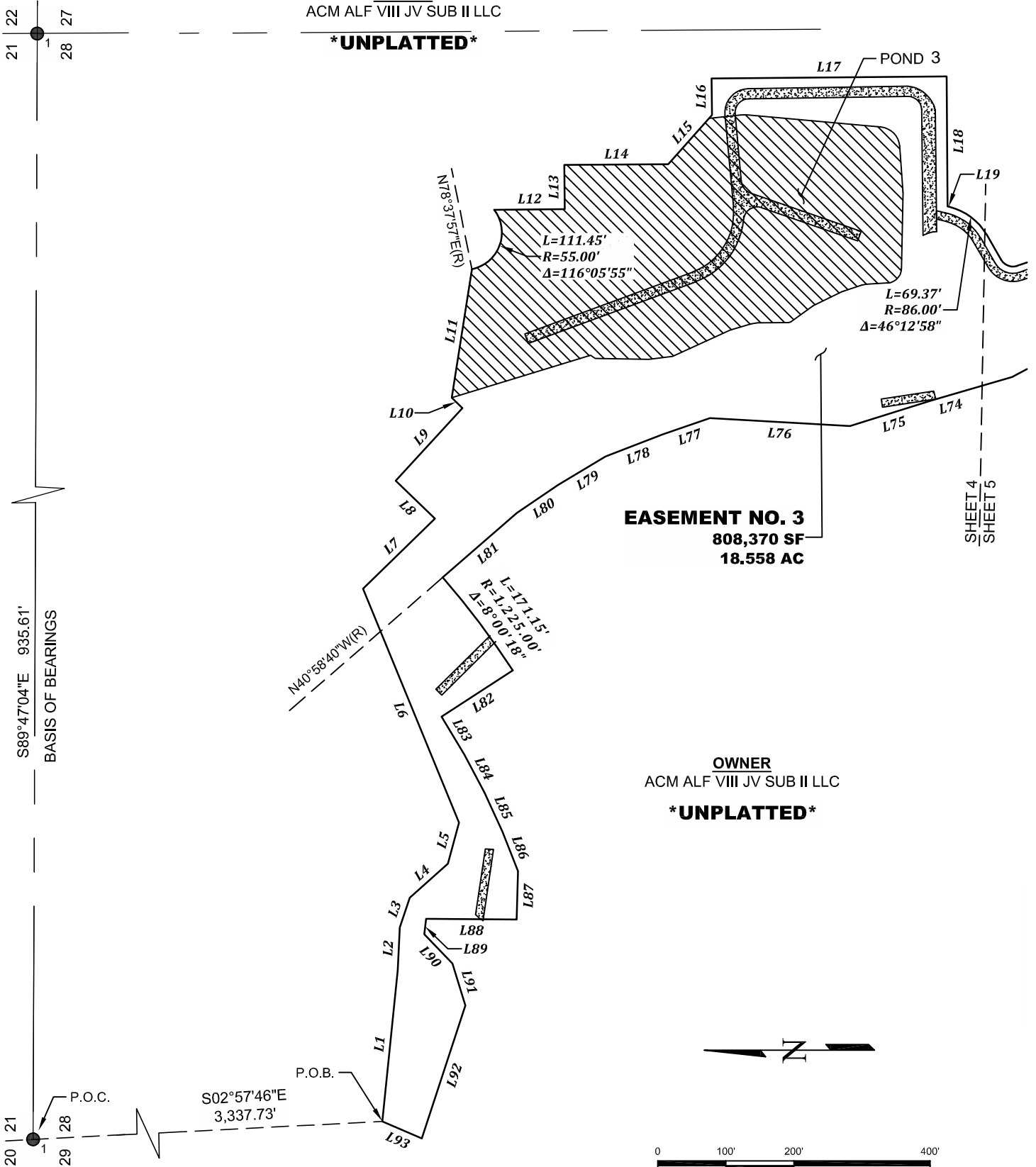

LEGEND:

- 1 FOUND 3-1/4" ALUMINUM SURVEYOR'S CAP STAMPED "PSINC LS 30087"
- * AREA NOT INCLUDED IN THIS SURVEY
- P.O.C POINT OF COMMENCING
- P.O.B. POINT OF BEGINNING
- (R) RADIAL BEARING
- ROAD ACCESS
- POND AREA

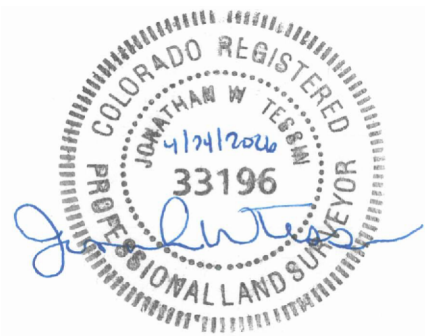

THIS DRAWING DOES NOT REPRESENT A MONUMENTED LAND SURVEY AND IS ONLY INTENDED TO DEPICT THE LEGAL DESCRIPTION.



EDWARD-JAMES SURVEYING, INC.
 926 Elkton Dr. Colorado Springs, CO 80907 (719) 576-1216
 4732 Eagleridge Circle Pueblo, CO 81008 (719) 545-6240
 4-20-2026 DRAINAGE EASEMENT
 JOB NO. 2117-00 SHEET 4 OF 6

EXHIBIT C3

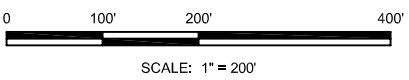
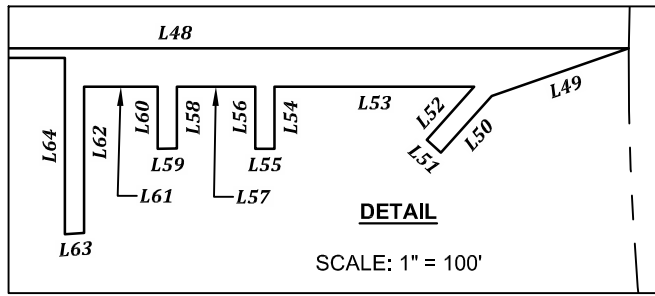

OWNER
ACM ALF VIII JV SUB II LLC
UNPLATTED

OWNER
ACM ALF VIII JV SUB II LLC
UNPLATTED

REC. NO.
208025323

EASEMENT NO. 3
808,370 SF
18.558 AC

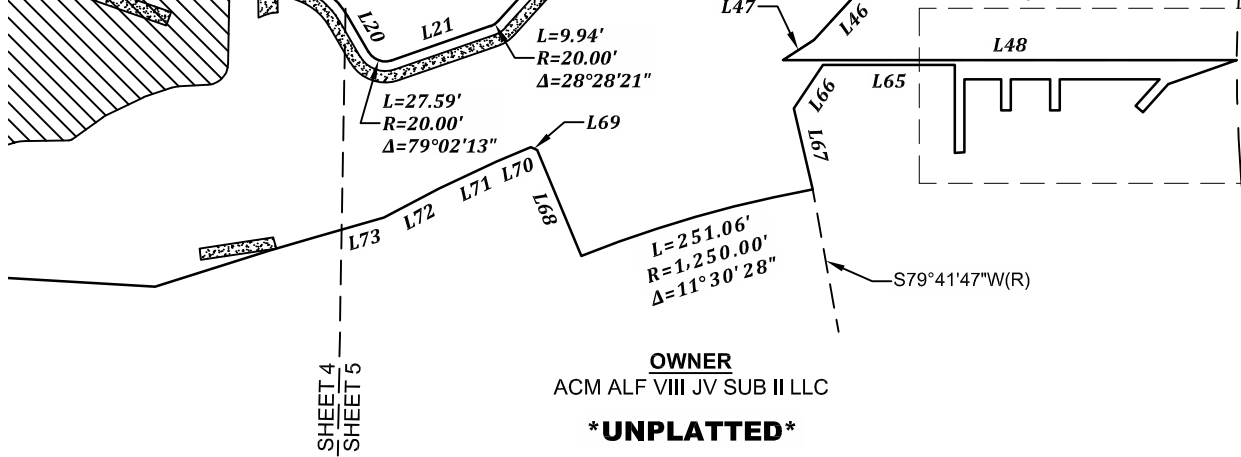
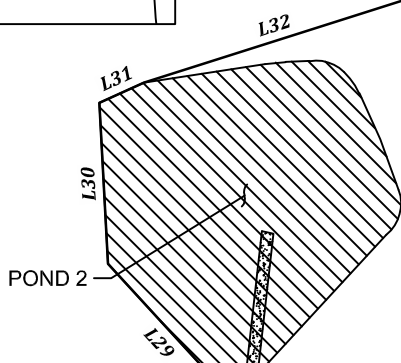
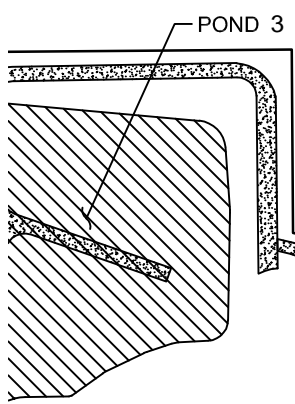

OWNER
ACM ALF VIII JV SUB II LLC
UNPLATTED

STAPLETON DRIVE
(130' R.O.W.)
REC. NO. 212064636

LEGEND:

- FOUND 3-1/4" ALUMINUM SURVEYOR'S CAP STAMPED "PSINC LS 30087"
- * AREA NOT INCLUDED IN THIS SURVEY
- P.O.C POINT OF COMMENCING
- P.O.B. POINT OF BEGINNING
- (R) RADIAL BEARING
- ROAD ACCESS

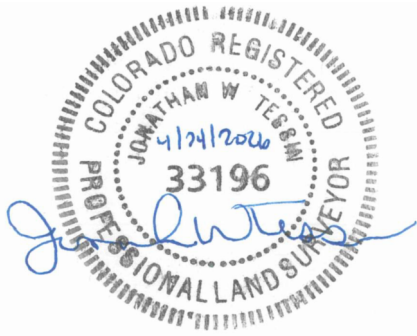

THIS DRAWING DOES NOT REPRESENT A MONUMENTED LAND SURVEY AND IS ONLY INTENDED TO DEPICT THE LEGAL DESCRIPTION.



EDWARD-JAMES SURVEYING, INC.
926 Elkton Dr. 4732 Eagleridge Circle
Colorado Springs, CO 80907 Pueblo, CO 81008
(719) 576-1216 (719) 545-6240
4-20-2026 JOB NO. 2117-00
DRAINAGE EASEMENT 3 SHEET 5 OF 6

EXHIBIT C3 LINE TABLE

LINE TABLE EASEMENT 1		
NO.	BEARING	LENGTH
L1	S84°07'01"E	223.34'
L2	S87°26'34"E	63.00'
L3	S71°11'29"E	45.82'
L4	S41°52'53"E	75.23'
L5	S74°50'57"E	62.49'
L6	N67°40'48"E	371.53'
L7	S44°11'17"E	147.36'
L8	N43°58'27"E	80.21'
L9	S47°22'50"E	145.02'
L10	N44°19'19"E	22.14'
L11	S81°05'02"E	190.87'
L12	S00°26'19"E	103.59'
L13	N89°33'41"E	65.00'
L14	S00°26'19"E	152.50'
L15	S48°19'16"E	96.59'
L16	N89°32'58"E	53.92'
L17	S00°27'02"E	345.12'
L18	S89°34'31"W	190.82'
L19	S13°38'53"W	3.14'

LINE TABLE EASEMENT 1		
NO.	BEARING	LENGTH
L20	S59°51'51"W	42.97'
L21	S19°10'22"E	109.24'
L22	S47°38'44"E	225.96'
L23	S73°16'59"E	83.70'
L24	N44°58'19"E	148.45'
L25	S45°01'41"E	104.00'
L26	S44°58'19"W	144.85'
L27	S64°59'02"E	23.80'
L28	S83°35'47"E	150.10'
L29	N47°33'57"E	193.25'
L30	N86°51'25"E	167.64'
L31	S24°23'26"E	50.77'
L32	S17°37'46"E	294.28'
L33	N90°00'00"W	36.51'
L34	S81°21'20"W	79.00'
L35	S69°17'32"W	67.16'
L36	S62°43'20"W	59.22'
L37	S80°50'46"W	53.31'
L38	N72°21'55"W	39.19'

LINE TABLE EASEMENT 1		
NO.	BEARING	LENGTH
L39	N65°00'13"W	28.10'
L40	N80°32'47"W	61.96'
L41	N88°09'15"W	52.66'
L42	S82°46'11"W	108.65'
L43	N61°19'38"W	141.06'
L44	N80°48'35"W	101.84'
L45	N64°09'57"W	94.87'
L46	N47°17'41"W	86.33'
L47	N33°21'54"W	38.41'
L48	S00°00'00"E	472.53'
L49	N19°11'11"W	75.54'
L50	N48°10'00"W	39.62'
L51	N41°45'56"E	10.02'
L52	S48°07'44"E	37.15'
L53	N00°00'00"E	104.03'
L54	N90°00'00"W	32.25'
L55	N00°00'00"E	10.00'
L56	N90°00'00"E	32.25'
L57	N00°00'00"E	40.82'

LINE TABLE EASEMENT 1		
NO.	BEARING	LENGTH
L58	S90°00'00"W	32.24'
L59	N00°04'28"W	10.00'
L60	N90°00'00"E	32.25'
L61	N00°00'00"E	38.31'
L62	N90°00'00"W	76.09'
L63	N03°30'47"W	10.02'
L64	N90°00'00"E	91.65'
L65	N00°00'47"W	137.46'
L66	N56°21'42"W	54.38'
L67	S76°54'43"W	86.50'
L68	N67°18'17"E	119.72'
L69	N22°28'23"E	7.09'
L70	N22°21'31"W	38.57'
L71	N25°07'25"W	66.02'
L72	N27°50'37"W	65.16'
L73	N16°07'17"W	73.88'
L74	N16°09'50"W	50.00'
L75	N17°29'03"W	124.83'
L76	N03°18'02"E	205.74'

LINE TABLE EASEMENT 1		
NO.	BEARING	LENGTH
L77	N19°08'47"W	73.79'
L78	N21°08'32"W	89.56'
L79	N30°56'30"W	81.87'
L80	N34°05'25"W	72.65'
L81	N41°02'14"W	144.45'
L82	N32°58'22"W	124.73'
L83	S58°57'56"W	65.28'
L84	S62°03'54"W	62.85'
L85	S65°20'20"W	62.85'
L86	S68°36'47"W	62.85'
L87	N88°35'57"W	70.92'
L88	N00°21'55"E	132.98'
L89	N83°07'18"W	22.85'
L90	S46°16'35"W	59.47'
L91	S72°34'31"W	64.44'
L92	N71°47'57"W	205.75'
L93	N23°23'58"E	63.18'

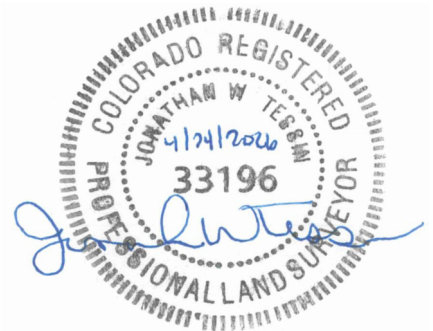

THIS DRAWING DOES NOT REPRESENT A MONUMENTED LAND SURVEY AND IS ONLY INTENDED TO DEPICT THE LEGAL DESCRIPTION.



EDWARD-JAMES SURVEYING, INC.
 926 Elkton Dr. 4732 Eagleridge Circle
 Colorado Springs, CO 80907 Pueblo, CO 81008
 (719) 576-1216 (719) 545-6240
 4-20-2026 JOB NO. 2117-00
DRAINAGE EASEMENT SHEET 6 OF 6

EXHIBIT D
Waterbury Filing No. 1
Operations and Maintenance Manual
Open Drainage Channel Inspections and Maintenance (O&M)
County Job No. PCF SF237

Routine maintenance of the open drainage channel system consists of litter and debris pickup, vegetation management, erosion control, and sediment removal when necessary. Removal of excessive shrubs and trees is required to ensure that the channel will flow in conformance with the original design. Mowing and vegetation management shall be performed with care to ensure that soils remain stable and not to cause erosion. Noxious weed management shall be performed as necessary and as required under project approval conditions. All dead trees and trees growing in the flowline of a structure such as a bridge or culvert shall be removed.

Removal of sediment shall be performed with the use of equipment such as a skid steer, backhoe, and front-end loader. The removed materials shall be hauled to an acceptable landfill site unless otherwise legally permitted to be utilized elsewhere. Materials are not to be stored onsite. Equipment shall utilize the designated access roads and shall not be used in a manner to cause damage to adjacent vegetated and stable areas to the extent possible. If drainage channels contain wetlands many activities, including maintenance, may be subject to regulation and permitting.

Erosion control and restoration work such as side slope reconstruction, revegetation, riprap installation, and other stabilization methods will require the use of heavy equipment.

Maintaining altered watercourses is a minimum requirement of the National Flood Insurance Program (NFIP). In fact, failure to maintain such watercourses may result in a revision to the community's Flood Insurance Rate Map (FIRM). If a stream is altered after the community's FIRM is published, the NFIP requires the community to ensure that the channel's carrying capacity is not adversely altered. This is required in 44 CFR 60.3(b)(7) of the Federal Emergency Management Agency's (FEMA's) NFIP regulations.
--

Table 1 – General Channel Maintenance Guidelines

Activity	Maintenance Action	Frequency of Action
Mowing, vegetation management, and lawn care	Occasional mowing to limit unwanted vegetation on areas outside of the bottom of the channel and the banks. Maintain irrigated turf grass as 2 to 4 inches tall and non-irrigated native turf grasses at 4 to 6. Vegetation along the channel banks and in the bottom of the channel shall be left uncut and allowed to grow.	Routine – depending on aesthetic requirements.
Debris and litter removal	Remove debris and litter from the entire channel to improve flow characteristics and aesthetics. Dispose of as appropriate.	Routine – including annual, pre-storm season (April and May) and following significant rainfall events.
Erosion and sediment control	Repair and revegetate eroded areas in the channel.	Non-routine –as necessary based on inspection.
Structural	Repair inflow structures, low flow channel linings, and energy dissipation structures as needed.	Non-routine – repair as needed based on regular inspections.
Inspections	Inspect channel to ensure continued function as initially intended. Check for erosion, slumping, excessive sedimentation, overgrowth, embankment and inflow integrity, and damage to any structural elements. Report any illicit discharge immediately.	Routine – annual inspection of hydraulic and structural facilities. Also check for obvious problems during routine maintenance visits.
Nuisance control	Address odor, insects, and other issues associated with stagnant or standing water.	Non-routine –as necessary per inspection or complaint.
Sediment removal	Remove accumulated sediment from the channel bottom.	Non-routine –as necessary per inspection.

Routine Maintenance Activities

The majority of this work consists of scheduled mowing, litter and debris pickups for the drainage channel during the growing season. It also includes activities such as weed control. These activities normally will be performed numerous times during the year. These items typically do not require any prior correspondence with EPC, however, completed inspection and maintenance forms shall be retained and submitted to EPC for each inspection and maintenance upon request. The Routine Maintenance Activities are summarized below, and further described in the following sections.

Table 2 – Summary of Routine Maintenance Activities

Activity	Maintenance Action	Look for:	Minimum Frequency
Mowing	2"-4" irrigated grass height; 4-6" natural grass height on areas outside of the bottom of the channel and the banks	Excessive grass height/aesthetics	Routine – twice annually
Litter / Debris Removal	Remove and dispose of litter and debris	Litter / debris in drainage channel	Routine – twice annually

Woody growth control / weed removal	Treat w/herbicide or hand pull	Noxious weeds, undesirable vegetation	Routine – minimum twice annually

Properly dispose of litter and debris materials at an approved landfill or recycling facility. It should be noted that major debris removal may require other regulatory permits prior to completing the work.

Noxious weeds and other unwanted vegetation must be treated as needed throughout the drainage channel. This activity can be performed either through mechanical means (mowing/pulling) or with herbicide. Consultation with the County Environmental Division is recommended prior to the use of herbicide. Herbicides should be utilized sparingly and as a last resort. All herbicide applications should be in accordance with the manufacturer’s recommendations.

Minor Maintenance Activities

This work consists of a variety of isolated or small-scale maintenance/operational problems. Most of this work can be completed by a small crew, hand tools, and small equipment. These items may require prior approval from EPC depending on the scope of work. Completed inspection and maintenance forms shall be retained for each inspection and maintenance period. In the event that the drainage channel needs to be dewatered, care should be given to ensure sediment, filter material and other pollutants are not discharged. The appropriate permits shall be obtained prior to any dewatering activity.

Table 3 – Summary of Minor Maintenance Activities

Activity	Maintenance Action	Look for:	Minimum Frequency
Sediment/Pollutant Removal	Remove and dispose of accumulated sediment from the channel bottom.	Minor sediment and pollution build-up in channel bottom; potential decrease in channel flow rate	Non-routine – as needed based on inspection.
Erosion Repair	Repair eroded areas and revegetate; address cause.	Rills/gullies on sides of channel	Non-routine – as needed, based on inspection.

Major Maintenance Activities

This work consists of larger maintenance/operational problems and failures within the stormwater drainage facilities. This work will likely require approval from EPC Engineering to ensure the proper maintenance is performed. This work requires that Engineering Staff review the original design and construction drawings to assess the situation and necessary maintenance activities. This work may also require more specialized maintenance

equipment, design plans/details, surveying, and assistance through private contractors and consultants. In the event that the drainage channel needs to be dewatered, care should be given to ensure sediment, filter material and other pollutants are not discharged. The appropriate permits shall be obtained prior to any dewatering activity.

Table 4 – Summary of Major Maintenance Activities

Activity	Maintenance Action	Look for:	Minimum Frequency
Major Sediment / Pollutant Removal	Remove and dispose of sediment. Repair vegetation as necessary	Large quantities of sediment in the channel and reduced conveyance rate/capacity	Non-routine –as necessary based on inspection.
Major Erosion Repair	Repair erosion – find cause of problem and address to avoid future erosion	Severe erosion including gullies, excessive soil displacement, unusual areas of settlement, holes	Non-routine –as necessary based on inspection.
Structural Repair	Structural repair to restore portions of the channel to its original design	Deterioration and/or damage to structural components – broken concrete, damaged pipe, drop/check structures or dissipators	Non-routine –as necessary based on inspection.
Drainage Channel Rebuild	Contact EPC Engineering	Overall channel failure	Non-routine –as needed due to complete failure of drainage channel

Inspection Procedures

Periodic inspections of drainage channels and associated stormwater control measures in developed areas are needed in every community to prevent the accumulation of debris deposited by storms, dumping, or natural processes. Inspections must be conducted at least once each year and after each storm that could adversely impact the drainage system. Inspections are also needed in response to citizen complaints.

Conduct annual visual inspections during the dry season to determine if there are problem inlets where sediment/trash or other pollutants accumulate. Inspection and maintenance records should be used to determine problem areas that may need to be checked more often. Appropriate action must be taken after an inspection identifies the need for maintenance or cleaning.

The attached form includes the typical information necessary for and during an inspection. Similar forms or electronic record keeping may be utilized if all relevant information is recorded. The entity responsible for channel maintenance is required to submit the periodic inspection reports upon request by County Staff. Inspections involving decisions about structural issues shall be signed by a licensed professional engineer.

Inspections of inflow structures including detention spillways and water quality outlet pipes discharging to the channel shall be coordinated with channel inspections.

Illicit discharges such as dumping of home goods or garbage, appliances, yard wastes, paint spills, abandoned oil containers and other pollutants shall be immediately reported to EPC Staff and other agencies as appropriate. Reference El Paso County Ordinance No. 07-01, as amended. EPC recommends that the responsible entity encourage public reporting of improper waste disposal by posting “No Dumping” signs, neighborhood notices, and/or social media when available, with contact information to report violations.

Wetlands

If drainage channels contain wetlands many activities, including maintenance, may be subject to regulation and permitting. The responsible maintenance entity shall maintain wetlands vegetation as appropriate and in consultation with the proper authorities including the U.S. Army Corps of Engineers when applicable. The responsible maintenance entity shall ensure proper training / licensing of contractors and staff to minimize the potential for damages to the wetlands.

All applicable safety and environmental considerations with regards to the application of any pesticides or herbicides shall be verified. It is also strongly encouraged that the responsible entity employ or consult a wetlands specialist or certified arborist with the ability to identify invasive/exotic species. Due to the sensitive nature of using chemicals near water bodies, a written Quality Assurance/Quality Control (QA/QC) plan shall be implemented.

Employees shall be trained in accordance with any local, state, and federal regulations and laws prior to any application of chemicals. A copy of the QA/QC plan must be submitted to the County Environmental Division prior to any chemical applications. In addition to the QA/QC plan, copies of the Safety Data Sheets (SDS) for all the chemicals being used shall be provided upon request.

The Clean Water Act (CWA) establishes the basic structure for regulating discharges of pollutants into the waters of the United States and regulating quality standards for surface waters. The basis of the CWA was enacted in 1948 and was called the Federal Water Pollution Control Act, but the Act was significantly reorganized and expanded in 1972. "Clean Water Act" became the Act's common name with amendments in 1972.

Section 404 - establishes a program to regulate the discharge of dredged and fill material into waters of the United States, including wetlands. CWA Section 404(b)(1) Guidelines – U.S. Environmental Protection Agency (EPA) (Although they are called “guidelines,” these criteria are established in regulations (40 CFR Part 230) and are legally binding.)

<https://www.epa.gov/cwa-404/clean-water-laws-regulations-and-executive-orders-related-section-404>

Open Drainage Channel Inspection Report Form

Date: _____ Inspector: _____

Type of inspection: Post-Storm _____ Complaint _____ Routine _____

Location: (Identify stream or basin name, downstream and upstream streets or reference points, and location of problem. Provide sketch as needed.)

Type of problem: Litter ___ Minor ___ Obstruction ___ Structural ___ Illicit Discharge** ___

Recommended maintenance: _____

Is equipment needed? _____ If so, list equipment needed: _____

Date: _____ Offsite Right of entry needed? _____

Work order description: _____

State permit(s) needed? _____ Work order number: _____

Date: _____ Crew chief: _____

Maintenance performed: _____

Inspected by: _____

Use other side for additional recommendations for this site.

****Report illicit discharges to the County and appropriate agencies.**