



2275 Waynoka Road
Suite L
Colorado Springs, CO 80915
(719) 597-0601
office@pinnacleesignsinc.com

Bluebird RV Storage Plan Image

INV-8814



Bluebird RV Storage
8550 Vollmer Place
Colorado Springs, CO
80908

Illuminated Freestanding
Sign

Frontage: 835ft
Proposed: 15sqft
Allowed: 64sqft

*Illumination will be a custom LED light bar under the top 6X6 of the frame, and will illuminate the entirety of the sign face.

Sign will be set in concrete forms and will not exceed 7ft in height.

Bluebird RV Storage Plan Image

INV-8814

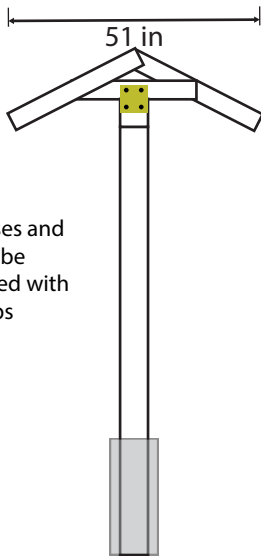
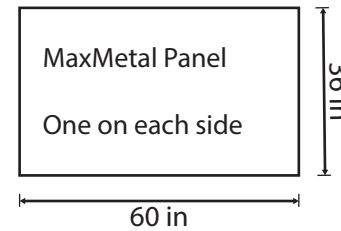
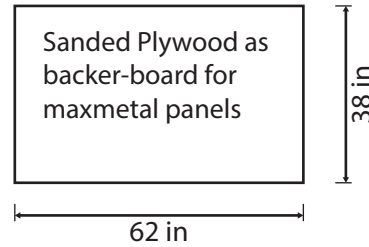
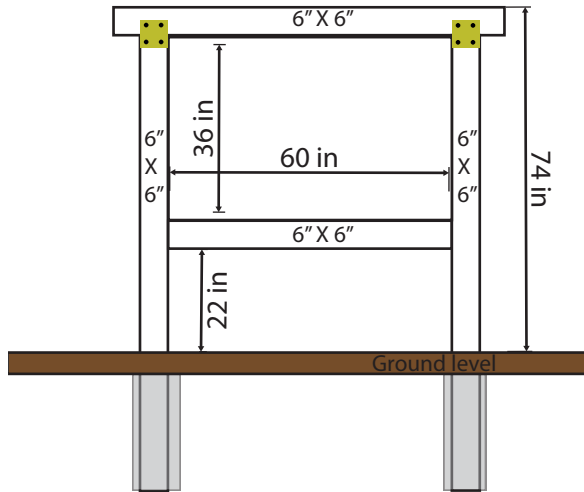

Roof trusses and posts will be constructed with steel straps



Bluebird RV Storage
8550 Vollmer Place
Colorado Springs, CO
80908

Illuminated Freestanding
Sign

Frontage: 835ft
Proposed: 15sqft
Allowed: 64sqft

*Illumination will be a custom LED light bar under the top 6X6 of the frame, and will illuminate the entirety of the sign face.

Sign will be set in concrete forms and will not exceed 7ft in height.