



2275 Waynoka Road  
Suite L  
Colorado Springs, CO 80915  
(719) 597-0601  
office@pinnacle-signsinc.com

# Bluebird RV Storage Plan Image

## INV-8814

### 15 sq ft



Bluebird RV Storage  
8550 Vollmer Place  
Colorado Springs, CO  
80908

Illuminated Freestanding  
Sign

Frontage: 835ft  
Proposed: 15sqft  
Allowed: 64sqft

\*Illumination will be a custom LED light bar under the top 6X6 of the frame, and will illuminate the entirety of the sign face.

Sign will be set in concrete forms and will not exceed 7ft in height.

# Bluebird RV Storage Plan Image

## INV-8814

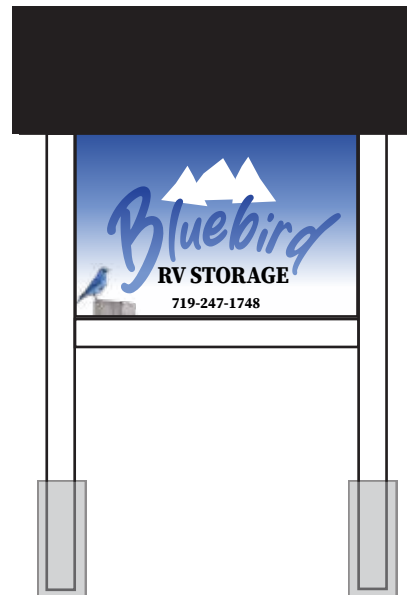
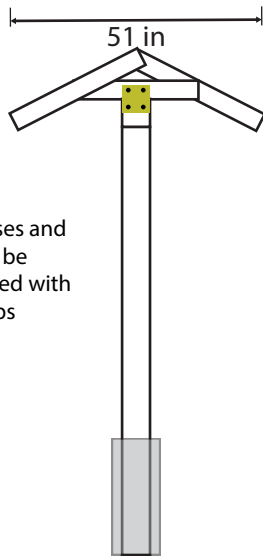
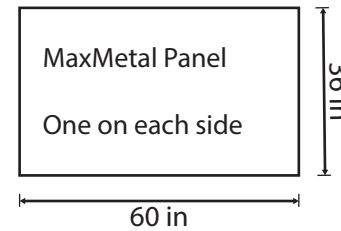
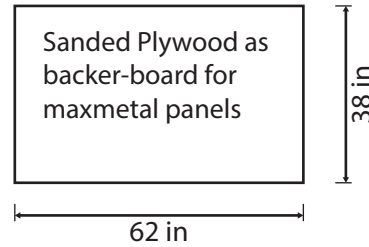
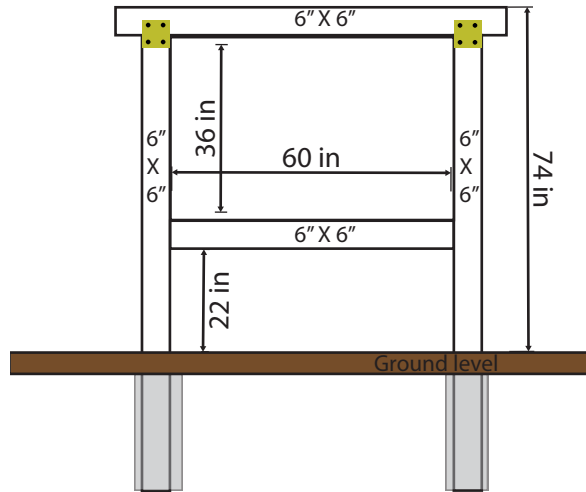

**15 sq ft**

Bluebird RV Storage  
8550 Vollmer Place  
Colorado Springs, CO  
80908

Illuminated Freestanding  
Sign

Frontage: 835ft  
Proposed: 15sqft  
Allowed: 64sqft

\*Illumination will be a custom LED light bar under the top 6X6 of the frame, and will illuminate the entirety of the sign face.

Sign will be set in concrete forms and will not exceed 7ft in height.

# Bluebird RV Storage Elevation Drawing

## INV-8814

15 sq ft



Elevation from the ground to the bottom of the sign face will be 22" to 24" off of the ground.

Total elevation from ground to top of the sign will be between 6'9" and 6'11"



2275 Waynoka Road  
 Suite L  
 Colorado Springs, CO 80915  
 (719) 597-0601  
 office@pinnaclesignsinc.com

# Bluebird RV Storage Site Map

## INV-8814



15 sq ft

Sign will be located on the Western side of the lot.

