



ENTECH
ENGINEERING, INC.

505 ELKTON DRIVE
COLORADO SPRINGS, CO 80907
PHONE (719) 531-5599

**PAVEMENT DESIGN REPORT
BRIARGATE PARKWAY SEGMENT 2
WHEATLAND DRIVE TO STERLING RANCH ROAD
EI PASO COUNTY, COLORADO**

PCD File No. CDR221

Prepared for:
SR LAND, LLC
20 Boulder Crescent, 1st Floor, Suite 100
Colorado Springs, CO 80903

Attn: Chaz Collins

December 31, 2024

Respectfully Submitted,

ENTECH ENGINEERING, INC.

Zachary C. Gutierrez E.I.T.
Geotechnical Engineering Staff

Reviewed by:

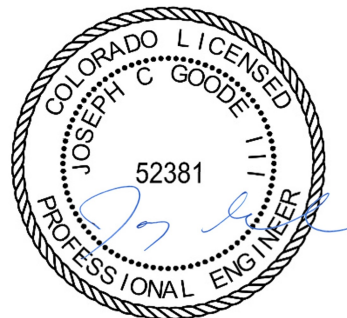

Joseph C. Goode III, P.E.
Sr. Engineer

ZCG:JCG/ed

Entech Job No. 231661

Table of Contents

1 Introduction 1

2 Project Description 1

3 Subsurface Explorations and Laboratory Testing 1

 3.1 Subsurface Exploration Program 1

 3.2 Geotechnical Index and Engineering Property Testing 2

4 Subgrade Conditions 2

 4.1 Subsurface Conditions 3

 4.2 Groundwater 3

5 Pavement Design Recommendations 3

 5.1 Subgrade Conditions 3

 5.2 Swell Mitigation 4

 5.3 Traffic Loading 4

 5.4 Pavement Design 4

6 Construction Recommendations 5

 6.1 Earthwork Recommendations for Pavement Subgrade 5

 6.1.1 Subgrade Preparation – Unbound Base Alternatives 5

 6.1.2 Cement-Treated Subgrade 6

 6.1.3 Fill Placement and Compaction 7

 6.1.4 Aggregate Base Course and Recycled Concrete Base 7

 6.2 Concrete Degradation Due to Sulfate Attack 7

 6.3 Construction Observation 8

7 Closure 8

Figures

Figure 1: Vicinity Map

Figure 2: Site and Exploration Plan

List of Appendices

Appendix A: Test Boring Logs

Appendix B: Laboratory Test Results

Appendix C: Pavement Design Calculations

1 Introduction

Entech Engineering, Inc. (Entech) completed this pavement design report for Briargate Parkway between Wheatland Drive and Sterling Ranch Road in the Sterling Ranch subdivision in El Paso County, Colorado. This report describes the subsurface exploration program and laboratory testing program conducted for the proposed roadway improvements and provides pavement section alternatives and construction recommendations. Entech participated in this project as a subconsultant to SR Land, LLC. The contents of this report, including the pavement design recommendations, are subject to the limitations and assumptions presented in Section 7.

2 Project Description

The proposed improvements include Segment 2 of Briargate Parkway between Wheatland Drive and Sterling Ranch Road within the Sterling Ranch subdivision (Figure 1). At the time of our subsurface exploration program, the existing roadway had been rough-graded. The proposed roadway will travel over Sand Creek via a new bridge crossing. Surrounding properties comprised vacant land and land being developed for future residential lots. Based on the development plans, Briargate Parkway is designated as a 4-lane urban principal arterial roadway.

3 Subsurface Explorations and Laboratory Testing

3.1 Subsurface Exploration Program

Subsurface conditions at the project site were explored by six test borings, designated TB-1 through TB-6, drilled on July 22, 2024. The locations of the test borings are shown on the Site and Exploration Plan (Figure 2). The borings were drilled to depths of 5 to 10 feet below the existing ground surface (bgs). The drilling was performed using a truck-mounted, continuous flight auger drill rig supplied and operated by Entech. Descriptive boring logs providing the lithologies of the subsurface conditions encountered during drilling are presented in Appendix A. Groundwater levels were measured in each of the open boreholes at the conclusion of drilling.

Soil and bedrock samples were obtained from the borings utilizing the Standard Penetration Test (ASTM D1586) using a split-barrel California sampler. Results of the Standard Penetration Test (SPT) are included on the boring logs in terms of N-values expressed in blows per foot (bpf). Soil and bedrock samples recovered from the borings were visually classified and recorded on the boring logs. The soil classifications were later verified utilizing laboratory testing and grouped by

soil type. The soil type numbers are included on the boring logs. It should be understood that the soil descriptions shown on the boring logs may vary between boring locations and sample depths. It should also be noted that the lines of stratigraphic separation shown on the boring logs represent approximate boundaries between soil types and the actual stratigraphic transitions may be more gradual or variable with location.

3.2 Geotechnical Index and Engineering Property Testing

Water content testing (ASTM D2216) was performed on the samples recovered from the borings, and the results are shown on the boring logs. Grain-Size Analysis (ASTM D422) and Atterberg Limits testing (ASTM D4318) were performed on selected samples to assist in classifying the materials encountered in the borings.

For pavement design, a Standard Proctor (ASTM D698), a Modified Proctor (ASTM D1557), and two California Bearing Ratio (CBR) tests (ASTM D1883) were completed. Soluble sulfate testing was performed on select soil samples to evaluate the potential for below-grade degradation of concrete due to sulfate attack. The laboratory testing results are presented in Appendix B and summarized in Table B-1.

Strength testing was performed on soil cement samples for Soil Type 1 and Soil Type 2. Testing was performed on soil cement samples prepared with 2% and 4% Portland Cement Type 1L. The 7-day average strength values of the 2% and 4% mix were 212 and 252 pounds per square inch (psi), respectively for the Soil Type 1 sample, and 181 and 218 psi, respectively for the Soil Type 2 sample. A 2% mix is recommended for both soil types based on the laboratory test results. A summary of the testing results is attached in Appendix B, Table B-2.

4 Subgrade Conditions

Three primary soil types were encountered in the test borings drilled for the subsurface investigation. Each soil type was classified in accordance with the Unified Soil Classification System (USCS) and the American Association of State Highway and Transportation Officials (AASHTO) soil classification system using the laboratory testing results and the observations made during drilling.

4.1 Subsurface Conditions

Subsurface conditions along the proposed roadway consisted of medium dense silty to clayey sand fill to sand with silt fill (SW, SM, Soil Type 1), medium stiff to stiff sandy clay fill (CL, SC, Soil Type 2), and medium dense to dense native silty sand to sand with silt (SM, SW-SM, Soil Type 3). Soil types and corresponding AASHTO soil classifications are listed as follows:

- Soil Type 1: A-1-b
- Soil Type 2: A-6 and A-7-6
- Soil Type 3: A-1-b

Laboratory test results are presented in Appendix B and are summarized in Table B-1.

4.2 Groundwater

Groundwater was not encountered in the test borings. Groundwater fluctuations are likely and will depend on seasonal variations, local precipitation, runoff, and other factors. We do not anticipate groundwater to affect the proposed roadway construction.

5 Pavement Design Recommendations

Pavement design recommendations were made in accordance with the *El Paso County Engineering Criteria Manual*.

5.1 Subgrade Conditions

California Bearing Ratio (CBR) testing was performed on two representative samples of the subgrade silty sand fill (Soil Type 1) from TB-1 and clayey sand fill (Soil Type 2) from TB-5 to determine the support characteristic of the subgrade soils for the roadway section. The results of the CBR testing are presented in Appendix B and summarized in Exhibit 1.

Exhibit 1: Subsurface Laboratory Testing Summary

Design Parameter	Value	
Soil Type	1 - Silty Sand Fill	2 - Clayey Sand Fill
CBR at 95%	16.99	4.71
Design CBR	10	4.7
Liquid Limit	NV	37
Plasticity Index	NP	18
Percent Passing 200	12.8	40.7
AASHTO Classification	A-1-b	A-6
Group Index	0	2
Unified Soils Classification	SM	SC

5.2 Swell Mitigation

El Paso County recommendations require swell mitigation of expansive soils criteria for roadway subgrade with swell testing results greater than 2% under a 150 pounds per square foot (psf) surcharge. Based on the swell testing completed and given the classification of the soils, mitigation for expansive soils is not required on this site.

5.3 Traffic Loading

Traffic data is not available for Briargate Parkway between Wheatland Drive and Sterling Ranch Road; however, the roadway is classified as an urban principal arterial based on the current development plans. The *El Paso County Pavement Design Criteria* provides default 18-kip equivalent single axle loading (ESAL) based street classifications. For design, a default ESAL value of 5,256,000 was used for the urban principal arterial designation.

5.4 Pavement Design

The recommended pavement sections were determined utilizing the *El Paso County Engineering Criteria Manual*, the CBR testing, and default ESAL. Design parameters used in the pavement analysis are presented in Exhibit 2. Pavement design alternatives for Soil Type 1 and Soil Type 2 are provided in Exhibit 2. Soil Type 1 is applicable between roadway stationing 19+00 and 31+50 and from stationing 40+50 to 44+00. Soil Type 2 is applicable between stationing 31+50 and 40+50. Delineations by Soil Type are presented in Figure 2.

Exhibit 2: Pavement Design Parameters

Design Parameter	Values
Reliability	90%
Standard Deviation	0.45
Serviceability Loss (Δ psi)	2.0
Design CBR – Soil Type 1	10
Design CBR – Soil Type 2	4.7
Resilient Modulus - Soil Type 1	15,000 psi
Resilient Modulus - Soil Type 2	7,065 psi
Structural Coefficients	
Hot Mix Asphalt	0.44
Aggregate Base Course	0.11
Cement-Treated Subgrade	0.11

Pavement sections recommended for Briargate Parkway are summarized in Exhibit 3. The pavement design calculations are presented in Appendix C.

Exhibit 3: Recommended Pavement Sections

Pavement Area	Roadway Designation	Design ESAL	Soil Type	Alternative ^{1&2}
Briargate Parkway Segment 2	Urban Principal Arterial	5,256,000	Type 1	1. 5.5 inches HMA over 10.0 inches ABC/RCB
				2. 6.0 inches HMA over 8.0 inches ABC/RCB
				3. 5.5 inches HMA over 10.0 inches CTS
			Type 2	1. 7.5 inches HMA over 12.0 inches ABC/RCB
				2. 8.0 inches HMA over 10.0 inches ABC/RCB
				3. 7.5 inches HMA over 12.0 inches CTS

ABC = Aggregate Base Course; ESAL = equivalent single axle loads; HMA = Hot Mix Asphalt; CTS = Cement-Treated Subgrade; RCB = Recycled Concrete Base

Notes:

1. All pavement alternatives meet the minimum sections required per *El Paso County Pavement Design Criteria*.
2. A deviation request will be required for CTS in El Paso County.

6 Construction Recommendations

Pavement design recommendations provided herein are contingent on good construction practices and poor construction techniques may result in poor performance. Our analyses assumed that this project will be constructed according to the *El Paso County Engineering Criteria Manual* and the *Pikes Peak Region Asphalt Paving Specifications*.

6.1 Earthwork Recommendations for Pavement Subgrade

Proper subgrade preparation is required for adequate pavement performance. Paving areas should be cleared of all deleterious materials including but not limited to existing pavements, utility poles, and fence poles. Surface vegetation, if any, should be removed by stripping, with the depth to be field determined.

6.1.1 Subgrade Preparation – Unbound Base Alternatives

If pavement section alternatives are selected utilizing aggregate base course (ABC) or recycled concrete base (RCB), the final subgrade surface should be scarified to a depth of 12 inches, moisture conditioned within +/- 2% of the optimum water content, and recompact to 95% of the Modified Proctor (ASTM 1557) maximum dry density.

The compacted surface below pavements should be proof-rolled with a fully loaded, tandem-axle, 10-yard dump truck or equivalent. Any areas that are delineated to be soft, loose, or yielding during proof-rolling should be removed and reconditioned or replaced.

6.1.2 Cement-Treated Subgrade

Prior to placement of cement stabilization, a preliminary proof roll should be completed with a fully loaded, tandem-axle, 10-yard dump truck or equivalent. Any areas that are delineated to be soft, loose, or yielding during proof-rolling should be removed and reconditioned or replaced.

Following the preliminary proof roll, the subgrade shall be stabilized by the addition of cement. The amount of cement applied shall be a minimum of 2% (by weight) of the subgrade's maximum dry density as determined by the Modified Proctor (ASTM D1557) for granular soils or by the Standard Proctor (ASTM D698) for cohesive soils. The cement should be spread evenly on the subgrade surface and be thoroughly mixed into the subgrade such that a uniform blend of soil and cement is achieved to the CTS design depth. Densification of the cement-stabilized subgrade should be completed to obtain a compaction of at least 95% of the subgrade maximum dry density as determined by the Modified Proctor (ASTM D1557) or by the Standard Proctor (ASTM D698). Satisfactory compaction of the subgrade shall occur within 90 minutes from the time of mixing the cement into the subgrade.

The following conditions shall be observed as part of the subgrade stabilization:

- Type I/II or Type 1L cement as supplied; a local supplier shall be used. All cement used for stabilization should come from the same source. If cement sources are changed, a new laboratory mix design should be completed.
- Moisture conditioning of the subgrade and/or mixing of the cement into the subgrade shall not occur when soil temperatures are below 40 degrees F. Cement-treated subgrades should be maintained at a temperature of 40 degrees F or greater until the subgrade has been compacted as required.
- Cement placement, cement mixing, and compaction of the cement-treated subgrade should be observed by Entech Engineering. Testing should include in-situ compaction tests and representative compacted specimens of the treated subgrade material for subsequent laboratory quality assurance testing.
- A minimum 7-day CTS compressive strength of 125 psi must be achieved.
- Soil strengths in excess of 275 psi will require microfracturing. Microfracturing will be completed using the Standard Method as defined by the *City of Colorado Springs Draft Standard Specification*, Section 305 – Chemically Treated Subgrade. Microfracturing will be performed with the same (or equivalent tonnage) steel drum vibratory roller used for compaction of the CTS. A minimum 12-ton roller shall be used. Three full passes with the

roller operating at maximum amplitude and traveling at 2- 3 mph shall be applied. If the treated material breaks up excessively at the surface, the vibration amplitude shall be decreased or eliminated.

6.1.3 Fill Placement and Compaction

Granular fill placed as part of the pavement subgrade shall consist of nonexpansive, granular soil, free of organic matter, unsuitable materials, debris, and cobbles greater than 3 inches in diameter. Additionally, any granular fill placed as part of the roadway subgrade should have a minimum CBR of 10. All granular fill placed within the pavement subgrade should be compacted to a minimum of 95% of the Modified Proctor (ASTM D1557) maximum dry density at +/-2% of optimum moisture content. Fill material should be placed in horizontal lifts such that each finished lift has a compacted thickness of 6 inches or less. Entech should approve any imported fill to be used within the pavement subgrade area prior to delivery to the site. ABC materials shall conform to the *El Paso County Standard Specifications Manual*, Table D-6, Aggregate Base Course Materials.

6.1.4 Aggregate Base Course and Recycled Concrete Base

ABC or RCB materials shall conform to the *El Paso County Standard Specifications Manual*, Table D-6, Aggregate Base Course Materials. ABC or RCB materials should be compacted to a minimum of 95% of the Modified Proctor (ASTM D1557) maximum dry density within +/-2% of optimum moisture content.

6.2 Concrete Degradation Due to Sulfate Attack

Sulfate solubility testing was conducted on several samples recovered from the test borings to evaluate the potential for sulfate attack on concrete. The test results indicated less than 0.01% soluble sulfate (by weight). The test results indicate the sulfate component of the in-place soils presents a negligible exposure threat to concrete placed below the site grade.

Type I/II or Type 1L cement is recommended for concrete on the site. To further avoid concrete degradation during construction, it is recommended that concrete not be placed on frozen or wet ground. Care should be taken to prevent the accumulation or ponding of water in the foundation excavation prior to the placement of concrete. If standing water is present in the foundation excavation, it should be removed by ditching to sumps and pumping the water away from the foundation area prior to concrete placement. If concrete is placed during periods of cold

temperatures, the concrete must be kept from freezing. This may require covering the concrete with insulated blankets and adding heat to prohibit freezing.

6.3 Construction Observation

Subgrade preparation for pavement structures should be observed by Entech in order to verify that (1) no anomalies are present, (2) materials similar to those described in this report have been encountered or placed, and (3) no soft spots, expansive or organic soil, or debris are present in the pavement subgrade prior to paving.

7 Closure

The subsurface investigation, geotechnical evaluation, and recommendations presented in this report are intended for use by SR Land, LLC with application to Briargate Parkway, Segment 2, in the Sterling Ranch roadway paving project in El Paso County, Colorado. In conducting the subsurface investigation, laboratory testing, engineering evaluation, and reporting, Entech Engineering, Inc. endeavored to work in accordance with generally accepted professional geotechnical and geologic practices and principles consistent with the level of care and skill ordinarily exercised by members of the geotechnical profession currently practicing in the same locality and under similar conditions. No other warranty, expressed or implied, is made. During final design and/or construction, if conditions are encountered that appear different from those described in this report, Entech Engineering, Inc. requests to be notified so that the evaluation and recommendations presented herein can be reviewed and modified as appropriate.

If there are any questions regarding the information provided herein, or if Entech Engineering, Inc. can be of further assistance, please do not hesitate to contact us.



ENTECH
ENGINEERING, INC.

VICINITY MAP

BRIARGATE PARKWAY, SEGMENT 2
SR LAND

JOB NO.
231661

FIG. 1

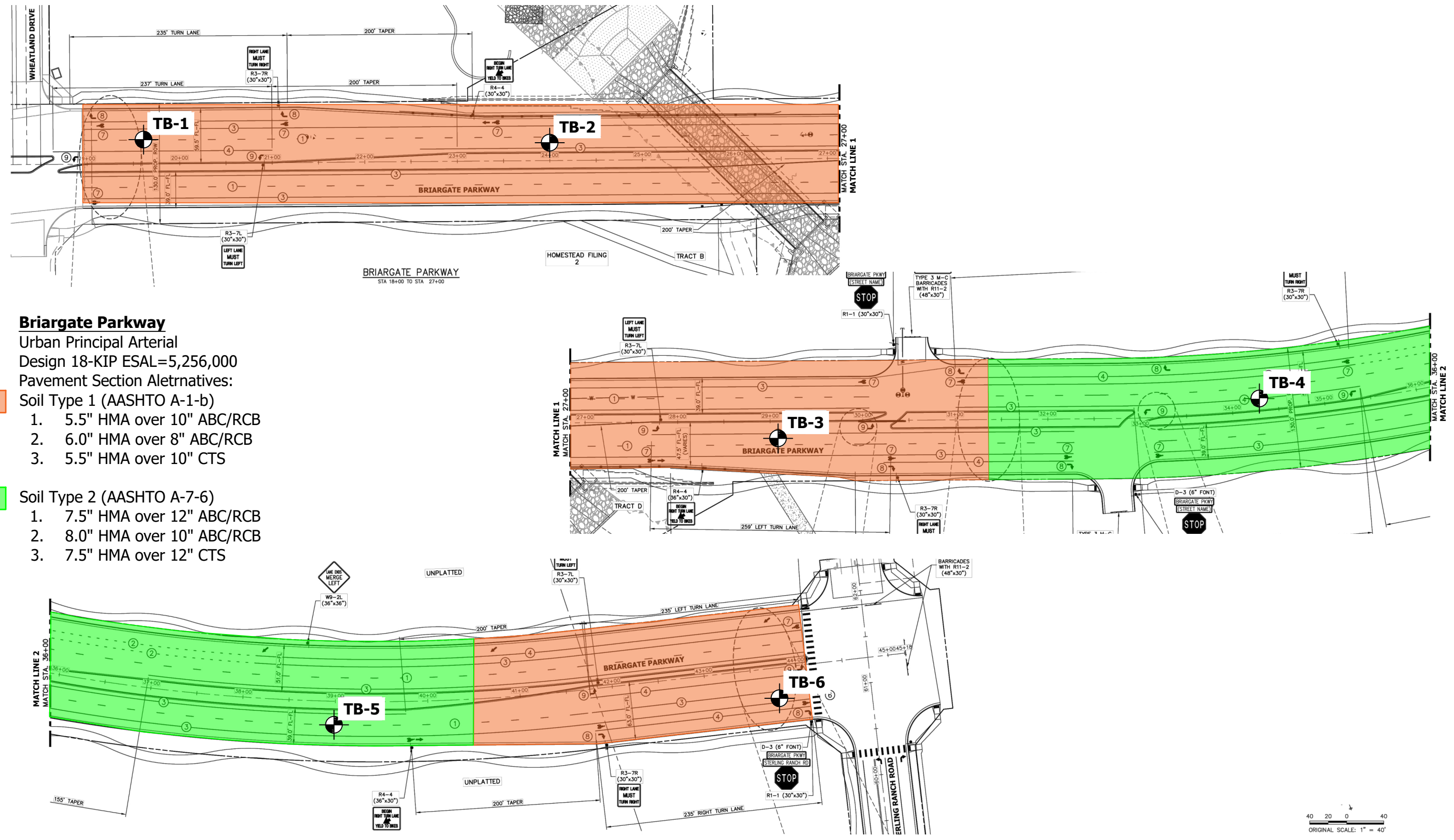

Briargate Parkway
 Urban Principal Arterial
 Design 18-KIP ESAL=5,256,000
 Pavement Section Alternatives:

- Soil Type 1 (AASHTO A-1-b)
 1. 5.5" HMA over 10" ABC/RCB
 2. 6.0" HMA over 8" ABC/RCB
 3. 5.5" HMA over 10" CTS

- Soil Type 2 (AASHTO A-7-6)
 1. 7.5" HMA over 12" ABC/RCB
 2. 8.0" HMA over 10" ABC/RCB
 3. 7.5" HMA over 12" CTS

TB- APPROXIMATE TEST BORING LOCATION AND NUMBER



SITE AND EXPLORATION PLAN
 BRIARGATE PARKWAY, SEGMENT 2
 SR LAND

JOB NO.
 231661
FIG. 2



APPENDIX A: Test Boring Logs

TEST BORING 1
DATE DRILLED 7/22/2024

TEST BORING 2
DATE DRILLED 7/22/2024

REMARKS

REMARKS

DRY TO 10', 7/22/24

SAND, WITH SILT, OLIVE,
MEDIUM DENSE, DRY to MOIST

Depth (ft)	Symbol	Samples	Blows per foot	Watercontent %	Soil Type
0-2			28	2.5	3
2-5			14	3.6	3
5-10			24	4.0	3

DRY TO 5', 7/22/24

FILL 0-2', SAND, SLIGHTLY SILTY,
OLIVE, MEDIUM DENSE, MOIST
SAND, SILTY, OLIVE, MEDIUM
DENSE, MOIST

Depth (ft)	Symbol	Samples	Blows per foot	Watercontent %	Soil Type
0-2			14	5.7	1
2-5			12	11.5	3



TEST BORING LOGS

BRIARGATE PARKWAY, SEGMENT 2
SR LAND

JOB NO.
231661

FIG. A-1

TEST BORING 3
 DATE DRILLED 7/22/2024

TEST BORING 4
 DATE DRILLED 7/22/2024

REMARKS

REMARKS

DRY TO 5', 7/22/24

FILL 0-5', SAND, SILTY, BROWN to GRAY, DENSE to MEDIUM DENSE, MOIST

Depth (ft)	Symbol	Samples	Blows per foot	Watercontent %	Soil Type
0-5	(Symbol: dots and dashes)	(Symbol: solid black)	36	10.1	1
5-10	(Symbol: dots and dashes)	(Symbol: solid black)	27	9.5	1
10-15	(Symbol: dots and dashes)	(Symbol: solid black)			
15-20	(Symbol: dots and dashes)	(Symbol: solid black)			
20-25	(Symbol: dots and dashes)	(Symbol: solid black)			

DRY TO 5', 7/22/24

FILL 0-5', CLAY, SANDY, OLIVE to BROWN, MEDIUM STIFF to STIFF, MOIST

Depth (ft)	Symbol	Samples	Blows per foot	Watercontent %	Soil Type
0-5	(Symbol: diagonal lines)	(Symbol: solid black)	7	19.8	2
5-10	(Symbol: diagonal lines)	(Symbol: solid black)	10	7.2	2
10-15	(Symbol: diagonal lines)	(Symbol: solid black)			
15-20	(Symbol: diagonal lines)	(Symbol: solid black)			
20-25	(Symbol: diagonal lines)	(Symbol: solid black)			



TEST BORING LOGS
 BRIARGATE PARKWAY, SEGMENT 2
 SR LAND

JOB NO.
 231661

FIG. A-2

TEST BORING 5
 DATE DRILLED 7/22/2024

TEST BORING 6
 DATE DRILLED 7/22/2024

REMARKS

REMARKS

DRY TO 5', 7/22/24

FILL 0-5', CLAY, SANDY, OLIVE to BROWN, VERY STIFF, MOIST

Depth (ft)	Symbol	Samples	Blows per foot	Watercontent %	Soil Type
0-5	[Diagonal Hatching]		19	8.2	2
5-6	[Diagonal Hatching]		19	6.7	2

DRY TO 5', 7/22/24

FILL 0-3', SAND, CLAYEY, OLIVE, MEDIUM DENSE, MOIST

SAND, SILTY, OLIVE, MEDIUM DENSE, MOIST

Depth (ft)	Symbol	Samples	Blows per foot	Watercontent %	Soil Type
0-3	[Dotted]		24	7.2	1
3-5	[Dotted]		23	4.6	3



TEST BORING LOGS
 BRIARGATE PARKWAY, SEGMENT 2
 SR LAND

JOB NO.
 231661

FIG. A-3



APPENDIX B: Laboratory Test Results

**TABLE B-1
SUMMARY OF LABORATORY TEST RESULTS**



SOIL TYPE	TEST BORING NO.	DEPTH (FT)	WATER (%)	DRY DENSITY (PCF)	PASSING NO. 200 SIEVE (%)	LIQUID LIMIT	PLASTIC LIMIT	PLASTIC INDEX	SULFATE (WT %)	SWELL/ COLLAPSE (%)	AASHTO CLASS. (GROUP INDEX)	USCS	SOIL DESCRIPTION
1, CBR	2	0-3	5.7		12.8	NV	NP	NP			A-1-b (0)	SM	FILL, SAND, SILTY
1	2	1-2	5.7		4.7	NV	NP	NP	0.00		A-1-b (0)	SW	FILL, SAND, SLIGHTLY SILTY
1	3	1-2	10.1		19.0	NV	NP	NP			A-1-b (0)	SM	FILL, SAND, SILTY
2, CBR	5	0-3	8.2		40.7	37	21	16			A-6 (2)	SC	FILL, SAND, CLAYEY
2	4	1-2	13.0	112.1	63.4	43	23	20		0.7	A-7-6 (11)	CL	FILL, CLAY, SANDY
2	5	1-2	13.0	112.8	56.4	43	23	20	0.00	0.1	A-7-6 (9)	CL	FILL, CLAY, SANDY
2	6	1-2	10.3	107.5	44.9					-0.5		SC	FILL, SAND, CLAYEY
3	1	1-2	2.5		7.9	NV	NP	NP			A-1-b (0)	SW-SM	SAND, WITH SILT
3	6	5	4.6		11.3	NV	NP	NP	<0.01		A-1-b (0)	SW-SM	SAND, WITH SILT



**TABLE B-2
SUMMARY OF CTS TEST RESULTS**

SOIL ADDITIVE TYPE II CEMENT
 CURING METHOD 100° HUMIDIFIED OVEN

<i>FIELD SAMPLE ID</i>	<i>ADDITIVE %</i>	<i>WATER %</i>	<i>DENSITY (dry)</i>	<i>AGE (days)</i>	<i>STRENGTH (psi)</i>
TB-2 @ 0-3'	2	7.8	121.1	5	217
TB-2 @ 0-3'	2	7.8	121.3	5	214
TB-2 @ 0-3'	2	7.8	121.3	5	204
AVERAGE:					212
TB-2 @ 0-3'	4	7.8	121.1	5	241
TB-2 @ 0-3'	4	7.8	121.2	5	250
TB-2 @ 0-3'	4	7.8	121.3	5	264
AVERAGE:					252
TB-5 @ 0-3'	2	12.9	108.2	5	182
TB-5 @ 0-3'	2	12.9	108.0	5	192
TB-5 @ 0-3'	2	12.9	108.2	5	169
AVERAGE:					181
TB-5 @ 0-3'	4	12.9	108.2	5	212
TB-5 @ 0-3'	4	12.9	108.1	5	224
TB-5 @ 0-3'	4	12.9	108.0	5	217
AVERAGE:					218

TEST BORING 2
 DEPTH (FT) 0-3

SOIL DESCRIPTION FILL, SAND, SILTY
 SOIL TYPE 1, CBR

**Sieve Analysis
 Grain Size Distribution**

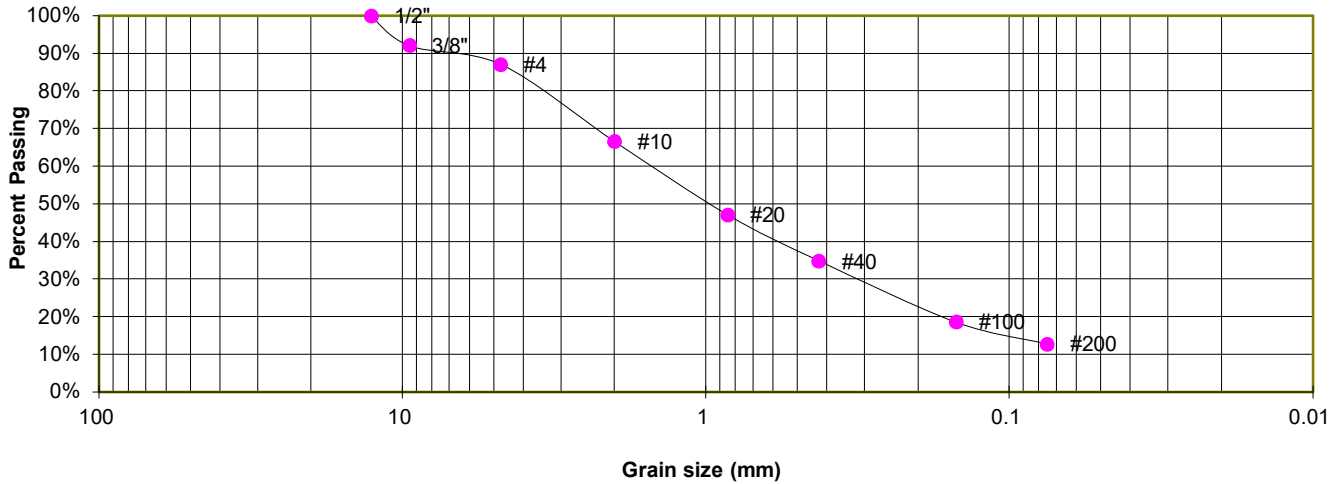

GRAIN SIZE ANALYSIS

U.S. Sieve #	Percent Finer
3"	
1 1/2"	
3/4"	
1/2"	100.0%
3/8"	92.1%
4	87.1%
10	66.6%
20	47.2%
40	34.9%
100	18.7%
200	12.8%

ATTERBERG LIMITS

Plastic Limit	NP
Liquid Limit	NV
Plastic Index	NP

SOIL CLASSIFICATION

USCS CLASSIFICATION: SM
 AASHTO CLASSIFICATION: A-1-b
 AASHTO GROUP INDEX: 0



LABORATORY TEST RESULTS

BRIARGATE PARKWAY, SEGMENT 2
 SR LAND

JOB NO.
 231661

FIG. B-1

TEST BORING 2
 DEPTH (FT) 1-2

SOIL DESCRIPTION FILL, SAND, SLIGHTLY SILTY
 SOIL TYPE 1

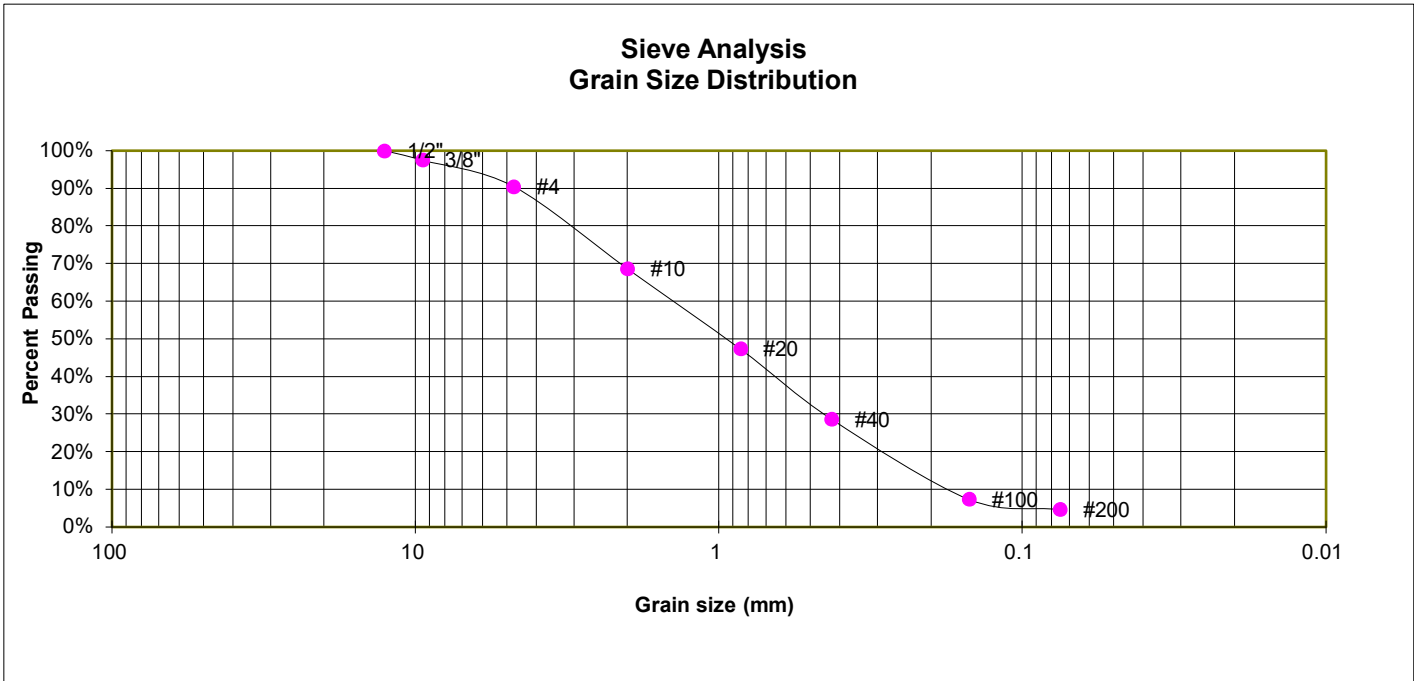

GRAIN SIZE ANALYSIS

U.S. Sieve #	Percent Finer
3"	
1 1/2"	
3/4"	
1/2"	100.0%
3/8"	97.6%
4	90.5%
10	68.7%
20	47.3%
40	28.6%
100	7.4%
200	4.7%

ATTERBERG LIMITS

Plastic Limit	NP
Liquid Limit	NV
Plastic Index	NP

SOIL CLASSIFICATION

USCS CLASSIFICATION: SW
 AASHTO CLASSIFICATION: A-1-b
 AASHTO GROUP INDEX: 0



LABORATORY TEST RESULTS

BRIARGATE PARKWAY, SEGMENT 2
 SR LAND

JOB NO.
 231661

FIG. B-2

TEST BORING 3
 DEPTH (FT) 1-2

SOIL DESCRIPTION FILL, SAND, SILTY
 SOIL TYPE 1

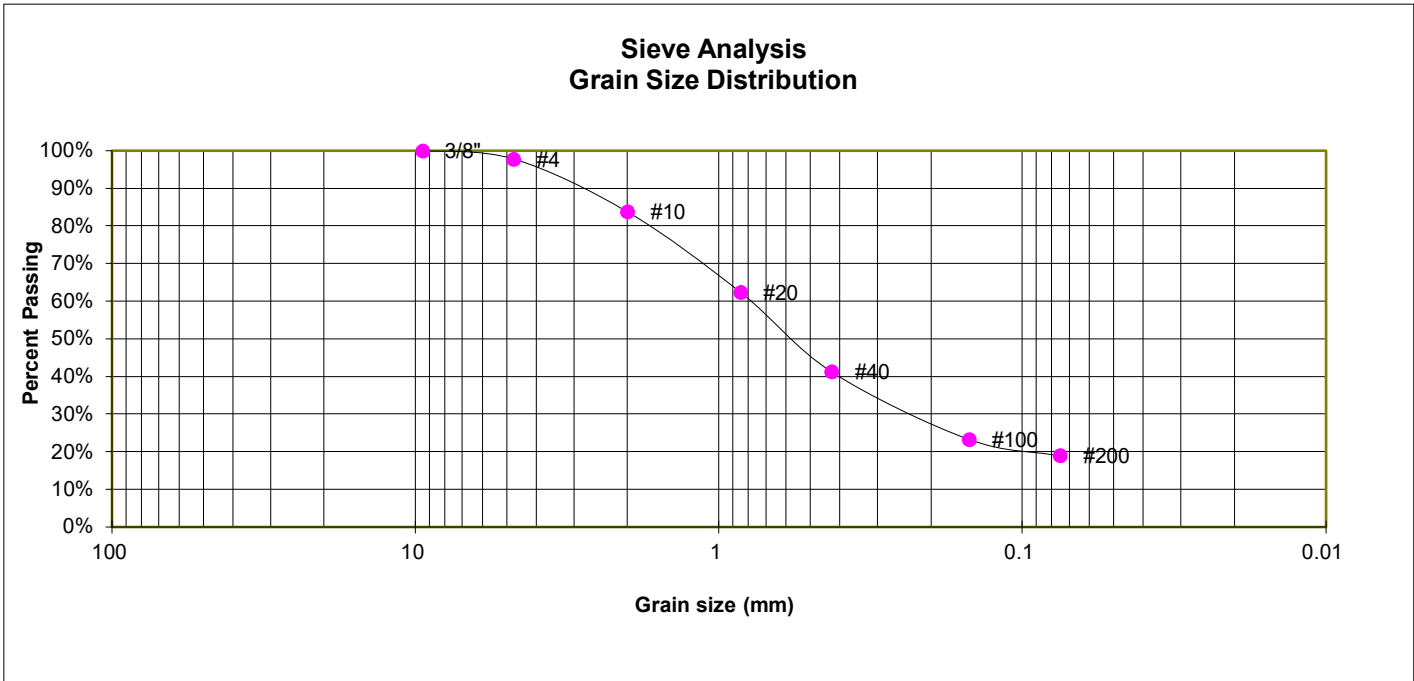

GRAIN SIZE ANALYSIS

U.S. Sieve #	Percent Finer
3"	
1 1/2"	
3/4"	
1/2"	
3/8"	100.0%
4	97.8%
10	83.8%
20	62.4%
40	41.3%
100	23.3%
200	19.0%

ATTERBERG LIMITS

Plastic Limit	NP
Liquid Limit	NV
Plastic Index	NP

SOIL CLASSIFICATION

USCS CLASSIFICATION: SM
 AASHTO CLASSIFICATION: A-1-b
 AASHTO GROUP INDEX: 0



LABORATORY TEST RESULTS

BRIARGATE PARKWAY, SEGMENT 2
 SR LAND

JOB NO.
 231661

FIG. B-3

TEST BORING 5
 DEPTH (FT) 0-3

SOIL DESCRIPTION FILL, SAND, CLAYEY
 SOIL TYPE 2, CBR

**Sieve Analysis
 Grain Size Distribution**

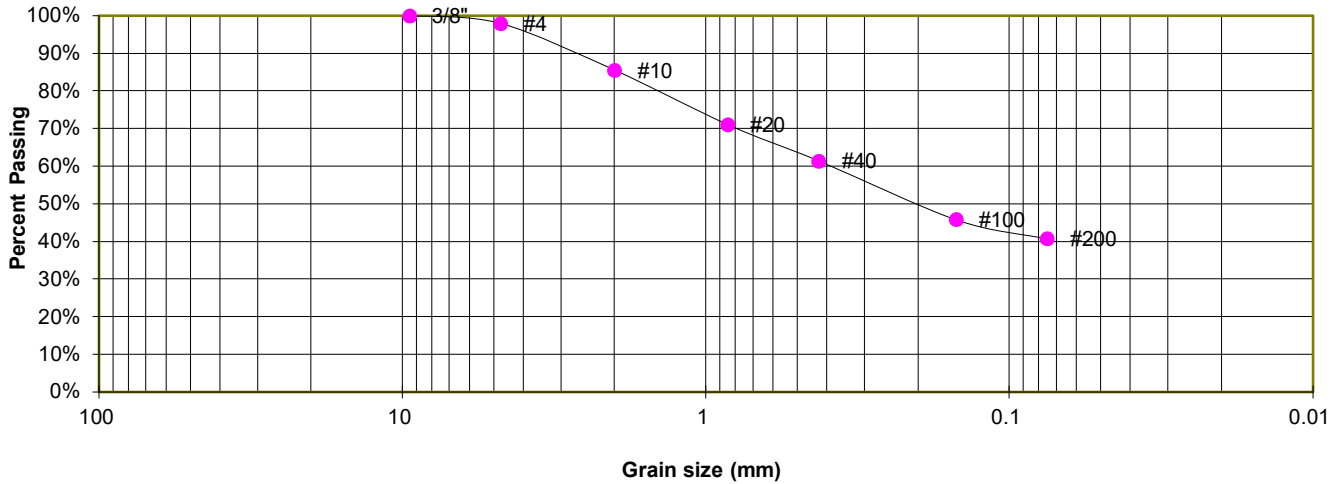

GRAIN SIZE ANALYSIS

U.S. Sieve #	Percent Finer
3"	
1 1/2"	
3/4"	
1/2"	
3/8"	100.0%
4	97.9%
10	85.5%
20	71.1%
40	61.4%
100	45.8%
200	40.7%

ATTERBERG LIMITS

Plastic Limit	21
Liquid Limit	37
Plastic Index	16

SOIL CLASSIFICATION

USCS CLASSIFICATION:	SC
AASHTO CLASSIFICATION:	A-6
AASHTO GROUP INDEX:	2



LABORATORY TEST RESULTS

BRIARGATE PARKWAY, SEGMENT 2
 SR LAND

JOB NO.
 231661

FIG. B-4

TEST BORING 4
 DEPTH (FT) 1-2

SOIL DESCRIPTION FILL, CLAY, SANDY
 SOIL TYPE 2

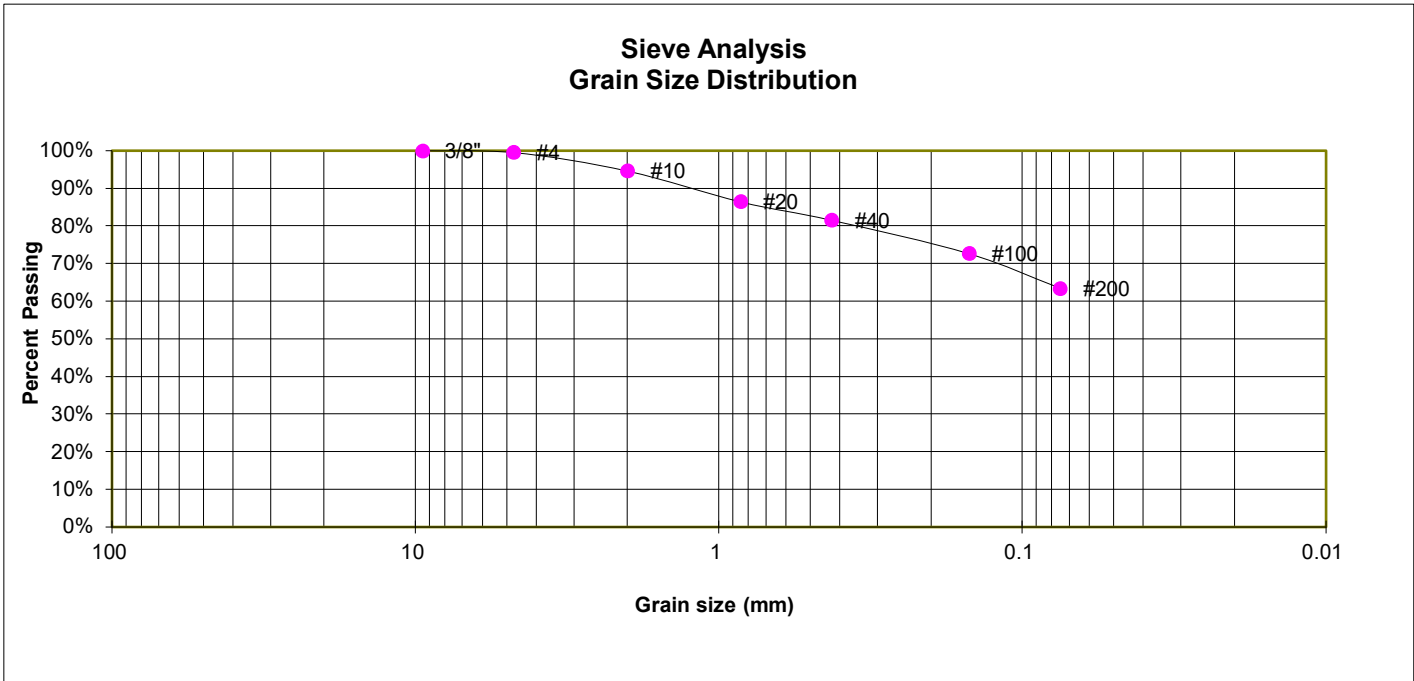

GRAIN SIZE ANALYSIS

U.S. Sieve #	Percent Finer
3"	
1 1/2"	
3/4"	
1/2"	
3/8"	100.0%
4	99.6%
10	94.6%
20	86.5%
40	81.5%
100	72.7%
200	63.4%

ATTERBERG LIMITS

Plastic Limit	23
Liquid Limit	43
Plastic Index	20

SOIL CLASSIFICATION

USCS CLASSIFICATION: CL
 AASHTO CLASSIFICATION: A-7-6
 AASHTO GROUP INDEX: 11



LABORATORY TEST RESULTS

BRIARGATE PARKWAY, SEGMENT 2
 SR LAND

JOB NO.
 231661

FIG. B-5

TEST BORING 5
 DEPTH (FT) 1-2

SOIL DESCRIPTION FILL, CLAY, SANDY
 SOIL TYPE 2

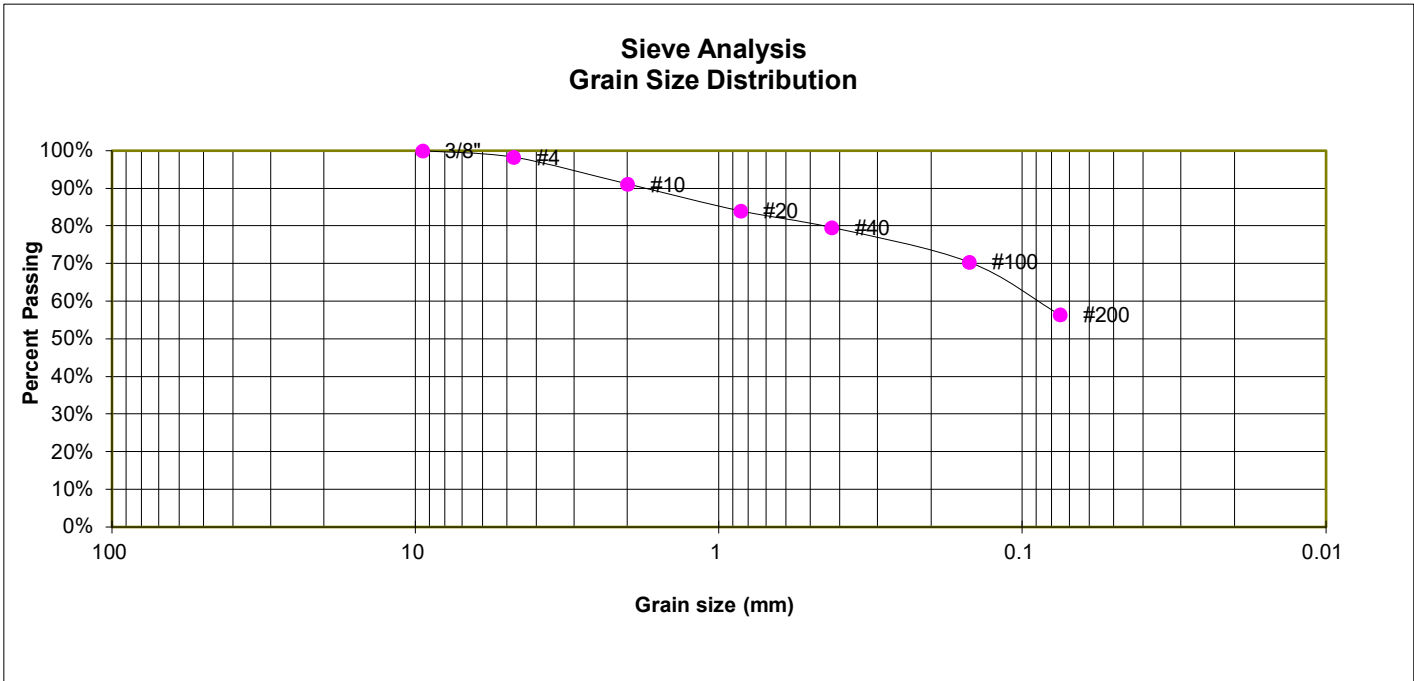

GRAIN SIZE ANALYSIS

U.S. Sieve #	Percent Finer
3"	
1 1/2"	
3/4"	
1/2"	
3/8"	100.0%
4	98.3%
10	91.1%
20	84.1%
40	79.6%
100	70.5%
200	56.4%

ATTERBERG LIMITS

Plastic Limit	23
Liquid Limit	43
Plastic Index	20

SOIL CLASSIFICATION

USCS CLASSIFICATION: CL
 AASHTO CLASSIFICATION: A-7-6
 AASHTO GROUP INDEX: 9



LABORATORY TEST RESULTS

BRIARGATE PARKWAY, SEGMENT 2
 SR LAND

JOB NO.
 231661

FIG. B-6

TEST BORING 6
DEPTH (FT) 1-2

SOIL DESCRIPTION FILL, SAND, CLAYEY
SOIL TYPE 2

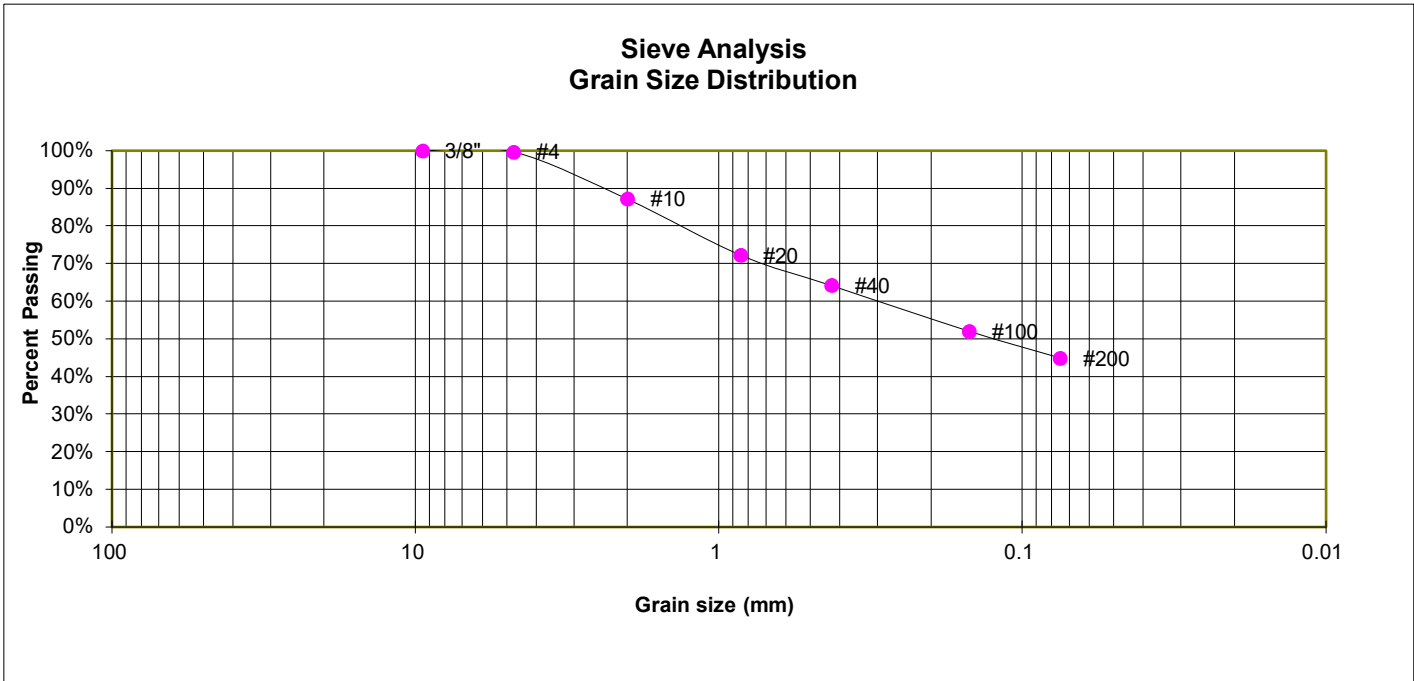

GRAIN SIZE ANALYSIS

U.S. Sieve #	Percent Finer
3"	
1 1/2"	
3/4"	
1/2"	
3/8"	100.0%
4	99.7%
10	87.2%
20	72.3%
40	64.2%
100	52.0%
200	44.9%

SOIL CLASSIFICATION

USCS CLASSIFICATION: SC
AASHTO CLASSIFICATION:
AASHTO GROUP INDEX:



LABORATORY TEST RESULTS

BRIARGATE PARKWAY, SEGMENT 2
SR LAND

JOB NO.
231661

FIG. B-7

TEST BORING 1
 DEPTH (FT) 1-2

SOIL DESCRIPTION SAND, WITH SILT
 SOIL TYPE 3

**Sieve Analysis
 Grain Size Distribution**

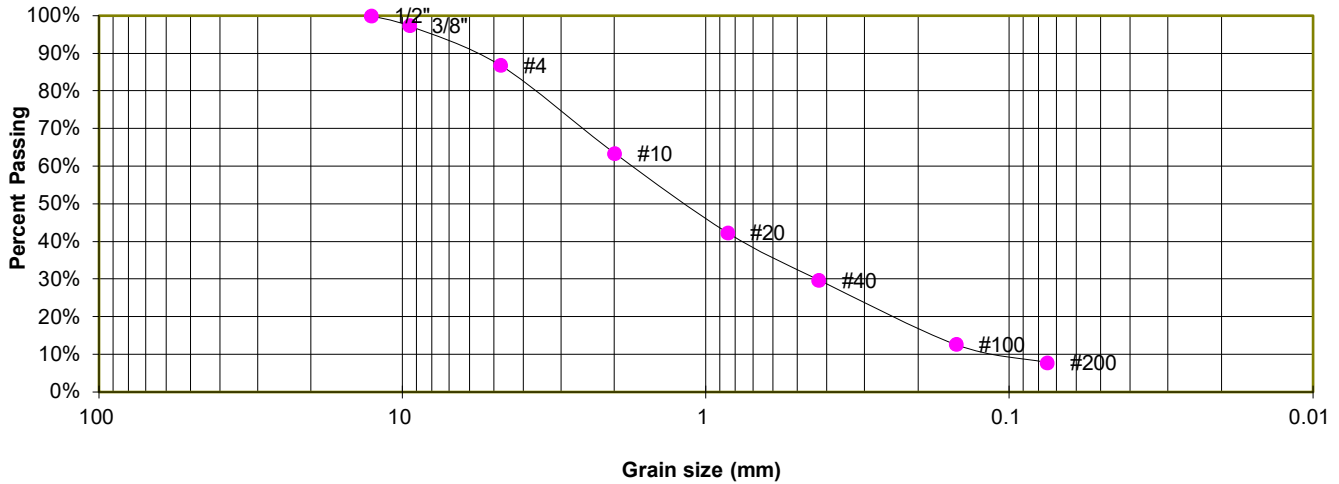

GRAIN SIZE ANALYSIS

U.S. Sieve #	Percent Finer
3"	
1 1/2"	
3/4"	
1/2"	100.0%
3/8"	97.4%
4	86.8%
10	63.4%
20	42.4%
40	29.8%
100	12.7%
200	7.9%

ATTERBERG LIMITS

Plastic Limit	NP
Liquid Limit	NV
Plastic Index	NP

SOIL CLASSIFICATION

USCS CLASSIFICATION: SW-SM
 AASHTO CLASSIFICATION: A-1-b
 AASHTO GROUP INDEX: 0



LABORATORY TEST RESULTS

BRIARGATE PARKWAY, SEGMENT 2
 SR LAND

JOB NO.
 231661

FIG. B-8

TEST BORING 6
 DEPTH (FT) 5

SOIL DESCRIPTION SAND, WITH SILT
 SOIL TYPE 3

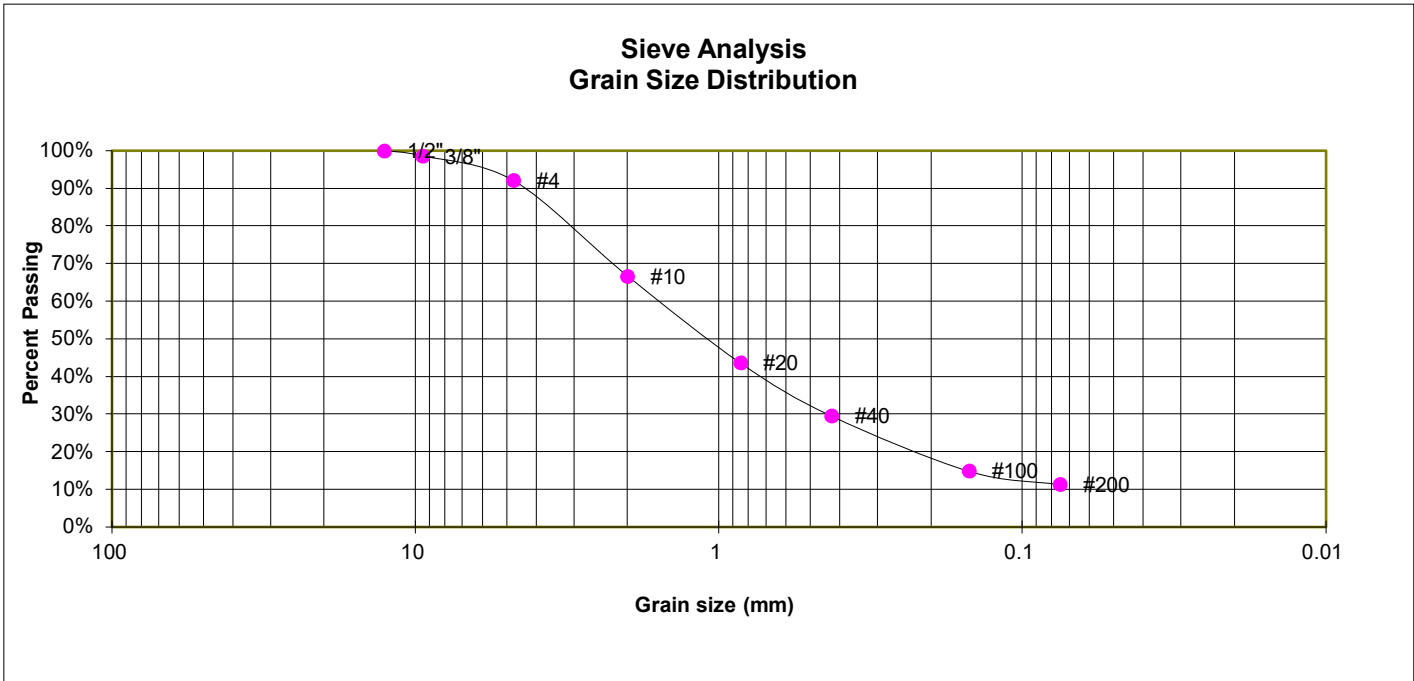

GRAIN SIZE ANALYSIS

U.S. Sieve #	Percent Finer
3"	
1 1/2"	
3/4"	
1/2"	100.0%
3/8"	98.7%
4	92.1%
10	66.7%
20	43.7%
40	29.5%
100	14.9%
200	11.3%

ATTERBERG LIMITS

Plastic Limit	NP
Liquid Limit	NV
Plastic Index	NP

SOIL CLASSIFICATION

USCS CLASSIFICATION: SW-SM
 AASHTO CLASSIFICATION: A-1-b
 AASHTO GROUP INDEX: 0



LABORATORY TEST RESULTS

BRIARGATE PARKWAY, SEGMENT 2
 SR LAND

JOB NO.
 231661

FIG. B-9

TEST BORING 4
DEPTH (FT) 1-2

SOIL DESCRIPTION FILL, CLAY, SANDY
SOIL TYPE 2

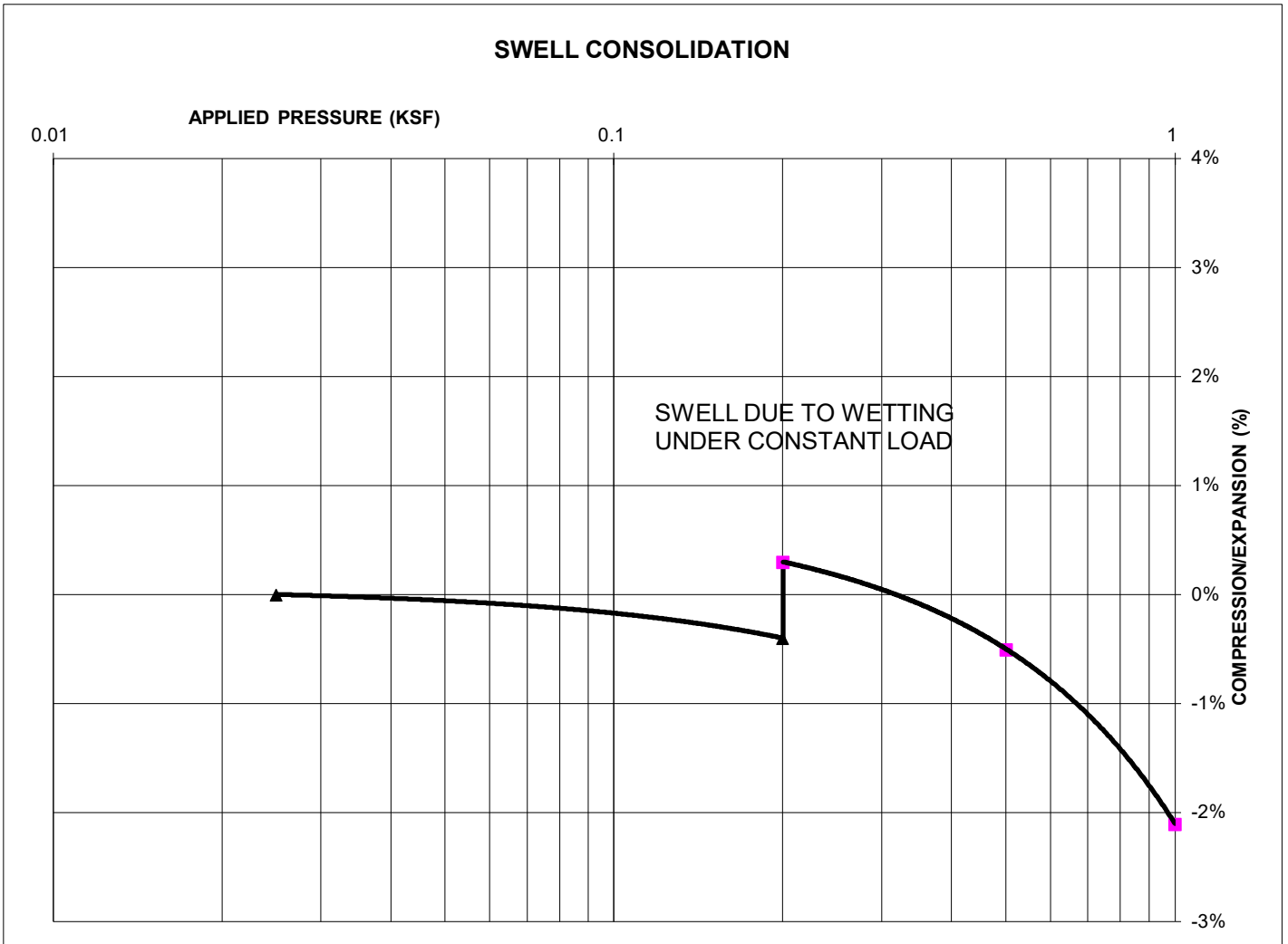

SWELL/COLLAPSE TEST RESULTS

NATURAL UNIT DRY WEIGHT (PCF): 112
NATURAL MOISTURE CONTENT: 13.0%
SWELL/COLLAPSE (%): 0.7%



SWELL TEST RESULTS

BRIARGATE PARKWAY, SEGMENT 2
SR LAND

JOB NO.
231661

FIG. B-10

TEST BORING 5
DEPTH (FT) 1-2

SOIL DESCRIPTION FILL, CLAY, SANDY
SOIL TYPE 2

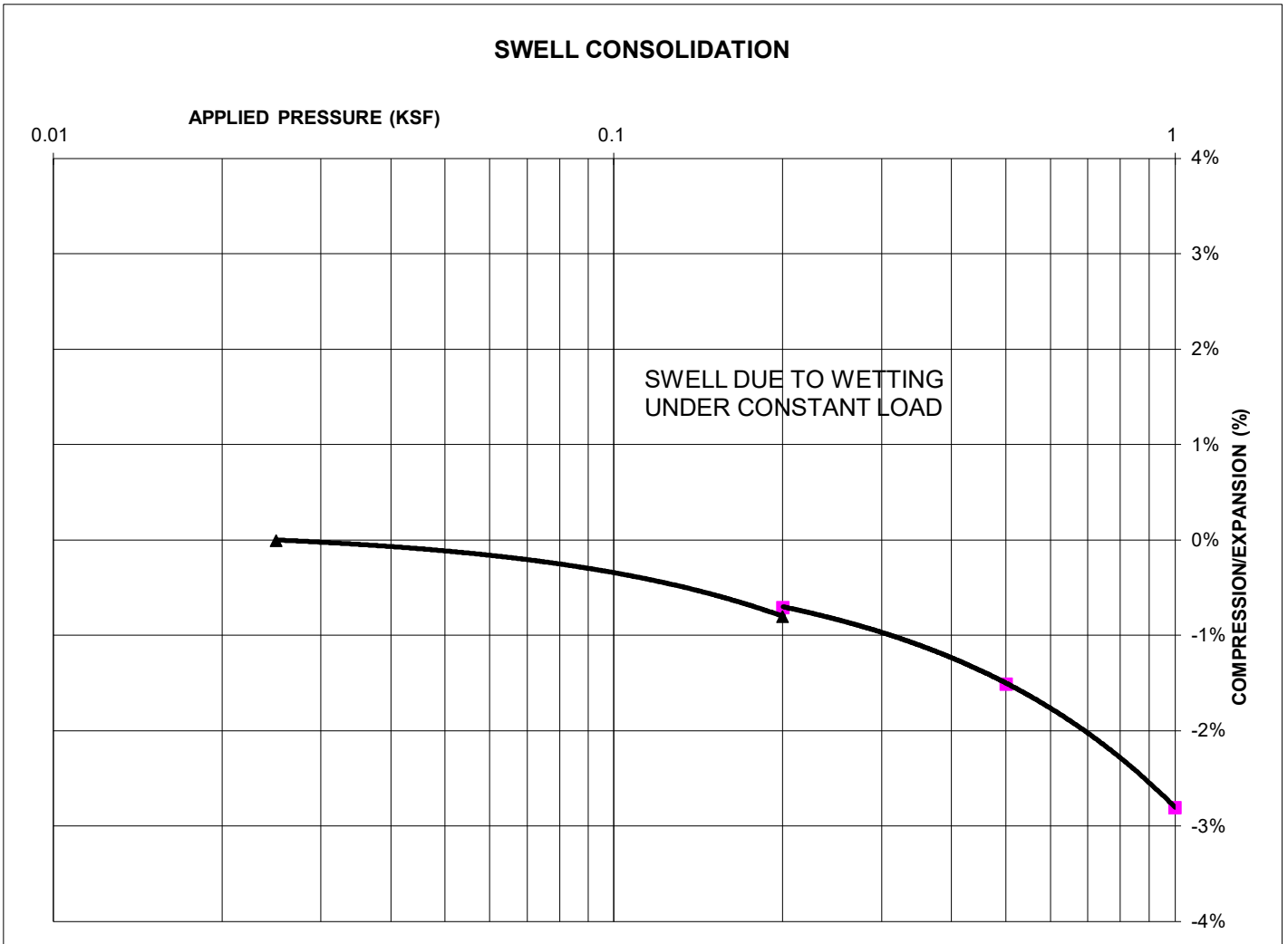

SWELL/COLLAPSE TEST RESULTS

NATURAL UNIT DRY WEIGHT (PCF): 113
NATURAL MOISTURE CONTENT: 13.0%
SWELL/COLLAPSE (%): 0.1%



SWELL TEST RESULTS

BRIARGATE PARKWAY, SEGMENT 2
SR LAND

JOB NO.
231661

FIG. B-11

TEST BORING 6
DEPTH (FT) 1-2

SOIL DESCRIPTION FILL, SAND, CLAYEY
SOIL TYPE 2

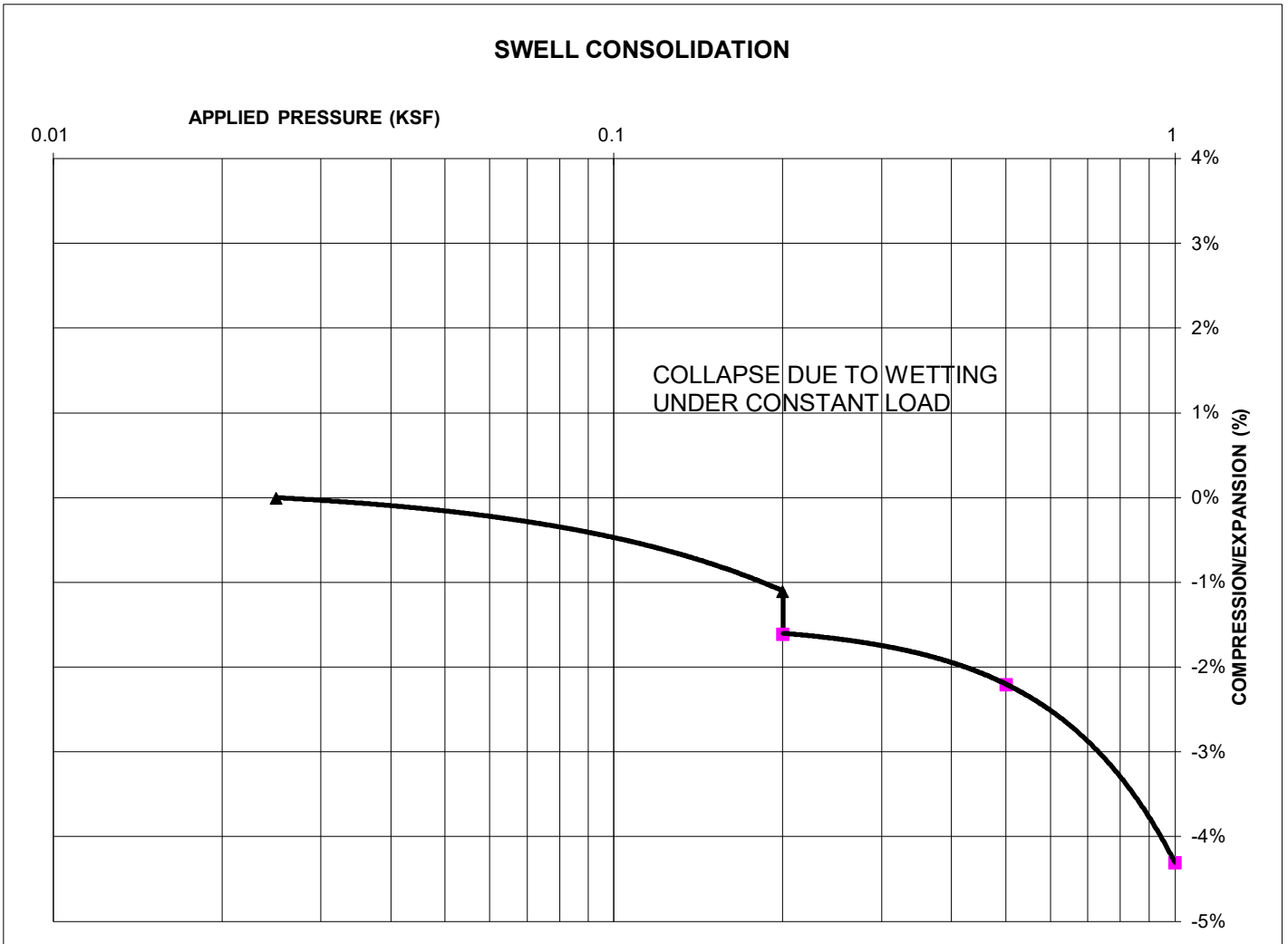

SWELL/COLLAPSE TEST RESULTS

NATURAL UNIT DRY WEIGHT (PCF): 107
NATURAL MOISTURE CONTENT: 10.3%
SWELL/COLLAPSE (%): -0.5%



SWELL TEST RESULTS

BRIARGATE PARKWAY, SEGMENT 2
SR LAND

JOB NO.
231661

FIG. B-12

SAMPLE LOCATION TB-2 @ 0-3'

SOIL DESCRIPTION FILL, SAND, SILTY, BROWN
SOIL TYPE 1

PROCTOR DATA

IDENTIFICATION: SM
PROCTOR TEST #: 1
TEST BY: EK
TEST DESIGNATION: ASTM-1557-A
MAXIMUM DRY DENSITY (PCF): 127.7
OPTIMUM MOISTURE: 7.8

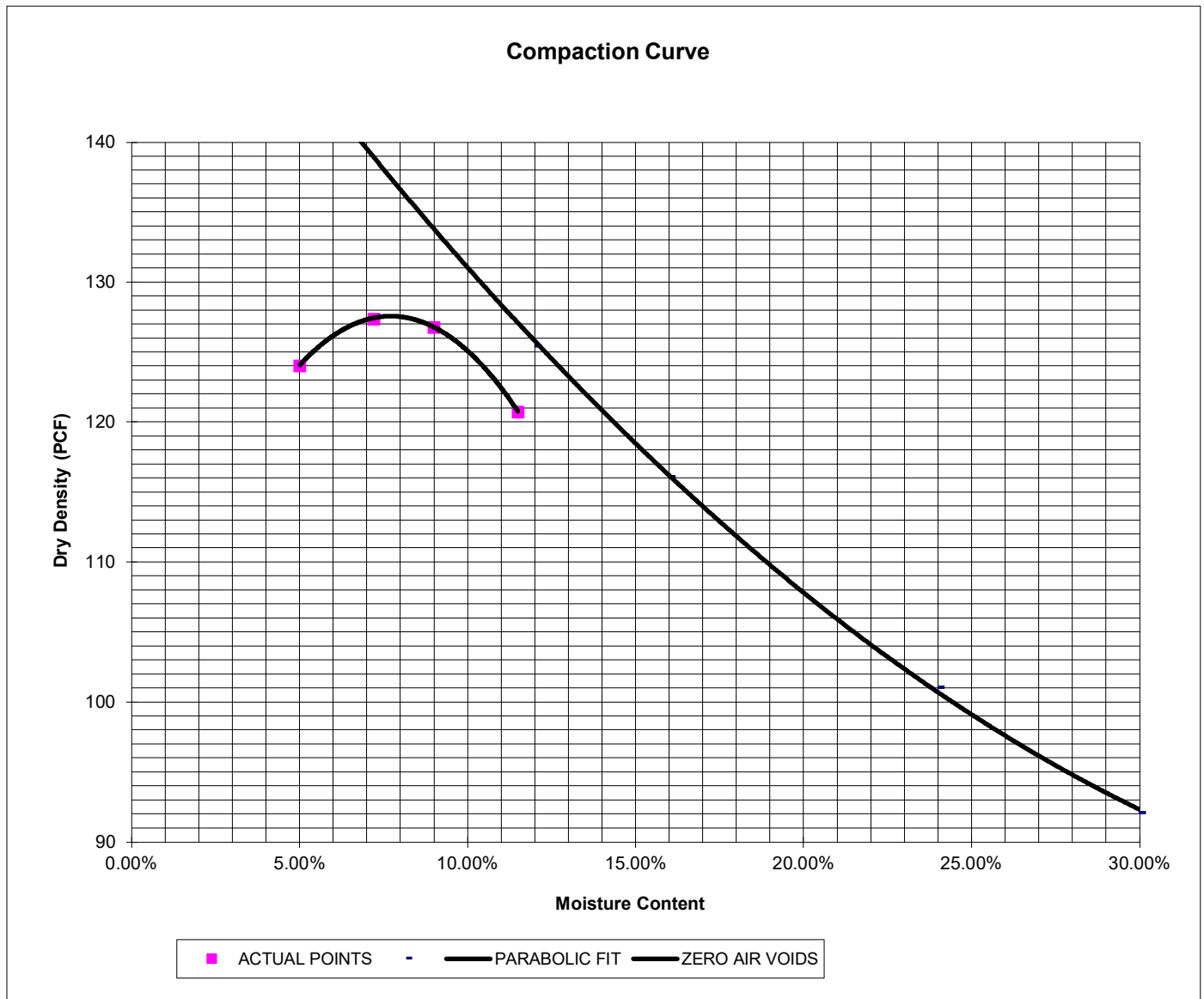

LABORATORY TEST RESULTS

BRIARGATE PARKWAY, SEGMENT 2
SR LAND

JOB NO.
231661

FIG. B-13

SAMPLE LOCATION TB-2 @ 0-3'

SOIL DESCRIPTION FILL, SAND, SILTY, BROWN
SOIL TYPE 1

CBR TEST LOAD DATA

Piston Diameter (cm): 4.958

Piston Area (in²): 2.993

Penetration Depth (inches)	10 BLOWS Mold # 1		25 BLOWS Mold # 2		56 BLOWS Mold # 3	
	Load (lbs)	Stress (psi)	Load (lbs)	Stress (psi)	Load (lbs)	Stress (psi)
0.000	0	0.00	0	0.00	0	0.00
0.025	126	42.11	226	75.52	317	105.93
0.050	191	63.83	384	128.32	469	156.72
0.075	244	81.54	497	166.08	545	182.12
0.100	296	98.91	583	194.82	617	206.18
0.125	326	108.94	660	220.55	734	245.28
0.150	377	125.98	780	260.65	868	290.06
0.175	396	132.33	841	281.04	927	309.77
0.200	414	138.35	918	306.77	1021	341.19
0.300	460	153.72	1090	364.24	1205	402.67
0.400	509	170.09	1250	417.71	1371	458.14
0.500	542	181.12	1314	439.10	1565	522.97

MOISTURE AND DENSITY DATA

	Mold # 1	Mold # 2	Mold # 3
Can #	353	345	351
Wt. Can	6.74	6.77	6.84
Wt. Can+Wet	180.61	164.79	190.39
Wt. Can+Dry	158.34	147.45	172.27
Wt. H2O	22.27	17.34	18.12
Wt. Dry Soil	151.6	140.68	165.43
Moisture Content	14.69%	12.33%	10.95%
Wet Density (PCF)	126.3	132.3	136.0
Dry Density (PCF)	117.2	122.8	126.2
% Compaction	92%	96%	99%
CBR	9.89	19.48	20.62

PROCTOR DATA

Maximum Dry Density (pcf)	127.7
Optimum Moisture	7.8
90% of Max. Dry Density (pcf)	114.9
95% of Max. Dry Density (pcf)	121.3

CBR at 90% of Max. Density = 5.98 ~ R VALUE 12

CBR at 95% of Max. Density = 16.99 ~ R VALUE 55



LABORATORY TEST RESULTS

BRIARGATE PARKWAY, SEGMENT 2
SR LAND

JOB NO.
231661

FIG. B-14

SAMPLE LOCATION TB-2 @ 0-3'

SOIL DESCRIPTION FILL, SAND, SILTY, BROWN
SOIL TYPE 1

Stress VS Penetration

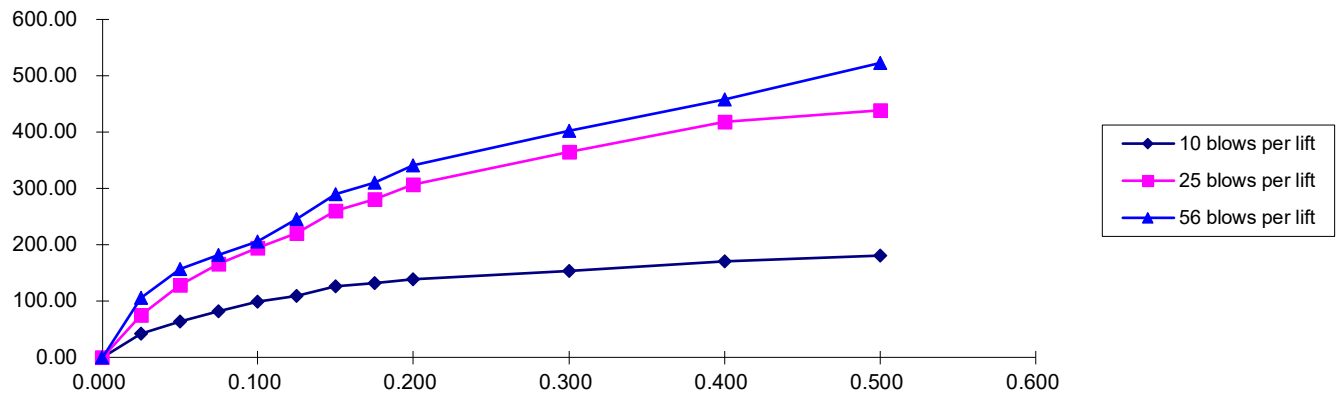

Bearing Ratio VS Dry Density

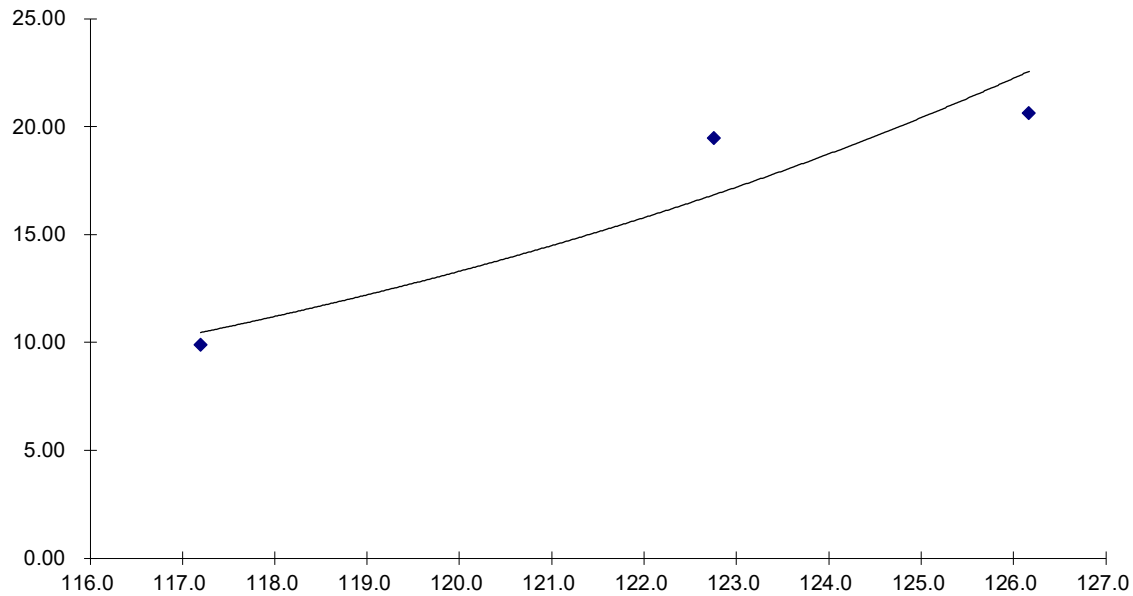

LABORATORY TEST RESULTS

BRIARGATE PARKWAY, SEGMENT 2
SR LAND

JOB NO.
231661

FIG. B-15

SAMPLE LOCATION TB-5 @ 0-3'

SOIL DESCRIPTION FILL, SAND, CLAYEY, BROWN
SOIL TYPE 2

PROCTOR DATA

IDENTIFICATION: CL
PROCTOR TEST #: 2
TEST BY: PH
TEST DESIGNATION: ASTM-698-A
MAXIMUM DRY DENSITY (PCF): 113.9
OPTIMUM MOISTURE: 12.9

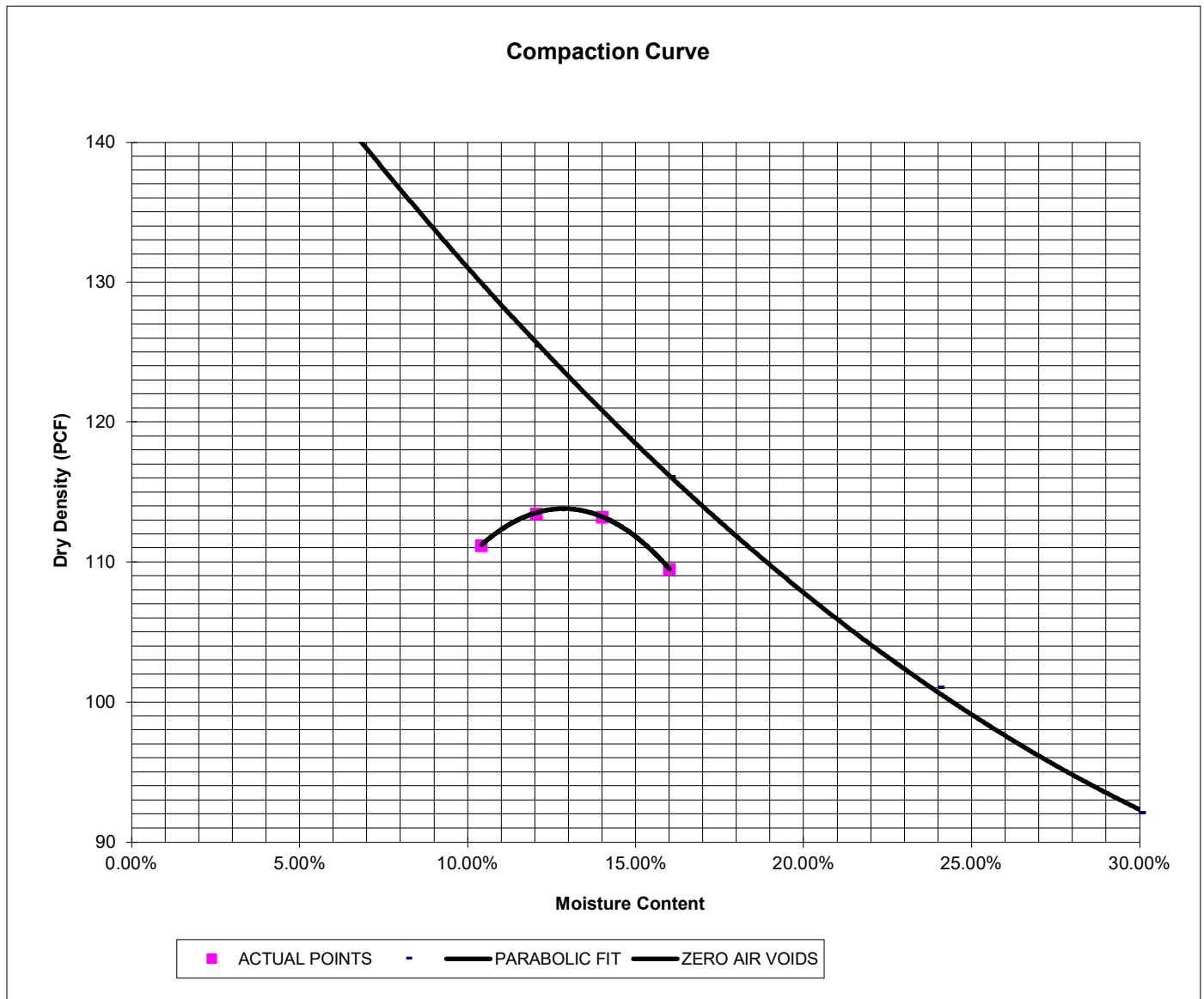

LABORATORY TEST RESULTS

BRIARGATE PARKWAY, SEGMENT 2
SR LAND

JOB NO.
231661

FIG. B-16

SAMPLE LOCATION TB-5 @ 0-3'

SOIL DESCRIPTION FILL, SAND, CLAYEY, BROWN
SOIL TYPE 2

CBR TEST LOAD DATA

Piston Diameter (cm): 4.958

Piston Area (in²): 2.993

Penetration Depth (inches)	10 BLOWS Mold # 1		25 BLOWS Mold # 2		56 BLOWS Mold # 3	
	Load (lbs)	Stress (psi)	Load (lbs)	Stress (psi)	Load (lbs)	Stress (psi)
0.000	0	0.00	0	0.00	0	0.00
0.025	31	10.36	61	20.38	71	23.73
0.050	51	17.04	103	34.42	108	36.09
0.075	62	20.72	123	41.10	134	44.78
0.100	68	22.72	136	45.45	184	61.49
0.125	82	27.40	163	54.47	240	80.20
0.150	89	29.74	177	59.15	310	103.59
0.175	97	32.41	194	64.83	365	121.97
0.200	106	35.42	211	70.51	404	135.00
0.300	145	48.45	289	96.57	672	224.56
0.400	160	53.47	320	106.93	797	266.33
0.500	172	57.48	365	121.97	930	310.78

MOISTURE AND DENSITY DATA

	Mold # 1	Mold # 2	Mold # 3
Can #	303	354	351
Wt. Can	8.52	8.07	7.95
Wt. Can+Wet	168.52	125.93	180.88
Wt. Can+Dry	142.22	109.94	153.49
Wt. H2O	26.3	15.99	27.39
Wt. Dry Soil	133.7	101.87	145.54
Moisture Content	19.67%	15.70%	18.82%
Wet Density (PCF)	117.8	121.6	126.9
Dry Density (PCF)	104.3	107.7	112.4
% Compaction	92%	95%	99%
CBR	2.27	4.54	6.15

PROCTOR DATA

Maximum Dry Density (pcf)	113.9
Optimum Moisture	12.9
90% of Max. Dry Density (pcf)	102.5
95% of Max. Dry Density (pcf)	108.2

CBR at 90% of Max. Density = 1.09	~ R VALUE 1
CBR at 95% of Max. Density = 4.71	~ R VALUE 10



LABORATORY TEST RESULTS

BRIARGATE PARKWAY, SEGMENT 2
SR LAND

JOB NO.
231661

FIG. B-17

SAMPLE LOCATION TB-5 @ 0-3'

SOIL DESCRIPTION FILL, SAND, CLAYEY, BROWN
SOIL TYPE 2

Stress VS Penetration

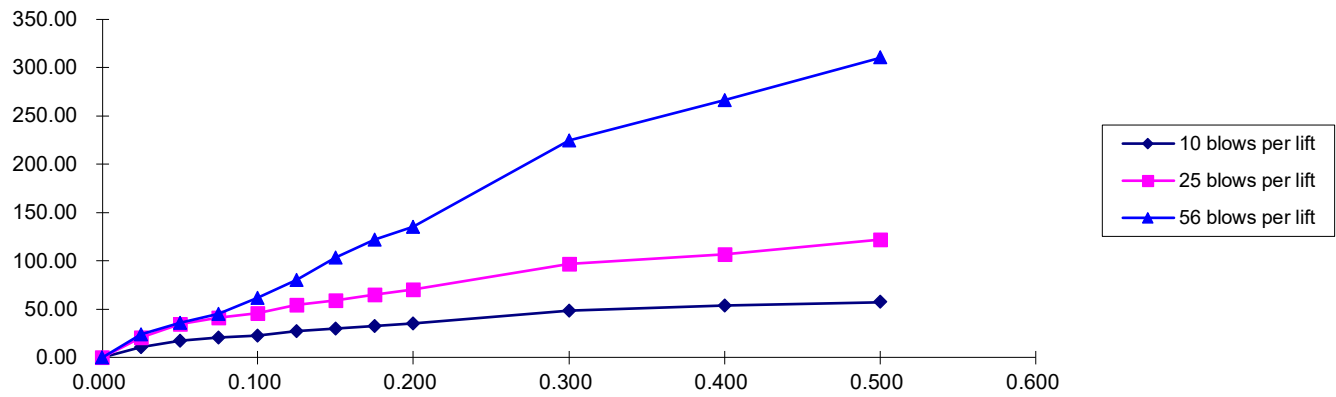

Bearing Ratio VS Dry Density

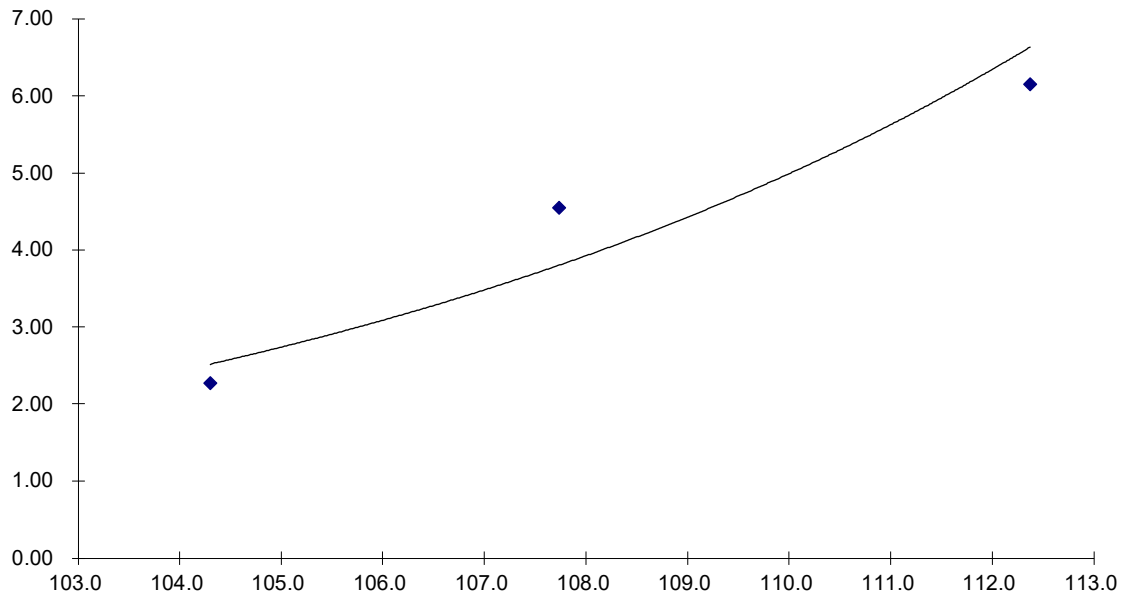

LABORATORY TEST RESULTS

BRIARGATE PARKWAY, SEGMENT 2
SR LAND

JOB NO.
231661

FIG. B-18



APPENDIX C: Pavement Design Calculations

FLEXIBLE PAVEMENT DESIGN

PROJECT DATA

Project Location: Briargate Parkway Segment 2, Soil Type 1
 Job Number: 231661

DESIGN DATA

Equivalent (18-kip) Single Axle Load Applications (ESAL):	ESAL (W_{18}) =	5,256,000
Design CBR	CBR =	10
Standard Deviation	S_o =	0.45
Loss in Serviceability	Δpsi =	2.0
Reliability	Reliability =	90
Reliability (z-statistic)	Z_R =	-1.28
Soil Resilient Modulus	M_R =	15,000 psi

Required Structural Number (SN): ➔ SN = 3.40

DESIGN EQUATIONS

Resilient Modulus

If using CBR:

$$M_R = (\text{CBR}) \times 1,500$$

If using R-Value:

$$M_R = 10^{[(S_1 + 18.72) / 6.24]} \text{ where: } S_1 = [(R\text{-value} - 5) / 11.29] + 3$$

Required Structural Number

$$\log_{10} W_{18} = Z_R \cdot S_o + 9.36 \cdot \log_{10} (\text{SN} + 1) - 0.20 + \frac{\log_{10} \left[\frac{\Delta \text{PSI}}{4.2 - 1.5} \right]}{0.40 + \frac{1094}{(\text{SN} + 1)^{5.19}}} + 2.32 \cdot \log_{10} M_R - 8.07$$

Pavement Section Thickness

$\text{SN}^* = C_1 D_1 + C_2 D_2$ where: C_1 = Strength Coefficient - HMA
 C_2 = Strength Coefficient - ABC/RCB
 D_1 = Depth of HMA (inches)
 D_2 = Depth of ABC/RCB (inches)

RECOMMENED THICKNESSES

Layer	Material	Structural Layer	Thickness (D^*_i)	SN^*_i	SN
1	HMA	$C_1 = 0.44$	5.5 inches	2.420	-
2	ABC/RCB	$C_2 = 0.11$	10.0 inches	1.100	
				SN* = 3.520	3.40

Pavement SN > Required SN, Design is Acceptable

FIG. C-1

FLEXIBLE PAVEMENT DESIGN

PROJECT DATA

Project Location: Briargate Parkway Segment 2, Soil Type 1
 Job Number: 231661

DESIGN DATA

Equivalent (18-kip) Single Axle Load Applications (ESAL):	ESAL (W_{18}) =	5,256,000
Design CBR	CBR =	10
Standard Deviation	S_o =	0.45
Loss in Serviceability	$\Delta\psi$ =	2.0
Reliability	Reliability =	90
Reliability (z-statistic)	Z_R =	-1.28
Soil Resilient Modulus	M_R =	15,000 psi

Required Structural Number (SN): ➔ SN = 3.40

DESIGN EQUATIONS

Resilient Modulus

If using CBR:

$$M_R = (\text{CBR}) \times 1,500$$

If using R-Value:

$$M_R = 10^{[(S_1 + 18.72) / 6.24]} \text{ where: } S_1 = [(R\text{-value} - 5) / 11.29] + 3$$

Required Structural Number

$$\log_{10} W_{18} = Z_R \cdot S_o + 9.36 \cdot \log_{10} (SN+1) - 0.20 + \frac{\log_{10} \left[\frac{\Delta \text{PSI}}{4.2 - 1.5} \right]}{0.40 + \frac{1094}{(SN+1)^{5.19}}} + 2.32 \cdot \log_{10} M_R - 8.07$$

Pavement Section Thickness

$SN^* = C_1 D_1 + C_2 D_2$ where: C_1 = Strength Coefficient - HMA
 C_2 = Strength Coefficient - ABC/RCB
 D_1 = Depth of HMA (inches)
 D_2 = Depth of ABC/RCB (inches)

RECOMMENED THICKNESSES

Layer	Material	Structural Layer	Thickness (D^*_i)	SN^*_i	SN
1	HMA	$C_1 = 0.44$	6.0 inches	2.640	-
2	ABC/RCB	$C_2 = 0.11$	8.0 inches	0.880	
				SN* = 3.520	3.40

Pavement SN > Required SN, Design is Acceptable

FIG. C-2

FLEXIBLE PAVEMENT DESIGN

PROJECT DATA

Project Location: Briargate Parkway Segment 2, Soil Type 1
 Job Number: 231661

DESIGN DATA

Equivalent (18-kip) Single Axle Load Applications (ESAL):	ESAL (W_{18}) =	5,256,000
Design CBR	CBR =	10
Standard Deviation	S_o =	0.45
Loss in Serviceability	Δpsi =	2.0
Reliability	Reliability =	90
Reliability (z-statistic)	Z_R =	-1.28
Soil Resilient Modulus	M_R =	15,000 psi

Required Structural Number (SN): ➔ SN = 3.40

DESIGN EQUATIONS

Resilient Modulus

If using CBR:

$$M_R = (\text{CBR}) \times 1,500$$

If using R-Value:

$$M_R = 10^{[(S_1 + 18.72) / 6.24]} \text{ where: } S_1 = [(R\text{-value} - 5) / 11.29] + 3$$

Required Structural Number

$$\log_{10} W_{18} = Z_R \cdot S_o + 9.36 \cdot \log_{10} (\text{SN} + 1) - 0.20 + \frac{\log_{10} \left[\frac{\Delta \text{PSI}}{4.2 - 1.5} \right]}{0.40 + \frac{1094}{(\text{SN} + 1)^{5.19}}} + 2.32 \cdot \log_{10} M_R - 8.07$$

Pavement Section Thickness

$\text{SN}^* = C_1 D_1 + C_2 D_2$ where: C_1 = Strength Coefficient - HMA
 C_2 = Strength Coefficient - CTS
 D_1 = Depth of HMA (inches)
 D_2 = Depth of CTS (inches)

RECOMMENED THICKNESSES

Layer	Material	Structural Layer	Thickness (D^*_i)	SN^*_i	SN
1	HMA	$C_1 = 0.44$	5.5 inches	2.420	-
2	CTS	$C_2 = 0.11$	10.0 inches	1.100	
				SN* = 3.520	3.40

Pavement SN > Required SN, Design is Acceptable

FIG. C-3

FLEXIBLE PAVEMENT DESIGN

PROJECT DATA

Project Location: Briargate Parkway Segment 2, Soil Type 2
 Job Number: 231661

DESIGN DATA

Equivalent (18-kip) Single Axle Load Applications (ESAL):	ESAL (W_{18}) =	5,256,000
Design CBR	CBR =	4.7
Standard Deviation	S_o =	0.45
Loss in Serviceability	$\Delta\psi$ =	2.0
Reliability	Reliability =	90
Reliability (z-statistic)	Z_R =	-1.28
Soil Resilient Modulus	M_R =	7,050 psi

Required Structural Number (SN): ➔ SN = 4.42

DESIGN EQUATIONS

Resilient Modulus

If using CBR:

$$M_R = (\text{CBR}) \times 1,500$$

If using R-Value:

$$M_R = 10^{[(S_1 + 18.72) / 6.24]} \text{ where: } S_1 = [(R\text{-value} - 5) / 11.29] + 3$$

Required Structural Number

$$\log_{10} W_{18} = Z_R \cdot S_o + 9.36 \cdot \log_{10} (SN+1) - 0.20 + \frac{\log_{10} \left[\frac{\Delta \text{ PSI }}{4.2 - 1.5} \right]}{0.40 + \frac{1094}{(SN+1)^{5.19}}} + 2.32 \cdot \log_{10} M_R - 8.07$$

Pavement Section Thickness

$SN^* = C_1 D_1 + C_2 D_2$ where: C_1 = Strength Coefficient - HMA
 C_2 = Strength Coefficient - ABC/RCB
 D_1 = Depth of HMA (inches)
 D_2 = Depth of ABC/RCB (inches)

RECOMMENED THICKNESSES

Layer	Material	Structural Layer	Thickness (D^*_i)	SN^*_i	SN
1	HMA	$C_1 = 0.44$	7.5 inches	3.300	-
2	ABC/RCB	$C_2 = 0.11$	12.0 inches	1.320	
				SN* = 4.620	4.42

Pavement SN > Required SN, Design is Acceptable

FIG. C-4

FLEXIBLE PAVEMENT DESIGN

PROJECT DATA

Project Location: Briargate Parkway Segment 2, Soil Type 2
 Job Number: 231661

DESIGN DATA

Equivalent (18-kip) Single Axle Load Applications (ESAL):	ESAL (W_{18}) =	5,256,000
Design CBR	CBR =	4.7
Standard Deviation	S_o =	0.45
Loss in Serviceability	$\Delta\psi$ =	2.0
Reliability	Reliability =	90
Reliability (z-statistic)	Z_R =	-1.28
Soil Resilient Modulus	M_R =	7,050 psi

Required Structural Number (SN): ➔ SN = 4.42

DESIGN EQUATIONS

Resilient Modulus

If using CBR:

$$M_R = (\text{CBR}) \times 1,500$$

If using R-Value:

$$M_R = 10^{[(S_1 + 18.72) / 6.24]} \text{ where: } S_1 = [(R\text{-value} - 5) / 11.29] + 3$$

Required Structural Number

$$\log_{10} W_{18} = Z_R \cdot S_o + 9.36 \cdot \log_{10} (SN+1) - 0.20 + \frac{\log_{10} \left[\frac{\Delta \text{PSI}}{4.2 - 1.5} \right]}{0.40 + \frac{1094}{(SN+1)^{5.19}}} + 2.32 \cdot \log_{10} M_R - 8.07$$

Pavement Section Thickness

$SN^* = C_1 D_1 + C_2 D_2$ where: C_1 = Strength Coefficient - HMA
 C_2 = Strength Coefficient - ABC/RBC
 D_1 = Depth of HMA (inches)
 D_2 = Depth of ABC/RBC (inches)

RECOMMENED THICKNESSES

Layer	Material	Structural Layer	Thickness (D^*_i)	SN^*_i	SN
1	HMA	$C_1 = 0.44$	8.0 inches	3.520	-
2	ABC/RBC	$C_2 = 0.11$	10.0 inches	1.100	
				SN* = 4.620	4.42

Pavement SN > Required SN, Design is Acceptable

FIG. C-5

FLEXIBLE PAVEMENT DESIGN

PROJECT DATA

Project Location: Briargate Parkway Segment 2, Soil Type 2
 Job Number: 231661

DESIGN DATA

Equivalent (18-kip) Single Axle Load Applications (ESAL):	ESAL (W_{18}) =	5,256,000
Design CBR	CBR =	4.7
Standard Deviation	S_o =	0.45
Loss in Serviceability	Δpsi =	2.0
Reliability	Reliability =	90
Reliability (z-statistic)	Z_R =	-1.28
Soil Resilient Modulus	M_R =	7,050 psi

Required Structural Number (SN): ➔ SN = 4.42

DESIGN EQUATIONS

Resilient Modulus

If using CBR:

$$M_R = (\text{CBR}) \times 1,500$$

If using R-Value:

$$M_R = 10^{[(S_1 + 18.72) / 6.24]} \text{ where: } S_1 = [(R\text{-value} - 5) / 11.29] + 3$$

Required Structural Number

$$\log_{10} W_{18} = Z_R \cdot S_o + 9.36 \cdot \log_{10} (\text{SN} + 1) - 0.20 + \frac{\log_{10} \left[\frac{\Delta \text{PSI}}{4.2 - 1.5} \right]}{0.40 + \frac{1094}{(\text{SN} + 1)^{5.19}}} + 2.32 \cdot \log_{10} M_R - 8.07$$

Pavement Section Thickness

$\text{SN}^* = C_1 D_1 + C_2 D_2$ where: C_1 = Strength Coefficient - HMA
 C_2 = Strength Coefficient - CTS
 D_1 = Depth of HMA (inches)
 D_2 = Depth of CTS (inches)

RECOMMENED THICKNESSES

Layer	Material	Structural Layer	Thickness (D^*_i)	SN^*_i	SN
1	HMA	$C_1 = 0.44$	7.5 inches	3.300	-
2	CTS	$C_2 = 0.11$	12.0 inches	1.320	
				SN* = 4.620	4.42

Pavement SN > Required SN, Design is Acceptable

FIG. C-6