

# VENETUCCI FARMS

A PORTION OF THE SW  $\frac{1}{4}$  OF THE SW  $\frac{1}{4}$  OF SECTION 11 AND A PORTION OF THE NW  $\frac{1}{4}$  OF SECTION 14, EL PASO, COUNTY  
5202 HWY 85-87, 5210 HWY 85-87, 5304 HWY 85-87 & 5304 HWY 85  
SPECIAL USE PERMIT - BUSINESS EVENT CENTER



N.E.S. Inc.  
619 N. Cascade Avenue, Suite 200  
Colorado Springs, CO 80903  
Tel. 719.471.0073  
Fax 719.471.0267  
www.nescolorado.com  
© 2012. All Rights Reserved.

## GENERAL NOTES

- This site, 5202 HIGHWAY 85-87 is not a designated F.E.M.A. Floodplain as determined by the flood insurance rate map, community panel number 08041C0746G AND 08041C0763G, effective December 7, 2018.
- The parties responsible for this plan have familiarized themselves with all current accessibility criteria and specifications and the proposed plan reflects all site elements required by the applicable ADA design standards and guidelines as published by the United States Department of Justice. Approval of this plan by El Paso County does not assure compliance with the ADA or any regulations or guidelines enacted or promulgated under or with respect to such laws.
- The owner agrees on behalf of him/herself and any developer or builder successors and assigns that Subdivider and/or said successors and assigns shall be required to pay traffic impact fees in accordance with the El Paso County Road Impact Fee Program Resolution (Resolution No. 19-471), or any amendments thereto, at or prior to the time of building permit submittals.

## LEGAL DESCRIPTION

The SW1/4 of the SW1/4 and those portions of the E1/2 of the SW1/4 and the SE1/4 of the NW1/4 and the SW1/4 of the SE1/4 of Section 11 lying West of the Colorado Springs and Pueblo Highway, and that portion of the NW1/4 of Section 14 lying North and East of the following described line: Beginning at a point on the North line of said Section 14 a distance of 422.6 feet East of the Northwest corner thereof; thence South 11°53' East 1031.9 feet; thence South 22°37' East 1131 feet; thence South 69°49' East 403.9 feet; thence North 79°34' East, 776.4 feet; thence South 59°36' East 458.48 feet; thence South along the East line of said NW1/4 - 376.34 feet to the Southeast corner of the NW1/4 of said Section 14; all being in Township 15 South, Range 66 West of the 6th P.M., El Paso County, Colorado. Excepting therefrom those tracts conveyed in deeds recorded February 10, 2004, at Reception No. 204023409; February 20, 2004 at Reception No. 204029383; and also excepting therefrom that four acre tract conveyed by deed recorded February 27, 2006 at Reception No. 206028784 of the recorded of the El Paso County Clerk and Recorder, County of El Paso, State of Colorado.

CONTAINING APPROXIMATE AREA: 187.23 AC

TRACT A ST DOMINIC'S CATHOLIC CHURCH (USE ALLOWED PER MOU DATED 2015)  
CONTAINING APPROXIMATE AREA: 4.24 AC

## KEY MAP

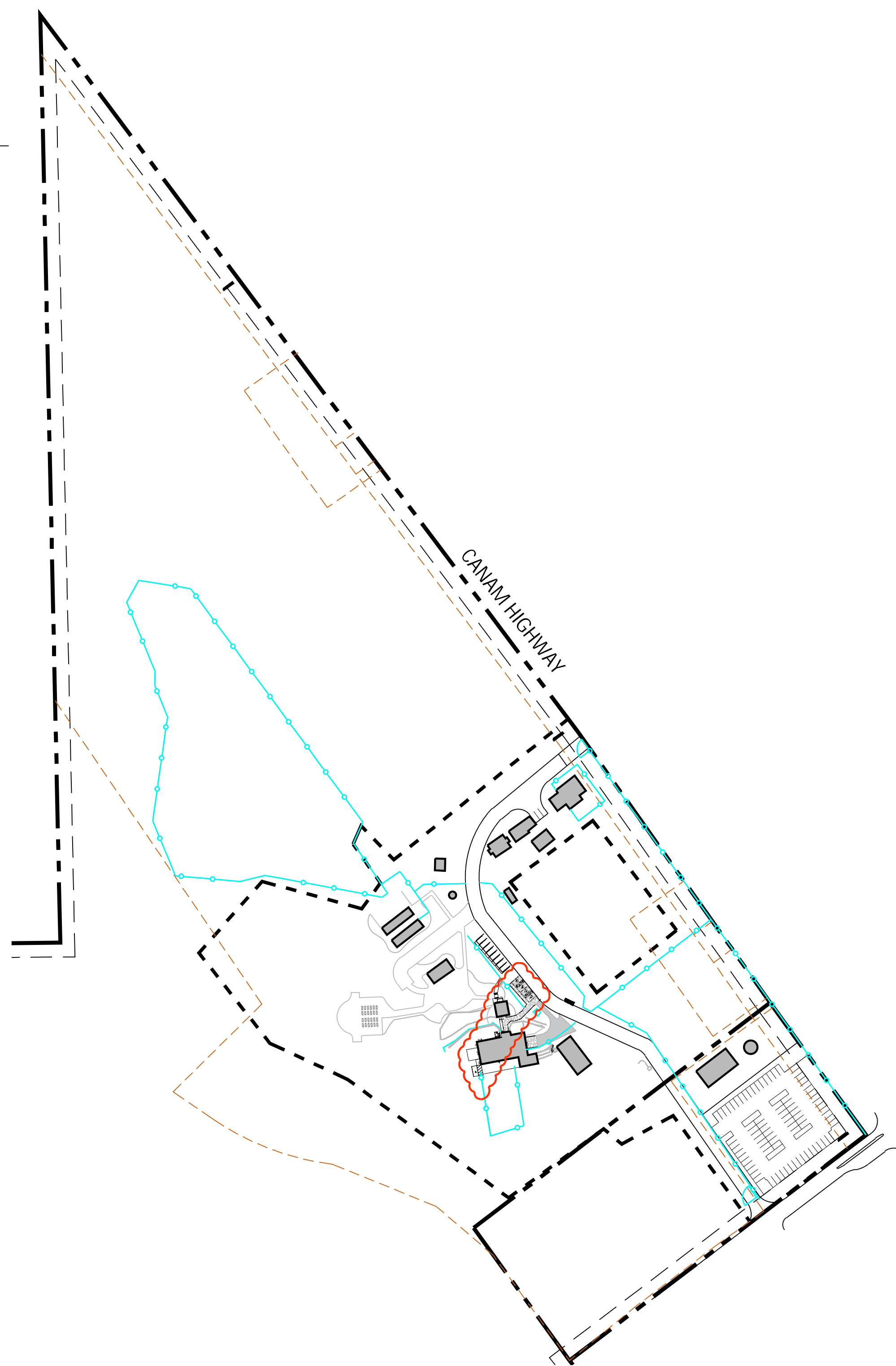

## VICINITY MAP

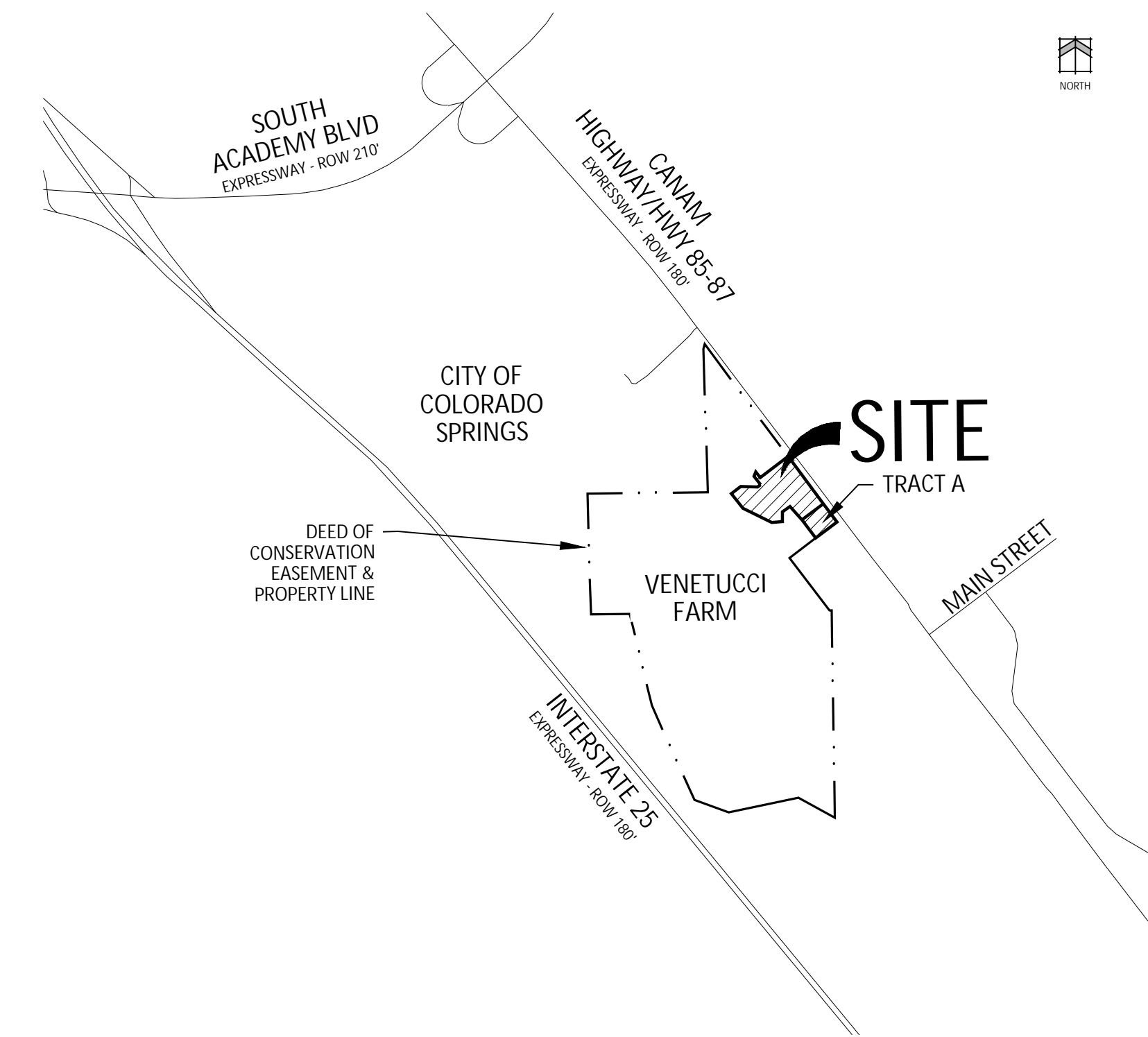

## SITE DATA

Tax ID Number:	6511300008
Total Area:	191.47 AC (10.12 AC (440,827 SQ. FT.) - Special Use Permit Area)
Development Schedule:	Fall 2026
Current Zoning:	A-5
Current Land Use:	Agriculture & Business Event Center Special Use (440,827 Sq. Ft.)
Building Setbacks:	
Front (East):	25 FT
Side:	25 FT
Rear (West):	25 FT
Existing Barn Footage:	7,722 SF.
Proposed Barn Footage:	7,850 SF.
Existing Barn Height:	34 FT
Proposed Barn Height:	34 FT
Proposed Restroom Building Footage:	565 SF.
Proposed Restroom Building Height:	17 FT
Business Event Center Area:	497,460 SF (11.42 AC) = 100%
Existing Buildings Area:	19,234 SF (0.44 AC) = 4%
Proposed Buildings Area:	19,927 SF (0.45 AC) = 4%
Open Space:	477,527 SF (10.97 AC) = 96%
Landscape Setbacks:	
East (Can Am Highway - Principal Arterial):	25 FT
North & South:	N/A
West (I-25 - Freeway - Expressway):	N/A
Parking:	
Formula:	Auditorium or similar place of Public Assembly (1sp per 100 SQ. FT.)
Required:	81 sp (8,053 SQ. FT./100 SQ. FT.)
Provided:	99 sp.
ADA Formula:	4 spaces required per 76-100 spaces
Required:	4 sp.
Provided:	5 sp. (incl. 1 van)

## PROJECT TEAM

OWNER:	PIKES PEAK REAL ESTATE FOUNDATION 315 E PIKES PEAK AVE., STE 120 COLORADO SPRINGS, CO 80903	PLANNER/ LANDSCAPE ARCHITECT:	N.E.S. INC. 619 N. CASCADE AVE., SUITE 200 COLORADO SPRINGS, CO 80903
ARCHITECT:	COMPASS TDG 101 N CASCADE AVE., SUITE 400 COLORADO SPRINGS, CO 80903	CIVIL:	R&R ENGINEERS 1635 W 13TH AVE., SUITE 310 DENVER, CO 80204

## SHEET INDEX

NUMBER	TITLE	DESCRIPTION
1	DP1.01	COVER
2	DP2.01	SITE PLAN
3	C4.0	UTILITY PLAN
4	C5.0	GRADING PLAN
5	LP1.01	LANDSCAPE NOTES & SCHEDULES
6	LP2.01	LANDSCAPE PLAN

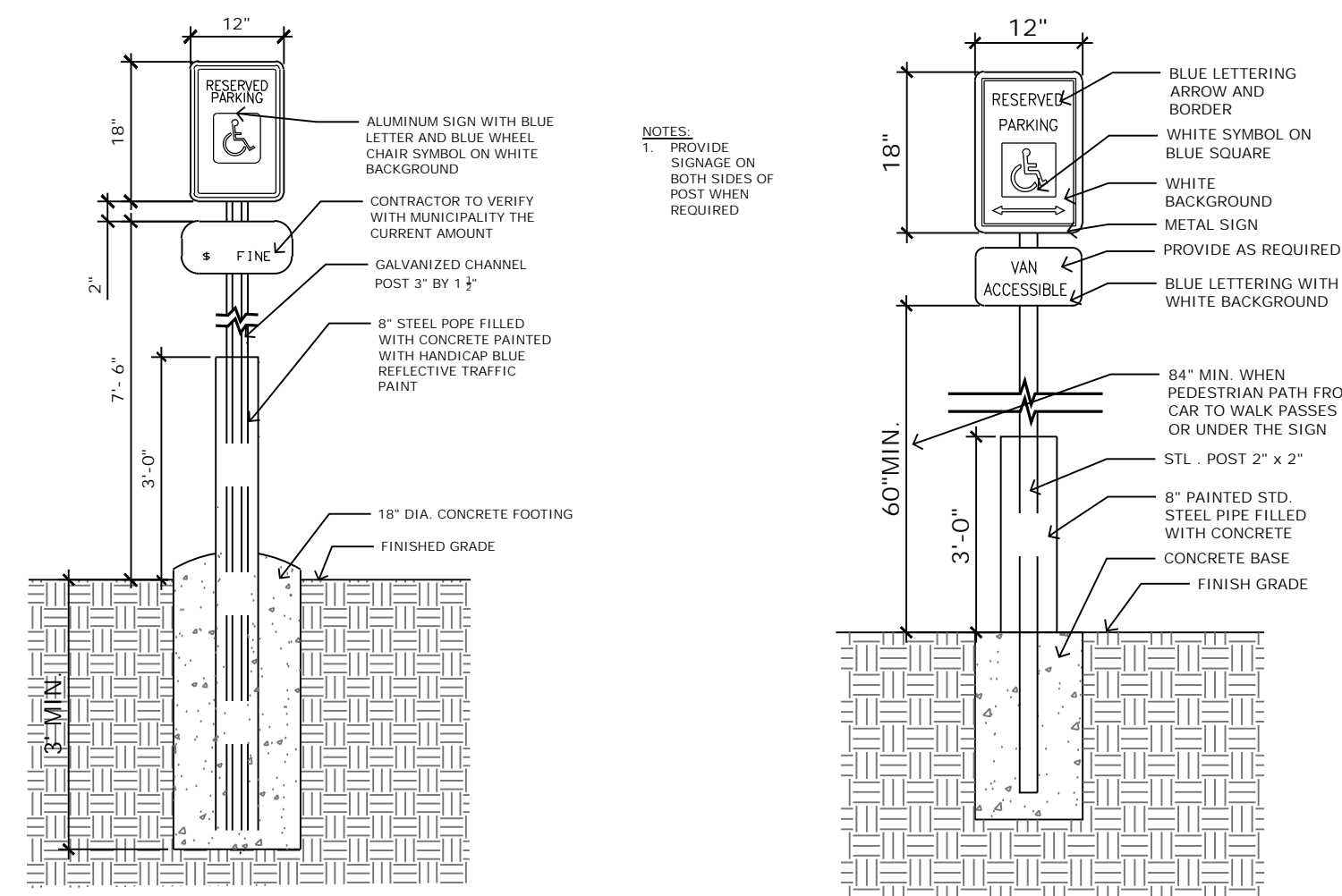

## 1 ADA/VAN ACCESSIBLE PARKING SIGNS

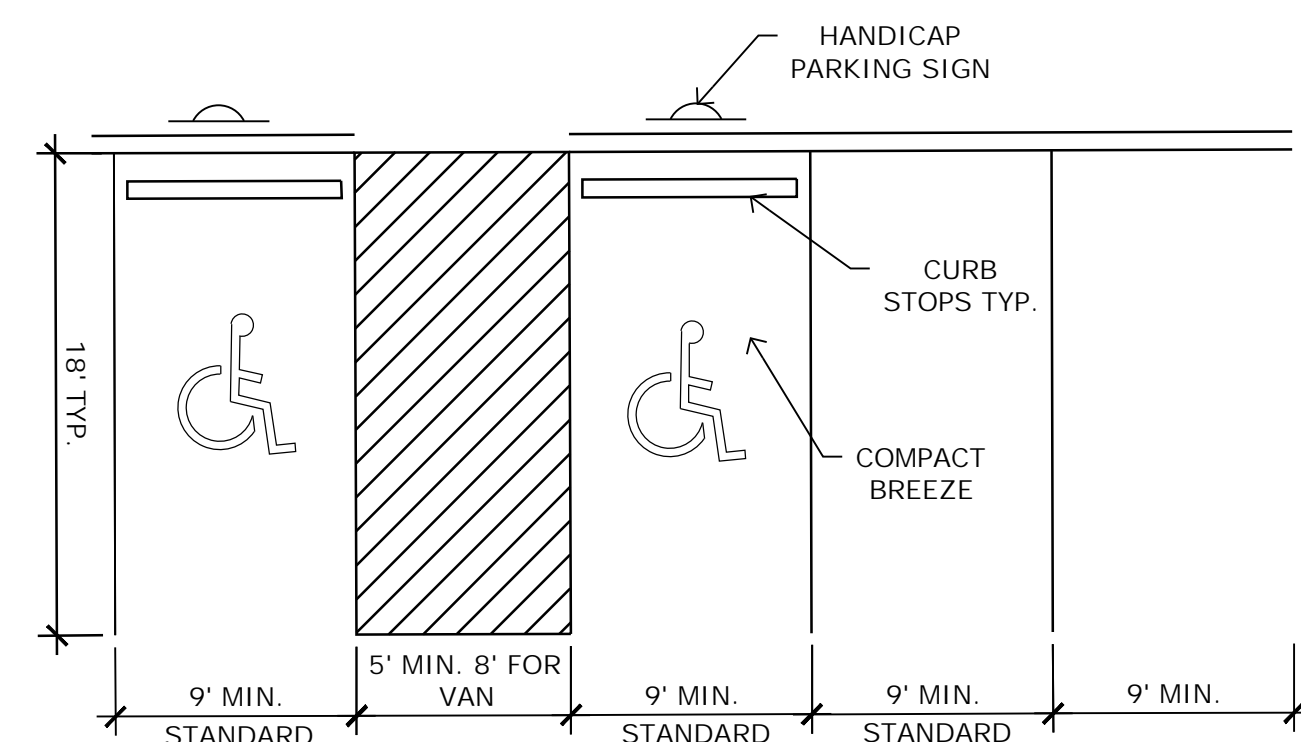

## 2 ADA & STANDARD PARKING STALL LAYOUT

## VENETUCCI FARMS

## BUSINESS EVENT CENTER

5202 S HIGHWAY 85-87

DATE: 05/15/26  
PROJECT MGR: J. ALWINE  
PREPARED BY: Y. LIU

## DEVELOPMENT PLAN AMENDMENT

DATE: BY: DESCRIPTION:

## COVER

## DP1.01

1 OF 6

PLAN FILE # CPC #



N.E.S. Inc.  
619 N. Cascade Avenue, Suite 200  
Colorado Springs, CO 80903  
Tel. 719.471.0073  
Fax 719.471.0267  
www.nescolorado.com  
© 2012. All Rights Reserved

# VENETUCCI FARMS

**BUSINESS EVENT CENTER**  
5202 S HIGHWAY 85-87

DATE: 05/15/26  
PROJECT MGR: J. ALWINE  
PREPARED BY: Y. LIU

## DEVELOPMENT PLAN AMENDMENT

DATE:	BY:	DESCRIPTION:

### SITE PLAN

# DP2.01

2 of 6  
CPC #

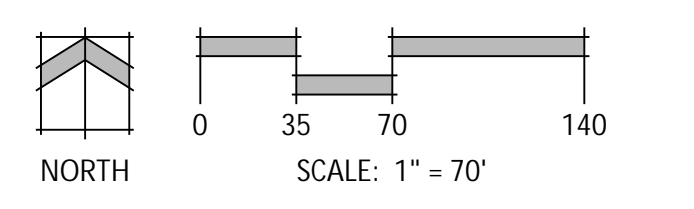
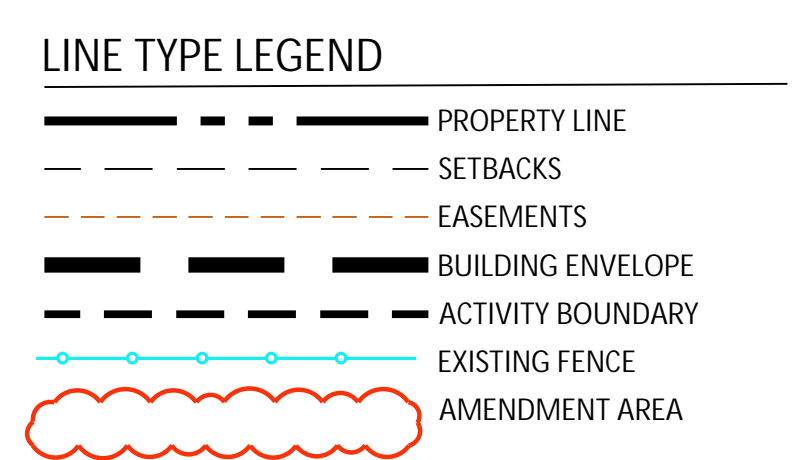
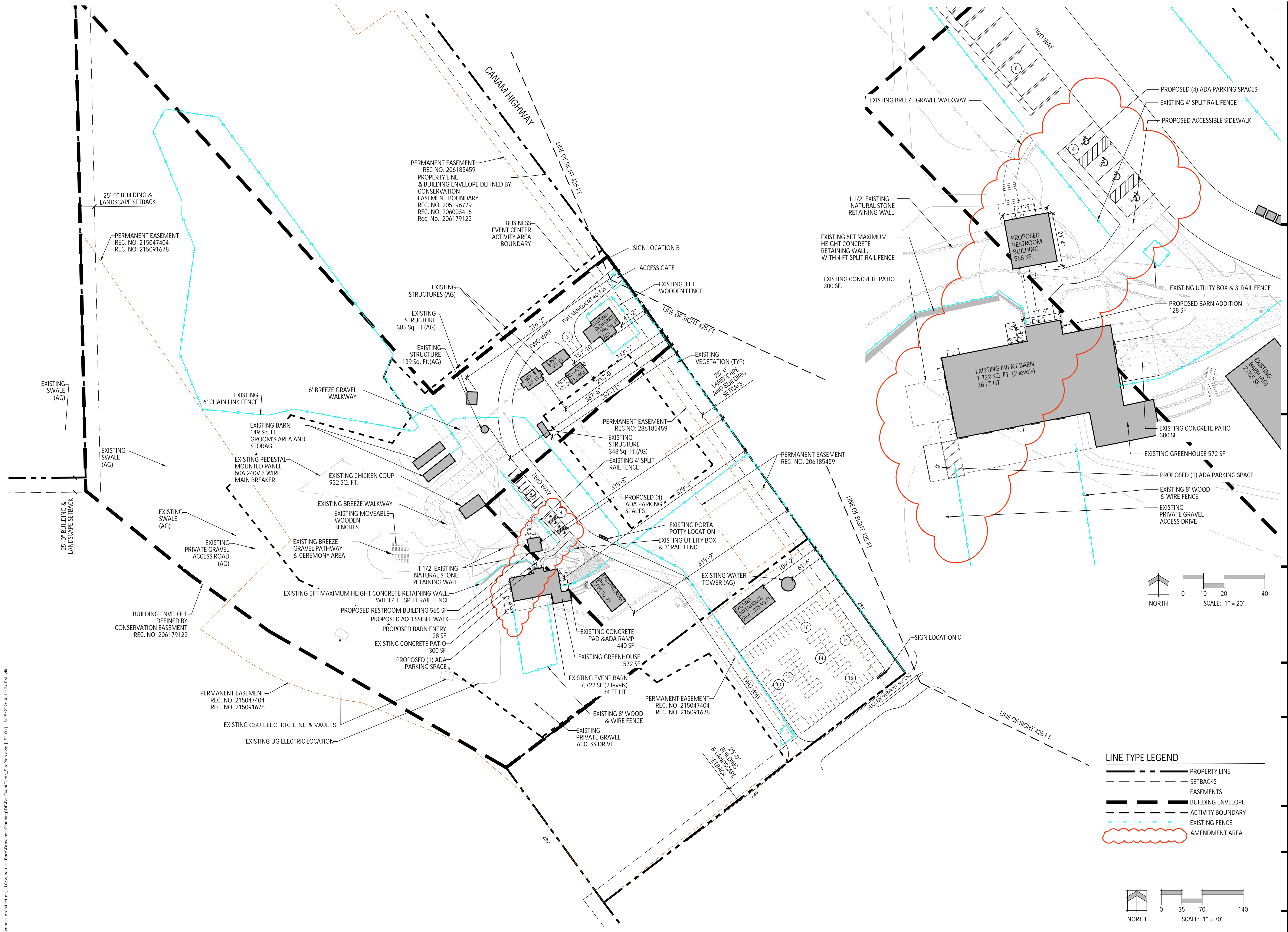

P:\Compass Architecture, LLC\Venetucci Farms\Drawings\Plan\BusinessEventCenter\_SitePlan.dwg (L1) (D1) 5/15/2026 4:11:24 PM ylu

# CONSTRUCTION DOCUMENTS VENETUCCI FARMS - BARN REMODEL

LOCATED IN THE SW QUARTER OF SECTION 11, TOWNSHIP 15 SOUTH, RANGE 66 WEST OF THE 6TH PRINCIPAL MERIDIAN  
CITY OF COLORADO SPRINGS, COUNTY OF EL PASO, STATE OF COLORADO

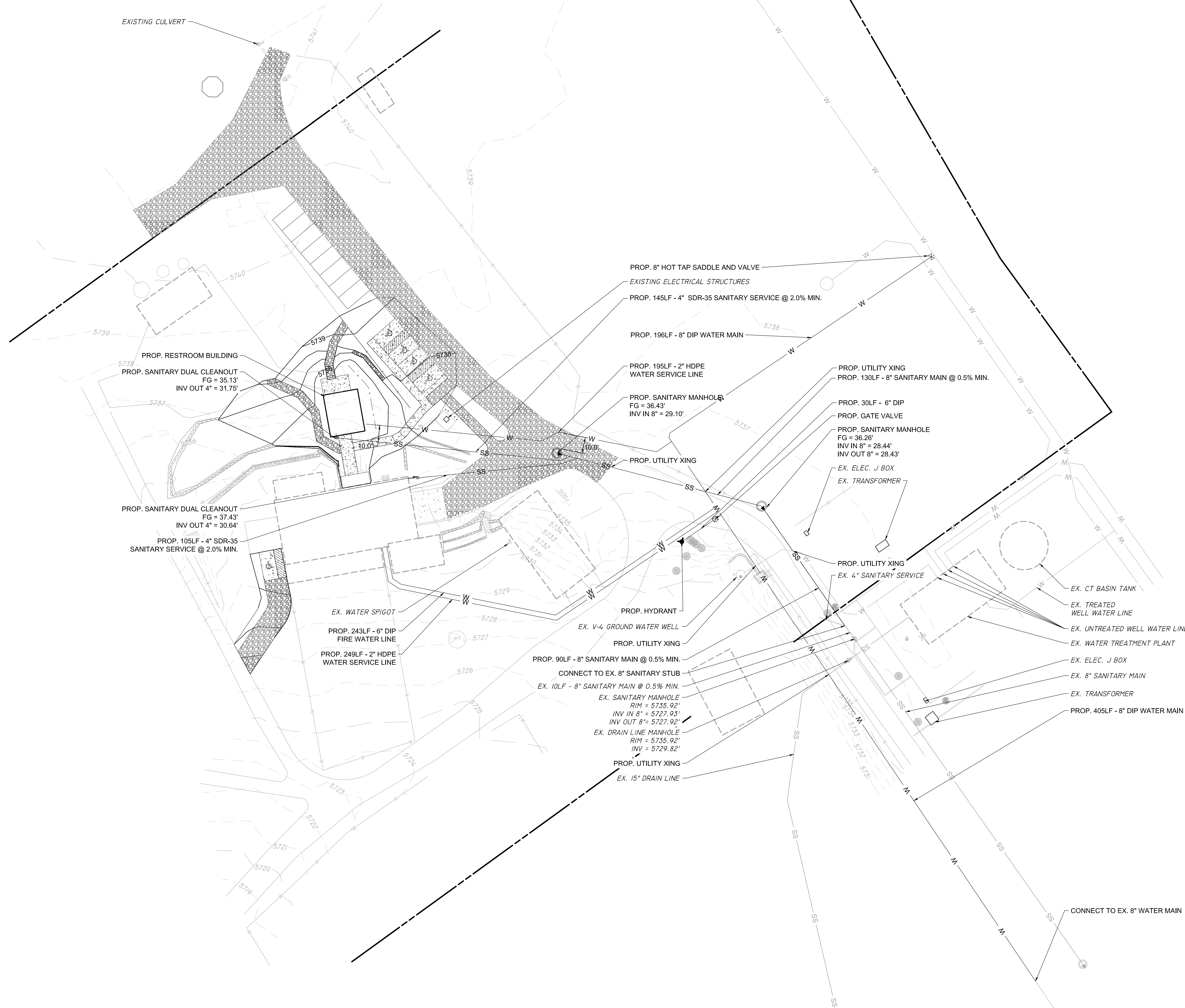

- NOTES:
- CLEARANCES BETWEEN WATER AND SEWER/STORM NEED TO BE 10 FEET HORIZONTAL AND 18 INCHES VERTICAL.
  - ALL WATER OR SEWER MAIN AND SERVICE INSTALLATION SHALL CONFORM WITH SECURITY WATER AND SANITATION DISTRICTS STANDARDS.
  - UTILITY LOCATIONS ARE APPROXIMATE AND SHALL BE VERIFIED IN FIELD BY CONTRACTOR PRIOR TO CONSTRUCTION VIA POT HOLE.
  - PROPOSED WATER AND SANITARY SERVICE SIZES ARE TO BE DETERMINED BASED ON PROVIDED USAGE RATE DATA.

NO.	REVISION	BY	DATE
1	50% CD SET	JBP	04/24/26
2	50% CD SET	JA	04/29/26
3	50% CD SET	JA	05/08/26



**R&R ENGINEERS-SURVEYORS, INC.**  
1635 WEST 13TH AVENUE, SUITE 310  
DENVER, COLORADO 80204  
PHONE: 303-753-6730

WWW.RRENGINEERS.COM

NOT FOR CONSTRUCTION

**VENETUCCI FARMS - BARN REMODEL**  
SITE ADDRESS: 5202, 5210, & 5304 S. HWY 85-87  
COLORADO SPRINGS, COLORADO 80911  
PREPARED FOR: COMPASS ARCHITECTURE  
101 NORTH CASCADE AVENUE, SUITE 400  
COLORADO SPRINGS, CO 80903

PLAN SHEET	
JOB NO.	CA26042
DATE:	04/10/2026
DWN:	JBP
CHKD:	TD
NAME	

UTILITY PLAN

NO. **C4.0**

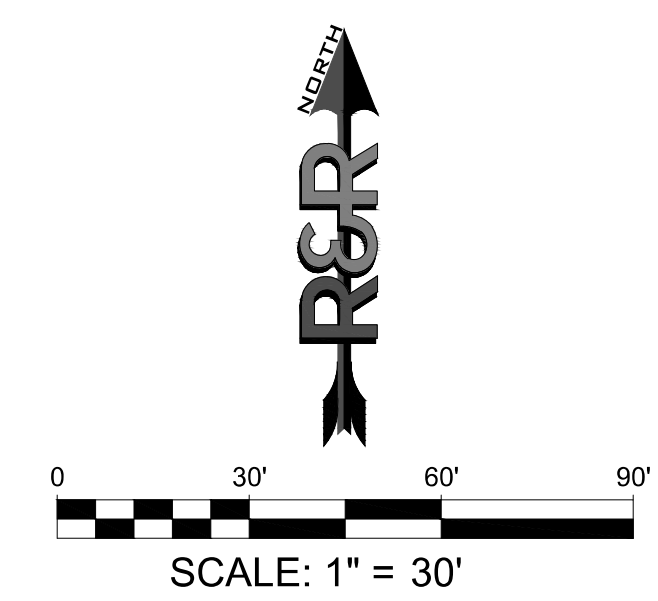

PATH:P:\CA26042 VENETUCCI FARMS - BARN REMODEL\ENGINEERING\5 DRAWINGS\PLANS\CA26042 - UTILITY PLAN.DWG, PLOT DATE: 5/9/2026 8:35:05 AM, BY: JACK ANDERSON

# CONSTRUCTION DOCUMENTS VENETUCCI FARMS - BARN REMODEL

LOCATED IN THE SW QUARTER OF SECTION 11, TOWNSHIP 15 SOUTH, RANGE 66 WEST OF THE 6TH PRINCIPAL MERIDIAN  
CITY OF COLORADO SPRINGS, COUNTY OF EL PASO, STATE OF COLORADO

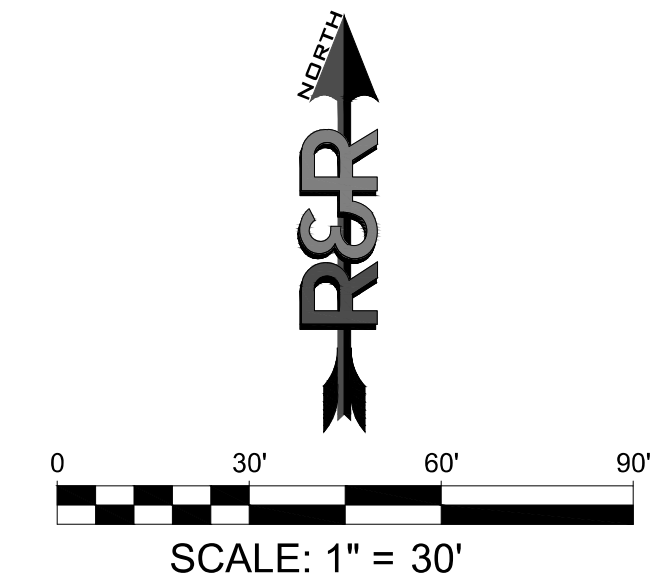

NO.	REVISION	BY	DATE
1	50% CD SET	JBP	04/24/26
2	50% CD SET	JA	04/20/26
3	50% CD SET	JA	05/08/26



**R&R ENGINEERS-SURVEYORS, INC.**  
1635 WEST 13TH AVENUE, SUITE 310  
DENVER, COLORADO 80204  
PHONE: 303-753-6730

WWW.RRENGINEERS.COM

NOT FOR CONSTRUCTION

**VENETUCCI FARMS - BARN REMODEL**  
SITE ADDRESS: 5202, 5210, & 5304 S. HWY 85-87  
COLORADO SPRINGS, COLORADO 80911  
PREPARED FOR: COMPASS ARCHITECTURE  
101 NORTH CASCADE AVENUE, SUITE 400  
COLORADO SPRINGS, CO 80903

PLAN SET	
JOB NO.	CA26042
DATE:	04/10/2026
DWN:	JBP
CHKD:	TD
NAME	

GRADING PLAN

NO. **C5.0**

PATH:P:\CA26042 VENETUCCI FARMS - BARN REMODEL\ENGINEERING\DRAWINGS\PLANS\CA26042 - GRADING PLANS.DWG, PLOT DATE: 5/8/2026 8:33:42 AM, BY: JACK ANDERSON

**EL PASO COUNTY NOTES**

1. ALL PLANTS NOT LABELED AS FULFILLING A COUNTY LANDSCAPE REQUIREMENT ARE "EXTRA" PER COUNTY STANDARDS, AND WILL BE INSTALLED AT THE OWNER'S DISCRETION.
2. ANY FIELD CHANGES OR DEVIATIONS TO THESE PLANS WITHOUT PRIOR COUNTY APPROVAL OF AN AMENDED DEVELOPMENT PLAN MAY RESULT IN A DELAY OF FINAL APPROVAL AND ISSUANCE OF A CERTIFICATE OF OCCUPANCY. THESE PLANS ARE FOR COUNTY APPROVALS ONLY AND ARE NOT TO BE UTILIZED FOR CONSTRUCTION.

**GENERAL NOTES**

1. FOR GRADING PLAN, REFER TO CIVIL ENGINEER'S DRAWINGS.
2. FOR STANDARD LIGHTING AND LOCATIONS, REFER TO PHOTOMETRIC PLAN.
3. A FULLY AUTOMATED SPRINKLER IRRIGATION SYSTEM WILL DRIP IRRIGATE ALL TREE, SHRUB, AND GROUND COVER PLANTING AREAS AND SPRAY ANY TURF. IRRIGATION PLAN WILL INCLUDE AN IRRIGATION SCHEDULE THAT NOTES APPLICATION RATES BASED ON TURF TYPE, AND NOTES RATES FOR NEWLY PLANTED PLANTS VS. ESTABLISHED PLANTS AND GENERAL RECOMMENDATIONS REGARDING SEASONAL ADJUSTMENTS (SPRING AND FALL).

**SOILS NOTES**

1. SOIL AMENDMENT - INCORPORATE 3 CUBIC YARDS/1000 SF AREA OF "PREMIUM 3 ORGANIC COMPOST", OR APPROVED EQUAL, ON SOD AREAS. INCORPORATE 2 CUBIC YARDS/1000 SF AREA OF ORGANIC COMPOST (DECOMPOSED MANURE) TO ALL NATIVE SEED AREAS. TILL INTO TOP 8" OF SOIL.
2. RECOMMENDED SOIL AMENDMENT FOR PLANTING PITS: TRI-MIX III AS SUPPLIED BY C&C SAND, TO BE APPLIED PER DETAILS.
3. A SIGNED AFFIDAVIT ATTESTING TO THE SOIL AMENDMENTS INCORPORATED TO CORRECT DEFICIENCIES SHALL BE INCLUDED WITH THE SOIL ANALYSIS PRIOR TO ISSUANCE OF A CERTIFICATE OF OCCUPANCY.
4. CONTRACTOR TO UTILIZE STOCKPILED TOPSOIL FROM GRADING OPERATION AS AVAIL. TILL INTO TOP 8" OF SOIL.
5. CONTRACTOR TO TEST AMENDED SOIL. FOR EACH STREET, TAKE 1 TEST IN FESCUE SOD/ALTERNATIVE TURF AREA, 1 TEST IN PLANTING BED AREA, AND 1 TEST IN SEEDED AREA, AND SUBMIT SOIL ANALYSIS TO LANDSCAPE ARCHITECT FOR APPROVAL PRIOR TO INSTALLING LANDSCAPE.
6. SUBMIT FERTILIZER PRODUCT SHEET TO LANDSCAPE ARCHITECT FOR APPROVAL PRIOR TO INSTALLATION. EXAMPLES FOR SUBMITTALS ARE: FESCUE SOD FERTILIZER, LOW ALTERNATE TURF FERTILIZER, TALL NATIVE SEED MIX FERTILIZER, ETC.
7. TILLING OF THE EXISTING SOIL TO INCORPORATE AMENDMENTS AND COUNTER ANY COMPACTION OR SOIL CONSOLIDATION SHALL BE REQUIRED FOR ALL LANDSCAPE PLANTING AREAS.

**SEED NOTES**

1. NATIVE SEED AREAS TO USE SEED MIX SPECIFIED. ALL SEED AREAS SHALL BE IRRIGATED UNTIL ESTABLISHMENT. SUBMIT SEED MIX PRODUCT INFORMATION TO L.A. FOR APPROVAL PRIOR TO INSTALLATION.
2. EROSION CONTROL BLANKET TO BE APPLIED ON ALL SEED AREAS WITH GREATER THAN 3:1 SLOPES.
3. EROSION CONTROL BLANKET TO BE: 150BN WITH 6" STEEL STAKES AVAILABLE FROM NORTH AMERICAN GREEN DISTRIBUTOR, NILEXENVIRONMENTAL INC. (303)766-2000, OR APPROVED EQUAL. SUBMIT SAMPLE AND PRODUCT INFO TO LANDSCAPE ARCHITECT (L.A.) FOR APPROVAL PRIOR TO INSTALLATION. INSTALL PER MANUFACTURER'S SPECIFICATIONS.
4. ALL SEED SHALL BE WARRANTED FOR ONE FULL YEAR AND BE IN SATISFACTORY CONDITION AT THE END OF THE WARRANTY PERIOD. NO AREA LARGER THAN 3"x3" WITHIN THE IRRIGATED SEEDING AREA, 12"x12" FOR NON-IRRIGATED SEEDING AREAS OF THIS PROJECT SHALL BE VOID OF SUBSTANTIAL GRASS 45 DAYS AFTER THE TIME OF SEEDING DURING THE GROWING SEASON.

**PLANTING NOTES**

1. ALL TREES TO RECEIVE 3 INCH DEPTH WOOD MULCH RING UNLESS OTHERWISE SPECIFIED. MULCH RINGS TO BE SIZED PER PLANTING DETAILS.
2. WOOD MULCH: GORILLA HAIR CEDAR WOOD MULCH SHALL BE USED UNLESS OTHERWISE SPECIFIED ON PLAN.
3. ALL TREES TO BE STAKED WITH WOOD STAKES. FOR 3" CAL. DECIDUOUS TREES AND EVERGREEN TREES OVER 8" USE 3 WOOD STAKES (STAKE TO GROUND LEVEL). SUBMIT STAKING MATERIALS PRODUCT INFO TO L.A. FOR APPROVAL PRIOR TO INSTALLATION.
4. ALL TREES TO BE STAKED FOR A MINIMUM OF 18 MONTHS. REMOVE STAKING MATERIALS ONCE TREE IS ESTABLISHED, WHICH MAY DEPEND ON TREE SPECIES, MATURITY AND SITE CONDITIONS.
5. CONTRACTOR IS RESPONSIBLE FOR INSTALLING ALL PLANT MATERIAL SHOWN ON THIS PLAN. IF ANY DISCREPANCIES ARE FOUND BETWEEN THE LANDSCAPE PLAN AND THE PLANT SCHEDULE, THE QUANTITIES SHOWN ON THE LANDSCAPE PLAN SUPERSEDE THOSE SHOWN ON THE PLANT SCHEDULE.
6. PLANTS SHALL BE WARRANTED FOR THE DURATION OF ONE FULL YEAR AFTER THE INSTALLATION (WARRANTY SHALL COVER 100% OF THE REPLACEMENT COST).
7. TREES SHALL MAINTAIN A 15-FOOT MINIMUM SEPARATION FROM WATER AND WASTEWATER MAINS AND A 6-FOOT MINIMUM SEPARATION FROM ELECTRIC AND GAS DISTRIBUTION LINES.
8. A 3' CLEAR SPACE SHALL BE MAINTAINED AROUND THE CIRCUMFERENCE OF FIRE HYDRANTS. ALL FIRE HYDRANTS WILL NOT BE OBSTRUCTED VISUALLY OR PHYSICALLY DUE TO VEGETATION.
9. ALL FIRE DEPARTMENT CONNECTIONS (FDC) SHALL NOT BE VISUALLY OR PHYSICALLY OBSTRUCTED BY LANDSCAPING.

**EXISTING VEGETATION NOTES**

1. ALL PRESERVATION AREAS CONTAINING VEGETATION DESIGNATED TO BE PRESERVED, SHALL BE FENCED OFF DURING CONSTRUCTION TO MINIMIZE DISTURBANCE IN THESE AREAS. ALL FENCING SHALL BE INSTALLED AROUND PRESERVED VEGETATION PRIOR TO ANY GRADING ON THE PROPERTY. A 4-FOOT ORANGE CONSTRUCTION SAFETY FENCE SHOULD BE USED IN THIS APPLICATION. SUBMIT PRODUCT INFO TO L.A. FOR APPROVAL PRIOR TO INSTALLATION.
2. EXISTING TREES TO BE EVALUATED FOR HEALTH AND PRUNED AS NEEDED.
3. ALL EXISTING TREES DESIGNATED TO REMAIN WILL NEED TO BE REPLACED IF NOT IN A HEALTHY CONDITION.

**EXISTING IRRIGATION NOTES**

1. CONTRACTOR TO FIELD VERIFY EXISTING IRRIGATION SYSTEM COMPONENTS AND LOCATIONS PRIOR TO STARTING CONSTRUCTION.
2. IRRIGATION TO BE DESIGN BUILD, EXPANDING THE EXISTING IRRIGATION SYSTEM IN PLACE TO WATER NEW LANDSCAPE MATERIALS.
3. TYPE, MANUFACTURER, AND SPECIFICATIONS OF NEW IRRIGATION COMPONENTS TO MATCH EXISTING IRRIGATION FOUND ON SITE. ALL IRRIGATION EQUIPMENT NOT OTHERWISE DETAILED OR SPECIFIED, SHALL BE INSTALLED AS PER MANUFACTURER'S RECOMMENDATIONS, DETAILS, AND SPECIFICATIONS. ACCEPTABLE MANUFACTURERS INCLUDE RAINBIRD, HUNTER, TORO, OR NETAFIM.
4. CONTRACTOR TO VERIFY EXISTING SYSTEM HAS A FUNCTIONING BACK FLOW PREVENTER THAT MEETS ALL LOCAL REQUIREMENTS.
5. CONTRACTOR TO SUBMIT CUT SHEETS FOR REVIEW AND APPROVAL PRIOR TO INSTALLATION.
6. NEW IRRIGATION CONTROL WIRE SHALL BE COMMON TRENCH WITH MAINLINE AND SHALL HAVE SEPARATE SLEEVE CROSSING ALL HARD CONSTRUCTION.
7. CONTRACTOR SHALL TAPE CLOSED ALL PROPOSED SLEEVE PIPE OPENINGS TO PREVENT DEBRIS FROM ENTERING SLEEVES.
8. FLOW AND RAIN SENSORS TO BE INSTALLED IF NEEDED AND CONTROLLER IS COMPATIBLE.
9. NEW IRRIGATION MAINLINE TO BE BURIED MINIMUM 24" DEPTH AND LATERALS TO BE BURIED MINIMUM 12" DEPTH.
10. NEW SLEEVING TO BE SCHEDULE 40 PVC INSTALLED AT TWICE THE SIZE OF THE MAINLINE AND/OR LATERALS.
11. TREES AND SHRUBS TO BE IRRIGATED VIA BURIED DRIP LINE WITH EMITTERS. PROVIDE 2 EMITTERS PER SHRUB/ GRASS AND 4 EMITTERS PER TREE. UNLESS TREES ARE LOCATED WITHIN SOD AREA.
12. SOD TO BE IRRIGATED VIA AUTOMATIC 6" POP UP SPRAYS.
13. NATIVE SEED TO BE IRRIGATED VIA AUTOMATIC 12" POP UP SPRAYS.
14. ALL HEADS TO BE ADJUSTED TO PREVENT OVER SPRAY ONTO BUILDING AND WALK-WAYS.
15. DRAWINGS ARE DIAGRAMMATIC, IRRIGATION COMPONENTS MAY BE SHOWN OUTSIDE OF PLANTING AREAS FOR CLARITY ONLY. CONTRACTOR SHALL AVOID CONFLICTS WITH PLANT MATERIALS AND ARCHITECTURAL FEATURES ALL PIPING AND WIRING SHALL BE INSTALLED IN PLANTING AREA OR IN SLEEVES. NO PIPING UNDER TREES OR SHRUBS WILL BE ACCEPTED.
16. CONTRACTOR WILL PROVIDE OWNER WITH A COMPLETE AND REPRODUCIBLE DRAWING OR IRRIGATION SYSTEM LAYOUT AS IT WAS INSTALLED. DRAWING SHOULD INCLUDE, BUT NOT BE LIMITED TO, LOCATIONS OF ZONES VALVES, MAIN, LATERAL, AND DISTRIBUTION LINES, SLEEVES, WATER METER, BACK FLOW PREVENTION DEVICE, SENSORS AND CONTROLLER. ALL HEADS TO BE ADJUSTED TO PREVENT OVER SPRAY ONTO BUILDING AND WALK-WAYS.
17. ALL CONSTRUCTION SHALL CONFORM TO CITY, COUNTY, STATE, AND FEDERAL REQUIREMENTS. IT SHALL BE THE RESPONSIBILITY OF THE IRRIGATION CONTRACTOR TO ENSURE THAT ALL IRRIGATION EQUIPMENT MEETS GOVERNMENT REGULATIONS. CONTRACTOR SHALL ALSO BE RESPONSIBLE FOR OBTAINING ANY NECESSARY PERMITS OR APPROVALS.

**LANDSCAPE SITE REQUIREMENTS**

LANDSCAPE SETBACK		STREET	LINEAR	SETBACK WIDTH		% LIVE GROUND PLANE	
STREET NAME/ ZONE BOUNDARY	CLASSIFICATION	FOOTAGE	REQ.	PROV.	REQ.	PROV.	
CanAm Highway	Principal Arterial	1158'	25'	25'	75%	75%	

NO. OF TREES (1/20')		EVERGREEN TREES		SHRUB SUBSTITUTES		ORN GRASSES SUBS.	
REQ.	EXISTING*	REQ.(50%)	EXISTING*	REQ.	PROV.	REQ.	PROV.
122	122	41	41	NA	N	NA	NA

INTERNAL NET SITE		INTERNAL AREA		NON-ACTIVE GREEN SPACE	
AREA	AREA %	REQ.	PROV.	REQ.	PROV.
101,521 SF	5%	5,076 SF	61,556 SF	47,832 SF	252,089 SF

NO. OF TREES (1/500)		SHRUB SUBSTITUTES		ORN GRASSES SUBS.		% LIVE GROUND PLANE	
REQ.	EXISTING*	REQ.	EXISTING*	REQ.	PROV.	REQ.	PROV.
10	10	NA				75%	75%

MOTOR VEHICLE		SHADE TREES (1/15 SPACES)		VEHICLE LOT FRONTAGES		2/3 LENGTH OF FRONTAGE (FT)	
NO. of Vehicle		REQ.	EXISTING*	REQ.	PROV.	REQ.	PROV.
Spaces provided		7	7	72'	48'		

Min 3' Screening		Length of Screening		% LIVE GROUND PLANE	
REQ.	EXISTING*	Wall or Berm Provided		REQ.	PROV.
16	16	NA	NA	75%	75%

**PLANT\_SCHEDULE**

DECIDUOUS TREES	CODE	QTY	BOTANICAL / COMMON NAME	HEIGHT	WIDTH	SIZE	COND
	Ap	16	Acer platanoides 'Cleveland' / Cleveland Norway Maple	40'	30'	1.5" Cal.	B&B
	Gt	4	Gleditsia triacanthos inermis / Thornless Honey Locust	60'	50'	1.5" Cal.	B&B
	Or	8	Quercus robur petraea / English Oak	70'	70'	1.5" Cal.	B&B
	Ta	9	Tilia americana / American Linden	70'	50'	1.5" Cal.	B&B
EVERGREEN TREES	CODE	QTY	BOTANICAL / COMMON NAME	HEIGHT	WIDTH	SIZE	COND
	Jw	26	Juniperus scopulorum 'Wichita Blue' / Wichita Blue Juniper	15'	6'	6 HT	B&B
	Pp	15	Picea pungens 'Glauca' / Colorado Blue Spruce	60'	20'	6 HT	B&B
	Pn	1	Pinus nigra nigra / Austrian Black Pine	60'	40'	6 HT	B&B
ORNAMENTAL TREES	CODE	QTY	BOTANICAL / COMMON NAME	HEIGHT	WIDTH	SIZE	COND
	Ms	6	Malus x 'Spring Snow' / Spring Snow Crabapple	25'	20'	1" Cal.	B&B
	Pc	11	Prunus x cistena / Purple Leaf Sand Cherry	10'	8'	1" Cal.	B&B
SHRUBS	CODE	QTY	BOTANICAL / COMMON NAME	HEIGHT	WIDTH	SIZE	COND
	Am	17	Achillea millefolium / Common Yarrow	3'	2'	#1 CONT	
	Cs	16	Calamagrostis x acutiflora 'Stricta' / Karl Foerster Feather Reed Grass	5'	3'	#1 CONT	
	Dg	41	Deschampsia cespitosa 'Goldtau' / Gold Dow Tufted Hair Grass	3'	2.5'	#1 CONT	
	Ea	14	Ericameria nauseosa nauseosa / Tall Blue Rabbitbrush	5'	5'	#5 CONT	
	Ls2	6	Liatris spicata / Blazing Star	3'	2'	#1 CONT	
	Rw	41	Rosa woodsii / Mountain Rose	5'	4'	#5 CONT	
	Sf	41	Solidago flexicaulis / Zigzag Goldenrod	3'	2'	#1 CONT	
	St	18	Sporobolus heterolepis 'Tara' / Tara Prairie Droopseed	2'	2'	#1 CONT	
DECIDUOUS SHRUBS	CODE	QTY	BOTANICAL / COMMON NAME	HEIGHT	WIDTH	SIZE	COND
	Ls	137	Lavandula x intermedia 'Super' / Super Lavandin	3'	3'	#5 CONT	
EVERGREEN SHRUBS	CODE	QTY	BOTANICAL / COMMON NAME	HEIGHT	WIDTH	SIZE	COND
	Jh	18	Juniperus horizontalis 'Blue Rug' / Blue Rug Juniper	6"	8"	#5 CONT	
	Pt	18	Pinus mugo 'Tannenbaum' / Tannenbaum Mugo Pine	15'	6'	#5 CONT	
	Pm	13	Pinus mugo 'White Bud' / White Bud Mugo Pine	4'	3-4'	#5 CONT	
	Pb	27	Prunus besseyi 'P0115' TM / Pawnee Buttes Sand Cherry	3'	6'	#5 CONT	



N.E.S. Inc.  
619 N. Cascade Avenue, Suite 200  
Colorado Springs, CO 80903

Tel. 719.471.0073  
Fax 719.471.0267

www.nescolorado.com

© 2012 All Rights Reserved

PLANNER / LANDSCAPE ARCHITECT

IN ASSOCIATION WITH

**VENETUCCI FARMS**

**BUSINESS EVENT CENTER**  
5202 S HIGHWAY  
85-87

PROJECT INFO  
DATE: 05/15/26  
PROJECT MGR: J. ALWINE  
PREPARED BY: Y. LIU

STAMP

**DEVELOPMENT PLAN AMENDMENT**

ISSUE INFO

DATE: BY: DESCRIPTION:

ISSUE / REVISION

**LANDSCAPE NOTES AND SCHEDULES**

SHEET DESCRIPTION

**LP1.01**

5 of 6

PLAN FILE #

CPC #

