

Stormwater Management Plan (SWMP)

for

Scenic View at Paint Brush Hills Pond Modifications

Owner/Operator:

Paint Brush Hills Metropolitan District
Robert Guevara
9985 Towner Avenue
Falcon, CO 80831
(719) 495-8188

Engineer /SWMP Preparer:

RG and Associates, LLC
Jordan Schneider, P.E.
4885 Ward Rd, Suite 100
Wheat Ridge, CO 80033
(303) 468-8476

Contractor:

Company: _____
SW Manager Name: _____
Address: _____

Phone: _____

Qualified Stormwater Manager:

Company: _____
SW Manager Name: _____
Address: _____

Phone: _____

SWMP Preparation Date: 5/5/2022

SWMP Revision Date: 5/5/2022

Revision No. 0

CDR-22-009

Table of Contents

SECTION 1: SITE EVALUATION, ASSESSMENT, AND PLANNING	4
1.1 Project/Site Information	4
1.2 Contact Information/Responsible Parties	4
1.3 Nature and Sequence of Construction Activity	5
1.4 Soils, Drainage Patterns, and Vegetation.....	5
1.5 Construction Site Estimates	6
1.6 Receiving Waters	6
1.7 Protected Site Features and Sensitive Areas.....	6
1.8 Potential Sources of Pollution.....	7
1.9 Anticipated Sources of Authorized Non-stormwater Discharge	10
SECTION 2: EROSION & SEDIMENT CONTROL MEASURES	12
2.1 Sediment Control Measures	12
2.2 Erosion Control Measures	13
2.3 Materials Management Control Measures	14
2.4 Site Management Control Measures	16
SECTION 3: CONSTRUCTION SITE PHASING & ESC PLAN	18
3.1 Construction Site Phasing Summary	18
3.2 Standard Notes For El Paso County Grading And Erosion Control Plans.....	18
SECTION 4: WASTE MANAGEMENT PLAN	22
4.1 Covering Outdoor Storage and Handling Areas	22
4.2 Spill Prevention and Response Plan	23
4.3 Good Housekeeping.....	26
4.4 Vehicle Maintenance, Fueling and Storage.....	28
4.5 Street Sweeping and Cleaning	30
4.6 Storm Sewer Cleaning.....	30
SECTION 5: STORMWATER INSPECTIONS	32
5.1 Inspections.....	32
5.2 Inspection Sequence.....	33
SECTION 6: RECORDKEEPING	35
6.1 Recordkeeping.....	35
SECTION 7: FINAL STABILIZATION	37
7.1 Final Stabilization Requirement	37
7.2 Final Stabilization Measures	37
7.3 Removal of Temporary CMs	37
7.4 Stormwater Permits Close-out.....	37
7.5 Long Term Stormwater Management.....	37
SWMP APPENDICES	39

Objectives:

The SWMP identifies possible pollutant sources that may contribute to stormwater pollution and identifies control measures to reduce or eliminate potential water quality impacts during construction activities. The SWMP must be completed and implemented prior to project breaking ground and revised by the contractor's Qualified Stormwater Manager as construction proceeds, to accurately reflect the conditions and practices at the site until final stabilization is reached. The SWMP meets the minimum requirements to comply with the State of Colorado CDPS General Permit for Stormwater Discharges Associated with Construction Activity, and the local regulations.

General Instructions:

To fill out the Stormwater Management Plan (SWMP) Template, select (double right click) the [blue text](#) and enter applicable information. When a blue box is present, check the applicable selection. **No sections shall be left blank!** If a section is "Not Applicable" to the project, select the [blue text](#) and enter "N/A".

Basic Acronyms:

ESC Plan: Erosion and Sediment Control Plan (Site Map)

CM: Control Measures or **BMP:** Best Management Practices

MS4: Municipal Separate Storm Sewer System

SECTION 1: SITE EVALUATION, ASSESSMENT, AND PLANNING

1.1 Project/Site Information

Project/Site Name: Scenic View at Paint Brush Hills Pond Modifications

Project Location: At the northeast corner of Stapleton Drive and Towner Avenue

See Appendix A for Vicinity Map

County: El Paso **City:** Falcon **State:** CO **ZIP Code:** 80831

Subdivision/Project: Scenic View at Paint Brush Hills

1.2 Contact Information/Responsible Parties

Owner/Operator

Paint Brush Hills Metropolitan District

Robert Guevara

9985 Towner Avenue, Falcon, CO 80831

Office #: (719) 495-8188

Email: robert@pbhmd.com

Site Superintendent:

Name: _____

Title: _____

Address: _____

Office #: _____ Cell #: _____ Email: _____

Qualified Stormwater Manager: Individual responsible for implementing, maintaining, and revising the SWMP, knowledgeable in the principles and practices of ESC and pollution prevention, with the skills to:

- Assess conditions at construction sites that could impact stormwater quality, and
- Assess the effectiveness of stormwater controls.
- Perform inspections

Primary Stormwater Manager:

Name: _____

Title: _____

Address: _____

Office #: _____ Cell #: _____ Email: _____

SWMP Prepared By:

RG and Associates, LLC

Jordan Schneider, PE; Project Engineer

4885 Ward Road, Suite 100

Wheat Ridge, CO 80033

Office #: (303) 468-8476

Cell #: (720) 633-3209

Email: jschneider@rgengineers.com

1.3 Nature and Sequence of Construction Activity

Project scope of work:

The scope of work for the Scenic View at Paint Brush Hills Pond Modifications Project consists of the removal of existing rip-rap, installation of a 49'-7" X 32'-1" concrete forebay with a concrete weir, 4' wide concrete trickle channel, and modifications to the existing outlet structure, consisting of removal and replacement of existing orifice plate and well-screen trash rack, site grading which consists of the addition of a one-foot high berm around the limits of the existing pond. The purpose of the Pond Modifications Project is to bring the Scenic View at Paint Brush Hills Pond to Mile High Flood District (MHFD) design standards.

The sequence of construction activity in general will consist of clearing and grubbing, temporary stabilization, installation of initial control measures, earthwork, flatwork, final grading, final stabilization, and removal of temporary control measures.

Type of construction activity:

- Residential Commercial Industrial Road Construction
 Linear Utility Other (please specify):

Estimated Project Start Date: June 20, 2022

Estimated Project Completion Date: August 31, 2022

Estimated Project Final Stabilization: September 9, 2022

Major phases of Construction:

- Initial CM Demolition Grading
 Utility Installation Interim CM Road Construction
 Vertical Construction Final Grade Final Stabilization CM
 Other:

Earth Work Summary:

Cut: 58 CY

Fill: 132 CY

1.4 Soils, Drainage Patterns, and Vegetation

Soil type:

The National Resources Conservation Service (NRCS) Site Soil Mapping shows the site to be 98% Pring Coarse Sandy Loam and 2% Columbine Gravelly Sandy Loam. Pring Coarse Sandy Loam is identified as being part of Hydrologic Soil Group B. Columbine Gravelly Sandy Loam is identified as being part of Hydrologic Soil Group A.

Soil's erosion potential:

According to the Soil Survey of El Paso County Area, Colorado, The Pring coarse sandy loam soils are deep and well drained, with rapid permeability and moderate water capacity. Surface runoff is

medium, and the hazard of erosion is moderate. Erosion control practices are needed to control soil blowing and water erosion on construction sites where the ground cover has been removed.

The Columbine gravelly sandy loam soils are deep, well drained to excessively drained, with very rapid permeability and low to moderate water capacity. Surface runoff is slow, and the hazard of erosion is slight to moderate.

Erosion control measures such as silt fence and sediment control logs will be installed prior to construction to prevent sediment migration from the site due to stormwater runoff.

Drainage pattern:

The Scenic View at Paint Brush Hills Pond Site generally slopes southwest and toward the Pond.

Existing Vegetation:

The Site consists of the following native weeds and grasses: Crested Wheat Grass, Perennial Rye, Western Wheat Grass, Smooth Brome Grass, Side oats Grama, Little Bluestem, Sand Dropseed, Switch Grass, Weeping Love Grass, Slender Wheat Grass. Methods used to determine approximately 70% vegetative ground cover of the Site included Site visits, photographs of the Site, and aerial imagery of the Site.

1.5 Construction Site Estimates

Total site area:

The total area of the Site is approximately 0.89 acres.

Area to be disturbed:

The total area of disturbance is expected to be approximately 0.47 acres.

1.6 Receiving Waters

Name and description of watershed:

The Site is located within the Falcon Area Drainage Basin and ultimately discharges to Black Squirrel Creek via storm sewer and open channel systems.

Distance from the project to the closest receiving water:

The Site is approximately 1 mile from Black Squirrel Creek.

Description of all stream crossings located within the construction site boundary:

There are no stream crossings located within the construction site boundary.

1.7 Protected Site Features and Sensitive Areas

Describe unique site feature or sensitive area to be preserved during construction:

There are no known unique site features or sensitive areas to be preserved during construction. The Site is within a residential subdivision and any unique site features, or sensitive areas have been identified by the Master Development Drainage Plan Report for the

subdivision; none were identified. Erosion and sediment control measures are to be implemented for reconstruction of the detention pond to mitigate sediment runoff to the adjacent shallow drainageway.

Describe any known soil or groundwater contamination:

None expected.

Describe management plan for contaminated soils and/or groundwater:

Contaminated soils and/or groundwater are not anticipated on this project.

1.8 Potential Sources of Pollution

Potential Pollution Source	Potential on this site?	Control Measures (CM)	CM Implementation (as needed)
Disturbed & Stored Soils - grading - spoils - stockpiles	YES	ESC CMs (IP, SF, SSA, TRM, RECP, TOP, SCL, SBB, RS, SB, ST) Preservation of existing vegetation (PV, VB, CF, CP) Materials management Solid waste management (SP, GH) Stockpile management (SP) Vehicle tracking control (VTC)	1. Delineate protected areas prior to construction. 2. Install CMs prior to construction. 3. Manage materials effectively once they arrive on site. 4. Place trash receptacles prior to construction. 5. Implement spill response. 6. Implement stockpile mgnt controls. 7. Delineate vehicle travel areas prior to construction, adjust as needed.
Vehicle Tracking - all permitted vehicle traffic	YES	ESC CMs (IP, SF, SSA, TRM, RECP, TOP, SCL, SBB, RS, SB, ST) Vehicle traffic controls Vehicle tracking controls (VTC) Street sweeping (SS)	1. Install CMs prior construction. 2. Delineate vehicle travel areas prior to construction, adjust as needed. 3. Install VTC prior to construction. 4. Implement SS as needed, in conjunction with start of construction.
Contaminated Soils	NO	Hazardous materials management (GH, CT) Spill response & notification (GH) Stockpile management (SP)	1. Implement hazardous materials management. 2. Implement spill response procedures. 3. Implement stockpile mgnt controls.

* Refer to Section 2, for acronyms used to identify CM details.

Potential Pollution Source	Potential on this site?	Control Measures (CM)	CM Implementation
Loading & Unloading - construction materials	YES	Material management (GH) Vehicle traffic controls (VTC)	1. Manage materials effectively once they arrive on site. 2. Delineate vehicle travel areas prior to construction, adjust as needed.

Vehicle/equipment maint. & fueling - gas, oil, - diesel - lubricants - hydraulic fluids	YES	Spill prevention controls (GH) Designated fuel storage area (GH) Spill response & notification (GH)	1. Designate fuel storage area. 2. Implement spill prevention controls. 3. Implement spill response and notification procedures.
Outdoor storage - building materials - fertilizers - chemicals	NO	Material storage procedures (GH)	1. Designate material storage areas prior to delivery. 2. Materials left outdoors must be covered if they can pollute stormwater. 3. Secondary containment must be used for hazardous materials.
Dust - wind transport - saw cutting	YES	Dust control (DC) Temporary soil stabilization (SF, SD, GB, SSA, TRM, RECP, TOP) Street sweeping (SS) Preservation of existing vegetation (PV, VB, CF)	1. Delineate protected areas prior to construction. 2. Implement dust control in conjunction with soil disturbing activities. 3. Implement temporary soil stabilization measures as soon as practical. 4. Implement street sweeping at the start of major construction and maintain as needed.
Routine Maintenance Activities - fertilizers - pesticides - detergents - solvents - fuels, oils, etc.	NO	Material storage (GH) Hazardous waste management (GH, CT) ESC CMs (IP, SF, SSA, TRM, RECP, TOP, SCL, SBB, RS, SB, ST)	1. Designate materials storage areas prior to site arrival. 2. Practice hazardous waste management procedures during the storage of such materials. 3. Install ESC measures prior to landscape work.
Non-industrial Waste - worker trash - portable toilets	YES	Sanitary waste (GH) Solid waste management (GH)	1. Place temporary sanitary facilities on site and prevent off-site discharges. 2. Place trash receptacles on site.
On-site Industrial Waste - construction debris, etc	YES	Waste management (GH) Liquid waste management (GH) Hazardous waste management (GH, CT)	1. Place trash receptacles on site. 2. Place designated watertight receptacles or washout area(s) prior to activities that produce liquid waste. 3. Implement hazardous waste management procedures.

* Refer to Section 2, for acronyms used to identify CM details.

Potential Pollution Source	Potential on this site?	Control Measures (CM)	CM Implementation
Concrete Truck Chute/Tool Washing	YES	Concrete washout area (CWA)	Install designated concrete washout(s) prior to concrete work.

Drywall Mud and Paint	NO	Liquid waste management (GH)	Place designated watertight receptacles or washout area(s) prior to activities that produce liquid waste.
Fly Ash - concrete - flow fill	YES	Concrete washout area (CWA) Hazardous waste management (GH)	1. Install designated CWA prior to concrete activities. 2. Implement hazardous waste management procedures.
Dedicated: - asphalt plants - concrete batch plants - masonry mixing stations	NO	Secondary containment Concrete washout area (CWA) Solid waste management (GH) Materials management (GH)	1. Install secondary containment CMs prior to using dedicated batch plants. 2. Establish dedicated washout area before construction begins. 3. Place trash receptacles on site. 4. Manage materials effectively once they arrive on site.
Waste from: - geo-tech test - potholing - saw cutting - utility borings for locates	NO	Dust control (DC) Material storage (GH) Solid waste management (GH)	1. Implement dust control in conjunction with soil disturbing activities. 2. Designate materials storage areas prior to their arrival on site. 3. Place trash receptacles on site.
Demolition of infrastructure: - concrete curb - asphalt road - steel/rebar	NO	Dust control (DC) Solid waste management (GH)	1. Implement dust control in conjunction with soil disturbing activities. 2. Place trash receptacles.
Electric Generator - pump	NO	Secondary containment Spill response & notification (GH) Hazardous waste management (GH, CT)	1. Install secondary containment CMs prior to using generators. 2. Implement hazardous waste management procedures.
Areas where <u>potential spills</u> can occur	NO	Hazardous waste management (GH) Spill response & notification (GH)	1. Implement hazardous waste management. 2. Implement spill response and notification procedures.

* Refer to Section 2, for acronyms used to identify CM details.

Potential hazardous material & chemical pollutants to stormwater:

Potentially on Site?	Material/ Chemical	Physical Description	Stormwater Pollutants	Location
NO	Fertilizer	Liquid or solid grains	Nitrogen, phosphorous	Newly seeded areas
NO	Cleaning solvents	Colorless, blue, or yellow-green liquid	Perchloroethylene, methylene chloride, trichloroethylene, petroleum distillates	Staging areas
NO	Asphalt	Black solid	Oil, petroleum distillates	Streets
YES	Concrete and Grout	White solid/grey liquid	Limestone, sand, pH, chromium	Curb and gutter, sidewalk, building construction
YES	Curing compounds	Creamy white liquid	Naphtha	Curb and gutter, sidewalk, driveways, concrete slabs
YES	Hydraulic oil/ fluids	Brown, oily petroleum hydrocarbon	Mineral oil	Leaks or broken hoses from equipment
YES	Gasoline	Colorless, pale brown or pink petroleum hydrocarbon	Benzene, ethyl benzene, toluene, xylene, MTBE	Secondary containment/staging area
YES	Antifreeze/ coolant	Clear green/yellow liquid	Ethylene glycol, propylene glycol, heavy metals (copper, lead, zinc)	Leaks or broken hoses from equipment or vehicles
YES	Sanitary toilets	Various colored liquid	Bacteria, parasites, and viruses	Staging areas

1.9 Anticipated Sources of Authorized Non-stormwater Discharge

Description and location of any anticipated allowable sources of non-stormwater discharge at the site. Check if applicable:

Natural springs, only if:

- Uncontaminated, and
- Spring flows are not exposed to land disturbance

Landscape irrigation return flow

Emergency fire fighting

Concrete washout (CWA), only if:

- Liquids from washing concrete tools and concrete mixer chutes are properly contained, and
- No concrete washout water leaves the site as surface runoff or reaches receiving waters

Liner under CWA is required if:

- The groundwater table level is high.
- CWA is within 400 feet of any natural drainage pathway or waterbody, or
- CWA is within 1,000 feet of any wells or drinking water sources.

Check if the CWA liner is needed for this site.

Description of any other anticipated allowable sources of non-stormwater discharge at the site:

There are no other anticipated allowable sources of non-stormwater discharge at the site. If other sources of non-stormwater discharge are encountered at the site, they will be recorded on the SWMP maps and control measures will be implemented accordingly.

SECTION 2: EROSION & SEDIMENT CONTROL MEASURES

2.1 Sediment Control Measures

Silt Fence (SF)		<input type="checkbox"/> Permanent	<input checked="" type="checkbox"/> Temporary
What: Description	SF is a woven geotextile fabric attached to wooden posts and trenched into the ground. It is used to intercept sheet flow runoff from disturbed areas.		
When: Installation	SF shall be installed prior to land disturbing activities. SF shall be removed when the upstream area is stabilized.		
Where: Location	SF shall be installed at the locations identified on the SWMP. SF is typically installed along the contour of slopes, which is down slope of a disturbed area to accept sheet flow and placed along the perimeter of a construction site. <i>SF is not designed to receive concentrated flow, or to be used a filter fabric.</i>		
How: Maintenance & Inspection	SF shall be installed per detail (Appendix 4). Inspect regularly and maintain SF throughout construction. Any section of SF that has a tear, hole, slumping, undercutting or has been bypassed shall be replaced. Accumulated sediment shall be removed before it reaches a depth of ½ the height of the of the silt fence usually 6 inches.		

Sediment Control Log (SCL)		<input type="checkbox"/> Permanent	<input checked="" type="checkbox"/> Temporary
What: Description	SCL, aka “Straw Wattle”, is a linear roll made of natural materials (straw, coconut fiber or other fibrous material), trenched into the ground and held with wooden stakes, used to intercept sheet flows from disturbed areas.		
When: Installation	SCL shall be installed during land disturbing activities, and it may also be installed after formation of a stockpile. Once the upstream area is stabilized, remove and properly dispose of the SCL. If disturbed areas exist after removal, the area shall be covered with top soil, seeded and mulched.		
Where: Location	SCL shall be installed at the locations identified on the ECSP. SCL are typically used for stockpile control, IP, and CD in small drainage ditches, on disturbed slopes to shorten flow lengths and/or as part of multi-layered perimeter control along receiving waters such as a stream, pond or wetland. SCL work well in combination with other layers of erosion and sediment controls. Stockpiles stored on impervious surfaces shall not be placed in a flowline and SCL shall be weighted. Stockpiles stored on pervious surfaces may be protected by pervious SCL, SF or adequate vegetative cover.		
How: Maintenance & Inspection	SCL shall be installed per detail (Appendix 4), along (parallel) the slope contour to avoid concentrating flows. Inspect regularly and maintain SCL throughout construction as they will eventually degrade. Accumulated sediment shall be removed before the depth is ½ the height of the SCL.		

Inlet Protection (IP) <input type="checkbox"/> <i>Permanent</i> <input type="checkbox"/> <i>Temporary</i>	
What: Description	IP is a permeable barrier that is installed around an inlet drain to filter runoff and remove sediment before entering the storm system. IP can be constructed of: RS, SCL, SF, blocks and RS, or other materials.
When: Installation	Install IP for existing catch basins prior to land disturbing activities upslope from the inlet. IP for proposed catch basins shall be installed immediately after the drain is constructed. IP and associated sediment must be removed and properly disposed of when the drainage area upstream is stabilized.
Where: Location	Install IP at the locations identified on the EC Plan. IP is not a stand-alone measure. It shall be used in conjunction with other up gradient measures.
How: Maintenance & Inspection	Install IP per detail (Appendix 4). IP shall enable the drain to function without completely blocking the flow. Inspect regularly and maintain IP throughout construction as it is the final measure before runoff enters the storm drain. Accumulated sediment shall be removed when it has reached ½ of the height of the IP or loses functionality, whichever comes first. IP is not standalone measure and shall be part of redundant system.

Rock Sock (RS) <input type="checkbox"/> <i>Permanent</i> <input checked="" type="checkbox"/> <i>Temporary</i>	
What: Description	RS is an elongated cylindrical filter constructed of gravel wrapped by wire mesh or woven geotextile (aka “curb socks” if placed at angles at curb line).
When: Installation	Install RS prior to land disturbing activities; once upstream stabilization is complete. Accumulated sediment shall be removed and properly disposed of.
Where: Location	RS shall be installed at the locations identified on the EC Plan. They are use for perimeter control of a disturbed area, or as part of IP.
How: Maintenance & Inspection	Install RS per detail (Appendix 4). Inspect regularly and maintain RS as they are susceptible to displacement and breakage due to vehicle traffic. Accumulated sediment shall be removed to maintain functionality.

2.2 Erosion Control Measures

Temporary and Permanent Seeding (TS/PS) <input checked="" type="checkbox"/> <i>Permanent</i> <input checked="" type="checkbox"/> <i>Temporary</i>	
What: Description	Seed is applied to disturbed areas in an effort to establish vegetation. TS is used to stabilize disturbed areas that will be inactive for an extended period. PM is used to stabilize areas at final grade that will not be otherwise stabilized. Effective seeding includes preparation of a seedbed, selection of an appropriate seed mixture, proper planting techniques, and protection of the seeded area with mulch, geotextile, or other appropriate measures. Mulching helps to protect the bare soil and must be secured by crimping, tackifiers, netting or other measures.
When: Installation	TS/PS shall be performed on temporary inactive surfaces and following the completion of final grading.

Where: Location	TS/PS shall be completed in the locations identified on the SWMP to stabilize areas at final grade that will not otherwise be stabilized.
How: Maintenance & Inspection	TS/PS and secured mulching shall be installed per seed mix specifications and detail (Appendix 4). Continuously inspect and maintain TS/PS and secured mulch throughout construction. Prepare the seedbed, select an appropriate seed mixture, use proper planting techniques and protect the seeded area with secured mulch.

Wind Erosion/Dust Control (DC)

Permanent **Temporary**

What: Description	DC helps keep sediments (from soils and stockpiles) from entering the air as a result of land disturbing construction activities. A variety of practices that focus on grading disturbed areas may be used.
When: Installation	Implement DC during conditions which result in the formation of dust from either construction activities or from naturally occurring winds. Do not overwater.
Where: Location	Dust abatement shall be completed throughout the project area where any material exists that has the potential to become airborne.
How: Maintenance & Inspection	DC measures shall be performed per detail (Appendix 4). Apply water or magnesium chloride, seed and mulch or use spray-on soil binders on disturbed areas. Water and magnesium chloride shall be applied such that concentrated flows do not form.

2.3 Materials Management Control Measures

Concrete Washout Areas (CWA)

Permanent **Temporary**

What: Description	A CWA is a specific area of the construction site designated and managed for concrete washing activities. Options available: excavation of a pit in the ground, use of an above ground storage area or use of prefabricated haul-away concrete washout containers.
When: Installation	CWA shall be installed prior to any concrete delivery to the construction site; and remove upon termination of use of the washout. Accumulated solid waste, including concrete waste and any contamination soils, must be removed from the site to a designated disposal location.
Where: Location	CWA shall be installed at the locations identified on the SWMP. If the groundwater table is high; or if the CWA will be placed within 400 ft of a natural drainage pathway/waterbody; or within 1,000 ft of a wells or drinking water source it must be lined.

How: Maintenance & Inspection	CWA shall be installed per detail (Appendix 4). Inspect regularly and maintain CWA throughout construction. Ensure adequate signage is in place identifying the location of the CWA. Remove concrete waste when filled to about ⅔ of CWA capacity to maintain functionality.
--	--

Stockpile Management (SP)

Permanent *Temporary*

What: Description	SP includes measures to minimize erosion and sediment transport from stockpiles. SP shall be used when soils or other erodible materials are stored at a construction site.
When: Installation	SP locations shall be determined during construction. If temporary removal of a CM is necessary to access the SP, ensure CMs area re-installed per detail drawing. When SP is no longer needed, properly dispose of excess materials and re-vegetate or stabilize the ground surface where the SP was located.
Where: Location	SP locations shall be placed away from areas where concentrated stormwater flow is anticipated, major drainage ways, gutters, and storm sewer inlets. SP locations shall be noted on the SWMP.
How: Maintenance & Inspection	SP shall be installed per detail (Appendix 4). Inspect regularly and maintain SP throughout construction. It is recommended to place SP on a pervious surface and protected from sediment transport with measures such as SCL, VB and/or SF. SP are only allowed on impervious surfaces if no other practical alternative exists. Provide weighted sediment control measures around the perimeter of the SP, such as RS or sand bags.

Street Sweeping (SS)

Permanent *Temporary*

What: Description	SS is used where vehicles track sediment onto paved roadways to reduce the transport of it into storm drain systems or surface waterways.
When: Installation	Manual SS or mechanical vacuuming SS shall be conducted when there is noticeable sediment accumulation on roadways adjacent to the construction site. SS shall be completed prior to any precipitation events, at the end of the workday as needed, and at the end of construction.
Where: Location	SS shall be utilized throughout the site and also on adjacent areas to construction.
How: Maintenance & Inspection	SS shall be performed per detail (Appendix 4). Use standard SS equipment to adequately remove sediment from roadways adjacent to the construction site.

2.4 Site Management Control Measures

Limits of Construction (LOC)	
<input type="checkbox"/> Permanent <input checked="" type="checkbox"/> Temporary	
What: Description	LOC is use to designate the area of land that will be disturbed by construction activities.
When: Installation	The permitted LOC shall be designated prior to land disturbing activities. If land is disturbed <u>outside</u> of the limits, then the State and Local stormwater construction discharge permits and SWMP/EC Plan must be amended.
Where: Location	The permitted LOC shall be identified on the EC Plan.
How: Maintenance & Inspection	LOC are typically delineated by silt fence or construction fence. Inspect LOC continuously and maintain the permitted LOC in an effort to not disturb land outside of the boundaries.
Vehicle Tracking Control (VTC)	
<input type="checkbox"/> Permanent <input checked="" type="checkbox"/> Temporary	
What: Description	VTC is a stabilized site access point that helps remove sediment from vehicle tires and reduces tracking of sediment onto paved surfaces.
When: Installation	Install VTC prior to any land disturbing activities; and removed when there is no longer the potential for vehicle tracking to occur.
Where: Location	VTC shall be installed at the location identified on the SWMP. Locate VTC where frequent vehicle traffic will exit the construction site onto a paved roadway.
How: Maintenance & Inspection	VTC shall be installed per detail (Appendix 4). All VTC must have non-woven geotextile fabric between the soil and rock pad. <u>Recycled concrete aggregate is not allowed because concrete dust elevates pH in stormwater.</u> Inspect regularly and maintain VTCs throughout construction. If the area becomes clogged with sediment, remove and dispose of excess sediment or replace material with a fresh layer of rock. Any sediment that is tracked onto adjacent roadways shall be cleaned with brooms, shovels (no water washing), or mechanically cleaned with a street vacuum sweeper.
Stabilized Staging Area (SSA)	
<input type="checkbox"/> Permanent <input checked="" type="checkbox"/> Temporary	
What: Description	SSA is a clearly designated area where construction equipment and vehicles, stockpiles, waste bins and other construction-related materials are stored. If the construction site is big, more than one SSA may be necessary.

<i>When: Installation</i>	SSA shall be installed prior to any land disturbing activities.
<i>Where: Location</i>	SSA shall be installed at the location identified on the SWMP.
<i>How: Maintenance & Inspection</i>	SSA shall be installed per detail (Appendix 4). Inspect regularly and maintain SSA throughout construction. A stable surface cover of rigid gravel shall be maintained as well as repairing any perimeter controls and following good housekeeping practices.

SECTION 3: CONSTRUCTION SITE PHASING & ESC PLAN

3.1 Construction Site Phasing Summary

Construction of the Scenic View at Paint Brush Hills Pond Modifications will occur in two phases.

Phase 1 will consist of the removal of existing rip-rap, installation of a concrete forebay and trickle channel, modifications to the existing outlet structure, and site grading. Initial control measures shall be installed prior to the beginning of construction activities. Initial control measures will include silt fence, sediment control log, inlet protection, vehicle tracking control, and a stabilized staging area. Any downstream, offsite storm inlets susceptible to storm water flow from the Site construction area are to be protected by inlet protection. A concrete washout area will be installed prior to concrete being delivered to the Site.

Final stabilization will occur after all concrete and site work has been completed. Final stabilization is achieved when all ground disturbing activities are complete and all disturbed areas either have a uniform vegetative cover with individual plan density of 70 percent of pre-disturbance levels established or equivalent permanent alternative stabilization method is implemented. All temporary sediment and erosion control measures shall be removed upon final stabilization and before permit closure. Erosion control blanket will be installed on all slopes steeper than 3:1.

Vehicle tracking of soils and construction debris off-site shall be minimized. Materials tracked offsite shall be cleaned up and properly disposed of immediately.

Construction activity is to be finalized upon El Paso County inspection for approval of final stabilized conditions.

3.2 Standard Notes For El Paso County Grading And Erosion Control Plans

1. Stormwater discharges from construction sites shall not cause or threaten to cause pollution, contamination, or degradation of State Waters. All work and earth disturbance shall be done in a manner that minimizes pollution of any on-site or off- site waters, including wetlands.
2. Notwithstanding anything depicted in these plans in words or graphic representation, all design and construction related to roads, storm drainage and erosion control shall conform to the standards and requirements of the most recent version of the relevant adopted El Paso County standards, including the Land Development Code, the Engineering Criteria Manual, the Drainage Criteria Manual, and the Drainage Criteria Manual Volume 2. Any deviations to regulations and standards must be requested, and approved, in writing.
3. A separate Stormwater Management Plan (SMWP) for this project shall be completed and an Erosion and Stormwater Quality Control Permit (ESQCP) issued prior to commencing construction. During construction the SWMP is the responsibility of the designated Qualified Stormwater Manager or Certified Erosion Control Inspector and shall be located on site at all times during construction and shall be kept up to date with work progress and

changes in the field.

4. Once the ESQCP is approved and a "Notice to Proceed" has been issued, the contractor may install the initial stage erosion and sediment control measures as indicated on the approved GEC. A Preconstruction Meeting between the contractor, engineer, and El Paso County will be held prior to any construction. It is the responsibility of the applicant to coordinate the meeting time and place with County staff.
5. Control measures must be installed prior to commencement of activities that may contribute pollutants to stormwater. Temporary sediment and erosion control measures for all slopes, channels, ditches, or any disturbed land area shall be completed immediately upon completion of the disturbance.
6. All temporary sediment and erosion control measures shall be maintained and remain in effective operating condition until permanent soil erosion control measures are implemented and final stabilization is established. All persons engaged in land disturbance activities shall assess the adequacy of control measures at the site and identify if changes to those control measures is needed to ensure the continued effective performance of the control measures. All changes to temporary sediment and erosion control measures must be incorporated into the Stormwater Management Plan prior to implementation.
7. Temporary stabilization shall be implemented on disturbed areas and stockpiles where ground disturbing construction activity has permanently ceased or temporarily ceased for longer than 14 days. An area that is going to remain in an interim state for more than 60 days shall also be stabilized.
8. Final stabilization must be implemented at all applicable construction sites. Final stabilization is achieved when all ground disturbing activities are complete and all disturbed areas either have a uniform vegetative cover with individual plan density of 70 percent of pre-disturbance levels established or equivalent permanent alternative stabilization method is implemented. All temporary sediment and erosion control measures shall be removed upon final stabilization and before permit closure.
9. All permanent stormwater management facilities shall be installed as defined in the approved plans. Any proposed changes that effect the hydrology or hydraulics of a permanent stormwater management structures must be approved by the ECM Administrator prior to implementation.
10. Any earth disturbance shall be conducted in such a manner so as to effectively minimize accelerated soil erosion and resulting sedimentation. All disturbances shall be designed, constructed, and completed so that the exposed area of any disturbed land shall be limited to the shortest practical period of time. Pre-existing vegetation shall be protected and maintained within 50 horizontal feet of a waters of the state, unless infeasible.
11. Compaction of soil must be prevented in areas designated for infiltration control measures or where final stabilization will be achieved by vegetative cover. Areas designated for infiltration control shall also be protected from sedimentation during construction until final stabilization is achieved.
12. Any temporary or permanent facility designed and constructed for the conveyance of stormwater around, through, or from the earth disturbance area shall be a stabilized

conveyance designed to minimize erosion and the discharge of sediment off site.

13. Concrete wash water shall be contained and disposed of in accordance with the SWMP. No wash water shall be discharged to or allowed to runoff to State Waters, including any surface or subsurface storm drainage system or facilities. Concrete washout shall not be located in an area where shallow groundwater may be present, or within 50 feet of a surface water body.
14. Dewatering operations: uncontaminated ground water may be discharged on site, but may not leave the site in the form of surface runoff.
15. Erosion control blanketing is to be used on slopes steeper than 3:1.
16. Building, construction, excavation, or other waste materials shall not be temporarily placed or stored in the street, alley, or other public way, unless in accordance with an approved Traffic Control Plan. BMP's may be required by El Paso County Engineering if deemed necessary, based on specific conditions and circumstances.
17. Vehicle tracking of soils and construction debris off-site shall be minimized. Materials tracked offsite shall be cleaned up and properly disposed of immediately.
18. Contractor shall be responsible for the removal of all wastes from the construction site for disposal in accordance with local and State regulatory requirements. No construction debris, tree slash, building material wastes or unused building materials shall be buried, dumped, or discharged at the site.
19. The owner, site developer, contractor, and/or their authorized agents shall be responsible for the removal of all construction debris, dirt, trash, rock, sediment, and sand that may accumulate in the storm sewer or other drainage conveyance system and stormwater appurtenances as a result of site development.
20. The quantity of materials stored on the project site shall be limited, as much as practical, to that quantity required to perform the work in an orderly sequence. All materials stored on-site shall be stored in a neat, orderly manner, in their original containers, with original manufacturer's labels.
21. No chemicals are to be used by the contractor, which have the potential to be released in stormwater unless permission for the use of a specific chemical is granted in writing by the ECM Administrator. In granting the use of such chemicals, special conditions and monitoring may be required.
22. Bulk storage of petroleum products or other liquid chemicals in excess of 55 gallons shall have adequate secondary containment protection to contain all spills and prevent any spilled material from entering State Waters, including any surface or subsurface storm drainage system or facilities.
23. No person shall cause the impediment of stormwater flow in the flow line of the curb and gutter or in the ditch flow line.
24. Individuals shall comply with the "Colorado Water Quality Control Act" (Title 25, Article 8, CRS), and the "Clean Water Act" (33 USC 1344), in addition to the requirements included in the DCM Volume II and the ECM Appendix I. All appropriate permits must

be obtained by the contractor prior to construction (NPDES, Floodplain, 404, fugitive dust, etc.). In the event of conflicts between these requirements and laws, rules, or regulations of other Federal, State, or County agencies, the more restrictive laws, rules, or regulations shall apply.

25. All construction traffic must enter/exit the site at approved construction access points.
26. Prior to actual construction the permittee shall verify the location of existing utilities.
27. A water source shall be available on-site during earthwork operations and utilized as required to minimize dust from earthwork equipment and wind.
28. The soils information for this site is based upon United States Department of Agriculture (USDA) Natural Resources Conservation Service (NRCS) for El Paso County, Colorado.
29. At least ten (10) days prior to the anticipated start of construction, for projects that will disturb 1 acre or more, the owner or operator of construction activity shall submit a permit application for stormwater discharge to the Colorado Department of Public Health and Environment, Water Quality Division. The application contains certification of completion of a stormwater management plan (SWMP), of which this grading and erosion control plan may be a part. For information or application materials contact:

Colorado Department of Public Health and Environment Water Quality Control Division
WQCD – Permits
4300 Cherry Creek Drive South Denver,
CO 80246-1530
Attn: Permits Unit

SECTION 4: WASTE MANAGEMENT PLAN

4.1 Covering Outdoor Storage and Handling Areas

Covering Outdoor Storage and Handling Areas

Permanent

Temporary

Description: When raw materials, byproducts, finished products, storage tanks, and other materials are stored or handled outdoors, stormwater runoff that comes in contact with the materials can become contaminated. Proactively covering storage and handling areas can be an effective source control for such areas. Coverings can be permanent or temporary and consist of tarp, plastic sheeting, roofing, enclosed structures, or other approaches that reduce exposure of materials to precipitation and wind.

Uses: Covering is appropriate for areas where solids (e.g., gravel, compost, building materials) or liquids (e.g., oil, gas, tar) are stored, prepared, or transferred. Cover the following areas that are applicable to this construction site:

- **Loading and Unloading:** Loading and unloading operations usually take place at outside storage or staging area on the construction site. Materials may be spilled during transfer between storage facilities and trucks during pumping of liquids, pneumatic transfer of dry chemicals, and mechanical transfer of bags, boxes, drums, or other containers by material handling equipment.
- **Aboveground Tanks/Liquid Storage:** Accidental releases of chemicals from above-ground liquid storage can contaminate stormwater with a variety of pollutants. Several common causes of accidental releases from above-ground storage include: external corrosion and structural failure, problems due to improper installation, spills and overfills due to operator error, failure of piping systems, and leaks or spills during pumping of liquids or gases between trucks to a storage facility.
- **Outside Manufacturing:** Common outside manufacturing activities may include parts assembly, rock grinding or crushing, metals painting or coating, grinding or sanding, degreasing, concrete manufacturing, parts cleaning or operations that use hazardous materials. These activities can result in dry deposition of dust, metal and wood shavings and liquid discharges of dripping or leaking fluids from equipment or process and other residuals being washed away in storm runoff. In addition, outside storage of materials and waste products may occur in conjunction with outside manufacturing.
- **Waste Management:** Wastes spilled, leached, or lost from outdoor waste management areas or outside manufacturing activities may accumulate in soils or on other surfaces and be carried away by storm runoff. There is also the potential for liquid wastes from surface impoundments to overflow to surface waters or soak the soil where they can be picked up by runoff. Possible stormwater contaminants include toxic compounds, oil and grease, oxygen-demanding organics, paints and solvents, heavy metals and high levels of suspended solids. Lack of coverage of waste receptacles can result in precipitation seeping through the material and collecting contaminants or the material being blown around the site and into the storm sewer system. Containment sources include waste

piles, wastewater and solid waste treatment and disposal, land application sites, dumpsters, or unlabeled drums.

- **Outside Storage of Materials:** Raw materials, intermediate products, byproducts, process residuals, finished products, containers, and materials storage areas can be sources of pollutants such as metals, oils and grease, sediment, and other contaminants. Pollutant transport can occur when solid materials wash off or dissolve into water, or when spills or leaks occur.

Practice Procedures:

- Where practical, conduct operations indoors. If outdoors, then select a temporary or permanent covering to reduce exposure of materials to precipitation and runoff.
- The type of covering selected depends on a variety of factors such as the type and size of activity being conducted, and materials involved. Types of cover range from relatively inexpensive tarps and plastic sheeting to overhead structures or fully enclosed buildings equipped with ventilation, lighting, etc.
- Covering practices should be combined with Good Housekeeping to be most effective.
- Tarps and plastic sheets require more frequent inspection and maintenance.

4.2 Spill Prevention and Response Plan

Spill Prevention & Response Plan

Permanent

Temporary

Spills and leaks of solid and liquid materials processed, handled or stored outdoors can be a source of stormwater pollution. Spilled substances can reach receiving waters when runoff washes these materials from impervious surfaces or when spills directly enter the storm system during dry weather conditions. Effective controls depend on spill prevention and response measures, proper training, and may include structural spill containment or control devices. Spill containment measures include temporary or permanent curbs or berms that surround a potential spill site. Berms may be constructed of concrete, earthen material, metal, synthetic liners, or other material. Spill control devices include valves, slide gates, or other devices that can control and contain spilled material.

Spill Prevention Measures:

- Train key employees in plan and provide clear, common-sense spill prevention practices and clean-up procedures to be strictly followed.
- Identify equipment that is exposed to precipitation, pollutants that may be generated and possible sources of leaks or discharges.
- Perform inspections and preventative maintenance of equipment for proper operation and to check for leaks or evidence of discharge (stains). Ensure repairs are completed or provide temporary leak containment until such repairs can be made.

- Drain used motor oil and other automotive fluids in a designated area away from storm inlets. Collect spent fluids and recycle or dispose of properly. Never dispose into storm or sanitary sewer.
- In fueling areas, clean up spills with dry methods (absorbents) and use damp cloths on gas pumps and damp mops on paved surfaces.
- Never hose down a spill or absorbent materials into the storm drain, or down into an interior floor drain which leads to the sanitary sewer system.
- Reduce stormwater contact with equipment and materials by implementing covered storage, reduce stormwater run-on and follow good housekeeping practices.
- Post signs at critical locations with Spill Prevention and Response Plan information.

Identification of Spill Areas: Spill prevention and response measures shall be implemented at construction sites in areas where materials may be spilled in quantities that can adversely impact receiving waters or the storm system. Identify potential spill areas, potential spill volumes, material types, frequency of material used, and drainage paths from spill areas with relation to storm sewer inlets, adjacent water bodies, structural CMs, and containment structures. Use this information to determine the types of spill prevention and control measures needed specific to the site conditions. Show the potential spill areas on the EC Plan:

- Loading and unloading areas
- Outdoor storage areas
- Outdoor manufacturing or processing activities
- Waste disposal
- Areas that generate significant dust or particulates that may later deposit on the ground
- Areas prone to spills based on past experience at the site
- Locations where other routine maintenance activities occur
- Areas where smaller leaks may occur (parking lots)

Material Handling Procedures: From a water quality perspective, the primary principle behind effective material handling practices is to minimize exposure to precipitation. Store the material indoors, otherwise implement the following outdoor materials handling procedures:

- Divert stormwater around materials storage areas.
- Keep bulk solid materials (raw materials, sand, gravel, topsoil, compost, concrete, packing materials, metal products, etc.) covered and protected from stormwater.
- When practical, store materials on impermeable surfaces.

- Store hazardous materials according to federal, state, and local requirements.
- Adopt procedures to reduce spills or leaks during filling or transfer of materials.
- Substitute less toxic or nontoxic materials for toxic materials.
- Store containers that are easily punctured or damaged away from high traffic areas.
- Add waste-capture containers such as collection pans for lubricating fluids.
- Store drums and containers with liquids on impermeable surfaces and provide secondary containment. Place drums stored outdoors on pallets to minimize contact with runoff.

Spill Response Procedures: Tailor spill response procedures to site-specific conditions and industry-specific regulatory requirements. Follow procedures:

- Contain and cleanup spills promptly after the spill is discovered.
- Sweep up small quantities of pollutants to reduce exposure to runoff.
- Place absorbents at fueling areas or areas susceptible to spills.
- Wipe up small spills with a rag, store rags in appropriate containers, dispose of rags properly or use a professional industrial cleaning service.
- Contain medium-sized spills with absorbents and use berms or absorbent "snakes" as temporary booms for the spill. Store and dispose of absorbents properly. Wet/dry vacuums may be used, but not for volatile fluids.
- Install drip pans below minor equipment leaks until a repair can be made.
- For large spills, first contain the spill and plug storm inlet where the liquid may migrate off-site, then clean up the spill.
- Excavation of spill areas to removed contaminated material may be required where large liquid spills occur on unpaved surfaces.
- Maintain an inventory of cleanup materials onsite and strategically locate them based on the types and quantities of chemicals present.
- Records of spills, leaks, or overflows that result in the discharge of pollutants must be documented and maintained.

Two approaches are used when implementing spill containment measures: 1) Design system to contain the entire spill; or 2) Use curbing to route spilled material to a collection basin. Both containment berming and curbing should be sized to safely contain or convey to a collection basin a spill from the largest storage tank, tanker truck, or other containment device in the possible spill area. The spill containment area must have an impermeable surface (impermeable liner, asphalt or concrete) to prevent groundwater contamination. Design containment system to enable collection and removal of spilled material through a pump or vacuum trucks, sorbent or gelling material, etc.

Material removed must be disposed of or recycled according to local, state, and federal standards. If the capacity of the spill containment is exceeded, supplemental measures should be available such as a portable containment device, sorbent materials, or gelling agents to solidify the material. Water that collects within containment areas due to rainfall or snowmelt must be appropriately treated before release from the spill area.

Emergency 24-Hour Site Contact (with spill response and clean-up authority):

Company Name: _____

Contact Name: _____

Office #: _____ Cell #: _____ Email: _____

Notification Procedures: Some spills may need to be reported to the State of Colorado, Water Quality Control Division and Adams County Stormwater Division immediately upon discovery. Releases of chemical, oil, petroleum product, sewage, etc., which may enter State Waters must be reported to: State of Colorado, 24-hour Emergency Spill Reporting Line: 1-877-518-5608. <https://www.colorado.gov/pacific/cdphe/wq-environmental-spills>.
Tri-County Health Department: 303-220-9200.

4.3 Good Housekeeping

Good Housekeeping Practices

Permanent **Temporary**

Description: Good housekeeping practices are designed to maintain a clean and orderly work environment. The most effective first steps towards preventing stormwater pollution at construction sites simply involve using common sense to improve the site's basic housekeeping methods. Poor housekeeping practices result in increased waste and potential for stormwater contamination. A clean and orderly work site reduces the possibility of accidental spills caused by mishandling of chemicals and equipment and should reduce safety hazards to personnel. A well-maintained material and chemical storage area will reduce the possibility of stormwater mixing with pollutants. Some simple procedures a site can use to promote good housekeeping include improved operation and maintenance of machinery and processes, material storage practices, material inventory controls, routine and regular clean-up schedules, maintaining well organized work areas, signage, and educational program for employees and the general public.

Practice Procedures for Operation and Maintenance:

- Maintain dry and clean floors and ground surfaces by using brooms, shovels, vacuums or cleaning machines, rather than wet clean-up methods.
- Regularly collect and dispose of garbage and waste material.
- Routinely inspect equipment to ensure that it is functioning properly without leaking and conduct preventative maintenance and needed repairs.
- Train employees on proper clean up and spill response procedures.
- Designate separate areas for auto parking, vehicle refueling and routine maintenance.
- Promptly clean up leaks, drips and other spills.

- Cover and maintain dumpsters and waste receptacles. Add additional dumpsters or increase frequency of waste collection if overflowing conditions reoccur.
- For outdoor painting and sanding: Conduct activities in designated areas that provide adequate protection to prevent overspray and uncontrolled emissions. All operations should be conducted on paved surfaces to facilitate cleanup. Use portable containment as necessary for outside operations. Clean up and properly dispose of excess paint, paint chips, protective coatings, grit waste, etc.
- Maintain vegetation on facility grounds in a manner that minimizes erosion. Follow the Landscape Maintenance and Pesticide, Herbicide and Fertilizer Usage CMs to ensure that minimum amounts of chemicals needed for healthy vegetation are applied to minimize transport of these materials in runoff.

Practice Procedures for Material Storage Practices:

- Provide adequate aisle space to facilitate material transfer and access for inspection.
- Store containers, drums, and bags away from direct traffic routes to reduce container damage resulting in accidental spills.
- Stack containers according to manufacturer's instructions to avoid damaging the containers from improper weight distribution. Also store materials in accordance with directions in Safety Data Sheets (SDSs).
- Store containers on pallets or similar devices to prevent corrosion of containers that results from containers coming in contact with moisture on the ground.
- Store toxic or hazardous liquids within curbed areas or secondary containers.

Practice Procedures for Material Inventory Practices: An up-to-date materials inventory can keep material costs down by preventing overstocking, track how materials are stored and handled onsite, and identify which materials and activities pose the most risk to the environment. Assign responsibility of hazardous material inventory to individuals trained to handle such materials. A material inventory should include these steps:

- Identify all chemical substances present at work site. Perform a walk-through of the site, review purchase orders, list all chemical substances used and obtain Safety Data Sheets (SDS) for all chemicals.
- Label all containers with name and type of substance, stock number, expiration date, health hazards, handling suggestions, and first aid information. Find info on the SDS.
- Clearly identify special handling, storage, use and disposal considerations for hazardous materials on the material inventory.
- Institute a shelf-life program to improve material tracking and inventory to reduce the amount of materials overstocked and ensure proper disposal of expired materials. Careful tracking of materials ordered can result in more efficient materials use. Decisions on the amounts of hazardous materials that are stored on site should include an evaluation-of any emergency control systems that are in place. All storage areas for hazardous materials should be designed to contain spills.

Practice Procedures for Training and Participation: Provide frequent and proper training in good housekeeping techniques to reduce mishandling of chemicals or equipment. Educate by:

- Discussing good housekeeping practices in training programs and meetings.
- Publicizing pollution prevention concepts through posters or signs.
- Posting bulletin boards with updated good housekeeping procedures and tips.

4.4 Vehicle Maintenance, Fueling and Storage

Vehicle Maintenance, Fueling and Storage

Permanent

Temporary

Description: Areas where vehicles are fueled, maintained, and stored/parked can be pollutant "hot spots" that can result in hydrocarbons, trace metals, and other pollutants being transported in precipitation runoff. Proper fueling operations, storage of automotive fluids and effective spill cleanup procedures can help reduce contamination of stormwater runoff from vehicle maintenance and fueling facilities. Fuel-related spills can occur due to lack of attention during fueling or "topping off" fuel tanks. Common activities at construction sites include vehicle fluid replacement and equipment replacement and repair. Some of the wastes generated maintaining automobiles include solvents (degreasers, paint thinners, etc.), antifreeze, brake fluid, brake pad dust, battery acid, motor oil, fuel, and lubricating grease.

Uses: procedures are applicable to vehicle maintenance and fueling. Vehicle wash water is considered process wastewater that will not be discharged to the storm sewer system.

Practice Procedures for Vehicle Maintenance: The most effective way to minimize wastes generated by automotive maintenance activities is to prevent their production in the first place. The following practices will be implemented:

- Perform maintenance activities inside or under cover. When repairs cannot be performed indoors, use drip pans or absorbents.
- Keep equipment clean and free of excessive oil and grease buildup.
- Promptly cleanup spills using dry methods and properly dispose of waste. When water is required, use as little as possible to clean spills, leaks, and drips.
- Use a solvent collection service to collect spent solvent used for parts cleaning.
- When using liquids for cleaning, use a centralized station to ensure that solvents and residues stay in one area. Locate drip pans and draining boards to direct solvents back into a solvent sink or holding tank for reuse.
- Store used oil for recycling in labeled tanks. Locate used oil tanks and drums away from storm sewer, flowing streams, and preferably indoors.
- Use non-hazardous or less hazardous alternatives when practical. For example, replace chlorinated organic solvents with non-chlorinated ones like kerosene or mineral spirits.
- Properly recycle or dispose of grease, oil, antifreeze, brake fluid, cleaning solutions, hydraulic fluid, batteries, transmission fluid, worn parts, filters, and rags.
- Drain and crush oil filters before recycling or disposal.

- Drain all fluids and remove batteries from salvage vehicles and equipment.
- Closely monitor parked vehicles for leaks and place pans under leaks to collect the fluids for proper disposal or recycling.
- Install berms or other measures to contain spills and prevent work surface runoff from entering storm sewer system.
- Develop a spill prevention plan with measures such as spill kits, and information about location of storm drains and how to protect them if a large spill occurs.
- Conduct periodic employee training to reinforce proper disposal practices.
- Promptly transfer used fluids to recycling drums or hazardous waste containers.
- Store cracked batteries in leak-proof secondary containers.
- Inspect outdoor storage areas regularly for drips, spills and improperly stored materials (for example: unlabeled containers, auto parts that might contain grease or fluids, etc). This is particularly important for parking areas for vehicles awaiting repair.
- Structural CMs, such as traps, installed in vehicle hotspot areas require routine cleanout of oil and grease. During heavy rainfall, cleanout is required more often to ensure that pollutants are not washed through the trap. Sediment removal is also required on a regular basis to keep the CM working efficiently.

Practice Procedures for Vehicle Fueling:

- Fueling areas should be designed to prevent stormwater runoff and spills. Fuel-dispensing areas should be paved with concrete or equivalent impervious surface, with an adequate slope to prevent ponding, and separated from the rest of the site by a grade break or berm to prevent run-on of precipitation.
- For sites using a mobile fuel truck, establish a designated fueling area. Place temporary "caps" over nearby catch basins or manhole covers so that if a spill occurs, it is prevented from entering the storm sewer. Secondary containment should be used when transferring fuel from the tank truck to the fuel tank. Cover storm drains in the vicinity. Install vapor recovery nozzles to help control drips, and reduce air pollution.
- Keep spill response information and spill cleanup materials onsite and readily available.
- Employ dry cleanup methods cleaning up fuel spills. Such methods include sweeping to remove litter and debris, and using rags and absorbents for leaks and spills.
- Water should not be used to wash fuel spill areas. During routine cleaning, use a damp cloth on the pumps and a damp mop on the pavement. Fuel dispensing nozzles should be fitted with automatic shutoff except where prohibited by fire department. Post signs at the fuel dispenser warning operators against "topping off" vehicle fuel tanks.
- Provide written procedures describing CMs to employees who will be fueling.

4.5 Street Sweeping and Cleaning

Street Sweeping (SS)

Permanent

Temporary

Description: SS uses either manual or mechanical pavement cleaning practices to collect or vacuum sediment, litter and other debris from the streets before being washed into storm sewers by runoff. This practice can reduce pollutant loading to receiving waters, reduce clogging of storm sewer pipes, prolong the life of infiltration CMs and reduce clogging of outlet structures in detention ponds. Mechanical designs include: broom and conveyor belt sweeper, wet or dry vacuum-assisted sweepers, and regenerative-air sweepers. The effectiveness depends upon particle loadings being swept, street texture, moisture conditions, parked cars, equipment conditions and frequency of cleaning.

Uses: SS is a technique in urban areas where sediment and litter accumulated on streets is of concern for aesthetic, sanitary, water and air quality reasons. SS is required at construction sites per SWMP to reduce off-site tracking.

Procedures:

1. SS may be performed manually (broom and shovel) or with a vacuum sweeper (no kick-broom). Choose the most effective approach for site conditions.
2. SS shall be completed when there is sediment tracking from the construction site exits into the public road or right-of-way.
3. SS frequency depends on presence of sediment tracking. If tracking is occurring, either a VTC shall be installed, the VTC needs maintenance, or the VTC is inadequate; all require SWMP updates.
4. Off-site sediment tracking from the construction site shall be swept immediately.
5. Conduct SS prior to precipitation events.
6. Operate sweepers at manufacturer recommended optimal speed levels.
7. Regularly inspect vehicles and equipment for leaks and repair promptly.
8. Keep accurate logs of number of curb-miles swept and amount of waste collected.
9. Dispose of SS debris and dirt at a landfill.
10. Do not store swept material along the side of the street or near a storm drain inlet.

4.6 Storm Sewer Cleaning

Storm Sewer System Cleaning

Permanent

Temporary

Description: Periodic storm sewer cleaning can help remove accumulated sediment, trash, and other pollutants from the storm system including inlets, pipes and also construction CMs. Routine cleaning reduces the amount of pollutants in the storm system and in receiving waters. Clogged

drains can cause overflow, leading to increase erosion. Cleaning increases dissolved oxygen, reduces levels of bacteria, and supports in-stream habitat. Areas with flat grades or low flows should be given special attention because they rarely achieve high enough flows to flush themselves. Water used in storm drain cleaning must be collected and properly disposed of, typically at a sanitary wastewater treatment facility. Simpler methods in localized areas can also include manual trash collection and shoveling sediment and debris from inlets and outlets. Frequency and prioritization of storm sewer cleaning is affected by the activity and intensity of construction and the proper installation and maintenance for construction CMs.

Uses: Inspection of the existing storm system is recommended prior construction to document condition. The storm sewer shall be cleaned at minimum at completion of construction.

Practice Guidelines: Inspect the storm system as part of the required stormwater inspection.

- **Technology available:** manual cleaning (shovel), vacuum cleaning and vacuum combination jet cleaning. Choose the most effective approach for site conditions.
- **Staff training:** train about maintenance, waste collection and disposal methods.
- **Waste disposal:** Most catch basin waste is acceptable for landfills. If hazardous material is suspected, it should be tested and disposed of accordingly.

SECTION 5: STORMWATER INSPECTIONS

5.1 Inspections

1. *Qualified Stormwater Management Inspection Personnel:*

Identify the inspection person(s) who will be responsible for conducting stormwater inspections and describe their qualifications:

2. *Inspection Frequency:*

Inspections shall start within 7 calendar days of commencement of construction activities.

Minimum Stormwater Inspection Schedule: A thorough inspection of the site inspection shall be performed in accordance with one of the following minimum frequencies:

- At least one inspection every 7 calendar days, or
- At least one inspection every 14 calendar days, if post-storm event inspections are conducted within 24 hours after the end of any precipitation or snowmelt event that causes surface erosion. Post-storm inspections may be used to fulfill the 14-day routine inspection requirement.

Post-Storm Inspections at Temporarily Idle Sites - For permittees choosing to combine 14-day inspections and post-storm-event inspections, if no construction activities will occur following a storm event, post-storm event inspections must be conducted prior to re-commencing construction activities, but no later than 72 hours following the storm event. The delay of any post-storm event inspection must be documented in the inspection record. Routine inspections must still be conducted at least every 14 calendar days.

Inspections at Completed Sites/Areas - When the site, or portions of a site are awaiting establishment of a vegetative ground cover and final stabilization, the permittee must conduct a thorough inspection of the stormwater management system at least once every 30 days. Post-storm event inspections are not required under this schedule. This reduced inspection schedule is allowed if all of the following criteria are met:

- i. All construction activities resulting in ground disturbance are complete;
- ii. All activities required for final stabilization, in accordance with the SWMP, have been completed, with the exception of the application of seed that has not occurred due to seasonal conditions or the necessity for additional seed application to augment previous efforts; and
- iii. The SWMP has been amended to locate those areas to be inspected in accordance with the reduced schedule allowed for in this paragraph.

The minimum inspection frequency required does not affect the permittee's responsibility to implement and maintain effective control measures as prescribed in the SWMP. Proper maintenance may require more frequent inspections.

3. *Inspection Procedures:*

- At minimum, inspect the construction site perimeter, all disturbed area, designated haul routes, material and/or waste storage areas that are exposed to precipitation,

discharge location(s), and locations where vehicles exit the site shall be inspected for evidence of, or the potential for, pollutants leaving the Permitted boundaries, entering the storm sewer system, or discharging to the MS4.

- Refer to **Section 5.2 Inspection Sequence**.
- Visually verify whether all implemented CMs are in effective operational condition and are working as designed in their specifications to minimize pollutant discharges.
- Determine if there are new potential sources of pollutants.
- Assess the adequacy of CMs at the site to identify areas requiring new or modified CMs to minimize pollutant discharges.
- Identify all areas of non-compliance and implement corrective action.

4. Correcting Problems:

Take steps to minimize the discharge of pollutants until a CM is implemented and operational, or an inadequate CM is replaced or corrected, and returned to effective operating condition. If it is infeasible to install or repair the CM immediately after discovering the deficiency, the following must be documented:

- (a) Describe why it is infeasible to initiate the installation or repair immediately; and
- (b) Provide a schedule for installing or repairing the CM and returning it to an effective operating condition asap.

Remove and properly dispose of any unauthorized release or discharge. Clean up any contaminated surfaces to minimize discharges of the material in subsequent storm events.

Responsible staff or company for making corrections:

5. Inspection Form:

Use the form¹ in **Appendix 6** for all Capital Improvement Projects. Place completed inspections or refer to where the inspections are kept electronically in **Appendix 7**. At a minimum the form should document:

- Inspection date;
- name & title of inspector;
- weather conditions;
- phase of construction;
- estimated acreage of disturbance at the time of inspection;
- location(s) of discharges of sediment or other pollutants from the site; location(s) of CMs needing maintenance;
- location(s) and identification of inadequate CMs;
- location(s) and identification of additional CMs needed that were not in place at the time of inspection;
- description of the minimum inspection frequency;
- deviations from the minimum inspection schedule; certification statement for corrective action(s) or inspection (if no actions).

5.2 Inspection Sequence

1. Plan your stormwater inspection

¹ An equivalent form may be used for all projects except Capital Improvement Projects.

- Use the inspection form (or equivalent) under **Appendix 6**.
- Obtain a copy of the EC Plan (Site Map) with CMs locations marked.
- Plan to walk the entire site, including discharge points from the site and any off-site support activities.
- Follow a consistent pattern each time to ensure you inspect all areas.

2. Determine Inspection frequency

- Site inspections must be conducted at least once every 7; or 14 calendar days.
- If 14-day inspections, then post-storm inspections must be conducted within 24 hours after the end of any precipitation or snowmelt event that causes surface erosion.
- 30-day inspections are conducted once construction is complete, temporary stabilizations has been installed and the site is waiting to reach final stabilization.

3. Inspect discharge points and downstream, off-site areas

- Inspect discharge locations to determine whether erosion and sediment control measures are effective.
- Inspect nearby downstream locations.
- Walk down the street to inspect off-site areas for signs of discharges.
- Inspect down slope existing catch basins to ensure they are free of sediment and other pollutants and to ensure that they are adequately protected.

4. Inspect perimeter controls and slopes

- Inspect perimeter controls to determine if sediment should be removed.
- Check the structural integrity of the CM. Determine if CM replacement is needed.
- Inspect slopes and temporary stockpiles to determine if erosion controls are effective.

5. Compare CMs in the EC Plan with the construction site conditions.

- Determine whether CMs are in place as required by the EC plan.
- Evaluate whether CMs have been adequately installed and maintained.
- Look for areas where CMs are needed but are missing on the field, or are not documented on the SWMP.

6. Inspect construction site entrances

- Inspect the construction exits to determine if there is tracking of sediment from the site onto the street.
- Refresh or replace the rock in designated entrances and concrete washout areas.
- Look for evidence of additional construction exits being used that are not in the SWMP or are not stabilized.
- Sweep the street if there is evidence of sediment accumulation.

7. Inspect sediment controls

- Inspect any sediment basins for sediment accumulation.
- Remove sediment when it reduces the capacity of the basin by $\frac{1}{3}$ of the design storage volume.

8. Inspect pollution prevention and good housekeeping practices

- Inspect trash areas to ensure that waste is properly contained.
- Inspect material storage and staging areas to verify that potential pollutant sources are not exposed to stormwater runoff.
- Verify that concrete, paint, and stucco washouts are being used properly and are correctly sized for the volume of wash water.
- Inspect vehicle/equipment fueling and maintenance areas for signs of stormwater pollutant exposure.

9. Inspect for final stabilization

- Inspect all temporary and permanent CMs for correct application and installation with the CM details.
- Remove sediment from the private storm sewer system - do not jet pollutants down into the public storm sewer system.

SECTION 6: RECORDKEEPING

6.1 Recordkeeping

The following records shall be available at the construction site, or be on-site when construction activities are occurring:

- ✓ An updated SWMP, reflecting current conditions and CMs.
- ✓ Keep record of SWMP/EC Plan changes made including the date and identification of the changes (*).
- ✓ Completed inspection reports, can be placed or electronically stored and the location referenced in **Appendix 7**
- ✓ Any document or plan incorporated by reference to the SWMP.

(*) The SWMP must be amended when the following occurs:

- 1) A change in design, construction, operation, or maintenance of the site requiring implementation of new or revised control measures;
- 2) The SWMP proves ineffective in controlling pollutants in stormwater runoff in compliance with the permit conditions;
- 3) Control measures identified in the SWMP are no longer necessary and are removed; and
- 4) Corrective actions are taken onsite that result in a change to the SWMP.

A notation must be included in the SWMP to identify the date of the site change, the control measure removed, or modified, the location(s) of those control measures, and any changes to the control measure(s). The permittee must ensure the site changes are reflected in the SWMP. The permittee is non-compliant with the permit until the SWMP revisions have been made

SWMP documentation required under this permit are considered reports that must be available to the public under Section 308(b) of the CWA and Section 61.5(4) of the CDPS regulations. The permittee must make plans available to members of the public upon request. However, the permittee may claim any portion of a SWMP as confidential in accordance with 40 CFR Part 2.

Records will be retained for a minimum period of at least 3 years after the CDPHE permit is terminated.

SECTION 7: FINAL STABILIZATION

7.1 Final Stabilization Requirement

Final Stabilization is reached when all ground disturbing activities are complete, and all disturbed areas have either been built on, paved over or a uniform vegetative cover has been established per SWMP. Prior to closing the State Stormwater Permit, all the items listed below must be completed in order for the construction site to be considered to have final stabilization.

1. The site has a uniform vegetative cover with a density of at least 70% compared to the original undisturbed site. Such cover must be capable of adequately controlling soil erosion.
2. If applicable, proper installation and maintenance of all approved, permanent, post-construction stormwater quality treatment drainage facilities.
3. Removal of all stockpiles of soil, construction material/debris, construction equipment, etc. from the construction site.
4. Streets, parking lots and other surrounding paved surfaces are clean and free of any sediment or debris.
5. Removal of sediment, debris or other pollutants within the private and adjacent public storm drainage system.
6. Restoration of any damaged public infrastructure caused by the construction activities.

7.2 Final Stabilization Measures

Final stabilization measures shall be installed per Erosion Control Details (Appendix 4).

7.3 Removal of Temporary CMs

Once the site has met the final stabilization conditions, the remaining temporary CMs such as perimeter controls, inlet protection, silt fence, etc. shall be removed and disposed of properly.

7.4 Stormwater Permits Close-out

Submit the CDPS Stormwater Discharge Permit [Inactivation Form](#) to CDPHE.

7.5 Long Term Stormwater Management

The Scenic View at Paint Brush Hills Detention Pond is an existing stormwater detention facility that was constructed for water quality capture, treatment, and detention of the 100-year storm event for the Scenic View Subdivision. The existing Pond is to be reconstructed with new

stormwater infrastructure to meet current standards including a concrete trickle channel throughout the pond bottom and a concrete forebay at the existing inlet pipe. Modifications to the existing outlet structure will consist of the installation of a new orifice plate and trash rack. The existing Pond footprint remains unchanged and is to remain with its current ownership and to follow the latest O&M Manual.

SWMP APPENDICES

Attach the following documentation:

<i>Appendix 1 - Project Vicinity Map</i>	<i>(Section 1.1)</i>
<i>Appendix 2 - State CDPS Stormwater Construction Permit and Additional Permits (if applicable)</i>	<i>(Section 1.2)</i>
<i>Appendix 3 - Pre-disturbance Photos</i>	<i>(Section 1.4)</i>
<i>Appendix 4 - Erosion and Sediment BMPs/CMs Details</i>	<i>(Section 1.10)</i>
<i>Appendix 5 - Erosion and Sediment Control Plan (ESC Plan) - Site Map</i>	<i>(Section 2.10)</i>
<i>Appendix 6 - Stormwater Inspection Form</i>	<i>(Section 5.1)</i>
<i>Appendix 7 - Completed Stormwater Inspection Logs</i>	<i>(Sections 5.3 & 5.5)</i>
<i>Appendix 8 - Agreement for off-site Control Measures (if applicable)</i>	<i>(Section 1.5)</i>

APPENDIX 1: Project Vicinity Map

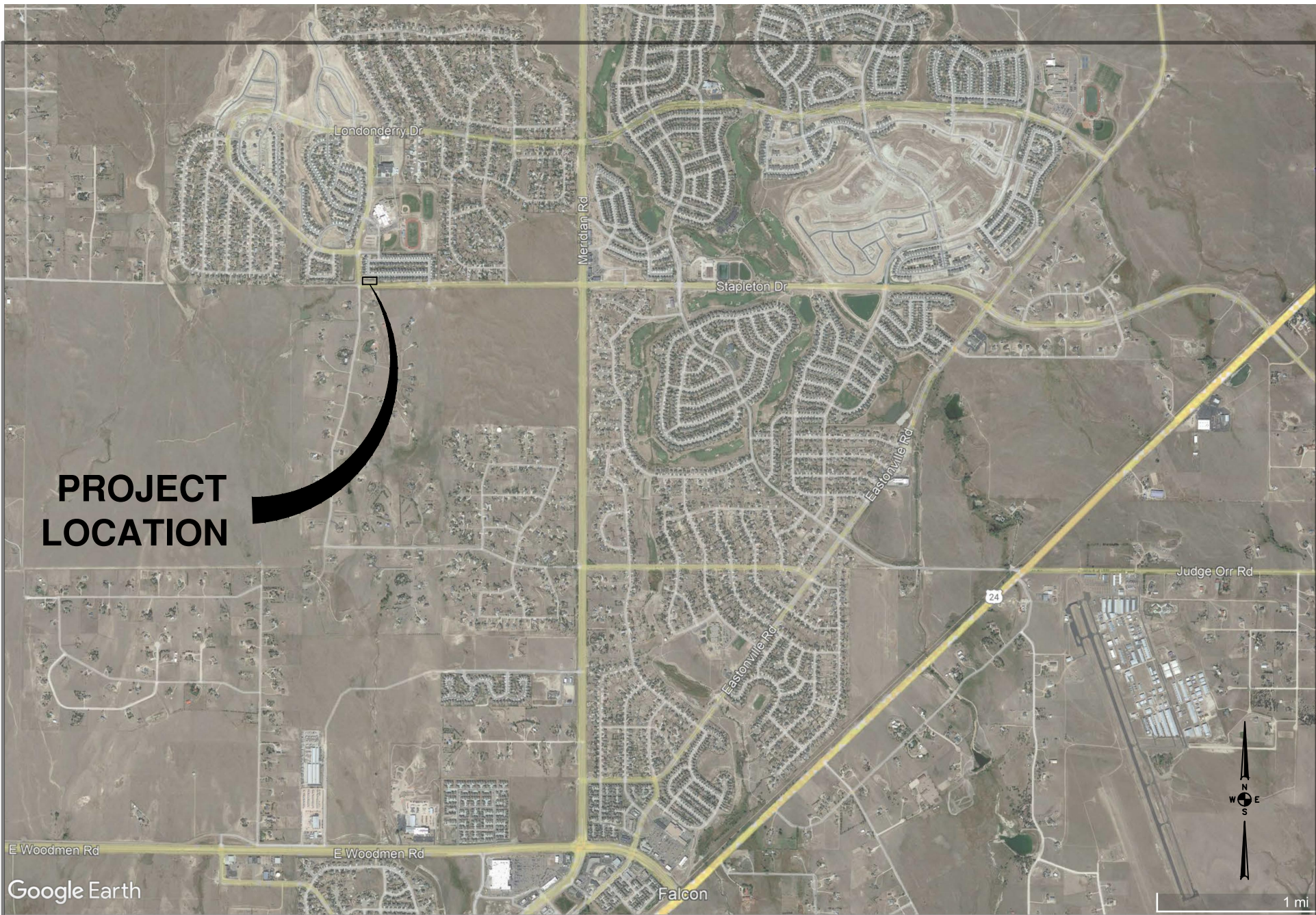

APPENDIX 2: CDPHE Stormwater Construction Permit and Additional Permits (if applicable)

EROSION AND STORMWATER QUALITY CONTROL PERMIT (ESQCP) EL PASO COUNTY APPLICATION AND PERMIT

EPC Project Number:

APPLICANT INFORMATION

PERMIT NUMBER

Owner Information	
Property Owner	
Applicant Name (Permit Holder)	
Company/Agency	
Position of Applicant	
Address (physical address, not PO Box)	
City	
State	
Zip Code	
Mailing address, if different from above	
Telephone	
FAX number	
Email Address	
Cellular Phone number	
Contractor/Operator Information	
Name (person of responsibility)	
Company	
Address (physical address, not PO Box)	
City	
State	
Zip Code	
Mailing address, if different from above	
Telephone	
FAX number	
Email Address	
Cellular Phone number	
Erosion Control Supervisor (ECS)*	
ECS Phone number*	
ECS Cellular Phone number*	

*Required for all applicants. May be provided at later date pending securing a contract when applicable.

PROJECT INFORMATION

Project Information	
Project Name	
Legal Description	
Address (or nearest major cross streets)	
Acreage (total and disturbed)	Total: acres Disturbed: acres
Schedule	Start of Construction: Completion of Construction: Final Stabilization:
Project Purpose	
Description of Project	
Tax Schedule Number	

FOR OFFICE USE ONLY

The following signature from the ECM Administrator signifies the approval of this ESQCP. All work shall be performed in accordance with the permit, the El Paso County Engineering Criteria Manual (ECM) Standards, City of Colorado Springs Drainage Criteria Manual, Volume 2 (DCM2) as adopted by El Paso County Addendum, approved plans, and any attached conditions. The approved plans are an enforceable part of the ESQCP. Construction activity, except for the installation of initial construction BMPs, is not permitted until issuance of a Construction Permit and Notice to Proceed.

Signature of ECM Administrator: _____

Date _____

1.1 REQUIRED SUBMISSIONS

In addition to this completed and signed application, the following items must be submitted to obtain an ESQCP:

- Permit fees;
- Stormwater Management Plan (SWMP) meeting the requirements of DCM2 and ECM either as part of the plan set or as a separate document;
- Operation and Maintenance Plan for any proposed permanent stormwater control measures; and
- Signed Private Detention Basin/Stormwater Quality Best Management Practice Maintenance Agreement and Easement, if any permanent stormwater control measures are to be constructed.

1.2 RESPONSIBILITY FOR DAMAGE

The County and its officers and employees, including but not limited to the ECM Administrator, shall not be answerable or accountable in any manner for damage to property or for injury to or death of any person, including but not limited to a permit holder, persons employed by the permit holder, or persons acting in behalf of the permit holder, from any cause. The permit holder shall be responsible for any liability imposed by law and for damage to property or injuries to or death of any person, including but not limited to the permit holder, persons employed by the permit holder, persons acting in behalf of the permit holder, arising out of work or other activity permitted and done under a permit, or arising out of the failure to perform the obligations under any permit with respect to maintenance or any other obligations, or resulting from defects or obstructions, or from any cause whatsoever during the progress of the work or other activity, or at any subsequent time work or other activity is being performed under the obligations provided by and contemplated by the permit.

The permit holder shall indemnify, save, and hold harmless the County and its officers and employees, including but not limited to the BOCC and ECM Administrator, from all claims, suits or actions of every name, kind and description brought for or on account of damage to property or injuries to or death of any person, including but not limited to the permit holder, persons employed by the permit holder, persons acting in behalf of the permit holder and the public, resulting from the performance of work or other activity under the permit, or arising out of the failure to perform obligations under any permit with respect to maintenance or any other obligations, or resulting from defects or obstructions, or from any cause whatsoever during the progress of the work or other activity, or at any subsequent time work or other activity is being performed under the obligations provided by and contemplated by the permit, except as otherwise provided by state law. The permit holder waives any and all rights to any type of expressed or implied indemnity against the County, its officers or employees. It is the intent of the parties that the permit holder will indemnify, save, and hold harmless the County, its officers and employees from any and all claims, suits or actions as set forth above regardless of the existence or degree of fault of or negligence, whether active or passive, primary or secondary, on the part of the County, the permit holder, persons employed by the permit holder, or persons acting in behalf of the permit holder

1.3 APPLICATION CERTIFICATION

We, as the Applicants or the representative of the Applicants, hereby certify that this application is correct and complete as per the requirements presented in this application, the El Paso County Engineering Criteria Manual, and Drainage Criteria Manual, Volume 2 and El Paso County Addendum.

We, as the Applicants or the representatives of the Applicants, have read and will comply with all of the requirements of the specified Stormwater Management Plan and any other documents specifying stormwater best management practices to be used on the site, including permit conditions that may be required by the ECM Administrator. We understand that the stormwater control measures are to be maintained on the site and revised as necessary to protect stormwater quality as the project progresses. We further understand that a Construction Permit must be obtained and all necessary stormwater quality control measures are to be installed in accordance with the SWMP, the El Paso County Engineering Criteria Manual, Drainage Criteria Manual, Volume 2 and El Paso County Addendum before land disturbance begins and that failure to comply will result in a Stop Work Order and may result in other penalties as allowed by law. We further understand and agree to indemnify, save, and hold harmless the County and its officers and employees, including but not limited to the BOCC and ECM Administrator, from all claims, suits or actions of every name, kind and description as outlined in Section 1.2 Responsibility for Damage

Signature of Owner or Representative

Date: _____

Print Name of Owner or Representative

Signature of Operator or Representative

Date: _____

Print Name of Operator or Representative

Permit Fee \$ _____

Surcharge \$ _____

Financial Surety \$ _____

Type of Surety _____

Total \$ _____

APPENDIX 3: Pre-Disturbance Photos



NORTH



NORTH

APPENDIX 4: Erosion & Sediment CMs/BMPs Details

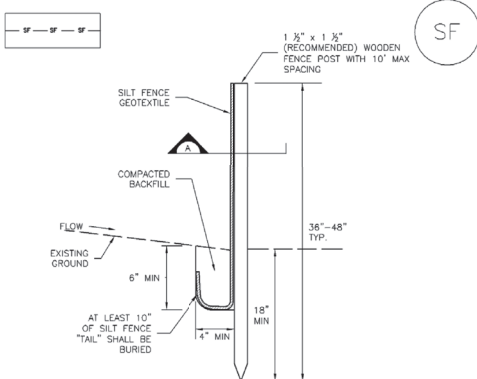

SILT FENCE

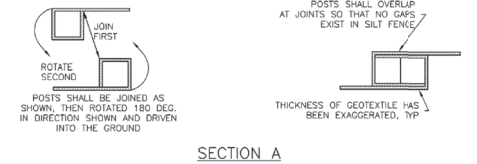

SECTION A

SILT FENCE INSTALLATION NOTES

- SILT FENCE MUST BE PLACED AWAY FROM THE TOE OF THE SLOPE TO ALLOW FOR WATER PONDING. SILT FENCE AT THE TOE OF A SLOPE SHOULD BE INSTALLED IN A FLAT LOCATION AT LEAST SEVERAL FEET (2-5 FT) FROM THE TOE OF THE SLOPE TO ALLOW ROOM FOR PONDING AND DEPOSITION.
- A UNIFORM 6" X 4" ANCHOR TRENCH SHALL BE EXCAVATED USING TRENCHER OR SILT FENCE INSTALLATION DEVICE. NO ROAD GRADERS, BACKHOES, OR SIMILAR EQUIPMENT SHALL BE USED.
- COMPACT ANCHOR TRENCH BY HAND WITH A "JUMPING JACK" OR BY WHEEL ROLLING. COMPACTOR SHALL BE SUCH THAT SILT FENCE RESISTS BEING PULLED OUT OF ANCHOR TRENCH BY HAND.
- SILT FENCE SHALL BE PULLED TIGHT AS IT IS ANCHORED TO THE STAKES. THERE SHOULD BE NO NOTICEABLE SAG BETWEEN STAKES AFTER IT HAS BEEN ANCHORED TO THE STAKES.
- SILT FENCE FABRIC SHALL BE ANCHORED TO THE STAKES USING 1" HEAVY DUTY STAPLES OR NAILS WITH 1" HEADS. STAPLES AND NAILS SHOULD BE PLACED 3" ALONG THE FABRIC DOWN THE STAKE.
- AT THE END OF A RUN OF SILT FENCE ALONG A CONTOUR, THE SILT FENCE SHOULD BE TURNED PERPENDICULAR TO THE CONTOUR TO CREATE A "J-HOOK." THE "J-HOOK" EXTENDING PERPENDICULAR TO THE CONTOUR SHOULD BE OF SUFFICIENT LENGTH TO KEEP RUNOFF FROM FLOWING AROUND THE END OF THE SILT FENCE (TYPICALLY 10' - 20').
- SILT FENCE SHALL BE INSTALLED PRIOR TO ANY LAND DISTURBING ACTIVITIES.

SILT FENCE MAINTENANCE NOTES

- INSPECT BMPs EACH WORKDAY, AND MAINTAIN THEM IN EFFECTIVE OPERATING CONDITION. MAINTENANCE OF BMPs SHOULD BE PROACTIVE, NOT REACTIVE. INSPECT BMPs AS SOON AS POSSIBLE (AND ALWAYS WITHIN 24 HOURS) FOLLOWING A STORM THAT CAUSES SURFACE EROSION, AND PERFORM NECESSARY MAINTENANCE.
- FREQUENT OBSERVATIONS AND MAINTENANCE ARE NECESSARY TO MAINTAIN BMPs IN EFFECTIVE OPERATING CONDITION. INSPECTIONS AND CORRECTIVE MEASURES SHOULD BE DOCUMENTED THOROUGHLY.
- WHERE BMPs HAVE FAILED, REPAIR OR REPLACEMENT SHOULD BE INITIATED UPON DISCOVERY OF THE FAILURE.
- SEDIMENT ACCUMULATED UPSTREAM OF THE SILT FENCE SHALL BE REMOVED AS NEEDED TO MAINTAIN THE FUNCTIONALITY OF THE BMP. TYPICALLY WHEN DEPTH OF ACCUMULATED SEDIMENTS IS APPROXIMATELY 1/2".
- REPAIR OR REPLACE SILT FENCE WHEN THERE ARE SIGNS OF WEAR, SUCH AS SAGGING, TEARING, OR COLLAPSE.
- SILT FENCE IS TO REMAIN IN PLACE UNTIL THE UPSTREAM DISTURBED AREA IS STABILIZED AND APPROVED BY THE LOCAL JURISDICTION, OR IS REPLACED BY AN EQUIVALENT PERIMETER SEDIMENT CONTROL BMP.
- WHEN SILT FENCE IS REMOVED, ALL DISTURBED AREAS SHALL BE COVERED WITH TOPSOIL, SEEDED AND MULCHED OR OTHERWISE STABILIZED AS APPROVED BY LOCAL JURISDICTION.

(DETAIL ADAPTED FROM TOWN OF PARKER, COLORADO AND CITY OF AURORA, NOT AVAILABLE IN AUTOCAD)

NOTE: MANY JURISDICTIONS HAVE BMP DETAILS THAT VARY FROM UDFCD STANDARD DETAILS. CONSULT WITH LOCAL JURISDICTIONS AS TO WHICH DETAIL SHOULD BE USED WHEN DIFFERENCES ARE NOTED.

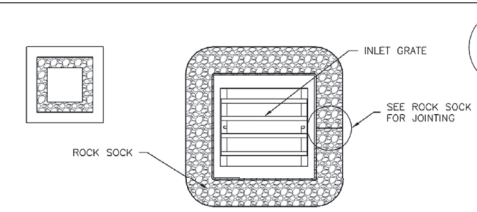

IP-3. ROCK SOCK SUMP/AREA INLET PROTECTION

ROCK SOCK SUMP/AREA INLET PROTECTION INSTALLATION NOTES

- SEE ROCK SOCK DESIGN DETAIL FOR INSTALLATION REQUIREMENTS.
- STRAW WATTLES/SEDIMENT CONTROL LOGS MAY BE USED IN PLACE OF ROCK SOCKS FOR INLETS IN PERVIOUS AREAS. INSTALL PER SEDIMENT CONTROL LOG DETAIL.

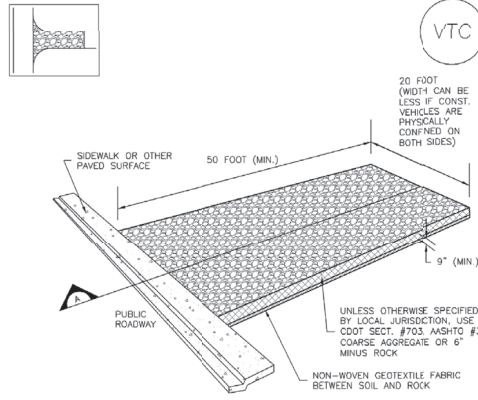

VTC-1. AGGREGATE VEHICLE TRACKING CONTROL

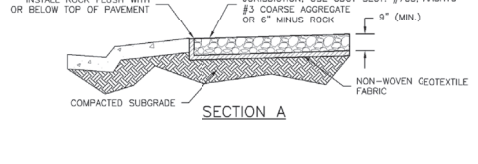

SECTION A

STABILIZED CONSTRUCTION ENTRANCE/EXIT INSTALLATION NOTES

- SEE PLAN VIEW FOR -LOCATION OF CONSTRUCTION ENTRANCE(S)/EXIT(S). -TYPE OF CONSTRUCTION ENTRANCE(S)/EXIT(S) (WITH/WITHOUT WHEEL WASH, CONSTRUCTION MAT OR TRM).
- CONSTRUCTION MAT OR TRM STABILIZED CONSTRUCTION ENTRANCES ARE ONLY TO BE USED ON SHORT DURATION PROJECTS (TYPICALLY RANGING FROM A WEEK TO A MONTH) WHERE THERE WILL BE LIMITED VEHICULAR ACCESS.
- A STABILIZED CONSTRUCTION ENTRANCE/EXIT SHALL BE LOCATED AT ALL ACCESS POINTS WHERE VEHICLES ACCESS THE CONSTRUCTION SITE FROM PAVED RIGHT-OF-WAYS.
- STABILIZED CONSTRUCTION ENTRANCE/EXIT SHALL BE INSTALLED PRIOR TO ANY LAND DISTURBING ACTIVITIES.
- A NON-WOVEN GEOTEXTILE FABRIC SHALL BE PLACED UNDER THE STABILIZED CONSTRUCTION ENTRANCE/EXIT PRIOR TO THE PLACEMENT OF ROCK.
- UNLESS OTHERWISE SPECIFIED BY LOCAL JURISDICTION, ROCK SHALL CONSIST OF DOT SECT. #703, ASHTO #3 COARSE AGGREGATE OR 6" (MINUS) ROCK.

STABILIZED CONSTRUCTION ENTRANCE/EXIT MAINTENANCE NOTES

- INSPECT BMPs EACH WORKDAY, AND MAINTAIN THEM IN EFFECTIVE OPERATING CONDITION. MAINTENANCE OF BMPs SHOULD BE PROACTIVE, NOT REACTIVE. INSPECT BMPs AS SOON AS POSSIBLE (AND ALWAYS WITHIN 24 HOURS) FOLLOWING A STORM THAT CAUSES SURFACE EROSION, AND PERFORM NECESSARY MAINTENANCE.
- FREQUENT OBSERVATIONS AND MAINTENANCE ARE NECESSARY TO MAINTAIN BMPs IN EFFECTIVE OPERATING CONDITION. INSPECTIONS AND CORRECTIVE MEASURES SHOULD BE DOCUMENTED THOROUGHLY.
- WHERE BMPs HAVE FAILED, REPAIR OR REPLACEMENT SHOULD BE INITIATED UPON DISCOVERY OF THE FAILURE.
- A ROCK SHALL BE REAPPLIED OR REGRADED AS NECESSARY TO THE STABILIZED ENTRANCE/EXIT TO MAINTAIN A CONSISTENT DEPTH.
- SEDIMENT TRACKED ONTO PAVED ROADS IS TO BE REMOVED THROUGHOUT THE DAY AND AT THE END OF THE DAY BY SHOVELING OR SWEEPING. SEDIMENT MAY NOT BE WASHED DOWN STORM SEWER DRAINS.

(DETAILS ADAPTED FROM CITY OF BROOMFIELD, COLORADO, NOT AVAILABLE IN AUTOCAD)

NOTE: MANY JURISDICTIONS HAVE BMP DETAILS THAT VARY FROM UDFCD STANDARD DETAILS. CONSULT WITH LOCAL JURISDICTIONS AS TO WHICH DETAIL SHOULD BE USED WHEN DIFFERENCES ARE NOTED.

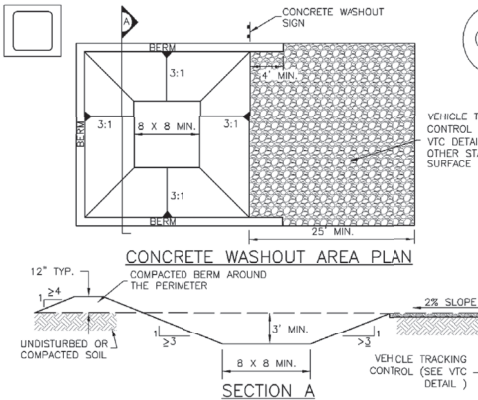

CWA-1. CONCRETE WASHOUT AREA

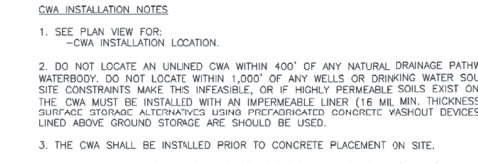

SECTION A

CWA INSTALLATION NOTES

- SEE PLAN VIEW FOR: -CWA INSTALLATION LOCATION.
- DO NOT LOCATE AN UNLINED CWA WITHIN 400' OF ANY NATURAL DRAINAGE PATHWAY OR WATERBODY. DO NOT LOCATE WITHIN 1,000' OF ANY WELLS OR DRINKING WATER SOURCES. IF SITE CONSTRAINTS MAKE THIS INFEASIBLE, OR IF HIGHLY PERMEABLE SOILS EXIST ON SITE, THE CWA MUST BE INSTALLED WITH AN IMPERMEABLE LINER (16 MIL MIN. THICKNESS) OR SURFACE STORAGE ALTERNATIVES USING PREFABRICATED CONCRETE WASHOUT DEVICES OR A LINED ABOVE GROUND STORAGE ARE SHOULD BE USED.
- THE CWA SHALL BE INSTALLED PRIOR TO CONCRETE PLACEMENT ON SITE.
- CWA SHALL INCLUDE A FLAT SUBSURFACE PIT THAT IS AT LEAST 8' BY 6' SLOPES LEADING OUT OF THE SUBSURFACE PIT SHALL BE 3:1 OR FLATTER. THE PIT SHALL BE AT LEAST 3' DEEP.
- BERM SURROUNDING SIDES AND BACK OF THE CWA SHALL HAVE MINIMUM HEIGHT OF 1'.
- VEHICLE TRACKING PAD SHALL BE SLOPED 2% TOWARDS THE CWA.
- SIGNS SHALL BE PLACED AT THE CONSTRUCTION ENTRANCE, AT THE CWA, AND ELSEWHERE AS NECESSARY TO CLEARLY INDICATE THE LOCATION OF THE CWA TO OPERATORS OF CONCRETE TRUCKS AND PUMP RIGS.
- USE EXCAVATED MATERIAL FOR PERIMETER BERM CONSTRUCTION.

CWA MAINTENANCE NOTES

- INSPECT BMPs EACH WORKDAY, AND MAINTAIN THEM IN EFFECTIVE OPERATING CONDITION. MAINTENANCE OF BMPs SHOULD BE PROACTIVE, NOT REACTIVE. INSPECT BMPs AS SOON AS POSSIBLE (AND ALWAYS WITHIN 24 HOURS) FOLLOWING A STORM THAT CAUSES SURFACE EROSION, AND PERFORM NECESSARY MAINTENANCE.
- FREQUENT OBSERVATIONS AND MAINTENANCE ARE NECESSARY TO MAINTAIN BMPs IN EFFECTIVE OPERATING CONDITION. INSPECTIONS AND CORRECTIVE MEASURES SHOULD BE DOCUMENTED THOROUGHLY.
- WHERE BMPs HAVE FAILED, REPAIR OR REPLACEMENT SHOULD BE INITIATED UPON DISCOVERY OF THE FAILURE.
- THE CWA SHALL BE REPAIRED, CLEANED, OR ENLARGED AS NECESSARY TO MAINTAIN CAPACITY FOR CONCRETE WASTE. CONCRETE MATERIALS, ACCUMULATED IN PIT, SHALL BE REMOVED ONCE THE MATERIALS HAVE REACHED A DEPTH OF 2'.
- CONCRETE WASHOUT WATER, WASTED PIECES OF CONCRETE AND ALL OTHER DEBRIS IN THE SUBSURFACE PIT SHALL BE TRANSPORTED FROM THE JOB SITE IN A WATER-TIGHT CONTAINER AND DISPOSED OF PROPERLY.
- THE CWA SHALL REMAIN IN PLACE UNTIL ALL CONCRETE FOR THE PROJECT IS PLACED.
- WHEN THE CWA IS REMOVED, COVER THE DISTURBED AREA WITH TOP SOIL, SEED AND MULCH OR OTHERWISE STABILIZED IN A MANNER APPROVED BY THE LOCAL JURISDICTION.

(DETAIL ADAPTED FROM DOUGLAS COUNTY, COLORADO AND THE CITY OF PARKER, COLORADO, NOT AVAILABLE IN AUTOCAD)

NOTE: MANY JURISDICTIONS HAVE BMP DETAILS THAT VARY FROM UDFCD STANDARD DETAILS. CONSULT WITH LOCAL JURISDICTIONS AS TO WHICH DETAIL SHOULD BE USED WHEN DIFFERENCES ARE NOTED.

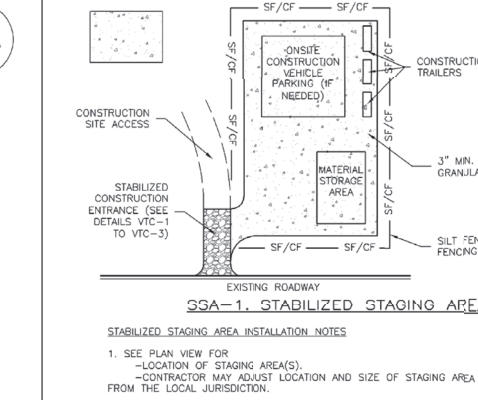

SSA-1. STABILIZED STAGING AREA

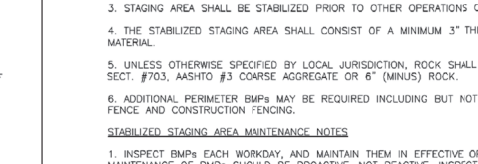

SECTION A

STABILIZED STAGING AREA INSTALLATION NOTES

- SEE PLAN VIEW FOR -LOCATION OF STAGING AREA(S). -CONTRACTOR MAY ADJUST LOCATION AND SIZE OF STAGING AREA WITH APPROVAL FROM THE LOCAL JURISDICTION.
- STABILIZED STAGING AREA SHOULD BE APPROPRIATE FOR THE NEEDS OF THE SITE. OVERSIZING RESULTS IN A LARGER AREA TO STABILIZE FOLLOWING CONSTRUCTION.
- STAGING AREA SHALL BE STABILIZED PRIOR TO OTHER OPERATIONS ON THE SITE.
- THE STABILIZED STAGING AREA SHALL CONSIST OF A MINIMUM 3" THICK GRANULAR MATERIAL.
- UNLESS OTHERWISE SPECIFIED BY LOCAL JURISDICTION, ROCK SHALL CONSIST OF DOT SECT. #703, ASHTO #3 COARSE AGGREGATE OR 6" (MINUS) ROCK.
- ADDITIONAL PERIMETER BMPs MAY BE REQUIRED INCLUDING BUT NOT LIMITED TO SILT FENCE AND CONSTRUCTION FENCING AS NEEDED.

STABILIZED STAGING AREA MAINTENANCE NOTES

- INSPECT BMPs EACH WORKDAY, AND MAINTAIN THEM IN EFFECTIVE OPERATING CONDITION. MAINTENANCE OF BMPs SHOULD BE PROACTIVE, NOT REACTIVE. INSPECT BMPs AS SOON AS POSSIBLE (AND ALWAYS WITHIN 24 HOURS) FOLLOWING A STORM THAT CAUSES SURFACE EROSION, AND PERFORM NECESSARY MAINTENANCE.
- FREQUENT OBSERVATIONS AND MAINTENANCE ARE NECESSARY TO MAINTAIN BMPs IN EFFECTIVE OPERATING CONDITION. INSPECTIONS AND CORRECTIVE MEASURES SHOULD BE DOCUMENTED THOROUGHLY.
- WHERE BMPs HAVE FAILED, REPAIR OR REPLACEMENT SHOULD BE INITIATED UPON DISCOVERY OF THE FAILURE.
- ROCK SHALL BE REAPPLIED OR REGRADED AS NECESSARY IF RUTTING OCCURS OR UNDERLYING SUBGRADE BECOMES EXPOSED.

(DETAILS ADAPTED FROM DOUGLAS COUNTY, COLORADO, NOT AVAILABLE IN AUTOCAD)

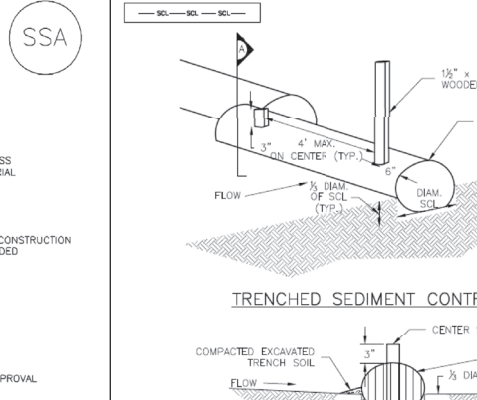

SCL-1. TRENCHED SEDIMENT CONTROL LOG



SECTION A

SEDIMENT CONTROL LOG INSTALLATION NOTES

- SEE PLAN VIEW FOR LOCATION AND LENGTH OF SEDIMENT CONTROL LOGS.
- SEDIMENT CONTROL LOGS THAT ACT AS A PERIMETER CONTROL SHALL BE INSTALLED PRIOR TO ANY UPGRADE LAND-DISTURBING ACTIVITIES.
- SEDIMENT CONTROL LOGS SHALL CONSIST OF STRAW, COMPOST, EXCELSIOR OR COCONUT FIBER, AND SHALL BE FREE OF ANY NOXIOUS WEED SEEDS OR DEFECTS INCLUDING RIPS, HOLES AND OBVIOUS WEAR.
- SEDIMENT CONTROL LOGS MAY BE USED AS SMALL CHECK DAMS IN DITCHES AND SWALES. HOWEVER, THEY SHOULD NOT BE USED IN PERENNIAL STREAMS.
- IT IS RECOMMENDED THAT SEDIMENT CONTROL LOGS BE TRENCHED INTO THE GROUND TO A DEPTH OF APPROXIMATELY 1/2 OF THE DIAMETER OF THE LOG. IF TRENCHING TO THIS DEPTH IS NOT FEASIBLE AND/OR DESIRABLE (SHORT TERM INSTALLATION WITH DESIRE NOT TO DAMAGE LANDSCAPE) A LESSER TRENCHING DEPTH MAY BE ACCEPTABLE WITH MORE ROBUST STAKING. COMPOST LOGS THAT ARE 8 LB/FT DO NOT NEED TO BE TRENCHED.
- THE UPHILL SIDE OF THE SEDIMENT CONTROL LOG SHALL BE BACKFILLED WITH SOIL OR FILTER MATERIAL THAT IS FREE OF ROCKS AND DEBRIS. THE SOIL SHALL BE TIGHTLY COMPACTED INTO THE SHAPE OF A RIGHT TRIANGLE USING A SHOVEL OR WEIGHTED LAWN ROLLER OR BLOWN IN PLACE.
- FOLLOW MANUFACTURERS' GUIDANCE FOR STAKING. IF MANUFACTURERS' INSTRUCTIONS DO NOT SPECIFY SPACING, STAKES SHALL BE PLACED ON 4' CENTERS AND EMBEDDED A MINIMUM OF 6" INTO THE GROUND. 3" OF THE STAKE SHALL PROTRUDE FROM THE TOP OF THE LOG. STAKES THAT ARE BROKEN PRIOR TO INSTALLATION SHALL BE REPLACED. COMPOST LOGS SHOULD BE STAKED 10' ON CENTER.

SEDIMENT CONTROL LOG MAINTENANCE NOTES

- INSPECT BMPs EACH WORKDAY, AND MAINTAIN THEM IN EFFECTIVE OPERATING CONDITION. MAINTENANCE OF BMPs SHOULD BE PROACTIVE, NOT REACTIVE. INSPECT BMPs AS SOON AS POSSIBLE (AND ALWAYS WITHIN 24 HOURS) FOLLOWING A STORM THAT CAUSES SURFACE EROSION, AND PERFORM NECESSARY MAINTENANCE.
- FREQUENT OBSERVATIONS AND MAINTENANCE ARE NECESSARY TO MAINTAIN BMPs IN EFFECTIVE OPERATING CONDITION. INSPECTIONS AND CORRECTIVE MEASURES SHOULD BE DOCUMENTED THOROUGHLY.
- WHERE BMPs HAVE FAILED, REPAIR OR REPLACEMENT SHOULD BE INITIATED UPON DISCOVERY OF THE FAILURE.
- SEDIMENT ACCUMULATED UPSTREAM OF SEDIMENT CONTROL LOG SHALL BE REMOVED AS NEEDED TO MAINTAIN FUNCTIONALITY OF THE BMP. TYPICALLY WHEN DEPTH OF ACCUMULATED SEDIMENTS IS APPROXIMATELY 1/2 OF THE HEIGHT OF THE SEDIMENT CONTROL LOG.
- SEDIMENT CONTROL LOG SHALL BE REMOVED AT THE END OF CONSTRUCTION. COMPOST FROM COMPOST LOGS MAY BE LEFT IN PLACE AS LONG AS BAGS ARE REMOVED AND THE AREA SEEDED. IF DISTURBED AREAS EXIST AFTER REMOVAL, THEY SHALL BE COVERED WITH TOP SOIL, SEEDED AND MULCHED OR OTHERWISE STABILIZED IN A MANNER APPROVED BY THE LOCAL JURISDICTION.

(DETAILS ADAPTED FROM TOWN OF PARKER, COLORADO, JEFFERSON COUNTY, COLORADO, DOUGLAS COUNTY, COLORADO, AND CITY OF AURORA, COLORADO, NOT AVAILABLE IN AUTOCAD)

NOTE: MANY JURISDICTIONS HAVE BMP DETAILS THAT VARY FROM UDFCD STANDARD DETAILS. CONSULT WITH LOCAL JURISDICTIONS AS TO WHICH DETAIL SHOULD BE USED WHEN DIFFERENCES ARE NOTED.

48 hours before you dig, call UTILITY NOTIFICATION CENTER OF COLORADO (UNCC) **811**

Gas, Electric, Telephone, Cable, and Pipeline Locations

SCALE VERIFICATION
BAR IS ONE INCH ON ORIGINAL DRAWING
IF NOT ONE INCH ON THIS SHEET SCALE ACCORDINGLY

NO.	DATE	BY	REVISIONS DESCRIPTION

ERG AND ASSOCIATES, LLC
4885 Ward Road, Suite 100 • Wheat Ridge, CO 80033
Del Norte • Gypsum • Wheat Ridge
303-293-8107 • www.ergengineers.com

SCENIC VIEW AT PAINT BRUSH HILLS DETENTION POND MODIFICATIONS

EROSION CONTROL DETAILS

DESIGNED FOR
PAINT BRUSH HILLS METROPOLITAN DISTRICT
EL PASO COUNTY, COLORADO

DRAWN BY:	JGS	DESIGNED BY:	GEW
JOB NUMBER:	1070.0022	DATE:	MAY 2022
SCALE:	N.T.S.	DRAWING NAME:	DETAILS
SHEET NO:	7	of	8

Seeding dates for the highest success probability of perennial species along the Front Range are generally in the spring from April through early May and in the fall after the first of September until the ground freezes. If the area is irrigated, seeding may occur in summer months, as well. See Table TS/PS-3 for appropriate seeding dates.

Table TS/PS-1. Minimum Drill Seeding Rates for Various Temporary Annual Grasses

Species ^a (Common name)	Growth Season ^b	Pounds of Pure Live Seed (PLS)/acre ^c	Planting Depth (inches)
1. Oats	Cool	35 - 50	1 - 2
2. Spring wheat	Cool	25 - 35	1 - 2
3. Spring barley	Cool	25 - 35	1 - 2
4. Annual ryegrass	Cool	10 - 15	½
5. Millet	Warm	3 - 15	½ - ¾
6. Sudangrass	Warm	5-10	½ - ¾
7. Sorghum	Warm	5-10	½ - ¾
8. Winter wheat	Cool	20-35	1 - 2
9. Winter barley	Cool	20-35	1 - 2
10. Winter rye	Cool	20-35	1 - 2
11. Triticale	Cool	25-40	1 - 2

^a Successful seeding of annual grass resulting in adequate plant growth will usually produce enough dead-plant residue to provide protection from wind and water erosion for an additional year. This assumes that the cover is not disturbed or mowed closer than 8 inches.

Hydraulic seeding may be substituted for drilling only where slopes are steeper than 3:1 or where access limitations exist. When hydraulic seeding is used, hydraulic mulching should be applied as a separate operation, when practical, to prevent the seeds from being encapsulated in the mulch.

^b See Table TS/PS-3 for seeding dates. Irrigation, if consistently applied, may extend the use of cool season species during the summer months.

^c Seeding rates should be doubled if seed is broadcast, or increased by 50 percent if done using a Brillion Drill or by hydraulic seeding.

Table TS/PS-2. Minimum Drill Seeding Rates for Perennial Grasses

Common Name	Botanical Name	Growth Season ^a	Growth Form	Seeds/Pound	Pounds of PLS/acre
Alkali Soil Seed Mix					
Alkali sacaton	<i>Sporobolus airoides</i>	Cool	Bunch	1,750,000	0.25
Basin wildrye	<i>Elymus cinereus</i>	Cool	Bunch	165,000	2.5
Sodar streambank wheatgrass	<i>Agropyron riparium 'Sodar'</i>	Cool	Sod	170,000	2.5
Jose tall wheatgrass	<i>Agropyron elongatum 'Jose'</i>	Cool	Bunch	79,000	7.0
Arriba western wheatgrass	<i>Agropyron smithii 'Arriba'</i>	Cool	Sod	110,000	5.5
Total					17.75
Fertile Loamy Soil Seed Mix					
Ephriam crested wheatgrass	<i>Agropyron cristatum 'Ephriam'</i>	Cool	Sod	175,000	2.0
Dural hard fescue	<i>Festuca ovina 'durascula'</i>	Cool	Bunch	565,000	1.0
Lincoln smooth brome	<i>Bromus inermis leysii 'Lincoln'</i>	Cool	Sod	130,000	3.0
Sodar streambank wheatgrass	<i>Agropyron riparium 'Sodar'</i>	Cool	Sod	170,000	2.5
Arriba western wheatgrass	<i>Agropyron smithii 'Arriba'</i>	Cool	Sod	110,000	7.0
Total					15.5
High Water Table Soil Seed Mix					
Meadow foxtail	<i>Alopecurus pratensis</i>	Cool	Sod	900,000	0.5
Redtop	<i>Agrostis alba</i>	Warm	Open sod	5,000,000	0.25
Reed canarygrass	<i>Phalaris arundinacea</i>	Cool	Sod	68,000	0.5
Lincoln smooth brome	<i>Bromus inermis leysii 'Lincoln'</i>	Cool	Sod	130,000	3.0
Pathfinder ewinggrass	<i>Panicum virgatum 'Pathfinder'</i>	Warm	Sod	380,000	1.0
Alkar tall wheatgrass	<i>Agropyron elongatum 'Alkar'</i>	Cool	Bunch	79,000	5.5
Total					10.75
Transition Turf Seed Mix^d					
Ruebens Canadian bluegrass	<i>Poa compressa 'Ruebens'</i>	Cool	Sod	2,500,000	0.5
Dural hard fescue	<i>Festuca ovina 'durascula'</i>	Cool	Bunch	565,000	1.0
Citation perennial ryegrass	<i>Lolium perenne 'Citation'</i>	Cool	Sod	247,000	3.0
Lincoln smooth brome	<i>Bromus inermis leysii 'Lincoln'</i>	Cool	Sod	130,000	3.0
Total					7.5

Table TS/PS-2. Minimum Drill Seeding Rates for Perennial Grasses (cont.)

Common Name	Botanical Name	Growth Season ^a	Growth Form	Seeds/Pound	Pounds of PLS/acre
Sandy Soil Seed Mix					
Blue grama	<i>Bouteloua gracilis</i>	Warm	Sod-forming bunchgrass	825,000	0.5
Camper little bluestem	<i>Setchachyrium scoparium 'Camper'</i>	Warm	Bunch	240,000	1.0
Prairie sandreed	<i>Calamovilfa longifolia</i>	Warm	Open sod	274,000	1.0
Sand dropseed	<i>Sporobolus cryptandrus</i>	Cool	Bunch	5,298,000	0.25
Vaughn sideoats grama	<i>Bouteloua curtipendula 'Vaughn'</i>	Warm	Sod	191,000	2.0
Arriba western wheatgrass	<i>Agropyron smithii 'Arriba'</i>	Cool	Sod	110,000	5.5
Total					10.25
Heavy Clay, Rocky Foothill Seed Mix					
Ephriam crested wheatgrass ^d	<i>Agropyron cristatum 'Ephriam'</i>	Cool	Sod	175,000	1.5
Oahe Intermediate wheatgrass	<i>Agropyron intermedium 'Oahe'</i>	Cool	Sod	115,000	5.5
Vaughn sideoats grama ^d	<i>Bouteloua curtipendula 'Vaughn'</i>	Warm	Sod	191,000	2.0
Lincoln smooth brome	<i>Bromus inermis leysii 'Lincoln'</i>	Cool	Sod	130,000	3.0
Arriba western wheatgrass	<i>Agropyron smithii 'Arriba'</i>	Cool	Sod	110,000	5.5
Total					17.5

^a All of the above seeding mixes and rates are based on drill seeding followed by crimped straw mulch. These rates should be doubled if seed is broadcast and should be increased by 50 percent if the seeding is done using a Brillion Drill or is applied through hydraulic seeding. Hydraulic seeding may be substituted for drilling only where slopes are steeper than 3:1. If hydraulic seeding is used, hydraulic mulching should be done as a separate operation.

^b See Table TS/PS-3 for seeding dates.

^c If site is to be irrigated, the transition turf seed rates should be doubled.

^d Crested wheatgrass should not be used on slopes steeper than 6H to 1V.

^e Can substitute 0.5 lbs PLS of blue grama for the 2.0 lbs PLS of Vaughn sideoats grama.

Table TS/PS-3. Seeding Dates for Annual and Perennial Grasses

Seeding Dates	Annual Grasses (Numbers in table reference species in Table TS/PS-1)		Perennial Grasses	
	Warm	Cool	Warm	Cool
January 1–March 15			✓	✓
March 16–April 30	4	1,2,3	✓	✓
May 1–May 15	4		✓	
May 16–June 30	4,5,6,7			
July 1–July 15	5,6,7			
July 16–August 31				
September 1–September 30		8,9,10,11		
October 1–December 31			✓	✓

Mulch

Cover seeded areas with mulch or an appropriate rolled erosion control product to promote establishment of vegetation. Anchor mulch by crimping, netting or use of a non-toxic tackifier. See the Mulching BMP Fact Sheet for additional guidance.

Maintenance and Removal

Monitor and observe seeded areas to identify areas of poor growth or areas that fail to germinate. Reseed and mulch these areas, as needed.

An area that has been permanently seeded should have a good stand of vegetation within one growing season if irrigated and within three growing seasons without irrigation in Colorado. Reseed portions of the site that fail to germinate or remain bare after the first growing season.

Seeded areas may require irrigation, particularly during extended dry periods. Targeted weed control may also be necessary.

Protect seeded areas from construction equipment and vehicle access.

MULCHING NOTES

INSTALLATION REQUIREMENTS

- ALL DISTURBED AREAS MUST BE MULCHED WITHIN 21 DAYS AFTER FINAL GRADE AND SEEDING AREAS ARE TO BE MULCHED WITHIN 24 HOURS AFTER SEEDING.
- MATERIAL USED FOR MULCH CAN BE CERTIFIED CLEAN, WEED- AND SEED-FREE LONG STEMMED FIELD OR MARSH HAY, OR STRAW OF OATS, BARLEY, WHEAT, RYE, OR TRITICALE CERTIFIED BY THE COLORADO DEPARTMENT OF AGRICULTURE WEED FREE FORAGE CERTIFICATION PROGRAM.
- HYDRAULIC MULCHING MATERIAL SHALL CONSIST OF VIRGIN WOOD FIBER MANUFACTURED FROM CLEAN WHOLE WOOD CHIPS. WOOD CHIPS CANNOT CONTAIN ANY GROWTH OR GERMINATION INHIBITORS OR BE PRODUCED FROM RECYCLED MATERIAL. GRAVEL CAN ALSO BE USED.
- MULCH IS TO BE APPLIED EVENLY AT A RATE OF 2 TONS PER ACRE.
- MULCH IS TO BE ANCHORED EITHER BY CRIMPING (TUCKING MULCH FIBERS 4 INCHES INTO THE SOIL), USING NETTING (USED ON SMALL AREAS WITH STEEP SLOPES), OR WITH A TACKIFIER.
- HYDRAULIC MULCHING AND TACKIFIERS ARE NOT TO BE USED IN THE PRESENCE OF FREE SURFACE WATER.

MAINTENANCE REQUIREMENTS

- REGULAR INSPECTIONS ARE TO BE MADE OF ALL MULCHED AREAS.
- MULCH IS TO BE REPLACED IMMEDIATELY IN THOSE AREAS IT HAS BEEN REMOVED, AND IF NECESSARY THE AREA SHOULD BE RESEEDED.

48 hours before you dig, CALL UTILITY NOTIFICATION CENTER OF COLORADO (UNCC) **811**
 Gas, Electric, Telephone, CATV and
 Potable Water, Sewer, Irrigation, Locations
SCALE VERIFICATION
 BAR IS ONE INCH ON ORIGINAL DRAWING
 IF NOT ONE INCH ON THIS SHEET
 SCALE ACCORDINGLY

NO.	REVISIONS DESCRIPTION	BY	DATE

ERG AND ASSOCIATES, LLC
 4883 Ward Road, Suite 100 • Wheat Ridge, CO 80033
 Del Norte • Gypsum • Wheat Ridge
 303-298-8107 • www.ergengineers.com

SCENIC VIEW AT PAINT BRUSH HILLS
 DETENTION POND MODIFICATIONS
 EROSION CONTROL DETAILS
 Paint Brush Hills Metropolitan District
 El Paso County, Colorado

DRAWN BY: JGS	DESIGNED BY: GEW
JOB NUMBER: 1070.0022	
DATE: MAY 2022	
SCALE: N.T.S.	
DRAWING NAME: DETAILS	
SHEET NO: 8 of 8	

APPENDIX 5: Erosion & Sediment Control Plan (ESC Plan) – Site Map

ESC Plan includes, at a minimum, the following:

1. Construction site boundaries;
2. Flow arrows that depict stormwater flow directions on-site and runoff direction;
3. Areas of ground disturbance including areas of borrow and fill;
4. Areas used for storage of soil;
5. Locations of all waste accumulation areas, including areas for liquid, concrete, masonry, and asphalt;
6. Locations of dedicated asphalt, concrete batch plants and masonry mixing stations;
7. Locations of all structural control measures;
8. Locations of all non-structural control measures;
9. Locations of springs, streams, wetlands and other state waters, including areas that require pre-existing vegetation be maintained within 50 ft of a receiving water; and
10. Locations of all stream crossings located within the construction site boundary.

S:\1070 - Paint Brush Hills Metropolitan District\1070.0022 - Scenic View Detention Pond\DWG\03 SITE PLAN.dwg, 08 EC PLAN, 5/12/2022 11:34:47 AM.
 DWG To PDF.pc3

EROSION CONTROL LEGEND

- (SF) — SF — PR SILT FENCE
- (VTC) [Pattern] PR VEHICLE TRACKING CONTROL
- (CW) [Symbol] PR CONCRETE WASHOUT
- (IP) [Symbol] PR INLET PROTECTION
- (SCL) [Symbol] PR SEDIMENT CONTROL LOG
- (ECB) [Pattern] PR EROSION CONTROL BLANKET
- (SM) [Pattern] PR SEEDING AND MULCHING

NOTE:
 1. SEED AND MULCH ALL DISTURBED AREAS.

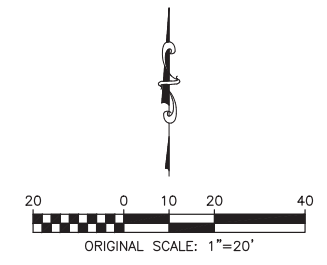
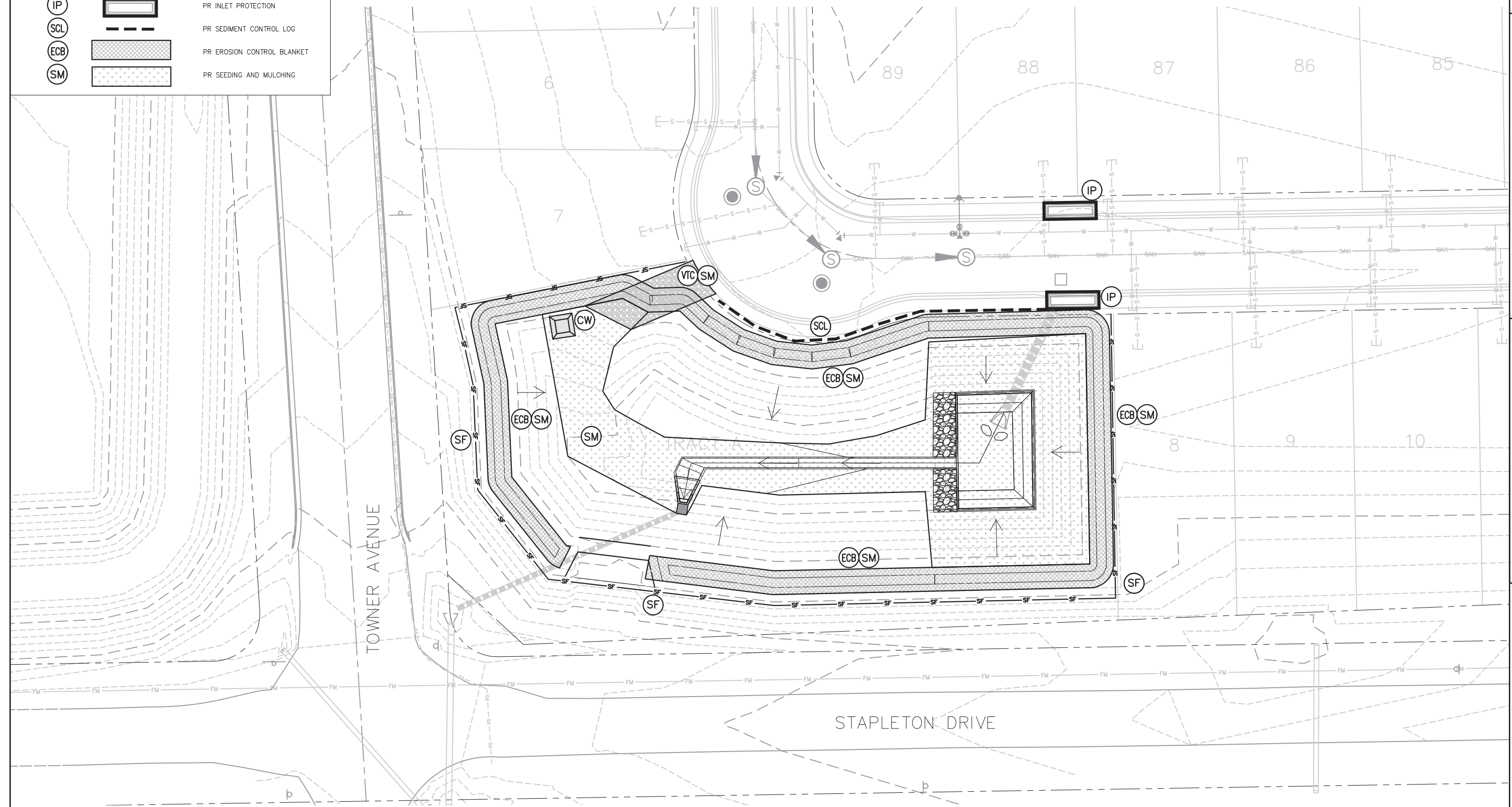

48 hours before you dig, CALL UTILITY NOTIFICATION CENTER OF COLORADO (UNCC) **811**
 Gas, Electric, Telephone, CATV and Potable Water, Sewer, Stormwater, and Irrigation Lines
 SCALE VERIFICATION
 BAR IS ONE INCH ON ORIGINAL DRAWING
 IF NOT ONE INCH ON THIS SHEET SCALE ACCORDINGLY

NO.	REVISIONS DESCRIPTION	DATE	BY

IRG AND ASSOCIATES, LLC
 4885 Ward Road, Suite 100 • Wheat Ridge, CO 80033
 Del Norte • Gypsum • Wheat Ridge
 303-299-8107 • www.igengineers.com

SCENIC VIEW AT PAINT BRUSH HILLS
 DETENTION POND MODIFICATIONS
 EROSION CONTROL PLAN
 PREPARED FOR
 PAINT BRUSH HILLS METROPOLITAN DISTRICT
 EL PASO COUNTY, COLORADO

DRAWN BY: JGS	DESIGNED BY: GEW
JOB NUMBER: 1070.0022	
DATE: MAY 2022	
SCALE: 1" = 20'	
DRAWING NAME: EROSION CONTROL	
SHEET NO: 6 of 8	

APPENDIX 6: Stormwater Inspection Form (Template)

Instructions:

This inspection report has been developed to complete the 7 day (or 14 day and storm event site inspections) and 30-day inspections at completed sites.

Contractor Construction Stormwater Site Inspection

General Information

Project Name: Project Name. **Project No.:** Project No. **CDPS Cert. No.:** COR-000000
Location: Location. **Date of Inspection:** Date of Inspection. **Start and End Time:** Start Time. / End Time.
Weather Conditions: Clear Cloudy Rain Sleet Fog Snow High Winds Other: Other. **Temperature:** Temp.
Present Phase of Construction: Phase. **Estimated Area of Disturbance (ac):** Est. Acreage.

Inspection Information

Type of Inspection: Choose an item. If Post-Storm Inspection, provide the storm information below:
 Type: Choose an item. Date: Date. Time: Time. Duration (hrs): Duration. Approximate Amount of Precipitation (in): Precipitation.
Has there been any deviations from the minimum inspection schedule? Yes No **If "Yes, describe:** Deviation.
Inspector's Name: Inspector's Name. **Inspector's Title:** Inspector's Title.
Is the above inspector a qualified stormwater manager? Yes No
Is there evidence of, or the potential for, pollutants leaving the construction site boundaries, entering the stormwater drainage system or discharging to state waters at the following locations? Yes No If "Yes", select all that apply below:
 Construction site perimeter; All disturbed areas; Designated haul routes; Material and waste storage areas exposed to precipitation;
 Locations where stormwater has the potential to discharge offsite; Locations where vehicles exit the site; Other: Other.

Noncompliance Reporting to CDPHE

The permittee shall report the following circumstances orally within twenty-four (24) hours from the time the permittee becomes aware of the circumstances, and shall mail to the division a written report containing the information requested within five (5) working days after becoming aware of the following circumstances. The division may waive the written report required if the oral report has been received within 24 hours.

- a. Endangerment to Health or the Environment
Circumstances leading to any noncompliance which may endanger health or the environment regardless of the cause of the incident (See Part II.L.6.a of the Permit)
- b. Numeric Effluent Limit Violations
 - o Circumstances leading to any unanticipated bypass which exceeds any effluent limitations (See Part II.L.6.b of the Permit)
 - o Circumstances leading to any upset which causes an exceedance of any effluent limitation (See Part II.L.6.c of the Permit)
 - o Daily maximum violations (See Part II.L.6.d of the Permit)*Numeric effluent limits are very uncommon in certifications under the COR400000 general permit. This category of noncompliance only applies if numeric effluent limits are included in a permit certification.*

Has there been an incident of noncompliance requiring 24-hour notification? Yes No If "Yes" please document below

Date and Time of Incident	Location and Description of Noncompliance	Description of Corrective Action	Date and Time of 24 Hour Oral Notification	Date of 5 Day Written Notification ²

² Attach copy of 5 day written notification to report. Indicate if written notification was waived, including the name of the division personnel who granted waiver.

* If winter conditions exclusions is selected as type of inspection, please attach a copy of the required documentation from Part I.D.4.c of the Permit.

Date.	Time.	Noncompliance.	Noncompliance.	Date.	Time.	Date.
-------	-------	----------------	----------------	-------	-------	-------

Sediment Control Measures					
Type	Maintenance Needed?	Inadequate Control Measure?	Additional Control Measure Needed?	Location and description of Maintenance or Corrective Action.	Date Corrected
Choose an item.	<input type="checkbox"/>	<input type="checkbox"/>	<input type="checkbox"/>	Click or tap here to enter text.	Date.

Erosion Control Measures					
Type	Maintenance Needed?	Inadequate Control Measure?	Additional Control Measure Needed?	Location and description of Maintenance or Corrective Action.	Date Corrected
Choose an item.	<input type="checkbox"/>	<input type="checkbox"/>	<input type="checkbox"/>	Click or tap here to enter text.	Date.

Materials Management Control Measures					
Type	Maintenance Needed?	Inadequate Control Measure?	Additional Control Measure Needed?	Location and description of Maintenance or Corrective Action.	Date Corrected

Choose an item.	<input type="checkbox"/>	<input type="checkbox"/>	<input type="checkbox"/>	Click or tap here to enter text.	Date.
-----------------	--------------------------	--------------------------	--------------------------	----------------------------------	-------

Site Management Control Measures					
Type	Maintenance Needed?	Inadequate Control Measure?	Additional Control Measure Needed?	Location and description of Maintenance or Corrective Action.	Date Corrected
Choose an item.	<input type="checkbox"/>	<input type="checkbox"/>	<input type="checkbox"/>	Click or tap here to enter text.	Date.

Field Notes
Click or tap here to enter text.

Certification Statement	
<p>After adequate corrective action(s) and maintenance have been taken, or where a report does not identify any incidents requiring corrective action or maintenance, the individual(s) designated as the Qualified Stormwater Manager, shall sign and certify the below statement:</p> <p>“I verify that, to the best of my knowledge and belief, all corrective action and maintenance items identified during the inspection are complete, and the site is currently in compliance with the permit.”</p>	
<p>Name of Qualified Stormwater Manager.</p> <hr/> <p>Name of Qualified Stormwater Manager</p>	<p>Title of Qualified Stormwater Manager.</p> <hr/> <p>Title of Qualified Stormwater Manager</p>
<p>Signature of Qualified Stormwater Manager</p> <hr/> <p>Signature of Qualified Stormwater Manager</p>	<p>Date.</p> <hr/> <p>Date</p>

APPENDIX 8: Completed Stormwater Inspection Logs

(File completed inspection forms or reference electronic location of inspections here)

APPENDIX 9: Agreement for off-site Control Measures

(if applicable)

Attach use agreement between the Permittee and the owner/operator of any control measures located outside of the permitted area, that are utilized by the Permittee's construction site for compliance with this permit, but not under the direct control of the Permittee.

The Permittee is responsible for ensuring that all control measures located outside of their permitted area, that are being utilized by the Permittee's construction site, are properly maintained and in compliance with all terms and conditions of the permit.

Include all information to any such off-site control measures located outside the permitted area, including location, installation specifications, design specifications and maintenance requirements



**PRIVATE DETENTION BASIN /
STORMWATER QUALITY BEST MANAGEMENT PRACTICE
MAINTENANCE AGREEMENT AND EASEMENT**

This PRIVATE DETENTION BASIN / STORMWATER QUALITY BEST MANAGEMENT PRACTICE MAINTENANCE AGREEMENT AND EASEMENT (Agreement) is made by and between EL PASO COUNTY by and through THE BOARD OF COUNTY COMMISSIONERS OF EL PASO COUNTY, COLORADO (Board or County) and Lorson South Land Corp. (Developer) and Paintbrush Hills Metropolitan District (Metro District), a quasi-municipal corporation and political subdivision of the State of Colorado. The above may occasionally be referred to herein singularly as "Party" and collectively as "Parties."

Recitals

A. WHEREAS, the District provides various municipal services to certain real property in El Paso County, Colorado referred to as Scenic View at Paint Brush Hills; and

B. WHEREAS, Developer is the owner of certain real estate (the Property or Subdivision) in El Paso County, Colorado, which Property is legally described in Exhibit A attached hereto and incorporated herein by this reference; and

C. WHEREAS, Developer desires to plat and develop on the Property a subdivision to be known as Scenic View at Paint Brush Hills; and

D. WHEREAS, the development of this Property will substantially increase the volume of water runoff and will decrease the quality of the stormwater runoff from the Property, and, therefore, it is in the best interest of public health, safety and welfare for the County to condition approval of this subdivision on Developer's promise to construct adequate drainage, water runoff control facilities, and stormwater quality structural Best Management Practices ("BMPs") for the subdivision; and

E. WHEREAS, Chapter 8, Section 8.4.5 of the El Paso County Land Development Code, as periodically amended, promulgated pursuant to Section 30-28-133(1), Colorado Revised Statutes (C.R.S.), requires the County to condition approval of all subdivisions on a developer's promise to construct adequate drainage, water runoff control facilities, and BMPs in subdivisions; and

F. WHEREAS, the Drainage Criteria Manual, Volume 2, as amended by Appendix I of the El Paso County Engineering Criteria Manual (ECM), as each may be periodically amended, promulgated pursuant to the County's Colorado Discharge Permit System General Permit (MS4 Permit) as required by Phase II of the National Pollutant Discharge Elimination System (NPDES), which MS4 Permit requires that the County take measures to protect the quality of stormwater from sediment and other contaminants, requires subdividers, developers, landowners, and owners of facilities located in the County's rights-of-way or easements to provide adequate permanent stormwater quality BMPs with new development or significant redevelopment; and

G. WHEREAS, Section 2.9 of the El Paso County Drainage Criteria Manual provides for a developer's promise to maintain a subdivision's drainage facilities in the event the County does not assume such responsibility; and

H. WHEREAS, developers in El Paso County have historically chosen water runoff detention basins as a means to provide adequate drainage and water runoff control in subdivisions, which basins, while effective, are less expensive for developers to construct than other methods of providing drainage and water runoff control; and

I. WHEREAS, Developer desires to construct for the subdivision one detention basin/stormwater quality BMP(s) ("detention basin/BMP(s)") as the means for providing adequate drainage and stormwater runoff control and to meet requirements of the County's MS4 Permit, and to provide for operating, cleaning, maintaining and repairing such detention basin/BMP(s); and

J. WHEREAS, Developer desires to construct the detention basin/BMP(s) on property that is or will be platted as Tract A, Scenic View at Paint Brush Hills, and as set forth on Exhibit B attached hereto; and

K. WHEREAS, Developer shall be charged with the duty of constructing the detention basin/BMP(s) and the Metro District shall be charged with the duties of operating, maintaining and repairing the detention basin/BMP(s) on the Property described in Exhibit B; and

L. WHEREAS, it is the County's experience that subdivision developers and property owners historically have not properly cleaned and otherwise not properly maintained and repaired these detention basins/BMPs, and that these detention basins/BMPs, when not so properly cleaned, maintained, and repaired, threaten the public health, safety and welfare; and

M. WHEREAS, the County, in order to protect the public health, safety and welfare, has historically expended valuable and limited public resources to so properly clean, maintain, and repair these detention basins/BMPs when developers and property owners have failed in their responsibilities, and therefore, the County desires the means to recover its costs incurred in the event the burden falls on the County to so clean, maintain and repair the detention basin/BMP(s) serving this Subdivision due to the Developer's or the Metro District's failure to meet its obligations to do the same; and

N. WHEREAS, the County conditions approval of this Subdivision on the Developer's promise to so construct the detention basin/BMP(s), and further conditions approval on the Metro District's promise to reimburse the County in the event the burden falls upon the County to so clean, maintain and/or repair the detention basin/BMP(s) serving this Subdivision; and

O. WHEREAS, the County could condition subdivision approval on the Developer's promise to construct a different and more expensive drainage, water runoff control system and BMPs than those proposed herein, which more expensive system would not create the possibility of the burden of cleaning, maintenance and repair expenses falling on the County; however, the County is willing to forego such right upon the performance of Developer's and the Metro District's promises contained herein; and

P. WHEREAS, the County, in order to secure performance of the promises contained herein, conditions approval of this Subdivision upon the Developer's grant herein of a perpetual Easement over a portion of the Property for the purpose of allowing the County to periodically access, inspect, and, when so necessary, to clean, maintain and/or repair the detention basin/BMP(s); and

Q. WHEREAS, Pursuant to Colorado Constitution, Article XIV, Section 18(2) and Section 29-1-203, Colorado Revised Statutes, governmental entities may cooperate and contract with each other to provide any function, services, or facilities lawfully authorized to each.

Agreement

NOW, THEREFORE, in consideration of the mutual Promises contained herein, the sufficiency of which are hereby acknowledged, the Parties agree as follows:

1. Incorporation of Recitals: The Parties incorporate the Recitals above into this Agreement.

2. Covenants Running with the Land: Developer and the Metro District agree that this entire Agreement and the performance thereof shall become a covenant running with the land, which land is legally described in Exhibit A attached hereto, and that this entire Agreement and the performance thereof shall be binding upon themselves, their respective successors and assigns.

3. Construction: Developer shall construct on that portion of the Property described in Exhibit B attached hereto and incorporated herein by this reference, one detention basin/BMP(s). Developer shall not commence construction of the detention basin/BMP(s) until the El Paso County Development Services Department (DSD) has approved in writing the plans and specifications for the detention basin/BMP(s) and this Agreement has been signed by all Parties and returned to the DSD. Developer shall complete construction of the detention basin/BMP(s) in substantial compliance with the County-approved plans and specifications for the detention basin/BMP(s). Failure to meet these requirements shall be a material breach of this Agreement, and shall entitle the County to pursue any remedies available to it at law or in equity to enforce the same. Construction of the detention basin/BMP(s) shall be substantially completed within one (1) year (defined as 365 days), which one year period will commence to run on the date the approved plat of this Subdivision is recorded in the records of the El Paso County Clerk and Recorder. Rough grading of the detention basin/BMP(s) must be completed and inspected by the El Paso County Development Services Department prior to commencing road construction.

In the event construction is not substantially completed within the one (1) year period, then the County may exercise its discretion to complete the project, and shall have the right to seek reimbursement from the Developer and its respective successors and assigns, for its actual costs and expenses incurred in the process of completing construction. The term actual costs and expenses shall be liberally construed in favor of the County, and shall include, but shall not be limited to, labor costs, tool and equipment costs, supply costs, and engineering and design costs, regardless of whether the County uses its own personnel, tools, equipment and supplies, etc. to correct the matter. In the event the County initiates any litigation or engages the services of legal counsel in order to enforce the Provisions arising herein, the County shall be entitled to its damages and costs, including reasonable attorney fees, regardless of whether the County contracts with outside legal counsel or utilizes in-house legal counsel for the same.

4. Maintenance: The Metro District agrees for itself and its successors and assigns, that it will regularly and routinely inspect, clean and maintain the detention basin/BMP(s), and otherwise keep the same in good repair, all at its own cost and expense. No trees or shrubs that will impair the

structural integrity of the detention basin/BMP(s) shall be planted or allowed to grow on the detention basin/BMP(s).

5. Creation of Easement: Developer hereby grants the County and the Metro District a non-exclusive perpetual easement upon and across that portion of the Property described in Exhibit B. The purpose of the easement is to allow the County and the Metro District to access, inspect, clean, repair and maintain the detention basin/BMP(s); however, the creation of the easement does not expressly or implicitly impose on the County a duty to so inspect, clean, repair or maintain the detention basin/BMP(s).

6. County's Rights and Obligations: Any time the County determines, in the sole exercise of its discretion, that the detention basin/BMP(s) is not properly cleaned, maintained and/or otherwise kept in good repair, the County shall give reasonable notice to the Developer, the Metro District and their respective successors and assigns, that the detention basin/BMP(s) needs to be cleaned, maintained and/or otherwise repaired. The notice shall provide a reasonable time to correct the problem(s). Should the responsible parties fail to correct the specified problem(s), the County may enter upon the Property to so correct the specified problem(s). Notice shall be effective to the above by the County's deposit of the same into the regular United States mail, postage pre-paid. Notwithstanding the foregoing, this Agreement does not expressly or implicitly impose on the County a duty to so inspect, clean, repair or maintain the detention basin/BMP(s).

7. Reimbursement of County's Costs / Covenant Running With the Land: The Developer and the Metro District agree and covenant, for themselves, their respective successors and assigns, that they will reimburse the County for its costs and expenses incurred in the process of completing construction of, cleaning, maintaining, and/or repairing the detention basin/BMP(s) pursuant to the provisions of this Agreement.

The term "actual costs and expenses" shall be liberally construed in favor of the County, and shall include, but shall not be limited to, labor costs, tools and equipment costs, supply costs, and engineering and design costs, regardless of whether the County uses its own personnel, tools, equipment and supplies, etc. to correct the matter. In the event the County initiates any litigation or engages the services of legal counsel in order to enforce the provisions arising herein, the County shall be entitled to its damages and costs, including reasonable attorney's fees, regardless of whether the County contracts with outside legal counsel or utilizes in-house legal counsel for the same.

8. Contingencies of Subdivision Approval: Developer's and the Metro District's execution of this Agreement is a condition of subdivision approval. Additional conditions of this Agreement include, but are not limited to, the following:

- a. Conveyance of Tract A, Scenic View at Paint Brush Hills, from Developer to the Metro District (which will include a reservation of easement in favor of the County for purposes of accessing, inspecting, cleaning, maintaining, and repairing the detention basin/BMP(s)), and recording of the Deed for the same; and
- b. A copy of the Covenants of the Subdivision, if applicable, establishing that the Metro District is obligated to inspect, clean, maintain, and repair the detention basin/BMP(s).

The County shall have the right, in the sole exercise of its discretion, to approve or disapprove any documentation submitted to it under the conditions of this Paragraph, including but not limited to, any separate agreement or amendment, if applicable, identifying any specific maintenance responsibilities not addressed herein. The County's rejection of any documentation submitted hereunder shall mean that the appropriate condition of this Agreement has not been fulfilled.

9. Agreement Monitored by El Paso County Development Services Department and/or El Paso County Department of Transportation: Any and all actions and decisions to be made hereunder by the County shall be made by the Director of the El Paso County Development Services Department and/or the Director of the El Paso County Department of Transportation. Accordingly, any and all documents, submissions, plan approvals, inspections, etc. shall be submitted to and shall be made by the Director of the Development Services Department and/or the Director of the El Paso County Department of Transportation.

10. Indemnification and Hold Harmless: To the extent authorized by law, Developer and the Metro District agree, for themselves, their respective successors and assigns, that they will indemnify, defend, and hold the County harmless from any and all loss, costs, damage, injury, liability, claim, lien, demand, action and causes of action whatsoever, whether at law or in equity, arising from or related to their respective intentional or negligent acts, errors or omissions or that of their agents, officers, servants, employees, invitees and licensees in the construction, operation, inspection, cleaning (including analyzing and disposing of any solid or hazardous wastes as defined by State and/or Federal environmental laws and regulations), maintenance, and repair of the detention basin/BMP(s), and such obligation arising under this Paragraph shall be joint and several. Nothing in this Paragraph shall be deemed to waive or otherwise limit the defense available to the County pursuant to the Colorado Governmental Immunity Act, Sections 24-10-101, *et seq.* C.R.S., or as otherwise provided by law.

11. Severability: In the event any Court of competent jurisdiction declares any part of this Agreement to be unenforceable, such declaration shall not affect the enforceability of the remaining parts of this Agreement.

12. Third Parties: This Agreement does not and shall not be deemed to confer upon or grant to any third party any right to claim damages or to bring any lawsuit, action or other proceeding against either the County, the Developer, the Metro District, or their respective successors and assigns, because of any breach hereof or because of any terms, covenants, agreements or conditions contained herein.

13. Solid Waste or Hazardous Materials: Should any refuse from the detention basin/BMP(s) be suspected or identified as solid waste or petroleum products, hazardous substances or hazardous materials (collectively referred to herein as "hazardous materials"), the Developer and the Metro District shall take all necessary and proper steps to characterize the solid waste or hazardous materials and properly dispose of it in accordance with applicable State and/or Federal environmental laws and regulations, including, but not limited to, the following: Solid Wastes Disposal Sites and Facilities Acts, §§ 30-20-100.5 – 30-20-119, C.R.S., Colorado Regulations Pertaining to Solid Waste Disposal Sites and Facilities, 6 C.C.R. 1007-2, *et seq.*, Solid Waste Disposal Act, 42 U.S.C. §§ 6901-6992k, and Federal Solid Waste Regulations 40 CFR Ch. I. The County shall not be responsible or liable for identifying, characterizing, cleaning up, or disposing of such solid waste or hazardous materials. Notwithstanding the previous sentence, should any refuse cleaned up and disposed of by the County be determined to be solid waste or hazardous materials, the Developer and the Metro District, but not the County, shall be

responsible and liable as the owner, generator, and/or transporter of said solid waste or hazardous materials.

14. Applicable Law and Venue: The laws, rules, and regulations of the State of Colorado and El Paso County shall be applicable in the enforcement, interpretation, and execution of this Agreement, except that Federal law may be applicable regarding solid waste or hazardous materials. Venue shall be in the El Paso County District Court.

15. Limitation on Developer's Obligation and Liability: The obligation and liability of the Developer hereunder shall only continue until such time as the Final Plat as described in Paragraph Three (3) of the Recitals set forth above is recorded and the Developer completes the construction of the detention basin/BMP(s) and transfers all applicable maintenance and operation responsibilities to the Metro District. By execution of this agreement, the Metro District agrees to accept all responsibilities and to perform all duties assigned to it, including those of the Developer, as specified herein, upon transfer of Tract A, Scenic View at Paint Brush Hills from Developer to the Metro District.

IN WITNESS WHEREOF, the Parties affix their signatures below.

Executed this 4th day of August, 2015, by:
Lorson South Land Corp.

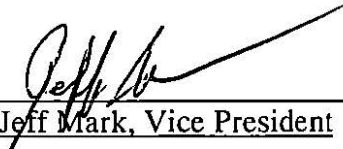
By: 
Jeff Mark, Vice President

The foregoing instrument was acknowledged before me this 4th day of August, 2015, by Jeff Mark, Vice President, Lorson South Land Corp.

Witness my hand and official seal.

My commission expires: 1/30/18

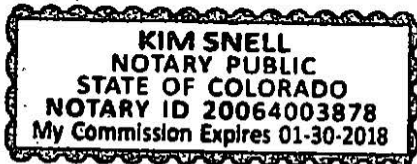

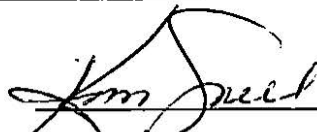
Notary Public

Executed this 4th day of August, 2015, by:
Paintbrush Hills Metropolitan District

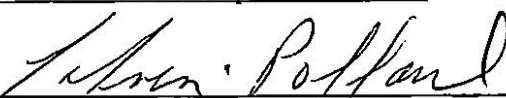
By: 
Calvin Pollard, Vice President

Attest:

The foregoing instrument was acknowledged before me this 14th day of August, 2015, by Calvin Pollard, Vice President, Paintbrush Hills Metropolitan District

Witness my hand and official seal.

My commission expires: 1/30/18



Kim Snell
Notary Public

Executed this 23rd day of September, 2015, by:

BOARD OF COUNTY COMMISSIONERS
OF EL PASO COUNTY, COLORADO

By: Amy Lathen

Amy Lathen, Chair

Attest:



Chuck Broerman
County Clerk and Recorder

The foregoing instrument was acknowledged before me this 12th day of August, 2015, by Amy Lathen, Chair of the Board of County Commissioners of El Paso County, Colorado, as Attested to by Chuck Broerman, County Clerk and Recorder.

Witness my hand and official seal.

My commission expires: March 12, 2016

Mary A. Bartelson
Notary Public

Approved as to Content and Form:

Lori L. Seago
Assistant County Attorney



Exhibit A

LEGAL DESCRIPTION – SCENIC VIEW AT PAINT BRUSH HILLS:

A TRACT OF LAND BEING A PORTION OF THE SOUTH ONE-HALF OF THE SOUTHWEST ONE-QUARTER (S1/2 SW1/4) OF SECTION 25, TOWNSHIP 12 SOUTH, RANGE 65 WEST OF THE 6TH P.M., EL PASO COUNTY, COLORADO AND BEING MORE PARTICULARLY DESCRIBED AS FOLLOWS:

COMMENCING AT THE SOUTHWEST CORNER OF SAID SECTION 25, AS MONUMENTED BY A 3-1/4" ALUMINUM CAP STAMPED "PLS 12103", FROM WHICH THE SOUTH ONE-QUARTER CORNER OF SAID SECTION 25 BEARS N89°04'59"E (PER THE RECORDED LAND SURVEY PLAT BY WK. CLARK AND ASSOCIATES, RECORDED UNDER RECEPTION NO. 99900373 AND ALSO SHOWN ON THE PLAT OF PAINT BRUSH HILLS FILING NO. 10, AS RECORDED UNDER RECEPTION NO. 203174940 OF THE RECORDS OF THE EL PASO COUNTY CLERK AND RECORDER), AS MONUMENTED BY A 2-1/2" ALUMINUM SURVEYORS CAP STAMPED "P.L.S. 4842" A DISTANCE OF 2627.52 FEET (2627.51 FEET OF RECORD PER LAND SURVEY PLAT) AND IS THE BASIS OF BEARINGS USED HEREIN;

THENCE ALONG THE SOUTHERLY AND EASTERLY BOUNDARY LINES OF SAID PAINT BRUSH HILLS FILING NO. 10 THE FOLLOWING THREE (3) COURSES:

1. THENCE S89°04'59"W ALONG THE SOUTHERLY RIGHT-OF-WAY LINE OF STAPLETON DRIVE, A DISTANCE OF 1096.61 FEET;
2. THENCE N03°33'39"E, A DISTANCE OF 60.06 FEET;
3. THENCE N89°04'59"E, A DISTANCE 19.10 FEET THE POINT OF BEGINNING;

THENCE ALONG THE EASTERLY BOUNDARY LINES OF SAID PAINT BRUSH HILLS FILING NO. 10 THE FOLLOWING TWO (2) COURSES:

1. THENCE ALONG THE ARC OF A 20.00 FOOT RADIUS CURVE TO THE RIGHT, THROUGH A CENTRAL ANGLE OF 87°21'22", AN ARC LENGTH OF 30.49 FEET (THE LONG CHORD OF WHICH BEARS N47°14'20"W, A LONG CHORD DISTANCE OF 27.62 FEET);
2. THENCE N03°33'39"W, A DISTANCE OF 512.15 FEET TO A POINT OF CURVE, SAID POINT ALSO BEING A POINT ON THE SOUTHERLY RIGHT-OF-WAY LINE OF ATTACHMENT A, AS DESCRIBED IN THE DEED RECORDED UNDER RECEPTION NO. 202022196 OF SAID COUNTY RECORDS;

THENCE ALONG SAID SOUTHERLY RIGHT-OF-WAY LINE THE FOLLOWING TWO (2) COURSES:

1. THENCE ALONG THE ARC OF A 20.00 FOOT RADIUS CURVE TO THE RIGHT, THROUGH A CENTRAL ANGLE OF 93°33'47", AN ARC LENGTH OF 32.66 FEET (THE LONG CHORD OF WHICH BEARS N43°13'14"E, A LONG CHORD DISTANCE OF 29.15 FEET);
2. THENCE S89°59'52"E, A DISTANCE OF 316.61 FEET TO A POINT ON THE WESTERLY LINE OF THE RIGHT-OF-WAY, AS DESCRIBED IN BOOK 2933 AT PAGE 873 OF SAID COUNTY

RECORDS SAID POINT ALSO BEING A POINT ON THE NORTHERLY LINE OF RESOLUTION NO. 03-366, AS RECORDED UNDER RECEPTION NO. 207118362 OF SAID COUNTY RECORDS;

THENCE S89°59'52"E ALONG SAID NORTHERLY LINE, A DISTANCE OF 60.08 FEET TO A POINT ON THE EASTERLY RIGHT-OF-WAY LINE OF SAID BOOK 2933 AT PAGE 873; THENCE ALONG SAID EASTERLY RIGHT-OF-WAY LINE ALONG THE ARC OF A 566.43 FOOT RADIUS CURVE TO THE RIGHT, THROUGH A CENTRAL ANGLE OF 03°02'10", AN ARC LENGTH OF 30.02 FEET (THE LONG CHORD OF WHICH BEARS N01°30'05"W, A LONG CHORD DISTANCE OF 30.01 FEET) TO A POINT ON THE SOUTHERLY LINE OF THE WARRANTY DEED, AS DESCRIBED IN BOOK 2732 AT PAGE 860 OF SAID COUNTY RECORDS;

THENCE S89°59'52"E ALONG SAID SOUTHERLY LINE, A DISTANCE OF 1073.71 FEET TO A POINT ON THE WESTERLY BOUNDARY LINE OF PAINT BRUSH HILLS FILING NO. 4, AS RECORDED IN BOOK C-4 AT PAGE 172 OF SAID COUNTY RECORDS;

THENCE S00°00'01"E ALONG SAID WESTERLY BOUNDARY LINE, A DISTANCE OF 558.42 FEET TO A POINT ON THE NORTHERLY RIGHT-OF-WAY LINE, AS DESCRIBED IN BOOK 2933 AT PAGE 873 OF SAID COUNTY RECORDS;

THENCE S89°04'59"W ALONG SAID NORTHERLY RIGHT-OF-WAY LINE, A DISTANCE OF 765.84 FEET TO THE NORTHEASTERLY CORNER OF THE RIGHT-OF-WAY LINE, AS DESCRIBED IN ATTACHMENT D, AS RECORDED UNDER RECEPTION NO. 202022196 OF SAID COUNTY RECORDS;

THENCE S89°04'59"W ALONG SAID NORTHERLY RIGHT-OF-WAY LINE, A DISTANCE OF 651.83 FEET TO THE POINT OF BEGINNING;

SAID TRACT OF LAND CONTAINS 18.76 ACRES OF LAND, MORE OR LESS.

