

# WOODFORD MANUFACTURING BUILDING ADDITION

LOT 1, BLOCK 1, WAYNOKA ROAD INDUSTRIAL  
2121 WAYNOKA ROAD, COLORADO SPRINGS 80915

## GRADING AND EROSION CONTROL PLANS El Paso County, Colorado

PREPARED FOR:

### HAMMERS CONSTRUCTION

1411 WOOLSEY HEIGHTS  
COLORADO SPRINGS, CO 80915

PREPARED BY:

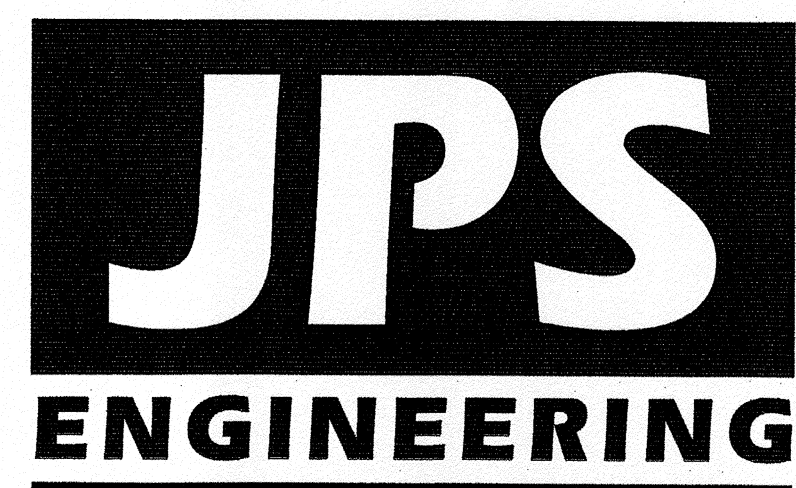

19 East Willamette Avenue  
Colorado Springs, Colorado 80903

OCTOBER, 2018

#### AGENCIES/CONTACTS

DEVELOPER:	HAMMERS CONSTRUCTION 1411 WOOLSEY HEIGHTS COLORADO SPRINGS, CO 80915 MR. JOE BUTLER (719) 570-1599	GAS DEPARTMENT:	BLACK HILLS ENERGY MR. SEBASTIAN SCHWENDER (719) 359-3176
CIVIL ENGINEER:	JPS ENGINEERING, INC. 19 E. WILLAMETTE AVENUE COLORADO SPRINGS, CO 80903 MR. JOHN P. SCHWAB, P.E. (719) 477-9429	ELECTRIC DEPARTMENT:	MOUNTAIN VIEW ELECTRIC ASSOCIATION 11140 E. WOODMEN ROAD COLORADO SPRINGS, CO 80908 MR. DAVE WALDNER (719) 495-2283
LOCAL ROADS & DRAINAGE:	EL PASO COUNTY PCD 2880 INTERNATIONAL CIRCLE COLORADO SPRINGS, CO 80910 MR. GILBERT LAFORCE, P.E. (719) 520-7945	TELEPHONE COMPANY:	QWEST COMMUNICATIONS (LOCATORS) (800) 922-1987
		FIRE DEPARTMENT:	FALCON FIRE PROTECTION DISTRICT (719) 495-4050

SHEET INDEX	
BY	DATE
G1	GEC TITLE SHEET
C1.1	SITE GRADING & EROSION CONTROL PLAN
C2	CIVIL NOTES & DETAILS
C3	GRADING & EROSION CONTROL NOTES AND DETAILS

**DESIGN ENGINEER'S STATEMENT:**  
THESE DETAILED PLANS AND SPECIFICATIONS WERE PREPARED UNDER MY DIRECTION AND SUPERVISION. SAID PLANS AND SPECIFICATIONS HAVE BEEN PREPARED ACCORDING TO THE CRITERIA ESTABLISHED BY THE COUNTY FOR DETAILED ROADWAY, DRAINAGE, GRADING AND EROSION CONTROL PLANS AND SPECIFICATIONS, AND SAID PLANS AND SPECIFICATIONS ARE IN CONFORMITY WITH APPLICABLE MASTER DRAINAGE PLANS AND MASTER TRANSPORTATION PLANS. SAID PLANS AND SPECIFICATIONS MEET THE PURPOSES FOR WHICH THE PARTICULAR ROADWAY AND DRAINAGE FACILITIES ARE DESIGNED AND ARE CORRECT TO THE BEST OF MY KNOWLEDGE AND BELIEF. I ACCEPT RESPONSIBILITY FOR LIABILITY FOR NEGLIGENCE, ERRORS OR OMISSIONS ON MY PART IN PREPARATION OF THESE DETAILED PLANS AND SPECIFICATIONS.

*John P. Schwab*  
JOHN P. SCHWAB, P.E. #29891      10/25/18  
DATE

**OWNER/DEVELOPER'S STATEMENT:**  
I, THE OWNER/DEVELOPER, HAVE READ AND WILL COMPLY WITH ALL OF THE REQUIREMENTS SPECIFIED IN THESE DETAILED PLANS AND SPECIFICATIONS.

*John P. Schwab*  
HAMMERS CONSTRUCTION  
1411 WOOLSEY HEIGHTS  
COLORADO SPRINGS, CO 80915      10-29-18  
DATE

**EL PASO COUNTY:**  
COUNTY PLAN REVIEW IS PROVIDED ONLY FOR GENERAL CONFORMANCE WITH COUNTY DESIGN CRITERIA. THE COUNTY IS NOT RESPONSIBLE FOR THE ACCURACY AND ADEQUACY OF THE DESIGN, DIMENSIONS, AND/OR ELEVATIONS WHICH SHALL BE CONFIRMED AT THE JOB SITE. THE COUNTY THROUGH THE APPROVAL OF THIS DOCUMENT ASSUMES NO RESPONSIBILITY FOR COMPLETENESS AND/OR ACCURACY OF THIS DOCUMENT.

FILED IN ACCORDANCE WITH THE REQUIREMENTS OF THE EL PASO COUNTY LAND DEVELOPMENT CODE, DRAINAGE CRITERIA MANUAL, AND ENGINEERING CRITERIA MANUAL AS AMENDED.

IN ACCORDANCE WITH ECM SECTION 1.12, THESE CONSTRUCTION DOCUMENTS WILL BE VALID FOR CONSTRUCTION FOR A PERIOD OF 2 YEARS FROM THE DATE SIGNED BY THE EL PASO COUNTY ENGINEER. IF CONSTRUCTION HAS NOT STARTED WITHIN THOSE 2 YEARS, THE PLANS WILL NEED TO BE RESUBMITTED FOR APPROVAL, INCLUDING PAYMENT OF REVIEW FEES AT THE PLANNING AND COMMUNITY DEVELOPMENT DIRECTOR'S DISCRETION.

JENNIFER IRVINE, P.E.,  
COUNTY ENGINEER / ECM ADMINISTRATOR      DATE

PCD PROJECT NO. PPR-1837

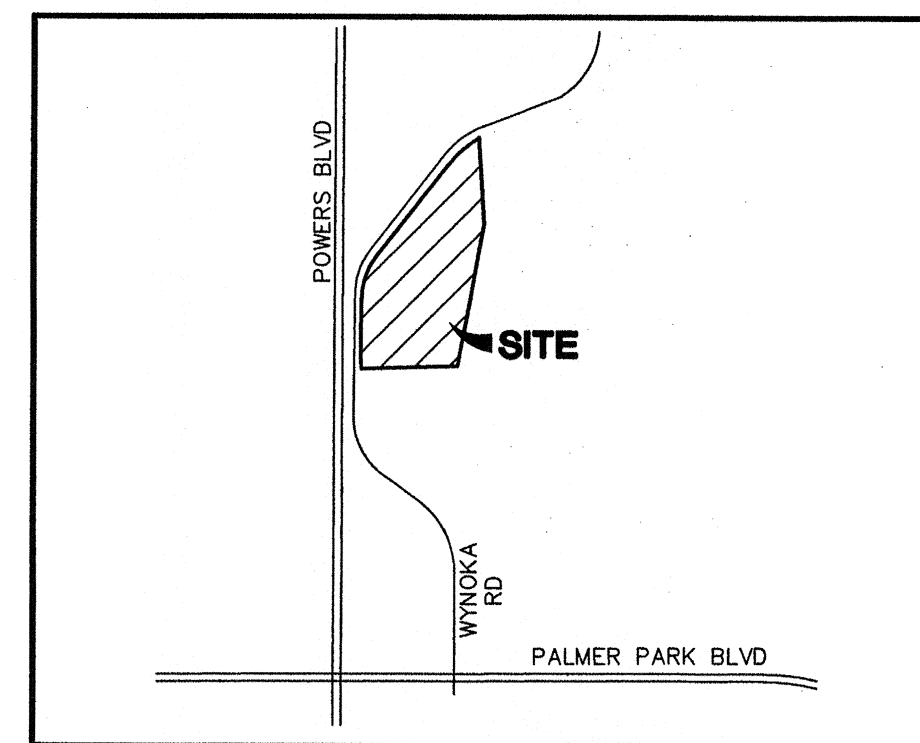

VICINITY MAP  
NOT TO SCALE

Z:\051801\hammers-woodford\dwg\civil\G1.dwg Oct 12, 2018 - 1:11pm

NOTE: NOTWITHSTANDING ANYTHING DEPICTED IN THESE PLANS IN WORDS OR GRAPHIC REPRESENTATION, ALL DESIGN AND CONSTRUCTION RELATED TO ROADS, STORM DRAINAGE AND EROSION CONTROL SHALL CONFORM TO THE STANDARDS AND REQUIREMENTS OF THE MOST RECENT VERSION OF THE RELEVANT ADOPTED EL PASO COUNTY STANDARDS, INCLUDING THE LAND DEVELOPMENT CODE, THE ENGINEERING CRITERIA MANUAL, THE DRAINAGE CRITERIA MANUAL, AND THE DRAINAGE CRITERIA MANUAL VOLUME 2. ANY DEVIATIONS FROM REGULATIONS AND STANDARDS MUST BE REQUESTED AND APPROVED IN WRITING TO BE ACCEPTABLE.

BENCHMARK:  
NGS BENCHMARK "R 76"  
ELEVATION=6289.86 (NAVD-1988)

**WOODFORD MANUFACTURING BUILDING ADDITION**  
2121 WAYNOKA RD, COLORADO SPRINGS, COLORADO 80915

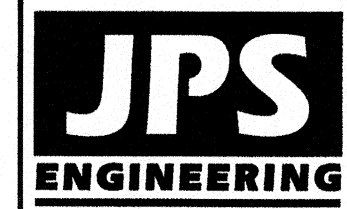

19 E. Willamette Ave.  
Colorado Springs, CO 80903  
PH: 719-477-9429  
FAX: 719-471-0766  
www.jpsengr.com



CALL UTILITY NOTIFICATION CENTER OF COLORADO  
1-800-922-1987  
CALL 2-BUSINESS DAYS IN ADVANCE BEFORE YOU DIG, GRADE, OR EXCAVATE FOR THE MARKING OF UNDERGROUND MEMBER UTILITIES.

No.	REVISION	BY	DATE
1	DP SUBMITTAL	JPS	7/24/18
2	COUNTY COMMENTS	JPS	9/14/18
3	COUNTY COMMENTS	JPS	10/12/18

**GEC TITLE SHEET**

HORZ. SCALE: 1"=20'	DRAWN: MSP
VERT. SCALE: N/A	DESIGNED: JPS
SURVEYED: -	CHECKED: JPS
CREATED: 9/14/18	LAST MODIFIED: 10/12/18
PROJECT NO: 051801	MODIFIED BY: BJW
SHEET:	<b>G1</b>



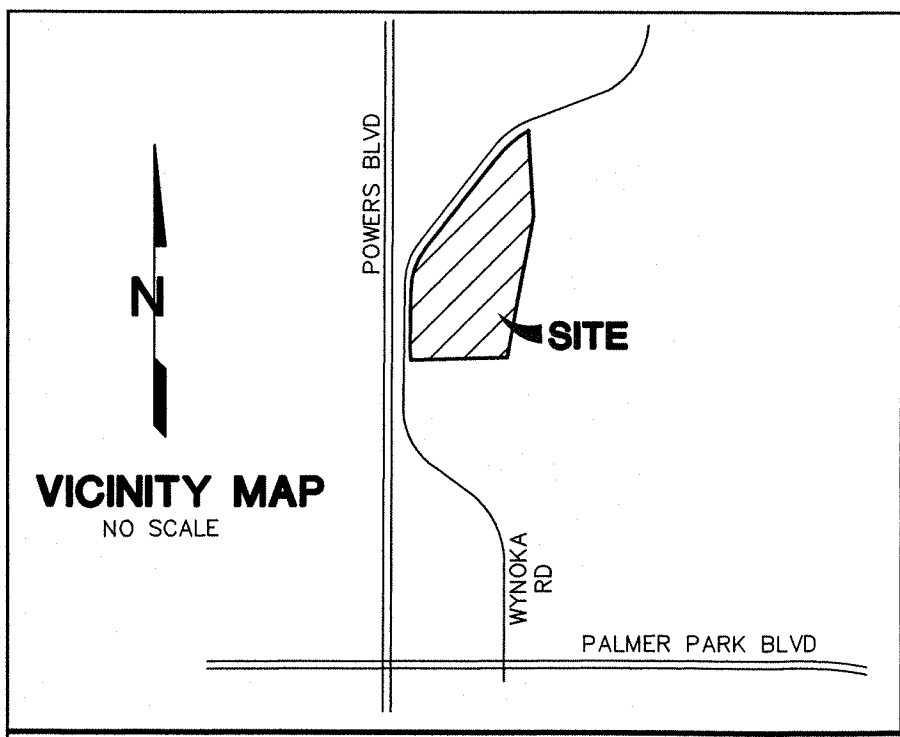

- EROSION CONTROL LEGEND:**
- (VTC) VEHICLE TRACKING CONTROL PAD
  - (SF) SILT FENCE
  - (SM) SEED & MULCH
  - (CWA) CONCRETE WASHOUT AREA (TO BE COMPLETELY CONTAINED & REMOVED UPON COMPLETION OF PROJECT)
  - (IP) INLET PROTECTION
  - (RG) RAIN GARDEN
  - (RR) RIPRAP APRON
  - (TSB) TEMPORARY SEDIMENT BASIN
  - (TSA) TEMPORARY STAGING AREA
- LEGEND:**
- 62.32 --- PROPOSED PROPERTY LINE
  - 62.32 --- EXISTING CONTOURS
  - 62.32 --- PROPOSED CONTOURS
  - x 31.5 --- EXISTING SPOT ELEVATIONS
  - x 31.5 --- PROPOSED SPOT ELEVATIONS
  - 1.0% --- PROPOSED GRADES
  - DS → ROOF DRAIN DOWNSPOUTS; INSTALL TRANSITION COUPLINGS & CONNECT TO SITE STORM SEWER W/ 6" PVC SD LATERALS @ 1.0% MIN. SLOPE (COORDINATE W/ ARCH / MEP PLANS)

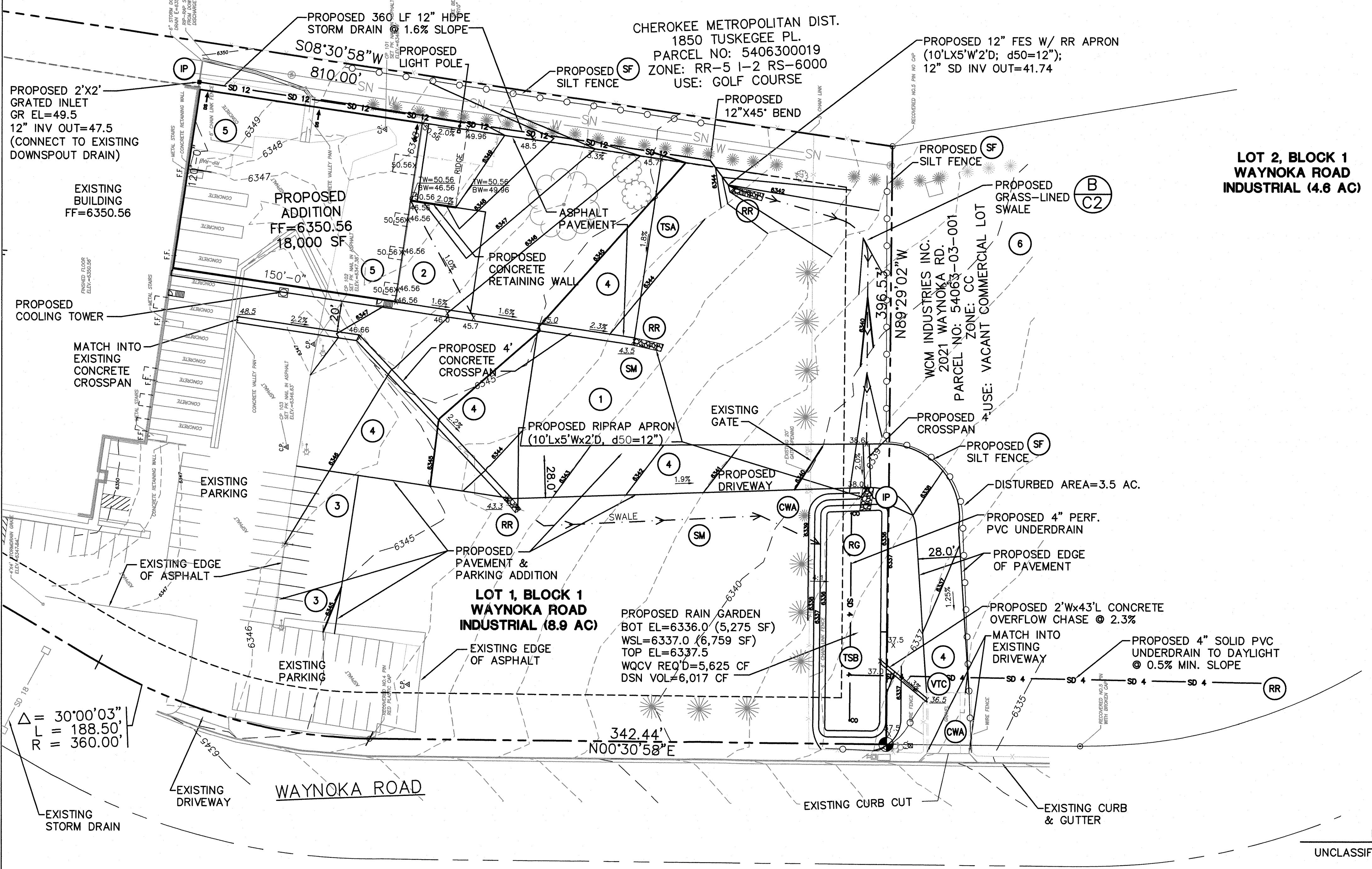
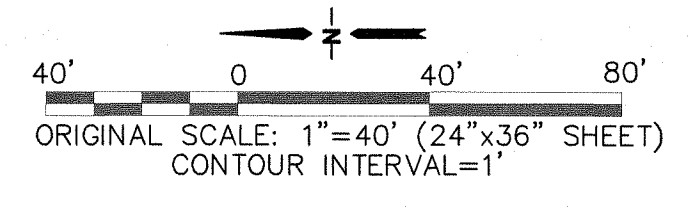

- KEYED NOTES:**
- 1 TOPSOIL STRIPPING / STOCKPILE AREA
  - 2 6" CONCRETE PAVEMENT (PER GEOTECHNICAL REPORT)
  - 3 3" ASPHALT PAVEMENT (PER GEOTECHNICAL REPORT)
  - 4 5" ASPHALT PAVEMENT (PER GEOTECHNICAL REPORT)
  - 5 PREPARE & COMPACT BUILDING FOUNDATION, SLABS, & PAVEMENT PER PROJECT GEOTECHNICAL REPORT
  - 6 CONTRACTOR MAY WASTE EXCESS CUT OR BORROW SUITABLE FILL MATERIAL FROM THIS AREA; MAINTAIN POSITIVE DRAINAGE & MATCH INTO EXISTING GRADES W/ 3:1 MAX. SLOPES

**ESTIMATED EARTHWORK QUANTITY:**  
 UNCLASSIFIED EXCAVATION (TOTAL CUT) = 374 CY  
 \* EMBANKMENT FILL = 1,357 CY  
 NET (FILL) = 983 CY  
 \* (ASSUMES 15% COMPACTION FACTOR)

NOTE: THIS ESTIMATE IS PROVIDED FOR INFORMATION ONLY, REPRESENTING THE CALCULATED BULK EARTHWORK VOLUME TO FINISHED GRADE, EXCLUDING ANY ADJUSTMENT FOR PAVEMENT DEPTHS, ETC. CONTRACTOR SHALL MAKE HIS OWN DETERMINATION OF EARTHWORK QUANTITIES AS BASIS FOR BID PRICING AND NOTIFY ENGINEER OF ANY DISCREPANCIES.

BENCHMARK:  
 NGS BENCHMARK "R 76".  
 ELEVATION=6289.86 (NAVD-1988)

COLORADO SPRINGS CITY OF  
 N. POWERS BLVD.  
 PARCEL NO: 64001-000-55  
 ZONE: PBC/CR AO AP22 SS  
 USE: POLITICAL SUBDIVISION

PCD PROJECT NO. PPR-1837

**WOODFORD MANUFACTURING BUILDING ADDITION**  
 2121 WAYNOKA RD, COLORADO SPRINGS, COLORADO 80915

**SITE GRADING & EROSION CONTROL PLAN**

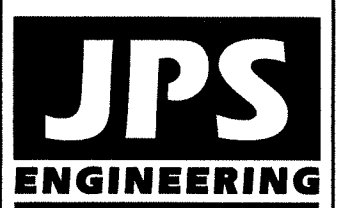

19 E. Willamette Ave.  
 Colorado Springs, CO  
 80903  
 PH: 719-477-9429  
 FAX: 719-471-0766  
 www.jpsengr.com

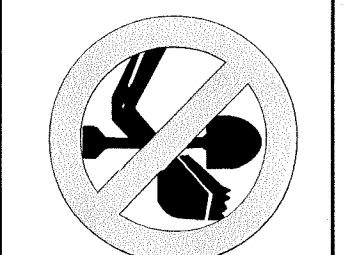

CALL UTILITY NOTIFICATION CENTER OF COLORADO  
 1-800-922-1987  
 CALL 2-BUSINESS DAYS IN ADVANCE BEFORE TYPING, GRADING, OR EXCAVATING FOR THE MEMBER UTILITIES.

No.	DATE	BY	REVISION
1	7/24/18	JPS	DP SUBMITTAL
2	9/18/18	JPS	COUNTY COMMENTS
3	10/12/18	JPS	COUNTY COMMENTS



HORZ. SCALE: 1"=40'	DRAWN: BJJ
VERT. SCALE: N/A	DESIGNED: JPS
SURVEYED: -	CHECKED: JPS
CREATED: 7/06/18	LAST MODIFIED: 10/12/18
PROJECT NO: 051801	MODIFIED BY: BJJ

**C1.1**

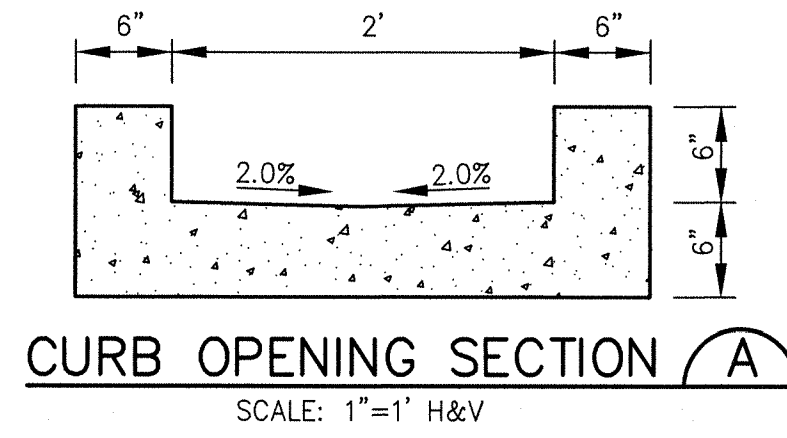

CURB OPENING SECTION A  
SCALE: 1"=1' H&V

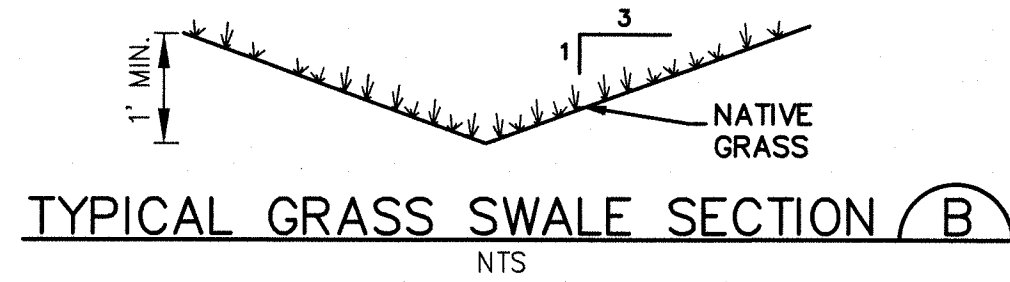

TYPICAL GRASS SWALE SECTION B  
NTS

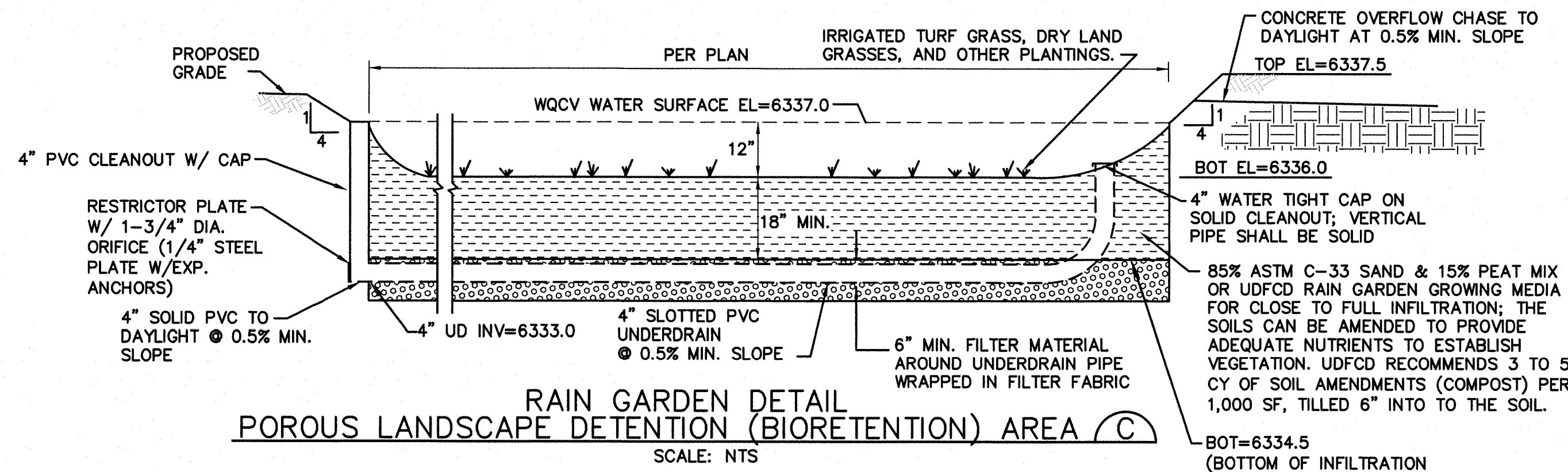

RAIN GARDEN DETAIL  
POROUS LANDSCAPE DETENTION (BIORETENTION) AREA C  
SCALE: NTS

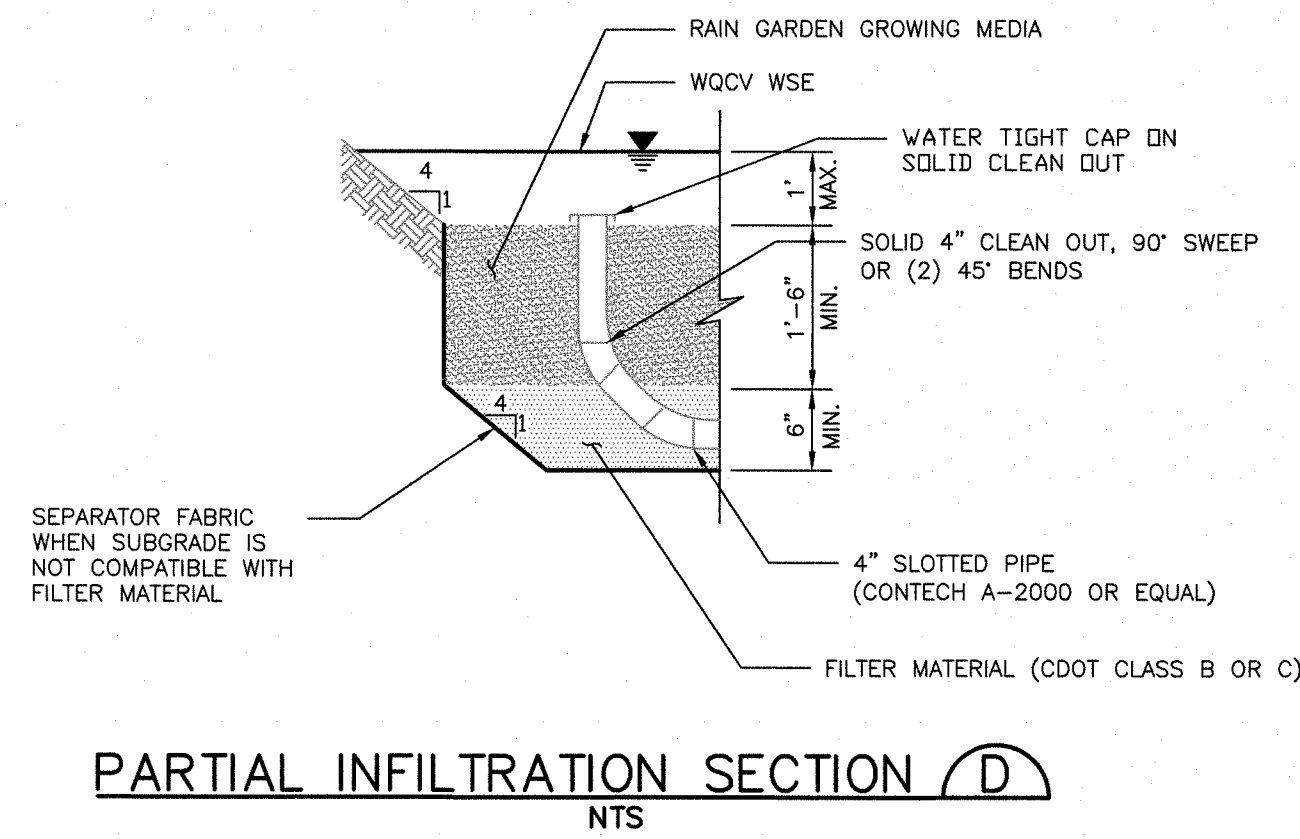

PARTIAL INFILTRATION SECTION D  
NTS

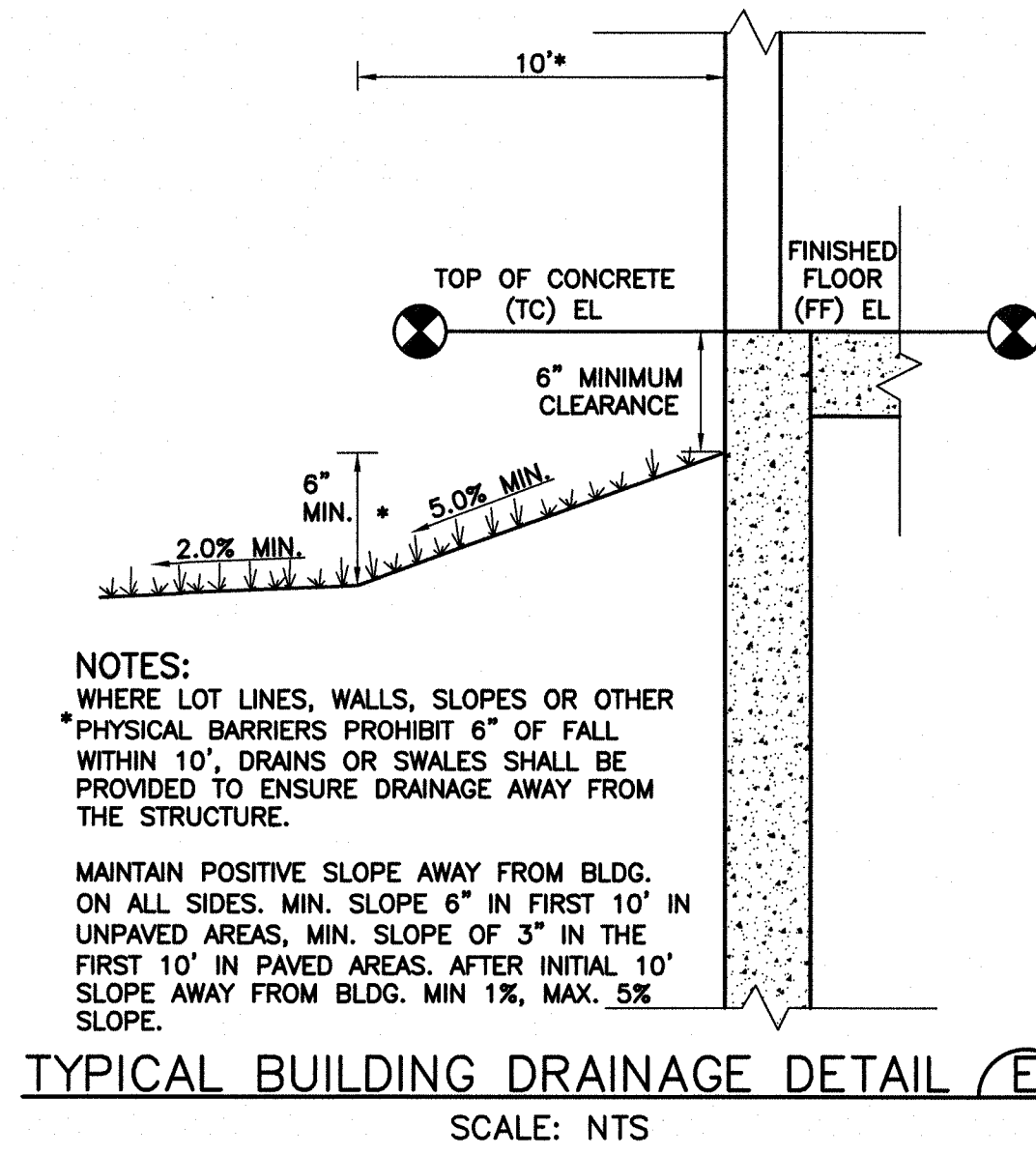

TYPICAL BUILDING DRAINAGE DETAIL E  
SCALE: NTS

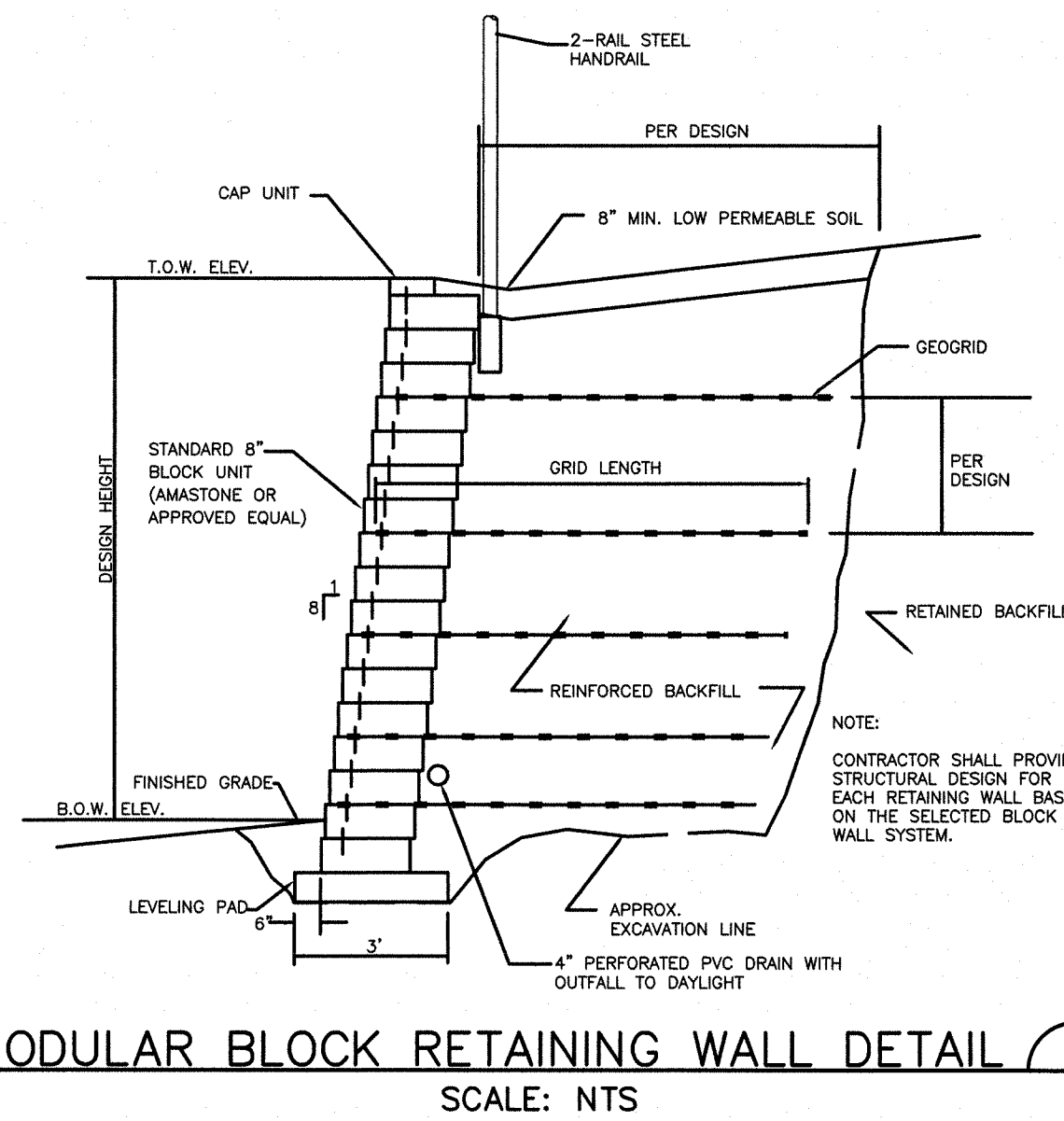

MODULAR BLOCK RETAINING WALL DETAIL F  
SCALE: NTS

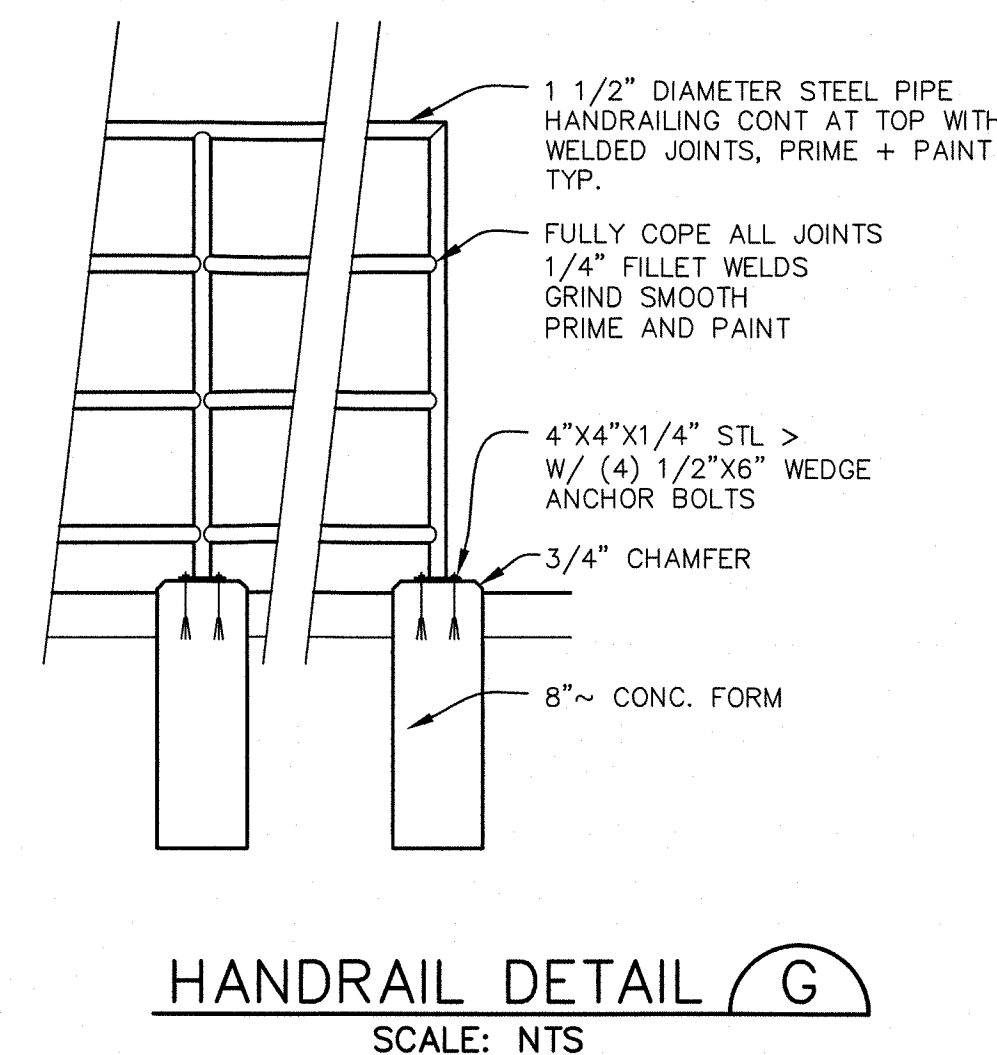

HANDRAIL DETAIL G  
SCALE: NTS

**GENERAL CIVIL NOTES:**

- All construction shall meet the following standards & specifications:
  - 2009 International Building Code.
  - Pikes Peak Regional Building Code, latest edition.
  - El Paso County Engineering Criteria Manual (ECM), latest edition.
  - Project Geotechnical Report.
- The contractor shall be responsible for the notification and field location of all existing utilities, whether shown on the plans or not, before beginning construction. Location of existing utilities shall be verified by the contractor prior to actual construction.
- The contractor shall have one (1) signed copy of these approved plans and one (1) copy of the appropriate design and construction standards and specifications at the job site at all times:
  - El Paso County Engineering Criteria Manual.
- Storm drain pipe shall be rcp class iii with class c bedding unless otherwise noted.
- Stationing is at centerline unless otherwise noted. All elevations are at flowline unless otherwise noted. All dimensions are from face of curb unless otherwise noted. Lengths shown for storm sewer pipes are to center of manhole.
- Contractor shall coordinate with gas, electric, telephone and cable t.v. Utility suppliers for installation of all utilities. Minimum cover for all dry utilities shall be 36".
- Contractor shall remove and dispose of all existing structures, debris, waste and other unsuitable fill material found within the limits of excavation.
- Match into existing grades at 3:1 max cut and fill slopes.
- Revegetation of all disturbed areas shall be done with 4" topsoil and dry land grass seed after fine grading is complete ("foothills seed mix").
- Erosion control shall consist of silt fence and hay bales as shown on the drawing, and topsoil with grass seed, which will be watered until vegetation has been re-established.
- The erosion control measures outlined on this plan are the responsibility of the contractor to monitor and replace, regrade, and rebuild as necessary until vegetation is re-established.
- Contractor shall implement best management practices in a manner that will protect adjacent properties and public facilities from the adverse effects of erosion and sedimentation as a result of construction and earthwork activities within the project site.
- Additional erosion control measures may be required as determined by site conditions.
- The contractor will take the necessary precautions to protect existing utilities from damage due to this operation. Any damage to the utilities will be repaired at the contractor's expense, and any service disruption will be settled by the contractor.
- All backfill, sub-base, and/or base course material shall be compacted per the project geotechnical report and County specifications.
- Concrete used in curb and gutter, sidewalk, and crossspan construction shall meet County criteria.
- All finished grades shall have a minimum 1.0% slope to provide positive drainage.
- Contractor shall obtain all required permits prior to beginning work.

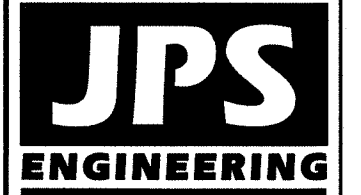

19 E. Willamette Ave.  
Colorado Springs, CO  
80903  
PH: 719-477-9429  
FAX: 719-471-0766  
www.jpsegr.com



CALL UTILITY NOTIFICATION  
CENTER OF COLORADO  
1-800-922-1987  
CALL 2-BUSINESS DAYS IN ADVANCE  
BEFORE YOU DIG, GRADE, OR EXCAVATE  
FOR THE MARKING OF UNDERGROUND  
MEMBER UTILITIES.

NO.	REVISION	DATE
1	DP SUBMITTAL	7/24/18
2	COUNTY COMMENTS	9/14/18

**WOODFORD MANUFACTURING BUILDING ADDITION**  
2121 WAYOKA RD, COLORADO SPRINGS, COLORADO 80915

**CIVIL NOTES & DETAILS**

HORIZ. SCALE:	N/A	DESIGNED:	BJJ
VERT. SCALE:	N/A	CHECKED:	JPS
SURVEYED:	-	CHECKED:	JPS
CREATED:	7/12/18	LAST MODIFIED:	10/12/18
PROJECT NO:	051801	MODIFIED BY:	BJJ
SHEET:	C2		

PCD PROJECT NO. PPR-1837





**STANDARD NOTES FOR EL PASO COUNTY GRADING AND EROSION CONTROL PLANS:**

- Construction may not commence until a Construction Permit is obtained from Development Services and a Preconstruction Conference is held with Development Services inspectors.
- Stormwater discharges from construction sites shall not cause or threaten to cause pollution, contamination, or degradation of State Waters. All work and earth disturbance shall be done in a manner that minimizes pollution of any on-site or off site waters, including wetlands.
- Notwithstanding anything depicted in these plans in words or graphic representation, all design and construction related to roads, storm drainage and erosion control shall conform to the standards and requirements of the most recent version of the relevant adopted El Paso County standards, including the Land Development Code, the Engineering Criteria Manual, the Drainage Criteria Manual, and the Drainage Criteria Manual Volume 2. Any deviations to regulations and standards must be requested, and approved, in writing.
- A separate Stormwater Management Plan (SMWP) for this project shall be completed and an Erosion and Stormwater Quality Control Permit (ESQCP) issued prior to commencing construction. During construction the SMWP is the responsibility of the designated Stormwater Manager, shall be located on site at all times and shall be kept up to date with work progress and changes in the field.
- Once the ESQCP has been issued, the contractor may install the initial stage erosion and sediment control BMPs as indicated on the GEC. A preconstruction meeting between the contractor, engineer, and El Paso County will be held prior to any construction. It is the responsibility of the applicant to coordinate the meeting time and place with County DSD inspections staff.
- Soil erosion control measures for all slopes, channels, ditches, or any disturbed land area shall be completed within 21 calendar days after final grading, or final earth disturbance, has been completed. Disturbed areas and stockpiles which are not at final grade but will remain dormant for longer than 30 days shall also be mulched within 21 days after interim grading. An area that is going to remain in an interim state for more than 60 days shall also be seeded. All temporary soil erosion control measures and BMPs shall be maintained until permanent soil erosion control measures are implemented and established.
- Temporary soil erosion control facilities shall be removed and earth disturbance areas graded and stabilized with permanent soil erosion control measures pursuant to standards and specification prescribed in the DCM Volume II and the Engineering Criteria Manual (ECM) appendix I.
- All persons engaged in earth disturbance shall implement and maintain acceptable soil erosion and sediment control measures including BMPs in conformance with the erosion control technical standards of the Drainage Criteria Manual (DCM) Volume II and in accordance with the Stormwater Management Plan (SMWP).
- All temporary erosion control facilities including BMPs and all permanent facilities intended to control erosion of any earth disturbance operations, shall be installed as defined in the approved plans, the SMWP and the DCM Volume II and maintained throughout the duration of the earth disturbance operation.
- Any earth disturbance shall be conducted in such a manner so as to effectively reduce accelerated soil erosion and resulting sedimentation. All disturbances shall be designed, constructed, and completed so that the exposed area of any disturbed land shall be limited to the shortest practical period of time.
- Any temporary or permanent facility designed and constructed for the conveyance of stormwater around, through, or from the earth disturbance area shall be designed to limit the discharge to a non-erosive velocity.
- Concrete wash water shall be contained and disposed of in accordance with the SMWP. No wash water shall be discharged to or allowed to runoff to State Waters, including any surface or subsurface storm drainage system or facilities.
- Erosion control blanketing is to be used on slopes steeper than 3:1.
- Building, construction, excavation, or other waste materials shall not be temporarily placed or stored in the street, alley, or other public way, unless in accordance with an approved Traffic Control Plan. BMP's may be required by El Paso County Engineering if deemed necessary, based on specific conditions and circumstances.
- Vehicle tracking of soils and construction debris off-site shall be minimized. Materials tracked offsite shall be cleaned up and properly disposed of immediately.
- Contractor shall be responsible for the removal of all wastes from the construction site for disposal in accordance with local and State regulatory requirements. No construction debris, tree slash, building material wastes or unused building materials shall be buried, dumped, or discharged at the site.
- The owner, site developer, contractor, and/or their authorized agents shall be responsible for the removal of all construction debris, dirt, trash, rock, sediment, and sand that may accumulate in the storm sewer or other drainage conveyance system and stormwater appurtenances as a result of site development.
- The quantity of materials stored on the project site shall be limited, as much as practical, to that quantity required to perform the work in an orderly sequence. All materials stored on-site shall be stored in a neat, orderly manner, in their original containers, with original manufacturer's labels.
- No chemicals are to be used by the contractor, which have the potential to be released in stormwater unless permission for the use of a specific chemical is granted in writing by the ECM Administrator. In granting the use of such chemicals, special conditions and monitoring may be required.
- Bulk storage structures for petroleum products and other chemicals shall have adequate protection so as to contain all spills and prevent any spilled material from entering State Waters, including any surface or subsurface storm drainage system or facilities.
- No person shall cause the impediment of stormwater flow in the flow line of the curb and gutter or in the ditchline.
- Individuals shall comply with the "Colorado Water Quality Control Act" (Title 25, Article 8, CRS), and the "Clean Water Act" (33 USC 1344), in addition to the requirements included in the DCM Volume II and the ECM Appendix I. All appropriate permits must be obtained by the contractor prior to construction (NPDES, Floodplain, 404, fugitive dust, etc.). In the event of conflicts between these requirements and laws, rules, or regulations of other Federal, State, or County agencies, the more restrictive laws, rules, or regulations shall apply.
- All construction traffic must enter/exit the site at approved construction access points.
- Prior to actual construction the permittee shall verify the location of existing utilities.
- A water source shall be available on site during earthwork operations and utilized as required to minimize dust from earthwork equipment and wind.
- The preliminary soils report for this site prepared by Entech Engineering, dated 2/18/13 shall be considered a part of these plans.
- At least ten days prior to the anticipated start of construction, for projects that will disturb 1 acre or more, the owner or operator of construction activity shall submit a permit application for stormwater discharge to the Colorado Department of Public Health and Environment, Water Quality Division. The application contains certification of completion of a stormwater management plan (SMWP), of which this grading and erosion control plan may be a part. For information or application materials contact:

Colorado Department of Public Health and Environment  
Water Quality Control Division  
WQCD - Permits  
4300 Cherry Creek Drive South  
Denver, CO 80246-1530  
Attn: Permits Unit

**ESTIMATED TIME SCHEDULE:**

INSTALL BMP'S SEPTEMBER, 2018  
SITE GRADING SEPTEMBER, 2018  
SEEDING & MULCHING APRIL, 2019  
STABILIZATION AUGUST, 2020  
TOTAL DISTURBED AREA: 3.5 ACRES  
RECEIVING WATERS: SAND CREEK

**EXISTING VEGETATION:**

NATIVE GRASSES (APPROXIMATELY 70 PERCENT COVERAGE)

**SEEDING MIX:**

GRASS	VARIETY	AMOUNT IN PLS LBS. PER ACRE
CRESTED WHEAT GRASS	EPHRAIM OR HYCREST	4.0 LBS.
PERENNIAL RYE	LINN	2.0 LBS.
WESTERN WHEATGRASS	SARTON	3.0 LBS.
SMOOTH BROME GRASS	LINGCOLN OR MANCHAR	5.0 LBS.
SIDEOLATS GRAMA	EPHRAIM	2.5 LBS.
TOTAL:		16.5 LBS.

SEEDING & FERTILIZER APPLICATION: DRILL SEED OR HYDRO-SEED PER CDOT SPEC. SECTION 212.

MULCHING APPLICATION: CONFORM TO CDOT SPEC-SECTION 217.

**SEDIMENT CONTROL MAINTENANCE PROGRAM:**

- PERIODIC SITE INSPECTIONS** FREQUENCY  
BI-WEEKLY  
RE-VEGETATION OF EXPOSED SOILS WITHIN 21 DAYS OF GRADING  
SEDIMENT REMOVAL FROM BMP'S MONTHLY  
REMOVAL OF BMP'S AFTER STABILIZATION ACHIEVED
- 1 AND AFTER ANY PRECIPITATION OR SNOW MELT EVENT THAT CAUSES SURFACE EROSION.  
2 ACCUMULATED SEDIMENT AND DEBRIS SHALL BE REMOVED WHEN THE SEDIMENT LEVEL REACHES ONE HALF THE HEIGHT OF THE BMP OR AT ANY TIME THAT SEDIMENT OR DEBRIS ADVERSELY IMPACTS THE FUNCTION OF THE BMP.

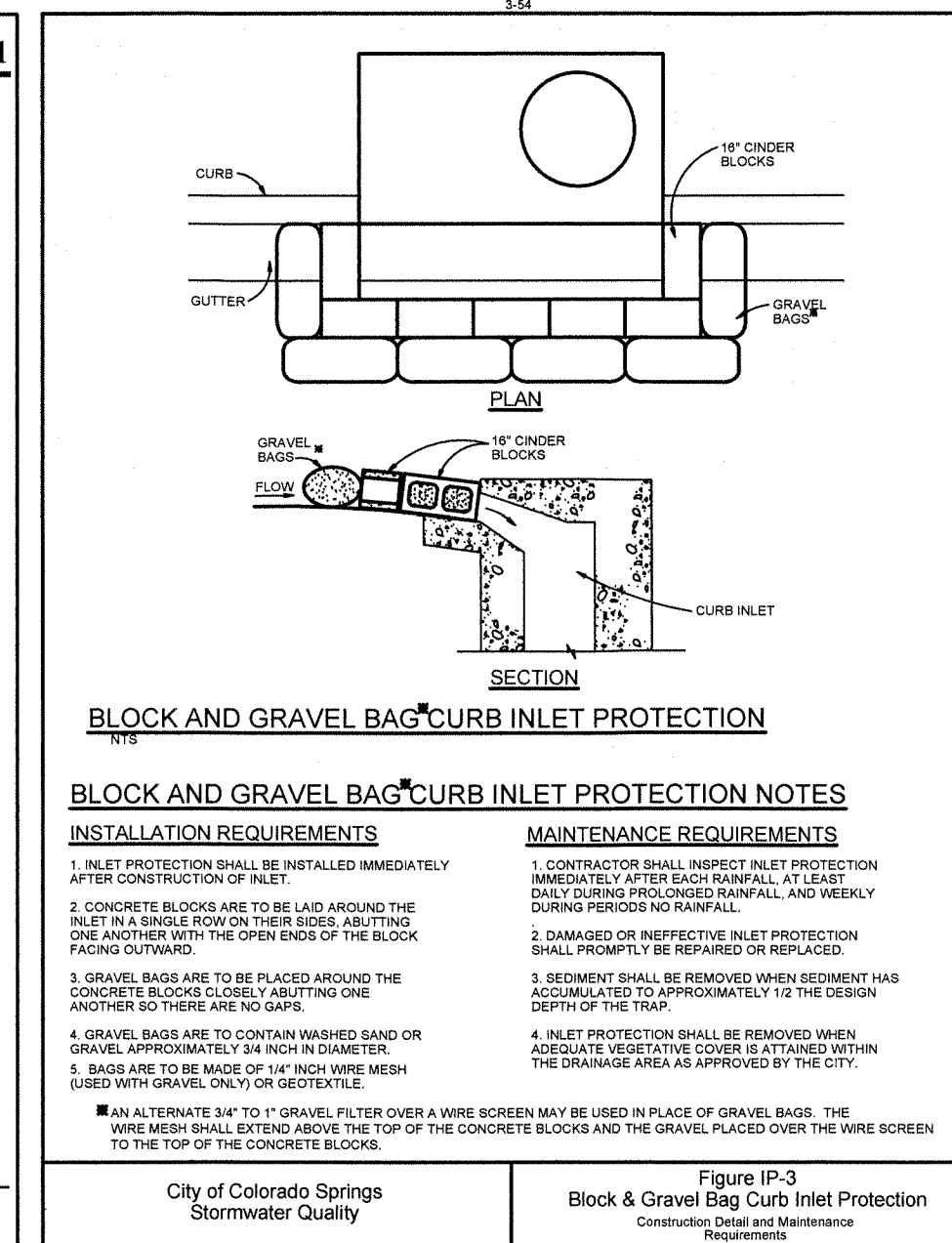
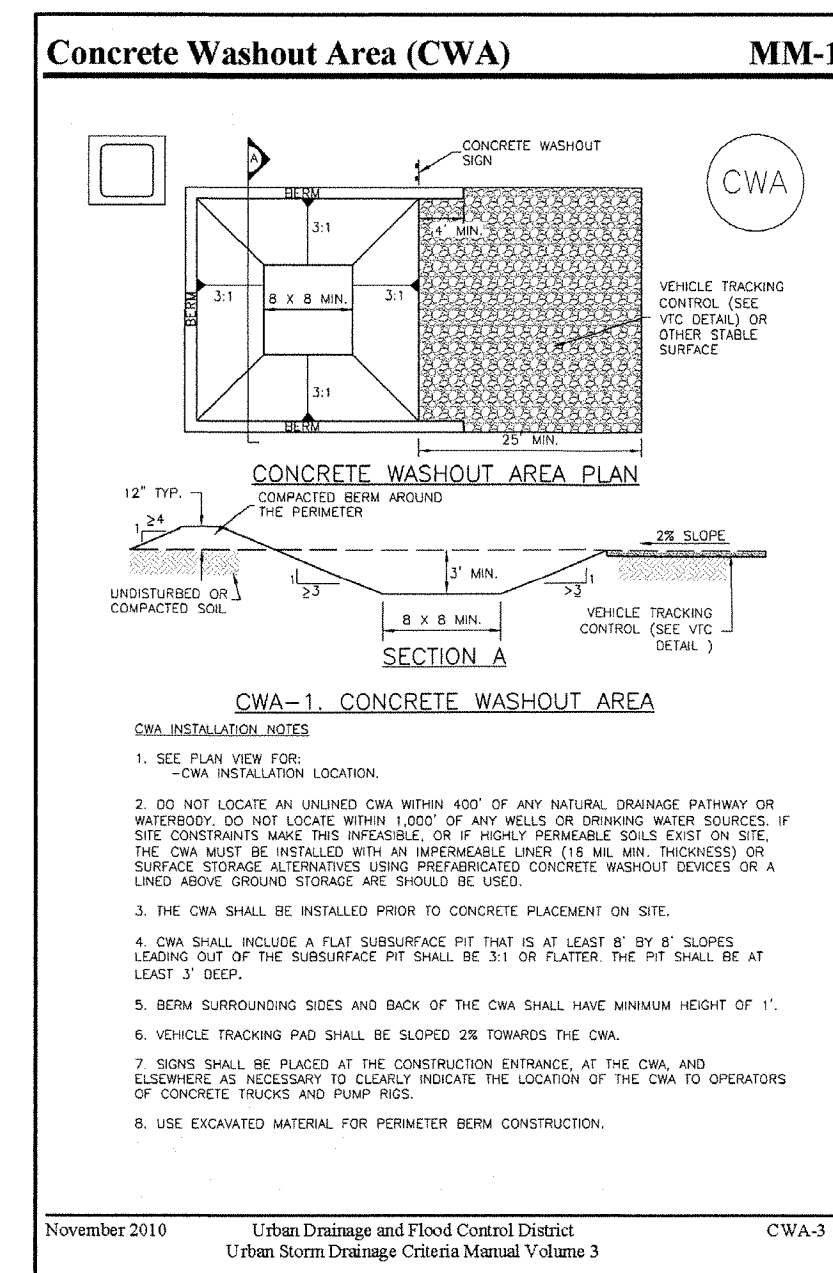
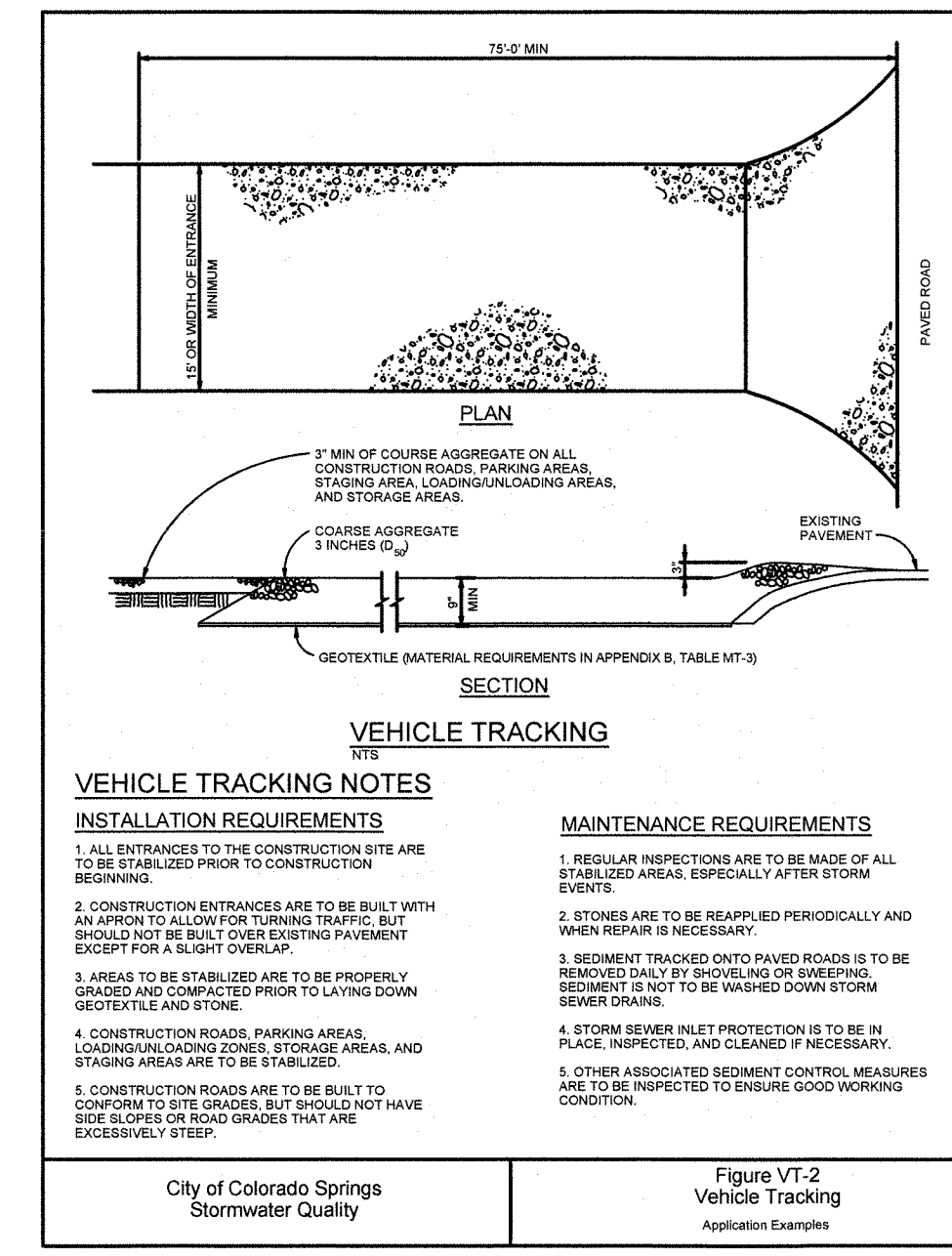
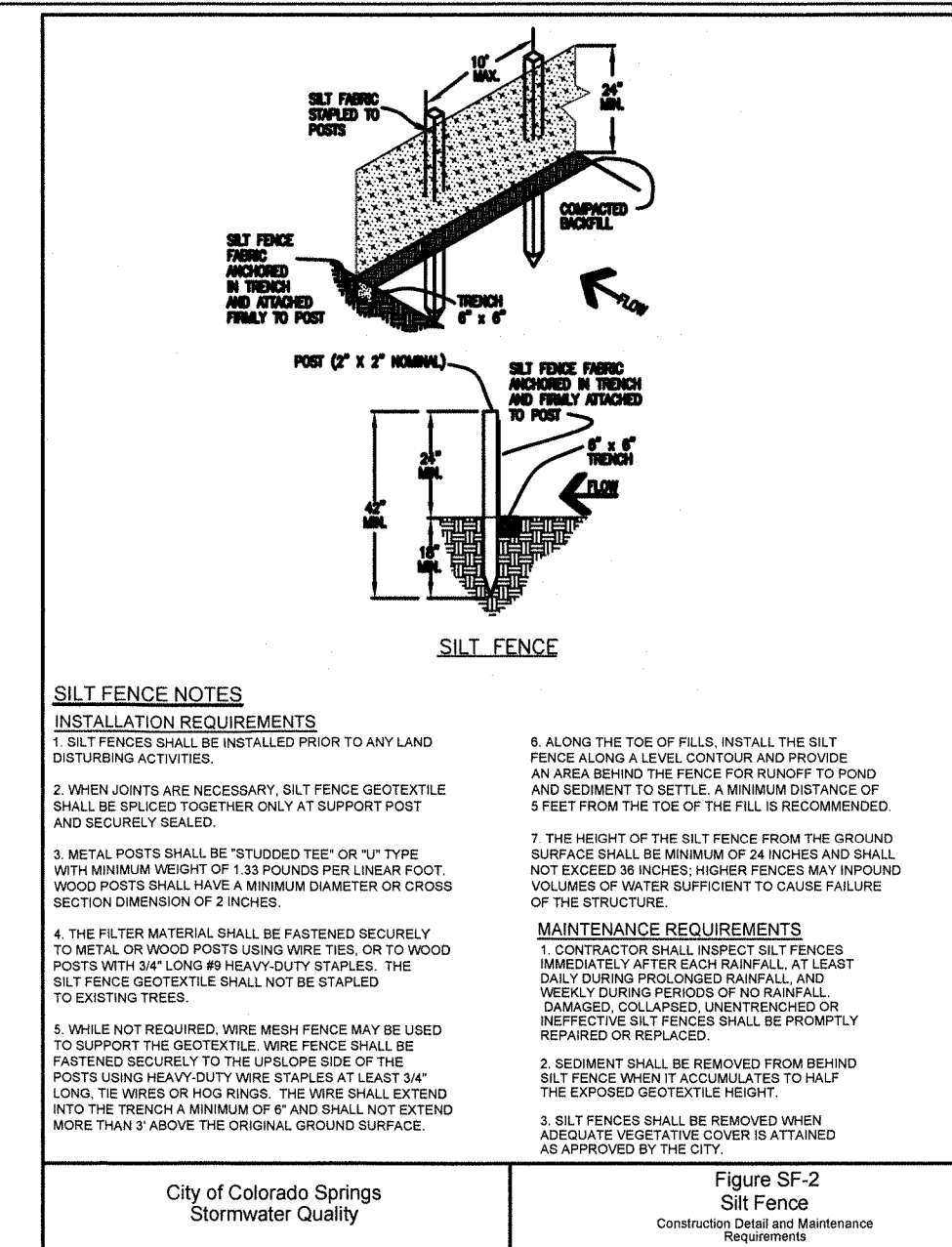

**WOODFORD MANUFACTURING BUILDING ADDITION**  
2121 WAYNOKA RD, COLORADO SPRINGS, COLORADO 80915

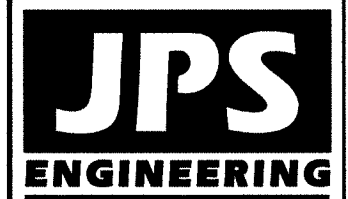

19 E. Wilamette Ave.  
Colorado Springs, CO 80903  
PH: 719-477-9429  
FAX: 719-471-0766  
www.jpsengr.com



CALL UTILITY NOTIFICATION CENTER OF COLORADO  
1-800-922-1987  
CALL 2-BUSINESS DAYS IN ADVANCE BEFORE YOU DIG, GRADE, OR EXCAVATE FOR THE MARKING OF UNDERGROUND MEMBER UTILITIES.

NO.	REVISION	DATE
1	DP SUBMITTAL	7/24/18
2	COUNTY COMMENTS	9/14/18

**GRADING & EROSION CONTROL NOTES & DETAILS**

HORIZ. SCALE: N/A DRAWN: BJJ  
VERT. SCALE: N/A DESIGNED: JPS  
SURVEYED: - CHECKED: JPS  
CREATED: 7/12/18 LAST MODIFIED: 9/14/18  
PROJECT NO: 051801 MODIFIED BY: BJJ  
SHEET: C3

PCD PROJECT NO. PPR-1837

