

Preliminary Drainage Report
for
Rolling Hills Ranch PUD
at
Meridian Ranch



EL PASO COUNTY, COLORADO

September 2019

Prepared For:

GTL DEVELOPMENT, INC.
P.O. Box 80036
San Diego, CA 92138

Prepared By:
Tech Contractors
11886 Stapleton Drive
Falcon, CO 80831
719.495.7444

PUDSP199

PCD Project No. PUDSP-19-XXX

CERTIFICATIONS

Design Engineer's Statement:

The attached drainage plan and report were prepared under my direction and supervision and are correct to the best of my knowledge and belief. Said drainage report has been prepared according to the criteria established by the County for drainage reports and said report is in conformity with the applicable master plan of the drainage basin. I accept responsibility for any liability caused by any negligent acts, errors or omissions on my part in preparing this report.

Thomas A. Kerby, P.E. #31429

Date

Owner/Developer's Statement:

I, the owner/developer have read and will comply with all of the requirements specified in this drainage report and plan.

Raul Guzman, Vice President
GTL Development, Inc.
P.O. Box 80036
San Diego, CA 92138

Date

El Paso County:

Filed in accordance with the requirements of the Drainage Criteria Manual, Volumes 1 & 2, El Paso County Engineering Criteria Manual and Land Development Code as amended.

Jennifer Irvine, P.E.
County Engineer / ECM Administrator

Date

Rolling Hills Ranch at Meridian Ranch PUD Preliminary Drainage Report

Table of Contents

EXECUTIVE SUMMARY	<i>i</i>
INTRODUCTION	<i>1</i>
Purpose	1
Scope	1
Background	1
EXISTING CONDITIONS	3
General Location	3
Land Use	3
Climate	3
Topography and Floodplains	3
Geology	3
Natural Hazards Analysis	6
DRAINAGE BASINS AND SUB-BASINS	6
DRAINAGE DESIGN CRITERIA	7
SCS Hydrograph Procedure	7
Full Spectrum Design	7
DRAINAGE CALCULATIONS	8
SCS General Overview	8
SCS Calculations	9
Historic Drainage - SCS Calculation Method	9
Interim Drainage - SCS Calculation Method	10
Future Drainage - SCS Calculation Method	12
Rational Calculations	14
Rational Narrative	14
Offsite Storm Drain System	15
Storm Drain System A	15
Storm Drain System B	15
Storm Drain System C	18
Storm Drain System D	19
Storm Drain System E	23
DETENTION PONDS	26
Existing Pond D Detention Storage Criteria	26
Existing Pond E Detention Storage Criteria	27
Pond G Detention Storage Criteria	29
Downstream Analysis	30
POND F – POND G CHANNEL	31
Methodology and Background	31
Design and Analysis	33
EROSION CONTROL DESIGN	35
General Concept	35
Four Step Process	35
Temporary Sedimentation Pond	36
Detention Pond	36
Silt Fence	36
Erosion Bales	36
Miscellaneous	36
REFERENCES	37

Figures

Figure 1: Vicinity Map2
Figure 2: FEMA Floodplain Map4
Figure 3: Soils Map5
Figure 4 - Meridian Ranch Rational Method – Basin Map APPENDIX H
Figure 5 - Meridian Ranch SCS Method – Historic Basin Map APPENDIX H
Figure 6 - Meridian Ranch SCS Method – Interim Basin Map APPENDIX H
Figure 7- Meridian Ranch SCS Method – Future Basin Map APPENDIX H
Figure 8- Pond D to Pond G Drainage Hec-Ras Map APPENDIX H

Tables

Table 1: SCS Runoff Curve Numbers7
Table 2: Detention Pond Summary:8
Table 3: Historic Drainage Basins – SCS9
Table 4: Interim Drainage Basins-SCS10
Table 5: Future Drainage Basins-SCS12
Table 6: Existing Pond D Summary Data27
Table 7: Existing Pond E Summary Data28
Table 8: Pond G Summary Data29
Table 9: Key Design Point Comparison - SCS30
Table 10 Manning's n Values32
Table 11 Natural Channel Design Parameters32

Appendices:

- Appendix A – Rational Calculations
- Appendix B - HEC-HMS Data
- Appendix C - Detention Pond Information
- Appendix D – Hec-Ras Analysis
- Appendix E – Outlet Protection Design
- Appendix F – Temporary Sedimentation Ponds
- Appendix G – Soil Resource Report
- Appendix H – Drainage Maps

EXECUTIVE SUMMARY

The purpose of the following Preliminary Drainage (PDR) is to present the changes to the drainage patterns as a result the Rolling Hills Ranch at Meridian Ranch PUD (Rolling Hills Ranch PUD) development. Runoff quantities and proposed facilities have been calculated using the current City of Colorado Springs/El Paso County Drainage Criteria Manual (DCM) (1994 version) and portions of the City of Colorado Springs Drainage Criteria Manual, Volume 1 (DCM-1) ((2014 version).

This report based on the current version of the Meridian Ranch Sketch Plan amendment as adopted by the El Paso County Board of Commissioners on March 13, 2018. Hydrologic calculations follow method outlined in Chapter 6 of the 2014 version of the City of Colorado Springs Drainage Criteria Manual (COSDCM) as adopted by the El Paso County Board of County Commissioners by Resolution 15-042. Chapter 6 addresses the hydrologic calculation methods and includes an updated hydrograph to be used with storm drainage runoff. The Board adopted by the same resolution, Section 3.2.1 of Chapter 13 of the COSDCM referencing Full Spectrum Detention; the concept “provides better control of the full range of runoff rates that pass through detention facilities than the convention multi-stage concept. This section of the COSDCM identifies the necessity to provide full spectrum detention but does not prescribe a methodology to reach such the detention requirements. This report includes hydrologic models from HEC-HMS for the historic, interim and future conditions for the 2-yr, 5-yr, 10-yr, 25-yr, 50-yr, and 100-yr design storm frequencies. The interim and the future conditions include detention facilities sized and modeled such that *“frequent and infrequent inflows are released at rates approximating undeveloped conditions”*

Rolling Hills Ranch PUD encompasses 252± acres and is located in Sections 20 and 29, Township 12 South, Range 64 West of the 6th Principal Meridian. It is approximately 12 miles northeast of the city of Colorado Springs, 2.5 miles north of the unincorporated town of Falcon, and immediately north of the Woodmen Hills development.

Rolling Hills Ranch is located within Gieck Ranch Drainage Basin. The Gieck Ranch Basin has been studied, but has not received final approval from El Paso County. The developer has agreed to meet the requirements of the studied Gieck Ranch Basin but as yet to be approved Drainage Basin Study.

Based on the aforementioned design parameters the development of the project will not adversely affect downstream properties.

INTRODUCTION

Purpose

The purpose of the following Preliminary Drainage Report (PDR) is to present proposed changes to the drainage patterns as a result of the development of Rolling Hills Ranch PUD. The report outlines the proposed drainage mitigation based on calculated developed flows in excess of allowable exiting runoff discharge.

Scope

The scope of this report includes:

- Location and description of the proposed development stating the proposed land use, density, acreage and adjacent features to the site.
- Calculations for design peak flows from all off-site tributary drainage areas.
- Calculations for design peak flows within the proposed project area for all drainage areas.
- Discussion of major drainage facilities required as a result of the development.
- Discussion and analysis of existing and proposed facilities.

Runoff quantities and proposed facilities have been calculated using the current City of Colorado Springs/El Paso County Drainage Criteria Manual (DCM) (1994 version) and those portions of the City of Colorado Springs Drainage Criteria Manual, Volume 1 (DCM-1) ((2014 version) adopted by Resolution 15-042 of the El Paso County Board of County Commissioners.

Background

On November 16, 2000 the El Paso County Board of County Commissioners approved the rezoning of the Meridian Ranch project (PUD-00-010) from A-35 to PUD with several conditions. Condition number seven stated in part that “drainage plans shall release and/or retain at approximately eight percent (80%) of historic rates.” At the time of the initial approvals there were no drainage improvements downstream of the Meridian Ranch project and the existing natural channels were shallow and undefined. There are no facilities located downstream of the Rolling Hills Ranch at Meridian Ranch PUD that will be adversely impacted by this development.

No development has occurred downstream of this project except for portions of the Falcon Regional Park providing ballparks and associated parking. The Meridian Ranch MDDP and this report indicate the Eastonville Road culvert crossing located downstream of this project does not provide enough capacity for the historic flow rates. It is anticipated that this culvert will be upgraded at the time of the Eastonville Road construction.

Current calculations show the future design discharge of the proposed Pond G to the Falcon Regional Park to be below historic flow rates at full buildout for the full spectrum of design storms.

Update paragraph to reference the specific project/resolution that removed this condition.

Rolling Hills Ranch PUD

Figure 1: Vicinity Map

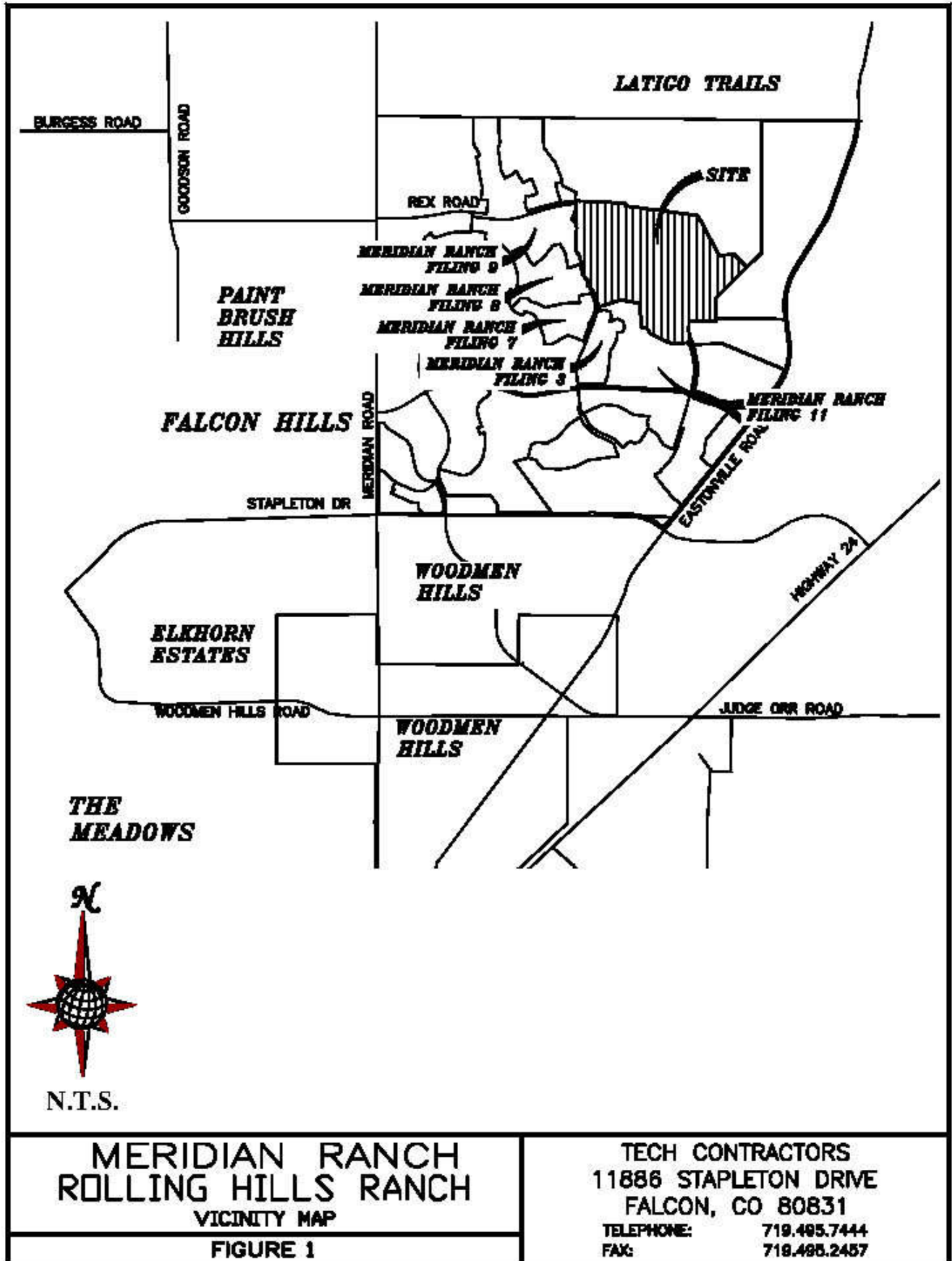

EXISTING CONDITIONS

General Location

Rolling Hills Ranch PUD project encompasses 252± acres and is located in Sections 20 and 29, Township 12 South, Range 64 West of the 6th Principal Meridian. It is approximately 12 miles northeast of the city of Colorado Springs, 2.5 miles north of the unincorporated town of Falcon, and immediately north of the Woodmen Hills development.

Land Use

Historically, ranching dominated the area surrounding Meridian Ranch; however, currently urbanization has occurred in the general vicinity. Most notably, urbanization is occurring to the north with Latigo Trails, to the south in the Woodmen Hills Subdivision, to the east in Four Way Ranch, to the west in the Falcon Hills subdivision, and to the northwest in the Paint Brush Hills subdivision.

Climate

Mild summers and winter, light precipitation; high evaporation and moderately high wind velocities characterize the climate of the study area. The average annual monthly temperature is 48.4 F with an average monthly low of 30.3 F in the winter and an average monthly high of 68.1 F in the summer. Two years in ten will have maximum temperature higher than 98 F and a minimum temperature lower than -16 F. Precipitation averages 15.73" annually, with 80% of this occurring during the months of April through September. The average annual Class A pan evaporation is 45 inches. (Soil Survey of El Paso County Area, Colorado).

Topography and Floodplains

The topography of the site is typical of a high desert, short prairie grass with relatively flat slopes generally ranging from 2% to 4%. The project site drains generally from the northwest to southeast and is tributary to the Black Squirrel Creek.

The Flood Insurance Rate Maps (FIRM No. 08041C0575-F dated 3/17/1997) indicates that the project is outside of any designated flood plain. Please see Figure 2: Rolling Hills Ranch PUD Federal Emergency Management Agency (FEMA) Floodplain Map.

update to the latest
FIRM

Geology

The National Resources Conservation Service (NRCS) soil survey records indicate that the service area is predominately covered by soils classified in the Columbine (65 ac.) and Stapleton series (188 ac.). These series are categorized in the Hydrological Soil Groups A & B.

The Columbine (19) gravelly sandy loam is a deep, well-drained to excessively drained soil formed in coarse textured material on alluvial terraces, fans and flood plains. Permeability of this soil is very rapid. Available water capacity is low to moderate, surface runoff is slow, and the hazard of erosion is slight to moderate. The Columbine series is categorized as a Hydrological Soil Group A.

This soil is used mainly for grazing livestock, for wildlife habitat and for home sites. The main limitation of this soil for urban development is a hazard of flooding in some areas.

Rolling Hills Ranch PUD

Figure 2: FEMA Floodplain Map

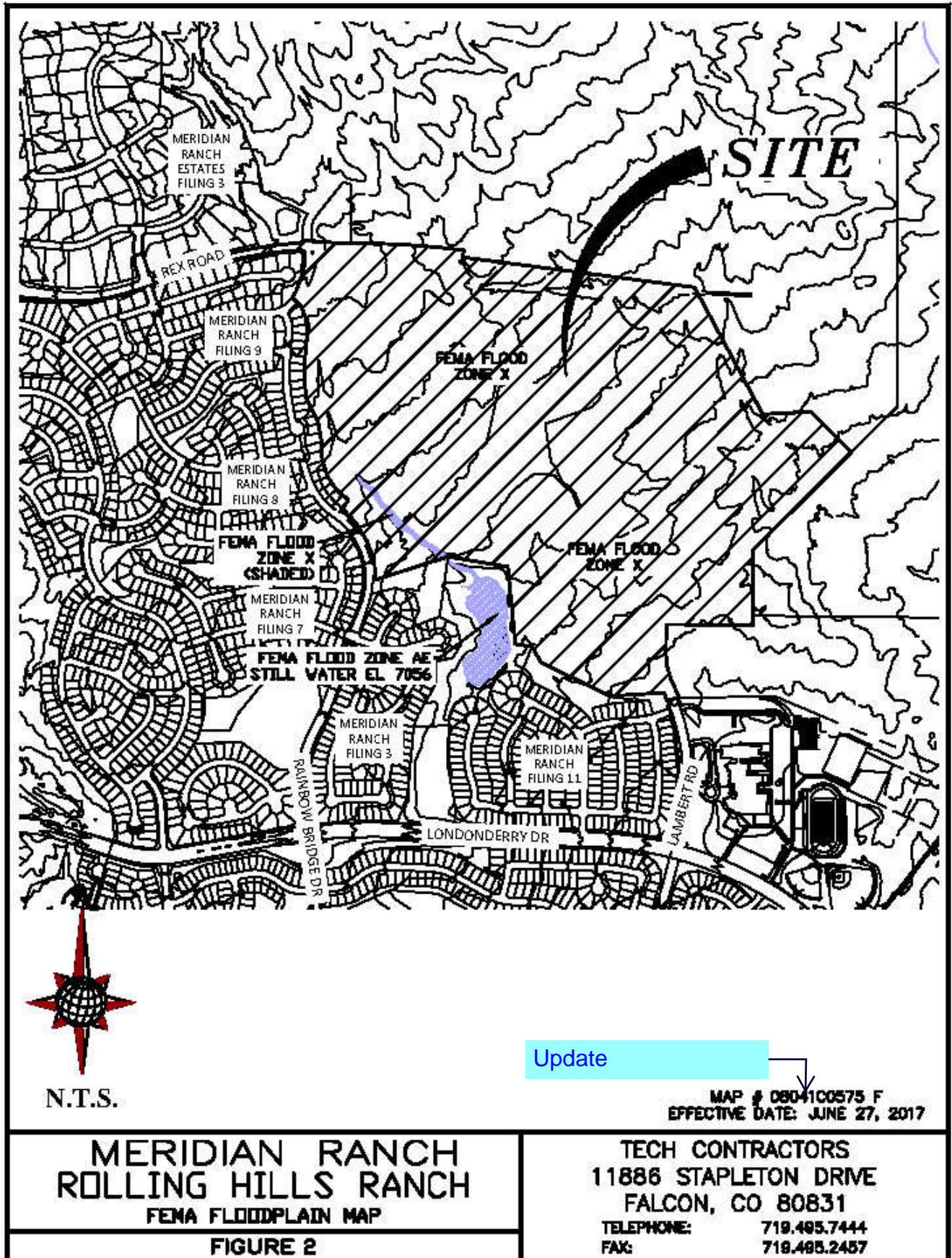

Rolling Hills Ranch PUD

Figure 3: Soils Map

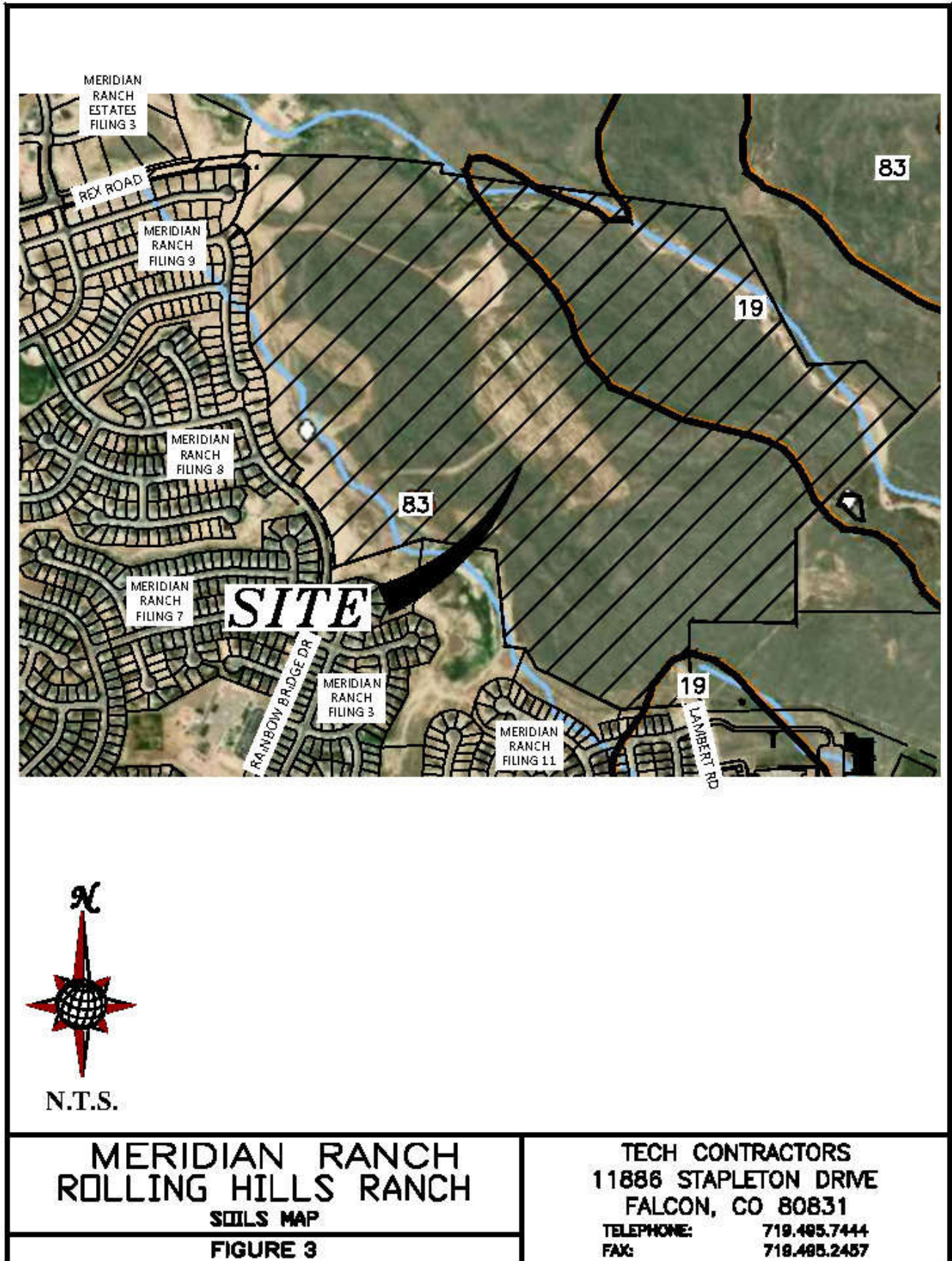

The Stapleton (83) sandy loam is a deep, non-calcareous, well-drained soil formed in alluvium derived from arkosic bedrock on uplands. Permeability of this soil is rapid. Available water capacity is moderate, surface runoff is slow, and the hazard of erosion and soil blowing is moderate. The Stapleton series is categorized as a Hydrological Soil Group B.

This soil is suited to habitat for open land and rangeland wildlife. The main limitation of this soil for urban development is frost-action potential.

Typically, these soils are well-drained, gravelly sandy loams that form on alluvial terraces and fans and exhibit high permeability and low available water capacity with depth to bedrock greater than 6 feet.

Note: (#) indicates Soil Conservation Survey soil classification number. See Figure 3 Rolling Hills Ranch PUD – Soils Map.

Natural Hazards Analysis

Natural hazards analysis indicates that no unusual surface or subsurface hazards are located near the vicinity. However, because the soils are cohesionless, sloughing of steep banks during drilling and/or excavation could occur. By citing improvements in a manner that provides an opportunity to lay the banks of excavations back at a 1:1 slope during construction, the problems associated with sloughing soils can be minimized.

DRAINAGE BASINS AND SUB-BASINS

The site is near the top of the Gieck Ranch Drainage Basin and accepts flow from areas north of the project site within portions of Meridian Ranch.

Three different scenarios were analyzed for the drainage conditions for the project.

The first scenario analyzes the historic conditions for Meridian Ranch. This condition has all of Meridian Ranch in the pre-development state; where the entirety of Meridian Ranch is modeled in its undeveloped, undisturbed condition, alternatively called the historic condition.

The second scenario is the interim conditions scenario and it consists of the current existing conditions for all tributary areas whether developed or undeveloped/historic with the addition of Rolling Hills Ranch PUD in the proposed developed condition. The current existing conditions assume all approved projects tributary to Rolling Hills Ranch and the Rolling Hills Ranch PUD are at full buildout. This condition was analyzed to ensure the full spectrum of historic flow rates exiting the Meridian Ranch development are maintained after the development of Rolling Hills Ranch PUD is completed.

The interim scenario was analyzed to ensure that the historic flow rates at the outlets of the proposed Pond G (Design Point G12) located upstream of and adjacent to the Falcon Regional Park and Pond E (Design Points H08 & H09) located along Eastonville Road were maintained. The development of Rolling Hills Ranch will complete the development of the areas tributary to Ponds D & E.

The final scenario analyzes the future build out conditions for the entirety of Meridian Ranch to ensure the storm drain facilities located at the discharge points of the project are able to properly convey the full spectrum of historic peak flow rates as the storm drainage exits the Meridian Ranch project along Eastonville Road and/or the Falcon Regional Park.

DRAINAGE DESIGN CRITERIA

SCS Hydrograph Procedure

The US Army Corp of Engineers HEC-HMS computer program was used to model the Soil Conservation Service (SCS) Hydrograph procedure to determine final design parameters for the major drainage facilities within the project. Onsite basin areas were calculated using aerial topography of the site and approved final design data. Times of concentration were estimated using the SCS procedures described in the DCM. Based upon the hydrologic soil type, the natural conditions found in the basins and the runoff curve numbers (CN) chart from Table 6-10 of the City of Colorado Springs DCM for Antecedent Runoff Condition II (ARC II), the following CN values were used for the given conditions.

Table 1: SCS Runoff Curve Numbers

Condition	CN*		
Residential Lots (5 acre)	63	School	80
Residential Lots (2.5 acre)	66	Parks/Open Space	62
Residential Lots (1 acre)	68	Commercial	85
Residential Lots (1/2 acre)	70	Roadways	98
Residential Lots (1/3 acre)	72	Graded	67
Residential Lots (1/4 acre)	75	Golf Course	62
Residential Lots (1/5 acre)	78	Latigo Undeveloped	65
Residential Lots (1/6 acre)	80	Undeveloped	61

*Curve Numbers were interpolated and based on amount of impervious area per lot. The 24 hour storm precipitation values were selected from the NOAA Atlas 14, Volume 8, Version 2 for the Meridian Ranch location (Latitude 38.9783°, Longitude -104.5842°, Elevation 7054 ft). These numbers along with SCS information were used as input to the U.S. Army Corp of Engineers HEC-HMS computer model to determine design runoffs. See the table for all the design storm events in Appendix A. These numbers along with SCS information were used as input to the U.S. Army Corp of Engineers HEC-HMS computer model to determine design runoffs.

Full Spectrum Design

The City of Colorado Springs adopted a new Drainage Criteria Manual (DCM) in 2014 which incorporated the use of *Full Spectrum Design* for storm drainage analysis for projects located within the city limits. El Paso County adopted portions of the City’s 2014 DCM by resolution in January 2015; the County resolution adopted Chapter 6 (Hydrology) and Section 3.2.1 of Chapter 13 (Full Spectrum Detention) for projects outside of the City of Colorado Springs establishing a 1 year review period to analyze the impacts of the Full Spectrum Design on the storm drainage analysis of projects. This report has incorporated the use of full spectrum in the analysis using the SCS Method to determine the size requirements for the detention pond during the interim and future conditions.

The idea behind full spectrum detention is to release the developed runoff flow rates that will approximate those of the pre-developed condition. The design of Pond G and the outlet control structure meets or exceeds the intent and spirit of the concept.

Table 2: Detention Pond Summary:

POND F				
	PEAK	PEAK	PEAK	PEAK
	CFS	CFS	AC-FT	FT
INTERIM CONDITIONS				
2-YEAR STORM	4.6	2.3	0.9	7130.1
5-YEAR STORM	21	8.0	1.8	7131.2
10-YEAR STORM	53	17	3.4	7132.7
25-YEAR STORM	120	60	5.3	7134.1
50-YEAR STORM	193	121	6.7	7134.9
100-YEAR STORM	285	177	8.8	7136.0
FUTURE CONDITIONS				
2-YEAR STORM	4.7	2.3	0.9	7130.1
5-YEAR STORM	22	8.1	1.9	7131.2
10-YEAR STORM	52	17	3.4	7132.7
25-YEAR STORM	120	61	5.3	7134.1
50-YEAR STORM	194	121	6.7	7134.9
100-YEAR STORM	286	177	8.8	7136.0

DRAINAGE CALCULATIONS

SCS General Overview

The project is located within the Gieck Ranch Drainage Basin; storm water runoff will be conveyed across the site overland and within existing and proposed storm drain networks to existing and proposed detention ponds. Those portions of the site tributary the existing Detention Pond D will be directed to an existing sedimentation pond to be located upstream of the pond then conveyed to the pond. Portions of the site are tributary the existing Detention Pond E; runoff will be directed to an existing sedimentation pond to be located upstream at the existing northern terminus of Lambert Road, collected then conveyed via an existing storm drain system to the pond. Portions of the site tributary to the proposed Detention Pond G will be directed to temporary sedimentation pond before being released into the existing natural channel and conveyed to the proposed pond. Additionally, the proposed detention Pond G will be utilized as a combination sedimentation/detention pond until such time as the tributary areas establish sufficient ground cover or development in the area is complete

The detention facilities have been adequately sized such that the developed flows detained and released will approximate the historic flow rates for the various design storm events as outlined in the El Paso County DCM and those sections of the City of Colorado Springs DCM-1 adopted by the El Paso County Board of County Commissioners. Existing facilities located downstream of the proposed development have been designed and/or constructed to accept the given release flow rates from Meridian Ranch. Those existing facilities have been reviewed sufficiently to verify the capacity to convey the storm flow rates from Meridian Ranch. See approved Meridian Ranch MDDP, dated January 2018.

Rear lots adjacent to the Falcon Regional Park will drain into open space and then will be directed via a shallow swale to the proposed detention pond prior to exiting the site.

The analysis shows the portion of the site tributary to existing Pond E releasing the developed peak flows below the historic flow rates for the full spectrum of design storms using the newly adopted unit hydrograph from the City DCM-1.

Figure 5: Meridian Ranch SCS Calculations – Historic Conditions Map, Figure 6: Meridian Ranch SCS Calculations – Interim Conditions Map and Figure 7: Meridian Ranch SCS Calculations – Future Conditions Map depict the historic, interim and future general drainage patterns for Rolling Hills Ranch PUD.

The purpose of this report is to show that the development of Rolling Hills Ranch PUD will not adversely impact the existing drainage facilities adjacent to and downstream of the developed area and the existing Ponds D & E are properly sized for the anticipated future development of Rolling Hills Ranch.

SCS Calculations

Historic Drainage - SCS Calculation Method

Following is a tabulation of the surface drainage characteristics under Existing Conditions using the SCS calculation method. Please refer to Figure 5 - Meridian Ranch SCS Calculations - Historic Basin Map.

Table 3: Historic Drainage Basins – SCS

HISTORIC MDDP (Full Spectrum)							
HYDROLOGIC ELEMENT	DRAINAGE AREA (SQ. MI.)	PEAK DISCHARGE Q100 (CFS)	PEAK DISCHARGE Q50 (CFS)	PEAK DISCHARGE Q25 (CFS)	PEAK DISCHARGE Q10 (CFS)	PEAK DISCHARGE Q5 (CFS)	PEAK DISCHARGE Q2 (CFS)
OS06	0.1313	81	53	31	12	3.9	0.5
OS06-G02	0.1313	79	52	31	12	3.8	0.5
OS05	0.0578	40	26	16	5.9	1.8	0.2
OS05-G01	0.0578	38	26	16	5.7	1.8	0.2
HG01	0.0547	33	21	13	4.8	1.6	0.2
G01	0.1125	71	47	28	10	3.3	0.5
G01-G02	0.1125	70	47	27	10	3.3	0.5
HG02	0.0906	46	30	18	6.9	2.4	0.4
G02	0.3344	194	129	76	28	9.4	1.4
G02-G03	0.3344	192	127	75	28	9.3	1.4
HG03	0.1828	79	51	31	12	4.4	0.8
OS07	0.0328	25	17	11	4.6	1.7	0.3
OS07-G03	0.0328	24	17	9.9	4.4	1.7	0.3
G03	0.55	295	195	115	44	15	2.4
G03-G04	0.55	286	192	113	43	15	2.4
OS09	0.1547	92	64	41	19	8.5	2.0
OS09-G04	0.1547	91	63	41	19	8.5	2.0

HISTORIC MDDP (Full Spectrum)							
HYDROLOGIC ELEMENT	DRAINAGE AREA (SQ. MI.)	PEAK DISCHARGE Q100 (CFS)	PEAK DISCHARGE Q50 (CFS)	PEAK DISCHARGE Q25 (CFS)	PEAK DISCHARGE Q10 (CFS)	PEAK DISCHARGE Q5 (CFS)	PEAK DISCHARGE Q2 (CFS)
HG04	0.0891	40	27	16	6.1	2.2	0.4
HG05	0.1125	50	33	19	7.6	2.7	0.5
OS08	0.0406	36	25	17	7.9	3.5	0.8
OS08-G04	0.0406	34	24	15	7.6	3.5	0.8
G04	0.9469	502	336	200	78	28	4.9
G04-G05	0.9469	496	322	193	78	28	4.9
HG06A	0.1375	50	33	20	7.8	2.9	0.5
G05	1.0844	544	355	212	86	31	5.4
G05-G06	1.0844	530	353	211	86	31	5.4
HG06B	0.1031	34	22	13	5.4	2.1	0.4
G06	1.1875	561	375	225	91	33	5.8
HG07	0.0984	47	31	18	7.1	2.4	0.4
HG07-G11	0.0984	47	31	18	7.0	2.4	0.4
HG08	0.1328	73	48	28	11	3.6	0.5
G11	0.2312	115	75	44	17	5.7	0.9
G11-G12	0.2312	114	75	44	17	5.6	0.9
HG09	0.1781	73	48	29	11	4.1	0.7
G12	0.4093	187	122	72	28	9.7	1.6
G12-H08	0.4093	183	121	71	28	9.7	1.6
HG10	0.1375	39	26	16	6.5	2.6	0.5
H08	0.5468	216	142	85	34	12	2.1
HG14	0.2297	81	53	32	13	4.8	0.9
HG13	0.0844	55	37	23	9.8	3.9	0.7
G07	0.0844	55	37	23	9.8	3.9	0.7
G07-G08	0.0844	54	37	23	9.7	3.8	0.7
G08	0.3141	119	78	48	20	7.6	1.5
HG15	0.2563	70	46	28	12	4.7	0.9
H13	0.2563	70	46	28	12	4.7	0.9
HG11	0.2047	77	51	30	12	4.5	0.8
H09	0.2047	77	51	30	12	4.5	0.8
HG12	0.1297	57	38	22	8.7	3.1	0.5
H10	0.1297	57	38	22	8.7	3.1	0.5

See approved Meridian Ranch MDDP (EPC File SKP171) dated January 2018 for complete hydrologic calculations and maps.

Interim Drainage - SCS Calculation Method

Following is a tabulation of the surface drainage characteristics for the interim conditions using the SCS calculation method. Please refer to Figure 5 - Meridian Ranch SCS Calculations – Interim Basins Map

Table 4: Interim Drainage Basins-SCS

INTERIM MDDP (Full Spectrum)							
	DRAINAGE AREA (SQ. MI.)	PEAK DISCHARGE Q100 (CFS)	PEAK DISCHARGE Q50 (CFS)	PEAK DISCHARGE Q25 (CFS)	PEAK DISCHARGE Q10 (CFS)	PEAK DISCHARGE Q5 (CFS)	PEAK DISCHARGE Q2 (CFS)
OS06	0.1313	80	52	30	12	3.8	0.5
G1a	0.1313	80	52	30	12	3.8	0.5
G1a-G2	0.1313	79	52	30	11	3.6	0.5
OS05	0.0578	39	26	15	5.6	1.8	0.2
OS05-G1	0.0578	39	25	15	5.5	1.7	0.2
FG01	0.0531	31	22	14	6.9	3.3	0.9
FG01-G1	0.0531	31	22	14	6.9	3.3	0.9
G1	0.1109	61	41	25	11	4.8	1.1
G1-G2	0.1109	60	41	25	11	4.8	1.1
FG02	0.0391	32	22	14	6.2	2.6	0.4
G2	0.2813	166	112	67	27	10	1.9
G2-G3	0.2813	163	108	66	27	10	1.9
FG03	0.0203	24	17	12	5.9	0.8	0.8
FG04	0.0172	22	16	11	5.8	3.1	0.9

INTERIM MDDP (Full Spectrum)							
	DRAINAGE AREA (SQ. MI.)	PEAK DISCHARGE Q100 (CFS)	PEAK DISCHARGE Q50 (CFS)	PEAK DISCHARGE Q25 (CFS)	PEAK DISCHARGE Q10 (CFS)	PEAK DISCHARGE Q5 (CFS)	PEAK DISCHARGE Q2 (CFS)
G3	0.3188	184	123	74	31	11	2.4
G3-POND F	0.3188	183	121	74	31	11	2.4
FG06	0.0658	46	32	20	9.1	3.9	0.7
OS07a-POND F	0.0170	13	9.0	5.7	2.4	0.9	0.1
POND F IN	0.4596	285	193	120	53	21	4.6
POND F	0.4596	177	121	60	17	8.0	2.3
POND F-G7	0.4596	177	120	60	17	8.0	2.3
FG22	0.0658	51	36	24	12	5.6	1.4
FG23a	0.0177	18	13	9.0	4.9	2.7	1.0
OS07b	0.0156	15	10.0	6.2	2.6	1.0	0.1
OS07b-G7	0.0156	13	9.2	5.4	2.3	0.9	0.1
G7	0.5587	215	145	72	22	10	2.9
G7-G10	0.5587	215	144	72	22	10	2.9
FG24	0.2503	110	73	43	17	6.2	1.1
OS09	0.1527	90	62	39	18	8.2	1.9
OS09-G10	0.1527	88	61	39	18	8.2	1.9
OS08	0.0397	35	24	16	7.5	3.4	0.7
OS08-G8	0.0397	34	24	15	7.2	3.3	0.7
G8	0.4427	227	154	94	41	17	3.4
G8-G10	0.4427	225	151	94	41	17	3.4
FG23b	0.0359	21	14	8.4	3.3	1.2	0.2
G10	1.0373	444	287	146	60	25	5.7
G10-G11	1.0373	442	285	145	60	25	5.7
FG23c	0.0070	5.8	4.2	2.8	1.4	0.7	0.2
G11	1.0443	445	287	146	61	25	5.8
FG25	0.1086	85	64	46	27	17	7.5
FG28	0.0673	38	26	16	6.7	2.7	0.5
POND G IN	1.2202	558	363	202	91	42	11
POND G	1.2202	399	237	117	35	13	4.2
G12	1.2202	399	237	117	35	13	4.2
G12-G06	1.2202	398	236	117	35	13	4.2
FG29	0.0997	60	39	23	8.7	2.8	0.4
FG32	0.0402	29	19	11	4.2	1.3	0.2
FG32-G06	0.0402	28	19	11	4.1	1.3	0.2
G06	1.3601	418	248	124	37	14	4.5
FG10A	0.0806	81	61	43	25	15	6.5
FG08A	0.0750	116	90	66	41	27	13
FG08A-G05	0.0750	110	86	64	41	27	13
FG08B	0.0630	86	67	49	31	20	10
FG08B-G05	0.0630	84	65	48	29	19	10
FG11	0.0625	75	59	44	28	19	9.8
FG09	0.0484	48	36	25	14	8.3	3.2
FG09-G05	0.0484	48	36	25	14	8.0	3.2
FG10B	0.0416	42	31	22	12	7.0	2.7
G05	0.3711	433	330	239	145	93	45
FG13	0.0534	34	24	15	7.5	3.6	0.9
FG12	0.0328	50	40	30	20	14	7.8
POND D IN	0.4573	509	387	280	168	107	52
POND D	0.4573	134	91	50	19	12	4.3
POND D-G17	0.4573	134	91	50	19	12	4.3
FG15	0.0103	15	12	9.0	5.8	3.9	2.1
FG15-G17A	0.0103	15	12	8.9	5.8	3.9	2.1
G17A	0.4676	137	93	51	19	12	4.4
FG14	0.1000	98	74	53	32	20	9.2
G17	0.5676	196	132	75	43	25	12
G17-G18	0.5676	196	131	75	43	25	12
FG16	0.0791	133	104	78	50	34	18
G18	0.6467	240	178	128	79	51	26
G18-POND E	0.6467	240	176	126	78	50	25
FG31	0.0922	116	92	69	45	31	17
FG30	0.0389	30	20	12	4.3	1.3	0.2
FG30-PONDHS	0.0389	28	19	11	4.2	1.2	0.2
POND HS	0.1311	112	63	40	28	19	10.0
FG17a	0.0694	101	78	57	35	23	12
FG17a-POND E	0.0694	99	76	56	35	23	11.6
FG18	0.0644	56	42	30	18	11	4.7

INTERIM MDDP (Full Spectrum)							
	DRAINAGE AREA (SQ. MI.)	PEAK DISCHARGE Q100 (CFS)	PEAK DISCHARGE Q50 (CFS)	PEAK DISCHARGE Q25 (CFS)	PEAK DISCHARGE Q10 (CFS)	PEAK DISCHARGE Q5 (CFS)	PEAK DISCHARGE Q2 (CFS)
FG18-POND E	0.0644	56	42	30	17	11	4.6
FG19	0.0527	84	66	50	33	23	13.1
FG17c	0.0313	31	22	14	6.5	2.8	0.5
FG17b	0.0214	39	31	24	16	11	6.1
POND E IN	1.0170	552	423	308	190	123	63.0
POND E	1.0170	233	144	74	28	15	6.1
H08	1.0170	200	130	66	22	11	3.7
H09	0.0000	34	14	7.9	5.7	3.9	2
FG34	0.0836	48	32	19	7.0	2.3	0.3
G14	0.0836	48	32	19	7.0	2.3	0.3
G14-G15	0.0836	48	32	18	7.0	2.3	0.3
FG35	0.0586	19	13	7.4	3.0	1.2	0.2
G15	0.1422	60	39	23	8.9	3.1	0.5
G15-G08	0.1422	59	39	23	8.8	3.1	0.5
FG37	0.1203	44	29	17	6.8	2.5	0.4
FG36	0.0281	16	10	6.0	2.4	0.9	0.1
FG36-G08	0.0281	15	10	6.0	2.4	0.8	0.1
G08	0.2906	114	75	44	18	6.4	1.1

See approved Meridian Ranch MDDP (EPC File SKP171) dated January 2018 for complete hydrologic calculations and maps.

Future Drainage - SCS Calculation Method

Following is a tabulation of the surface drainage characteristics for the future conditions using the SCS calculation method. Please refer to Figure 6 - Meridian Ranch SCS Calculations – Future Basins Map

Table 5: Future Drainage Basins-SCS

FUTURE MDDP (Full Spectrum)							
	DRAINAGE AREA (SQ. MI.)	PEAK DISCHARGE Q100 (CFS)	PEAK DISCHARGE Q50 (CFS)	PEAK DISCHARGE Q25 (CFS)	PEAK DISCHARGE Q10 (CFS)	PEAK DISCHARGE Q5 (CFS)	PEAK DISCHARGE Q2 (CFS)
OS06	0.1313	80	52	30	12	3.8	0.5
G1a	0.1313	80	52	30	12	3.8	0.5
G1a-G2	0.1313	79	52	30	11	3.6	0.5
OS05	0.0578	39	26	15	5.6	1.8	0.2
OS05-G1	0.0578	39	25	15	5.5	1.7	0.2
FG01	0.0538	31	22	14	7.0	3.4	0.9
FG01-G1	0.0538	31	22	14	6.9	3.4	0.9
G1	0.1116	61	41	25	11	4.9	1.1
G1-G2	0.1116	61	41	25	11	4.8	1.1
FG02	0.0391	32	22	14	6.4	2.7	0.5
G2	0.2820	167	112	67	27	10	1.9
G2-G3	0.2820	163	109	66	27	10	1.9
FG03	0.0203	24	17	12	5.9	0.8	0.8
FG04	0.0172	22	16	11	5.8	3.1	0.9
G3	0.3195	185	123	74	31	11	2.4
G3-POND F	0.3195	183	121	74	31	11	2.4
FG06	0.0608	49	34	22	10	4.6	0.9
FG05	0.0580	45	33	23	12	6.7	2.4
OS07a	0.0170	14	9.2	5.7	2.5	0.9	0.1
OS07a-POND F	0.0170	13	9.0	5.7	2.4	0.9	0.1
POND F IN	0.4553	286	194	120	52	22	4.7
POND F	0.4553	177	121	61	17	8.1	2.3
POND F-G7	0.4553	177	120	60	17	8.1	2.3
FG21b	0.0170	25	20	15	9.6	6.5	3.5
FG21a	0.0072	7.2	5.0	3.2	1.4	0.5	0.1
FG21a-G7	0.0072	6.8	4.9	2.7	1.4	0.5	0.1
G7	0.4795	186	126	64	18	8.8	3.6

FUTURE MDDP (Full Spectrum)							
	DRAINAGE AREA (SQ. MI.)	PEAK DISCHARGE Q100 (CFS)	PEAK DISCHARGE Q50 (CFS)	PEAK DISCHARGE Q25 (CFS)	PEAK DISCHARGE Q10 (CFS)	PEAK DISCHARGE Q5 (CFS)	PEAK DISCHARGE Q2 (CFS)
G7-G8	0.4795	185	126	64	18	8.8	3.5
FG22	0.1380	102	73	47	24	12	3.3
OS08	0.0406	35	25	16	7.7	3.4	0.7
OS08-G8	0.0406	34	24	15	7.5	3.4	0.7
FG23a	0.0216	21	15	10	5.2	2.7	0.8
OS07b	0.0156	15	10	6.2	2.6	1.0	0.1
OS07b-G7	0.0156	14	9.7	6.0	2.4	0.9	0.1
G8	0.6953	291	186	95	47	24	7.4
G8-G10	0.6953	288	186	94	46	24	7.4
OS09	0.1527	90	62	39	18	8.2	1.9
OS09-G10	0.1527	88	62	39	18	8.2	1.9
FG24	0.1373	105	76	50	26	13	4.0
G9	0.2900	180	125	81	38	17	4.4
G9-G10	0.2900	178	125	79	37	17	4.4
FG23b	0.0286	23	16	10	4.6	2.0	0.4
G10	1.0139	478	307	174	80	39	12
G10-G11	1.0139	474	305	173	80	38	12
FG23c	0.0122	12	8.7	5.7	3.0	1.5	0.4
G11	1.0261	479	308	176	81	39	12
FG25	0.1086	85	64	46	27	17	7.5
FG26	0.0863	78	58	40	22	12	4.6
FG26-POND G	0.0863	77	57	39	22	12	4.5
FG27	0.0500	52	40	29	17	11	5.0
FG28	0.0245	18	13	8.5	4.1	2.0	0.5
POND G IN	1.2955	684	454	287	145	78	28
POND G	1.2955	478	333	170	56	22	5.1
G12	1.2955	478	333	170	56	22	5.1
G12-G06	1.2955	478	332	170	56	22	5.1
FG29	0.0997	60	39	23	8.7	2.8	0.4
FG32	0.0402	72	57	44	29	20	11
FG32-G06	0.0402	69	54	41	27	18	11
G06	1.4354	506	352	181	61	24	11
FG10A	0.0806	81	61	43	25	15	6.5
FG08A	0.0750	116	90	66	41	27	13
FG08A-G05	0.0750	110	86	64	41	27	13
FG08B	0.0630	86	67	49	31	20	10
FG08B-G05	0.0630	84	65	48	29	19	10
FG11	0.0625	75	59	44	28	19	9.8
FG09	0.0484	48	36	25	14	8.3	3.2
FG09-G05	0.0484	48	36	25	14	8.0	3.2
FG10B	0.0416	42	31	22	12	7.0	2.7
G05	0.3711	433	330	239	145	93	45
FG13	0.0534	34	24	15	7.5	3.6	0.9
FG12	0.0328	50	40	30	20	14	7.8
POND D IN	0.4573	509	387	280	168	107	52
POND D	0.4573	134	91	50	19	12	4.3
POND D-G17	0.4573	134	91	50	19	12	4.3
FG15	0.0103	15	12	9.0	5.8	3.9	2.1
FG15-G17A	0.0103	15	12	8.9	5.8	3.9	2.1
G17A	0.4676	137	93	51	19	12	4.4
FG14	0.1000	98	74	53	32	20	9.2
G17	0.5676	196	132	75	43	25	12
G17-G18	0.5676	196	131	75	43	25	12
FG16	0.0791	133	104	78	50	34	18
G18	0.6467	240	178	128	79	51	26
G18-POND E	0.6467	240	176	126	78	50	25
FG31	0.0922	116	92	69	45	31	17
FG30	0.0389	73	57	44	29	20	11
FG30-PONDHS	0.0389	70	56	42	27	18	11
POND HS	0.1311	153	106	53	36	26	15
FG17a	0.0694	101	78	57	35	23	12
FG17a-POND E	0.0694	99	76	56	35	23	12

FUTURE MDDP (Full Spectrum)							
	DRAINAGE AREA (SQ. MI.)	PEAK DISCHARGE Q100 (CFS)	PEAK DISCHARGE Q50 (CFS)	PEAK DISCHARGE Q25 (CFS)	PEAK DISCHARGE Q10 (CFS)	PEAK DISCHARGE Q5 (CFS)	PEAK DISCHARGE Q2 (CFS)
FG18	0.0644	56	42	30	18	11	4.7
FG18-POND E	0.0644	56	42	30	17	11	4.6
FG19	0.0527	84	66	50	33	23	13
FG17c	0.0313	31	22	14	6.5	2.8	0.5
FG17b	0.0214	39	31	24	16	11	6.1
POND E IN	1.0170	610	432	318	197	126	64
POND E	1.0170	242	153	80	30	16	6.6
H08	1.0170	205	137	72	24	12	4.1
H09	0.0000	37	16	8.3	5.9	4.1	2.4
FG34	0.0600	34	23	13	5.5	2.0	0.3
G14	0.0600	34	23	13	5.5	2.0	0.3
G14-G15	0.0600	34	22	13	5.4	2.0	0.3
FG35	0.0344	20	13	8.3	3.5	1.5	0.3
G15	0.0944	53	36	21	8.7	3.3	0.6
G15-G08	0.0944	52	35	21	8.7	3.3	0.6
FG37	0.0797	41	27	16	6.0	2.0	0.3
FG36	0.0281	14	9.4	5.5	2.1	0.7	0.1
FG36-G08	0.0281	14	9.3	5.4	2.1	0.7	0.1
G08	0.2022	106	69	41	16	5.8	1.0

See approved Meridian Ranch MDDP (EPC File SKP171) dated January 2018 for complete hydrologic calculations and maps.

Rational Calculations

The Rational Hydrologic Calculation Method was used to estimate the total runoff from the 5-year and the 100-year design storm and thus establish the storm drainage system design. Using the rational calculation methodology outlined in the Hydrology Section (Ch 6) of the COSDCM coupled with the El Paso County EPCDCM an effective storm drainage design for Rolling Hills Ranch PUD has been designed. The storm drainage facilities have been designed such that the minor storm will be captured by the inlets and conveyed by the storm drain pipes such that the street flow does not overtop the curbs. The storm drainage facility has been designed such that the major storm will be captured by the inlets and conveyed by the storm drain pipes such that the street flow does not exceed the right-of-way widths for residential streets and the hydraulic grade line will be less than one foot below the surface.

The site is located within the Gieck Ranch Drainage Basin; the project will discharge the collected surface flow from the project into an existing natural drainage course or into existing downstream facilities properly sized to safely convey the storm water flows away from the project without damaging adjacent property.

Rational hydrologic calculations were performed for the entire PUD area and hydraulic calculations will be provided in the final drainage report at final plat. The storm drain runoff will be collected by a series of inlets and storm drain pipe then conveyed through the project and discharged either into an existing storm drain system located within Lambert Road discharged into the existing Pond E, directly into Pond D or into the proposed Pond G.

Rational Narrative

The following is a detailed narrative of the storm drainage system located in Rolling Hills Ranch PUD. The description is organized by system beginning on the west in the Bennett

Ranch portion of Rolling Hills Ranch and ending on the east side of the project in the Gieck Ranch Basin.

Offsite Storm Drain System

Not labeled on the rational drainage map

- Basin OS1 (4.4 acres, $Q_5 = 1.3$ CFS, $Q_{100} = 8.6$ CFS) is located north the existing Meridian Service Metropolitan District Water Filtration Building on land that will remain in undeveloped. Underlying the land are major transmission watermains and the master plan for this area is to remain undeveloped in its natural condition. The area will receive no developed runoff and the surface runoff will sheet flow will collect in an existing swale and traverse the area in a southerly direction toward a proposed Type C inlet CB4. All of the runoff is captured by the inlet and conveyed toward the future rip-rap lined channel to be constructed with Rolling Hills Ranch Filing 1 located adjacent and south of the filtration building. The captured flow is conveyed downstream via a 24" RCP.

Storm Drain System A

- Basin A01 (7.5 acres, $Q_5 = 8.6$ CFS, $Q_{100} = 22$ CFS) contains lots in Rolling Hills Ranch 3 adjacent to Rex Rd and along Monument Vista Ln at the northern end of the project. The surface runoff will sheet flow off of the residential lots and directed to a 15' Type R forced sump inlet located at I01. All of the 5-year storm flow is captured by this inlet ($Q_5 = 8.6$ CFS) and most of the 100-yr storm flow is captured ($Q_{100} = 14$ CFS) with the remaining flow ($Q_{100} = 8.6$ CFS) continuing downstream to Inlet 02. The captured flow is conveyed downstream via a 24" RCP to Storm Manhole 01.
- Basin A02 (2.2 acres, $Q_5 = 2.0$ CFS, $Q_{100} = 6.5$ CFS) contains lots within Rolling Hills 3 along Monument Vista Ln and Rolling Peaks Dr. The surface runoff will sheet flow off of the residential lots and be combined with the flow from Basin A01 for a total of 10.5 CFS. All of the flow is captured by this inlet and conveyed downstream via an 18" RCP to Storm Manhole 01.
Per ECM 1.7.1.C.4, Stormwater from the site must not discharge to a water of the state before being discharged to a WQCV control measure.
- Basin A03 (0.8 acres, $Q_5 = 1.0$ CFS, $Q_{100} = 3.0$ CFS) contains lots in Rolling Hills 3 along the east side of Rolling Peaks Dr. The surface runoff will sheet flow off of the residential lots and be directed to the street then to a 10' Type R forced sump inlet located at I03. All of the flow is captured by this inlet and conveyed downstream via a 24" RCP to the natural drainage course.
For System B, need to evaluate if the above criteria is applicable since Pond D is immediately downstream but the outfall discharges to the channel leading into the pond and I assume if it is a FEMA floodplain then it is waters of the state.

Storm Drain System B

- Basin B01 (2.3 acres, $Q_5 = 2.2$ CFS, $Q_{100} = 6.4$ CFS) contains lots in Rolling Hills Ranch 1 along east side of Rolling Peaks Dr. The surface runoff will sheet flow off of the residential lots and directed to the street then to a 10' Type R forced sump inlet located at I04. All of the flow is captured by this inlet and conveyed downstream via a 18" RCP to Inlet 05.

- Basin B02 (5.6 acres, $Q_5 = 5.2$ CFS, $Q_{100} = 15$ CFS) contains lots in Rolling Hills Ranch 1 along west side of Rolling Peaks Dr. The surface runoff will sheet flow off of the residential lots and directed to the street then to a 15' Type R forced sump inlet located at I05. All of the 5-year storm flow is captured by this inlet ($Q_5 = 5.2$ CFS) and most of the 100-yr storm flow is captured ($Q_{100} = 14$ CFS) with the remaining flow ($Q_{100} = 1.8$ CFS) continuing downstream to Inlet 14. The captured flow is conveyed downstream via a 24" RCP to Storm Manhole 02 then to Storm Manhole 03.
- The total pipe flow conveyed to Storm Manhole 03 is $Q_5 = 7.3$ CFS, $Q_{100} = 20$ CFS.
- Basin B03 (4.3 acres, $Q_5 = 4.2$ CFS, $Q_{100} = 12$ CFS) contains lots along Rolling Mesa Dr, Evening Creek Dr and Monument Vista Ln in Rolling Hills Ranch 1 and 3. The surface runoff will sheet flow off of the residential lots and be conveyed Design Point 1 (DP01) at the intersection of Rolling Mesa Dr and Evening Creek Dr. The crosses the intersection via a crossspan then continues along Rolling Mesa Dr through Basin B04 to inlet I06.
- Basin B04 (3.0 acres, $Q_5 = 2.9$ CFS, $Q_{100} = 8.5$ CFS) contains lots along the east side of Rolling Mesa Dr. The surface runoff will sheet flow off of the residential lots and directed to the street then to a 20' Type R forced sump inlet located at I06 where it combines with the surface runoff from DP01. All of the 5-year storm flow is captured by this inlet ($Q_5 = 6.2$ CFS) and most of the 100-yr storm flow is captured ($Q_{100} = 17$ CFS) with the remaining flow ($Q_{100} = 1.2$ CFS) continuing downstream to Inlet 10. The captured flow is conveyed downstream via an 18" RCP to Storm Manhole 03 where it is combined with flow from MH02 then conveyed to Storm Manhole 04.
- The total pipe flow conveyed from MH03 to Storm Manhole 04 via a 30" RCP is $Q_5 = 13$ CFS, $Q_{100} = 36$ CFS.
- Basin B05 (3.2 acres, $Q_5 = 3.1$ CFS, $Q_{100} = 9.1$ CFS) contains lots in Rolling Hills Ranch 1 along the west side of Rolling Mesa Dr. The surface runoff will sheet flow off of the residential lots and directed to the street then to a 10' Type R forced sump inlet located at I07. All of the flow is captured by this inlet and conveyed downstream via an 18" RCP to Storm Manhole 04.
- The total pipe flow conveyed from MH04 to Storm Manhole 05 via a 36" RCP is $Q_5 = 16$ CFS, $Q_{100} = 44$ CFS.
- Basin B06 (3.1 acres, $Q_5 = 3.3$ CFS, $Q_{100} = 9.9$ CFS) contains lots in Rolling Hills Ranch 1 along the east side of Evening Creek Dr. The surface runoff will sheet flow off of the residential lots and directed to the street then to a 10' Type R forced sump inlet located at I08. Most of the flow is captured by this inlet ($Q_5 = 3.7$ CFS, $Q_{100} = 9.2$ CFS) with the remaining ($Q_5 = 0.5$ CFS, $Q_{100} = 3.4$ CFS) continuing downstream to Inlet 12. The captured flow is conveyed downstream via an 18" RCP to Storm Manhole 05.

- The total pipe flow conveyed from MH05 to Storm Manhole 06 via a 36" RCP is $Q_5=18$ CFS, $Q_{100}=51$ CFS.
- Basin B07 (4.8 acres, $Q_5=4.3$ CFS, $Q_{100}=13$ CFS) contains lots in Rolling Hills Ranch 1 along the west side of Evening Creek Dr. The surface runoff will sheet flow off of the residential lots and directed to the street then to a 20' Type R flow-by inlet located at I09. All of the flow is captured by this inlet and conveyed downstream via an 18" RCP to Storm Manhole 06.
- The total pipe flow conveyed from MH06 to Storm Manhole 07, then to MH10 via a 36" RCP is $Q_5=22$ CFS, $Q_{100}=59$ CFS.
- Basin B08 (2.5 acres, $Q_5=2.5$ CFS, $Q_{100}=7.3$ CFS) contains lots in Rolling Hills Ranch 1 along east side of Rolling Mesa Dr. The surface runoff will sheet flow off of the residential lots and directed to the street then to a 10' Type R forced sump inlet located at I10. 100-year flow-by from inlet I06 contributes minor flows to inlet I10 for a total 100-year flow of 7.6 CFS. All of the flow is captured by this inlet and conveyed downstream via an 18" RCP to Storm Manholes 08 & 09.
- Basin B09 (2.7 acres, $Q_5=2.6$ CFS, $Q_{100}=7.7$ CFS) contains lots in Rolling Hills Ranch 1 along south side of Parkland Dr. The surface runoff will sheet flow off of the residential lots and directed to the street then to a 10' Type R sump inlet located at I11. All of the flow is captured by this inlet and conveyed downstream via an 18" RCP to Storm Manhole 09.
- Basin B10 (3.3 acres, $Q_5=3.1$ CFS, $Q_{100}=9.2$ CFS) contains lots in Rolling Hills Ranch 1 along west side of Rolling Mesa Dr. The surface runoff will sheet flow off of the residential lots and directed to the street then to a 20' Type R sump inlet located at I12 where it is combined with the surface flow from Basin B11. All of the flow is captured by this inlet and conveyed downstream via an 18" RCP to Storm Manhole 09.
- Basin B11 (3.1 acres, $Q_5=2.9$ CFS, $Q_{100}=8.6$ CFS) contains lots in Rolling Hills Ranch 1 along east side of Evening Creek Dr. The surface runoff will sheet flow off of the residential lots and directed to the street then to a 20' Type R sump inlet located at I12 where it is combined with the surface flow from Basin B10 and flow-by from B07. All of the flow ($Q_5=5.4$ CFS, $Q_{100}=18$ CFS) is captured by this inlet and conveyed downstream via an 18" RCP to Storm Manhole 09.
- The total pipe flow conveyed to Storm Manhole 09 is $Q_5=10$ CFS, $Q_{100}=31$ CFS and is conveyed to Manhole 10 via a 24" RCP. At manhole 10, the flow will combine with the flow from Storm Manhole 07 for a total flow of 30 CFS for the 5-year event and 85 CFS for the 100-year event. The pipe will discharge via a 42" RCP to the existing Pond D constructed in 2012.

Storm Drain System C

- Basin C01 (3.2 acres, $Q_5 = 3.1$ CFS, $Q_{100} = 9.0$ CFS) contains lots in Rolling Hills Ranch 1 along east side of Rolling Peaks Dr. The surface runoff will sheet flow off of the residential lots and directed to the street then to a 10' Type R forced sump inlet located at I13. All of the flow is captured by this inlet and conveyed downstream via an 18" RCP to Storm Manhole 11.
- Basin C02 (3.5 acres, $Q_5 = 3.4$ CFS, $Q_{100} = 10$ CFS) contains lots in Rolling Hills Ranch 1 along west side of Rolling Peaks Dr. The surface runoff will sheet flow off of the residential lots and directed to the street then to a 15' Type R forced sump inlet located at I14. All of the flow is captured by this inlet and conveyed downstream via an 18" RCP to Storm Manhole 11.
- The total pipe flow conveyed from MH11 to Storm Manhole 12 via a 24" RCP is $Q_5 = 6.0$ CFS, $Q_{100} = 18$ CFS.
- Basin C03 (1.3 acres, $Q_5 = 1.4$ CFS, $Q_{100} = 4.0$ CFS) contains lots along Rolling Peaks Dr, Parkland Dr and Crooked Hill Dr in Rolling Hills Ranch 1 and 2. The surface runoff will sheet flow off of the residential lots and be conveyed to a 5' Type R forced sump inlet located at I15. All of the flow is captured by this inlet and conveyed downstream via an 18" RCP to Storm Manhole 12.
- Basin C04 (3.1 acres, $Q_5 = 3.2$ CFS, $Q_{100} = 9.4$ CFS) contains lots along Rolling Peaks Dr, Parkland Dr and Crooked Hill Dr in Rolling Hills Ranch 1. The surface runoff will sheet flow off of the residential lots and be conveyed to a 5' Type R forced sump inlet located at I16. All of the 5-year storm flow is captured by this inlet ($Q_5 = 3.2$ CFS) and most of the 100-yr storm flow is captured ($Q_{100} = 6.3$ CFS) with the remaining flow ($Q_{100} = 3.1$ CFS) continuing downstream to Inlet 18. The captured flow is conveyed downstream via an 18" RCP to Storm Manhole 12.
- The total pipe flow conveyed from MH12 to Storm Manhole 13 via a 30" RCP is $Q_5 = 9.5$ CFS, $Q_{100} = 26$ CFS.
- Basin C05 (0.6 acres, $Q_5 = 0.6$ CFS, $Q_{100} = 1.8$ CFS) contains lots along Rolling Peaks Dr and Crooked Hill Dr in Rolling Hills Ranch 2. The surface runoff will sheet flow off of the residential lots and be conveyed to a 5' Type R sump inlet located at I17. All of the flow is captured by this inlet and conveyed downstream via an 18" RCP to Storm Manhole 13.
- Basin C06 (1.0 acres, $Q_5 = 1.0$ CFS, $Q_{100} = 3.1$ CFS) contains lots along Rolling Peaks Dr Crooked Hill Dr in Rolling Hills Ranch 1. The surface runoff will sheet flow off of the residential lots, combine with flow-by ($Q_{100} = 3.1$ CFS) from inlet I16 and be conveyed to a 5' Type R sump inlet located at I18. All of the flow ($Q_5 = 1.0$ CFS, $Q_{100} = 6.0$ CFS) is captured by this inlet and conveyed downstream via an 18" RCP to Storm Manhole 13.

- The total pipe flow conveyed from MH13 to Storm Manhole 14 via a 36" RCP is $Q_5=11$ CFS, $Q_{100}=32$ CFS.
- Basin C07 (0.9 acres, $Q_5=0.9$ CFS, $Q_{100}=2.5$ CFS) contains runoff from an open space tract in Rolling Hills Ranch 3. The surface runoff will sheet flow off of the adjacent residential lots and be conveyed to a Type C grated inlet located at CB1. All of the flow is captured by this inlet and conveyed downstream via an 18" RCP to Storm Manhole 14.
- The total pipe flow conveyed to Storm Manhole 14 is $Q_5=11$ CFS, $Q_{100}=34$ CFS and is conveyed to Pond D via a 31" RCP.

Storm Drain System D

- Basin D01 (6.9 acres, $Q_5=6.8$ CFS, $Q_{100}=14$ CFS) contains lots in Rolling Hills Ranch 3 along east side of Bluffpoint Dr. The surface runoff will sheet flow off of the residential lots directed to the street to Design Point 1 then combined with flow-by from I19 for a 5-year flow of 6.8 CFS and a 100-year flow of 14 CFS. The surface flow will continue inlet I19. All of the 5-year storm flow is captured by this inlet ($Q_5=6.8$ CFS) and most of the 100-yr storm flow is captured ($Q_{100}=14$ CFS) with the remaining flow ($Q_{100}=5.7$ CFS) continuing downstream to Design Point 2. The captured flow is conveyed downstream via an 18" RCP to Storm Manhole 15 and via a 24" RCP to Storm Manhole 16.
- Basin D02 (3.8 acres, $Q_5=3.8$ CFS, $Q_{100}=11$ CFS) contains lots in Rolling Hills Ranch 3 along west side of Crooked Bluff Dr. The surface runoff will sheet flow off of the residential lots directed to the street to Design Point 2 then combined with flow-by from I19 for a 5-year flow of 3.8 CFS and a 100-year flow of 16 CFS. The surface flow will continue inlet I20.
- Basin D03 (3.8 acres, $Q_5=4.1$ CFS, $Q_{100}=12$ CFS) contains lots along the west side of Coastal Hills Ln in Rolling Hills Ranch. The surface runoff will sheet flow off of the residential lots and be conveyed to a 20' Type R forced sump inlet located at I20 where it is combined with the surface flow from DP2 for a 5-year flow of 7.3 CFS and a 100-year flow of 21 CFS. All of the 5-year storm flow is captured by this inlet ($Q_5=7.3$ CFS) and most of the 100-yr storm flow is captured ($Q_{100}=17$ CFS) with the remaining flow ($Q_{100}=3.4$ CFS) continuing downstream to Design Point 3. The captured flow is conveyed downstream via an 18" RCP to Storm Manhole 16.
- The total pipe flow conveyed from MH16 to Storm Manhole 17 via a 30" RCP is $Q_5=14$ CFS, $Q_{100}=30$ CFS.
- Basin D04 (5.3 acres, $Q_5=5.0$ CFS, $Q_{100}=14$ CFS) contains lots along the west side of Coastal Hills Ln and Bluffpoint Dr in Rolling Hills Ranch 3. The surface runoff will sheet flow off of the residential lots directed to the street to Design Point 3 then combined with flow-by from I20 for a 5-year flow of 5.0 CFS and a 100-year flow of 17 CFS. The surface flow will continue inlet I21.

Provide a narrative regarding the overflow path. Similar comments for all the other storm drain system. Is the typical side lot easement between the two lots sufficient for the given flow?

- Basin D05 (2.0 acres, $Q_5 = 2.2$ CFS, $Q_{100} = 6.3$ CFS) contains lots along Crooked Hill Dr and Rolling Ranch Dr in Rolling Hills Ranch 1. The surface runoff will sheet flow off of the residential lots and be conveyed to a 15' Type R forced sump inlet located at I21 where it is combined with the surface flow from DP3 and flow-by from I22 for a 5-year flow of 6.9 CFS and a 100-year flow of 24 CFS. All of the 5-year storm flow is captured by this inlet ($Q_5 = 6.9$ CFS) and most of the 100-yr storm flow is captured ($Q_{100} = 14$ CFS) with the remaining flow ($Q_{100} = 10$ CFS) continuing downstream to inlet I26. The captured flow is conveyed downstream via an 18" RCP to Storm Manhole 17.
- The total pipe flow conveyed from MH17 to Storm Manhole 19 via a 30" RCP is $Q_5 = 20$ CFS, $Q_{100} = 41$ CFS.
- Basin D06 (3.2 acres, $Q_5 = 3.2$ CFS, $Q_{100} = 9.0$ CFS) contains lots along the east side of Rolling Ranch Dr in Rolling Hills Ranch 3. The surface runoff will sheet flow off of the residential lots and be conveyed to a 15' Type R flow-by inlet located at I22. Most of the flow is captured by this inlet ($Q_5 = 2.6$ CFS, $Q_{100} = 6.2$ CFS) with the remaining ($Q_5 = 0.6$ CFS, $Q_{100} = 2.8$ CFS) continuing downstream to Inlet 21. The captured flow is conveyed downstream via an 18" RCP to Storm Manhole 18.
- Basin D07 (6.6 acres, $Q_5 = 6.9$ CFS, $Q_{100} = 20$ CFS) contains lots along the west side of Rolling Ranch Dr in Rolling Hills Ranch 31. The surface runoff will sheet flow off of the residential lots and be conveyed to a 10' Type R forced sump inlet located at I23. All of the 5-year storm flow is captured by this inlet ($Q_5 = 6.9$ CFS) and most of the 100-yr storm flow is captured ($Q_{100} = 9.9$ CFS) with the remaining flow ($Q_{100} = 9.6$ CFS) continuing downstream to inlet I24. The captured flow is conveyed downstream via an 18" RCP to Storm Manhole 18.
- The total pipe flow conveyed from MH18 to Storm Manhole 19 via a 24" RCP is $Q_5 = 9.1$ CFS, $Q_{100} = 16$ CFS.
- Basin D08 (1.6 acres, $Q_5 = 1.8$ CFS, $Q_{100} = 5.1$ CFS) contains lots along the west side of Rolling Ranch Dr in Rolling Hills Ranch 3. The surface runoff will sheet flow off of the residential lots and be conveyed to a 10' Type R forced sump inlet located at I24. All of the 5-year storm flow is captured by this inlet ($Q_5 = 1.8$ CFS) and most of the 100-yr storm flow is captured ($Q_{100} = 9.9$ CFS) with the remaining flow ($Q_{100} = 3.5$ CFS) continuing downstream to inlet I25. The captured flow is conveyed downstream via an 18" RCP to Storm Manhole 18.
- The total pipe flow conveyed from MH19 to Storm Manhole 20 via a 42" RCP is $Q_5 = 29$ CFS, $Q_{100} = 64$ CFS.
- Basin D09 (0.9 acres, $Q_5 = 1.2$ CFS, $Q_{100} = 3.4$ CFS) contains runoff from an open space tract in Rolling Hills Ranch 3. The surface runoff will sheet flow off of the adjacent residential lots and be conveyed to a Type C grated inlet located at CB2. All

of the flow is captured by this inlet and conveyed downstream via an 18" RCP to inlet I25.

- Basin D10 (0.8 acres, $Q_5 = 0.9$ CFS, $Q_{100} = 2.5$ CFS) contains lots along Crooked Hill Dr and Rolling Ranch Dr in Rolling Hills Ranch 3. The surface runoff will sheet flow off of the residential lots and be conveyed to a 10' Type R sump inlet located at I25. All of the flow is captured by this inlet and conveyed downstream via an 18" RCP to Storm Manhole 20.
- Basin D11 (4.2 acres, $Q_5 = 2.4$ CFS, $Q_{100} = 6.9$ CFS) contains runoff from an open space in Rolling Hills Ranch 3. The surface runoff will sheet flow off of the adjacent residential lots and be conveyed to an 18" flared end section located at ES1. All of the flow is captured by this inlet and conveyed downstream via an 18" RCP to inlet I26.
- Basin D12 (2.7 acres, $Q_5 = 2.4$ CFS, $Q_{100} = 6.9$ CFS) contains lots along Crooked Hill Dr and Rolling Ranch Dr in Rolling Hills Ranch 3. The surface runoff will sheet flow off of the residential lots, combine with flow-by ($Q_{100} = 9.5$ CFS) from inlet I21 and be conveyed to a 20' Type R sump inlet located at I26. All of the flow is captured by this inlet and conveyed downstream via a 24" RCP to Storm Manhole 20.
- The total pipe flow conveyed from MH20 to Storm Manhole 21 via a 42" RCP is $Q_5 = 29$ CFS, $Q_{100} = 71$ CFS.
- Basin D13 (1.8 acres, $Q_5 = 2.2$ CFS, $Q_{100} = 5.8$ CFS) contains lots along the west side of Rolling Ranch Dr in Rolling Hills Ranch 2. The surface runoff will sheet flow off of the residential lots and be conveyed to a 15' Type R flow-by inlet located at I27. Most of the flow is captured by this inlet ($Q_5 = 1.7$ CFS, $Q_{100} = 3.9$ CFS) with the remaining ($Q_5 = 0.4$ CFS, $Q_{100} = 1.8$ CFS) continuing downstream to inlet I33. The captured flow is conveyed downstream via an 18" RCP to Storm Manhole 21.
- The total pipe flow conveyed from MH21 to Storm Manhole 23 via a 42" RCP is $Q_5 = 29$ CFS, $Q_{100} = 72$ CFS.
- Basin D14 (6.5 acres, $Q_5 = 6.3$ CFS, $Q_{100} = 18$ CFS) contains lots in Rolling Hills Ranch 2 along Overlook Bluff Ln, Foggy Meadows Dr and Foggy Bend Ln. The surface runoff will sheet flow off of the residential lots and directed to the street then to a 10' Type R forced sump inlet located at I28. All of the 5-year storm flow is captured by this inlet ($Q_5 = 6.3$ CFS) and most of the 100-yr storm flow is captured ($Q_{100} = 9.9$ CFS) with the remaining flow ($Q_{100} = 7.9$ CFS) continuing downstream to inlet I31. The captured flow is conveyed downstream via an 18" RCP to Storm Manhole 22.
- Basin D15 (6.4 acres, $Q_5 = 6.2$ CFS, $Q_{100} = 18$ CFS) contains lots in Rolling Hills Ranch 2 along Overlook Bluff Ln, Foggy Meadows Dr and Foggy Bend Ln. The surface runoff will sheet flow off of the residential lots and directed to the street then to a 10' Type R forced sump inlet located at I29. All of the 5-year storm flow is

- captured by this inlet ($Q_5 = 6.2$ CFS) and most of the 100-yr storm flow is captured ($Q_{100} = 9.9$ CFS) with the remaining flow ($Q_{100} = 7.7$ CFS) continuing downstream to inlet I30. The captured flow is conveyed downstream via an 18" RCP to Storm Manhole 22.
- The total pipe flow conveyed from MH22 to Storm Manhole 23 via a 24" RCP is $Q_5 = 12$ CFS, $Q_{100} = 20$ CFS and combine with the pipe flow from MH21. The total pipe flow conveyed from MH23 to Storm Manhole 24 via a 28" RCP is $Q_5 = 35$ CFS, $Q_{100} = 84$ CFS.
 - Basin D16 (4.0 acres, $Q_5 = 4.2$ CFS, $Q_{100} = 12$ CFS) contains lots along Morning Hills Dr, Morning Ridge Ln and Foggy Meadows Dr in Rolling Hills Ranch 2. The surface runoff will sheet flow off of the residential lots and be conveyed to a 10' Type R forced sump inlet located at I30.. All of the 5-year storm flow is captured by this inlet ($Q_5 = 4.2$ CFS) and most of the 100-yr storm flow is captured ($Q_{100} = 9.9$ CFS) with the remaining flow ($Q_{100} = 7.3$ CFS) continuing downstream to inlet I31. The captured flow is conveyed downstream via an 18" RCP to Storm Manhole 24
 - The total pipe flow conveyed from MH24 to Storm Manhole 25 then to Storm Manhole 26 via a 48" RCP is $Q_5 = 37$ CFS, $Q_{100} = 90$ CFS.
 - Basin D17 (5.1 acres, $Q_5 = 5.3$ CFS, $Q_{100} = 15$ CFS) contains lots in Rolling Hills Ranch 2 along Morning Hills Dr and Foggy Meadows Dr. The surface runoff will sheet flow off of the residential lots combined with additional surface flow from I28 and I30, then directed along the street then to a 15' Type R sump inlet located at I31. All of the 5-year storm flow is captured by this inlet ($Q_5 = 5.3$ CFS) and most of the 100-yr storm flow is captured ($Q_{100} = 24$ CFS) with the remaining flow ($Q_{100} = 2.5$ CFS) continuing downstream to inlet I32. The captured flow is conveyed downstream via a 30" RCP to Storm Manhole 26.
 - The total pipe flow conveyed from MH26 to inlet 32 via a 48" RCP is $Q_5 = 41$ CFS, $Q_{100} = 106$ CFS.
 - Basin D18 (3.1 acres, $Q_5 = 3.0$ CFS, $Q_{100} = 8.4$ CFS) contains lots in Rolling Hills Ranch 2 along Morning Hills Dr, Morning Ridge Ln and Overlook Bluff Ln. The surface runoff will sheet flow off of the residential lots directed to the street to a 15' Type R sump inlet located at I32 and combined with flow-by from I31. All of the flow ($Q_5 = 3.0$ CFS, $Q_{100} = 10$ CFS) is captured by this inlet and combined with flow from Storm Manhole 26.
 - The pipe flow conveyed from Storm Manhole 26 is $Q_5 = 41$ CFS, $Q_{100} = 106$ CFS is combined with the surface flow captured by I32 ($Q_5 = 3.0$ CFS, $Q_{100} = 10$ CFS) for a total 5-year flow of 43 CFS and a total 100-year flow of 113 CFS, then conveyed to the proposed Pond G.

Storm Drain System E

- Basin E01 (5.4 acres, $Q_5 = 6.2$ CFS, $Q_{100} = 17$ CFS) contains lots along Valley Peak Dr, Rolling Ranch Dr and Woods Grove Dr in Rolling Hills Ranch 2. The surface runoff will sheet flow off of the residential lots and be conveyed to a 20' Type R forced sump inlet located at I33. All of the flow is captured by this inlet and conveyed downstream via an 18" RCP to Storm Manhole 27 then to Storm Manhole 28.
- Basin E02 (6.5 acres, $Q_5 = 7.3$ CFS, $Q_{100} = 19$ CFS) contains lots along Valley Peak Dr, Woods Grove Dr and Savannah Falls Ct in Rolling Hills Ranch 2. The surface runoff will sheet flow off of the residential lots and be conveyed to a 20' Type R forced sump inlet located at I30. All of the 5-year storm flow is captured by this inlet ($Q_5 = 7.3$ CFS) and most of the 100-yr storm flow is captured ($Q_{100} = 17$ CFS) with the remaining flow ($Q_{100} = 2.3$ CFS) continuing downstream to inlet I37. The captured flow is conveyed downstream via an 18" RCP to Storm Manhole 28.
- The total pipe flow conveyed from MH28 to Storm Manhole 29 via a 30" RCP is $Q_5 = 14$ CFS, $Q_{100} = 35$ CFS.
- Basin E03 (5.8 acres, $Q_5 = 6.5$ CFS, $Q_{100} = 17$ CFS) contains lots along Rolling Ranch Dr, Woods Grove Dr, New Ranch Ln and Morning Hills Dr in Rolling Hills Ranch 2. The surface runoff will sheet flow off of the residential lots and be conveyed to a 15' Type R forced sump inlet located at I35. All of the 5-year storm flow is captured by this inlet ($Q_5 = 6.5$ CFS) and most of the 100-yr storm flow is captured ($Q_{100} = 14$ CFS) with the remaining flow ($Q_{100} = 3.7$ CFS) continuing downstream to inlet I36. The captured flow is conveyed downstream via an 18" RCP to Storm Manhole 29.
- The total pipe flow conveyed from MH29 to Storm Manhole 30 via a 36" RCP is $Q_5 = 20$ CFS, $Q_{100} = 47$ CFS.
- Basin E04 (3.1 acres, $Q_5 = 3.9$ CFS, $Q_{100} = 9.7$ CFS) contains lots along New Ranch Ln and Morning Hills Dr in Rolling Hills Ranch 2. The surface runoff will sheet flow off of the residential lots and be conveyed to a 15' Type R forced sump inlet located at I36. All of the flow ($Q_5 = 3.9$ CFS, $Q_{100} = 13$ CFS) is captured by this inlet and conveyed downstream via an 18" RCP to Storm Manhole 30.
- Basin E05 (2.6 acres, $Q_5 = 2.7$ CFS, $Q_{100} = 7.2$ CFS) contains lots along Woods Grove Dr and Savannah Falls Ct in Rolling Hills Ranch 2. The surface runoff will sheet flow off of the residential lots and be conveyed to a 15' Type R flow-by inlet located at I37. Most of the flow is captured by this inlet ($Q_5 = 2.3$ CFS, $Q_{100} = 6.0$ CFS) with the remaining ($Q_5 = 0.4$ CFS, $Q_{100} = 2.7$ CFS) continuing downstream to Inlet I41. The captured flow is conveyed downstream via an 18" RCP to Storm Manhole 30.
- The total pipe flow conveyed from MH30 to Storm Manhole 31 and Storm Manhole 36 via a 36" RCP is $Q_5 = 24$ CFS, $Q_{100} = 61$ CFS.

- Basin E06 (1.3 acres, $Q_5 = 1.4$ CFS, $Q_{100} = 4.2$ CFS) contains lots along Valley Peak Dr in Rolling Hills Ranch 2. The surface runoff will sheet flow off of the residential lots and be conveyed to a 5' Type R forced sump inlet located at I38. All of the flow is captured by this inlet and conveyed downstream via an 18" RCP to Storm Manhole 32 then to Storm Manhole 33.
- Basin E07 (2.1 acres, $Q_5 = 2.5$ CFS, $Q_{100} = 6.7$ CFS) contains lots along Rolling Peaks Dr and Valley Peak Dr in Rolling Hills Ranch 2. The surface runoff will sheet flow off of the residential lots and be conveyed to a 15' Type R flow-by inlet located at I39. Most of the flow is captured by this inlet ($Q_5 = 2.0$ CFS, $Q_{100} = 4.5$ CFS) with the remaining ($Q_5 = 0.5$ CFS, $Q_{100} = 2.2$ CFS) continuing downstream to Inlet I41. The captured flow is conveyed downstream via an 18" RCP to Storm Manhole 33.
- The total pipe flow conveyed from MH33 to Storm Manhole 34 via an 18" RCP is $Q_5 = 3.5$ CFS, $Q_{100} = 8.5$ CFS.
- Basin E08 (4.2 acres, $Q_5 = 4.8$ CFS, $Q_{100} = 13$ CFS) contains lots surrounded by Rolling Peaks Dr, Valley Peak Dr, Summer Ridge Dr and Bridge Way in Rolling Hills Ranch 2. The surface runoff will sheet flow off of the residential lots and be conveyed to a 10' Type R forced sump inlet located at I40. All of the 5-year storm flow is captured by this inlet ($Q_5 = 4.8$ CFS) and most of the 100-yr storm flow is captured ($Q_{100} = 10$ CFS) with the remaining flow ($Q_{100} = 2.8$ CFS) continuing downstream to an existing inlet located at the intersection of Park Gate Dr. with Lambert Rd. The captured flow is conveyed downstream via an 18" RCP to Storm Manhole 34.
- The total pipe flow conveyed from MH34 to Storm Manhole 35 then to Storm Manhole 36 via a 24" RCP is $Q_5 = 8.0$ CFS, $Q_{100} = 18$ CFS.
- Basin E09 (5.4 acres, $Q_5 = 6.2$ CFS, $Q_{100} = 17$ CFS) contains lots along Rolling Peaks Dr in Rolling Hills Ranch 2. The surface runoff will sheet flow off of the residential lots and be conveyed to a 15' Type R sump inlet located at I41. All of the 5-year storm flow is captured by this inlet ($Q_5 = 6.2$ CFS) and most of the 100-yr storm flow is captured ($Q_{100} = 14$ CFS) with the remaining flow ($Q_{100} = 3.9$ CFS) continuing downstream to Inlet I43. The captured flow is conveyed downstream via a 24" RCP to Storm Manhole 36.
- The total combined pipe flow from MH30, MH34 and I41 is conveyed to Storm Manhole 37 via a 42" RCP is $Q_5 = 35$ CFS, $Q_{100} = 86$ CFS.
- Basin E10 (7.0 acres, $Q_5 = 7.0$ CFS, $Q_{100} = 10$ CFS) contains lots along Summer Ridge Dr in Rolling Hills Ranch 2. The surface runoff will sheet flow off of the residential lots and be conveyed to a 20' Type R sump inlet located at I42. All of the flow is captured by this inlet and conveyed downstream via a 24" RCP to Storm Manhole 37.

- The total combined pipe flow from MH37 is conveyed to Storm Manhole 38 via a 48" RCP is $Q_5 = 41$ CFS, $Q_{100} = 102$ CFS.
- Basin E11 (13 acres, $Q_5 = 6.3$ CFS, $Q_{100} = 18$ CFS) contains runoff from an open space tract in Rolling Hills Ranch 2. The surface runoff will sheet flow off of the residential lots and be conveyed to a Type C grated inlet located at CB3. All of the flow is captured by this inlet and conveyed downstream via a 24" RCP to Storm Manhole 37.
- Basin E12 (1.6 acres, $Q_5 = 3.6$ CFS, $Q_{100} = 7.5$ CFS) contains runoff from Rolling Peaks Dr and Lambert Rd in Rolling Hills Ranch 2. The surface runoff will be collected in the curb and gutter then conveyed to a 20' Type R flow-by inlet located at I43. Most of the flow is captured by this inlet ($Q_5 = 3.2$ CFS, $Q_{100} = 7.1$ CFS) with the remaining ($Q_5 = 0.4$ CFS, $Q_{100} = 2.1$ CFS) continuing downstream to Inlet I41. The captured flow is conveyed downstream via an 18" RCP to Storm Manhole 38.
- The total combined pipe flow from MH38, I43 and CB3 is conveyed to an existing Storm Manhole EJ02 via a 54" RCP is $Q_5 = 52$ CFS, $Q_{100} = 131$ CFS.
- Basin E13 (6.0 acres, $Q_5 = 8.2$ CFS, $Q_{100} = 19$ CFS) contains runoff from Park Gate Rd, Lambert Rd. found in Meridian Ranch Filing 11A and Rolling Peaks Dr in Rolling Hills Ranch 2. The surface runoff will sheet flow off of the residential lots and be conveyed to an existing 15' Type R forced sump inlet constructed with the improvements associated with Meridian Ranch Filing 11A located at EI1. All of the 5-year storm flow is captured by this inlet ($Q_5 = 6.0$ CFS) and most of the 100-yr storm flow is captured ($Q_{100} = 13$ CFS) with the remaining flow ($Q_{100} = 6.5$ CFS) continuing downstream to an existing inlet located along the west side of Lambert Rd. The captured flow is conveyed downstream via an 18" RCP to existing manhole EJ01.
- The existing storm drain system at existing manhole EJ01 conveys storm flow from other parts of Meridian Ranch Filing 11A and the discharge from Pond D. The flow rates upstream of EJ01 as from the SCS model are 12 CFS for the 5-year storm and 136 CFS for the 100-year storm. The coefficient-area (CA) figure from the approved Final Drainage Report for Meridian Ranch Filing 11A and the time of concentration was adjusted to match the flow rate from the SCS Model to replicate the flow rate in the storm drain. The total flow from Meridian Ranch Filing 11A from MH EJ01 to EJ02 is 22 CFS for the 5-year storm and 140 CFS for the 100-year storm.
- The total combined storm flow at MH EJ02 from Rolling Hills, Meridian Ranch Filing 11A and the discharge from Pond D is 39 CFS for the 5-year storm and 182 CFS for the 100-year storm. The existing storm drain located within Lambert Rd was installed with the construction of the Falcon High School in 2007. The anticipated 10-year flow rate at 128 CFS and the 100-year flow rate for the storm drain was 245 CFS per the approved 2007 Londonderry-Lambert Final Drainage Report. The approved Final Drainage Report for Meridian Ranch Filing 11A shows the 5-year flow rate at

63 CFS and 212 CFS for the 100-year storm. These calculations result buildout flow rates ($Q_5 = 39$ CFS, $Q_{100} = 182$ CFS) below the previously approved drainage reports, therefore this development will not have any adverse impacts on the existing storm drain located in Lambert Road.

DETENTION PONDS

Existing Pond D Detention Storage Criteria

The existing Detention Pond D is located east of Rainbow Bridge Dr., northeast of Meridian Ranch Filing 3, and was constructed as a part of the Meridian Ranch Filing 3 Improvements; the pond is owned and maintained by the Meridian Service Metropolitan District. It has been in operation since 2012 with no reported issues between the Meridian Service Metropolitan District and El Paso County as a part of the Meridian Ranch Filing 3 Final Plat project.

The SCS calculation method was used to determine the detention pond to ensure the developed runoff does not adversely impact drainage patterns downstream. Pond D and existing Pond E work in series such that the peak flow rates from the Meridian Ranch development affect the drainage patterns downstream of Eastonville Road. Storm drainage runoff will enter the pond from upstream development via existing pipe networks and overland from existing rear lots adjacent to the pond. The ultimate future build-out design of the tributary areas was analyzed to insure the sizing of the pond would be adequate after development of Meridian Ranch is complete. This SCS calculation can be found in the appendix.

An analysis of the SCS calculations show the development of Rolling Hills Ranch and the discharge flow rates from Pond D do not adversely impact the downstream drainage patterns. **No additional improvements or modifications are necessary to this pond as a result of the full buildout of Rolling Hills Ranch PUD.** Table 6 provides summary data for the various design storms for the completed development for all areas tributary to Pond D including Rolling Hills Ranch PUD. Rolling Hills Ranch completes the development of all areas tributary to Pond E.

A water quality capture volume (WQCV) was added to the required storage volume for the final build out condition. The purpose of the WQCV is to allow particulates to settle out and accumulate over time to improve water quality and to maintain full volume for detention during the life of the facility for a major storm event. The WQCV of 1.0 ac-ft. was added to the detention volume of the minor storm and half (0.5 ac-ft.) was added for the major storm. This was accomplished with respect to providing a starting detention volume of 1.0 ft. for the 5-year storm and 0.5 ft. for the 100-year storm. The resulting storage elevations remain well below the emergency spillway elevation. See Appendix B for more information.

The WQCV was calculated by using the equations found in the Criteria Manual (DCM). The release rate from the WQCV helps minimize downstream impacts. Detaining the WQCV also serves to cleanse the "first

With development complete for the tributary basins for Pond D and E, provide supporting calculation that shows these two ponds are in compliance with Senate Bill 15-212 either via the UD-Detention worksheet or the SDI Worksheet.

Include a narrative discussing the results.

Provide additional clarification. The paragraph above notes no additional improvements or modification which seem to contradict the statement that WQCV is added for the build out condition. How is this accomplished without modifying the outlet to provide the 40hr drain time for the required WQCV?

flush” of runoff from the higher initial concentration of sediment and pollutants by allowing for settlement to occur. This greatly improves the quality of runoff, leaving the facility and reduces the potential for erosion. The positive impact on water quality is expected to be significant, particularly during the construction phase of the development.

Table 6: Existing Pond D Summary Data

EXISTING POND D				
	PEAK INFLOW	PEAK OUTFLOW	PEAK STORAGE	PEAK ELEVATION
	CFS	CFS	AC-FT	FT
INTERIM CONDITIONS				
2-YEAR STORM	52	4.3	4.8	7053.2
5-YEAR STORM	107	12	7.4	7053.9
10-YEAR STORM	168	19	11.1	7054.7
25-YEAR STORM	280	50	15.9	7055.6
50-YEAR STORM	387	91	20.1	7056.3
100-YEAR STORM	509	134	25.5	7057.1
FUTURE CONDITIONS				
2-YEAR STORM	52	4.3	4.8	7053.2
5-YEAR STORM	107	12	7.3	7053.9
10-YEAR STORM	168	19	11.1	7054.7
25-YEAR STORM	280	50	15.9	7055.6
50-YEAR STORM	387	91	20.1	7056.3
100-YEAR STORM	509	134	25.5	7057.1

Existing Pond E Detention Storage Criteria

Existing Detention Pond E is located south of Londonderry and west of Eastonville, and was constructed as a part of the Meridian Ranch Filing 11 Grading, the is owned and maintained by the Meridian Service Metropolitan District (MSMD). It has been in operation since 2013 with no reported issues. A maintenance agreement between the Meridian Service Metropolitan District and El Paso County has been recorded as a part of the Meridian Ranch Filing 11A Final Plat process.

The SCS calculation method was used to determine inflow and outflow from the detention pond to ensure the developed runoff does not overcharge the pond and the discharges do not adversely impact drainage patterns downstream of Eastonville Road. Storm drainage runoff will enter the pond from upstream development via existing pipe networks and overland from existing rear lots adjacent to the pond. The ultimate future build-out design of the tributary areas was analyzed to insure the sizing of the pond would be adequate after development of Meridian Ranch is complete. This SCS calculation can be found in the appendix.

An analysis of the SCS calculations show the development of Rolling Hills Ranch and the discharge flow rates from Pond E approximate those of the historic flow rates at Eastonville Road. No additional improvements or modifications are necessary to this pond as a result of

the full buildout of Rolling Hills Ranch PUD. Table 7 provides summary data for the various design storms for the completed development for all areas tributary to Pond E including Rolling Hills Ranch PUD. Rolling Hills Ranch completes the development of all areas tributary to Pond E.

Table 7: Existing Pond E Summary Data

EXISTING POND E				
	PEAK INFLOW	PEAK OUTFLOW	PEAK STORAGE	PEAK ELEVATION
	CFS	CFS	AC-FT	FT
INTERIM CONDITIONS				
2-YEAR STORM	63	6.1	10.9	6970.6
5-YEAR STORM	123	15	18.0	6971.4
10-YEAR STORM	190	28	23.0	6971.9
25-YEAR STORM	308	74	30.0	6972.5
50-YEAR STORM	423	144	36.4	6973.1
100-YEAR STORM	552	233	42.4	6973.6
FUTURE CONDITIONS				
2-YEAR STORM	64	6.6	10.9	6970.6
5-YEAR STORM	126	16	18.0	6971.4
10-YEAR STORM	197	30	23.0	6971.9
25-YEAR STORM	318	80	30.0	6972.5
50-YEAR STORM	432	153	36.4	6973.1
100-YEAR STORM	610	242	42.4	6973.6

A water quality capture volume (WQCV) was added to the required storage volume for the final build out condition. The purpose of the WQCV is to allow particulates to settle out and accumulate over time to improve water quality and to maintain full volume for detention during the life of the facility for a major storm event. The WQCV of 1.5 ac-ft. was added to the detention of the minor storm and half (0.75 ac-ft.) was added to the detention volume of the major storm. This was accomplished with respect to the HEC-HMS computer run by providing a starting detention volume of 1.5 ft. for the 5-year storm and 0.75 ft. for the 100-year storm. The resulting storage elevations remain well below the emergency spillway elevation. See Appendix B for more information.

The WQCV was calculated by using the equations found in Volume 2, of the Drainage Criteria Manual (DCM). The release rate from the WQCV is generally very small, which helps minimize downstream impacts. Detaining the WQCV also serves to cleanse the “first flush” of runoff from the higher initial concentration of sediment and pollutants by allowing for settlement to occur. This greatly improves the quality of runoff, leaving the facility and reduces the potential for erosion. The positive impact on water quality is expected to be significant, particularly during the construction phase of the development.

Pond G Detention Storage Criteria

Detention Pond G is to be constructed with Rolling Hills Ranch PUD grading in anticipation of the future development of the Rolling Hills Ranch PUD in accordance with the approved Sketch Plan. The pond will be located within the Gieck Ranch Drainage Basin in the eastern portion of Rolling Hills Ranch adjacent to the Falcon Regional Park. The pond will be owned and maintained by the Meridian Service Metropolitan District (MSMD) and a maintenance agreement between the Meridian Service Metropolitan District and El Paso County will be recorded with the Rolling Hills Ranch Filing 1 final plat.

Table 8: Pond G Summary Data

POND G				
	PEAK INFLOW	PEAK OUTFLOW	PEAK STORAGE	PEAK ELEVATION
	CFS	CFS	AC-FT	FT
INTERIM CONDITIONS				
2-YEAR STORM	10.8	4.2	3.4	7026.4
5-YEAR STORM	42	13	8.1	7027.4
10-YEAR STORM	91	35	11.3	7028.0
25-YEAR STORM	202	117	15.5	7028.8
50-YEAR STORM	363	237	19.4	7029.4
100-YEAR STORM	558	399	24.1	7030.0
FUTURE CONDITIONS				
2-YEAR STORM	28	5.1	5.3	7026.8
5-YEAR STORM	78	22	8.3	7027.4
10-YEAR STORM	145	56	11.1	7027.9
25-YEAR STORM	287	170	15.7	7028.7
50-YEAR STORM	454	333	20.0	7029.5
100-YEAR STORM	684	478	25.3	7030.3

Pond G and existing Pond F, located upstream of Rolling Hills Ranch work in series such that the peak flow rates from the Meridian Ranch development do not adversely affect the drainage patterns downstream of the Meridian Ranch project. The pond is designed to accommodate the developed final inflow from all of the remaining areas to be developed within Meridian Ranch minus the areas tributary to Ponds D and E. Permanent concrete control structure has been designed to handle full build out of the tributary area and reduce the developed flows to approximate the historic peak flow rates for the full spectrum of design storms.

WQCV calculations were completed for Pond G based on proposed future development of the proposed tributary area to the pond; this analysis shows that Pond G will require 0.9 acre-ft of storage for water quality for all the areas tributary to the pond. The control structure at DP H12 is proposed to consist of a 12” diameter water quality control riser with a trash grate having a top elevation of 7025.20 to achieve the required 0.9 ac-ft of storage.

The WQCV was calculated by using the equations found in Volume 2, of the Drainage Criteria Manual (DCM). The release rate from the WQCV is generally very small, which helps minimize downstream impacts. Detaining the WQCV also serves to cleanse the “first flush” of runoff from the higher initial concentration of sediment and pollutants by allowing for settlement to occur. This greatly improves the quality of runoff, leaving the facility and reduces the potential for erosion. The positive impact on water quality is expected to be significant, particularly during the construction phase of the development.

The proposed concrete control structure the outlet of Pond G will attenuate the peak developed flow rates to approximately historic peak rates for the full spectrum of design storms as per the requirements set forth in Resolution 15-042 adopted by the Board of County Commissioners, County of El Paso. The control structure consists of a water quality control standpipe, a rectangular slotted orifice located on the front and a grated top to reduce the developed peak flow rates. Table 8 provides summary data for the various design storms for the completed development for all areas tributary to Pond G including Rolling Hills Ranch PUD.

Downstream Analysis

The outlets (DP H08 & H09) for Pond E located along Eastonville Road upstream of 4-Way Ranch Filing 1 were analyzed in detail with the 2018 MDDP associated with the most recent Meridian Ranch Sketch Plan Amendment. The information can be found in Appendix D of the January 2018 Meridian Ranch MDDP. Below you will find a summary table providing release rates of flow for each Pond E outlet. See the Downstream Channel Analysis Appendix in the WindingWalk Filing 1 Final Drainage Report for a letter to the El Paso County Engineer regarding channel stability and analysis.

Table 9: Key Design Point Comparison - SCS

MERIDIAN RANCH DISCHARGE KEY DESIGN POINTS (FUTURE)						
		PEAK DISCHARGE Q ₁₀₀ (CFS)	PEAK DISCHARGE Q ₅₀ (CFS)	PEAK DISCHARGE Q ₂₅ (CFS)	PEAK DISCHARGE Q ₁₀ (CFS)	PEAK DISCHARGE Q ₅ (CFS)
G12 - POND G OUTLET REGIONAL PARK (G05 - HISTORIC)	Historic	544	355	212	86	31
	Future	478	333	170	56	22
	% of Historic	88%	94%	80%	65%	70%
G06 - EASTONVILLE ROAD ¹	Historic	561	375	225	91	33
	Future	506	352	181	60.7	24
	% of Historic	90%	94%	81%	67%	72%
H08 - EASTONVILLE ROAD (POND E NORTH OUTLET)	Historic	216	142	85	34	12
	Future	205	137	72	24	12
	% of Historic	95%	96%	85%	72%	97%
H09 - EASTONVILLE ROAD (POND E SOUTH OUTLET)	Historic	77	51	30	12	4.5
	Future	37	16	8.3	5.9	4.1
	% of Historic	48%	31%	27%	49%	92%
G14 - REGIONAL PARK (G07 - HISTORIC)	Historic	55	37	23	9.8	3.9
	Future	34	23	13	5.5	2.0
	% of Historic	62%	61%	58%	56%	51%
G08 - EASTONVILLE ROAD ¹	Historic	119	78	48	20	7.6
	Future	106	69	41	16	5.8
	% of Historic	90%	89%	87%	82%	77%

¹ Flow rate at Eastonville Rd. listed for reference only

The outlet (DP G12) for Pond G is located west of the Falcon Regional Park, upstream of Eastonville Rd (DP G06). Pond G will discharge 479 CFS during the 100-yr storm event into an existing natural drainage course that traverses the regional park. The 100-year historical peak flow rate at the western boundary of the regional park is 544 CFS. The calculated 100-year developed flow rate will be 88% of the historic flow rate. The developed peak flow rate for the full spectrum of design storms are calculated to be below that of the corresponding historic peak flow rates. See Table 9 for a complete comparative list of the peak flow rates for the key design points impacted by the development of Rolling Hills Ranch.

POND F – POND G CHANNEL

Methodology and Background

The drainage way within the proposed development is best characterized as wide sandy bottom trapezoidal/parabolic channel, with some sparse amounts of vegetation along the side embankments. The drainage way conveys the storm runoff released from existing Pond F and surrounding areas easterly to the proposed Pond G. The drainage course conveys water only during runoff events. The channel will require relocation and shaping immediately downstream of Pond F as it runs along the north side of future Rex Road. The channel will remain in its natural condition between Rex Road and Pond G. A HecRas hydraulic analysis was completed for this channel in order to determine the stability of the sandy bottom channel after development occurs in the surrounding area.

Due to the nature and conditions of the existing channel, efforts were made to preserve it as closely to natural conditions outside the limits of the development. The El Paso County/City of Colorado Springs Drainage Criteria Manual (DCM) references the report Design Guidelines and Criteria for Channels and Hydraulic Structures on Sandy Soils by Simons, Li and Associates for design within sandy bottom channels and the Urban Drainage Criteria Manual for the design calculations as needed. Both of these manuals are referenced within the DCM and were referred to while analyzing the drainage way. The Final Drainage Report for Meridian Ranch Filing 1 was also referenced while analyzing this drainage way, since this drainage course is very similar in nature to the drainage ways found in Meridian Ranch Filing 1.

“A sand-bed channel generally is continually changing its position and shape as a consequence of hydraulic forces acting on its bed and banks. Natural and man-induced changes in rivers frequently set in motion responses that can be propagated for long distances. The response of a river to natural and man-induced changes often occurs in spite of attempts to control the river environment,” Simons, Li and Associates. The design of a stable channel requires the understanding of the steady-state transport of sand sized sediments. Most factors affecting alluvial stream channel geometry are: stream discharge, sediment load, longitudinal slope, vegetation, type of sediment, and manmade alterations.

This natural drainage way can be defined as a ‘straight’ channel, it does not follow sinuous course. It is not braided or excessively meandering. The drainage path does have some minor

meanderings, but does not have multiple channels divided by bars and islands or large alternating S-shaped bends with deep scour pools.

Development will always alter the natural drainage system, such as increasing the peak flow rates, decreasing the sediment load encroaching in to the floodplain, etc. This drainage way

Table 8-3. Design parameters for naturalized channels

Design Parameter	Design Value
Maximum 100-year depth outside of bankfull channel	5 ft
Channel roughness values	Per Table 8-5
Maximum 5-year velocity, main channel (within bankfull channel width) (ft/s)	5 ft/s
Maximum 100-year velocity, main channel (within bankfull channel width) (ft/s)	7 ft/s
Scour coefficient No., 5-year, main channel (within bankfull channel width)	0.7
Scour coefficient No., 100-year, main channel (within bankfull channel width)	0.8
Maximum shear stress, 100-year, main channel (within bankfull channel width)	1.2 lb/sf
Minimum bankfull capacity of bankfull channel (based on future development conditions)	70% of 2-year discharge or 10% of 100-yr discharge, whichever is greater
Minimum bankfull channel geometry	Per Table 8-2
Minimum bankfull channel width/depth ratio (Equation 8-3)	9
Minimum entrenchment ratio (Equation 8-4)	3
Maximum longitudinal slope of low flow channel (assuming lined, unvegetated low flow channel)	0.2 percent
Minimum bankfull channel sinuosity (Equation 8-5)	1.1 to 1.3
Maximum overbank side slope	4(H):1(V)
Maximum bankfull side slope	2.5(H):1(V)
Minimum radius of curvature	2.5 times top width

Highly equivalent to a 1.5-year event based on extrapolation of regional data.

ad with the construction of Pond F at the upstream end with a depth slightly less than historic and higher at the lower end prior to entering the proposed Pond G detention pond. The flow rates are then lower as they are released from Pond G.

Velocity, depth flow shear are considered to be important factors when working within an alluvial drainage way, with velocity being the most important. As a general rule, the sediment transport increases with flow velocity to the fourth power at low discharges and larger powers at high-flow discharges. The scouring power of the water increases in proportion to a third and fifth power of the depth.

The City/County Drainage Criteria manual offers limited guidance on evaluating sandy bottom natural drainage courses for stability. Sections 4, 5 and 7 found in Chapter 8 of the

Urban Storm Drainage Criteria Manual (UDCM), Open Channels, provide some additional guidance toward analyzing natural drainage courses. Section 4 introduces the concept of stream stability. Section 5 applies the principles from Chapter 4 such that engineered channels can emulate natural streams. Section 7 provides guidelines on using HecRas to create a hydraulic model for the channel. This drainage course was evaluated gleaning guidance and recommendations from both Manuals.

The DCM provided guidance on Mannings n value for evaluating sandy bottom natural drainage courses for stability. Using Table 10-1 found on page 10-9 a Mannings n value of 0.0275 for the sandy bottom channel should be used. That is derived from using the base value of 0.020 for earth bottom adding 0.005 for minor irregularities, adding another .0025 for occasional channel variations. Where vegetation is present, between stations 37+61 and 39+97, an additional 0.005 was added. See table above.

Design Parameters for Natural Channels			
	100-year ¹	5-year ²	2-year ²
Velocity	7 ft/s	5 ft/s	2.5 ft/s ¹
Shear	1.2 lb/sf	0.6 lb/sf	0.6 lb/sf
¹ 100-year storm used when assessing water surface elevation and flow depth.			
² 5-year and 2-yr storms used when assessing velocity and shear stress.			
³ Sandy Loam from Table 10-3 DCM.			

Table 11 Natural Channel Design Parameters

What's the source for footnotes 1 & 2.
Per UDCM the natural channel must have the hydraulic conditions identified in Table 8-3. Assessing velocity and shear also includes the 100yr.

Table have no reference to footnote 3.

The UDCM provided guidance on target velocity and shear stress values for natural channel in Table 8-3 found on page 8-50 of Chapter 8. The UDCM suggests multiple design storms be used to perform the evaluation, this report evaluated the 2-year, 5-year and 100-year storms using HecRas (see Appendix X for complete input and results) to determine the velocities and shear stress encountered within the channel. The table right shows the target values for velocity and shear stress. The UDCM suggests using the 100-yr storm event to analyze the water surface elevation and flow depth and use the 5-year and 2-year storms to evaluate the storm flow velocity and shear stress on the channel bottom.

Design and Analysis

The area between Pond F and Rex Road will require to be reshaped into a trapezoidal channel with a 20 ft bottom width and 4:1 side slopes. The proposed channel will be lined with light rip-rap ($d_{50} = 9$ in.) along the bottom and 2 ft up the side slopes.

The future Rex Road crossing is estimated to be a 10' x 4' reinforced concrete box or equivalent size. The crossing is proposed to be designed and constructed with the Rolling Hills Ranch Filing 3 project. During the interim period, the crossing area (channel) will be lined with light rip-rap similar to the upstream channel.

The drainage course downstream of the Rex Road crossing is to remain in its natural condition. The drainage way is approximately 3-4 in depth, moderately windy, with a sandy bottom through most of it. It is very similar to the two Bennett courses located to the west in Meridian Ranch Filing 1 prior to development occurring there.

The drainage way was evaluated for maximum flow depth using the flow rate from the 100-year design storm. It was further evaluated for stability using the 2-year design storm flow rate. Chapter 10 of the DCM in conjunction with sections from Chapter 8 of the UDCM provided guidance in evaluating the natural drainage course.

A Manning n value of 0.035 was used for the side slopes of the trapezoidal channel where erosion control blanket will be used to temporarily stabilize the slopes until vegetation is established. The side slopes of the natural channel have significant variations and vegetation present, therefore a value of 0.040 was used to check channel bottom and bank stability. The calculation results show the channel flows depths are between 1.5 and 2.0 feet deep well below the top of the drainage course banks.

It is recommended to evaluate the drainage hydraulics over a range of flow rates. The 2-year, 5-year and 100-year peak flow rates were selected to be evaluated. The 2-year storm peak flow rate was used to evaluate the stream bottom stability. The USDCM suggests an average maximum flow velocity of 5 fps for sandy soils; where the City/County DCM suggests a lower value of 2.5 fps. The 2.5 fps value was as the bench mark value for the 2-year storm. The 5-year and 100-year design storms were used to evaluate the bank stability and flow depth. The overbank average velocities for these storms were analyzed against the need for rip-rap protection along the embankment within the natural sections of the drainage course. UDCM suggests increasing the Manning's n value for the 100-year storm for evaluating the flow depth. This is to emulate the increased vegetative cover over time that would cause an increased flow depth.

Looking at the section of the drainage way that will remain in its natural sandy bottom condition, the shear stress exhibited by the storm flow remains well below the 0.6 lbs/sf benchmark suggested by the UDCM. The velocity within the channel remained below the 2.5 fps in all sections except downstream of station 11+73 near the rip-rap section leading into the Pond G, station 23+26 to 25+00. But of particular note the shear stress remained at or below 0.3 lbs/sf and the velocity remained below 3.0 fps, indicating the drainage course is stable during the most frequent storm events.

The hydraulic analysis for the 5-year storm event yields velocities below 5 fps along the channel bottom and less than 3 fps in the overbanks within the sandy bottom section of the drainage channel. The stress shear values range from less than 0.1 lbs/sf to less than 0.6 lbs/sf. The values fall well below the target design values.

The HecRas hydraulic analysis for the 100-year shows the highest channel bottom velocity at 8.2 fps with an average velocity at 5.4 fps. The velocities along the overbanks calculated to below 5 fps. It appears there may be locations where erosion could occur along the sandy bottom during the rare 100-year event, but the more numerous lesser storm events would compensate for those events. The initial 100-year hydraulic calculations showed potential erosion along the right overbank between stations 27+00 to 20+50, therefore rip-rap protection was added the right overbank between those sections. The model was rerun showing lower velocities and shear stress along the right overbank.

Based on the analysis of the results of the hydraulic model, it appears the drainage way is stable with little potential for erosion of the sandy bottom channel and the overbanks. However, since the drainage way is a sandy bottom channel and the unpredictability of those types of channels, no model can accurately predict how the channel will behave in post development conditions, therefore careful monitoring of the channel bottom and overbanks will need to be a part of the regular maintenance schedule every few years. Placement of additional rip-rap along the overbanks may be necessary where erosion appears. If channel bottom head cutting appears, a grade control structure may need to be installed to protect the integrity of the sandy bottom natural channel section.

EROSION CONTROL DESIGN

General Concept

Historically, erosion on this property has been held to a minimum by a variety of natural features and agricultural practices including:

- Substantial prairie grass growth
- Construction of drainage arresting berms
- Construction of multiple stock ponds along drainage courses

Existing temporary sediment ponds will also help to minimize erosion by reducing both the volume and velocity of the peak runoff.

During construction, best management practices (BMP) for erosion control will be employed based on El Paso county Criteria. BMP's will be utilized as deemed necessary by the contractor and/or engineer and are not limited to the measures shown on the construction drawing set. The contractor shall minimize the amount of area disturbed during all construction activities.

In general the following shall be applied in developing the sequence of major activities:

- Install down-slope and side-slope perimeter BMP's before the land disturbing activity occurs.
- Do not disturb an area until it is necessary for the construction activity to proceed
- Cover or stabilize as soon as possible.
- Time the construction activities to reduce the impacts from seasonal climatic changes or weather events.
- The construction of filtration BMP's should wait until the end of the construction project when upstream drainage areas have been stabilized.
- Do not remove the temporary perimeter controls until after all upstream areas are stabilized.

Four Step Process

The following four step process is recommended for selecting structural BMP's in developing urban areas:

Step 1: Employ Runoff Reduction Practices

This development incorporates wider rights-of-way than other developments, thus decreasing the amount area devoted to pavement. The rights-of-way within Meridian Ranch are 20% wider, 60 ft. instead of 50 ft., creating more landscaped area within the development.

The project has over ten acres of open space, accounting for over 20% of the entire project, creating a lower density development.

Home owners and builders are encouraged to direct roof drains to the sideyards where the runoff will travel overland to the streets and creating an opportunity to allow the runoff to infiltrate into the ground.

See comments in the drainage map. WQCV needed prior to discharge into waters of the state.

Step 2: Stabilize Drainageways

The drainage swale located adjacent and south of the project was designed to have a wide flat bottom and slope reducing the velocity of the concentrated flow traveling along the drainageway. The construction of the swale also included erosion control mat along the entire length of the swale. At steeper sections of the swale straw logs or rip-rap has been installed to reduce velocities and erosion.

Step 3: Provide Water Quality Capture Volume (WQCV)

An existing extended detention pond with water quality capture volume is located to the east of the project that was designed to accommodate the runoff from this development.

Step 4: Consider Need for Industrial and Commercial BMP's

This project is neither industrial nor commercial and therefore this section does not apply.

sediment control for the areas upstream during construction.

Temporary Sedimentation Pond

Temporary sedimentation ponds installed during the overlot grading process will act as the primary water quality control for the areas upstream. Runoff will travel overland toward the existing sedimentation ponds, collected and diverted into the proposed storm drain system and discharged into existing downstream systems. The pond will provide initial sediment control over exposed upstream areas.

Detention Pond

The detention ponds will act as the primary water quality control for the areas within the project boundaries. Runoff will be collected by the proposed storm drainage system and diverted into the detention pond where practical. The pond will serve a dual purpose: first, by facilitating the settling of sediment in runoff during and after construction (by means of the WQCV) and, second, by maintaining runoff at or below existing levels.

Silt Fence

Silt fence will be placed along downstream limits of disturbed areas. This will prevent suspended sediment from leaving the site during infrastructure construction. Silt fencing is to remain in place until vegetation is reestablished.

Erosion Bales

Erosion bales will be placed ten (10) feet from the inlet of all culverts during construction to prevent culverts from filling with sediment. Erosion bales will remain in place until vegetation is reestablished. Erosion bale checks will be used on slopes greater than 1 percent to reduce flow velocities until vegetation is reestablished.

Miscellaneous

Best erosion control practices will be utilized as deemed necessary by the Contractor or Engineer and are not limited to the measures described above.

REFERENCES

1. “City of Colorado Springs/El Paso County Drainage Criteria Manual” September 1987, Revised November 1991, Revised October 1994.
2. Chapter 6, Hydrology and Chapter 11, Storage, Section 3.2.1 of the “City of Colorado Springs Drainage Criteria Manual” May 2014.
3. “Volume 2, El Paso County/City of Colorado Springs Drainage Criteria Manual-Stormwater Quality Policies, Procedures and Best Management Practices” November 1, 2002.
4. Flood Insurance Rate Study for El Paso County, Colorado and Incorporated Areas. Federal Emergency Management Agency, Revised March 17, 1997.
5. Soils Survey of El Paso County area, Natural Resources Conservation Services of Colorado.
6. Master Development Drainage Plan Meridian Ranch. August 2000. Prepared by URS Corp.
7. Revision to Master Development Drainage Plan Meridian Ranch. May 2015. Prepared by Tech Contractors.
8. Master Development Drainage Plan Latigo Trails. October 2001. Prepared by URS Corp.
9. Final Drainage Report for Meridian Ranch Filing 1. November 2001. Prepared by URS Corp.
10. Preliminary Drainage Plan for Meridian Ranch Phase II. September 2003. Prepared by URS.
11. Final Drainage Plan for The Trails Filing No.7. March 2005. Prepared by URS.
12. Final Drainage Report for Meridian Ranch Filing 3. August 2011. Prepared by Tech Contractors.
13. Preliminary and Final Drainage Report for Meridian Ranch Filing 7. June 2012. Prepared by Tech Contractors.
14. Final Drainage Report for Meridian Ranch Estates Filing 2. July 2013. Prepared by Tech Contractors.
15. Final Drainage Report for Meridian Ranch Filing 11A. March 2014. Prepared by Tech Contractors.
16. Preliminary and Final Drainage Report for Meridian Ranch Filing 8. December 2014. Prepared by Tech Contractors.

17. Preliminary and Final Drainage Report for Meridian Ranch Filing 4B. April 2014. Prepared by Tech Contractors.
18. Final Drainage Report for Stonebridge Filing 1 at Meridian Ranch. June 2014. Prepared by Tech Contractors.
19. Final Drainage Report for Meridian Ranch Filing 9. May 2015. Prepared by Tech Contractors.
20. Revision to Master Development Drainage Plan Meridian Ranch. July 2015. Prepared by Tech Contractors.
21. Final Drainage Report for Meridian Ranch Estates Filing 3. October 2015. Prepared by Tech Contractors.
22. Final Drainage Report for the Vistas Filing 1 at Meridian Ranch. July 2016. Prepared by Tech Contractors.
23. Final Drainage Report for Stonebridge Filing 2 at Meridian Ranch. September 2016. Prepared by Tech Contractors.
24. Final Drainage Report for Stonebridge Filing 3 at Meridian Ranch. April 2017. Prepared by Tech Contractors.
25. Interim Drainage Report for WindingWalk Grading. February 2018. Prepared by Tech Contractors.
26. Revision to Master Development Drainage Plan Meridian Ranch. January 2018. Prepared by Tech Contractors.
27. Preliminary Drainage Report for WindingWalk Filings 1 & 2 PUD and Final Drainage Report for WindingWalk Filing 1 at Meridian Ranch. April 2018. Prepared by Tech Contractors.
28. Final Drainage Report for WindingWalk Filing 2 at Meridian Ranch. August 2018. Prepared by Tech Contractors.
29. Final Drainage Report for Stonebridge Filing 4 at Meridian Ranch. September 2018. Prepared by Tech Contractors.
30. “Urban Storm Drainage Criteria Manual” September 1969, Revised January 2016.
31. Design Guidelines & Criteria – Channels & Hydraulic Structures on Sandy Soil, June 1981 by Simons, Li & Associates.

Appendices

Appendix A – Rational Calculations

Table 6-6. Runoff Coefficients for Rational Method
(Source: UDFCD 2001)

Land Use or Surface Characteristics	Percent Impervious	Runoff Coefficients											
		2-year		5-year		10-year		25-year		50-year		100-year	
		HSG A&B	HSG C&D	HSG A&B	HSG C&D	HSG A&B	HSG C&D	HSG A&B	HSG C&D	HSG A&B	HSG C&D	HSG A&B	HSG C&D
Business													
Commercial Areas	95	0.79	0.80	0.81	0.82	0.83	0.84	0.85	0.87	0.87	0.88	0.88	0.89
Neighborhood Areas	70	0.45	0.49	0.49	0.53	0.53	0.57	0.58	0.62	0.60	0.65	0.62	0.68
Residential													
1/8 Acre or less	65	0.41	0.45	0.45	0.49	0.49	0.54	0.54	0.59	0.57	0.62	0.59	0.65
1/4 Acre	40	0.23	0.28	0.30	0.35	0.36	0.42	0.42	0.50	0.46	0.54	0.50	0.58
1/3 Acre	30	0.18	0.22	0.25	0.30	0.32	0.38	0.39	0.47	0.43	0.52	0.47	0.57
1/2 Acre	25	0.15	0.20	0.22	0.28	0.30	0.36	0.37	0.46	0.41	0.51	0.46	0.56
1 Acre	20	0.12	0.17	0.20	0.26	0.27	0.34	0.35	0.44	0.40	0.50	0.44	0.55
Industrial													
Light Areas	80	0.57	0.60	0.59	0.63	0.63	0.66	0.66	0.70	0.68	0.72	0.70	0.74
Heavy Areas	90	0.71	0.73	0.73	0.75	0.75	0.77	0.78	0.80	0.80	0.82	0.81	0.83
Parks and Cemeteries													
Parks and Cemeteries	7	0.05	0.09	0.12	0.19	0.20	0.29	0.30	0.40	0.34	0.46	0.39	0.52
Playgrounds	13	0.07	0.13	0.16	0.23	0.24	0.31	0.32	0.42	0.37	0.48	0.41	0.54
Railroad Yard Areas	40	0.23	0.28	0.30	0.35	0.36	0.42	0.42	0.50	0.46	0.54	0.50	0.58
Undeveloped Areas													
Historic Flow Analysis-- Greenbelts, Agriculture	2	0.03	0.05	0.09	0.16	0.17	0.26	0.26	0.38	0.31	0.45	0.36	0.51
Pasture/Meadow	0	0.02	0.04	0.08	0.15	0.15	0.25	0.25	0.37	0.30	0.44	0.35	0.50
Forest	0	0.02	0.04	0.08	0.15	0.15	0.25	0.25	0.37	0.30	0.44	0.35	0.50
Exposed Rock	100	0.89	0.89	0.90	0.90	0.92	0.92	0.94	0.94	0.95	0.95	0.96	0.96
Offsite Flow Analysis (when landuse is undefined)	45	0.26	0.31	0.32	0.37	0.38	0.44	0.44	0.51	0.48	0.55	0.51	0.59
Streets													
Paved	100	0.89	0.89	0.90	0.90	0.92	0.92	0.94	0.94	0.95	0.95	0.96	0.96
Gravel	80	0.57	0.60	0.59	0.63	0.63	0.66	0.66	0.70	0.68	0.72	0.70	0.74
Drive and Walks													
Drive and Walks	100	0.89	0.89	0.90	0.90	0.92	0.92	0.94	0.94	0.95	0.95	0.96	0.96
Roofs	90	0.71	0.73	0.73	0.75	0.75	0.77	0.78	0.80	0.80	0.82	0.81	0.83
Lawns	0	0.02	0.04	0.08	0.15	0.15	0.25	0.25	0.37	0.30	0.44	0.35	0.50

Figure 6-5. Colorado Springs Rainfall Intensity Duration Frequency

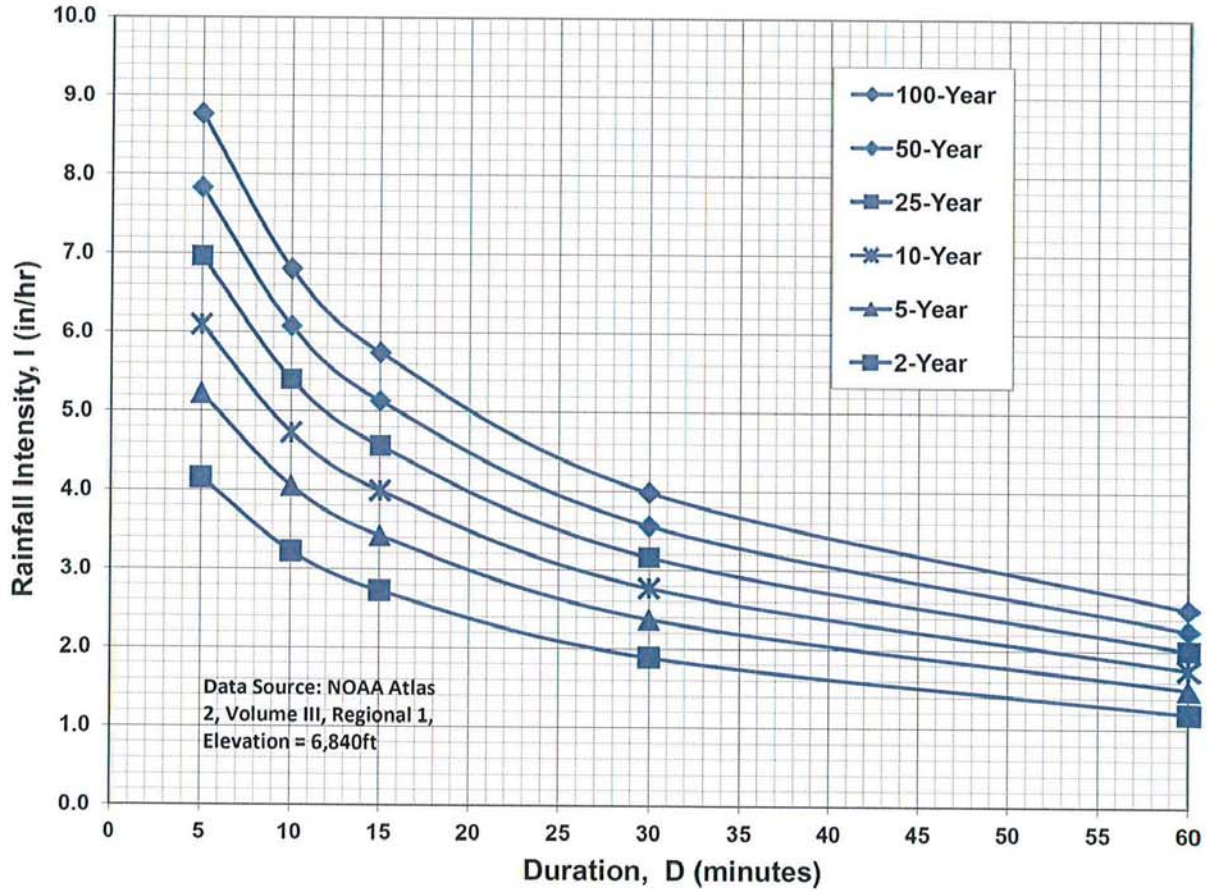

IDF Equations

$$I_{100} = -2.52 \ln(D) + 12.735$$

$$I_{50} = -2.25 \ln(D) + 11.375$$

$$I_{25} = -2.00 \ln(D) + 10.111$$

$$I_{10} = -1.75 \ln(D) + 8.847$$

$$I_5 = -1.50 \ln(D) + 7.583$$

$$I_2 = -1.19 \ln(D) + 6.035$$

Note: Values calculated by equations may not precisely duplicate values read from figure.

COMPOSITE 'C' FACTORS

PROJECT: Rolling Hills Ranch PUD											9/3/2019
BASIN DESIGNATION	AREA (AC.)								COMPOSITE FACTOR		Percent Impervious
	UNDEV	2 DU/AC	3 DU/AC	4 DU/AC	5 DU/AC	STREETS	OPEN SPACE PARKS/GC	TOTAL	5-year	100-year	
OS1	4.4							4.4	0.09	0.36	0.0%
A01		1.2	2.2			1.1	2.9	7.5	0.34	0.52	28.8%
A02		0.8	1.4					2.2	0.24	0.47	28.2%
A03		0.3	0.5			0.1		0.8	0.29	0.50	33.7%
B01			1.1	1.2				2.3	0.28	0.49	35.1%
B02			2.8	2.9				5.6	0.28	0.49	35.1%
B03			1.8	1.9			0.7	4.3	0.27	0.47	29.6%
B04			1.5	1.6				3.0	0.28	0.49	35.1%
B05			1.6	1.7				3.2	0.28	0.49	35.1%
B06			1.5	1.6				3.1	0.28	0.49	35.1%
B07			2.3	2.4				4.8	0.28	0.49	35.1%
B08			1.2	1.3				2.5	0.28	0.49	35.1%
B09			1.3	1.4				2.7	0.28	0.49	35.1%
B10			1.6	1.7				3.3	0.28	0.49	35.1%
B11			1.5	1.6				3.1	0.28	0.49	35.1%
C01			1.5	1.6				3.2	0.28	0.49	35.1%
C02			1.7	1.8				3.5	0.28	0.49	35.1%
C03			0.7	0.7				1.3	0.28	0.49	35.1%
C04			1.5	1.6				3.1	0.28	0.49	35.1%
C05			0.3	0.3				0.6	0.28	0.49	35.2%
C06			0.5	0.5				1.0	0.28	0.49	35.1%
C07			0.2	0.2			0.6	0.9	0.25	0.44	14.4%
D01			1.0	5.9				6.9	0.29	0.50	38.6%
D02			0.6	3.3				3.8	0.29	0.50	38.6%
D03			0.6	3.3				3.8	0.29	0.50	38.6%
D04			0.8	4.5				5.3	0.29	0.50	38.6%
D05			0.3	1.7				2.0	0.29	0.50	38.6%
D06			0.5	2.7				3.2	0.29	0.50	38.6%
D07			0.9	5.7				6.6	0.29	0.50	38.6%
D08			0.2	1.4				1.6	0.29	0.50	38.6%
D09			0.1	0.5			1.1	1.6	0.26	0.44	13.9%
D10			0.1	0.7				0.8	0.29	0.50	38.5%
D11			0.4	2.2			1.6	4.2	0.27	0.46	24.6%
D12			0.4	2.3				2.7	0.29	0.50	38.6%
D13				0.9	0.9			1.8	0.32	0.51	41.4%
D14			0.9	5.5				6.5	0.29	0.50	38.6%
D15			0.9	5.4				6.4	0.29	0.50	38.6%
D16			0.6	3.4				4.0	0.29	0.50	38.6%
D17			0.7	4.4				5.1	0.29	0.50	38.6%
D18			0.5	2.7				3.1	0.29	0.50	38.6%
E01				2.8	2.6			5.4	0.32	0.51	41.4%
E02				3.4	3.1			6.5	0.32	0.51	41.4%
E03				3.1	2.8			5.8	0.32	0.51	41.4%
E04				1.4	1.3	0.3	0.2	3.1	0.37	0.54	43.8%
E05				1.3	1.2			2.6	0.32	0.51	41.4%
E06				0.7	0.6			1.3	0.32	0.51	41.4%
E07				1.1	1.0			2.1	0.32	0.51	41.4%
E08				2.2	2.0			4.2	0.32	0.51	41.4%
E09				2.9	2.6			5.4	0.32	0.51	41.4%
E10				3.7	3.3			7.0	0.32	0.51	41.4%
E11				1.0	2.1		9.9	13.0	0.26	0.44	11.6%
E12						1.0	0.6	1.6	0.64	0.74	61.4%
E13				1.3	2.5	1.0	1.2	6.0	0.41	0.57	44.0%
TOTAL	4	3	39	107	26	3	20	202.1	0.30	0.49	34.7%

TIME OF CONCENTRATION

PROJECT: **Rolling Hills Ranch PUD**

DATE: 9/3/2019

TIME OF CONCENTRATION																	
SUBBASIN DATA			INIT./OVERLAND TIME (T _i)				TRAVEL TIME (T _t)							TOTAL Ti+Tt(Min.)	Tc Check (Urbanized Basins)		FINAL T _c (min)
BASIN DESIGNATION	C ₅	AREA (AC)	LENGTH (FT)	ΔH	SLOPE %	Ti (Min.)*	LENGTH (FT)	ΔH	SLOPE %	CONVEYANCE		VEL. (FPS)	Tt(Min.)**		L (FT)	Tc = (L/180) + 10	
										TYPE	COEF.						
OS1	0.09	4.4	185	6.0	3.2%	17.0	1275	34	2.7%	L	7	1.1	18.6	35.6	1460.00	18.1	18.1
A01	0.34	7.5	185	9.0	4.9%	11.2	985	25	2.5%	P	20	3.2	5.2	16.4	1170.00	16.5	16.4
A02	0.24	2.2	214	4.5	2.1%	18.0	230	4	1.7%	P	20	2.6	1.5	19.5	444.00	12.5	12.5
A03	0.29	0.8	25	0.5	2.0%	5.9	230	4	1.7%	P	20	2.6	1.5	7.4	255.00	11.4	7.4
B01	0.28	2.3	242	6.0	2.5%	17.4	838	16	1.9%	P	20	2.8	5.1	22.4	1080.00	16.0	16.0
B02	0.28	5.6	300	9.0	3.0%	18.2	902	17	1.9%	P	20	2.7	5.5	23.6	1202.00	16.7	16.7
B03	0.27	4.3	280	10.0	3.6%	16.7	494	11	2.1%	P	20	2.9	2.8	19.5	774.00	14.3	14.3
B04	0.28	3.0	43	0.9	2.0%	7.9	1352	26	1.9%	P	20	2.8	8.1	16.0	1395.00	17.8	16.0
B05	0.28	3.2	130	2.6	2.0%	13.7	845	20	2.4%	P	20	3.1	4.6	18.3	975.00	15.4	15.4
B06	0.28	3.1	30	0.6	2.0%	6.6	914	19	2.1%	P	20	2.9	5.3	11.9	944.00	15.2	11.9
B07	0.28	4.8	67	1.3	2.0%	9.8	1380	25	1.8%	P	20	2.7	8.5	18.4	1447.00	18.0	18.0
B08	0.28	2.5	155	3.2	2.1%	14.8	731	16	2.2%	P	20	3.0	4.1	18.9	886.00	14.9	14.9
B09	0.28	2.7	155	3.2	2.1%	14.8	916	18	1.9%	P	20	2.8	5.5	20.3	1071.00	16.0	16.0
B10	0.28	3.3	160	3.2	2.0%	15.2	962	18	1.8%	P	20	2.7	5.9	21.1	1122.00	16.2	16.2
B11	0.28	3.1	155	3.2	2.1%	14.8	843	18	2.1%	P	20	2.9	4.9	19.7	998.00	15.5	15.5
C01	0.28	3.2	155	3.2	2.1%	14.8	745	20	2.7%	P	20	3.3	3.8	18.6	900.00	15.0	15.0
C02	0.28	3.5	160	4.2	2.6%	13.9	745	20	2.7%	P	20	3.3	3.8	17.6	905.00	15.0	15.0
C03	0.28	1.3	135	2.7	2.0%	13.9	404	4	1.0%	P	20	2.0	3.4	17.3	539.00	13.0	13.0
C04	0.28	3.1	217	4.5	2.1%	17.5	346	3	0.9%	P	20	1.9	3.1	20.6	563.00	13.1	13.1
C05	0.28	0.6	80	1.6	2.0%	10.7	334	3	0.9%	P	20	1.9	2.9	13.7	414.00	12.3	12.3
C06	0.28	1.0	50	1.0	2.0%	8.5	602	5	0.8%	P	20	1.8	5.5	14.0	652.00	13.6	13.6
C07	0.25	0.9	160	3.0	1.9%	15.9	167	2	1.0%	G	15	1.5	1.8	17.8	327.00	11.8	11.8
D01	0.29	6.9	125	2.5	2.0%	13.1	1060	23	2.2%	P	20	2.9	6.0	19.1	1185.00	16.6	16.6
D02	0.29	3.8	260	10.0	3.8%	15.2	880	16	1.8%	P	20	2.7	5.4	20.7	1140.00	16.3	16.3
D03	0.29	3.8	40	0.8	2.0%	7.4	1140	28	2.4%	P	20	3.1	6.1	13.5	1180.00	16.6	13.5

TIME OF CONCENTRATION																	
SUBBASIN DATA			INIT./OVERLAND TIME (T _i)				TRAVEL TIME (T _t)							TOTAL T _i +T _t (Min.)	T _c Check (Urbanized Basins)		FINAL T _c (min)
BASIN DESIGNATION	C _s	AREA (AC)	LENGTH (FT)	ΔH	SLOPE %	T _i (Min.)*	LENGTH (FT)	ΔH	SLOPE %	CONVEYANCE		VEL. (FPS)	T _t (Min.)**		L (FT)	T _c = (L/180) + 10	
										TYPE	COEF.						
D04	0.29	5.3	90	1.8	2.0%	11.1	1350	32	2.4%	P	20	3.1	7.3	18.4	1440.00	18.0	18.0
D05	0.29	2.0	155	3.1	2.0%	14.6	350	5	1.4%	P	20	2.4	2.4	17.1	505.00	12.8	12.8
D06	0.29	3.2	140	2.8	2.0%	13.9	1005	26	2.6%	P	20	3.2	5.2	19.1	1145.00	16.4	16.4
D07	0.29	6.6	160	3.2	2.0%	14.9	675	20	3.0%	P	20	3.4	3.3	18.1	835.00	14.6	14.6
D08	0.29	1.6	150	3.0	2.0%	14.4	405	4	1.0%	P	20	2.0	3.4	17.8	555.00	13.1	13.1
D09	0.26	1.6	175	3.5	2.0%	16.2	285	3	1.0%	L	7	0.7	6.8	23.0	NON-URBAN AREA		23.0
D10	0.29	0.8	80	1.6	2.0%	10.5	435	4	0.9%	P	20	1.9	3.8	14.3	515.00	12.9	12.9
D11	0.27	4.2	195	6.0	3.1%	14.6	975	10	1.0%	L	7	0.7	22.9	37.5	NON-URBAN AREA		37.5
D12	0.29	2.7	150	3.0	2.0%	14.4	1565	16	1.0%	P	20	2.0	12.9	27.3	1715.00	19.5	19.5
D13	0.32	1.8	145	2.9	2.0%	13.6	405	8	2.0%	P	20	2.8	2.4	16.0	550.00	13.1	13.1
D14	0.29	6.5	150	3.0	2.0%	14.4	1120	14	1.3%	P	20	2.2	8.3	22.7	1270.00	17.1	17.1
D15	0.29	6.4	145	2.9	2.0%	14.1	1110	15	1.4%	P	20	2.3	8.0	22.1	1255.00	17.0	17.0
D16	0.29	4.0	255	5.1	2.0%	18.8	500	13	2.6%	P	20	3.2	2.6	21.3	755.00	14.2	14.2
D17	0.29	5.1	245	4.9	2.0%	18.4	660	14	2.1%	P	20	2.9	3.8	22.2	905.00	15.0	15.0
D18	0.29	3.1	100	2.0	2.0%	11.7	1390	24	1.7%	P	20	2.6	8.8	20.6	1490.00	18.3	18.3
E01	0.32	5.4	165	3.3	2.0%	14.5	672	17	2.5%	P	20	3.2	3.5	18.0	837.00	14.7	14.7
E02	0.32	6.5	268	13.0	4.9%	13.8	700	20	2.9%	P	20	3.4	3.5	17.2	968.00	15.4	15.4
E03	0.32	5.8	247	6.0	2.4%	16.6	795	6	0.8%	P	20	1.7	7.6	24.3	1042.00	15.8	15.8
E04	0.37	3.1	50	1.0	2.0%	7.6	1115	8	0.7%	P	20	1.7	11.0	18.5	1165.00	16.5	16.5
E05	0.32	2.6	242	12.0	5.0%	13.0	1140	26	2.3%	P	20	3.0	6.3	19.3	1382.00	17.7	17.7
E06	0.32	1.3	140	2.8	2.0%	13.4	307	6	2.0%	P	20	2.8	1.8	15.2	447.00	12.5	12.5
E07	0.32	2.1	280	11.0	3.9%	15.1	200	8	4.0%	P	20	4.0	0.8	15.9	480.00	12.7	12.7
E08	0.32	4.2	140	2.8	2.0%	13.4	740	16	2.2%	P	20	2.9	4.2	17.6	880.00	14.9	14.9
E09	0.32	5.4	255	8.0	3.1%	15.5	625	18	2.9%	P	20	3.4	3.1	18.6	880.00	14.9	14.9
E10	0.32	7.0	172	6.0	3.5%	12.3	1583	35	2.2%	P	20	3.0	8.9	21.2	1755.00	19.8	19.8
E11	0.26	13.0	182	3.0	1.6%	17.5	1696	35	2.1%	L	7	1.0	28.1	45.6	NON-URBAN AREA		45.6
E12	0.64	1.6	25	0.5	2.0%	3.3	1350	12	0.9%	P	20	1.9	11.9	15.3	1375.00	17.6	15.3
E13	0.41	6.0	161	6.0	3.7%	10.3	1188	22	1.9%	P	20	2.7	7.3	17.6	1349.00	17.5	17.5

TIME OF CONCENTRATION																
SUBBASIN DATA			INIT./OVERLAND TIME (T _i)				TRAVEL TIME (T _t)						TOTAL T _i +T _t (Min.)	T _c Check (Urbanized Basins)		FINAL T _c (min)
BASIN DESIGNATION	C _s	AREA (AC)	LENGTH (FT)	ΔH	SLOPE %	T _i (Min.)*	LENGTH (FT)	ΔH	SLOPE %	CONVEYANCE		VEL. (FPS)		T _t (Min.)**	L (FT)	
			11A Designation		FROM APPROVED MERIDIAN RANCH FILING 11A FINAL DRAINAGE REPORT DATED MARCH 2014											
Ex1	0.61	1.1	4													11.2
Ex2	0.55	1.3	5													10.6
Ex3	0.77	1.7	20													15.5
Ex4	0.53	1.8	15													11.8
Ex5	0.57	2.3	14													14.8
Ex6	0.47	1.4	16													10.4
Ex7	0.44	1.4	17													10.0
Ex8	0.38	2.2	18													12.0

Notes:	$* T_i = \frac{0.395 (1.1 - C_5) L^{0.5}}{S^{0.33}}$	
	$V = C_v S_w^{0.5}$	$** T_t = L \times V$

TYPE OF SURFACE		C _v
HEAVY MEADOW	H	2.5
TILLAGE/FIELD	T	5
RIPRAP (not buried)	R	6.5
SHORT PASTURE AND LAWNS	L	7
NEARLY BARE GROUND	B	10
GRASSED WATERWAY	G	15
PAVED AREAS	P	20

DESIGN POINT	DIRECT RUNOFF											TOTAL RUNOFF						OVERLAND TRAVEL TIME								
	BASIN	AREA (AC)	Tc (Min.)	I (in./ hr.)		COEFF. ©		CA		Q		Sum Tc (min.)	I (in./ hr.)		CA		Q		DESTINATION DP	CONVEYANCE TYPE	COEFFICIENT C _v	SLOPE %	VEL. (FPS)	LENGTH (FT)	TRAVEL TIME TT	
				(5 YR)	(100 YR)	(5 YR)	(100 YR)	(5 YR)	(100 YR)	(5 YR)	(100 YR)		(5 YR)	(100 YR)	(5 YR)	(100 YR)										
DEVELOPED																										
I32	D18	3.1	18.3	3.22	5.41	0.29	0.50	0.92	1.55	3.0	8.4	22.2	2.93	4.92	0.92	2.06	3.0	10								
I33	E01	5.4	14.7	3.56	5.97	0.32	0.51	1.74	2.77	6.2	17	16.9	3.35	5.62	1.85	3.06	6.2	17	I34	P	20.0	1.90%	2.8	315	1.9	
I34	E02	6.5	15.4	3.48	5.85	0.32	0.51	2.10	3.33	7.3	19	18.8	3.19	5.35	2.10	3.33	7.3	19	I37	P	20.0	1.40%	2.4	360	2.5	
I35	E03	5.8	15.8	3.44	5.78	0.32	0.51	1.88	2.99	6.5	17						6.5	17	I36	P	20.0	0.85%	1.8	175	1.6	
I36	E04	3.1	16.5	3.38	5.67	0.37	0.54	1.15	1.71	3.9	9.7	17.4	3.30	5.54	1.15	2.35	3.9	13								
I37	E05	2.6	17.7	3.27	5.50	0.32	0.51	0.83	1.31	2.7	7.2	21.3	3.00	5.03	0.83	1.73	2.7	8.7	I41	P	20.0	0.90%	1.9	280	2.5	
I38	E06	1.3	12.5	3.80	6.37	0.32	0.51	0.41	0.65	1.6	4.2						1.6	4.2								
I39	E07	2.1	12.7	3.77	6.34	0.32	0.51	0.66	1.05	2.5	6.7						2.5	6.7	I41	P	20.0	2.80%	3.3	675	3.4	
I40	E08	4.2	14.9	3.53	5.93	0.32	0.51	1.35	2.14	4.8	13						4.8	13	E11	P	20.0	2.30%	3.0	1290	7.1	
I41	E09	5.4	14.9	3.53	5.93	0.32	0.51	1.76	2.80	6.2	17	23.8	2.83	4.75	2.05	3.69	6.2	18	I43	P	20.0	1.10%	2.1	545	4.3	
I42	E10	7.0	19.8	3.11	5.22	0.32	0.51	2.26	3.59	7.0	19						7.0	19								
CB3	E11	13.0	45.6	1.85	3.11	0.26	0.44	3.42	5.69	6.3	18						6.3	18								
I43	E12	1.6	15.3	3.49	5.86	0.64	0.74	1.02	1.19	3.6	7.0	25.6	2.72	4.56	1.02	2.02	3.6	9.2	E13	P	20.0	1.25%	2.2	1190	8.9	
E11	E13	6.0	17.5	3.29	5.52	0.41	0.57	2.48	3.45	8.2	19	22.0	2.95	4.95	2.48	3.92	8.2	19	E12	P	20.0	1.25%	2.2	560	4.2	
E12	Ex1	1.1	11.2	3.96	6.65	0.61	0.72	0.65	0.76	2.6	5.1	21.7	2.97	4.98	0.65	2.07	2.6	10	E19	P	20.0	1.25%	2.2	565	4.2	
E19	Ex2	1.3	10.6	4.04	6.79	0.55	0.67	0.69	0.84	2.8	5.7	25.9	2.70	4.54	1.16	2.39	3.1	11								
E13	Ex3	1.7	15.5	3.47	5.83	0.77	0.85	1.31	1.45	4.6	8.5	24.1	2.81	4.71	1.45	1.92	4.6	9.1	EX							
E14	Ex4	1.8	11.8	3.88	6.52	0.53	0.65	0.96	1.18	3.7	7.7						3.7	7.7	² Q ₅ =1.2 CFS, Q ₁₀₀ =3.1 TO STONEBRIDGE FILING 3							
E15	Ex5	2.3	14.8	3.54	5.94	0.57	0.68	1.28	1.54	4.5	9.1						4.5	9.1	E16	P	20.0	4.00%	4.0	805	3.4	
E16	Ex6	1.4	10.4	4.07	6.83	0.47	0.60	0.65	0.83	2.6	5.7	18.2	3.23	5.43	0.94	1.32	3.0	7.2	E17	P	20.0	4.00%	4.0	700	2.9	
E17	Ex7	1.4	10.0	4.13	6.93	0.44	0.58	0.63	0.83	2.6	5.8	21.1	3.01	5.05	0.83	1.25	2.6	6.3	E18	P	20.0	2.00%	2.8	410	2.4	
E18	Ex8	2.2	12.0	3.86	6.47	0.38	0.54	0.85	1.21	3.3	7.8	23.5	2.85	4.78	1.01	1.59	3.3	7.8	E19	P	20.0	2.00%	2.8	50	0.3	

TYPE OF SURFACE		C _v
HEAVY MEADOW	H	3
TILLAGE/FIELD	T	5
RIPRAP (not buried)	R	7
SHORT PASTURE AND LAWNS	L	7
NEARLY BARE GROUND	B	10
GRASSED WATERWAY	G	15
PAVED AREAS	P	20

**STORM DRAINAGE SYSTEM DESIGN
INLET CALCULATIONS**

PROJECT: **Rolling Hills Ranch PUD**

Date: 9/3/2019

DP	BASIN	Inlet size L(i)	Proposed or Existing	INLET TYPE	CROSS SLOPE	STREET SLOPE	T _c	Q _{Total}		Q _{Capture}				Q _{Flow-by}				DEPTH (max)		SPREAD	
								Q ₅ (cfs)	Q ₁₀₀ (cfs)	Q ₅ (cfs)	Q ₁₀₀ (cfs)	CA _{eqv.} (5-yr)	CA _{eqv.} (100-yr)	Q ₅ (cfs)	Q ₁₀₀ (cfs)	CA _{eqv.} (5-yr)	CA _{eqv.} (100-yr)	Q ₅ (ft)	Q ₁₀₀ (ft)	Q ₅ (ft)	Q ₁₀₀ (ft)
CB4	OS1	Type C	PROP	SUMP	2.0%		18.1	1.3	9	1.3	9	0.40	1.58	-	-	-	-	0.18	0.51		
I01	A01	15	PROP	SUMP ¹	2.0%		16.4	8.6	22	8.6	14	2.55	2.39	-	8.6	-	1.51	0.47	0.47		
I02	A02	10	PROP	SUMP	2.0%		16.9	2.0	14	2.0	14	0.60	2.54	-	-	-	-	0.50	0.70		
I03	A03	5	PROP	SUMP	2.0%		7.4	1.0	3.1	1.0	3.1	0.23	0.40	-	-	-	-	0.50	0.70		
I04	B01	10	PROP	SUMP ¹	2.0%		16.0	2.2	6.4	2.2	6.4	0.63	1.11	-	-	-	-	0.47	0.47		
I05	B02	15	PROP	SUMP ¹	2.0%		16.7	5.2	15	5.2	14	1.55	2.41	-	1.8	-	0.33	0.47	0.47		
I06	B04	20	PROP	SUMP ¹	2.0%		19.7	6.2	18	6.2	17	2.01	3.30	-	1.2	-	0.23	0.47	0.47		
I07	B05	10	PROP	SUMP ¹	2.0%		15.4	3.1	9.1	3.1	9.1	0.89	1.56	-	-	-	-	0.47	0.47		
I08	B06	10	PROP	SUMP ¹	2.0%		11.9	3.3	9.9	3.3	9.9	0.86	1.52	-	-	-	-	0.47	0.47		
I09	B07	20	PROP	FLOW-BY	2.0%	1.0%	18.0	4.3	13	3.7	9.2	1.15	1.68	0.5	3.4	0.16	0.63	0.33	0.46	12.4	18.6
I10	B08	10	PROP	SUMP ¹	2.0%		19.9	2.5	7.6	2.5	7.6	0.80	1.46	-	-	-	-	0.47	0.47		
I11	B09	10	PROP	SUMP	2.0%		16.0	2.6	7.7	2.6	7.7	0.76	1.33	-	-	-	-	0.50	0.70		
I12	B10 B11	20	PROP	SUMP	2.0%		24.0	5.4	18	5.4	18	1.92	3.73	-	-	-	-	0.50	0.70		
I13	C01	10	PROP	SUMP ¹	2.0%		15.0	3.1	9.0	3.1	9.0	0.87	1.53	-	-	-	-	0.47	0.47		
I14	C02	15	PROP	SUMP ¹	2.0%		21.2	3.4	10	3.4	10	1.14	2.04	-	-	-	-	0.47	0.47		
I15	C03	5	PROP	SUMP ¹	2.0%		13.0	1.4	4.0	1.4	4.0	0.37	0.65	-	-	-	-	0.47	0.47		
I16	C04	5	PROP	SUMP ¹	2.0%		13.1	3.2	9.4	3.2	6.3	0.85	1.01	-	3.1	-	0.50	0.47	0.47		
I17	C05	5	PROP	SUMP	2.0%		12.3	0.6	1.8	0.6	1.8	0.16	0.28	-	-	-	-	0.50	0.70		
I18	C06	5	PROP	SUMP	2.0%		14.5	1.0	6.0	1.0	6.0	0.29	1.00	-	-	-	-	0.50	0.70		
CB1	C07	Type C	PROP	SUMP	2.0%		11.8	0.9	2.5	0.9	2.5	0.22	0.39	-	-	-	-	0.13	0.27		
I19	D01	15	PROP	SUMP ¹	2.0%		16.6	6.8	19	6.8	14	2.01	2.40	-	5.7	-	1.00	0.47	0.47		
I20	D03	20	PROP	SUMP ¹	2.0%		18.1	7.3	21	7.3	17	2.25	3.17	-	3.4	-	0.63	0.47	0.47		
I21	D05	15	PROP	SUMP ¹	2.0%		21.4	6.9	24	6.9	14	2.31	2.71	-	10	-	2.04	0.47	0.47		
I22	D06	15	PROP	FLOW-BY	2.0%	1.0%	16.4	3.2	9.0	2.6	6.2	0.77	1.09	0.6	2.8	0.17	0.50	0.31	0.41	11.1	16.5
I23	D07	10	PROP	SUMP ¹	2.0%		14.6	6.9	20	6.9	9.9	1.93	1.66	-	9.6	-	1.60	0.47	0.47		
I24	D08	10	PROP	SUMP ¹	2.0%		17.3	1.8	13	1.8	9.9	0.54	1.79	-	3.5	-	0.63	0.47	0.47		

¹ Forced sump at intersection

DP	BASIN	Inlet size L(i)	Proposed or Existing	INLET TYPE	CROSS SLOPE	STREET SLOPE	T _c	Q _{Total}		Q _{Capture}				Q _{Flow-by}				DEPTH (max)		SPREAD	
								Q ₅ (cfs)	Q ₁₀₀ (cfs)	Q ₅ (cfs)	Q ₁₀₀ (cfs)	CA _{eqv.} (5-yr)	CA _{eqv.} (100-yr)	Q ₅ (cfs)	Q ₁₀₀ (cfs)	CA _{eqv.} (5-yr)	CA _{eqv.} (100-yr)	Q ₅ (ft)	Q ₁₀₀ (ft)	Q ₅ (ft)	Q ₁₀₀ (ft)
CB2	D09	Type C	PROP	SUMP	2.0%		23.0	1.2	3.4	1.2	3.4	0.42	0.71	-	-	-	-	0.17	0.34		
I25	D10	10	PROP	SUMP	2.0%		19.2	0.9	5.4	0.9	5.4	0.28	1.03	-	-	-	-	0.50	0.70		
ES1	D11	FES	PROP	SUMP	2.0%		37.5	2.4	6.9	2.4	6.9	1.13	1.93	-	-	-	-	0.27	0.47		
I26	D12	20	PROP	SUMP	2.0%		23.3	2.4	16	2.4	16	0.85	3.36	-	-	-	-	0.50	0.70		
I27	D13	15	PROP	FLOW-BY	2.0%	2.0%	13.1	2.2	5.8	1.7	3.9	0.47	0.63	0.4	1.8	0.11	0.29	0.25	0.33	8.5	12.2
I28	D14	10	PROP	SUMP ¹	2.0%		17.1	6.3	18	6.3	9.9	1.89	1.78	-	7.9	-	1.42	0.47	0.47		
I29	D15	10	PROP	SUMP ¹	2.0%		17.0	6.2	18	6.2	9.9	1.86	1.77	-	7.7	-	1.37	0.47	0.47		
I30	D16	10	PROP	SUMP ¹	2.0%		20.4	4.2	17	4.2	9.9	1.39	1.94	-	7.3	-	1.43	0.47	0.47		
I31	D17	15	PROP	SUMP	2.0%		21.9	5.3	27	5.3	24	1.79	4.89	-	2.5	-	0.51	0.50	0.70		
I32	D18	15	PROP	SUMP	2.0%		22.2	3.0	10	3.0	10	1.01	2.06	-	-	-	-	0.50	0.70		
							0.0														
I33	E01	20	PROP	SUMP ¹	2.0%		16.9	6.2	17	6.2	17	1.85	3.06	-	-	-	-	0.47	0.47		
I34	E02	20	PROP	SUMP ¹	2.0%		18.8	7.3	19	7.3	17	2.29	3.22	-	2.3	-	0.42	0.47	0.47		
I35	E03	15	PROP	SUMP ¹	2.0%		15.8	6.5	17	6.5	14	1.88	2.35	-	3.7	-	0.64	0.47	0.47		
I36	E04	15	PROP	SUMP ¹	2.0%		17.4	3.9	13	3.9	13	1.18	2.35	-	-	-	-	0.47	0.47		
I37	E05	15	PROP	FLOW-BY	2.0%	1.0%	21.3	2.7	8.7	2.3	6.0	0.76	1.20	0.4	2.7	0.14	0.54	0.29	0.41	10.5	16.2
I38	E06	5	PROP	SUMP ¹	2.0%		12.5	1.6	4.2	1.6	4.2	0.41	0.65	-	-	-	-	0.47	0.47		
I39	E07	15	PROP	FLOW-BY	2.0%	2.0%	12.7	2.5	6.7	2.0	4.5	0.52	0.70	0.5	2.2	0.14	0.35	0.26	0.34	8.9	12.9
I40	E08	10	PROP	SUMP ¹	2.0%		14.9	4.8	13	4.8	9.9	1.35	1.67	-	2.8	-	0.47	0.47	0.47		
I41	E09	15	PROP	SUMP ¹	2.0%		23.8	6.2	18	6.2	14	2.20	2.86	-	3.9	-	0.83	0.47	0.47		
I42	E10	20	PROP	SUMP	2.0%		19.8	7.0	19	7.0	19	2.26	3.59	-	-	-	-	0.50	0.70		
CB3	E11	Type C	PROP	SUMP	2.0%		45.6	6.3	18	6.3	18	3.42	5.69	-	-	-	-	0.45	0.70		
I43	E12	20	PROP	FLOW-BY	2.0%	1.0%	25.6	3.6	9.2	3.2	7.1	1.19	1.55	0.4	2.1	0.13	0.47	0.32	0.42	11.6	16.6
EI1	E13	15	PROP	SUMP ¹	2.0%		22.0	8.2	19	8.2	13	2.77	2.61	-	6.5	-	1.31	0.45	0.45		
EI2	Ex1	10	PROP	FLOW-BY	2.0%	1.3%	21.7	2.6	10	1.8	5.1	0.61	1.01	0.8	5.3	0.26	1.06	0.28	0.41	9.8	16.5
EI9	Ex2	10	PROP	SUMP	2.0%		25.9	3.1	11	3.1	11	1.16	2.39	-	-	-	-	0.50	0.70		
EI3	Ex3	15	PROP	FLOW-BY	2.0%	1.0%	24.1	4.6	9.1	3.5	6.2	1.25	1.32	1.0	2.8	0.37	0.60	0.34	0.41	12.7	16.5
EI4	Ex4	10	PROP	FLOW-BY	2.0%	1.0%	11.8	3.7	7.7	2.5	4.6	0.65	0.71	1.2	3.1	0.31	0.47	0.32	0.39	11.8	15.5
EI5	Ex5	15	PROP	FLOW-BY	2.0%	1.0%	14.8	4.5	9.1	3.5	6.3	0.99	1.05	1.0	2.9	0.29	0.48	0.34	0.42	12.7	16.5
EI6	Ex6	20	PROP	FLOW-BY	2.0%	4.0%	18.2	3.0	7.2	2.4	4.9	0.74	0.90	0.6	2.3	0.20	0.42	0.25	0.32	8.4	11.6
EI7	Ex7	20	PROP	FLOW-BY	2.0%	4.0%	21.1	2.6	6.3	2.1	4.4	0.70	0.87	0.5	1.9	0.17	0.38	0.24	0.31	8.0	11.1
EI8	Ex8	15	PROP	FLOW-BY	2.0%	1.0%	23.5	3.3	7.8	2.7	5.5	0.93	1.15	0.6	2.3	0.21	0.48	0.31	0.40	11.2	15.6

¹ Forced sump at intersection

**STORM DRAINAGE SYSTEM DESIGN
(RATIONAL METHOD PROCEDURE)
PIPE ROUTING**

PROJECT: **Rolling Hills Ranch PUD**

Date: 9/3/2019

UPSTREAM DESIGN POINT	UPSTREAM BASIN	INLET FLOW							SYSTEM FLOW						TRAVEL TIME							
		Tc (Min.)	I (in./ hr.)		CA		Q		Sum Tc (min.)	I (in./ hr.)		CA		Q		PIPE DIA	ROUGHNESS (n)	DESTINATION DP	SLOPE %	LENGTH (FT)	VEL. (FPS) (Estimate)*	TRAVEL TIME TT
			(5 YR)	(100 YR)	(5 YR)	(100 YR)	(5 YR)	(100 YR)		(5 YR)	(100 YR)	(5 YR)	(100 YR)	(5 YR)	(100 YR)							
CB4	OS1	18.1	3.2	5.4	0.40	1.58	1.3	8.6						1.3	8.6	24.0	0.013	OSJ1	1.02%	229	7.3	0.5
OSJ1									18.6	3.20	5.36	0.40	1.58	1.3	8.5	24.0	0.013	OSJ2	1.99%	396	10.2	0.6
OSJ2									19.3	3.14	5.28	0.40	1.58	1.2	8.4	24.0	0.013	OS5	4.67%	177	15.6	0.2
OS5									19.5	3.13	5.25	0.40	1.58	1.2	8.3							
I02	A02	16.9	3.34	5.61	0.60	2.54	2.0	14						2.0	14	18	0.013	J01	8.57%	4.7	17	0.0
J01									16.9	3.34	5.61	0.60	2.54	2.0	14	24	0.013	I03	1.01%	25	7	0.1
I03	A03	7.4	4.59	7.71	0.23	0.40	1.0	3.1	17.0	3.34	5.60	0.83	2.93	2.8	16	24	0.013	OS1	2.67%	172	12	0.2
									17.2													
I04	B01	16.0	3.42	5.75	0.63	1.11	2.2	6.4						2.2	6.4	18	0.013	I05	0.53%	75	4	0.3
I05	B02	16.7	3.36	5.64	1.55	2.41	5.2	14	16.7	3.36	5.64	2.18	3.52	7.3	20	24	0.013	J02	0.97%	5.2	7	0.0
J02									16.7	3.36	5.64	2.18	3.52	7.3	20	24	0.013	J03	0.51%	215	5	0.7
I06	B04	19.7	3.11	5.23	2.01	3.30	6.2	17						6.2	17	18	0.013	J03	19.34%	5.2	26	0.0
J03									19.7	3.11	5.23	4.19	6.82	13	36	30	0.013	J04	0.53%	75	6	0.2
I07	B05	15.4	3.48	5.84	0.89	1.56	3.1	9.1						3.1	9.1	18	0.013	J04	19.34%	5.2	26	0.0
J04									19.9	3.10	5.20	5.08	8.38	16	44	36	0.013	J05	0.51%	225	7	0.6
I08	B06	11.9	3.87	6.50	0.86	1.52	3.3	9.9						3.3	9.9	18	0.013	J05	19.34%	5.2	26	0.0
J05									20.4	3.06	5.13	5.94	9.90	18	51	36	0.013	J06	0.54%	64	7	0.2
I09	B07	18.0	3.24	5.45	1.15	1.68	3.7	9.2						3.7	9.2	18	0.013	J06	9.67%	5.2	19	0.0
J06									20.6	3.05	5.11	7.08	11.58	22	59	36	0.013	J07	1.29%	448	11	0.7
J07									21.3	3.00	5.03	7.08	11.58	21	58	36	0.013	J10	2.46%	407	15	0.5
I10	B08	19.9	3.09	5.19	0.80	1.46	2.5	7.6						2.5	7.6	18	0.013	J08	0.56%	54	4	0.2
J08									20.1	3.08	5.17	0.80	1.46	2.5	7.5	18	0.013	J09	0.75%	193	5	0.6
I11	B09	16.0	3.43	5.76	0.76	1.33	2.6	7.7						2.6	7.7	18	0.013	J09	0.99%	25	6	0.1
I12	B10 B11	24.0	2.82	4.73	1.92	3.73	5.4	18						5.4	18	18	0.013	J09	4.84%	5.2	13	0.0
J09									24.0	2.82	4.73	3.48	6.51	9.8	31	24	0.013	J10	0.60%	83	6	0.2
J10									24.2	2.80	4.70	10.56	18.09	30	85	42	0.013	OS2	2.06%	267	15	0.3

* Velocity estimated for calculation of travel time. Refer to Hydraulics for calculated velocity.

UPSTREAM DESIGN POINT	UPSTREAM BASIN	INLET FLOW								SYSTEM FLOW						TRAVEL TIME						
		Tc (Min.)	I (in./ hr.)		CA		Q		Sum Tc (min.)	I (in./ hr.)		CA		Q		PIPE DIA	ROUGHNESS (n)	DESTINATION DP	SLOPE %	LENGTH (FT)	VEL. (FPS) (Estimate)*	TRAVEL TIME Tt
			(5 YR)	(100 YR)	(5 YR)	(100 YR)	(5 YR)	(100 YR)		(5 YR)	(100 YR)	(5 YR)	(100 YR)	(5 YR)	(100 YR)							
I13	C01	15.0	3.52	5.91	0.87	1.53	3.1	9.0						3.1	9.0	24	0.013	J11	1.00%	45	7	0.1
I14	C02	21.2	3.00	5.04	1.14	2.04	3.4	10						3.4	10	24	0.013	J11	2.58%	25	12	0.0
J11									21.2	3.00	5.03	2.01	3.57	6.0	18	24	0.013	J12	1.02%	295	7	0.7
I15	C03	13.0	3.74	6.27	0.37	0.65	1.4	4.0						1.4	4.0	18	0.013	J12	1.00%	45	6	0.1
I16	C04	13.1	3.72	6.25	0.85	1.01	3.2	6.3						3.2	6.3	18	0.013	J12	1.59%	25	8	0.1
J12									21.9	2.95	4.96	3.23	5.22	9.5	26	30	0.013	J13	0.64%	165	7	0.4
I17	C05	12.3	3.82	6.41	0.16	0.28	0.6	1.8						0.6	1.8	18	0.013	J13	0.99%	25	6	0.1
I18	C06	14.5	3.57	6.00	0.29	1.00	1.0	6.0						1.0	6.0	18	0.013	J13	4.84%	5.2	13	0.0
J13									22.3	2.92	4.91	3.68	6.50	11	32	36	0.013	J14	0.98%	77	9	0.1
CB1	C07	11.8	3.88	6.51	0.22	0.39	0.9	2.5						0.9	2.5	18	0.013	J14	2.81%	68	10	0.1
J14									22.5	2.92	4.89	3.91	6.89	11	34	36	0.013	OS3	1.03%	472	10	0.8
									23.3													
I19	D01	16.6	3.37	5.66	2.01	2.40	6.8	14						6.8	14	18	0.013	J15	1.03%	54	6	0.1
J15									16.7	3.36	5.64	2.01	2.40	6.8	14	24	0.013	J16	7.30%	252	20	0.2
I20	D03	18.1	3.24	5.43	2.25	3.17	7.3	17						7.3	17	18	0.013	J16	0.99%	25	6	0.1
J16									18.1	3.24	5.43	4.26	5.57	14	30	30	0.013	J17	0.57%	331	6	0.9
I21	D05	21.4	2.99	5.01	2.31	2.71	6.9	14						6.9	14	24	0.013	J17	0.97%	5.2	7	0.0
J17									21.5	2.98	5.01	6.57	8.28	20	41	30	0.013	J19	1.02%	25	8	0.0
I22	D06	16.4	3.39	5.69	0.77	1.09	2.6	6.2						2.6	6.2	18	0.013	J18	3.01%	43	10	0.1
I23	D07	14.6	3.56	5.97	1.93	1.66	6.9	9.9						6.9	9.9	18	0.013	J18	1.00%	45	6	0.1
J18									16.4	3.38	5.68	2.70	2.75	9.1	16	24	0.013	J19	0.98%	296	7	0.7
I24	D08	17.3	3.30	5.55	0.54	1.79	1.8	9.9						1.8	9.9	24	0.013	J19	0.90%	45	7	0.1
J19									21.5	2.98	5.00	9.80	12.83	29	64	42	0.013	J20	2.78%	204	17	0.2
CB2	D09	23.0	2.88	4.83	0.42	0.71	1.2	3.4						1.2	3.4	18	0.013	I25	4.21%	32	12	0.0
I25	D10	19.2	3.15	5.29	0.28	1.03	0.9	5.4	23.1	2.88	4.83	0.70	1.74	2.0	8.4	18	0.013	J20	8.11%	25	17	0.0
ES1	D11	37.5	2.15	3.60	1.13	1.93	2.4	6.9						2.4	6.9	18	0.013	I26	0.56%	54	4	0.2
I26	D12	23.3	2.86	4.80	0.85	3.36	2.4	16	37.7	2.14	3.59	1.99	5.28	4.3	19	24	0.013	J20	1.07%	4.7	7	0.0
J20									37.7	2.14	3.59	12.49	19.85	29	71	42	0.013	J21	0.75%	510	9	0.9
I27	D13	13.1	3.73	6.26	0.47	0.63	1.7	3.9						1.7	3.9	18	0.013	J21	1.01%	30	6	0.1
J21									38.6	2.10	3.53	12.96	20.48	29	72	42	0.013	J23	2.59%	301	17	0.3
I28	D14	17.1	3.33	5.59	1.89	1.78	6.3	9.9						6.3	9.9	18	0.013	J22	1.40%	32	7	0.1
I29	D15	17.0	3.34	5.60	1.86	1.77	6.2	9.9						6.2	9.9	18	0.013	J22	0.99%	25	6	0.1
J22									17.1	3.32	5.58	3.75	3.55	12	20	24	0.013	J23	5.17%	24	16	0.0

* Velocity estimated for calculation of travel time. Refer to Hydraulics for calculated velocity.

UPSTREAM DESIGN POINT	UPSTREAM BASIN	INLET FLOW								SYSTEM FLOW						TRAVEL TIME						
		Tc (Min.)	I (in./ hr.)		CA		Q		Sum Tc (min.)	I (in./ hr.)		CA		Q		PIPE DIA	ROUGHNESS (n)	DESTINATION DP	SLOPE %	LENGTH (FT)	VEL. (FPS) (Estimate)*	TRAVEL TIME Tt
			(5 YR)	(100 YR)	(5 YR)	(100 YR)	(5 YR)	(100 YR)		(5 YR)	(100 YR)	(5 YR)	(100 YR)	(5 YR)	(100 YR)							
J23									38.9	2.09	3.51	16.71	24.03	35	84	48	0.013	J24	2.19%	595	17	0.6
I30	D16	20.4	3.06	5.13	1.39	1.94	4.2	9.9						4.2	9.9	18	0.013	J24	8.57%	4.7	17	0.0
J24									39.5	2.07	3.47	18.10	25.97	37	90	48	0.013	J25	1.00%	40	11	0.1
J25									39.6	2.07	3.47	18.10	25.97	37	90	48	0.013	J26	1.87%	129	16	0.1
I31	D17	21.9	2.96	4.96	1.79	4.89	5.3	24						5.3	24	30	0.013	J26	6.10%	4.9	21	0.0
J26									39.7	2.06	3.46	19.88	30.86	41	107	48	0.013	I32	1.03%	24	12	0.0
I32	D18	22.2	2.93	4.92	1.01	2.06	3.0	10	39.7	2.06	3.45	20.89	32.91	43	114	54	0.013	OS4	0.60%	195	10	0.3
									40.1													
I33	E01	16.9	3.35	5.62	1.85	3.06	6.2	17						6.2	17	18	0.013	J27	0.76%	53	5	0.2
J27									17.0	3.33	5.59	1.85	3.06	6.2	17	18	0.013	J28	2.35%	245	9	0.4
I34	E02	18.8	3.19	5.35	2.29	3.22	7.3	17.2						7.3	17	18	0.013	J28	0.99%	25	6	0.1
J28									17.5	3.29	5.53	4.15	6.28	14	35	30	0.013	J29	1.91%	175	12	0.3
I35	E03	15.8	3.44	5.78	1.88	2.35	6.5	13.6						6.5	14	18	0.013	J29	1.00%	45	6	0.1
J29									17.7	3.27	5.49	6.03	8.63	20	47	36	0.013	J30	0.70%	179	8	0.4
I36	E04	17.4	3.30	5.54	1.18	2.35	3.9	13.0						3.9	13	18	0.013	J30	1.01%	25	6	0.1
I37	E05	21.3	3.00	5.03	0.76	1.20	2.3	6.0						2.3	6.0	18	0.013	J30	5.35%	4.7	14	0.0
J30									21.3	3.00	5.03	7.97	12.18	24	61	36	0.013	J31	1.03%	44	10	0.1
J31									21.4	2.99	5.02	7.97	12.18	24	61	36	0.013	J36	0.79%	272	8	0.5
I38	E06	12.5	3.80	6.37	0.41	0.65	1.6	4.2						1.6	4.2	18	0.013	J32	1.16%	90	6	0.2
J32									12.7	3.77	6.33	0.41	0.65	1.5	4.1	18	0.013	J33	4.61%	348	13	0.5
I39	E07	12.7	3.77	6.34	0.52	0.70	2.0	4.5						2.0	4.5	18	0.013	J33	3.70%	26	11	0.0
J33									13.2	3.72	6.24	0.93	1.36	3.5	8.5	18	0.013	J34	1.95%	151	8	0.3
I40	E08	14.9	3.53	5.93	1.35	1.67	4.8	9.9						4.8	9.9	18	0.013	J34	1.04%	24	6	0.1
J34									15.0	3.53	5.92	2.28	3.03	8.0	18	24	0.013	J35	3.02%	478	13	0.6
J35									15.6	3.46	5.81	2.28	3.03	8.0	18	24	0.013	J36	1.29%	62	8	0.1
I41	E09	23.8	2.83	4.75	2.20	2.86	6.2	14						6.2	14	24	0.013	J36	1.03%	24	7	0.1
J36									23.8	2.83	4.75	12.45	18.07	35	86	42	0.013	J37	1.03%	316	11	0.5
I42	E10	19.8	3.11	5.22	2.26	3.59	7.0	19						7.0	19	24	0.013	J37	1.04%	106	7	0.2
J37									24.3	2.80	4.69	14.71	21.66	41	102	48	0.013	J38	1.22%	201	13	0.3
CB3	E11	45.6	1.85	3.11	3.42	5.69	6.3	18						6.3	18	18	0.013	J38	1.52%	112	7	0.3
I43	E12	25.6	2.72	4.56	1.19	1.55	3.2	7.1						3.2	7.1	18	0.013	J38	1.14%	13	6	0.0

* Velocity estimated for calculation of travel time. Refer to Hydraulics for calculated velocity.

UPSTREAM DESIGN POINT	UPSTREAM BASIN	INLET FLOW							SYSTEM FLOW							TRAVEL TIME						
		Tc (Min.)	I (in./hr.)		CA		Q		Sum Tc (min.)	I (in./hr.)		CA		Q		PIPE DIA	ROUGHNESS (n)	DESTINATION DP	SLOPE %	LENGTH (FT)	VEL. (FPS) (Estimate)*	TRAVEL TIME TT
			(5 YR)	(100 YR)	(5 YR)	(100 YR)	(5 YR)	(100 YR)		(5 YR)	(100 YR)	(5 YR)	(100 YR)	(5 YR)	(100 YR)							
J38									25.7	2.72	4.56	19.32	28.90	52	132	54	0.013	EJ01	2.39%	227	19	0.2
E11	E13	22.0	2.95	4.95	2.77	2.61	8.2	13						8.2	13	18	0.013	EJ02	2.20%	4.5	9	0.0
CA'S FROM MERIDIAN RANCH FILING 11A FDR, TIME OF CONCENTRATION ADJUSTED TO MATCH FLOW RATE FROM SCS METHOD									87.5	0.88	1.47	22.47	92.72	20	136							
EJ02									87.5	0.88	1.47	25.24	95.33	22	140	54	0.013	EJ01	0.49%	67	9	0.1

* Velocity estimated for calculation of travel time. Refer to Hydraulics for calculated velocity.

Storm Drain Hydraulics:

STORM DRAINAGE SYSTEM DESIGN HYDRAULICS

PROJECT: **Rolling Hills Ranch PUD**

Date: 9/3/2019

Label	Upstrm Node	Dnstrm Node	Inlet CA (acres)	Inlet Tc (min)	Inlet Flow (ft³/s)	System CA (acres)	System Flow Time (min)	System Intensity (in/hr)	Section Size (in)	Length (ft)	Slope (%)	Capacity (Full Flow) (ft³/s)	System Flow (ft³/s)	Velocity (Ave) (ft/s)	Elevation Ground (Upstrm) (ft)	Hydraulic Grade Line (Upstrm) (ft)	Invert (Upstrm) (ft)	Elevation Ground (Dnstrm) (ft)	Hydraulic Grade Line (Dnstrm) (ft)	Invert (Dnstrm) (ft)
P99	CB4	OSJ1	1.58	18.1	8.7	1.58	18.1	5.44	24	228.62	1.01%	23	8.7	6.7	7142.00	7137.8	7136.75	7139.93	7135.5	7134.45
P100	OSJ1	OSJ2				1.58	18.7	5.36	24	396.00	1.99%	32	8.5	8.6	7139.93	7135.5	7134.45	7132.00	7127.6	7126.55
P101	OSJ2	OS5				1.58	19.4	5.26	24	183.00	4.67%	49	8.4	11.6	7132.00	7127.6	7126.55	7123.00	7118.6	7118.00

Hydraulics will be reviewed with the final plat.

Appendix B - HEC-HMS Data

Input Data

Rolling Hills Ranch PUD

BASIN	AREA		CURVE NO.	LAG TIME (min)
	(acre)	(mi ²)		
HISTORIC				
OS05	37	0.0578	61.0	15.2
OS06	84	0.1313	61.0	18.7
OS07	21	0.0328	63.1	15.4
OS08	26	0.0406	65.7	15.9
OS09	98	0.1527	65.0	29.5
HG01	35	0.0547	61.0	19.6
HG02	58	0.0906	61.0	25.4
HG03	117	0.1828	61.1	33.8
HG04	57	0.0891	61.0	30.7
HG05	72	0.1125	61.0	31.8
HG06A	88	0.1375	61.0	43.2
HG06B	66	0.1031	61.0	49.5
HG07	63	0.0984	61.0	28.3
HG08	85	0.1328	61.0	22.9
HG09	114	0.1781	61.0	35.6
HG10	88	0.1375	61.0	61.4
HG11	131	0.2047	61.0	40.4
HG12	83	0.1297	61.0	32.0
HG13	54	0.0844	63.1	21.2
HG14	147	0.2297	61.0	45.1
HG15	164	0.2563	61.0	65.1
HG18	21	0.0328	61.0	14.1
HG19	3	0.0047	61.0	6.1
HG20	1	0.0016	61.0	6.9
HG21	14	0.0219	61.0	13.8
INTERIM				
BASIN	AREA		CURVE NO.	LAG TIME (min)
	(acre)	(mi ²)		
OS05	37	0.0578	61.0	15.2
OS06	84	0.1313	61.0	18.7
OS07a	11	0.0170	63.1	13.9
OS07b	10	0.0156	63.1	10.9
OS08	25	0.0397	65.7	15.9
OS09	98	0.1527	65.0	29.5
FG01	34	0.0531	66.4	33.8
FG02	25	0.0391	64.4	16.1
FG03	13	0.0203	68.0	11.6
FG04	11	0.0172	68.0	7.6
FG05	37	0.0580	70.1	28.7
FG06	39	0.0608	65.4	18.2
FG08A	48	0.0750	76.8	13.3

BASIN	AREA		CURVE NO.	LAG TIME (min)
	(acre)	(mi ²)		
FG08B	40	0.0630	76.7	16.6
FG09	31	0.0484	71.7	20.8
FG10a	52	0.0806	73.2	23.3
FG10b	27	0.0416	71.4	20.0
FG11	40	0.0625	78.2	23.2
FG12	21	0.0328	80.0	16.1
FG13	34	0.0534	66.3	29.6
FG14	64	0.1000	74.6	26.4
FG15	7	0.0103	78.6	15.6
FG16	51	0.0791	78.8	13.0
FG17a	44	0.0694	76.5	14.4
FG17b	14	0.0214	79.9	11.4
FG17c	20	0.0313	65.2	11.8
FG18	41	0.0644	73.5	29.9
FG19	34	0.0527	80.3	15.3
FG19a	5	0.0077	75.2	16.4
FG20	7	0.0109	92.9	10.1
FG22	42	0.0658	64.5	20.9
FG23a	11	0.0177	70.3	18.7
FG23b	23	0.0359	61.8	21.5
FG23c	5	0.0070	67.8	20.6
FG24	160	0.2503	61.3	32.3
FG25	70	0.1086	74.1	36.6
FG28	43	0.0673	63.0	25.6
FG29	64	0.0997	61.0	19.1
FG30	25	0.0389	61.0	12.0
FG31	59	0.0922	80.0	24.0
FG32	26	0.0402	61.0	13.6
FG33	19	0.0302	69.2	19.3
FG34	54	0.0836	61.0	20.1
FG35	38	0.0586	61.1	50.0
FG36	18	0.0281	61.6	23.6
FG37	77	0.1203	61.0	41.6
FUTURE				
BASIN	AREA		CURVE NO.	LAG TIME (min)
	(acre)	(mi ²)		
OS05	37	0.0578	61.0	15.2
OS06	84	0.1313	61.0	18.7
OS07a	11	0.0170	63.1	13.9
OS07b	10	0.0156	63.1	10.9
OS08	26	0.0406	65.7	15.9
OS09	98	0.1527	65.0	29.5

BASIN	AREA		CURVE NO.	LAG TIME (min)
	(acre)	(mi ²)		
FG01	34	0.0538	66.4	33.8
FG02	25	0.0391	64.6	16.1
FG03	13	0.0203	68.0	11.6
FG04	11	0.0172	68.0	7.6
FG05	37	0.0580	70.1	28.7
FG06	39	0.0608	65.4	18.4
FG08A	48	0.0750	76.8	13.3
FG08B	40	0.0630	76.7	16.6
FG09	31	0.0484	71.7	20.8
FG10a	52	0.0806	73.2	23.3
FG10b	27	0.0416	71.4	20.0
FG11	40	0.0625	78.2	23.2
FG12	21	0.0328	80.0	16.1
FG13	34	0.0534	66.3	29.6
FG14	64	0.1000	74.6	26.4
FG15	7	0.0103	78.6	15.6
FG16	51	0.0791	78.8	13.0
FG17a	44	0.0694	76.5	14.4
FG17b	14	0.0214	79.9	11.4
FG17c	20	0.0313	65.2	11.8
FG18	41	0.0644	73.5	29.9
FG19	34	0.0527	80.3	15.3
FG19a	5	0.0077	75.2	16.4
FG20	7	0.0109	92.9	10.1
FG21a	5	0.0072	63.9	10.1
FG21b	11	0.0170	78.5	15.3
FG22	88	0.1380	67.3	24.8
FG23a	14	0.0216	68.6	18.0
FG23b	18	0.0286	64.7	16.5
FG23c	8	0.0122	67.3	14.0
FG24	88	0.1373	68.1	24.9
FG25	70	0.1086	74.1	36.6
FG26	55	0.0863	70.7	23.1
FG27	32	0.0500	74.7	23.9
FG28	16	0.0245	66.6	23.0
FG29	64	0.0997	61.0	19.1
FG30	25	0.0389	61.0	10.9
FG31	59	0.0922	80.0	24.0
FG32	26	0.0402	61.0	12.1
FG33	19	0.0302	73.5	19.3
FG34	38	0.0600	62.0	23.5
FG35	22	0.0344	63.4	26.4
FG36	18	0.0281	61.0	25.0
FG37	51	0.0797	61.0	24.7



POINT PRECIPITATION FREQUENCY ESTIMATES

Sanja Perica, Deborah Martin, Sandra Pavlovic, Ishani Roy, Michael St. Laurent, Carl Trypaluk,
 Dale Unruh, Michael Yekta, Geoffery Bonnin

NOAA, National Weather Service, Silver Spring, Maryland

[PF_tabular](#) | [PF_graphical](#) | [Maps & aeriels](#)

PF tabular

PDS-based point precipitation frequency estimates with 90% confidence intervals (in inches)¹										
Duration	Average recurrence interval (years)									
	1	2	5	10	25	50	100	200	500	1000
5-min	0.239 (0.190-0.301)	0.291 (0.232-0.367)	0.381 (0.302-0.482)	0.460 (0.363-0.585)	0.576 (0.442-0.764)	0.670 (0.501-0.899)	0.770 (0.556-1.06)	0.875 (0.606-1.23)	1.02 (0.680-1.48)	1.14 (0.737-1.66)
10-min	0.349 (0.278-0.441)	0.426 (0.339-0.538)	0.558 (0.443-0.706)	0.674 (0.532-0.857)	0.843 (0.647-1.12)	0.982 (0.734-1.32)	1.13 (0.814-1.55)	1.28 (0.888-1.80)	1.50 (0.996-2.16)	1.67 (1.08-2.44)
15-min	0.426 (0.340-0.538)	0.519 (0.413-0.656)	0.680 (0.540-0.861)	0.822 (0.648-1.04)	1.03 (0.789-1.36)	1.20 (0.895-1.61)	1.37 (0.993-1.89)	1.56 (1.08-2.20)	1.82 (1.22-2.64)	2.03 (1.31-2.97)
30-min	0.608 (0.485-0.768)	0.741 (0.590-0.936)	0.969 (0.769-1.23)	1.17 (0.923-1.49)	1.46 (1.12-1.94)	1.70 (1.27-2.28)	1.95 (1.41-2.68)	2.21 (1.53-3.12)	2.58 (1.72-3.73)	2.87 (1.86-4.20)
60-min	0.778 (0.620-0.982)	0.934 (0.744-1.18)	1.21 (0.962-1.54)	1.47 (1.16-1.86)	1.84 (1.42-2.46)	2.16 (1.62-2.91)	2.50 (1.81-3.44)	2.87 (1.99-4.05)	3.38 (2.26-4.91)	3.80 (2.46-5.56)
2-hr	0.948 (0.762-1.19)	1.13 (0.905-1.41)	1.46 (1.16-1.83)	1.76 (1.40-2.22)	2.23 (1.73-2.96)	2.62 (1.99-3.51)	3.05 (2.23-4.18)	3.52 (2.47-4.95)	4.19 (2.82-6.04)	4.73 (3.09-6.87)
3-hr	1.04 (0.839-1.29)	1.22 (0.986-1.52)	1.57 (1.26-1.96)	1.90 (1.51-2.38)	2.41 (1.90-3.21)	2.86 (2.18-3.83)	3.35 (2.47-4.59)	3.90 (2.75-5.47)	4.68 (3.18-6.75)	5.33 (3.50-7.71)
6-hr	1.21 (0.980-1.49)	1.40 (1.14-1.73)	1.78 (1.44-2.21)	2.16 (1.74-2.68)	2.76 (2.19-3.65)	3.29 (2.53-4.38)	3.88 (2.88-5.28)	4.53 (3.23-6.34)	5.49 (3.76-7.88)	6.29 (4.17-9.04)
12-hr	1.39 (1.14-1.70)	1.62 (1.33-1.98)	2.06 (1.68-2.53)	2.48 (2.02-3.06)	3.16 (2.53-4.14)	3.76 (2.92-4.96)	4.42 (3.31-5.97)	5.15 (3.70-7.14)	6.22 (4.30-8.85)	7.10 (4.75-10.1)
24-hr	1.61 (1.33-1.95)	1.88 (1.55-2.29)	2.39 (1.97-2.92)	2.88 (2.35-3.52)	3.63 (2.91-4.69)	4.27 (3.34-5.58)	4.98 (3.75-6.66)	5.75 (4.17-7.90)	6.87 (4.78-9.70)	7.79 (5.25-11.1)
2-day	1.86 (1.55-2.24)	2.19 (1.83-2.64)	2.79 (2.31-3.36)	3.33 (2.75-4.04)	4.15 (3.35-5.30)	4.85 (3.81-6.25)	5.59 (4.25-7.39)	6.40 (4.67-8.70)	7.55 (5.30-10.6)	8.49 (5.77-12.0)
3-day	2.04 (1.71-2.45)	2.41 (2.01-2.88)	3.05 (2.54-3.66)	3.63 (3.01-4.38)	4.51 (3.65-5.71)	5.24 (4.14-6.72)	6.03 (4.59-7.92)	6.87 (5.03-9.29)	8.07 (5.69-11.2)	9.04 (6.18-12.7)
4-day	2.20 (1.85-2.62)	2.58 (2.16-3.08)	3.25 (2.72-3.89)	3.86 (3.21-4.63)	4.77 (3.87-6.01)	5.53 (4.38-7.06)	6.34 (4.85-8.31)	7.22 (5.31-9.73)	8.46 (5.98-11.7)	9.46 (6.50-13.2)
7-day	2.60 (2.20-3.08)	3.00 (2.54-3.56)	3.71 (3.13-4.41)	4.36 (3.65-5.20)	5.33 (4.36-6.67)	6.14 (4.89-7.78)	7.00 (5.40-9.11)	7.93 (5.87-10.6)	9.26 (6.59-12.8)	10.3 (7.14-14.4)
10-day	2.96 (2.51-3.48)	3.39 (2.88-4.00)	4.16 (3.52-4.92)	4.85 (4.08-5.76)	5.88 (4.82-7.31)	6.73 (5.38-8.48)	7.63 (5.91-9.88)	8.61 (6.39-11.5)	9.97 (7.13-13.7)	11.1 (7.70-15.4)
20-day	3.95 (3.38-4.61)	4.55 (3.89-5.32)	5.57 (4.75-6.52)	6.44 (5.46-7.58)	7.68 (6.32-9.39)	8.67 (6.97-10.8)	9.69 (7.54-12.4)	10.8 (8.04-14.1)	12.2 (8.79-16.6)	13.3 (9.36-18.4)
30-day	4.75 (4.09-5.51)	5.49 (4.72-6.38)	6.70 (5.74-7.81)	7.72 (6.58-9.04)	9.12 (7.52-11.1)	10.2 (8.24-12.6)	11.3 (8.83-14.3)	12.4 (9.32-16.2)	13.9 (10.1-18.7)	15.0 (10.6-20.6)
45-day	5.73 (4.96-6.62)	6.62 (5.72-7.65)	8.05 (6.93-9.33)	9.21 (7.89-10.7)	10.8 (8.91-12.9)	12.0 (9.68-14.6)	13.1 (10.3-16.5)	14.3 (10.7-18.5)	15.8 (11.4-21.1)	16.9 (12.0-23.0)
60-day	6.56 (5.70-7.55)	7.55 (6.55-8.69)	9.12 (7.88-10.5)	10.4 (8.92-12.0)	12.1 (9.98-14.4)	13.3 (10.8-16.1)	14.5 (11.4-18.1)	15.6 (11.8-20.2)	17.1 (12.5-22.8)	18.2 (12.9-24.8)

¹ Precipitation frequency (PF) estimates in this table are based on frequency analysis of partial duration series (PDS).

Numbers in parenthesis are PF estimates at lower and upper bounds of the 90% confidence interval. The probability that precipitation frequency estimates (for a given duration and average recurrence interval) will be greater than the upper bound (or less than the lower bound) is 5%. Estimates at upper bounds are not checked against probable maximum precipitation (PMP) estimates and may be higher than currently valid PMP values.

Please refer to NOAA Atlas 14 document for more information.

HISTORIC MDDP (100-YEAR)				
HYDROLOGIC ELEMENT	DRAINAGE AREA (SQ. MI.)	DISCHARGE PEAK Q100 (CFS)	TIME OF PEAK	TOTAL VOLUME Q100 (AC. FT.)
OS06	0.1313	81	01Jul2015, 12:12	9.4
OS06-G02	0.1313	79	01Jul2015, 12:24	9.3
OS05	0.0578	40	01Jul2015, 12:12	4.2
OS05-G01	0.0578	38	01Jul2015, 12:12	4.1
HG01	0.0547	33	01Jul2015, 12:12	3.9
G01	0.1125	71	01Jul2015, 12:12	8.0
G01-G02	0.1125	70	01Jul2015, 12:24	7.9
HG02	0.0906	46	01Jul2015, 12:24	6.5
G02	0.3344	194	01Jul2015, 12:24	23.7
G02-G03	0.3344	192	01Jul2015, 12:30	23.4
HG03	0.1828	79	01Jul2015, 12:30	13.1
OS07	0.0328	25	01Jul2015, 12:12	2.6
OS07-G03	0.0328	24	01Jul2015, 12:30	2.5
G03	0.5500	295	01Jul2015, 12:30	38.9
G03-G04	0.5500	286	01Jul2015, 12:30	38.6
OS09	0.1547	92	01Jul2015, 12:24	13.3
OS09-G04	0.1547	91	01Jul2015, 12:30	13.2
HG04	0.0891	40	01Jul2015, 12:30	6.3
HG05	0.1125	50	01Jul2015, 12:30	8.0
OS08	0.0406	36	01Jul2015, 12:12	3.6
OS08-G04	0.0406	34	01Jul2015, 12:30	3.5
G04	0.9469	502	01Jul2015, 12:30	69.6
G04-G05	0.9469	496	01Jul2015, 12:36	69.3
HG06A	0.1375	50	01Jul2015, 12:42	9.7
G05	1.0844	544	01Jul2015, 12:36	79.1
G05-G06	1.0844	530	01Jul2015, 12:36	78.6
HG06B	0.1031	34	01Jul2015, 12:48	7.3
G06	1.1875	561	01Jul2015, 12:36	85.9
HG07	0.0984	47	01Jul2015, 12:24	7.0
HG07-G11	0.0984	47	01Jul2015, 12:30	7.0
HG08	0.1328	73	01Jul2015, 12:18	9.5
G11	0.2312	115	01Jul2015, 12:24	16.5
G11-G12	0.2312	114	01Jul2015, 12:30	16.3
HG09	0.1781	73	01Jul2015, 12:30	12.7
G12	0.4093	187	01Jul2015, 12:30	29.0
G12-H08	0.4093	183	01Jul2015, 12:36	28.3
HG10	0.1375	39	01Jul2015, 13:06	9.6
H08	0.5468	216	01Jul2015, 12:42	38.0
HG14	0.2297	81	01Jul2015, 12:42	16.2
HG13	0.0844	55	01Jul2015, 12:18	6.7
G07	0.0844	55	01Jul2015, 12:18	6.7
G07-G08	0.0844	54	01Jul2015, 12:18	6.6
G08	0.3141	119	01Jul2015, 12:30	22.9
HG15	0.2563	70	01Jul2015, 13:06	17.9
H13	0.2563	70	01Jul2015, 13:06	17.9
HG11	0.2047	77	01Jul2015, 12:36	14.5
H09	0.2047	77	01Jul2015, 12:36	14.5
HG12	0.1297	57	01Jul2015, 12:30	9.2
H10	0.1297	57	01Jul2015, 12:30	9.2

Highlighted green rows reference key design points (Typical all charts this section)

HAEGLER HISTORIC

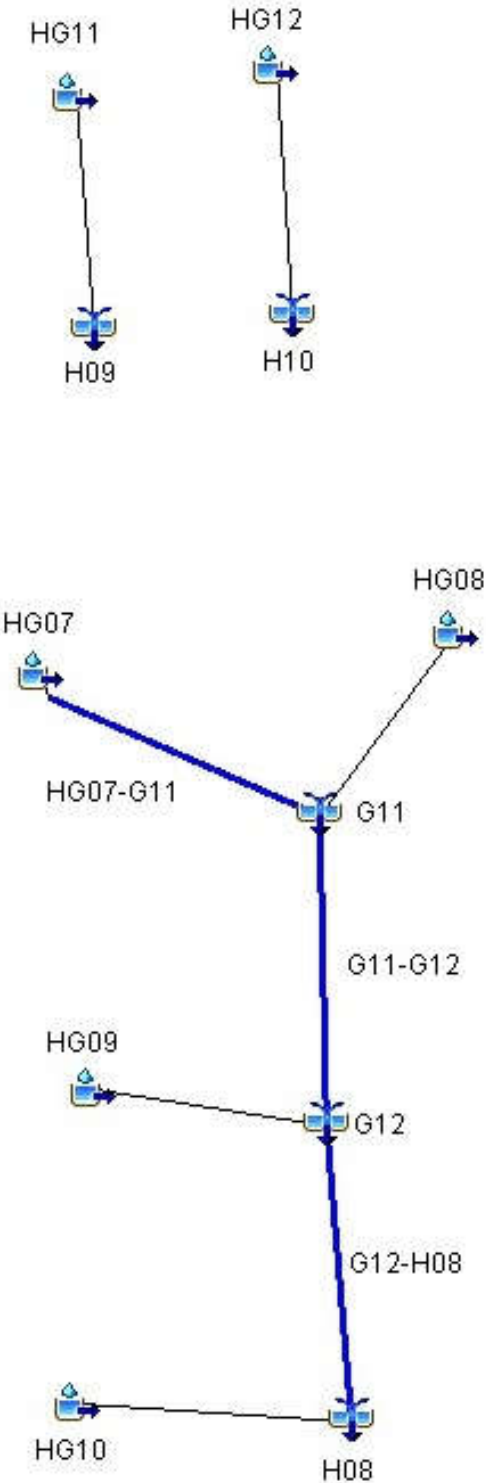

HISTORIC MDDP (50-YEAR)				
HYDROLOGIC ELEMENT	DRAINAGE AREA (SQ. MI.)	DISCHARGE PEAK Q50 (CFS)	TIME OF PEAK	TOTAL VOLUME Q50 (AC. FT.)
OS06	0.1313	53	01Jul2015, 12:12	6.6
OS06-G02	0.1313	52	01Jul2015, 12:24	6.5
OS05	0.0578	26	01Jul2015, 12:12	2.9
OS05-G01	0.0578	26	01Jul2015, 12:18	2.9
HG01	0.0547	21	01Jul2015, 12:18	2.8
G01	0.1125	47	01Jul2015, 12:18	5.6
G01-G02	0.1125	47	01Jul2015, 12:24	5.5
HG02	0.0906	30	01Jul2015, 12:24	4.5
G02	0.3344	129	01Jul2015, 12:24	16.6
G02-G03	0.3344	127	01Jul2015, 12:30	16.3
HG03	0.1828	51	01Jul2015, 12:30	9.2
OS07	0.0328	17	01Jul2015, 12:12	1.9
OS07-G03	0.0328	17	01Jul2015, 12:30	1.8
G03	0.5500	195	01Jul2015, 12:30	27.3
G03-G04	0.5500	192	01Jul2015, 12:36	27.0
OS09	0.1547	64	01Jul2015, 12:24	9.7
OS09-G04	0.1547	63	01Jul2015, 12:36	9.5
HG04	0.0891	27	01Jul2015, 12:30	4.5
HG05	0.1125	33	01Jul2015, 12:30	5.6
OS08	0.0406	25	01Jul2015, 12:12	2.6
OS08-G04	0.0406	24	01Jul2015, 12:36	2.5
G04	0.9469	336	01Jul2015, 12:36	49.1
G04-G05	0.9469	322	01Jul2015, 12:42	48.9
HG06A	0.1375	33	01Jul2015, 12:42	6.8
G05	1.0844	355	01Jul2015, 12:42	55.7
G05-G06	1.0844	353	01Jul2015, 12:42	55.3
HG06B	0.1031	22	01Jul2015, 12:54	5.1
G06	1.1875	375	01Jul2015, 12:42	60.4
HG07	0.0984	31	01Jul2015, 12:24	4.9
HG07-G11	0.0984	31	01Jul2015, 12:30	4.9
HG08	0.1328	48	01Jul2015, 12:18	6.7
G11	0.2312	75	01Jul2015, 12:24	11.6
G11-G12	0.2312	75	01Jul2015, 12:30	11.4
HG09	0.1781	48	01Jul2015, 12:36	8.9
G12	0.4093	122	01Jul2015, 12:30	20.3
G12-H08	0.4093	121	01Jul2015, 12:42	19.8
HG10	0.1375	26	01Jul2015, 13:06	6.7
H08	0.5468	142	01Jul2015, 12:42	26.6
HG14	0.2297	53	01Jul2015, 12:48	11.4
HG13	0.0844	37	01Jul2015, 12:18	4.8
G07	0.0844	37	01Jul2015, 12:18	4.8
G07-G08	0.0844	37	01Jul2015, 12:24	4.7
G08	0.3141	78	01Jul2015, 12:30	16.1
HG15	0.2563	46	01Jul2015, 13:12	12.5
H13	0.2563	46	01Jul2015, 13:12	12.5
HG11	0.2047	51	01Jul2015, 12:42	10.2
H09	0.2047	51	01Jul2015, 12:42	10.2
HG12	0.1297	38	01Jul2015, 12:30	6.5
H10	0.1297	38	01Jul2015, 12:30	6.5

Highlighted green rows reference key design points (Typical all charts this section)

GIECK. HISTORIC

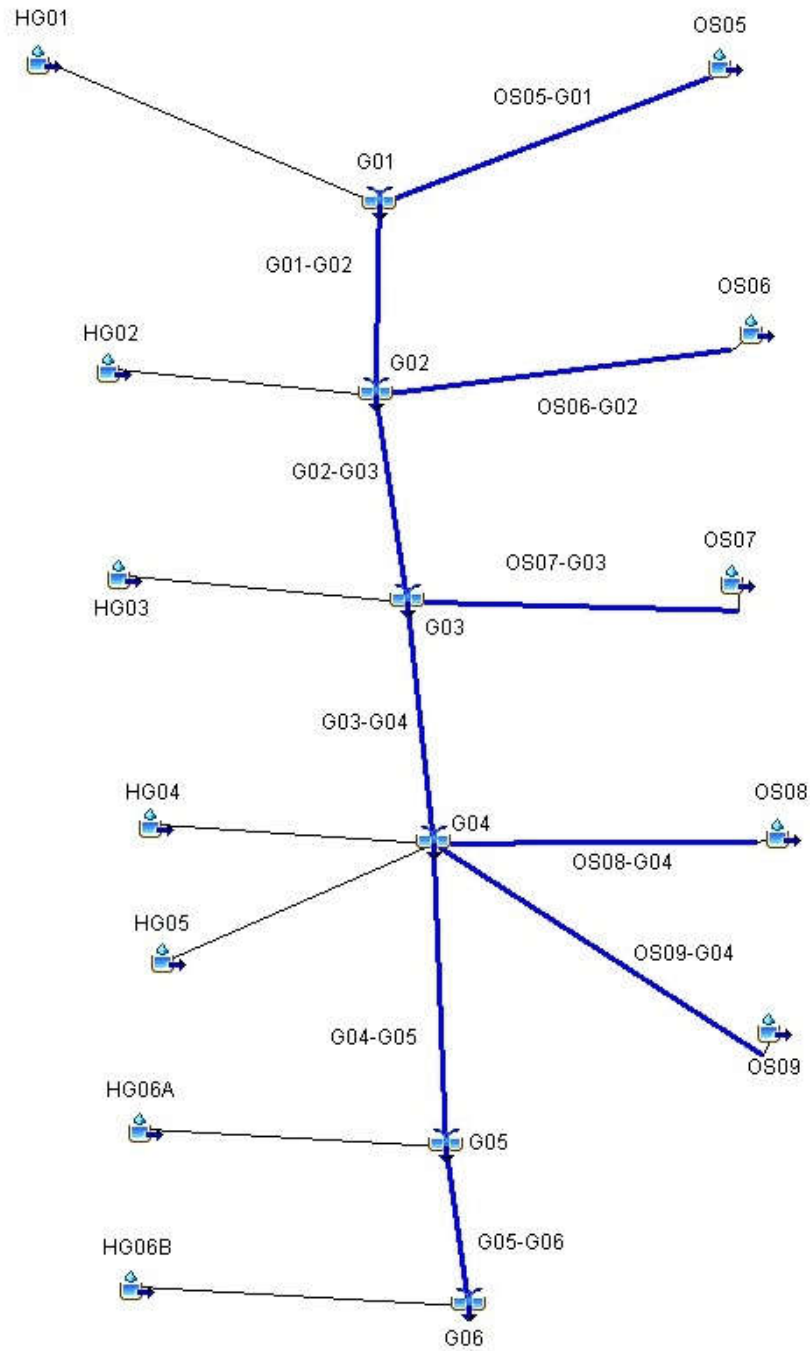

HISTORIC MDDP (25-YEAR)				
HYDROLOGIC ELEMENT	DRAINAGE AREA (SQ. MI.)	DISCHARGE PEAK Q25 (CFS)	TIME OF PEAK	TOTAL VOLUME Q25 (AC. FT.)
OS06	0.1313	31	01Jul2015, 12:18	4.4
OS06-G02	0.1313	31	01Jul2015, 12:24	4.3
OS05	0.0578	16	01Jul2015, 12:12	1.9
OS05-G01	0.0578	16	01Jul2015, 12:18	1.9
HG01	0.0547	13	01Jul2015, 12:18	1.8
G01	0.1125	28	01Jul2015, 12:18	3.7
G01-G02	0.1125	27	01Jul2015, 12:24	3.7
HG02	0.0906	18	01Jul2015, 12:24	3.0
G02	0.3344	76	01Jul2015, 12:24	11.0
G02-G03	0.3344	75	01Jul2015, 12:36	10.7
HG03	0.1828	31	01Jul2015, 12:36	6.1
OS07	0.0328	11	01Jul2015, 12:12	1.3
OS07-G03	0.0328	9.9	01Jul2015, 12:36	1.2
G03	0.5500	115	01Jul2015, 12:36	18.0
G03-G04	0.5500	113	01Jul2015, 12:42	17.8
OS09	0.1547	41	01Jul2015, 12:30	6.7
OS09-G04	0.1547	41	01Jul2015, 12:36	6.5
HG04	0.0891	16	01Jul2015, 12:30	2.9
HG05	0.1125	19	01Jul2015, 12:30	3.7
OS08	0.0406	17	01Jul2015, 12:12	1.8
OS08-G04	0.0406	15	01Jul2015, 12:42	1.8
G04	0.9469	200	01Jul2015, 12:42	32.8
G04-G05	0.9469	193	01Jul2015, 12:42	32.6
HG06A	0.1375	20	01Jul2015, 12:48	4.5
G05	1.0844	212	01Jul2015, 12:42	37.1
G05-G06	1.0844	211	01Jul2015, 12:48	36.8
HG06B	0.1031	13	01Jul2015, 12:54	3.4
G06	1.1875	225	01Jul2015, 12:48	40.2
HG07	0.0984	18	01Jul2015, 12:30	3.3
HG07-G11	0.0984	18	01Jul2015, 12:30	3.2
HG08	0.1328	28	01Jul2015, 12:18	4.4
G11	0.2312	44	01Jul2015, 12:24	7.6
G11-G12	0.2312	44	01Jul2015, 12:30	7.5
HG09	0.1781	29	01Jul2015, 12:36	5.9
G12	0.4093	72	01Jul2015, 12:36	13.4
G12-H08	0.4093	71	01Jul2015, 12:48	13.0
HG10	0.1375	16	01Jul2015, 13:06	4.5
H08	0.5468	85	01Jul2015, 12:48	17.5
HG14	0.2297	32	01Jul2015, 12:48	7.5
HG13	0.0844	23	01Jul2015, 12:18	3.2
G07	0.0844	23	01Jul2015, 12:18	3.2
G07-G08	0.0844	23	01Jul2015, 12:24	3.2
G08	0.3141	48	01Jul2015, 12:36	10.7
HG15	0.2563	28	01Jul2015, 13:12	8.3
H13	0.2563	28	01Jul2015, 13:12	8.3
HG11	0.2047	30	01Jul2015, 12:42	6.7
H09	0.2047	30	01Jul2015, 12:42	6.7
HG12	0.1297	22	01Jul2015, 12:30	4.3
H10	0.1297	22	01Jul2015, 12:30	4.3

Highlighted green rows reference key design points (Typical all charts this section)

HISTORIC MDDP (10-YEAR)				
HYDROLOGIC ELEMENT	DRAINAGE AREA (SQ. MI.)	DISCHARGE PEAK Q10 (CFS)	TIME OF PEAK	TOTAL VOLUME Q10 (AC. FT.)
OS06	0.1313	12	01Jul2015, 12:18	2.2
OS06-G02	0.1313	12	01Jul2015, 12:30	2.2
OS05	0.0578	5.9	01Jul2015, 12:12	1.0
OS05-G01	0.0578	5.7	01Jul2015, 12:24	1.0
HG01	0.0547	4.8	01Jul2015, 12:18	0.9
G01	0.1125	10	01Jul2015, 12:18	1.9
G01-G02	0.1125	10	01Jul2015, 12:36	1.8
HG02	0.0906	6.9	01Jul2015, 12:30	1.5
G02	0.3344	28	01Jul2015, 12:30	5.5
G02-G03	0.3344	28	01Jul2015, 12:48	5.4
HG03	0.1828	12	01Jul2015, 12:36	3.1
OS07	0.0328	4.6	01Jul2015, 12:12	0.7
OS07-G03	0.0328	4.4	01Jul2015, 12:42	0.7
G03	0.5500	44	01Jul2015, 12:48	9.1
G03-G04	0.5500	43	01Jul2015, 12:54	9.0
OS09	0.1547	19	01Jul2015, 12:30	3.7
OS09-G04	0.1547	19	01Jul2015, 12:42	3.6
HG04	0.0891	6.1	01Jul2015, 12:36	1.5
HG05	0.1125	7.6	01Jul2015, 12:36	1.9
OS08	0.0406	7.9	01Jul2015, 12:12	1.0
OS08-G04	0.0406	7.6	01Jul2015, 12:48	1.0
G04	0.9469	78	01Jul2015, 12:48	17.0
G04-G05	0.9469	78	01Jul2015, 12:54	16.8
HG06A	0.1375	7.8	01Jul2015, 12:54	2.3
G05	1.0844	86	01Jul2015, 12:54	19.1
G05-G06	1.0844	86	01Jul2015, 13:00	18.9
HG06B	0.1031	5.4	01Jul2015, 13:00	1.7
G06	1.1875	91	01Jul2015, 13:00	20.6
HG07	0.0984	7.1	01Jul2015, 12:30	1.6
HG07-G11	0.0984	7.0	01Jul2015, 12:36	1.6
HG08	0.1328	11	01Jul2015, 12:24	2.2
G11	0.2312	17	01Jul2015, 12:30	3.9
G11-G12	0.2312	17	01Jul2015, 12:42	3.8
HG09	0.1781	11	01Jul2015, 12:42	3.0
G12	0.4093	28	01Jul2015, 12:42	6.8
G12-H08	0.4093	28	01Jul2015, 13:00	6.5
HG10	0.1375	6.5	01Jul2015, 13:18	2.2
H08	0.5468	34	01Jul2015, 13:00	8.8
HG14	0.2297	13	01Jul2015, 12:54	3.8
HG13	0.0844	9.8	01Jul2015, 12:18	1.7
G07	0.0844	9.8	01Jul2015, 12:18	1.7
G07-G08	0.0844	9.7	01Jul2015, 12:30	1.7
G08	0.3141	20	01Jul2015, 12:36	5.5
HG15	0.2563	12	01Jul2015, 13:24	4.2
H13	0.2563	12	01Jul2015, 13:24	4.2
HG11	0.2047	12	01Jul2015, 12:48	3.4
H09	0.2047	12	01Jul2015, 12:48	3.4
HG12	0.1297	8.7	01Jul2015, 12:36	2.2
H10	0.1297	8.7	01Jul2015, 12:36	2.2

Highlighted green rows reference key design points (Typical all charts this section)

HISTORIC MDDP (5-YEAR)				
HYDROLOGIC ELEMENT	DRAINAGE AREA (SQ. MI.)	DISCHARGE PEAK Q5 (CFS)	TIME OF PEAK	TOTAL VOLUME Q5 (AC. FT.)
OS06	0.1313	3.9	01Jul2015, 12:24	1.1
OS06-G02	0.1313	3.8	01Jul2015, 12:42	1.1
OS05	0.0578	1.8	01Jul2015, 12:18	0.5
OS05-G01	0.0578	1.8	01Jul2015, 12:30	0.5
HG01	0.0547	1.6	01Jul2015, 12:24	0.5
G01	0.1125	3.3	01Jul2015, 12:30	1.0
G01-G02	0.1125	3.3	01Jul2015, 12:42	0.9
HG02	0.0906	2.4	01Jul2015, 12:36	0.8
G02	0.3344	9.4	01Jul2015, 12:42	2.8
G02-G03	0.3344	9.3	01Jul2015, 13:00	2.7
HG03	0.1828	4.4	01Jul2015, 12:48	1.6
OS07	0.0328	1.7	01Jul2015, 12:18	0.4
OS07-G03	0.0328	1.7	01Jul2015, 13:00	0.4
G03	0.5500	15	01Jul2015, 13:00	4.7
G03-G04	0.5500	15	01Jul2015, 13:12	4.5
OS09	0.1547	8.5	01Jul2015, 12:36	2.1
OS09-G04	0.1547	8.5	01Jul2015, 12:48	2.0
HG04	0.0891	2.2	01Jul2015, 12:42	0.8
HG05	0.1125	2.7	01Jul2015, 12:42	1.0
OS08	0.0406	3.5	01Jul2015, 12:12	0.6
OS08-G04	0.0406	3.5	01Jul2015, 13:00	0.6
G04	0.9469	28	01Jul2015, 13:12	8.9
G04-G05	0.9469	28	01Jul2015, 13:18	8.8
HG06A	0.1375	2.9	01Jul2015, 13:00	1.2
G05	1.0844	31	01Jul2015, 13:18	9.9
G05-G06	1.0844	31	01Jul2015, 13:24	9.8
HG06B	0.1031	2.1	01Jul2015, 13:12	0.9
G06	1.1875	33	01Jul2015, 13:24	10.6
HG07	0.0984	2.4	01Jul2015, 12:42	0.8
HG07-G11	0.0984	2.4	01Jul2015, 12:48	0.8
HG08	0.1328	3.6	01Jul2015, 12:30	1.1
G11	0.2312	5.7	01Jul2015, 12:42	2.0
G11-G12	0.2312	5.6	01Jul2015, 12:54	1.9
HG09	0.1781	4.1	01Jul2015, 12:48	1.5
G12	0.4093	9.7	01Jul2015, 12:54	3.4
G12-H08	0.4093	9.7	01Jul2015, 13:18	3.3
HG10	0.1375	2.6	01Jul2015, 13:30	1.1
H08	0.5468	12	01Jul2015, 13:18	4.4
HG14	0.2297	4.8	01Jul2015, 13:06	1.9
HG13	0.0844	3.9	01Jul2015, 12:24	0.9
G07	0.0844	3.9	01Jul2015, 12:24	0.9
G07-G08	0.0844	3.8	01Jul2015, 12:36	0.9
G08	0.3141	7.6	01Jul2015, 12:54	2.8
HG15	0.2563	4.7	01Jul2015, 13:36	2.1
H13	0.2563	4.7	01Jul2015, 13:36	2.1
HG11	0.2047	4.5	01Jul2015, 13:00	1.7
H09	0.2047	4.5	01Jul2015, 13:00	1.7
HG12	0.1297	3.1	01Jul2015, 12:42	1.1
H10	0.1297	3.1	01Jul2015, 12:42	1.1

Highlighted green rows reference key design points (Typical all charts this section)

HISTORIC MDDP (2-YEAR)				
HYDROLOGIC ELEMENT	DRAINAGE AREA (SQ. MI.)	DISCHARGE PEAK Q2 (CFS)	TIME OF PEAK	TOTAL VOLUME Q2 (AC. FT.)
OS06	0.1313	0.5	01Jul2015, 13:30	0.4
OS06-G02	0.1313	0.5	01Jul2015, 14:00	0.3
OS05	0.0578	0.2	01Jul2015, 13:18	0.2
OS05-G01	0.0578	0.2	01Jul2015, 13:36	0.2
HG01	0.0547	0.2	01Jul2015, 13:30	0.1
G01	0.1125	0.5	01Jul2015, 13:36	0.3
G01-G02	0.1125	0.5	01Jul2015, 14:00	0.3
HG02	0.0906	0.4	01Jul2015, 13:42	0.2
G02	0.3344	1.4	01Jul2015, 13:54	0.9
G02-G03	0.3344	1.4	01Jul2015, 14:30	0.8
HG03	0.1828	0.8	01Jul2015, 13:48	0.5
OS07	0.0328	0.3	01Jul2015, 12:54	0.1
OS07-G03	0.0328	0.3	01Jul2015, 14:12	0.1
G03	0.5500	2.4	01Jul2015, 14:18	1.4
G03-G04	0.5500	2.4	01Jul2015, 14:36	1.3
OS09	0.1547	2.0	01Jul2015, 12:54	0.8
OS09-G04	0.1547	2.0	01Jul2015, 13:18	0.8
HG04	0.0891	0.4	01Jul2015, 13:48	0.2
HG05	0.1125	0.5	01Jul2015, 13:48	0.3
OS08	0.0406	0.8	01Jul2015, 12:24	0.2
OS08-G04	0.0406	0.8	01Jul2015, 13:36	0.2
G04	0.9469	4.9	01Jul2015, 14:30	2.9
G04-G05	0.9469	4.9	01Jul2015, 14:42	2.8
HG06A	0.1375	0.5	01Jul2015, 14:12	0.4
G05	1.0844	5.4	01Jul2015, 14:42	3.2
G05-G06	1.0844	5.4	01Jul2015, 14:54	3.1
HG06B	0.1031	0.4	01Jul2015, 14:24	0.3
G06	1.1875	5.8	01Jul2015, 14:54	3.4
HG07	0.0984	0.4	01Jul2015, 13:42	0.3
HG07-G11	0.0984	0.4	01Jul2015, 14:00	0.3
HG08	0.1328	0.5	01Jul2015, 13:36	0.4
G11	0.2312	0.9	01Jul2015, 13:48	0.6
G11-G12	0.2312	0.9	01Jul2015, 14:12	0.6
HG09	0.1781	0.7	01Jul2015, 13:54	0.5
G12	0.4093	1.6	01Jul2015, 14:06	1.0
G12-H08	0.4093	1.6	01Jul2015, 14:54	0.9
HG10	0.1375	0.5	01Jul2015, 14:42	0.3
H08	0.5468	2.1	01Jul2015, 14:48	1.3
HG14	0.2297	0.9	01Jul2015, 14:18	0.6
HG13	0.0844	0.7	01Jul2015, 13:00	0.3
G07	0.0844	0.7	01Jul2015, 13:00	0.3
G07-G08	0.0844	0.7	01Jul2015, 13:18	0.3
G08	0.3141	1.5	01Jul2015, 13:54	0.9
HG15	0.2563	0.9	01Jul2015, 14:48	0.6
H13	0.2563	0.9	01Jul2015, 14:48	0.6
HG11	0.2047	0.8	01Jul2015, 14:06	0.5
H09	0.2047	0.8	01Jul2015, 14:06	0.5
HG12	0.1297	0.5	01Jul2015, 13:48	0.3
H10	0.1297	0.5	01Jul2015, 13:48	0.3

Highlighted green rows reference key design points (Typical all charts this section)

INTERIM MDDP (100-YEAR)				
HYDROLOGIC ELEMENT	DRAINAGE AREA (SQ. MI.)	PEAK DISCHARGE Q100 (CFS)	TIME OF PEAK	TOTAL VOLUME Q100 (AC. FT.)
OS06	0.1313	80	01Jul2015, 12:12	9.3
G1a	0.1313	80	01Jul2015, 12:12	9.3
G1a-G2	0.1313	79	01Jul2015, 12:18	9.2
OS05	0.0578	39	01Jul2015, 12:12	4.1
OS05-G1	0.0578	39	01Jul2015, 12:12	4.1
FG01	0.0531	31	01Jul2015, 12:30	4.8
FG01-G1	0.0531	31	01Jul2015, 12:30	4.8
G1	0.1109	61	01Jul2015, 12:18	8.9
G1-G2	0.1109	60	01Jul2015, 12:18	8.9
FG02	0.0391	32	01Jul2015, 12:12	3.3
G2	0.2813	166	01Jul2015, 12:18	21.4
G2-G3	0.2813	163	01Jul2015, 12:18	21.2
FG03	0.0203	24	01Jul2015, 12:06	2.0
FG04	0.0172	22	01Jul2015, 12:00	1.7
G3	0.3188	184	01Jul2015, 12:18	24.9
G3-POND F	0.3188	183	01Jul2015, 12:18	24.9
FG06	0.0658	46	01Jul2015, 12:18	5.5
OS07a-POND F	0.0170	13	01Jul2015, 12:18	1.3
POND F	0.4596	177	01Jul2015, 12:42	35.8
POND F-G7	0.4596	177	01Jul2015, 12:42	35.6
FG22	0.0658	51	01Jul2015, 12:18	6.0
FG23a	0.0177	18	01Jul2015, 12:12	1.9
OS07b	0.0156	15	01Jul2015, 12:06	1.2
OS07b-G7	0.0156	13	01Jul2015, 12:24	1.2
G7	0.5587	215	01Jul2015, 12:36	44.7
G7-G10	0.5587	215	01Jul2015, 12:42	44.3
FG24	0.2503	110	01Jul2015, 12:30	17.9
OS09	0.1527	90	01Jul2015, 12:24	13.0
OS09-G10	0.1527	88	01Jul2015, 12:30	12.8
OS08	0.0397	35	01Jul2015, 12:12	3.5
OS08-G8	0.0397	34	01Jul2015, 12:24	3.4
G8	0.4427	227	01Jul2015, 12:30	34.1
G8-G10	0.4427	225	01Jul2015, 12:30	34.0
FG23b	0.0359	21	01Jul2015, 12:18	2.6
G10	1.0373	444	01Jul2015, 12:36	81.0
G10-G11	1.0373	442	01Jul2015, 12:36	80.9
FG23c	0.0070	6	01Jul2015, 12:12	0.7
G11	1.0443	445	01Jul2015, 12:36	81.6
FG25	0.1086	85	01Jul2015, 12:30	13.3
FG28	0.0673	38	01Jul2015, 12:18	5.2
POND G IN	1.2202	558	01Jul2015, 12:36	100.2
POND G	1.2202	399	01Jul2015, 13:00	91.3
G12	1.2202	399	01Jul2015, 13:00	91.3
G12-G06	1.2202	398	01Jul2015, 13:06	90.7
FG29	0.0997	60	01Jul2015, 12:12	7.1
FG32	0.0402	29	01Jul2015, 12:06	2.9
FG32-G06	0.0402	28	01Jul2015, 12:12	2.8
G06	1.3601	418	01Jul2015, 13:06	100.6
FG10A	0.0806	81	01Jul2015, 12:18	9.6
FG08A	0.0750	116	01Jul2015, 12:06	10.2

Highlighted green rows reference key design points (Typical all charts this section)

INTERIM MDDP (100-YEAR)				
HYDROLOGIC ELEMENT	DRAINAGE AREA (SQ. MI.)	PEAK DISCHARGE Q100 (CFS)	TIME OF PEAK	TOTAL VOLUME Q100 (AC. FT.)
FG08A-G05	0.0750	110	01Jul2015, 12:12	10.2
FG08B	0.0630	86	01Jul2015, 12:12	8.5
FG08B-G05	0.0630	84	01Jul2015, 12:12	8.5
FG11	0.0625	75	01Jul2015, 12:18	8.9
FG09	0.0484	48	01Jul2015, 12:12	5.5
FG09-G05	0.0484	48	01Jul2015, 12:18	5.5
FG10B	0.0416	42	01Jul2015, 12:12	4.6
G05	0.3711	433	01Jul2015, 12:12	47.3
FG13	0.0534	34	01Jul2015, 12:24	4.8
FG12	0.0328	50	01Jul2015, 12:12	5.0
POND D IN	0.4573	509	01Jul2015, 12:12	57.0
POND D	0.4573	134	01Jul2015, 13:00	46.8
POND D-G17	0.4573	134	01Jul2015, 13:00	46.7
FG15	0.0103	15	01Jul2015, 12:06	1.5
FG15-G17A	0.0103	15	01Jul2015, 12:12	1.5
G17A	0.4676	137	01Jul2015, 13:00	48.2
FG14	0.1000	98	01Jul2015, 12:18	12.5
G17	0.5676	196	01Jul2015, 12:30	60.8
G17-G18	0.5676	196	01Jul2015, 12:36	60.7
FG16	0.0791	133	01Jul2015, 12:06	11.5
G18	0.6467	240	01Jul2015, 12:24	72.2
G18-POND E	0.6467	240	01Jul2015, 12:24	72.2
FG31	0.0922	116	01Jul2015, 12:18	13.9
FG30	0.0389	30	01Jul2015, 12:06	2.8
FG30-PONDHS	0.0389	28	01Jul2015, 12:18	2.7
POND HS	0.1311	112	01Jul2015, 12:30	16.6
FG17a	0.0694	101	01Jul2015, 12:06	9.3
FG17a-POND E	0.0694	99	01Jul2015, 12:06	9.3
FG18	0.0644	56	01Jul2015, 12:24	7.7
FG18-POND E	0.0644	56	01Jul2015, 12:24	7.7
FG19	0.0527	84	01Jul2015, 12:06	8.0
FG17c	0.0313	31	01Jul2015, 12:06	2.7
FG17b	0.0214	39	01Jul2015, 12:06	3.2
POND E IN	1.0170	552	01Jul2015, 12:12	119.8
POND E	1.0170	233	01Jul2015, 13:36	95.8
H08	1.0170	200	01Jul2015, 13:36	83.8
H09	0.0000	34	01Jul2015, 13:36	12.0
FG34	0.0836	48	01Jul2015, 12:18	5.9
G14	0.0836	48	01Jul2015, 12:18	5.9
G14-G15	0.0836	48	01Jul2015, 12:18	5.9
FG35	0.0586	19	01Jul2015, 12:48	4.1
G15	0.1422	60	01Jul2015, 12:24	9.9
G15-G08	0.1422	59	01Jul2015, 12:24	9.9
FG37	0.1203	44	01Jul2015, 12:42	8.4
FG36	0.0281	16	01Jul2015, 12:18	2.0
FG36-G08	0.0281	15	01Jul2015, 12:24	2.0
G08	0.2906	114	01Jul2015, 12:30	20.3

Highlighted green rows reference key design points (Typical all charts this section)

INTERIM MDDP (50-YEAR)				
HYDROLOGIC ELEMENT	DRAINAGE AREA (SQ. MI.)	PEAK DISCHARGE Q50 (CFS)	TIME OF PEAK	TOTAL VOLUME Q50 (AC. FT.)
OS06	0.1313	52	01Jul2015, 12:12	6.5
G1a	0.1313	52	01Jul2015, 12:12	6.5
G1a-G2	0.1313	52	01Jul2015, 12:18	6.5
OS05	0.0578	26	01Jul2015, 12:12	2.9
OS05-G1	0.0578	25	01Jul2015, 12:12	2.9
FG01	0.0531	22	01Jul2015, 12:30	3.5
FG01-G1	0.0531	22	01Jul2015, 12:30	3.5
G1	0.1109	41	01Jul2015, 12:18	6.4
G1-G2	0.1109	41	01Jul2015, 12:18	6.4
FG02	0.0391	22	01Jul2015, 12:12	2.4
G2	0.2813	112	01Jul2015, 12:18	15.2
G2-G3	0.2813	108	01Jul2015, 12:24	15.1
FG03	0.0203	17	01Jul2015, 12:06	1.5
FG04	0.0172	16	01Jul2015, 12:00	1.2
G3	0.3188	123	01Jul2015, 12:18	17.8
G3-POND F	0.3188	121	01Jul2015, 12:18	17.8
FG06	0.0658	32	01Jul2015, 12:18	4.0
OS07a-POND F	0.0170	9	01Jul2015, 12:18	0.9
POND F	0.4596	121	01Jul2015, 12:42	25.7
POND F-G7	0.4596	120	01Jul2015, 12:48	25.5
FG22	0.0658	36	01Jul2015, 12:18	4.4
FG23a	0.0177	13	01Jul2015, 12:12	1.4
OS07b	0.0156	10.0	01Jul2015, 12:06	0.9
OS07b-G7	0.0156	9	01Jul2015, 12:24	0.9
G7	0.5587	145	01Jul2015, 12:42	32.2
G7-G10	0.5587	144	01Jul2015, 12:48	31.9
FG24	0.2503	73	01Jul2015, 12:30	12.6
OS09	0.1527	62	01Jul2015, 12:24	9.4
OS09-G10	0.1527	61	01Jul2015, 12:36	9.3
OS08	0.0397	24	01Jul2015, 12:12	2.6
OS08-G8	0.0397	24	01Jul2015, 12:24	2.5
G8	0.4427	154	01Jul2015, 12:30	24.4
G8-G10	0.4427	151	01Jul2015, 12:30	24.3
FG23b	0.0359	14	01Jul2015, 12:18	1.9
G10	1.0373	287	01Jul2015, 12:42	58.1
G10-G11	1.0373	285	01Jul2015, 12:42	58.0
FG23c	0.0070	4.2	01Jul2015, 12:18	0.5
G11	1.0443	287	01Jul2015, 12:42	58.5
FG25	0.1086	64	01Jul2015, 12:30	10.2
FG28	0.0673	26	01Jul2015, 12:24	3.7
POND G IN	1.2202	363	01Jul2015, 12:42	72.5
POND G	1.2202	237	01Jul2015, 13:12	64.2
G12	1.2202	237	01Jul2015, 13:12	64.2
G12-G06	1.2202	236	01Jul2015, 13:18	63.8
FG29	0.0997	39	01Jul2015, 12:18	5.0
FG32	0.0402	19	01Jul2015, 12:12	2.0
FG32-G06	0.0402	19	01Jul2015, 12:12	2.0
G06	1.3601	248	01Jul2015, 13:18	70.7
FG10A	0.0806	61	01Jul2015, 12:18	7.3
FG08A	0.0750	90	01Jul2015, 12:06	7.9

Highlighted green rows reference key design points (Typical all charts this section)

INTERIM MDDP (50-YEAR)				
HYDROLOGIC ELEMENT	DRAINAGE AREA (SQ. MI.)	PEAK DISCHARGE Q50 (CFS)	TIME OF PEAK	TOTAL VOLUME Q50 (AC. FT.)
FG08A-G05	0.0750	86	01Jul2015, 12:12	7.9
FG08B	0.0630	67	01Jul2015, 12:12	6.6
FG08B-G05	0.0630	65	01Jul2015, 12:12	6.6
FG11	0.0625	59	01Jul2015, 12:18	7.0
FG09	0.0484	36	01Jul2015, 12:12	4.1
FG09-G05	0.0484	36	01Jul2015, 12:18	4.1
FG10B	0.0416	31	01Jul2015, 12:12	3.5
G05	0.3711	330	01Jul2015, 12:12	36.4
FG13	0.0534	24	01Jul2015, 12:24	3.5
FG12	0.0328	40	01Jul2015, 12:12	3.9
POND D IN	0.4573	387	01Jul2015, 12:12	43.9
POND D	0.4573	91	01Jul2015, 13:06	34.7
POND D-G17	0.4573	91	01Jul2015, 13:06	34.6
FG15	0.0103	12	01Jul2015, 12:12	1.2
FG15-G17A	0.0103	12	01Jul2015, 12:12	1.2
G17A	0.4676	93	01Jul2015, 13:06	35.8
FG14	0.1000	74	01Jul2015, 12:18	9.6
G17	0.5676	132	01Jul2015, 12:36	45.4
G17-G18	0.5676	131	01Jul2015, 12:36	45.4
FG16	0.0791	104	01Jul2015, 12:06	9.0
G18	0.6467	178	01Jul2015, 12:12	54.4
G18-POND E	0.6467	176	01Jul2015, 12:12	54.4
FG31	0.0922	92	01Jul2015, 12:18	11.0
FG30	0.0389	20	01Jul2015, 12:06	1.9
FG30-PONDHS	0.0389	19	01Jul2015, 12:18	1.9
POND HS	0.1311	63	01Jul2015, 12:36	12.9
FG17a	0.0694	78	01Jul2015, 12:06	7.3
FG17a-POND E	0.0694	76	01Jul2015, 12:06	7.3
FG18	0.0644	42	01Jul2015, 12:24	5.9
FG18-POND E	0.0644	42	01Jul2015, 12:24	5.9
FG19	0.0527	66	01Jul2015, 12:06	6.4
FG17c	0.0313	22	01Jul2015, 12:06	2.0
FG17b	0.0214	31	01Jul2015, 12:06	2.5
POND E IN	1.0170	423	01Jul2015, 12:12	91.3
POND E	1.0170	144	01Jul2015, 14:00	68.1
H08	1.0170	130	01Jul2015, 14:00	59.8
H09	0.0000	14	01Jul2015, 14:00	8.3
FG34	0.0836	32	01Jul2015, 12:18	4.2
G14	0.0836	32	01Jul2015, 12:18	4.2
G14-G15	0.0836	32	01Jul2015, 12:24	4.1
FG35	0.0586	13	01Jul2015, 12:54	2.9
G15	0.1422	39	01Jul2015, 12:24	7.0
G15-G08	0.1422	39	01Jul2015, 12:30	6.9
FG37	0.1203	29	01Jul2015, 12:42	5.9
FG36	0.0281	10	01Jul2015, 12:18	1.4
FG36-G08	0.0281	10	01Jul2015, 12:24	1.4
G08	0.2906	75	01Jul2015, 12:30	14.3

Highlighted green rows reference key design points (Typical all charts this section)

INTERIM MDDP (25-YEAR)				
HYDROLOGIC ELEMENT	DRAINAGE AREA (SQ. MI.)	PEAK DISCHARGE Q25 (CFS)	TIME OF PEAK	TOTAL VOLUME Q25 (AC. FT.)
OS06	0.1313	30	01Jul2015, 12:18	4.3
G1a	0.1313	30	01Jul2015, 12:18	4.3
G1a-G2	0.1313	30	01Jul2015, 12:18	4.2
OS05	0.0578	15	01Jul2015, 12:12	1.9
OS05-G1	0.0578	15	01Jul2015, 12:12	1.9
FG01	0.0531	14	01Jul2015, 12:30	2.4
FG01-G1	0.0531	14	01Jul2015, 12:30	2.4
G1	0.1109	25	01Jul2015, 12:18	4.3
G1-G2	0.1109	25	01Jul2015, 12:24	4.3
FG02	0.0391	14	01Jul2015, 12:12	1.6
G2	0.2813	67	01Jul2015, 12:18	10.2
G2-G3	0.2813	66	01Jul2015, 12:24	10.1
FG03	0.0203	12	01Jul2015, 12:06	1.0
FG04	0.0172	11	01Jul2015, 12:00	0.9
G3	0.3188	74	01Jul2015, 12:24	12.0
G3-POND F	0.3188	74	01Jul2015, 12:24	12.0
FG06	0.0658	20	01Jul2015, 12:18	2.7
OS07a-POND F	0.0170	6	01Jul2015, 12:24	0.6
POND F	0.4596	60	01Jul2015, 12:54	17.2
POND F-G7	0.4596	60	01Jul2015, 13:00	17.1
FG22	0.0658	24	01Jul2015, 12:18	3.1
FG23a	0.0177	9	01Jul2015, 12:12	1.0
OS07b	0.0156	6.2	01Jul2015, 12:06	0.6
OS07b-G7	0.0156	5	01Jul2015, 12:30	0.6
G7	0.5587	72	01Jul2015, 13:00	21.8
G7-G10	0.5587	72	01Jul2015, 13:06	21.5
FG24	0.2503	43	01Jul2015, 12:30	8.3
OS09	0.1527	39	01Jul2015, 12:30	6.4
OS09-G10	0.1527	39	01Jul2015, 12:36	6.3
OS08	0.0397	16	01Jul2015, 12:12	1.8
OS08-G8	0.0397	15	01Jul2015, 12:24	1.7
G8	0.4427	94	01Jul2015, 12:30	16.3
G8-G10	0.4427	94	01Jul2015, 12:36	16.2
FG23b	0.0359	8	01Jul2015, 12:18	1.2
G10	1.0373	146	01Jul2015, 12:48	39.0
G10-G11	1.0373	145	01Jul2015, 12:48	38.9
FG23c	0.0070	2.8	01Jul2015, 12:18	0.4
G11	1.0443	146	01Jul2015, 12:48	39.3
FG25	0.1086	46	01Jul2015, 12:30	7.5
FG28	0.0673	15.9	01Jul2015, 12:24	2.5
POND G IN	1.2202	202	01Jul2015, 12:36	49.3
POND G	1.2202	117	01Jul2015, 13:36	41.7
G12	1.2202	117	01Jul2015, 13:36	41.7
G12-G06	1.2202	117	01Jul2015, 13:42	41.4
FG29	0.0997	23	01Jul2015, 12:18	3.3
FG32	0.0402	11	01Jul2015, 12:12	1.3
FG32-G06	0.0402	11	01Jul2015, 12:12	1.3
G06	1.3601	124	01Jul2015, 13:36	45.9
FG10A	0.0806	43	01Jul2015, 12:18	5.4
FG08A	0.0750	66	01Jul2015, 12:06	5.9

Highlighted green rows reference key design points (Typical all charts this section)

INTERIM MDDP (25-YEAR)				
HYDROLOGIC ELEMENT	DRAINAGE AREA (SQ. MI.)	PEAK DISCHARGE Q25 (CFS)	TIME OF PEAK	TOTAL VOLUME Q25 (AC. FT.)
FG08A-G05	0.0750	64	01Jul2015, 12:12	5.9
FG08B	0.0630	49	01Jul2015, 12:12	5.0
FG08B-G05	0.0630	48	01Jul2015, 12:12	4.9
FG11	0.0625	44	01Jul2015, 12:18	5.2
FG09	0.0484	25	01Jul2015, 12:18	3.0
FG09-G05	0.0484	25	01Jul2015, 12:18	3.0
FG10B	0.0416	22	01Jul2015, 12:12	2.5
G05	0.3711	239	01Jul2015, 12:12	26.9
FG13	0.0534	15	01Jul2015, 12:24	2.4
FG12	0.0328	30	01Jul2015, 12:12	3.0
POND D IN	0.4573	280	01Jul2015, 12:12	32.4
POND D	0.4573	50	01Jul2015, 13:24	24.3
POND D-G17	0.4573	50	01Jul2015, 13:24	24.3
FG15	0.0103	9.0	01Jul2015, 12:12	0.9
FG15-G17A	0.0103	8.9	01Jul2015, 12:12	0.9
G17A	0.4676	51	01Jul2015, 13:24	25.2
FG14	0.1000	53	01Jul2015, 12:18	7.1
G17	0.5676	75	01Jul2015, 12:24	32.3
G17-G18	0.5676	75	01Jul2015, 12:24	32.2
FG16	0.0791	78	01Jul2015, 12:06	6.8
G18	0.6467	128	01Jul2015, 12:12	39.1
G18-POND E	0.6467	126	01Jul2015, 12:12	39.0
FG31	0.0922	69	01Jul2015, 12:18	8.4
FG30	0.0389	12	01Jul2015, 12:06	1.3
FG30-PONDHS	0.0389	11	01Jul2015, 12:18	1.3
POND HS	0.1311	40	01Jul2015, 12:42	9.6
FG17a	0.0694	57	01Jul2015, 12:06	5.4
FG17a-POND E	0.0694	56	01Jul2015, 12:12	5.4
FG18	0.0644	30	01Jul2015, 12:24	4.3
FG18-POND E	0.0644	30	01Jul2015, 12:24	4.3
FG19	0.0527	50	01Jul2015, 12:06	4.9
FG17c	0.0313	14	01Jul2015, 12:06	1.4
FG17b	0.0214	24	01Jul2015, 12:06	1.9
POND E IN	1.0170	308	01Jul2015, 12:12	66.5
POND E	1.0170	74	01Jul2015, 14:42	44.4
H08	1.0170	66	01Jul2015, 14:42	37.8
H09	0.0000	7.9	01Jul2015, 14:42	6.6
FG34	0.0836	19	01Jul2015, 12:18	2.7
G14	0.0836	19	01Jul2015, 12:18	2.7
G14-G15	0.0836	18	01Jul2015, 12:24	2.7
FG35	0.0586	7	01Jul2015, 12:54	1.9
G15	0.1422	23	01Jul2015, 12:30	4.6
G15-G08	0.1422	23	01Jul2015, 12:30	4.5
FG37	0.1203	17	01Jul2015, 12:42	3.9
FG36	0.0281	6	01Jul2015, 12:24	1.0
FG36-G08	0.0281	6	01Jul2015, 12:30	0.9
G08	0.2906	44	01Jul2015, 12:36	9.3

Highlighted green rows reference key design points (Typical all charts this section)

INTERIM MDDP (10-YEAR)				
HYDROLOGIC ELEMENT	DRAINAGE AREA (SQ. MI.)	PEAK DISCHARGE Q10 (CFS)	TIME OF PEAK	TOTAL VOLUME Q10 (AC. FT.)
OS06	0.1313	12	01Jul2015, 12:18	2.2
G1a	0.1313	12	01Jul2015, 12:18	2.2
G1a-G2	0.1313	11	01Jul2015, 12:24	2.1
OS05	0.0578	6	01Jul2015, 12:12	1.0
OS05-G1	0.0578	6	01Jul2015, 12:18	1.0
FG01	0.0531	7	01Jul2015, 12:36	1.4
FG01-G1	0.0531	7	01Jul2015, 12:36	1.4
G1	0.1109	11	01Jul2015, 12:24	2.3
G1-G2	0.1109	11	01Jul2015, 12:30	2.3
FG02	0.0391	6	01Jul2015, 12:12	0.9
G2	0.2813	27	01Jul2015, 12:24	5.3
G2-G3	0.2813	27	01Jul2015, 12:30	5.3
FG03	0.0203	6	01Jul2015, 12:06	0.6
FG04	0.0172	6	01Jul2015, 12:06	0.5
G3	0.3188	31	01Jul2015, 12:30	6.4
G3-POND F	0.3188	31	01Jul2015, 12:30	6.4
FG06	0.0658	9	01Jul2015, 12:18	1.5
OS07a-POND F	0.0170	2	01Jul2015, 12:30	0.3
POND F	0.4596	17	01Jul2015, 13:48	9.3
POND F-G7	0.4596	17	01Jul2015, 13:54	9.2
FG22	0.0658	12	01Jul2015, 12:18	1.7
FG23a	0.0177	5	01Jul2015, 12:12	0.6
OS07b	0.0156	3	01Jul2015, 12:06	0.3
OS07b-G7	0.0156	2.3	01Jul2015, 12:36	0.3
G7	0.5587	22	01Jul2015, 12:54	11.9
G7-G10	0.5587	22	01Jul2015, 13:06	11.7
FG24	0.2503	17.0	01Jul2015, 12:36	4.2
OS09	0.1527	18	01Jul2015, 12:30	3.5
OS09-G10	0.1527	18	01Jul2015, 12:42	3.5
OS08	0.0397	8	01Jul2015, 12:12	1.0
OS08-G8	0.0397	7	01Jul2015, 12:30	1.0
G8	0.4427	41	01Jul2015, 12:36	8.6
G8-G10	0.4427	40.8	01Jul2015, 12:42	8.6
FG23b	0.0359	3.3	01Jul2015, 12:24	0.6
G10	1.0373	60	01Jul2015, 12:48	20.9
G10-G11	1.0373	60	01Jul2015, 12:48	20.9
FG23c	0.0070	1.4	01Jul2015, 12:18	0.2
G11	1.0443	61	01Jul2015, 12:48	21.1
FG25	0.1086	27	01Jul2015, 12:36	4.7
FG28	0.0673	6.7	01Jul2015, 12:24	1.3
POND G IN	1.2202	91	01Jul2015, 12:42	27.1
POND G	1.2202	35	01Jul2015, 14:48	20.8
G12	1.2202	35	01Jul2015, 14:48	20.8
G12-G06	1.2202	35	01Jul2015, 15:00	20.6
FG29	0.0997	8.7	01Jul2015, 12:18	1.6
FG32	0.0402	4	01Jul2015, 12:12	0.7
FG32-G06	0.0402	4	01Jul2015, 12:18	0.7
G06	1.3601	37	01Jul2015, 14:54	22.9
FG10A	0.0806	25	01Jul2015, 12:18	3.3
FG08A	0.0750	41	01Jul2015, 12:06	3.8

Highlighted green rows reference key design points (Typical all charts this section)

INTERIM MDDP (10-YEAR)				
HYDROLOGIC ELEMENT	DRAINAGE AREA (SQ. MI.)	PEAK DISCHARGE Q10 (CFS)	TIME OF PEAK	TOTAL VOLUME Q10 (AC. FT.)
FG08A-G05	0.0750	41	01Jul2015, 12:12	3.8
FG08B	0.0630	31	01Jul2015, 12:12	3.2
FG08B-G05	0.0630	29	01Jul2015, 12:18	3.2
FG11	0.0625	28	01Jul2015, 12:18	3.4
FG09	0.0484	14	01Jul2015, 12:18	1.8
FG09-G05	0.0484	14	01Jul2015, 12:18	1.8
FG10B	0.0416	12	01Jul2015, 12:18	1.5
G05	0.3711	145	01Jul2015, 12:18	17.1
FG13	0.0534	7.5	01Jul2015, 12:30	1.4
FG12	0.0328	20	01Jul2015, 12:12	2.0
POND D IN	0.4573	168	01Jul2015, 12:18	20.4
POND D	0.4573	19	01Jul2015, 14:24	14.8
POND D-G17	0.4573	19	01Jul2015, 14:24	14.8
FG15	0.0103	5.8	01Jul2015, 12:12	0.6
FG15-G17A	0.0103	5.8	01Jul2015, 12:12	0.6
G17A	0.4676	19	01Jul2015, 14:12	15.3
FG14	0.1000	32	01Jul2015, 12:24	4.5
G17	0.5676	43	01Jul2015, 12:24	19.8
G17-G18	0.5676	43	01Jul2015, 12:30	19.8
FG16	0.0791	50	01Jul2015, 12:06	4.5
G18	0.6467	79	01Jul2015, 12:12	24.3
G18-POND E	0.6467	78	01Jul2015, 12:12	24.3
FG31	0.0922	45	01Jul2015, 12:18	5.6
FG30	0.0389	4	01Jul2015, 12:12	0.6
FG30-PONDHS	0.0389	4	01Jul2015, 12:24	0.6
POND HS	0.1311	28	01Jul2015, 12:42	6.2
FG17a	0.0694	35	01Jul2015, 12:06	3.5
FG17a-POND E	0.0694	35	01Jul2015, 12:12	3.5
FG18	0.0644	18	01Jul2015, 12:24	2.7
FG18-POND E	0.0644	17	01Jul2015, 12:30	2.7
FG19	0.0527	33	01Jul2015, 12:12	3.3
FG17c	0.0313	6.5	01Jul2015, 12:06	0.7
FG17b	0.0214	16	01Jul2015, 12:06	1.3
POND E IN	1.0170	190	01Jul2015, 12:12	42.0
POND E	1.0170	28	01Jul2015, 18:00	22.9
H08	1.0170	22	01Jul2015, 18:00	17.8
H09	0.0000	5.7	01Jul2015, 18:00	5.1
FG34	0.0836	7	01Jul2015, 12:18	1.4
G14	0.0836	7	01Jul2015, 12:18	1.4
G14-G15	0.0836	7	01Jul2015, 12:30	1.3
FG35	0.0586	3	01Jul2015, 13:00	1.0
G15	0.1422	9	01Jul2015, 12:36	2.3
G15-G08	0.1422	9	01Jul2015, 12:36	2.3
FG37	0.1203	7	01Jul2015, 12:48	1.9
FG36	0.0281	2	01Jul2015, 12:24	0.5
FG36-G08	0.0281	2	01Jul2015, 12:36	0.5
G08	0.2906	18	01Jul2015, 12:42	4.7

Highlighted green rows reference key design points (Typical all charts this section)

INTERIM MDDP (5-YEAR)				
HYDROLOGIC ELEMENT	DRAINAGE AREA (SQ. MI.)	PEAK DISCHARGE Q5 (CFS)	TIME OF PEAK	TOTAL VOLUME Q5 (AC. FT.)
OS06	0.1313	3.8	01Jul2015, 12:24	1.1
G1a	0.1313	3.8	01Jul2015, 12:24	1.1
G1a-G2	0.1313	3.6	01Jul2015, 12:36	1.1
OS05	0.0578	1.8	01Jul2015, 12:18	0.5
OS05-G1	0.0578	1.7	01Jul2015, 12:24	0.5
FG01	0.0531	3.3	01Jul2015, 12:36	0.8
FG01-G1	0.0531	3.3	01Jul2015, 12:36	0.8
G1	0.1109	4.8	01Jul2015, 12:36	1.3
G1-G2	0.1109	4.8	01Jul2015, 12:36	1.3
FG02	0.0391	2.6	01Jul2015, 12:18	0.5
G2	0.2813	10	01Jul2015, 12:30	2.9
G2-G3	0.2813	10	01Jul2015, 12:42	2.8
FG03	0.0203	0.8	01Jul2015, 12:12	0.2
FG04	0.0172	3.1	01Jul2015, 12:06	0.3
G3	0.3188	11	01Jul2015, 12:36	3.3
G3-POND F	0.3188	11	01Jul2015, 12:42	3.3
FG06	0.0658	3.9	01Jul2015, 12:24	0.8
OS07a-POND F	0.0170	0.9	01Jul2015, 12:36	0.2
POND F	0.4596	8.0	01Jul2015, 14:12	5.0
POND F-G7	0.4596	8.0	01Jul2015, 14:18	4.9
FG22	0.0658	5.6	01Jul2015, 12:18	1.0
FG23a	0.0177	2.7	01Jul2015, 12:18	0.4
OS07b	0.0156	1.0	01Jul2015, 12:12	0.2
OS07b-G7	0.0156	0.9	01Jul2015, 12:42	0.2
G7	0.5587	10.0	01Jul2015, 14:00	6.5
G7-G10	0.5587	10.0	01Jul2015, 14:12	6.4
FG24	0.2503	6.2	01Jul2015, 12:42	2.2
OS09	0.1527	8.2	01Jul2015, 12:36	2.0
OS09-G10	0.1527	8.2	01Jul2015, 12:48	2.0
OS08	0.0397	3.4	01Jul2015, 12:12	0.6
OS08-G8	0.0397	3.3	01Jul2015, 12:36	0.5
G8	0.4427	17.1	01Jul2015, 12:42	4.7
G8-G10	0.4427	17.1	01Jul2015, 12:48	4.6
FG23b	0.0359	1.2	01Jul2015, 12:30	0.3
G10	1.0373	25	01Jul2015, 12:48	11.4
G10-G11	1.0373	25	01Jul2015, 12:54	11.4
FG23c	0.0070	0.7	01Jul2015, 12:18	0.1
G11	1.0443	25	01Jul2015, 12:54	11.5
FG25	0.1086	17	01Jul2015, 12:36	3.1
FG28	0.0673	2.7	01Jul2015, 12:30	0.7
POND G IN	1.2202	42	01Jul2015, 12:48	15.3
POND G	1.2202	13	01Jul2015, 17:36	9.6
G12	1.2202	13	01Jul2015, 17:36	9.6
G12-G06	1.2202	13	01Jul2015, 17:48	9.5
FG29	0.0997	2.8	01Jul2015, 12:24	0.8
FG32	0.0402	1	01Jul2015, 12:18	0.3
FG32-G06	0.0402	1	01Jul2015, 12:24	0.3
G06	1.3601	14	01Jul2015, 17:48	10.6
FG10A	0.0806	15	01Jul2015, 12:18	2.2
FG08A	0.0750	27	01Jul2015, 12:06	2.6

Highlighted green rows reference key design points (Typical all charts this section)

INTERIM MDDP (5-YEAR)				
HYDROLOGIC ELEMENT	DRAINAGE AREA (SQ. MI.)	PEAK DISCHARGE Q5 (CFS)	TIME OF PEAK	TOTAL VOLUME Q5 (AC. FT.)
FG08A-G05	0.0750	27	01Jul2015, 12:12	2.6
FG08B	0.0630	20	01Jul2015, 12:12	2.2
FG08B-G05	0.0630	19	01Jul2015, 12:18	2.2
FG11	0.0625	19	01Jul2015, 12:18	2.4
FG09	0.0484	8	01Jul2015, 12:18	1.2
FG09-G05	0.0484	8	01Jul2015, 12:24	1.2
FG10B	0.0416	7	01Jul2015, 12:18	1.0
G05	0.3711	93	01Jul2015, 12:18	11.4
FG13	0.0534	4	01Jul2015, 12:30	0.8
FG12	0.0328	14	01Jul2015, 12:12	1.4
POND D IN	0.4573	107	01Jul2015, 12:18	13.6
POND D	0.4573	12	01Jul2015, 14:36	9.2
POND D-G17	0.4573	12	01Jul2015, 14:42	9.2
FG15	0.0103	4	01Jul2015, 12:12	0.4
FG15-G17A	0.0103	4	01Jul2015, 12:12	0.4
G17A	0.4676	12	01Jul2015, 14:36	9.6
FG14	0.1000	20	01Jul2015, 12:24	3.0
G17	0.5676	25	01Jul2015, 12:24	12.5
G17-G18	0.5676	25	01Jul2015, 12:24	12.5
FG16	0.0791	34	01Jul2015, 12:06	3.1
G18	0.6467	51	01Jul2015, 12:12	15.7
G18-POND E	0.6467	50	01Jul2015, 12:12	15.6
FG31	0.0922	31	01Jul2015, 12:18	3.9
FG30	0.0389	1	01Jul2015, 12:12	0.3
FG30-PONDHS	0.0389	1	01Jul2015, 12:36	0.3
POND HS	0.1311	19	01Jul2015, 12:42	4.2
FG17a	0.0694	23	01Jul2015, 12:12	2.4
FG17a-POND E	0.0694	23	01Jul2015, 12:12	2.4
FG18	0.0644	11	01Jul2015, 12:30	1.8
FG18-POND E	0.0644	11	01Jul2015, 12:30	1.8
FG19	0.0527	23	01Jul2015, 12:12	2.3
FG17c	0.0313	3	01Jul2015, 12:12	0.4
FG17b	0.0214	11	01Jul2015, 12:06	0.9
POND E IN	1.0170	123	01Jul2015, 12:12	27.7
POND E	1.0170	15	01Jul2015, 20:18	12.1
H08	1.0170	11	01Jul2015, 20:18	8.6
H09	0.0000	4	01Jul2015, 20:18	3.5
FG34	0.0836	2	01Jul2015, 12:24	0.7
G14	0.0836	2	01Jul2015, 12:24	0.7
G14-G15	0.0836	2	01Jul2015, 12:42	0.7
FG35	0.0586	1	01Jul2015, 13:12	0.5
G15	0.1422	3	01Jul2015, 12:48	1.2
G15-G08	0.1422	3	01Jul2015, 12:54	1.2
FG37	0.1203	3	01Jul2015, 13:00	1.0
FG36	0.0281	1	01Jul2015, 12:30	0.3
FG36-G08	0.0281	1	01Jul2015, 12:42	0.3
G08	0.2906	6	01Jul2015, 12:54	2.4

Highlighted green rows reference key design points (Typical all charts this section)

INTERIM MDDP (2-YEAR)				
HYDROLOGIC ELEMENT	DRAINAGE AREA (SQ. MI.)	PEAK DISCHARGE Q2 (CFS)	TIME OF PEAK	TOTAL VOLUME Q2 (AC. FT.)
OS06	0.1313	0.5	01Jul2015, 13:30	0.3
G1a	0.1313	0.5	01Jul2015, 13:30	0.3
G1a-G2	0.1313	0.5	01Jul2015, 13:48	0.3
OS05	0.0578	0.2	01Jul2015, 13:24	0.2
OS05-G1	0.0578	0.2	01Jul2015, 13:30	0.2
FG01	0.0531	0.9	01Jul2015, 12:48	0.3
FG01-G1	0.0531	0.9	01Jul2015, 12:48	0.3
G1	0.1109	1.1	01Jul2015, 12:54	0.5
G1-G2	0.1109	1.1	01Jul2015, 13:00	0.5
FG02	0.0391	0.4	01Jul2015, 12:36	0.2
G2	0.2813	1.9	01Jul2015, 13:18	1.0
G2-G3	0.2813	1.9	01Jul2015, 13:30	1.0
FG03	0.0203	0.8	01Jul2015, 12:12	0.2
FG04	0.0172	0.9	01Jul2015, 12:06	0.1
G3	0.3188	2.4	01Jul2015, 13:24	1.3
G3-POND F	0.3188	2.4	01Jul2015, 13:30	1.3
FG06	0.0658	0.7	01Jul2015, 12:42	0.3
OS07a-POND F	0.0170	0.1	01Jul2015, 13:30	0.1
POND F	0.4596	2.3	01Jul2015, 16:12	1.9
POND F-G7	0.4596	2.3	01Jul2015, 16:24	1.9
FG22	0.0658	1.4	01Jul2015, 12:30	0.4
FG23a	0.0177	1.0	01Jul2015, 12:18	0.2
OS07b	0.0156	0.1	01Jul2015, 12:48	0.1
OS07b-G7	0.0156	0.1	01Jul2015, 13:42	0.1
G7	0.5587	2.9	01Jul2015, 16:30	2.6
G7-G10	0.5587	2.9	01Jul2015, 16:48	2.5
FG24	0.2503	1.1	01Jul2015, 13:48	0.7
OS09	0.1527	1.9	01Jul2015, 12:54	0.8
OS09-G10	0.1527	1.9	01Jul2015, 13:18	0.8
OS08	0.0397	0.7	01Jul2015, 12:24	0.2
OS08-G8	0.0397	0.7	01Jul2015, 12:54	0.2
G8	0.4427	3.4	01Jul2015, 13:24	1.7
G8-G10	0.4427	3.4	01Jul2015, 13:30	1.6
FG23b	0.0359	0.2	01Jul2015, 13:18	0.1
G10	1.0373	5.7	01Jul2015, 13:54	4.3
G10-G11	1.0373	5.7	01Jul2015, 13:54	4.3
FG23c	0.0070	0.2	01Jul2015, 12:24	0.1
G11	1.0443	5.8	01Jul2015, 13:42	4.3
FG25	0.1086	7.5	01Jul2015, 12:36	1.7
FG28	0.0673	0.5	01Jul2015, 13:12	0.3
POND G IN	1.2202	10.8	01Jul2015, 13:12	6.3
POND G	1.2202	4.2	02Jul2015, 00:00	4.0
G12	1.2202	4.2	02Jul2015, 00:00	4.0
G12-G06	1.2202	4.2	02Jul2015, 00:00	3.9
FG29	0.0997	0.4	01Jul2015, 13:36	0.3
FG32	0.0402	0	01Jul2015, 13:18	0.1
FG32-G06	0.0402	0	01Jul2015, 13:30	0.1
G06	1.3601	4	01Jul2015, 23:42	4.3
FG10A	0.0806	6.5	01Jul2015, 12:24	1.1
FG08A	0.0750	13	01Jul2015, 12:12	1.5

Highlighted green rows reference key design points (Typical all charts this section)

INTERIM MDDP (2-YEAR)				
HYDROLOGIC ELEMENT	DRAINAGE AREA (SQ. MI.)	PEAK DISCHARGE Q2 (CFS)	TIME OF PEAK	TOTAL VOLUME Q2 (AC. FT.)
FG08A-G05	0.0750	13	01Jul2015, 12:18	1.5
FG08B	0.0630	10	01Jul2015, 12:12	1.2
FG08B-G05	0.0630	10	01Jul2015, 12:18	1.2
FG11	0.0625	10	01Jul2015, 12:18	1.4
FG09	0.0484	3	01Jul2015, 12:18	0.6
FG09-G05	0.0484	3	01Jul2015, 12:24	0.6
FG10B	0.0416	3	01Jul2015, 12:18	0.5
G05	0.3711	45	01Jul2015, 12:18	6.3
FG13	0.0534	1	01Jul2015, 12:42	0.3
FG12	0.0328	8	01Jul2015, 12:12	0.8
POND D IN	0.4573	52	01Jul2015, 12:18	7.5
POND D	0.4573	4	01Jul2015, 18:00	4.0
POND D-G17	0.4573	4	01Jul2015, 18:06	4.0
FG15	0.0103	2	01Jul2015, 12:12	0.2
FG15-G17A	0.0103	2	01Jul2015, 12:12	0.2
G17A	0.4676	4	01Jul2015, 17:54	4.2
FG14	0.1000	9	01Jul2015, 12:24	1.6
G17	0.5676	12	01Jul2015, 12:24	5.8
G17-G18	0.5676	12	01Jul2015, 12:30	5.8
FG16	0.0791	18	01Jul2015, 12:06	1.8
G18	0.6467	26	01Jul2015, 12:12	7.6
G18-POND E	0.6467	25	01Jul2015, 12:12	7.6
FG31	0.0922	17	01Jul2015, 12:18	2.4
FG30	0.0389	0	01Jul2015, 13:18	0.1
FG30-PONDHS	0.0389	0	01Jul2015, 13:48	0.1
POND HS	0.1311	10	01Jul2015, 12:42	2.5
FG17a	0.0694	12	01Jul2015, 12:12	1.3
FG17a-POND E	0.0694	12	01Jul2015, 12:12	1.3
FG18	0.0644	5	01Jul2015, 12:30	0.9
FG18-POND E	0.0644	5	01Jul2015, 12:30	0.9
FG19	0.0527	13	01Jul2015, 12:12	1.4
FG17c	0.0313	1	01Jul2015, 12:18	0.2
FG17b	0.0214	6	01Jul2015, 12:06	0.5
POND E IN	1.0170	63	01Jul2015, 12:12	14.5
POND E	1.0170	6	02Jul2015, 00:00	5.7
H08	1.0170	4	02Jul2015, 00:00	3.4
H09	0.0000	2	02Jul2015, 00:00	2.3
FG34	0.0836	0	01Jul2015, 13:36	0.2
G14	0.0836	0	01Jul2015, 13:36	0.2
G14-G15	0.0836	0	01Jul2015, 14:00	0.2
FG35	0.0586	0	01Jul2015, 14:24	0.1
G15	0.1422	1	01Jul2015, 14:06	0.4
G15-G08	0.1422	1	01Jul2015, 14:18	0.3
FG37	0.1203	0	01Jul2015, 14:12	0.3
FG36	0.0281	0	01Jul2015, 13:30	0.1
FG36-G08	0.0281	0	01Jul2015, 13:48	0.1
G08	0.2906	1	01Jul2015, 14:12	0.7

Highlighted green rows reference key design points (Typical all charts this section)

HAEGLER INTERIM CONDITIONS

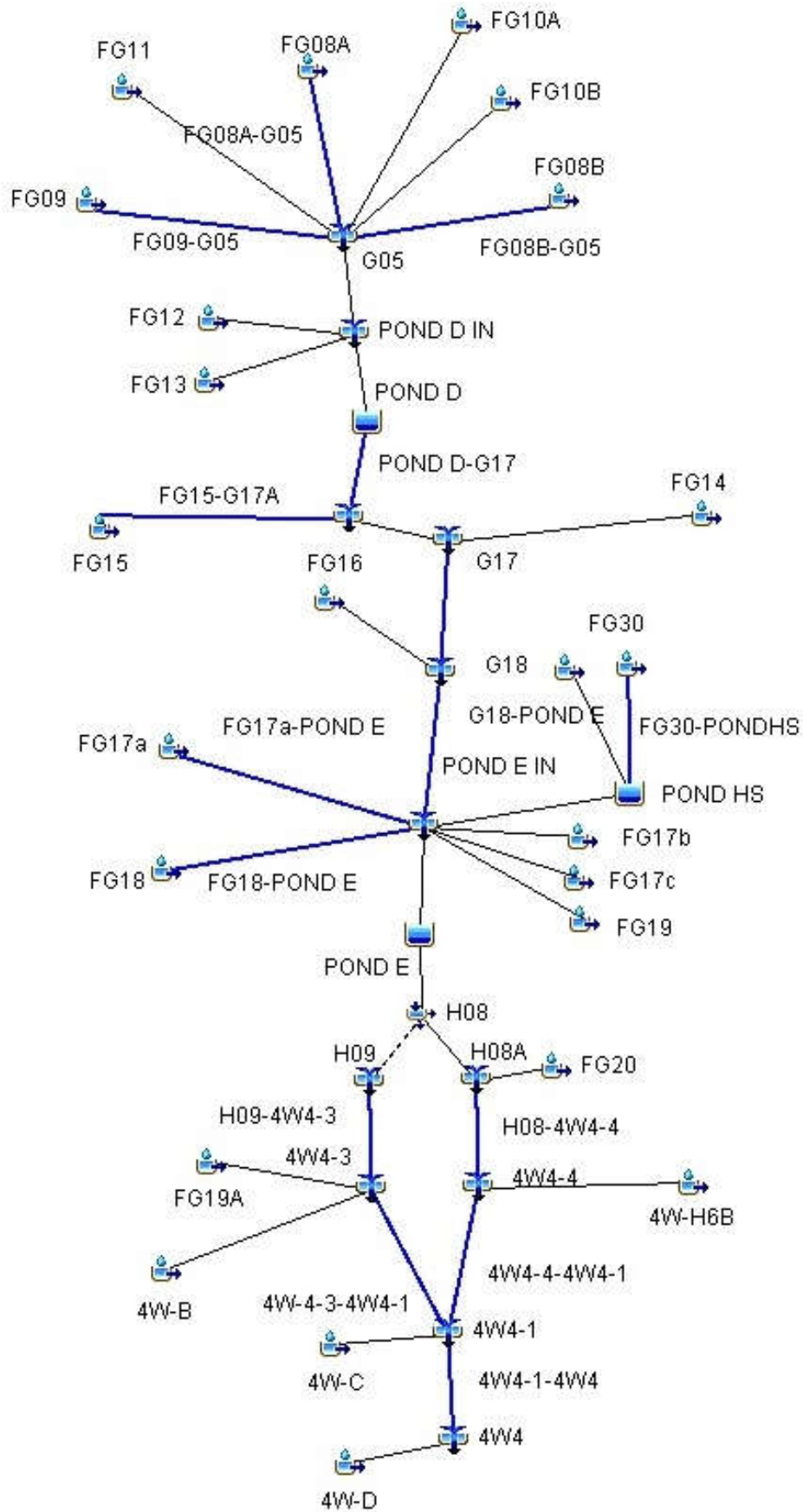

GIECK INTERIM CONDITIONS

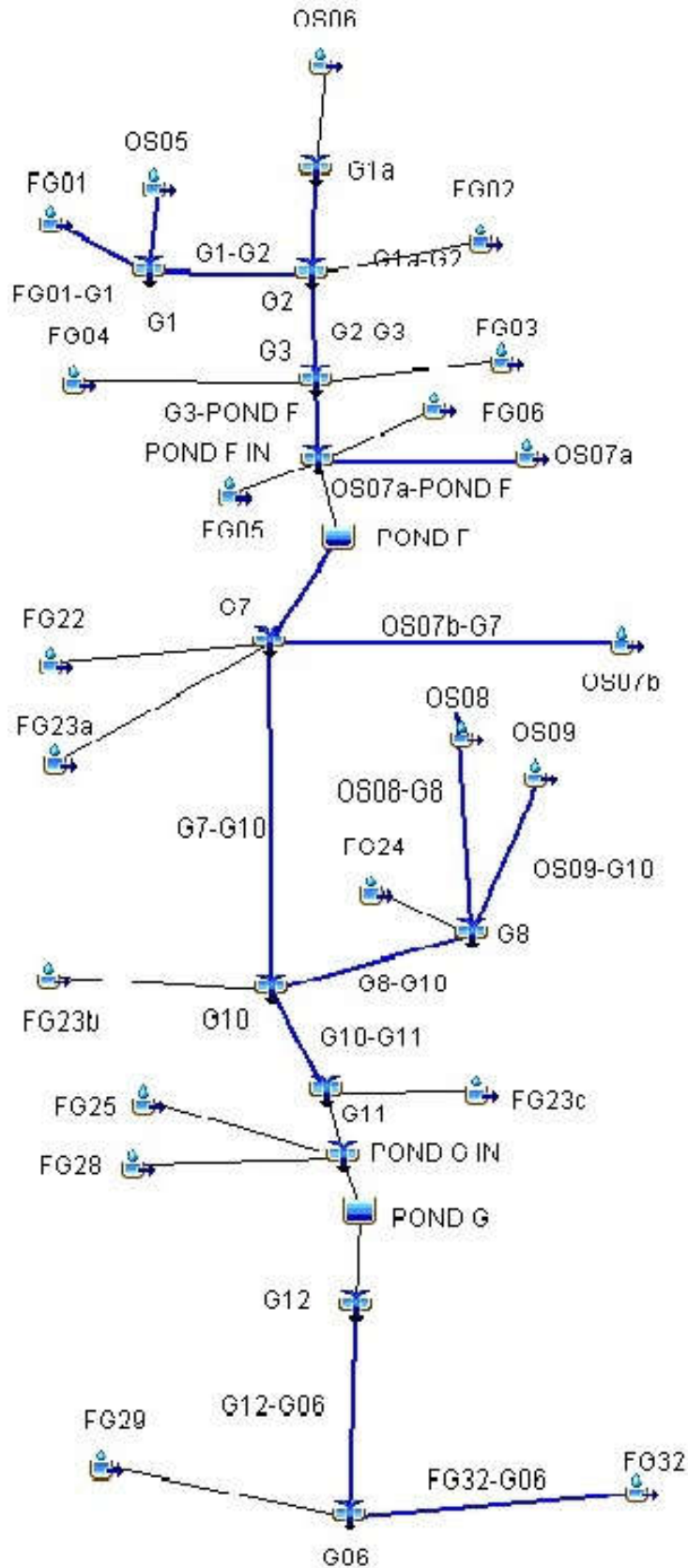

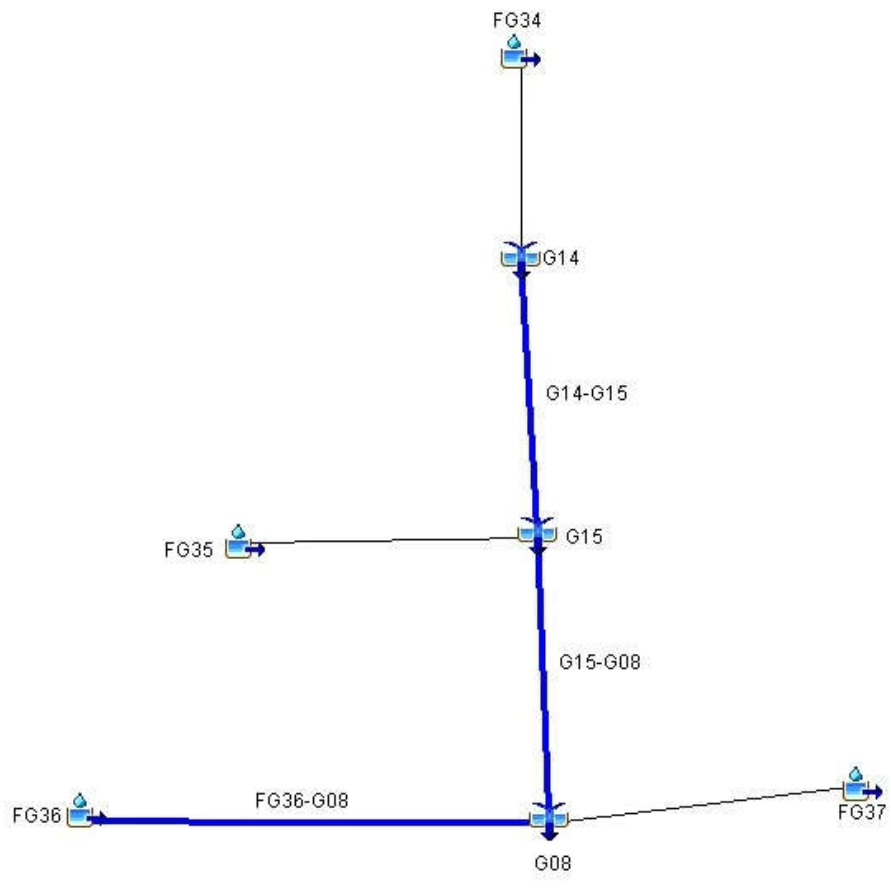

FUTURE MDDP (100-YEAR)				
HYDROLOGIC ELEMENT	DRAINAGE AREA (SQ. MI.)	PEAK DISCHARGE Q100 (CFS)	TIME OF PEAK	TOTAL VOLUME Q100 (AC. FT.)
OS06	0.1313	80	01Jul2015, 12:12	9.3
G1a	0.1313	80	01Jul2015, 12:12	9.3
G1a-G2	0.1313	79	01Jul2015, 12:18	9.2
OS05	0.0578	39	01Jul2015, 12:12	4.1
OS05-G1	0.0578	39	01Jul2015, 12:12	4.1
FG01	0.0538	31	01Jul2015, 12:30	4.9
FG01-G1	0.0538	31	01Jul2015, 12:30	4.9
G1	0.1116	61	01Jul2015, 12:18	9.0
G1-G2	0.1116	61	01Jul2015, 12:18	9.0
FG02	0.0391	32	01Jul2015, 12:12	3.3
G2	0.2820	167	01Jul2015, 12:18	21.5
G2-G3	0.2820	163	01Jul2015, 12:18	21.3
FG03	0.0203	24	01Jul2015, 12:06	2.0
FG04	0.0172	22	01Jul2015, 12:00	1.7
G3	0.3195	185	01Jul2015, 12:18	25.0
G3-POND F	0.3195	183	01Jul2015, 12:18	25.0
FG06	0.0608	49	01Jul2015, 12:12	5.3
FG05	0.0580	45	01Jul2015, 12:24	6.1
OS07a	0.0170	14	01Jul2015, 12:06	1.3
OS07a-POND F	0.0170	13	01Jul2015, 12:18	1.3
POND F IN	0.4553	286	01Jul2015, 12:18	37.7
POND F	0.4553	177	01Jul2015, 12:42	35.7
POND F-G7	0.4553	177	01Jul2015, 12:42	35.5
FG21b	0.0170	25	01Jul2015, 12:06	2.4
FG21a	0.0072	7	01Jul2015, 12:06	0.6
FG21a-G7	0.0072	7	01Jul2015, 12:18	0.6
G7	0.4795	186	01Jul2015, 12:42	38.5
G7-G8	0.4795	185	01Jul2015, 12:42	38.5
FG22	0.1380	102	01Jul2015, 12:18	13.0
OS08	0.0406	35	01Jul2015, 12:12	3.6
OS08-G8	0.0406	34	01Jul2015, 12:12	3.6
FG23a	0.0216	21	01Jul2015, 12:12	2.2
OS07b	0.0156	15	01Jul2015, 12:06	1.2
OS07b-G7	0.0156	14	01Jul2015, 12:12	1.2
G8	0.6953	291	01Jul2015, 12:30	58.5
G8-G10	0.6953	288	01Jul2015, 12:30	58.3
OS09	0.1527	90	01Jul2015, 12:24	13.0
OS09-G10	0.1527	88	01Jul2015, 12:36	12.8
FG24	0.1373	105	01Jul2015, 12:18	13.4
G9	0.2900	180	01Jul2015, 12:24	26.2
G9-G10	0.2900	178	01Jul2015, 12:30	26.2
FG23b	0.0286	23	01Jul2015, 12:12	2.4
G10	1.0139	478	01Jul2015, 12:30	86.9
G10-G11	1.0139	474	01Jul2015, 12:30	86.7
FG23c	0.0122	12	01Jul2015, 12:06	1.2
G11	1.0261	479	01Jul2015, 12:30	87.9
FG25	0.1086	85	01Jul2015, 12:30	13.3
FG26	0.0863	78	01Jul2015, 12:18	9.4
FG26-POND G	0.0863	77	01Jul2015, 12:18	9.4
FG27	0.0500	52	01Jul2015, 12:18	6.3
FG28	0.0245	18	01Jul2015, 12:18	2.2

Highlighted green rows reference key design points (Typical all charts this section)

FUTURE MDDP (100-YEAR)				
HYDROLOGIC ELEMENT	DRAINAGE AREA (SQ. MI.)	PEAK DISCHARGE Q100 (CFS)	TIME OF PEAK	TOTAL VOLUME Q100 (AC. FT.)
POND G IN	1.2955	684	01Jul2015, 12:30	119.1
POND G	1.2955	478	01Jul2015, 12:54	110.0
G12	1.2955	478	01Jul2015, 12:54	110.0
G12-G06	1.2955	478	01Jul2015, 13:00	109.3
FG29	0.0997	60	01Jul2015, 12:12	7.1
FG32	0.0402	72	01Jul2015, 12:06	6.1
FG32-G06	0.0402	69	01Jul2015, 12:06	6.1
G06	1.4354	506	01Jul2015, 12:54	122.5
FG10A	0.0806	81	01Jul2015, 12:18	9.6
FG08A	0.0750	116	01Jul2015, 12:06	10.2
FG08A-G05	0.0750	110	01Jul2015, 12:12	10.2
FG08B	0.0630	86	01Jul2015, 12:12	8.5
FG08B-G05	0.0630	84	01Jul2015, 12:12	8.5
FG11	0.0625	75	01Jul2015, 12:18	8.9
FG09	0.0484	48	01Jul2015, 12:12	5.5
FG09-G05	0.0484	48	01Jul2015, 12:18	5.5
FG10B	0.0416	42	01Jul2015, 12:12	4.6
G05	0.3711	433	01Jul2015, 12:12	47.3
FG13	0.0534	34	01Jul2015, 12:24	4.8
FG12	0.0328	50	01Jul2015, 12:12	5.0
POND D IN	0.4573	509	01Jul2015, 12:12	57.0
POND D	0.4573	134	01Jul2015, 13:00	46.8
POND D-G17	0.4573	134	01Jul2015, 13:00	46.7
FG15	0.0103	15	01Jul2015, 12:06	1.5
FG15-G17A	0.0103	15	01Jul2015, 12:12	1.5
G17A	0.4676	137	01Jul2015, 13:00	48.2
FG14	0.1000	98	01Jul2015, 12:18	12.5
G17	0.5676	196	01Jul2015, 12:30	60.8
G17-G18	0.5676	196	01Jul2015, 12:36	60.7
FG16	0.0791	133	01Jul2015, 12:06	11.5
G18	0.6467	240	01Jul2015, 12:24	72.2
G18-POND E	0.6467	240	01Jul2015, 12:24	72.2
FG31	0.0922	116	01Jul2015, 12:18	13.9
FG30	0.0389	73	01Jul2015, 12:06	5.9
FG30-PONDHS	0.0389	70	01Jul2015, 12:12	5.8
POND HS	0.1311	153	01Jul2015, 12:24	19.7
FG17a	0.0694	101	01Jul2015, 12:06	9.3
FG17a-POND E	0.0694	99	01Jul2015, 12:06	9.3
FG18	0.0644	56	01Jul2015, 12:24	7.7
FG18-POND E	0.0644	56	01Jul2015, 12:24	7.7
FG19	0.0527	84	01Jul2015, 12:06	8.0
FG17c	0.0313	31	01Jul2015, 12:06	2.7
FG17b	0.0214	39	01Jul2015, 12:06	3.2
POND E IN	1.0170	610	01Jul2015, 12:18	122.9
POND E	1.0170	242	01Jul2015, 13:30	98.9
H08	1.0170	205	01Jul2015, 13:30	86.2
H09	0.0000	37	01Jul2015, 13:30	12.6

Highlighted green rows reference key design points (Typical all charts this section)

FUTURE MDDP (100-YEAR)				
HYDROLOGIC ELEMENT	DRAINAGE AREA (SQ. MI.)	PEAK DISCHARGE Q100 (CFS)	TIME OF PEAK	TOTAL VOLUME Q100 (AC. FT.)
FG34	0.0600	34	01Jul2015, 12:18	4.5
G14	0.0600	34	01Jul2015, 12:18	4.5
G14-G15	0.0600	34	01Jul2015, 12:24	4.4
FG35	0.0344	20	01Jul2015, 12:24	2.7
G15	0.0944	53	01Jul2015, 12:24	7.1
G15-G08	0.0944	52	01Jul2015, 12:24	7.1
FG37	0.0797	41	01Jul2015, 12:18	5.6
FG36	0.0281	14	01Jul2015, 12:18	2.0
FG36-G08	0.0281	14	01Jul2015, 12:24	2.0
G08	0.2022	106	01Jul2015, 12:24	14.7

Highlighted green rows reference key design points (Typical all charts this section)

FUTURE MDDP (50-YEAR)				
HYDROLOGIC ELEMENT	DRAINAGE AREA (SQ. MI.)	PEAK DISCHARGE Q50 (CFS)	TIME OF PEAK	TOTAL VOLUME Q50 (AC. FT.)
OS06	0.1313	52	01Jul2015, 12:12	6.5
G1a	0.1313	52	01Jul2015, 12:12	6.5
G1a-G2	0.1313	52	01Jul2015, 12:18	6.5
OS05	0.0578	26	01Jul2015, 12:12	2.9
OS05-G1	0.0578	25	01Jul2015, 12:12	2.9
FG01	0.0538	22	01Jul2015, 12:30	3.6
FG01-G1	0.0538	22	01Jul2015, 12:30	3.6
G1	0.1116	41	01Jul2015, 12:18	6.4
G1-G2	0.1116	41	01Jul2015, 12:18	6.4
FG02	0.0391	22	01Jul2015, 12:12	2.4
G2	0.2820	112	01Jul2015, 12:18	15.3
G2-G3	0.2820	109	01Jul2015, 12:24	15.2
FG03	0.0203	17	01Jul2015, 12:06	1.5
FG04	0.0172	16	01Jul2015, 12:00	1.2
G3	0.3195	123	01Jul2015, 12:18	17.9
G3-POND F	0.3195	121	01Jul2015, 12:18	17.9
FG06	0.0608	34	01Jul2015, 12:12	3.9
FG05	0.0580	33	01Jul2015, 12:24	4.6
OS07a	0.0170	9	01Jul2015, 12:12	1.0
OS07a-POND F	0.0170	9	01Jul2015, 12:18	0.9
POND F IN	0.4553	194	01Jul2015, 12:18	27.3
POND F	0.4553	121	01Jul2015, 12:42	25.6
POND F-G7	0.4553	120	01Jul2015, 12:48	25.5
FG21b	0.0170	20	01Jul2015, 12:06	1.9
FG21a	0.0072	5	01Jul2015, 12:06	0.4
FG21a-G7	0.0072	5	01Jul2015, 12:18	0.4
G7	0.4795	126	01Jul2015, 12:48	27.8
G7-G8	0.4795	126	01Jul2015, 12:48	27.8
FG22	0.1380	73	01Jul2015, 12:18	9.6
OS08	0.0406	25	01Jul2015, 12:12	2.6
OS08-G8	0.0406	24	01Jul2015, 12:12	2.6
FG23a	0.0216	15	01Jul2015, 12:12	1.6
OS07b	0.0156	10	01Jul2015, 12:06	0.9
OS07b-G7	0.0156	10	01Jul2015, 12:12	0.9
G8	0.6953	186	01Jul2015, 12:36	42.5
G8-G10	0.6953	186	01Jul2015, 12:42	42.3
OS09	0.1527	62	01Jul2015, 12:24	9.4
OS09-G10	0.1527	62	01Jul2015, 12:36	9.3
FG24	0.1373	76	01Jul2015, 12:18	9.9
G9	0.2900	125	01Jul2015, 12:30	19.2
G9-G10	0.2900	125.0	01Jul2015, 12:30	19.2
FG23b	0.0286	16	01Jul2015, 12:12	1.8
G10	1.0139	307	01Jul2015, 12:36	63.2
G10-G11	1.0139	305	01Jul2015, 12:36	63.0
FG23c	0.0122	9	01Jul2015, 12:06	0.9
G11	1.0261	308	01Jul2015, 12:36	63.9
FG25	0.1086	64	01Jul2015, 12:30	10.2
FG26	0.0863	58	01Jul2015, 12:18	7.1
FG26-POND G	0.0863	57	01Jul2015, 12:18	7.0
FG27	0.0500	40	01Jul2015, 12:18	4.8
FG28	0.0245	13	01Jul2015, 12:18	1.6

Highlighted green rows reference key design points (Typical all charts this section)

FUTURE MDDP (50-YEAR)				
HYDROLOGIC ELEMENT	DRAINAGE AREA (SQ. MI.)	PEAK DISCHARGE Q50 (CFS)	TIME OF PEAK	TOTAL VOLUME Q50 (AC. FT.)
POND G IN	1.2955	454	01Jul2015, 12:30	87.6
POND G	1.2955	333	01Jul2015, 13:00	79.1
G12	1.2955	333	01Jul2015, 13:00	79.1
G12-G06	1.2955	332	01Jul2015, 13:00	78.6
FG29	0.0997	39	01Jul2015, 12:18	5.0
FG32	0.0402	57	01Jul2015, 12:06	4.8
FG32-G06	0.0402	54	01Jul2015, 12:06	4.8
G06	1.4354	352	01Jul2015, 13:00	88.4
FG10A	0.0806	61	01Jul2015, 12:18	7.3
FG08A	0.0750	90	01Jul2015, 12:06	7.9
FG08A-G05	0.0750	86	01Jul2015, 12:12	7.9
FG08B	0.0630	67	01Jul2015, 12:12	6.6
FG08B-G05	0.0630	65	01Jul2015, 12:12	6.6
FG11	0.0625	59	01Jul2015, 12:18	7.0
FG09	0.0484	36	01Jul2015, 12:12	4.1
FG09-G05	0.0484	36	01Jul2015, 12:18	4.1
FG10B	0.0416	31	01Jul2015, 12:12	3.5
G05	0.3711	330	01Jul2015, 12:12	36.4
FG13	0.0534	24	01Jul2015, 12:24	3.5
FG12	0.0328	40	01Jul2015, 12:12	3.9
POND D IN	0.4573	387	01Jul2015, 12:12	43.9
POND D	0.4573	91	01Jul2015, 13:06	34.7
POND D-G17	0.4573	91	01Jul2015, 13:06	34.6
FG15	0.0103	12	01Jul2015, 12:12	1.2
FG15-G17A	0.0103	12	01Jul2015, 12:12	1.2
G17A	0.4676	93	01Jul2015, 13:06	35.8
FG14	0.1000	74	01Jul2015, 12:18	9.6
G17	0.5676	132	01Jul2015, 12:36	45.4
G17-G18	0.5676	131	01Jul2015, 12:36	45.4
FG16	0.0791	104	01Jul2015, 12:06	9.0
G18	0.6467	178	01Jul2015, 12:12	54.4
G18-POND E	0.6467	176	01Jul2015, 12:12	54.4
FG31	0.0922	92	01Jul2015, 12:18	11.0
FG30	0.0389	57	01Jul2015, 12:06	4.7
FG30-PONDHS	0.0389	56	01Jul2015, 12:12	4.6
POND HS	0.1311	106	01Jul2015, 12:30	15.5
FG17a	0.0694	78	01Jul2015, 12:06	7.3
FG17a-POND E	0.0694	76	01Jul2015, 12:06	7.3
FG18	0.0644	42	01Jul2015, 12:24	5.9
FG18-POND E	0.0644	42	01Jul2015, 12:24	5.9
FG19	0.0527	66	01Jul2015, 12:06	6.4
FG17c	0.0313	22	01Jul2015, 12:06	2.0
FG17b	0.0214	31	01Jul2015, 12:06	2.5
POND E IN	1.0170	432	01Jul2015, 12:12	94.0
POND E	1.0170	153	01Jul2015, 13:54	70.7
H08	1.0170	137	01Jul2015, 13:54	62.1
H09	0.0000	16	01Jul2015, 13:54	8.5

Highlighted green rows reference key design points (Typical all charts this section)

FUTURE MDDP (50-YEAR)				
HYDROLOGIC ELEMENT	DRAINAGE AREA (SQ. MI.)	PEAK DISCHARGE Q50 (CFS)	TIME OF PEAK	TOTAL VOLUME Q50 (AC. FT.)
FG34	0.0600	23	01Jul2015, 12:18	3.2
G14	0.0600	23	01Jul2015, 12:18	3.2
G14-G15	0.0600	22	01Jul2015, 12:24	3.1
FG35	0.0344	13.4	01Jul2015, 12:24	2.0
G15	0.0944	35.6	01Jul2015, 12:24	5.1
G15-G08	0.0944	35	01Jul2015, 12:30	5.0
FG37	0.0797	27	01Jul2015, 12:24	4.0
FG36	0.0281	9	01Jul2015, 12:24	1.4
FG36-G08	0.0281	9	01Jul2015, 12:30	1.4
G08	0.2022	69	01Jul2015, 12:24	10.4

Highlighted green rows reference key design points (Typical all charts this section)

FUTURE MDDP (25-YEAR)				
HYDROLOGIC ELEMENT	DRAINAGE AREA (SQ. MI.)	PEAK DISCHARGE Q25 (CFS)	TIME OF PEAK	TOTAL VOLUME Q25 (AC. FT.)
OS06	0.1313	30	01Jul2015, 12:18	4.3
G1a	0.1313	30	01Jul2015, 12:18	4.3
G1a-G2	0.1313	30	01Jul2015, 12:18	4.2
OS05	0.0578	15	01Jul2015, 12:12	1.9
OS05-G1	0.0578	15	01Jul2015, 12:12	1.9
FG01	0.0538	14	01Jul2015, 12:30	2.5
FG01-G1	0.0538	14	01Jul2015, 12:30	2.5
G1	0.1116	25	01Jul2015, 12:18	4.4
G1-G2	0.1116	25	01Jul2015, 12:24	4.3
FG02	0.0391	14	01Jul2015, 12:12	1.6
G2	0.2820	67	01Jul2015, 12:18	10.2
G2-G3	0.2820	66	01Jul2015, 12:24	10.1
FG03	0.0203	12	01Jul2015, 12:06	1.0
FG04	0.0172	11	01Jul2015, 12:00	0.9
G3	0.3195	74	01Jul2015, 12:24	12.0
G3-POND F	0.3195	74	01Jul2015, 12:24	12.0
FG06	0.0608	22	01Jul2015, 12:12	2.7
FG05	0.0580	23	01Jul2015, 12:24	3.3
OS07a	0.0170	6	01Jul2015, 12:12	0.6
OS07a-POND F	0.0170	6	01Jul2015, 12:24	0.6
POND F IN	0.4553	120	01Jul2015, 12:24	18.6
POND F	0.4553	61	01Jul2015, 12:54	17.2
POND F-G7	0.4553	60	01Jul2015, 13:00	17.1
FG21b	0.0170	15	01Jul2015, 12:12	1.5
FG21a	0.0072	3	01Jul2015, 12:06	0.3
FG21a-G7	0.0072	3	01Jul2015, 12:24	0.3
G7	0.4795	64	01Jul2015, 13:00	18.8
G7-G8	0.4795	64	01Jul2015, 13:00	18.8
FG22	0.1380	47	01Jul2015, 12:18	6.7
OS08	0.0406	16	01Jul2015, 12:12	1.8
OS08-G8	0.0406	15	01Jul2015, 12:18	1.8
FG23a	0.0216	10	01Jul2015, 12:12	1.1
OS07b	0.0156	6	01Jul2015, 12:06	0.6
OS07b-G7	0.0156	6	01Jul2015, 12:12	0.6
G8	0.6953	95	01Jul2015, 12:18	29.0
G8-G10	0.6953	94	01Jul2015, 12:24	28.9
OS09	0.1527	39	01Jul2015, 12:30	6.4
OS09-G10	0.1527	39	01Jul2015, 12:36	6.3
FG24	0.1373	50	01Jul2015, 12:18	7.0
G9	0.2900	81	01Jul2015, 12:30	13.3
G9-G10	0.2900	79.0	01Jul2015, 12:30	13.3
FG23b	0.0286	10	01Jul2015, 12:12	1.2
G10	1.0139	174	01Jul2015, 12:30	43.3
G10-G11	1.0139	173	01Jul2015, 12:30	43.2
FG23c	0.0122	6	01Jul2015, 12:12	0.6
G11	1.0261	176	01Jul2015, 12:30	43.8
FG25	0.1086	45.9	01Jul2015, 12:30	7.5
FG26	0.0863	40	01Jul2015, 12:18	5.1
FG26-POND G	0.0863	39	01Jul2015, 12:18	5.0
FG27	0.0500	29	01Jul2015, 12:18	3.6
FG28	0.0245	8	01Jul2015, 12:18	1.1

Highlighted green rows reference key design points (Typical all charts this section)

FUTURE MDDP (25-YEAR)				
HYDROLOGIC ELEMENT	DRAINAGE AREA (SQ. MI.)	PEAK DISCHARGE Q25 (CFS)	TIME OF PEAK	TOTAL VOLUME Q25 (AC. FT.)
POND G IN	1.2955	287	01Jul2015, 12:24	61.0
POND G	1.2955	170	01Jul2015, 13:12	53.1
G12	1.2955	170	01Jul2015, 13:12	53.1
G12-G06	1.2955	170	01Jul2015, 13:18	52.7
FG29	0.0997	23	01Jul2015, 12:18	3.3
FG32	0.0402	44	01Jul2015, 12:06	3.7
FG32-G06	0.0402	41	01Jul2015, 12:06	3.7
G06	1.4354	181	01Jul2015, 13:18	59.6
FG10A	0.0806	43	01Jul2015, 12:18	5.4
FG08A	0.0750	66	01Jul2015, 12:06	5.9
FG08A-G05	0.0750	64	01Jul2015, 12:12	5.9
FG08B	0.0630	49	01Jul2015, 12:12	5.0
FG08B-G05	0.0630	48	01Jul2015, 12:12	4.9
FG11	0.0625	44	01Jul2015, 12:18	5.2
FG09	0.0484	25	01Jul2015, 12:18	3.0
FG09-G05	0.0484	25	01Jul2015, 12:18	3.0
FG10B	0.0416	22	01Jul2015, 12:12	2.5
G05	0.3711	239	01Jul2015, 12:12	26.9
FG13	0.0534	15	01Jul2015, 12:24	2.4
FG12	0.0328	30.2	01Jul2015, 12:12	3.0
POND D IN	0.4573	279.7	01Jul2015, 12:12	32.4
POND D	0.4573	50	01Jul2015, 13:24	24.3
POND D-G17	0.4573	50	01Jul2015, 13:24	24.3
FG15	0.0103	9	01Jul2015, 12:12	0.9
FG15-G17A	0.0103	9	01Jul2015, 12:12	0.9
G17A	0.4676	51	01Jul2015, 13:24	25.2
FG14	0.1000	53	01Jul2015, 12:18	7.1
G17	0.5676	75	01Jul2015, 12:24	32.3
G17-G18	0.5676	75	01Jul2015, 12:24	32.2
FG16	0.0791	78	01Jul2015, 12:06	6.8
G18	0.6467	128	01Jul2015, 12:12	39.1
G18-POND E	0.6467	126	01Jul2015, 12:12	39.0
FG31	0.0922	69	01Jul2015, 12:18	8.4
FG30	0.0389	44	01Jul2015, 12:06	3.5
FG30-PONDHS	0.0389	42	01Jul2015, 12:12	3.5
POND HS	0.1311	53	01Jul2015, 12:42	11.9
FG17a	0.0694	57	01Jul2015, 12:06	5.4
FG17a-POND E	0.0694	56	01Jul2015, 12:12	5.4
FG18	0.0644	30	01Jul2015, 12:24	4.3
FG18-POND E	0.0644	30	01Jul2015, 12:24	4.3
FG19	0.0527	50	01Jul2015, 12:06	4.9
FG17c	0.0313	14	01Jul2015, 12:06	1.4
FG17b	0.0214	24	01Jul2015, 12:06	1.9
POND E IN	1.0170	318	01Jul2015, 12:12	68.8
POND E	1.0170	80	01Jul2015, 14:36	46.5
H08	1.0170	72	01Jul2015, 14:36	39.8
H09	0.0000	8	01Jul2015, 14:36	6.7

Highlighted green rows reference key design points (Typical all charts this section)

FUTURE MDDP (25-YEAR)				
HYDROLOGIC ELEMENT	DRAINAGE AREA (SQ. MI.)	PEAK DISCHARGE Q25 (CFS)	TIME OF PEAK	TOTAL VOLUME Q25 (AC. FT.)
FG34	0.0600	13	01Jul2015, 12:24	2.1
G14	0.0600	13	01Jul2015, 12:24	2.1
G14-G15	0.0600	13	01Jul2015, 12:30	2.1
FG35	0.0344	8.3	01Jul2015, 12:24	1.3
G15	0.0944	21.3	01Jul2015, 12:30	3.4
G15-G08	0.0944	21	01Jul2015, 12:30	3.3
FG37	0.0797	16	01Jul2015, 12:24	2.6
FG36	0.0281	5	01Jul2015, 12:24	0.9
FG36-G08	0.0281	5	01Jul2015, 12:30	0.9
G08	0.2022	41	01Jul2015, 12:30	6.8

Highlighted green rows reference key design points (Typical all charts this section)

FUTURE MDDP (10-YEAR)				
HYDROLOGIC ELEMENT	DRAINAGE AREA (SQ. MI.)	PEAK DISCHARGE Q10 (CFS)	TIME OF PEAK	TOTAL VOLUME Q10 (AC. FT.)
OS06	0.1313	12	01Jul2015, 12:18	2.2
G1a	0.1313	12	01Jul2015, 12:18	2.2
G1a-G2	0.1313	11	01Jul2015, 12:24	2.1
OS05	0.0578	5.6	01Jul2015, 12:12	1.0
OS05-G1	0.0578	5.5	01Jul2015, 12:18	1.0
FG01	0.0538	7.0	01Jul2015, 12:36	1.4
FG01-G1	0.0538	6.9	01Jul2015, 12:36	1.4
G1	0.1116	11	01Jul2015, 12:24	2.3
G1-G2	0.1116	11	01Jul2015, 12:30	2.3
FG02	0.0391	6.4	01Jul2015, 12:12	0.9
G2	0.2820	27	01Jul2015, 12:24	5.4
G2-G3	0.2820	27	01Jul2015, 12:30	5.3
FG03	0.0203	5.9	01Jul2015, 12:06	0.6
FG04	0.0172	5.8	01Jul2015, 12:06	0.5
G3	0.3195	31	01Jul2015, 12:30	6.4
G3-POND F	0.3195	31	01Jul2015, 12:30	6.4
FG06	0.0608	10	01Jul2015, 12:18	1.5
FG05	0.0580	12.2	01Jul2015, 12:24	2.0
OS07a	0.0170	2	01Jul2015, 12:12	0.3
OS07a-POND F	0.0170	2	01Jul2015, 12:30	0.3
POND F IN	0.4553	52.3	01Jul2015, 12:30	10.2
POND F	0.4553	16.7	01Jul2015, 13:48	9.3
POND F-G7	0.4553	16.7	01Jul2015, 13:54	9.3
FG21b	0.0170	9.6	01Jul2015, 12:12	1.0
FG21a	0.0072	1	01Jul2015, 12:06	0.2
FG21a-G7	0.0072	1	01Jul2015, 12:24	0.2
G7	0.4795	18	01Jul2015, 13:36	10.4
G7-G8	0.4795	17.9	01Jul2015, 13:42	10.3
FG22	0.1380	24.0	01Jul2015, 12:24	3.8
OS08	0.0406	7.7	01Jul2015, 12:12	1.0
OS08-G8	0.0406	7	01Jul2015, 12:18	1.0
FG23a	0.0216	5	01Jul2015, 12:12	0.7
OS07b	0.0156	3	01Jul2015, 12:06	0.3
OS07b-G7	0.0156	2	01Jul2015, 12:18	0.3
G8	0.6953	47	01Jul2015, 12:18	16.1
G8-G10	0.6953	46	01Jul2015, 12:24	16.0
OS09	0.1527	18	01Jul2015, 12:30	3.5
OS09-G10	0.1527	18.1	01Jul2015, 12:42	3.5
FG24	0.1373	26	01Jul2015, 12:24	4.0
G9	0.2900	38	01Jul2015, 12:36	7.5
G9-G10	0.2900	36.8	01Jul2015, 12:36	7.5
FG23b	0.0286	5	01Jul2015, 12:12	0.7
G10	1.0139	80	01Jul2015, 12:30	24.2
G10-G11	1.0139	80	01Jul2015, 12:36	24.1
FG23c	0.0122	3	01Jul2015, 12:12	0.3
G11	1.0261	81	01Jul2015, 12:36	24.4
FG25	0.1086	27.1	01Jul2015, 12:36	4.7
FG26	0.0863	22	01Jul2015, 12:18	3.0
FG26-POND G	0.0863	22	01Jul2015, 12:24	3.0
FG27	0.0500	17	01Jul2015, 12:18	2.3
FG28	0.0245	4	01Jul2015, 12:18	0.6

Highlighted green rows reference key design points (Typical all charts this section)

FUTURE MDDP (10-YEAR)				
HYDROLOGIC ELEMENT	DRAINAGE AREA (SQ. MI.)	PEAK DISCHARGE Q10 (CFS)	TIME OF PEAK	TOTAL VOLUME Q10 (AC. FT.)
POND G IN	1.2955	145.4	01Jul2015, 12:30	35.0
POND G	1.2955	56	01Jul2015, 13:54	28.5
G12	1.2955	56	01Jul2015, 13:54	28.5
G12-G06	1.2955	56	01Jul2015, 14:00	28.2
FG29	0.0997	9	01Jul2015, 12:18	1.6
FG32	0.0402	29	01Jul2015, 12:06	2.4
FG32-G06	0.0402	27	01Jul2015, 12:06	2.4
G06	1.4354	61	01Jul2015, 13:54	32.3
FG10A	0.0806	25	01Jul2015, 12:18	3.3
FG08A	0.0750	41	01Jul2015, 12:06	3.8
FG08A-G05	0.0750	41	01Jul2015, 12:12	3.8
FG08B	0.0630	31	01Jul2015, 12:12	3.2
FG08B-G05	0.0630	29	01Jul2015, 12:18	3.2
FG11	0.0625	28	01Jul2015, 12:18	3.4
FG09	0.0484	14.3	01Jul2015, 12:18	1.8
FG09-G05	0.0484	14	01Jul2015, 12:18	1.8
FG10B	0.0416	12	01Jul2015, 12:18	1.5
G05	0.3711	145	01Jul2015, 12:18	17.1
FG13	0.0534	7	01Jul2015, 12:30	1.4
FG12	0.0328	19.9	01Jul2015, 12:12	2.0
POND D IN	0.4573	168.0	01Jul2015, 12:18	20.4
POND D	0.4573	19	01Jul2015, 14:24	14.8
POND D-G17	0.4573	19	01Jul2015, 14:24	14.8
FG15	0.0103	6	01Jul2015, 12:12	0.6
FG15-G17A	0.0103	6	01Jul2015, 12:12	0.6
G17A	0.4676	19	01Jul2015, 14:12	15.3
FG14	0.1000	32	01Jul2015, 12:24	4.5
G17	0.5676	43	01Jul2015, 12:24	19.8
G17-G18	0.5676	43	01Jul2015, 12:30	19.8
FG16	0.0791	50	01Jul2015, 12:06	4.5
G18	0.6467	79	01Jul2015, 12:12	24.3
G18-POND E	0.6467	78	01Jul2015, 12:12	24.3
FG31	0.0922	45	01Jul2015, 12:18	5.6
FG30	0.0389	29	01Jul2015, 12:06	2.4
FG30-PONDHS	0.0389	27	01Jul2015, 12:12	2.3
POND HS	0.1311	36	01Jul2015, 12:42	7.9
FG17a	0.0694	35	01Jul2015, 12:06	3.5
FG17a-POND E	0.0694	35.1	01Jul2015, 12:12	3.5
FG18	0.0644	18	01Jul2015, 12:24	2.7
FG18-POND E	0.0644	17	01Jul2015, 12:30	2.7
FG19	0.0527	33	01Jul2015, 12:12	3.3
FG17c	0.0313	7	01Jul2015, 12:06	0.7
FG17b	0.0214	16	01Jul2015, 12:06	1.3
POND E IN	1.0170	197	01Jul2015, 12:12	43.7
POND E	1.0170	30	01Jul2015, 17:36	24.4
H08	1.0170	24.1	01Jul2015, 17:36	19.1
H09	0.0000	6	01Jul2015, 17:36	5.3

Highlighted green rows reference key design points (Typical all charts this section)

FUTURE MDDP (10-YEAR)				
HYDROLOGIC ELEMENT	DRAINAGE AREA (SQ. MI.)	PEAK DISCHARGE Q10 (CFS)	TIME OF PEAK	TOTAL VOLUME Q10 (AC. FT.)
FG34	0.0600	5.5	01Jul2015, 12:24	1.1
G14	0.0600	5.5	01Jul2015, 12:24	1.1
G14-G15	0.0600	5.4	01Jul2015, 12:36	1.1
FG35	0.0344	3.5	01Jul2015, 12:30	0.7
G15	0.0944	8.7	01Jul2015, 12:36	1.8
G15-G08	0.0944	9	01Jul2015, 12:36	1.7
FG37	0.0797	6	01Jul2015, 12:24	1.3
FG36	0.0281	2	01Jul2015, 12:30	0.5
FG36-G08	0.0281	2	01Jul2015, 12:36	0.5
G08	0.2022	16	01Jul2015, 12:36	3.5

Highlighted green rows reference key design points (Typical all charts this section)

FUTURE MDDP (5-YEAR)				
HYDROLOGIC ELEMENT	DRAINAGE AREA (SQ. MI.)	PEAK DISCHARGE Q5 (CFS)	TIME OF PEAK	TOTAL VOLUME Q5 (AC. FT.)
OS06	0.1313	3.8	01Jul2015, 12:24	1.1
G1a	0.1313	3.8	01Jul2015, 12:24	1.1
G1a-G2	0.1313	3.6	01Jul2015, 12:36	1.1
OS05	0.0578	1.8	01Jul2015, 12:18	0.5
OS05-G1	0.0578	1.7	01Jul2015, 12:24	0.5
FG01	0.0538	3.4	01Jul2015, 12:36	0.8
FG01-G1	0.0538	3.4	01Jul2015, 12:36	0.8
G1	0.1116	4.9	01Jul2015, 12:36	1.3
G1-G2	0.1116	4.8	01Jul2015, 12:36	1.3
FG02	0.0391	2.7	01Jul2015, 12:18	0.5
G2	0.2820	10	01Jul2015, 12:30	2.9
G2-G3	0.2820	10	01Jul2015, 12:42	2.9
FG03	0.0203	0.8	01Jul2015, 12:12	0.2
FG04	0.0172	3.1	01Jul2015, 12:06	0.3
G3	0.3195	11	01Jul2015, 12:36	3.3
G3-POND F	0.3195	11	01Jul2015, 12:42	3.3
FG06	0.0608	4.6	01Jul2015, 12:18	0.8
FG05	0.0580	6.7	01Jul2015, 12:30	1.2
OS07a	0.0170	0.9	01Jul2015, 12:12	0.2
OS07a-POND F	0.0170	0.9	01Jul2015, 12:36	0.2
POND F IN	0.4553	21.6	01Jul2015, 12:36	5.6
POND F	0.4553	8.1	01Jul2015, 14:06	5.0
POND F-G7	0.4553	8.1	01Jul2015, 14:18	5.0
FG21b	0.0170	6.5	01Jul2015, 12:12	0.7
FG21a	0.0072	0.5	01Jul2015, 12:06	0.1
FG21a-G7	0.0072	0.5	01Jul2015, 12:30	0.1
G7	0.4795	9	01Jul2015, 14:12	5.7
G7-G8	0.4795	8.8	01Jul2015, 14:12	5.7
FG22	0.1380	12.0	01Jul2015, 12:24	2.3
OS08	0.0406	3.4	01Jul2015, 12:12	0.6
OS08-G8	0.0406	3	01Jul2015, 12:18	0.6
FG23a	0.0216	3	01Jul2015, 12:18	0.4
OS07b	0.0156	1.0	01Jul2015, 12:12	0.2
OS07b-G7	0.0156	0.9	01Jul2015, 12:18	0.2
G8	0.6953	24	01Jul2015, 12:18	9.1
G8-G10	0.6953	24	01Jul2015, 12:24	9.1
OS09	0.1527	8	01Jul2015, 12:36	2.0
OS09-G10	0.1527	8.2	01Jul2015, 12:48	2.0
FG24	0.1373	13	01Jul2015, 12:24	2.4
G9	0.2900	17	01Jul2015, 12:48	4.4
G9-G10	0.2900	16.8	01Jul2015, 12:48	4.4
FG23b	0.0286	2	01Jul2015, 12:18	0.4
G10	1.0139	39	01Jul2015, 12:24	13.8
G10-G11	1.0139	38.4	01Jul2015, 12:30	13.7
FG23c	0.0122	1.5	01Jul2015, 12:12	0.2
G11	1.0261	39.2	01Jul2015, 12:30	13.9
FG25	0.1086	16.7	01Jul2015, 12:36	3.1
FG26	0.0863	12	01Jul2015, 12:24	1.9
FG26-POND G	0.0863	12	01Jul2015, 12:24	1.9
FG27	0.0500	11	01Jul2015, 12:18	1.5
FG28	0.0245	2	01Jul2015, 12:24	0.4

Highlighted green rows reference key design points (Typical all charts this section)

FUTURE MDDP (5-YEAR)				
HYDROLOGIC ELEMENT	DRAINAGE AREA (SQ. MI.)	PEAK DISCHARGE Q5 (CFS)	TIME OF PEAK	TOTAL VOLUME Q5 (AC. FT.)
POND G IN	1.2955	78.1	01Jul2015, 12:30	20.8
POND G	1.2955	22	01Jul2015, 15:18	14.9
G12	1.2955	22	01Jul2015, 15:18	14.9
G12-G06	1.2955	22	01Jul2015, 15:24	14.7
FG29	0.0997	3	01Jul2015, 12:24	0.8
FG32	0.0402	20	01Jul2015, 12:06	1.7
FG32-G06	0.0402	18	01Jul2015, 12:12	1.7
G06	1.4354	24	01Jul2015, 15:24	17.3
FG10A	0.0806	15	01Jul2015, 12:18	2.2
FG08A	0.0750	27	01Jul2015, 12:06	2.6
FG08A-G05	0.0750	26.5	01Jul2015, 12:12	2.6
FG08B	0.0630	20.1	01Jul2015, 12:12	2.2
FG08B-G05	0.0630	19.5	01Jul2015, 12:18	2.2
FG11	0.0625	19	01Jul2015, 12:18	2.4
FG09	0.0484	8.3	01Jul2015, 12:18	1.2
FG09-G05	0.0484	8	01Jul2015, 12:24	1.2
FG10B	0.0416	7	01Jul2015, 12:18	1.0
G05	0.3711	93	01Jul2015, 12:18	11.4
FG13	0.0534	4	01Jul2015, 12:30	0.8
FG12	0.0328	13.7	01Jul2015, 12:12	1.4
POND D IN	0.4573	107.0	01Jul2015, 12:18	13.6
POND D	0.4573	12	01Jul2015, 14:36	9.2
POND D-G17	0.4573	12	01Jul2015, 14:42	9.2
FG15	0.0103	4	01Jul2015, 12:12	0.4
FG15-G17A	0.0103	4	01Jul2015, 12:12	0.4
G17A	0.4676	12	01Jul2015, 14:36	9.6
FG14	0.1000	20	01Jul2015, 12:24	3.0
G17	0.5676	25	01Jul2015, 12:24	12.5
G17-G18	0.5676	25	01Jul2015, 12:24	12.5
FG16	0.0791	34	01Jul2015, 12:06	3.1
G18	0.6467	51	01Jul2015, 12:12	15.7
G18-POND E	0.6467	50	01Jul2015, 12:12	15.6
FG31	0.0922	31	01Jul2015, 12:18	3.9
FG30	0.0389	20	01Jul2015, 12:06	1.7
FG30-PONDHS	0.0389	18	01Jul2015, 12:12	1.6
POND HS	0.1311	26	01Jul2015, 12:36	5.6
FG17a	0.0694	23	01Jul2015, 12:12	2.4
FG17a-POND E	0.0694	22.9	01Jul2015, 12:12	2.4
FG18	0.0644	11	01Jul2015, 12:30	1.8
FG18-POND E	0.0644	11	01Jul2015, 12:30	1.8
FG19	0.0527	23	01Jul2015, 12:12	2.3
FG17c	0.0313	3	01Jul2015, 12:12	0.4
FG17b	0.0214	11	01Jul2015, 12:06	0.9
POND E IN	1.0170	126	01Jul2015, 12:12	29.0
POND E	1.0170	16	01Jul2015, 20:00	13.1
H08	1.0170	11.8	01Jul2015, 20:00	9.4
H09	0.0000	4.1	01Jul2015, 20:00	3.7

Highlighted green rows reference key design points (Typical all charts this section)

FUTURE MDDP (5-YEAR)				
HYDROLOGIC ELEMENT	DRAINAGE AREA (SQ. MI.)	PEAK DISCHARGE Q5 (CFS)	TIME OF PEAK	TOTAL VOLUME Q5 (AC. FT.)
FG34	0.0600	2.0	01Jul2015, 12:30	0.6
G14	0.0600	2.0	01Jul2015, 12:30	0.6
G14-G15	0.0600	2.0	01Jul2015, 12:42	0.6
FG35	0.0344	1.5	01Jul2015, 12:30	0.4
G15	0.0944	3.3	01Jul2015, 12:42	0.9
G15-G08	0.0944	3.3	01Jul2015, 12:48	0.9
FG37	0.0797	2.0	01Jul2015, 12:36	0.7
FG36	0.0281	0.7	01Jul2015, 12:36	0.2
FG36-G08	0.0281	0.7	01Jul2015, 12:48	0.2
G08	0.2022	5.8	01Jul2015, 12:48	1.8

Highlighted green rows reference key design points (Typical all charts this section)

FUTURE MDDP (2-YEAR)				
HYDROLOGIC ELEMENT	DRAINAGE AREA (SQ. MI.)	PEAK DISCHARGE Q2 (CFS)	TIME OF PEAK	TOTAL VOLUME Q2 (AC. FT.)
OS06	0.1313	0.5	01Jul2015, 13:30	0.3
G1a	0.1313	0.5	01Jul2015, 13:30	0.3
G1a-G2	0.1313	0.5	01Jul2015, 13:48	0.3
OS05	0.0578	0.2	01Jul2015, 13:24	0.2
OS05-G1	0.0578	0.2	01Jul2015, 13:30	0.2
FG01	0.0538	0.9	01Jul2015, 12:48	0.3
FG01-G1	0.0538	0.9	01Jul2015, 12:48	0.3
G1	0.1116	1.1	01Jul2015, 12:54	0.5
G1-G2	0.1116	1.1	01Jul2015, 13:00	0.5
FG02	0.0391	0.5	01Jul2015, 12:30	0.2
G2	0.2820	1.9	01Jul2015, 13:18	1.0
G2-G3	0.2820	1.9	01Jul2015, 13:30	1.0
FG03	0.0203	0.8	01Jul2015, 12:12	0.2
FG04	0.0172	0.9	01Jul2015, 12:06	0.1
G3	0.3195	2.4	01Jul2015, 13:24	1.3
G3-POND F	0.3195	2.4	01Jul2015, 13:30	1.3
FG06	0.0608	0.9	01Jul2015, 12:24	0.3
FG05	0.0580	2.4	01Jul2015, 12:30	0.6
OS07a	0.0170	0.1	01Jul2015, 12:48	0.1
OS07a-POND F	0.0170	0.1	01Jul2015, 13:30	0.1
POND F IN	0.4553	4.7	01Jul2015, 12:48	2.3
POND F	0.4553	2.3	01Jul2015, 16:00	2.0
POND F-G7	0.4553	2.3	01Jul2015, 16:12	1.9
FG21b	0.0170	3.5	01Jul2015, 12:12	0.4
FG21a	0.0072	0.1	01Jul2015, 12:24	0.0
FG21a-G7	0.0072	0.1	01Jul2015, 13:12	0.0
G7	0.4795	3.6	01Jul2015, 12:12	2.4
G7-G8	0.4795	3.5	01Jul2015, 12:12	2.3
FG22	0.1380	3.3	01Jul2015, 12:30	1.0
OS08	0.0406	0.7	01Jul2015, 12:24	0.2
OS08-G8	0.0406	0.7	01Jul2015, 12:30	0.2
FG23a	0.0216	0.8	01Jul2015, 12:18	0.2
OS07b	0.0156	0.1	01Jul2015, 12:48	0.1
OS07b-G7	0.0156	0.1	01Jul2015, 13:00	0.1
G8	0.6953	7.4	01Jul2015, 12:24	3.8
G8-G10	0.6953	7.4	01Jul2015, 12:30	3.8
OS09	0.1527	1.9	01Jul2015, 12:54	0.8
OS09-G10	0.1527	1.9	01Jul2015, 13:18	0.8
FG24	0.1373	4	01Jul2015, 12:30	1.1
G9	0.2900	4	01Jul2015, 13:12	1.9
G9-G10	0.2900	4.4	01Jul2015, 13:12	1.9
FG23b	0.0286	0	01Jul2015, 12:30	0.1
G10	1.0139	11.7	01Jul2015, 12:30	5.8
G10-G11	1.0139	11.6	01Jul2015, 12:36	5.8
FG23c	0.0122	0.4	01Jul2015, 12:18	0.1
G11	1.0261	11.9	01Jul2015, 12:36	5.9
FG25	0.1086	7.5	01Jul2015, 12:36	1.7
FG26	0.0863	5	01Jul2015, 12:24	0.9
FG26-POND G	0.0863	4.5	01Jul2015, 12:30	0.9
FG27	0.0500	5.0	01Jul2015, 12:24	0.8
FG28	0.0245	0.5	01Jul2015, 12:30	0.2

Highlighted green rows reference key design points (Typical all charts this section)

FUTURE MDDP (2-YEAR)				
HYDROLOGIC ELEMENT	DRAINAGE AREA (SQ. MI.)	PEAK DISCHARGE Q2 (CFS)	TIME OF PEAK	TOTAL VOLUME Q2 (AC. FT.)
POND G IN	1.2955	28.0	01Jul2015, 12:36	9.4
POND G	1.2955	5	02Jul2015, 00:00	5.1
G12	1.2955	5	02Jul2015, 00:00	5.1
G12-G06	1.2955	5	02Jul2015, 00:00	5.0
FG29	0.0997	0.4	01Jul2015, 13:36	0.3
FG32	0.0402	11	01Jul2015, 12:06	1.0
FG32-G06	0.0402	11	01Jul2015, 12:12	1.0
G06	1.4354	11	01Jul2015, 12:12	6.3
FG10A	0.0806	7	01Jul2015, 12:24	1.1
FG08A	0.0750	13.4	01Jul2015, 12:12	1.5
FG08A-G05	0.0750	13.1	01Jul2015, 12:18	1.5
FG08B	0.0630	10.1	01Jul2015, 12:12	1.2
FG08B-G05	0.0630	10.0	01Jul2015, 12:18	1.2
FG11	0.0625	10	01Jul2015, 12:18	1.4
FG09	0.0484	3.2	01Jul2015, 12:18	0.6
FG09-G05	0.0484	3.2	01Jul2015, 12:24	0.6
FG10B	0.0416	3	01Jul2015, 12:18	0.5
G05	0.3711	44.7	01Jul2015, 12:18	6.3
FG13	0.0534	0.9	01Jul2015, 12:42	0.3
FG12	0.0328	7.8	01Jul2015, 12:12	0.8
POND D IN	0.4573	52.1	01Jul2015, 12:18	7.5
POND D	0.4573	4.3	01Jul2015, 18:00	4.0
POND D-G17	0.4573	4.3	01Jul2015, 18:06	4.0
FG15	0.0103	2	01Jul2015, 12:12	0.2
FG15-G17A	0.0103	2	01Jul2015, 12:12	0.2
G17A	0.4676	4	01Jul2015, 17:54	4.2
FG14	0.1000	9	01Jul2015, 12:24	1.6
G17	0.5676	12	01Jul2015, 12:24	5.8
G17-G18	0.5676	12	01Jul2015, 12:30	5.8
FG16	0.0791	18	01Jul2015, 12:06	1.8
G18	0.6467	26	01Jul2015, 12:12	7.6
G18-POND E	0.6467	25	01Jul2015, 12:12	7.6
FG31	0.0922	17	01Jul2015, 12:18	2.4
FG30	0.0389	11	01Jul2015, 12:06	1.0
FG30-PONDHS	0.0389	10.9	01Jul2015, 12:18	1.0
POND HS	0.1311	14.8	01Jul2015, 12:42	3.3
FG17a	0.0694	12	01Jul2015, 12:12	1.3
FG17a-POND E	0.0694	11.6	01Jul2015, 12:12	1.3
FG18	0.0644	4.7	01Jul2015, 12:30	0.9
FG18-POND E	0.0644	5	01Jul2015, 12:30	0.9
FG19	0.0527	13.1	01Jul2015, 12:12	1.4
FG17c	0.0313	0.5	01Jul2015, 12:18	0.2
FG17b	0.0214	6.1	01Jul2015, 12:06	0.5
POND E IN	1.0170	64.0	01Jul2015, 12:12	15.4
POND E	1.0170	6.6	02Jul2015, 00:00	5.9
H08	1.0170	4.1	02Jul2015, 00:00	3.6
H09	0.0000	2.4	02Jul2015, 00:00	2.3

Highlighted green rows reference key design points (Typical all charts this section)

FUTURE MDDP (2-YEAR)				
HYDROLOGIC ELEMENT	DRAINAGE AREA (SQ. MI.)	PEAK DISCHARGE Q2 (CFS)	TIME OF PEAK	TOTAL VOLUME Q2 (AC. FT.)
FG34	0.0600	0.3	01Jul2015, 13:18	0.2
G14	0.0600	0.3	01Jul2015, 13:18	0.2
G14-G15	0.0600	0.3	01Jul2015, 13:48	0.2
FG35	0.0344	0.3	01Jul2015, 13:06	0.1
G15	0.0944	0.6	01Jul2015, 13:36	0.3
G15-G08	0.0944	0.6	01Jul2015, 13:48	0.3
FG37	0.0797	0.3	01Jul2015, 13:42	0.2
FG36	0.0281	0.1	01Jul2015, 13:42	0.1
FG36-G08	0.0281	0.1	01Jul2015, 14:00	0.1
G08	0.2022	1.0	01Jul2015, 13:48	0.6

Highlighted green rows reference key design points (Typical all charts this section)

HAEGLER FUTURE CONDITIONS

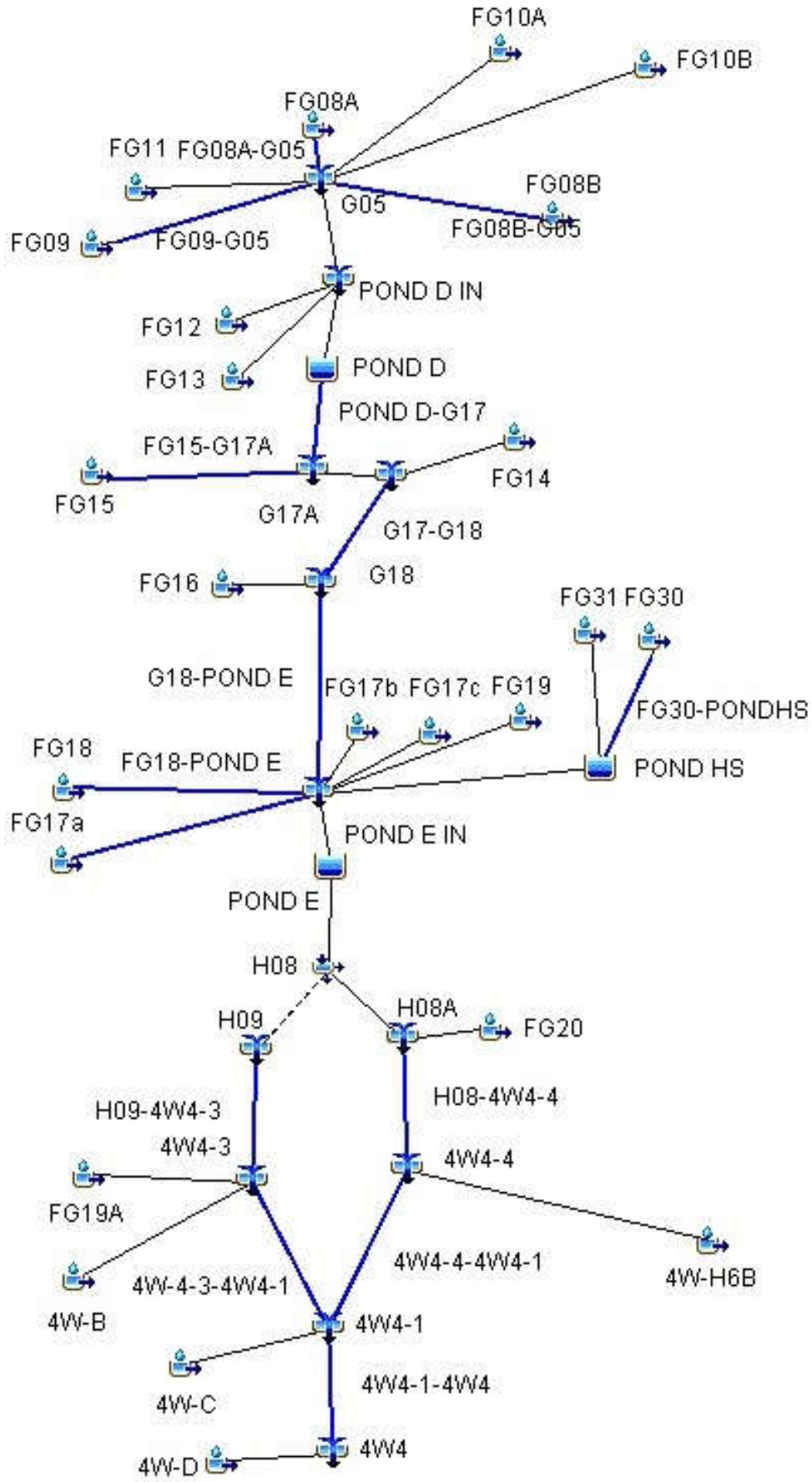

GIECK FUTURE CONDITIONS

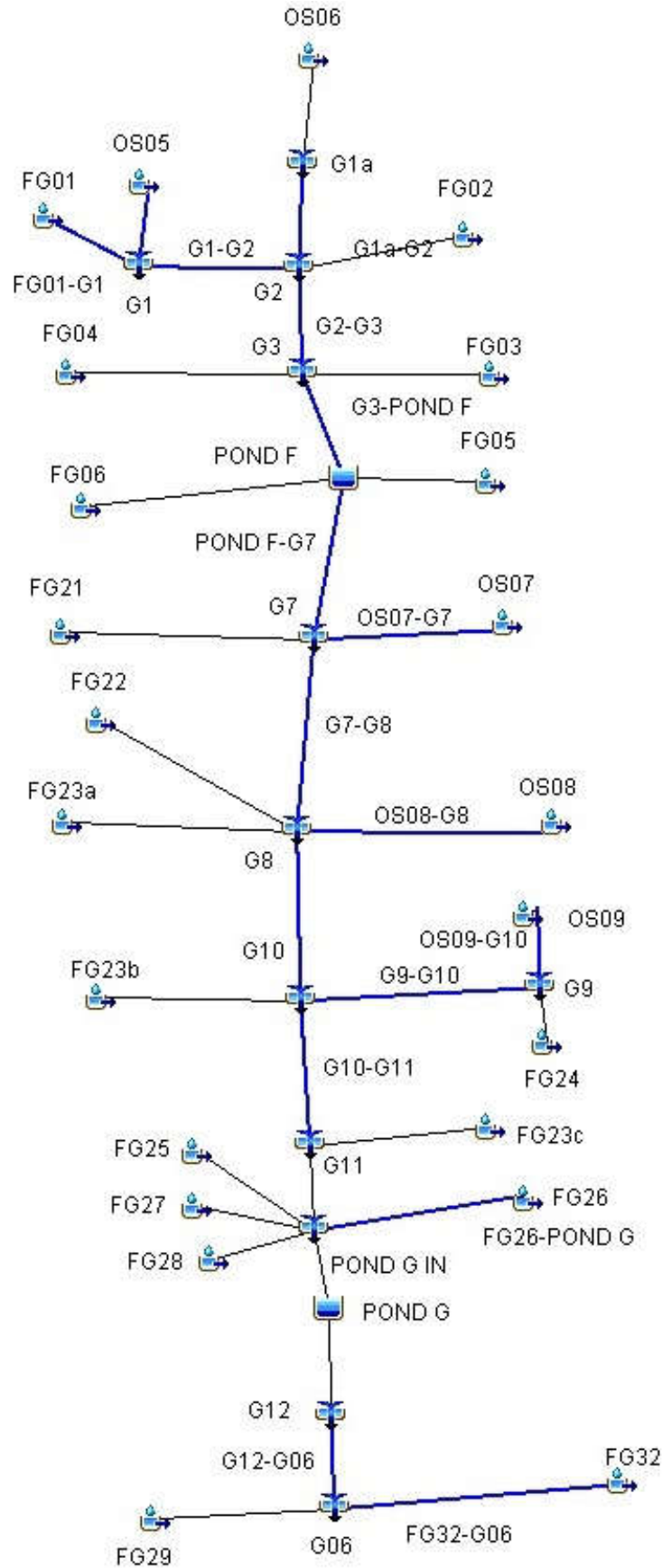

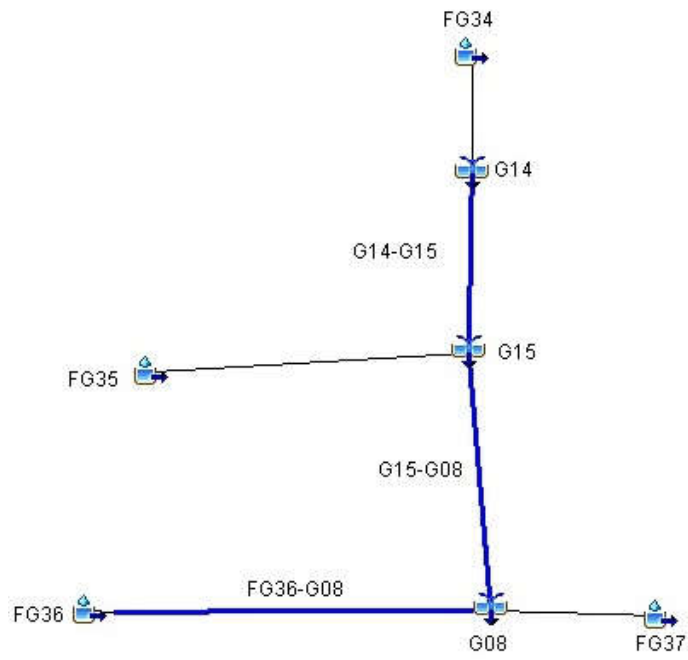

Appendix C - Detention Pond Information

STAGE/STORAGE/DISCHARGE CURVES FOR DETENTION POND ANALYSIS

**Meridian Ranch Proposed Detention Pond D - Interim AS-BUILT
Geick Basin - El Paso County, Colorado**

Data for spillway and embankment:

embankment length =	710
embankment elev =	7060
spillway length =	100
spillway elevation =	7058
100 year storage elev.=	7057.1
100 year storage vol.=	25.5
100 year discharge=	134
5 year storage elev.=	7053.9
5 year storage vol.=	7.4
5 year discharge=	12
WQCV storage vol.=	1.0
WQCV depth =	2.42
1/2 WQCV storage vol.=	0.50

Data for outlet pipe and grate:

		Dimensions						
Type	Width (ft.)	X Height (ft.)	Dia.(in)	(sqft)				
Rectangular		Orifice 1:	0.03	2.42	Area =	0.072	Elev to cl =	7050.21
Circular		Orifice 2:		8	Area =	0.349	Elev to cl =	7051.42
Rectangular		Orifice 3:	5	0.5	Area =	2.500	Elev to cl =	7053.35
None Selected		Orifice 4:			Area =	0.000	Elev to cl =	

Stand Pipe Dimensions	
Rec Grate	6 x 4.25 Elev = 7054.9
Circ. Grate	dia. Elev =

Outlet Culvert Dimensions			
Width (ft.)	Height (ft.)	Dia. (ft.)	Type
Outlet Culvert	x	4	Circular
Area	12.6	TOP	
Outlet I. E.	7048.1	7052.5	
Wall Thick.	5 in.		

50 year storage elev.=	7056.3
50 year discharge=	91
25 year storage elev.=	7055.6
25 year discharge=	50
10 year storage elev.=	7054.7
10 year discharge=	19
2 year storage elev.=	7053.2
2 year discharge=	4.3

STAGE		STORAGE				DISCHARGE										REALIZED CULVERT OUTFLOW	TOTAL FLOW	
ELEV	HEIGHT	AREA		VOLUME		TOP OF BANK	SPILLWAY	ORIFICE (max outflow)				GRATE (max outflow)	PIPE					
		sqft	acre	acft	cum acft			1	2	3	4		1	2				
7049	0	0	0.0	0.00	0.00	-	-	-	-	-	-	-	-	-	-	-	-	-
7050	1	10705	0.2	0.1	0.12	-	-	0.2	-	-	-	-	-	13	-	-	0.2	0.15
7051	2	36676	0.8	0.5	0.67	-	-	0.3	-	-	-	-	-	33	-	-	0.3	0.31
7052	3	71989	1.7	1.2	1.91	-	-	0.5	1.3	-	-	-	-	60	-	-	1.8	1.8
7053	4	133440	3.1	2.4	4.27	-	-	0.6	2.1	-	-	-	-	90	-	-	2.7	2.7
7054	5	178828	4.1	3.6	7.86	-	-	0.7	2.7	9.7	-	-	-	119	-	-	13.1	13
7055	6	221269	5.1	4.6	12.45	-	-	0.8	3.2	15.5	-	-	1.4	139	-	-	21	21
7055.5	6.5	245509	5.6	2.7	15.13	-	-	0.8	3.4	17.7	-	-	20.2	148	-	-	42	42
7056	7	269749	6.2	5.6	18.08	-	-	0.8	3.6	20	-	-	50	157	-	-	74	74
7058	9	337508	7.7	13.9	32.03	-	-	1.0	4.3	26	-	-	216	188	-	-	188	188
7060	11	405520	9.3	31.0	49.09	-	848.5	1.1	4.9	31	-	-	277	214	-	-	214	1,063
						-	-	-	-	-	-	-	-	-	-	-	-	-

- Notes:
- 1) Top-of-bank and spillway flows are weir equations from section 11.3.1 in the DCM. $Q=CLH^{1.5}$ (C=3.0)
 - 2) Orifice flows are also from section 11.3.1. $Q=CA(2gH)^{.5}$ (C=.6)
 - 3) Grate flows are determined from equations 7-2 and 7-3. Weir Flow $Q=(3PH^{1.5})/F$, Orifice Flow $Q=4.815*AH^{0.5}$
 - 4) Pipe flows use the lesser of: 1) Inlet control equations 27 & 28, page 146 of HDS No. 5 - or - 2) Allowable Pipe Flow equation on page 11-9 of the DCM. Use Table 9, page 147-148, HDS No. 5 for formulas 26 & 27.

STAGE/STORAGE/DISCHARGE CURVES FOR DETENTION POND ANALYSIS

Meridian Ranch Existing Detention Pond E- FINAL INTERIM (TOTAL FLOWS)

Gieck Basin - El Paso County, Colorado

embankment length =	1860
embankment elev =	6976
spillway length =	200
spillway elevation =	6974.5
100 year storage elev.=	6973.6
100 year storage vol.=	42.4
100 year discharge=	242
5 year storage elev.=	6971.4
5 year storage vol.=	18.0
5 year discharge=	16
WQCV storage elev.=	6968.9
WQCV storage vol.=	1.5
WQCV depth =	1.9
1/2 WQCV storage elev.=	6968.3
1/2 WQCV storage vol.=	0.75

50 year storage elev.=	6973.1
50 year storage vol.=	36.4
50 year discharge=	153
25 year storage elev.=	6972.5
25 year storage vol.=	30.0
25 year discharge=	80
10 year storage elev.=	6971.9
10 year storage vol.=	23.0
10 year discharge=	30
2 year storage elev.=	6970.6
2 year storage vol.=	10.9
2 year discharge=	6.6

STAGE		STORAGE				TOTAL DISCHARGE											
ELEV	HEIGHT	AREA		VOLUME		TOP OF BANK	SPILLWAY	ORIFICE (max outflow)			4	GRATE (max outflow)		PIPE		REALIZED CULVERT OUTFLOW	TOTAL FLOW
		sqft	acre	acft	cum acft			1	2	3		Rectangular	1	2			
6967	0	1808	0.04	0.0	0.00	-	-	-	-	-	-	-	-	1.4	-	-	-
6967.5	0.5	16136.5	0.37	0.1	0.10	-	-	0.0	-	-	-	-	-	13	-	0.03	0.03
6968	1	30465	0.70	0.3	0.37	-	-	0.1	-	-	-	-	-	26	-	0.11	0.11
6968.5	1.5	81028.5	1.86	0.6	1.01	-	-	0.2	-	-	-	-	-	47	-	0.23	0.23
6969	2	131592	3.02	1.2	2.23	-	-	0.4	-	-	-	-	-	77	-	0.4	0.37
6969.5	2.5	201294.5	4.62	1.9	4.14	-	-	0.5	-	3.0	-	-	-	110	-	3.5	3.5
6970	3	270997	6.22	4.6	6.85	-	-	0.6	-	4	-	-	-	146	-	5	4.9
6970.5	3.5	329360	7.56	3.4	10.30	-	-	0.6	0.2	5	-	-	-	183	-	6	6.1
6970.75	3.75	358540.75	8.23	2.0	12.27	-	-	0.7	1.2	6	-	-	-	203	-	8	7.6
6971	4	387722	8.90	7.6	14.41	-	-	0.7	3.1	6	-	-	-	218	-	10	9.8
6971.25	4.25	408751	9.38	2.3	16.70	-	-	0.7	5.5	6	0.20	-	-	236	-	13	13
6971.5	4.5	429780	9.87	4.7	19.10	-	-	0.7	8	7	3.0	-	-	252	-	18	18
6971.75	4.75	450809	10.35	2.5	21.63	-	-	0.8	10	7	7.3	-	-	266	-	25	25
6972	5	471838	10.83	5.2	24.28	-	-	0.8	12	7	13	2.4	-	280	-	35	35
6972.25	5.25	482595.75	11.08	2.7	27.02	-	-	0.8	13	8	17	16	-	292	-	54	54
6972.5	5.5	493354	11.33	5.5	29.82	-	-	0.8	14	8	20	35	-	304	-	78	78
6973	6	514869	11.82	5.8	35.60	-	-	0.9	16	9	30	87	-	327	-	142	142
6973.25	6.25	518272	11.90	3.0	38.57	-	-	0.9	17	9	35	121	-	338	-	183	183
6973.5	6.5	521675	11.98	5.9	41.55	-	-	0.9	18	9	41	163	-	349	-	232	232
6974	7	528481	12.13	12.0	47.58	-	-	1.0	20	10	53	259	-	369	-	307	307
6976	9	553685	12.71	24.8	72.42	-	1,102	1.1	25	11	83	729	-	443	-	443	1,545

- Notes:
- 1) Top-of-bank and spillway flows are weir equations from section 11.3.1 in the DCM. $Q=CLH^{1.5}$ (C=3.0)
 - 2) Orifice flows are also from section 11.3.1. $Q=CA(2gH)^{0.5}$ (C=.6)
 - 3) Grate flows are determined from equations 7-2 and 7-3. Weir Flow $Q=(3PH^{1.5})/F$, Orifice Flow $Q=4.815*AH^{0.5}$
 - 4) Pipe flows use the lesser of: 1) Inlet control equations 27 & 28, page 146 of HDS No. 5 - or - 2) Allowable Pipe Flow equation on page 11-9 of the DCM. Use Table 9, page 147-148, HDS No. 5 for formulas 26 & 27.

STAGE/STORAGE/DISCHARGE CURVES FOR DETENTION POND ANALYSIS

Meridian Ranch Existing Detention Pond E-INTERIM FUTURE (H08)

Gieck Basin - El Paso County, Colorado

Data for spillway and embankment:

embankment length =	1860
embankment elev =	6976
spillway length =	200
spillway elevation =	6974
100 year storage elev.=	6973.6
100 year storage vol.=	42.4
100 year discharge=	205
5 year storage elev.=	6971.4
5 year storage vol.=	18.0
5 year discharge=	12
WQCV storage elev.=	6968.9
WQCV storage vol.=	1.5
1/2 WQCV storage elev.=	6968.3
1/2 WQCV storage vol.=	0.8

Data for outlet pipe and grate:

Type	H or V	Width (ft.)	Height (ft.)	Dia.(in)	Area =	(sqft)	Invert Elev =
Rectangular	Orifice 1:	V	0.0248	1.65	Area =	0.041	6967.18
Rectangular	Orifice 2:	V	2	0.8	Area =	1.600	6970.40
Circular	Orifice 3:	H		10	Area =	0.545	6969.00
Rectangular	Orifice 4:	V	6	0.7	Area =	4.200	6971.20

Stand Pipe Dimensions

Rec Grate	11	x	7	Elev =	6971.90
Circ. Grate		dia.		Elev =	6971.90

50 year storage elev.=	6973.1
50 year discharge=	137
25 year storage elev.=	6972.5
25 year discharge=	72
10 year storage elev.=	6971.9
10 year discharge=	24
2 year storage elev.=	6970.6
2 year discharge=	4.1

Outlet Culvert Dimensions

	Width (ft.)	Height (ft.)	Dia. (ft.)	Type
Outlet Culvert		x	3.5	Circular
Area	9.6		TOP	
Outlet I. E.	6966.8		6970.58	
Wall Thick.	4	in.		

STAGE		STORAGE				DISCHARGE										REALIZED CULVERT OUTFLOW	TOTAL FLOW
ELEV	HEIGHT	AREA		VOLUME		TOP OF BANK	SPILLWAY	ORIFICE (max outflow)				GRATE (max outflow)	PIPE				
		sqft	acre	acft	cum acft			1	2	3	4		Rectangular	1	2		
6967	0	1808	0.04	0.0	0.0			-	-	-	-	-	-	0.91		-	-
6967.5	0.5	16136.5	0.37	0.1	0.1			0.0	-	-	-	-	-	8.0		0.01	0.01
6968	1	30465	0.70	0.3	0.4			0.1	-	-	-	-	-	18		0.06	0.06
6968.5	1.5	81028.5	1.86	0.6	1.0			0.1	-	-	-	-	-	30		0.11	0.11
6969	2	131592	3.02	1.2	2.2			0.2	-	-	-	-	-	52		0.2	0.2
6969.5	2.5	201294.5	4.62	1.9	4.1			0.2	1.9	-	-	-	-	75		2.1	2.1
6970	3	270997	6.22	4.6	6.9			0.3	-	2.6	-	-	-	97		2.9	2.9
6970.5	3.5	329359.5	7.56	3.4	10			0.3	0.2	3.2	-	-	-	122		3.7	3.7
6970.75	3.75	358540.75	8.23	2.0	12.3			0.3	1.2	3.5	-	-	-	135		5	5.0
6971	4	387722	8.90	7.6	14			0.3	2.8	3.7	-	-	-	146		7	6.8
6971.25	4.25	408751	9.38	2.3	17			0.4	4.7	3.9	0.2	-	-	157		9	9.2
6971.5	4.5	429780	9.87	4.7	19			0.4	6.4	4	3.0	-	-	167		14	14
6971.75	4.75	450809	10.35	2.5	22			0.4	7.5	4	7.3	-	-	176		20	20
6972	5	471838	10.83	5.2	24			0.4	8	5	13	2	-	185		29	29
6972.25	5.25	482595.75	11.08	2.7	27			0.4	9	5	17	16	-	193		47	47
6972.5	5.5	493354	11.33	5.5	30			0.4	10	5	20	35	-	201		70	70
6973	6	514869	11.82	5.8	36			0.4	11	5	24	87	-	217		128	128
6973.25	6.25	518272	11.90	3.0	39			0.5	12	5	26	118	-	224		162	162
6973.5	6.5	521675	11.98	5.9	42			0.5	13	6	28	152	-	231		199	199
6974	7	528481	12.13	12.0	48			0.5	14	6	32	228	-	244		244	244
6976	9	553685	12.71	24.8	72			0.6	18	7	43	623	-	291		291	291

- Notes:
- 1) Top-of-bank and spillway flows are weir equations from section 11.3.1 in the DCM. $Q=CLH^{1.5}$ (C=3.0)
 - 2) Orifice flows are also from section 11.3.1. $Q=CA(2gH)^{.5}$ (C=.6)
 - 3) Grate flows are determined from equations 7-2 and 7-3. Weir Flow $Q=(3PH^{1.5})/F$, Orifice Flow $Q=4.815*AH^{0.5}$
 - 4) Pipe flows use the lesser of: 1) Inlet control equations 27 & 28, page 146 of HDS No. 5 - or - 2) Allowable Pipe Flow equation on page 11-9 of the DCM. Use Table 9, page 147-148, HDS No. 5 for formulas 26 & 27.

STAGE/STORAGE/DISCHARGE CURVES FOR DETENTION POND ANALYSIS

Meridian Ranch Existing Detention Pond E-INTERIM FUTURE (H09)

Gieck Basin - El Paso County, Colorado

Data for spillway and embankment:

embankment length =	1860
embankment elev =	6976
spillway length =	200
spillway elevation =	6974.5
100 year storage elev.=	6973.6
100 year storage vol.=	42.4
100 year discharge=	37
5 year storage elev.=	6971.4
5 year storage vol.=	18.0
5 year discharge=	4.1
WQCV storage elev.=	6968.9
WQCV storage vol.=	1.5
1/2 WQCV storage elev.=	6968.3
1/2 WQCV storage vol.=	0.75

Data for outlet pipe and grate:

		Dimensions					
Type	H or V	Width (ft.)	X Height (ft.)	Dia.(in)	(sqft)		
Rectangular	Orifice 1:	V	0.0248	1.65	Area =	0.041	Invert Elev = 6967.18
Rectangular	Orifice 2:	V	0.75	1	Area =	0.750	Invert Elev = 6970.75
Circular	Orifice 3:	H		8	Area =	0.349	Invert Elev = 6969.00
Rectangular	Orifice 4:	V	3.5	1.25	Area =	4.375	Invert Elev = 6971.75

Stand Pipe Dimensions

Rec Grate	4.25	x	3	Elev =	6973.00
Circ. Grate		dia.		Elev =	6973.00

50 year storage elev.=	6973.1
50 year discharge=	16
25 year storage elev.=	6972.5
25 year discharge=	8.3
10 year storage elev.=	6971.9
10 year discharge=	5.9
2 year storage elev.=	6970.6
2 year discharge=	2.4

Outlet Culvert Dimensions

	Width (ft.)		Height (ft.)	Dia. (ft.)	Type
Outlet Culvert		x		3.5	Circular
Area	9.6		TOP		
Outlet I. E.	6966.8		6970.7		
Wall Thick.	5	in.			

STAGE		STORAGE				DISCHARGE										REALIZED CULVERT OUTFLOW		TOTAL FLOW
ELEV	HEIGHT	AREA		VOLUME		TOP OF BANK	SPILLWAY	ORIFICE (max outflow)				GRATE (max outflow)	PIPE		REALIZED CULVERT OUTFLOW	TOTAL FLOW		
		sqft	acre	acft	cum acft			1	2	3	4		Rectangular	1			2	
6967	0	1808	0.04	0.0	0.0			-	-	-	-	-	-	0.45		-	-	
6967.5	0.5	16136.5	0.37	0.1	0.1			0.0	-	-	-	-	-	5.0		0.01	0.01	
6968	1	30465	0.70	0.3	0.4			0.1	-	-	-	-	-	8.8		0.06	0.06	
6968.5	1.5	81028.5	1.86	0.6	1.0			0.1	-	-	-	-	-	17		0.11	0.11	
6969	2	131592	3.02	1.2	2.2			0.2	-	-	-	-	-	26		0.2	0.18	
6969.5	2.5	201294.5	4.62	1.9	4.1			0.2	-	1.2	-	-	-	35		1.4	1.4	
6970	3	270997	6.22	4.6	6.9			0.3	-	1.7	-	-	-	48		2.0	2.0	
6970.5	3.5	329359.5	7.56	3.4	10.3			0.3	-	2.1	-	-	-	61		2.4	2.4	
6970.75	3.75	358540.75	8.23	2.0	12.3			0.3	-	2.2	-	-	-	68		2.6	2.6	
6971	4	387722	8.90	7.6	14.4			0.3	0.3	2.4	-	-	-	73		3.0	3.0	
6971.25	4.25	408751	9.38	2.3	16.7			0.4	0.8	2.5	-	-	-	79		3.7	3.7	
6971.5	4.5	429780	9.87	4.7	19.1			0.4	1.5	2.7	-	-	-	85		4.5	4.5	
6971.75	4.75	450809	10.35	2.5	21.6			0.4	2.3	2.8	-	-	-	90		5.4	5.4	
6972	5	471838	10.83	5.2	24.3			0.4	3.1	2.9	-	-	-	95		6.4	6.4	
6972.25	5.25	482595.75	11.08	2.7	27.0			0.4	3.6	3.0	-	-	-	99		7.0	7.0	
6972.5	5.5	493354	11.33	5.5	29.8			0.4	4.0	3.1	0.5	-	-	103		8	8.1	
6973	6	514869	11.82	5.8	35.6			0.4	4.8	3.4	5.2	-	-	111		14	14	
6973.25	6.25	518272	11.90	3.0	38.6			0.5	5.1	3.5	8.6	4	-	114		21	21	
6973.5	6.5	521675	11.98	5.9	41.6			0.5	5.4	3.6	13	11	-	118		33	33	
6974	7	528481	12.13	12.0	47.6			0.5	6.0	3.8	22	31	-	125		63	63	
6976	9	553685	12.71	24.8	72.4			0.6	7.9	4.4	40	106	-	151		151	151	

- Notes:
- 1) Top-of-bank and spillway flows are weir equations from section 11.3.1 in the DCM. $Q=CLH^{1.5}$ (C=3.0)
 - 2) Orifice flows are also from section 11.3.1. $Q=CA(2gH)^{.5}$ (C=.6)
 - 3) Grate flows are determined from equations 7-2 and 7-3. Weir Flow $Q=(3PH^{1.5})/F$, Orifice Flow $Q=4.815*AH^{0.5}$
 - 4) Pipe flows use the lesser of: 1) Inlet control equations 27 & 28, page 146 of HDS No. 5 - or - 2) Allowable Pipe Flow equation on page 11-9 of the DCM. Use Table 9, page 147-148, HDS No. 5 for formulas 26 & 27.

STAGE/STORAGE/DISCHARGE CURVES FOR DETENTION POND ANALYSIS

Meridian Ranch Proposed Detention Pond F INTERIM-Final

Geick Basin - El Paso County, Colorado

Data for spillway and embankment:

embankment length =	285
embankment elev =	7138.5
spillway length =	87
spillway elevation =	7137.5
100 year storage elev.=	7136.0
100 year storage vol.=	8.8
100 year discharge=	177
5 year storage elev.=	7131.2
5 year storage vol.=	1.8
5 year discharge=	8.0
WQCV storage elev.=	7129.1
WQCV storage vol.=	0.3
1/2 WQCV storage elev.=	7128.6
1/2 WQCV storage vol.=	0.15

Data for outlet pipe and grate:

Type	H or V	Dimensions Width (ft.) X Height (ft.)	Dia.(in)	Area =	(sqft)	Elev to cl =
Rectangular	Orifice 1:	V	0.0131	1.25		7128.45
Rectangular	Orifice 2:	V	4	0.5		7130.75
Circular	Orifice 3:	H		8		7129.20
None Selected	Orifice 4:				0.000	

Stand Pipe Dimensions

Rec Grate	6	x	3	Elev =	7133
Circ. Grate		dia.		Elev =	7133

50 year storage elev.=	7134.9
50 year discharge=	121
25 year storage elev.=	7134.1
25 year discharge=	60
10 year storage elev.=	7132.7
10 year discharge=	17
2 year storage elev.=	7130.1
2 year discharge=	2.3

Outlet Culvert Dimensions

Outlet Culvert	Width (ft.)		Height (ft.)	Dia. (ft.)	Type
	12.6	x	TOP	4	Circular
Area	7126.6		7131.0		
Outlet I. E.	5	in.			
Wall Thick.					

STAGE		STORAGE				DISCHARGE										
ELEV	HEIGHT	AREA		VOLUME		TOP OF BANK	SPILLWAY	ORIFICE (max outflow)				GRATE (max outflow)	PIPE		REALIZED CULVERT OUTFLOW	TOTAL FLOW
		sqft	acre	acft	cum acft			1	2	3	4		1	2		
7127.7	0	0	0.00	0.00	0.00	-	-	-	-	-	-	-	-	-	-	-
7128	0.3	2170	0.05	0.01	0.01	-	-	0.0	-	-	-	-	-	11	0.0	0.0
7129	1.3	17730	0.41	0.23	0.24	-	-	0.1	-	-	-	-	-	31	0.1	0.1
7130	2.3	33290	0.76	0.59	0.82	-	-	0.1	-	1.5	-	-	-	57	1.6	1.6
7131	3.3	39060	0.90	0.83	1.65	-	-	0.1	4.2	2.3	-	-	-	117	6.6	6.6
7132	4.3	44830	1.03	0.96	2.61	-	-	0.1	10.8	2.8	-	-	-	117	14	14
7133	5.3	55137.5	1.27	1.15	3.76	-	-	0.2	14.4	3.3	-	-	-	142	18	18
7134	6.3	65445	1.50	1.38	5.15	-	-	0.2	17.4	3.7	-	36	-	162	57	57
7135	7.3	79535	1.83	1.66	6.81	-	-	0.2	19.9	4.0	-	102	-	175	126	126
7136	8.3	93625	2.15	1.99	8.80	-	-	0.2	22.1	4.4	-	150	-	187	177	177
7137	9.3	111620	2.56	2.36	11.15	-	-	0.2	24.1	4.7	-	173	-	200	200	200
7138	10.3	129615	2.98	2.77	13.92	-	92.3	0.2	25.9	5.0	-	194	-	211	211	303
7138.5	10.8					-	261.0	0.3	26.8	5.1	-	203	-	211	-	261

- Notes:
- 1) Top-of-bank and spillway flows are weir equations from section 11.3.1 in the DCM. $Q=CLH^{1.5}$ (C=3.0)
 - 2) Orifice flows are also from section 11.3.1. $Q=CA(2gH)^{0.5}$ (C=.6)
 - 3) Grate flows are determined from equations 7-2 and 7-3. Weir Flow $Q=(3PH^{1.5})/F$, Orifice Flow $Q=4.815*AH^{0.5}$
 - 4) Pipe flows use the lesser of: 1) Inlet control equations 27 & 28, page 146 of HDS No. 5 - or - 2) Allowable Pipe Flow equation on page 11-9 of the DCM. Use Table 9, page 147-148, HDS No. 5 for formulas 26 & 27.

As discussed in the early assistance, use the UD-Detention worksheet for the outlet structure design calculation. Outlet structure shall be designed per the standard outlet structure detail (see the detail provided with the recent ECM update (Resolution 19-245) Colorado

STAGE/STORAGE/DISCHARGE CURV

Meridian Ranch Proposed Detention Pond
Gieck Basin - El Paso

Data for spillway and embankment:

embankment length =	500
embankment elev =	7034
spillway length =	130
spillway elevation =	7031.5
100 year storage elev.=	7030.0
100 year storage vol.=	24.1
100 year discharge=	399
5 year storage elev.=	7027.4
5 year storage vol.=	8.1
5 year discharge=	13
WQCV storage elev.=	7025.8
WQCV storage vol.=	0.9
1/2 WQCV storage elev.=	7024.9
1/2 WQCV storage vol.=	0.45

Data for outlet pipe and grate:

Type	Orifice	H or V	Dimensions			Area =	(sqft)	Elev to cl =	
			Width (ft.)	X	Height (ft.)				
Rectangular	Orifice 1:	V	0.0414		1.40	0.058	7024.00		
Rectangular	Orifice 2:	V	8.5		1.1	9.350	7027.55		
Circular	Orifice 3:	H			12	0.785	7025.40		
Rectangular	Orifice 4:	V	4		0.6	2.400	7027.80		
Rectangular	Orifice 5:	V	8.5		1.1	9.350	7027.55		

Stand Pipe Dimensions				
Rec Grate	20	x	8	Elev = 7028.10
Circ. Grate		dia.		Elev = 7028.10

50 year storage elev.=	7029.4
50 year discharge=	237
25 year storage elev.=	7028.8
25 year discharge=	117
10 year storage elev.=	7028.0
10 year discharge=	35
2 year storage elev.=	7026.4
2 year discharge=	4.2

Outlet Culvert Dimensions

	Width (ft.)		Height (ft.)	Dia. (ft.)	Type
Outlet Culvert	10	x	4		Rectangular
Area	40.0		TOP		
Outlet I. E.	7022.5		7027.50		
Wall Thick.	12	in.			

STAGE		STORAGE				DISCHARGE											REALIZED CULVERT OUTFLOW		TOTAL FLOW
ELEV	HEIGHT	AREA		VOLUME		TOP OF BANK	SPILLWAY	ORIFICE (max outflow)					GRATE (max outflow)	PIPE		REALIZED CULVERT OUTFLOW	TOTAL FLOW		
		sqft	acre	acft	cum acft			1	2	3	4	5		Rectangular	1			2	
7023.3	0	0	0.00	0.0	0.00	-	-	-	-	-	-	-	-	-	12	-	-	-	
7024	0.7	2232	0.05	0.0	0.02	-	-	0.1	-	-	-	-	-	-	51	0.1	0.07		
7025	1.7	39917	0.92	0.5	0.50	-	-	0.3	-	-	-	-	-	-	111	0.3	0.28		
7026	2.7	126469	2.90	1.9	2.41	-	-	0.4	-	2.9	-	-	-	-	184	3.3	3.3		
7026.5	3.2	166675	3.83	3.6	4.06	-	-	0.4	-	4.0	-	-	-	-	224	4.4	4.4		
7027	3.7	206880	4.75	2.1	6.20	-	-	0.5	-	4.8	-	-	-	-	268	5.3	5.3		
7027.5	4.2	232032	5.33	4.6	8.64	-	-	0.5	9.0	5.5	-	9.0	-	-	304	15	15		
7028	4.7	257183	5.90	5.3	11.53	-	-	0.6	25.5	6.1	4.2	25.5	-	-	337	36	36		
7028.5	5.2	264196	6.07	5.7	14.33	-	-	0.6	43.9	6.7	9.7	43.9	27	-	373	88	88		
7029	5.7	271209	6.23	6.1	17.59	-	-	0.6	54.2	7.2	12.7	54.2	92	-	406	167	167		
7029.5	6.2	276106	6.34	11.7	20.30	-	-	0.7	70.5	7.7	17.1	70.5	179	-	436	275	275		
7030	6.7	281003	6.45	9.4	23.72	-	-	0.7	77.3	8.1	19.0	77.3	283	-	464	388	388		
7030.5	7.2	286003	6.57	6.5	26.75	-	-	0.7	77.3	8.5	19.0	77.3	402	-	491	491	491		
7031	7.7	291002	6.68	6.6	30.28	-	-	0.7	83.6	8.9	20.7	83.6	533	-	516	516	516		
7031.5	8.2	296443	6.81	6.7	33.44	-	-	0.8	89.5	9.3	22.2	89.5	677	-	540	540	540		
7032	8.7	301883	6.93	3.4	36.87	137.9	137.9	0.8	95.0	9.7	23.7	95.0	832	-	563	563	701		
7032.5	9.2	309236	7.10	7.0	40.39	390.0	390.0	0.8	100.2	10.1	25.1	100.2	997	-	586	586	976		
7033	9.7	316589	7.27	3.6	44.0	716.5	716.5	0.8	105.1	10.4	26.4	105.1	1,171	-	607	607	1,323		

- Notes:
- 1) Top-of-bank and spillway flows are weir equations from section 11.3.1 in the DCM. $Q=CLH^{1.5}$ (C=3.0)
 - 2) Orifice flows are also from section 11.3.1. $Q=CA(2gH)^{.5}$ (C=.6)
 - 3) Grate flows are determined from equations 7-2 and 7-3. Weir Flow $Q=(3PH^{1.5})/F$, Orifice Flow $Q=4.815*AH^{.5}$
 - 4) Pipe flows use the lesser of: 1) Inlet control equations 27 & 28, page 146 of HDS No. 5 - or - 2) Allowable Pipe Flow equation on page 11-9 of the DCM. Use Table 9, page 147-148, HDS No. 5 for formulas 26 & 27.

STAGE/STORAGE/DISCHARGE CURVES FOR DETENTION POND ANALYSIS

Meridian Ranch Proposed Detention Pond D - Future AS-BUILT

Geick Basin - El Paso County, Colorado

Data for spillway and embankment:

embankment length =	710
embankment elev =	7060
spillway length =	100
spillway elevation =	7058
100 year storage elev.=	7057.1
100 year storage vol.=	25.5
100 year discharge=	134
5 year storage elev.=	7053.9
5 year storage vol.=	7.3
5 year discharge=	12
WQCV storage vol.=	1.0
WQCV depth =	2.42
1/2 WQCV storage vol.=	0.50

Data for outlet pipe and grate:

		Dimensions					
Type		Width (ft.)	X Height (ft.)	Dia.(in)		(sqft)	
Rectangular	Orifice 1:	0.03	2.42		Area =	0.072	Elev to cl = 7050.21
Circular	Orifice 2:			8	Area =	0.349	Elev to cl = 7051.42
Rectangular	Orifice 3:	5	0.5		Area =	2.500	Elev to cl = 7053.35
None Selected	Orifice 4:				Area =	0.000	Elev to cl =

Stand Pipe Dimensions	
Rec Grate	6 x 4.25 Elev = 7054.9
Circ. Grate	dia. Elev =

Outlet Culvert Dimensions	
Outlet Culvert	12.6 x 4.25 TOP
Area	12.6 x 4.25 TOP
Outlet I. E.	7048.1 7052.5
Wall Thick.	5 in.

Type	
Circular	

50 year storage elev.=	7056.3
50 year discharge=	91
25 year storage elev.=	7055.6
25 year discharge=	50
10 year storage elev.=	7054.7
10 year discharge=	19
2 year storage elev.=	7053.2
2 year discharge=	4.3

STAGE		STORAGE				DISCHARGE										REALIZED CULVERT OUTFLOW		TOTAL FLOW
ELEV	HEIGHT	AREA		VOLUME		TOP OF BANK	SPILLWAY	ORIFICE (max outflow)				GRATE (max outflow)	PIPE		REALIZED CULVERT OUTFLOW	TOTAL FLOW		
		sqft	acre	acft	cum acft			1	2	3	4		1	2				
7049	0	0	0.0	0.00	0.00	-	-	-	-	-	-	-	-	-	-	-	-	
7050	1	10705	0.2	0.1	0.12	-	-	0.2	-	-	-	-	-	13	-	0.2	0.15	
7051	2	36676	0.8	0.5	0.67	-	-	0.3	-	-	-	-	-	33	-	0.3	0.31	
7052	3	71989	1.7	1.2	1.91	-	-	0.5	1.3	-	-	-	-	60	-	1.8	1.8	
7053	4	133440	3.1	2.4	4.27	-	-	0.6	2.1	-	-	-	-	90	-	2.7	2.7	
7054	5	178828	4.1	3.6	7.86	-	-	0.7	2.7	9.7	-	-	-	119	-	13.1	13	
7055	6	221269	5.1	4.6	12.45	-	-	0.8	3.2	15.5	-	-	1.4	139	-	21	21	
7055.5	6.5	245509	5.6	2.7	15.13	-	-	0.8	3.4	17.7	-	-	20.2	148	-	42	42	
7056	7	269749	6.2	5.6	18.08	-	-	0.8	3.6	20	-	-	50	157	-	74	74	
7058	9	337508	7.7	13.9	32.03	-	-	1.0	4.3	26	-	-	216	188	-	188	188	
7060	11	405520	9.3	31.0	49.09	-	848.5	1.1	4.9	31	-	-	277	214	-	214	1,063	
-	-	-	-	-	-	-	-	-	-	-	-	-	-	-	-	-	-	

- Notes:
- 1) Top-of-bank and spillway flows are weir equations from section 11.3.1 in the DCM. $Q=CLH^{1.5}$ (C=3.0)
 - 2) Orifice flows are also from section 11.3.1. $Q=CA(2gH)^{0.5}$ (C=.6)
 - 3) Grate flows are determined from equations 7-2 and 7-3. Weir Flow $Q=(3PH^{1.5})/F$, Orifice Flow $Q=4.815*AH^{0.5}$
 - 4) Pipe flows use the lesser of: 1) Inlet control equations 27 & 28, page 146 of HDS No. 5 - or - 2) Allowable Pipe Flow equation on page 11-9 of the DCM. Use Table 9, page 147-148, HDS No. 5 for formulas 26 & 27.

STAGE/STORAGE/DISCHARGE CURVES FOR DETENTION POND ANALYSIS

Meridian Ranch Existing Detention Pond E- FINAL FUTURE (TOTAL FLOWS)

Gieck Basin - El Paso County, Colorado

embankment length =	1860
embankment elev =	6976
spillway length =	200
spillway elevation =	6974.5
100 year storage elev.=	6973.6
100 year storage vol.=	42.4
100 year discharge=	242
5 year storage elev.=	6971.4
5 year storage vol.=	18.0
5 year discharge=	16
WQCV storage elev.=	6968.9
WQCV storage vol.=	1.5
WQCV depth =	1.9
1/2 WQCV storage elev.=	6968.3
1/2 WQCV storage vol.=	0.75

50 year storage elev.=	6973.1
50 year storage vol.=	36.4
50 year discharge=	153
25 year storage elev.=	6972.5
25 year storage vol.=	30.0
25 year discharge=	80
10 year storage elev.=	6971.9
10 year storage vol.=	23.0
10 year discharge=	30
2 year storage elev.=	6970.6
2 year storage vol.=	10.9
2 year discharge=	6.6

STAGE		STORAGE				TOTAL DISCHARGE										REALIZED CULVERT OUTFLOW	TOTAL FLOW	
ELEV	HEIGHT	AREA		VOLUME		TOP OF BANK	SPILLWAY	ORIFICE (max outflow)				GRATE (max outflow)		PIPE				
		sqft	acre	acft	cum acft			1	2	3	4	Rectangular		1	2			
6967	0	1808	0.04	0.0	0.00	-	-	-	-	-	-	-	-	-	1.4	-	-	-
6967.5	0.5	16136.5	0.37	0.1	0.10	-	-	0.0	-	-	-	-	-	-	13	-	0.03	0.03
6968	1	30465	0.70	0.3	0.37	-	-	0.1	-	-	-	-	-	-	26	-	0.11	0.11
6968.5	1.5	81028.5	1.86	0.6	1.01	-	-	0.2	-	-	-	-	-	-	47	-	0.23	0.23
6969	2	131592	3.02	1.2	2.23	-	-	0.4	-	-	-	-	-	-	77	-	0.4	0.37
6969.5	2.5	201294.5	4.62	1.9	4.14	-	-	0.5	-	3.0	-	-	-	-	110	-	3.5	3.5
6970	3	270997	6.22	4.6	6.85	-	-	0.6	-	4	-	-	-	-	146	-	5	4.9
6970.5	3.5	329360	7.56	3.4	10.30	-	-	0.6	0.2	5	-	-	-	-	183	-	6	6.1
6970.75	3.75	358540.75	8.23	2.0	12.27	-	-	0.7	1.2	6	-	-	-	-	203	-	8	7.6
6971	4	387722	8.90	7.6	14.41	-	-	0.7	3.1	6	-	-	-	-	218	-	10	9.8
6971.25	4.25	408751	9.38	2.3	16.70	-	-	0.7	5.5	6	0.20	-	-	-	236	-	13	13
6971.5	4.5	429780	9.87	4.7	19.10	-	-	0.7	8	7	3.0	-	-	-	252	-	18	18
6971.75	4.75	450809	10.35	2.5	21.63	-	-	0.8	10	7	7.3	-	-	-	266	-	25	25
6972	5	471838	10.83	5.2	24.28	-	-	0.8	12	7	13	2.4	-	-	280	-	35	35
6972.25	5.25	482595.75	11.08	2.7	27.02	-	-	0.8	13	8	17	16	-	-	292	-	54	54
6972.5	5.5	493354	11.33	5.5	29.82	-	-	0.8	14	8	20	35	-	-	304	-	78	78
6973	6	514869	11.82	5.8	35.60	-	-	0.9	16	9	30	87	-	-	327	-	142	142
6973.25	6.25	518272	11.90	3.0	38.57	-	-	0.9	17	9	35	121	-	-	338	-	183	183
6973.5	6.5	521675	11.98	5.9	41.55	-	-	0.9	18	9	41	163	-	-	349	-	232	232
6974	7	528481	12.13	12.0	47.58	-	-	1.0	20	10	53	259	-	-	369	-	307	307
6976	9	553685	12.71	24.8	72.42	-	1,102	1.1	25	11	83	729	-	-	443	-	443	1,545

- Notes:
- 1) Top-of-bank and spillway flows are weir equations from section 11.3.1 in the DCM. $Q=CLH^{1.5}$ (C=3.0)
 - 2) Orifice flows are also from section 11.3.1. $Q=CA(2gH)^{.5}$ (C=.6)
 - 3) Grate flows are determined from equations 7-2 and 7-3. Weir Flow $Q=(3PH^{1.5})/F$, Orifice Flow $Q=4.815*AH^{0.5}$
 - 4) Pipe flows use the lesser of: 1) Inlet control equations 27 & 28, page 146 of HDS No. 5 - or - 2) Allowable Pipe Flow equation on page 11-9 of the DCM. Use Table 9, page 147-148, HDS No. 5 for formulas 26 & 27.

STAGE/STORAGE/DISCHARGE CURVES FOR DETENTION POND ANALYSIS

Meridian Ranch Existing Detention Pond E-FINAL FUTURE (H08)

Gieck Basin - El Paso County, Colorado

Data for spillway and embankment:

embankment length =	1860
embankment elev =	6976
spillway length =	200
spillway elevation =	6974
100 year storage elev.=	6973.6
100 year storage vol.=	42.4
100 year discharge=	205
5 year storage elev.=	6971.4
5 year storage vol.=	18.0
5 year discharge=	12
WQCV storage elev.=	6968.9
WQCV storage vol.=	1.5
1/2 WQCV storage elev.=	6968.3
1/2 WQCV storage vol.=	0.75

Data for outlet pipe and grate:

Type	H or V	Width (ft.)	Height (ft.)	Dia.(in)	Area = (sqft)	Invert Elev =
Rectangular	Orifice 1:	V	0.0248	1.65	0.041	6967.18
Rectangular	Orifice 2:	V	2	0.8	1.600	6970.40
Circular	Orifice 3:	H		10	0.545	6969.00
Rectangular	Orifice 4:	V	6	0.7	4.200	6971.20

Stand Pipe Dimensions

Rec Grate	11	x	7	Elev =	6971.90
Circ. Grate		dia.		Elev =	6971.90

50 year storage elev.=	6973.1
50 year discharge=	137
25 year storage elev.=	6972.5
25 year discharge=	72
10 year storage elev.=	6971.9
10 year discharge=	24
2 year storage elev.=	6970.6
2 year discharge=	4.1

Outlet Culvert Dimensions

Outlet Culvert	Width (ft.)	Height (ft.)	Dia. (ft.)	Type
Outlet Culvert	x		3.5	Circular
Area	9.6	TOP		
Outlet I. E.	6966.8	6970.58		
Wall Thick.	4	in.		

STAGE		STORAGE				DISCHARGE				GRATE (max outflow)		PIPE		REALIZED CULVERT OUTFLOW	TOTAL FLOW	
ELEV	HEIGHT	AREA		VOLUME		TOP OF BANK	SPILLWAY	ORIFICE (max outflow)				Rectangular	PIPE			
		sqft	acre	acft	cum acft			1	2	3	4		1	2		
6967	0	1808	0.04	0.0	0.0			-	-	-	-	-	0.91		-	-
6967.5	0.5	16136.5	0.37	0.1	0.1			0.0	-	-	-	-	8.0		0.01	0.01
6968	1	30465	0.70	0.3	0.4			0.1	-	-	-	-	18		0.06	0.06
6968.5	1.5	81028.5	1.86	0.6	1.0			0.1	-	-	-	-	30		0.11	0.11
6969	2	131592	3.02	1.2	2.2			0.2	-	-	-	-	52		0.2	0.2
6969.5	2.5	201294.5	4.62	1.9	4.1			0.2	-	1.9	-	-	75		2.1	2.1
6970	3	270997	6.22	4.6	6.9			0.3	-	2.6	-	-	97		2.9	2.9
6970.5	3.5	329359.5	7.56	3.4	10			0.3	0.2	3.2	-	-	122		3.7	3.7
6970.75	3.75	358540.75	8.23	2.0	12.3			0.3	1.2	3.5	-	-	135		5	5.0
6971	4	387722	8.90	7.6	14			0.3	2.8	3.7	-	-	146		7	6.8
6971.25	4.25	408751	9.38	2.3	17			0.4	4.7	3.9	0.2	-	157		9	9.2
6971.5	4.5	429780	9.87	4.7	19			0.4	6.4	4	3.0	-	167		14	14
6971.75	4.75	450809	10.35	2.5	22			0.4	7.5	4	7.3	-	176		20	20
6972	5	471838	10.83	5.2	24			0.4	8	5	13	2	185		29	29
6972.25	5.25	482595.75	11.08	2.7	27			0.4	9	5	17	16	193		47	47
6972.5	5.5	493354	11.33	5.5	30			0.4	10	5	20	35	201		70	70
6973	6	514869	11.82	5.8	36			0.4	11	5	24	87	217		128	128
6973.25	6.25	518272	11.90	3.0	39			0.5	12	5	26	118	224		162	162
6973.5	6.5	521675	11.98	5.9	42			0.5	13	6	28	152	231		199	199
6974	7	528481	12.13	12.0	48			0.5	14	6	32	228	244		244	244
6976	9	553685	12.71	24.8	72			0.6	18	7	43	623	291		291	291

- Notes:
- 1) Top-of-bank and spillway flows are weir equations from section 11.3.1 in the DCM. $Q=CLH^{1.5}$ (C=3.0)
 - 2) Orifice flows are also from section 11.3.1. $Q=CA(2gH)^{.5}$ (C=6)
 - 3) Grate flows are determined from equations 7-2 and 7-3. Weir Flow $Q=(3PH^{1.5})/F$, Orifice Flow $Q=4.815*AH^{0.5}$
 - 4) Pipe flows use the lesser of: 1) Inlet control equations 27 & 28, page 146 of HDS No. 5 - or - 2) Allowable Pipe Flow equation on page 11-9 of the DCM. Use Table 9, page 147-148, HDS No. 5 for formulas 26 & 27.

STAGE/STORAGE/DISCHARGE CURVES FOR DETENTION POND ANALYSIS

Meridian Ranch Existing Detention Pond E-FINAL FUTURE (H09)

Gieck Basin - El Paso County, Colorado

Data for spillway and embankment:

embankment length =	1860
embankment elev =	6976
spillway length =	200
spillway elevation =	6974.5
100 year storage elev.=	6973.6
100 year storage vol.=	42.4
100 year discharge=	37
5 year storage elev.=	6971.4
5 year storage vol.=	18.0
5 year discharge=	4.1
WQCV storage elev.=	6968.9
WQCV storage vol.=	1.5
1/2 WQCV storage elev.=	6968.3
1/2 WQCV storage vol.=	0.8

Data for outlet pipe and grate:

Type		H or V	Dimensions Width (ft.) X Height (ft.)		Dia.(in)	(sqft)			
Rectangular	Orifice 1:	V	0.0248	1.65		Area =	0.041	Invert Elev =	6967.18
Rectangular	Orifice 2:	V	0.75	1		Area =	0.750	Invert Elev =	6970.75
Circular	Orifice 3:	H			8	Area =	0.349	Invert Elev =	6969.00
Rectangular	Orifice 4:	V	3.5	1.25		Area =	4.375	Invert Elev =	6971.75

Stand Pipe Dimensions					
Rec Grate		4.25	x	3	Elev = 6973.00
Circ. Grate			dia.		Elev = 6973.00

50 year storage elev.=	6973.1
50 year discharge=	16
25 year storage elev.=	6972.5
25 year discharge=	8.3
10 year storage elev.=	6971.9
10 year discharge=	5.9
2 year storage elev.=	6970.6
2 year discharge=	2.4

Outlet Culvert Dimensions

Outlet Culvert	Width (ft.)		Height (ft.)	Dia. (ft.)	Type
Outlet Culvert		x		3.5	Circular
Area	9.6		TOP		
Outlet I. E.	6966.8		6970.7		
Wall Thick.	5	in.			

STAGE		STORAGE				DISCHARGE								REALIZED CULVERT OUTFLOW	TOTAL FLOW	
ELEV	HEIGHT	AREA		VOLUME		TOP OF BANK	SPILLWAY	ORIFICE (max outflow)				GRATE (max outflow)	PIPE		REALIZED CULVERT OUTFLOW	TOTAL FLOW
		sqft	acre	acft	cum acft			1	2	3	4		1	2		
6967	0	1808	0.04	0.0	0.0			-	-	-	-	-	0.45	-	-	
6967.5	0.5	16136.5	0.37	0.1	0.1			0.0	-	-	-	-	5.0	0.01	0.01	
6968	1	30465	0.70	0.3	0.4			0.1	-	-	-	-	8.8	0.06	0.06	
6968.5	1.5	81028.5	1.86	0.6	1.0			0.1	-	-	-	-	17	0.11	0.11	
6969	2	131592	3.02	1.2	2.2			0.2	-	-	-	-	26	0.2	0.18	
6969.5	2.5	201294.5	4.62	1.9	4.1			0.2	-	-	1.2	-	35	1.4	1.4	
6970	3	270997	6.22	4.6	6.9			0.3	-	-	1.7	-	48	2.0	2.0	
6970.5	3.5	329359.5	7.56	3.4	10.3			0.3	-	-	2.1	-	61	2.4	2.4	
6970.75	3.75	358540.75	8.23	2.0	12.3			0.3	-	-	2.2	-	68	2.6	2.6	
6971	4	387722	8.90	7.6	14.4			0.3	0.3	2.4	-	-	73	3.0	3.0	
6971.25	4.25	408751	9.38	2.3	16.7			0.4	0.8	2.5	-	-	79	3.7	3.7	
6971.5	4.5	429780	9.87	4.7	19.1			0.4	1.5	2.7	-	-	85	4.5	4.5	
6971.75	4.75	450809	10.35	2.5	21.6			0.4	2.3	2.8	-	-	90	5.4	5.4	
6972	5	471838	10.83	5.2	24.3			0.4	3.1	2.9	-	-	95	6.4	6.4	
6972.25	5.25	482595.75	11.08	2.7	27.0			0.4	3.6	3.0	-	-	99	7.0	7.0	
6972.5	5.5	493354	11.33	5.5	29.8			0.4	4.0	3.1	0.5	-	103	8	8.1	
6973	6	514869	11.82	5.8	35.6			0.4	4.8	3.4	5.2	-	111	14	14	
6973.25	6.25	518272	11.90	3.0	38.6			0.5	5.1	3.5	8.6	4	114	21	21	
6973.5	6.5	521675	11.98	5.9	41.6			0.5	5.4	3.6	13	11	118	33	33	
6974	7	528481	12.13	12.0	47.6			0.5	6.0	3.8	22	31	125	63	63	
6976	9	553685	12.71	24.8	72.4			0.6	7.9	4.4	40	106	151	151	151	

- Notes:
- 1) Top-of-bank and spillway flows are weir equations from section 11.3.1 in the DCM. $Q=CLH^{1.5}$ (C=3.0)
 - 2) Orifice flows are also from section 11.3.1. $Q=CA(2gH)^{0.5}$ (C=.6)
 - 3) Grate flows are determined from equations 7-2 and 7-3. Weir Flow $Q=(3PH^{1.5})/F$, Orifice Flow $Q=4.815*AH^{0.5}$
 - 4) Pipe flows use the lesser of: 1) Inlet control equations 27 & 28, page 146 of HDS No. 5 - or - 2) Allowable Pipe Flow equation on page 11-9 of the DCM. Use Table 9, page 147-148, HDS No. 5 for formulas 26 & 27.

STAGE/STORAGE/DISCHARGE CURVES FOR DETENTION POND ANALYSIS

Meridian Ranch Proposed Detention Pond F-Final

Geick Basin - El Paso County, Colorado

Data for spillway and embankment:

embankment length =	285
embankment elev =	7138.5
spillway length =	87
spillway elevation =	7137.5
100 year storage elev.=	7136.0
100 year storage vol.=	8.8
100 year discharge=	177
5 year storage elev.=	7131.2
5 year storage vol.=	1.9
5 year discharge=	8.1
WQCV storage elev.=	7129.1
WQCV storage vol.=	0.3
1/2 WQCV storage elev.=	7128.6
1/2 WQCV storage vol.=	0.15

Data for outlet pipe and grate:

Type	H or V	Width (ft.)	Height (ft.)	Dia.(in)	Area =	(sqft)	Elev to cl =
Rectangular	Orifice 1:	V	0.0131	1.25	0.016	0.016	7128.45
Rectangular	Orifice 2:	V	4	0.5	2.000	2.000	7130.75
Circular	Orifice 3:	H		8	0.349	0.349	7129.20
None Selected	Orifice 4:				0.000	0.000	

Stand Pipe Dimensions

Rec Grate	6	x	3	Elev =	7133
Circ. Grate		dia.		Elev =	7133

50 year storage elev.=	7134.9
50 year discharge=	121
25 year storage elev.=	7134.1
25 year discharge=	61
10 year storage elev.=	7132.7
10 year discharge=	17
2 year storage elev.=	7130.1
2 year discharge=	2.3

Outlet Culvert Dimensions

Outlet Culvert	Width (ft.)	Height (ft.)	Dia. (ft.)	Type
Area	12.6	TOP	4	Circular
Outlet I. E.	7126.6	7131.0		
Wall Thick.	5	in.		

STAGE		STORAGE				DISCHARGE										REALIZED CULVERT OUTFLOW	TOTAL FLOW	
ELEV	HEIGHT	AREA		VOLUME		TOP OF BANK	SPILLWAY	ORIFICE (max outflow)				GRATE (max outflow)	PIPE					
		sqft	acre	acft	cum acft			1	2	3	4		Rectangular	1	2			
7127.7	0	0	0.00	0.00	0.00	-	-	-	-	-	-	-	-	-	-	-	-	-
7128	0.3	2170	0.05	0.01	0.01	-	-	0.0	-	-	-	-	-	-	11	-	0.0	0.0
7129	1.3	17730	0.41	0.23	0.24	-	-	0.1	-	-	-	-	-	-	31	-	0.1	0.1
7130	2.3	33290	0.76	0.59	0.82	-	-	0.1	-	-	1.5	-	-	-	57	-	1.6	1.6
7131	3.3	39060	0.90	0.83	1.65	-	-	0.1	4.2	2.3	-	-	-	-	117	-	6.6	6.6
7132	4.3	44830	1.03	0.96	2.61	-	-	0.1	10.8	2.8	-	-	-	-	117	-	14	14
7133	5.3	55137.5	1.27	1.15	3.76	-	-	0.2	14.4	3.3	-	-	-	-	142	-	18	18
7134	6.3	65445	1.50	1.38	5.15	-	-	0.2	17.4	3.7	-	-	36	-	162	-	57	57
7135	7.3	79535	1.83	1.66	6.81	-	-	0.2	19.9	4.0	-	-	102	-	175	-	126	126
7136	8.3	93625	2.15	1.99	8.80	-	-	0.2	22.1	4.4	-	-	150	-	187	-	177	177
7137	9.3	111620	2.56	2.36	11.15	-	-	0.2	24.1	4.7	-	-	173	-	200	-	200	200
7138	10.3	129615	2.98	2.77	13.92	-	92.3	0.2	25.9	5.0	-	-	194	-	211	-	211	303
7138.5	10.8					-	261.0	0.3	26.8	5.1	-	-	203	-	211	-	-	261

- Notes:
- 1) Top-of-bank and spillway flows are weir equations from section 11.3.1 in the DCM. $Q=CLH^{1.5}$ (C=3.0)
 - 2) Orifice flows are also from section 11.3.1. $Q=CA(2gH)^{0.5}$ (C=6)
 - 3) Grate flows are determined from equations 7-2 and 7-3. Weir Flow $Q=(3PH^{1.5})/F$, Orifice Flow $Q=4.815*AH^{0.5}$
 - 4) Pipe flows use the lesser of: 1) Inlet control equations 27 & 28, page 146 of HDS No. 5 - or - 2) Allowable Pipe Flow equation on page 11-9 of the DCM. Use Table 9, page 147-148, HDS No. 5 for formulas 26 & 27.

STAGE/STORAGE/DISCHARGE CURVES FOR DETENTION POND ANALYSIS

**Meridian Ranch Proposed Detention Pond G-FINAL FUTURE DESIGN (G12)
Gieck Basin - El Paso County, Colorado**

Data for spillway and embankment:

embankment length =	500
embankment elev =	7033.5
spillway length =	130
spillway elevation =	7031.5
100 year storage elev.=	7030.3
100 year storage vol.=	25.3
100 year discharge=	478
5 year storage elev.=	7027.4
5 year storage vol.=	8.3
5 year discharge=	22
WQCV storage elev.=	7025.2
WQCV storage vol.=	0.9
1/2 WQCV storage elev.=	7024.9
1/2 WQCV storage vol.=	0.45

Data for outlet pipe and grate:

Type	Orifice	H or V	Dimensions		Dia.(in)	Area =	Area (sqft)		
			Width (ft.)	X Height (ft.)			Elev to cl =		
Rectangular	Orifice 1:	V	0.0263	1.90		0.050	Elev to cl =		7024.25
Rectangular	Orifice 2:	V	8.5	1.1		9.350	Elev to cl =		7027.55
Circular	Orifice 3:	H			12	0.785	Elev to cl =		7025.20
Rectangular	Orifice 4:	V	4	0.6		2.400	Elev to cl =		7027.80
Rectangular	Orifice 5:	V	8.5	1.1		9.350	Elev to cl =		7027.55

Stand Pipe Dimensions	
Rec Grate	20 x 8 Elev = 7028.10
Circ. Grate	dia. Elev = 7028.10

50 year storage elev.=	7029.5
50 year discharge=	333
25 year storage elev.=	7028.7
25 year discharge=	170
10 year storage elev.=	7027.9
10 year discharge=	56
2 year storage elev.=	7026.8
2 year discharge=	5.1

Outlet Culvert Dimensions

	Width (ft.)		Height (ft.)	Dia. (ft.)	Type
Outlet Culvert	10	x	4		Rectangular
Area	40.0		TOP		
Outlet I. E.	7022.5		7027.50		
Wall Thick.	12	in.			

STAGE		STORAGE				DISCHARGE											REALIZED CULVERT OUTFLOW	TOTAL FLOW
ELEV	HEIGHT	AREA		VOLUME		TOP OF BANK	SPILLWAY	ORIFICE (max outflow)					GRATE (max outflow)		PIPE			
		sqft	acre	acft	cum acft			1	2	3	4	5	Rectangular	1	2			
7023.3	0	0	0.00	0.0	0.00	-	-	-	-	-	-	-	-	-	-	12	-	-
7024	0.7	2232	0.05	0.0	0.02	-	-	0.0	-	-	-	-	-	-	-	51	0.0	0.05
7025	1.7	39917	0.92	0.5	0.50	-	-	0.2	-	-	-	-	-	-	-	111	0.2	0.17
7026	2.7	126469	2.90	1.9	2.41	-	-	0.3	-	3.4	-	-	-	-	-	184	3.7	3.7
7026.5	3.2	166675	3.83	3.6	4.06	-	-	0.4	-	4.3	-	-	-	-	-	224	4.7	4.7
7027	3.7	206880	4.75	2.1	6.20	-	-	0.4	-	5.1	-	-	-	-	-	268	5.5	5.5
7027.5	4.2	232032	5.33	4.6	8.64	-	-	0.4	9.0	5.7	-	9.0	-	-	-	304	24	24
7028	4.7	257183	5.90	5.3	11.5	-	-	0.5	25.5	6.3	4.2	25.5	-	-	-	337	62	62
7028.5	5.2	264196	6.07	5.7	14.3	-	-	0.5	43.9	6.9	9.7	43.9	27	-	-	373	132	132
7029	5.7	271209	6.23	6.1	17.6	-	-	0.5	54.2	7.4	12.7	54.2	92	-	-	406	221	221
7029.5	6.2	276106	6.34	11.7	20.3	-	-	0.6	70.5	7.8	17.1	70.5	179	-	-	436	345	345
7030	6.7	281003	6.45	9.4	23.7	-	-	0.6	77.3	8.3	19.0	77.3	283	-	-	464	464	464
7030.5	7.2	286003	6.57	6.5	26.8	-	-	0.6	77.3	8.7	19.0	77.3	402	-	-	491	491	491
7031	7.7	291002	6.68	6.6	30.3	-	-	0.6	83.6	9.1	20.7	83.6	533	-	-	516	516	516
7031.5	8.2	296443	6.81	6.7	33.4	-	-	0.6	89.5	9.5	22.2	89.5	677	-	-	540	540	540
7032	8.7	301883	6.93	3.4	36.9	137.9	137.9	0.7	95.0	9.9	23.7	95.0	832	-	-	563	563	701
7032.5	9.2	309236	7.10	7.0	40.4	390.0	390.0	0.7	100.2	10.2	25.1	100.2	997	-	-	586	586	976
7033	9.7	316589	7.27	3.6	44.0	716.5	716.5	0.7	105.1	10.6	26.4	105.1	1,171	-	-	607	607	1,323

- Notes:
- 1) Top-of-bank and spillway flows are weir equations from section 11.3.1 in the DCM. $Q=CLH^{1.5}$ (C=3.0)
 - 2) Orifice flows are also from section 11.3.1. $Q=CA(2gH)^{.5}$ (C=.6)
 - 3) Grate flows are determined from equations 7-2 and 7-3. Weir Flow $Q=(3PH^{1.5})/F$, Orifice Flow $Q=4.815*AH^{0.5}$
 - 4) Pipe flows use the lesser of: 1) Inlet control equations 27 & 28, page 146 of HDS No. 5 - or - 2) Allowable Pipe Flow equation on page 11-9 of the DCM. Use Table 9, page 147-148, HDS No. 5 for formulas 26 & 27.

FUTURE POND G

WQCV Control Riser Calculations

TRIBUTARY AREA	577	acres
DRAIN TIME	40	hr
	<i>a</i>	1
IMPERVIOUSNESS RATIO	<i>i</i>	0.18
DEPTH OF OUTLET	1.9	
WQCV	0.11	inches
WQCV DESIGN VOL	0.9	ac-ft
	K_{40}	0.36
AREA PER RISER ¹	<i>a</i>	7.67 in ²
No. of Columns	1	
No. of Holes	3	per column
Area per Hole	2.56	in ²
Hole size	1 3/4	in
Steel Plate Thickness	1/4	in
¹ AREA PER ROW PER RISER		
Actual area per row per hole:	2.41	in ²
Actual area per riser:	7.2	in ²
Actual area per riser:	0.050	ft ²

TABLE SB-2							
Hole Dia (in)		Area per Row (in ²)					
Holes per Row		1	2	3	4	5	6
Min steel thickness		1/4	5/16	3/8	3/8	3/8	1/2
1/4	0.2500	0.05	0.10	0.15	0.20	0.25	0.29
5/16	0.3125	0.08	0.15	0.23	0.31	0.38	0.46
3/8	0.3750	0.11	0.22	0.33	0.44	0.55	0.66
7/16	0.4375	0.15	0.30	0.45	0.60	0.75	0.90
1/2	0.5000	0.20	0.39	0.59	0.79	0.98	1.18
9/16	0.5625	0.25	0.50	0.75	0.99	1.24	1.49
5/8	0.6250	0.31	0.61	0.92	1.23	1.53	1.84
11/16	0.6875	0.37	0.74	1.11	1.48	1.86	2.23
3/4	0.7500	0.44	0.88	1.33	1.77	2.21	2.65
7/8	0.8750	0.60	1.20	1.80	2.41	3.01	3.61
1	1.0000	0.79	1.57	2.36	3.14	3.93	4.71
1 1/8	1.1250	0.99	1.99	2.98	3.98	4.97	5.96
1 1/4	1.2500	1.23	2.45	3.68	4.91	6.14	7.36
1 3/8	1.3750	1.48	2.97	4.45	5.94	7.42	8.91
1 1/2	1.5000	1.77	3.53	5.30	7.07	8.84	10.60
1 5/8	1.6250	2.07	4.15	6.22	8.30	10.37	12.44
1 3/4	1.7500	2.41	4.81	7.22	9.62	12.03	14.43
1 7/8	1.8750	2.76	5.52	8.28	11.04	13.81	16.57
2	2.0000	3.14	6.28	9.42	12.57	15.71	18.85
n = Number of columns of perforations							

ROLLING HILLS RANCH PUD INTERIM CONDITION

Simulation Run: RHPUD-100 YR Reservoir: POND D

Start of Run: 01Jul2015, 00:00 Basin Model: WW Grading
End of Run: 02Jul2015, 00:00 Meteorologic Model: SCS TYPE IIA 100YR
Compute Time: 14Mar2018 13:11:34 Control Specifications: 24 HR-2 MIN.

Volume Units: AC-FT

Computed Results:

Peak Inflow: 509(CFS) Date/Time of Peak Inflow: 01Jul2015, 12:12
Peak Outflow: 134 (CFS) Date/Time of Peak Outflow: 01Jul2015, 13:00
Total Inflow : 57.0 (AC-FT) Peak Storage: 25.5 (AC-FT)
Total Outflow: 46.8 (AC-FT) Peak Elevation: 7057.1 (FT)

Simulation Run: RHPUD-005 YR Reservoir: POND D

Start of Run: 01Jul2015, 00:00 Basin Model: WW Grading
End of Run: 02Jul2015, 00:00 Meteorologic Model: SCS TYPE IIA 005YR
Compute Time: 14Mar2018 13:11:34 Control Specifications: 24 HR-2 MIN.

Volume Units: AC-FT

Computed Results:

Peak Inflow: 107 (CFS) Date/Time of Peak Inflow: 01Jul2015, 12:18
Peak Outflow: 12 (CFS) Date/Time of Peak Outflow: 01Jul2015, 14:36
Total Inflow : 13.6 (AC-FT) Peak Storage: 7.4 (AC-FT)
Total Outflow: 9.2 (AC-FT) Peak Elevation: 7053.9 (FT)

Simulation Run: RHPUD-100 YR Reservoir: POND E

Start of Run: 01Jul2015, 00:00 Basin Model: WW Grading
End of Run: 02Jul2015, 00:00 Meteorologic Model: SCS TYPE IIA 100YR
Compute Time: 14Mar2018 13:11:34 Control Specifications: 24 HR-2 MIN.

Volume Units: AC-FT

Computed Results:

Peak Inflow: 610 (CFS) Date/Time of Peak Inflow: 01Jul2015, 12:18
Peak Outflow: 242 (CFS) Date/Time of Peak Outflow: 01Jul2015, 13:30
Total Inflow : 122.9 (AC-FT) Peak Storage: 42.4 (AC-FT)
Total Outflow: 98.9 (AC-FT) Peak Elevation: 6973.6 (FT)

Simulation Run: RHPUD-005 YR Reservoir: POND E

Start of Run: 01Jul2015, 00:00 Basin Model: WW Grading
End of Run: 02Jul2015, 00:00 Meteorologic Model: SCS TYPE IIA 005YR
Compute Time: 14Mar2018 13:11:34 Control Specifications: 24 HR-2 MIN.

Volume Units: AC-FT

Computed Results:

Peak Inflow: 126 (CFS)	Date/Time of Peak Inflow: 01Jul2015, 12:12
Peak Outflow: 16 (CFS)	Date/Time of Peak Outflow: 01Jul2015, 20:00
Total Inflow : 29.0 (AC-FT)	Peak Storage: 18.0 (AC-FT)
Total Outflow: 13.1 (AC-FT)	Peak Elevation: 6971.4 (FT)

Simulation Run: RHPUD-100 YR Reservoir: POND F

Start of Run: 01Jul2015, 00:00 Basin Model: WW Grading
End of Run: 02Jul2015, 00:00 Meteorologic Model: SCS TYPE IIA 100YR
Compute Time: 14Mar2018 13:11:34 Control Specifications: 24 HR-2 MIN.

Volume Units: AC-FT

Computed Results:

Peak Inflow: 242(CFS)	Date/Time of Peak Inflow: 01Jul2015, 12:18
Peak Outflow: 155 (CFS)	Date/Time of Peak Outflow: 01Jul2015, 12:42
Total Inflow : 33.5 (AC-FT)	Peak Storage: 7.6 (AC-FT)
Total Outflow: 31.6 (AC-FT)	Peak Elevation: 7135.6 (FT)

Simulation Run: RHPUD-005 YR Reservoir: POND F

Start of Run: 01Jul2015, 00:00 Basin Model: WW Grading
End of Run: 02Jul2015, 00:00 Meteorologic Model: SCS TYPE IIA 005YR
Compute Time: 14Mar2018 13:11:34 Control Specifications: 24 HR-2 MIN.

Volume Units: AC-FT

Computed Results:

Peak Inflow: 18 (CFS)	Date/Time of Peak Inflow: 01Jul2015, 12:36
Peak Outflow: 6.5 (CFS)	Date/Time of Peak Outflow: 01Jul2015, 14:24
Total Inflow : 4.8 (AC-FT)	Peak Storage: 1.5 (AC-FT)
Total Outflow: 4.3 (AC-FT)	Peak Elevation: 7131.0 (FT)

Simulation Run: RHPUD-100 YR Reservoir: POND G

Start of Run: 01Jul2015, 00:00 Basin Model: WW Grading
End of Run: 02Jul2015, 00:00 Meteorologic Model: SCS TYPE IIA 100YR
Compute Time: 14Mar2018 13:11:34 Control Specifications: 24 HR-2 MIN.

Volume Units: AC-FT

Computed Results:

Peak Inflow: 504 (CFS)	Date/Time of Peak Inflow: 01Jul2015, 12:36
Peak Outflow: 369 (CFS)	Date/Time of Peak Outflow: 01Jul2015, 13:06
Total Inflow : 95.6 (AC-FT)	Peak Storage: 23.1 (AC-FT)
Total Outflow: 86.8 (AC-FT)	Peak Elevation: 7029.9 (FT)

Simulation Run: RHPUD-005 YR Reservoir: POND G

Start of Run: 01Jul2015, 00:00 Basin Model: WW Grading
End of Run: 02Jul2015, 00:00 Meteorologic Model: SCS TYPE IIA 005YR
Compute Time: 14Mar2018 13:11:34 Control Specifications: 24 HR-2 MIN.

Volume Units: AC-FT

Computed Results:

Peak Inflow: 38 (CFS)	Date/Time of Peak Inflow: 01Jul2015, 12:48
Peak Outflow: 12 (CFS)	Date/Time of Peak Outflow: 01Jul2015, 18:18
Total Inflow : 14.2 (AC-FT)	Peak Storage: 7.8 (AC-FT)
Total Outflow: 8.6 (AC-FT)	Peak Elevation: 7025.8 (FT)

ROLLING HILLS RANCH PUD FUTURE CONDITION
Simulation Run: F-100 YR Reservoir: POND D

Start of Run: 01Jul2015, 00:00 Basin Model: Future SCS
End of Run: 02Jul2015, 00:00 Meteorologic Model: SCS TYPE IIA 100YR
Compute Time: 14Mar2018 13:11:34 Control Specifications: 24 HR-2 MIN.

Volume Units: AC-FT

Computed Results:

Peak Inflow: 509 (CFS)	Date/Time of Peak Inflow: 01Jul2015, 12:12
Peak Outflow: 134 (CFS)	Date/Time of Peak Outflow: 01Jul2015, 13:00
Total Inflow : 57.0 (AC-FT)	Peak Storage: 25.5 (AC-FT)
Total Outflow: 46.8 (AC-FT)	Peak Elevation: 7057.1 (FT)

Simulation Run: F-005 YR Reservoir: POND D

Start of Run: 01Jul2015, 00:00 Basin Model: Future SCS
End of Run: 02Jul2015, 00:00 Meteorologic Model: SCS TYPE IIA 005YR
Compute Time: 14Mar2018 13:26:34 Control Specifications: 24 HR-2 MIN.

Volume Units: AC-FT

Computed Results:

Peak Inflow: 107 (CFS)	Date/Time of Peak Inflow: 01Jul2015, 12:18
Peak Outflow: 12 (CFS)	Date/Time of Peak Outflow: 01Jul2015, 14:36
Total Inflow : 13.6 (AC-FT)	Peak Storage: 7.5 (AC-FT)
Total Outflow: 9.2 (AC-FT)	Peak Elevation: 7053.9 (FT)

Simulation Run: F-100 YR Reservoir: POND E

Start of Run: 01Jul2015, 00:00 Basin Model: Future SCS
End of Run: 02Jul2015, 00:00 Meteorologic Model: SCS TYPE IIA 100YR
Compute Time: 14Mar2018 13:11:34 Control Specifications: 24 HR-2 MIN.

Volume Units: AC-FT

Computed Results:

Peak Inflow: 610 (CFS)	Date/Time of Peak Inflow: 01Jul2015, 12:18
Peak Outflow: 242 (CFS)	Date/Time of Peak Outflow: 01Jul2015, 13:30
Total Inflow : 122.9 (AC-FT)	Peak Storage: 42.4 (AC-FT)
Total Outflow: 98.9 (AC-FT)	Peak Elevation: 6973.6 (FT)

Simulation Run: F-005 YR Reservoir: POND E

Start of Run: 01Jul2015, 00:00 Basin Model: Future SCS
End of Run: 02Jul2015, 00:00 Meteorologic Model: SCS TYPE IIA 005YR
Compute Time: 14Mar2018 13:26:34 Control Specifications: 24 HR-2 MIN.

Volume Units: AC-FT

Computed Results:

Peak Inflow: 126 (CFS)	Date/Time of Peak Inflow: 01Jul2015, 12:12
Peak Outflow: 16 (CFS)	Date/Time of Peak Outflow: 01Jul2015, 20:00
Total Inflow : 29.0 (AC-FT)	Peak Storage: 18.0 (AC-FT)
Total Outflow: 13.1 (AC-FT)	Peak Elevation: 6971.4 (FT)

Simulation Run: F-100 YR Reservoir: POND F

Start of Run: 01Jul2015, 00:00 Basin Model: Future SCS
End of Run: 02Jul2015, 00:00 Meteorologic Model: SCS TYPE IIA 100YR
Compute Time: 14Mar2018 13:11:34 Control Specifications: 24 HR-2 MIN.

Volume Units: AC-FT

Computed Results:

Peak Inflow: 256(CFS)	Date/Time of Peak Inflow: 01Jul2015, 12:18
Peak Outflow: 164 (CFS)	Date/Time of Peak Outflow: 01Jul2015, 12:42
Total Inflow : 35.3 (AC-FT)	Peak Storage: 8.0 (AC-FT)
Total Outflow: 33.4 (AC-FT)	Peak Elevation: 7135.8 (FT)

Simulation Run: F-005 YR Reservoir: POND F

Start of Run: 01Jul2015, 00:00 Basin Model: Future SCS
End of Run: 02Jul2015, 00:00 Meteorologic Model: SCS TYPE IIA 005YR
Compute Time: 14Mar2018 13:26:34 Control Specifications: 24 HR-2 MIN.

Volume Units: AC-FT

Computed Results:

Peak Inflow: 19 (CFS)	Date/Time of Peak Inflow: 01Jul2015, 12:36
Peak Outflow: 7.2 (CFS)	Date/Time of Peak Outflow: 01Jul2015, 14:18
Total Inflow : 5.1 (AC-FT)	Peak Storage: 1.6 (AC-FT)
Total Outflow: 4.6 (AC-FT)	Peak Elevation: 7131.1 (FT)

Simulation Run: F-100 YR Reservoir: POND G

Start of Run: 01Jul2015, 00:00 Basin Model: Future SCS
End of Run: 02Jul2015, 00:00 Meteorologic Model: SCS TYPE IIA 100YR
Compute Time: 14Mar2018 13:11:34 Control Specifications: 24 HR-2 MIN.

Volume Units: AC-FT

Computed Results:

Peak Inflow: 694 (CFS)	Date/Time of Peak Inflow: 01Jul2015, 12:06
Peak Outflow: 479 (CFS)	Date/Time of Peak Outflow: 01Jul2015, 12:32
Total Inflow : 119.4 (AC-FT)	Peak Storage: 25.4 (AC-FT)
Total Outflow: 110.2 (AC-FT)	Peak Elevation: 7030.3 (FT)

Simulation Run: F-005 YR Reservoir: POND G

Start of Run: 01Jul2015, 00:00 Basin Model: Future SCS
End of Run: 02Jul2015, 00:00 Meteorologic Model: SCS TYPE IIA 005YR
Compute Time: 14Mar2018 13:26:34 Control Specifications: 24 HR-2 MIN.

Volume Units: AC-FT

Computed Results:

Peak Inflow: 73 (CFS)	Date/Time of Peak Inflow: 01Jul2015, 12:30
Peak Outflow: 21 (CFS)	Date/Time of Peak Outflow: 01Jul2015, 15:24
Total Inflow : 20.4 (AC-FT)	Peak Storage: 8.2 (AC-FT)
Total Outflow: 14.5 (AC-FT)	Peak Elevation: 7027.4 (FT)

Appendix D – Hec-Ras Analysis

	River Sta	Profile	Q Total	Depth of Flow	Min Ch El	W.S. Elev	Crit W.S.	E.G. Elev	E.G. Slope	Vel Chnl	Flow Area	Top Width	Froude #
			(cfs)	(ft)	(ft)	(ft)	(ft)	(ft)	(ft/ft)	(ft/s)	(sq ft)	(ft)	Chl
RIP-RAP LINED	5688	Q100	164	1.6	7125.5	7127.1	7127.0	7127.4	0.0397	4.5	36.6	39.0	0.80
	5607	Q100	164	1.5	7124.0	7125.5		7125.7	0.0126	3.1	53.1	44.7	0.47
	5558	Q100	164	2.1	7123.0	7125.1		7125.2	0.0081	2.8	58.4	36.6	0.39
	5358	Q100	164	1.7	7121.0	7122.7	7122.2	7122.9	0.0176	3.7	44.9	33.4	0.56
	5055	Q100	164	1.2	7112.0	7113.2	7113.2	7113.7	0.0643	5.7	29.0	29.7	1.01
	4765	Q100	164	2.0	7104.0	7106.0	7105.2	7106.1	0.0095	3.0	55.5	35.9	0.42
	4750	Q100	164	1.9	7103.9	7105.8		7106.0	0.0108	3.1	53.1	35.4	0.44
	4477	Q100	191	2.2	7101.1	7103.3		7103.4	0.0083	3.0	63.6	38.5	0.40
	4469	Q100	191	2.2	7101.0	7103.2		7103.3	0.0081	3.0	64.6	38.9	0.40
	4269	Q100	191	1.8	7099.0	7100.8		7101.1	0.0175	3.8	50.0	34.6	0.56
	4162	Q100	191	1.3	7096.0	7097.3	7097.3	7097.8	0.0620	5.9	32.3	30.3	1.01
	4087	Q100	191	1.1	7089.3	7090.4	7090.5	7091.0	0.0726	5.8	32.9	35.8	1.07
3997	Q100	208	1.8	7086.0	7087.8	7087.4	7088.1	0.0089	4.6	49.2	35.8	0.63	
NATURAL SANDY BOTTOM	3761	Q100	300	2.0	7082.0	7084.0	7084.0	7084.8	0.0196	7.7	44.7	28.7	0.97
	3500	Q100	300	2.0	7077.5	7079.5	7079.3	7080.0	0.0137	6.0	58.7	45.9	0.79
	3250	Q100	300	1.4	7074.1	7075.5	7075.5	7076.1	0.0175	6.2	52.6	49.1	0.96
	3100	Q100	300	1.9	7071.1	7073.0	7072.9	7073.6	0.0134	6.8	52.8	38.4	0.89
	3011	Q100	300	1.7	7070.0	7071.7	7071.7	7072.3	0.0158	6.9	53.8	45.9	0.95
	2887	Q100	300	1.6	7068.0	7069.6	7069.4	7070.0	0.0132	5.8	58.3	50.9	0.85
	2740	Q100	300	1.4	7066.0	7067.4	7067.4	7067.6	0.0192	3.5	85.9	166.1	0.87
	2500	Q100	300	1.4	7060.8	7062.2	7062.2	7062.7	0.0217	5.8	57.2	63.1	1.03
	2326	Q100	300	1.5	7056.9	7058.4	7058.4	7058.8	0.0225	5.4	62.7	87.3	1.02
	2187	Q100	300	1.8	7054.0	7055.8	7055.8	7056.4	0.0140	6.9	58.3	60.1	0.91
	2045	Q100	300	1.7	7052.0	7053.7	7053.6	7054.1	0.0146	5.3	66.8	70.4	0.86
	1899	Q100	493	1.6	7049.3	7050.9	7050.9	7051.4	0.0191	7.0	93.6	86.7	1.02
	1770	Q100	493	1.6	7046.6	7048.2	7048.3	7048.9	0.0197	7.5	80.6	70.4	1.06
	1589	Q100	493	1.2	7042.0	7043.2	7043.4	7044.1	0.0354	8.2	67.1	70.3	1.34
	1354	Q100	493	2.0	7037.7	7039.7	7039.7	7040.4	0.0165	7.1	79.8	61.1	0.97
1209	Q100	493	1.6	7036.0	7037.6	7037.3	7038.0	0.0107	5.5	98.2	73.7	0.78	
1173	Q100	493	2.0	7035.0	7037.0		7037.6	0.0109	6.6	88.1	53.2	0.82	
RIP-RAP	1122	Q100	493	2.1	7034.0	7036.1		7036.7	0.0344	6.1	80.7	46.9	0.81
	1098	Q100	493	1.9	7033.0	7034.9	7034.9	7035.6	0.0544	7.1	69.5	44.9	1.00
	1000	Q100	493	1.6	7026.4	7028.0	7028.3	7029.1	0.0837	8.2	60.1	43.2	1.22

	River Sta	Profile	Q Total	Depth of Flow	Min Ch El	W.S. Elev	Crit W.S.	E.G. Elev	E.G. Slope	Vel Chnl	Flow Area	Top Width	Froude #
			(cfs)	(ft)	(ft)	(ft)	(ft)	(ft)	(ft/ft)	(ft/s)	(sq ft)	(ft)	Chl
RIP-RAP LINED	5688	Q5	7.0	0.6	7125.5	7126.1	7125.8	7126.2	0.0095	1.0	6.9	21.8	0.32
	5607	Q5	7.0	0.13	7124.0	7124.1	7124.1	7124.2	0.1290	2.1	3.4	26.6	1.03
	5558	Q5	7.0	0.42	7123.0	7123.4	7123.2	7123.4	0.0039	0.8	9.2	23.4	0.21
	5358	Q5	7.0	0.16	7121.0	7121.2	7121.2	7121.2	0.1107	2.2	3.2	21.3	0.98
	5055	Q5	7.0	0.16	7112.0	7112.2	7112.2	7112.2	0.1154	2.2	3.2	21.3	1.00
	4765	Q5	7.0	0.35	7104.0	7104.4	7104.2	7104.4	0.0075	0.9	7.5	22.8	0.29
	4750	Q5	7.0	0.30	7103.9	7104.2		7104.2	0.0124	1.1	6.4	22.4	0.36
	4477	Q5	9.0	0.39	7101.1	7101.5		7101.5	0.0084	1.1	8.5	23.3	0.31
	4469	Q5	9.0	0.42	7101.0	7101.4	7101.2	7101.4	0.0066	1.0	9.1	23.6	0.28
	4269	Q5	9.0	0.31	7099.0	7099.3	7099.2	7099.3	0.0196	1.4	6.5	22.4	0.46
	4162	Q5	9.0	0.24	7096.0	7096.2	7096.2	7096.3	0.0454	1.8	5.0	21.9	0.67
	4087	Q5	9.0	0.18	7089.3	7089.5	7089.5	7089.6	0.1043	2.3	4.0	23.1	0.97
3997	Q5	12	0.36	7086.0	7086.4	7086.3	7086.4	0.0114	1.9	6.2	25.3	0.68	
NATURAL SANDY BOTTOM	3761	Q5	21	0.37	7082.0	7082.4	7082.4	7082.5	0.0210	3.4	6.4	18.6	0.99
	3500	Q5	21	0.56	7077.5	7078.1	7078.0	7078.2	0.0114	2.5	8.6	24.6	0.72
	3250	Q5	21	0.36	7074.1	7074.5	7074.5	7074.6	0.0184	2.8	7.6	32.5	1.01
	3100	Q5	21	0.46	7071.1	7071.6	7071.5	7071.7	0.0108	2.8	7.5	22.9	0.84
	3011	Q5	21	0.37	7070.0	7070.4	7070.4	7070.5	0.0159	3.2	6.8	23.9	0.99
	2887	Q5	21	0.28	7068.0	7068.3	7068.3	7068.5	0.0471	3.8	5.6	30.4	1.56
	2740	Q5	21	0.40	7066.0	7066.4	7066.4	7066.5	0.0169	3.0	7.2	26.5	1.00
	2500	Q5	21	0.43	7060.8	7061.2	7061.3	7061.4	0.0278	3.5	6.4	27.7	1.25
	2326	Q5	21	0.45	7056.9	7057.4	7057.4	7057.5	0.0184	3.1	7.0	26.8	1.04
	2187	Q5	21	0.28	7054.0	7054.3	7054.3	7054.5	0.0258	3.7	5.9	22.2	1.23
	2045	Q5	21	0.45	7052.0	7052.5	7052.5	7052.6	0.0150	3.4	6.7	20.3	0.99
	1899	Q5	38	0.45	7049.3	7049.8	7049.8	7049.9	0.0201	3.5	12.2	45.9	1.11
	1770	Q5	38	0.30	7046.6	7046.9	7046.9	7047.1	0.0237	3.7	10.8	39.8	1.20
	1589	Q5	38	0.26	7042.0	7042.3	7042.3	7042.4	0.0278	3.4	11.4	51.5	1.24
	1354	Q5	38	0.63	7037.7	7038.3	7038.3	7038.5	0.0127	3.7	10.6	23.5	0.95
1209	Q5	38	0.25	7036.0	7036.3	7036.3	7036.4	0.0175	2.8	13.7	56.7	1.00	
1173	Q5	38	0.30	7035.0	7035.3	7035.4	7035.6	0.0294	4.1	9.6	34.8	1.33	
RIP-RAP	1122	Q5	38	0.52	7034.0	7034.5	7034.4	7034.6	0.0259	2.3	16.7	34.2	0.57
	1098	Q5	38	0.36	7033.0	7033.4	7033.4	7033.5	0.0898	3.4	11.3	32.9	1.01
	1000	Q5	38	0.39	7026.4	7026.8	7026.8	7026.9	0.0667	3.1	12.4	33.1	0.88

	River Sta	Profile	Q Total	Depth of Flow	Min Ch El	W.S. Elev	Crit W.S.	E.G. Elev	E.G. Slope	Vel Chnl	Flow Area	Top Width	Froude #
			(cfs)	(ft)	(ft)	(ft)	(ft)	(ft)	(ft/ft)	(ft/s)	(sq ft)	(ft)	Chl
RIP-RAP LINED	5688	Q2	2.0	0.32	7125.50	7125.82	7125.65	7125.83	0.0083	0.9	2.3	8.3	0.29
	5607	Q2	2.0	0.06	7124.00	7124.06	7124.06	7124.09	0.1219	1.3	1.6	25.8	0.89
	5558	Q2	2.0	0.21	7123.00	7123.21	7123.07	7123.21	0.0036	0.5	4.3	21.7	0.18
	5358	Q2	2.0	0.07	7121.00	7121.07	7121.07	7121.10	0.1263	1.4	1.5	20.6	0.92
	5055	Q2	2.0	0.06	7112.00	7112.06	7112.06	7112.10	0.1768	1.5	1.3	20.5	1.07
	4765	Q2	2.0	0.18	7104.00	7104.18	7104.07	7104.18	0.0063	0.6	3.6	21.4	0.24
	4750	Q2	2.0	0.15	7103.90	7104.05		7104.05	0.0111	0.7	3.0	21.2	0.31
	4477	Q2	2.4	0.17	7101.10	7101.27		7101.28	0.0098	0.7	3.5	21.4	0.30
	4469	Q2	2.4	0.19	7101.00	7101.19	7101.08	7101.20	0.0063	0.6	4.1	21.7	0.24
	4269	Q2	2.4	0.14	7099.00	7099.14	7099.07	7099.15	0.0201	0.9	2.8	21.1	0.41
	4162	Q2	2.4	0.11	7096.00	7096.11		7096.13	0.0422	1.1	2.3	20.9	0.57
	4087	Q2	2.4	0.08	7089.30	7089.38	7089.38	7089.41	0.1168	1.4	1.7	21.4	0.90
3997	Q2	3.2	0.22	7086.00	7086.22	7086.15	7086.24	0.0082	1.1	2.8	19.8	0.53	
NATURAL SANDY BOTTOM	3761	Q2	6.2	0.16	7082.00	7082.16	7082.16	7082.24	0.0278	2.3	2.8	17.3	0.99
	3500	Q2	6.2	0.34	7077.50	7077.84	7077.76	7077.88	0.0100	1.6	3.8	17.6	0.62
	3250	Q2	6.2	0.19	7074.10	7074.29	7074.29	7074.35	0.0212	2.1	3.0	21.8	0.99
	3100	Q2	6.2	0.28	7071.10	7071.38	7071.33	7071.42	0.0089	1.7	3.7	19.5	0.68
	3011	Q2	6.2	0.19	7070.00	7070.19	7070.19	7070.26	0.0210	2.1	2.9	20.5	1.00
	2887	Q2	6.2	0.22	7068.00	7068.22	7068.18	7068.26	0.0096	1.5	4.1	26.6	0.68
	2740	Q2	6.2	0.20	7066.00	7066.20	7066.20	7066.28	0.0201	2.2	2.8	18.3	0.99
	2500	Q2	6.2	0.20	7060.80	7061.00	7061.01	7061.11	0.0230	2.7	2.5	14.4	1.09
	2326	Q2	6.2	0.21	7056.90	7057.11	7057.12	7057.23	0.0216	2.7	2.3	11.9	1.07
	2187	Q2	6.2	0.17	7054.00	7054.17	7054.15	7054.22	0.0122	1.8	3.5	21.3	0.78
	2045	Q2	6.2	0.23	7052.00	7052.23	7052.21	7052.31	0.0147	2.3	2.9	15.3	0.89
	1899	Q2	11	0.29	7049.30	7049.59	7049.59	7049.66	0.0200	2.2	5.3	36.1	0.99
	1770	Q2	11	0.14	7046.60	7046.74	7046.75	7046.82	0.0243	2.3	4.9	36.5	1.07
	1589	Q2	11	0.14	7042.00	7042.14	7042.15	7042.21	0.0267	2.1	5.4	48.9	1.08
	1354	Q2	11	0.36	7037.70	7038.06	7038.01	7038.14	0.0101	2.3	4.9	18.6	0.77
1209	Q2	11	0.12	7036.00	7036.12	7036.12	7036.16	0.0190	1.8	6.3	54.9	0.92	
1173	Q2	11	0.14	7035.00	7035.14	7035.16	7035.25	0.0352	2.7	4.2	32.2	1.28	
RIP-RAP	1122	Q2	11	0.26	7034.00	7034.26	7034.16	7034.29	0.0220	1.4	8.1	32.1	0.47
	1098	Q2	11	0.16	7033.00	7033.16	7033.16	7033.24	0.1236	2.3	4.8	31.3	1.04
	1000	Q2	11	0.19	7026.40	7026.59	7026.56	7026.64	0.0666	1.9	5.8	31.5	0.78

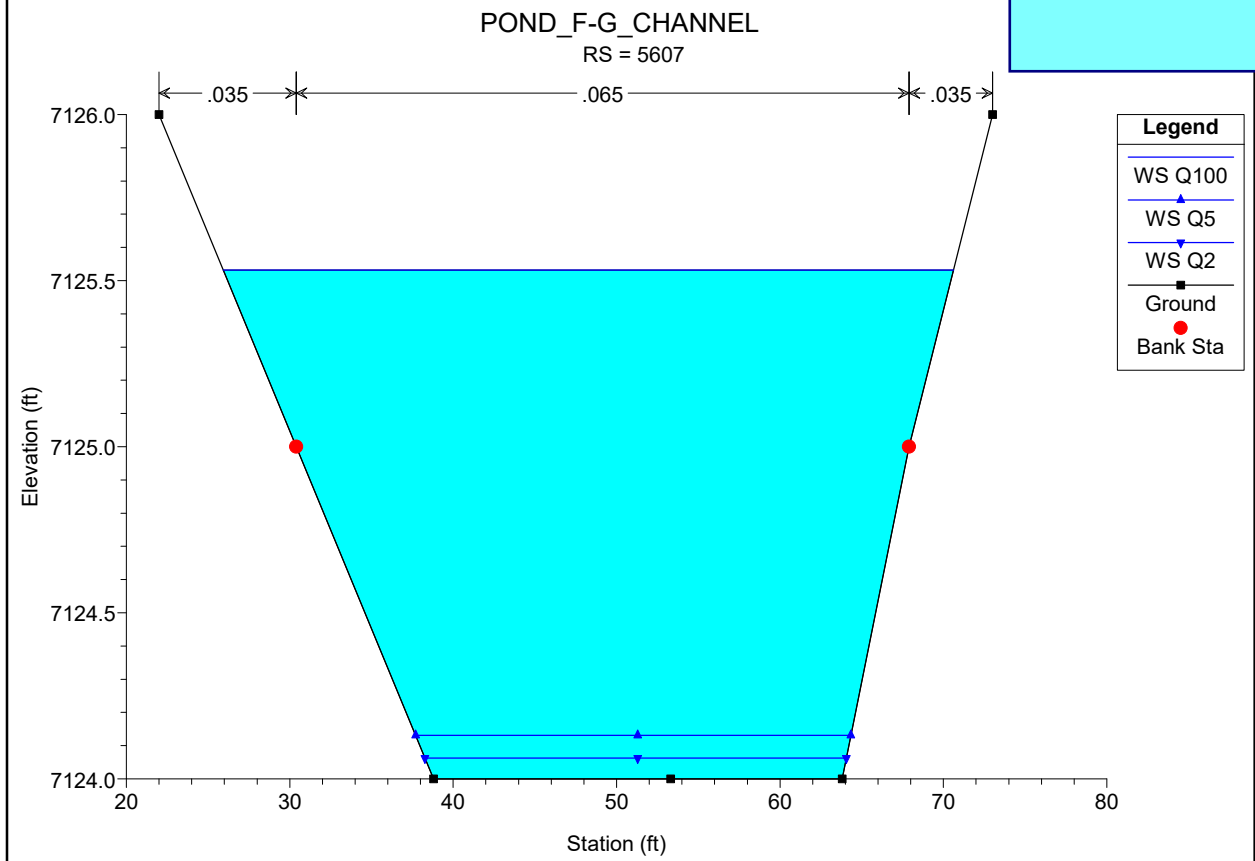
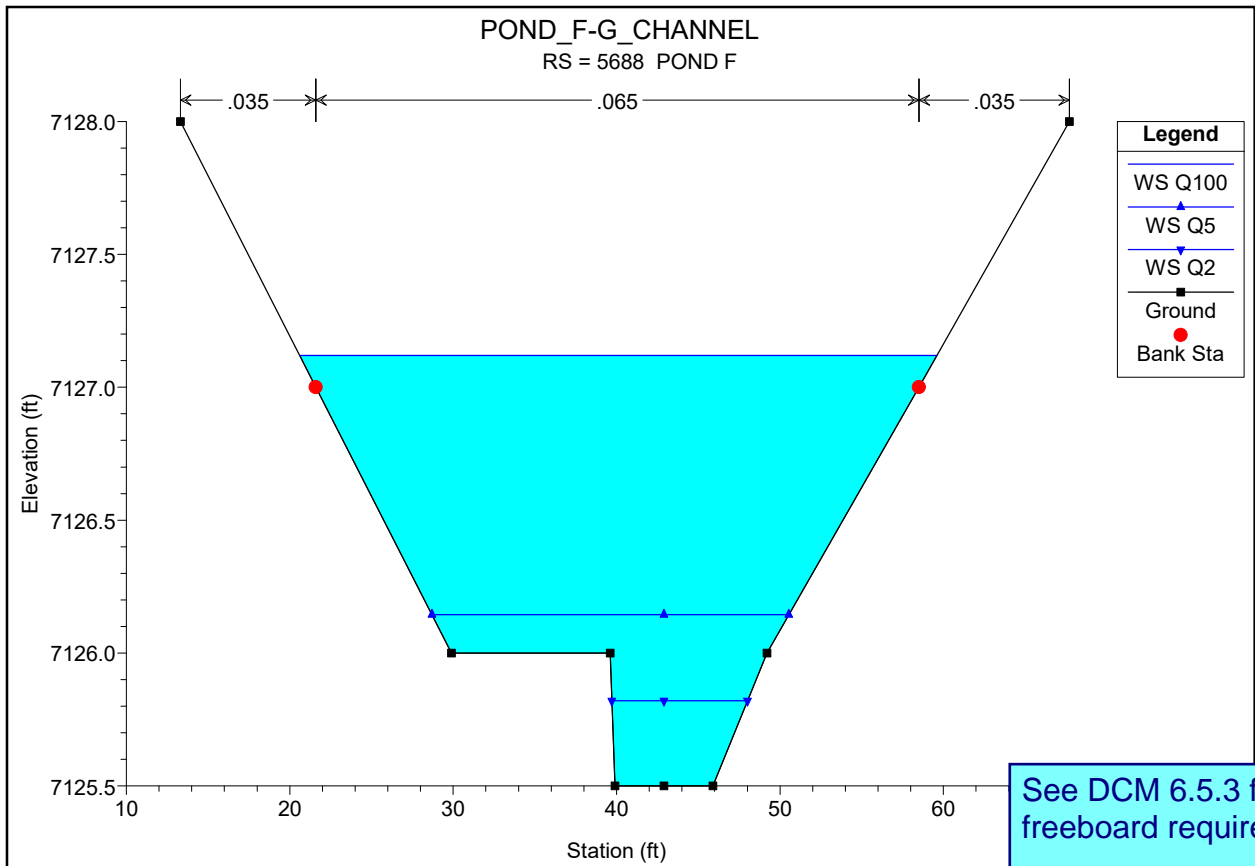

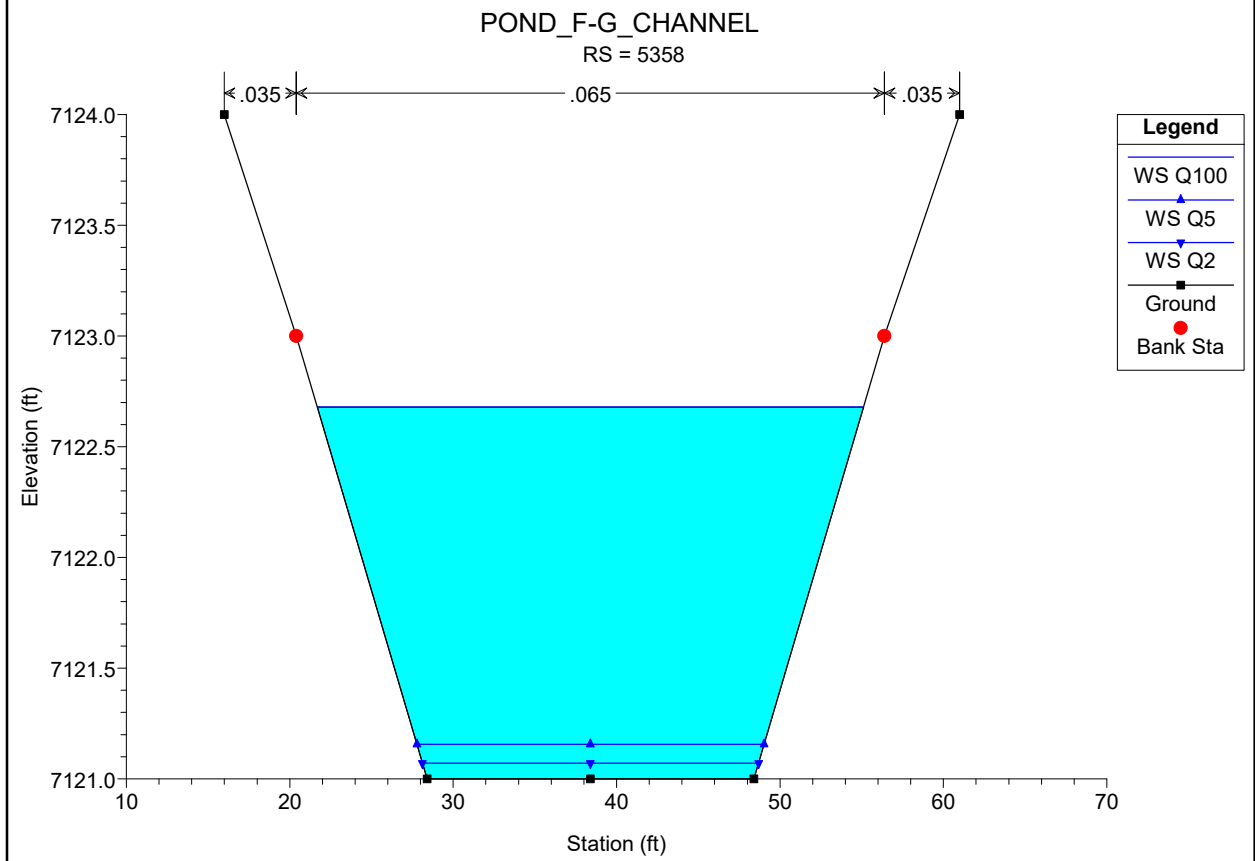
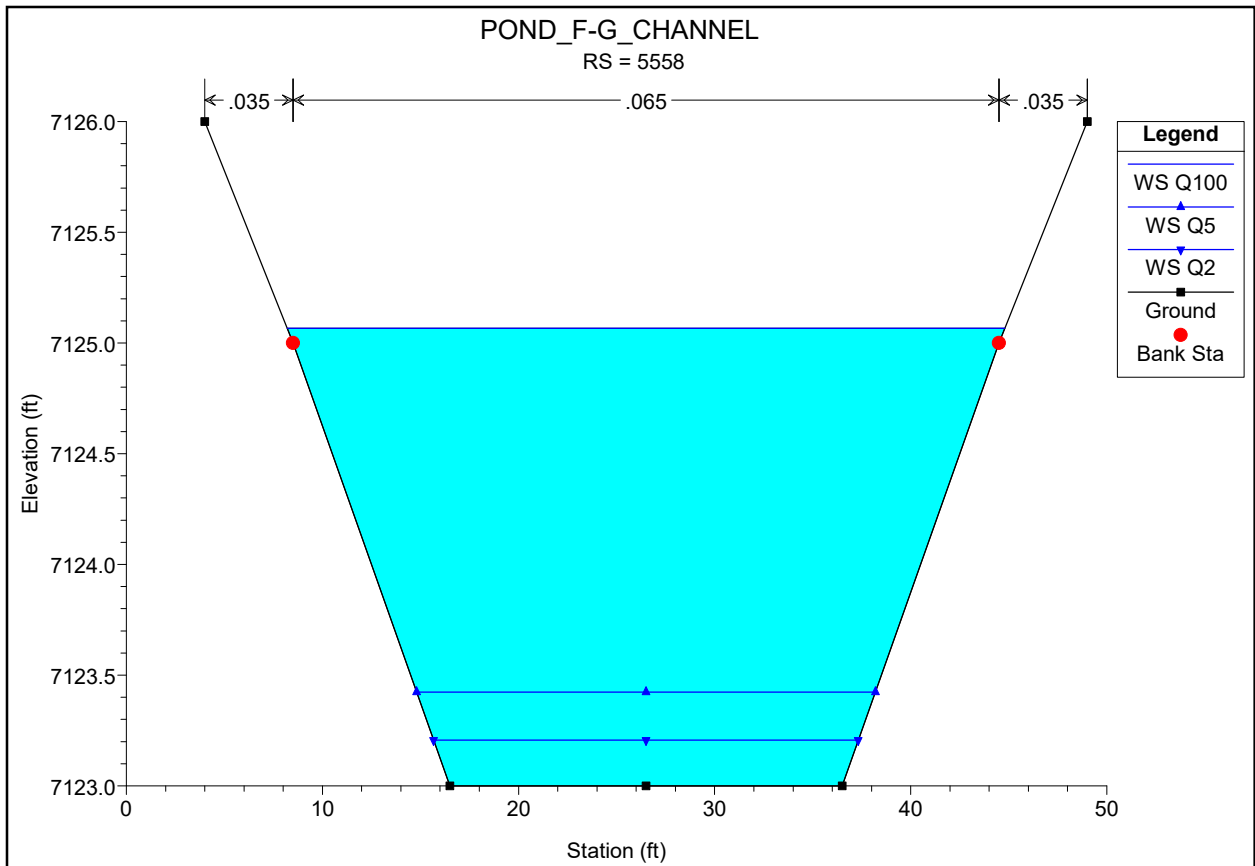

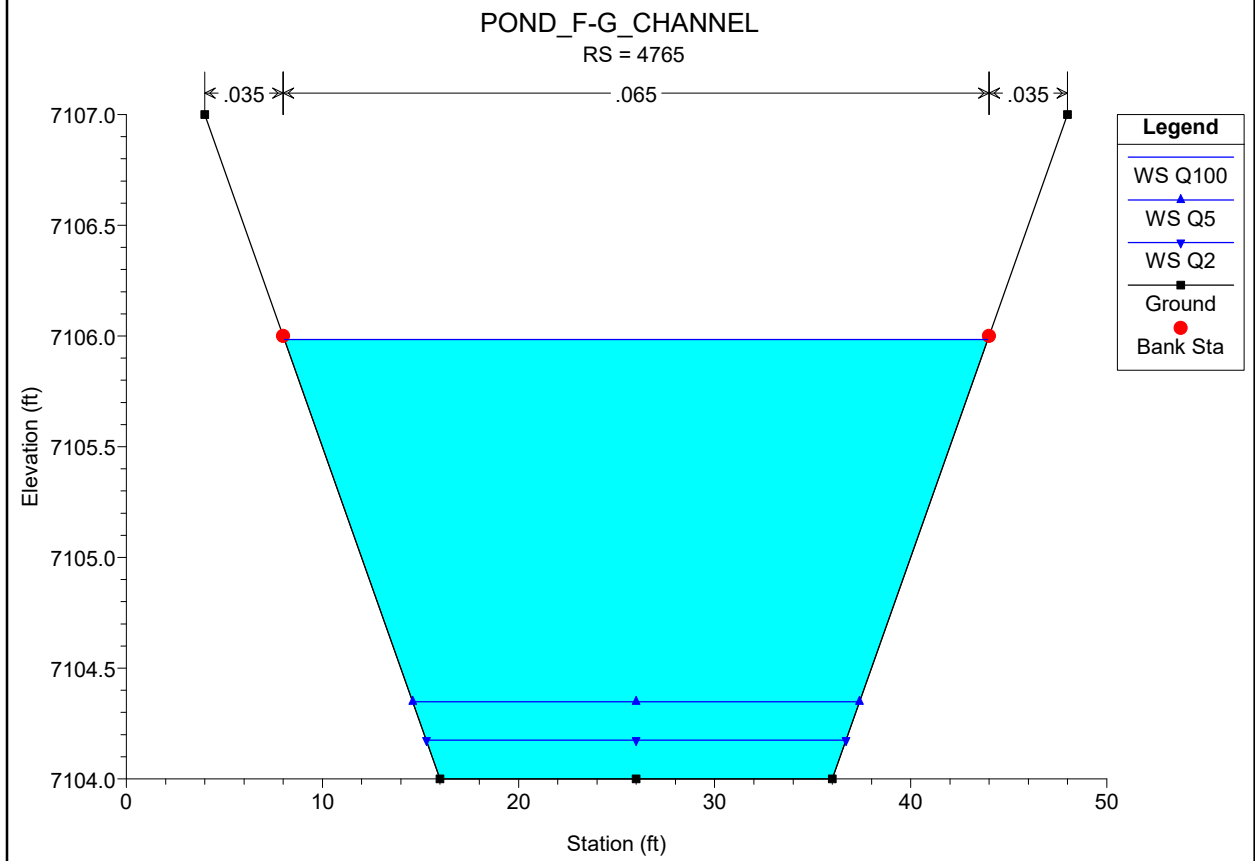
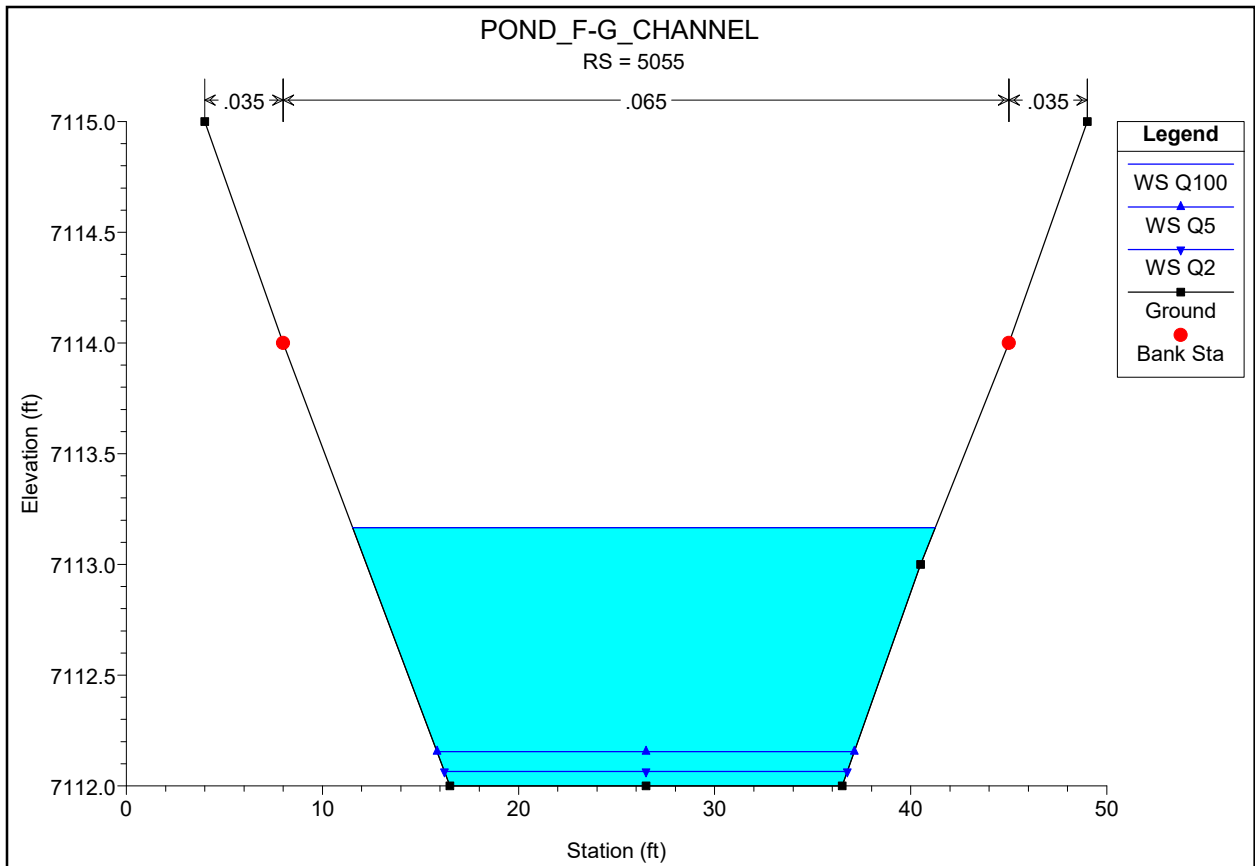

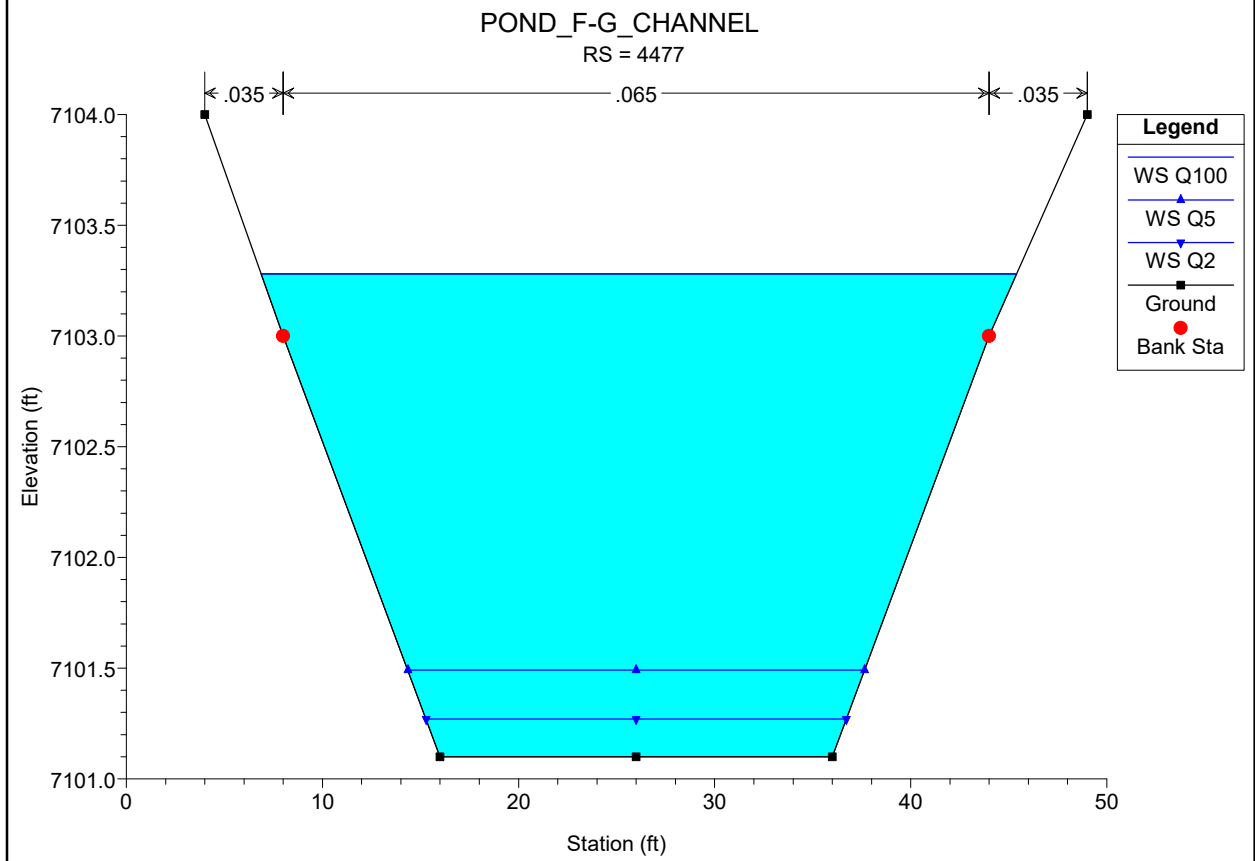
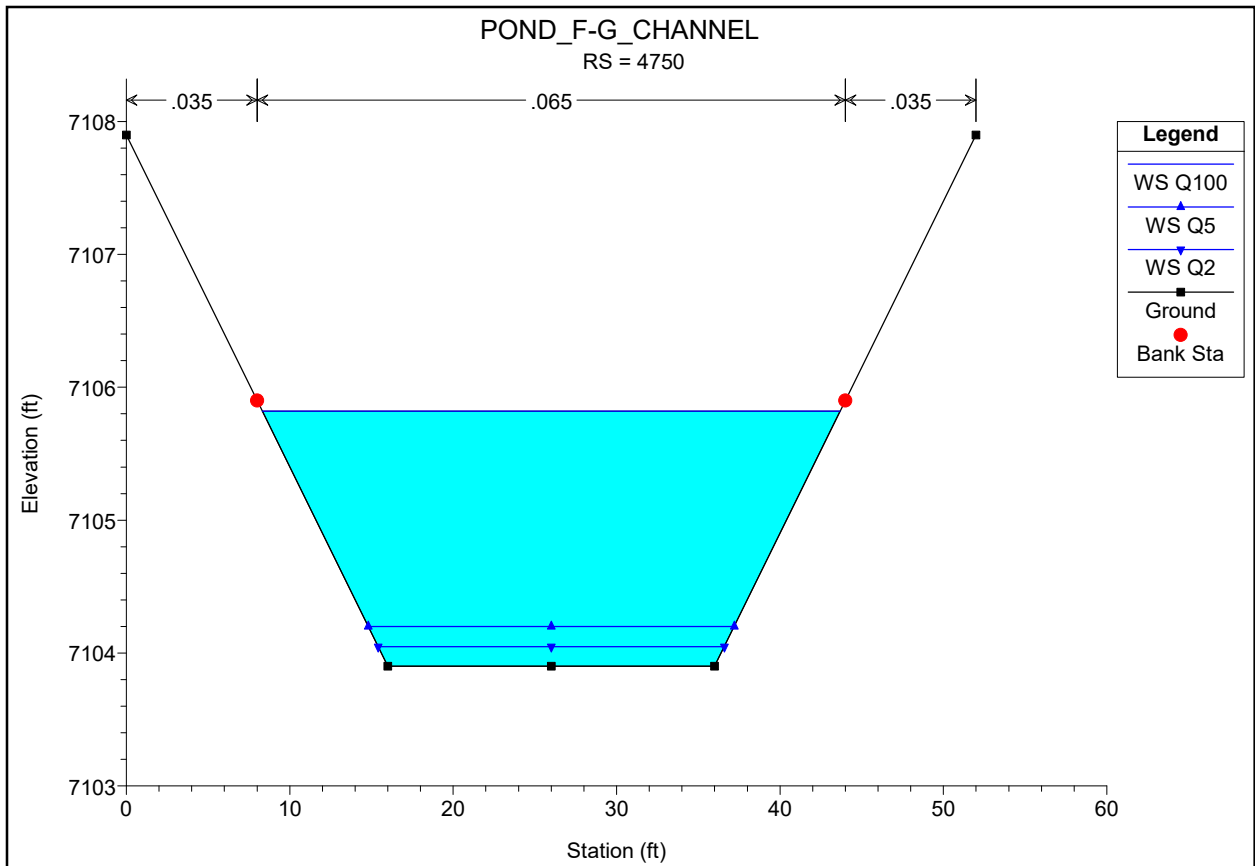

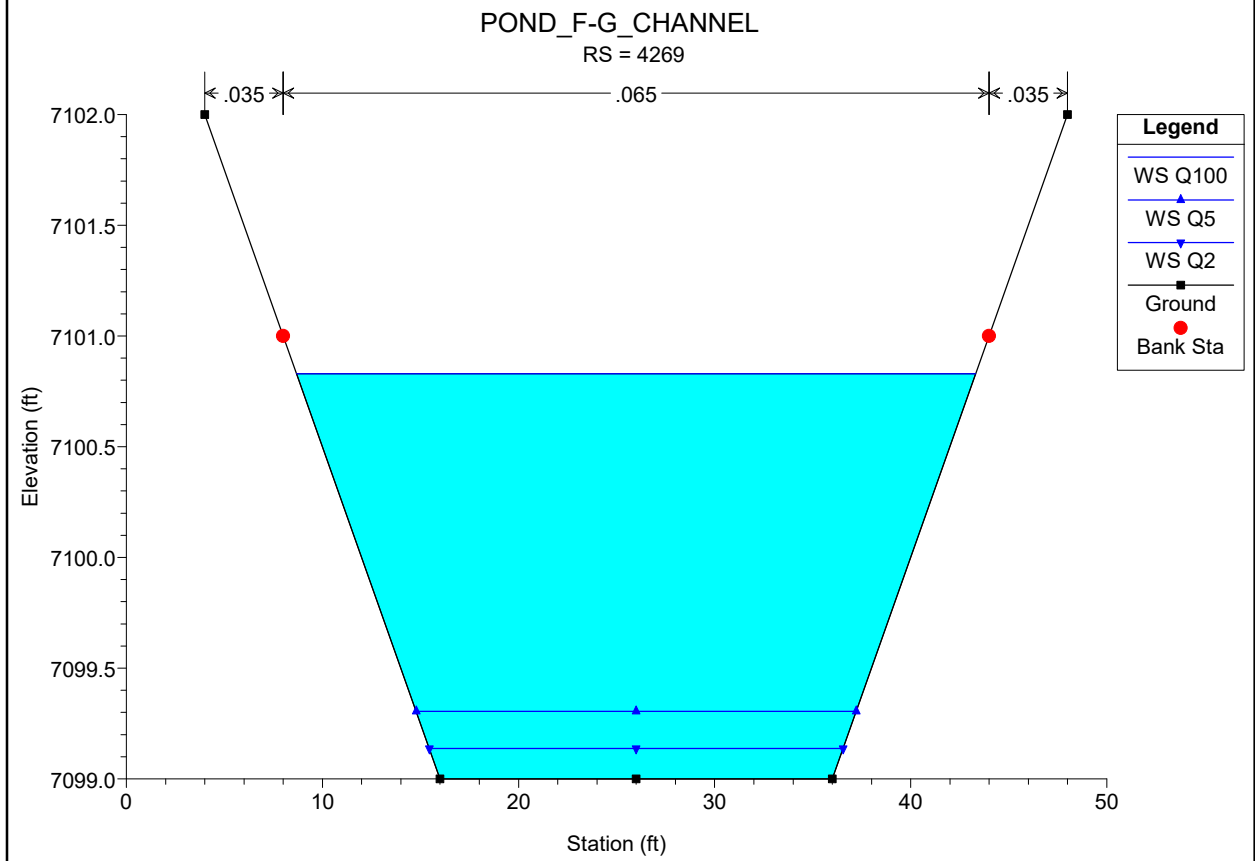
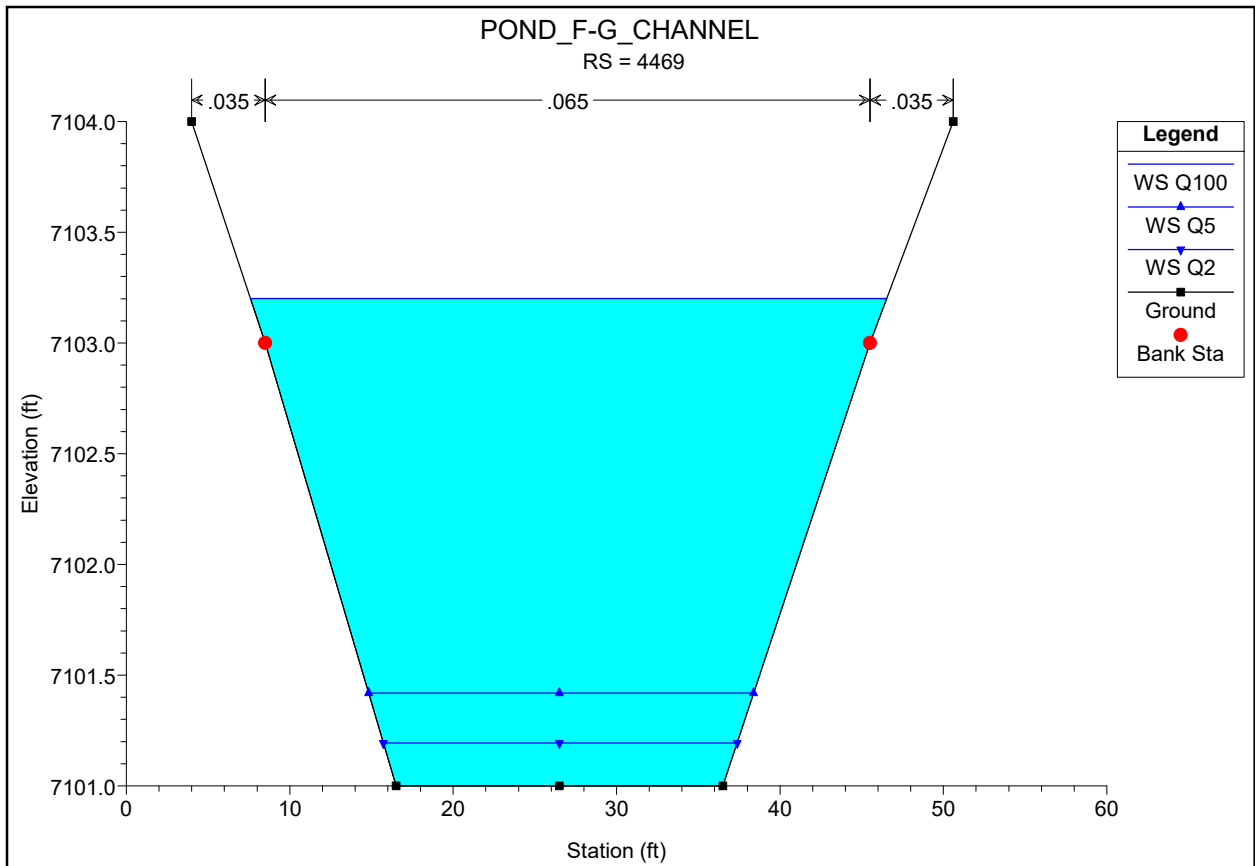

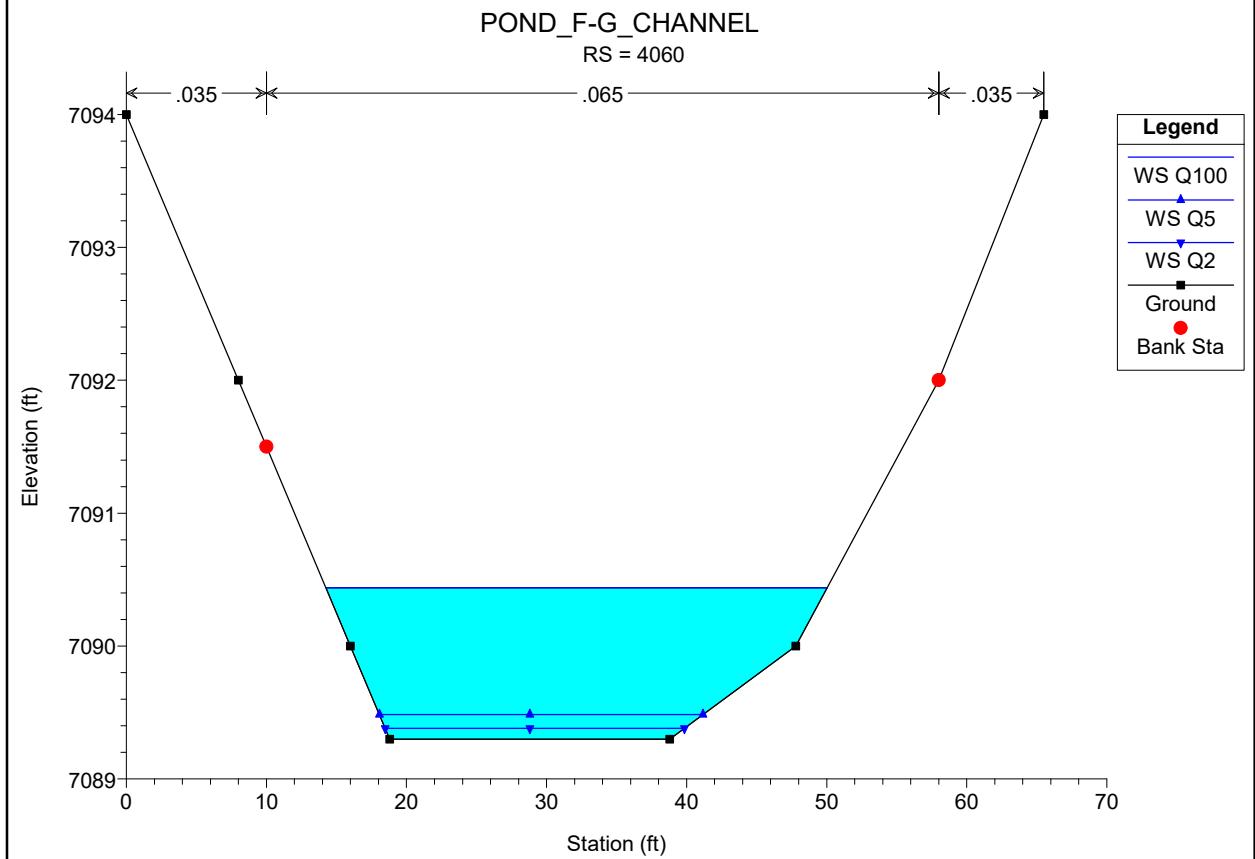
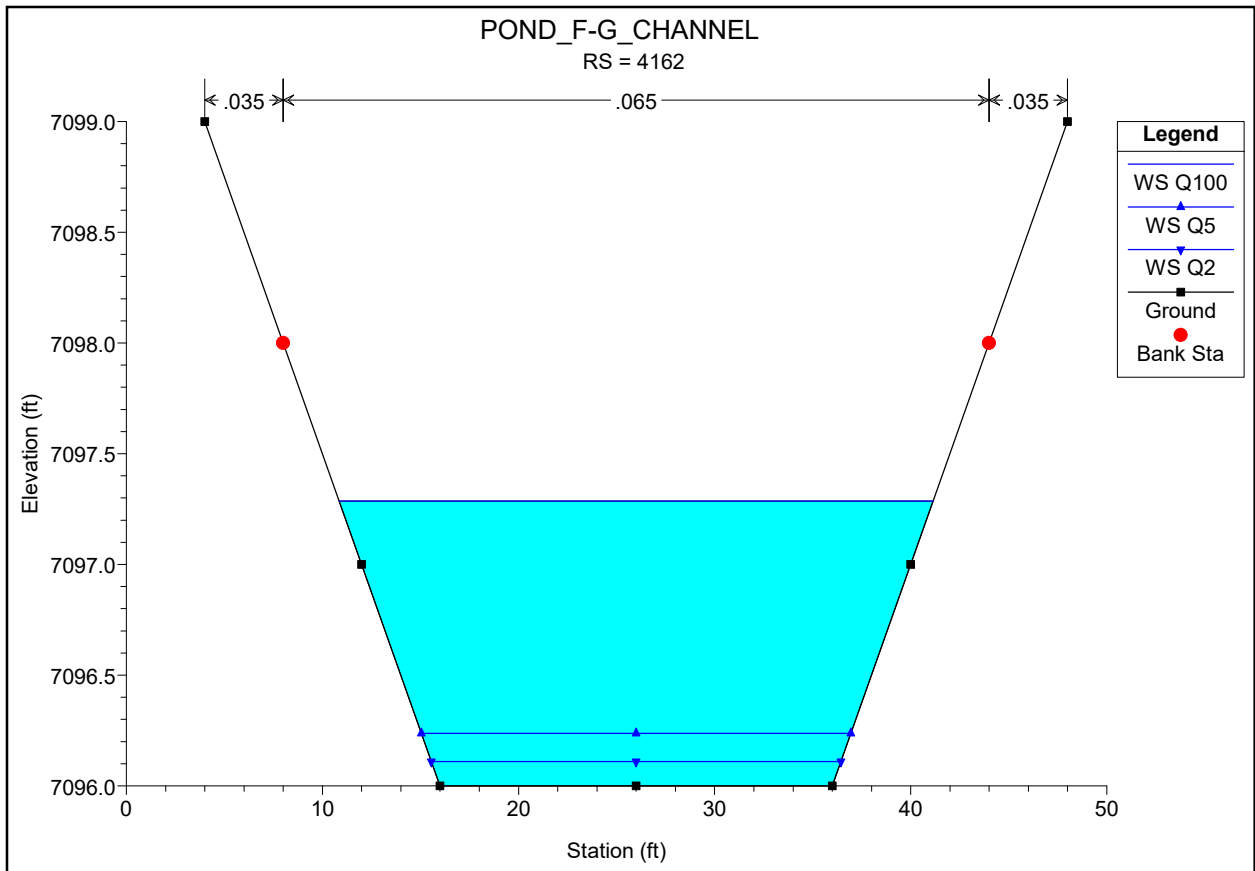

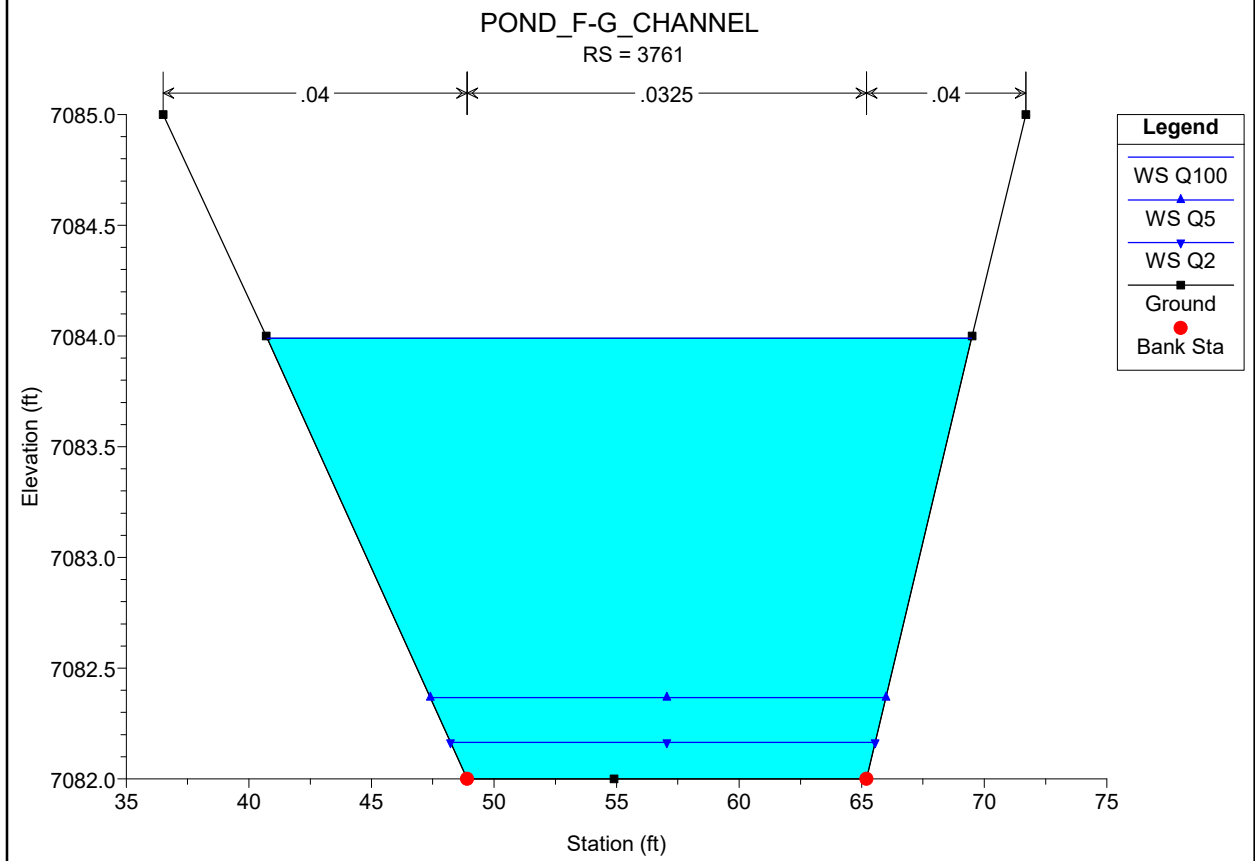
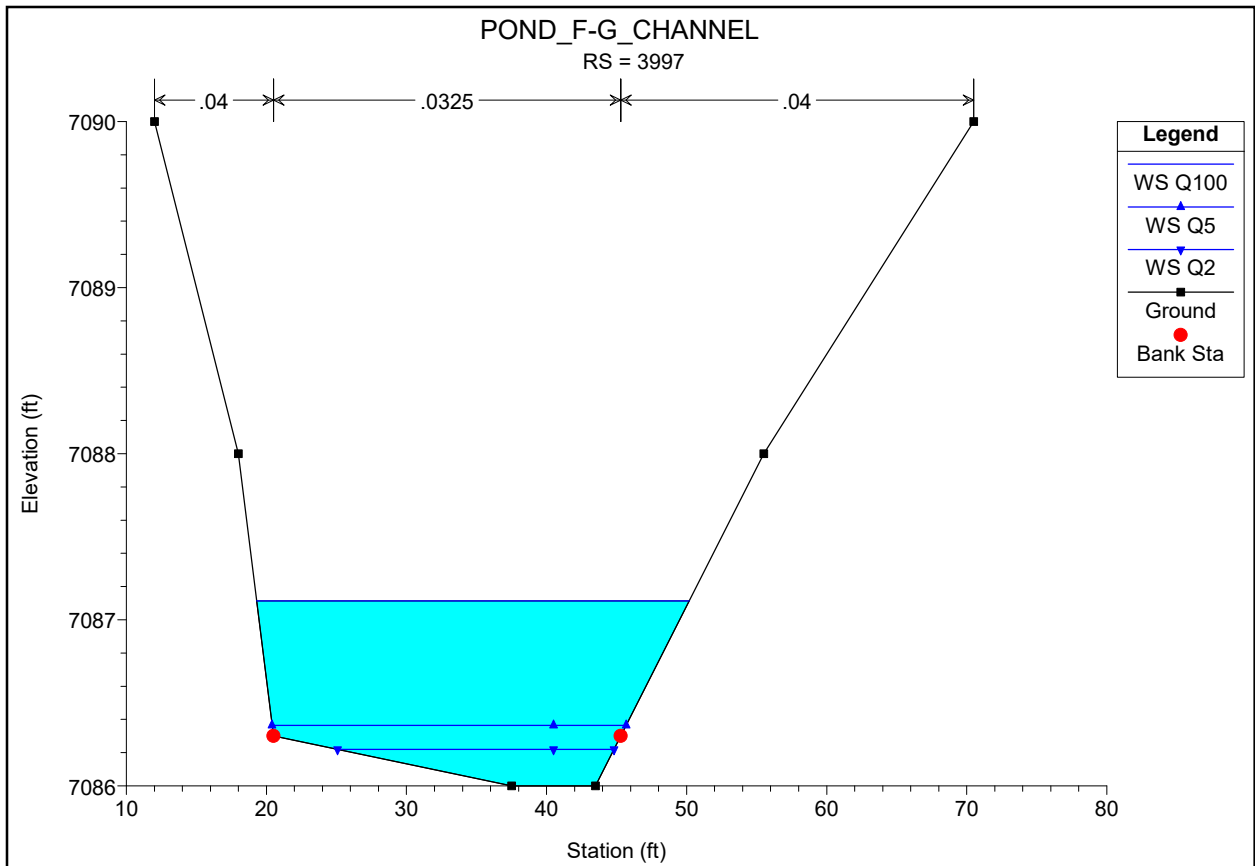

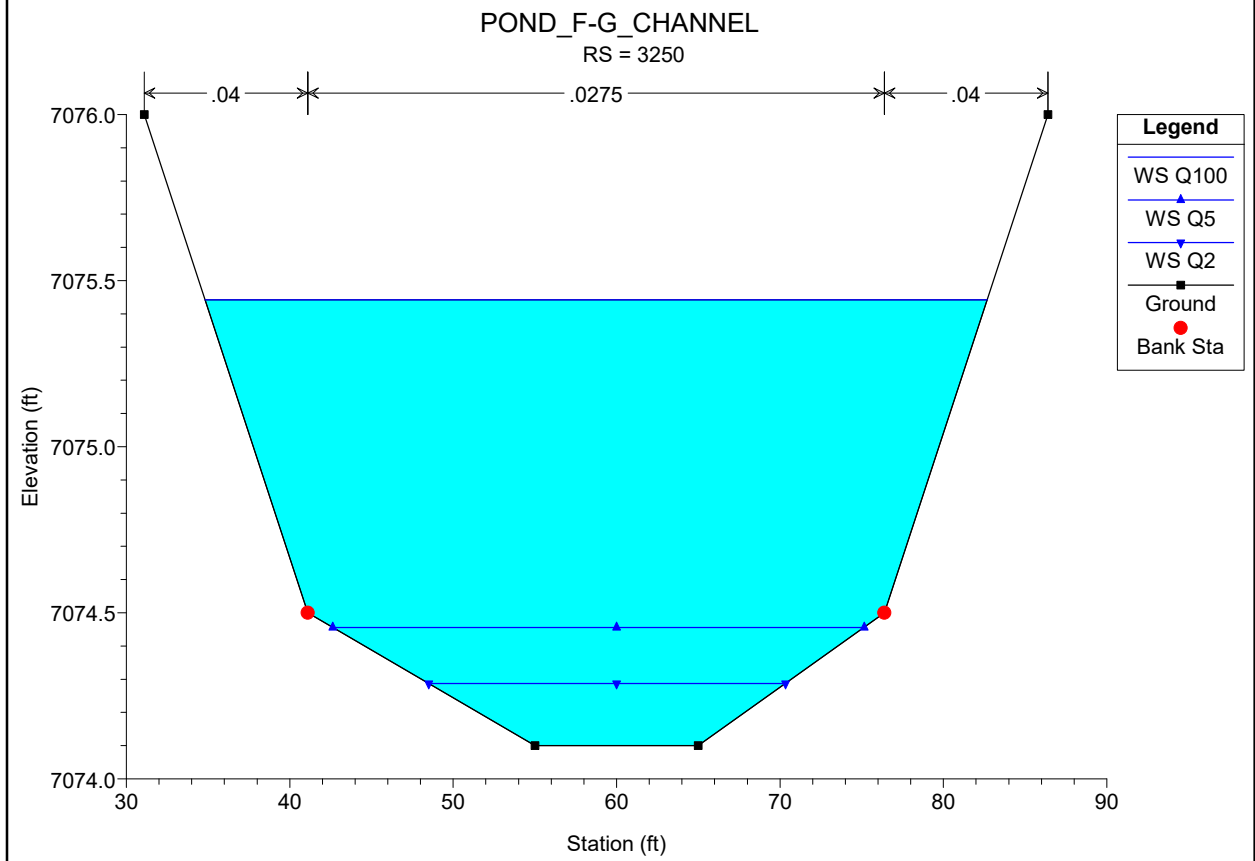
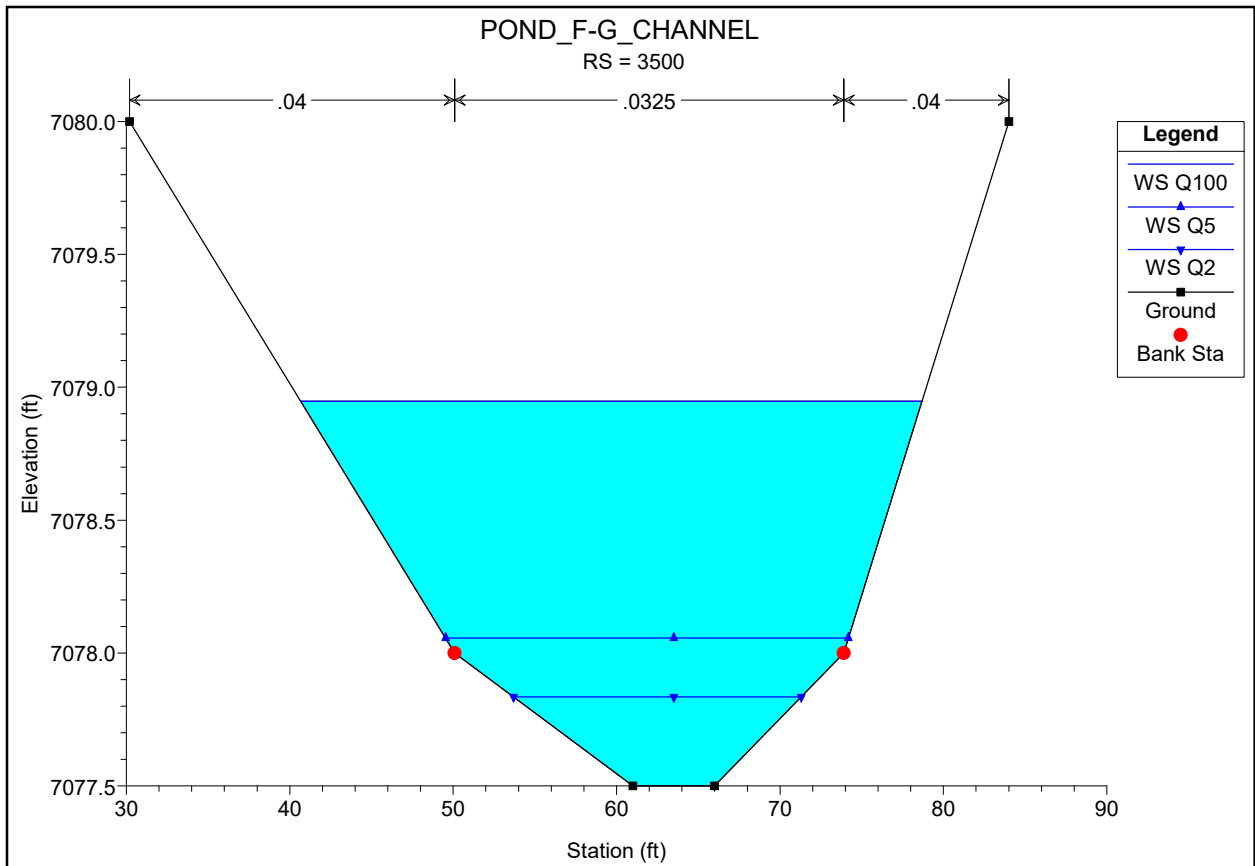

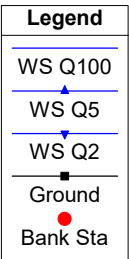
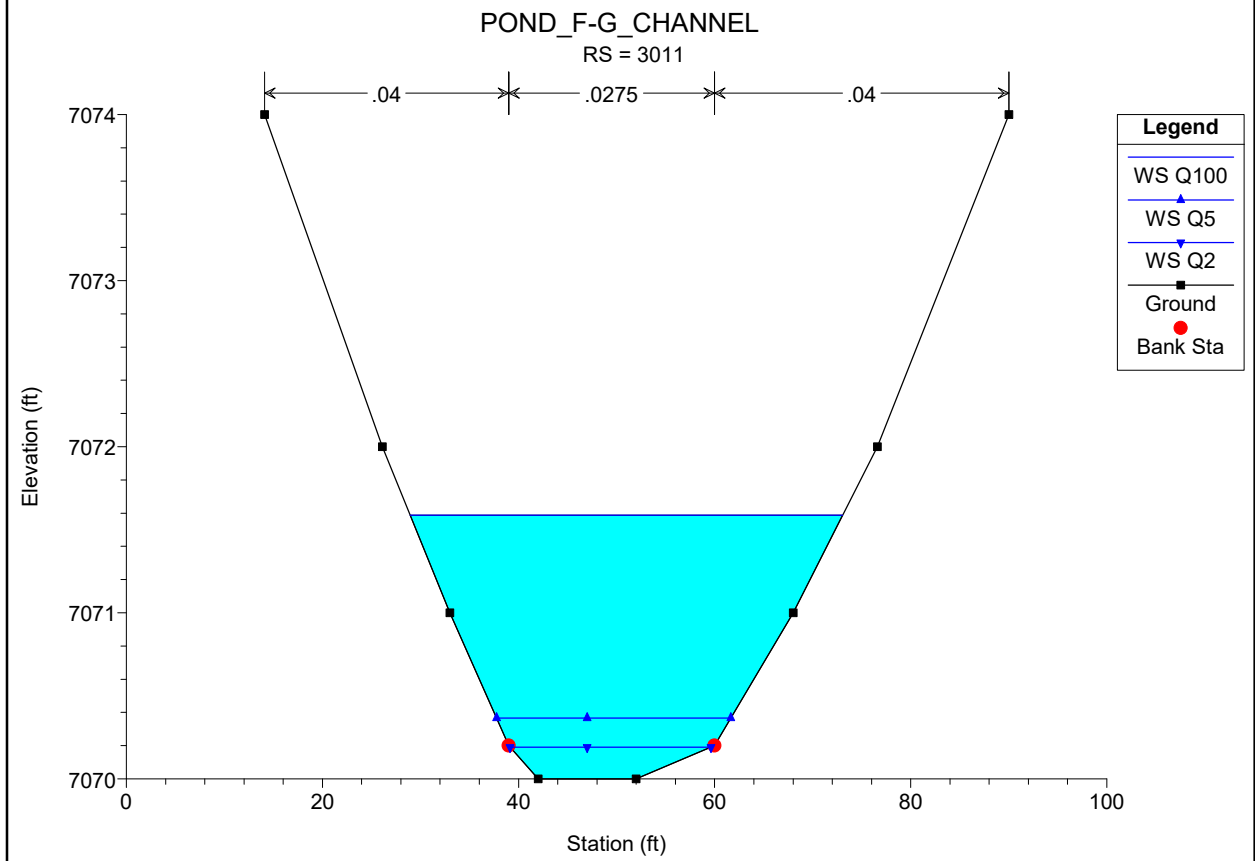
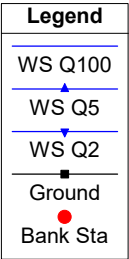
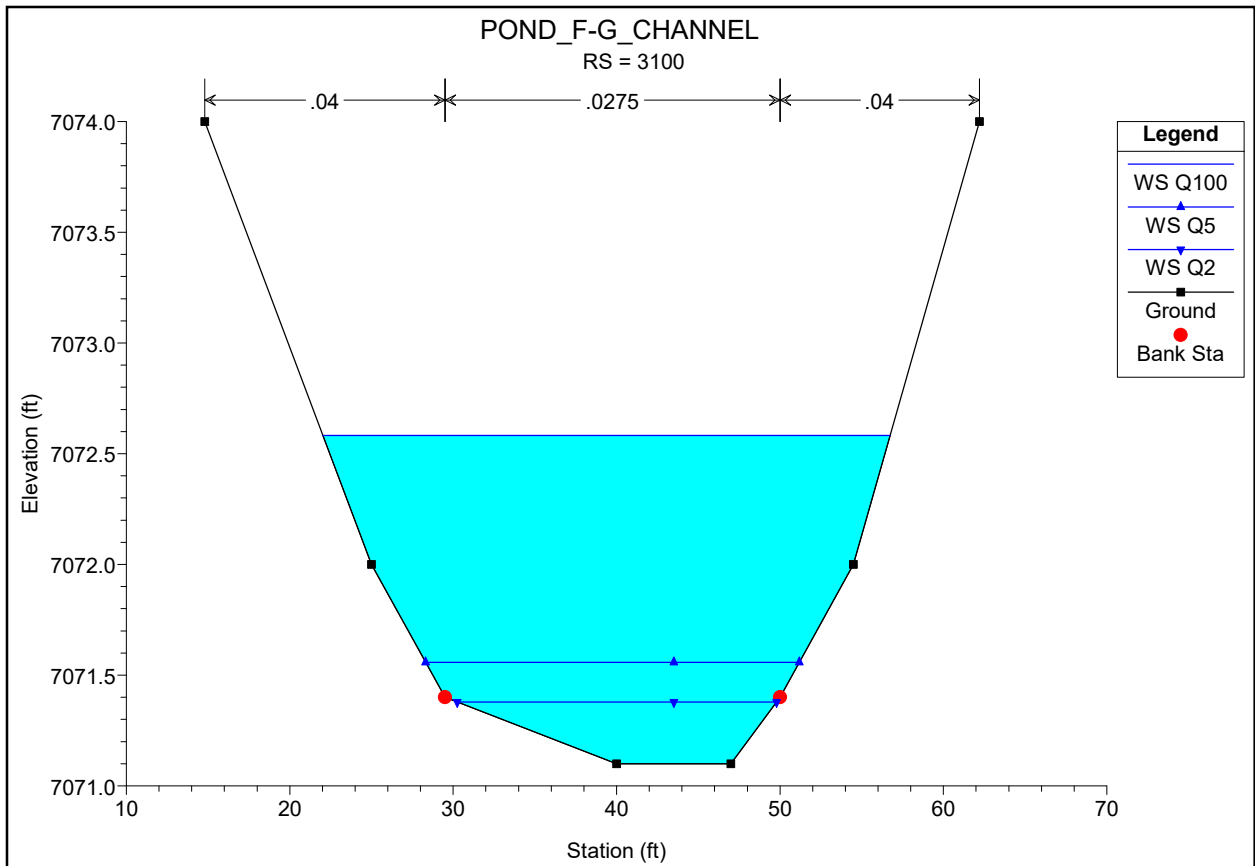

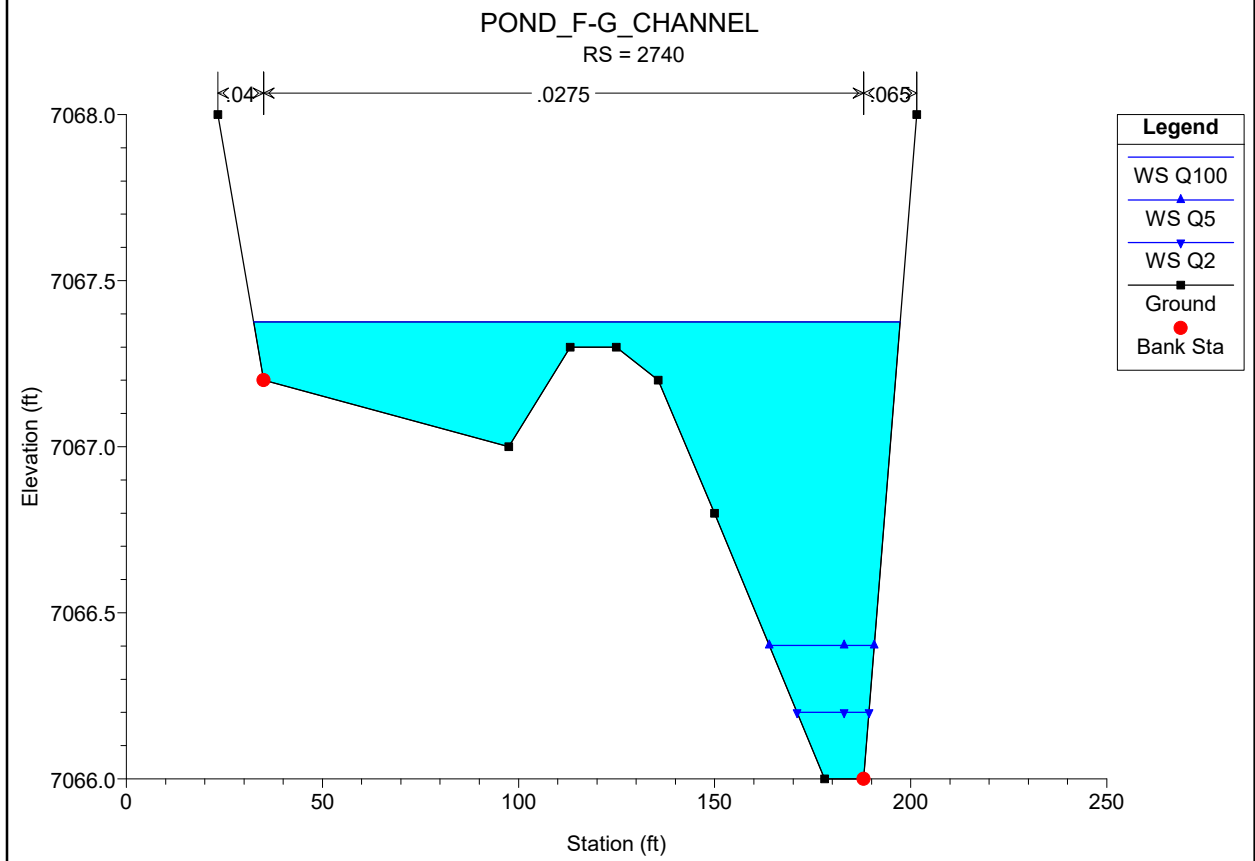
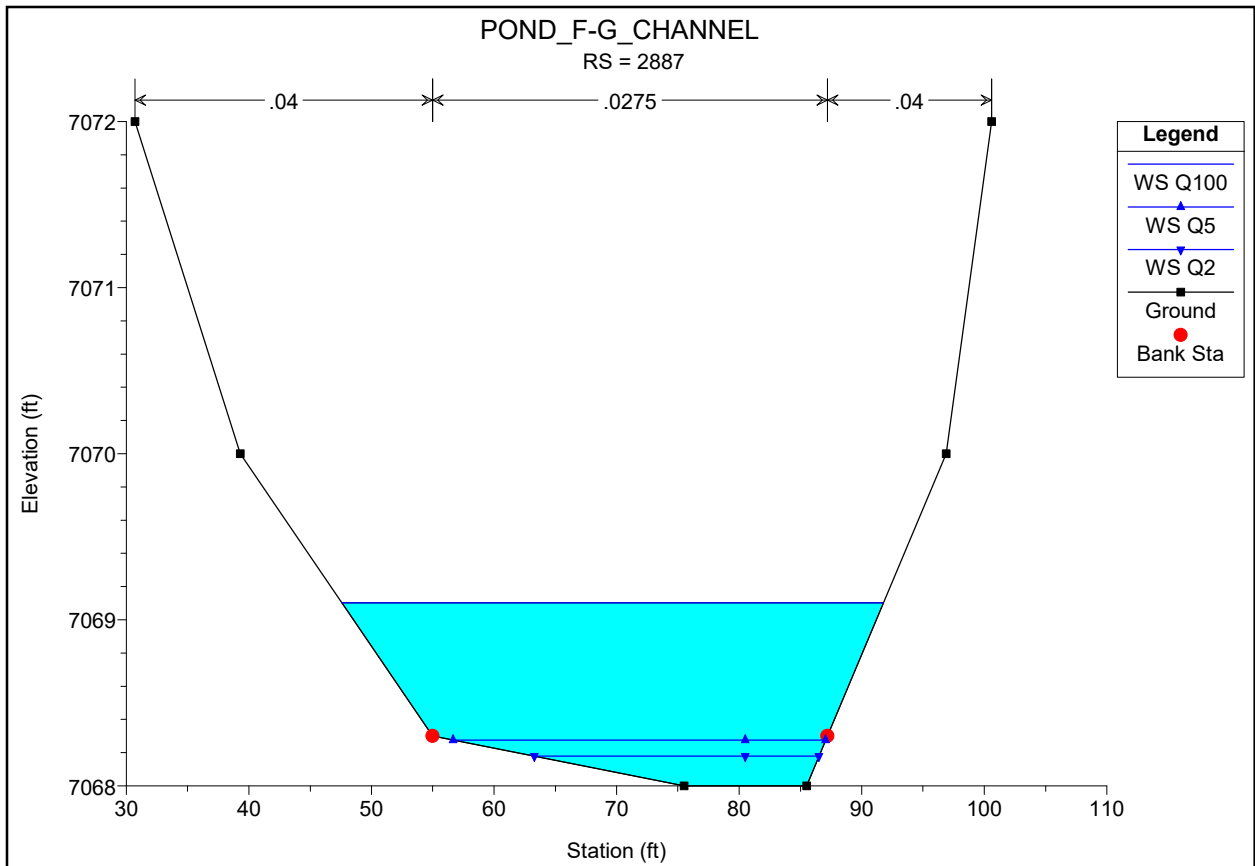

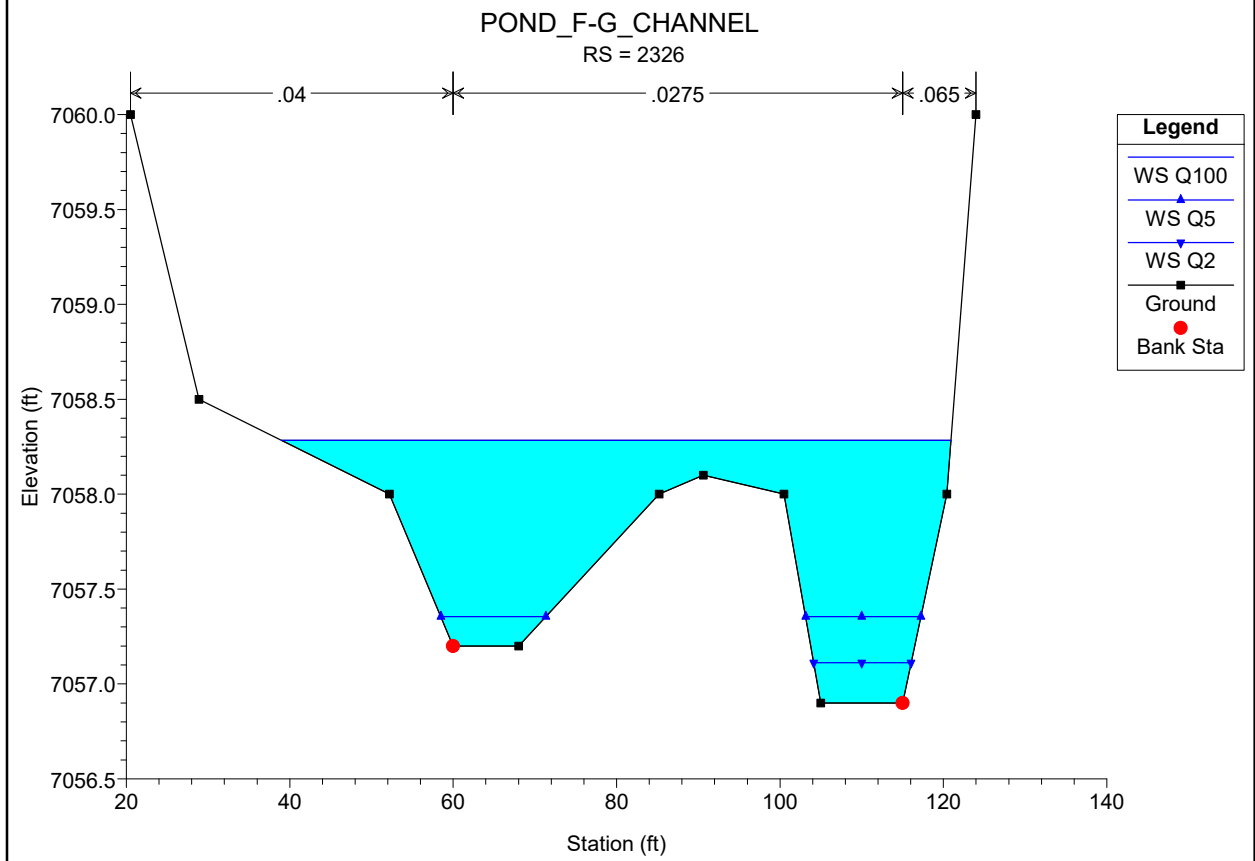
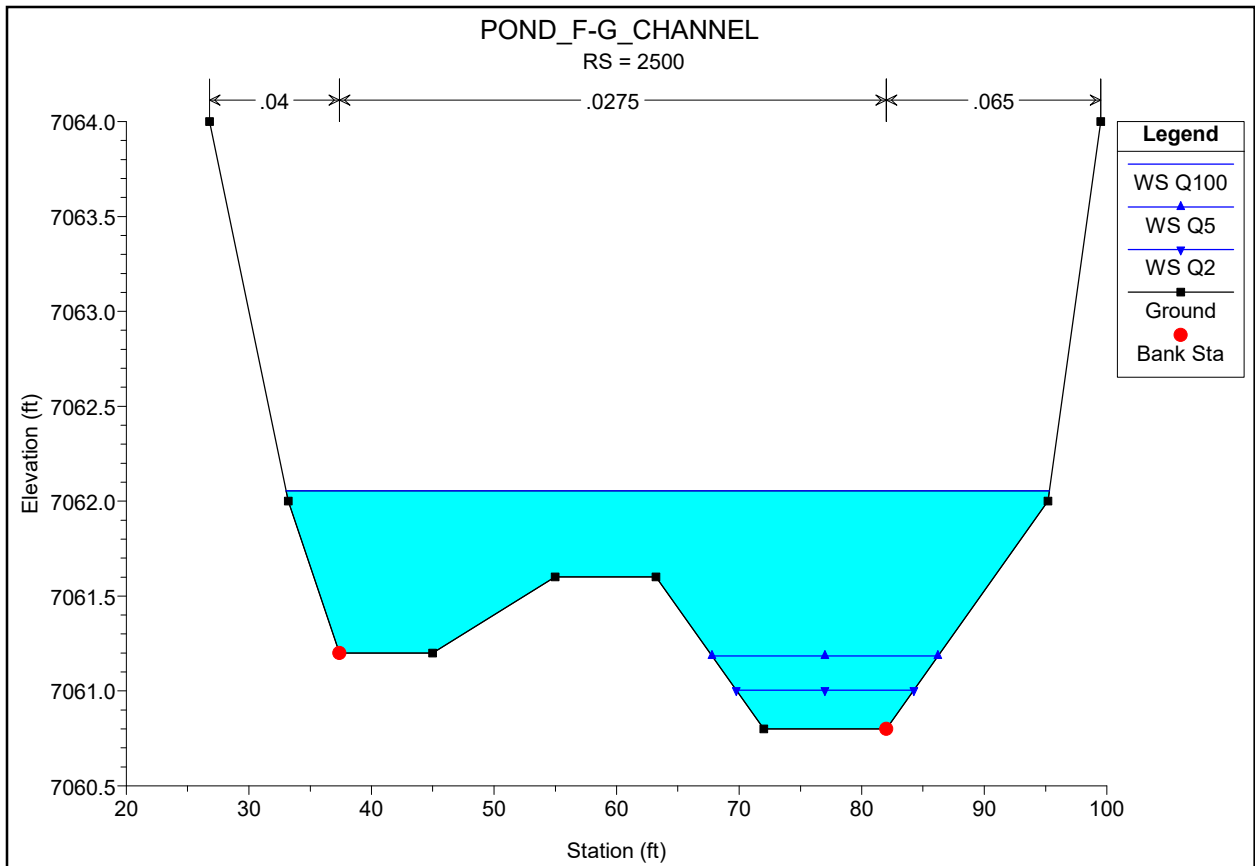

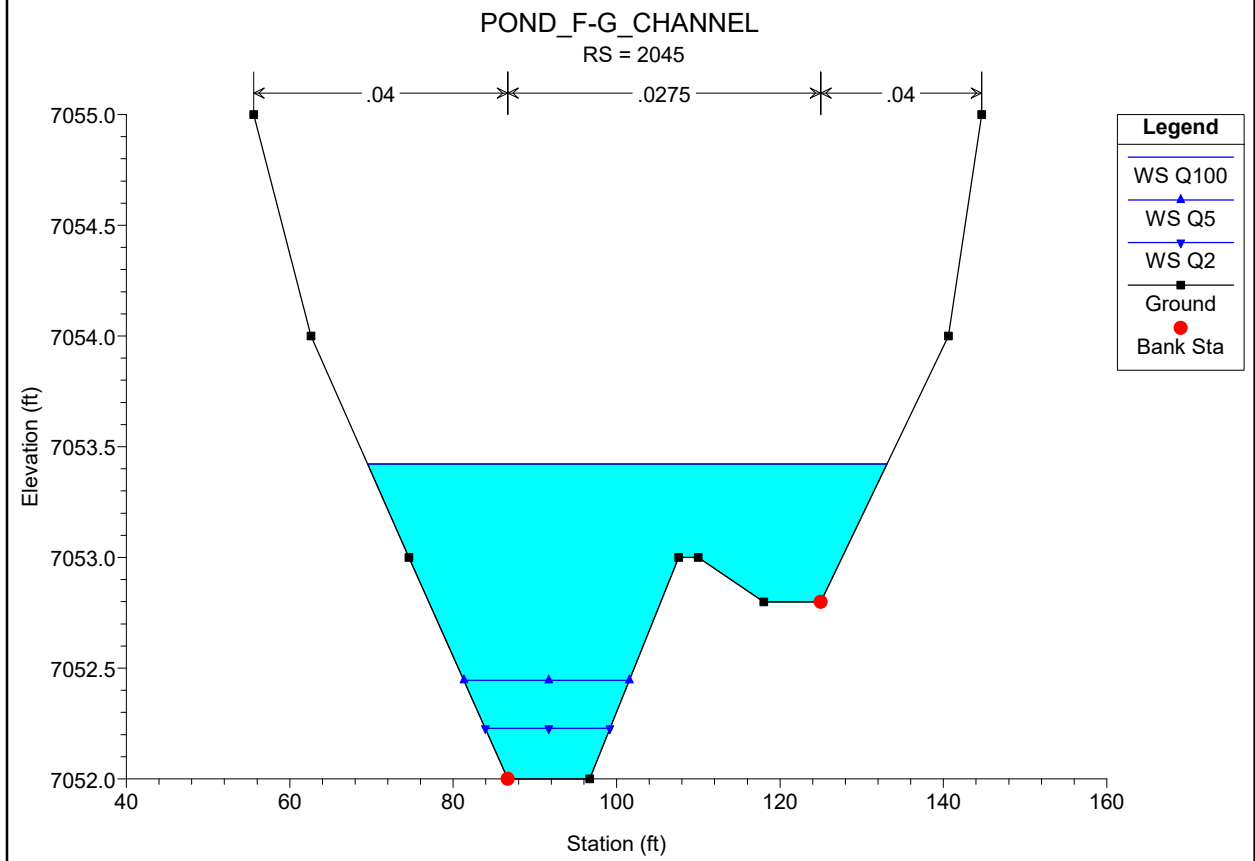
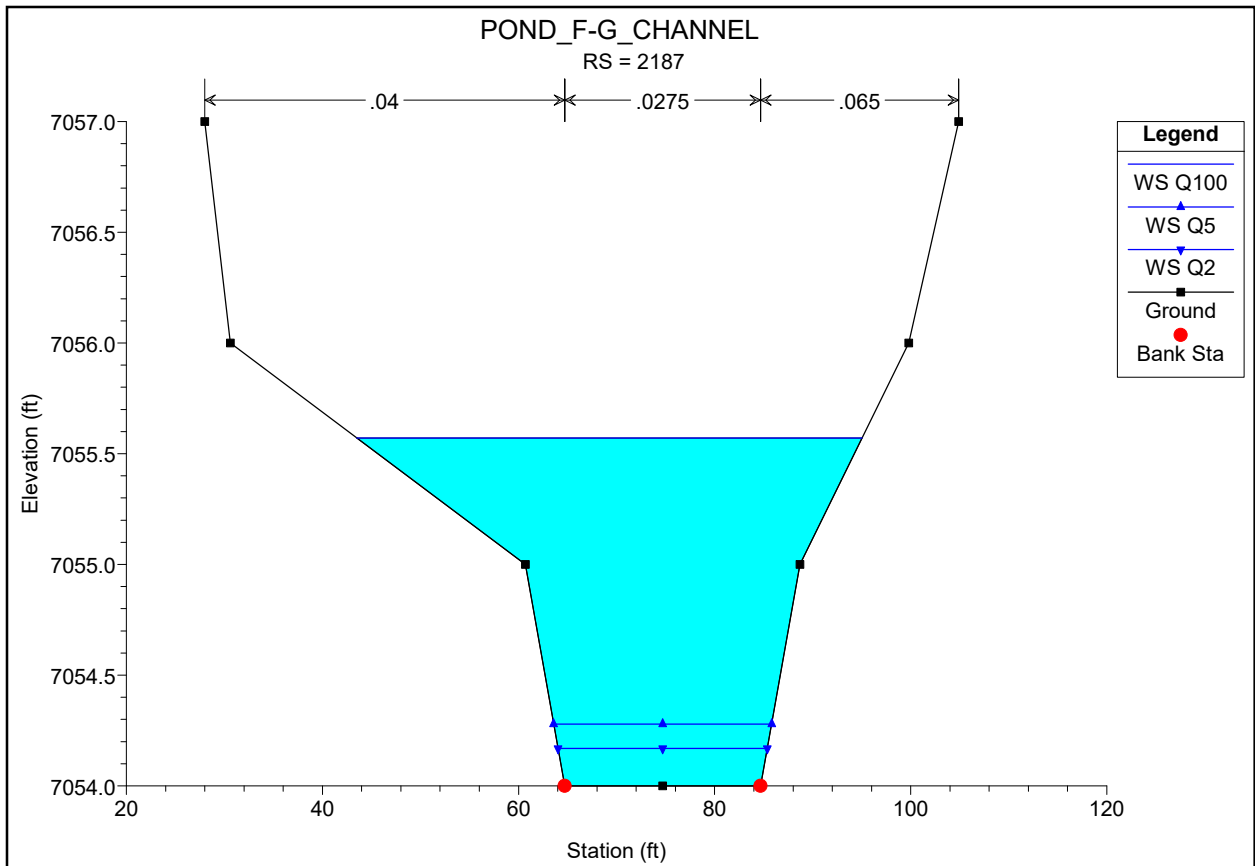

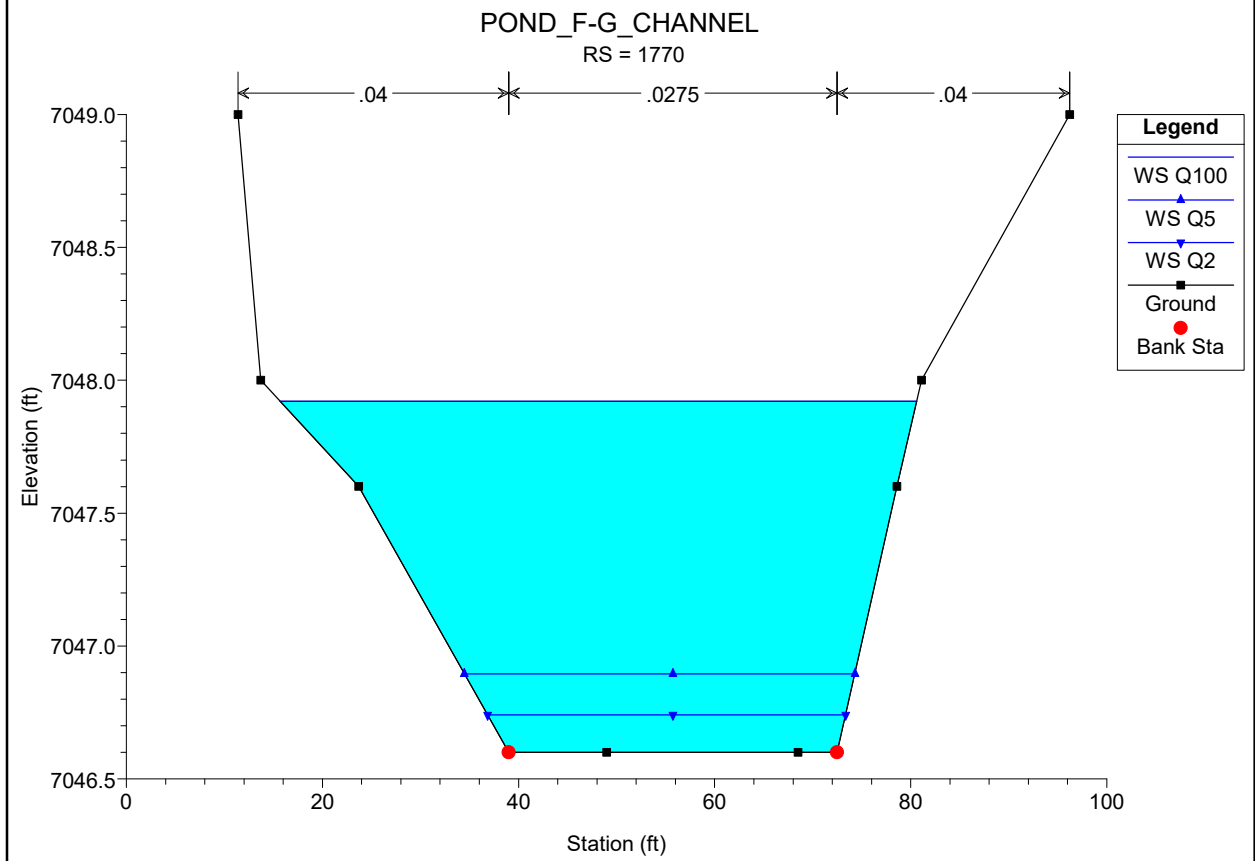
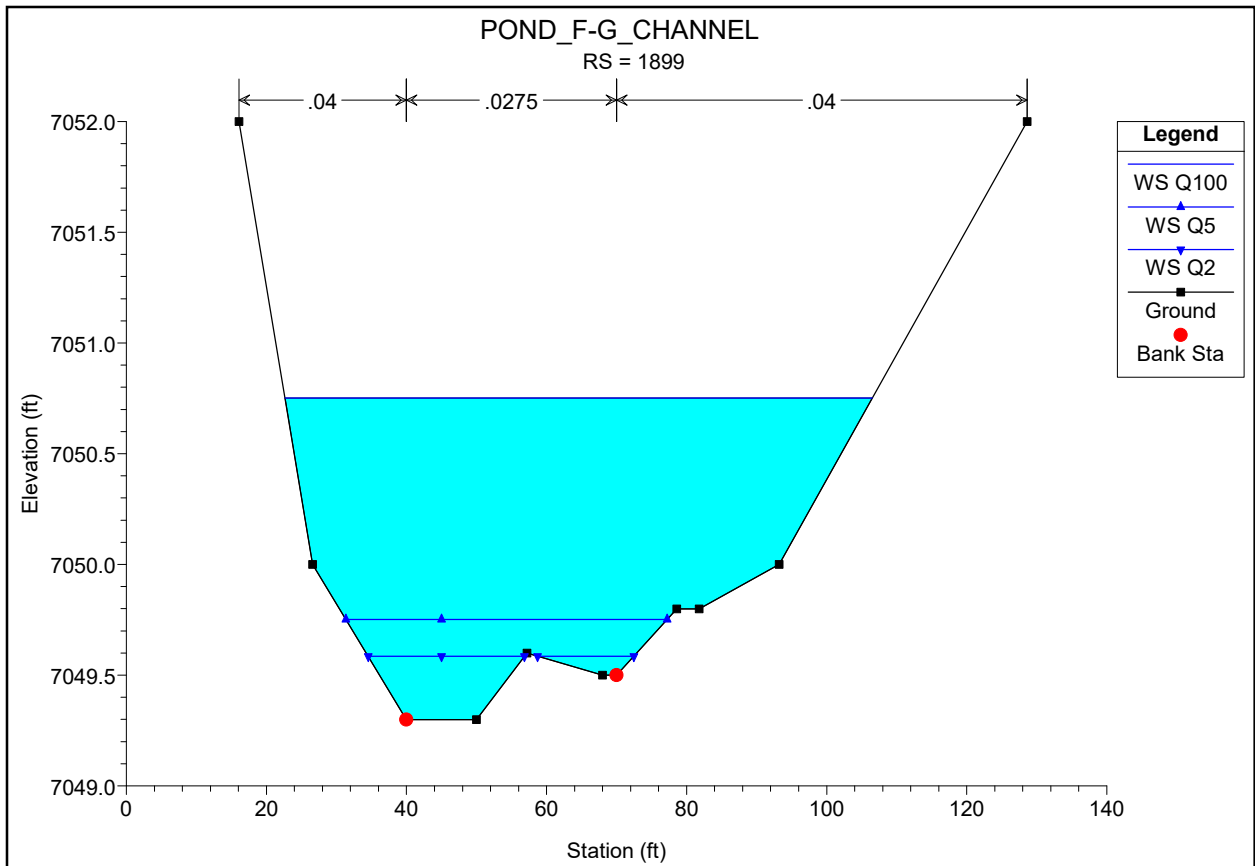

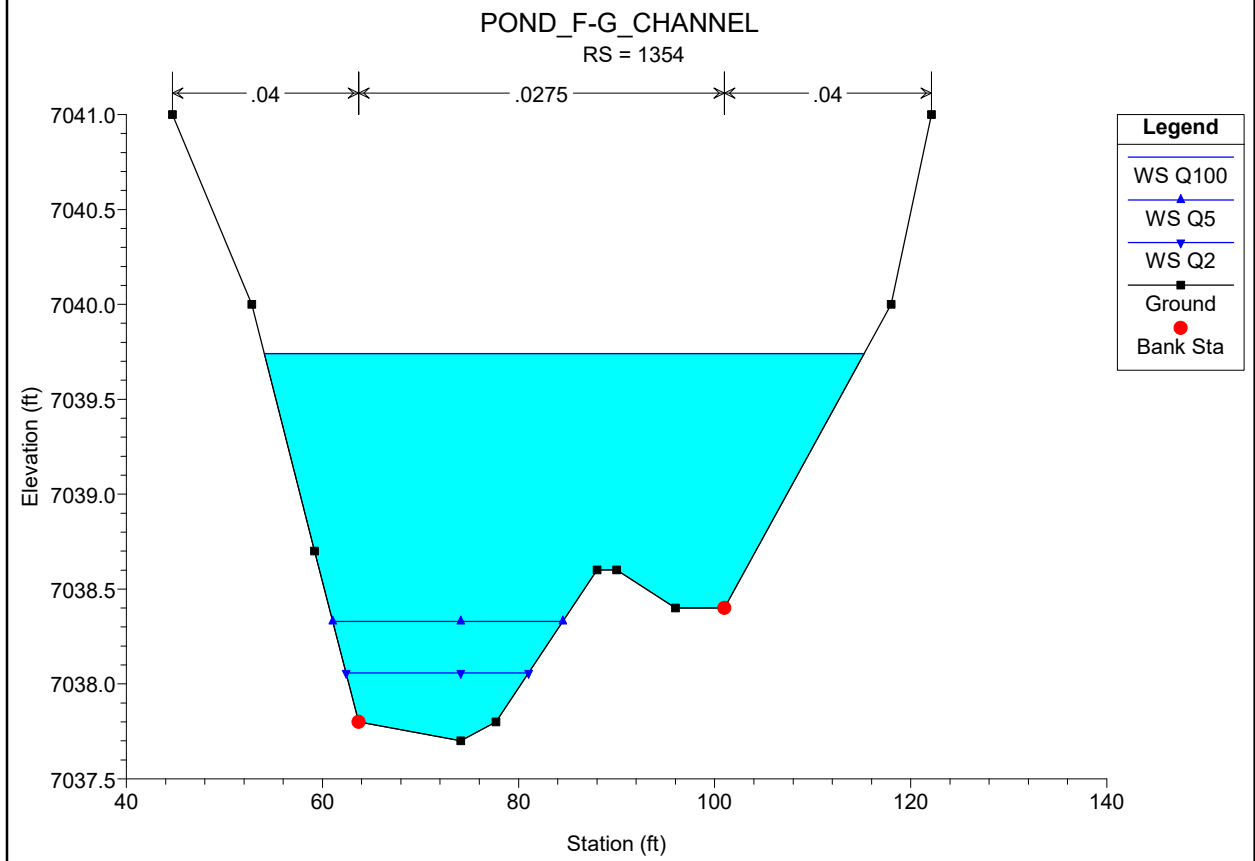
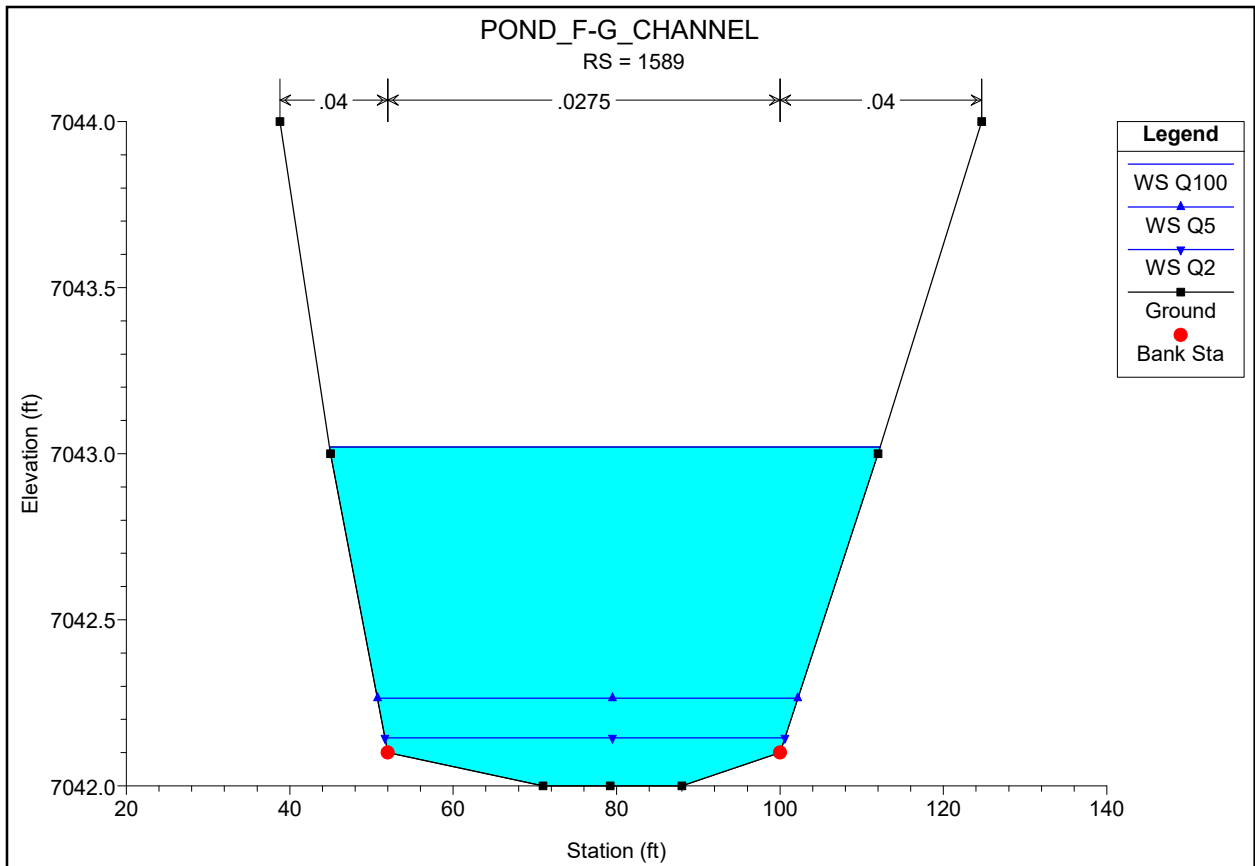

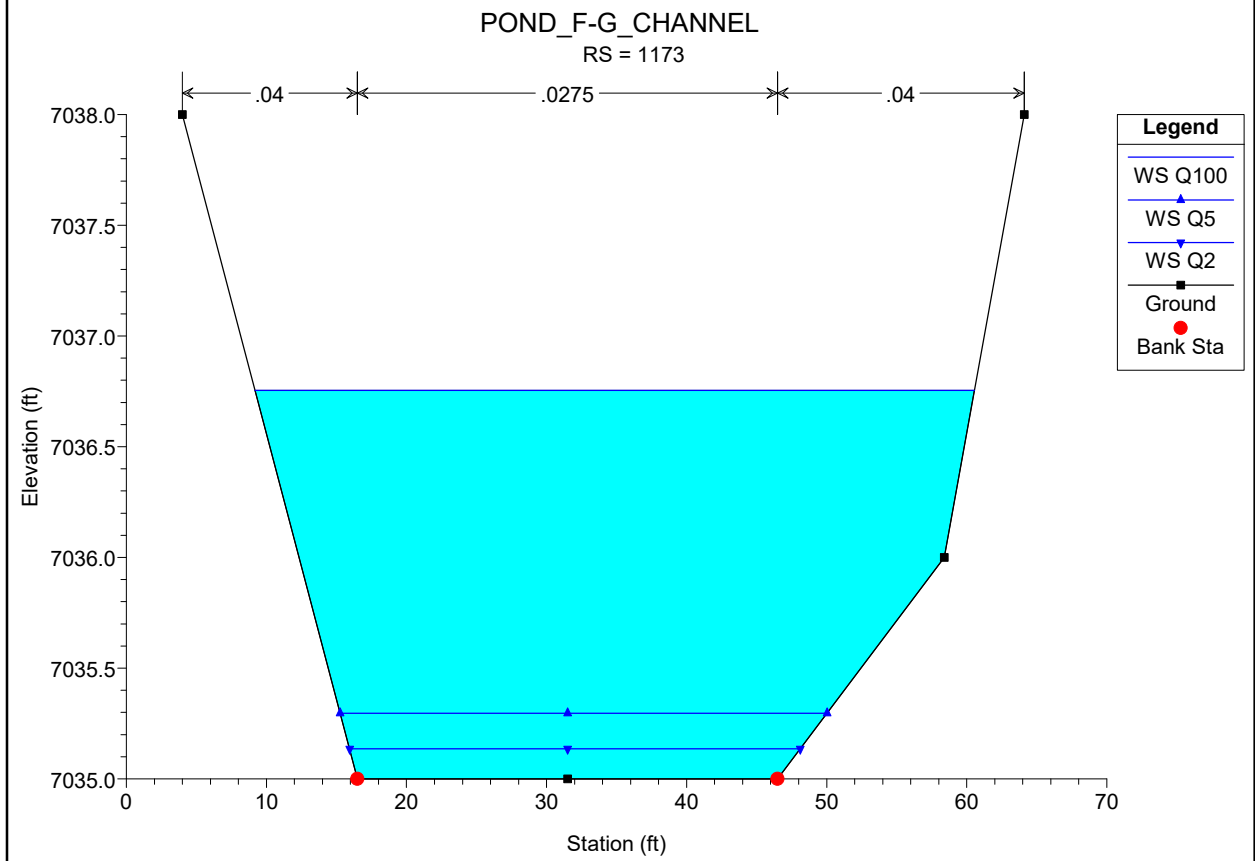
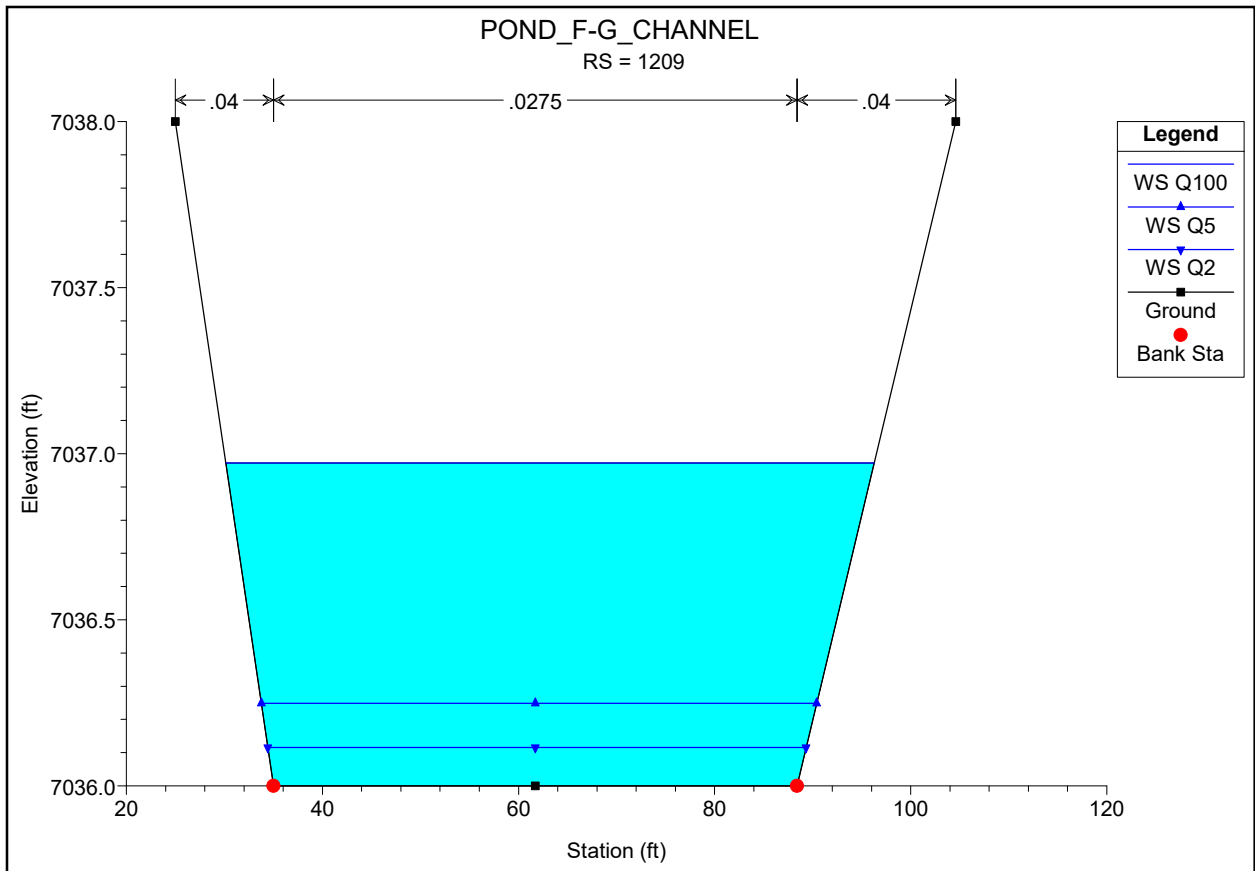

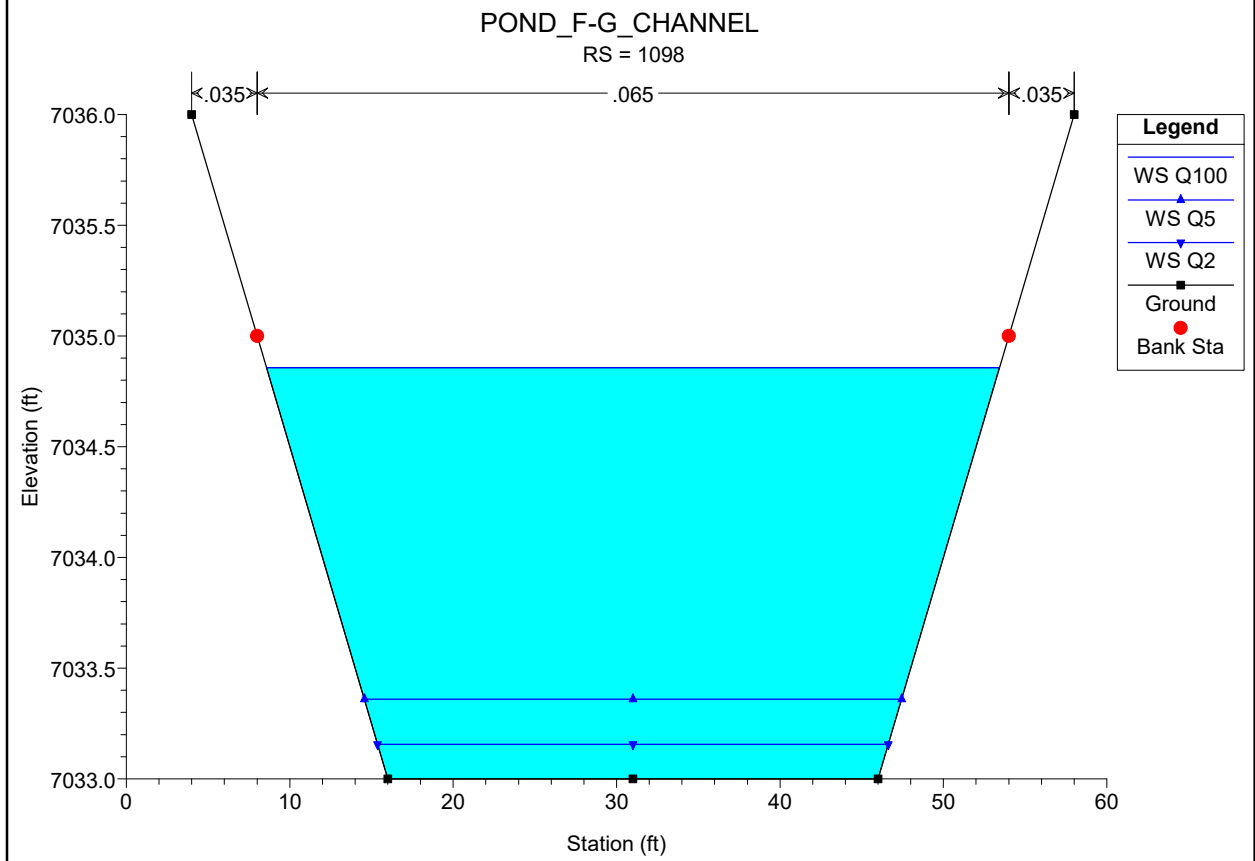
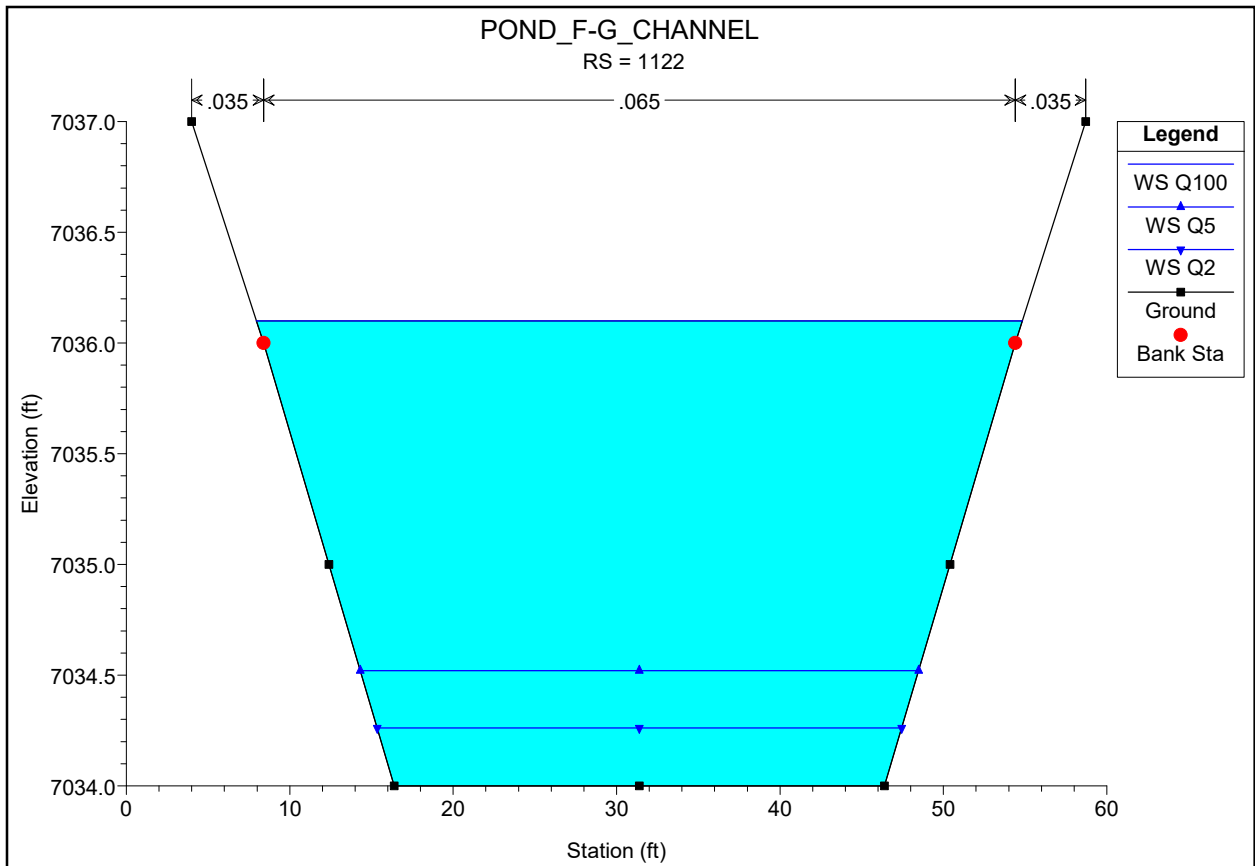

POND_F-G_CHANNEL

RS = 1000

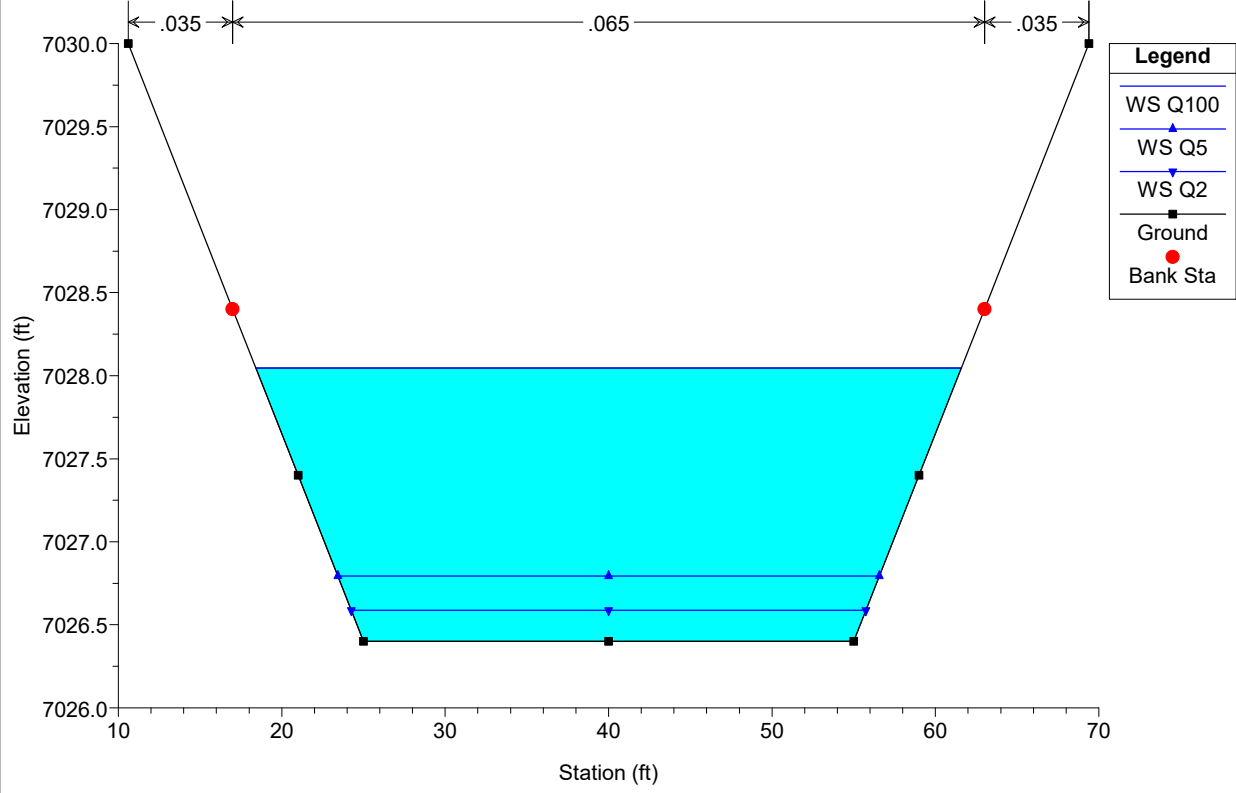

Plan: Plan 02 POND F-G CHANNEL MAIN CHANNEL RS: 5688 Profile: Q100

E.G. Elev (ft)	7127.44	Element	Left OB	Channel	Right OB
Vel Head (ft)	0.31	Wt. n-Val.	0.045	0.065	0.045
W.S. Elev (ft)	7127.12	Reach Len. (ft)	81.00	83.00	89.00
Crit W.S. (ft)	7126.98	Flow Area (sq ft)	0.06	36.50	0.07
E.G. Slope (ft/ft)	0.039733	Area (sq ft)	0.06	36.50	0.07
Q Total (cfs)	164.00	Flow (cfs)	0.06	163.87	0.07
Top Width (ft)	39.04	Top Width (ft)	1.01	36.90	1.12
Vel Total (ft/s)	4.48	Avg. Vel. (ft/s)	1.02	4.49	1.02
Max Chl Dpth (ft)	1.62	Hydr. Depth (ft)	0.06	0.99	0.06
Conv. Total (cfs)	822.8	Conv. (cfs)	0.3	822.1	0.3
Length Wtd. (ft)	83.01	Wetted Per. (ft)	1.02	37.33	1.13
Min Ch El (ft)	7125.50	Shear (lb/sq ft)	0.15	2.43	0.15
Alpha	1.00	Stream Power (lb/ft s)	0.15	10.89	0.15
Frctn Loss (ft)	1.71	Cum Volume (acre-ft)	0.58	5.21	0.56
C & E Loss (ft)	0.05	Cum SA (acres)	0.83	4.17	0.78

Plan: Plan 02 POND F-G CHANNEL MAIN CHANNEL RS: 5607 Profile: Q100

E.G. Elev (ft)	7125.68	Element	Left OB	Channel	Right OB
Vel Head (ft)	0.15	Wt. n-Val.	0.045	0.065	0.045
W.S. Elev (ft)	7125.53	Reach Len. (ft)	46.00	49.00	50.00
Crit W.S. (ft)		Flow Area (sq ft)	1.19	51.23	0.72
E.G. Slope (ft/ft)	0.012563	Area (sq ft)	1.19	51.23	0.72
Q Total (cfs)	164.00	Flow (cfs)	1.82	161.09	1.09
Top Width (ft)	44.69	Top Width (ft)	4.47	37.50	2.72
Vel Total (ft/s)	3.09	Avg. Vel. (ft/s)	1.53	3.14	1.51
Max Chl Dpth (ft)	1.53	Hydr. Depth (ft)	0.27	1.37	0.27
Conv. Total (cfs)	1463.2	Conv. (cfs)	16.2	1437.2	9.8
Length Wtd. (ft)	48.99	Wetted Per. (ft)	4.51	37.68	2.77
Min Ch El (ft)	7124.00	Shear (lb/sq ft)	0.21	1.07	0.21
Alpha	1.02	Stream Power (lb/ft s)	0.32	3.35	0.31
Frctn Loss (ft)	0.49	Cum Volume (acre-ft)	0.58	5.13	0.56
C & E Loss (ft)	0.01	Cum SA (acres)	0.83	4.09	0.77

Plan: Plan 02 POND F-G CHANNEL MAIN CHANNEL RS: 5558 Profile: Q100

E.G. Elev (ft)	7125.19	Element	Left OB	Channel	Right OB
Vel Head (ft)	0.12	Wt. n-Val.	0.045	0.065	0.045
W.S. Elev (ft)	7125.07	Reach Len. (ft)	200.00	200.00	201.00
Crit W.S. (ft)		Flow Area (sq ft)	0.01	58.37	0.01
E.G. Slope (ft/ft)	0.008073	Area (sq ft)	0.01	58.37	0.01
Q Total (cfs)	164.00	Flow (cfs)	0.00	163.99	0.00
Top Width (ft)	36.59	Top Width (ft)	0.30	36.00	0.30
Vel Total (ft/s)	2.81	Avg. Vel. (ft/s)	0.30	2.81	0.30
Max Chl Dpth (ft)	2.07	Hydr. Depth (ft)	0.03	1.62	0.03
Conv. Total (cfs)	1825.2	Conv. (cfs)	0.0	1825.2	0.0
Length Wtd. (ft)	200.00	Wetted Per. (ft)	0.30	36.49	0.30
Min Ch El (ft)	7123.00	Shear (lb/sq ft)	0.02	0.81	0.02
Alpha	1.00	Stream Power (lb/ft s)	0.00	2.27	0.00
Frctn Loss (ft)	2.29	Cum Volume (acre-ft)	0.58	5.07	0.56
C & E Loss (ft)	0.01	Cum SA (acres)	0.82	4.05	0.77

Plan: Plan 02 POND F-G CHANNEL MAIN CHANNEL RS: 5358 Profile: Q100

E.G. Elev (ft)	7122.89	Element	Left OB	Channel	Right OB
Vel Head (ft)	0.21	Wt. n-Val.		0.065	
W.S. Elev (ft)	7122.68	Reach Len. (ft)	303.00	303.00	301.00
Crit W.S. (ft)	7122.18	Flow Area (sq ft)		44.85	
E.G. Slope (ft/ft)	0.017581	Area (sq ft)		44.85	
Q Total (cfs)	164.00	Flow (cfs)		164.00	
Top Width (ft)	33.43	Top Width (ft)		33.43	
Vel Total (ft/s)	3.66	Avg. Vel. (ft/s)		3.66	
Max Chl Dpth (ft)	1.68	Hydr. Depth (ft)		1.34	
Conv. Total (cfs)	1236.9	Conv. (cfs)		1236.9	
Length Wtd. (ft)	303.00	Wetted Per. (ft)		33.84	
Min Ch El (ft)	7121.00	Shear (lb/sq ft)		1.45	
Alpha	1.00	Stream Power (lb/ft s)		5.32	
Frctn Loss (ft)	9.19	Cum Volume (acre-ft)	0.58	4.83	0.56
C & E Loss (ft)	0.03	Cum SA (acres)	0.82	3.89	0.77

Plan: Plan 02 POND F-G CHANNEL MAIN CHANNEL RS: 5055 Profile: Q100

E.G. Elev (ft)	7113.67	Element	Left OB	Channel	Right OB
Vel Head (ft)	0.50	Wt. n-Val.		0.065	
W.S. Elev (ft)	7113.17	Reach Len. (ft)	291.00	290.00	289.00
Crit W.S. (ft)	7113.17	Flow Area (sq ft)		28.95	
E.G. Slope (ft/ft)	0.064349	Area (sq ft)		28.95	
Q Total (cfs)	164.00	Flow (cfs)		164.00	
Top Width (ft)	29.71	Top Width (ft)		29.71	
Vel Total (ft/s)	5.66	Avg. Vel. (ft/s)		5.66	
Max Chl Dpth (ft)	1.17	Hydr. Depth (ft)		0.97	
Conv. Total (cfs)	646.5	Conv. (cfs)		646.5	
Length Wtd. (ft)	290.00	Wetted Per. (ft)		29.98	
Min Ch El (ft)	7112.00	Shear (lb/sq ft)		3.88	
Alpha	1.00	Stream Power (lb/ft s)		21.97	
Frctn Loss (ft)	5.77	Cum Volume (acre-ft)	0.58	4.57	0.56
C & E Loss (ft)	0.11	Cum SA (acres)	0.82	3.67	0.77

Plan: Plan 02 POND F-G CHANNEL MAIN CHANNEL RS: 4765 Profile: Q100

E.G. Elev (ft)	7106.12	Element	Left OB	Channel	Right OB
Vel Head (ft)	0.14	Wt. n-Val.		0.065	
W.S. Elev (ft)	7105.99	Reach Len. (ft)	15.00	15.00	15.00
Crit W.S. (ft)	7105.17	Flow Area (sq ft)		55.46	
E.G. Slope (ft/ft)	0.009535	Area (sq ft)		55.46	
Q Total (cfs)	164.00	Flow (cfs)		164.00	
Top Width (ft)	35.88	Top Width (ft)		35.88	
Vel Total (ft/s)	2.96	Avg. Vel. (ft/s)		2.96	
Max Chl Dpth (ft)	1.98	Hydr. Depth (ft)		1.55	
Conv. Total (cfs)	1679.5	Conv. (cfs)		1679.5	
Length Wtd. (ft)	15.00	Wetted Per. (ft)		36.37	
Min Ch El (ft)	7104.00	Shear (lb/sq ft)		0.91	
Alpha	1.00	Stream Power (lb/ft s)		2.68	
Frctn Loss (ft)	0.15	Cum Volume (acre-ft)	0.58	4.29	0.56
C & E Loss (ft)	0.00	Cum SA (acres)	0.82	3.46	0.77

Plan: Plan 02 POND F-G CHANNEL MAIN CHANNEL RS: 4750 Profile: Q100

E.G. Elev (ft)	7105.97	Element	Left OB	Channel	Right OB
Vel Head (ft)	0.15	Wt. n-Val.		0.065	
W.S. Elev (ft)	7105.82	Reach Len. (ft)	273.00	273.00	270.00
Crit W.S. (ft)		Flow Area (sq ft)		53.14	
E.G. Slope (ft/ft)	0.010775	Area (sq ft)		53.14	
Q Total (cfs)	164.00	Flow (cfs)		164.00	
Top Width (ft)	35.36	Top Width (ft)		35.36	
Vel Total (ft/s)	3.09	Avg. Vel. (ft/s)		3.09	
Max Chl Dpth (ft)	1.92	Hydr. Depth (ft)		1.50	
Conv. Total (cfs)	1579.9	Conv. (cfs)		1579.9	
Length Wtd. (ft)	273.00	Wetted Per. (ft)		35.83	
Min Ch El (ft)	7103.90	Shear (lb/sq ft)		1.00	
Alpha	1.00	Stream Power (lb/ft s)		3.08	
Frctn Loss (ft)	2.55	Cum Volume (acre-ft)	0.58	4.27	0.56
C & E Loss (ft)	0.00	Cum SA (acres)	0.82	3.44	0.77

Plan: Plan 02 POND F-G CHANNEL MAIN CHANNEL RS: 4477 Profile: Q100

E.G. Elev (ft)	7103.42	Element	Left OB	Channel	Right OB
Vel Head (ft)	0.14	Wt. n-Val.	0.045	0.065	0.045
W.S. Elev (ft)	7103.28	Reach Len. (ft)	27.00	10.00	1.00
Crit W.S. (ft)		Flow Area (sq ft)	0.16	63.29	0.20
E.G. Slope (ft/ft)	0.008326	Area (sq ft)	0.16	63.29	0.20
Q Total (cfs)	191.00	Flow (cfs)	0.13	190.72	0.16
Top Width (ft)	38.52	Top Width (ft)	1.12	36.00	1.40
Vel Total (ft/s)	3.00	Avg. Vel. (ft/s)	0.80	3.01	0.80
Max Chl Dpth (ft)	2.18	Hydr. Depth (ft)	0.14	1.76	0.14
Conv. Total (cfs)	2093.3	Conv. (cfs)	1.4	2090.2	1.7
Length Wtd. (ft)	10.00	Wetted Per. (ft)	1.16	36.45	1.43
Min Ch El (ft)	7101.10	Shear (lb/sq ft)	0.07	0.90	0.07
Alpha	1.01	Stream Power (lb/ft s)	0.06	2.72	0.06
Frctn Loss (ft)	0.08	Cum Volume (acre-ft)	0.58	3.91	0.56
C & E Loss (ft)	0.00	Cum SA (acres)	0.82	3.22	0.77

Plan: Plan 02 POND F-G CHANNEL MAIN CHANNEL RS: 4469 Profile: Q100

E.G. Elev (ft)	7103.34	Element	Left OB	Channel	Right OB
Vel Head (ft)	0.14	Wt. n-Val.	0.045	0.065	0.045
W.S. Elev (ft)	7103.20	Reach Len. (ft)	199.00	198.00	193.00
Crit W.S. (ft)		Flow Area (sq ft)	0.09	64.44	0.10
E.G. Slope (ft/ft)	0.008146	Area (sq ft)	0.09	64.44	0.10
Q Total (cfs)	191.00	Flow (cfs)	0.06	190.88	0.07
Top Width (ft)	38.93	Top Width (ft)	0.91	37.00	1.03
Vel Total (ft/s)	2.95	Avg. Vel. (ft/s)	0.63	2.96	0.64
Max Chl Dpth (ft)	2.20	Hydr. Depth (ft)	0.10	1.74	0.10
Conv. Total (cfs)	2116.3	Conv. (cfs)	0.6	2114.9	0.7
Length Wtd. (ft)	198.00	Wetted Per. (ft)	0.93	37.47	1.05
Min Ch El (ft)	7101.00	Shear (lb/sq ft)	0.05	0.87	0.05
Alpha	1.00	Stream Power (lb/ft s)	0.03	2.59	0.03
Frctn Loss (ft)	2.28	Cum Volume (acre-ft)	0.58	3.89	0.56
C & E Loss (ft)	0.01	Cum SA (acres)	0.82	3.21	0.77

Plan: Plan 02 POND F-G CHANNEL MAIN CHANNEL RS: 4269 Profile: Q100

E.G. Elev (ft)	7101.06	Element	Left OB	Channel	Right OB
Vel Head (ft)	0.23	Wt. n-Val.		0.065	
W.S. Elev (ft)	7100.83	Reach Len. (ft)	105.00	107.00	105.00
Crit W.S. (ft)		Flow Area (sq ft)		49.95	
E.G. Slope (ft/ft)	0.017468	Area (sq ft)		49.95	
Q Total (cfs)	191.00	Flow (cfs)		191.00	
Top Width (ft)	34.63	Top Width (ft)		34.63	
Vel Total (ft/s)	3.82	Avg. Vel. (ft/s)		3.82	
Max Chl Dpth (ft)	1.83	Hydr. Depth (ft)		1.44	
Conv. Total (cfs)	1445.1	Conv. (cfs)		1445.1	
Length Wtd. (ft)	107.00	Wetted Per. (ft)		35.08	
Min Ch El (ft)	7099.00	Shear (lb/sq ft)		1.55	
Alpha	1.00	Stream Power (lb/ft s)		5.94	
Frctn Loss (ft)	3.19	Cum Volume (acre-ft)	0.58	3.63	0.56
C & E Loss (ft)	0.03	Cum SA (acres)	0.82	3.05	0.76

Plan: Plan 02 POND F-G CHANNEL MAIN CHANNEL RS: 4162 Profile: Q100

E.G. Elev (ft)	7097.83	Element	Left OB	Channel	Right OB
Vel Head (ft)	0.54	Wt. n-Val.		0.065	
W.S. Elev (ft)	7097.29	Reach Len. (ft)	100.00	102.00	86.00
Crit W.S. (ft)	7097.29	Flow Area (sq ft)		32.34	
E.G. Slope (ft/ft)	0.062021	Area (sq ft)		32.34	
Q Total (cfs)	191.00	Flow (cfs)		191.00	
Top Width (ft)	30.29	Top Width (ft)		30.29	
Vel Total (ft/s)	5.91	Avg. Vel. (ft/s)		5.91	
Max Chl Dpth (ft)	1.29	Hydr. Depth (ft)		1.07	
Conv. Total (cfs)	766.9	Conv. (cfs)		766.9	
Length Wtd. (ft)	102.00	Wetted Per. (ft)		30.61	
Min Ch El (ft)	7096.00	Shear (lb/sq ft)		4.09	
Alpha	1.00	Stream Power (lb/ft s)		24.16	
Frctn Loss (ft)	6.87	Cum Volume (acre-ft)	0.58	3.53	0.56
C & E Loss (ft)	0.01	Cum SA (acres)	0.82	2.97	0.76

Plan: Plan 02 POND F-G CHANNEL MAIN CHANNEL RS: 4060 Profile: Q100

E.G. Elev (ft)	7090.96	Element	Left OB	Channel	Right OB
Vel Head (ft)	0.52	Wt. n-Val.		0.065	
W.S. Elev (ft)	7090.44	Reach Len. (ft)	47.00	63.00	108.00
Crit W.S. (ft)	7090.48	Flow Area (sq ft)		32.92	
E.G. Slope (ft/ft)	0.072560	Area (sq ft)		32.92	
Q Total (cfs)	191.00	Flow (cfs)		191.00	
Top Width (ft)	35.78	Top Width (ft)		35.78	
Vel Total (ft/s)	5.80	Avg. Vel. (ft/s)		5.80	
Max Chl Dpth (ft)	1.14	Hydr. Depth (ft)		0.92	
Conv. Total (cfs)	709.1	Conv. (cfs)		709.1	
Length Wtd. (ft)	64.53	Wetted Per. (ft)		35.99	
Min Ch El (ft)	7089.30	Shear (lb/sq ft)		4.14	
Alpha	1.00	Stream Power (lb/ft s)		24.04	
Frctn Loss (ft)	1.18	Cum Volume (acre-ft)	0.58	3.46	0.56
C & E Loss (ft)	0.05	Cum SA (acres)	0.82	2.89	0.76

why are these blank

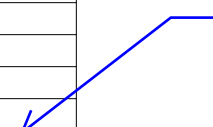

Plan: Plan 02 POND F-G CHANNEL MAIN CHANNEL RS: 3997 Profile: Q100

E.G. Elev (ft)	7088.08	Element	Left OB	Channel	Right OB
Vel Head (ft)	0.31	Wt. n-Val.	0.050	0.043	0.050
W.S. Elev (ft)	7087.77	Reach Len. (ft)	235.00	236.00	233.00
Crit W.S. (ft)	7087.38	Flow Area (sq ft)	1.59	41.09	6.49
E.G. Slope (ft/ft)	0.008941	Area (sq ft)	1.59	41.09	6.49
Q Total (cfs)	208.00	Flow (cfs)	3.21	190.07	14.72
Top Width (ft)	35.79	Top Width (ft)	2.16	24.80	8.82
Vel Total (ft/s)	4.23	Avg. Vel. (ft/s)	2.02	4.63	2.27
Max Chl Dpth (ft)	1.77	Hydr. Depth (ft)	0.74	1.66	0.74
Conv. Total (cfs)	2199.7	Conv. (cfs)	33.9	2010.1	155.7
Length Wtd. (ft)	235.74	Wetted Per. (ft)	2.62	24.83	8.94
Min Ch El (ft)	7086.00	Shear (lb/sq ft)	0.34	0.92	0.40
Alpha	1.12	Stream Power (lb/ft s)	0.68	4.27	0.92
Frctn Loss (ft)	3.23	Cum Volume (acre-ft)	0.58	3.40	0.55
C & E Loss (ft)	0.05	Cum SA (acres)	0.82	2.85	0.75

Plan: Plan 02 POND F-G CHANNEL MAIN CHANNEL RS: 3761 Profile: Q100

E.G. Elev (ft)	7084.81	Element	Left OB	Channel	Right OB
Vel Head (ft)	0.82	Wt. n-Val.	0.050	0.043	0.050
W.S. Elev (ft)	7083.99	Reach Len. (ft)	263.00	261.00	255.00
Crit W.S. (ft)	7083.99	Flow Area (sq ft)	8.09	32.39	4.24
E.G. Slope (ft/ft)	0.019617	Area (sq ft)	8.09	32.39	4.24
Q Total (cfs)	300.00	Flow (cfs)	32.89	250.63	16.47
Top Width (ft)	28.72	Top Width (ft)	8.15	16.30	4.27
Vel Total (ft/s)	6.71	Avg. Vel. (ft/s)	4.06	7.74	3.88
Max Chl Dpth (ft)	1.99	Hydr. Depth (ft)	0.99	1.99	0.99
Conv. Total (cfs)	2142.0	Conv. (cfs)	234.9	1789.5	117.6
Length Wtd. (ft)	260.89	Wetted Per. (ft)	8.38	16.30	4.71
Min Ch El (ft)	7082.00	Shear (lb/sq ft)	1.18	2.43	1.10
Alpha	1.17	Stream Power (lb/ft s)	4.80	18.83	4.28
Frctn Loss (ft)	4.24	Cum Volume (acre-ft)	0.55	3.20	0.52
C & E Loss (ft)	0.10	Cum SA (acres)	0.79	2.74	0.72

Plan: Plan 02 POND F-G CHANNEL MAIN CHANNEL RS: 3500 Profile: Q100

E.G. Elev (ft)	7079.97	Element	Left OB	Channel	Right OB
Vel Head (ft)	0.49	Wt. n-Val.	0.050	0.043	0.050
W.S. Elev (ft)	7079.48	Reach Len. (ft)	256.00	250.00	250.00
Crit W.S. (ft)	7079.31	Flow Area (sq ft)	10.83	42.32	5.50
E.G. Slope (ft/ft)	0.013694	Area (sq ft)	10.83	42.32	5.50
Q Total (cfs)	300.00	Flow (cfs)	30.66	253.93	15.41
Top Width (ft)	45.93	Top Width (ft)	14.68	23.80	7.45
Vel Total (ft/s)	5.12	Avg. Vel. (ft/s)	2.83	6.00	2.80
Max Chl Dpth (ft)	1.98	Hydr. Depth (ft)	0.74	1.78	0.74
Conv. Total (cfs)	2563.6	Conv. (cfs)	262.0	2169.9	131.7
Length Wtd. (ft)	250.40	Wetted Per. (ft)	14.76	23.83	7.60
Min Ch El (ft)	7077.50	Shear (lb/sq ft)	0.63	1.52	0.62
Alpha	1.21	Stream Power (lb/ft s)	1.78	9.11	1.73
Frctn Loss (ft)	3.86	Cum Volume (acre-ft)	0.50	2.98	0.49
C & E Loss (ft)	0.01	Cum SA (acres)	0.72	2.62	0.68

Plan: Plan 02 POND F-G CHANNEL MAIN CHANNEL RS: 3250 Profile: Q100

E.G. Elev (ft)	7076.10	Element	Left OB	Channel	Right OB
Vel Head (ft)	0.57	Wt. n-Val.	0.050	0.038	0.050
W.S. Elev (ft)	7075.53	Reach Len. (ft)	147.00	150.00	157.00
Crit W.S. (ft)	7075.53	Flow Area (sq ft)	3.55	45.48	3.55
E.G. Slope (ft/ft)	0.017500	Area (sq ft)	3.55	45.48	3.55
Q Total (cfs)	300.00	Flow (cfs)	8.91	282.19	8.91
Top Width (ft)	49.06	Top Width (ft)	6.88	35.30	6.88
Vel Total (ft/s)	5.71	Avg. Vel. (ft/s)	2.51	6.20	2.51
Max Chl Dpth (ft)	1.43	Hydr. Depth (ft)	0.52	1.29	0.52
Conv. Total (cfs)	2267.8	Conv. (cfs)	67.3	2133.1	67.3
Length Wtd. (ft)	150.22	Wetted Per. (ft)	6.96	35.31	6.96
Min Ch El (ft)	7074.10	Shear (lb/sq ft)	0.56	1.41	0.56
Alpha	1.12	Stream Power (lb/ft s)	1.40	8.73	1.40
Frctn Loss (ft)	2.29	Cum Volume (acre-ft)	0.45	2.73	0.46
C & E Loss (ft)	0.00	Cum SA (acres)	0.66	2.45	0.64

Plan: Plan 02 POND F-G CHANNEL MAIN CHANNEL RS: 3100 Profile: Q100

E.G. Elev (ft)	7073.61	Element	Left OB	Channel	Right OB
Vel Head (ft)	0.62	Wt. n-Val.	0.050	0.038	0.050
W.S. Elev (ft)	7072.99	Reach Len. (ft)	109.00	89.00	65.00
Crit W.S. (ft)	7072.91	Flow Area (sq ft)	8.33	36.78	7.72
E.G. Slope (ft/ft)	0.013416	Area (sq ft)	8.33	36.78	7.72
Q Total (cfs)	300.00	Flow (cfs)	25.93	249.14	24.93
Top Width (ft)	38.39	Top Width (ft)	9.57	20.50	8.32
Vel Total (ft/s)	5.68	Avg. Vel. (ft/s)	3.11	6.77	3.23
Max Chl Dpth (ft)	1.89	Hydr. Depth (ft)	0.87	1.79	0.93
Conv. Total (cfs)	2590.0	Conv. (cfs)	223.8	2150.9	215.2
Length Wtd. (ft)	88.35	Wetted Per. (ft)	9.70	20.52	8.49
Min Ch El (ft)	7071.10	Shear (lb/sq ft)	0.72	1.50	0.76
Alpha	1.23	Stream Power (lb/ft s)	2.24	10.17	2.46
Frctn Loss (ft)	1.28	Cum Volume (acre-ft)	0.43	2.59	0.44
C & E Loss (ft)	0.00	Cum SA (acres)	0.63	2.35	0.61

Plan: Plan 02 POND F-G CHANNEL MAIN CHANNEL RS: 3011 Profile: Q100

E.G. Elev (ft)	7072.33	Element	Left OB	Channel	Right OB
Vel Head (ft)	0.63	Wt. n-Val.	0.050	0.038	0.050
W.S. Elev (ft)	7071.70	Reach Len. (ft)	108.00	124.00	132.00
Crit W.S. (ft)	7071.70	Flow Area (sq ft)	8.29	34.60	10.91
E.G. Slope (ft/ft)	0.015751	Area (sq ft)	8.29	34.60	10.91
Q Total (cfs)	300.00	Flow (cfs)	25.72	240.00	34.29
Top Width (ft)	45.85	Top Width (ft)	10.83	21.00	14.02
Vel Total (ft/s)	5.58	Avg. Vel. (ft/s)	3.10	6.94	3.14
Max Chl Dpth (ft)	1.70	Hydr. Depth (ft)	0.77	1.65	0.78
Conv. Total (cfs)	2390.4	Conv. (cfs)	204.9	1912.3	273.2
Length Wtd. (ft)	123.44	Wetted Per. (ft)	10.93	21.01	14.10
Min Ch El (ft)	7070.00	Shear (lb/sq ft)	0.75	1.62	0.76
Alpha	1.30	Stream Power (lb/ft s)	2.31	11.23	2.39
Frctn Loss (ft)	1.78	Cum Volume (acre-ft)	0.41	2.51	0.43
C & E Loss (ft)	0.04	Cum SA (acres)	0.60	2.31	0.60

Plan: Plan 02 POND F-G CHANNEL MAIN CHANNEL RS: 2887 Profile: Q100

E.G. Elev (ft)	7070.03	Element	Left OB	Channel	Right OB
Vel Head (ft)	0.49	Wt. n-Val.	0.050	0.038	0.050
W.S. Elev (ft)	7069.55	Reach Len. (ft)	137.00	147.00	150.00
Crit W.S. (ft)	7069.44	Flow Area (sq ft)	7.20	46.53	4.45
E.G. Slope (ft/ft)	0.013250	Area (sq ft)	7.20	46.53	4.45
Q Total (cfs)	300.00	Flow (cfs)	17.91	271.09	11.00
Top Width (ft)	50.85	Top Width (ft)	11.53	32.20	7.12
Vel Total (ft/s)	5.16	Avg. Vel. (ft/s)	2.49	5.83	2.47
Max Chl Dpth (ft)	1.55	Hydr. Depth (ft)	0.62	1.44	0.62
Conv. Total (cfs)	2606.3	Conv. (cfs)	155.6	2355.1	95.6
Length Wtd. (ft)	146.84	Wetted Per. (ft)	11.60	32.23	7.23
Min Ch El (ft)	7068.00	Shear (lb/sq ft)	0.51	1.19	0.51
Alpha	1.18	Stream Power (lb/ft s)	1.28	6.96	1.26
Frctn Loss (ft)	2.31	Cum Volume (acre-ft)	0.39	2.40	0.41
C & E Loss (ft)	0.09	Cum SA (acres)	0.57	2.23	0.57

Plan: Plan 02 POND F-G CHANNEL MAIN CHANNEL RS: 2740 Profile: Q100

E.G. Elev (ft)	7067.63	Element	Left OB	Channel	Right OB
Vel Head (ft)	0.19	Wt. n-Val.	0.050	0.038	0.065
W.S. Elev (ft)	7067.44	Reach Len. (ft)	250.00	240.00	248.00
Crit W.S. (ft)	7067.37	Flow Area (sq ft)	0.43	79.77	7.03
E.G. Slope (ft/ft)	0.018959	Area (sq ft)	0.43	79.77	7.03
Q Total (cfs)	300.00	Flow (cfs)	0.43	281.91	17.66
Top Width (ft)	166.29	Top Width (ft)	3.55	153.00	9.74
Vel Total (ft/s)	3.44	Avg. Vel. (ft/s)	1.00	3.53	2.51
Max Chl Dpth (ft)	1.44	Hydr. Depth (ft)	0.12	0.52	0.72
Conv. Total (cfs)	2178.8	Conv. (cfs)	3.1	2047.4	128.3
Length Wtd. (ft)	240.80	Wetted Per. (ft)	3.56	153.02	9.85
Min Ch El (ft)	7066.00	Shear (lb/sq ft)	0.14	0.62	0.84
Alpha	1.02	Stream Power (lb/ft s)	0.14	2.18	2.12
Frctn Loss (ft)	4.90	Cum Volume (acre-ft)	0.38	2.18	0.39
C & E Loss (ft)	0.03	Cum SA (acres)	0.55	1.92	0.54

Plan: Plan 02 POND F-G CHANNEL MAIN CHANNEL RS: 2500 Profile: Q100

E.G. Elev (ft)	7062.71	Element	Left OB	Channel	Right OB
Vel Head (ft)	0.48	Wt. n-Val.	0.050	0.038	0.065
W.S. Elev (ft)	7062.23	Reach Len. (ft)	182.00	174.00	176.00
Crit W.S. (ft)	7062.23	Flow Area (sq ft)	2.71	44.48	10.96
E.G. Slope (ft/ft)	0.021914	Area (sq ft)	2.71	44.48	10.96
Q Total (cfs)	300.00	Flow (cfs)	7.89	260.28	31.82
Top Width (ft)	63.21	Top Width (ft)	4.92	44.60	13.69
Vel Total (ft/s)	5.16	Avg. Vel. (ft/s)	2.91	5.85	2.90
Max Chl Dpth (ft)	1.43	Hydr. Depth (ft)	0.55	1.00	0.80
Conv. Total (cfs)	2026.6	Conv. (cfs)	53.3	1758.3	215.0
Length Wtd. (ft)	174.58	Wetted Per. (ft)	5.03	44.64	13.79
Min Ch El (ft)	7060.80	Shear (lb/sq ft)	0.74	1.36	1.09
Alpha	1.16	Stream Power (lb/ft s)	2.15	7.98	3.16
Frctn Loss (ft)	3.87	Cum Volume (acre-ft)	0.37	1.84	0.34
C & E Loss (ft)	0.02	Cum SA (acres)	0.53	1.38	0.47

Plan: Plan 02 POND F-G CHANNEL MAIN CHANNEL RS: 2326 Profile: Q100

E.G. Elev (ft)	7058.81	Element	Left OB	Channel	Right OB
Vel Head (ft)	0.41	Wt. n-Val.	0.050	0.038	0.065
W.S. Elev (ft)	7058.40	Reach Len. (ft)	113.00	139.00	138.00
Crit W.S. (ft)	7058.40	Flow Area (sq ft)	10.02	48.09	5.29
E.G. Slope (ft/ft)	0.022466	Area (sq ft)	10.02	48.09	5.29
Q Total (cfs)	300.00	Flow (cfs)	23.28	260.67	16.05
Top Width (ft)	87.65	Top Width (ft)	26.53	55.00	6.12
Vel Total (ft/s)	4.73	Avg. Vel. (ft/s)	2.32	5.42	3.04
Max Chl Dpth (ft)	1.50	Hydr. Depth (ft)	0.38	0.87	0.86
Conv. Total (cfs)	2001.5	Conv. (cfs)	155.3	1739.1	107.1
Length Wtd. (ft)	136.47	Wetted Per. (ft)	26.57	55.15	6.34
Min Ch El (ft)	7056.90	Shear (lb/sq ft)	0.53	1.22	1.17
Alpha	1.18	Stream Power (lb/ft s)	1.23	6.63	3.55
Frctn Loss (ft)	2.37	Cum Volume (acre-ft)	0.35	1.66	0.30
C & E Loss (ft)	0.02	Cum SA (acres)	0.46	1.18	0.43

Plan: Plan 02 POND F-G CHANNEL MAIN CHANNEL RS: 2187 Profile: Q100

E.G. Elev (ft)	7056.42	Element	Left OB	Channel	Right OB
Vel Head (ft)	0.62	Wt. n-Val.	0.050	0.038	0.065
W.S. Elev (ft)	7055.80	Reach Len. (ft)	152.00	142.00	133.00
Crit W.S. (ft)	7055.83	Flow Area (sq ft)	14.85	36.02	8.76
E.G. Slope (ft/ft)	0.013802	Area (sq ft)	14.85	36.02	8.76
Q Total (cfs)	300.00	Flow (cfs)	33.79	248.16	18.05
Top Width (ft)	60.99	Top Width (ft)	28.10	20.00	12.89
Vel Total (ft/s)	5.03	Avg. Vel. (ft/s)	2.28	6.89	2.06
Max Chl Dpth (ft)	1.80	Hydr. Depth (ft)	0.53	1.80	0.68
Conv. Total (cfs)	2553.6	Conv. (cfs)	287.6	2112.3	153.6
Length Wtd. (ft)	143.07	Wetted Per. (ft)	28.24	20.00	13.05
Min Ch El (ft)	7054.00	Shear (lb/sq ft)	0.45	1.55	0.58
Alpha	1.58	Stream Power (lb/ft s)	1.03	10.69	1.19
Frctn Loss (ft)	1.96	Cum Volume (acre-ft)	0.31	1.52	0.28
C & E Loss (ft)	0.07	Cum SA (acres)	0.39	1.06	0.40

Plan: Plan 02 POND F-G CHANNEL MAIN CHANNEL RS: 2045 Profile: Q100

E.G. Elev (ft)	7054.06	Element	Left OB	Channel	Right OB
Vel Head (ft)	0.37	Wt. n-Val.	0.050	0.038	0.050
W.S. Elev (ft)	7053.69	Reach Len. (ft)	180.00	146.00	152.00
Crit W.S. (ft)	7053.57	Flow Area (sq ft)	17.34	44.25	5.20
E.G. Slope (ft/ft)	0.014635	Area (sq ft)	17.34	44.25	5.20
Q Total (cfs)	300.00	Flow (cfs)	55.77	233.31	10.91
Top Width (ft)	70.36	Top Width (ft)	20.43	38.30	11.63
Vel Total (ft/s)	4.49	Avg. Vel. (ft/s)	3.22	5.27	2.10
Max Chl Dpth (ft)	1.69	Hydr. Depth (ft)	0.85	1.16	0.45
Conv. Total (cfs)	2479.9	Conv. (cfs)	461.0	1928.6	90.2
Length Wtd. (ft)	152.64	Wetted Per. (ft)	20.50	38.35	11.66
Min Ch El (ft)	7052.00	Shear (lb/sq ft)	0.77	1.05	0.41
Alpha	1.18	Stream Power (lb/ft s)	2.49	5.56	0.86
Frctn Loss (ft)	2.62	Cum Volume (acre-ft)	0.26	1.39	0.26
C & E Loss (ft)	0.02	Cum SA (acres)	0.31	0.96	0.36

Plan: Plan 02 POND F-G CHANNEL MAIN CHANNEL RS: 1899 Profile: Q100

E.G. Elev (ft)	7051.43	Element	Left OB	Channel	Right OB
Vel Head (ft)	0.55	Wt. n-Val.	0.050	0.038	0.050
W.S. Elev (ft)	7050.88	Reach Len. (ft)	136.00	129.00	118.00
Crit W.S. (ft)	7050.88	Flow Area (sq ft)	18.47	43.15	31.96
E.G. Slope (ft/ft)	0.019077	Area (sq ft)	18.47	43.15	31.96
Q Total (cfs)	493.00	Flow (cfs)	76.82	300.81	115.37
Top Width (ft)	86.74	Top Width (ft)	18.01	30.00	38.73
Vel Total (ft/s)	5.27	Avg. Vel. (ft/s)	4.16	6.97	3.61
Max Chl Dpth (ft)	1.58	Hydr. Depth (ft)	1.03	1.44	0.83
Conv. Total (cfs)	3569.4	Conv. (cfs)	556.2	2177.9	835.3
Length Wtd. (ft)	128.49	Wetted Per. (ft)	18.11	30.01	38.76
Min Ch El (ft)	7049.30	Shear (lb/sq ft)	1.21	1.71	0.98
Alpha	1.28	Stream Power (lb/ft s)	5.05	11.94	3.54
Frctn Loss (ft)	2.49	Cum Volume (acre-ft)	0.18	1.25	0.19
C & E Loss (ft)	0.02	Cum SA (acres)	0.23	0.85	0.27

Plan: Plan 02 POND F-G CHANNEL MAIN CHANNEL RS: 1770 Profile: Q100

E.G. Elev (ft)	7048.92	Element	Left OB	Channel	Right OB
Vel Head (ft)	0.74	Wt. n-Val.	0.050	0.038	0.050
W.S. Elev (ft)	7048.17	Reach Len. (ft)	185.00	181.00	227.00
Crit W.S. (ft)	7048.28	Flow Area (sq ft)	20.18	52.69	7.70
E.G. Slope (ft/ft)	0.019732	Area (sq ft)	20.18	52.69	7.70
Q Total (cfs)	493.00	Flow (cfs)	71.54	396.61	24.86
Top Width (ft)	70.41	Top Width (ft)	25.70	33.50	11.21
Vel Total (ft/s)	6.12	Avg. Vel. (ft/s)	3.55	7.53	3.23
Max Chl Dpth (ft)	1.57	Hydr. Depth (ft)	0.79	1.57	0.69
Conv. Total (cfs)	3509.6	Conv. (cfs)	509.3	2823.4	176.9
Length Wtd. (ft)	183.85	Wetted Per. (ft)	25.77	33.50	11.33
Min Ch El (ft)	7046.60	Shear (lb/sq ft)	0.96	1.94	0.84
Alpha	1.28	Stream Power (lb/ft s)	3.42	14.58	2.70
Frctn Loss (ft)	4.76	Cum Volume (acre-ft)	0.12	1.10	0.14
C & E Loss (ft)	0.02	Cum SA (acres)	0.16	0.75	0.21

Plan: Plan 02 POND F-G CHANNEL MAIN CHANNEL RS: 1589 Profile: Q100

E.G. Elev (ft)	7044.13	Element	Left OB	Channel	Right OB
Vel Head (ft)	0.96	Wt. n-Val.	0.050	0.038	0.050
W.S. Elev (ft)	7043.18	Reach Len. (ft)	227.00	235.00	218.00
Crit W.S. (ft)	7043.43	Flow Area (sq ft)	4.48	54.89	7.70
E.G. Slope (ft/ft)	0.035433	Area (sq ft)	4.48	54.89	7.70
Q Total (cfs)	493.00	Flow (cfs)	16.78	447.65	28.58
Top Width (ft)	70.32	Top Width (ft)	8.09	48.00	14.23
Vel Total (ft/s)	7.35	Avg. Vel. (ft/s)	3.75	8.16	3.71
Max Chl Dpth (ft)	1.18	Hydr. Depth (ft)	0.55	1.14	0.54
Conv. Total (cfs)	2619.1	Conv. (cfs)	89.1	2378.1	151.8
Length Wtd. (ft)	233.43	Wetted Per. (ft)	8.16	48.00	14.27
Min Ch El (ft)	7042.00	Shear (lb/sq ft)	1.21	2.53	1.19
Alpha	1.14	Stream Power (lb/ft s)	4.55	20.63	4.43
Frctn Loss (ft)	3.59	Cum Volume (acre-ft)	0.07	0.88	0.10
C & E Loss (ft)	0.02	Cum SA (acres)	0.09	0.58	0.14

Plan: Plan 02 POND F-G CHANNEL MAIN CHANNEL RS: 1354 Profile: Q100

E.G. Elev (ft)	7040.44	Element	Left OB	Channel	Right OB
Vel Head (ft)	0.70	Wt. n-Val.	0.050	0.038	0.050
W.S. Elev (ft)	7039.74	Reach Len. (ft)	141.00	145.00	164.00
Crit W.S. (ft)	7039.74	Flow Area (sq ft)	9.32	60.99	9.47
E.G. Slope (ft/ft)	0.016528	Area (sq ft)	9.32	60.99	9.47
Q Total (cfs)	493.00	Flow (cfs)	34.47	430.96	27.57
Top Width (ft)	61.09	Top Width (ft)	9.60	37.30	14.19
Vel Total (ft/s)	6.18	Avg. Vel. (ft/s)	3.70	7.07	2.91
Max Chl Dpth (ft)	2.04	Hydr. Depth (ft)	0.97	1.63	0.67
Conv. Total (cfs)	3834.8	Conv. (cfs)	268.1	3352.2	214.5
Length Wtd. (ft)	145.81	Wetted Per. (ft)	9.79	37.33	14.25
Min Ch El (ft)	7037.70	Shear (lb/sq ft)	0.98	1.69	0.69
Alpha	1.18	Stream Power (lb/ft s)	3.63	11.91	2.00
Frctn Loss (ft)	1.92	Cum Volume (acre-ft)	0.04	0.57	0.06
C & E Loss (ft)	0.08	Cum SA (acres)	0.04	0.35	0.07

Plan: Plan 02 POND F-G CHANNEL MAIN CHANNEL RS: 1209 Profile: Q100

E.G. Elev (ft)	7037.98	Element	Left OB	Channel	Right OB
Vel Head (ft)	0.44	Wt. n-Val.	0.050	0.038	0.050
W.S. Elev (ft)	7037.55	Reach Len. (ft)	35.00	36.00	32.00
Crit W.S. (ft)	7037.33	Flow Area (sq ft)	5.97	82.55	9.68
E.G. Slope (ft/ft)	0.010718	Area (sq ft)	5.97	82.55	9.68
Q Total (cfs)	493.00	Flow (cfs)	15.28	452.76	24.95
Top Width (ft)	73.65	Top Width (ft)	7.73	53.40	12.52
Vel Total (ft/s)	5.02	Avg. Vel. (ft/s)	2.56	5.48	2.58
Max Chl Dpth (ft)	1.55	Hydr. Depth (ft)	0.77	1.55	0.77
Conv. Total (cfs)	4761.9	Conv. (cfs)	147.6	4373.3	241.0
Length Wtd. (ft)	35.57	Wetted Per. (ft)	7.88	53.40	12.62
Min Ch El (ft)	7036.00	Shear (lb/sq ft)	0.51	1.03	0.51
Alpha	1.12	Stream Power (lb/ft s)	1.30	5.67	1.32
Frctn Loss (ft)	0.38	Cum Volume (acre-ft)	0.01	0.33	0.02
C & E Loss (ft)	0.01	Cum SA (acres)	0.01	0.20	0.02

Plan: Plan 02 POND F-G CHANNEL MAIN CHANNEL RS: 1173 Profile: Q100

E.G. Elev (ft)	7037.59	Element	Left OB	Channel	Right OB
Vel Head (ft)	0.58	Wt. n-Val.	0.050	0.038	0.050
W.S. Elev (ft)	7037.01	Reach Len. (ft)	50.00	51.00	50.00
Crit W.S. (ft)		Flow Area (sq ft)	8.41	60.26	19.40
E.G. Slope (ft/ft)	0.010852	Area (sq ft)	8.41	60.26	19.40
Q Total (cfs)	493.00	Flow (cfs)	25.62	396.02	71.36
Top Width (ft)	53.15	Top Width (ft)	8.37	30.00	14.78
Vel Total (ft/s)	5.60	Avg. Vel. (ft/s)	3.05	6.57	3.68
Max Chl Dpth (ft)	2.01	Hydr. Depth (ft)	1.00	2.01	1.31
Conv. Total (cfs)	4732.6	Conv. (cfs)	245.9	3801.7	685.0
Length Wtd. (ft)	50.90	Wetted Per. (ft)	8.61	30.00	14.99
Min Ch El (ft)	7035.00	Shear (lb/sq ft)	0.66	1.36	0.88
Alpha	1.19	Stream Power (lb/ft s)	2.02	8.94	3.23
Frctn Loss (ft)	0.91	Cum Volume (acre-ft)	0.00	0.27	0.01
C & E Loss (ft)	0.00	Cum SA (acres)	0.01	0.17	0.01

Plan: Plan 02 POND F-G CHANNEL MAIN CHANNEL RS: 1122 Profile: Q100

E.G. Elev (ft)	7036.68	Element	Left OB	Channel	Right OB
Vel Head (ft)	0.58	Wt. n-Val.	0.045	0.065	0.045
W.S. Elev (ft)	7036.10	Reach Len. (ft)	24.00	24.00	24.00
Crit W.S. (ft)		Flow Area (sq ft)	0.02	80.60	0.02
E.G. Slope (ft/ft)	0.034365	Area (sq ft)	0.02	80.60	0.02
Q Total (cfs)	493.00	Flow (cfs)	0.02	492.96	0.02
Top Width (ft)	46.87	Top Width (ft)	0.44	46.00	0.43
Vel Total (ft/s)	6.11	Avg. Vel. (ft/s)	0.82	6.12	0.82
Max Chl Dpth (ft)	2.10	Hydr. Depth (ft)	0.05	1.75	0.05
Conv. Total (cfs)	2659.4	Conv. (cfs)	0.1	2659.3	0.1
Length Wtd. (ft)	24.00	Wetted Per. (ft)	0.45	46.49	0.44
Min Ch El (ft)	7034.00	Shear (lb/sq ft)	0.10	3.72	0.10
Alpha	1.00	Stream Power (lb/ft s)	0.09	22.75	0.09
Frctn Loss (ft)	1.02	Cum Volume (acre-ft)	0.00	0.19	0.00
C & E Loss (ft)	0.02	Cum SA (acres)	0.00	0.12	0.00

Plan: Plan 02 POND F-G CHANNEL MAIN CHANNEL RS: 1098 Profile: Q100

E.G. Elev (ft)	7035.64	Element	Left OB	Channel	Right OB
Vel Head (ft)	0.78	Wt. n-Val.		0.065	
W.S. Elev (ft)	7034.86	Reach Len. (ft)	99.00	98.00	100.00
Crit W.S. (ft)	7034.86	Flow Area (sq ft)		69.50	
E.G. Slope (ft/ft)	0.054432	Area (sq ft)		69.50	
Q Total (cfs)	493.00	Flow (cfs)		493.00	
Top Width (ft)	44.86	Top Width (ft)		44.86	
Vel Total (ft/s)	7.09	Avg. Vel. (ft/s)		7.09	
Max Chl Dpth (ft)	1.86	Hydr. Depth (ft)		1.55	
Conv. Total (cfs)	2113.1	Conv. (cfs)		2113.1	
Length Wtd. (ft)	98.00	Wetted Per. (ft)		45.31	
Min Ch El (ft)	7033.00	Shear (lb/sq ft)		5.21	
Alpha	1.00	Stream Power (lb/ft s)		36.97	
Frctn Loss (ft)	6.53	Cum Volume (acre-ft)		0.15	
C & E Loss (ft)	0.03	Cum SA (acres)		0.10	

Plan: Plan 02 POND F-G CHANNEL MAIN CHANNEL RS: 1000 Profile: Q100

E.G. Elev (ft)	7029.09	Element	Left OB	Channel	Right OB
Vel Head (ft)	1.04	Wt. n-Val.		0.065	
W.S. Elev (ft)	7028.04	Reach Len. (ft)			
Crit W.S. (ft)	7028.26	Flow Area (sq ft)		60.13	
E.G. Slope (ft/ft)	0.083670	Area (sq ft)		60.13	
Q Total (cfs)	493.00	Flow (cfs)		493.00	
Top Width (ft)	43.15	Top Width (ft)		43.15	
Vel Total (ft/s)	8.20	Avg. Vel. (ft/s)		8.20	
Max Chl Dpth (ft)	1.64	Hydr. Depth (ft)		1.39	
Conv. Total (cfs)	1704.4	Conv. (cfs)		1704.4	
Length Wtd. (ft)		Wetted Per. (ft)		43.56	
Min Ch El (ft)	7026.40	Shear (lb/sq ft)		7.21	
Alpha	1.00	Stream Power (lb/ft s)		59.12	
Frctn Loss (ft)		Cum Volume (acre-ft)			
C & E Loss (ft)		Cum SA (acres)			

Plan: Plan 02 POND F-G CHANNEL MAIN CHANNEL RS: 5688 Profile: Q5

E.G. Elev (ft)	7126.16	Element	Left OB	Channel	Right OB
Vel Head (ft)	0.02	Wt. n-Val.		0.065	
W.S. Elev (ft)	7126.14	Reach Len. (ft)	81.00	83.00	89.00
Crit W.S. (ft)	7125.83	Flow Area (sq ft)		6.86	
E.G. Slope (ft/ft)	0.009509	Area (sq ft)		6.86	
Q Total (cfs)	7.00	Flow (cfs)		7.00	
Top Width (ft)	21.84	Top Width (ft)		21.84	
Vel Total (ft/s)	1.02	Avg. Vel. (ft/s)		1.02	
Max Chl Dpth (ft)	0.64	Hydr. Depth (ft)		0.31	
Conv. Total (cfs)	71.8	Conv. (cfs)		71.8	
Length Wtd. (ft)	83.00	Wetted Per. (ft)		22.17	
Min Ch El (ft)	7125.50	Shear (lb/sq ft)		0.18	
Alpha	1.00	Stream Power (lb/ft s)		0.19	
Frctn Loss (ft)	1.95	Cum Volume (acre-ft)	0.02	0.77	0.02
C & E Loss (ft)	0.01	Cum SA (acres)	0.12	2.72	0.11

Plan: Plan 02 POND F-G CHANNEL MAIN CHANNEL RS: 5607 Profile: Q5

E.G. Elev (ft)	7124.20	Element	Left OB	Channel	Right OB
Vel Head (ft)	0.07	Wt. n-Val.		0.065	
W.S. Elev (ft)	7124.13	Reach Len. (ft)	46.00	49.00	50.00
Crit W.S. (ft)	7124.13	Flow Area (sq ft)		3.38	
E.G. Slope (ft/ft)	0.129046	Area (sq ft)		3.38	
Q Total (cfs)	7.00	Flow (cfs)		7.00	
Top Width (ft)	26.64	Top Width (ft)		26.64	
Vel Total (ft/s)	2.07	Avg. Vel. (ft/s)		2.07	
Max Chl Dpth (ft)	0.13	Hydr. Depth (ft)		0.13	
Conv. Total (cfs)	19.5	Conv. (cfs)		19.5	
Length Wtd. (ft)	49.00	Wetted Per. (ft)		26.66	
Min Ch El (ft)	7124.00	Shear (lb/sq ft)		1.02	
Alpha	1.00	Stream Power (lb/ft s)		2.12	
Frctn Loss (ft)	0.55	Cum Volume (acre-ft)	0.02	0.76	0.02
C & E Loss (ft)	0.02	Cum SA (acres)	0.12	2.68	0.11

Plan: Plan 02 POND F-G CHANNEL MAIN CHANNEL RS: 5558 Profile: Q5

E.G. Elev (ft)	7123.43	Element	Left OB	Channel	Right OB
Vel Head (ft)	0.01	Wt. n-Val.		0.065	
W.S. Elev (ft)	7123.42	Reach Len. (ft)	200.00	200.00	201.00
Crit W.S. (ft)	7123.16	Flow Area (sq ft)		9.20	
E.G. Slope (ft/ft)	0.003874	Area (sq ft)		9.20	
Q Total (cfs)	7.00	Flow (cfs)		7.00	
Top Width (ft)	23.39	Top Width (ft)		23.39	
Vel Total (ft/s)	0.76	Avg. Vel. (ft/s)		0.76	
Max Chl Dpth (ft)	0.42	Hydr. Depth (ft)		0.39	
Conv. Total (cfs)	112.5	Conv. (cfs)		112.5	
Length Wtd. (ft)	200.00	Wetted Per. (ft)		23.49	
Min Ch El (ft)	7123.00	Shear (lb/sq ft)		0.09	
Alpha	1.00	Stream Power (lb/ft s)		0.07	
Frctn Loss (ft)	2.20	Cum Volume (acre-ft)	0.02	0.75	0.02
C & E Loss (ft)	0.01	Cum SA (acres)	0.12	2.65	0.11

Plan: Plan 02 POND F-G CHANNEL MAIN CHANNEL RS: 5358 Profile: Q5

E.G. Elev (ft)	7121.23	Element	Left OB	Channel	Right OB
Vel Head (ft)	0.07	Wt. n-Val.		0.065	
W.S. Elev (ft)	7121.16	Reach Len. (ft)	303.00	303.00	301.00
Crit W.S. (ft)	7121.16	Flow Area (sq ft)		3.23	
E.G. Slope (ft/ft)	0.110739	Area (sq ft)		3.23	
Q Total (cfs)	7.00	Flow (cfs)		7.00	
Top Width (ft)	21.25	Top Width (ft)		21.25	
Vel Total (ft/s)	2.17	Avg. Vel. (ft/s)		2.17	
Max Chl Dpth (ft)	0.16	Hydr. Depth (ft)		0.15	
Conv. Total (cfs)	21.0	Conv. (cfs)		21.0	
Length Wtd. (ft)		Wetted Per. (ft)		21.29	
Min Ch El (ft)	7121.00	Shear (lb/sq ft)		1.05	
Alpha	1.00	Stream Power (lb/ft s)		2.27	
Frctn Loss (ft)		Cum Volume (acre-ft)	0.02	0.72	0.02
C & E Loss (ft)		Cum SA (acres)	0.12	2.55	0.11

Plan: Plan 02 POND F-G CHANNEL MAIN CHANNEL RS: 5055 Profile: Q5

E.G. Elev (ft)	7112.23	Element	Left OB	Channel	Right OB
Vel Head (ft)	0.07	Wt. n-Val.		0.065	
W.S. Elev (ft)	7112.16	Reach Len. (ft)	291.00	290.00	289.00
Crit W.S. (ft)	7112.16	Flow Area (sq ft)		3.19	
E.G. Slope (ft/ft)	0.115406	Area (sq ft)		3.19	
Q Total (cfs)	7.00	Flow (cfs)		7.00	
Top Width (ft)	21.28	Top Width (ft)		21.28	
Vel Total (ft/s)	2.19	Avg. Vel. (ft/s)		2.19	
Max Chl Dpth (ft)	0.15	Hydr. Depth (ft)		0.15	
Conv. Total (cfs)	20.6	Conv. (cfs)		20.6	
Length Wtd. (ft)	290.00	Wetted Per. (ft)		21.31	
Min Ch El (ft)	7112.00	Shear (lb/sq ft)		1.08	
Alpha	1.00	Stream Power (lb/ft s)		2.37	
Frctn Loss (ft)	5.55	Cum Volume (acre-ft)	0.02	0.70	0.02
C & E Loss (ft)	0.02	Cum SA (acres)	0.12	2.40	0.11

Plan: Plan 02 POND F-G CHANNEL MAIN CHANNEL RS: 4765 Profile: Q5

E.G. Elev (ft)	7104.36	Element	Left OB	Channel	Right OB
Vel Head (ft)	0.01	Wt. n-Val.		0.065	
W.S. Elev (ft)	7104.35	Reach Len. (ft)	15.00	15.00	15.00
Crit W.S. (ft)	7104.16	Flow Area (sq ft)		7.45	
E.G. Slope (ft/ft)	0.007545	Area (sq ft)		7.45	
Q Total (cfs)	7.00	Flow (cfs)		7.00	
Top Width (ft)	22.79	Top Width (ft)		22.79	
Vel Total (ft/s)	0.94	Avg. Vel. (ft/s)		0.94	
Max Chl Dpth (ft)	0.35	Hydr. Depth (ft)		0.33	
Conv. Total (cfs)	80.6	Conv. (cfs)		80.6	
Length Wtd. (ft)	15.00	Wetted Per. (ft)		22.87	
Min Ch El (ft)	7104.00	Shear (lb/sq ft)		0.15	
Alpha	1.00	Stream Power (lb/ft s)		0.14	
Frctn Loss (ft)	0.14	Cum Volume (acre-ft)	0.02	0.66	0.02
C & E Loss (ft)	0.00	Cum SA (acres)	0.12	2.25	0.11

Plan: Plan 02 POND F-G CHANNEL MAIN CHANNEL RS: 4750 Profile: Q5

E.G. Elev (ft)	7104.22	Element	Left OB	Channel	Right OB
Vel Head (ft)	0.02	Wt. n-Val.		0.065	
W.S. Elev (ft)	7104.20	Reach Len. (ft)	273.00	273.00	270.00
Crit W.S. (ft)		Flow Area (sq ft)		6.37	
E.G. Slope (ft/ft)	0.012435	Area (sq ft)		6.37	
Q Total (cfs)	7.00	Flow (cfs)		7.00	
Top Width (ft)	22.40	Top Width (ft)		22.40	
Vel Total (ft/s)	1.10	Avg. Vel. (ft/s)		1.10	
Max Chl Dpth (ft)	0.30	Hydr. Depth (ft)		0.28	
Conv. Total (cfs)	62.8	Conv. (cfs)		62.8	
Length Wtd. (ft)	273.00	Wetted Per. (ft)		22.48	
Min Ch El (ft)	7103.90	Shear (lb/sq ft)		0.22	
Alpha	1.00	Stream Power (lb/ft s)		0.24	
Frctn Loss (ft)	2.70	Cum Volume (acre-ft)	0.02	0.66	0.02
C & E Loss (ft)	0.00	Cum SA (acres)	0.12	2.25	0.11

Plan: Plan 02 POND F-G CHANNEL MAIN CHANNEL RS: 4477 Profile: Q5

E.G. Elev (ft)	7101.51	Element	Left OB	Channel	Right OB
Vel Head (ft)	0.02	Wt. n-Val.		0.065	
W.S. Elev (ft)	7101.49	Reach Len. (ft)	27.00	10.00	1.00
Crit W.S. (ft)		Flow Area (sq ft)		8.46	
E.G. Slope (ft/ft)	0.008416	Area (sq ft)		8.46	
Q Total (cfs)	9.00	Flow (cfs)		9.00	
Top Width (ft)	23.29	Top Width (ft)		23.29	
Vel Total (ft/s)	1.06	Avg. Vel. (ft/s)		1.06	
Max Chl Dpth (ft)	0.39	Hydr. Depth (ft)		0.36	
Conv. Total (cfs)	98.1	Conv. (cfs)		98.1	
Length Wtd. (ft)	10.00	Wetted Per. (ft)		23.38	
Min Ch El (ft)	7101.10	Shear (lb/sq ft)		0.19	
Alpha	1.00	Stream Power (lb/ft s)		0.20	
Frctn Loss (ft)	0.07	Cum Volume (acre-ft)	0.02	0.62	0.02
C & E Loss (ft)	0.00	Cum SA (acres)	0.12	2.10	0.11

Plan: Plan 02 POND F-G CHANNEL MAIN CHANNEL RS: 4469 Profile: Q5

E.G. Elev (ft)	7101.44	Element	Left OB	Channel	Right OB
Vel Head (ft)	0.02	Wt. n-Val.		0.065	
W.S. Elev (ft)	7101.42	Reach Len. (ft)	199.00	198.00	193.00
Crit W.S. (ft)	7101.18	Flow Area (sq ft)		9.14	
E.G. Slope (ft/ft)	0.006604	Area (sq ft)		9.14	
Q Total (cfs)	9.00	Flow (cfs)		9.00	
Top Width (ft)	23.57	Top Width (ft)		23.57	
Vel Total (ft/s)	0.99	Avg. Vel. (ft/s)		0.99	
Max Chl Dpth (ft)	0.42	Hydr. Depth (ft)		0.39	
Conv. Total (cfs)	110.7	Conv. (cfs)		110.7	
Length Wtd. (ft)	198.00	Wetted Per. (ft)		23.66	
Min Ch El (ft)	7101.00	Shear (lb/sq ft)		0.16	
Alpha	1.00	Stream Power (lb/ft s)		0.16	
Frctn Loss (ft)	2.09	Cum Volume (acre-ft)	0.02	0.61	0.02
C & E Loss (ft)	0.00	Cum SA (acres)	0.12	2.10	0.11

Plan: Plan 02 POND F-G CHANNEL MAIN CHANNEL RS: 4269 Profile: Q5

E.G. Elev (ft)	7099.34	Element	Left OB	Channel	Right OB
Vel Head (ft)	0.03	Wt. n-Val.		0.065	
W.S. Elev (ft)	7099.31	Reach Len. (ft)	105.00	107.00	105.00
Crit W.S. (ft)	7099.18	Flow Area (sq ft)		6.47	
E.G. Slope (ft/ft)	0.019572	Area (sq ft)		6.47	
Q Total (cfs)	9.00	Flow (cfs)		9.00	
Top Width (ft)	22.44	Top Width (ft)		22.44	
Vel Total (ft/s)	1.39	Avg. Vel. (ft/s)		1.39	
Max Chl Dpth (ft)	0.30	Hydr. Depth (ft)		0.29	
Conv. Total (cfs)	64.3	Conv. (cfs)		64.3	
Length Wtd. (ft)	107.00	Wetted Per. (ft)		22.51	
Min Ch El (ft)	7099.00	Shear (lb/sq ft)		0.35	
Alpha	1.00	Stream Power (lb/ft s)		0.49	
Frctn Loss (ft)	3.05	Cum Volume (acre-ft)	0.02	0.58	0.02
C & E Loss (ft)	0.00	Cum SA (acres)	0.12	1.99	0.11

Plan: Plan 02 POND F-G CHANNEL MAIN CHANNEL RS: 4162 Profile: Q5

E.G. Elev (ft)	7096.29	Element	Left OB	Channel	Right OB
Vel Head (ft)	0.05	Wt. n-Val.		0.065	
W.S. Elev (ft)	7096.24	Reach Len. (ft)	100.00	102.00	86.00
Crit W.S. (ft)	7096.18	Flow Area (sq ft)		4.97	
E.G. Slope (ft/ft)	0.045447	Area (sq ft)		4.97	
Q Total (cfs)	9.00	Flow (cfs)		9.00	
Top Width (ft)	21.90	Top Width (ft)		21.90	
Vel Total (ft/s)	1.81	Avg. Vel. (ft/s)		1.81	
Max Chl Dpth (ft)	0.24	Hydr. Depth (ft)		0.23	
Conv. Total (cfs)	42.2	Conv. (cfs)		42.2	
Length Wtd. (ft)	102.00	Wetted Per. (ft)		21.96	
Min Ch El (ft)	7096.00	Shear (lb/sq ft)		0.64	
Alpha	1.00	Stream Power (lb/ft s)		1.16	
Frctn Loss (ft)	6.73	Cum Volume (acre-ft)	0.02	0.56	0.02
C & E Loss (ft)	0.00	Cum SA (acres)	0.12	1.94	0.11

Plan: Plan 02 POND F-G CHANNEL MAIN CHANNEL RS: 4060 Profile: Q5

E.G. Elev (ft)	7089.56	Element	Left OB	Channel	Right OB
Vel Head (ft)	0.08	Wt. n-Val.		0.065	
W.S. Elev (ft)	7089.48	Reach Len. (ft)	47.00	63.00	108.00
Crit W.S. (ft)	7089.48	Flow Area (sq ft)		3.96	
E.G. Slope (ft/ft)	0.104292	Area (sq ft)		3.96	
Q Total (cfs)	9.00	Flow (cfs)		9.00	
Top Width (ft)	23.09	Top Width (ft)		23.09	
Vel Total (ft/s)	2.28	Avg. Vel. (ft/s)		2.28	
Max Chl Dpth (ft)	0.18	Hydr. Depth (ft)		0.17	
Conv. Total (cfs)	27.9	Conv. (cfs)		27.9	
Length Wtd. (ft)	63.01	Wetted Per. (ft)		23.12	
Min Ch El (ft)	7089.30	Shear (lb/sq ft)		1.11	
Alpha	1.00	Stream Power (lb/ft s)		2.53	
Frctn Loss (ft)	1.41	Cum Volume (acre-ft)	0.02	0.55	0.02
C & E Loss (ft)	0.01	Cum SA (acres)	0.12	1.88	0.11

Plan: Plan 02 POND F-G CHANNEL MAIN CHANNEL RS: 3997 Profile: Q5

E.G. Elev (ft)	7086.42	Element	Left OB	Channel	Right OB
Vel Head (ft)	0.06	Wt. n-Val.	0.000	0.033	0.040
W.S. Elev (ft)	7086.36	Reach Len. (ft)	235.00	236.00	233.00
Crit W.S. (ft)	7086.30	Flow Area (sq ft)	0.00	6.20	0.01
E.G. Slope (ft/ft)	0.011364	Area (sq ft)	0.00	6.20	0.01
Q Total (cfs)	12.00	Flow (cfs)	0.00	11.99	0.00
Top Width (ft)	25.28	Top Width (ft)	0.09	24.80	0.38
Vel Total (ft/s)	1.93	Avg. Vel. (ft/s)	0.35	1.93	0.40
Max Chl Dpth (ft)	0.36	Hydr. Depth (ft)	0.03	0.25	0.03
Conv. Total (cfs)	112.6	Conv. (cfs)	0.0	112.5	0.0
Length Wtd. (ft)	235.96	Wetted Per. (ft)	0.11	24.83	0.39
Min Ch El (ft)	7086.00	Shear (lb/sq ft)		0.18	0.02
Alpha	1.00	Stream Power (lb/ft s)		0.34	0.01
Frctn Loss (ft)	3.88	Cum Volume (acre-ft)	0.02	0.55	0.02
C & E Loss (ft)	0.01	Cum SA (acres)	0.12	1.85	0.11

Plan: Plan 02 POND F-G CHANNEL MAIN CHANNEL RS: 3761 Profile: Q5

E.G. Elev (ft)	7082.54	Element	Left OB	Channel	Right OB
Vel Head (ft)	0.17	Wt. n-Val.	0.040	0.033	0.040
W.S. Elev (ft)	7082.37	Reach Len. (ft)	263.00	261.00	255.00
Crit W.S. (ft)	7082.37	Flow Area (sq ft)	0.28	5.98	0.14
E.G. Slope (ft/ft)	0.021012	Area (sq ft)	0.28	5.98	0.14
Q Total (cfs)	21.00	Flow (cfs)	0.47	20.29	0.24
Top Width (ft)	18.59	Top Width (ft)	1.50	16.30	0.79
Vel Total (ft/s)	3.28	Avg. Vel. (ft/s)	1.70	3.40	1.63
Max Chl Dpth (ft)	0.37	Hydr. Depth (ft)	0.18	0.37	0.18
Conv. Total (cfs)	144.9	Conv. (cfs)	3.2	140.0	1.6
Length Wtd. (ft)	260.99	Wetted Per. (ft)	1.55	16.30	0.87
Min Ch El (ft)	7082.00	Shear (lb/sq ft)	0.23	0.48	0.22
Alpha	1.04	Stream Power (lb/ft s)	0.40	1.63	0.36
Frctn Loss (ft)	3.94	Cum Volume (acre-ft)	0.02	0.51	0.02
C & E Loss (ft)	0.02	Cum SA (acres)	0.11	1.74	0.11

Plan: Plan 02 POND F-G CHANNEL MAIN CHANNEL RS: 3500 Profile: Q5

E.G. Elev (ft)	7078.15	Element	Left OB	Channel	Right OB
Vel Head (ft)	0.09	Wt. n-Val.	0.040	0.033	0.040
W.S. Elev (ft)	7078.06	Reach Len. (ft)	256.00	250.00	250.00
Crit W.S. (ft)	7077.98	Flow Area (sq ft)	0.02	8.54	0.01
E.G. Slope (ft/ft)	0.011369	Area (sq ft)	0.02	8.54	0.01
Q Total (cfs)	21.00	Flow (cfs)	0.01	20.99	0.00
Top Width (ft)	24.64	Top Width (ft)	0.56	23.80	0.28
Vel Total (ft/s)	2.45	Avg. Vel. (ft/s)	0.36	2.46	0.36
Max Chl Dpth (ft)	0.56	Hydr. Depth (ft)	0.03	0.36	0.03
Conv. Total (cfs)	197.0	Conv. (cfs)	0.1	196.9	0.0
Length Wtd. (ft)	250.00	Wetted Per. (ft)	0.56	23.83	0.29
Min Ch El (ft)	7077.50	Shear (lb/sq ft)	0.02	0.25	0.02
Alpha	1.00	Stream Power (lb/ft s)	0.01	0.63	0.01
Frctn Loss (ft)	3.57	Cum Volume (acre-ft)	0.02	0.47	0.02
C & E Loss (ft)	0.00	Cum SA (acres)	0.11	1.62	0.10

Plan: Plan 02 POND F-G CHANNEL MAIN CHANNEL RS: 3250 Profile: Q5

E.G. Elev (ft)	7074.58	Element	Left OB	Channel	Right OB
Vel Head (ft)	0.12	Wt. n-Val.		0.028	
W.S. Elev (ft)	7074.46	Reach Len. (ft)	147.00	150.00	157.00
Crit W.S. (ft)	7074.46	Flow Area (sq ft)		7.57	
E.G. Slope (ft/ft)	0.018435	Area (sq ft)		7.57	
Q Total (cfs)	21.00	Flow (cfs)		21.00	
Top Width (ft)	32.52	Top Width (ft)		32.52	
Vel Total (ft/s)	2.77	Avg. Vel. (ft/s)		2.77	
Max Chl Dpth (ft)	0.36	Hydr. Depth (ft)		0.23	
Conv. Total (cfs)	154.7	Conv. (cfs)		154.7	
Length Wtd. (ft)	150.01	Wetted Per. (ft)		32.53	
Min Ch El (ft)	7074.10	Shear (lb/sq ft)		0.27	
Alpha	1.00	Stream Power (lb/ft s)		0.74	
Frctn Loss (ft)	2.08	Cum Volume (acre-ft)	0.02	0.42	0.02
C & E Loss (ft)	0.00	Cum SA (acres)	0.11	1.46	0.10

Plan: Plan 02 POND F-G CHANNEL MAIN CHANNEL RS: 3100 Profile: Q5

E.G. Elev (ft)	7071.68	Element	Left OB	Channel	Right OB
Vel Head (ft)	0.12	Wt. n-Val.	0.040	0.028	0.040
W.S. Elev (ft)	7071.56	Reach Len. (ft)	109.00	89.00	65.00
Crit W.S. (ft)	7071.52	Flow Area (sq ft)	0.09	7.36	0.09
E.G. Slope (ft/ft)	0.010827	Area (sq ft)	0.09	7.36	0.09
Q Total (cfs)	21.00	Flow (cfs)	0.07	20.87	0.07
Top Width (ft)	22.87	Top Width (ft)	1.18	20.50	1.18
Vel Total (ft/s)	2.78	Avg. Vel. (ft/s)	0.71	2.84	0.71
Max Chl Dpth (ft)	0.46	Hydr. Depth (ft)	0.08	0.36	0.08
Conv. Total (cfs)	201.8	Conv. (cfs)	0.6	200.6	0.6
Length Wtd. (ft)	88.97	Wetted Per. (ft)	1.19	20.52	1.19
Min Ch El (ft)	7071.10	Shear (lb/sq ft)	0.05	0.24	0.05
Alpha	1.03	Stream Power (lb/ft s)	0.04	0.69	0.04
Frctn Loss (ft)	1.16	Cum Volume (acre-ft)	0.02	0.40	0.02
C & E Loss (ft)	0.00	Cum SA (acres)	0.10	1.37	0.10

Plan: Plan 02 POND F-G CHANNEL MAIN CHANNEL RS: 3011 Profile: Q5

E.G. Elev (ft)	7070.52	Element	Left OB	Channel	Right OB
Vel Head (ft)	0.15	Wt. n-Val.	0.040	0.028	0.040
W.S. Elev (ft)	7070.37	Reach Len. (ft)	108.00	124.00	132.00
Crit W.S. (ft)	7070.37	Flow Area (sq ft)	0.10	6.60	0.14
E.G. Slope (ft/ft)	0.015908	Area (sq ft)	0.10	6.60	0.14
Q Total (cfs)	21.00	Flow (cfs)	0.09	20.78	0.12
Top Width (ft)	23.91	Top Width (ft)	1.25	21.00	1.67
Vel Total (ft/s)	3.07	Avg. Vel. (ft/s)	0.89	3.15	0.89
Max Chl Dpth (ft)	0.37	Hydr. Depth (ft)	0.08	0.31	0.08
Conv. Total (cfs)	166.5	Conv. (cfs)	0.7	164.8	1.0
Length Wtd. (ft)	123.99	Wetted Per. (ft)	1.26	21.01	1.67
Min Ch El (ft)	7070.00	Shear (lb/sq ft)	0.08	0.31	0.08
Alpha	1.04	Stream Power (lb/ft s)	0.07	0.98	0.07
Frctn Loss (ft)	2.11	Cum Volume (acre-ft)	0.02	0.38	0.02
C & E Loss (ft)	0.01	Cum SA (acres)	0.10	1.32	0.10

Plan: Plan 02 POND F-G CHANNEL MAIN CHANNEL RS: 2887 Profile: Q5

E.G. Elev (ft)	7068.50	Element	Left OB	Channel	Right OB
Vel Head (ft)	0.22	Wt. n-Val.		0.028	
W.S. Elev (ft)	7068.28	Reach Len. (ft)	137.00	147.00	150.00
Crit W.S. (ft)	7068.34	Flow Area (sq ft)		5.56	
E.G. Slope (ft/ft)	0.047051	Area (sq ft)		5.56	
Q Total (cfs)	21.00	Flow (cfs)		21.00	
Top Width (ft)	30.39	Top Width (ft)		30.39	
Vel Total (ft/s)	3.78	Avg. Vel. (ft/s)		3.78	
Max Chl Dpth (ft)	0.28	Hydr. Depth (ft)		0.18	
Conv. Total (cfs)	96.8	Conv. (cfs)		96.8	
Length Wtd. (ft)	147.06	Wetted Per. (ft)		30.42	
Min Ch El (ft)	7068.00	Shear (lb/sq ft)		0.54	
Alpha	1.00	Stream Power (lb/ft s)		2.03	
Frctn Loss (ft)	1.93	Cum Volume (acre-ft)	0.02	0.37	0.02
C & E Loss (ft)	0.01	Cum SA (acres)	0.10	1.25	0.09

Plan: Plan 02 POND F-G CHANNEL MAIN CHANNEL RS: 2740 Profile: Q5

E.G. Elev (ft)	7066.53	Element	Left OB	Channel	Right OB
Vel Head (ft)	0.14	Wt. n-Val.		0.028	0.040
W.S. Elev (ft)	7066.40	Reach Len. (ft)	250.00	240.00	248.00
Crit W.S. (ft)	7066.40	Flow Area (sq ft)		6.69	0.53
E.G. Slope (ft/ft)	0.016882	Area (sq ft)		6.69	0.53
Q Total (cfs)	21.00	Flow (cfs)		20.14	0.86
Top Width (ft)	26.52	Top Width (ft)		23.85	2.67
Vel Total (ft/s)	2.91	Avg. Vel. (ft/s)		3.01	1.63
Max Chl Dpth (ft)	0.40	Hydr. Depth (ft)		0.28	0.20
Conv. Total (cfs)	161.6	Conv. (cfs)		155.0	6.6
Length Wtd. (ft)	240.58	Wetted Per. (ft)		23.85	2.70
Min Ch El (ft)	7066.00	Shear (lb/sq ft)		0.30	0.21
Alpha	1.04	Stream Power (lb/ft s)		0.89	0.34
Frctn Loss (ft)	5.13	Cum Volume (acre-ft)	0.02	0.35	0.01
C & E Loss (ft)	0.00	Cum SA (acres)	0.10	1.16	0.09

Plan: Plan 02 POND F-G CHANNEL MAIN CHANNEL RS: 2500 Profile: Q5

E.G. Elev (ft)	7061.40	Element	Left OB	Channel	Right OB
Vel Head (ft)	0.17	Wt. n-Val.	0.000	0.028	0.040
W.S. Elev (ft)	7061.23	Reach Len. (ft)	182.00	174.00	176.00
Crit W.S. (ft)	7061.26	Flow Area (sq ft)	0.00	5.44	0.99
E.G. Slope (ft/ft)	0.027793	Area (sq ft)	0.00	5.44	0.99
Q Total (cfs)	21.00	Flow (cfs)	0.00	18.81	2.19
Top Width (ft)	27.71	Top Width (ft)	0.13	22.90	4.68
Vel Total (ft/s)	3.26	Avg. Vel. (ft/s)	0.33	3.46	2.20
Max Chl Dpth (ft)	0.43	Hydr. Depth (ft)	0.01	0.24	0.21
Conv. Total (cfs)	126.0	Conv. (cfs)	0.0	112.8	13.1
Length Wtd. (ft)	174.17	Wetted Per. (ft)	0.13	22.92	4.70
Min Ch El (ft)	7060.80	Shear (lb/sq ft)		0.41	0.37
Alpha	1.05	Stream Power (lb/ft s)		1.42	0.81
Frctn Loss (ft)	3.90	Cum Volume (acre-ft)	0.02	0.31	0.01
C & E Loss (ft)	0.01	Cum SA (acres)	0.10	1.03	0.07

Plan: Plan 02 POND F-G CHANNEL MAIN CHANNEL RS: 2326 Profile: Q5

E.G. Elev (ft)	7057.50	Element	Left OB	Channel	Right OB
Vel Head (ft)	0.15	Wt. n-Val.	0.040	0.028	0.040
W.S. Elev (ft)	7057.35	Reach Len. (ft)	113.00	139.00	138.00
Crit W.S. (ft)	7057.36	Flow Area (sq ft)	0.11	6.41	0.50
E.G. Slope (ft/ft)	0.018421	Area (sq ft)	0.11	6.41	0.50
Q Total (cfs)	21.00	Flow (cfs)	0.10	19.97	0.93
Top Width (ft)	26.84	Top Width (ft)	1.49	23.13	2.22
Vel Total (ft/s)	2.99	Avg. Vel. (ft/s)	0.90	3.11	1.85
Max Chl Dpth (ft)	0.45	Hydr. Depth (ft)	0.08	0.28	0.23
Conv. Total (cfs)	154.7	Conv. (cfs)	0.8	147.1	6.8
Length Wtd. (ft)	138.76	Wetted Per. (ft)	1.49	23.19	2.27
Min Ch El (ft)	7056.90	Shear (lb/sq ft)	0.09	0.32	0.26
Alpha	1.05	Stream Power (lb/ft s)	0.08	0.99	0.47
Frctn Loss (ft)	3.00	Cum Volume (acre-ft)	0.02	0.29	0.01
C & E Loss (ft)	0.01	Cum SA (acres)	0.09	0.94	0.06

Plan: Plan 02 POND F-G CHANNEL MAIN CHANNEL RS: 2187 Profile: Q5

E.G. Elev (ft)	7054.49	Element	Left OB	Channel	Right OB
Vel Head (ft)	0.21	Wt. n-Val.	0.040	0.028	0.040
W.S. Elev (ft)	7054.28	Reach Len. (ft)	152.00	142.00	133.00
Crit W.S. (ft)	7054.32	Flow Area (sq ft)	0.15	5.56	0.15
E.G. Slope (ft/ft)	0.025755	Area (sq ft)	0.15	5.56	0.15
Q Total (cfs)	21.00	Flow (cfs)	0.24	20.52	0.24
Top Width (ft)	22.22	Top Width (ft)	1.11	20.00	1.11
Vel Total (ft/s)	3.58	Avg. Vel. (ft/s)	1.57	3.69	1.57
Max Chl Dpth (ft)	0.28	Hydr. Depth (ft)	0.14	0.28	0.14
Conv. Total (cfs)	130.9	Conv. (cfs)	1.5	127.8	1.5
Length Wtd. (ft)	142.49	Wetted Per. (ft)	1.15	20.00	1.15
Min Ch El (ft)	7054.00	Shear (lb/sq ft)	0.22	0.45	0.22
Alpha	1.04	Stream Power (lb/ft s)	0.34	1.65	0.34
Frctn Loss (ft)	1.86	Cum Volume (acre-ft)	0.02	0.27	0.01
C & E Loss (ft)	0.00	Cum SA (acres)	0.09	0.87	0.05

Plan: Plan 02 POND F-G CHANNEL MAIN CHANNEL RS: 2045 Profile: Q5

E.G. Elev (ft)	7052.62	Element	Left OB	Channel	Right OB
Vel Head (ft)	0.17	Wt. n-Val.	0.040	0.028	
W.S. Elev (ft)	7052.45	Reach Len. (ft)	180.00	146.00	152.00
Crit W.S. (ft)	7052.45	Flow Area (sq ft)	1.20	5.54	
E.G. Slope (ft/ft)	0.015018	Area (sq ft)	1.20	5.54	
Q Total (cfs)	21.00	Flow (cfs)	2.01	18.99	
Top Width (ft)	20.25	Top Width (ft)	5.39	14.86	
Vel Total (ft/s)	3.11	Avg. Vel. (ft/s)	1.67	3.43	
Max Chl Dpth (ft)	0.45	Hydr. Depth (ft)	0.22	0.37	
Conv. Total (cfs)	171.4	Conv. (cfs)	16.4	155.0	
Length Wtd. (ft)	149.47	Wetted Per. (ft)	5.41	14.88	
Min Ch El (ft)	7052.00	Shear (lb/sq ft)	0.21	0.35	
Alpha	1.12	Stream Power (lb/ft s)	0.35	1.20	
Frctn Loss (ft)	2.69	Cum Volume (acre-ft)	0.02	0.25	0.01
C & E Loss (ft)	0.00	Cum SA (acres)	0.08	0.81	0.05

Plan: Plan 02 POND F-G CHANNEL MAIN CHANNEL RS: 1899 Profile: Q5

E.G. Elev (ft)	7049.93	Element	Left OB	Channel	Right OB
Vel Head (ft)	0.17	Wt. n-Val.	0.040	0.028	0.040
W.S. Elev (ft)	7049.75	Reach Len. (ft)	136.00	129.00	118.00
Crit W.S. (ft)	7049.78	Flow Area (sq ft)	1.95	9.37	0.91
E.G. Slope (ft/ft)	0.020079	Area (sq ft)	1.95	9.37	0.91
Q Total (cfs)	38.00	Flow (cfs)	3.81	33.00	1.20
Top Width (ft)	45.86	Top Width (ft)	8.64	30.00	7.21
Vel Total (ft/s)	3.11	Avg. Vel. (ft/s)	1.95	3.52	1.32
Max Chl Dpth (ft)	0.45	Hydr. Depth (ft)	0.23	0.31	0.13
Conv. Total (cfs)	268.2	Conv. (cfs)	26.9	232.9	8.5
Length Wtd. (ft)	129.21	Wetted Per. (ft)	8.66	30.01	7.22
Min Ch El (ft)	7049.30	Shear (lb/sq ft)	0.28	0.39	0.16
Alpha	1.16	Stream Power (lb/ft s)	0.55	1.38	0.21
Frctn Loss (ft)	2.81	Cum Volume (acre-ft)	0.01	0.23	0.00
C & E Loss (ft)	0.00	Cum SA (acres)	0.05	0.74	0.04

Plan: Plan 02 POND F-G CHANNEL MAIN CHANNEL RS: 1770 Profile: Q5

E.G. Elev (ft)	7047.10	Element	Left OB	Channel	Right OB
Vel Head (ft)	0.20	Wt. n-Val.	0.040	0.028	0.040
W.S. Elev (ft)	7046.90	Reach Len. (ft)	185.00	181.00	227.00
Crit W.S. (ft)	7046.93	Flow Area (sq ft)	0.67	9.90	0.27
E.G. Slope (ft/ft)	0.023699	Area (sq ft)	0.67	9.90	0.27
Q Total (cfs)	38.00	Flow (cfs)	1.07	36.51	0.42
Top Width (ft)	39.82	Top Width (ft)	4.52	33.50	1.80
Vel Total (ft/s)	3.51	Avg. Vel. (ft/s)	1.60	3.69	1.58
Max Chl Dpth (ft)	0.30	Hydr. Depth (ft)	0.15	0.30	0.15
Conv. Total (cfs)	246.8	Conv. (cfs)	6.9	237.2	2.7
Length Wtd. (ft)	181.44	Wetted Per. (ft)	4.53	33.50	1.83
Min Ch El (ft)	7046.60	Shear (lb/sq ft)	0.22	0.44	0.22
Alpha	1.07	Stream Power (lb/ft s)	0.35	1.61	0.34
Frctn Loss (ft)	4.65	Cum Volume (acre-ft)	0.01	0.20	0.00
C & E Loss (ft)	0.01	Cum SA (acres)	0.03	0.64	0.02

Plan: Plan 02 POND F-G CHANNEL MAIN CHANNEL RS: 1589 Profile: Q5

E.G. Elev (ft)	7042.44	Element	Left OB	Channel	Right OB
Vel Head (ft)	0.18	Wt. n-Val.	0.040	0.028	0.040
W.S. Elev (ft)	7042.26	Reach Len. (ft)	227.00	235.00	218.00
Crit W.S. (ft)	7042.30	Flow Area (sq ft)	0.10	11.10	0.18
E.G. Slope (ft/ft)	0.027755	Area (sq ft)	0.10	11.10	0.18
Q Total (cfs)	38.00	Flow (cfs)	0.12	37.67	0.21
Top Width (ft)	51.45	Top Width (ft)	1.27	48.00	2.18
Vel Total (ft/s)	3.34	Avg. Vel. (ft/s)	1.16	3.39	1.16
Max Chl Dpth (ft)	0.26	Hydr. Depth (ft)	0.08	0.23	0.08
Conv. Total (cfs)	228.1	Conv. (cfs)	0.7	226.1	1.2
Length Wtd. (ft)	234.80	Wetted Per. (ft)	1.28	48.00	2.19
Min Ch El (ft)	7042.00	Shear (lb/sq ft)	0.14	0.40	0.14
Alpha	1.03	Stream Power (lb/ft s)	0.16	1.36	0.16
Frctn Loss (ft)	3.43	Cum Volume (acre-ft)	0.00	0.15	0.00
C & E Loss (ft)	0.01	Cum SA (acres)	0.02	0.47	0.01

Plan: Plan 02 POND F-G CHANNEL MAIN CHANNEL RS: 1354 Profile: Q5

E.G. Elev (ft)	7038.54	Element	Left OB	Channel	Right OB
Vel Head (ft)	0.21	Wt. n-Val.	0.040	0.028	
W.S. Elev (ft)	7038.33	Reach Len. (ft)	141.00	145.00	164.00
Crit W.S. (ft)	7038.31	Flow Area (sq ft)	0.70	9.92	
E.G. Slope (ft/ft)	0.012685	Area (sq ft)	0.70	9.92	
Q Total (cfs)	38.00	Flow (cfs)	1.19	36.81	
Top Width (ft)	23.47	Top Width (ft)	2.65	20.82	
Vel Total (ft/s)	3.58	Avg. Vel. (ft/s)	1.70	3.71	
Max Chl Dpth (ft)	0.63	Hydr. Depth (ft)	0.26	0.48	
Conv. Total (cfs)	337.4	Conv. (cfs)	10.6	326.8	
Length Wtd. (ft)	145.00	Wetted Per. (ft)	2.70	20.84	
Min Ch El (ft)	7037.70	Shear (lb/sq ft)	0.21	0.38	
Alpha	1.05	Stream Power (lb/ft s)	0.35	1.40	
Frctn Loss (ft)	2.15	Cum Volume (acre-ft)	0.00	0.10	0.00
C & E Loss (ft)	0.03	Cum SA (acres)	0.01	0.29	0.01

Plan: Plan 02 POND F-G CHANNEL MAIN CHANNEL RS: 1209 Profile: Q5

E.G. Elev (ft)	7036.37	Element	Left OB	Channel	Right OB
Vel Head (ft)	0.12	Wt. n-Val.	0.040	0.028	0.040
W.S. Elev (ft)	7036.25	Reach Len. (ft)	35.00	36.00	32.00
Crit W.S. (ft)	7036.25	Flow Area (sq ft)	0.15	13.27	0.25
E.G. Slope (ft/ft)	0.017508	Area (sq ft)	0.15	13.27	0.25
Q Total (cfs)	38.00	Flow (cfs)	0.19	37.51	0.30
Top Width (ft)	56.66	Top Width (ft)	1.24	53.40	2.01
Vel Total (ft/s)	2.78	Avg. Vel. (ft/s)	1.21	2.83	1.22
Max Chl Dpth (ft)	0.25	Hydr. Depth (ft)	0.12	0.25	0.12
Conv. Total (cfs)	287.2	Conv. (cfs)	1.4	283.5	2.3
Length Wtd. (ft)	35.93	Wetted Per. (ft)	1.27	53.40	2.03
Min Ch El (ft)	7036.00	Shear (lb/sq ft)	0.13	0.27	0.13
Alpha	1.02	Stream Power (lb/ft s)	0.16	0.77	0.16
Frctn Loss (ft)	0.80	Cum Volume (acre-ft)	0.00	0.06	0.00
C & E Loss (ft)	0.01	Cum SA (acres)	0.00	0.16	0.00

Plan: Plan 02 POND F-G CHANNEL MAIN CHANNEL RS: 1173 Profile: Q5

E.G. Elev (ft)	7035.55	Element	Left OB	Channel	Right OB
Vel Head (ft)	0.26	Wt. n-Val.	0.040	0.028	0.040
W.S. Elev (ft)	7035.30	Reach Len. (ft)	50.00	51.00	50.00
Crit W.S. (ft)	7035.37	Flow Area (sq ft)	0.18	8.91	0.52
E.G. Slope (ft/ft)	0.029436	Area (sq ft)	0.18	8.91	0.52
Q Total (cfs)	38.00	Flow (cfs)	0.32	36.74	0.93
Top Width (ft)	34.77	Top Width (ft)	1.24	30.00	3.53
Vel Total (ft/s)	3.95	Avg. Vel. (ft/s)	1.75	4.13	1.78
Max Chl Dpth (ft)	0.30	Hydr. Depth (ft)	0.15	0.30	0.15
Conv. Total (cfs)	221.5	Conv. (cfs)	1.9	214.2	5.4
Length Wtd. (ft)	50.98	Wetted Per. (ft)	1.27	30.00	3.55
Min Ch El (ft)	7035.00	Shear (lb/sq ft)	0.27	0.55	0.27
Alpha	1.06	Stream Power (lb/ft s)	0.47	2.25	0.48
Frctn Loss (ft)	0.91	Cum Volume (acre-ft)	0.00	0.05	0.00
C & E Loss (ft)	0.02	Cum SA (acres)	0.00	0.13	0.00

Plan: Plan 02 POND F-G CHANNEL MAIN CHANNEL RS: 1122 Profile: Q5

E.G. Elev (ft)	7034.60	Element	Left OB	Channel	Right OB
Vel Head (ft)	0.08	Wt. n-Val.		0.065	
W.S. Elev (ft)	7034.52	Reach Len. (ft)	24.00	24.00	24.00
Crit W.S. (ft)	7034.36	Flow Area (sq ft)		16.68	
E.G. Slope (ft/ft)	0.025947	Area (sq ft)		16.68	
Q Total (cfs)	38.00	Flow (cfs)		38.00	
Top Width (ft)	34.16	Top Width (ft)		34.16	
Vel Total (ft/s)	2.28	Avg. Vel. (ft/s)		2.28	
Max Chl Dpth (ft)	0.52	Hydr. Depth (ft)		0.49	
Conv. Total (cfs)	235.9	Conv. (cfs)		235.9	
Length Wtd. (ft)	24.00	Wetted Per. (ft)		34.29	
Min Ch El (ft)	7034.00	Shear (lb/sq ft)		0.79	
Alpha	1.00	Stream Power (lb/ft s)		1.80	
Frctn Loss (ft)	1.05	Cum Volume (acre-ft)		0.03	
C & E Loss (ft)	0.01	Cum SA (acres)		0.09	

Plan: Plan 02 POND F-G CHANNEL MAIN CHANNEL RS: 1098 Profile: Q5

E.G. Elev (ft)	7033.54	Element	Left OB	Channel	Right OB
Vel Head (ft)	0.18	Wt. n-Val.		0.065	
W.S. Elev (ft)	7033.36	Reach Len. (ft)	99.00	98.00	100.00
Crit W.S. (ft)	7033.36	Flow Area (sq ft)		11.31	
E.G. Slope (ft/ft)	0.089841	Area (sq ft)		11.31	
Q Total (cfs)	38.00	Flow (cfs)		38.00	
Top Width (ft)	32.88	Top Width (ft)		32.88	
Vel Total (ft/s)	3.36	Avg. Vel. (ft/s)		3.36	
Max Chl Dpth (ft)	0.36	Hydr. Depth (ft)		0.34	
Conv. Total (cfs)	126.8	Conv. (cfs)		126.8	
Length Wtd. (ft)		Wetted Per. (ft)		32.97	
Min Ch El (ft)	7033.00	Shear (lb/sq ft)		1.92	
Alpha	1.00	Stream Power (lb/ft s)		6.46	
Frctn Loss (ft)		Cum Volume (acre-ft)		0.03	
C & E Loss (ft)		Cum SA (acres)		0.07	

Plan: Plan 02 POND F-G CHANNEL MAIN CHANNEL RS: 1000 Profile: Q5

E.G. Elev (ft)	7026.94	Element	Left OB	Channel	Right OB
Vel Head (ft)	0.15	Wt. n-Val.		0.065	
W.S. Elev (ft)	7026.79	Reach Len. (ft)			
Crit W.S. (ft)	7026.76	Flow Area (sq ft)		12.41	
E.G. Slope (ft/ft)	0.066742	Area (sq ft)		12.41	
Q Total (cfs)	38.00	Flow (cfs)		38.00	
Top Width (ft)	33.14	Top Width (ft)		33.14	
Vel Total (ft/s)	3.06	Avg. Vel. (ft/s)		3.06	
Max Chl Dpth (ft)	0.39	Hydr. Depth (ft)		0.37	
Conv. Total (cfs)	147.1	Conv. (cfs)		147.1	
Length Wtd. (ft)		Wetted Per. (ft)		33.24	
Min Ch El (ft)	7026.40	Shear (lb/sq ft)		1.56	
Alpha	1.00	Stream Power (lb/ft s)		4.76	
Frctn Loss (ft)		Cum Volume (acre-ft)			
C & E Loss (ft)		Cum SA (acres)			

Plan: Plan 02 POND F-G CHANNEL MAIN CHANNEL RS: 5688 Profile: Q2

E.G. Elev (ft)	7125.83	Element	Left OB	Channel	Right OB
Vel Head (ft)	0.01	Wt. n-Val.		0.065	
W.S. Elev (ft)	7125.82	Reach Len. (ft)	81.00	83.00	89.00
Crit W.S. (ft)	7125.65	Flow Area (sq ft)		2.30	
E.G. Slope (ft/ft)	0.008344	Area (sq ft)		2.30	
Q Total (cfs)	2.00	Flow (cfs)		2.00	
Top Width (ft)	8.31	Top Width (ft)		8.31	
Vel Total (ft/s)	0.87	Avg. Vel. (ft/s)		0.87	
Max Chl Dpth (ft)	0.32	Hydr. Depth (ft)		0.28	
Conv. Total (cfs)	21.9	Conv. (cfs)		21.9	
Length Wtd. (ft)	83.00	Wetted Per. (ft)		8.52	
Min Ch El (ft)	7125.50	Shear (lb/sq ft)		0.14	
Alpha	1.00	Stream Power (lb/ft s)		0.12	
Frctn Loss (ft)	1.74	Cum Volume (acre-ft)	0.01	0.35	0.00
C & E Loss (ft)	0.00	Cum SA (acres)	0.05	2.39	0.04

Plan: Plan 02 POND F-G CHANNEL MAIN CHANNEL RS: 5607 Profile: Q2

E.G. Elev (ft)	7124.09	Element	Left OB	Channel	Right OB
Vel Head (ft)	0.02	Wt. n-Val.		0.065	
W.S. Elev (ft)	7124.06	Reach Len. (ft)	46.00	49.00	50.00
Crit W.S. (ft)	7124.06	Flow Area (sq ft)		1.60	
E.G. Slope (ft/ft)	0.121920	Area (sq ft)		1.60	
Q Total (cfs)	2.00	Flow (cfs)		2.00	
Top Width (ft)	25.79	Top Width (ft)		25.79	
Vel Total (ft/s)	1.25	Avg. Vel. (ft/s)		1.25	
Max Chl Dpth (ft)	0.06	Hydr. Depth (ft)		0.06	
Conv. Total (cfs)	5.7	Conv. (cfs)		5.7	
Length Wtd. (ft)	49.00	Wetted Per. (ft)		25.80	
Min Ch El (ft)	7124.00	Shear (lb/sq ft)		0.47	
Alpha	1.00	Stream Power (lb/ft s)		0.59	
Frctn Loss (ft)	0.51	Cum Volume (acre-ft)	0.01	0.35	0.00
C & E Loss (ft)	0.01	Cum SA (acres)	0.05	2.35	0.04

Plan: Plan 02 POND F-G CHANNEL MAIN CHANNEL RS: 5558 Profile: Q2

E.G. Elev (ft)	7123.21	Element	Left OB	Channel	Right OB
Vel Head (ft)	0.00	Wt. n-Val.		0.065	
W.S. Elev (ft)	7123.21	Reach Len. (ft)	200.00	200.00	201.00
Crit W.S. (ft)	7123.07	Flow Area (sq ft)		4.30	
E.G. Slope (ft/ft)	0.003580	Area (sq ft)		4.30	
Q Total (cfs)	2.00	Flow (cfs)		2.00	
Top Width (ft)	21.65	Top Width (ft)		21.65	
Vel Total (ft/s)	0.46	Avg. Vel. (ft/s)		0.46	
Max Chl Dpth (ft)	0.21	Hydr. Depth (ft)		0.20	
Conv. Total (cfs)	33.4	Conv. (cfs)		33.4	
Length Wtd. (ft)	200.00	Wetted Per. (ft)		21.70	
Min Ch El (ft)	7123.00	Shear (lb/sq ft)		0.04	
Alpha	1.00	Stream Power (lb/ft s)		0.02	
Frctn Loss (ft)	2.10	Cum Volume (acre-ft)	0.01	0.34	0.00
C & E Loss (ft)	0.00	Cum SA (acres)	0.05	2.33	0.04

Plan: Plan 02 POND F-G CHANNEL MAIN CHANNEL RS: 5358 Profile: Q2

E.G. Elev (ft)	7121.10	Element	Left OB	Channel	Right OB
Vel Head (ft)	0.03	Wt. n-Val.		0.065	
W.S. Elev (ft)	7121.07	Reach Len. (ft)	303.00	303.00	301.00
Crit W.S. (ft)	7121.07	Flow Area (sq ft)		1.45	
E.G. Slope (ft/ft)	0.126291	Area (sq ft)		1.45	
Q Total (cfs)	2.00	Flow (cfs)		2.00	
Top Width (ft)	20.57	Top Width (ft)		20.57	
Vel Total (ft/s)	1.38	Avg. Vel. (ft/s)		1.38	
Max Chl Dpth (ft)	0.07	Hydr. Depth (ft)		0.07	
Conv. Total (cfs)	5.6	Conv. (cfs)		5.6	
Length Wtd. (ft)		Wetted Per. (ft)		20.59	
Min Ch El (ft)	7121.00	Shear (lb/sq ft)		0.55	
Alpha	1.00	Stream Power (lb/ft s)		0.77	
Frctn Loss (ft)		Cum Volume (acre-ft)	0.01	0.33	0.00
C & E Loss (ft)		Cum SA (acres)	0.05	2.23	0.04

Plan: Plan 02 POND F-G CHANNEL MAIN CHANNEL RS: 5055 Profile: Q2

E.G. Elev (ft)	7112.10	Element	Left OB	Channel	Right OB
Vel Head (ft)	0.04	Wt. n-Val.		0.065	
W.S. Elev (ft)	7112.06	Reach Len. (ft)	291.00	290.00	289.00
Crit W.S. (ft)	7112.06	Flow Area (sq ft)		1.31	
E.G. Slope (ft/ft)	0.176821	Area (sq ft)		1.31	
Q Total (cfs)	2.00	Flow (cfs)		2.00	
Top Width (ft)	20.53	Top Width (ft)		20.53	
Vel Total (ft/s)	1.53	Avg. Vel. (ft/s)		1.53	
Max Chl Dpth (ft)	0.06	Hydr. Depth (ft)		0.06	
Conv. Total (cfs)	4.8	Conv. (cfs)		4.8	
Length Wtd. (ft)	290.00	Wetted Per. (ft)		20.55	
Min Ch El (ft)	7112.00	Shear (lb/sq ft)		0.70	
Alpha	1.00	Stream Power (lb/ft s)		1.07	
Frctn Loss (ft)	5.15	Cum Volume (acre-ft)	0.01	0.32	0.00
C & E Loss (ft)	0.01	Cum SA (acres)	0.05	2.09	0.04

Plan: Plan 02 POND F-G CHANNEL MAIN CHANNEL RS: 4765 Profile: Q2

E.G. Elev (ft)	7104.18	Element	Left OB	Channel	Right OB
Vel Head (ft)	0.00	Wt. n-Val.		0.065	
W.S. Elev (ft)	7104.18	Reach Len. (ft)	15.00	15.00	15.00
Crit W.S. (ft)	7104.07	Flow Area (sq ft)		3.62	
E.G. Slope (ft/ft)	0.006269	Area (sq ft)		3.62	
Q Total (cfs)	2.00	Flow (cfs)		2.00	
Top Width (ft)	21.40	Top Width (ft)		21.40	
Vel Total (ft/s)	0.55	Avg. Vel. (ft/s)		0.55	
Max Chl Dpth (ft)	0.17	Hydr. Depth (ft)		0.17	
Conv. Total (cfs)	25.3	Conv. (cfs)		25.3	
Length Wtd. (ft)	15.00	Wetted Per. (ft)		21.44	
Min Ch El (ft)	7104.00	Shear (lb/sq ft)		0.07	
Alpha	1.00	Stream Power (lb/ft s)		0.04	
Frctn Loss (ft)	0.12	Cum Volume (acre-ft)	0.01	0.31	0.00
C & E Loss (ft)	0.00	Cum SA (acres)	0.05	1.95	0.04

Plan: Plan 02 POND F-G CHANNEL MAIN CHANNEL RS: 4750 Profile: Q2

E.G. Elev (ft)	7104.05	Element	Left OB	Channel	Right OB
Vel Head (ft)	0.01	Wt. n-Val.		0.065	
W.S. Elev (ft)	7104.05	Reach Len. (ft)	273.00	273.00	270.00
Crit W.S. (ft)		Flow Area (sq ft)		3.04	
E.G. Slope (ft/ft)	0.011092	Area (sq ft)		3.04	
Q Total (cfs)	2.00	Flow (cfs)		2.00	
Top Width (ft)	21.18	Top Width (ft)		21.18	
Vel Total (ft/s)	0.66	Avg. Vel. (ft/s)		0.66	
Max Chl Dpth (ft)	0.15	Hydr. Depth (ft)		0.14	
Conv. Total (cfs)	19.0	Conv. (cfs)		19.0	
Length Wtd. (ft)	273.00	Wetted Per. (ft)		21.22	
Min Ch El (ft)	7103.90	Shear (lb/sq ft)		0.10	
Alpha	1.00	Stream Power (lb/ft s)		0.07	
Frctn Loss (ft)	2.79	Cum Volume (acre-ft)	0.01	0.30	0.00
C & E Loss (ft)	0.00	Cum SA (acres)	0.05	1.94	0.04

Plan: Plan 02 POND F-G CHANNEL MAIN CHANNEL RS: 4477 Profile: Q2

E.G. Elev (ft)	7101.28	Element	Left OB	Channel	Right OB
Vel Head (ft)	0.01	Wt. n-Val.		0.065	
W.S. Elev (ft)	7101.27	Reach Len. (ft)	27.00	10.00	1.00
Crit W.S. (ft)		Flow Area (sq ft)		3.53	
E.G. Slope (ft/ft)	0.009819	Area (sq ft)		3.53	
Q Total (cfs)	2.40	Flow (cfs)		2.40	
Top Width (ft)	21.44	Top Width (ft)		21.44	
Vel Total (ft/s)	0.68	Avg. Vel. (ft/s)		0.68	
Max Chl Dpth (ft)	0.17	Hydr. Depth (ft)		0.16	
Conv. Total (cfs)	24.2	Conv. (cfs)		24.2	
Length Wtd. (ft)	10.00	Wetted Per. (ft)		21.48	
Min Ch El (ft)	7101.10	Shear (lb/sq ft)		0.10	
Alpha	1.00	Stream Power (lb/ft s)		0.07	
Frctn Loss (ft)	0.08	Cum Volume (acre-ft)	0.01	0.28	0.00
C & E Loss (ft)	0.00	Cum SA (acres)	0.05	1.81	0.04

Plan: Plan 02 POND F-G CHANNEL MAIN CHANNEL RS: 4469 Profile: Q2

E.G. Elev (ft)	7101.20	Element	Left OB	Channel	Right OB
Vel Head (ft)	0.01	Wt. n-Val.		0.065	
W.S. Elev (ft)	7101.19	Reach Len. (ft)	199.00	198.00	193.00
Crit W.S. (ft)	7101.08	Flow Area (sq ft)		4.05	
E.G. Slope (ft/ft)	0.006313	Area (sq ft)		4.05	
Q Total (cfs)	2.40	Flow (cfs)		2.40	
Top Width (ft)	21.65	Top Width (ft)		21.65	
Vel Total (ft/s)	0.59	Avg. Vel. (ft/s)		0.59	
Max Chl Dpth (ft)	0.19	Hydr. Depth (ft)		0.19	
Conv. Total (cfs)	30.2	Conv. (cfs)		30.2	
Length Wtd. (ft)	198.00	Wetted Per. (ft)		21.70	
Min Ch El (ft)	7101.00	Shear (lb/sq ft)		0.07	
Alpha	1.00	Stream Power (lb/ft s)		0.04	
Frctn Loss (ft)	2.05	Cum Volume (acre-ft)	0.01	0.28	0.00
C & E Loss (ft)	0.00	Cum SA (acres)	0.05	1.80	0.04

Plan: Plan 02 POND F-G CHANNEL MAIN CHANNEL RS: 4269 Profile: Q2

E.G. Elev (ft)	7099.15	Element	Left OB	Channel	Right OB
Vel Head (ft)	0.01	Wt. n-Val.		0.065	
W.S. Elev (ft)	7099.14	Reach Len. (ft)	105.00	107.00	105.00
Crit W.S. (ft)	7099.07	Flow Area (sq ft)		2.83	
E.G. Slope (ft/ft)	0.020096	Area (sq ft)		2.83	
Q Total (cfs)	2.40	Flow (cfs)		2.40	
Top Width (ft)	21.10	Top Width (ft)		21.10	
Vel Total (ft/s)	0.85	Avg. Vel. (ft/s)		0.85	
Max Chl Dpth (ft)	0.14	Hydr. Depth (ft)		0.13	
Conv. Total (cfs)	16.9	Conv. (cfs)		16.9	
Length Wtd. (ft)	107.00	Wetted Per. (ft)		21.14	
Min Ch El (ft)	7099.00	Shear (lb/sq ft)		0.17	
Alpha	1.00	Stream Power (lb/ft s)		0.14	
Frctn Loss (ft)	3.01	Cum Volume (acre-ft)	0.01	0.27	0.00
C & E Loss (ft)	0.00	Cum SA (acres)	0.05	1.71	0.04

Plan: Plan 02 POND F-G CHANNEL MAIN CHANNEL RS: 4162 Profile: Q2

E.G. Elev (ft)	7096.13	Element	Left OB	Channel	Right OB
Vel Head (ft)	0.02	Wt. n-Val.		0.065	
W.S. Elev (ft)	7096.11	Reach Len. (ft)	100.00	102.00	86.00
Crit W.S. (ft)		Flow Area (sq ft)		2.26	
E.G. Slope (ft/ft)	0.042179	Area (sq ft)		2.26	
Q Total (cfs)	2.40	Flow (cfs)		2.40	
Top Width (ft)	20.88	Top Width (ft)		20.88	
Vel Total (ft/s)	1.06	Avg. Vel. (ft/s)		1.06	
Max Chl Dpth (ft)	0.11	Hydr. Depth (ft)		0.11	
Conv. Total (cfs)	11.7	Conv. (cfs)		11.7	
Length Wtd. (ft)	102.00	Wetted Per. (ft)		20.91	
Min Ch El (ft)	7096.00	Shear (lb/sq ft)		0.28	
Alpha	1.00	Stream Power (lb/ft s)		0.30	
Frctn Loss (ft)	6.72	Cum Volume (acre-ft)	0.01	0.26	0.00
C & E Loss (ft)	0.00	Cum SA (acres)	0.05	1.65	0.04

Plan: Plan 02 POND F-G CHANNEL MAIN CHANNEL RS: 4060 Profile: Q2

E.G. Elev (ft)	7089.41	Element	Left OB	Channel	Right OB
Vel Head (ft)	0.03	Wt. n-Val.		0.065	
W.S. Elev (ft)	7089.38	Reach Len. (ft)	47.00	63.00	108.00
Crit W.S. (ft)	7089.38	Flow Area (sq ft)		1.68	
E.G. Slope (ft/ft)	0.116844	Area (sq ft)		1.68	
Q Total (cfs)	2.40	Flow (cfs)		2.40	
Top Width (ft)	21.37	Top Width (ft)		21.37	
Vel Total (ft/s)	1.43	Avg. Vel. (ft/s)		1.43	
Max Chl Dpth (ft)	0.08	Hydr. Depth (ft)		0.08	
Conv. Total (cfs)	7.0	Conv. (cfs)		7.0	
Length Wtd. (ft)	63.00	Wetted Per. (ft)		21.38	
Min Ch El (ft)	7089.30	Shear (lb/sq ft)		0.57	
Alpha	1.00	Stream Power (lb/ft s)		0.82	
Frctn Loss (ft)	1.11	Cum Volume (acre-ft)	0.01	0.26	0.00
C & E Loss (ft)	0.00	Cum SA (acres)	0.05	1.60	0.04

Plan: Plan 02 POND F-G CHANNEL MAIN CHANNEL RS: 3997 Profile: Q2

E.G. Elev (ft)	7086.24	Element	Left OB	Channel	Right OB
Vel Head (ft)	0.02	Wt. n-Val.		0.033	
W.S. Elev (ft)	7086.22	Reach Len. (ft)	235.00	236.00	233.00
Crit W.S. (ft)	7086.15	Flow Area (sq ft)		2.82	
E.G. Slope (ft/ft)	0.008240	Area (sq ft)		2.82	
Q Total (cfs)	3.20	Flow (cfs)		3.20	
Top Width (ft)	19.75	Top Width (ft)		19.75	
Vel Total (ft/s)	1.13	Avg. Vel. (ft/s)		1.13	
Max Chl Dpth (ft)	0.22	Hydr. Depth (ft)		0.14	
Conv. Total (cfs)	35.3	Conv. (cfs)		35.3	
Length Wtd. (ft)	235.98	Wetted Per. (ft)		19.77	
Min Ch El (ft)	7086.00	Shear (lb/sq ft)		0.07	
Alpha	1.00	Stream Power (lb/ft s)		0.08	
Frctn Loss (ft)	3.99	Cum Volume (acre-ft)	0.01	0.25	0.00
C & E Loss (ft)	0.01	Cum SA (acres)	0.05	1.58	0.04

Plan: Plan 02 POND F-G CHANNEL MAIN CHANNEL RS: 3761 Profile: Q2

E.G. Elev (ft)	7082.24	Element	Left OB	Channel	Right OB
Vel Head (ft)	0.08	Wt. n-Val.	0.040	0.033	0.040
W.S. Elev (ft)	7082.16	Reach Len. (ft)	263.00	261.00	255.00
Crit W.S. (ft)	7082.16	Flow Area (sq ft)	0.06	2.67	0.03
E.G. Slope (ft/ft)	0.027760	Area (sq ft)	0.06	2.67	0.03
Q Total (cfs)	6.20	Flow (cfs)	0.06	6.11	0.03
Top Width (ft)	17.33	Top Width (ft)	0.67	16.30	0.35
Vel Total (ft/s)	2.25	Avg. Vel. (ft/s)	1.15	2.28	1.09
Max Chl Dpth (ft)	0.16	Hydr. Depth (ft)	0.08	0.16	0.08
Conv. Total (cfs)	37.2	Conv. (cfs)	0.4	36.6	0.2
Length Wtd. (ft)	260.99	Wetted Per. (ft)	0.69	16.30	0.39
Min Ch El (ft)	7082.00	Shear (lb/sq ft)	0.14	0.28	0.13
Alpha	1.02	Stream Power (lb/ft s)	0.16	0.65	0.14
Frctn Loss (ft)	4.07	Cum Volume (acre-ft)	0.01	0.24	0.00
C & E Loss (ft)	0.01	Cum SA (acres)	0.05	1.48	0.04

Plan: Plan 02 POND F-G CHANNEL MAIN CHANNEL RS: 3500 Profile: Q2

E.G. Elev (ft)	7077.88	Element	Left OB	Channel	Right OB
Vel Head (ft)	0.04	Wt. n-Val.		0.033	
W.S. Elev (ft)	7077.84	Reach Len. (ft)	256.00	250.00	250.00
Crit W.S. (ft)	7077.76	Flow Area (sq ft)		3.78	
E.G. Slope (ft/ft)	0.009979	Area (sq ft)		3.78	
Q Total (cfs)	6.20	Flow (cfs)		6.20	
Top Width (ft)	17.59	Top Width (ft)		17.59	
Vel Total (ft/s)	1.64	Avg. Vel. (ft/s)		1.64	
Max Chl Dpth (ft)	0.33	Hydr. Depth (ft)		0.22	
Conv. Total (cfs)	62.1	Conv. (cfs)		62.1	
Length Wtd. (ft)	250.00	Wetted Per. (ft)		17.61	
Min Ch El (ft)	7077.50	Shear (lb/sq ft)		0.13	
Alpha	1.00	Stream Power (lb/ft s)		0.22	
Frctn Loss (ft)	3.51	Cum Volume (acre-ft)	0.01	0.22	0.00
C & E Loss (ft)	0.00	Cum SA (acres)	0.05	1.38	0.04

Plan: Plan 02 POND F-G CHANNEL MAIN CHANNEL RS: 3250 Profile: Q2

E.G. Elev (ft)	7074.35	Element	Left OB	Channel	Right OB
Vel Head (ft)	0.07	Wt. n-Val.		0.028	
W.S. Elev (ft)	7074.29	Reach Len. (ft)	147.00	150.00	157.00
Crit W.S. (ft)	7074.29	Flow Area (sq ft)		2.98	
E.G. Slope (ft/ft)	0.021187	Area (sq ft)		2.98	
Q Total (cfs)	6.20	Flow (cfs)		6.20	
Top Width (ft)	21.83	Top Width (ft)		21.83	
Vel Total (ft/s)	2.08	Avg. Vel. (ft/s)		2.08	
Max Chl Dpth (ft)	0.19	Hydr. Depth (ft)		0.14	
Conv. Total (cfs)	42.6	Conv. (cfs)		42.6	
Length Wtd. (ft)	150.00	Wetted Per. (ft)		21.84	
Min Ch El (ft)	7074.10	Shear (lb/sq ft)		0.18	
Alpha	1.00	Stream Power (lb/ft s)		0.38	
Frctn Loss (ft)	1.97	Cum Volume (acre-ft)	0.01	0.20	0.00
C & E Loss (ft)	0.01	Cum SA (acres)	0.05	1.26	0.04

Plan: Plan 02 POND F-G CHANNEL MAIN CHANNEL RS: 3100 Profile: Q2

E.G. Elev (ft)	7071.42	Element	Left OB	Channel	Right OB
Vel Head (ft)	0.04	Wt. n-Val.		0.028	
W.S. Elev (ft)	7071.38	Reach Len. (ft)	109.00	89.00	65.00
Crit W.S. (ft)	7071.33	Flow Area (sq ft)		3.69	
E.G. Slope (ft/ft)	0.008913	Area (sq ft)		3.69	
Q Total (cfs)	6.20	Flow (cfs)		6.20	
Top Width (ft)	19.53	Top Width (ft)		19.53	
Vel Total (ft/s)	1.68	Avg. Vel. (ft/s)		1.68	
Max Chl Dpth (ft)	0.28	Hydr. Depth (ft)		0.19	
Conv. Total (cfs)	65.7	Conv. (cfs)		65.7	
Length Wtd. (ft)	89.00	Wetted Per. (ft)		19.55	
Min Ch El (ft)	7071.10	Shear (lb/sq ft)		0.11	
Alpha	1.00	Stream Power (lb/ft s)		0.18	
Frctn Loss (ft)	1.16	Cum Volume (acre-ft)	0.01	0.19	0.00
C & E Loss (ft)	0.00	Cum SA (acres)	0.05	1.19	0.04

Plan: Plan 02 POND F-G CHANNEL MAIN CHANNEL RS: 3011 Profile: Q2

E.G. Elev (ft)	7070.26	Element	Left OB	Channel	Right OB
Vel Head (ft)	0.07	Wt. n-Val.		0.028	
W.S. Elev (ft)	7070.19	Reach Len. (ft)	108.00	124.00	132.00
Crit W.S. (ft)	7070.19	Flow Area (sq ft)		2.91	
E.G. Slope (ft/ft)	0.020982	Area (sq ft)		2.91	
Q Total (cfs)	6.20	Flow (cfs)		6.20	
Top Width (ft)	20.49	Top Width (ft)		20.49	
Vel Total (ft/s)	2.13	Avg. Vel. (ft/s)		2.13	
Max Chl Dpth (ft)	0.19	Hydr. Depth (ft)		0.14	
Conv. Total (cfs)	42.8	Conv. (cfs)		42.8	
Length Wtd. (ft)	124.00	Wetted Per. (ft)		20.50	
Min Ch El (ft)	7070.00	Shear (lb/sq ft)		0.19	
Alpha	1.00	Stream Power (lb/ft s)		0.40	
Frctn Loss (ft)	1.69	Cum Volume (acre-ft)	0.01	0.18	0.00
C & E Loss (ft)	0.01	Cum SA (acres)	0.05	1.15	0.04

Plan: Plan 02 POND F-G CHANNEL MAIN CHANNEL RS: 2887 Profile: Q2

E.G. Elev (ft)	7068.26	Element	Left OB	Channel	Right OB
Vel Head (ft)	0.04	Wt. n-Val.		0.028	
W.S. Elev (ft)	7068.22	Reach Len. (ft)	137.00	147.00	150.00
Crit W.S. (ft)	7068.18	Flow Area (sq ft)		4.09	
E.G. Slope (ft/ft)	0.009561	Area (sq ft)		4.09	
Q Total (cfs)	6.20	Flow (cfs)		6.20	
Top Width (ft)	26.56	Top Width (ft)		26.56	
Vel Total (ft/s)	1.52	Avg. Vel. (ft/s)		1.52	
Max Chl Dpth (ft)	0.22	Hydr. Depth (ft)		0.15	
Conv. Total (cfs)	63.4	Conv. (cfs)		63.4	
Length Wtd. (ft)	147.04	Wetted Per. (ft)		26.58	
Min Ch El (ft)	7068.00	Shear (lb/sq ft)		0.09	
Alpha	1.00	Stream Power (lb/ft s)		0.14	
Frctn Loss (ft)	1.97	Cum Volume (acre-ft)	0.01	0.17	0.00
C & E Loss (ft)	0.00	Cum SA (acres)	0.05	1.08	0.04

Plan: Plan 02 POND F-G CHANNEL MAIN CHANNEL RS: 2740 Profile: Q2

E.G. Elev (ft)	7066.28	Element	Left OB	Channel	Right OB
Vel Head (ft)	0.08	Wt. n-Val.		0.028	0.040
W.S. Elev (ft)	7066.20	Reach Len. (ft)	250.00	240.00	248.00
Crit W.S. (ft)	7066.20	Flow Area (sq ft)		2.70	0.13
E.G. Slope (ft/ft)	0.020095	Area (sq ft)		2.70	0.13
Q Total (cfs)	6.20	Flow (cfs)		6.05	0.15
Top Width (ft)	18.34	Top Width (ft)		16.99	1.35
Vel Total (ft/s)	2.19	Avg. Vel. (ft/s)		2.24	1.13
Max Chl Dpth (ft)	0.20	Hydr. Depth (ft)		0.16	0.10
Conv. Total (cfs)	43.7	Conv. (cfs)		42.7	1.1
Length Wtd. (ft)	240.27	Wetted Per. (ft)		16.99	1.36
Min Ch El (ft)	7066.00	Shear (lb/sq ft)		0.20	0.12
Alpha	1.03	Stream Power (lb/ft s)		0.45	0.14
Frctn Loss (ft)	5.16	Cum Volume (acre-ft)	0.01	0.16	0.00
C & E Loss (ft)	0.00	Cum SA (acres)	0.05	1.01	0.04

Plan: Plan 02 POND F-G CHANNEL MAIN CHANNEL RS: 2500 Profile: Q2

E.G. Elev (ft)	7061.11	Element	Left OB	Channel	Right OB
Vel Head (ft)	0.11	Wt. n-Val.		0.028	0.040
W.S. Elev (ft)	7061.00	Reach Len. (ft)	182.00	174.00	176.00
Crit W.S. (ft)	7061.01	Flow Area (sq ft)		2.24	0.22
E.G. Slope (ft/ft)	0.023044	Area (sq ft)		2.24	0.22
Q Total (cfs)	6.20	Flow (cfs)		5.93	0.27
Top Width (ft)	14.44	Top Width (ft)		12.22	2.22
Vel Total (ft/s)	2.52	Avg. Vel. (ft/s)		2.65	1.22
Max Chl Dpth (ft)	0.20	Hydr. Depth (ft)		0.18	0.10
Conv. Total (cfs)	40.8	Conv. (cfs)		39.0	1.8
Length Wtd. (ft)	174.07	Wetted Per. (ft)		12.23	2.23
Min Ch El (ft)	7060.80	Shear (lb/sq ft)		0.26	0.14
Alpha	1.07	Stream Power (lb/ft s)		0.70	0.18
Frctn Loss (ft)	3.88	Cum Volume (acre-ft)	0.01	0.15	0.00
C & E Loss (ft)	0.00	Cum SA (acres)	0.05	0.93	0.03

Plan: Plan 02 POND F-G CHANNEL MAIN CHANNEL RS: 2326 Profile: Q2

E.G. Elev (ft)	7057.23	Element	Left OB	Channel	Right OB
Vel Head (ft)	0.11	Wt. n-Val.		0.028	0.040
W.S. Elev (ft)	7057.11	Reach Len. (ft)	113.00	139.00	138.00
Crit W.S. (ft)	7057.12	Flow Area (sq ft)		2.21	0.11
E.G. Slope (ft/ft)	0.021619	Area (sq ft)		2.21	0.11
Q Total (cfs)	6.20	Flow (cfs)		6.07	0.13
Top Width (ft)	11.91	Top Width (ft)		10.87	1.04
Vel Total (ft/s)	2.67	Avg. Vel. (ft/s)		2.74	1.21
Max Chl Dpth (ft)	0.21	Hydr. Depth (ft)		0.20	0.11
Conv. Total (cfs)	42.2	Conv. (cfs)		41.3	0.9
Length Wtd. (ft)	138.89	Wetted Per. (ft)		10.89	1.06
Min Ch El (ft)	7056.90	Shear (lb/sq ft)		0.27	0.14
Alpha	1.04	Stream Power (lb/ft s)		0.75	0.17
Frctn Loss (ft)	2.10	Cum Volume (acre-ft)	0.01	0.14	0.00
C & E Loss (ft)	0.02	Cum SA (acres)	0.05	0.88	0.02

Plan: Plan 02 POND F-G CHANNEL MAIN CHANNEL RS: 2187 Profile: Q2

E.G. Elev (ft)	7054.22	Element	Left OB	Channel	Right OB
Vel Head (ft)	0.05	Wt. n-Val.	0.040	0.028	0.040
W.S. Elev (ft)	7054.17	Reach Len. (ft)	152.00	142.00	133.00
Crit W.S. (ft)	7054.15	Flow Area (sq ft)	0.06	3.36	0.06
E.G. Slope (ft/ft)	0.012237	Area (sq ft)	0.06	3.36	0.06
Q Total (cfs)	6.20	Flow (cfs)	0.04	6.11	0.04
Top Width (ft)	21.34	Top Width (ft)	0.67	20.00	0.67
Vel Total (ft/s)	1.79	Avg. Vel. (ft/s)	0.77	1.82	0.77
Max Chl Dpth (ft)	0.17	Hydr. Depth (ft)	0.08	0.17	0.08
Conv. Total (cfs)	56.0	Conv. (cfs)	0.4	55.3	0.4
Length Wtd. (ft)	142.27	Wetted Per. (ft)	0.69	20.00	0.69
Min Ch El (ft)	7054.00	Shear (lb/sq ft)	0.06	0.13	0.06
Alpha	1.03	Stream Power (lb/ft s)	0.05	0.23	0.05
Frctn Loss (ft)	1.90	Cum Volume (acre-ft)	0.01	0.13	0.00
C & E Loss (ft)	0.00	Cum SA (acres)	0.05	0.83	0.02

Plan: Plan 02 POND F-G CHANNEL MAIN CHANNEL RS: 2045 Profile: Q2

E.G. Elev (ft)	7052.31	Element	Left OB	Channel	Right OB
Vel Head (ft)	0.08	Wt. n-Val.	0.040	0.028	
W.S. Elev (ft)	7052.23	Reach Len. (ft)	180.00	146.00	152.00
Crit W.S. (ft)	7052.21	Flow Area (sq ft)	0.32	2.57	
E.G. Slope (ft/ft)	0.014710	Area (sq ft)	0.32	2.57	
Q Total (cfs)	6.20	Flow (cfs)	0.33	5.87	
Top Width (ft)	15.26	Top Width (ft)	2.77	12.49	
Vel Total (ft/s)	2.15	Avg. Vel. (ft/s)	1.06	2.28	
Max Chl Dpth (ft)	0.23	Hydr. Depth (ft)	0.11	0.21	
Conv. Total (cfs)	51.1	Conv. (cfs)	2.8	48.4	
Length Wtd. (ft)	148.91	Wetted Per. (ft)	2.77	12.50	
Min Ch El (ft)	7052.00	Shear (lb/sq ft)	0.10	0.19	
Alpha	1.08	Stream Power (lb/ft s)	0.11	0.43	
Frctn Loss (ft)	2.65	Cum Volume (acre-ft)	0.00	0.12	0.00
C & E Loss (ft)	0.00	Cum SA (acres)	0.04	0.78	0.02

Plan: Plan 02 POND F-G CHANNEL MAIN CHANNEL RS: 1899 Profile: Q2

E.G. Elev (ft)	7049.66	Element	Left OB	Channel	Right OB
Vel Head (ft)	0.07	Wt. n-Val.	0.040	0.028	0.040
W.S. Elev (ft)	7049.59	Reach Len. (ft)	136.00	129.00	118.00
Crit W.S. (ft)	7049.59	Flow Area (sq ft)	0.78	4.41	0.11
E.G. Slope (ft/ft)	0.019999	Area (sq ft)	0.78	4.41	0.11
Q Total (cfs)	11.00	Flow (cfs)	1.12	9.81	0.07
Top Width (ft)	36.07	Top Width (ft)	5.48	28.13	2.47
Vel Total (ft/s)	2.07	Avg. Vel. (ft/s)	1.44	2.22	0.64
Max Chl Dpth (ft)	0.29	Hydr. Depth (ft)	0.14	0.16	0.04
Conv. Total (cfs)	77.8	Conv. (cfs)	8.0	69.3	0.5
Length Wtd. (ft)	129.34	Wetted Per. (ft)	5.48	28.14	2.47
Min Ch El (ft)	7049.30	Shear (lb/sq ft)	0.18	0.20	0.05
Alpha	1.07	Stream Power (lb/ft s)	0.26	0.44	0.03
Frctn Loss (ft)	2.84	Cum Volume (acre-ft)	0.00	0.11	0.00
C & E Loss (ft)	0.00	Cum SA (acres)	0.03	0.71	0.01

Plan: Plan 02 POND F-G CHANNEL MAIN CHANNEL RS: 1770 Profile: Q2

E.G. Elev (ft)	7046.82	Element	Left OB	Channel	Right OB
Vel Head (ft)	0.08	Wt. n-Val.	0.040	0.028	0.040
W.S. Elev (ft)	7046.74	Reach Len. (ft)	185.00	181.00	227.00
Crit W.S. (ft)	7046.75	Flow Area (sq ft)	0.15	4.73	0.06
E.G. Slope (ft/ft)	0.024289	Area (sq ft)	0.15	4.73	0.06
Q Total (cfs)	11.00	Flow (cfs)	0.15	10.79	0.06
Top Width (ft)	36.52	Top Width (ft)	2.16	33.50	0.86
Vel Total (ft/s)	2.23	Avg. Vel. (ft/s)	0.99	2.28	0.98
Max Chl Dpth (ft)	0.14	Hydr. Depth (ft)	0.07	0.14	0.07
Conv. Total (cfs)	70.6	Conv. (cfs)	1.0	69.2	0.4
Length Wtd. (ft)	181.17	Wetted Per. (ft)	2.16	33.50	0.87
Min Ch El (ft)	7046.60	Shear (lb/sq ft)	0.11	0.21	0.11
Alpha	1.03	Stream Power (lb/ft s)	0.11	0.49	0.10
Frctn Loss (ft)	4.61	Cum Volume (acre-ft)	0.00	0.09	0.00
C & E Loss (ft)	0.00	Cum SA (acres)	0.01	0.62	0.01

Plan: Plan 02 POND F-G CHANNEL MAIN CHANNEL RS: 1589 Profile: Q2

E.G. Elev (ft)	7042.21	Element	Left OB	Channel	Right OB
Vel Head (ft)	0.07	Wt. n-Val.	0.040	0.028	0.040
W.S. Elev (ft)	7042.14	Reach Len. (ft)	227.00	235.00	218.00
Crit W.S. (ft)	7042.15	Flow Area (sq ft)	0.01	5.36	0.01
E.G. Slope (ft/ft)	0.026737	Area (sq ft)	0.01	5.36	0.01
Q Total (cfs)	11.00	Flow (cfs)	0.00	10.99	0.01
Top Width (ft)	48.93	Top Width (ft)	0.34	48.00	0.59
Vel Total (ft/s)	2.04	Avg. Vel. (ft/s)	0.47	2.05	0.48
Max Chl Dpth (ft)	0.14	Hydr. Depth (ft)	0.02	0.11	0.02
Conv. Total (cfs)	67.3	Conv. (cfs)	0.0	67.2	0.0
Length Wtd. (ft)	234.94	Wetted Per. (ft)	0.34	48.00	0.59
Min Ch El (ft)	7042.00	Shear (lb/sq ft)	0.04	0.19	0.04
Alpha	1.01	Stream Power (lb/ft s)	0.02	0.38	0.02
Frctn Loss (ft)	3.54	Cum Volume (acre-ft)	0.00	0.07	0.00
C & E Loss (ft)	0.00	Cum SA (acres)	0.01	0.45	0.01

Plan: Plan 02 POND F-G CHANNEL MAIN CHANNEL RS: 1354 Profile: Q2

E.G. Elev (ft)	7038.14	Element	Left OB	Channel	Right OB
Vel Head (ft)	0.08	Wt. n-Val.	0.040	0.028	
W.S. Elev (ft)	7038.06	Reach Len. (ft)	141.00	145.00	164.00
Crit W.S. (ft)	7038.01	Flow Area (sq ft)	0.17	4.74	
E.G. Slope (ft/ft)	0.010080	Area (sq ft)	0.17	4.74	
Q Total (cfs)	11.00	Flow (cfs)	0.16	10.84	
Top Width (ft)	18.62	Top Width (ft)	1.29	17.32	
Vel Total (ft/s)	2.24	Avg. Vel. (ft/s)	0.94	2.29	
Max Chl Dpth (ft)	0.36	Hydr. Depth (ft)	0.13	0.27	
Conv. Total (cfs)	109.6	Conv. (cfs)	1.6	108.0	
Length Wtd. (ft)	145.00	Wetted Per. (ft)	1.32	17.34	
Min Ch El (ft)	7037.70	Shear (lb/sq ft)	0.08	0.17	
Alpha	1.03	Stream Power (lb/ft s)	0.07	0.39	
Frctn Loss (ft)	1.96	Cum Volume (acre-ft)	0.00	0.04	0.00
C & E Loss (ft)	0.01	Cum SA (acres)	0.00	0.28	0.00

Plan: Plan 02 POND F-G CHANNEL MAIN CHANNEL RS: 1209 Profile: Q2

E.G. Elev (ft)	7036.16	Element	Left OB	Channel	Right OB
Vel Head (ft)	0.05	Wt. n-Val.	0.040	0.028	0.040
W.S. Elev (ft)	7036.12	Reach Len. (ft)	35.00	36.00	32.00
Crit W.S. (ft)	7036.12	Flow Area (sq ft)	0.03	6.18	0.05
E.G. Slope (ft/ft)	0.019012	Area (sq ft)	0.03	6.18	0.05
Q Total (cfs)	11.00	Flow (cfs)	0.03	10.93	0.04
Top Width (ft)	54.92	Top Width (ft)	0.58	53.40	0.94
Vel Total (ft/s)	1.76	Avg. Vel. (ft/s)	0.76	1.77	0.76
Max Chl Dpth (ft)	0.12	Hydr. Depth (ft)	0.06	0.12	0.06
Conv. Total (cfs)	79.8	Conv. (cfs)	0.2	79.3	0.3
Length Wtd. (ft)	35.97	Wetted Per. (ft)	0.59	53.40	0.94
Min Ch El (ft)	7036.00	Shear (lb/sq ft)	0.07	0.14	0.07
Alpha	1.01	Stream Power (lb/ft s)	0.05	0.24	0.05
Frctn Loss (ft)	0.91	Cum Volume (acre-ft)	0.00	0.03	0.00
C & E Loss (ft)	0.01	Cum SA (acres)	0.00	0.16	0.00

Plan: Plan 02 POND F-G CHANNEL MAIN CHANNEL RS: 1173 Profile: Q2

E.G. Elev (ft)	7035.25	Element	Left OB	Channel	Right OB
Vel Head (ft)	0.11	Wt. n-Val.	0.040	0.028	0.040
W.S. Elev (ft)	7035.14	Reach Len. (ft)	50.00	51.00	50.00
Crit W.S. (ft)	7035.16	Flow Area (sq ft)	0.04	4.06	0.11
E.G. Slope (ft/ft)	0.035152	Area (sq ft)	0.04	4.06	0.11
Q Total (cfs)	11.00	Flow (cfs)	0.04	10.83	0.13
Top Width (ft)	32.17	Top Width (ft)	0.56	30.00	1.61
Vel Total (ft/s)	2.62	Avg. Vel. (ft/s)	1.13	2.67	1.15
Max Chl Dpth (ft)	0.14	Hydr. Depth (ft)	0.07	0.14	0.07
Conv. Total (cfs)	58.7	Conv. (cfs)	0.2	57.8	0.7
Length Wtd. (ft)	50.99	Wetted Per. (ft)	0.58	30.00	1.62
Min Ch El (ft)	7035.00	Shear (lb/sq ft)	0.14	0.30	0.15
Alpha	1.03	Stream Power (lb/ft s)	0.16	0.79	0.17
Frctn Loss (ft)	0.94	Cum Volume (acre-ft)	0.00	0.02	0.00
C & E Loss (ft)	0.01	Cum SA (acres)	0.00	0.12	0.00

Plan: Plan 02 POND F-G CHANNEL MAIN CHANNEL RS: 1122 Profile: Q2

E.G. Elev (ft)	7034.29	Element	Left OB	Channel	Right OB
Vel Head (ft)	0.03	Wt. n-Val.		0.065	
W.S. Elev (ft)	7034.26	Reach Len. (ft)	24.00	24.00	24.00
Crit W.S. (ft)	7034.16	Flow Area (sq ft)		8.13	
E.G. Slope (ft/ft)	0.021953	Area (sq ft)		8.13	
Q Total (cfs)	11.00	Flow (cfs)		11.00	
Top Width (ft)	32.09	Top Width (ft)		32.09	
Vel Total (ft/s)	1.35	Avg. Vel. (ft/s)		1.35	
Max Chl Dpth (ft)	0.26	Hydr. Depth (ft)		0.25	
Conv. Total (cfs)	74.2	Conv. (cfs)		74.2	
Length Wtd. (ft)	24.00	Wetted Per. (ft)		32.16	
Min Ch El (ft)	7034.00	Shear (lb/sq ft)		0.35	
Alpha	1.00	Stream Power (lb/ft s)		0.47	
Frctn Loss (ft)	1.04	Cum Volume (acre-ft)		0.02	
C & E Loss (ft)	0.01	Cum SA (acres)		0.09	

Plan: Plan 02 POND F-G CHANNEL MAIN CHANNEL RS: 1098 Profile: Q2

E.G. Elev (ft)	7033.24	Element	Left OB	Channel	Right OB
Vel Head (ft)	0.08	Wt. n-Val.		0.065	
W.S. Elev (ft)	7033.16	Reach Len. (ft)	99.00	98.00	100.00
Crit W.S. (ft)	7033.16	Flow Area (sq ft)		4.79	
E.G. Slope (ft/ft)	0.123637	Area (sq ft)		4.79	
Q Total (cfs)	11.00	Flow (cfs)		11.00	
Top Width (ft)	31.25	Top Width (ft)		31.25	
Vel Total (ft/s)	2.30	Avg. Vel. (ft/s)		2.30	
Max Chl Dpth (ft)	0.16	Hydr. Depth (ft)		0.15	
Conv. Total (cfs)	31.3	Conv. (cfs)		31.3	
Length Wtd. (ft)		Wetted Per. (ft)		31.29	
Min Ch El (ft)	7033.00	Shear (lb/sq ft)		1.18	
Alpha	1.00	Stream Power (lb/ft s)		2.71	
Frctn Loss (ft)		Cum Volume (acre-ft)		0.01	
C & E Loss (ft)		Cum SA (acres)		0.07	

Plan: Plan 02 POND F-G CHANNEL MAIN CHANNEL RS: 1000 Profile: Q2

E.G. Elev (ft)	7026.64	Element	Left OB	Channel	Right OB
Vel Head (ft)	0.06	Wt. n-Val.		0.065	
W.S. Elev (ft)	7026.59	Reach Len. (ft)			
Crit W.S. (ft)	7026.56	Flow Area (sq ft)		5.78	
E.G. Slope (ft/ft)	0.066570	Area (sq ft)		5.78	
Q Total (cfs)	11.00	Flow (cfs)		11.00	
Top Width (ft)	31.50	Top Width (ft)		31.50	
Vel Total (ft/s)	1.90	Avg. Vel. (ft/s)		1.90	
Max Chl Dpth (ft)	0.19	Hydr. Depth (ft)		0.18	
Conv. Total (cfs)	42.6	Conv. (cfs)		42.6	
Length Wtd. (ft)		Wetted Per. (ft)		31.55	
Min Ch El (ft)	7026.40	Shear (lb/sq ft)		0.76	
Alpha	1.00	Stream Power (lb/ft s)		1.45	
Frctn Loss (ft)		Cum Volume (acre-ft)			
C & E Loss (ft)		Cum SA (acres)			

Appendix E – Outlet Protection Design

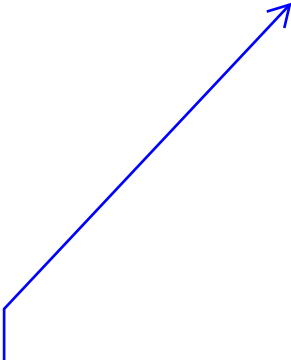

Hydraulic analysis will be reviewed with the final plat.

Again, enter Figure HS-19a using the smaller d/D (or d/H) ratio to find the A/A_{full} ratio. Then,

$$A = (A/A_{full})A_{full} \quad (\text{HS-16c})$$

Finally,

$$V = Q/A \quad (\text{HS-16d})$$

In which for Equations 16a through 16d above:

A_{full} = cross-sectional area of the pipe (ft²)

A = area of the design flow in the end of the pipe (ft²)

n = Manning's n for the pipe full depth

Q_{full} = pipe full discharge at its slope (cfs)

R = hydraulic radius of the pipe flowing full, ft [$R_{full} = D/4$ for circular pipes, $R_{full} = A_{full}/(2H + 2w)$ for rectangular pipes, where D = diameter of a circular conduit, H = height of a rectangular conduit, and w = width of a rectangular conduit (ft)]

S_o = longitudinal slope of the pipe (ft/ft)

V = design flow velocity at the pipe outlet (ft/sec)

V_{full} = flow velocity of the pipe flowing full (ft/sec)

3.4.3.2 Riprap Size

For the design velocity, use [Figure HS-20c](#) to find the size and type of the riprap to use in the scour protection basin downstream of the pipe outlet (i.e., B18, H, M or L). First, calculate the riprap sizing design parameter, P_d , namely,

$$P_d = (V^2 + gd)^{1/2} \quad (\text{HS-16e})$$

in which:

V = design flow velocity at pipe outlet (ft/sec)

g = acceleration due to gravity = 32.2 ft/sec²

d = design depth of flow at pipe outlet (ft)

necessary when the receiving or downstream channel may have little or no flow or tailwater at time when the pipe or culvert is in operation. Design criteria are provided in Figures HS-19a through HS-20c.

3.4.2 Objective

By providing a low tailwater basin at the end of a storm sewer conduit or culvert, the kinetic energy of the discharge is dissipated under controlled conditions without causing scour at the channel bottom.

[Photograph HS-12](#) shows a fairly large low tailwater basin.

3.4.3 Low Tailwater Basin Design

Low tailwater is defined as being equal to or less than $\frac{1}{3}$ of the height of the storm sewer, that is:

$$y_t \leq \frac{D}{3} \quad \text{or} \quad y_t \leq \frac{H}{3}$$

in which:

y_t = tailwater depth at design

D = diameter of circular pipe (ft)

H = height of rectangular pipe (ft)

3.4.3.1 Finding Flow Depth and Velocity of Storm Sewer Outlet Pipe

The first step in the design of a scour protection basin at the outlet of a storm sewer is to find the depth and velocity of flow at the outlet. Pipe-full flow can be found using Manning's equation.

$$Q_{full} = \frac{1.49}{n} A_{full} (R_{full})^{2/3} S_o^{1/2} \quad (\text{HS-16a})$$

Then and the pipe-full velocity can be found using the continuity equation.

$$V_{full} = Q_{full} / A_{full} \quad (\text{HS-16a})$$

The normal depth of flow, d , and the velocity in a conduit can be found with the aid of [Figure HS-20a](#) and [Figure HS-20b](#). Using the known design discharge, Q , and the calculated pipe-full discharge, Q_{full} , enter Figure HS-20a with the value of Q/Q_{full} and find d/D for a circular pipe or d/H for a rectangular pipe.

Compare the value of d/D (or d/H) with the one obtained from Figure HS-20b using the Froude parameter.

$$Q/D^{2.5} \quad \text{or} \quad Q/(wH^{1/5}) \quad (\text{HS-16a})$$

Choose the smaller of the two (d/D or d/H) ratios to calculate the flow depth at the end of the pipe.

$$d = D(d/D) \quad \text{or} \quad d = H(d/H) \quad (\text{HS-16b})$$

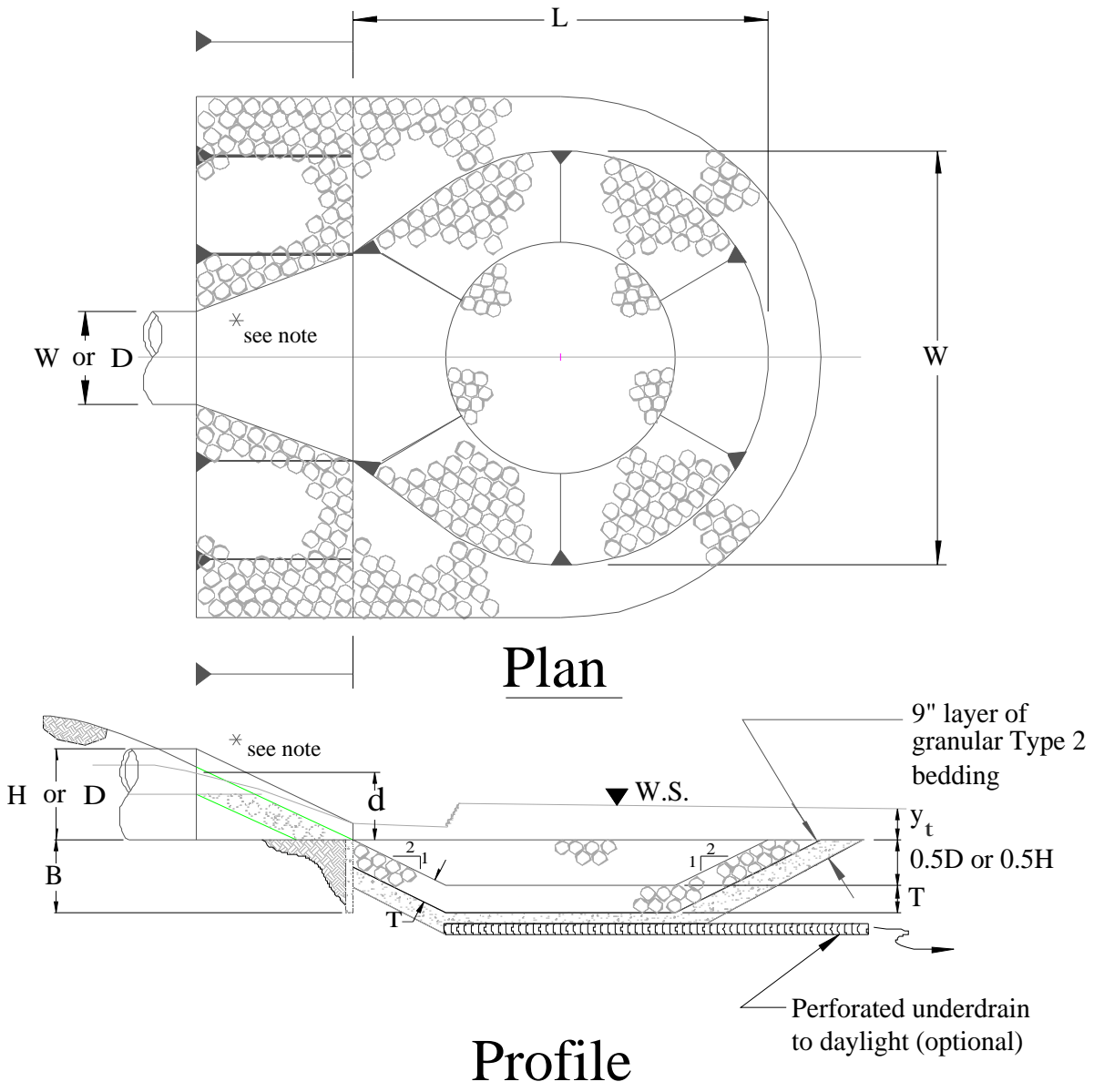

* Note: For rectangular conduits use a standard design for a headwall with wingwalls, paved bottom between the wingwalls, with an end cutoff wall extending to a minimum depth equal to B

**Figure HS-19—Low Tailwater Riprap Basins for Storm Sewer Pipe Outlets—
Low Tailwater Basin at Pipe Outlets
(Stevens and Urbonas 1996)**

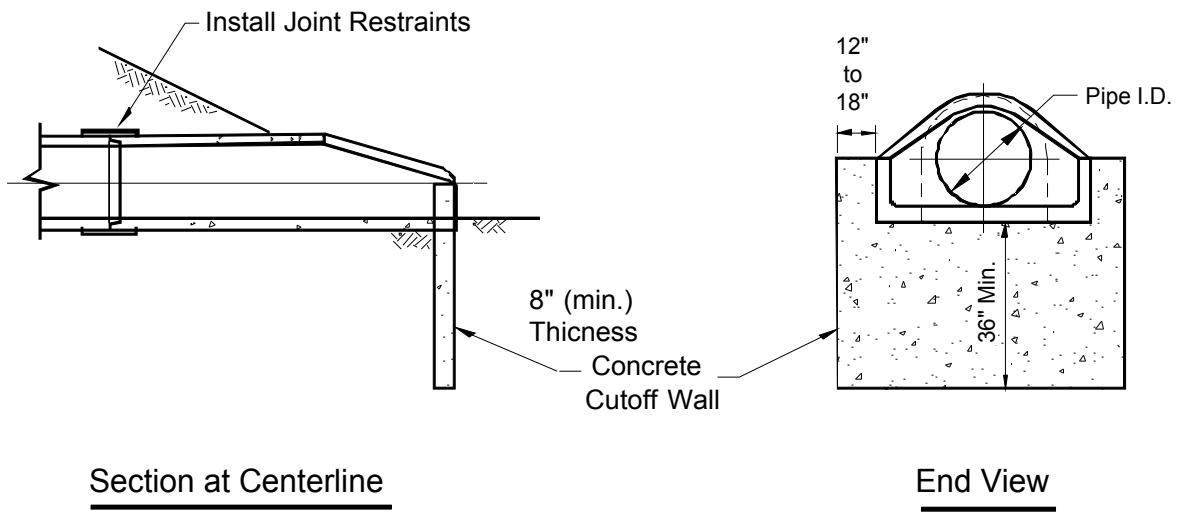
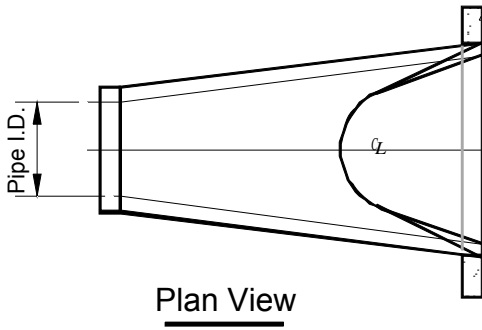

Figure HS-19a—Concrete Flared End Section with Cutoff Wall for all Pipe Outlets



Photograph HS-12—Upstream and downstream views of a low tailwater basin in Douglas County protecting downstream wetland area. Burying and revegetation of the rock would blend the structure better with the adjacent terrain.

When the riprap sizing design parameter indicates conditions that place the design above the Type H riprap line in [Figure HS-20](#), use B18, or larger, grouted boulders. An alternative to a grouted boulder or loose riprap basin is to use the standard USBR Impact Basin VI or one of its modified versions, described earlier in this Chapter of the *Manual*.

After the riprap size has been selected, the minimum thickness of the riprap layer, *T*, in feet, in the basin is set at:

$$T = 1.75D_{50} \tag{HS-17}$$

in which:

*D*₅₀ = the median size of the riprap (see Table HS-9.)

Table HS-9—Median (i.e., *D*₅₀) Size of District's Riprap/Boulder

Riprap Type	<i>D</i> ₅₀ —Median Rock Size (inches)
L	9
M	12
H	18
B18	18 (minimum dimension of grouted boulders)

3.4.3.3 Basin Length

The minimum length of the basin, *L*, in [Figure HS-19](#), is defined as being the greater of the following:

for circular pipe: $L = 4D$ or $L = (D)^{1/2} \left(\frac{V}{2} \right)$ (HS-18)

for rectangular pipe: $L = 4H$ or $L = (H)^{1/2} \left(\frac{V}{2} \right)$ (HS-19)

in which:

L = basin length

H = height of rectangular conduit

V = design flow velocity at outlet

D = diameter of circular conduit

3.4.3.4 Basin Width

The minimum width, W , of the basin downstream of the pipe's flared end section is set as follows:

for circular pipes: $W = 4D$ (HS-20)

for rectangular pipe: $W = w + 4H$ (HS-21)

in which,

W = basin width ([Figure HS-19](#))

D = diameter of circular conduit

w = width of rectangular conduit

3.4.3.5 Other Design Requirements

All slopes in the pre-shaped riprapped basin are 2H to 1V.

Provide pipe joint fasteners and a structural concrete cutoff wall at the end of the flared end section for a circular pipe or a headwall with wingwalls and a paved bottom between the walls, both with a cutoff wall that extends down to a depth of:

$$B = \frac{D}{2} + T \text{ or } B = \frac{H}{2} + T \quad (\text{HS-22})$$

in which,

B = cutoff wall depth

D = diameter of circular conduit

T = Equation HS-17

The riprap must be extended up the outlet embankment's slope to the mid-pipe level.

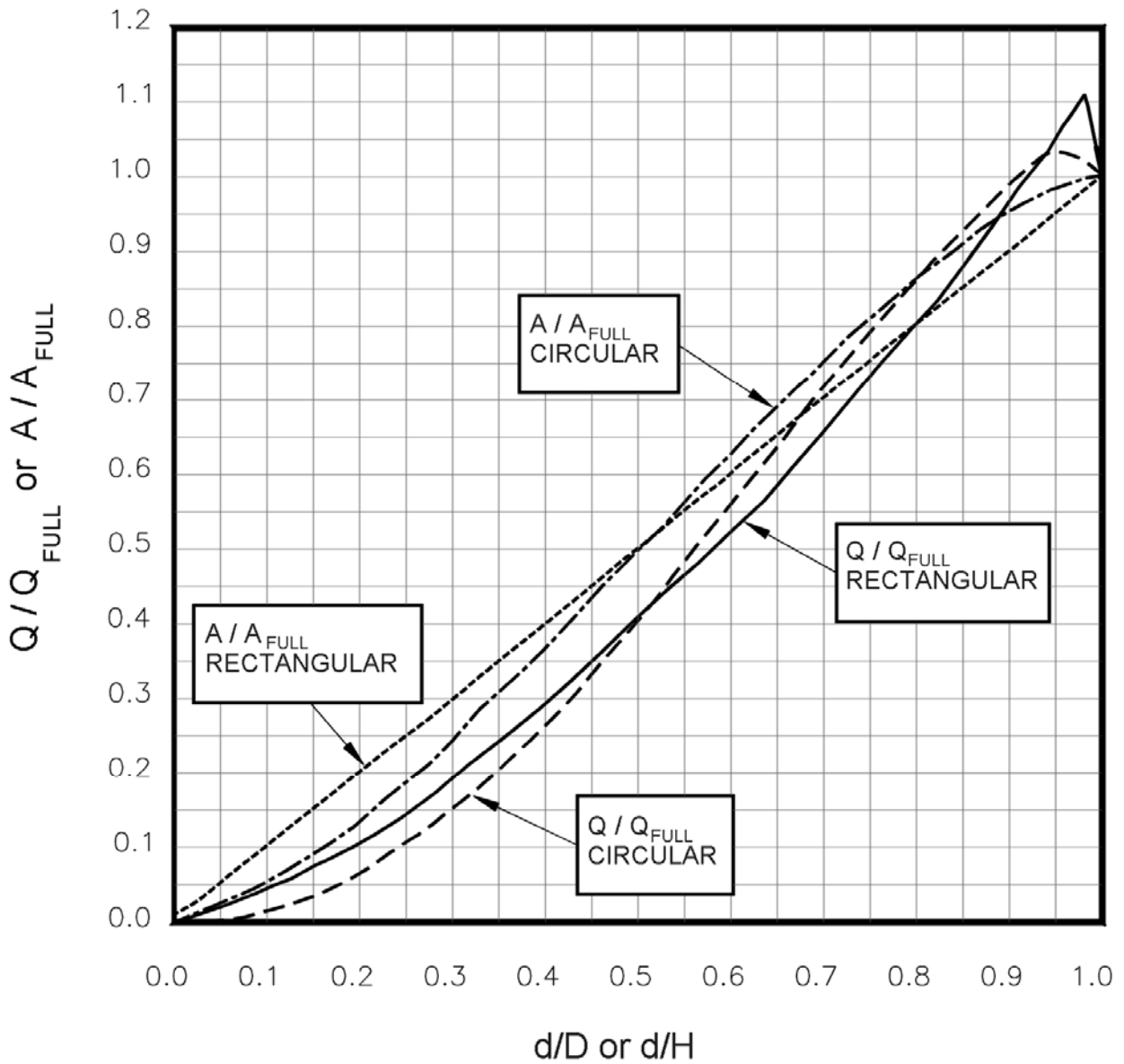

**Figure HS-20a—Low Tailwater Riprap Basins for Storm Sewer Pipe Outlets—
Discharge and Flow Area Relationships for Circular and Rectangular Pipes**
(Ratios for Flow Based on Manning's n Varying With Depth)
(Stevens and Urbonas 1996)

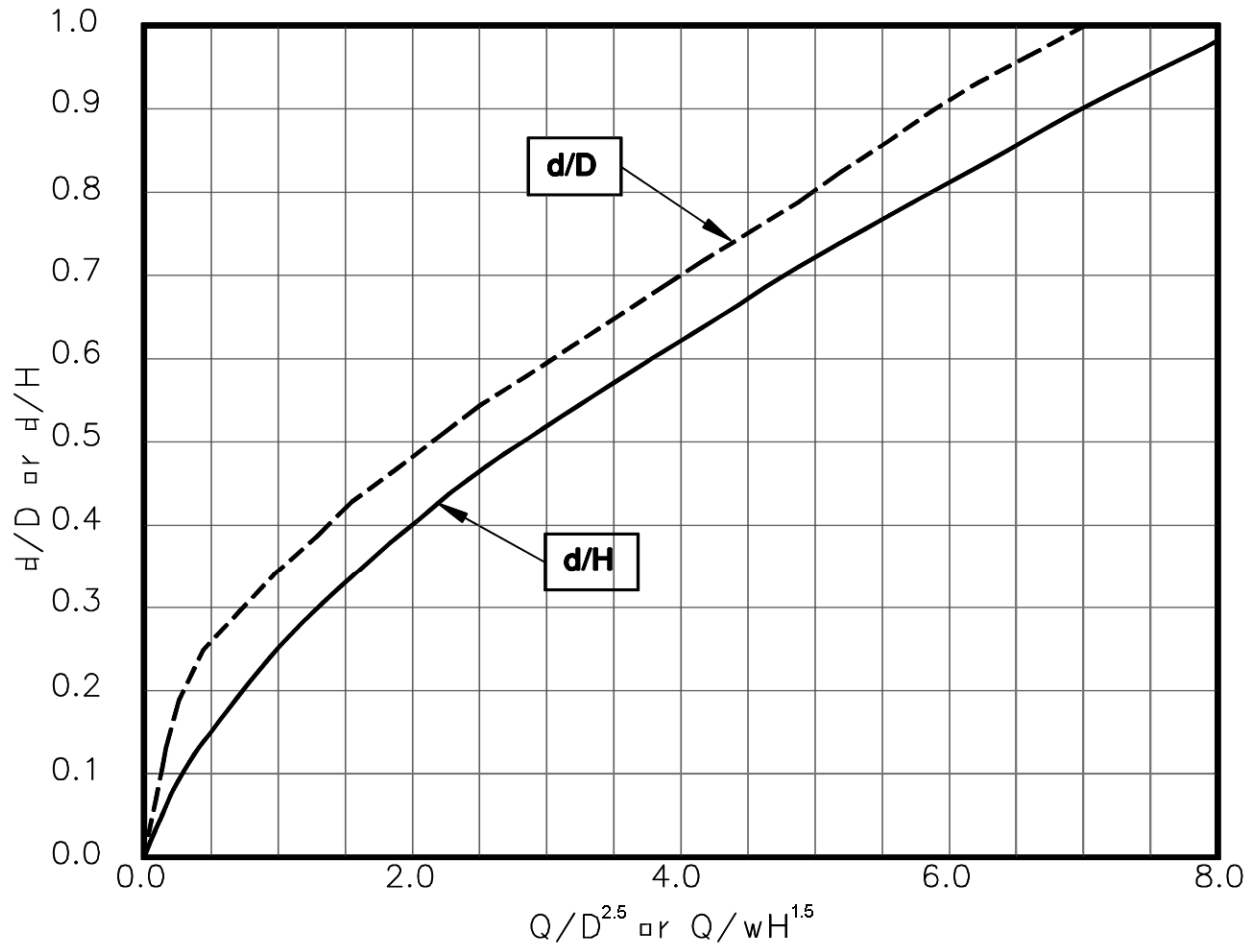
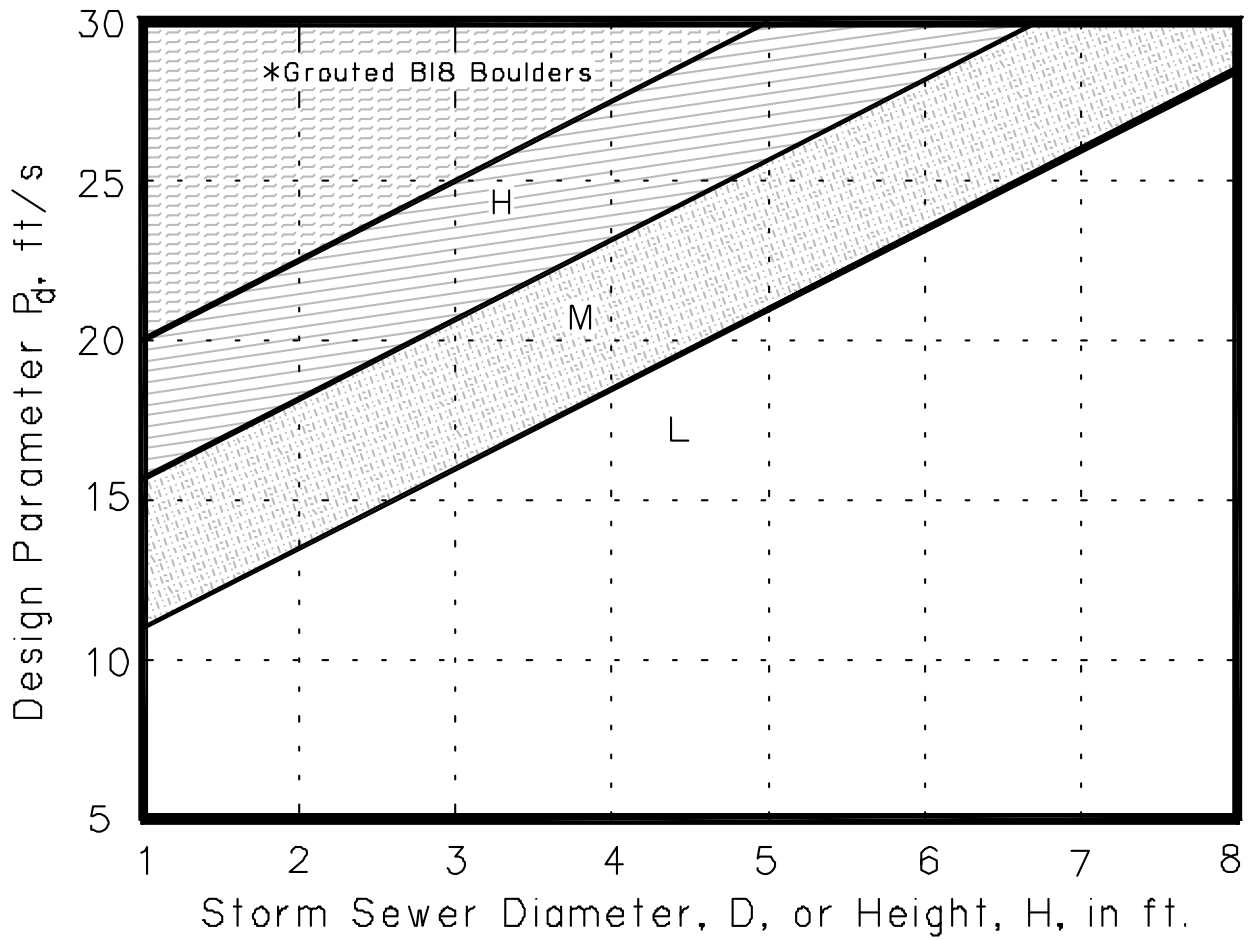

Figure HS-20b—Low Tailwater Riprap Basins for Storm Sewer Pipe Outlets—
Brink Depth for Horizontal Pipe Outlets
 (Stevens and Urbonas 1996)



**Figure HS-20c—Low Tailwater Riprap Basins for Storm Sewer Pipe Outlets—
Riprap Selection Chart for Low Tailwater Basin at Pipe Outlet**
(Stevens and Urbonas 1996)

RIP RAP PLUNGE POOL

Urban Drainage & Flood Control District Pipe Outlet Design
Low Tailwater Design ($y_t \leq D/3$)

OUTLET # **OS-1**

Outlet Size (D) :	24	in.	Discharge (q):	16	CFS
Capacity (Q): (full flow)	37	CFS	Flow depth (d): (calculated)	12.7	in.

Q _{full} =	37 CFS	q/Q _{full} =	0.43
A _{full} =	3.1 SF		
V _{full} =	11.8 FPS	Q/D ^{2.5} =	2.8

d/D	0.53	from HS-20a using q/Q _{full}
d/D	0.59	from HS-20b using Q/D ^{2.5}

A' (A/A _{full})	0.53	from HS-20a using smaller d/D from above	Flow Area (a=A' x A _{full})	1.7	SF
------------------------------	------	---	--	-----	----

Outlet Velocity (V = q/a) 9.6 FPS

$P_d = (V^2 + gd)^{1/2} =$ 11

RIP-RAP SIZE: **M** from HS-20c

d₅₀ = 12 in T=1.75xd₅₀ 1.75 ft

Basin Length (L)	8.0 FT.	Cutoff Wall Depth	2.75 FT
Basin Width (W)	8.0 FT.	(B=D/2+T)	

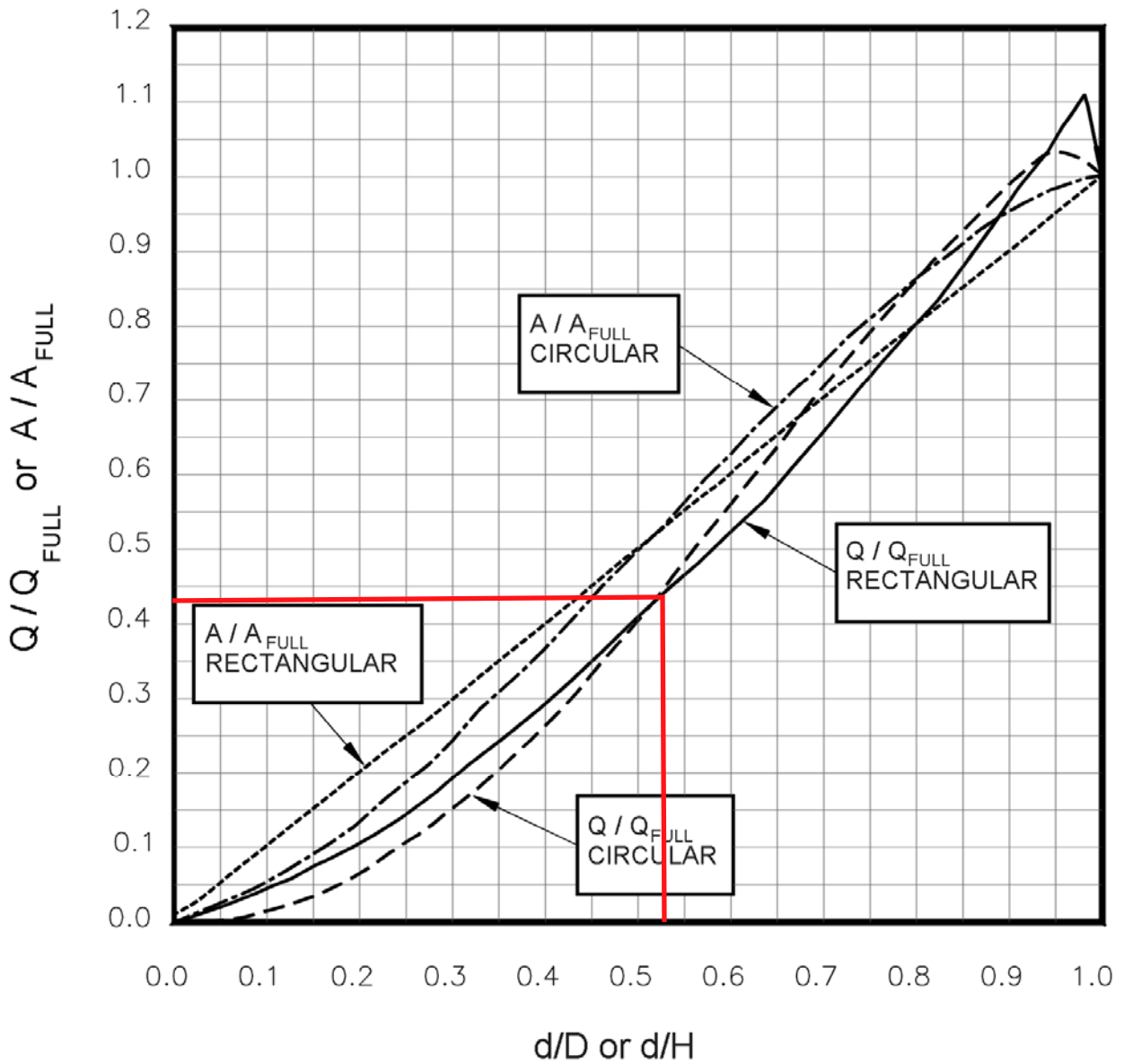

**Figure HS-20a—Low Tailwater Riprap Basins for Storm Sewer Pipe Outlets—
Discharge and Flow Area Relationships for Circular and Rectangular Pipes**
(Ratios for Flow Based on Manning's n Varying With Depth)
(Stevens and Urbonas 1996)

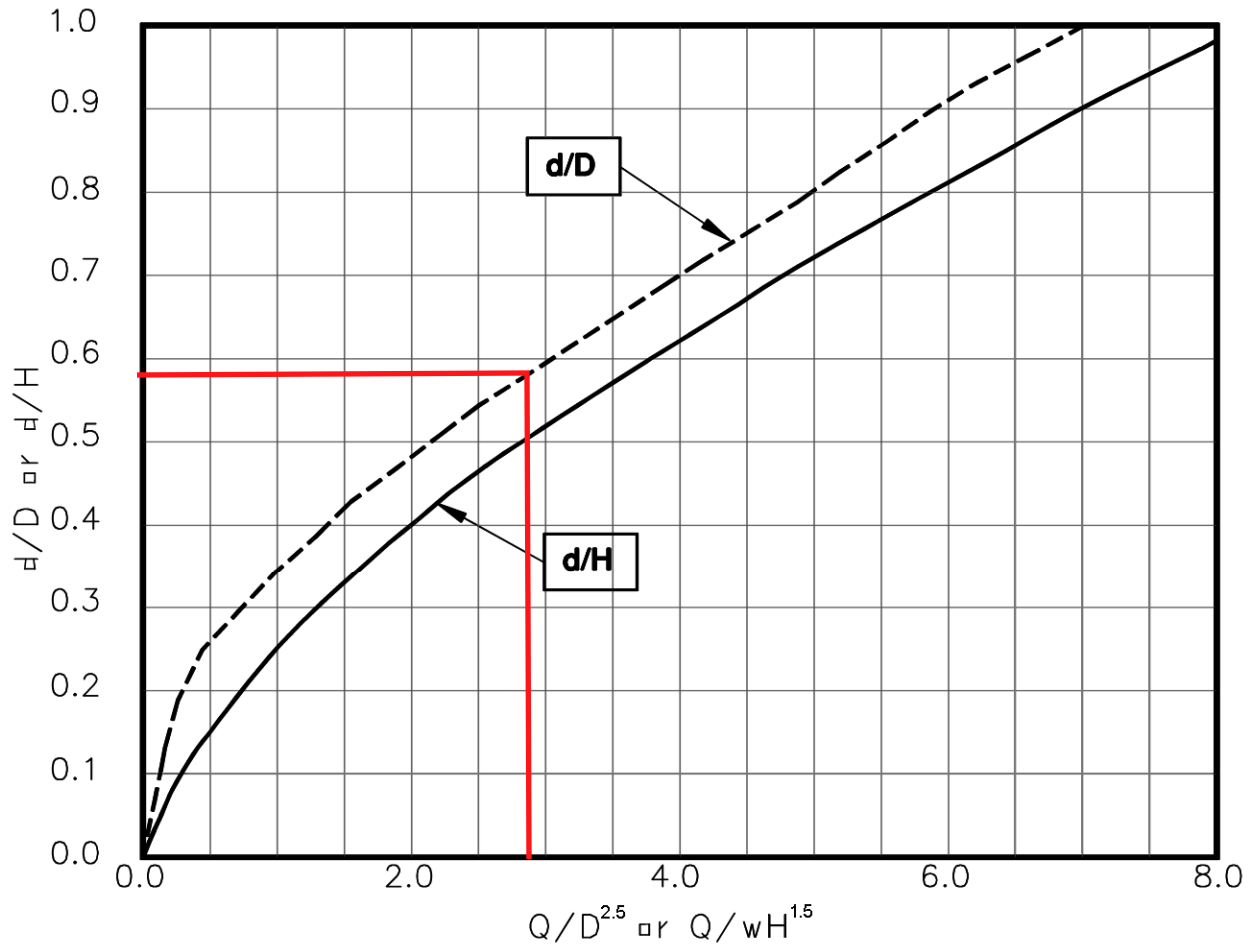

**Figure HS-20b—Low Tailwater Riprap Basins for Storm Sewer Pipe Outlets—
Brink Depth for Horizontal Pipe Outlets**
(Stevens and Urbonas 1996)

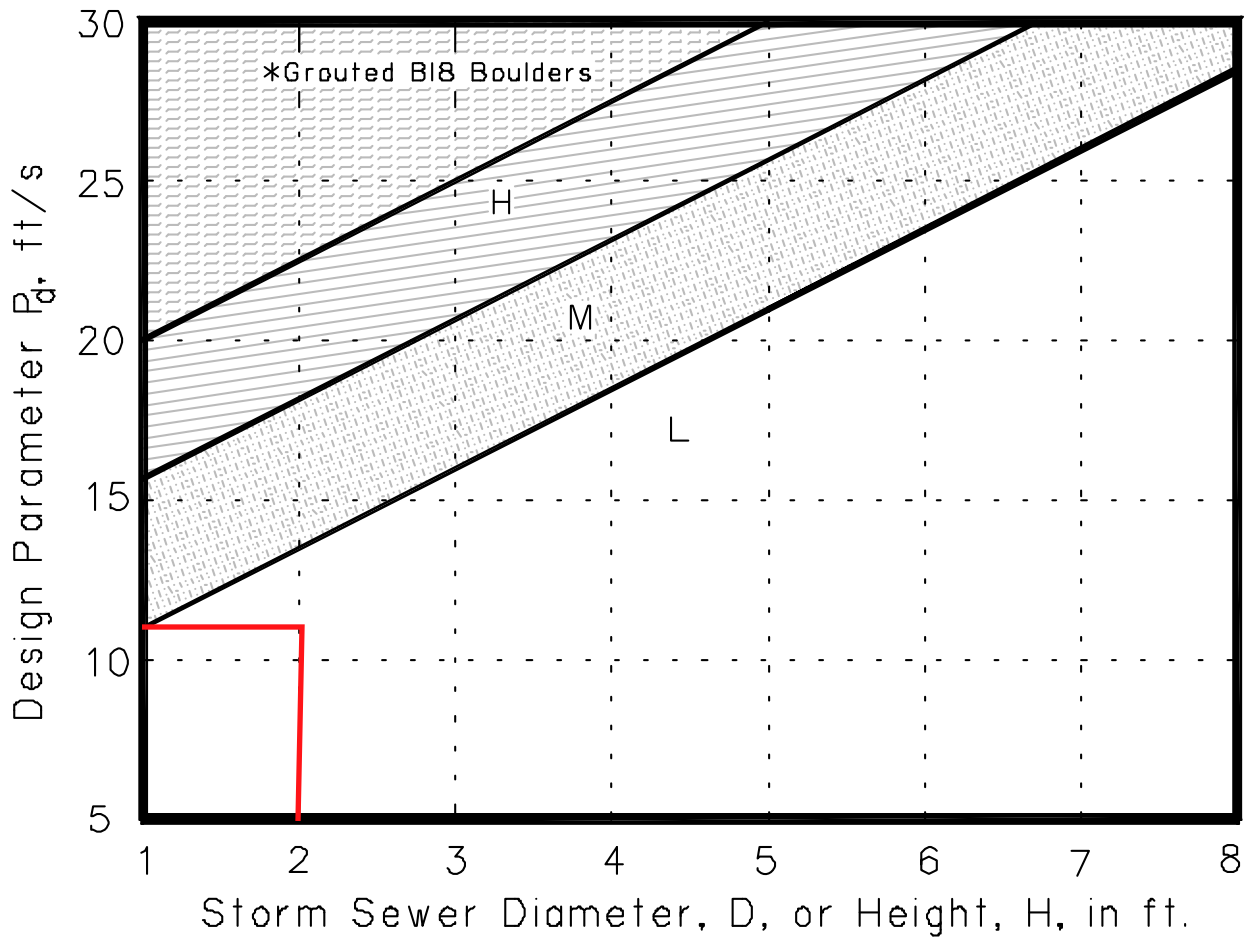

**Figure HS-20c—Low Tailwater Riprap Basins for Storm Sewer Pipe Outlets—
Riprap Selection Chart for Low Tailwater Basin at Pipe Outlet**
(Stevens and Urbonas 1996)

RIP RAP PLUNGE POOL

Urban Drainage & Flood Control District Pipe Outlet Design
Low Tailwater Design ($y_t \leq D/3$)

OUTLET # **OS-2**

Outlet Size (D) :	42	in.	Discharge (q):	86	CFS
Capacity (Q): (full flow)	144	CFS	Flow depth (d): (calculated)	26.3	in.

Q _{full} =	144 CFS	q/Q _{full} =	0.60
A _{full} =	9.6 SF		
V _{full} =	15.0 FPS	Q/D ^{2.5} =	3.8

d/D	0.63	from HS-20a using q/Q _{full}
d/D	0.68	from HS-20b using Q/D ^{2.5}

A' (A/A _{full})	0.63	from HS-20a using smaller d/D from above	Flow Area (a=A' x A _{full})	6.0	SF
------------------------------	------	---	--	-----	----

Outlet Velocity (V = q/a) 14.3 FPS

$P_d = (V^2 + gd)^{1/2} =$ 17

RIP-RAP SIZE: **M** from HS-20c

d₅₀ = 12 in T = 1.75 x d₅₀ 1.75 ft

Basin Length (L)	14.0 FT.	Cutoff Wall Depth	3.5	FT
Basin Width (W)	14.0 FT.	(B=D/2+T)		

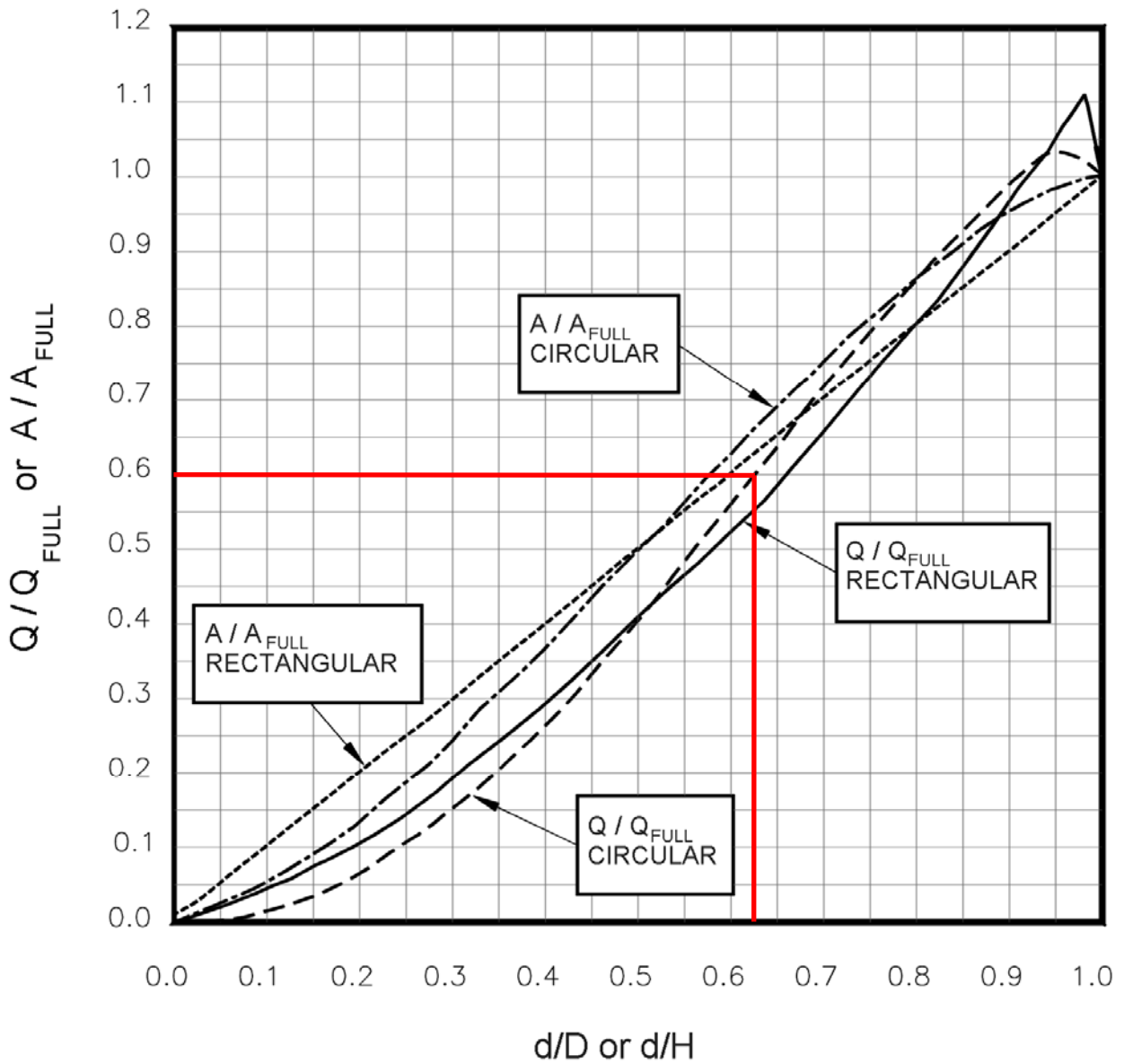

**Figure HS-20a—Low Tailwater Riprap Basins for Storm Sewer Pipe Outlets—
Discharge and Flow Area Relationships for Circular and Rectangular Pipes**
(Ratios for Flow Based on Manning's n Varying With Depth)
(Stevens and Urbonas 1996)

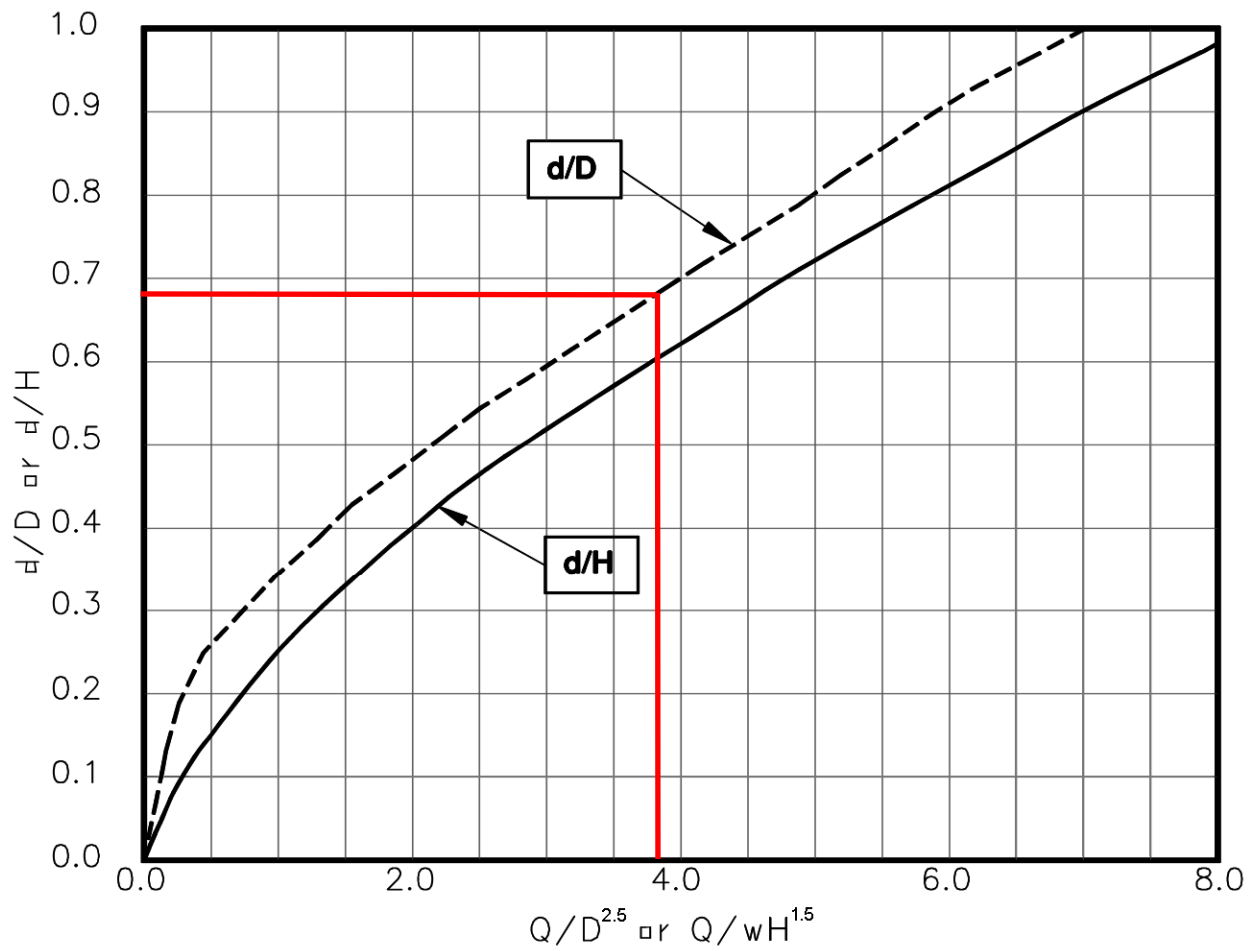

**Figure HS-20b—Low Tailwater Riprap Basins for Storm Sewer Pipe Outlets—
Brink Depth for Horizontal Pipe Outlets**
(Stevens and Urbonas 1996)

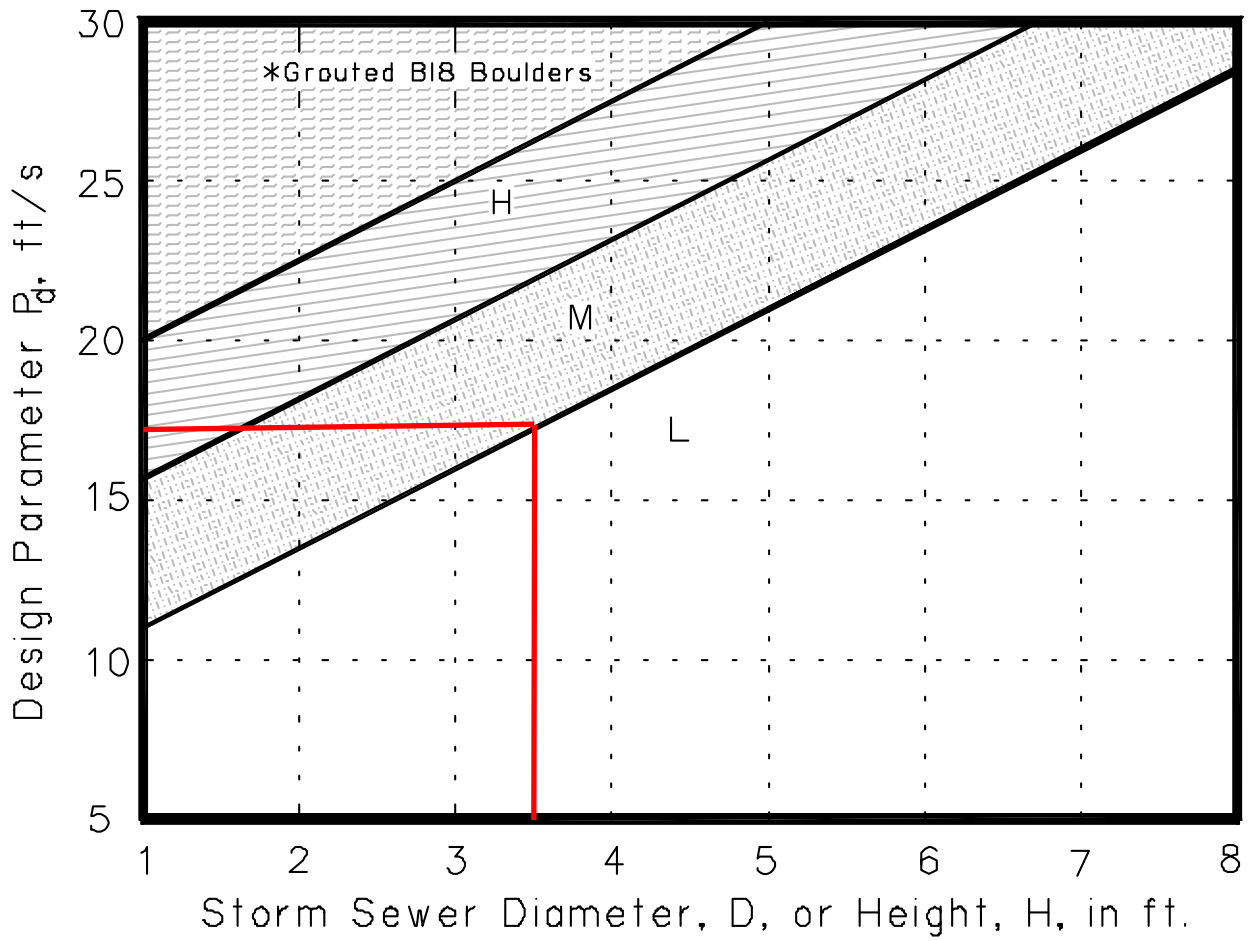

**Figure HS-20c—Low Tailwater Riprap Basins for Storm Sewer Pipe Outlets—
Riprap Selection Chart for Low Tailwater Basin at Pipe Outlet
(Stevens and Urbonas 1996)**

RIP RAP PLUNGE POOL

Urban Drainage & Flood Control District Pipe Outlet Design
Low Tailwater Design ($y_t \leq D/3$)

OUTLET # OS-3

Outlet Size (D): 36 in. Discharge (q): 34 CFS
Capacity (Q): 68 CFS Flow depth (d): 18.0 in.
(full flow) (calculated)

$Q_{full} = 68$ CFS $q/Q_{full} = 0.50$
 $A_{full} = 7.1$ SF
 $V_{full} = 9.6$ FPS $Q/D^{2.5} = 2.2$

$d/D = 0.56$ from HS-20a using q/Q_{full}
 $d/D = 0.50$ from HS-20b using $Q/D^{2.5}$

$A' = 0.50$ from HS-20a using smaller d/D from above Flow Area (a= $A' \times A_{full}$) 3.5 SF

Outlet Velocity (V) 9.6 FPS
= q/a

$P_d = (V^2 + gd)^{1/2} = 12$

RIP-RAP SIZE: M from HS-20c
 $d_{50} = 12$ in $T = 1.75d_{50} = 1.75$ ft

Basin Length (L) 12.0 FT. Cutoff Wall Depth 3.25 FT
Basin Width (W) 12.0 FT. ($B = D/2 + T$)

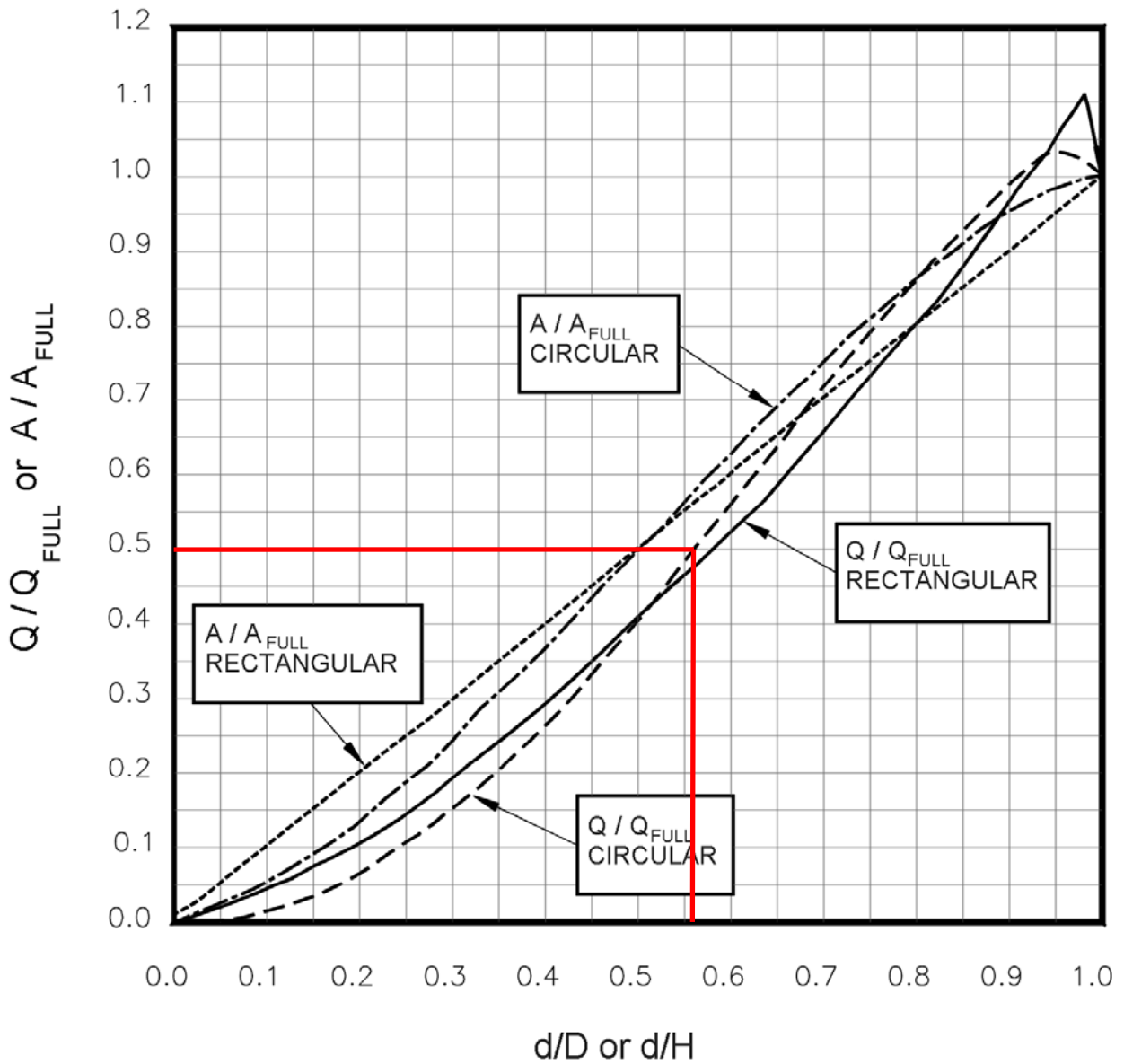

**Figure HS-20a—Low Tailwater Riprap Basins for Storm Sewer Pipe Outlets—
Discharge and Flow Area Relationships for Circular and Rectangular Pipes**
(Ratios for Flow Based on Manning's n Varying With Depth)
(Stevens and Urbonas 1996)

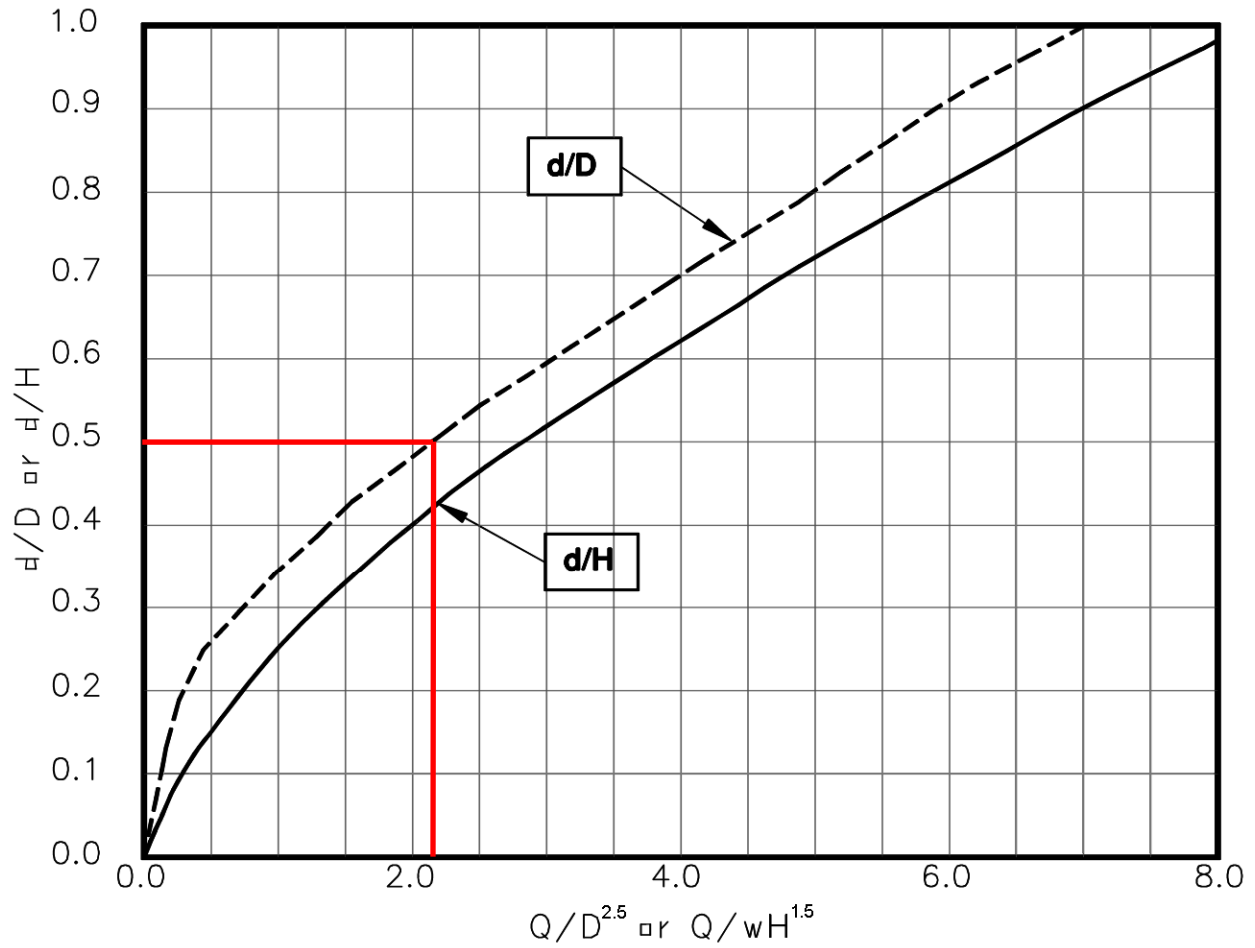

**Figure HS-20b—Low Tailwater Riprap Basins for Storm Sewer Pipe Outlets—
Brink Depth for Horizontal Pipe Outlets**
(Stevens and Urbonas 1996)

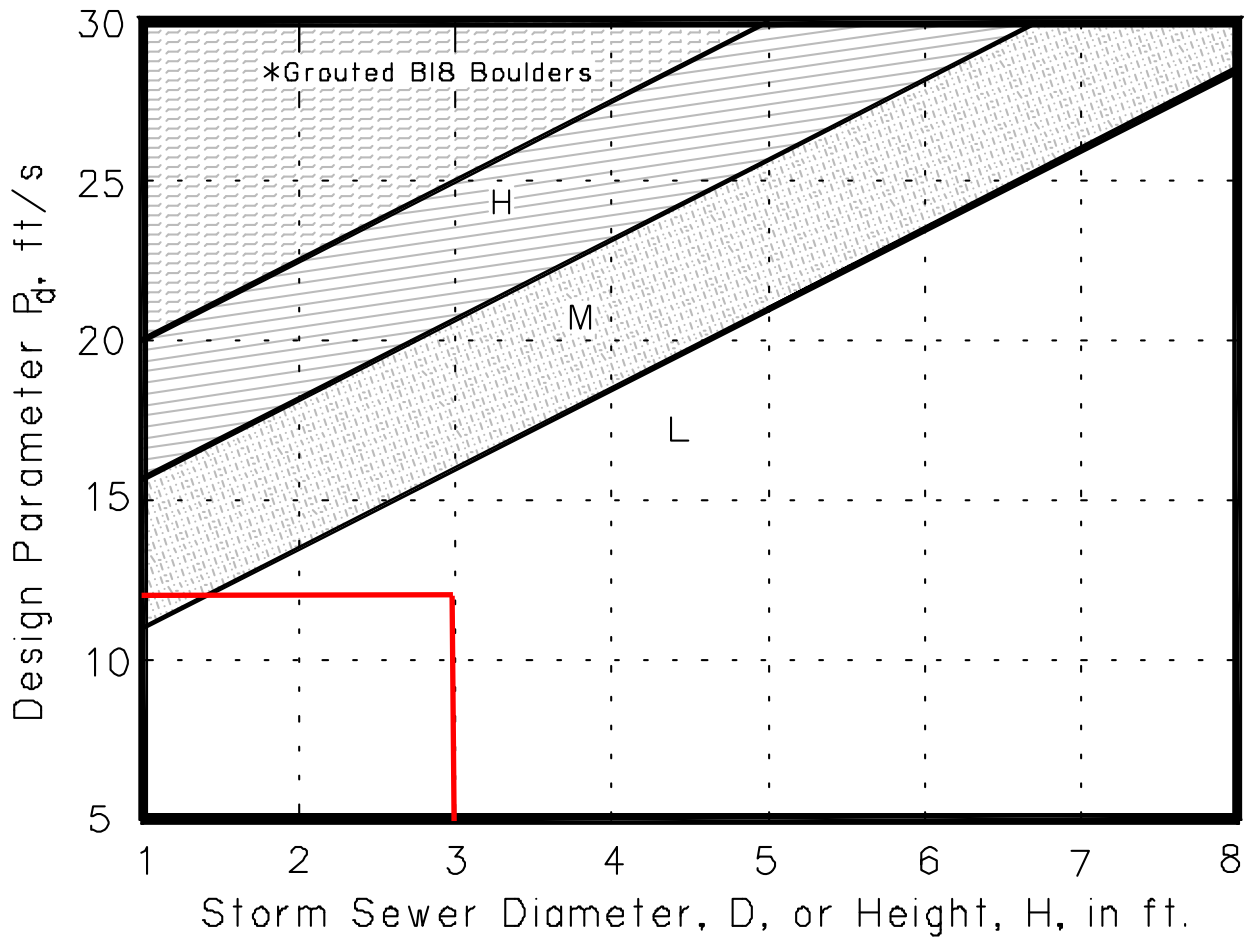

**Figure HS-20c—Low Tailwater Riprap Basins for Storm Sewer Pipe Outlets—
Riprap Selection Chart for Low Tailwater Basin at Pipe Outlet**
(Stevens and Urbonas 1996)

RIP RAP PLUNGE POOL

Urban Drainage & Flood Control District Pipe Outlet Design
Low Tailwater Design ($y_t \leq D/3$)

OUTLET # **OS-4**

Outlet Size (D) :	54	in.	Discharge (q):	115	CFS
Capacity (Q): (full flow)	153	CFS	Flow depth (d): (calculated)	31.3	in.

Q _{full} =	153 CFS	q/Q _{full} =	0.75
A _{full} =	15.9 SF		
V _{full} =	9.6 FPS	Q/D ^{2.5} =	2.7

d/D	0.72	from HS-20a using q/Q _{full}
d/D	0.58	from HS-20b using Q/D ^{2.5}

A' (A/A _{full})	0.58	from HS-20a using smaller d/D from above	Flow Area (a=A' x A _{full})	9.2	SF
------------------------------	------	---	--	-----	----

Outlet Velocity (V = q/a) 12.5 FPS

$P_d = (V^2 + gd)^{1/2} =$ 15

RIP-RAP SIZE: **M** from HS-20c

d₅₀ = 12 in T = 1.75 x d₅₀ 1.75 ft

Basin Length (L)	18.0 FT.	Cutoff Wall Depth	4	FT
Basin Width (W)	18.0 FT.	(B=D/2+T)		

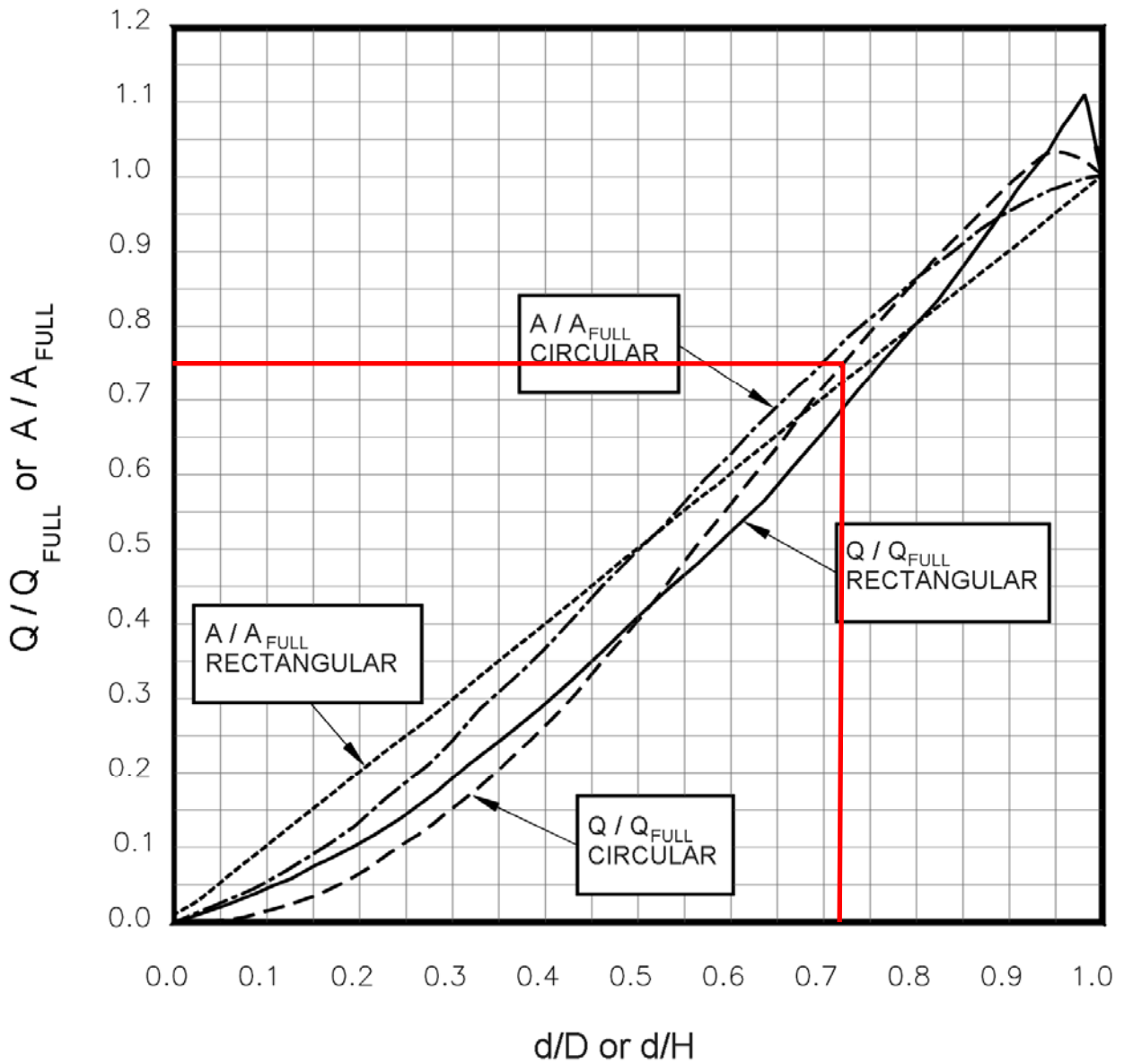

**Figure HS-20a—Low Tailwater Riprap Basins for Storm Sewer Pipe Outlets—
Discharge and Flow Area Relationships for Circular and Rectangular Pipes**
(Ratios for Flow Based on Manning's n Varying With Depth)
(Stevens and Urbonas 1996)

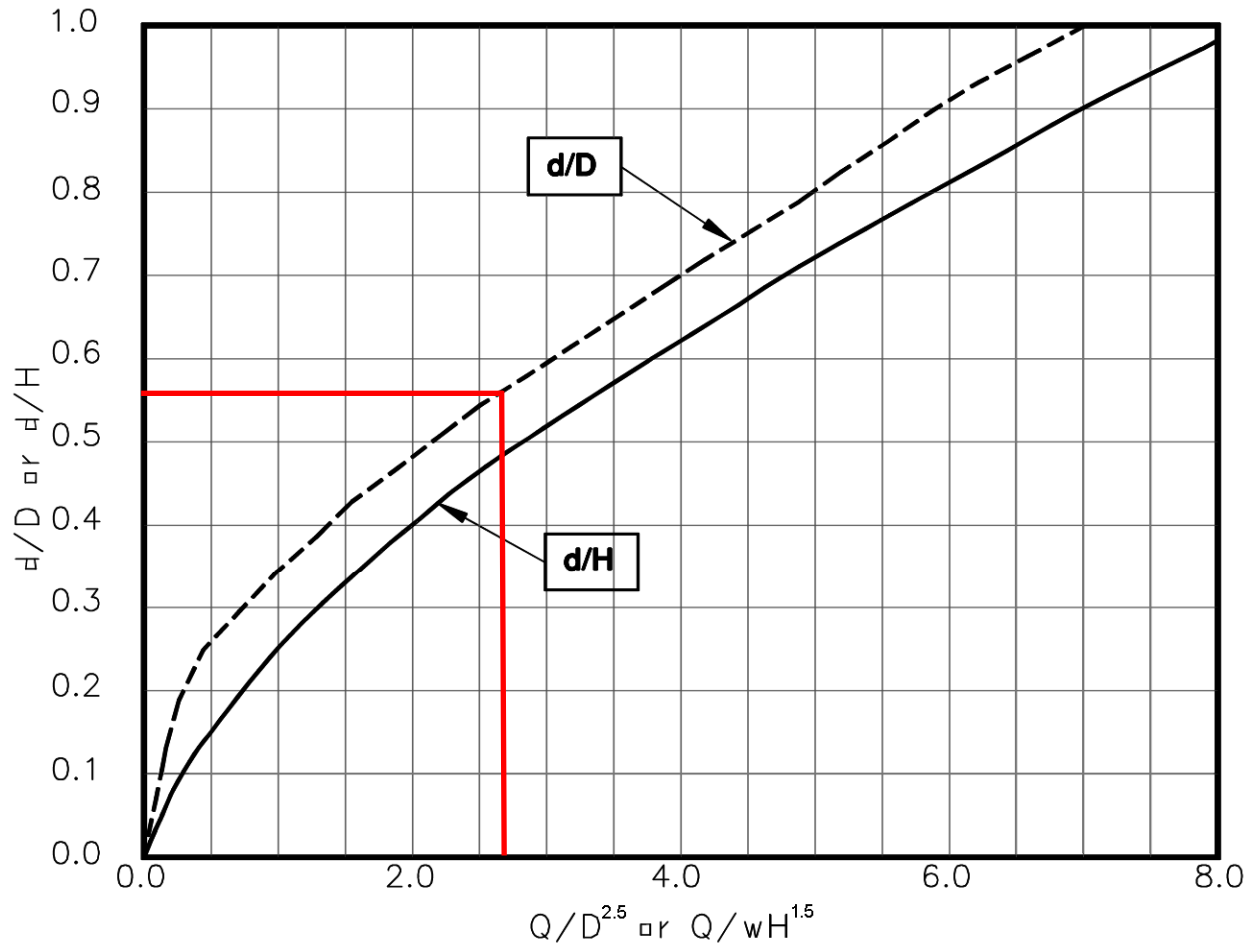

**Figure HS-20b—Low Tailwater Riprap Basins for Storm Sewer Pipe Outlets—
Brink Depth for Horizontal Pipe Outlets**
(Stevens and Urbonas 1996)

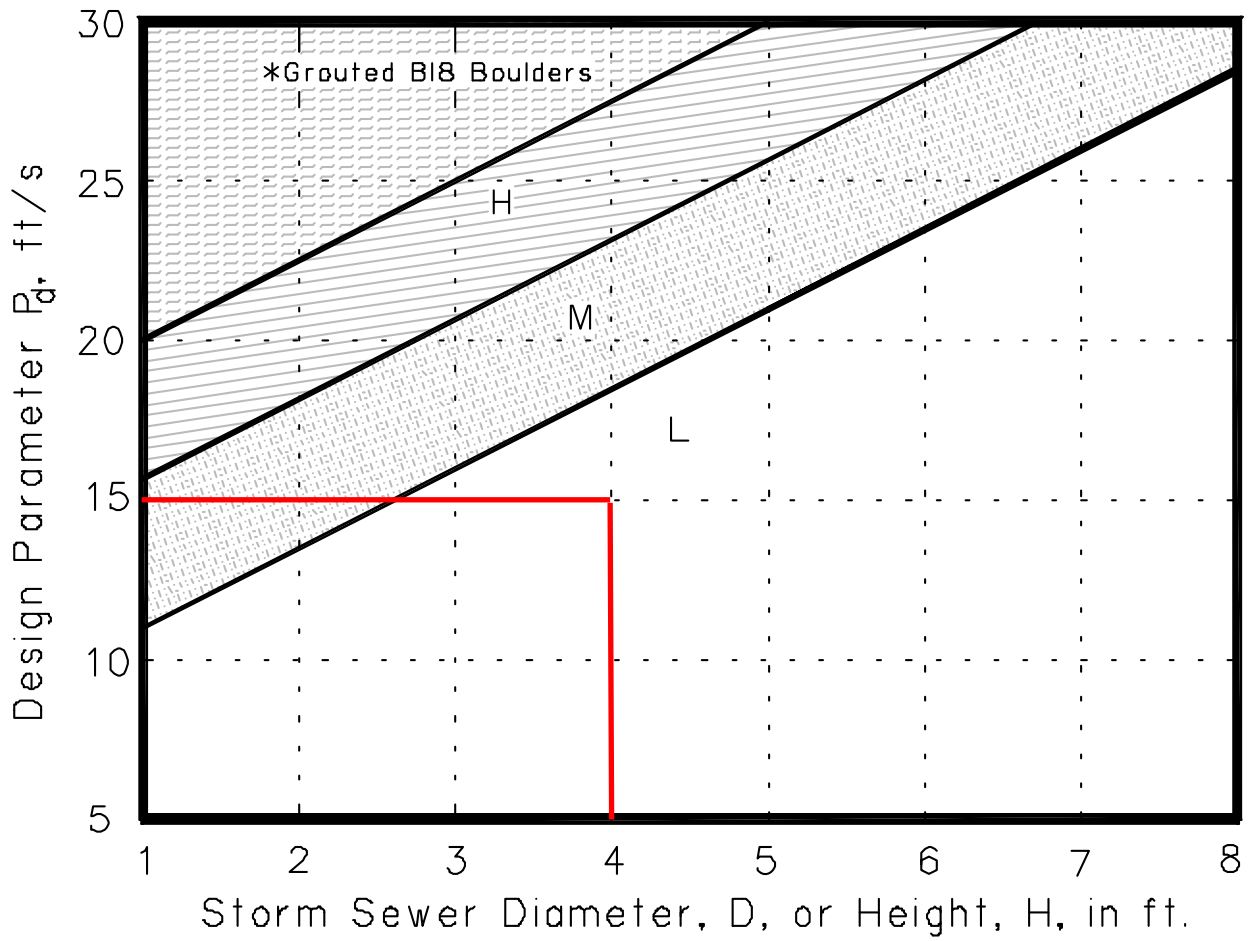

**Figure HS-20c—Low Tailwater Riprap Basins for Storm Sewer Pipe Outlets—
Riprap Selection Chart for Low Tailwater Basin at Pipe Outlet**
(Stevens and Urbonas 1996)

RIP RAP PLUNGE POOL

Urban Drainage & Flood Control District Pipe Outlet Design
Low Tailwater Design ($y_t \leq D/3$)

OUTLET # **OS-5**

Outlet Size (D) :	24	in.	Discharge (q):	8.3	CFS
Capacity (Q): (full flow)	49	CFS	Flow depth (d): (calculated)	8.4	in.

Q _{full} =	49 CFS	q/Q _{full} =	0.17
A _{full} =	3.1 SF		
V _{full} =	15.6 FPS	Q/D ^{2.5} =	1.5

d/D	0.35	from HS-20a using q/Q _{full}
d/D	0.42	from HS-20b using Q/D ^{2.5}

A' (A/A _{full})	0.35	from HS-20a using smaller d/D from above	Flow Area (a=A' x A _{full})	1.1	SF
------------------------------	------	---	--	-----	----

Outlet Velocity (V) = q/a = 7.5 FPS

$$P_d = (V^2 + gd)^{1/2} = 9$$

RIP-RAP SIZE: **M** from HS-20c

$$d_{50} = 12 \text{ in} \quad T = 1.75d_{50} = 1.75 \text{ ft}$$

Basin Length (L)	8.0 FT.	Cutoff Wall Depth	2.75	FT
Basin Width (W)	8.0 FT.	(B=D/2+T)		

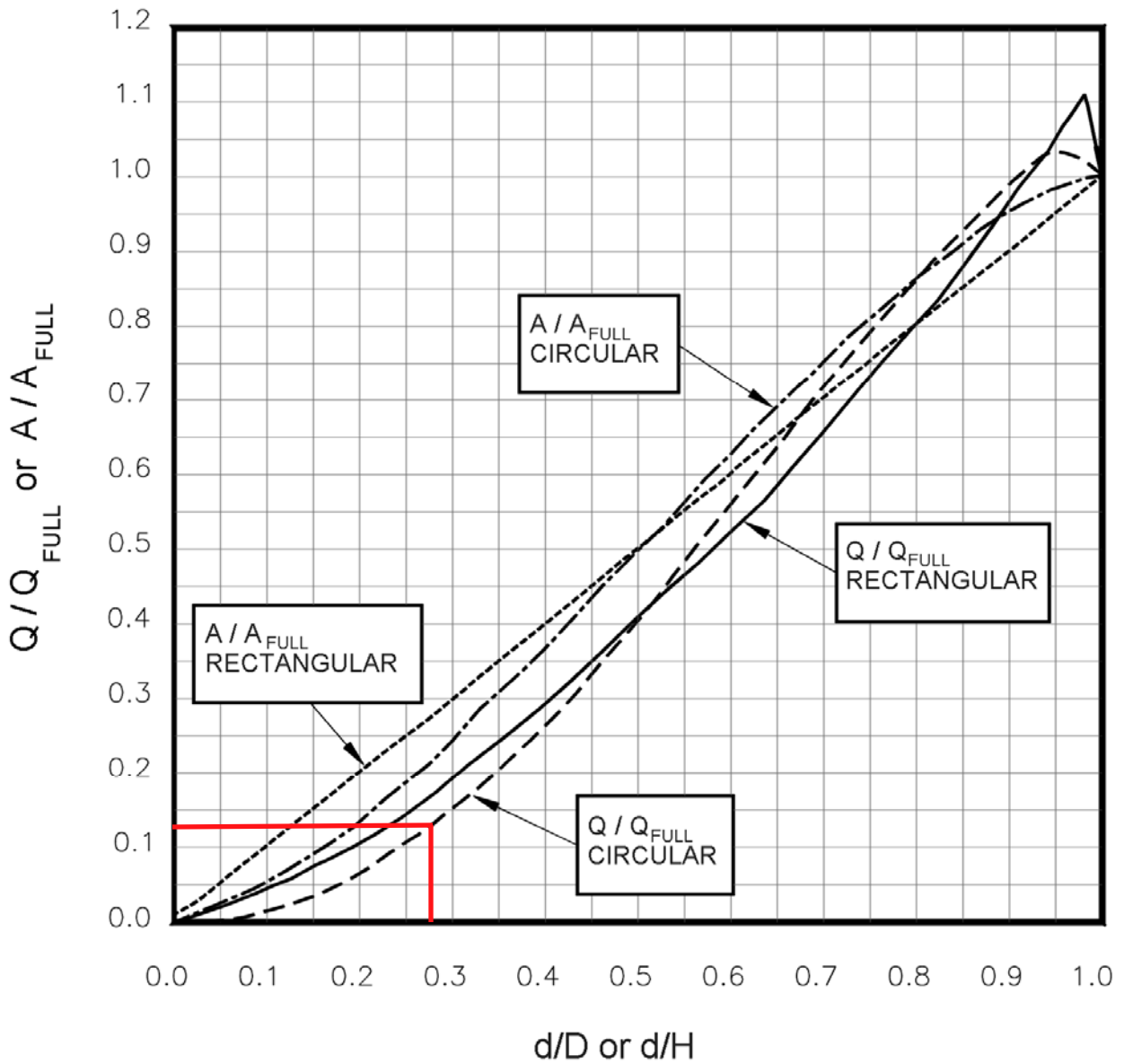

**Figure HS-20a—Low Tailwater Riprap Basins for Storm Sewer Pipe Outlets—
Discharge and Flow Area Relationships for Circular and Rectangular Pipes**
(Ratios for Flow Based on Manning's n Varying With Depth)
(Stevens and Urbonas 1996)

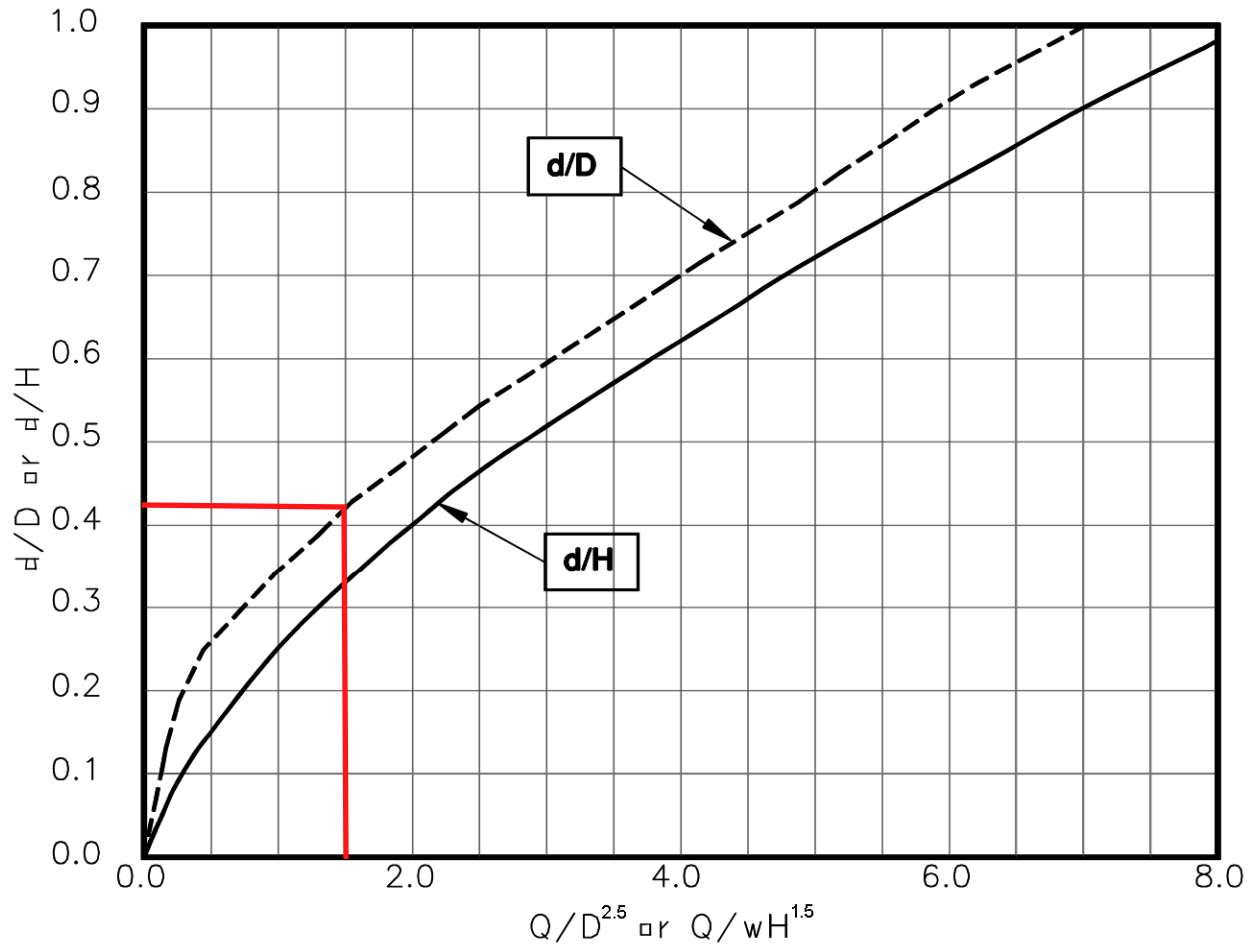

**Figure HS-20b—Low Tailwater Riprap Basins for Storm Sewer Pipe Outlets—
Brink Depth for Horizontal Pipe Outlets**
(Stevens and Urbonas 1996)

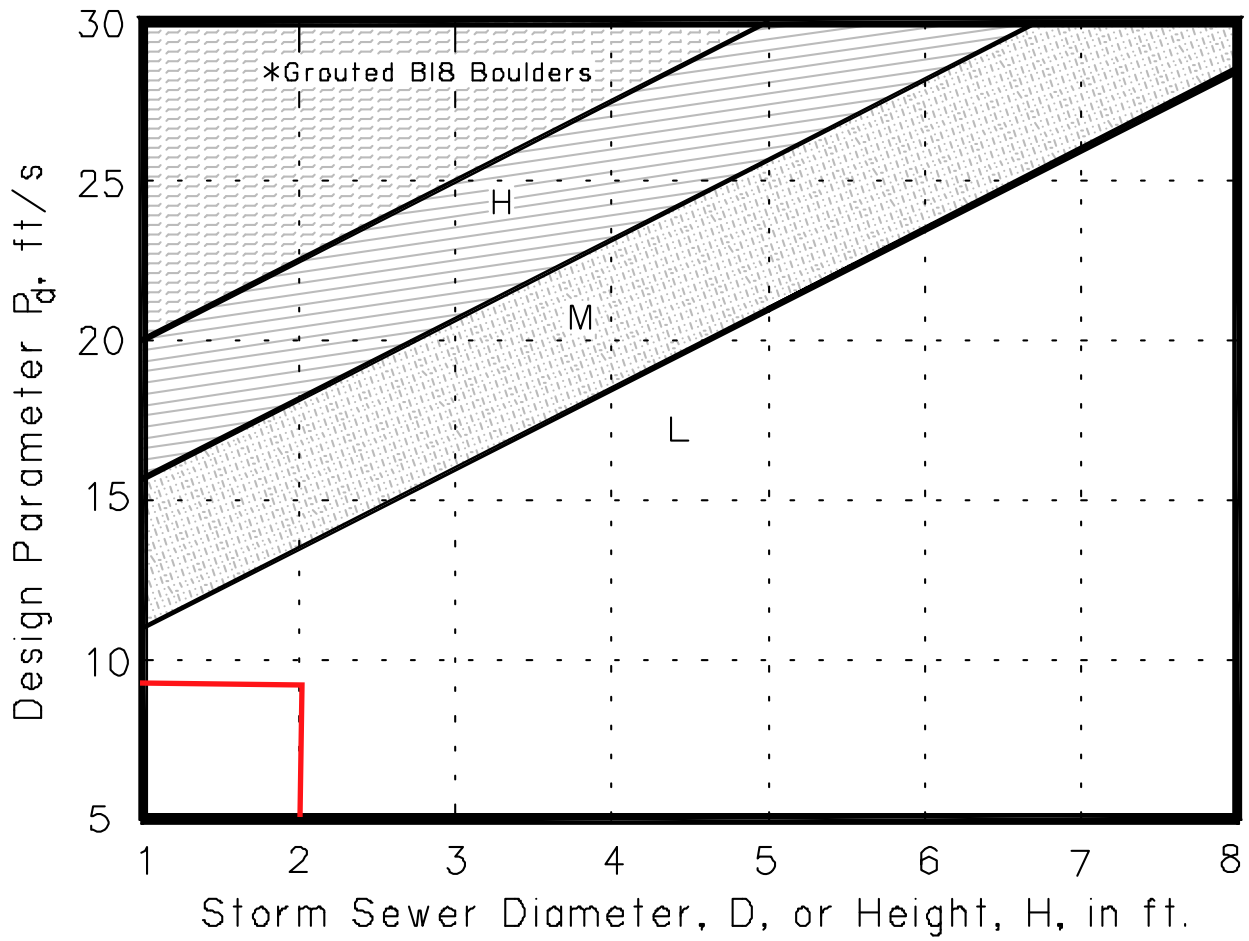

**Figure HS-20c—Low Tailwater Riprap Basins for Storm Sewer Pipe Outlets—
Riprap Selection Chart for Low Tailwater Basin at Pipe Outlet**
(Stevens and Urbonas 1996)

RIP RAP PLUNGE POOL

Urban Drainage & Flood Control District Pipe Outlet Design
Low Tailwater Design ($y_t \leq H/3$)

OUTLET # **POND G**

Outlet Size (H) :	48	in.	Discharge (q):	478	CFS
Capacity (Q): (full flow)	479	CFS	Flow depth (d): (calculated)	39.1	in.
Retangular Width	10				

Q _{full} =	479 CFS	q/Q _{full} =	1.00
A _{full} =	40.0 SF		
V _{full} =	12.0 FPS	Q/wH ^{1.5} =	6.0

d/H	1.00	from HS-20a using Q/Q _{full}
d/H	0.82	from HS-20b using Q/wH ^{1.5}

A' (A/A _{full})	0.82	from HS-20a using smaller d/D from above	Flow Area (a=A' x A _{full})	32.6	SF
------------------------------	------	---	--	------	----

Outlet Velocity (V) = q/a = 14.7 FPS

$$P_d = (V^2 + gd)^{1/2} = 18$$

RIP-RAP SIZE: **M** from HS-20c

$$d_{50} = 12 \text{ in} \quad T = 1.75 \times d_{50} = 1.75 \text{ ft}$$

Basin Length (L)	16.0 FT.	Cutoff Wall Depth	3.75	FT
Basin Width (W)	26.0 FT.	(B=H/2+T)		

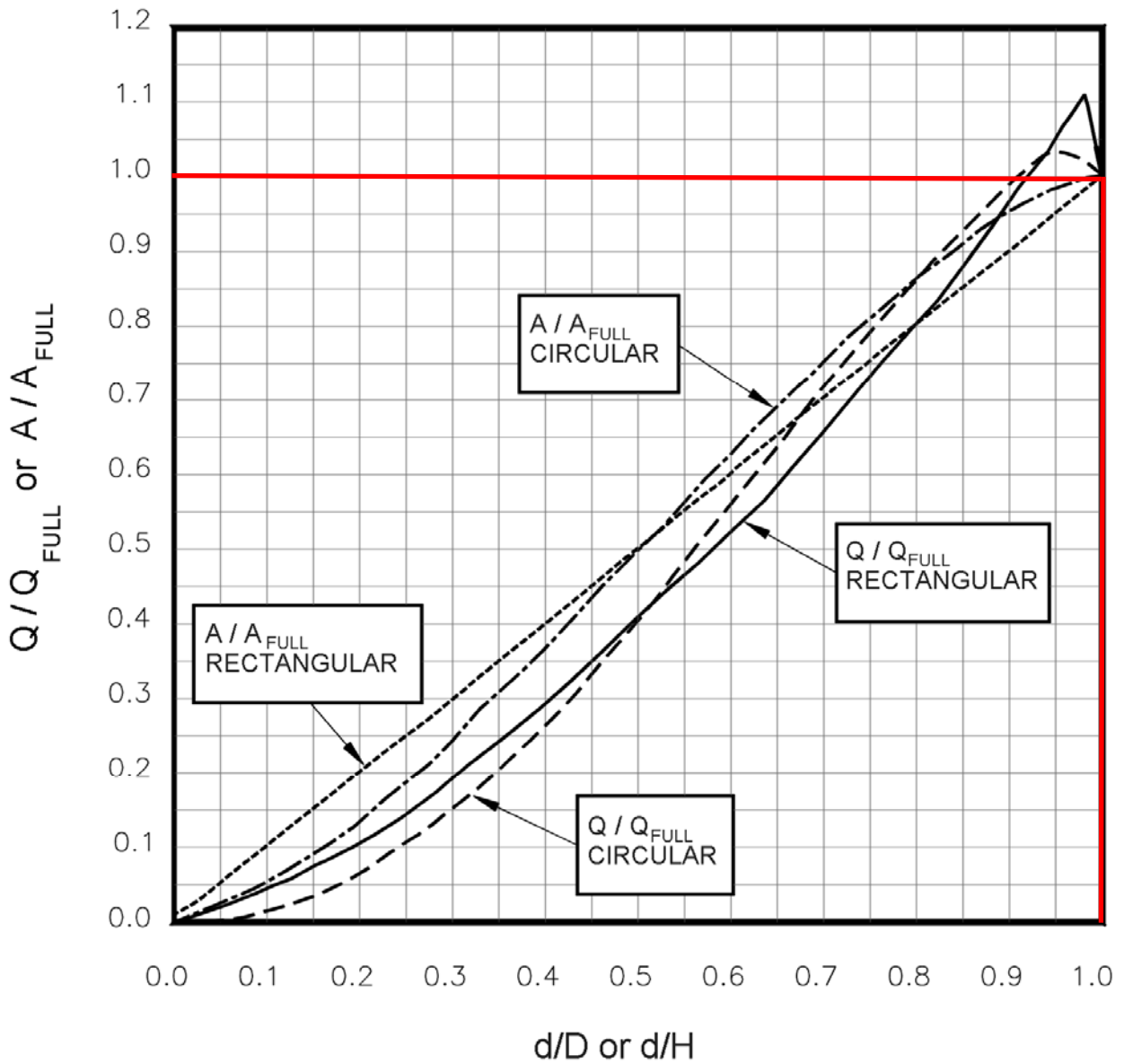

**Figure HS-20a—Low Tailwater Riprap Basins for Storm Sewer Pipe Outlets—
Discharge and Flow Area Relationships for Circular and Rectangular Pipes**
(Ratios for Flow Based on Manning's n Varying With Depth)
(Stevens and Urbonas 1996)

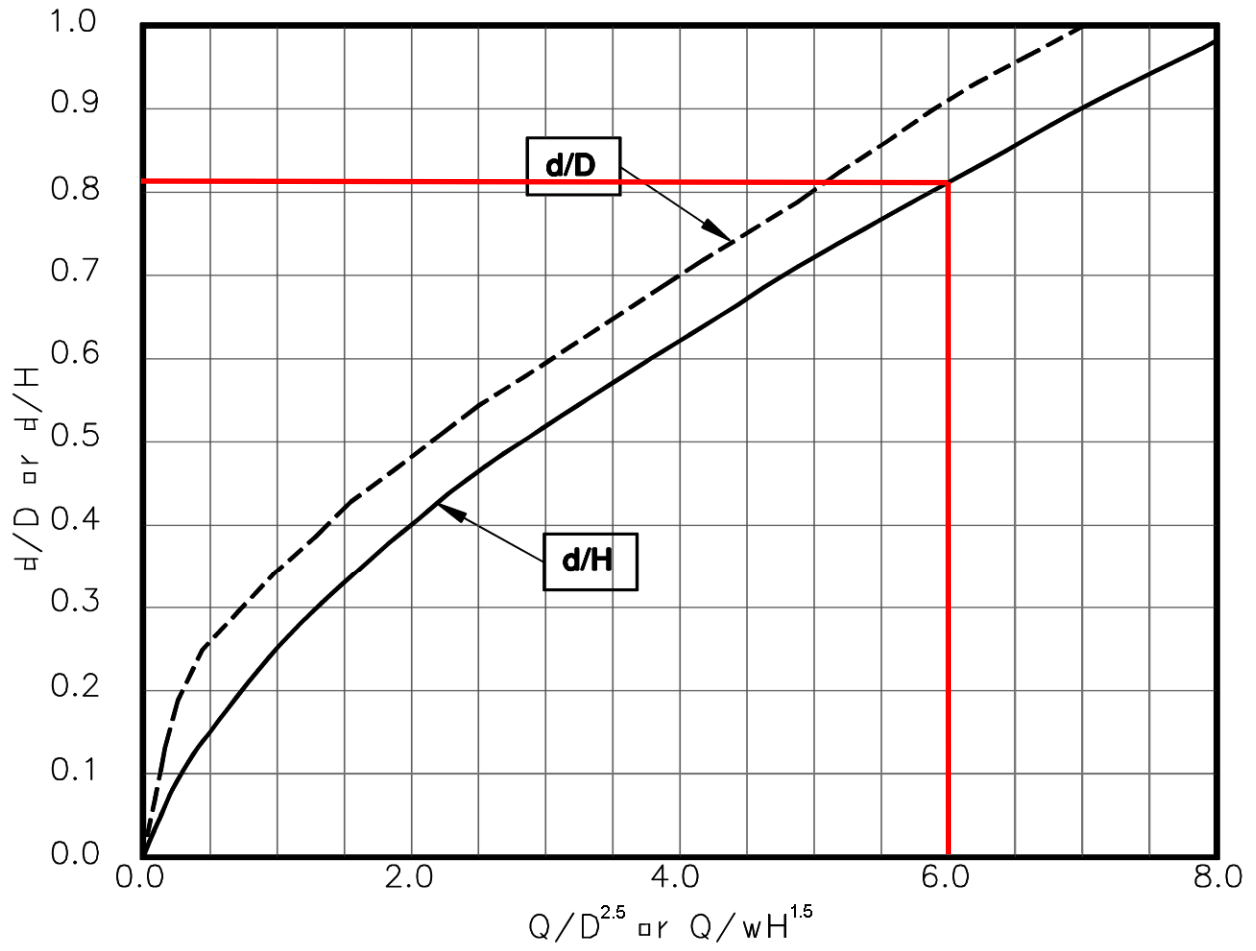

**Figure HS-20b—Low Tailwater Riprap Basins for Storm Sewer Pipe Outlets—
Brink Depth for Horizontal Pipe Outlets**
(Stevens and Urbonas 1996)

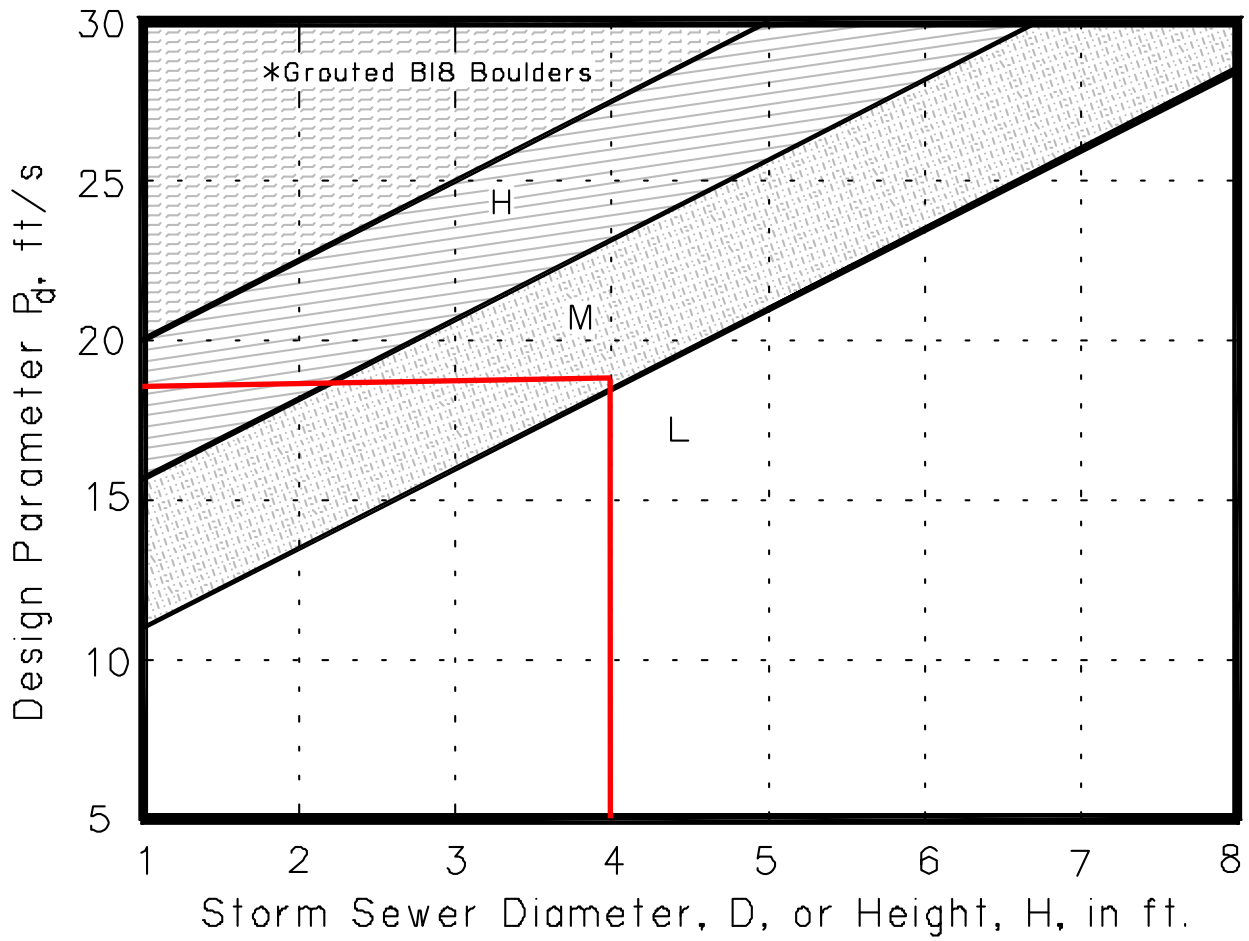

**Figure HS-20c—Low Tailwater Riprap Basins for Storm Sewer Pipe Outlets—
Riprap Selection Chart for Low Tailwater Basin at Pipe Outlet**
(Stevens and Urbonas 1996)

Appendix F – Temporary Sedimentation Ponds

**ROLLING HILLS RANCH GRADING
TEMPORARY SEDIMENTATION SIZING**

TEMP POND 1

Tributary Area: Required Volume Depth at Outlet
29.5 ac. 1.2 ac-ft 6.7 ft.

Area required
per Row
1.0 in²

WS Elev: 7075.2

No. of
columns
4

Hole size
9/16 in

STAGE			STORAGE			
STAGE	ELEV	HEIGHT	AREA		VOLUME	
			sqft	acre	acft	cum acft
1	7068.5	0	30	0.001	0.000	0.00
2	7069	0.5	1364	0.03	0.01	0.01
3	7070	1.5	4094	0.09	0.06	0.07
4	7071	2.5	6862	0.16	0.13	0.20
5	7072	3.5	8467	0.19	0.18	0.37
6	7073	4.5	10128	0.23	0.21	0.59
7	7074	5.5	11846	0.27	0.25	0.84
8	7075	6.5	13620	0.31	0.29	1.13
9	7076	7.5	15452	0.35	1.10	1.47

Minimum steel thickness		1	2	3	4	5	6
		1/4	5/16	3/8	3/8	3/8	1/2
1/2	0.5000	0.20	0.39	0.59	0.79	0.98	1.18
9/16	0.5625	0.25	0.50	0.75	0.99	1.24	1.49
5/8	0.6250	0.31	0.61	0.92	1.23	1.53	1.84
11/16	0.6875	0.37	0.74	1.11	1.48	1.86	2.23
3/4	0.7500	0.44	0.88	1.33	1.77	2.21	2.65
13/16	0.8125	0.52	1.04	1.56	2.07	2.59	3.11
7/8	0.8750	0.60	1.20	1.80	2.41	3.01	3.61
15/16	0.9375	0.69	1.38	2.07	2.76	3.45	4.14
1	1.0000	0.79	1.57	2.36	3.14	3.93	4.71
1 1/16	1.0625	0.89	1.77	2.66	3.55	4.43	5.32

* 4 Columns of 13/16 holes existing.

**ROLLING HILLS RANCH GRADING
TEMPORARY SEDIMENTATION SIZING**

TEMP POND 2

Tributary Area: 24.9 ac. Required Volume: 1.0 ac-ft Depth at Outlet: 5.1 ft.

Area required
per Row
0.9 in²

WS Elev: 7036.6

No. of columns: 1
Hole size: 1 1/16 in

STAGE			STORAGE			
STAGE	ELEV	HEIGHT	AREA		VOLUME	
			sqft	acre	acft	cum acft
1	7031.5	0	10	0.000	0.000	0.00
2	7032	0.5	2660	0.06	0.02	0.02
3	7033	1.5	7570	0.17	0.12	0.13
4	7034	2.5	9179	0.21	0.19	0.33
5	7035	3.5	10861	0.25	0.23	0.56
6	7036	4.5	12614	0.29	0.27	0.82
7	7037	5.5	14438	0.33	0.31	1.13

Minimum steel thickness		1	2	3	4	5	6
		1/4	5/16	3/8	3/8	3/8	1/2
1/2	0.5000	0.20	0.39	0.59	0.79	0.98	1.18
9/16	0.5625	0.25	0.50	0.75	0.99	1.24	1.49
5/8	0.6250	0.31	0.61	0.92	1.23	1.53	1.84
11/16	0.6875	0.37	0.74	1.11	1.48	1.86	2.23
3/4	0.7500	0.44	0.88	1.33	1.77	2.21	2.65
13/16	0.8125	0.52	1.04	1.56	2.07	2.59	3.11
7/8	0.8750	0.60	1.20	1.80	2.41	3.01	3.61
15/16	0.9375	0.69	1.38	2.07	2.76	3.45	4.14
1	1.0000	0.79	1.57	2.36	3.14	3.93	4.71
1 1/16	1.0625	0.89	1.77	2.66	3.55	4.43	5.32

* 4 Columns of 13/16 holes existing.

**ROLLING HILLS RANCH GRADING
TEMPORARY SEDIMENTATION SIZING**

TEMP POND 3

Tributary Area: Required Volume Depth at Outlet
7.6 ac. 0.3 ac-ft 1.9 ft.

Area required
per Row
0.8 in²

WS Elev: 7063.4

No. of columns
1
Hole size
1 in

STAGE			STORAGE			
STAGE	ELEV	HEIGHT	AREA		VOLUME	
			sqft	acre	acft	cum acft
1	7061.5	0	10	0.000	0.000	0.00
2	7062	0.5	3807	0.09	0.02	0.02
3	7063	1.5	9900	0.23	0.16	0.18
4	7064	2.5	16892	0.39	0.31	0.49
5	7065	3.5	21531	0.49	0.44	0.93
6	7066	4.5	27137	0.62	0.56	1.49

TABLE SB-2

Minimum steel thickness		1	2	3	4	5	6
		1/4	5/16	3/8	3/8	3/8	1/2
1/2	0.5000	0.20	0.39	0.59	0.79	0.98	1.18
9/16	0.5625	0.25	0.50	0.75	0.99	1.24	1.49
5/8	0.6250	0.31	0.61	0.92	1.23	1.53	1.84
11/16	0.6875	0.37	0.74	1.11	1.48	1.86	2.23
3/4	0.7500	0.44	0.88	1.33	1.77	2.21	2.65
13/16	0.8125	0.52	1.04	1.56	2.07	2.59	3.11
7/8	0.8750	0.60	1.20	1.80	2.41	3.01	3.61
15/16	0.9375	0.69	1.38	2.07	2.76	3.45	4.14
1	1.0000	0.79	1.57	2.36	3.14	3.93	4.71
1 1/16	1.0625	0.89	1.77	2.66	3.55	4.43	5.32

* 4 Columns of 13/16 holes existing.

**ROLLING HILLS RANCH GRADING
TEMPORARY SEDIMENTATION SIZING**

TEMP POND 4

Tributary Area: Required Volume Depth at Outlet
5.8 ac. 0.2 ac-ft 1.7 ft.

Area required
per Row
0.8 in²

WS Elev: 7057.2

No. of columns Hole size
1 1 in

STAGE			STORAGE			
STAGE	ELEV	HEIGHT	AREA		VOLUME	
			sqft	acre	acft	cum acft
1	7055.5	0	10	0.000	0.000	0.00
2	7056	0.5	3763	0.09	0.02	0.02
3	7057	1.5	8129	0.19	0.14	0.16
4	7058	2.5	9414	0.22	0.20	0.36

Minimum steel thickness		1	2	3	4	5	6
		1/4	5/16	3/8	3/8	3/8	1/2
1/2	0.5000	0.20	0.39	0.59	0.79	0.98	1.18
9/16	0.5625	0.25	0.50	0.75	0.99	1.24	1.49
5/8	0.6250	0.31	0.61	0.92	1.23	1.53	1.84
11/16	0.6875	0.37	0.74	1.11	1.48	1.86	2.23
3/4	0.7500	0.44	0.88	1.33	1.77	2.21	2.65
13/16	0.8125	0.52	1.04	1.56	2.07	2.59	3.11
7/8	0.8750	0.60	1.20	1.80	2.41	3.01	3.61
15/16	0.9375	0.69	1.38	2.07	2.76	3.45	4.14
1	1.0000	0.79	1.57	2.36	3.14	3.93	4.71
1 1/16	1.0625	0.89	1.77	2.66	3.55	4.43	5.32

* 4 Columns of 13/16 holes existing.

**ROLLING HILLS RANCH GRADING
TEMPORARY SEDIMENTATION SIZING**

TEMP POND 5

Tributary Area: Required Volume Depth at Outlet
4.5 ac. 0.2 ac-ft 2.2 ft.

Area required
per Row
0.5 in²

WS Elev: 7026.7

No. of
columns
2

Hole size
9/16 in

STAGE			STORAGE			
STAGE	ELEV	HEIGHT	AREA		VOLUME	
			sqft	acre	acft	cum acft
1	7024.5	0	10	0.000	0.000	0.00
2	7025	0.5	785	0.02	0.00	0.00
3	7026	1.5	3560	0.08	0.05	0.05
4	7027	2.5	4630	0.11	0.09	0.15
5	7028	3.5	5785	0.13	0.21	0.27

Minimum steel thickness		1	2	3	4	5	6
		1/4	5/16	3/8	3/8	3/8	1/2
1/2	0.5000	0.20	0.39	0.59	0.79	0.98	1.18
9/16	0.5625	0.25	0.50	0.75	0.99	1.24	1.49
5/8	0.6250	0.31	0.61	0.92	1.23	1.53	1.84
11/16	0.6875	0.37	0.74	1.11	1.48	1.86	2.23
3/4	0.7500	0.44	0.88	1.33	1.77	2.21	2.65
13/16	0.8125	0.52	1.04	1.56	2.07	2.59	3.11
7/8	0.8750	0.60	1.20	1.80	2.41	3.01	3.61
15/16	0.9375	0.69	1.38	2.07	2.76	3.45	4.14
1	1.0000	0.79	1.57	2.36	3.14	3.93	4.71
1 1/16	1.0625	0.89	1.77	2.66	3.55	4.43	5.32

* 4 Columns of 13/16 holes existing.

**ROLLING HILLS RANCH GRADING
SEDIMENTATION SIZING**

PERMANENT POND 6

Tributary Area: 12.5 ac. Required Volume: 0.5 ac-ft Depth at Outlet: 3.7 ft.

Area required
per Row
0.6 in²

WS Elev: 7094.6

No. of columns: 1
Hole size: 7/8 in

STAGE			STORAGE			
STAGE	ELEV	HEIGHT	AREA		VOLUME	
			sqft	acre	acft	cum acft
1	7090.9	0	0	0.000	0.000	0.00
2	7091	0.1	44	0.00	0.00	0.00
3	7092	1.1	5600	0.13	0.06	0.06
4	7093	2.1	6835	0.16	0.14	0.21
5	7094	3.1	8170	0.19	0.17	0.38
6	7095	4.1	9606	0.22	0.20	0.58

Minimum steel thickness		1	2	3	4	5	6
		1/4	5/16	3/8	3/8	3/8	1/2
1/2	0.5000	0.20	0.39	0.59	0.79	0.98	1.18
9/16	0.5625	0.25	0.50	0.75	0.99	1.24	1.49
5/8	0.6250	0.31	0.61	0.92	1.23	1.53	1.84
11/16	0.6875	0.37	0.74	1.11	1.48	1.86	2.23
3/4	0.7500	0.44	0.88	1.33	1.77	2.21	2.65
13/16	0.8125	0.52	1.04	1.56	2.07	2.59	3.11
7/8	0.8750	0.60	1.20	1.80	2.41	3.01	3.61
15/16	0.9375	0.69	1.38	2.07	2.76	3.45	4.14
1	1.0000	0.79	1.57	2.36	3.14	3.93	4.71
1 1/16	1.0625	0.89	1.77	2.66	3.55	4.43	5.32

* 4 Columns of 13/16 holes existing.

**ROLLING HILLS RANCH GRADING
TEMPORARY SEDIMENTATION SIZING**

LAMBERT POND

Tributary Area: Required Volume Depth at Outlet
53.5 ac. 2.2 ac-ft 8.7 ft.

Area required
per Row
1.7 in²

WS Elev: 7019.3

No. of
columns
3 Hole size
13/16 in

STAGE			STORAGE			
STAGE	ELEV	HEIGHT	AREA		VOLUME	
			sqft	acre	acft	cum acft
1	7010.6	0	10	0.000	0.000	0.00
2	7011	0.4	810	0.02	0.00	0.00
3	7012	1.4	3352	0.08	0.05	0.05
4	7013	2.4	6498	0.15	0.11	0.16
5	7014	3.4	9562	0.22	0.18	0.35
6	7015	4.4	11631	0.27	0.57	0.57
7	7016	5.4	13756	0.32	0.79	0.84
8	7017	6.4	15939	0.37	1.03	1.19
9	7018	7.4	18178	0.42	1.27	1.62
10	7019	8.4	20473	0.47	0.44	2.07
11	7020	9.4	22825	0.52	0.50	2.56

Minimum steel thickness		1	2	3	4	5	6
		1/4	5/16	3/8	3/8	3/8	1/2
1/4	0.2500	0.05	0.10	0.15	0.20	0.25	0.29
5/16	0.3125	0.08	0.15	0.23	0.31	0.38	0.46
3/8	0.3750	0.11	0.22	0.33	0.44	0.55	0.66
7/16	0.4375	0.15	0.30	0.45	0.60	0.75	0.90
1/2	0.5000	0.20	0.39	0.59	0.79	0.98	1.18
9/16	0.5625	0.25	0.50	0.75	0.99	1.24	1.49
5/8	0.6250	0.31	0.61	0.92	1.23	1.53	1.84
11/16	0.6875	0.37	0.74	1.11	1.48	1.86	2.23
3/4	0.7500	0.44	0.88	1.33	1.77	2.21	2.65
13/16	0.8125	0.52	1.04	1.56	2.07	2.59	3.11

Appendix G – Soil Resource Report



United States
Department of
Agriculture

NRCS

Natural
Resources
Conservation
Service

A product of the National
Cooperative Soil Survey,
a joint effort of the United
States Department of
Agriculture and other
Federal agencies, State
agencies including the
Agricultural Experiment
Stations, and local
participants

Custom Soil Resource Report for El Paso County Area, Colorado

ROLLING HILLS RANCH PUD



Preface

Soil surveys contain information that affects land use planning in survey areas. They highlight soil limitations that affect various land uses and provide information about the properties of the soils in the survey areas. Soil surveys are designed for many different users, including farmers, ranchers, foresters, agronomists, urban planners, community officials, engineers, developers, builders, and home buyers. Also, conservationists, teachers, students, and specialists in recreation, waste disposal, and pollution control can use the surveys to help them understand, protect, or enhance the environment.

Various land use regulations of Federal, State, and local governments may impose special restrictions on land use or land treatment. Soil surveys identify soil properties that are used in making various land use or land treatment decisions. The information is intended to help the land users identify and reduce the effects of soil limitations on various land uses. The landowner or user is responsible for identifying and complying with existing laws and regulations.

Although soil survey information can be used for general farm, local, and wider area planning, onsite investigation is needed to supplement this information in some cases. Examples include soil quality assessments (<http://www.nrcs.usda.gov/wps/portal/nrcs/main/soils/health/>) and certain conservation and engineering applications. For more detailed information, contact your local USDA Service Center (<https://offices.sc.egov.usda.gov/locator/app?agency=nrcs>) or your NRCS State Soil Scientist (http://www.nrcs.usda.gov/wps/portal/nrcs/detail/soils/contactus/?cid=nrcs142p2_053951).

Great differences in soil properties can occur within short distances. Some soils are seasonally wet or subject to flooding. Some are too unstable to be used as a foundation for buildings or roads. Clayey or wet soils are poorly suited to use as septic tank absorption fields. A high water table makes a soil poorly suited to basements or underground installations.

The National Cooperative Soil Survey is a joint effort of the United States Department of Agriculture and other Federal agencies, State agencies including the Agricultural Experiment Stations, and local agencies. The Natural Resources Conservation Service (NRCS) has leadership for the Federal part of the National Cooperative Soil Survey.

Information about soils is updated periodically. Updated information is available through the NRCS Web Soil Survey, the site for official soil survey information.

The U.S. Department of Agriculture (USDA) prohibits discrimination in all its programs and activities on the basis of race, color, national origin, age, disability, and where applicable, sex, marital status, familial status, parental status, religion, sexual orientation, genetic information, political beliefs, reprisal, or because all or a part of an individual's income is derived from any public assistance program. (Not all prohibited bases apply to all programs.) Persons with disabilities who require

alternative means for communication of program information (Braille, large print, audiotape, etc.) should contact USDA's TARGET Center at (202) 720-2600 (voice and TDD). To file a complaint of discrimination, write to USDA, Director, Office of Civil Rights, 1400 Independence Avenue, S.W., Washington, D.C. 20250-9410 or call (800) 795-3272 (voice) or (202) 720-6382 (TDD). USDA is an equal opportunity provider and employer.

Contents

Preface	2
How Soil Surveys Are Made	5
Soil Map	8
Soil Map.....	9
Legend.....	10
Map Unit Legend.....	11
Map Unit Descriptions.....	11
El Paso County Area, Colorado.....	13
19—Columbine gravelly sandy loam, 0 to 3 percent slopes.....	13
83—Stapleton sandy loam, 3 to 8 percent slopes.....	14
References	16

How Soil Surveys Are Made

Soil surveys are made to provide information about the soils and miscellaneous areas in a specific area. They include a description of the soils and miscellaneous areas and their location on the landscape and tables that show soil properties and limitations affecting various uses. Soil scientists observed the steepness, length, and shape of the slopes; the general pattern of drainage; the kinds of crops and native plants; and the kinds of bedrock. They observed and described many soil profiles. A soil profile is the sequence of natural layers, or horizons, in a soil. The profile extends from the surface down into the unconsolidated material in which the soil formed or from the surface down to bedrock. The unconsolidated material is devoid of roots and other living organisms and has not been changed by other biological activity.

Currently, soils are mapped according to the boundaries of major land resource areas (MLRAs). MLRAs are geographically associated land resource units that share common characteristics related to physiography, geology, climate, water resources, soils, biological resources, and land uses (USDA, 2006). Soil survey areas typically consist of parts of one or more MLRA.

The soils and miscellaneous areas in a survey area occur in an orderly pattern that is related to the geology, landforms, relief, climate, and natural vegetation of the area. Each kind of soil and miscellaneous area is associated with a particular kind of landform or with a segment of the landform. By observing the soils and miscellaneous areas in the survey area and relating their position to specific segments of the landform, a soil scientist develops a concept, or model, of how they were formed. Thus, during mapping, this model enables the soil scientist to predict with a considerable degree of accuracy the kind of soil or miscellaneous area at a specific location on the landscape.

Commonly, individual soils on the landscape merge into one another as their characteristics gradually change. To construct an accurate soil map, however, soil scientists must determine the boundaries between the soils. They can observe only a limited number of soil profiles. Nevertheless, these observations, supplemented by an understanding of the soil-vegetation-landscape relationship, are sufficient to verify predictions of the kinds of soil in an area and to determine the boundaries.

Soil scientists recorded the characteristics of the soil profiles that they studied. They noted soil color, texture, size and shape of soil aggregates, kind and amount of rock fragments, distribution of plant roots, reaction, and other features that enable them to identify soils. After describing the soils in the survey area and determining their properties, the soil scientists assigned the soils to taxonomic classes (units). Taxonomic classes are concepts. Each taxonomic class has a set of soil characteristics with precisely defined limits. The classes are used as a basis for comparison to classify soils systematically. Soil taxonomy, the system of taxonomic classification used in the United States, is based mainly on the kind and character of soil properties and the arrangement of horizons within the profile. After the soil

Custom Soil Resource Report

scientists classified and named the soils in the survey area, they compared the individual soils with similar soils in the same taxonomic class in other areas so that they could confirm data and assemble additional data based on experience and research.

The objective of soil mapping is not to delineate pure map unit components; the objective is to separate the landscape into landforms or landform segments that have similar use and management requirements. Each map unit is defined by a unique combination of soil components and/or miscellaneous areas in predictable proportions. Some components may be highly contrasting to the other components of the map unit. The presence of minor components in a map unit in no way diminishes the usefulness or accuracy of the data. The delineation of such landforms and landform segments on the map provides sufficient information for the development of resource plans. If intensive use of small areas is planned, onsite investigation is needed to define and locate the soils and miscellaneous areas.

Soil scientists make many field observations in the process of producing a soil map. The frequency of observation is dependent upon several factors, including scale of mapping, intensity of mapping, design of map units, complexity of the landscape, and experience of the soil scientist. Observations are made to test and refine the soil-landscape model and predictions and to verify the classification of the soils at specific locations. Once the soil-landscape model is refined, a significantly smaller number of measurements of individual soil properties are made and recorded. These measurements may include field measurements, such as those for color, depth to bedrock, and texture, and laboratory measurements, such as those for content of sand, silt, clay, salt, and other components. Properties of each soil typically vary from one point to another across the landscape.

Observations for map unit components are aggregated to develop ranges of characteristics for the components. The aggregated values are presented. Direct measurements do not exist for every property presented for every map unit component. Values for some properties are estimated from combinations of other properties.

While a soil survey is in progress, samples of some of the soils in the area generally are collected for laboratory analyses and for engineering tests. Soil scientists interpret the data from these analyses and tests as well as the field-observed characteristics and the soil properties to determine the expected behavior of the soils under different uses. Interpretations for all of the soils are field tested through observation of the soils in different uses and under different levels of management. Some interpretations are modified to fit local conditions, and some new interpretations are developed to meet local needs. Data are assembled from other sources, such as research information, production records, and field experience of specialists. For example, data on crop yields under defined levels of management are assembled from farm records and from field or plot experiments on the same kinds of soil.

Predictions about soil behavior are based not only on soil properties but also on such variables as climate and biological activity. Soil conditions are predictable over long periods of time, but they are not predictable from year to year. For example, soil scientists can predict with a fairly high degree of accuracy that a given soil will have a high water table within certain depths in most years, but they cannot predict that a high water table will always be at a specific level in the soil on a specific date.

After soil scientists located and identified the significant natural bodies of soil in the survey area, they drew the boundaries of these bodies on aerial photographs and

Custom Soil Resource Report

identified each as a specific map unit. Aerial photographs show trees, buildings, fields, roads, and rivers, all of which help in locating boundaries accurately.

Soil Map

The soil map section includes the soil map for the defined area of interest, a list of soil map units on the map and extent of each map unit, and cartographic symbols displayed on the map. Also presented are various metadata about data used to produce the map, and a description of each soil map unit.

Custom Soil Resource Report Soil Map



Map Scale: 1:15,400 if printed on A landscape (11" x 8.5") sheet.

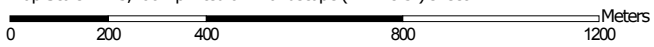

Map projection: Web Mercator Corner coordinates: WGS84 Edge tics: UTM Zone 13N WGS84



Custom Soil Resource Report

MAP LEGEND

Area of Interest (AOI)

 Area of Interest (AOI)

Soils

 Soil Map Unit Polygons

 Soil Map Unit Lines

 Soil Map Unit Points

Special Point Features

 Blowout

 Borrow Pit

 Clay Spot

 Closed Depression

 Gravel Pit

 Gravelly Spot

 Landfill

 Lava Flow

 Marsh or swamp

 Mine or Quarry

 Miscellaneous Water

 Perennial Water

 Rock Outcrop

 Saline Spot

 Sandy Spot

 Severely Eroded Spot

 Sinkhole

 Slide or Slip

 Sodic Spot

 Spoil Area

 Stony Spot

 Very Stony Spot

 Wet Spot

 Other

 Special Line Features

Water Features

 Streams and Canals

Transportation

 Rails

 Interstate Highways

 US Routes

 Major Roads

 Local Roads

Background

 Aerial Photography

MAP INFORMATION

The soil surveys that comprise your AOI were mapped at 1:24,000.

Please rely on the bar scale on each map sheet for map measurements.

Source of Map: Natural Resources Conservation Service

Web Soil Survey URL:

Coordinate System: Web Mercator (EPSG:3857)

Maps from the Web Soil Survey are based on the Web Mercator projection, which preserves direction and shape but distorts distance and area. A projection that preserves area, such as the Albers equal-area conic projection, should be used if more accurate calculations of distance or area are required.

This product is generated from the USDA-NRCS certified data as of the version date(s) listed below.

Soil Survey Area: El Paso County Area, Colorado

Survey Area Data: Version 16, Sep 10, 2018

Soil map units are labeled (as space allows) for map scales 1:50,000 or larger.

Date(s) aerial images were photographed: Jun 7, 2016—Aug 17, 2017

The orthophoto or other base map on which the soil lines were compiled and digitized probably differs from the background imagery displayed on these maps. As a result, some minor shifting of map unit boundaries may be evident.

Map Unit Legend

Map Unit Symbol	Map Unit Name	Acres in AOI	Percent of AOI
19	Columbine gravelly sandy loam, 0 to 3 percent slopes	387.7	31.2%
83	Stapleton sandy loam, 3 to 8 percent slopes	855.6	68.8%
Totals for Area of Interest		1,243.3	100.0%

Map Unit Descriptions

The map units delineated on the detailed soil maps in a soil survey represent the soils or miscellaneous areas in the survey area. The map unit descriptions, along with the maps, can be used to determine the composition and properties of a unit.

A map unit delineation on a soil map represents an area dominated by one or more major kinds of soil or miscellaneous areas. A map unit is identified and named according to the taxonomic classification of the dominant soils. Within a taxonomic class there are precisely defined limits for the properties of the soils. On the landscape, however, the soils are natural phenomena, and they have the characteristic variability of all natural phenomena. Thus, the range of some observed properties may extend beyond the limits defined for a taxonomic class. Areas of soils of a single taxonomic class rarely, if ever, can be mapped without including areas of other taxonomic classes. Consequently, every map unit is made up of the soils or miscellaneous areas for which it is named and some minor components that belong to taxonomic classes other than those of the major soils.

Most minor soils have properties similar to those of the dominant soil or soils in the map unit, and thus they do not affect use and management. These are called noncontrasting, or similar, components. They may or may not be mentioned in a particular map unit description. Other minor components, however, have properties and behavioral characteristics divergent enough to affect use or to require different management. These are called contrasting, or dissimilar, components. They generally are in small areas and could not be mapped separately because of the scale used. Some small areas of strongly contrasting soils or miscellaneous areas are identified by a special symbol on the maps. If included in the database for a given area, the contrasting minor components are identified in the map unit descriptions along with some characteristics of each. A few areas of minor components may not have been observed, and consequently they are not mentioned in the descriptions, especially where the pattern was so complex that it was impractical to make enough observations to identify all the soils and miscellaneous areas on the landscape.

The presence of minor components in a map unit in no way diminishes the usefulness or accuracy of the data. The objective of mapping is not to delineate pure taxonomic classes but rather to separate the landscape into landforms or landform segments that have similar use and management requirements. The delineation of such segments on the map provides sufficient information for the development of resource plans. If intensive use of small areas is planned, however,

Custom Soil Resource Report

onsite investigation is needed to define and locate the soils and miscellaneous areas.

An identifying symbol precedes the map unit name in the map unit descriptions. Each description includes general facts about the unit and gives important soil properties and qualities.

Soils that have profiles that are almost alike make up a *soil series*. Except for differences in texture of the surface layer, all the soils of a series have major horizons that are similar in composition, thickness, and arrangement.

Soils of one series can differ in texture of the surface layer, slope, stoniness, salinity, degree of erosion, and other characteristics that affect their use. On the basis of such differences, a soil series is divided into *soil phases*. Most of the areas shown on the detailed soil maps are phases of soil series. The name of a soil phase commonly indicates a feature that affects use or management. For example, Alpha silt loam, 0 to 2 percent slopes, is a phase of the Alpha series.

Some map units are made up of two or more major soils or miscellaneous areas. These map units are complexes, associations, or undifferentiated groups.

A *complex* consists of two or more soils or miscellaneous areas in such an intricate pattern or in such small areas that they cannot be shown separately on the maps. The pattern and proportion of the soils or miscellaneous areas are somewhat similar in all areas. Alpha-Beta complex, 0 to 6 percent slopes, is an example.

An *association* is made up of two or more geographically associated soils or miscellaneous areas that are shown as one unit on the maps. Because of present or anticipated uses of the map units in the survey area, it was not considered practical or necessary to map the soils or miscellaneous areas separately. The pattern and relative proportion of the soils or miscellaneous areas are somewhat similar. Alpha-Beta association, 0 to 2 percent slopes, is an example.

An *undifferentiated group* is made up of two or more soils or miscellaneous areas that could be mapped individually but are mapped as one unit because similar interpretations can be made for use and management. The pattern and proportion of the soils or miscellaneous areas in a mapped area are not uniform. An area can be made up of only one of the major soils or miscellaneous areas, or it can be made up of all of them. Alpha and Beta soils, 0 to 2 percent slopes, is an example.

Some surveys include *miscellaneous areas*. Such areas have little or no soil material and support little or no vegetation. Rock outcrop is an example.

El Paso County Area, Colorado

19—Columbine gravelly sandy loam, 0 to 3 percent slopes

Map Unit Setting

National map unit symbol: 367p
Elevation: 6,500 to 7,300 feet
Mean annual precipitation: 14 to 16 inches
Mean annual air temperature: 46 to 50 degrees F
Frost-free period: 125 to 145 days
Farmland classification: Not prime farmland

Map Unit Composition

Columbine and similar soils: 85 percent
Estimates are based on observations, descriptions, and transects of the mapunit.

Description of Columbine

Setting

Landform: Flood plains, fan terraces, fans
Down-slope shape: Linear
Across-slope shape: Linear
Parent material: Alluvium

Typical profile

A - 0 to 14 inches: gravelly sandy loam
C - 14 to 60 inches: very gravelly loamy sand

Properties and qualities

Slope: 0 to 3 percent
Depth to restrictive feature: More than 80 inches
Natural drainage class: Well drained
Runoff class: Very low
Capacity of the most limiting layer to transmit water (Ksat): High to very high (5.95 to 19.98 in/hr)
Depth to water table: More than 80 inches
Frequency of flooding: None
Frequency of ponding: None
Available water storage in profile: Very low (about 2.5 inches)

Interpretive groups

Land capability classification (irrigated): 4e
Land capability classification (nonirrigated): 6e
Hydrologic Soil Group: A
Ecological site: Gravelly Foothill (R049BY214CO)
Hydric soil rating: No

Minor Components

Fluvaquentic haplaquolls

Percent of map unit:
Landform: Swales
Hydric soil rating: Yes

Pleasant

Percent of map unit:

Custom Soil Resource Report

Landform: Depressions
Hydric soil rating: Yes

Other soils

Percent of map unit:
Hydric soil rating: No

83—Stapleton sandy loam, 3 to 8 percent slopes

Map Unit Setting

National map unit symbol: 369z
Elevation: 6,500 to 7,300 feet
Mean annual precipitation: 14 to 16 inches
Mean annual air temperature: 46 to 48 degrees F
Frost-free period: 125 to 145 days
Farmland classification: Not prime farmland

Map Unit Composition

Stapleton and similar soils: 80 percent
Estimates are based on observations, descriptions, and transects of the mapunit.

Description of Stapleton

Setting

Landform: Hills
Landform position (three-dimensional): Side slope
Down-slope shape: Linear
Across-slope shape: Linear
Parent material: Sandy alluvium derived from arkose

Typical profile

A - 0 to 11 inches: sandy loam
Bw - 11 to 17 inches: gravelly sandy loam
C - 17 to 60 inches: gravelly loamy sand

Properties and qualities

Slope: 3 to 8 percent
Depth to restrictive feature: More than 80 inches
Natural drainage class: Well drained
Runoff class: Low
Capacity of the most limiting layer to transmit water (Ksat): High (2.00 to 6.00 in/hr)
Depth to water table: More than 80 inches
Frequency of flooding: None
Frequency of ponding: None
Available water storage in profile: Low (about 4.7 inches)

Interpretive groups

Land capability classification (irrigated): None specified
Land capability classification (nonirrigated): 3e
Hydrologic Soil Group: B

Custom Soil Resource Report

Ecological site: Gravelly Foothill (R049BY214CO)
Hydric soil rating: No

Minor Components

Pleasant

Percent of map unit:
Landform: Depressions
Hydric soil rating: Yes

Fluvaquentic haplaquolls

Percent of map unit:
Landform: Swales
Hydric soil rating: Yes

Other soils

Percent of map unit:
Hydric soil rating: No

References

- American Association of State Highway and Transportation Officials (AASHTO). 2004. Standard specifications for transportation materials and methods of sampling and testing. 24th edition.
- American Society for Testing and Materials (ASTM). 2005. Standard classification of soils for engineering purposes. ASTM Standard D2487-00.
- Cowardin, L.M., V. Carter, F.C. Golet, and E.T. LaRoe. 1979. Classification of wetlands and deep-water habitats of the United States. U.S. Fish and Wildlife Service FWS/OBS-79/31.
- Federal Register. July 13, 1994. Changes in hydric soils of the United States.
- Federal Register. September 18, 2002. Hydric soils of the United States.
- Hurt, G.W., and L.M. Vasilas, editors. Version 6.0, 2006. Field indicators of hydric soils in the United States.
- National Research Council. 1995. Wetlands: Characteristics and boundaries.
- Soil Survey Division Staff. 1993. Soil survey manual. Soil Conservation Service. U.S. Department of Agriculture Handbook 18. http://www.nrcs.usda.gov/wps/portal/nrcs/detail/national/soils/?cid=nrcs142p2_054262
- Soil Survey Staff. 1999. Soil taxonomy: A basic system of soil classification for making and interpreting soil surveys. 2nd edition. Natural Resources Conservation Service, U.S. Department of Agriculture Handbook 436. http://www.nrcs.usda.gov/wps/portal/nrcs/detail/national/soils/?cid=nrcs142p2_053577
- Soil Survey Staff. 2010. Keys to soil taxonomy. 11th edition. U.S. Department of Agriculture, Natural Resources Conservation Service. http://www.nrcs.usda.gov/wps/portal/nrcs/detail/national/soils/?cid=nrcs142p2_053580
- Tiner, R.W., Jr. 1985. Wetlands of Delaware. U.S. Fish and Wildlife Service and Delaware Department of Natural Resources and Environmental Control, Wetlands Section.
- United States Army Corps of Engineers, Environmental Laboratory. 1987. Corps of Engineers wetlands delineation manual. Waterways Experiment Station Technical Report Y-87-1.
- United States Department of Agriculture, Natural Resources Conservation Service. National forestry manual. http://www.nrcs.usda.gov/wps/portal/nrcs/detail/soils/home/?cid=nrcs142p2_053374
- United States Department of Agriculture, Natural Resources Conservation Service. National range and pasture handbook. <http://www.nrcs.usda.gov/wps/portal/nrcs/detail/national/landuse/rangepasture/?cid=stelprdb1043084>

Custom Soil Resource Report

United States Department of Agriculture, Natural Resources Conservation Service. National soil survey handbook, title 430-VI. http://www.nrcs.usda.gov/wps/portal/nrcs/detail/soils/scientists/?cid=nrcs142p2_054242

United States Department of Agriculture, Natural Resources Conservation Service. 2006. Land resource regions and major land resource areas of the United States, the Caribbean, and the Pacific Basin. U.S. Department of Agriculture Handbook 296. http://www.nrcs.usda.gov/wps/portal/nrcs/detail/national/soils/?cid=nrcs142p2_053624

United States Department of Agriculture, Soil Conservation Service. 1961. Land capability classification. U.S. Department of Agriculture Handbook 210. http://www.nrcs.usda.gov/Internet/FSE_DOCUMENTS/nrcs142p2_052290.pdf

Appendix H – Drainage Maps

NOTE:
 COUNTY PLAN REVIEW IS PROVIDED ONLY FOR GENERAL CONFORMANCE WITH COUNTY DESIGN CRITERIA. THE COUNTY IS NOT RESPONSIBLE FOR THE ACCURACY AND ADEQUACY OF THE DESIGN, DIMENSIONS, AND/OR ELEVATIONS WHICH SHALL BE CONFIRMED AT THE JOB SITE. THE COUNTY THROUGH THE APPROVAL OF THIS DOCUMENT ASSUMES NO RESPONSIBILITY FOR THE COMPLETENESS AND/OR ACCURACY OF THIS DOCUMENT.

BENCH MARK:
 INTERSECTION OF WOODMEN RD AND MERIDIAN ROAD AT SW CORNER (BRASS CAP W/ NO. GF-9)
 ELEVATION = 6874.00

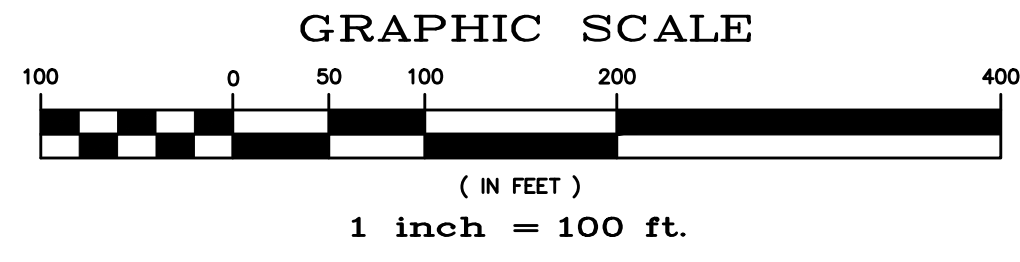

- G01 BASIN DESIGNATION
- 2.7
0.40
0.05 SUB-WATERSHED DESIGNATION
- 61 BASIN AREA IN ACRES
- DESIGN POINT DESIGNATION
- MAJOR BASIN BOUNDARY
- SUB-BASIN BOUNDARY
- EXISTING CONTOUR
- PROPOSED CONTOUR
- PROPOSED STORM SEWER
- INITIAL OVERLAND TIME (Ti)
- TRAVEL TIME (Tt)
- OVERLAND TIME (To)

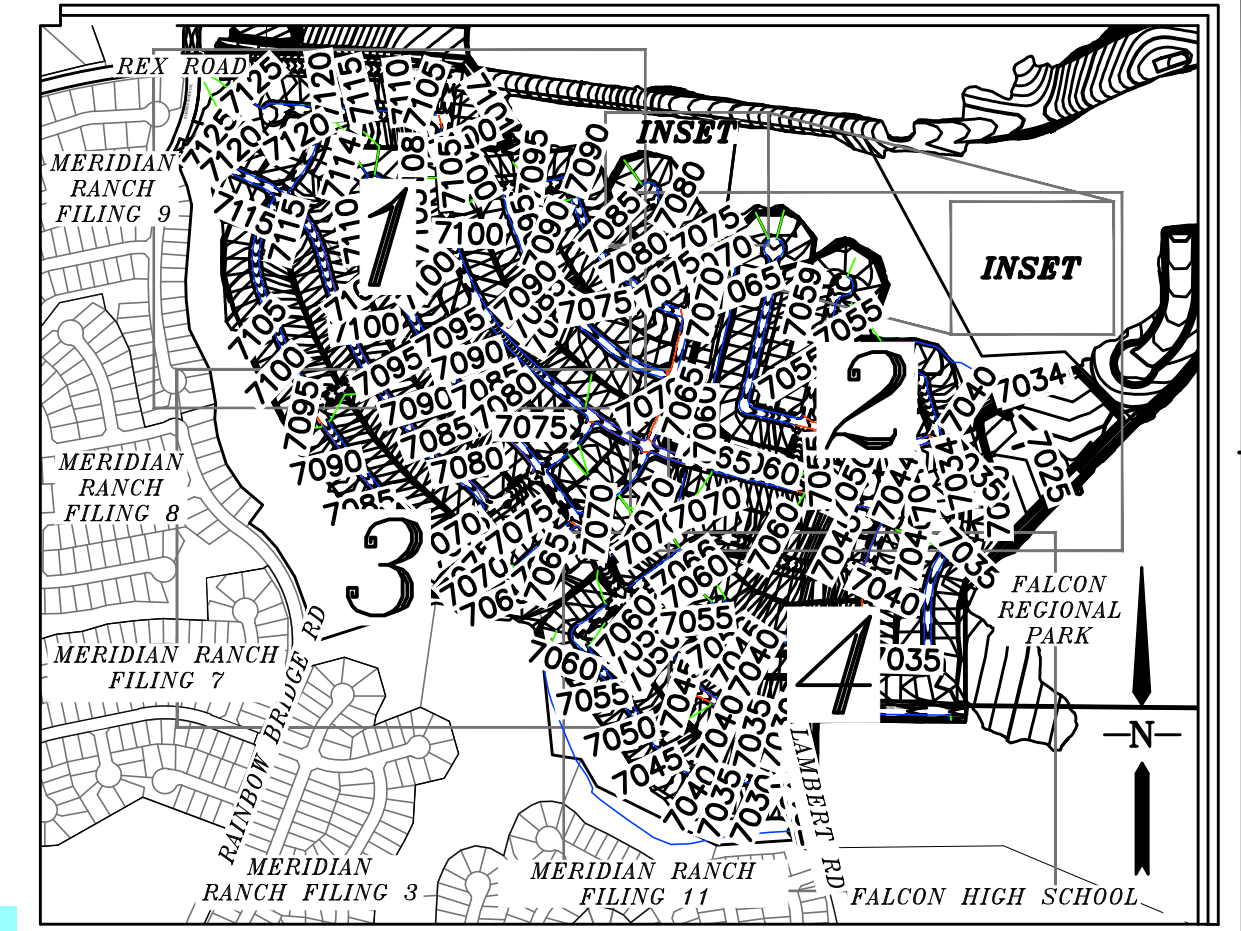

INDEX MAP
 N.T.S.

DP	BASIN	AREA (AC)	Q(5) (CFS)	Q(100) (CFS)	INLET	Q(5) (CFS)	Q(100) (CFS)	PIPE		
I02	A01	5.50	5.8	16	PR 10" FORCED SUMP	5.8	9.9	24" RCP		
A02	2.20	2.0	12	PR 10" SUMP	2.0	12	18" RCP			
J01								7.8	22	24" RCP
I03	A03	0.73	0.8	2.6	PR 5" SUMP	0.8	2.3	24" RCP		
I04	B01	2.29	2.2	6.4	PR 10" FORCED SUMP	2.2	6.4	18" RCP		
I05	B02	5.63	5.2	15	PR 15" FORCED SUMP	7.3	20	24" RCP		
J02								7.3	20	24" RCP
DP1	B03	4.34	4.2	12						
I06	B04	3.03	6.2	18	PR 20" FORCED SUMP	6.2	17	18" RCP		
I07	B05	3.22	3.1	9.1	PR 10" FORCED SUMP	3.1	9.1	18" RCP		
I08	B06	3.13	3.3	9.9	PR 10" FORCED SUMP	3.3	9.9	18" RCP		
I09	B07	4.76	4.3	13	PR 20" FLOW-BY	3.7	9.2	18" RCP		
I10	B08	2.54	2.5	7.6	PR 10" FORCED SUMP	2.5	7.6	18" RCP		
J06								21.6	59	36" RCP
I07								21.2	58	36" RCP
I10	B08	2.54	2.5	7.6	PR 10" FORCED SUMP	2.5	7.6	18" RCP		
J08								2.5	7.5	18" RCP
I11	B09	2.64	2.5	7.4	PR 10" SUMP	2.5	7.4	18" RCP		
I12	B10 & B11	6.38	8.5	27	PR 20" SUMP	5.4	18	18" RCP		
J09								9.7	31	24" RCP
I10								29.5	85	42" RCP
I13	C01	3.15	3.1	9.0	PR 10" FORCED SUMP	3.1	9.0	24" RCP		
I14	C02	3.54	3.4	10	PR 15" FORCED SUMP	3.4	10	24" RCP		
J11								6.0	18	24" RCP
I15	C03	1.33	1.4	4.0	PR 5" FORCED SUMP	1.4	4.0	18" RCP		
I16	C04	3.10	3.2	9.4	PR 5" FORCED SUMP	3.2	9.4	18" RCP		
J12								9.5	26	30" RCP
I17	C05	0.58	0.6	1.8	PR 5" SUMP	0.6	1.8	18" RCP		
I18	C06	1.03	1.0	6.0	PR 5" SUMP	1.0	6.0	18" RCP		
J13								10.8	32	36" RCP
CB1	C07	0.88	0.9	2.5	PR Type C	0.9	2.5	18" RCP		
J14								11.4	34	36" RCP
I19	D01	6.87	6.8	19	PR 15" FORCED SUMP	6.8	19	24" RCP		
J15								6.8	14	24" RCP
DP2	D02	3.83	3.8	16						
I20	D03	3.84	7.3	21	PR 20" FORCED SUMP	7.3	17	18" RCP		
J16								13.8	30	30" RCP
DP3	D04	4.78	4.5	16						
I21	D05	2.00	6.6	23	PR 15" FORCED SUMP	6.6	14	24" RCP		
J17								19.3	41	30" RCP
I22	D06	3.72	3.7	10	PR 15" FLOW-BY	2.9	7.0	18" RCP		
I23	D07	6.59	6.9	20	PR 10" FORCED SUMP	6.9	9.9	18" RCP		
J18								9.5	16	24" RCP
I24	D08	1.64	1.8	13	PR 10" FORCED SUMP	1.8	9.9	24" RCP		
J19								29.2	65	42" RCP
CB2	D09	1.63	1.2	3.4	PR Type C	1.2	3.4	18" RCP		
I25	D10	0.81	0.9	5.4	PR 10" SUMP	2.0	8.4	18" RCP		
ES1	D11	4.16	2.4	6.9	" FES	2.4	6.9	18" RCP		
I26	D12	2.67	2.4	15	PR 20" SUMP	4.3	18	24" RCP		
J20								29.2	71	42" RCP
I27	D13	1.79	2.2	5.8	PR 15" FLOW-BY	1.7	3.9	18" RCP		
J21								29.2	72	42" RCP
I28	D14	6.45	6.3	18	PR 10" FORCED SUMP	6.3	9.9	18" RCP		
I29	D15	6.35	6.2	18	PR 10" FORCED SUMP	6.2	9.9	18" RCP		
J22								12.4	20	24" RCP
J23								34.8	84	48" RCP
I30	D16	4.02	4.2	17	PR 10" FORCED SUMP	4.2	9.9	18" RCP		
J24								37.3	90	48" RCP
I25								37.3	90	48" RCP
I31	D17	5.13	5.3	27	PR 15" SUMP	5.3	24	30" RCP		
J26								40.8	106	48" RCP
I32	D18	3.13	3.0	10	PR 15" SUMP	4.29	11.3	54" RCP		
J33	E01	5.38	6.2	17	PR 20" FORCED SUMP	6.2	17	18" RCP		
J27								6.2	17	18" RCP
I34	E02	6.48	7.3	19	PR 20" FORCED SUMP	7.3	17	18" RCP		
J28								13.7	35	30" RCP
I35	E03	5.82	6.5	17	PR 15" FORCED SUMP	6.5	14	18" RCP		
J29								19.7	47	36" RCP
I36	E04	3.14	3.9	13	PR 15" FORCED SUMP	3.9	13	18" RCP		
I37	E05	2.55	2.7	8.7	PR 15" FLOW-BY	2.3	6.0	18" RCP		
J30								23.9	61	36" RCP
J31								23.8	61	36" RCP
I38	E06	1.27	1.6	4.2	PR 5" FORCED SUMP	1.6	4.2	18" RCP		
J32								1.5	4.1	18" RCP
I39	E07	2.05	2.5	6.7	PR 15" FLOW-BY	2.0	4.5	18" RCP		
J33								3.5	8.5	18" RCP
I40	E08	4.17	4.8	13	PR 10" FORCED SUMP	4.8	9.9	18" RCP		
J34								8.0	18	24" RCP
J35								8.0	18	24" RCP
I41	E09	5.44	6.2	18	PR 15" FORCED SUMP	6.2	14	24" RCP		
J36								35.2	86	42" RCP
I42	E10	6.98	7.0	19	PR 20" SUMP	7.0	19	24" RCP		
J37								41.1	102	48" RCP
CB3	E11	13.04	6.3	18	PR Type C	6.3	18	18" RCP		
I43	E12	1.60	3.6	9.2	PR 20" FLOW-BY	3.2	7.1	18" RCP		
J38								52.4	131	54" RCP
E11	E13	6.02	8.2	19	EX 15" FORCED SUMP	8.2	13	18" RCP		

SEE SHEET 2

SEE SHEET 3

Verify. The highlighted appears to drain into

Identify the waters of the state.

Per ECM 1.7.1.C.4, Stormwater from the site must not discharge to a water of the state before being discharged to a WQCV control measure.
 Storm Drain System A must drain to a WQ BMP prior to discharging into the drainage way.
 Label all permanent WQ BMP. Provide a pond summary table or callout.

TECH CONTRACTORS
 11886 STAPLETON DRIVE
 FALCON, CO 80831
 TELEPHONE: 719.495.7444
 FAX: 719.495.3349

MERIDIAN RANCH

RATIONAL DRAINAGE MAP
 PRELIMINARY DRAINAGE REPORT
 ROLLING HILLS RANGE

Drawn by: TAL
 Checked by: -
 Date: APR 2019

Scale: 1" = 100'

1 of 4

No.	Revisions	Date	Inst.	Appr.	Date

S:\OneDrive\Civil\Proj\Rolling Hills Filing 1\DWG\Plan Sheets\Drainage Maps\PRDR\ational basin map pud - rolling hills.dwg, 4/17/2019 9:56:50 AM

NOTE:
 COUNTY PLAN REVIEW IS PROVIDED ONLY FOR GENERAL CONFORMANCE WITH COUNTY DESIGN CRITERIA. THE COUNTY IS NOT RESPONSIBLE FOR THE ACCURACY AND ADEQUACY OF THE DESIGN, DIMENSIONS, AND/OR ELEVATIONS WHICH SHALL BE CONFIRMED AT THE JOB SITE. THE COUNTY THROUGH THE APPROVAL OF THIS DOCUMENT ASSUMES NO RESPONSIBILITY FOR THE COMPLETENESS AND/OR ACCURACY OF THIS DOCUMENT.

BENCH MARK:
 INTERSECTION OF WOODMEN RD AND MERIDIAN ROAD AT SW CORNER (BRASS CAP W/ NO. GF-9)
 ELEVATION = 6874.00

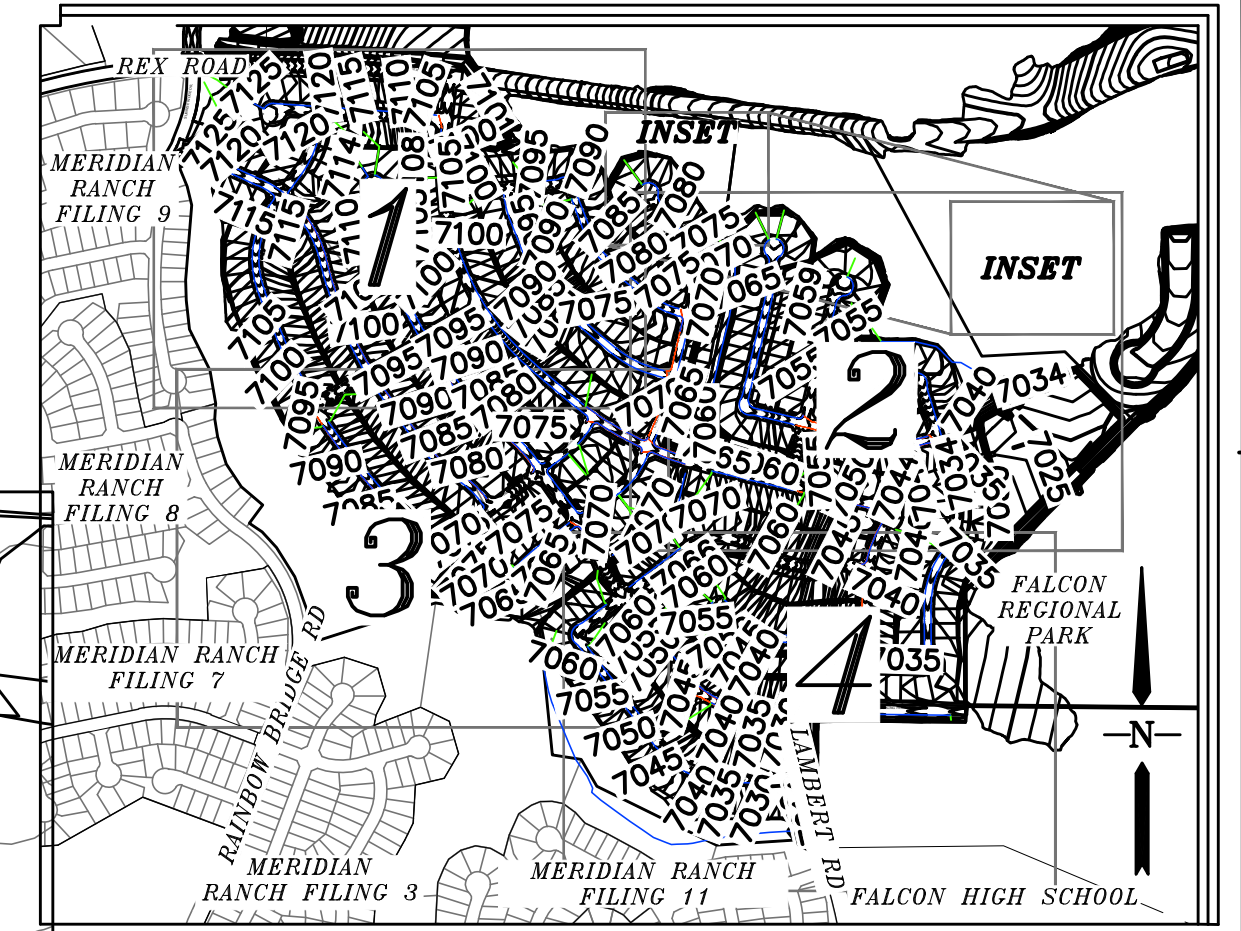
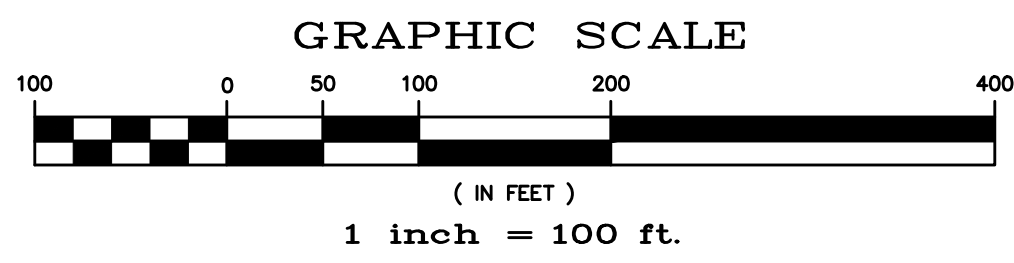

INDEX MAP
 N.T.S.

Per ECM I.7.1.C.4. Stormwater from the site must not discharge to a water of the state before being discharged to a WQCV control measure.
 WQCV required for the lots draining directly into the waters of the state.

SEE INSET RIGHT

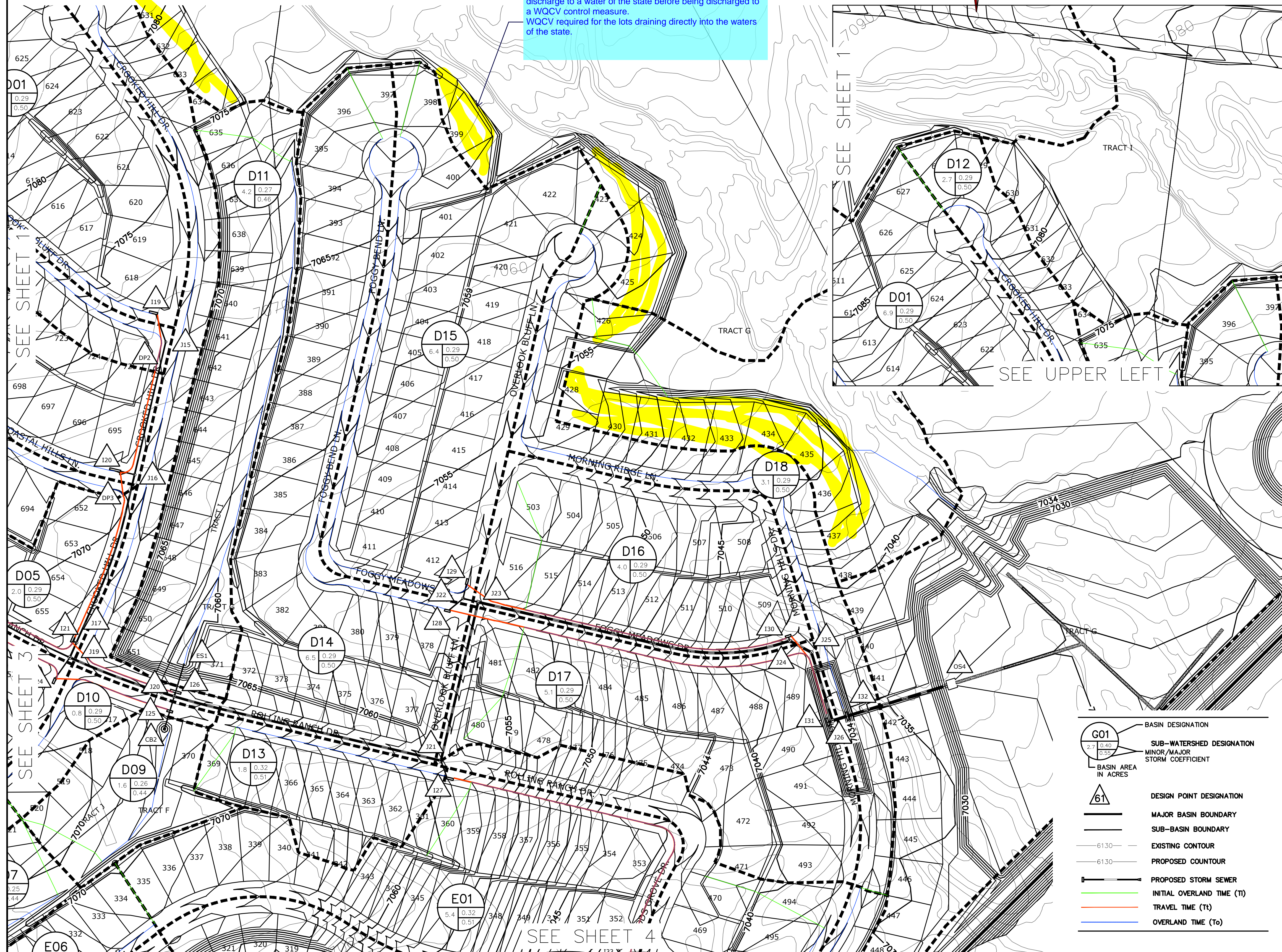

DP	Basin	Area (AC)	Q(5) (CFS)	Q(100) (CFS)	Inlet	Q(5) (CFS)	Q(100) (CFS)	Pipe
I02	A01	5.50	5.8	16	PR 10" FORCED SUMP	5.8	9.9	24" RCP
J01	A02	2.20	2.0	12	PR 10" SUMP	7.8	22	24" RCP
I03	A03	0.73	0.8	2.6	PR 5" SUMP	8.4	23	24" RCP
I04	B01	2.29	2.2	6.4	PR 10" FORCED SUMP	2.2	6.4	18" RCP
I05	B02	5.63	5.2	15	PR 15" FORCED SUMP	7.3	20	24" RCP
J02	B03	4.34	4.2	12	PR 10" FORCED SUMP	13.0	36	30" RCP
I06	B04	3.03	6.2	18	PR 20" FORCED SUMP	6.2	17	18" RCP
J03	B05	3.22	3.1	9.1	PR 10" FORCED SUMP	3.1	9.1	18" RCP
J04	B06	3.13	3.3	9.9	PR 10" FORCED SUMP	15.7	44	36" RCP
I08	B07	4.76	4.3	13	PR 20" FLOW-BY	3.7	9.2	18" RCP
J05	B08	2.64	2.5	7.4	PR 10" SUMP	18.2	51	36" RCP
I09	B09	6.38	8.5	27	PR 20" SUMP	9.7	31	24" RCP
J06	B10	6.11	6.38	8.5	PR 20" SUMP	21.2	58	36" RCP
J10	B11	2.54	2.5	7.6	PR 10" FORCED SUMP	2.5	7.6	18" RCP
J08	B12	2.64	2.5	7.4	PR 10" SUMP	2.5	7.4	18" RCP
I11	B13	2.64	2.5	7.4	PR 10" SUMP	5.4	18	18" RCP
I12	B14	6.11	6.38	8.5	PR 20" SUMP	9.7	31	24" RCP
J09	C01	3.15	3.1	9.0	PR 10" FORCED SUMP	3.1	9.0	24" RCP
I13	C02	3.54	3.4	10.0	PR 15" FORCED SUMP	3.4	10	24" RCP
J11	C03	3.15	3.1	9.0	PR 15" FORCED SUMP	6.0	18	24" RCP
I15	C04	1.33	1.4	4.0	PR 5" FORCED SUMP	1.4	4.0	18" RCP
I16	C05	3.10	3.2	9.4	PR 5" FORCED SUMP	3.2	6.3	18" RCP
J12	C06	0.58	0.6	1.8	PR 5" SUMP	9.5	26	30" RCP
I17	C07	1.03	1.0	6.0	PR 5" SUMP	0.6	1.8	18" RCP
I18	C08	1.03	1.0	6.0	PR 5" SUMP	1.0	6.0	18" RCP
J13	C09	0.88	0.9	2.5	PR Type C	10.8	32	36" RCP
C01	C10	0.88	0.9	2.5	PR Type C	0.9	2.5	18" RCP
J14	C11	0.88	0.9	2.5	PR Type C	11.4	34	36" RCP
I19	D01	6.87	6.8	19	PR 15" FORCED SUMP	6.8	14	18" RCP
J15	D02	3.83	3.8	16	PR 20" FORCED SUMP	6.8	14	24" RCP
I20	D03	3.84	3.8	16	PR 20" FORCED SUMP	7.3	17	18" RCP
I16	D04	4.78	4.5	16	PR 15" FORCED SUMP	13.8	30	30" RCP
DP3	D05	2.00	6.6	23	PR 15" FORCED SUMP	6.6	14	24" RCP
J17	D06	3.72	3.7	10	PR 15" FLOW-BY	19.3	41	30" RCP
I22	D07	6.59	6.9	20	PR 10" FORCED SUMP	2.9	7.0	18" RCP
I18	D08	1.64	1.8	5.1	PR 10" FORCED SUMP	6.9	9.9	18" RCP
I24	D09	1.63	1.2	3.4	PR 10" FORCED SUMP	9.5	16	24" RCP
I24	D10	4.16	2.4	6.9	PR 10" FORCED SUMP	1.8	9.9	24" RCP
I26	D11	2.67	2.4	15	PR 20" SUMP	29.2	65	42" RCP
J19	D12	1.79	2.2	5.8	PR 15" FLOW-BY	1.7	3.9	18" RCP
J21	D13	1.79	2.2	5.8	PR 15" FLOW-BY	29.2	72	42" RCP
I28	D14	6.45	6.3	18	PR 10" FORCED SUMP	1.2	3.4	18" RCP
I29	D15	6.35	6.2	18	PR 10" FORCED SUMP	2.0	8.4	18" RCP
J22	D16	4.02	4.2	17	PR 10" FORCED SUMP	2.4	6.9	18" RCP
J23	D17	5.13	5.3	27	PR 15" SUMP	4.3	18	24" RCP
J20	D18	3.13	3.0	10	PR 15" SUMP	29.2	71	42" RCP
I31	E01	5.38	6.2	17	PR 20" FORCED SUMP	29.2	71	42" RCP
I32	E02	6.48	7.3	19	PR 20" FORCED SUMP	1.7	3.9	18" RCP
I34	E03	5.82	6.5	17	PR 15" FORCED SUMP	40.8	106	48" RCP
J27	E04	3.14	3.9	13	PR 15" FORCED SUMP	42.9	113	54" RCP
J28	E05	2.55	2.7	8.7	PR 15" FLOW-BY	6.2	17	18" RCP
I35	E06	1.27	1.6	4.2	PR 5" FORCED SUMP	7.3	17	18" RCP
J29	E07	2.05	2.5	6.7	PR 15" FLOW-BY	13.7	35	30" RCP
I36	E08	4.17	4.8	13	PR 10" FORCED SUMP	6.5	14	18" RCP
J30	E09	5.44	6.2	18	PR 15" FORCED SUMP	19.7	47	36" RCP
J31	E10	6.98	7.0	19	PR 20" SUMP	3.9	13	18" RCP
I37	E11	13.04	6.3	18	PR Type C	2.3	6.0	18" RCP
I38	E12	1.60	3.8	9.2	PR 20" FLOW-BY	23.9	61	36" RCP
J38	E13	6.02	8.2	19	EX 15" FORCED SUMP	23.8	61	36" RCP
I39	E14	6.98	7.0	19	PR 20" SUMP	1.6	4.2	18" RCP
I40	E15	4.17	4.8	13	PR 10" FORCED SUMP	1.5	4.1	18" RCP
I41	E16	1.27	1.6	4.2	PR 5" FORCED SUMP	2.0	4.5	18" RCP
I42	E17	2.05	2.5	6.7	PR 15" FLOW-BY	3.5	8.5	18" RCP
I43	E18	1.60	3.8	9.2	PR 20" FLOW-BY	4.8	9.9	18" RCP
I44	E19	5.44	6.2	18	PR 15" FORCED SUMP	8.0	18	24" RCP
I45	E20	6.98	7.0	19	PR 20" SUMP	8.0	18	24" RCP
I46	E21	4.17	4.8	13	PR 10" FORCED SUMP	6.2	14	24" RCP
I47	E22	1.27	1.6	4.2	PR 5" FORCED SUMP	35.2	86	42" RCP
I48	E23	2.05	2.5	6.7	PR 15" FLOW-BY	7.0	19	24" RCP
I49	E24	1.60	3.8	9.2	PR 20" FLOW-BY	41.1	102	48" RCP
I50	E25	6.02	8.2	19	EX 15" FORCED SUMP	6.3	18	18" RCP
I51	E26	6.02	8.2	19	EX 15" FORCED SUMP	52.4	131	54" RCP
I52	E27	6.02	8.2	19	EX 15" FORCED SUMP	8.2	13	18" RCP

- G01** BASIN DESIGNATION
- SUB-WATERSHED DESIGNATION**
- MINOR/MAJOR STORM COEFFICIENT**
- BASIN AREA IN ACRES**
- 61** DESIGN POINT DESIGNATION
- MAJOR BASIN BOUNDARY**
- SUB-BASIN BOUNDARY**
- EXISTING CONTOUR**
- PROPOSED CONTOUR**
- PROPOSED STORM SEWER**
- INITIAL OVERLAND TIME (T_i)**
- TRAVEL TIME (T_t)**
- OVERLAND TIME (T_o)**

TECH CONTRACTORS		11886 STAPLETON DRIVE		FALCON, CO 80831		TELEPHONE: 719.495.7444		FAX: 719.495.3349	
RATIONAL DRAINAGE MAP		PRELIMINARY DRAINAGE REPORT		ROLLING HILLS RANGE		Scale 1" = 100'		1 of 4	
Drawn by	TAL	Checked by	-	Date	APR 2019	Revisions		No.	Date
Meridian Ranch		No.		Date		Appr.		Date	

S:\OneDrive\Civil\Proj\Rolling Hills Filing 1\DWG\Plan Sheets\Drainage Maps\DR\Drainage basin map.pud - rolling hills.dwg, 4/17/2019 9:57:57 AM

NOTE:

COUNTY PLAN REVIEW IS PROVIDED ONLY FOR GENERAL CONFORMANCE WITH COUNTY DESIGN CRITERIA. THE COUNTY IS NOT RESPONSIBLE FOR THE ACCURACY AND ADEQUACY OF THE DESIGN, DIMENSIONS, AND/OR ELEVATIONS WHICH SHALL BE CONFIRMED AT THE JOB SITE. THE COUNTY THROUGH THE APPROVAL OF THIS DOCUMENT ASSUMES NO RESPONSIBILITY FOR THE COMPLETENESS AND/OR ACCURACY OF THIS DOCUMENT.

BENCH MARK:

INTERSECTION OF WOODMEN RD AND MERIDIAN ROAD AT SW CORNER (BRASS CAP W/ NO. GF-9)
ELEVATION = 6874.00

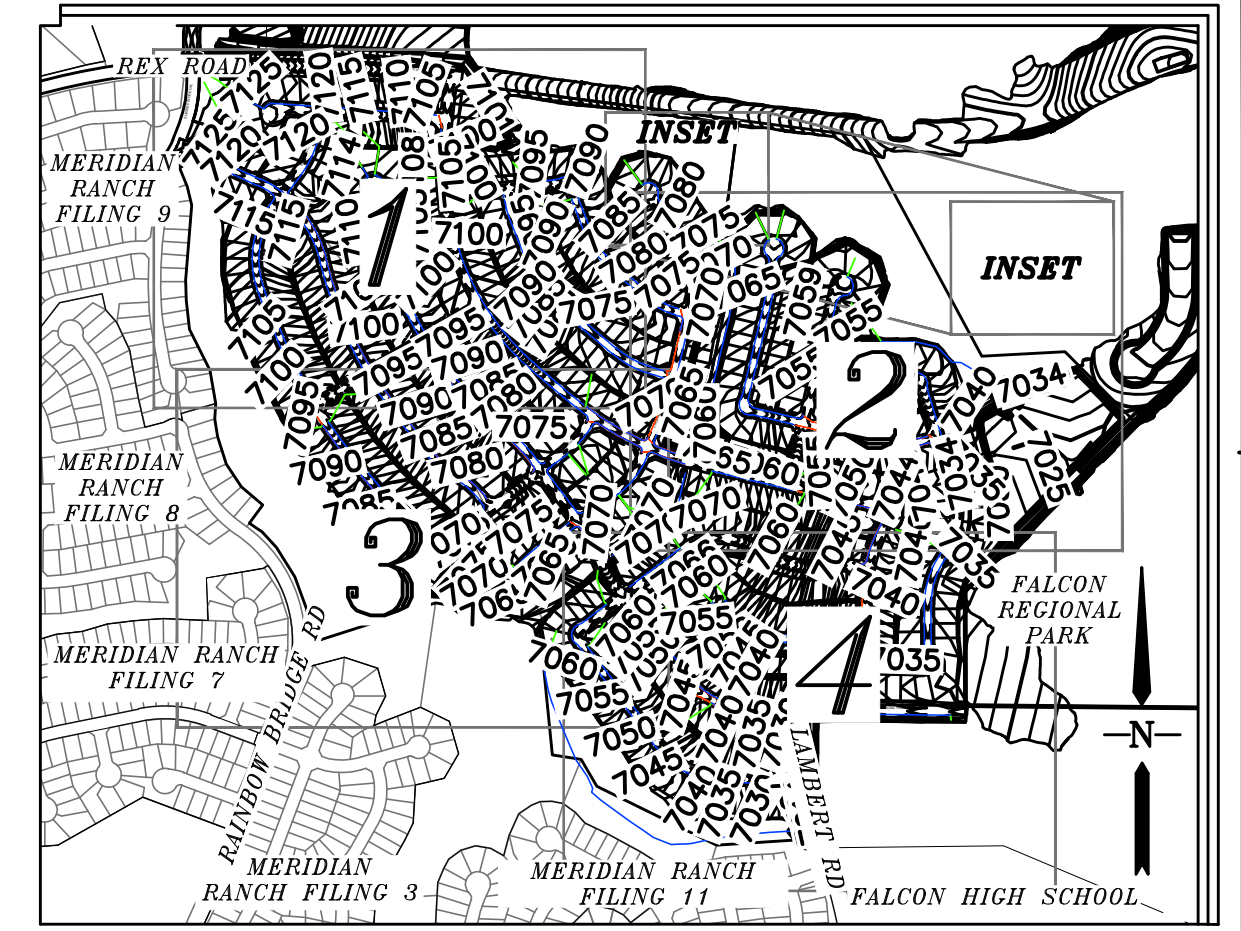
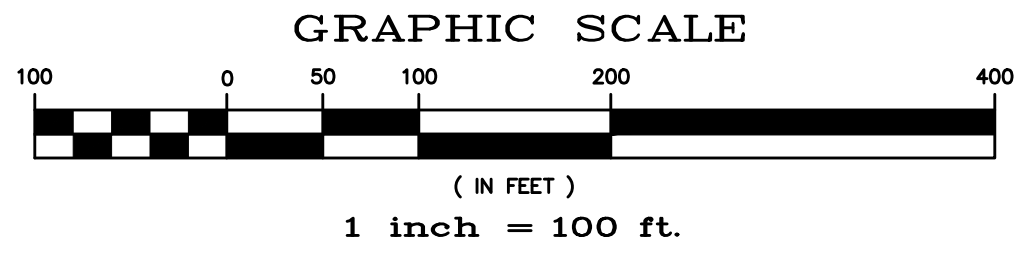

INDEX MAP
N.T.S.

DP	BASIN	AREA (AC)	Q(5) (CFS)	Q(100) (CFS)	INLET	Q(5) (CFS)	Q(100) (CFS)	PIPE
101	A01	5.50	5.8	16	PR 10" FORCED SUMP	5.8	9.9	24" RCP
102	A02	2.20	2.0	12	PR 10" SUMP	2.0	12	18" RCP
103	A03	0.73	0.8	2.6	PR 5" SUMP	2.8	22	24" RCP
104	B01	2.29	2.2	6.4	PR 10" FORCED SUMP	2.2	6.4	18" RCP
105	B02	5.63	5.2	15	PR 15" FORCED SUMP	7.3	20	24" RCP
106	B03	4.34	4.2	12	PR 20" FORCED SUMP	7.8	22	24" RCP
107	B04	3.03	6.2	18	PR 20" FORCED SUMP	8.4	23	24" RCP
108	B05	3.22	3.1	9.1	PR 10" FORCED SUMP	15.7	44	36" RCP
109	B06	3.13	3.3	9.9	PR 10" FORCED SUMP	3.3	9.9	18" RCP
110	B07	4.76	4.3	13	PR 20" FLOW-BY	18.2	31	36" RCP
111	B08	2.64	2.5	7.4	PR 10" SUMP	21.6	59	36" RCP
112	B09	6.38	8.5	27	PR 20" SUMP	21.2	58	36" RCP
113	C01	3.15	3.1	9.0	PR 10" FORCED SUMP	2.5	7.6	18" RCP
114	C02	3.54	3.4	10	PR 10" FORCED SUMP	2.5	7.4	18" RCP
115	C03	1.33	1.4	4.0	PR 5" FORCED SUMP	3.4	10	24" RCP
116	C04	3.10	3.2	9.4	PR 5" FORCED SUMP	6.0	18	24" RCP
117	C05	0.58	0.6	1.8	PR 5" SUMP	1.4	4.0	18" RCP
118	C06	1.03	1.0	6.0	PR 5" SUMP	3.2	6.3	18" RCP
119	C07	0.88	0.9	2.5	PR Type C	9.5	26	30" RCP
120	D01	6.87	6.8	19	PR 15" FORCED SUMP	0.6	1.8	18" RCP
121	D02	3.83	3.8	16	PR 15" FORCED SUMP	10.8	32	36" RCP
122	D03	3.84	7.3	21	PR 20" FORCED SUMP	11.4	34	36" RCP
123	D04	4.78	4.5	16	PR 15" FORCED SUMP	11.4	34	36" RCP
124	D05	2.00	6.6	23	PR 15" FORCED SUMP	6.8	14	18" RCP
125	D06	3.72	3.7	10	PR 15" FLOW-BY	6.8	14	18" RCP
126	D07	6.59	6.9	20	PR 10" FORCED SUMP	13.8	30	30" RCP
127	D08	1.64	1.8	13	PR 10" FORCED SUMP	6.6	14	24" RCP
128	D09	1.63	1.2	3.4	PR Type C	19.3	41	30" RCP
129	D10	0.81	0.9	5.4	PR 10" SUMP	2.9	7.0	18" RCP
130	D11	4.16	2.4	6.9	" FES	6.9	9.9	18" RCP
131	D12	2.67	2.4	15	PR 20" SUMP	6.9	9.9	18" RCP
132	D13	1.79	2.2	5.8	PR 15" FLOW-BY	9.5	16	24" RCP
133	D14	6.45	6.3	18	PR 10" FORCED SUMP	1.8	9.9	18" RCP
134	D15	6.35	6.2	18	PR 10" FORCED SUMP	29.2	65	42" RCP
135	D16	4.02	4.2	17	PR 10" FORCED SUMP	1.2	3.4	18" RCP
136	D17	5.13	5.3	27	PR 15" SUMP	2.0	8.4	18" RCP
137	D18	3.13	3.0	10	PR 15" SUMP	2.4	6.9	18" RCP
138	E01	5.38	6.2	17	PR 20" FORCED SUMP	4.3	18	24" RCP
139	E02	6.48	7.3	19	PR 20" FORCED SUMP	4.3	18	24" RCP
140	E03	5.82	6.5	17	PR 15" FORCED SUMP	4.2	9.9	18" RCP
141	E04	3.14	3.9	13	PR 15" FORCED SUMP	34.8	84	48" RCP
142	E05	2.55	2.7	8.7	PR 15" FLOW-BY	4.2	9.9	18" RCP
143	E06	1.27	1.6	4.2	PR 5" FORCED SUMP	4.2	9.9	18" RCP
144	E07	2.05	2.5	6.7	PR 15" FLOW-BY	37.3	90	48" RCP
145	E08	4.17	4.8	13	PR 10" FORCED SUMP	37.3	90	48" RCP
146	E09	5.44	6.2	18	PR 15" FORCED SUMP	3.5	8.5	18" RCP
147	E10	6.98	7.0	19	PR 20" SUMP	4.8	9.9	18" RCP
148	E11	13.04	6.3	18	PR Type C	8.0	18	24" RCP
149	E12	1.60	3.6	9.2	PR 20" FLOW-BY	8.0	18	24" RCP
150	E13	6.02	8.2	19	EX 15" FORCED SUMP	52.4	131	54" RCP
151	E13	6.02	8.2	19	EX 15" FORCED SUMP	8.2	13	18" RCP

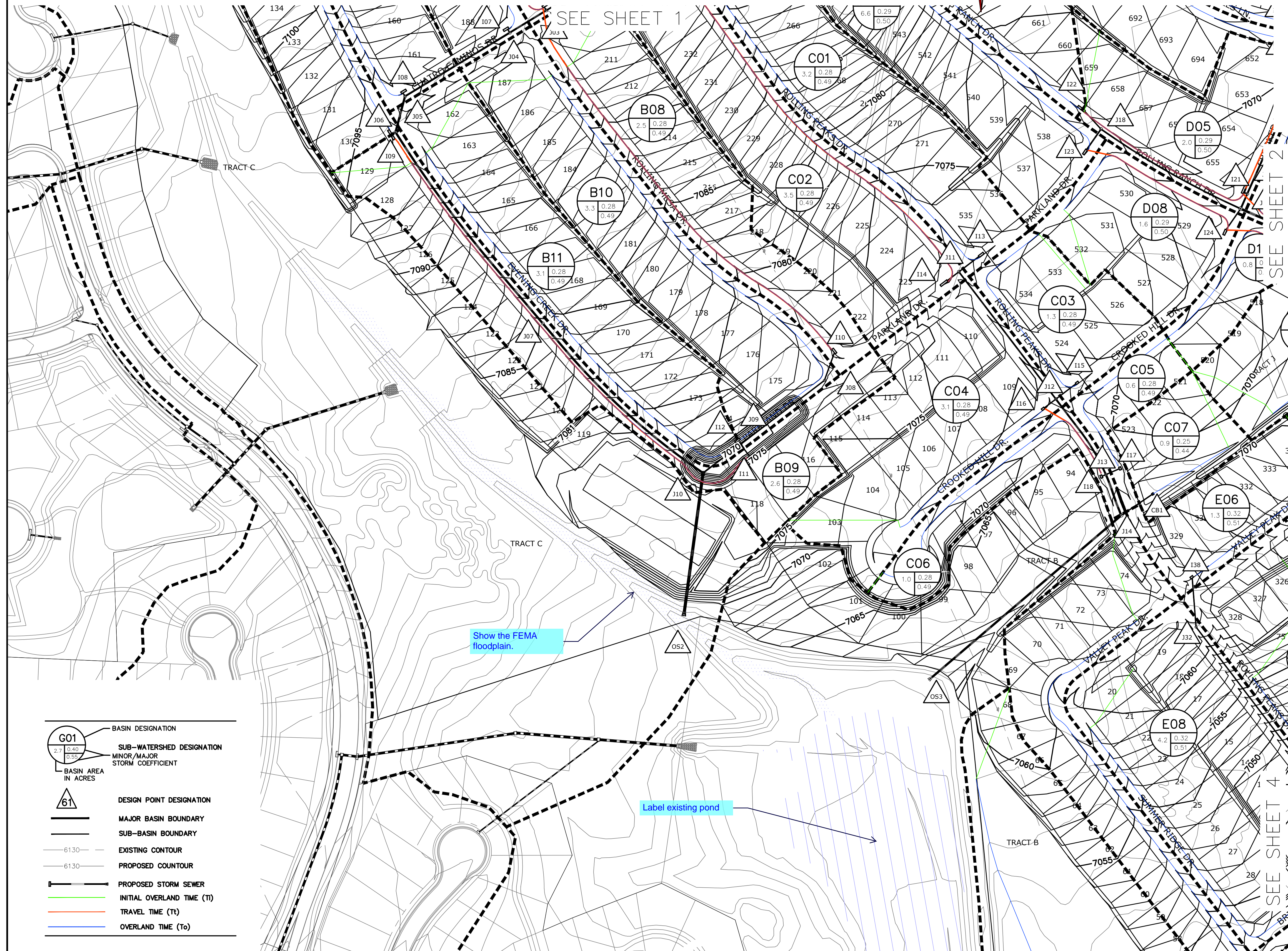

- G01** BASIN DESIGNATION
- 2.7** SUB-WATERSHED DESIGNATION
- 0.40** MINOR/MAJOR STORM COEFFICIENT
- 0.55** STORM COEFFICIENT
- 61** BASIN AREA IN ACRES
- 61** DESIGN POINT DESIGNATION
- MAJOR BASIN BOUNDARY
- SUB-BASIN BOUNDARY
- EXISTING CONTOUR
- PROPOSED CONTOUR
- PROPOSED STORM SEWER
- INITIAL OVERLAND TIME (T_i)
- TRAVEL TIME (T_t)
- OVERLAND TIME (T_o)

TECH CONTRACTORS
11886 STAPLETON DRIVE
FALCON, CO 80831
TELEPHONE: 719.495.7444
FAX: 719.495.3349

MERIDIAN RANCH

RATIONAL DRAINAGE MAP
PRELIMINARY DRAINAGE REPORT
ROLLING HILLS RANGE

Drawn by: **TAL**
Checked by: **-**
Date: **APR 2019**

Scale: **1" = 100'**
1 of 4

No.	Revisions	Date	Inst.	Appr.	Date

NOTE:
 COUNTY PLAN REVIEW IS PROVIDED ONLY FOR GENERAL CONFORMANCE WITH COUNTY DESIGN CRITERIA. THE COUNTY IS NOT RESPONSIBLE FOR THE ACCURACY AND ADEQUACY OF THE DESIGN, DIMENSIONS, AND/OR ELEVATIONS WHICH SHALL BE CONFIRMED AT THE JOB SITE. THE COUNTY THROUGH THE APPROVAL OF THIS DOCUMENT ASSUMES NO RESPONSIBILITY FOR THE COMPLETENESS AND/OR ACCURACY OF THIS DOCUMENT.

BENCH MARK:
 INTERSECTION OF WOODMEN RD AND MERIDIAN ROAD AT SW CORNER (BRASS CAP W/ NO. GF-9)
 ELEVATION = 6874.00

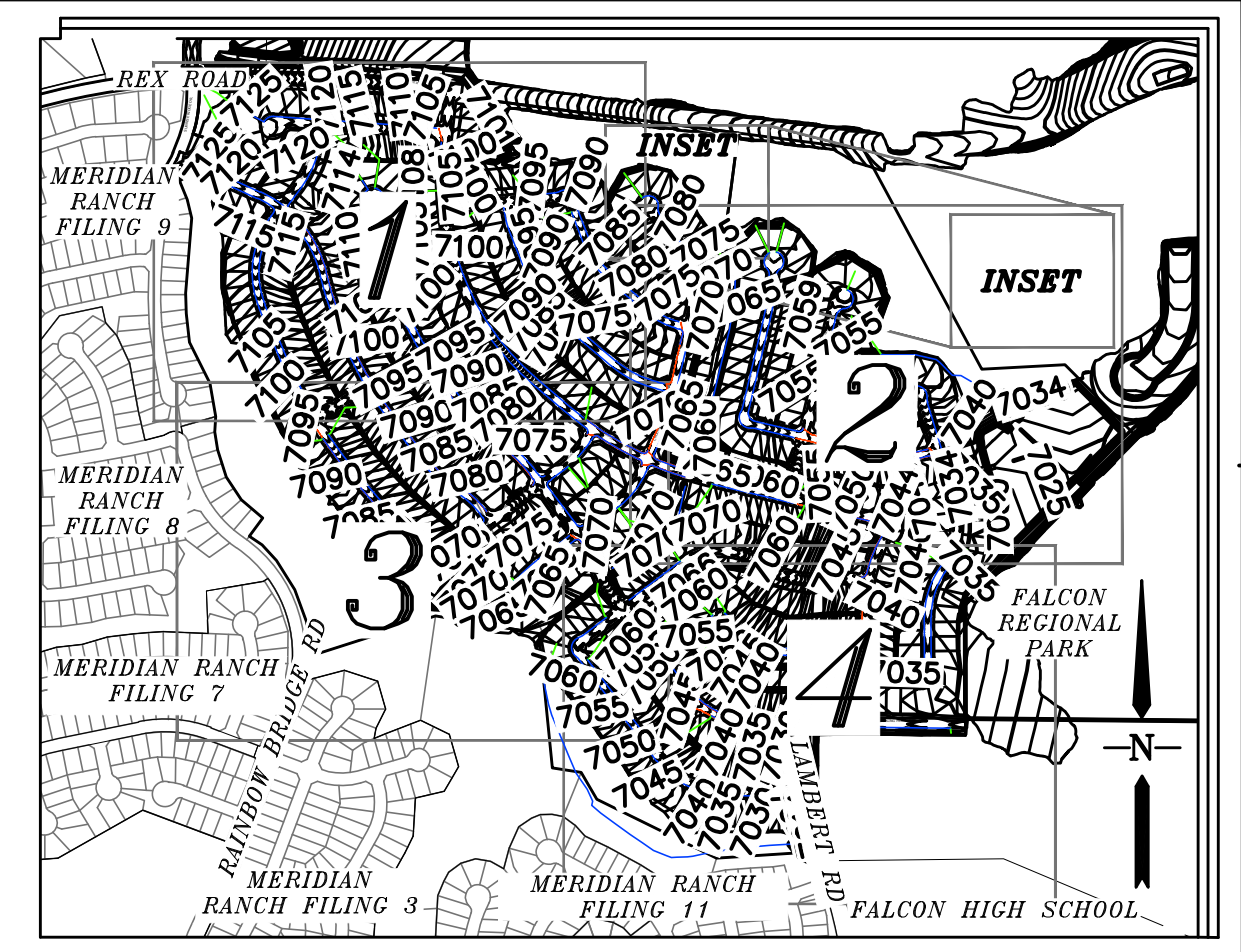
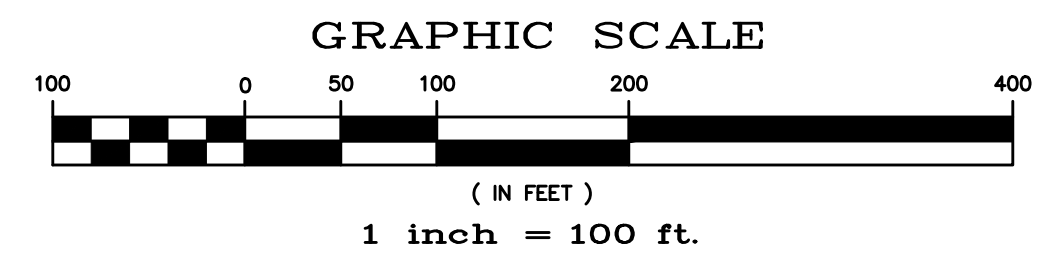

INDEX MAP
 N.T.S.

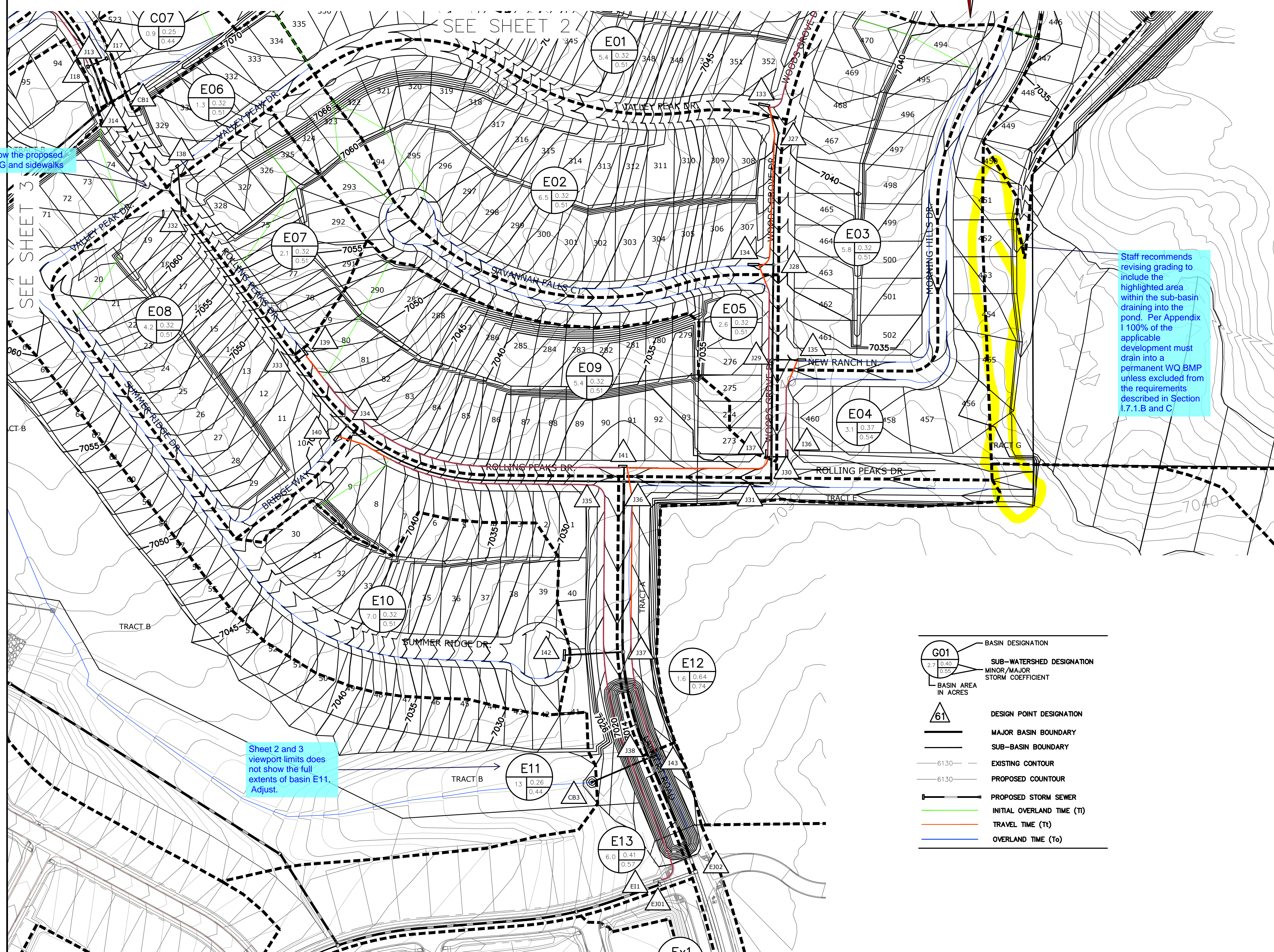

Staff recommends revising grading to include the highlighted area within the sub-basin draining into the pond. Per Appendix I 100% of the applicable development must drain into a permanent WQ BMP unless excluded from the requirements described in Section I.7.1.B and C

Sheet 2 and 3 viewport limits does not show the full extents of basin E11. Adjust.

- G01 BASIN DESIGNATION
- 2.7 0.40 0.35 SUB-WATERSHED DESIGNATION MINOR/MAJOR STORM COEFFICIENT
- △ 61 BASIN AREA IN ACRES
- △ 61 DESIGN POINT DESIGNATION
- MAJOR BASIN BOUNDARY
- SUB-BASIN BOUNDARY
- 6130 EXISTING CONTOUR
- 6130 PROPOSED CONTOUR
- PROPOSED STORM SEWER
- INITIAL OVERLAND TIME (Ti)
- TRAVEL TIME (Tt)
- OVERLAND TIME (To)

DP	BASIN	AREA (AC)	Q(5) (CFS)	Q(100) (CFS)	INLET	Q(5) (CFS)	Q(100) (CFS)	PIPE
102	A01	5.50	5.8	16	PR 10" FORCED SUMP	5.8	9.9	24" RCP
103	A02	2.20	2.0	12	PR 10" SUMP	2.0	12	18" RCP
101	A01	1.20	1.1	3	PR 10" SUMP	1.1	7.8	24" RCP
104	A03	0.73	0.8	2.6	PR 5" SUMP	0.8	2.3	24" RCP
104	B01	2.29	2.2	6.4	PR 10" FORCED SUMP	2.2	6.4	18" RCP
105	B02	5.63	5.2	15	PR 15" FORCED SUMP	7.3	20	24" RCP
J02						7.3	20	24" RCP
DP1	B03	4.34	4.2	12	PR 20" FORCED SUMP	6.2	17	18" RCP
106	B04	3.03	6.2	18	PR 20" FORCED SUMP	13.0	36	30" RCP
107	B05	3.22	3.1	9.1	PR 10" FORCED SUMP	3.1	9.1	18" RCP
J04						15.7	44	36" RCP
108	B06	3.13	3.3	9.9	PR 10" FORCED SUMP	3.3	9.9	18" RCP
J05						18.2	51	36" RCP
109	B07	4.76	4.3	13	PR 20" FLOW-BY	3.7	9.2	18" RCP
J06						21.6	59	36" RCP
J07						21.2	58	36" RCP
110	B08	2.54	2.5	7.6	PR 10" FORCED SUMP	2.5	7.6	18" RCP
J08						2.5	7.5	18" RCP
111	B09	2.64	2.5	7.4	PR 10" SUMP	2.5	7.4	18" RCP
112	B10 & B11	6.38	8.5	27	PR 20" SUMP	5.4	18	18" RCP
109						9.7	31	24" RCP
110						29.5	85	42" RCP
113	C01	3.15	3.1	9.0	PR 10" FORCED SUMP	3.1	9.0	24" RCP
114	C02	3.54	3.4	10	PR 15" FORCED SUMP	3.4	10	24" RCP
J11						6.0	18	24" RCP
115	C03	1.33	1.4	4.0	PR 5" FORCED SUMP	1.4	4.0	18" RCP
116	C04	3.10	3.2	9.4	PR 5" FORCED SUMP	3.2	6.3	18" RCP
J12						9.5	26	30" RCP
117	C05	0.58	0.6	1.8	PR 5" SUMP	0.6	1.8	18" RCP
118	C06	1.03	1.0	6.0	PR 5" SUMP	1.0	6.0	18" RCP
J13						10.8	32	36" RCP
CB1	C07	0.88	0.9	2.5	PR Type C	0.9	2.5	18" RCP
J14						11.4	34	36" RCP
119	D01	6.87	6.8	19	PR 15" FORCED SUMP	6.8	14	18" RCP
J15						6.8	14	24" RCP
DP2	D02	3.83	3.8	16				
116	D03	3.84	7.3	21	PR 20" FORCED SUMP	7.3	17	18" RCP
116						13.8	30	30" RCP
DP3	D04	4.78	4.5	16				
J21	D05	2.00	6.6	23	PR 15" FLOW SUMP	6.6	14	24" RCP
J17						19.3	41	30" RCP
J22	D06	3.72	3.7	10	PR 15" FLOW-BY	2.9	7.0	18" RCP
J23	D07	6.59	6.9	20	PR 10" FORCED SUMP	6.9	9.9	18" RCP
118						9.5	16	24" RCP
124	D08	1.64	1.8	13	PR 10" FORCED SUMP	1.8	9.9	24" RCP
J19						29.2	65	42" RCP
CB2	D09	1.63	1.2	3.4	PR Type C	1.2	3.4	18" RCP
125	D10	0.81	0.9	5.4	PR 10" SUMP	2.0	8.4	18" RCP
ES1	D11	4.16	2.4	6.9	FES	2.4	6.9	18" RCP
126	D12	2.67	2.4	15	PR 20" SUMP	4.3	18	24" RCP
120						29.2	71	42" RCP
J27	D13	1.79	2.2	5.8	PR 15" FLOW-BY	1.7	3.9	18" RCP
J21						29.2	72	42" RCP
J28	D14	6.45	6.3	18	PR 10" FORCED SUMP	6.3	9.9	18" RCP
J29	D15	6.35	6.2	18	PR 10" FORCED SUMP	6.2	9.9	18" RCP
J22						12.4	20	24" RCP
J23						34.8	84	48" RCP
130	D16	4.02	4.2	17	PR 10" FORCED SUMP	4.2	9.9	18" RCP
J24						37.3	90	48" RCP
J25						37.3	90	48" RCP
131	D17	5.13	5.3	27	PR 15" SUMP	5.3	24	30" RCP
J26						40.8	106	48" RCP
J32	D18	3.13	3.0	10	PR 15" SUMP	42.9	113	54" RCP
133	E01	5.38	6.2	17	PR 20" FORCED SUMP	6.2	17	18" RCP
J27						6.2	17	18" RCP
134	E02	6.48	7.3	19	PR 20" FORCED SUMP	7.3	17	18" RCP
J28						13.7	35	30" RCP
135	E03	5.82	6.5	17	PR 15" FORCED SUMP	6.5	14	18" RCP
J29						19.7	47	36" RCP
136	E04	3.14	3.9	13	PR 15" FORCED SUMP	3.9	13	18" RCP
137	E05	2.55	2.7	8.7	PR 15" FLOW-BY	2.3	6.0	18" RCP
J30						23.9	61	36" RCP
J31						23.8	61	36" RCP
138	E06	1.27	1.6	4.2	PR 5" FORCED SUMP	1.6	4.2	18" RCP
J32						1.5	4.1	18" RCP
139	E07	2.05	2.5	6.7	PR 15" FLOW-BY	2.0	4.5	18" RCP
J33						3.5	8.5	18" RCP
140	E08	4.17	4.8	13	PR 10" FORCED SUMP	4.8	9.9	18" RCP
J34						8.0	18	24" RCP
J35						8.0	18	24" RCP
141	E09	5.44	6.2	18				
J36						14	24" RCP	
142	E10	6.98	7.0	19				
J37						15	24" RCP	
CB3	E11	13.04	6.3	18	PR Type C	6.3	18	18" RCP
J38						52.4	131	54" RCP
E11	E13	6.02	8.2	19	PR 15" FORCED SUMP	8.2	13	18" RCP

update page numbers for the rational drainage map

TECH CONTRACTORS
 11886 STAPLETON DRIVE
 FALCON, CO 80831
 TELEPHONE: 719.495.7444
 FAX: 719.495.3349

RATIONAL DRAINAGE MAP
PRELIMINARY DRAINAGE REPORT
ROLLING HILLS RANGE

Drawn by: *TAL*
 Checked by: *-*
 Date: *APR. 2019*

Scale: *1" = 100'*
 Page: *4* of *4*

ROLLING HILLS RANCH MERIDIAN RANCH

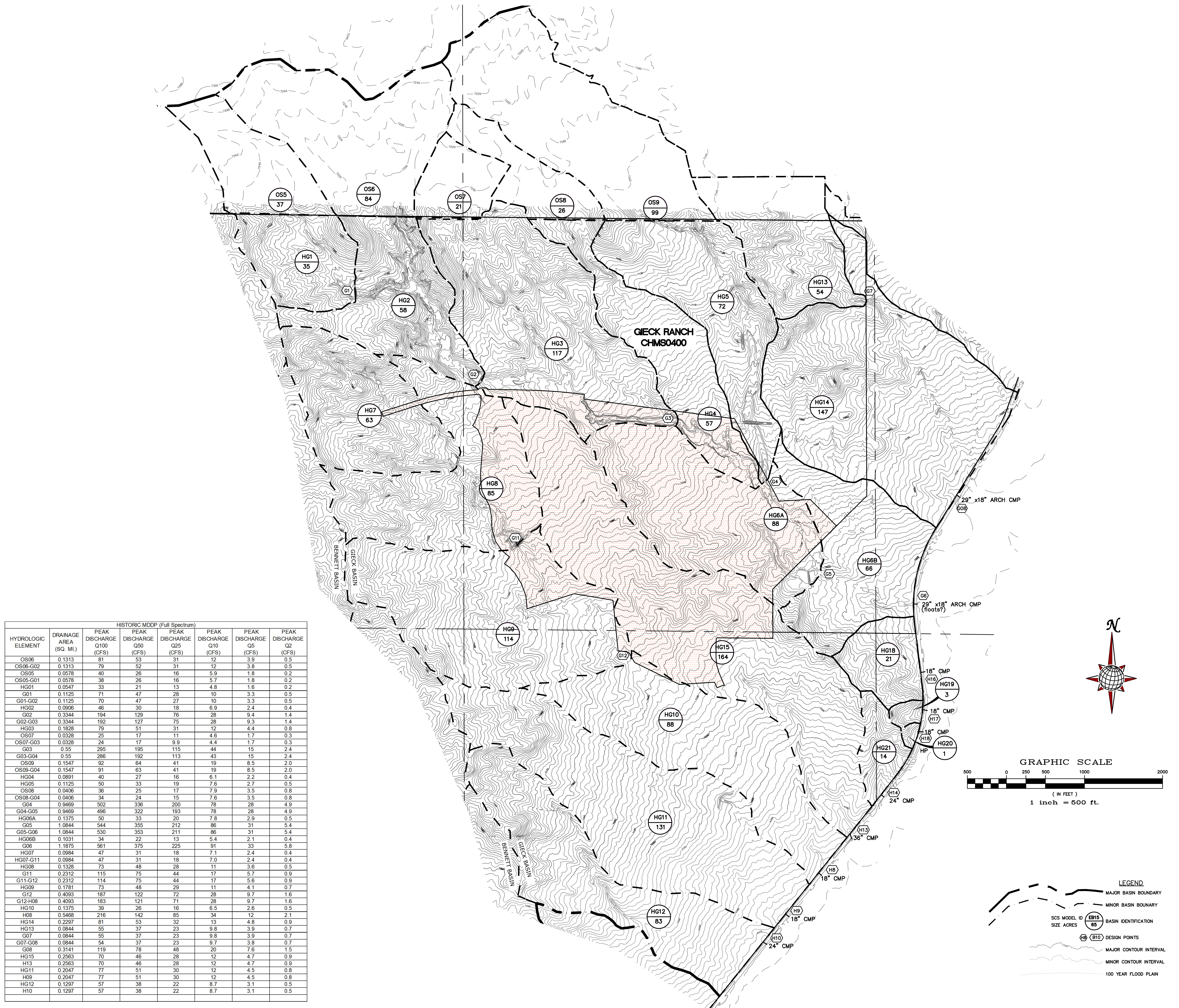

HYDROLOGIC ELEMENT	DRAINAGE AREA (SQ. MI.)	HISTORIC MDDP (Full Spectrum)					
		PEAK DISCHARGE Q100 (CFS)	PEAK DISCHARGE Q50 (CFS)	PEAK DISCHARGE Q25 (CFS)	PEAK DISCHARGE Q10 (CFS)	PEAK DISCHARGE Q5 (CFS)	PEAK DISCHARGE Q2 (CFS)
OS06	0.1313	81	53	31	12	3.9	0.5
OS06-G02	0.1313	79	52	31	12	3.8	0.5
OS05	0.0578	40	26	16	5.9	1.8	0.2
OS05-G01	0.0578	38	26	16	5.7	1.8	0.2
HG01	0.0547	33	21	13	4.8	1.6	0.2
G01	0.1125	71	47	28	10	3.3	0.5
G01-G02	0.1125	70	47	27	10	3.3	0.5
HG02	0.0906	46	30	18	6.9	2.4	0.4
G02	0.3344	194	129	76	28	9.4	1.4
G02-G03	0.3344	192	127	75	28	9.3	1.4
HG03	0.1828	79	51	31	12	4.4	0.8
OS07	0.0328	25	17	11	4.6	1.7	0.3
OS07-G03	0.0328	24	17	9.9	4.4	1.7	0.3
G03	0.55	295	195	115	44	15	2.4
G03-G04	0.55	286	192	113	43	15	2.4
OS09	0.1547	92	64	41	19	8.5	2.0
OS09-G04	0.1547	91	63	41	19	8.5	2.0
HG04	0.0891	40	27	16	6.1	2.2	0.4
HG05	0.1125	50	33	19	7.6	2.7	0.5
OS08	0.0406	36	25	17	7.9	3.5	0.8
OS08-G04	0.0406	34	24	15	7.6	3.5	0.8
G04	0.9469	502	336	200	78	28	4.9
G04-G05	0.9469	496	322	193	76	28	4.9
HG06A	0.1375	50	33	20	7.8	2.9	0.5
G05	1.0844	544	355	212	86	31	5.4
G05-G06	1.0844	530	353	211	86	31	5.4
HG06B	0.1031	34	22	13	5.4	2.1	0.4
G06	1.1875	561	375	225	91	33	5.8
HG07	0.0984	47	31	18	7.1	2.4	0.4
HG07-G11	0.0984	47	31	18	7.0	2.4	0.4
HG08	0.1328	73	48	28	11	3.6	0.5
G11	0.2312	115	75	44	17	5.7	0.9
G11-G12	0.2312	114	75	44	17	5.6	0.9
HG09	0.1781	73	48	29	11	4.1	0.7
G12	0.4093	187	122	72	28	9.7	1.6
G12-H08	0.4093	183	121	71	28	9.7	1.6
HG10	0.1375	39	26	16	6.5	2.6	0.5
H08	0.5468	216	142	85	34	12	2.1
HG14	0.2297	81	53	32	13	4.8	0.9
HG13	0.0844	55	37	23	9.8	3.9	0.7
G07	0.0844	55	37	23	9.8	3.9	0.7
G07-G08	0.0844	54	37	23	9.7	3.8	0.7
G08	0.3141	119	78	48	20	7.6	1.5
HG15	0.2563	70	46	28	12	4.7	0.9
H13	0.2563	70	46	28	12	4.7	0.9
HG11	0.2047	77	51	30	12	4.5	0.8
H09	0.2047	77	51	30	12	4.5	0.8
HG12	0.1297	57	38	22	8.7	3.1	0.5
H10	0.1297	57	38	22	8.7	3.1	0.5

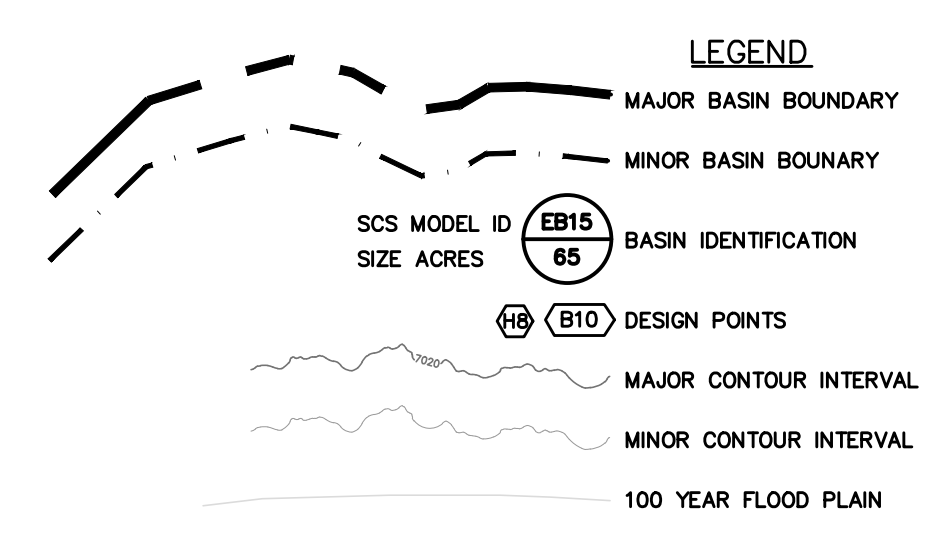
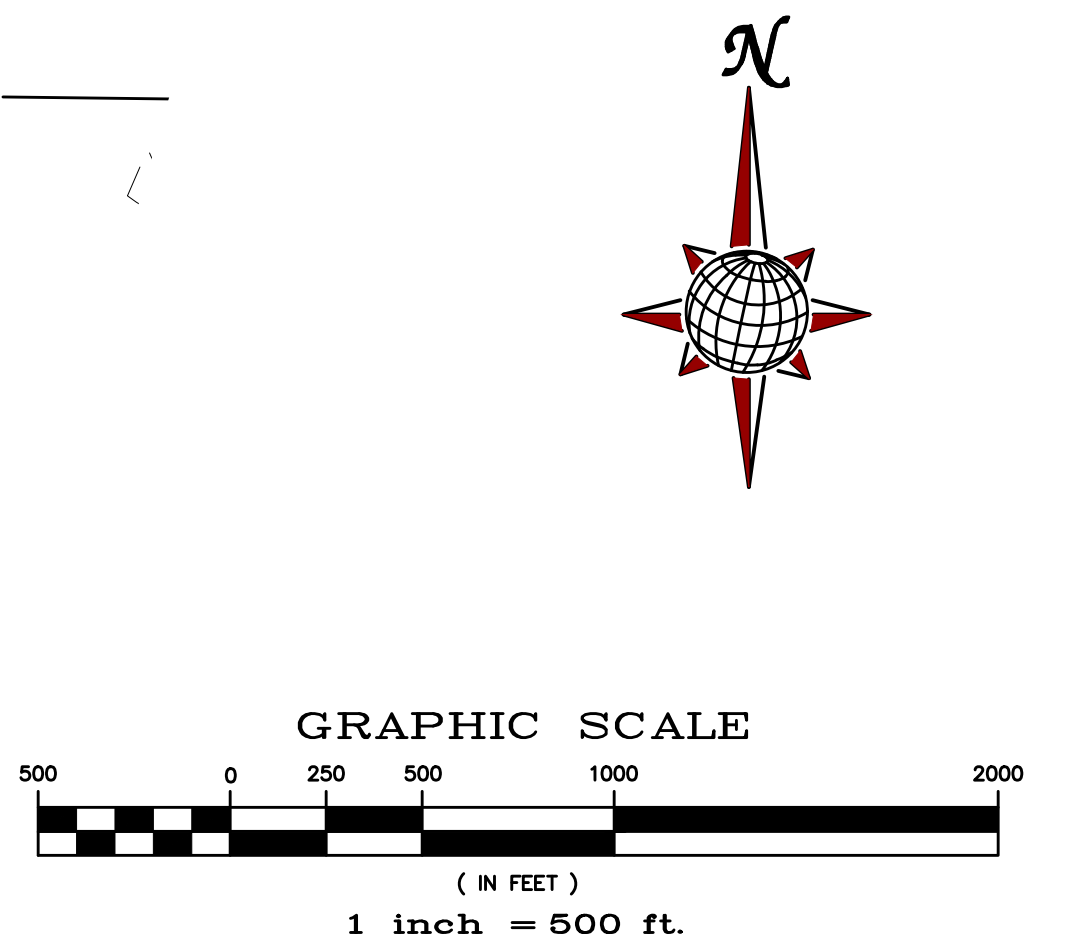

TECH CONTRACTORS
11886 STAPLETON DRIVE
FALCON, CO 80831
TELEPHONE: 719.495.7444

HISTORIC CONDITIONS - SCS MAP

AUG 2019

FIGURE 4

ROLLING HILL RANCH PUD MERIDIAN RANCH

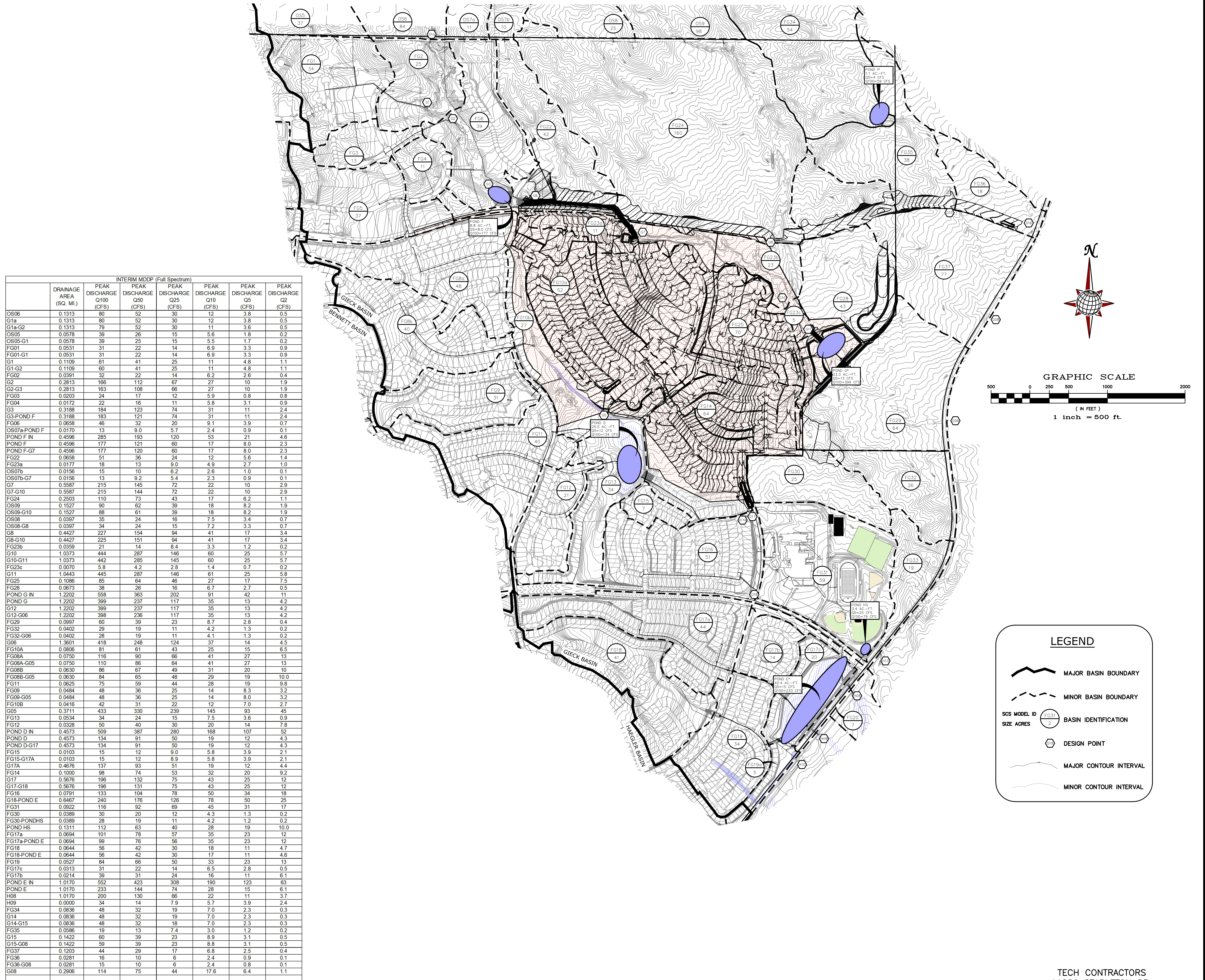

DRAINAGE AREA (SQ. MI.)	INTERIM MDDP (Full Spectrum)						
	PEAK DISCHARGE Q100 (CFS)	PEAK DISCHARGE Q50 (CFS)	PEAK DISCHARGE Q25 (CFS)	PEAK DISCHARGE Q10 (CFS)	PEAK DISCHARGE Q5 (CFS)	PEAK DISCHARGE Q2 (CFS)	
OS06	0.1313	80	52	30	12	3.8	0.5
G1a	0.1313	80	52	30	12	3.8	0.5
G1a-G2	0.1313	79	52	30	11	3.6	0.5
OS05	0.0578	39	26	15	5.6	1.8	0.2
OS05-G1	0.0578	39	25	15	5.5	1.7	0.2
FG01	0.0531	31	22	14	6.9	3.3	0.9
FG01-G1	0.0531	31	22	14	6.9	3.3	0.9
G1	0.1109	61	41	25	11	4.8	1.1
G1-G2	0.1109	60	41	25	11	4.8	1.1
FG02	0.0391	32	22	14	6.2	2.6	0.4
G2	0.2813	168	112	67	27	10	1.9
G2-G3	0.2813	163	108	66	27	10	1.9
FG03	0.0203	24	17	12	5.9	0.8	0.8
FG04	0.0172	22	16	11	5.8	3.1	0.9
G3	0.3188	184	123	74	31	11	2.4
G3-POND F	0.3188	183	121	74	31	11	2.4
FG06	0.0658	46	32	20	9.1	3.9	0.7
OS07a-POND F	0.0170	13	9.0	5.7	2.4	0.9	0.1
POND F IN	0.4586	285	193	120	53	21	4.6
POND F	0.4586	177	121	60	17	8.0	2.3
POND F-G7	0.4586	177	120	60	17	8.0	2.3
FG22	0.0658	51	36	24	12	5.6	1.4
FG23a	0.0177	18	13	9.0	4.9	2.7	1.0
OS07b-G10	0.0156	15	10	6.2	2.6	1.0	0.1
OS07b-G7	0.0156	13	9.2	5.4	2.3	0.9	0.1
G7	0.5587	215	145	72	22	10	2.9
G7-G10	0.5587	215	144	72	22	10	2.9
FG24	0.2503	110	73	43	17	6.2	1.1
OS09	0.1527	90	62	39	18	8.2	1.9
OS09-G10	0.1527	88	61	38	18	8.2	1.9
OS08	0.0397	35	24	16	7.5	3.4	0.7
OS08-G8	0.0397	34	24	15	7.2	3.3	0.7
G8	0.4427	227	154	94	41	17	3.4
G8-G10	0.4427	225	151	94	41	17	3.4
FG23b	0.0359	21	14	8.4	3.3	1.2	0.2
G10	1.0373	444	287	146	60	25	5.7
G10-G11	1.0373	442	286	145	60	25	5.7
FG23c	0.0070	5.8	4.2	2.8	1.4	0.7	0.2
G11	1.0443	445	287	146	61	25	5.8
FG25	0.1086	85	64	46	27	17	7.5
FG28	0.0673	38	26	16	6.7	2.7	0.5
POND G IN	1.2202	558	363	202	91	42	11
POND G	1.2202	398	237	117	35	13	4.2
G12	1.2202	399	237	117	35	13	4.2
G12-G06	1.2202	398	236	117	35	13	4.2
FG29	0.0997	60	39	23	8.7	2.8	0.4
FG32	0.0402	29	19	11	4.2	1.3	0.2
FG32-G06	0.0402	28	19	11	4.1	1.3	0.2
G06	1.3601	418	248	124	37	14	4.5
FG10a	0.0806	81	61	43	25	15	6.5
FG08a	0.0750	116	90	66	41	27	13
FG08a-G05	0.0750	110	86	64	41	27	13
FG08b	0.0630	86	67	49	31	20	10
FG08b-G05	0.0630	84	65	48	29	19	10.0
FG11	0.0625	75	59	44	28	19	9.8
FG09	0.0484	48	36	25	14	8.3	3.2
FG09-G05	0.0484	48	36	25	14	8.0	3.2
FG10b	0.0416	42	31	22	12	7.0	2.7
G05	0.3711	433	330	239	145	93	45
FG13	0.0534	34	24	15	7.5	3.6	0.9
FG12	0.0328	50	40	30	20	14	7.8
POND D IN	0.4573	509	367	280	168	107	52
POND D	0.4573	134	91	50	19	12	4.3
POND D-G17	0.4573	134	91	50	19	12	4.3
FG15	0.0103	15	12	9.0	5.8	3.9	2.1
FG15-G17a	0.0103	15	12	8.9	5.8	3.9	2.1
G17a	0.4676	137	93	51	19	12	4.4
FG14	0.1000	98	74	53	32	20	9.2
G17	0.5676	198	132	75	43	25	12
G17-G18	0.5676	196	131	75	43	25	12
FG16	0.0791	133	104	78	50	34	18
G18-POND E	0.6467	240	176	126	78	50	25
FG31	0.0922	116	92	69	45	31	17
FG30	0.0389	30	20	12	4.3	1.3	0.2
FG30-PONDHS	0.0389	28	19	11	4.2	1.2	0.2
POND HS	0.1311	112	63	40	28	19	10.0
FG17a	0.0694	101	78	57	35	23	12
FG17a-POND E	0.0694	99	76	56	35	23	12
FG18	0.0644	56	42	30	18	11	4.7
FG18-POND E	0.0644	56	42	30	17	11	4.6
FG19	0.0627	84	66	50	33	23	13
FG17b	0.0313	31	22	14	6.5	2.8	0.5
FG17b	0.0214	39	31	24	16	11	6.1
POND E IN	1.0170	552	423	308	190	123	63
POND E	1.0170	233	144	74	28	15	6.1
H08	1.0170	200	130	66	22	11	3.7
H09	0.0000	34	14	7.9	5.7	3.9	2.4
FG34	0.0836	48	32	19	7.0	2.3	0.3
G14	0.0836	48	32	19	7.0	2.3	0.3
G14-G15	0.0836	48	32	18	7.0	2.3	0.3
FG35	0.0586	19	13	7.4	3.0	1.2	0.2
G15	0.1422	60	39	23	8.9	3.1	0.5
G15-G08	0.1422	59	39	23	8.8	3.1	0.5
FG37	0.1203	44	29	17	6.8	2.5	0.4
FG36	0.0281	16	10	6	2.4	0.9	0.1
FG36-G08	0.0281	15	10	6	2.4	0.8	0.1
G08	0.2906	114	75	44	17.6	6.4	1.1

*NOTE: PRELIMINARY STORAGE VOLUMES AND OUTFLOW QUANTITIES HAVE BEEN PROVIDED FOR EACH OF THE FUTURE DETENTION FACILITIES LOCATED WITHIN THE DEVELOPMENT. THE ACTUAL STORAGE VOLUMES AND DISCHARGE RATES WILL BE DETERMINED UPON A COMPLETE ANALYSIS FOR EACH DETENTION FACILITY PRIOR TO CONSTRUCTION. THE VALUES GIVEN FOR DISCHARGE AND VOLUME ARE ESTIMATES FOR PLANNING PURPOSES ONLY.

INTERIM CONDITIONS - SCS MAP

AUG 2019

FIGURE 5

ROLLING HILL RANCH PUD MERIDIAN RANCH

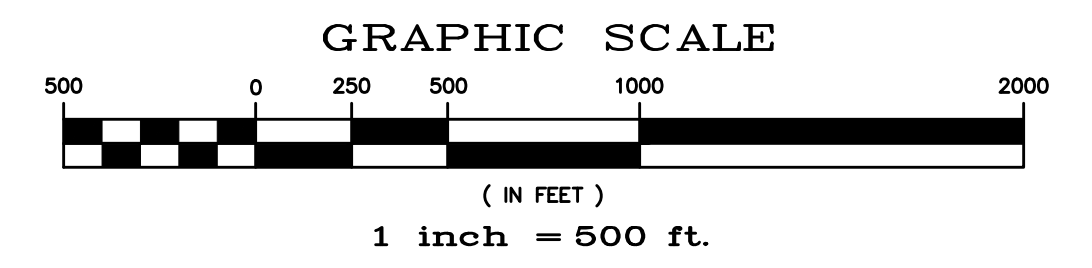

	DRAINAGE AREA (SQ. MI.)	FUTURE MDDP (Full Spectrum)					
		PEAK DISCHARGE Q100 (CFS)	PEAK DISCHARGE Q50 (CFS)	PEAK DISCHARGE Q25 (CFS)	PEAK DISCHARGE Q10 (CFS)	PEAK DISCHARGE Q5 (CFS)	PEAK DISCHARGE Q2 (CFS)
OS06	0.1313	80	52	30	12	3.8	0.5
G1a	0.1313	80	52	30	12	3.8	0.5
G1a-G2	0.1313	79	52	30	11	3.6	0.5
OS05	0.0578	39	26	15	5.6	1.8	0.2
OS05-G1	0.0578	39	25	15	5.5	1.7	0.2
FG01	0.0538	31	22	14	7.0	3.4	0.9
FG01-G1	0.0538	31	22	14	6.9	3.4	0.9
G1	0.1116	61	41	25	11	4.9	1.1
G1-G2	0.1116	61	41	25	11	4.8	1.1
FG02	0.0391	32	22	14	6.4	2.7	0.5
G2	0.2820	167	112	67	27	10	1.9
G2-G3	0.2820	163	109	66	27	10	1.9
FG03	0.0203	24	17	12	5.9	0.8	0.8
FG04	0.0172	22	16	11	5.8	3.1	0.9
G3	0.3195	185	123	74	31	11	2.4
G3-POND F	0.3195	183	121	74	31	11	2.4
FG06	0.0608	49	34	22	10	4.6	0.9
FG05	0.0580	45	33	23	12	6.7	2.4
OS07a	0.0170	14	9.2	5.7	2.5	0.9	0.1
OS07a-POND F	0.0170	13	9.0	5.7	2.4	0.9	0.1
POND F IN	0.4553	296	194	120	52	22	4.7
POND F	0.4553	177	121	61	17	8.1	2.3
POND F-G7	0.4553	177	120	60	17	8.1	2.3
FG21b	0.0170	25	20	15	9.6	6.5	3.5
FG21a	0.0072	7.2	5.0	3.2	1.4	0.5	0.1
FG21a-G7	0.0072	6.8	4.9	2.7	1.4	0.5	0.1
G7	0.4795	186	126	64	18	8.8	3.6
G7-G8	0.4795	185	126	64	18	8.8	3.5
FG22	0.1380	102	73	47	24	12	3.3
OS08	0.0406	35	25	16	7.7	3.4	0.7
OS08-G8	0.0406	34	24	15	7.5	3.4	0.7
FG23a	0.0216	21	15	10	5.2	2.7	0.8
OS07b	0.0156	15	10	6.2	2.6	1.0	0.1
OS07b-G7	0.0156	14	10	6.0	2.4	0.9	0.1
G8	0.6953	291	186	95	47	24	7.4
G8-G10	0.6953	288	186	94	46	24	7.4
OS09	0.1527	90	62	39	18	8.2	1.9
OS09-G10	0.1527	88	62	39	18	8.2	1.9
FG24	0.1373	105	76	50	26	15	4.0
G9	0.2900	180	125	81	38	17	4.4
G9-G10	0.2900	178	125	79	37	17	4.4
FG23b	0.0286	23	16	10	4.6	2.0	0.4
G10	1.0139	478	307	174	80	39	12
G10-G11	1.0139	474	305	173	80	38	12
FG23c	0.0122	12	8.7	5.7	3.0	1.5	0.4
G11	1.0261	479	308	176	81	39	12
FG25	0.1086	85	64	46	27	17	7.5
FG26	0.0863	78	58	40	22	12	4.6
FG26-POND G	0.0863	77	57	39	22	12	4.5
FG27	0.0500	52	40	29	17	11	5.0
FG28	0.0245	18	13	8.5	4.1	2.0	0.5
POND G IN	1.2955	684	454	287	145	75	28
POND G	1.2955	478	333	170	56	22	5.1
G12	1.2955	478	333	170	56	22	5.1
G12-G06	1.2955	478	332	170	56	22	5.1
FG29	0.0997	60	39	23	8.7	2.8	0.4
FG32	0.0402	72	57	44	26	20	1.1
FG32-G06	0.0402	69	54	41	27	18	1.1
G06	1.4354	506	352	181	61	24	1.1
FG10A	0.0806	81	61	43	25	15	6.5
FG08A	0.0750	116	90	66	41	27	1.3
FG08A-G05	0.0750	110	86	64	41	27	1.3
FG08E	0.0630	86	67	49	31	20	1.0
FG08B-G05	0.0630	84	65	48	29	19	1.0
FG11	0.0625	75	59	44	28	19	9.8
FG09	0.0484	48	36	25	14	8.3	3.2
FG09-G05	0.0484	48	36	25	14	8.0	3.2
FG10B	0.0416	42	31	22	12	7.0	2.7
G05	0.3711	433	330	239	145	93	45
FG13	0.0534	34	24	15	7.5	3.8	0.9
FG12	0.0328	50	40	30	20	14	7.8
POND D IN	0.4573	509	387	280	168	107	52
POND D	0.4573	134	91	50	19	12	4.3
POND D-G17	0.4573	134	91	50	19	12	4.3
FG15	0.0103	15	12	9.0	5.8	3.9	2.1
FG15-G17A	0.0103	15	12	8.9	5.8	3.9	2.1
G17A	0.4676	137	93	51	19	12	4.4
FG14	0.1000	98	74	53	32	20	9.2
G17	0.5676	196	132	75	43	25	12
G17-G18	0.5676	196	131	75	43	25	12
FG16	0.0791	133	104	78	50	34	18
G18	0.6467	240	178	128	79	51	26
G18-POND E	0.6467	240	176	128	78	50	25
FG31	0.0922	116	92	69	45	31	17
FG30	0.0389	73	57	44	29	20	1.1
FG30-PONDHS	0.0389	70	56	42	27	18	1.1
POND HS	0.1311	153	106	53	36	26	15
FG17a	0.0694	101	78	57	35	23	12
FG17a-POND E	0.0694	99	76	56	35	23	12
FG18	0.0644	66	42	30	18	11	4.7
FG18-POND E	0.0644	56	42	30	17	11	4.6
FG19	0.0527	84	66	50	33	23	1.3
FG17c	0.0313	31	22	14	6.5	2.8	0.5
FG17b	0.0214	39	31	24	16	11	6.1
POND E IN	1.0170	610	432	318	197	126	64
POND E	1.0170	242	153	90	30	16	6.6
H08	1.0170	205	137	72	24	12	4.1
H09	0.0000	37	16	8.3	5.9	4.1	2.4
FG34	0.0600	34	23	13	5.5	2.0	0.3
G14	0.0600	34	23	13	5.5	2.0	0.3
G14-G15	0.0600	34	22	13	5.4	2.0	0.3
FG35	0.0344	20	13	8.3	3.5	1.5	0.3
G15	0.0944	53	36	21	8.7	3.3	0.6
G15-G08	0.0944	52	35	21	8.7	3.3	0.6
FG37	0.0797	41	27	16	6.0	2.0	0.3
FG36	0.0281	14	9.4	5.5	2.1	0.7	0.1
FG36-G08	0.0281	14	9.3	5.4	2.1	0.7	0.1
G08	0.2022	106	69	41	16	5.8	1.0

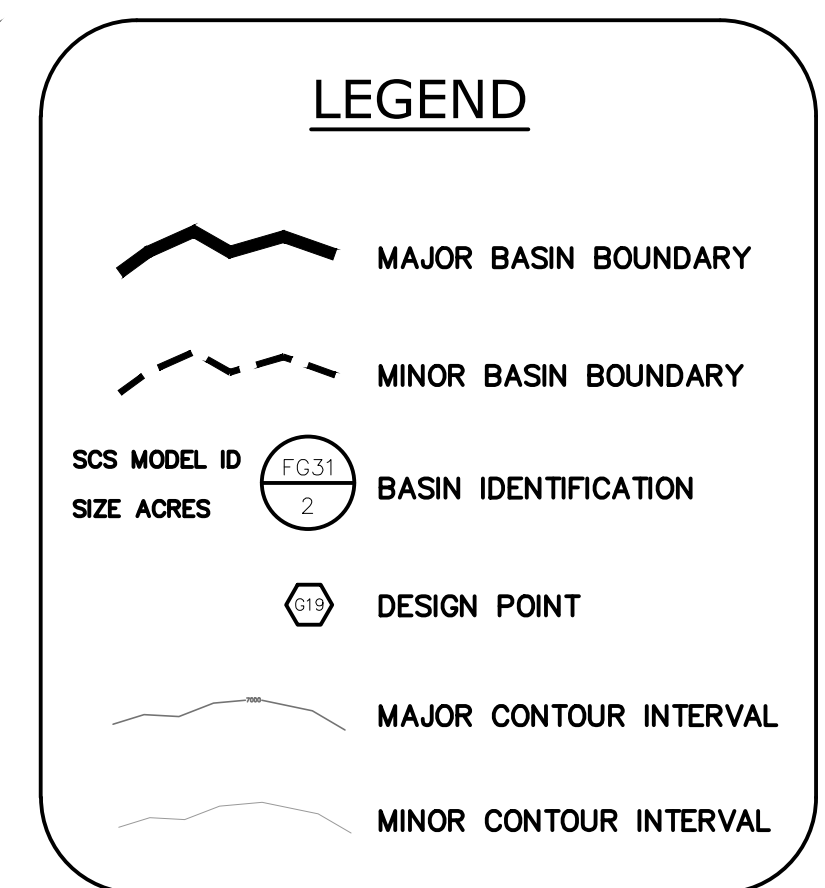
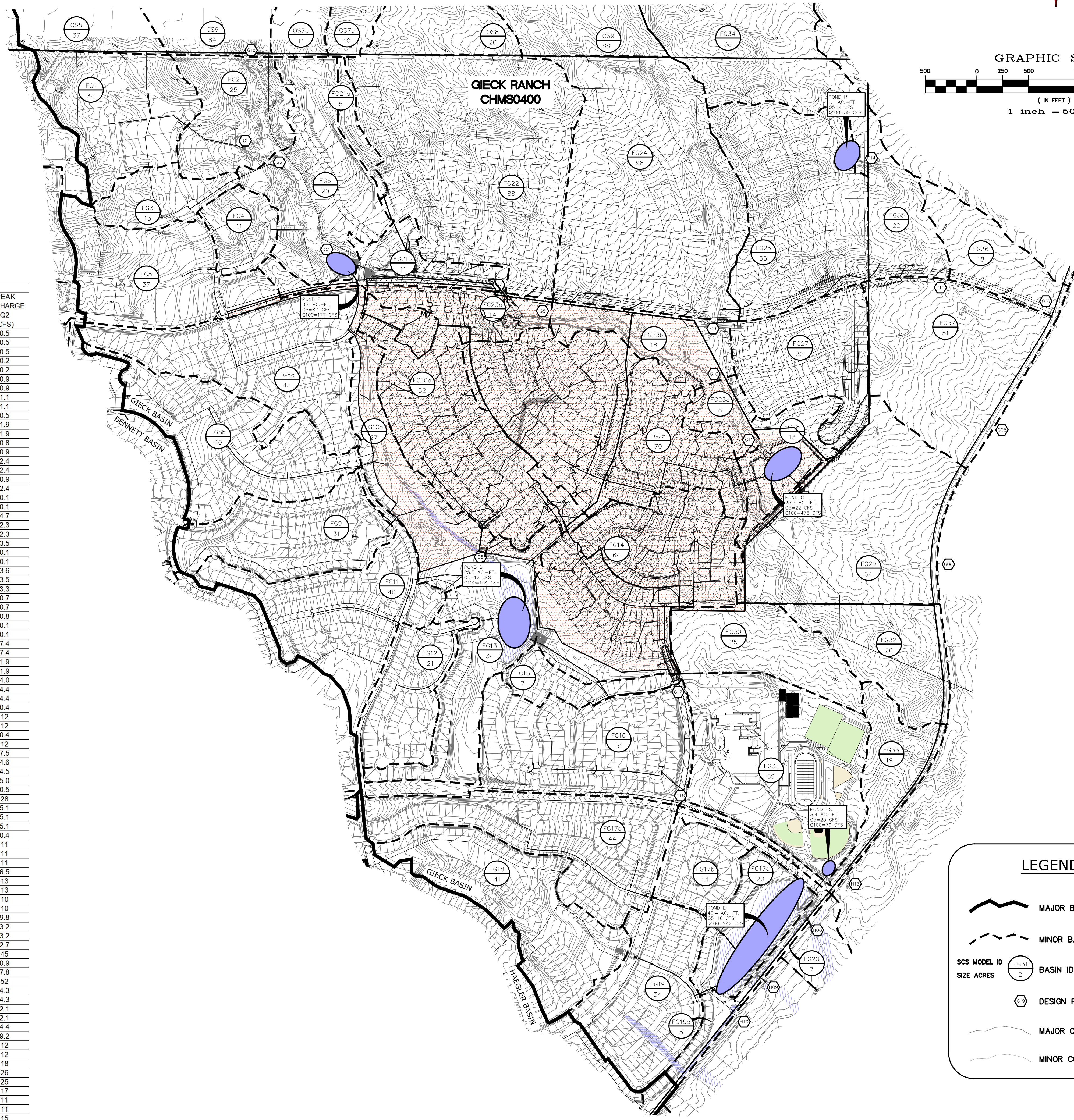

*NOTE: PRELIMINARY STORAGE VOLUMES AND OUTFLOW QUANTITIES HAVE BEEN PROVIDED FOR EACH OF THE FUTURE DETENTION FACILITIES LOCATED WITHIN THE DEVELOPMENT. THE ACTUAL STORAGE VOLUMES AND DISCHARGE RATES WILL BE DETERMINED UPON A COMPLETE ANALYSIS FOR EACH DETENTION FACILITY PRIOR TO CONSTRUCTION. THE VALUES GIVEN FOR DISCHARGE AND VOLUME ARE ESTIMATES FOR PLANNING PURPOSES ONLY.

DEVELOPED CONDITIONS - SCS MAP

TECH CONTRACTORS
11886 STAPLETON DR.
FALCON, CO 80831
TELEPHONE: 719.495.7444

