

November 26, 2018



**ENTECH**  
ENGINEERING, INC.

505 ELKTON DRIVE  
COLORADO SPRINGS, CO 80907  
PHONE (719) 531-5599  
FAX (719) 531-5238

Larry and Barbara Cohn  
10950 Yoemans Park Drive  
Colorado Springs, CO 80908

Re: Plot Plan Review  
12710 Sylvan Meadows Drive  
Lot 27, Sylvan Meadows Filing No. 2  
Colorado Springs, Colorado

Ref: Entech Engineering, Inc. September 29, 1999, *Soil Geology and Wastewater Study, Sylvan Meadows Filing No. 2, El Paso County, Colorado.*  
Entech Job No. 66539.

Entech Engineering, Inc. November 20, 2018, *Subsurface Soil Investigation, 12710 Sylvan Meadows Drive, Lot 27, Sylvan Meadows Filing No. 2, El Paso County, Colorado.*  
Entech Job No. 181683.

Dear Mr. and Mrs. Cohn:

As requested, personnel of Entech Engineering, Inc. have reviewed geologic conditions for Lot 27. The site lies in the Sylvan Meadows Subdivision that was previously investigated by Entech Engineering, Inc. as a part of the above referenced Soil, Geology and Wastewater Study. The site has since been investigated as part of this review in the above referenced Subsurface Soil Investigation by Entech Engineering, Inc. is presented in Appendix A.

The site was observed on November 19, 2018 by personnel of Entech Engineering, Inc. The Geology/Engineering Geology Map is presented in Figure 1. Site photographs are included in Appendix B.

According to the Soil, Geology and Wastewater Study, portions of the site were mapped as seasonally shallow groundwater areas. Since then, the roadways have been constructed and lot corners staked. The areas with the seasonally shallow groundwater areas have been delineated more accurately for this lot and are indicated on Figure 1. A no-build area was designated on the original plat to avoid the seasonally shallow groundwater areas. The seasonally shallow groundwater area has been modified based on the staked lot corners. It is our opinion that the proposed house location is acceptable for the site conditions and the no-build area should be modified to accommodate the revised seasonally high groundwater area. Two test borings were placed in the approximate area of the proposed building. Groundwater was encountered at 19 feet in Test Boring No 1 and Test Boring No. 2 did not encounter water. The foundation should be kept as shallow as possible to avoid the potential of shallow groundwater. Regrading in areas of seasonal shallow groundwater and directing surface drainage away from the structure can also raise the foundation above the groundwater level and mitigate the hazard. Specific recommendations have been provided in the Subsurface Soil Investigation Appendix A.

Larry and Barbara Cohn  
Plot Plan Review  
12710 Sylvan Meadows Drive  
Lot 27, Sylvan Meadows Filing No. 2  
Colorado Springs, Colorado  
Page Two

We trust this has provided you with the information you required. If you have any questions or need additional information, please do not hesitate to contact us.

Respectfully Submitted,  
ENTECH ENGINEERING, INC.



Logan L. Langford  
Geologist



Kristen Andrew-Hoeser, P.G.  
Engineering Geologist

LLL/III

Encl.

Entech Job No. 181683  
AAprojects/2018/181683 ppr

Reviewed by:

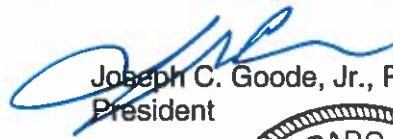

Joseph C. Goode, Jr., P.E.  
President

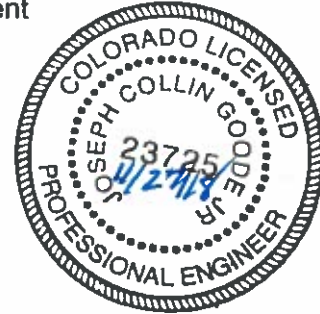

**FIGURES**

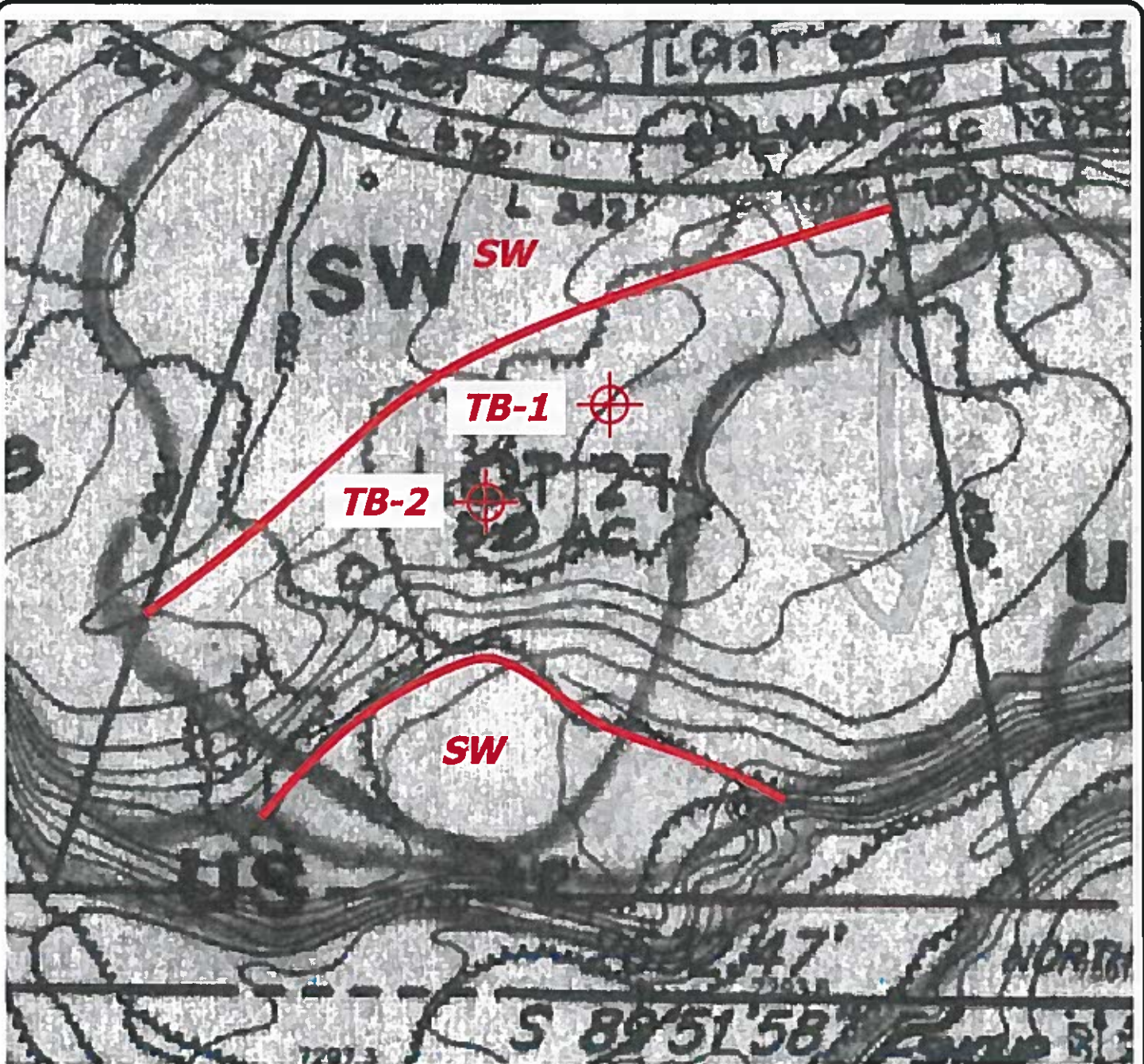

**TB- APPROXIMATE TEST BORING LOCATION AND NUMBER**

**SW- SEASONALLY HIGH GROUNDWATER AREAS**



**ENTECH**  
**ENGINEERING, INC.**  
 585 ELKTON DRIVE  
 COLORADO SPRINGS, CO. 80907 (719) 531-3599

**SITE PLAN/TEST BORING LOCATION MAP**  
 12710 SYLVAN MEADOWS DRIVE  
 LOT 27, SYLVAN MEADOWS FILING NO. 2  
 COLORADO SPRINGS, COLORADO  
 FOR: LARRY AND BARBARA COHN

DRAWN:  
 LLL

DATE:  
 11/20/18

CHECKED:

DATE:

JOB NO.:  
 181683

FIG NO.:  
 1

**APPENDIX A: Entech Engineering, Inc.**  
**Subsurface Soil Investigation, Entech Job No. 181683**



November 26, 2018



**ENTECH**  
ENGINEERING, INC.

505 ELKTON DRIVE  
COLORADO SPRINGS, CO 80907  
PHONE (719) 531-5599  
FAX (719) 531-5238

Larry and Barbara Cohn  
10950 Yoemans Park Drive  
Colorado Springs, CO 80908

Re: Subsurface Soil Investigation  
12710 Sylvan Meadows Drive  
Lot 27, Sylvan Meadows Filing No. 2  
Colorado Springs, Colorado

Dear Mr. and Mrs. Cohn:

Personnel of Entech Engineering, Inc. have drilled two shallow test borings at the site referenced above. Specific findings for the site are presented in this letter.

**Soil Classification:**

Soil types observed in the test boring and test pit on this site were found to consist of a thin layer of silty sand overlying silty sandstone and sandy claystone.

**Allowable Bearing Capacity:**

An allowable bearing pressure of 3500 psf is recommended for the undisturbed very dense sandstone, 2400 psf is recommended for structural fill, if overexcavation is required. An equivalent hydrostatic fluid pressure (in the active state) of 45 pcf is recommended for the native granular soils and imported structural fill.

**Soil Moisture Conditions:**

Moist. Groundwater was encountered subsequent to drilling in Test Boring No. 1 at a depth of 19 feet. It is anticipated that the proposed shallow foundation will not be impacted by shallow water. However, it should be noted that fluctuations in groundwater conditions may occur due to variations in rainfall or other factors not readily apparent at this time. Isolated sand layers within the soil profile can carry water in the subsurface. Water may also flow on top of less permeable clay lenses or bedrock.

**Expansion Potential:**

Highly expansive claystone is commonly found interbedded within the sandstone in this area. Claystone was encountered in Test Boring No. 1 at a depth of 17 feet.

**Fill:**

None.

Larry and Barbara Cohn  
Subsurface Soil Investigation  
12710 Sylvan Meadows Drive  
Lot 27, Sylvan Meadows Filing No. 2  
Colorado Springs, Colorado

**Special Considerations:**

Areas of seasonal shallow groundwater have been mapped on the site (Figure 1). It is anticipated there is sufficient room on the lot to avoid these areas. The foundation should be kept as high as possible to avoid impacts of water. Drains will be necessary for below grade areas.

If expansive soils are encountered at or near foundation grade overexcavation will be required. Excavation of site sand materials is anticipated to be moderate with a rubber-tired equipment. Excavation of the dense sandstone will likely require track mounted equipment. Site granular materials are suitable for use as structural fill pending approval by Entech Engineering, Inc.

**Foundation Type:**

A spread footing (16")/stemwall foundation system, is anticipated for this site. Point load bearing pads should be sized for the allowable bearing capacity given. **This does not constitute a foundation design.** Qualified personnel should verify that building loads do not exceed the bearing value given in this letter. The bottoms of exterior foundations should be located at least 30 inches below finished grade for frost protection.

**Foundation Configuration Remarks:**

The configuration of the foundation system is critical to its performance. The position of foundation windows, jogs, steps and the relative elevation of adjacent and opposite walls determine foundation performance. Improper placement of the above can result in differential and lateral foundation movement. In addition, foundation walls over 4 feet in height should not span over 30 feet in length without specific design.

**Reinforcing:**

Reinforcing should be designed to permit foundation walls to span a minimum of 10 feet under the design load. Foundation walls retaining over 4 feet of soil should be designed to resist an equivalent fluid pressure (in the active state) of 45 pcf. Expansive soils should not be used as backfill material.

**Floor Slabs:**

Floor slabs on grade, if any should be separated from structural portions of the building and allowed to float freely. Interior partitions must be constructed in such a manner that they do not transmit floor slab movement to the roof or overlying floor. Backfill placed below floor slabs should be compacted to a minimum of 95% of its maximum Modified Proctor Dry Density, ASTM D- 1557.

Larry and Barbara Cohn  
Subsurface Soil Investigation  
12710 Sylvan Meadows Drive  
Lot 27, Sylvan Meadows Filing No. 2  
Colorado Springs, Colorado

### **Drainage and Grading:**

The ground surface must be sloped away from the building to provide positive drainage away from the foundation. We recommend an equivalent slope of 6 inches in the first 10 feet (5%) surrounding the structure, where possible, or as required to quickly remove surface water. Where a 5% slope cannot be achieved practically, such as around patios, at inside foundation corners, and between a house and nearby sidewalk, we believe it is desirable to establish as much slope as possible and to avoid irrigation in the area. Roof downspouts should discharge beyond the limits of backfill. We recommend providing splash blocks and downspout extensions to discharge runoff beyond the limits of backfill.

Homebuyers should maintain the surface grading and drainage installed by the builder to assure water is not directed toward the foundations and does not pond near the house. Landscaping should be carefully designed to minimize irrigation adjacent to the foundation. We do not recommend use of impervious plastic membranes below landscaped areas near foundations; geotextile fabrics can control weed growth while allowing evaporation. Plants used close to foundation walls should be limited to those with low moisture requirements; irrigated grass should not be located within 5 feet of the foundation. Sprinklers should not discharge water within 5 feet of foundations. Irrigation should be limited to the minimum amount sufficient to maintain vegetation. Application of more water will increase the potential for slab and foundation movements.

### **Subdrain:**

A subsurface perimeter drain should be placed around useable space below grade and is recommended around the entire structure in the foundation excavation. A typical drain detail is attached.

### **Backfill:**

Backfill should be compacted to 95% of its maximum Modified Proctor Dry Density, ASTM D-1557. Backfill must be compacted by mechanical means. No water flooding techniques of any type should be used in the compaction of backfill on this site. Expansive soils are not to be used as foundation backfill.

### **Concrete:**

Type II cement is recommended for all concrete on this site. Concrete should not be placed on frozen or wet ground. Care should be taken to prevent the accumulation and ponding of water in the footing excavation prior to the placement of concrete. If standing water is present in the excavation, it should be removed by the installing sumps and pumping the water away from the building area. If concrete is placed during periods of cold temperatures, the concrete must be



Larry and Barbara Cohn  
Subsurface Soil Investigation  
12710 Sylvan Meadows Drive  
Lot 27, Sylvan Meadows Filing No. 2  
Colorado Springs, Colorado

kept from freezing. This may require covering the concrete with insulated blankets and heating to prohibit freezing.

**Open Foundation Excavation Observation:**

The open foundation excavation should be observed prior to construction of the foundation in order to verify that no anomalies are present, that materials at the proper design bearing capacity have been encountered, and that no soft spots or debris are present in the foundation area.

**Remarks:**

The recommendations provided in this letter are based upon the observed soil parameters, anticipated foundation loads, and accepted engineering procedures. The recommendations are intended to minimize differential movement resulting from the heaving of expansive soils or resulting from settlement induced by the application of building loads. It must be recognized that the foundation may undergo movement. In addition, concrete floor slabs may experience movement; therefore, adherence to those recommendations which would isolate floor slabs from columns, walls, partitions or other structural components is extremely important, if damage to the superstructure is to be minimized. Any subsequent owners should be apprised of the soil conditions and advised to maintain good practice in the future with regard to surface and subsurface drainage, framing of partitions above floor slabs, drywall and finish work above floor slabs, etc.

We trust this has provided you with the information you required. If you have any questions or need additional information, please do not hesitate to contact us.

Respectfully Submitted,

ENTECH ENGINEERING, INC.



Logan L. Langford  
Geologist

LLL/slf

Entech Job No. 181683  
AAprojects/2018/181683 ssi

Reviewed by:



Joseph C. Goode, Jr.,  
President



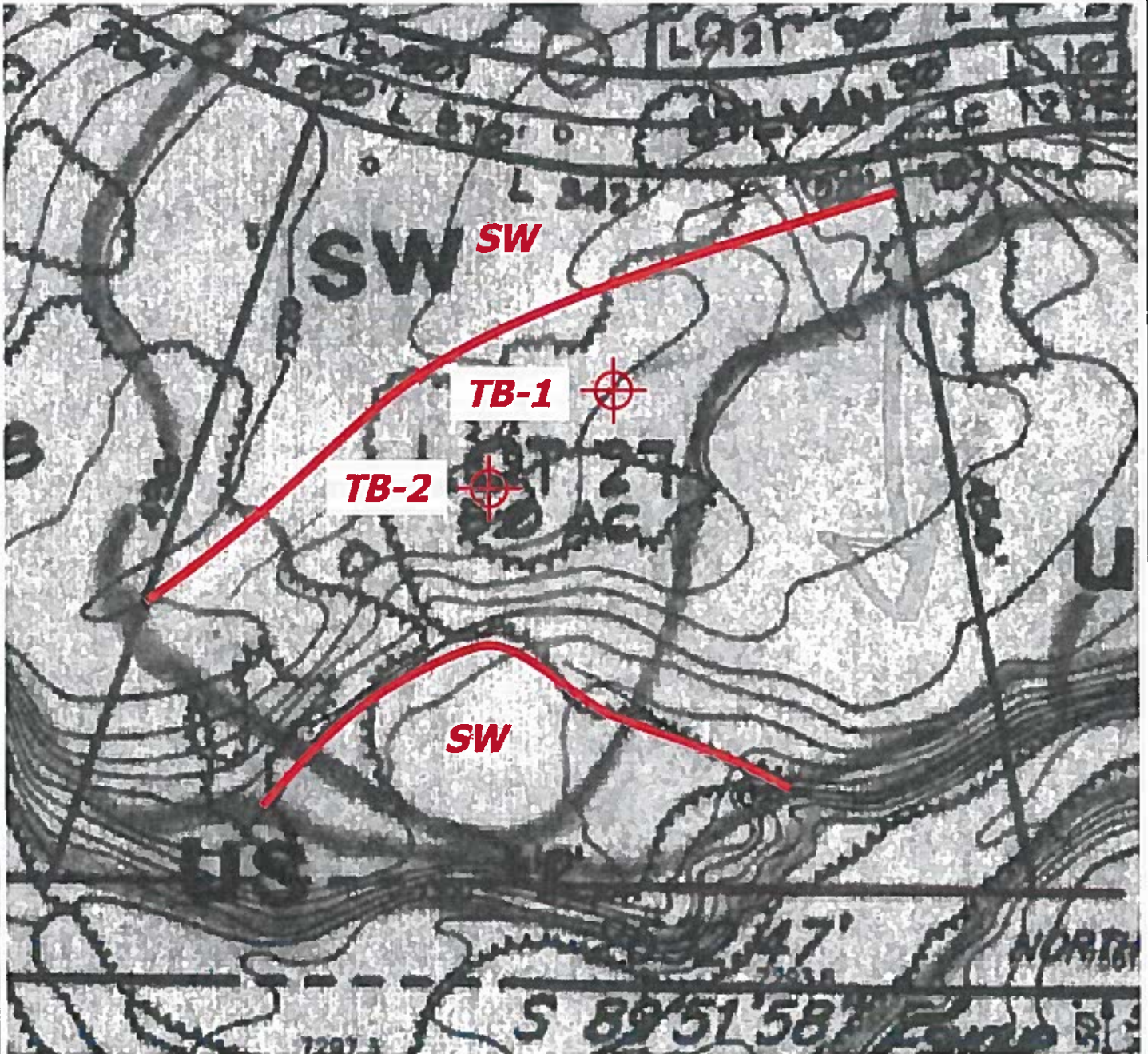

**TB- APPROXIMATE TEST BORING LOCATION AND NUMBER**

**SW- SEASONALLY HIGH GROUNDWATER AREAS**



**ENTECH**  
**ENGINEERING, INC.**  
585 ELAKTON DRIVE  
 COLORADO SPRINGS, CO. 80907 (719) 531-5599

**SITE PLAN/TEST BORING LOCATION MAP**  
 12710 SYLVAN MEADOWS DRIVE  
 LOT 27, SYLVAN MEADOWS FILING NO. 2  
 COLORADO SPRINGS, COLORADO  
 FOR: LARRY AND BARBARA COHN

**DRAWN:**  
 LLL

**DATE:**  
 11/20/18

**CHECKED:**

**DATE:**

**JOB NO.:**  
 181683

**FIG NO.:**  
 1

TEST BORING NO. 1  
 DATE DRILLED 11/10/2018  
 Job # 181683

TEST BORING NO. 2  
 DATE DRILLED 11/10/2018  
 CLIENT LARRY & BARBARA COHN  
 LOCATION 12710 SYLVAN MEADOWS DR.

REMARKS

REMARKS

WATER AT 19', 11/19/18

SAND, SILTY, BROWN  
 SANDSTONE, SILTY, FINE TO  
 COARSE GRAINED, TAN, VERY  
 DENSE, MOIST

CLAYSTONE, SANDY, GRAY  
 BROWN, MOIST

\* - BULK SAMPLE TAKEN



Depth (ft)	Symbol	Samples	Blows per foot	Watercontent %	Soil Type
0	11				
5			50 6"	8.6	
5			50 4"	7.1	
10			50 6"	10.7	
15			50 6"	9.5	
20			*	8.1	

DRY TO 15', 11/19/18

SAND, SILTY, BROWN  
 SANDSTONE, SILTY, FINE TO  
 COARSE GRAINED, TAN, VERY  
 DENSE, MOIST

CLAYEY LENSES

Depth (ft)	Symbol	Samples	Blows per foot	Watercontent %	Soil Type
0	11				
5			45 6"	6.6	
5			50 6"	10.4	
10			50 4"	16.1	
15			50 4"	20.3	
20					



**ENTECH**  
 ENGINEERING, INC.  
 505 ELKTON DRIVE  
 COLORADO SPRINGS, COLORADO 80907

TEST BORING LOG

DRAWN:	DATE:	CHECKED:	DATE:
		LLH	11/20/19

JOB NO.:  
181683

FIG NO.:

2

BORING NO.	1	UNIFIED CLASSIFICATION	SM	TEST BY	BL
DEPTH(ft)	2-3	AASHTO CLASSIFICATION		JOB NO.	181683
CLIENT	LARRY & BARBARA COHN				
PROJECT	12710 SYLVAN MEADOWS DR.				

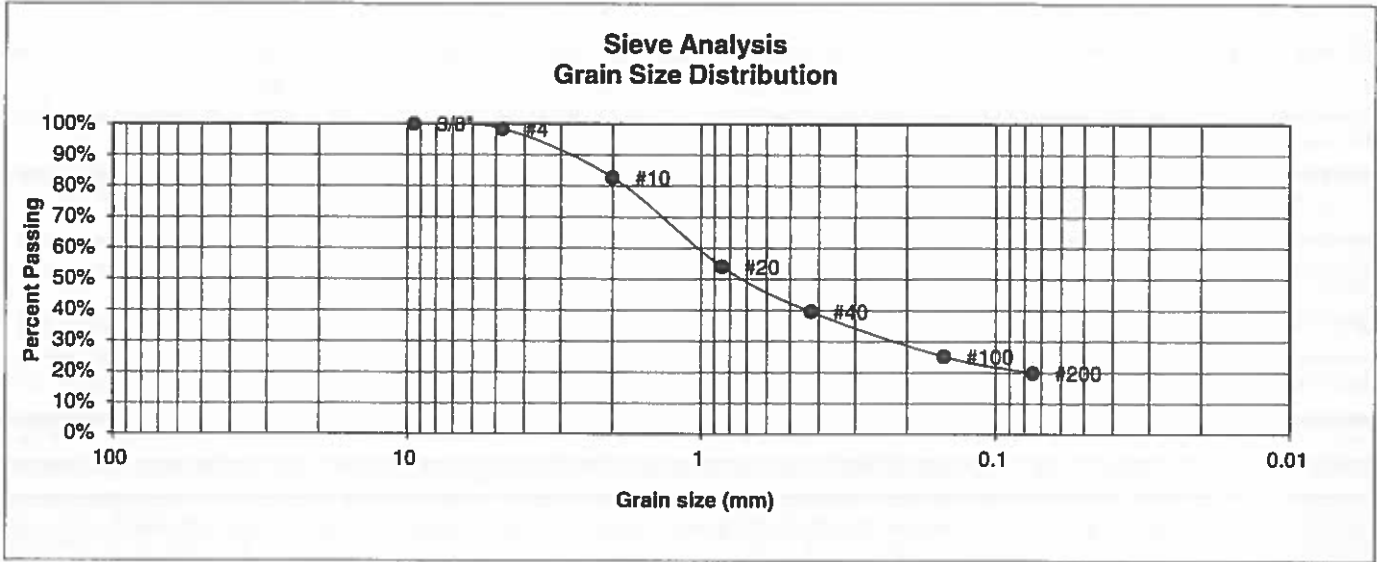

U.S. Sieve #	Percent Finer
3"	
1 1/2"	
3/4"	
1/2"	
3/8"	100.0%
4	98.4%
10	82.7%
20	54.1%
40	39.6%
100	25.2%
200	19.9%

**Atterberg Limits**  
 Plastic Limit  
 Liquid Limit  
 Plastic Index

**Swell**  
 Moisture at start  
 Moisture at finish  
 Moisture increase  
 Initial dry density (pcf)  
 Swell (psf)



**ENTECH  
ENGINEERING, INC.**

505 ELKTON DRIVE  
COLORADO SPRINGS, COLORADO 80907

**LABORATORY TEST  
RESULTS**

DRAWN:	DATE:	CHECKED:	DATE:
		<i>W</i>	6/14/10

JOB NO.:  
181683

FIG NO.:  
3

BORING NO.	1	UNIFIED CLASSIFICATION	CL	TEST BY	BL
DEPTH(ft)	20	AASHTO CLASSIFICATION		JOB NO.	181683
CLIENT	LARRY & BARBARA COHN				
PROJECT	12710 SYLVAN MEADOWS DR.				

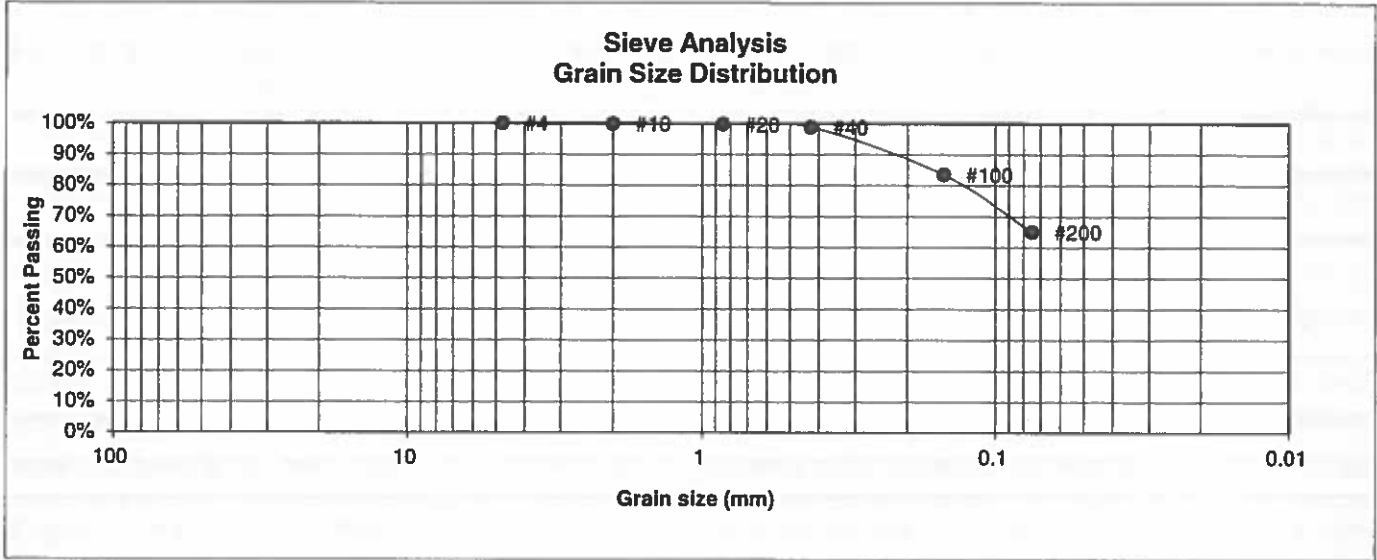

U.S. Sieve #	Percent Finer
3"	
1 1/2"	
3/4"	
1/2"	
3/8"	
4	100.0%
10	99.9%
20	99.7%
40	98.9%
100	83.5%
200	65.1%

**Atterberg Limits**  
 Plastic Limit  
 Liquid Limit  
 Plastic Index

**Swell**  
 Moisture at start  
 Moisture at finish  
 Moisture increase  
 Initial dry density (pcf)  
 Swell (psf)



**ENTECH  
ENGINEERING, INC.**

505 ELKTON DRIVE  
COLORADO SPRINGS, COLORADO 80907

**LABORATORY TEST  
RESULTS**

DRAWN:

DATE:

CHECKED: *h*

DATE: 11/19/10

JOB NO.:  
181683

FIG NO.:

4



BORING NO.	2	UNIFIED CLASSIFICATION	SM	TEST BY	BL
DEPTH(ft)	5	AASHTO CLASSIFICATION		JOB NO.	181683
CLIENT	LARRY & BARBARA COHN				
PROJECT	12710 SYLVAN MEADOWS DR.				

**Sieve Analysis  
Grain Size Distribution**

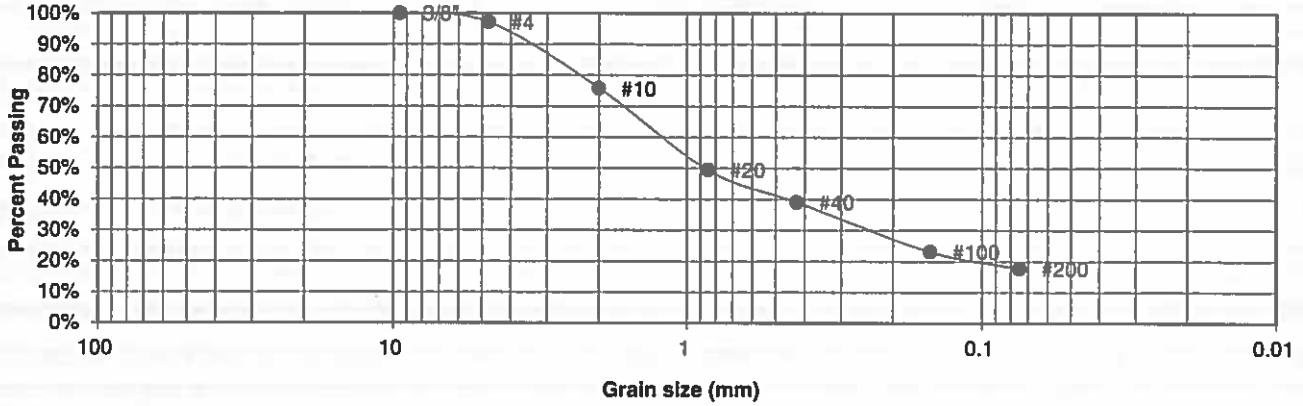

U.S. Sieve #	Percent Finer
3"	
1 1/2"	
3/4"	
1/2"	
3/8"	100.0%
4	97.2%
10	75.9%
20	49.5%
40	39.1%
100	23.2%
200	17.7%

**Atterberg Limits**  
 Plastic Limit  
 Liquid Limit  
 Plastic Index

**Swell**  
 Moisture at start  
 Moisture at finish  
 Moisture increase  
 Initial dry density (pcf)  
 Swell (psf)



**ENTECH  
ENGINEERING, INC.**

505 ELKTON DRIVE  
COLORADO SPRINGS, COLORADO 80907

**LABORATORY TEST  
RESULTS**

DRAWN:

DATE:

CHECKED: *[Signature]*

DATE:

11/14/18

JOB NO.:  
181683

FIG NO.:

5



BORING NO.	2	UNIFIED CLASSIFICATION	SM	TEST BY	BL
DEPTH(ft)	15	AASHTO CLASSIFICATION		JOB NO.	181683
CLIENT	LARRY & BARBARA COHN				
PROJECT	12710 SYLVAN MEADOWS DR.				

**Sieve Analysis  
Grain Size Distribution**

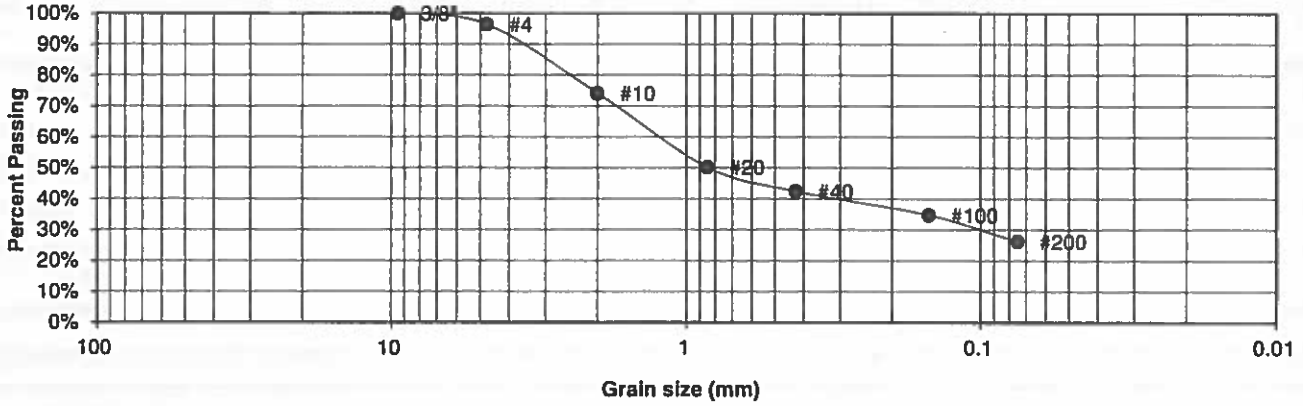

U.S. Sieve #	Percent Finer
3"	
1 1/2"	
3/4"	
1/2"	
3/8"	100.0%
4	96.4%
10	74.1%
20	50.2%
40	42.4%
100	34.7%
200	26.2%

**Atterberg Limits**  
 Plastic Limit  
 Liquid Limit  
 Plastic Index

**Swell**  
 Moisture at start  
 Moisture at finish  
 Moisture increase  
 Initial dry density (pcf)  
 Swell (psf)



**ENTECH  
ENGINEERING, INC.**

505 ELKTON DRIVE  
COLORADO SPRINGS, COLORADO 80907

**LABORATORY TEST  
RESULTS**

DRAWN:

DATE:

CHECKED: *h*

DATE: 11/14/12

JOB NO.:  
181683

FIG NO.:

6

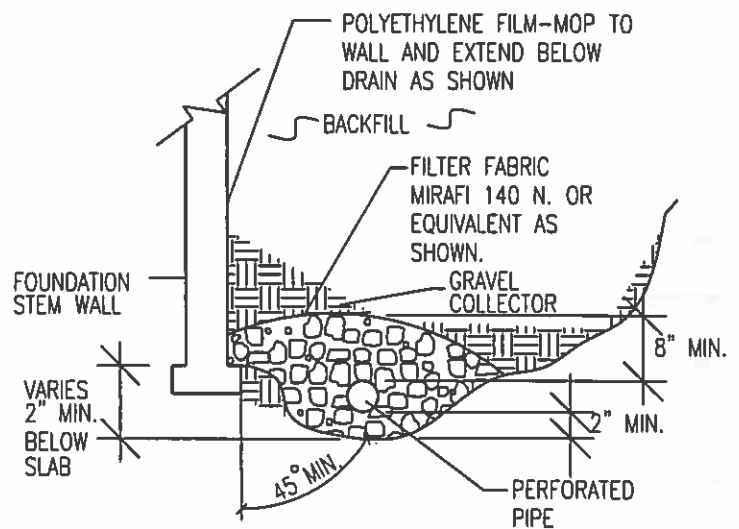
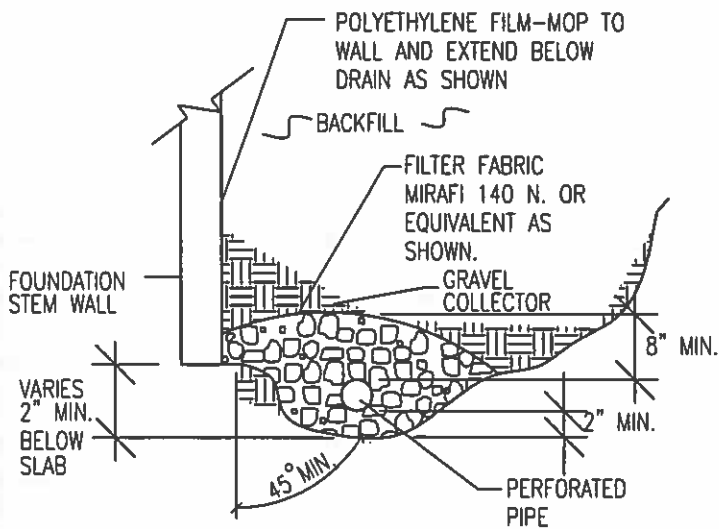

NOTES:

-GRAVEL SIZE IS RELATED TO DIAMETER OF PIPE PERFORATIONS-85% GRAVEL GREATER THAN 2x PERFORATION DIAMETER.

-PIPE DIAMETER DEPENDS UPON EXPECTED SEEPAGE. 4-INCH DIAMETER IS MOST OFTEN USED.

-ALL PIPE SHALL BE PERFORATED PLASTIC. THE DISCHARGE PORTION OF THE PIPE SHOULD BE NON-PERFORATED PIPE.

-FLEXIBLE PIPE MAY BE USED UP TO 8 FEET IN DEPTH, IF SUCH PIPE IS DESIGNED TO WITHSTAND THE PRESSURES. RIGID PLASTIC PIPE WOULD OTHERWISE BE REQUIRED.

-MINIMUM GRADE FOR DRAIN PIPE TO BE 1% OR 3 INCHES OF FALL IN 25 FEET.

-DRAIN TO BE PROVIDED WITH A FREE GRAVITY OUTFALL, IF POSSIBLE. A SUMP AND PUMP MAY BE USED IF GRAVITY OUT FALL IS NOT AVAILABLE.



**ENTECH**  
ENGINEERING, INC.  
505 ELKTON DRIVE  
COLORADO SPRINGS, CO. 80907 (719) 531-5599

*PERIMETER DRAIN DETAIL*

DRAWN:

DATE DRAWN:

DESIGNED BY:

CHECKED:

DS

LLL

JOB NO.:  
181683

FIG. NO.:  
7

## **APPENDIX B: Site Photographs**



**Looking west towards  
the proposed building  
area.**

October 19, 2018

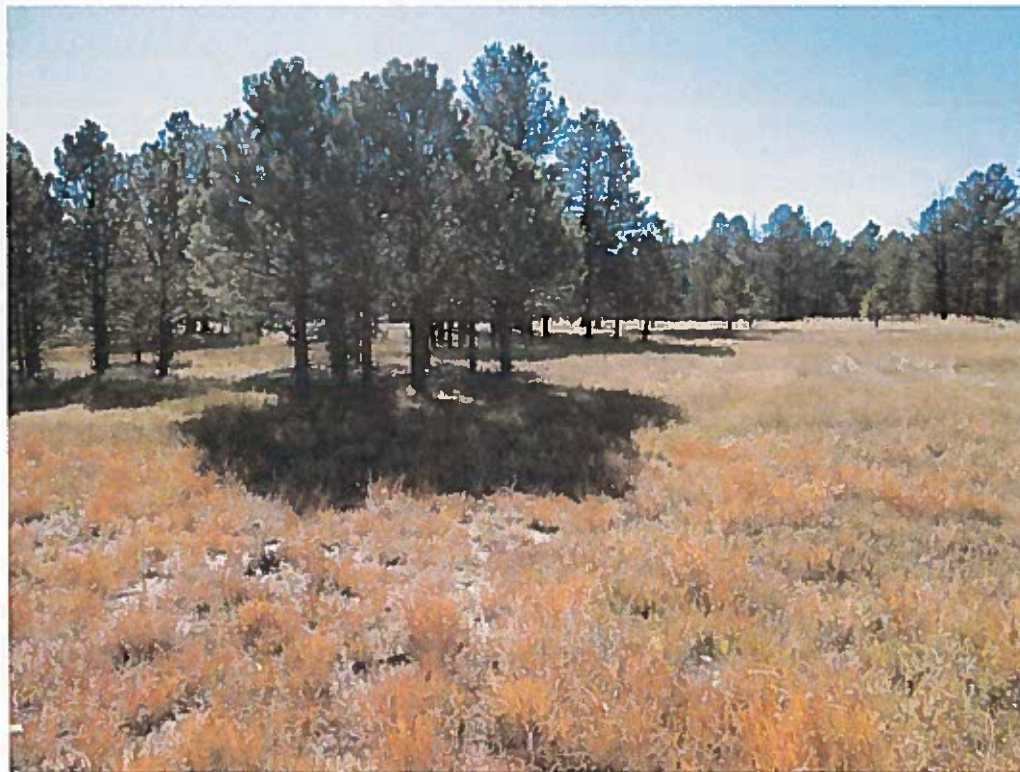

**Looking south from  
the northern edge of  
the lot.**

October 19, 2018