



ENTECH
ENGINEERING, INC.

505 ELKTON DRIVE
COLORADO SPRINGS, CO 80907
PHONE (719) 531-5599

**WASTEWATER STUDY
JAYNES PROPERTY – PRELIMINARY PLAN
POCO ROAD AND VOLLMER ROAD
EL PASO COUNTY, COLORADO**

Prepared for:
**Elite Properties of America, LLC
2138 Flying Horse Club Drive
Colorado Springs, CO 80921**

Attn: Loren Moreland

this does not include requirements for central system report in Chapter 8.4.8; not map the 2 suitable septic sites for rural lots per Section 8.4.7. Please review Code and update

November 21, 2023

Respectfully Submitted,

ENTECH ENGINEERING, INC.

Reviewed by:

Logan L. Langford, P.G.
Sr. Geologist



Joseph C. Goode Jr., P.E.
President

LLL

Table of Contents

1 SUMMARY..... 1

2 GENERAL SITE CONDITIONS AND PROJECT DESCRIPTION 2

3 SCOPE OF THE REPORT 2

4 FIELD INVESTIGATION 3

5 SOIL, GEOLOGY, AND ENGINEERING GEOLOGY..... 4

 5.1 General Geology 4

 5.2 Soil Conservation Survey 4

 5.3 Site Stratigraphy 4

 5.4 Soil Conditions 5

 5.5 Groundwater 6

6 ON-SITE WASTEWATER TREATMENT 7

7 CLOSURE..... 8

8 BIBLIOGRAPHY.....10

FIGURES

- Figure 1: Vicinity Map
- Figure 2: USGS Map
- Figure 3: Development Plan/Test Boring Location Map
- Figure 4: Soil Survey Map
- Figure 5: Falcon NW Quadrangle Geology Map
- Figure 6: Geology Map/Engineering Geology
- Figure 7: Floodplain Map
- Figure 8: OWTS Suitability Map

APPENDIX A: Site Photographs

APPENDIX B: Test Boring Logs

APPENDIX C: Laboratory Test Results

APPENDIX D: Soil Survey Descriptions

APPENDIX E: Test Pit Logs and Laboratory Test Results

APPENDIX F: El Paso County Health Department Septic Records

1 SUMMARY

Project Location

The project lies in portions of the S½ of Section 28, and a portion of the NW¼ of Section 33, Township 12 South, Range 65 West of the 6th Principal Meridian in El Paso County, Colorado. The site is located approximately three miles northeast of Colorado Springs, Colorado.

Project Description

The project is approximately one hundred and forty-two acres. Development is to consist of residential, neighborhood commercial, a detention pond, and parks/open spaces are proposed for the site. Five new lots and one existing lot along Poco Road will utilize individual water wells and onsite wastewater treatment systems (OWTS). The remainder of the site will utilize central sewer and water.

Scope of Report

This report presents the results of our geologic evaluation and treatment of engineering geologic hazards and wastewater study for the new lots along Poco Road.

Land Use and Engineering Geology

This site was found to be suitable for the proposed development. Areas were encountered where the geologic conditions will impose some constraints on development and land use. These include areas of artificial fill, potentially expansive soils, shallow bedrock, ponded water, shallow groundwater, seasonal shallow groundwater and potentially seasonally shallow groundwater areas, and radon. Based on the proposed development plan, it appears that these areas will have some impact on the development. These conditions will be discussed in greater detail in the report.

In general, it is our opinion that the development can be achieved if the observed geologic conditions on site are either avoided or properly mitigated. All recommendations are subject to the limitations discussed in the report.

2 GENERAL SITE CONDITIONS AND PROJECT DESCRIPTION

The site is located in portions of the S½ of Section 28, and a portion of the NW¼ of Section 33, Township 12 South, Range 65 West of the 6th Principal Meridian in El Paso County, Colorado. The site is located approximately three miles northeast of Colorado Springs, Colorado, at the southwest corner of Poco Road and Vollmer Road. The location of the site is as shown on the Vicinity Map, Figure 1.

Generally, the topography of the site is gradually to moderately sloping to the south. The drainages on site flow in a southerly direction through the central portion of the site. Drainages are located in the eastern and western portions of the site, and a pond is in the eastern portion of the site. The pond had standing water at the time of our site observations, and water was not observed in the drainages. The site boundaries are indicated on the USGS Map, Figure 2. Previous land uses have included rural residential, grazing and pastureland. The site contains primarily field grasses, weeds, cacti, and yuccas, with areas of scattered trees and ponderosa pine trees located across the north central portion of the site. Site photographs, taken October 19, 2021, are included in Appendix A and locations are shown on Figure 3.

Total acreage involved in the proposed development is one hundred and forty-two acres. The development will consist of residential, neighborhood commercial, a detention pond, and parks/open spaces. Most of the development will be serviced by central sewer and water. Five new lots and one existing lot along Poco Road will utilize individual water wells and onsite wastewater treatment systems (OWTS). Preliminary grading plans show significant cuts in the central portion of the site. These cuts are not located on the larger lots which will have onsite wastewater. A Preliminary Concept Plan is presented in Figure 4.

3 SCOPE OF THE REPORT

The scope of the report will include a general geologic analysis utilizing published geologic data. Detailed site-specific mapping will be conducted to obtain general information in respect to major geographic and geologic features, geologic descriptions and their effects on the development of the property.

4 FIELD INVESTIGATION

Our field investigation consisted of the preparation of a geologic map of any bedrock features and significant surficial deposits. The Natural Resource Conservation Service (NRCS), previously the Soil Conservation Service (SCS) survey was also reviewed to evaluate the site. The position of mappable units within the subject property are shown on the Geologic Map. Our mapping procedures involved both field reconnaissance and measurements and air photo reconnaissance and interpretation. The same mapping procedures have also been utilized to produce the Engineering Geology Map which identified pertinent geologic conditions affecting development. The field mapping was performed by personnel of Entech Engineering, Inc. on October 19, 2021.

Entech Engineering, Inc. prepared a Preliminary Subsurface Soil Investigation for the site dated October 25, 2021 (Reference 1). Thirteen Test Borings were drilled across the site as part of the Preliminary Subsurface Soil Investigation to determine general soil and bedrock characteristics. Information from this investigation was use in preparing this report. The locations of the test borings are indicated on the Site Plan/Test Boring Location Map, Figure 3. Recently one additional test boring was drilled, and eight (8) temporary piezometers (P-1 – P-8) were placed adjacent to previous borings with shallow groundwater conditions, and in proposed cut areas as part of additional investigation for the proposed development. The piezometers will be measured periodically to obtain seasonal groundwater fluctuations across the site. The Summary of Laboratory Testing Results and Test Boring Logs are presented in Appendix B. Results of this testing will be discussed later in this report.

Laboratory testing was also performed on some of the soils to classify and determine the soils engineering characteristics. Laboratory tests included grain-size analysis ASTM D-422, Atterberg Limits ASTM D-4318, volume change testing using Swell/Consolidation test. Sulfate testing was performed on select samples to evaluate potential for below grade concrete degradation due to sulfate attack. Results of the laboratory testing are included in Appendix C. A Summary of Laboratory Test Results is presented in Table C-1.

Two test pits were excavated on the northern side of the project site where 5 new rural residential lots are proposed. The test pits were placed in anticipated OWTS location to determine soil and bedrock conditions and general suitability for OWTS locations. The Test Pit Logs and Laboratory Testing results are included in Appendix E.

5 SOIL, GEOLOGY, AND ENGINEERING GEOLOGY

5.1 General Geology

Physiographically, the site lies in the western portion of the Great Plains Physiographic Province. Approximately 12 miles to the west is a major structural feature known as the Rampart Range Fault. This fault marks the boundary between the Great Plains Physiographic Province and the Southern Rocky Mountain Province. The site exists within the southeastern edge of a large structural feature known as the Denver Basin. Bedrock in the area tends to be very gently dipping in a northeasterly direction (Reference 2). The rocks in the area of the site are sedimentary in nature and typically Upper Cretaceous in age. The bedrock underlying the site consists of the Dawson Formation. Overlying this formation are unconsolidated deposits of man-made, and alluvial soils of Quaternary Age. The alluvial soils were deposited by water on site and as stream terraces along Sand Creek and the drainages located on the site. Man-made soils exist as fill piles located in the southern portion of the site. The site's stratigraphy will be discussed in more detail in Section 5.3.

5.2 Soil Conservation Survey

The Natural Resource Conservation Service (Reference 2), previously the Soil Conservation Service (Reference 3) has mapped one soil type on the site (Figure 4). In general, the soils are classified as coarse sandy loam. The soils are described as follows:

<u>Type</u>	<u>Description</u>
71	Pring coarse sandy loam, 3 to 8% slopes

Complete descriptions of each soil type are presented in Appendix D. The soils have generally been described to have moderate to moderately rapid permeabilities. Possible hazards with soil erosion are present on the site. The erosion potential can be controlled with vegetation. The majority of the soils have been described to have moderate erosion hazards.

5.3 Site Stratigraphy

The Falcon NW Quadrangle Geology Map showing the site is presented in Figure 5 (Reference 4). The Geology Map prepared for the site is presented in Figure 6. Three mappable units were identified on this site which are described as follows:

- Qaf Artificial Fill of Quaternary Age:** These recent man-made deposits associated with a fill berm located in the southern portion of the site. The berm is currently located in the proposed pond area and will likely be removed during site grading.
- Tkd Dawson Formation of Tertiary to Cretaceous Age:** The Dawson formation typically consists of arkosic sandstone with interbedded fine-grained sandstone, siltstone and claystone. Overlying this formation is a variable layer of residual and/or colluvial soils. The residual soils were derived from the in-situ weathering of the bedrock materials on-site. The colluvial soils have been transported by the action of sheetwash and gravity. These soils consisted of silty to clayey sands and sandy clays.

The bedrock underlying the site consists of the Dawson Formation of Tertiary to Cretaceous Age. The Dawson Formation typically consists of arkosic sandstone with interbedded fine-grained sandstone, siltstone, and claystone. Overlying this formation are variable layers of eolian sands, alluvial deposits, and residual soil. The residual soils were derived from the in-situ weathering of the bedrock materials on-site. These soils consisted of silty to clayey sands and sandy clays.

The soils listed above were mapped from site-specific mapping, the *Geologic Map of the Falcon NW Quadrangle* distributed by the Colorado Geological Survey in 2003 (Reference 5), the *Geologic Map of the Colorado Springs-Castle Rock Area*, distributed by the US Geological Survey in 1979 (Reference 6), and the *Geologic Map of the Denver 1^o x 2^o Quadrangle*, distributed by the US Geological Survey in 1981 (Reference 7). The Test Borings and Profile Holes were also used in evaluating the site and are included in Appendix B. The Geology Map prepared for the site is presented in Figure 7.

5.4 Soil Conditions

The soils encountered in the Test Borings can be grouped into three general soil types. The soils were classified using the Unified Soil Classification System (USCS).

Soil Type 1 is classified as silty sand, sand with silt, and clayey sand (SW-SM, SM, SC). The sand was encountered in all the test borings at the ground surface extending to depths ranging from 1 to 9 feet bgs. The sand was encountered at medium dense to dense states. The majority of the samples indicated medium dense states. Swell/Consolidation Testing on a sample of the clayey sand resulted in a volume change of 1.9 percent, indicating a low to moderate expansion potential.

Soil Type 2 is classified as sandstone with silt and silty sandstone (SM-SW, SM). The sandstone was encountered in all of the test borings at depths of 3 to 9 feet bgs extending to depths of 14 to 19 feet or the termination of the borings (12.5 to 20 feet). The sandstone was encountered at very dense states.

Soil Type 3 is classified as siltstone and claystone (ML, CL). The siltstone and claystone were encountered in TB-3, TB-6, TB-7, and TB-11 at 14 to 19 feet bgs extending to the termination of the test borings (20 feet). The siltstone and claystone were encountered at hard consistencies. The claystone is typically moderately to highly expansive in the area. Swell/Consolidation Testing on samples of the siltstone and claystone resulted in a volume changes of 1.8 to 2.8 percent, indicated a low to moderate expansion potentials.

The Test Boring Logs are presented in Appendix B. Laboratory Test Results are presented in Appendix C, and a Summary of Laboratory Test Results is presented in Table C-1.

5.5 Groundwater

Groundwater was encountered in Test Boring Nos. 2, 3, 4, 6, 7, 9, 10, 11, and 12 at depths ranging from 6 to 28 feet bgs subsequent to drilling. Depth to groundwater is shown in the Test Boring Location Map, Figure 2, and on each test boring log. Areas of water, seasonal shallow groundwater water, and potential seasonal shallow groundwater have been mapped along the drainages on-site. These areas are discussed in the following section. Fluctuation in groundwater conditions may occur due to variations in rainfall and other factors not readily apparent at this time.

Recently eight (8) temporary piezometers (P-1 – P-8) were placed adjacent to previous borings with shallow groundwater conditions across the site as part of additional investigation for the proposed development. The piezometers will be measured periodically to obtain seasonal groundwater fluctuations across the site. Groundwater was encountered in piezometers in four of the eight piezometers at depths of 6.5 to 28 feet. The latest readings from the eight piezometers are shown on the table below. Piezometers P1 – P4 were installed on August 22, 2023, and P5 – P8 were installed on October 24, 2023.

Exhibit 1: Temporary Piezometers – Jaynes Property

Piezometer, and Total Depth (ft.)	Groundwater Level (ft.) 10/25/23
P1, 13'	Dry
P2, 13'	10.75
P3, 13'	8.5
P4, 13'	6.5
P5, 15'	Dry
P6, 35'	28
P7, 25'	Dry
P8, 20'	Dry

It should be noted that in the sandy materials on-site, some groundwater conditions might be encountered due to the variability in the soil profile. Isolated sand and gravel layers within the soils, sometimes only a few feet in thickness and width, can carry water in the subsurface. Groundwater may also flow on top of the underlying bedrock. Builders and planners should be cognizant of the potential for the occurrence of such subsurface water features during construction on-site and deal with each individual issue as necessary at the time of construction. The shallow water areas will typically be avoided by the individual wastewater treatment systems.

6 ON-SITE WASTEWATER TREATMENT

The site was evaluated for individual on-site wastewater treatment systems in accordance with the El Paso Land Development Code. Two (2) tactile test pits were excavated on the site. The test pits were placed in potential locations of future systems. The approximate locations of the Test Pits are indicated in Figure 3, and on the Septic Suitability Map, Figure 8. Test Pit Logs and Laboratory Test Results in Appendix E. Existing El Paso County Health Department records for the system located on proposed Lot 8455 Poco Road are included in Appendix F.

The Natural Resource Conservation Service (Reference 5), previously the Soil Conservation Service (Reference 6) has been mapped with two soil descriptions. The Soil Survey Map (Reference 5) is presented in Figure 4, and the Soil Survey Descriptions are presented in Appendix D. The soils are described as having slow to rapid percolation rates. The majority of the soils have been described to have moderate permeabilities.

Drainage areas mapped with potential seasonally shallow groundwater are located on the proposed lots. In these areas a 25-foot setback for the soil treatment area will be required. This will limit the potential buildable areas on the lots depending on the final size of the anticipated

OWTS. Signs of seasonally occurring groundwater were observed in the test pits at 4 to 6 feet. Weathered bedrock was encountered at approximately 3 to 5 feet in the test pits.

Soils encountered in the tactile test pits consisted of gravelly sandy loam, and sandy clay loam overlying highly weathered to weathered clayey to silty sandstone. The limiting layers encountered in the test pits are gravelly sandy loam (2A – R-1), sandy clay loam (Soil Type 3A), and sandstone (gravelly sandy clay when classified as a soil, Soil Type 4A). The soil types correspond to LTAR values ranging from 0.80 to 0.15 gallons per day per square foot. Additional investigation may identify areas where suitable conventional systems could be used on the lots.

In summary, it is our opinion the site is suitable for individual on-site wastewater treatment systems (OWTS) and that contamination of surface and subsurface water resources should not occur provided the OWTS sites are evaluated and installed according to El Paso County and State Guidelines and properly maintained. Based on the testing performed as part of this investigation designed systems should be anticipated for new the lots. A Septic Suitability Map is presented in Figure 8. OWTS sites should not be located within defined drainages. Individual soil testing is required on the lots prior to construction. Absorption fields must be located a minimum of 100 feet from any well, including those on adjacent properties. Absorption fields must also be located a minimum of 50 feet from any drainages, floodplains or ponded areas and 25 feet from dry gulches.

7 CLOSURE

It is our opinion that the existing geologic engineering and geologic conditions will impose some constraints on development and construction of the site. Most of these conditions can be mitigated through proper engineering design and construction practices. The proposed development and use are consistent with anticipated geologic and engineering geologic conditions.

It should be pointed out that because of the nature of data obtained by random sampling of such variable and non-homogeneous materials as soil and rock, it is important that we be informed of any differences observed between surface and subsurface conditions encountered in construction and those assumed in the body of this report. Individual investigations for building sites will be required prior to construction. Construction and design personnel should be made familiar with the contents of this report. Reporting such discrepancies to Entech Engineering, Inc.



soon after they are discovered would be greatly appreciated and could possibly help avoid construction and development problems.

This report has been prepared for Elite Properties of America, LLC for application to the proposed project in accordance with generally accepted geologic soil and engineering practices. No other warranty expressed or implied is made.

We trust that this report has provided you with all the information that you required. Should you require additional information, please do not hesitate to contact Entech Engineering, Inc.

8 BIBLIOGRAPHY

1. Entech Engineering, Inc., dated October 25, 2021. *Preliminary Subsurface Soil Investigation, Poco Road and Vollmer Road, Parcel Nos. 52280-00-024 and 52280-00-025, El Paso County, Colorado*. Entech Job No. 212381.
2. Bryant, Bruce; McGrew, Laura W, and Wobus, Reinhard A. 1981. *Geologic Structure Map of the Denver 1° x 2° Quadrangle, North-Central Colorado*. Sheet 2. U.S. Geologic Survey. Map I-1163.
3. Natural Resource Conservation Service, September 22, 2015. *Web Soil Survey*. United States Department Agriculture, <http://websoilsurvey.sc.egov.usda.gov/App/HomePage.htm>.
4. United States Department of Agriculture Soil Conservation Service. June 1981. *Soil Survey of El Paso County Area, Colorado*.
5. Madole, Richard F., 2003. *Geologic Map of the Falcon NW Quadrangle, El Paso County, Colorado*. Colorado Geological Survey. Open-File Report 03-8.
6. Trimble, Donald E. and Machette, Michael N. 1979. *Geologic Map of the Colorado Springs-Castle Rock Area, Front Range Urban Corridor, Colorado*. USGS, Map I-857-F.
7. Bryant, Bruce; McGrew, Laura W. and Wobus, Reinhard A. 1981. *Geologic Map of the Denver 1° x 2° Quadrangle, North-Central Colorado*. U.S. Geologic Survey. Map 1-1163.
8. Federal Emergency Management Agency. December 7, 2018. *Flood Insurance Rate Maps for El Paso County, Colorado and Incorporated Areas*. Map Numbers 08041CO533G and 08041CO535G.
9. Colorado Geological Survey. 1991. *Results of the 1987-88 EPA Supported Radon Study in Colorado*. Open-file Report 91-4.
10. El Paso County Planning Development. December 1995. *El Paso County Aggregate Resource Evaluation Maps*.
11. Schwochow, S.D.; Shroba, R.R. and Wicklein, P.C. 1974. *Atlas of Sand, Gravel, and Quarry Aggregate Resources, Colorado Front Range Counties*. Colorado Geological Survey. Special Publication 5-B.
12. Keller, John W.; TerBest, Harry and Garrison, Rachel E. 2003. *Evaluation of Mineral and Mineral Fuel Potential of El Paso County State Mineral Lands Administered by the Colorado State Land Board*. Colorado Geological Survey. Open-File Report 03-07.

FIGURES

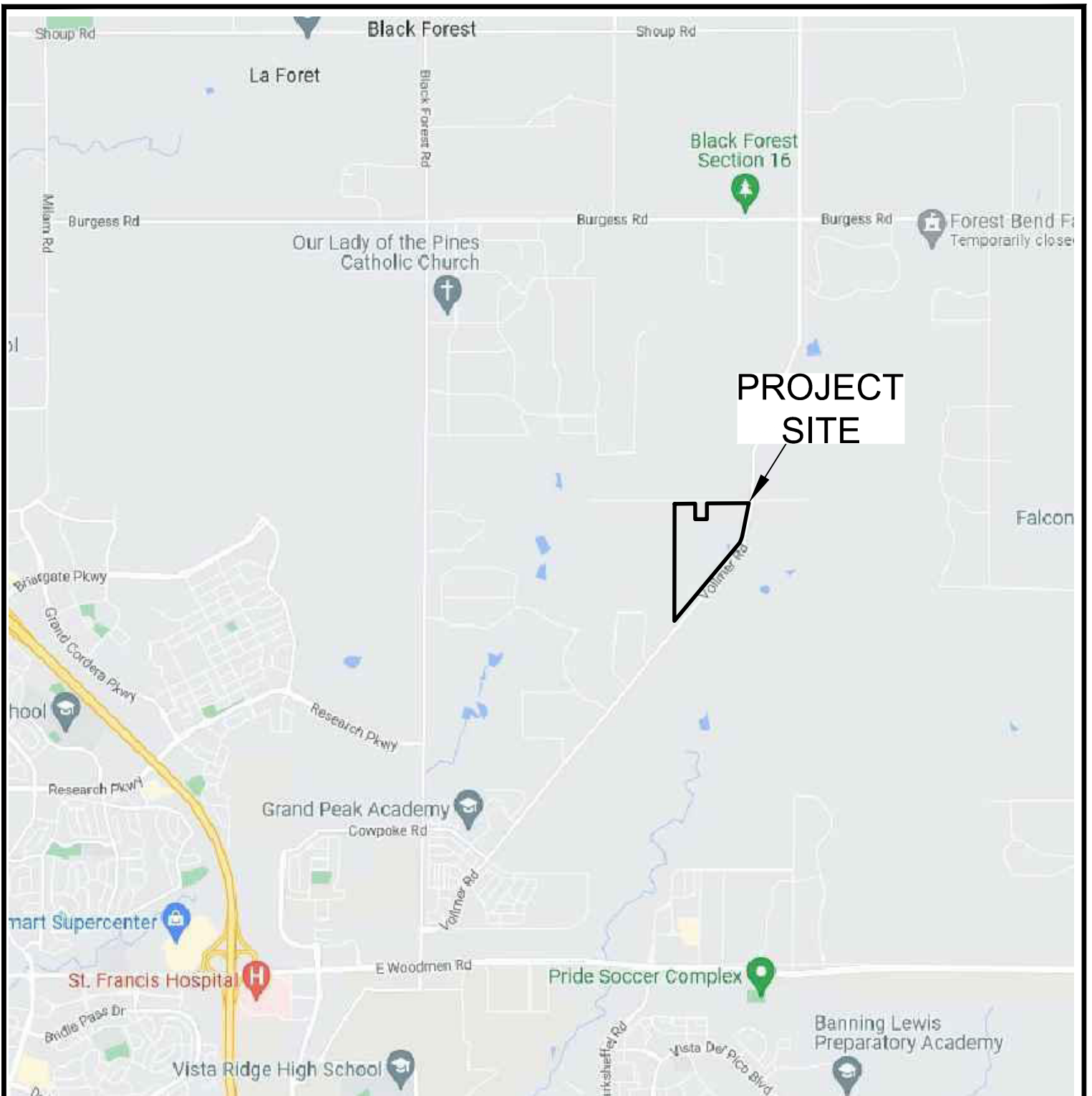

VICINITY MAP
 JAYNES SITE
 POCO ROAD & VOLLMER ROAD
 EL PASO COUNTY, CO
 ELITE PROPERTIES OF AMERICA, INC.

JOB NO.
 2212381

FIG. 1

T012S R065W

PROJECT SITE

28

POCO RD

VOLLMER RD

Sand Cr

7200

KILINVER CT

7200

GLIDER LOOP

Sand Cr

7100

ONE LN

LOCHWINNOCH LN

33



ENTECH
ENGINEERING, INC.



USGS TOPOGRAPHY MAP
JAYNES SITE
POCO ROAD & VOLLMER ROAD
EL PASO COUNTY, CO
ELITE PROPERTIES OF AMERICA, INC.

JOB NO.
212381

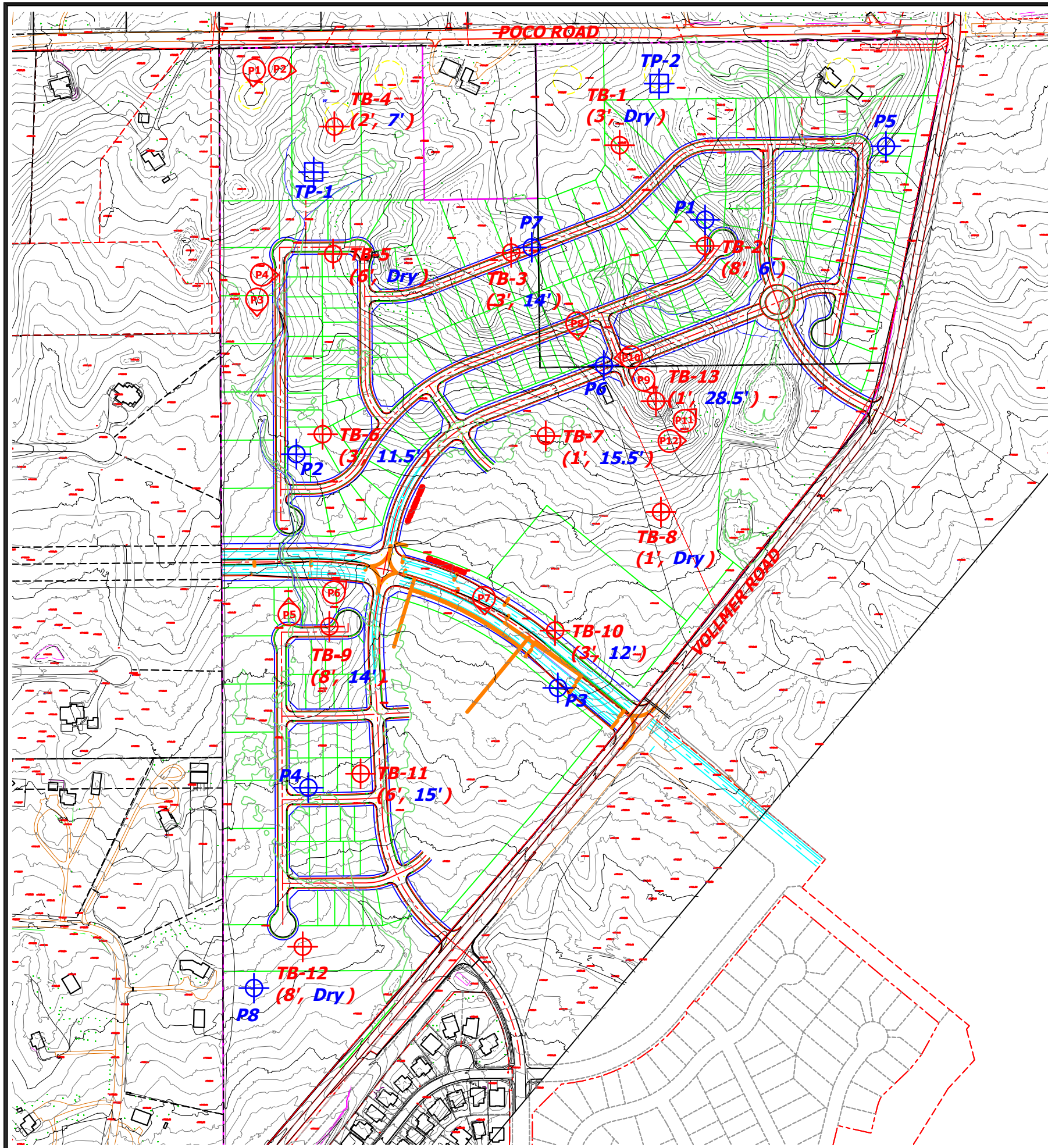
FIG. 2



LEGEND:

-  TB- APPROXIMATE TEST BORING LOCATION AND NUMBER
(depth of bedrock in feet, depth of groundwater in feet)
-  - APPROXIMATE PHOTOGRAPH LOCATION AND NUMBER
-  P- APPROXIMATE PIEZOMETER LOCATION AND NUMBER



REVISION	BY



SITE AND EXPLORATION PLAN
 JAYNES SITE
 POCO ROAD & VOLLMER ROAD
 EL PASO COUNTY, CO
 ELITE PROPERTIES OF AMERICA, INC.

JOB NO.
212381
FIG. 3

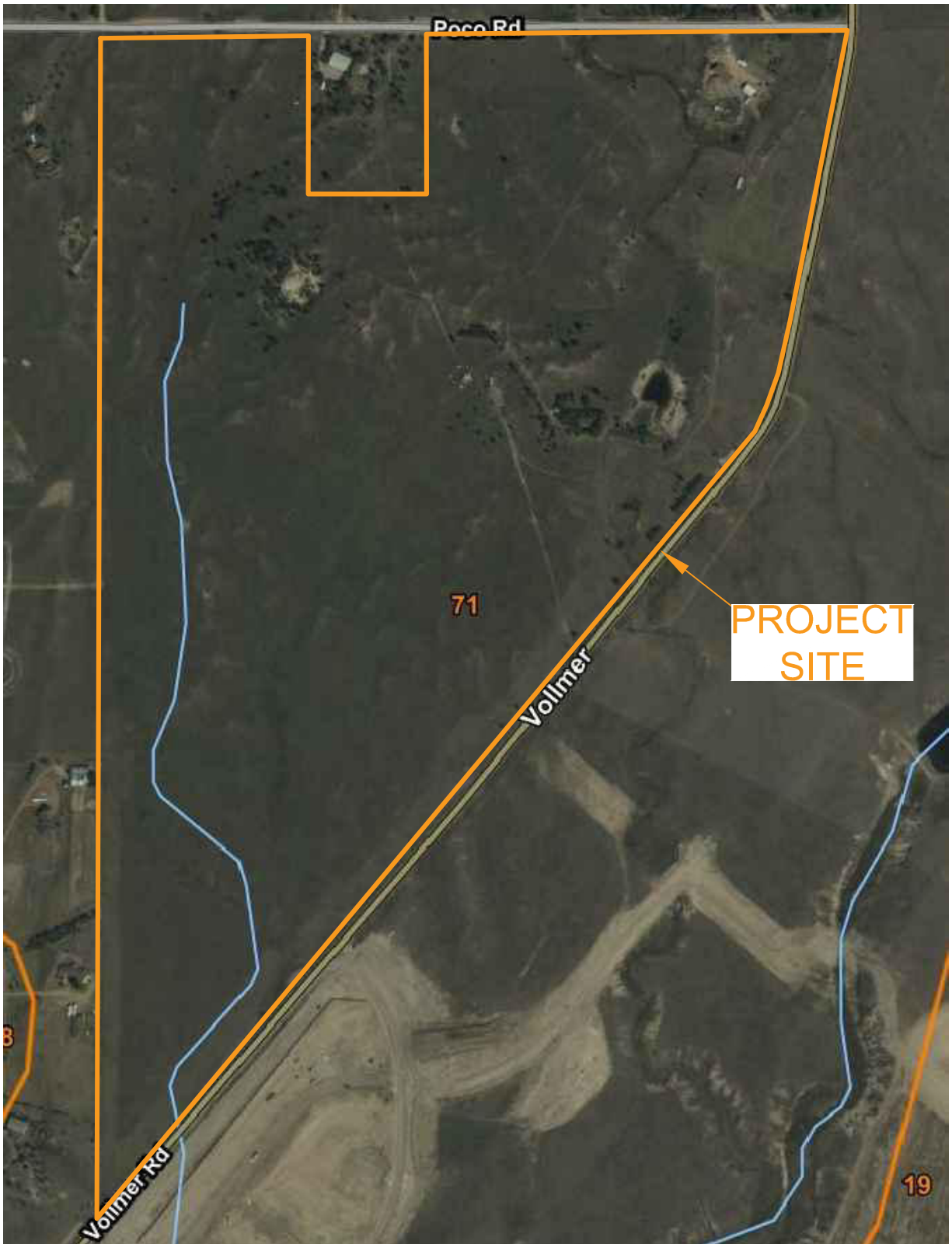

SOIL SURVEY MAP
JAYNES SITE
POCO ROAD & VOLLMER ROAD
EL PASO COUNTY, CO
ELITE PROPERTIES OF AMERICA, INC.

JOB NO.
212831

FIG. 4

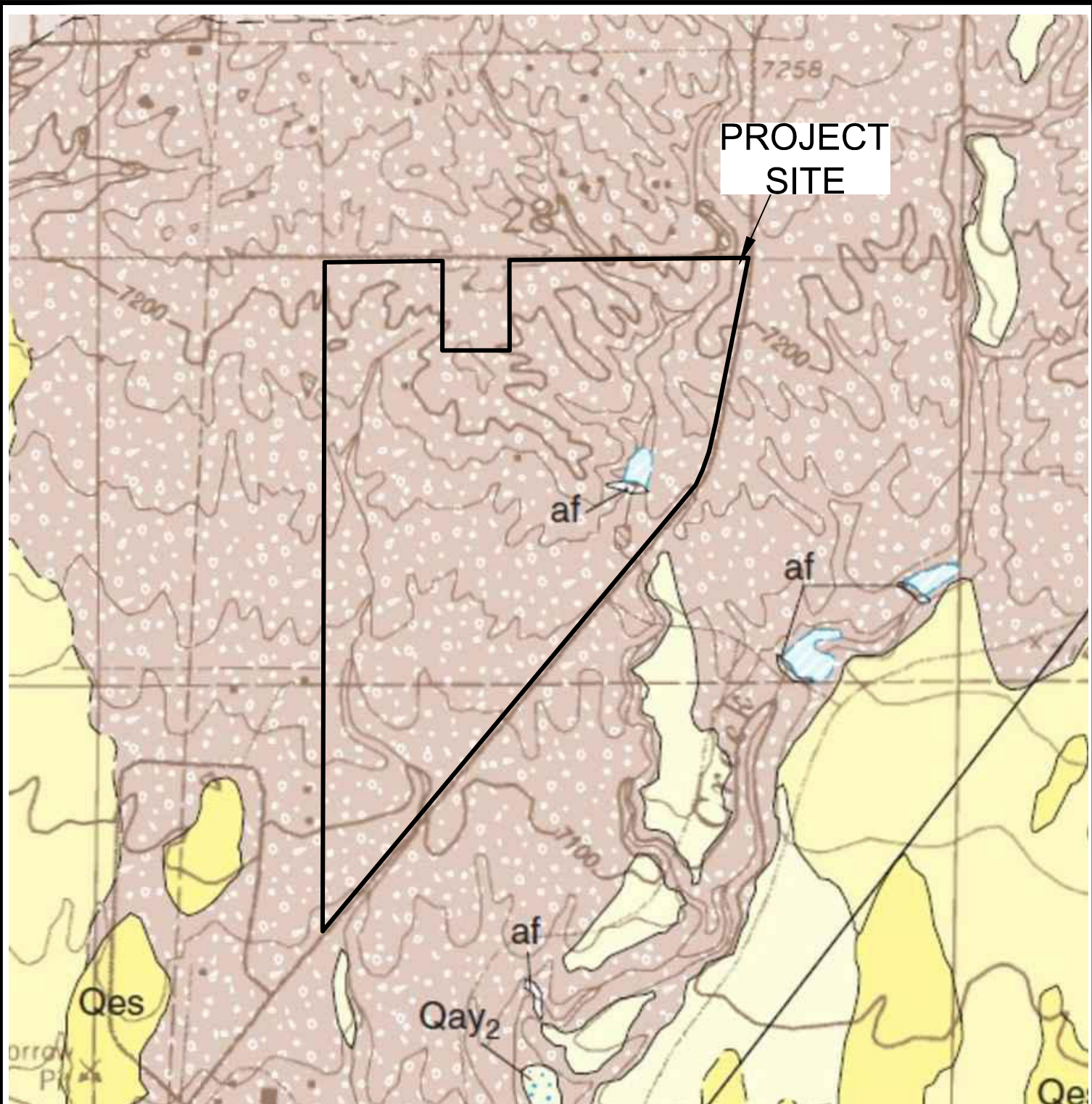

**FALCON NW QUADRANGLE
GEOLOGIC MAP**

JAYNES SITE
POCO ROAD & VOLLMER ROAD
EL PASO COUNTY, CO
ELITE PROPERTIES OF AMERICA, INC.

JOB NO.
212381

FIG. 5

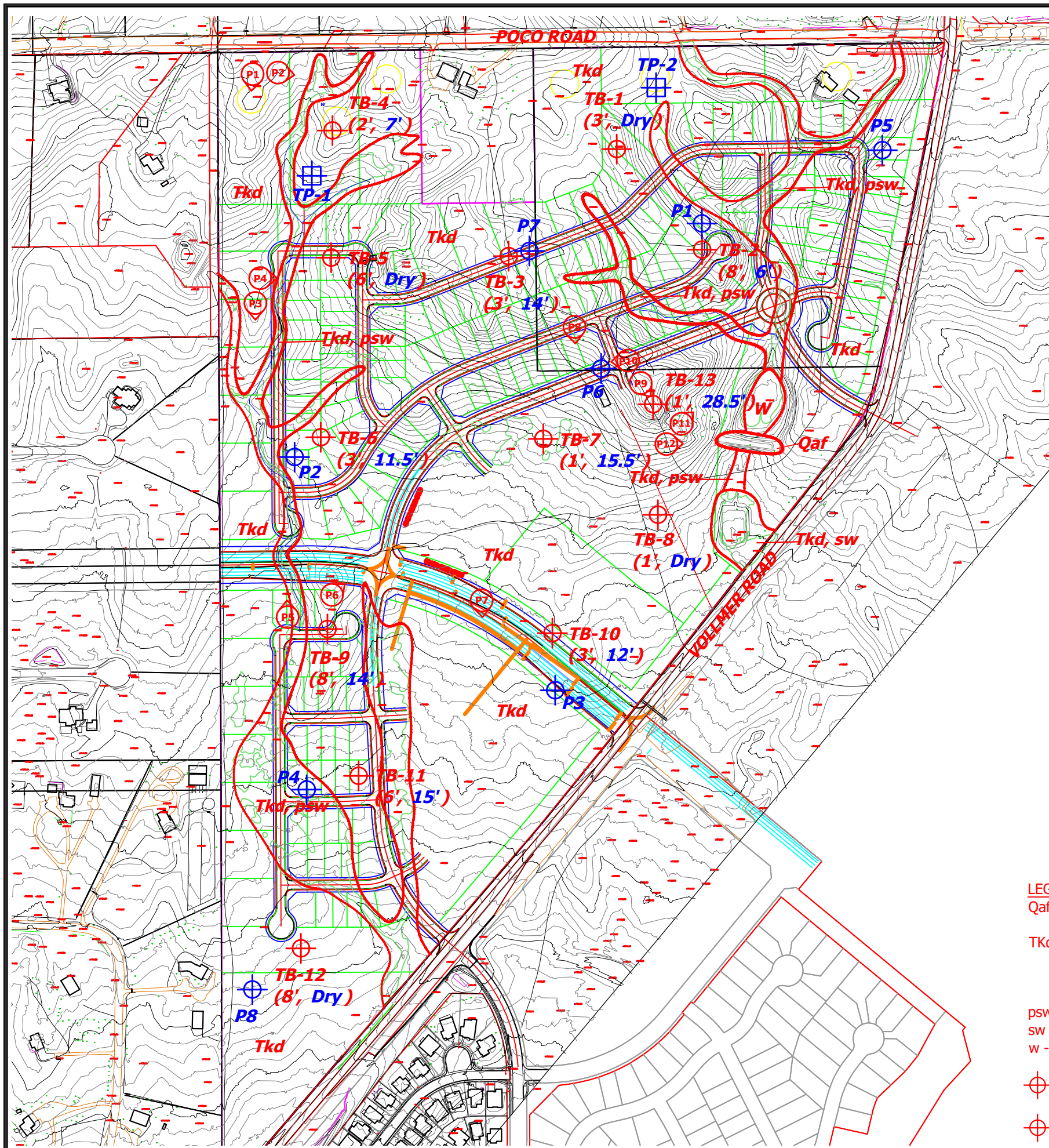

LEGEND:

- Qaf - Artificial Fill of Quaternary Age:
man-made fill deposits
- Tkd - Dawson Formation of Tertiary to Cretaceous Age:
variable layer of sheetwash and residual soil deposits overlying
arkosic sandstone with siltstone and claystone lenses
- psw - potential seasonally shallow groundwater area
- sw - seasonally wet area
- w - areas of ponded/flowing water
- ⊕ - TB- APPROXIMATE TEST BORING LOCATION AND NUMBER
(depth of bedrock in feet, depth of groundwater in feet)
- ⊕ - P- APPROXIMATE PIEZOMETER LOCATION AND NUMBER



REVISION	BY



GEOLOGY/ENGINEERING MAP
 JAYNES SITE
 POCO ROAD & VOLLMER ROAD
 EL PASO COUNTY, CO
 ELITE PROPERTIES OF AMERICA, INC.

JOB NO.
212381
FIG. 6

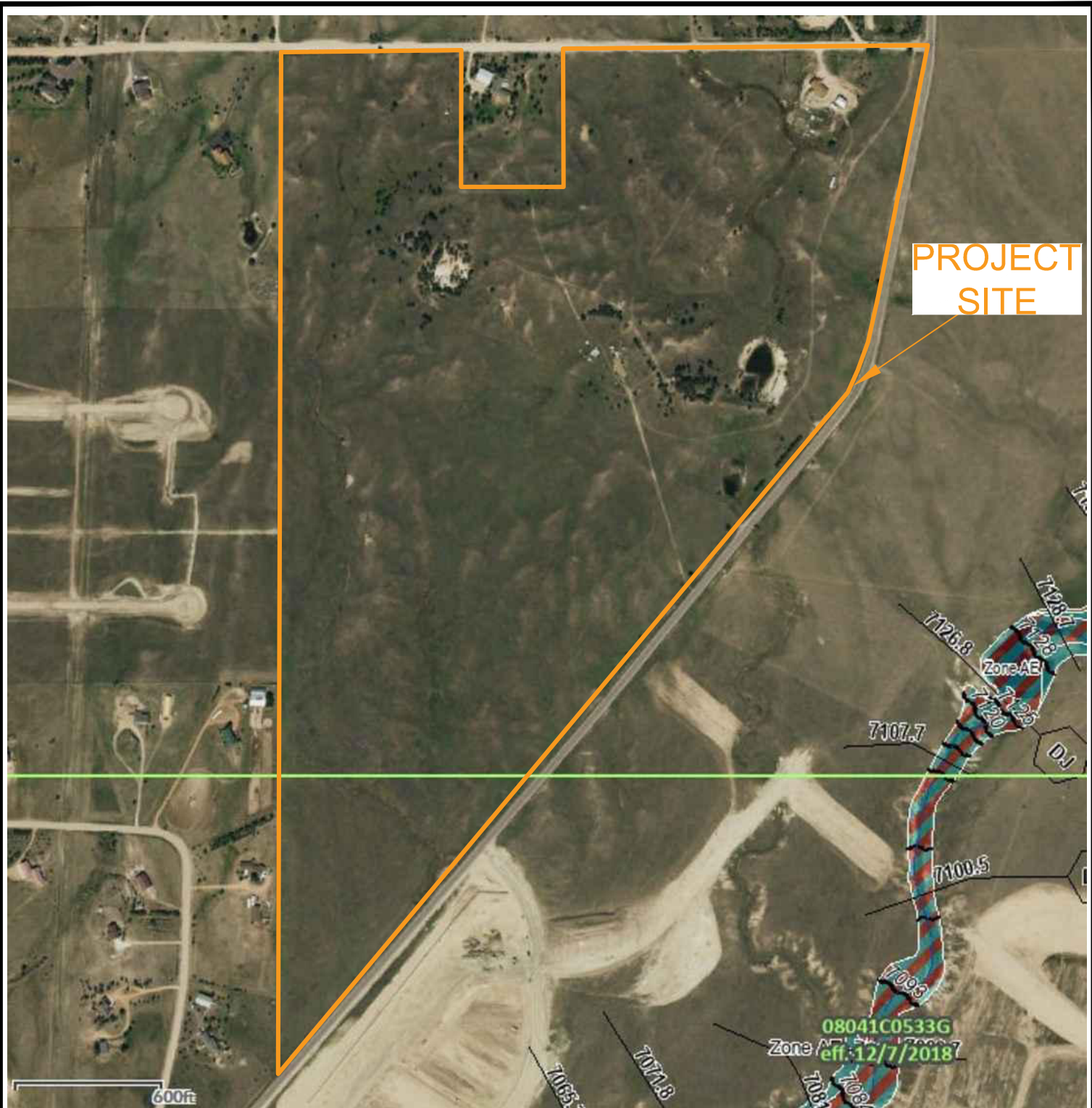

PROJECT SITE



FEMA FLOODPLAIN MAP
 JAYNES SITE
 POCO ROAD & VOLLMER ROAD
 EL PASO COUNTY, CO
 ELITE PROPERTIES OF AMERICA, INC.

JOB NO.
212381

FIG. 7

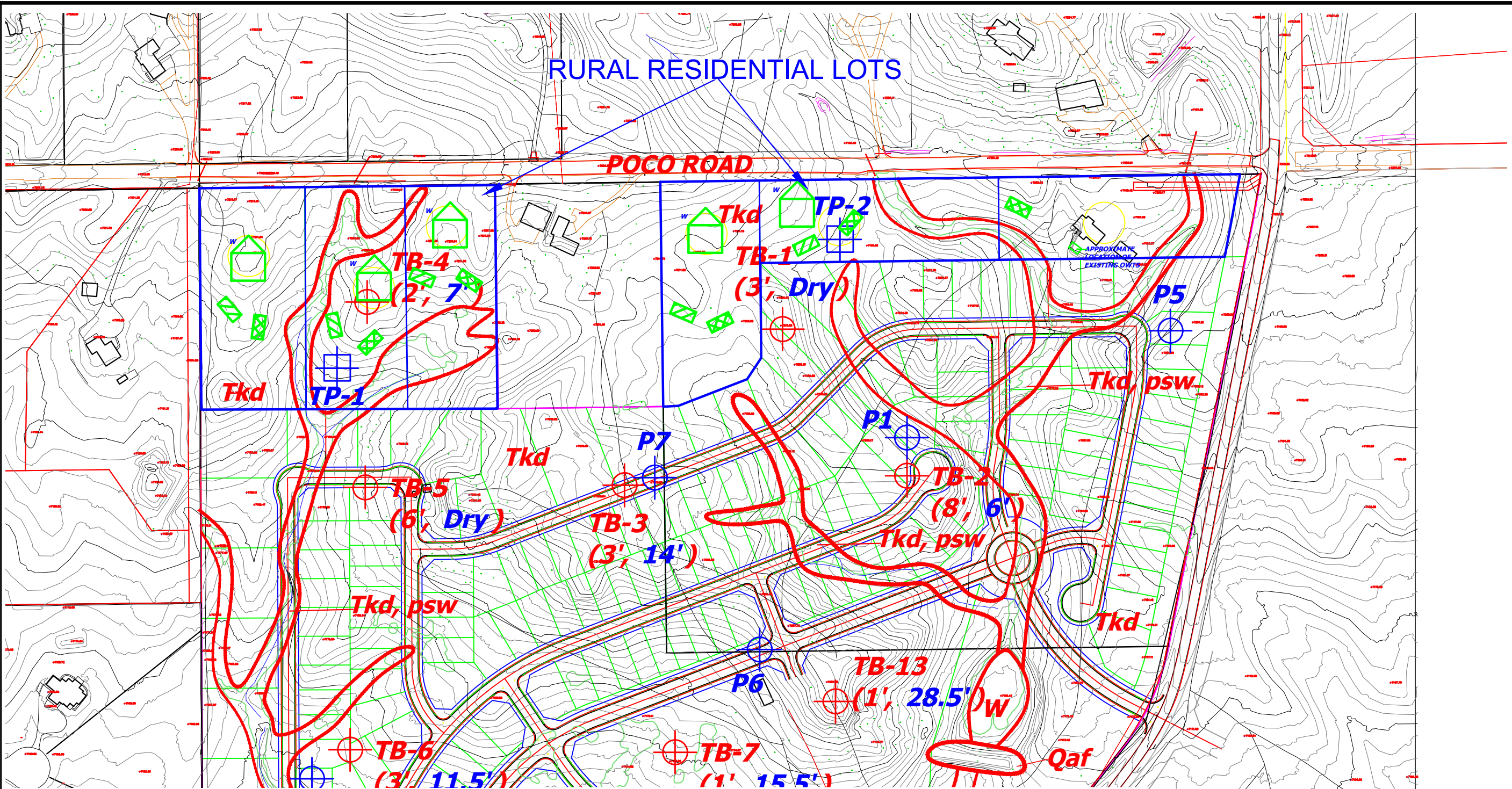

GEOLOGY MAP LEGEND:

- Qaf - Artificial Fill of Quaternary Age: man-made fill deposits
- Tkd - Dawson Formation of Tertiary to Cretaceous Age: variable layer of sheetwash and residual soil deposits overlying arkosic sandstone with siltstone and claystone lenses
- psw - potential seasonally shallow groundwater area
- sw - seasonally wet area
- w - areas of ponded/flowing water
- ⊕ - TB- APPROXIMATE TEST BORING LOCATION AND NUMBER (depth of bedrock in feet, depth of groundwater in feet)
- ⊕ - P- APPROXIMATE PIEZOMETER LOCATION AND NUMBER

OWTS MAP LEGEND:

- ⊕ - APPROXIMATE TEST PIT LOCATION AND NUMBER
- ▧ - OWTS LOCATION
- ▨ - ALTERNATE OWTS LOCATION
- ⊕_w - HOUSE LOCATION AND WATER WELL

REVISION	BY



GEOLOGY/ENGINEERING MAP
JAYNES SITE
POCO ROAD & VOLLMER ROAD
EL PASO COUNTY, CO
ELITE PROPERTIES OF AMERICA, INC.

JOB NO.
212381
FIG. 8

APPENDIX A: Site Photographs

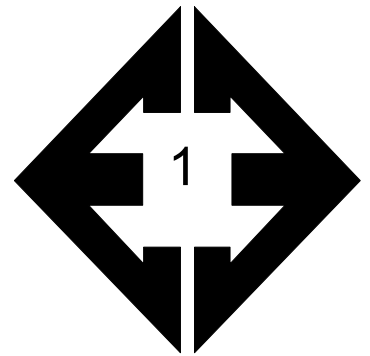

Looking south from the northwestern corner of the site.

October 19, 2021

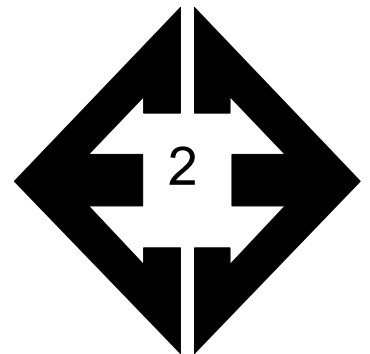

Looking east from the northwestern portion of the site.

October 19, 2021

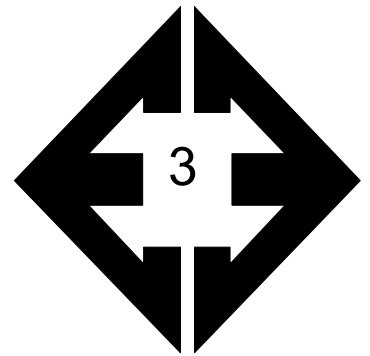

**Looking south from
the western side of the
site.**

October 19, 2021

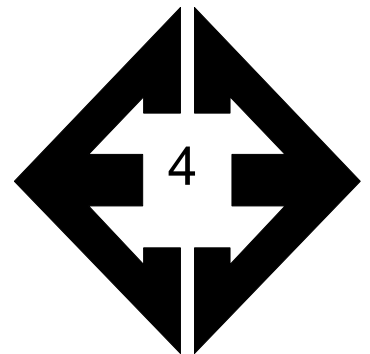

**Looking east from the
western side of the
site.**

October 19, 2021

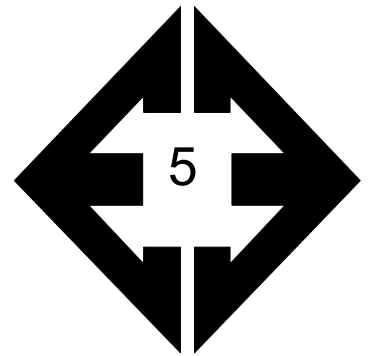

**Looking north along
drainage in the
southwestern portion
of the site.**

October 19, 2021

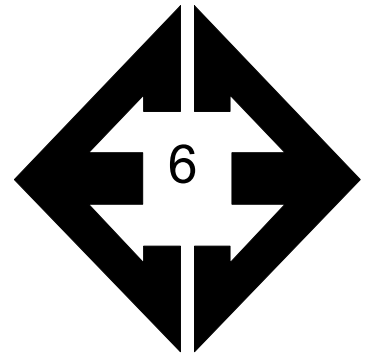

**Looking northeast
from the southwestern
portion of the site.**

October 19, 2021

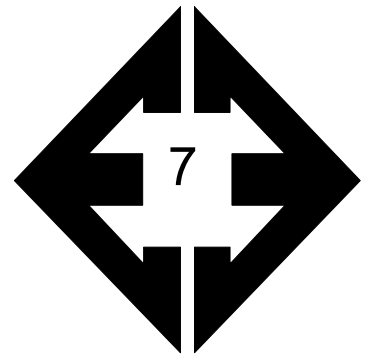

**Looking south from
the central portion of
the site.**

October 19, 2021

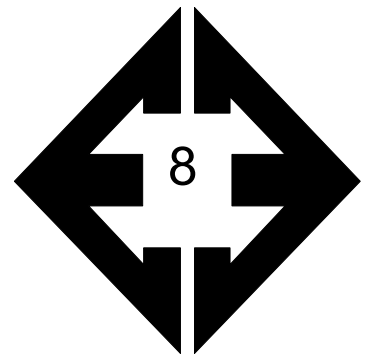

**Looking south from
the north-central
portion of the site.**

October 19, 2021

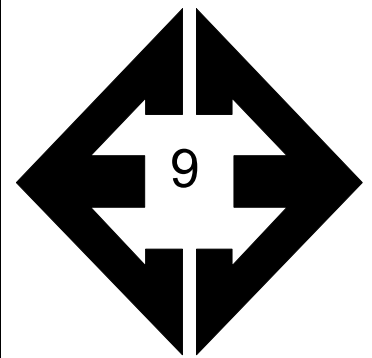

**Looking southeast
from the central
portion of the site.**

October 19, 2021

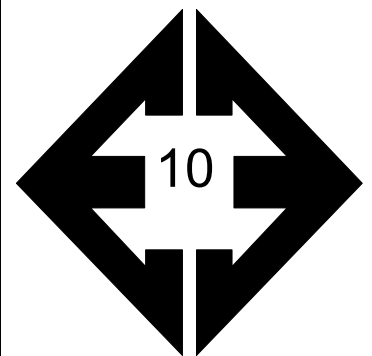

**Looking west from the
central portion of the
site.**

October 19, 2021

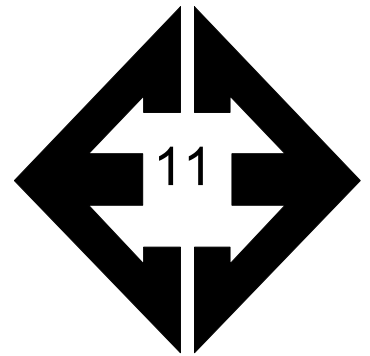

**Looking northeast
towards pond in the
northeastern portion of
the site.**

October 19, 2021

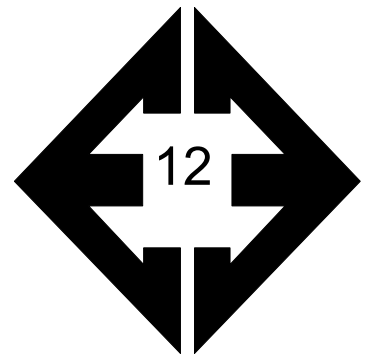

**Looking east along
earthen dam in the
eastern portion of the
site.**

October 19, 2021

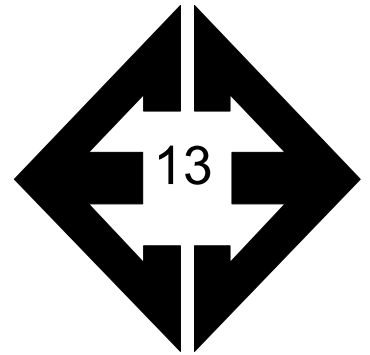

**Looking north from the
central portion of the
site.**

September 28, 2023

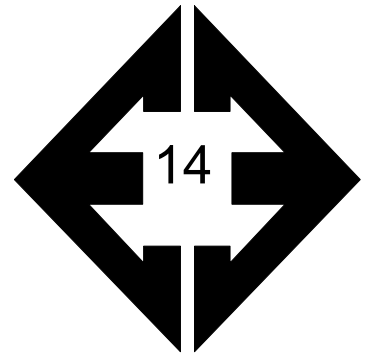

**Looking east from the
central portion of the
site.**

September 28, 2023

APPENDIX B: Test Boring and Piezometer Logs

TABLE B-1
DEPTH TO GROUNDWATER AND BEDROCK

TEST BORING	DEPTH TO GROUNDWATER (ft.)	DEPTH TO BEDROCK (ft.)
1	>20	3
2	6	8
3	14	3
4	7	2
5	>20	6
6	11.5	3
7	15.5	1
8	>20	1
9	14	8
10	12	3
11	15	6
12	>20	8
P-1	>12.5	6
P-2	12	1
P-3	7	9
P-4	5.5	7

TEST BORING 1
 DATE DRILLED 9/2/2021

TEST BORING 2
 DATE DRILLED 9/2/2021

REMARKS	Depth (ft)	Symbol	Samples	Blows per foot	Watercontent %	Soil Type	REMARKS	Depth (ft)	Symbol	Samples	Blows per foot	Watercontent %	Soil Type
DRY TO 20', 10/6/21							WATER @ 6', 10/6/21						
SAND, SILTY, BROWN, DENSE, MOIST				43	5.4	1	SAND, SILTY, TAN, MEDIUM DENSE, DRY to MOIST				13	2.0	1
SANDSTONE, VERY WEAK, TAN, HIGHLY WEATHERED. (SAND, SILTY, VERY DENSE, MOIST)	5			50 9"	9.6	2		5			26	6.3	1
CLAYEY LENS	10			50 8"	10.0	2	SANDSTONE, VERY WEAK, TAN, HIGHLY WEATHERED, (SAND, SILTY, VERY DENSE, MOIST)	10			50 8"	6.5	2
	15			50 5"	7.9	2		15			50 10"	8.1	2
	20			50 7"	8.4	2	SANDSTONE, VERY WEAK, TAN, HIGHLY WEATHERED, (SAND, CLAYEY, VERY DENSE, MOIST)	20			50 4"	8.9	2



TEST BORING LOGS
 POCO RD. AND VOLLMER RD.
 ELITE PROPERTIES

JOB NO.
 212381
FIG. B-1

TEST BORING 3
 DATE DRILLED 9/2/2021

TEST BORING 4
 DATE DRILLED 9/2/2021

REMARKS	Depth (ft)	Symbol	Samples	Blows per foot	Watercontent %	Soil Type
WATER @ 14', 10/6/21						
SAND, SILTY, BROWN, DENSE, MOIST				43	6.5	1
SANDSTONE, VERY WEAK, TAN, HIGHLY WEATHERED, (SAND, SILTY, VERY DENSE, MOIST)	5		50	5.7	2	
			8"			
	10		50	8.5	2	
			7"			
	15		50	11.9	2	
			8"			
SILTSTONE, VERY WEAK, BLUE-GRAY, HIGHLY WEATHERED, (SILT, SANDY, HARD, MOIST)	20		50	15.0	3	
			8"			

REMARKS	Depth (ft)	Symbol	Samples	Blows per foot	Watercontent %	Soil Type
WATER @ 7', 10/6/21						
SAND, SILTY, BROWN						1
SANDSTONE, VERY WEAK, TAN, HIGHLY WEATHERED, (SAND, SILTY, VERY DENSE, MOIST)	5		50	5.6	2	
			9"			
	5		50	9.6	2	
			8"			
	10		50	12.1	2	
			7"			
	15		50	7.3	2	
			4"			
	20		50	10.6	2	
			7"			



TEST BORING LOGS
 POCO RD. AND VOLLMER RD.
 ELITE PROPERTIES

JOB NO.
 212381
FIG. B-2

TEST BORING 5
DATE DRILLED 9/2/2021

TEST BORING 6
DATE DRILLED 9/2/2021

REMARKS

REMARKS

DRY TO 20', 10/6/21

SAND, SILTY, TAN, MEDIUM
DENSE, DRY

SANDSTONE, VERY WEAK, TAN,
HIGHLY WEATHERED, (SAND,
SILTY, VERY DENSE, MOIST)

Depth (ft)	Symbol	Samples	Blows per foot	Watercontent %	Soil Type
			13	2.5	1
5			21	2.2	1
10			50 9"	6.6	2
15			50 6"	8.0	2
20			50 7"	7.6	2

WATER @ 11.5', 10/6/21

SAND, SILTY, BROWN, DENSE,
MOIST

SANDSTONE, VERY WEAK, TAN,
HIGHLY WEATHERED, (SAND,
SILTY, VERY DENSE, MOIST)

CLAYSTONE, VERY WEAK, BLUE-
GRAY, HIGHLY WEATHERED,
(CLAY, SANDY, HARD, MOIST)

Depth (ft)	Symbol	Samples	Blows per foot	Watercontent %	Soil Type
			43	4.6	1
5			50 9"	7.3	2
10			50 10"	10.7	2
15			50 7"	14.6	3
20			50 7"	14.4	3



TEST BORING LOGS
POCO RD. AND VOLLMER RD.
ELITE PROPERTIES

JOB NO.
212381

FIG. B-3

TEST BORING 7
 DATE DRILLED 9/2/2021

TEST BORING 8
 DATE DRILLED 9/2/2021

REMARKS

REMARKS

WATER @ 15.5', 10/6/21

DRY TO 20', 10/6/21

Depth (ft)	Symbol	Samples	Blows per foot	Watercontent %	Soil Type
1					1
2			50 8"	3.8	2
5			50 9"	9.1	2
10			50 8"	9.6	2
15			50 8"	11.5	2
20			50 6"	13.7	3

Depth (ft)	Symbol	Samples	Blows per foot	Watercontent %	Soil Type
1					1
2			50	11.1	2
5			50 9"	8.5	2
10			50 8"	10.1	2
15			50 6"	9.3	2
20			50 7"	11.9	2

CLAYSTONE, VERY EWAK, GRAY,
 HIGHLY WEATHERED, (CLAY,
 SANDY, HARD, MOIST)



TEST BORING LOGS
 POCO RD. AND VOLLMER RD.
 ELITE PROPERTIES

JOB NO.
 212381

FIG. B-4

TEST BORING 9
 DATE DRILLED 9/2/2021

TEST BORING 10
 DATE DRILLED 9/2/2021

REMARKS

REMARKS

WATER @ 14', 10/6/21

SAND, SILTY, TAN, MEDIUM
 DENSE, MOIST

SANDSTONE, VERY WEAK, TAN,
 HIGHLY WEATHERED, (SAND,
 SILTY, VERY DENSE, MOIST)

Depth (ft)	Symbol	Samples	Blows per foot	Watercontent %	Soil Type
5			13	4.2	1
			12	6.1	1
10			50 8"	11.1	2
15			50 8"	9.5	2
20			50 6"	11.9	2



WATER @ 12', 10/6/21

SAND, SILTY, TAN, MEDIUM
 DENSE, MOIST

SANDSTONE, VERY WEAK, TAN,
 HIGHLY WEATHERED, (SAND,
 WITH SILT, VERY DENSE, MOIST)

Depth (ft)	Symbol	Samples	Blows per foot	Watercontent %	Soil Type
5			18	3.5	1
			50 8"	8.5	2
10			50 8"	10.1	2
15			50 6"	12.0	2
20			50 8"	14.9	2



TEST BORING LOGS
 POCO RD. AND VOLLMER RD.
 ELITE PROPERTIES

JOB NO.
 212381

FIG. B-5

TEST BORING 11
 DATE DRILLED 9/2/2021

TEST BORING 12
 DATE DRILLED 9/2/2021

REMARKS

REMARKS

WATER @ 15', 10/6/21

DRY TO 20', 10/6/21

SAND, WITH SILT, TAN, MEDIUM DENSE to DENSE, DRY to MOIST

SAND, SILTY, BROWN, MEDIUM DENSE, MOIST

SANDSTONE, VERY WEAK, TAN, HIGHLY WEATHERED, (SAND, SILTY, VERY DENSE, MOIST)

CLAYEY LENS

SANDSTONE, VERY WEAK, TAN, HIGHLY WEATHERED, (SAND, SILTY, VERY DENSE, MOIST)

WEATHERED CLAYSTONE, VERY WEAK, GRAY, HIGHLY WEATHERED. (CLAY, SANDY,

Depth (ft)	Symbol	Samples	Blows per foot	Watercontent %	Soil Type
10			10	1.6	1
5			37	3.5	1
10			50 5"	8.5	2
15			50 6"	12.7	2
20			34	11.4	3

Depth (ft)	Symbol	Samples	Blows per foot	Watercontent %	Soil Type
17			17	4.0	1
5			26	12.6	1
10			50 9"	9.9	2
15			50 7"	8.9	2
20			50 6"	10.6	2



TEST BORING LOGS
 POCO RD. AND VOLLMER RD.
 ELITE PROPERTIES

JOB NO.
 212381

FIG. B-6

TEST BORING P-1
 DATE DRILLED 8/22/2023

TEST BORING P-2
 DATE DRILLED 8/22/2023

REMARKS

REMARKS

DRY TO 12.5', 8/23/23

WATER @ 12', 8/23/23

SAND, WITH SILT, TAN, MEDIUM DENSE, DRY

SAND, SILTY, BROWN SANDSTONE, VERY WEAK, BROWN, HIGHLY WEATHERED, (SAND, SILTY, VERY DENSE,

SANDSTONE, VERY WEAK, TAN, HIGHLY WEATHERED, (SAND, SILTY, VERY DENSE, MOIST)

Depth (ft)	Symbol	Samples	Blows per foot	Watercontent %	Soil Type	Depth (ft)	Symbol	Samples	Blows per foot	Watercontent %	Soil Type
0 - 12.5	(Dotted pattern)		16	2.8	1	0 - 12	(Dotted pattern)		50 11"	7.0	2
12.5 - 14	(Dotted pattern)		50 9"	3.7	2	12 - 14	(Dotted pattern)		50 9"	5.5	2
14 - 20	(Dotted pattern)					14 - 20	(Dotted pattern)				



TEST BORING LOGS
 POCO ROAD AND VOLLMER ROAD
 ELITE PROPERTIES

JOB NO.
 212381

FIG. B-7

TEST BORING P-3
 DATE DRILLED 8/22/2023

TEST BORING P-4
 DATE DRILLED 8/22/2023

REMARKS

REMARKS

WATER @ 7', 8/23/23

SAND, CLAYEY, OLIVE, MEDIUM DENSE, MOIST

SANDSTONE, VERY WEAK, GRAY, HIGHLY WEATHERED, (SAND, SILTY, VERY DENSE, MOIST)

Depth (ft)	Symbol	Samples	Blows per foot	Watercontent %	Soil Type
5			15	13.4	1
10			<u>50</u> 7"	8.2	2
15					
20					

WATER @ 5.5', 8/23/23

SAND, CLAYEY, OLIVE, LOOSE, MOIST

SANDSTONE, VERY WEAK, OLIVE, HIGHLY WEATHERED, (SAND, SILTY, VERY DENSE, MOIST)

Depth (ft)	Symbol	Samples	Blows per foot	Watercontent %	Soil Type
5			9	10.6	1
10			<u>50</u> 8"	9.3	2
15					
20					



TEST BORING LOGS
 POCO ROAD AND VOLLMER ROAD
 ELITE PROPERTIES

JOB NO.
 212381

FIG. B-8

TEST BORING P-5
 DATE DRILLED 10/24/2023

TEST BORING P-6
 DATE DRILLED 10/24/2023

REMARKS

REMARKS

DRY TO 15', 10/24/23

SANDSTONE, VERY WEAK, TAN,
 RESIDUAL SOIL (SAND, WITH SILT,
 VERY DENSE, MOIST)

Depth (ft)	Symbol	Samples	Blows per foot	Watercontent %	Soil Type
5			50 10"	3.4	1
			50 11"	7.8	1
10			50 6"	11.3	1
15			50 6"	8.5	1
20					

DRY TO 35', 10/24/23

SANDSTONE, VERY WEAK, TAN,
 RESIDUAL SOIL (SAND,SILTY, VERY
 DENSE, MOIST)

Depth (ft)	Symbol	Samples	Blows per foot	Watercontent %	Soil Type
5			50 10"	7.8	1
			50 8"	9.9	1
10			50 6"	9.4	1
15			50 7"	9.6	1
20			50 8"	9.9	1
25			50 8"	12.2	1
30			50 9"	11.7	1
35			50 8"	15.9	1



TEST BORING LOGS

POCO & VOLLMER
 ELITE PROPERTIES

JOB NO.
 212381

FIG. B-9

TEST BORING P-7
 DATE DRILLED 10/24/2023

TEST BORING P-8
 DATE DRILLED 10/24/2023

REMARKS

REMARKS

DRY TO 25', 10/24/23

SANDSTONE, VERY WEAK, TAN,
 RESIDUAL SOIL (SAND, SILTY,
 VERY DENSE, MOIST)

Depth (ft)	Symbol	Samples	Blows per foot	Watercontent %	Soil Type
5			50 9"	6.8	1
5			50 8"	13.3	1
10			50 7"	11.4	1
15			50 8"	12.7	1
20			50 5"	12.1	1
25			50 7"	12.6	1

DRY TO 20', 10/24/23

SAND, GRAVELLY, SILTY, BROWN,
 DENSE, MOIST

CLAYSTONE, WEAK, BROWN,
 HIGHLY WEATHERED (CLAY,
 SANDY, HARD, MOIST)
 SANDSTONE, VERY WEAK,
 BROWN, HIGHLY WEATHERED
 (SAND, SILTY, VERY DENSE,

Depth (ft)	Symbol	Samples	Blows per foot	Watercontent %	Soil Type
5			30	8.8	1A
5			45	9.2	1A
10			37	14.7	2
15			50 6"	8.6	1
20			50 7"	13.5	1



TEST BORING LOGS

POCO & VOLLMER
 ELITE PROPERTIES

JOB NO.
 212381

FIG. B-10

APPENDIX C: Laboratory Testing Results

**TABLE C-1
SUMMARY OF LABORATORY TEST RESULTS**

SOIL TYPE	TEST BORING NO.	DEPTH (FT)	WATER (%)	DRY DENSITY (PCF)	PASSING NO. 200 SIEVE (%)	LIQUID LIMIT	PLASTIC LIMIT	PLASTIC INDEX	SULFATE (WT %)	FHA SWELL (PSF)	SWELL/ CONSOL (%)	USCS	SOIL DESCRIPTION
1	1	2-3			14.6	NV	NP	NP	<0.01			SM	SAND, SILTY
1	5	5			15.2							SM	SAND, SILTY
1	6	2-3			15.8							SM	SAND, SILTY
1	9	5			15.8							SM	SAND, SILTY
1	11	2-3			7.9							SW-SM	SAND, WITH SILT
1	12	5	16.9	112.5	30.1						1.9	SC	SAND, CLAYEY
1	P-1	2-3			5.0							SW-SM	SAND, WITH SILT
1	P-3	1-2			37.1							SC	SAND, CLAYEY
1	P-4	2-3			29.6							SC	SAND, CLAYEY
2	2	10			10.5	NV	NP	NP	<0.01			SW-SM	SANDSTONE, (SAND, WITH SILT)
2	4	5			16.3							SM	SANDSTONE, (SAND, SILTY)
2	P-2	2-3			13.9							SM	SANDSTONE, (SAND, SILTY)
2	7	10			20.1							SM	SANDSTONE, (SAND, SILTY)
2	8	2-3			24.1							SM	SANDSTONE, (SAND, SILTY)
2	10	10			11.9							SW-SM	SANDSTONE, (SAND, WITH SILT)
3	3	20	16.0	114.6	57.9	38	26	12	0.00		2.8	ML	SILTSTONE, (SILT, SANDY)
3	6	20	14.7	118.7	83.7						1.8	CL	CLAYSTONE, (CLAY, SANDY)

TEST BORING 1
 DEPTH (FT) 2-3

SOIL DESCRIPTION SAND, SILTY
 SOIL TYPE 1

**Sieve Analysis
 Grain Size Distribution**

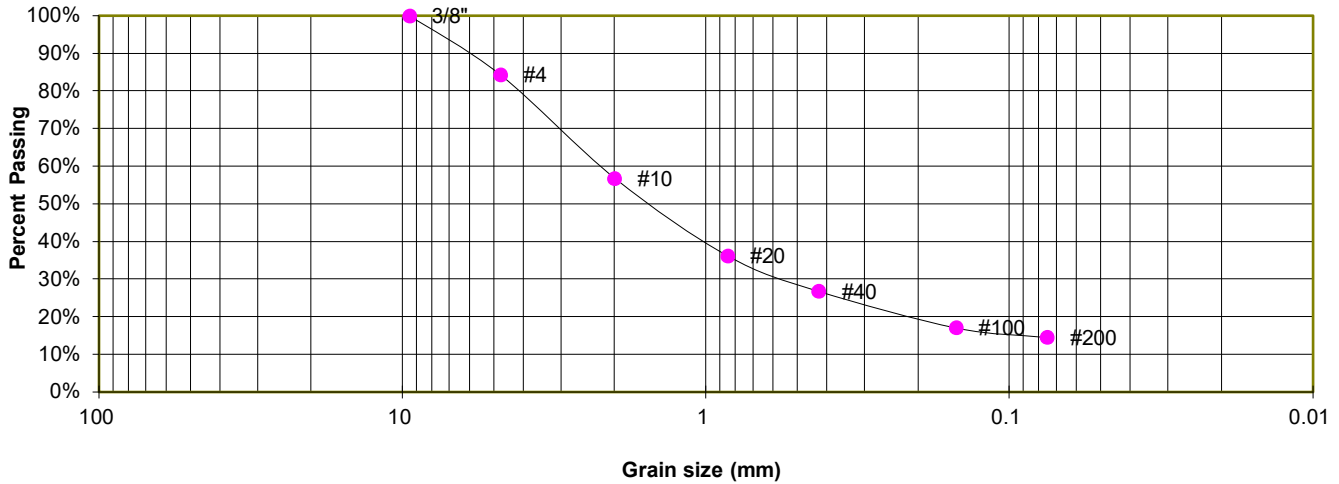

GRAIN SIZE ANALYSIS

U.S. Sieve #	Percent Finer
3"	
1 1/2"	
3/4"	
1/2"	
3/8"	100.0%
4	84.3%
10	56.8%
20	36.2%
40	26.8%
100	17.1%
200	14.6%

ATTERBERG LIMITS

Plastic Limit	NP
Liquid Limit	NV
Plastic Index	NP

SOIL CLASSIFICATION

USCS CLASSIFICATION: SM



LABORATORY TEST RESULTS

POCO RD. AND VOLLMER RD.
 ELITE PROPERTIES

JOB NO.
 212381

FIG. C-1

TEST BORING 5
 DEPTH (FT) 5

SOIL DESCRIPTION SAND, SILTY
 SOIL TYPE 1

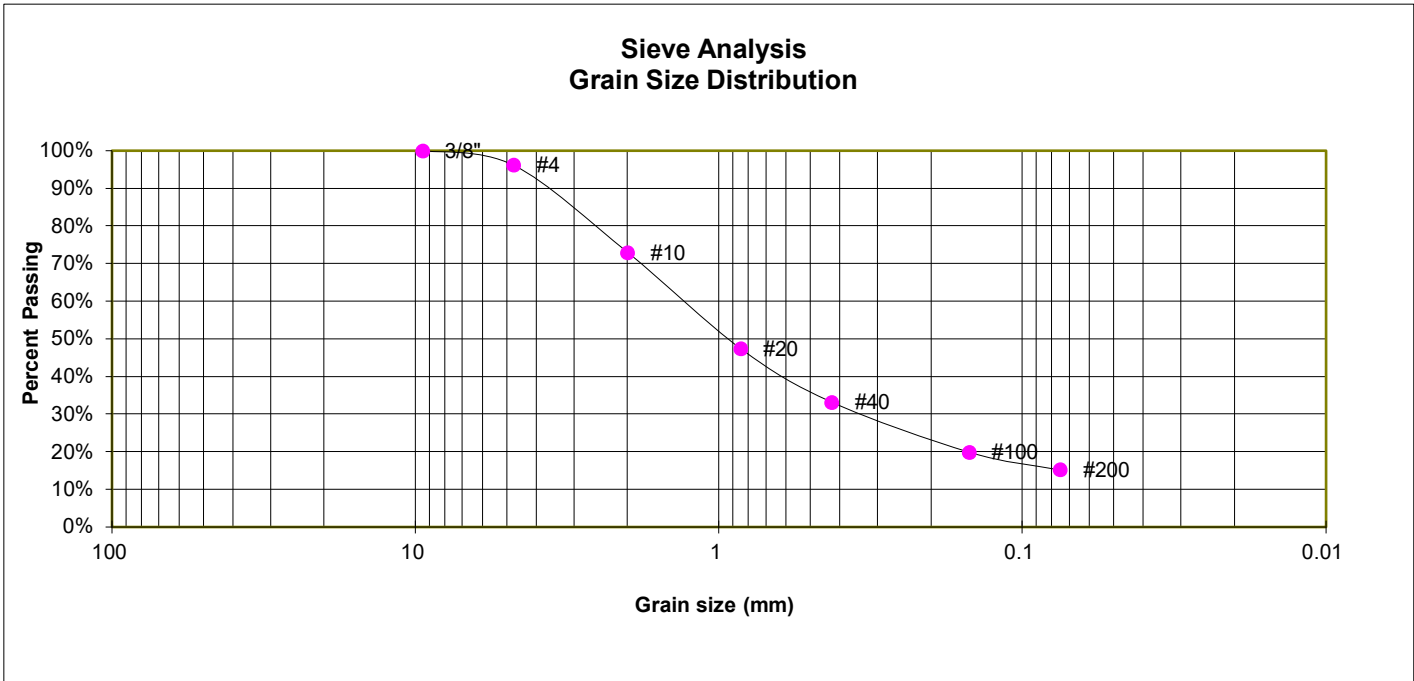

GRAIN SIZE ANALYSIS

U.S. Sieve #	Percent Finer
3"	
1 1/2"	
3/4"	
1/2"	
3/8"	100.0%
4	96.2%
10	72.9%
20	47.5%
40	33.2%
100	19.9%
200	15.2%

SOIL CLASSIFICATION

USCS CLASSIFICATION: SM



LABORATORY TEST RESULTS

POCO RD. AND VOLLMER RD.
 ELITE PROPERTIES

JOB NO.
 212381

FIG. C-2

TEST BORING 6
 DEPTH (FT) 2-3

SOIL DESCRIPTION SAND, SILTY
 SOIL TYPE 1

**Sieve Analysis
 Grain Size Distribution**

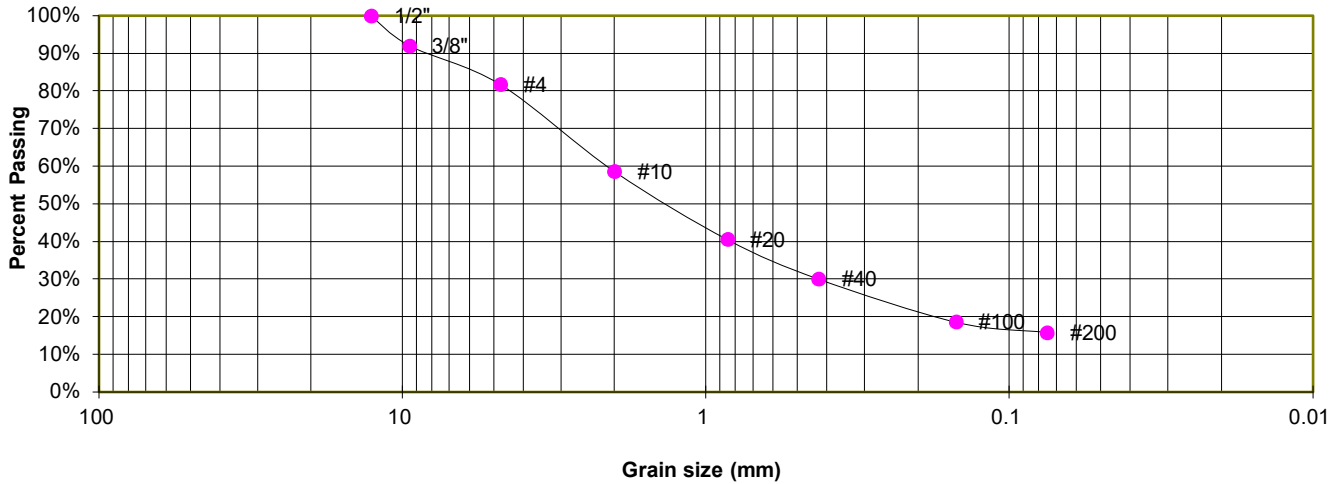

GRAIN SIZE ANALYSIS

U.S. Sieve #	Percent Finer
3"	
1 1/2"	
3/4"	
1/2"	100.0%
3/8"	92.0%
4	81.7%
10	58.6%
20	40.6%
40	30.0%
100	18.6%
200	15.8%

SOIL CLASSIFICATION

USCS CLASSIFICATION: SM



LABORATORY TEST RESULTS

POCO RD. AND VOLLMER RD.
 ELITE PROPERTIES

JOB NO.
 212381

FIG. C-3

TEST BORING 9
DEPTH (FT) 5

SOIL DESCRIPTION SAND, SILTY
SOIL TYPE 1

Sieve Analysis Grain Size Distribution

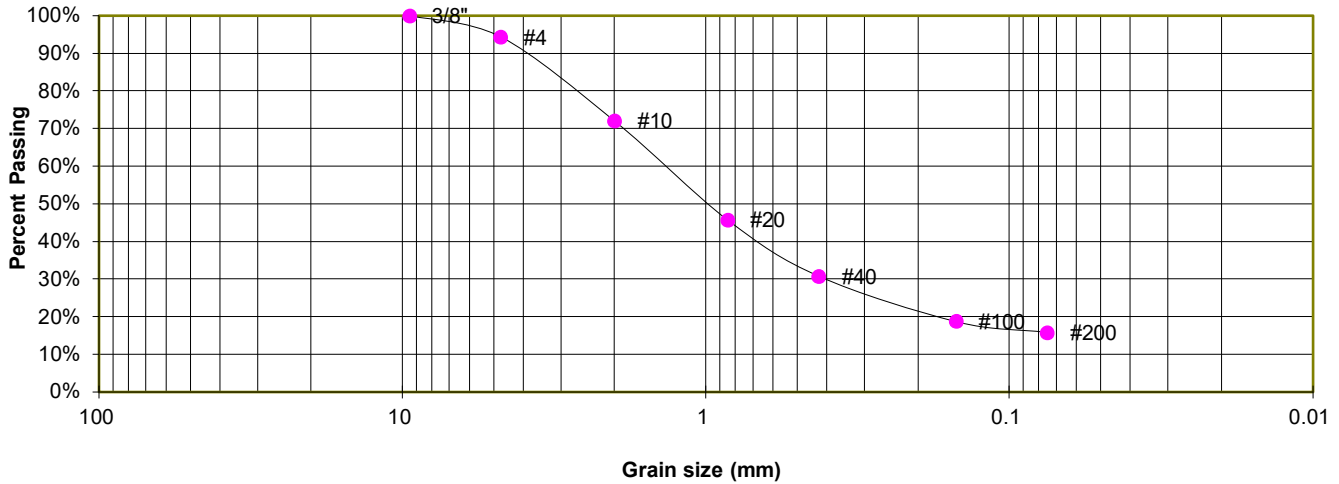

GRAIN SIZE ANALYSIS

U.S. Sieve #	Percent Finer
3"	
1 1/2"	
3/4"	
1/2"	
3/8"	100.0%
4	94.4%
10	72.0%
20	45.8%
40	30.8%
100	18.8%
200	15.8%

SOIL CLASSIFICATION

USCS CLASSIFICATION: SM



LABORATORY TEST RESULTS

POCO RD. AND VOLLMER RD.
ELITE PROPERTIES

JOB NO.
212381

FIG. C-4

TEST BORING 11
 DEPTH (FT) 2-3

SOIL DESCRIPTION SAND, WITH SILT
 SOIL TYPE 1

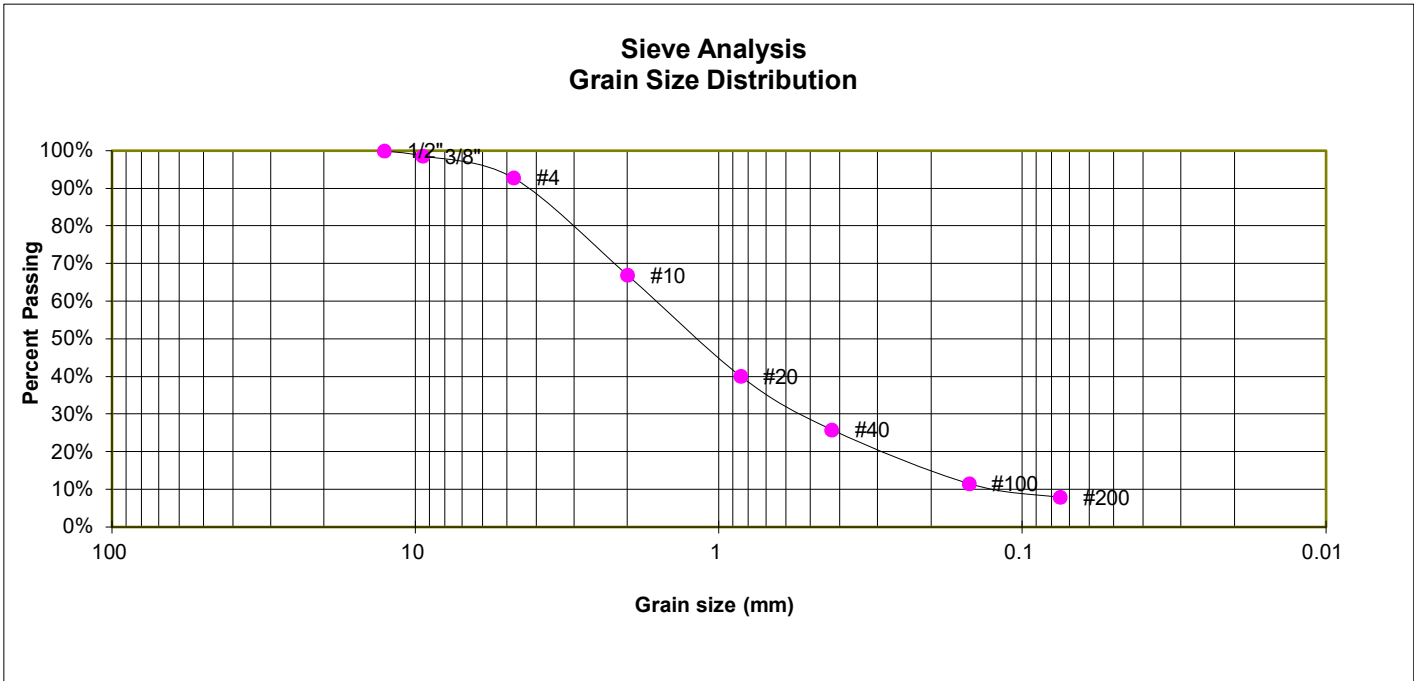

GRAIN SIZE ANALYSIS

U.S. Sieve #	Percent Finer
3"	
1 1/2"	
3/4"	
1/2"	100.0%
3/8"	98.6%
4	92.8%
10	67.0%
20	40.1%
40	25.9%
100	11.6%
200	7.9%

5

SOIL CLASSIFICATION

USCS CLASSIFICATION: SW-SM



LABORATORY TEST RESULTS

POCO RD. AND VOLLMER RD.
 ELITE PROPERTIES

JOB NO.
 212381

FIG. C-5

TEST BORING 12
DEPTH (FT) 5

SOIL DESCRIPTION SAND, CLAYEY
SOIL TYPE 1

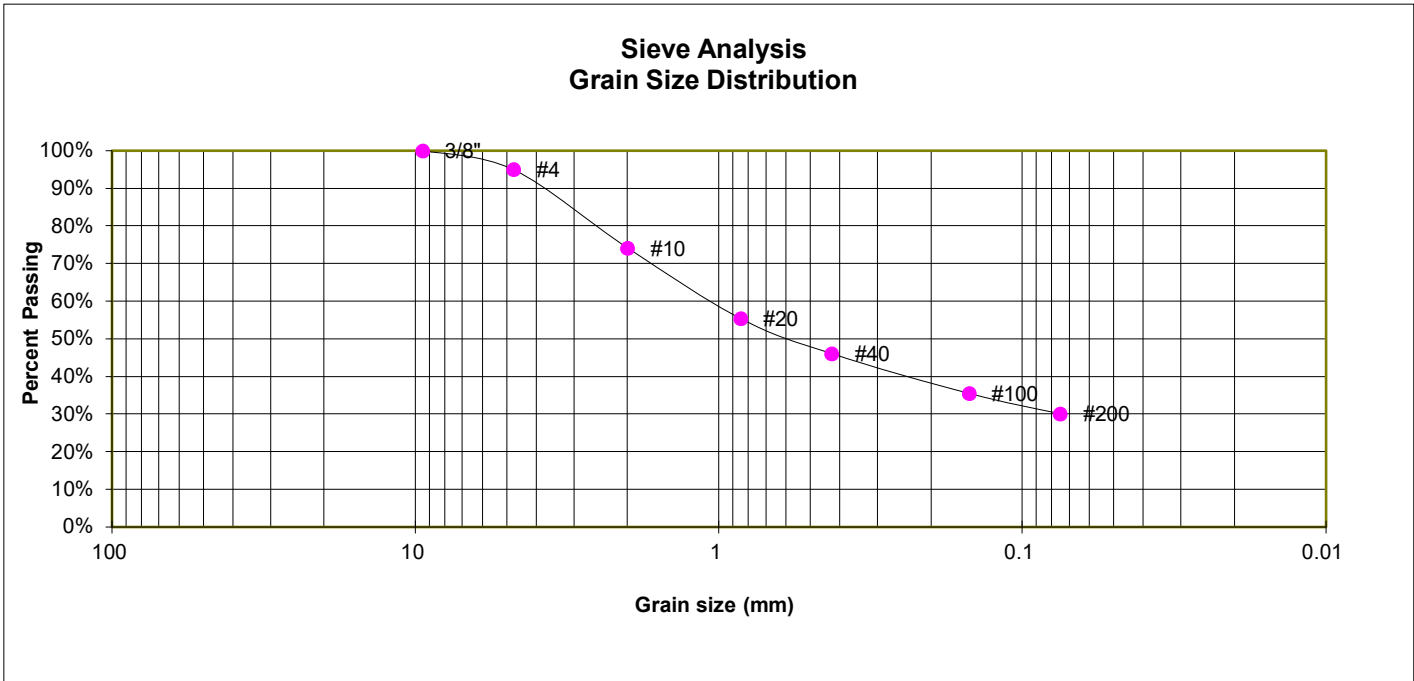

GRAIN SIZE ANALYSIS

U.S. Sieve #	Percent Finer
3"	
1 1/2"	
3/4"	
1/2"	
3/8"	100.0%
4	95.0%
10	74.1%
20	55.4%
40	46.1%
100	35.6%
200	30.1%

SOIL CLASSIFICATION

USCS CLASSIFICATION: SC



LABORATORY TEST RESULTS

POCO RD. AND VOLLMER RD.
ELITE PROPERTIES

JOB NO.
212381

FIG. C-6

TEST BORING P-1
 DEPTH (FT) 2-3

SOIL DESCRIPTION SAND, WITH SILT
 SOIL TYPE 1

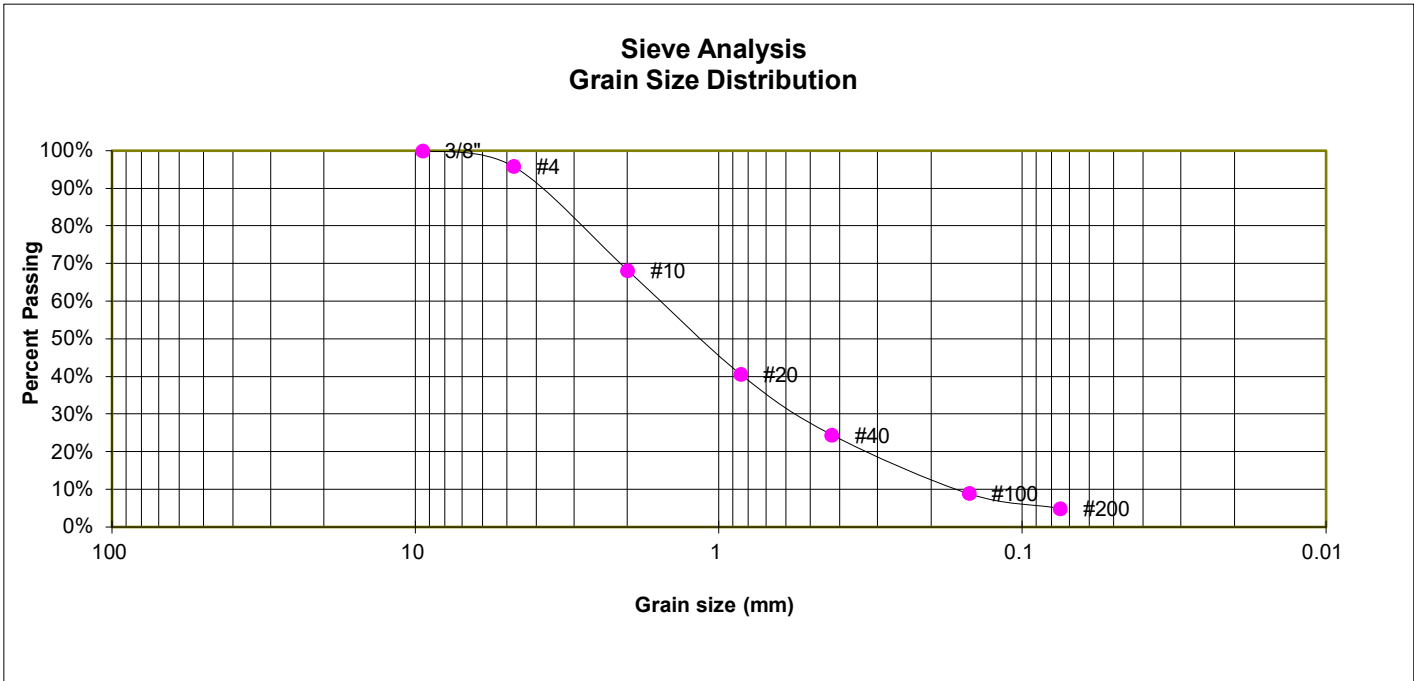

GRAIN SIZE ANALYSIS

U.S. Sieve #	Percent Finer
3"	
1 1/2"	
3/4"	
1/2"	
3/8"	100.0%
4	95.8%
10	68.2%
20	40.6%
40	24.5%
100	8.9%
200	5.0%

SOIL CLASSIFICATION

USCS CLASSIFICATION: SW-SM



LABORATORY TEST RESULTS

POCO ROAD AND VOLLMER ROAD
 ELITE PROPERTIES

JOB NO.
 212381

FIG. C-7

TEST BORING P-3
DEPTH (FT) 1-2

SOIL DESCRIPTION SAND, CLAYEY
SOIL TYPE 1

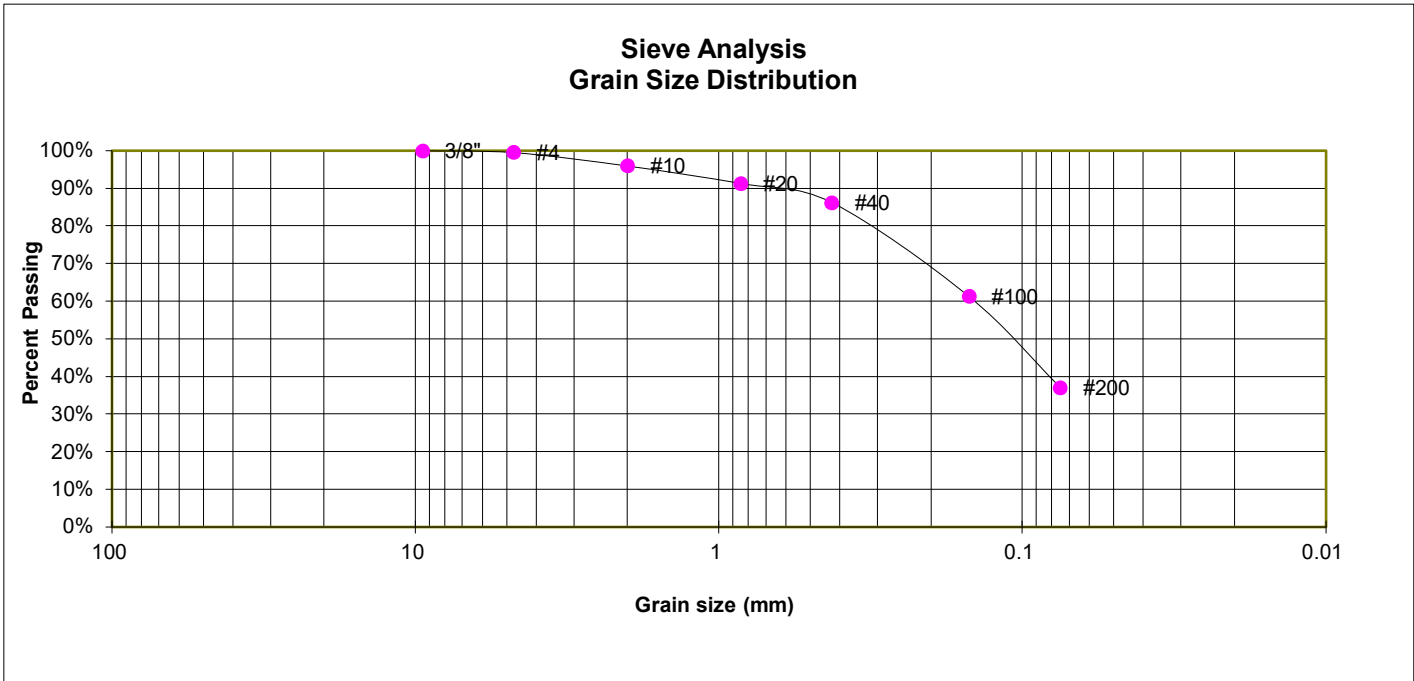

GRAIN SIZE ANALYSIS

U.S. Sieve #	Percent Finer
3"	
1 1/2"	
3/4"	
1/2"	
3/8"	100.0%
4	99.6%
10	96.0%
20	91.3%
40	86.2%
100	61.4%
200	37.1%

SOIL CLASSIFICATION

USCS CLASSIFICATION: SC



LABORATORY TEST RESULTS

POCO ROAD AND VOLLMER ROAD
ELITE PROPERTIES

JOB NO.
212381

FIG. C-8

TEST BORING P-4
DEPTH (FT) 2-3

SOIL DESCRIPTION SAND, CLAYEY
SOIL TYPE 1

Sieve Analysis Grain Size Distribution

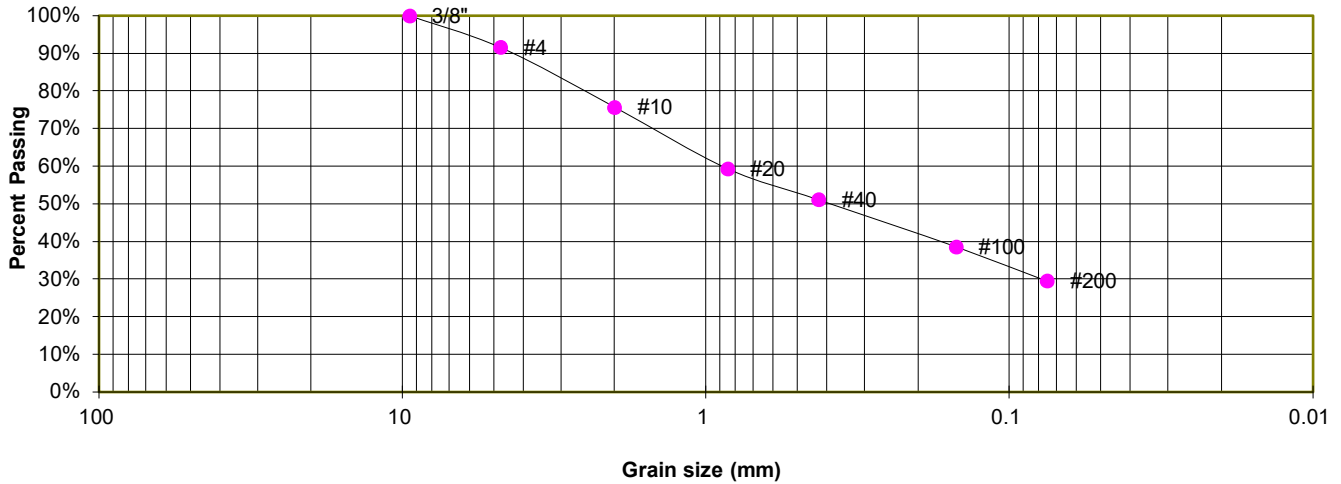

GRAIN SIZE ANALYSIS

U.S. Sieve #	Percent Finer
3"	
1 1/2"	
3/4"	
1/2"	
3/8"	100.0%
4	91.6%
10	75.7%
20	59.3%
40	51.2%
100	38.6%
200	29.6%

SOIL CLASSIFICATION

USCS CLASSIFICATION: SC



LABORATORY TEST RESULTS

POCO ROAD AND VOLLMER ROAD
ELITE PROPERTIES

JOB NO.
212381

FIG. C-9

TEST BORING 2
 DEPTH (FT) 10

SOIL DESCRIPTION SANDSTONE, (SAND, WITH SILT)
 SOIL TYPE 2

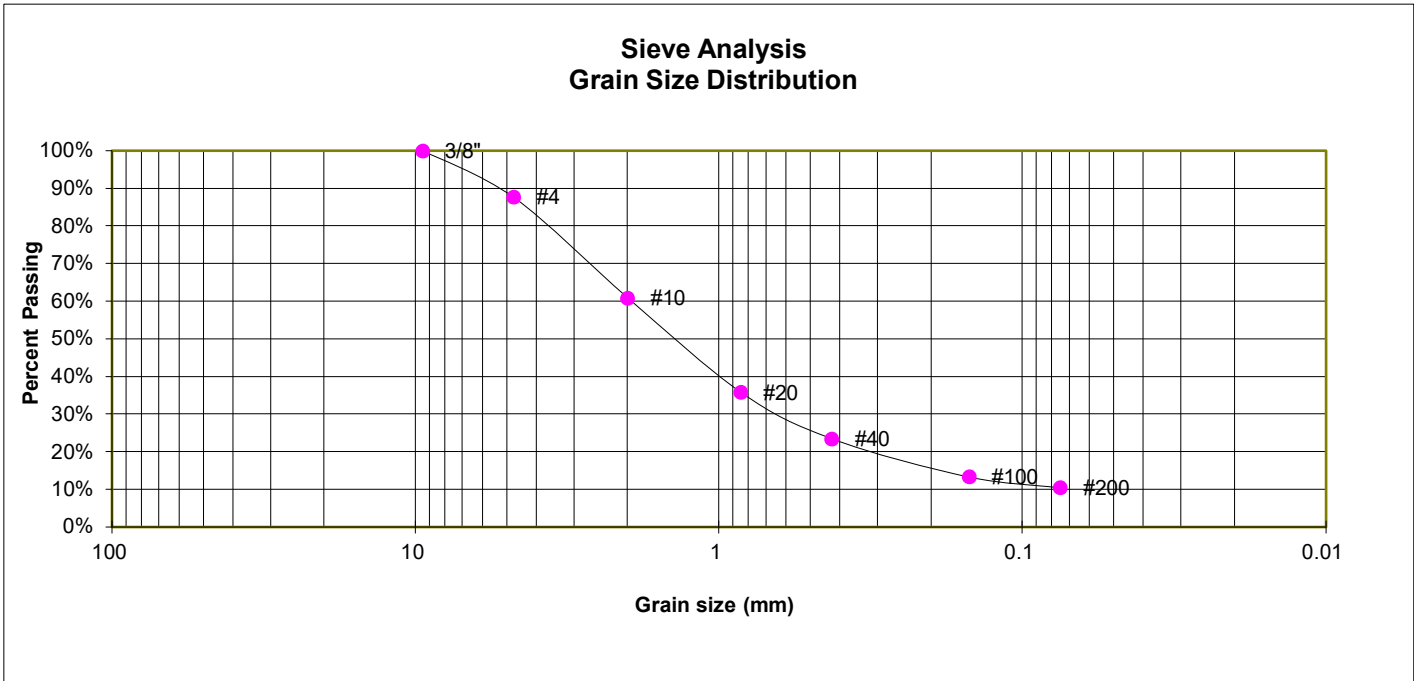

GRAIN SIZE ANALYSIS

U.S. Sieve #	Percent Finer
3"	
1 1/2"	
3/4"	
1/2"	
3/8"	100.0%
4	87.6%
10	60.9%
20	35.9%
40	23.4%
100	13.4%
200	10.5%

ATTERBERG LIMITS

Plastic Limit	NP
Liquid Limit	NV
Plastic Index	NP

SOIL CLASSIFICATION

USCS CLASSIFICATION: SW-SM



LABORATORY TEST RESULTS

POCO RD. AND VOLLMER RD.
 ELITE PROPERTIES

JOB NO.
 212381

FIG. C-10

TEST BORING 4
 DEPTH (FT) 5

SOIL DESCRIPTION SANDSTONE, (SAND, SILTY)
 SOIL TYPE 2

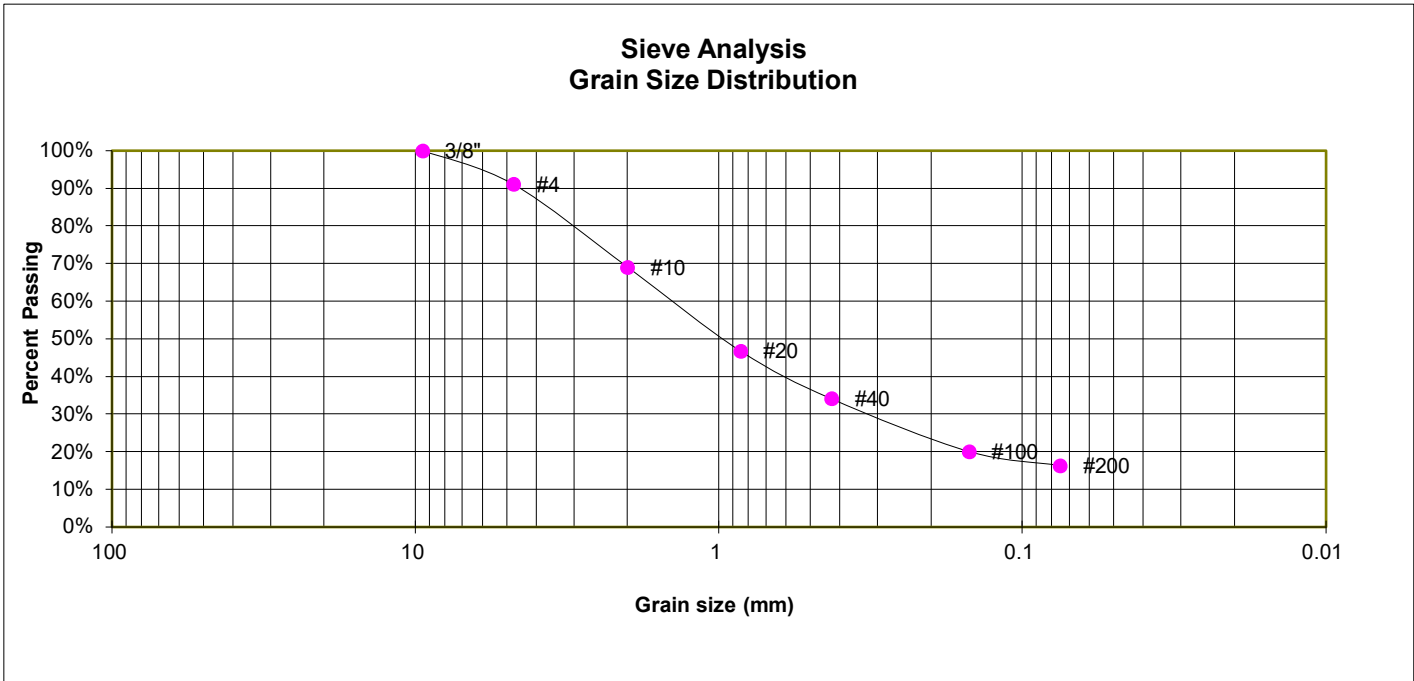

GRAIN SIZE ANALYSIS

U.S. Sieve #	Percent Finer
3"	
1 1/2"	
3/4"	
1/2"	
3/8"	100.0%
4	91.1%
10	69.0%
20	46.8%
40	34.1%
100	20.1%
200	16.3%

SOIL CLASSIFICATION

USCS CLASSIFICATION: SM



LABORATORY TEST RESULTS

POCO RD. AND VOLLMER RD.
 ELITE PROPERTIES

JOB NO.
 212381

FIG. C-11

TEST BORING P-2
DEPTH (FT) 2-3

SOIL DESCRIPTION SANDSTONE, (SAND, SILTY)
SOIL TYPE 2

Sieve Analysis Grain Size Distribution

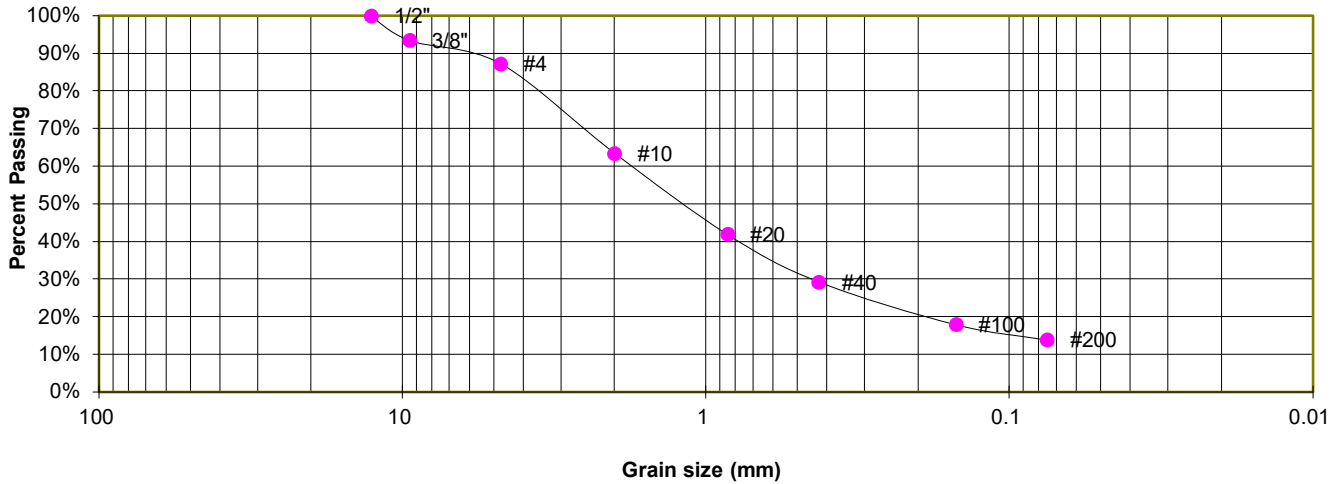

GRAIN SIZE ANALYSIS

U.S. Sieve #	Percent Finer
3"	
1 1/2"	
3/4"	
1/2"	100.0%
3/8"	93.5%
4	87.3%
10	63.5%
20	41.9%
40	29.3%
100	18.0%
200	13.9%

SOIL CLASSIFICATION

USCS CLASSIFICATION: SM



LABORATORY TEST RESULTS

POCO ROAD AND VOLLMER ROAD
ELITE PROPERTIES

JOB NO.
212381

FIG. C-12

TEST BORING 7
DEPTH (FT) 10

SOIL DESCRIPTION SANDSTONE, (SAND, SILTY)
SOIL TYPE 2

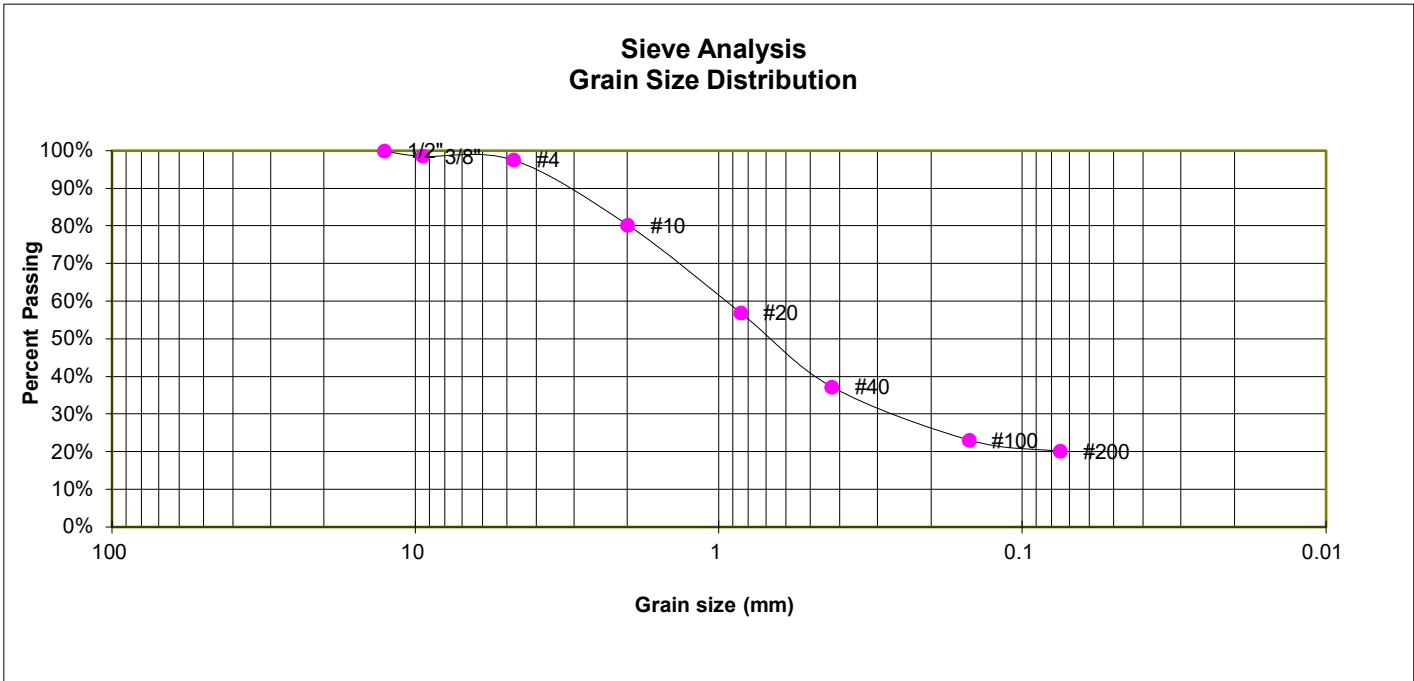

GRAIN SIZE ANALYSIS

U.S. Sieve #	Percent Finer
3"	
1 1/2"	
3/4"	
1/2"	100.0%
3/8"	98.6%
4	97.6%
10	80.3%
20	57.0%
40	37.3%
100	23.2%
200	20.1%

SOIL CLASSIFICATION

USCS CLASSIFICATION: SM



LABORATORY TEST RESULTS

POCO RD. AND VOLLMER RD.
ELITE PROPERTIES

JOB NO.
212381

FIG. C-13

TEST BORING 8
DEPTH (FT) 2-3

SOIL DESCRIPTION SANDSTONE, (SAND, SILTY)
SOIL TYPE 2

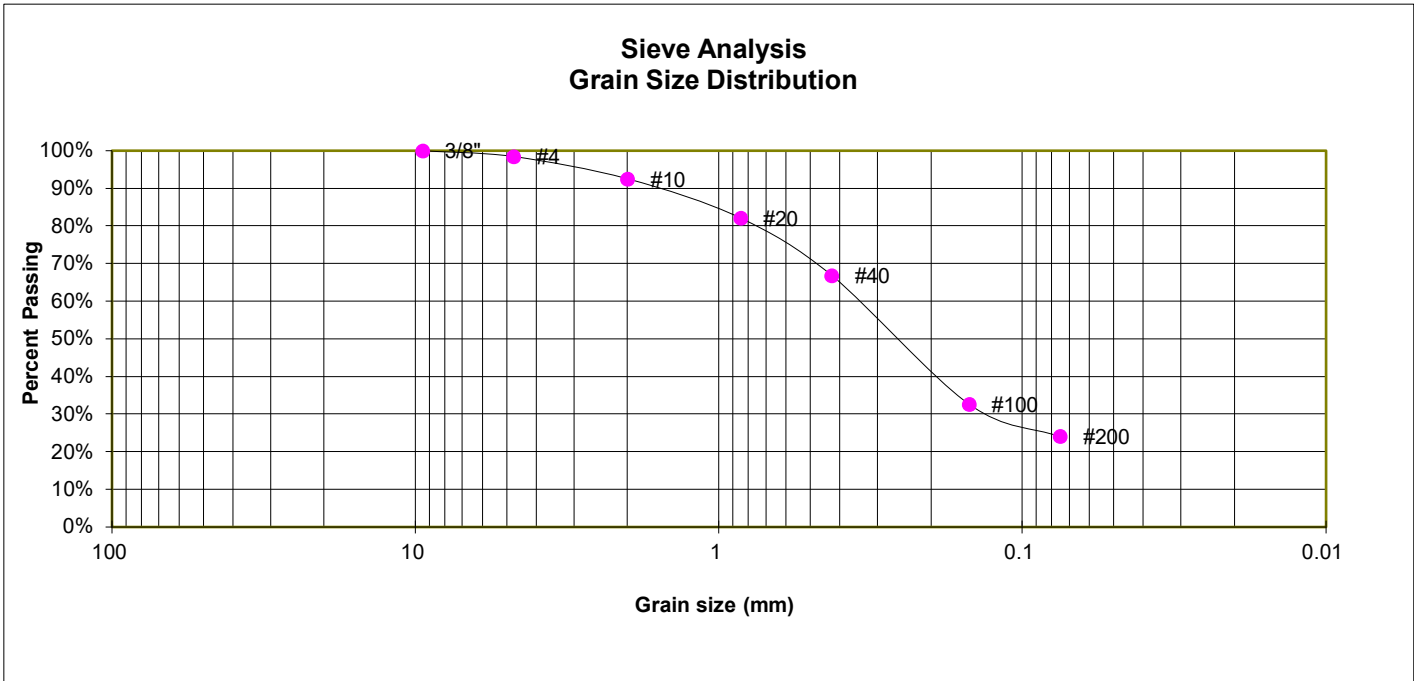

GRAIN SIZE ANALYSIS

U.S. Sieve #	Percent Finer
3"	
1 1/2"	
3/4"	
1/2"	
3/8"	100.0%
4	98.5%
10	92.5%
20	82.1%
40	66.8%
100	32.6%
200	24.1%

SOIL CLASSIFICATION

USCS CLASSIFICATION: SM



LABORATORY TEST RESULTS

POCO RD. AND VOLLMER RD.
ELITE PROPERTIES

JOB NO.
212381

FIG. C-14

TEST BORING 10
 DEPTH (FT) 10

SOIL DESCRIPTION SANDSTONE, (SAND, WITH SILT)
 SOIL TYPE 2

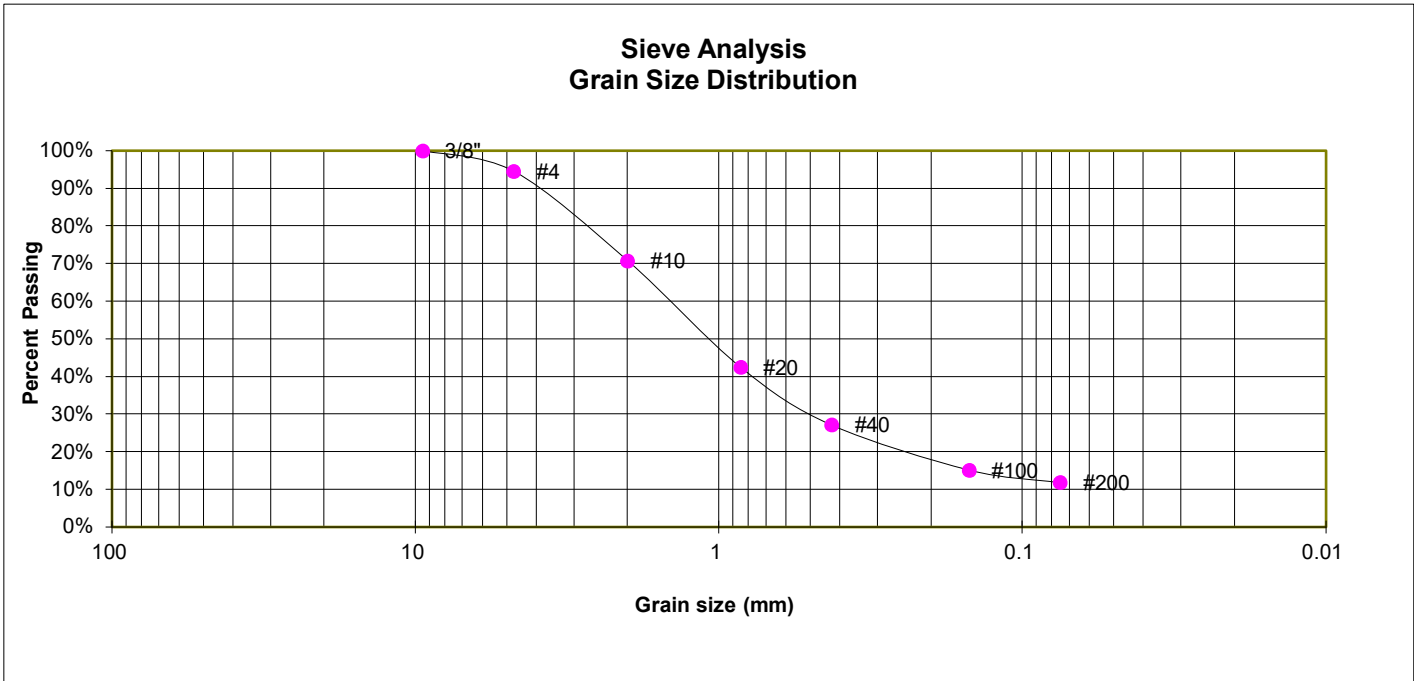

GRAIN SIZE ANALYSIS

U.S. Sieve #	Percent Finer
3"	
1 1/2"	
3/4"	
1/2"	
3/8"	100.0%
4	94.6%
10	70.8%
20	42.5%
40	27.2%
100	15.2%
200	11.9%

SOIL CLASSIFICATION

USCS CLASSIFICATION: SW-SM



LABORATORY TEST RESULTS

POCO RD. AND VOLLMER RD.
 ELITE PROPERTIES

JOB NO.
 212381

FIG. C-15

TEST BORING 3
 DEPTH (FT) 20

SOIL DESCRIPTION SILTSTONE, (SILT, SANDY)
 SOIL TYPE 3

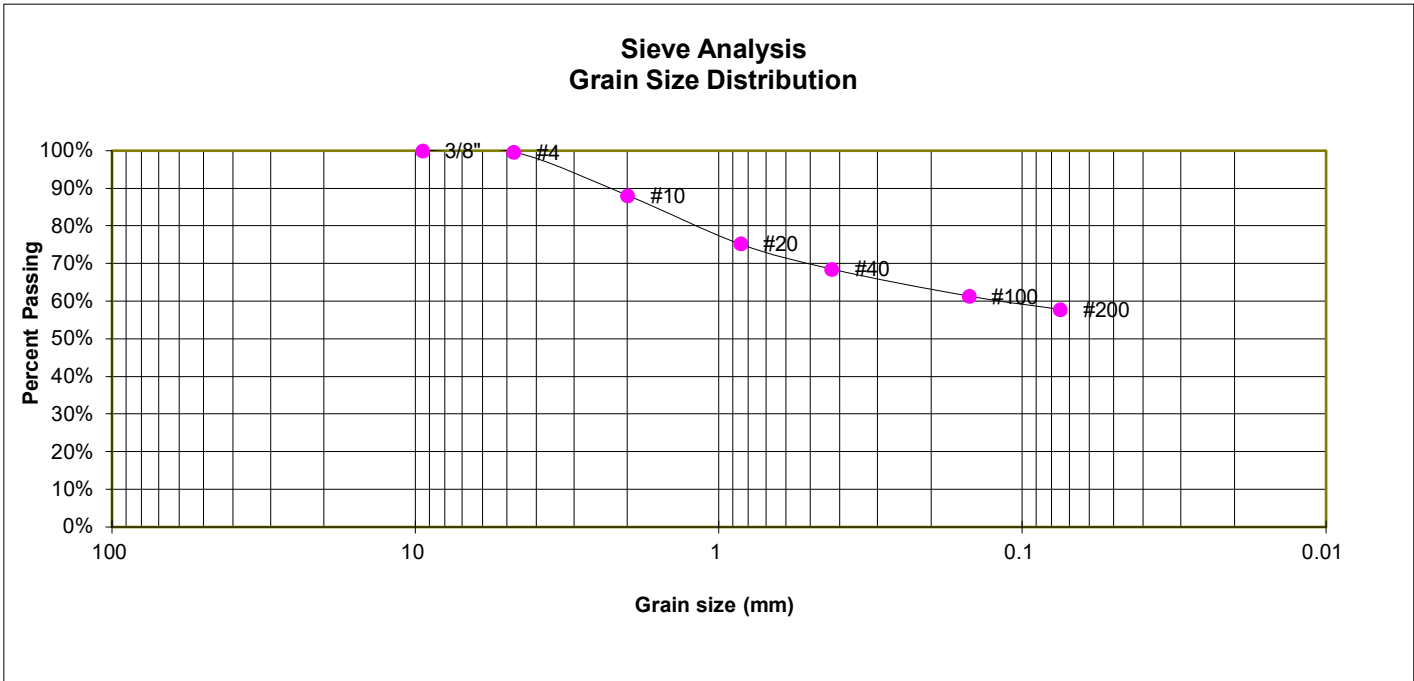

GRAIN SIZE ANALYSIS

U.S. Sieve #	Percent Finer
3"	
1 1/2"	
3/4"	
1/2"	
3/8"	100.0%
4	99.7%
10	88.1%
20	75.3%
40	68.6%
100	61.4%
200	57.9%

ATTERBERG LIMITS

Plastic Limit	26
Liquid Limit	38
Plastic Index	12

SOIL CLASSIFICATION

USCS CLASSIFICATION: ML



LABORATORY TEST RESULTS

POCO RD. AND VOLLMER RD.
 ELITE PROPERTIES

JOB NO.
 212381

FIG. C-16

TEST BORING 6
 DEPTH (FT) 20

SOIL DESCRIPTION CLAYSTONE, (CLAY, SANDY)
 SOIL TYPE 3

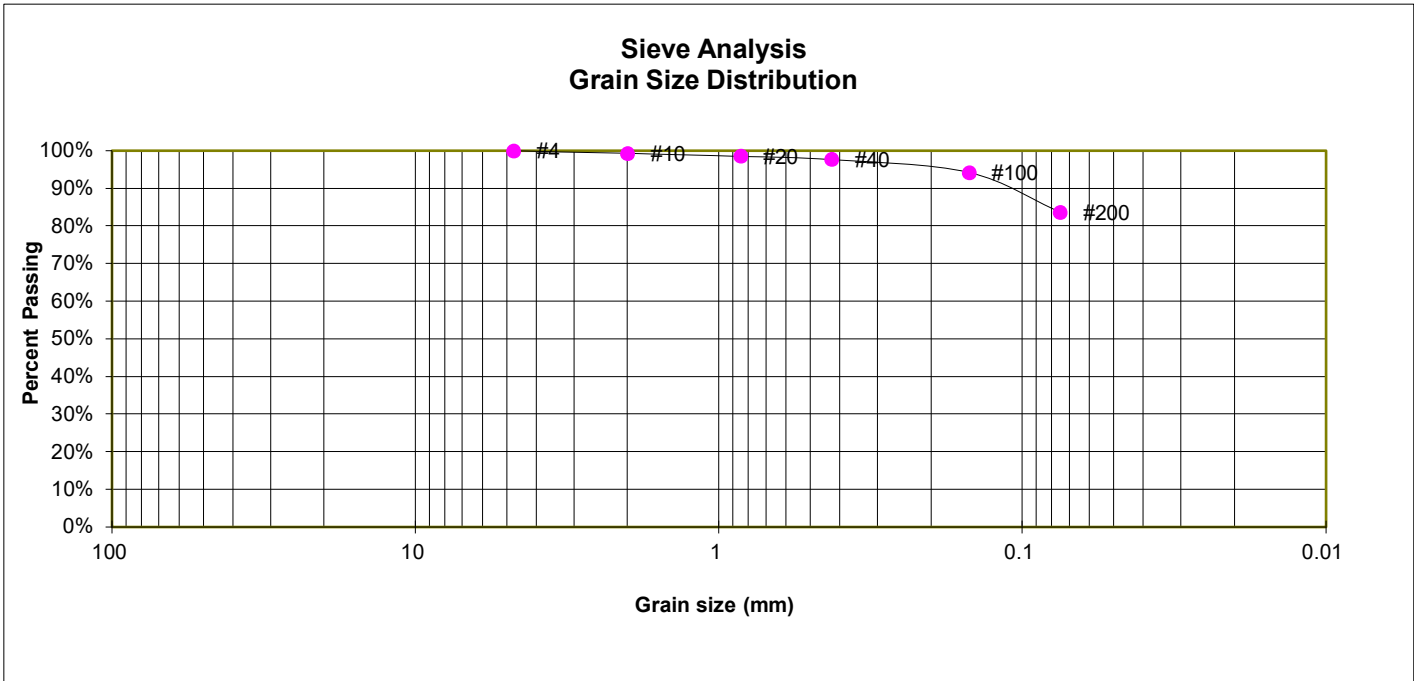

GRAIN SIZE ANALYSIS

U.S. Sieve #	Percent Finer
3"	
1 1/2"	
3/4"	
1/2"	
3/8"	
4	100.0%
10	99.3%
20	98.5%
40	97.7%
100	94.2%
200	83.7%

SOIL CLASSIFICATION

USCS CLASSIFICATION: CL



LABORATORY TEST RESULTS

POCO RD. AND VOLLMER RD.
 ELITE PROPERTIES

JOB NO.
 212381

FIG. C-17

TEST BORING 12
DEPTH (FT) 5

SOIL DESCRIPTION SAND, SILTY
SOIL TYPE 1

SWELL CONSOLIDATION

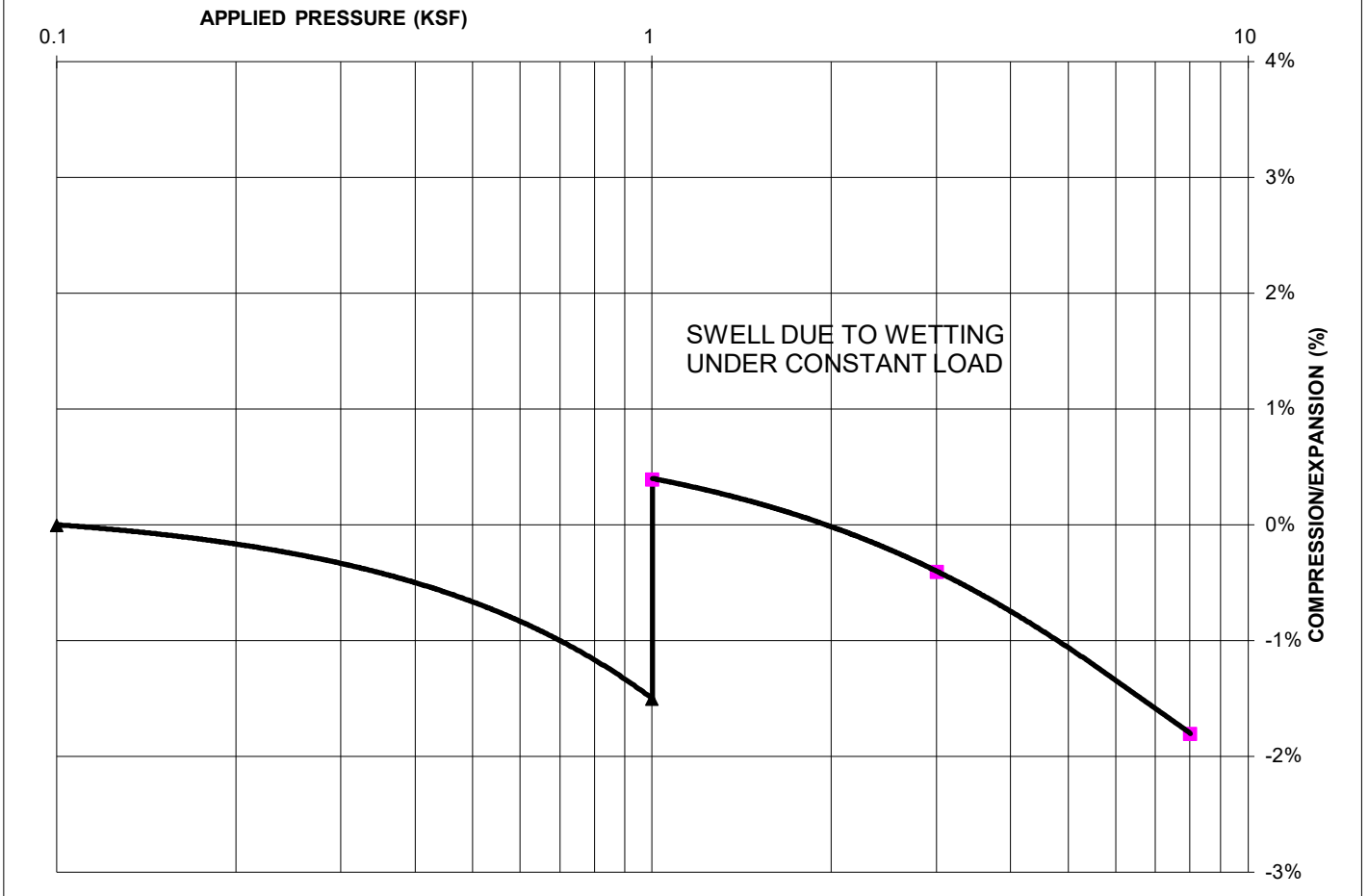

SWELL/CONSOLIDATION TEST RESULTS

NATURAL UNIT DRY WEIGHT (PCF): 112
NATURAL MOISTURE CONTENT: 16.9%
SWELL/CONSOLIDATION (%): 1.9%



SWELL/CONSOLIDATION TEST RESULTS

POCO RD. AND VOLLMER RD.
ELITE PROPERTIES

JOB NO.
212381

FIG. C-18

TEST BORING 3
DEPTH (FT) 20

SOIL DESCRIPTION SILTSTONE, (SILT, SANDY)
SOIL TYPE 3

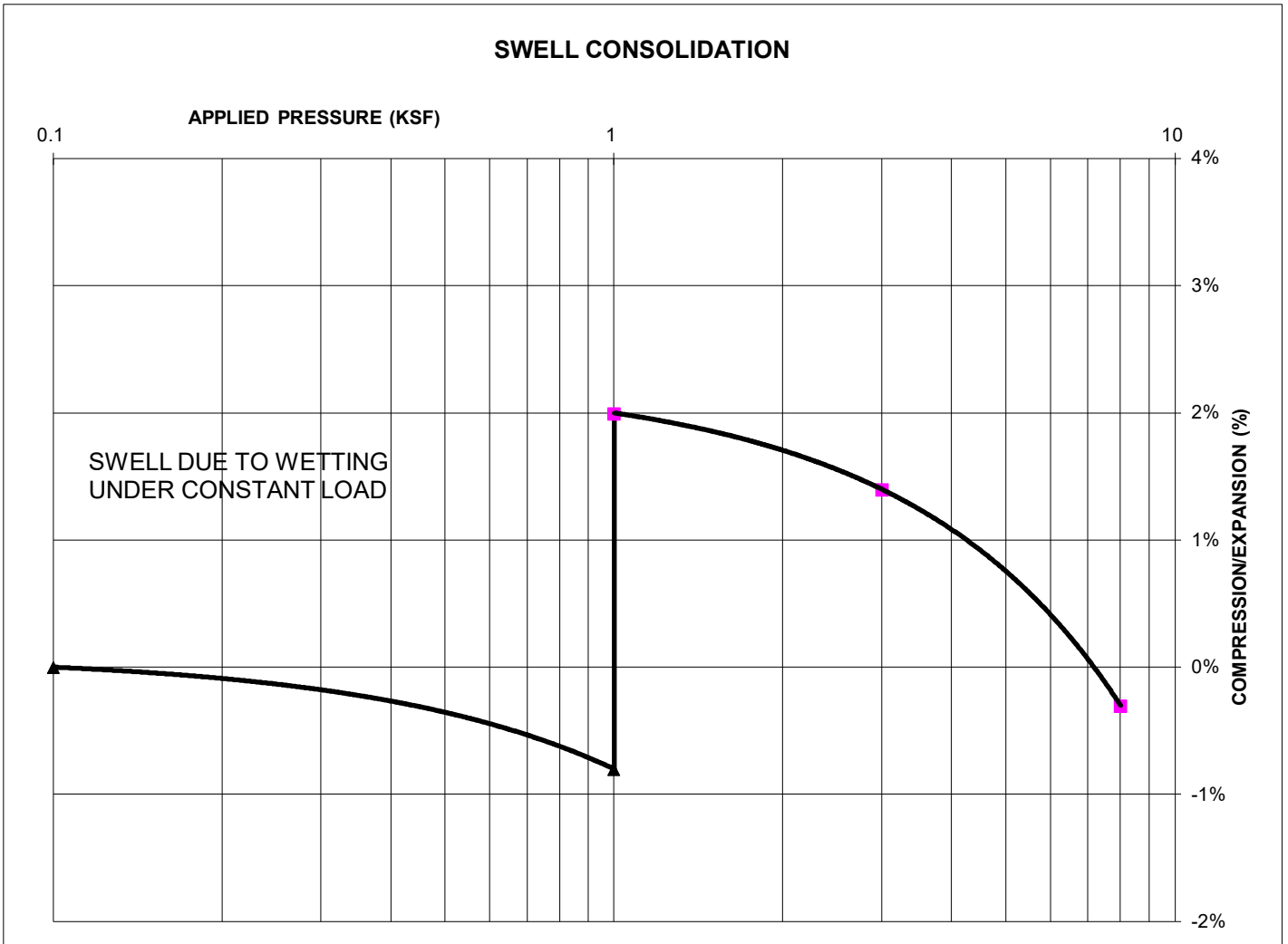

SWELL/CONSOLIDATION TEST RESULTS

NATURAL UNIT DRY WEIGHT (PCF): 115
NATURAL MOISTURE CONTENT: 16.0%
SWELL/CONSOLIDATION (%): 2.8%



**SWELL/CONSOLIDATION
TEST RESULTS**

POCO RD. AND VOLLMER RD.
ELITE PROPERTIES

JOB NO.
212381

FIG. C-19

TEST BORING 6
DEPTH (FT) 20

SOIL DESCRIPTION CLAYSTONE, (CLAY, SANDY)
SOIL TYPE 3

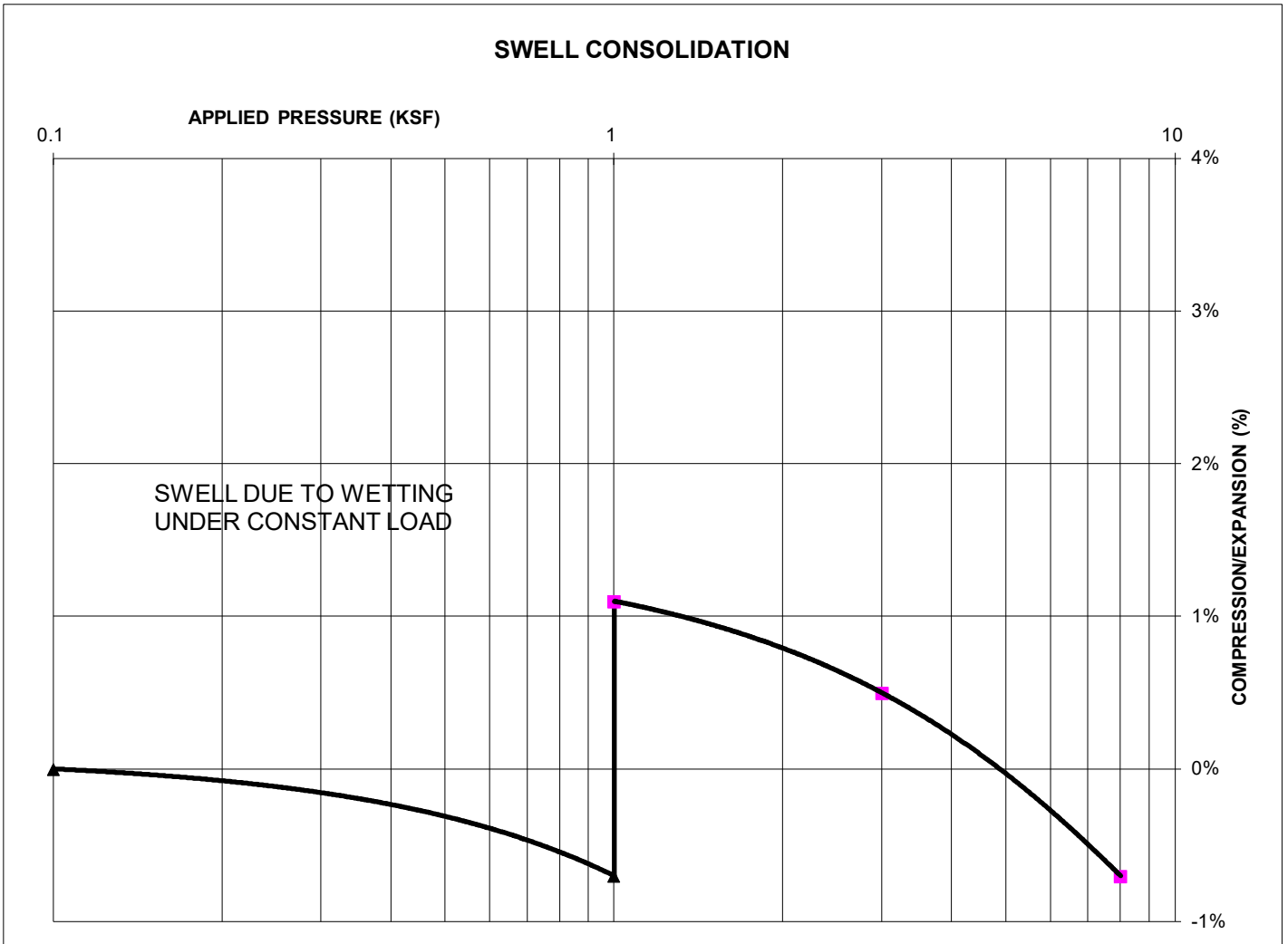

SWELL/CONSOLIDATION TEST RESULTS

NATURAL UNIT DRY WEIGHT (PCF): 119
NATURAL MOISTURE CONTENT: 14.7%
SWELL/CONSOLIDATION (%): 1.8%



**SWELL/CONSOLIDATION
TEST RESULTS**

POCO RD. AND VOLLMER RD.
ELITE PROPERTIES

JOB NO.
212381

FIG. C-20

APPENDIX D: Soil Survey Descriptions

El Paso County Area, Colorado

71—Pring coarse sandy loam, 3 to 8 percent slopes

Map Unit Setting

National map unit symbol: 369k

Elevation: 6,800 to 7,600 feet

Farmland classification: Not prime farmland

Map Unit Composition

Pring and similar soils: 85 percent

Estimates are based on observations, descriptions, and transects of the mapunit.

Description of Pring

Setting

Landform: Hills

Landform position (three-dimensional): Side slope

Down-slope shape: Linear

Across-slope shape: Linear

Parent material: Arkosic alluvium derived from sedimentary rock

Typical profile

A - 0 to 14 inches: coarse sandy loam

C - 14 to 60 inches: gravelly sandy loam

Properties and qualities

Slope: 3 to 8 percent

Depth to restrictive feature: More than 80 inches

Drainage class: Well drained

Runoff class: Low

Capacity of the most limiting layer to transmit water (Ksat): High
(2.00 to 6.00 in/hr)

Depth to water table: More than 80 inches

Frequency of flooding: None

Frequency of ponding: None

Available water supply, 0 to 60 inches: Low (about 6.0 inches)

Interpretive groups

Land capability classification (irrigated): None specified

Land capability classification (nonirrigated): 3e

Hydrologic Soil Group: B

Ecological site: R048AY222CO - Loamy Park

Hydric soil rating: No

Minor Components

Pleasant

Percent of map unit:

Landform: Depressions

Hydric soil rating: Yes



Other soils

Percent of map unit:

Hydric soil rating: No

Data Source Information

Soil Survey Area: El Paso County Area, Colorado

Survey Area Data: Version 19, Aug 31, 2021



APPENDIX E: Test Pit Logs and Laboratory Testing Results

TEST PIT 1
DATE EXCAVATED 9/8/2023

TEST PIT 2
DATE EXCAVATED 9/8/2023

REMARKS

REMARKS

REMARKS	Depth (ft)	Symbol	Samples	Soil Structure Shape	Soil Structure Grade	Soil Type	REMARKS	Depth (ft)	Symbol	Samples	Soil Structure Shape	Soil Structure Grade	Soil Type
TOPSOIL 0-12", SANDY CLAY LOAM, DARK BROWN	1						TOPSOIL 0-12", SANDY CLAY LOAM, DARK BROWN	1					
GRAVELLY SANDY LOAM, FINE TO COARSE GRAINED, BROWN, MOIST	2			GR	S	2A	SANDY CLAY LOAM, FINE TO COARSE GRAINED, BROWN, MOIST	2			GR	W	3A
	3			R-1				3					
	4						WEATHERED SILTY TO CLAYEY SANDSTONE, FINE TO COARSE GRAINED, GRAY BROWN, VERY MOIST	4			MA		4A
	5							5					
HIGHLY WEATHERED CLAYEY SANDSTONE, FINE TO COARSE GRAINED, GRAY BROWN, MOIST	6			MA				6					
	7							7					
*REDOXIMORPHIC FEATURES OBSERVED AT 6'	8						*REDOXIMORPHIC FEATURES OBSERVED AT 4'	8					
	9							9					
	10							10					

Soil Structure Shape

- granular - gr
- platy - pl
- blocky - bl
- prismatic - pr
- single grain - sg
- massive - ma

Soil Structure Grade

- weak - w
- moderate - m
- strong - s
- loose - l



TEST PIT LOGS

POCO AND VOLLMER
ELITE PROPERTIES

JOB NO.
212381

FIG. E-1

TEST PIT	TP-1	SOIL DESCRIPTION SAND, WITH SILT
DEPTH (FT)	3	

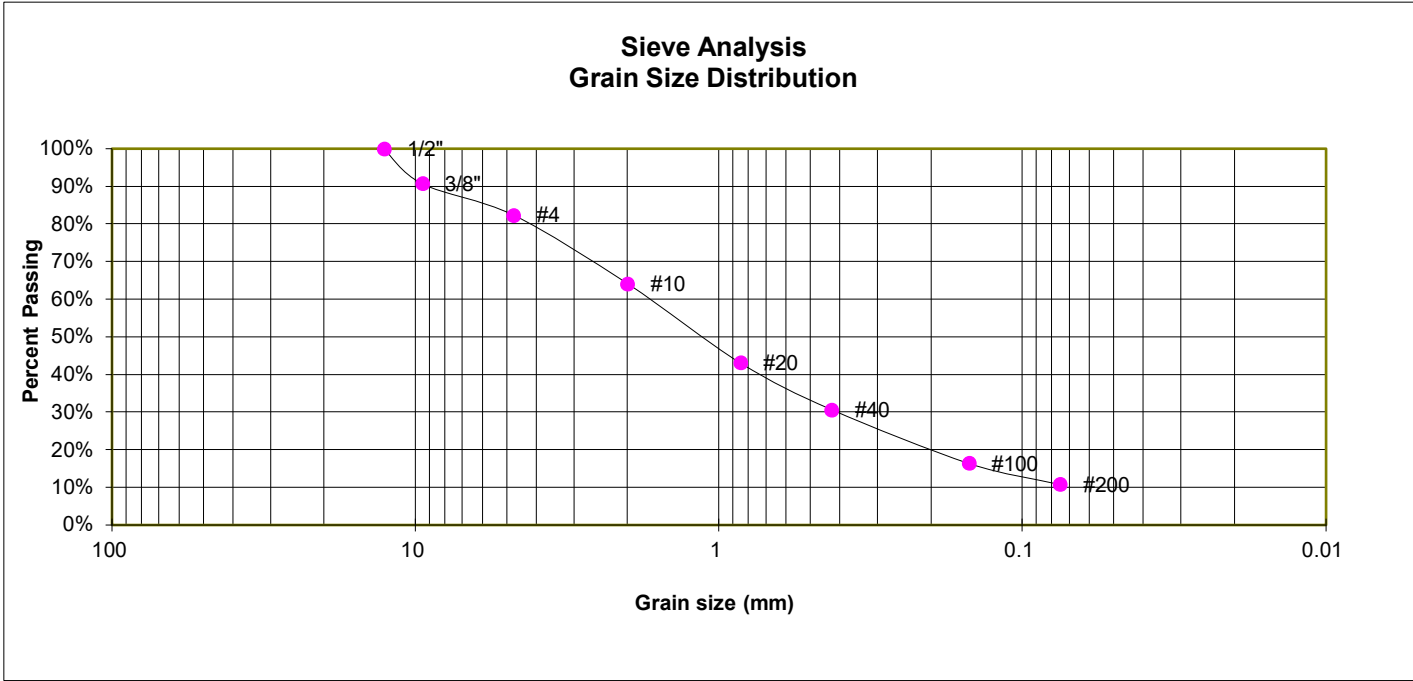

GRAIN SIZE ANALYSIS

U.S. Sieve #	Percent Finer
3"	
1 1/2"	
3/4"	
1/2"	100.0%
3/8"	90.7%
4	82.4%
10	64.1%
20	43.1%
40	30.7%
100	16.4%
200	10.8%

SOIL CLASSIFICATION

USCS CLASSIFICATION: SW-SM



LABORATORY TEST RESULTS

POCO AND VOLLMER
ELITE PROPERTIES

JOB NO.
212381

E-2

TEST PIT	TP-2	SOIL DESCRIPTION SAND, CLAYEY
DEPTH (FT)	4	

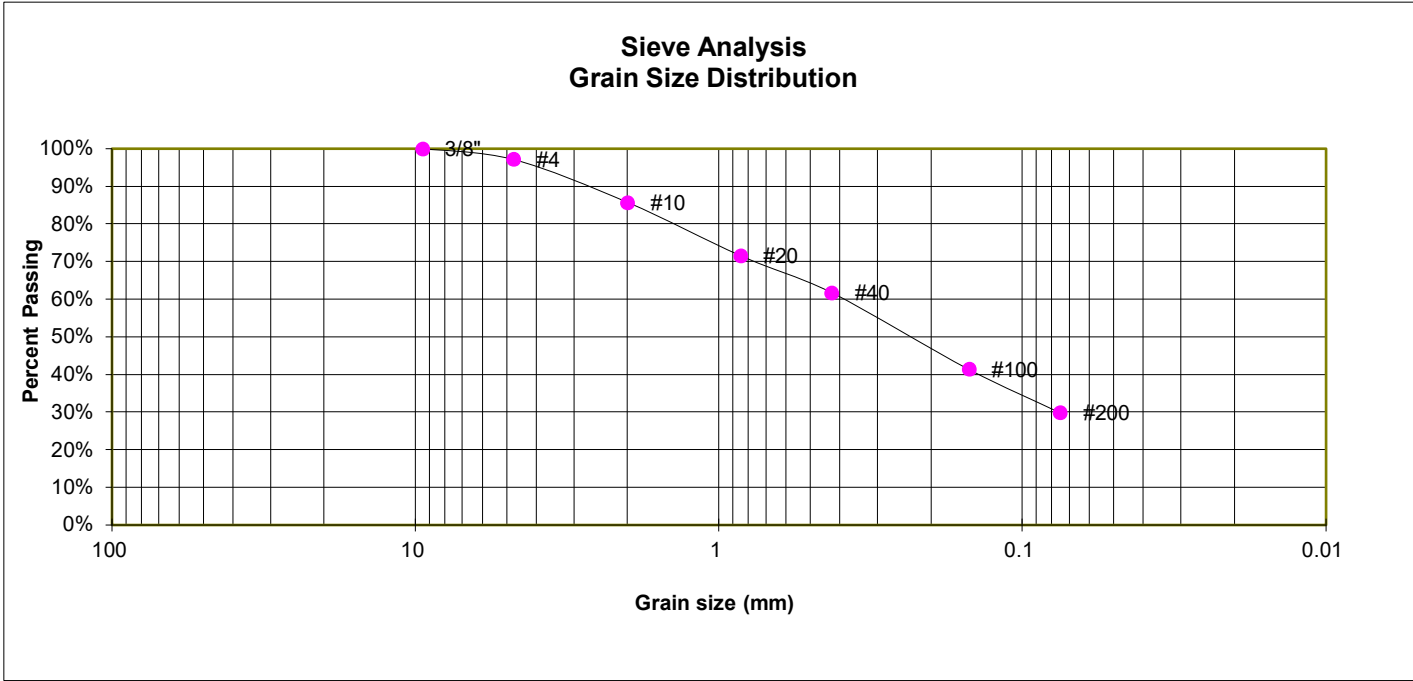

GRAIN SIZE ANALYSIS

U.S. Sieve #	Percent Finer
3"	
1 1/2"	
3/4"	
1/2"	
3/8"	100.0%
4	97.2%
10	85.8%
20	71.6%
40	61.7%
100	41.4%
200	29.9%

SOIL CLASSIFICATION

USCS CLASSIFICATION: SC



LABORATORY TEST RESULTS

POCO AND VOLLMER
ELITE PROPERTIES

JOB NO.
212381

E-3

**APPENDIX F: El Paso County Health Department
Septic Records 8455 Poco Road**

ON-SITE WASTEWATER SYSTEM INSPECTION FORM

PERMIT # 30644

DATE Aug 24, 2012

APPROVED YES NO

Environmental Health Specialist: J. Christensen

Address: 8455 Poco Rd. 80908 Owner John Jaynes

Legal Description: S2 SEC 28-12-65

Residence #Bedrooms 2 Commercial System Installer Owner

SEPTIC TANK: Construction Material Concrete * Capacity Gallon 1250

DISPOSAL FIELD:

Trench: Depth (Range) _____ Width _____ Total Length _____ Sq. Ft. _____

Bed: Depth (Range) _____ Width 26 Total Length 40 Sq. Ft. 1040

Depth of Rock _____ 'Under PVC _____ Type of cover on Rock "To be installed"

DRYWELLS: # of Pits _____ Rings(Pit 1) _____ Rings(Pit2) _____ Working Depth #1 _____ #2 _____

Size (L x W) #1 _____ #2 _____ Total Sq. Ft. _____

ROCKLESS SYSTEMS:

Standard Chamber: Type _____ #Chambers _____ Sq. Ft./Chamber _____ Bed _____ Trench _____

High Profile Units: Type _____ #Chambers _____ Sq. Ft./Chamber _____ Bed _____ Trench _____

Reduction Allowed _____ % Sq. Ft. Required 1007 Depth (Range) _____

Sq. Ft. Installed _____ Equivalent Sq. Ft. Installed with Reduction _____

Engineer Design: Y N Engineering Firm Gequest Approval Letter Provided: Y N

Well installed at time of septic inspection: Y N Public Water: Y N

*Approval will be revoked if in the future the well is found to be within 50 feet of the septic tank and/or 100 feet of the disposal field.

Notes: * Septic tank capacity sufficient for 3 bedroom.
4 feet of sand fill bottom of absorption bed.
All pipe is 4" SDR35

Well ●

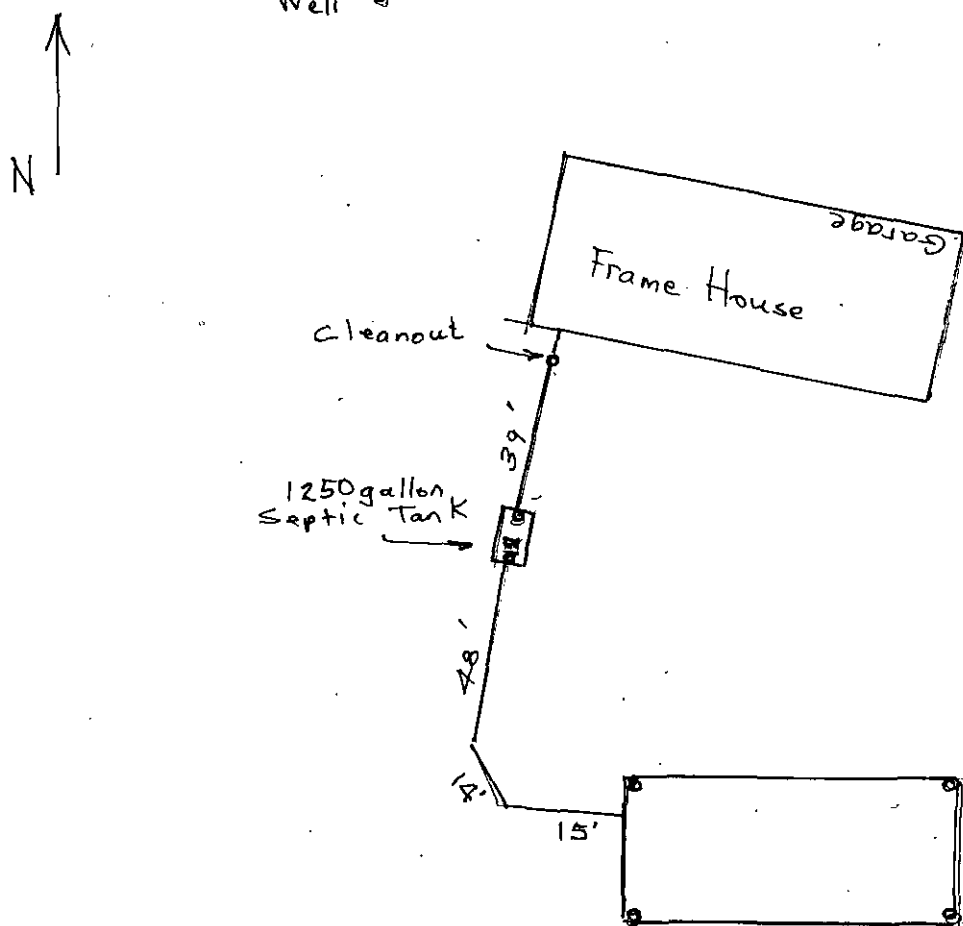

Absorption Bed
Rock + pipe
26' x 40'
Inspection ports
at corners

Sealed off

**EL PASO COUNTY
DEPARTMENT OF HEALTH AND ENVIRONMENT
301 S Union Blvd, Colorado Springs, Colorado 719-575-8635
ONSITE WASTE WATER SYSTEM PERMIT**

May 16, 12 - Will be in next week. Is in process of ins tall. JC

OWNER NAME: JOHN JAYNES PERMIT NUMBER: 0030644
 ADDRESS: 8455 POCO RD
 CITY, STATE, ZIP: COLORADO SPRINGS, CO 80908 DATE PERMITTED: 02/15/2011
 PHONE NUMBER: (719) 649-8584 (Home Phone)

This permit is issued in accordance with 25-10-207 Colorado Revised Statues. PERMIT EXPIRES upon completion-installation of sewage-disposal system or at the end of twelve (12) months from date of issue - whichever occurs first -(unless work is in progress). If both a building and an ISDS permit are issued for the same property and revokable if all stated requirements are not met. Sewage disposal system to be installed by an El Paso County Licensed System Contractor or the property owner.

THIS PERMIT DOES NOT DENOTE APPROVAL OF ZONING AND ACREAGE REQUIREMENTS.

PERMIT EXPIRATION DATE: 02/15/2012
 Expires twelve months from date of issue

Janet Christensen
 578-3141

WATER SOURCE: Well or Spring

MINIMUM SEPTIC TANK SIZE:	1000	GALLONS	MINIMUM ABSORPTION AREA REQUIRED	1007	SQ FT
---------------------------	------	---------	----------------------------------	------	-------

PLANNING DEPARTMENT	<input checked="" type="checkbox"/>	ENUMERATION	<input checked="" type="checkbox"/>	FLOOD PLAIN	<input checked="" type="checkbox"/>	WASTEWATER	<input checked="" type="checkbox"/>
---------------------	-------------------------------------	-------------	-------------------------------------	-------------	-------------------------------------	------------	-------------------------------------

COMMENTS:

* FOR INSPECTIONS CALL 719-575-8699 BEFORE 8:30 A.M. OF THE DAY TO BE INSPECTED. (WEEKENDS & HOLIDAYS EXCLUDED)
LEAVE THE ENTIRE SEWAGE DISPOSAL SYSTEM UNCOVERED FOR FINAL INSPECTION

DUE TO ENCOUNTERING BEDROCK AT 3 FEET AN ENGINEER DESIGN SYSTEM SHALL BE INSTALLED AT THIS SITE. INSTALL SYSTEM PER ATTACHED P.E. DESIGN (ROCK AND PIPE BED) IN AREA OF THE SOIL PERCOLATION TEST. HEALTH DEPT MUST INSPECT SYSTEM PRIOR TO BACKFILL. AN ENGINEERS LETTER OF APPROVAL MUST BE RECEIVED BY THIS OFFICE BEFORE FINAL APPROVAL MAY BE GRANTED

The Health Office shall assume no responsibility in case of failure or inadequacy of a sewage-disposal system, beyond consulting in good faith with the property owner or representative. Free access to the property shall be authorized at reasonable time for the purpose of making such inspections as are necessary to determine compliance with requirements of this law.

FOR ADMINISTRATOR USE ONLY

Permit Ready:	Called	495-4914	Mailed
Final Inspection Requested:	BY:	<i>JB</i>	Date Called In:
	Phone #	3/2/11	Septic Site will be ready:

March 14, 2012 Left message @ cell phone for owner to call.
 March 15, 2012 John returned call. Wants to renew permit.
 8/23/12 - 3:28PM John Jaynes - Final Requested 649-8584. House is not finished - built. Ran out of Money. Septic not started.



EL PASO COUNTY DEPARTMENT OF HEALTH & ENVIRONMENT

301 South Union Boulevard • Colorado Springs, CO • 80910-3123 •

(719) 578-3199 • Fax: (719) 578-3188

Record I.D. 30644

*ALL PAYMENTS ARE DUE AT TIME OF SUBMITTAL IN CASH, CHECK, or MAJOR CREDIT CARD

APPLICATION FOR AN ONSITE WASTEWATER SYSTEM PERMIT

NEW PERMIT MINOR REPAIR PERMIT MAJOR REPAIR PERMIT

Owner John Jaynes Daytime Phone (719) 649-8584

Address of Property 8455 Poco Rd City & Zip Colo Spgs. 80908

Legal Description 20-12-65

Owner's MAILING Address 8225 Poco Rd City, State & Zip Colo Spgs. Co. 80908

Lot Size 35.12 acres Tax Schedule # 52280-00-025

Type of Building: Frame Modular Mobile Commercial Manufactured Other

Water Supply: Well or Spring Cistern Public Inside City Limits: No Yes-City

MAIL PERMIT - OR - PICK UP PERMIT FAX - FAX TO AND # disconnected 495-4914-H

MAXIMUM POTENTIAL NUMBER OF BEDROOMS 2

Percolation Test Attached N Basement N Garbage Disposal N Clothes Washer N

I have supplied a plot plan as described on the back of this form. I acknowledge the completeness of the application is conditional upon such further mandatory and additional tests and reports as may be required by the Department to be made and furnished by an applicant for purposes of evaluating the application, and issuance of the permit is subject to such terms and conditions as deemed necessary to ensure compliance with rules and regulations adopted pursuant to C.R.S. 25-10-107 et. seq. I hereby certify all represented to be true and correct to the best of my knowledge and belief, and are designed to be relied on by the El Paso County Department of Health and Environment in evaluating the same for purposes of issuing the permit applied for herein. I further understand any falsification or misrepresentation may result in the denial of the application or revocation of any permit granted based upon said application and in legal action for perjury as provided by law.

OWNER'S/OWNER'S AGENT SIGNATURE John Jaynes Date 2/15/11

You will be notified by telephone when your permit is ready for pick up. Please allow a minimum of 10 days for new septic.

DEPARTMENT OF HEALTH USE ONLY

1000 gallons Minimum Tank Capacity

1007 ft^2 Minimum Absorption Area

1 March 2011 Date of Site Inspection

REMARKS Due to encountering bedrock at 3 feet an engineer design shall be system shall be installed at this site. Install system per attached P.E. design (rock + pipe bed) in area of the soil percolation test. Health dept. must inspect system prior to backfill. An engineer's letter of approval must be received by this office before final approval may be granted.

EHS INSPECTOR Janet Christian DATE 03/01/11 APPROVED DENIED

CURRENT FEES AS APPROVED BY EL PASO COUNTY BOARD OF HEALTH

New Permit: \$306.00 EPCDHE Charge + \$23.00 CDPHE Surcharge + \$147.00 EPC Planning Surcharge = \$476.00
Major repair permit: \$344.00 EPCDHE Charge + \$23.00 CDPHE Surcharge = \$367.00
Minor repair permit: \$141.00 EPCDHE Charge + \$23.00 CDPHE Surcharge = \$164.00

DATE TO LAND DEVELOPMENT/WASTEWATER: 2-15-11 PR
DATE TO FLOODPLAIN/ENUMERATIONS: 2-15-11 PR

PLEASE COMPLETE THE BACK OF THIS FORM

1) We require an original of your **PERCOLATION (PERC) TEST** with an original licensed engineer's (PE) stamp and signature as well as a plot of the percolation test hole locations with measurements from a fixed reference point. (A faxed copy directly from the engineering firm to this office is acceptable.)

2) **PROPERTY ADDRESS OR LOT NUMBER MUST BE POSTED AND PERC HOLES MUST BE CLEARLY MARKED OR AN ADDITIONAL CHARGE FOR A RETURN TRIP TO THE SITE MAY BE ASSESSED.**

3) A **PLOT PLAN** must be drawn (not to scale) on an 8 1/2 x 11 inch sheet. The plot plan must include:

- | | | |
|---|--|------------------------------|
| 1) a north bearing | 5) proposed septic system site | distance of percolation test |
| 2) property lines | 6) alternate septic system site | two property lines. |
| 3) property dimensions | 7) driveway (proposed or | |
| 4) all buildings (proposed or existing) | existing and name of adjoining street) | |

4) Initial any of the following features that apply to your property and **INCLUDE** them on your **PLOT PLAN**.

- | | | |
|----------------------------------|--|--|
| <input type="checkbox"/> Well(s) | <input type="checkbox"/> Adjacent property well(s) | <input type="checkbox"/> Subsoil drain |
| <input type="checkbox"/> Cistern | <input type="checkbox"/> Water line | |

5) Initial any of the following that are within 100 feet of your proposed septic system and **INCLUDE** on your **PLOT PLAN**.

- | | |
|--|--|
| <input type="checkbox"/> Spring(s) | <input type="checkbox"/> Lake(s) |
| <input type="checkbox"/> Pond(s) | <input type="checkbox"/> Stream(s) |
| <input type="checkbox"/> Dry Gulch(es) | <input checked="" type="checkbox"/> Natural drainage |

110'

6) **GIVE COMPLETE DIRECTIONS TO THE PROPERTY FROM A MAIN HIGHWAY**

Woodman Rd. Turn North on Black Forest Rd.
Right (East) on Vollmer Rd about 3 miles
Turn Left on Poco Rd. about 500'
Driveway on Left.