

FOREST EDGE DRIVE 60'-0" R.O.W.

FOREST EDGE DRIVE 60'-0" R.O.W.

60'-0" R.O.W.
PROPERTY LINE (TYP.) N 00°03'34" E 314.590'

25'-0" SETBACK
18'-0"± DRIVEWAY ACCESS

173'-4"

PROPERTY LINE (TYP.) N 89°53'10" E 692.010'

25'-0" SETBACK

RR-5 SETBACKS
FRONT 25'-0"
SIDES 25'-0"
REAR 25'-0"

MAX LOT COV = 25%
MAX HEIGHT = 30'-0"

1" = 20'-0"

APPROX LOCATION EXISTING STA

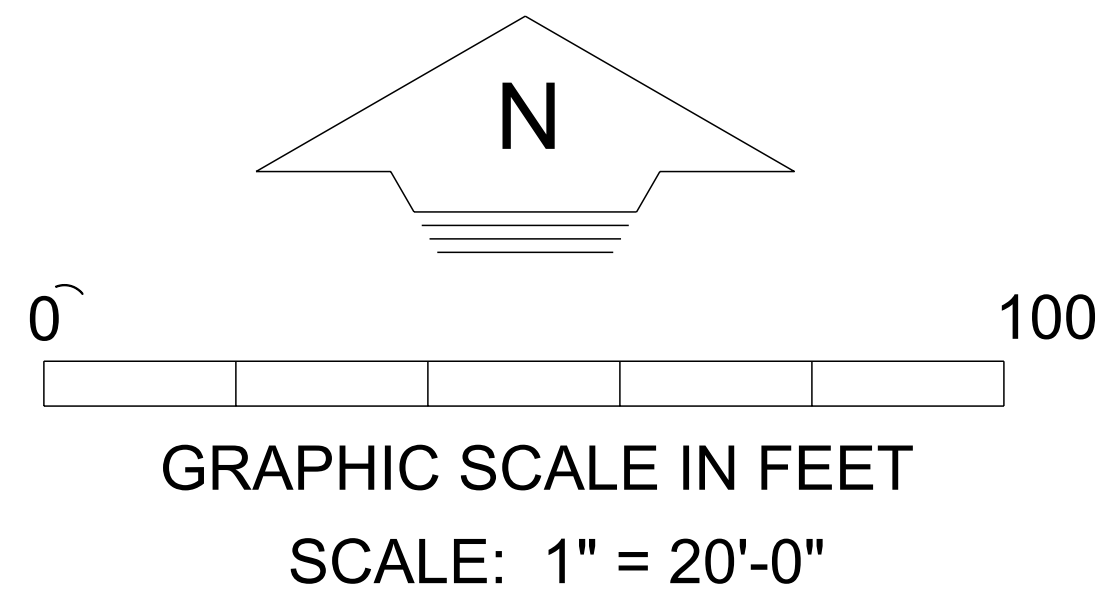

Project Name
Forest Edge Addition
File Prefix
ADR - Administrative Relief
Year
2022
Applicant/Responsible Party
Nighthawk Design
c/o RODNEY B. WIEBE
hawkcompanies@gmail.com
(719) 477-9460
Owner
Kelly and Timothy Hromadka
(719) 291-3401
timhromadka@gmail.com
11275 Forest Edge Drive
Colorado Springs, Colorado 80908
EA Number
EA21192
File Number
ADR222

11275 FOREST EDGE ROAD
SCHDL# 6223000012
227,383± SF
5.22 ACRES

LEGAL:
TRACT IN NW4 SEC 23-12-66 AS FOLS,
COM AT NW COR OF SD SEC. TH S ON W LN THEREOF 660 FT,
E PARA WITH N LN OF NW4 1444 FT, S AT R/A 345 FT FOR POB,
TH CONT ON LAST COURSE 315 FT, E AT R/A 722 FT,
N AT R/A 315 FT, TH W 722 FT TO POB

RR-5
SETBACKS
FRONT 25'-0"
SIDES 25'-0"
REAR 25'-0"

LOT COV. = 1.2%
MAX LOT COV. = 25%
MAX HEIGHT = 30'-0"

WOOD BARN

PROPERTY LINE (TYP.) S 00°04'11" W 314.720'
25'-0" SETBACK
80'-0"±

S 89°53'47" W 691.300' PROPERTY LINE (TYP.)

CODE INFORMATION:	
2017	Pikes Peak Regional Building Code (2017 PPRBC)
2015	International Residential Code (2015 IRC)*
2015	International Energy Conservation Code* (IECC)
2015	International Mechanical Code*
2015	International Fuel Gas Code*
2018	International Plumbing Code**
2020	National Electric Code**
*	As amended by 2017 PPRBC
**	Or the latest edition adopted by the State of Colorado

STRUCTURAL DESIGN LOADS:			
	Live Load	Dead Load	Total Load
Floor	40 psf	16 psf	56 psf
Roof	40 psf	24 psf	64 psf
Wind	130 mph - Vult		
ENTRY/VAULT	60 psf	77 psf	137 psf
REAR DECK	60 psf	12 psf	72 psf

AREA TABLE:	
LOWER LEVEL (FINISHED)	1,264 SF
LOWER LEVEL TOTAL (INC. VLT MECH STAIRS)	1,373 SF
MAIN LEVEL	1,853 SF
DETACHED Garage	480 Sq.Ft.

- GENERAL NOTES:**
- The contractor and homeowner shall review and verify all information on these drawings and be responsible for the same. Report all discrepancies to the designer for proper adjustment.
 - All smoke detectors (SD) must be interconnected (Hardwired) and shall have battery back-up.
 - LP gas-burning appliances are not permitted in basement or crawl space areas.
 - A Colorado licensed architect or engineer shall design all footings and foundation walls. This report/design shall be incorporated with these drawings and shall be available at the building site at all times.
 - All foundations and piers (including deck supports) shall bear on undisturbed soil. All footings and piers shall be protected with a minimum earthen cover of 30" for frost protection.
 - All dimensions shown on these drawings are to face of framing members unless specifically indicated to the contrary. Noted dimensions shall take precedence over scaled dimensions. PLEASE DO NOT SCALE DRAWINGS.
 - All structural hardware shown on these drawings shall be as manufactured by Simpson Strong-Tie Company of San Leandro, California. The home designer prior to installation shall approve any substitutions.
 - Roof ventilation shall equal 1/150 of the net attic area with 50% located at the eaves and 50% located at the upper portion of the area to be ventilated. A minimum of 1 inch of air space shall be provided between the insulation and the roof sheathing at eaves. (Compliance with 2009 IRC 806.2 is mandatory)
 - Cover to vent to exterior > 30" from any openings.

WOOD BARN	400 Sq.Ft.
TOTAL LOT AREA	(5.22 AC.) 227,383± Sq.Ft.
TOTAL COVERED AREA	2,733 Sq.Ft.
LOT COVERAGE	1.20%

PRECISE CONSTRUCTION
Colorado Springs, Colorado
CONTRACTOR
Jared Sagapolu
719-492-1353

11275 FOREST EDGE, COLORADO SPRINGS, CO
Area: 5.22 ACRES
Schedule #: 6223000012
Owner: KELLY and TIMOTHY HROMADKA
Mailing Address: 11275 FOREST EDGE DR COLORADO SPRINGS CO. 80908-3727

REVISION	DATE
SITE PLAN ANALYSIS	09-28-2021
REVISED PER EPC/PCD NOTES	05-03-2022
PCD FILE NO. ADR-22-002	