



**August 28, 2023**

El Paso County  
Attn: Mr. Ryan Howser  
El Paso County Planning

RE: Crossroads Mixed Use Filing No. 2 Master Sign Plan, **Re-Submittal**

Dear Mr. Howser,

The Crossroads Comprehensive Sign Guidelines document is being re-submitted to address your review comments dated 3/31/2023.

You will find the following changes on the pages listed:

- 6- Note 2.1M was removed calling for signs to be illuminated from below due to development being in a recognized flight path to the Colorado Springs airport.
- 7- Notes 2.2B & C were added to address required signage location and setbacks regarding size of signage and proximity to property lines.
- 11- Note 2.3A4 was added to address required signage location and setbacks regarding size of signage and proximity to property lines.  
  
Note 2.3A5 was added to address allowed height of signage in relation to building height.
- 13- Note 2.4A5 was added to address required signage location and setbacks regarding size of signage and proximity to property lines.

Please let me know if you have any questions on these changes and if there is anything further that you need to finalize these Signage Guidelines for the Crossroads Development.

Sincerely,

A handwritten signature in blue ink, appearing to read 'Greg Johnson', written in a cursive style.

Greg Johnson  
RTA Architects

Cc: Doug Abernethy – RTA Architects

**R.T.A., Inc.**  
19 S. Tejon Street, Suite 300  
Colorado Springs, CO 80903

ph 719-471-7566  
fx 719-471-1174  
[www.rtaarchitects.com](http://www.rtaarchitects.com)



# CROSSROADS

COMPREHENSIVE SIGN GUIDELINES

Comprehensive Sign Guidelines were developed in collaboration by the following:



RTA Architects, Inc.  
19 South Tejon Street, Suite 300  
Colorado Springs, CO 80903



Equity Group  
90 S. Cascade Ave. #1500  
Colorado Springs, CO 80903

# Crossroads Development **Table of Contents**

**Sec. 100** Submittal Requirements . . . . . 4

**Sec. 200** Signage . . . . . 5

    2.1 Comprehensive Site Plan . . . . . 5

    2.2 Monument Signs . . . . . 7

    2.3 Pylon Signs - Anchor & Major Retail Identification. . . . . 10

    2.4 Multi-Tenant Signs . . . . . 12

    2.5 Multi-Tenant Wayfinding Signs (Vehicular Directional) . . . . . 14

    2.6 Primary Identification Wall-Mounted Signs . . . . . 15

    2.7 Secondary Identification Signs. . . . . 19





## Section 100 Submittal Requirements

### 1.1 Submittal Requirements

Buyer/Tenant (collectively “Owner” or “Owners”) of any property owned or controlled, as of 02.02.23, by Crossroads Development Company LLC, its owners, shareholders, or affiliates, and located in the Crossroads Development, El Paso County, Colorado, shall submit all development plans and preliminary and final construction documents (collectively the “Plans”) to the Architectural Review Committee (ARC) for the Crossroads development. Electronic Plans shall be submitted for review and approval, which will be returned with comments. Submittals shall include: site plan, roof plan, exterior building elevations, landscape plan, and all signage details. Elevation and signage submittals shall include all colors and materials utilized, along with their percentages. No plans shall be submitted to El Paso County until any and all such Plans are approved by the ARC. If County submittal is made prior to approval by the ARC, any changes required by review of the ARC shall be incorporated by the Owner into applicable amended Plans to the County, at such Owner’s expense. The ARC, in its sole discretion, may make exceptions to any of the rules or guidelines contained herein.

## Section 200 Signage

### 2.1 Comprehensive Sign Plan

A. Crossroad's Development comprehensive sign package includes a hierarchy of sign types. The different sign types address the particular needs of the overall development, anchor, large format retail Tenants, Multi-Tenant retail buildings, and individual pad buildings responding to their need for visibility from highway 24, highway 94, Meadowbrook Parkway, and private roadways. The signage design provides a balance between the Tenants' need for visibility and branding recognition with the size, character, and connectivity needed to fully integrate the signage program with the buildings and development.

B. The Comprehensive Sign Plan (CSP) illustrates the areas targeted for such signage as well as the signage types. The CSP is subject to change pending final Tenant commitments, however, the signage principals should not be adversely affected by subsequent modifications to the plan.

C. It should be understood that the final development plan may vary from what is illustrated in the CSP and that all Parcels and Pad Site development will not require or be assigned all types of signage proposed. Upon request, the ARC will review each site and its use, location, and proximity to other similar or neighboring uses in determining any judgment or variance from the CSP or Sign Guidelines.

D. An overall sign program must be submitted for review and approval to the ARC for each Tenant, or Parcel and must include all exterior signs.

E. All development proposals shall indicate size, height, type, color, material, illumination, and location of all proposed Tenant, building, commercial, and directional signage including any construction leasing signage.

F. Only the signs and logos that identify a Tenant, business, or store name shall be allowed on any sign panel.

G. All signs, including the supporting structure, shall conform to the development standard.

H. All wiring and conduits shall be concealed.

I. The placement of signs on roofs is prohibited unless specifically approved by the ARC.

J. Sign type and location shall conform to the CSP. For some sites on which it can be demonstrated that an undue hardship exists due to unusual circumstances or unique orientations, the ARC may review additional signs or alternative locations as viable solutions.

K. When external light sources are directed at the sign surface, light sources shall be concealed.

L. LED lamps are the standard throughout the Center as well as the development standard lighting source for all signs.

M. The sign types outlined in this chapter are as follows:

- 2.2 Monument Signs
- 2.3 Pylon Signs - Anchor & Major Retail Identification
- 2.4 Multi -Tenant Signs
- 2.5 Multi -Tenant Wayfinding Signs (Vehicular Directional)
- 2.6 Wall Mounted Signs
- 2.7 Secondary Identification Signs

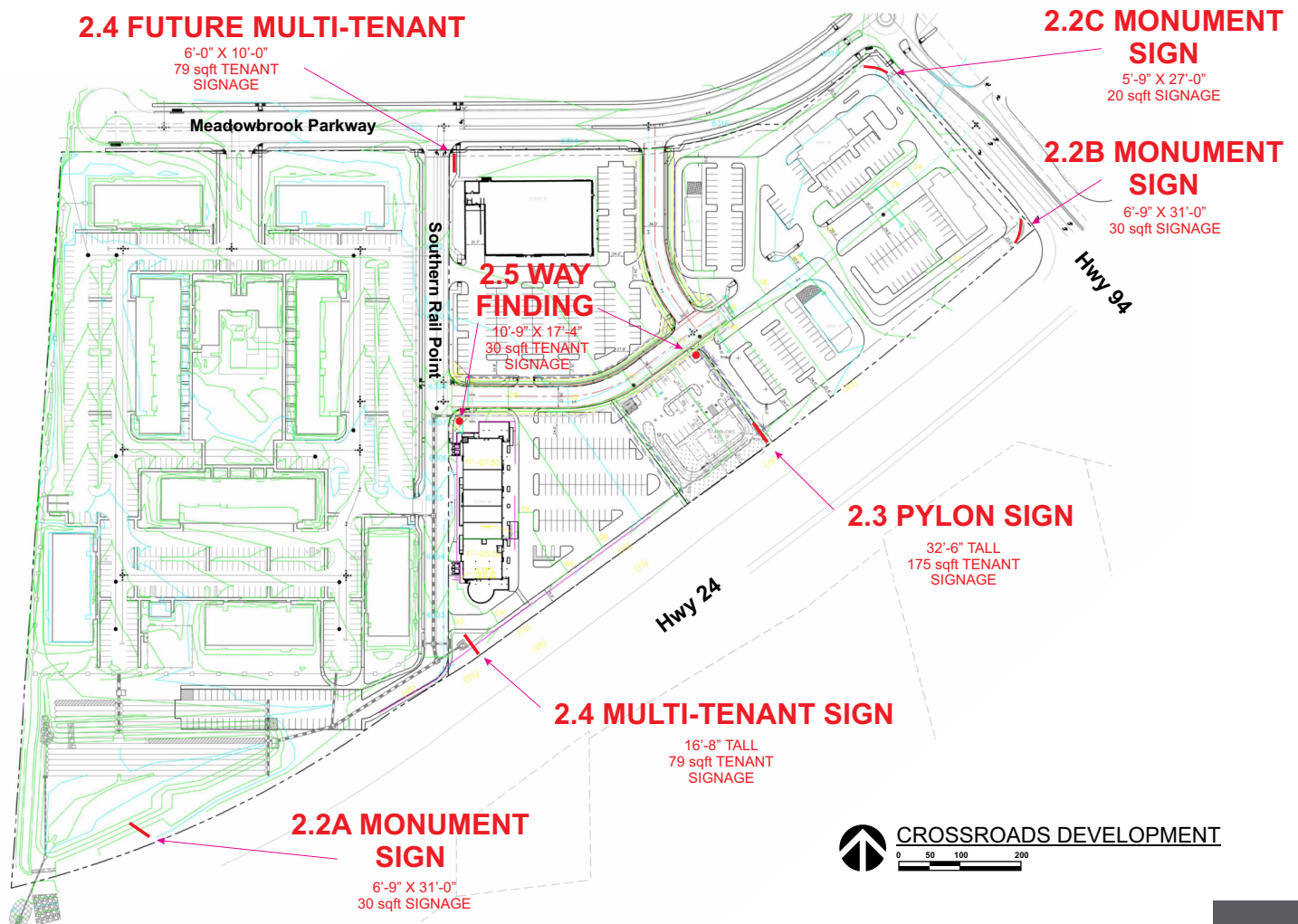

## 2.2 Monument Signs

A. The Monument Signs are sculptural steel panels that partially wrap concrete site walls. They occur at locations noted on the CSP and will mark entry to the development. The Monument Signs will have center branding panels and the name of the center. The signage area on these signs is 20-30 sq ft.

B. Monument signs that are 6'-0" tall or taller must be set back a minimum of 10'-0" from property line.

C. Monument signs that are shorter than 6'-0" tall must be set back a minimum of 3'-0" from property line.

### KEYNOTE LEGEND

- M1 1/2" THICK CORTEN STEEL BRANDING PANEL
- M2 12" THICK BOARD FORMED CONCRETE WALL
- M3 2" DEEP STAINLESS STEEL CHANNEL  
LETTERING MOUNTED TO PLATE, FONT:  
JOSEFIN SANS EXTRALIGHT
- M4 CORTEN STEEL DOWN LIT CANOPY

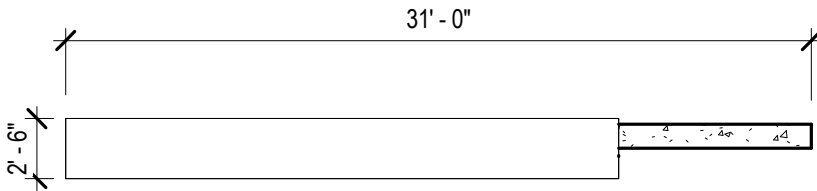

### FREESTANDING MONUMENT SIGN - 2.2A - PLAN

1/8" = 1'-0"

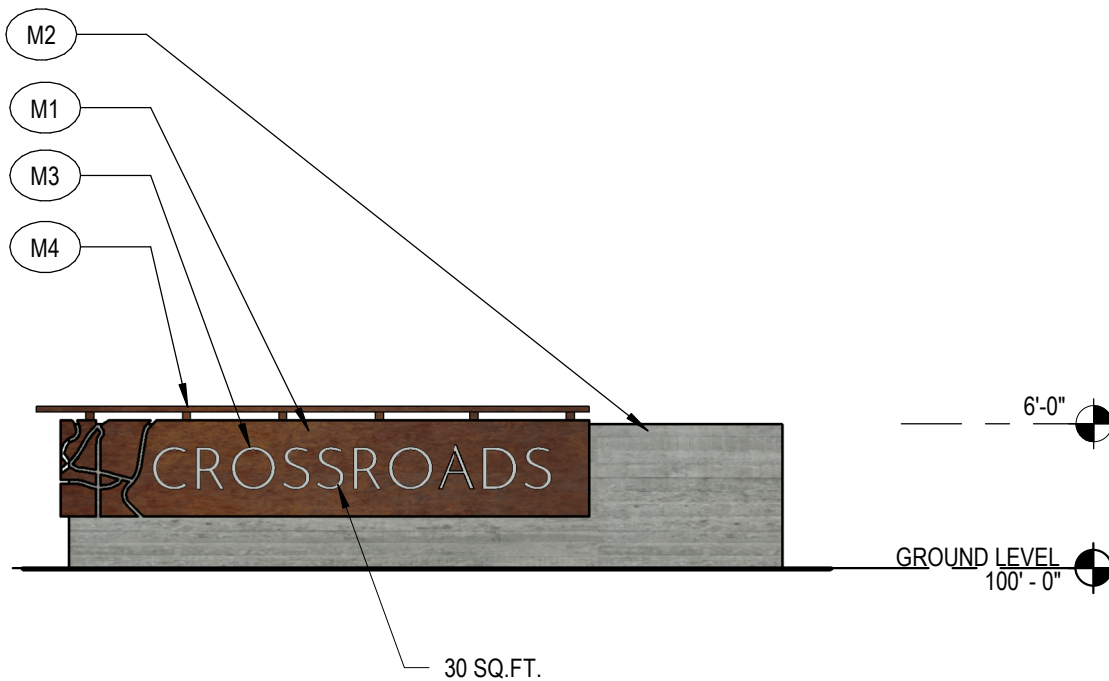

### FREESTANDING MONUMENT SIGN - 2.2A - ELEVATION

1/8" = 1'-0"

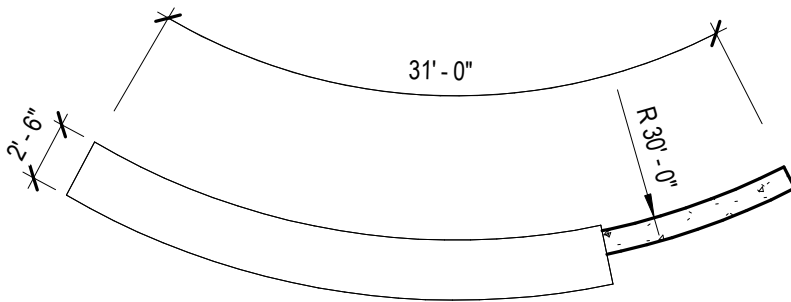

### KEYNOTE LEGEND

- M1 1/2" THICK CORTEN STEEL BRANDING PANEL
- M2 12" THICK BOARD FORMED CONCRETE WALL
- M3 2" DEEP STAINLESS STEEL CHANNEL LETTERING MOUNTED TO PLATE, FONT: JOSEFIN SANS EXTRALIGHT
- M4 CORTEN STEEL DOWN LIT CANOPY

## FREESTANDING MONUMENT SIGN - 2.2B - PLAN

1/8" = 1'-0"

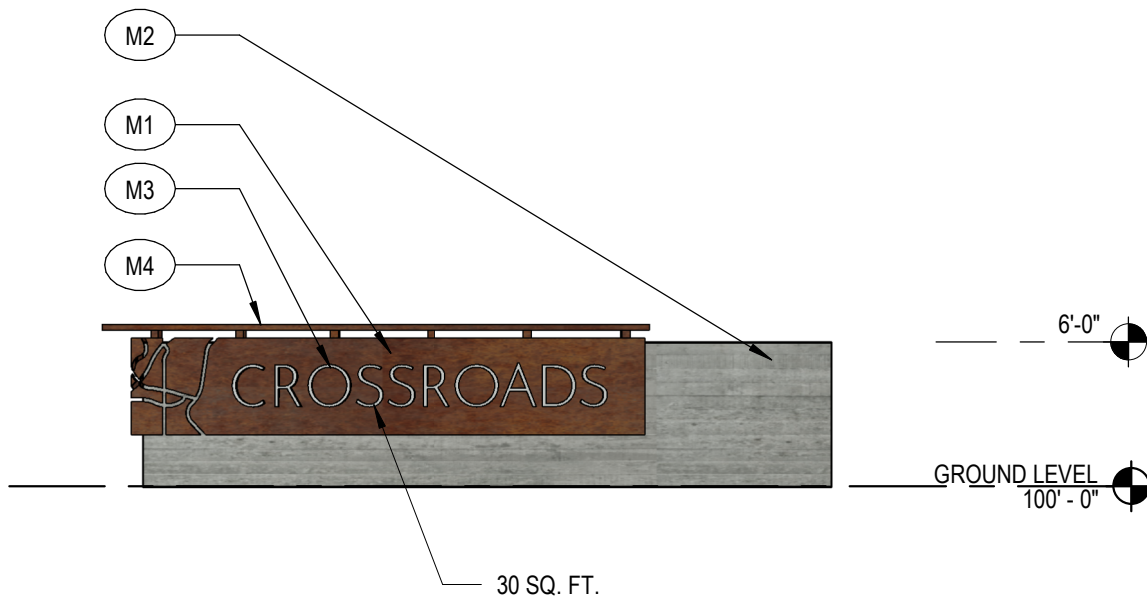

## FREESTANDING MONUMENT SIGN - 2.2B - ELEVATION

1/8" = 1'-0"

### KEYNOTE LEGEND

- M1 1/2" THICK CORTEN STEEL BRANDING PANEL
- M2 12" THICK BOARD FORMED CONCRETE WALL
- M3 2" DEEP STAINLESS STEEL CHANNEL  
LETTERING MOUNTED TO PLATE, FONT:  
JOSEFIN SANS EXTRALIGHT
- M4 CORTEN STEEL DOWN LIT CANOPY

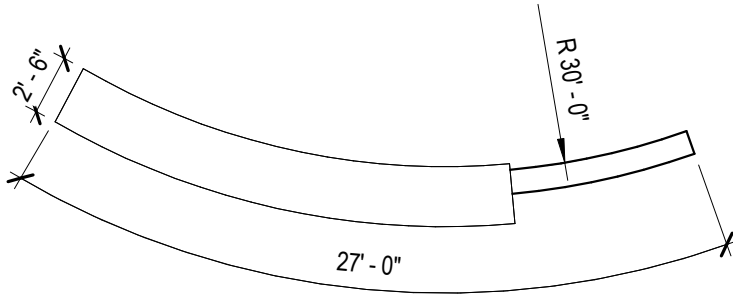

### FREESTANDING MONUMENT SIGN - 2.2C - PLAN

1/8" = 1'-0"

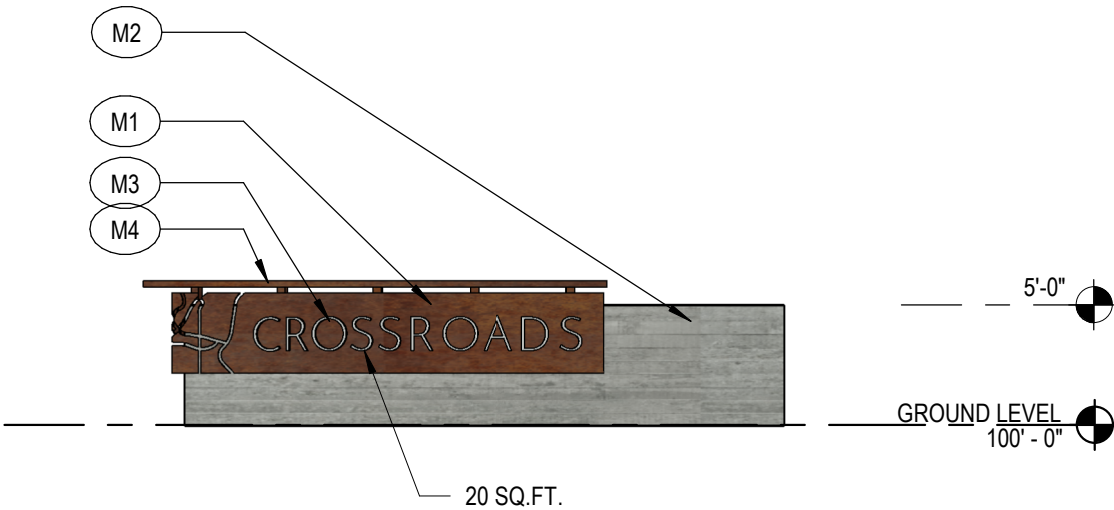

### FREESTANDING MONUMENT SIGN - 2.2C - ELEVATION

1/8" = 1'-0"

## 2.3 Project Identification Pylon Signs

### A. General Design Requirements

1. The Pylon signs are located on the site plan.
2. No pedestrian activity or contact is anticipated due to proposed locations.
3. The Pylon Signs are to be constructed of steel columns, an arched steel development panel, illuminated logo element, an internally lit sign panel box with push through acrylic lettering, and opaque sign cabinet. The pylon will complement the architecture of the development. These signs sit upon a project standard concrete base.
4. Freestanding signs taller than 6'-0" shall be set back a minimum distance of 10'-0" from lot line.
5. The maximum height of a freestanding sign shall not exceed the height of the building with which the sign is associated.
6. Maximum sign height: 32.5 ft.
7. Maximum graphic sign area: 175 sq. ft. total.



### KEYNOTE LEGEND

- S1 METAL ROOF
- S2 10" WIDE FLANGE STEEL COLUMN
- S3 4" STEEL ANGLE TRELLIS
- S4 26" ROLLED CORTEN STEEL CHANNEL
- S5 HSS 5X4 STEEL TUBE
- S6 CONCRETE BASE, HT. VARIES DUE TO TOPOGRAPHY
- S8 TENANT METAL SIGN PANEL WITH PUSH THROUGH ACRYLIC LETTERING
- S9 24" DEEP INTERNALLY LIT STEEL SIGN PANEL BOX
- S11 INTERNALLY ILLUMINATED CAP WITH STEEL OVERLAY PANEL
- S12 17" INTERNALLY ILLUMINATED PUSH THROUGH ACRYLIC LETTERING, FONT: JOSEFIN SANS EXTRALIGHT

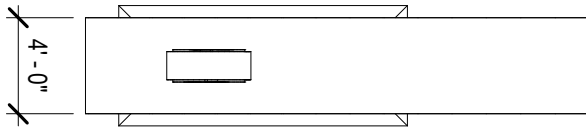

### FREESTANDING PYLON SIGN - 2.3A - PLAN

1/8" = 1'-0"

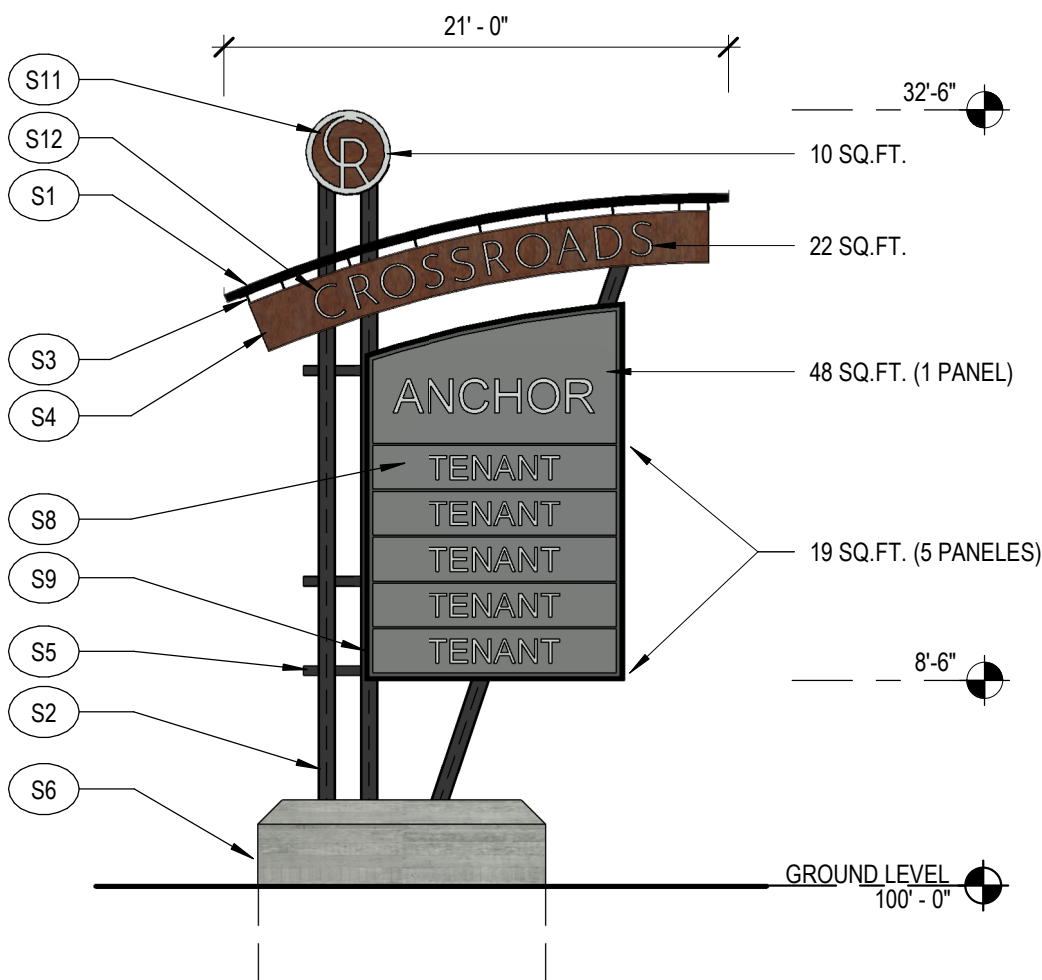

TOTAL SIGN AREA = 175 SQ.FT. PER SIDE

### FREESTANDING PYLON SIGN - 2.3A - ELEVATION

1/8" = 1'-0"

## 2.4 Multi-Tenant Signs - Anchor & Major Retail Identification

### A. General Design Requirements

1. Multi-tenant Signs are located along Highway 24 and Meadowbrook parkway and are as evenly spaced as possible within the site conditions. They shall consist of the typical curved roof cap and internally illuminated sign panels. The structure is consistent with the architecture of the buildings. The Multi-tenant signs sit atop a project standard concrete base.
2. Only Tenants located away from Highway 24 will be allowed copy on Multi-tenant signs. Tenants fronting the highway will not have copy on the Multi-tenant signs. Location, size, and position on the sign may be negotiated between Tenants and the Developer.
3. Individual buildings and pad sites are not allowed to have their own low-profile or pylon signs.
4. Tenant sign cabinets shall be internally illuminated. Tenants shall all have white copy color incorporated into the prototypical standard project standard opaque background panels. Final formatting of the Tenant sign panels shall be reviewed and approved by the ARC.
5. Freestanding signs taller than 6'-0" shall be set back a minimum distance of 10'-0" from lot line.
6. Maximum sign height: 16'-8" ft.
7. Maximum sign area: 79 sq ft. per face

### KEYNOTE LEGEND

- S2 10" WIDE FLANGE STEEL COLUMN
- S6 CONCRETE BASE, HT. VARIES DUE TO TOPOGRAPHY
- S7 DIMENSIONAL METAL CAN WITH METAL LOGO OVERLAY
- S8 TENANT METAL SIGN PANEL WITH PUSH THROUGH ACRYLIC LETTERING
- S10 21" DEEP INTERNALLY LIT STEEL SIGN PANEL BOX
- S13 CORTEN STEEL ROOF PANEL

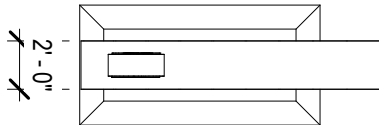

### MULTI TENANT SIGN - 2.4A - PLAN

1/8" = 1'-0"

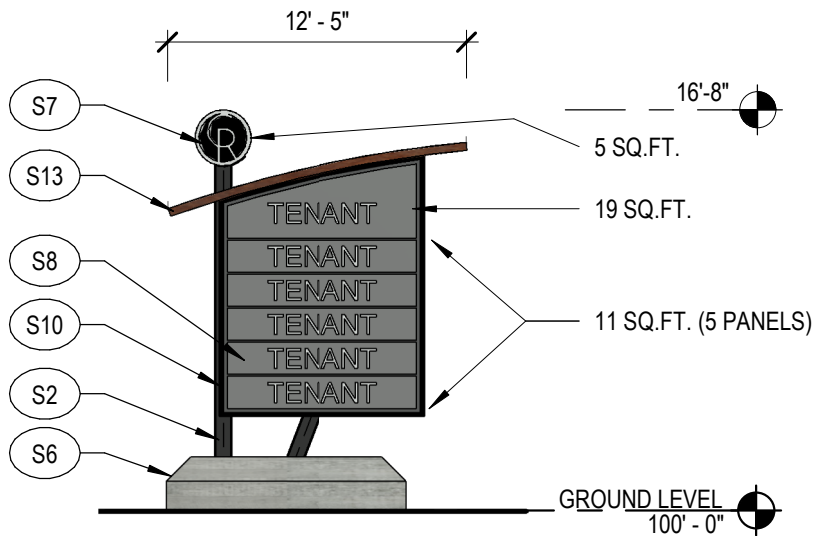

TOTAL SIGN AREA = 79 SQ.FT. PER SIDE

### FREESTANDING MULTI-TENANT SIGN - 2.4A - ELEVATION

1/8" = 1'-0"

2.5 Vehicular Directional Signs

A. Metal cantilevered signage supported by a steel column are subject to final review and approval by the ARC. Sign area shall not exceed 15 sq ft. per face. Lettering shall be silver 4" tall, reflective lettering. Font shall be Josefin Sans ExtraLight. Sign height shall not exceed 10 feet.

KEYNOTE LEGEND

- S2 10" WIDE FLANGE STEEL COLUMN
- S6 CONCRETE BASE, HT. VARIES DUE TO TOPOGRAPHY
- S14 LAYERED STEEL ICON CAP
- S15 STEEL TENANT DIRECTIONAL PANEL

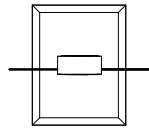

MULTI TENANT WAYFINDING SIGN - 2.5A - PLAN

1/8" = 1'-0"

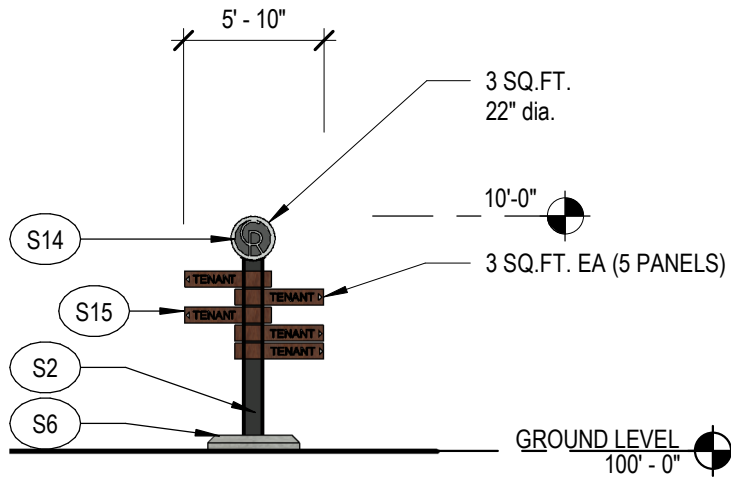

TOTAL SIGN AREA = 15 SQ.FT. PER SIDE

FREESTANDING MULTI-TENANT WAYFINDING SIGN - 2.5A - ELEVATION

1/8" = 1'-0"

## 2.6 Primary Identification Wall-Mounted Signs

User Group: Anchor Tenants, Large Format Major/Minor Retailers, Inline Retail Shops, and Pad Site tenants.

### A. General Design Requirements

1. Wall signs should be composed in such a manner as to compliment the building architecture.
2. All Anchor and Major Retail Tenants' primary wall signage panel could be subtly illuminated from external sources regardless of whether or not the letters are internally illuminated. Light sources shall be shielded from view from either above or below the sign display. The intent is to enliven the front façade by highlighting the façade's shape and profile and avoiding the illuminated sign letters from "floating" when seen at night.
3. The area of a sign shall be measured in conformance with the regulations as described below.
  - a. Signs without backing (Fig. 1): The area of signs consisting of individual letters or symbols mounted directly to the building wall shall be measured by determining the sum of the area of the smallest single continuous rectangle enclosing the extreme limits of each message. A total of eight straight lines may be used to enclose or define the sign perimeter.
  - b. The sign background and building wall shall be integral to the architecture of the building. In some cases, the sign background may contain a contrasting or alternative color to the adjacent building. (Fig. 2 & 3)
  - c. Signs with backing shall have their area calculated in the same manner as for signs without backing except when the background panel is of a distinctive color or material and its sole purpose is to enlarge the appearance of the text. In such cases, the ARC will render a decision whether or not the sign background shall be included in calculating the maximum sign area.
4. All signs shall be subject to review and prior approval by the ARC. Approval or disapproval of sign submittals based on aesthetics of design shall remain the sole right of the ARC.
5. All signs shall be constructed and installed, including electrical hook-up, at the Tenant's expense.
6. All signs work shall be done by licensed contractors only and must conform to existing codes, regulations, and permits obtained by the Tenant.

Fig. 1



Fig. 2



Fig. 3



Fig. 4

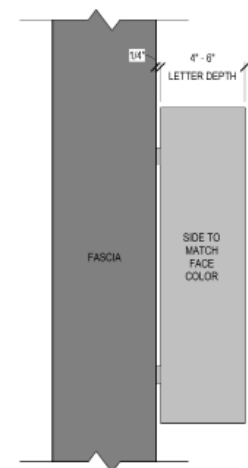

7. Design, size, layout, and materials for signs shall conform in all respects with the design drawings approved by the ARC. Any non-conforming or unapproved signs will be removed at the Tenant's expense.
8. No audible, flashing, or animated signs shall be permitted.
9. All letter fasteners to the fascia shall be concealed. All letters shall be pegged ¼" from the fascia. (Fig. 4)
10. Lowercase letters g, j, p, q, and y may extend below the text line a maximum of 50% of the letter height.
11. Each stroke shall be a minimum of 2 inches wide. The depth of letters shall not be less than 4 inches or more than 6 inches.
12. Letters shall be mounted directly to the sign fascia without an intervening raceway. All signs shall be mounted with the horizontal centerline of the display centered within the sign panel. Except for stacked lines of text the sign shall be installed to align with the adjacent sign.
13. The sides of letters shall have their color match the face of the lettering. Pan channel trim caps are to be painted with industrial enamel matte finish.
14. "Neon" tubing can be reviewed as an acceptable method of feature sign illumination but must be reviewed and approved by the ARC.
15. In order to minimize light pollution, buildings or tenants that have a wall that is immediately adjacent to Southern Rail Point, the North South street dividing Crossroads retail development from adjacent residential property, may not have internally illuminated, signage on the west façade.

B. Major Retail Buildings (between 10,000 and 40,000 sq ft.)

1. Major Retail buildings shown inline on the master site plan are allowed one primary identification wall sign on their primary entrance façade. Sign area is limited to 1.875 sq ft. per foot of building frontage. Letter height shall not exceed 72 inches.
2. Tenants that have an adjacent façade that fronts to a private roadway or parking lot are allowed an additional identification wall sign per façade, limited in area to 1.875 sq ft. per foot of building frontage. Letter height shall not exceed 60 inches.
3. No single Tenant's sign shall exceed 300 sq ft. in area.
4. Multi-tenant Major Retail sign area is limited to 1.875 sq ft. per foot of building frontage with Tenant frontage determined by the length of a Tenant's demised frontage.
5. No individual Tenant's sign in a Multi-tenant building shall exceed 200 sq ft. in area.

#### D. Multi-Tenant Retail Buildings (between 1000 and 10,000 sq ft.)

1. Retail buildings divided into Multi-Tenant spaces are allowed identification wall signage for each Tenant. Tenants are allowed two principal identification wall signs; one installed above their primary entrance storefront and the other on their opposite or secondary frontage.
2. Sign area is limited to 1.875 sq ft. times the length of their Tenant frontage. Letter height shall not exceed 24 inches.
3. No individual sign shall exceed 20 sq ft.
4. Tenants that have an adjacent façade that fronts a second public or private roadway are allowed one additional wall sign and limited in area to 1.875 sq ft. in area times the façade length but no larger than their primary identification wall sign area. Letter height shall not exceed 24 inches.
5. Tenant signs in a multi-Tenant building shall be separated from one another by a minimum of 5 feet and shall not extend within 2 ½ feet of the demised premise, line, or unless approved otherwise by the ARC. (Fig. 5)
6. Tenant signage shall not be located within 5 feet of the ends of the building or within the dedicated structural module at the ends of the building. (Fig. 5)

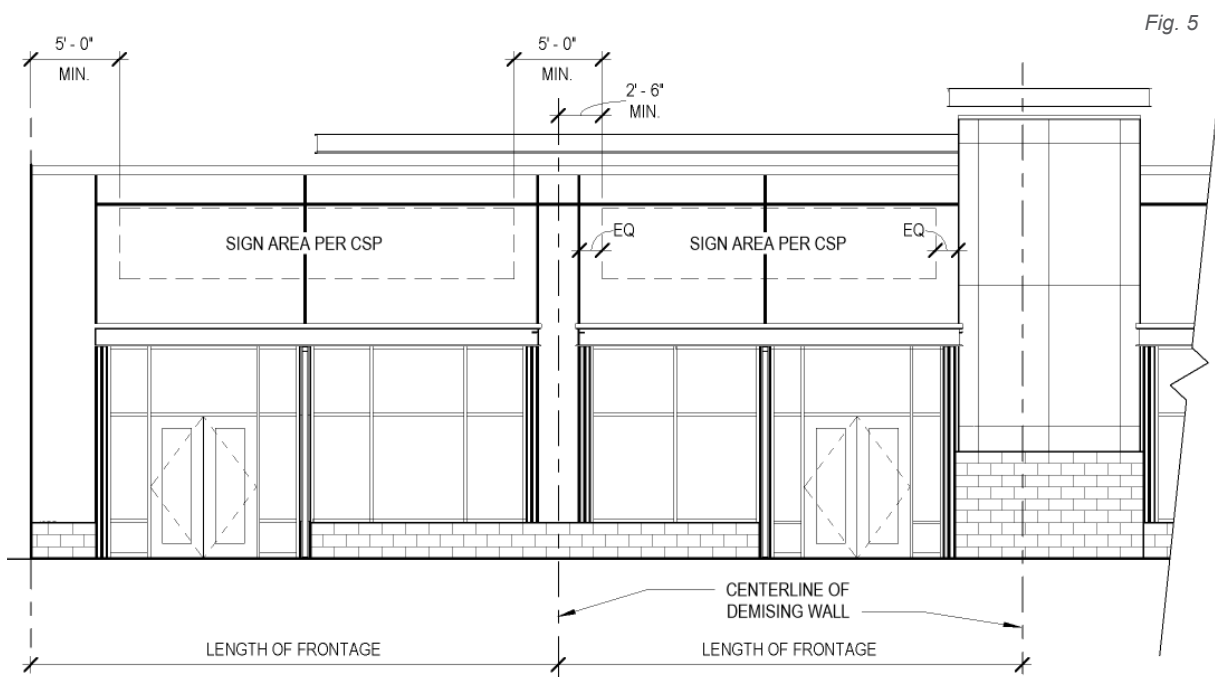

**E. Pad Site Buildings** (between 1000 and 10,000 sq ft.)

1. Individual and Multi-Tenant Pad Site buildings are allowed two principal identification wall signs. One sign shall be installed on their primary entrance façade, the other on the opposite or secondary façade.
2. Sign area is limited to 1.875 sq ft. per foot of building frontage. Letter height shall not exceed 36 inches.
3. No individual sign shall exceed 140 sq ft.
4. Single Tenant buildings fronting a second public or private street shall be allowed one additional identification wall sign but limited in area to 1.875 sq ft. times the length of the secondary façade. Letter height shall not exceed 30 inches.



## 2.7 Secondary Identification Signs

User Group: Pad Site Buildings, In-line Retail Buildings, Major retail Buildings and Retail Anchors

### A. General Requirements

1. Secondary signage is smaller in scale, pedestrian-oriented, and helps create a more welcoming and informative environment for guests.
2. Secondary signage should state the business identity or type of business and is encouraged under all entrance canopies, arcades and porticos. Secondary sign area shall not count towards the primary identification or wall sign area. Tenants are allowed up to a maximum 10% of their allowable primary ID signage for secondary sign area.
3. Secondary under-canopy signs shall be located above entrances and below canopies for Multi-Tenant Inline buildings and constructed in the project standard format with steel. Large-format Retail Tenants that have individual entrance canopies may face their sign toward the primary parking field.
4. Awning, blade, window, plaque, suspended, and changeable signs are also highly encouraged and will be reviewed by the ARC on a case-by-case basis.
5. All secondary signs shall be non-illuminated. Sign colors, graphics, and letter fonts shall be submitted for review by the ARC.

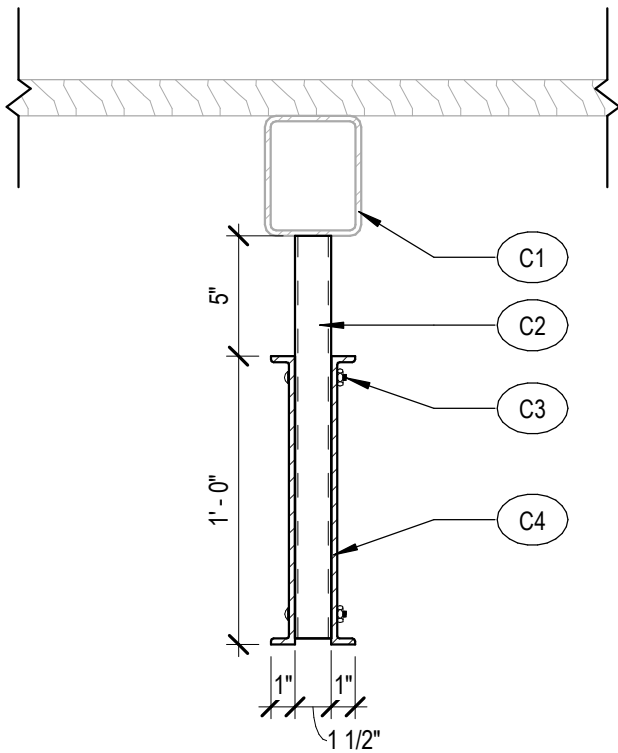

### KEYNOTE LEGEND

- C1 CANOPY STRUCTURE
- C2 1 1/2" STEEL TUBE
- C3 THROUGH BOLT CONNECTION
- C4 12" STEEL CHANNEL
- C5 6" VINYL TENANT COPY

### REQUIRED UNDER CANOPY SIGN - 2.7A - SECTION

1 1/2" = 1'-0"

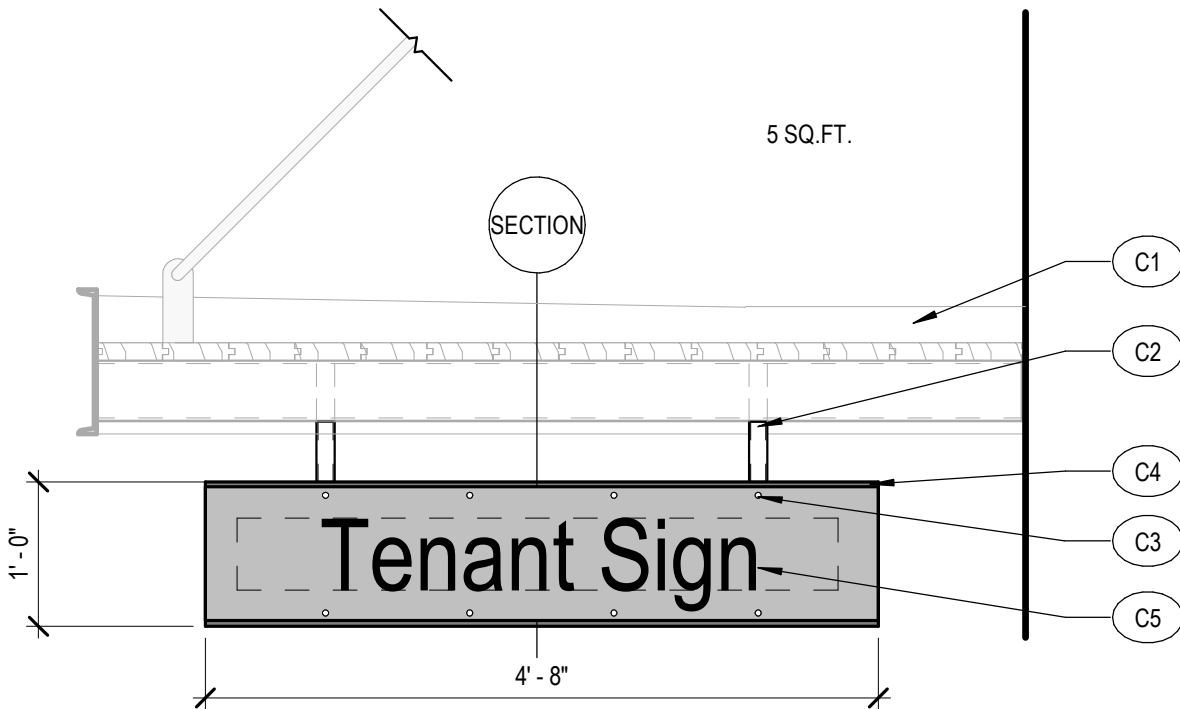

### REQUIRED UNDER CANOPY SIGN - 2.7A - ELEVATION

3/4" = 1'-0"



CROSSROADS