



**EL PASO COUNTY DEVELOPMENT SERVICES DEPARTMENT
SIGN APPLICATION**

DATE: 7/24/18

Business

Name: Allstate
Address: 7685 McLaughlin Rd., Ste. 120
Peyton, CO 80831

Zone: PBC
Legal Description: LOT 1, WOODMEN HILLS, EIL NO 7J

Type of Sign

Illuminated: X
Non-Illuminated:
Valuation: \$9,500.00

Storefront Length &/or Width: 19'-1/2"

Proposed Sign Sq. Ft. 67.5

Existing Sign Sq. Ft.

Total Sign Sq. Ft. 67.5

Contractor Information

Name: **SPECTRUM**
Address: 2255 Spectra Dr.
Colorado Springs, CO 80904
Phone: 719-520-5167
Type of License: D5A
Contractor ID#: 11425

Vicinity Map
Tax Schedule # 4307210006
Please show major intersections.



Elevation Drawing

Indicate storefront length & placement of sign.

SEE ATTACHED

Sign Plan

(Please indicate dimensions and sign copy)

Sign 1

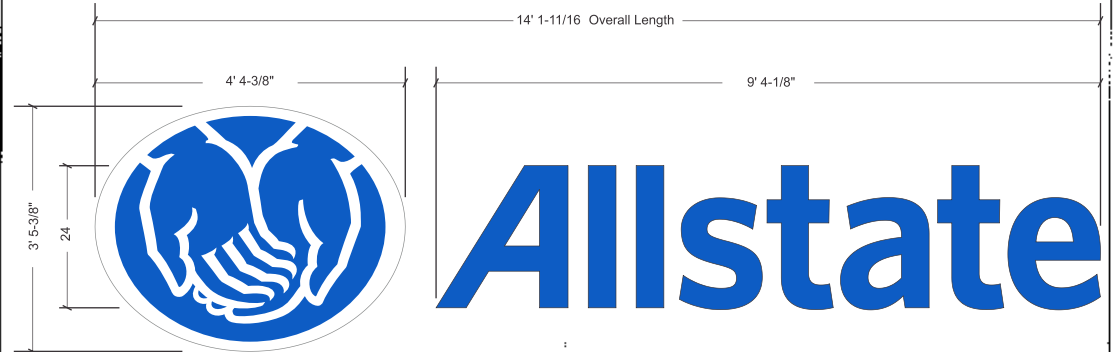

Sign 2

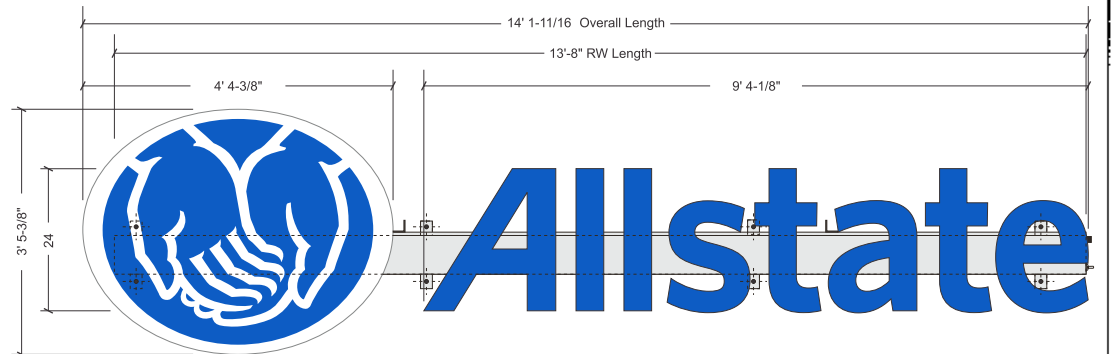

For Development Services Use Only

Approved Date: _____ Resubmittal? Yes _____ No _____
Denied Date: _____
Comments: _____

Fee of \$262.00 must accompany this Application. Additional signs at time of first Application are \$125.00. Make checks payable to El Paso County.

Sign 1



WEST ELEVATION

Sign 2



EAST ELEVATION